

REAR AXLE AND REAR SUSPENSION

SECTION RA

CONTENTS

PRECAUTIONS AND PREPARATION	2	Inspection	12
Precautions.....	2	Strut Assembly.....	12
Special Service Tools	2	Upper Rubber Seat And Bushing	13
Commercial Service Tools.....	3	Strut Mounting Insulator	13
REAR AXLE AND REAR SUSPENSION	4	Coil Spring	13
ON-VEHICLE SERVICE	5	Assembly	13
Rear Axle and Rear Suspension Parts.....	5	REAR SUSPENSION — Parallel Link, Radius	
Rear Wheel Bearing	5	Link and Stabilizer Bar	14
Rear Wheel Alignment.....	6	Removal and Installation	14
Preliminary Inspection	6	Parallel Link And Radius Link.....	14
Camber	6	Stabilizer Bar	14
Toe-In.....	6	SERVICE DATA AND SPECIFICATIONS (SDS)	15
REAR AXLE — Wheel Hub	8	General Specifications	15
Removal	8	Coil Spring	15
Installation	9	Stabilizer Bar	15
REAR SUSPENSION	10	Strut.....	15
Removal and Installation	11	Inspection and Adjustment	15
REAR SUSPENSION — Coil Spring and Strut		Wheel Alignment (Unladen*).....	15
Assembly	12	Wheel Bearing	15
Disassembly	12		

GI

MA

EM

LC

EF &
EC

FE

CL

MT

AT

FA

RA

BR

ST

BF

HA

EL

IDX

PRECAUTIONS AND PREPARATION

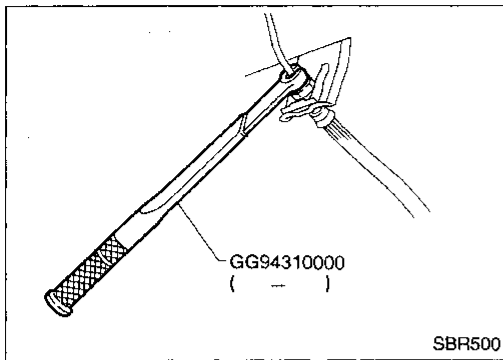

Precautions

- When installing rubber parts, final tightening must be carried out under unladen condition* with tires on ground.
- *: Fuel, radiator coolant and engine oil full. Spare tire, jack, hand tools and mats in designated positions.
- When removing each suspension part, check wheel alignment and adjust if necessary.
- Do not jack up at the parallel links.
- Use flare nut wrench when removing or installing brake tubes.
- Always torque brake lines when installing.

Special Service Tools

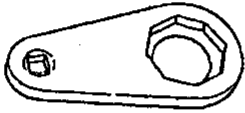
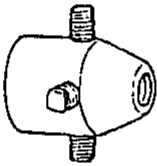
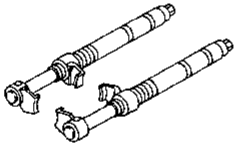
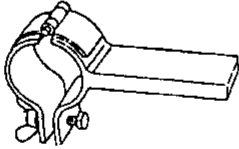
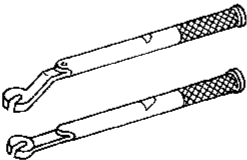
Tool number (Kent-Moore No.) Tool name	Description	
ST35490000 (J26083) Gland packing wrench		Removing and installing gland packing
KV401021S0 (-) Bearing race drift		Installing wheel bearing outer race
HT71780000 (-) Spring compressor		Removing and installing coil spring
ST35652000 (-) Strut attachment		Fixing strut assembly
GG94310000 (-) Flare nut wrench		Removing and installing brake piping

PRECAUTIONS AND PREPARATION

Commercial Service Tools

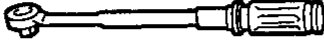
Tool name	Description	
Flare nut crows foot		GI MA
Torque wrench		EM LC
		EF & EC
		FE
		CL
		MT
		AT
		FA
		RA
		BR
		ST
		BF
		HA
		EL
		IDX

REAR AXLE AND REAR SUSPENSION

When installing rubber parts, final tightening must be carried out under unladen condition* with tires on ground.

* Fuel, radiator coolant and engine oil full.
Spare tire, jack, hand tools and mats in designated positions.

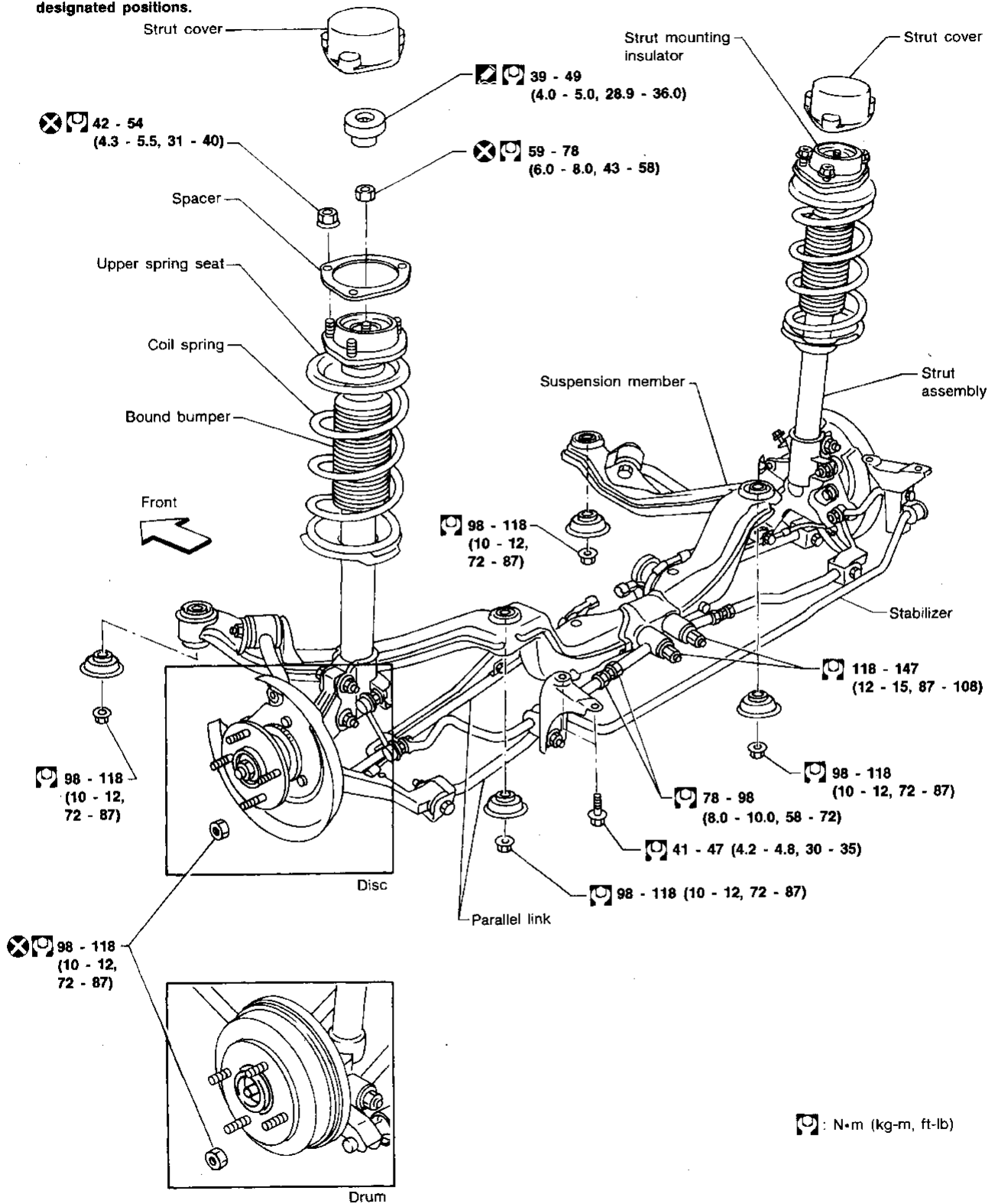

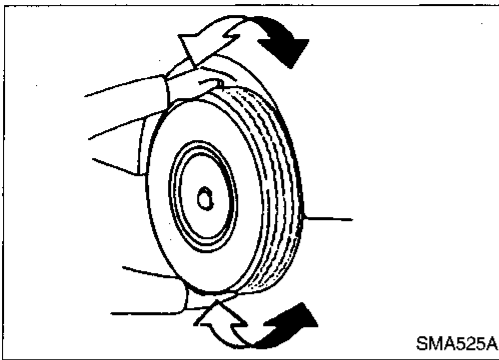

Rear Axle and Rear Suspension Parts

Check axle and suspension parts for looseness, wear or damage.

- Shake each rear wheel to check excessive play.

- Retighten all nuts and bolts to the specified torque.
Tightening torque: Refer to RA-10.

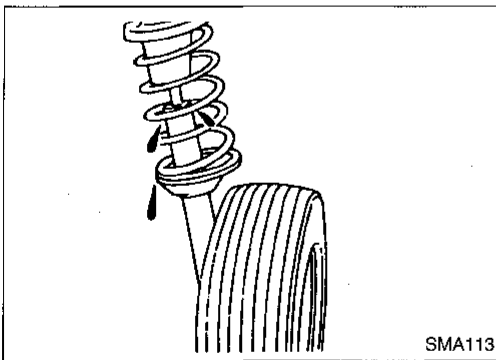
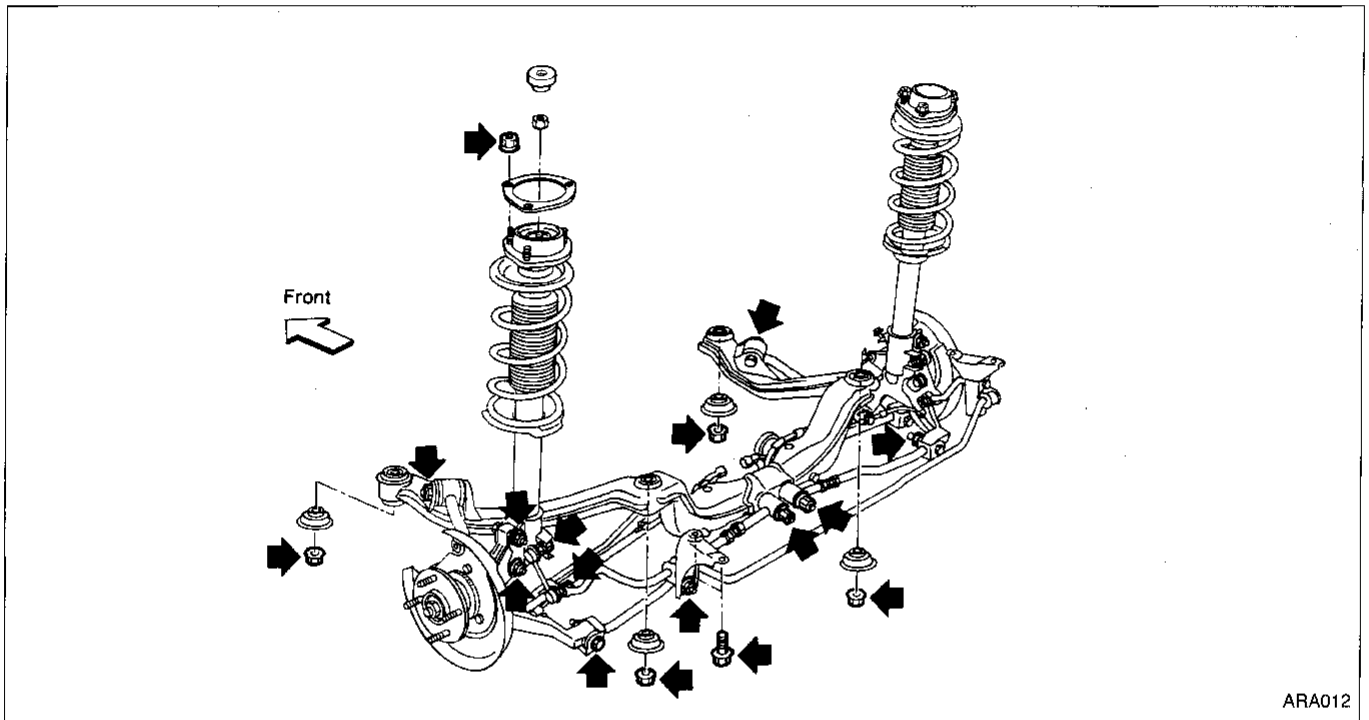

- Check strut (shock absorber) for oil leakage or other damage.
- Check wheelarch height. Refer to FA section ("Front Axle and Front Suspension Parts", "ON-VEHICLE SERVICE").

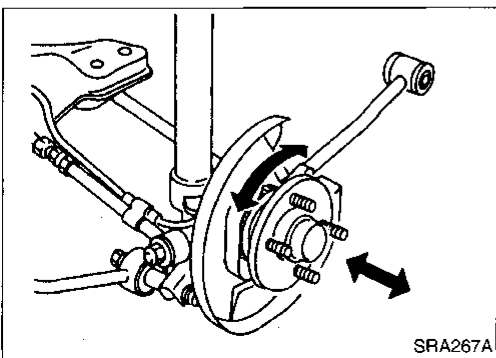

Rear Wheel Bearing

- Check axial end play.

Axial end play:

0.05 mm (0.0020 in) or less

- Check that wheel bearings operate smoothly.
- Check tightening torque of wheel bearing lock nut.

⌘: 186 - 255 N·m

(19 - 26 kg-m, 137 - 188 ft-lb)

- If there is any axial end play or wheel bearing does not turn smoothly, replace wheel bearing assembly. Refer to RA-8.

GI
MA
EM
LC
EF &
EC
FE
CL
MT
AT
FA
RA
BR
ST
BF
HA
EL
IDX

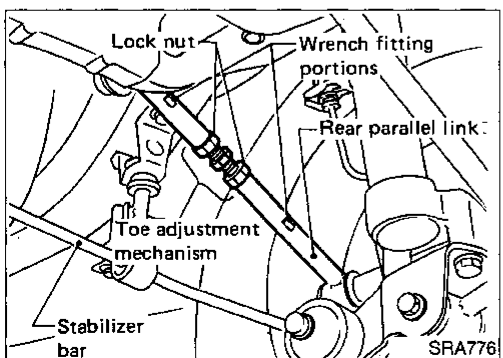
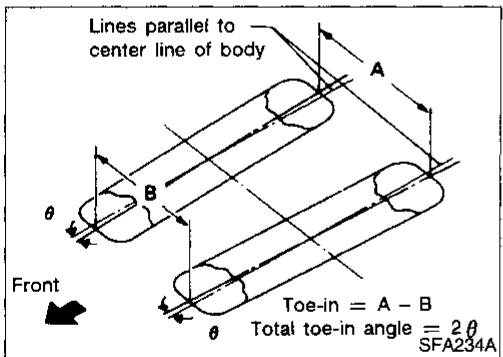
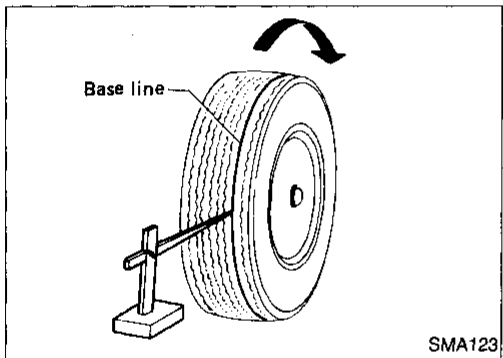
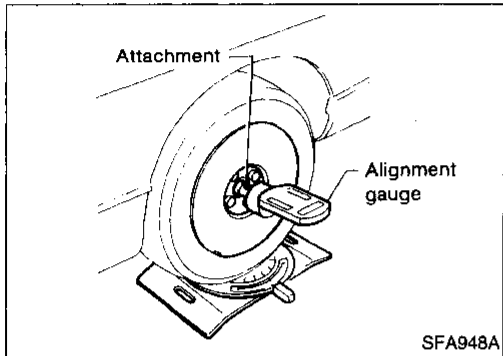
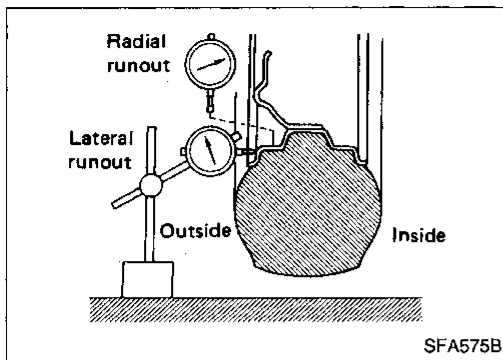

Rear Wheel Alignment

PRELIMINARY INSPECTION

Make following checks. Adjust, repair or replace if necessary.

- Check tires for wear and for improper inflation.
- Check rear wheel bearings for looseness.
- Check wheel runout.

Wheel runout: Refer to FA section ("Inspection and Adjustment", "SDS").

- Check that rear strut (shock absorber) works properly.
- Check rear axle and rear suspension parts for looseness.
- Check vehicle posture (Unladen*).

*: Fuel, radiator and engine oil full. Spare tire, jack, hand tools and mats in designated positions.

CAMBER

Camber is preset at factory and cannot be adjusted.

Camber:

Refer to SDS, RA-15.

- If the camber is not within specification, inspect and replace any damaged or worn rear suspension parts.

TOE-IN

1. Draw a base line around the tread.
- After lowering rear of vehicle, move it up and down to eliminate friction.

2. Measure toe-in.
- Measure distance "A" and "B" at the same height as hub center.

Toe-in:

Refer to SDS, RA-15.

3. Adjust toe-in by varying the lengths of rear parallel links.

ON-VEHICLE SERVICE

Rear Wheel Alignment (Cont'd)

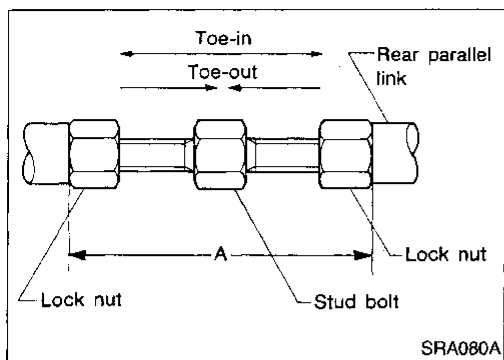

- Adjust left and right rear parallel links to the same length "A".
- Tighten lock nut while holding rear parallel link with wrench to prevent bushing from twisting.

Standard length "A":

50 - 55 mm (1.97 - 2.17 in)

GI

MA

EM

LC

EF &
EC

FE

CL

MT

AT

FA

RA

BR

ST

BF

HA

EL

IDX

REAR AXLE — Wheel Hub

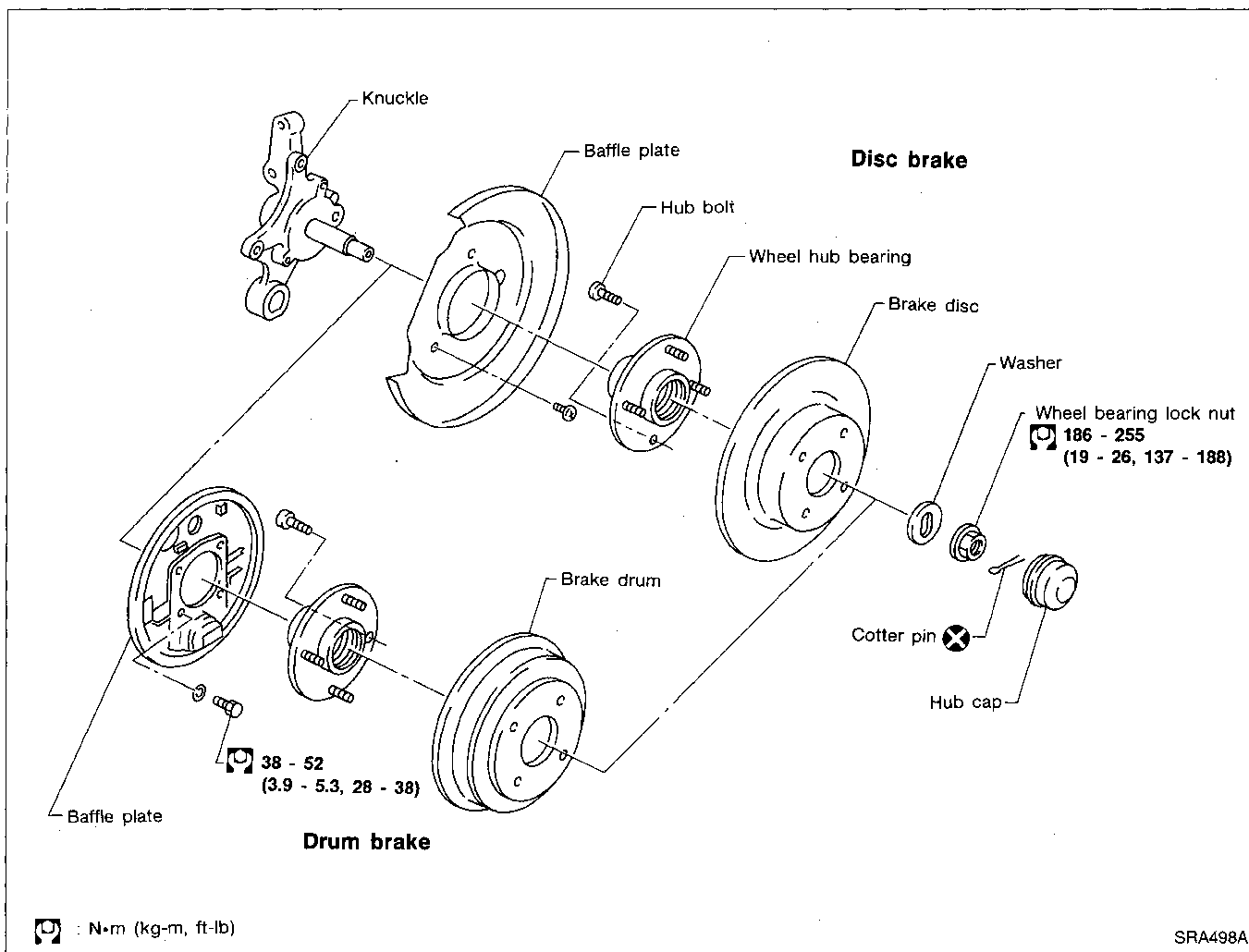

Removal

CAUTION:

Wheel hub bearing usually does not require maintenance. If any of the following occurs, replace wheel hub bearing assembly.

- Growling noise is emitted from wheel hub bearing during operation.
- Wheel hub bearing drags or turns roughly when hub is turned with your hand after bearing lock nut is tightened to specified torque.
- Wheel hub bearing is removed from knuckle spindle.

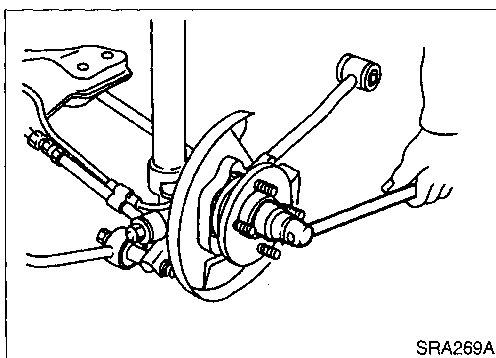

- 1) Remove brake caliper assembly.
- 2) Remove wheel bearing lock nut.

Brake hose does not need to be disconnected from brake caliper.

Be careful not to depress brake pedal, or piston will pop out. Make sure brake hose is not twisted.

REAR AXLE — Wheel Hub

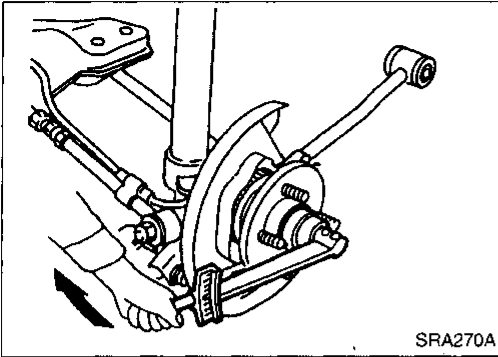

Installation

- Install wheel hub bearing.
- Tighten wheel bearing lock nut.
⚙️: 186 - 255 N·m
(19 - 26 kg-m, 137 - 188 ft-lb)
- Check that wheel bearings operate smoothly.

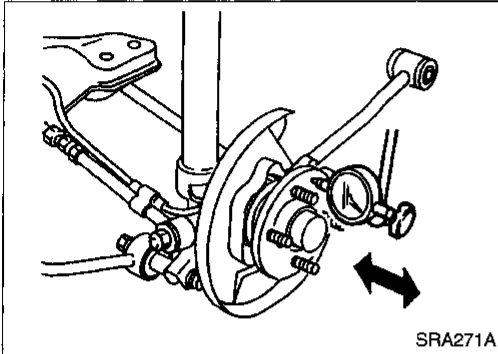

- Check wheel bearing axial end play.
Axial end play:
0.05 mm (0.0020 in) or less

GI

MA

EM

LC

EF &
EC

FE

CL

MT

AT

FA

RA

BR

ST

BF

HA

EL

IDX

REAR SUSPENSION

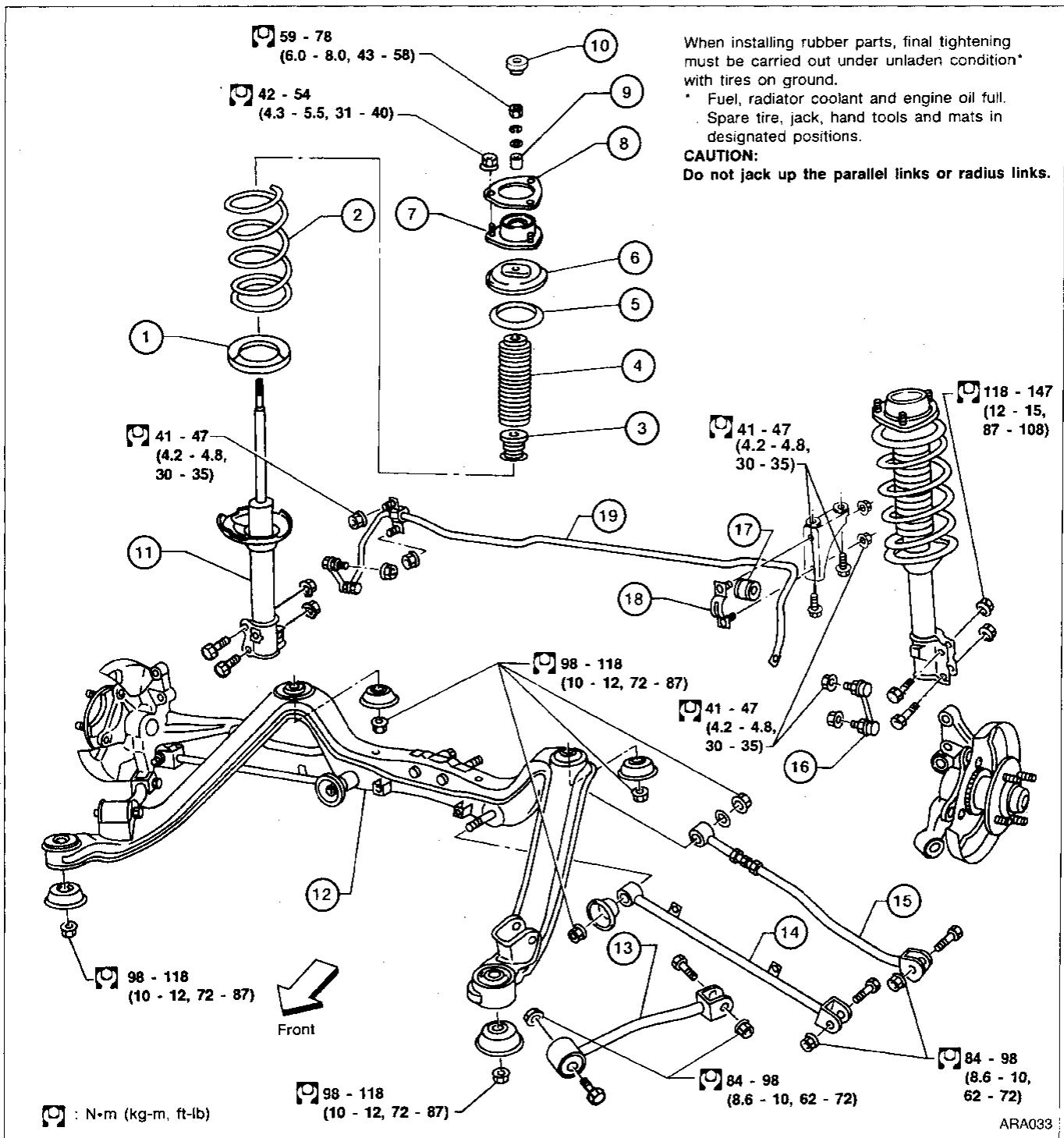

- | | | |
|----------------------------|----------------------------|-----------------------|
| ① Lower spring rubber seat | ⑦ Strut mounting insulator | ⑬ Radius link |
| ② Coil spring | ⑧ Spacer | ⑭ Front parallel link |
| ③ Bound bumper | ⑨ Strut mounting collar | ⑮ Rear parallel link |
| ④ Dust cover | ⑩ Strut damper | ⑯ Connecting rod |
| ⑤ Upper spring rubber seat | ⑪ Strut assembly | ⑰ Bushing |
| ⑥ Upper spring seat | ⑫ Suspension member | ⑱ Clamp |
| | | ⑲ Stabilizer bar |

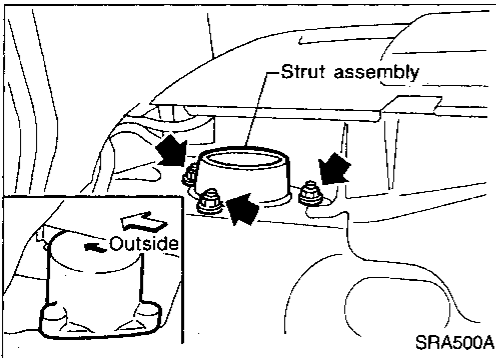
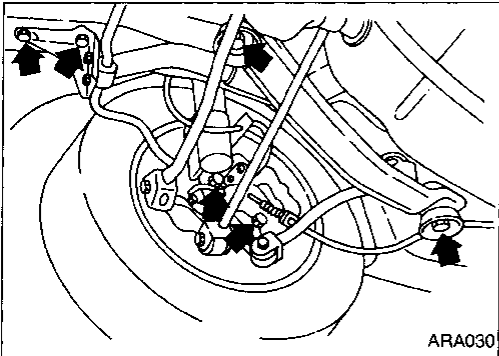
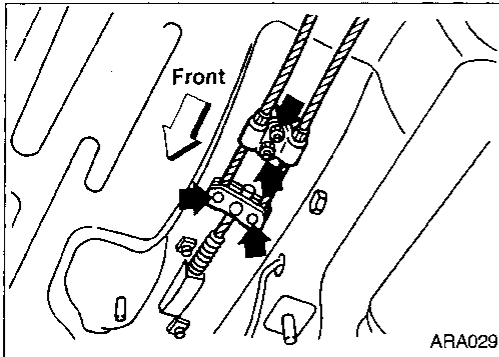

Removal and Installation

CAUTION:

Do not jack up at the parallel links or radius links.

- Disconnect brake hydraulic line and parking brake cable at equalizer. (Models with rear drum brake.)

- Remove suspension assembly.

- 1) Disconnect parking brake cable from caliper. (Models with rear disc brake.)
- 2) Remove brake caliper assembly. (Models with rear disc brake.)

Brake hose need not be disconnected from brake caliper. Be careful not to depress brake pedal, or piston will pop out. Make sure brake hose is not twisted.

- 3) Remove parking brake cable fixing bolts. (Models with rear drum brake.)
- 4) Remove stabilizer fixing bolts and suspension member fixing bolts.
- 5) Remove rear seat. Refer to BF section ("Rear Seat", "SEAT").
- 6) Remove rear parcel shelf. Refer to BF section ("Interior", "INTERIOR AND EXTERIOR").

- 7) Remove strut securing nuts (Upper side). Then pull out strut assembly.

Do not remove piston rod lock nut on vehicle.

GI

MA

EM

LC

EF &

EC

FE

CL

NT

AT

FA

RA

BR

ST

BF

HA

EL

IDX

REAR SUSPENSION — Coil Spring and Strut Assembly

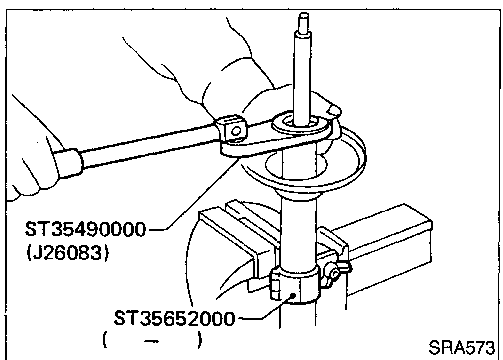
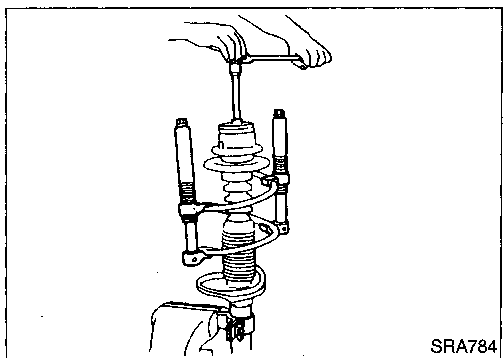
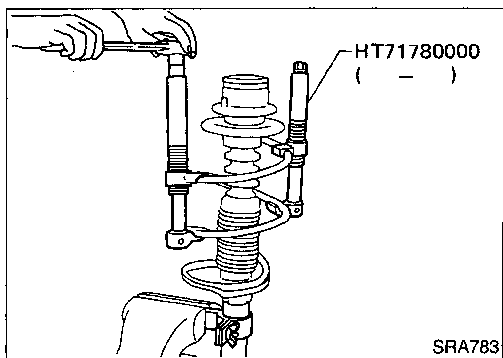
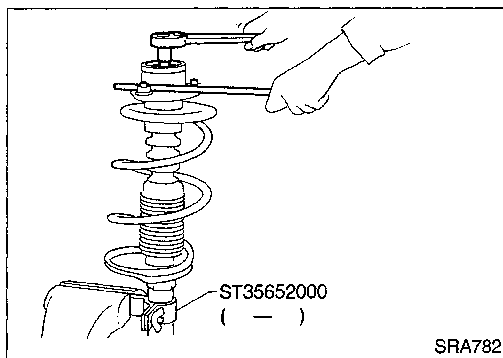

Disassembly

1. Set strut assembly in vise with attachment, then **loosen** piston rod lock nut.

Do not remove piston rod lock nut at this time.

2. Compress spring with Tool so that the strut mounting insulator can be turned by hand.

3. Remove piston rod lock nut.

4. Remove gland packing with Tool.

Avoid getting dirt and dust into gland packing portion.

5. Retract piston rod by pushing it down until it bottoms. Then, slowly withdraw piston rod from cylinder together with piston guide.

Inspection

STRUT ASSEMBLY

- Check for smooth operation through a full stroke, both compression and extension.
- Check for oil leakage occurring on welded or gland packing portions.
- Check piston rod for cracks, deformation or other damage. Replace if necessary.

REAR SUSPENSION — Coil Spring and Strut Assembly

Inspection (Cont'd)

UPPER RUBBER SEAT AND BUSHING

Check rubber parts for deterioration or cracks.
Replace if necessary.

GI

STRUT MOUNTING INSULATOR

- Check cemented rubber-to-metal portion for melting or cracks.
- Check rubber parts for deterioration.

MA

EM

COIL SPRING

Check for cracks, deformation or other damage.
Replace if necessary.

LC

EF &
EC

FE

CL

MT

AT

FA

RA

BR

ST

BF

HA

EL

IDX

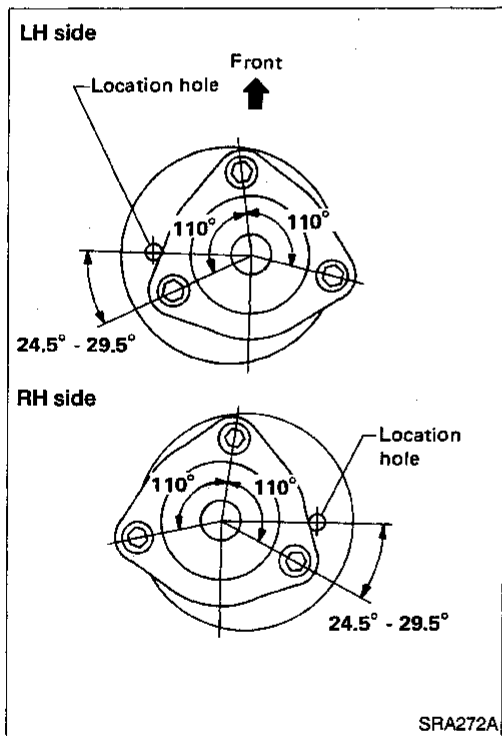

Assembly

1. Locate upper spring seat as shown.

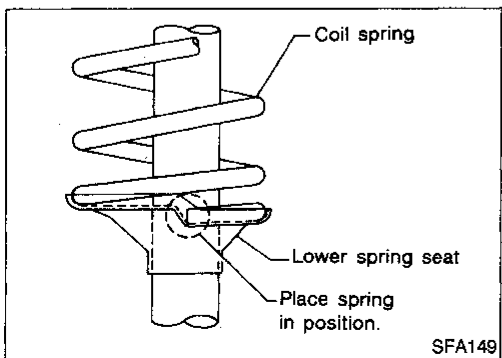

2. After placing coil spring in position on lower spring seat, release spring compressor gradually.

REAR SUSPENSION — Parallel Link, Radius Link and Stabilizer Bar

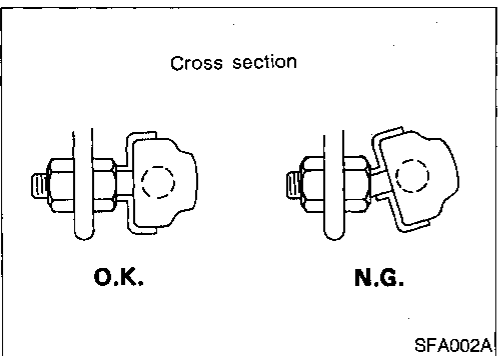
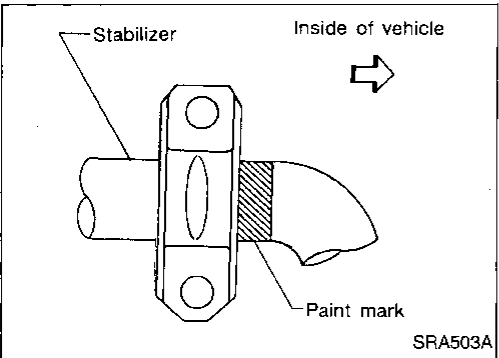
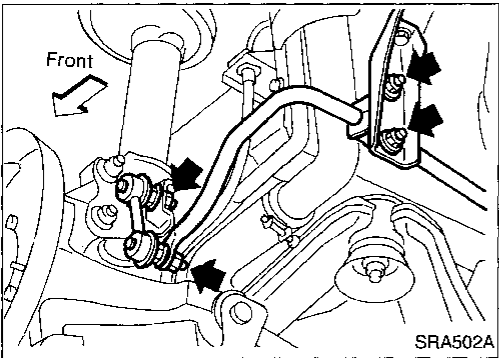
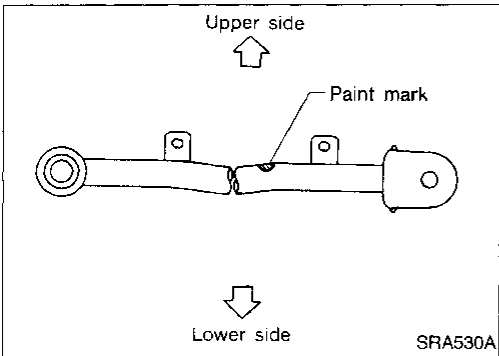
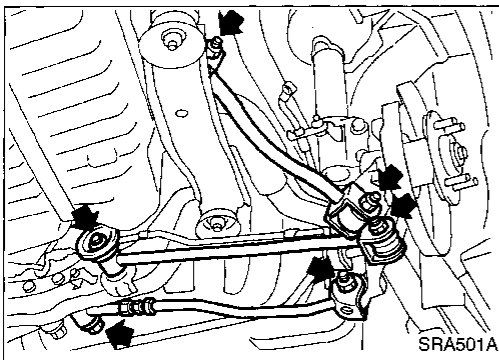

Removal and Installation

PARALLEL LINK AND RADIUS LINK

- Remove parallel link and radius link.
- Models without ABS —
- When installing front parallel link, make sure that paint mark faces in the correct direction.
- During installation, final tightening must be carried out at curb weight with tires on the ground.
- After installation, check wheel alignment. Refer to RA-6.
- Check parallel link for cracks, deformation or other damage. Replace if necessary.
- Check radius link for cracks, deformation or other damage. Replace if necessary.

STABILIZER BAR

- Remove stabilizer bar.
- When installing stabilizer, align paint marks with inside edge of clamps.
- Install stabilizer bar with ball joint socket properly placed.

SERVICE DATA AND SPECIFICATIONS (SDS)

General Specifications

COIL SPRING

Applied model		XE/GLE/GXE	SE
Wire diameter	mm (in)	11.9 (0.469)	12.2 (0.480)
Coil diameter	mm (in)	141.8 (5.58)	142.4 (5.61)
Free length	mm (in)	315 (12.40)	303.5 (11.95)
Spring constant	N/mm (kg/mm, lb/in)	19.6 (2.0, 112)	21.6 (2.2, 123)
Identification color		Yellow x 2	Yellow x 1, Pink x 1

STABILIZER BAR

Applied model		XE/GLE/GXE	SE
Diameter	mm (in)	15 (0.59)	16 (0.63)

STRUT

Applied model		SE	XE/GLE/GXE
Piston rod diameter	mm (in)	22 (0.87)	
Damping force [at 0.3 m (1.0 ft)/sec.]	N (kg, lb)		
Expansion		765 - 1,040 (78 - 106, 172 - 234)	608 - 824 (62 - 84, 137 - 185)
Compression		363 - 539 (37 - 55, 82 - 121)	265 - 402 (27 - 41, 60 - 90)

Inspection and Adjustment

WHEEL ALIGNMENT (Unladen*)

Applied model		All
Camber	degree	- 2°00' to - 0°30'
Toe-in		
A - B	mm (in)	1 - 3 (0.04 - 0.12)
Total angle 2θ	degree	6' - 18'

* Fuel, radiator coolant and engine oil full.
Spare tire, jack, hand tools and mats in designated positions.

WHEEL BEARING

Applied model		All
Wheel bearing axial end play	mm (in)	0.05 (0.0020) or less
Wheel bearing lock nut tightening torque	N•m (kg-m, ft-lb)	186 - 255 (19 - 26, 137 - 188)

GI
MA
EM
LC
EF &
EC
FE
CL
MT
AT
FA
RA
BR
ST
BF
HA
EL
IDX