

# FRONT AXLE & FRONT SUSPENSION

## SECTION **FA**

### CONTENTS

<b>PRECAUTIONS AND PREPARATION</b> .....	2	Boot .....	17	GI
Precautions .....	2	Joint assembly (Transaxle side) .....	17	MA
Special Service Tools.....	2	Joint assembly (Wheel side).....	17	EM
Commercial Service Tools .....	2	Support bearing.....	17	LC
<b>FRONT AXLE AND FRONT SUSPENSION</b> .....	3	Support bearing bracket.....	17	EC
<b>ON-VEHICLE SERVICE</b> .....	4	Assembly .....	17	FE
Front Axle and Front Suspension Parts .....	4	Wheel side.....	18	CL
Front Wheel Bearing.....	5	Transaxle side .....	19	MT
Front Wheel Alignment .....	5	Support bearing.....	20	AT
Preliminary Inspection .....	6	<b>FRONT SUSPENSION</b> .....	21	FA
Camber, Caster And Kingpin Inclination .....	6	Coil Spring and Strut Assembly .....	22	RA
Toe-In .....	6	Removal And Installation.....	22	BR
Front Wheel Turning Angle.....	7	Disassembly .....	22	ST
Drive Shaft.....	7	Inspection .....	22	RS
<b>FRONT AXLE</b> .....	8	Strut assembly.....	22	BT
Wheel Hub and Knuckle .....	9	Strut mounting insulator .....	23	HA
Removal.....	9	Thrust bearing .....	23	EL
Installation.....	10	Coil spring and insulator .....	23	IDX
Disassembly .....	10	Assembly .....	23	
Wheel hub .....	10	Stabilizer Bar.....	24	
Wheel bearing .....	11	Removal And Installation.....	24	
Inspection .....	11	Inspection .....	24	
Wheel hub and knuckle.....	11	Transverse Link and Lower Ball Joint .....	25	
Snap ring .....	11	Removal And Installation.....	25	
Assembly .....	12	Inspection .....	25	
Drive Shaft .....	13	<b>SERVICE DATA AND SPECIFICATIONS (SDS)</b> .....	26	
Removal.....	13	General Specifications .....	26	
Installation.....	14	Coil Spring .....	26	
Transaxle side .....	14	Strut .....	26	
Wheel side.....	14	Front Stabilizer Bar.....	26	
Components .....	15	Wheelarch Height.....	26	
Disassembly .....	15	Drive Shaft.....	26	
Transaxle side .....	15	Inspection and Adjustment.....	27	
Wheel side.....	16	Wheel Alignment.....	27	
Support bearing.....	16	Wheel Bearing .....	27	
Inspection .....	17	Lower Ball Joint.....	27	
Drive shaft.....	17	Wheel Runout.....	27	

## PRECAUTIONS AND PREPARATION

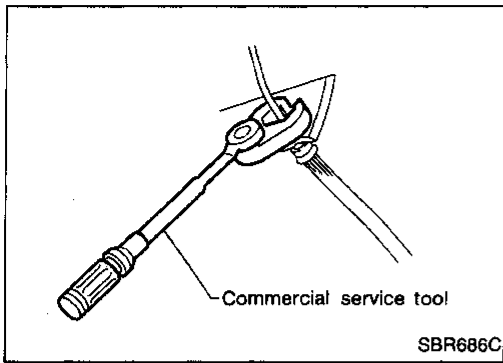

### Precautions

- When installing rubber parts, final tightening must be carried out under unladen condition\* with tires on ground.
- \*: Fuel, radiator coolant and engine oil full. Spare tire, jack, hand tools and mats in designated positions.
- When removing each suspension part, check wheel alignment and adjust if necessary.
- Use flare nut wrench when removing or installing brake tubes.
- Always torque brake lines when installing.

### Special Service Tools

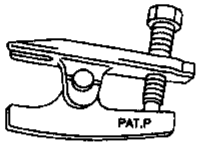
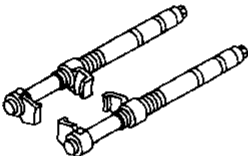
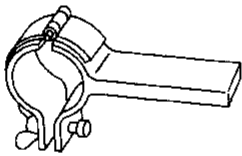
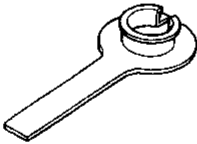
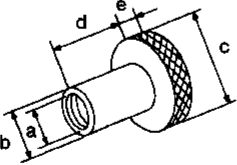
Tool number (Kent-Moore No.) Tool name	Description
HT72520000 (J25730-A) Ball joint remover	 <p style="text-align: right;">Removing tie-rod outer end and lower ball joint</p>
HT71780000 ( — ) Spring compressor	 <p style="text-align: right;">Removing and installing coil spring</p>
ST35652000 ( — ) Strut attachment	 <p style="text-align: right;">Fixing strut assembly</p>
KV38106700 (J34296) KV38106800 (J34297) Differential side oil seal protector	 <p style="text-align: right;">Installing drive shaft</p> <p style="text-align: right;">LH: KV38106700 RH: KV38106800</p>
IM23600800 Attachment Wheel Alignment	 <p style="text-align: right;">Measure wheel alignment</p> <p style="text-align: right;">a: Screw m24 x 1.5 b: 35 (1.38) dia. c: 65 (2.56) dia. d: 56 (2.20) e: 12 (0.47)      Unit: mm (in)</p>

### Commercial Service Tools

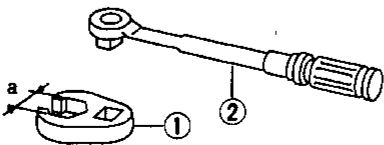
Tool name	Description
① Flare nut crows foot ② Torque wrench	 <p style="text-align: right;">Removing and installing each brake piping</p> <p style="text-align: right;">a: 10 mm (0.39 in)</p>

# FRONT AXLE AND FRONT SUSPENSION

When installing rubber parts, final tightening must be carried out under unladen condition\* with tires on ground.

- \* Fuel, radiator coolant and engine oil full.
- Spare tire, jack, hand tools and mats in designated positions.

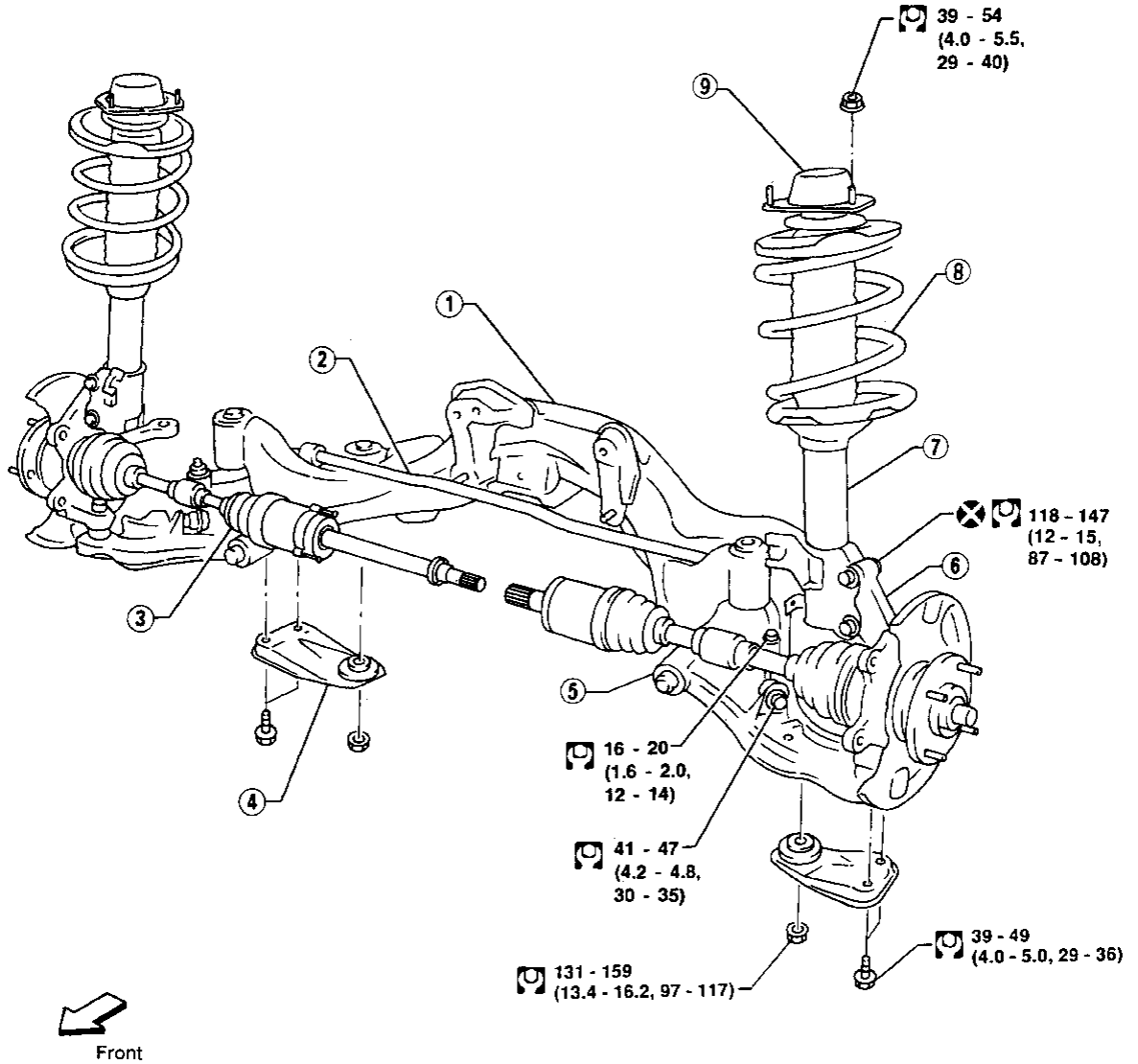

: N·m (kg·m, ft·lb)

AFA038

- ① Suspension member
- ② Stabilizer bar
- ③ Drive shaft

- ④ Rebound stopper
- ⑤ Transverse link
- ⑥ Knuckle

- ⑦ Strut assembly
- ⑧ Coil spring
- ⑨ Strut mounting insulator assembly

GI  
MA  
EM  
LC  
EC  
FE  
CL  
MT  
AT  
FA  
RA  
BR  
ST  
RS  
BT  
HA  
EL  
IDX

## Front Axle and Front Suspension Parts

Check front axle and front suspension parts for looseness, cracks, wear or other damage.

- Shake each front wheel to check for excessive play.

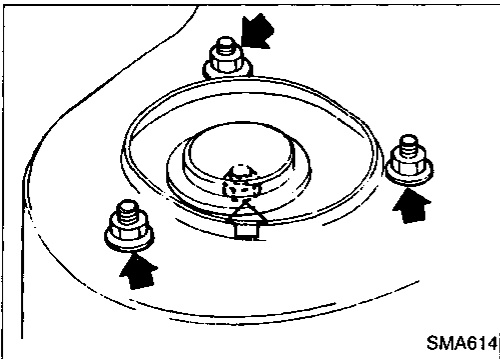
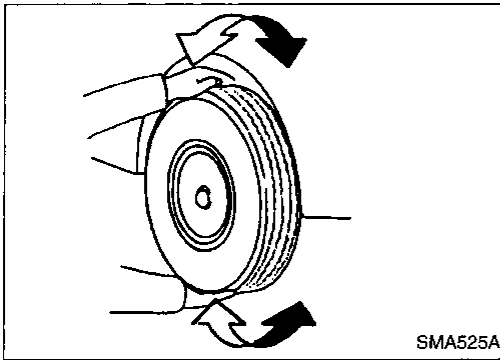

- Make sure that cotter pin is inserted.
- Retighten all nuts and bolts to the specified torque.

**Tightening torque:**  
Refer to FA-21.

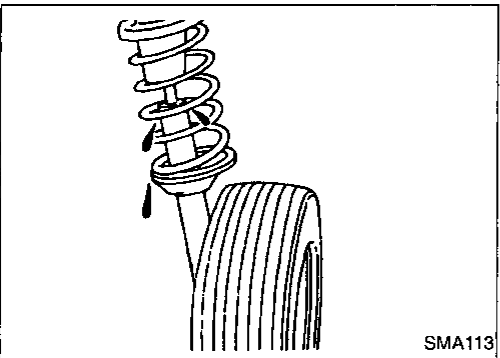
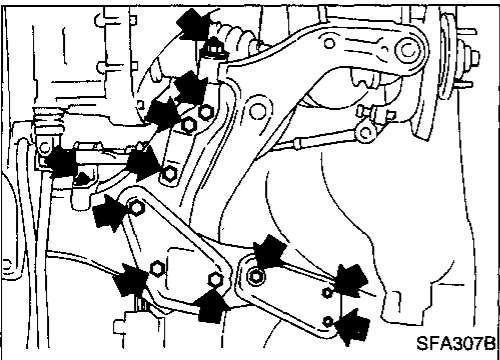

- Check strut (shock absorber) for oil leakage or other damage.

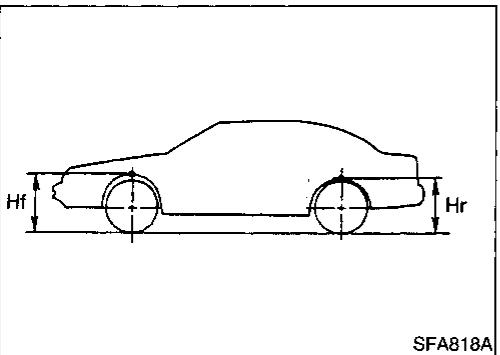

- Check spring height from top of wheelarch to ground using the following procedure.

a. Park vehicle on a level surface with unladen\*.

\*: Fuel, radiator coolant and engine oil full. Spare tire, jack, hand tools and mats in designated positions.

b. Check tires for proper inflation and wear (tread wear indicator must not be showing).

c. Bounce vehicle up and down several times and measure dimensions Hf and Hr. Refer to FA-26.

Spring height is not adjustable. If out of specification, check for worn springs or suspension parts.

## ON-VEHICLE SERVICE

### Front Axle and Front Suspension Parts (Cont'd)

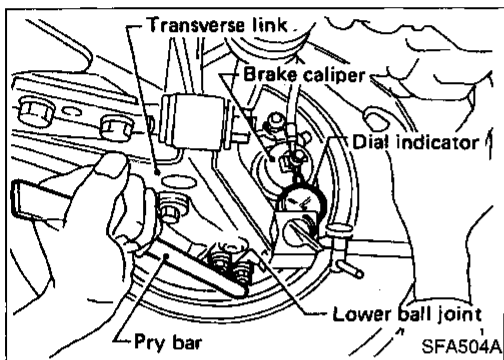
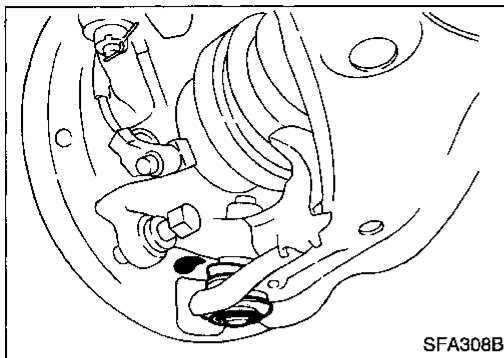

- Check suspension ball joint for grease leakage and ball joint dust cover for cracks or other damage. If ball joint dust cover is cracked or damaged, replace transverse link.

GI

MA

EM

LC

- Check suspension ball joint end play.
  - a. Jack up front of vehicle and set the stands.
  - b. Clamp dial indicator onto transverse link and place indicator tip on lower edge of brake caliper.
  - c. Make sure front wheels are straight and brake pedal is depressed.
  - d. Place a pry bar between transverse link and inner rim of road wheel.
  - e. While raising and releasing pry bar, observe maximum dial indicator value.

EC

FE

CL

#### Vertical end play:

**0 mm (0 in)**

If ball joint vertical end play exists, remove the transverse link and recheck the ball joint. Refer to FA-25.

MT

AT

**FA**

RA

BR

ST

RS

BT

HA

EL

IDX

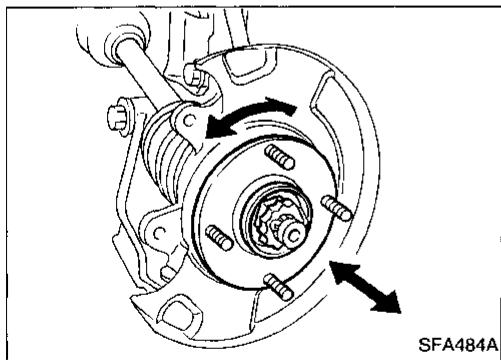

### Front Wheel Bearing

- Check that wheel bearings operate smoothly.
- Check axial end play.

#### Axial end play:

**0.05 mm (0.0020 in) or less**

- If out of specification or wheel bearing does not turn smoothly, replace wheel bearing assembly. Refer to FA-9.

### Front Wheel Alignment

Before checking front wheel alignment, be sure to make a preliminary inspection with vehicle unladen\*.

\*: Fuel, radiator coolant and engine oil full. Spare tire, jack, hand tools and mats in designated positions.

# ON-VEHICLE SERVICE

## Front Wheel Alignment (Cont'd)

### PRELIMINARY INSPECTION

1. Check tires for wear and improper inflation.
2. Check wheel runout.

#### Wheel runout:

Refer to SDS, FA-27.

3. Check front wheel bearings for looseness.
4. Check front suspension for looseness.
5. Check steering linkage for looseness.
6. Check that front shock absorbers work properly by using the standard bounce test.
7. Check vehicle posture (Unladen).

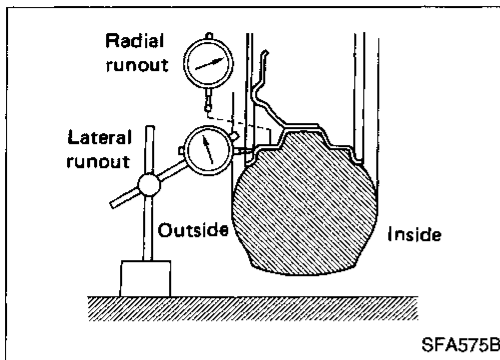

### CAMBER, CASTER AND KINGPIN INCLINATION

Camber, caster and kingpin inclination are preset at factory and cannot be adjusted.

1. Measure camber, caster and kingpin inclination of both right and left wheels with a suitable alignment gauge.

#### Camber, Caster and Kingpin inclination:

Refer to SDS, FA-27.

2. If camber, caster and kingpin inclination are not within specification, inspect front suspension parts. Replace damaged or worn out parts.

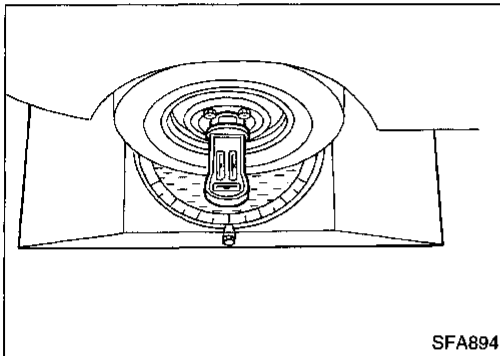

### TOE-IN

Measure toe-in using following procedure.

#### WARNING:

- Perform following procedure always on a flat surface.
- Make sure that no person is in front of the vehicle before pushing it.

1. Move front of vehicle up and down to stabilize the posture.
2. Push the vehicle straight ahead about 5 m (196.9 in).
3. Put a mark on base line of thread (rear side) at the same height of hub center to be measuring point.

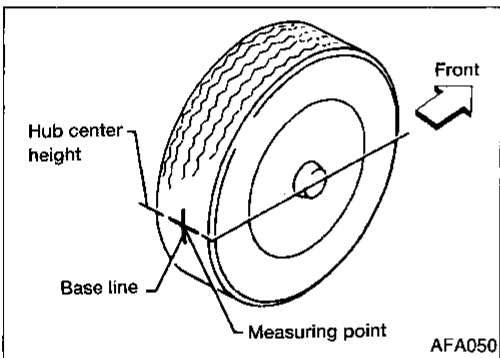

4. Measure distance "A" (rear side).
5. Push the vehicle slowly ahead to turn the wheels around 180 degrees.

If the wheels have turned more than 180 degrees, try the above procedure again from the beginning. Never push vehicle backward.

6. Measure distance "B" (front side).

#### Toe-in (A - B):

Refer to SDS, FA-27.

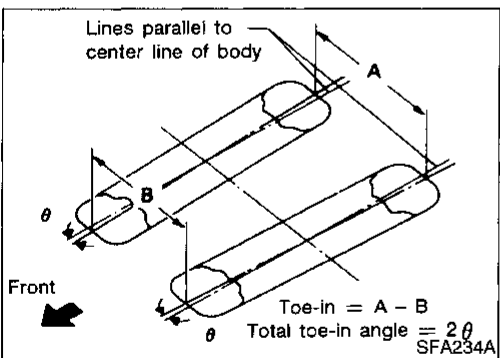

7. Adjust toe-in by varying the length of steering tie-rods.
  - a. Loosen lock nuts.
  - b. Adjust toe-in by screwing tie-rods in or out.

#### Standard length "L":

Refer to ST section.

- c. Tighten lock nuts to specified torque.

#### Lock nut tightening torque:

Refer to ST section.

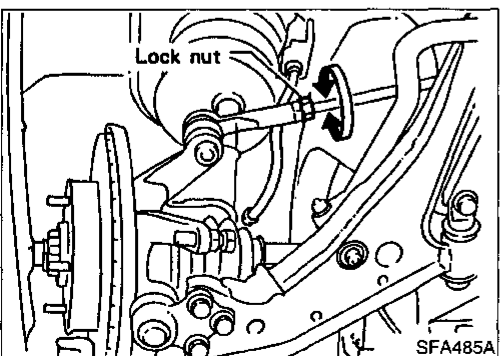

# ON-VEHICLE SERVICE

## Front Wheel Alignment (Cont'd)

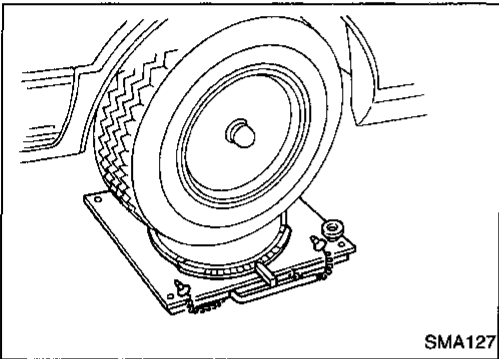
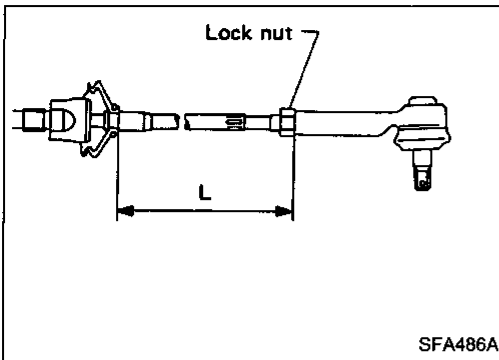

### FRONT WHEEL TURNING ANGLE

1. Set wheels in straight-ahead position. Then move vehicle forward until front wheels rest on turning radius gauge properly.

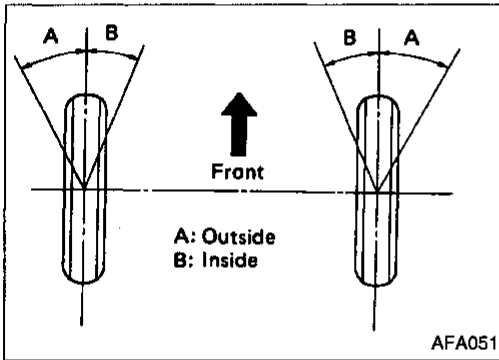

2. Rotate steering wheel all the way right and left; measure turning angle.

#### Wheel turning angle (Full turn):

Inside wheel:  $31^{\circ}30'$  -  $35^{\circ}30'$

Outside wheel:  $25^{\circ}36'$  -  $29^{\circ}36'$

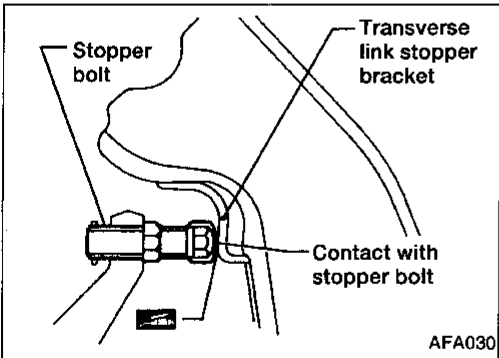

3. If stopper bolt head does not contact stopper bracket at specified outside wheel angle, adjust stopper bolt to contact stopper bracket at correct angle.

Adjust protrusion of stopper bolt before placing stopper bolt cap.

Apply grease to face of stopper bracket that bolt touches.

#### Stopper bolt lock nut tightening torque:

54 - 72 N·m (5.5 - 7.3 kg·m, 40 - 53 ft·lb)

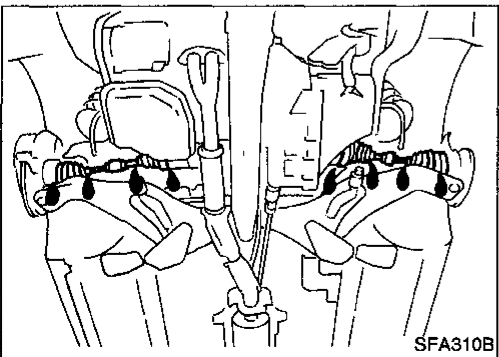

### Drive Shaft

Check for grease leakage or other damage.

GI

MA

EM

LC

EC

FE

CL

MT

AT

FA

RA

BR

ST

RS

BT

HA

EL

IDX

# FRONT AXLE

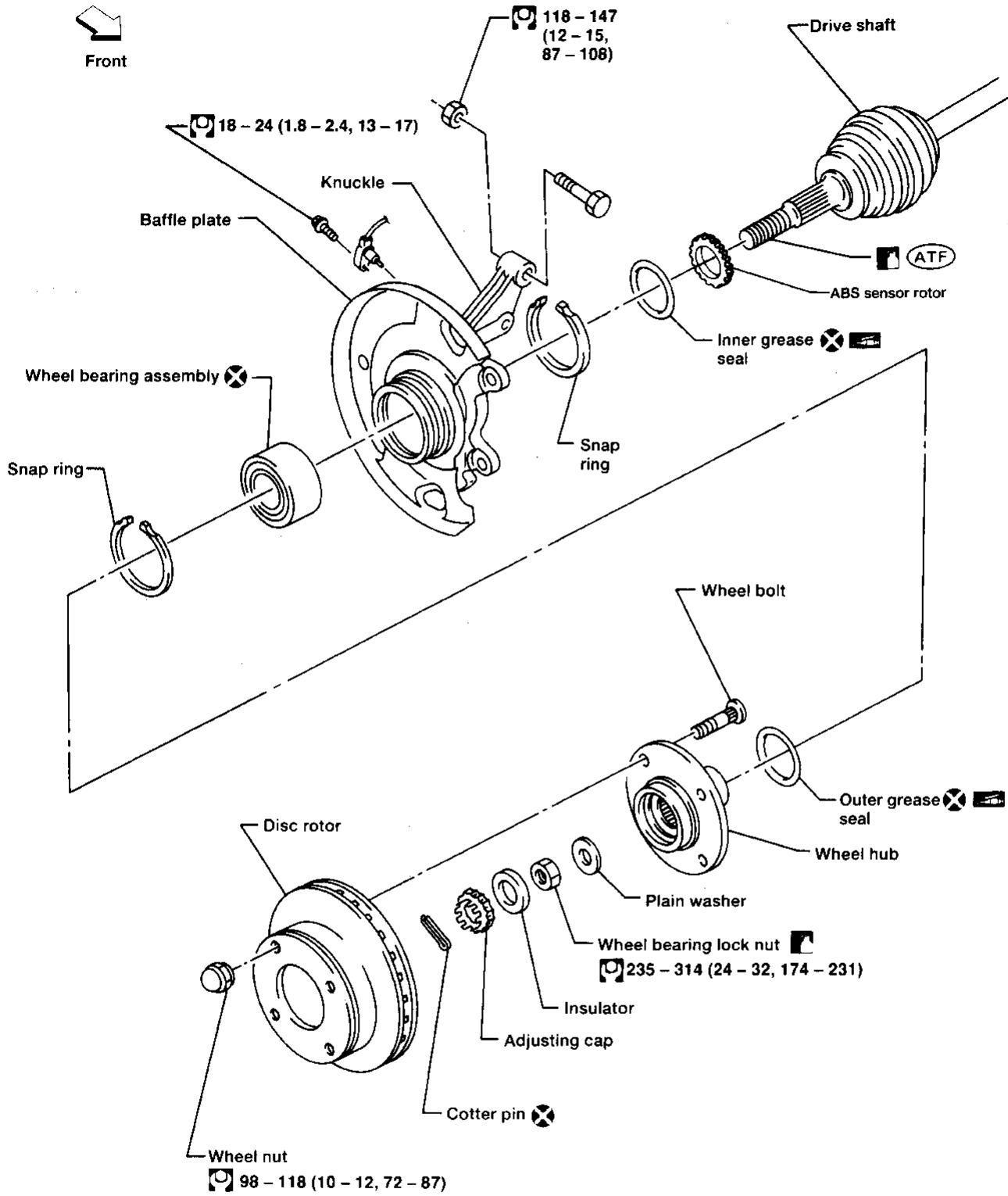

: N·m (kg-m, ft-lb)

AFA046



# FRONT AXLE

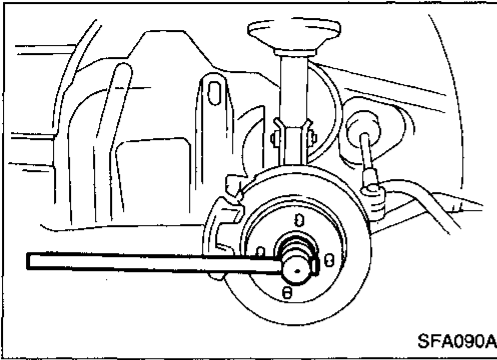

## Wheel Hub and Knuckle REMOVAL

### CAUTION:

Before removing the front axle assembly, disconnect the ABS wheel sensor from the assembly. Then remove it away from the front axle assembly area.

Failure to do so may result in damaged sensor wires and the sensor becoming inoperative.

1. Remove wheel bearing lock nut.

GI

MA

EM

LC

EC

FE

CL

MT

AT

FA

RA

BR

ST

RS

BT

HA

EL

IDX

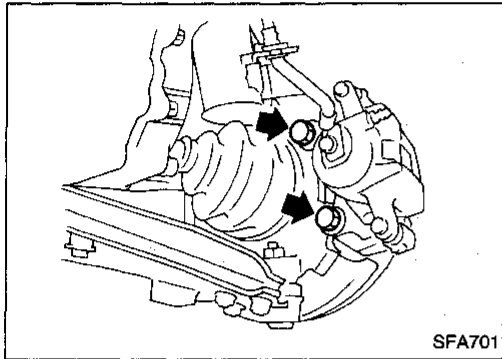

2. Remove brake caliper assembly and disc rotor.

Brake hose need not be disconnected from brake caliper. Suspend brake caliper with wire so as not to stretch brake hose.

Make sure brake hose is not twisted.

Be careful not to depress brake pedal, or piston will pop out.

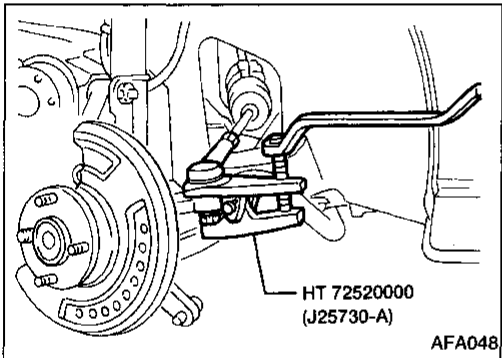

3. Separate tie-rod from knuckle with Tool.

Install stud nut conversely on stud bolt to prevent damage to stud bolt.

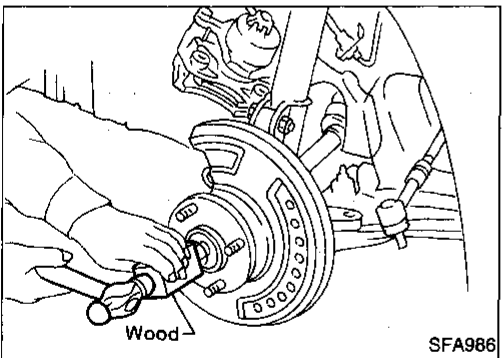

4. Separate drive shaft from knuckle by lightly tapping it. If it is hard to remove, use a puller.

When removing drive shaft, cover boots with shop towel to prevent damage to them.

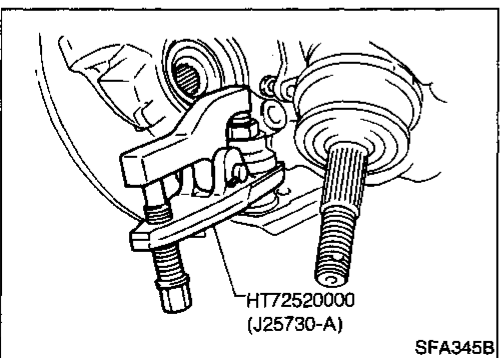

5. Loosen lower ball joint tightening nut.

6. Separate knuckle from lower ball joint stud with Tool.

7. Remove knuckle from transverse link.

## FRONT AXLE

### Wheel Hub and Knuckle (Cont'd)

8. Remove strut lower mounting bolts.

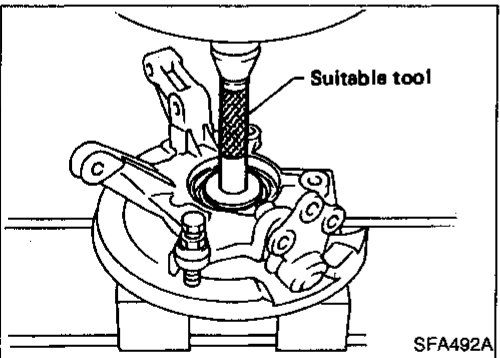
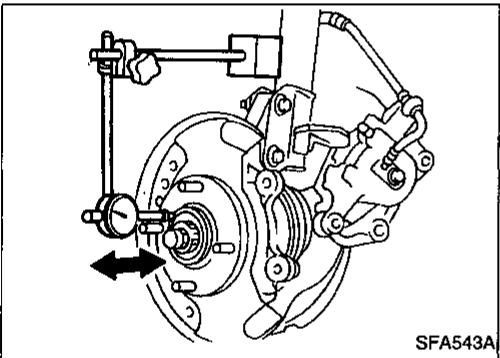
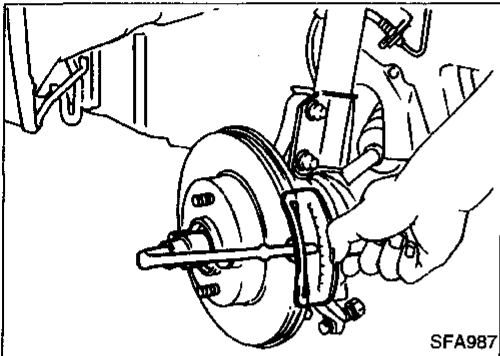
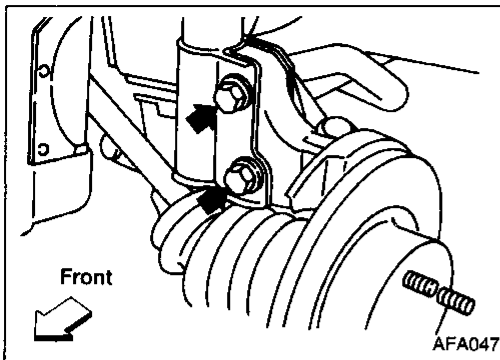

### INSTALLATION

1. Install knuckle with wheel hub.
  - Replace strut lower mounting nuts.**When installing knuckle to strut, be sure to hold bolts and tighten nuts.**

**Torque:** 118 - 147 N·m (12 - 15 kg·m, 87 - 108 ft·lb)

**Before tightening wheel bearing lock nut, apply oil to threaded portion of drive shaft and to both sides of plain washer.**

2. Tighten wheel bearing lock nut.  
**Torque:** 235 - 314 N·m (24 - 32 kg·m, 174 - 231 ft·lb)

3. Check wheel bearing axial end play.

**Axial end play:**

**0.05 mm (0.0020 in) or less.**

### DISASSEMBLY

#### CAUTION:

**When removing wheel hub or wheel bearing from knuckle, replace wheel bearing assembly (outer race, inner races and grease seals) with a new one.**

**Wheel bearing usually does not require maintenance. If any of the following symptoms are noted, replace wheel bearing assembly.**

- Growling noise is emitted from wheel bearing during operation.
- Wheel bearing drags or turns roughly. This occurs when turning hub by hand after bearing lock nut is tightened to specified torque.

#### Wheel hub

Press out hub with inner race (outside) from knuckle with a suitable tool.

## FRONT AXLE

### Wheel Hub and Knuckle (Cont'd)

#### Wheel bearing

When replacing wheel bearing, replace wheel bearing assembly (inner races and outer race).

1. Remove bearing inner race (outside), then remove outer grease seal.

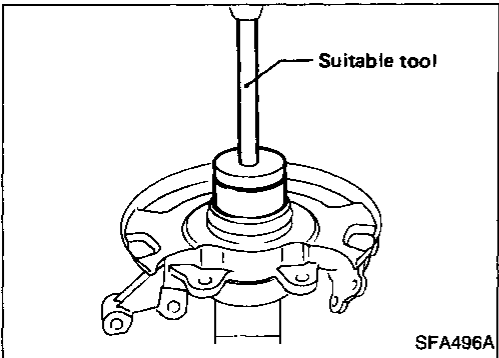
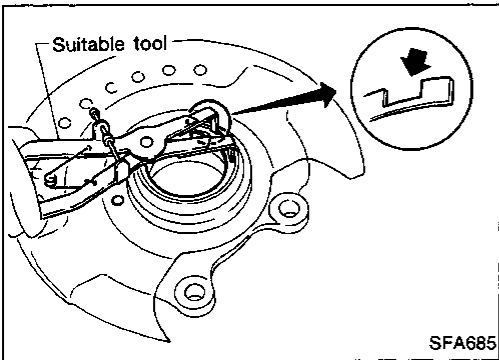
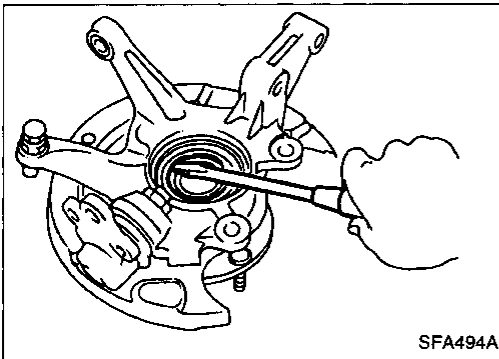
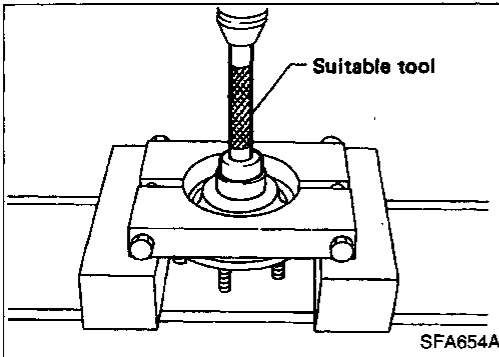

2. Remove inner grease seal from knuckle.

3. Remove inner and outer snap rings.

4. Press out bearing outer race.

#### INSPECTION

##### Wheel hub and knuckle

Check wheel hub and knuckle for cracks by using a magnetic exploration or dyeing test.

##### Snap ring

Check snap ring for wear or cracks. Replace if necessary.

GI

MA

EM

LC

EC

FE

CL

MT

AT

FA

RA

BR

ST

RS

BT

HA

EL

IDX

# FRONT AXLE

## Wheel Hub and Knuckle (Cont'd)

### ASSEMBLY

1. Install inner snap ring into groove of knuckle.
2. Press new wheel bearing assembly into knuckle.

**Maximum load P:**

**29 kN (3 ton, 3.3 US ton, 3.0 Imp ton)**

### CAUTION:

- Do not press inner race of wheel bearing assembly.
  - Do not apply oil or grease to mating surfaces of wheel bearing outer race and knuckle.
3. Install outer snap ring into groove of knuckle.
  4. Pack grease seal lip with multi-purpose grease.

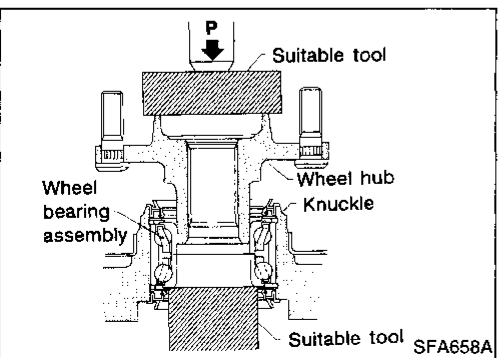
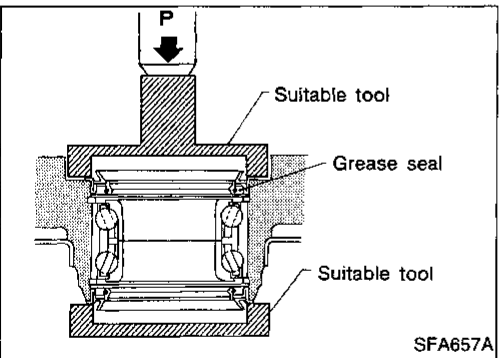
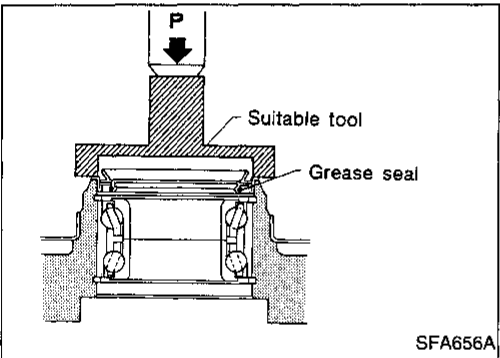
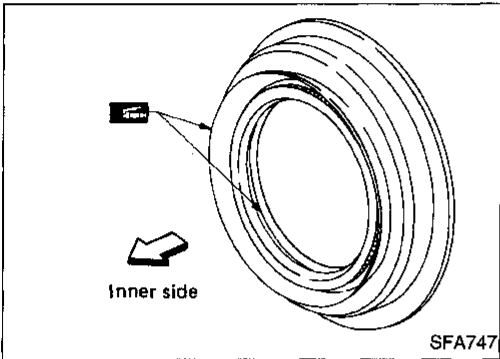
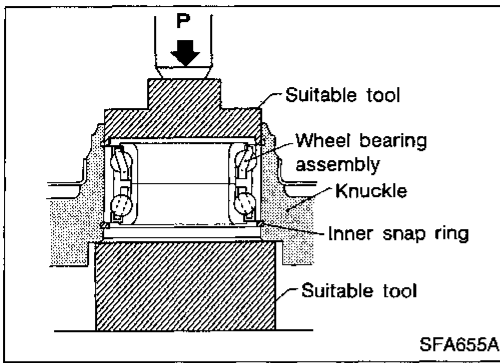

5. Install outer grease seal.

6. Install inner grease seal.

7. Press wheel hub into knuckle.

**Maximum load P:**

**29 kN (3 ton, 3.3 US ton, 3.0 Imp ton)**

**Be careful not to damage grease seal.**

## FRONT AXLE

### Wheel Hub and Knuckle (Cont'd)

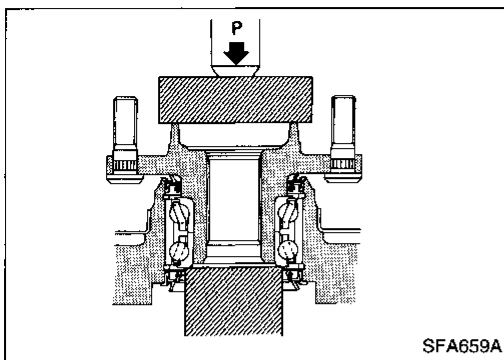

8. Check bearing operation.

a. Add load P with press.

Load P:

34.3 - 49.0 kN

(3.5 - 5.0 ton, 3.9 - 5.5 US ton, 3.44 - 4.92 Imp ton)

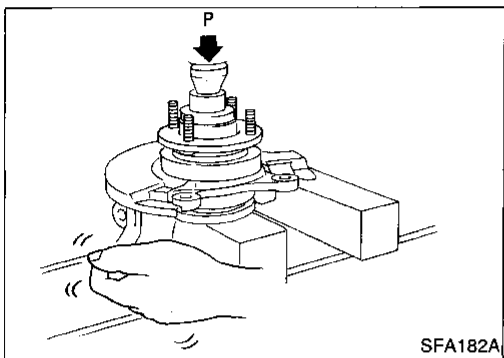

b. Spin knuckle several turns in both directions to make sure that wheel bearings operate smoothly.

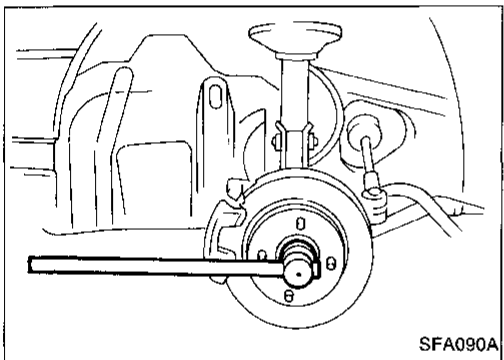

### Drive Shaft

#### REMOVAL

1. Remove wheel bearing lock nut.

**Brake caliper need not be disconnected.**

**Do not twist or stretch brake hose when moving components.**

2. Remove cotter pin and nut securing lower ball joint to knuckle.

3. Strike knuckle with a hammer and pull down transverse link to separate lower ball joint from knuckle.

4. Remove tie-rod ball joint.

5. Separate drive shaft from knuckle by slightly tapping it. If it is hard to remove, use a puller.

**When removing drive shaft, cover boots with shop towel to prevent damage to them.**

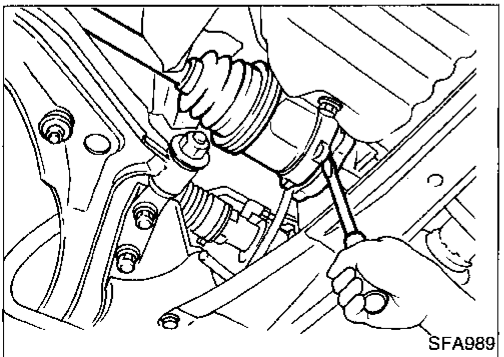
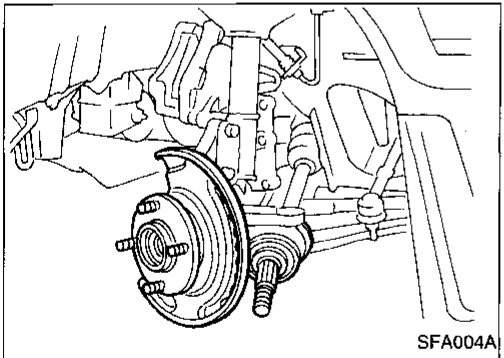

6. Remove right drive shaft from transaxle.

GI

MA

EM

LC

EC

FE

CL

MT

AT

FA

RA

BR

ST

RS

BT

HA

EL

IDX

## FRONT AXLE

### Drive Shaft (Cont'd)

7. Remove left drive shaft with a suitable tool.

#### — FOR M/T MODELS —

- Pry drive shaft from transaxle as shown at left.

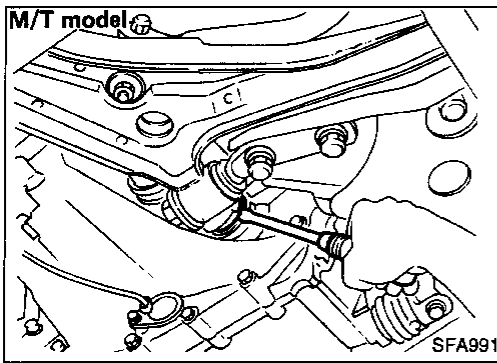

#### A/T model

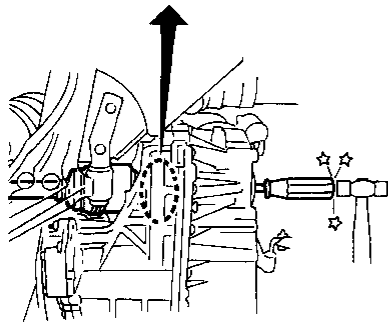
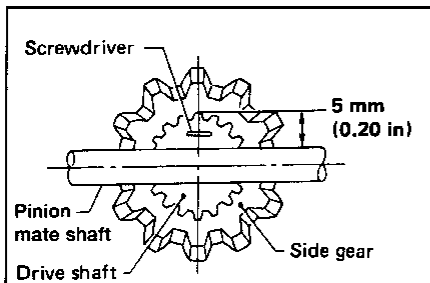

AFA035

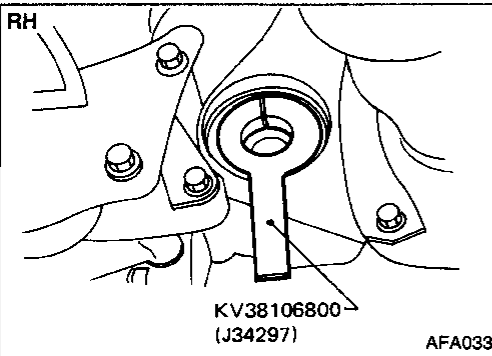

## INSTALLATION

### Transaxle side

1. Drive a new oil seal to transaxle. Refer to MT or AT section ("Differential Side Oil Seal Replacement", "ON-VEHICLE SERVICE").
2. Set Tool along the inner circumference of oil seal (transaxle side).

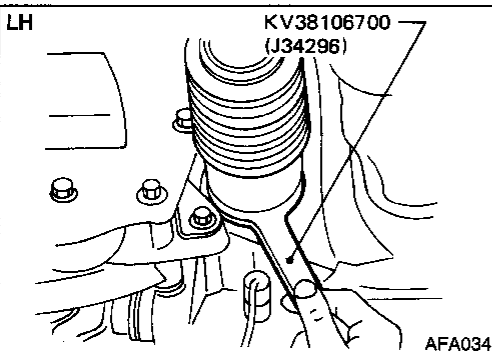

3. Insert drive shaft into transaxle. Be sure to properly align the serrations and then withdraw Tool.
4. Push drive shaft, then press-fit circular clip on the drive shaft into circular clip groove of side gear.
5. After its insertion, try to pull the flange out of the slide joint by hand. If it pulls out, the circular clip is not properly meshed with the side gear.

### Wheel side

1. Install drive shaft into knuckle.
2. Tighten wheel bearing lock nut. Refer to FA-10.

# FRONT AXLE

## Drive Shaft (Cont'd) COMPONENTS

### CAUTION:

- Circular clips should be properly meshed with differential side gear (transaxle side) and with joint assembly (wheel side). Make sure they will not come out.
- Be careful not to damage boots. Use suitable protector or cloth during removal and installation.

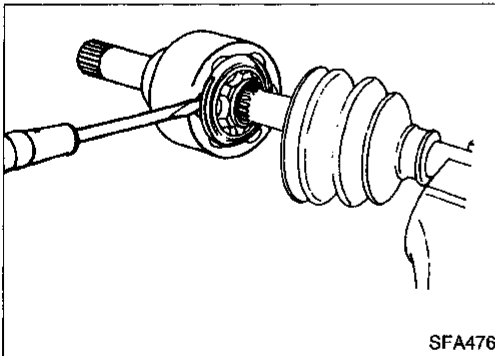
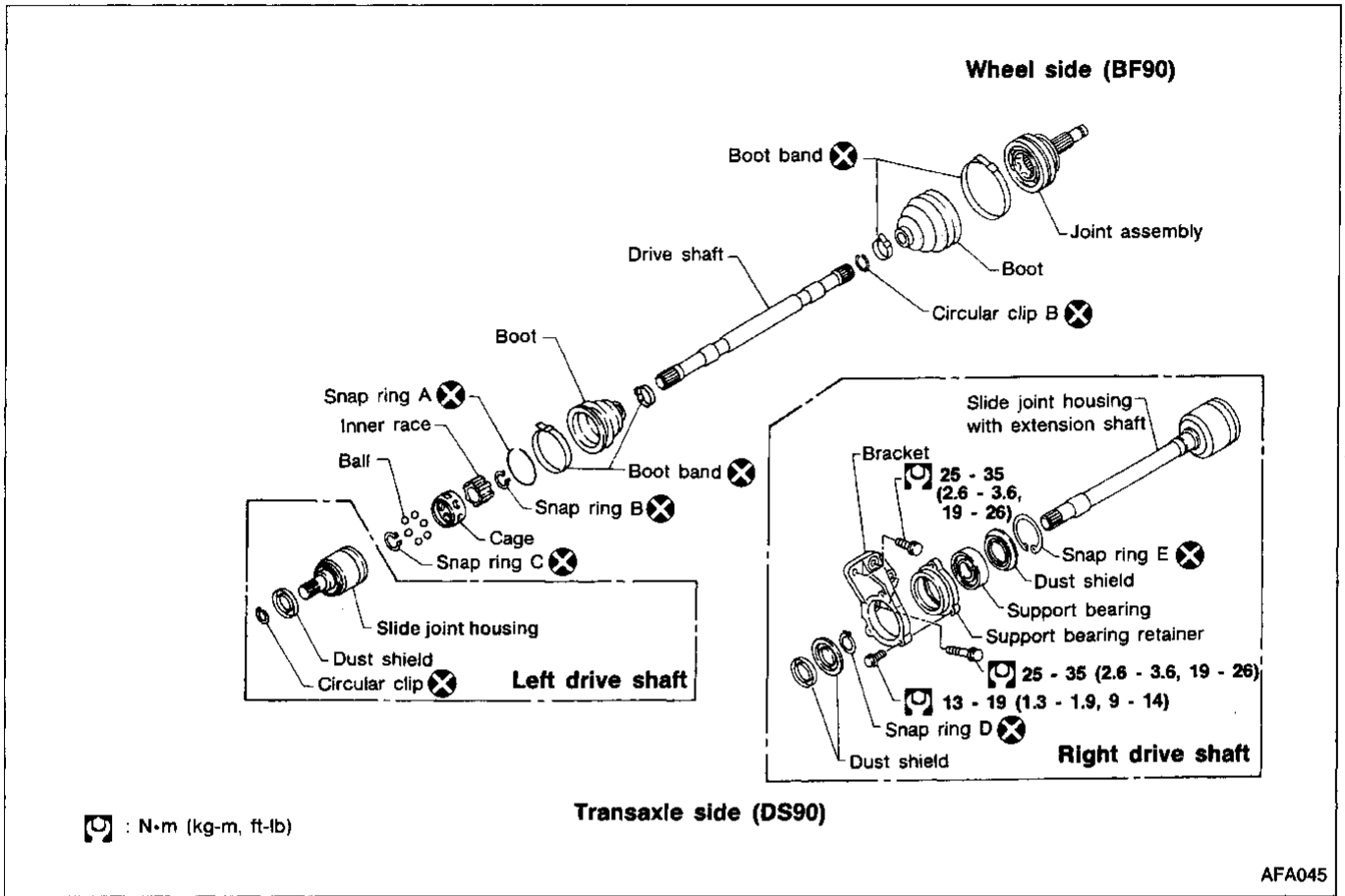

### DISASSEMBLY

#### Transaxle side

1. Remove boot bands.
2. Put matching marks on slide joint housing and inner race, before separating joint assembly.
3. Pry off snap ring "A" with a screwdriver, and pull out slide joint housing.

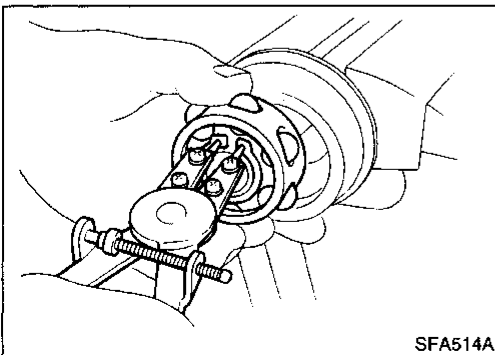

4. Put matching marks on inner race and drive shaft.
5. Remove snap ring "C", then remove ball cage, inner race and balls as a unit.
6. Remove snap ring "B".
7. Draw out boot.

**Cover drive shaft serrations with tape so as not to damage the boot.**

## FRONT AXLE

### Drive Shaft (Cont'd)

#### Wheel side

#### CAUTION:

The joint on the wheel side cannot be disassembled.

1. Before separating joint assembly, put matching marks on drive shaft and joint assembly.
  2. Separate joint assembly with a suitable tool.
- Be careful not to damage threads on drive shaft.**
3. Remove boot bands.

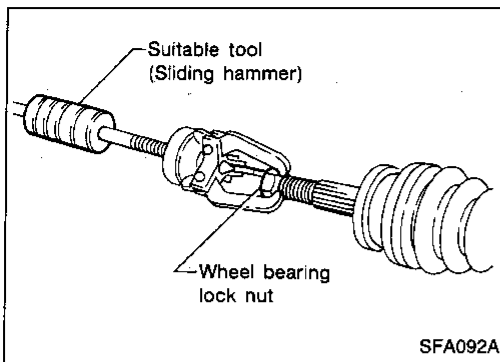

#### Support bearing

1. Remove dust shield.

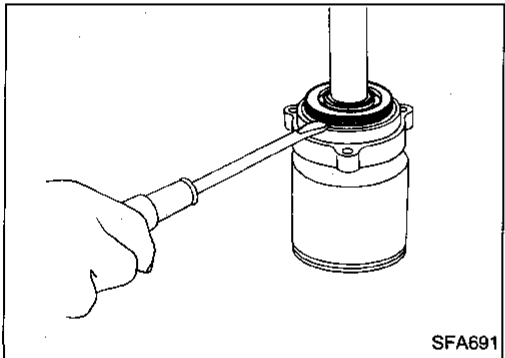
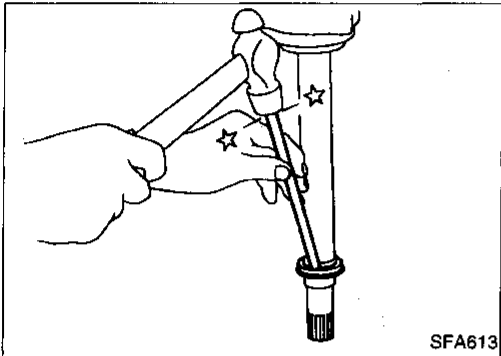

2. Remove snap ring.

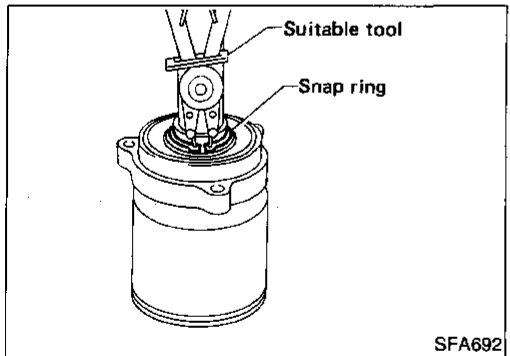

3. Press support bearing assembly off of drive shaft.

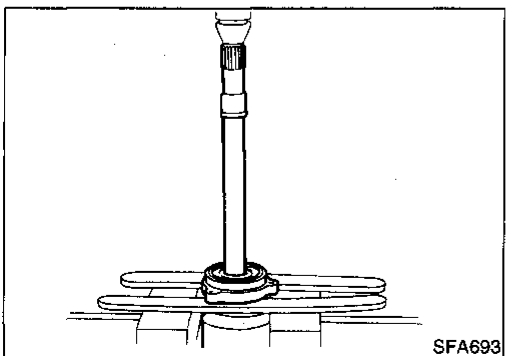



## FRONT AXLE

### Drive Shaft (Cont'd)

4. Separate support bearing from retainer.

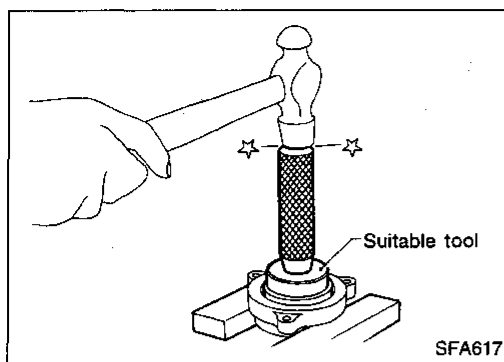

### INSPECTION

Thoroughly clean all parts in cleaning solvent, and dry with compressed air. Check parts for evidence of deformation or other damage.

#### Drive shaft

Replace drive shaft if it is twisted or cracked.

#### Boot

Check boot for fatigue, cracks, or wear. Replace boot with new boot bands.

#### Joint assembly (Transaxle side)

Replace joint assembly if it is deformed or damaged.

#### Joint assembly (Wheel side)

Replace joint assembly if it is deformed or damaged.

#### Support bearing

Make sure wheel bearing rolls freely and is free from noise, cracks, pitting or wear.

#### Support bearing bracket

Check support bearing bracket for cracks with a magnetic exploration or dyeing test.

### ASSEMBLY

- After drive shaft has been assembled, ensure that it moves smoothly over its entire range without binding.
- Use NISSAN GENUINE GREASE or equivalent after every overhaul.

GI

MA

EM

LC

EC

FE

CL

MT

AT

FA

RA

BR

ST

RS

BT

HA

EL

IDX

## FRONT AXLE

### Drive Shaft (Cont'd)

#### Wheel side

1. Install boot and new small boot band on drive shaft.  
**Cover drive shaft serration with tape so as not to damage boot during installation.**

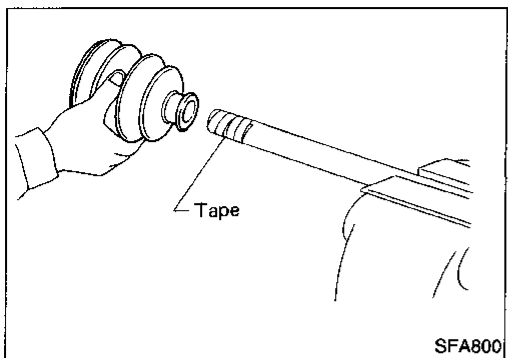

2. Set joint assembly onto drive shaft by lightly tapping it. Secure joint assembly, ensuring marks which were made during disassembly are properly aligned.

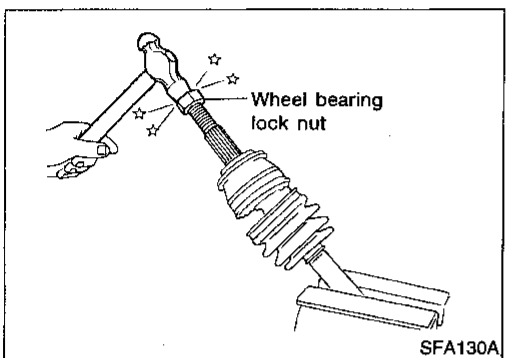

3. Pack drive shaft with specified amount of grease.  
**Specified amount of grease:  
100 - 120 g (3.53 - 4.23 oz)**

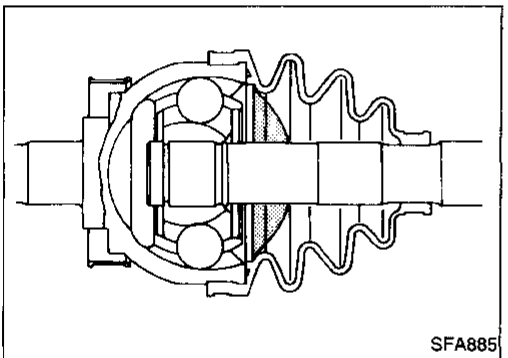

4. Make sure that boot is properly installed on the drive shaft groove. Set boot so that it does not swell and deform when its length is "L<sub>1</sub>".  
**Length "L<sub>1</sub>":  
84.5 - 86.5 mm (3.327 - 3.406 in)**

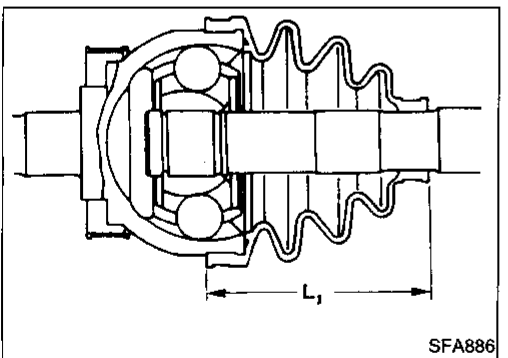

5. Lock new larger and smaller boot bands securely with a suitable tool.

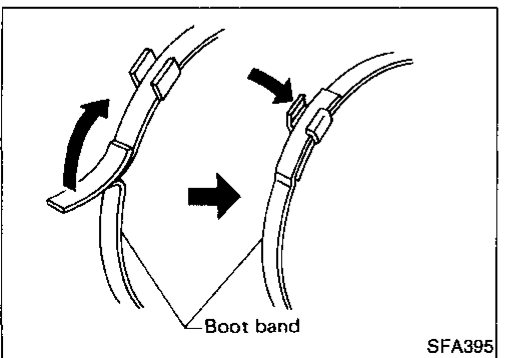

# FRONT AXLE

## Drive Shaft (Cont'd)

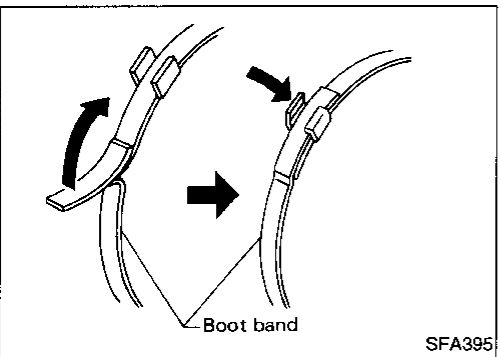
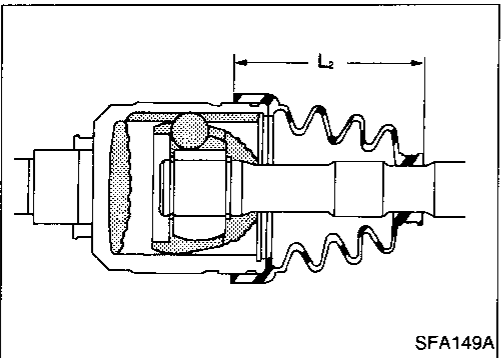
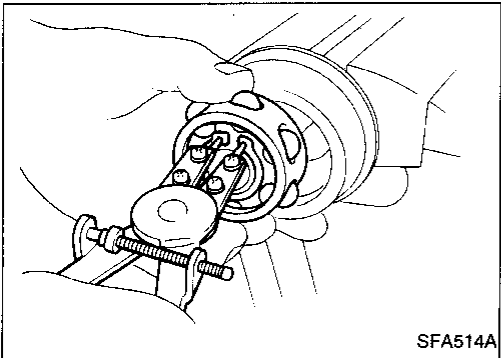
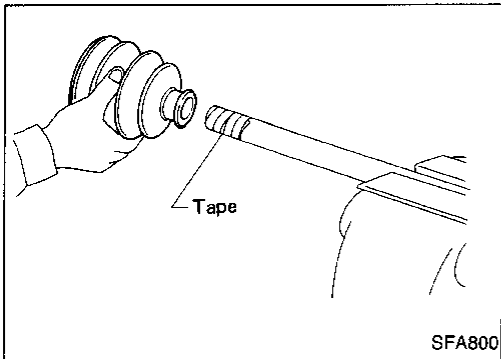
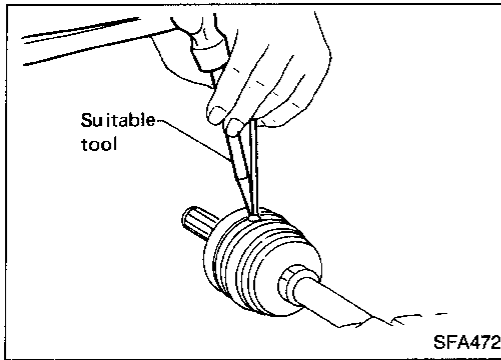

### Transaxle side

1. Install boot and new small boot band on drive shaft.  
**Cover drive shaft serration with tape so as not to damage boot during installation.**

2. Install new snap ring "B", then securely install ball cage, inner race and balls as a unit, making sure the marks which were made during disassembly are properly aligned.
3. Install new snap ring "C".

4. Pack drive shaft with specified amount of grease.

#### Specified amount of grease:

**145 - 165 g (5.11 - 5.82 oz)**

5. Install slide joint housing, then install new snap ring "A".
6. Make sure that boot is properly installed on the drive shaft groove.  
Set boot so that it does not swell and deform when its length is "L<sub>2</sub>".

#### Length "L<sub>2</sub>":

**97 - 99 mm (3.82 - 3.90 in)**

7. Lock new larger and smaller boot bands securely with a suitable tool.

GI

MA

EM

LC

EC

FE

CL

MT

AT

FA

RA

BR

ST

RS

BT

HA

EL

IDX

# FRONT AXLE

## Drive Shaft (Cont'd)

### Support bearing

1. Install bearing into retainer.

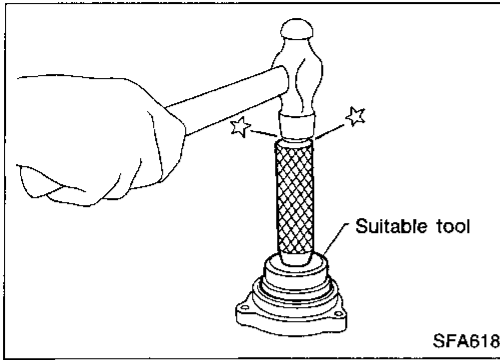

2. Press drive shaft into bearing.

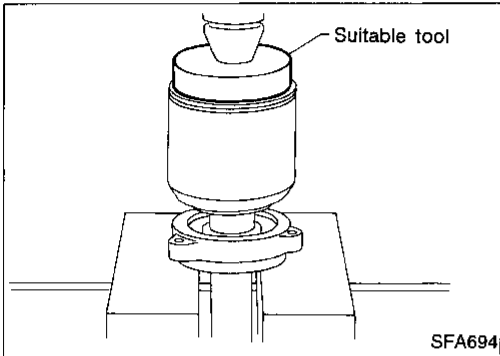

3. Install snap ring.

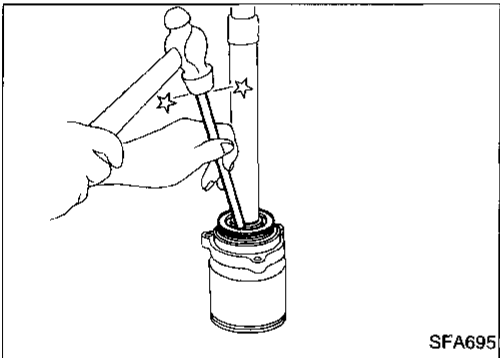

4. Install new dust shield.

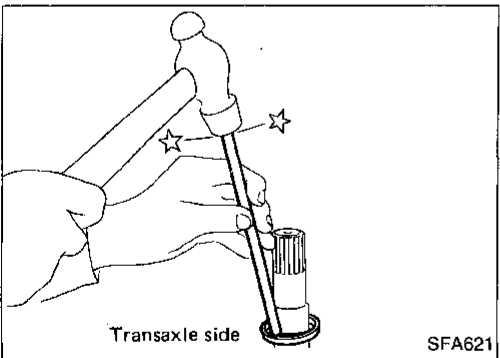

# FRONT SUSPENSION

When installing rubber parts, final tightening must be carried out under unladen condition\* with tires on ground.

\* Fuel, radiator coolant and engine oil full.  
Spare tire, jack, hand tools and mats in designated positions.

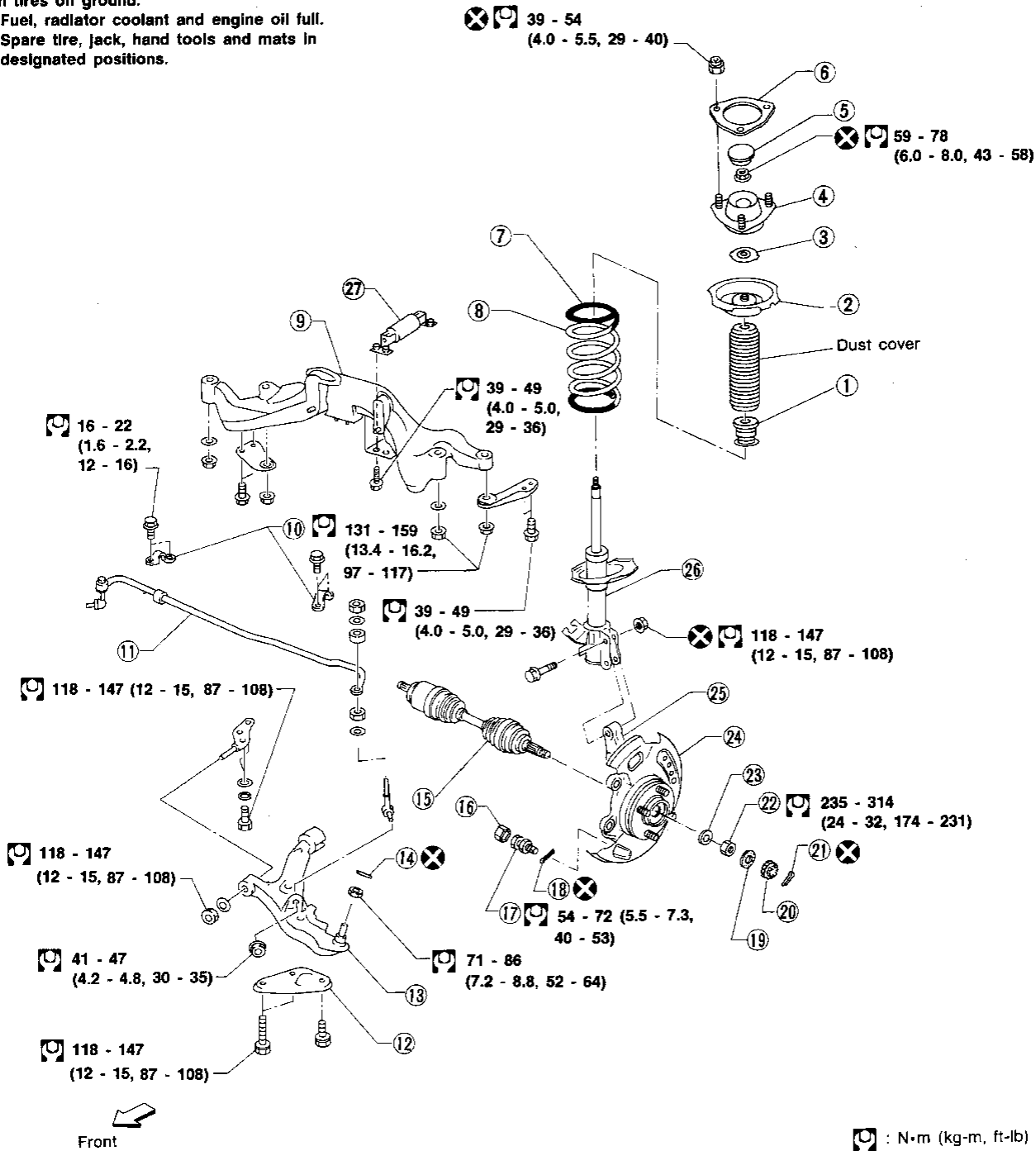

GI

MA

EM

LC

EC

FE

CL

MT

AT

FA

RA

BR

ST

RS

BT

HA

AFA049

EL

IDX

- ① Bound bumper assembly
- ② Upper spring seat
- ③ Dust seal
- ④ Strut insulator
- ⑤ Cap
- ⑥ Spacer
- ⑦ (Polyurethane tube)
- ⑧ Coil spring
- ⑨ Front suspension member

- ⑩ Stabilizer clamp
- ⑪ Stabilizer
- ⑫ Compression rod clamp
- ⑬ Transverse link
- ⑭ Cotter pin
- ⑮ Drive shaft
- ⑯ Cap
- ⑰ Stopper bolt
- ⑱ Cotter pin

- ⑲ Insulator (Rubber)
- ⑳ Adjusting cap
- ㉑ Cotter pin
- ㉒ Wheel bearing lock nut
- ㉓ Plain washer
- ㉔ Baffle plate
- ㉕ Knuckle
- ㉖ Strut assembly
- ㉗ Dynamic damper assembly

# FRONT SUSPENSION

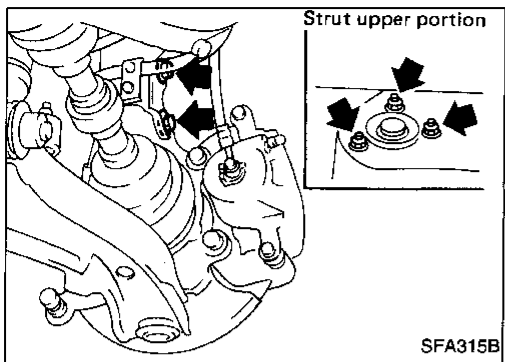

## Coil Spring and Strut Assembly

### REMOVAL AND INSTALLATION

- Remove strut assembly fixing bolts and nuts (to hoodledge).  
**Do not remove piston rod lock nut on vehicle.**

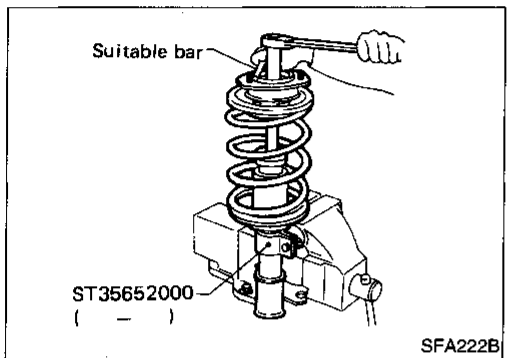

### DISASSEMBLY

1. Set strut assembly in vise with Tool, then **loosen** piston rod lock nut.

**Do not remove piston rod lock nut at this time.**

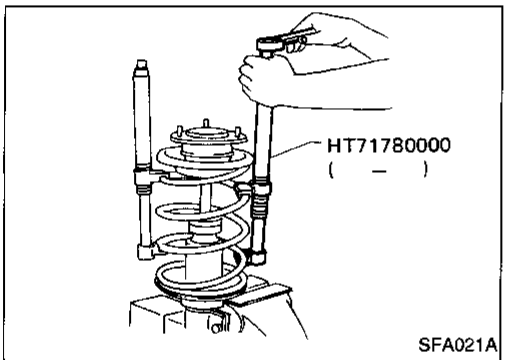

2. Compress spring with Tool so that the strut mounting insulator can be turned by hand.

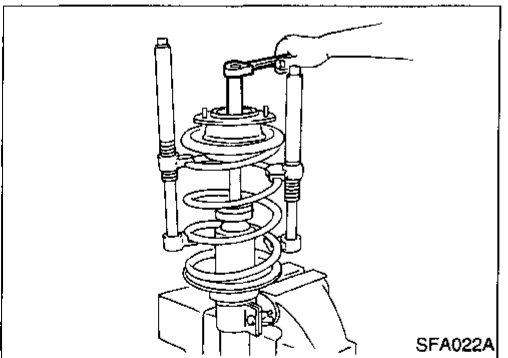

3. Remove piston rod lock nut.

### INSPECTION

#### Strut assembly

- Check for smooth operation through a full stroke, both compression and extension.
- Check for oil leakage occurring on welded or gland packing portion.
- Check piston rod for cracks, deformation or other damage.
- Replace if necessary.

# FRONT SUSPENSION

## Coil Spring and Strut Assembly (Cont'd)

### Strut mounting insulator

- Check cemented rubber-to-metal portion for separation or cracks.
- Check rubber parts for deterioration.

GI

### Thrust bearing

- Check thrust bearing parts for abnormal noise or excessive rattle in axial direction.
- Replace if necessary.

MA

EM

### Coil spring and insulator

- Check for cracks, deformation or other damage. Replace if necessary.

LC

EC

FE

CL

MT

AT

FA

RA

BR

ST

RS

BT

HA

EL

IDX

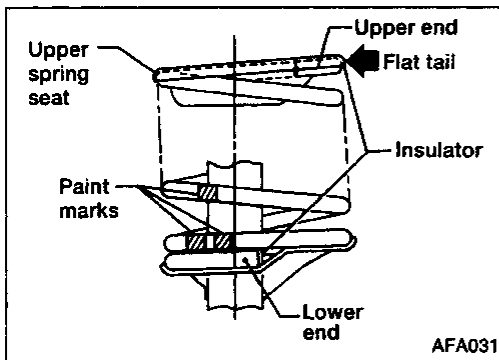

### ASSEMBLY

- When installing coil spring on strut, it must be positioned as shown in the figure at left.

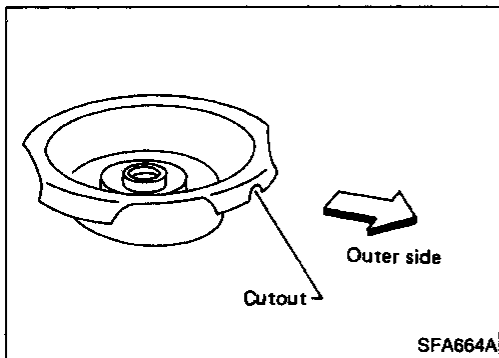

- Install upper spring seat with its cutout facing the outer side of vehicle, in line with the strut-to-knuckle attachment points.

- Replace strut lower mounting nuts.

**When installing strut to knuckle, be sure to hold bolts and tighten nuts.**

**□: 118 - 147 N·m  
(12 - 15 kg·m, 87 - 108 ft·lb)**

## FRONT SUSPENSION

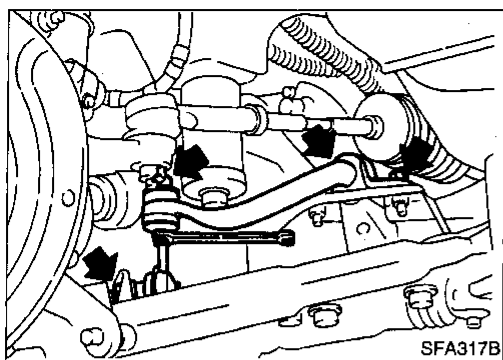

### Stabilizer Bar

#### REMOVAL AND INSTALLATION

- Remove stabilizer bar.
- When installing stabilizer, make sure that paint mark and clamp face in their correct directions.

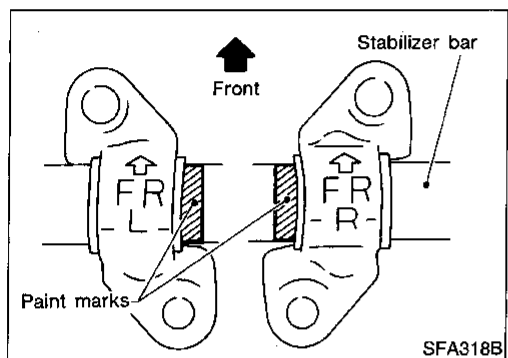

- Make sure that slit in bushing is in the position shown in the figure.

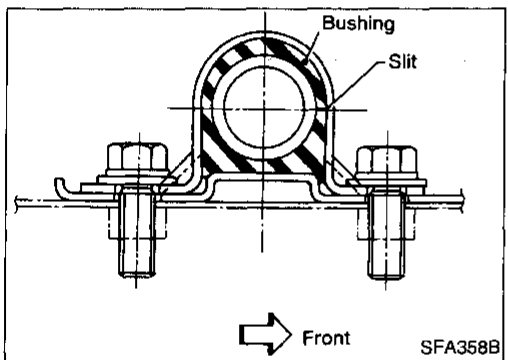

#### INSPECTION

- Check stabilizer for deformation or cracks. Replace if necessary.
- Check rubber bushings for deterioration or cracks. Replace if necessary.
- Check ball joint can rotate in all directions. If movement is not smooth and free, replace stabilizer bar link.

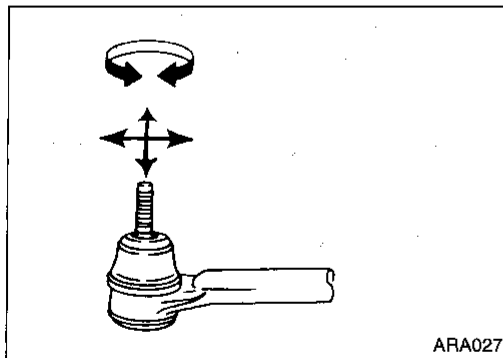



## Transverse Link and Lower Ball Joint

### REMOVAL AND INSTALLATION

1. Remove stabilizer connecting rod from transverse link.
2. Remove cotter pin and lock nut securing lower ball joint to knuckle.
3. Strike knuckle with a hammer to separate lower ball joint from knuckle.

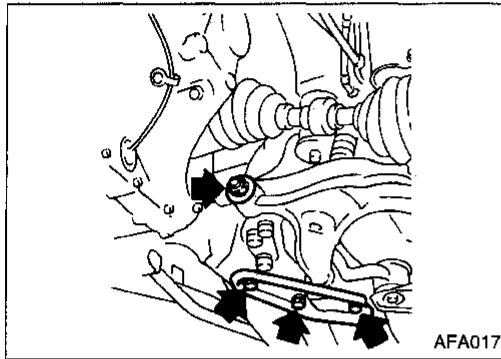

4. Remove bolts and nuts shown at left.
5. Remove transverse link and lower ball joint.
6. Install fixing bolts and nuts.
  - Tightening torque:**
  - Refer to FA-21.**
7. During installation, final tightening must be carried out at curb weight with tires on the ground.
8. After installation, check wheel alignment. Refer to FA-5.

### INSPECTION

- Check transverse link for damage, cracks or deformation. Replace if necessary.
- Check rubber bushing for damage, cracks and deformation. Replace transverse link if necessary.

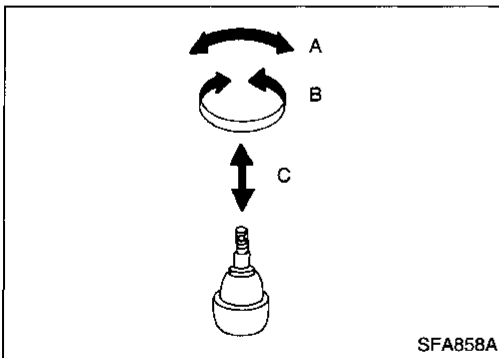

- Check ball joint for play. Replace transverse link assembly if any of the following cases occur:
- Ball stud is worn.
- Joint is hard to swing.
- Play in axial direction is excessive.

Before checking, turn ball joint at least 10 revolutions so that ball joint is properly broken in.

**Swinging force "A":**

**(measuring point: cotter pin hole of ball stud):**  
7.8 - 54.9 N (0.8 - 5.6 kg, 1.8 - 12.3 lb)

**Turning torque "B":**

0.5 - 3.4 N·m (5 - 35 kg-cm, 4.3 - 30.4 in-lb)

**Vertical end play "C":**

0 mm (0 in)

- Check dust cover for damage. Replace it and cover clamp if necessary.

# SERVICE DATA AND SPECIFICATIONS (SDS)

## General Specifications

### COIL SPRING

Applied model	XE/GXE	XE/GXE/ GLE	SE	
	M/T	A/T	M/T	A/T
Wire diameter mm (in)	13.4 (0.528)	13.6 (0.535)	13.6 (0.535)	13.8 (0.543)
Outer coil diameter mm (in)	173.8 (6.84)	174.2 (6.86)		174.6 (6.87)
Free length mm (in)	396 (15.59)	401.8 (15.79)	378.6 (14.91)	391.9 (15.43)
Spring constant N/mm (kg/mm, lb/in)	21.6 (2.2, 123)		23.5 (2.4, 134)	
Identification color	White x 2	White x 1, Yellow x 1	White x 1, Pink x 1	White x 1, Light green x 1

### STRUT

Applied model	XE/GLE/GXE	SE
Piston rod diameter mm (in)	22 (0.87)	
Damping force [at 0.3 m (1.0 ft)/sec.] N (kg, lb)		
Expansion	991 - 1,324 (101 - 135, 223 - 298)	1,089 - 1,461 (111 - 149, 245 - 329)
Compression	206 - 324 (21 - 33, 46 - 73)	432 - 598 (44 - 61, 97 - 135)

### FRONT STABILIZER BAR

Applied model	M/T	A/T
Stabilizer diameter mm (in)	21.0 (0.827)	
Identification color	Green	Pink

### WHEELARCH HEIGHT (Unladen\*)

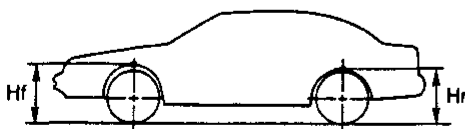

SFA818A

Applied model	XE/GLE/GXE	SE
Front (Hf) mm (in)	691 (27.20)	690 (27.17)
Rear (Hr) mm (in)	680 (26.77)	678 (26.69)

\*: Fuel, radiator coolant and engine oil full. Spare tire, jack, hand tools and mate in designated positions.

### DRIVE SHAFT

Applied model	All
Joint type	
Transaxle side	DS90
Wheel side	BF90
Boot length mm (in)	
Transaxle side (L <sub>2</sub> )	97 - 99 (3.82 - 3.90)
Wheel side (L <sub>1</sub> )	84.5 - 86.5 (3.327 - 3.406)
Grease	Nissan genuine grease or equivalent
Capacity g (oz)	
Transaxle side	145 - 165 (5.11 - 5.82)
Wheel side	100 - 120 (3.53 - 4.23)

#### Transaxle side

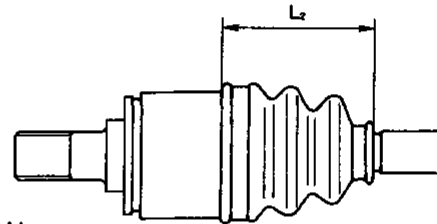

#### Wheel side

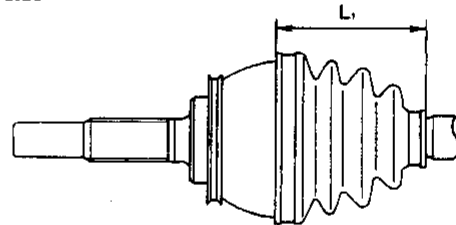

# SERVICE DATA AND SPECIFICATIONS (SDS)

## Inspection and Adjustment

### WHEEL ALIGNMENT (Unladen\*1)

Applied model		All
Camber	degree	-0°50' to 0°40'
Caster	degree	1°55' - 3°25'
Kingpin inclination	degree	13°20' - 14°50'
Toe-in		
A - B	mm (in)	0 - 2 (0 - 0.08)
Total angle 2θ	degree	0' - 12'
Front wheel turning angle		
Full turn*2	Inside	31°30' - 35°30'
	Outside	25°36' - 29°36'

\*1: Fuel, radiator coolant and engine oil full. Spare tire, jack, hand tools and mats in designated positions.

\*2: On power steering models, wheel turning force (at circumference of steering wheel) of 98 to 147 N (10 to 15 kg, 22 to 33 lb) with engine idle.

### WHEEL BEARING

Wheel bearing axial end play limit	mm (in)	0.05 (0.0020) or less
Wheel bearing lock nut tightening torque	N-m (kg-m, ft-lb)	235 - 314 (24 - 32, 174 - 231)

### LOWER BALL JOINT

Swinging force (Measured at cotter pin hole)		
	N (kg, lb)	7.8 - 54.9 (0.8 - 5.6, 1.8 - 12.3)
Turning torque		
	N-m (kg-cm, in-lb)	0.5 - 3.4 (5 - 35, 4.3 - 30.4)
Vertical end play limit		
	mm (in)	0 (0)

### WHEEL RUNOUT

	Unit: mm (in)	
Wheel type	Aluminum wheel	Steel wheel
Maximum radial runout limit	0.3 (0.012) or less	0.5 (0.020) or less
Maximum lateral runout limit	0.3 (0.012) or less	0.8 (0.031) or less

GI  
MA  
EM  
LC  
EC  
FE  
CL  
MT  
AT  
FA  
RA  
BR  
ST  
RS  
BT  
HA  
EL  
IDX