

FRONT AXLE & FRONT SUSPENSION

SECTION **FA**

CONTENTS

| | | | |
|---|---|--|----|
| PRECAUTIONS AND PREPARATION | 2 | Drive Shaft | 9 |
| Precautions | 2 | FRONT AXLE | 10 |
| Special Service Tools..... | 2 | Wheel Hub and Knuckle | 11 |
| Commercial Service Tools | 3 | Drive Shaft | 15 |
| NOISE, VIBRATION AND HARSHNESS (NVH) | | FRONT SUSPENSION | 23 |
| TROUBLESHOOTING | 4 | Coil Spring and Strut Assembly | 24 |
| NVH Troubleshooting Chart..... | 4 | Stabilizer Bar..... | 25 |
| FRONT SUSPENSION SYSTEM | 5 | Transverse Link and Lower Ball Joint | 26 |
| ON-VEHICLE SERVICE | 6 | SERVICE DATA AND SPECIFICATIONS (SDS) | 28 |
| Front Axle and Front Suspension Parts | 6 | General Specifications | 28 |
| Front Wheel Bearing..... | 7 | Inspection and Adjustment..... | 28 |
| Front Wheel Alignment | 7 | | |

GI

MA

EM

LC

EC

FE

CL

MT

AT

FA

RA

BR

ST

RS

BT

HA

EL

IDX

PRECAUTIONS AND PREPARATION

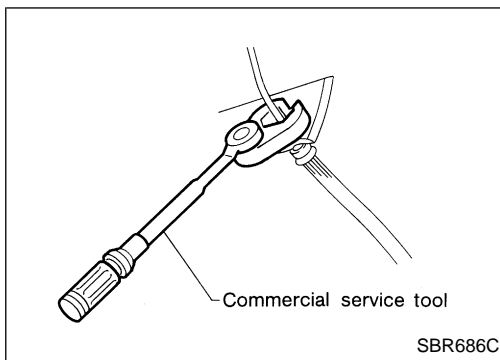

Precautions

- When installing rubber parts, final tightening must be carried out under unladen condition* with tires on ground.
- *: Fuel, radiator coolant and engine oil full. Spare tire, jack, hand tools and mats in designated positions.
- After installing suspension parts, check wheel alignment and adjust if necessary.
- Use flare nut wrench when removing or installing brake tubes.
- Always torque brake lines when installing.

Special Service Tools

The actual shapes of Kent-Moore tools may differ from those of special service tools illustrated here.

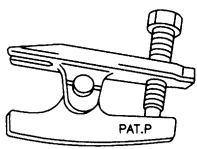
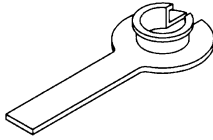
| Tool number (Kent-Moore No.) Tool name | Description | |
|--|---|--|
| HT72520000 (J25730-A) Ball joint remover |  <p style="text-align: center;">PAT.P</p> <p>NT146</p> | Removing tie-rod outer end and lower ball joint |
| KV38106700 (J34296) KV38106800 (J34297) Differential side oil seal protector |  <p>NT147</p> | Installing drive shaft LH: KV38106700 RH: KV38106800 |

PRECAUTIONS AND PREPARATION

Commercial Service Tools

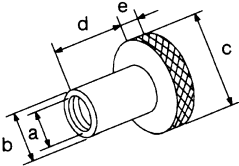
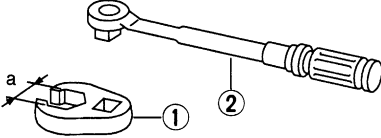
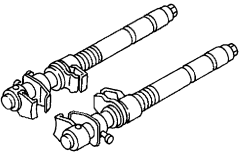
| Tool name | Description | |
|--|--|----------------|
| Attachment Wheel Alignment |  <p>NT148</p> <p>Measure wheel alignment</p> <p>a: Screw M24 x 1.5 b: 35 mm (1.38 in) dia. c: 65 mm (2.56 in) dia. d: 56 mm (2.20 in) e: 12 mm (0.47 in)</p> | GI MA EM |
| <p>① Flare nut crowfoot</p> <p>② Torque wrench</p> |  <p>NT360</p> <p>Removing and installing brake piping</p> <p>a: 10 mm (0.39 in)</p> | LC EC FE |
| Spring compressor |  <p>NT717</p> <p>Removing and installing coil spring</p> | CL MT |

AT

FA

RA

BR

ST

RS

BT

HA

EL

IDX

NOISE, VIBRATION AND HARSHNESS (NVH) TROUBLESHOOTING.

NVH Troubleshooting Chart

Use the chart below to find the cause of the symptom. If necessary, repair or replace these parts

| | | Excessive joint angle | Joint sliding resistance | Improper installation, looseness | Shock absorber deformation, Damage or deflection | Bushing or mounting deterioration | Parts interference | Spring fatigue | Suspension looseness | Incorrect wheel alignment | Stabilizer bar fatigue | Wheel bearing damage, looseness | Imbalance | Out-of-round | Incorrect air pressure | Uneven tire wear | Deformation or damage | Non-uniformity | Incorrect tire size | REAR AXLE AND REAR SUSPENSION | TIRES | ROAD WHEEL | STEERING | BRAKES | DRIVE SHAFT | |
|------------------------------------|---------------------------------|-------------------------------|--------------------------|----------------------------------|--|-----------------------------------|--------------------|----------------|----------------------|---------------------------|------------------------|---------------------------------|-----------|-------------------|------------------------|------------------|-----------------------|----------------|---------------------|--------------------------------|-------------------|------------|----------|-------------------|-------------------|---|
| Reference page | | — | FA-19 | FA-5, 23 | FA-24 | — | — | FA-6 | FA-23 | FA-7, SDS | FA-28 | FA-6 | FA-7 | SDS in MA section | FA-7, SDS | FA-28 | — | — | — | Wheels and Tires in GI section | NVH in RA section | — | — | NVH in ST section | NVH in BR section | |
| Possible cause and SUSPECTED PARTS | | | | | | | | | | | | | | | | | | | | | | | | | | |
| Symptom | DRIVE SHAFT | Noise, Vibration | X | X | | | | | | | | | | | | | | | | X | X | X | X | X | | |
| | | Shake | X | | | | | | | | | | | X | | | | | | | X | X | X | X | X | |
| | FRONT AXLE AND FRONT SUSPENSION | Noise | | | X | X | X | X | X | X | | | | | | | | | | | X | X | | X | X | X |
| | | Shake | | | X | X | X | X | | X | | | | | | | | | | | X | X | X | X | X | X |
| | | Vibration | | | X | X | X | X | X | | | | | | | | | | | | X | X | | X | | X |
| | | Shimmy | | | X | X | X | X | | | X | | | | | | | | | | X | X | X | X | X | |
| | | Judder | | | X | X | X | | | | | | | | | | | | | | X | X | X | X | X | |
| | | Poor quality Ride or handling | | | X | X | X | X | X | | X | X | X | | | | | | | | X | X | X | | | |
| | TIRES | Noise | | | X | | | | | | | | | X | X | X | X | X | X | | X | | X | X | X | X |
| | | Shake | | | X | | | | | | | | | X | X | X | X | X | | X | X | | X | X | X | X |
| | | Vibration | | | | | | | | | | | | | | X | | | | X | X | | | X | | X |
| | | Shimmy | | | X | | | | | | | | | X | X | X | X | X | X | X | X | X | | X | X | |
| | | Judder | | | X | | | | | | | | | X | X | X | X | X | | X | X | | X | X | X | |
| | | Poor quality Ride or handling | | | X | | | | | | | | | X | X | X | X | X | | X | X | | X | | | |
| | ROAD WHEEL | Noise | | | X | | | | | | | | | X | X | | | X | | | X | X | | X | X | X |
| | | Shake | | | X | | | | | | | | | X | X | | | X | | | X | X | | X | X | X |
| | | Shimmy, judder | | | X | | | | | | | | | X | X | | | X | | | X | X | | X | X | |
| | | Poor quality Ride or handling | | | X | | | | | | | | | X | X | | | X | | | X | X | | | | |

X : Applicable

FRONT SUSPENSION SYSTEM

SEC. 391-400-401

When installing rubber parts, final tightening must be carried out under unladen condition* with tires on ground.

* Fuel, radiator coolant and engine oil full.
Spare tire, jack, hand tools and mats in designated positions.

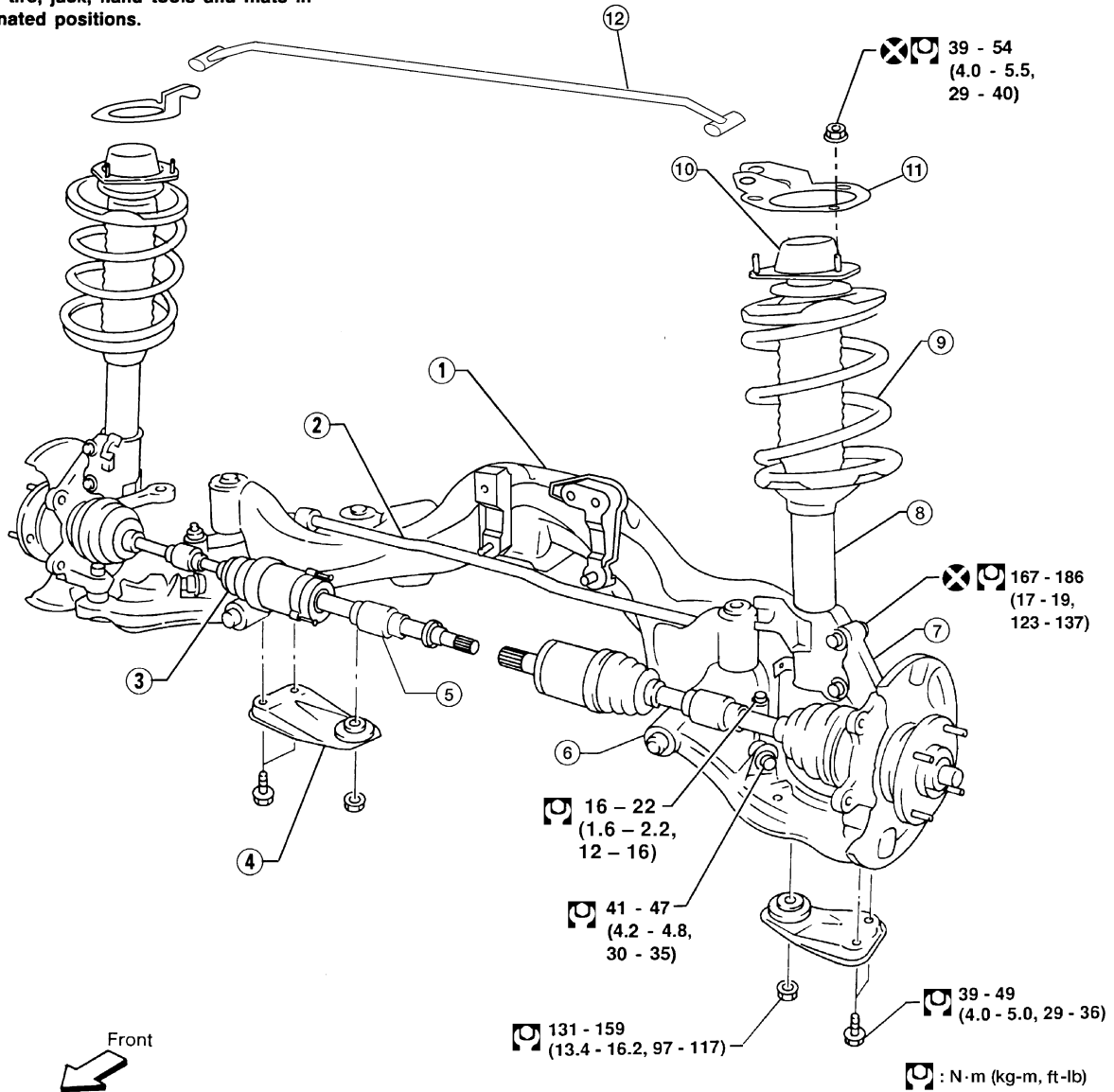

- | | | |
|---------------------|-------------------|-------------------------------------|
| ① Suspension member | ⑤ Dynamic damper | ⑨ Coil spring |
| ② Stabilizer bar | ⑥ Transverse link | ⑩ Strut mounting insulator assembly |
| ③ Drive shaft | ⑦ Knuckle | ⑪ Tower bar bracket (if equipped) |
| ④ Rebound stopper | ⑧ Strut assembly | ⑫ Strut tower bar (if equipped) |

WFA017

GI
MA
EM
LC
EC
FE
CL
MT
AT
FA
RA
BR
ST
RS
BT
HA
EL
IDX

ON-VEHICLE SERVICE

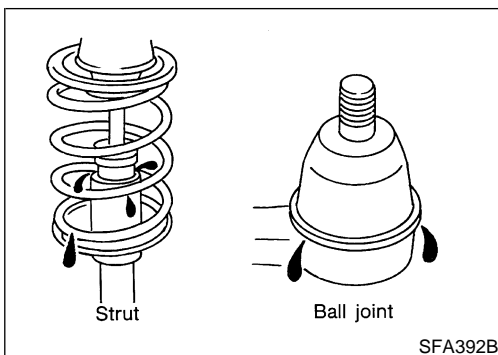
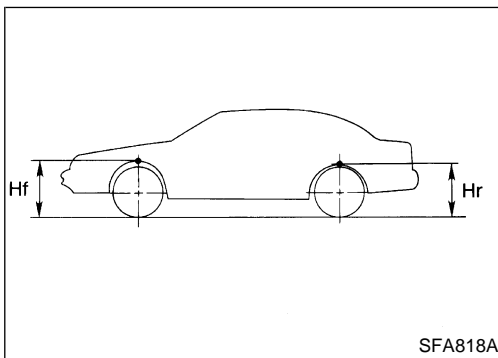
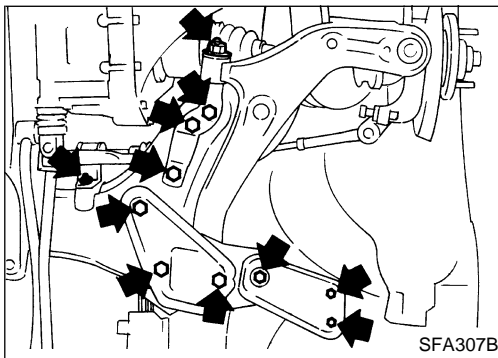
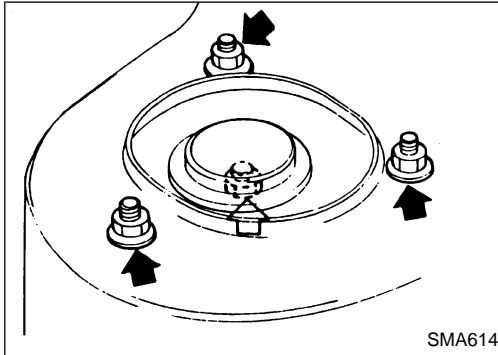
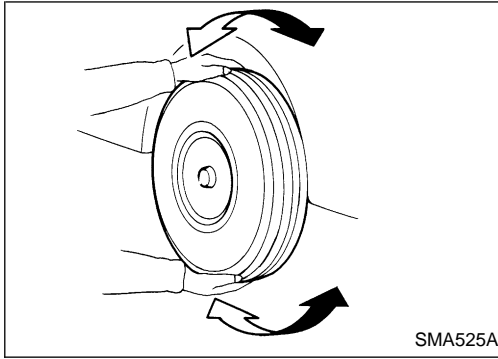

Front Axle and Front Suspension Parts

- Check front axle and front suspension parts for excessive play, cracks, wear or other damage.
 - a. Shake each front wheel to check for excessive play.
 - b. Make sure that cotter pin is inserted.
- If looseness is noted, check wheel bearing axial end play, then ball joint for play.

- c. Retighten all nuts and bolts to the specified torque.

Tightening torque:

Refer to FRONT SUSPENSION, FA-23.

- Check spring height from top of wheelarch to ground using the following procedure:
 - a. Park vehicle on a level surface with vehicle unladen*.

*: Fuel, radiator coolant and engine oil full. Spare tire, jack, hand tools and mats in designated positions.

 - b. Check tires for proper inflation and wear (tread wear indicator must not be showing).
 - c. Bounce vehicle up and down several times and measure dimensions Hf and Hr. Refer to FA-29.

Spring height is not adjustable. If out of specification, check for worn springs or suspension parts.

- Check strut (shock absorber) for oil leakage or other damage.
- Check suspension ball joint for grease leakage and ball joint dust cover for cracks or other damage. If ball joint dust cover is cracked or damaged, replace transverse link.

ON-VEHICLE SERVICE

Front Axle and Front Suspension Parts (Cont'd)

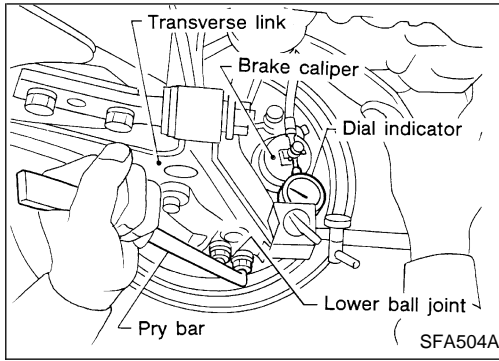

- Check suspension ball joint end play.
 - a. Jack up front of vehicle and set the stands.
 - b. Clamp dial indicator onto transverse link and place indicator tip on lower edge of brake caliper.
 - c. Make sure front wheels are straight and brake pedal is depressed.
 - d. Place a pry bar between transverse link and inner rim of road wheel.
 - e. While pushing and releasing pry bar, observe maximum dial indicator value.

Vertical end play:
0 mm (0 in)

If ball joint vertical end play exists, remove the transverse link and recheck the ball joint. Refer to FA-26.

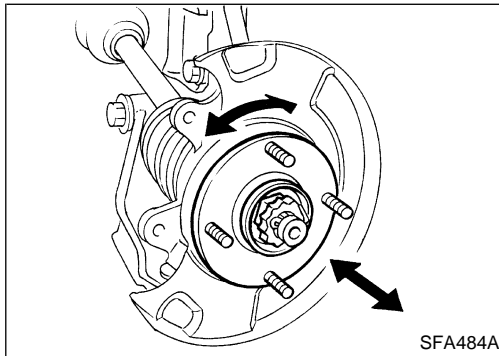

Front Wheel Bearing

- Check that wheel bearings operate smoothly.
- Check axial end play.

Axial end play:
0.05 mm (0.0020 in) or less

- If out of specification or wheel bearing does not turn smoothly, replace wheel bearing assembly. Refer to FA-11.

Front Wheel Alignment

Before checking front wheel alignment, be sure to make a preliminary inspection (Unladen*).

*: Fuel, radiator coolant and engine oil full. Spare tire, jack, hand tools and mats in designated positions.

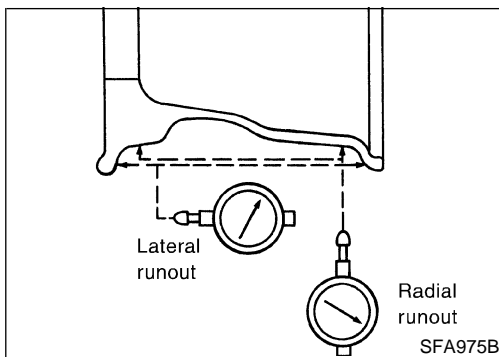

PRELIMINARY INSPECTION

1. Check tires for wear and proper inflation.
2. Check wheels for deformation, cracks and other damage. If deformed, remove wheel and check wheel runout.
 - a. Remove tire from wheel and mount wheel on a tire balance machine.
 - b. Set dial indicator as shown in the illustration.

Wheel runout: (Dial indicator value):
Refer to SDS, FA-29.
3. Check front wheel bearings for looseness.
4. Check front suspension for looseness.

ON-VEHICLE SERVICE

Front Wheel Alignment (Cont'd)

5. Check steering linkage for looseness.
6. Check that struts work properly by using the standard bounce test.
7. Check vehicle posture (Unladen).

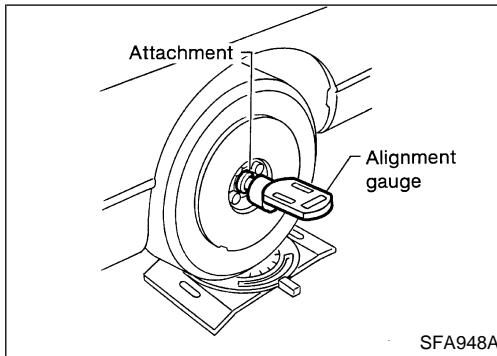

CAMBER, CASTER AND KINGPIN INCLINATION

Camber, caster and kingpin inclination are preset at factory and cannot be adjusted.

1. Measure camber, caster and kingpin inclination of both right and left wheels with a suitable alignment gauge.

Camber, caster and kingpin inclination:

Refer to SDS, FA-28.

2. If camber, caster and kingpin inclination are not within specification, inspect front suspension parts. Replace damaged or worn out parts.

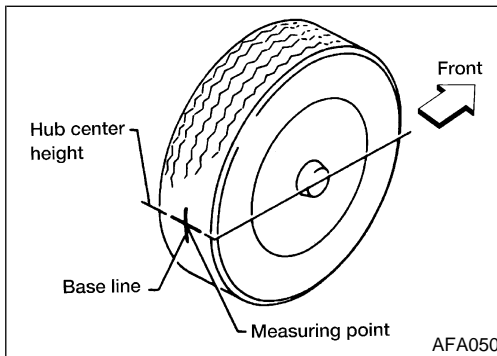

TOE-IN

Measure toe-in using the following procedure.

WARNING:

- Always perform the following procedure on a flat surface.
 - Make sure that no one is in front of the vehicle before pushing it.
1. Bounce front of vehicle up and down to stabilize the posture.
 2. Push the vehicle straight ahead about 5 m (16 ft).
 3. Put a mark on base line of tread (rear side) of both tires at the same height as hub center. These are measuring points.
 4. Measure distance "A" (rear side).
 5. Push the vehicle slowly ahead to rotate the wheels 180 degrees (1/2 turn).

If the wheels have rotated more than 180 degrees (1/2 turn), try the above procedure again from the beginning. Never push vehicle backward.

6. Measure distance "B" (front side).

Total toe-in (A-B):

Refer to SDS, FA-28.

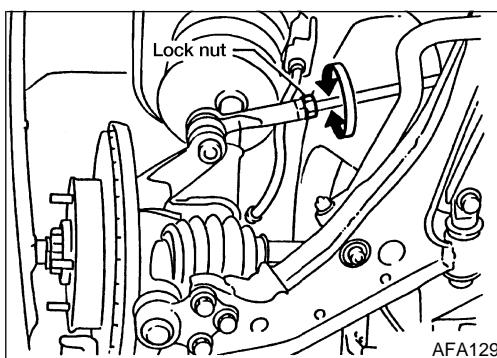
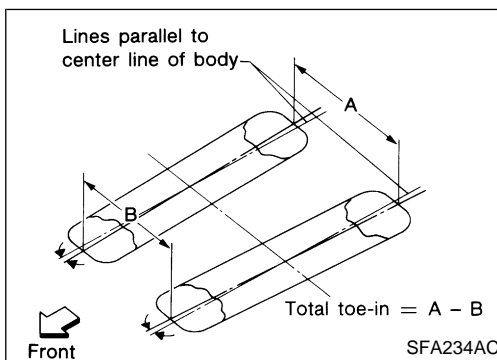

7. Adjust toe-in by varying the length of steering tie-rods.
 - a. Loosen lock nuts.
 - b. Adjust toe-in by screwing tie-rods in or out.

Standard length "L":

Refer to ST section ("General Specifications", "SDS").

- c. Tighten lock nuts to specified torque.

⚙️: 37 - 46 N·m (3.8 - 4.7 kg·m, 27 - 35 ft·lb)

ON-VEHICLE SERVICE

Front Wheel Alignment (Cont'd)

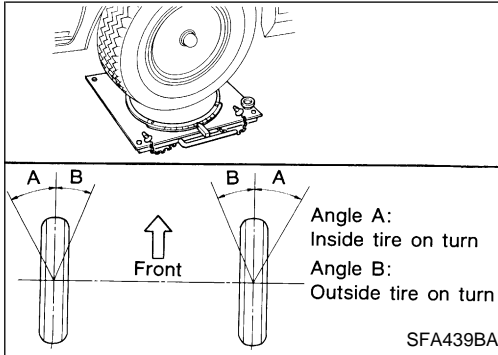
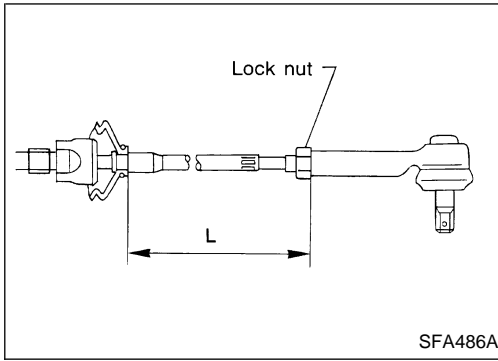

FRONT WHEEL TURNING ANGLE

1. Set wheels in straight-ahead position. Move vehicle forward until front wheels rest properly on turning radius gauge.
 2. Rotate steering wheel all the way right and left; measure turning angle.
- Turn steering wheel to full lock and apply force (at circumference of steering wheel) of 98 to 147 N (10 to 15 kg, 22 to 33 lb) with engine at idle.
 - **Do not hold the steering wheel on full lock for more than 15 seconds.**

Wheel turning angle (Full turn):

Refer to SDS, FA-28.

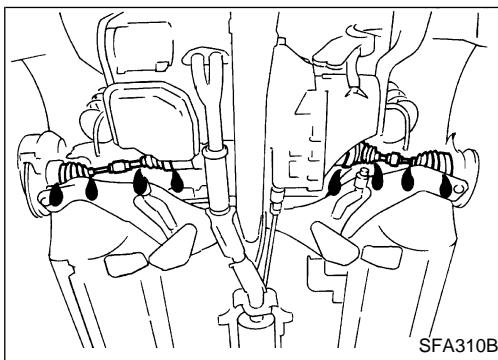

Drive Shaft

Check for grease leakage or other damage.

GI
MA
EM
LC
EC
FE
CL
MT
AT
FA
RA
BR
ST
RS
BT
HA
EL
IDX

FRONT AXLE

SEC. 400

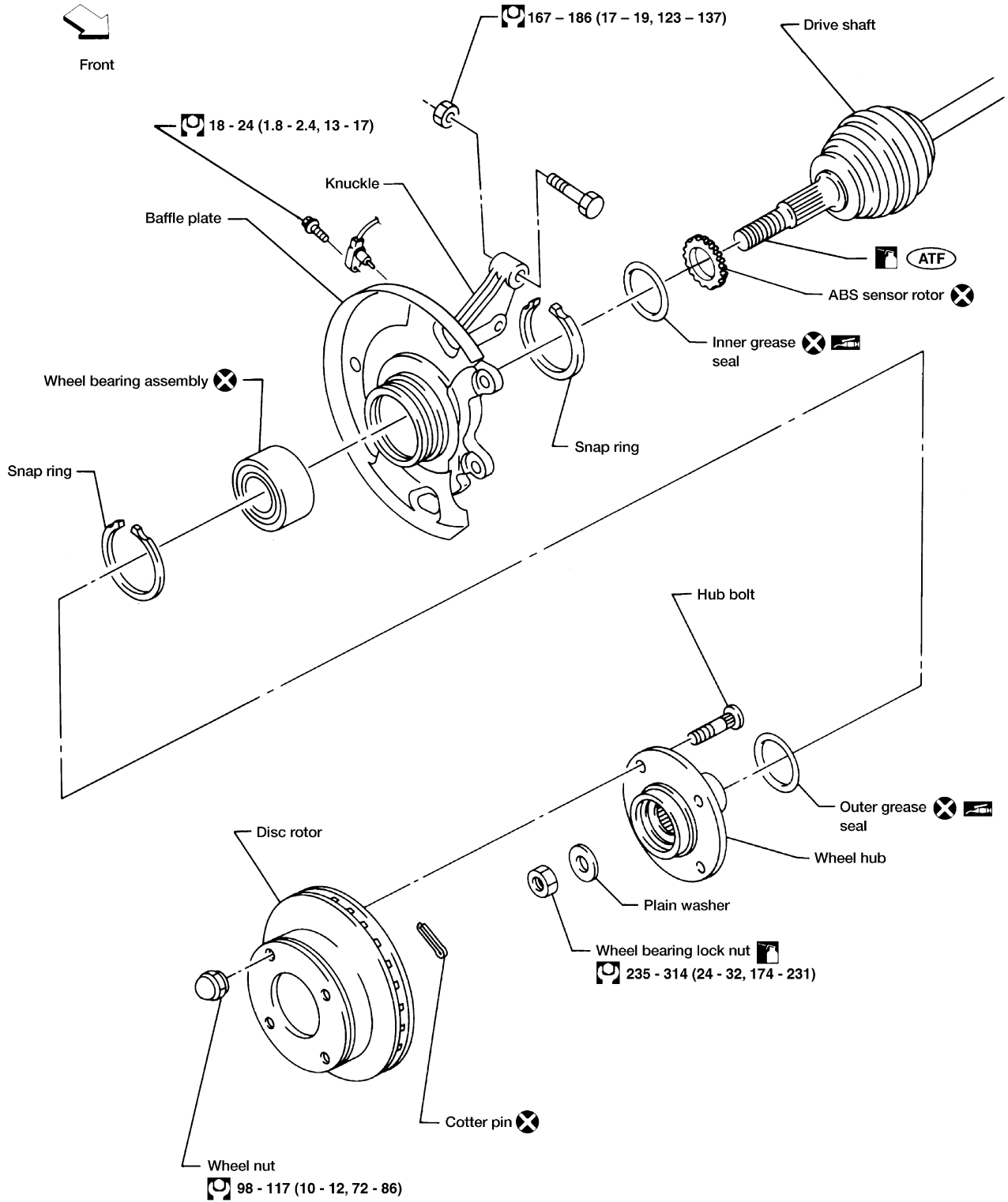

FRONT AXLE

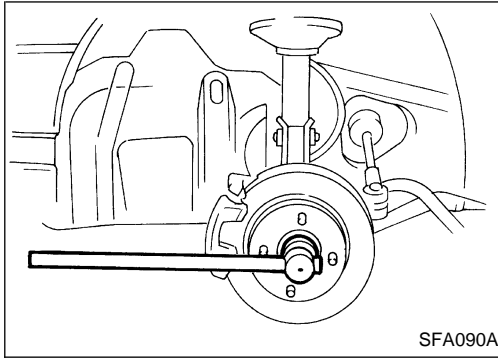

Wheel Hub and Knuckle REMOVAL

CAUTION:

Before removing the front axle assembly, disconnect the ABS wheel sensor from the assembly. Move it away from the front axle assembly area. Failure to do so may result in damaged sensor wires and the sensor becoming inoperative.

1. Remove wheel bearing lock nut.
2. Remove brake caliper assembly and rotor.
 - Brake hose need not be disconnected from brake caliper.
 - Suspend brake caliper with wire so as not to stretch brake hose.
 - Make sure brake hose is not twisted.
 - Be careful not to depress brake pedal, or caliper piston will pop out.
3. Separate tie-rod from knuckle with Tool.
 - Install stud nut conversely on stud bolt to prevent damage to stud bolt.
4. Remove strut lower mounting bolts.
5. Separate drive shaft from knuckle by lightly tapping it. If it is hard to remove, use a puller.
 - When removing drive shaft, cover boots with shop towel to prevent damaging them.

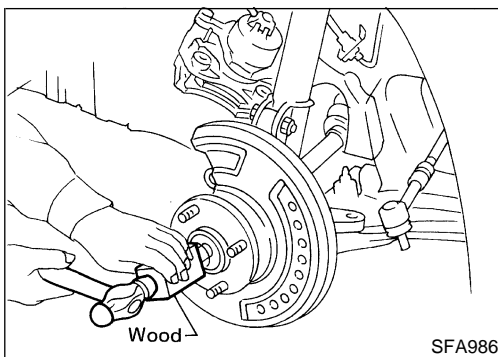
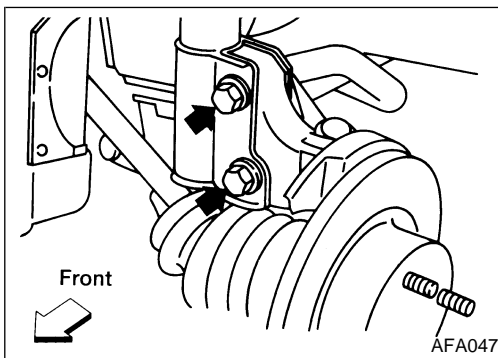
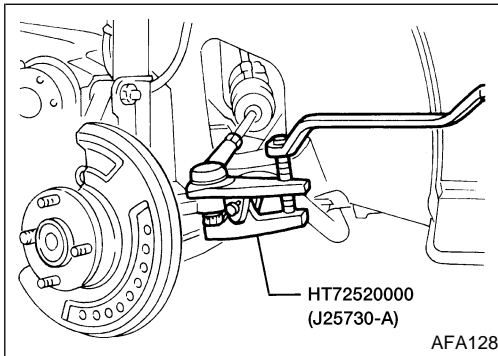
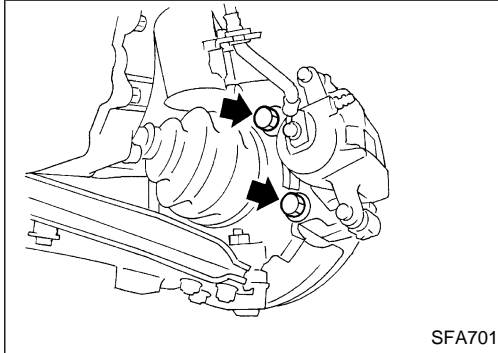

GI
MA
EM
LC
EC
FE
CL
MT
AT
FA
RA
BR
ST
RS
BT
HA
EL
IDX

FRONT AXLE

Wheel Hub and Knuckle (Cont'd)

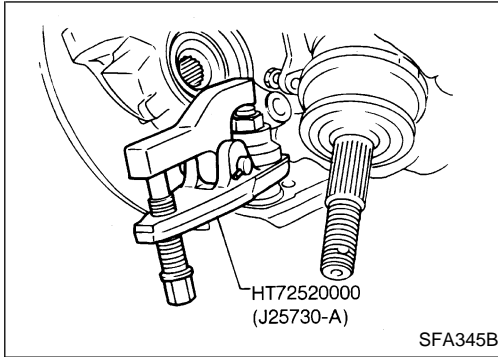

6. Loosen lower ball joint tightening nut.
7. Separate knuckle from lower ball joint stud with Tool.
8. Remove knuckle from transverse link.

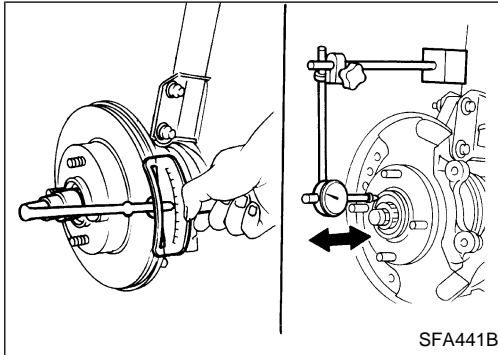

INSTALLATION

1. Install knuckle with wheel hub.
 - Replace strut lower mounting nuts.
 - **When installing knuckle to strut, be sure to hold bolts while tightening nuts.**
 - : 167 - 186 N·m (17 - 19 kg-m, 123 - 137 ft-lb)
2. Tighten tie-rod ball joint nut.
 - : 29 - 39 N·m (3.0 - 4.0 kg-m, 22 - 29 ft-lb)
 - **Apply ATF to threaded portion of drive shaft and both sides of plain washer.**
3. Install brake caliper assembly and rotor.
 - **Make sure brake hose is not twisted.**
4. Tighten wheel bearing lock nut.
 - : 235 - 314 N·m (24 - 32 kg-m, 174 - 231 ft-lb)
5. Check wheel bearing axial end play.
 - Axial end play:**
0.05 mm (0.0020 in) or less.

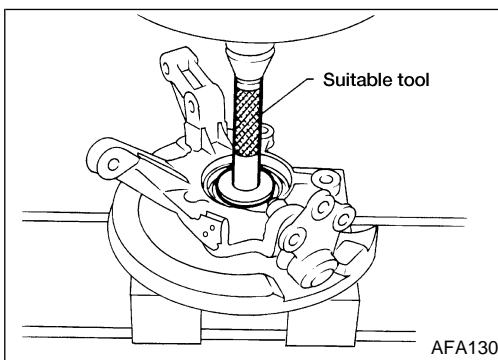

DISASSEMBLY

CAUTION:

When removing wheel hub or wheel bearing from knuckle, replace wheel bearing assembly (outer race, inner race and grease seals) with a new one.

Wheel bearing does not usually require maintenance. If any of the following symptoms are noted, replace wheel bearing assembly.

- Growling noise is emitted from wheel bearing during operation.
- Wheel bearing drags or turns roughly. This occurs when turning hub by hand after bearing lock nut is tightened to specified torque.

Wheel hub

Press out hub with inner race (outside) from knuckle with a suitable tool.

FRONT AXLE

Wheel Hub and Knuckle (Cont'd)

Wheel bearing

When replacing wheel bearing, replace wheel bearing assembly (inner race and outer race).

1. Remove bearing inner race (outside), then remove outer grease seal.
2. Remove inner grease seal from knuckle.
3. Remove inner and outer snap rings.
4. Press out bearing outer race.

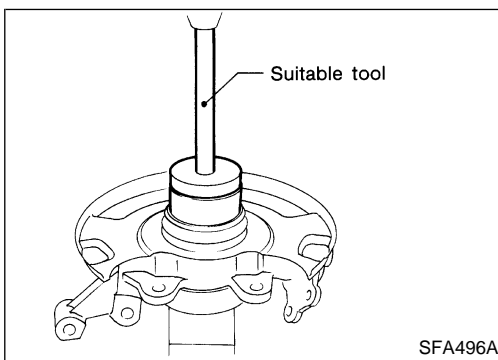
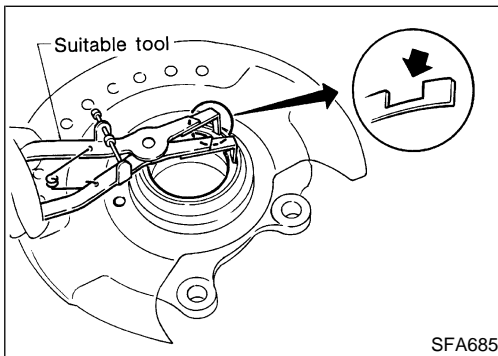
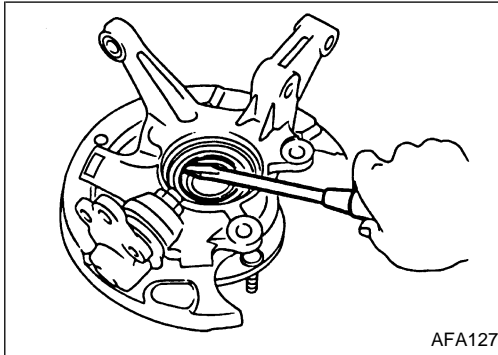
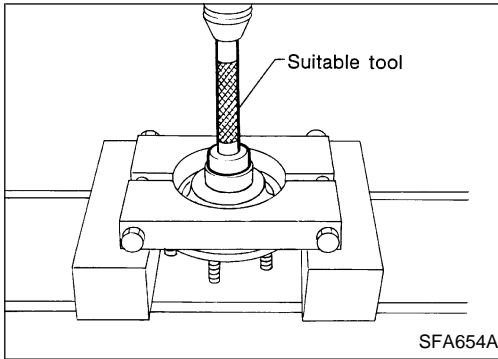

INSPECTION

Wheel hub and knuckle

Check wheel hub and knuckle for cracks by using a magnetic exploration or dyeing test.

Snap ring

Check snap ring for wear or cracks. Replace if necessary.

GI

MA

EM

LC

EC

FE

CL

MT

AT

FA

RA

BR

ST

RS

BT

HA

EL

IDX

FRONT AXLE

Wheel Hub and Knuckle (Cont'd)

ASSEMBLY

1. Install inner snap ring into groove of knuckle.
2. Press new wheel bearing assembly into knuckle.

Maximum load P:

29 kN (3 ton, 3.3 US ton, 3.0 Imp ton)

CAUTION:

- Do not press inner race of wheel bearing assembly.
 - Do not apply oil or grease to mating surfaces of wheel bearing outer race and knuckle.
3. Install outer snap ring into groove of knuckle.
 4. Pack grease seal lip with multi-purpose grease.

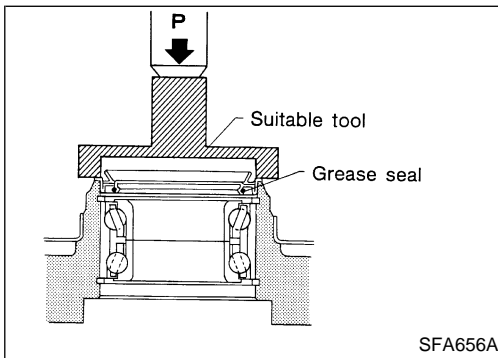
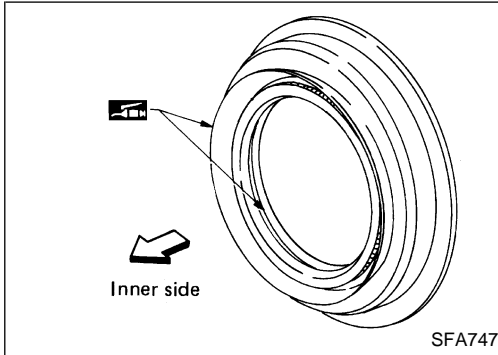
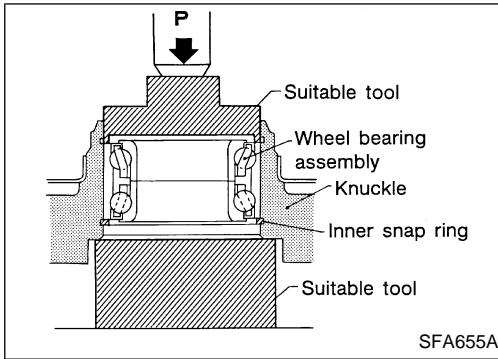

5. Install outer grease seal.

Maximum load P:

10 kN (1 ton, 1.1 US ton, 1.0 Imp ton)

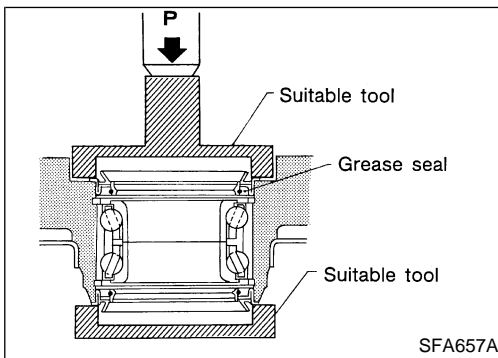

6. Install inner grease seal.

Maximum load P:

10 kN (1 ton, 1.1 US ton, 1.0 Imp ton)

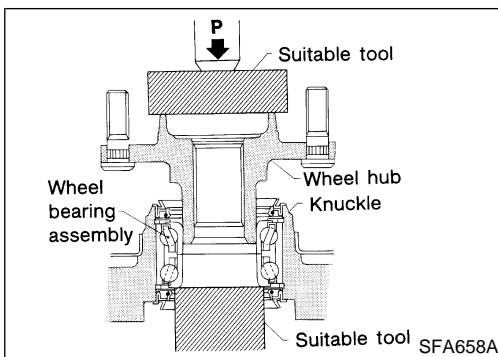

7. Press wheel hub into knuckle.

Maximum load P:

29 kN (3 ton, 3.3 US ton, 3.0 Imp ton)

- Be careful not to damage grease seal.

FRONT AXLE

Wheel Hub and Knuckle (Cont'd)

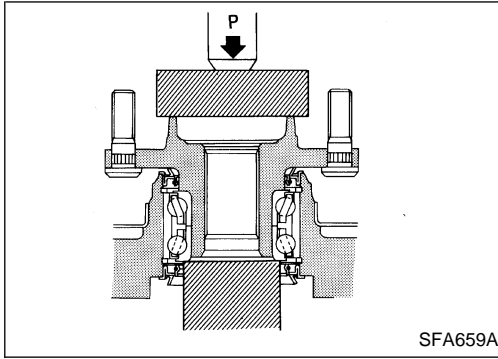

8. Check bearing operation.
- a. Add load P with press.

Load P:

34.3 - 68.7 kN

(3.5 - 7.0 ton, 3.9 - 7.7 US ton, 3.44 - 6.89 Imp ton)

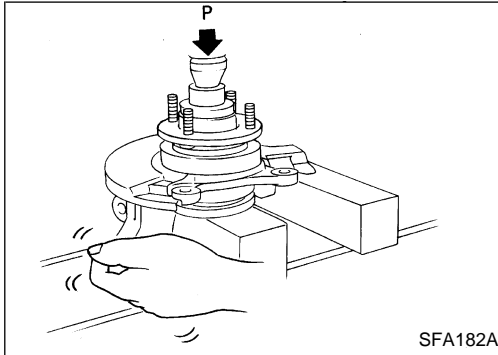

- b. Spin knuckle several turns in both directions.
- c. Make sure that wheel bearings operate smoothly.

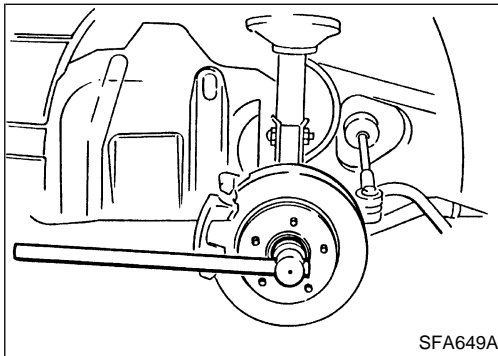

Drive Shaft

REMOVAL

1. Remove wheel bearing lock nut.
 - **Brake caliper need not be disconnected.**
 - **Do not twist or stretch brake hose when moving components.**

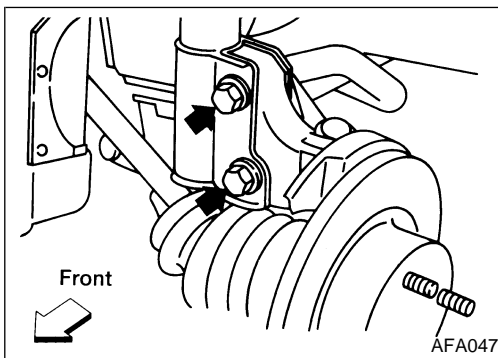

2. Remove strut lower mounting bolts.
3. Remove brake hose clip.

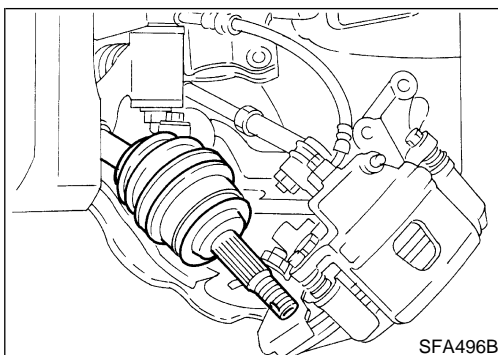

4. Separate drive shaft from knuckle by slightly tapping it.
When removing drive shaft, cover boots with shop towel to prevent damage to them.

Refer to FRONT AXLE — Wheel Hub and Knuckle, FA-11.

GI
MA
EM
LC
EC
FE
CL
MT
AT
FA
RA
BR
ST
RS
BT
HA
EL
IDX

FRONT AXLE

Drive Shaft (Cont'd)

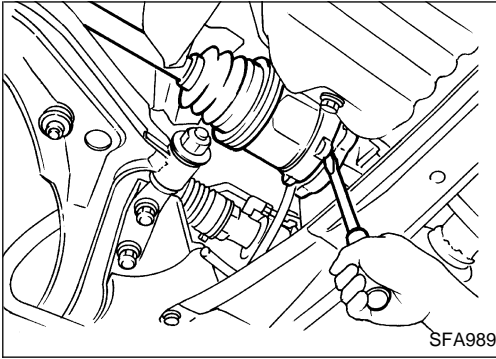

5. Remove support bearing bolts and pull drive shaft from transaxle.

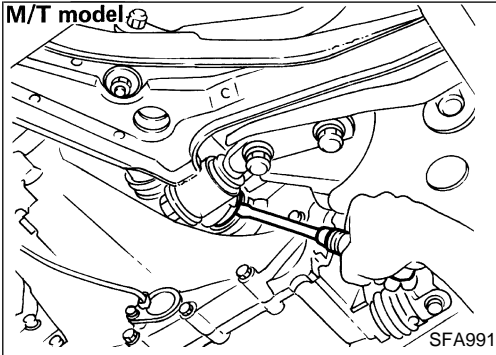

6. Remove left drive shaft with a suitable tool.

— FOR M/T MODELS —

- Pry drive shaft from transaxle as shown at left.

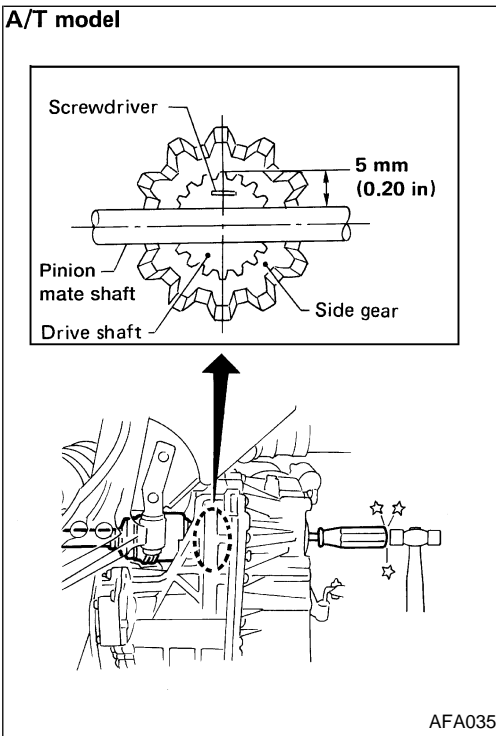

— FOR A/T MODELS —

- Insert screwdriver into transaxle opening for right drive shaft and strike with a hammer.
- **Be careful not to damage pinion mate shaft and side gear.**

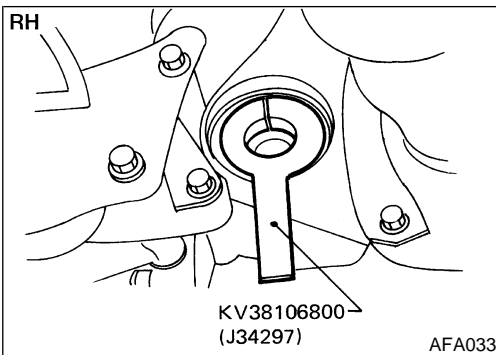

INSTALLATION

Transaxle side

1. Drive a new oil seal to transaxle. Refer to MT or AT sections ("Differential Side Oil Seal Replacement", "ON-VEHICLE SERVICE").
2. Set Tool along the inner circumference of oil seal (transaxle side).

FRONT AXLE

Drive Shaft (Cont'd)

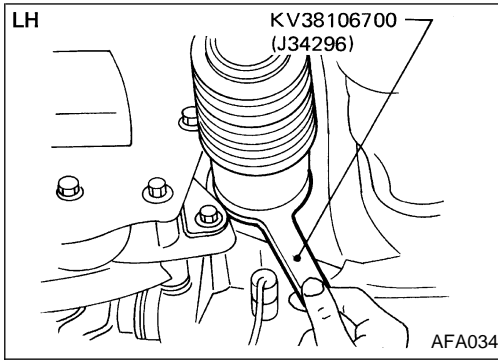

3. Insert drive shaft into transaxle. Be sure to properly align the serrations and then withdraw Tool.
4. Push drive shaft, then press-fit circular clip on the drive shaft into circular clip groove of side gear.
5. After its insertion, try to pull the flange out of the slide joint by hand. If it pulls out, the circular clip is not properly meshed with the side gear.

Wheel side

1. Install drive shaft into knuckle.
2. Tighten wheel bearing lock nut. Refer to FA-12.

COMPONENTS

CAUTION:

- Circular clips should be properly meshed with differential side gear (transaxle side) and with joint assembly (wheel side). Make sure they will not come out.
- Be careful not to damage boots. Use suitable protector or cloth during removal and installation.

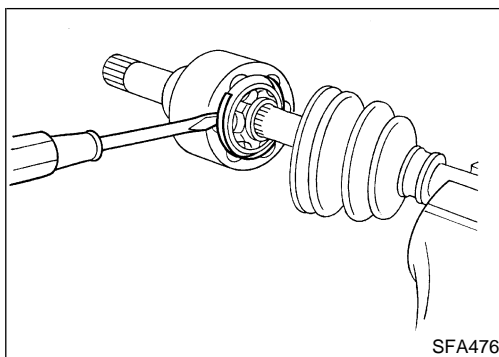
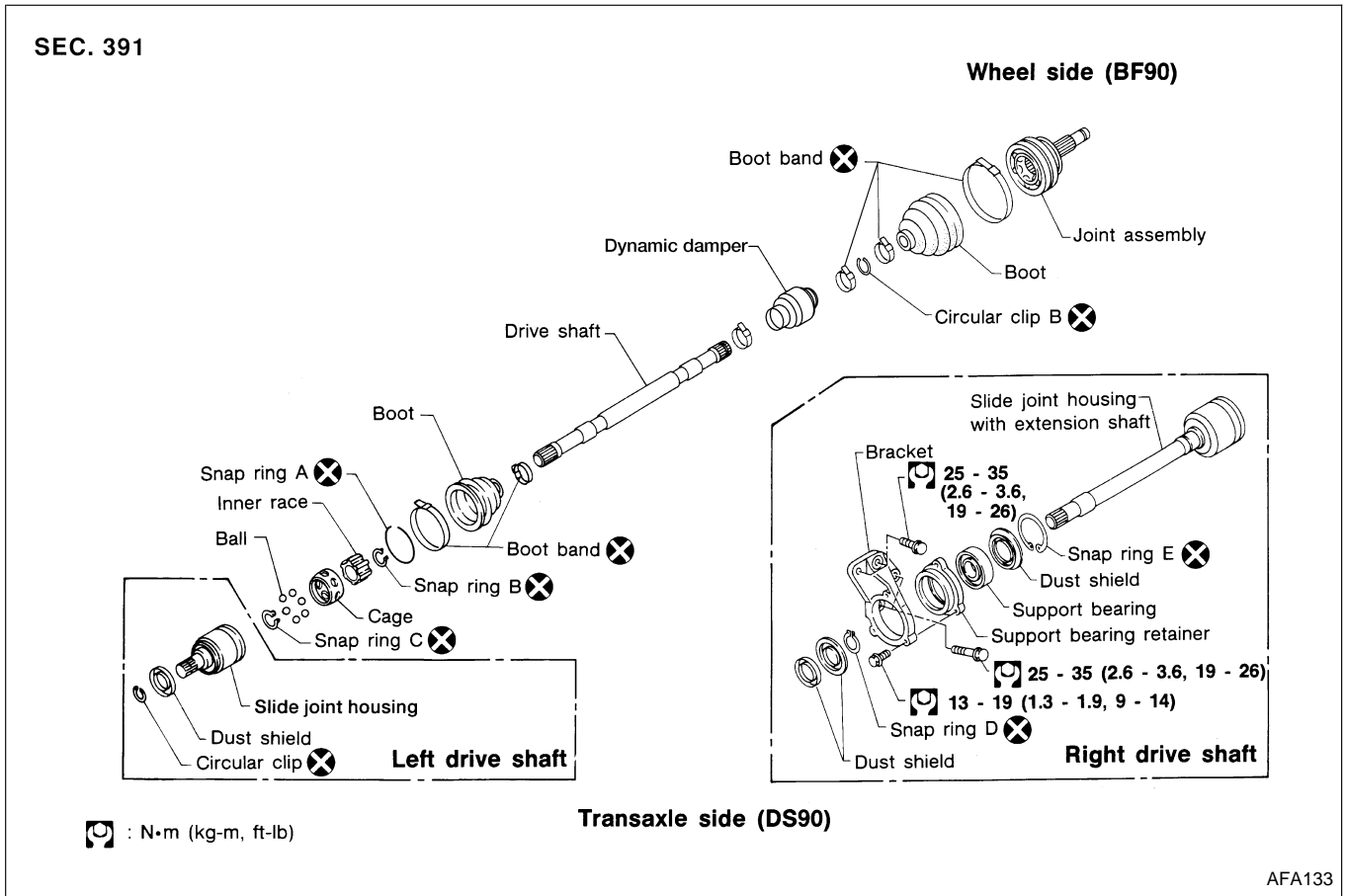

DISASSEMBLY

Transaxle side

1. Remove boot bands.
2. Put matching marks on slide joint housing and inner race, before separating joint assembly.
3. Remove snap ring "A" with a screwdriver, and pull out slide joint housing.

FRONT AXLE

Drive Shaft (Cont'd)

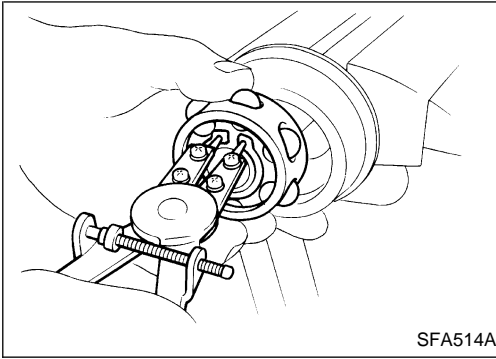

4. Put matching marks on inner race and drive shaft.
 5. Remove snap ring "C", then remove ball cage, inner race and balls as a unit.
 6. Remove snap ring "B".
 7. Draw out boot.
- **Cover drive shaft serrations with tape so as not to damage the boot.**

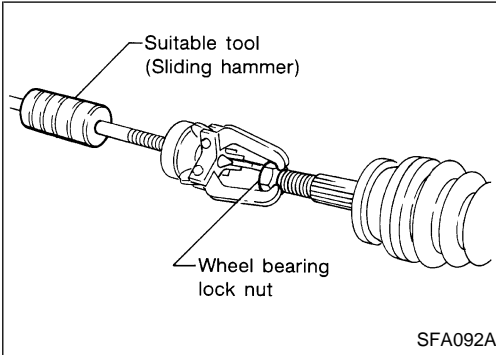

Wheel side

CAUTION:

The joint on the wheel side cannot be disassembled.

1. Before separating joint assembly, put matching marks on drive shaft and joint assembly.
2. Separate joint assembly with a suitable tool.
- **Be careful not to damage threads on drive shaft.**
3. Remove boot bands.
4. Remove the sensor rotor using suitable puller and bearing replacer.

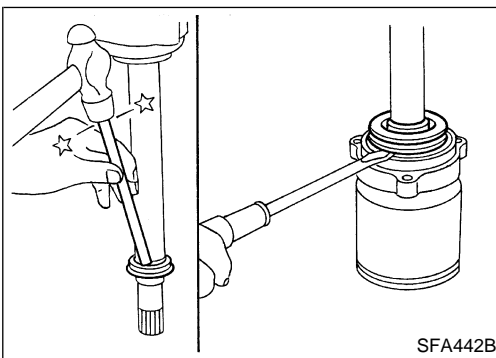
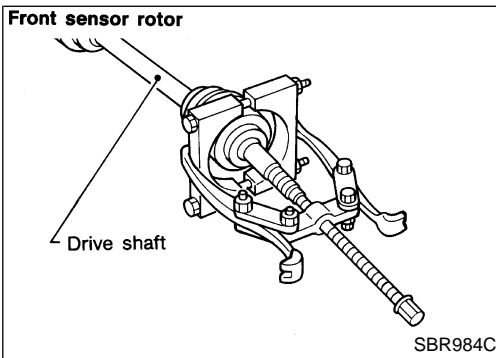

Support bearing

1. Remove dust shield.
2. Remove snap ring.

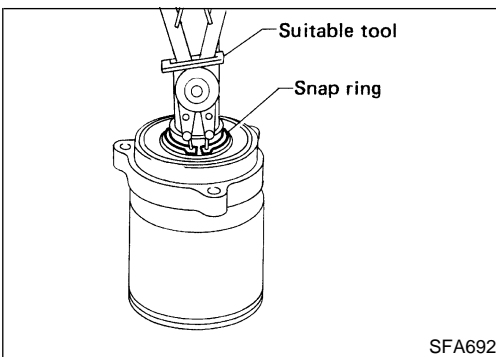

FRONT AXLE

Drive Shaft (Cont'd)

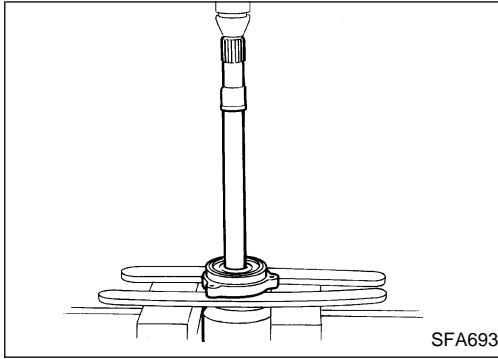

3. Press support bearing assembly off drive shaft.

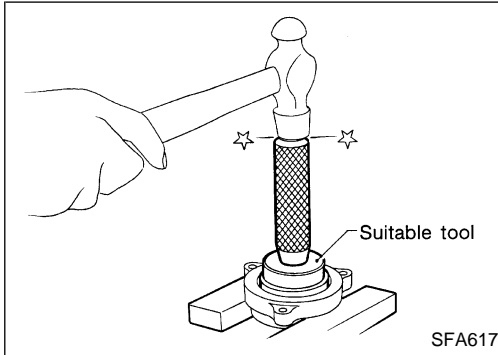

4. Separate support bearing from retainer.

INSPECTION

Thoroughly clean all parts in cleaning solvent, then dry with compressed air. Check parts for evidence of deformation or other damage.

Drive shaft

Replace drive shaft if it is twisted or cracked.

Boot

Check boot for fatigue, cracks, or wear. Replace boot with new boot bands.

Joint assembly (Transaxle side)

Replace joint assembly if it is deformed, damaged or operates abnormally.

Joint assembly (Wheel side)

Replace joint assembly if it is deformed, damaged or operates abnormally.

Support bearing

Make sure wheel bearing rolls freely and is free from noise, cracks, pitting or wear.

Support bearing bracket

Check support bearing bracket for cracks with a magnetic exploration or dyeing test.

GI
MA
EM
LC
EC
FE
CL
MT
AT
FA
RA
BR
ST
RS
BT
HA
EL
IDX

FRONT AXLE

Drive Shaft (Cont'd) ASSEMBLY

CAUTION:

- After drive shaft has been assembled, ensure that it moves smoothly over its entire range without binding.
- Use Genuine NISSAN grease or equivalent after every overhaul.

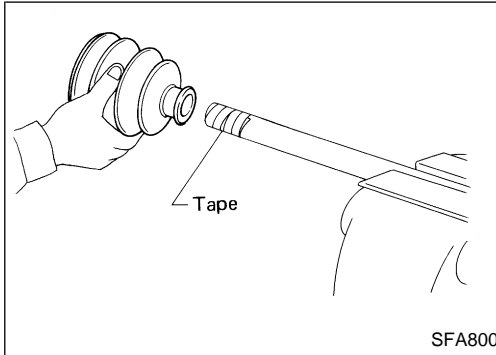

Wheel side

1. Install boot and new small boot band on drive shaft.
- **Cover drive shaft serration with tape so as not to damage boot during installation.**

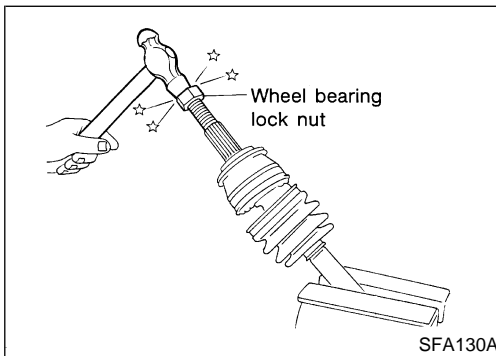

2. Set joint assembly onto drive shaft by lightly tapping it. Make sure joint assembly matching marks which were made during disassembly are properly aligned.

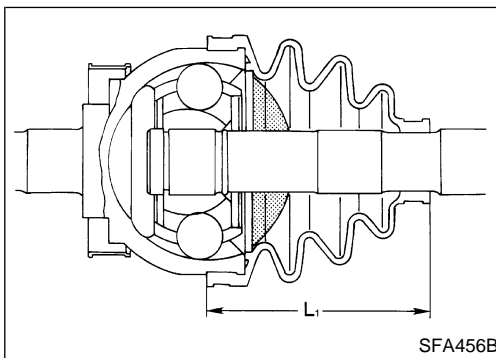

3. Pack drive shaft with specified amount of grease.
**Specified amount of grease:
75 - 95 g (2.65 - 3.35 oz)**
4. Make sure that boot is properly installed on the drive shaft groove. Set boot so that it does not swell and deform when its length is "L₁".
**Length "L₁":
84.5 - 86.5 mm (3.327 - 3.406 in)**

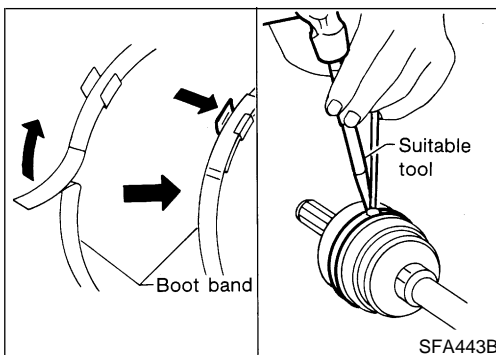

5. Lock new larger and smaller boot bands securely with a suitable tool.

FRONT AXLE

Drive Shaft (Cont'd)

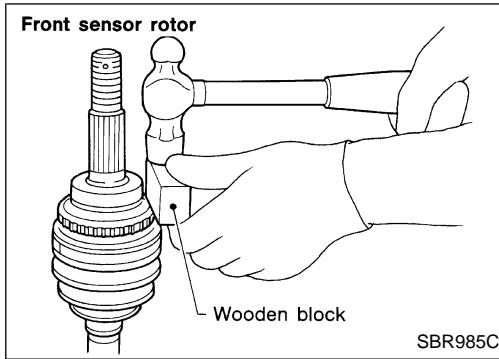

6. Install the sensor rotor. For front sensor rotor, use hammer and wooden block. For rear sensor rotor, use suitable drift and press.
- Always replace sensor rotor with new one.

Dynamic damper

1. Use new damper bands when installing.
2. Install dynamic damper from stationary-joint side while holding it securely.

Length:

Unit: mm (in)

| | A/T | | M/T | |
|-----|-----------------|-----------------|-----------------|-----------------|
| | RE4F04A | | RS5F50A | |
| | RH | LH | RH | LH |
| "A" | 203.1 (8.00) | 196.6 (7.31) | 203.1 (8.00) | 196.6 (7.31) |
| "B" | 70 (2.76) | 70 (1.97) | 70 (2.76) | 70 (1.97) |

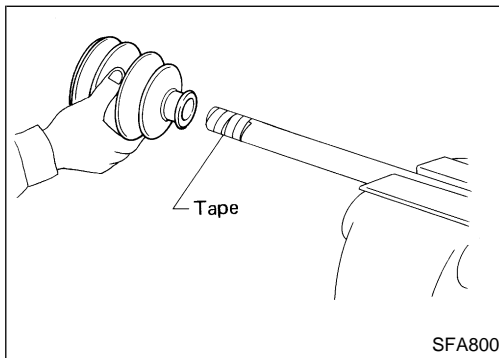
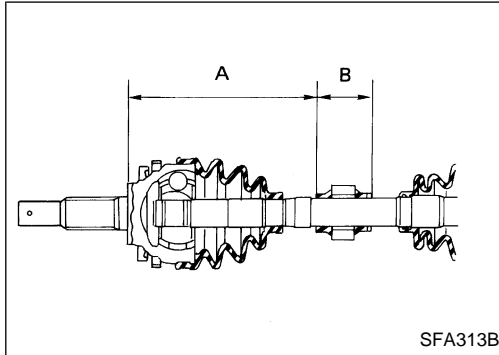

Transaxle side

1. Install boot and new small boot band on drive shaft.
- **Cover drive shaft serration with tape so as not to damage boot during installation.**

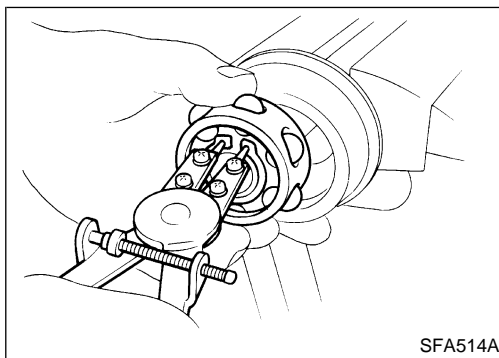

2. Install new snap ring "B", then securely install ball cage, inner race and balls as a unit, making sure the marks which were made during disassembly are properly aligned.
3. Install new snap ring "C".

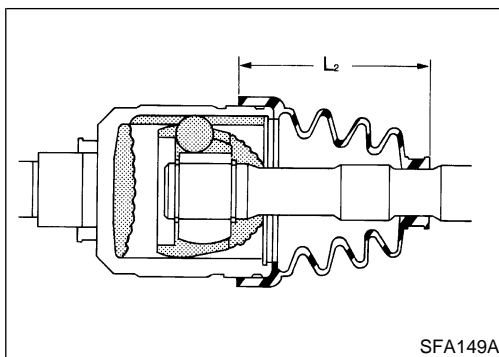

4. Pack drive shaft with specified amount of grease.

Specified amount of grease:

130 - 150 g (4.59 - 5.29 oz)

5. Install slide joint housing, then install new snap ring "A".
6. Make sure that boot is properly installed on the drive shaft groove.
Set boot so that it does not swell and deform when its length is "L₂".

Length "L₂":

97 - 99 mm (3.82 - 3.90 in)

FRONT AXLE

Drive Shaft (Cont'd)

7. Lock new larger and smaller boot bands securely with a suitable tool.

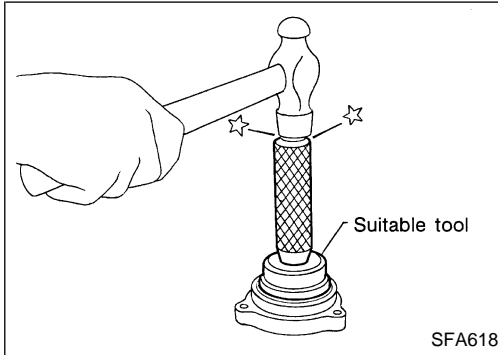
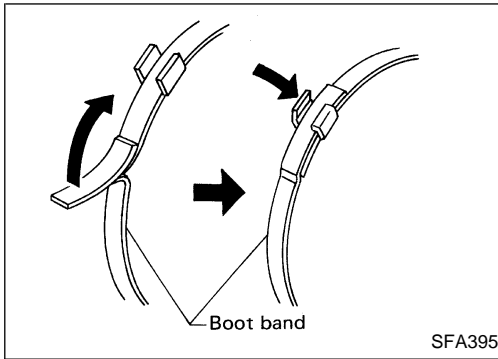

Support bearing

1. Install bearing into retainer.

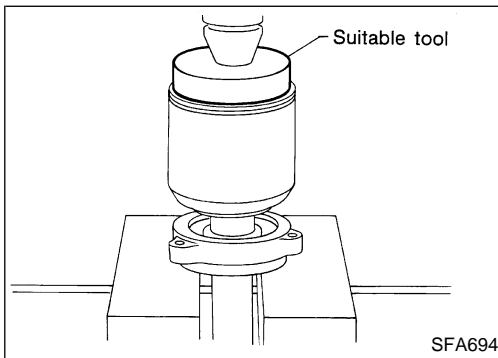

2. Press drive shaft into bearing.

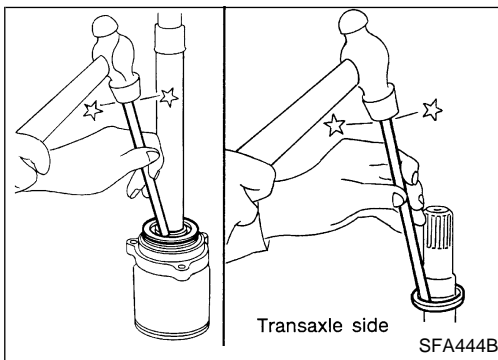

3. Install snap ring.
4. Install new dust shield.

FRONT SUSPENSION

SEC. 391-400-401

When installing rubber parts, final tightening must be carried out under unladen condition* with tires on ground.

* Fuel, radiator coolant and engine oil full.
Spare tire, jack, hand tools and mats in designated positions.

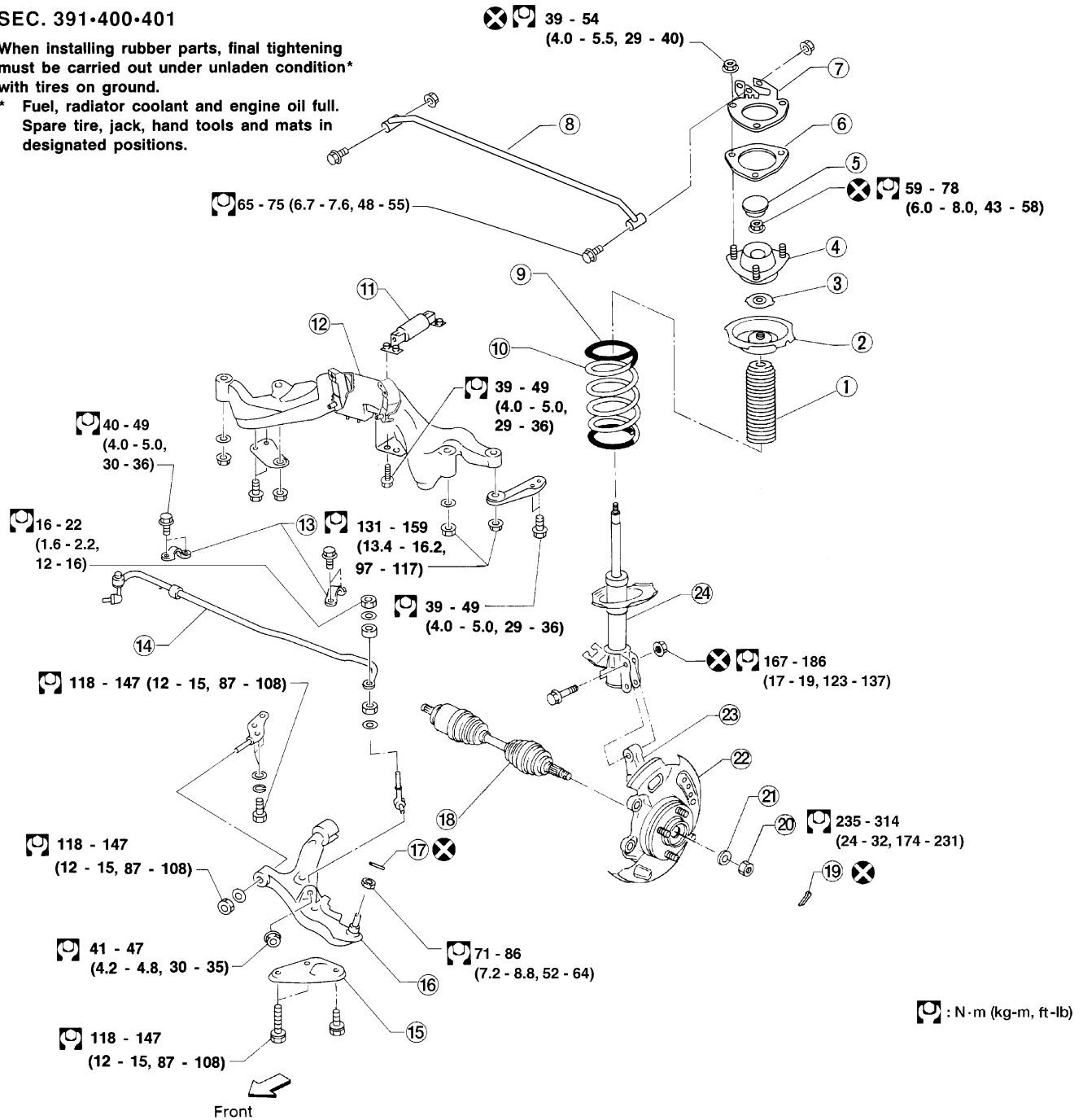

: N·m (kg-m, ft-lb)

- | | | |
|-----------------------------------|---|--------------------------|
| ① Bound bumper with dust cover | ⑨ Polyurethane tube | ⑯ Transverse link |
| ② Upper spring seat | ⑩ Coil spring | ⑰ Cotter pin |
| ③ Dust seal | ⑪ Front suspension damper assembly (A/T models except XE) | ⑱ Cotter pin |
| ④ Strut insulator | ⑫ Front suspension member | ⑳ Wheel bearing lock nut |
| ⑤ Cap (if equipped) | ⑬ Stabilizer clamp | ㉑ Plain washer |
| ⑥ Spacer | ⑭ Stabilizer | ㉒ Baffle plate |
| ⑦ Tower bar bracket (if equipped) | ⑮ Compression rod clamp | ㉓ Knuckle |
| ⑧ Strut tower bar (if equipped) | | ㉔ Strut assembly |

GI
MA
EM
LC
EC
FE
CL
MT
AT
FA
RA
BR
ST
RS
BT
HA
EL
IDX

FRONT SUSPENSION

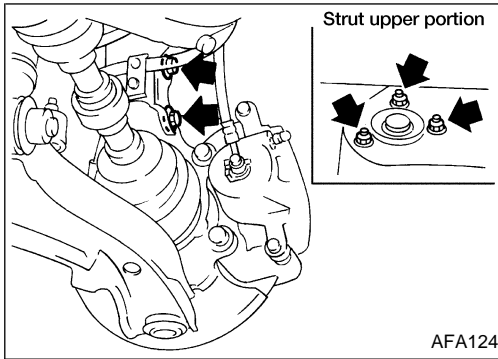

Coil Spring and Strut Assembly

REMOVAL AND INSTALLATION

- Remove strut assembly fixing bolts and nuts (from hoodledge).

WARNING:

Do not remove piston rod lock nut on vehicle.

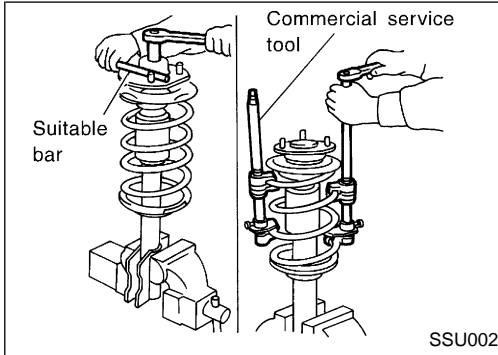

DISASSEMBLY

1. Set strut assembly in vise, then **loosen** piston rod lock nut.

WARNING:

Do not remove piston rod lock nut at this time.

2. Compress spring with Tool so that the strut mounting insulator can be turned by hand.

WARNING:

Make sure that the pawls of the two spring compressors are firmly hooked on the spring. The spring compressors must be tightened alternately so as not to tilt the spring.

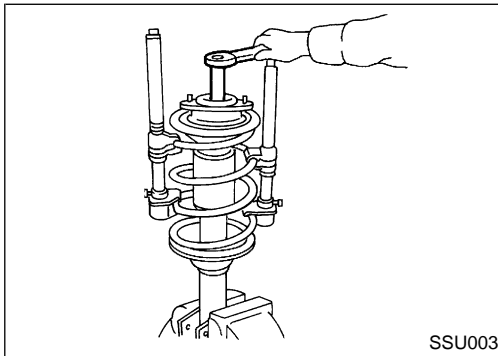

3. Remove piston rod lock nut.

INSPECTION

Strut assembly

- Check for smooth operation through a full stroke, both compression and extension.
- Check for oil leakage occurring on welded or gland packing portion.
- Check piston rod for cracks, deformation or other damage.
- Replace if necessary.

Strut mounting insulator

- Check cemented rubber-to-metal portion for separation or cracks.
- Check rubber parts for deterioration.

Thrust bearing

- Check thrust bearing parts for abnormal noise or excessive rattle in axial direction.
- Replace if necessary.

Coil spring and insulator

- Check for cracks, deformation or other damage. Replace if necessary.

FRONT SUSPENSION

Coil Spring and Strut Assembly (Cont'd) ASSEMBLY

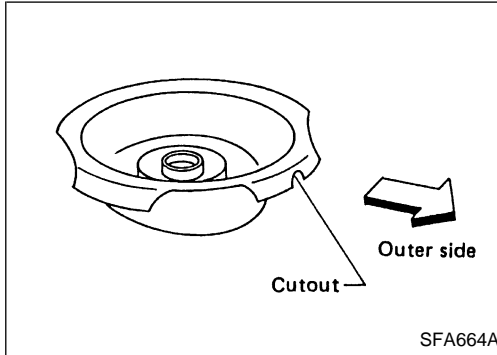
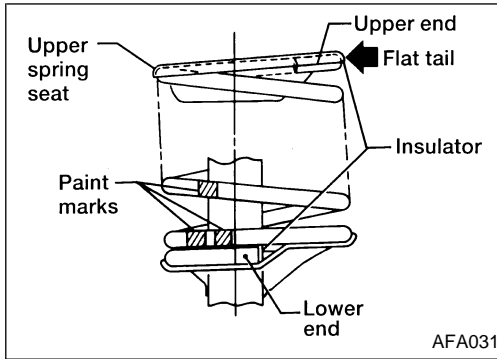

- When installing coil spring on strut, it must be positioned as shown in the figure at left.

- Install upper spring seat with its cutout facing the outer side of vehicle, in line with the strut-to-knuckle attachment points.
- Replace strut lower mounting nuts.
- **When installing strut to knuckle, be sure to hold bolts and tighten nuts.**
⚙️: 167 - 186 N·m
(17 - 19 kg·m, 123 - 137 ft·lb)

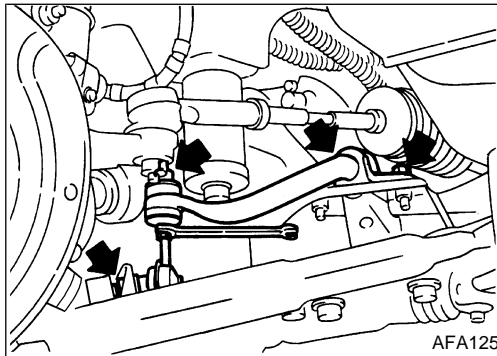

Stabilizer Bar

REMOVAL AND INSTALLATION

- Remove stabilizer bar.

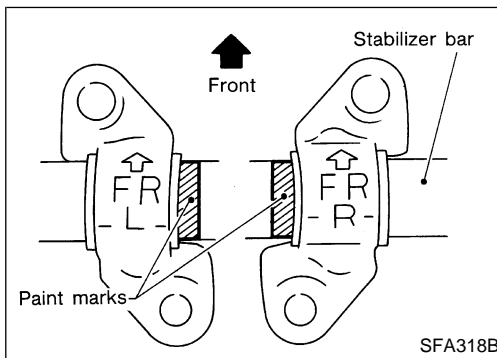

- When installing stabilizer, make sure the paint mark and clamp face in their correct directions.

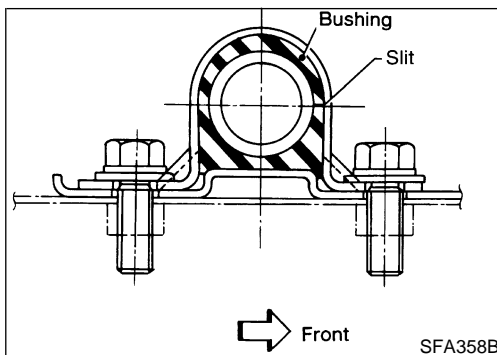

- Make sure that slit in bushing is in the position shown in the figure.

GI
MA
EM
LC
EC
FE
CL
MT
AT
FA
RA
BR
ST
RS
BT
HA
EL
IDX

FRONT SUSPENSION

Stabilizer Bar (Cont'd)

INSPECTION

- Check stabilizer for deformation or cracks. Replace if necessary.
- Check rubber bushings for deterioration or cracks. Replace if necessary.
- Check that ball joint can rotate in all directions. If movement is not smooth and free, replace stabilizer bar link.

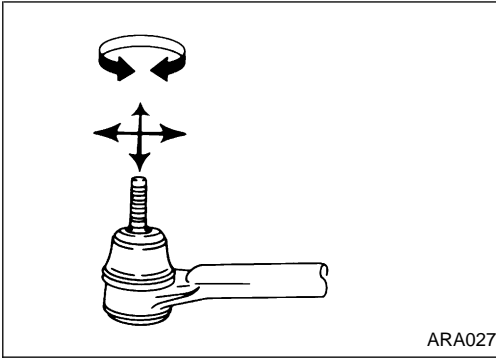

Transverse Link and Lower Ball Joint

REMOVAL AND INSTALLATION

1. Remove stabilizer connecting rod from transverse link.
2. Remove cotter pin and lock nut securing lower ball joint to knuckle.
3. Strike knuckle with a hammer to separate lower ball joint from knuckle.

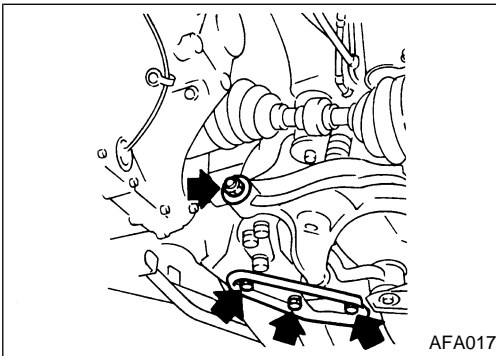

4. Remove bolts and nuts shown at left.
 5. Remove transverse link and lower ball joint.
 6. Install fixing bolts and nuts.
- **During installation, final tightening must be carried out at curb weight with tires on the ground.**
- Tightening torque:**
Refer to FRONT SUSPENSION, FA-23.
7. After installation, check wheel alignment. Refer to FA-7.

INSPECTION

- Check transverse link for damage, cracks or deformation. Replace if necessary.
- Check rubber bushing for damage, cracks and deformation. Replace transverse link if necessary.

FRONT SUSPENSION

Transverse Link and Lower Ball Joint (Cont'd)

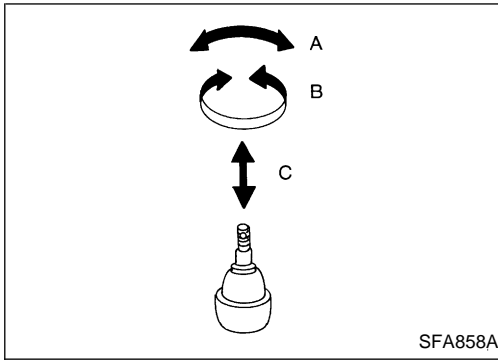

- Check ball joint for play. Replace transverse link assembly if any of the following cases occur:
 - Ball stud is worn.
 - Joint is hard to swing.
 - Play in axial direction is excessive.Before checking, turn ball joint at least 10 revolutions so that ball joint is properly broken in.

Swinging force "A":

(measuring point: cotter pin hole of ball stud):

7.8 - 54.9 N (0.8 - 5.6 kg, 1.8 - 12.3 lb)

Turning torque "B":

0.5 - 3.4 N·m (5 - 35 kg-cm, 4.3 - 30.4 in-lb)

Vertical end play "C":

0 mm (0 in)

- Check dust cover for damage. Replace it and cover clamp if necessary.

GI

MA

EM

LC

EC

FE

CL

MT

AT

FA

RA

BR

ST

RS

BT

HA

EL

IDX

SERVICE DATA AND SPECIFICATIONS (SDS)

General Specifications

| | |
|-----------------|-------------------------------|
| Suspension type | Independent Macpherson Struts |
| Strut type | Double-acting hydraulic |
| Stabilizer | Standard equipment |

Inspection and Adjustment

WHEEL ALIGNMENT (Unladen*1)

| | | | | | |
|-------------------------|-----------------------------------|-----------------------------------|-----------------------------------|-----------------|-----------------|
| Camber | Degree minute (Decimal degree) | Minimum | -0°51' (-0.85°) | | |
| | | Nominal | -0°06' (-0.10°) | | |
| | | Maximum | 0°39' (0.65°) | | |
| | | Left and right difference | 45' (0.75°) | | |
| Caster | Degree minute (Decimal degree) | Minimum | 1°55' (1.92°) | | |
| | | Nominal | 2°40' (2.67°) | | |
| | | Maximum | 3°25' (3.42°) | | |
| | | Left and right difference | 45' (0.75°) | | |
| Kingpin inclination | Degree minute (Decimal degree) | Minimum | 13°20' (13.33°) | | |
| | | Nominal | 14°05' (14.08°) | | |
| | | Maximum | 14°50' (14.83°) | | |
| Total toe-in | mm (in) | Minimum | 0 (0) | | |
| | | Nominal | 1 (0.04) | | |
| | | Maximum | 2 (0.08) | | |
| Angle (left plus right) | Degree minute (Decimal degree) | Minimum | 0' (0.00°) | | |
| | | Nominal | 6' (0.10°) | | |
| | | Maximum | 12' (0.20°) | | |
| Wheel turning angle | Inside | Degree minute (Decimal degree) | Minimum | 32°06' (32.10°) | |
| | | | Nominal | 35°06' (35.10°) | |
| | | | Maximum | 36°06' (36.10°) | |
| | Full turn*2 | Outside | Degree minute (Decimal degree) | Minimum | 26°18' (26.30°) |
| | | | | Nominal | 29°18' (29.30°) |
| | | | | Maximum | 30°18' (30.30°) |

*1: Fuel, radiator coolant and engine oil full. Spare tire, jack, hand tools and mats in designated positions.

*2: Wheel turning force (at circumference of steering wheel) of 98 to 147 N (10 to 15 kg, 22 to 33 lb) with engine idle.

SERVICE DATA AND SPECIFICATIONS (SDS)

Inspection and Adjustment (Cont'd)

WHEELARCH HEIGHT (Unladen*)

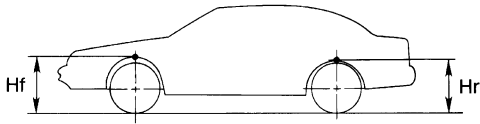

SFA818A

| Applied model | | XE/GLE/GXE | SE |
|---------------|---------|-------------|-------------|
| Front (Hf) | mm (in) | 691 (27.20) | 690 (27.17) |
| Rear (Hr) | mm (in) | 680 (26.77) | 678 (26.69) |

*: Fuel, radiator coolant and engine oil full. Spare tire, jack, hand tools and mats in designated positions.

WHEEL BEARING

| | | |
|--|-------------------|--------------------------------|
| Wheel bearing axial end play limit | mm (in) | 0.05 (0.0020) or less |
| Wheel bearing lock nut tightening torque | N·m (kg·m, ft·lb) | 235 - 314 (24 - 32, 174 - 231) |

LOWER BALL JOINT

| | | |
|---|--------------------|------------------------------------|
| Swinging force (Measured at cotter pin hole) | N (kg, lb) | 7.8 - 54.9 (0.8 - 5.6, 1.8 - 12.3) |
| Turning torque | N·m (kg·cm, in·lb) | 0.5 - 3.4 (5 - 35, 4.3 - 30.4) |
| Vertical end play limit | mm (in) | 0 (0) |

WHEEL RUNOUT

Unit: mm (in)

| Wheel type | Aluminum wheel | Steel wheel | |
|------------------------------|---------------------|---------------------|---------------------|
| | | Inside | Outside |
| Maximum radial runout limit | 0.3 (0.012) or less | 0.8 (0.031) or less | 0.4 (0.016) or less |
| Maximum lateral runout limit | 0.3 (0.012) or less | 1.0 (0.039) or less | 0.9 (0.035) or less |

DRIVE SHAFT

| | |
|----------------------------------|--|
| Applied model | All |
| Joint type | |
| Transaxle side | DS90 |
| Wheel side | BF90 |
| Boot length | mm (in) |
| Transaxle side (L ₂) | 97 - 99 (3.82 - 3.90) |
| Wheel side (L ₁) | 84.5 - 86.5 (3.327 - 3.406) |
| Grease | NISSAN Genuine Grease or equivalent |
| Capacity | g (oz) |
| Transaxle side | 130 - 150 (4.59 - 5.29) |
| Wheel side | 75 - 95 (2.65 - 3.35) |

Transaxle side

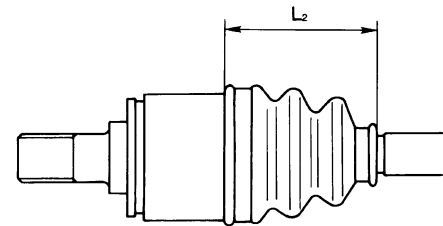

SFA961A

Wheel side

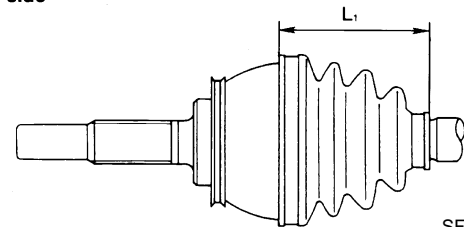

SFA962A

NOTES