

LT
SECTION
LIGHTING SYSTEM

A
B
C

CONTENTS

<p>PRECAUTIONS 4</p> <p> Precautions for Supplemental Restraint System (SRS) "AIR BAG" and "SEAT BELT PRE-TENSIONER" 4</p> <p> General precautions for service operations 4</p> <p>HEADLAMP (FOR USA) 5</p> <p> Component Parts and Harness Connector Location... 5</p> <p> System Description 5</p> <p> OUTLINE 5</p> <p> BATTERY SAVER CONTROL 6</p> <p> AUTO LIGHT OPERATION 6</p> <p> XENON HEADLAMP (IF EQUIPPED) 6</p> <p> CAN Communication System Description 7</p> <p> Wiring Diagram — H/LAMP — 8</p> <p> HALOGEN 8</p> <p> XENON 10</p> <p> Terminals and Reference Values for BCM 12</p> <p> Terminals and Reference Values for IPDM E/R 13</p> <p> How to Proceed With Trouble Diagnosis 13</p> <p> Preliminary Check 13</p> <p> CHECK POWER SUPPLY AND GROUND CIRCUIT 13</p> <p> CONSULT-II Function (BCM) 15</p> <p> CONSULT-II OPERATION 15</p> <p> DATA MONITOR 16</p> <p> ACTIVE TEST 16</p> <p> CONSULT-II Function (IPDM E/R) 17</p> <p> CONSULT-II OPERATION 17</p> <p> DATA MONITOR 18</p> <p> ACTIVE TEST 18</p> <p> Headlamp HI Does Not Illuminate (Both Sides) 19</p> <p> Headlamp HI Does Not Illuminate (One Side) 21</p> <p> High-Beam Indicator Lamp Does Not Illuminate ... 22</p> <p> Headlamp LO Does Not Illuminate (Both Sides) ... 22</p> <p> Headlamp LO Does Not Illuminate (One Side) 24</p> <p> Headlamps Do Not Turn OFF 25</p> <p> One Xenon Headlamp Does Not Illuminate At Full Brightness 26</p> <p> One Xenon Headlamp Flickers 26</p> <p> Aiming Adjustment 27</p>	<p> HEADLAMP AIMING 27</p> <p> AIMING ADJUSTMENT 28</p> <p> Bulb Replacement 28</p> <p> HEADLAMP 28</p> <p> FRONT TURN SIGNAL LAMP 29</p> <p> Removal and Installation 29</p> <p> COMBINATION LAMP 29</p> <p> Disassembly and Assembly 30</p> <p> COMBINATION LAMP - XENON TYPE 30</p> <p>HEADLAMP (FOR CANADA) - DAYTIME LIGHT SYSTEM - 32</p> <p> Component Parts and Harness Connector Location.. 32</p> <p> System Description 32</p> <p> HEADLAMP OPERATION 33</p> <p> BATTERY SAVER CONTROL 34</p> <p> AUTO LIGHT OPERATION 34</p> <p> DAYTIME LIGHT OPERATION 34</p> <p> XENON HEADLAMP (IF EQUIPPED) 34</p> <p> OPERATION 34</p> <p> CAN Communication System Description 35</p> <p> Schematic 36</p> <p> Wiring Diagram — DTRL — 37</p> <p> How to Proceed With Trouble Diagnosis 40</p> <p> Preliminary Check 40</p> <p> CHECK BCM CONFIGURATION 40</p> <p> Trouble Diagnosis 41</p> <p> Aiming Adjustment 42</p> <p> Bulb Replacement 42</p> <p> Disassembly and Assembly 42</p> <p> Removal and Installation 42</p> <p> DAYTIME LIGHT CONTROL UNIT 42</p> <p>AUTO LIGHT SYSTEM 43</p> <p> Component Parts and Harness Connector Location.. 43</p> <p> System Description 43</p> <p> OUTLINE 43</p> <p> BATTERY SAVER CONTROL 44</p> <p> SHUT OFF DELAY 44</p> <p> CAN Communication System Description 44</p> <p> Major Components and Functions 44</p> <p> Wiring Diagram — AUTO/L — 45</p>
---	---

D
E
F
G
H
I
J
LT
L
M

Terminals and Reference Values for BCM	47	CUIT	80
Terminals and Reference Values for IPDM E/R	48	CONSULT-II Function (BCM)	81
How to Proceed With Trouble Diagnosis	49	CONSULT-II OPERATION	81
Preliminary Check	49	DATA MONITOR	82
SETTING CHANGE FUNCTIONS	49	ACTIVE TEST	82
CHECK BCM CONFIGURATION	49	Turn Signal Lamp Does Not Operate	82
CHECK POWER SUPPLY AND GROUND CIR- CUIT	49	Hazard Warning Lamp Does Not Operate But Turn Signal Lamps Operate	84
CONSULT-II Function (BCM)	51	Turn Signal Indicator Lamp Does Not Operate	85
CONSULT-II OPERATION	51	Bulb Replacement	85
WORK SUPPORT	52	FRONT TURN SIGNAL LAMP	85
DATA MONITOR	52	REAR TURN SIGNAL LAMP	85
ACTIVE TEST	53	Removal and Installation	85
CONSULT-II Function (IPDM E/R)	54	FRONT TURN SIGNAL LAMP	85
CONSULT-II OPERATION	54	REAR TURN SIGNAL LAMP	85
DATA MONITOR	55	LIGHTING AND TURN SIGNAL SWITCH	86
ACTIVE TEST	55	Removal and Installation	86
Trouble Diagnosis Chart by Symptom	56	REMOVAL	86
Lighting Switch Inspection	56	Switch Circuit Inspection	86
Auto Light Sensor System Inspection	57	HAZARD SWITCH	87
FRONT FOG LAMP	59	Removal and Installation	87
Component Parts and Harness Connector Location..	59	REMOVAL	87
System Description	59	COMBINATION SWITCH	88
OUTLINE	59	Wiring Diagram — COMBSW —	88
BATTERY SAVER CONTROL	60	Combination Switch Reading Function	89
CAN Communication System Description	60	CONSULT-II Function (BCM)	89
Wiring Diagram — F/FOG —	61	CONSULT-II OPERATION	89
Terminals and Reference Values for BCM	62	DATA MONITOR	90
Terminals and Reference Values for IPDM E/R	63	Combination Switch Inspection	91
How to Proceed With Trouble Diagnosis	63	Removal and Installation	93
Preliminary Check	64	Switch Circuit Inspection	93
CHECK POWER SUPPLY AND GROUND CIR- CUIT	64	STOP LAMP	94
CONSULT-II Function	65	Wiring Diagram — STOP/L —	94
Front Fog Lamps Do Not Illuminate (Both Sides) ...	65	Bulb Replacement	96
Front Fog Lamp Does Not Illuminate (One Side) ...	66	HIGH MOUNTED STOP LAMP	96
Aiming Adjustment	67	WITHOUT REAR AIR SPOILER	96
ALL EXCEPT SE-R MODELS	67	STOP LAMP	96
SE-R MODELS	67	Removal and Installation	96
Bulb Replacement	69	HIGH-MOUNTED STOP LAMP	96
ALL EXCEPT SE-R MODELS	69	WITH REAR AIR SPOILER EXCEPT SE-R	96
SE-R MODELS	69	WITHOUT REAR AIR SPOILER	96
Removal and Installation	69	REAR COMBINATION LAMP	96
ALL EXCEPT SE-R MODELS	69	BACK-UP LAMP	97
SE-R MODELS	70	Wiring Diagram — BACK/L —	97
TURN SIGNAL AND HAZARD WARNING LAMPS..	71	Bulb Replacement	98
Component Parts and Harness Connector Location..	71	REMOVAL	98
System Description	71	INSTALLATION	98
TURN SIGNAL OPERATION	71	Removal and Installation	98
HAZARD LAMP OPERATION	72	PARKING, LICENSE PLATE AND TAIL LAMPS	99
REMOTE KEYLESS ENTRY SYSTEM OPERA- TION	73	Component Parts and Harness Connector Location..	99
CAN Communication System Description	73	System Description	99
Schematic	74	OPERATION BY LIGHTING SWITCH	99
Wiring Diagram — TURN —	75	BATTERY SAVER CONTROL	100
Terminals and Reference Values for BCM	78	CAN Communication System Description	100
How to Proceed With Trouble Diagnosis	79	Schematic	101
Preliminary Check	80	Wiring Diagram — TAIL/L —	102
CHECK POWER SUPPLY AND GROUND CIR-		Terminals and Reference Values for BCM	105
		Terminals and Reference Values for IPDM E/R ...	106
		How to Proceed With Trouble Diagnosis	106

Preliminary Check	107	DATA MONITOR	126	
CHECK POWER SUPPLY AND GROUND CIR- CUIT	107	ACTIVE TEST	127	A
CONSULT-II Functions	108	Interior Room Lamp Control Does Not Operate ..	128	
Parking, License Plate and/or Tail Lamps Do Not Illuminate	108	Ignition Keyhole Illumination Control Does Not Operate	129	B
Parking, License Plate and Tail Lamps Do Not Turn OFF (After Approx. 10 Minutes)	112	All Step Lamps Do Not Operate	131	
Bulb Replacement	113	All Interior Room Lamps Do Not Operate	132	
LICENSE PLATE LAMP	113	Bulb Replacement	132	C
FRONT TURN SIGNAL (PARKING) LAMP	113	ROOM OR SPOT LAMP	132	
TAIL LAMP	113	STEP LAMP	132	
Removal and Installation	113	VANITY MIRROR LAMP	132	
LICENSE PLATE LAMP	113	TRUNK ROOM LAMP	133	D
FRONT TURN SIGNAL (PARKING) LAMP	113	Removal and Installation	133	
REAR COMBINATION LAMP	113	IGNITION KEYHOLE ILLUMINATION LAMP ...	133	
INTERIOR ROOM LAMP	114	ROOM LAMP	133	E
Component Parts and Harness Connector Location	114	STEP LAMP	133	
System Description	114	TRUNK ROOM LAMP	134	
POWER SUPPLY AND GROUND	114	ILLUMINATION	135	F
SWITCH OPERATION	115	Component Parts and Harness Connector Location	135	
ROOM LAMP TIMER OPERATION	116	System Description	135	
INTERIOR LAMP BATTERY SAVER CONTROL	117	ILLUMINATION OPERATION BY LIGHTING		
Schematic	118	SWITCH	136	G
Wiring Diagram — INT/L —	119	BATTERY SAVER CONTROL	137	
Models With Vanity Lamps	122	CAN Communication System Description	137	
Terminals and Reference Values for BCM	123	Schematic	138	H
How to Proceed With Trouble Diagnosis	124	Wiring Diagram — ILL —	139	
Preliminary Check	124	Bulb Replacement	143	
INSPECTION FOR POWER SUPPLY AND		GLOVE BOX LAMP	143	I
GROUND CIRCUIT	124	Removal and Installation	143	
CONSULT-II Function (BCM)	125	ILLUMINATION CONTROL SWITCH	143	
CONSULT-II OPERATION	125	BULB SPECIFICATIONS	144	J
WORK SUPPORT	126	Headlamp	144	
		Exterior Lamp	144	
		Interior Lamp/Illumination	144	

LT

L

M

PRECAUTIONS

PRECAUTIONS

PFP:00011

Precautions for Supplemental Restraint System (SRS) “AIR BAG” and “SEAT BELT PRE-TENSIONER”

EKS008LD

The Supplemental Restraint System such as “AIR BAG” and “SEAT BELT PRE-TENSIONER”, used along with a front seat belt, helps to reduce the risk or severity of injury to the driver and front passenger for certain types of collision. This system includes seat belt switch inputs and dual stage front air bag modules. The SRS system uses the seat belt switches to determine the front air bag deployment, and may only deploy one front air bag, depending on the severity of a collision and whether the front occupants are belted or unbelted. Information necessary to service the system safely is included in the SRS and SB section of this Service Manual.

WARNING:

- To avoid rendering the SRS inoperative, which could increase the risk of personal injury or death in the event of a collision which would result in air bag inflation, all maintenance must be performed by an authorized NISSAN/INFINITI dealer.
- Improper maintenance, including incorrect removal and installation of the SRS, can lead to personal injury caused by unintentional activation of the system. For removal of Spiral Cable and Air Bag Module, see the SRS section.
- Do not use electrical test equipment on any circuit related to the SRS unless instructed to in this Service Manual. SRS wiring harnesses can be identified by yellow and/or orange harnesses or harness connectors.

General precautions for service operations

EKS008LE

- Never work with wet hands.
- The xenon headlamp system includes a high voltage generating part. Be sure to disconnect battery negative cable (negative terminal) or power fuse before removing, installing, or touching the xenon headlamp (including lamp bulb).
- Turn the lighting switch OFF before disconnecting and connecting the connector.
- When turning the xenon headlamp on and while it is illuminated, never touch the harness, bulb, and socket of the headlamp.
- When checking the headlamp on/off operation, check it on vehicle and with the power connected to the vehicle-side connector.
- Do not touch the headlamp bulb glass surface with bare hands or allow oil or grease to get on it. Do not touch the headlamp bulb just after the headlamp is turned off, because it is very hot.
- Install the xenon headlamp bulb socket correctly. If it is installed improperly, high-voltage leak or corona discharge may occur that can melt the bulb, connector, and housing. Do not illuminate the xenon headlamp bulb out of the headlamp housing. Doing so can cause fire and harm your eyes.
- When the bulb has burned out, wrap it in a thick vinyl bag and discard. Do not break the bulb.
- Leaving the bulb removed from the headlamp housing for a long period of time can deteriorate the performance of the lens and reflector (dirt, clouding). Always prepare a new bulb and have it on hand when replacing the bulb.
- When adjusting the headlamp aiming, turn the aiming adjustment screw only in the tightening direction. (If it is necessary to loosen the screw, first fully loosen the screw, and then turn it in the tightening direction.)
- Do not use organic solvent (paint thinner or gasoline) to clean lamps and to remove old sealant.

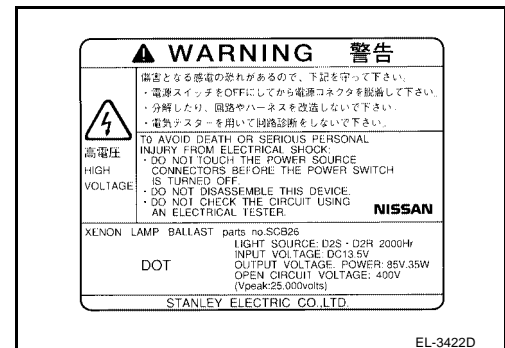
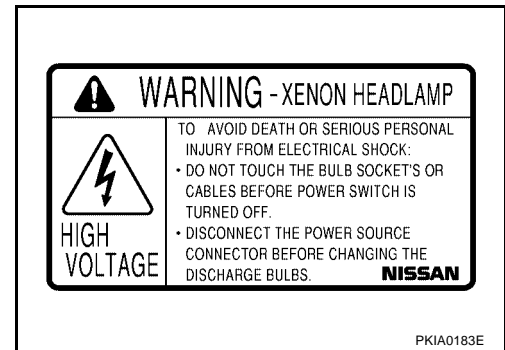

HEADLAMP (FOR USA)

PF2:26010

EKS008LG

HEADLAMP (FOR USA)

Component Parts and Harness Connector Location

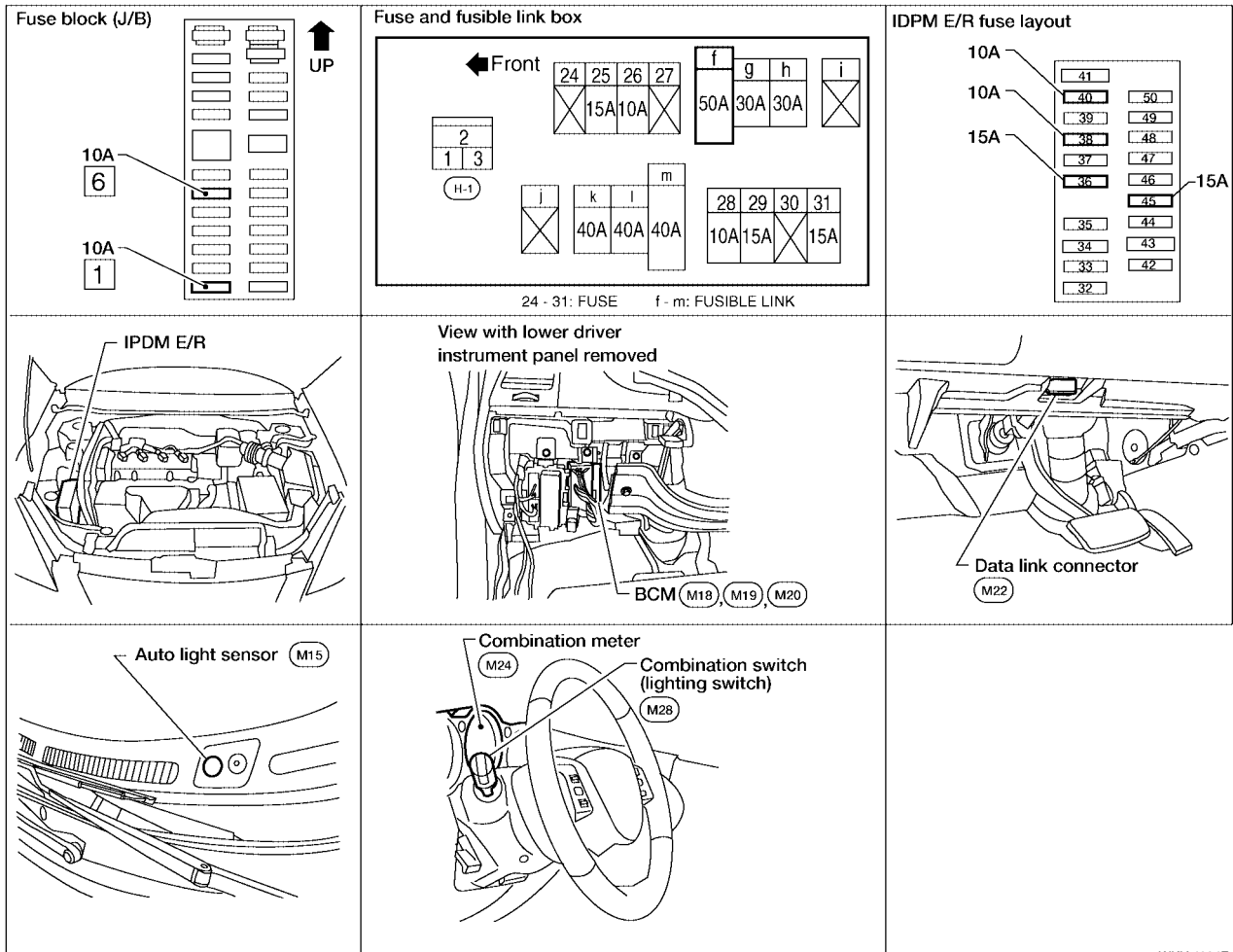

WKIA4084E

EKS008LH

System Description

Control of the headlamp system operation is dependent upon the position of the combination switch (lighting switch). When the lighting switch is placed in the 2ND position, the BCM (body control module) receives input requesting the headlamps (and tail lamps) to illuminate. This input is communicated to the IPDM E/R (intelligent power distribution module engine room) across the CAN communication lines. The CPU (central processing unit) of the IPDM E/R controls the headlamp high and headlamp low relay coils. When energized, these relays direct power to the respective headlamps, which then illuminate.

OUTLINE

Power is supplied at all times

- to headlamp high relay, located in the IPDM E/R, and
- to headlamp low relay, located in the IPDM E/R, and
- through 50A fusible link (letter f , located in the fuse and fusible link box)
- to BCM terminal 70.

With the ignition switch in the ON or START position, power is supplied

- through 10A fuse [No. 1, located in the fuse block (J/B)]
- to BCM terminal 38.

With the ignition switch in the ACC or ON position, power is supplied

- through 10A fuse [No. 6, located in the fuse block (J/B)]
- to BCM terminal 11.

Ground is supplied

A
B
C
D
E
F
G
H
I
J

LT

L
M

HEADLAMP (FOR USA)

- to BCM terminal 67
- through grounds F14, M57 and M61.

Low Beam Operation

With the lighting switch in 2ND position, the BCM receives input requesting the headlamps to illuminate. This input is communicated to the IPDM E/R across the CAN communication lines. The CPU of the IPDM E/R controls the headlamp low relay coil. When energized, this relay directs power

- through 15A fuse (No. 36, located in the IPDM E/R)
- through IPDM E/R terminal 20
- to headlamp RH terminal 1, and
- through 15A fuse (No. 45, located in the IPDM E/R)
- through IPDM E/R terminal 30
- to headlamp LH terminal 1.

Ground is supplied

- to headlamp RH terminal 2
- to headlamp LH terminal 2
- through grounds E15 and E24.

With power and ground supplied, low beam headlamps illuminate.

High Beam Operation/Flash-to-Pass Operation

With the lighting switch in 2ND position and placed in HIGH or PASS position, the BCM receives input requesting the headlamp high beams to illuminate. This input is communicated to the IPDM E/R across the CAN communication lines. The CPU of the combination meter controls the ON/OFF status of the HIGH BEAM indicator. The CPU of the IPDM E/R controls the headlamp high relay coil. When energized, this relay directs power

- through 10A fuse (No. 40, located in the IPDM E/R)
- through IPDM E/R terminal 27
- to headlamp RH terminal 1, and
- through 10A fuse (No. 38, located in the IPDM E/R)
- through IPDM E/R terminal 28
- to headlamp LH terminal 1.

Ground is supplied

- to headlamp RH terminal 2
- to headlamp LH terminal 2
- through grounds E15 and E24.

With power and ground supplied, the high beam headlamps illuminate.

BATTERY SAVER CONTROL

When the combination switch (lighting switch) is in the 2ND position (ON) and the ignition switch is turned from ON or ACC to OFF, the battery saver control feature is activated.

Under this condition, the headlamps remain illuminated for 5 minutes, unless the combination switch (lighting switch) position is changed. If the combination switch (lighting switch) position is changed, then the headlamps are turned off.

AUTO LIGHT OPERATION

Refer to [LT-43, "System Description"](#) for auto light operation.

XENON HEADLAMP (IF EQUIPPED)

The low beam headlamps may be equipped with xenon type bulbs. Xenon bulbs do not use a filament. Instead, they produce light when a high voltage current is passed between two tungsten electrodes through a mixture of xenon (an inert gas) and certain other metal halides. In addition to added lighting power, electronic control of the power supply gives the headlamps stable quality and tone color.

Following are some of the advantages of the xenon type headlamp.

- The light produced by the headlamps is a white color comparable to sunlight that is easy on the eyes.
- Light output is nearly double that of halogen headlamps, affording increased area of illumination.

HEADLAMP (FOR USA)

- The light features a high relative spectral distribution at wavelengths to which the human eye is most sensitive. This means that even in the rain, more light is reflected back from the road surface toward the vehicle for added visibility.
- Power consumption is approximately 25 percent less than halogen headlamps, reducing battery load.

CAN Communication System Description

EKS008LI

Refer to [LAN-20, "CAN COMMUNICATION"](#) .

A

B

C

D

E

F

G

H

I

J

LT

L

M

HEADLAMP (FOR USA)

EKS008LJ

Wiring Diagram — H/LAMP — HALOGEN

LT-H/LAMP-01

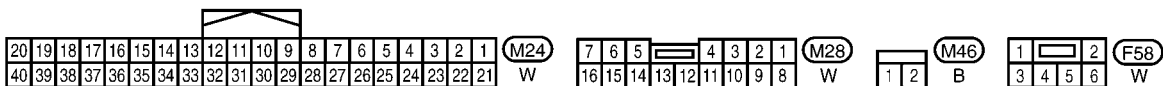
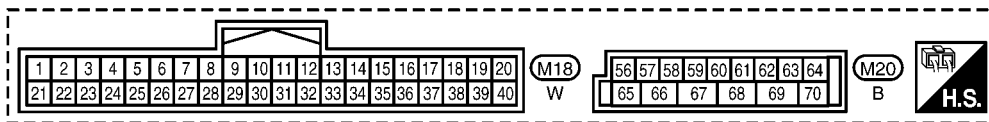
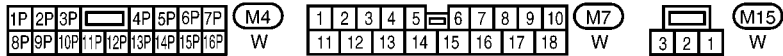
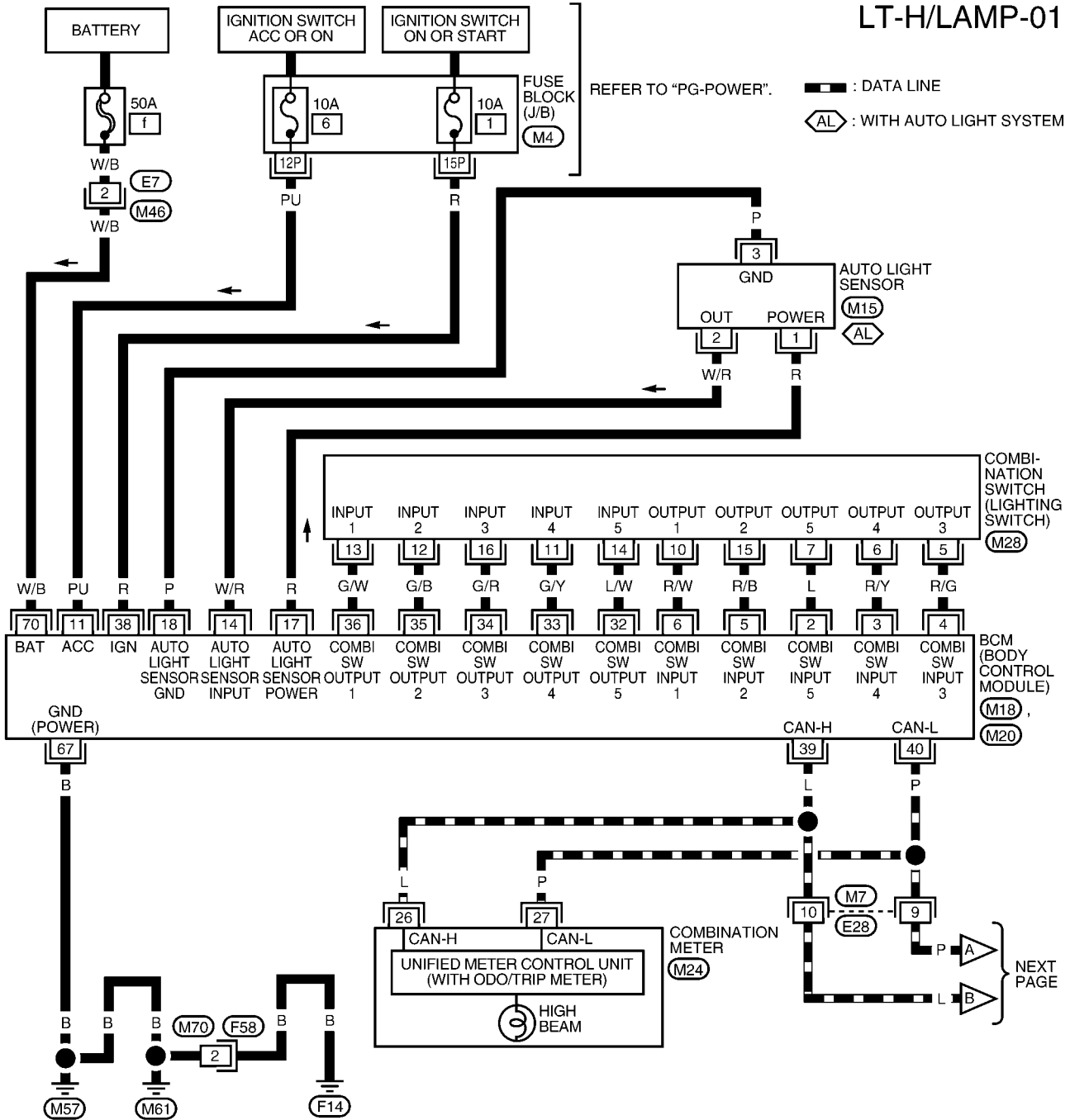

WKWA1360E

HEADLAMP (FOR USA)

LT-H/LAMP-02

DATA LINE

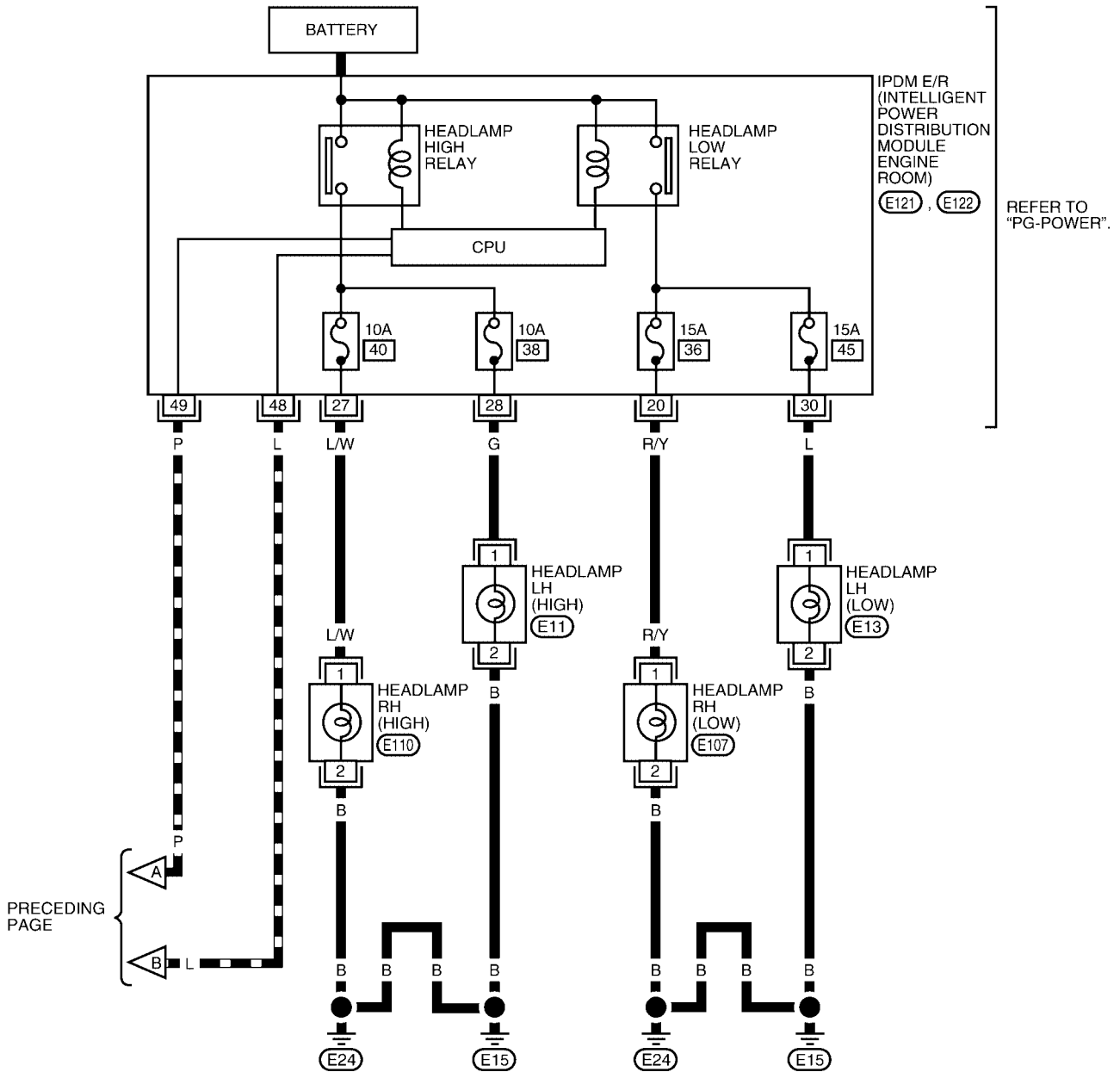

A
B
C
D
E
F
G
H
I
J
LT
L
M

HEADLAMP (FOR USA)

XENON

LT-H/LAMP-03

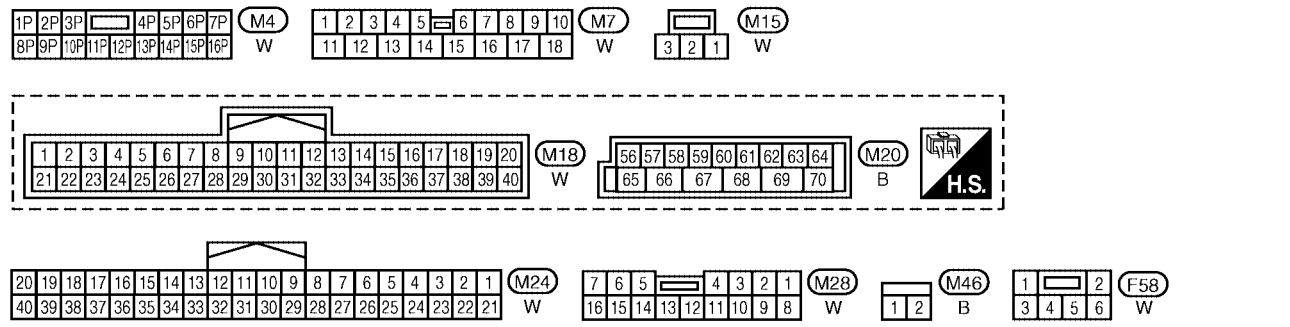
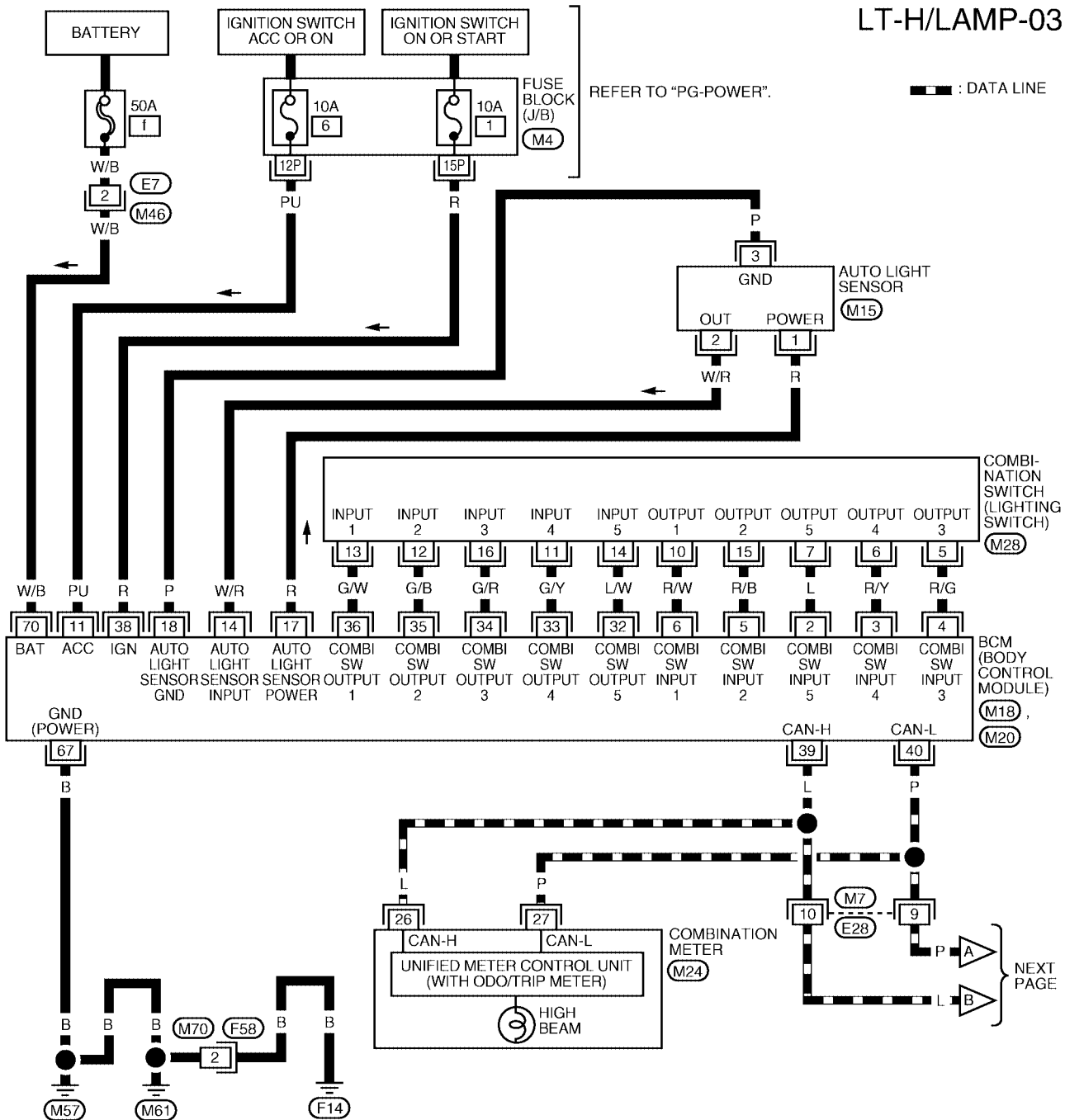

WKWA1301E

HEADLAMP (FOR USA)

LT-H/LAMP-04

— : DATA LINE

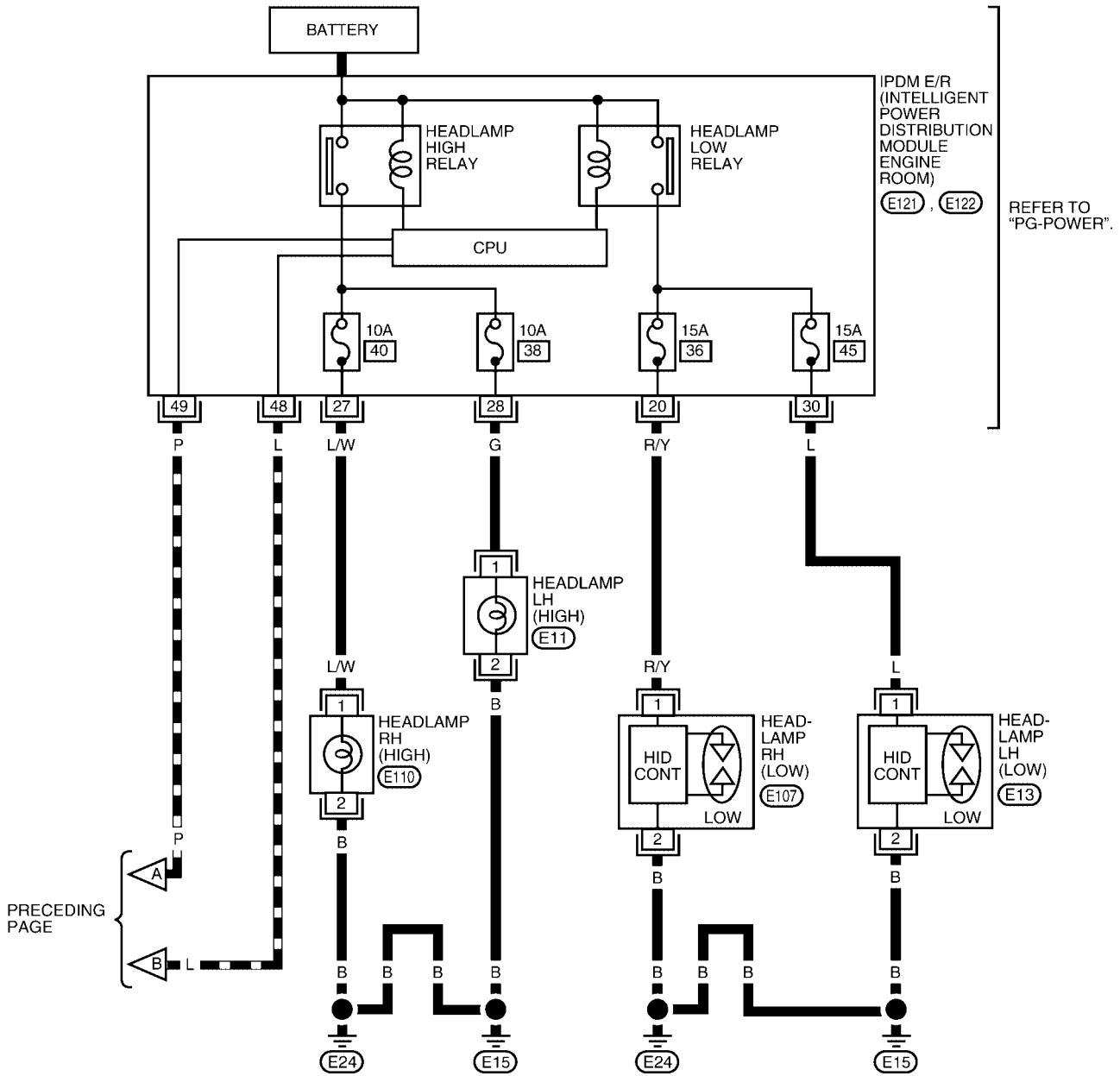

PRECEDING PAGE

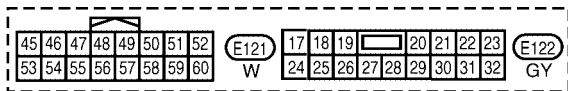
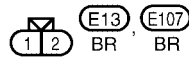
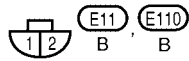



WKWA1362E

HEADLAMP (FOR USA)

Terminals and Reference Values for BCM

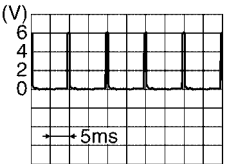
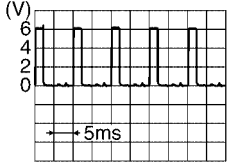
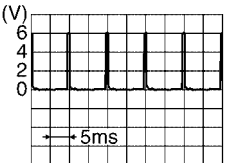
EKS008LK

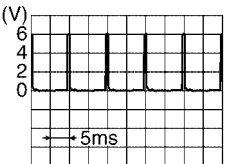
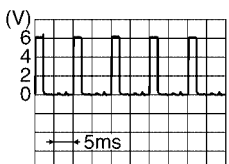
Terminal No.	Wire color	Signal name	Measuring condition		Reference value (Approx.)
			Ignition switch	Operation or condition	
2	L	Combination switch input 5	ON	Lighting, turn, wiper OFF Wiper dial position 4	 <p style="text-align: right;">SKIA5291E</p>
3	R/Y	Combination switch input 4	ON	Lighting, turn, wiper OFF Wiper dial position 4	 <p style="text-align: right;">SKIA5292E</p>
4	R/G	Combination switch input 3	ON	Lighting, turn, wiper OFF Wiper dial position 4	 <p style="text-align: right;">SKIA5291E</p>
5	R/B	Combination switch input 2	ON	Lighting, turn, wiper OFF Wiper dial position 4	 <p style="text-align: right;">SKIA5292E</p>
6	R/W	Combination switch input 1			
11	PU	Ignition switch (ACC)	ACC	—	Battery voltage
32	L/W	Combination switch output 5	ON	Lighting, turn, wiper OFF Wiper dial position 4	 <p style="text-align: right;">SKIA5291E</p>
33	G/Y	Combination switch output 4	ON	Lighting, turn, wiper OFF Wiper dial position 4	 <p style="text-align: right;">SKIA5292E</p>
34	G/R	Combination switch output 3	ON	Lighting, turn, wiper OFF Wiper dial position 4	 <p style="text-align: right;">SKIA5291E</p>

HEADLAMP (FOR USA)

Terminal No.	Wire color	Signal name	Measuring condition		Reference value (Approx.)
			Ignition switch	Operation or condition	
35	G/B	Combination switch output 2	ON	Lighting, turn, wiper OFF Wiper dial position 4	
36	G/W	Combination switch output 1			
38	R	Ignition switch (ON)	ON	—	Battery voltage
39	L	CAN-H	—	—	—
40	P	CAN-L	—	—	—
67	B	Ground	ON	—	0V
70	W/B	Battery power supply (fusible link)	OFF	—	Battery voltage

Terminals and Reference Values for IPDM E/R

EKS008LL

Terminal No.	Wire color	Signal name	Measuring condition		Reference value (Approx.)
			Ignition switch	Operation or condition	
20	R/Y	Headlamp low (RH)	ON	Lighting switch 2ND position	OFF 0V
					ON Battery voltage
27	L/W	Headlamp high (RH)	ON	Lighting switch HIGH or PASS position	OFF 0V
					ON Battery voltage
28	G	Headlamp high (LH)	ON	Lighting switch HIGH or PASS position	OFF 0V
					ON Battery voltage
30	L	Headlamp low (LH)	ON	Lighting switch 2ND position	OFF 0V
					ON Battery voltage
48	L	CAN-H	—	—	—
49	P	CAN-L	—	—	—

How to Proceed With Trouble Diagnosis

EKS008LM

1. Confirm the symptom or customer complaint.
2. Understand operation description and function description. Refer to [LT-5, "System Description"](#).
3. Perform the Preliminary Check. Refer to [LT-13, "Preliminary Check"](#).
4. Check symptom and repair or replace the cause of malfunction.
5. Do the headlamps operate normally? If YES: GO TO 6. If NO: GO TO 4.
6. Inspection End.

Preliminary Check

EKS008LN

CHECK POWER SUPPLY AND GROUND CIRCUIT

1. CHECK FUSES AND FUSIBLE LINK

Check for blown fuses or fusible link.

Unit	Power source	Fuse and fusible link No.
BCM	Battery	f
	Ignition switch ACC or ON position	6
	Ignition switch ON or START position	1

HEADLAMP (FOR USA)

Unit	Power source	Fuse and fusible link No.
IPDM E/R	Battery	36
		38
		40
		45

Refer to [LT-8, "Wiring Diagram — H/LAMP —"](#) .

OK or NG

OK >> GO TO 2.

NG >> If fuse or fusible link is blown, be sure to eliminate cause of malfunction before installing new fuse or fusible link. Refer to [PG-4, "POWER SUPPLY ROUTING CIRCUIT"](#) .

2. CHECK POWER SUPPLY CIRCUIT

1. Disconnect BCM connectors.
2. Check voltage between BCM harness connector terminals and ground.

BCM (+)		(-)	Ignition switch position		
Connector	Terminal		OFF	ACC	ON
M18	11	Ground	0V	Battery voltage	Battery voltage
	38		0V	0V	Battery voltage
M20	70		Battery voltage	Battery voltage	Battery voltage

OK or NG

OK >> GO TO 3.

NG >> Check harness for open between BCM and fuse or fusible link.

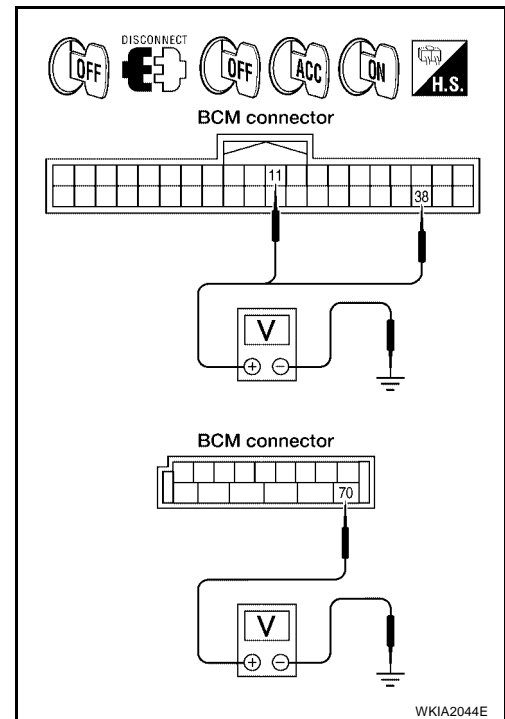

3. CHECK GROUND CIRCUIT

Check continuity between BCM harness connector terminal and ground.

BCM			Continuity
Connector	Terminal		
M20	67	Ground	Yes

OK or NG

OK >> Inspection End.

NG >> Check ground circuit harness.

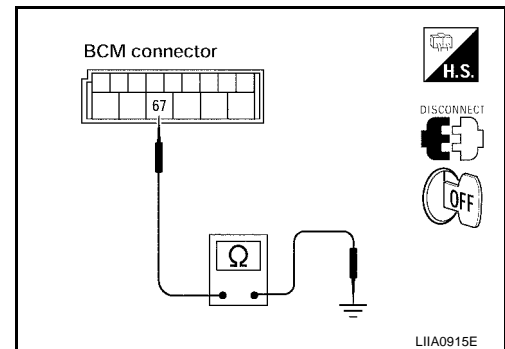

HEADLAMP (FOR USA)

CONSULT-II Function (BCM)

EKS008LO

CONSULT-II can display each diagnostic item using the diagnostic test modes shown following.

BCM diagnostic test item	Diagnostic mode	Description
Inspection by part	WORK SUPPORT	Supports inspections and adjustments. Commands are transmitted to the BCM for setting the status suitable for required operation, input/output signals are received from the BCM and received data is displayed.
	DATA MONITOR	Displays BCM input/output data in real time.
	ACTIVE TEST	Operation of electrical loads can be checked by sending drive signal to them.
	SELF-DIAG RESULTS	Displays BCM self-diagnosis results.
	CAN DIAG SUPPORT MNTR	The result of transmit/receive diagnosis of CAN communication can be read.
	ECU PART NUMBER	BCM part number can be read.
	CONFIGURATION	Performs BCM configuration read/write functions.

CONSULT-II OPERATION

CAUTION:

If CONSULT-II is used with no connection of CONSULT-II CONVERTER, malfunctions might be detected in self-diagnosis depending on control unit which carries out CAN communication.

1. With the ignition switch OFF, connect CONSULT-II and CONSULT-II CONVERTER to the data link connector, then turn ignition switch ON.

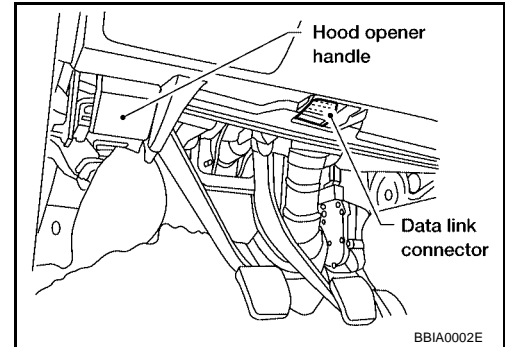

2. Touch "START (NISSAN BASED VHCL)".

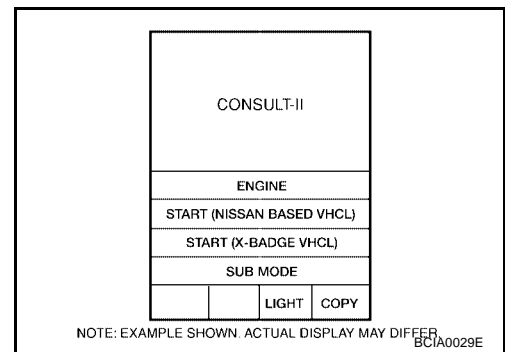

3. Touch "BCM" on "SELECT SYSTEM" screen. If "BCM" is not indicated, go to [GI-39, "Consult-II Data Link Connector \(DLC\) Circuit"](#).

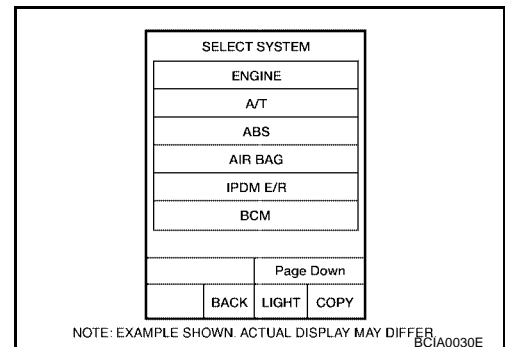

HEADLAMP (FOR USA)

4. Select the desired part to be diagnosed on the "SELECT TEST ITEM" screen.

SELECT TEST ITEM			
HEAD LAMP			
WIPER			
FLASHER			
AIR CONDITIONER			
COMB SW			
BCM			
Scroll Up		Page Down	
BACK	LIGHT	COPY	

LKIA0183E

DATA MONITOR

Operation Procedure

1. Touch "HEAD LAMP" on "SELECT TEST ITEM" screen.
2. Touch "DATA MONITOR" on "SELECT DIAG MODE" screen.
3. Touch either "ALL SIGNALS" or "SELECTION FROM MENU" on the "SELECT MONITOR ITEM" screen.

ALL SIGNALS	Monitors all the signals.
SELECTION FROM MENU	Selects and monitors individual signal.

4. Touch "START".
5. When "SELECTION FROM MENU" is selected, touch individual items to be monitored. When "ALL SIGNALS" is selected, all the items will be monitored.
6. Touch "RECORD" while monitoring, then the status of the monitored item can be recorded. To stop recording, touch "STOP".

Display Item List

Monitor item name "OPERATION OR UNIT"	Contents
IGN ON SW "ON/OFF"	Displays "IGN position (ON)/OFF, ACC position (OFF)" judged from the ignition switch signal.
ACC ON SW "ON/OFF"	Displays "ACC (ON)/OFF, Ignition OFF (OFF)" status judged from ignition switch signal.
HI BEAM SW "ON/OFF"	Displays status (high beam switch: ON/Others: OFF) of high beam switch judged from lighting switch signal.
HEAD LAMP SW 1 "ON/OFF"	Displays status (headlamp switch: ON/Others: OFF) of headlamp switch judged from lighting switch signal.
HEAD LAMP SW 2 "ON/OFF"	Displays status (headlamp switch 2: ON/Others: OFF) of headlamp switch 2 judged from lighting switch signal.
LIGHT SW 1ST "ON/OFF"	Displays status (lighting switch 1st position: ON/Others: OFF) of light switch judged from lighting switch signal.
PASSING SW "ON/OFF"	Displays status (flash-to-pass switch: ON/Others: OFF) of flash-to-pass switch judged from lighting switch signal.

ACTIVE TEST

Operation Procedure

1. Touch "HEAD LAMP" on "SELECT TEST ITEM" screen.
2. Touch "ACTIVE TEST" on "SELECT DIAG MODE" screen.
3. Touch item to be tested and check operation of the selected item.
4. During the operation check, touching "BACK" deactivates the operation.

Display Item List

Test item	Display on CONSULT-II screen	Description
Tail light relay output	TAIL LAMP	Allows tail light relay to operate by switching ON-OFF at your option.

HEADLAMP (FOR USA)

Test item	Display on CONSULT-II screen	Description
Headlamp relay output	HEAD LAMP	Allows headlamp relay to operate by switching ON-OFF at your option.
Front fog lamp relay output	FR FOG LAMP	Allows fog lamp relay to operate by switching ON-OFF at your option.

CONSULT-II Function (IPDM E/R)

EKS008LP

CONSULT-II can display each diagnostic item using the diagnostic test modes shown following.

IPDM E/R diagnostic Mode	Description
SELF-DIAG RESULTS	Displays IPDM E/R self-diagnosis results.
DATA MONITOR	Displays IPDM E/R input/output data in real time.
CAN DIAG SUPPORT MNTR	The result of transmit/receive diagnosis of CAN communication can be read.
ACTIVE TEST	Operation of electrical loads can be checked by sending drive signal to them.

CONSULT-II OPERATION

CAUTION:

If CONSULT-II is used with no connection of CONSULT-II CONVERTER, malfunctions might be detected in self-diagnosis depending on control unit which carries out CAN communication.

1. With the ignition switch OFF, connect CONSULT-II and CONSULT-II CONVERTER to the data link connector, then turn the ignition switch ON.

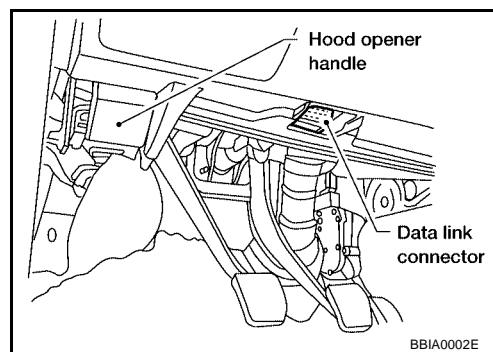

2. Touch "START (NISSAN BASED VHCL)".

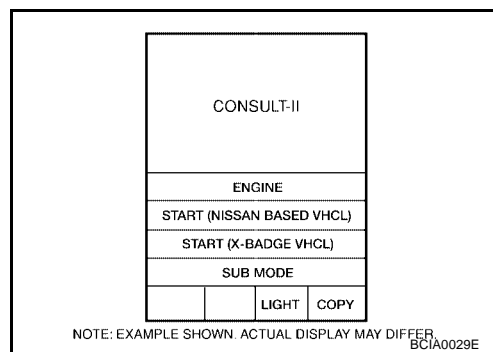

3. Touch "IPDM E/R" on "SELECT SYSTEM" screen. If "IPDM E/R" is not displayed, go to [GI-39, "Consult-II Data Link Connector \(DLC\) Circuit"](#).

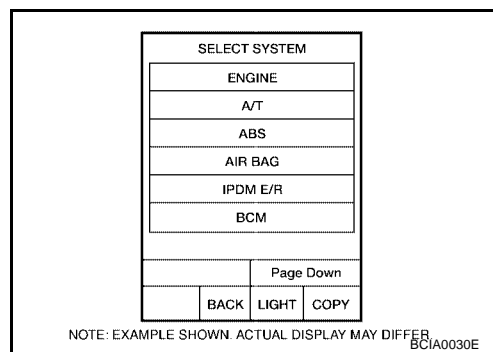

HEADLAMP (FOR USA)

4. Select the desired part to be diagnosed on the "SELECT DIAG MODE" screen.

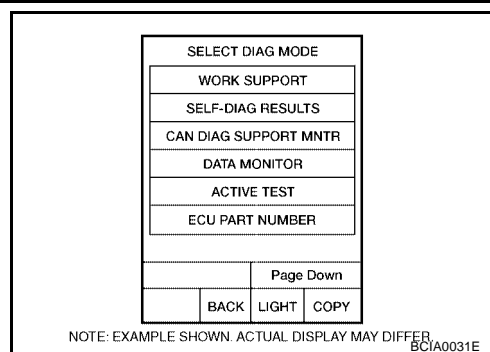

DATA MONITOR

Operation Procedure

1. Touch "DATA MONITOR" on "SELECT DIAG MODE" screen.
2. Touch "ALL SIGNALS", "MAIN SIGNALS" or "SELECTION FROM MENU" on the "SELECT MONITOR ITEM" screen.

ALL SIGNALS	All items will be monitored.
MAIN SIGNALS	Monitor the predetermined item.
SELECTION FROM MENU	Select any item for monitoring.

3. Touch "START".
4. Touch the required monitoring item on "SELECTION FROM MENU". In "ALL SIGNALS", all items are monitored. In "MAIN SIGNALS", predetermined items are monitored.
5. Touch "RECORD" while monitoring to record the status of the item being monitored. To stop recording, touch "STOP".

All Items, Main Items, Select Item Menu

Item name	CONSULT-II screen display	Display or unit	Monitor item selection			Description
			ALL SIGNALS	MAIN SIGNALS	SELECTION FROM MENU	
Parking, license plate and tail lamps request	TAIL&CLR REQ	ON/OFF	×	×	×	Signal status input from BCM
Headlamp low beam request	HL LO REQ	ON/OFF	×	×	×	Signal status input from BCM
Headlamp high beam request	HL HI REQ	ON/OFF	×	×	×	Signal status input from BCM
Front fog lamps request	FR FOG REQ	ON/OFF	×	×	×	Signal status input from BCM

NOTE:

Perform monitoring of IPDM E/R data with the ignition switch ON. When the ignition switch is at ACC, the display may not be correct.

ACTIVE TEST

Operation Procedure

1. Touch "ACTIVE TEST" on "SELECT DIAG MODE" screen.
2. Touch item to be tested, and check operation.
3. Touch "START".
4. Touch "STOP" while testing to stop the operation.

Test item	CONSULT-II screen display	Description
Tail lamp relay output	TAIL LAMP	Allows tail lamp relay to operate by switching operation ON-OFF at your option

HEADLAMP (FOR USA)

Test item	CONSULT-II screen display	Description
Headlamp relay (HI, LO) output	LAMPS	Allows headlamp relay (HI, LO) to operate by switching operation (OFF, HI, LO) at your option (Head lamp high beam repeats ON-OFF every 1 second).
Front fog lamp relay (FOG) output		Allows fog lamp relay (FOG) to operate by switching operation ON-OFF at your option

Headlamp HI Does Not Illuminate (Both Sides)

EKS008LQ

1. HEADLAMP ACTIVE TEST

1. Select "IPDM E/R" on CONSULT-II, and select "ACTIVE TEST" on "SELECT DIAG MODE" screen.
2. Select "LAMPS" on "SELECT TEST ITEM" screen.
3. Touch "HI" on "ACTIVE TEST" screen.
4. Make sure HI beam headlamps operate.

HI beam headlamps should operate.

OK or NG

- OK >> GO TO 2.
 NG >> GO TO 4.

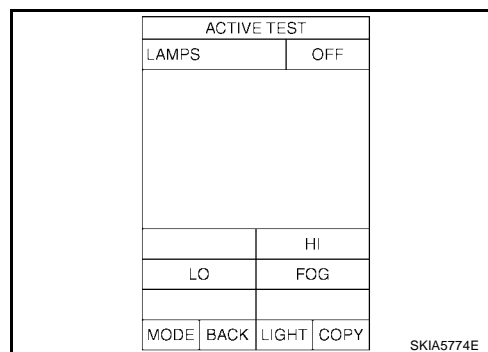

2. INSPECTION 1 BETWEEN COMBINATION SWITCH AND BCM

Select "BCM" on CONSULT-II. Carry out BCM self-diagnosis.

Displayed results of self-diagnosis

NO MALFUNCTION DETECTED>> GO TO 3.

CAN COMMUNICATION OR CAN SYSTEM>> Inspect the BCM CAN communications system. Refer to [LAN-20, "CAN COMMUNICATION"](#).

OPEN DETECT 1 - 5>> Inspect combination switch system. Refer to [LT-91, "Combination Switch Inspection"](#).

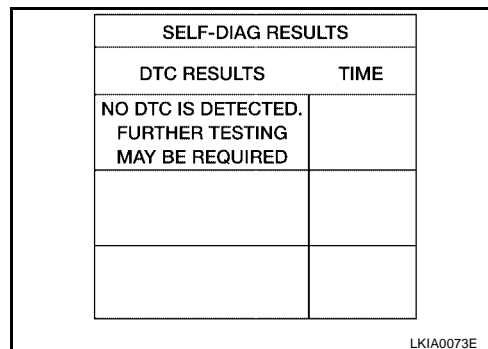

3. INSPECTION 2 BETWEEN COMBINATION SWITCH AND BCM

Select "BCM" on CONSULT-II. With "HEAD LAMP" data monitor, make sure "HI BEAM SW" turns ON-OFF linked with operation of lighting switch.

When lighting switch is in HIGH position : HI BEAM SW ON

OK or NG

- OK >> Replace BCM. Refer to [BCS-20, "Removal and Installation of BCM"](#).
- NG >> Replace lighting switch. Refer to [LT-86, "Removal and Installation"](#).

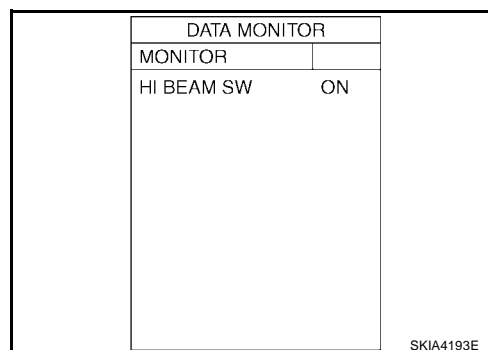

HEADLAMP (FOR USA)

4. CHECK HEADLAMP INPUT SIGNAL

1. Turn ignition switch OFF.
2. Disconnect headlamp RH and LH (high) connectors.
3. Turn ignition switch ON.
4. Select "IPDM E/R" on CONSULT-II, and select "ACTIVE TEST" on "SELECT DIAG MODE" screen.
5. Select "LAMPS" on "SELECT TEST ITEM" screen.
6. Touch "HI" on "ACTIVE TEST" screen.
7. When headlamp high beam is operating, check voltage between headlamp RH and LH (high) harness connector terminals and ground.

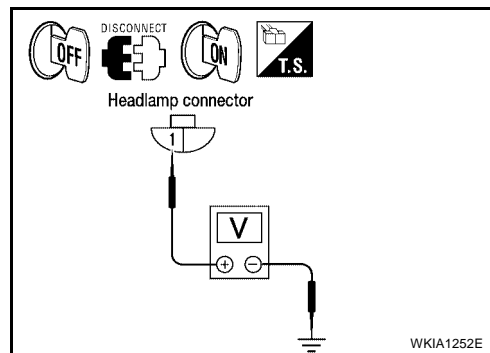

Headlamp (high)		Terminal	(-)	Voltage (Approx.)
(+)				
Connector	Terminal			
RH	E110	1	Ground	Battery voltage
LH	E11			

OK or NG

- OK >> GO TO 6.
 NG >> GO TO 5.

5. CHECK HEADLAMP CIRCUIT

1. Turn ignition switch OFF.
2. Disconnect IPDM E/R connector.
3. Check continuity between IPDM E/R harness connector terminals and headlamp RH and LH (high) harness connector terminals.

A		B		Continuity
IPDM E/R connector	Terminal	Headlamp (high) connector	Terminal	
E122	27	RH	E110	Yes
	28	LH	E11	

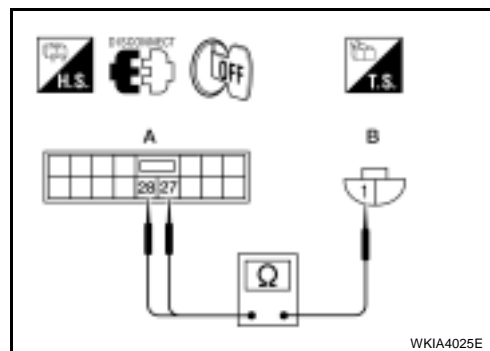

OK or NG

- OK >> Replace IPDM E/R. Refer to [PG-28, "Removal and Installation of IPDM E/R"](#) .
 NG >> Repair harness or connector.

6. CHECK HEADLAMP GROUND

1. Turn ignition switch OFF.
2. Check continuity between headlamp RH (high) harness connector E110 terminal 2 and ground.

2 - Ground : Continuity should exist.

3. Check continuity between headlamp LH (high) harness connector E11 terminal 2 and ground.

2 - Ground : Continuity should exist.

OK or NG

- OK >> Check headlamp connector for damage or poor connection. Repair as necessary.
 NG >> Repair harness or connector.

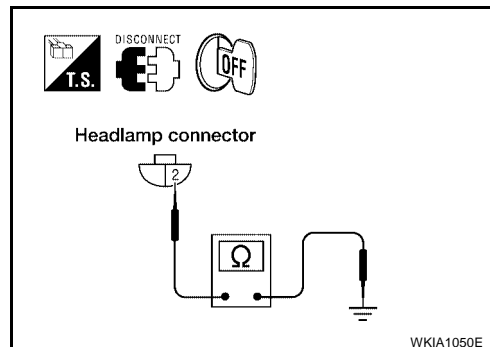

HEADLAMP (FOR USA)

EKS008LR

Headlamp HI Does Not Illuminate (One Side)

1. BULB INSPECTION

Inspect inoperative headlamp bulb.

OK or NG

OK >> GO TO 2.

NG >> Replace headlamp bulb. Refer to [LT-28, "HEADLAMP"](#) .

2. CHECK POWER TO HEADLAMP

1. Disconnect inoperative headlamp (high) connector.
2. Turn the high beam headlamps ON.
3. Check voltage between inoperative headlamp (high) connector terminal and ground.

Headlamp (high)		Terminal	(-)	Voltage (Approx.)
(+)				
Connector		1	Ground	Battery voltage
RH	E110			
LH	E11			

OK or NG

OK >> GO TO 3.

NG >> GO TO 4.

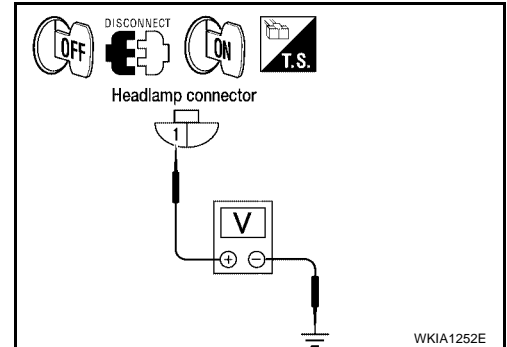

3. CHECK HEADLAMP GROUND

1. Turn the high beam headlamps OFF.
2. Check continuity between inoperative headlamp (high) connector terminal and ground.

Headlamp (high)		Terminal	Ground	Continuity
Connector				
RH	E110	2	Ground	Yes
LH	E11			

OK or NG

OK >> Check headlamp (high) connector for damage or poor connection. Repair as necessary.

NG >> Repair open circuit in harness between inoperative headlamp and ground.

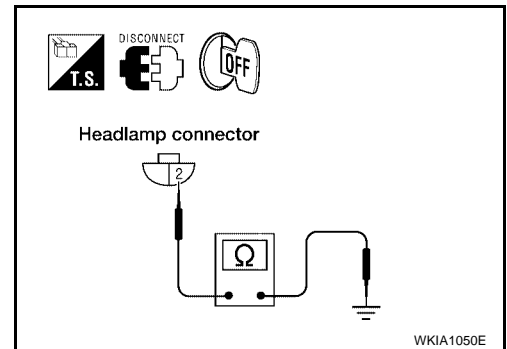

A
B
C
D
E
F
G
H
I
J
LT
L
M

HEADLAMP (FOR USA)

4. INSPECTION BETWEEN IPDM E/R AND HEADLAMPS

1. Disconnect IPDM E/R connector and headlamp connector.
2. Check continuity between IPDM E/R harness connector terminals and inoperative headlamp harness connector terminals.

A		B		Continuity	
IPDM E/R connector	Terminal	Headlamp (high) connector	Terminal		
E122	27	RH	E110	1	Yes
	28	LH	E11		

OK or NG

- OK >> Replace IPDM E/R. Refer to [PG-28, "Removal and Installation of IPDM E/R"](#).
- NG >> Check for short circuits and open circuits in harness between IPDM E/R and headlamps. Repair as necessary.

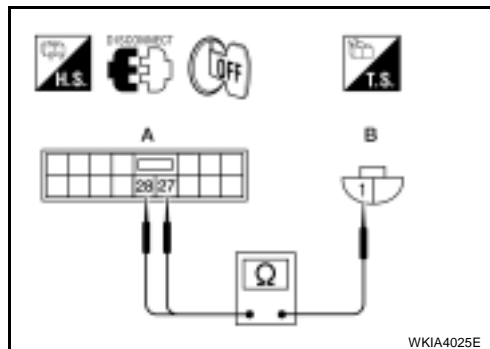

High-Beam Indicator Lamp Does Not Illuminate

EKS008LS

1. BULB INSPECTION

Inspect CAN communication system. Refer to [LAN-20, "CAN COMMUNICATION"](#).

OK or NG

- OK >> Replace combination meter. Refer to [IP-13, "COMBINATION METER"](#).
- NG >> Repair as necessary.

Headlamp LO Does Not Illuminate (Both Sides)

EKS008LT

1. HEADLAMP ACTIVE TEST

1. Select "IPDM E/R" on CONSULT-II, and select "ACTIVE TEST" on "SELECT DIAG MODE" screen.
2. Select "LAMPS" on "SELECT TEST ITEM" screen.
3. Touch "LO" on "ACTIVE TEST" screen.
4. Make sure low beam headlamps operate.

Low beam headlamps should operate.

OK or NG

- OK >> GO TO 2.
- NG >> GO TO 4.

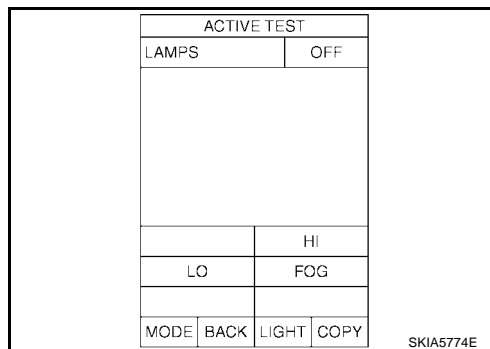

2. INSPECTION 1 BETWEEN COMBINATION SWITCH AND BCM

Select "BCM" on CONSULT-II. Carry out BCM self-diagnosis.

Displayed results of self-diagnosis

NO MALFUNCTION DETECTED>> GO TO 3.

CAN COMMUNICATION OR CAN SYSTEM>> Inspect the BCM CAN communications system. Refer to [LAN-20, "CAN COMMUNICATION"](#).

OPEN DETECT 1 - 5>> Inspect combination switch system. Refer to [LT-89, "Combination Switch Reading Function"](#).

HEAD LAMP 1 SW or HEAD LAMP 2 SW>> Replace combination switch. Refer to [LT-93, "Removal and Installation"](#).

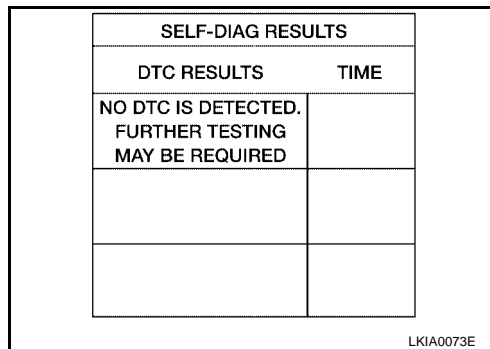

HEADLAMP (FOR USA)

3. INSPECTION 2 BETWEEN COMBINATION SWITCH AND BCM

Select "BCM" on CONSULT-II. With "HEAD LAMP" data monitor, make sure "HEAD LAMP SW 1" and "HEAD LAMP SW 2" turns ON-OFF linked with operation of lighting switch.

When lighting switch is in 2ND position :
HEAD LAMP SW 1 ON
HEAD LAMP SW 2 ON

OK or NG

- OK >> Replace BCM. Refer to [BCS-20, "Removal and Installation of BCM"](#).
- NG >> Replace combination switch. Refer to [LT-93, "Removal and Installation"](#).

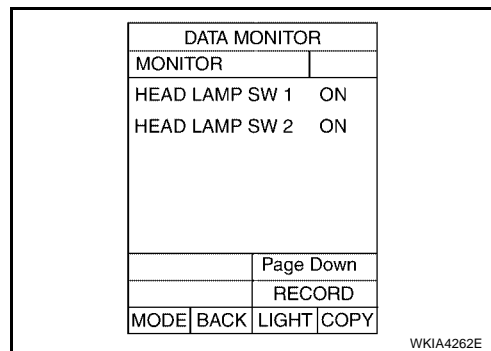

4. CHECK HEADLAMP INPUT SIGNAL

- Turn ignition switch OFF.
- Disconnect headlamp RH and LH (low) connectors.
- Turn ignition switch ON.
- Select "IPDM E/R" on CONSULT-II, and select "ACTIVE TEST" on "SELECT DIAG MODE" screen.
- Select "LAMPS" on "SELECT TEST ITEM" screen.
- Touch "LO" on "ACTIVE TEST" screen.
- When headlamp low beam is operating, check voltage between headlamp RH and LH (low) harness connector terminals and ground.

Terminals				Voltage (Approx.)
(+)		(-)		
Headlamp (low) connector	Terminal			
RH	E107	1	Ground	Battery voltage
LH	E13			

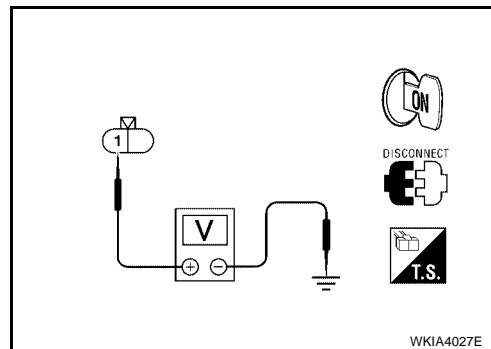

OK or NG

- OK >> GO TO 6.
- NG >> GO TO 5.

5. CHECK HEADLAMP CIRCUIT

- Turn ignition switch OFF.
- Disconnect IPDM E/R connector.
- Check continuity between IPDM E/R harness connector terminals and headlamp RH and LH (low) harness connector terminals.

A		B		Continuity
IPDM E/R connector	Terminal	Headlamp (low) connector	Terminal	
E122	20	RH	E107	Yes
	30	LH	E13	

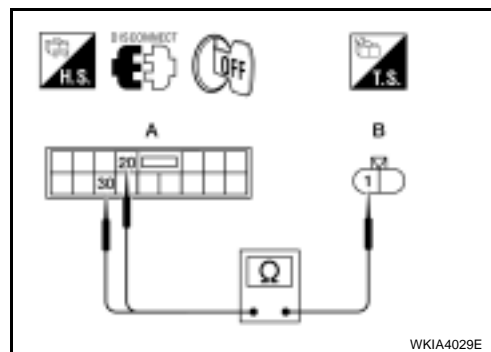

OK or NG

- OK >> Replace IPDM E/R. Refer to [PG-28, "Removal and Installation of IPDM E/R"](#).
- NG >> Repair harness or connector.

HEADLAMP (FOR USA)

6. CHECK HEADLAMP GROUND

1. Turn ignition switch OFF.
2. Check continuity between headlamp RH and LH (low) harness connector terminals and ground.

Headlamp (low) connector		Terminals		Continuity
		Terminal		
RH	E107	2	Ground	Yes
LH	E13			

OK or NG

- OK >> Check headlamp connector for damage or poor connection. Repair as necessary.
- NG >> Repair harness or connector.

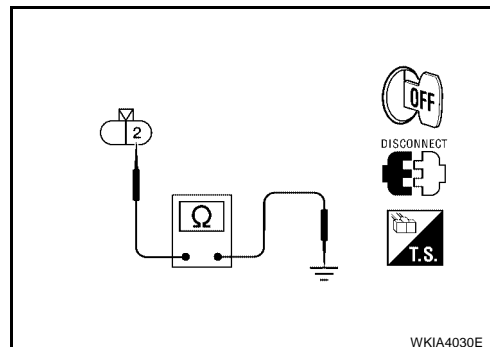

Headlamp LO Does Not Illuminate (One Side)

EKS008LU

1. BULB INSPECTION

Inspect inoperative headlamp bulb.

OK or NG

- OK >> GO TO 2.
- NG >> Replace headlamp bulb. Refer to [LT-28, "HEADLAMP"](#).

2. CHECK POWER TO HEADLAMP

1. Disconnect inoperative headlamp (low) connector.
2. Turn the low beam headlamps ON.
3. Check voltage between inoperative headlamp (low) connector terminal and ground.

Headlamp (low) connector		Terminals		Voltage (Approx.)
		(+)	(-)	
RH	E107	1	Ground	Battery voltage
LH	E13			

OK or NG

- OK >> GO TO 3.
- NG >> GO TO 4.

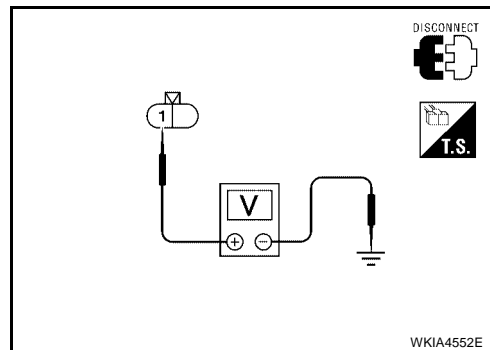

HEADLAMP (FOR USA)

3. CHECK HEADLAMP GROUND

1. Turn the low beam headlamps OFF.
2. Check continuity between inoperative headlamp (low) connector terminal and ground.

Headlamp (low) connector		Terminals		Continuity
RH	E107	Terminal		
LH	E13	2	Ground	Yes

OK or NG

- OK >> Check headlamp (low) and IPDM E/R connector. Repair as necessary.
- NG >> Repair open circuit in harness between inoperative headlamp and ground.

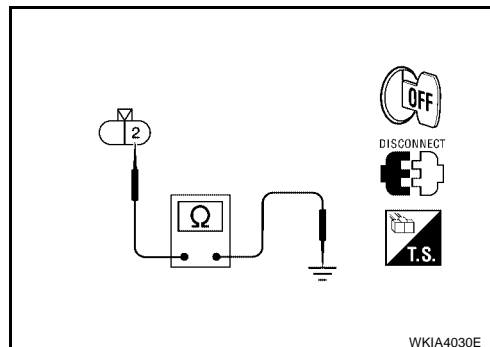

4. INSPECTION BETWEEN IPDM E/R AND HEADLAMPS

1. Disconnect IPDM E/R connector.
2. Check continuity between IPDM E/R harness connector terminal and inoperative headlamp (low) harness connector terminal.

IPDM E/R connector	A		B		Continuity
	Terminal	Headlamp (low) connector	Terminal		
E122	20	RH E107	1		Yes
	30	LH E13			

OK or NG

- OK >> Replace IPDM E/R. Refer to [PG-28, "Removal and Installation of IPDM E/R"](#).
- NG >> Check for short circuits and open circuits in harness between IPDM E/R and headlamps. Repair as necessary.

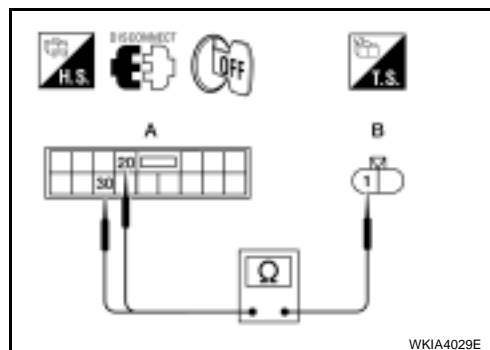

Headlamps Do Not Turn OFF

1. CHECK COMBINATION SWITCH INPUT SIGNAL

Select "BCM" on CONSULT-II. With "HEAD LAMP" data monitor, make sure "HEAD LAMP SW 1" and "HEAD LAMP SW 2" turns ON-OFF linked with operation of lighting switch.

When lighting switch is in OFF position : HEAD LAMP SW 1 OFF
: HEAD LAMP SW 2 OFF

OK or NG

- OK >> Replace IPDM E/R. Refer to [PG-28, "Removal and Installation of IPDM E/R"](#).
- NG >> GO TO 2.

DATA MONITOR	
MONITOR	
HEAD LAMP SW 1	OFF
HEAD LAMP SW 2	OFF

2. CHECK LIGHTING SWITCH

Check lighting switch. Refer to [LT-89, "Combination Switch Reading Function"](#).

OK or NG

- OK >> GO TO 3.
- NG >> Replace lighting switch. Refer to [LT-93, "Removal and Installation"](#).

HEADLAMP (FOR USA)

3. CHECKING CAN COMMUNICATIONS BETWEEN BCM AND IPDM E/R

Select "BCM" on CONSULT-II and perform self-diagnosis for BCM.

Display of self-diagnosis results

NO DTC>> Replace IPDM E/R. Refer to [PG-28, "Removal and Installation of IPDM E/R"](#) .

CAN COMM CIRCUIT>> Refer to [LAN-20, "CAN COMMUNICATION"](#) .

SELF-DIAG RESULTS			
DTC RESULTS		TIME	
CAN COMM CIRCUIT [U1000]		PAST	
ERASE		PRINT	
MODE	BACK	LIGHT	COPY

SKIA1039E

One Xenon Headlamp Does Not Illuminate At Full Brightness

EKS008LW

1. COMPONENT INSPECTION

Check the inoperative headlamp subharness for open or short circuits.

OK or NG

OK >> Replace headlamp bulb. Refer to [LT-28, "Bulb Replacement"](#) . Check operation of headlamp. If headlamp still does not illuminate at full brightness, replace ballast and check operation. Refer to [LT-30, "Disassembly and Assembly"](#) . If headlamp still does not illuminate at full brightness, replace ignitor. Refer to [LT-30, "Disassembly and Assembly"](#) .

NG >> Replace headlamp subharness.

One Xenon Headlamp Flickers

EKS008LX

1. CHECK SYSTEM OPERATION

Turn the low beam headlamps ON and check operation.

NOTE:

Xenon headlamps may flicker momentarily when the headlamps are turned ON. This is normal and does not indicate a fault. Diagnosis of flickering headlamps should only be performed if the headlamps continue to flicker for more than 3 seconds after turning headlamps ON.

OK or NG

OK >> System is operating correctly.

NG >> GO TO 2.

2. COMPONENT INSPECTION

Check the inoperative headlamp subharness for open or short circuits.

OK or NG

OK >> Replace ballast. Refer to [LT-30, "Disassembly and Assembly"](#) . Check operation of headlamp. If headlamp still flickers, replace igniter and check operation. If headlamp still flickers, replace headlamp bulb. Refer to [LT-28, "Bulb Replacement"](#) .

NG >> Replace headlamp subharness.

HEADLAMP (FOR USA)

Aiming Adjustment

EKS008LY

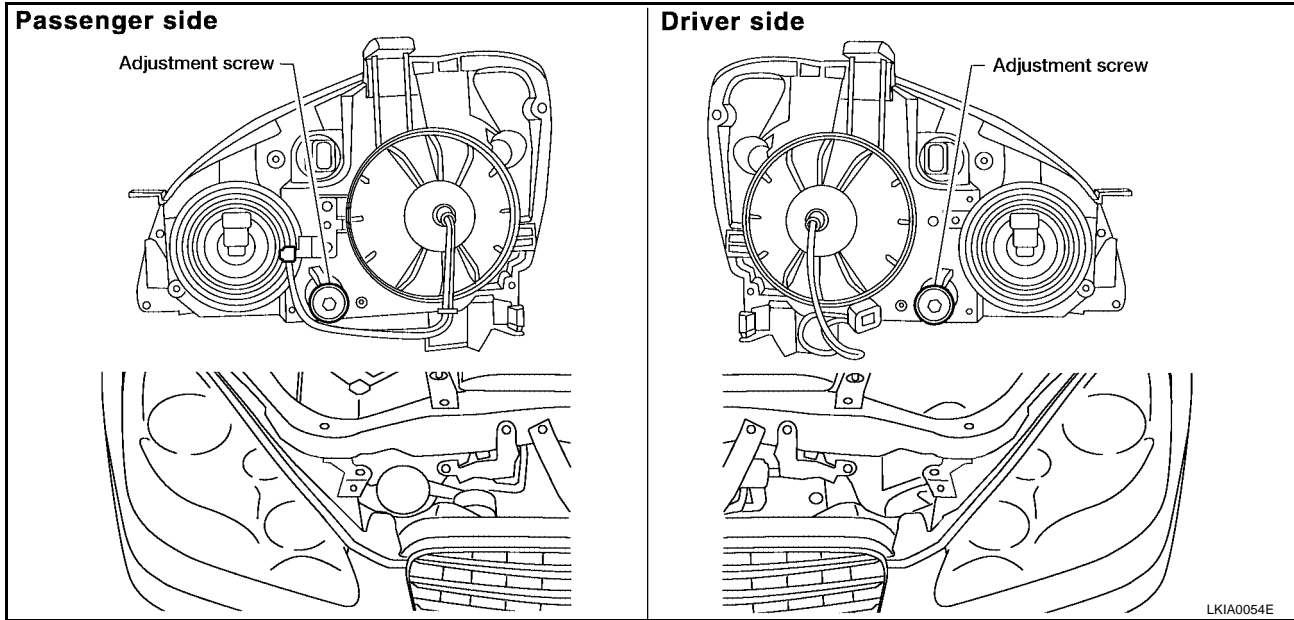

For details, refer to the regulations in your area.

HEADLAMP AIMING

NOTE:

- If the vehicle front body has been repaired and/or the headlamp assembly has been replaced, check headlamp aiming.
- Before performing headlamp aiming adjustment, check the following:
 - Confirm which type of headlamp is in vehicle.
 - Ensure all tires are inflated to correct pressure.
 - Place vehicle and screen on level surface.
 - Ensure there is no load in vehicle other than the driver (or equivalent weight placed in driver's position).
 - Ensure engine coolant and engine oil are filled to correct level and fuel tank is full.
 - Confirm spare tire, jack and tools are properly stowed.

A
B
C
D
E
F
G
H
I
J
LT
L
M

HEADLAMP (FOR USA)

AIMING ADJUSTMENT

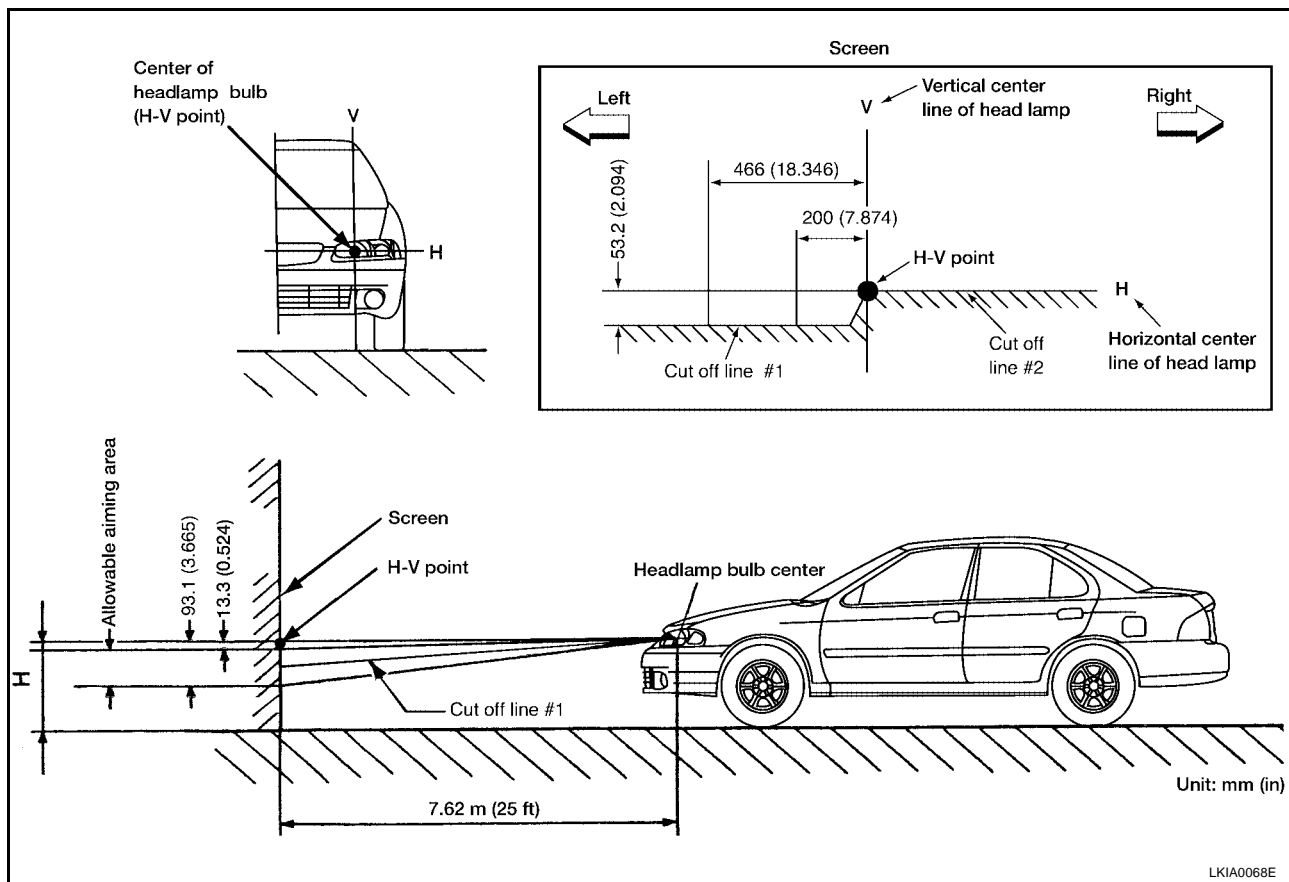

- Basic illuminating area for adjustment should be within the range shown on the aiming chart. Adjust headlamps accordingly.
- First loosen the adjusting screw all the way and then make adjustment by tightening the screw.
 1. Turn headlamp low beam on.
 2. Use adjusting screws to perform aiming adjustment.

Bulb Replacement HEADLAMP

EKS008LZ

CAUTION:

- Do not touch the glass of bulb directly by hand. Keep grease and other oily substances away from bulb. Do not touch bulb by hand while it is lit or right after being turned off, burning may result.
- Do not leave bulb out of fog lamp reflector for a long time, dust, moisture, and smoke may affect performance of fog lamp.

Removal

1. Disconnect negative battery cable.
2. Turn the headlamp bulb plastic cap counterclockwise to unlock and remove it.
3. Turn the bulb socket counterclockwise to unlock and remove it (xenon).
4. Disconnect the electrical connectors from the bulb terminals (halogen).
5. Unlock the retaining springs and remove the bulb.
6. Release the ignitor and remove from the plastic cap (xenon).
7. Turn the high beam lamp socket counterclockwise to unlock and remove it.

Installation

CAUTION:

After installing the bulb, be sure to install the plastic cap securely to ensure watertightness. Installation is in the reverse order of removal.

HEADLAMP (FOR USA)

FRONT TURN SIGNAL LAMP

Removal

1. Turn the bulb socket counterclockwise to unlock it.
2. Pull the bulb to remove it.

Installation

Installation is in the reverse order of removal.

CAUTION:

After installing a headlamp bulb, be sure to install the bulb socket securely to ensure watertightness.

Removal and Installation COMBINATION LAMP

EKS008M0

Removal

1. Disconnect the negative battery cable (xenon only).
2. Remove the front fascia. Refer to [EI-14, "FRONT BUMPER"](#).
3. Ensure lighting switch is OFF.
4. Remove the headlamp assembly bolts.
5. Pull the headlamp assembly toward the front of the vehicle, disconnect connectors and remove headlamp assembly.

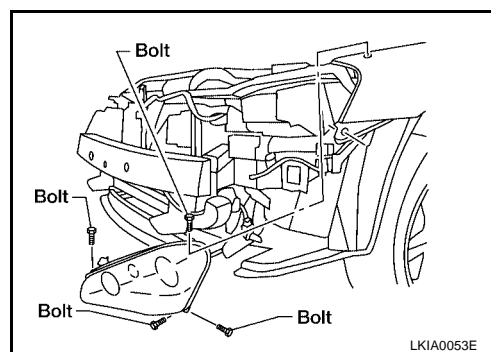

Installation

Installation is in the reverse order of removal.

NOTE:

Confirm headlamp aiming adjustment. Refer to [LT-27, "Aiming Adjustment"](#).

A
B
C
D
E
F
G
H
I
J
LT
L
M

HEADLAMP (FOR USA)

Disassembly and Assembly COMBINATION LAMP - XENON TYPE

EKS008M1

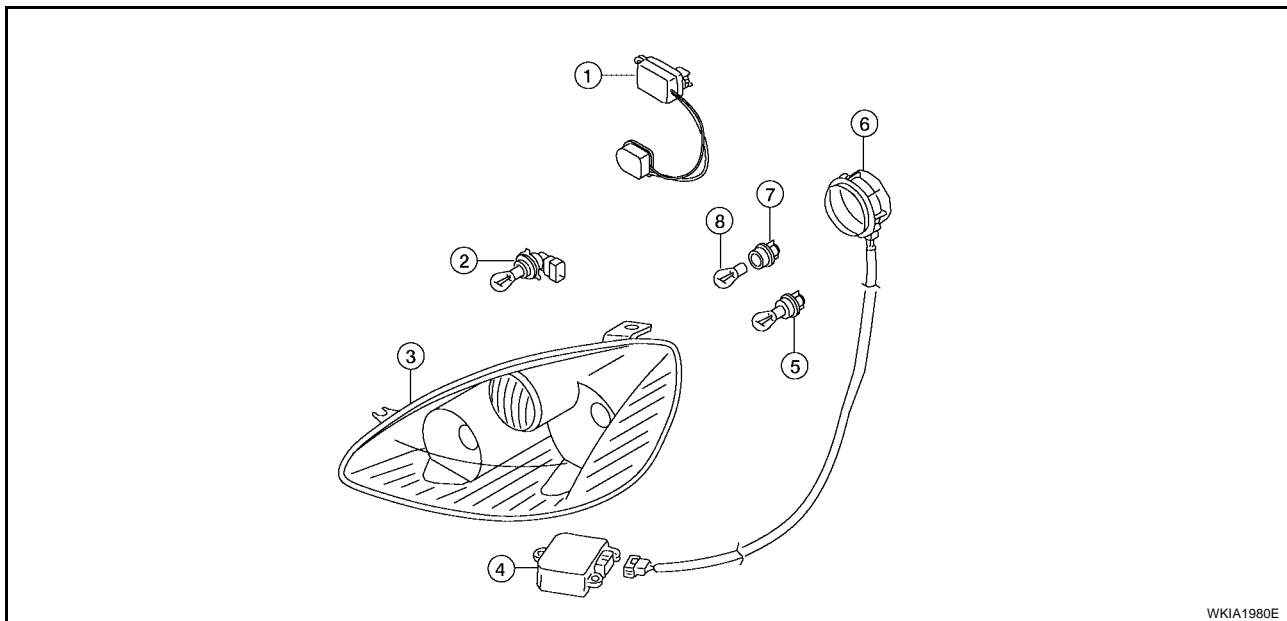

WKIA1980E

- | | | |
|--------------------------|-----------------------------|----------------------|
| 1. Ignitor | 2. Halogen bulb (high beam) | 3. Headlamp assembly |
| 4. Ballast | 5. Xenon bulb (low beam) | 6. Plastic cap |
| 7. Turn/park bulb socket | 8. Park/turn bulb | |

Disassembly

1. Turn the low beam plastic cap counterclockwise to unlock and remove it.
2. Turn the bulb socket counterclockwise to unlock and remove it.
3. Unlock the retaining springs and remove the low beam bulb.
4. Release the ignitor and remove from the plastic cap.
5. Turn the high beam lamp socket counterclockwise to unlock and remove it.
6. Turn the front turn signal lamp bulb socket counterclockwise and unlock it.
7. Remove the front turn signal lamp bulb from its socket.

Assembly

Assembly is in the reverse order of disassembly.

CAUTION:

- After installing the xenon bulb, be sure to install the bulb socket and plastic cap securely to ensure watertightness.

HEADLAMP (FOR USA)

COMBINATION LAMP - HALOGEN

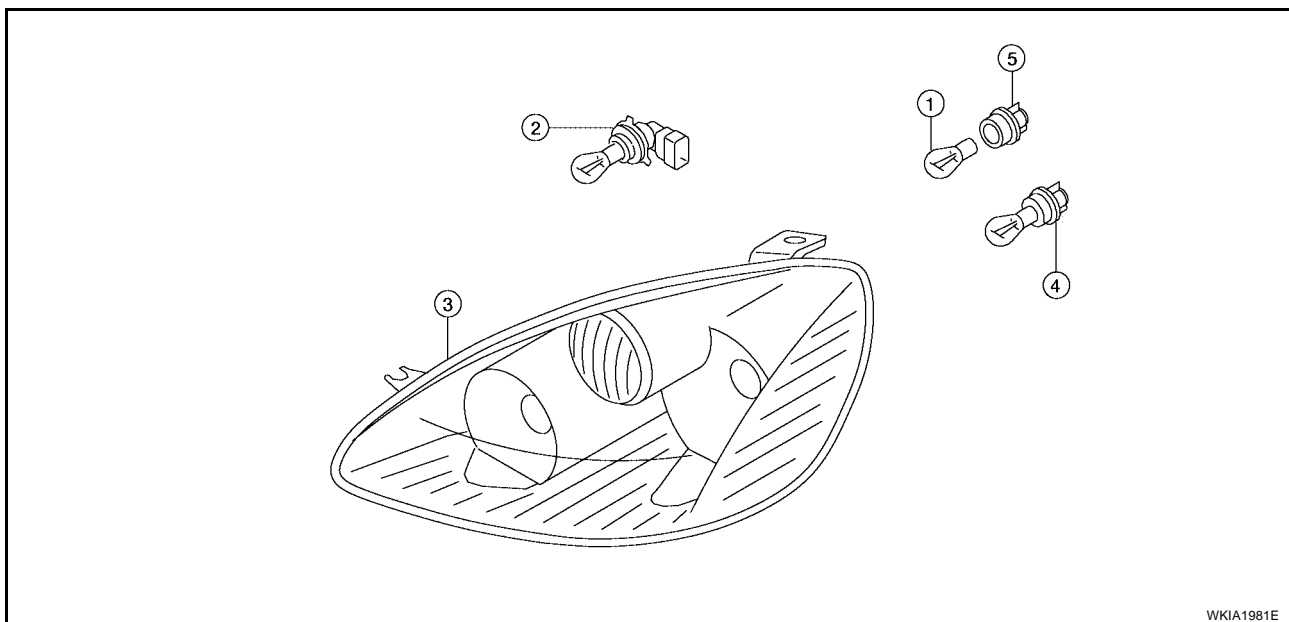

1. Turn/park bulb 2. Halogen bulb (high beam) 3. Headlamp assembly
4. Halogen bulb (low beam) 5. Turn/park bulb socket

Disassembly

1. Turn the low beam plastic cap counterclockwise to unlock and remove it.
2. Disconnect the electrical connectors from the bulb terminals.
3. Unlock the retaining springs and remove the low beam bulb.
4. Turn the high beam lamp socket counterclockwise to unlock and remove it.
5. Turn the front turn signal lamp bulb socket counterclockwise and unlock it.
6. Remove the front turn signal lamp bulb from its socket.

Assembly

Assembly is in the reverse order of disassembly.

CAUTION:

- After installing the xenon bulb, be sure to install the bulb socket and plastic cap securely to ensure watertightness.

A
B
C
D
E
F
G
H
I
J
LT
L
M

HEADLAMP (FOR CANADA) - DAYTIME LIGHT SYSTEM -

HEADLAMP (FOR CANADA) - DAYTIME LIGHT SYSTEM -

PFP:26010

Component Parts and Harness Connector Location

EKS008M2

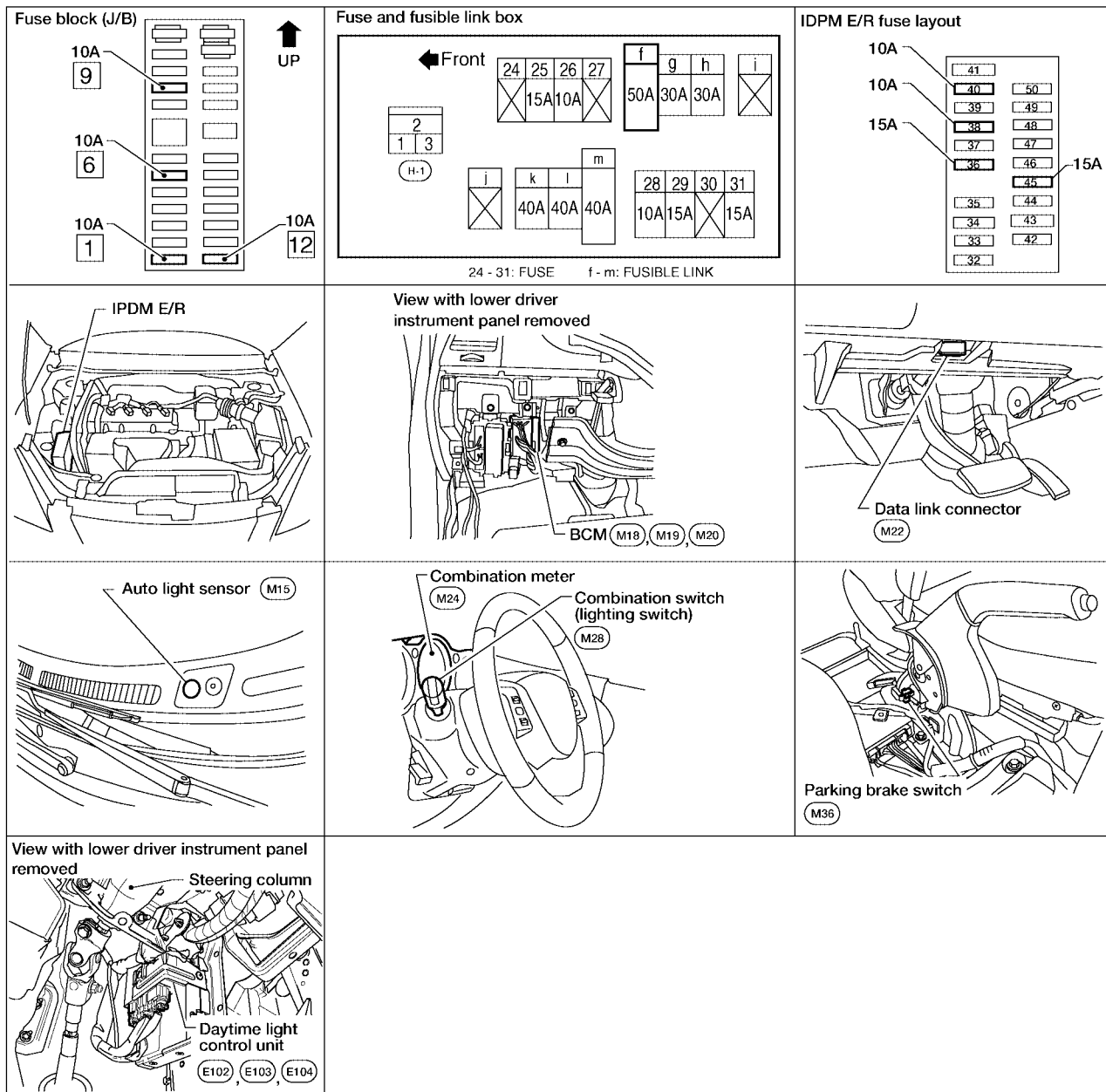

WKIA4085E

System Description

EKS008M3

The headlamp system for Canada vehicles is equipped with a daytime light control unit that activates the high beam headlamps at approximately half illumination whenever the engine is running. If the parking brake is applied before the engine is started the daytime lights will not be illuminated. The daytime lights will illuminate once the parking brake is released. Thereafter, the daytime lights will continue to operate when the parking brake is applied.

Battery saver system is controlled by the BCM (body control module).

Power is supplied at all times

- to headlamp high relay located in the IPDM E/R (intelligent power distribution module engine room), and
- through 50A fusible link (letter f, located in the fuse and fusible link box)
- to BCM terminal 70.

HEADLAMP (FOR CANADA) - DAYTIME LIGHT SYSTEM -

With the ignition switch in the ON or START position, power is supplied

- through 10A fuse [No. 12, located in the fuse block (J/B)]
- to daytime light control unit terminal 3, and
- through 10A fuse [No. 1, located in the fuse block (J/B)]
- to BCM terminal 38.

With the ignition switch in the ACC or ON position, power is supplied

- through 10A fuse [No. 6, located in the fuse block (J/B)]
- to BCM terminal 11.

With the ignition switch in the START position, power is supplied

- through 10A fuse [No. 9, located in the fuse block (J/B)]
- to daytime light control unit terminal 2.

Ground is supplied

- to daytime light control unit terminals 13, 14 and 16
- through grounds E15 and E24, and
- to BCM terminal 67
- through grounds F14, M57 and M61.

HEADLAMP OPERATION

Low Beam Operation

With the lighting switch in 2ND position, the BCM receives input requesting the headlamps to illuminate. This input is communicated to the IPDM E/R across the CAN communication lines. The CPU (central processing unit) of the IPDM E/R controls the headlamp low relay coil. When energized, this relay directs power

- through 15A fuse (No. 36, located in the IPDM E/R)
- through IPDM E/R terminal 20
- to RH headlamp terminal 1, and
- through 15A fuse (No. 45, located in the IPDM E/R)
- through IPDM E/R terminal 30
- to LH headlamp terminal 1.

Ground is supplied

- to RH headlamp terminal 2
- to LH headlamp terminal 2
- through grounds E15 and E24.

With power and ground supplied, low beam headlamps illuminate.

High Beam Operation/Flash-to-Pass Operation

With the lighting switch in 2ND position and placed in HIGH or PASS position, the BCM receives input requesting the headlamp high beams to illuminate. This input is communicated to the IPDM E/R across the CAN communication lines. The CPU of the combination meter controls the ON/OFF status of the HIGH BEAM indicator. The CPU of the IPDM E/R controls the headlamp high relay coil. When energized, this relay directs power

- through 10A fuse (No. 40, located in the IPDM E/R)
- through IPDM E/R terminal 27
- to daytime light control unit terminal 4
- through daytime light control unit terminal 7
- to RH headlamp terminal 1, and
- through 10A fuse (No. 38, located in the IPDM E/R)
- through IPDM E/R terminal 28
- to daytime light control unit terminal 5
- through daytime light control unit terminal 6
- to LH headlamp terminal 1.

Ground is supplied

- to RH headlamp terminal 2

A

B

C

D

E

F

G

H

I

J

LT

L

M

HEADLAMP (FOR CANADA) - DAYTIME LIGHT SYSTEM -

- to daytime light control unit terminal 9
- through daytime light control unit terminal 14
- through grounds E15 and E24, and
- to LH headlamp terminal 2
- to daytime light control unit terminal 10
- through daytime light control unit terminal 13
- through grounds E15 and E24.

With power and ground supplied, the high beam headlamps illuminate.

BATTERY SAVER CONTROL

With the combination switch (lighting switch) is in the 2ND position (ON) and the ignition switch is turned from ON or ACC to OFF, the battery saver control feature is activated.

Under this condition, the headlamps remain illuminated for 5 minutes unless the combination switch (lighting switch) position is changed. If the combination switch (lighting switch) position is changed, then the headlamps are turned off.

AUTO LIGHT OPERATION

For auto light operation, refer to [LT-43, "System Description"](#) .

DAYTIME LIGHT OPERATION

With the engine running, the lighting switch in the OFF or 1ST position and parking brake released, power is supplied

- through daytime light control unit terminal 7
- to RH headlamp terminal 1
- through RH headlamp terminal 2
- to daytime light control unit terminal 9, and
- through daytime light control unit terminal 6
- to LH headlamp terminal 1
- through LH headlamp terminal 2
- to daytime light control unit terminal 10.

Ground is supplied

- to daytime light control unit terminals 13, 14 and 16
- through grounds E15 and E24.

Because the high beam headlamps are now wired in series, they operate at half illumination.

XENON HEADLAMP (IF EQUIPPED)

The low beam headlamps may be equipped with xenon type bulbs. Xenon bulbs do not use a filament. Instead, they produce light when a high voltage current is passed between two tungsten electrodes through a mixture of xenon (an inert gas) and certain other metal halides. In addition to added lighting power, electronic control of the power supply gives the headlamps stable quality and tone color.

Following are some of the advantages of the xenon type headlamp.

- The light produced by the headlamps is a white color comparable to sunlight that is easy on the eyes.
- Light output is nearly double that of halogen headlamps, affording increased area of illumination.
- The light features a high relative spectral distribution at wavelengths to which the human eye is most sensitive. This means that even in the rain, more light is reflected back from the road surface toward the vehicle for added visibility.
- Power consumption is approximately 25 percent less than halogen headlamps, reducing battery load.

OPERATION

After starting the engine with the lighting switch in the "OFF" or 1ST position, the headlamp high beam automatically turns on. Lighting switch operations other than the above are the same as conventional light systems.

HEADLAMP (FOR CANADA) - DAYTIME LIGHT SYSTEM -

Engine		With engine stopped									With engine running								
Lighting switch		OFF			1ST			2ND			OFF			1ST			2ND		
		Hi	Lo	P	Hi	Lo	P	Hi	Lo	P	Hi	Lo	P	Hi	Lo	P	Hi	Lo	P
Headlamp	High beam	-	-	-	-	-	×	×	-	×	●*	●*	×	●*	●*	×	×	-	×
	Low beam	-	-	-	-	-	×	×	×	×	-	-	×	-	-	×	×	×	×
Tail lamp		-	-	-	×	×	×	×	×	×	-	-	-	×	×	×	×	×	×
License and instrument illumination lamp		-	-	-	×	×	×	×	×	×	-	-	-	×	×	×	×	×	×

- Hi: "HIGH BEAM" position
- Lo: "LOW BEAM" position
- P: "FLASH TO PASS" position
- ×: Lamp "ON"
- -: Lamp "OFF"
- ●: Lamp dims. (Added functions)
- *: When starting the engine with the parking brake released, the daytime lights will operate.
When starting the engine with the parking brake pulled, the daytime lights will not operate.

CAN Communication System Description

EKS008M4

Refer to [LAN-20, "CAN COMMUNICATION"](#).

A
B
C
D
E
F
G
H
I
J
LT
L
M

LT

HEADLAMP (FOR CANADA) - DAYTIME LIGHT SYSTEM -

Schematic

EKS008M5

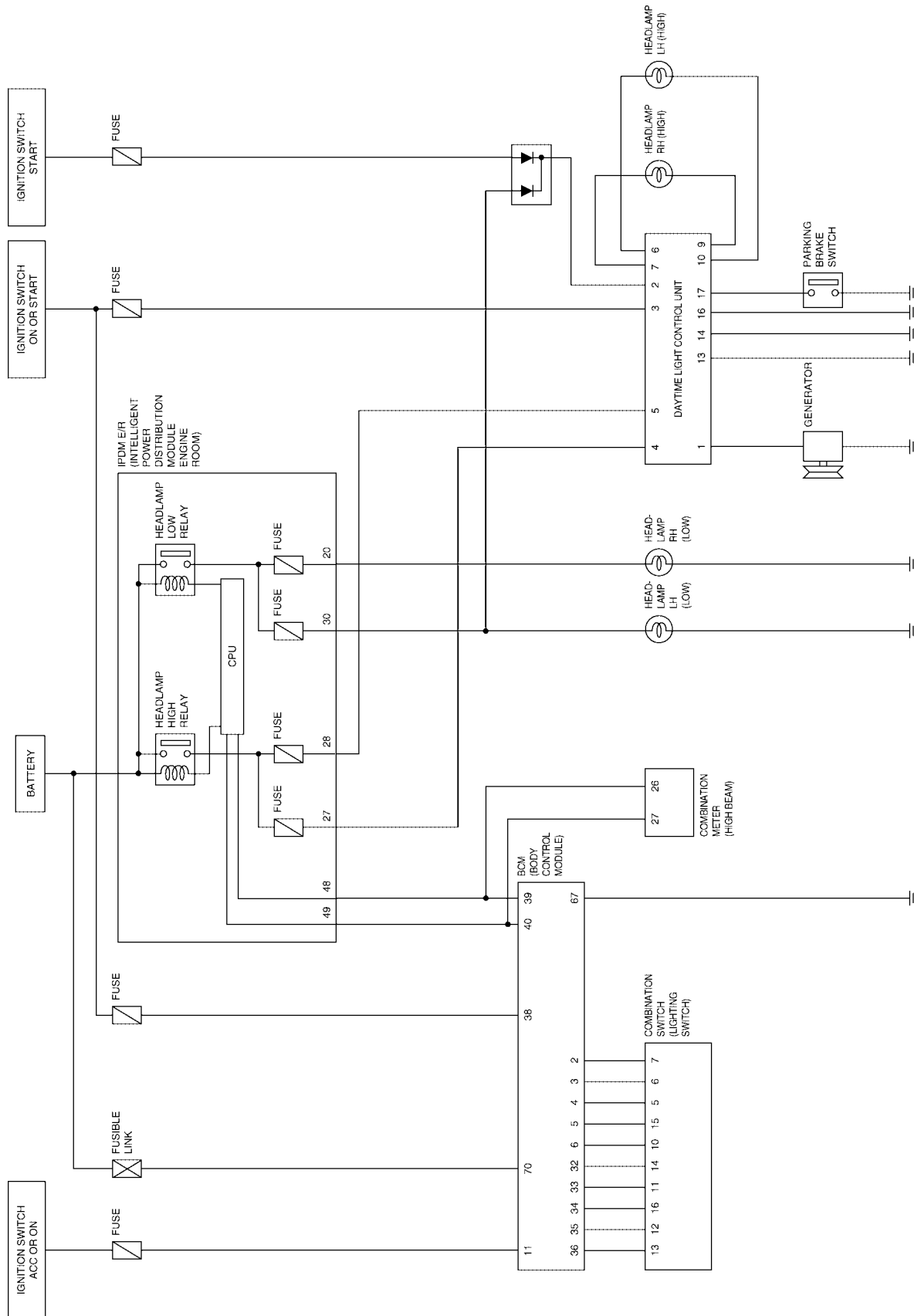

WKWA1364E

HEADLAMP (FOR CANADA) - DAYTIME LIGHT SYSTEM -

Wiring Diagram — DTRL —

EKS008M6

LT-DTRL-01

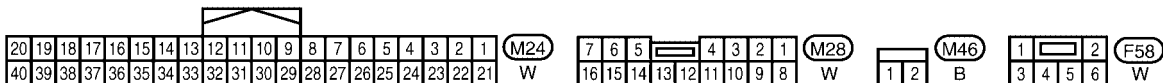
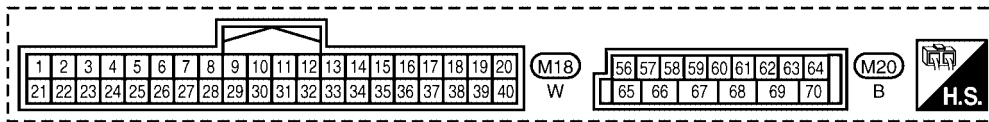
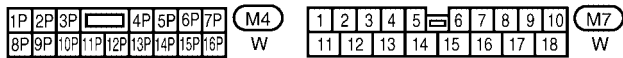
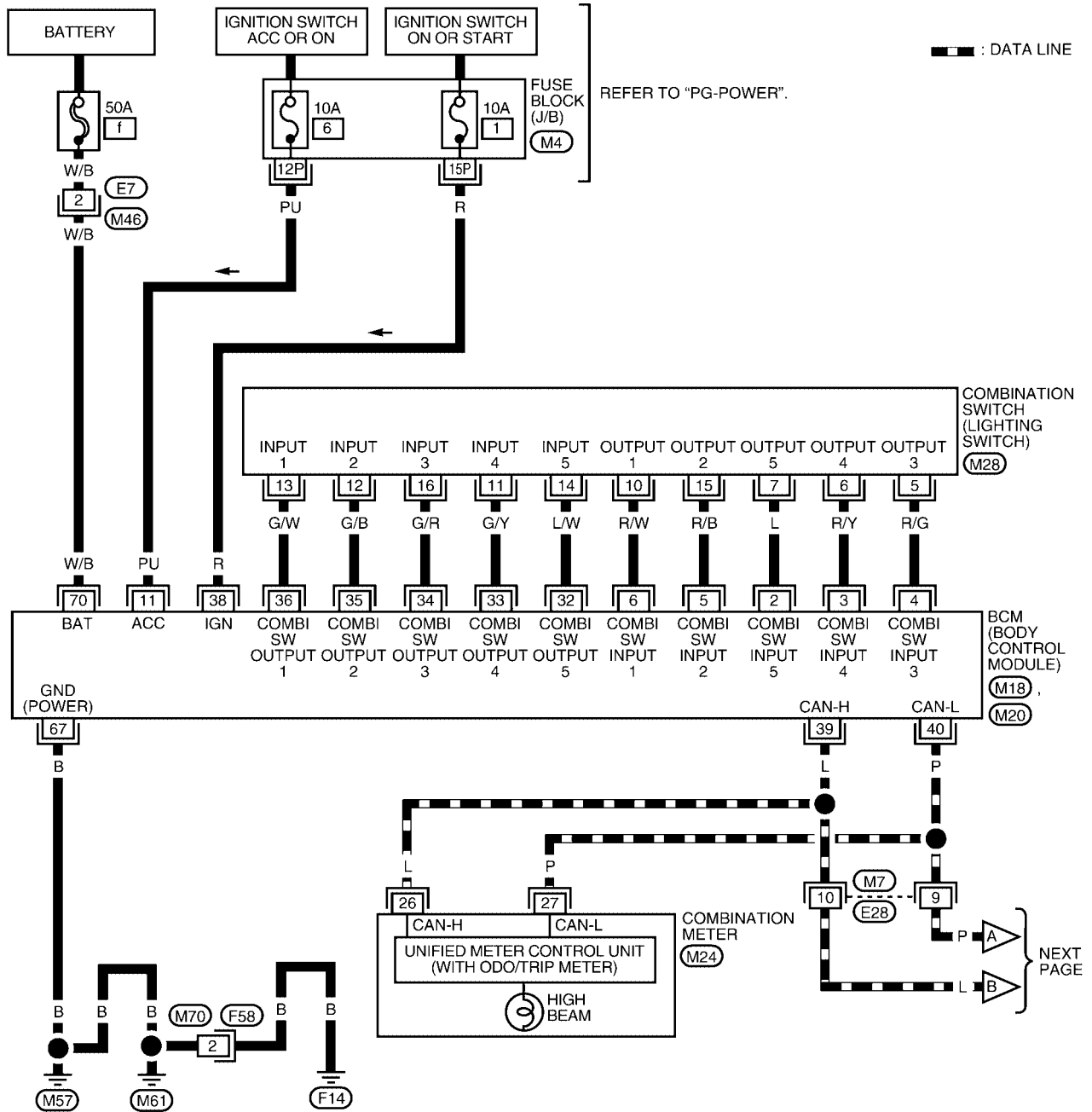

WKWA1365E

HEADLAMP (FOR CANADA) - DAYTIME LIGHT SYSTEM -

LT-DTRL-02

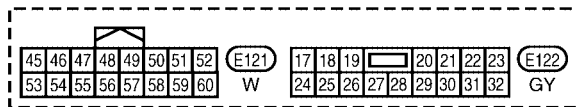
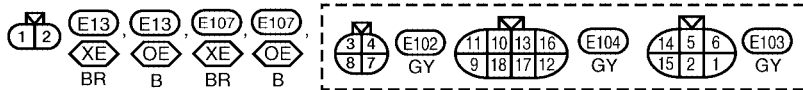
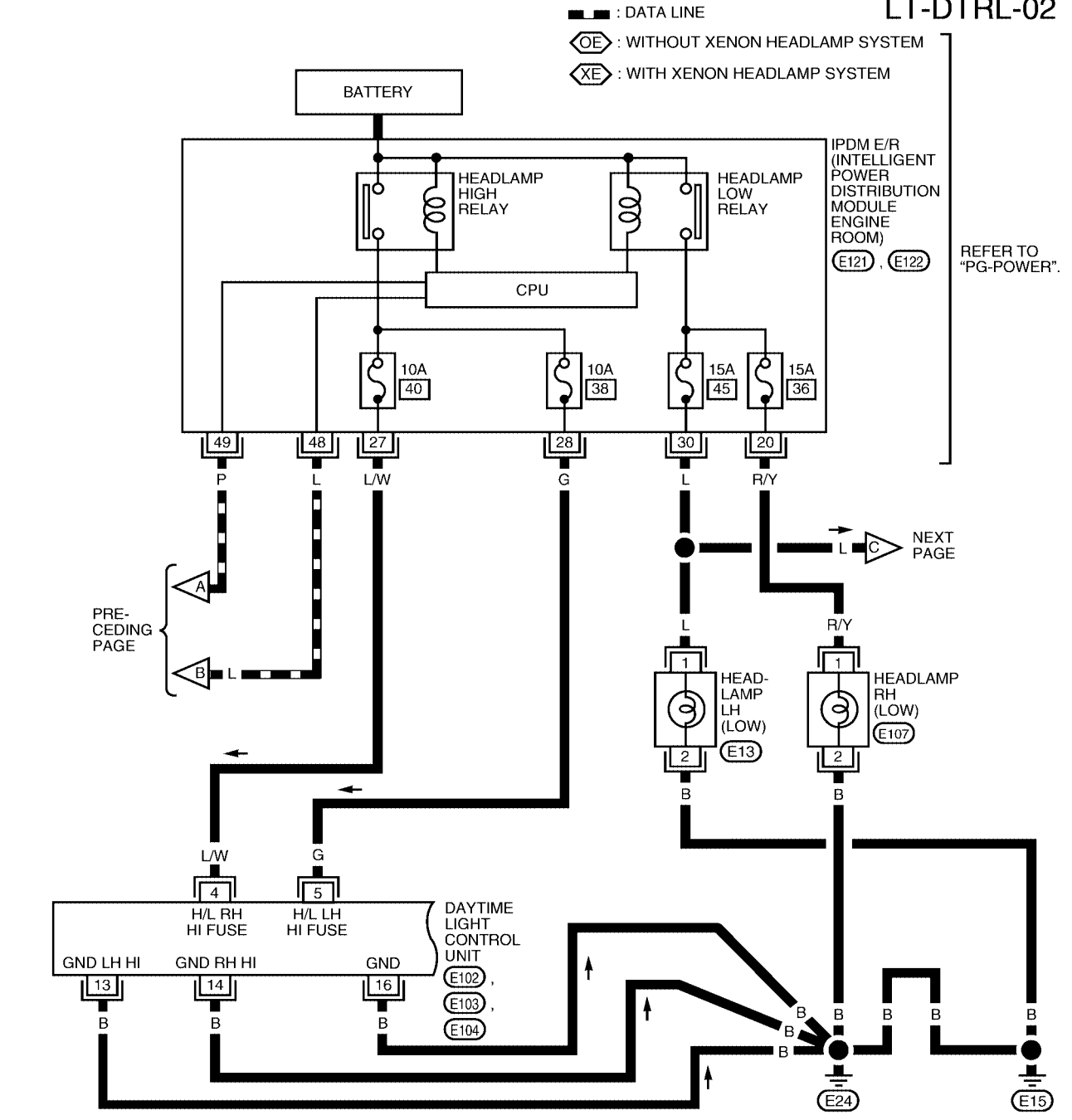

WKWA2971E

HEADLAMP (FOR CANADA) - DAYTIME LIGHT SYSTEM -

LT-DTRL-03

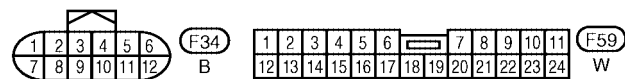
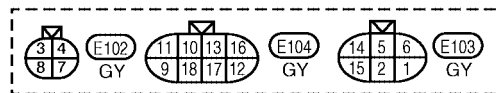
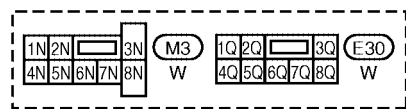
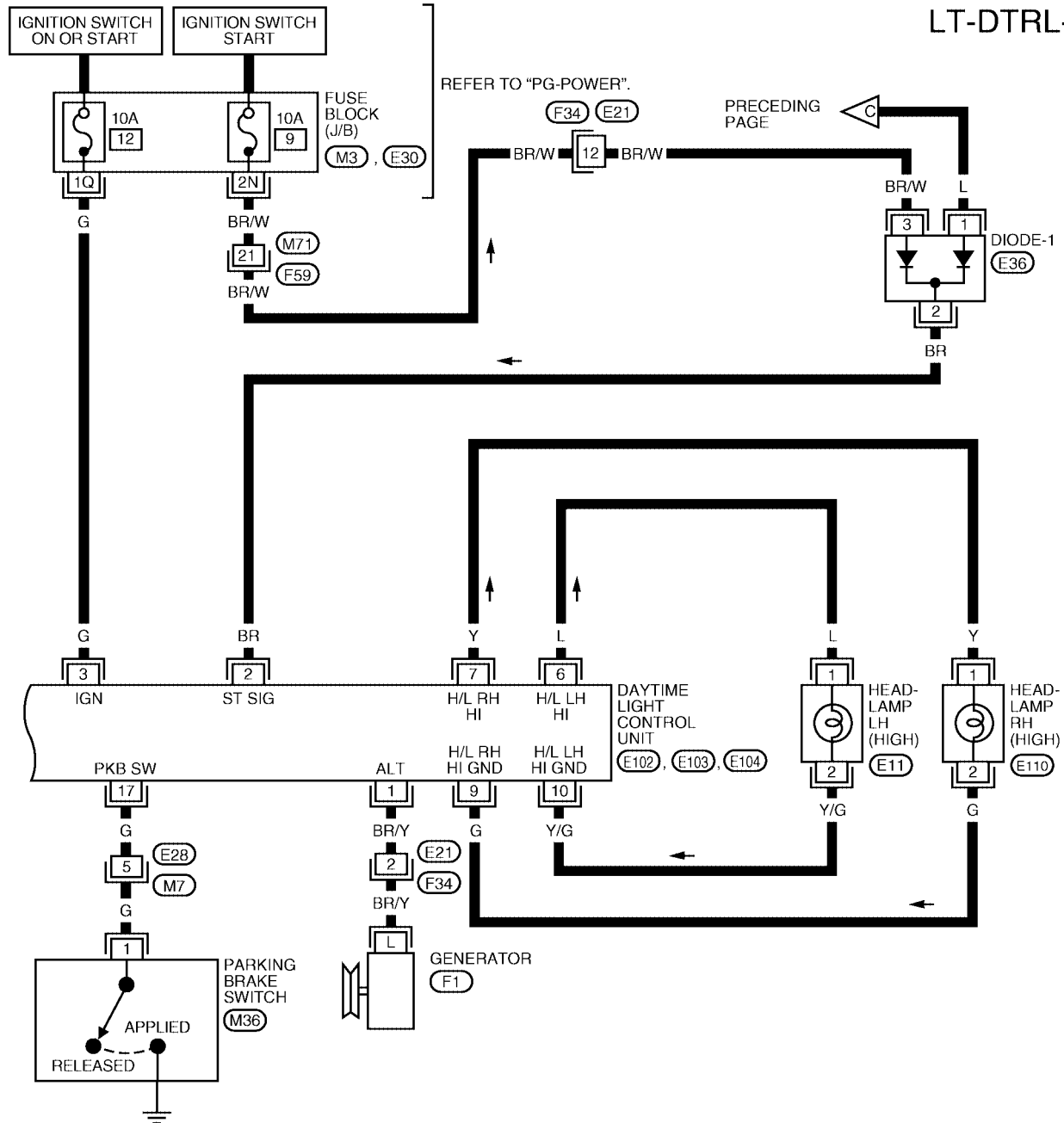

WKWA1367E

HEADLAMP (FOR CANADA) - DAYTIME LIGHT SYSTEM -

How to Proceed With Trouble Diagnosis

EKS008M7

1. Confirm the symptom or customer complaint.
2. Understand operation description and function description. Refer to [LT-32, "System Description"](#) .
3. Perform the Preliminary Check. Refer to [LT-40, "Preliminary Check"](#) .
4. Check symptom and repair or replace the cause of malfunction.
5. Does the daytime light system operate normally? If YES: GO TO 6. If NO: GO TO 4.
6. Inspection End.

Preliminary Check

EKS008M8

CHECK BCM CONFIGURATION

1. CHECK BCM CONFIGURATION

Confirm BCM configuration for "DTRL" is set to "WITH". Refer to [BCS-14, "READ CONFIGURATION PROCEDURE"](#) .

OK or NG

- OK >> GO TO Trouble Diagnosis. Refer to [LT-41, "Trouble Diagnosis"](#) .
- NG >> Change BCM configuration for "DTRL" to "WITH". Refer to [BCS-16, "WRITE CONFIGURATION PROCEDURE"](#) .

HEADLAMP (FOR CANADA) - DAYTIME LIGHT SYSTEM -

Trouble Diagnosis

EKS008M9

TERMINALS AND REFERENCE VALUE FOR DAYTIME LIGHT CONTROL UNIT

Terminal No.	Wire color	Item	Condition	Voltage (Approx.)
1	BR/Y	Generator	When turning ignition switch to "ON"	Less than 1V
			When engine is running	Battery voltage
			When turning ignition switch to "OFF"	Less than 1V
2	BR	Start signal	When turning ignition switch to "START"	Battery voltage
			When turning ignition switch to "ON" from "START"	Less than 1V
			When turning ignition switch to "OFF"	Less than 1V
3	G	Power source	When turning ignition switch to "ON"	Battery voltage
			When turning ignition switch to "START"	Battery voltage
			When turning ignition switch to "OFF"	Less than 1V
4	LW	LH HI fuse	When lighting switch is turned to the 2ND position with "HI BEAM" or "FLASH TO PASS" position	Battery voltage
			When lighting switch is turned to "FLASH TO PASS" position with ignition switch "ON" position	Battery voltage
5	G	RH HI fuse	When lighting switch is turned to the 2ND position with "HI BEAM" or "FLASH TO PASS" position	Battery voltage
			When lighting switch is turned to "FLASH TO PASS" position with ignition switch "ON" position	Battery voltage
6	L	LH HI beam	When lighting switch is turned to the 2ND position with "HI BEAM" or "FLASH TO PASS" position	Battery voltage
			When releasing parking brake with engine running and turning lighting switch to "OFF" (daytime light operation) CAUTION: Block wheels and ensure selector lever is in N or P position.	Half battery voltage
7	Y	RH HI beam	When lighting switch is turned to the 2ND position with "HI BEAM" or "FLASH TO PASS" position	Battery voltage
			When releasing parking brake with engine running and turning lighting switch to "OFF" (daytime light operation) CAUTION: Block wheels and ensure selector lever is in N or P position.	Battery voltage
9	G	RH HI beam (ground)	When turning lighting switch to the 2ND position with "HI BEAM" or "FLASH TO PASS" position	Less than 1V
			When releasing parking brake with engine running and turning lighting switch to "OFF" (daytime light operation) CAUTION: Block wheels and ensure selector lever is in N or P position.	Half battery voltage
10	Y/G	LH HI beam (ground)	When turning lighting switch to the 2ND position with "HI BEAM" or "FLASH TO PASS" position	Less than 1V
			When releasing parking brake with engine running and turning lighting switch to "OFF" (daytime light operation) CAUTION: Block wheels and ensure selector lever is in N or P position.	Less than 1V
13	B	Ground (LH HI)	—	—
14	B	Ground (RH HI)	—	—
16	B	Ground	—	—

HEADLAMP (FOR CANADA) - DAYTIME LIGHT SYSTEM -

Terminal No.	Wire color	Item	Condition	Voltage (Approx.)
17	G	Parking brake switch	When parking brake is released	Battery voltage
			When parking brake is set	Less than 1V

Aiming Adjustment

EKS00GAE

Refer to [LT-27, "Aiming Adjustment"](#) .

Bulb Replacement

EKS00GAF

Refer to [LT-28, "Bulb Replacement"](#) .

Disassembly and Assembly

EKS00GAG

Refer to [LT-30, "Disassembly and Assembly"](#) .

Removal and Installation

EKS00GAH

Refer to [LT-29, "Removal and Installation"](#) .

DAYTIME LIGHT CONTROL UNIT

Removal

1. Remove instrument lower cover LH. Refer to [IP-13, "INSTRUMENT LOWER COVER LH"](#) .
2. Remove daytime light control unit screw.
3. Disconnect electrical connectors.
4. Remove daytime light control unit.

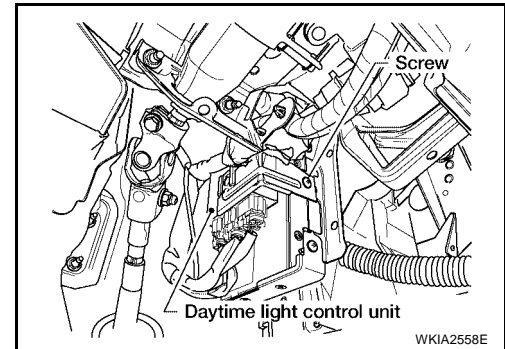

Installation

Installation is in the reverse order of removal.

AUTO LIGHT SYSTEM

Component Parts and Harness Connector Location

EKS008MB

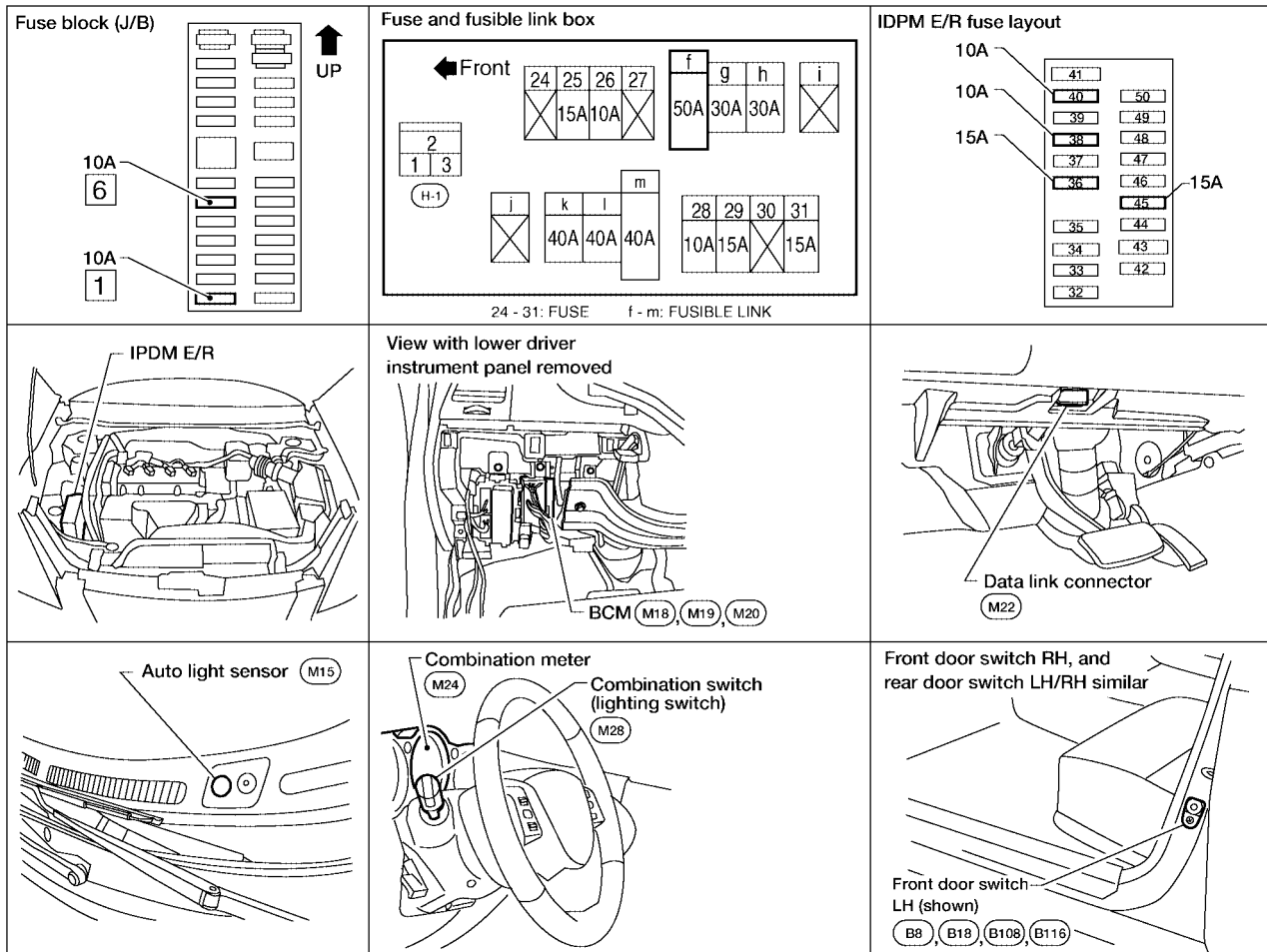

WKIA4086E

System Description

EKS008MC

This system automatically turns the parking lamps and the headlamps on and off in accordance with ambient light.

Timing for when the lamps turn on/off can be selected using four modes.

OUTLINE

The auto light control system uses an optical sensor that detects the brightness of outside light.

When the lighting switch is in AUTO position, it automatically turns on/off the parking lamps and the headlamps (and fog lamps, if equipped) in accordance with the ambient light. Sensitivity can be adjusted in four steps. For the details of the setting, refer to [LT-49. "SETTING CHANGE FUNCTIONS"](#).

When the lighting switch is in "AUTO" position, power is supplied

- through BCM (body control module) terminal 17
- to auto light sensor terminal 1.

When lighting switch is in "AUTO" position, ground is supplied

- to auto light sensor terminal 3
- through BCM terminal 18.

When ignition switch is turned to "ON" or "START" position and when outside brightness is darker than prescribed level, input is supplied

- through auto light sensor terminal 2
- to BCM terminal 14.

The headlamps will then illuminate. For a description of headlamp operation, refer to [LT-5. "System Description"](#).

AUTO LIGHT SYSTEM

BATTERY SAVER CONTROL

When the combination switch (lighting switch) is in the AUTO position, and the ignition switch is turned from ON or ACC to OFF, and one of the doors is opened, the battery saver feature is activated.

Under this condition, the headlamps remain illuminated for 5 minutes, unless the combination switch (lighting switch) position is changed. If the combination switch (lighting switch) position is changed, then the headlamps are turned off.

SHUT OFF DELAY

When the ignition switch is turned from ON to OFF while the auto light system is activated and the headlamps are illuminated, the shut off delay feature is activated. Under this condition, the BCM no longer receives a voltage signal at terminal 38 and this starts the auto light shut off delay timer. The shut off delay timer is active until one of the doors is opened or the combination switch (lighting switch) position is changed. If one of the doors is opened, the shut off delay feature is deactivated and the battery saver control feature is activated. If the combination switch (lighting switch) position is changed, the headlamps are turned off.

CAN Communication System Description

EKS008MD

Refer to [LAN-20, "CAN COMMUNICATION"](#) .

Major Components and Functions

EKS008ME

Components	Functions
BCM	<ul style="list-style-type: none">● Turns on/off circuits of tail light and headlamp according to signals from light sensor, lighting switch (AUTO), front door switch LH, ignition switch (ON, OFF), and vehicle signal from combination meter.
Auto light sensor	<ul style="list-style-type: none">● Converts ambient light (lux) to voltage and sends it to BCM. (Detects light from 50 to 1,300 lux)
Combination meter	<ul style="list-style-type: none">● Sends vehicle signal to BCM via CAN communication line.

AUTO LIGHT SYSTEM

Wiring Diagram — AUTO/L —

EKS008MF

LT-AUTO/L-01

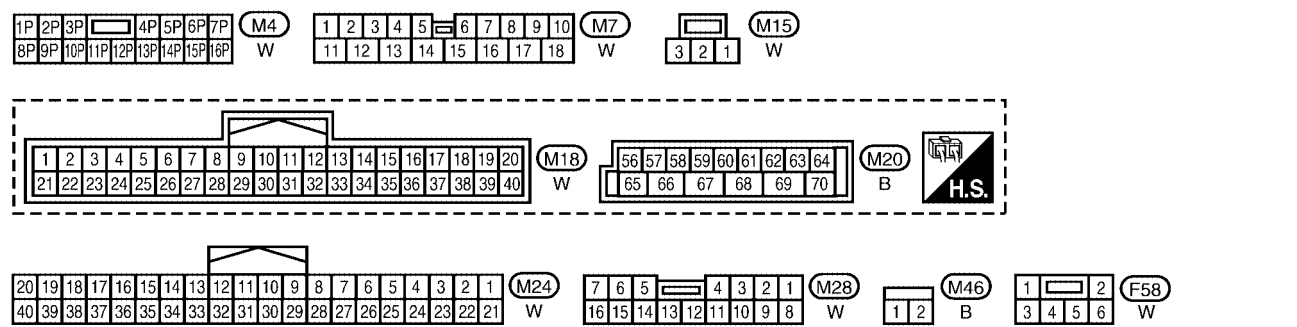
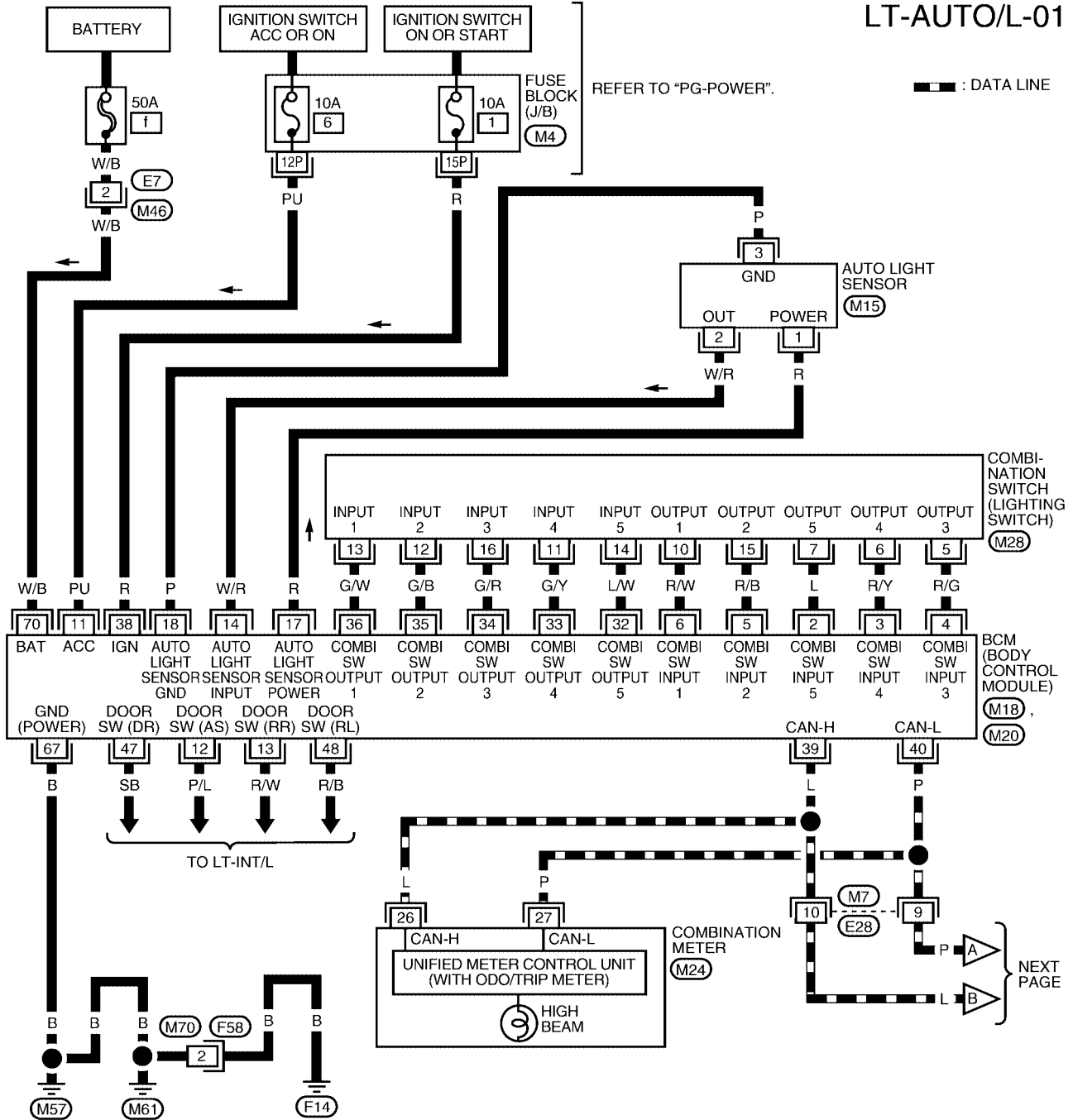

AUTO LIGHT SYSTEM

LT-AUTO/L-02

— : DATA LINE

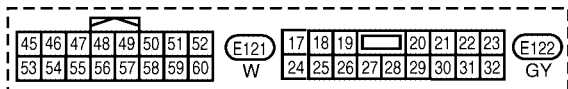
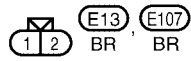
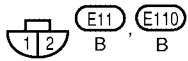
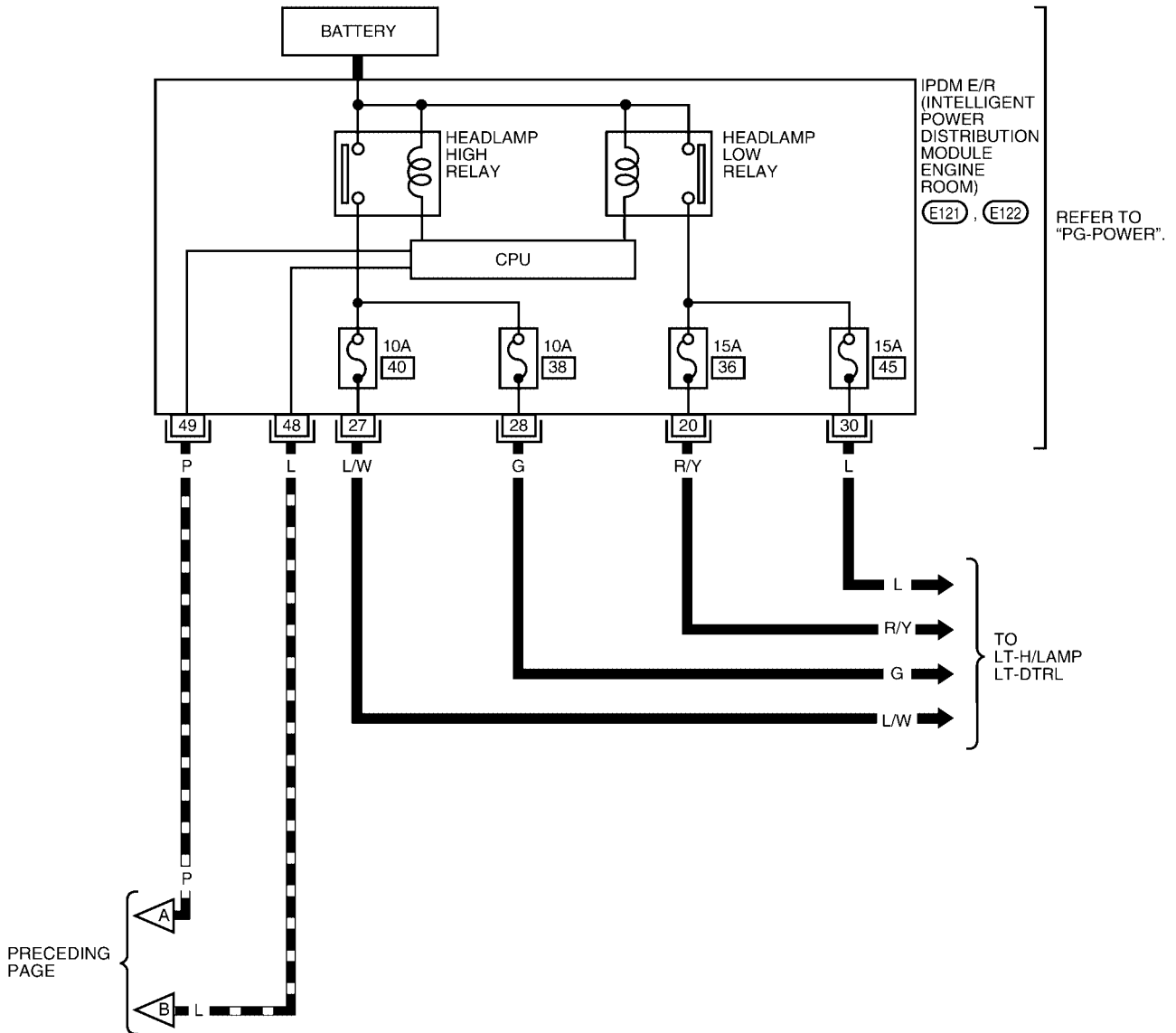



WKWA1368E

AUTO LIGHT SYSTEM

Terminals and Reference Values for BCM

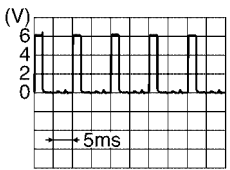
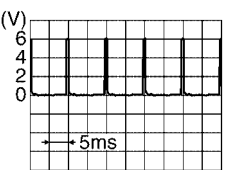
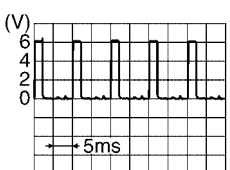
EKS008MG

Terminal No.	Wire color	Signal name	Measuring condition		Reference value (Approx.)	
			Ignition switch	Operation or condition		
2	L	Combination switch input 5	ON	Lighting, turn, wiper OFF Wiper dial position 4	 <p style="text-align: right; font-size: small;">SKIA5291E</p>	
3	R/Y	Combination switch input 4	ON	Lighting, turn, wiper OFF Wiper dial position 4	 <p style="text-align: right; font-size: small;">SKIA5292E</p>	
4	R/G	Combination switch input 3	ON	Lighting, turn, wiper OFF Wiper dial position 4	 <p style="text-align: right; font-size: small;">SKIA5291E</p>	
5	R/B	Combination switch input 2	ON	Lighting, turn, wiper OFF Wiper dial position 4	 <p style="text-align: right; font-size: small;">SKIA5292E</p>	
6	R/W	Combination switch input 1				
11	PU	Ignition switch (ACC)	ACC	—	Battery voltage	
12	P/L	Front door switch RH signal	OFF	Front door switch RH	ON (open)	0V
					OFF (closed)	Battery voltage
13	R/W	Rear door switch RH signal	OFF	Rear door switch RH	ON (open)	0V
					OFF (closed)	Battery voltage
14	W/R	Auto light sensor signal	ON	When auto light sensor is illuminated	3.1 V or more ^{Note}	
				When auto light sensor is not illuminated	0.6 V or less	
17	R	Auto light sensor power supply	ON	—	5V	
18	P	Sensor ground	ON	—	0V	
32	L/W	Combination switch output 5	ON	Lighting, turn, wiper OFF Wiper dial position 4	 <p style="text-align: right; font-size: small;">SKIA5291E</p>	

A
B
C
D
E
F
G
H
I
J
LT

AUTO LIGHT SYSTEM

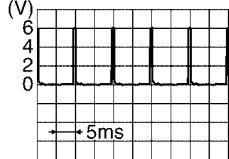
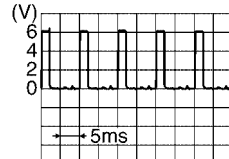
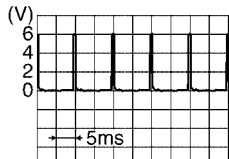
Terminal No.	Wire color	Signal name	Measuring condition		Reference value (Approx.)	
			Ignition switch	Operation or condition		
33	G/Y	Combination switch output 4	ON	Lighting, turn, wiper OFF Wiper dial position 4	 SKIA5292E	
34	G/R	Combination switch output 3	ON	Lighting, turn, wiper OFF Wiper dial position 4	 SKIA5291E	
35	G/B	Combination switch output 2	ON	Lighting, turn, wiper OFF Wiper dial position 4	 SKIA5292E	
36	G/W	Combination switch output 1				
38	R	Ignition switch (ON)	ON	—	Battery voltage	
39	L	CAN-H	—	—	—	
40	P	CAN-L	—	—	—	
47	SB	Front door switch LH signal	OFF	Front door switch LH	ON (open)	0V
					OFF (closed)	Battery voltage
48	R/B	Rear door switch LH signal	OFF	Rear door switch LH	ON (open)	0V
					OFF (closed)	Battery voltage
67	B	Ground	ON	—	0V	
70	W/B	Battery power supply (fusible link)	OFF	—	Battery voltage	

NOTE:

Optical sensor must be completely subjected to work lamp light. If the optical sensor is insufficiently illuminated, the measured value may not satisfy standard.

Terminals and Reference Values for IPDM E/R

EKS008MH

Terminal No.	Wire color	Signal name	Measuring condition		Reference value (Approx.)	
			Ignition switch	Operation or condition		
20	R/Y	Headlamp low (RH)	ON	Lighting switch 2ND position	OFF	0V
					ON	Battery voltage
27	L/W	Headlamp high (RH)	ON	Lighting switch HIGH or PASS position	OFF	0V
					ON	Battery voltage
28	G	Headlamp high (LH)	ON	Lighting switch HIGH or PASS position	OFF	0V
					ON	Battery voltage

AUTO LIGHT SYSTEM

Terminal No.	Wire color	Signal name	Measuring condition		Reference value (Approx.)
			Ignition switch	Operation or condition	
30	L	Headlamp low (LH)	ON	Lighting switch 2ND position	0V
					Battery voltage
48	L	CAN-H	—	—	—
49	P	CAN-L	—	—	—

How to Proceed With Trouble Diagnosis

EKS008MI

1. Confirm the symptom or customer complaint.
2. Understand operation description and function description. Refer to [LT-43, "System Description"](#).
3. Carry out the Preliminary Check. Refer to [LT-49, "Preliminary Check"](#).
4. Check symptom and repair or replace the cause of malfunction. Refer to [LT-56, "Trouble Diagnosis Chart by Symptom"](#).
5. Does the auto light system operate normally? If YES: GO TO 6. If NO: GO TO 4.
6. Inspection End.

Preliminary Check

EKS008MJ

SETTING CHANGE FUNCTIONS

- Sensitivity of auto light system can be adjusted using CONSULT-II. Refer to [LT-52, "WORK SUPPORT"](#).

CHECK BCM CONFIGURATION

1. CHECK BCM CONFIGURATION

Confirm BCM configuration for "AUTO LIGHT" is set to "WITH". Refer to [BCS-14, "READ CONFIGURATION PROCEDURE"](#).

OK or NG

- OK >> Continue preliminary check. Refer to [LT-49, "CHECK POWER SUPPLY AND GROUND CIRCUIT"](#).
- NG >> Change BCM configuration for "AUTO LIGHT" to "WITH". Refer to [BCS-16, "WRITE CONFIGURATION PROCEDURE"](#).

CHECK POWER SUPPLY AND GROUND CIRCUIT

1. CHECK FUSES OR FUSIBLE LINK

Check for blown fuses or fusible link.

Unit	Power source	Fuse and fusible link No.
BCM	Battery	f
	Ignition switch ACC or ON position	6
	Ignition switch ON or START position	1
IPDM E/R	Battery	36
		38
		40
		45

Refer to [LT-45, "Wiring Diagram — AUTO/L —"](#).

OK or NG

- OK >> GO TO 2.
- NG >> If fuse or fusible link is blown, be sure to eliminate cause of malfunction before installing new fuse or fusible link. Refer to [PG-4, "POWER SUPPLY ROUTING CIRCUIT"](#).

AUTO LIGHT SYSTEM

2. CHECK POWER SUPPLY CIRCUIT

1. Disconnect BCM connectors.
2. Check voltage between BCM harness connector terminals and ground.

BCM		(-)	Ignition switch position		
(+)			OFF	ACC	ON
Connector	Terminal				
M18	11	Ground	0V	Battery voltage	Battery voltage
	38		0V	0V	Battery voltage
M20	70		Battery voltage	Battery voltage	Battery voltage

OK or NG

OK >> GO TO 3.

NG >> Check harness for open between BCM and fuse or fusible link.

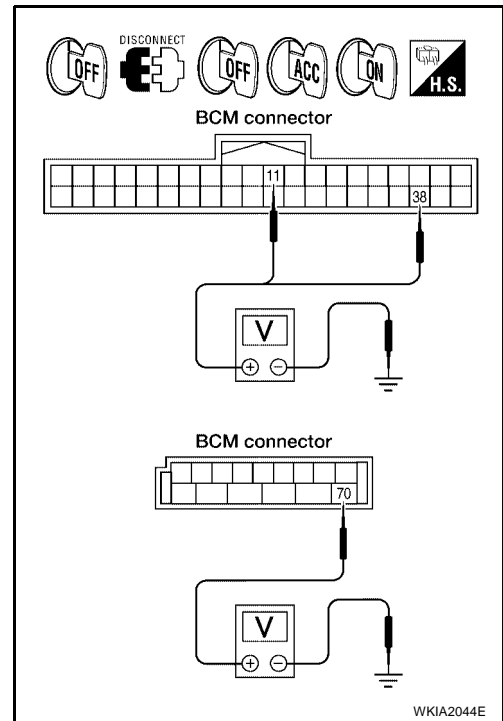

WKIA2044E

3. CHECK GROUND CIRCUIT

Check continuity between BCM harness connector terminal and ground.

BCM			Continuity
Connector	Terminal		
M20	67	Ground	Yes

OK or NG

OK >> Inspection End.

NG >> Check ground circuit harness.

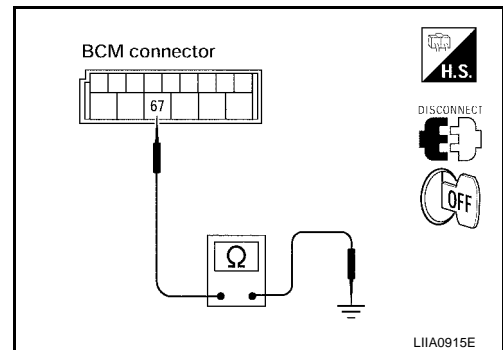

LIA0915E

AUTO LIGHT SYSTEM

CONSULT-II Function (BCM)

EKS008MK

CONSULT-II can display each diagnostic item using the diagnostic test modes shown following.

BCM diagnostic test item	Diagnostic mode	Description
Inspection by part	WORK SUPPORT	Supports inspections and adjustments. Commands are transmitted to the BCM for setting the status suitable for required operation, input/output signals are received from the BCM and received data is displayed.
	DATA MONITOR	Displays BCM input/output data in real time.
	ACTIVE TEST	Operation of electrical loads can be checked by sending drive signal to them.
	SELF-DIAG RESULTS	Displays BCM self-diagnosis results.
	CAN DIAG SUPPORT MNTR	The result of transmit/receive diagnosis of CAN communication can be read.
	ECU PART NUMBER	BCM part number can be read.
	CONFIGURATION	Performs BCM configuration read/write functions.

CONSULT-II OPERATION

CAUTION:

If CONSULT-II is used with no connection of CONSULT-II CONVERTER, malfunctions might be detected in self-diagnosis depending on control unit which carries out CAN communication.

1. With the ignition switch OFF, connect CONSULT-II and CONSULT-II CONVERTER to the data link connector, then turn ignition switch ON.

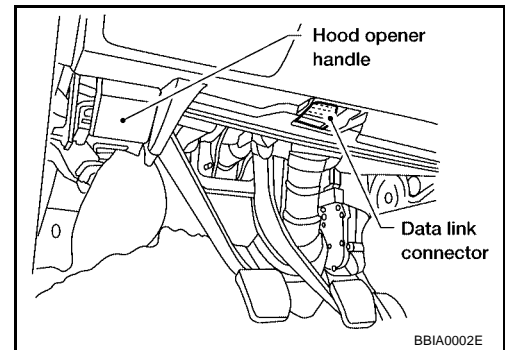

2. Touch "START (NISSAN BASED VHCL)".

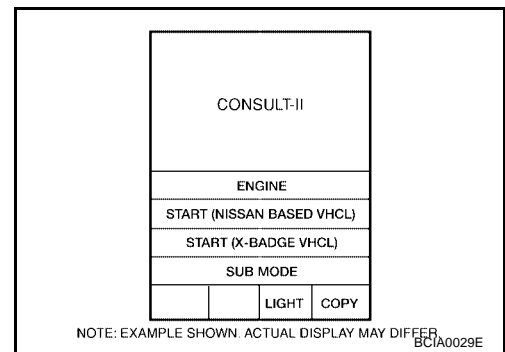

3. Touch "BCM" on "SELECT SYSTEM" screen. If "BCM" is not indicated, go to [GI-39, "Consult-II Data Link Connector \(DLC\) Circuit"](#).

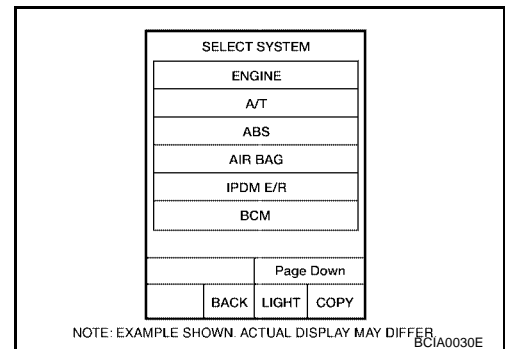

AUTO LIGHT SYSTEM

4. Select the desired part to be diagnosed on the "SELECT TEST ITEM" screen.

SELECT TEST ITEM			
HEAD LAMP			
WIPER			
FLASHER			
AIR CONDITIONER			
COMB SW			
BCM			
Scroll Up		Page Down	
	BACK	LIGHT	COPY

LKIA0183E

WORK SUPPORT

Operation Procedure

1. Touch "HEAD LAMP" on "SELECT TEST ITEM" screen.
2. Touch "WORK SUPPORT" on "SELECT DIAG MODE" screen.
3. Touch item setting to be changed on "SELECT WORK ITEM" screen.
4. Touch "START".
5. Touch the item setting desired.
6. Touch "CHANGE SETT".
7. The setting will be changed and "CUSTOMIZING COMPLETED" will be displayed.
8. Touch "END".

Work Support Setting Item

Work Support item	Description	Mode	Setting status
BATTERY SAVER SET	Function is not enabled, battery saver operation cannot be changed.	On	Function is not enabled, battery saver operation cannot be changed.
		Off	
CUSTOM A/LIGHT SETTING	Sensitivity of auto light can be selected and set from four modes.	Mode1	Factory setting
		Mode 2	More sensitive setting compared to factory setting (The time required for lamp light-up is shorter than "Normal").
		Mode 3	Less sensitive setting compared to factory setting (The time required for lamp light-up is longer than "Normal").
		Mode 4	Less sensitive setting compared to Mode 3 (The time required for lamp light-up is longer than Mode 3).
ILL DELAY SET	The timer that turns off the headlamps (and fog lamps, if turned on) after the last door is closed can be selected and set from 8 modes.	Mode 1	45 seconds (Factory setting)
		Mode 2	0 seconds (immediate shutoff)
		Mode 3	30 seconds
		Mode 4	60 seconds
		Mode 5	90 seconds
		Mode 6	120 seconds
		Mode 7	150 seconds
Mode 8	180 seconds		

DATA MONITOR

Operation Procedure

1. Touch "HEAD LAMP" on "SELECT TEST ITEM" screen.
2. Touch "DATA MONITOR" on "SELECT DIAG MODE" screen.
3. Touch either "ALL SIGNALS" or "SELECTION FROM MENU" on "SELECT MONITOR ITEM" screen.

ALL SIGNALS	Monitors all the signals.
SELECTION FROM MENU	Selects and monitors individual signal.

AUTO LIGHT SYSTEM

4. Touch "START".
5. When "SELECTION FROM MENU" is selected, touch items to be monitored. When "ALL SIGNALS" is selected, all the signals will be monitored.
6. Touch "RECORD" while monitoring, then the status of the monitored item can be recorded. To stop recording, touch "STOP".

Display Item List

Monitor item name "OPERATION OR UNIT"	Contents
IGN ON SW "ON/OFF"	Displays "IGN position (ON)/OFF, ACC position (OFF)" judged from the ignition switch signal.
ACC ON SW "ON/OFF"	Displays "ACC (ON)/OFF, Ignition OFF (OFF)" status judged from ignition switch signal.
HI BEAM SW "ON/OFF"	Displays status (high beam switch: ON/Others: OFF) of high beam switch judged from lighting switch signal.
HEAD LAMP SW 1 "ON/OFF"	Displays status (headlamp switch: ON/Others: OFF) of headlamp switch judged from lighting switch signal.
HEAD LAMP SW 2 "ON/OFF"	Displays status (headlamp switch 2: ON/Others: OFF) of headlamp switch 2 judged from lighting switch signal.
LIGHT SW 1ST "ON/OFF"	Displays status (lighting switch 1st position: ON/Others: OFF) of light switch judged from lighting switch signal.
AUTO LIGHT SW "ON/OFF"	Displays status of the lighting switch as judged from the lighting switch signal. (AUTO position: ON/Other than AUTO position: OFF)
PASSING SW "ON/OFF"	Displays status (flash-to-pass switch: ON/Others: OFF) of flash-to-pass switch judged from lighting switch signal.
DOOR SW-DR "ON/OFF"	Displays status of the front door LH as judged from the front door switch LH signal. (Door is open: ON/Door is closed: OFF)
DOOR SW-AS "ON/OFF"	Displays status of the front door RH as judged from the front door switch RH signal. (Door is open: ON/Door is closed: OFF)
DOOR SW-RR "ON/OFF"	Displays status of the rear door RH as judged from the rear door switch RH signal. (Door is open: ON/Door is closed: OFF)
DOOR SW-RL "ON/OFF"	Displays status of the rear door LH as judged from the rear door switch LH signal. (Door is open: ON/Door is closed: OFF)
OPTICAL SENSOR [0 - 5V]	Displays "ambient light (close to 5V when light/close to 0V when dark)" judged from auto light sensor signal.

ACTIVE TEST

Operation Procedure

1. Touch "HEAD LAMP" on "SELECT TEST ITEM" screen.
2. Touch "ACTIVE TEST" on "SELECT DIAG MODE" screen.
3. Touch item to be tested and check operation of the selected item.
4. During the operation check, touching "BACK" deactivates the operation.

Display Item List

Test item	Display on CONSULT-II screen	Description
Headlamp relay output	HEAD LAMP	Allows headlamp relay to operate by switching ON-OFF at your option.

AUTO LIGHT SYSTEM

CONSULT-II Function (IPDM E/R)

EKS008ML

CONSULT-II can display each diagnostic item using the diagnostic test modes shown following.

IPDM E/R diagnostic Mode	Description
SELF-DIAG RESULTS	Displays IPDM E/R self-diagnosis results.
DATA MONITOR	Displays IPDM E/R input/output data in real time.
CAN DIAG SUPPORT MNTR	The result of transmit/receive diagnosis of CAN communication can be read.
ACTIVE TEST	Operation of electrical loads can be checked by sending drive signal to them.

CONSULT-II OPERATION

CAUTION:

If CONSULT-II is used with no connection of CONSULT-II CONVERTER, malfunctions might be detected in self-diagnosis depending on control unit which carries out CAN communication.

1. With the ignition switch OFF, connect CONSULT-II and CONSULT-II CONVERTER to the data link connector, then turn the ignition switch ON.

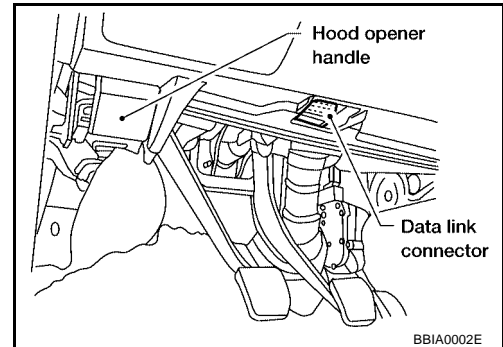

2. Touch "START (NISSAN BASED VHCL)".

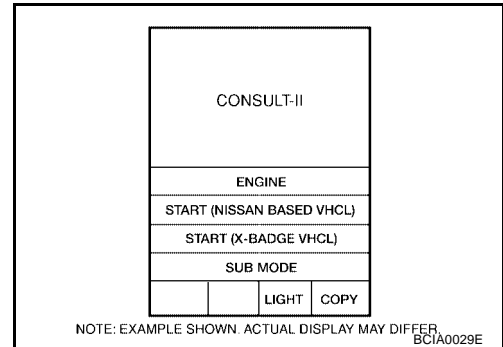

3. Touch "IPDM E/R" on "SELECT SYSTEM" screen. If "IPDM E/R" is not displayed, go to [G1-39, "Consult-II Data Link Connector \(DLC\) Circuit"](#).

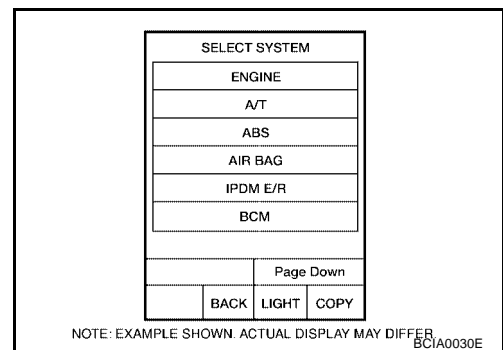

AUTO LIGHT SYSTEM

- Select the desired part to be diagnosed on the "SELECT DIAG MODE" screen.

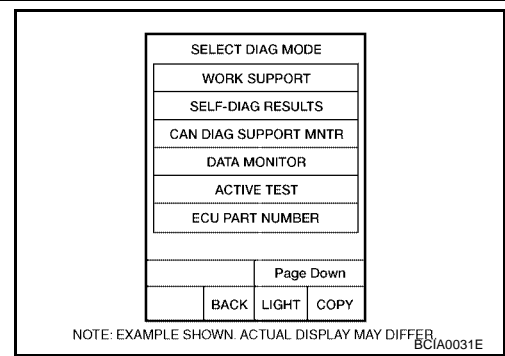

DATA MONITOR

Operation Procedure

- Touch "DATA MONITOR" on "SELECT DIAG MODE" screen.
- Touch "ALL SIGNALS", "MAIN SIGNALS" or "SELECTION FROM MENU" on the "SELECT MONITOR ITEM" screen.

ALL SIGNALS	All items will be monitored.
MAIN SIGNALS	Monitor the predetermined item.
SELECTION FROM MENU	Select any item for monitoring.

- Touch "START".
- Touch the required monitoring item on "SELECTION FROM MENU". In "ALL SIGNALS", all items are monitored. In "MAIN SIGNALS", predetermined items are monitored.
- Touch "RECORD" while monitoring to record the status of the item being monitored. To stop recording, touch "STOP".

All Items, Main Items, Select Item Menu

Item name	CONSULT-II screen display	Display or unit	Monitor item selection			Description
			ALL SIGNALS	MAIN SIGNALS	SELECTION FROM MENU	
Parking, license plate and tail lamps request	TAIL&CLR REQ	ON/OFF	×	×	×	Signal status input from BCM
Headlamp low beam request	HL LO REQ	ON/OFF	×	×	×	Signal status input from BCM
Headlamp high beam request	HL HI REQ	ON/OFF	×	×	×	Signal status input from BCM

NOTE:

Perform monitoring of IPDM E/R data with the ignition switch ON. When the ignition switch is at ACC, the display may not be correct.

ACTIVE TEST

Operation Procedure

- Touch "ACTIVE TEST" on "SELECT DIAG MODE" screen.
- Touch item to be tested, and check operation.
- Touch "START".
- Touch "STOP" while testing to stop the operation.

Test item	CONSULT-II screen display	Description
Headlamp relay (HI, LO) output	LAMPS	Allows headlamp relay (HI, LO) to operate by switching operation (OFF, HI, LO) at your option (Headlamp high beam repeats ON-OFF every 1 second).
Front fog lamp relay output		Allows fog lamp relay to operate by switching operation ON-OFF at your option.

AUTO LIGHT SYSTEM

Trouble Diagnosis Chart by Symptom

EKS008MM

Trouble phenomenon	Malfunction system and reference
<ul style="list-style-type: none"> ● Parking lamps and headlamps will not illuminate when outside of the vehicle becomes dark. (Lighting switch 1st position and 2nd position operate normally.) ● Parking lamps and headlamp will not go out when outside of the vehicle becomes light. (Lighting switch 1st position and 2nd position operate normally.) ● Headlamps go out when outside of the vehicle becomes light, but parking lamps stay on. 	<ul style="list-style-type: none"> ● Refer to LT-52, "WORK SUPPORT" . ● Refer to LT-56, "Lighting Switch Inspection" . ● Refer to LT-57, "Auto Light Sensor System Inspection" . <p>If above systems are normal, replace BCM. Refer to BCS-20, "Removal and Installation of BCM" .</p>
<p>Parking lamps illuminate when outside of the vehicle becomes dark, but headlamps stay off. (Lighting switch 1st position and 2nd position operate normally.)</p>	<ul style="list-style-type: none"> ● Refer to LT-52, "WORK SUPPORT" . ● Refer to LT-57, "Auto Light Sensor System Inspection" . <p>If above systems are normal, replace BCM. Refer to BCS-20, "Removal and Installation of BCM" .</p>
<p>Auto light adjustment system will not operate. (Lighting switch AUTO, 1st position and 2nd position operate normally.)</p>	<ul style="list-style-type: none"> ● Refer to LT-57, "Auto Light Sensor System Inspection" . <p>If above system is normal, replace BCM. Refer to BCS-20, "Removal and Installation of BCM" .</p>
<p>Auto light adjustment system will not operate.</p>	<ul style="list-style-type: none"> ● CAN communication line to BCM inspection. Refer to LAN-20, "CAN COMMUNICATION" .
<p>Shut off delay feature will not operate.</p>	<ul style="list-style-type: none"> ● CAN communication line to BCM inspection. Refer to LAN-20, "CAN COMMUNICATION" . ● Refer to BL-31, "Door Switch Check" . <p>If above system is normal, replace BCM. Refer to BCS-20, "Removal and Installation of BCM" .</p>

Lighting Switch Inspection

EKS008MN

1. CHECK LIGHTING SWITCH INPUT SIGNAL

Ⓟ With CONSULT-II

Select "BCM" on CONSULT-II. With "HEAD LAMP" data monitor, make sure "AUTO LIGHT SW" turns ON-OFF linked with operation of lighting switch.

When lighting switch is in AUTO position : AUTO LIGHT SW ON

ⓧ Without CONSULT-II

Refer to [LT-91, "Combination Switch Inspection"](#) .

OK or NG

OK >> Inspection End.

NG >> Check lighting switch. Refer to [LT-91, "Combination Switch Inspection"](#) .

DATA MONITOR	
MONITOR	
AUTO LIGHT SW	ON

SKIA4196E

AUTO LIGHT SYSTEM

EKS008MO

Auto Light Sensor System Inspection

1. OUTPUT SIGNAL INSPECTION

④ With CONSULT-II

Select "BCM" in CONSULT-II. Using "OPTICAL SENSOR" data from "DATA MONITOR", check difference in the voltage when the auto light sensor is illuminated and not illuminated.

Light sensor illuminated : 3.1V or more

Light sensor not illuminated : 0.6V or less

NOTE:

If the auto light sensor is insufficiently illuminated, the measured value may not satisfy the standard.

⊗ Without CONSULT-II

GO TO 2.

OK or NG

OK >> Inspection End.

NG >> GO TO 2.

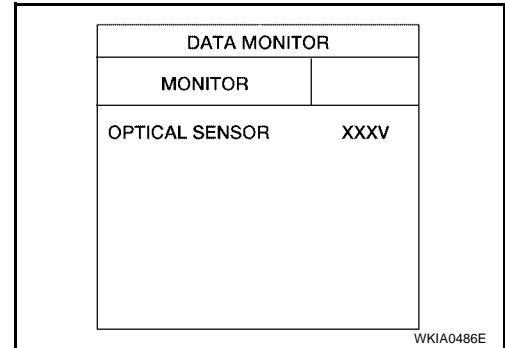

2. POWER SUPPLY CIRCUIT CONTINUITY INSPECTION

1. Turn ignition switch OFF.
2. Disconnect BCM and auto light sensor connectors.
3. Check continuity between BCM harness connector M18 terminal 17 and auto light sensor harness connector M15 terminal 1.

17 - 1 : Continuity should exist.

4. Check continuity between BCM harness connector M18 terminal 17 and ground.

17 - Ground : Continuity should not exist.

OK or NG

OK >> GO TO 3.

NG >> Repair harness or connector.

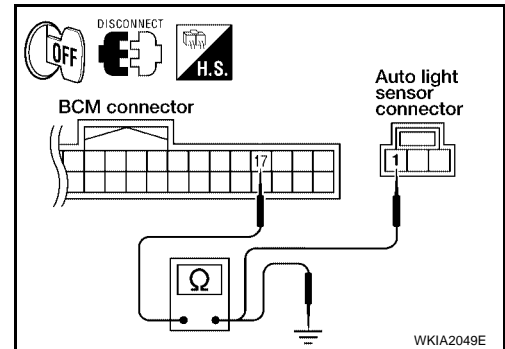

3. OUTPUT CIRCUIT CONTINUITY INSPECTION

1. Check continuity between BCM harness connector M18 terminal 14 and auto light sensor harness connector M15 terminal 2.

14 - 2 : Continuity should exist.

2. Check continuity between BCM harness connector M18 terminal 14 and ground.

14 - Ground : Continuity should not exist.

OK or NG

OK >> GO TO 4.

NG >> Repair harness or connector.

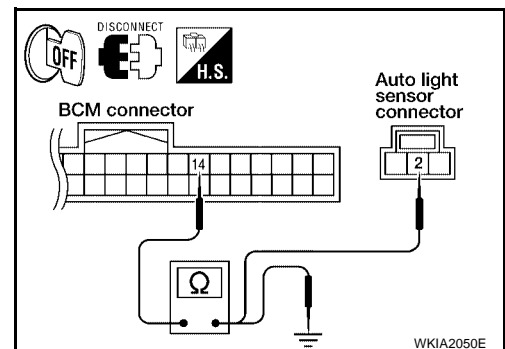

AUTO LIGHT SYSTEM

4. GROUND CIRCUIT CONTINUITY INSPECTION

1. Check continuity between BCM harness connector M18 terminal 18 and auto light sensor harness connector M15 terminal 3.

18 - 3 : Continuity should exist.

2. Check continuity between BCM harness connector M18 terminal 18 and ground.

18 - Ground : Continuity should not exist.

OK or NG

OK >> GO TO 5.

NG >> Repair harness or connector.

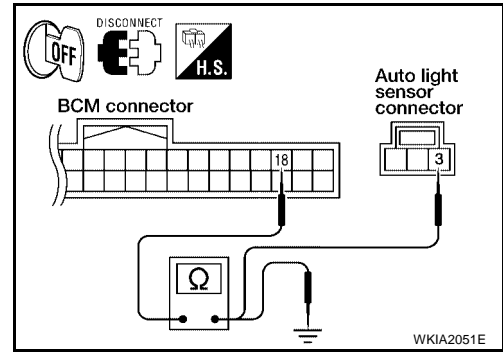

5. SENSOR VOLTAGE INSPECTION

1. Connect BCM connector.
2. Turn ignition switch ON.
3. Check voltage between BCM harness connector M18 terminal 17 and ground.

17 - Ground : Should be approx. 5V.

OK or NG

OK >> Replace the auto light sensor.

NG >> Replace BCM. Refer to [BCS-20, "Removal and Installation of BCM"](#) .

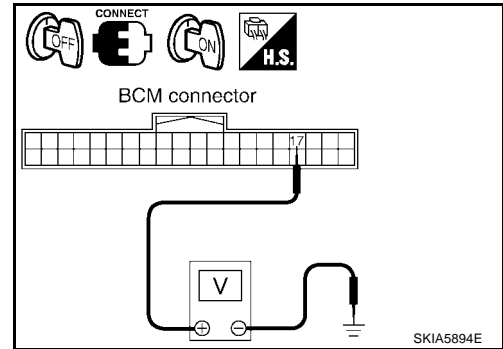

FRONT FOG LAMP

PF26150

FRONT FOG LAMP

Component Parts and Harness Connector Location

EKS00A85

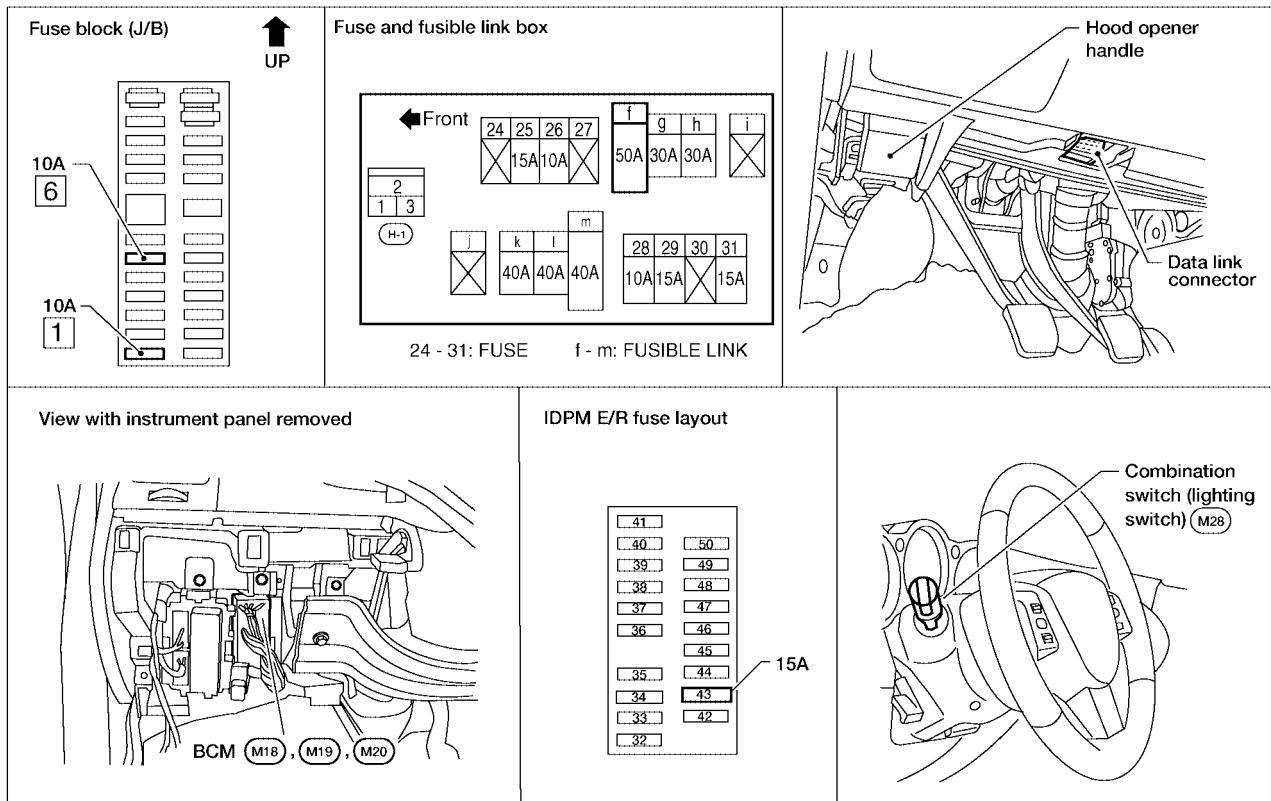

WKIA4087E

System Description

EKS008MP

Control of the fog lamps is dependent upon the position of the combination switch (lighting switch). The lighting switch must be in the AUTO position (with auto light system) or headlamps position (LOW beam is ON) for front fog lamp operation. When the lighting switch is placed in the fog lamp position, the BCM (body control module) receives input requesting the fog lamps to illuminate. This input is communicated to the IPDM E/R (intelligent power distribution module engine room) across the CAN communication lines. The CPU (central processing unit) of the IPDM E/R controls the front fog lamp relay coil. When energized, this relay directs power to the front fog lamps.

OUTLINE

Power is supplied at all times

- through 15A fuse (No. 43, located in the IPDM E/R)
- to front fog lamp relay, located in the IPDM E/R, and
- through 50A fusible link (letter f, located in the fuse and fusible link box)
- to BCM terminal 70.

When the ignition switch is in ON or START position, power is supplied

- through 10A fuse [No. 1, located in the fuse block (J/B)]
- to BCM terminal 38.

When the ignition switch is in ACC or ON position, power is supplied

- through 10A fuse [No. 6, located in the fuse block (J/B)]
- to BCM terminal 11.

Ground is supplied

- to BCM terminal 67
- through grounds F14, M57 and M61.

FRONT FOG LAMP

FOG LAMP OPERATION

The fog lamp switch is built into the combination switch. The lighting switch can only be in AUTO position (with auto light system) or headlamps position (low beam is ON) and the fog lamp switch must be ON for fog lamp operation.

With the fog lamp switch in the ON position, the CPU of the IPDM E/R grounds the coil side of the fog lamp relay. The fog lamp relay then directs power

- through IPDM E/R terminal 37
- to front fog lamp LH terminal 1, and
- through IPDM E/R terminal 36
- to front fog lamp RH terminal 1.

Ground is supplied

- to front fog lamp LH terminal 2
- through grounds E15 and E24, and
- to front fog lamp RH terminal 2
- through grounds E15 and E24.

With power and grounds supplied, the front fog lamps illuminate.

BATTERY SAVER CONTROL

When the fog lamp switch is ON and the ignition switch is turned from ON to ACC or OFF, or if the ignition switch is in the OFF position when the fog lamp switch is turned ON, the battery saver control feature is activated.

Under this condition, the fog lamps (and headlamps) remain illuminated for 5 minutes, unless the combination switch (lighting switch) position is changed. If the combination switch (lighting switch) position is changed, then the fog lamps (and headlamps) are turned off.

CAN Communication System Description

EKS008MQ

Refer to [LAN-20, "CAN COMMUNICATION"](#) .

FRONT FOG LAMP

Wiring Diagram — F/FOG —

EKS008MR

LT-F/FOG-01

— : DATA LINE

REFER TO "PG-POWER".

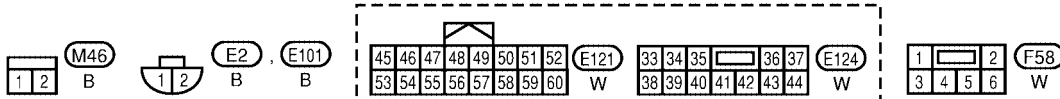
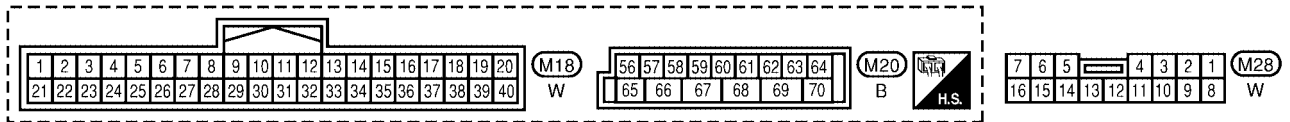
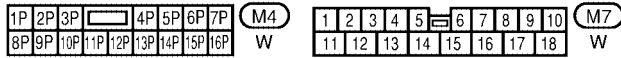
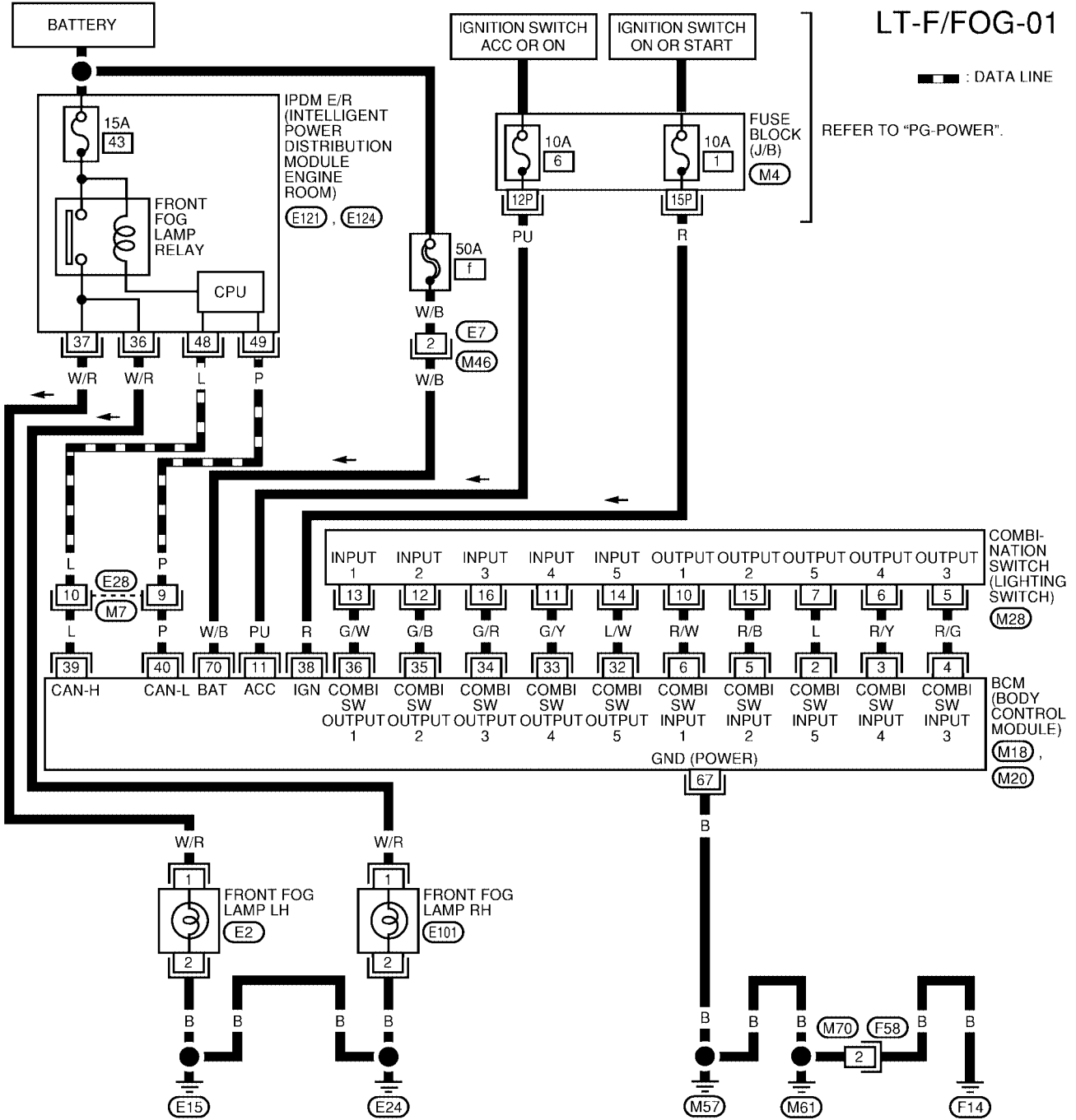





WKWA1369E

FRONT FOG LAMP

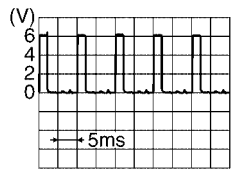
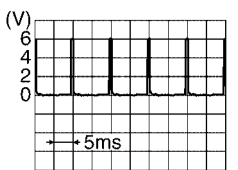
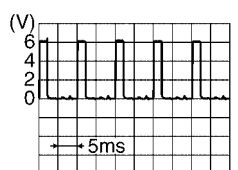
Terminals and Reference Values for BCM

EKS008MS

Terminal No.	Wire color	Signal name	Measuring condition		Reference value (Approx.)
			Ignition switch	Operation or condition	
2	L	Combination switch input 5	ON	Lighting, turn, wiper OFF Wiper dial position 4	 <p style="text-align: right;">SKIA5291E</p>
3	R/Y	Combination switch input 4	ON	Lighting, turn, wiper OFF Wiper dial position 4	 <p style="text-align: right;">SKIA5292E</p>
4	R/G	Combination switch input 3	ON	Lighting, turn, wiper OFF Wiper dial position 4	 <p style="text-align: right;">SKIA5291E</p>
5	R/B	Combination switch input 2	ON	Lighting, turn, wiper OFF Wiper dial position 4	 <p style="text-align: right;">SKIA5292E</p>
6	R/W	Combination switch input 1			
11	PU	Ignition switch (ACC)	ACC	—	Battery voltage
32	L/W	Combination switch output 5	ON	Lighting, turn, wiper OFF Wiper dial position 4	 <p style="text-align: right;">SKIA5291E</p>
33	G/Y	Combination switch output 4	ON	Lighting, turn, wiper OFF Wiper dial position 4	 <p style="text-align: right;">SKIA5292E</p>
34	G/R	Combination switch output 3	ON	Lighting, turn, wiper OFF Wiper dial position 4	 <p style="text-align: right;">SKIA5291E</p>

FRONT FOG LAMP

Terminal No.	Wire color	Signal name	Measuring condition		Reference value (Approx.)
			Ignition switch	Operation or condition	
35	G/B	Combination switch output 2	ON	Lighting, turn, wiper OFF Wiper dial position 4	
36	G/W	Combination switch output 1			
38	R	Ignition switch (ON)	ON	—	Battery voltage
39	L	CAN-H	—	—	—
40	P	CAN-L	—	—	—
67	B	Ground	ON	—	0V
70	W/B	Battery power supply (fusible link)	OFF	—	Battery voltage

Terminals and Reference Values for IPDM E/R

EKS008MT

Terminal No.	Wire color	Signal name	Measuring condition		Reference value (Approx.)	
			Ignition switch	Operation or condition		
36	W/R	Front fog lamp (RH)	ON	Lighting switch must be in the 2ND position or AUTO position (LOW beam is ON) and the front fog lamp switch must be ON	OFF	0V
					ON	Battery voltage
37	W/R	Front fog lamp (LH)	ON	Lighting switch must be in the 2ND position or AUTO position (LOW beam is ON) and the front fog lamp switch must be ON	OFF	0V
					ON	Battery voltage
48	L	CAN-H	—	—	—	
49	P	CAN-L	—	—	—	

How to Proceed With Trouble Diagnosis

EKS008MU

1. Confirm the symptom or customer complaint.
2. Understand operation description and function description. Refer to [LT-59, "System Description"](#) .
3. Perform the Preliminary Check. Refer to [LT-64, "Preliminary Check"](#) .
4. Check symptom and repair or replace the cause of malfunction.
5. Do the front fog lamps operate normally? If YES: GO TO 6. If NO: GO TO 4.
6. Inspection End.

FRONT FOG LAMP

EKS008MV

Preliminary Check CHECK POWER SUPPLY AND GROUND CIRCUIT

1. CHECK FUSES OR FUSIBLE LINK

Check for blown fuses or fusible link.

Unit	Power source	Fuse and fusible link No.
BCM	Battery	f
	Ignition switch ACC or ON position	6
	Ignition switch ON or START position	1
IPDM E/R	Battery	43

Refer to [LT-61, "Wiring Diagram — F/FOG —"](#) .

OK or NG

OK >> GO TO 2.

NG >> If fuse or fusible link is blown, be sure to eliminate cause of malfunction before installing new fuse or fusible link. Refer to [PG-4, "POWER SUPPLY ROUTING CIRCUIT"](#) .

2. CHECK POWER SUPPLY CIRCUIT

1. Disconnect BCM connectors.
2. Check voltage between BCM harness connector terminals and ground.

BCM (+)		(-)	Ignition switch position		
Connector	Terminal		OFF	ACC	ON
M18	11	Ground	0V	Battery voltage	Battery voltage
	38		0V	0V	Battery voltage
M20	70		Battery voltage	Battery voltage	Battery voltage

OK or NG

OK >> GO TO 3.

NG >> Check harness for open between BCM and fuse or fusible link.

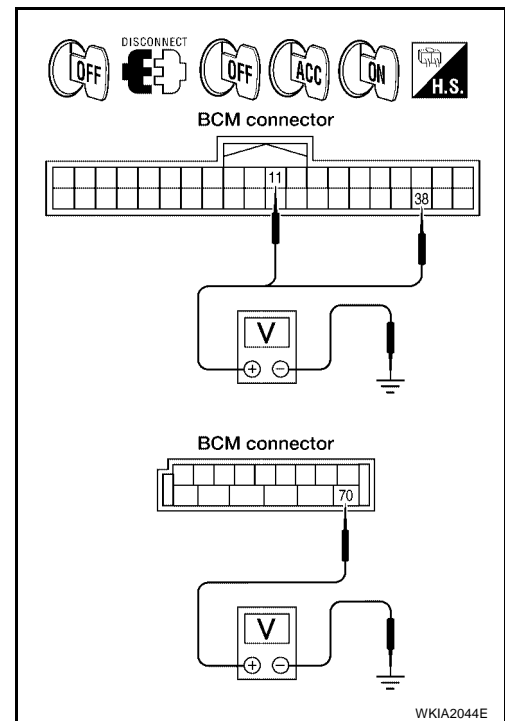

WKIA2044E

3. CHECK GROUND CIRCUIT

Check continuity between BCM harness connector terminal and ground.

BCM		Continuity
Connector	Terminal	
M20	67	Ground Yes

OK or NG

OK >> Inspection End.

NG >> Check ground circuit harness.

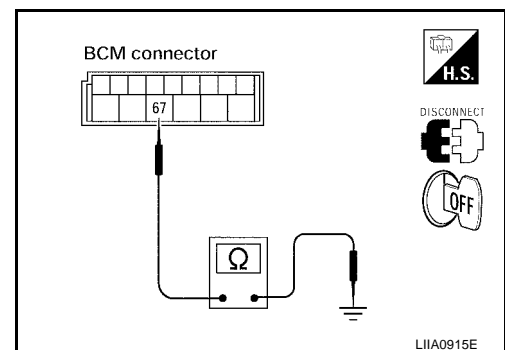

LIIA0915E

FRONT FOG LAMP

CONSULT-II Function

EKS008MW

Refer to [LT-15, "CONSULT-II Function \(BCM\)"](#) in HEADLAMP (FOR USA).
 Refer to [LT-17, "CONSULT-II Function \(IPDM E/R\)"](#) in HEADLAMP (FOR USA).

Front Fog Lamps Do Not Illuminate (Both Sides)

EKS008MX

1. FOG LAMP ACTIVE TEST

1. Select "IPDM E/R" on CONSULT-II, and select "ACTIVE TEST" on "SELECT DIAG MODE" screen.
2. Select "LAMPS" on "SELECT TEST ITEM" screen.
3. Touch "FOG" on "ACTIVE TEST" screen.
4. Make sure fog lamps operate.

Fog lamps should operate.

OK or NG

- OK >> GO TO 2.
 NG >> GO TO 4.

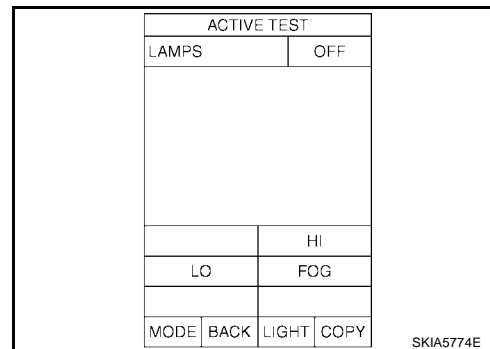

2. INSPECTION 1 BETWEEN COMBINATION SWITCH AND BCM

Select "BCM" on CONSULT-II. Carry out BCM self-diagnosis.

Displayed results of self-diagnosis

- NO MALFUNCTION DETECTED>> GO TO 3.
 CAN COMMUNICATION OR CAN SYSTEM>> Inspect the BCM CAN communications system. Refer to [LAN-20, "CAN COMMUNICATION"](#).
 OPEN DETECT 1 - 5>> Inspect combination switch system. Refer to [LT-91, "Combination Switch Inspection"](#).

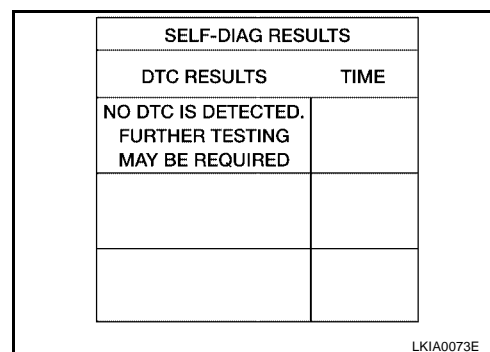

3. INSPECTION 2 BETWEEN COMBINATION SWITCH AND BCM

Select "BCM" on CONSULT-II. With "HEAD LAMP" data monitor, make sure "FR FOG SW" turns ON-OFF linked with operation of lighting switch.

**When lighting switch is in : FR FOG SW ON
 FOG position**

OK or NG

- OK >> Replace BCM. Refer to [BCS-20, "Removal and Installation of BCM"](#).
 NG >> Replace lighting switch. Refer to [LT-86, "Removal and Installation"](#).

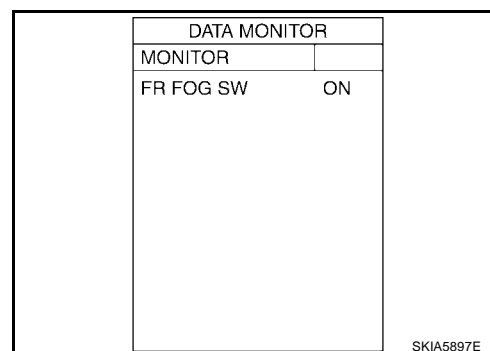

FRONT FOG LAMP

4. IPDM E/R INSPECTION

1. Turn ignition switch OFF.
2. Disconnect front fog lamp left/right harness connector.
3. Start auto active test. Refer to [PG-22, "Auto Active Test"](#) .
4. When front fog lamp relay is operating, check voltage between left/right front fog lamp connector terminals and ground.

Terminals		Terminal	(-)	Voltage (Approx.)
(+) Front fog lamp connector				
RH	E101	1	Ground	Battery voltage
LH	E2			

OK or NG

- OK >> Check front fog lamp bulbs and replace as necessary.
 NG >> Replace IPDM E/R. Refer to [PG-28, "Removal and Installation of IPDM E/R"](#) .

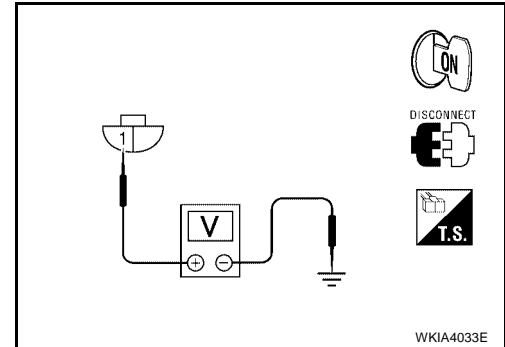

Front Fog Lamp Does Not Illuminate (One Side)

EKS008MY

1. BULB INSPECTION

Inspect bulb of lamp which does not illuminate.

OK or NG

- OK >> GO TO 2.
 NG >> Replace front fog lamp bulb. Refer to [LT-69, "Bulb Replacement"](#) .

2. INSPECTION BETWEEN IPDM E/R AND FRONT FOG LAMPS

1. Disconnect IPDM E/R connector and inoperative front fog lamp connector.
2. Check continuity between harness connector terminals of IPDM E/R and harness connector terminal of front fog lamps.

A		B		Continuity
IPDM E/R connector	Terminal	Front fog lamp connector	Terminal	
E124	36	RH	E101	Yes
	37	LH	E2	

OK or NG

- OK >> Check ground circuit. If OK, replace IPDM E/R. Refer to [PG-28, "Removal and Installation of IPDM E/R"](#) . If NG, repair harness or connector.
 NG >> Check for short circuits and open circuits in harness between IPDM E/R and front fog lamps.

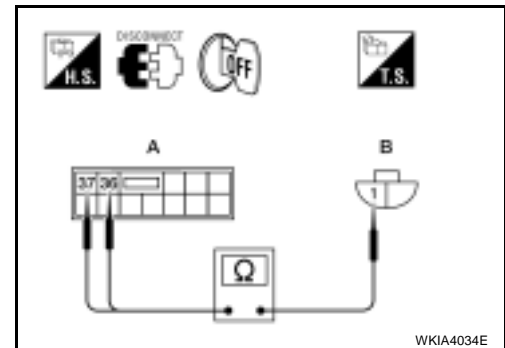

FRONT FOG LAMP

EKS008MZ

Aiming Adjustment ALL EXCEPT SE-R MODELS

The fog lamp is a semi-sealed beam type which uses a replaceable halogen bulb. Before performing aiming adjustment, make sure of the following.

- Keep all tires inflated to correct pressure.
- Place vehicle on level ground.
- See that vehicle is unloaded (except for full levels of coolant, engine oil and fuel, and spare tire, jack, and tools). Have the driver or equivalent weight placed in driver seat.

Adjust aiming in the vertical direction by turning the adjusting screw.

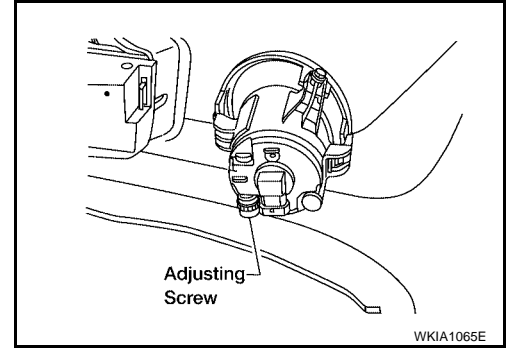

1. Set the distance between the screen and the center of the fog lamp lens as shown.
2. Turn front fog lamps ON.

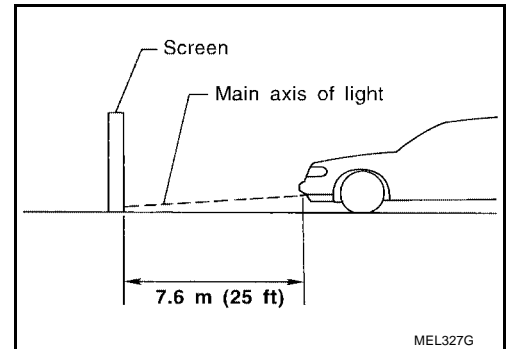

3. Adjust front fog lamps using adjusting screw so that the top edge of the high intensity zone is 100 mm (4 in) below the height of the fog lamp centers as shown.
- When performing adjustment, if necessary, cover the headlamps and opposite fog lamp.

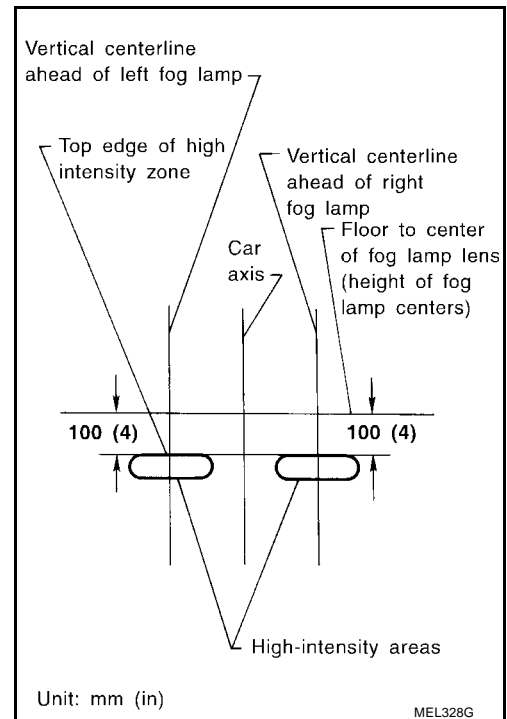

SE-R MODELS

The fog lamp is a semi-sealed beam type which uses a replaceable halogen bulb. Before performing aiming adjustment, make sure of the following.

- Keep all tires inflated to correct pressure.

A
B
C
D
E
F
G
H
I
J
LT
L
M

FRONT FOG LAMP

- Place vehicle on level ground.
- See that vehicle is unloaded (except for full levels of coolant, engine oil and fuel, and spare tire, jack, and tools). Have the driver or equivalent weight placed in driver seat.

Adjust aiming in the vertical direction by turning the adjusting screw.

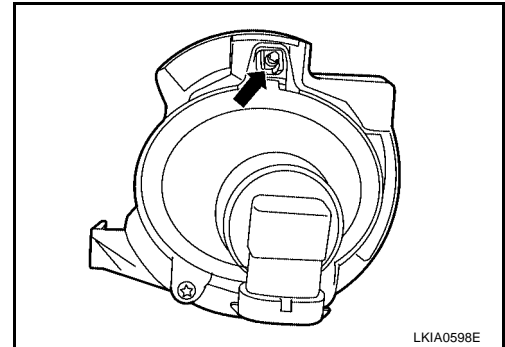

1. Set the distance between the screen and the center of the fog lamp lens as shown.
2. Turn front fog lamps ON.

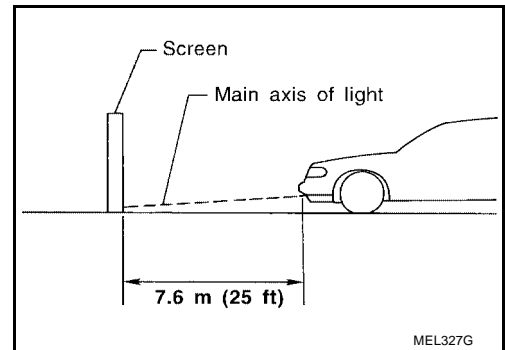

3. Adjust front fog lamps using adjusting screw so that the top edge of the high intensity zone is 100 mm (4 in) below the height of the fog lamp centers as shown.
- When performing adjustment, if necessary, cover the headlamps and opposite fog lamp.

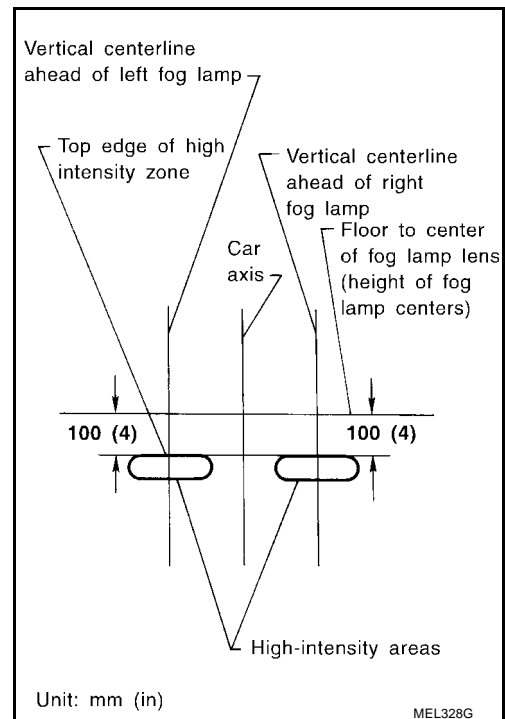

FRONT FOG LAMP

EKS008N0

Bulb Replacement ALL EXCEPT SE-R MODELS

Removal

The fog lamp is a semi-sealed beam type which uses a replaceable halogen bulb.

CAUTION:

- Do not touch the glass of bulb directly by hand. Keep grease and other oily substances away from it. Do not touch bulb by hand while it is lit or right after being turned off. Burning may result.
 - Do not leave bulb out of fog lamp reflector for a long time because dust, moisture smoke, etc. may affect the performance of fog lamp. When replacing bulb, be sure to replace it with new one.
1. Position the front fender protector aside. Refer to [EI-21, "Removal and Installation"](#).
 2. Disconnect electrical connector.
 3. Turn the bulb counterclockwise to remove it.

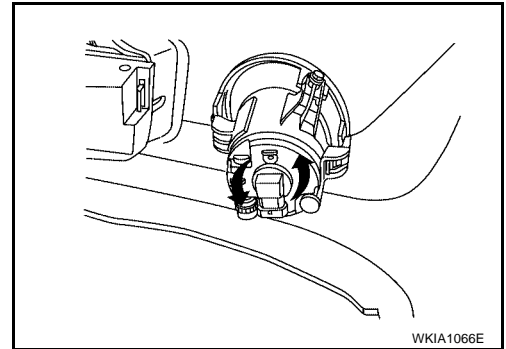

Installation

Installation is in the reverse order of removal.

SE-R MODELS

Removal

The fog lamp is a semi-sealed beam type which uses a replaceable halogen bulb.

CAUTION:

- Do not touch the glass of bulb directly by hand. Keep grease and other oily substances away from it. Do not touch bulb by hand while it is lit or right after being turned off. Burning may result.
 - Do not leave bulb out of fog lamp reflector for a long time because dust, moisture smoke, etc. may affect the performance of fog lamp. When replacing bulb, be sure to replace it with new one.
1. Remove the engine undercover using power tools.
 2. Disconnect electrical connector.
 3. Turn the bulb counterclockwise to remove it.

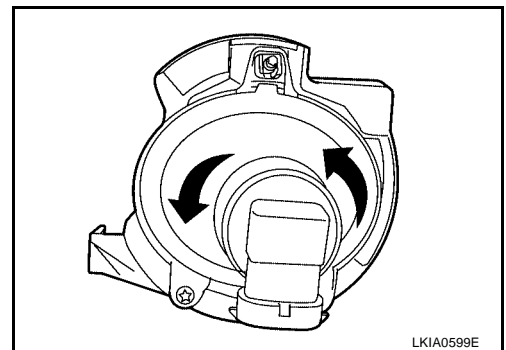

Installation

Installation is in the reverse order of removal.

Removal and Installation ALL EXCEPT SE-R MODELS

EKS008N1

Removal

The fog lamp is a semi-sealed beam type which uses a replaceable halogen bulb.

A
B
C
D
E
F
G
H
I
J
LT
L
M

FRONT FOG LAMP

CAUTION:

- Do not leave fog lamp assembly without bulb for a long period of time. Dust, moisture, smoke, etc. entering the fog lamp body may affect the performance. Remove the bulb from the headlamp assembly just before replacement bulb is installed.
 - Grasp only the plastic base when handling the bulb. Never touch the glass envelope. Touching the glass could significantly affect the bulb life and/or fog lamp performance.
1. Remove inner splash shield.
 2. Position the fender protector aside. Refer to [EI-21, "Removal and Installation"](#) .
 3. Disconnect electrical connector.
 4. Remove bolt from top of fog lamp.
 5. Remove fog lamp.

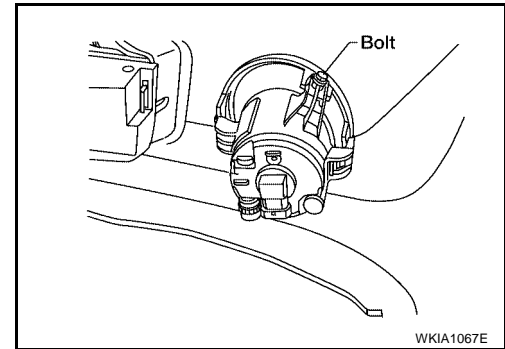

Installation

Installation is in the reverse order of removal.
Confirm fog lamp aiming adjustment. Refer to [LT-67, "Aiming Adjustment"](#) .

SE-R MODELS

Removal

1. Remove the engine under cover using power tools.
2. Disconnect electrical connector.
3. Remove the fog lamp bolts from top and bottom of fog lamp.
4. Remove fog lamp.

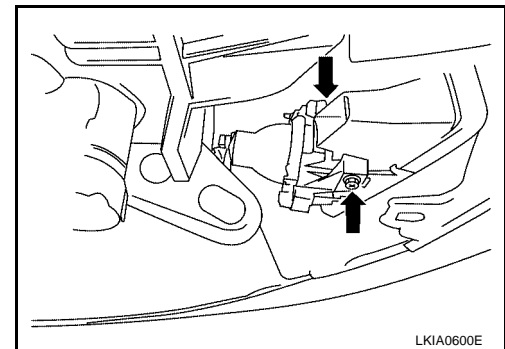

Installation

Installation is in the reverse order of removal.
Confirm fog lamp aiming adjustment. Refer to [LT-67, "Aiming Adjustment"](#) .

TURN SIGNAL AND HAZARD WARNING LAMPS

PF26120

EKS00A86

TURN SIGNAL AND HAZARD WARNING LAMPS

Component Parts and Harness Connector Location

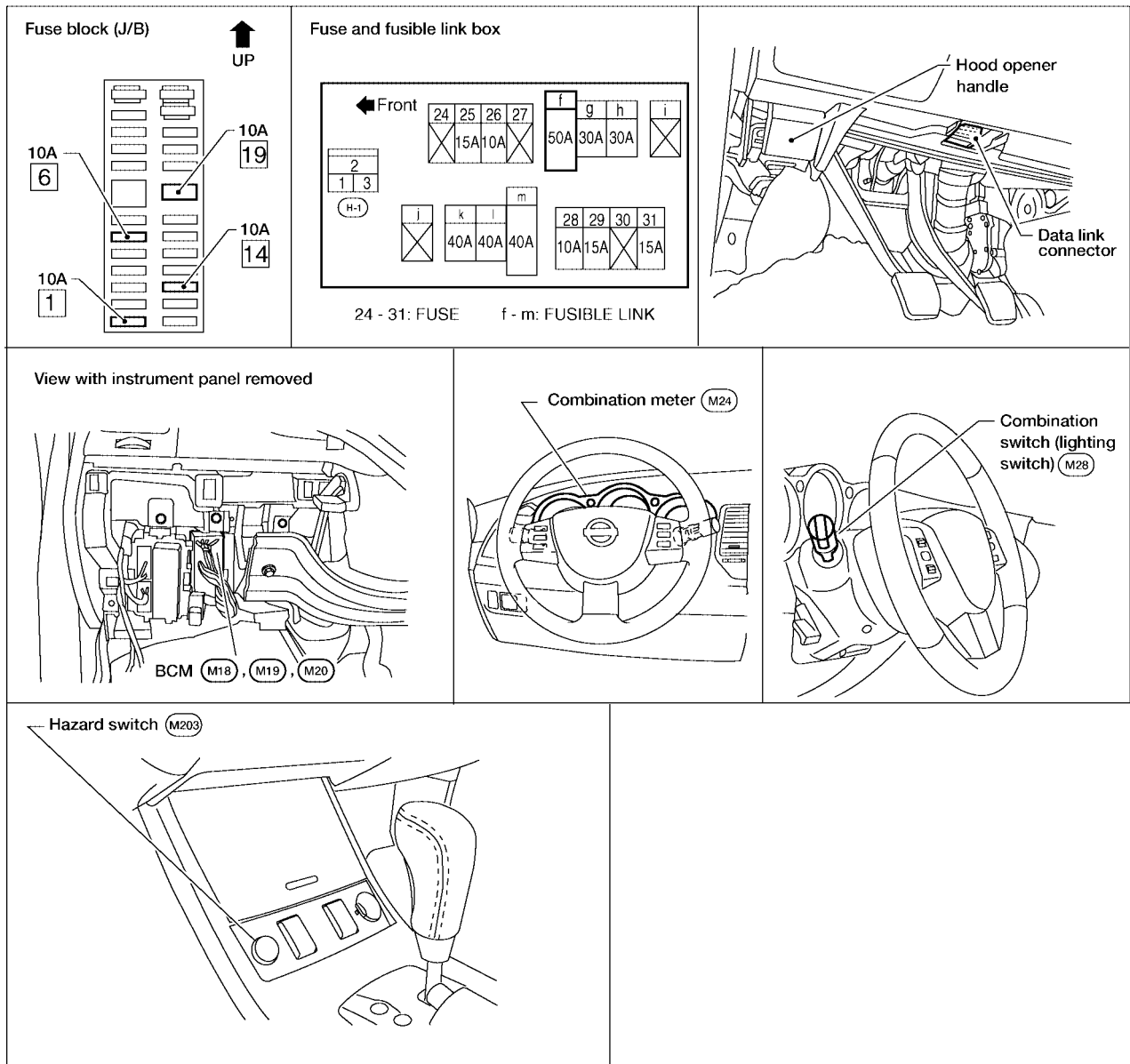

WKIA4088E

EKS008N2

System Description TURN SIGNAL OPERATION

When the ignition switch is in the ON or START position, power is supplied

- through 10A fuse [No. 1, located in the fuse block (J/B)]
- to BCM (body control module) terminal 38, and
- through 10A fuse [No. 14, located in the fuse block (J/B)]
- to combination meter terminal 22.

Ground is supplied

- to BCM terminal 67 and
- to combination meter terminals 23, 25 and 28
- through grounds F14, M57 and M61.

LH Turn

When the turn signal switch (combination switch) is moved to the L position, the BCM receives input requesting the left turn signals to flash. The BCM then supplies power

A
B
C
D
E
F
G
H
I
J
LT
L
M

TURN SIGNAL AND HAZARD WARNING LAMPS

- to front turn signal lamp LH terminal 3
- to rear turn signal lamp LH (part of the rear combination lamp LH) terminal 3.

Ground is supplied

- to front turn signal lamp LH terminal 2
- through grounds E15 and E24, and
- to rear turn signal lamp LH terminal 5
- through grounds B7 and B19.

The BCM sends a signal to combination meter across the CAN communication lines. This input is processed by the CPU (central processing unit) of the combination meter, which in turn supplies ground to the left turn signal indicator lamp.

With power and ground supplied, the BCM controls the flashing of the LH turn signal lamps.

RH Turn

When the turn signal switch (combination switch) is moved to the R position, the BCM receives input requesting the right turn signals to flash. The BCM then supplies power

- to front turn signal lamp RH terminal 3
- to rear turn signal lamp RH (part of the rear combination lamp RH) terminal 3.

Ground is supplied

- to front turn signal lamp RH terminal 2
- through grounds E15 and E24, and
- to rear turn signal lamp RH terminal 5
- through grounds B7 and B19.

The BCM sends a signal to combination meter across the CAN communication lines. This input is processed by the CPU of the combination meter, which in turn supplies ground to the right turn signal indicator lamp.

With power and ground supplied, the BCM controls the flashing of the RH turn signal lamps.

HAZARD LAMP OPERATION

Power is supplied at all times

- through 50A fusible link (letter f , located in the fuse and fusible link box)
- to BCM terminal 70, and
- through 10A fuse [No. 19, located in the fuse block (J/B)]
- to combination meter terminal 21.

Ground is supplied

- to hazard switch terminal 3
- to BCM terminal 67
- to combination meter terminals 23, 25 and 28
- through grounds F14, M57 and M61.

When the hazard switch is depressed, ground is supplied

- to BCM terminal 29
- through hazard lamp switch terminal 2.

The BCM then supplies power

- to front turn signal lamp LH terminal 3
- to front turn signal lamp RH terminal 3
- to rear turn signal lamp LH terminal 3
- to rear turn signal lamp RH terminal 3.

Ground is supplied

- to front turn signal lamp LH terminal 2
- to front turn signal lamp RH terminal 2
- through grounds E15 and E24, and
- to rear turn signal lamp LH terminal 5
- to rear turn signal lamp RH terminal 5

TURN SIGNAL AND HAZARD WARNING LAMPS

- through grounds B7 and B19.

The BCM sends a signal to combination meter across the CAN communication lines. This input is processed by the CPU of the combination meter, which in turn supplies ground to the left and right turn signal indicator lamps.

With power and ground supplied, the BCM controls the flashing of the hazard warning lamps.

REMOTE KEYLESS ENTRY SYSTEM OPERATION

Power is supplied at all times

- through 50A fusible link (letter f , located in the fuse and fusible link box)
- to BCM terminal 70, and
- through 10A fuse [No. 19, located in the fuse block (J/B)]
- to combination meter terminal 21.

Ground is supplied

- to BCM terminal 67 and
- to combination meter terminals 23, 25 and 28
- through grounds F14, M57 and M61.

When the remote keyless entry system is triggered by input from the keyfob, the BCM supplies power

- to front turn signal lamp LH terminal 3
- to front turn signal lamp RH terminal 3
- to rear turn signal lamp LH terminal 3
- to rear turn signal lamp RH terminal 3.

Ground is supplied

- to front turn signal lamp LH terminal 2
- to front turn signal lamp RH terminal 2
- through grounds E15 and E24, and
- to rear turn signal lamp LH terminal 5
- to rear turn signal lamp RH terminal 5
- through grounds B7 and B19.

The BCM sends a signal to combination meter across the CAN communication lines. This input is processed by the CPU of the combination meter, which in turn supplies ground to the left and right turn signal indicator lamps.

With power and ground supplied, the BCM controls the flashing of the hazard warning lamps when keyfob is used to activate the remote keyless entry system.

CAN Communication System Description

EKS008N3

Refer to [LAN-20, "CAN COMMUNICATION"](#) .

TURN SIGNAL AND HAZARD WARNING LAMPS

Schematic

EKS008N4

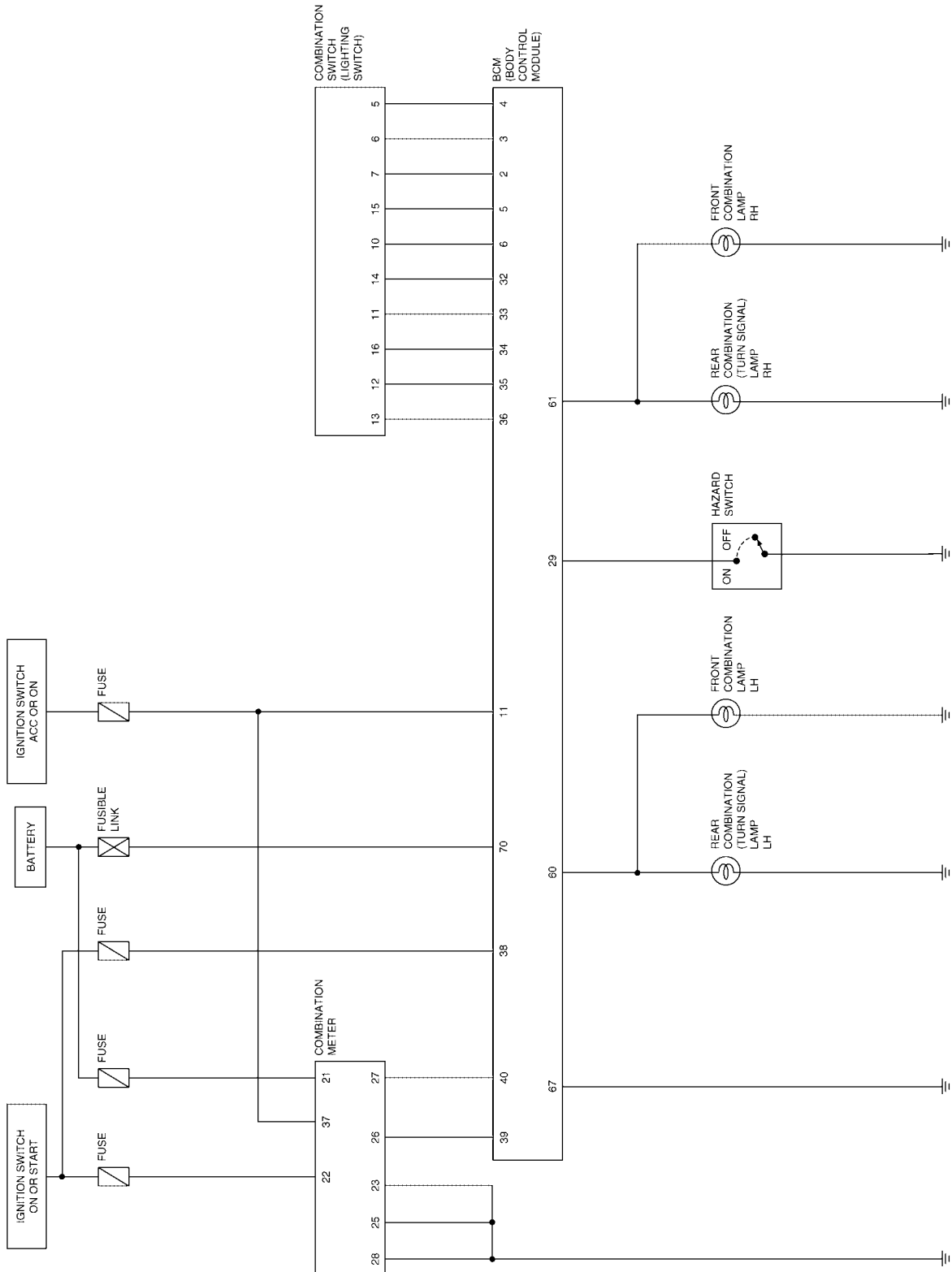

WKWA1370E

TURN SIGNAL AND HAZARD WARNING LAMPS

Wiring Diagram — TURN —

EKS008N5

LT-TURN-01

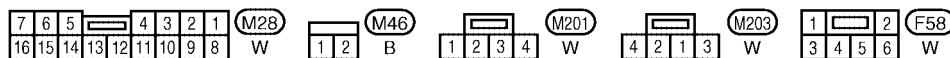
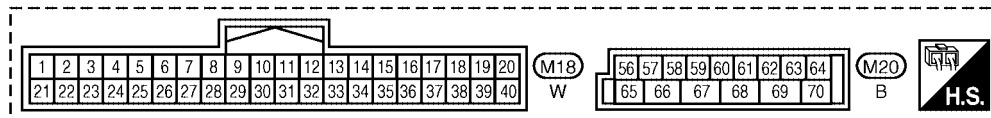
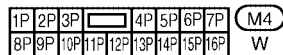
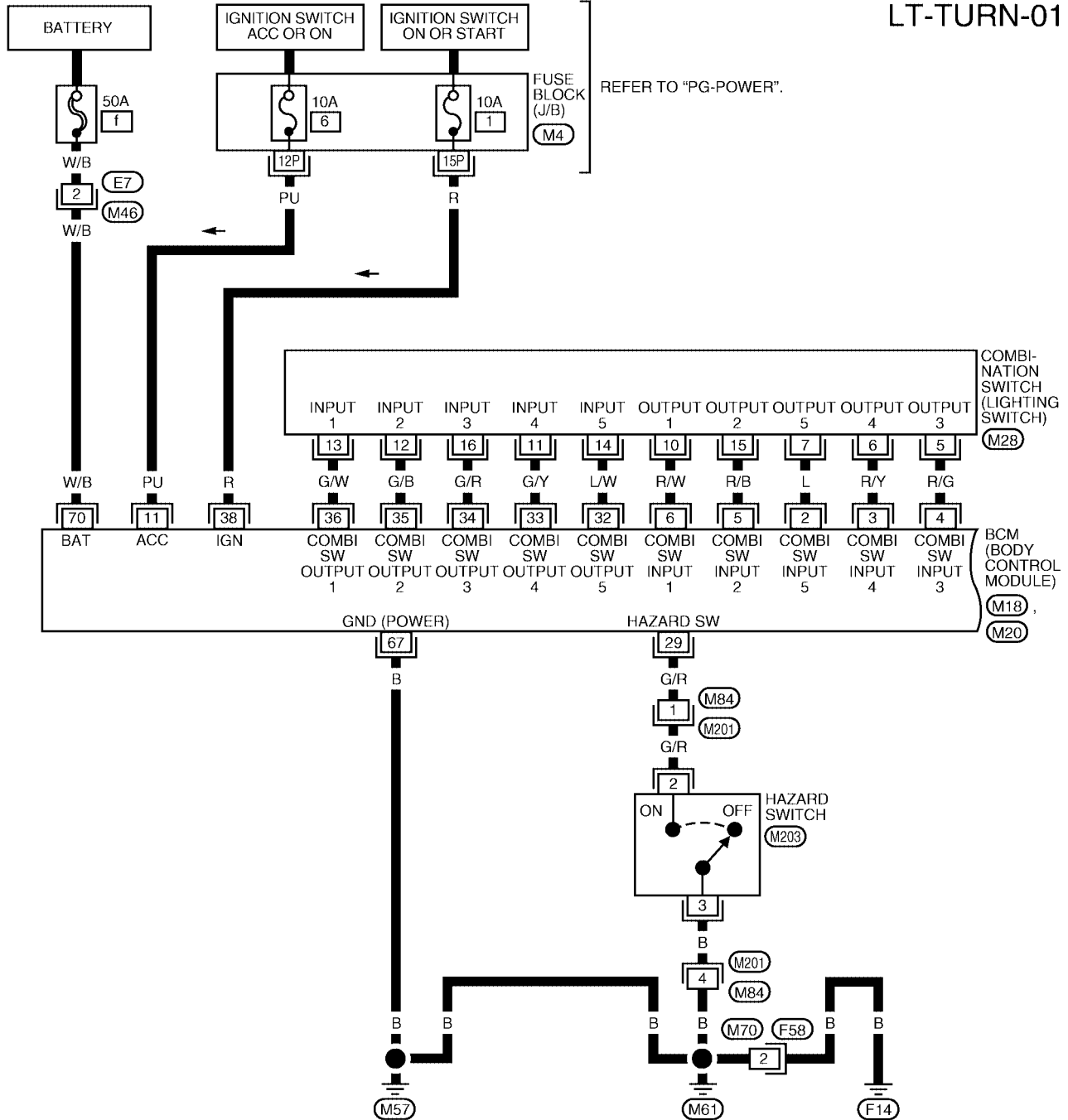

WKWA1537E

TURN SIGNAL AND HAZARD WARNING LAMPS

LT-TURN-02

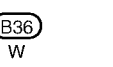
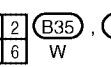
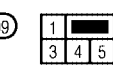
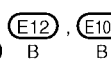
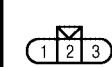
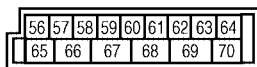
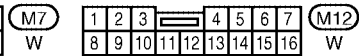
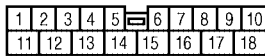
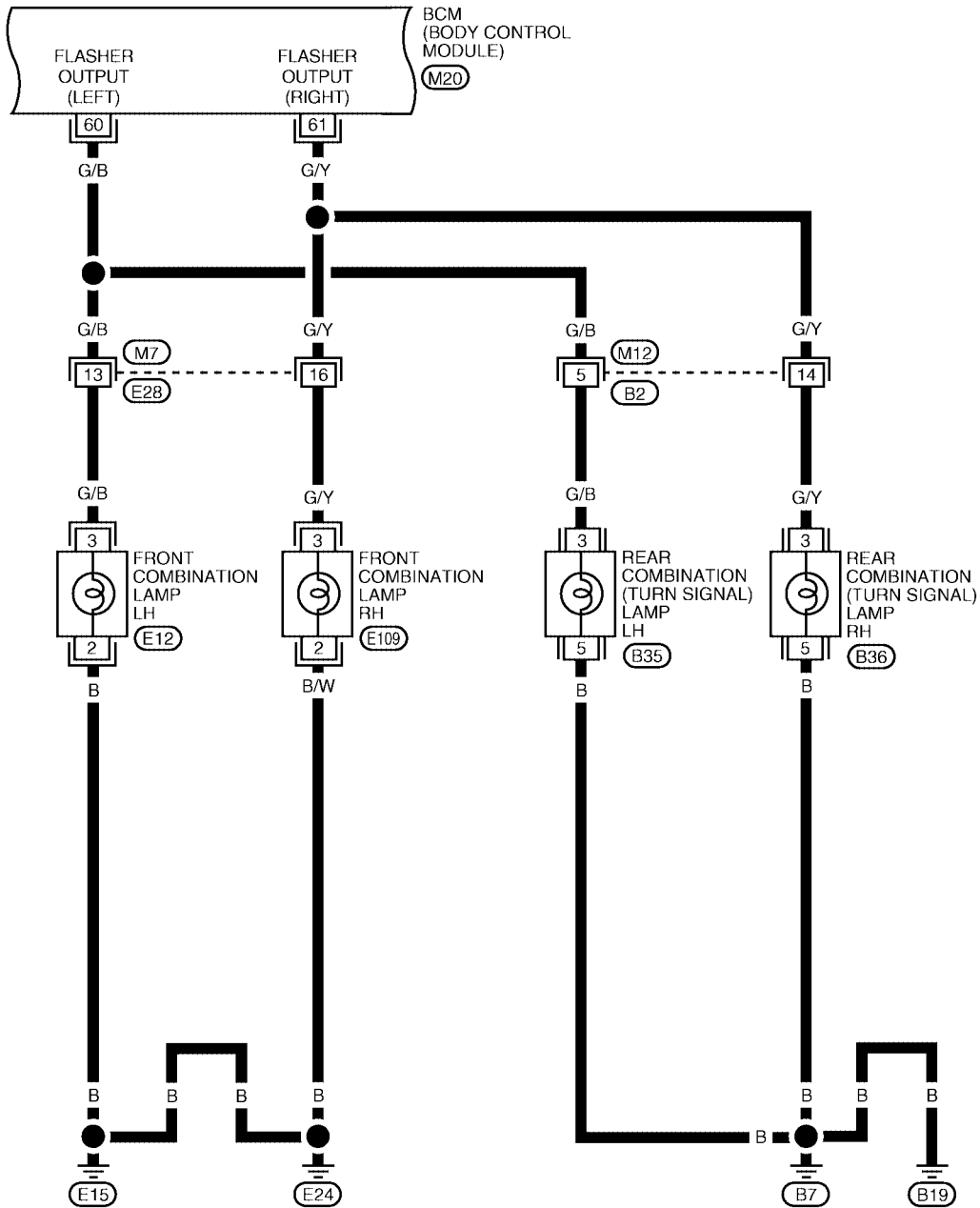

WKWA1538E

TURN SIGNAL AND HAZARD WARNING LAMPS

LT-TURN-03

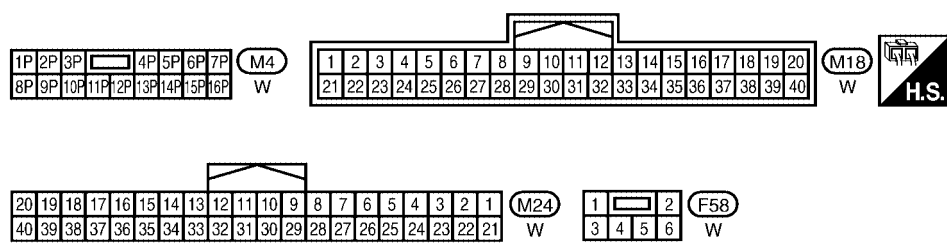
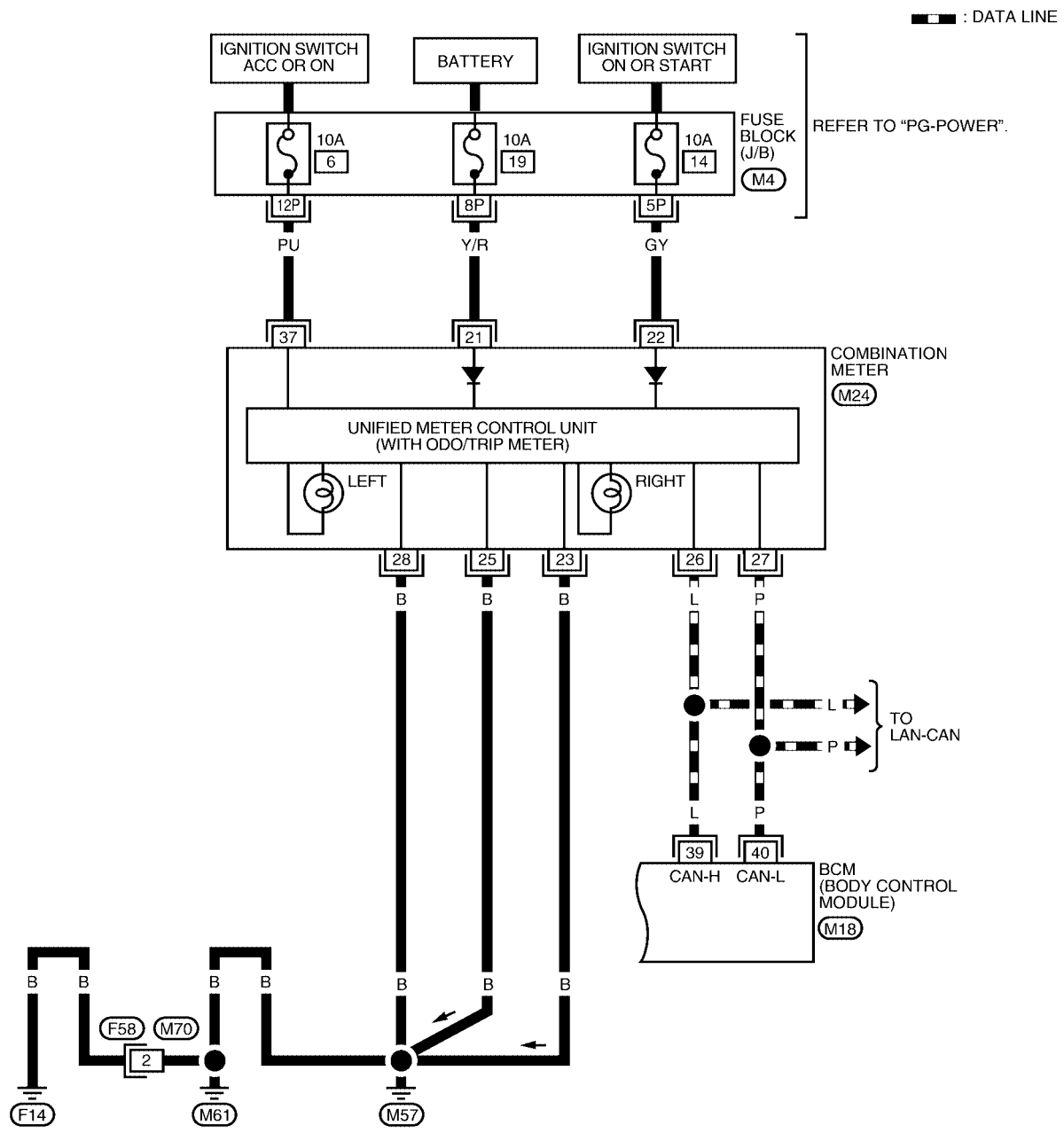



WKWA2972E

TURN SIGNAL AND HAZARD WARNING LAMPS

Terminals and Reference Values for BCM

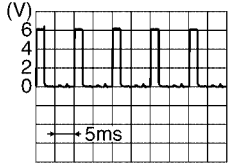
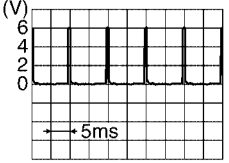
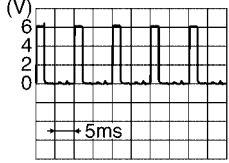
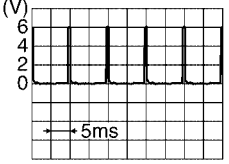
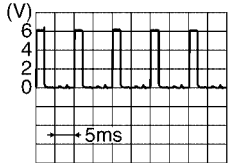
EKS008N6

Terminal No.	Wire color	Signal name	Measuring condition		Reference value (Approx.)	
			Ignition switch	Operation or condition		
2	L	Combination switch input 5	ON	Lighting, turn, wiper OFF Wiper dial position 4	 <p style="text-align: right;">SKIA5291E</p>	
3	R/Y	Combination switch input 4	ON	Lighting, turn, wiper OFF Wiper dial position 4	 <p style="text-align: right;">SKIA5292E</p>	
4	R/G	Combination switch input 3	ON	Lighting, turn, wiper OFF Wiper dial position 4	 <p style="text-align: right;">SKIA5291E</p>	
5	R/B	Combination switch input 2	ON	Lighting, turn, wiper OFF Wiper dial position 4	 <p style="text-align: right;">SKIA5292E</p>	
6	R/W	Combination switch input 1				
11	PU	Ignition switch (ACC)	ACC	—	Battery voltage	
29	G/R	Hazard switch signal	OFF	Hazard switch	ON	0V
					OFF	5V
32	L/W	Combination switch output 5	ON	Lighting, turn, wiper OFF Wiper dial position 4	 <p style="text-align: right;">SKIA5291E</p>	
33	G/Y	Combination switch output 4	ON	Lighting, turn, wiper OFF Wiper dial position 4	 <p style="text-align: right;">SKIA5292E</p>	

TURN SIGNAL AND HAZARD WARNING LAMPS

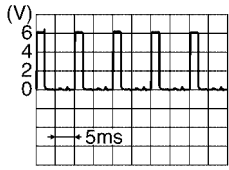
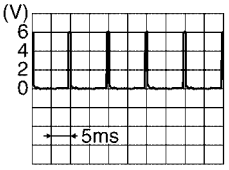
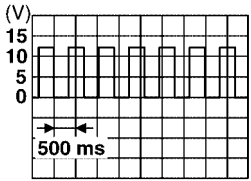
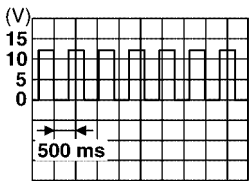
Terminal No.	Wire color	Signal name	Measuring condition		Reference value (Approx.)	
			Ignition switch	Operation or condition		
34	G/R	Combination switch output 3	ON	Lighting, turn, wiper OFF Wiper dial position 4	 SKIA5291E	
35	G/B	Combination switch output 2	ON	Lighting, turn, wiper OFF Wiper dial position 4	 SKIA5292E	
36	G/W	Combination switch output 1				
38	R	Ignition switch (ON)	ON	—	Battery voltage	
39	L	CAN-H	—	—	—	
40	P	CAN-L	—	—	—	
60	G/B	Flasher output (left)	ON	Combina- tion switch	Turn left ON	 SKIA3009J
61	G/Y	Flasher output (right)	ON	Combina- tion switch	Turn right ON	 SKIA3009J
67	B	Ground	ON	—	0V	
70	W/B	Battery power supply (fusible link)	OFF	—	Battery voltage	

How to Proceed With Trouble Diagnosis

EKS008N7

1. Confirm the symptom or customer complaint.
2. Understand operation description and function description. Refer to [LT-71, "System Description"](#) .
3. Perform the Preliminary Check. Refer to [LT-80, "Preliminary Check"](#) .
4. Check symptom and repair or replace the cause of malfunction.
5. Do the turn signal and hazard warning lamps operate normally? If YES: GO TO 6. If NO: GO TO 4.
6. Inspection End.

TURN SIGNAL AND HAZARD WARNING LAMPS

EKS008N8

Preliminary Check CHECK POWER SUPPLY AND GROUND CIRCUIT

1. CHECK FUSES OR FUSIBLE LINK

Check for blown fuses or fusible link.

Unit	Power source	Fuse and fusible link No.
BCM	Battery	f
	Ignition switch ACC or ON	6
	Ignition switch ON or START position	1

Refer to [LT-75, "Wiring Diagram — TURN —"](#).

OK or NG

OK >> GO TO 2.

NG >> If fuse or fusible link is blown, be sure to eliminate cause of malfunction before installing new fuse or fusible link. Refer to [PG-4, "POWER SUPPLY ROUTING CIRCUIT"](#).

2. CHECK POWER SUPPLY CIRCUIT

1. Disconnect BCM connectors.
2. Check voltage between BCM harness connector terminals and ground.

BCM (+)		(-)	Ignition switch position		
Connector	Terminal		OFF	ACC	ON
M18	11	Ground	0V	Battery voltage	Battery voltage
	38		0V	0V	Battery voltage
M20	70		Battery voltage	Battery voltage	Battery voltage

OK or NG

OK >> GO TO 3.

NG >> Check harness for open between BCM and fuse or fusible link.

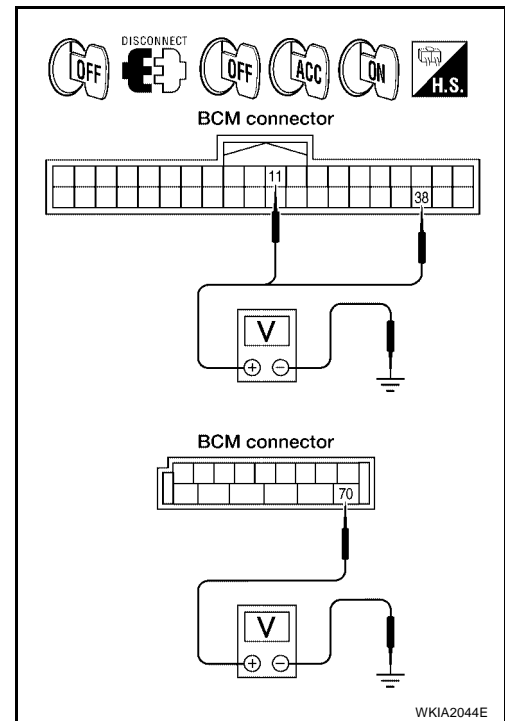

WKIA2044E

3. CHECK GROUND CIRCUIT

Check continuity between BCM harness connector terminal and ground.

BCM		Continuity
Connector	Terminal	
M20	67	Ground Yes

OK or NG

OK >> Inspection End.

NG >> Check ground circuit harness.

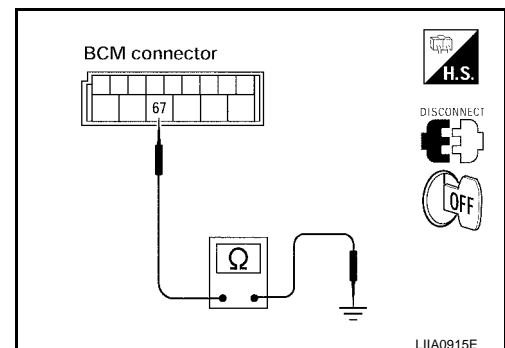

LIA0915E

TURN SIGNAL AND HAZARD WARNING LAMPS

CONSULT-II Function (BCM)

EKS008N9

CONSULT-II can display each diagnostic item using the diagnostic test modes shown following.

BCM diagnostic test item	Diagnostic mode	Description
Inspection by part	WORK SUPPORT	Supports inspections and adjustments. Commands are transmitted to the BCM for setting the status suitable for required operation, input/output signals are received from the BCM and received data is displayed.
	DATA MONITOR	Displays BCM input/output data in real time.
	ACTIVE TEST	Operation of electrical loads can be checked by sending drive signal to them.
	SELF-DIAG RESULTS	Displays BCM self-diagnosis results.
	CAN DIAG SUPPORT MNTR	The result of transmit/receive diagnosis of CAN communication can be read.
	ECU PART NUMBER	BCM part number can be read.
	CONFIGURATION	Performs BCM configuration read/write functions.

CONSULT-II OPERATION

CAUTION:

If CONSULT-II is used with no connection of CONSULT-II CONVERTER, malfunctions might be detected in self-diagnosis depending on control unit which carries out CAN communication.

1. With the ignition switch OFF, connect CONSULT-II and CONSULT-II CONVERTER to the data link connector, then turn ignition switch ON.

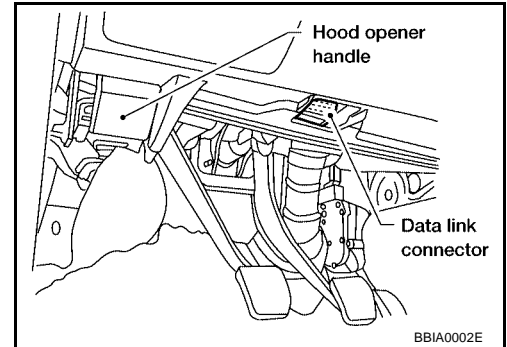

2. Touch "START (NISSAN BASED VHCL)".

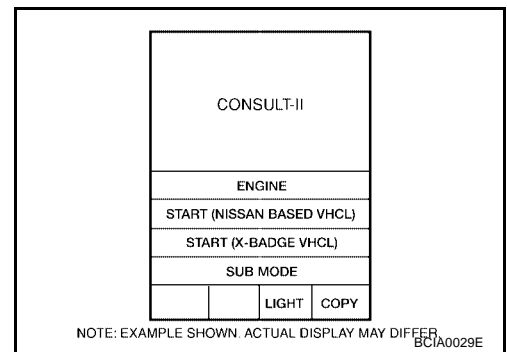

3. Touch "BCM" on "SELECT SYSTEM" screen. If "BCM" is not indicated, go to [GI-39, "Consult-II Data Link Connector \(DLC\) Circuit"](#).

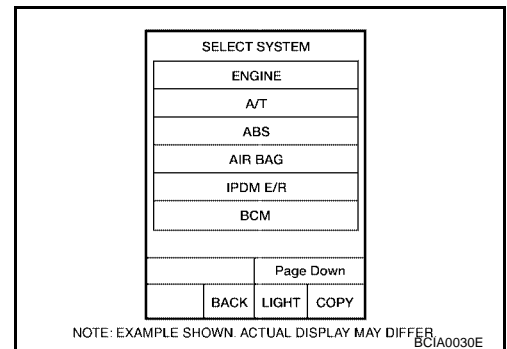

TURN SIGNAL AND HAZARD WARNING LAMPS

- Select the desired part to be diagnosed on the "SELECT TEST ITEM" screen.

SELECT TEST ITEM			
HEAD LAMP			
WIPER			
FLASHER			
AIR CONDITIONER			
COMB SW			
BCM			
Scroll Up		Page Down	
BACK	LIGHT	COPY	

LKIA0183E

DATA MONITOR

Operation Procedure

- Touch "FLASHER" on "SELECT TEST ITEM" screen.
- Touch "DATA MONITOR" on "SELECT DIAG MODE" screen.
- Touch either "ALL SIGNALS" or "SELECTION FROM MENU" on the "SELECT MONITOR ITEM" screen.

ALL SIGNALS	Monitors all the signals.
SELECTION FROM MENU	Selects and monitors the individual signal.

- Touch "START".
- When "SELECTION FROM MENU" is selected, touch items to be monitored. When "ALL SIGNALS" is selected, all the items will be monitored.
- Touch "RECORD" while monitoring, then the status of the monitored item can be recorded. To stop recording, touch "STOP".

Display Item List

Monitor item name "OPERATION OR UNIT"	Contents
IGN ON SW "ON/OFF"	Displays "IGN position (ON)/OFF, ACC position (OFF)" judged from the ignition switch signal.
HAZARD SW "ON/OFF"	Displays "Hazard ON (ON)/Hazard OFF (OFF)" status, determined from hazard switch signal.
TURN SIGNAL R "ON/OFF"	Displays "Turn right (ON)/Other (OFF)" status, determined from lighting switch signal.
TURN SIGNAL L "ON/OFF"	Displays "Turn left (ON)/Other (OFF)" status, determined from lighting switch signal.

ACTIVE TEST

Operation Procedure

- Touch "FLASHER" on "SELECT TEST ITEM" screen.
- Touch "ACTIVE TEST" on "SELECT DIAG MODE" screen.
- Touch item to be tested and check operation of the selected item.
- During the operation check, touching "BACK" deactivates the operation.

Display Item List

Test item	Description
FLASHER (RH)	Turn signal lamp (right) can be operated by any ON-OFF operations.
FLASHER (LH)	Turn signal lamp (left) can be operated by any ON-OFF operations.

Turn Signal Lamp Does Not Operate

EKS008NA

1. BULB INSPECTION

Check each turn signal lamp bulb to make sure correct bulbs are installed. Refer to [LT-144, "Exterior Lamp"](#) .

OK or NG

OK >> GO TO 2.

NG >> Replace bulb. Refer to [LT-29, "FRONT TURN SIGNAL LAMP"](#) or [LT-113, "TAIL LAMP"](#) .

TURN SIGNAL AND HAZARD WARNING LAMPS

2. INSPECTION 1 BETWEEN COMBINATION SWITCH AND BCM

Select "BCM" on CONSULT-II. Carry out BCM self-diagnosis.

Displayed results of self-diagnosis

Diagnosis system 1 - 5>> Combination switch system malfunction.

Refer to [LT-91, "Combination Switch Inspection"](#) .

No malfunction detected>> GO TO 3.

SELF-DIAG RESULTS	
DTC RESULTS	TIME
NO DTC IS DETECTED. FURTHER TESTING MAY BE REQUIRED	

LKIA0073E

3. INSPECTION 2 BETWEEN COMBINATION SWITCH AND BCM

Select "BCM" on CONSULT-II. With "FLASHER" data monitor, check that "TURN SIGNAL R" and "TURN SIGNAL L" turn ON-OFF according to operation of turn signal switch.

OK or NG

OK >> GO TO 4.

NG >> Replace lighting switch. Refer to [LT-86, "Removal and Installation"](#) .

DATA MONITOR	
MONITOR	
IGN ON SW	ON
HAZARD SW	ON
TURN SIGNAL R	OFF
TURN SIGNAL L	OFF

LKIA0083E

4. INSPECTION 1 BETWEEN BCM AND TURN SIGNAL LAMPS

1. Select "BCM" on CONSULT-II. Select "FLASHER" active test.

2. Check that "FLASHER RH" and "FLASHER LH" operate.

OK or NG

OK >> Replace BCM. Refer to [BCS-20, "Removal and Installation of BCM"](#) .

NG >> GO TO 5.

ACTIVE TEST			
FLASHER		OFF	
RH	LH		
MODE	BACK	LIGHT	COPY

SKIA6190E

5. INSPECTION 2 BETWEEN BCM AND TURN SIGNAL LAMPS

1. Disconnect BCM connector and all turn signal lamp connectors.

2. Check continuity between BCM harness connector terminals and ground.

BCM			Continuity
Connector	Terminal		
LH	M20	60	Ground
RH		61	
			No

OK or NG

OK >> Replace BCM. Refer to [BCS-20, "Removal and Installation of BCM"](#) .

NG >> Check for short circuit in harnesses between BCM and each turn signal and repair as necessary.

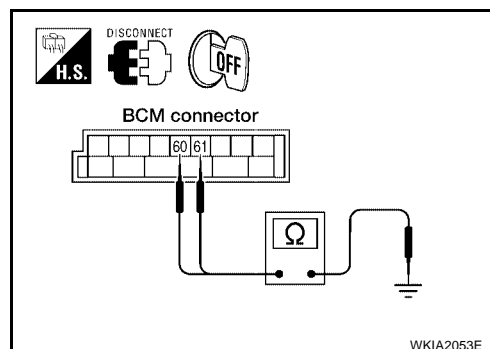

TURN SIGNAL AND HAZARD WARNING LAMPS

Hazard Warning Lamp Does Not Operate But Turn Signal Lamps Operate

EKS008NB

1. CHECK BULB

Make sure bulb standard of each turn signal lamp is correct. Refer to [LT-144, "Exterior Lamp"](#) .

OK or NG

OK >> GO TO 2.

NG >> Replace turn signal lamp bulb. Refer to [LT-29, "FRONT TURN SIGNAL LAMP"](#) or [LT-113, "TAIL LAMP"](#) .

2. CHECK HAZARD SWITCH INPUT SIGNAL

Ⓟ With CONSULT-II

Select "BCM" on CONSULT-II. With "FLASHER" data monitor, make sure "HAZARD SW" turns ON-OFF linked with operation of hazard switch.

When hazard switch is in : HAZARD SW ON ON position

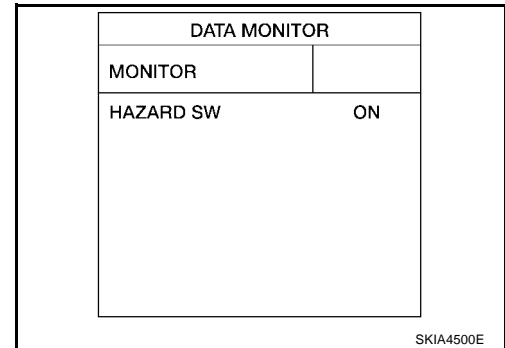

⊗ Without CONSULT-II

Check voltage between BCM harness connector terminal 29 and ground.

BCM (+)		(-)	Condition	Voltage (Approx.)
Connector	Terminal			
M18	29	Ground	Hazard switch is ON	0V
			Hazard switch is OFF	5V

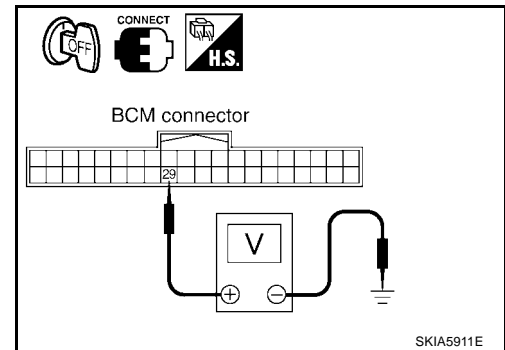

OK or NG

OK >> Replace BCM. Refer to [BCS-20, "Removal and Installation of BCM"](#) .

NG >> GO TO 3.

3. CHECK HAZARD SWITCH CIRCUIT

1. Turn ignition switch OFF.
2. Disconnect BCM connector and hazard switch connector.
3. Check continuity between BCM harness connector M18 terminal 29 and hazard switch harness connector M203 terminal 2.

29 - 2 : Continuity should exist.

OK or NG

OK >> GO TO 4.

NG >> Repair harness or connector.

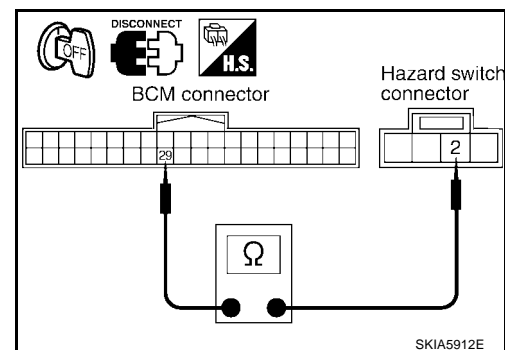

TURN SIGNAL AND HAZARD WARNING LAMPS

4. CHECK GROUND

Check continuity between hazard switch harness connector M203 terminal 1 and ground.

1 - Ground : Continuity should exist.

OK or NG

- OK >> GO TO 5.
- NG >> Repair harness or connector.

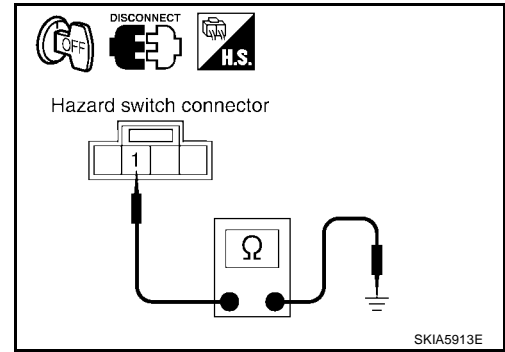

5. CHECK HAZARD SWITCH

Check continuity of hazard switch.

Hazard switch		Condition	Continuity
Terminal			
1	2	Hazard switch is ON	Yes
		Hazard switch is OFF	No

OK or NG

- OK >> Replace BCM if turn signal lamps does not work after setting the connector again. Refer to [BCS-20, "Removal and Installation of BCM"](#) .
- NG >> Replace hazard switch. Refer to [LT-87, "Removal and Installation"](#) .

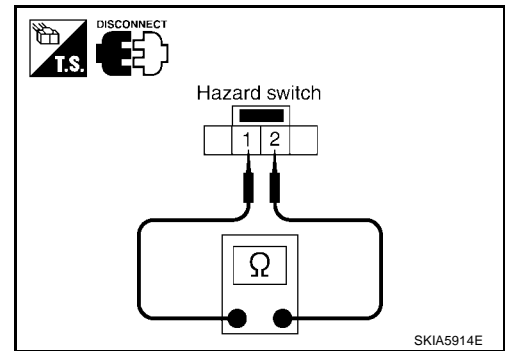

Turn Signal Indicator Lamp Does Not Operate

1. CAN COMMUNICATION INSPECTION

Check CAN communication. Refer to [LAN-20, "CAN COMMUNICATION"](#) .

OK or NG

- OK >> Replace combination meter. Refer to [IP-13, "COMBINATION METER"](#) .
- NG >> Repair as necessary.

Bulb Replacement FRONT TURN SIGNAL LAMP

Refer to [LT-29, "FRONT TURN SIGNAL LAMP"](#) .

REAR TURN SIGNAL LAMP

Refer to [LT-113, "TAIL LAMP"](#) .

Removal and Installation FRONT TURN SIGNAL LAMP

Refer to [LT-29, "Removal and Installation"](#) .

REAR TURN SIGNAL LAMP

Refer to [LT-113, "REAR COMBINATION LAMP"](#) .

LIGHTING AND TURN SIGNAL SWITCH

LIGHTING AND TURN SIGNAL SWITCH

PFP:25540

Removal and Installation

EKS008NF

REMOVAL

1. Remove the steering column cover. Refer to [PS-10, "STEERING COLUMN"](#)
2. Pinch tabs and slide out lighting and turn signal switch (combination switch).

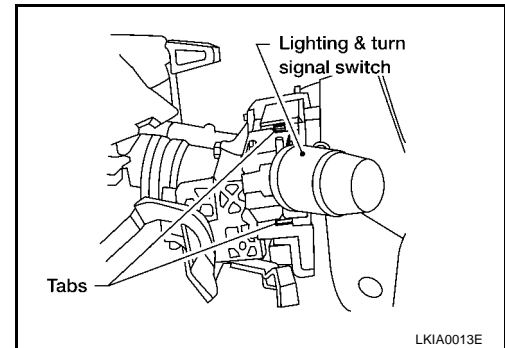

Installation

Installation is in the reverse order of removal.

Switch Circuit Inspection

EKS008NG

Refer to [LT-91, "Combination Switch Inspection"](#) .

HAZARD SWITCH

HAZARD SWITCH

PFP:25290

Removal and Installation

EKS008NH

REMOVAL

1. Remove front air control finisher. Refer to [IP-10, "INSTRUMENT PANEL ASSEMBLY"](#) .
2. Remove A/T finisher or M/T finisher. Refer to [IP-14, "A/T FINISHER"](#) or [IP-14, "M/T FINISHER"](#) .
3. Remove hazard switch screws.
4. Remove hazard switch.

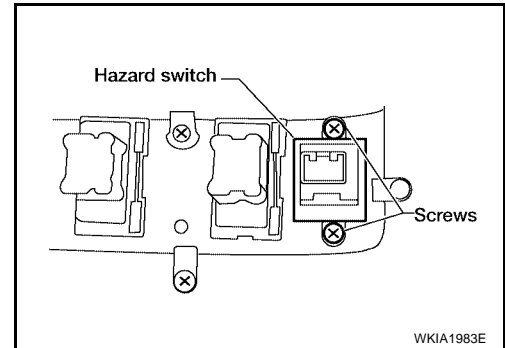

Installation

Installation is in the reverse order of removal.

A
B
C
D
E
F
G
H
I
J
LT
L
M

COMBINATION SWITCH

PF25567

EKS008NI

COMBINATION SWITCH

Wiring Diagram — COMBSW —

LT-COMBSW-01

— : DATA LINE

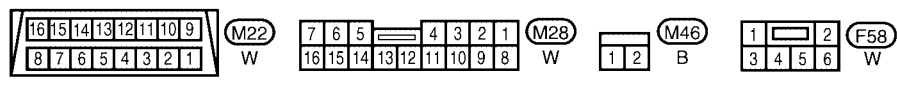
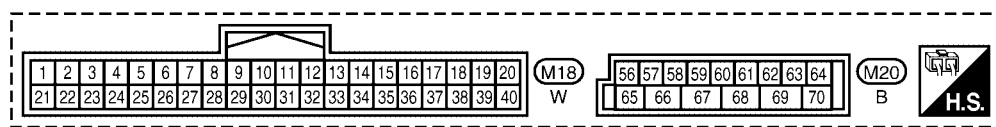
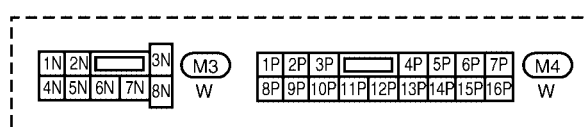
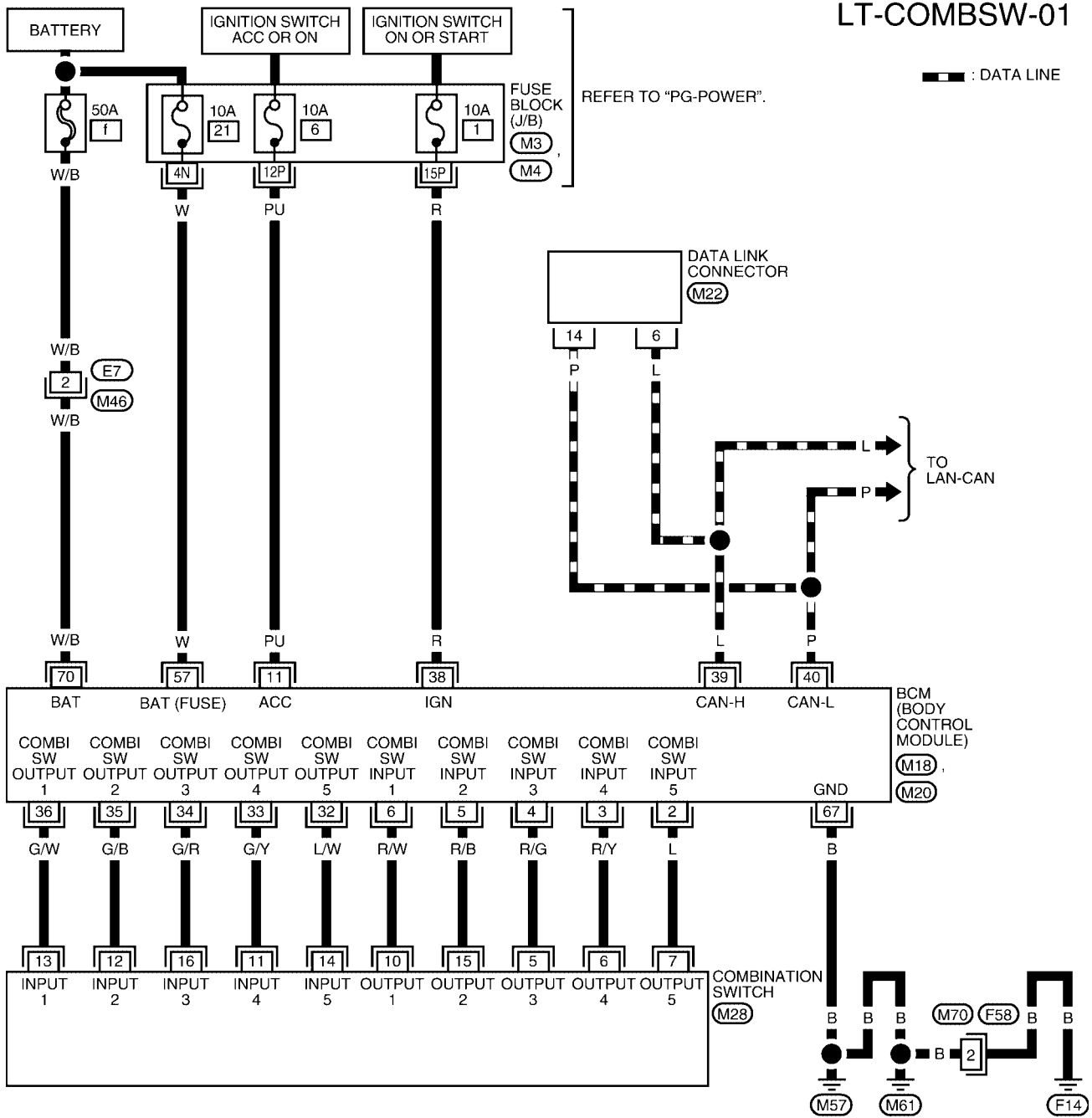

WKWA1379E

COMBINATION SWITCH

Combination Switch Reading Function

EKS008NJ

Refer to [BCS-3, "COMBINATION SWITCH READING FUNCTION"](#) .

CONSULT-II Function (BCM)

EKS008NK

CONSULT-II can display each diagnostic item using the diagnostic test modes shown following.

BCM diagnostic test item	Diagnostic mode	Description
Inspection by part	WORK SUPPORT	Supports inspections and adjustments. Commands are transmitted to the BCM for setting the status suitable for required operation, input/output signals are received from the BCM and received data is displayed.
	DATA MONITOR	Displays BCM input/output data in real time.
	ACTIVE TEST	Operation of electrical loads can be checked by sending drive signal to them.
	SELF-DIAG RESULTS	Displays BCM self-diagnosis results.
	CAN DIAG SUPPORT MNTR	The result of transmit/receive diagnosis of CAN communication can be read.
	ECU PART NUMBER	BCM part number can be read.
	CONFIGURATION	Performs BCM configuration read/write functions.

CONSULT-II OPERATION

CAUTION:

If CONSULT-II is used with no connection of CONSULT-II CONVERTER, malfunctions might be detected in self-diagnosis depending on control unit which carries out CAN communication.

1. With the ignition switch OFF, connect CONSULT-II and CONSULT-II CONVERTER to the data link connector, then turn ignition switch ON.

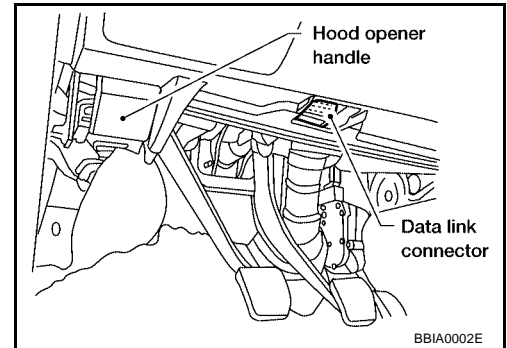

2. Touch "START (NISSAN BASED VHCL)".

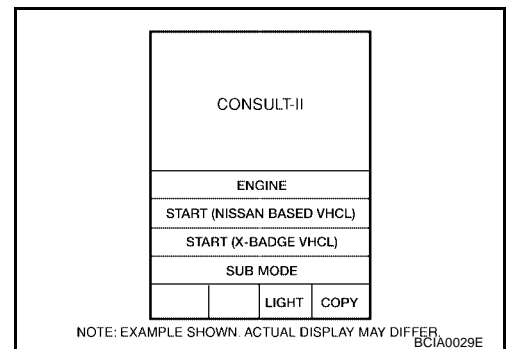

3. Touch "BCM" on "SELECT SYSTEM" screen. If "BCM" is not indicated, go to [GI-39, "Consult-II Data Link Connector \(DLC\) Circuit"](#) .

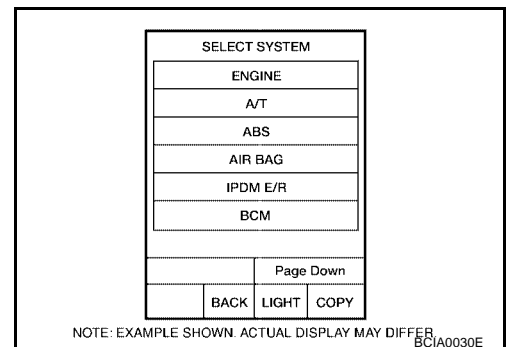

COMBINATION SWITCH

4. Touch "COMB SW" on "SELECT TEST ITEM" screen.

SELECT TEST ITEM			
HEAD LAMP			
WIPER			
FLASHER			
AIR CONDITIONER			
COMB SW			
BCM			
Scroll Up		Page Down	
	BACK	LIGHT	COPY

LKIA0183E

DATA MONITOR

Operation Procedure

1. Touch "COMB SW" on "SELECT TEST ITEM" screen.
2. Touch "DATA MONITOR" on "SELECT DIAG MODE" screen.
3. Touch either "ALL SIGNALS" or "SELECTION FROM MENU" on "SELECT MONITOR ITEM" screen.

ALL SIGNALS	Monitors all the signals.
SELECTION FROM MENU	Selects and monitors individual signal.

4. Touch "START".
5. When "SELECTION FROM MENU" is selected, touch items to be monitored. When "ALL SIGNALS" is selected, all the signals will be monitored.
6. Touch "RECORD" while monitoring, then the status of the monitored item can be recorded. To stop recording, touch "STOP".

Display Item List

Monitor item name "OPERATION OR UNIT"	Contents
TURN SIGNAL R "ON/OFF"	Displays "Turn Right (ON)/Other (OFF)" status, determined from lighting switch signal.
TURN SIGNAL L "ON/OFF"	Displays "Turn Left (ON)/Other (OFF)" status, determined from lighting switch signal.
HI BEAM SW "ON/OFF"	Displays status (high beam switch: ON/Others: OFF) of high beam switch judged from lighting switch signal.
HEAD LAMP SW 1 "ON/OFF"	Displays "Headlamp switch 1 (ON)/Other (OFF)" status, determined from lighting switch signal.
HEAD LAMP SW 2 "ON/OFF"	Displays status (headlamp switch 2: ON/Others: OFF) of headlamp switch 2 judged from lighting switch signal.
LIGHT SW 1ST "ON/OFF"	Displays status (lighting switch 1st position: ON/Others: OFF) of lighting switch judged from lighting switch signal.
PASSING SW "ON/OFF"	Displays status (flash-to-pass switch: ON/Others: OFF) of flash-to-pass switch judged from lighting switch signal.
AUTO LIGHT SW "ON/OFF"	Displays "Auto light switch (ON)/Other (OFF)" status, determined from lighting switch signal.
FR FOG SW "ON/OFF"	Displays "Front fog lamp switch (ON)/Other (OFF)" status, determined from lighting switch signal.
FR WIPER HI "ON/OFF"	Displays "Front Wiper HI (ON)/Other (OFF)" status, determined from wiper switch signal.
FR WIPER LOW "ON/OFF"	Displays "Front Wiper LOW (ON)/Other (OFF)" status, determined from wiper switch signal.
FR WIPER INT "ON/OFF"	Displays "Front Wiper INT (ON)/Other (OFF)" status, determined from wiper switch signal.
FR WASHER SW "ON/OFF"	Displays "Front Washer Switch (ON)/Other (OFF)" status, determined from wiper switch signal.
INT VOLUME [1 - 7]	Displays intermittent operation knob setting (1 - 7), determined from wiper switch signal.

COMBINATION SWITCH

EKS008NL

Combination Switch Inspection

1. SYSTEM CHECK

Referring to table below, check to which system the malfunctioning switch belongs.

System 1	System 2	System 3	System 4	System 5
—	FR WASHER	FR WIPER LO	TURN LH	TURN RH
FR WIPER HI	—	FR WIPER INT	PASSING	HEAD LAMP1
INT VOLUME 1	—	—	HEAD LAMP2	HI BEAM
—	INT VOLUME 3	AUTO LIGHT	—	TAIL LAMP
INT VOLUME 2	—	—	FR FOG	—

>> GO TO 2.

2. SYSTEM CHECK

 With CONSULT-II

CAUTION:

If CONSULT-II is used with no connection of CONSULT-II CONVERTER, malfunctions might be detected in self-diagnosis depending on control unit which carries out CAN communication.

1. Connect CONSULT-II and select "COMB SW" on "SELECT TEST ITEM" screen.
2. Select "DATA MONITOR".
3. Select "START" and confirm that other switches in malfunctioning system operate normally.

Example: When auto light switch is malfunctioning, confirm that "FRONT WIPER LOW" and "FRONT WIPER INT" in System 3, to which the auto light switch belongs, turn ON-OFF normally.

DATA MONITOR	
MONITOR	
TURN SIGNAL R	OFF
TURN SIGNAL L	OFF
HIBEAM SW	OFF
HEAD LAMP SW1	OFF
HEAD LAMP SW2	OFF
LIGHT SW 1ST	OFF
PASSING SW	OFF
AUTO LIGHT SW	OFF
FR FOG SW	OFF
	Page Down
	RECORD
MODE	BACK
LIGHT	COPY

SKIA7075E

 Without CONSULT-II

Operate combination switch and confirm that other switches in malfunctioning system operate normally.

Example: When auto light switch is malfunctioning, confirm that "FRONT WIPER LOW" and "FRONT WIPER INT" in System 3, to which the auto light switch belongs, operate normally.

Check results

- Other switches in malfunctioning system operate normally.>> Replace lighting switch or wiper switch. Refer to [LT-86. "Removal and Installation"](#) (for lighting switch) or [WW-29. "Removal and Installation"](#).
- Other switches in malfunctioning system do not operate normally.>> GO TO 3.

COMBINATION SWITCH

3. HARNESS INSPECTION

1. Turn ignition switch OFF.
2. Disconnect BCM and combination switch connectors.
3. Check continuity between BCM harness connector of the suspect system and the corresponding combination switch connector terminals.

Suspect system	BCM		Combination switch		Continuity
	Connector	Terminal	Connector	Terminal	
1	M18	Input 1	6	M28	10
		Output 1	36		13
2		Input 2	5		15
		Output 2	35		12
3		Input 3	4		5
		Output 3	34		16
4		Input 4	3		6
		Output 4	33		11
5		Input 5	2		7
		Output 5	32		14

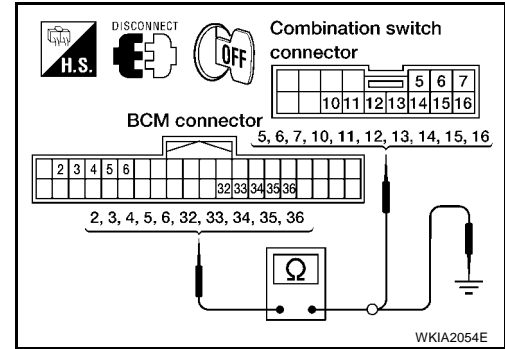

4. Check for continuity between each terminal of BCM harness connector in suspect malfunctioning system and ground.

Suspect system	BCM		Continuity		
	Connector	Terminal			
1	M18	Input 1	6	Ground	No
		Output 1	36		
2		Input 2	5		
		Output 2	35		
3		Input 3	4		
		Output 3	34		
4		Input 4	3		
		Output 4	33		
5		Input 5	2		
		Output 5	32		

OK or NG

OK >> GO TO 4.

NG >> Check harness between BCM and combination switch for open or short circuit.

COMBINATION SWITCH

4. BCM OUTPUT TERMINAL INSPECTION

1. Turn lighting switch and wiper switch to OFF.
2. Set wiper dial to position 4.
3. Connect BCM and combination switch connectors.
4. Turn ignition switch ON, and check combination switch input (BCM output) terminal voltage waveform of suspect malfunctioning system.

Suspect system	Combination switch		(-)	
	(+)			
	Connector	Terminal		
1	M28	Input 1	10	Ground
2		Input 2	15	
3		Input 3	5	
4		Input 4	6	
5		Input 5	7	

OK or NG

- OK >> Open circuit in combination switch, GO TO 5.
 NG >> Replace BCM. Refer to [BCS-20, "Removal and Installation of BCM"](#).

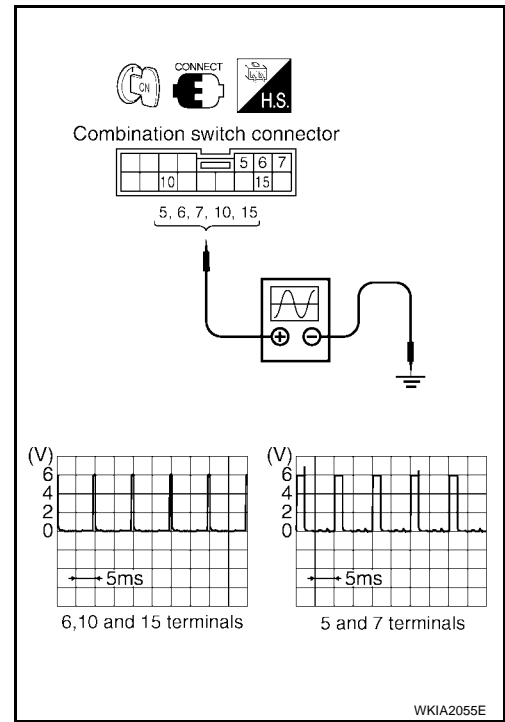

5. COMBINATION SWITCH INSPECTION

Referring to table below, perform combination switch inspection.

Procedure									
1	2		3	4		5	6		7
Replace lighting switch.	Confirm check results.	OK	Inspection End	Confirm check results.	OK	Inspection End	Confirm check results.	OK	Inspection End
		NG	Replace wiper switch.		NG	Replace switch base.		NG	Confirm symptom again.

>> Inspection End.

Removal and Installation

For details, refer to [LT-86, "Removal and Installation"](#).

Switch Circuit Inspection

For details, refer to [LT-91, "Combination Switch Inspection"](#).

STOP LAMP

PF26550

STOP LAMP

Wiring Diagram — STOP/L —

EKS008NO

LT-STOP/L-01

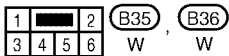
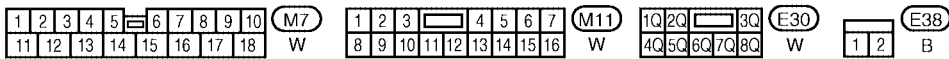
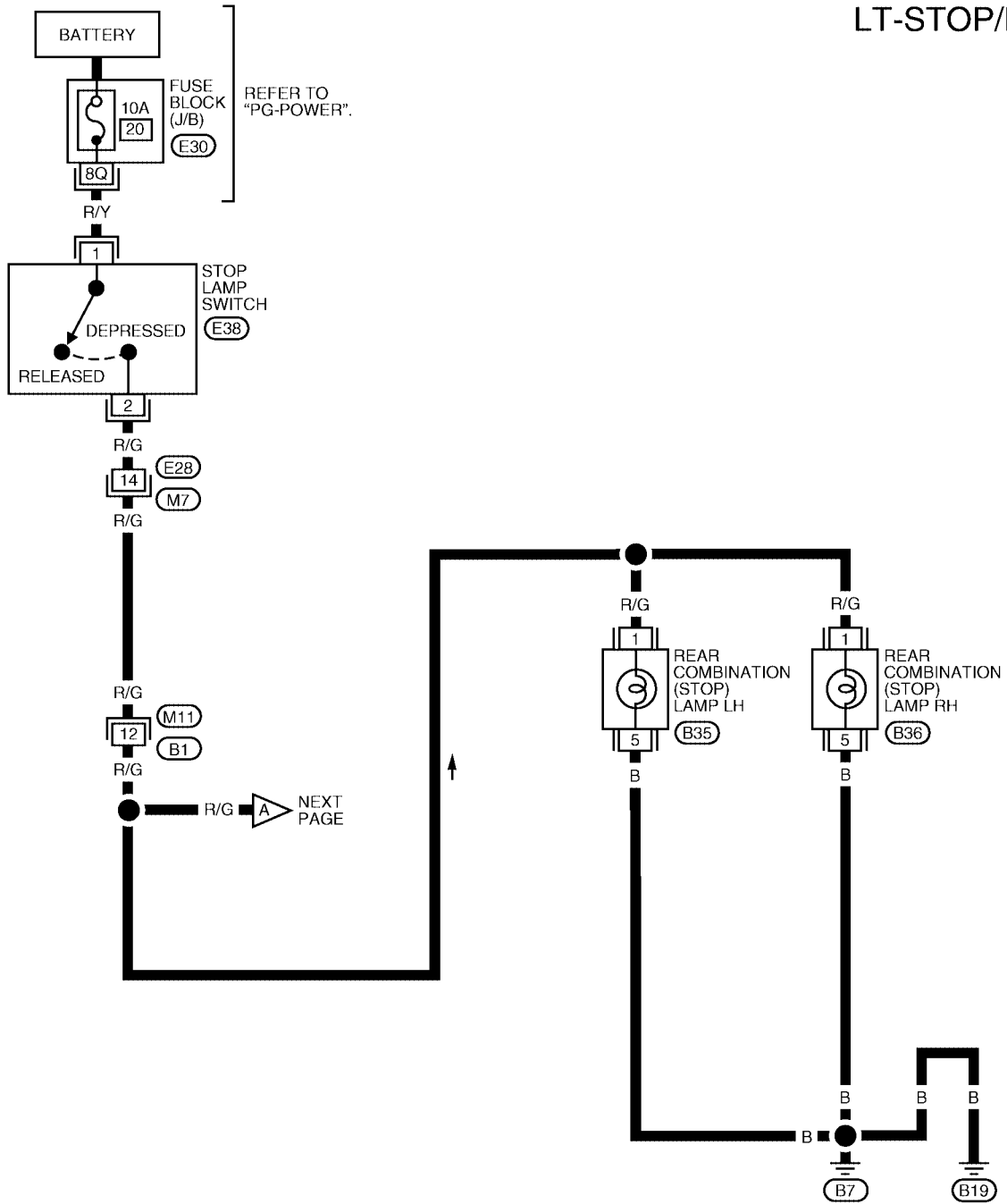

WKWA1539E

STOP LAMP

LT-STOP/L-02

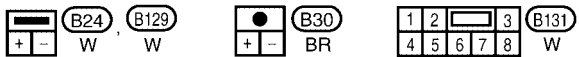
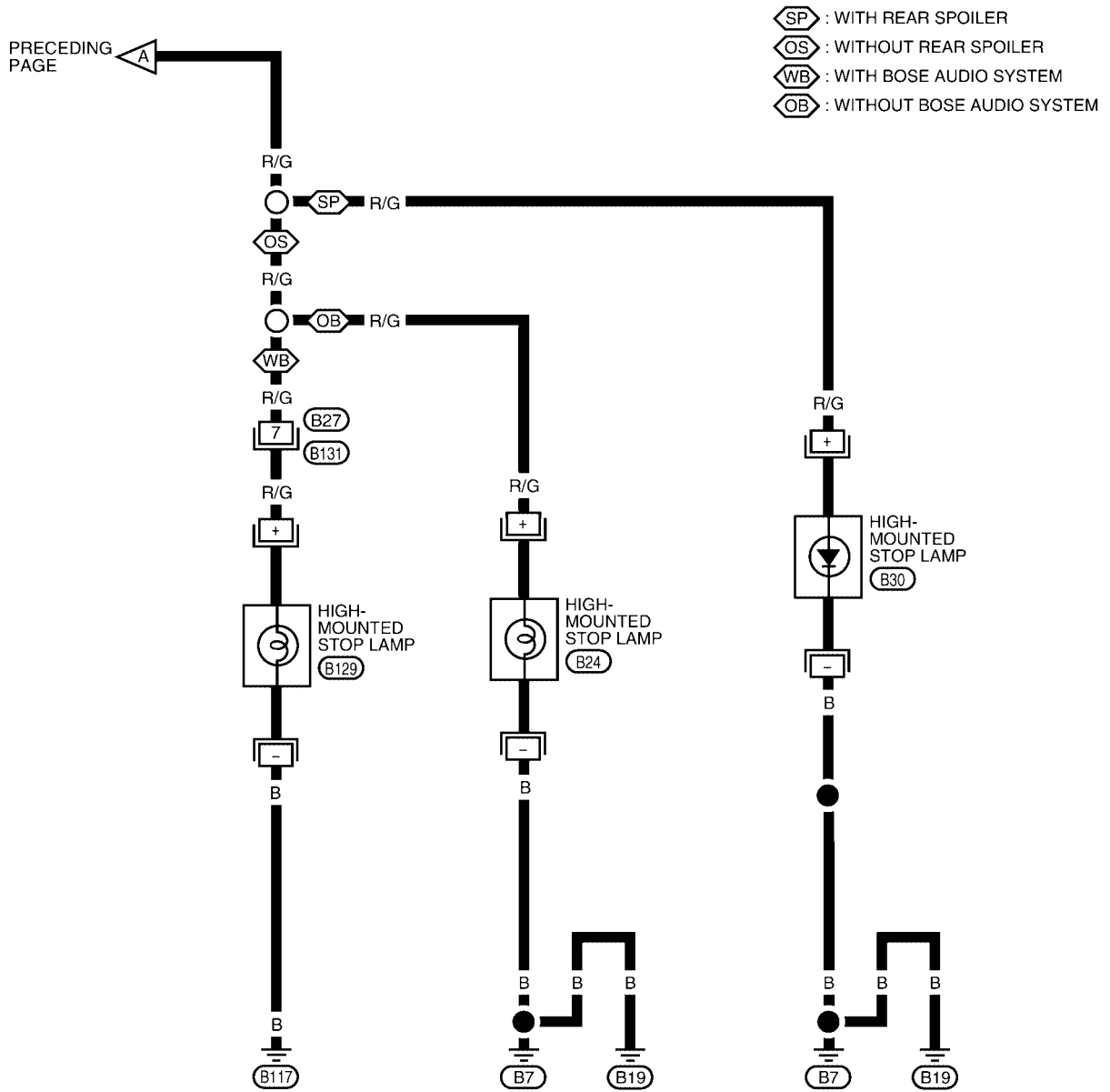

WKWA1372E

STOP LAMP

EKS008NP

Bulb Replacement HIGH MOUNTED STOP LAMP

With Rear Air Spoiler

When this vehicle is equipped with a rear air spoiler, the high-mounted stop lamp uses an LED circuit board instead of a bulb. The LED circuit board is not serviceable and must be replaced as an assembly.

WITHOUT REAR AIR SPOILER

Removal

1. Remove high-mounted stop lamp assembly. Refer to [LT-96, "Removal and Installation"](#).
2. Turn bulb socket counterclockwise to unlock and remove from lamp assembly.
3. Turn bulb counterclockwise to remove from socket.

Installation

Installation is in the reverse order of removal.

STOP LAMP

Removal

1. Remove rear combination lamp. Refer to [LT-96, "REAR COMBINATION LAMP"](#).
2. Turn bulb socket counterclockwise to unlock and remove from combination lamp assembly.
3. Turn bulb counterclockwise to remove from bulb socket.

Installation

Installation is in the reverse order of removal.

Removal and Installation HIGH-MOUNTED STOP LAMP

EKS008NR

With Rear Air Spoiler SE-R

The high-mounted stop lamp is part of the rear air spoiler. Refer to [EI-24, "REAR AIR SPOILER"](#).

WITH REAR AIR SPOILER EXCEPT SE-R

For rear air spoiler removal and installation procedures, refer to [EI-24, "Removal and Installation"](#).

WITHOUT REAR AIR SPOILER

Removal

1. Slide high-mounted stop lamp assembly rearward on parcel shelf to give clearance to front tabs.
2. Lift front of lamp assembly up and bring forward to give clearance to rear tabs.
3. Disconnect connector, and remove from vehicle.

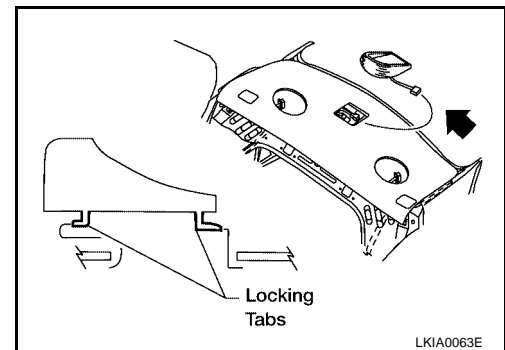

Installation

Installation is in the reverse order of removal.

REAR COMBINATION LAMP

Removal

1. Displace trunk room trim as needed. Refer to [EI-38, "Removal and Installation"](#).
2. From trunk, remove nuts securing rear combination lamp assembly.
3. Disconnect connectors and remove assembly.

Installation

Installation is in the reverse order of removal.

BACK-UP LAMP

PF26550

EKS008NT

BACK-UP LAMP

Wiring Diagram — BACK/L —

LT-BACK/L-01

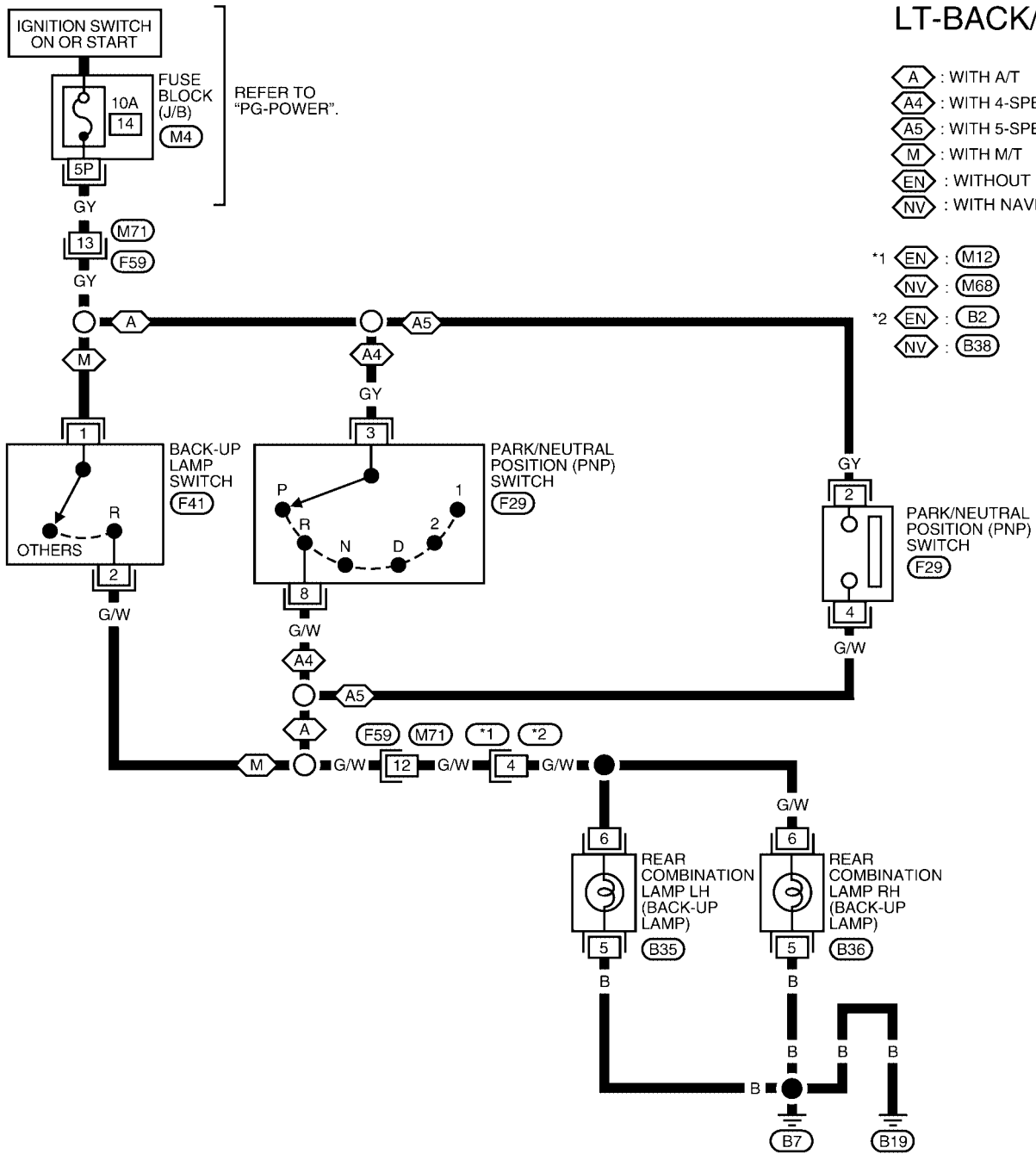

- A** : WITH A/T
- A4** : WITH 4-SPEED A/T
- A5** : WITH 5-SPEED A/T
- M** : WITH M/T
- EN** : WITHOUT NAVI
- NV** : WITH NAVI

- *1 **EN** : **M12**
- NV** : **M68**
- *2 **EN** : **B2**
- NV** : **B38**

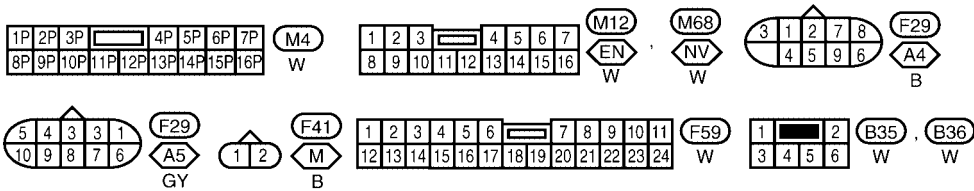

BACK-UP LAMP

Bulb Replacement

EKS008NU

REMOVAL

1. Remove rear combination lamp. Refer to [LT-96, "REAR COMBINATION LAMP"](#) .
2. Turn bulb socket counterclockwise to unlock and remove.
3. Pull bulb from socket to remove.

INSTALLATION

Installation is in the reverse order of removal.

Removal and Installation

EKS008NV

Refer to [LT-96, "REAR COMBINATION LAMP"](#) .

PARKING, LICENSE PLATE AND TAIL LAMPS

PF2:26550

Component Parts and Harness Connector Location

EKS00A88

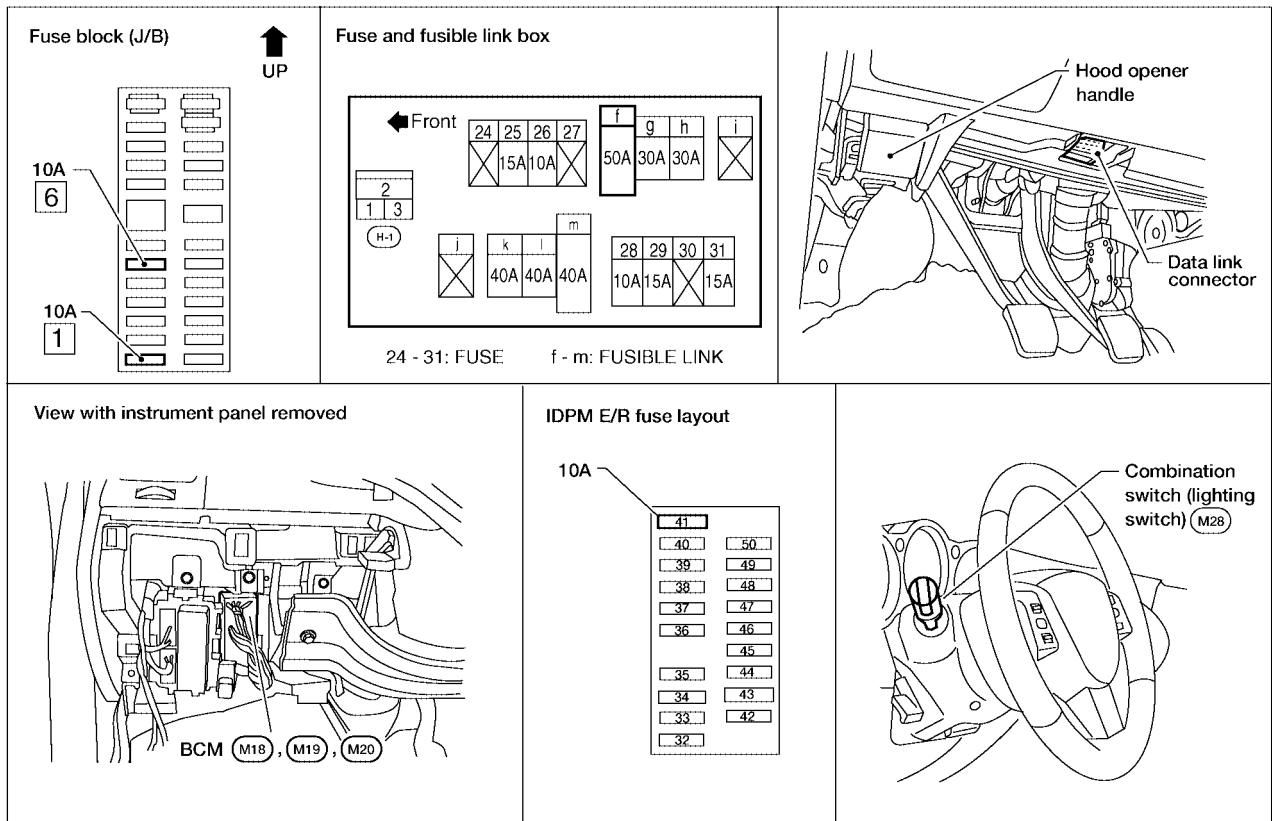

WKIA4089E

System Description

EKS008NV

Control of the parking, license plate, and tail lamp operation is dependent upon the position of the lighting switch (combination switch). When the lighting switch is placed in the 1ST position, the BCM (body control module) receives input signal requesting the parking, license plate, and tail lamps to illuminate. This input signal is communicated to the IPDM E/R (intelligent power distribution module engine room) across the CAN communication lines. The CPU (central processing unit) of the IPDM E/R controls the tail lamp relay coil. When energized, this relay directs power to the parking, license plate, and tail lamps, which then illuminate. Power is supplied at all times

- through 10A fuse (No. 41, located in the IPDM E/R)
- to tail lamp relay, located in the IPDM E/R, and
- through 50A fusible link (letter f, located in the fuse and fusible link box)
- to BCM terminal 70.

With the ignition switch in the ON or START position, power is supplied

- through 10A fuse [No. 1, located in the fuse block (J/B)]
- to BCM terminal 38.

With the ignition switch in the ACC or ON position, power is supplied

- through 10A fuse [No. 6, located in the fuse block (J/B)]
- to BCM terminal 11.

Ground is supplied

- to BCM terminal 67
- through grounds F14, M57 and M61.

OPERATION BY LIGHTING SWITCH

With the lighting switch in the 1st or 2nd position (or if the auto light system is activated), the BCM receives input signal requesting the parking, license plate, and tail lamps to illuminate. This input signal is communi-

A
B
C
D
E
F
G
H
I
J
LT
L
M

PARKING, LICENSE PLATE AND TAIL LAMPS

cated to the IPDM E/R across the CAN communication lines. The CPU of the IPDM E/R controls the tail lamp relay coil. When energized, this relay directs power

- through terminal 22 of the IPDM E/R
- to front combination lamp LH terminal 1
- to front combination lamp RH terminal 1
- to rear combination lamp LH terminal 2
- to rear combination lamp RH terminal 2
- to license lamp LH terminal +
- to license lamp RH terminal +.

Ground is supplied

- to front combination lamp LH terminal 2
- to front combination lamp RH terminal 2
- through grounds E15 and E24, and
- to rear combination lamp LH terminal 5
- to rear combination lamp RH terminal 5
- to license lamp LH terminal –
- to license lamp RH terminal –
- through grounds B7 and B19.

With power and ground supplied, the parking, license and tail lamps illuminate.

BATTERY SAVER CONTROL

When the combination switch (lighting switch) is in the 1ST (or 2ND) position and the ignition switch is turned from ON or ACC to OFF, the battery saver control feature is activated.

Under this condition, the parking, license plate, and tail lamps remain illuminated for 5 minutes, unless the combination switch (lighting switch) position is changed. If the combination switch (lighting switch) position is changed, then the parking, license plate and tail lamps are turned off.

CAN Communication System Description

EKS008NX

Refer to [LAN-20, "CAN COMMUNICATION"](#) .

PARKING, LICENSE PLATE AND TAIL LAMPS

Schematic

EKS008NY

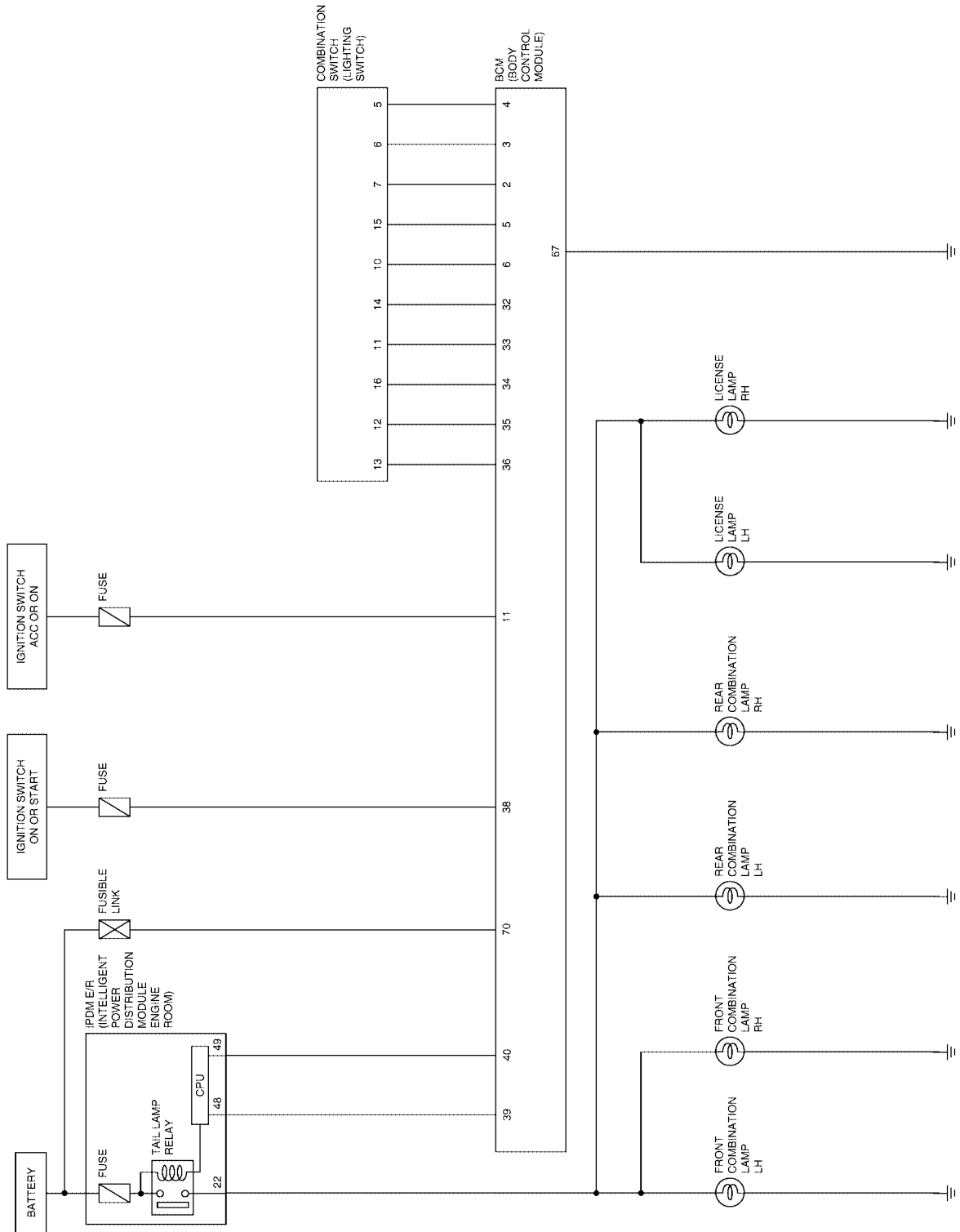

A
B
C
D
E
F
G
H
I
J
LT
L
M

PARKING, LICENSE PLATE AND TAIL LAMPS

EKS008NZ

Wiring Diagram — TAIL/L —

LT-TAIL/L-01

— : DATA LINE

REFER TO "PG-POWER".

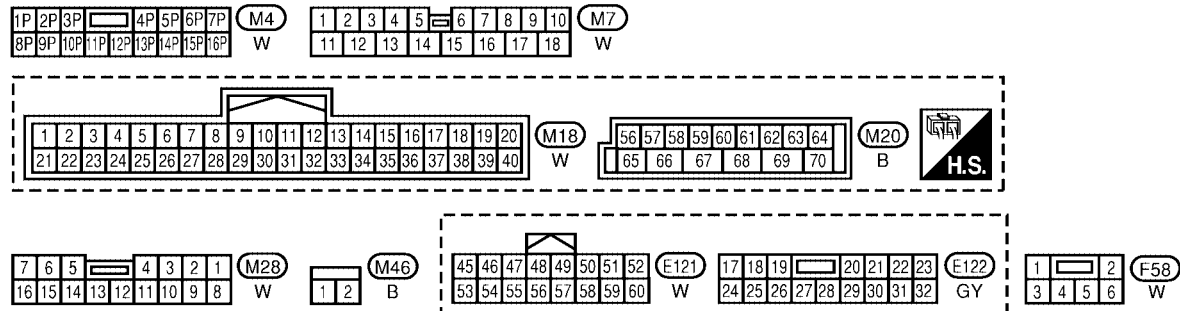
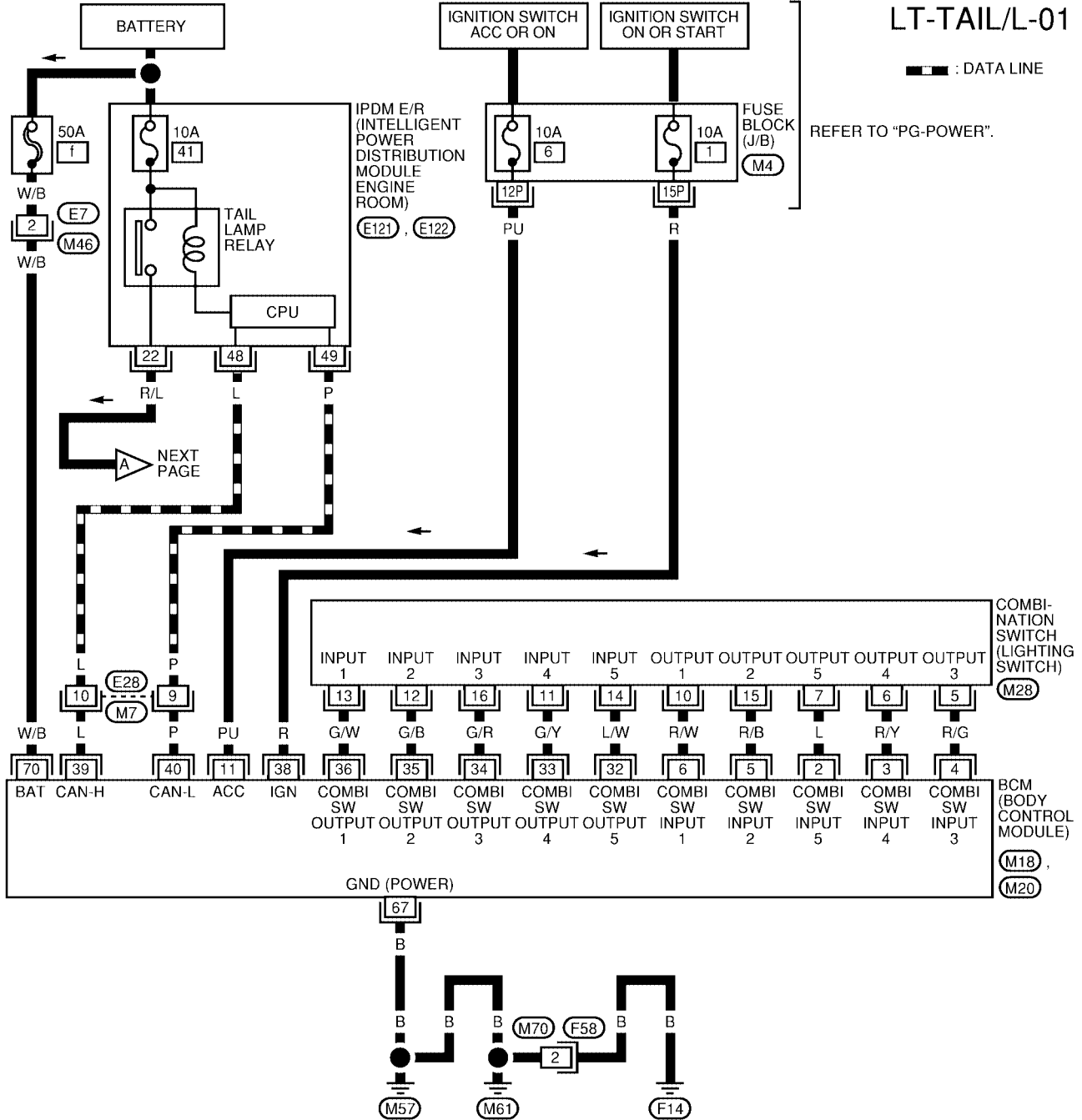

WKWA1317E

PARKING, LICENSE PLATE AND TAIL LAMPS

LT-TAIL/L-02

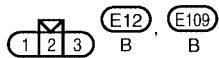
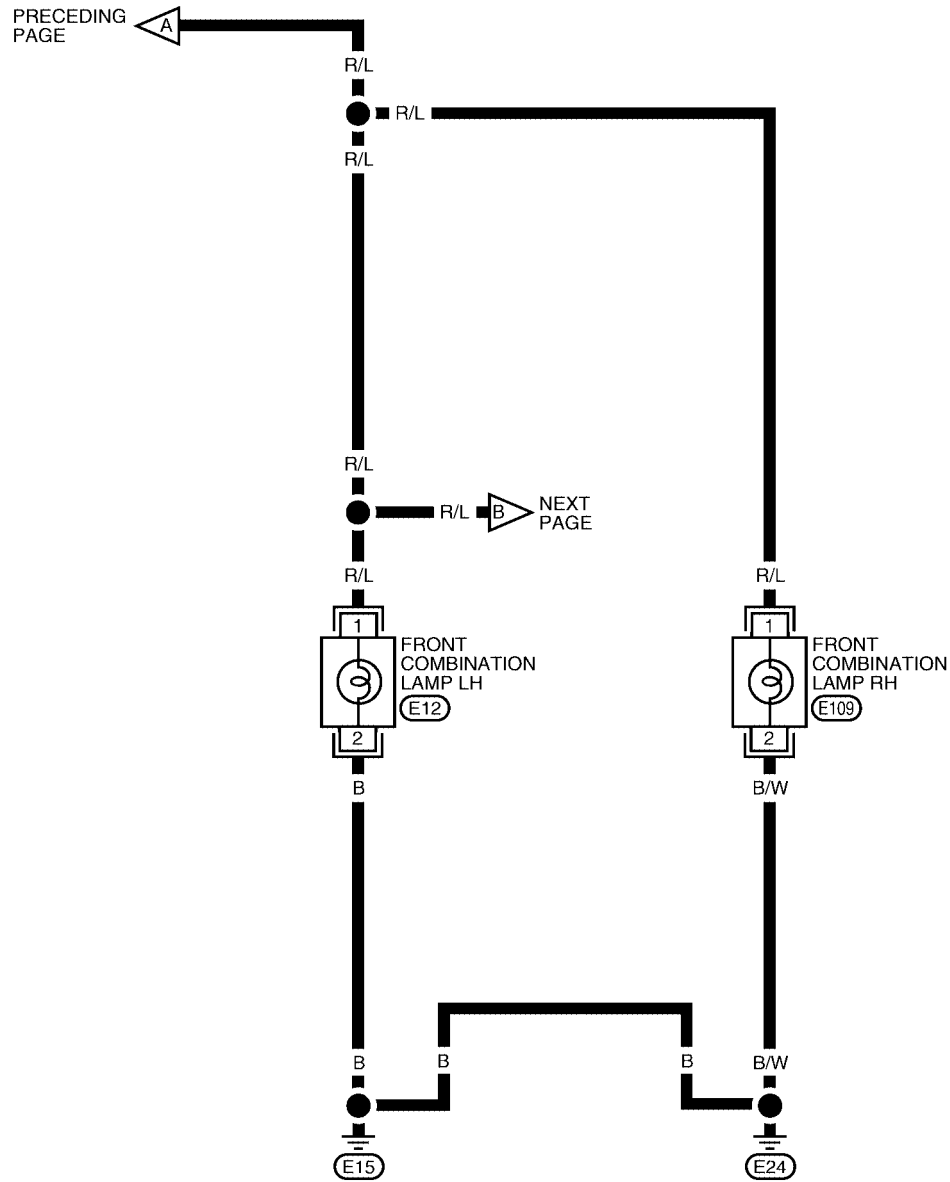

A
B
C
D
E
F
G
H
I
J
LT
L
M

WKWA0193E

PARKING, LICENSE PLATE AND TAIL LAMPS

LT-TAIL/L-03

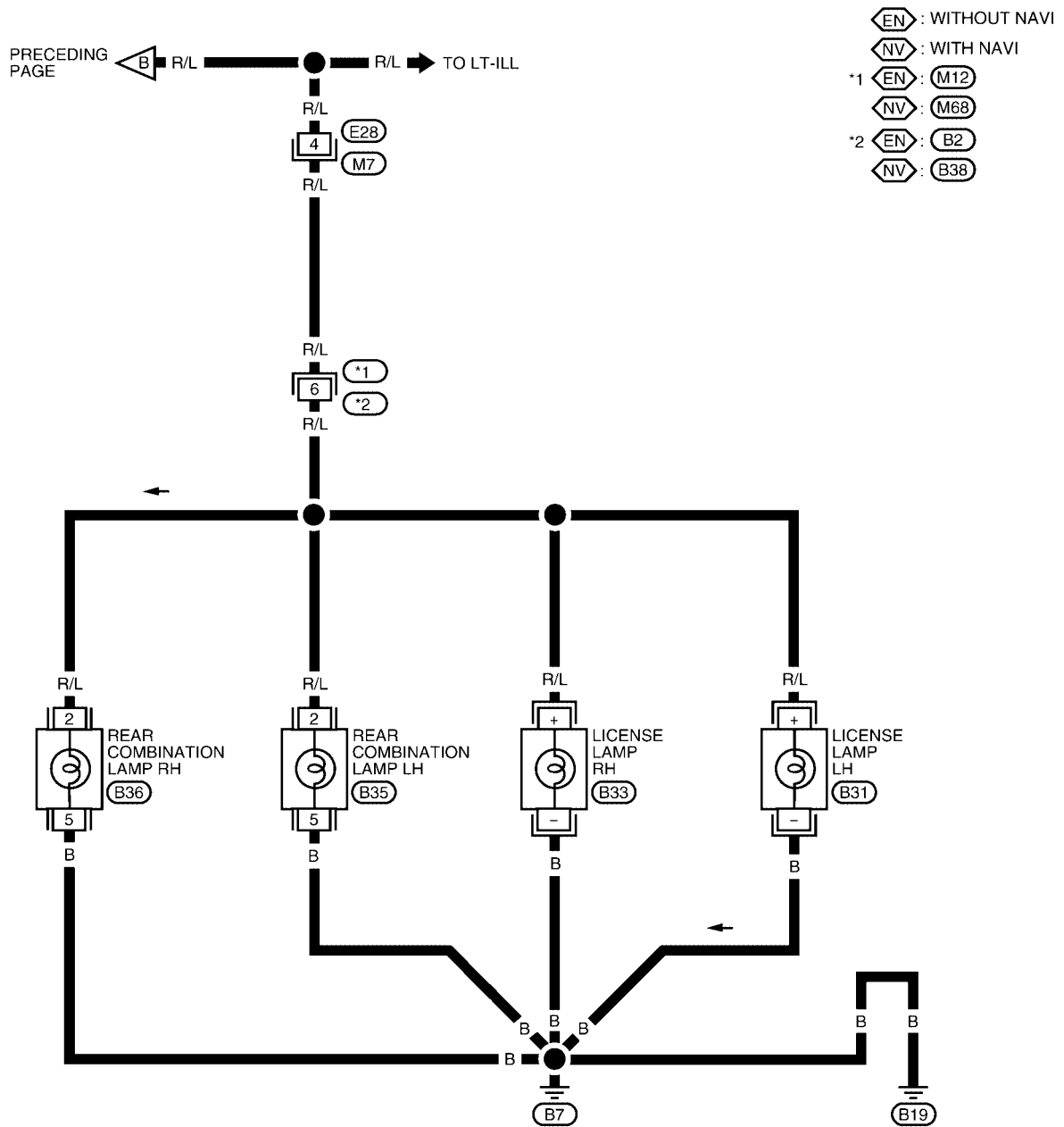

- EN : WITHOUT NAVI
- NV : WITH NAVI
- *1 EN : M12
- NV : M68
- *2 EN : B2
- NV : B38

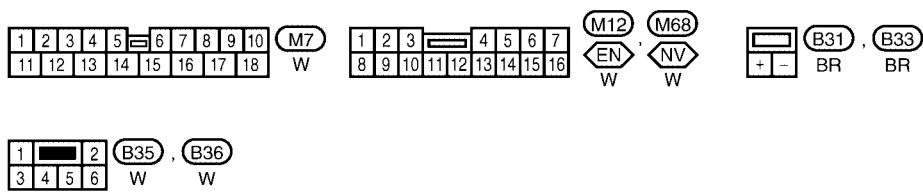





WKWA1374E

PARKING, LICENSE PLATE AND TAIL LAMPS

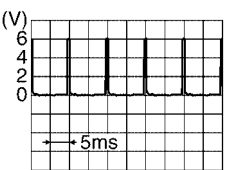
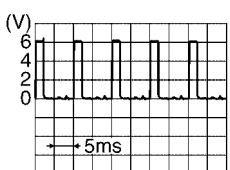
Terminals and Reference Values for BCM

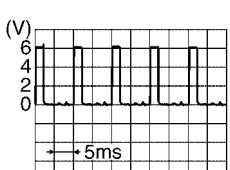
EKS00800

Terminal No.	Wire color	Signal name	Measuring condition		Reference value (Approx.)
			Ignition switch	Operation or condition	
2	L	Combination switch input 5	ON	Lighting, turn, wiper OFF Wiper dial position 4	 <p style="text-align: right;">SKIA5291E</p>
3	R/Y	Combination switch input 4	ON	Lighting, turn, wiper OFF Wiper dial position 4	 <p style="text-align: right;">SKIA5292E</p>
4	R/G	Combination switch input 3	ON	Lighting, turn, wiper OFF Wiper dial position 4	 <p style="text-align: right;">SKIA5291E</p>
5	R/B	Combination switch input 2	ON	Lighting, turn, wiper OFF Wiper dial position 4	 <p style="text-align: right;">SKIA5292E</p>
6	R/W	Combination switch input 1			
11	PU	Ignition switch (ACC)	ACC	—	Battery voltage
32	L/W	Combination switch output 5	ON	Lighting, turn, wiper OFF Wiper dial position 4	 <p style="text-align: right;">SKIA5291E</p>
33	G/Y	Combination switch output 4	ON	Lighting, turn, wiper OFF Wiper dial position 4	 <p style="text-align: right;">SKIA5292E</p>
34	G/R	Combination switch output 3	ON	Lighting, turn, wiper OFF Wiper dial position 4	 <p style="text-align: right;">SKIA5291E</p>

A
B
C
D
E
F
G
H
I
J
LT
L
M

PARKING, LICENSE PLATE AND TAIL LAMPS

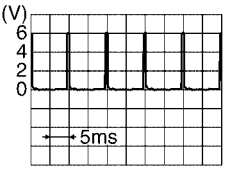
Terminal No.	Wire color	Signal name	Measuring condition		Reference value (Approx.)
			Ignition switch	Operation or condition	
35	G/B	Combination switch output 2	ON	Lighting, turn, wiper OFF Wiper dial position 4	
36	G/W	Combination switch output 1			
38	R	Ignition switch (ON)	ON	—	Battery voltage
39	L	CAN-H	—	—	—
40	P	CAN-L	—	—	—
67	B	Ground	ON	—	0V
70	W/B	Battery power supply (fusible link)	OFF	—	Battery voltage

Terminals and Reference Values for IPDM E/R

EKS00801

Terminal No.	Wire color	Signal name	Measuring condition		Reference value (Approx.)
			Ignition switch	Operation or condition	
22	R/L	Parking, license, and tail lamp	ON	Lighting switch 1ST position	OFF 0V
					ON Battery voltage
48	L	CAN-H	—	—	—
49	P	CAN-L	—	—	—

How to Proceed With Trouble Diagnosis

EKS00802

1. Confirm the symptom or customer complaint.
2. Understand operation description and function description. Refer to [LT-99, "System Description"](#).
3. Perform the Preliminary Check. Refer to [LT-107, "Preliminary Check"](#).
4. Check symptom and repair or replace the cause of malfunction.
5. Do the parking, license plate and tail lamps operate normally? If YES: GO TO 6. If NO: GO TO 4.
6. Inspection End.

PARKING, LICENSE PLATE AND TAIL LAMPS

EKS00803

Preliminary Check CHECK POWER SUPPLY AND GROUND CIRCUIT

1. CHECK FUSES OR FUSIBLE LINK

Check for blown fuses or fusible link.

Unit	Power source	Fuse and fusible link No.
BCM	Battery	f
	Ignition switch ACC or ON	6
	Ignition switch ON or START position	1
IPDM E/R	Battery	41

Refer to [LT-102, "Wiring Diagram — TAIL/L —"](#).

OK or NG

OK >> GO TO 2.

NG >> If fuse or fusible link is blown, be sure to eliminate cause of malfunction before installing new fuse or fusible link. Refer to [PG-4, "POWER SUPPLY ROUTING CIRCUIT"](#).

2. CHECK POWER SUPPLY CIRCUIT

1. Disconnect BCM connectors.
2. Check voltage between BCM harness connector terminals and ground.

BCM (+)		(-)	Ignition switch position		
Connector	Terminal		OFF	ACC	ON
M18	11	Ground	0V	Battery voltage	Battery voltage
	38		0V	0V	Battery voltage
M20	70		Battery voltage	Battery voltage	Battery voltage

OK or NG

OK >> GO TO 3.

NG >> Check harness for open between BCM and fuse or fusible link.

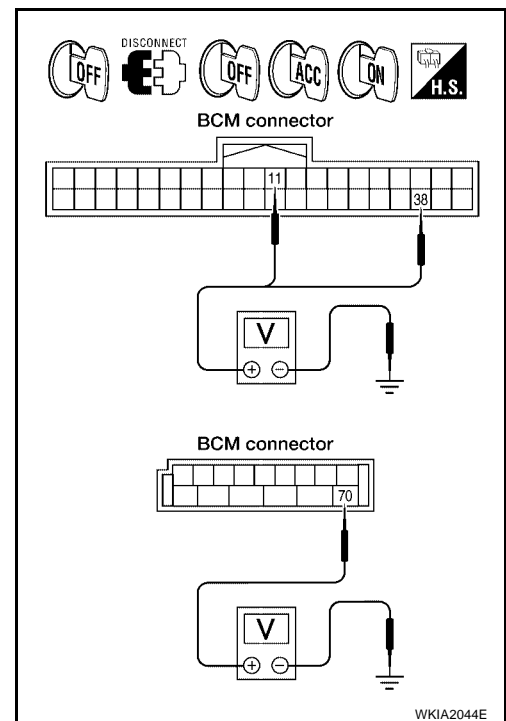

3. CHECK GROUND CIRCUIT

Check continuity between BCM harness connector terminal and ground.

BCM		Continuity
Connector	Terminal	
M20	67	Ground Yes

OK or NG

OK >> Inspection End.

NG >> Check ground circuit harness.

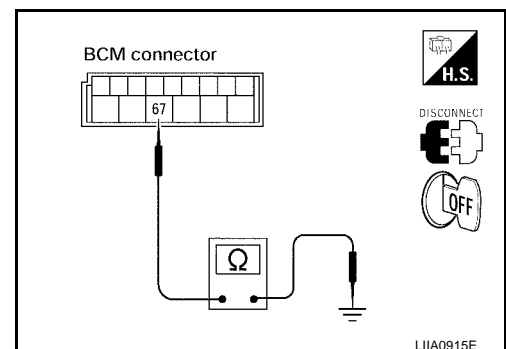

PARKING, LICENSE PLATE AND TAIL LAMPS

CONSULT-II Functions

EKS00804

Refer to [LT-15, "CONSULT-II Function \(BCM\)"](#) in HEADLAMP (FOR USA).

Refer to [LT-17, "CONSULT-II Function \(IPDM E/R\)"](#) in HEADLAMP (FOR USA).

Parking, License Plate and/or Tail Lamps Do Not Illuminate

EKS00805

1. CHECK COMBINATION SWITCH INPUT SIGNAL

Ⓟ With CONSULT-II

Select "BCM" on CONSULT-II. With "HEAD LAMP" data monitor, make sure "LIGHT SW 1ST" turns ON-OFF linked with operation of lighting switch.

**When lighting switch is in : LIGHT SW 1ST ON
1ST position**

ⓧ Without CONSULT-II

Refer to [LT-91, "Combination Switch Inspection"](#).

OK or NG

OK >> GO TO 2.

NG >> Check lighting switch. Refer to [LT-91, "Combination Switch Inspection"](#).

DATA MONITOR	
MONITOR	
LIGHT SW 1ST	ON

SKIA5956E

2. ACTIVE TEST

Ⓟ With CONSULT-II

1. Select "IPDM E/R" on CONSULT-II, and select "ACTIVE TEST" on "SELECT DIAG MODE" screen.
2. Select "TAIL LAMP" on "SELECT TEST ITEM" screen.
3. Touch "ON" on "ACTIVE TEST" screen.
4. Make sure parking, license plate, side marker and tail lamp operation.

Parking, license plate, side marker and tail lamp should operate.

ⓧ Without CONSULT-II

1. Start auto active test. Refer to [PG-22, "Auto Active Test"](#).
2. Make sure parking, license plate, side marker and tail lamps operate.

Parking, license plate, side marker and tail lamp should operate.

OK or NG

OK >> GO TO 3.

NG >> GO TO 4.

ACTIVE TEST			
TAIL LAMP		OFF	
ON			
MODE	BACK	LIGHT	COPY

SKIA5957E

PARKING, LICENSE PLATE AND TAIL LAMPS

3. CHECK IPDM E/R

1. Select "IPDM E/R" on CONSULT-II, and select "DATA MONITOR" on "SELECT DIAG MODE" screen.
2. Make sure "TAIL&CLR REQ" turns ON when lighting switch is in 1ST position.

When lighting switch is in 1ST position : TAIL&CLR REQ ON

OK or NG

- OK >> Replace IPDM E/R. Refer to [PG-28, "Removal and Installation of IPDM E/R"](#) .
- NG >> Replace BCM. Refer to [BCS-20, "Removal and Installation of BCM"](#) .

DATA MONITOR			
MONITOR			
TAIL&CLR REQ		ON	
RECORD			
MODE	BACK	LIGHT	COPY

SKIA5958E

A
B
C
D
E
F
G
H
I
J
LT
L
M

PARKING, LICENSE PLATE AND TAIL LAMPS

4. CHECK INPUT SIGNAL

Ⓟ With CONSULT-II

1. Turn ignition switch OFF.
2. Disconnect front combination lamp, license plate lamp and rear combination lamp connectors.
3. Turn ignition switch ON.
4. Select "IPDM E/R" on CONSULT-II, and select "ACTIVE TEST" on "SELECT DIAG MODE" screen.
5. Select "TAIL LAMP" on "SELECT TEST ITEM" screen.
6. Touch "ON" on "ACTIVE TEST" screen.
7. When tail lamp is operating, check voltage between front combination lamp, license plate lamp, rear combination lamp harness connector and ground.

ⓧ Without CONSULT-II

1. Turn ignition switch OFF.
2. Disconnect front combination lamp, license plate lamp and rear combination lamp connectors.
3. Start auto active test. Refer to [PG-22, "Auto Active Test"](#) .
4. When tail lamp is operating, check voltage between front combination lamp, license plate lamp, rear combination lamp harness connector and ground.

Terminals		Terminal	(-)	Voltage (Approx.)
(+)				
Front combination lamp connector		1	Ground	Battery voltage
RH	E109			
LH	E12			

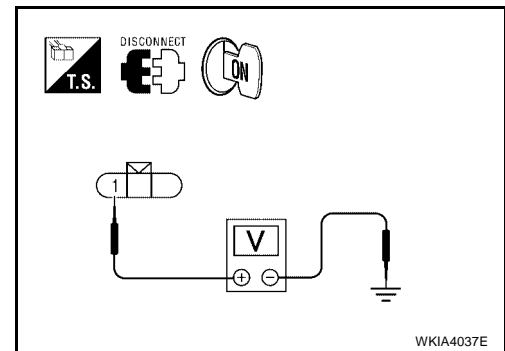

License plate lamp		Terminal	(-)	Voltage (Approx.)
(+)				
Connector		+	Ground	Battery voltage
RH	B33			
LH	B31			

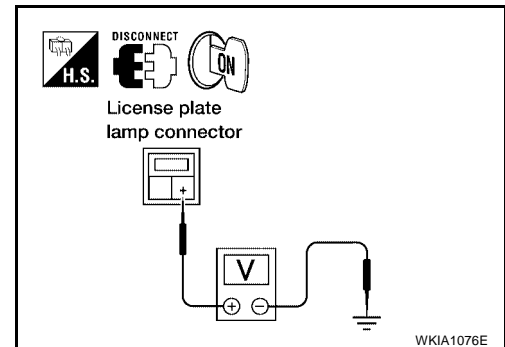

Terminals		Terminal	(-)	Voltage (Approx.)
(+)				
Rear combination lamp connector		2	Ground	Battery voltage
RH	B36			
LH	B35			

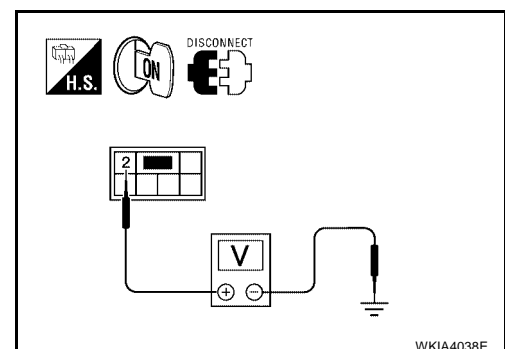

OK or NG

- OK >> GO TO 6.
 NG >> GO TO 5.

PARKING, LICENSE PLATE AND TAIL LAMPS

5. CHECK PARKING, LICENSE PLATE AND TAIL LAMP CIRCUIT

1. Turn ignition switch OFF.
2. Disconnect IPDM E/R connector.
3. Check continuity between IPDM E/R harness connector and front combination lamp harness connector.

A		B		Continuity	
IPDM E/R connector	Terminal	Front combination lamp connector			
E122	22	RH	E109	1	Yes
		LH	E12		

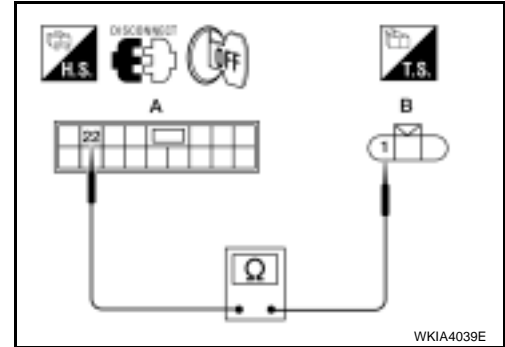

4. Check continuity between IPDM E/R harness connector and license plate lamp harness connector.

IPDM E/R		License plate lamp		Continuity	
Connector	Terminal	Connector	Terminal		
E122	22	RH	B33	+	Yes
		LH	B31		

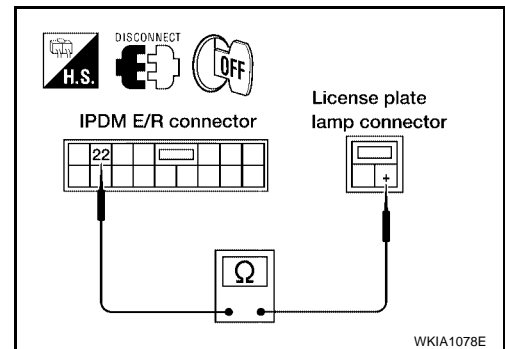

5. Check continuity between IPDM E/R harness connector and rear combination lamp harness connector.

IPDM E/R		Rear combination lamp		Continuity	
Connector	Terminal	Connector	Terminal		
E122	22	RH	B36	2	Yes
		LH	B35		

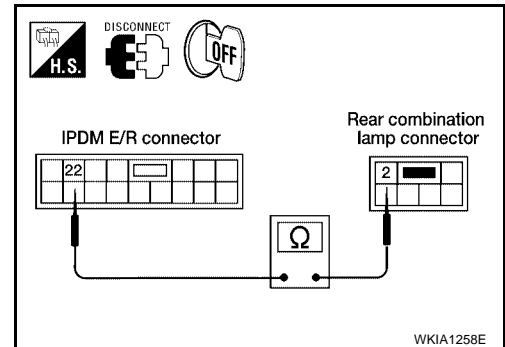

OK or NG

- OK >> Replace IPDM E/R. Refer to [PG-28, "Removal and Installation of IPDM E/R"](#) .
- NG >> Repair harness or connector.

PARKING, LICENSE PLATE AND TAIL LAMPS

6. CHECK GROUND

1. Turn ignition switch OFF.
2. Check continuity between front combination lamp harness connector and ground.

Front combination lamp connector		Terminal		Continuity
RH	E109	2	Ground	Yes
LH	E12			

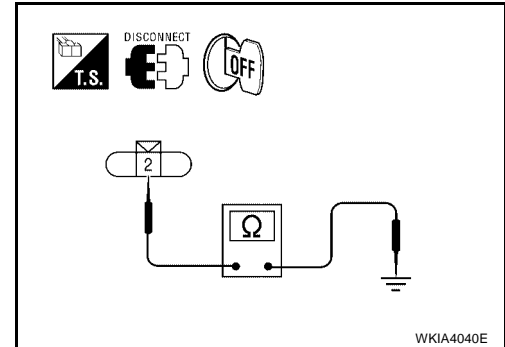

3. Check continuity between license lamp plate harness connector and ground.

License plate lamp		Terminal		Continuity
Connector				
RH	B33	-	Ground	Yes
LH	B31			

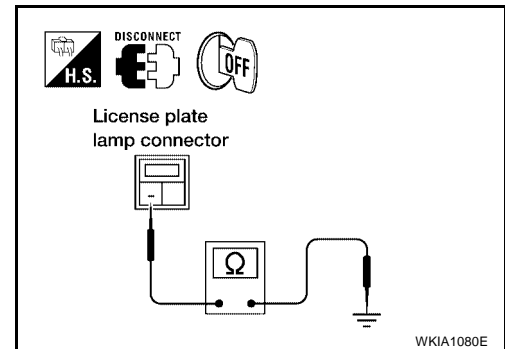

4. Check continuity between rear combination lamp harness connector and ground.

Rear combination lamp		Terminal		Continuity
Connector				
RH	B36	5	Ground	Yes
LH	B35			

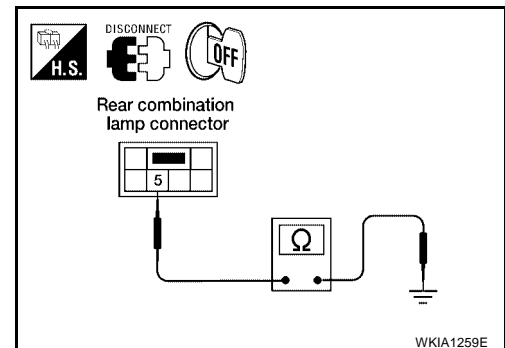

OK or NG

- OK >> Check bulbs.
- NG >> Repair harness or connector.

Parking, License Plate and Tail Lamps Do Not Turn OFF (After Approx. 10 Minutes)

EKS00806

1. CHECK IPDM E/R

1. Turn ignition switch ON. Turn the combination switch (lighting switch) to the OFF position. Turn ignition switch OFF.
2. Verify that the parking, license plate, and tail lamps turn on and off after approximately 10 minutes.

OK or NG

- OK >> Ignition relay malfunction. Refer to [PG-17, "Function of Detecting Ignition Relay Malfunction"](#).
- NG >> Inspection End.

PARKING, LICENSE PLATE AND TAIL LAMPS

Bulb Replacement LICENSE PLATE LAMP

EKS00807

Removal

1. Position trunk lid finisher aside.
2. Turn bulb socket counterclockwise to unlock and remove.
3. Pull bulb to remove from socket.

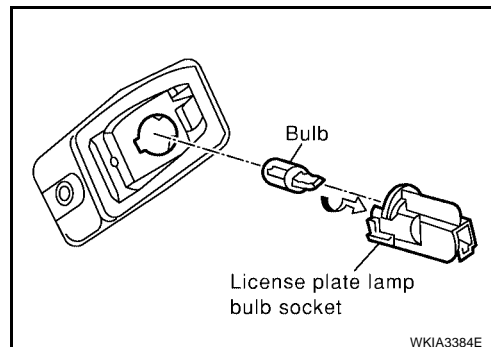

Installation

Installation is in the reverse order of removal.

FRONT TURN SIGNAL (PARKING) LAMP

For bulb replacement, refer to [LT-85, "FRONT TURN SIGNAL LAMP"](#).

TAIL LAMP

Removal

1. Remove rear combination lamp. Refer to [LT-96, "REAR COMBINATION LAMP"](#).
2. Turn bulb socket counterclockwise to unlock and remove.
3. Pull bulb to remove from socket.

Installation

Installation is in the reverse order of removal.

Removal and Installation LICENSE PLATE LAMP

EKS00808

Removal

1. Remove the license plate finisher. Refer to [EI-23, "Removal and Installation"](#).
2. Disconnect the license plate lamp connector.
3. Remove the license plate lamp mounting screw and remove the license plate lamp from the vehicle.

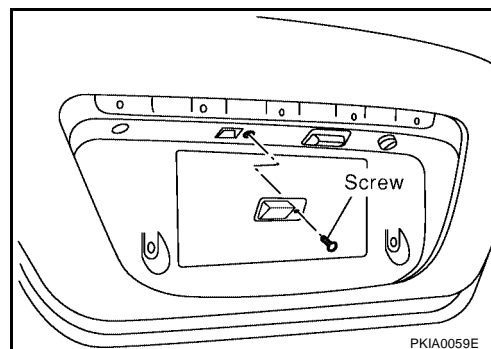

Installation

Installation is in the reverse order of removal.

FRONT TURN SIGNAL (PARKING) LAMP

For front turn signal (parking) lamp removal and installation procedures, refer to [LT-29, "Removal and Installation"](#).

REAR COMBINATION LAMP

For rear combination lamp removal and installation procedures, refer to [LT-96, "REAR COMBINATION LAMP"](#).

INTERIOR ROOM LAMP

PFP:26410

INTERIOR ROOM LAMP

Component Parts and Harness Connector Location

EKS00809

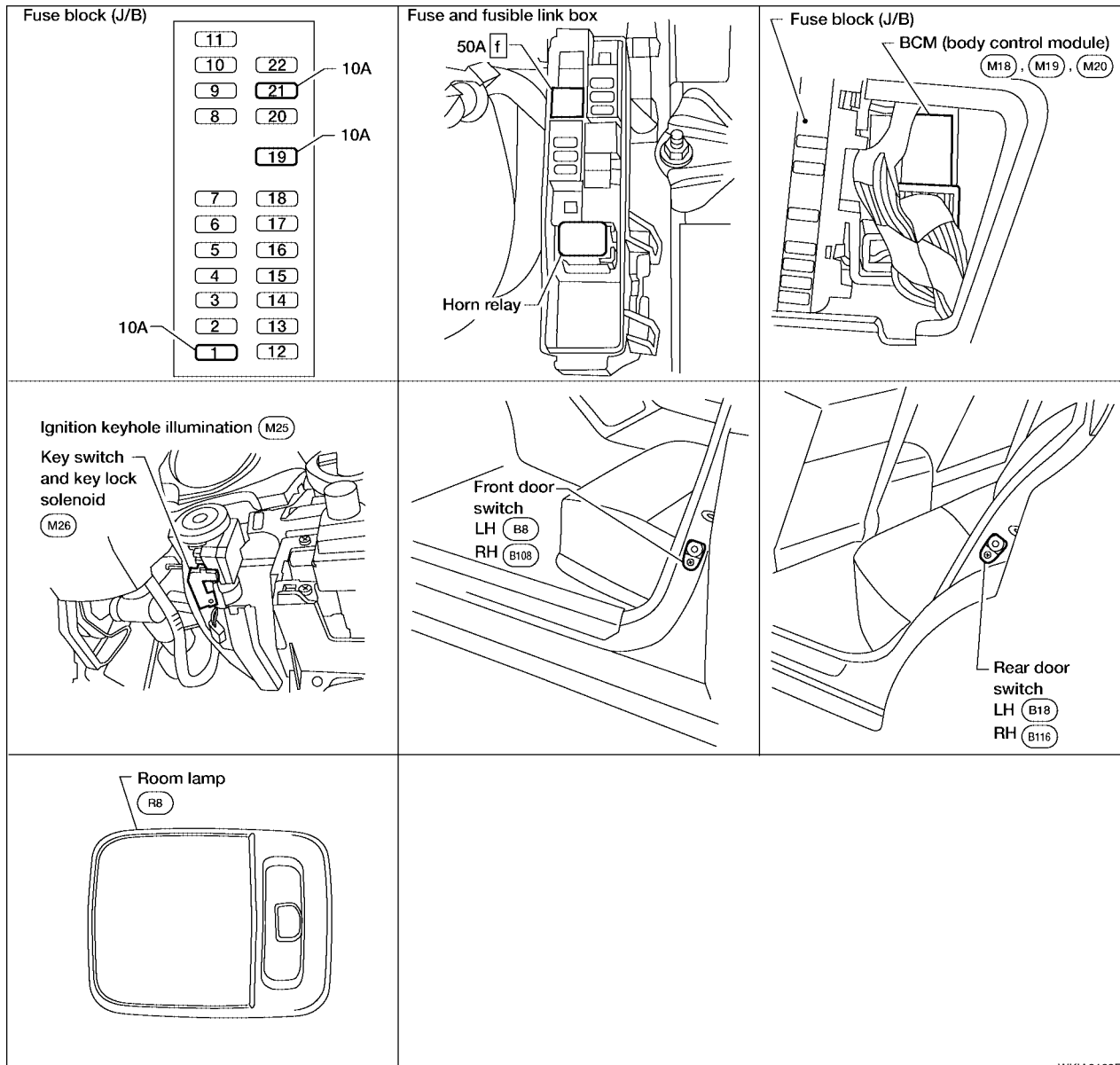

WKIA3163E

System Description

EKS0080A

When room lamp switch is in DOOR position, room lamp ON/OFF is controlled by timer according to signals from switches including key switch and key lock solenoid, front door switch LH, unlock signal from keyfob (with remote keyless entry system), door lock/unlock switch, front door lock assembly LH (key cylinder switch), and ignition switch.

When room lamp turns ON, there is a gradual brightening over 1 second. When room lamp turns OFF, there is a gradual dimming over 1 second.

The room lamp timer is controlled by the BCM (body control module).

Room lamp timer control settings can be changed with CONSULT-II.

Ignition keyhole illumination turns ON when front door LH is opened (door switch ON) or key is removed from key cylinder. Illumination turns OFF when the ignition switch is turned ON or by room lamp timer.

Step lamp turns ON when a front or rear door is opened (door switch ON). Lamp turns OFF when front and rear doors are closed (all door switches OFF).

POWER SUPPLY AND GROUND

Power is supplied at all times

- through 10A fuse [No. 21, located in the fuse block (J/B)]

INTERIOR ROOM LAMP

- to key switch and key lock solenoid terminal 3
- to BCM terminal 57, and
- through 50A fusible link (letter f , located in the fuse and fusible link box)
- to BCM terminal 70.

When the key is inserted in ignition switch, power is supplied

- through the key switch and key lock solenoid terminal 4
- to BCM terminal 37.

With the ignition switch in the ON or START position, power is supplied

- through 10A fuse [No. 1, located in the fuse block (J/B)]
- to BCM terminal 38.

Ground is supplied

- to BCM terminal 67
- through grounds F14, M57 and M61.

When the front door LH is opened, ground is supplied

- to BCM terminal 47
- through case ground of front door switch LH.

When the front door RH is opened, ground is supplied

- to BCM terminal 12
- through case ground of front door switch RH.

When the rear door LH is opened, ground is supplied

- to BCM terminal 48
- through case ground of rear door switch LH.

When the rear door RH is opened, ground is supplied

- to BCM terminal 13
- through case ground of rear door switch RH.

The BCM also receives a ground signal when

- either front door is unlocked with the lock/unlock switch
- the doors are unlocked with keyfob (with remote keyless entry system)
- the front door LH is unlocked with key (key cylinder unlock signal).

When a signal, or combination of signals is received by BCM, ground is supplied

- to interior room lamp terminal 2
- through BCM terminal 63, and
- to trunk room lamp terminal –
- through BCM terminal 49, and
- to step lamp RH and LH terminal –
- through BCM terminal 62, and
- to ignition keyhole illumination lamp terminal +
- through BCM terminal 1.

With power and ground supplied, the lamps illuminate.

SWITCH OPERATION

When front door switch LH is ON (door is opened), ground is supplied

- to ignition keyhole illumination terminal +
- through BCM terminal 1.

And power is supplied

- through BCM terminal 56
- to ignition keyhole illumination terminal –.

When any door switch is ON (door is opened), ground is supplied

- to front step lamp LH and RH terminal –

A

B

C

D

E

F

G

H

I

J

LT

L

M

INTERIOR ROOM LAMP

- through BCM terminal 62.

And power is supplied

- through BCM terminal 56
- to step lamp LH and RH terminal +.

When spot lamp switch is ON, ground is supplied

- to spot lamp terminal –
- through grounds F14, M57 and M61.

And power is supplied

- through BCM terminal 56
- to spot lamp terminal +.

When vanity mirror lamp (LH or RH) is ON, ground is supplied

- to vanity mirror lamp (LH and RH) terminal 2
- through grounds F14, M57 and M61.

And power is supplied

- through 10A fuse [No. 19, located in the fuse block (J/B)]
- to vanity mirror lamp (LH and RH) terminal 1.

When trunk room lamp is ON, ground is supplied

- to trunk room lamp terminal –
- through BCM terminal 49.

And power is supplied

- through BCM terminal 56
- to trunk room lamp terminal +.

ROOM LAMP TIMER OPERATION

When interior room lamp switch is in DOOR position and when all conditions below are met, BCM performs timer control (maximum 30 seconds) for interior room lamp ON/OFF.

Power is supplied

- through 10A fuse [No. 21, located in the fuse block (J/B)]
- to key switch and key lock solenoid terminal 3.

Key is removed from ignition key cylinder (key switch OFF), power will not be supplied to BCM terminal 37.

Ground is supplied

- to BCM terminal 22 (with left and right front power window anti-pinch system) or terminals 7, 8, 45 and 46 (with left front only power window anti-pinch system)
- through main power window and door lock/unlock switch, power window and door lock/unlock switch RH and front door lock assembly (key cylinder switch).

At the time that either front door is opened, BCM detects that door is unlocked. It determines that interior room lamp timer operation conditions are met and turns the interior room lamp ON for 30 seconds.

When key is in ignition key cylinder (key switch ON), power is supplied

- through key switch and key lock solenoid terminal 4
- to BCM terminal 37.

When key is removed from key switch (key switch OFF), power supply to BCM terminal 37 is terminated. BCM detects that key has been removed, determines that interior room lamp timer conditions are met and turns the interior room lamp ON for 30 seconds.

When front door LH opens → closes and the key is not inserted in the key switch (key switch OFF), BCM terminal 47 changes between 0V (door open) → 12V (door closed). The BCM determines that conditions for interior room lamp operation are met and turns the interior room lamp ON for 30 seconds.

Timer control is canceled under the following conditions.

- Front door LH is locked [when locked with keyfob, main power window and door lock/unlock switch, or front door lock assembly (key cylinder switch)]
- Front door LH is opened (front door switch LH turns ON)
- Ignition switch ON.

INTERIOR ROOM LAMP

INTERIOR LAMP BATTERY SAVER CONTROL

If interior lamp is left ON, it will not be turned out even when door is closed.

BCM turns off interior lamp automatically to save battery 30 minutes after ignition switch is turned OFF.

BCM controls interior lamps listed below:

- Step lamp
- Spot lamp
- Trunk room lamp
- Interior room lamp
- Ignition keyhole illumination lamp

After lamps turn OFF by the battery saver system, the lamps illuminate again when

- signal received from keyfob or main power window and door lock/unlock switch, or front door lock assembly (key cylinder switch) is locked or unlocked
- door is opened or closed
- key is removed from or inserted in ignition key cylinder.

Interior lamp battery saver control period can be changed by the function setting of CONSULT-II.

A

B

C

D

E

F

G

H

I

J

LT

L

M

INTERIOR ROOM LAMP

Schematic

EKS0080B

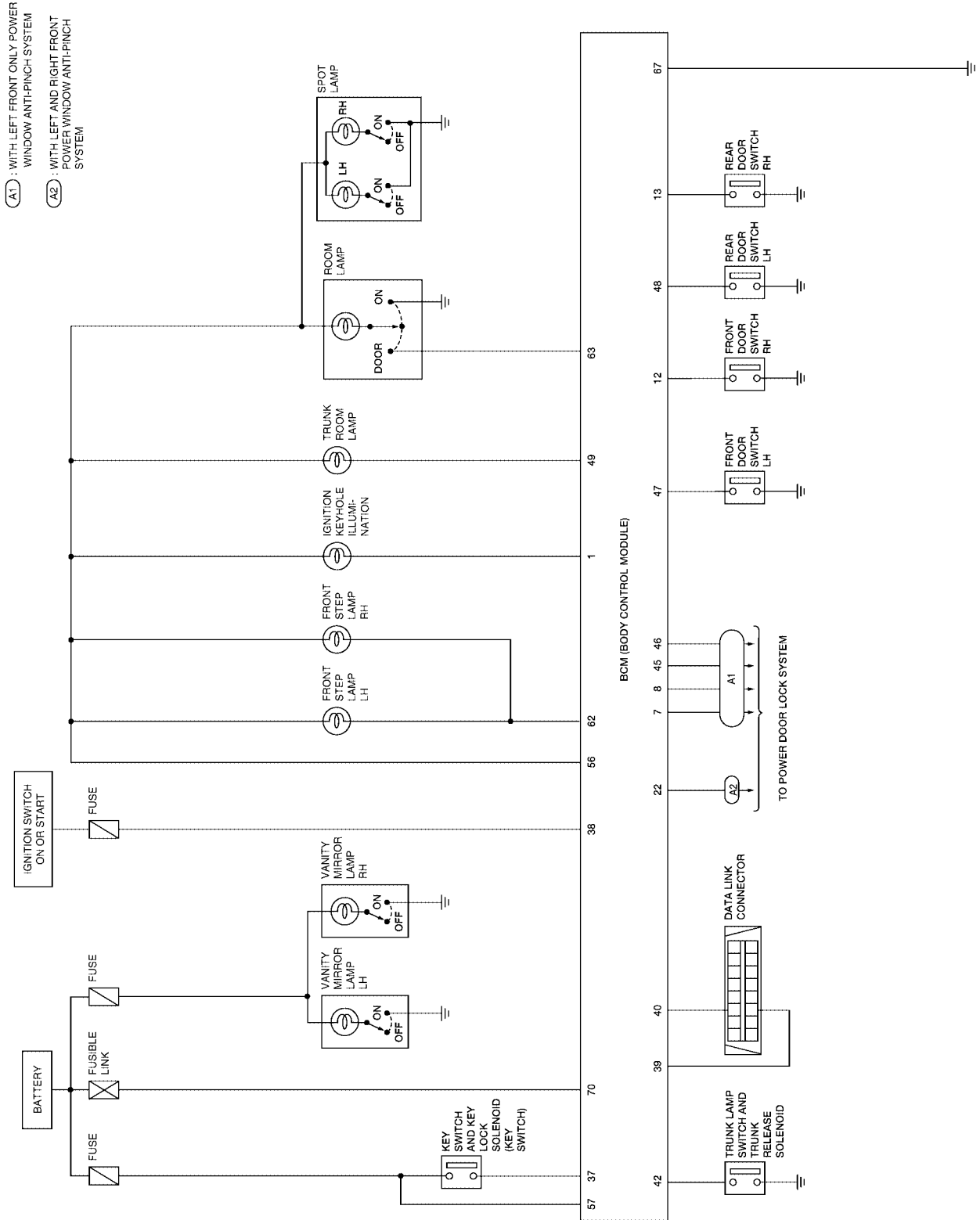

WKWA1393E

INTERIOR ROOM LAMP

Wiring Diagram — INT/L —

EKS0080C

LT-INT/L-01

— : DATA LINE

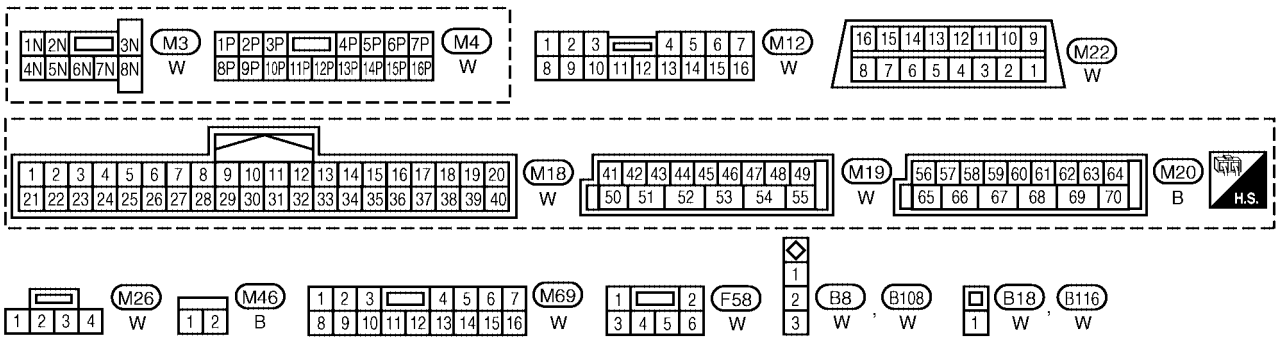
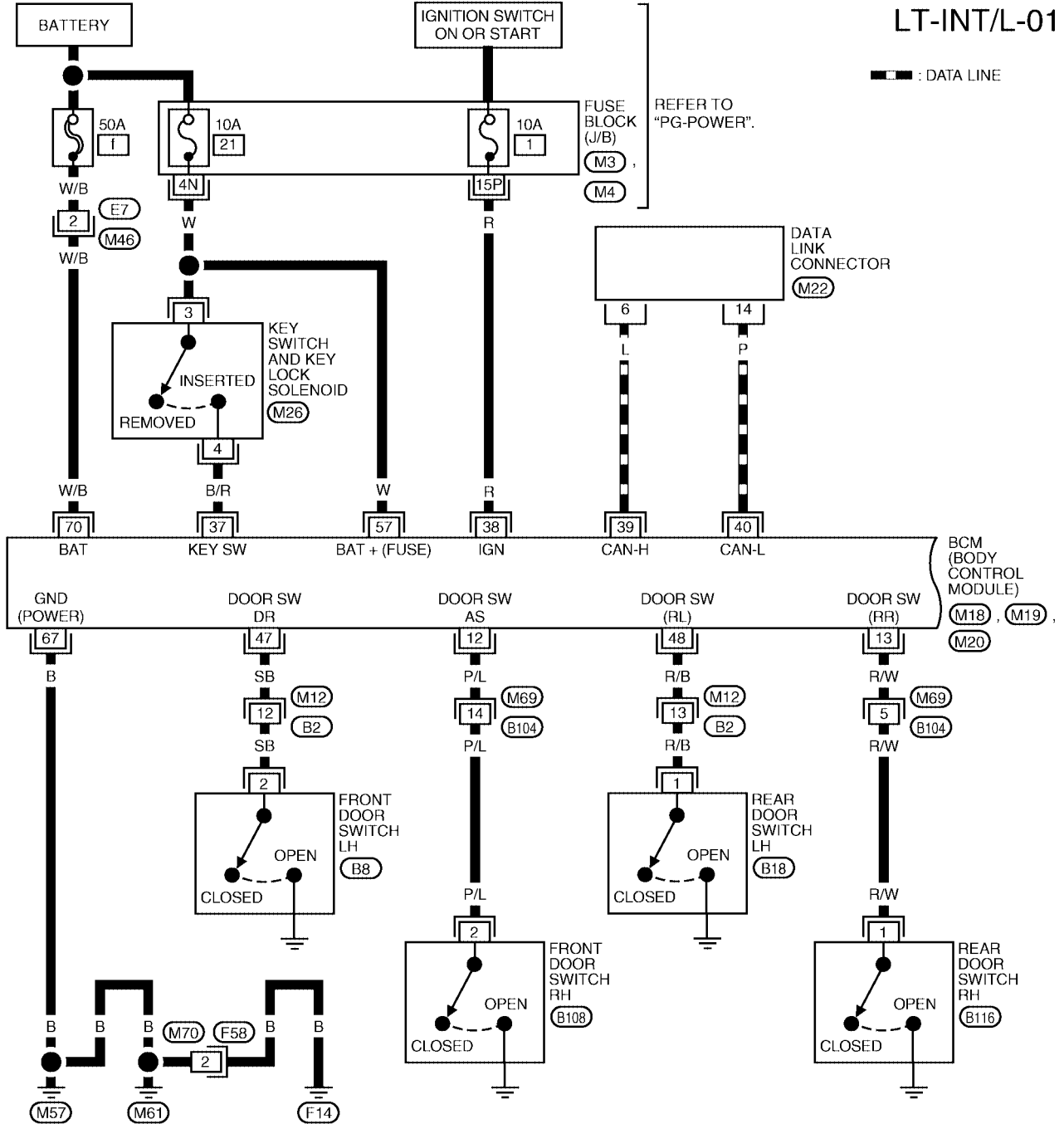

WKWA1319E

INTERIOR ROOM LAMP

LT-INT/L-02

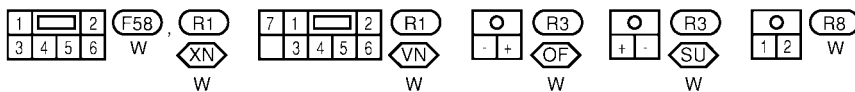
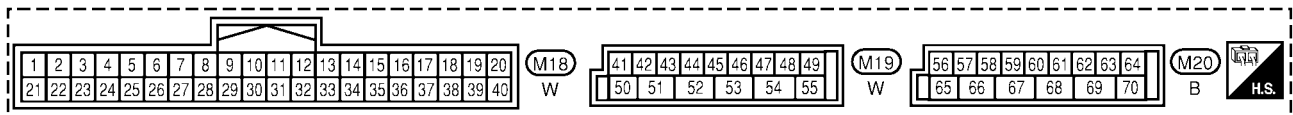
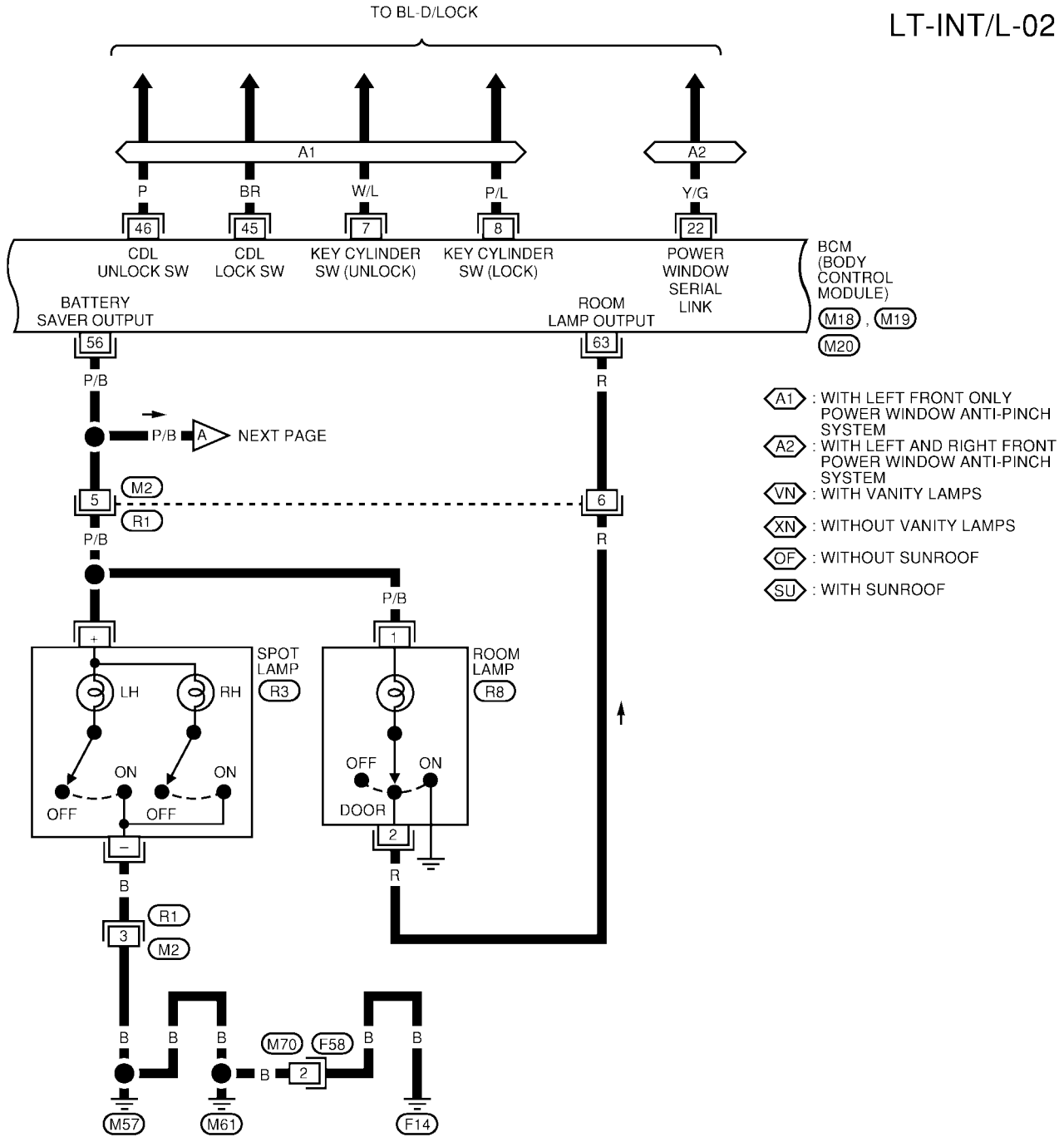

WKWA1394E

INTERIOR ROOM LAMP

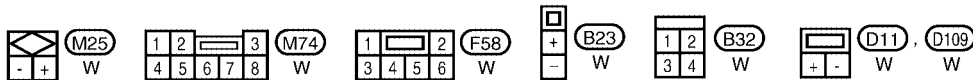
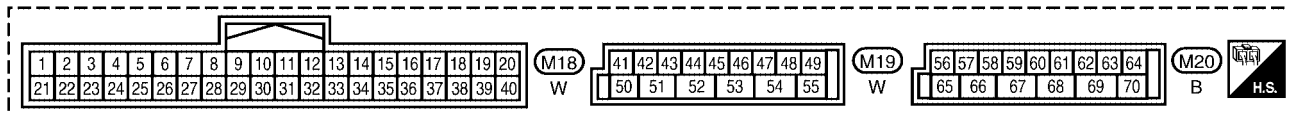
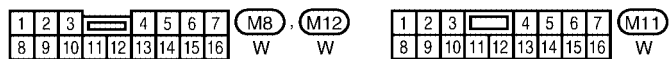
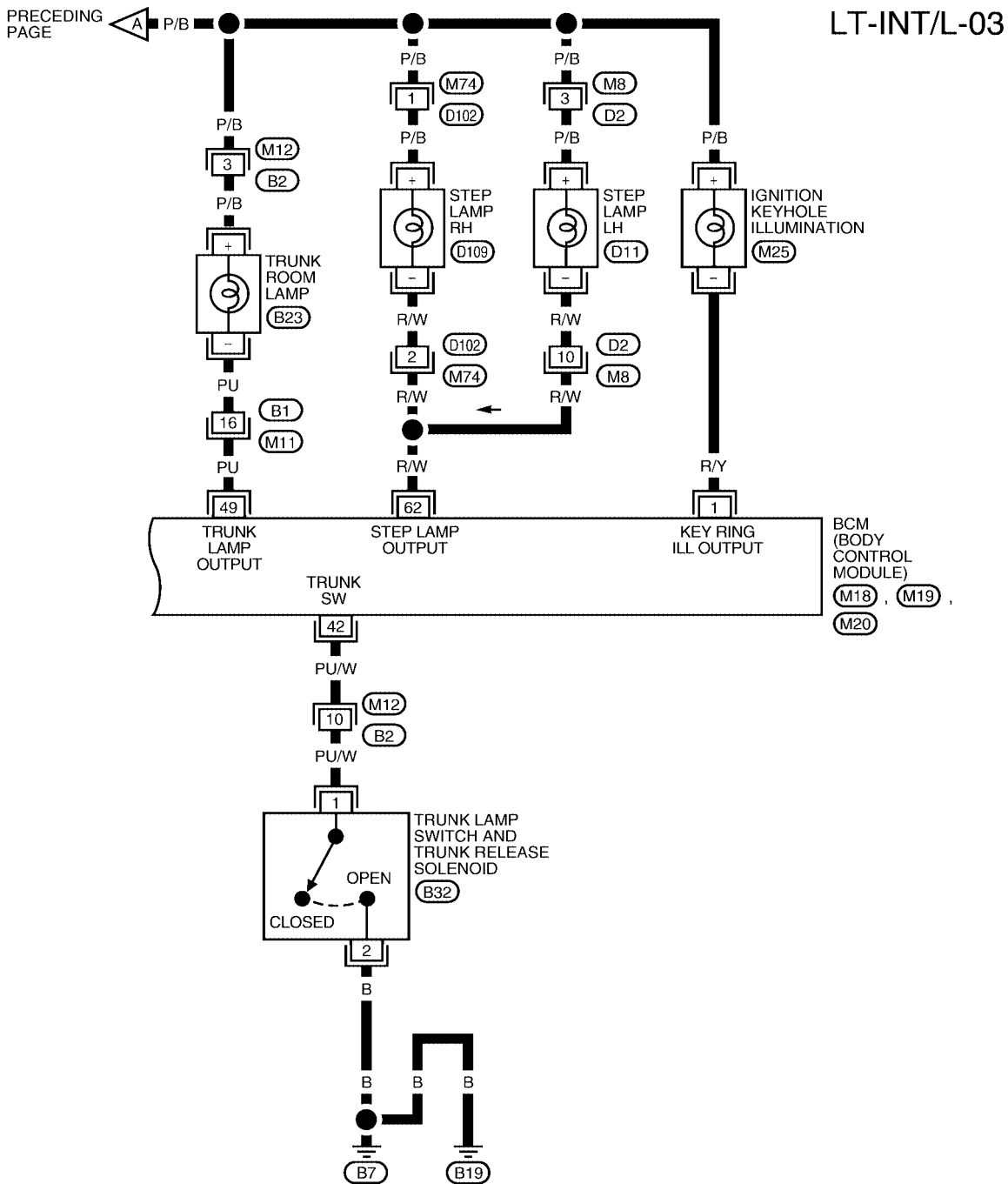

WKWA1395E

INTERIOR ROOM LAMP

EKS009Y8

Models With Vanity Lamps

LT-INT/L-04

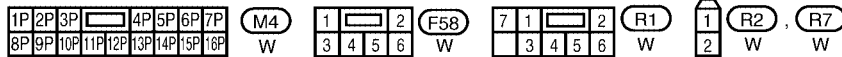
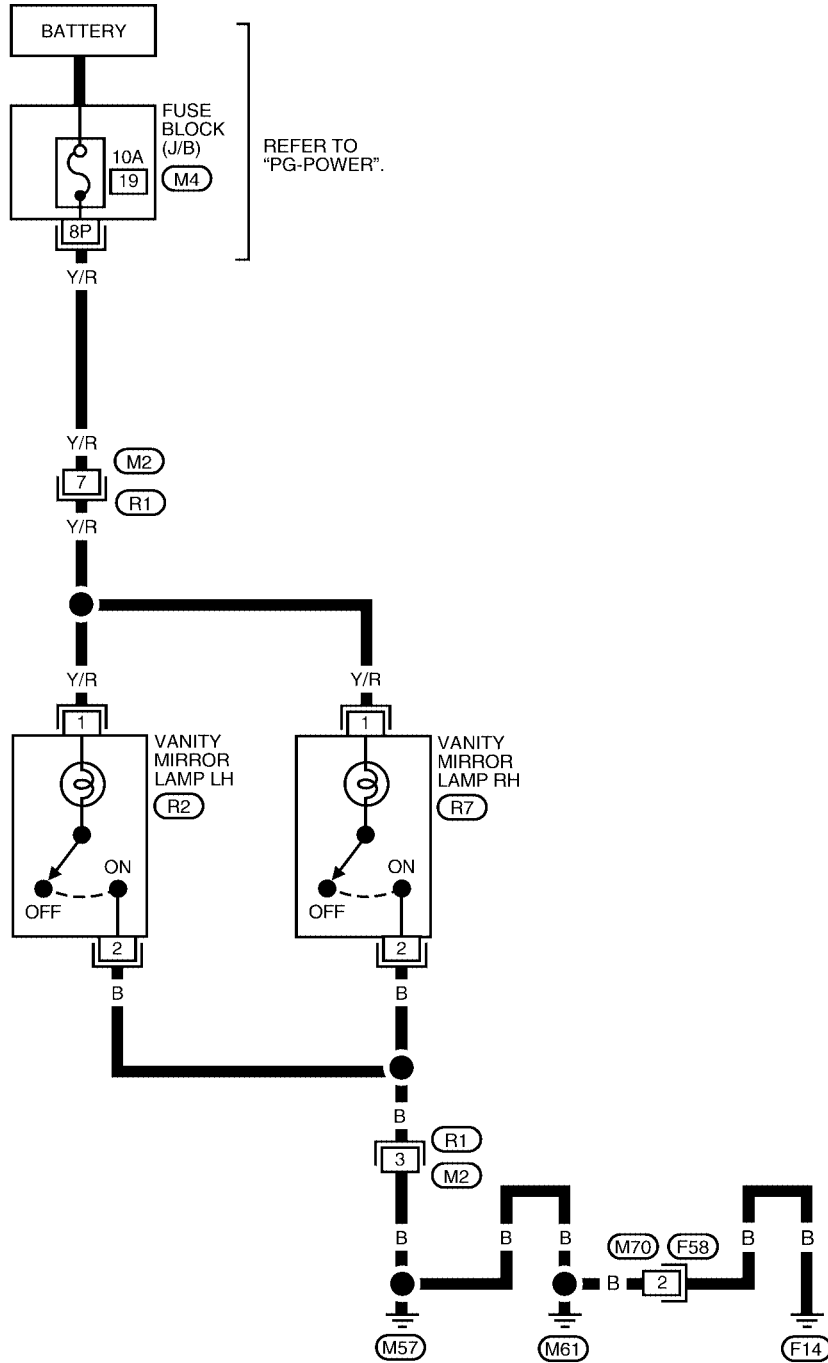

WKWA2974E

INTERIOR ROOM LAMP

Terminals and Reference Values for BCM

EKS0080D

Terminal No.	Wire color	Signal name	Measuring condition		Reference value (Approx.)
			Ignition switch	Operation or condition	
1	R/Y	Ignition keyhole illumination signal	OFF	Door is locked. (SW OFF)	Battery voltage
				Door is unlocked. (SW ON)	0V
7	W/L	Front door key cylinder switch LH (unlock)	OFF	OFF (neutral position)	5V
				ON (unlocked position)	0V
8	P/L	Front door key cylinder switch LH (lock)	OFF	OFF (neutral position)	5V
				ON (locked position)	0V
12	P/L	Front door switch RH signal	OFF	Front door switch RH ON (open)	0V
				OFF (closed)	Battery voltage
13	R/W	Rear door switch RH signal	OFF	Rear door switch RH ON (open)	0V
				OFF (closed)	Battery voltage
22	Y/G	Power window switch serial link	—	When ignition switch ON or power window timer operates	
37	B/R	Key-in switch detection signal	OFF	Vehicle key is removed.	0V
				Vehicle key is inserted.	Battery voltage
38	R	Ignition power supply	ON	—	Battery voltage
39	L	CAN-H	—	—	—
40	P	CAN-L	—	—	—
42	PU/W	Trunk lamp switch signal	OFF	Trunk lid ON (open)	0V
				OFF (closed)	Battery voltage
45	BR	Lock switch signal	OFF	Door lock and unlock switch OFF (neutral position)	Battery voltage
				ON (locked position)	0V
46	P	Unlock switch signal	OFF	Door lock and unlock switch OFF (neutral position)	Battery voltage
				ON (unlocked position)	0V
47	SB	Front door switch LH signal	OFF	Front door switch LH ON (open)	0V
				OFF (closed)	Battery voltage
48	R/B	Rear door switch LH signal	OFF	Rear door switch LH ON (open)	0V
				OFF (closed)	Battery voltage
49	PU	Trunk room lamp signal	OFF	Trunk lid is open (ON)	0V
				Trunk lid is closed (OFF)	Battery voltage
56	P/B	Battery saver output signal	OFF	30 minutes after ignition switch is turned to OFF	0V
			ON	—	Battery voltage
57	W	Battery power supply (fuse)	OFF	—	Battery voltage
62	R/W	Step lamp signal	OFF	Any door is open (ON)	0V
				All doors are closed (OFF)	Battery voltage

INTERIOR ROOM LAMP

Terminal No.	Wire color	Signal name	Measuring condition			Reference value (Approx.)	
			Ignition switch	Operation or condition			
63	R	Interior room lamp output signal	OFF	Interior room lamp switch: DOOR position	Any door switch	ON (open)	0V
						OFF (closed)	Battery voltage
67	B	Ground	ON	—		0V	
70	W/B	Battery power supply (fusible link)	OFF	—		Battery voltage	

How to Proceed With Trouble Diagnosis

EKS0080E

1. Confirm the symptom or customer complaint.
2. Understand operation description and function description. Refer to [LT-114, "System Description"](#).
3. Carry out the Preliminary Check. Refer to [LT-124, "Preliminary Check"](#).
4. Check symptom and repair or replace the cause of malfunction.
5. Does the interior room lamp operate normally? If YES: GO TO 6. If NO: GO TO 4.
6. Inspection End.

Preliminary Check INSPECTION FOR POWER SUPPLY AND GROUND CIRCUIT

EKS0080F

1. CHECK FUSES AND FUSIBLE LINK

Check for blown BCM fuses or fusible link.

Unit	Power source	Fuse and fusible link No.
BCM	Battery	f
		21
	Ignition switch ON or START position	1

Refer to [LT-119, "Wiring Diagram — INT/L —"](#).

OK or NG

- OK >> GO TO 2.
 NG >> If fuse or fusible link is blown, be sure to eliminate cause of malfunction before installing new fuse or fusible link. Refer to [PG-4, "POWER SUPPLY ROUTING CIRCUIT"](#).

2. CHECK POWER SUPPLY CIRCUIT

1. Disconnect BCM connectors.
2. Check voltage between BCM connector terminals and ground.

BCM (+)		(-)	Ignition switch position	
Connector	Terminal		OFF	ON
M18	38	Ground	0V	Battery voltage
M20	57		Battery voltage	Battery voltage
	70		Battery voltage	Battery voltage

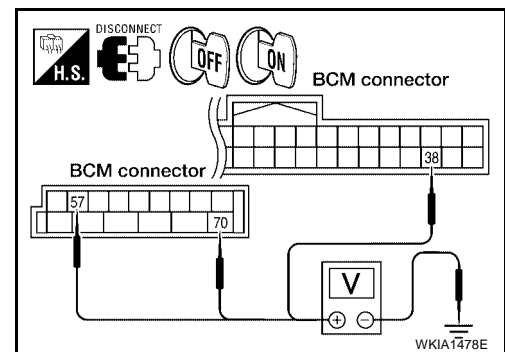

OK or NG

- OK >> GO TO 3.
 NG >> Check harness for open between BCM and fuse or fusible link.

INTERIOR ROOM LAMP

3. CHECK GROUND CIRCUIT

Check continuity between BCM connector terminal and ground.

BCM			Continuity
Connector	Terminal		
M19	67	Ground	Yes

OK or NG

- OK >> Inspection End.
- NG >> Check harness ground circuit.

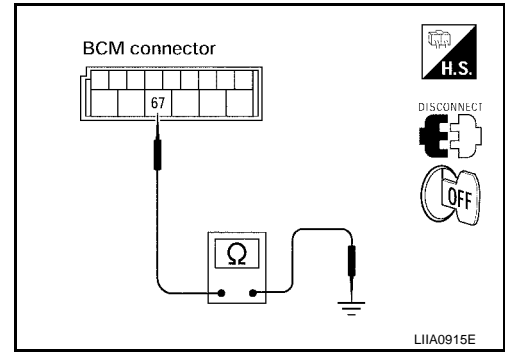

CONSULT-II Function (BCM)

EKS0080G

CONSULT-II can display each diagnostic item using the diagnostic test modes shown following.

BCM diagnostic test item	Diagnostic mode	Description
Inspection by part	WORK SUPPORT	Supports inspections and adjustments. Commands are transmitted to the BCM for setting the status suitable for required operation, input/output signals are received from the BCM and received data is displayed.
	DATA MONITOR	Displays BCM input/output data in real time.
	ACTIVE TEST	Operation of electrical loads can be checked by sending drive signal to them.
	SELF-DIAG RESULTS	Displays BCM self-diagnosis results.
	CAN DIAG SUPPORT MNTR	The result of transmit/receive diagnosis of CAN communication can be read.
	ECU PART NUMBER	BCM part number can be read.
	CONFIGURATION	Performs BCM configuration read/write functions.

CONSULT-II OPERATION

CAUTION:

If CONSULT-II is used with no connection of CONSULT-II CONVERTER, malfunctions might be detected in self-diagnosis depending on control unit which carries out CAN communication.

- With the ignition switch OFF, connect CONSULT-II and CONSULT-II CONVERTER to the data link connector, then turn ignition switch ON.

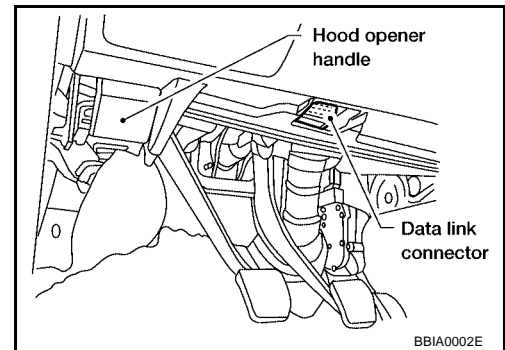

- Touch "START (NISSAN BASED VHCL)".

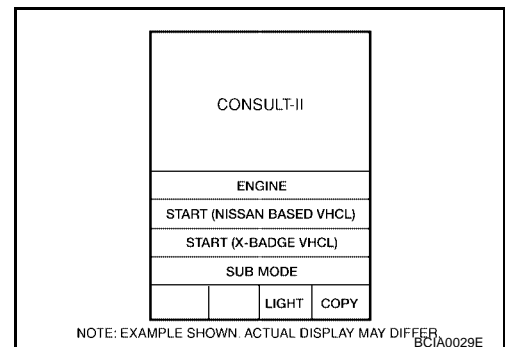

INTERIOR ROOM LAMP

3. Touch "BCM" on "SELECT SYSTEM" screen.
If "BCM" is not indicated, go to [GI-39, "Consult-II Data Link Connector \(DLC\) Circuit"](#).

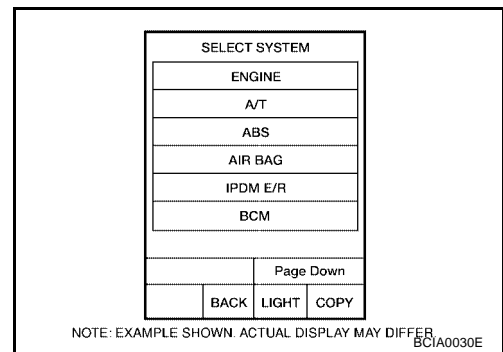

4. Select the desired part to be diagnosed on the "SELECT TEST ITEM" screen.

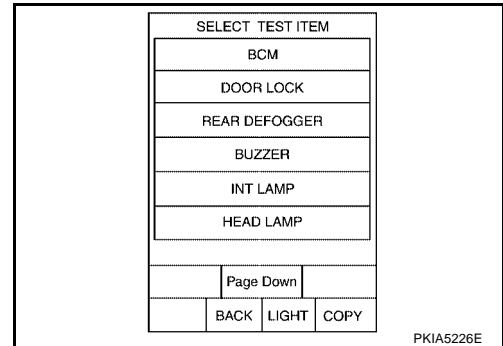

WORK SUPPORT

Operation Procedure

1. Touch "INT LAMP" on "SELECT TEST ITEM" screen.
2. Touch "WORK SUPPORT" on "SELECT DIAG MODE" screen.
3. Touch "SET I/L D-UNLCK INTCON", "ROOM LAMP ON TIME SET" or "ROOM LAMP OFF TIME SET" on "SELECT WORK ITEM" screen.
4. Touch "START".
5. Touch "CHANGE SETT".
6. The setting will be changed and "CUSTOMIZING COMPLETED" will be displayed.
7. Touch "END".

Display Item List

Item	Description	CONSULT-II
SET I/L D-UNLCK INTCON	The 30 seconds glowing function the interior room lamps and the ignition keyhole illumination can be selected when front door LH is released (unlocked).	ON/OFF
ROOM LAMP ON TIME SET	The time in order to escalate illumination can be adjusted when the interior room lamps and the ignition keyhole illumination is turned on.	MODE 1 - 7
ROOM LAMP OFF TIME SET	The time in order to diminish illumination can be adjusted when the interior room lamps and the ignition keyhole illumination is turned off.	MODE 1 - 7

Reference between "MODE" and "TIME" for "TURN ON/OFF".

MODE	1	2	3	4	5	6	7
Time (sec.)	0.5	1	2	3	4	5	0

DATA MONITOR

Operation Procedure

1. Touch "INT LAMP" on "SELECT TEST ITEM" screen.
2. Touch "DATA MONITOR" on "SELECT DIAG MODE" screen.
3. Touch either "ALL SIGNALS" or "SELECTION FROM MENU" on "SELECT MONITOR ITEM" screen.

INTERIOR ROOM LAMP

ALL SIGNALS	Monitors all the signals.
SELECTION FROM MENU	Selects and monitors the individual signal.

4. Touch "START".
5. When "SELECTION FROM MENU" is selected, touch items to be monitored. When "ALL SIGNALS" is selected, all the items will be monitored.
6. Touch "RECORD" while monitoring, then the status of the monitored item can be recorded. To stop recording, touch "STOP".

Display Item List

Monitor item	Contents
IGN ON SW	"ON/OFF" Displays "IGN position (ON)/OFF, ACC position (OFF)" judged from the ignition switch signal.
KEY ON SW	"ON/OFF" Displays "Key inserted (ON)/key removed (OFF)" status judged from the key switch signal.
DOOR SW-DR	"ON/OFF" Displays status of the front door LH as judged from the front door switch LH signal. (Door is open: ON/Door is closed: OFF)
DOOR SW-AS	"ON/OFF" Displays "Door open (ON)/Door closed (OFF)" status, determined from front door switch RH signal.
DOOR SW-RR	"ON/OFF" Displays "Door open (ON)/Door closed (OFF)" status, determined from rear door switch RH signal.
DOOR SW-RL	"ON/OFF" Displays "Door open (ON)/Door closed (OFF)" status, determined from rear door switch LH signal.
BACK DOOR SW	"ON/OFF" Displays "Door open (ON)/Door closed (OFF)" status, determined from back door switch signal.
KEY CYL LK-SW	"ON/OFF" Displays "Door locked (ON)" status, determined from key cylinder lock switch in front door LH.
KEY CYL UN-SW	"ON/OFF" Displays "Door unlocked (OFF)" status, determined from key cylinder lock switch in front door LH.
CDL LOCK SW	"ON/OFF" Displays "Door locked (ON)/Door unlocked (OFF)" status, determined from locking detection switch in front door LH.
CDL UNLOCK SW	"ON/OFF" Displays "Door unlocked (OFF)" status, determined from locking detection switch in front door RH.
KEYLESS LOCK	"ON/OFF" Displays "Locked (ON)/Other (OFF)" status, determined from lock signal.
KEYLESS UNLOCK	"ON/OFF" Displays "Unlocked (ON)/Other (OFF)" status, determined from unlock signal.

ACTIVE TEST

Operation Procedure

1. Touch "INT LAMP" on "SELECT TEST ITEM" screen.
2. Touch "ACTIVE TEST" on "SELECT DIAG MODE" screen.
3. Touch item to be tested and check operation of the selected item.
4. During the operation check, touching "BACK" deactivates the operation.

Display Item List

Test item	Description
INT LAMP	Interior room lamp can be operated by any ON-OFF operations.
IGN ILLUM	Ignition keyhole illumination can be operated by ON-OFF operation.
STEP LAMP TEST	Step lamp can be operated by ON-OFF operation.
LUGGAGE LAMP TEST	Trunk room lamp can be operated by ON-OFF operation.

INTERIOR ROOM LAMP

EKS0080H

Interior Room Lamp Control Does Not Operate

1. CHECK EACH SWITCH

Select "BCM" on CONSULT-II. With "INT LAMP" data monitor, make sure switches listed in display item list turn ON-OFF linked with switch operation. Refer to [LT-127, "Display Item List"](#) for switches and their functions.

OK or NG

- OK >> GO TO 2.
- NG >> Inspect malfunctioning switch system.

DATA MONITOR	
MONITOR	
IGN ON SW	ON
KEY ON SW	ON
DOOR SW-DR	ON
DOOR SW-AS	ON
DOOR SW-RR	OFF
DOOR SW-RL	OFF
BACK DOOR SW	OFF
KEY CYL LK-SW	OFF
KEY CYL UN-SW	OFF

SKIA5930E

2. ACTIVE TEST

- Select "BCM" on CONSULT-II. Select "INT LAMP" active test.
- When room lamp switch is in DOOR position, use active test to make sure room lamp operates.

OK or NG

- OK >> Replace BCM. Refer to [BCS-20, "Removal and Installation of BCM"](#).
- NG >> GO TO 3.

ACTIVE TEST	
INT LAMP	ON
	OFF

LKIA0092E

3. CHECK ROOM LAMP INPUT

- Turn ignition switch OFF.
- Check voltage between room lamp harness connector R8 terminal 1 and ground.

1 - Ground : Battery voltage should exist.

OK or NG

- OK >> GO TO 4.
- NG >> GO TO 6.

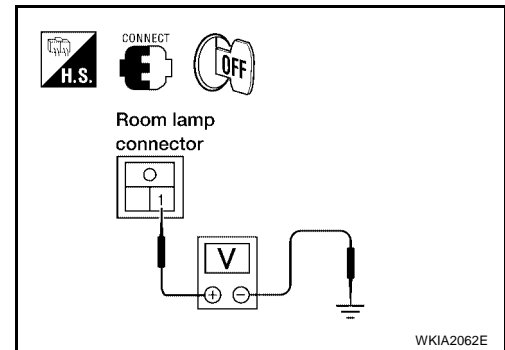

4. CHECK ROOM LAMP

- Disconnect room lamp connector.
- Check continuity between room lamp terminals.

Room lamp Terminal		Condition	Continuity
1	2		
		Room lamp switch is DOOR	Yes
		Room lamp switch is OFF	No

OK or NG

- OK >> GO TO 5.
- NG >> Replace room lamp. Refer to [LT-132, "ROOM OR SPOT LAMP"](#).

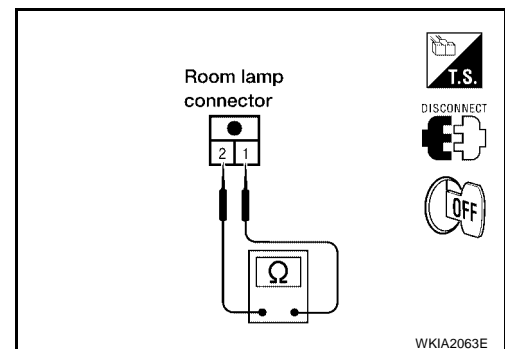

INTERIOR ROOM LAMP

5. CHECK ROOM LAMP CIRCUIT

1. Disconnect BCM connector.
2. Check continuity between BCM harness connector M20 terminal 56 and room lamp harness connector R8 terminal 1.

56 - 1 : Continuity should exist.

OK or NG

OK >> Replace BCM if interior lamp does not work after setting the connector again. Refer to [BCS-20, "Removal and Installation of BCM"](#).

NG >> Repair harness or connector.

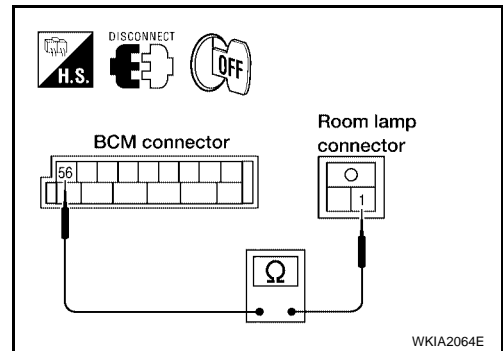

6. CHECK ROOM LAMP CIRCUIT

1. Disconnect BCM connector and room lamp connector.
2. Check continuity between BCM harness connector M20 terminal 63 and room lamp harness connector R8 terminal 2.

63 - 2 : Continuity should exist.

OK or NG

OK >> Replace BCM if interior lamp does not work after setting the connector again. Refer to [BCS-20, "Removal and Installation of BCM"](#).

NG >> Repair harness or connector.

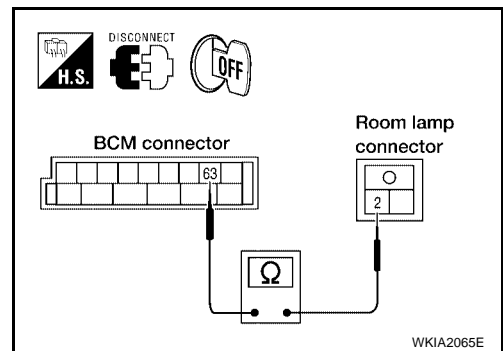

Ignition Keyhole Illumination Control Does Not Operate

EKS0080I

1. CHECK EACH SWITCH

Select "BCM" on CONSULT-II. With "INT LAMP" data monitor, make sure switches listed in display item list turn ON-OFF linked with switch operation. Refer to [LT-127, "Display Item List"](#) for switches and their functions.

OK or NG

OK >> GO TO 2.

NG >> Inspect malfunctioning switch system.

DATA MONITOR	
MONITOR	
IGN ON SW	ON
KEY ON SW	ON
DOOR SW-DR	ON
DOOR SW-AS	ON
DOOR SW-RR	OFF
DOOR SW-RL	OFF
BACK DOOR SW	OFF
KEY CYL LK-SW	OFF
KEY CYL UN-SW	OFF

SKIA5930E

2. ACTIVE TEST

1. Select "BCM" on CONSULT-II. Select "INT LAMP".
2. Select "IGN ILLUM" active test to make sure lamp operates.

OK or NG

OK >> Replace BCM. Refer to [BCS-20, "Removal and Installation of BCM"](#).

NG >> GO TO 3.

ACTIVE TEST	
IGN ILLUM	ON
	OFF

SKIA3992E

INTERIOR ROOM LAMP

3. CHECK IGNITION KEYHOLE ILLUMINATION INPUT

1. Turn ignition switch OFF.
2. Check voltage between ignition keyhole illumination harness connector M25 terminal + and ground.

+ - Ground : Battery voltage should exist.

OK or NG

- OK >> GO TO 4.
NG >> GO TO 6.

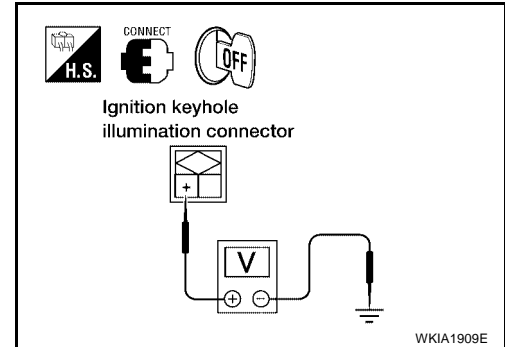

4. CHECK IGNITION KEYHOLE ILLUMINATION BULB

1. Disconnect ignition keyhole illumination connector.
2. Check continuity between ignition keyhole illumination terminals + and -.

+ - - : Continuity should exist.

OK or NG

- OK >> GO TO 5.
NG >> Replace ignition keyhole illumination bulb. Refer to [LT-133. "IGNITION KEYHOLE ILLUMINATION LAMP"](#).

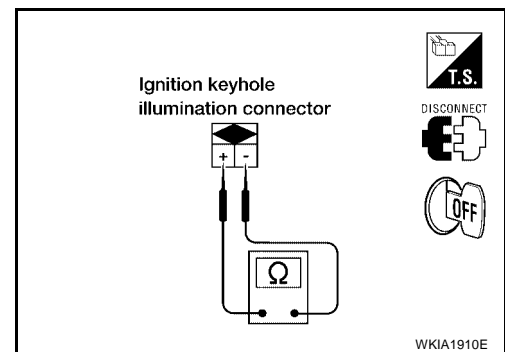

5. CHECK IGNITION KEYHOLE ILLUMINATION CIRCUIT

1. Disconnect BCM connector.
2. Check continuity between BCM harness connector M18 terminal 1 and ignition keyhole illumination harness connector M25 terminal -.

- - 1 : Continuity should exist.

OK or NG

- OK >> Replace BCM if ignition keyhole illumination does not work after setting the connector again. Refer to [BCS-20. "Removal and Installation of BCM"](#).
- NG >> Repair harness or connector.

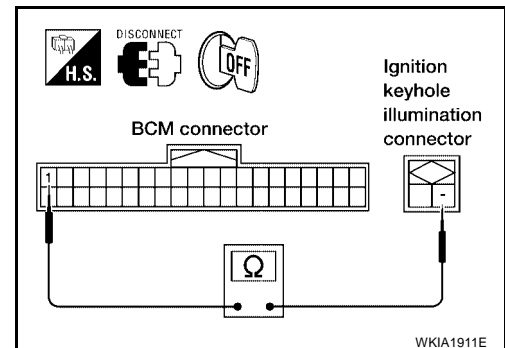

6. CHECK IGNITION KEYHOLE ILLUMINATION CIRCUIT

1. Disconnect BCM connector and ignition keyhole illumination connector.
2. Check continuity between BCM harness connector M20 terminal 56 and ignition keyhole illumination harness connector M25 terminal +.

+ - 56 : Continuity should exist.

OK or NG

- OK >> Replace BCM if ignition keyhole illumination does not work after setting the connector again. Refer to [BCS-20. "Removal and Installation of BCM"](#).
- NG >> Repair harness or connector.

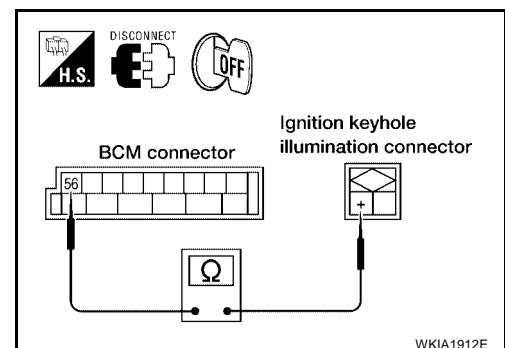

INTERIOR ROOM LAMP

EKS0080J

All Step Lamps Do Not Operate

1. CHECK EACH DOOR SWITCH

Select "BCM" on CONSULT-II. With "INT LAMP" data monitor, make sure switches listed below turn ON-OFF linked with switch operation.

Switch name	CONSULT screen
Front door switch LH	DOOR SW-DR
Front door switch RH	DOOR SW-AS
Rear door switch RH	DOOR SW-RR
Rear door switch LH	DOOR SW-RL

OK or NG

- OK >> GO TO 2.
- NG >> Inspect malfunctioning switch system.

DATA MONITOR	
MONITOR	
IGN ON SW	ON
KEY ON SW	ON
DOOR SW-DR	ON
DOOR SW-AS	ON
DOOR SW-RR	OFF
DOOR SW-RL	OFF
BACK DOOR SW	OFF
KEY CYL LK-SW	OFF
KEY CYL UN-SW	OFF

SKIA5930E

2. CHECK STEP LAMP INPUT

- Turn ignition switch OFF.
- Check voltage between step lamp LH harness connector D11 terminal + and ground.

+ - Ground : Battery voltage should exist.

OK or NG

- OK >> GO TO 3.
- NG >> GO TO 4.

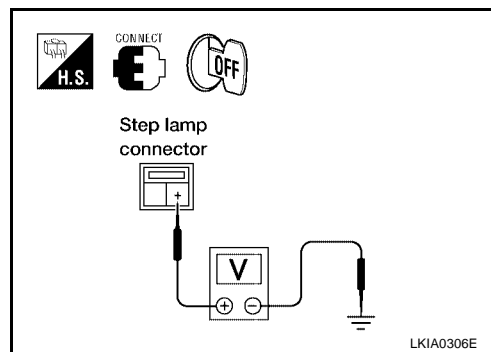

3. CHECK STEP LAMP CIRCUIT

- Disconnect BCM connector and step lamp LH connector.
- Check continuity between BCM harness connector M20 terminal 62 and step lamp LH harness connector D11 terminal -.

-- 62 : Continuity should exist.

OK or NG

- OK >> Replace BCM if step lamp does not work after setting the connector again. Refer to [BCS-20, "Removal and Installation of BCM"](#).
- NG >> Repair harness or connector.

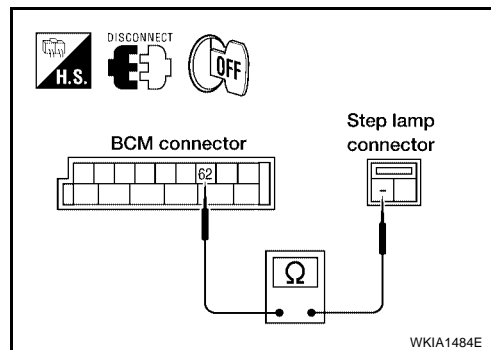

4. CHECK STEP LAMP CIRCUIT

- Disconnect BCM connector and step lamp LH connector.
- Check continuity between BCM harness connector M20 terminal 56 and step lamp LH harness connector D11 terminal +.

+ - 56 : Continuity should exist.

OK or NG

- OK >> Replace BCM if step lamp does not work after setting the connector again. Refer to [BCS-20, "Removal and Installation of BCM"](#).
- NG >> Repair harness or connector.

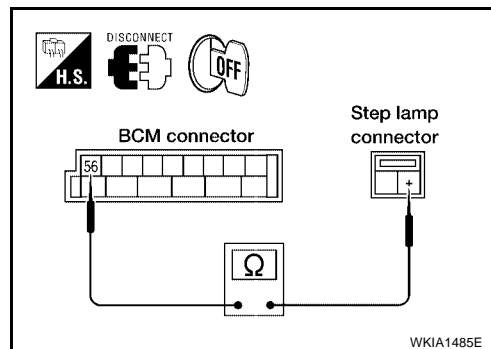

INTERIOR ROOM LAMP

All Interior Room Lamps Do Not Operate

EKS0080K

1. CHECK POWER SUPPLY CIRCUIT

1. All interior room lamps switch are OFF.
2. Turn ignition switch ON.
3. Check voltage between BCM harness connector M20 terminal 56 and ground.

56 - Ground : Battery voltage should exist.

OK or NG

OK >> Repair harness or connector. To prevent making a short circuit, be sure to disconnect battery negative cable after repairing harness, and then reconnect.

NG >> Replace BCM. Refer to [BCS-20, "Removal and Installation of BCM"](#).

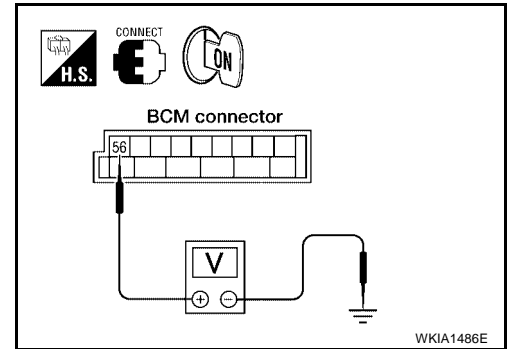

Bulb Replacement ROOM OR SPOT LAMP

EKS0080L

Removal

1. Insert a thin screwdriver in the notch and carefully remove the lens.
2. Remove the bulb.

Installation

Installation is in the reverse order of removal.

STEP LAMP

Removal

1. Carefully remove lamp assembly from door finisher.
2. Remove the bulb.

Installation

Installation is in the reverse order of removal.

VANITY MIRROR LAMP

Removal

1. Insert a thin screwdriver in the notch and carefully remove the lens.
2. Remove the bulb.

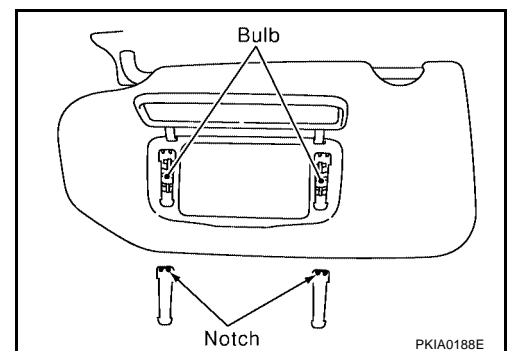

Installation

Installation is in the reverse order of removal.

INTERIOR ROOM LAMP

TRUNK ROOM LAMP

Removal

1. Unfold tab A and open the lens.
2. Remove the bulb.

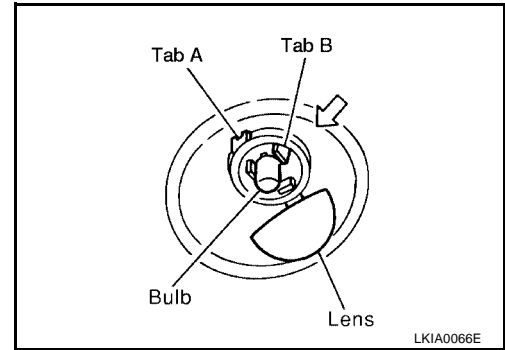

Installation

Installation is in the reverse order of removal.

Removal and Installation IGNITION KEYHOLE ILLUMINATION LAMP

Removal

1. Remove the instrument lower cover LH. Refer to [IP-13, "INSTRUMENT LOWER COVER LH"](#).
2. Turn the bulb socket counterclockwise and unlock it.

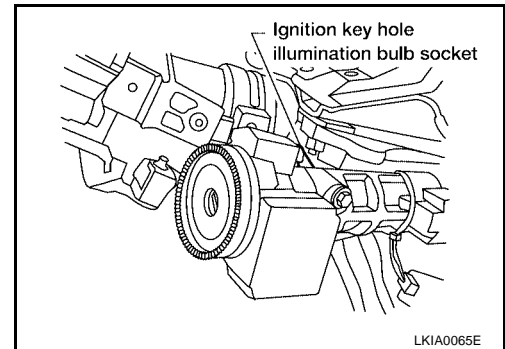

Installation

Installation is in the reverse order of removal.

ROOM LAMP

Removal

1. Carefully remove the lens.
2. Remove the screws.
3. Disconnect the connector and remove the room lamp.

Installation

Installation is in the reverse order of removal.

STEP LAMP

Removal

1. Carefully remove lamp assembly from door finisher.
2. Disconnect electrical connector.

Installation

Installation is in the reverse order of removal.

A
B
C
D
E
F
G
H
I
J

LT

L
M

INTERIOR ROOM LAMP

TRUNK ROOM LAMP

Removal

1. Unfold tab A and open the lens.
2. Remove the trunk room lamp while pressing tab B in the direction of the arrow.
3. Disconnect the trunk room lamp connector.

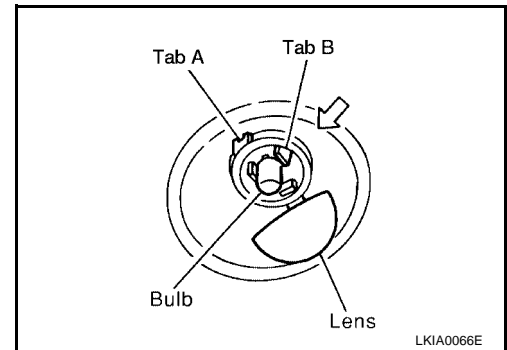

Installation

Installation is in the reverse order of removal.

ILLUMINATION

Component Parts and Harness Connector Location

EKS00A87

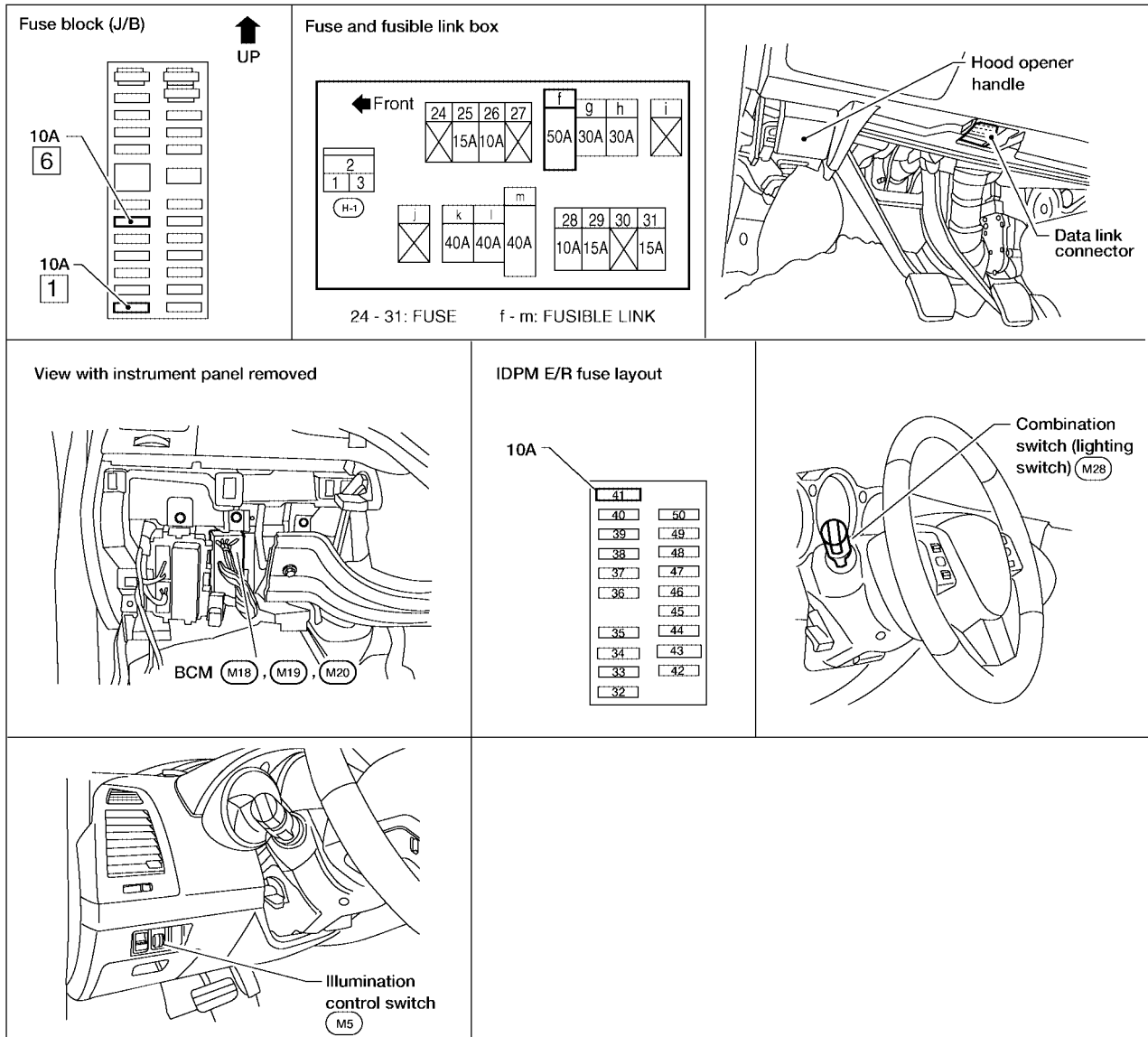

WKIA4090E

EKS0080N

System Description

Control of the illumination lamps operation is dependent upon the position of the lighting switch (combination switch). When the lighting switch is placed in the 1ST or 2ND position (or if the auto light system is activated) the BCM (body control module) receives input requesting the illumination lamps to illuminate. This input is communicated to the IPDM E/R (intelligent power distribution module engine room) across the CAN communication lines. The CPU (central processing unit) of the IPDM E/R controls the tail lamp relay coil. When energized, this relay directs power to the illumination lamps, which then illuminate. Power is supplied at all times

- through 10A fuse (No. 41, located in the IPDM E/R)
- to tail lamp relay, located in the IPDM E/R, and
- through 50A fusible link (letter f , located in the fuse and fusible link box)
- to BCM terminal 70.

With the ignition switch in the ON or START position, power is supplied

- through 10A fuse [No. 1, located in the fuse block (J/B)]
- to BCM terminal 38.

A
B
C
D
E
F
G
H
I
J
LT
L
M

ILLUMINATION

With the ignition switch in the ACC or ON position, power is supplied

- through 10A fuse [No. 6, located in the fuse block (J/B)]
- to BCM terminal 11.

Ground is supplied

- to BCM terminal 67
- through grounds F14, M57 and M61.

ILLUMINATION OPERATION BY LIGHTING SWITCH

With the lighting switch in the 1ST or 2ND position (or if the auto light system is activated), the BCM receives input requesting the illumination lamps to illuminate. This input is communicated to the IPDM E/R across the CAN communication lines. The CPU of the IPDM E/R controls the tail lamp relay coil which, when energized, directs power

- through IPDM E/R terminal 22
- to illumination control switch terminal 1
- to combination meter terminal 31
- to A/T device terminal 15 (with A/T)
- to TCS ON/OFF switch terminal 3 (with TCS)
- to audio unit terminal 8
- to hazard switch terminal 3
- to heated seat switch LH and RH terminal 1 (with heated seats)
- to front air control terminal 12
- to AV switch terminal 3 (with NAVI)
- to NAVI control unit terminal 26 (with NAVI)
- to glove box lamp terminal +.

With the ignition switch in ON or START, power is also supplied

- through BCM terminal 68
- to rear power window switch LH terminal 5
- to rear power window switch RH terminal 5
- to front power window switch RH terminal 5 (with left front only power window anti-pinch system) or terminal 13 (with left and right front power window anti-pinch system)
- to main power window and door lock/unlock switch terminal 12 (with left front only power window anti-pinch system) or terminal 17 (with left and right front power window anti-pinch system).

Ground is supplied

- to illumination control switch terminal 3
- to glove box lamp terminal –
- to combination meter terminal 24
- through grounds F14, M57 and M61, and
- to rear power window switch RH terminal 8
- through ground B117, and
- to rear power window switch LH terminal 8
- to NAVI control unit terminal 30 (with NAVI)
- through grounds B7 and B19.

The main power window and door lock/unlock switch and the front power window switch RH illumination circuits are case grounded.

Controlled ground is supplied

- through illumination control switch terminal 2
- to combination meter terminal 32
- to A/T device terminal 16 (with A/T)
- to TCS ON/OFF switch terminal 4 (with TCS)
- to audio unit terminal 7
- to hazard switch terminal 4

ILLUMINATION

- to heated seat switch LH and RH terminal 2 (with heated seats)
- to front air control terminal 11
- to AV switch terminal 4 (with NAVI).

With power and ground supplied, illumination lamps illuminate.

BATTERY SAVER CONTROL

When the combination switch (lighting switch) is in the 1ST or 2ND position (or if auto light system is activated) and the ignition switch is turned from ON or ACC to OFF, the battery saver control feature is activated.

Under this condition, the illumination lamps remain illuminated for 30 minutes unless the combination switch (lighting switch) position is changed. If the combination switch (lighting switch) position is changed, then the illumination lamps are turned off after a 30 second delay.

When the lighting switch is turned from OFF to 1ST or 2ND position (or if auto light system is activated) after illumination lamps have been turned off by the battery saver control, the illumination lamps illuminate again.

CAN Communication System Description

EKS00800

Refer to [LAN-20, "CAN COMMUNICATION"](#) .

A

B

C

D

E

F

G

H

I

J

LT

L

M

ILLUMINATION

Schematic

EKS0080P

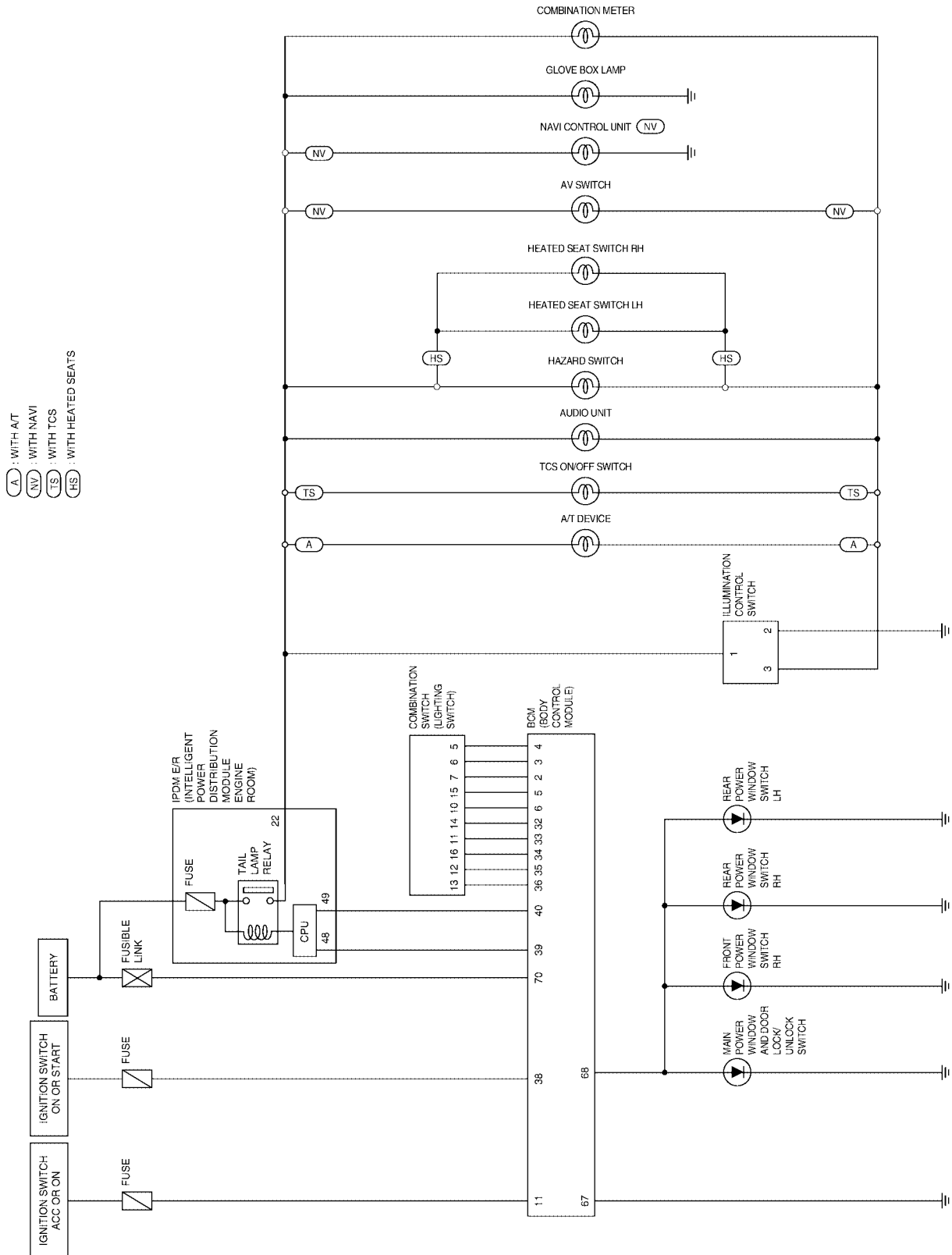

WKWA3665E

ILLUMINATION

Wiring Diagram — ILL —

EKS00800

LT-ILL-01

— : DATA LINE

REFER TO "PG-POWER".

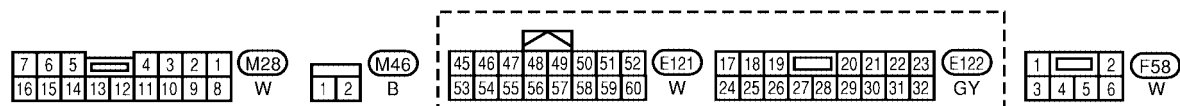
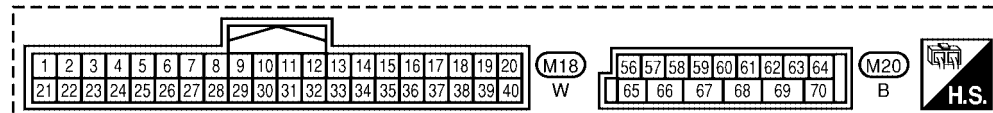
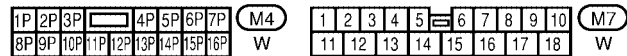
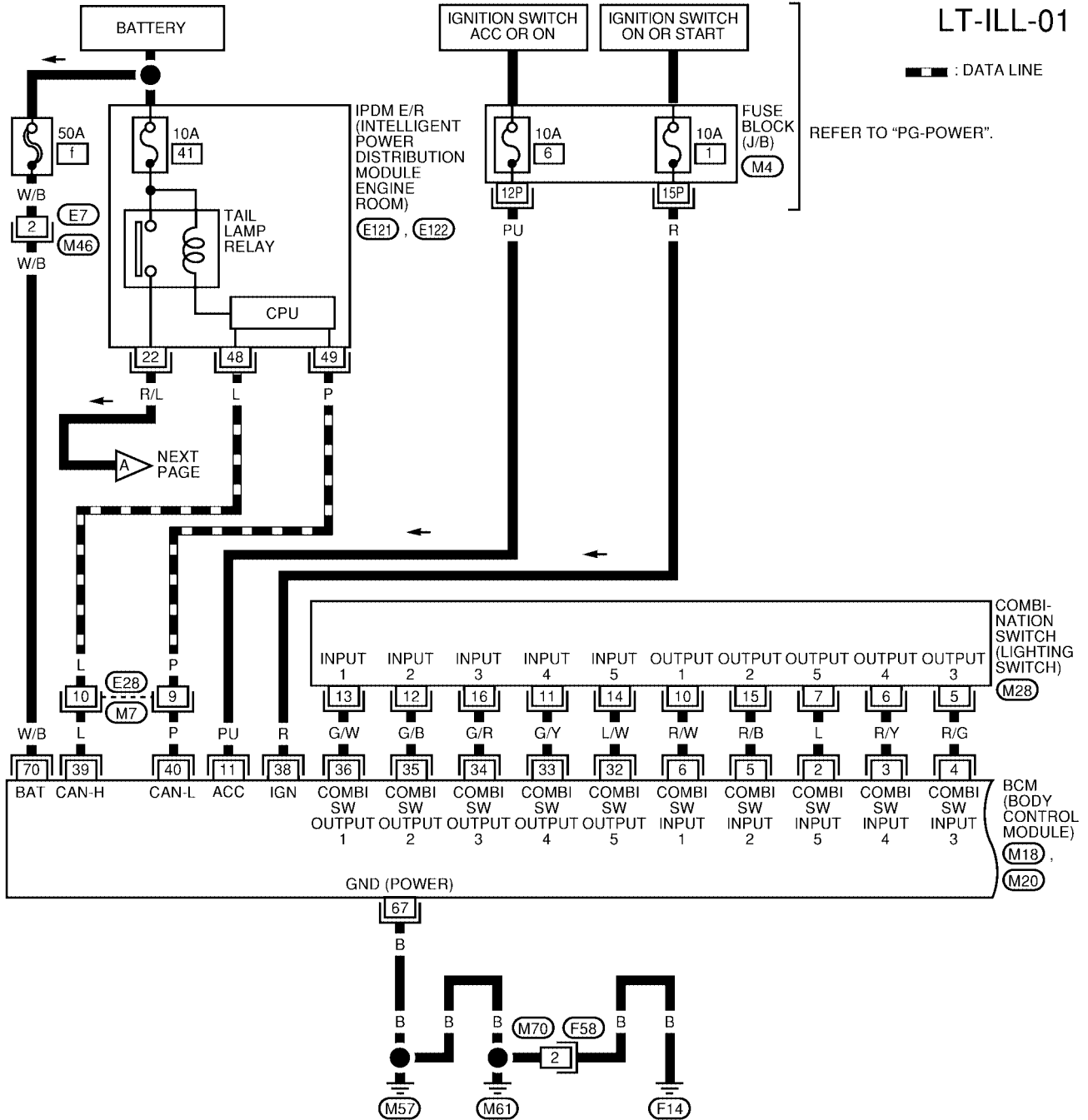

WKWA1321E

ILLUMINATION

LT-ILL-02

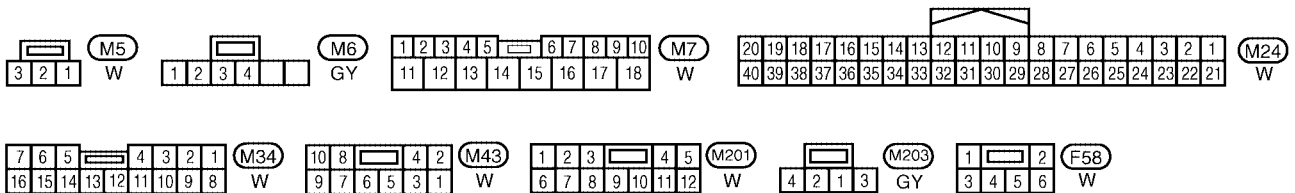
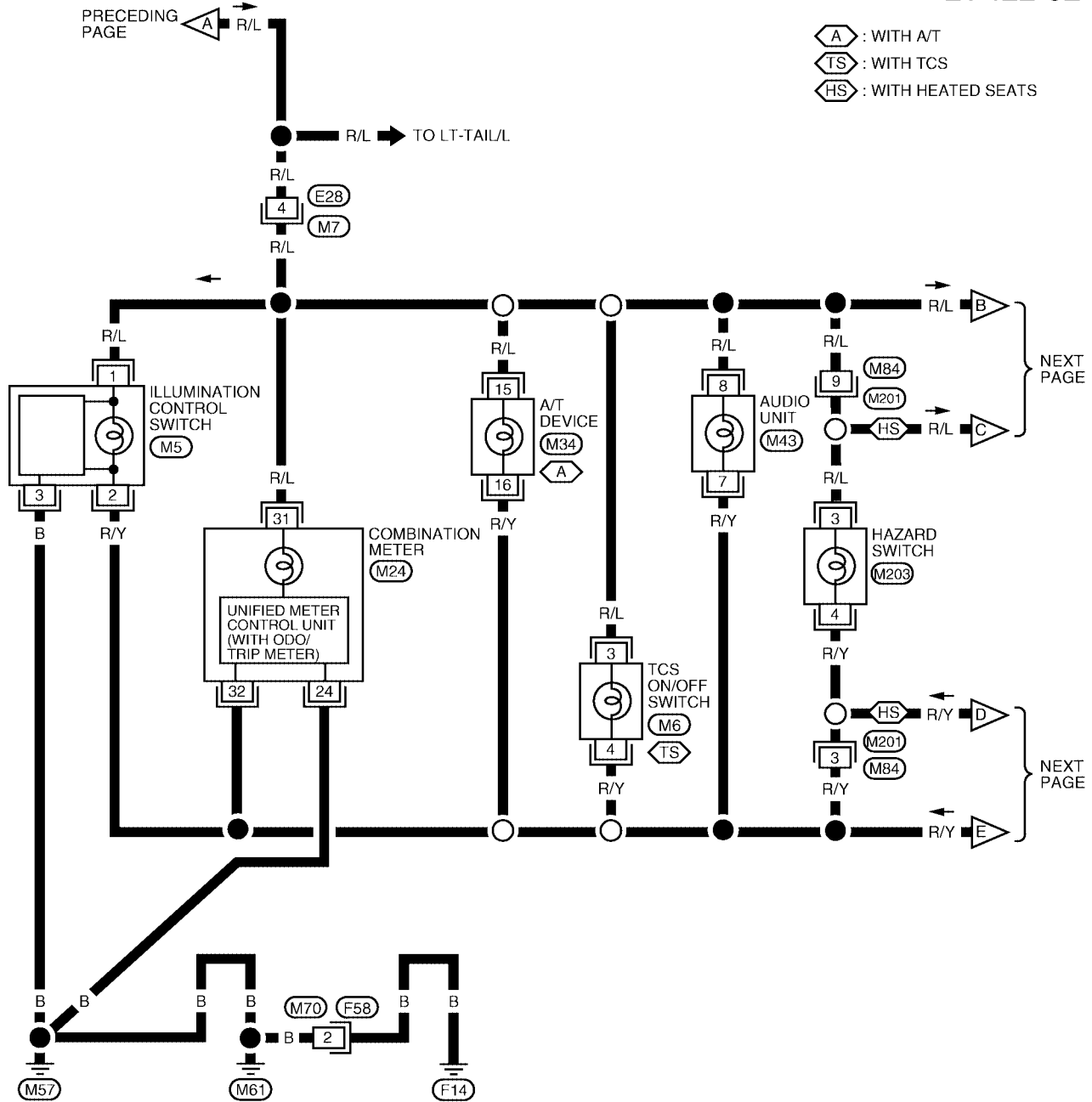

WKWA1839E

ILLUMINATION

LT-ILL-03

HS : WITH HEATED SEATS
 NV : WITH NAVI

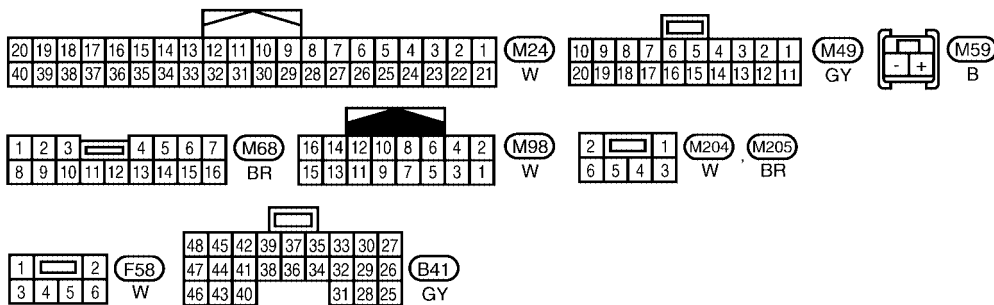
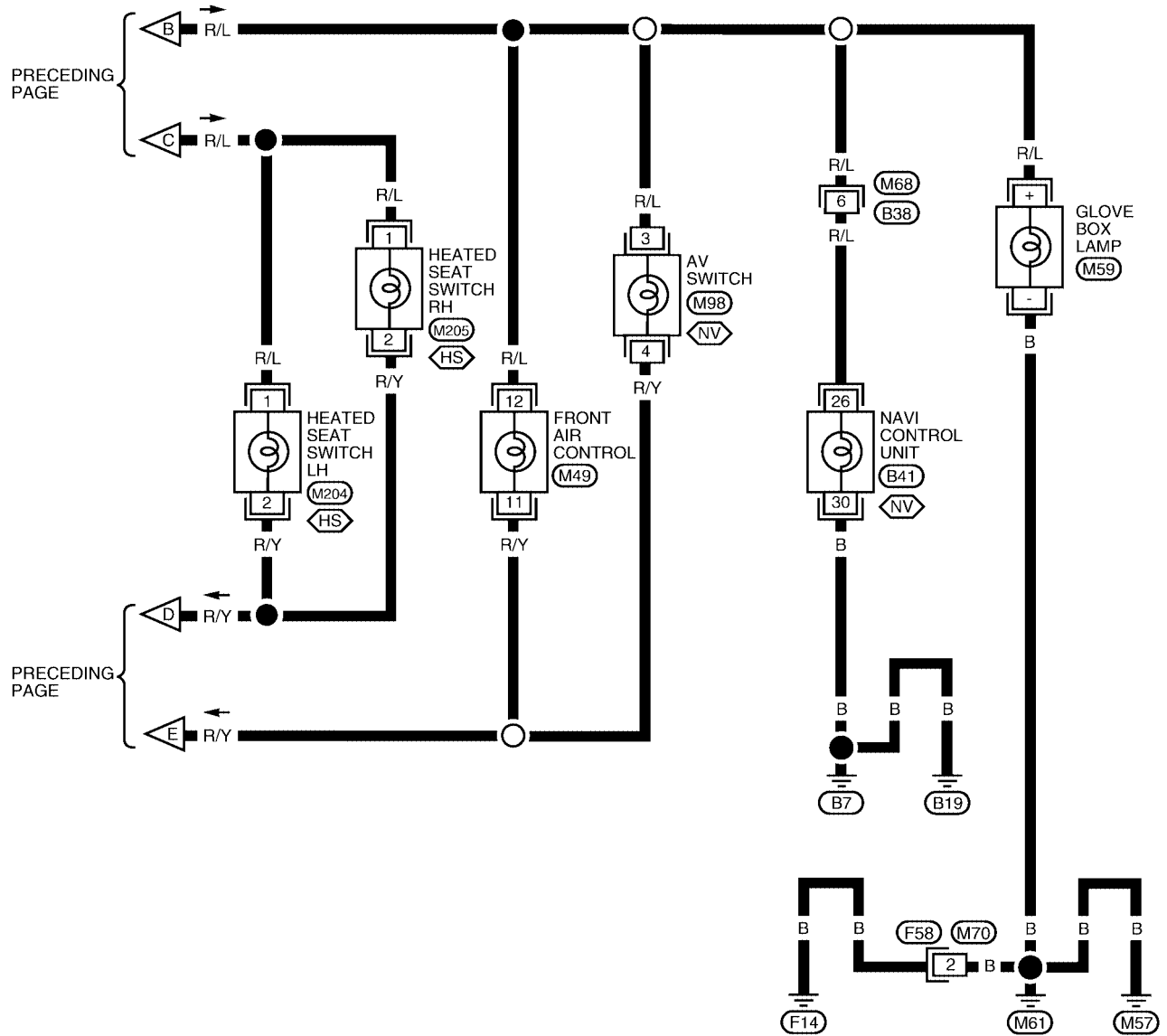

WKWA3566E

ILLUMINATION

LT-ILL-04

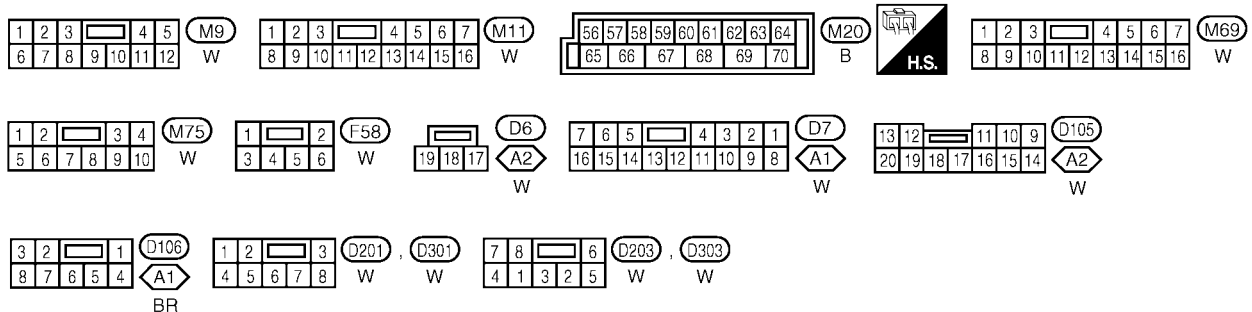
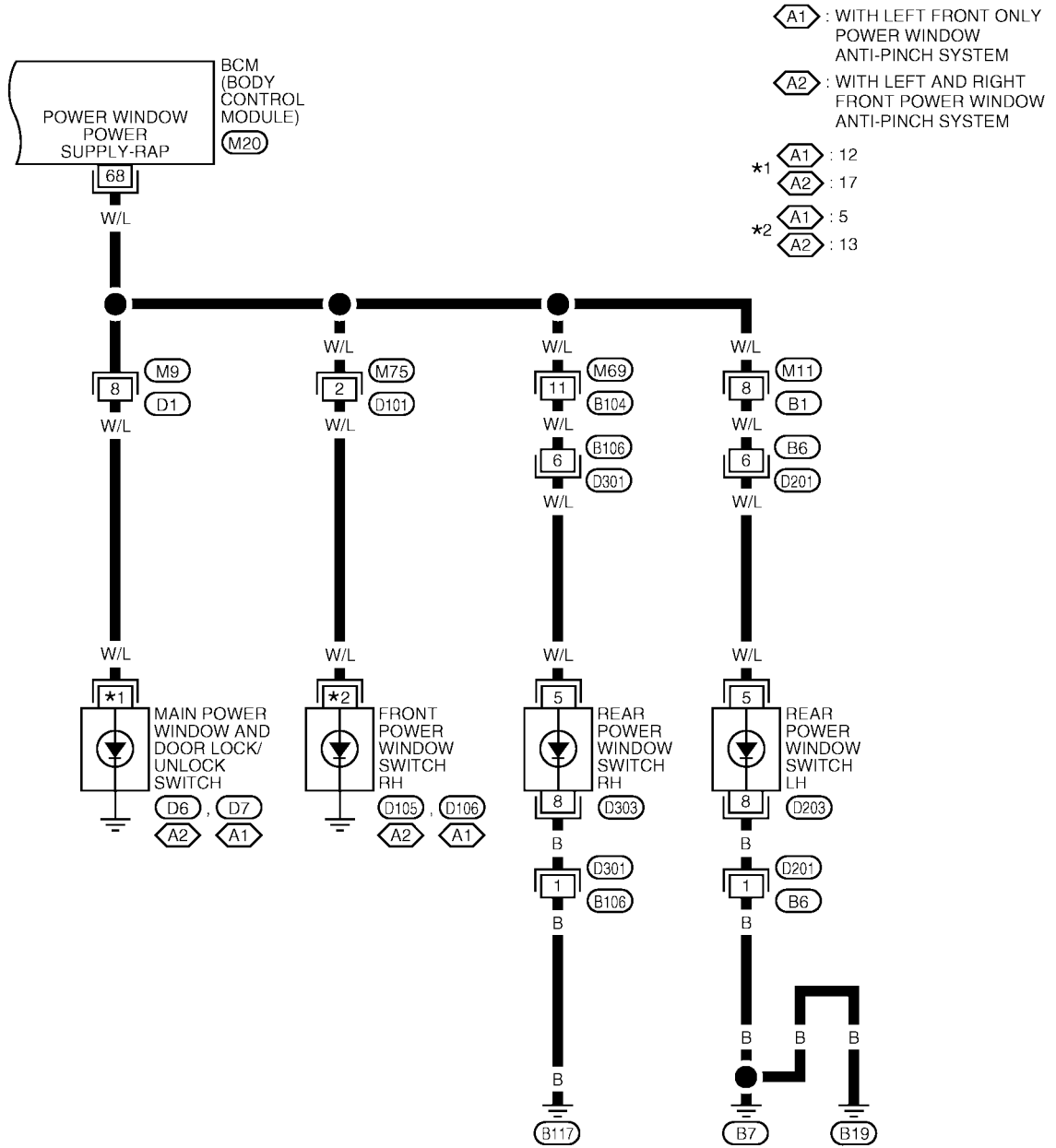

WKWA1324E

ILLUMINATION

Bulb Replacement GLOVE BOX LAMP

EKS008OR

Removal

1. Through the passenger air bag connector access in the top of the glove box, remove bulb socket by turning counterclockwise.
2. Pull the bulb from the socket to remove.

Installation

Installation is in the reverse order of removal.

Removal and Installation ILLUMINATION CONTROL SWITCH

EKS00GAI

Removal

1. Remove instrument lower cover LH. Refer to [IP-13, "INSTRUMENT LOWER COVER LH"](#).
2. Carefully release the illumination control switch retaining tabs and remove the unit from the driver lower instrument panel.

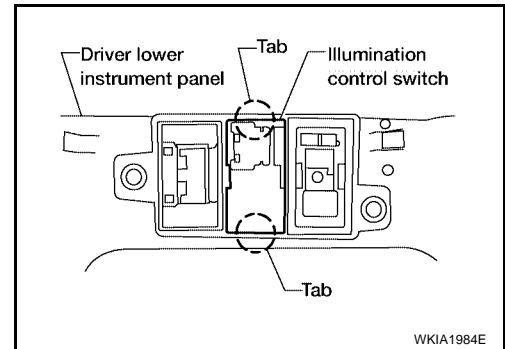

Installation

Installation is in the reverse order of removal.

A
B
C
D
E
F
G
H
I
J
LT
L
M

LT

BULB SPECIFICATIONS

BULB SPECIFICATIONS

PFP:26297

Headlamp

EKS0080S

Item	Wattage (W)*
Low (halogen)	55 (H1)
Low (xenon)	35 (D2R)
High	60W (HB3)

*: Always check with the Parts Department for the latest parts information.

Exterior Lamp

EKS0080T

Item	Wattage (W)*	
Front combination lamp	27/8 (amber)	
Rear combination lamp	Turn signal lamp/parking lamp	27/8
	Stop/Tail lamp	27/8
	Turn signal lamp	27
	Back-up lamp	13
	Side marker lamp	5
Fog lamp	55 (H11)	
License plate lamp	5	
High-mounted stop lamp (parcel shelf mount)	18	
High-mounted stop lamp (rear air spoiler mount)	*	

*: Always check with the Parts Department for the latest parts information.

Interior Lamp/Illumination

EKS0080U

Item	Wattage (W)*
Glove box lamp	3.4
Ignition keyhole illumination lamp	0.74*
Spot lamp	10
Room lamp	8
Step lamp	3.8
Trunk room lamp	3.4
Vanity mirror lamp	1.4*

*: Always check with the Parts Department for the latest parts information.