

A
B
C
D

WT

SECTION

ROAD WHEELS & TIRES

CONTENTS

WT

<p>BASIC INSPECTION 3</p> <p>DIAGNOSIS AND REPAIR WORKFLOW 3</p> <p style="padding-left: 20px;">Repair Work Flow3</p> <p>INSPECTION AND ADJUSTMENT 5</p> <p style="padding-left: 20px;">Preliminary Check5</p> <p style="padding-left: 20px;">Transmitter Wake Up Operation5</p> <p style="padding-left: 20px;">ID Registration Procedure6</p> <p>FUNCTION DIAGNOSIS 8</p> <p>TPMS 8</p> <p style="padding-left: 20px;">System Diagram8</p> <p style="padding-left: 20px;">System Description8</p> <p style="padding-left: 20px;">System Components9</p> <p>DIAGNOSIS SYSTEM (BCM)11</p> <p style="padding-left: 20px;">CONSULT-III Function (BCM) 11</p> <p style="padding-left: 20px;">Self-Diagnosis 11</p> <p>COMPONENT DIAGNOSIS13</p> <p>C1708 - C1711 DATA FROM TRANSMITTER NOT BEING RECEIVED13</p> <p style="padding-left: 20px;">Data from Transmitter Not Being Received 13</p> <p>C1712 - C1715, C1720 - C1723, C1724 - C1727 TRANSMITTER MALFUNCTION14</p> <p style="padding-left: 20px;">Transmitter Malfunction 14</p> <p>C1716 - C1719 TRANSMITTER PRESSURE MALFUNCTION15</p> <p style="padding-left: 20px;">Transmitter Pressure Malfunction 15</p> <p>C1729 VEHICLE SPEED SIGNAL16</p> <p style="padding-left: 20px;">Vehicle Speed Signal 16</p> <p>C1734 CONTROL UNIT17</p> <p style="padding-left: 20px;">Control Unit 17</p> <p>ECU DIAGNOSIS18</p>	<p>BCM (BODY CONTROL MODULE)18</p> <p style="padding-left: 20px;">Terminals and Reference Values (BCM)18</p> <p style="padding-left: 20px;">Wiring Diagram — Coupe18</p> <p style="padding-left: 20px;">Wiring Diagram — Sedan21</p> <p style="padding-left: 20px;">Self-Diagnosis23</p> <p style="padding-left: 20px;">Flash Code Chart24</p> <p>SYMPTOM DIAGNOSIS26</p> <p>TPMS26</p> <p style="padding-left: 20px;">Symptom Table26</p> <p>LOW TIRE PRESSURE WARNING LAMP DOES NOT TURN ON27</p> <p style="padding-left: 20px;">Low Tire Pressure Warning Lamp Does Not Come On When Ignition Switch Is Turned On27</p> <p>LOW TIRE PRESSURE WARNING LAMP STAYS ON28</p> <p style="padding-left: 20px;">Low Tire Pressure Warning Lamp Stays On When Ignition Switch Is Turned On28</p> <p>LOW TIRE PRESSURE WARNING LAMP BLINKS29</p> <p style="padding-left: 20px;">Low Tire Pressure Warning Lamp Flashes When Ignition Switch Is Turned On29</p> <p>HAZARD WARNING LAMPS FLASH30</p> <p style="padding-left: 20px;">Hazard Warning Lamps Flash When Ignition Switch Is Turned On30</p> <p>ID REGISTRATION CANNOT BE COMPLETED31</p> <p style="padding-left: 20px;">ID Registration Cannot Be Completed31</p> <p>NOISE, VIBRATION AND HARSHNESS (NVH) TROUBLESHOOTING32</p> <p style="padding-left: 20px;">NVH Troubleshooting Chart32</p> <p>PRECAUTION33</p> <p>PRECAUTIONS33</p>	<p>F</p> <p>G</p> <p>H</p> <p>I</p> <p>J</p> <p>K</p> <p>L</p> <p>M</p> <p>N</p> <p>O</p> <p>P</p>
--	--	--

Supplemental Restraint System (SRS) AIR BAG and SEAT BELT PRE-TENSIONER	33	Removal and Installation	36
Precaution for work	33	ROAD WHEEL TIRE ASSEMBLY	37
PREPARATION	34	Adjustment	37
PREPARATION	34	REMOVAL AND INSTALLATION	39
Special Service Tool	34	TRANSMITTER	39
Commercial Service Tools	34	Removal and Installation	39
ON-VEHICLE MAINTENANCE	35	SERVICE DATA AND SPECIFICATIONS (SDS)	41
ROAD WHEEL	35	SERVICE DATA AND SPECIFICATIONS (SDS)	41
Inspection	35	Road Wheel	41
ON-VEHICLE REPAIR	36	Tire	41
TIRE PRESSURE RECEIVER	36		

DIAGNOSIS AND REPAIR WORKFLOW

< BASIC INSPECTION >

BASIC INSPECTION

DIAGNOSIS AND REPAIR WORKFLOW

Repair Work Flow

INFOID:000000001342568

WORK FLOW

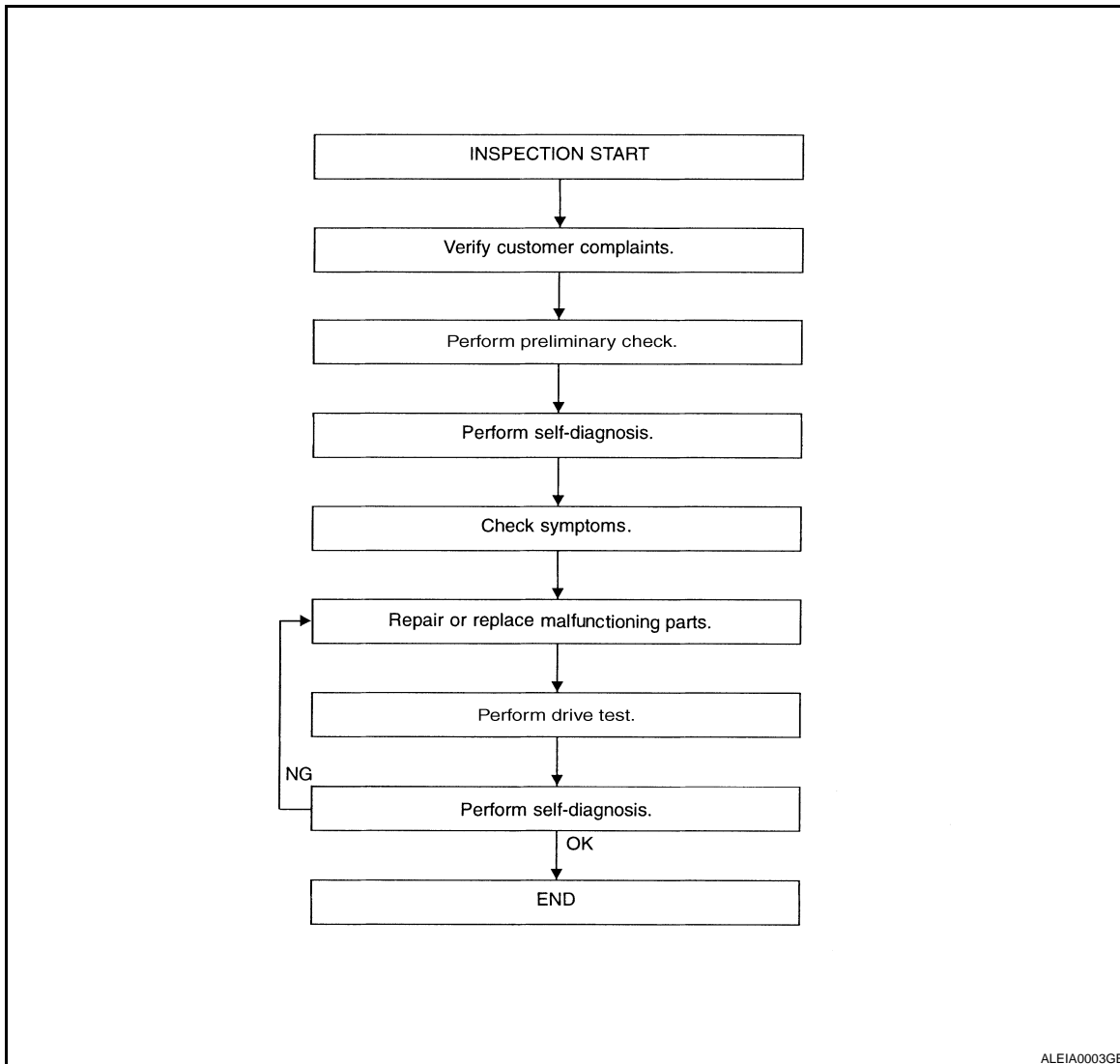

[WT-5. "Preliminary Check"](#)

[WT-11. "Self-Diagnosis"](#)

[WT-26. "Symptom Table"](#)

DETAILED FLOW

1. CUSTOMER INFORMATION

Interview the customer to obtain detailed information about the symptom.

>> GO TO 2

2. PRELIMINARY CHECK

Perform preliminary check. Refer to [WT-5. "Preliminary Check"](#)

>> GO TO 3

DIAGNOSIS AND REPAIR WORKFLOW

< BASIC INSPECTION >

3.SELF-DIAGNOSIS

Perform SELF-DIAGNOSIS. Refer to [WT-11. "Self-Diagnosis"](#) (with CONSULT-III) or [WT-24. "Flash Code Chart"](#) (without CONSULT-III).

>> GO TO 4

4.SYMPTOM

Check for symptoms. Refer to [WT-26. "Symptom Table"](#).

>> GO TO 5

5.MALFUNCTIONING PARTS

Repair or replace the applicable parts.

>> GO TO 6

6.DRIVE TEST

1. Perform a drive test.
2. Check the low tire pressure warning lamp.

>> GO TO 7

7.SELF-DIAGNOSIS

Perform SELF-DIAGNOSIS. Refer to [WT-11. "Self-Diagnosis"](#) (with CONSULT-III) or [WT-24. "Flash Code Chart"](#) (without CONSULT-III).

Are any DTC's displayed?

- YES >> GO TO 5
NO >> INSPECTION END

INSPECTION AND ADJUSTMENT

< BASIC INSPECTION >

INSPECTION AND ADJUSTMENT

Preliminary Check

INFOID:000000001342569

1. TIRE PRESSURE

Check all tire pressures. Refer to [WT-41, "Tire"](#).

OK or NG

- OK >> GO TO 2
- NG >> Adjust tire pressure to specified value.

2. LOW TIRE PRESSURE WARNING LAMP

Check low tire pressure warning lamp activation.

Does the low tire pressure warning lamp activate for one second when ignition switch is turned ON?

- YES >> GO TO 3
- NO >> GO TO [WT-27, "Low Tire Pressure Warning Lamp Does Not Come On When Ignition Switch Is Turned On"](#).

3. BCM CONNECTOR

1. Disconnect BCM harness connectors.
2. Check terminals for damage or loose connection.
3. Reconnect harness connector.

OK or NG

- OK >> GO TO 4
- NG >> Repair or replace damaged parts.

4. TRANSMITTER ACTIVATION TOOL

Check battery in transmitter activation tool.

OK or NG

- OK >> Perform SELF-DIAGNOSIS. Refer to [WT-23, "Self-Diagnosis"](#).
- NG >> Replace battery in transmitter activation tool.

Transmitter Wake Up Operation

INFOID:000000001342570

NOTE:

This procedure must be done after replacement of a low tire pressure warning transmitter or BCM. New replacement transmitters are provided "asleep" and must first be "woken up" using Transmitter Activation Tool J-45295 before ID registration can be performed.

1. Turn ignition switch ON. Push the transmitter activation tool against the tire near the front left transmitter. Press the button for 5 seconds. The hazard warning lamps flash per the following diagram.

Tool number : (J-45295)

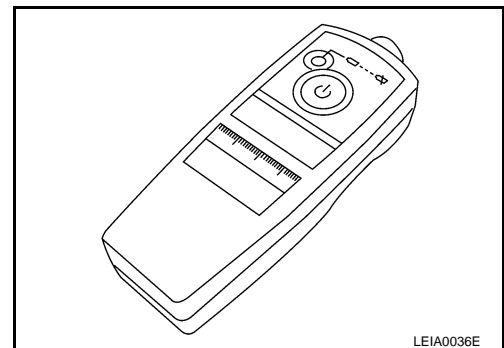

LEIA0036E

2. Repeat this procedure for each tire in the following order: FL, FR, RR, RL.

INSPECTION AND ADJUSTMENT

< BASIC INSPECTION >

- When the BCM finishes assigning each tire ID, the BCM flashes the hazard warning lamps and sends flashing indicator status by CAN according to the following time chart.

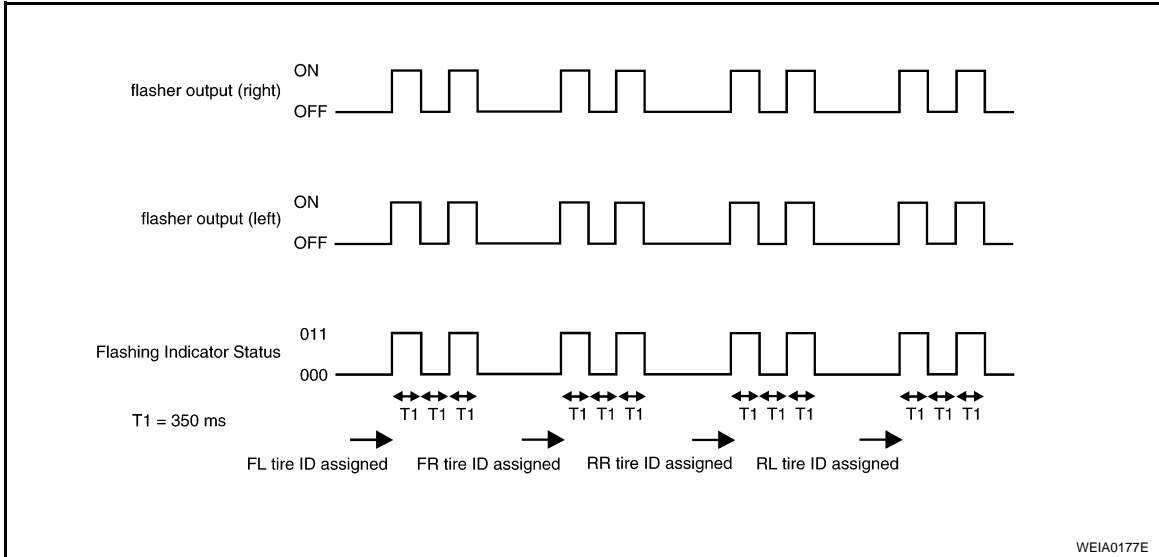

- After completing wake up of all transmitters, make sure low tire pressure warning lamp goes out.

ID Registration Procedure

INFOID:000000001342571

ID REGISTRATION WITH TRANSMITTER ACTIVATION TOOL

NOTE:

This procedure must be done after replacement of a low tire pressure warning transmitter or BCM. New replacement transmitters are provided "asleep" and must first be "woken up" using Transmitter Activation Tool J-45295 before ID registration can be performed.

- Connect CONSULT-III.
- Select "ID REGIST" under BCM.
- Push the transmitter activation tool against the tire near the front left transmitter. Press the button for 5 seconds.

Tool number : (J-45295)

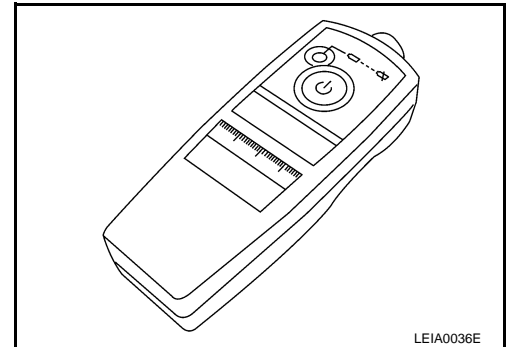

- Register the IDs in order from FR LH, FR RH, RR RH and RR LH. When ID registration of each wheel has been completed, the hazard warning lamps flash.

Step	Activation tire position	Hazard warning lamp	CONSULT-III
1	Front LH	2 times flashing	"YET" ↓ "DONE"
2	Front RH		
3	Rear RH		
4	Rear LH		

- After completing all ID registrations, press "END" to complete the procedure.

NOTE:

Be sure to register all of the IDs in order from FR LH, FR RH, RR RH, to RR LH, or the self-diagnostic results display will not function properly.

ID REGISTRATION WITHOUT TRANSMITTER ACTIVATION TOOL

NOTE:

INSPECTION AND ADJUSTMENT

< BASIC INSPECTION >

This procedure must be done after replacement of a low tire pressure warning transmitter or BCM. New replacement transmitters are provided "asleep" and must first be "woken up" using Transmitter Activation Tool J-45295 before ID registration can be performed.

1. Connect CONSULT-III.
2. Select "ID REGIST" under BCM.
3. Adjust the tire pressures to the values shown in the table and drive the vehicle at 40 km/h (25 MPH) or more for a few minutes.

Tire position	Tire pressure kPa (kg/cm ² , psi)
Front LH	250 (2.5, 36)
Front RH	230 (2.3, 33)
Rear RH	210 (2.1, 30)
Rear LH	190 (1.9, 27)

4. After completing all ID registrations, press "END" to complete the procedure.

Activation tire position	CONSULT-III
Front LH	"YET" ↓ "DONE"
Front RH	
Rear RH	
Rear LH	

5. Inflate all tires to proper pressure. Refer to [WT-41, "Tire"](#).

TPMS

< FUNCTION DIAGNOSIS >

FUNCTION DIAGNOSIS

TPMS

System Diagram

INFOID:000000001342572

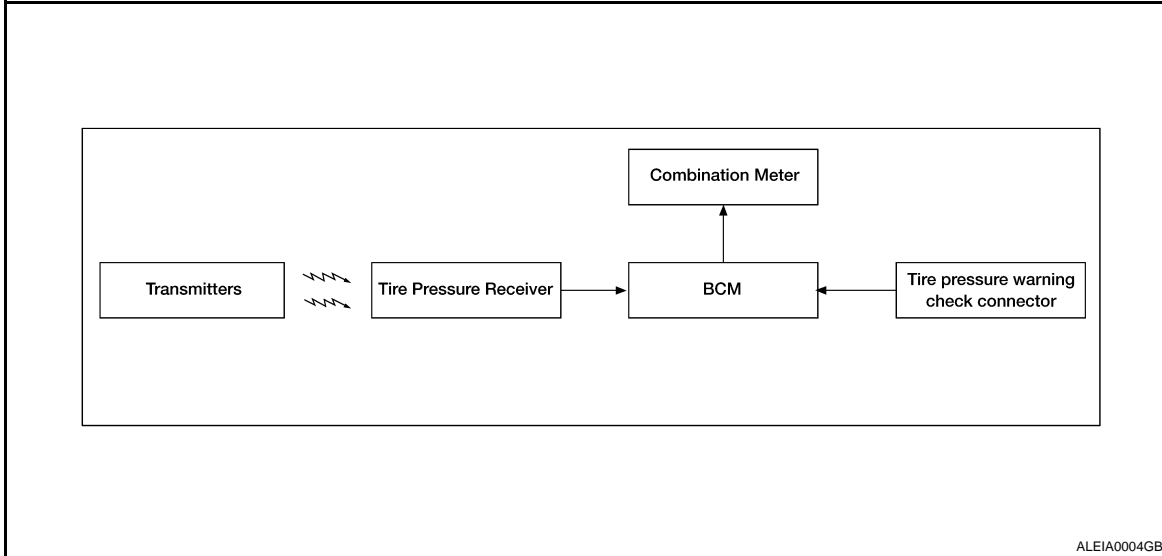

ALEIA0004GB

System Description

INFOID:000000001342573

BODY CONTROL MODULE (BCM)

The BCM is shown with the instrument panel LH removed. The BCM reads the air pressure signal received by the tire pressure receiver, and controls the low tire pressure warning lamp as shown below. It also has a self-diagnosis function to detect a system malfunction.

Condition	Low tire pressure warning lamp
System normal	On for 1 second after ignition ON
Tire pressure less than 174.1 kPa (1.775 kg/cm ² , 25.25 psi)	ON
Tire pressure monitoring system malfunction	After key ON, flashes once per second for 1 minute, then stays ON

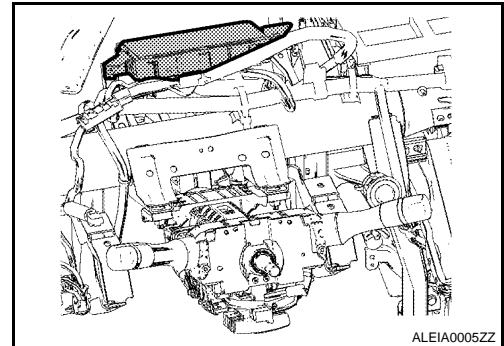

ALEIA0005ZZ

TRANSMITTER

A sensor-transmitter integrated with a valve is installed in each wheel. It transmits a detected air pressure signal in the form of a radio wave when the vehicle is moving. The radio signal is received by the tire pressure receiver.

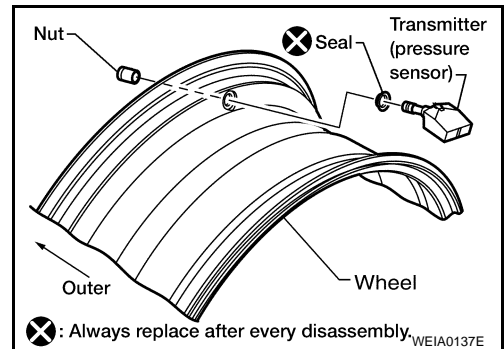

TIRE PRESSURE RECEIVER

TPMS

< FUNCTION DIAGNOSIS >

The tire pressure receiver (1) is located next to the steering column assembly (2) and is shown with the lower instrument panel LH removed. The tire pressure receiver receives the air pressure signal transmitted by the transmitter in each wheel.

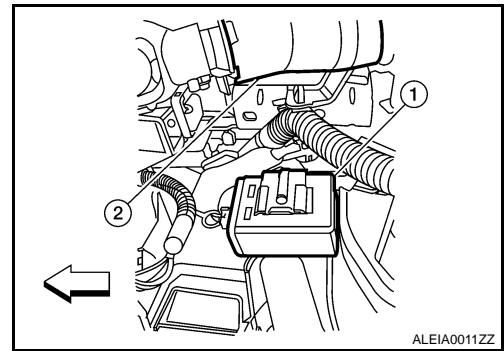

COMBINATION METER

The combination meter receives tire pressure status from the BCM using CAN communication. When a low tire pressure condition is sensed by the BCM, the low tire pressure warning lamp is activated.

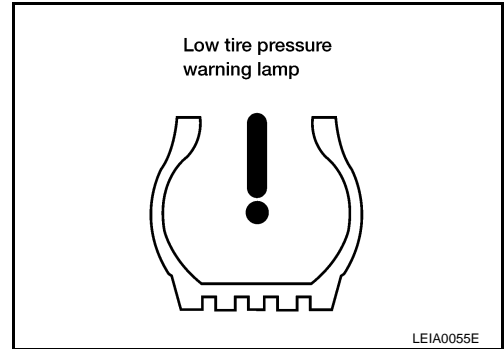

TIRE PRESSURE WARNING CHECK CONNECTOR

The tire pressure warning check connector can be grounded in order to initiate self-diagnosis without a CONSULT-III. The tire pressure warning check connector is located behind the lower portion of the instrument panel LH. Refer to [PG-98. "Harness Layout"](#).

System Components

INFOID:000000001342574

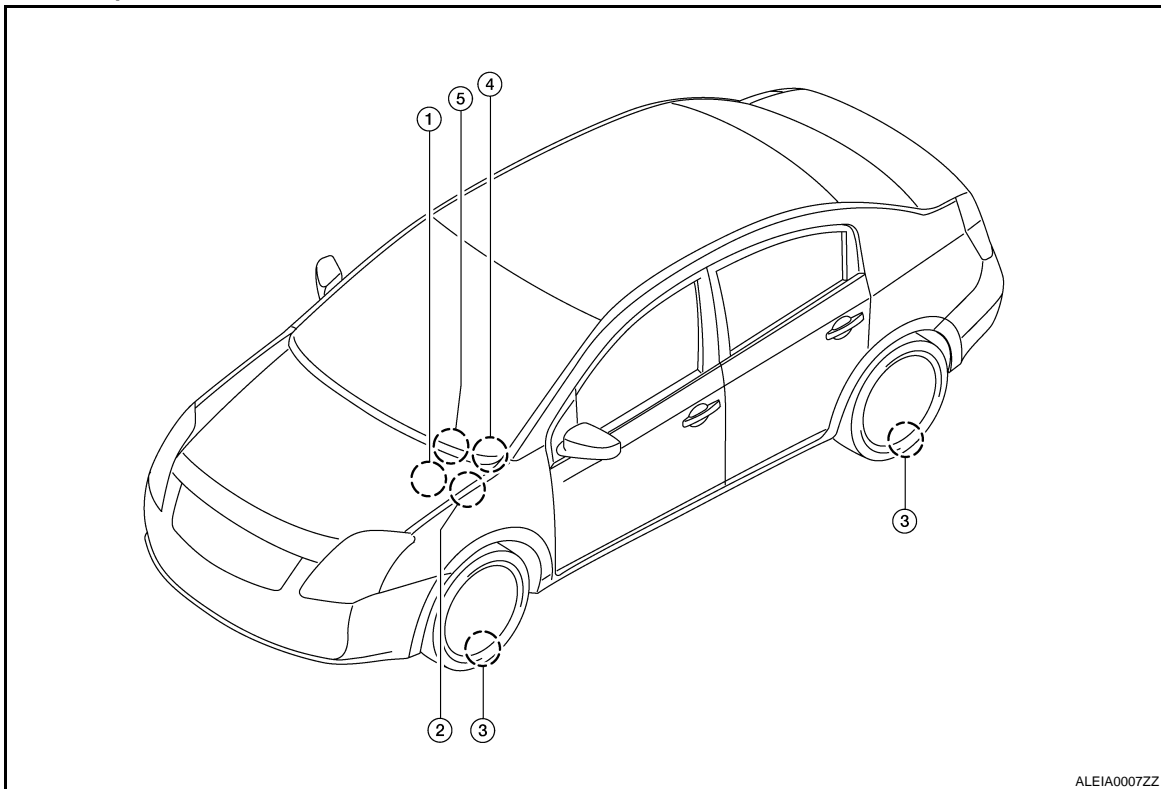

A
B
C
D
WT
F
G
H
I
J
K
L
M
N
O
P

TPMS

< FUNCTION DIAGNOSIS >

- | | | |
|----------------------------------|---|-----------------|
| 1. Tire pressure receiver
M70 | 2. Tire pressure warning check connector
M62 | 3. Transmitters |
| 4. Combination meter
M24 | 5. BCM
M16, M17, M18, M19 | |

DIAGNOSIS SYSTEM (BCM)

< FUNCTION DIAGNOSIS >

DIAGNOSIS SYSTEM (BCM)

CONSULT-III Function (BCM)

INFOID:000000001342575

CONSULT-III can display each diagnostic item using the diagnostic test modes shown following.

Diagnostic mode	Description
WORK SUPPORT	Supports inspections and adjustments. Commands are transmitted to the BCM for setting the status suitable for required operation, input/output signals are received from the BCM and received data is displayed.
DATA MONITOR	Displays BCM input/output data in real time.
ACTIVE TEST	Operation of electrical loads can be checked by sending drive signal to them.
SELF-DIAG RESULTS	Displays BCM self-diagnosis results.
CAN DIAG SUPPORT MNTR	The result of transmit/receive diagnosis of CAN communication can be read.
ECU PART NUMBER	BCM part number can be read.
CONFIGURATION	Performs BCM configuration read/write functions.

Self-Diagnosis

INFOID:000000001342576

DESCRIPTION

During driving, the tire pressure monitoring system receives the signal transmitted from the transmitter installed in each wheel, and turns on the low tire pressure warning lamp when the tire pressure becomes low. The control unit (BCM) for this system has pressure judgement and self-diagnosis functions.

FUNCTION

When the tire pressure monitoring system detects low inflation pressure or an internal malfunction, the low tire pressure warning lamp in the combination meter comes on. The malfunction is indicated by the low tire pressure warning lamp flashing.

CONSULT-III Application to Tire Pressure Monitoring System

ITEM	SELF-DIAGNOSTIC RESULTS	DATA MONITOR
Front - Left transmitter	×	×
Front - Right transmitter	×	×
Rear - Left transmitter	×	×
Rear - Right transmitter	×	×
Warning lamp	—	×
Vehicle speed	×	×
CAN Communication	×	×

× : Applicable

— : Not applicable

Data Monitor Mode

MONITOR	CONDITION	SPECIFICATION
VHCL SPEED	Drive vehicle.	Vehicle speed (km/h or MPH)
AIR PRESS FL AIR PRESS FR AIR PRESS RR AIR PRESS RL	<ul style="list-style-type: none"> Drive vehicle for a few minutes. or <ul style="list-style-type: none"> Ignition switch ON and activation tool is transmitting activation signals. 	Tire pressure (kPa or psi)

DIAGNOSIS SYSTEM (BCM)

< FUNCTION DIAGNOSIS >

MONITOR	CONDITION	SPECIFICATION
ID REGST FL1 ID REGST FR1 ID REGST RR1 ID REGST RL1	Ignition switch ON	ID not registered: YET ID registered: DONE
WARNING LAMP		Low tire pressure warning lamp on: ON Low tire pressure warning lamp off: OFF

NOTE:

Before performing the self-diagnosis, be sure to register the ID, or the actual malfunction location may be different from that displayed on CONSULT-III.

C1708 - C1711 DATA FROM TRANSMITTER NOT BEING RECEIVED

< COMPONENT DIAGNOSIS >

COMPONENT DIAGNOSIS

C1708 - C1711 DATA FROM TRANSMITTER NOT BEING RECEIVED

Data from Transmitter Not Being Received

INFOID:000000001342577

MALFUNCTION CODE NO. 21, 22, 23 or 24

1. CHECK BCM

Drive for several minutes. Check all tire pressures with CONSULT-III.

Are all tire pressures displayed as 0 kPa?

- YES >> GO TO 2
- NO >> GO TO 3

2. CHECK TIRE PRESSURE RECEIVER CONNECTOR

Check tire pressure receiver connector for damage or loose connections.

OK or NG

- OK >> Replace BCM, then GO TO 3. Refer to [BCS-88. "Removal and Installation"](#).
- NG >> Repair or replace tire pressure receiver connector.

3. PERFORM ID REGISTRATION

Carry out ID registration of all transmitters. Refer to [WT-6. "ID Registration Procedure"](#).

Is there a tire that cannot register ID?

- YES >> Replace malfunctioning transmitter, then GO TO 5. Refer to [WT-39. "Removal and Installation"](#).
- NO >> GO TO 4

4. DRIVE VEHICLE

1. Drive at a speed of 40 km/h (25 MPH) or more for several minutes without stopping.
2. Check all tire pressures with CONSULT-III within 15 minutes after vehicle speed becomes 17 km/h (11 MPH).

Does "DATA MONITOR ITEM" display tire pressure as normal without any warning lamp?

- YES >> Inspection End.
- NO >> GO TO 5

5. ID REGISTRATION AND VEHICLE DRIVING

1. Carry out ID registration of all transmitters.
2. Drive at a speed of 40 km/h (25 MPH) or more for 3 minutes, and then drive the vehicle at any speed for 10 minutes.
3. Check all tire pressures with CONSULT-III within 5 minutes.

Does "DATA MONITOR ITEM" display tire pressure as normal without any warning lamp?

- YES >> Inspection End.
- NO >> Proceed to the inspection applicable to DTC.

C1712 - C1715, C1720 - C1723, C1724 - C1727 TRANSMITTER MALFUNCTION

< COMPONENT DIAGNOSIS >

C1712 - C1715, C1720 - C1723, C1724 - C1727 TRANSMITTER MALFUNCTION

Transmitter Malfunction

INFOID:000000001342578

MALFUNCTION CODE NO. 31 - 34, 41 - 44, 45 - 48

1. PERFORM ID REGISTRATION

1. Carry out ID registration of all transmitters. Refer to [WT-6, "ID Registration Procedure"](#).
2. Drive at a speed of 40 km/h (25 MPH) or more for 3 minutes, and then drive the vehicle at any speed for 10 minutes.

>> GO TO 2

2. REPLACE TRANSMITTER

1. Check low tire pressure warning lamp again for flashing, replace malfunctioning transmitter. Refer to [WT-39, "Removal and Installation"](#).
2. Carry out ID registration of all transmitters.

Can ID registration of all transmitters be completed?

YES >> GO TO 3

NO >> GO TO [WT-13, "Data from Transmitter Not Being Received"](#).

3. DRIVE VEHICLE

1. Drive at a speed of 40 km/h (25 MPH) or more for 3 minutes, and then drive the vehicle at any speed for 10 minutes.
2. Check all tire pressures with CONSULT-III within 5 minutes.

Does "DATA MONITOR ITEM" display tire pressure as normal without any warning lamp?

YES >> Inspection End.

NO >> Replace malfunctioning transmitter, and perform Step 3 again.

C1716 - C1719 TRANSMITTER PRESSURE MALFUNCTION

< COMPONENT DIAGNOSIS >

C1716 - C1719 TRANSMITTER PRESSURE MALFUNCTION

Transmitter Pressure Malfunction

INFOID:000000001342579

MALFUNCTION CODE NO. 35 - 38

1. CHECK ALL TIRE PRESSURES

Check all tire pressures. Refer to [WT-41, "Tire"](#).

Are there any tires with pressure of 64 psi or more?

YES >> Adjust tire pressure to specified value.

NO >> GO TO 2

2. ID REGISTRATION AND VEHICLE DRIVING

1. Carry out ID registration of all transmitters. Refer to [WT-6, "ID Registration Procedure"](#).

2. Drive at a speed of 40 km/h (25 MPH) or more for several minutes without stopping.

3. Check all tire pressures with CONSULT-III within 15 minutes after vehicle speed becomes 17 km/h (11 MPH).

Does "DATA MONITOR ITEM" display 64 psi or more?

YES >> Replace transmitter. Refer to [WT-39, "Removal and Installation"](#). GO TO 3.

NO >> GO TO 3

3. ID REGISTRATION AND VEHICLE DRIVING

1. Carry out ID registration of all transmitters.

2. Drive at a speed of 40 km/h (25 MPH) or more for 3 minutes, and then drive the vehicle at any speed for 10 minutes.

3. Check all tire pressures with CONSULT-III within 5 minutes.

Does "DATA MONITOR ITEM" display tire pressure as normal without any warning lamp?

YES >> Inspection End.

NO >> Proceed to the inspection applicable to DTC.

A

B

C

D

WT

F

G

H

I

J

K

L

M

N

O

P

C1729 VEHICLE SPEED SIGNAL

< COMPONENT DIAGNOSIS >

C1729 VEHICLE SPEED SIGNAL

Vehicle Speed Signal

INFOID:000000001836964

MALFUNCTION CODE NO. 52

1. CHECK SELF-DIAGNOSTIC RESULTS

1. On "SELECT DIAG MODE", select the "SELF-DIAG RESULT" screen.
2. Check display contents on "SELF DIAG RESULT" screen.

Is the "CAN COMM CIRCUIT" displayed in the self-diagnosis display?

- YES >> Perform trouble diagnosis for CAN communication system. Refer to [LAN-25. "CAN System Specification Chart"](#).
- NO >> Check combination meter. Refer to [MWI-38. "CONSULT-III Function \(METER/M&A\)"](#).

C1734 CONTROL UNIT

< COMPONENT DIAGNOSIS >

C1734 CONTROL UNIT

Control Unit

INFOID:000000001836965

MALFUNCTION CODE NO. 53

1. SELF-DIAGNOSTIC RESULTS

1. On "SELECT DIAG" mode, select the "SELF-DIAG RESULT" screen for BCM.
2. Check display contents on "SELF-DIAG RESULT".

Does self-diagnostic results indicate any DTC other than C1734?

- YES >> Perform trouble diagnosis for DTC. Refer to [BCS-85, "DTC Index"](#).
 NO >> GO TO 2.

2. CHECK BCM HARNESS CONNECTORS

Check BCM harness connectors for damage or loose connections.

Are the BCM harness connectors damaged or loose?

- YES >> Repair or replace damaged parts.
 NO >> GO TO 3.

3. BCM POWER SUPPLY AND GROUND

Check BCM power supply and ground. Refer to [BCS-36, "Diagnosis Procedure"](#).

Are the power supply and grounds normal?

- YES >> GO TO 4.
 NO >> Repair power supply or grounds as necessary.

4. CHECK HARNESS BETWEEN BCM AND TIRE PRESSURE RECEIVER

1. Turn ignition switch "OFF"
2. Disconnect BCM harness connector M18 (A) and tire pressure receiver harness connector M70 (B).
3. Check continuity between BCM harness connector and tire pressure receiver harness connector.

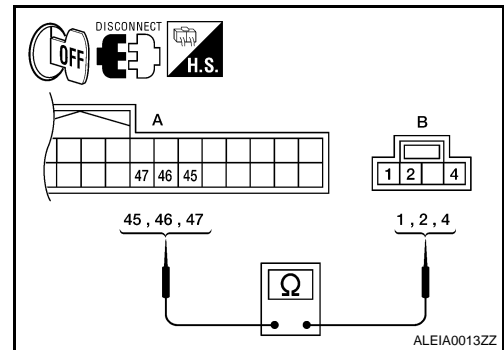

BCM		Tire pressure receiver		Continuity
Connector	Terminal	Connector	Terminal	
M18	45	M70	1	YES
	46		4	
	47		2	

Does continuity exist?

- YES >> GO TO 5.
 NO >> Repair circuits as necessary.

5. BCM INPUT/OUTPUT SIGNALS

Check BCM input/output signals. Refer to [BCS-41, "Reference Value"](#).

Are the inputs and outputs normal?

- YES >> Inspection End.
 NO >> Replace BCM. Refer to [BCS-88, "Removal and Installation"](#).

BCM (BODY CONTROL MODULE)

< ECU DIAGNOSIS >

ECU DIAGNOSIS

BCM (BODY CONTROL MODULE)

Terminals and Reference Values (BCM)

INFOID:000000001342581

Refer to [BCS-41, "Reference Value"](#).

Wiring Diagram — Coupe

INFOID:000000001342582

--- : DATA LINE

TIRE PRESSURE MONITORING SYSTEM

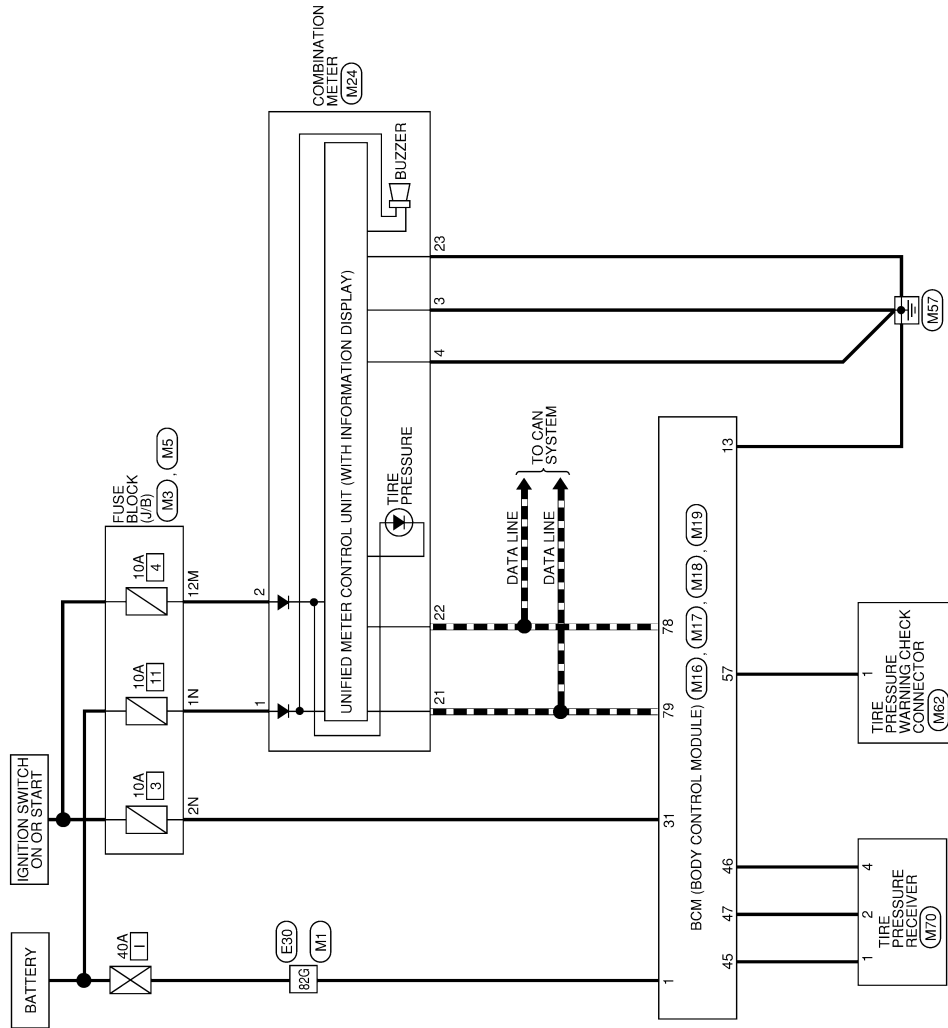

BCM (BODY CONTROL MODULE)

< ECU DIAGNOSIS >

TIRE PRESSURE MONITORING SYSTEM CONNECTORS

Connector No.	M1
Connector Name	WIRE TO WIRE
Connector Color	WHITE

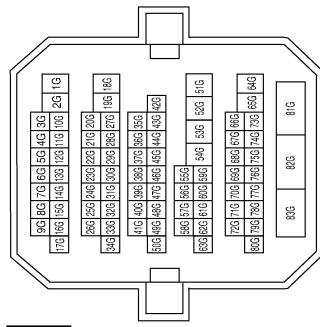

Terminal No.	82G	Color of Wire	W/B	Signal Name	—
--------------	-----	---------------	-----	-------------	---

Connector No.	M3
Connector Name	FUSE BLOCK (J/B)
Connector Color	WHITE

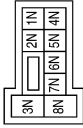

Terminal No.	1N	Color of Wire	W/L	Signal Name	—
Terminal No.	2N	Color of Wire	G	Signal Name	—

Connector No.	M5
Connector Name	FUSE BLOCK (J/B)
Connector Color	WHITE

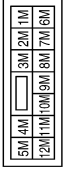

Terminal No.	12M	Color of Wire	P	Signal Name	—
--------------	-----	---------------	---	-------------	---

Connector No.	M16
Connector Name	BCM (BODY CONTROL MODULE)
Connector Color	BLACK



Terminal No.	1	Color of Wire	W/B	Signal Name	BAT_POWER_F/L
--------------	---	---------------	-----	-------------	---------------

Connector No.	M17
Connector Name	BCM (BODY CONTROL MODULE)
Connector Color	WHITE

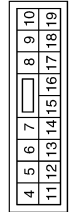

Terminal No.	13	Color of Wire	B	Signal Name	GND1
--------------	----	---------------	---	-------------	------

Connector No.	M18
Connector Name	BCM (BODY CONTROL MODULE)
Connector Color	GREEN

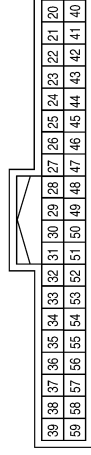

Terminal No.	31	Color of Wire	G	Signal Name	IGN_F/B
Terminal No.	45	Color of Wire	P	Signal Name	GND_RF2_A/L
Terminal No.	46	Color of Wire	V/W	Signal Name	A/L_SENS_KEYLESS_TUNER_POWER_SUPPLY
Terminal No.	47	Color of Wire	G/O	Signal Name	KEYLESS_TUNER_SIGNAL
Terminal No.	57	Color of Wire	W	Signal Name	TPMS_MODE_TRIGGER_SW

BCM (BODY CONTROL MODULE)

< ECU DIAGNOSIS >

Connector No.	M62
Connector Name	TIRE PRESSURE WARNING CHECK CONNECTOR
Connector Color	WHITE



Terminal No.	Color of Wire	Signal Name
1	W	LOW_TIRE

Connector No.	M24
Connector Name	COMBINATION METER
Connector Color	WHITE



1	2	3	4	5	6	7	8	9	10	11	12	13	14	15	16	17	18	19	20	21	22	23	24	25	26	27	28	29	30	31	32	33	34	35	36	37	38	39	40
---	---	---	---	---	---	---	---	---	----	----	----	----	----	----	----	----	----	----	----	----	----	----	----	----	----	----	----	----	----	----	----	----	----	----	----	----	----	----	----

Terminal No.	Color of Wire	Signal Name
1	W/L	BATT
2	O	IGN
3	B	GND
4	B	GND
21	L	CAN-H
22	P	CAN-L
23	B	GND

Connector No.	M19
Connector Name	BCM (BODY CONTROL MODULE)
Connector Color	BLACK



79	78	77	76	75	74	73	72	71	70	69	68	67	66	65	64	63	62	61	60	59	58	57	56	55	54	53	52	51	50	49	48	47	46	45	44	43	42	41	40
----	----	----	----	----	----	----	----	----	----	----	----	----	----	----	----	----	----	----	----	----	----	----	----	----	----	----	----	----	----	----	----	----	----	----	----	----	----	----	----

Terminal No.	Color of Wire	Signal Name
78	P	CAN-L
79	L	CAN-H

Terminal No.	82G	Color of Wire	W/B	Signal Name	-
--------------	-----	---------------	-----	-------------	---

Connector No.	E30
Connector Name	WIRE TO WIRE
Connector Color	WHITE

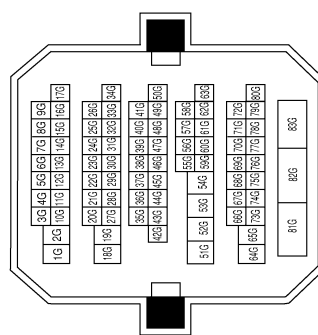

BCM (BODY CONTROL MODULE)

< ECU DIAGNOSIS >

Wiring Diagram — Sedan

INFOID:000000003219933

TIRE PRESSURE MONITORING SYSTEM

--- : DATA LINE

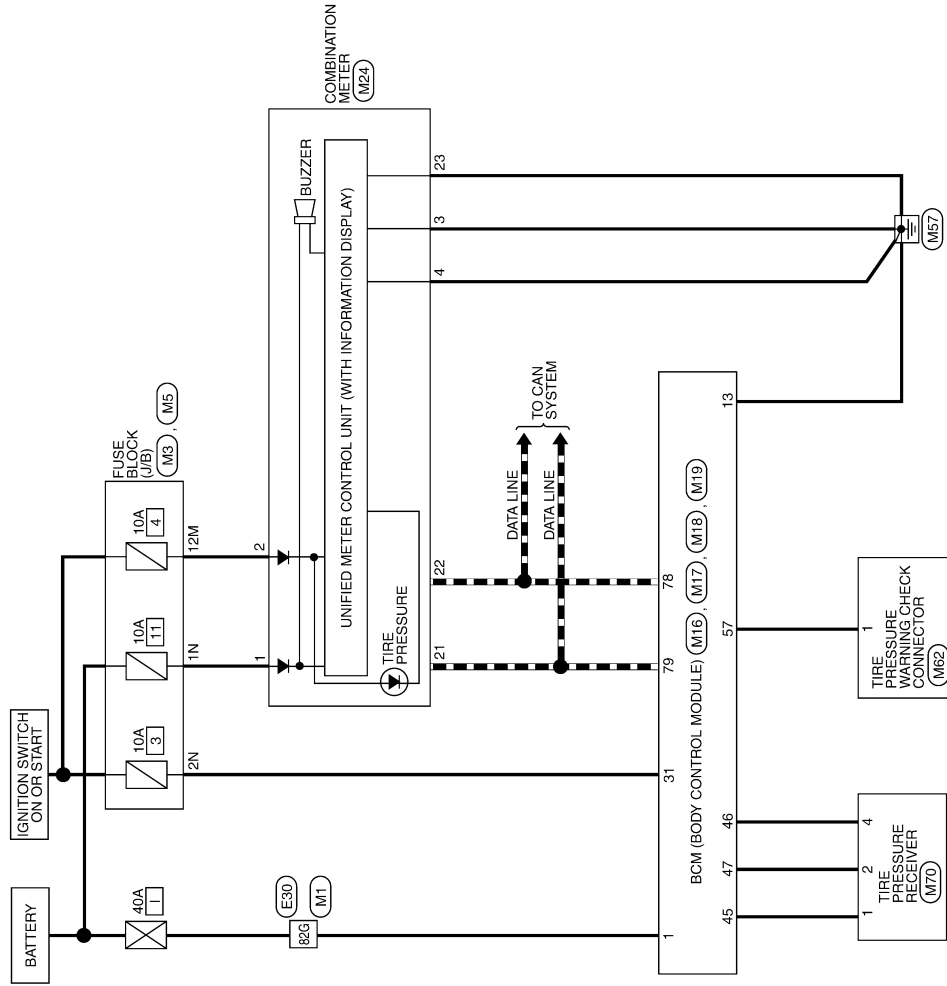

AWEWA0011GI

A
B
C
D
WT
F
G
H
I
J
K
L
M
N
O
P

BCM (BODY CONTROL MODULE)

< ECU DIAGNOSIS >

TIRE PRESSURE MONITORING SYSTEM CONNECTORS

Connector No.	M1
Connector Name	WIRE TO WIRE
Connector Color	WHITE

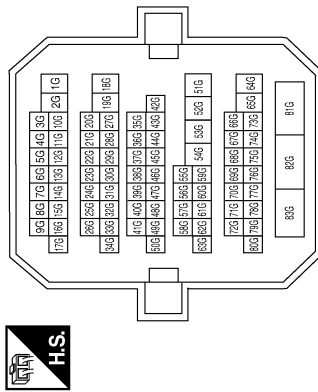

Terminal No.	82G	Color of Wire	W/B	Signal Name	—
--------------	-----	---------------	-----	-------------	---

Connector No.	M3
Connector Name	FUSE BLOCK (J/B)
Connector Color	WHITE

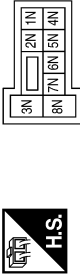

Terminal No.	1N	Color of Wire	W/L	Signal Name	—
Terminal No.	2N	Color of Wire	G	Signal Name	—

Connector No.	M5
Connector Name	FUSE BLOCK (J/B)
Connector Color	WHITE

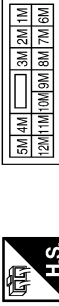

Terminal No.	12M	Color of Wire	P	Signal Name	—
--------------	-----	---------------	---	-------------	---

Connector No.	M17
Connector Name	BCM (BODY CONTROL MODULE)
Connector Color	WHITE

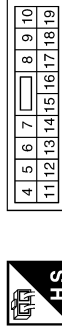

Terminal No.	13	Color of Wire	B	Signal Name	GND1
--------------	----	---------------	---	-------------	------

Connector No.	M16
Connector Name	BCM (BODY CONTROL MODULE)
Connector Color	BLACK



Terminal No.	1	Color of Wire	W/B	Signal Name	BAT_POWER_F/L
--------------	---	---------------	-----	-------------	---------------

Connector No.	M18
Connector Name	BCM (BODY CONTROL MODULE)
Connector Color	GREEN

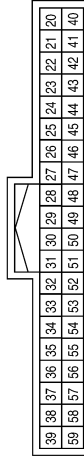

Terminal No.	31	Color of Wire	G	Signal Name	IGN_F/B
Terminal No.	45	Color of Wire	P	Signal Name	GND_RF2_A/L
Terminal No.	46	Color of Wire	V/W	Signal Name	A/L_SENS_KEYLESS_TUNER_POWER_SUPPLY
Terminal No.	47	Color of Wire	G/O	Signal Name	KEYLESS_TUNER_SIGNAL
Terminal No.	57	Color of Wire	W	Signal Name	TPMS_MODE_TRIGGER_SW

ALEIA0009GB

BCM (BODY CONTROL MODULE)

< ECU DIAGNOSIS >

Connector No.	M62
Connector Name	TIRE PRESSURE WARNING CHECK CONNECTOR
Connector Color	WHITE



Terminal No.	Color of Wire	Signal Name
1	W	LOW_TIRE

Connector No.	M24
Connector Name	COMBINATION METER
Connector Color	WHITE



1	2	3	4	5	6	7	8	9	10	11	12	13	14	15	16	17	18	19	20
21	22	23	24	25	26	27	28	29	30	31	32	33	34	35	36	37	38	39	40

Terminal No.	Color of Wire	Signal Name
1	W/L	BATT
2	O	IGN
3	B	GND
4	B	GND
21	L	CAN-H
22	P	CAN-L
23	B	GND

Connector No.	M19
Connector Name	BCM (BODY CONTROL MODULE)
Connector Color	BLACK



79	78	77	76	75	74	73	72	71	70	69	68	67	66	65	64	63	62	61	60
59	58	57	56	55	54	53	52	51	50	49	48	47	46	45	44	43	42	41	40

Terminal No.	Color of Wire	Signal Name
78	P	CAN-L
79	L	CAN-H

Terminal No.	82G	Color of Wire	W/B	Signal Name	-
--------------	-----	---------------	-----	-------------	---

Connector No.	E30
Connector Name	WIRE TO WIRE
Connector Color	WHITE

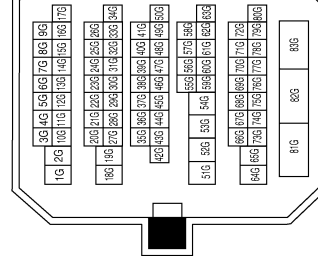

Connector No.	M70
Connector Name	TIRE PRESSURE RECEIVER
Connector Color	WHITE

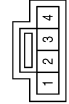

Terminal No.	Color of Wire	Signal Name
1	P	GND
2	G/O	SIGNAL
4	V/W	POWER

Self-Diagnosis

FUNCTION

Self-Diagnostic Results Mode

AWEIA0032GB

INFOID:000000001342583

A
B
C
D
WT
F
G
H
I
J
K
L
M
N
O
P

BCM (BODY CONTROL MODULE)

< ECU DIAGNOSIS >

Diagnostic item	Diagnostic item is detected when ...	Reference page
LOW - PRESSURE - FL [C1704] LOW - PRESSURE - FR [C1705] LOW - PRESSURE - RR [C1706] LOW - PRESSURE - RL [C1707]	Tire pressures dropped below specified value. Refer to WT-8, "System Description" .	—
[NO-DATA] - FL [C1708] [NO-DATA] - FR [C1709] [NO-DATA] - RR [C1710] [NO-DATA] - RL [C1711]	Data from FL transmitter cannot be received. Data from FR transmitter cannot be received. Data from RR transmitter cannot be received. Data from RL transmitter cannot be received.	WT-13
[CHECKSUM- ERR] - FL [C1712] [CHECKSUM- ERR] - FR [C1713] [CHECKSUM- ERR] - RR [C1714] [CHECKSUM- ERR] - RL [C1715]	Checksum data from FL transmitter is malfunctioning. Checksum data from FR transmitter is malfunctioning. Checksum data from RR transmitter is malfunctioning. Checksum data from RL transmitter is malfunctioning.	WT-14
[PRESSDATA- ERR] - FL [C1716] [PRESSDATA- ERR] - FR [C1717] [PRESSDATA- ERR] - RR [C1718] [PRESSDATA- ERR] - RL [C1719]	Air pressure data from FL transmitter is malfunctioning. Air pressure data from FR transmitter is malfunctioning. Air pressure data from RR transmitter is malfunctioning. Air pressure data from RL transmitter is malfunctioning.	WT-15
[CODE- ERR] - FL [C1720] [CODE- ERR] - FR [C1721] [CODE- ERR] - RR [C1722] [CODE- ERR] - RL [C1723]	Function code data from FL transmitter is malfunctioning. Function code data from FR transmitter is malfunctioning. Function code data from RR transmitter is malfunctioning. Function code data from RL transmitter is malfunctioning.	WT-14
[BATT - VOLT - LOW] - FL [C1724] [BATT - VOLT - LOW] - FR [C1725] [BATT - VOLT - LOW] - RR [C1726] [BATT - VOLT - LOW] - RL [C1727]	Battery voltage of FL transmitter drops. Battery voltage of FR transmitter drops. Battery voltage of RR transmitter drops. Battery voltage of RL transmitter drops.	WT-14
VHCL_SPEED_SIG_ERR [C1729]	Vehicle speed signal is in error.	WT-16
CONTROL MODULE [C1734]	TPMS malfunction in BCM.	WT-17

NOTE:

Before performing the self-diagnosis, be sure to register the ID or else the actual malfunction location may be different from that displayed on CONSULT-III.

Flash Code Chart

INFOID:000000001342584

Flash Code	Malfunction part	Reference page
15 16 17 18	Tire pressure dropped below specified value. Refer to WT-8, "System Description" .	—
21 22 23 24	Transmitter no data (FL) Transmitter no data (FR) Transmitter no data (RR) Transmitter no data (RL)	WT-13
31 32 33 34	Transmitter checksum error (FL) Transmitter checksum error (FR) Transmitter checksum error (RR) Transmitter checksum error (RL)	WT-14
35 36 37 38	Transmitter pressure data error (FL) Transmitter pressure data error (FR) Transmitter pressure data error (RR) Transmitter pressure data error (RL)	WT-15
41 42 43 44	Transmitter function code error (FL) Transmitter function code error (FR) Transmitter function code error (RR) Transmitter function code error (RL)	WT-14

BCM (BODY CONTROL MODULE)

< ECU DIAGNOSIS >

Flash Code	Malfunction part	Reference page	
45	Transmitter battery voltage low (FL)		A
46	Transmitter battery voltage low (FR)		
47	Transmitter battery voltage low (RR)	WT-14	B
48	Transmitter battery voltage low (RL)		
52	Vehicle speed signal	WT-16	
53	TPMS malfunction in BCM	WT-17	C

D

WT

F

G

H

I

J

K

L

M

N

O

P

TPMS

< SYMPTOM DIAGNOSIS >

SYMPTOM DIAGNOSIS

TPMS

Symptom Table

INFOID:000000001836966

Symptom	Reference
Low tire pressure warning lamp does not come on when ignition switch is turned on.	WT-27
Low tire pressure warning lamp stays on when ignition switch is turned on.	WT-28
Low tire pressure warning lamp flashes when ignition switch is turned on.	WT-29
Hazard warning lamps flash when ignition switch is turned on.	WT-30
ID registration cannot be completed.	WT-31

LOW TIRE PRESSURE WARNING LAMP DOES NOT TURN ON

< SYMPTOM DIAGNOSIS >

LOW TIRE PRESSURE WARNING LAMP DOES NOT TURN ON

Low Tire Pressure Warning Lamp Does Not Come On When Ignition Switch Is Turned On

INFOID:000000001342586

DIAGNOSTIC PROCEDURE

1.SELF-DIAGNOSTIC RESULT CHECK

Using CONSULT-III, check display contents of BCM in SELF-DIAGNOSIS.

Is "CAN COMM CIRCUIT" displayed in the self-diagnosis display items?

YES >> Malfunction in CAN communication system. Refer to [LAN-25. "CAN System Specification Chart"](#).

NO >> GO TO 2

2.CHECK COMBINATION METER

Check combination meter operation. Refer to [MWI-38. "CONSULT-III Function \(METER/M&A\)"](#).

Inspection results OK?

OK >> GO TO 3

NG >> Replace combination meter. Refer to [IP-11. "Removal and Installation"](#).

3.CHECK LOW TIRE PRESSURE WARNING LAMP

Disconnect BCM harness connector.

Does the low tire pressure warning lamp activate?

YES >> Replace BCM. Refer to [BCS-88. "Removal and Installation"](#).

NO >> Check combination meter operation.

A
B
C
D
WT
F
G
H
I
J
K
L
M
N
O
P

LOW TIRE PRESSURE WARNING LAMP STAYS ON

< SYMPTOM DIAGNOSIS >

LOW TIRE PRESSURE WARNING LAMP STAYS ON

Low Tire Pressure Warning Lamp Stays On When Ignition Switch Is Turned On

INFOID:000000001342587

DIAGNOSTIC PROCEDURE

1.CHECK BCM CONNECTORS

1. Turn ignition switch OFF.
2. Disconnect BCM harness connectors.
3. Check terminals for damage or loose connections.

OK or NG?

- OK >> GO TO 2
NG >> Repair or replace damaged parts.

2.CHECK BCM POWER SUPPLY AND GROUND CIRCUITS

Refer to [BCS-36. "Diagnosis Procedure"](#).

OK or NG?

- OK >> Replace BCM. Refer to [BCS-88. "Removal and Installation"](#).
NG >> Repair BCM circuits.

LOW TIRE PRESSURE WARNING LAMP BLINKS

< SYMPTOM DIAGNOSIS >

LOW TIRE PRESSURE WARNING LAMP BLINKS

Low Tire Pressure Warning Lamp Flashes When Ignition Switch Is Turned On

INFOID:000000001342588

NOTE:

If low tire pressure warning lamp flashes as shown, the system is normal.

Flash Mode A

- This mode shows transmitter status is OFF-mode.
Carry out transmitter wake up operation. Refer to [WT-5, "Transmitter Wake Up Operation"](#).

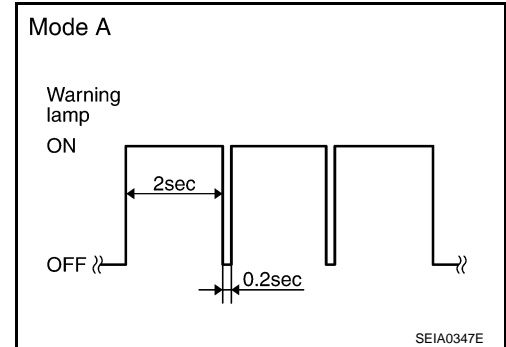

DIAGNOSTIC PROCEDURE

1. CHECK BCM CONNECTORS

1. Turn ignition switch OFF.
2. Disconnect BCM harness connectors.
3. Check terminals for damage or loose connections.

Inspection results OK?

- OK >> GO TO 2
NG >> Repair or replace damaged parts.

2. CHECK TIRE PRESSURE WARNING CHECK CONNECTOR CIRCUIT

Check continuity between BCM harness connector M18 terminal 57 and ground.

Continuity should not exist.

OK or NG

- OK >> Replace BCM. Refer to [BCS-88, "Removal and Installation"](#).
- NG >> Repair circuit for short to ground.

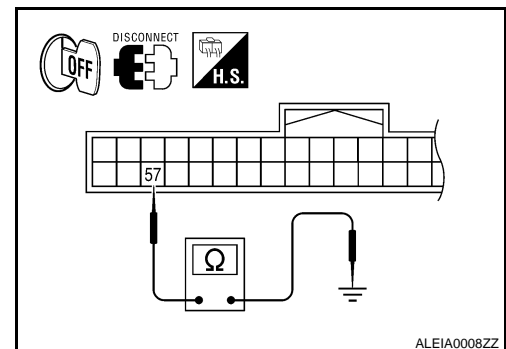

HAZARD WARNING LAMPS FLASH

< SYMPTOM DIAGNOSIS >

HAZARD WARNING LAMPS FLASH

Hazard Warning Lamps Flash When Ignition Switch Is Turned On

INFOID:000000001342589

DIAGNOSTIC PROCEDURE

1.CHECK BCM GROUND CIRCUIT

Check BCM ground circuit. Refer to [BCS-36, "Diagnosis Procedure"](#).

OK or NG

- OK >> Replace BCM. Refer to [BCS-88, "Removal and Installation"](#).
- NG >> Repair BCM ground circuit.

ID REGISTRATION CANNOT BE COMPLETED

< SYMPTOM DIAGNOSIS >

ID REGISTRATION CANNOT BE COMPLETED

ID Registration Cannot Be Completed

INFOID:000000001342590

DIAGNOSTIC PROCEDURE

1. PERFORM ID REGISTRATION OF ALL TRANSMITTERS

Carry out ID registration of all transmitters. Refer to [WT-6, "ID Registration Procedure"](#).

Can ID registration of all transmitters be completed?

YES >> Inspection End.

NO >> GO TO [WT-13, "Data from Transmitter Not Being Received"](#).

A

B

C

D

WT

F

G

H

I

J

K

L

M

N

O

P

NOISE, VIBRATION AND HARSHNESS (NVH) TROUBLESHOOTING

< SYMPTOM DIAGNOSIS >

NOISE, VIBRATION AND HARSHNESS (NVH) TROUBLESHOOTING

NVH Troubleshooting Chart

INFOID:000000001342591

Use chart below to help you find the cause of the symptom. If necessary, repair or replace these parts.

Symptom		Possible cause and SUSPECTED PARTS													Reference page			
		Improper installation, looseness	Out-of-round	Imbalance	Incorrect tire pressure	Uneven tire wear	Deformation or damage	Non-uniformity	Incorrect tire size	FRONT AXLE AND FRONT SUSPENSION	REAR AXLE AND REAR SUSPENSION	TIRES	ROAD WHEELS	DRIVE SHAFT	BRAKE	STEERING		
TIRES	Noise	x	x	x	x	x	x	x		x	x		x	x	x	x	WT-35	
	Shake	x	x	x	x	x	x		x	x	x		x	x	x	x	WT-35	
	Vibration				x				x	x	x			x			WT-35	
	Shimmy	x	x	x	x	x	x	x	x	x	x		x		x	x	WT-41	
	Shudder	x	x	x	x	x	x		x	x	x		x		x	x	WT-35	
	Poor quality ride or handling	x	x	x	x	x	x		x	x		x	x					—
	Noise	x	x	x						x	x	x		x	x	x		—
	Shake	x	x	x										x	x	x		WT-41
ROAD WHEEL	Shimmy, Shudder	x	x	x									x	x	x		WT-41	
	Poor quality ride or handling	x	x	x									x	x	x		WT-41	
	Noise																WT-41	
	Shake																WT-41	
		FRONT AXLE AND FRONT SUSPENSION													FAX-2, "NVH Troubleshooting Chart"			
		REAR AXLE AND REAR SUSPENSION													RAX-2, "NVH Troubleshooting Chart"			
		TIRES													Refer to TIRES in this chart.			
		ROAD WHEELS													Refer to ROAD WHEEL in this chart.			
		DRIVE SHAFT													FAX-2, "NVH Troubleshooting Chart"			
		BRAKE													BR-3, "NVH Troubleshooting Chart"			
		STEERING													ST-3, "NVH Troubleshooting Chart"			

x: Applicable

PRECAUTIONS

< PRECAUTION >

PRECAUTION

PRECAUTIONS

Supplemental Restraint System (SRS) AIR BAG and SEAT BELT PRE-TENSIONER

INFOID:000000001836963

The Supplemental Restraint System such as "AIR BAG" and "SEAT BELT PRE-TENSIONER", used along with a front seat belt, helps to reduce the risk or severity of injury to the driver and front passenger for certain types of collision. This system includes seat belt switch inputs and dual stage front air bag modules. The SRS system uses the seat belt switches to determine the front air bag deployment, and may only deploy one front air bag, depending on the severity of a collision and whether the front occupants are belted or unbelted. Information necessary to service the system safely is included in the SR and SB section of this Service Manual.

WARNING:

- To avoid rendering the SRS inoperative, which could increase the risk of personal injury or death in the event of a collision which would result in air bag inflation, all maintenance must be performed by an authorized NISSAN/INFINITI dealer.
- Improper maintenance, including incorrect removal and installation of the SRS, can lead to personal injury caused by unintentional activation of the system. For removal of Spiral Cable and Air Bag Module, see the SR section.
- Do not use electrical test equipment on any circuit related to the SRS unless instructed to in this Service Manual. SRS wiring harnesses can be identified by yellow and/or orange harnesses or harness connectors.

Precaution for work

INFOID:000000001342593

- After removing and installing the opening/closing parts, be sure to carry out fitting adjustments to check their operation.
- Check the lubrication level, damage, and wear of each part. If necessary, grease or replace it.

A
B
C
D
WT
F
G
H
I
J
K
L
M
N
O
P

PREPARATION

< PREPARATION >

PREPARATION

PREPARATION

Special Service Tool

INFOID:000000001342594

The actual shapes of Kent-Moore tools may differ from those of special service tools illustrated here.

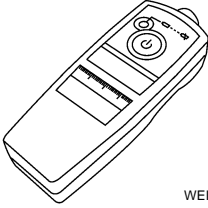
Tool number (Kent-Moore No.) Tool name	Description
KV991B1000 (J-45295) Transmitter activation tool  WEIA0144E	<ul style="list-style-type: none">• Transmitter wake up operation• ID registration procedure

Commercial Service Tools

INFOID:000000001342595

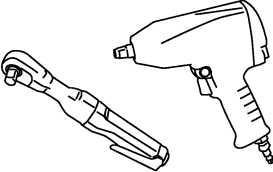
Tool name	Description
Power tool  PBIC0190E	Loosening bolts and nuts

ROAD WHEEL

< ON-VEHICLE MAINTENANCE >

ON-VEHICLE MAINTENANCE

ROAD WHEEL

Inspection

INFOID:000000001342596

ALUMINUM WHEEL

1. Check tires for wear and improper inflation.
2. Check wheels for deformation, cracks and other damage. If deformed, remove wheel and check wheel runout.
 - a. Remove tire from aluminum wheel and mount on a tire balance machine.
 - b. Set dial indicator as shown in the figure.

Wheel runout (Dial indicator value):

Refer to [WT-41](#).

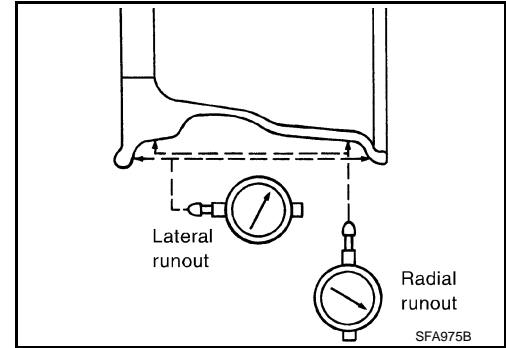

STEEL WHEEL

1. Check tires for wear and improper inflation.
2. Check wheels for deformation, cracks and other damage. If deformed, remove wheel and check wheel runout.
 - a. Remove tire from steel wheel and mount on a tire balance machine.
 - b. Set two dial indicators as shown in the figure.
 - c. Set each dial indicator to 0.
 - d. Rotate wheel and check dial indicators at several points around the circumference of the wheel.
 - e. Calculate runout at each point as shown below.

Radial runout = (A+B)/2

Lateral runout = (C+D)/2

- f. Select maximum positive runout value and the maximum negative value. Add the two values to determine total runout. In case a positive or negative value is not available, use the maximum value (negative or positive) for total runout. If the total runout value exceeds the limit, replace steel wheel.

Wheel runout : Refer to [WT-41](#).

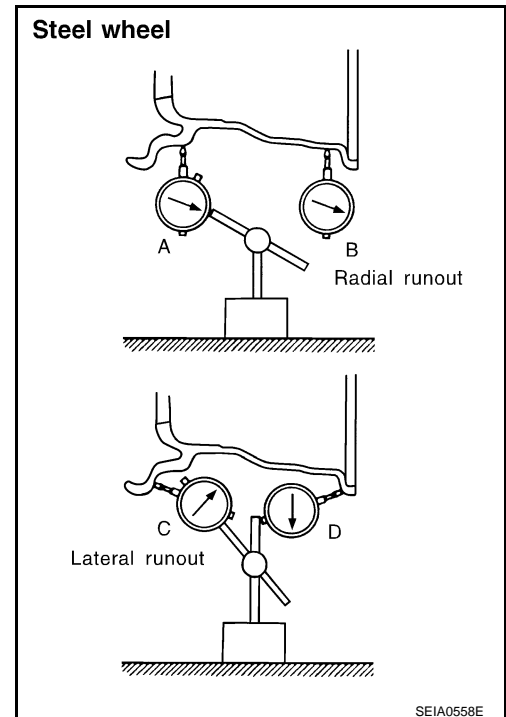

TIRE PRESSURE RECEIVER

< ON-VEHICLE REPAIR >

ON-VEHICLE REPAIR

TIRE PRESSURE RECEIVER

Removal and Installation

INFOID:000000001342597

REMOVAL

1. Remove instrument driver lower panel and locate tire pressure receiver (1) to the right of the steering column (2). Refer to [JP-11, "Removal and Installation"](#).
2. Disconnect tire pressure receiver electrical connector, then remove tire pressure receiver (1) from bracket using a suitable tool to release the bracket.

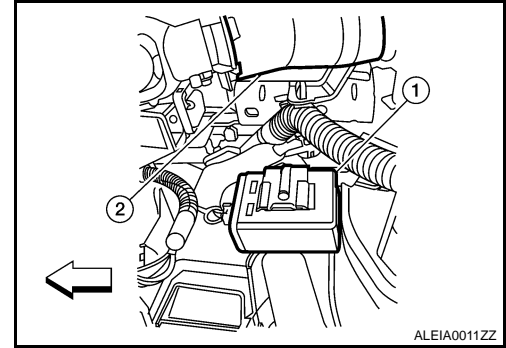

INSTALLATION

Installation is the reverse order of removal.

ROAD WHEEL TIRE ASSEMBLY

< ON-VEHICLE REPAIR >

ROAD WHEEL TIRE ASSEMBLY

Adjustment

INFOID:000000001342598

WHEEL BALANCE

1. Remove inner and outer balance weights from the wheel.
CAUTION:
 - Be careful not to scratch the wheel during removal procedures.
2. Using releasing agent, remove double-faced adhesive tape from the wheel.
CAUTION:
 - Be careful not to scratch the wheel during removal.
 - After removing double-faced adhesive tape, wipe clean traces of releasing agent from the wheel.
3. Set wheel on wheel balancer using the center hole as a guide. Start the tire balance machine.
 - If a tire balance machine has adhesion balance weight mode settings and drive-in weight mode setting, select and adjust a drive-in weight mode suitable for wheels.
4. When inner and outer unbalance values are shown on the wheel balancer indicator, multiply outer unbalance value by 1.6 to determine balance weight that should be used. Select the outer balance weight with a value closest to the calculated value and install it to the designated outer position of, or at the designated angle in relation to the road wheel.

CAUTION:

- Do not install the inner balance weight before installing the outer balance weight.
- Before installing the balance weight, be sure to clean the mating surface of the wheel.

Indicated unbalance value $\times 5/3 =$ balance weight to be installed

Calculation example:

23 g (0.81 oz.) $\times 5/3 = 38.33$ g (1.35 oz.) = 40 g (1.41 oz.) balance weight (closer to calculated balance weight value)

Note that balance weight value must be closer to the calculated balance weight value.

Example:

37.4 g = 35 g (1.23 oz.)

37.5 g = 40 g (1.41 oz.)

- a. Install balance weight in the position shown.
- b. When installing balance weight to wheels, set it into the grooved area on the inner wall of the wheel as shown so that the balance weight center is aligned with the wheel balancer indication position (angle).

CAUTION:

- Always use genuine Nissan adhesion balance weights.
- Balance weights are not reusable; always replace with new ones.
- Do not install more than three sheets of balance weight.

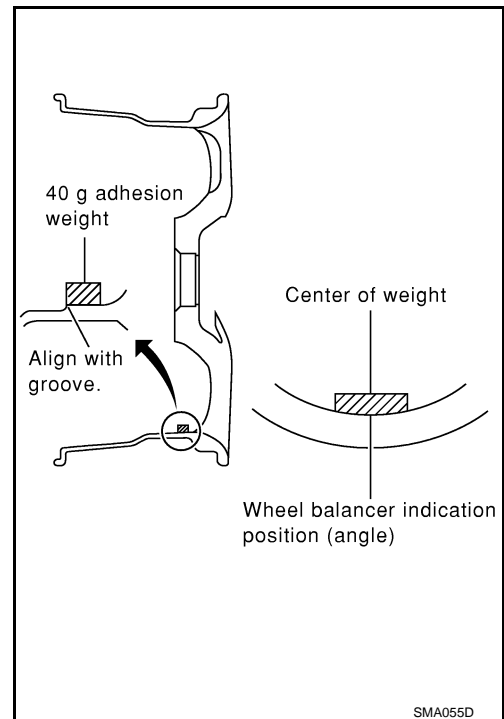
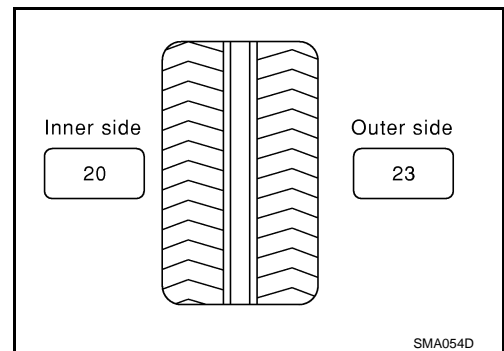

A
B
C
D
WT
F
G
H
I
J
K
L
M
N
O
P

ROAD WHEEL TIRE ASSEMBLY

< ON-VEHICLE REPAIR >

- c. If calculated balance weight value exceeds 50 g (1.76 oz.), install two balance weight sheets in line with each other as shown.

CAUTION:

Do not install one balance weight sheet on top of another.

5. Start wheel balancer again.
6. Install drive-in balance weight on inner side of road wheel in the wheel balancer indication position (angle).

CAUTION:

Do not install more than two balance weights.

7. Start wheel balancer. Make sure that inner and outer residual unbalance values are 5 g (0.18 oz.) each or below.
• If either residual unbalance value exceeds 5 g (0.18 oz.), repeat installation procedures.

Wheel balance (Maximum allowable unbalance):

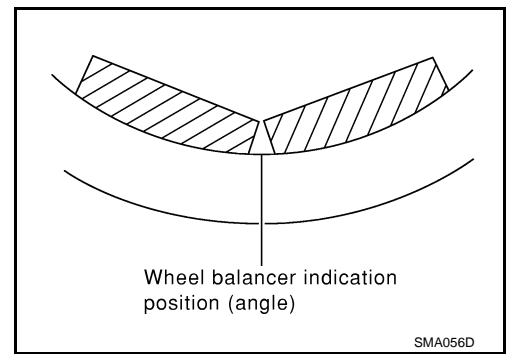

Maximum allowable unbalance	Dynamic (At rim flange)	5 g (0.18 oz.) (one side)
	Static	10 g (0.35 oz.)

TIRE ROTATION

- Follow the maintenance schedule for tire rotation service intervals. Refer to [MA-4, "Explanation General Maintenance"](#).
- Do not include the T-type spare tire when rotating the tires.

CAUTION:

- When installing wheels, tighten them diagonally by dividing the work two to three times in order to prevent the wheels from developing any distortion.**
- Be careful not to tighten wheel nut at torque exceeding the criteria for preventing strain of disc rotor.**

Tightening torque of wheel nut : 112 N·m (11 kg·m, 83 ft·lb)

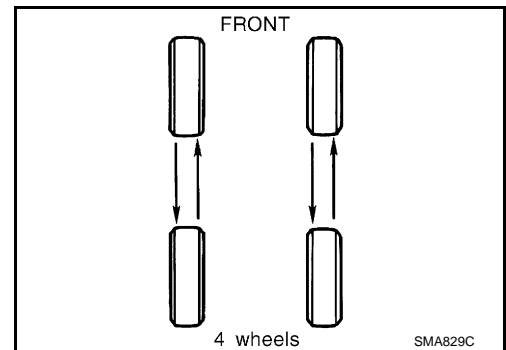

TRANSMITTER

< REMOVAL AND INSTALLATION >

REMOVAL AND INSTALLATION

TRANSMITTER

Removal and Installation

INFOID:000000001342599

REMOVAL

1. Deflate tire. Unscrew transmitter retaining nut and allow transmitter to fall into tire.
2. Gently bounce tire so that transmitter falls to bottom of tire. Place on tire changing machine and break both tire beads ensuring that the transmitter remains at the bottom of the tire.

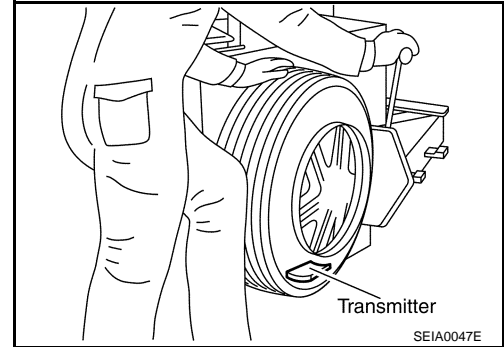

3. Turn tire so that valve hole is at bottom and bounce so that transmitter is near valve hole. Carefully lift tire onto turntable and position valve hole (and transmitter) 270 degree from mounting/dismounting head.
4. Lubricate tire well and remove first side of the tire. Reach inside the tire and remove the transmitter.

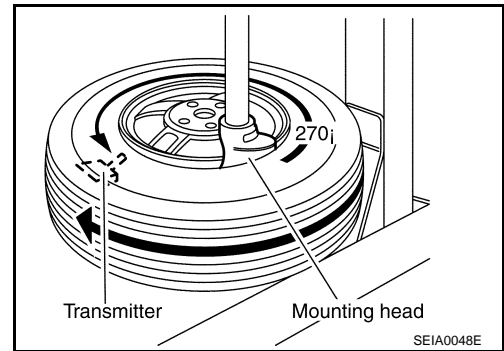

INSTALLATION

1. Put first side of tire onto rim.

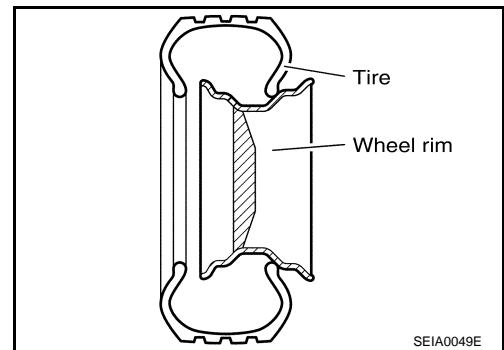

2. Mount transmitter on rim and tighten nut.
CAUTION:
Speed for tightening nut should be less than 10 rpm.

Transmitter nut : 7.7 N·m (0.79 kg·m, 68 in-lb)

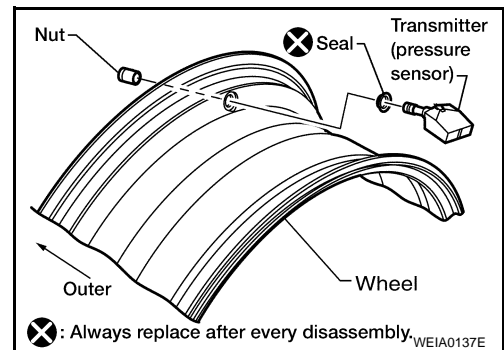

⊗: Always replace after every disassembly.

TRANSMITTER

< REMOVAL AND INSTALLATION >

3. Place wheel on turntable of tire machine. Ensure that transmitter is 270 degree from mounting head when second side of tire is fitted.

NOTE:

Do not touch transmitter at mounting head.

4. Lubricate tire well and fit second side of tire as normal. Ensure that tire does not rotate relative to rim.
5. Inflate tire and fit to appropriate wheel position.

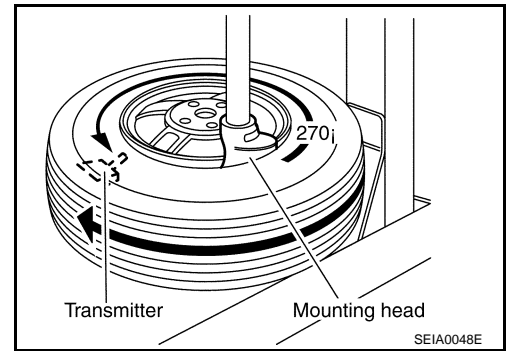

SERVICE DATA AND SPECIFICATIONS (SDS)

< SERVICE DATA AND SPECIFICATIONS (SDS)

SERVICE DATA AND SPECIFICATIONS (SDS)

SERVICE DATA AND SPECIFICATIONS (SDS)

Road Wheel

INFOID:0000000001342600

Standard item		Allowable value	
		Aluminum	Steel (for emergency use)
Maximum radial runout limit	Lateral deflection	Less than 0.3 mm (0.012 in)	Less than 1.5 mm (0.059 in)
	Radial deflection	Less than 0.3 mm (0.012 in)	Less than 1.5 mm (0.059 in)
Maximum allowable unbalance	Dynamic (At rim flange)	Less than 5 g (0.18 oz) (one side)	
	Static (At rim flange)	Less than 10 g (0.35 oz)	

Tire

INFOID:0000000001342601

Unit: kPa (kg/cm², psi)

Tire size	Air pressure	
	Front tire	Rear tire
215/60R16	220 (2.2, 32)	220 (2.2, 32)
215/55R17	230 (2.3, 33)	230 (2.3, 33)
T135/70R16	420 (4.2, 60)	420 (4.2, 60)
T135/90D16	420 (4.2, 60)	420 (4.2, 60)