

SECTION **RSU**
 REAR SUSPENSION

A
 B
 C
 D
 E
 F
 G
 H
 I
 J
 K
 L
 M
 N
 O
 P

RSU

CONTENTS

SYMPTOM DIAGNOSIS	2	REAR SUSPENSION ASSEMBLY	10
NOISE, VIBRATION AND HARSHNESS (NVH) TROUBLESHOOTING	2	Exploded View	10
NVH Troubleshooting Chart	2	Removal and Installation	12
PRECAUTION	3	ON-VEHICLE REPAIR	13
PRECAUTIONS	3	REAR LOWER LINK & COIL SPRING	13
Caution for Supplemental Restraint System (SRS) "AIR BAG" and "SEAT BELT PRE-TENSIONER"	3	Removal and Installation	13
Necessary for Steering Wheel Rotation After Battery Disconnect	3	FRONT LOWER LINK	14
Service Notice or Precautions	3	Removal and Installation	14
PREPARATION	5	RADIUS ROD	15
PREPARATION	5	Removal and Installation	15
Special Service Tool	5	REAR STABILIZER	16
Commercial Service Tool	5	Removal and Installation	16
ON-VEHICLE MAINTENANCE	6	SUSPENSION ARM	17
REAR SUSPENSION ASSEMBLY	6	Removal and Installation	17
On-vehicle Service	6	SERVICE DATA AND SPECIFICATIONS (SDS)	18
Inspection	6	SERVICE DATA AND SPECIFICATIONS (SDS)	18
Inspection and Adjustment	7	General Specification (Rear)	18
REMOVAL AND INSTALLATION	10	Rear Wheel Alignment (Unladen*)	18
		Ball Joint	18
		Wheelarch Height (Unladen*1)	19

NOISE, VIBRATION AND HARSHNESS (NVH) TROUBLESHOOTING

< SYMPTOM DIAGNOSIS >

SYMPTOM DIAGNOSIS

NOISE, VIBRATION AND HARSHNESS (NVH) TROUBLESHOOTING

NVH Troubleshooting Chart

INFOID:000000004205671

Use the chart below to help you find the cause of the symptom. If necessary, repair or replace these parts.

Symptom		Possible cause and SUSPECTED PARTS														Reference page	
		Improper installation, looseness	Shock absorber deformation, damage or deflection	Bushing or mounting deterioration	Parts interference	Spring fatigue	Suspension looseness	Incorrect wheel alignment	Stabilizer bar fatigue	FRONT AXLE	FRONT SUSPENSION	TIRES	ROAD WHEEL	DRIVE SHAFT	BRAKES		STEERING
REAR SUSPENSION	Noise	x	x	x	x	x	x			x	x	x	x	x	x	x	RSU-6
	Shake	x	x	x	x		x			x	x	x	x	x	x	x	RSU-6
	Vibration	x	x	x	x	x				x	x	x		x			—
	Shimmy	x	x	x	x			x		x	x	x	x		x	x	—
	Shudder	x	x	x						x	x	x	x		x	x	—
	Poor quality ride or handling	x	x	x	x	x		x	x	x	x	x	x				RSU-7
																	RSU-6
																	FAX-2, "NVH Troubleshooting Chart"
																	FSU-2, "NVH Troubleshooting Chart"
																	WT-61, "NVH Troubleshooting Chart"
																	WT-61, "NVH Troubleshooting Chart"
																	FAX-2, "NVH Troubleshooting Chart"
																	BR-6, "NVH Troubleshooting Chart"
																	ST-3, "NVH Troubleshooting Chart"

x: Applicable

PRECAUTIONS

< PRECAUTION >

PRECAUTION

PRECAUTIONS

Precaution for Supplemental Restraint System (SRS) "AIR BAG" and "SEAT BELT PRE-TENSIONER"

INFOID:000000004205672

The Supplemental Restraint System such as "AIR BAG" and "SEAT BELT PRE-TENSIONER", used along with a front seat belt, helps to reduce the risk or severity of injury to the driver and front passenger for certain types of collision. This system includes seat belt switch inputs and dual stage front air bag modules. The SRS system uses the seat belt switches to determine the front air bag deployment, and may only deploy one front air bag, depending on the severity of a collision and whether the front occupants are belted or unbelted. Information necessary to service the system safely is included in the SR and SB section of this Service Manual.

WARNING:

- To avoid rendering the SRS inoperative, which could increase the risk of personal injury or death in the event of a collision which would result in air bag inflation, all maintenance must be performed by an authorized NISSAN/INFINITI dealer.
- Improper maintenance, including incorrect removal and installation of the SRS, can lead to personal injury caused by unintentional activation of the system. For removal of Spiral Cable and Air Bag Module, see the SR section.
- Do not use electrical test equipment on any circuit related to the SRS unless instructed to in this Service Manual. SRS wiring harnesses can be identified by yellow and/or orange harnesses or harness connectors.

Necessary for Steering Wheel Rotation After Battery Disconnect

INFOID:000000004501329

NOTE:

- Before removing and installing any control units, first turn the push-button ignition switch to the LOCK position, then disconnect both battery cables.
- After finishing work, confirm that all control unit connectors are connected properly, then re-connect both battery cables.
- Always use CONSULT-III to perform self-diagnosis as a part of each function inspection after finishing work. If a DTC is detected, perform trouble diagnosis according to self-diagnosis results.

This vehicle is equipped with a push-button ignition switch and a steering lock unit.

If the battery is disconnected or discharged, the steering wheel will lock and cannot be turned.

If turning the steering wheel is required with the battery disconnected or discharged, follow the procedure below before starting the repair operation.

OPERATION PROCEDURE

1. Connect both battery cables.

NOTE:

Supply power using jumper cables if battery is discharged.

2. Carry the Intelligent Key or insert it to the key slot and turn the push-button ignition switch to ACC position. (At this time, the steering lock will be released.)
3. Disconnect both battery cables. The steering lock will remain released with both battery cables disconnected and the steering wheel can be turned.
4. Perform the necessary repair operation.
5. When the repair work is completed, re-connect both battery cables. With the brake pedal released, turn the push-button ignition switch from ACC position to ON position, then to LOCK position. (The steering wheel will lock when the push-button ignition switch is turned to LOCK position.)
6. Perform self-diagnosis check of all control units using CONSULT-III.

Service Notice or Precautions

INFOID:000000004205673

- When installing rubber bushings, the final tightening must be carried out under unladen conditions with tires on ground. Oil might shorten the life of rubber bushings. Be sure to wipe off any spilled oil.
- Unladen conditions mean that fuel, engine coolant and lubricant are full. Spare tire, jack, hand tools and mats are in designated positions.
- After servicing suspension parts, be sure to check wheel alignment.

PRECAUTIONS

< PRECAUTION >

- Self-lock nuts are not reusable. Always use new ones when installing. Since new self-lock nuts are pre-oiled, tighten as they are.

PREPARATION

< PREPARATION >

PREPARATION

PREPARATION

Special Service Tool

INFOID:000000004205674

Tool number Tool name	Description
HT72520000 (J-25730-A) Ball joint remover	Removing upper ball joint
ST3127S000 (J-25765-A) Preload gauge	Measuring ball joint rotating torque

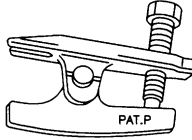

NT146

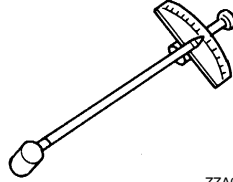

ZZA0806D

Commercial Service Tool

INFOID:000000004205675

Tool name	Description
Power tool	Loosening bolts and nuts

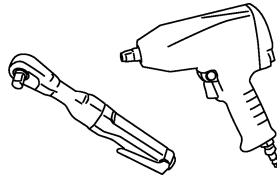

PBIC0190E

A
B
C
D
RSU
F
G
H
I
J
K
L
M
N
O
P

REAR SUSPENSION ASSEMBLY

< ON-VEHICLE MAINTENANCE >

ON-VEHICLE MAINTENANCE

REAR SUSPENSION ASSEMBLY

On-vehicle Service

INFOID:000000004205676

- Check the suspension parts for excessive play, cracks, wear or damage. Shake each rear wheel to check for excessive play.
- Retighten all nuts and bolts to the specified torque.
- Make sure that the cotter pin is installed.
- Check the shock absorber for oil leakage or other damage.
- Check the wheelarch height. Refer to [RSU-19, "Wheelarch Height \(Unladen*1\)"](#).
- Check the suspension ball joint for grease leakage and the ball joint dust cover for cracks or other damage.

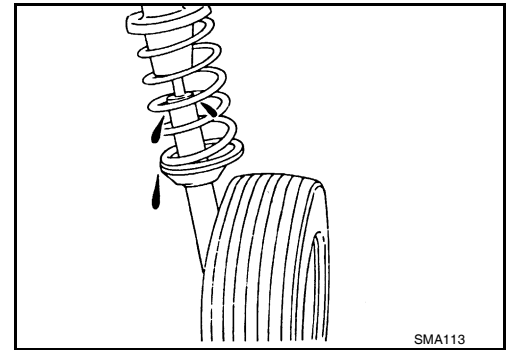

Inspection

INFOID:000000004205677

SHOCK ABSORBER ASSEMBLY

- Check for smooth operation through a full stroke for both compression and extension.
- Check for oil leakage on the welded or gland packing portions.
- Check the shock absorber piston rod for cracks, deformation, or other damage and replace if necessary.

SUSPENSION ARM

- Check the suspension arm for damage, cracks, deformation and replace if necessary.
- Check the rubber bushings for damage, cracks and deformation. Replace suspension arm if necessary.
- Check the ball joint. Replace the suspension arm assembly if any of the following conditions exist:
 - Ball stud is worn.
 - Joint is hard to swing.
 - Check if the swinging force (A), rotating torque (B), or vertical end play (C) is out of specification using Tool.

Tool number : ST3127S000 (J-25765-A)

NOTE:

Before checking specifications, turn the ball joint at least 10 revolutions so the ball joint is properly broken in.

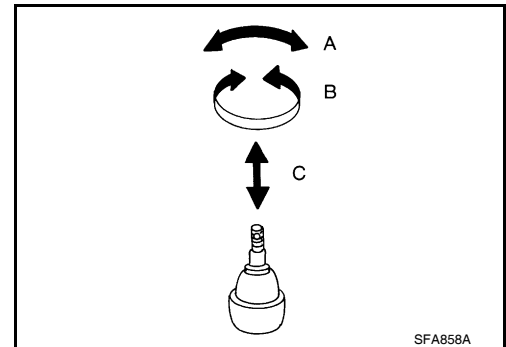

Swinging force (A) : Refer to [RSU-18, "Ball Joint"](#).

Rotating torque (B) : Refer to [RSU-18, "Ball Joint"](#).

Vertical end play (C) : Refer to [RSU-18, "Ball Joint"](#).

RADIUS ROD

- Check the radius rod for any deformation, cracks, or damage and replace if necessary.
- After installing the radius rod, check the wheel alignment and adjust if necessary. Refer to [RSU-18, "Rear Wheel Alignment \(Unladen*\)"](#).

FRONT LOWER LINK

- Check the front lower link for any deformation, cracks, or damage and replace if necessary.

UPPER AND LOWER RUBBER SEATS

- Check the upper and lower rubber seats for deterioration, or cracks and replace if necessary.

REAR LOWER LINK AND COIL SPRING

REAR SUSPENSION ASSEMBLY

< ON-VEHICLE MAINTENANCE >

- Check the rear lower link and coil spring for any deformation, cracks, or other damage and replace if necessary. A

STABILIZER BAR

- Check the stabilizer bar and clamps for any deformation, cracks, or damage and replace if necessary. B
- Check the rubber bushings for deterioration, or cracks and replace if necessary.

Inspection and Adjustment

INFOID:000000004205678

Before checking the rear wheel alignment, make a preliminary inspection. C

- Measure the wheel alignment under unladen conditions.

NOTE:

Unladen conditions mean that fuel, engine coolant, and lubricants are full. That the spare tire, jack, hand tools, and mats are in their designated positions. D

PRELIMINARY INSPECTION

- Check the tires for wear and for improper inflation.
- Check the wheels for deformation, cracks, and other damage. Remove the wheel and check the wheel runout. Refer to [WT-64, "Inspection"](#).
- Check the rear wheel bearings for looseness.
- Check the rear suspension for looseness.
- Check that the rear shock absorbers work properly.
- Check the wheelarch height in the unladen condition. Refer to [RSU-19, "Wheelarch Height \(Unladen*1\)"](#). RSU

GENERAL INFORMATION AND RECOMMENDATIONS

1. A Four-Wheel Thrust Alignment should be performed.
 - This type of alignment is recommended for any NISSAN vehicle.
 - The four-wheel "thrust" process helps ensure that the vehicle is properly aligned and the steering wheel is centered.
 - The alignment machine itself should be capable of accepting any NISSAN vehicle.
 - The alignment machine should be checked to ensure that it is level.
2. Make sure the alignment machine is properly calibrated.
 - Your alignment machine should be regularly calibrated in order to give correct information.
 - Check with the manufacturer of your specific alignment machine for their recommended Service/Calibration Schedule. F

THE ALIGNMENT PROCESS

IMPORTANT: Use only the alignment specifications listed in this Service Manual. Refer to [RSU-19, "Wheelarch Height \(Unladen*1\)"](#). G

1. When displaying the alignment settings, many alignment machines use "indicators": (Green/red, plus or minus, Go/No Go). **Do NOT use these indicators.**
 - The alignment specifications programmed into your alignment machine that operate these indicators may not be correct.
 - This may result in an ERROR. H
2. Some newer alignment machines are equipped with an optional "Rolling Compensation" method to "compensate" the sensors (alignment targets or head units). **Do NOT use this "Rolling Compensation" method.**
 - Use the "Jacking Compensation" method. After installing the alignment targets or head units, raise the vehicle and rotate the wheels 1/2 turn both ways.
 - See Instructions in the alignment machine you are using for more information. I

CAMBER

- Measure the camber of both the right and left wheels using a suitable alignment gauge and adjust using the following procedure. J

REAR SUSPENSION ASSEMBLY

< ON-VEHICLE MAINTENANCE >

Camber : Refer to [RSU-18, "Rear Wheel Alignment \(Unladen*\)"](#).

- If the camber is not within specification, adjust the camber by turning the adjusting bolts in the same direction.

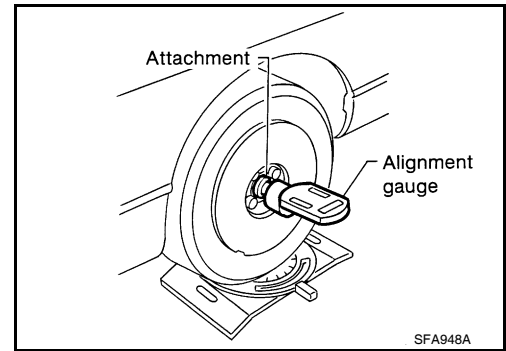

1. Turn the adjusting bolts in the same direction to calibrate.

NOTE:

Camber changes about 5° with each graduation of the adjusting bolt.

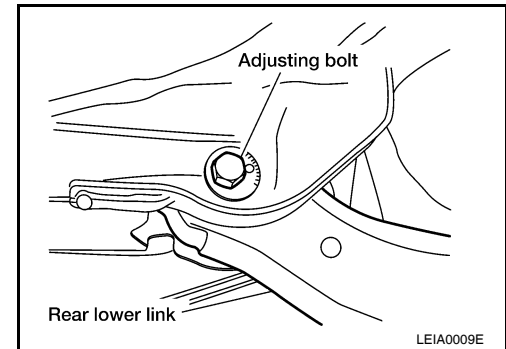
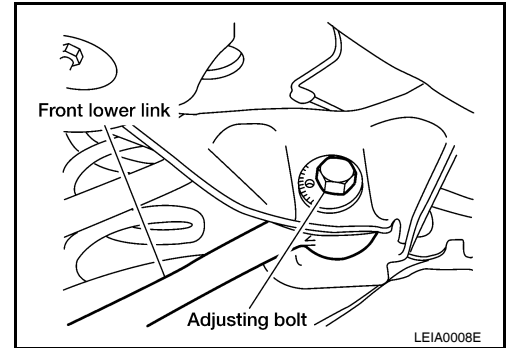

2. Tighten the adjusting bolt nuts to the specified torque.

Adjusting bolt nuts : Refer to [RSU-10, "Exploded View"](#).

TOE-IN

Measure the toe-in using the following procedure. If out of specification, inspect and replace any damaged or worn rear suspension parts before adjusting.

WARNING:

- Always perform the following procedure on a flat surface.
- Make sure that no person is in front of the vehicle before pushing it.

1. Bounce rear of vehicle up and down to stabilize the posture.
2. Push the vehicle straight ahead about 5 m (16 ft).
3. Put a mark on base line of the tread (rear side) of both tires at the same height of hub center. This mark is a measuring point.

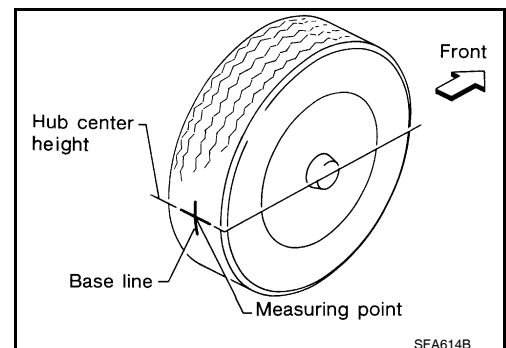

REAR SUSPENSION ASSEMBLY

< ON-VEHICLE MAINTENANCE >

4. Measure distance (A) from rear side.
5. Push the vehicle slowly ahead to rotate the wheels 180° degrees (1/2 a turn).
 - If the wheels have rotated more than 180° degrees (1/2 a turn), try the above procedure again from the beginning. Never push vehicle backward.
6. Measure distance (B) from front side.

Total toe-in : Refer to [RSU-18, "Rear Wheel Alignment \(Unladen*\)"](#).

7. Adjust toe-in by turning adjusting bolts.

NOTE:

Toe changes about 1.5 mm (0.059 in) [One side] with each graduation of the adjusting bolt.

8. Tighten the adjusting bolt nuts to the specified torque.

Adjusting bolt nuts : Refer to [RSU-10, "Exploded View"](#).

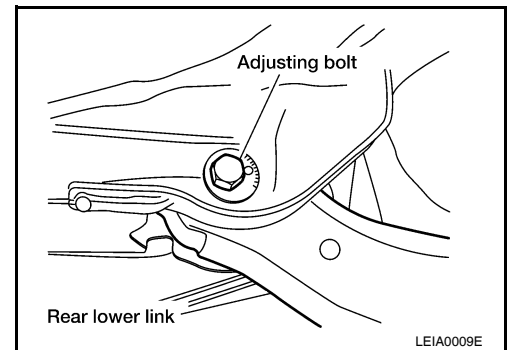
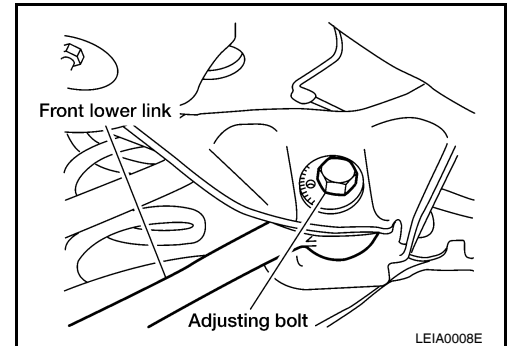
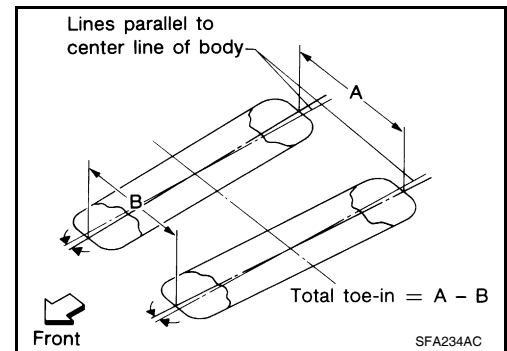

A
B
C
D
RSU
F
G
H
I
J
K
L
M
N
O
P

REAR SUSPENSION ASSEMBLY

< REMOVAL AND INSTALLATION >

REMOVAL AND INSTALLATION

REAR SUSPENSION ASSEMBLY

Exploded View

INFOID:000000004205679

SEDAN

SEC. 430 • 431

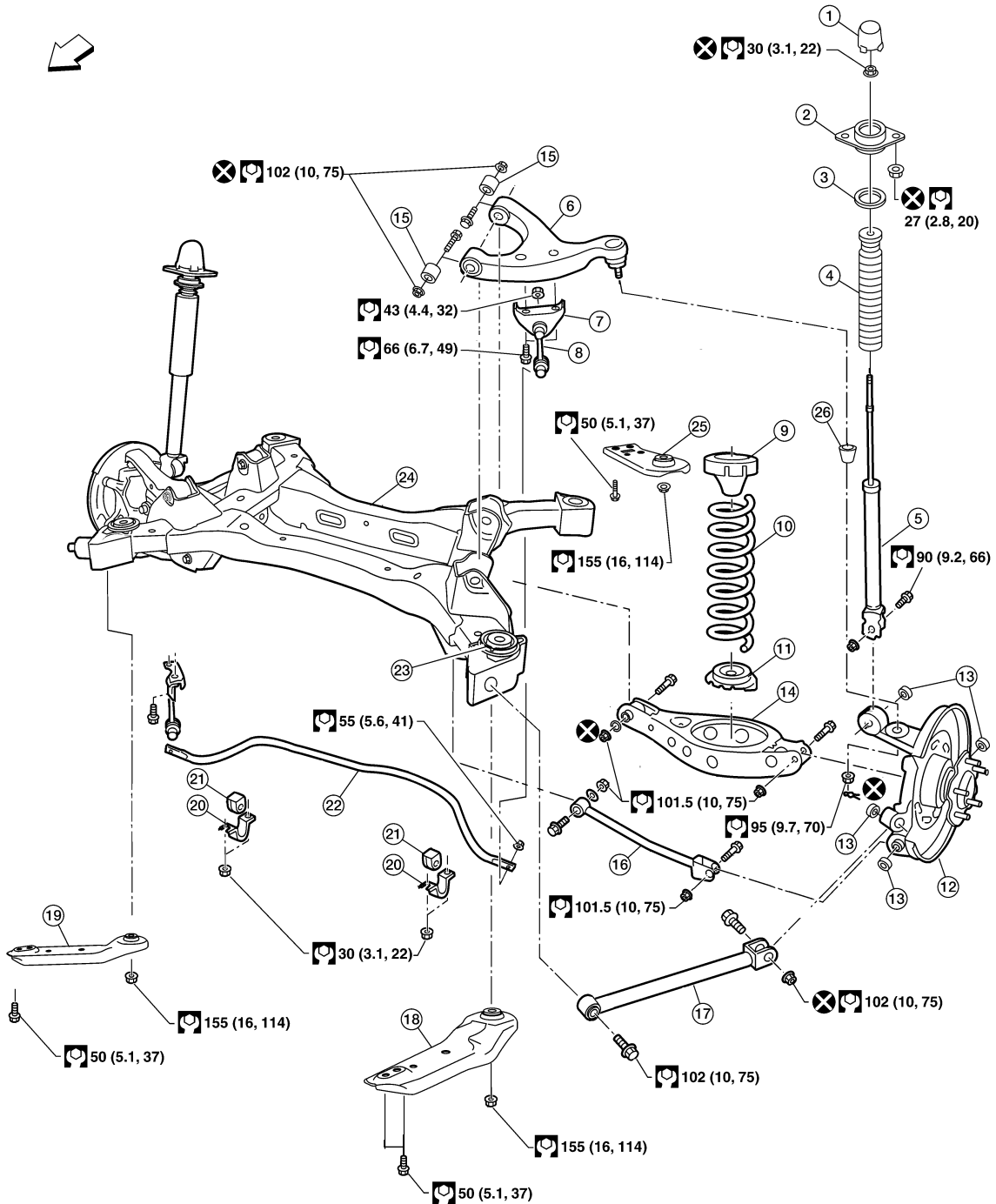

AWEIA0127GB

- | | | |
|---------------------------------|-----------------------------|----------------------------|
| 1. Cap | 2. Shock absorber insulator | 3. Shock absorber seal |
| 4. Bound bumper | 5. Shock absorber | 6. Suspension arm |
| 7. Connecting rod mount bracket | 8. Connecting rod | 9. Upper rubber seat |
| 10. Coil spring | 11. Lower rubber seat | 12. Knuckle |
| 13. Knuckle bushing | 14. Rear lower link | 15. Suspension arm bushing |

RSU-10

REAR SUSPENSION ASSEMBLY

< REMOVAL AND INSTALLATION >

- | | | |
|----------------------------|--------------------------|----------------------------|
| 16. Front lower link | 17. Radius arm | 18. Front member stay (LH) |
| 19. Front member stay (RH) | 20. Stabilizer bar clamp | 21. Bushing |
| 22. Stabilizer bar | 23. Member stopper | 24. Rear suspension member |
| 25. Rear member stay | 26. Ball seat | ⇐ Front |

COUPE

SEC. 430 • 431

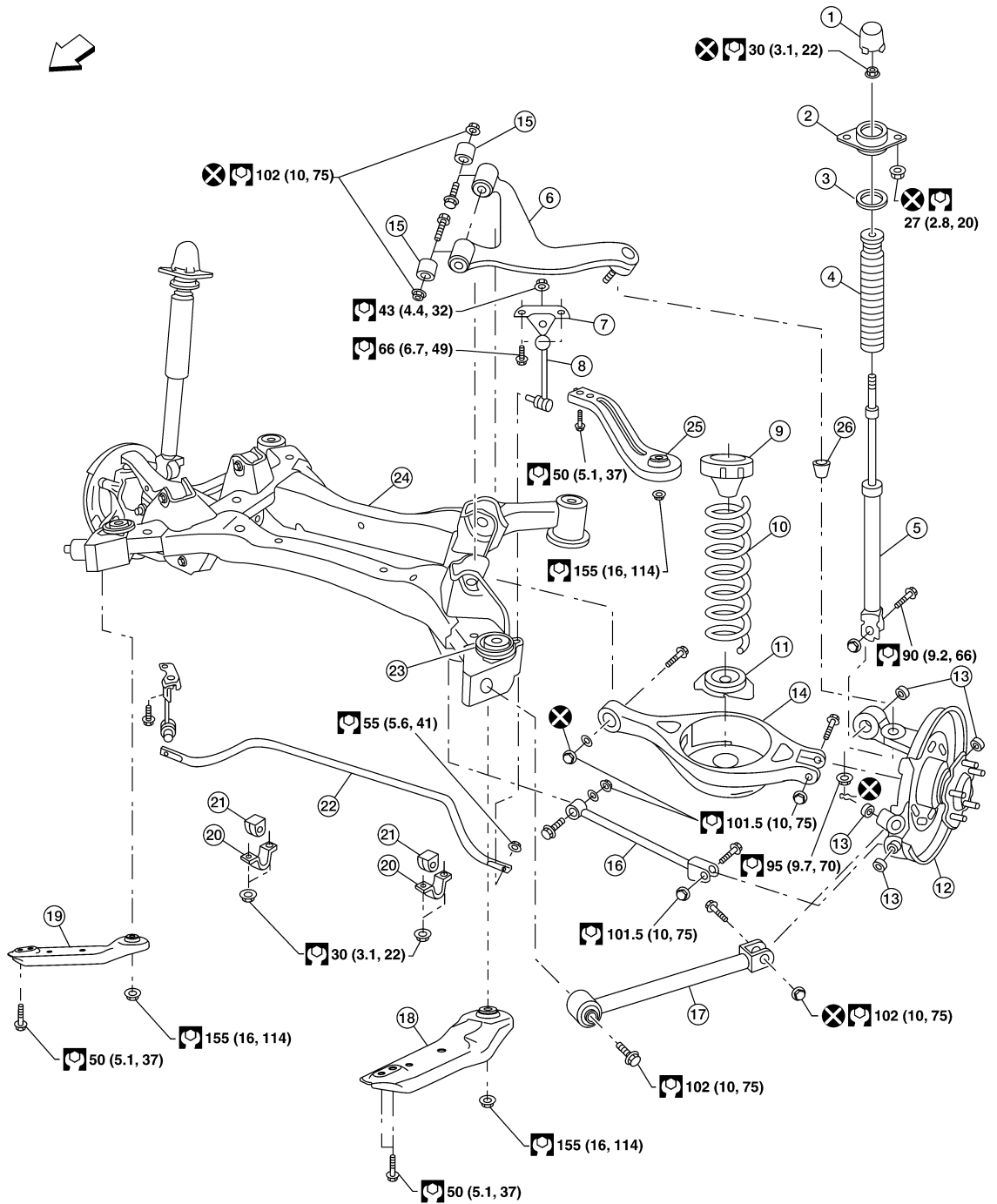

- | | | |
|---------------------------------|-----------------------------|----------------------------|
| 1. Cap | 2. Shock absorber insulator | 3. Shock absorber seal |
| 4. Bound bumper | 5. Shock absorber | 6. Suspension arm |
| 7. Connecting rod mount bracket | 8. Connecting rod | 9. Upper rubber seat |
| 10. Coil spring | 11. Lower rubber seat | 12. Knuckle |
| 13. Knuckle bushing | 14. Rear lower link | 15. Suspension arm bushing |

REAR SUSPENSION ASSEMBLY

< REMOVAL AND INSTALLATION >

16. Front lower link	17. Radius arm	18. Front member stay (LH)
19. Front member stay (RH)	20. Stabilizer bar clamp	21. Bushing
22. Stabilizer bar	23. Member stopper	24. Rear suspension member
25. Rear member stay	26. Ball seat	⇐ Front

Removal and Installation

INFOID:000000004205680

Removal

CAUTION:

Before removing the rear suspension assembly, disconnect the ABS wheel sensor from the assembly. Failure to do so may result in damage to the sensor wires and the sensor becoming inoperative.

1. Remove the center exhaust tube with muffler(s). Refer to [EX-6, "Removal and Installation"](#) (QR25DE) or [EX-12, "Removal and Installation"](#) (VQ35DE).
2. Remove brake caliper assembly and reposition aside, without disconnecting the hydraulic hose, using power tools. Refer to [BR-35, "BRAKE CALIPER ASSEMBLY : Exploded View"](#).
 - Leave the brake hydraulic hose connected to the brake caliper.
 - Do not depress the brake pedal, or the caliper piston will pop out.
 - Do not pull or twist the brake hydraulic hose.
3. Remove brake rotor. Refer to [BR-35, "BRAKE CALIPER ASSEMBLY : Exploded View"](#).
4. Disconnect parking brake cable from knuckle. Refer to [PB-6, "PEDAL TYPE : Exploded View"](#) (pedal type), [PB-7, "LEVER TYPE : Exploded View"](#) (lever type).
5. Remove rear wheel sensors. Refer to [BRC-63, "Removal and Installation"](#) (ABS), [BRC-134, "Removal and Installation"](#) (TCS/ABS), [BRC-236, "Removal and Installation"](#) (VDC/TCS/ABS).
6. Remove lower shock absorber nuts using power tools.
7. Remove lower control arm link adjusting bolt and arm. Refer to [RSU-13, "Removal and Installation"](#).
8. Remove upper ball joint nut and cotter pin. Refer to [RSU-10, "Exploded View"](#).
9. Disconnect radius rod member side. Refer to [RSU-15, "Removal and Installation"](#).
10. Disconnect lower link adjusting bolt. Refer to [RSU-14, "Removal and Installation"](#).
11. Remove knuckle. Refer to [RSU-10, "Exploded View"](#).
12. Remove stabilizer bar. Refer to [RSU-16, "Removal and Installation"](#).
13. Disconnect lower link adjusting bolt. Refer to [RSU-14, "Removal and Installation"](#).
14. Disconnect member harness.
15. Support the rear suspension assembly using a suitable jack.
16. Remove the suspension member nuts and member stay bolts using power tools.
17. Lower the rear suspension assembly.

Installation

Installation is in the reverse order of removal.

- Check the rear wheel alignment and adjust if necessary. Refer to [RSU-18, "Rear Wheel Alignment \(Unladen*\)"](#).

REAR LOWER LINK & COIL SPRING

< ON-VEHICLE REPAIR >

ON-VEHICLE REPAIR

REAR LOWER LINK & COIL SPRING

Removal and Installation

INFOID:000000004205681

Removal

1. Loosen the rear lower link bolt and nut from the suspension member side.
2. Support the rear lower link by placing a suitable jack under the knuckle.
3. Remove the rear lower link adjusting bolt and nut from the suspension member side using power tool.
 - Do not reuse the adjusting nut, use a new adjusting nut for installation.
4. Slowly lower the jack to lower the rear lower link and coil spring.
5. Remove the upper rubber seat, coil spring, and lower rubber seat from the rear lower link.
6. Remove rear lower link bolt and nut from the suspension member side using power tool.
7. Remove the rear lower link.

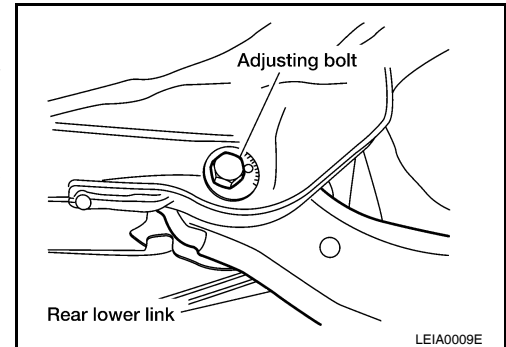

Installation

Installation is in the reverse order of removal.

- Do not reuse the adjusting nut, use a new adjusting nut for installation.
- Check that the projecting part inside the upper rubber seat and the bracket flange are attached as shown.
- Check that the projection part outside the upper rubber seat is directed toward the front of the vehicle.
- Position the hollow of the lower rubber seat with the groove part of the rear lower link.
- Install the coil spring so that the side with the two paint markers is directed toward the lower side.
- Check the rear wheel alignment and adjust if necessary. Refer to [RSU-18. "Rear Wheel Alignment \(Unladen*\)"](#).

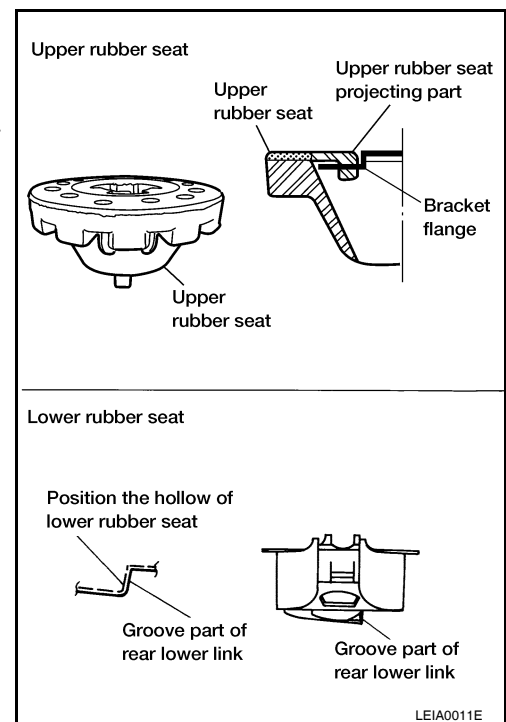

FRONT LOWER LINK

< ON-VEHICLE REPAIR >

FRONT LOWER LINK

Removal and Installation

INFOID:000000004205682

Removal

1. Remove the front lower link nut and bolt from the knuckle side and the adjusting bolt and nut from the suspension member side using power tools.
 - Do not reuse the adjusting nut, use a new adjusting nut for installation.
2. Remove the front lower link.

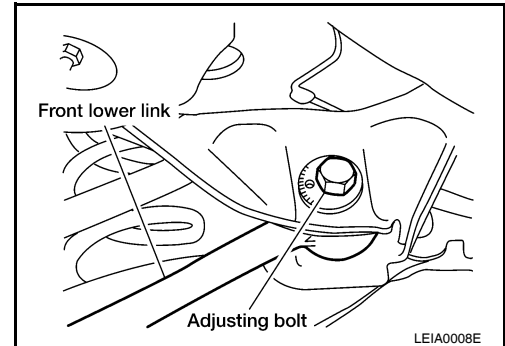

Installation

Installation is in the reverse order of removal.

- Do not reuse the adjusting nut, use a new adjusting nut for installation.
- Check the rear wheel alignment and adjust if necessary. Refer to [RSU-18, "Rear Wheel Alignment \(Unladen*\)"](#).

RADIUS ROD

< ON-VEHICLE REPAIR >

RADIUS ROD

Removal and Installation

INFOID:000000004205683

Removal

1. Remove the rear suspension assembly. Refer to [RSU-12, "Removal and Installation"](#).
2. Remove the radius rod using power tools.

Installation

Installation is in the reverse order of removal.

- Check the rear wheel alignment and adjust if necessary. Refer to [RSU-18, "Rear Wheel Alignment \(Unladen*\)"](#).

A

B

C

D

RSU

F

G

H

I

J

K

L

M

N

O

P

REAR STABILIZER

< ON-VEHICLE REPAIR >

REAR STABILIZER

Removal and Installation

INFOID:000000004205684

Removal

1. Disconnect the stabilizer bar from connecting rod, using power tools.
2. Remove the stabilizer bar clamps and bushings using power tools.
3. Remove the stabilizer bar.

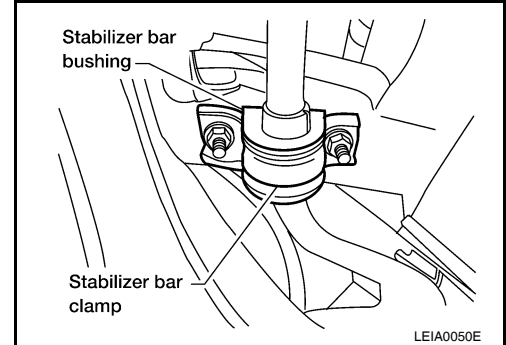

Installation

Installation is in the reverse order of removal.

SUSPENSION ARM

< ON-VEHICLE REPAIR >

SUSPENSION ARM

Removal and Installation

INFOID:000000004205685

Removal

1. Remove the rear suspension assembly. Refer to [RSU-12. "Removal and Installation"](#).
2. Remove the connecting rod bracket from the suspension arm using power tools.
3. Remove the two suspension arm bolts and nuts from the suspension member side of the suspension arm using power tools.
4. Remove the ball joint cotter pin and lock nut using power tools.
 - Discard the cotter pin, use a new cotter pin for installation.
5. Remove the suspension arm from the knuckle using Tool.

Tool number : HT72520000 (J-25730-A)

CAUTION:

- Do not damage ball joint when removing.
- While using Tool, temporarily tighten the nut so as not to damage screw threads.

Installation

Installation is in the reverse order of removal.

- Discard the cotter pin, use a new cotter pin for installation.
- Check the rear wheel alignment and adjust if necessary. Refer to [RSU-18. "Rear Wheel Alignment \(Unladen*\)"](#).

A
B
C
D
E
F
G
H
I
J
K
L
M
N
O
P

RSU

SERVICE DATA AND SPECIFICATIONS (SDS)

< SERVICE DATA AND SPECIFICATIONS (SDS)

SERVICE DATA AND SPECIFICATIONS (SDS)

SERVICE DATA AND SPECIFICATIONS (SDS)

General Specification (Rear)

INFOID:000000004205686

Suspension type	Multi-link independent suspension
Shock absorber type	Double-acting hydraulic

Rear Wheel Alignment (Unladen*)

INFOID:000000004205687

SEDAN

Market		USA and Canada	Mexico
Camber Degree minute (Decimal degree)	Minimum	-1° 07' (-1.12°)	-0° 16' (-0.27°)
	Nominal	-0° 37' (-0.62°)	0° 12' (0.20°)
	Maximum	-0° 07' (-0.12°)	0° 42' (0.70°)
Total toe-in	Distance difference between RH and LH side mm (in) [Degree minute (decimal degree)]	Minimum	-2 mm (-0.08 in) [-0° 5' (-0.08°)]
		Nominal	0 mm (0 in) [0° 00' (0.00°)]
		Maximum	2 mm (0.08 in) [0° 5' (0.08°)]
	Angle (left or right) Degree minute (decimal degree)	0° 6' (0.110°)	0° 6' (0.108°)

*: Fuel, radiator coolant and engine oil full. Spare tire, jack, hand tools and mats in designated positions.

COUPE

Market		USA and Canada	Mexico
Camber Degree minute (Decimal degree)	Minimum	-1° 24' (-1.394°)	-0° 35' (-0.584°)
	Nominal	-0° 54' (-0.894°)	-0° 5' (-0.084°)
	Maximum	-0° 24' (-0.394°)	0° 25' (0.416°)
Total toe-in	Distance difference between RH and LH side mm (in) [Degree minute (decimal degree)]	Minimum	-2 mm (-0.08 in) [-0° 5' (-0.08°)]
		Nominal	0 mm (0 in) [0° 00' (0.00°)]
		Maximum	2 mm (0.08 in) [0° 5' (0.08°)]
	Angle (left plus right) Degree minute (decimal degree)	0° 6' (0.112°)	

*: Fuel, engine coolant and engine oil full. Spare tire, jack, hand tools and mats in designated positions.

Ball Joint

INFOID:000000004205688

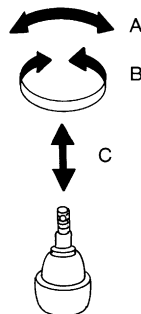

SFA858A

Swinging force "A" (Measuring point: cotter pin hole of ball stud) N (kg-f, lb-f)	7.8 - 54.9 (0.8 - 5.6, 1.8 - 12.3)
Turning torque "B" N·m (kg-cm, in-lb)	0.49 - 3.43 (5.0 - 35.0, 4.3 - 30.4)
Vertical end play "C" mm (in)	0 (0)

SERVICE DATA AND SPECIFICATIONS (SDS)

< SERVICE DATA AND SPECIFICATIONS (SDS)

Wheelarch Height (Unladen*1)

INFOID:000000004205689

SEDAN (QR25DE)

Unit: mm (in)

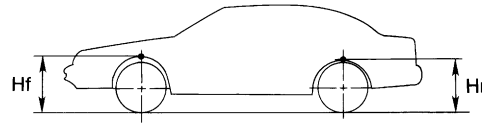

SFA818A

Market	USA		Canada		Mexico
Tire size	P215/60R16		P215/60R16		P215/60R16
Front (Hf)	717 (28.23)		715 (28.15)		727 (28.62)
Rear (Hr)	711 (27.99)		715 (28.15)		731 (28.78)

*1: Fuel, engine coolant and engine oil full. Spare tire, jack, hand tools and mats in designated positions.

SEDAN (VQ35DE)

Unit: mm (in)

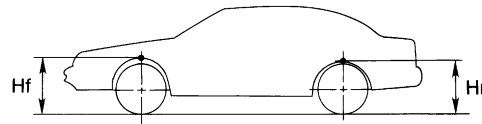

SFA818A

Market	USA		Canada		Mexico
Tire size	P215/60R16	P215/55R17	P215/60R16	P215/55R17	P215/55R17
Front (Hf)	716 (28.19)	715 (28.15)	714 (28.11)	716 (28.19)	725 (28.54)
Rear (Hr)	711 (27.99)	711 (27.99)	715 (28.15)	711 (27.99)	731 (28.78)

*1: Fuel, engine coolant and engine oil full. Spare tire, jack, hand tools and mats in designated positions.

COUPE

Unit: mm (in)

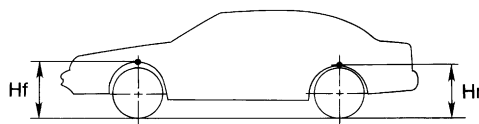

SFA818A

Market	USA		Canada		Mexico
Engine	QR25DE	VQ35DE	QR25DE	VQ35DE	VQ35DE

SERVICE DATA AND SPECIFICATIONS (SDS)

< SERVICE DATA AND SPECIFICATIONS (SDS)

Tire size	P215/60R16	P235/45R18	P215/60R16	P235/45R18	P235/45R18
Front (Hf)	715 (28.15)	713 (28.07)	713 (28.07)	711(27.99)	723 (28.46)
Rear (Hr)	722 (28.43)	722 (28.43)	727 (28.62)	726 (28.58)	722 (28.43)

*1: Fuel, engine coolant and engine oil full. Spare tire, jack, hand tools and mats in designated positions.