

A
LU
C
D
E
F
G
H
I
J
K
L
M
N
O
P

SECTION LU

ENGINE LUBRICATION SYSTEM

CONTENTS

<p style="text-align: center;">QR25DE</p> <p>PRECAUTION 3</p> <p>PRECAUTIONS 3</p> <p style="padding-left: 20px;">Precaution for Supplemental Restraint System (SRS) "AIR BAG" and "SEAT BELT PRE-TENSIONER"3</p> <p style="padding-left: 20px;">Precaution for Liquid Gasket3</p> <p>PREPARATION 5</p> <p>PREPARATION 5</p> <p style="padding-left: 20px;">Special Service Tool5</p> <p style="padding-left: 20px;">Commercial Service Tool5</p> <p>FUNCTION DIAGNOSIS 7</p> <p>LUBRICATION SYSTEM 7</p> <p style="padding-left: 20px;">Lubrication Circuit7</p> <p style="padding-left: 20px;">Schematic7</p> <p>ON-VEHICLE MAINTENANCE 9</p> <p>ENGINE OIL 9</p> <p style="padding-left: 20px;">Inspection9</p> <p style="padding-left: 20px;">Changing Engine Oil 10</p> <p>OIL FILTER11</p> <p style="padding-left: 20px;">Removal and Installation 11</p> <p>ON-VEHICLE REPAIR13</p> <p>OIL PUMP13</p> <p style="padding-left: 20px;">Removal and Installation 13</p> <p style="padding-left: 20px;">Disassembly and Assembly 13</p> <p>OIL COOLER16</p> <p style="padding-left: 20px;">Removal and Installation 16</p> <p>SERVICE DATA AND SPECIFICATIONS (SDS)18</p>	<p>SERVICE DATA AND SPECIFICATIONS (SDS)18</p> <p style="padding-left: 20px;">Oil Pressure18</p> <p style="padding-left: 20px;">Oil Pump18</p> <p style="padding-left: 20px;">Regulator Valve18</p> <p style="padding-left: 20px;">Oil Capacity18</p> <p style="text-align: center;">VQ35DE</p> <p>PRECAUTION19</p> <p>PRECAUTIONS19</p> <p style="padding-left: 20px;">Precaution for Supplemental Restraint System (SRS) "AIR BAG" and "SEAT BELT PRE-TENSIONER"19</p> <p style="padding-left: 20px;">Precaution for Liquid Gasket19</p> <p>PREPARATION21</p> <p>PREPARATION21</p> <p style="padding-left: 20px;">Special Service Tool21</p> <p style="padding-left: 20px;">Commercial Service Tool21</p> <p>FUNCTION DIAGNOSIS23</p> <p>LUBRICATION SYSTEM23</p> <p style="padding-left: 20px;">Lubrication Circuit23</p> <p style="padding-left: 20px;">Schematic24</p> <p>ON-VEHICLE MAINTENANCE25</p> <p>ENGINE OIL25</p> <p style="padding-left: 20px;">Inspection25</p> <p style="padding-left: 20px;">Changing Engine Oil26</p> <p>OIL FILTER27</p> <p style="padding-left: 20px;">Removal and Installation27</p> <p>ON-VEHICLE REPAIR29</p> <p>OIL PUMP29</p> <p style="padding-left: 20px;">Removal and Installation29</p> <p style="padding-left: 20px;">Disassembly and Assembly29</p>
--	--

OIL COOLER	32
Removal and Installation	32

SERVICE DATA AND SPECIFICATIONS (SDS)	34
--	-----------

SERVICE DATA AND SPECIFICATIONS (SDS)	34
Oil Pressure	34
Regulator Valve	34
Oil Pump	34
Oil Capacity	34

PRECAUTION

PRECAUTIONS

Precaution for Supplemental Restraint System (SRS) "AIR BAG" and "SEAT BELT PRE-TENSIONER"

INFOID:000000005783136

The Supplemental Restraint System such as "AIR BAG" and "SEAT BELT PRE-TENSIONER", used along with a front seat belt, helps to reduce the risk or severity of injury to the driver and front passenger for certain types of collision. This system includes seat belt switch inputs and dual stage front air bag modules. The SRS system uses the seat belt switches to determine the front air bag deployment, and may only deploy one front air bag, depending on the severity of a collision and whether the front occupants are belted or unbelted. Information necessary to service the system safely is included in the SR and SB section of this Service Manual.

WARNING:

- To avoid rendering the SRS inoperative, which could increase the risk of personal injury or death in the event of a collision which would result in air bag inflation, all maintenance must be performed by an authorized NISSAN/INFINITI dealer.
- Improper maintenance, including incorrect removal and installation of the SRS, can lead to personal injury caused by unintentional activation of the system. For removal of Spiral Cable and Air Bag Module, see the SR section.
- Do not use electrical test equipment on any circuit related to the SRS unless instructed to in this Service Manual. SRS wiring harnesses can be identified by yellow and/or orange harnesses or harness connectors.

PRECAUTIONS WHEN USING POWER TOOLS (AIR OR ELECTRIC) AND HAMMERS

WARNING:

- When working near the Airbag Diagnosis Sensor Unit or other Airbag System sensors with the Ignition ON or engine running, DO NOT use air or electric power tools or strike near the sensor(s) with a hammer. Heavy vibration could activate the sensor(s) and deploy the air bag(s), possibly causing serious injury.
- When using air or electric power tools or hammers, always switch the Ignition OFF, disconnect the battery, and wait at least 3 minutes before performing any service.

Precaution for Liquid Gasket

INFOID:000000005434750

REMOVAL OF LIQUID GASKET SEALING

- After removing nuts and bolts, separate the mating surface, using Tool and remove old liquid gasket sealing.

Tool number : KV10111100 (J-37228)

CAUTION:

Be careful not to damage the mating surfaces.

- Tap (1) Tool to insert it, and then slide it (2) by tapping on the side as shown.
- In areas where Tool is difficult to use, use plastic hammer to lightly tap the parts, to remove it.

CAUTION:

If for some unavoidable reason suitable tool such as screwdriver is used, be careful not to damage the mating surfaces.

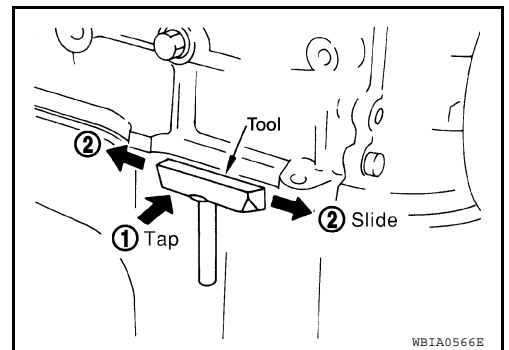

LIQUID GASKET APPLICATION PROCEDURE

PRECAUTIONS

[QR25DE]

< PRECAUTION >

1. Remove old liquid gasket adhering to the liquid gasket application surface and the mating surface, Using scraper.
 - Remove liquid gasket completely from the groove of the liquid gasket application surface, bolts, and bolt holes.
2. Thoroughly clean the mating surfaces and remove adhering moisture, grease and foreign materials.

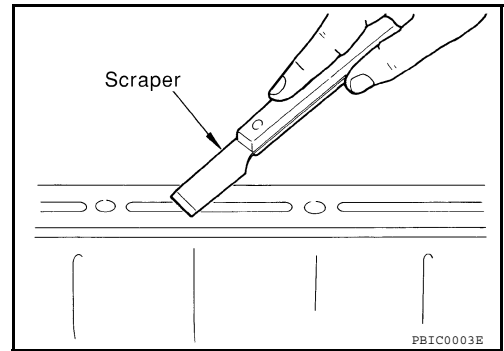

3. Attach liquid gasket tube to Tool.

Tool number : WS39930000 (—)

Use Genuine RTV Silicone Sealant or equivalent. Refer to [GI-15, "Recommended Chemical Products and Sealants"](#).

4. Apply liquid gasket without breaks to the specified location with the specified dimensions.
 - If there is a groove for the liquid gasket application, apply liquid gasket to the groove.

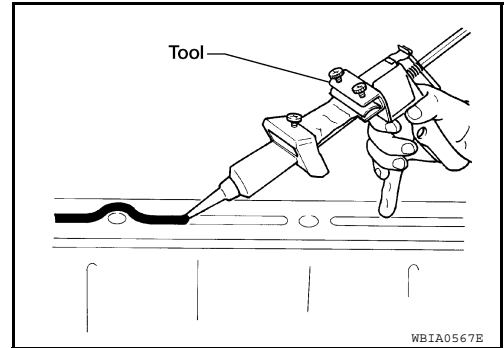

- As for the bolt holes, normally apply liquid gasket inside the holes. Occasionally, it should be applied outside the holes. Make sure to read the text of service manual.
- Within five minutes of liquid gasket application, install the mating component.
- If liquid gasket protrudes, wipe it off immediately.
- Do not retighten nuts or bolts after the installation.
- After 30 minutes or more have passed from the installation, fill engine oil and engine coolant.

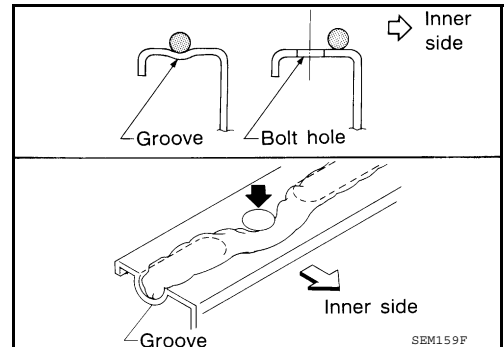

CAUTION:

If there are specific instructions in this manual, observe them.

PREPARATION

< PREPARATION >

[QR25DE]

PREPARATION

PREPARATION

Special Service Tool

INFOID:000000005434751

The actual shape of the Kent-Moore tools may differ from those tools illustrated here.

Tool number (Kent Moore No.) Tool name	Description
ST25051001 (J-25695-1) Oil pressure gauge	Measuring oil pressure Maximum measuring range: 2,452 kPa (25 kg/cm², 356 psi)
ST25052000 (J-25695-2) Hose	Adapting oil pressure gauge to cylinder block
KV10115801 (J-38956) Oil filter wrench	Removing and installing oil filter
KV10111100 (J-37228) Seal cutter	Removing steel oil pan and rear timing chain case
WS39930000 (—) Tube presser	Pressing the tube of liquid gasket

Commercial Service Tool

INFOID:000000005434752

A
LU
C
D
E
F
G
H
I
J
K
L
M
N
O
P

PREPARATION

< PREPARATION >

[QR25DE]

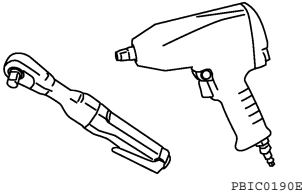
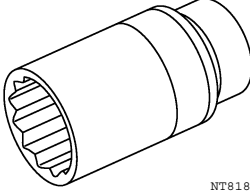
Tool name	Description
<p data-bbox="140 197 252 222">Power tool</p>  <p data-bbox="836 417 911 432">PBIC0190E</p>	<p data-bbox="997 197 1254 222">Loosening bolts and nuts</p>
<p data-bbox="140 449 272 474">Deep socket</p>  <p data-bbox="836 669 879 684">NT818</p>	<p data-bbox="997 449 1437 506">Removing and installing oil pressure switch Deep socket 26 mm, 3/8 drive</p>

LUBRICATION SYSTEM

< FUNCTION DIAGNOSIS >

[QR25DE]

FUNCTION DIAGNOSIS

LUBRICATION SYSTEM

Lubrication Circuit

INFOID:000000005434753

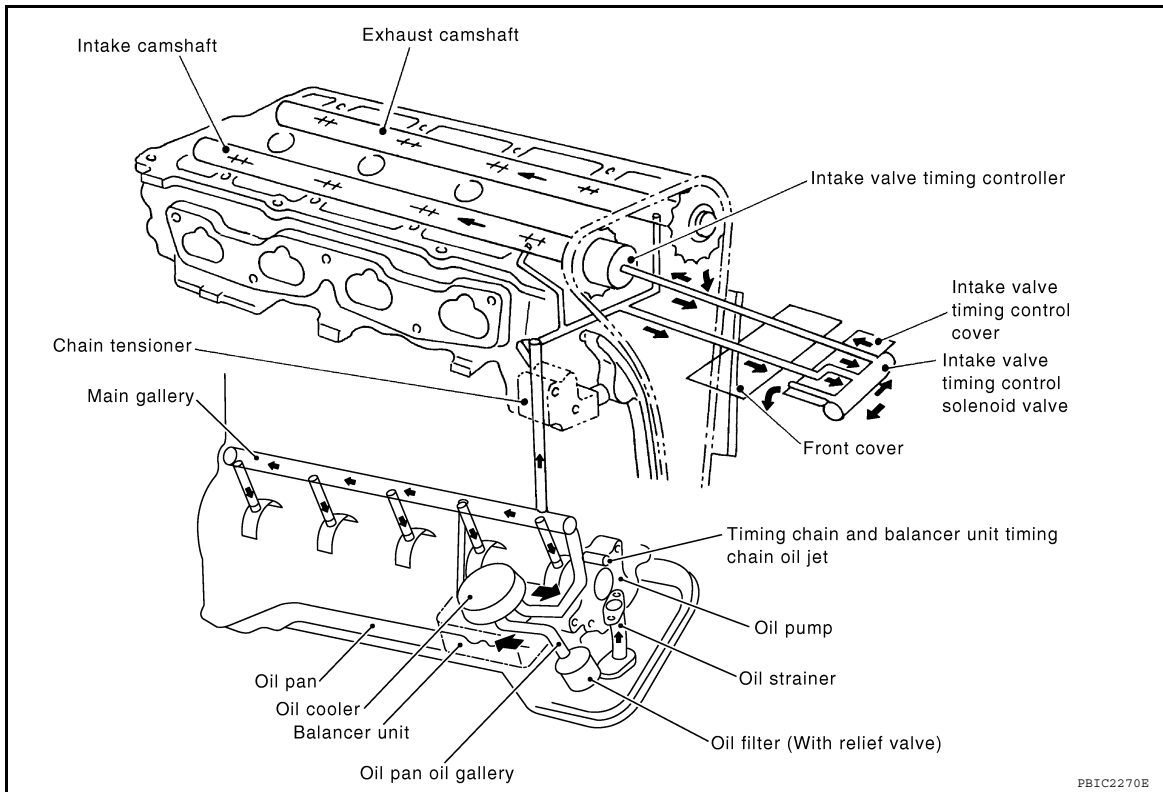

Schematic

INFOID:000000005434754

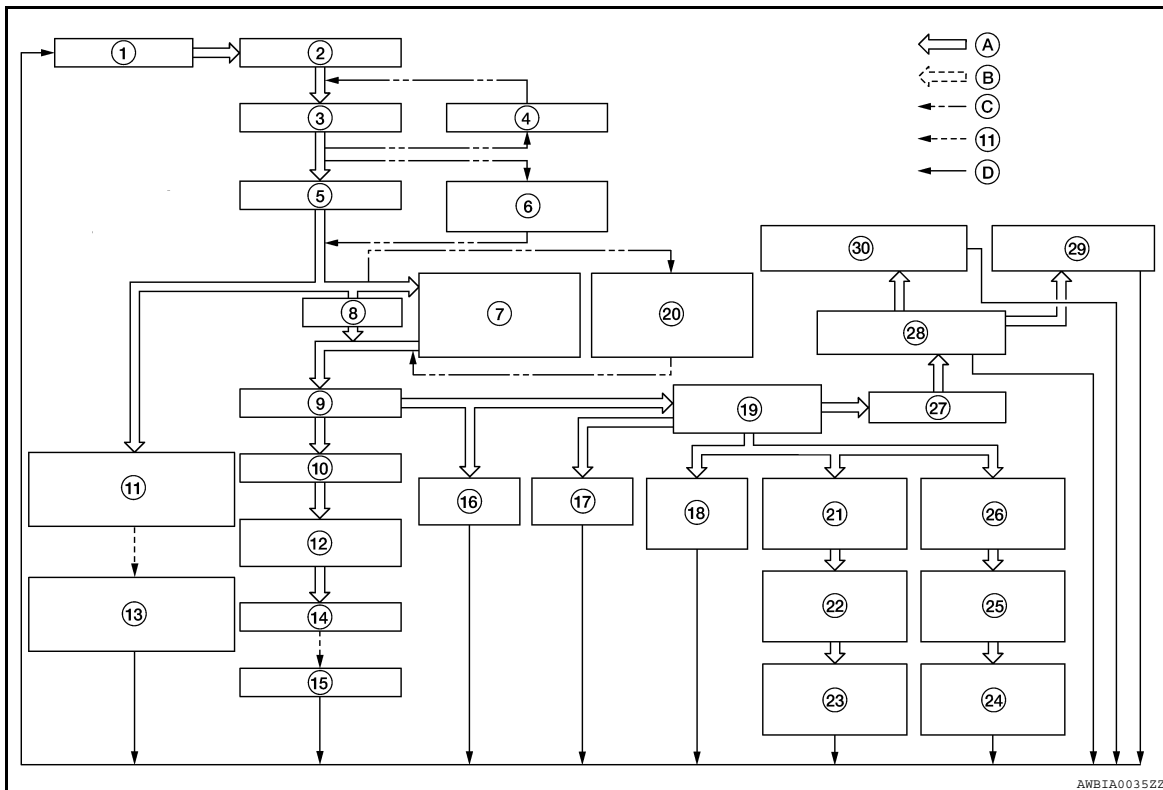

LUBRICATION SYSTEM

< FUNCTION DIAGNOSIS >

[QR25DE]

-
- | | | |
|---|---|--|
| 1. Oil pan | 2. Oil strainer | 3. Oil pump |
| 4. Regulator valve | 5. Oil filter | 6. Relief valve (Built in oil filter) |
| 7. Oil cooler | 8. Bypass | 9. Main gallery |
| 10. Main bearing | 11. Timing chain and balancer unit timing chain oil jet | 12. Connecting rod bearing |
| 13. Timing chain and balancer unit timing chain | 14. Connecting rod | 15. Piston |
| 16. Balancer unit | 17. Chain tensioner | 18. Camshaft bracket (No.1) |
| 19. Cylinder head oil gallery | 20. Relief valve | 21. Intake camshaft bracket (No.2) |
| 22. Intake camshaft oil passage | 23. Intake camshaft journal | 24. Exhaust camshaft journal |
| 25. Exhaust camshaft oil passage | 26. Exhaust camshaft bracket (No.2) | 27. Front cover |
| 28. Intake valve timing control cover | 29. Intake valve timing controller | 30. Intake valve timing control solenoid valve |
| A. Oil passage | B. Return oil passage | C. Bypass |
| D. To oil pan | | |

ON-VEHICLE MAINTENANCE

ENGINE OIL

Inspection

INFOID:000000005434755

A

LU

OIL LEVEL

- Before starting the engine, check the oil level. If the engine is already started, stop it and allow 10 minutes before checking.
- Check that the oil level is within the range on the dipstick.
- If it is out of range, add oil as necessary. Refer to [LU-9, "Inspection"](#).

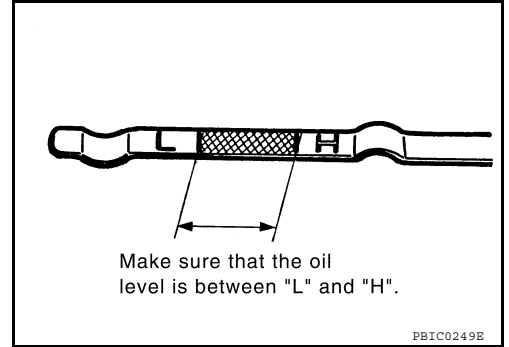

C

D

E

F

ENGINE OIL APPEARANCE

- Check engine oil for white milky appearance or excessive contamination.
- If engine oil becomes milky, it is highly probable that it is contaminated with engine coolant. Repair or replace damaged parts.

G

OIL LEAKAGE

Check for oil leakage around the following areas:

- Oil pan
- Oil pan drain plug
- Oil pressure switch
- Oil filter
- Oil cooler
- IVTC cover
- Front cover
- Mating surface between cylinder block and cylinder head
- Mating surface between cylinder head and rocker cover
- Crankshaft oil seal (front and rear)

H

I

J

K

OIL PRESSURE CHECK

WARNING:

- Be careful not to burn yourself, as engine oil may be hot.
- For M/T models, put the gearshift lever in the Neutral "N" position. For CVT models, put the CVT shift selector in the Park "P" position.

L

M

1. Check engine oil level. Refer to [LU-9, "Inspection"](#).
2. Remove engine under cover. Refer to [EXT-14, "Removal and Installation"](#) (Coupe models) or [EXT-36, "Removal and Installation"](#) (Sedan models).

N

3. Disconnect oil pressure switch harness connector at oil pressure switch. Remove oil pressure switch and install Tools.

CAUTION:

Do not drop or shock oil pressure switch.

Tool numbers : ST25051001 (J-25695-1)
: ST25052000 (J-25695-2)

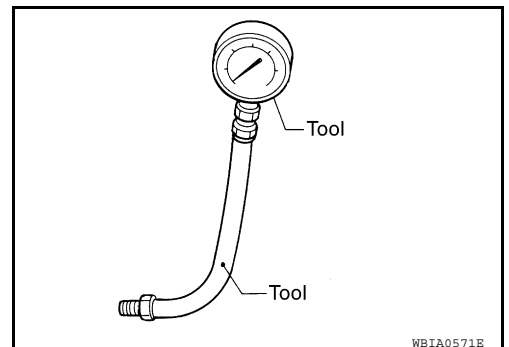

O

P

4. Start engine and warm it up to normal operating temperature.
5. Check oil pressure with engine running under no-load, using Tool. Refer to [LU-18, "Oil Pressure"](#).

NOTE:

When engine oil temperature is low, engine oil pressure becomes high.
If difference is extreme, check oil passage and oil pump for oil leaks.

6. After the inspections, install oil pressure switch as follows:
 - a. Remove old liquid gasket adhering to oil pressure switch and oil cooler.
 - b. Apply liquid gasket and tighten oil pressure switch to the specification.
Use Genuine RTV Silicone Sealant or equivalent. Refer to [GI-15, "Recommended Chemical Products and Sealants"](#).

Oil pressure switch : Refer to [LU-16, "Removal and Installation"](#).

- c. After warming up engine, make sure there are no leaks of engine oil with engine running.

Changing Engine Oil

INFOID:000000005434756

WARNING:

- **Be careful not to burn yourself, as the engine oil may be hot.**
 - **Prolonged and repeated contact with used engine oil may cause skin cancer: try to avoid direct skin contact with used oil. If skin contact is made, wash thoroughly with soap or hand cleaner as soon as possible.**
1. Position the vehicle so it is level on the hoist.
 2. Warm up the engine and check for oil leaks from the engine.
 3. Stop engine and wait for 10 minutes.
 4. Remove the oil pan drain plug and oil filler cap.
 5. Drain the engine oil.
 6. Install the oil pan drain plug with a new washer and refill the engine with new engine oil.

Oil specification and viscosity : Refer to [MA-15, "FOR USA AND CANADA : Engine Oil Recommendation"](#)

Oil pan drain plug : Refer to [EM-32, "Removal and Installation"](#)

CAUTION:

- **Be sure to clean the oil pan drain plug and install using a new washer.**
 - **The refill capacity depends on the oil temperature and drain time. Use these specifications for reference only. Always use the dipstick to determine when the proper amount of oil is in the engine.**
7. Warm up the engine and check around the drain plug and oil filter for oil leaks.
 8. Stop the engine and wait for 10 minutes.
 9. Check the oil level using the dipstick.

CAUTION:

Do not overfill the engine with engine oil.

OIL FILTER

Removal and Installation

INFOID:000000005434757

REMOVAL

1. Drain engine oil. Refer to [LU-10, "Changing Engine Oil"](#)
2. Remove the oil filter using Tool.

Tool number : KV10115801 (J-38956)

WARNING:

- Be careful not to get burned, the engine and engine oil may be hot.

CAUTION:

- When removing, prepare a shop cloth to absorb any oil leakage or spillage.
- Do not allow engine oil to adhere to the drive belts.
- Completely wipe off any oil that adheres to the engine and the vehicle.

- The oil filter has a built in pressure relief valve. Use a genuine NISSAN oil filter or equivalent

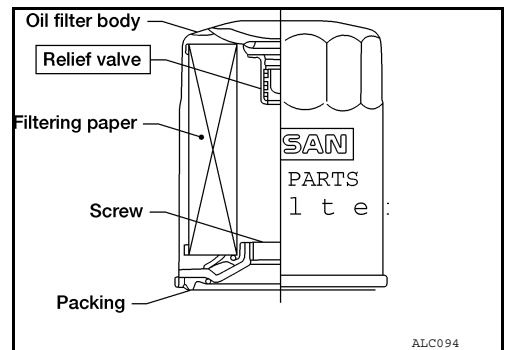
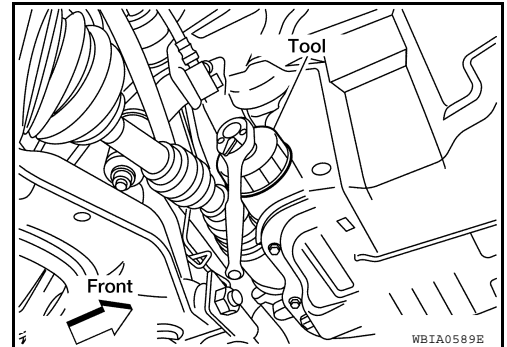

INSTALLATION

1. Remove foreign materials adhering to the oil filter installation surface.
2. Apply clean engine oil to the oil seal contact surface of the new oil filter.

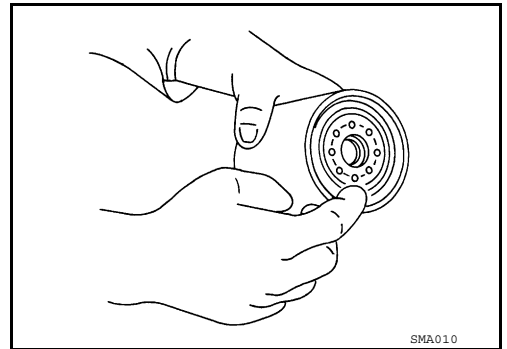

3. Screw the oil filter manually until it touches the installation surface, then tighten it by 2/3 turn. Or tighten to specification below.

Oil filter : 18.0 N·m (1.8 kg·m, 13 ft·lb)

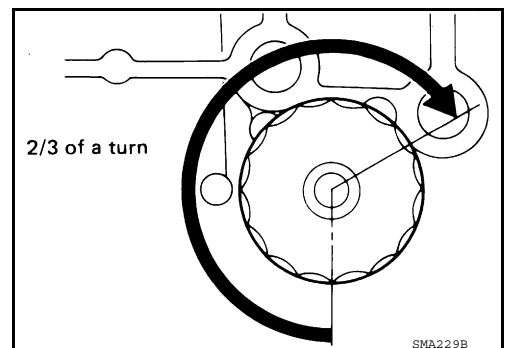

4. Refill engine with new engine oil. Refer to [LU-10, "Changing Engine Oil"](#).

OIL FILTER

< ON-VEHICLE MAINTENANCE >

[QR25DE]

5. After warming up the engine, check for any engine oil leaks.

ON-VEHICLE REPAIR

OIL PUMP

Removal and Installation

INFOID:000000005434758

- The oil pump is part of the front cover. For removal and installation of the oil pump, it is necessary to remove and install the front cover. Refer to [EM-52. "Removal and Installation"](#).

Disassembly and Assembly

INFOID:000000005434759

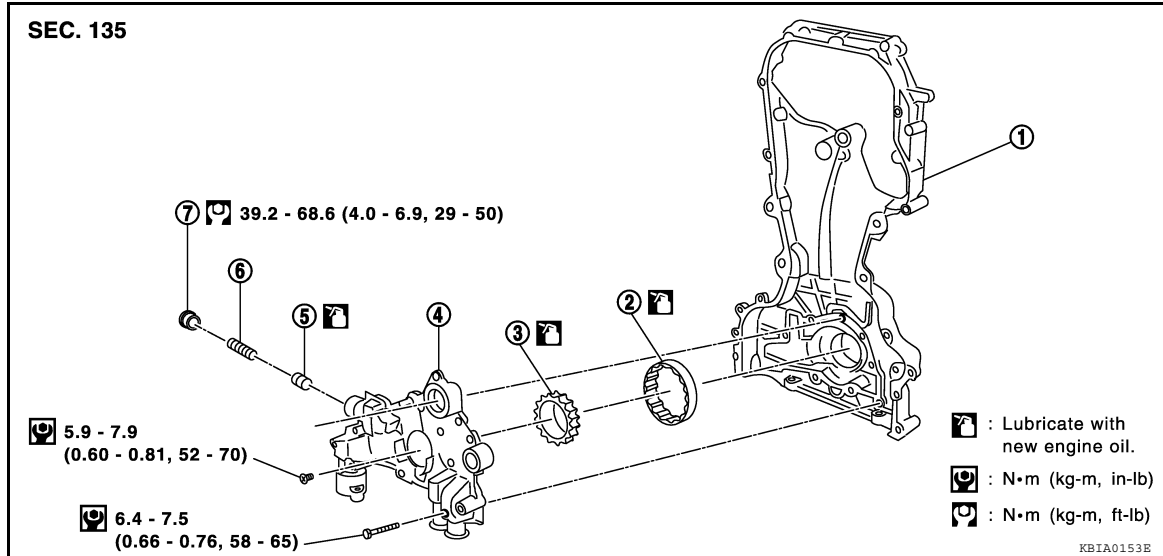

- | | | |
|-------------------|--------------------|----------------|
| 1. Front cover | 2. Outer rotor | 3. Inner rotor |
| 4. Oil pump cover | 5. Regulator valve | 6. Spring |
| 7. Regulator plug | | |

CAUTION:

Before assembly, apply new engine oil to the parts as shown above.

DISASSEMBLY

1. Remove the oil pump cover.
2. Remove inner rotor and outer rotor from front cover.
3. After removing regulator plug, remove regulator spring and regulator valve.

INSPECTION AFTER DISASSEMBLY

Measure the clearance of the oil pump parts to check they are within specification.

1. Measure clearance with feeler gauge as follows:
 - Clearance between outer rotor and oil pump body (position 1).

Standard : 0.114 - 0.179 mm (0.0045 - 0.0070 in)

- Tip clearance between inner rotor and outer rotor (position 2).

Standard : 0.170 - 0.220 mm (0.0067 - 0.0087 in)

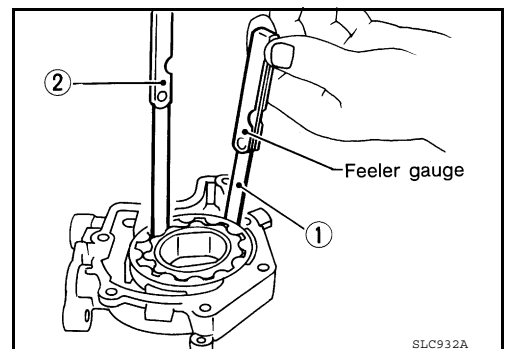

SLC932A

OIL PUMP

[QR25DE]

< ON-VEHICLE REPAIR >

2. Measure clearance with feeler gauge and straightedge as follows:

- Side clearance between inner rotor and oil pump body (position 3).

Standard : 0.030 - 0.070 mm (0.0012 - 0.0028 in)

- Side clearance between outer rotor and oil pump body (position 4).

Standard : 0.060 - 0.110 mm (0.0024 - 0.0043 in)

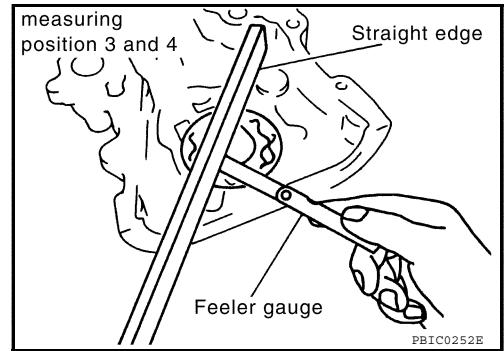

3. Calculate the clearance between inner rotor and oil pump body as follows:

- Measure the outer diameter of protruded portion of inner rotor (Position 5).

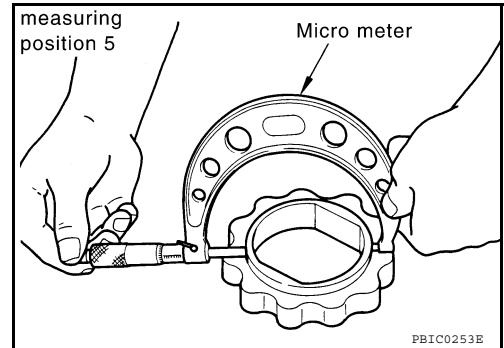

- Measure the inner diameter of oil pump body with inside micrometer (Position 6).
- (Clearance) = (Inner diameter of oil pump body) – (Outer diameter of inner rotor).

Standard : 0.035 - 0.070 mm (0.0014 - 0.0028 in)

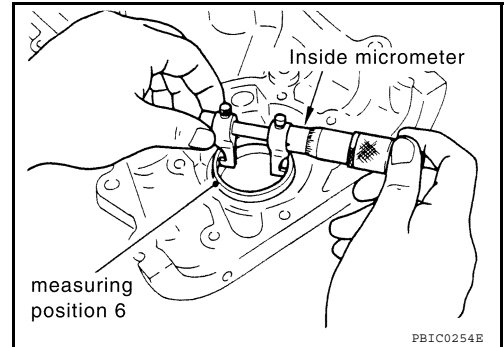

4. Calculate regulator valve clearance as follows:

- (Clearance) = D1 (Valve hole diameter) – D2 (Outer diameter of valve)

Standard : 0.040 - 0.097 mm (0.0016 - 0.0038 in)

CAUTION:

Coat regulator valve with engine oil.

Check that it falls smoothly into the valve hole by its own weight.

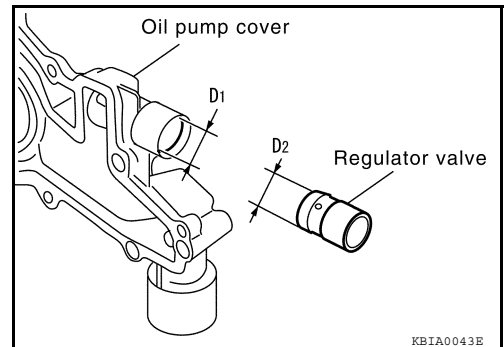

ASSEMBLY

Assembly is in the reverse order of disassembly.

OIL PUMP

[QR25DE]

< ON-VEHICLE REPAIR >

- Install the inner rotor and outer rotor with the punched marks on the oil pump cover side.

CAUTION:

Before assembly apply new engine oil to the parts as specified.

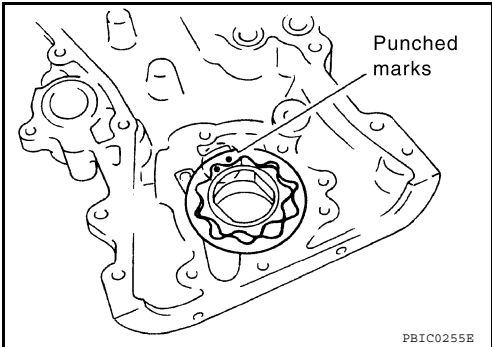

A
LU
C
D
E
F
G
H
I
J
K
L
M
N
O
P

OIL COOLER

< ON-VEHICLE REPAIR >

[QR25DE]

OIL COOLER

Removal and Installation

INFOID:000000005434760

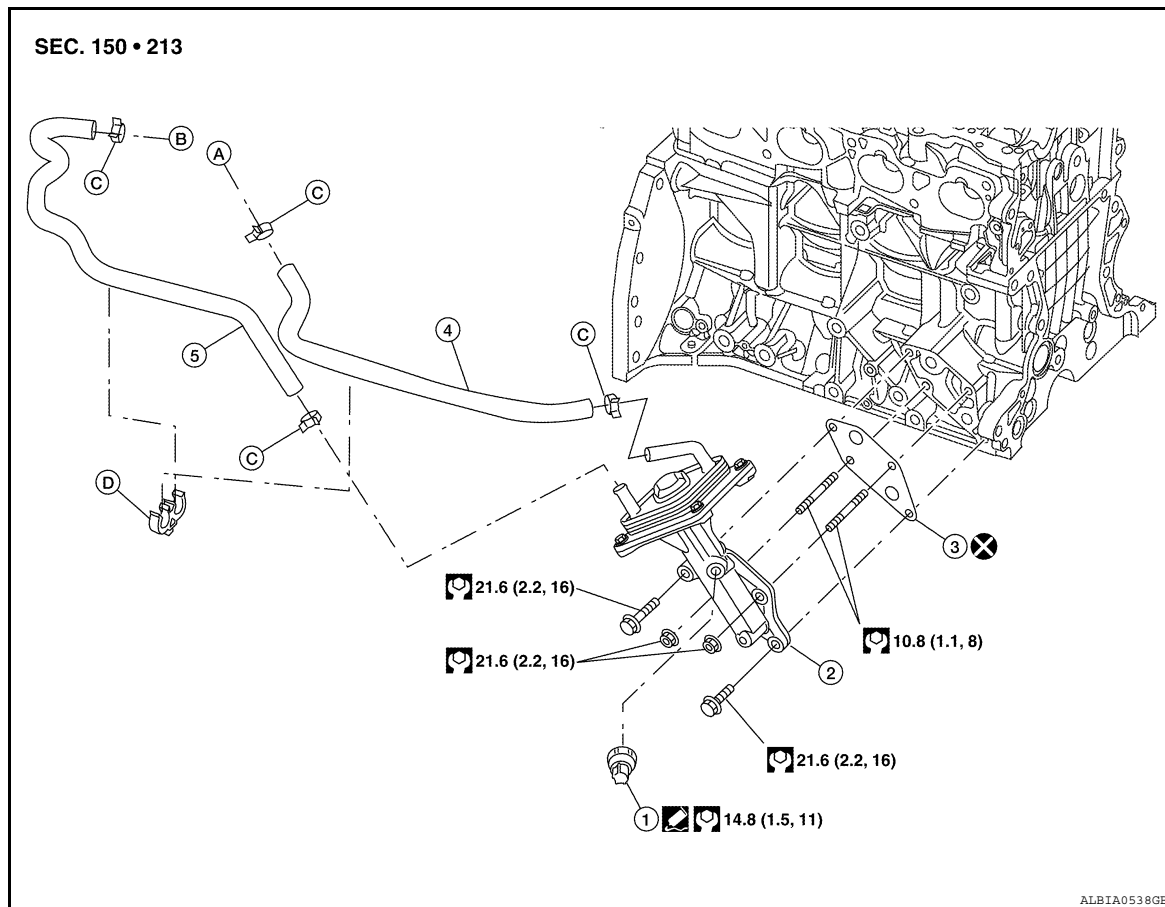

- | | | |
|----------------------------|-----------------------|-----------------------------------|
| 1. Oil pressure switch | 2. Oil cooler | 3. Gasket |
| 4. Water hose (outlet) | 5. Water hose (inlet) | A. To water control valve housing |
| B. To heater pipe assembly | C. Hose clamp | D. Clip |

WARNING:

Be careful not to get burned, engine coolant and engine oil may be hot.

CAUTION:

- When removing oil cooler, prepare a shop cloth to absorb any engine oil leakage or spillage.
- Completely wipe off any engine oil that adheres to the engine and the vehicle.

REMOVAL

1. Drain engine oil. Refer to [LU-10. "Changing Engine Oil"](#).
2. Drain engine coolant. Refer to [CO-12. "Changing Engine Coolant"](#).
CAUTION:
Do not spill coolant on the drive belt.
3. Remove front RH wheel and tire. Refer to [WT-65. "Adjustment"](#).
4. Remove RH fender protector side cover. Refer to [EXT-20. "Removal and Installation"](#) (Coupe models) or [EXT-42. "Removal and Installation"](#) (Sedan models).
5. Remove front exhaust tube. Refer to [EX-5. "Exploded View"](#).
6. Disconnect the oil pressure switch connector and remove the oil pressure switch.
CAUTION:
Do not drop or shock the oil pressure switch.
7. Disconnect water hoses from oil cooler.

OIL COOLER

< ON-VEHICLE REPAIR >

[QR25DE]

NOTE:

For reference during installation, put matching marks on oil cooler hoses.

8. Remove oil cooler bolts and oil cooler.
9. Remove oil cooler gasket.

INSPECTION AFTER REMOVAL

1. Check oil cooler for cracks.
2. Check oil cooler for clogging by blowing through coolant inlet. If necessary, replace oil cooler assembly.

INSTALLATION

Installation is in the reverse order of removal.

- Always replace oil cooler gasket.
- Remove any old liquid gasket adhering to the oil pressure switch and oil cooler before installing the oil pressure switch.

INSPECTION AFTER INSTALLATION

Start engine and check for leaks of engine oil or coolant.

A
LU
C
D
E
F
G
H
I
J
K
L
M
N
O
P

SERVICE DATA AND SPECIFICATIONS (SDS)

< SERVICE DATA AND SPECIFICATIONS (SDS)

[QR25DE]

SERVICE DATA AND SPECIFICATIONS (SDS)

SERVICE DATA AND SPECIFICATIONS (SDS)

Oil Pressure

INFOID:000000005434761

Unit: kPa (kg/cm², psi)

Engine speed	Approximate discharge oil pressure
Idle speed	More than 98 (1.0, 14)
2,000 rpm	294 (3.0, 43)
6,000 rpm	392 (4.0, 57)

Oil Pump

INFOID:000000005434762

Unit: mm (in)

Body to outer rotor radial clearance	0.114 - 0.179 (0.0045 - 0.0070)
Inner rotor to outer rotor tip clearance	0.170 - 0.220 (0.0067 - 0.0087)
Body to inner rotor axial clearance	0.030 - 0.070 (0.0012 - 0.0028)
Body to outer rotor axial clearance	0.060 - 0.110 (0.0024 - 0.0043)
Inner rotor to brazed portion of housing clearance	0.035 - 0.070 (0.0014 - 0.0028)

Regulator Valve

INFOID:000000005434763

Unit: mm (in)

Regulator valve to oil pump cover clearance	0.040 - 0.097 (0.0016 - 0.0038)
---	---------------------------------

Oil Capacity

INFOID:000000005434764

Unit: ℓ (US qt, Imp qt)

Drain and refill	With oil filter change	Approximately 4.6 (4 7/8, 4)
	Without oil filter change	Approximately 4.3 (4 1/2, 3 3/4)
Dry engine (engine overhaul)		Approximately 5.4 (5 3/4, 4 3/4)

PRECAUTION

PRECAUTIONS

Precaution for Supplemental Restraint System (SRS) "AIR BAG" and "SEAT BELT PRE-TENSIONER"

INFOID:000000005783137

The Supplemental Restraint System such as "AIR BAG" and "SEAT BELT PRE-TENSIONER", used along with a front seat belt, helps to reduce the risk or severity of injury to the driver and front passenger for certain types of collision. This system includes seat belt switch inputs and dual stage front air bag modules. The SRS system uses the seat belt switches to determine the front air bag deployment, and may only deploy one front air bag, depending on the severity of a collision and whether the front occupants are belted or unbelted. Information necessary to service the system safely is included in the SR and SB section of this Service Manual.

WARNING:

- To avoid rendering the SRS inoperative, which could increase the risk of personal injury or death in the event of a collision which would result in air bag inflation, all maintenance must be performed by an authorized NISSAN/INFINITI dealer.
- Improper maintenance, including incorrect removal and installation of the SRS, can lead to personal injury caused by unintentional activation of the system. For removal of Spiral Cable and Air Bag Module, see the SR section.
- Do not use electrical test equipment on any circuit related to the SRS unless instructed to in this Service Manual. SRS wiring harnesses can be identified by yellow and/or orange harnesses or harness connectors.

PRECAUTIONS WHEN USING POWER TOOLS (AIR OR ELECTRIC) AND HAMMERS

WARNING:

- When working near the Airbag Diagnosis Sensor Unit or other Airbag System sensors with the Ignition ON or engine running, DO NOT use air or electric power tools or strike near the sensor(s) with a hammer. Heavy vibration could activate the sensor(s) and deploy the air bag(s), possibly causing serious injury.
- When using air or electric power tools or hammers, always switch the Ignition OFF, disconnect the battery, and wait at least 3 minutes before performing any service.

Precaution for Liquid Gasket

INFOID:000000005434767

REMOVAL OF LIQUID GASKET SEALING

- After removing nuts and bolts, separate the mating surface, using Tool and remove old liquid gasket sealing.

Tool number : KV10111100 (J-37228)

CAUTION:

Be careful not to damage the mating surfaces.

- Tap (1) Tool to insert it, and then slide it (2) by tapping on the side as shown.
- In areas where Tool is difficult to use, use plastic hammer to lightly tap the parts, to remove it.

CAUTION:

If for some unavoidable reason suitable tool such as screwdriver is used, be careful not to damage the mating surfaces.

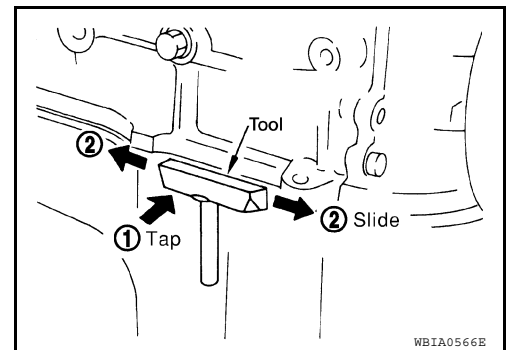

LIQUID GASKET APPLICATION PROCEDURE

PRECAUTIONS

[VQ35DE]

< PRECAUTION >

1. Remove old liquid gasket adhering to the liquid gasket application surface and the mating surface, Using scraper.
 - Remove liquid gasket completely from the groove of the liquid gasket application surface, bolts, and bolt holes.
2. Thoroughly clean the mating surfaces and remove adhering moisture, grease and foreign materials.

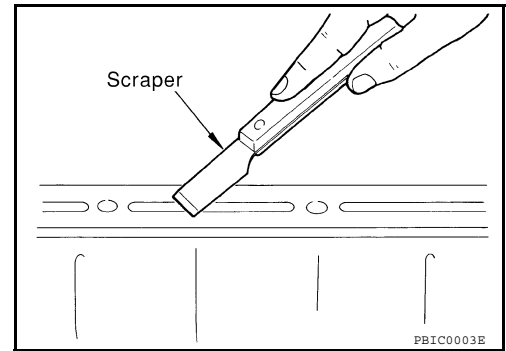

3. Attach liquid gasket tube to Tool.

Tool number : WS39930000 (—)

Use Genuine RTV Silicone Sealant or equivalent. Refer to [GI-15, "Recommended Chemical Products and Sealants"](#).

4. Apply liquid gasket without breaks to the specified location with the specified dimensions.
 - If there is a groove for the liquid gasket application, apply liquid gasket to the groove.

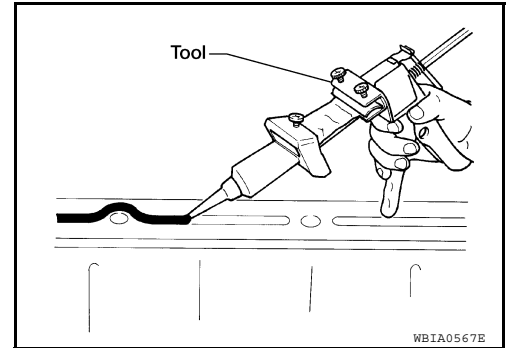

- As for the bolt holes, normally apply liquid gasket inside the holes. Occasionally, it should be applied outside the holes. Make sure to read the text of service manual.
- Within five minutes of liquid gasket application, install the mating component.
- If liquid gasket protrudes, wipe it off immediately.
- Do not retighten nuts or bolts after the installation.
- After 30 minutes or more have passed from the installation, fill engine oil and engine coolant.

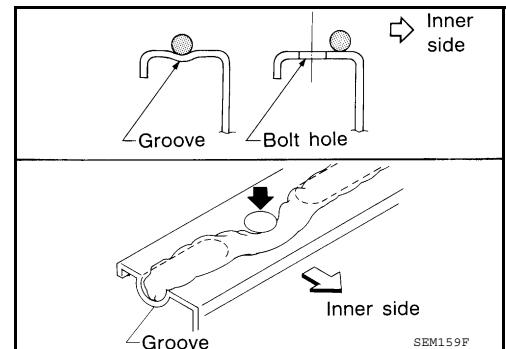

CAUTION:

If there are specific instructions in this manual, observe them.

PREPARATION

< PREPARATION >

[VQ35DE]

PREPARATION

PREPARATION

Special Service Tool

INFOID:000000005434768

A

LU

The actual shapes of Kent-Moore tools may differ from those of special service tools illustrated here.

Tool number (Kent-Moore No.) Tool name	Description
ST25051001 (J-25695-1) Oil pressure gauge	Measuring oil pressure Maximum measuring range: 2,452 kPa (25 kg-cm², 356 psi)
ST25052000 (J-25695-2) Hose	Adapting oil pressure gauge to upper oil pan
KV10115801 (J-38956) Oil filter wrench	Removing and installing oil filter
KV10111100 (J-37228) Seal cutter	Removing steel oil pan and rear timing chain case
WS39930000 (—) Tube presser	Pressing the tube of liquid gasket

C

D

E

F

G

H

I

J

K

L

M

N

O

P

Commercial Service Tool

INFOID:000000005434769

PREPARATION

< PREPARATION >

[VQ35DE]

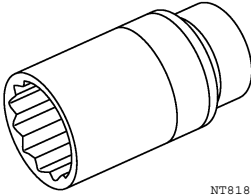
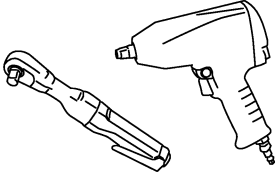
Tool name	Description
<p data-bbox="140 197 272 224">Deep socket</p>  <p data-bbox="836 417 880 432">NT818</p>	<p data-bbox="999 197 1437 254">Removing and installing oil pressure switch Deep socket 26 mm, 3/8 drive</p>
<p data-bbox="140 449 264 476">Power tools</p>  <p data-bbox="836 667 911 682">PBIC0190E</p>	<p data-bbox="999 449 1254 476">Loosening nuts and bolts</p>

FUNCTION DIAGNOSIS

LUBRICATION SYSTEM

Lubrication Circuit

INFOID:000000005434770

A

LU

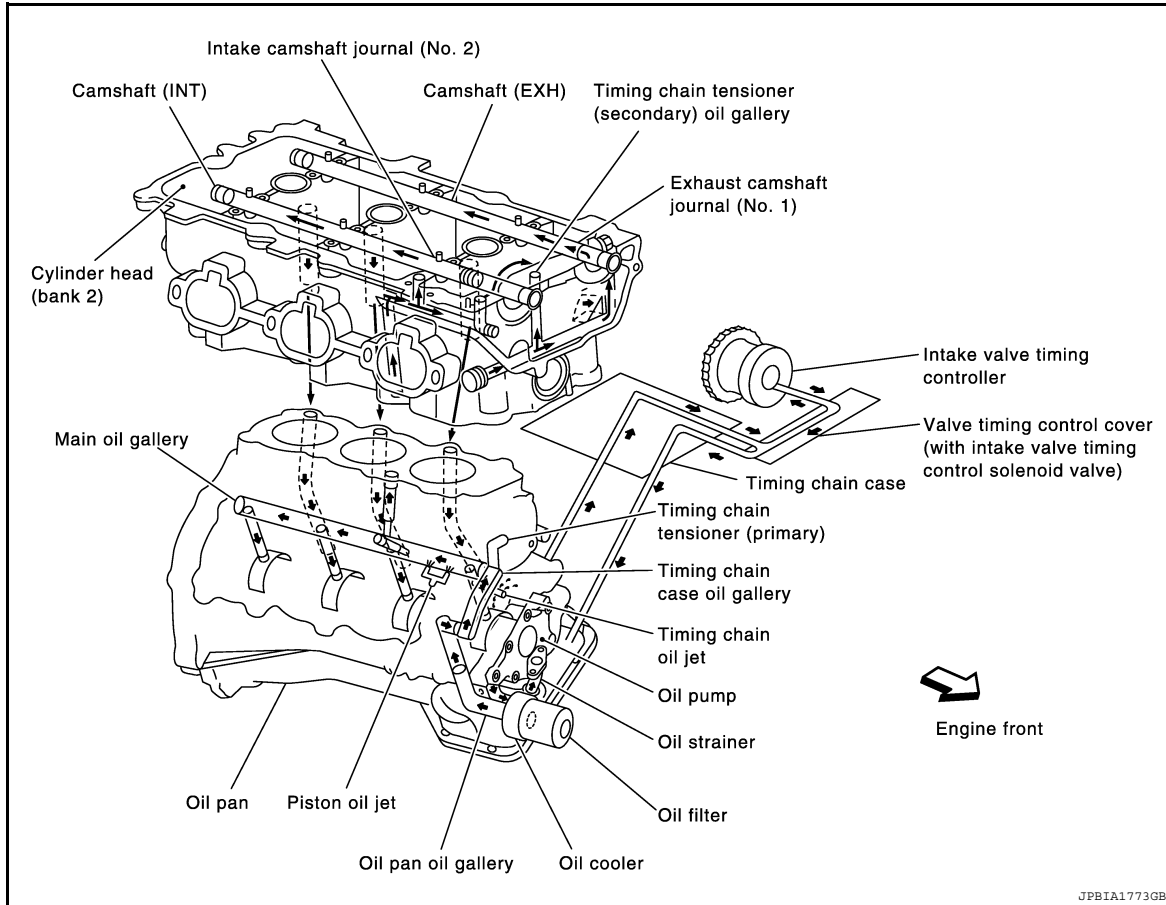

C

D

E

F

G

H

I

J

K

L

M

N

O

P

LUBRICATION SYSTEM

< FUNCTION DIAGNOSIS >

[VQ35DE]

Schematic

INFOID:000000005434771

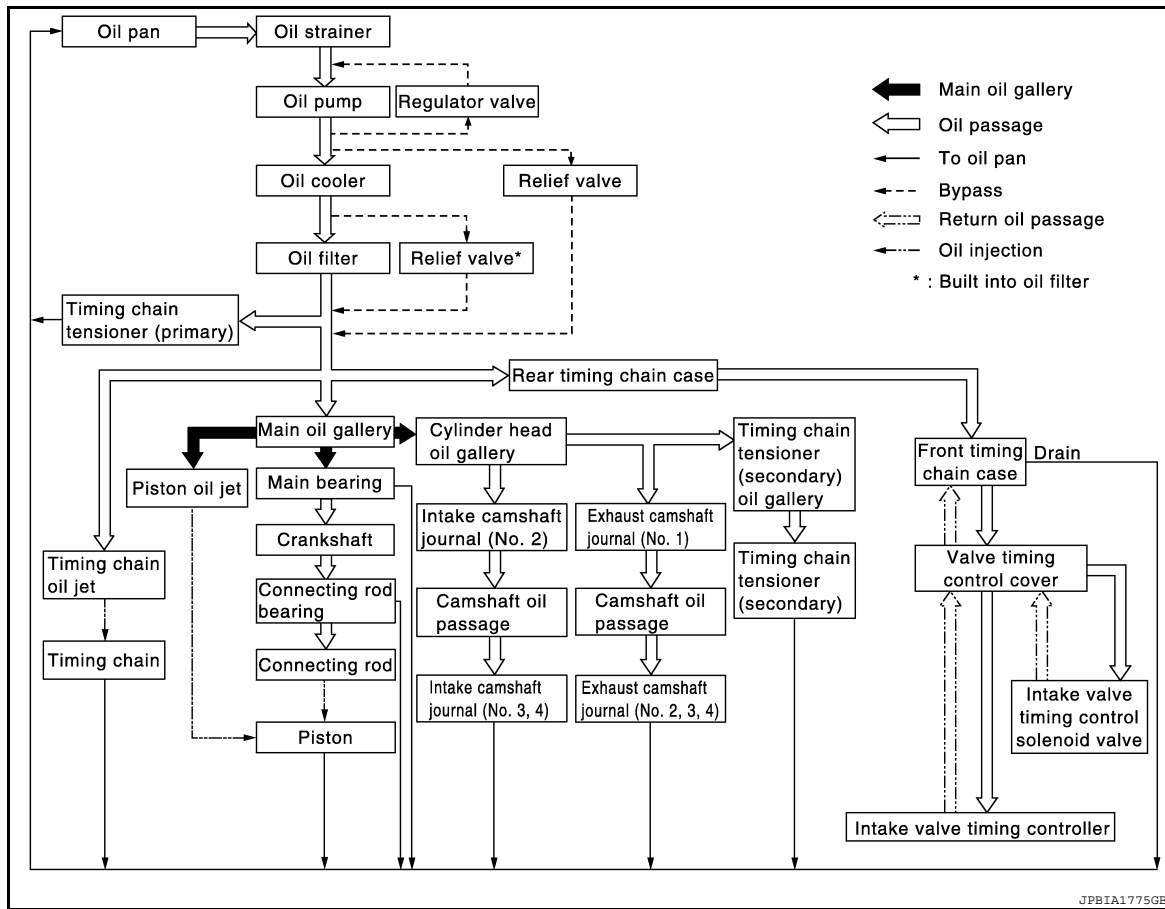

ON-VEHICLE MAINTENANCE

ENGINE OIL

Inspection

INFOID:000000005434772

OIL LEVEL

NOTE:

- Before starting the engine, check the oil level. If the engine is already started, stop it and allow 10 minutes before checking.
- Check that the oil level is within the range as indicated on the dipstick.
- If it is out of range, add oil as necessary. Refer to [LU-25](#).

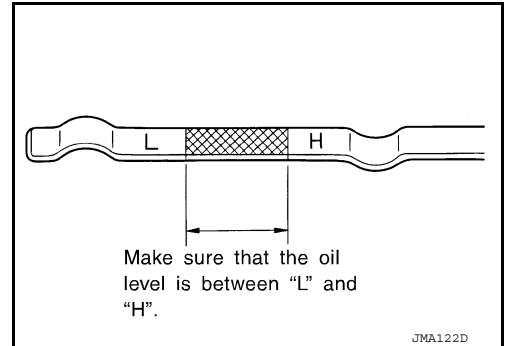

ENGINE OIL APPEARANCE

- Check engine oil for white milky appearance or excessive contamination.
- If engine oil becomes milky, it is highly probable that it is contaminated with engine coolant. Repair or replace damaged parts.

OIL LEAKAGE

Check for oil leakage around the following areas:

- Oil pan
- Oil pan drain plug
- Oil pressure switch
- Oil filter
- Oil cooler
- IVTC cover
- Front cover
- Mating surface between cylinder block and cylinder head
- Mating surface between cylinder head and rocker cover
- Crank oil seal (front and rear)

OIL PRESSURE CHECK

WARNING:

- Be careful not to burn yourself, as engine oil may be hot.
- For M/T models, put the gearshift lever in the Neutral "N" position. For CVT models, put the CVT shift selector in the Park "P" position.

1. Check the oil level.
2. Remove engine under cover. Refer to [EXT-14, "Removal and Installation"](#) (Coupe models) or [EXT-36, "Removal and Installation"](#) (Sedan models).
3. Disconnect oil pressure switch harness connector at the oil pressure switch. Remove oil pressure switch and install Tools.

CAUTION:

Do not drop or shock oil pressure switch.

Tool numbers : ST25051001 (J-25695-1)
: ST25052000 (J-25695-2)

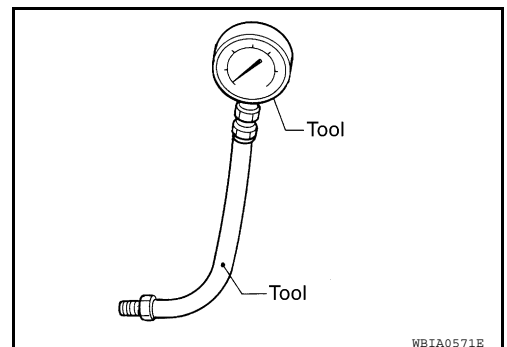

4. Start the engine and warm it up to normal operating temperature.
5. Check oil pressure with engine running under no-load, using Tool. Refer to [LU-34, "Oil Pressure"](#).

ENGINE OIL

< ON-VEHICLE MAINTENANCE >

[VQ35DE]

If difference is extreme, check oil passage and oil pump for oil leaks.

6. After the inspections, install the oil pressure switch as follows:
 - a. Remove the old sealant adhering to oil pressure switch and engine.
 - b. Apply thread sealant and tighten the oil pressure switch to specification.
Use Genuine High Performance Thread Sealant, or equivalent. Refer to [GI-15, "Recommended Chemical Products and Sealants"](#).

Oil pressure switch : 14.7 N-m (1.5 kg-m, 11 ft-lb)

- c. After warming up engine, make sure there are no leaks of engine oil with engine running.

Changing Engine Oil

INFOID:000000005434773

WARNING:

- **Be careful not to burn yourself, as the engine oil may be hot.**
 - **Prolonged and repeated contact with used engine oil may cause skin cancer; try to avoid direct skin contact with used oil. If skin contact is made, wash thoroughly with soap or hand cleaner as soon as possible.**
1. Position the vehicle so it is level on the hoist.
 2. Warm up the engine and check for oil leaks from the engine.
 3. Stop engine and wait for 10 minutes.
 4. Remove the oil pan drain plug and oil filler cap.
 5. Drain the engine oil.
 6. Install the oil pan drain plug with a new washer and refill the engine with new engine oil.

Oil specification and viscosity : Refer to [MA-15, "FOR USA AND CANADA : Engine Oil Recommendation"](#).

Oil pan drain plug : 34.3 N-m (3.5 kg-m, 25 ft-lb)

CAUTION:

- **Be sure to clean the oil pan drain plug and install with a new washer.**
 - **The refill capacity depends on the oil temperature and drain time. Use these specifications for reference only. Always use the dipstick to determine when the proper amount of oil is in the engine.**
7. Warm up the engine and check around the oil pan drain plug and oil filter for oil leaks.
 8. Stop engine and wait for 10 minutes.
 9. Check the engine oil level using the dipstick.

CAUTION:

Do not overfill the engine with engine oil.

OIL FILTER

Removal and Installation

INFOID:000000005434774

REMOVAL

1. Drain engine oil. Refer to [LU-26, "Changing Engine Oil"](#).
2. Remove the RH fender protector side cover. Refer to [EXT-20, "Removal and Installation"](#) (Coupe models) or [EXT-42, "Removal and Installation"](#) (Sedan models).
3. Remove the oil filter using Tool (A) as shown.

Tool number : KV10115801 (J-38956)

WARNING:

- Be careful not to get burned, the engine and engine oil may be hot.

CAUTION:

- When removing, prepare a shop cloth to absorb any oil leakage or spillage.
- Do not allow engine oil to adhere to the drive belts.
- Completely wipe off any oil that adheres to the engine and the vehicle.

- The oil filter has a built in pressure relief valve. Use a genuine NISSAN oil filter or equivalent

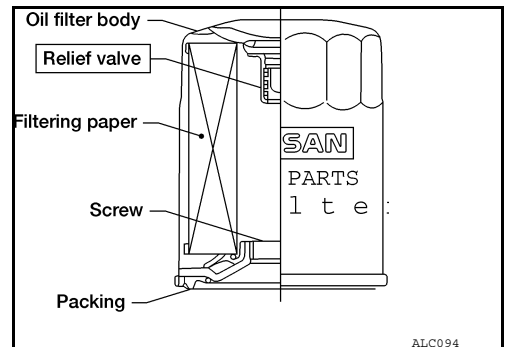
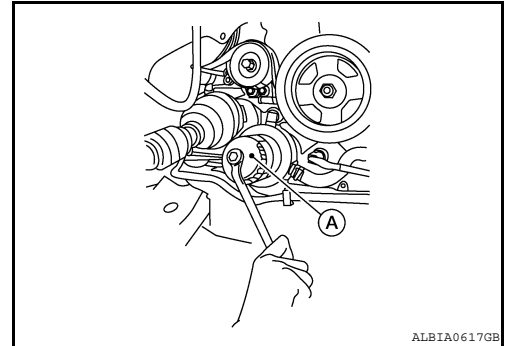

INSTALLATION

1. Remove foreign materials adhering to the oil filter installation surface.
2. Apply clean engine oil to the oil seal contact surface of the new oil filter.

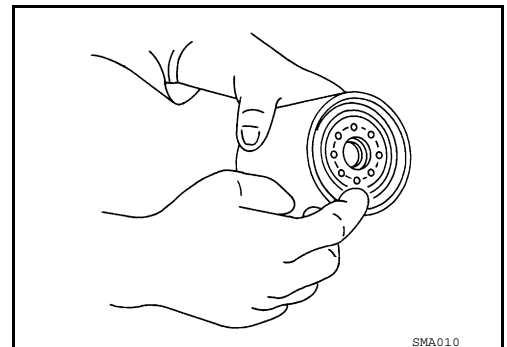

OIL FILTER

< ON-VEHICLE MAINTENANCE >

[VQ35DE]

3. Screw the oil filter manually until it touches the installation surface, then tighten it by 2/3 turn. Or tighten to specification below.

Oil filter : 18.0 N·m (1.8 kg-m, 13 ft-lb)

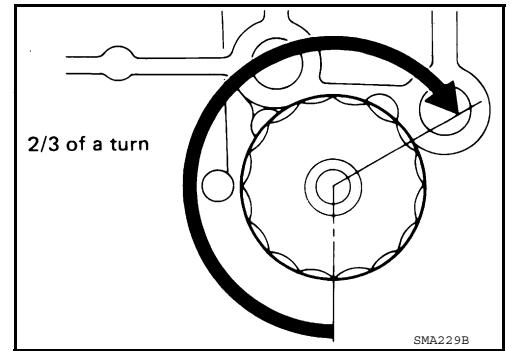

4. Refill engine with new engine oil. Refer to [LU-26. "Changing Engine Oil"](#).
5. After warming up the engine, check for any engine oil leaks.
6. Install the RH fender protector side cover. Refer to [EXT-20. "Removal and Installation"](#) (Coupe models) or [EXT-42. "Removal and Installation"](#) (Sedan models).

ON-VEHICLE REPAIR

OIL PUMP

Removal and Installation

INFOID:000000005434775

REMOVAL

1. Remove the lower and upper oil pan. Refer to [EM-142, "Removal and Installation \(Upper Oil Pan M/T Models\)"](#) (M/T models) or [EM-146, "Removal and Installation \(Upper Oil Pan CVT Models\)"](#) (CVT models).
2. Remove the timing chain. Refer to [EM-170, "Removal"](#).
3. Remove oil pump assembly.

INSTALLATION

Installation is in the reverse order of removal.

Disassembly and Assembly

INFOID:000000005434776

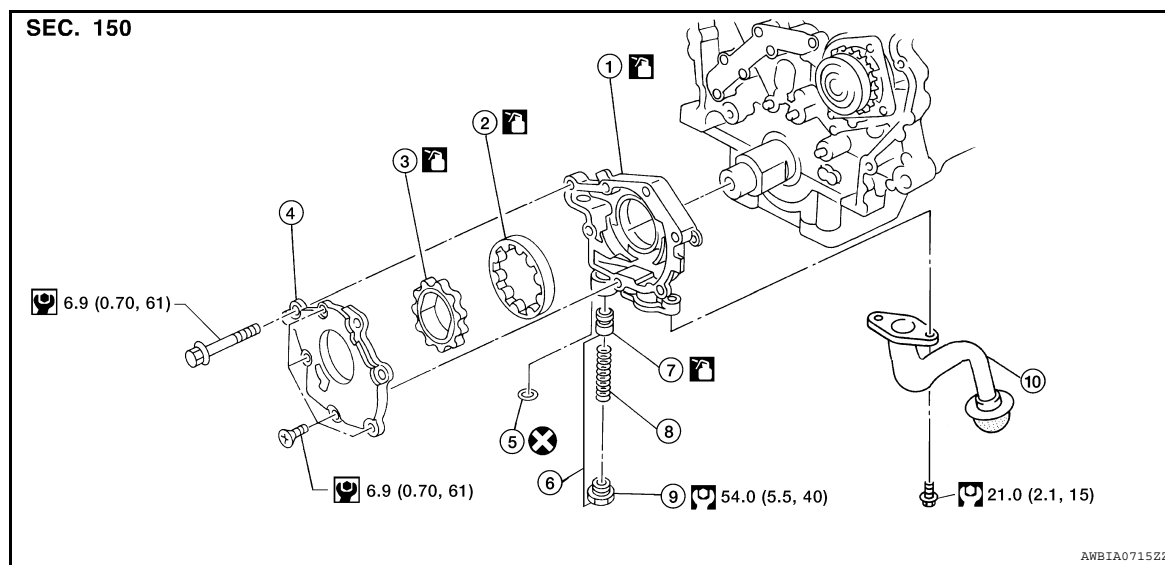

- | | | |
|---------------------|----------------|------------------------|
| 1. Oil pump housing | 2. Outer rotor | 3. Inner rotor |
| 4. Oil pump cover | 5. O-ring | 6. Regulator valve set |
| 7. Regulator valve | 8. Spring | 9. Regulator plug |
| 10. Oil strainer | | |

CAUTION:

Before assembly apply new engine oil to the parts as shown above.

DISASSEMBLY

1. Remove the oil pump cover.
2. Remove inner rotor and outer rotor from oil pump housing.

CAUTION:

The outer rotor has directional vanes in relation to the rotation of the oil pump shaft. Note the outer rotor vane direction for assembly.

3. Remove oil strainer from oil pump housing.
4. After removing regulator plug, remove spring and regulator valve.

INSPECTION AFTER DISASSEMBLY

Clearance of Oil Pump Parts

OIL PUMP

[VQ35DE]

< ON-VEHICLE REPAIR >

- Measure clearance with feeler gauge.
- Clearance between outer rotor and oil pump body (position 1).

Standard : 0.114 - 0.260 mm (0.0045 - 0.0102 in)

- Tip clearance between inner rotor and outer rotor (position 2).

Standard : Below 0.180 mm (0.0071 in)

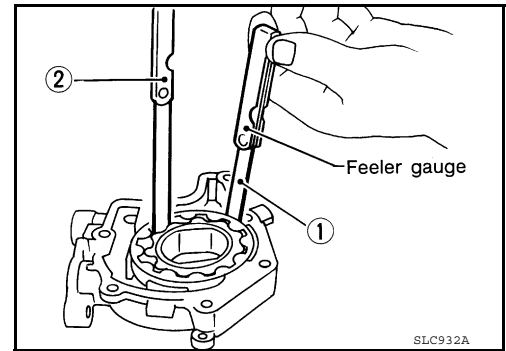

- Measure clearance with feeler gauge and straightedge.
- Side clearance between inner rotor and oil pump body (position 3).

Standard : 0.030 - 0.070 mm (0.0012 - 0.0028 in)

- Side clearance between outer rotor and oil pump body (position 4).

Standard : 0.050 - 0.110 mm (0.0020 - 0.0043 in)

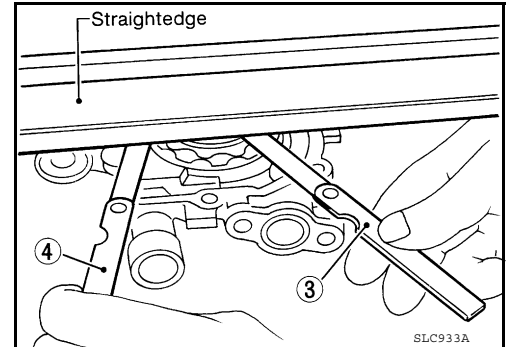

- Calculate the clearance between inner rotor and oil pump body as follows.

1. Measure the outer diameter of protruded portion of inner rotor (position A).
2. Measure the inner diameter of oil pump body with inside micrometer (position B).
(clearance 5) = (inner diameter of oil pump body B) – (outer diameter of inner rotor A)

Standard : 0.045 - 0.091 mm (0.0018 - 0.0036 in)

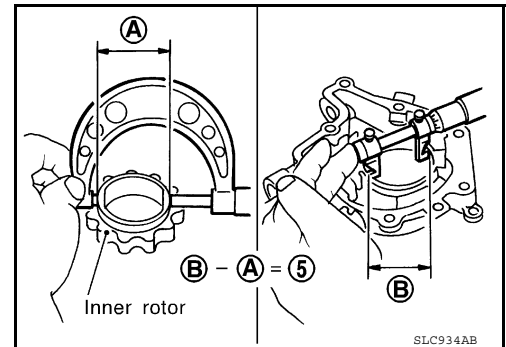

Regulator Valve

1. Visually inspect components for wear and damage.
2. Check oil pressure regulator valve sliding surface and valve spring.
3. Coat regulator valve with engine oil. Check that it falls smoothly into the valve hole by its own weight.

If damaged, replace regulator valve set or oil pump body.

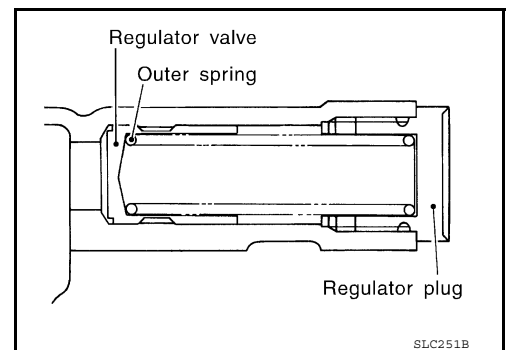

Regulator Valve Clearance

OIL PUMP

[VQ35DE]

< ON-VEHICLE REPAIR >

(Clearance 6) = D (Valve hole diameter) – E (Outer diameter of valve)

Standard : 0.040 - 0.097 mm (0.0016 - 0.0038 in)

If it exceeds the standard, replace the oil pump body.

CAUTION:

Coat regulator valve with engine oil.

Check that it falls smoothly into the valve hole by its own weight.

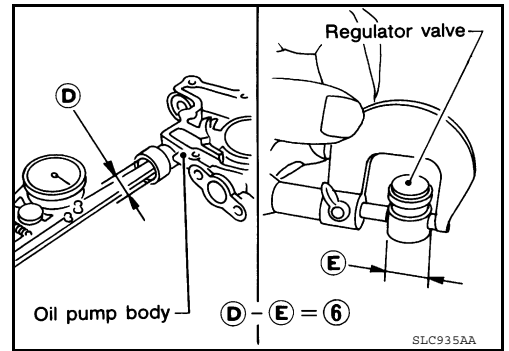

Assembly

Assembly is in the reverse order of disassembly.

- Assemble the outer rotor in the correct vane orientation to rotation as noted during disassembly, and the inner rotor with the groove on the oil pump cover side.

CAUTION:

Before assembly apply new engine oil to the parts as specified.

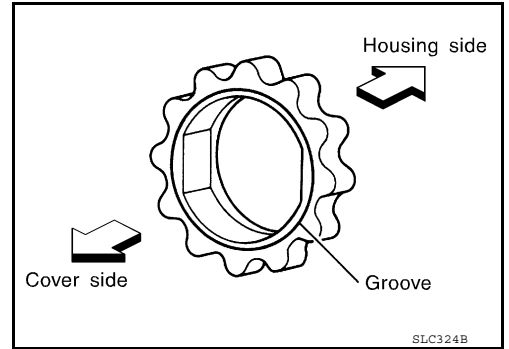

A
LU
C
D
E
F
G
H
I
J
K
L
M
N
O
P

OIL COOLER

< ON-VEHICLE REPAIR >

[VQ35DE]

OIL COOLER

Removal and Installation

INFOID:000000005434777

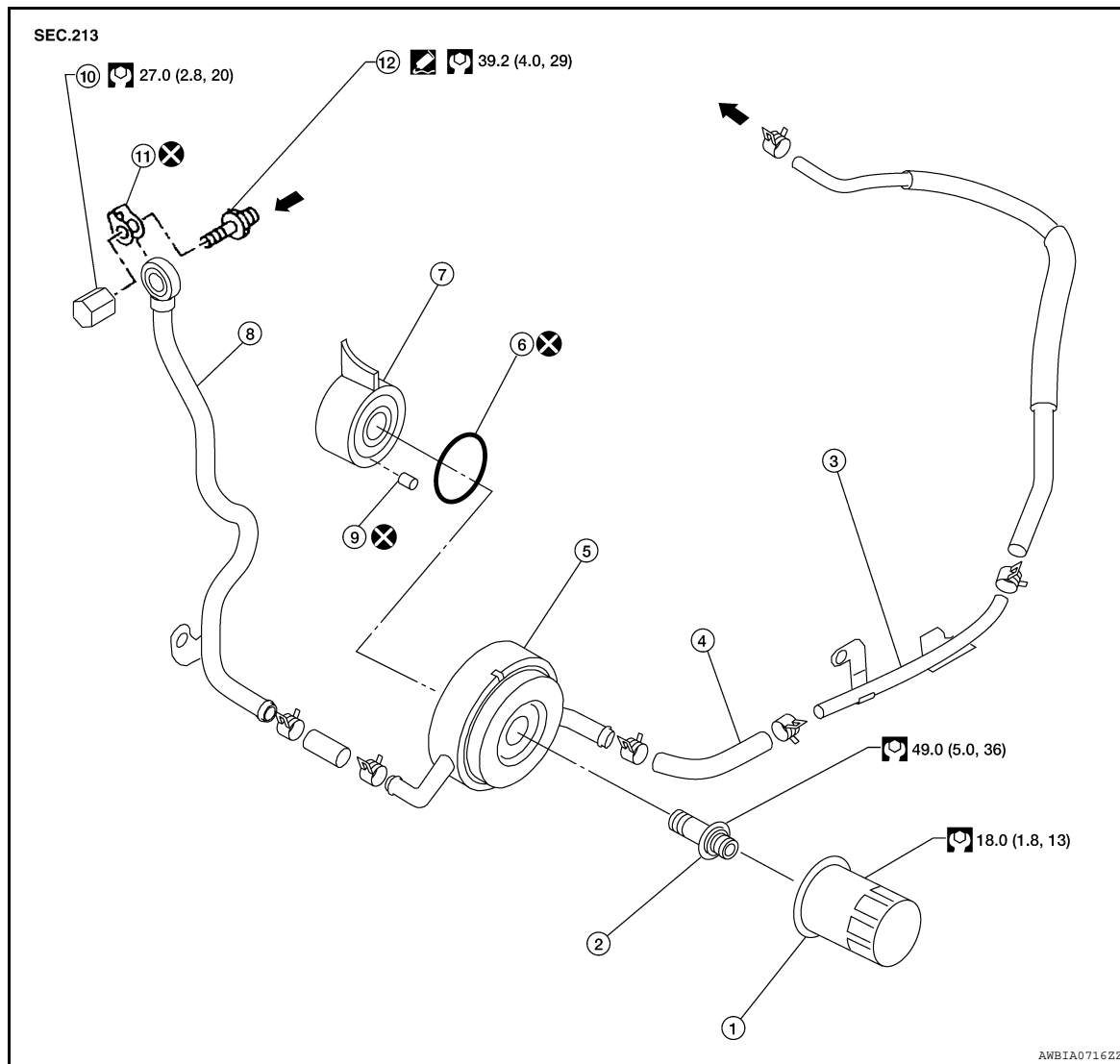

- | | | |
|----------------------|--------------------|---------------------|
| 1. Oil filter | 2. Oil cooler bolt | 3. Water pipe |
| 4. Water hose | 5. Oil cooler | 6. O-ring |
| 7. Oil pan | 8. Water pipe | 9. Relief valve |
| 10. Water drain plug | 11. Copper gasket | 12. Water connector |
- ← Coolant flow

WARNING:

Be careful not to get burned, engine coolant and engine oil may be hot.

CAUTION:

- When removing oil cooler, prepare a shop cloth to absorb any engine oil leakage or spillage.
- Completely wipe off any engine oil that adheres to the engine and the vehicle.

REMOVAL

1. Remove front RH wheel and tire. Refer to [WT-65, "Adjustment"](#).
2. Remove RH fender protector side cover. Refer to [EXT-20, "Removal and Installation"](#) (Coupe models) or [EXT-42, "Removal and Installation"](#) (Sedan models).
3. Drain engine coolant. Refer to [CO-34, "Changing Engine Coolant"](#).
 - Do not spill coolant on the drive belt.

OIL COOLER

< ON-VEHICLE REPAIR >

[VQ35DE]

4. Disconnect water hoses from oil cooler.
5. Remove the oil filter. Refer to [LU-27, "Removal and Installation"](#).
6. Remove the oil cooler.

A

INSPECTION AFTER REMOVAL

LU

1. Check oil cooler for cracks.
2. Check oil cooler for clogging by blowing through coolant inlet. If necessary, replace oil cooler assembly.

Oil Pressure Relief Valve

C

Inspect oil pressure relief valve for movement, cracks and breaks by pushing the ball. If replacement is necessary, remove valve by prying it out with a suitable tool. Install a new valve in place by tapping it.

D

INSTALLATION

Installation is in the reverse order of removal.

CAUTION:

When installing the oil cooler, align the oil cooler stopper with the stopper of the oil pan.

E

INSPECTION AFTER INSTALLATION

Start engine and check for leaks of engine oil or coolant.

F

G

H

I

J

K

L

M

N

O

P

SERVICE DATA AND SPECIFICATIONS (SDS)

< SERVICE DATA AND SPECIFICATIONS (SDS)

[VQ35DE]

SERVICE DATA AND SPECIFICATIONS (SDS)

SERVICE DATA AND SPECIFICATIONS (SDS)

Oil Pressure

INFOID:000000005434778

Unit: kPa (kg/cm², psi)

Engine speed	Approximate discharge oil pressure
Idle speed	More than 98 (1.0, 14)
2,000 rpm	294 (3.0, 43)

Regulator Valve

INFOID:000000005434779

Unit: mm (in)

Regulator valve to oil pump cover clearance	0.040 - 0.097 (0.0016 - 0.0038)
---	---------------------------------

Oil Pump

INFOID:000000005434780

Unit: mm (in)

Body to outer rotor radial clearance	0.114 - 0.260 (0.0045 - 0.0102)
Inner rotor to outer rotor tip clearance	Below 0.180 (0.0071)
Body to inner rotor axial clearance	0.030 - 0.070 (0.0012 - 0.0028)
Body to outer rotor axial clearance	0.050 - 0.110 (0.0020 - 0.0043)
Inner rotor to brazed portion of housing clearance	0.045 - 0.091 (0.0018 - 0.0036)

Oil Capacity

INFOID:000000005434781

Unit: ℓ (US qt, Imp qt)

Drain and refill	With oil filter change	Approximately 4.8 (5-1/8, 4-1/4)
	Without oil filter change	Approximately 4.5 (4-3/4, 4)
Dry engine (engine overhaul)		Approximately 5.3 (5-5/8, 4-5/8)