

ENGINE LUBRICATION & COOLING SYSTEMS

SECTION LC

GI
MA
EM

LC

CONTENTS

EC

FE

CL

MT

AT

FA

RA

BR

ST

RS

BT

HA

EL

IDX

PRECAUTIONS	2	Oil Pump Inspection	16
Supplemental Restraint System (SRS) "AIR BAG"	2	ENGINE COOLING SYSTEM	17
Liquid Gasket Application Procedure	2	Cooling Circuit	17
PREPARATION	3	System Check	17
Special Service Tools	3	Checking Cooling System Hoses	17
<input type="text"/> SR <input type="text"/>		Water Hose Drawing	18
ENGINE LUBRICATION SYSTEM	4	Checking Cooling System For Leaks	19
Lubrication Circuit	4	Checking Radiator Cap	19
Oil Pressure Check	4	Water Pump	20
Oil Pump	5	Thermostat	21
Removal	5	Water Outlet	22
Disassembly And Assembly	5	Radiator	23
Inspection	6	<input type="text"/> SR, GA <input type="text"/>	
Regulator Valve Inspection	7	ENGINE COOLING SYSTEM	24
Installation	7	Overheating Cause Analysis	24
Oil Filter	7	SERVICE DATA AND SPECIFICATIONS (SDS)	25
ENGINE COOLING SYSTEM	8		
Cooling Circuit	8		
System Check	8		
Checking Cooling System Hoses	8		
Checking Cooling System For Leaks	8		
Checking Radiator Cap	9		
Water Pump	9		
Thermostat	10		
Water Outlet	11		
Radiator	12		
<input type="text"/> GA <input type="text"/>			
ENGINE LUBRICATION SYSTEM	13		
Lubrication Circuit	13		
Oil Pressure Check	14		
Oil Pump	15		
Removal And Installation	15		
Disassembly And Assembly	15		
Regulator Valve Inspection	15		
Oil Pressure Relief Valve Inspection	16		

PRECAUTIONS

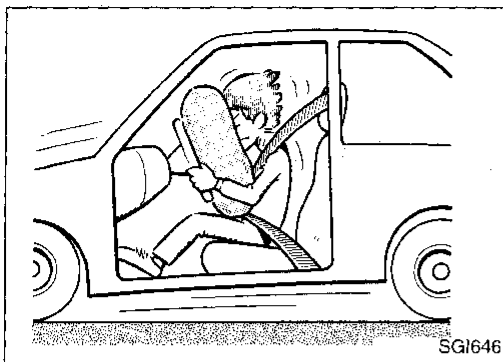

Supplemental Restraint System (SRS) "AIR BAG"

The Supplemental Restraint System "Air Bag", used along with a seat belt, helps to reduce the risk or severity of injury to the driver and front passenger in a frontal collision. The Supplemental Restraint System consists of air bag modules (located in the center of the steering wheel and on the instrument panel on the passenger side), a diagnosis sensor unit, warning lamp, wiring harness and spiral cable. Information necessary to service the system safely is included in the **RS section** of this Service Manual.

WARNING:

- To avoid rendering the SRS inoperative, which could increase the risk of personal injury or death in the event of a collision which would result in air bag inflation, all maintenance must be performed by an authorized NISSAN dealer.
- Improper maintenance, including incorrect removal and installation of the SRS, can lead to personal injury caused by unintentional activation of the system.
- All SRS electrical wiring harnesses and connectors are covered with yellow outer insulation. Do not use electrical test equipment on any circuit related to the SRS.

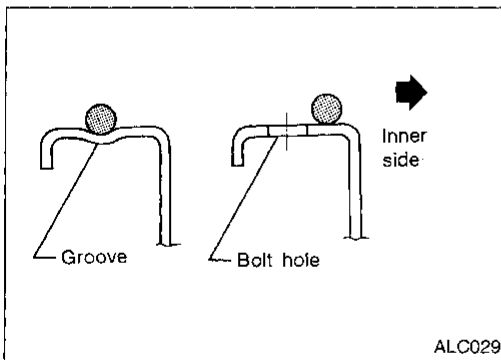

Liquid Gasket Application Procedure

- Use a scraper to remove all traces of old liquid gasket from mating surfaces and grooves. Also, completely clean any oil from these areas.
- Apply a continuous bead of liquid gasket to mating surfaces. (Use Genuine Liquid Gasket or equivalent.)
 - For oil pan, be sure liquid gasket diameter is 4.0 to 5.0 mm (0.157 to 0.197 in) wide for SR engine and 3.5 to 4.5 mm (0.138 to 0.177 in) wide for GA engine.
 - For areas except oil pan, be sure liquid gasket diameter is 2.0 to 3.0 mm (0.079 to 0.118 in).
- Apply liquid gasket around the inner side of bolt holes (unless otherwise specified).
- Assembly should be done within 5 minutes after coating.
- Wait at least 30 minutes before refilling engine oil and engine coolant.

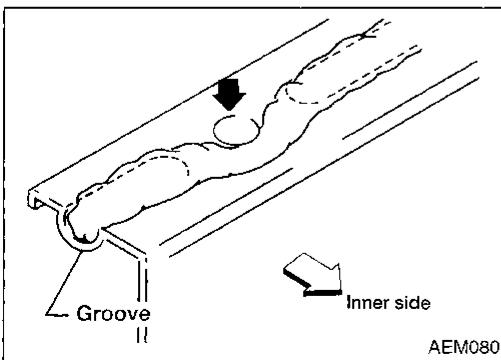

PREPARATION

Special Service Tools

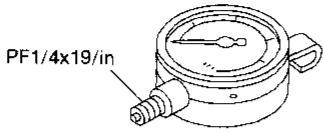
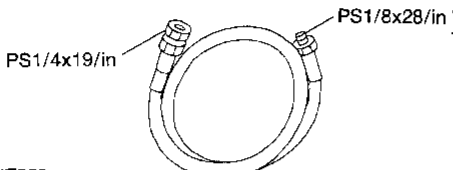
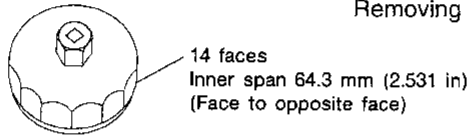
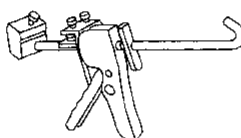
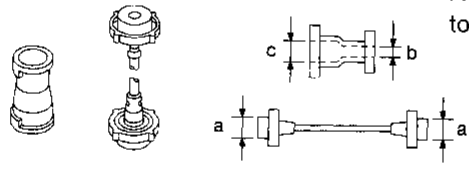
Tool number (Kent-Moore No.) Tool name	Description	Engine application	
		SR	GA
ST25051001 (J25695-1) Oil pressure gauge	 <p>Measuring oil pressure</p> <p>Maximum measuring range: 2,452 kPa (24 kg/cm², 356 psi)</p>	X	X
NT558			
ST25052000 (J25695-2) Hose	 <p>Adapting oil pressure gauge to cylinder block</p>	X	X
NT559			
KV10115801 (J38956) Oil filter wrench	 <p>Removing oil filter</p> <p>14 faces Inner span 64.3 mm (2.531 in) (Face to opposite face)</p>	X	—
NT362			
WS39930000 (—) Tube presser	 <p>Pressing the tube of liquid gasket</p>	X	X
NT052			
EG17650301 (J33984-A) Radiator cap tester adapter	 <p>Adapting radiator cap tester to radiator filler neck</p> <p>a: 28 (1.10) dia. b: 31.4 (1.236) dia. c: 41.3 (1.626) dia. Unit: mm (in)</p>	X	X
NT564			

GI
MA
EM
LC
EC
FE
CL
MT
AT
FA
RA
BR
ST
RS
BT
HA
EL
IDX

Lubrication Circuit

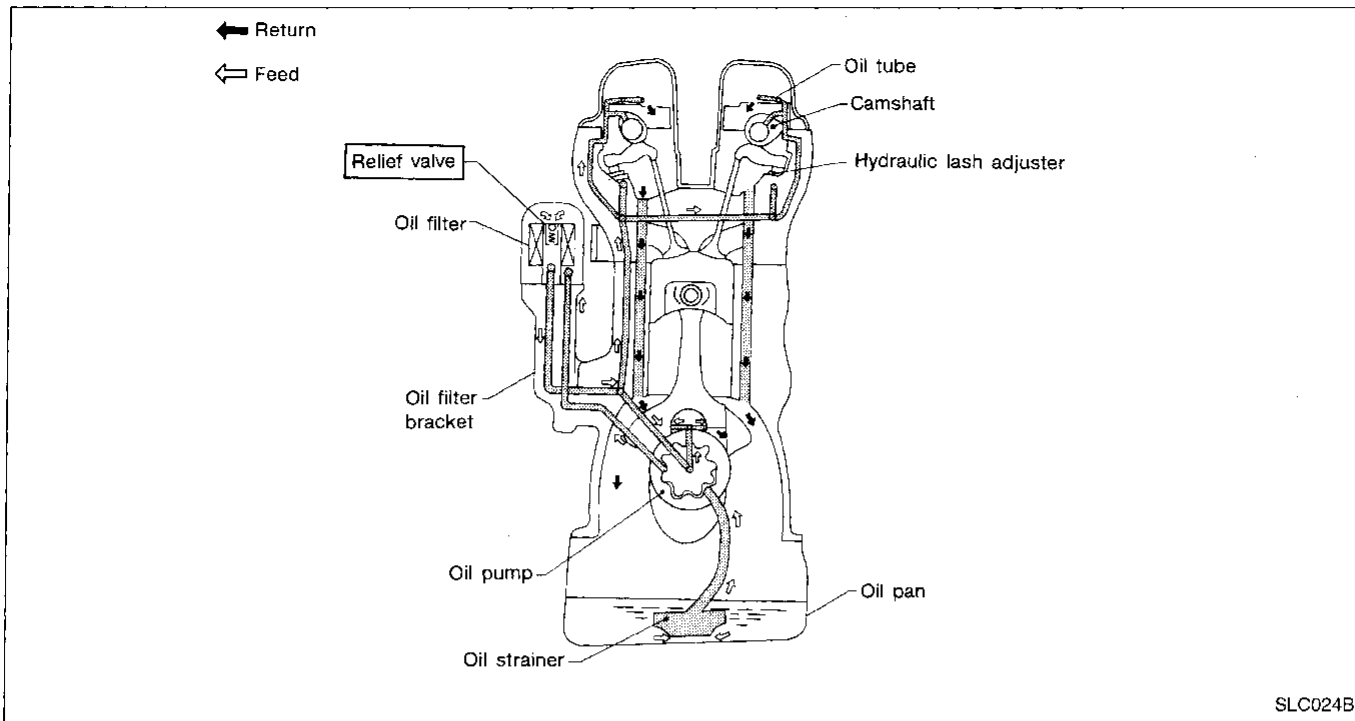

SLC024B

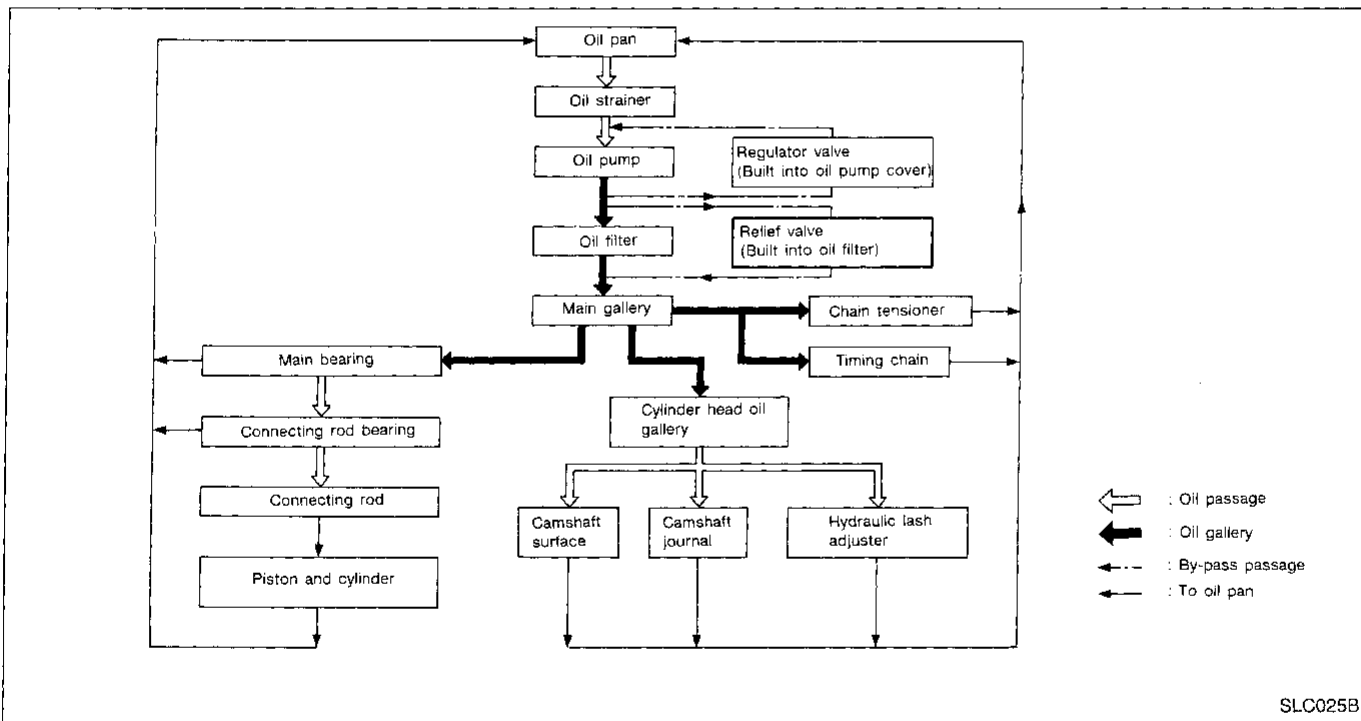

SLC025B

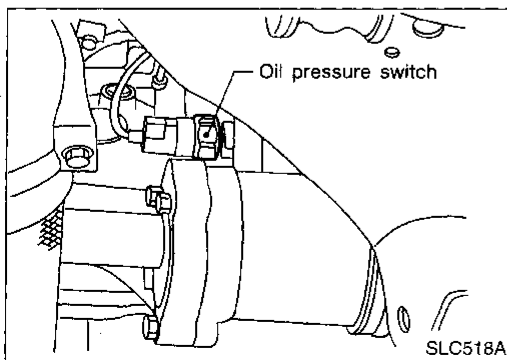

SLC518A

Oil Pressure Check

WARNING:

- Be careful not to burn yourself, as the engine and oil may be hot.
- For M/T models, put gearshift lever in Neutral "N" position. For A/T models, put selector lever in Park "P" position.

1. Check oil level.
2. Remove oil pressure switch.

Oil Pressure Check (Cont'd)

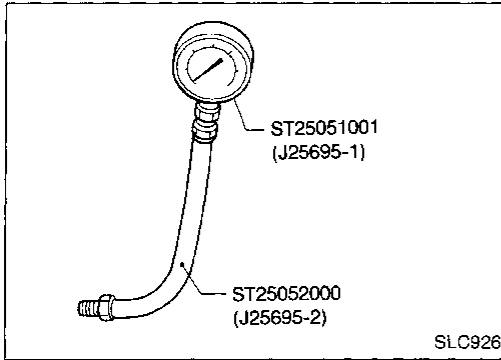

3. Install pressure gauge.
4. Start engine and warm it up to normal operating temperature.
5. Check oil pressure with engine running under no-load.

Engine speed rpm	Approximate discharge pressure kPa (kg/cm ² , psi)
Idle speed	More than 78 (0.8, 11)
3,200	314 - 392 (3.2 - 4.0, 46 - 57)

If difference is extreme, check oil passage and oil pump for oil leaks.

6. Install oil pressure switch with sealant.

Oil Pump

REMOVAL

1. Remove drive belts.
2. Remove cylinder head. Refer to EM section ("Removal", "CYLINDER HEAD").
3. Remove oil pans. Refer to EM section ("Removal", "OIL PAN").
4. Remove oil strainer and baffle plate.
5. Remove front cover assembly.

DISASSEMBLY AND ASSEMBLY

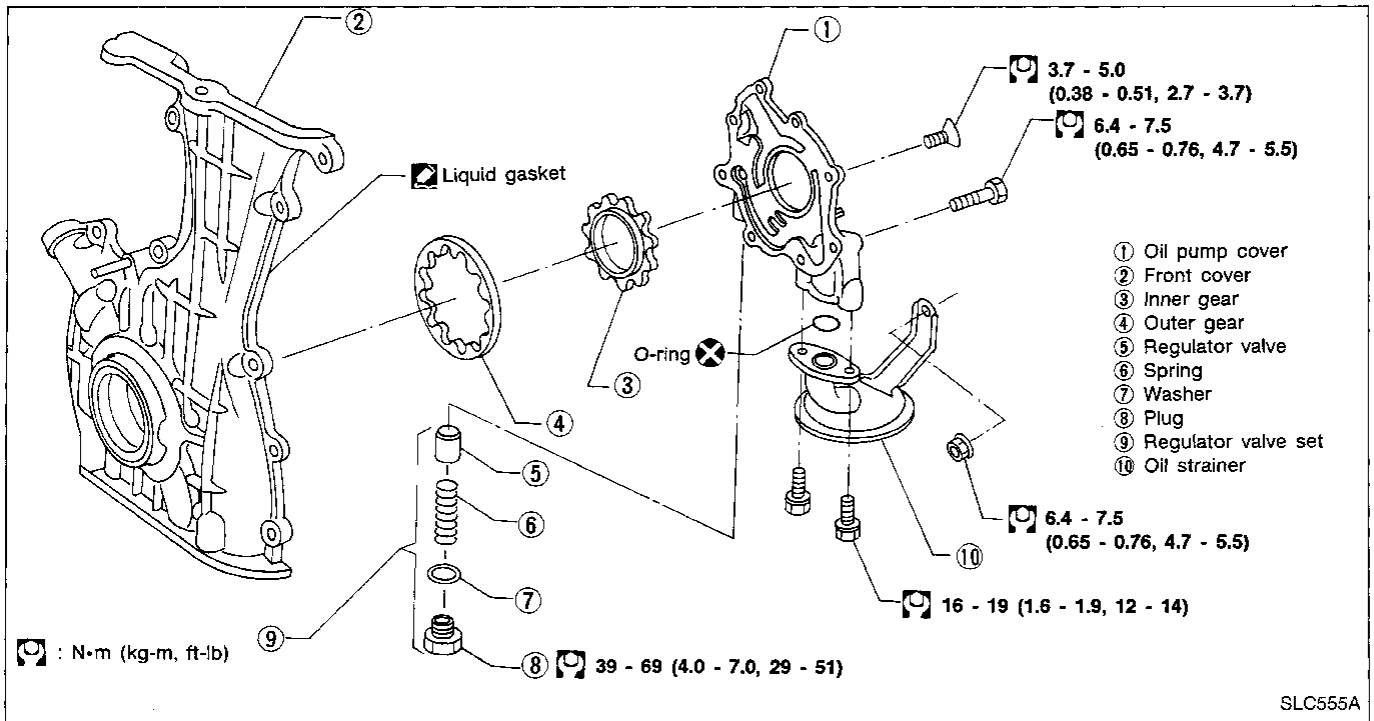

Oil Pump (Cont'd)

INSPECTION

Using a feeler gauge, check the following clearances:

Standard clearance:

Unit: mm (in)

Body to outer gear clearance ①	0.114 - 0.200 (0.0045 - 0.0079)
Inner gear to outer gear tip clearance ②	Below 0.18 (0.0071)
Body to inner gear clearance ③	0.05 - 0.09 (0.0020 - 0.0035)
Body to outer gear clearance ④	0.05 - 0.11 (0.0020 - 0.0043)
Inner gear to brazed portion of housing clearance ⑤	0.045 - 0.091 (0.0018 - 0.0036)

- If the tip clearance (②) exceeds the limit, replace gear set.
- If body to gear clearances (① , ③ , ④ , ⑤) exceed the limit, replace front cover assembly.

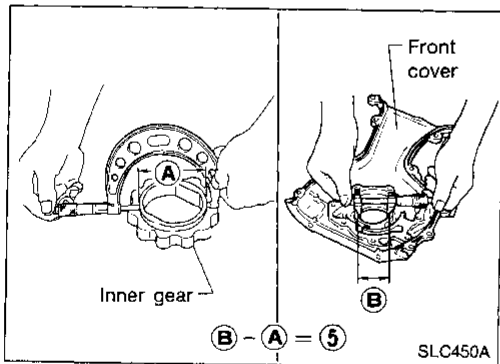
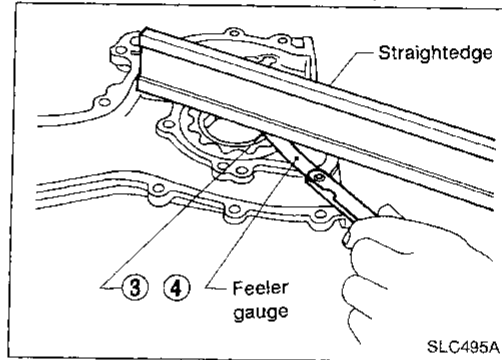
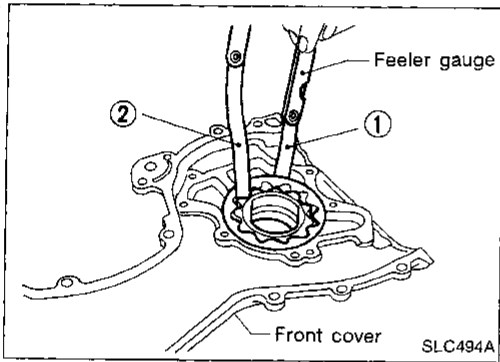

SLC854A

Oil Pump (Cont'd)

REGULATOR VALVE INSPECTION

1. Visually inspect components for wear and damage.
2. Check oil pressure regulator valve sliding surface and valve spring.
3. Coat regulator valve with engine oil. Check that it falls smoothly into the valve hole by its own weight.

If damaged, replace regulator valve set or oil pump assembly.

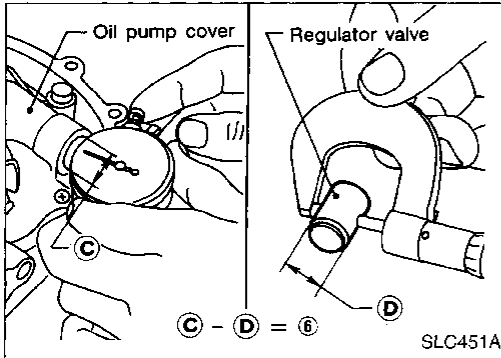
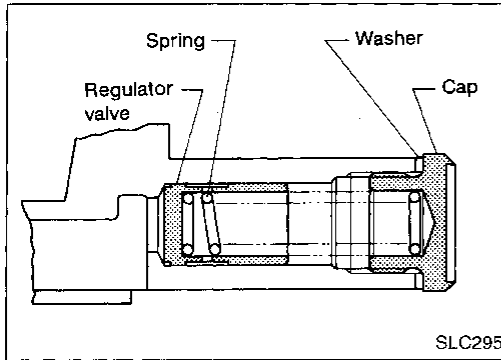

4. Check regulator valve to oil pump cover clearance.

Clearance:

⑥ : 0.040 - 0.097 mm (0.0016 - 0.0038 in)

If it exceeds the limit, replace oil pump cover.

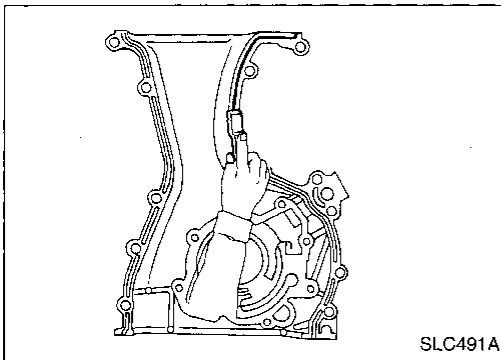

INSTALLATION

- Always replace oil seal and O-ring with new ones. Refer to EM section ("OIL SEAL REPLACEMENT").
- When installing oil pump, apply engine oil to gears.
- Be sure that O-rings are properly fitted.
- Use a scraper to remove old liquid gasket from mating surface of front cover.
- Also remove traces of liquid gasket from mating surface of cylinder block.

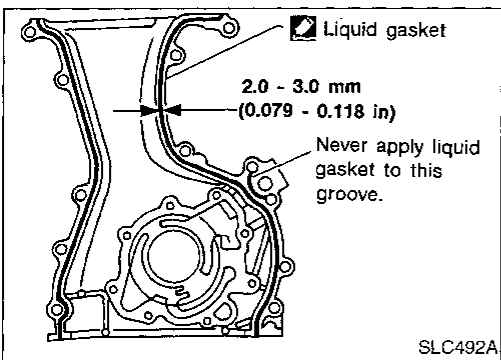

1. Apply a continuous bead of liquid gasket to mating surface of front cover assembly.
- Use Genuine Liquid Gasket or equivalent.
2. Installation is the reverse order of removal.

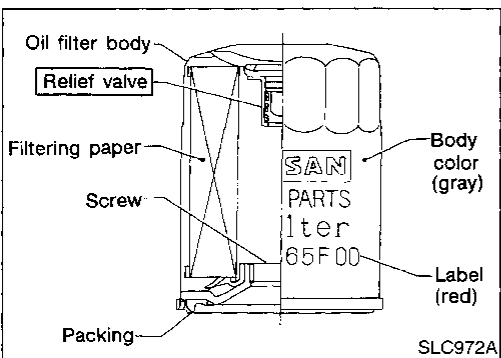

Oil Filter

The oil filter is a small, full-flow cartridge type and is provided with a relief valve.

- The new and previous oil filter designs differ from each other and are not interchangeable.
- Use Tool KV10115801 (J38956) for removing oil filter.

GL

MA

EM

LC

EC

FE

CL

MT

AT

FA

RA

BR

ST

RS

BT

HA

EL

IDX

Cooling Circuit

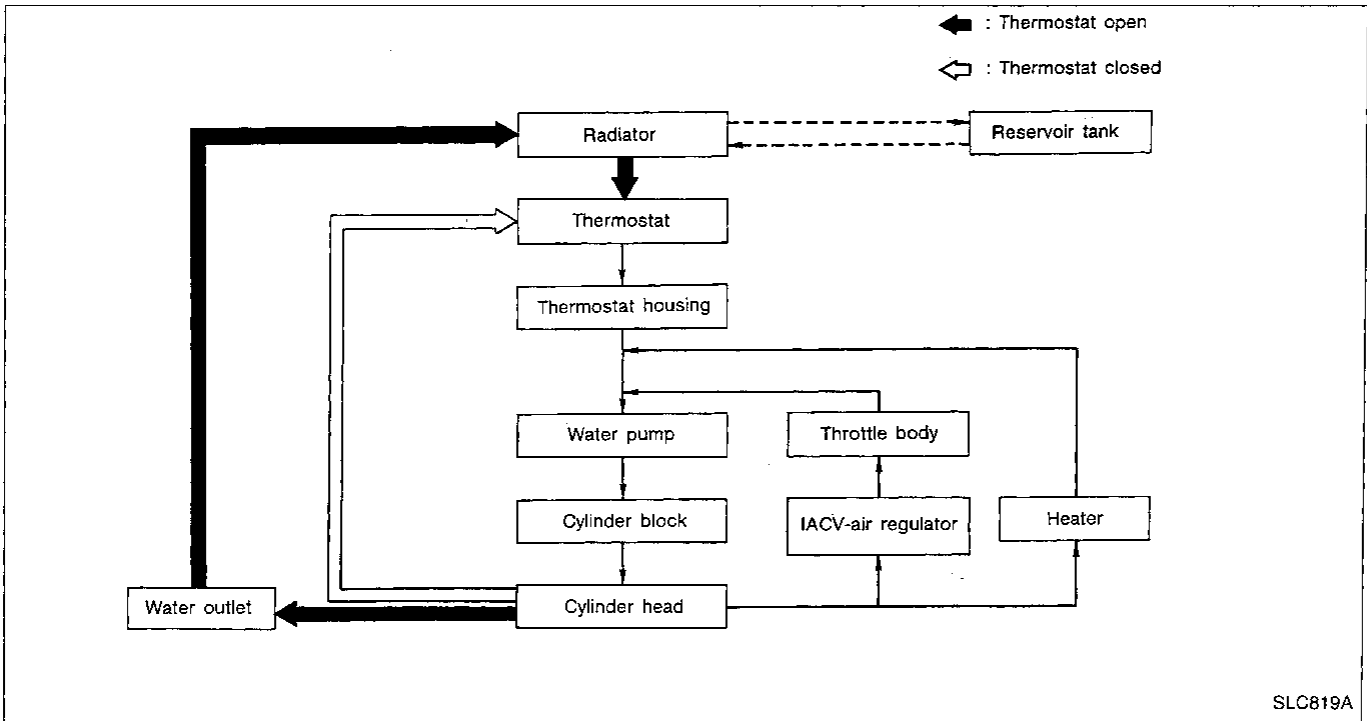

System Check

WARNING:

Never remove the radiator cap when the engine is hot. Serious burns could occur from high pressure coolant escaping from the radiator.

Wrap a thick cloth around the cap. Slowly turn it a quarter turn to allow built-up pressure to escape. Carefully remove the cap by turning it all the way.

CHECKING COOLING SYSTEM HOSES

Check hoses for the following:

- Improper attachment
- Leaks
- Cracks
- Damage
- Chafing
- Deterioration

CHECKING COOLING SYSTEM FOR LEAKS

To check for leakage, apply pressure to the cooling system with a tester.

Testing pressure:

157 kPa (1.6 kg/cm², 23 psi)

CAUTION:

Higher pressure than specified may cause radiator damage.

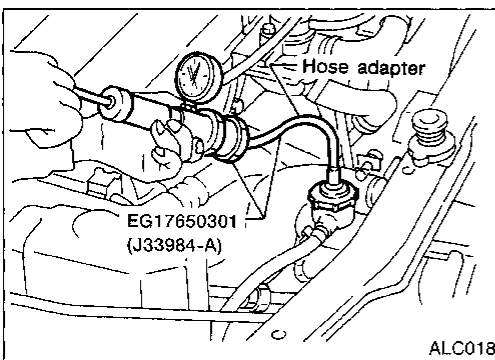

System Check (Cont'd) CHECKING RADIATOR CAP

To check radiator cap, apply pressure to cap with a tester.

Radiator cap relief pressure:

Standard

78 - 98 kPa (0.8 - 1.0 kg/cm², 11 - 14 psi)

Limit

59 - 98 kPa (0.6 - 1.0 kg/cm², 9 - 14 psi)

GI

MA

EM

LC

EC

FE

CL

MT

AT

FA

RA

BR

ST

RS

BT

HA

EL

IDX

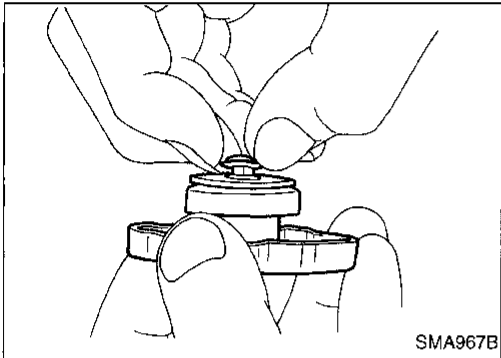
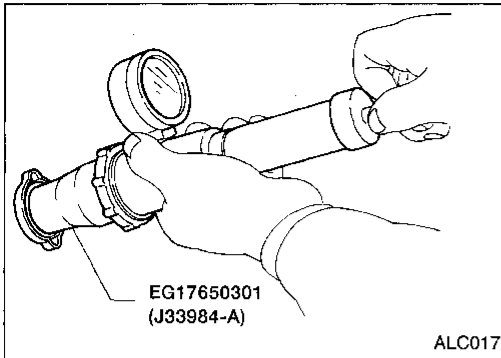

Pull the negative pressure valve to open it.
Check that it closes completely when released.

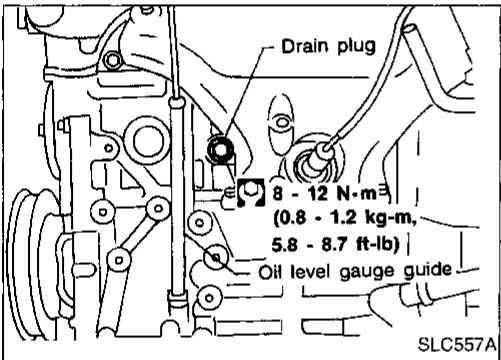

Water Pump

REMOVAL

1. Drain coolant from radiator and cylinder block.
Refer to MA section ("DRAINING ENGINE COOLANT", "Changing Engine Coolant").
2. Loosen water pump pulley bolts.
3. Remove drive belts.
4. Remove front RH wheel, engine side cover and front cover.
5. Remove three lower water pump bolts.

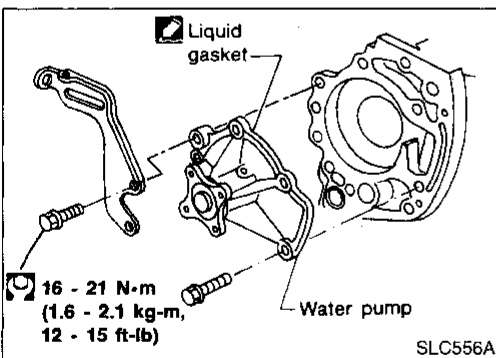

6. Position jack to support engine and remove front engine mount.
7. Remove remaining water pump bolt to remove water pump.

CAUTION:

- When removing water pump assembly, be careful not to get coolant on drive belt.
- Water pump cannot be disassembled and should be replaced as a unit.
- After installing water pump, connect hose and clamp securely, then check for leaks using radiator cap tester.

INSPECTION

- Check body assembly for rust or corrosion.
- Check for rough operation due to excessive end play.

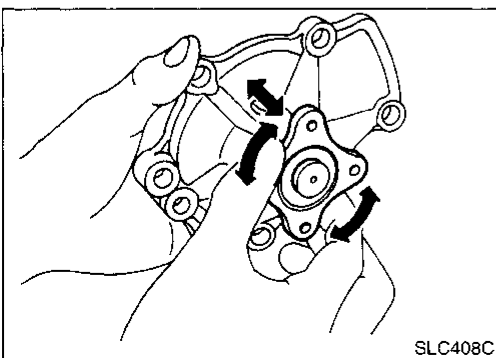

Water Pump (Cont'd)

INSTALLATION

1. Use a scraper to remove liquid gasket from water pump.
 - Also remove traces of liquid gasket from mating surface of cylinder block.

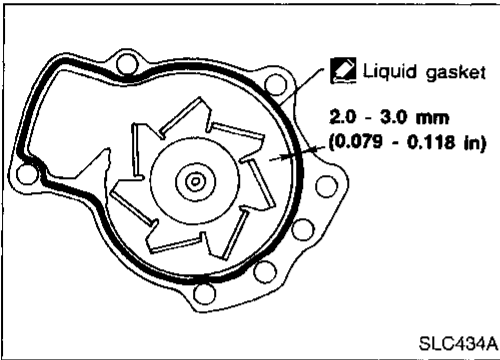
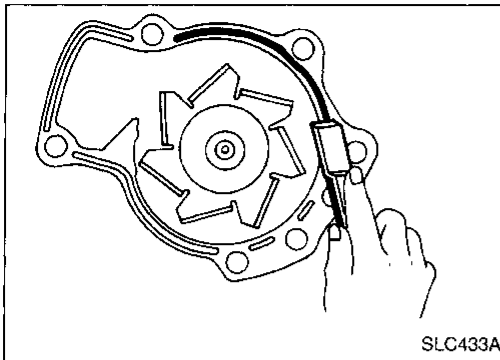

2. Apply a continuous bead of liquid gasket to mating surface of water pump.
 - Use Genuine Liquid Gasket or equivalent.

When filling radiator with coolant, refer to MA section ("REFILLING ENGINE COOLANT", "Changing Engine Coolant").

When installing drive belts, refer to MA section ("Checking Drive Belts", "ENGINE MAINTENANCE").

Thermostat

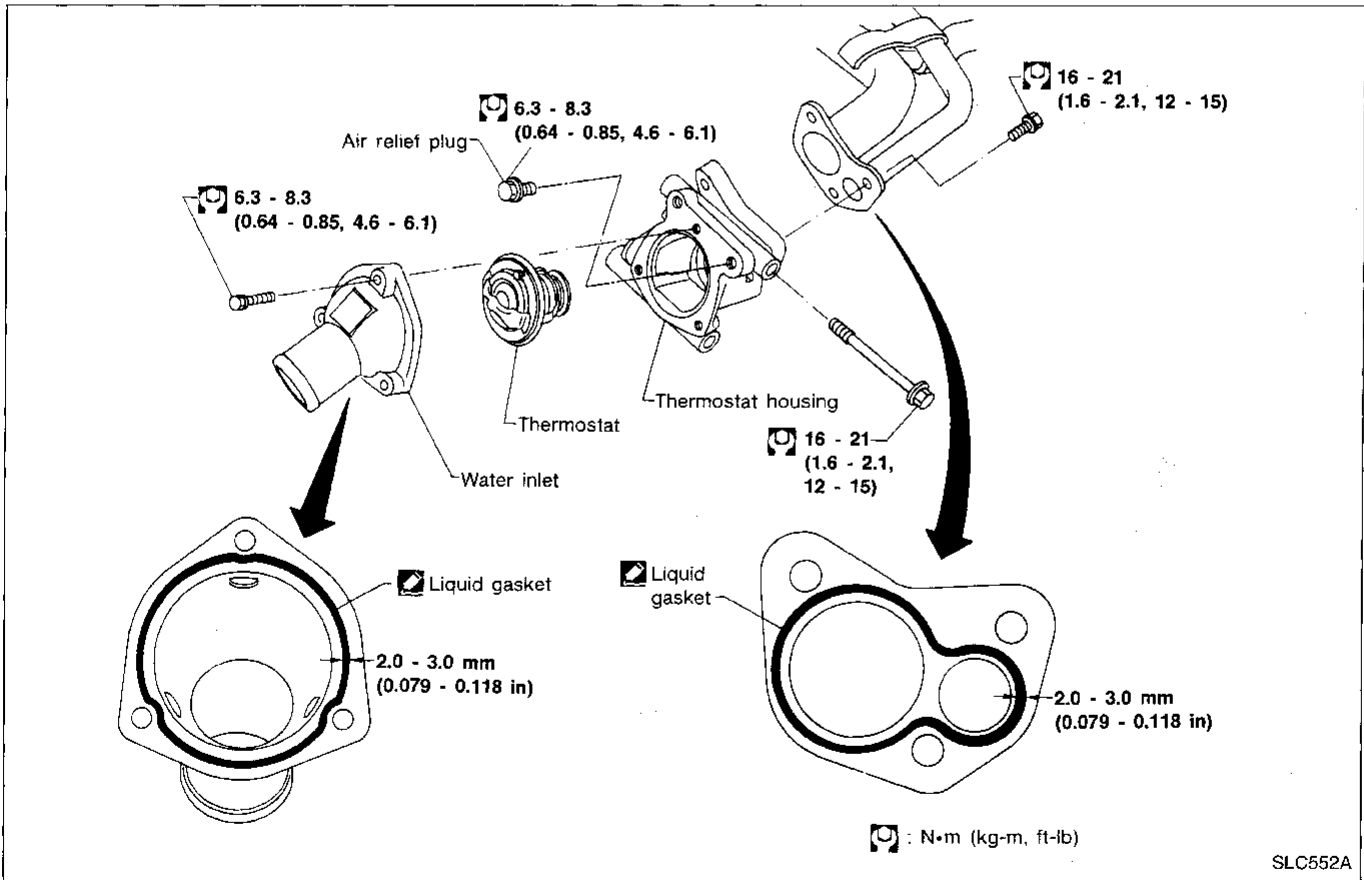

Thermostat (Cont'd)

Be careful not to spill coolant over engine compartment.
Use a rag to absorb coolant.

REMOVAL AND INSTALLATION

1. Drain engine coolant.
2. Remove lower radiator hose.
3. Remove water inlet, then take out thermostat.

GI

MA

EM

LC

EC

FE

CL

MT

AT

FA

RA

BR

ST

RS

BT

HA

EL

DX

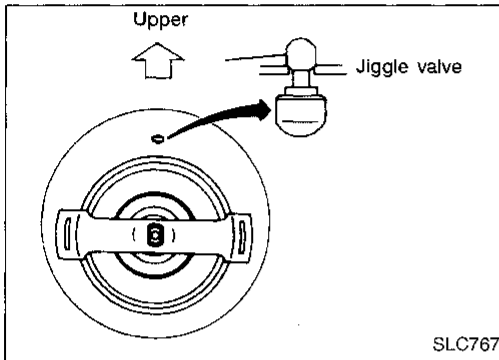

4. Install thermostat with jiggle valve or air bleeder at upper side.

- Apply a continuous bead of liquid gasket to mating surface of water inlet.
- After installation, run engine for a few minutes, and check for leaks.

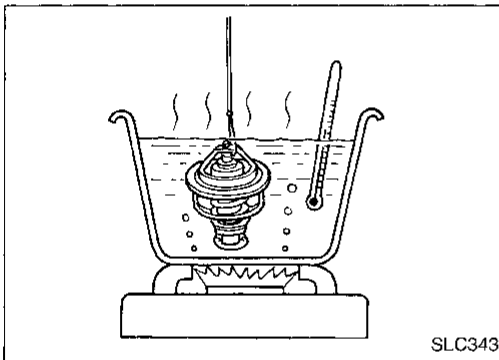

INSPECTION

1. Check for valve seating condition at normal room temperature. It should seat tightly.
2. Check valve opening temperature and valve lift.

Valve opening temperature	°C (°F)	76.5 (170)
Valve lift	mm/°C (in/°F)	More than 8/90 (0.31/194)

3. Then check if valve closes at 5°C (9°F) below valve opening temperature.

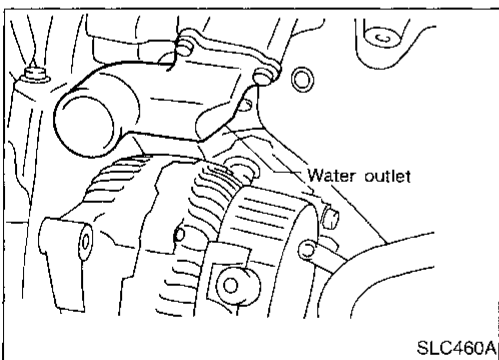

Water Outlet

INSPECTION

Visually inspect for water leaks. If there is leakage, apply liquid gasket.

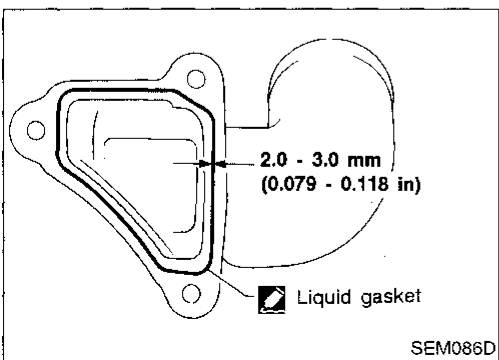

INSTALLATION

1. Use a scraper to remove old liquid gasket from water inlet.
 - Also remove traces of liquid gasket from mating surface of cylinder head.
2. Apply a continuous bead of liquid gasket to mating surface of water outlet.
 - Use Genuine Liquid Gasket or equivalent.

Radiator

SEC. 214

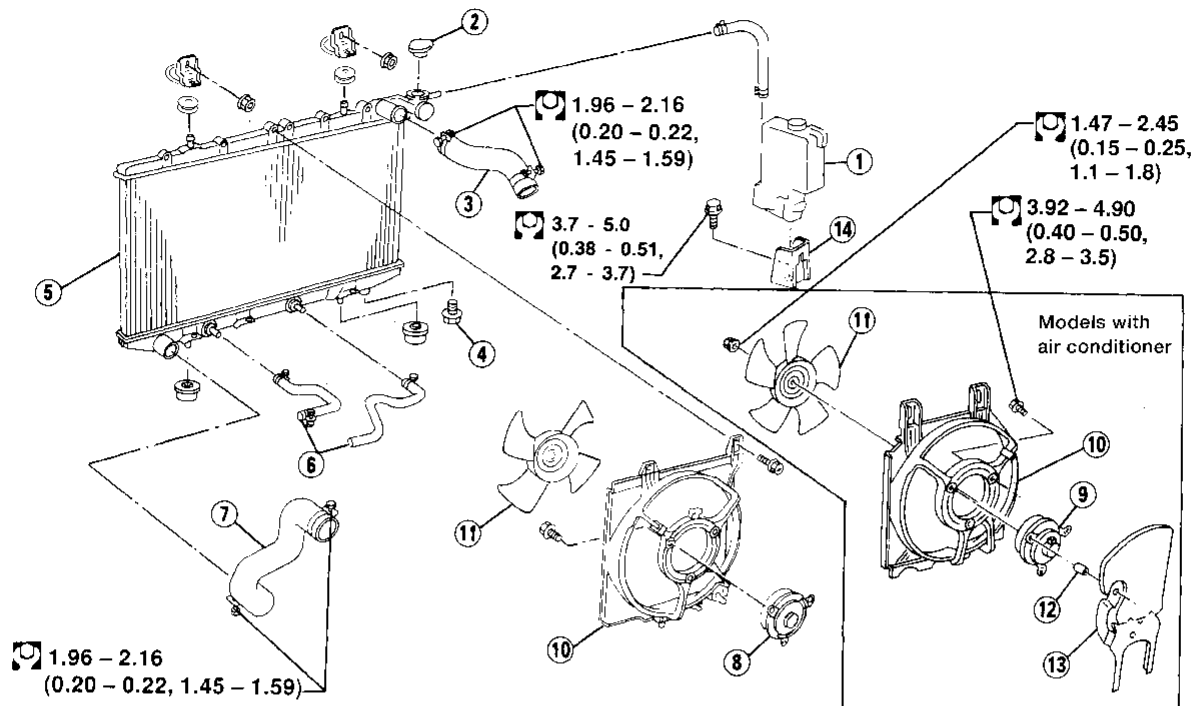

ALC019

- | | | |
|-----------------------|---------------------------------|----------------------------|
| ① Reservoir tank | ⑥ Oil cooler hoses (A/T models) | ⑪ Cooling fan |
| ② Radiator cap | ⑦ Lower radiator hose | ⑫ Shield spacer |
| ③ Upper radiator hose | ⑧ Cooling fan motor-1 | ⑬ Cooling fan motor shield |
| ④ Radiator drain plug | ⑨ Cooling fan motor-2 | ⑭ Reservoir tank bracket |
| ⑤ Radiator | ⑩ Radiator shroud | |

Cooling fan control system

Cooling fans are controlled by the ECM. For details, refer to EC section ("Cooling Fan", "TROUBLE DIAGNOSIS FOR DTC 28").

Refilling engine coolant

For details on refilling engine coolant, refer to MA section ("REFILLING ENGINE COOLANT", "Changing Engine Coolant").

Lubrication Circuit

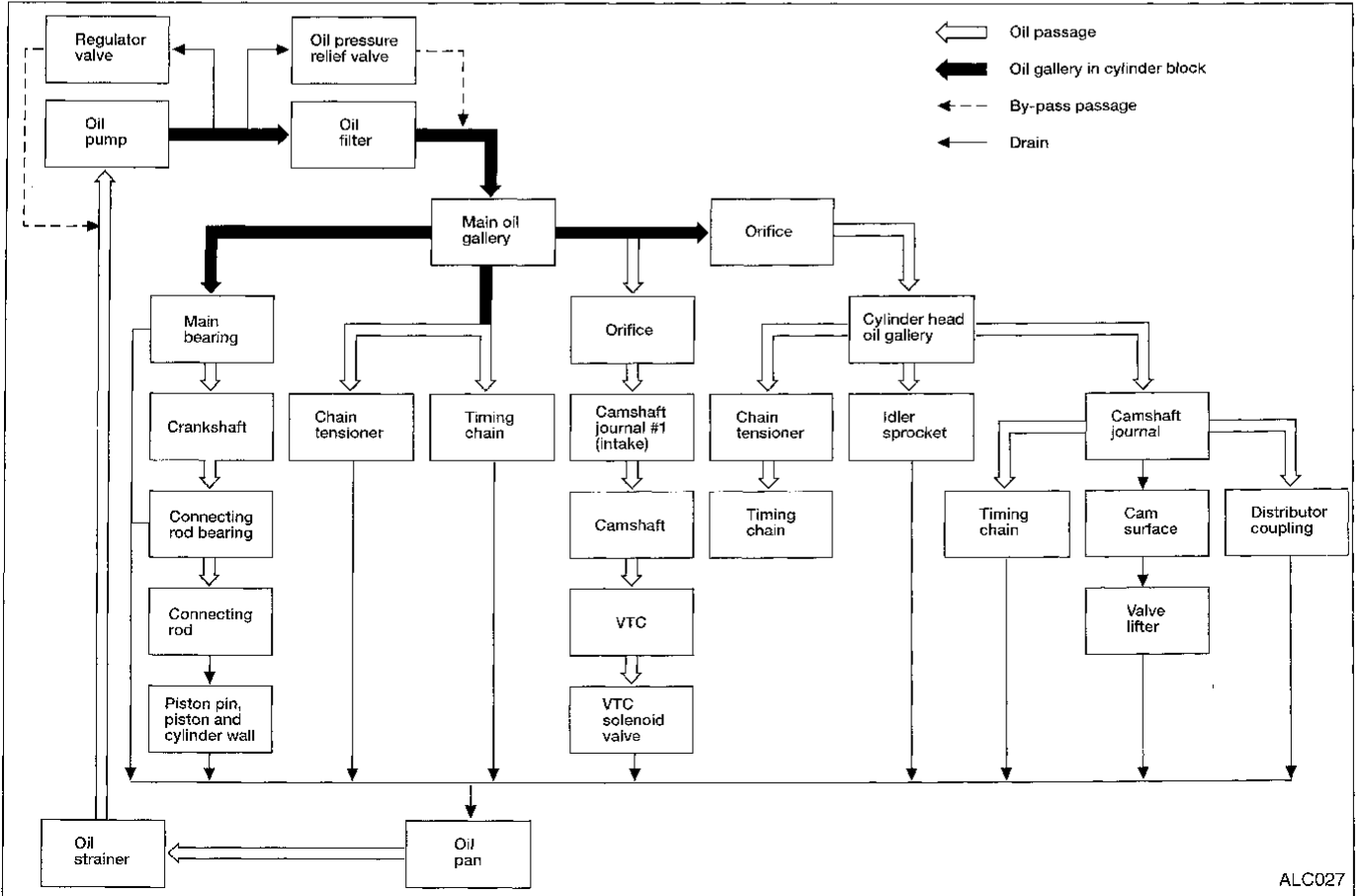
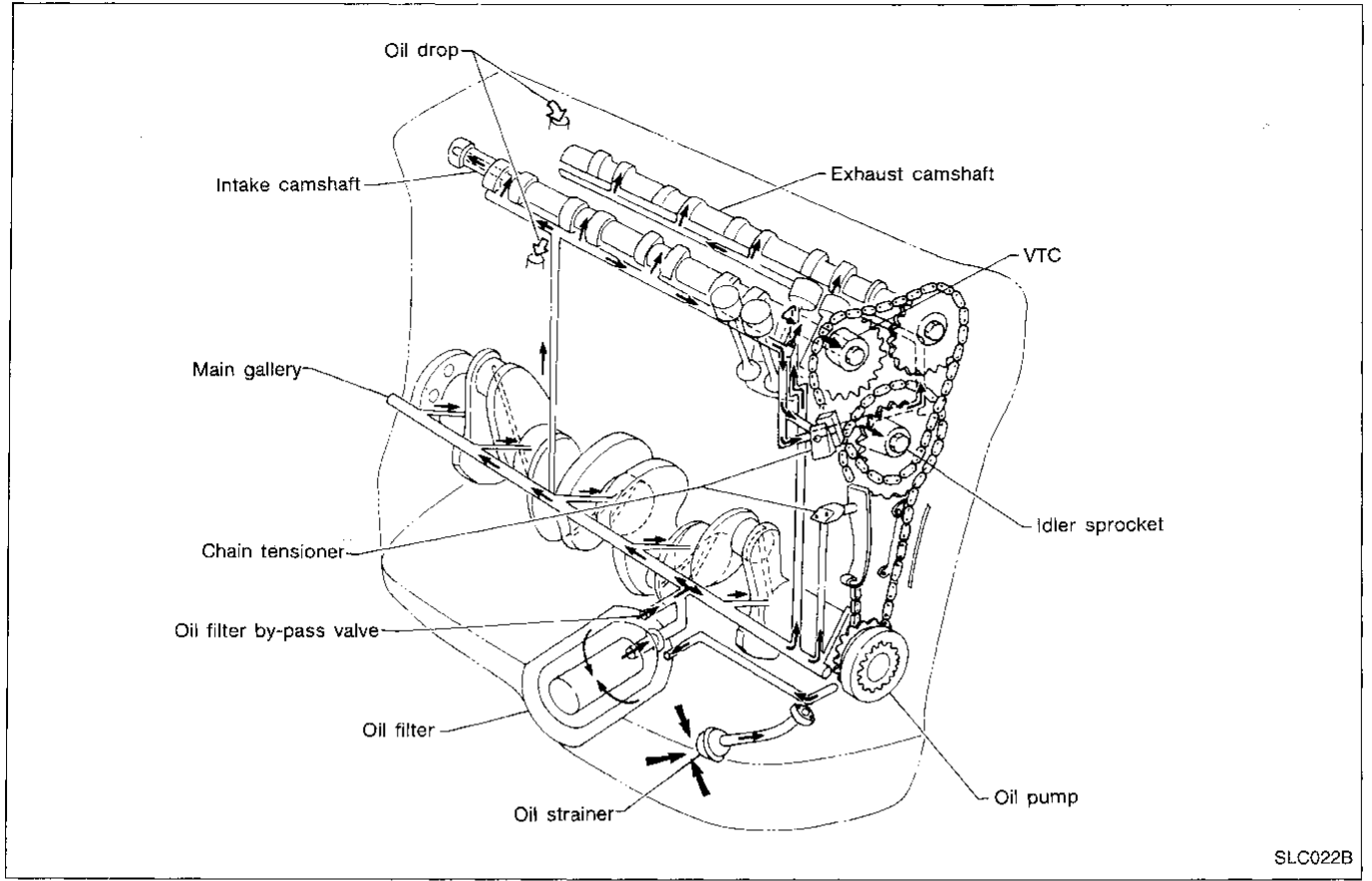

GI
MA
EM
LC
EC
FE
CL
MT
AT
FA
RA
BR
ST
RS
BT
HA
EL
IDX

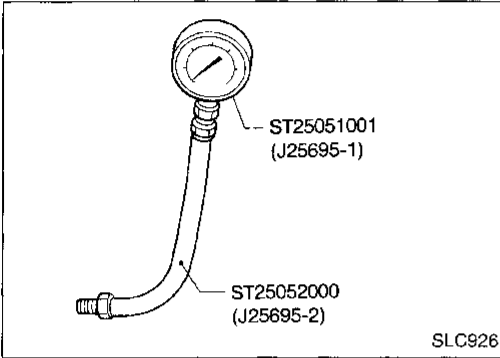
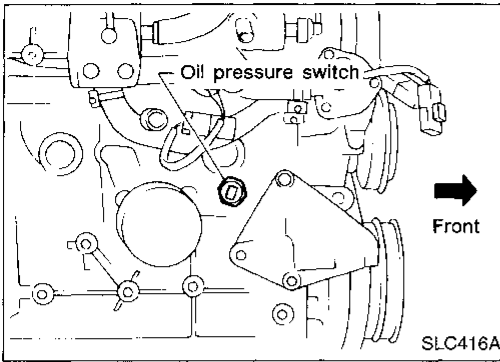

Oil Pressure Check

WARNING:

- Be careful not to burn yourself, as the engine and oil may be hot.
- For M/T models, put gearshift lever in Neutral "N" position. For A/T models, put selector lever in Park "P" position.

1. Check oil level.
2. Remove oil pressure switch.

3. Install pressure gauge.
4. Start engine and warm it up to normal operating temperature.
5. Check oil pressure with engine running under no-load.

Engine speed rpm	Approximate discharge pressure kPa (kg/cm ² , psi)
Idle speed	49 - 186 (0.5 - 1.9, 7 - 27)
3,000	343 - 441 (3.5 - 4.5, 50 - 64)

If difference is extreme, check oil passage and oil pump for oil leaks.

6. Install oil pressure switch with sealant.

Oil Pump

REMOVAL AND INSTALLATION

- Always replace oil seal with a new one. Refer to EM section ("OIL SEAL REPLACEMENT").
 - When installing oil pump, apply engine oil to gears.
 - Make sure that O-ring is fitted properly.
1. Drain engine oil.
 2. Remove drive belts.
 3. Remove cylinder head. Refer to EM section ("TIMING CHAIN").
 4. Remove oil pan. Refer to EM section ("OIL PAN").
 5. Remove oil strainer.
 6. Remove front cover.
 7. Install front cover. Refer to EM section ("TIMING CHAIN").
 8. Reinstall any parts in reverse order of removal.

DISASSEMBLY AND ASSEMBLY

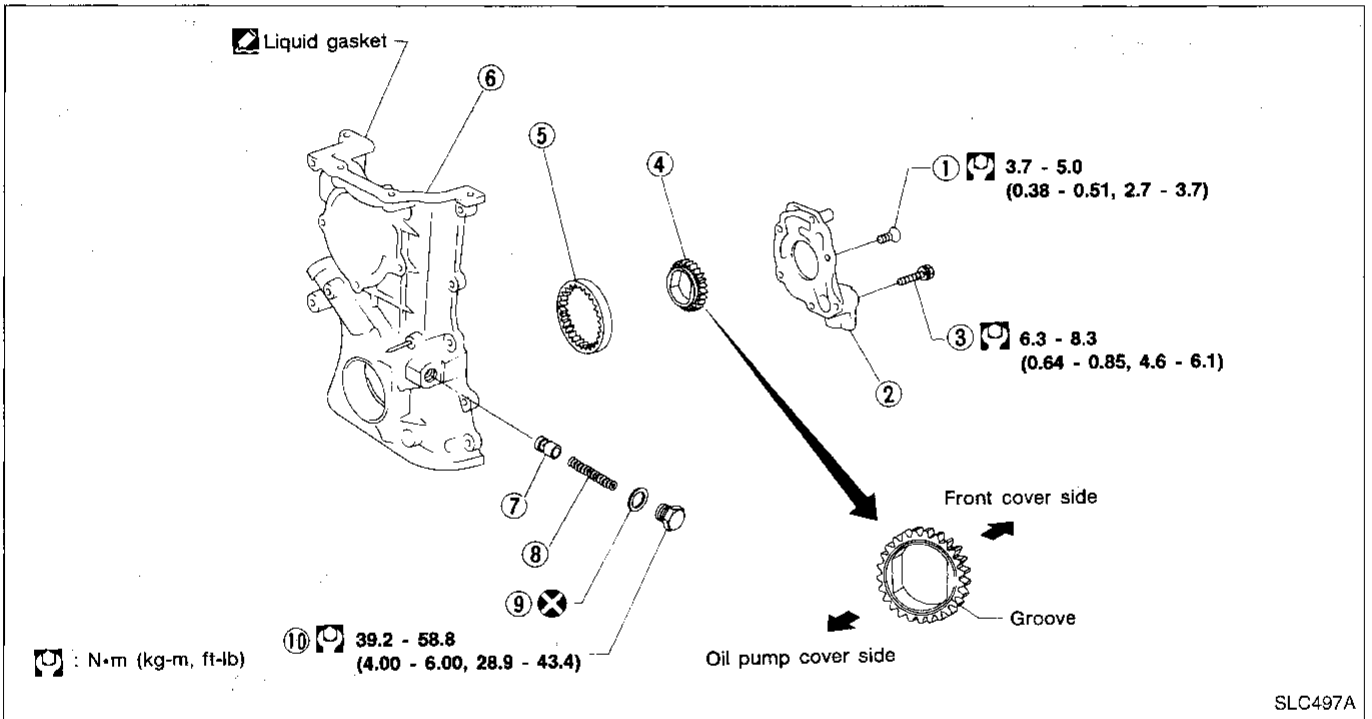

- | | | |
|------------------|-------------------|----------|
| ① Screw | ⑤ Outer gear | ⑧ Spring |
| ② Oil pump cover | ⑥ Front cover | ⑨ Washer |
| ③ Bolt | ⑦ Regulator valve | ⑩ Plug |
| ④ Inner gear | | |

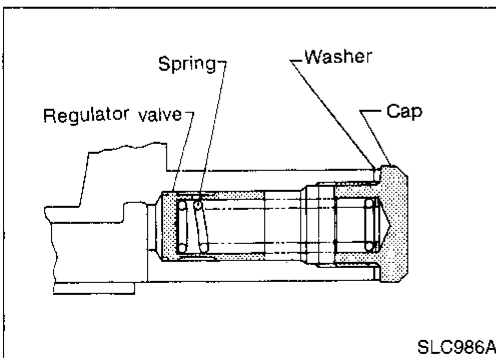

REGULATOR VALVE INSPECTION

1. Visually inspect components for wear and damage.
2. Check oil pressure regulator valve sliding surface and valve spring.
3. Coat regulator valve with engine oil. Check that it falls smoothly into the valve hole by its own weight.

If damaged, replace regulator valve set or oil pump assembly.

Oil Pump (Cont'd)

OIL PRESSURE RELIEF VALVE INSPECTION

Inspect oil pressure relief valve for movement, cracks and breaks by pushing the ball. If replacement is necessary, remove valve by prying it out with suitable tool. Install a new valve in place by tapping it.

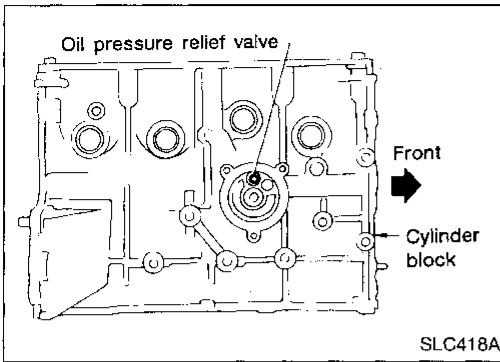

OIL PUMP INSPECTION

Using a feeler gauge, check the following clearances.

Standard clearance:

Unit: mm (in)

Body to outer gear clearance ①	0.110 - 0.200 (0.0043 - 0.0079)
Inner gear to crescent clearance ②	0.217 - 0.327 (0.0085 - 0.0129)
Outer gear to crescent clearance ③	0.21 - 0.32 (0.0083 - 0.0126)
Body to inner gear clearance ④	0.05 - 0.09 (0.0020 - 0.0035)
Body to outer gear clearance ⑤	0.05 - 0.11 (0.0020 - 0.0043)
Inner gear to brazed portion of housing clearance ⑥	0.045 - 0.091 (0.0018 - 0.0036)

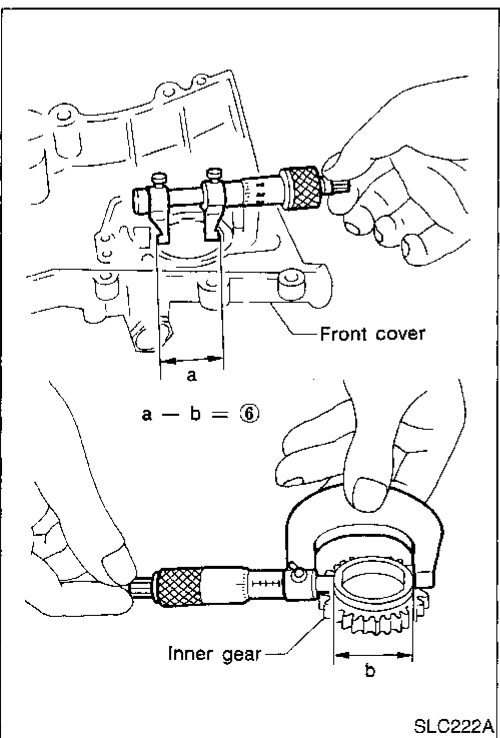
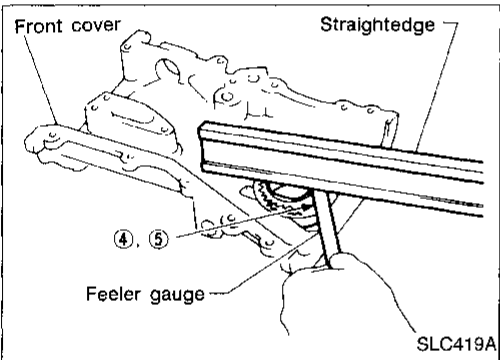
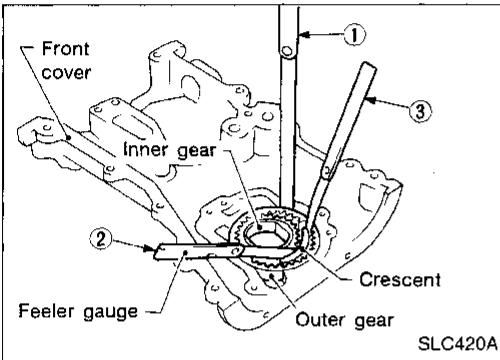

- If the tip clearance (②) exceeds the limit, replace gear set.
- If body to gear clearances (① , ③ , ④ , ⑤ , ⑥) exceed the limit, replace front cover assembly.

Cooling Circuit

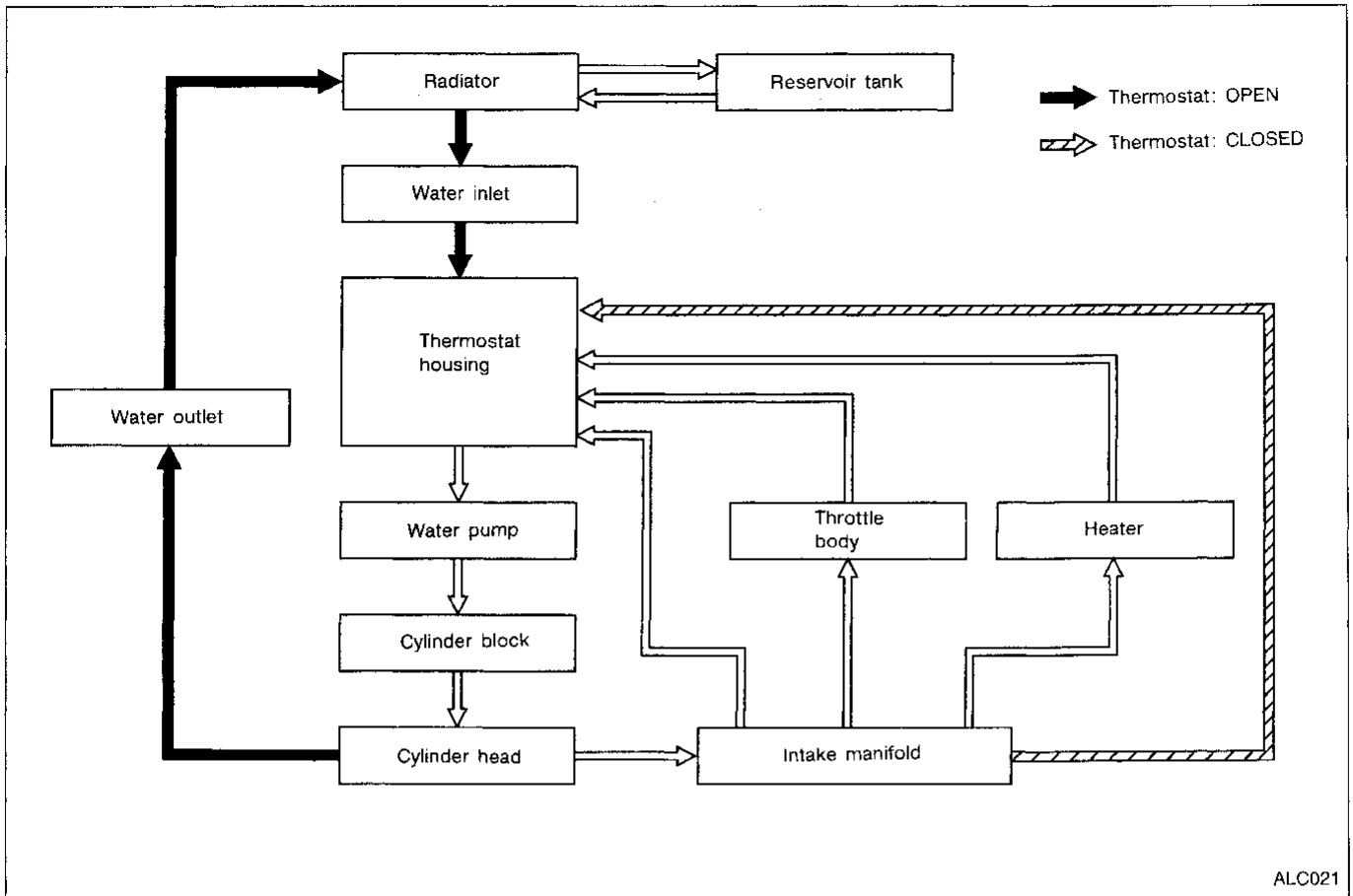

System Check

WARNING:

Never remove the radiator cap when the engine is hot. Serious burns could occur from high pressure fluid escaping from the radiator.

Wrap a thick cloth around the cap. Slowly turn it a quarter turn to allow built-up pressure to escape. Carefully remove the cap by turning it all the way.

CHECKING COOLING SYSTEM HOSES

Check hoses for the following:

- Improper attachment
- Leaks
- Cracks
- Damage
- Chafing
- Deterioration

Water Hose Drawing

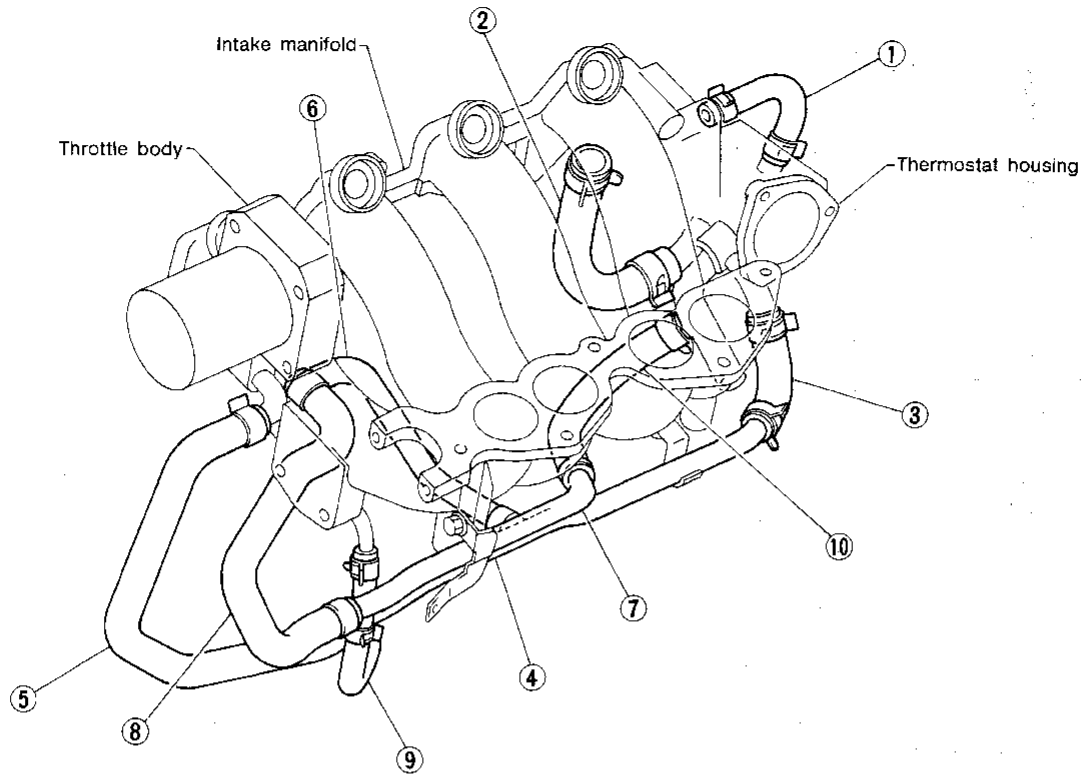

- | | | |
|---|---------------------------------------|--|
| ① Intake manifold to Thermostat housing (upper) | ④ Water pipe lower | ⑧ Throttle body to Water pipe upper |
| ② Intake manifold to Thermostat housing (lower) | ⑤ Water pipe lower to Throttle body | ⑨ Intake manifold to Water pipe upper |
| ③ Water jacket to Water pipe lower | ⑥ Water pipe lower to Intake manifold | ⑩ Water pipe upper to Thermostat housing |
| | ⑦ Water pipe upper | |

SLC021B

Water Hose Drawing (Cont'd)

CHECKING COOLING SYSTEM FOR LEAKS

To check for leakage, apply pressure to the cooling system with a tester.

Testing pressure:
157 kPa (1.6 kg/cm², 23 psi)

CAUTION:
Higher pressure than specified may cause radiator damage.

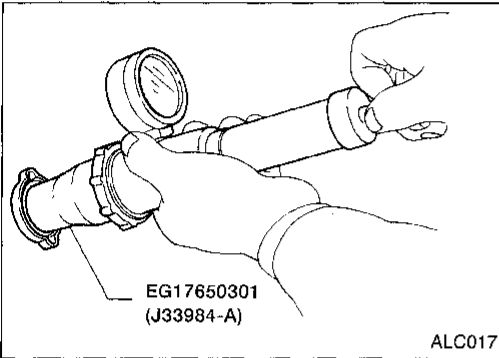
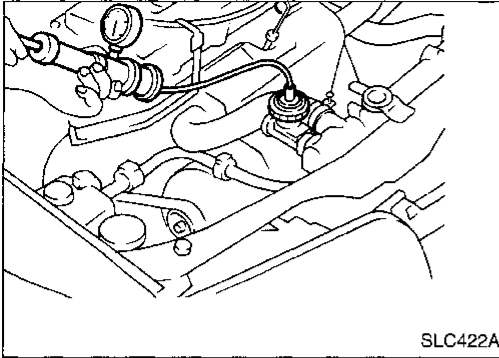

CHECKING RADIATOR CAP

To check radiator cap, apply pressure to cap with a tester.

Radiator cap relief pressure:
Standard
78 - 98 kPa (0.8 - 1.0 kg/cm², 11 - 14 psi)
Limit
59 - 98 kPa (0.6 - 1.0 kg/cm², 9 - 14 psi)

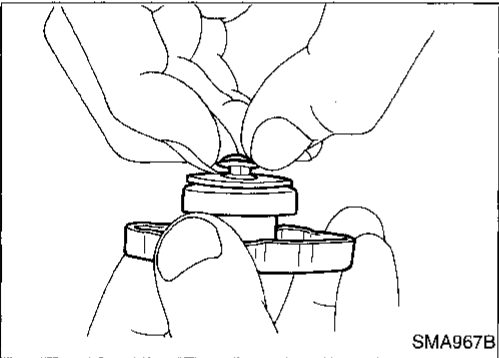

Pull the negative pressure valve to open it.
Check that it closes completely when released.

GI

MA

EM

LC

EC

FE

CL

MT

AT

FA

RA

BR

ST

RS

BT

HA

EL

IDX

Water Pump

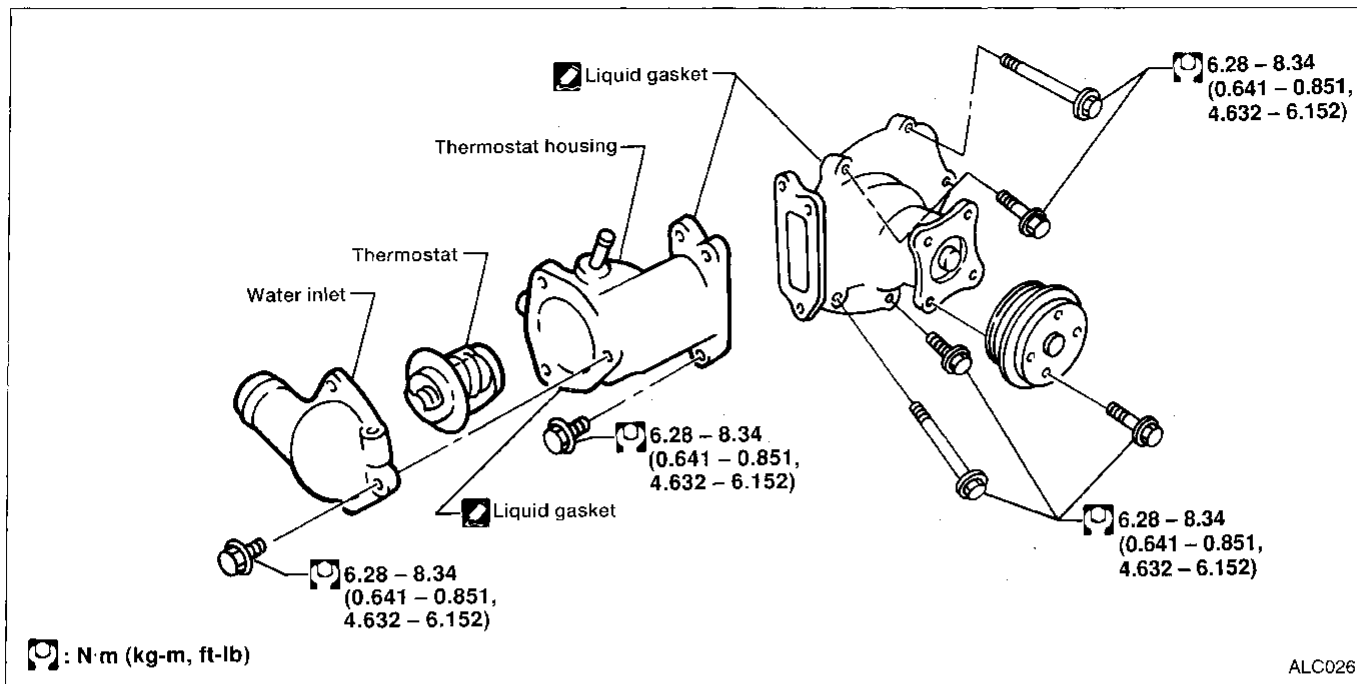
**CAUTION:**

- When removing water pump assembly, be careful not to get coolant on drive belt.
- Water pump cannot be disassembled and should be replaced as a unit.
- After installing water pump, connect hoses and clamps securely, then check for leaks using radiator cap tester.

REMOVAL

1. Drain coolant from radiator and cylinder block. Refer to MA section ("DRAINING ENGINE COOLANT", "Changing Engine Coolant").
2. Remove cylinder head front mounting bracket.
3. Loosen water pump pulley bolts.
4. Remove drive belts for power steering pump.
5. Remove water pump pulley.
6. Remove coolant hoses from water inlet and thermostat housing.
7. Remove water pump bolts.
8. Remove water pump with thermostat housing.

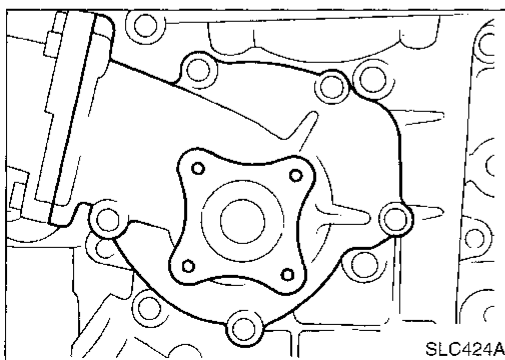

Water Pump (Cont'd)

INSPECTION

- Check body assembly and vane for rust or corrosion.
- Check for rough operation due to excessive end play.

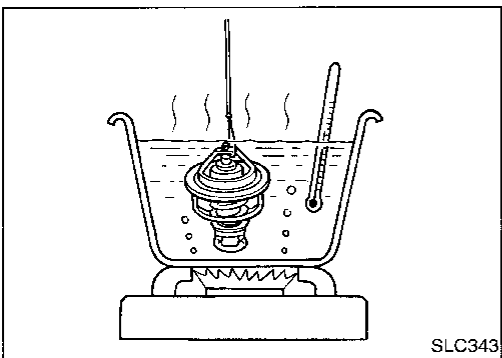
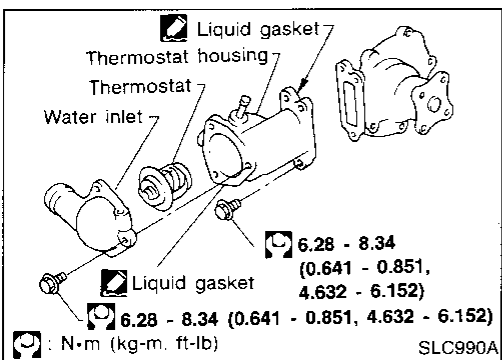
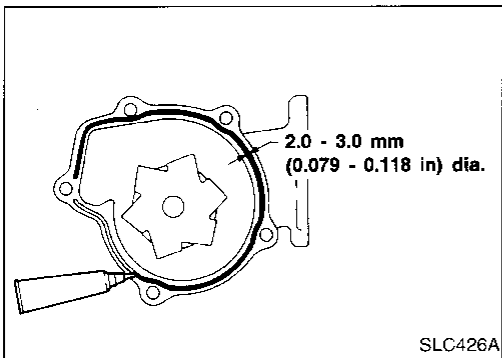
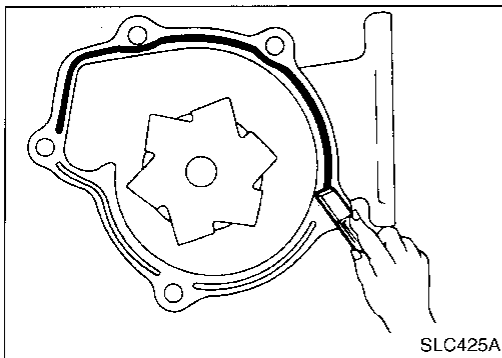
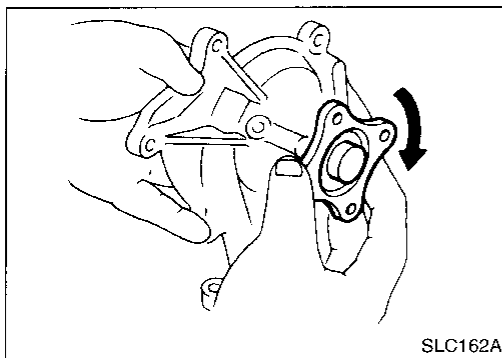

INSTALLATION

1. Use a scraper to remove liquid gasket from water pump and thermostat housing.
- Also remove old liquid gasket from mating surface of cylinder block.

2. Apply a continuous bead of liquid gasket to mating surface of water pump.

- Use Genuine Liquid Gasket or equivalent.

When installing drive belts, refer to MA section ("Checking Drive Belts").

When filling radiator with coolant, refer to MA section ("REFILLING ENGINE COOLANT", "Changing Engine Coolant").

Thermostat

Be careful not to spill coolant over engine compartment. Use a rag to absorb coolant.

INSPECTION

1. Check for valve seating condition at normal room temperature. It should seat tightly.
2. Check valve opening temperature and valve lift.

Valve opening temperature	°C (°F)	76.5 (170)
Valve lift	mm/°C (in/°F)	More than 8/90 (0.31/194)

3. Then check if valve closes at 5°C (9°F) below valve opening temperature.

CI

MA

EM

LC

EC

FE

CL

MT

AT

FA

RA

BR

ST

RS

BT

HA

EL

IDX

Thermostat (Cont'd)**INSTALLATION**

- When installing water inlet apply liquid gasket as shown.

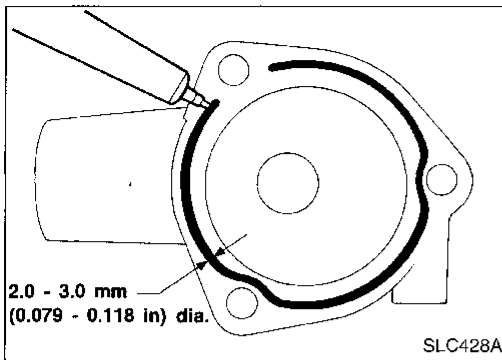

- Install thermostat with jiggle valve or air bleeder at upper side.

After installation, run engine for a few minutes, and check for leaks.

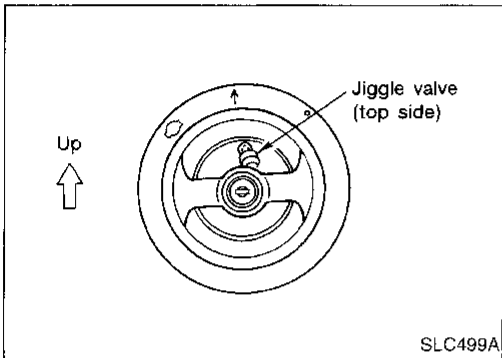
**Water Outlet****INSPECTION**

Visually inspect for water leaks. If there is leakage, apply liquid gasket.

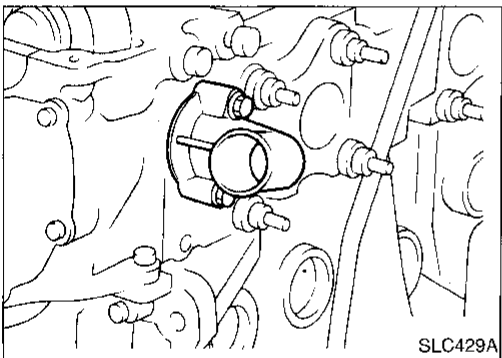
**INSTALLATION**

1. Use a scraper to remove old liquid gasket from water inlet.
- Also remove traces of liquid gasket from mating surface of cylinder head.
2. Apply a continuous bead of liquid gasket to mating surface of water outlet.
- Use a Genuine Liquid Gasket or equivalent.

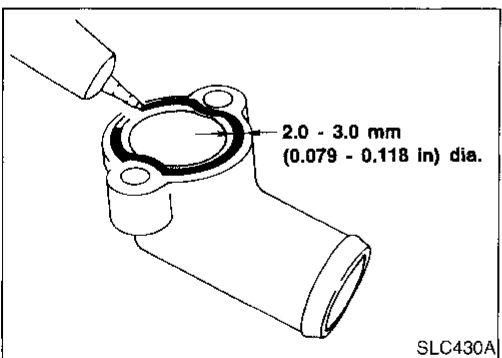

Radiator

SEC. 214

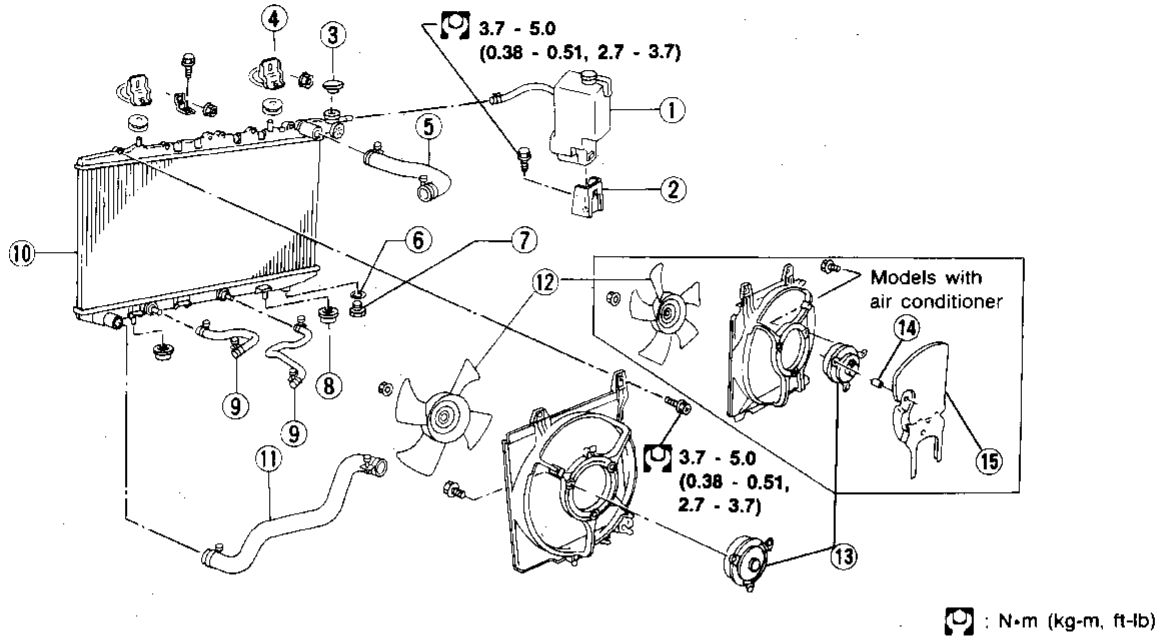

ALC020

- | | | |
|--------------------------|---------------------------------|----------------------------|
| ① Reservoir tank | ⑥ Washer | ⑪ Lower radiator hose |
| ② Reservoir tank bracket | ⑦ Radiator drain plug | ⑫ Cooling fan |
| ③ Radiator cap | ⑧ Mounting rubber | ⑬ Cooling fan motor |
| ④ Mounting bracket | ⑨ Oil cooler hoses (A/T models) | ⑭ Shield spacer |
| ⑤ Upper radiator hose | ⑩ Radiator | ⑮ Cooling fan motor shield |

Cooling fan control system

Cooling fans are controlled by the ECM. For details, refer to EC section ("Cooling Fan", "TROUBLE DIAGNOSIS FOR DTC 28").

Refilling engine coolant

For details on refilling engine coolant, refer to MA section ("REFILLING ENGINE COOLANT", "Changing Engine Coolant").

GI

MA

EM

LC

EC

FE

CL

MT

AT

FA

RA

BR

ST

RS

BT

HA

EL

IDX

Overheating Cause Analysis

		Symptom	Check items	
Cooling system parts malfunction	Poor heat transfer	Water pump malfunction	Worn or loose drive belt	—
		Thermostat stuck closed	—	
		Damaged fins	Dust contamination or paper clogging	
			Mechanical damage	
	Clogged radiator cooling tube	Excess foreign material (rust, dirt, sand, etc.)		
	Reduced air flow	Cooling fan does not operate	—	—
		High resistance to fan rotation		
		Damaged fan blades		
	Damaged radiator shroud	—	—	—
	Improper coolant mixture ratio	—	—	—
	Poor coolant quality	—	—	—
Insufficient coolant	Coolant leaks	Cooling hose	Loose clamp	
			Cracked hose	
		Water pump	Poor sealing	
		Radiator cap	Loose	
			Poor sealing	
		Radiator	O-ring for damage, deterioration or improper fitting	
	Cracked radiator tank			
	Cracked radiator core			
Reservoir tank	Cracked reservoir tank			
Overflowing reservoir tank	Exhaust gas leaks into cooling system	Cylinder head deterioration		
		Cylinder head gasket deterioration		
Except cooling system parts malfunction	Overload on engine	Abusive driving	High engine rpm under no load	
			Driving in low gear for extended time	
			Driving at extremely high speed	
		Powertrain system malfunction	—	
		Installed improper size wheels and tires		
	Dragging brakes			
	Improper ignition timing			
	Blocked or restricted air flow	Blocked bumper	—	—
Blocked radiator grille		Installed car brassiere		
		Mud contamination or paper clogging		
Blocked radiator		—		
Blocked condenser		—		
Installed large fog lamp	—			

Engine Lubrication System (SR)

Oil pressure check

Engine speed rpm	Approximate discharge pressure kPa (kg/cm ² , psi)
Idle speed	More than 78 (0.8, 11)
3,200	314 - 392 (3.2 - 4.0, 46 - 57)

Regulator valve inspection

Unit: mm (in)

Regulator valve to oil pump cover clearance	0.040 - 0.097 (0.0016 - 0.0038)
---	---------------------------------

Oil pump inspection

Unit: mm (in)

Body to outer gear clearance	0.114 - 0.200 (0.0045 - 0.0079)
Inner gear to outer gear tip clearance	Below 0.18 (0.0071)
Body to inner gear clearance	0.05 - 0.09 (0.0020 - 0.0035)
Body to outer gear clearance	0.05 - 0.11 (0.0020 - 0.0043)
Inner gear to brazed portion of housing clearance	0.045 - 0.091 (0.0018 - 0.0036)

Engine Cooling System (SR)

Thermostat

Valve opening temperature	°C (°F)	76.5 (170)
Max. valve lift	mm/°C (in/°F)	8/90 (0.31/194)

Radiator

Unit: kPa (kg/cm², psi)

Cap relief pressure	Standard	78 - 98 (0.8 - 1.0, 11 - 14)
	Limit	59 - 98 (0.6 - 1.0, 9 - 14)
Leakage test pressure		157 (1.6, 23)

Engine Lubrication System (GA)

Oil pressure check

Engine speed rpm	Approximate discharge pressure kPa (kg/cm ² , psi)
Idle speed	49 - 186 (0.5 - 1.9, 7 - 27)
3,000	343 - 441 (3.5 - 4.5, 50 - 64)

Oil pump inspection

Unit: mm (in)

Body to outer gear clearance	0.110 - 0.200 (0.0043 - 0.0079)
Inner gear to crescent clearance	0.217 - 0.327 (0.0085 - 0.0129)
Outer gear to crescent clearance	0.21 - 0.32 (0.0083 - 0.0126)
Body to inner gear clearance	0.05 - 0.09 (0.0020 - 0.0035)
Body to outer gear clearance	0.05 - 0.11 (0.0020 - 0.0043)
Inner gear to brazed portion of housing clearance	0.045 - 0.091 (0.0018 - 0.0036)

Engine Cooling System (GA)

Thermostat

Standard

Valve opening temperature	°C (°F)	76.5 (170)
Maximum valve lift	mm/°C (in/°F)	8/90 (0.31/194)

Radiator

Unit: kPa (kg/cm², psi)

Cap relief pressure	Standard	78 - 98 (0.8 - 1.0, 11 - 14)
	Limit	59 - 98 (0.6 - 1.0, 9 - 14)
Leakage test pressure		157 (1.6, 23)