

STEERING SYSTEM

SECTION **ST**

GI

MA

EM

LC

EC

FE

CL

MT

AT

FA

RA

BR

ST

RS

BT

HA

EL

IDX

CONTENTS

PRECAUTIONS AND PREPARATION	2	Inspection.....	13
Supplemental Restraint System (SRS) "Air Bag"	2	Boot	13
Steering System	2	Rack.....	13
Special Service Tools.....	2	Pinion Assembly	13
Commercial Service Tools	4	Tie-Rod Outer And Inner Sockets	14
ON-VEHICLE SERVICE	5	Assembly and Adjustment	14
Checking and Adjusting Drive Belts (For power steering)	5	Steering Gear	14
Checking Fluid Level	5	Tie-Rod And Boot	15
Checking Fluid Leakage	5	POWER STEERING GEAR AND LINKAGE (Model PR24T)	17
Bleeding Hydraulic System.....	6	Removal and Installation	17
Checking Steering Wheel Turning Force (For power steering)	6	Disassembly.....	20
Checking Hydraulic System.....	7	Inspection.....	20
STEERING WHEEL AND STEERING COLUMN	8	Boot	20
Removal	8	Tie-Rod Outer And Inner Sockets	20
Steering Wheel.....	8	Assembly.....	20
Steering Column.....	9	POWER STEERING PUMP	23
Installation	9	Pre-disassembly Inspection	23
Steering Column.....	9	Disassembly.....	24
Disassembly and Assembly	10	Inspection.....	24
Tilt mechanism	11	Assembly	25
Inspection.....	11	SERVICE DATA AND SPECIFICATIONS (SDS)	26
MANUAL STEERING GEAR AND LINKAGE (Model R24N)	12	General Specifications	26
Removal and Installation	12	Inspection and Adjustment.....	26
Disassembly.....	13	General	26
		Steering Column.....	26
		Steering Gear And Linkage	26
		Power Steering	27

PRECAUTIONS AND PREPARATION

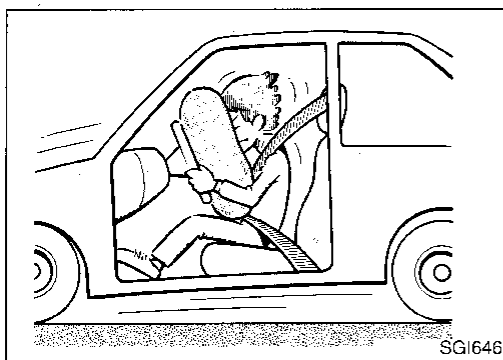

Precautions

SUPPLEMENTAL RESTRAINT SYSTEM (SRS) "AIR BAG"

The Supplemental Restraint System "Air Bag", used along with a seat belt, helps to reduce the risk or severity of injury to the driver and front passenger in a frontal collision. The Supplemental Restraint System consists of air bag modules (located in the center of the steering wheel and on the instrument panel on the passenger side), a diagnosis sensor unit, warning lamp, wiring harness and spiral cable. Information necessary to service the system safely is included in the **RS section** of this Service Manual.

WARNING:

- To avoid rendering the SRS inoperative, which could increase the risk of personal injury or death in the event of a collision, which would result in air bag inflation, all maintenance must be performed by an authorized NISSAN dealer.
- Improper maintenance, including incorrect removal and installation of the SRS, can lead to personal injury caused by unintentional activation of the system.
- All SRS electrical wiring harnesses and connectors are covered with yellow outer insulation. Do not use electrical test equipment on any circuit related to the SRS.

STEERING SYSTEM

- Before disassembly, thoroughly clean the outside of the unit.
 - Disassembly should be done in a clean work area. It is important to prevent the internal parts from becoming contaminated by dirt or other foreign matter.
 - Place disassembled parts in order, on a parts rack, for easier and proper assembly.
 - Use nylon cloths or paper towels to clean the parts; common shop rags can leave lint that might interfere with their operation.
 - Before inspection or reassembly, carefully clean all parts with a general purpose, non-flammable solvent.
 - Before assembly, apply a coat of recommended ATF* to hydraulic parts. Petroleum jelly may be applied to O-rings and seals. Do not use any grease.
 - Replace all gaskets, seals and O-rings. Avoid damaging O-rings, seals and gaskets during installation. Perform functional tests whenever designated.
- *: Automatic Transmission Fluid type DEXRON™ II or equivalent.

Special Service Tools

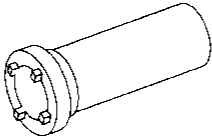
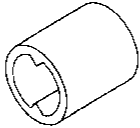
Tool number (Kent-Moore No.) Tool name	Description	Unit application		
		Manual steering	Power steering	
KV48102000 (J28822) End cover socket wrench	 NT168	Removing and installing rear cover and end cover	X	X
KV48100700 (J26364) Torque adapter	 NT169	Measuring pinion rotating torque	—	X

PRECAUTIONS AND PREPARATION

Special Service Tools (Cont'd)

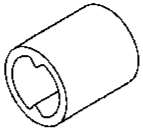
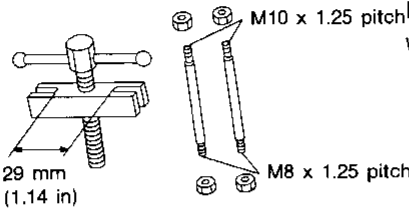
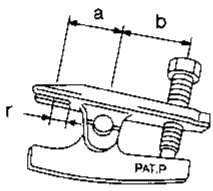
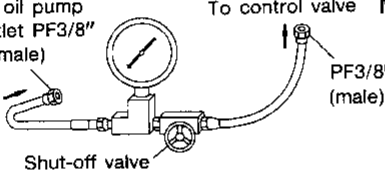
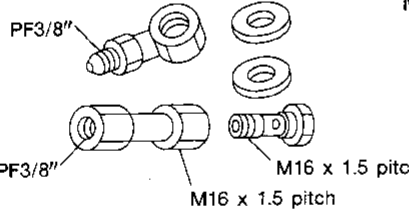
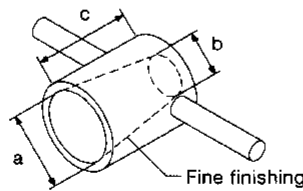
Tool number (Kent-Moore No.) Tool name	Description	Unit application				
		Manual steering	Power steering			
KV48101100 (J26364) Torque adapter	 NT169	Measuring pinion rotating torque		X	—	GI MA EM
ST27180001 (J25726-A) Steering wheel puller	 NT544	Removing and installing steering wheel		X	X	LC EC
HT72520000 (J25730-A) Ball joint remover	 NT546	Removing ball joint		X	X	FE CL MT
ST27091000 (J26357 and J26357-10) Pressure gauge	 NT547	Measuring oil pressure		—	X	AT FA
KV48102500 (J33914) Pressure gauge adapter	 NT542	Measuring oil pressure		—	X	RA BR
KV48104400 (—) Rack seal ring reformer	 NT550	Reforming teflon ring		—	X	ST RS BT HA

GI
MA
EM
LC
EC
FE
CL
MT
AT
FA
RA
BR
ST
RS
BT
HA
EL
EDX

PRECAUTIONS AND PREPARATION

Special Service Tools (Cont'd)

Tool number (Kent-Moore No.) Tool name	Description	Unit application	
		Manual steering	Power steering
ST3127S000 ① GG91030000 (See J25765-A) Torque wrench ② HT62940000 (—) Socket adapter ③ HT62900000 (—) Socket adapter	<p style="text-align: center;">Measuring turning torque</p> <p>1 1/4"</p> <p>2 1/4" to 3/8"</p> <p>3 3/8" to 1/2"</p> <p>Torque wrench with range of 2.9 N·m (30 kg-cm, 26 in-lb)</p>	X	X
NT541			

Commercial Service Tools

Tool name	Description	Unit application	
		Manual steering	Power steering
Rear oil seal drift	<p style="text-align: center;">Installing rear oil seal a : 28 mm (1.10) dia.</p>	—	X
NT063			
Pinion oil seal drift	<p style="text-align: center;">Installing pinion oil seal a : 35 mm (1.38 in) dia.</p>	—	X
NT063			
Power steering pump attachment	<p style="text-align: center;">Disassembling and assembling power steering pump</p> <p>R21 (0.83)</p> <p>11 (0.43) dia.</p> <p>42 (1.65)</p> <p>95 (3.74)</p> <p>62 (2.44)</p> <p>15 (0.59)</p> <p>12 (0.47)</p> <p>40 (1.57)</p> <p>12 (0.47)</p> <p>90 (3.54)</p> <p>Welding</p> <p>Unit: mm (in)</p>	—	— (For power steering pump)
NT179			

Checking and Adjusting Drive Belts (For power steering)

Refer to MA section ("Checking Drive Belts", "ENGINE MAINTENANCE").

GI

MA

EM

LC

EC

FE

CL

MT

AT

FA

RA

BR

ST

RS

BT

HA

EL

IDX

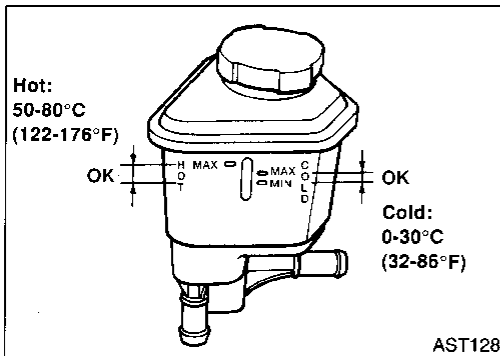

Checking Fluid Level

Check fluid level referring to the scale on reservoir tank.

Use "HOT" range for fluid temperatures of 50 to 80°C (122 to 176°F).

Use "COLD" range for fluid temperatures of 0 to 30°C (32 to 86°F).

CAUTION:

- Do not overfill.
- Recommended fluid is Automatic Transmission Fluid type DEXRON™ II or equivalent.

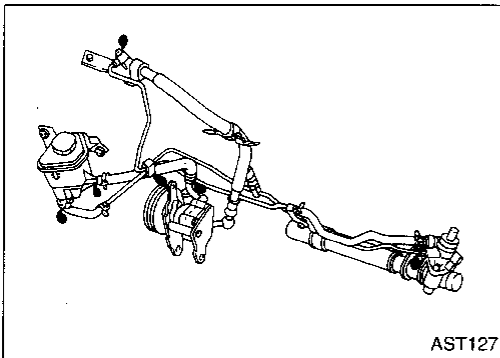

Checking Fluid Leakage

Check the lines for improper attachment, leaks, cracks, damage, chafing or deterioration.

1. Run engine between idle speed and 1,000 rpm.

Make sure fluid temperature in reservoir tank rises to 60 to 80°C (140 to 176°F).

2. Turn steering wheel right-to-left several times.
3. Hold steering wheel at each "lock" position for five seconds and carefully check for fluid leakage.

CAUTION:

Do not hold the steering wheel in a locked position for more than 15 seconds.

4. If fluid leakage at connectors is noticed, loosen flare nut and then retighten.

Do not overtighten connector as this can damage O-ring, washer and connector.

Bleeding Hydraulic System

1. Raise front end of vehicle until wheels are clear of the ground.
 2. Add fluid into oil tank to specified level. Then quickly turn steering wheel fully to right and left and lightly touch steering stoppers.
Repeat steering wheel operation until fluid level no longer decreases.
 3. Start engine.
Repeat step 2 above.
- Incomplete air bleeding will cause the following to occur. When this happens, bleed air again.
 - a. Air bubbles in reservoir tank
 - b. Clicking noise in power steering pump
 - c. Excessive buzzing in power steering pump
- Fluid noise may occur in the valve or power steering pump. This is common when the vehicle is stationary or while turning the steering wheel slowly. This does not affect the performance or durability of the system.

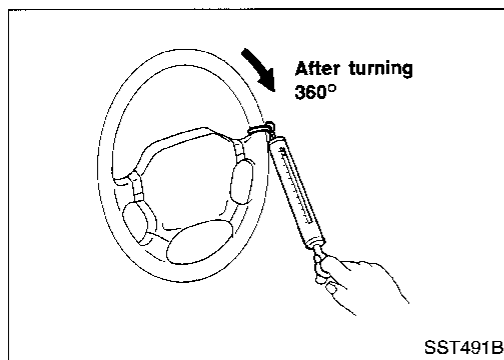

Checking Steering Wheel Turning Force (For power steering)

1. Park vehicle on a level, dry surface and set parking brake.
2. Start engine.
3. Bring power steering fluid up to adequate operating temperature. [Make sure temperature of fluid is approximately 60 to 80°C (140 to 176°F).]

Tires need to be inflated to normal pressure.

4. Check steering wheel turning force when steering wheel has been turned 360° from the neutral position.

Steering wheel turning force:

39 N (4 kg, 9 lb) or less

5. If steering wheel turning force is out of specification, check rack sliding force.
 - a. Disconnect steering column lower joint and knuckle arms from the gear.
 - b. Start and run engine at idle to make sure steering fluid has reached normal operating temperature.
 - c. Pull tie-rod slowly to move it from neutral position to ± 11.5 mm (± 0.453 in) at speed of 3.5 mm (0.138 in)/s. Check that rack sliding force is within specification.

Average rack sliding force:

107 - 245 N (11 - 25 kg, 24 - 55 lb)

Maximum rack sliding force:

294 N (30 kg, 66 lb)

6. If rack sliding force is not within specification, replace steering gear assembly.
7. If rack sliding force is OK, inspect steering column. Refer to ST-11.

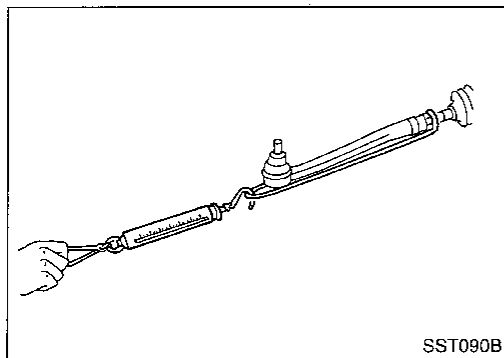

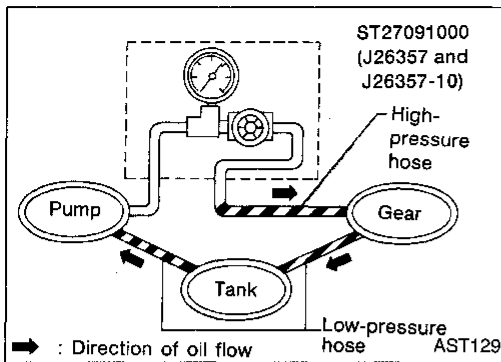

Checking Hydraulic System

Before starting, check belt tension, driving pulley and tire pressure.

1. Set Tool. Open shut-off valve. Then bleed air. Refer to "Bleeding Hydraulic System", ST-6.
2. Run engine.

Make sure fluid temperature in reservoir tank rises to 60 to 80°C (140 to 176°F).

WARNING:

Warm up engine with shut-off valve fully opened. If engine is started with shut-off valve closed, fluid pressure in power steering pump increases to maximum. This will raise fluid temperature abnormally.

3. Check pressure with steering wheel fully turned to left and right positions with engine idling at 1,000 rpm.

CAUTION:

Do not hold the steering wheel in a locked position for more than 15 seconds.

Power steering pump maximum pressure:

7,159 - 7,748 kPa

(73 - 79 kg/cm², 1,038 - 1,123 psi)

4. If power steering pressure is below the standard pressure, slowly close shut-off valve and check pressure.

CAUTION:

Do not close shut-off valve for more than 15 seconds.

- When pressure reaches standard pressure, gear is damaged.
 - When pressure remains below standard pressure, pump is damaged.
5. If power steering pressure is higher than standard pressure, check power steering pump flow control valve.
 6. After checking hydraulic system, remove Tool and add fluid as necessary. Then completely bleed air out of system.

GI

MA

EM

LC

EC

FE

CL

MT

AT

FA

RA

BR

ST

RS

BT

HA

EL

IDX

STEERING WHEEL AND STEERING COLUMN

Removal and Installation

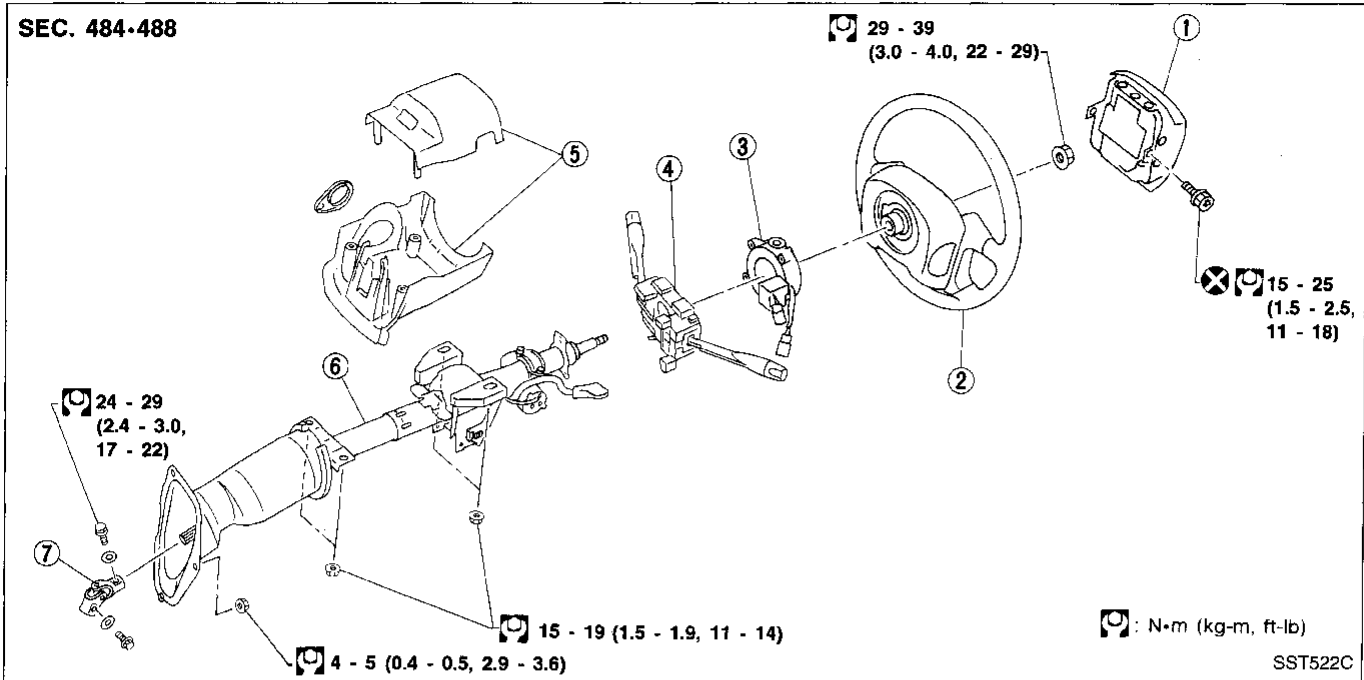

- | | | |
|------------------|----------------------|----------------------------|
| ① Air bag module | ④ Combination switch | ⑥ Steering column assembly |
| ② Steering wheel | ⑤ Column cover | ⑦ Lower joint |
| ③ Spiral cable | | |

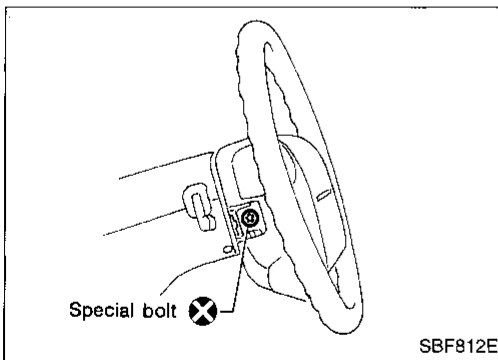

Removal

STEERING WHEEL

- Remove air bag module and spiral cable. Refer to RS section ("Removal — Air Bag Module and Spiral Cable", "SUPPLEMENTAL RESTRAINT SYSTEM").

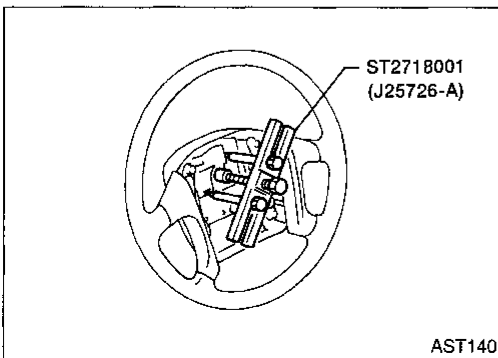

- Remove steering wheel with Tool.

STEERING WHEEL AND STEERING COLUMN

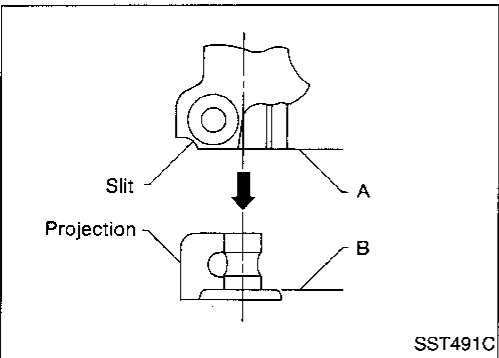
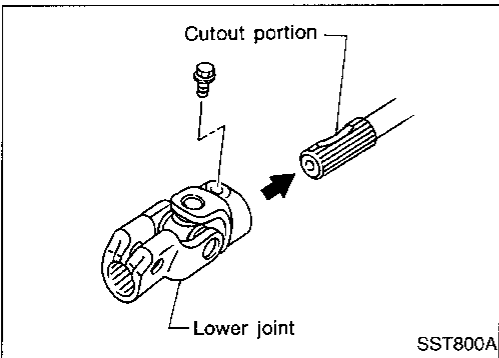
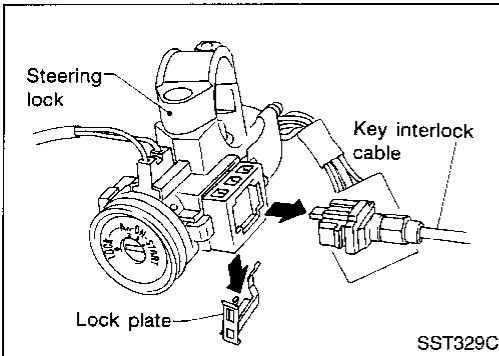
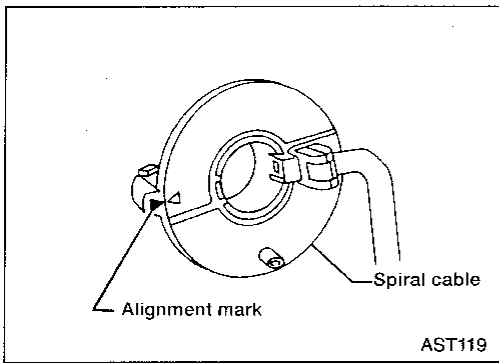

Removal (Cont'd)

STEERING COLUMN

- Align spiral cable correctly when installing steering wheel.

CAUTION:

- The rotation of the spiral cable (SRS "Air bag" component part) is limited. If the steering gear must be removed, set the front wheels in the straight-ahead direction. Do not rotate the steering column while the steering gear is removed.
- Remove the steering wheel before removing the steering lower joint to avoid damaging the SRS spiral cable.
- Remove key interlock cable (A/T models).

Installation

STEERING COLUMN

- When installing steering column, fingertighten all lower bracket and clamp retaining bolts; then tighten them securely. Do not apply undue stress to steering column.
- When attaching coupling joint, be sure tightening bolt faces cutout portion.

- Align slit of lower joint with projection on dust cover. Insert joint until surface A contacts surface B.

CAUTION:

After installation, turn steering wheel to make sure it moves smoothly. Ensure the number of turns from the straight forward position to left and right locks are the same. Be sure that the steering wheel is in a neutral position when driving straight ahead.

GI

MA

EM

LC

EC

FE

CL

MT

AT

FA

RA

BR

ST

RS

BT

HA

EL

IDX

STEERING WHEEL AND STEERING COLUMN

Disassembly and Assembly

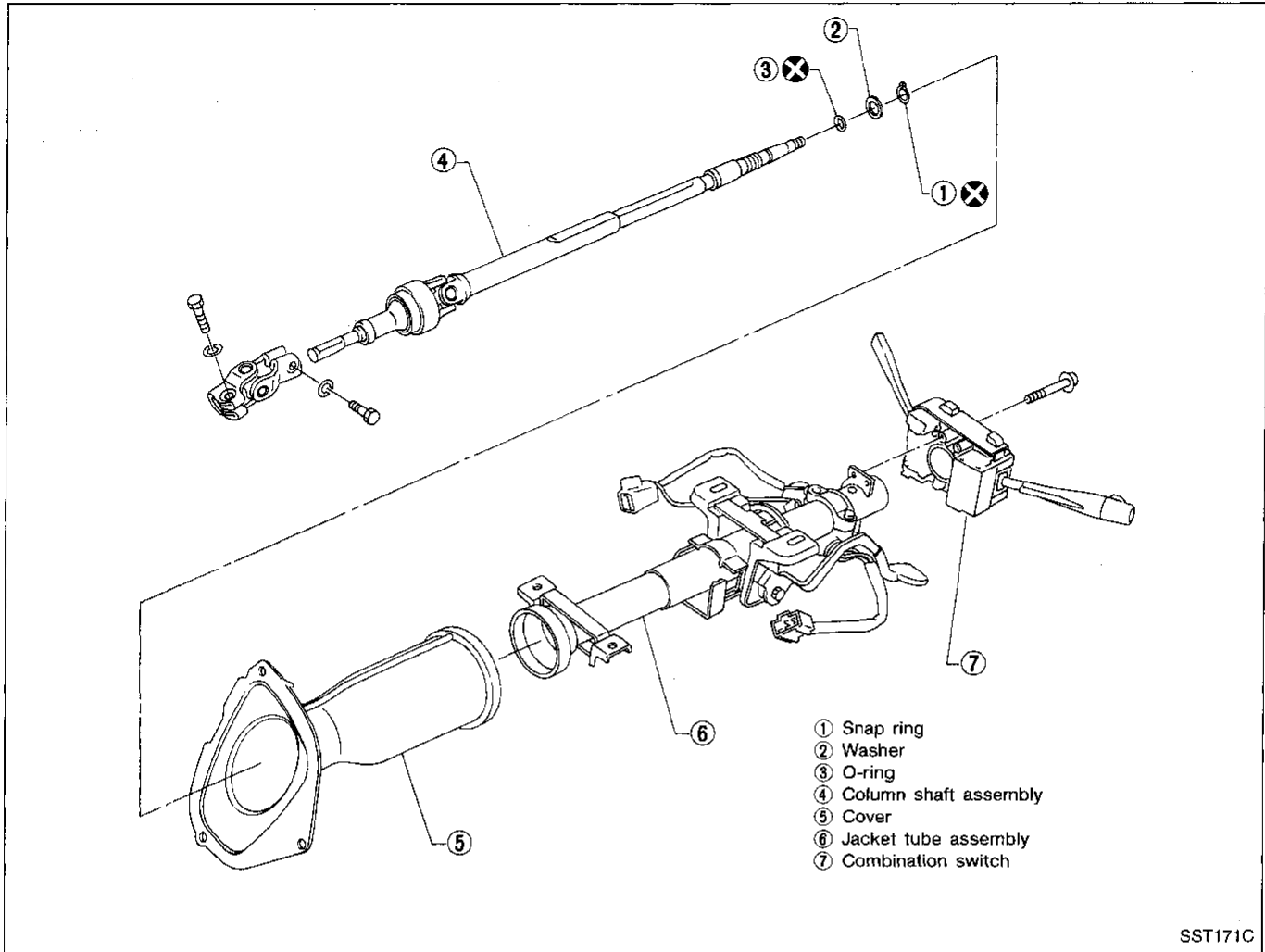

- When disassembling and assembling, unlock steering lock with key.
- Remove combination switch.

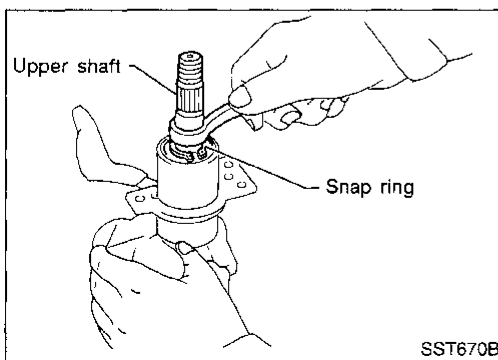

- Ensure that rounded surface of snap ring faces toward bearing when snap ring is installed.
- Install snap ring on upper shaft with a suitable tool.

STEERING WHEEL AND STEERING COLUMN

Disassembly and Assembly (Cont'd)

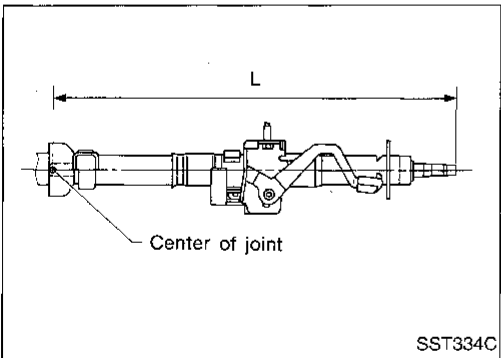
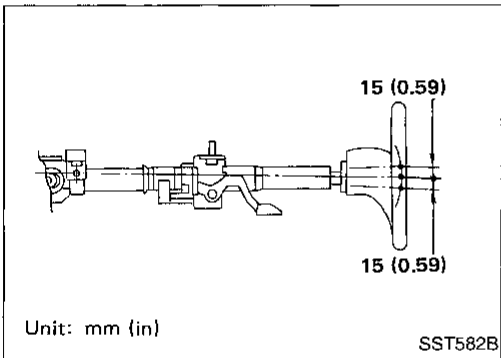
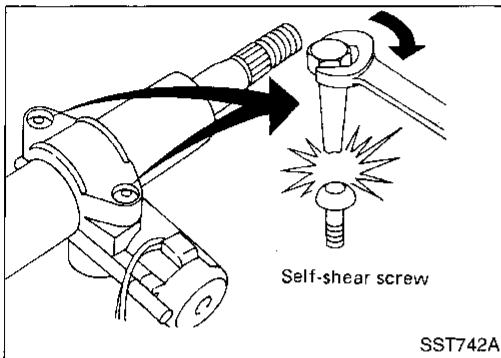
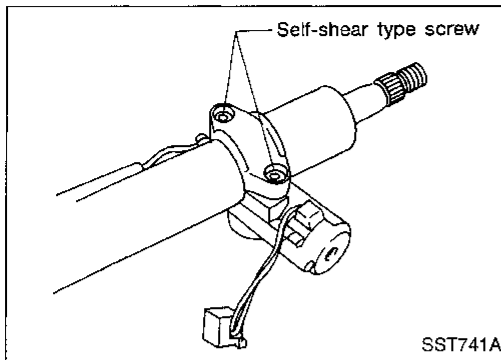

Steering lock

- a. Break self-shear type screws with a drill or other appropriate tool.

- b. Install self-shear type screws and then cut off self-shear type screw heads.

Tilt mechanism

- After installing steering column, check tilt mechanism operation.

Inspection

- When steering wheel does not turn smoothly, check the steering column as follows and replace damaged parts.
 - a. Check column bearings for damage or unevenness. Lubricate with recommended multi-purpose grease or replace steering column as an assembly, if necessary.
 - b. Check jacket tube for deformation or breakage.
- When the vehicle is involved in a light collision, check column length "L". If it is not within specifications, replace steering column as an assembly.

Column length "L":

535.9 - 538.1 mm (21.10 - 21.18 in)

GI

MA

EM

LC

EC

FE

CL

MT

AT

FA

RA

BR

ST

RS

BT

HA

EL

IDX

MANUAL STEERING GEAR AND LINKAGE (Model R24N)

Removal and Installation

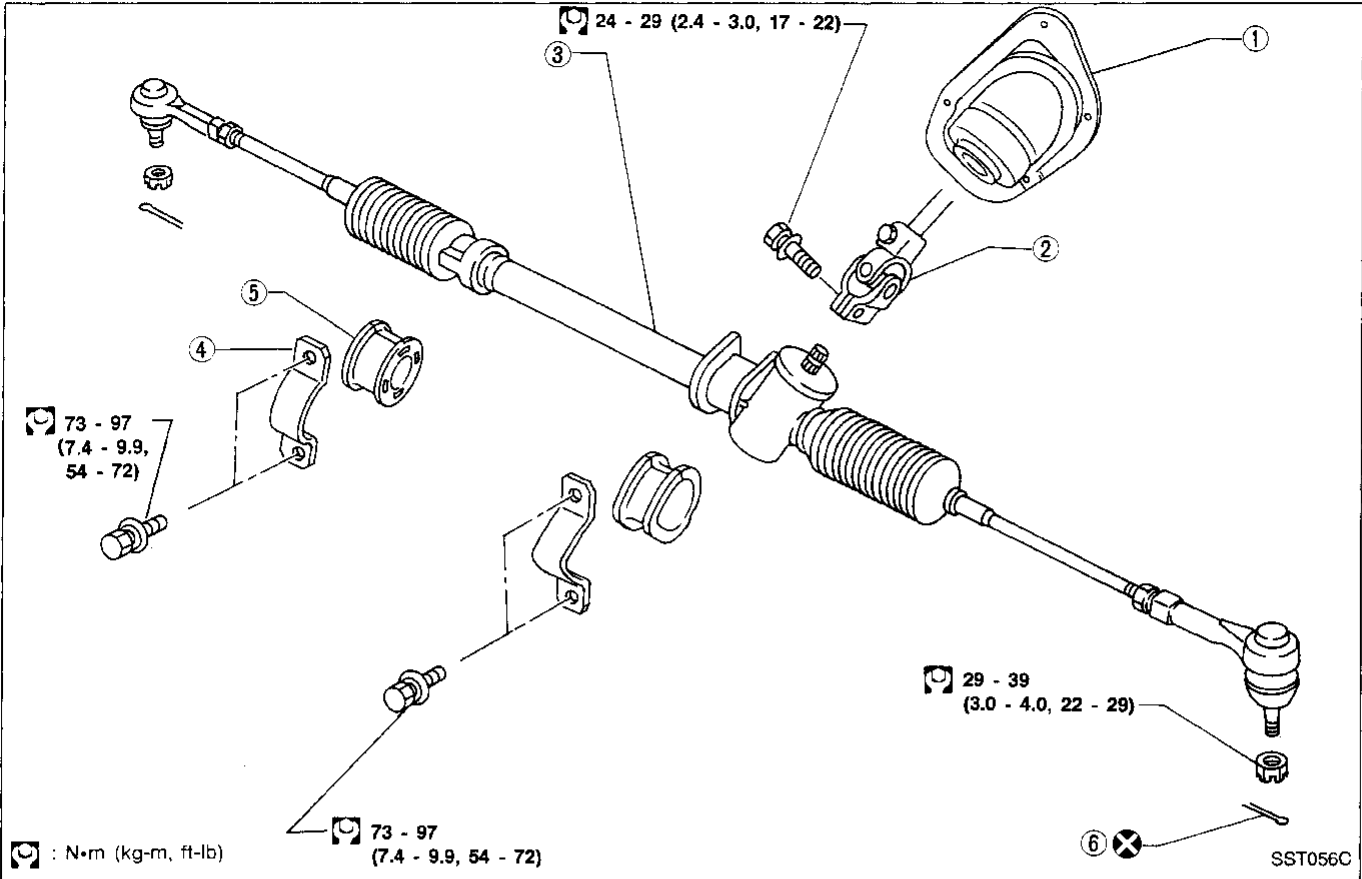

- | | | |
|---------------|---------------------------------|---------------------------|
| ① Hole cover | ③ Manual steering gear assembly | ⑤ Rack mounting insulator |
| ② Lower joint | ④ Steering gear mounting clamp | ⑥ Cotter pin |

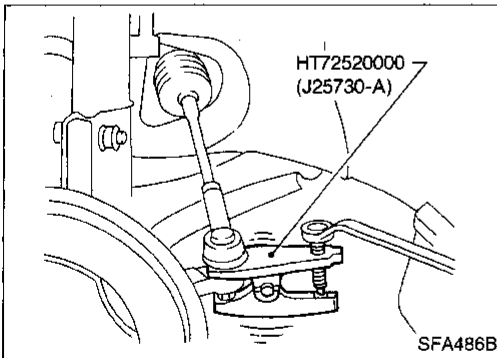

CAUTION:

The rotation of the spiral cable (SRS "Airbag" component part) is limited. If the steering gear must be removed, set the front wheels in the straight-ahead direction. Do not rotate the steering column while the steering gear is removed.

- Detach tie-rod outer sockets from knuckle arms with Tool.

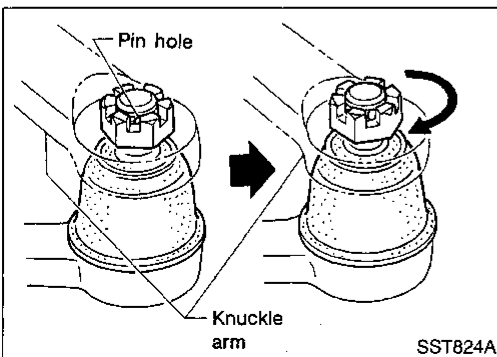

- Initially, tighten nut on tie-rod outer socket and knuckle arm to 29 to 39 N·m (3 to 4 kg-m, 22 to 29 ft-lb).
- Tighten nut further to align nut groove with the first pin hole so cotter pin can be installed.

CAUTION:

Tightening torque must not exceed 49 N·m (5 kg-m, 36 ft-lb).

MANUAL STEERING GEAR AND LINKAGE (Model R24N)

Disassembly

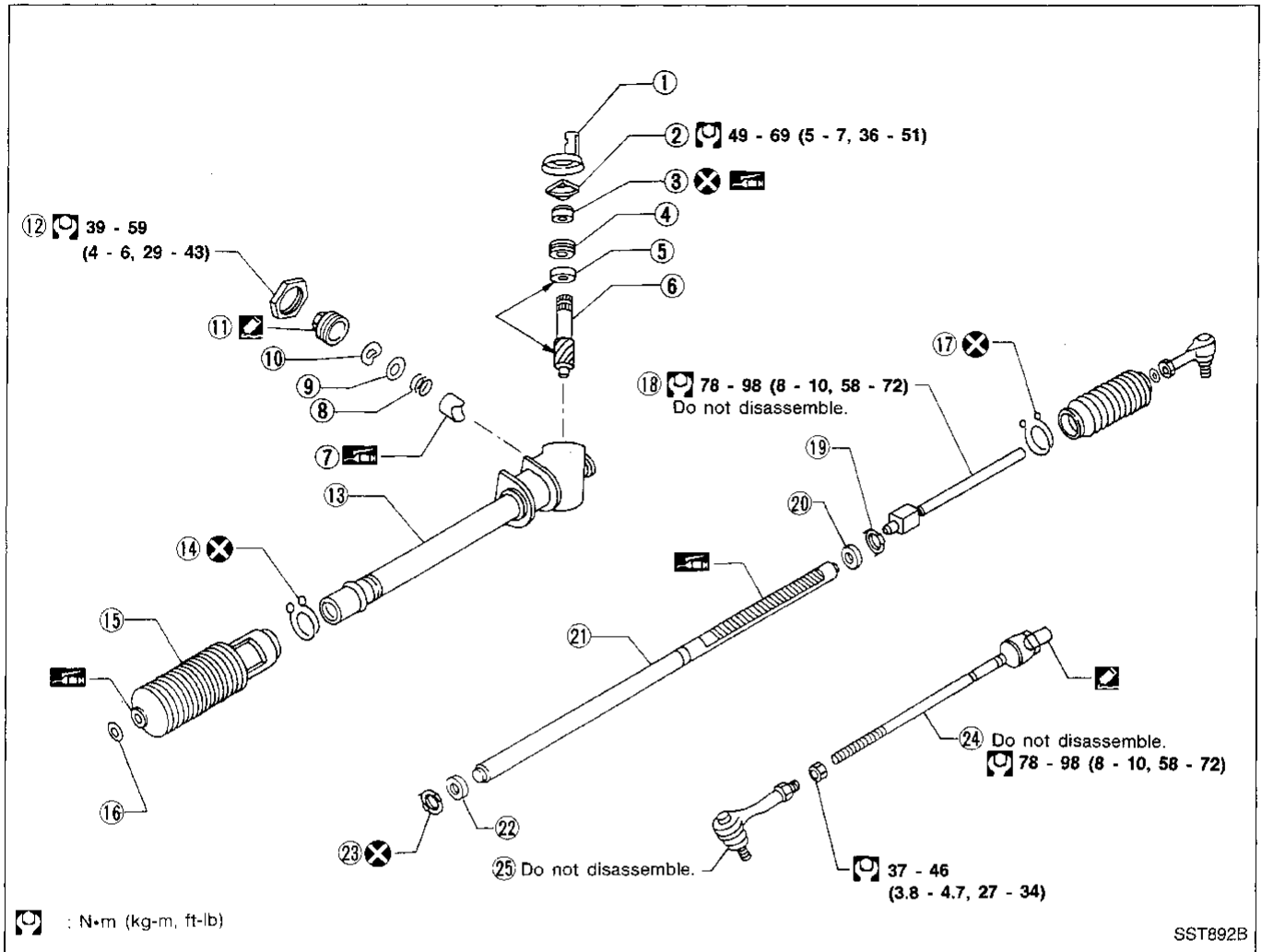

- ① Guide chip
- ② Rear cover lock nut
- ③ Dust seal
- ④ Rear cover
- ⑤ Pinion bearing
- ⑥ Pinion assembly
- ⑦ Retainer
- ⑧ Retaining spring
- ⑨ Plain washer

- ⑩ Wave washer
- ⑪ Adjusting screw
- ⑫ Adjusting lock nut
- ⑬ Gear housing assembly
- ⑭ Boot clamp
- ⑮ Boot
- ⑯ Boot band
- ⑰ Boot clamp

- ⑱ Tie-rod inner socket
- ⑲ Lock plate
- ⑳ Spacer
- ㉑ Rack
- ㉒ Spacer
- ㉓ Lock plate
- ㉔ Tie-rod inner socket
- ㉕ Tie-rod outer socket

Inspection

BOOT

Check condition of boot. If it is cracked excessively, replace it.

RACK

Thoroughly examine rack gear. If rack gear is damaged, cracked or worn, replace.

PINION ASSEMBLY

- Thoroughly examine pinion gear. If pinion gear is damaged, cracked or worn, replace.
- Check that all bearings roll freely. Ensure that balls, rollers and races in the bearing assemblies are not cracked, pitted or worn. Replace if necessary.

GI
MA
EM
LC
EC
FE
CL
MT
AT
FA
RA
BR
ST
RS
BT
HA
EL
IDX

MANUAL STEERING GEAR AND LINKAGE (Model R24N)

Inspection (Cont'd)

TIE-ROD OUTER AND INNER SOCKETS

- Check outer and inner ball joints for swinging force "A" and axial end play "C".

Refer to SDS, ST-26.

- Check outer ball joint for rotating torque "B".

Refer to SDS, ST-26.

- Check condition of dust cover. If excessively cracked, replace it.

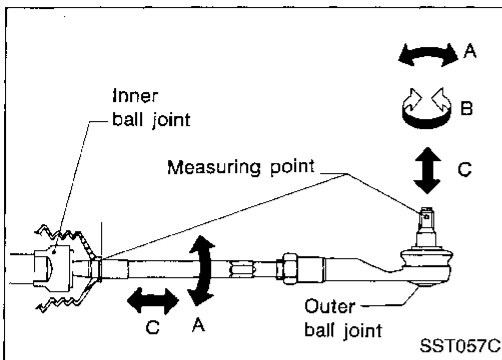

Assembly and Adjustment

STEERING GEAR

1. Insert rack gear from gear housing side.
2. Set rack gear in neutral position.

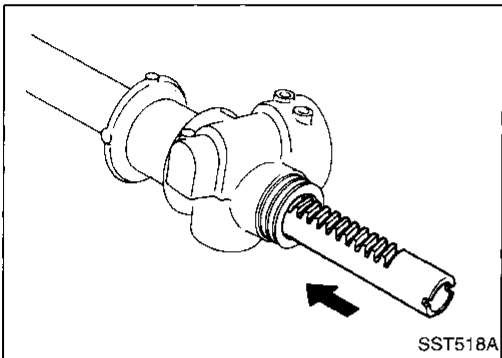

3. Insert pinion assembly, then set guide chip at neutral position as shown in figure. Pinion rack gear should be held in place.

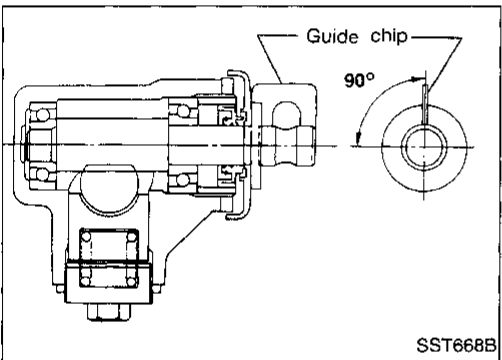

4. Install rear cover with Tool and secure with lock nut.

Tool number: KV48102000 (J28822)

- Before installing rear cover, apply locking sealant to threaded areas. Do not allow sealant to get into pinion bearing.

- Apply a coat of multi-purpose grease to sealing lips of dust seal.

CAUTION:

Wrap cellophane tape around pinion gear end when installing dust seal.

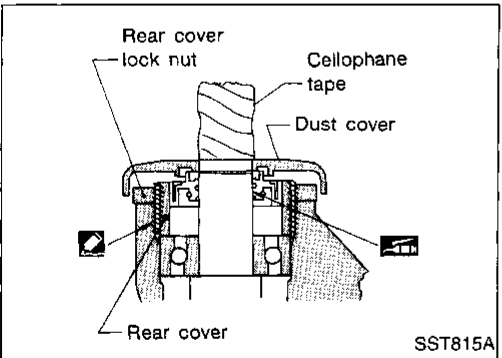

5. Insert retainer, spring, plain washer and wave washer. Then, install adjusting screw.

- Apply a coat of locking sealant to threaded areas of retainer cover.

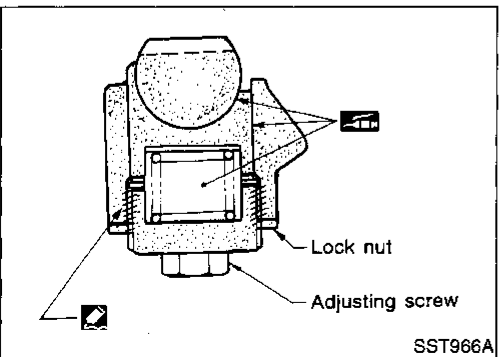

MANUAL STEERING GEAR AND LINKAGE (Model R24N)

Assembly and Adjustment (Cont'd)

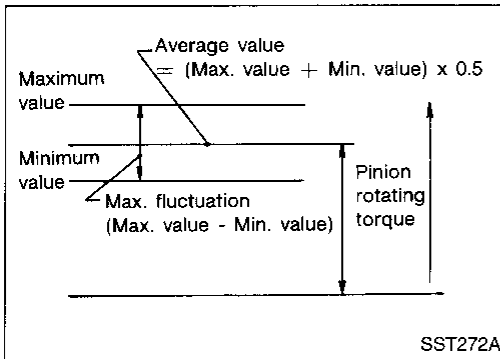
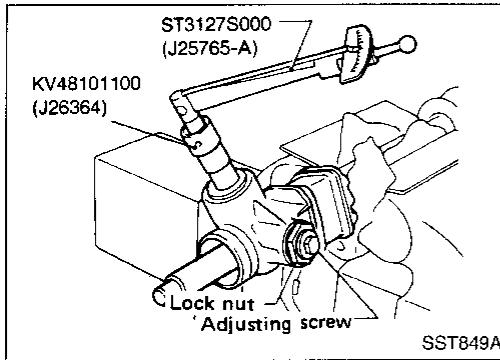

6. Adjust pinion rotating torque as follows:
 - a. Set gears to neutral position.
 - b. Loosen lock nut.
 - c. Tighten adjusting screw to a torque of 9.8 N·m (100 kg·cm, 87 in·lb).
 - d. Loosen adjusting screw and retighten it to a torque of 9.8 N·m (100 kg·cm, 87 in·lb).
 - e. Loosen adjusting screw within 60° until specified pinion torque is obtained. Ensure that pinion-to-rack play is less than 0.1 mm (0.004 in) when 15 N·m (1.5 kg·m, 11 ft·lb) torque is applied to pinion.
 - f. Prevent adjusting nut from rotating and tighten lock nut to specified torque 39 to 59 N·m (4 to 6 kg·m, 29 to 43 ft·lb) holding adjusting screw in place.
 - g. While slowly rotating pinion in the ±100° range from neutral position, make sure its rotating torque is within the specifications.

Within ±100° from the neutral position:

Average rotating torque

0.7 - 1.2 N·m (7 - 12 kg·cm, 6.1 - 10.4 in·lb)

Maximum torque deviation

0.3 N·m (3 kg·cm, 2.6 in·lb)

Except for above measuring range:

Maximum rotating torque

1.5 N·m (15 kg·cm, 13 in·lb)

Maximum force deviation

0.5 N·m (5 kg·cm, 4.3 in·lb)

- h. If pinion rotating torque is not within the specifications, readjust.

If pinion rotating torque is outside the specifications after adjustment has been made, replace retainer spring.

If pinion rotating torque is still out of specifications after replacing retainer spring, replace gear assembly.

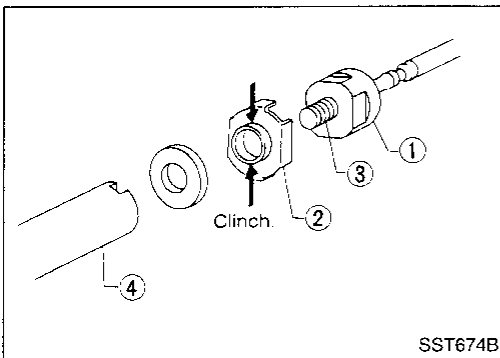

7. Install new lock plate.
 - Attach lock plate (2) to side rod inner socket (1).
 - Apply locking sealant to inner socket threads (3).
 - Screw inner socket into rack (4) and tighten to specified torque.
 - Clinch two places of lock plate at rack's groove.

CAUTION:

To prevent scratching the boot, remove burrs from lock plate.

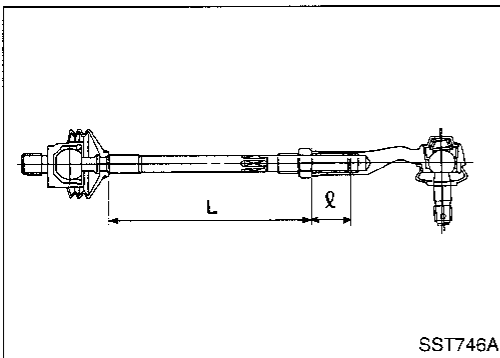

TIE-ROD AND BOOT

1. Install boot on tie-rod inner socket.
2. Apply locking sealant to threaded portion of inner socket. Install tie-rod inner socket to rack end together with new lock plate.
3. Install lock nut and outer socket to inner socket. Adjust tie-rod length "L" and tighten lock nut.

Tie-rod length "L": Refer to SDS, ST-26.

Screwed length "l": 32 mm (1.26 in) or more

MANUAL STEERING GEAR AND LINKAGE (Model R24N)

Assembly and Adjustment (Cont'd)

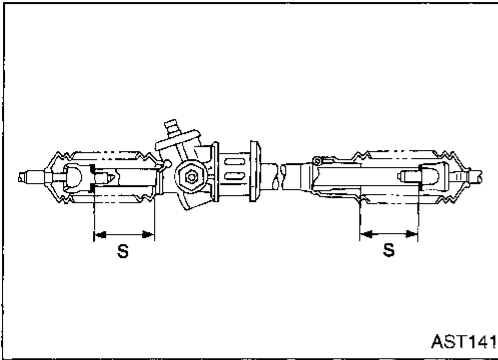

4. Measure rack stroke.
Measure stroke "S":
Refer to SDS, ST-27.

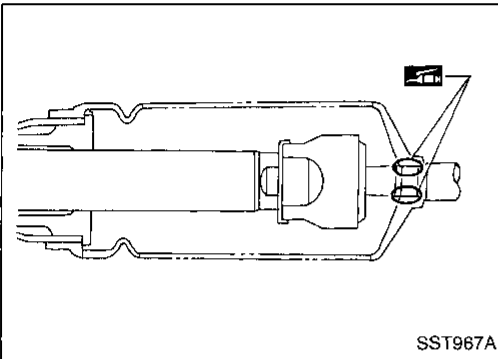

5. Before installing boot, coat the contact surfaces between boot and tie-rod with grease.

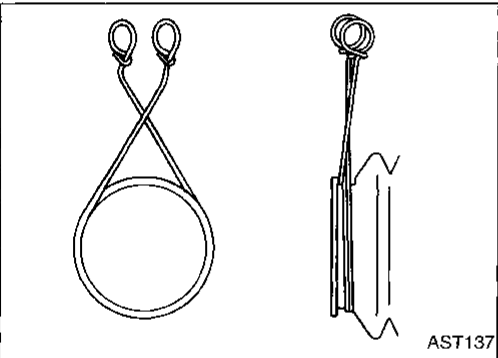

6. Install boot clamps.
 - To install, wrap boot clamp around boot groove twice. Use a screwdriver to tighten clamps. Twist rings at both ends 4 to 4-1/2 turns while pulling them with a force of approx. 98 N (10 kg, 22 lb).
 - Do not cross wire on boot.

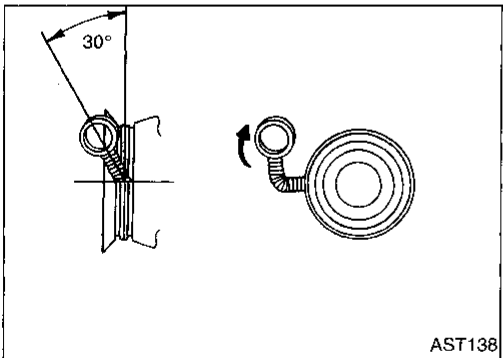

- Bend twisted end of boot clamp as shown at left. (This will prevent interference with other parts.)

POWER STEERING GEAR AND LINKAGE (Model PR24T)

Removal and Installation

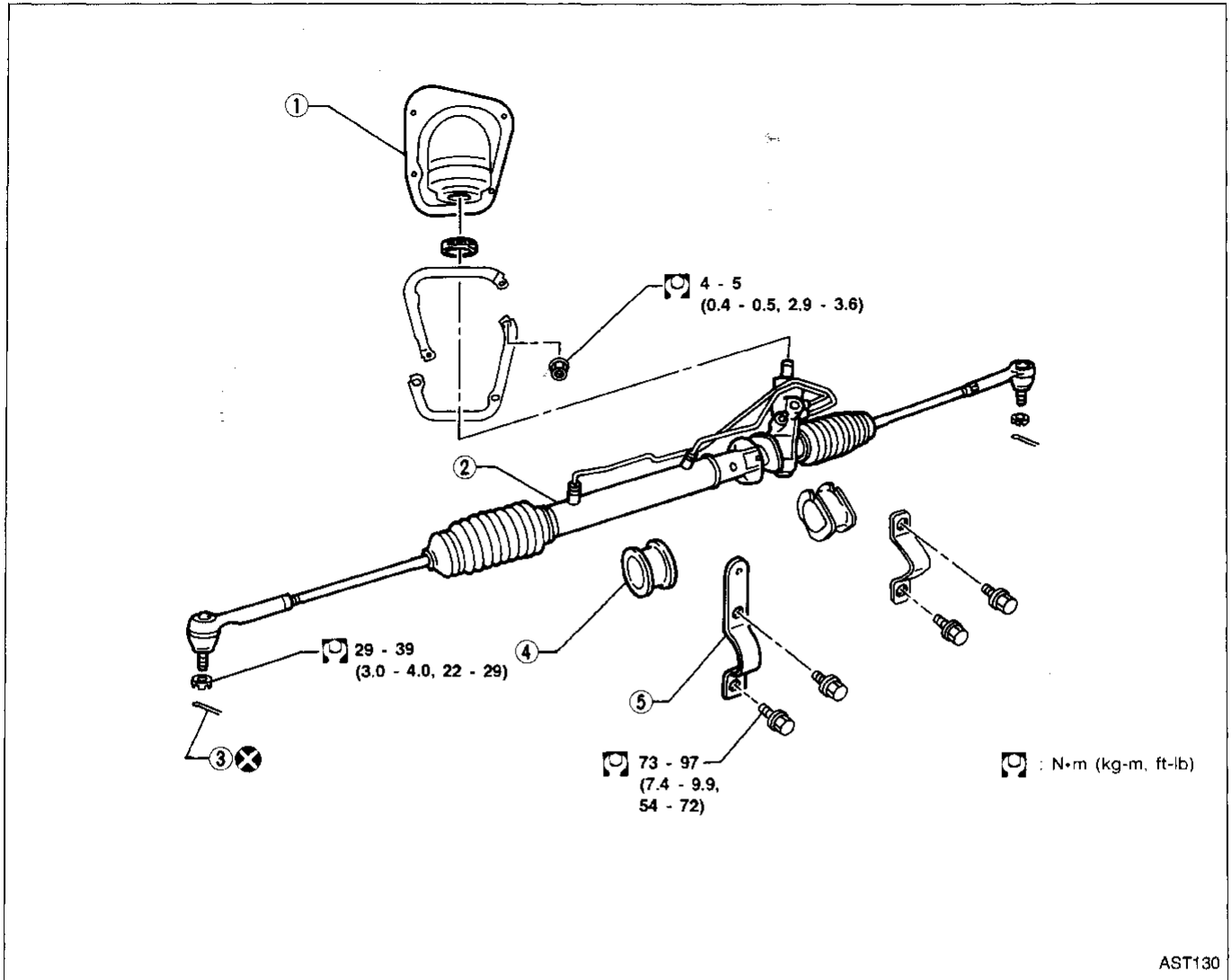

- ① Hole cover
- ② Gear and linkage assembly

- ③ Cotter pin
- ④ Rack mounting insulator

- ⑤ Gear housing mounting bracket

CAUTION:

The rotation of the spiral cable (SRS "Air bag" component part) is limited. If the steering gear must be removed, set the front wheels in the straight-ahead position. Do not rotate the steering column while the steering gear is removed.

- Loosen upper clamp on dust boot in engine compartment.
- Remove lower bolt from coupling joint.
- Detach tie-rod outer sockets from knuckle arms with Tool.

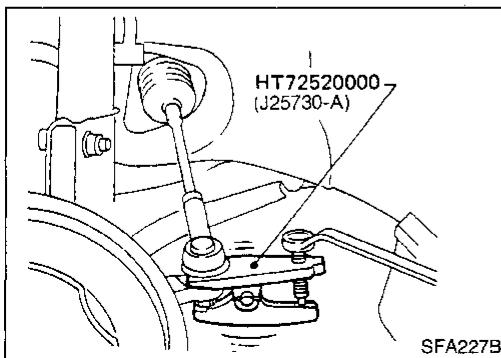

GI
MA
EM
LC
EC
FE
CL
MT
AT
FA
RA
BR
ST
RS
BT
HA
EL
IDX

POWER STEERING GEAR AND LINKAGE (Model PR24T)

Removal and Installation (Cont'd)

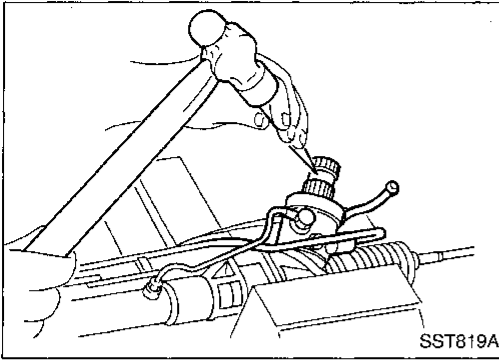

- After removing steering gear from vehicle, mark pinion shaft and pinion housing to record neutral position.

- To install, set left and right dust boots to equal deflection. Align matching marks on pinion shaft and pinion housing.

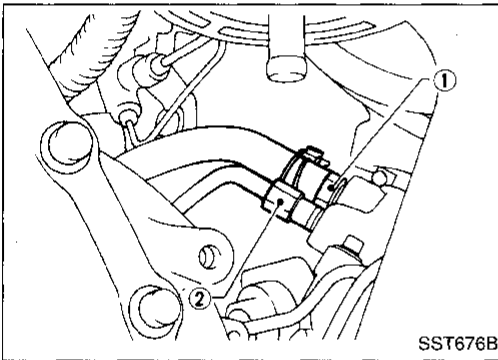

- The O-ring in low-pressure pipe connector ① is larger than in high-pressure connector ②. Take care to install the proper O-ring.
- Observe specified tightening torque when tightening high-pressure and low-pressure pipe connectors. Excessive tightening can damage threads or connector O-ring.

Connector tightening torque:

Low-pressure side ①

27 - 39 N·m (2.8 - 4.0 kg-m, 20 - 29 ft-lb)

High-pressure side ②

15 - 25 N·m (1.5 - 2.5 kg-m, 11 - 18 ft-lb)

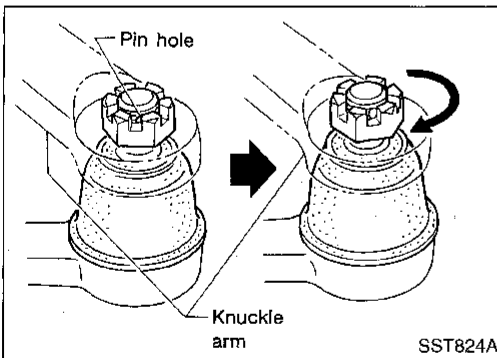

- Initially, tighten nut on tie-rod outer socket and knuckle arm to 29 to 39 N·m (3 to 4 kg-m, 22 to 29 ft-lb). Then tighten further to align nut groove with first pin hole so cotter pin can be installed.

CAUTION:

Tightening torque must not exceed 49 N·m (5 kg-m, 36 ft-lb).

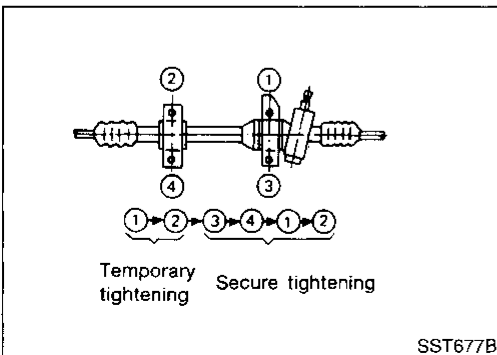

- Tighten gear housing mounting bracket bolts in the order shown.

POWER STEERING GEAR AND LINKAGE (Model PR24T)

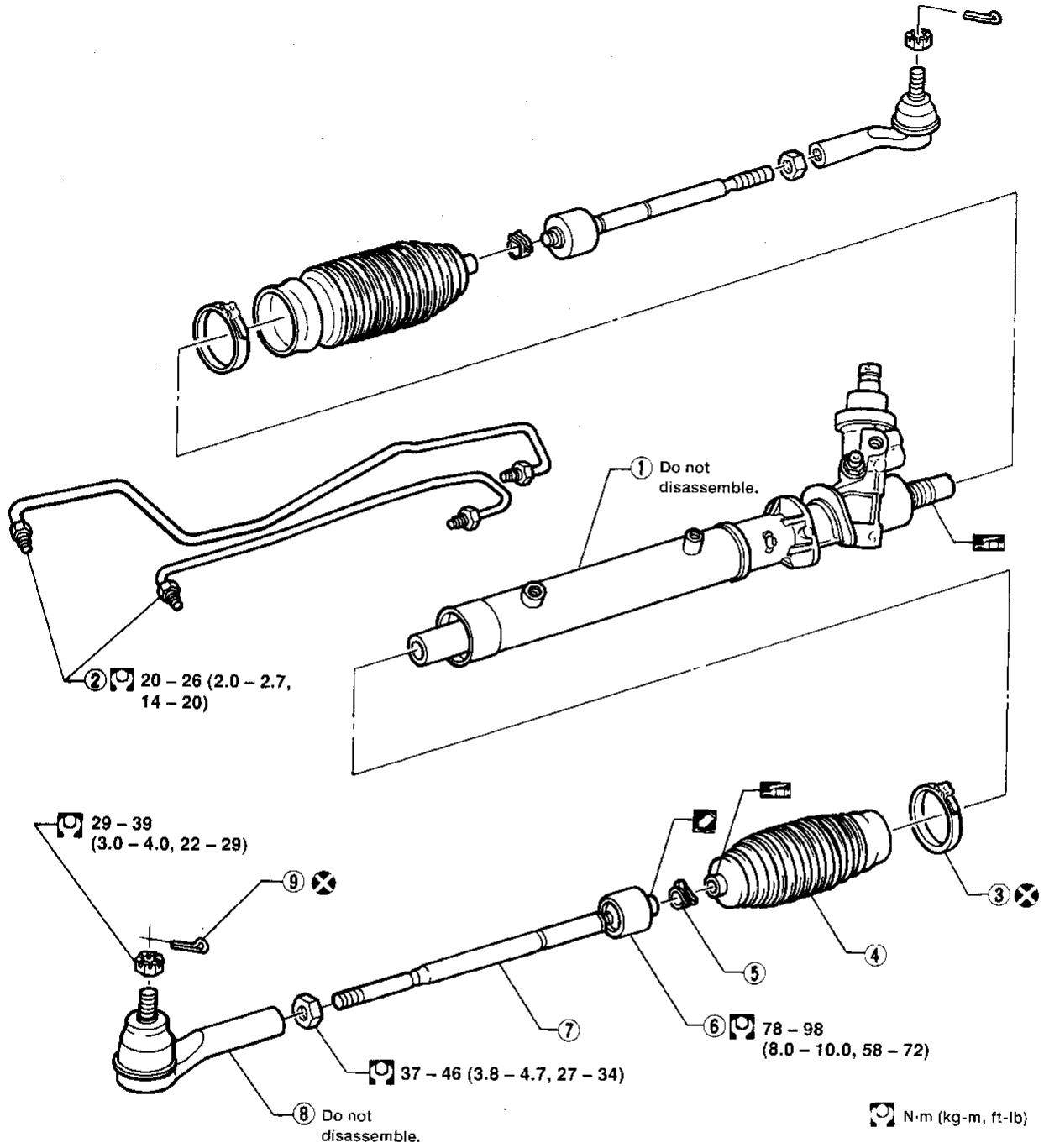

- ① Steering gear
- ② Gear housing tube
- ③ Boot clamp

- ④ Dust boot
- ⑤ Boot band
- ⑥ Tie-rod inner socket

- ⑦ Tie-rod
- ⑧ Tie-rod outer socket
- ⑨ Cotter pin

AST131

CI
MA
EM
LC
EC
FE
CL
MT
AT
FA
RA
BR
ST
RS
BT
HA
EL
IDX

POWER STEERING GEAR AND LINKAGE (Model PR24T)

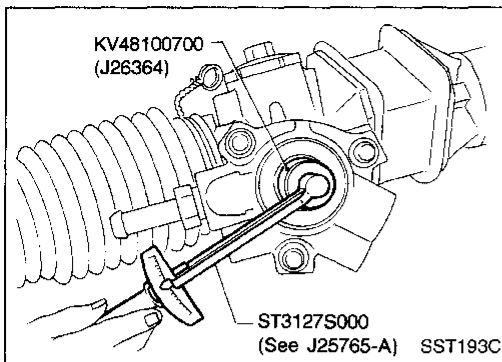

Disassembly

1. Prior to disassembling, measure pinion rotating torque. Record the pinion rotating torque as a reference. Refer to step 6 of "Assembly" for reference torque data.
 - Before measuring, disconnect gear housing tube and drain fluid.
 - Use soft jaws when holding steering gear housing. Handle gear housing carefully, as it is made of aluminum. Do not grip cylinder in a vise.
2. Remove tie-rod outer sockets and boots.
3. Remove tie-rod inner sockets.

Inspection

Thoroughly clean all parts in cleaning solvent or automatic transmission fluid type DEXRON™II or equivalent. Blow dry with compressed air, if available.

BOOT

Check condition of boot. If cracked excessively, replace it.

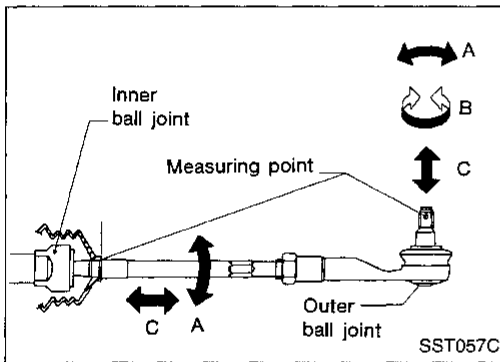

TIE-ROD OUTER AND INNER SOCKETS

- Check outer and inner ball joints for swinging force "A" and axial end play "C".

Refer to SDS, ST-26.

- Check outer ball joint for rotating torque "B".

Refer to SDS, ST-26.

- Check condition of dust cover. If excessively cracked, replace outer tie-rod.

Assembly

1. Install tie-rod inner sockets, dust boots and outer sockets. Apply locking sealant to inner socket threads.

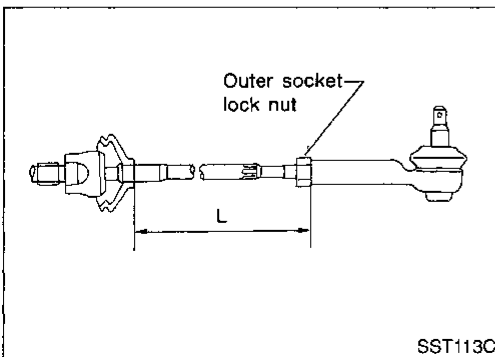

2. Tighten outer socket lock nut.
Tie-rod length "L":
Refer to SDS, ST-26.

POWER STEERING GEAR AND LINKAGE (Model PR24T)

Assembly (Cont'd)

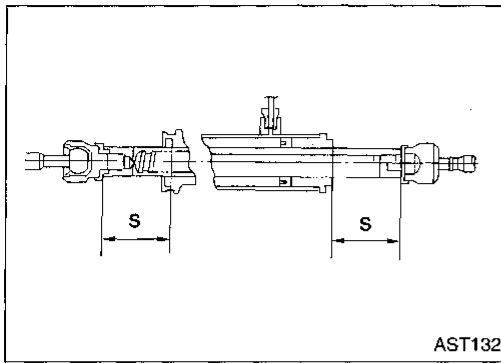

3. Measure rack stroke.
Rack stroke "S":
Refer to SDS, ST-27.

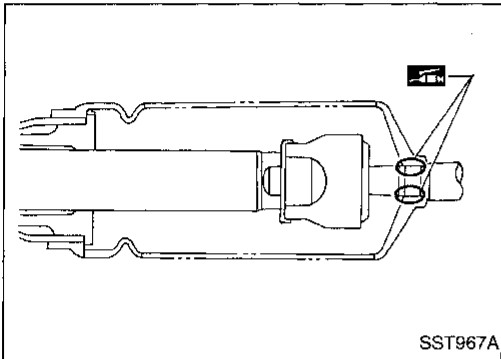

4. Before installing boot, coat the contact surfaces between boot and tie-rod with grease.

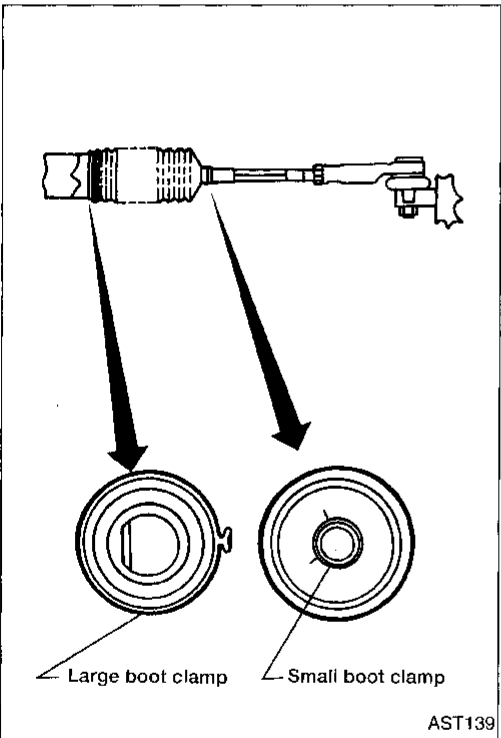

5. Install boot clamps.
 - Install large boot clamp using suitable tool and crimp securely.
 - Install small boot clamp as shown.

GI

MA

EM

LC

EC

FE

CL

MT

AT

FA

RA

BR

ST

RS

BT

HA

EL

IDX

POWER STEERING GEAR AND LINKAGE (Model PR24T)

Assembly (Cont'd)

6. Measure pinion rotating torque.
 - Within $\pm 100^\circ$ from the neutral position:**
 - Average rotating torque**
0.3 - 1.3 N·m (3 - 13 kg-cm, 2.6 - 11.3 in-lb)
 - Maximum torque deviation**
0.6 N·m (6 kg-cm, 5.2 in-lb)
 - Except for above measuring range:**
 - Maximum rotating torque**
1.9 N·m (19 kg-cm, 16 in-lb)
 - Maximum force deviation**
0.6 N·m (6 kg-cm, 5.2 in-lb)
- If pinion rotating torque is not within the specifications, replace steering gear assembly.

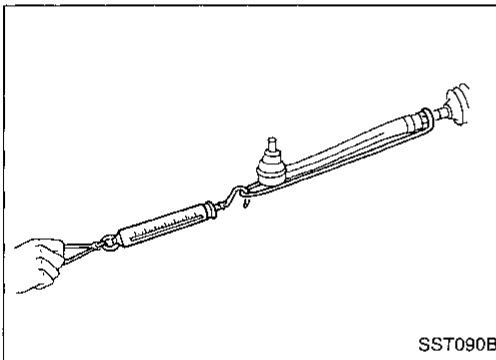

7. Check rack sliding force on vehicle as follows:
 - a. Install steering gear onto vehicle, but do not connect tie-rod to knuckle arm.
 - b. Connect all piping and fill with steering fluid.
 - c. Start engine and bleed air completely.
 - d. Disconnect steering column lower joint from the gear.
 - e. Keep engine at idle and make sure steering fluid has reached normal operating temperature.
 - f. Check rack sliding force while pulling tie-rod slowly in the ± 11.5 mm (± 0.453 in) range from the neutral position.
 - Rack sliding force:**
107 - 245 N (11 - 25 kg, 24 - 55 lb)
 - g. Check sliding force outside above range.
 - Rack sliding force:**
Not more than 294 N (30 kg, 66 lb)
- If rack sliding force is not within specification, replace gear assembly.

POWER STEERING PUMP

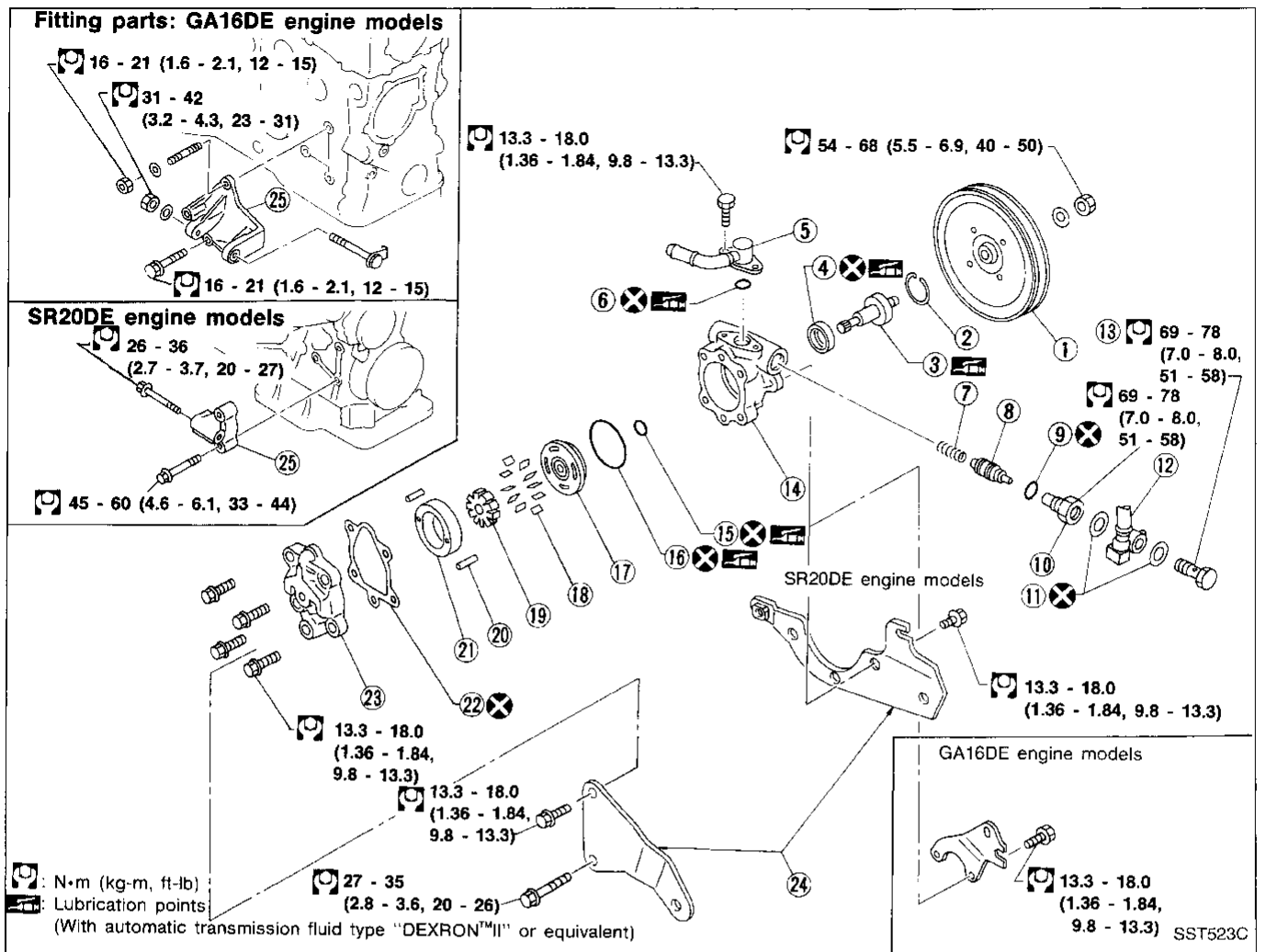

- | | | |
|-----------------|--------------------|-------------------------------|
| ① Pulley | ⑩ Connector | ⑱ Vane |
| ② Snap ring | ⑪ Washer | ⑲ Rotor |
| ③ Drive shaft | ⑫ Joint | ⑳ Pin |
| ④ Oil seal | ⑬ Connector bolt | ㉑ Cam ring |
| ⑤ Suction pipe | ⑭ Front housing | ㉒ Gasket |
| ⑥ O-ring | ⑮ O-ring | ㉓ Rear housing |
| ⑦ Spring | ⑯ O-ring | ㉔ Mounting bracket |
| ⑧ Control valve | ⑰ Front side plate | ㉕ Power steering pump bracket |
| ⑨ O-ring | | |

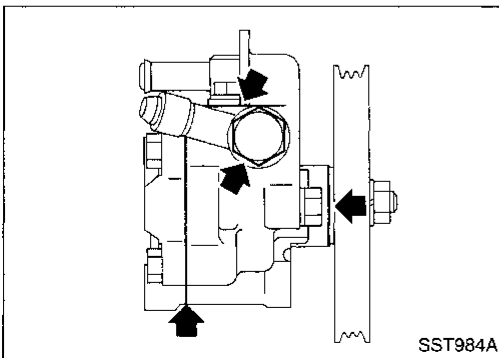

Pre-disassembly Inspection

Disassemble the power steering pump only if the following items are found:

- Oil leak from any point shown in the figure.
- Deformed or damaged pulley.
- Poor performance.

POWER STEERING PUMP

Disassembly

CAUTION:

- Parts which can be disassembled are strictly limited. Never disassemble parts other than those specified.
- Disassemble in as clean a place as possible.
- Clean your hands before disassembly.
- Do not use rags; use nylon cloths or paper towels.
- When disassembling and reassembling, do not let foreign matter enter or contact the parts.

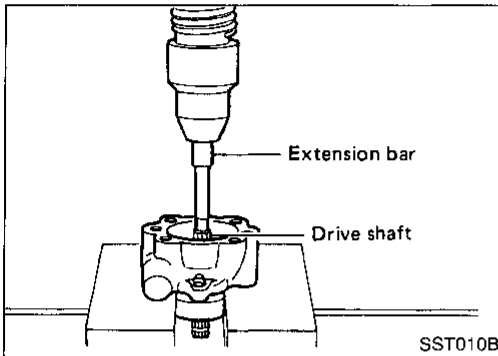

- Remove snap ring, then draw drive shaft out.
Be careful not to drop drive shaft.

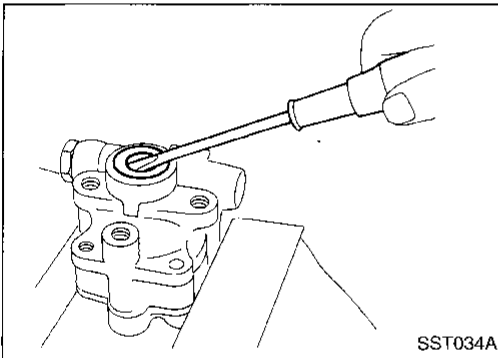

- Remove oil seal.
Be careful not to damage front housing.

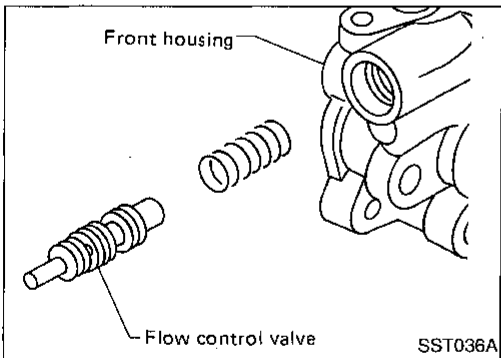

- Remove connector and flow control valve with spring.
Be careful not to drop flow control valve.

Inspection

- If pulley is cracked or deformed, replace it.
- If an oil leak is found around pulley shaft oil seal, replace the seal.
- If serration on pulley or pulley shaft is deformed or worn, replace it.

POWER STEERING PUMP

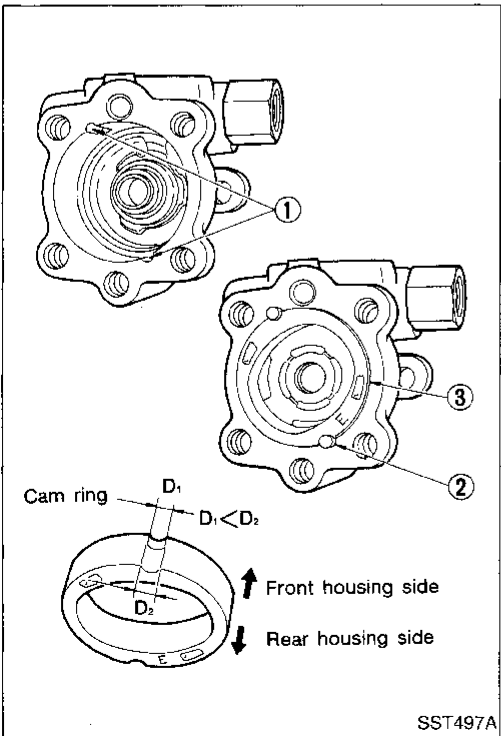
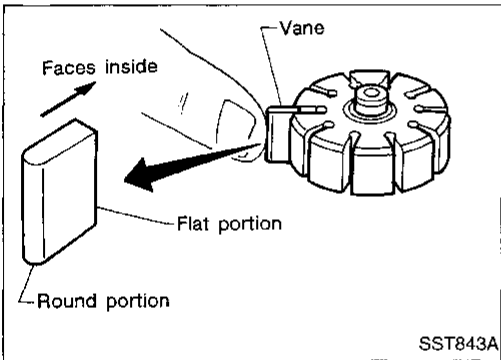
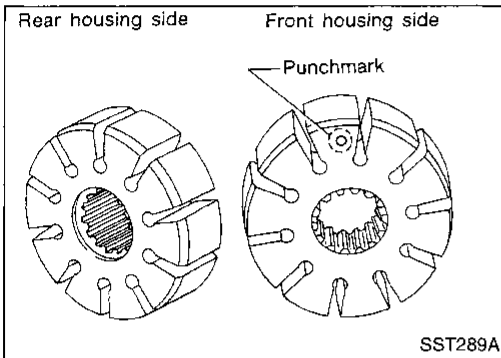
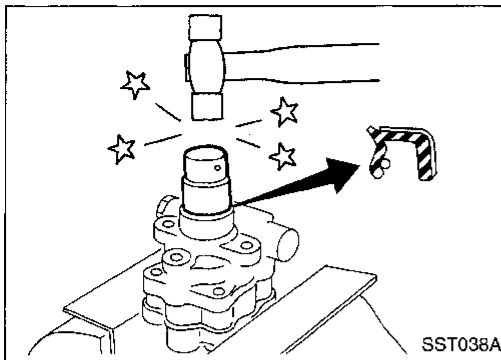

Assembly

Assemble power steering pump, noting the following instructions:

- Make sure O-rings and oil seal are properly installed.
- Always install new O-rings and oil seal.
- Be careful of oil seal direction.
- Cam ring, rotor and vanes must be replaced as a set if necessary.
- Coat each part with ATF when assembling.

- Pay attention to the direction of rotor.

- When assembling vanes to rotor, rounded surfaces of vanes must face cam ring side.

- Insert pin ② into pin groove ① of front housing and front side plate. Then install cam ring ③ as shown at left.

Cam ring:

D_1 is less than D_2

GI

MA

EM

LC

EC

FE

CL

MT

AT

FA

RA

BR

ST

RS

BT

HA

EL

IDX

SERVICE DATA AND SPECIFICATIONS (SDS)

General Specifications

Steering model	Manual steering	Power steering
Steering gear type	R24N	PR24T
Steering overall gear ratio	23.2	17.5
Turns of steering wheel (Lock to lock)	4.21	3.02
Steering column type	Collapsible, tilt	

Inspection and Adjustment

GENERAL

Steering wheel axial play mm (in)	0 (0)
Steering wheel play limit mm (in)	35 (1.38)
Maximum movement of gear housing mm (in)	±2 (±0.08)

STEERING COLUMN

Steering column length "L" mm (in)	535.9 - 538.1 (21.10 - 21.18)
---------------------------------------	----------------------------------

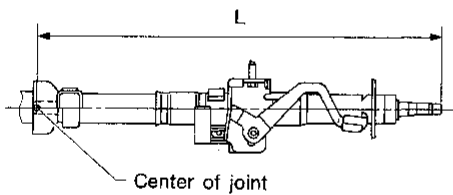

SST334C

STEERING GEAR AND LINKAGE

Steering gear type	R24N	PR24T
Tie-rod outer ball joint		
Swinging force "A" at cotter pin hole N (kg, lb)	6.9 - 64.7 (0.7 - 6.6, 1.5 - 14.6)	
Rotating torque "B" N-m (kg-cm, in-lb)	0.3 - 2.9 (3 - 30, 2.6 - 26.0)	
Axial end play limit "C" mm (in)	Less than 0.5 (0.020)	
Tie-rod inner ball joint		
Swinging force*1 "A" N (kg, lb)	1.2 - 215.8 (0.12 - 22, 0.26 - 48.5)	
Axial end play limit "C" mm (in)	0.4 (0.016)	
Tie-rod standard length "L" mm (in)	186 (7.32)	140.6 (5.54)

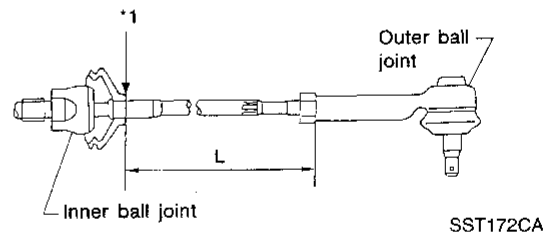

*1: Measuring point of swing force

SERVICE DATA AND SPECIFICATIONS (SDS)

Inspection and Adjustment (Cont'd)

STEERING GEAR AND LINKAGE (Cont'd)

Steering gear type	R24N	PR24T
Rack stroke "S" mm (in)	69-71 (2.72 - 2.80) 70 (2.76)	65 (2.56)

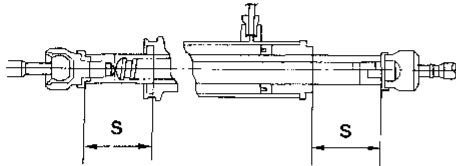

AST132

Steering gear type	R24N	PR24T
Retainer adjustment		
Adjusting screw		
Initial tightening torque N·m (kg-cm, in-lb)	9.8 (100, 87)	No adjustment
Retightening torque after loosening N·m (kg-cm, in-lb)	—	No adjustment
Tightening torque after gear has settled N·m (kg-cm, in-lb)	—	No adjustment
Returning angle degree	Less than 60° [Within play of 0.1 mm (0.004 in)/15 N·m (1.5 kg-m, 11 ft-lb)]	No adjustment
Pinion gear preload without gear oil N·m (kg-cm, in-lb)		
Within ±100° from the neutral position		
Average rotating torque	0.7 - 1.2 (7 - 12, 6.1 - 10.4)	0.3 - 1.3 (3 - 13, 2.6 - 11.3)
Maximum torque deviation	0.3 (3, 2.6)	0.6 (6, 5.2)
Except above range		
Maximum rotating torque	1.5 (15, 13)	1.9 (19, 16)
Maximum torque deviation	0.5 (5, 4.3)	0.6 (6, 5.2)

POWER STEERING

Steering gear type	PR24T
Rack sliding force N (kg, lb)	
Under normal operating oil pressure	
Range within ±11.5 mm (±0.453 in) from the neutral position	107 - 245 (11 - 25, 24 - 55)
Except above range	Not more than 294 (30, 66)
Steering wheel turning force (Measured at one full turn from the neutral position) N (kg, lb)	39 (4, 9) or less
Fluid capacity (Approximate) ℓ (US qt, Imp qt)	1 (1-1/8, 7/8)
Power steering pump maximum pressure kPa (kg/cm ² , psi)	7,159 - 7,748 (73 - 79, 1,038 - 1,123)

GI
 MA
 EM
 LC
 EC
 FE
 CL
 MT
 AT
 FA
 RA
 BR
ST
 RS
 BT
 HA
 EL
 DX