

## SECTION **EC**

### CONTENTS

<b>PRECAUTIONS AND PREPARATION</b> .....	2
Special Service Tools.....	2
Supplemental Restraint System (SRS) "AIR BAG".....	2
Precautions for On-Board Diagnostic (OBD) System of Engine and A/T.....	3
Engine Fuel & Emission Control System.....	4
Precautions.....	5

SR

<b>ENGINE AND EMISSION CONTROL OVERALL SYSTEM</b> .....	7
Circuit Diagram.....	7
System Diagram.....	8
ECCS Component Parts Location.....	9
Vacuum Hose Drawing.....	13
System Chart.....	14
<b>ENGINE AND EMISSION BASIC CONTROL SYSTEM DESCRIPTION</b> .....	15
Multiport Fuel Injection (MFI) System.....	15
Distributor Ignition (DI) System.....	17
Air Conditioning Cut Control.....	18
Fuel Cut Control (at no load & high engine speed).....	19
<b>EVAPORATIVE EMISSION SYSTEM</b> .....	21
<b>POSITIVE CRANKCASE VENTILATION</b> .....	23
<b>BASIC SERVICE PROCEDURE</b> .....	24
Fuel Pressure Release.....	24
Fuel Pressure Check.....	24
Fuel Pressure Regulator Check.....	25
Injector Removal and Installation.....	25
Idle Speed/Ignition Timing/Idle Mixture Ratio Adjustment.....	26
<b>ON-BOARD DIAGNOSTIC SYSTEM DESCRIPTION</b> .....	33
Introduction.....	33
Two Trip Detection Logic.....	33

Diagnostic Trouble Code (DTC).....	33
Freeze Frame Data.....	34
Malfunction Indicator Lamp (MIL).....	35
OBD System Operation Chart.....	39
CONSULT.....	44
Generic Scan Tool (GST).....	56
<b>TROUBLE DIAGNOSIS — Introduction</b> .....	58
<b>TROUBLE DIAGNOSIS — Work Flow</b> .....	60
<b>TROUBLE DIAGNOSIS — Basic Inspection</b> .....	62
<b>TROUBLE DIAGNOSIS — General Description</b> .....	65
Diagnostic Trouble Code (DTC) Chart.....	65
Fail-Safe Chart.....	76
Symptom Matrix Chart.....	77
CONSULT Reference Value in Data Monitor Mode.....	80
Major Sensor Reference Graph in Data Monitor Mode.....	82
ECM Terminals and Reference Value.....	84
<b>TROUBLE DIAGNOSIS FOR POWER SUPPLY</b> .....	90
Main Power Supply and Ground Circuit.....	90
<b>TROUBLE DIAGNOSIS FOR DTC P0100</b> .....	93
Mass Air Flow Sensor (MAFS) (DTC: 0102).....	93
<b>TROUBLE DIAGNOSIS FOR DTC P0110</b> .....	98
Intake Air Temperature Sensor (DTC: 0401).....	98
<b>TROUBLE DIAGNOSIS FOR DTC P0115</b> .....	103
Engine Coolant Temperature Sensor (ECTS) (DTC: 0103).....	103
<b>TROUBLE DIAGNOSIS FOR DTC P0120</b> .....	107
Throttle Position Sensor (DTC: 0403).....	107
<b>TROUBLE DIAGNOSIS FOR DTC P0125</b> .....	112
Engine Coolant Temperature (ECT) Sensor (DTC: 0908).....	112
<b>TROUBLE DIAGNOSIS FOR DTC P0130</b> .....	117
Front Heated Oxygen Sensor (Front HO2S) (DTC: 0303).....	117
<b>TROUBLE DIAGNOSIS FOR DTC P0130</b> .....	122
Closed Loop Control (DTC: 0307).....	122
<b>TROUBLE DIAGNOSIS FOR DTC P0135</b> .....	123

# CONTENTS (Cont'd.)

Front Heated Oxygen Sensor Heater (DTC: 0901) .....	123
<b>TROUBLE DIAGNOSIS FOR DTC P0136</b> .....	126
Rear Heated Oxygen Sensor (Rear HO2S) (DTC: 0707) .....	126
<b>TROUBLE DIAGNOSIS FOR DTC P0170</b> .....	131
Fuel Injection System Function (DTC: 0706) .....	131
<b>TROUBLE DIAGNOSIS FOR DTC P0300 - P0304</b> .....	136
No. 4 - 1 Cylinder Misfire, Multiple Cylinder Misfire (DTC: 0701 - 0605) .....	136
<b>TROUBLE DIAGNOSIS FOR DTC P0325</b> .....	140
Knock Sensor (KS) (DTC: 0304) .....	140
<b>TROUBLE DIAGNOSIS FOR DTC P0335</b> .....	143
Crankshaft Position Sensor (CKPS) (OBD) (DTC: 0802) .....	143
<b>TROUBLE DIAGNOSIS FOR DTC P0340</b> .....	147
Camshaft Position Sensor (CMPS)(DTC: 0101) .....	147
<b>TROUBLE DIAGNOSIS FOR DTC P0400</b> .....	152
EGR Function (DTC: 0302) .....	152
<b>TROUBLE DIAGNOSIS FOR DTC P0402</b> .....	161
EGRC-BPT Valve Function (DTC: 0306) .....	161
<b>TROUBLE DIAGNOSIS FOR DTC P0420</b> .....	163
Three Way Catalyst Function (DTC: 0702) .....	163
<b>TROUBLE DIAGNOSIS FOR DTC P0500</b> .....	166
Vehicle Speed Sensor (VSS) (DTC: 0104) .....	166
<b>TROUBLE DIAGNOSIS FOR DTC P0505</b> .....	170
Idle Air Control Valve (IACV) — Auxiliary Air Control (AAC) Valve (DTC: 0205) .....	170
<b>TROUBLE DIAGNOSIS FOR DTC P0605</b> .....	174
Engine Control Module (ECM)-ECCS Control Module (DTC: 0301) .....	174
<b>TROUBLE DIAGNOSIS FOR DTC P0705</b> .....	176
Park/Neutral Position Switch (DTC: 1003) .....	176
<b>TROUBLE DIAGNOSIS FOR DTC P1320</b> .....	181
Ignition Signal (DTC: 0201) .....	181
<b>TROUBLE DIAGNOSIS FOR DTC P1336</b> .....	186
Crankshaft Position Sensor (CKPS) (OBD) (COG) (DTC: 0905) .....	186
<b>TROUBLE DIAGNOSIS FOR DTC P1400</b> .....	190
EGR Valve and EVAP Canister Purge Control Solenoid Valve (DTC: 1005) .....	190
<b>TROUBLE DIAGNOSIS FOR DTC P1401</b> .....	194
EGR Temperature Sensor (DTC: 0305) .....	194
<b>TROUBLE DIAGNOSIS FOR DTC P1605</b> .....	198
A/T Diagnosis Communication Line (DTC: 0804) .....	198
<b>TROUBLE DIAGNOSIS FOR DTC P1900</b> .....	201
Cooling Fan (Overheat) (DTC: 0208) .....	201

<b>TROUBLE DIAGNOSIS FOR NON-DETECTABLE ITEMS</b> .....	214
Injector .....	214
Start Signal .....	217
Fuel Pump .....	219
Power Steering Oil Pressure Switch .....	224
IACV-Air Regulator .....	227
IACV-FICD Solenoid Valve .....	230
MIL & Data Link Connectors .....	233

[ ]      **GA**      [ ]

<b>ENGINE AND EMISSION CONTROL OVERALL SYSTEM</b> .....	234
Circuit Diagram .....	234
System Diagram .....	235
ECCS Component Parts Location .....	236
Vacuum Hose Drawing .....	239
System Chart .....	240
<b>ENGINE AND EMISSION BASIC CONTROL SYSTEM DESCRIPTION</b> .....	241
Multiport Fuel Injection (MFI) System .....	241
Distributor Ignition (DI) System .....	244
Air Conditioning Cut Control .....	245
Fuel Cut Control (at no load & high engine speed) .....	245
<b>EVAPORATIVE EMISSION SYSTEM</b> .....	246
<b>POSITIVE CRANKCASE VENTILATION</b> .....	248
<b>BASIC SERVICE PROCEDURE</b> .....	249
Fuel Pressure Release .....	249
Fuel Pressure Check .....	249
Fuel Pressure Regulator Check .....	250
Injector Removal and Installation .....	250
Fast Idle Cam (FIC) .....	251
Idle Speed/Ignition Timing/Idle Mixture Ratio Adjustment .....	253
<b>ON-BOARD DIAGNOSTIC SYSTEM DESCRIPTION</b> .....	260
Introduction .....	260
Two Trip Detection Logic .....	260
Diagnostic Trouble Code (DTC) .....	260
Freeze Frame Data .....	261
Malfunction Indicator Lamp (MIL) .....	262
OBD System Operation Chart .....	265
CONSULT .....	270
Generic Scan Tool (GST) .....	282
<b>TROUBLE DIAGNOSIS — Introduction</b> .....	284
<b>TROUBLE DIAGNOSIS — Work Flow</b> .....	286
<b>TROUBLE DIAGNOSIS — Basic Inspection</b> .....	288
<b>TROUBLE DIAGNOSIS — General Description</b> .....	291

GI

MA

EM

LC

EC

FE

CL

MT

AT

FA

RA

BR

ST

RS

BT

HA

EL

IDX

# CONTENTS (Cont'd.)

Diagnostic Trouble Code (DTC) Chart .....	291	EGRC-BPT Valve Function (DTC: 0306).....	386
Fail-Safe Chart.....	300	<b>TROUBLE DIAGNOSIS FOR DTC P0420</b> .....	388
Symptom Matrix Chart.....	301	Three Way Catalyst Function (DTC: 0702).....	388
CONSULT Reference Value in Data Monitor		<b>TROUBLE DIAGNOSIS FOR DTC P0500</b> .....	391
Mode .....	304	Vehicle Speed Sensor (VSS) (DTC: 0104) .....	391
Major Sensor Reference Graph in Data		<b>TROUBLE DIAGNOSIS FOR DTC P0505</b> .....	395
Monitor Mode.....	307	Idle Air Control Valve (IACV) — Auxiliary Air	
ECM Terminals and Reference Value.....	309	Control (AAC) Valve (DTC: 0205) .....	395
<b>TROUBLE DIAGNOSIS FOR POWER SUPPLY</b> ...	315	<b>TROUBLE DIAGNOSIS FOR DTC P0605</b> .....	399
Main Power Supply and Ground Circuit.....	315	Engine Control Module (ECM)-ECCS Control	
<b>TROUBLE DIAGNOSIS FOR DTC P0100</b> .....	318	Module (DTC: 0301) .....	399
Mass Air Flow Sensor (MAFS) (DTC: 0102).....	318	<b>TROUBLE DIAGNOSIS FOR DTC P0705</b> .....	401
<b>TROUBLE DIAGNOSIS FOR DTC P0110</b> .....	323	Park/Neutral Position Switch (DTC: 1003).....	401
Intake Air Temperature Sensor (DTC: 0401).....	323	<b>TROUBLE DIAGNOSIS FOR DTC P1110</b> .....	404
<b>TROUBLE DIAGNOSIS FOR DTC P0115</b> .....	328	Valve Timing Control (VTC) (DTC: 0805).....	404
Engine Coolant Temperature Sensor (ECTS)		<b>TROUBLE DIAGNOSIS FOR DTC P1320</b> .....	411
(DTC: 0103) .....	328	Ignition Signal (DTC: 0201) .....	411
<b>TROUBLE DIAGNOSIS FOR DTC P0120</b> .....	332	<b>TROUBLE DIAGNOSIS FOR DTC P1336</b> .....	416
Throttle Position Sensor (DTC: 0403) .....	332	Crankshaft Position Sensor (CKPS) (OBD)	
<b>TROUBLE DIAGNOSIS FOR DTC P0125</b> .....	337	(COG) (DTC: 0905) .....	416
Engine Coolant Temperature (ECT) Sensor		<b>TROUBLE DIAGNOSIS FOR DTC P1400</b> .....	420
(DTC: 0908) .....	337	EGR Valve and EVAP Canister Purge Control	
<b>TROUBLE DIAGNOSIS FOR DTC P0130</b> .....	342	Solenoid Valve (DTC: 1005).....	420
Front Oxygen Sensor* (Front O2S) (DTC:		<b>TROUBLE DIAGNOSIS FOR DTC P1401</b> .....	424
0303).....	342	EGR Temperature Sensor (DTC: 0305) .....	424
<b>TROUBLE DIAGNOSIS FOR DTC P0130</b> .....	347	<b>TROUBLE DIAGNOSIS FOR DTC P1550</b> .....	428
Closed Loop Control (DTC: 0307).....	347	Torque Converter Clutch Solenoid Valve (DTC:	
<b>TROUBLE DIAGNOSIS FOR DTC P0135</b> .....	348	0904).....	428
Front Heated Oxygen Sensor Heater (DTC:		<b>TROUBLE DIAGNOSIS FOR DTC P1900</b> .....	430
0901) .....	348	Cooling Fan (Overheat) (DTC: 0208).....	430
<b>TROUBLE DIAGNOSIS FOR DTC P0136</b> .....	351	<b>TROUBLE DIAGNOSIS FOR</b>	
Rear Heated Oxygen Sensor (Rear HO2S)		<b>NON-DETECTABLE ITEMS</b> .....	439
(DTC: 0707) .....	351	Injector .....	439
<b>TROUBLE DIAGNOSIS FOR DTC P0170</b> .....	356	Start Signal .....	442
Fuel Injection System Function (DTC: 0706) .....	356	Fuel Pump.....	444
<b>TROUBLE DIAGNOSIS FOR DTC P0300 -</b>		Power Steering Oil Pressure Switch .....	448
<b>P0304</b> .....	361	IACV-FICD Solenoid Valve .....	451
No. 4 - 1 Cylinder Misfire, Multiple Cylinder		Electrical Load Signal .....	454
Misfire (DTC: 0701 - 0605).....	361	MIL & Data Link Connectors.....	457
<b>TROUBLE DIAGNOSIS FOR DTC P0325</b> .....	365		
Knock Sensor (KS) (DTC: 0304) .....	365	<b>SR</b> <input type="text"/>	
<b>TROUBLE DIAGNOSIS FOR DTC P0335</b> .....	368		
Crankshaft Position Sensor (CKPS) (OBD)		<b>TROUBLE DIAGNOSIS — Index</b> .....	458
(DTC: 0802) .....	368	Alphabetical & P No. Index for DTC.....	458
<b>TROUBLE DIAGNOSIS FOR DTC P0340</b> .....	372		
Camshaft Position Sensor (CMPS)(DTC:		<b>GA</b> <input type="text"/>	
0101) .....	372		
<b>TROUBLE DIAGNOSIS FOR DTC P0400</b> .....	377	<b>TROUBLE DIAGNOSIS — Index</b> .....	459
EGR Function (DTC: 0302) .....	377	Alphabetical & P No. Index for DTC.....	459
<b>TROUBLE DIAGNOSIS FOR DTC P0402</b> .....	386		

# CONTENTS (Cont'd.)

\_\_\_\_\_ SR \_\_\_\_\_ GA \_\_\_\_\_

**SERVICE DATA AND SPECIFICATIONS (SDS) ... 460**  
General Specifications ..... 460  
Inspection and Adjustment..... 460

**SERVICE DATA AND SPECIFICATIONS (SDS) ... 462**  
General Specifications ..... 462  
Inspection and Adjustment..... 462

GI

MA

EM

LC

**EC**

FE

CL

MT

AT

FA

RA

BR

ST

RS

BT

HA

EL

IDX

**When you read wiring diagrams:**  
• Read GI section, "HOW TO READ WIRING DIAGRAMS".  
• Read EL section, "POWER SUPPLY ROUTING" for power distribution circuit.  
**When you perform trouble diagnoses, read GI section, "HOW TO FOLLOW FLOW CHART IN TROUBLE DIAGNOSES" and "HOW TO PERFORM EFFICIENT DIAGNOSIS FOR AN ELECTRICAL INCIDENT".**



# PRECAUTIONS AND PREPARATION

## Special Service Tools

The actual shapes of Kent-Moore tools may differ from those of special service tools illustrated here.

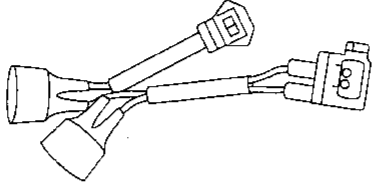
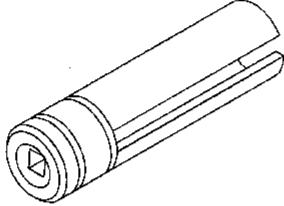
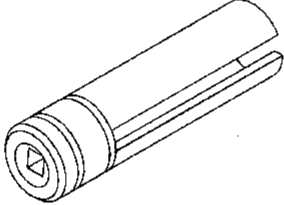
Tool number (Kent-Moore No.) Tool name	Description	Engine application		
		SR	GA	
EG11140000 (J36777-6) Ignition coil adapter harness	 NT338	Measuring engine speed	X	X
(J36471-A) Front heated oxygen sensor wrench	 NT379	Loosening or tightening front heated oxygen sensor	X	X
(J36470) Rear heated oxygen sensor wrench	 NT379	Loosening or tightening rear heated oxygen sensor	X	X

## Supplemental Restraint System (SRS) "AIR BAG"

The Supplemental Restraint System "Air Bag", used along with a seat belt, helps to reduce the risk or severity of injury to the driver and front passenger in a frontal collision. The Supplemental Restraint System consists of air bag modules (located in the center of the steering wheel and on the instrument panel on the passenger side), a diagnosis sensor unit, warning lamp, wiring harness and spiral cable. Information necessary to service the system safely is included in the **RS section** of this Service Manual.

**WARNING:**

- To avoid rendering the SRS inoperative, which could increase the risk of personal injury or death in the event of a collision which would result in air bag inflation, all maintenance must be performed by an authorized NISSAN dealer.
- Improper maintenance, including incorrect removal and installation of the SRS, can lead to personal injury caused by unintentional activation of the system.
- Do not use electrical test equipment on any circuit related to the SRS unless instructed to in this Service Manual. SRS wiring harnesses are covered with yellow insulation either just before the harness connectors or for the complete harness, for easy identification.

## Precautions for On-Board Diagnostic (OBD) System of Engine and A/T

The ECM (ECCS control module) has an on-board diagnostic system. It will light up the malfunction indicator lamp (MIL) to warn the driver of a malfunction causing emission deterioration.

### CAUTION:

- Be sure to turn the ignition switch "OFF" and disconnect the negative battery terminal before any repair or inspection work. The open/short circuit of related switches, sensors, solenoid valves, etc. will cause the MIL to light up.
- Be sure to connect and lock the connectors securely after work. A loose (unlocked) connector will cause the MIL to light up due to the open circuit. (Be sure the connector is free from water, grease, dirt, bent terminals, etc.)
- Be sure to route and secure the harnesses properly after work. The interference of the harness with a bracket, etc. may cause the MIL to light up due to the short circuit.
- Be sure to connect rubber tubes properly after work. A misconnected or disconnected rubber tube may cause the MIL to light up due to the malfunction of the EGR system or fuel injection system, etc.
- Be sure to erase the unnecessary malfunction information (repairs completed) from the ECM or A/T control unit before returning the vehicle to the customer.

GI

MA

EM

LC

EC

FE

CL

MT

AT

FA

RA

BR

ST

RS

BT

HA

EL

IDX

## Engine Fuel & Emission Control System

### BATTERY

- Always use a 12 volt battery as power source.
- Do not attempt to disconnect battery cables while engine is running.

### ECM

- Do not disassemble ECM (ECCS control module).
- Do not turn on-board diagnostic test mode selector forcibly.
- If a battery terminal is disconnected, the memory will return to the ECM value. The ECM will now start to self-control at its initial value. Engine operation can vary slightly when the terminal is disconnected. However, this is not an indication of a problem. Do not replace parts because of a slight variation.

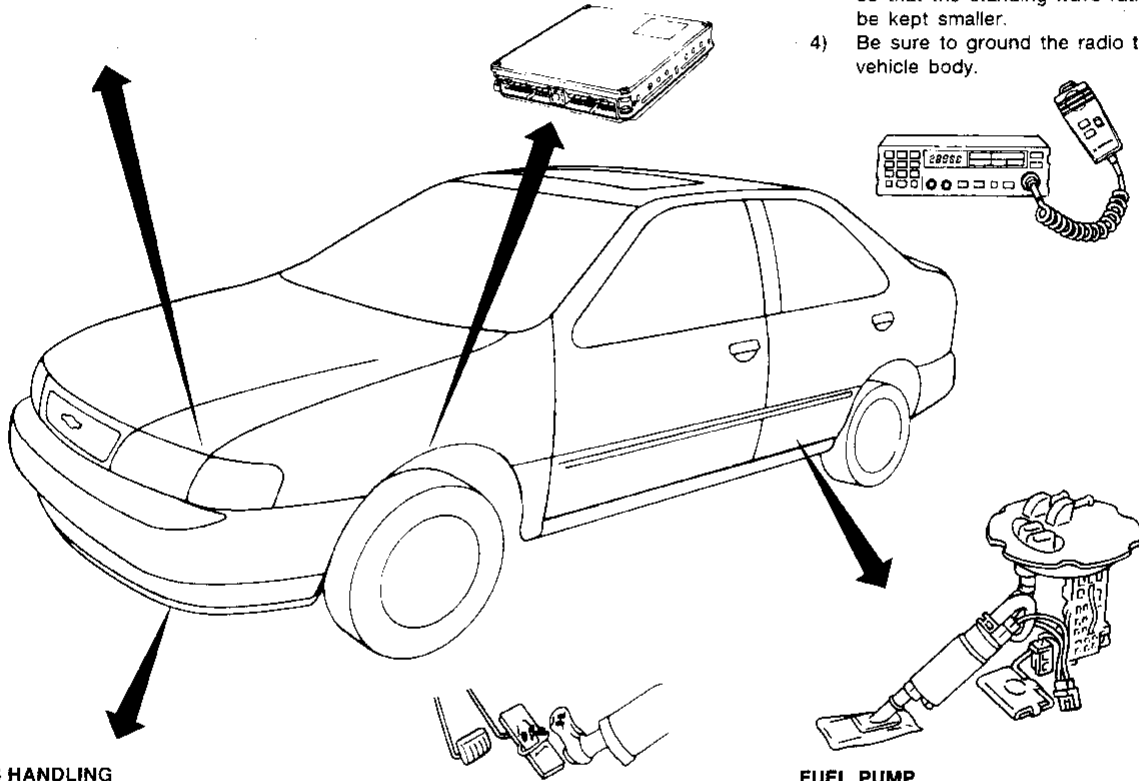

### ECCS PARTS HANDLING

- Handle mass air flow sensor carefully to avoid damage.
- Do not disassemble mass air flow sensor.
- Do not clean mass air flow sensor with any type of detergent.
- Do not disassemble IAC valve-AAC valve.
- Even a slight leak in the air intake system can cause serious problems.
- Do not shock or jar the camshaft position sensor.

### WHEN STARTING

- Do not depress accelerator pedal when starting.
- Immediately after starting, do not rev up engine unnecessarily.
- Do not rev up engine just prior to shutdown.

### WIRELESS EQUIPMENT

- When installing C.B. ham radio or a mobile phone, be sure to observe the following as it may adversely affect electronic control systems depending on its installation location.
  - 1) Keep the antenna as far as possible away from the electronic control units.
  - 2) Keep the antenna feeder line more the 20 cm (8 in) away from the harness of electronic controls. Do not let them run parallel for a long distance.
  - 3) Adjust the antenna and feeder line so that the standing-wave ratio can be kept smaller.
  - 4) Be sure to ground the radio to vehicle body.

### FUEL PUMP

- Do not operate fuel pump when there is no fuel in lines.
- Tighten fuel hose clamps to the specified torque.

### ECM HARNESS HANDLING

- Securely connect ECM harness connectors. A poor connection can cause an extremely high (surge) voltage to develop in coil and condenser, thus resulting in damage to ICs.
- Keep ECM harness at least 10 cm (4 in) away from adjacent harnesses, to prevent an ECM system malfunction due to receiving external noise, degraded operation of ICs, etc.
- Keep ECM parts and harnesses dry.
- Before removing parts, turn off ignition switch and then disconnect battery ground cable.

# PRECAUTIONS AND PREPARATION

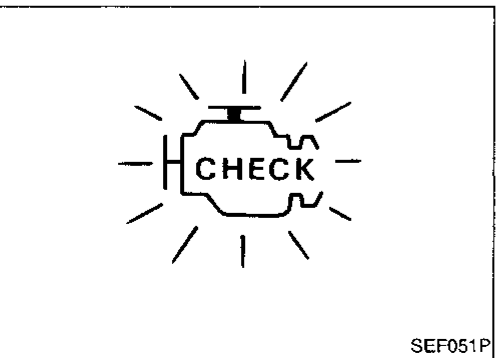
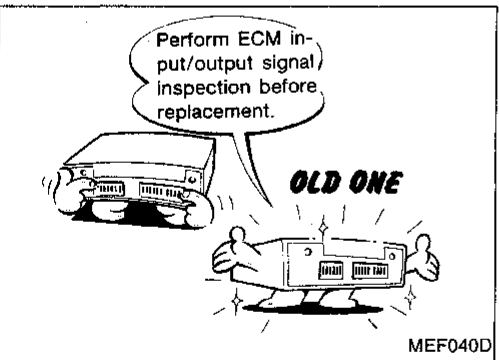
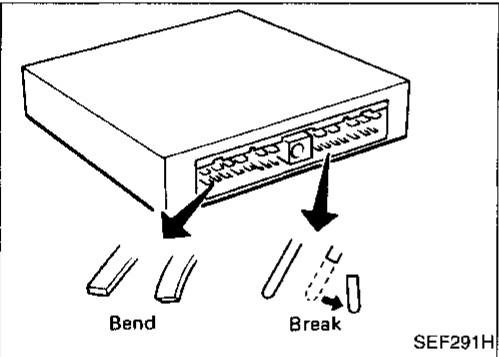
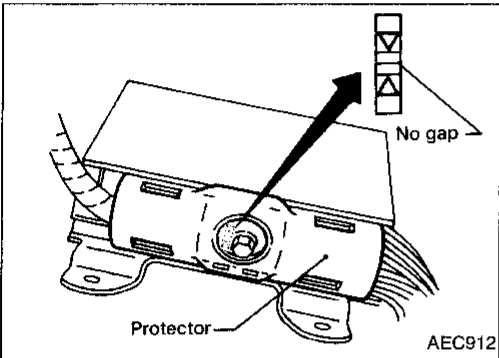
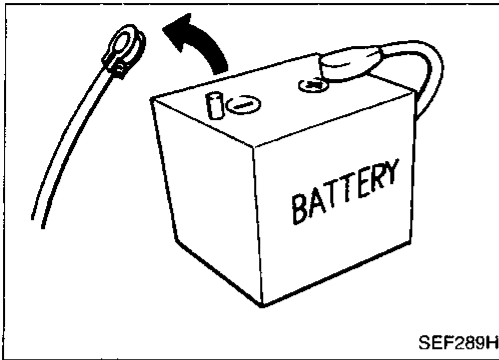

## Precautions

- Before connecting or disconnecting the ECM harness connector, turn ignition switch OFF and disconnect negative battery terminal. Failure to do so may damage the ECM because battery voltage is applied to ECM even if ignition switch is turned off.
- When connecting ECM harness connector, tighten securing bolt until the gap between orange indicators disappears.
- When connecting or disconnecting pin connectors into or from ECM, take care not to damage pin terminals (bend or break). Make sure that there are not any bends or breaks on ECM pin terminal, when connecting pin connectors.
- Before replacing ECM, perform Terminals and Reference Value inspection and make sure ECM functions properly. Refer to EC-84 for SR engine model and EC-310 for GA engine model.
- After performing each TROUBLE DIAGNOSIS, perform "OVERALL FUNCTION CHECK" or "DTC (Diagnostic Trouble Code) CONFIRMATION PROCEDURE". The DTC should not be displayed in the "DTC CONFIRMATION PROCEDURE" if the repair is completed. The "OVERALL FUNCTION CHECK" should be a good result if the repair is completed.

GI

MA

EM

LC

EC

FE

CL

MT

AT

FA

RA

BR

ST

RS

BT

HA

EL

IDX

## PRECAUTIONS AND PREPARATION

### Precautions (Cont'd)

- When measuring ECM signals with a circuit tester, never allow the two tester probes to contact. Accidental contact of probes will cause a short circuit and damage the ECM power transistor.

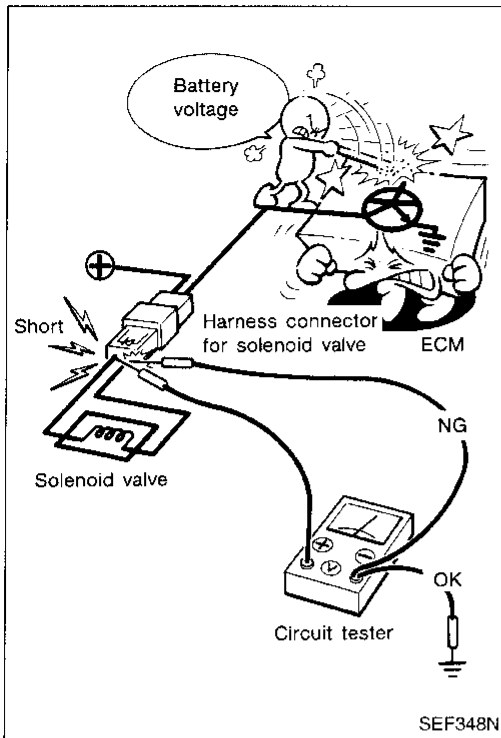

Circuit Diagram

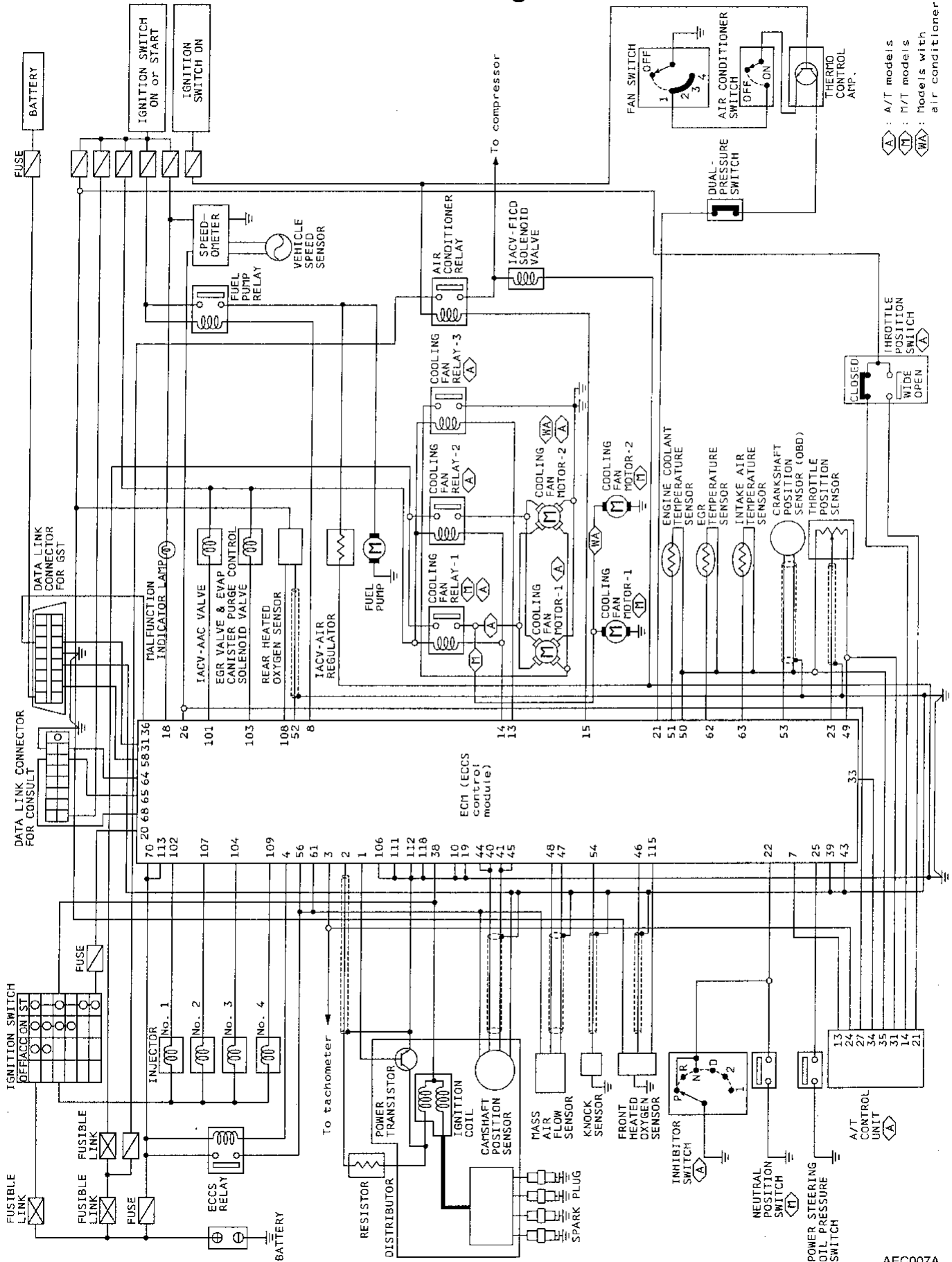

G  
 MA  
 EM  
 LC  
**EC**  
 FE  
 CL  
 MT  
 AT  
 FA  
 RA  
 BR  
 ST  
 ES  
 BT  
 HA  
 EL  
 IDX

System Diagram

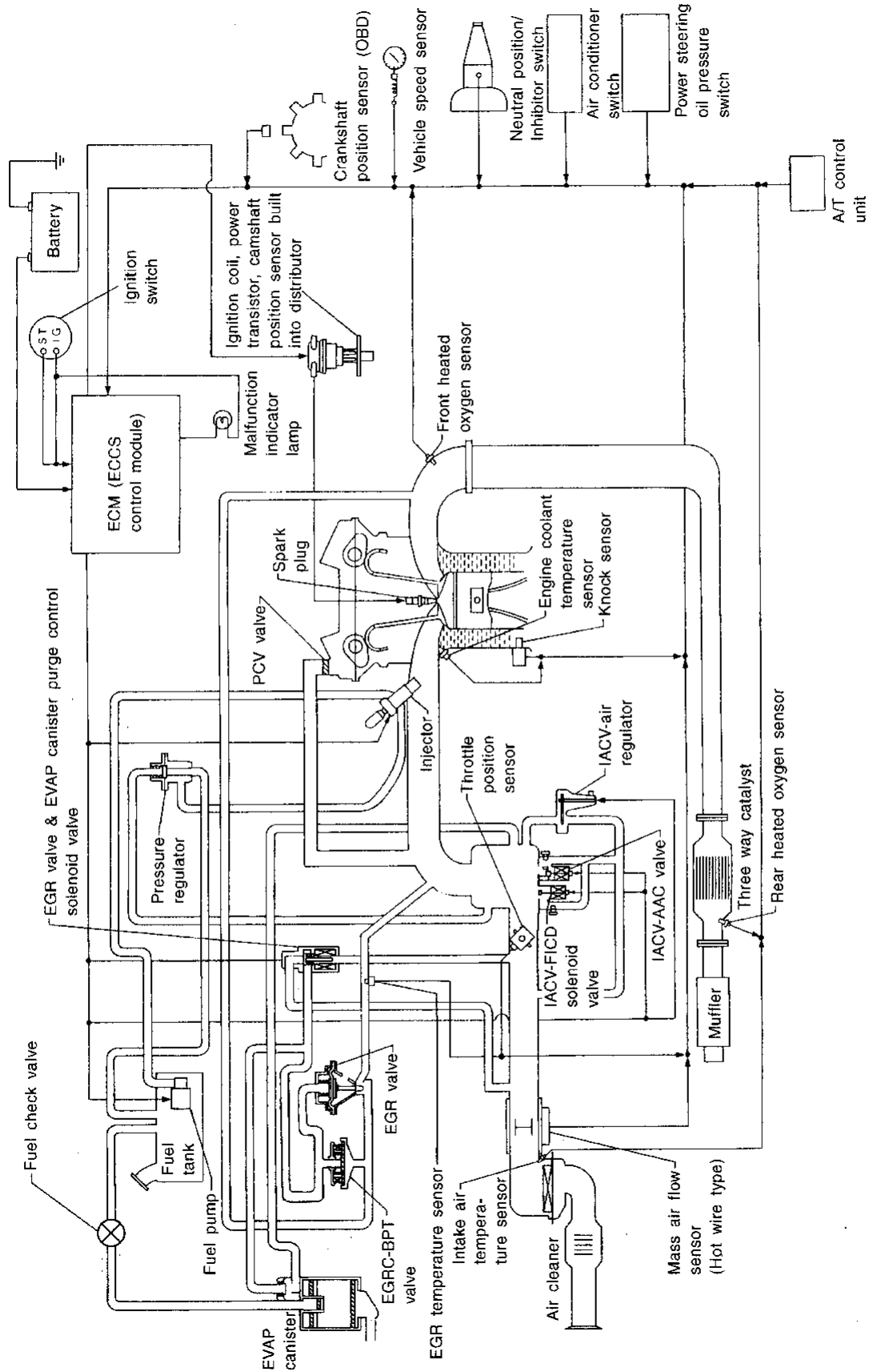

ECCS Component Parts Location

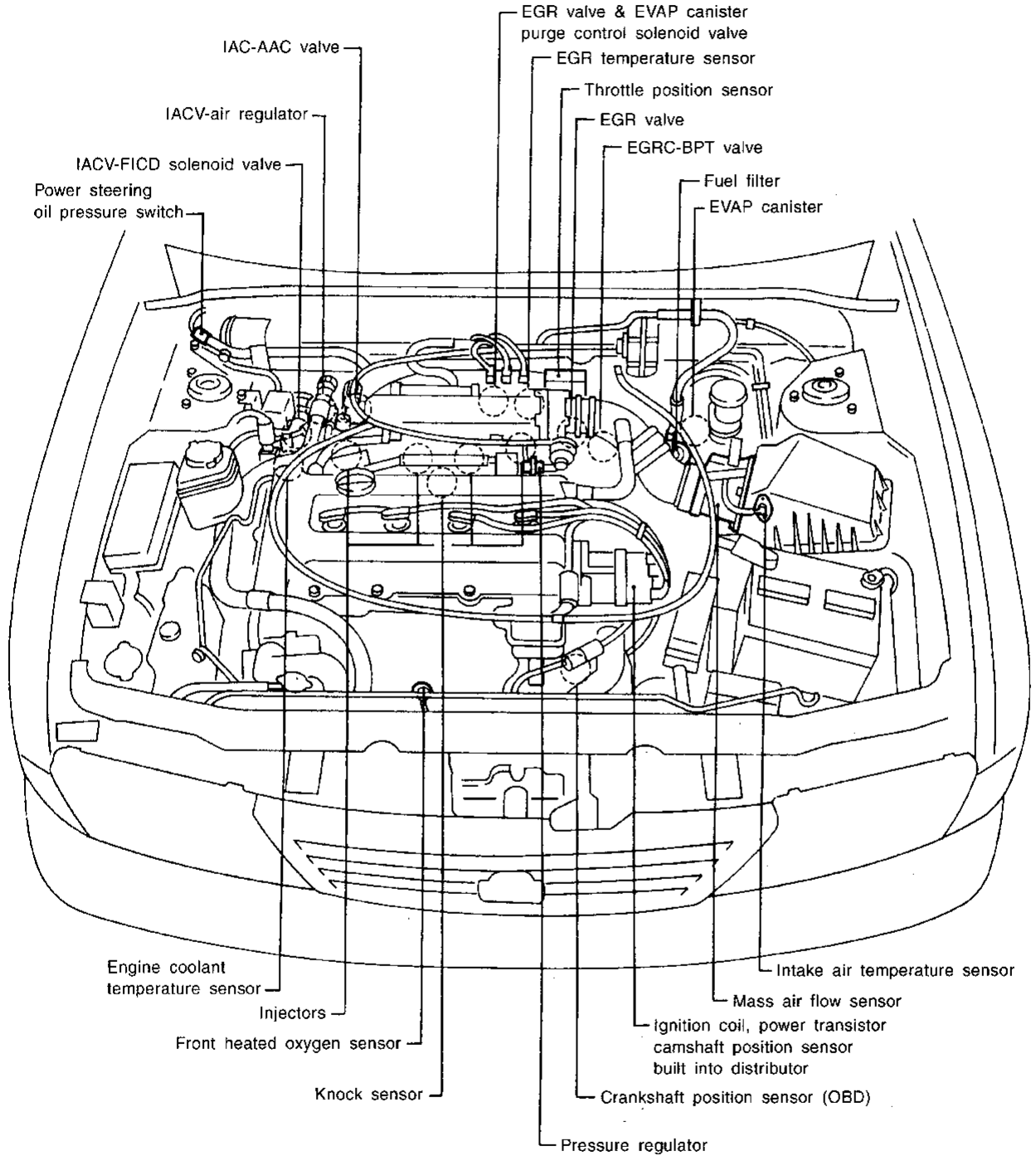

GI  
MA  
EM  
LC  
**EC**  
FE  
CL  
MT  
AT  
FA  
RA  
BR  
ST  
RS  
BT  
HA  
EL  
IDX



ECCS Component Parts Location (Cont'd)

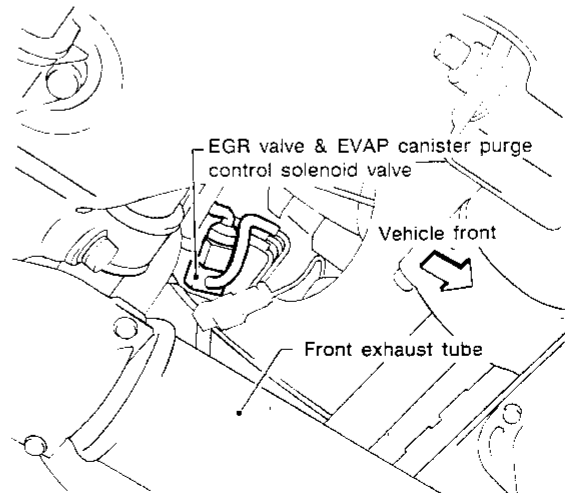
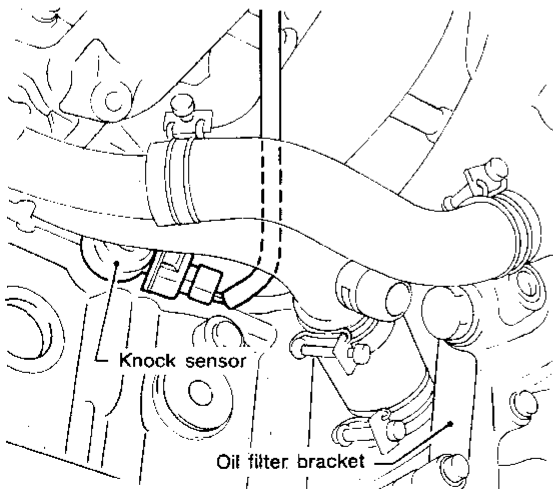
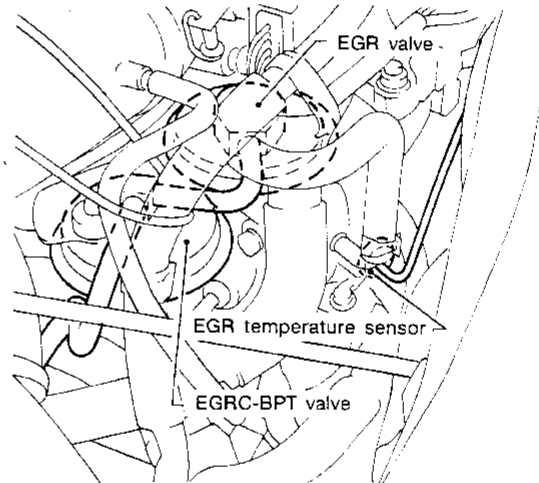
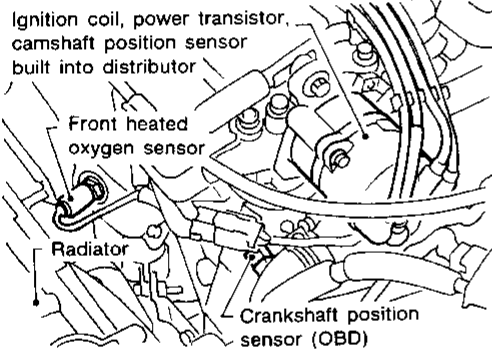
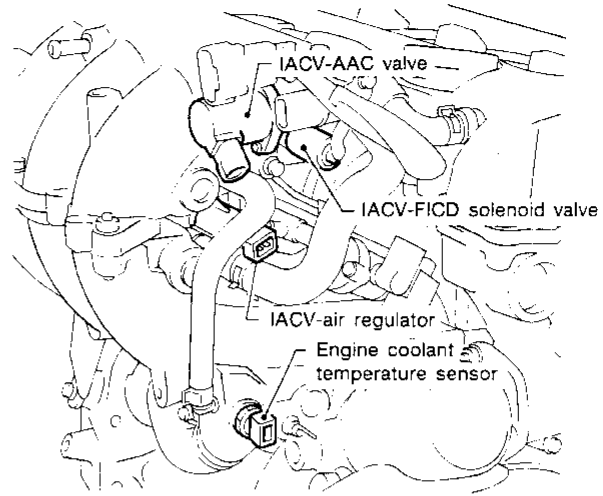
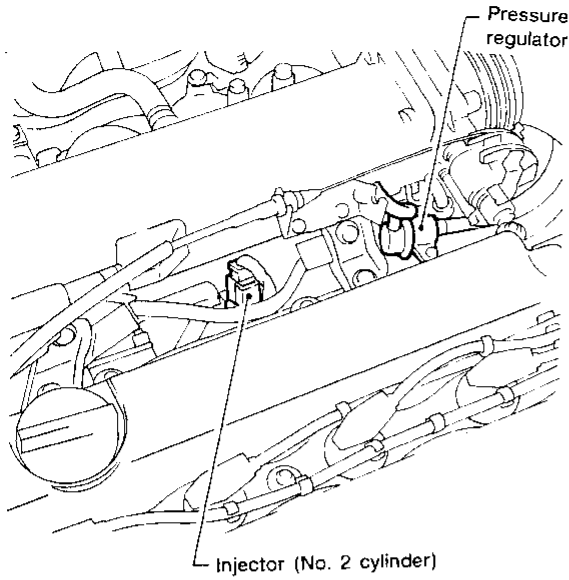

ECCS Component Parts Location (Cont'd)

Left side view

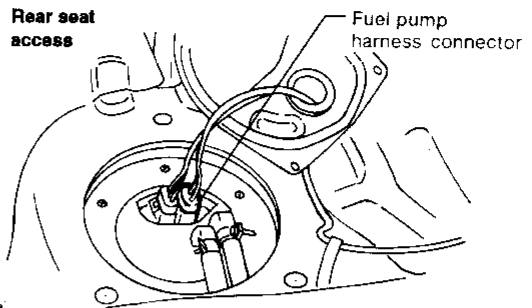
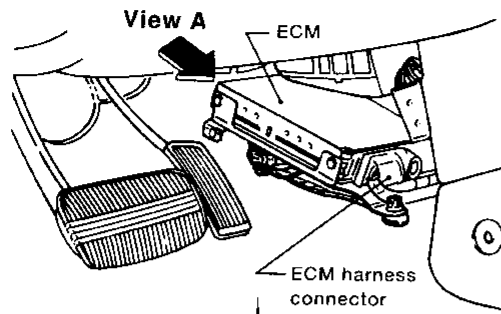

View A

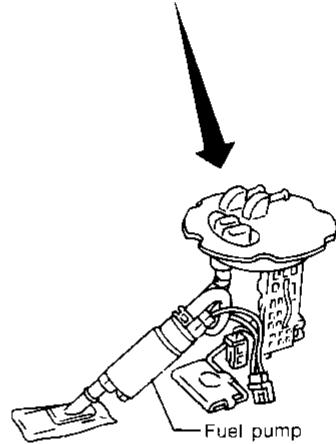
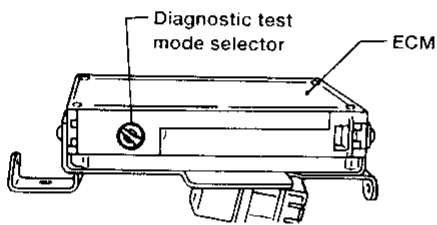

AEC803

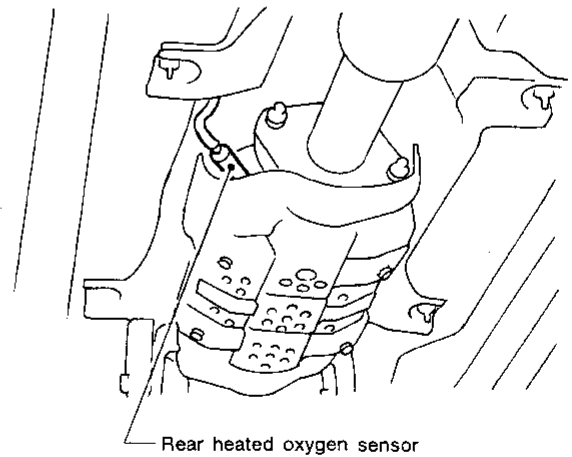
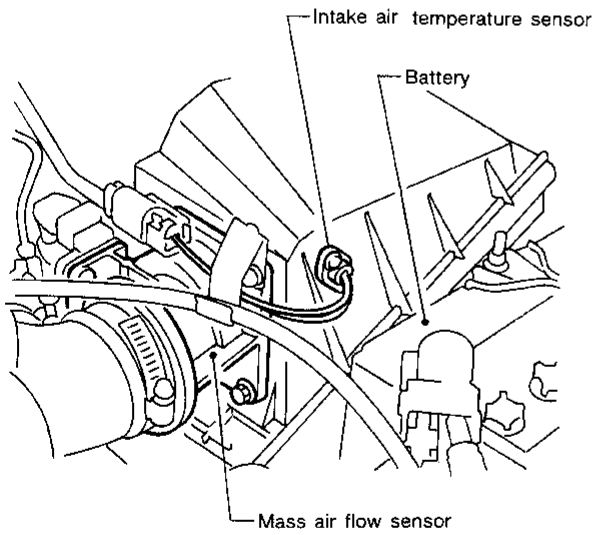

SEF048P

GI

MA

EM

LC

EC

FE

CL

MT

AT

FA

RA

BR

ST

RS

BT

HA

EL

EDX

## ECCS Component Parts Location (Cont'd)

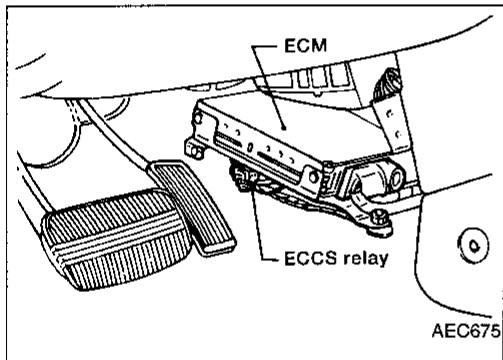
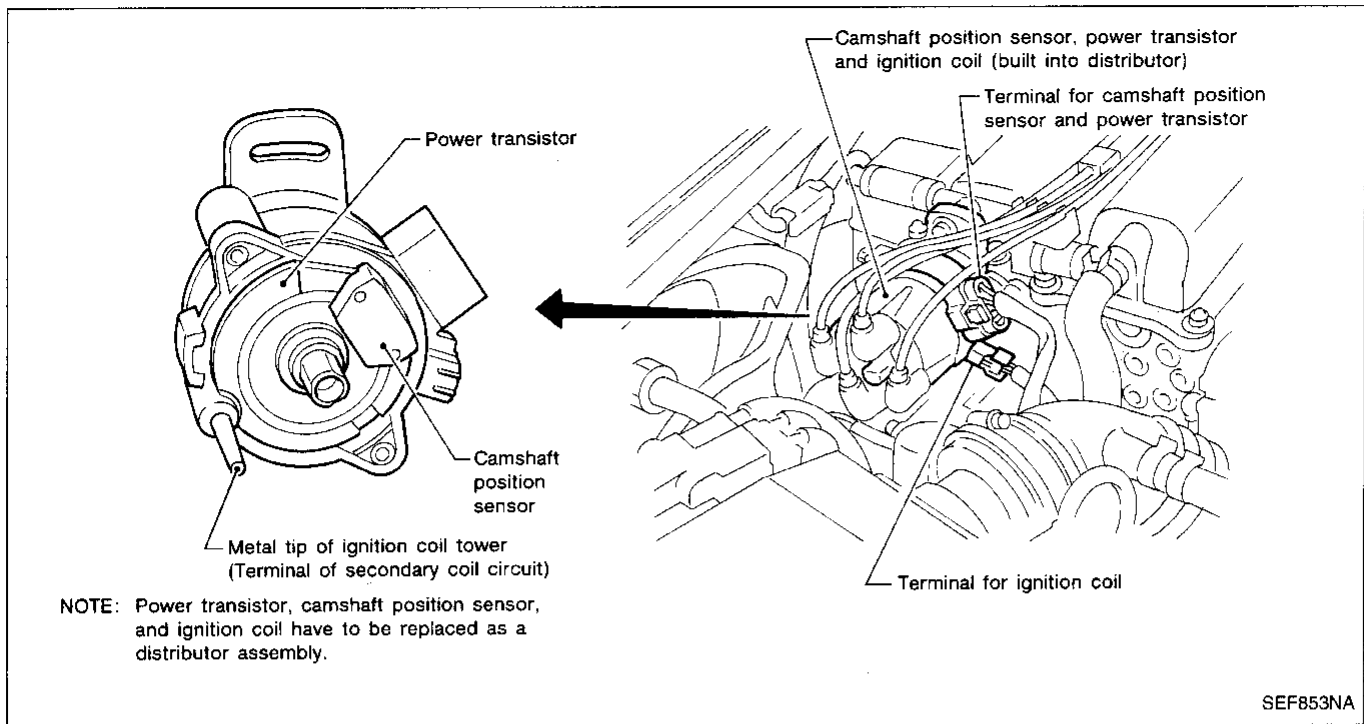

Vacuum Hose Drawing

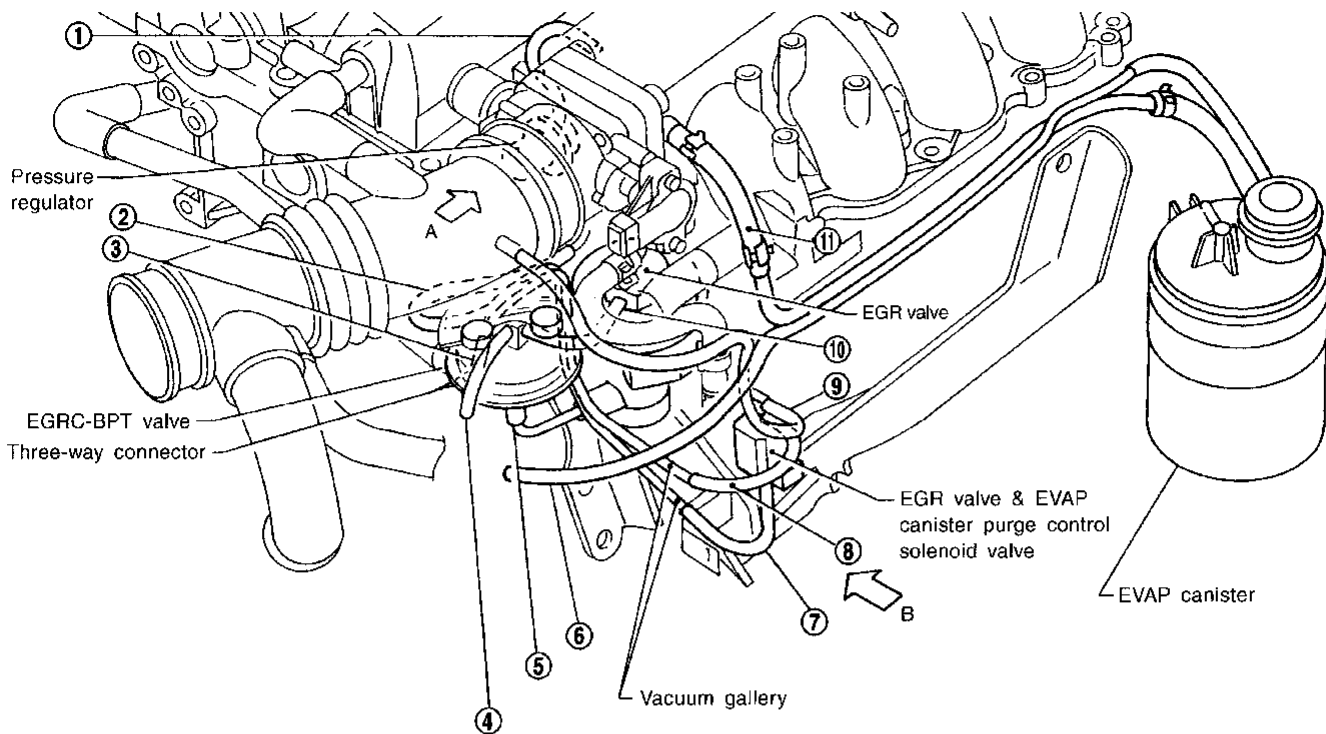

View A

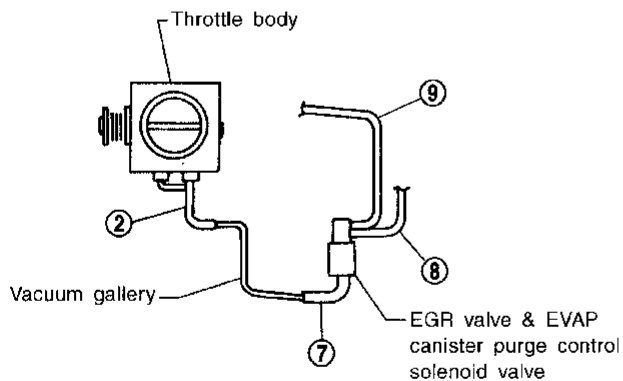

View B

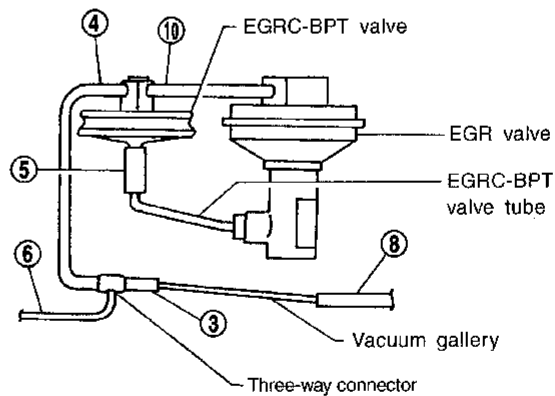

SEF218R

- ① Pressure regulator to intake manifold collector
- ② Throttle body to vacuum gallery
- ③ Three-way connector to vacuum gallery
- ④ EGRC-BPT valve to three-way connector
- ⑤ EGRC-BPT valve to EGRC-BPT valve tube
- ⑥ Three-way connector to canister (vacuum line)
- ⑦ EGR valve & EVAP canister purge control solenoid valve to vacuum gallery (for throttle body)
- ⑧ EGR valve & EVAP canister purge control solenoid valve to vacuum gallery (for three-way connector)
- ⑨ EGR valve & EVAP canister purge control solenoid valve to air duct
- ⑩ EGRC-BPT valve to EGR valve
- ⑪ EVAP canister (purge line) to intake manifold collector

Refer to "System Diagram" in ENGINE AND EMISSION CONTROL OVERALL SYSTEM for vacuum control system.

GI  
MA  
EM  
LC  
EC  
FE  
CL  
MT  
AT  
FA  
RA  
BR  
ST  
RS  
BT  
HA  
EL  
IDX

System Chart

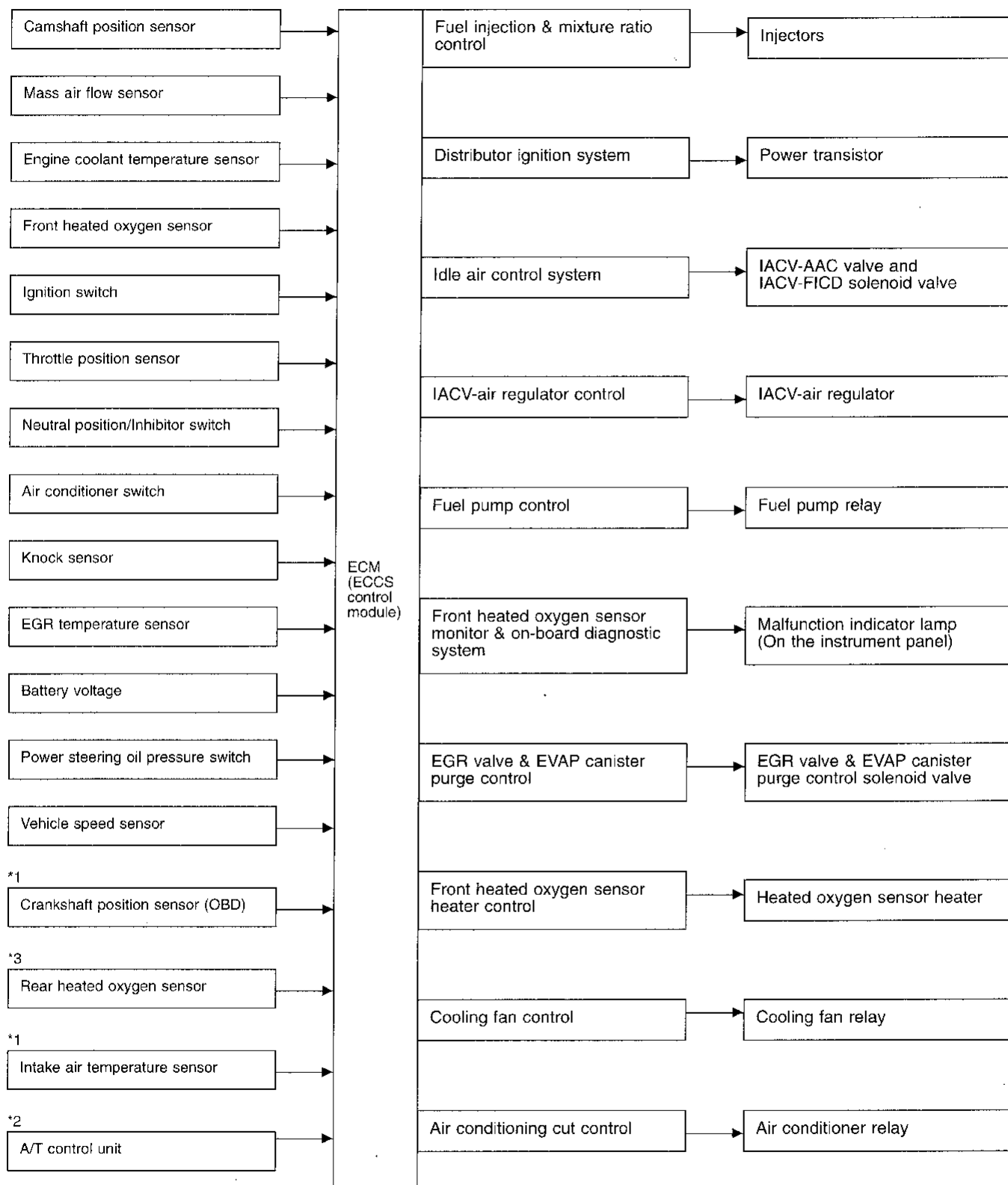

\*1: These sensors are not directly used to control the engine system. They are used only for the on-board diagnosis.

\*2: The DTC related to A/T will be sent to ECM.

\*3: Under normal conditions, this sensor is not for engine control operation.

## Multiport Fuel Injection (MFI) System

### INPUT/OUTPUT SIGNAL LINE

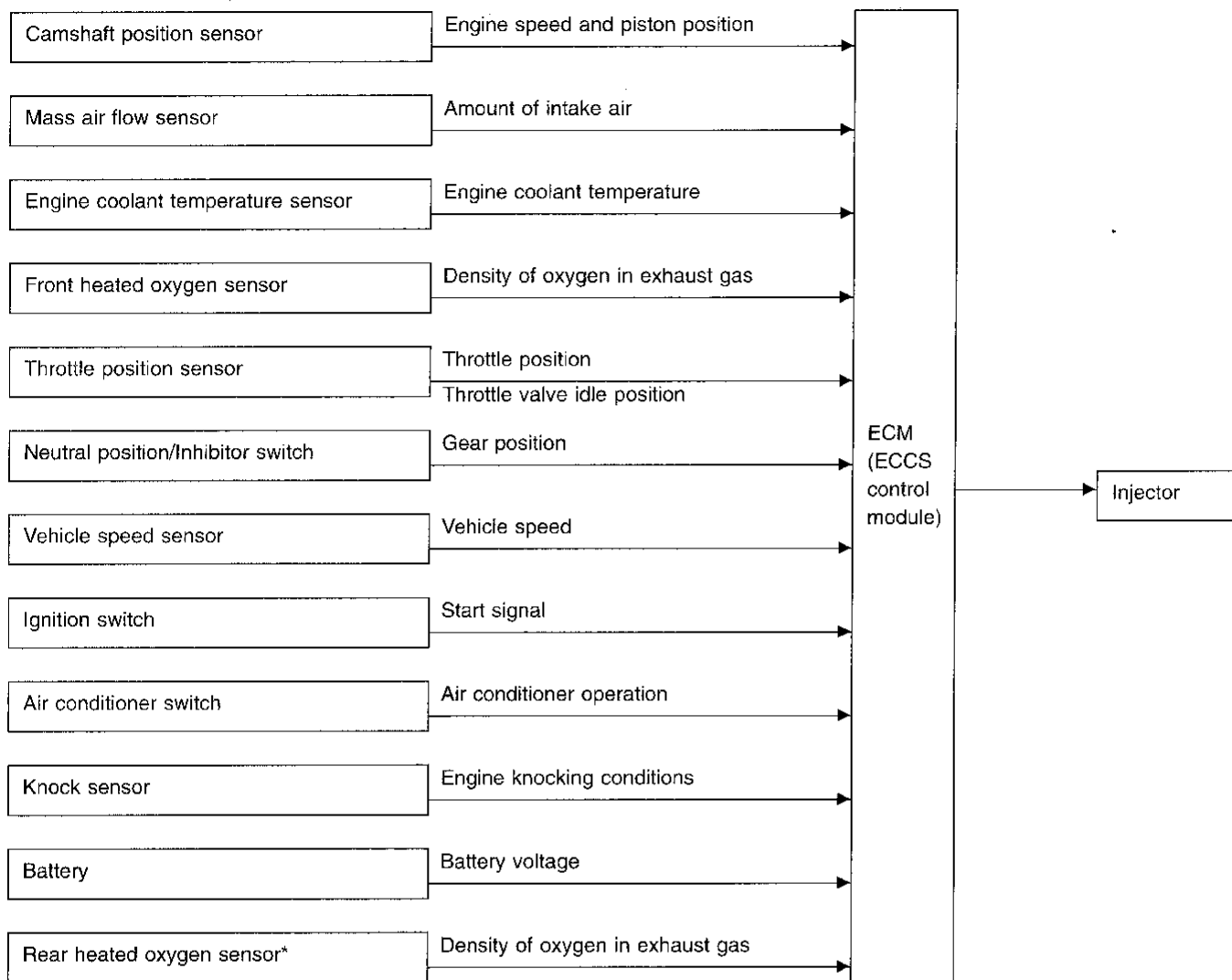

\* Under normal conditions, this sensor is not for engine control operation.

### BASIC MULTI-PORT FUEL INJECTION SYSTEM

The amount of fuel injected from the fuel injector is determined by the ECM. The ECM controls the length of time the valve remains open (injection pulse duration). The amount of fuel injected is a program value in the ECM memory. The program value is preset by engine operating conditions. These conditions are determined by input signals (for engine speed and intake air) from both the camshaft position sensor and the mass air flow sensor.

### VARIOUS FUEL INJECTION INCREASE/DECREASE COMPENSATION

In addition, the amount of fuel injected is compensated to improve engine performance under various operating conditions as listed below.

<Fuel increase>

- During warm-up
- When starting the engine
- During acceleration
- Hot-engine operation
- When selector lever is changed from "N" to "D" (A/T models only)
- High-load operation

<Fuel decrease>

- During deceleration

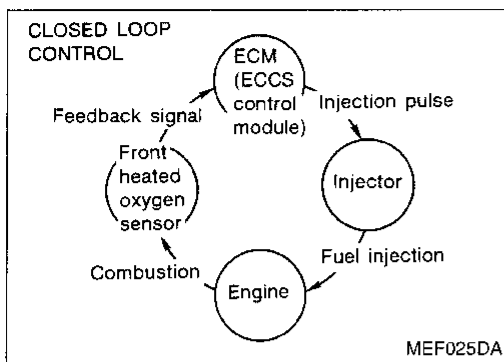

**Multipoint Fuel Injection (MFI) System (Cont'd)  
MIXTURE RATIO FEEDBACK CONTROL (CLOSED LOOP CONTROL)**

The mixture ratio feedback system provides the best air-fuel mixture ratio for driveability and emission control. The three way catalyst can then better reduce CO, HC and NOx emissions. This system uses a front heated oxygen sensor in the exhaust manifold to monitor if the engine operation is rich or lean. The ECM adjusts the injection pulse width according to the sensor voltage signal. For more information about the front heated oxygen sensor, refer to EC-117. This maintains the mixture ratio within the range of stoichiometric (ideal air-fuel mixture).

This stage is referred to as the closed loop control condition. Rear heated oxygen sensor is located downstream of the three way catalyst. Even if the switching characteristics of the front heated oxygen sensor shift, the air-fuel ratio is controlled to stoichiometric by the signal from the rear heated oxygen sensor.

**OPEN LOOP CONTROL**

The open loop system condition refers to when the ECM detects any of the following conditions. Feedback control stops in order to maintain stabilized fuel combustion.

- Deceleration and acceleration
- High-load, high-speed operation
- Engine idling
- Malfunction of front heated oxygen sensor or its circuit
- Insufficient activation of front heated oxygen sensor at low engine coolant temperature
- High-engine coolant temperature
- After shifting from "N" to "D"
- During warm-up
- When starting the engine

**MIXTURE RATIO SELF-LEARNING CONTROL**

The mixture ratio feedback control system monitors the mixture ratio signal transmitted from the front heated oxygen sensor. This feedback signal is then sent to the ECM. The ECM controls the basic mixture ratio as close to the theoretical mixture ratio as possible. However, the basic mixture ratio is not necessarily controlled as originally designed. Both manufacturing differences (i.e., mass air flow sensor hot wire) and characteristic changes during operation (i.e., injector clogging) directly affect mixture ratio. Accordingly, the difference between the basic and theoretical mixture ratios is monitored in this system. This is then computed in terms of "injection pulse duration" to automatically compensate for the difference between the two ratios.

"Fuel trim" refers to the feedback compensation value compared against the basic injection duration. Fuel trim includes short-term fuel trim and long-term fuel trim.

"Short-term fuel trim" is the short-term fuel compensation used to maintain the mixture ratio at its theoretical value. The signal from the front heated oxygen sensor indicates whether the mixture ratio is RICH or LEAN compared to the theoretical value. The signal then triggers a reduction in fuel volume if the mixture ratio is rich, and an increase in fuel volume if it is lean.

"Long-term fuel trim" is overall fuel compensation carried out long-term to compensate for continual deviation of the short-term fuel trim from the central value. Such deviation will occur due to individual engine differences, wear over time and changes in the usage environment.

**Multiport Fuel Injection (MFI) System (Cont'd)**

**FUEL INJECTION TIMING**

Two types of systems are used.

**Sequential multiport fuel injection system**

Fuel is injected into each cylinder during each engine cycle according to the firing order. This system is used when the engine is running.

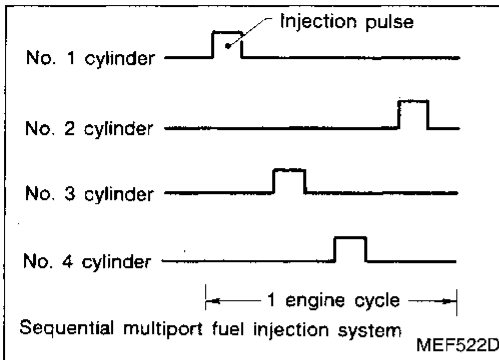

**Simultaneous multiport fuel injection system**

Fuel is injected simultaneously into all four cylinders twice each engine cycle. In other words, pulse signals of the same width are simultaneously transmitted from the ECM.

The four injectors will then receive the signals two times for each engine cycle.

This system is used when the engine is being started and/or if the fail-safe system (CPU) is operating.

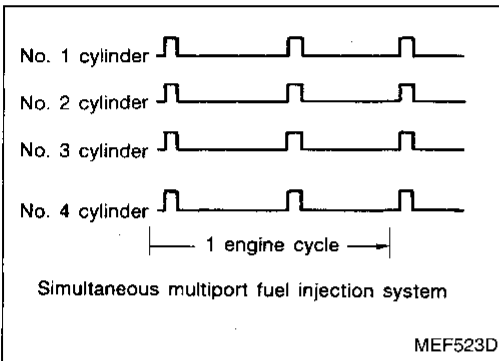

**FUEL SHUT-OFF**

Fuel to each cylinder is cut off during deceleration or operation of the engine at excessively high speeds.

**Distributor Ignition (DI) System**

**INPUT/OUTPUT SIGNAL LINE**

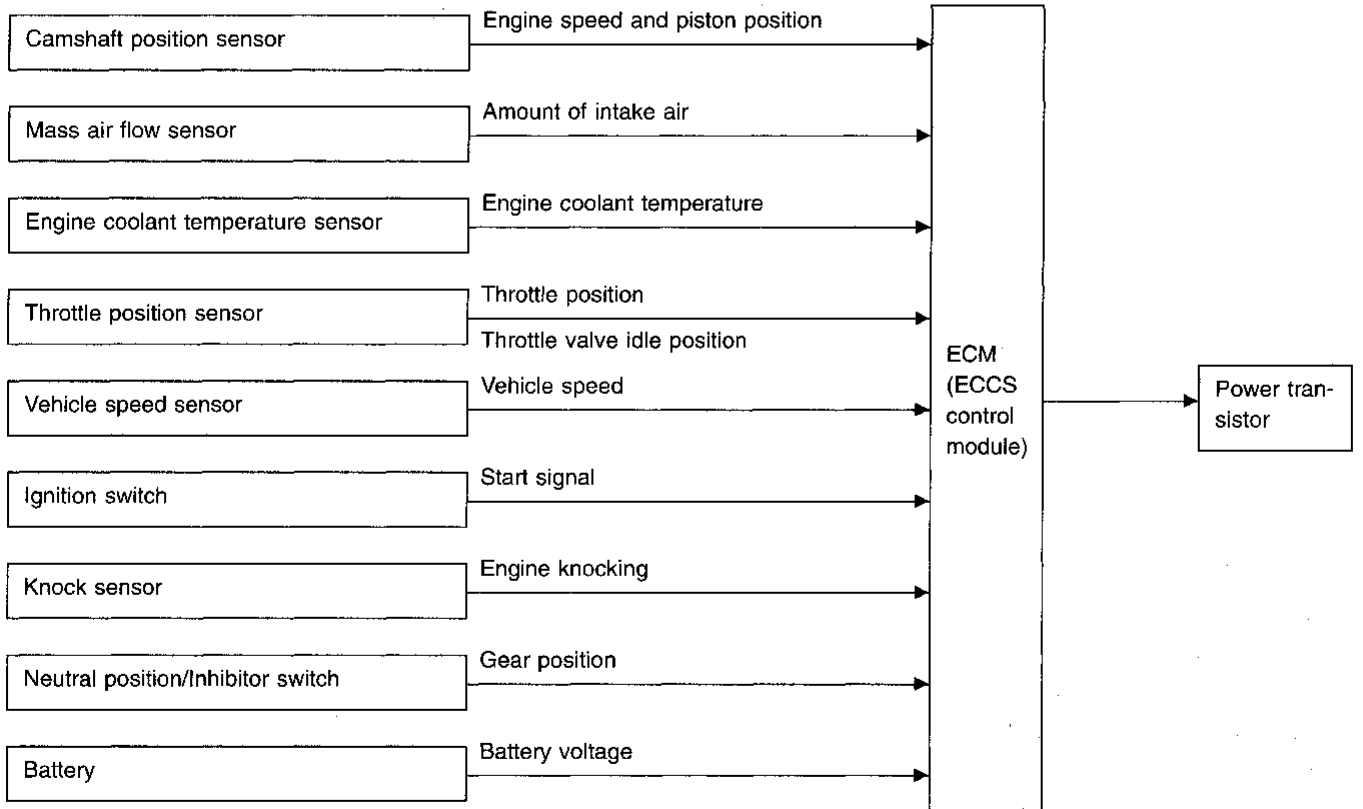



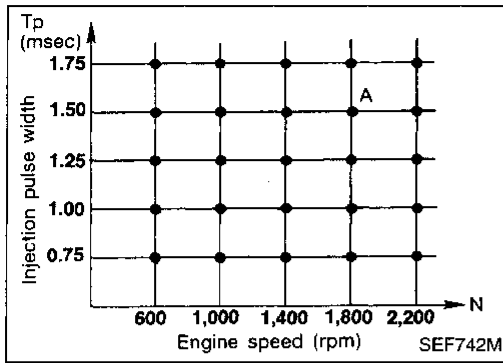

**Distributor Ignition (DI) System (Cont'd)**

**SYSTEM DESCRIPTION**

The ignition timing is controlled by the ECM to maintain the best air-fuel ratio for every running condition of the engine.

The ignition timing data is stored in the ECM. This data forms the map shown.

The ECM receives information such as the injection pulse width and camshaft position sensor signal. Computing this information, ignition signals are transmitted to the power transistor.

e.g., N: 1,800 rpm, Tp: 1.50 msec  
A °BTDC

During the following conditions, the ignition timing is revised by the ECM according to the other data stored in the ECM.

- At starting
- During warm-up
- At idle
- Hot engine operation
- During acceleration

The knock sensor retard system is designed only for emergencies. The basic ignition timing is programmed within the anti-knocking zone, if recommended fuel is used under dry conditions. The retard system does not operate under normal driving conditions.

If engine knocking occurs, the knock sensor monitors the condition. The signal is transmitted to the ECM (ECCS control module). The ECM retards the ignition timing to eliminate the knocking condition.

**Air Conditioning Cut Control**

**INPUT/OUTPUT SIGNAL LINE**

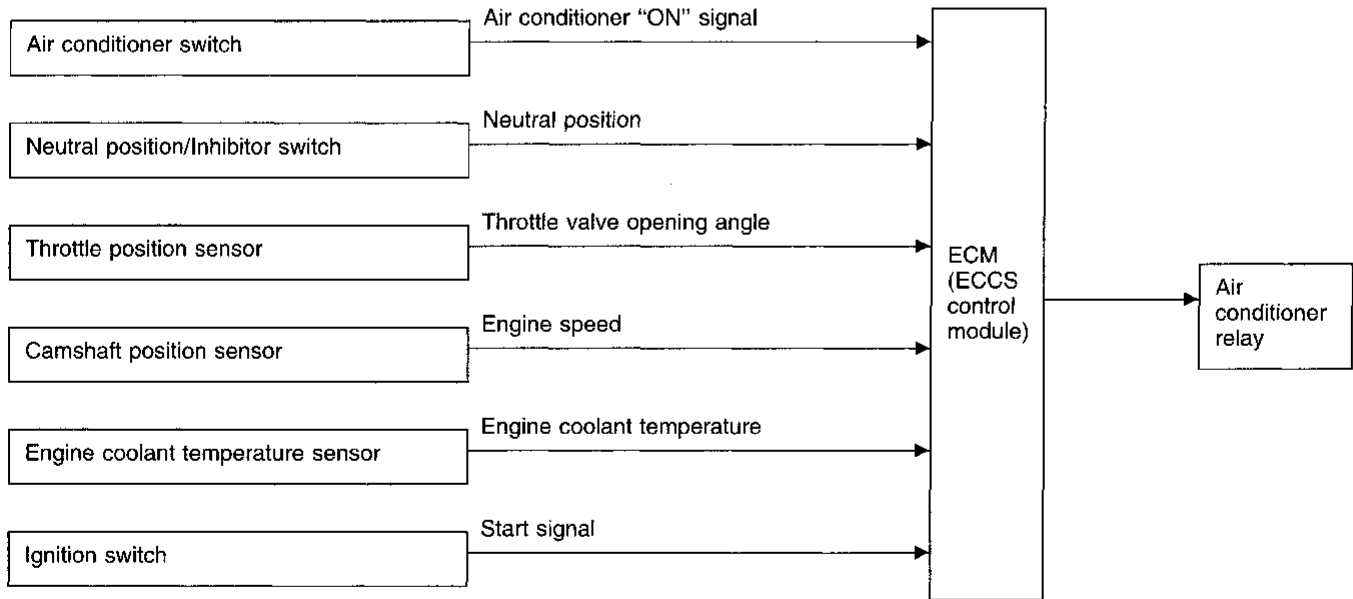

**SYSTEM DESCRIPTION**

This system improves acceleration when the air conditioner is used.

When the accelerator pedal is fully depressed, the air conditioner is turned off for a few seconds.

When engine coolant temperature becomes excessively high, the air conditioner is turned off. This continues until the coolant temperature returns to normal.

**Fuel Cut Control (at no load & high engine speed)**

**INPUT/OUTPUT SIGNAL LINE**

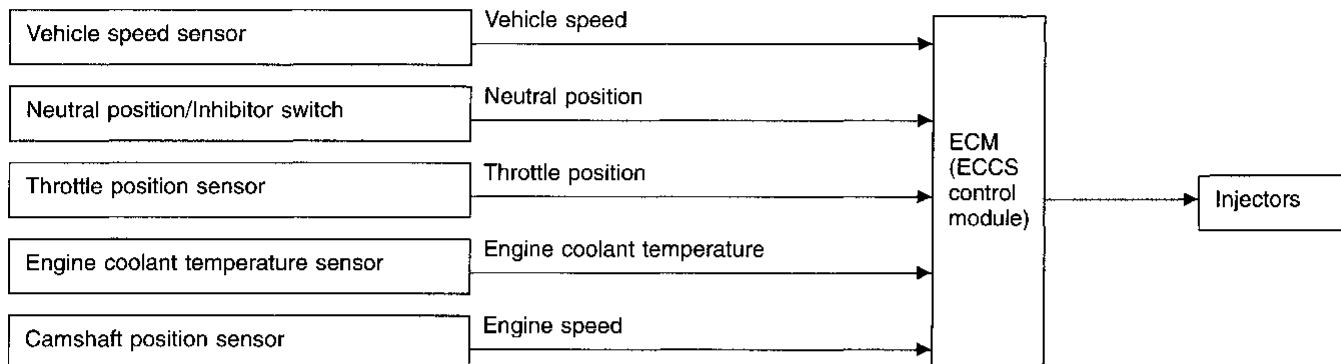

If the engine speed is above 3,950 rpm with no load (for example, in neutral and engine speed over 3,950 rpm) fuel will be cut off after some time. The exact time when the fuel is cut off varies based on engine speed. Fuel cut will operate until the engine speed reaches 1,150 rpm, then fuel cut is cancelled.

**NOTE:**

**This function is different than deceleration control listed under “Multiport Fuel Injection (MFI) System” on EC-15.**

GI

MA

EM

LC

**EC**

FE

CL

MT

AT

FA

RA

BR

ST

RS

BT

HA

EL

IDX

**NOTES**

Description

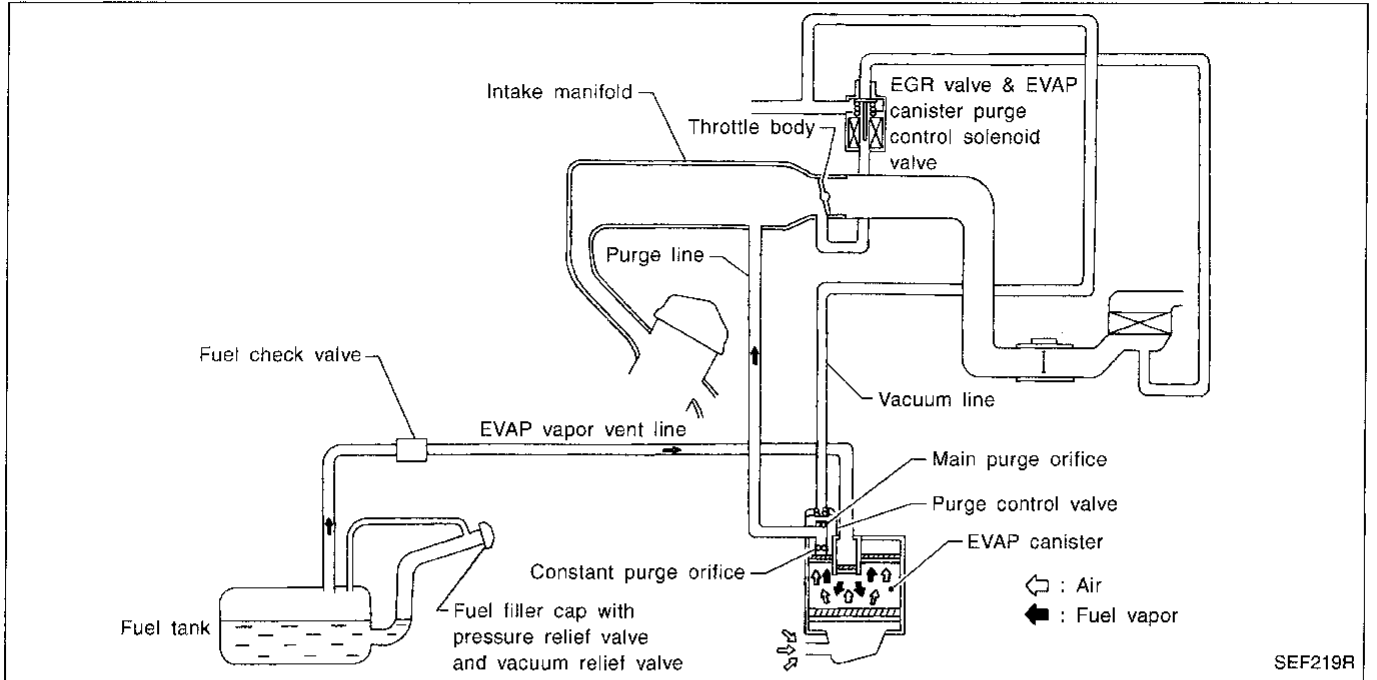

The evaporative emission system is used to reduce hydrocarbons emitted into the atmosphere from the fuel system. This reduction of hydrocarbons is accomplished by activated charcoals in the EVAP canister.

The fuel vapor from sealed fuel tank is led into the EVAP canister when the engine is off. The fuel vapor is then stored in the EVAP canister. The EVAP canister retains the fuel vapor until the EVAP canister is purged by air.

When the engine is running, the air is drawn through the bottom of the EVAP canister. The fuel vapor will then be led to the intake manifold.

When the engine runs at idle, the purge control valve is closed. Only a small amount of vapor flows into the intake manifold through the constant purge orifice.

As the engine speed increases and the throttle vacuum rises, the purge control valve opens. The vapor is sucked through both main purge and constant purge orifices.

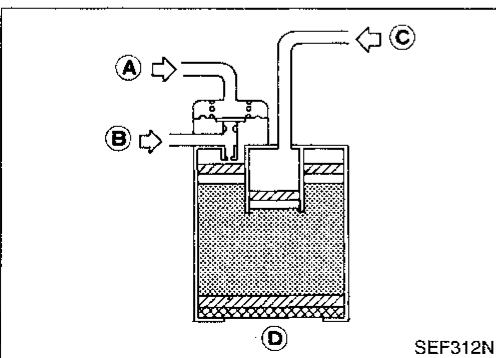

Inspection

EVAP CANISTER

Check EVAP canister as follows:

1. Blow air in port (A) and check that there is no leakage.
2. Apply vacuum to port (A). [Approximately -13.3 to -20.0 kPa (-100 to -150 mmHg, -3.94 to -5.91 inHg)]
3. Cover port (D) by hand.
4. Blow air in port (C) and check that it flows freely out of port (B).

GI

MA

EM

LC

EC

FE

CL

MT

AT

FA

RA

BR

ST

RS

BT

HA

EL

IDX

**Inspection (Cont'd)****FUEL CHECK VALVE****Check valve operation**

1. Blow air through connector on fuel tank side.  
A considerable resistance should be felt and a portion of air flow should be directed toward the EVAP canister side.
2. Blow air through connector on EVAP canister side.  
Air flow should be smoothly directed toward fuel tank side.
3. If fuel check valve is suspected of not properly functioning in steps 1 and 2 above, replace it.

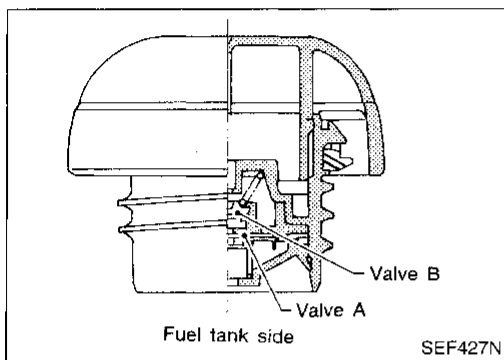
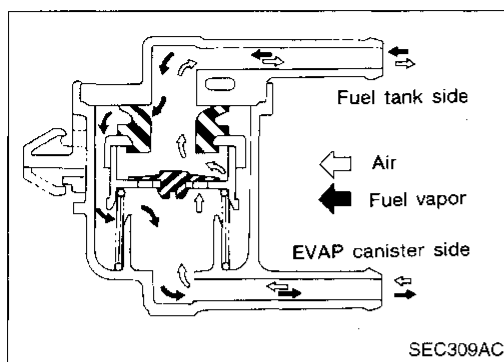
**FUEL TANK VACUUM RELIEF VALVE**

1. Wipe clean valve housing.
2. Suck air through the cap. A slight resistance accompanied by valve clicks indicates that valve A is in good mechanical condition. Note also that, by further sucking air, the resistance should disappear with valve clicks.
3. Blow air on fuel tank side and ensure that continuity of air passage exists through valve B.
4. If valve is clogged or if no resistance is felt, replace cap as an assembly.

**Use only a genuine filler cap as a replacement.**

**Description**

This system returns blow-by gas to the intake manifold collector.

The positive crankcase ventilation (PCV) valve is provided to conduct crankcase blow-by gas to the intake manifold.

During partial throttle operation of the engine, the intake manifold sucks the blow-by gas through the PCV valve.

Normally, the capacity of the valve is sufficient to handle any blow-by and a small amount of ventilating air.

The ventilating air is then drawn from the air duct

into the crankcase. In this process the air passes through the hose connecting air inlet tubes to rocker cover.

Under full-throttle condition, the manifold vacuum is insufficient to draw the blow-by flow through the valve. The flow goes through the hose connection in the reverse direction.

On vehicles with an excessively high blow-by, the valve does not meet the requirement. This is because some of the flow will go through the hose connection to the intake manifold collector under all conditions.

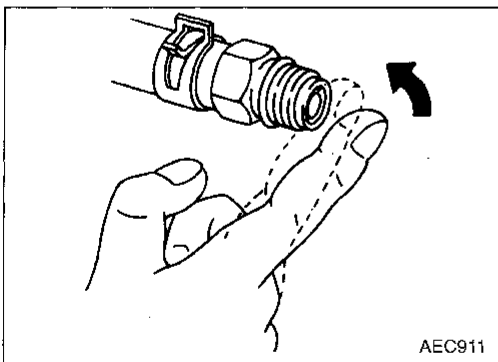
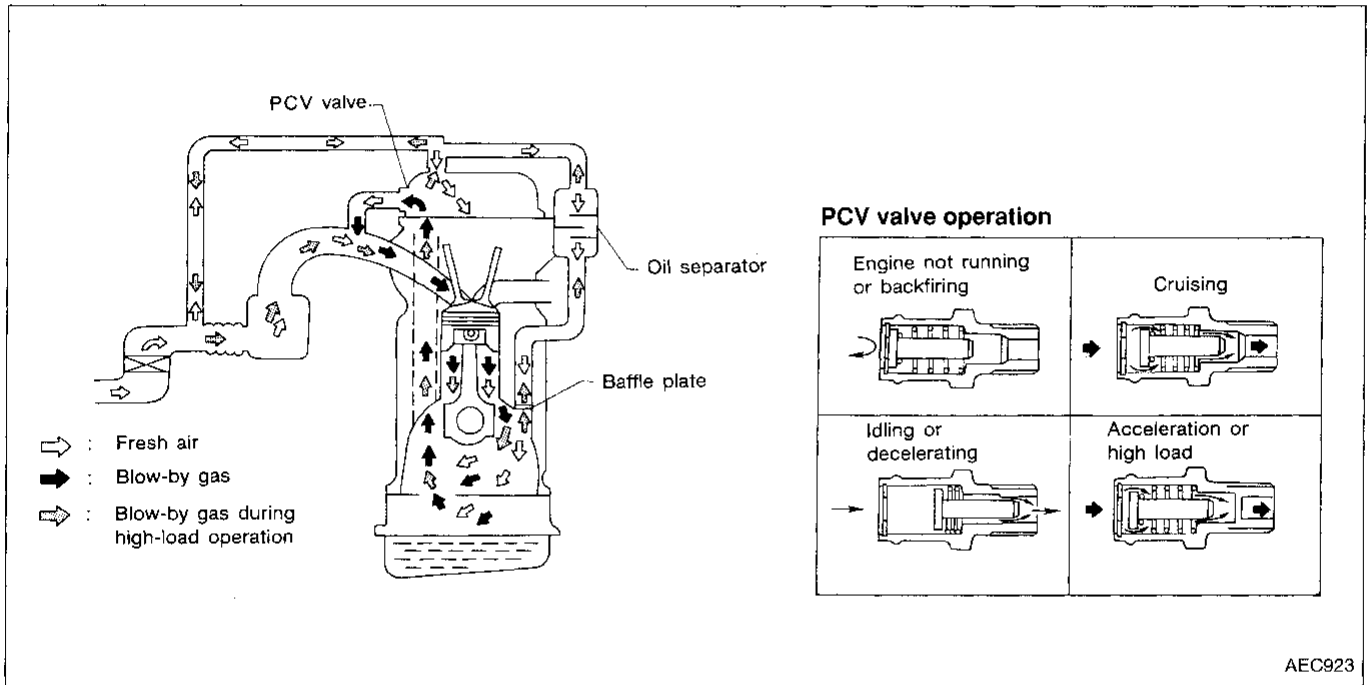

**Inspection**

**PCV (Positive Crankcase Ventilation)**

With engine running at idle, remove PCV valve from rocker cover. A properly working valve makes a hissing noise as air passes through it. A strong vacuum should be felt immediately when a finger is placed over the valve inlet.

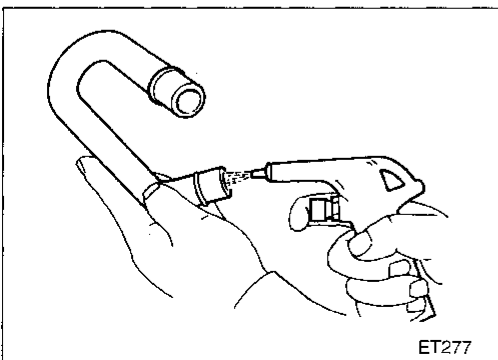

**VENTILATION HOSE**

1. Check hoses and hose connections for leaks.
2. Disconnect all hoses and clean with compressed air. If any hose cannot be freed of obstructions, replace.

CI  
MA  
EW  
LC  
EC  
EE  
CL  
MT  
AT  
FA  
RA  
BR  
ST  
RS  
ET  
HA  
EL  
IDX

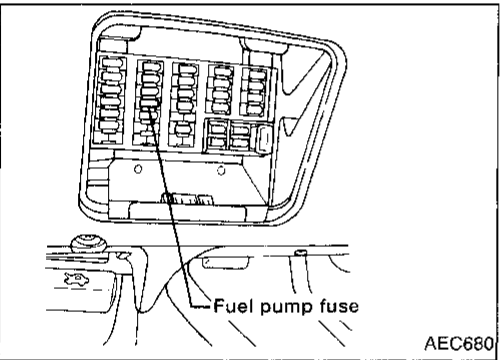
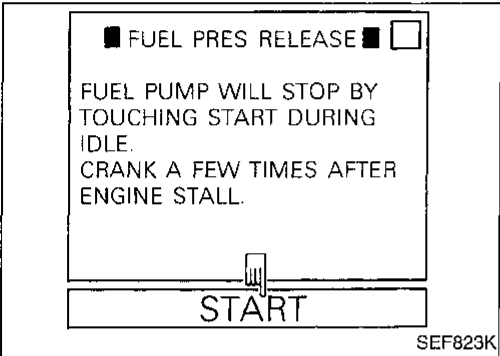
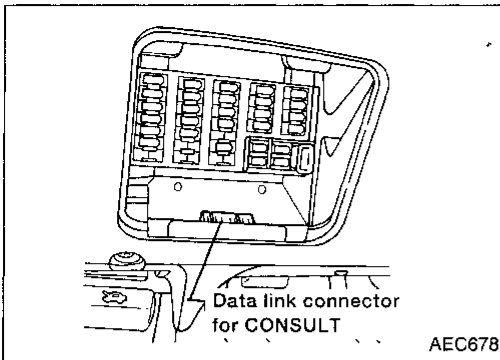

## Fuel Pressure Release

Before disconnecting fuel line, release fuel pressure from fuel line to eliminate danger.

1. Turn ignition switch "ON".
2. Perform "FUEL PRESSURE RELEASE" in "WORK SUPPORT" mode with CONSULT.
3. Start engine.
4. After engine stalls, crank it two or three times to release all fuel pressure.
5. Turn ignition switch "OFF".

1. Remove fuse for fuel pump.
2. Start engine.
3. After engine stalls, crank it two or three times to release all fuel pressure.
4. Turn ignition switch off and reconnect fuel pump fuse.

## Fuel Pressure Check

- When reconnecting fuel line, always use new clamps.
- Make sure that clamp screw does not contact adjacent parts.
- Use a torque driver to tighten clamps.
- Use Pressure Gauge to check fuel pressure.
- Do not perform fuel pressure check with system operating. Fuel pressure gauge may indicate false readings.

1. Release fuel pressure to zero.
2. Disconnect fuel hose between fuel filter and fuel tube (engine side).
3. Install pressure gauge between fuel filter and fuel tube.
4. Start engine and check for fuel leakage.
5. Read the indication of fuel pressure gauge.

At idling:

With vacuum hose connected

Approximately 235 kPa (2.4 kg/cm<sup>2</sup>, 34 psi)

With vacuum hose disconnected

Approximately 294 kPa (3.0 kg/cm<sup>2</sup>, 43 psi)

If results are unsatisfactory, perform Fuel Pressure Regulator Check.

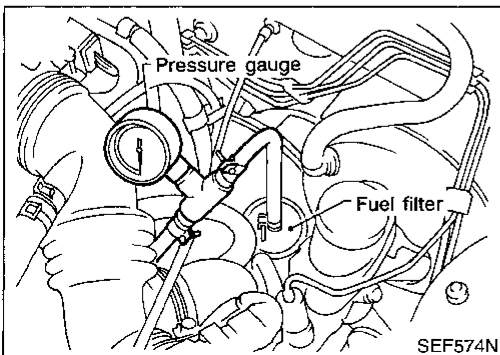

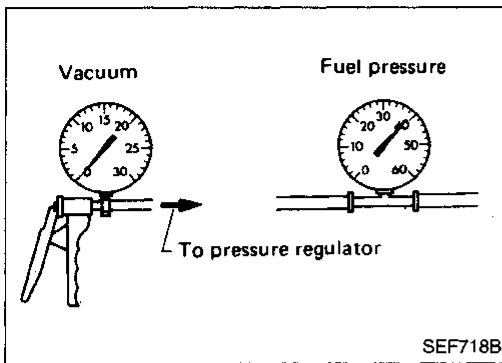

### Fuel Pressure Regulator Check

1. Stop engine and disconnect fuel pressure regulator vacuum hose from intake manifold.
2. Plug intake manifold with a rubber cap.
3. Connect variable vacuum source to fuel pressure regulator.
4. Start engine and read indication of fuel pressure gauge as vacuum is changed.

**Fuel pressure should decrease as vacuum increases. If results are unsatisfactory, replace fuel pressure regulator.**

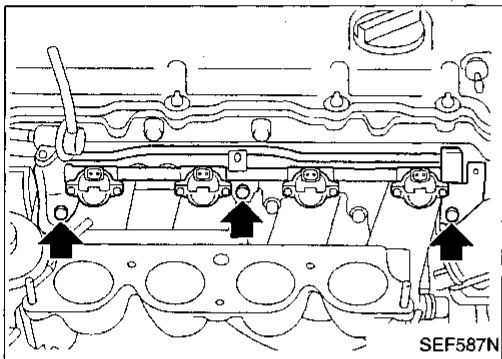

### Injector Removal and Installation

1. Release fuel pressure to zero.
2. Remove intake manifold collector. Refer to EM section ("CYLINDER HEAD").
3. Disconnect vacuum hose from pressure regulator.
4. Disconnect fuel hoses from fuel tube assembly.
5. Disconnect injector harness connectors.
6. Remove injectors with fuel tube assembly.

- Push injector tail piece.
- Do not pull on the connector.

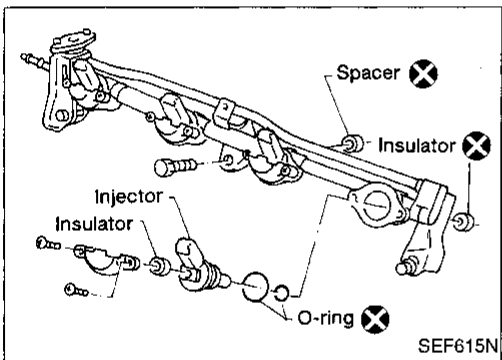

7. Install injectors.
  - Clean exterior of injector tail piece.
  - Use new O-rings.

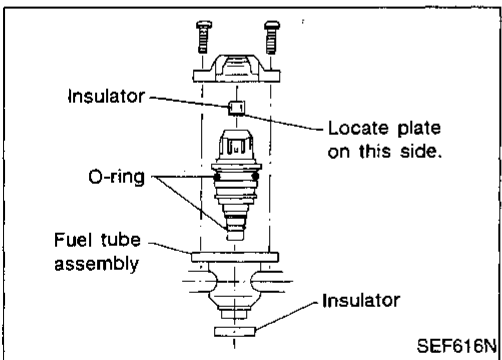

8. Install injectors with fuel tube assembly to intake manifold.
9. Install fuel hoses to fuel tube assembly.

**Lubricate fuel hoses with a smear of silicone oil.**

10. Reinstall any parts removed in reverse order of removal.

**CAUTION:**

**After properly connecting fuel hose to injector and fuel tube assembly, check connection for fuel leakage.**

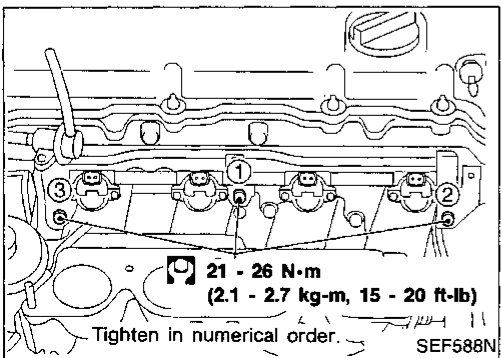



### Idle Speed/Ignition Timing/Idle Mixture Ratio Adjustment

**PREPARATION**

• Make sure that the following parts are in good order.

- (1) Battery
- (2) Ignition system
- (3) Engine oil and coolant levels
- (4) Fuses
- (5) ECM harness connector
- (6) Vacuum hoses
- (7) Air intake system  
(Oil filler cap, oil level gauge, etc.)
- (8) Fuel pressure
- (9) Engine compression
- (10) EGR valve operation
- (11) Throttle valve

- On models equipped with air conditioner, checks should be carried out while the air conditioner is "OFF".
- On models equipped with automatic transaxle, when checking idle speed, ignition timing and mixture ratio, checks should be carried out while shift lever is in "N" position.
- When measuring "CO" percentage, insert probe more than 40 cm (15.7 in) into tail pipe.
- Turn off headlamps, heater blower, rear defogger.
- Keep front wheels pointed straight ahead.
- Make the check after the cooling fan has stopped.

**Overall inspection sequence**

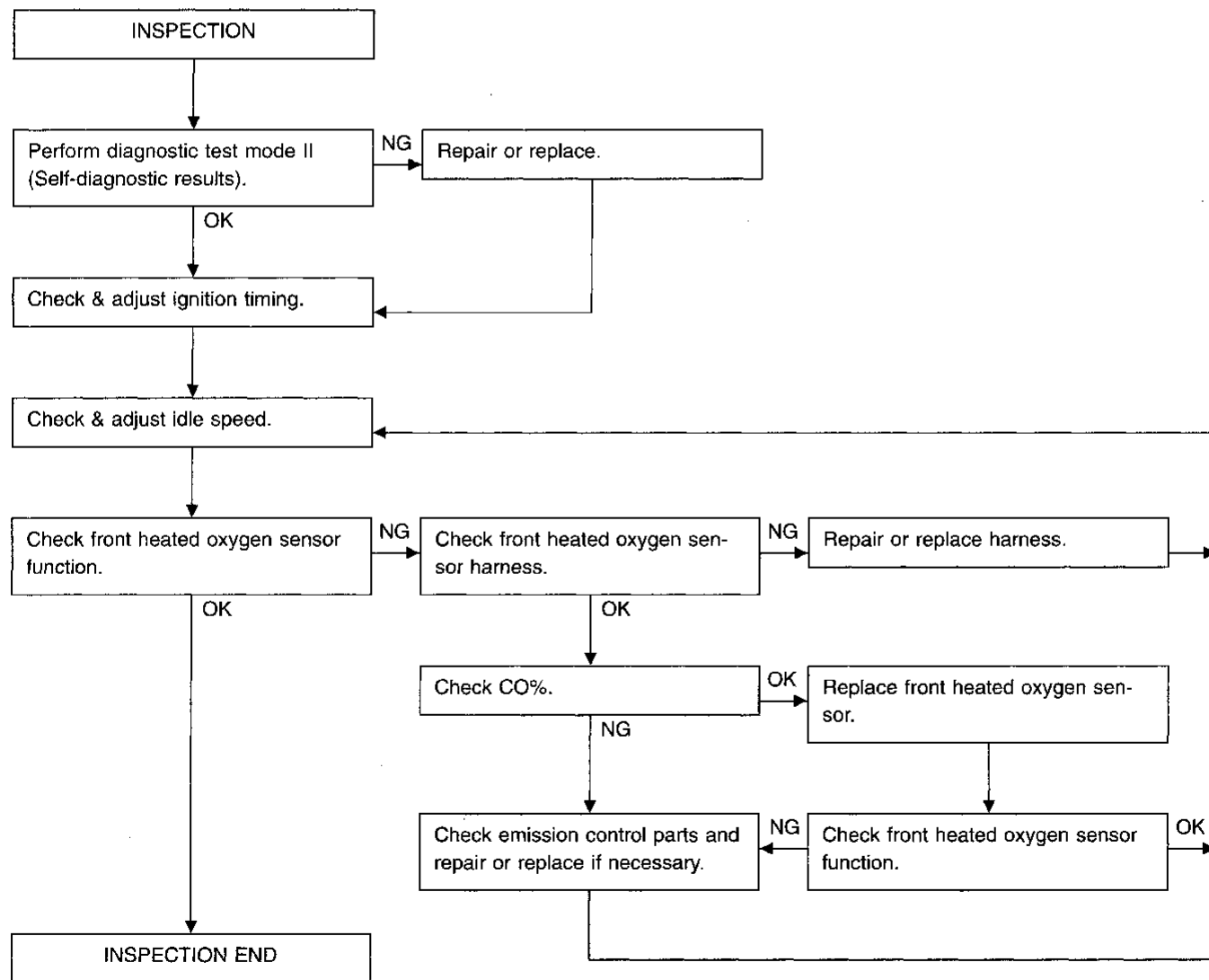

# Idle Speed/Ignition Timing/Idle Mixture Ratio Adjustment (Cont'd)

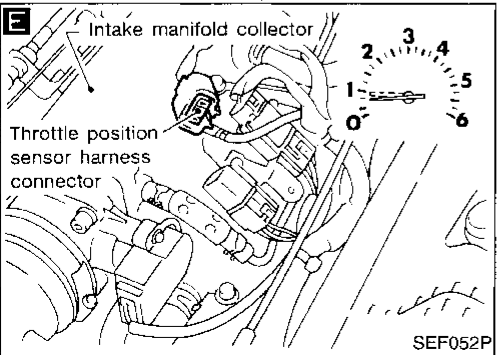
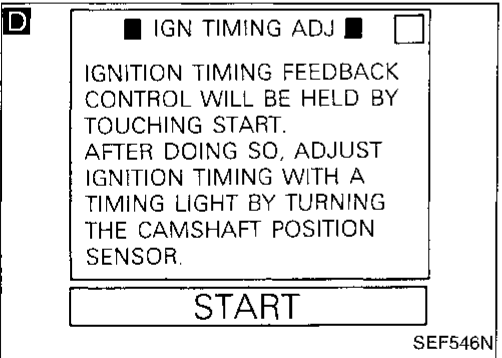
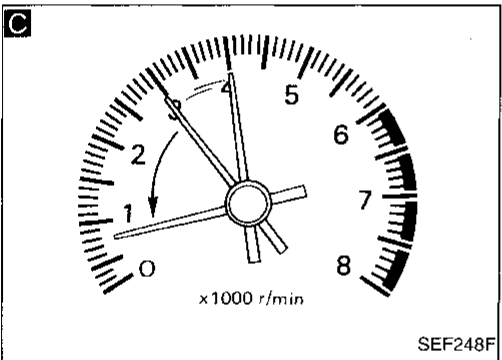
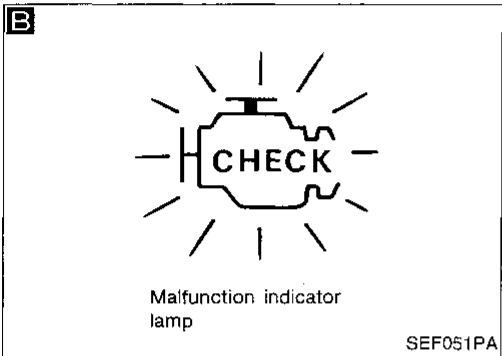
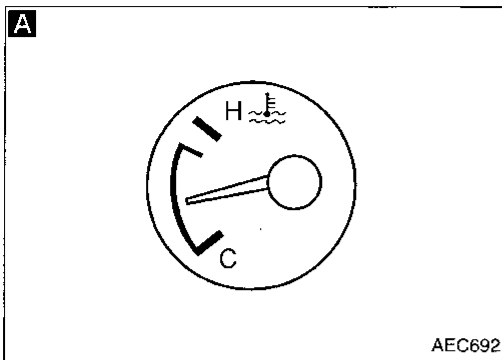

START

Visually check the following:

- Air cleaner clogging
- Hoses and duct for leaks
- EGR valve operation
- Electrical connectors
- Gasket (intake manifold, cylinder head, exhaust system)
- Throttle valve and throttle position sensor operation

**A** Start engine and warm it up until engine coolant temperature indicator points to the middle of gauge. Ensure engine speed stays below 1,000 rpm.

Open engine hood and run engine at about 2,000 rpm for about 2 minutes under no-load.

**B** Perform the Diagnostic Test Mode II (Self-diagnostic results).

OK → NG → Repair or replace components as necessary.

**C** Run engine at about 2,000 rpm for about 2 minutes under no-load. Rev engine two or three times under no-load, then run engine at idle speed for about 1 minute.

**D E**

1. Select "IGNITION TIMING ADJ" in WORK SUPPORT mode.  
2. Touch "START".

OR

1. Turn off engine and disconnect throttle position sensor harness connector.  
2. Start engine.

Rev engine (2,000 - 3,000 rpm) 2 or 3 times under no-load, then run engine at idle speed.

(Go to next page.)

GI  
MA  
EM  
LC  
EC  
FE  
CL  
WT  
AT  
FA  
RA  
BR  
ST  
RS  
BT  
HA  
EL  
IDX

Idle Speed/Ignition Timing/Idle Mixture Ratio Adjustment (Cont'd)

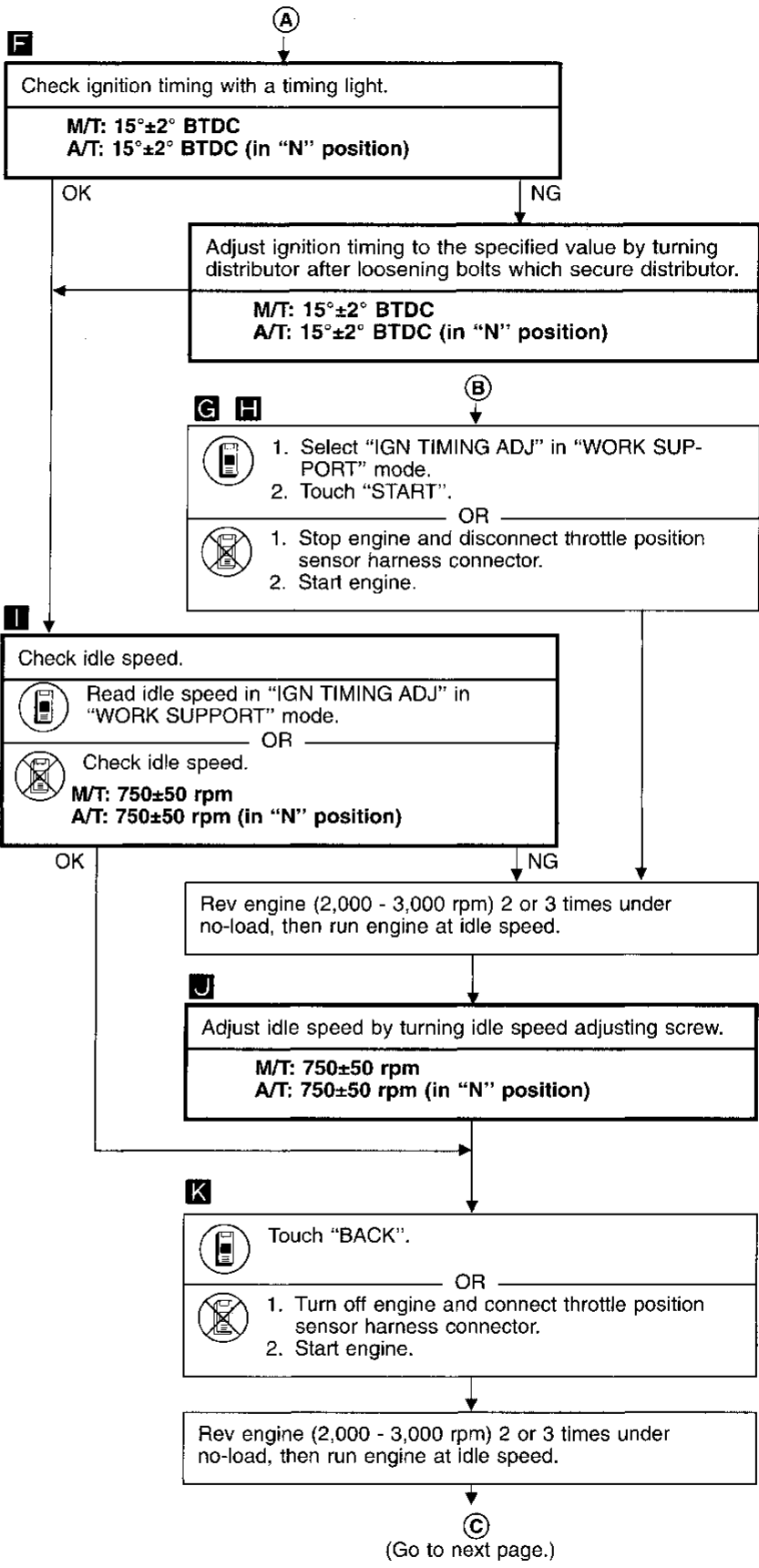
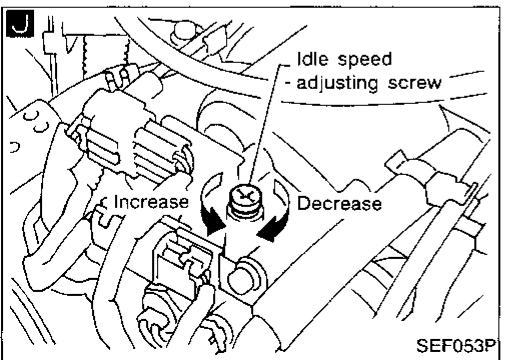
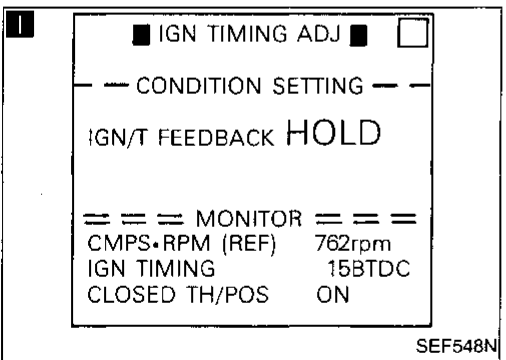
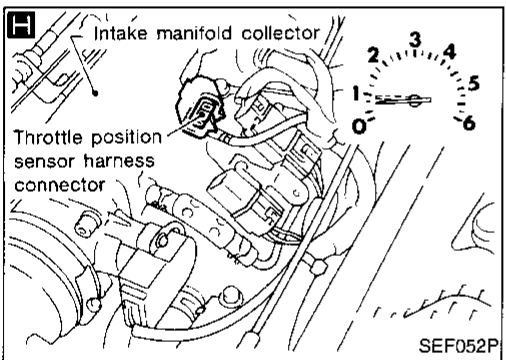
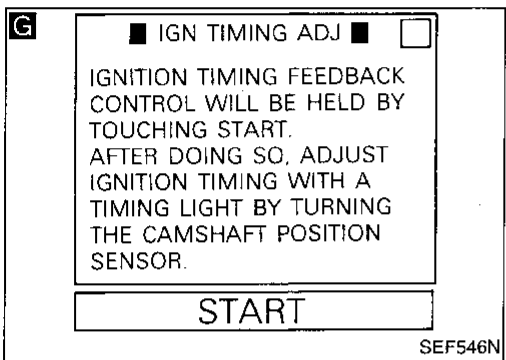
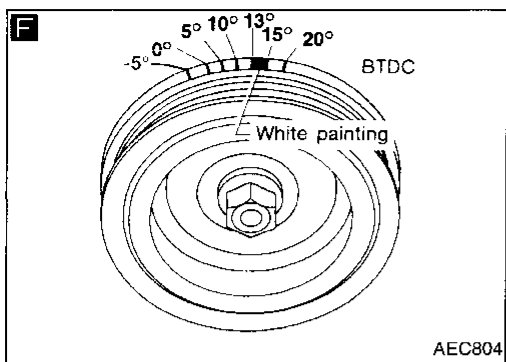

Idle Speed/Ignition Timing/Idle Mixture Ratio Adjustment (Cont'd)

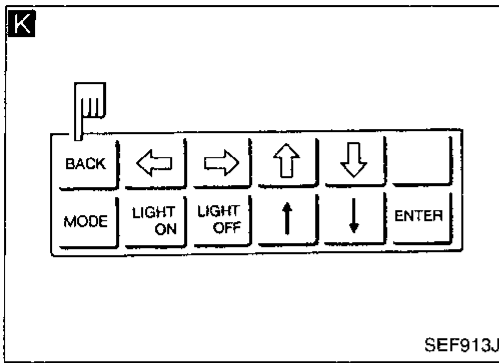

SEF913J

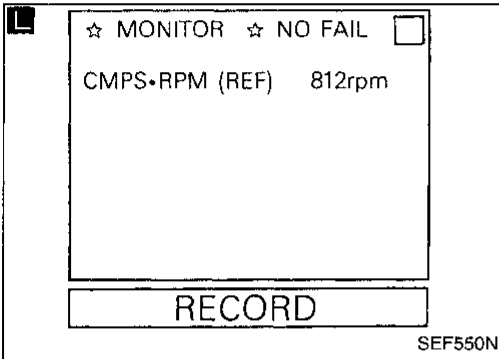

SEF550N

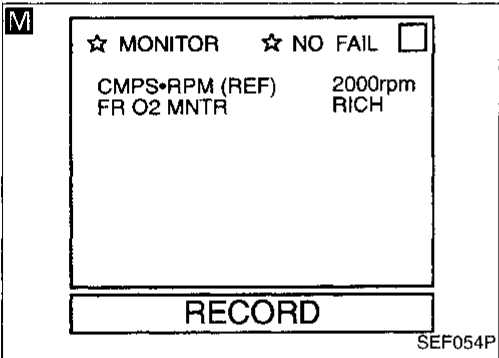

SEF054P

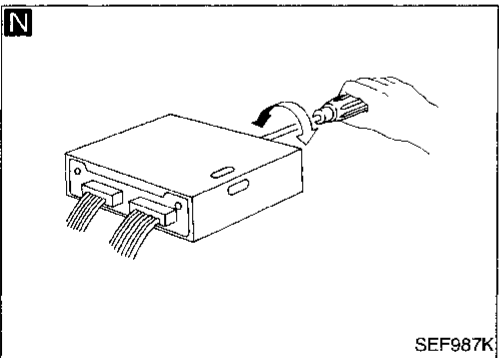

SEF987K

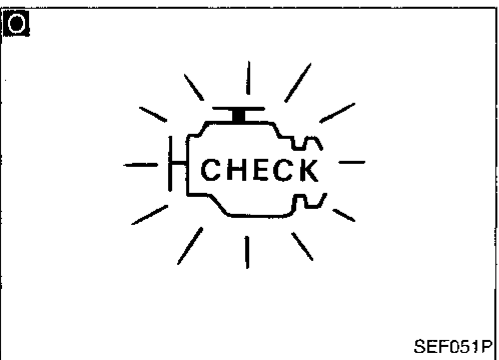

SEF051P

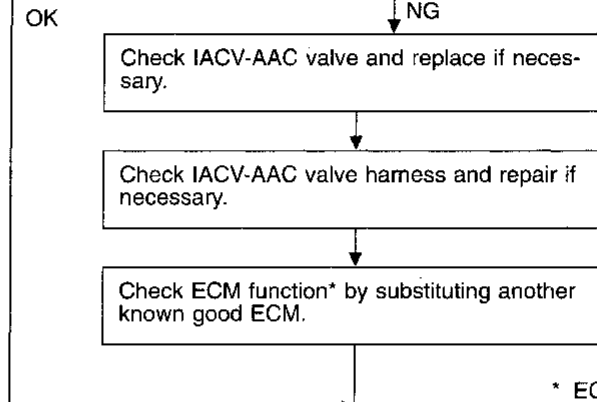
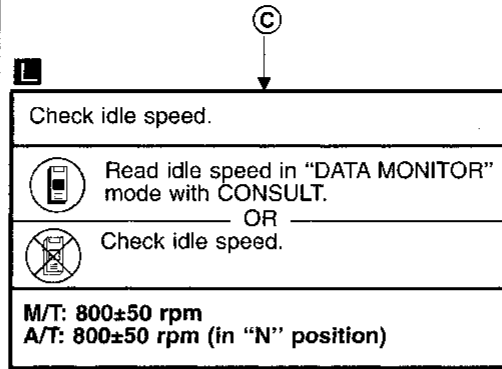

\* ECM may be the cause of a problem, but this is rarely the case.

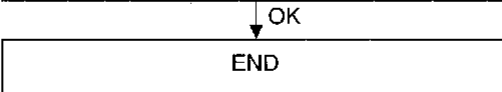
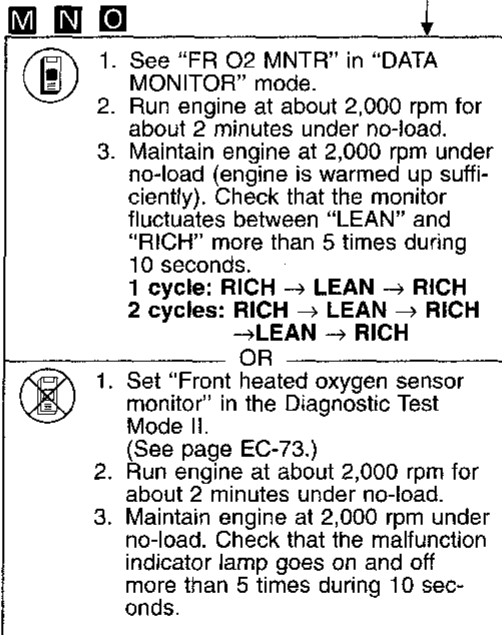

GI  
MA  
EM  
LC  
EC  
FE  
CL  
MT  
AT  
FA  
RA  
BR  
ST  
RS  
BT  
HA  
EL  
IDX

Idle Speed/Ignition Timing/Idle Mixture Ratio Adjustment (Cont'd)

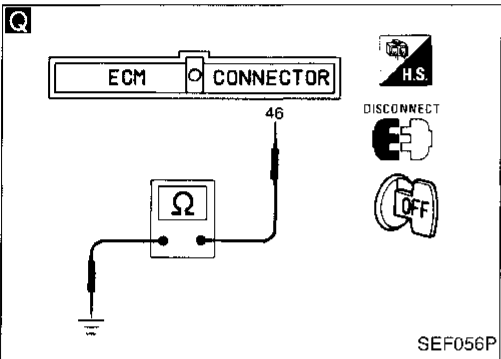
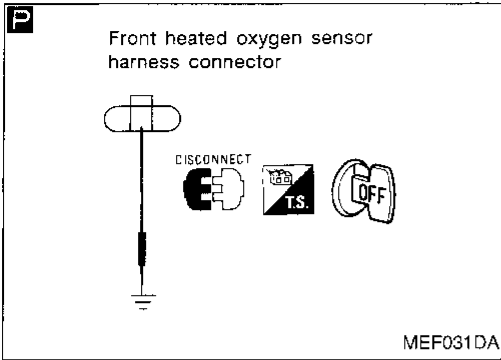

- P Q**
- Check front heated oxygen sensor harness:
1. Turn off engine and disconnect battery ground cable.
  2. Disconnect ECM harness connector from ECM.
  3. Disconnect front heated oxygen sensor harness connector. Then connect harness side terminal for front heated oxygen sensor to ground with a jumper wire.
  4. Check for continuity between terminal (46) of ECM harness connector and body ground.

Continuity exists .....OK  
 Continuity does not exist.....NG

OK → Connect ECM harness connector to ECM.

NG → Repair or replace harness. → **B** (Go to EC-28.)

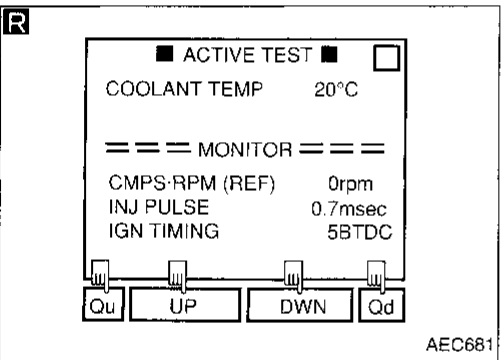

- R S**
1. Connect battery ground cable.
  2. Select "ENG COOLANT TEMP" in "ACTIVE TEST" mode.
  3. Set "COOLANT TEMP" to 20°C (68°F) by touching "Qu" and "Qd" and "UP", "DOWN".
- OR
1. Disconnect engine coolant temperature sensor harness connector.
  2. Connect a resistor (2.5 kΩ) between terminals of engine coolant temperature sensor harness connector.
  3. Connect battery ground cable.

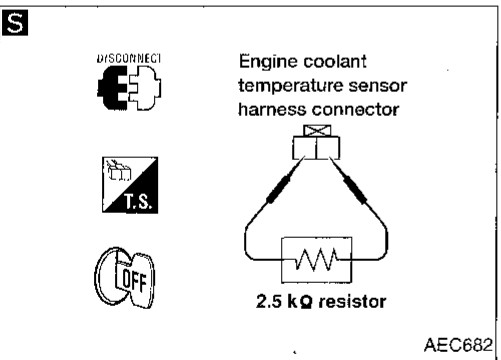

**T**

Start engine and warm it up until engine coolant temperature indicator points to middle of gauge.  
 (Be sure to start engine after setting "COOLANT TEMP" or installing a 2.5 kΩ resistor.)

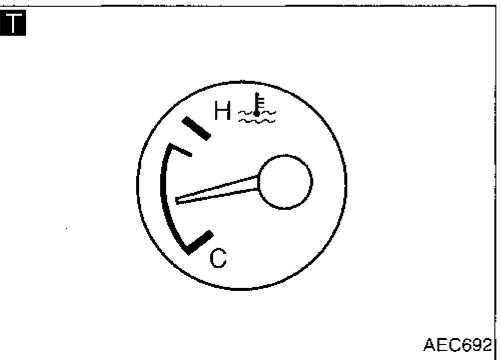

**E**  
 (Go to next page.)

Idle Speed/Ignition Timing/Idle Mixture Ratio Adjustment (Cont'd)

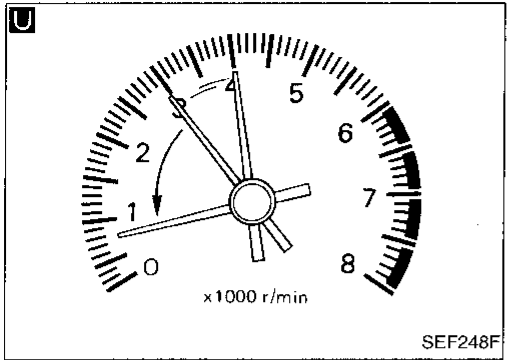

**U**  
Rev engine two or three times under no-load, then run engine at idle speed.

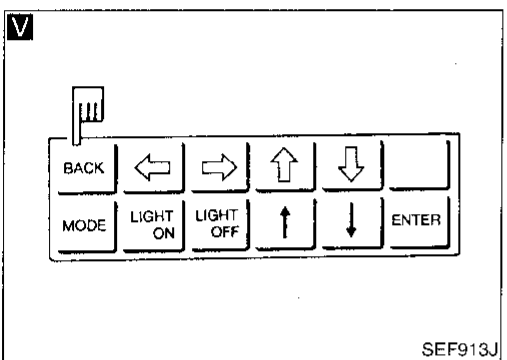

**V**  
Check "CO"%.  
**Idle CO: Less than 10% and engine runs smoothly.**  
After checking CO%,  
1. Touch "BACK".  
OR  
1. Disconnect the resistor from terminals of engine coolant temperature sensor harness connector.  
2. Connect engine coolant temperature sensor harness connector to engine coolant temperature sensor.

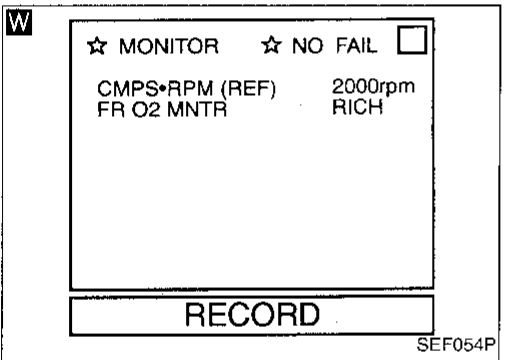

NG  
OK  
Replace front heated oxygen sensor.

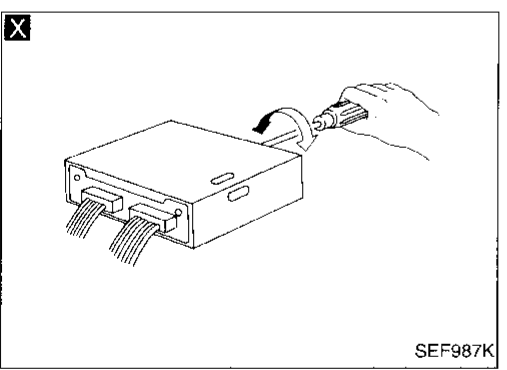

**W X Y**  
1. See "FR O2 MNTR" in "Data monitor" mode.  
2. Maintain engine at 2,000 rpm under no-load (engine is warmed up sufficiently). Check that the monitor fluctuates between "LEAN" and "RICH" more than 5 times during 10 seconds.  
**1 cycle: RICH → LEAN → RICH**  
**2 cycles: RICH → LEAN → RICH → LEAN → RICH**  
OR  
1. Set "Front heated oxygen sensor monitor" in the Diagnostic Test Mode II. (Refer to EC-73.)  
2. Maintain engine at 2,000 rpm under no-load. Check that the malfunction indicator lamp goes ON and OFF more than 5 times during 10 seconds.

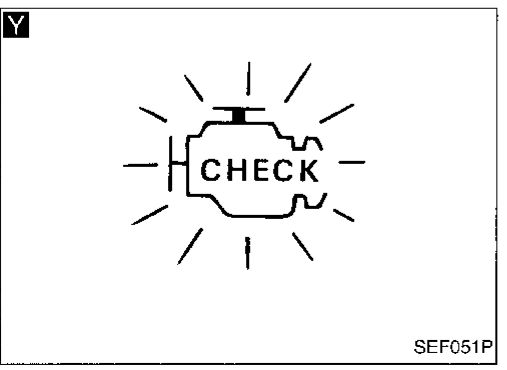

NG  
OK  
**F** (Go to next page.)  
**B** (Go to EC-28.)

GI  
MA  
EM  
LC  
EC  
FE  
CL  
MT  
AT  
FA  
RA  
BR  
ST  
FS  
BT  
HA  
EL  
IDX

**Idle Speed/Ignition Timing/Idle Mixture Ratio Adjustment (Cont'd)**

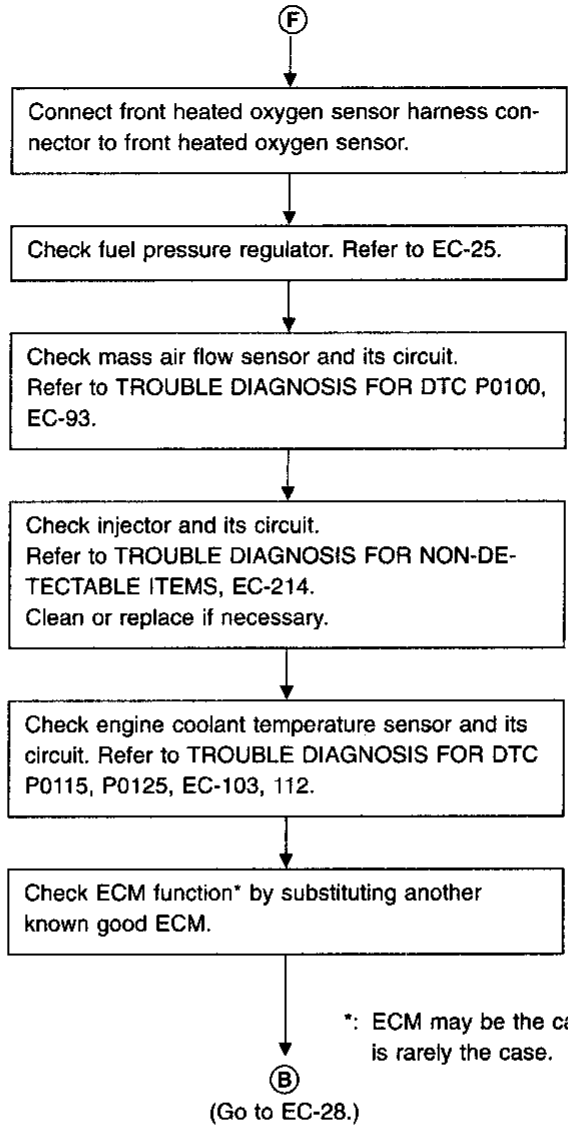

\*: ECM may be the cause of a problem, but this is rarely the case.

**Introduction**

The ECM (ECCS control module) has an on-board diagnostic system, which detects engine system malfunctions related to sensors or actuators. The malfunction indicator lamp (MIL) on the instrument panel lights up when the same malfunction is detected in two consecutive trips (Two Trip Detection Logic).

**Two Trip Detection Logic**

When a malfunction is detected for the first time, the malfunction (DTC and freeze frame data) is stored in the ECM memory. <1st trip> The malfunction indicator lamp will not light up at this stage. If the same malfunction is detected during the next drive, this second detection causes the malfunction indicator lamp to light up. <2nd trip> Specific on-board diagnostic items will light up or blink the MIL even in the 1st trip as below.

Items	MIL		
	1st trip		2nd trip lighting up
	Blinking	Lighting up	
Misfire (Possible three way catalyst damage)— DTC: P0300-P0304 (0701-0605) is being detected	X		
Misfire (Possible three way catalyst damage)— DTC: P0300-P0304 (0701-0605) has been detected		X	
Three way catalyst function — DTC: P0420 (0702)		X	
Closed loop control — DTC: P0130 (0307)		X	
Except above			X

The “trip” in the “Two Trip Detection Logic” means performing of the “DTC Confirmation Procedure”.

**Diagnostic Trouble Code (DTC)**

**HOW TO READ DTC**



The diagnostic trouble code can be read by the following methods.

(Either code for the 1st trip or the 2nd trip can be read.)

1. The number of blinks of the malfunction indicator lamp in the Diagnostic Test Mode II (Self-Diagnostic Results) Examples: 0101, 0201, 1003, 1104, etc.  
These DTCs are controlled by NISSAN.
  2. CONSULT or GST (Generic Scan Tool) Examples: P0340, P1320, P0705, P0750, etc.  
These DTCs are prescribed by SAE J2012.
- **Output of the trouble code means that the indicated circuit has a malfunction. However, in case of the Mode II and GST they do not indicate whether the malfunction is still occurring or occurred in the past and returned to normal. CONSULT can identify them. Therefore, using CONSULT (if available) is recommended.**

**HOW TO ERASE DTC**

The diagnostic trouble code can be erased by the following methods.

-  Changing the diagnostic test mode from Diagnostic Test Mode II to Mode I by turning the mode selector on the ECM. (Refer to EC-37.)
-  Selecting “ERASE” in the “SELF DIAG RESULTS” mode with CONSULT.
-  Selecting Mode 4 with GST (Generic Scan Tool).
- **If the battery terminal is disconnected, the diagnostic trouble code will be lost within 24 hours.**
- **When you erase the DTC, using CONSULT or GST is easier and quicker than switching the mode selector on the ECM.**

**HOW TO ERASE DTC**

- **If a DTC is displayed for both ECM and A/T control unit, it needs to be erased for both ECM and A/T control unit.**
  - **If diagnostic trouble code is not for A/T related items (refer to EC-73), skip steps 2 through 4.**
1. If the ignition switch stays “ON” after repair work, be sure to turn ignition switch “OFF” once. Wait for at least 3 seconds and then turn it “ON” (engine stopped) again.
  2. Turn CONSULT “ON” and touch “A/T”.
  3. Touch “SELF-DIAG RESULTS”.
  4. Touch “ERASE”. (The DTC in the A/T control unit will be erased.) Touch “BACK” twice.
  5. Touch “ENGINE”.
  6. Touch “SELF-DIAG RESULTS”.
  7. Touch “ERASE”. (The DTC in the ECM will be erased.)



Diagnostic Trouble Code (DTC) (Cont'd)

How to erase DTC (With CONSULT)

1. If the ignition switch stays "ON" after repair work, be sure to turn ignition switch "OFF" once. Wait at least 5 seconds and then turn it "ON" (engine stopped) again.

SELECT SYSTEM
ENGINE
A/T

2. Turn CONSULT "ON", and touch "A/T".

SELECT DIAG MODE
SELF-DIAG RESULTS
DATA MONITOR
ECU PART NUMBER

3. Touch "SELF-DIAG RESULTS".

SELF-DIAG RESULTS
FAILURE DETECTED
SHIFT SOLENOID/V A
ERASE
PRINT

4. Touch "ERASE". (The DTC in the A/T control unit will be erased.)

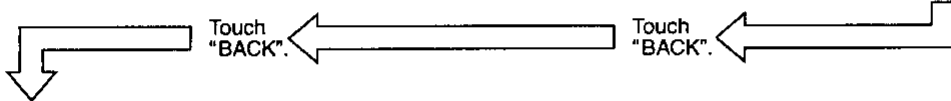

SELECT SYSTEM
ENGINE
A/T

5. Touch "ENGINE".

SELECT DIAG MODE
WORK SUPPORT
SELF-DIAG RESULTS
DATA MONITOR
ACTIVE TEST
FUNCTION TEST
FREEZE FRAME DATA

6. Touch "SELF-DIAG RESULTS".

SELF-DIAG RESULTS
FAILURE DETECTED
SHIFT SOLENOID/V A
[P0750]
TIME
0
ERASE
PRINT

7. Touch "ERASE". (The DTC in the ECM will be erased.)

SEF338QA



HOW TO ERASE DTC

- If the diagnostic trouble code is not for A/T related items (refer to EC-73), skip step 2.

1. If the ignition switch stays "ON" after repair work, be sure to turn ignition switch "OFF" once. Wait for at least 5 seconds and then turn it "ON" (engine stopped) again.
2. Perform "SELF-DIAGNOSTIC PROCEDURE (Without CONSULT)" in AT section titled "TROUBLE DIAGNOSIS", "Self-diagnosis". (The engine warm-up step can be skipped when performing the diagnosis only to erase the DTC.)
3. Select Mode 4 with GST (Generic Scan Tool).



HOW TO ERASE DTC

- If the diagnostic trouble code is not for A/T related items (refer to EC-73), skip step 2.

1. If the ignition switch stays "ON" after repair work, be sure to turn ignition switch "OFF" once. Wait for at least 3 seconds and then turn it "ON" again.
2. Perform "SELF-DIAGNOSTIC PROCEDURE (Without CONSULT)" in AT section "TROUBLE DIAGNOSIS", "Self-diagnosis".
3. Change the diagnostic test mode from Mode II to Mode I by turning the mode selector on the ECM. (See page EC-37.)

Freeze Frame Data

The ECM has a memory function which stores the driving condition at the moment the ECM detects a malfunction. This includes fuel system status, calculated load value, engine coolant temperature, short fuel trim, long fuel trim, engine speed, vehicle speed.

Stored data is called Freeze Frame Data.

The data is useful for tracking down conditions at the time of the malfunction. Such conditions include

Freeze Frame Data (Cont'd)

whether vehicle was running or stopped, engine warm up, air-fuel ratio, etc. This data can be utilized to duplicate the malfunction and to diagnose the trouble. The data will be erased along with the diagnostic trouble code by the above-mentioned method. The data can be stored only for the 1st trip. It can not be renewed even at the 2nd trip. The freeze frame data can be stored for only one item. Therefore, the ECM has the following priorities to update the data.

Priority	Detected items
1	Misfires — DTC: P0300-P0304 (0701-0605) Fuel Injection System Function — DTC: P0170 (0706)
2	Except the above items (includes A/T items)

For example, an EGR malfunction (Priority: 2) was detected and the freeze frame data was stored at the 1st trip. After that, misfire (Priority: 1) is detected in another trip, and freeze frame data is updated from the EGR malfunction for the misfire.

GI  
MA  
EM  
LC

EC

FE

CL

MT

AT

FA

RA

BR

ST

RS

BT

HA

EL

IDX

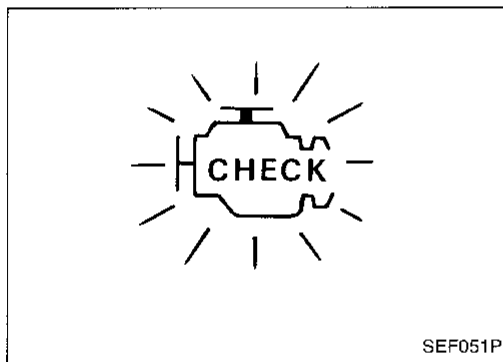

Malfunction Indicator Lamp (MIL)

- The malfunction indicator lamp will light up when the ignition switch is turned ON without the engine running. This is a bulb check.
  - If the malfunction indicator lamp does not light up, refer to EL section (“WARNING LAMPS AND CHIME”) or see EC-233.
- When the engine is started, the malfunction indicator lamp should go off. If the lamp remains on, the on-board diagnostic system has detected an engine system malfunction.



ON-BOARD DIAGNOSTIC SYSTEM FUNCTION

The on-board diagnostic system has the following four functions.

- BULB CHECK** : This function checks the MIL bulb for damage (blown, open circuit, etc.).
- MALFUNCTION WARNING** : This is a usual driving condition. When a malfunction is detected twice (two trip detection logic), the MIL will light up to inform the driver that a malfunction has been detected. Only the following malfunctions will light up or blink the MIL even in the 1st trip.
  - “Misfire (Possible three way catalyst damage)”
  - “Three way catalyst function”
  - “Closed loop control”
- SELF-DIAGNOSTIC RESULTS** : This function allows diagnostic trouble codes to be read.
- FRONT HEATED OXYGEN SENSOR MONITOR** : This function allows the fuel mixture condition (lean or rich), monitored by front heated oxygen sensor, to be read.

Refer to “HOW TO SWITCH DIAGNOSTIC TEST MODES” on next page.

**Malfunction Indicator Lamp (MIL) (Cont'd)**

Condition		Diagnostic Test Mode I	Diagnostic Test Mode II
Ignition switch in "ON" position 	Engine stopped 	BULB CHECK	SELF-DIAGNOSTIC RESULTS
	Engine running 	MALFUNCTION WARNING	FRONT HEATED OXYGEN SENSOR MONITOR

Malfunction Indicator Lamp (MIL) (Cont'd)  
HOW TO SWITCH DIAGNOSTIC TEST MODES

CI  
MA  
EM  
LC  
EC  
FE  
CL  
MT  
AT  
FA  
RA  
BR  
ST  
RS  
BT  
HA  
EL  
IDX

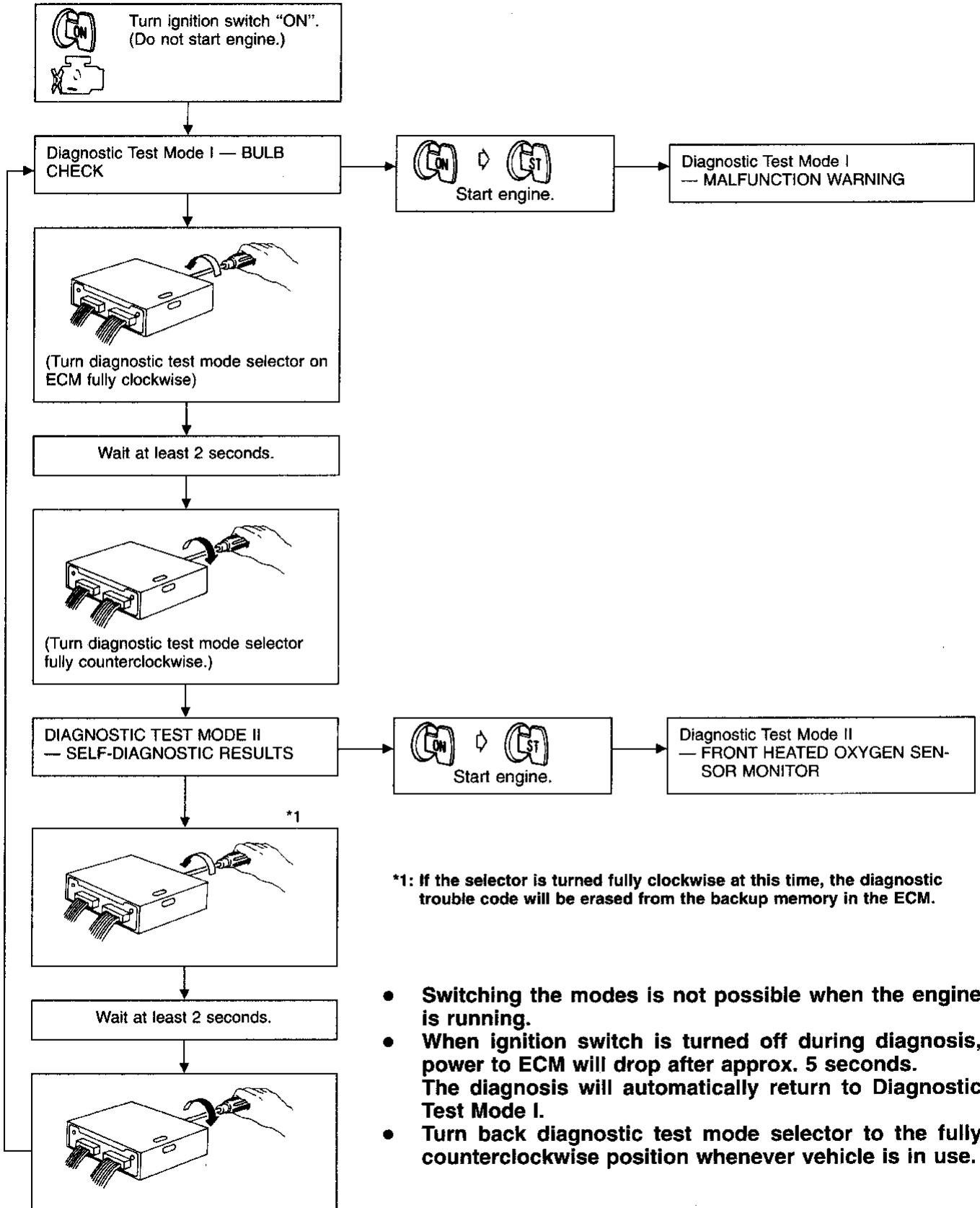

Malfunction Indicator Lamp (MIL) (Cont'd)

DIAGNOSTIC TEST MODE I—BULB CHECK

In this mode, the MALFUNCTION INDICATOR LAMP on the instrument panel should stay ON. If it remains OFF, check the bulb. Refer to EL section (“WARNING LAMPS AND CHIME”) or see EC-233.

DIAGNOSTIC TEST MODE I—MALFUNCTION WARNING

MALFUNCTION INDICATOR LAMP	Condition
ON	When the malfunction is detected or the ECM's CPU is malfunctioning. (The “1 trip” or “2 trip” is shown in the “MIL Illumination” of the “DTC Chart”.) Refer to EC-65.
OFF	No malfunction.

- These Diagnostic Trouble Code Numbers are clarified in Diagnostic Test Mode II (SELF-DIAGNOSTIC RESULTS).

DIAGNOSTIC TEST MODE II—SELF-DIAGNOSTIC RESULTS

In this mode, a diagnostic trouble code is indicated by the number of blinks of the MALFUNCTION INDICATOR LAMP as shown below.

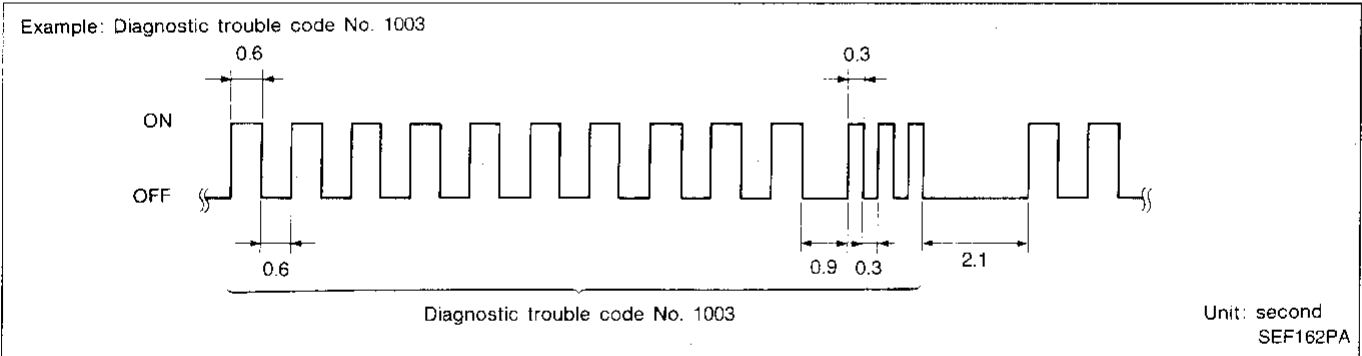
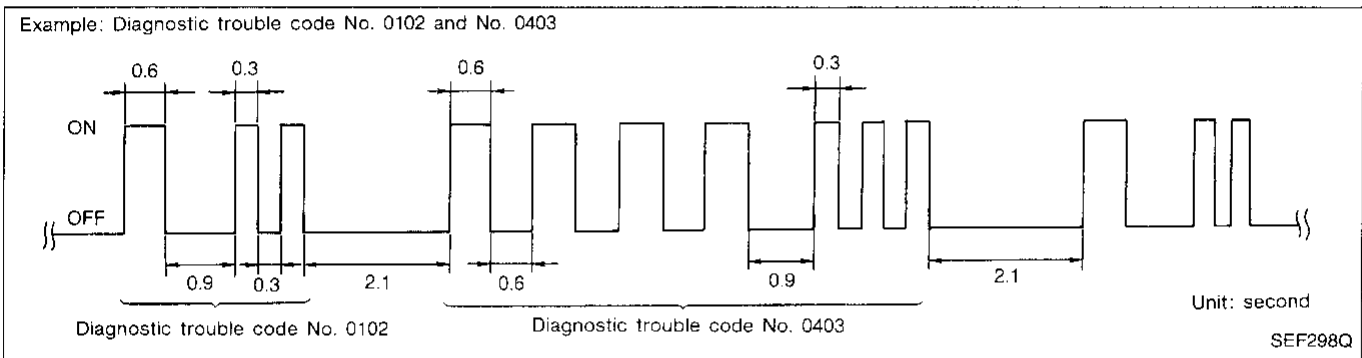

Long (0.6 second) blinking indicates the number of ten digits, and short (0.3 second) blinking indicates the number of single digits. For example, the malfunction indicator lamp blinks 10 times for 6 seconds (0.6 sec x 10 times) and then it blinks three times for about 1 second (0.3 sec x 3 times). This indicates the DTC “1003” and refers to the malfunction of the park/neutral position switch.

In this way, all the detected malfunctions are classified by their diagnostic trouble code numbers. The DTC “0505” refers to no malfunction. (See DIAGNOSTIC TROUBLE CODE CHART, refer to EC-65.)

HOW TO ERASE DIAGNOSTIC TEST MODE II (Self-diagnostic results)

The diagnostic trouble code can be erased from the backup memory in the ECM when the diagnostic test mode is changed from Diagnostic Test Mode II to Diagnostic Test Mode I. (Refer to “HOW TO SWITCH DIAGNOSTIC TEST MODES” on previous page.)

- If the battery terminal is disconnected, the diagnostic trouble code will be lost from the backup memory within 24 hours.
- Be careful not to erase the stored memory before starting trouble diagnoses.

**Malfunction Indicator Lamp (MIL) (Cont'd)**

**DIAGNOSTIC TEST MODE II—FRONT HEATED OXYGEN SENSOR MONITOR**

In this mode, the MALFUNCTION INDICATOR LAMP displays the condition of the fuel mixture (lean or rich) which is monitored by the front heated oxygen sensor.

MALFUNCTION INDICATOR LAMP	Fuel mixture condition in the exhaust gas	Air fuel ratio feedback control condition
ON	Lean	Closed loop system
OFF	Rich	
*Remains ON or OFF	Any condition	Open loop system

\*: Maintains conditions just before switching to open loop.

To check the front heated oxygen sensor function, start engine in Diagnostic Test Mode II. Then warm it up until engine coolant temperature indicator points to middle of gauge.

Next run engine at about 2,000 rpm for about 2 minutes under no-load conditions. Make sure that the MALFUNCTION INDICATOR LAMP comes ON more than 5 times within 10 seconds with engine running at 2,000 rpm under no-load.

**OBD System Operation Chart**

**RELATIONSHIP BETWEEN MIL, DTC, CONSULT AND DETECTABLE ITEMS**

- When a malfunction is detected for the first time, the DTC and the freeze frame data are stored in the ECM memory.
- When the same malfunction is detected in two consecutive trips, the MIL will come on. For details, refer to "Two Trip Detection Logic" on EC-33.
- The MIL will go off after the vehicle is driven three times with no malfunction. The drive is counted only when the recorded driving pattern is met (as stored in the ECM). If another malfunction occurs while counting, the counter will reset. The MIL will remain on until the vehicle is driven (in the recorded driving pattern) three times with no malfunction.
- The DTC and the freeze frame data can be displayed until the vehicle is driven 40 times (except for Misfire and Fuel Injection System). For Misfire and Fuel Injection System, the DTC and freeze frame data can be displayed until the vehicle is driven 80 times. The "TIME" IN "SELF-DIAGNOSTIC RESULTS" mode of CONSULT will count in response to the number of times the vehicle is driven.

**SUMMARY CHART**

Items	MIL (goes off)	DTC, Freeze Frame Data (no display)
Fuel Injection System	3 (pattern C)	80 (pattern B)
Misfire	3 (pattern C)	80 (pattern B)
Except the aboves	3 (pattern B)	40 (pattern A)

Details about patterns "A", "B", and "C" are on EC-41.

OBd System Operation Chart (Cont'd)

RELATIONSHIP BETWEEN MIL, DTC, CONSULT AND DRIVING PATTERNS FOR "MISFIRE <EXHAUST QUALITY DETERIORATION>", "FUEL INJECTION SYSTEM"

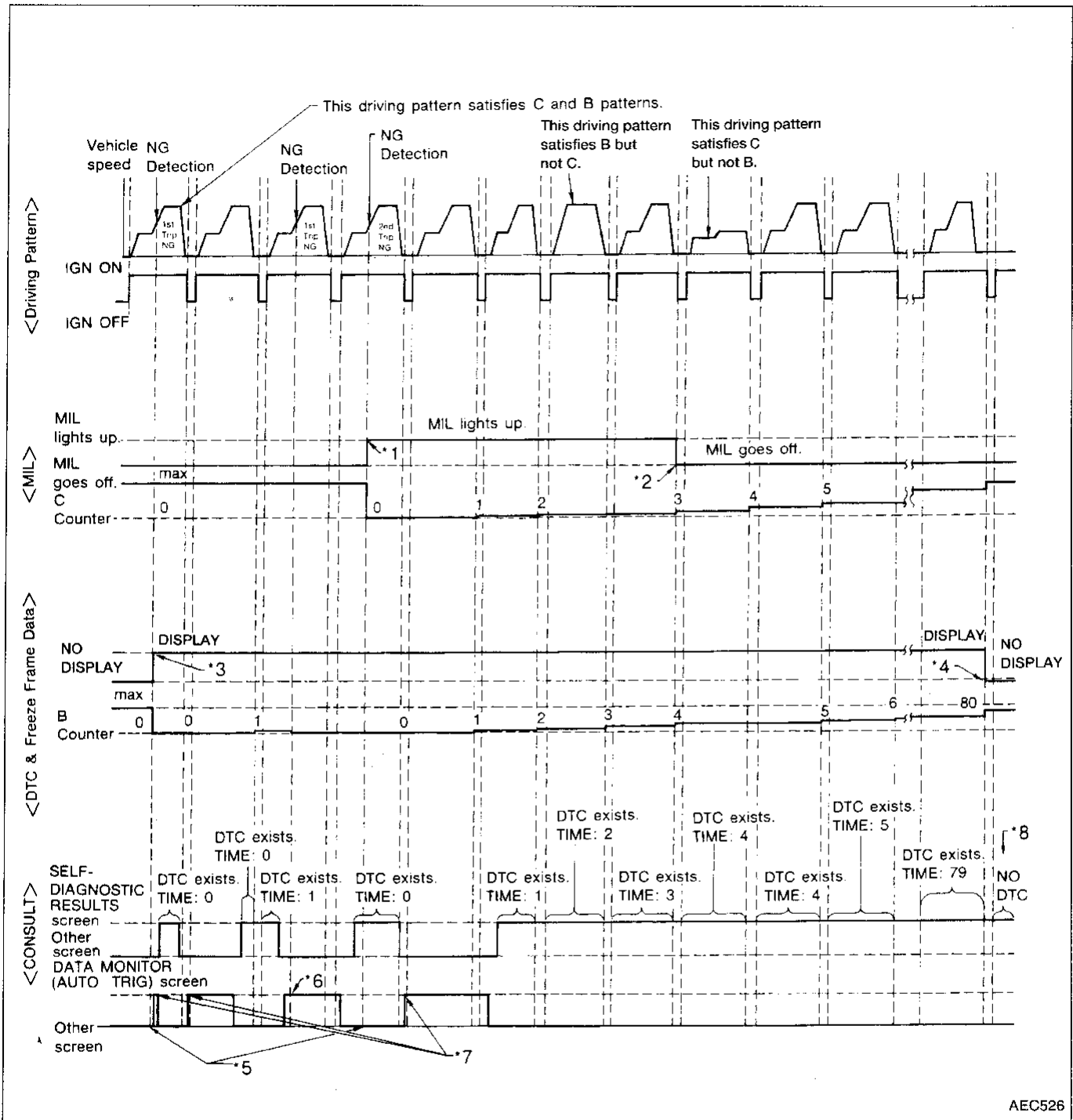

AEC526

- \*1: When the same malfunction is detected in two consecutive trips, MIL will light up.
- \*2: MIL will go off after vehicle is driven three times (pattern C) without any malfunctions.
- \*3: When a malfunction is detected for the first time, the DTC and the freeze frame data will be stored in ECM.
- \*4: The DTC and the freeze frame data will not be displayed any longer after vehicle is driven 80 times (pattern B) without the same malfunction. (The DTC and the freeze frame data still remain in ECM.)

- \*5: Other screen except DATA MONITOR (AUTO TRIG) can not display the malfunction.
- \*6: DATA MONITOR (AUTO TRIG) can display the malfunction at the moment it is detected.
- \*7: The malfunction can not be displayed because the timing to set DATA MONITOR (AUTO TRIG) screen was missed against the NG detection.
- \*8: The DTC and the freeze frame data will not be displayed any longer after vehicle is driven 80 times (pattern B) without the same malfunction. (The DTC and the freeze frame data still remain in ECM.)

OBd System Operation Chart (Cont'd)

EXPLANATION FOR DRIVING PATTERNS FOR "MISFIRE <EXHAUST QUALITY DETERIORATION>", "FUEL INJECTION SYSTEM"

<Driving pattern A>

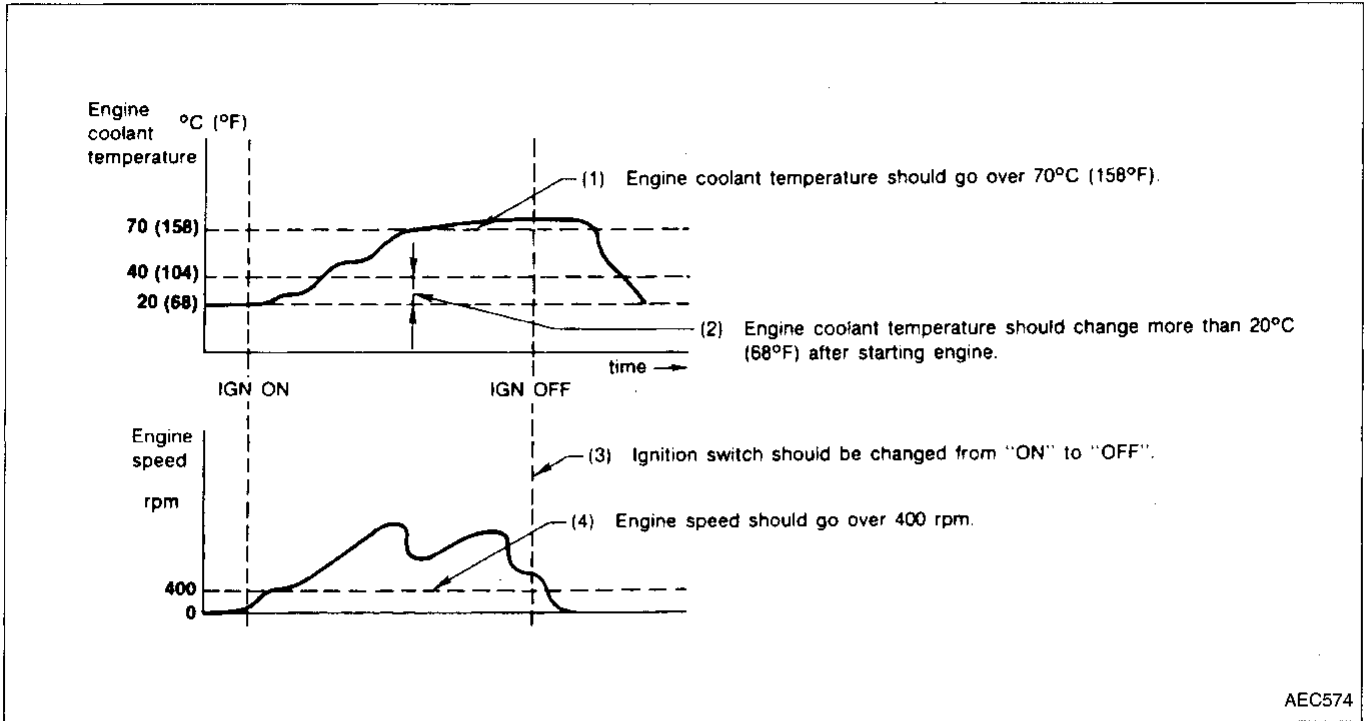

<Driving pattern B>

Driving pattern B means vehicle operation is as follows:

All components and systems should be monitored at least once by the OBD system.

- The B counter will reset when the malfunction is detected twice regardless of the driving pattern.
- The B counter will count the number of times driving pattern B is satisfied without the malfunction.
- The DTC will not be displayed after the B counter reaches 80.

<Driving pattern C>

Driving pattern C means vehicle operation is as follows:

(1) Driving pattern A should be satisfied.

(2) The following conditions should be satisfied at the same time:

Engine speed: (Engine speed in the freeze frame data)  $\pm 375$  rpm

Calculated load value: (Calculated load value in the freeze frame data)  $\times (1 \pm 0.1)$  [%]

Engine coolant temperature (T) condition:

- When the freeze frame data shows lower than 70°C (158°F), "T" should be lower than 70°C (158°F).
- When the freeze frame data shows higher than or equal to 70°C (158°F), "T" should be higher than or equal to 70°C (158°F).

Example:

If the stored freeze frame data is as follows:

Engine speed: 850 rpm, Calculated load value: 30%, Engine coolant temperature: 80°C (176°F)

To be satisfied with driving pattern C, the vehicle should run under the following conditions:

Engine speed: 475 - 1,225 rpm, Calculated load value: 27 - 33%, Engine coolant temperature: more than 70°C (158°F)

- The C counter will be cleared when the malfunction is detected regardless of (1), (2). (\*1 in "OBD SYSTEM OPERATION CHART")
- The C counter will be counted up when (1), (2) are satisfied without the same malfunction.
- The MIL will go off when the C counter reaches 3. (\*2 in "OBD SYSTEM OPERATION CHART")



OBd System Operation Chart (Cont'd)

RELATIONSHIP BETWEEN MIL, DTC, CONSULT AND DRIVING PATTERNS EXCEPT FOR "MISFIRE <EXHAUST QUALITY DETERIORATION>", "FUEL INJECTION SYSTEM"

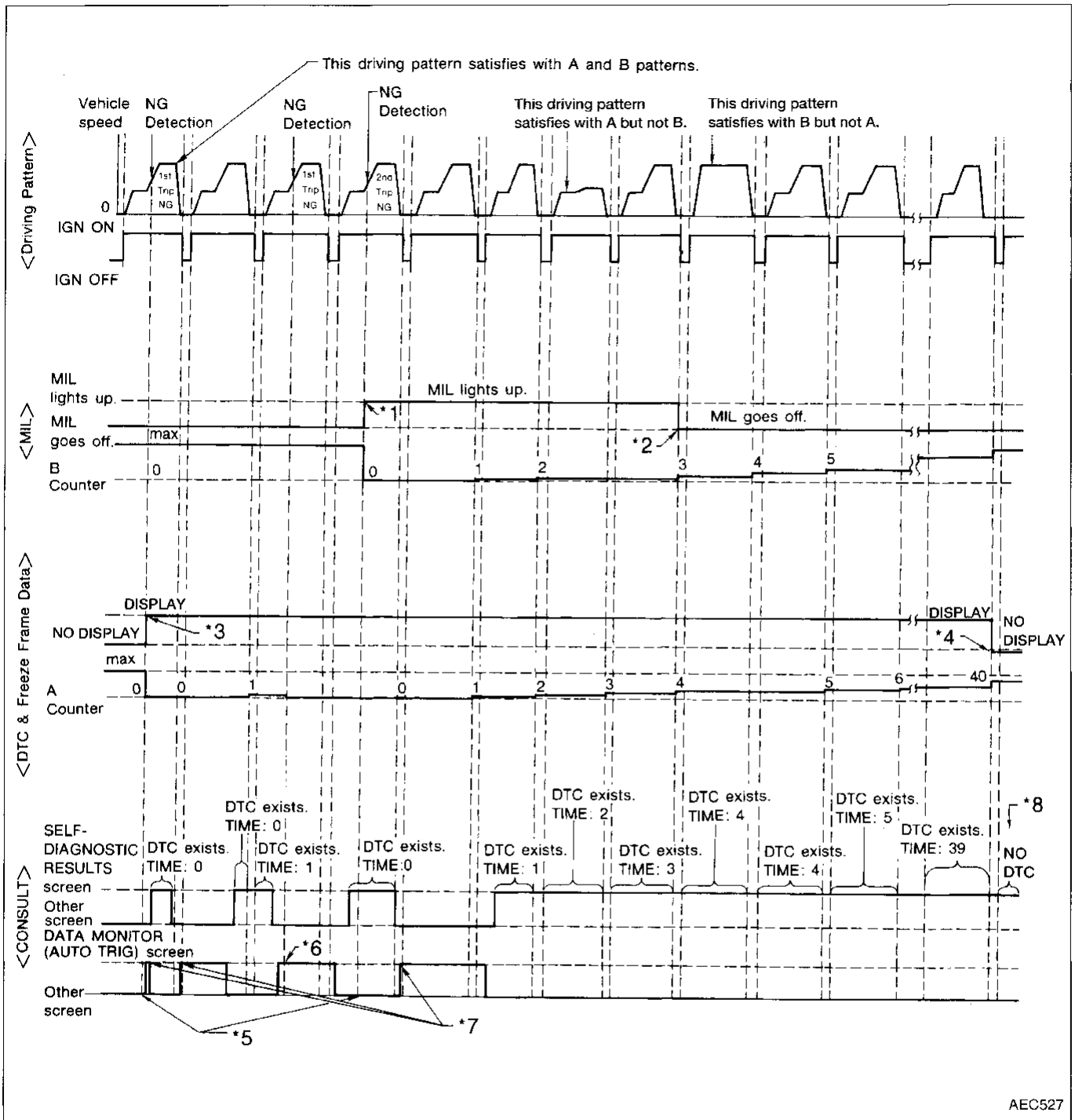

AEC527

- \*1: When the same malfunction is detected in two consecutive trips, MIL will light up.
- \*2: MIL will go off after vehicle is driven three times (pattern B) without any malfunctions.
- \*3: When a malfunction is detected for the first time, the DTC and the freeze frame data will be stored in ECM.
- \*4: The DTC and the freeze frame data will not be displayed after vehicle is driven 40 times (pattern A) without the same malfunction. (The DTC and the freeze frame data still remain in ECM.)

- \*5: Other screen except DATA MONITOR (AUTO TRIG) can not display the malfunction.
- \*6: DATA MONITOR (AUTO TRIG) can display the malfunction at the moment it is detected.
- \*7: The malfunction can not be displayed because the timing to set DATA MONITOR (AUTO TRIG) screen was missed against the NG detection.
- \*8: The DTC and the freeze frame data will not be displayed after vehicle is driven 40 times (pattern A) without the same malfunction. (The DTC and the freeze frame data still remain in ECM.)

## OBD System Operation Chart (Cont'd)

## EXPLANATION FOR DRIVING PATTERNS EXCEPT FOR "MISFIRE &lt;EXHAUST QUALITY DETERIORATION&gt;", "FUEL INJECTION SYSTEM"

## ⟨Driving pattern A⟩

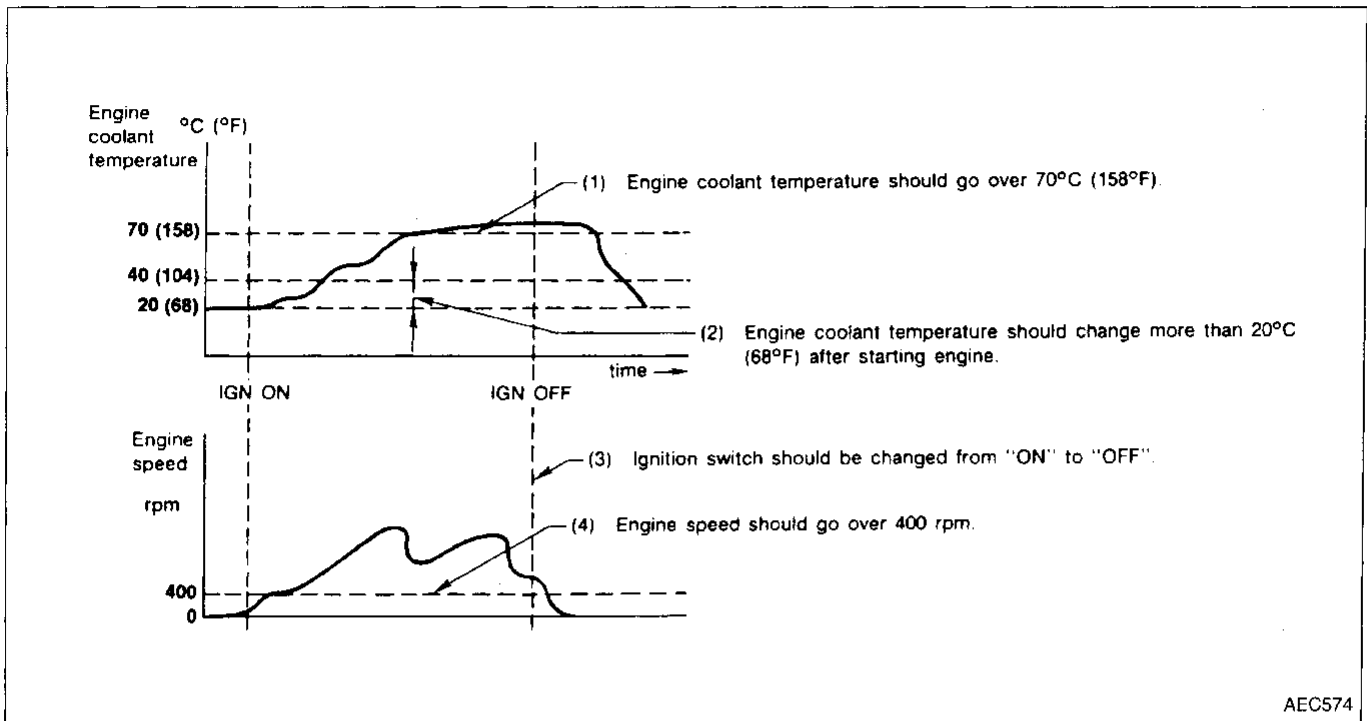

- The A counter will be cleared when the malfunction is detected regardless of (1) - (4).
- The A counter will be counted up when (1) - (4) are satisfied without the same malfunction.
- The DTC will not be displayed after the A counter reaches 40.

## ⟨Driving pattern B⟩

Driving pattern B means vehicle operation is as follows:

All components and systems should be monitored at least once by the OBD system.

- The B counter will be cleared when the malfunction is detected twice regardless of the driving pattern (\*1 in "OBD SYSTEM OPERATION CHART").
- The B counter will be counted up when driving pattern B is satisfied without any malfunctions.
- The MIL will go off when the B counter reaches 3 (\*2 in "OBD SYSTEM OPERATION CHART").

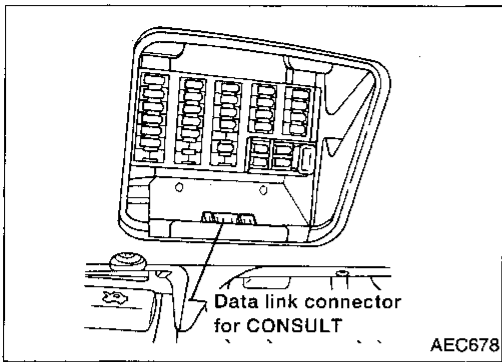

**CONSULT**

**CONSULT INSPECTION PROCEDURE**

1. Turn off ignition switch.
2. Connect "CONSULT" to data link connector for CONSULT. (Data link connector for CONSULT is located behind the fuse box cover.)

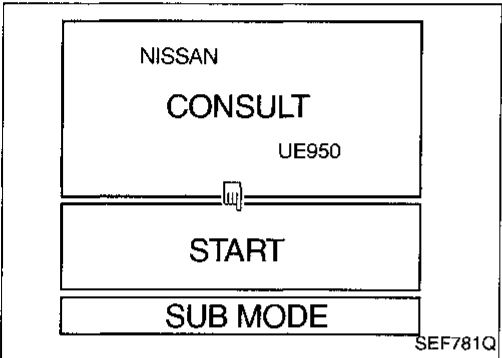

3. Turn on ignition switch.
4. Touch "START".

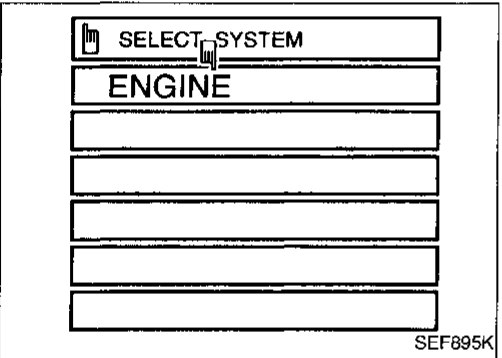

5. Touch "ENGINE".

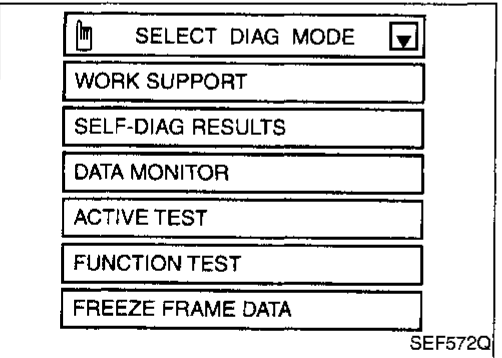

6. Perform each diagnostic test mode according to each service procedure.

**For further information, see the CONSULT Operation Manual.**

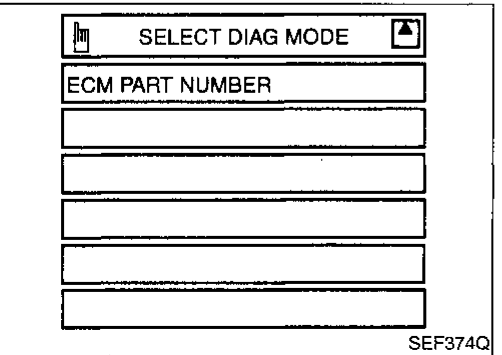

CONSULT (Cont'd)

ECCS COMPONENT PARTS/CONTROL SYSTEMS APPLICATION

Item		DIAGNOSTIC TEST MODE						
		WORK SUP-PORT	SELF-DIAG-NOSTIC RESULTS	DATA MONITOR	ACTIVE TEST	FUNC-TION TEST	FREEZE FRAME DATA *1	
ECCS COMPONENT PARTS	INPUT	Camshaft position sensor		X	X			X
		Mass air flow sensor		X	X			
		Engine coolant temperature sensor		X	X	X		X
		Front heated oxygen sensor		X	X		X	
		Rear heated oxygen sensor		X	X			
		Vehicle speed sensor		X	X		X	X
		Throttle position sensor	X	X	X		X	
		EGR temperature sensor		X	X			
		Intake air temperature sensor		X	X			
		Crankshaft position sensor (OBD)		X				
		Knock sensor		X				
		Ignition switch (start signal)			X		X	
		Closed throttle position switch			X		X	
		Air conditioner switch			X			
		Park/Neutral position switch		X	X		X	
	Power steering oil pressure switch			X		X		
	Battery voltage			X				
	OUTPUT	Injectors			X	X	X	
		Power transistor (Ignition timing)	X	X (Igni-tion sig-nal)	X	X	X	
		IACV-AAC valve	X	X	X	X	X	
Air conditioner relay				X				
Fuel pump relay		X		X	X	X		
Cooling fan			X	X	X	X		
EGR valve & EVAP canister purge control solenoid valve			X	X	X	X		
Front heated oxygen sensor heater			X	X				
Calculated load value			X			X		

X: Applicable

\*1: The items appear on CONSULT screen in FREEZE FRAME DATA mode only if a diagnostic trouble code (DTC) is detected. For details, refer to EC-54.

GI  
MA  
EM  
LC  
EC  
FE  
CL  
MT  
AT  
FA  
RA  
BR  
ST  
RS  
BT  
HA  
EL  
IDX

**CONSULT (Cont'd)**

**FUNCTION**

Diagnostic test mode	Function
Work support	A technician can adjust some devices faster and more accurately by following indications on CONSULT.
Self-diagnostic results	Self-diagnostic results can be read and erased quickly.
Data monitor	Input/Output data in the ECM can be read.
Active test	CONSULT drives some actuators apart from the ECM's and also shifts some parameters in a specified range.
ECM part numbers	ECM part numbers can be read.
Function test	Conducted by CONSULT instead of a technician to determine whether each system is "OK" or "NG".
Freeze frame data	ECM stores the driving condition at the moment a malfunction is detected, and stored data can be read. For details, refer to "Freeze Frame Data" (EC-54).

**WORK SUPPORT MODE**

WORK ITEM	CONDITION	USAGE
THRTL POS SEN ADJ	CHECK THE THROTTLE POSITION SENSOR SIGNAL. ADJUST IT TO THE SPECIFIED VALUE BY ROTATING THE SENSOR BODY UNDER THE FOLLOWING CONDITIONS. <ul style="list-style-type: none"> <li>● IGN SW "ON"</li> <li>● ENG NOT RUNNING</li> <li>● ACC PEDAL NOT PRESSED</li> </ul>	When adjusting throttle position sensor initial position
IGNITION TIMING ADJ	● IGNITION TIMING FEEDBACK CONTROL WILL BE HELD BY TOUCHING "START". AFTER DOING SO, ADJUST IGNITION TIMING WITH A TIMING LIGHT BY TURNING THE CAMSHAFT POSITION SENSOR.	When adjusting initial ignition timing
IACV-AAC VALVE ADJ	SET ENGINE SPEED AT THE SPECIFIED VALUE UNDER THE FOLLOWING CONDITIONS. <ul style="list-style-type: none"> <li>● ENGINE WARMED UP</li> <li>● NO-LOAD</li> </ul>	When adjusting idle speed
FUEL PRESSURE RELEASE	● FUEL PUMP WILL STOP BY TOUCHING "START" DURING IDLING. CRANK A FEW TIMES AFTER ENGINE STALLS.	When releasing fuel pressure from fuel line

**CONSULT (Cont'd)**

**SELF-DIAGNOSTIC MODE**

Regarding items detected in "SELF-DIAG RESULTS" mode, refer to "Diagnostic Trouble Code (DTC) Chart" (See page EC-65.)

**DATA MONITOR MODE**

Monitored item [Unit]	ECM input signals	Main signals	Description	Remarks
CMPS-RPM (REF) [rpm]	○	○	<ul style="list-style-type: none"> <li>Indicates the engine speed computed from the REF signal (180° signal) of the camshaft position sensor.</li> </ul>	<ul style="list-style-type: none"> <li>Accuracy becomes poor if engine speed drops below the idle rpm.</li> <li>If the signal is interrupted while the engine is running, an abnormal value may be indicated.</li> </ul>
MAS AIR/FL SE [V]	○	○	<ul style="list-style-type: none"> <li>The signal voltage of the mass air flow sensor is displayed.</li> </ul>	<ul style="list-style-type: none"> <li>When the engine is stopped, a certain value is indicated.</li> </ul>
COOLAN TEMP/S [°C] or [°F]	○	○	<ul style="list-style-type: none"> <li>The engine coolant temperature (determined by the signal voltage of the engine coolant temperature sensor) is displayed.</li> </ul>	<ul style="list-style-type: none"> <li>When the engine coolant temperature sensor is open or short-circuited, ECM enters fail-safe mode. The engine coolant temperature determined by the ECM is displayed.</li> </ul>
FR O2 SENSOR [V]	○	○	<ul style="list-style-type: none"> <li>The signal voltage of the front heated oxygen sensor is displayed.</li> </ul>	
RR O2 SENSOR [V]	○	○	<ul style="list-style-type: none"> <li>The signal voltage of the rear heated oxygen sensor is displayed.</li> </ul>	
FR O2 MNTR [RICH/LEAN]	○	○	<ul style="list-style-type: none"> <li>Display of front heated oxygen sensor signal during air-fuel ratio feedback control: RICH ... means the mixture became "rich", and control is being affected toward a leaner mixture. LEAN ... means the mixture became "lean", and control is being affected toward a rich mixture.</li> </ul>	<ul style="list-style-type: none"> <li>After turning ON the ignition switch, "RICH" is displayed until air-fuel mixture ratio feedback control begins.</li> <li>When the air-fuel ratio feedback is clamped, the value just before the clamping is displayed continuously.</li> </ul>
RR O2 MNTR [RICH/LEAN]	○		<ul style="list-style-type: none"> <li>Display of rear heated oxygen sensor signal: RICH ... means the amount of oxygen after three way catalyst is relatively large. LEAN ... means the amount of oxygen after three way catalyst is relatively small.</li> </ul>	<ul style="list-style-type: none"> <li>When the engine is stopped, a certain value is indicated.</li> </ul>
VHCL SPEED SE [km/h] or [mph]	○	○	<ul style="list-style-type: none"> <li>The vehicle speed computed from the vehicle speed sensor signal is displayed.</li> </ul>	

**NOTE:**  
Any monitored item that does not match the vehicle being diagnosed is deleted from the display automatically.

## CONSULT (Cont'd)

Monitored item [Unit]	ECM input signals	Main signals	Description	Remarks
BATTERY VOLT [V]	<input type="radio"/>	<input type="radio"/>	<ul style="list-style-type: none"> <li>The power supply voltage of ECM is displayed.</li> </ul>	
THRTL POS SEN [V]	<input type="radio"/>	<input type="radio"/>	<ul style="list-style-type: none"> <li>The throttle position sensor signal voltage is displayed.</li> </ul>	
EGR TEMP SEN [V]	<input type="radio"/>		<ul style="list-style-type: none"> <li>The signal voltage of the EGR temperature sensor is displayed.</li> </ul>	
INT/A TEMP SE [°C] or [°F]	<input type="radio"/>		<ul style="list-style-type: none"> <li>The intake air temperature determined by the signal voltage of the intake air temperature sensor is indicated.</li> </ul>	
START SIGNAL [ON/OFF]	<input type="radio"/>	<input type="radio"/>	<ul style="list-style-type: none"> <li>Indicates [ON/OFF] condition from the starter signal.</li> </ul>	<ul style="list-style-type: none"> <li>After starting the engine, [OFF] is displayed regardless of the starter signal.</li> </ul>
CLSD THL/P SW [ON/OFF]	<input type="radio"/>	<input type="radio"/>	<ul style="list-style-type: none"> <li>Indicates the closed throttle position [ON/OFF] determined by the closed throttle position switch (A/T models) or throttle position sensor (M/T models) signal.</li> <li>ON: Closed throttle position</li> <li>OFF: Other than closed throttle position</li> </ul>	
AIR COND SIG [ON/OFF]	<input type="radio"/>	<input type="radio"/>	<ul style="list-style-type: none"> <li>Indicates [ON/OFF] condition of the air conditioner switch as determined by the air conditioning signal.</li> </ul>	
P/N POSI SW [ON/OFF]	<input type="radio"/>	<input type="radio"/>	<ul style="list-style-type: none"> <li>Indicates [ON/OFF] condition from the park/neutral position switch signal.</li> </ul>	
PW/ST SIGNAL [ON/OFF]	<input type="radio"/>	<input type="radio"/>	<ul style="list-style-type: none"> <li>Indicates [ON/OFF] condition of the power steering oil pressure switch determined by the power steering oil pressure signal.</li> </ul>	
IGNITION SW [ON/OFF]	<input type="radio"/>		<ul style="list-style-type: none"> <li>Indicates [ON/OFF] condition from ignition switch.</li> </ul>	
INJ PULSE [msec]		<input type="radio"/>	<ul style="list-style-type: none"> <li>Indicates the actual fuel injection pulse width compensated by ECM according to the input signals.</li> </ul>	<ul style="list-style-type: none"> <li>When the engine is stopped, a certain computed value is indicated.</li> </ul>
B/FUEL SCHDL [msec]		<input type="radio"/>	<ul style="list-style-type: none"> <li>"Base fuel schedule" indicates the fuel injection pulse width programmed into ECM, prior to any learned on-board correction.</li> </ul>	
IGN TIMING [BTDC]		<input type="radio"/>	<ul style="list-style-type: none"> <li>Indicates the ignition timing computed by ECM according to the input signals.</li> </ul>	

CONSULT (Cont'd)

Monitored item [Unit]	ECM input signals	Main signals	Description	Remarks
IACV-AAC/V [%]		○	<ul style="list-style-type: none"> <li>Indicates the idle air control valve (AAC valve) control value computed by ECM according to the input signals.</li> </ul>	
A/F ALPHA [%]		○	<ul style="list-style-type: none"> <li>Indicates the mean value of the air-fuel ratio feedback correction factor per cycle.</li> </ul>	<ul style="list-style-type: none"> <li>When the engine is stopped, a certain value is indicated.</li> <li>This data also includes the data for the air-fuel ratio learning control.</li> </ul>
AIR COND RLY [ON/OFF]			<ul style="list-style-type: none"> <li>Indicates the air conditioner relay control condition (determined by ECM according to the input signal).</li> </ul>	
FUEL PUMP RLY [ON/OFF]			<ul style="list-style-type: none"> <li>Indicates the fuel pump relay control condition determined by ECM according to the input signals.</li> </ul>	
COOLING FAN [HI/LOW/OFF]			<ul style="list-style-type: none"> <li>Indicates the control condition of the cooling fans (determined by ECM according to the input signal). HI ... High speed operation LOW ... Low speed operation OFF ... Stopped</li> </ul>	
EGRC SOL/V [ON/OFF]			<ul style="list-style-type: none"> <li>Indicates the control condition of the EGR valve &amp; EVAP canister purge control solenoid valve (determined by ECM according to the input signal). ON ... EGR and EVAP canister purge operation cut-off OFF ... EGR and EVAP canister purge operation not cut-off</li> </ul>	
O2 SEN HEATER [ON/OFF]			<ul style="list-style-type: none"> <li>Indicates [ON/OFF] condition of front heated oxygen sensor heater determined by ECM according to the input signals .</li> </ul>	
CAL/LD VALUE [%]			<ul style="list-style-type: none"> <li>"Calculated load value" indicates the value of the current airflow divided by peak airflow.</li> </ul>	
ABSOL TH-P/S [%]			<ul style="list-style-type: none"> <li>"Absolute throttle position sensor" indicates the throttle opening computed by ECM according to the signal voltage of the throttle position sensor.</li> </ul>	
MASS AIRFLOW [gm/s]			<ul style="list-style-type: none"> <li>Indicates the mass air flow computed by ECM according to the signal voltage of the mass air flow sensor.</li> </ul>	
VOLTAGE [V]			<ul style="list-style-type: none"> <li>Voltage measured by the voltage probe.</li> </ul>	
PULSE [msec] or [Hz] or [%]			<ul style="list-style-type: none"> <li>Pulse width, frequency or duty cycle measured by the pulse probe.</li> </ul>	<ul style="list-style-type: none"> <li>Only "#" is displayed if item is unable to be measured.</li> <li>Figures with "#'s are temporary ones. They are the same figures as an actual piece of data which was just previously measured.</li> </ul>

GI  
MA  
EM  
LC  
EC  
FE  
CL  
MT  
AT  
FA  
RA  
BR  
ST  
RS  
BT  
HA  
EL  
IDX



**CONSULT (Cont'd)**

**ACTIVE TEST MODE**

TEST ITEM	CONDITION	JUDGEMENT	CHECK ITEM (REMEDY)
FUEL INJECTION	<ul style="list-style-type: none"> <li>● Engine: Return to the original trouble condition</li> <li>● Change the amount of fuel injection using CONSULT.</li> </ul>	If trouble symptom disappears, see CHECK ITEM.	<ul style="list-style-type: none"> <li>● Harness and connector</li> <li>● Fuel injectors</li> <li>● Front heated oxygen sensor</li> </ul>
IACV-AAC/V OPENING	<ul style="list-style-type: none"> <li>● Engine: After warming up, idle the engine.</li> <li>● Change the IACV-AAC valve opening percent using CONSULT.</li> </ul>	Engine speed changes according to the opening percent.	<ul style="list-style-type: none"> <li>● Harness and connector</li> <li>● IACV-AAC valve</li> </ul>
ENG COOLANT TEMP	<ul style="list-style-type: none"> <li>● Engine: Return to the original trouble condition</li> <li>● Change the engine coolant temperature indication using CONSULT.</li> </ul>	If trouble symptom disappears, see CHECK ITEM.	<ul style="list-style-type: none"> <li>● Harness and connector</li> <li>● Engine coolant temperature sensor</li> <li>● Fuel injectors</li> </ul>
IGNITION TIMING	<ul style="list-style-type: none"> <li>● Engine: Return to the original trouble condition</li> <li>● Timing light: Set</li> <li>● Retard the ignition timing using CONSULT.</li> </ul>	If trouble symptom disappears, see CHECK ITEM.	<ul style="list-style-type: none"> <li>● Adjust initial ignition timing</li> </ul>
POWER BALANCE	<ul style="list-style-type: none"> <li>● Engine: After warming up, idle the engine.</li> <li>● A/C switch "OFF"</li> <li>● Shift lever "N"</li> <li>● Cut off each injector signal one at a time using CONSULT.</li> </ul>	Engine runs rough or dies.	<ul style="list-style-type: none"> <li>● Harness and connector</li> <li>● Compression</li> <li>● Injectors</li> <li>● Power transistor</li> <li>● Spark plugs</li> <li>● Ignition coils</li> </ul>
COOLING FAN	<ul style="list-style-type: none"> <li>● Ignition switch: ON</li> <li>● Turn the cooling fan "ON" and "OFF" using CONSULT.</li> </ul>	Cooling fan moves and stops.	<ul style="list-style-type: none"> <li>● Harness and connector</li> <li>● Cooling fan motor</li> </ul>
FUEL PUMP RELAY	<ul style="list-style-type: none"> <li>● Ignition switch: ON (Engine stopped)</li> <li>● Turn the fuel pump relay "ON" and "OFF" using CONSULT and listen to operating sound.</li> </ul>	Fuel pump relay makes the operating sound.	<ul style="list-style-type: none"> <li>● Harness and connector</li> <li>● Fuel pump relay</li> </ul>
EGRC SOLENOID VALVE	<ul style="list-style-type: none"> <li>● Ignition switch: ON</li> <li>● Turn solenoid valve "ON" and "OFF" with the CONSULT and listen to operating sound.</li> </ul>	Solenoid valve makes an operating sound.	<ul style="list-style-type: none"> <li>● Harness and connector</li> <li>● Solenoid valve</li> </ul>
SELF-LEARNING CONT	<ul style="list-style-type: none"> <li>● In this test, the coefficient of self-learning control mixture ratio returns to the original coefficient by touching "CLEAR" on the screen.</li> </ul>		

**CONSULT (Cont'd)**

**FUNCTION TEST MODE**

FUNCTION TEST ITEM	CONDITION	JUDGEMENT		CHECK ITEM (REMEDY)
SELF-DIAG RESULTS	<ul style="list-style-type: none"> <li>● Ignition switch: ON (Engine stopped)</li> <li>● Displays the results of on-board diagnostic system.</li> </ul>	—		Objective system
CLOSED THROTTLE POSI	<ul style="list-style-type: none"> <li>● Ignition switch: ON (Engine stopped)</li> <li>● Closed throttle position switch circuit is tested when throttle is opened and closed fully. (Closed throttle position is selected by throttle position sensor.)</li> </ul>	Throttle valve: opened	OFF	<ul style="list-style-type: none"> <li>● Harness and connector</li> <li>● Throttle position sensor</li> <li>● Throttle position sensor adjustment</li> <li>● Throttle linkage</li> <li>● Verify operation in DATA MONITOR mode.</li> </ul>
		Throttle valve: closed	ON	
THROTTLE POSI SEN CKT	<ul style="list-style-type: none"> <li>● Ignition switch: ON (Engine stopped)</li> <li>● Throttle position sensor circuit is tested when throttle is opened and closed fully.</li> </ul>	Range (Throttle valve fully opened — Throttle valve fully closed)	More than 3.0V	<ul style="list-style-type: none"> <li>● Harness and connector</li> <li>● Throttle position sensor</li> <li>● Throttle position sensor adjustment</li> <li>● Throttle linkage</li> <li>● Verify operation in DATA MONITOR mode.</li> </ul>
PARK/NEUT POSI SW CKT	<ul style="list-style-type: none"> <li>● Ignition switch: ON (Engine stopped)</li> <li>● Inhibitor/Neutral position switch circuit is tested when shift lever is manipulated.</li> </ul>	Out of N/P positions	OFF	<ul style="list-style-type: none"> <li>● Harness and connector</li> <li>● Neutral position switch or inhibitor switch</li> <li>● Linkage or inhibitor switch adjustment</li> </ul>
		In N/P positions	ON	
FUEL PUMP CIRCUIT	<ul style="list-style-type: none"> <li>● Ignition switch: ON (Engine stopped)</li> <li>● Fuel pump circuit is tested by checking the pulsation in fuel pressure when fuel tube is pinched.</li> </ul>	There is pressure pulsation on the fuel feed hose.		<ul style="list-style-type: none"> <li>● Harness and connector</li> <li>● Fuel pump</li> <li>● Fuel pump relay</li> <li>● Fuel filter clogging</li> <li>● Fuel level</li> </ul>
EGRC SOL/V CIRCUIT	<ul style="list-style-type: none"> <li>● Ignition switch: ON (Engine stopped)</li> <li>● EGR valve &amp; EVAP canister purge control solenoid valve circuit is tested by checking solenoid valve operating noise.</li> </ul>	The solenoid valve makes an operating sound every 3 seconds.		<ul style="list-style-type: none"> <li>● Harness and connector</li> <li>● EGR valve &amp; EVAP canister purge control solenoid valve</li> </ul>
COOLING FAN CIRCUIT	<ul style="list-style-type: none"> <li>● Ignition switch: ON (Engine stopped)</li> <li>● Cooling fan circuit is tested when cooling fan is rotated.</li> </ul>	The cooling fan rotates and stops every 3 seconds.		<ul style="list-style-type: none"> <li>● Harness and connector</li> <li>● Cooling fan motor</li> <li>● Cooling fan relay</li> </ul>

GI  
MA  
EM  
LC  
**EC**  
FE  
CL  
MT  
AT  
FA  
RA  
BR  
ST  
RS  
BT  
HA  
EL  
IDX

**CONSULT (Cont'd)**

FUNCTION TEST ITEM	CONDITION	JUDGEMENT		CHECK ITEM (REMEDY)
START SIGNAL CIRCUIT	<ul style="list-style-type: none"> <li>● Ignition switch: ON → START</li> <li>● Start signal circuit is tested when engine is started by operating the starter. Before cranking, battery voltage and engine coolant temperature are displayed. During cranking, average battery voltage, mass air flow sensor output voltage and cranking speed are displayed.</li> </ul>	Start signal: OFF → ON		<ul style="list-style-type: none"> <li>● Harness and connector</li> <li>● Ignition switch</li> </ul>
PW/ST SIGNAL CIRCUIT	<ul style="list-style-type: none"> <li>● Ignition switch: ON (Engine running)</li> <li>● Power steering circuit is tested when steering wheel is rotated fully and then set to a straight line running position.</li> </ul>	Locked position	ON	<ul style="list-style-type: none"> <li>● Harness and connector</li> <li>● Power steering oil pressure switch</li> <li>● Power steering oil pump</li> </ul>
VEHICLE SPEED SEN CKT	<ul style="list-style-type: none"> <li>● Vehicle speed sensor circuit is tested when vehicle is running at a speed of 10 km/h (6 MPH) or higher.</li> </ul>	Vehicle speed sensor input signal is greater than 4 km/h (2 MPH)		<ul style="list-style-type: none"> <li>● Harness and connector</li> <li>● Vehicle speed sensor</li> <li>● Electric speedometer</li> </ul>
IGN TIMING ADJ	<ul style="list-style-type: none"> <li>● After warming up, idle the engine.</li> <li>● Ignition timing adjustment is checked by reading ignition timing with a timing light and checking whether it agrees with specifications.</li> </ul>	The timing light indicates the same value on the screen.		<ul style="list-style-type: none"> <li>● Adjust ignition timing (by moving camshaft position sensor or distributor)</li> <li>● Camshaft position sensor drive mechanism</li> </ul>
MIXTURE RATIO TEST	<ul style="list-style-type: none"> <li>● Air-fuel ratio feedback circuit (injection system, ignition system, vacuum system, etc.) is tested by examining the front heated oxygen sensor output at 2,000 rpm under non-loaded state.</li> </ul>	Front heated oxygen sensor COUNT: More than 5 times during 10 seconds		<ul style="list-style-type: none"> <li>● INJECTION SYS (Injector, fuel pressure regulator, harness or connector)</li> <li>● IGNITION SYS (Spark plug, power transistor, ignition coil, harness or connector)</li> <li>● VACUUM SYS (Intake air leaks)</li> <li>● Front heated oxygen sensor circuit</li> <li>● Front heated oxygen sensor operation</li> <li>● Fuel pressure high or low</li> <li>● Mass air flow sensor</li> </ul>

CONSULT (Cont'd)

FUNCTION TEST ITEM	CONDITION	JUDGEMENT	CHECK ITEM (REMEDY)
POWER BALANCE	<ul style="list-style-type: none"> <li>● After warming up, idle the engine.</li> <li>● Injector operation of each cylinder is stopped one after another, and resultant change in engine rotation is examined to evaluate combustion of each cylinder. (This is only displayed for models where a sequential multipoint fuel injection system is used.)</li> </ul>	Difference in engine speed is greater than 25 rpm before and after cutting off the injector of each cylinder.	<ul style="list-style-type: none"> <li>● Injector circuit (Injector, harness or connector)</li> <li>● Ignition circuit (Spark plug, power transistor, ignition coil, harness or connector)</li> <li>● Compression</li> <li>● Valve timing</li> </ul>
IACV-AAC/V SYSTEM	<ul style="list-style-type: none"> <li>● After warming up, idle the engine.</li> <li>● IACV-AAC valve system is tested by detecting change in engine speed when IACV-AAC valve opening is changed to 0%, 20% and 80%.</li> </ul>	Difference in engine speed is greater than 150 rpm between when valve opening is at 80% and at 20%.	<ul style="list-style-type: none"> <li>● Harness and connector</li> <li>● IACV-AAC valve</li> <li>● Air passage restriction between air inlet and IACV-AAC valve</li> <li>● IAS (Idle adjusting screw) adjustment</li> </ul>

GI

MA

EM

LC

**EC**

FE

CL

MT

AT

FA

RA

BR

ST

RS

BT

HA

EL

IDX

**CONSULT (Cont'd)**

**FREEZE FRAME DATA**

Freeze frame data item	Description
DIAG TROUBLE CODE [PXXXX]	<ul style="list-style-type: none"> <li>● ECCS component part/control system has a trouble code, it is displayed as "PXXXX". [Refer to "Alphabetical &amp; P No. Index for DTC" (EC-458).]</li> </ul>
FUEL SYS DATA	<ul style="list-style-type: none"> <li>● "Fuel injection system status" at the moment a malfunction is detected is displayed.</li> <li>● One mode in the following is displayed.                      "MODE 2": Open loop due to detected system malfunction                      "MODE 3": Open loop due to driving conditions (power enrichment, deceleration enrichment)                      "MODE 4": Closed loop - using heated oxygen sensor(s) as feedback for fuel control                      "MODE 5": Open loop - has not yet satisfied condition to go to closed loop</li> </ul>
CAL/LD VALUE [%]	<ul style="list-style-type: none"> <li>● The calculated load value at the moment a malfunction is detected is displayed.</li> </ul>
COOLANT TEMP [°C] or [°F]	<ul style="list-style-type: none"> <li>● The engine coolant temperature at the moment a malfunction is detected is displayed.</li> </ul>
S-FUEL TRIM [%]	<ul style="list-style-type: none"> <li>● "Short-term fuel trim" at the moment a malfunction is detected is displayed.</li> <li>● The short-term fuel trim indicates dynamic or instantaneous feedback compensation to the base fuel schedule.</li> </ul>
L-FUEL TRIM [%]	<ul style="list-style-type: none"> <li>● "Long-term fuel trim" at the moment a malfunction is detected is displayed.</li> <li>● The long-term fuel trim indicates much more gradual feedback compensation to the base fuel schedule than short-term fuel trim.</li> </ul>
ENGINE SPEED [rpm]	<ul style="list-style-type: none"> <li>● The engine speed at the moment a malfunction is detected is displayed.</li> </ul>
VHCL SPEED [km/h] or [mph]	<ul style="list-style-type: none"> <li>● The vehicle speed at the moment a malfunction is detected is displayed.</li> </ul>

CONSULT (Cont'd)

REAL TIME DIAGNOSIS IN DATA MONITOR MODE

CONSULT has two kinds of triggers and they can be selected by touching "SETTING" in "DATA MONITOR" mode.

1. "AUTO TRIG" (Automatic trigger):
  - The malfunction will be identified on the CONSULT screen in real time. In other words, DTC and malfunction item will be displayed at the moment the malfunction is detected by ECM.
  - DATA MONITOR can be performed continuously until a malfunction is detected. However, DATA MONITOR cannot continue any longer after the malfunction detection.
2. "MANU TRIG" (Manual trigger):
  - DTC and malfunction item will not be displayed automatically on CONSULT screen even though a malfunction is detected by ECM.
  - DATA MONITOR can be performed continuously even though a malfunction is detected.

Use these triggers as follows:

1. "AUTO TRIG"
  - While trying to detect the DTC by performing the "DTC CONFIRMATION PROCEDURE", be sure to select to "DATA MONITOR (AUTO TRIG)" mode. You can confirm the malfunction at the moment it is detected.
  - While narrowing down the possible causes, CONSULT should be set in "DATA MONITOR (AUTO TRIG)" mode, especially in case the incident is intermittent. Inspect the circuit by gently shaking (or twisting) suspicious connectors, components and harness in the "DTC CONFIRMATION PROCEDURE". The moment a malfunction is found the DTC will be displayed. (Refer to GI section, "Incident Simulation Tests" in "HOW TO PERFORM EFFICIENT DIAGNOSIS FOR AN ELECTRICAL INCIDENT".)
2. "MANU TRIG"
  - If the malfunction is displayed as soon as "DATA MONITOR" is selected, reset CONSULT to "MANU TRIG". By selecting "MANU TRIG" you can monitor and store the data. The data can be utilized for further diagnosis, such as a comparison with the value for the normal operating condition.

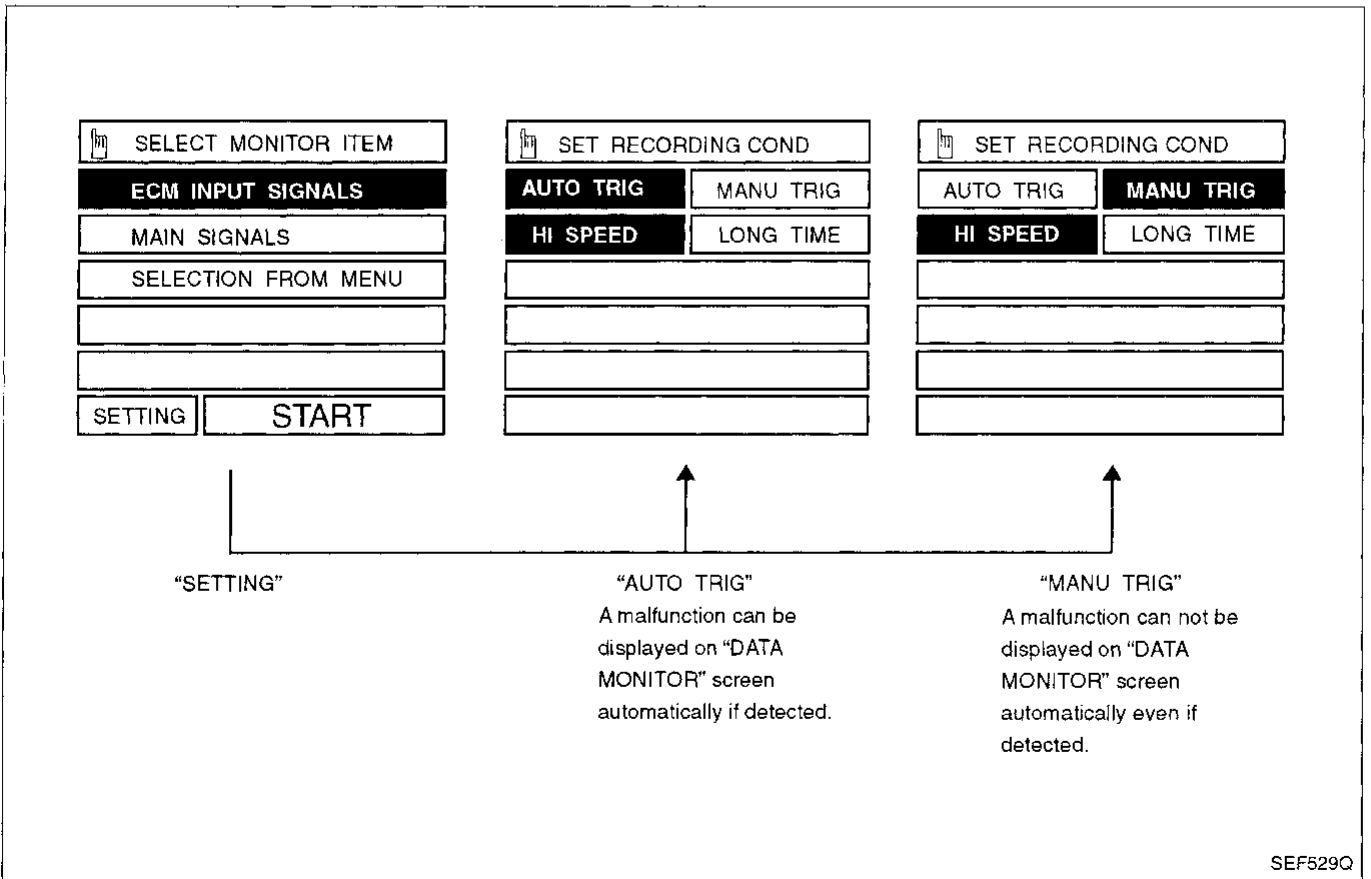

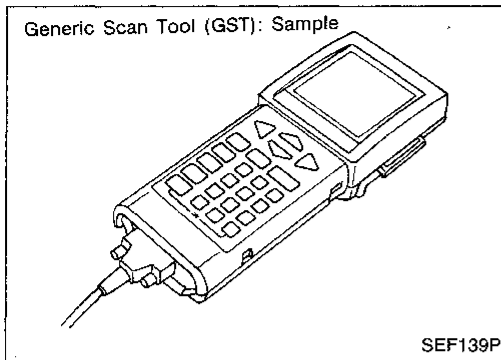

## Generic Scan Tool (GST)

### DESCRIPTION

Generic Scan Tool (OBDII scan tool) complying with SAE J1978 has five different functions explained on the next page. ISO9141 is used as the protocol. The name "GST" or "Generic Scan Tool" is used in this service manual.

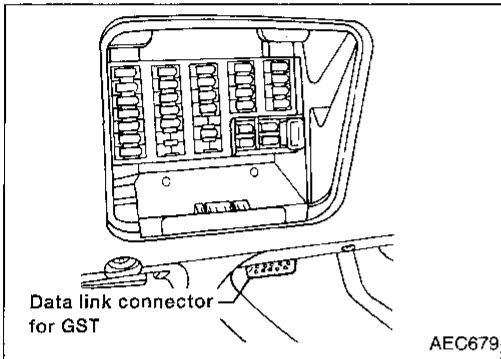

### GST INSPECTION PROCEDURE

1. Turn off ignition switch.
2. Connect "GST" to data link connector for GST. (Data link connector for GST is located under LH dash panel near the fuse box cover.)

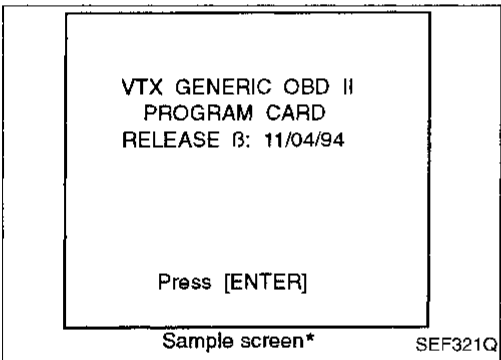

3. Turn on ignition switch.
4. Enter the program according to instruction on the screen or in the operation manual.  
(\*: Regarding GST screens in this section, sample screens are shown.)

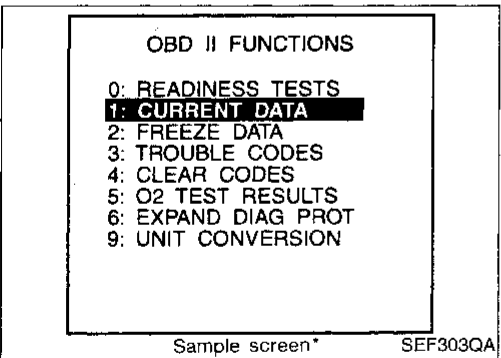

5. Perform each diagnostic mode according to each service procedure.

**For further information, see the GST Operation Manual of the tool maker.**

**Generic Scan Tool (GST) (Cont'd)**

**FUNCTION**

Diagnostic test mode		Function
MODE 1	(Current data)	This mode gains access to current emission-related data values, including analog inputs and outputs, digital inputs and outputs, and system status information.
MODE 2	(Freeze data)	This mode gains access to emission-related data value which were stored by ECM during the freeze frame. Refer to "Freeze Frame Data" (EC-54).
MODE 3	(Trouble codes)	This mode gains access to emission-related powertrain trouble codes which were stored by ECM.
MODE 4	(Clear codes)	This mode can clear all emission-related diagnostic information. This includes: <ul style="list-style-type: none"> <li>● Clear number of diagnostic trouble codes (MODE 1)</li> <li>● Clear diagnostic trouble codes (MODE 3)</li> <li>● Clear trouble code for freeze frame data (MODE 1)</li> <li>● Clear freeze frame data (MODE 2)</li> <li>● Clear oxygen sensor test data (MODE 5)</li> <li>● Reset status of system monitoring test (MODE 1)</li> </ul>
MODE 5	(O2 test results)	This mode gains access to the on-board heated oxygen sensor monitoring test results.

GI  
MA  
EM  
LC  
**EC**  
FE  
CL  
MT  
AT  
FA  
RA  
BR  
ST  
RS  
BT  
HA  
EL  
IDX



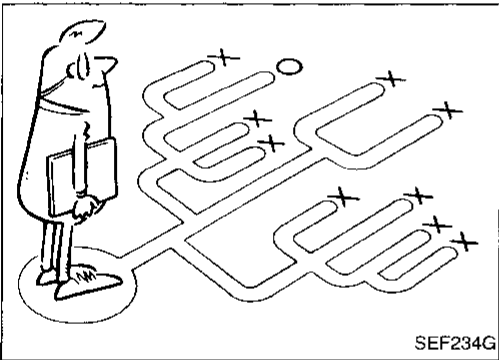
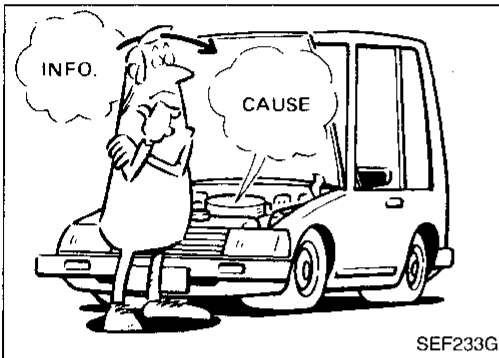
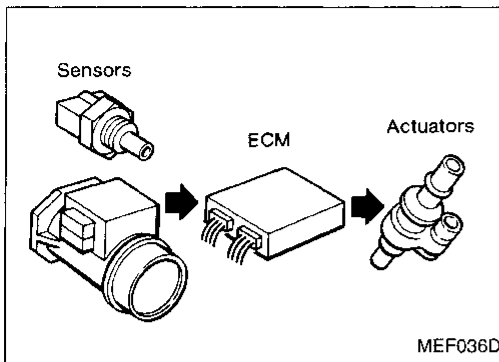

## Introduction

The engine has an ECM to control major systems such as fuel control, ignition control, idle air control system, etc. The ECM accepts input signals from sensors and instantly drives actuators. It is essential that both input and output signals are proper and stable. At the same time, it is important that there are no problems such as vacuum leaks, fouled spark plugs, or other problems with the engine.

It is much more difficult to diagnose a problem that occurs intermittently rather than continuously. Most intermittent problems are caused by poor electric connections or improper wiring. In this case, careful checking of suspected circuits may help prevent the replacement of good parts.

A visual check only may not find the cause of the problems. A road test with CONSULT (or GST) or a circuit tester connected should be performed. Follow the "Work Flow" on the next page. Before undertaking actual checks, take a few minutes to talk with a customer who approaches with a driveability complaint. The customer can supply good information about such problems, especially intermittent ones. Find out what symptoms are present and under what conditions they occur. A "Diagnostic Worksheet" like the example on next page should be used. Start your diagnosis by looking for "conventional" problems first. This will help troubleshoot driveability problems on an electronically controlled engine vehicle.



Work Flow

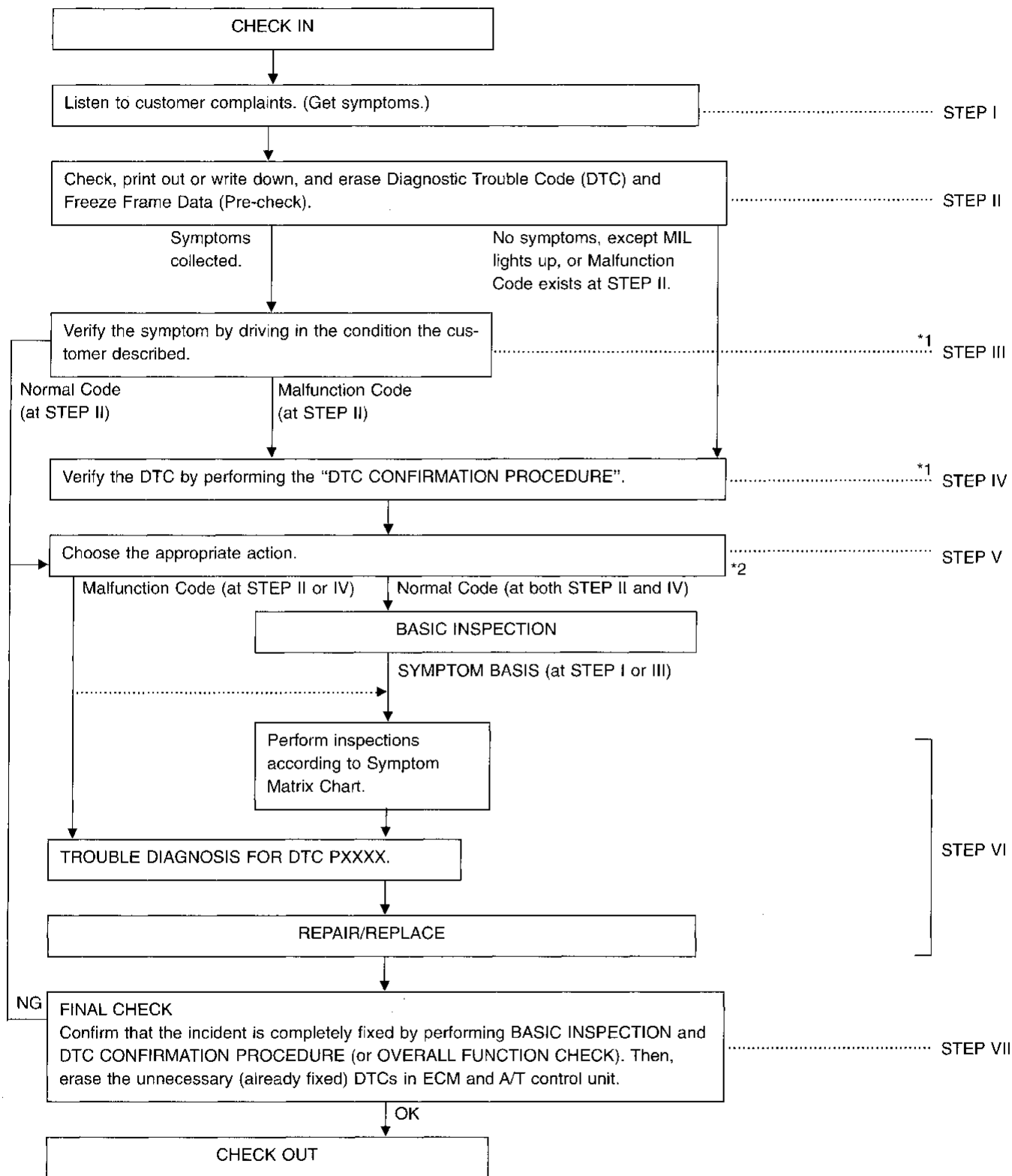

\*1: If the incident cannot be duplicated, refer to GI section (“Incident Simulation Tests”, “HOW TO PERFORM EFFICIENT DIAGNOSIS FOR AN ELECTRICAL INCIDENT”).

\*2: If the on-board diagnostic system cannot be performed, check main power supply and ground circuit. Refer to “TROUBLE DIAGNOSIS FOR POWER SUPPLY”, EC-90.

Description for Work Flow

STEP	DESCRIPTION	
STEP I	Get detailed information about the conditions and the environment when the incident/symptom occurred using the "DIAGNOSTIC WORKSHEET" as shown on the next page.	GI
STEP II	Before confirming the concern, check and write down (print out using CONSULT or Generic Scan Tool) the Diagnostic Trouble Code (DTC) and the freeze frame data, then erase the code and the data. Refer to EC-33.) The DTC and the freeze frame data can be used when duplicating the incident at STEP III & IV. Study the relationship between the cause, specified by DTC, and the symptom described by the customer. (The "Symptom Matrix Chart" will be useful. Refer to EC-77.)	MA EM
STEP III	Try to confirm the symptom and under what conditions the incident occurs. The "DIAGNOSTIC WORK SHEET" and the freeze frame data are useful to verify the incident. Connect CONSULT to the vehicle in DATA MONITOR (AUTO TRIG) mode and check real time diagnosis results. If the incident cannot be verified, perform INCIDENT SIMULATION TESTS. Refer to GI section. If the malfunction code is detected, skip STEP IV and perform STEP V.	LC EC
STEP IV	Try to detect the Diagnostic Trouble Code (DTC) by driving in (or performing) the "DTC CONFIRMATION PROCEDURE". Check and read the DTC and freeze frame data by using CONSULT or Generic Scan Tool. During the DTC verification, be sure to connect CONSULT to the vehicle in DATA MONITOR (AUTO TRIG) mode and check real time diagnosis results. If the incident cannot be verified, perform INCIDENT SIMULATION TESTS. Refer to GI section. In case the "DTC CONFIRMATION PROCEDURE" is not available, perform the "OVERALL FUNCTION CHECK" instead. The DTC cannot be displayed by this check, however, this simplified "check" is an effective alternative. The "NG" result of the "OVERALL FUNCTION CHECK" is the same as the DTC detection.	FE CL MT
STEP V	Take the appropriate action based on the results of STEP I through IV. If the malfunction code is indicated, proceed to TROUBLE DIAGNOSIS FOR DTC PXXXX. If the normal code is indicated, proceed to the BASIC INSPECTION. Refer to EC-62. Then perform inspections according to the Symptom Matrix Chart. Refer to EC-77.	AT
STEP VI	Identify where to begin diagnosis based on the relationship study between symptom and possible causes. Inspect the system for mechanical binding, loose connectors or wiring damage using (tracing) "Harness Layouts". Gently shake the related connectors, components or wiring harness with CONSULT set in "DATA MONITOR (AUTO TRIG)" mode. Check the voltage of the related ECM terminals or monitor the output data from the related sensors with CONSULT. Refer to EC-80. The "DIAGNOSTIC PROCEDURE" in EC section contains a description based on open circuit inspection. A short circuit inspection is also required for the circuit check in the DIAGNOSTIC PROCEDURE. For details, refer to GI section ("Circuit Inspection", "HOW TO PERFORM EFFICIENT DIAGNOSIS FOR AN ELECTRICAL INCIDENT"). Repair or replace the malfunction parts.	FA RA BR
STEP VII	Once you have repaired the circuit or replaced a component, you need to run the engine in the same conditions and circumstances which resulted in the customer's initial complaint. Perform the "DTC CONFIRMATION PROCEDURE" and confirm the normal code (Diagnostic trouble code No. 0505 or P0000) is detected. If the incident is still detected in the final check, perform STEP VI by using a different method from the previous one. Before returning the vehicle to the customer, be sure to erase the unnecessary (already fixed) DTC in ECM and A/T control unit. (Refer to EC-33.)	ST RS BT

HA

EL

IDX

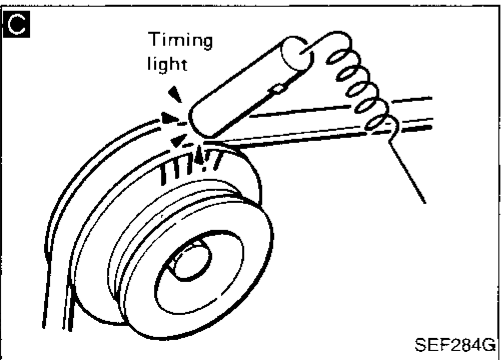
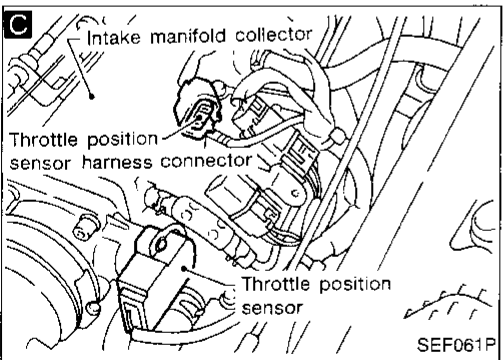
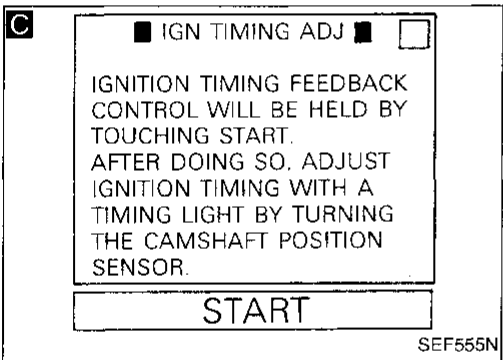
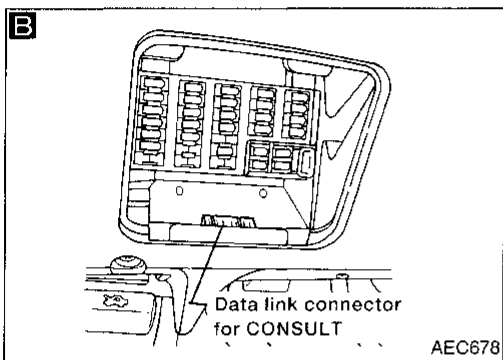
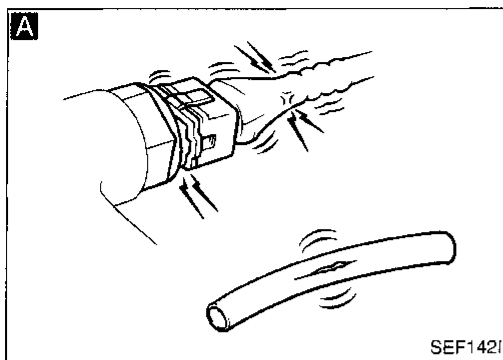

### Basic Inspection

**Precaution:**

Perform Basic Inspection without electrical or mechanical loads applied;

- Headlamp switch is OFF,
- Air conditioner switch is OFF,
- Rear defogger switch is OFF,
- Steering wheel is in the straight-ahead position, etc.

**A**

**BEFORE STARTING**

1. Check service records for any recent repairs that may indicate a related problem, or the current need for scheduled maintenance.
2. Open engine hood and check the following:
  - Harness connectors for improper connections
  - Vacuum hoses for splits, kinks, or improper connections
  - Wiring for improper connections, pinches, or cuts

**B**

**CONNECT CONSULT TO THE VEHICLE.**  
Connect "CONSULT" to the data link connector for CONSULT and select "ENGINE" from the menu. Refer to EC-44.

**DOES ENGINE START?**

No → Go to **E**.

**C**

**CHECK IGNITION TIMING.**

1. Warm up engine sufficiently.
2. Select "IGN TIMING ADJ" in "WORK SUPPORT" mode.
3. Touch "START".
4. Check ignition timing at idle using timing light.

**Ignition timing:**  
**15°±2° BTDC**

---

1. Warm up engine sufficiently.
2. Stop engine and disconnect throttle position sensor harness connector.
3. Start engine.
4. Check ignition timing at idle using timing light.

**Ignition timing:**  
**15°±2° BTDC**

NG → Adjust ignition timing by turning camshaft position sensor.

OK  
↓  
(Go to **A** on next page.)

Basic Inspection (Cont'd)

**D** ■ IGN TIMING ADJ ■ □

IGNITION TIMING FEEDBACK CONTROL WILL BE HELD BY TOUCHING START. AFTER DOING SO, ADJUST IGNITION TIMING WITH A TIMING LIGHT BY TURNING THE CAMSHAFT POSITION SENSOR.

START

SEF546N

**D** (A)

**CHECK IDLE ADJ. SCREW INITIAL SET RPM.**

1. Select "IGN TIMING ADJ" in "WORK SUPPORT" mode.  
2. When touching "START", does engine speed fall to  $750 \pm 50$  rpm (A/T in "N" position)?

OR

Does engine run at  $750 \pm 50$  rpm (A/T in "N" position)?

NG → Adjust engine speed by turning idle adjusting screw.

OK →

**E**

Throttle position sensor harness connector

Close throttle position switch connector

AEC908

**E**

**CHECK CLOSED THROTTLE POSITION SWITCH IDLE POSITION (A/T model only).**

1. Disconnect throttle position sensor harness connector and closed throttle position switch harness connector.  
2. Check continuity between closed throttle position switch connector terminals ② and ③ as follows: Raise engine speed to 2,000 rpm then gradually lower.

Continuity should exist (closed throttle position switch should close) at  $1,050 \pm 150$  rpm (transaxle in "N" position).

NG → Adjust continuity signal by rotating throttle position sensor body. Then, go to (B).

OK →

**E**

DISCONNECT T.S.

Closed throttle position switch connector

AEC915

Reconnect throttle position sensor harness connector and closed throttle position switch harness connector.

OK →

**F** ■ THRTL POS SEN ADJ ■ □

\*\*\* ADJ MONITOR \*\*\*

THRTL POS SEN 0.52V

===== MONITOR =====

CMPS•RPM (REF) 0rpm  
CLSD THL/P ON

SEF165P

**F**

**CHECK THROTTLE POSITION SENSOR IDLE POSITION (M/T model only).**

1. Perform "THRTL POS SEN ADJ" in "WORK SUPPORT" mode.  
2. Check that output voltage of throttle position sensor is approx. 0.35 to 0.65V (Throttle valve fully closes.) and "CLSD THL/P SW" stays "ON".

OR

Measure output voltage of throttle position sensor using voltmeter, and check that it is approx. 0.35 to 0.65V. (Throttle valve fully closed.)

NG → Adjust output voltage to 0.50V by rotating throttle position sensor body.

OK →

**RESET IDLE POSITION MEMORY.**

1. Warm up engine sufficiently.
2. Turn ignition switch "OFF" and wait at least 5 seconds.
3. Disconnect throttle position sensor harness connector.
4. Start engine and wait at least 5 seconds in "N" position.
5. Reconnect throttle position sensor harness connector while running engine.

**F** M/T models

Intake manifold collector

H.S.

Throttle position sensor harness connector

AEC805

OK →

(Go to next page.)

(B)

CI  
MA  
EM  
LC  
EC  
FE  
CL  
MT  
AT  
FA  
RA  
BR  
ST  
RS  
BT  
HA  
EL  
IDX

## Basic Inspection (Cont'd)

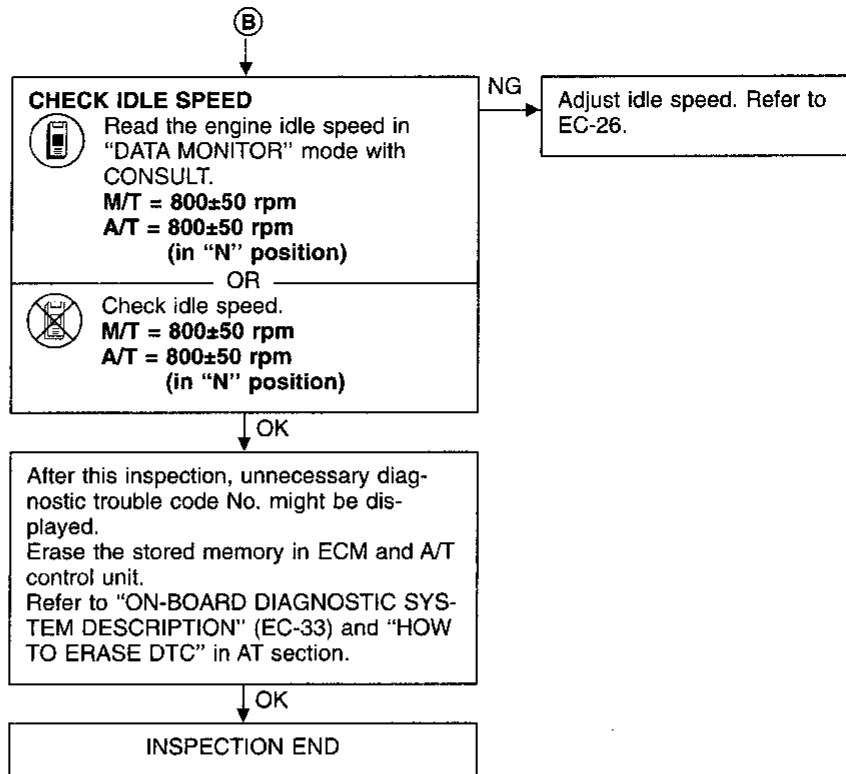

Diagnostic Trouble Code (DTC) Chart

ENGINE RELATED ITEMS

Diagnostic trouble code No.		Detected items (Screen terms for CONSULT, "SELF-DIAG RESULTS" mode)	Malfunction is detected when ...
CONSULT GST	MIL		
(P0000)	0505	No failure (NO SELF DIAGNOSTIC FAILURE INDICATED...)	<ul style="list-style-type: none"> <li>● No malfunction related to OBD system is detected by either ECM or A/T control unit.</li> </ul>
P0100	0102	Mass air flow sensor circuit (MASS AIR FLOW SEN)	<ul style="list-style-type: none"> <li>● An excessively high or low voltage is detected by ECM.</li> <li>● Voltage sent to ECM is not practical when compared with the camshaft position sensor signal and throttle position sensor signal.</li> </ul>
P0110	0401	Intake air temperature sensor circuit (INT AIR TEMP SEN)	<ul style="list-style-type: none"> <li>● An excessively low or high voltage from the sensor is detected by the ECM.</li> <li>● Voltage sent to ECM is not practical when compared with the engine coolant temperature sensor signal.</li> </ul>
P0115	0103	Engine coolant temperature sensor circuit (COOLANT TEMP SEN)	<ul style="list-style-type: none"> <li>● An excessively high or low voltage from the sensor is detected by the ECM.</li> </ul>
P0120	0403	Throttle position sensor circuit (THROTTLE POSI SEN)	<ul style="list-style-type: none"> <li>● An excessively low or high voltage from the sensor is detected by the ECM.</li> <li>● Voltage sent to ECM is not practical when compared with the mass air flow sensor and camshaft position sensor signals.</li> </ul>
P0125	0908	Engine coolant temperature sensor function (*COOLANT TEMP SEN)	<ul style="list-style-type: none"> <li>● Voltage sent to ECM from the sensor is not practical, even when some time has passed after starting the engine.</li> <li>● Engine coolant temperature is insufficient for closed loop fuel control.</li> </ul>
P0130	0307	Closed loop control (CLOSED LOOP)	<ul style="list-style-type: none"> <li>● The closed loop control function does not operate even when vehicle is driving in the specified condition.</li> </ul>
P0130	0303	Front heated oxygen sensor circuit (FRONT O2 SENSOR)	<ul style="list-style-type: none"> <li>● An excessively high voltage from the sensor is detected by the ECM.</li> <li>● The voltage from the sensor is constantly approx. 0.3V.</li> <li>● The specified maximum and minimum voltages from the sensor are not reached.</li> <li>● It takes more than the specified time for the sensor to respond between rich and lean.</li> </ul>

**Note: A dead (weak) battery will reduce the accuracy of the on-board diagnosis and may cause the MIL to light up without any malfunctions.**

Abbreviations for Quick Reference of "DTC CONFIRMATION PROCEDURE"

IGN: ON : Turning the ignition switch ON is required for checking the function of the sensor, switch, solenoid and circuit.

RUNNING: Running engine is required for checking the function of the sensor, switch, solenoid and circuit.

LIFTING : Lifting up the vehicle, running engine and spinning wheels are required.

DRIVING : Driving the vehicle in the specified pattern is required.

Abbreviations for Quick Reference of "OVERALL FUNCTION CHECK"

IGN: ON : Turning the ignition switch ON is required for the ECM to detect a malfunction (if one exists).

RUNNING: Running engine is required for the ECM to detect a malfunction (if one exists).

LIFTING : Lifting up the vehicle, running engine and spinning wheels are required for the ECM to detect a malfunction (if one exists).

DRIVING : Driving the vehicle in the specified pattern is required for the ECM to detect a malfunction (if one exists).



**Diagnostic Trouble Code (DTC) Chart (Cont'd)**

X: Applicable  
—: Not applicable

Check Items (Possible Cause)	"DTC CONFIRMATION PROCEDURE" Quick Ref. *1	"OVERALL FUNCTION CHECK" Quick Ref. *2	Fail Safe System	MIL Illumination	Reference Page
● No failure	—	—	—	—	—
● Harness or connectors (The sensor circuit is open or shorted.) ● Mass air flow sensor	RUNNING	RUNNING	X	2 trip	EC-93
● Harness or connectors (The sensor circuit is open or shorted.) ● Intake air temperature sensor	IGN: ON	—	—	2 trip	EC-98
● Harness or connectors (The sensor circuit is open or shorted.) ● Engine coolant temperature sensor	IGN: ON	—	X	2 trip	EC-103
● Harness or connectors (The sensor circuit is open or shorted.) ● Throttle position sensor	—	IGN: ON	X	2 trip	EC-107
● Harness or connectors (High resistance in the sensor circuit.) ● Engine coolant temperature sensor ● Thermostat	—	RUNNING	—	2 trip	EC-112
● The front heated oxygen sensor circuit is open or shorted. ● Front heated oxygen sensor	—	RUNNING	—	1 trip	EC-122
● Harness or connectors (The sensor circuit is open or shorted.) ● Front heated oxygen sensor ● Injectors ● Intake air leaks ● Fuel pressure	—	RUNNING	—	2 trip	EC-117

\*1: ● This is Quick Reference of "DTC CONFIRMATION PROCEDURE".

Details are described in each TROUBLE DIAGNOSIS FOR DTC PXXXX.

\*2: ● The "OVERALL FUNCTION CHECK" is a simplified and effective way to inspect a component or circuit.

In some cases, the "OVERALL FUNCTION CHECK" is used rather than a "DIAGNOSTIC TROUBLE CODE CONFIRMATION PROCEDURE".

When no DTC CONFIRMATION PROCEDURE is available, the "NG" result of the OVERALL FUNCTION CHECK can be considered to mean the same as a DTC detection.

● During an "NG" OVERALL FUNCTION CHECK, the DTC might not be confirmed.

● This is Quick Reference of "OVERALL FUNCTION CHECK".

Details are described in each TROUBLE DIAGNOSIS FOR DTC PXXXX.

**Diagnostic Trouble Code (DTC) Chart (Cont'd)**

**ENGINE RELATED ITEMS**

Diagnostic trouble code No.		Detected items (Screen terms for CONSULT, "SELF-DIAG RESULTS" mode)	Malfunction is detected when ...	
CONSULT GST	MIL			
P0135	0901	Front heated oxygen sensor heater circuit (FR O2 SEN HEATER)	<ul style="list-style-type: none"> <li>● The current amperage in the heater circuit is out of the normal range. (An improper voltage drop signal is sent to ECM through the heater.)</li> </ul>	
P0136	0707	Rear heated oxygen sensor circuit (REAR O2 SENSOR)	<ul style="list-style-type: none"> <li>● An excessively high voltage from the sensor is detected by the ECM.</li> <li>● The specified maximum and minimum voltages from the sensor are not reached.</li> <li>● It takes more than the specified time for the sensor to respond between rich and lean.</li> </ul>	
P0170	0706	Fuel injection system function (FUEL INJ SYSTEM)	<ul style="list-style-type: none"> <li>● Fuel injection system does not operate properly.</li> <li>● The amount of mixture ratio compensation is excessive. (The mixture ratio is too lean or too rich.)</li> </ul>	
P0300	0701	Multiple cylinders' misfire (MULTI CYL MISFIRE)	(Three way catalyst damage) The misfire occurs, which will damage three way catalyst by over-heating.	(Exhaust quality deterioration) The misfire occurs, which will not damage three way catalyst but will affect emission deterioration.
P0301	0608	No. 1 cylinder's misfire (CYL 1 MISFIRE)		
P0302	0607	No. 2 cylinder's misfire (CYL 2 MISFIRE)		
P0303	0606	No. 3 cylinder's misfire (CYL 3 MISFIRE)		
P0304	0605	No. 4 cylinder's misfire (CYL 4 MISFIRE)		
P0325 (*3)	0304	Knock sensor circuit (KNOCK SENSOR)	<ul style="list-style-type: none"> <li>● An excessively low or high voltage from the sensor is detected by the ECM.</li> </ul>	
P0335	0802	Crankshaft position sensor (OBD) circuit (CRANK POS SEN (OBD))	<ul style="list-style-type: none"> <li>● The proper pulse signal from the sensor is not detected by the ECM while the engine is running at the specified rpm.</li> </ul>	

**Note: A dead (weak) battery will reduce the accuracy of the on-board diagnosis and may cause the MIL to light up without any malfunctions.**

Abbreviations for Quick Reference of "DTC CONFIRMATION PROCEDURE"

IGN: ON : Turning the ignition switch ON is required for checking the function of the sensor, switch, solenoid and circuit.

RUNNING: Running engine is required for checking the function of the sensor, switch, solenoid and circuit.

LIFTING : Lifting up the vehicle, running engine and spinning wheels are required.

DRIVING : Driving the vehicle in the specified pattern is required.

Abbreviations for Quick Reference of "OVERALL FUNCTION CHECK"

IGN: ON : Turning the ignition switch ON is required for the ECM to detect a malfunction (if one exists).

RUNNING: Running engine is required for the ECM to detect a malfunction (if one exists).

LIFTING : Lifting up the vehicle, running engine and spinning wheels are required for the ECM to detect a malfunction (if one exists).

DRIVING : Driving the vehicle in the specified pattern is required for the ECM to detect a malfunction (if one exists).

\*3: Freeze frame data is not stored in the ECM for the "Knock sensor". The MIL will not light up for a "Knock sensor" malfunction.

**Diagnostic Trouble Code (DTC) Chart (Cont'd)**

X: Applicable  
—: Not applicable

Check Items (Possible Cause)	"DTC *1 CONFIRMA- TION PRO- CEDURE" Quick Ref.	*2 "OVERALL FUNCTION CHECK" Quick Ref.	Fail Safe System	MIL Illumination	Reference Page
<ul style="list-style-type: none"> <li>● Harness or connectors (The heater circuit is open or shorted.)</li> <li>● Front heated oxygen sensor heater</li> </ul>	RUNNING	—	—	2 trip	EC-123
<ul style="list-style-type: none"> <li>● Harness or connectors (The sensor circuit is open or shorted.)</li> <li>● Rear heated oxygen sensor</li> <li>● Fuel pressure</li> <li>● Injectors</li> <li>● Intake air leaks</li> </ul>	—	RUNNING (DRIVING)	—	2 trip	EC-126
<ul style="list-style-type: none"> <li>● Intake air leak</li> <li>● Front heated oxygen sensor</li> <li>● Injectors</li> <li>● Exhaust gas leaks</li> <li>● Incorrect fuel pressure</li> <li>● Mass air flow sensor</li> <li>● Lack of fuel</li> </ul>	RUNNING	—	—	2 trip	EC-131
<ul style="list-style-type: none"> <li>● Improper spark plug</li> <li>● Ignition secondary circuit is open or shorted</li> <li>● Insufficient compression</li> <li>● Incorrect fuel pressure</li> <li>● EGR valve</li> <li>● Injector circuit is open or shorted</li> <li>● Injectors</li> <li>● Intake air leaks</li> <li>● Lack of fuel</li> <li>● Magnetized flywheel (drive plate)</li> </ul>	DRIVING	—	—	(Three way catalyst dam- age) 1 trip  (Exhaust quality dete- rioration) 2 trip	EC-136
<ul style="list-style-type: none"> <li>● Harness or connectors (The sensor circuit is open or shorted.)</li> <li>● Knock sensor</li> </ul>	RUNNING	—	—	—	EC-140
<ul style="list-style-type: none"> <li>● Harness or connectors (The sensor circuit is open.)</li> <li>● Crankshaft position sensor (OBD)</li> </ul>	RUNNING	—	—	2 trip	EC-143

\*1: ● This is Quick Reference of "DTC CONFIRMATION PROCEDURE".

Details are described in each TROUBLE DIAGNOSIS FOR DTC PXXXX.

\*2: ● The "OVERALL FUNCTION CHECK" is a simplified and effective way to inspect a component or circuit.

In some cases, the "OVERALL FUNCTION CHECK" is used rather than a "DIAGNOSTIC TROUBLE CODE CONFIRMATION PROCEDURE".

When no DTC CONFIRMATION PROCEDURE is available, the "NG" result of the OVERALL FUNCTION CHECK can be considered to mean the same as a DTC detection.

● During an "NG" OVERALL FUNCTION CHECK, the DTC might not be confirmed.

● This is Quick Reference of "OVERALL FUNCTION CHECK".

Details are described in each TROUBLE DIAGNOSIS FOR DTC PXXXX.

**Diagnostic Trouble Code (DTC) Chart (Cont'd)**

**ENGINE RELATED ITEMS**

Diagnostic trouble code No.		Detected items (Screen terms for CONSULT, "SELF-DIAG RESULTS" mode)	Malfunction is detected when ...
CONSULT GST	MIL		
P0340	0101	Camshaft position sensor circuit (CAMSHAFT POSI SEN)	<ul style="list-style-type: none"> <li>• Either 1° or 180° signal is not detected by the ECM for the first few seconds during engine cranking.</li> <li>• Either 1° or 180° signal is not detected by the ECM often enough while the engine speed is higher than the specified rpm.</li> <li>• The relation between 1° and 180° signals is not in the normal range during the specified rpm.</li> </ul>
P0400	0302	EGR function (EGR SYSTEM)	<ul style="list-style-type: none"> <li>• The EGR flow is excessively low or high during the specified driving condition.</li> </ul>
P0402	0306	EGRC-BPT valve function (EGRC-BPT VALVE)	<ul style="list-style-type: none"> <li>• EGRC-BPT valve does not operate properly.</li> </ul>
P0420	0702	Three way catalyst function (TW CATALYST SYSTEM)	<ul style="list-style-type: none"> <li>• Three way catalyst does not operate properly.</li> <li>• Three way catalyst does not have enough oxygen storage capacity.</li> </ul>
P0500	0104	Vehicle speed sensor circuit (VEHICLE SPEED SEN)	<ul style="list-style-type: none"> <li>• The almost 0 km/h (0 MPH) signal from the sensor is detected by the ECM even when vehicle is driving.</li> </ul>
P0505	0205	Idle speed control function (IACV-AAC VALVE)	<ul style="list-style-type: none"> <li>• The idle speed control function does not operate properly.</li> </ul>
P0605	0301	ECM (ECM)	<ul style="list-style-type: none"> <li>• ECM calculation function is malfunctioning.</li> </ul>
P0705	1003	Park/Neutral position switch circuit (PARK/NEUT POSI SW)	<ul style="list-style-type: none"> <li>• The signal of the park/neutral position switch is not changed in the process of engine starting and driving.</li> </ul>
P1320	0201	Ignition signal circuit (IGN SIGNAL-PRIMARY)	<ul style="list-style-type: none"> <li>• The ignition signal in the primary circuit is not detected by the ECM during engine cranking or running.</li> </ul>

GI  
MA  
EM  
LC  
EC  
FE  
CL  
MT  
AT  
FA  
RA  
BR  
ST  
RS  
BT

**Note: A dead (weak) battery will reduce the accuracy of the on-board diagnosis and may cause the MIL to light up without any malfunctions.**

HA

**Abbreviations for Quick Reference of "DTC CONFIRMATION PROCEDURE"**

- IGN: ON : Turning the ignition switch ON is required for checking the function of the sensor, switch, solenoid and circuit.
- RUNNING: Running engine is required for checking the function of the sensor, switch, solenoid and circuit.
- LIFTING : Lifting up the vehicle, running engine and spinning wheels are required.
- DRIVING : Driving the vehicle in the specified pattern is required.

EL

**Abbreviations for Quick Reference of "OVERALL FUNCTION CHECK"**

- IGN: ON : Turning the ignition switch ON is required for the ECM to detect a malfunction (if one exists).
- RUNNING: Running engine is required for the ECM to detect a malfunction (if one exists).
- LIFTING : Lifting up the vehicle, running engine and spinning wheels are required for the ECM to detect a malfunction (if one exists).
- DRIVING : Driving the vehicle in the specified pattern is required for the ECM to detect a malfunction (if one exists).

IDX

**Diagnostic Trouble Code (DTC) Chart (Cont'd)**

X: Applicable  
—: Not applicable

Check Items (Possible Cause)	"DTC *1 CONFIRMA- TION PRO- CEDURE" Quick Ref.	"OVERALL FUNCTION CHECK" Quick Ref.	Fail Safe System	MIL Illumination	Reference Page
<ul style="list-style-type: none"> <li>● Harness or connectors (The sensor circuit is open or shorted.)</li> <li>● Camshaft position sensor</li> <li>● Starter motor</li> <li>● Starting system circuit (EL section)</li> <li>● Dead (Weak) battery</li> </ul>	RUNNING	—	—	2 trip	EC-147
<ul style="list-style-type: none"> <li>● EGR valve stuck closed, open or leaking</li> <li>● Passage blocked</li> <li>● EGR valve and EVAP canister purge control solenoid valve</li> <li>● Tube leaking for EGR valve vacuum</li> <li>● EGRC-BPT valve leaking</li> <li>● EGR temperature sensor</li> </ul>	—	RUNNING	—	2 trip	EC-152
<ul style="list-style-type: none"> <li>● EGRC-BPT valve</li> <li>● Rubber tube (blocked or misconnected)</li> </ul>	—	RUNNING	—	2 trip	EC-161
<ul style="list-style-type: none"> <li>● Three way catalyst</li> <li>● Exhaust tube</li> <li>● Intake air leaks</li> <li>● Injectors</li> <li>● Injector leaks</li> </ul>	—	RUNNING	—	1 trip	EC-163
<ul style="list-style-type: none"> <li>● Harness or connectors (The sensor circuit is open or shorted.)</li> <li>● Vehicle speed sensor</li> </ul>	DRIVING	LIFTING	—	2 trip	EC-166
<ul style="list-style-type: none"> <li>● Harness or connectors (The valve circuit is shorted.)</li> <li>● IACV-AAC valve</li> </ul>	RUNNING	—	—	2 trip	EC-170
<ul style="list-style-type: none"> <li>● Harness or connectors (The valve circuit is open.)</li> <li>● IACV-AAC valve</li> </ul>	IGN: ON				
<ul style="list-style-type: none"> <li>● ECM (ECCS control module)</li> </ul>	RUNNING	—	X	2 trip	EC-174
<ul style="list-style-type: none"> <li>● Harness or connectors (The switch circuit is open or shorted.)</li> <li>● Neutral position switch</li> <li>● Inhibitor switch</li> </ul>	—	IGN: ON	—	2 trip	EC-176
<ul style="list-style-type: none"> <li>● Harness or connectors (The ignition primary circuit is open or shorted.)</li> <li>● Power transistor unit</li> <li>● Resistor</li> <li>● Camshaft position sensor</li> <li>● Camshaft position sensor circuit</li> </ul>	RUNNING	—	—	2 trip	EC-181

\*1: ● This is Quick Reference of "DTC CONFIRMATION PROCEDURE".

Details are described in each TROUBLE DIAGNOSIS FOR DTC PXXXX.

\*2: ● The "OVERALL FUNCTION CHECK" is a simplified and effective way to inspect a component or circuit.

In some cases, the "OVERALL FUNCTION CHECK" is used rather than a "DIAGNOSTIC TROUBLE CODE CONFIRMATION PROCEDURE".

When no DTC CONFIRMATION PROCEDURE is available, the "NG" result of the OVERALL FUNCTION CHECK can be considered to mean the same as a DTC detection.

● During an "NG" OVERALL FUNCTION CHECK, the DTC might not be confirmed.

● This is Quick Reference of "OVERALL FUNCTION CHECK".

Details are described in each TROUBLE DIAGNOSIS FOR DTC PXXXX.

**Diagnostic Trouble Code (DTC) Chart (Cont'd)**

**ENGINE RELATED ITEMS**

Diagnostic trouble code No.		Detected items (Screen terms for CONSULT, "SELF-DIAG RESULTS" mode)	Malfunction is detected when ...
CONSULT GST	MIL		
P1336	0905	Crankshaft position sensor (OBD) [CRANK P/S (OBD)-COG]	<ul style="list-style-type: none"> <li>The chipping of the flywheel or drive plate gear tooth (cog) is detected by the ECM.</li> </ul>
P1400	1005	EGR valve and EVAP canister purge control solenoid valve circuit (EGRC SOLENOID/V)	<ul style="list-style-type: none"> <li>An improper voltage signal is detected by the ECM through the solenoid valve.</li> </ul>
P1401	0305	EGR temperature sensor circuit (EGR TEMP SENSOR)	<ul style="list-style-type: none"> <li>An excessively low or high voltage from the sensor is detected by the ECM, even when engine coolant temperature is low or high.</li> </ul>
P1605	0804	A/T diagnosis communication line (A/T DIAG COMM LINE)	<ul style="list-style-type: none"> <li>An incorrect signal from A/T control unit is detected by the ECM.</li> </ul>
P1900 (*4)	0208	Cooling fan circuit (OVER HEAT)	<ul style="list-style-type: none"> <li>Cooling fan does not operate properly. (Overheat)</li> <li>Cooling system does not operate properly. (Overheat)</li> <li>Engine coolant was not added to the system using the proper filling method.</li> </ul>

**Note: A dead (weak) battery will reduce the accuracy of the on-board diagnosis and may cause the MIL to light up without any malfunctions.**

Abbreviations for Quick Reference of "DTC CONFIRMATION PROCEDURE"

- IGN: ON : Turning the ignition switch ON is required for checking the function of the sensor, switch, solenoid and circuit.
- RUNNING: Running engine is required for checking the function of the sensor, switch, solenoid and circuit.
- LIFTING : Lifting up the vehicle, running engine and spinning wheels are required.
- DRIVING : Driving the vehicle in the specified pattern is required.

Abbreviations for Quick Reference of "OVERALL FUNCTION CHECK"

- IGN: ON : Turning the ignition switch ON is required for the ECM to detect a malfunction (if one exists).
- RUNNING: Running engine is required for the ECM to detect a malfunction (if one exists).
- LIFTING : Lifting up the vehicle, running engine and spinning wheels are required for the ECM to detect a malfunction (if one exists).
- DRIVING : Driving the vehicle in the specified pattern is required for the ECM to detect a malfunction (if one exists).

\*4: Diagnostic trouble code No. P1900 is not displayed in SELF-DIAGNOSTIC RESULTS mode with CONSULT.

**Diagnostic Trouble Code (DTC) Chart (Cont'd)**

X: Applicable  
—: Not applicable

Check Items (Possible Cause)	"DTC CONFIRMATION PROCEDURE" Quick Ref. *1	"OVERALL FUNCTION CHECK" Quick Ref. *2	Fail Safe System	MIL Illumination	Reference Page
<ul style="list-style-type: none"> <li>● Harness or connectors</li> <li>● Crankshaft position sensor (OBD)</li> <li>● Flywheel (Drive plate)</li> </ul>	RUNNING	—	—	2 trip	EC-186
<ul style="list-style-type: none"> <li>● Harness or connectors (The valve circuit is open or shorted.)</li> <li>● EGR valve and EVAP canister purge control solenoid valve</li> </ul>	—	IGN: ON (RUNNING)	—	2 trip	EC-190
<ul style="list-style-type: none"> <li>● Harness or connectors (The sensor circuit is open or shorted.)</li> <li>● EGR temperature sensor</li> </ul>	RUNNING	—	—	2 trip	EC-194
<ul style="list-style-type: none"> <li>● Harness or connectors (The communication line circuit is open or shorted.)</li> <li>● Dead (Weak) battery</li> <li>● A/T control unit</li> </ul>	RUNNING	—	—	2 trip	EC-198
<ul style="list-style-type: none"> <li>● Harness or connectors. (The cooling fan circuit is open or shorted.)</li> <li>● Cooling fan</li> <li>● Radiator hose</li> <li>● Radiator</li> <li>● Radiator cap</li> <li>● Water pump</li> <li>● Thermostat</li> </ul> <p>For more information, refer to "MAIN 12 CAUSES OF OVERHEATING", (EC-212).</p>	—	IGN: ON (RUNNING)	—	2 trip	EC-201

\*1: ● This is Quick Reference of "DTC CONFIRMATION PROCEDURE".

Details are described in each TROUBLE DIAGNOSIS FOR DTC PXXXX.

\*2: ● The "OVERALL FUNCTION CHECK" is a simplified and effective way to inspect a component or circuit.

In some cases, the "OVERALL FUNCTION CHECK" is used rather than a "DIAGNOSTIC TROUBLE CODE CONFIRMATION PROCEDURE".

When no DTC CONFIRMATION PROCEDURE is available, the "NG" result of the OVERALL FUNCTION CHECK can be considered to mean the same as a DTC detection.

● During an "NG" OVERALL FUNCTION CHECK, the DTC might not be confirmed.

● This is Quick Reference of "OVERALL FUNCTION CHECK".

Details are described in each TROUBLE DIAGNOSIS FOR DTC PXXXX.

## Diagnostic Trouble Code (DTC) Chart (Cont'd)

**A/T RELATED ITEMS (Be sure to erase the DTC stored in ECM after the A/T related repair.)**

Diagnostic trouble code No.		Detected items (Screen terms for CONSULT, "SELF-DIAG RESULTS" mode)	Malfunction is detected when ...
CONSULT GST	MIL		
P0705	1101	Inhibitor switch circuit (INHIBITOR SWITCH)	● A/T control unit does not receive the correct voltage signal from the switch based on the gear position.
P0710	1208	Fluid temperature sensor (FLUID TEMP SENSOR)	● A/T control unit receives an excessively low or high voltage from the sensor.
P0720	1102	Revolution sensor (VHCL SPEED SEN-A/T)	● A/T control unit does not receive the proper voltage signal from the sensor.
P0725	1207	Engine speed signal (ENGINE SPEED SIG)	● A/T control unit does not receive the proper voltage signal from the ECM.
P0731	1103	Improper shifting to 1st gear position (A/T 1ST SIGNAL)	● A/T cannot be shifted to the 1st gear position even if electrical circuit is good.
P0732	1104	Improper shifting to 2nd gear position (A/T 2ND SIGNAL)	● A/T cannot be shifted to the 2nd gear position even if electrical circuit is good.
P0733	1105	Improper shifting to 3rd gear position (A/T 3RD SIGNAL)	● A/T cannot be shifted to the 3rd gear position even if electrical circuit is good.
P0734	1106	Improper shifting to 4th gear position or TCC (A/T 4TH SIGNAL OR TCC)	● A/T cannot be shifted to the 4th gear position or perform lock-up even if electrical circuit is good.
P0740	1204	T/C clutch solenoid valve (TOR CONV CLUTCH SV)	● A/T control unit detects the improper voltage drop when it tries to operate the solenoid valve.
P0745	1205	Line pressure solenoid valve (LINE PRESSURE S/V)	● A/T control unit detects the improper voltage drop when it tries to operate the solenoid valve.
P0750	1108	Shift solenoid valve A (SHIFT SOLENOID/V A)	● A/T control unit detects the improper voltage drop when it tries to operate the solenoid valve.
P0755	1201	Shift solenoid valve B (SHIFT SOLENOID/V B)	● A/T control unit detects the improper voltage drop when it tries to operate the solenoid valve.
P1705	1206	Throttle position sensor (THRTL POSI SEN-A/T)	● A/T control unit receives an excessively low or high voltage from the sensor.
P1760	1203	Overrun clutch solenoid valve (OVERRUN CLUTCH S/V)	● A/T control unit detects the improper voltage drop when it tries to operate the solenoid valve.

\*1: DRIVING pattern 1-6 means as follows:

Pattern 1 should meet b and c.

Pattern 2 should meet a and c.

Pattern 3 should meet a through e.

Pattern 4 should meet a and b.

Pattern 5 should meet a through c.

Pattern 6 should meet a through d.

a: Selector lever is in "D" position.

b: Vehicle speed is over 10 km/h (6 MPH).

c: Throttle opening is over 1/8.

d: Engine speed is over 450 rpm.

e: A/T fluid temperature is 20 - 120°C (68 - 248°F).



**Diagnostic Trouble Code (DTC) Chart (Cont'd)**

X: Applicable  
—: Not applicable

Check Items (Possible Cause)	"DTC *1 CONFIRMA- TION PRO- CEDURE" Quick Ref.	*2 "OVERALL FUNCTION CHECK" Quick Ref.	Fail Safe System	MIL Illumination	Reference Page
<ul style="list-style-type: none"> <li>● Harness or connectors (The switch circuit is open or shorted.)</li> <li>● Inhibitor switch</li> </ul>	DRIVING (pattern 1)	—	—	2 trip	See "Self- diagnosis", "TROUBLE DIAG- NOSES" in AT section.
<ul style="list-style-type: none"> <li>● Harness or connectors (The sensor circuit is open or shorted.)</li> <li>● Fluid temperature sensor</li> </ul>	DRIVING (pattern 6)	—	X	2 trip	
<ul style="list-style-type: none"> <li>● Harness or connectors (The sensor circuit is open or shorted.)</li> <li>● Revolution sensor</li> </ul>	DRIVING (pattern 2)	—	X	2 trip	
<ul style="list-style-type: none"> <li>● Harness or connectors (The signal circuit is open or shorted.)</li> </ul>	DRIVING (pattern 5)	—	X	2 trip	
<ul style="list-style-type: none"> <li>● Shift solenoid valve A</li> <li>● Shift solenoid valve B</li> <li>● Overrun clutch solenoid valve</li> <li>● Line pressure solenoid valve</li> <li>● Each clutch</li> <li>● Hydraulic control circuit</li> </ul>	DRIVING (pattern 3)	—	—	2 trip	
<ul style="list-style-type: none"> <li>● T/C clutch solenoid valve</li> </ul>					
<ul style="list-style-type: none"> <li>● Harness or connectors (The solenoid circuit is open or shorted.)</li> <li>● T/C clutch solenoid valve</li> </ul>	IGN: ON	—	X	2 trip	
<ul style="list-style-type: none"> <li>● Harness or connectors (The solenoid circuit is open or shorted.)</li> <li>● Line pressure solenoid valve</li> </ul>	IGN: ON	—	X	2 trip	
<ul style="list-style-type: none"> <li>● Harness or connectors (The solenoid circuit is open or shorted.)</li> <li>● Shift solenoid valve A</li> </ul>	IGN: ON	—	X	2 trip	
<ul style="list-style-type: none"> <li>● Harness or connectors (The solenoid circuit is open or shorted.)</li> <li>● Shift solenoid valve B</li> </ul>	IGN: ON	—	X	2 trip	
<ul style="list-style-type: none"> <li>● Harness or connectors (The sensor circuit is open or shorted.)</li> <li>● Throttle position sensor</li> </ul>	DRIVING (pattern 4)	—	X	2 trip	
<ul style="list-style-type: none"> <li>● Harness or connectors (The solenoid circuit is open or shorted.)</li> <li>● Overrun clutch solenoid valve</li> </ul>	IGN: ON	—	X	2 trip	

\*1: ● This is Quick Reference of "DTC CONFIRMATION PROCEDURE".

Details are described in each TROUBLE DIAGNOSIS FOR DTC PXXXX.

\*2: ● The "OVERALL FUNCTION CHECK" is a simplified and effective way to inspect a component or circuit.

In some cases, the "OVERALL FUNCTION CHECK" is used rather than a "DIAGNOSTIC TROUBLE CODE CONFIRMATION PROCEDURE".

When no DTC CONFIRMATION PROCEDURE is available, the "NG" result of the OVERALL FUNCTION CHECK can be considered to mean the same as a DTC detection.

● During an "NG" OVERALL FUNCTION CHECK, the DTC might not be confirmed.

● This is Quick Reference of "OVERALL FUNCTION CHECK".

Details are described in each TROUBLE DIAGNOSIS FOR DTC PXXXX.

**Diagnostic Trouble Code (DTC) Chart (Cont'd)**

**INSPECTION PRIORITY (ENGINE RELATED ITEMS)**

If some DTCs are displayed at the same time, perform inspections one by one based on the following priority chart.

Priority	Detected items (DTC)		
1	<ul style="list-style-type: none"> <li>● ECM (P0605, 0301)</li> <li>● Mass air flow sensor circuit (P0100, 0102)</li> <li>● Throttle position sensor circuit (P0120, 0403)</li> <li>● EGRC solenoid valve circuit (P1400, 1005)</li> <li>● A/T diagnosis communication line (P1605, 0804)</li> </ul>	<ul style="list-style-type: none"> <li>● Camshaft position sensor circuit (P0340, 0101)</li> <li>● Vehicle speed sensor circuit (P0500, 0104)</li> <li>● Intake air temperature sensor circuit (P0110, 0401)</li> <li>● Knock sensor circuit (P0325, 0304)</li> </ul>	<ul style="list-style-type: none"> <li>● Engine coolant temperature sensor circuit (P0115, 0103) (P0125, 0908)</li> <li>● Ignition signal circuit (P1320, 0201)</li> <li>● Park/Neutral position switch circuit (P0705, 1003)</li> </ul>
2	<ul style="list-style-type: none"> <li>● EGR temperature sensor circuit (P1401, 0305)</li> <li>● A/T related sensors, solenoid valves and switches (P0705, 1101) (P0720, 1102) (P0750, 1108) (P0755, 1201) (P0740, 1204) (P0745, 1205) (P0725, 1207) (P0710, 1208)</li> </ul>	<ul style="list-style-type: none"> <li>● Crankshaft position sensor circuit (P0335, 0802) (P1336, 0905)</li> <li>● Cooling fan circuit (P1900, 0208)</li> <li>● Front heated oxygen sensor heater circuit (P0135, 0901)</li> </ul>	<ul style="list-style-type: none"> <li>● Front heated oxygen sensor circuit (P0130, 0303)</li> <li>● Rear heated oxygen sensor circuit (P0136, 0707)</li> </ul>
3	<ul style="list-style-type: none"> <li>● EGR function (P0400, 0302)</li> <li>● EGRC-BPT valve function (P0402, 0306)</li> <li>● IACV-AAC valve circuit (P0505, 0205)</li> </ul>	<ul style="list-style-type: none"> <li>● Misfire (P0300 - P0304, 0701 - 0605)</li> <li>● Closed loop control (P0130, 0307)</li> <li>● Improper shifting (P0731 - P0734, 1103 - 1106)</li> </ul>	<ul style="list-style-type: none"> <li>● Fuel injection system function (P0170, 0706)</li> <li>● Three way catalyst function (P0420, 0702)</li> </ul>

CI  
MA  
EM  
LC  
**EC**  
FE  
CL  
MT  
AT  
FA  
RA  
BR  
ST  
RS  
BT  
HA  
EL  
IDX

**Fail-Safe Chart**

The ECM enters fail-safe mode, if any of the following DTCs is recorded due to the open or short circuit.

DTC No.		Detected items	Engine operating condition in fail-safe mode														
CONSULT GST	MIL																
P0100	0102	Mass air flow sensor circuit	Engine speed will not rise more than 2,400 rpm due to the fuel cut.														
P0115	0103	Engine coolant temperature sensor circuit	<p>Engine coolant temperature will be determined based on the time after turning ignition switch "ON" or "START".</p> <table border="1"> <thead> <tr> <th>Condition</th> <th>Engine coolant temperature decided</th> </tr> </thead> <tbody> <tr> <td>Just as ignition switch is turned ON or Start</td> <td>40°C (104°F)</td> </tr> <tr> <td>More than 4 minutes after ignition ON or Start</td> <td>80°C (176°F)</td> </tr> <tr> <td>Except as shown above</td> <td>40 - 80°C (104 - 176°F) (Depends on the time)</td> </tr> </tbody> </table>	Condition	Engine coolant temperature decided	Just as ignition switch is turned ON or Start	40°C (104°F)	More than 4 minutes after ignition ON or Start	80°C (176°F)	Except as shown above	40 - 80°C (104 - 176°F) (Depends on the time)						
Condition	Engine coolant temperature decided																
Just as ignition switch is turned ON or Start	40°C (104°F)																
More than 4 minutes after ignition ON or Start	80°C (176°F)																
Except as shown above	40 - 80°C (104 - 176°F) (Depends on the time)																
P0120	0403	Throttle position sensor circuit	<p>Throttle position will be determined based on the injected fuel amount and the engine speed. Therefore, acceleration will be poor.</p> <table border="1"> <thead> <tr> <th>Condition</th> <th>Driving condition</th> </tr> </thead> <tbody> <tr> <td>When engine is idling</td> <td>Normal</td> </tr> <tr> <td>When accelerating</td> <td>Poor acceleration</td> </tr> </tbody> </table>	Condition	Driving condition	When engine is idling	Normal	When accelerating	Poor acceleration								
Condition	Driving condition																
When engine is idling	Normal																
When accelerating	Poor acceleration																
—	—	Start signal circuit	<p>If the ECM always receives a start signal, the ECM will judge the start signal "OFF" when engine speed is above 1,000 rpm. This prevents extra enrichment. After the engine speed is below 200 rpm, start-up enrichment will be allowed until the engine speed reaches 1,000 rpm.</p>														
—	—	ECM	<p><b>Fail-safe system activating condition when ECM is malfunctioning</b> The computing function of the ECM was judged to be malfunctioning. When the fail-safe system activates (i.e., if the ECM detects a malfunction condition in the CPU of ECM), the MALFUNCTION INDICATOR LAMP on the instrument panel lights to warn the driver.</p> <p><b>Engine control, with fail-safe system, operates when ECM is malfunctioning</b> When the fail-safe system is operating, fuel injection, ignition timing, fuel pump operation, IACV-AAC valve operation and cooling fan operation are controlled under certain limitations.</p> <table border="1"> <thead> <tr> <th></th> <th>Operation</th> </tr> </thead> <tbody> <tr> <td>Engine speed</td> <td>Engine speed will not rise more than 3,000 rpm</td> </tr> <tr> <td>Fuel injection</td> <td>Simultaneous multiport fuel injection system</td> </tr> <tr> <td>Ignition timing</td> <td>Ignition timing is fixed at the preset valve</td> </tr> <tr> <td>Fuel pump</td> <td>Fuel pump relay is "ON" when engine is running and "OFF" when engine stalls</td> </tr> <tr> <td>IACV-AAC valve</td> <td>Full open</td> </tr> <tr> <td>Cooling fans</td> <td>Cooling fan relay "ON" (High speed condition) when engine is running, and "OFF" when engine stalls</td> </tr> </tbody> </table>		Operation	Engine speed	Engine speed will not rise more than 3,000 rpm	Fuel injection	Simultaneous multiport fuel injection system	Ignition timing	Ignition timing is fixed at the preset valve	Fuel pump	Fuel pump relay is "ON" when engine is running and "OFF" when engine stalls	IACV-AAC valve	Full open	Cooling fans	Cooling fan relay "ON" (High speed condition) when engine is running, and "OFF" when engine stalls
	Operation																
Engine speed	Engine speed will not rise more than 3,000 rpm																
Fuel injection	Simultaneous multiport fuel injection system																
Ignition timing	Ignition timing is fixed at the preset valve																
Fuel pump	Fuel pump relay is "ON" when engine is running and "OFF" when engine stalls																
IACV-AAC valve	Full open																
Cooling fans	Cooling fan relay "ON" (High speed condition) when engine is running, and "OFF" when engine stalls																

Symptom Matrix Chart

SYSTEM — Basic engine control system		SYMPTOM													Reference page
		HARD/NO START/RESTART (EXCP. HA)	ENGINE STALL	HESITATION/SURGING/FLAT SPOT	SPARK KNOCK/DETONATION	LACK OF POWER/POOR ACCELERATION	HIGH IDLE/LOW IDLE	ROUGH IDLE/HUNTING	IDLING VIBRATION	SLOW/NO RETURN TO IDLE	OVERHEATS/WATER TEMPERATURE HIGH	EXCESSIVE FUEL CONSUMPTION	EXCESSIVE OIL CONSUMPTION	BATTERY DEAD (UNDER CHARGE)	
		AA	AB	AC	AD	AE	AF	AG	AH	AJ	AK	AL	AM	HA	
Fuel	Fuel pump circuit	●	●	●	○	●	○	●	●	○		●		○	EC-219
	Fuel pressure regulator system	●	●	●	○	●	○	●	●	○		●			EC-24
	Injector circuit	●	●	●	○	●		●	●			●			EC-214
	Evaporative emission system	○	○	○	○	○	○	○	○	○		○			EC-21
Air	Positive crankcase ventilation system	○	○	●	○	○	○	●	●	○		○	○		EC-23
	IACV-Air regulator	●	●	●	○	●	●	●	●	●		○			EC-227
	Incorrect idle speed adjustment	○	○				○	○	○	○		○			EC-26
	IACV-AAC valve circuit	●	●	●	○	●	●	●	●	●		●		○	EC-170
	IACV-FICD solenoid valve circuit	○	○	○	○	○	○	○	○	○		○			EC-230
Ignition	Incorrect ignition timing adjustment	○	○	●	●	●		●	●			●			EC-26
	Ignition circuit	●	●	●	●	●		●	●			●			EC-181
EGR	EGR valve & EVAP canister purge control solenoid valve circuit		●	●	●	○						●			EC-190
	EGR system	○	●	●	●	○	○	●	●	○		○			EC-152
Main power supply and ground circuit		○	○	○	○	○		○	○		○	○		○	EC-90
Cooling	Cooling fan circuit	○	○	○	○	○	○	○	○	○	○			○	EC-201
Air conditioner circuit		○	○	○	○	○	○	○	○	○		○		○	HA section

● : High Possibility Item  
○ : Low Possibility Item

(continued on next page)

GI  
MA  
EM  
LC  
**EC**  
FE  
CL  
MT  
AT  
FA  
RA  
BR  
ST  
RS  
BT  
HA  
EL  
IDX

# TROUBLE DIAGNOSIS — General Description

## Symptom Matrix Chart (Cont'd)

SR

SYSTEM  
— ECCS system

Reference page

		SYMPTOM													
		HARD/NO START/RESTART (EXCP. HA)	ENGINE STALL	HESITATION/SURGING/FLAT SPOT	SPARK KNOCK/DETONATION	LACK OF POWER/POOR ACCELERATION	HIGH IDLE/LOW IDLE	ROUGH IDLE/HUNTING	IDLING VIBRATION	SLOW/NO RETURN TO IDLE	OVERHEATS/WATER TEMPERATURE HIGH	EXCESSIVE FUEL CONSUMPTION	EXCESSIVE OIL CONSUMPTION	BATTERY DEAD (UNDER CHARGE)	
		AA	AB	AC	AD	AE	AF	AG	AH	AJ	AK	AL	AM	HA	
ECCS	Camshaft position sensor circuit	●	●	●	○	○		○	○			○			EC-147
	Mass air flow sensor circuit	●	●	●	○	●		●	●			●			EC-93
	Front heated oxygen sensor circuit		●	●	○	●		●	●			●			EC-117
	Engine coolant temperature sensor circuit	●	●	●	○	●	●	●	●	●			●		EC-103, 112
	Throttle position sensor circuit		●	●		●	●	●	●	●			●		EC-107
	Incorrect throttle position sensor adjustment		●	○		○	●	○	○		●		○		EC-63
	Vehicle speed sensor circuit		○	○		○							○		EC-166
	Knock sensor circuit			○	○	○							○		EC-140
	ECM	○	○	○	○	○	○	○	○	○	○	○	○		EC-174, 76
	Start signal circuit	○													EC-217
	Park/Neutral position switch circuit			○		○		○	○				○		EC-176
	Power steering oil pressure switch circuit		○					○	○						EC-224

● : High Possibility Item  
○ : Low Possibility Item

(continued on next page)

Symptom Matrix Chart (Cont'd)

SYSTEM — Engine mechanical & other		SYMPTOM													Reference page		
		HARD/NO START/RESTART (EXCP. HA)	ENGINE STALL	HESITATION/SURGING/FLAT SPOT	SPARK KNOCK/DETONATION	LACK OF POWER/POOR ACCELERATION	HIGH IDLE/LOW IDLE	ROUGH IDLE/HUNTING	IDLING VIBRATION	SLOW/NO RETURN TO IDLE	OVERHEATS/WATER TEMPERATURE HIGH	EXCESSIVE FUEL CONSUMPTION	EXCESSIVE OIL CONSUMPTION	BATTERY DEAD (UNDER CHARGE)			
		AA	AB	AC	AD	AE	AF	AG	AH	AJ	AK	AL	AM	HA			
Fuel	Fuel tank	○	○														
	Fuel piping	○	○	○	○	○		○	○			○					
	Vapor lock		○														
	Valve deposit	○	○	○	○	○		○	○			○					
	Poor fuel (Heavy weight gasoline, Low octane)	○	○	○	○	○		○	○			○					
Air	Air duct		○	○		○		○	○			○					
	Air cleaner		○	○		○		○	○			○					
	Air leakage from air duct (Mass air flow sensor — throttle body)	○	○	○	○	○	○	○	○	○		○					
	Throttle body, Throttle wire	●	●	●		●	●	●	●	●		●					FE section
	Air leakage from intake manifold/Collector/Gasket	○	●	○	○	○	○	○	○	○		○					
Cranking	Battery	○	○	○		○		○	○			○			○		
	Alternator circuit	○	○	○		○		○	○			○			○		EL section
	Starter circuit	●															
	Flywheel	●															
	Clutch interlock switch	○															CL section
	Inhibitor switch	○															AT section
Engine	Cylinder head	●	●	●	●	●		●	●			○					
	Cylinder head gasket	●	●	○	○	●		○	○		○	○	○				
	Cylinder block	●	○	○	○	○		○	○			○	○				
	Piston	●	●	○	●	○		○	○			○	○				
	Piston ring	●	○	○	○	○		○	○			○	○				
	Connecting rod	○	○	○	○	○		○	○			○	○				
	Bearing	○	○	○	○	○		○	○			○	○				
	Crankshaft	○	○	○	○	○		○	○			○	○				
Valve mechanism	Timing chain	●	●	●	○	●		○	○			○					
	Camshaft	●	●	●	○	○		●	●			○					
	Intake valve	●	○	○	●	○						○	○				
	Exhaust valve	●	○	○	○	○		○	○			○	○				
	Hydraulic lash adjuster		○	○	○	○		○	○			○	○				
Exhaust	Exhaust manifold/Tube/Muffler/Gasket	○	○	○	○	○		○	○			○					
	Three way catalyst	●	●	○	○	○		○	○			○					
Lubrication	Oil pan/Oil strainer/Oil pump/Oil filter/Oil gallery	●	○	○	○	○		●	●			○	○				
	Oil level (Low)/Filthy oil	○	○	○	○	○		○	○			○	○				
Cooling	Radiator/Hose/Radiator filler cap	○	○	○	○	○		○	○			○	○				
	Thermostat	○	○	○	○	○		○	○			○	○				
	Water pump	○	○	○	○	○		○	○			○	○				
	Water gallery	○	○	○	○	○		○	○			○	○				
	Cooling fan	○	○	○	○	○		○	○			○	○				
	Coolant level (low)/Contaminated coolant	○	○	○	○	○		○	○			○	○				

● : High Possibility Item  
○ : Low Possibility Item

GI

MA

EM

LC

EC

FE

CL

MT

AT

FA

PA

BR

ST

RS

BT

HA

EL

IDX

### CONSULT Reference Value in Data Monitor Mode

Remarks:

- Specification data are reference values.
- Specification data are output/input values which are detected or supplied by the ECM at the connector.
- \* Specification data may not be directly related to their components signals/values/operations.  
(i.e., Adjust ignition timing with a timing light before monitoring IGN TIMING. Specification data might be displayed even when ignition timing is not adjusted to specification. This IGN TIMING monitors the data calculated by the ECM according to the input signals from the camshaft position sensor and other ignition timing related sensors.)
- If the real-time diagnosis results are NG, and the on-board diagnostic system results are OK, when diagnosing the mass air flow sensor, first check to see if the fuel pump control circuit is normal.

MONITOR ITEM	CONDITION		SPECIFICATION
CMPS-RPM (REF)	<ul style="list-style-type: none"> <li>● Tachometer: Connect</li> <li>● Run engine and compare tachometer indication with the CONSULT value.</li> </ul>		Almost the same speed as the CONSULT value.
MAS AIR/FL SE	<ul style="list-style-type: none"> <li>● Engine: After warming up</li> <li>● Air conditioner switch: OFF</li> <li>● Shift lever: "N"</li> <li>● No-load</li> </ul>	Idle	1.3 - 1.7V
		2,000 rpm	1.7 - 2.1V
COOLAN TEMP/S	<ul style="list-style-type: none"> <li>● Engine: After warming up</li> </ul>		More than 70°C (158°F)
FR O2 SENSOR			0 - 0.3V ↔ 0.6 - 1.0V
FR O2 MNTR	<ul style="list-style-type: none"> <li>● Engine: After warming up</li> </ul>	Maintaining engine speed at 2,000 rpm	LEAN ↔ RICH Changes more than 5 times during 10 seconds.
RR O2 SENSOR			0 ↔ Approx. 1.5V
RR O2 MNTR	<ul style="list-style-type: none"> <li>● Engine: After warming up</li> </ul>	Maintaining engine speed at 2,000 rpm	LEAN ↔ RICH
VHCL SPEED SE	<ul style="list-style-type: none"> <li>● Turn drive wheels and compare speedometer indication with the CONSULT value</li> </ul>		Almost the same speed as the CONSULT value
BATTERY VOLT	<ul style="list-style-type: none"> <li>● Ignition switch: ON (Engine stopped)</li> </ul>		11 - 14V
THRTL POS SEN	<ul style="list-style-type: none"> <li>● Ignition switch: ON (Engine stopped)</li> </ul>	Throttle valve fully closed	0.35 - 0.65V
		Throttle valve fully opened	Approx. 4.0V
EGR TEMP SEN	<ul style="list-style-type: none"> <li>● Engine: After warming up</li> </ul>		Less than 4.5V
START SIGNAL	<ul style="list-style-type: none"> <li>● Ignition switch: ON → START → ON</li> </ul>		OFF → ON → OFF
CLSD THL/P SW	<ul style="list-style-type: none"> <li>● Ignition switch: ON (Engine stopped)</li> </ul>	Throttle valve: Idle position	ON
		Throttle valve: Slightly open	OFF
AIR COND SIG	<ul style="list-style-type: none"> <li>● Engine: After warming up, idle the engine</li> </ul>	Air conditioner switch: OFF	OFF
		Air conditioner switch: ON (Compressor operates)	ON
P/N POSI SW	<ul style="list-style-type: none"> <li>● Ignition switch: ON</li> </ul>	Shift lever "P" or "N"	ON
		Except above	OFF

**CONSULT Reference Value in Data Monitor Mode (Cont'd)**

MONITOR ITEM	CONDITION		SPECIFICATION
PW/ST SIGNAL	<ul style="list-style-type: none"> <li>● Engine: After warming up, idle the engine</li> </ul>	Steering wheel in neutral position (forward direction)	OFF
		The steering wheel is turned	ON
IGNITION SW	<ul style="list-style-type: none"> <li>● Ignition switch: ON → OFF</li> </ul>		ON → OFF
INJ PULSE	<ul style="list-style-type: none"> <li>● Engine: After warming up</li> <li>● Air conditioner switch: OFF</li> <li>● Shift lever: "N"</li> <li>● No-load</li> </ul>	Idle	2.4 - 3.2 msec.
		2,000 rpm	1.9 - 2.8 msec.
B/FUEL SCHDL	ditto	Idle	1.0 - 1.6 msec
		2,000 rpm	0.7 - 1.3 msec
IGN TIMING	ditto	Idle	13 - 15° BTDC
		2,000 rpm	More than 25° BTDC
IACV-AAC/V	ditto	Idle	20 - 40%
		2,000 rpm	—
A/F ALPHA	<ul style="list-style-type: none"> <li>● Engine: After warming up</li> </ul>	Maintaining engine speed at 2,000 rpm	53 - 155%
AIR COND RLY	<ul style="list-style-type: none"> <li>● Air conditioner switch: OFF → ON</li> </ul>		OFF → ON
FUEL PUMP RLY	<ul style="list-style-type: none"> <li>● Ignition switch is turned to ON (Operates for 5 seconds)</li> <li>● Engine running and cranking</li> <li>● When engine is stopped (stops in 1.0 seconds)</li> </ul>		ON
		<ul style="list-style-type: none"> <li>● Except as shown above</li> </ul>	OFF
COOLING FAN	<ul style="list-style-type: none"> <li>● After warming up engine, idle the engine.</li> <li>● Air conditioner switch: OFF</li> </ul>	Engine coolant temperature is 94°C (201°F) or less for A/T models, and 99°C (210°F) or less for M/T models	OFF
		Engine coolant temperature is between 95°C (203°F) and 104°C (219°F) for A/T models only	LOW
		Engine coolant temperature is 105°C (221°F) or more for A/T models, and 100°C (212°F) or more for M/T models	HIGH
EGRC SOL/V	<ul style="list-style-type: none"> <li>● Engine: After warming up</li> <li>● Air conditioner switch: OFF</li> <li>● Shift lever: "N"</li> <li>● No-load</li> </ul>	Idle	ON
		2,000 rpm	OFF
O2 SEN HEATER	<ul style="list-style-type: none"> <li>● Engine speed: Idle</li> <li>● Engine speed: Above 3,200 rpm</li> </ul>		ON
			OFF
CAL/LD VALUE	<ul style="list-style-type: none"> <li>● Engine: After warming up</li> <li>● Air conditioner switch: OFF</li> <li>● Shift lever: "N"</li> <li>● No-load</li> </ul>	Idle	20.0 - 35.5%
		2,500 rpm	17.0 - 30.0%
ABSOL TH/P/S	<ul style="list-style-type: none"> <li>● Ignition switch: ON (Engine stopped)</li> </ul>	Throttle valve fully closed	0.0%
		Throttle valve fully opened	Approx. 88%
MASS AIRFLOW	<ul style="list-style-type: none"> <li>● Engine: After warming up</li> <li>● Air conditioner switch: OFF</li> <li>● Shift lever: "N"</li> <li>● No-load</li> </ul>	Idle	2.5 - 5.0 gm/s
		2,500 rpm	7.1 - 12.5 gm/s

GI  
MA  
EM  
LC  
**EC**  
FE  
CL  
MT  
AT  
FA  
RA  
BR  
ST  
RS  
BT  
HA  
EL  
IDX



### Major Sensor Reference Graph in Data Monitor Mode

The following are the major sensor reference graphs in "DATA MONITOR" mode. (Select "HI SPEED" in "DATA MONITOR" with CONSULT.)

#### THRTL POS SEN, ABSOL TH·P/S, CLSD THL/P SW

Below is the data for "THRTL POS SEN", "ABSOL TH·P/S" and "CLSD THL/P SW" when depressing the accelerator pedal with the ignition switch "ON".

The signal of "THRTL POS SEN" and "ABSOL TH·P/S" should rise gradually without any intermittent drop or rise after "CLSD THL/P SW" is changed from "ON" to "OFF".

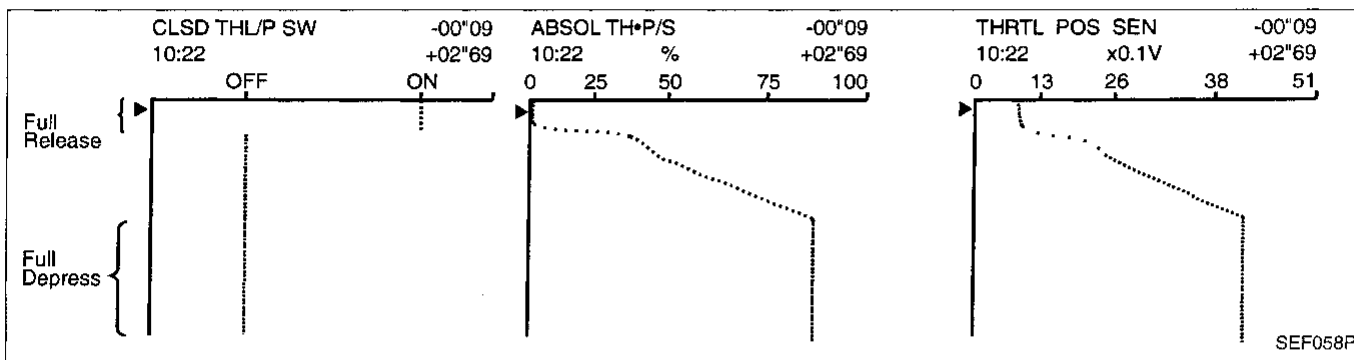

#### CMPS·RPM (REF), MAS AIR/FL SE, THRTL POS SEN, RR O2 SENSOR, FR O2 SENSOR, INJ PULSE

Below is the data for "CMPS·RPM (REF)", "MAS AIR/FL SE", "THRTL POS SEN", "RR O2 SENSOR", "FR O2 SENSOR" and "INJ PULSE" when revving quickly up to 4,800 rpm under no load after warming up engine sufficiently.

Each value is for reference, the exact value may vary.

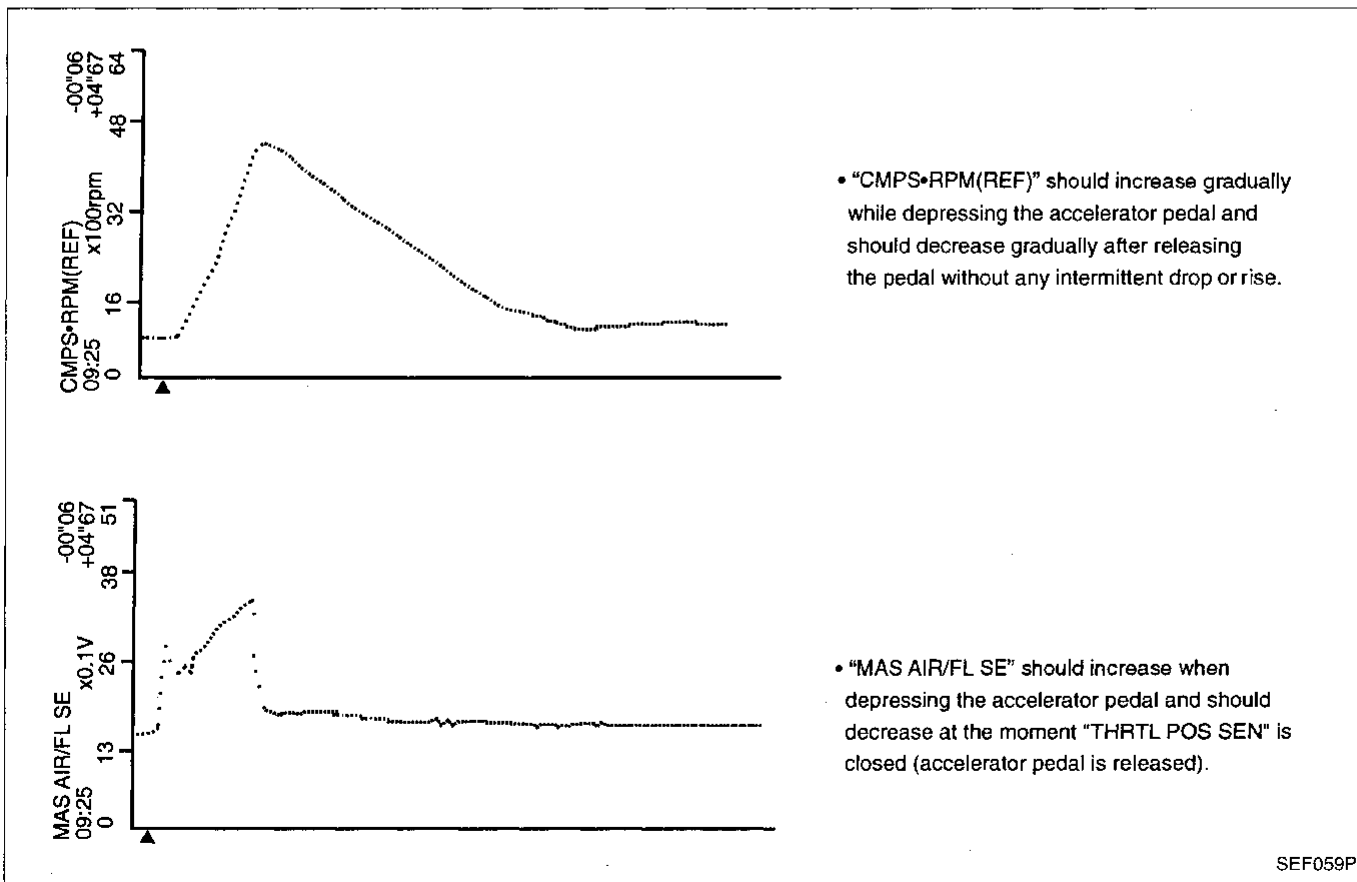

Major Sensor Reference Graph in Data Monitor Mode (Cont'd)

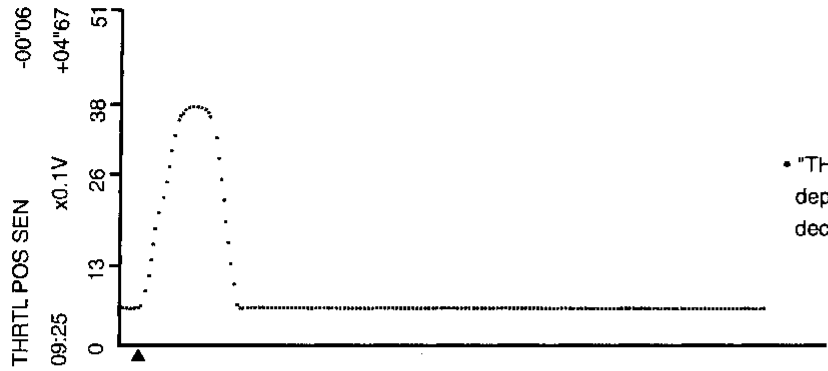

• "THRTL POS SEN" should increase while depressing the accelerator pedal and should decrease while releasing it.

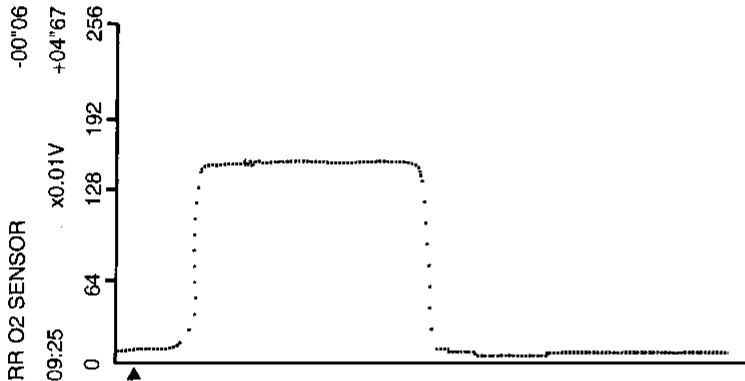

• "RR O2 SENSOR" may increase immediately after depressing the accelerator pedal and may decrease after releasing the pedal.

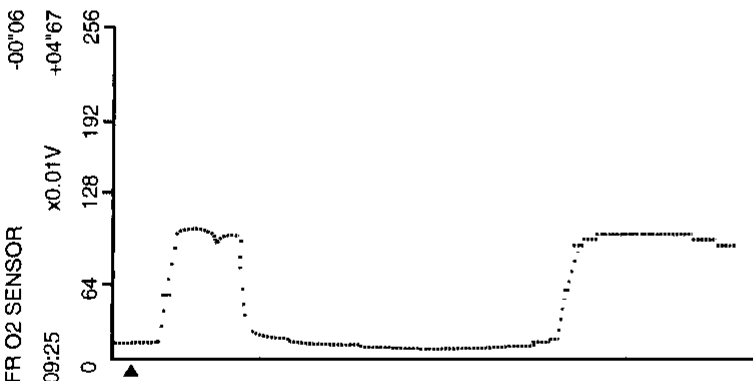

• "FR O2 SENSOR" may increase immediately after depressing the accelerator pedal and may decrease after releasing the pedal.

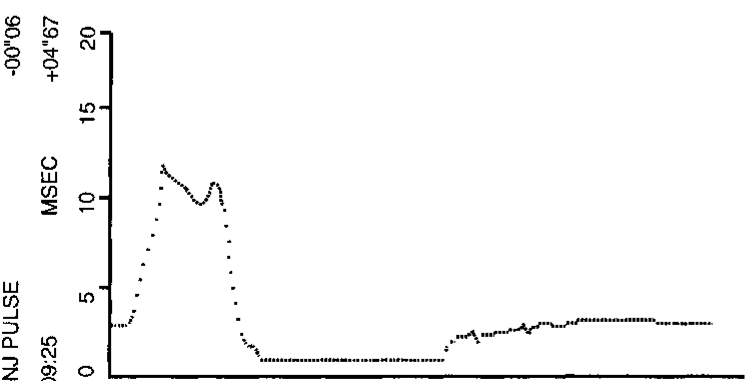

• "INJ PULSE" should increase when depressing the accelerator pedal and should decrease when the pedal is released.

GI  
MA  
EM  
LC  
**EC**  
FE  
CL  
MT  
AT  
FA  
RA  
BR  
ST  
RS  
BT  
HA  
EL  
DX

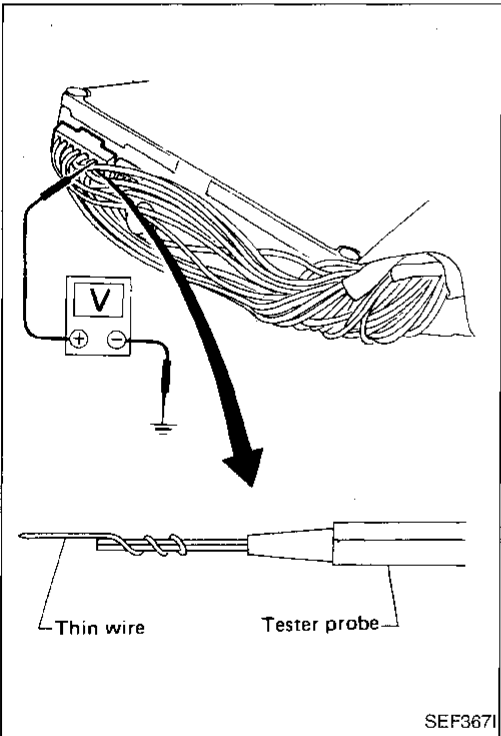
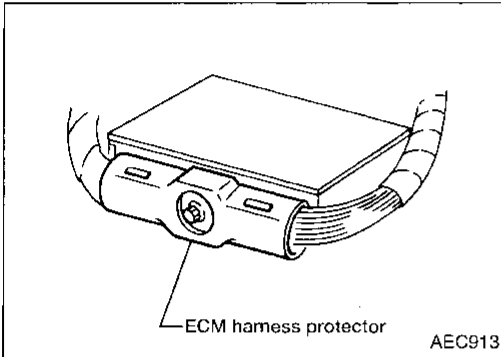
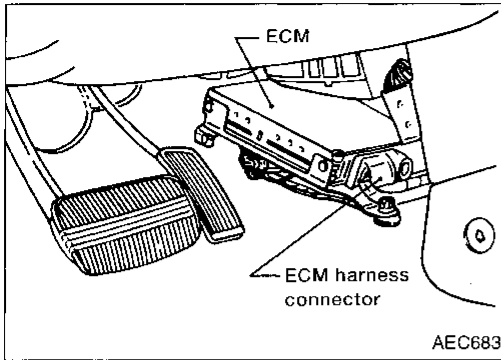

**ECM Terminals and Reference Value**

**PREPARATION**

1. ECM is located behind the center console. For this inspection, remove the front passenger center console panel.
2. Remove ECM harness protector.
3. Perform all voltage measurements with the connectors connected. Extend tester probe as shown to perform tests easily.

**ECM HARNESS CONNECTOR TERMINAL LAYOUT**

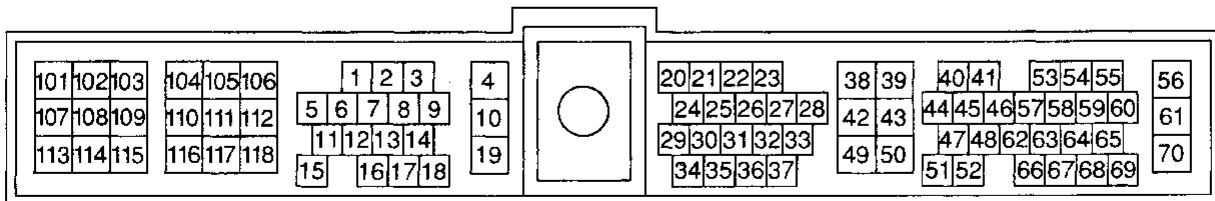

SEF064P

**ECM Terminals and Reference Value (Cont'd)**

**ECM INSPECTION TABLE**

Specification data are reference values and are measured between each terminal and ④ (ECCS ground).

TER-MINAL NO.	WIRE COLOR	ITEM	CONDITION	DATA (DC Voltage)
1	W/B	Ignition signal	Engine is running. └ Idle speed	0.2 - 0.3V*
			Engine is running. └ Engine speed is 2,000 rpm	Approximately 0.5V*
2	GY/R	Ignition check	Engine is running. └ Idle speed	Approximately 12V*
3	L/OR	Tachometer	Engine is running. └ Idle speed	Approximately 7V*
4	W/G	ECCS relay (Self-shutoff)	Engine is running. └ Ignition switch "OFF" └ For a few seconds after turning ignition switch "OFF"	0 - 1V
			Ignition switch "OFF" └ A few seconds passed after turning ignition switch "OFF"	BATTERY VOLTAGE (11 - 14V)
7	PU (A/T models)	A/T check signal	Ignition switch "ON" └ Engine is running.	1.0 - 8.0V
8	B/P	Fuel pump relay	Ignition switch "ON" └ For 5 seconds after turning ignition switch "ON"	0.07 - 0.20V
			Engine is running. └ Ignition switch "ON" └ More than 5 seconds after turning ignition switch "ON"	BATTERY VOLTAGE (11 - 14V)
10	B	ECCS ground	Engine is running. └ Idle speed	Engine ground
13	LG (A/T models)	Cooling fan relay (High)	Engine is running. └ Cooling fan is not operating	BATTERY VOLTAGE (11 - 14V)
			Engine is running. └ Cooling fan (High) is operating	0.07 - 0.10V
14	LG/R	Cooling fan relay (Low)	Engine is running. └ Cooling fan is not operating	BATTERY VOLTAGE (11 - 14V)
			Engine is running. └ Cooling fan (Low) is operating	0.07 - 0.10V

\*Average voltage for pulse signal (Actual pulse signal can be confirmed by oscilloscope.)

CI  
MA  
EM  
LC  
EC  
FE  
CL  
MT  
AT  
FA  
BA  
BR  
ST  
RS  
BT  
HA  
EL  
DX

**ECM Terminals and Reference Value (Cont'd)**

TER-MINAL NO.	WIRE COLOR	ITEM	CONDITION	DATA (DC Voltage)
15	G/Y	Air conditioner relay	Engine is running. └ Both A/C switch and blower switch are "ON"	0.08 - 0.2V
			Engine is running. └ A/C switch is "OFF"	BATTERY VOLTAGE (11 - 14V)
18	OR/L	Malfunction indicator lamp	Ignition switch "ON"	Approximately 80mV
			Engine is running. └ Idle speed	BATTERY VOLTAGE (11 - 14V)
19	B	ECCS ground	Engine is running. └ Idle speed	Engine ground
20	B/Y	Start signal	Ignition switch "ON"	Approximately 0V
			Ignition switch "START"	BATTERY VOLTAGE (11 - 14V)
21	R/L	Air conditioner switch	Engine is running. └ Both air conditioner switch and blower switch are "ON" (Compressor operates)	Approximately 0V
			Engine is running. └ Air conditioner switch is "OFF"	BATTERY VOLTAGE (11 - 14V)
22	G/OR	Neutral position switch (M/T models) Inhibitor switch (A/T models)	Ignition switch "ON" └ Gear position is "Neutral position" (M/T models) └ Gear position is "N" or "P" (A/T models)	Approximately 0V
			Ignition switch "ON" └ Except the above gear position	BATTERY VOLTAGE (11 - 14V)
23	Y	Throttle position sensor	Ignition switch "ON" └ Accelerator pedal released	0.35 - 0.65V
			Ignition switch "ON" └ Accelerator pedal fully depressed	Approximately 4V
25	SB	Power steering oil pressure switch	Engine is running. └ Steering wheel is being turned	Approximately 0V
			Engine is running. └ Steering wheel is not being turned	Approximately 5V
26	PU/R	Vehicle speed sensor	Engine is running. └ Slowly rotating front wheels	Approximately 1.8 - 2.4V* (AC voltage)

\*Average voltage for pulse signal (Actual pulse signal can be confirmed by oscilloscope.)

ECM Terminals and Reference Value (Cont'd)

TER-MINAL NO.	WIRE COLOR	ITEM	CONDITION	DATA (DC Voltage)	
33	W/R	Throttle position sensor signal	Ignition switch "ON" └ Accelerator pedal released	Approximately 0.4V	GI MA
			Ignition switch "ON" └ Accelerator pedal fully depressed	Approximately 3V	EM
38	B/R	Ignition switch	Ignition switch "OFF"	0V	
			Ignition switch "ON"	BATTERY VOLTAGE (11 - 14V)	LC
39	B	ECCS ground	Engine is running. └ Idle speed	Engine ground	EC
40 44	L L	Camshaft position sensor (Reference signal)	Engine is running. └ Idle speed	Approximately 2.7V* (AC voltage)	FE
43	B	ECCS ground	Engine is running. └ Idle speed	Engine ground (Probe this terminal with ⊖ tester probe when measuring.)	CL MT
41 45	B/W B/W	Camshaft position sensor (Position signal)	Engine is running. └ Idle speed	Approximately 2.7V* (AC voltage)	AT
46	W	Front heated oxygen sensor	Engine is running. └ After warming up sufficiently and engine speed is 2,000 rpm	0 - Approximately 1.0V (periodically change)	FA
47	OR	Mass air flow sensor	Engine is running. (Warm-up condition) └ Idle speed	1.3 - 1.7V	RA
			Engine is running. (Warm-up condition) └ Engine speed is 2,000 rpm	1.7 - 2.1V	BR
48	W	Mass air flow sensor ground	Engine is running. (Warm-up condition) └ Idle speed	0.005 - 0.02V	ST
49	P/L	Throttle position sensor power supply	Ignition switch "ON"	Approximately 5V	RS
50	B	Sensors' ground	Engine is running. (Warm-up condition) └ Idle speed	0.001 - 0.02V	BT
51	BR/Y	Engine coolant temperature sensor	Engine is running.	0 - 4.84V Output voltage varies with engine coolant temperature.	HA
52	W	Rear heated oxygen sensor	Engine is running. └ After warming up sufficiently and engine speed is 2,000 rpm	0 - Approximately 2.2V**	EL IDX

\*Average voltage for pulse signal (Actual pulse signal can be confirmed by oscilloscope.)

\*\*During the on-board diagnosis for the open circuit, approx. 1.5 - 5V will appear. This is not a malfunction. (Refer to page EC-126.)

**ECM Terminals and Reference Value (Cont'd)**

TER-MINAL NO.	WIRE COLOR	ITEM	CONDITION	DATA (DC Voltage)
53	W	Crankshaft position sensor (OBD)	Engine is running. (A/T: N range, M/T: Neutral) └ Idle speed (Air conditioner switch "OFF")	More than 0.4V* (AC voltage)
54	W	Knock sensor	Engine is running. └ Idle speed	2.0 - 3.0V
56 61	W/R W/R	Power supply for ECM	Ignition switch "ON"	BATTERY VOLTAGE (11 - 14V)
58	L/B	Data link connector for GST	Engine is running. └ Idle speed (GST is disconnected)	6 - 10V
62	R/B	EGR temperature sensor	Engine is running. (Warm-up condition) └ Idle speed	Less than 4.5V
			Engine is running. (Warm-up condition) └ EGR system is operating	0 - 1.5V
63	R/Y	Intake air temperature sensor	Engine is running.	0 - 5.0V Output voltage varies with intake air temperature.
64	G/B	Data link connector for CONSULT	Engine is running.	Approximately 0V
65	GY/L		└ Idle speed (CONSULT is connected and turned on)	Approximately 4 - 9V
68	G/W			Approximately 3.5V*
70	W/L	Power supply (Back-up)	Ignition switch "OFF"	BATTERY VOLTAGE (11 - 14V)
101	SB	IACV-AAC valve	Engine is running. └ Idle speed	Approximately 5 - 14V
			Engine is running. └ Steering wheel is being turned └ Air conditioner is operating └ Headlamps are in high position	5 - 9V
102	R/B	Injector No. 1	Engine is running	BATTERY VOLTAGE (11 - 14V)
104	G/B	Injector No. 3		
107	Y/B	Injector No. 2		
109	L/B	Injector No. 4		
103	P	EGR valve & EVAP canister purge control solenoid valve	Engine is running. (Warm-up condition) └ Engine speed is 2,000 rpm	BATTERY VOLTAGE (11 - 14V)
			Engine is running. (Warm-up condition) └ Idle speed	0.06 - 0.11V
106	B	ECCS ground	Engine is running. └ Idle speed	Engine ground

\*Average voltage for pulse signal (Actual pulse signal can be confirmed by oscilloscope.)

ECM Terminals and Reference Value (Cont'd)

TER-MINAL NO.	WIRE COLOR	ITEM	CONDITION	DATA (DC Voltage)
108	R/Y	Rear heated oxygen sensor heater	Ignition switch "ON" Engine is running.	Approximately 0.2V
111	B	Rear heated oxygen sensor heater ground	Engine is running. └ Idle speed	0.02 - 0.07V
112	B	ECCS ground	Engine is running. └ Idle speed	Engine ground
113	W/L	Current return	Engine is running. └ Idle speed	BATTERY VOLTAGE (11 - 14V)
115	OR	Front heated oxygen sensor heater	Engine is running. └ Engine speed is below 3,200 rpm	Approximately 0.2V
			Engine is running. └ Engine speed is above 3,200 rpm	BATTERY VOLTAGE (11 - 14V)
118	B	ECCS ground	Engine is running. └ Idle speed	Engine ground

GI  
MA  
EM  
LC  
EC  
FE  
CL  
MT  
AT  
FA  
RA  
BR  
ST  
RS  
BT  
HA  
EL  
IDX



Main Power Supply and Ground Circuit

EC-MAIN-01

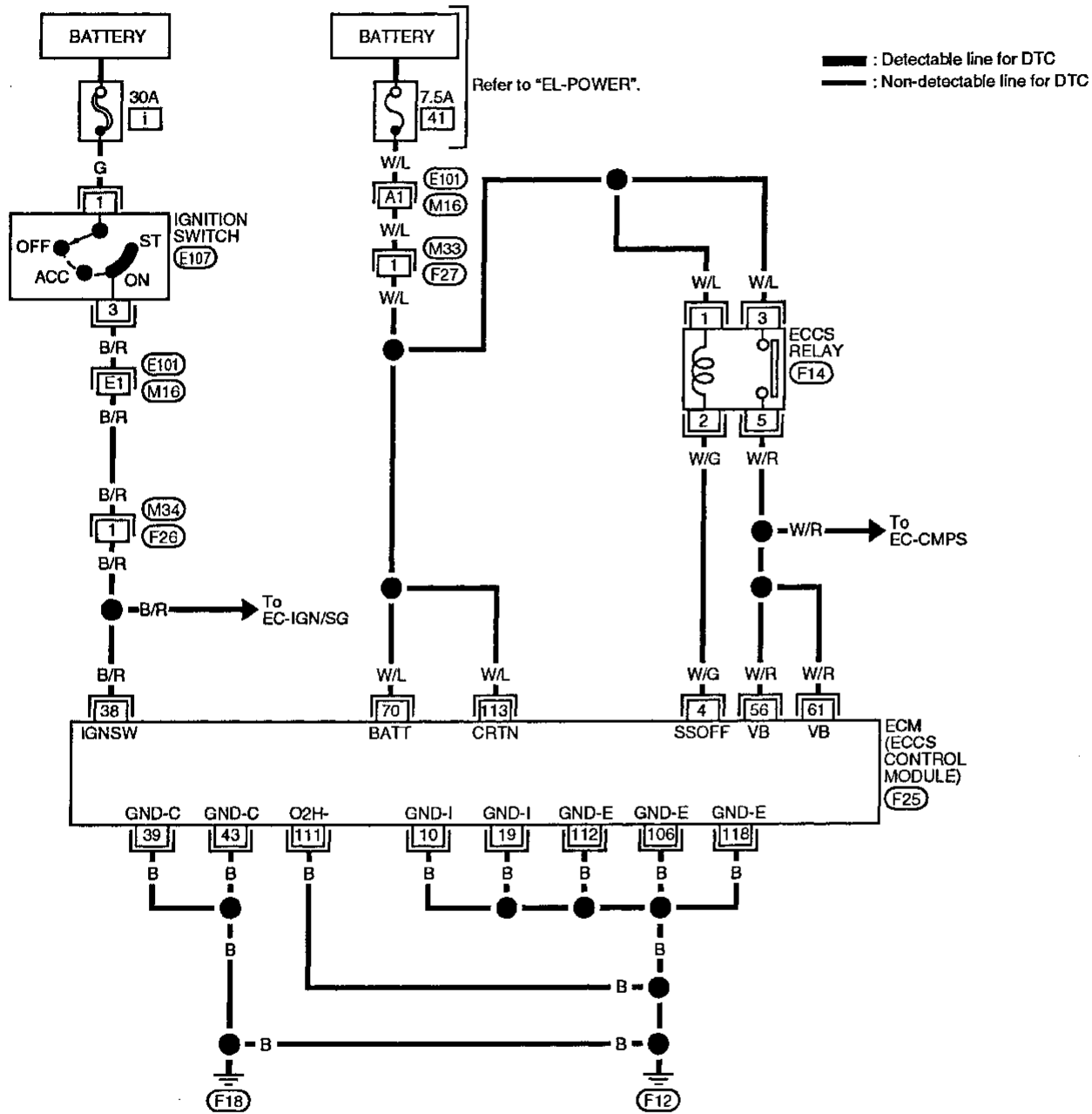

Refer to last page (Foldout page).

(M16), (E101)

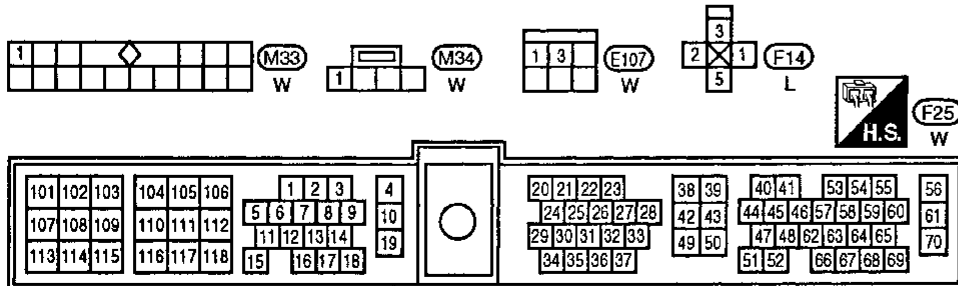

Main Power Supply and Ground Circuit (Cont'd)

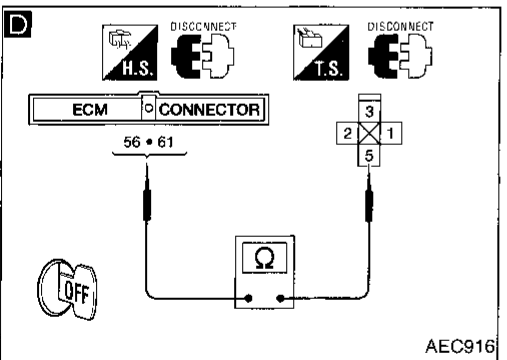
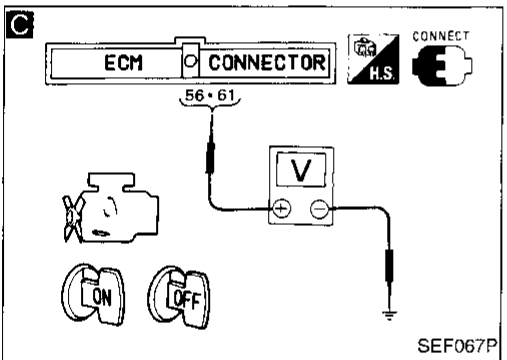
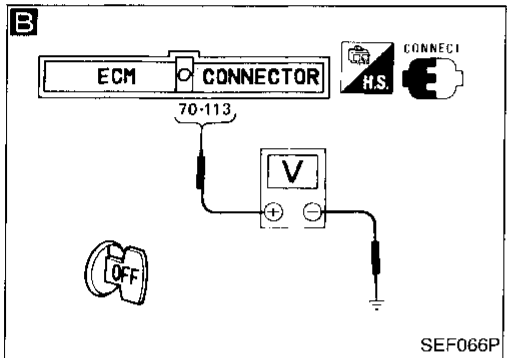
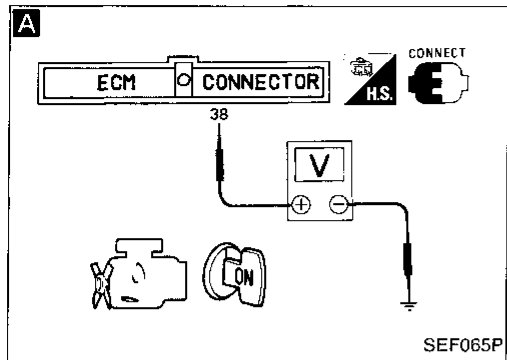

```

    graph TD
        Start[INSPECTION START] --> Q1{Start engine.  
Is engine running?}
        Q1 -- No --> A[A]
        Q1 -- Yes --> B[B]
        
        A["CHECK POWER SUPPLY-I.  
1. Turn ignition switch "ON".  
2. Check voltage between ECM terminal (38) and ground with CONSULT or tester.  
Voltage: Battery voltage  
If NG, check the following.  
• Harness connectors (M16), (E101)  
• Harness connectors (F26), (M34)  
• Harness for open or short between ECM and ignition switch  
If NG, repair harness or connectors."] -- OK --> H1[Go to H "CHECK GROUND CIRCUIT" on next page.]
        
        B["CHECK POWER SUPPLY-II.  
1. Stop engine.  
2. Check voltage between ECM terminals (70), (113) and ground with CONSULT or tester.  
Voltage: Battery voltage"] -- NG --> H2["Check the following.  
• Harness connectors (M16), (E101)  
• Harness connectors (F27), (M33)  
• 7.5A fuse  
• Harness for open or short between ECM and battery  
If NG, repair harness or connectors."]
        B -- OK --> C[C]
        
        C["CHECK POWER SUPPLY-III.  
1. Turn ignition switch "ON" and then "OFF".  
2. Check voltage between ECM terminals (56), (61) and ground with CONSULT or tester.  
Voltage:  
After turning ignition switch "OFF", battery voltage will exist for a few seconds, then drop to approximately 0V."] -- OK --> H3[Go to H "CHECK GROUND CIRCUIT" on next page.]
        C -- NG --> Case1[Case-1]
        C -- NG --> Case2[Case-2]
        
        Case1 --> H4[Go to G "CHECK ECCS RELAY" on next page.]
        Case2 --> H4
        
        H4 --> A2((A))
        A2 --> End((Go to next page.))
    
```

GI  
MA  
EM  
LC  
EC  
FE  
CL  
MT  
AT  
FA  
RA  
BR  
ST  
RS  
BT  
HA  
EL  
IDX

Main Power Supply and Ground Circuit (Cont'd)

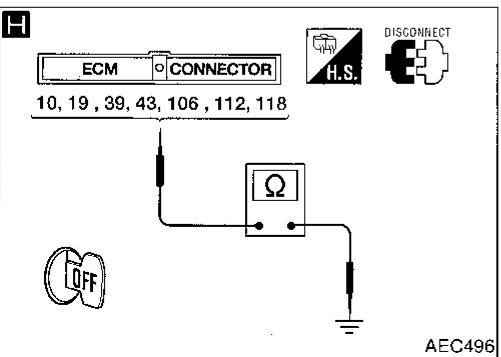
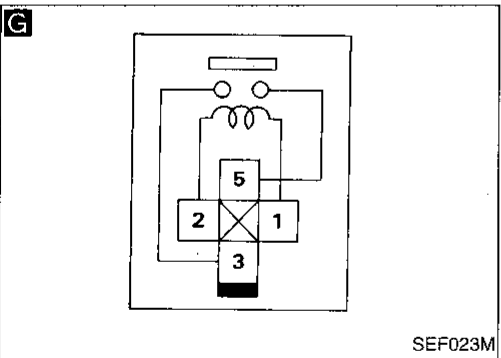
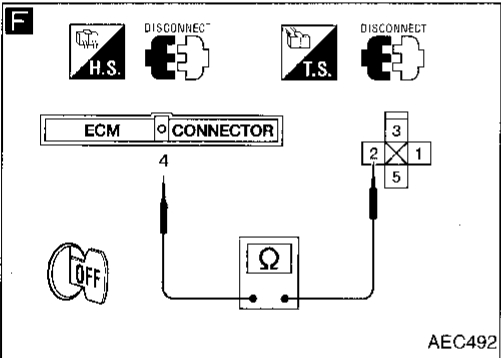
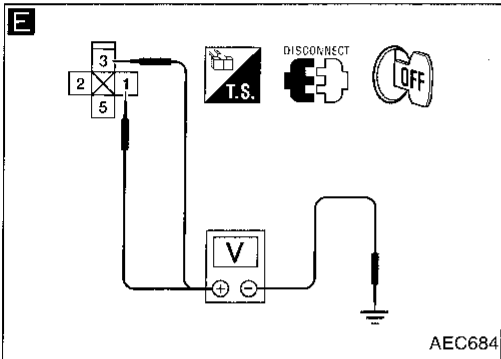
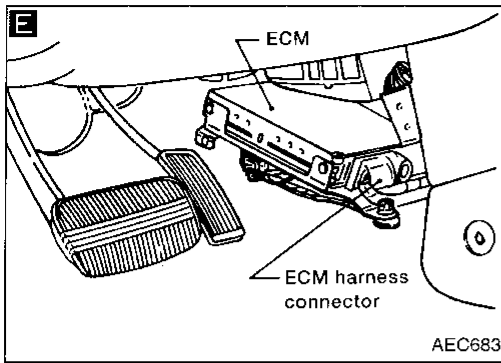

**D**

**CHECK HARNESS CONTINUITY BETWEEN ECCS RELAY AND ECM**

1. Disconnect ECM harness connector.
2. Disconnect ECCS relay harness connector.
3. Check harness continuity between ECM terminals ⑤⑥, ⑥① and terminal ⑤. **Continuity should exist.** If OK, check harness for short.

NG → Repair harness or connectors.

OK →

**E**

**CHECK VOLTAGE BETWEEN ECCS RELAY AND GROUND.**

Check voltage between terminals ①, ③ and ground with CONSULT or tester. **Voltage: Battery voltage**

NG → Check the following.  
● Harness for open or short between ECCS relay and battery  
If NG, repair harness or connectors.

OK →

**F**

**CHECK OUTPUT SIGNAL CIRCUIT.**

Check harness continuity between ECM terminal ④ and terminal ②. **Continuity should exist.** If OK, check harness for short.

NG → Repair harness or connectors.

OK →

**G**

**CHECK ECCS RELAY.**

1. Apply 12V direct current between relay terminals ① and ②.
2. Check continuity between relay terminals ③ and ⑤.

**12V (① - ②) applied:**  
**Continuity exists.**  
**No voltage applied:**  
**No continuity**

NG → Replace ECCS relay.

OK →

**H**

**CHECK GROUND CIRCUIT.**

1. Turn ignition switch "OFF".
2. Disconnect ECM harness connector.
3. Check harness continuity between ECM terminals ⑩, ⑱, ③⑨, ④③, ⑩⑥, ⑪②, ⑪⑧ and engine ground. **Continuity should exist.** If OK, check harness for short.

NG → Repair harness or connectors.

OK →

Check ECM pin terminals for damage and check the connection of ECM harness connector.

INSPECTION END

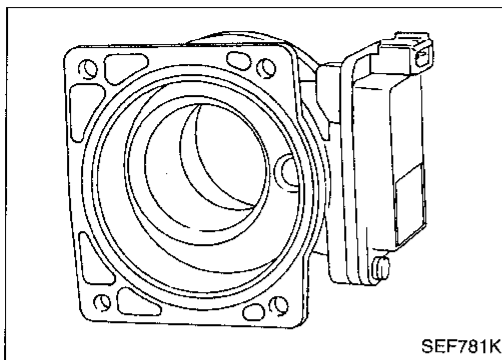

**Mass Air Flow Sensor (MAFS) (DTC: 0102)**

The mass air flow sensor is placed in the stream of intake air. It measures the intake flow rate by measuring a part of the entire intake flow. It consists of a hot wire that is supplied with electric current from the ECM. The temperature of the hot wire is controlled by the ECM a certain amount. The heat generated by the hot wire is reduced as the intake air flows around it. The more air, the greater the heat loss.

Therefore, the ECM must supply more electric current to maintain the temperature of the hot wire as air flow increases. The ECM detects the air flow by means of this current change.

Diagnostic Trouble Code No.	Malfunction is detected when ...	Check Item (Possible Cause)
P0100 0102	A) An excessively high or low voltage from the sensor is sent to ECM. ..... B), C) Voltage sent to ECM is not practical when compared with the camshaft position sensor and throttle position sensor signals.	<ul style="list-style-type: none"> <li>● Harness or connectors (The sensor circuit is open or shorted.)</li> <li>● Mass air flow sensor</li> </ul>

**DIAGNOSTIC TROUBLE CODE CONFIRMATION PROCEDURE**

**Procedure for malfunction A**

- 1) Turn ignition switch "ON", and wait at least 6 seconds.
- 2) Select "DATA MONITOR" mode with CONSULT.
- 3) Start engine and wait at least 3 seconds.

OR

- 1) Turn ignition switch "ON", and wait at least 6 seconds.
- 2) Start engine and wait at least 3 seconds.
- 3) Select "MODE 3" with GST.

OR

- 1) Turn ignition switch "ON", and wait at least 6 seconds.
- 2) Start engine and wait at least 3 seconds.
- 3) Turn ignition switch "OFF", wait at least 5 seconds and then turn "ON".
- 4) Perform "Diagnostic Test Mode II" (Self-diagnostic results) with ECM.

GI  
MA  
EM  
LC  
EC  
FE  
CL  
MT  
AT  
FA  
RA  
BR  
ST  
RS  
BT  
HA  
EL  
DX

**Mass Air Flow Sensor (MAFS) (DTC: 0102)  
(Cont'd)**

**Procedure for malfunction B**

- 1) Turn ignition switch "ON".
- 2) Select "DATA MONITOR" mode with CONSULT.
- 3) Start engine and warm it up sufficiently.
- 4) Run engine for at least 10 seconds at idle speed.

OR

- 1) Turn ignition switch "ON".
- 2) Start engine and warm it up sufficiently.
- 3) Run engine for at least 10 seconds at idle speed.
- 4) Select "MODE 3" with GST.

OR

- 1) Turn ignition switch "ON".
- 2) Start engine and warm it up sufficiently.
- 3) Run engine for at least 10 seconds at idle speed.
- 4) Turn ignition switch "OFF", wait at least 5 seconds and then turn "ON".
- 5) Perform "Diagnostic Test Mode II" (Self-diagnostic results) with ECM.

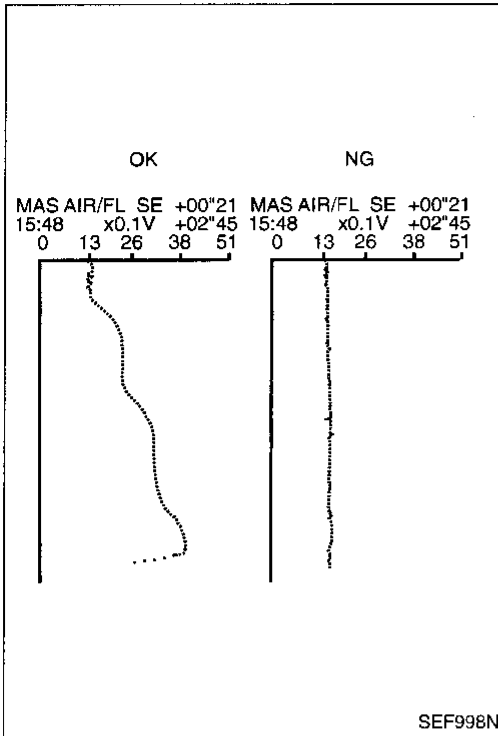

**OVERALL FUNCTION CHECK**

Use this procedure to check the overall function of the mass air flow sensor circuit. During this check, a DTC might not be confirmed.

**Procedure for malfunction C**

- 1) Turn ignition switch "ON".
- 2) Start engine and warm it up sufficiently.
- 3) Select "DATA MONITOR" mode with CONSULT.
- 4) Check the voltage of mass air flow sensor with "DATA MONITOR".
- 5) Check for linear voltage rise in response to increases to about 4,000 rpm in engine speed.

OR

- 1) Turn ignition switch "ON".
- 2) Start engine and warm it up sufficiently.
- 3) Select "MODE 1" with GST.
- 4) Check the mass air flow with "MODE 1".
- 5) Check for linear mass air flow rise in response to increases to about 4,000 rpm in engine speed.

OR

- 1) Turn ignition switch "ON".
- 2) Start engine and warm it up sufficiently.
- 3) Check the voltage between ECM terminal (47) and ground.
- 4) Check for linear voltage rise in response to increases to about 4,000 rpm in engine speed.

<b>FUEL SYS #1</b>	<b>OPEN</b>
FUEL SYS #2	UNUSED
CALC LOAD	22%
COOLANT TEMP	30°C
SHORT FT #1	0%
LONG FT #1	2%
ENGINE SPD	1000RPM
VEHICLE SPD	0km/h
IGN ADVANCE	20.0°
INTAKE AIR	26°C
MAF	0.0gm/sec
THROTTLE POS	0%
O2S LOCATION	3
O2S B1,S1	0.680V
O2FT B1,S1	0%
O2S B1,S2	0.080V

SEF003P

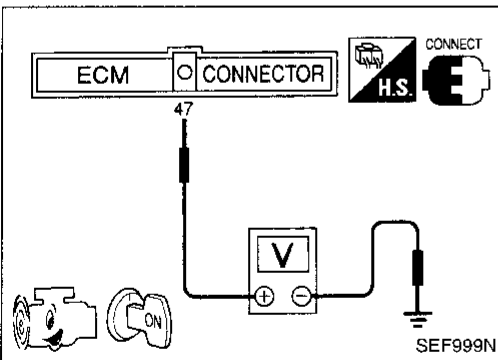

Mass Air Flow Sensor (MAFS) (DTC: 0102)  
(Cont'd)

EC-MAFS-01

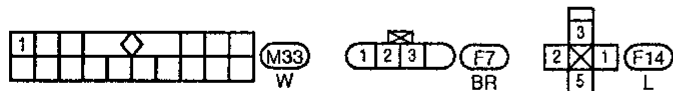
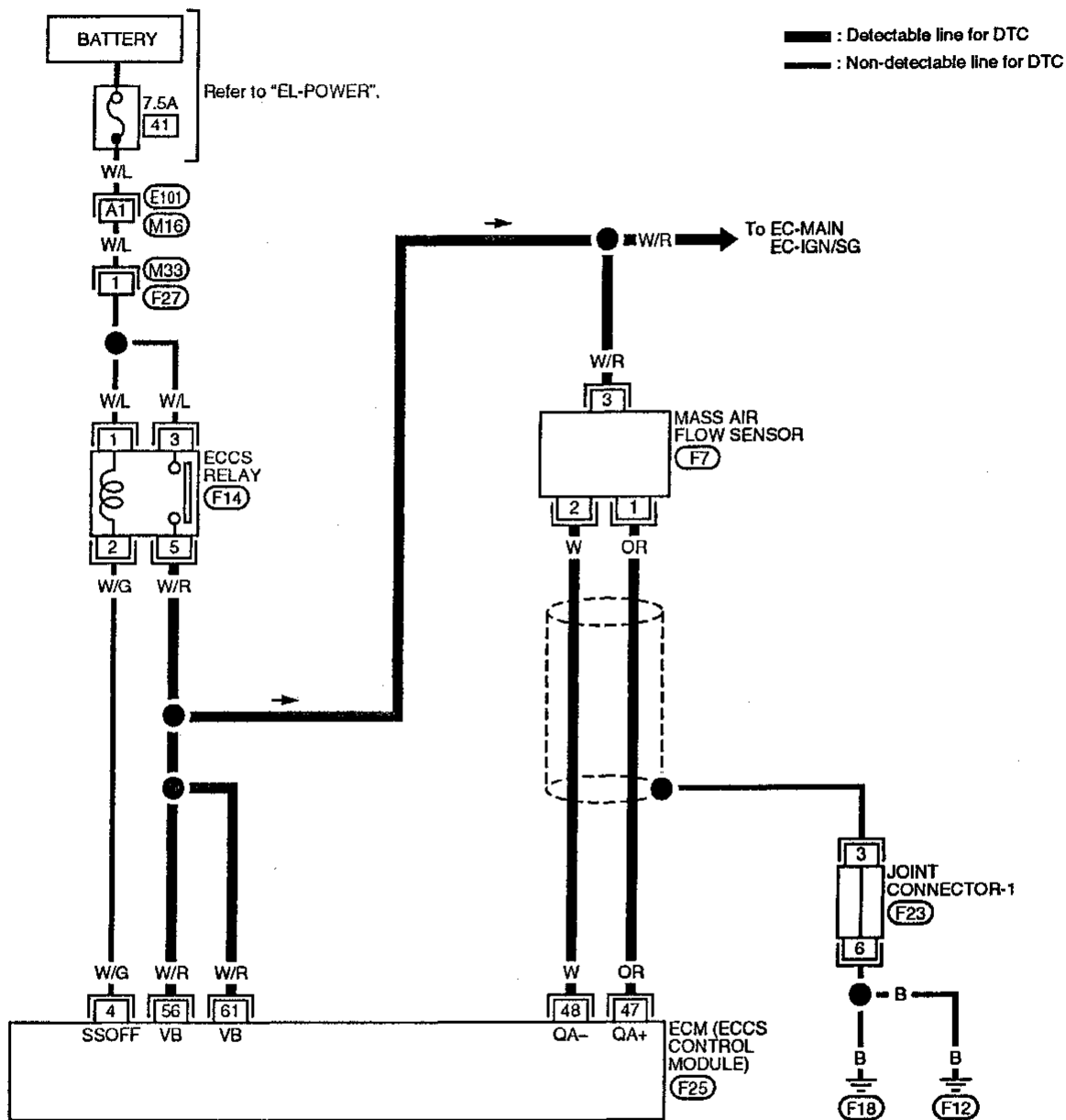

Refer to last page (Foldout page).

(M16, E101)  
(F23)

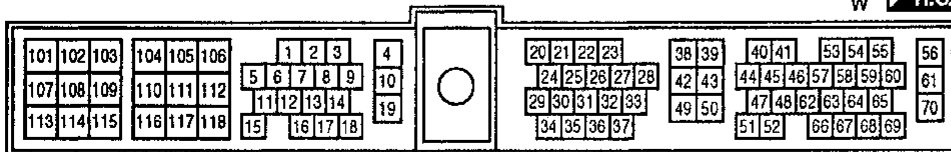

Mass Air Flow Sensor (MAFS) (DTC: 0102)  
(Cont'd)

DIAGNOSTIC PROCEDURE

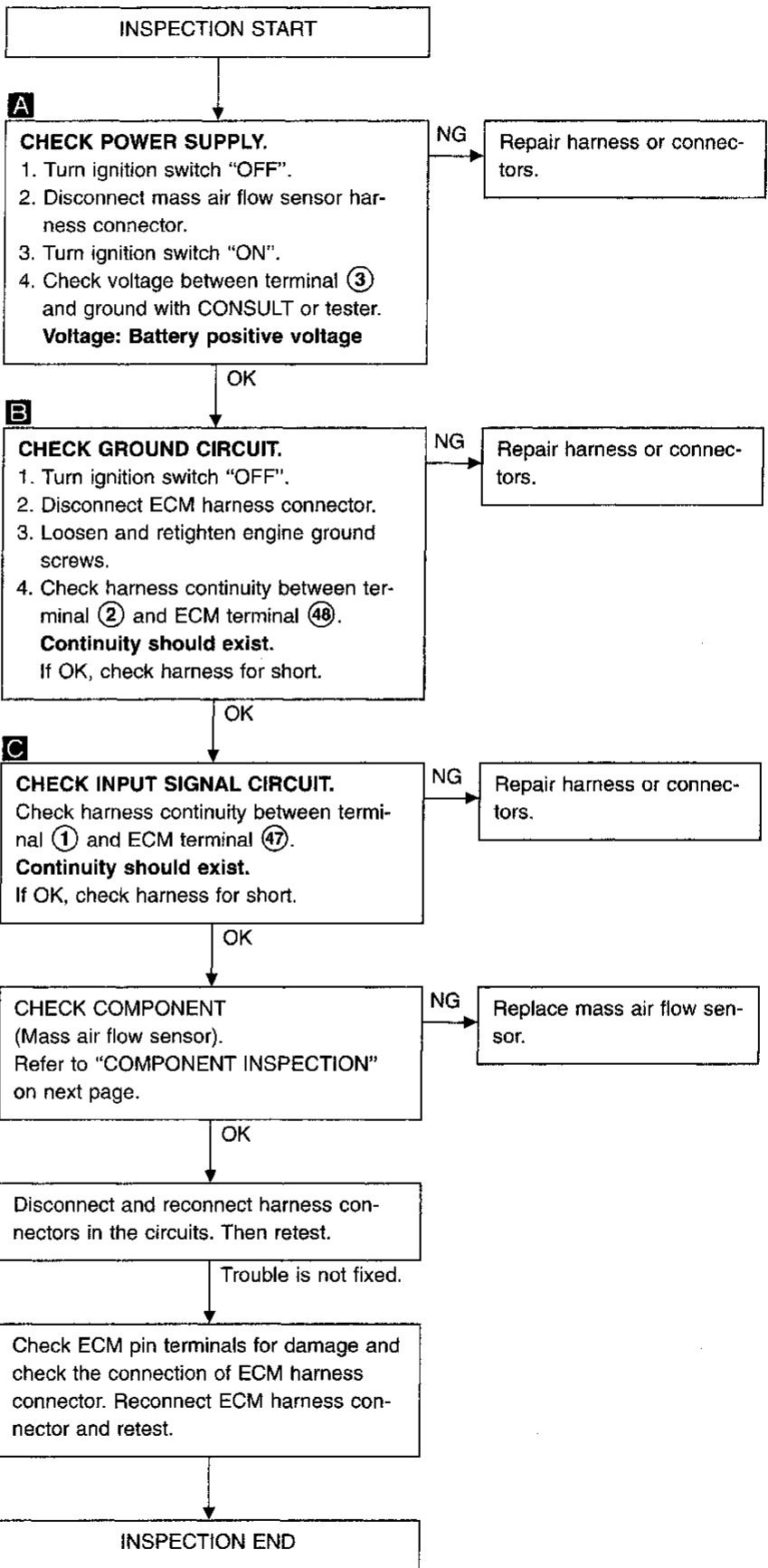
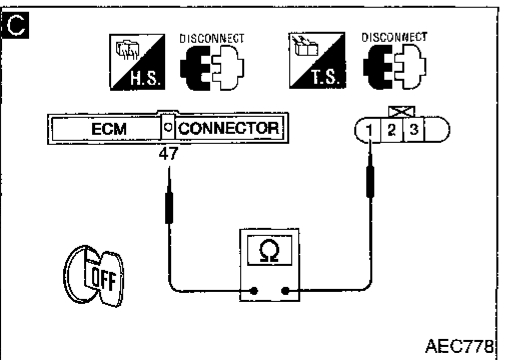
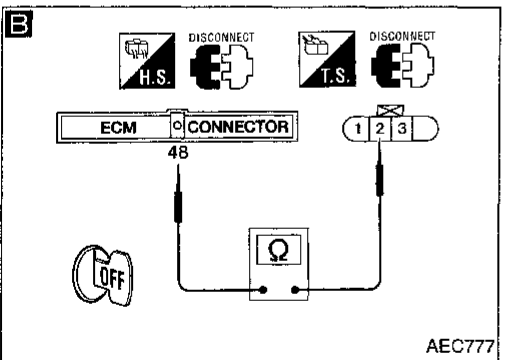
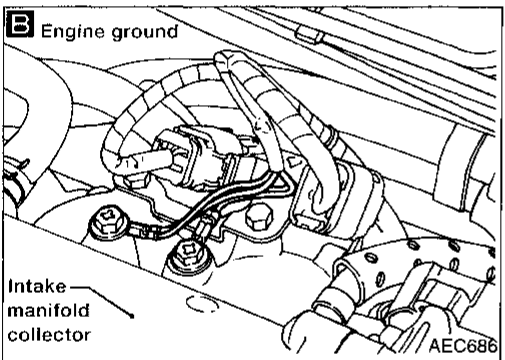
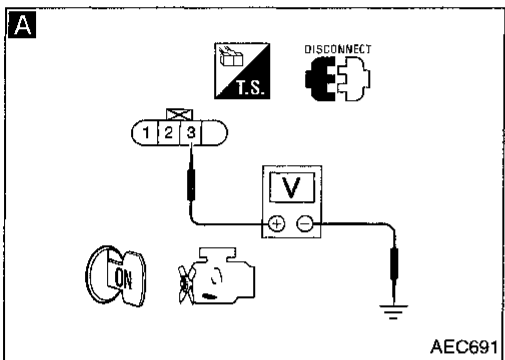
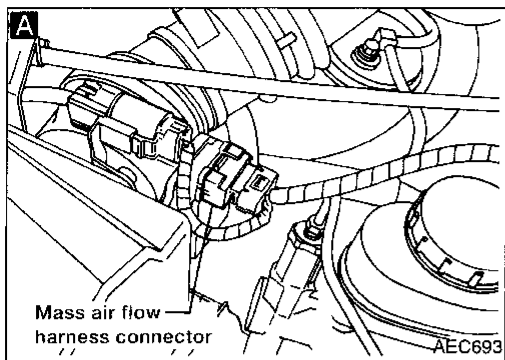

Mass Air Flow Sensor (MAFS) (DTC: 0102)  
(Cont'd)

COMPONENT INSPECTION

Mass air flow sensor

1. Turn ignition switch "ON".
2. Start engine and warm it up sufficiently.
3. Check voltage between terminal ① and ground.

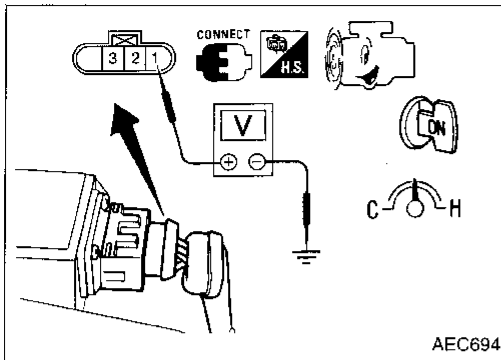

AEC694

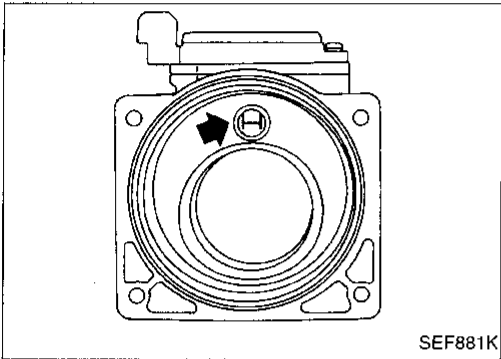

SEF881K

Conditions	Voltage V
Ignition switch "ON" (Engine stopped.)	Less than 1.0
Idle (Engine is warmed-up sufficiently.)	1.3 - 1.7
Idle to about 4,000 rpm*	1.3 - 1.7 to Approx. 4.0

\*: Check for linear voltage rise in response to increases to about 4,000 rpm in engine speed.

4. If NG, remove mass air flow sensor from air duct. Check hot wire for damage or dust.

GI

MA

EM

LC

EC

FE

CL

WT

AT

FA

RA

BR

ST

RS

BT

HA

EL

IDX



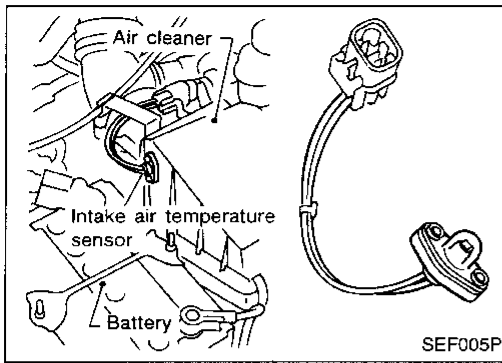

**Intake Air Temperature Sensor (DTC: 0401)**

The intake air temperature sensor mounted to the air cleaner housing, detects intake air temperature and transmits a signal to the ECM.

The temperature sensing unit uses a thermistor which is sensitive to the change in temperature. Electrical resistance of the thermistor decreases in response to the temperature rise.

This sensor is not used to control the engine system. It is used only for the on-board diagnosis.

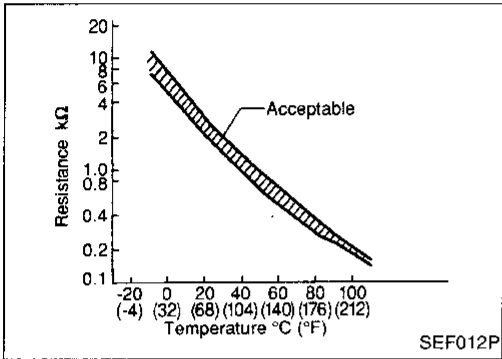

(Reference data)

Intake air temperature °C (°F)	Resistance kΩ
20 (68)	2.1 - 2.9
80 (176)	0.27 - 0.38

Diagnostic Trouble Code No.	Malfunction is detected when ...	Check Item (Possible Cause)
P0110 0401	<p>A) An excessively low or high voltage from the sensor is sent to ECM.</p> <p>B) Voltage sent to ECM is not practical when compared with the engine coolant temperature sensor signal.</p>	<ul style="list-style-type: none"> <li>• Harness or connectors (The sensor circuit is open or shorted.)</li> <li>• Intake air temperature sensor.</li> </ul>

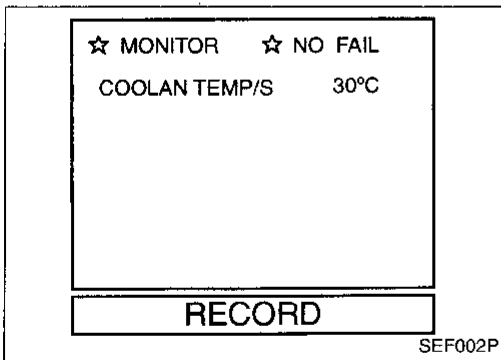

**DIAGNOSTIC TROUBLE CODE CONFIRMATION PROCEDURE**

**Procedure for malfunction A and B**

- 1) Wait until engine coolant temperature is less than 90°C (194°F).
  - (a) Turn ignition switch "ON".
  - (b) Select "DATA MONITOR" mode with CONSULT.
  - (c) Check the engine coolant temperature.
  - (d) If the engine coolant temperature is not less than 90°C (194°F), turn ignition switch "OFF" and cool down engine.
- 2) Turn ignition switch "ON".
- 3) Select "DATA MONITOR" mode with CONSULT.
- 4) Wait at least 5 seconds.

OR

Intake Air Temperature Sensor (DTC: 0401)  
(Cont'd)

FUEL SYS #1	OPEN
FUEL SYS #2	UNUSED
CALC LOAD	0%
<b>COOLANT TEMP</b>	<b>28°C</b>
SHORT FT #1	0%
LONG FT #1	0%
ENGINE SPD	0RPM
VEHICLE SPD	0km/h
IGN ADVANCE	5.0°
INTAKE AIR	25°C
MAF	0.0gm/sec
THROTTLE POS	0%
O2S LOCATION	3
O2S B1,S1	0.380V
O2FT B1,S1	0%
O2S B1,S2	0.000V

SEF950N

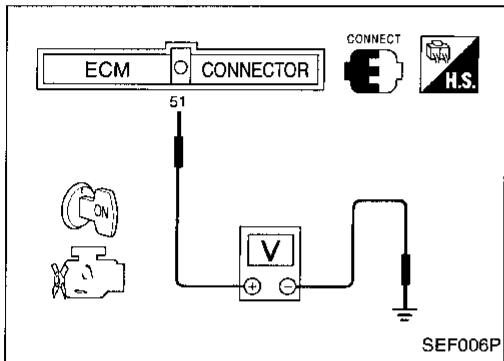

- 1) Wait until engine coolant temperature is less than 90°C (194°F).
  - (a) Turn ignition switch "ON".
  - (b) Select MODE 1 with GST.
  - (c) Check the engine coolant temperature.
  - (d) If the engine coolant temperature is not less than 90°C (194°F), turn ignition switch "OFF" and cool down engine.
- 2) Turn ignition switch "ON" and wait at least 5 seconds.
- 3) Select MODE 3 with GST.

OR



- 1) Wait until engine coolant temperature is less than 90°C (194°F).
  - (a) Turn ignition switch "ON".
  - (b) Check voltage between ECM terminal 51 and ground.
 

**Voltage: More than 1.2 (V)**
  - (c) If the voltage is not more than 1.2V, turn ignition switch "OFF" and cool down engine.
- 2) Turn ignition switch "ON" wait at least 5 seconds.
- 3) Turn ignition switch "OFF", wait at least 5 seconds and then turn "ON".
- 4) Perform "Diagnostic Test Mode II" (Self-diagnostic results) with ECM.

GI

MA

EM

LC

EC

FE

CL

MT

AT

FA

RA

BR

ST

RS

BT

HA

EL

IDX

Intake Air Temperature Sensor (DTC: 0401)  
(Cont'd)

EC-IATS-01

- : Detectable line for DTC
- - - : Non-detectable line for DTC
- ⬡ : A/T models

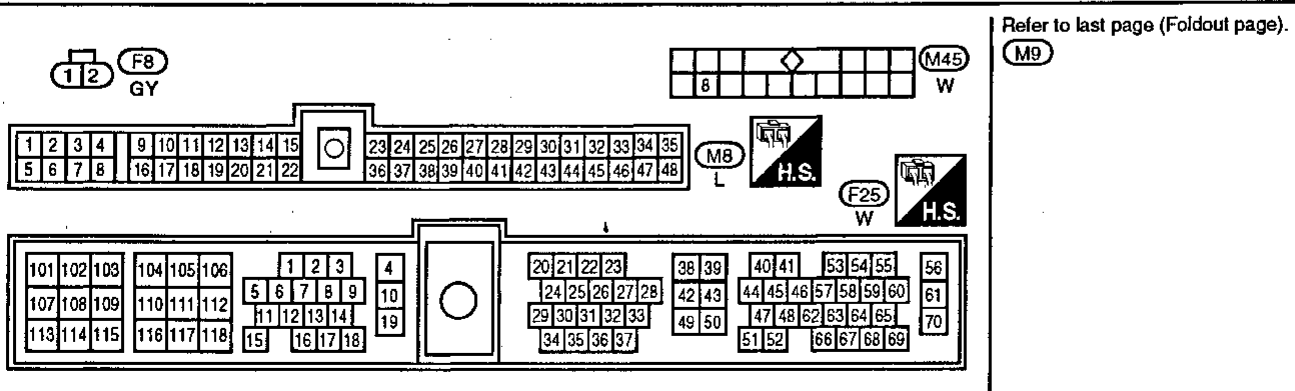
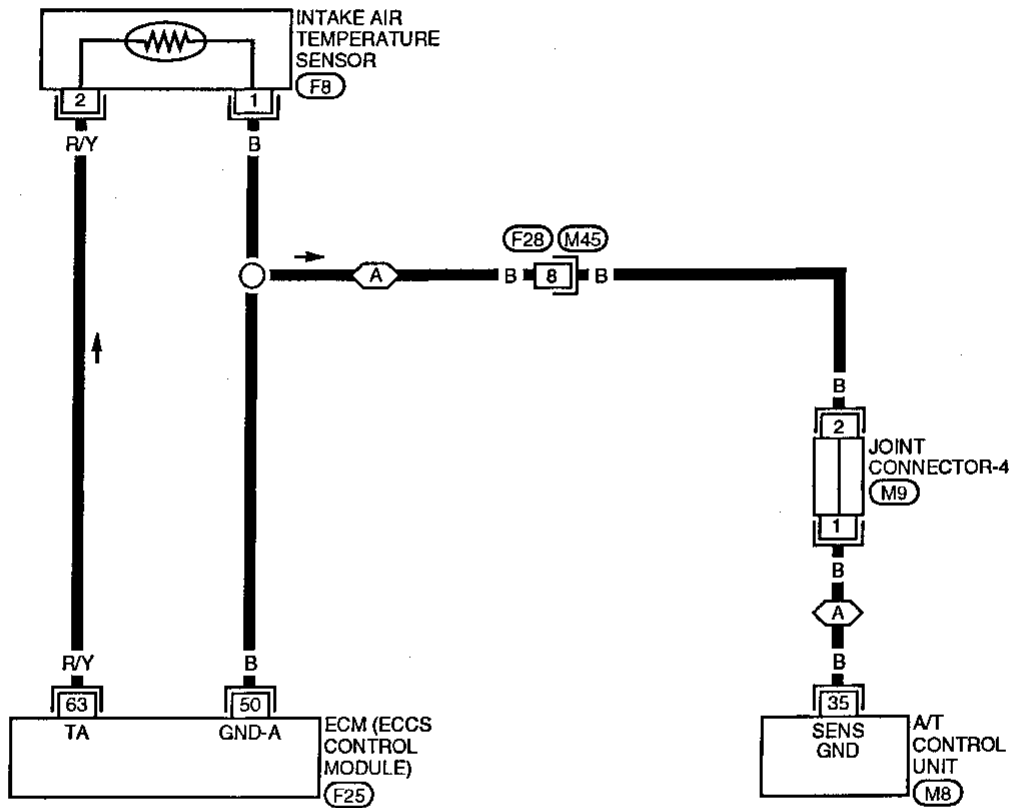

Refer to last page (Foldout page).

Intake Air Temperature Sensor (DTC: 0401)  
(Cont'd)

DIAGNOSTIC PROCEDURE

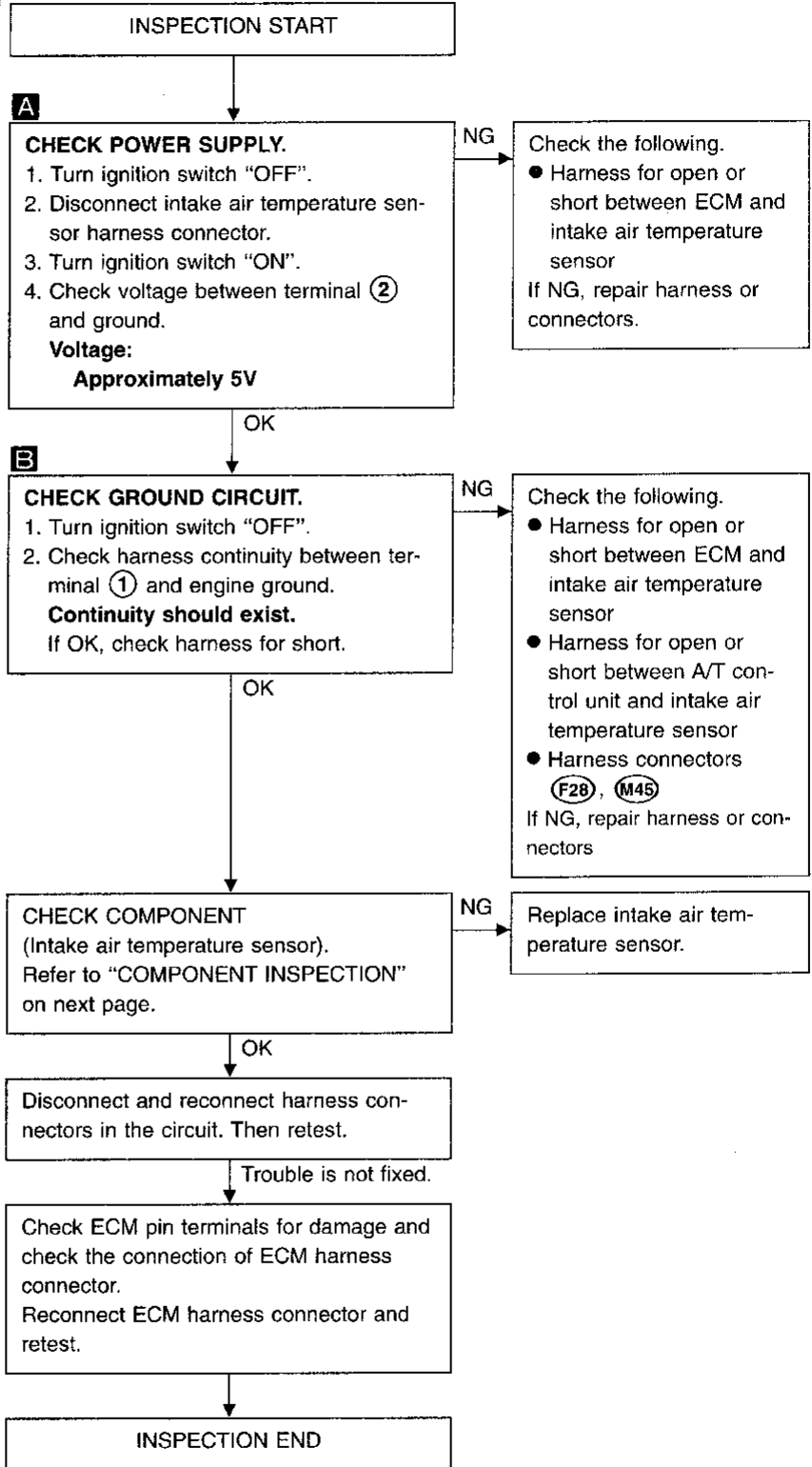
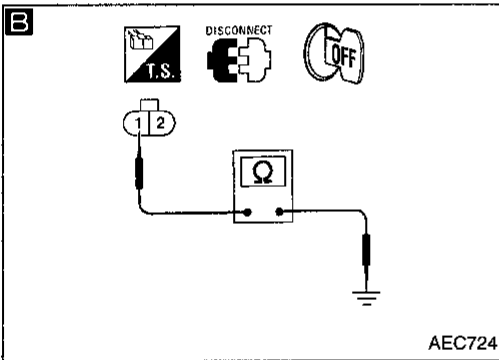
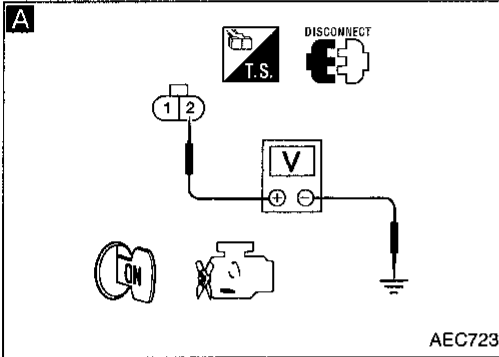
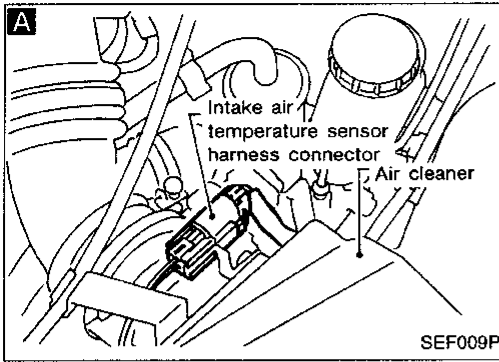

CI  
MA  
EM  
LC  
EC  
FE  
CL  
MT  
AT  
FA  
RA  
BR  
ST  
RS  
BT  
HA  
EL  
IDX

**Intake Air Temperature Sensor (DTC: 0401)  
(Cont'd)**

**COMPONENT INSPECTION**

**Intake air temperature sensor**

Check resistance as shown in the figure.

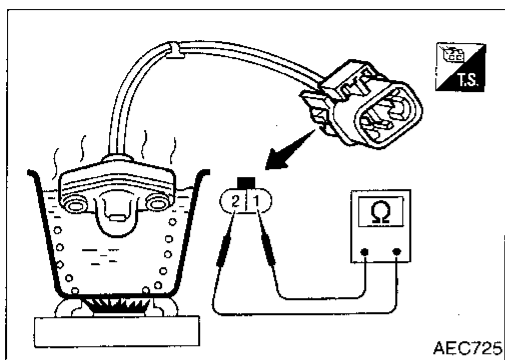

AEC725

Intake air temperature °C (°F)	Resistance kΩ
20 (68)	2.1 - 2.9
80 (176)	0.27 - 0.38

If NG, replace intake air temperature sensor.

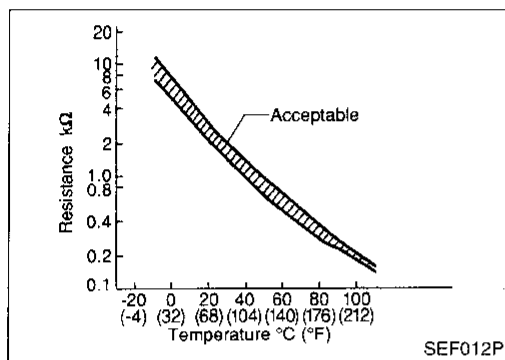

SEF012P

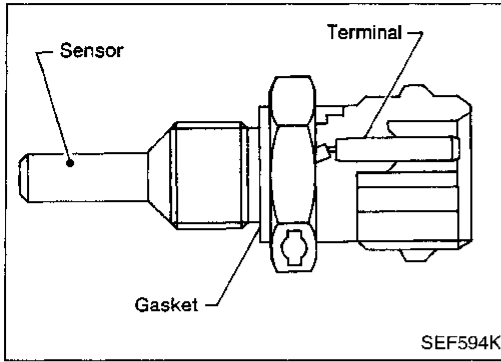

### Engine Coolant Temperature Sensor (ECTS) (DTC: 0103)

The engine coolant temperature sensor is used to detect the engine coolant temperature. The sensor modifies a voltage signal from the ECM. The modified signal returns to the ECM as the engine coolant temperature input. The sensor uses a thermistor which is sensitive to the change in temperature. The electrical resistance of the thermistor decreases as temperature increases.

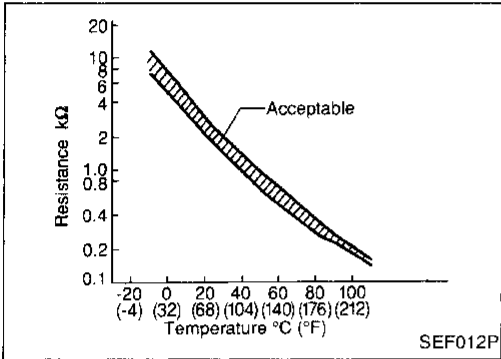

#### <Reference data>

Engine coolant temperature °C (°F)	Voltage (V)	Resistance (kΩ)
-10 (14)	4.4	9.2
20 (68)	3.5	2.5
50 (122)	2.2	0.8
90 (194)	0.9	0.2

Diagnostic Trouble Code No.	Malfunction is detected when ...	Check Items (Possible Cause)
P0115 0103	<ul style="list-style-type: none"> <li>An excessively high or low voltage from the sensor is sent to ECM.</li> </ul>	<ul style="list-style-type: none"> <li>Harness or connectors (The sensor circuit is open or shorted.)</li> <li>Engine coolant temperature sensor</li> </ul>

### DIAGNOSTIC TROUBLE CODE CONFIRMATION PROCEDURE

- 1) Turn ignition switch "ON".
  - 2) Select "DATA MONITOR" mode with CONSULT.
  - 3) Wait at least 5 seconds.
- OR
- 1) Turn ignition switch "ON" and wait at least 5 seconds.
  - 2) Select "MODE 3" with GST.
- OR
- 1) Turn ignition switch "ON" and wait at least 5 seconds.
  - 2) Turn ignition switch "OFF", wait at least 5 seconds and then turn "ON".
  - 3) Perform "Diagnostic Test Mode II" (Self-diagnostic results) with ECM.

Engine Coolant Temperature Sensor (ECTS)  
(DTC: 0103) (Cont'd)

EC-ECTS-01

— : Detectable line for DTC  
 — : Non-detectable line for DTC  
 (A) : A/T models

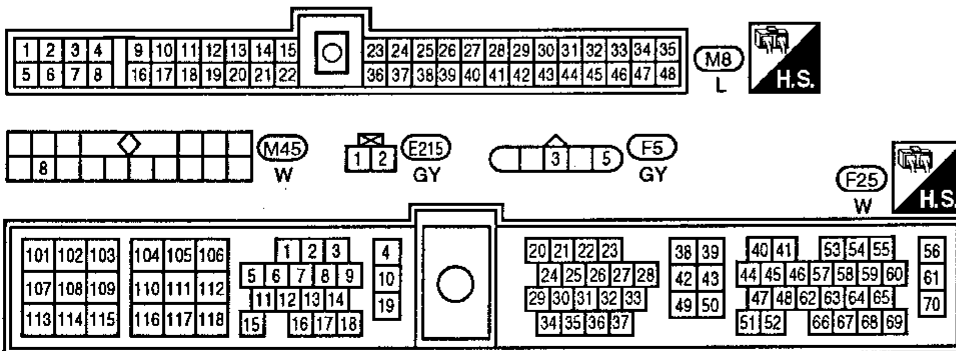
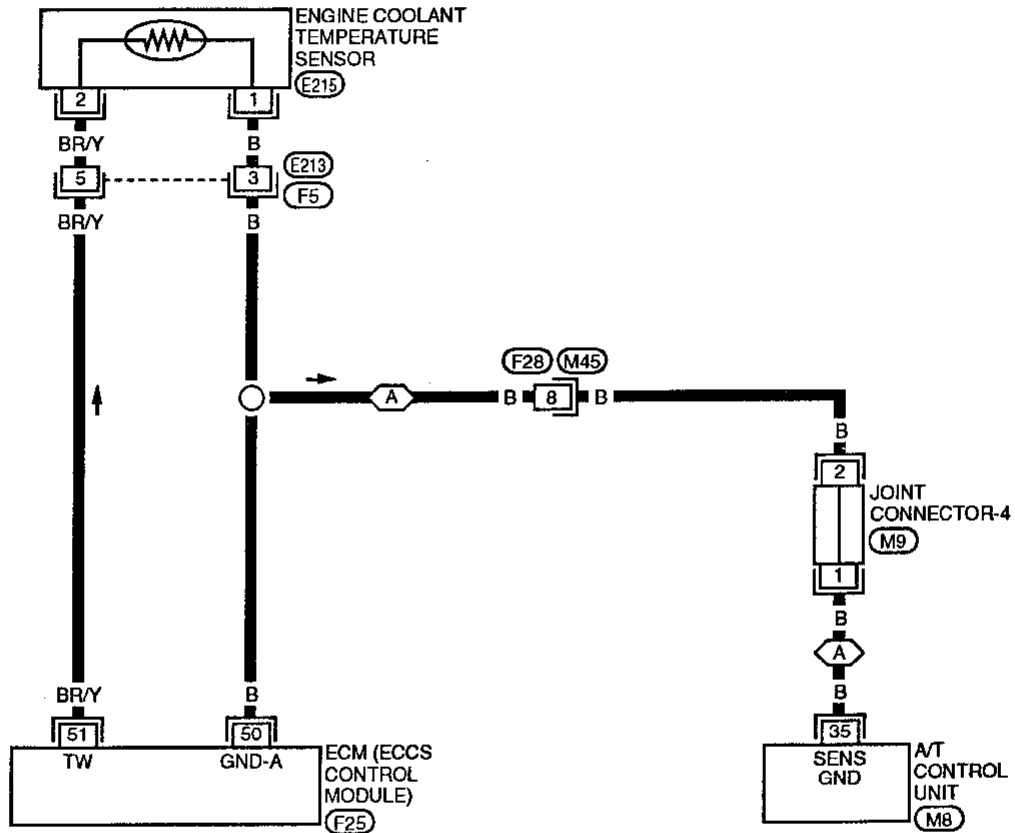

Refer to last page (Foldout page).

(M9)

# Engine Coolant Temperature Sensor (ECTS) (DTC: 0103) (Cont'd)

## DIAGNOSTIC PROCEDURE

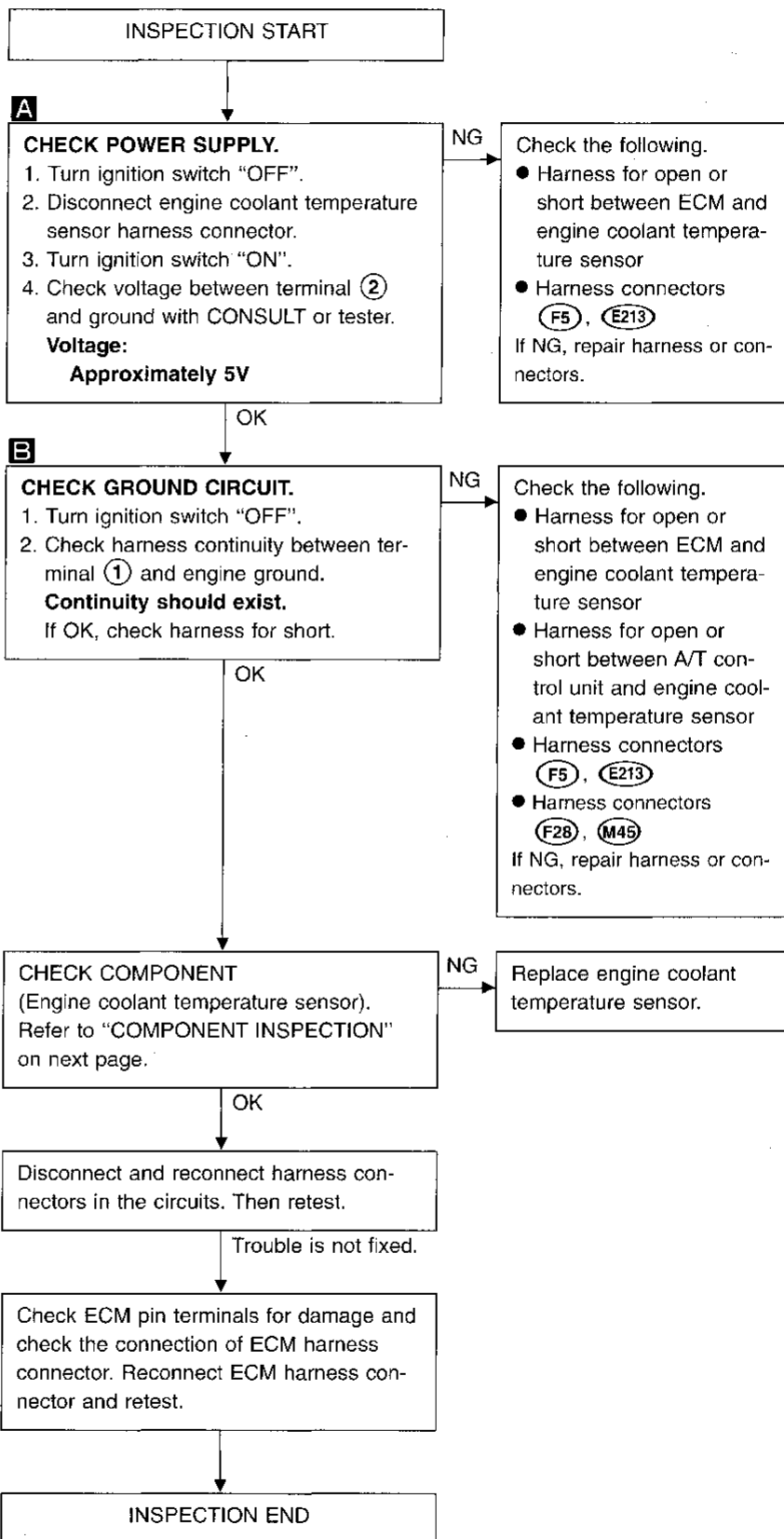
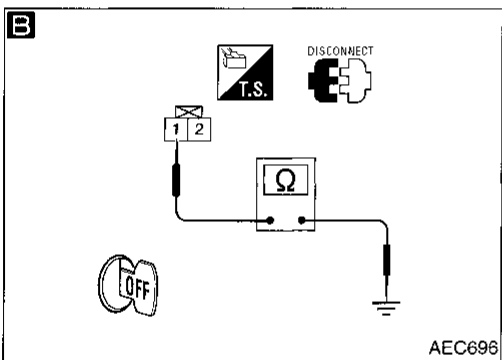
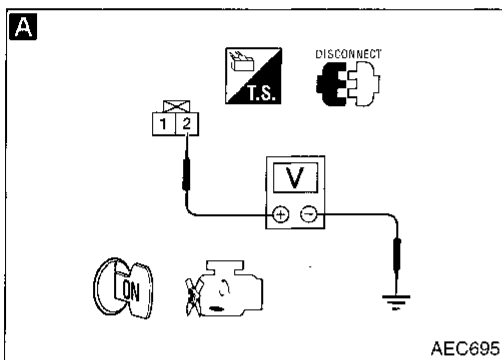
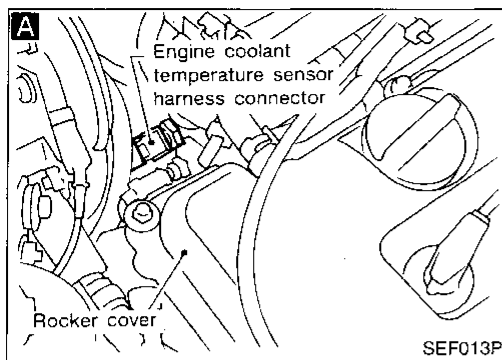

GI

MA

EM

LC

EC

FE

CL

MT

AT

FA

RA

BR

ST

RS

BT

HA

EL

IDX



**Engine Coolant Temperature Sensor (ECTS)  
(DTC: 0103) (Cont'd)**

**COMPONENT INSPECTION**

**Engine coolant temperature sensor**

Check resistance as shown in the figure.

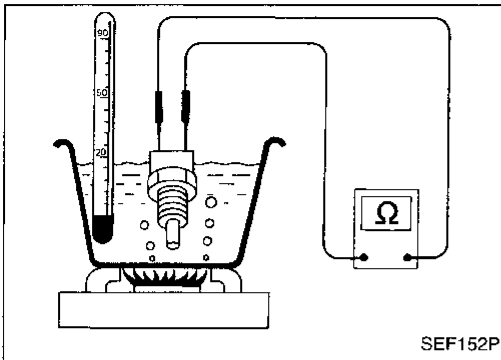

Temperature °C (°F)	Resistance kΩ
20 (68)	2.1 - 2.9
50 (122)	0.68 - 1.00
90 (194)	0.236 - 0.260

If NG, replace engine coolant temperature sensor.

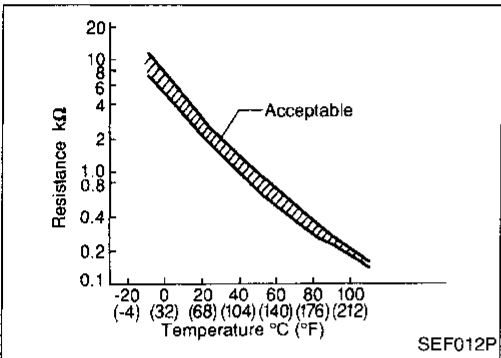

For M/T model

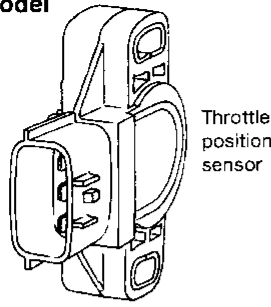

Throttle position sensor

SEF089KA

### Throttle Position Sensor (DTC: 0403)

The throttle position sensor responds to the accelerator pedal movement. This sensor is a kind of potentiometer which transforms the throttle position into output voltage, and emits the voltage signal to the ECM. In addition, the sensor detects the opening and closing speed of the throttle valve and feeds the voltage signal to the ECM.

Idle position of the throttle valve is determined by the ECM receiving the signal from the throttle position sensor. This one controls engine operation such as fuel cut. On the other hand, "Wide open and closed throttle position switch", which is built into the throttle position sensor unit on A/T model, is not used for engine control.

For A/T model

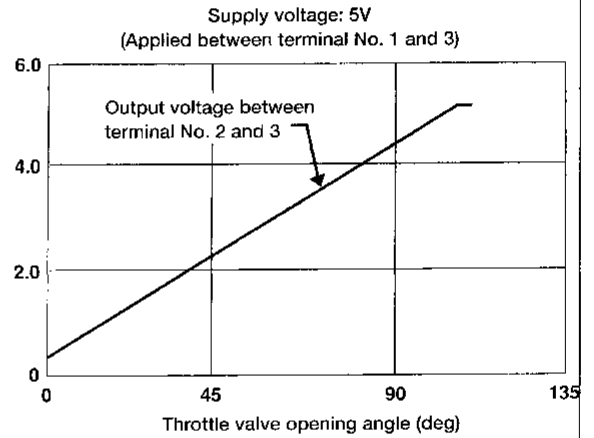
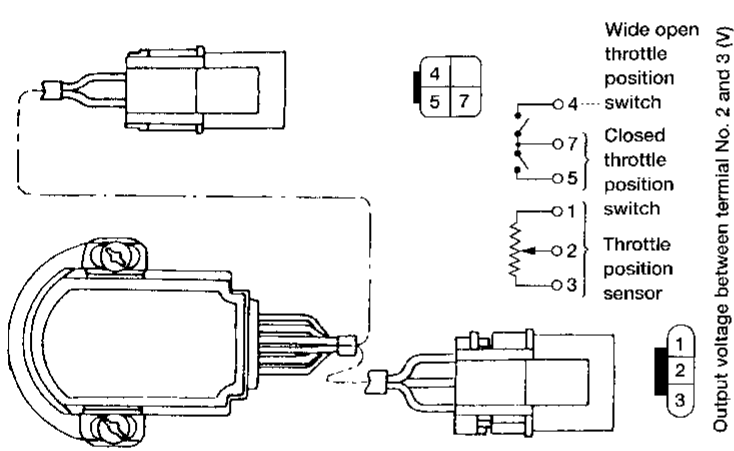

AEC726

Diagnostic Trouble Code No.	Malfunction is detected when ...	Check Item (Possible Cause)
P0120 0403	<ul style="list-style-type: none"> <li>An excessively low or high voltage from the sensor is sent to ECM.</li> <li>Voltage sent to ECM is not practical when compared with mass air flow sensor and camshaft position sensor signals.</li> </ul>	<ul style="list-style-type: none"> <li>Harness or connectors (The sensor circuit is open or shorted.)</li> <li>Throttle position sensor</li> </ul>

GI  
MA  
EM  
LC  
EC  
FE  
CL  
MT  
AT  
FA  
RA  
BR  
ST  
RS  
BT  
HA  
EL  
DX

Throttle Position Sensor (DTC: 0403) (Cont'd)

OVERALL FUNCTION CHECK

Use this procedure to check the overall function of the throttle position sensor. During this check, a DTC might not be confirmed.

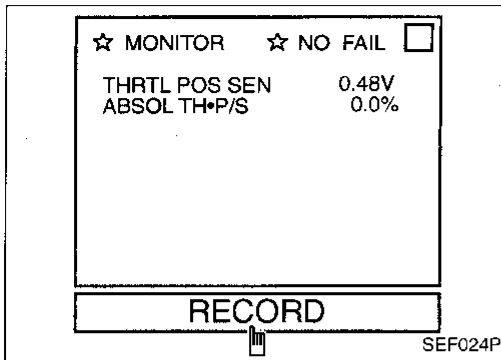

- 1) Turn ignition switch "ON".
- 2) Select "MANU TRIG" and "HI SPEED" in "DATA MONITOR" mode with CONSULT.
- 3) Select "THRTL POS SEN" and "ABSOL TH/PS" in "DATA MONITOR" mode with CONSULT.
- 4) Press RECORD on CONSULT SCREEN at the same time accelerator pedal is depressed.
- 5) Print out the recorded data and check the following:
  - The voltage when accelerator pedal fully released is approximately 0.35 - 0.65V.
  - The voltage rise is linear in response to accelerator pedal depression.
  - The voltage when accelerator pedal fully depressed is approximately 4V.

OR



- 1) Turn ignition switch "ON".
- 2) Check the voltage between ECM terminal ②③ and ④③ (ground) and check the following:
  - The voltage when accelerator pedal fully released is approximately 0.35 - 0.65V.
  - The voltage rise is linear in response to accelerator pedal depression.
  - The voltage when accelerator pedal fully depressed is approximately 4V.

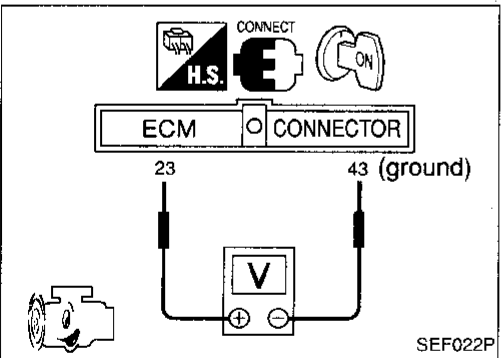
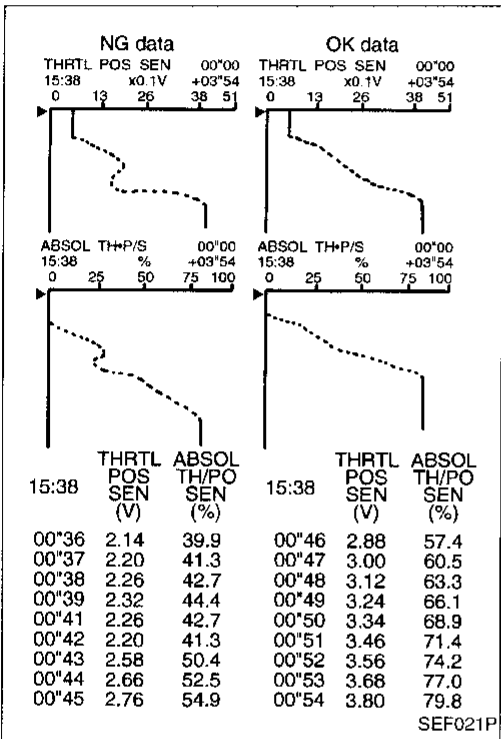

Throttle Position Sensor (DTC: 0403) (Cont'd)

EC-TPS-01

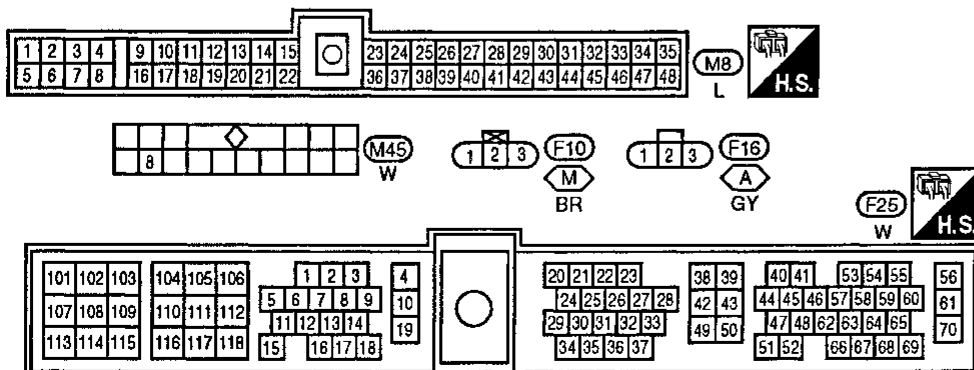
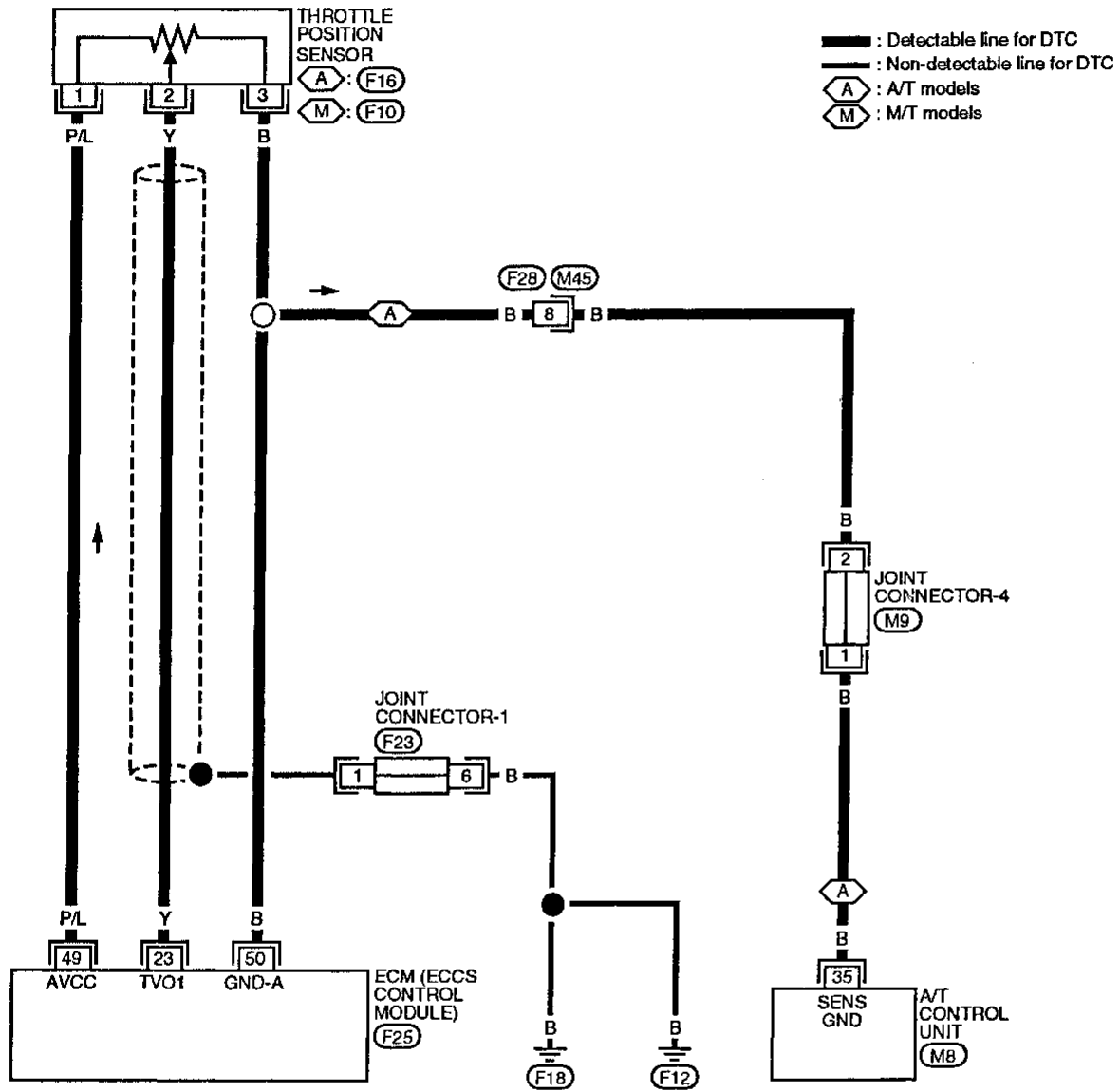

Refer to last page (Foldout page).

M9  
F23

Throttle Position Sensor (DTC: 0403) (Cont'd)  
DIAGNOSTIC PROCEDURE

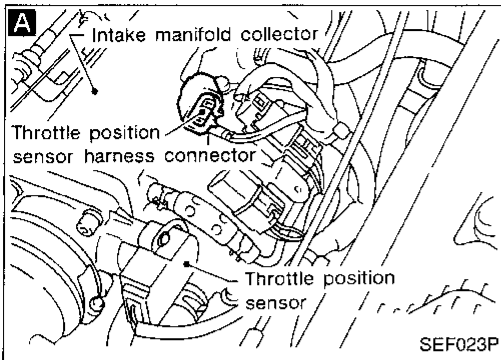

INSPECTION START

**A**  
**CHECK POWER SUPPLY.**  
1. Turn ignition switch "OFF".  
2. Disconnect throttle position sensor harness connector.  
3. Turn ignition switch "ON".  
4. Check voltage between terminal ① and ground with CONSULT or tester.  
**Voltage: Approximately 5V**

NG → Repair harness or connectors.

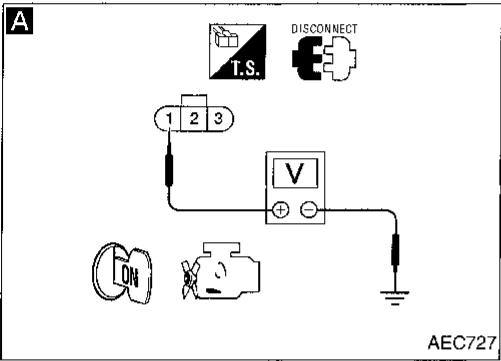

**B**  
**CHECK GROUND CIRCUIT.**  
1. Turn ignition switch "OFF".  
2. Loosen and retighten engine ground screw.  
3. Check harness continuity between terminal ③ and engine ground.  
**Continuity should exist.**  
If OK, check harness for short.

NG → Check the following.  
● Harness connectors (F28, M45)  
● Harness for open or short between ECM and throttle position sensor  
● Harness for open or short between A/T control unit and throttle position sensor  
If NG, repair harness or connectors.

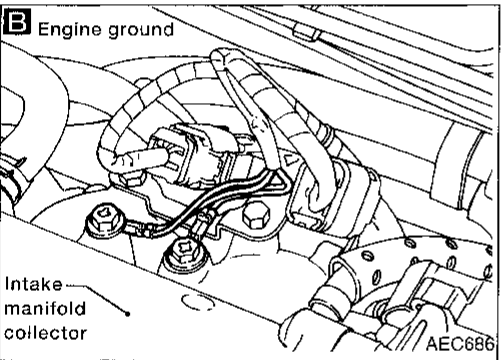

**C**  
**CHECK INPUT SIGNAL CIRCUIT.**  
1. Disconnect ECM harness connector.  
2. Check harness continuity between ECM terminal ②③ and terminal ②.  
**Continuity should exist.**  
If OK, check harness for short.

NG → Repair harness or connectors.

ADJUST THROTTLE POSITION SENSOR.  
Perform "Basic Inspection", EC-62.

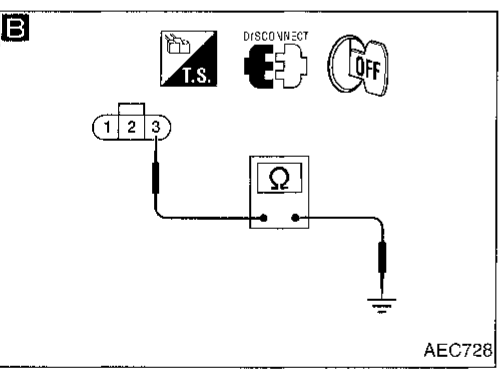

**CHECK COMPONENT (Throttle position sensor).**  
Refer to "COMPONENT INSPECTION" on next page.

NG → Replace throttle position sensor. To adjust it, perform "Basic Inspection", EC-62.

Disconnect and reconnect harness connectors in the circuit. Then retest.

Trouble is not fixed.

Check ECM pin terminals for damage and check the connection of ECM harness connector. Reconnect ECM harness connector and retest.

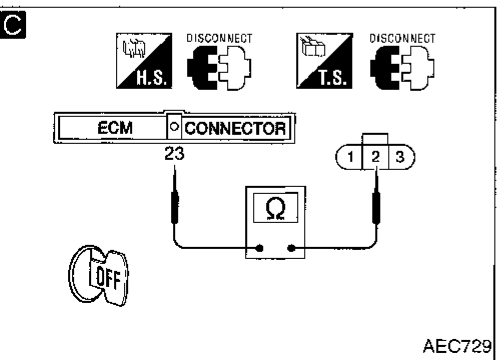

INSPECTION END

Throttle Position Sensor (DTC: 0403) (Cont'd)

COMPONENT INSPECTION

Throttle position sensor

1. Disconnect throttle position sensor harness connector.
2. Make sure that resistance between terminals ② and ③ changes when opening throttle valve manually.

GI

MA

EM

LC

EC

FE

CL

WT

AT

FA

RA

BR

ST

RS

BT

HA

EL

IDX

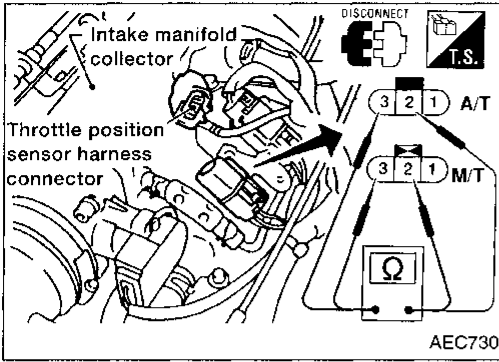

Throttle valve conditions	Resistance [at 25°C (77°F)]
Completely closed	Approximately 1 kΩ
Partially open	1 - 10 kΩ
Completely open	Approximately 10 kΩ

If NG, replace throttle position sensor.  
To adjust it, perform "Basic Inspection", EC-62.

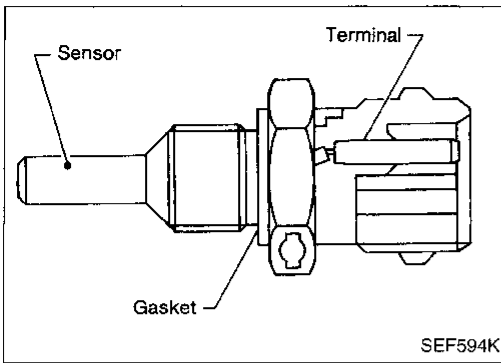

### Engine Coolant Temperature (ECT) Sensor (DTC: 0908)

The engine coolant temperature sensor is used to detect the engine coolant temperature. The sensor modifies a voltage signal from the ECM. The modified signal returns to the ECM as the engine coolant temperature input. The sensor uses a thermistor which is sensitive to the change in temperature. The electrical resistance of the thermistor decreases as temperature increases.

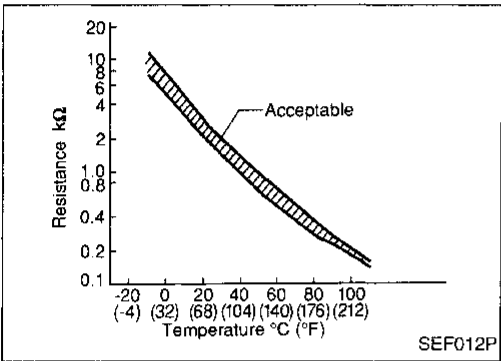

<Reference data>

Engine coolant temperature °C (°F)	Voltage (V)	Resistance (kΩ)
-10 (14)	4.4	9.2
20 (68)	3.5	2.1 - 2.9
50 (122)	2.2	0.68 - 1.00
90 (194)	0.9	0.236 - 0.260

Diagnostic Trouble Code No.	Malfunction is detected when ...	Check Items (Possible Cause)
P0125 0908	<ul style="list-style-type: none"> <li>● Voltage sent to ECM from the sensor is not practical, even when some time has passed after starting the engine.</li> <li>● Engine coolant temperature is insufficient for closed loop fuel control.</li> </ul>	<ul style="list-style-type: none"> <li>● Harness or connectors (High resistance in the circuit)</li> <li>● Engine coolant temperature sensor</li> <li>● Thermostat</li> </ul>

**Engine Coolant Temperature (ECT) Sensor (DTC: 0908) (Cont'd)**

**OVERALL FUNCTION CHECK**

Use this procedure to check the overall function of the engine coolant temperature sensor circuit. During this check, a DTC might not be confirmed.

**Note: If both DTC P0115 (0103) and P0125 (0908) are displayed, first perform TROUBLE DIAGNOSIS FOR DTC P0115 (0103). Refer to EC-103.**

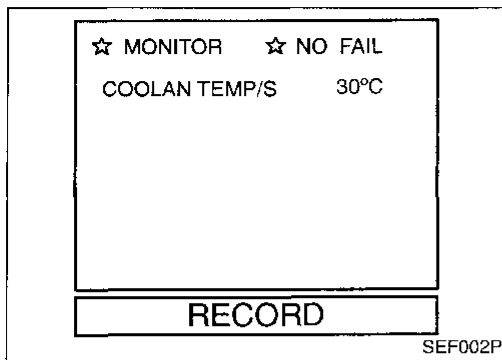

SEF002P

FUEL SYS #1	OPEN
FUEL SYS #2	UNUSED
CALC LOAD	22%
COOLANT TEMP	30°C
SHORT FT #1	0%
LONG FT #1	2%
ENGINE SPD	1000RPM
VEHICLE SPD	0km/h
IGN ADVANCE	20.0°
INTAKE AIR	26°C
MAF	0.0gm/sec
THROTTLE POS	0%
O2S LOCATION	3
O2S B1,S1	0.680V
O2FT B1,S1	0%
O2S B1,S2	0.080V

SEF003P

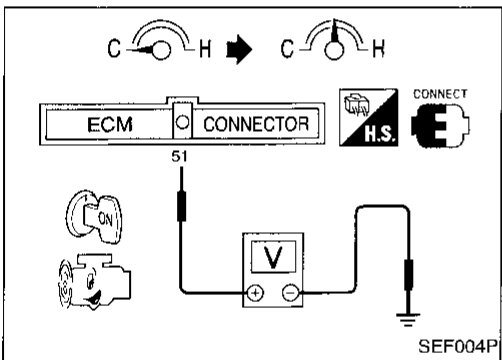

SEF004P



- 1) Turn ignition switch "ON".
- 2) Select "COOLANT TEMP/S" in "DATA MONITOR" mode with CONSULT.
- 3) Start engine and run it at idle speed.
- 4) Check that the engine coolant temperature rises to 25°C (77°F) or more within 15 minutes. (Be careful not to overheat engine.)

OR



- 1) Turn ignition switch "ON".
- 2) Select "MODE 1" with GST.
- 3) Start engine and run it at idle speed.
- 4) Check that the engine coolant temperature rises to 25°C (77°F) or more within 15 minutes. (Be careful not to overheat engine.)

OR



- 1) Turn ignition switch "ON".
- 2) Probe voltage meter between ECM terminal ⑤1 and ground.
- 3) Start engine and run it at idle speed.
- 4) Check that voltage of engine coolant temperature changes to less than 3.3 (V) within 15 minutes. (Be careful not to overheat engine.)

GI

MA

EM

LC

EC

FE

CL

MT

AT

FA

RA

BR

ST

RS

BT

HA

EL

IDX



Engine Coolant Temperature (ECT) Sensor  
(DTC: 0908) (Cont'd)

EC-ECTS-01

— : Detectable line for DTC  
 — : Non-detectable line for DTC  
 A : A/T models

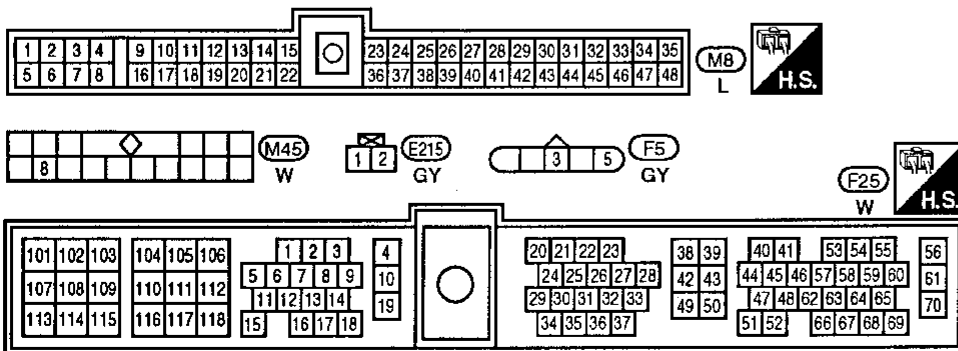
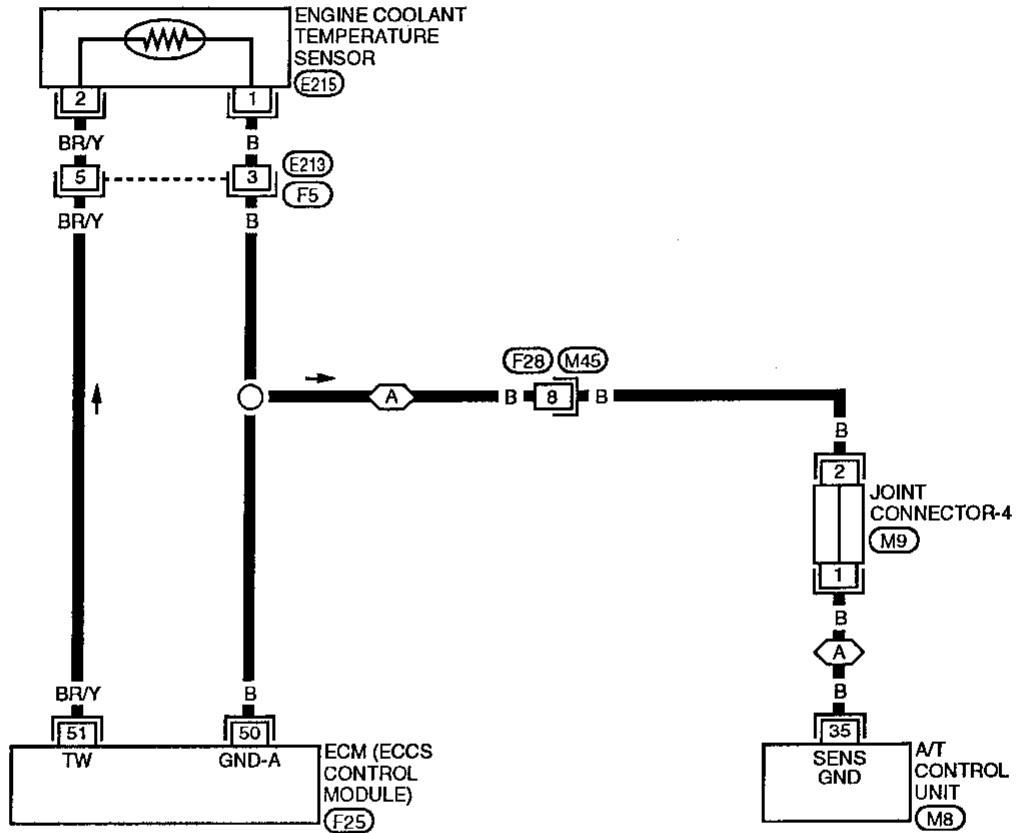

Refer to last page (Foldout page).  
 M9

Engine Coolant Temperature (ECT) Sensor (DTC: 0908) (Cont'd)

DIAGNOSTIC PROCEDURE

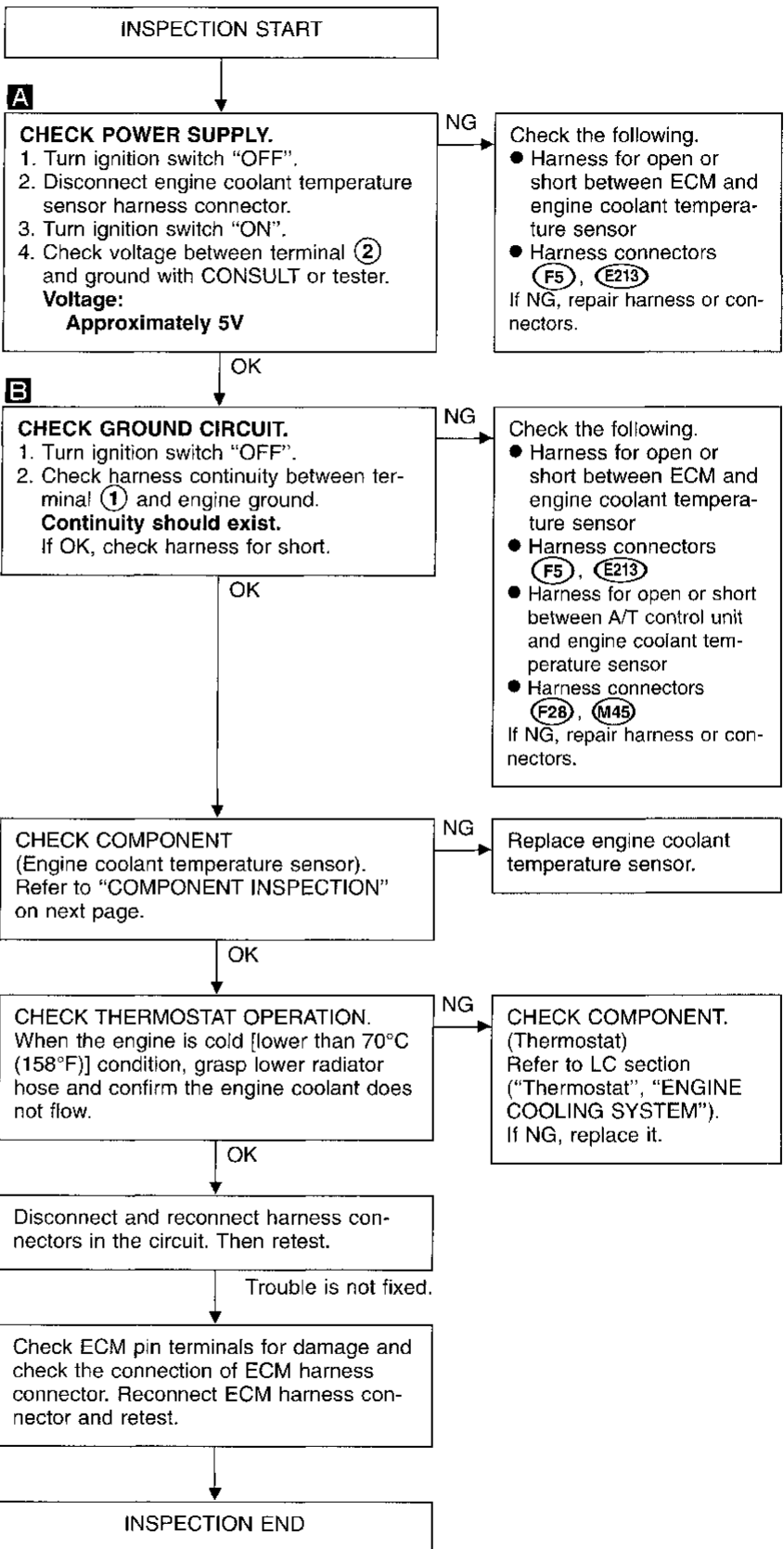
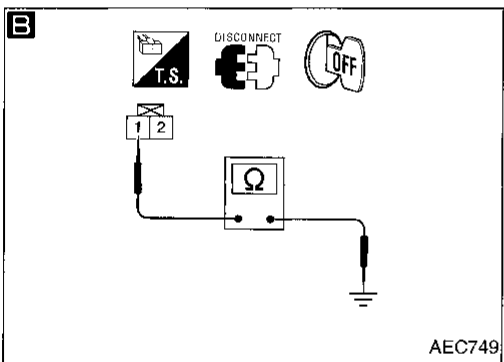
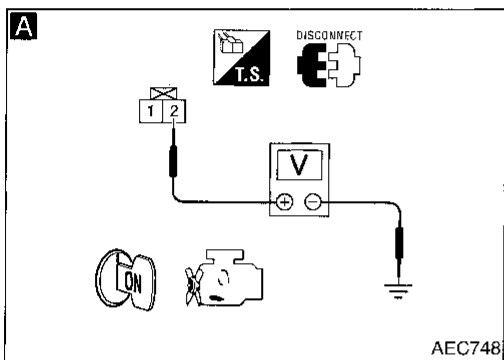
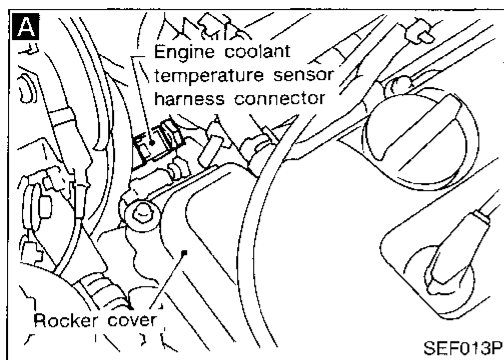

GI  
MA  
EM  
LC  
EC  
FE  
CL  
MT  
AT  
FA  
RA  
BR  
ST  
RS  
BT  
HA  
EL  
IDX

## Engine Coolant Temperature (ECT) Sensor (DTC: 0908) (Cont'd)

### COMPONENT INSPECTION

#### Engine coolant temperature sensor

Check resistance as shown in the figure.

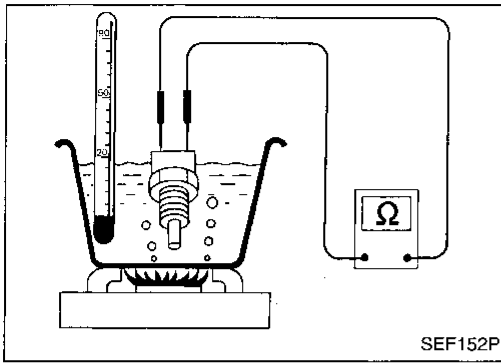

Temperature °C (°F)	Resistance (k $\Omega$ )
20 (68)	2.1 - 2.9
50 (122)	0.68 - 1.0
90 (194)	0.236 - 0.260

If NG, replace engine coolant temperature sensor.

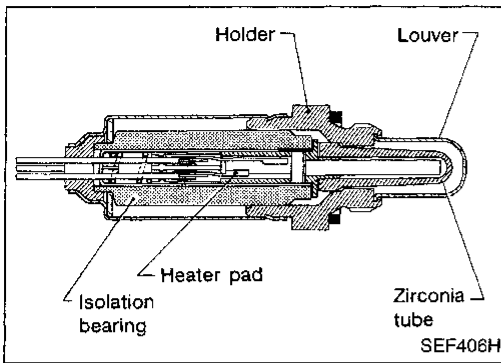

### Front Heated Oxygen Sensor (Front HO2S) (DTC: 0303)

The front HO2S is placed into the exhaust manifold. It detects the amount of oxygen in the exhaust gas compared to the outside air. The sensor has a closed-end tube made of ceramic zirconia. The zirconia generates voltage from approximately 1V in richer conditions to 0V in leaner conditions. The sensor signal is sent to the ECM. The ECM adjusts the injection pulse duration to achieve the ideal air-fuel ratio. The ideal air-fuel ratio occurs near the radical change from 1V to 0V.

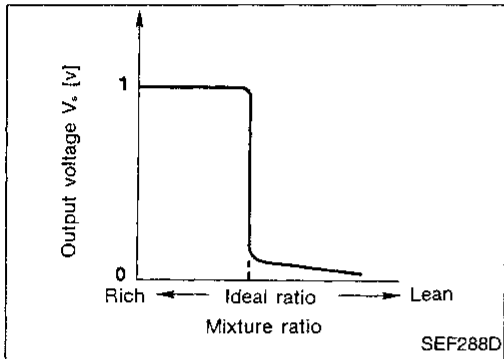

Diagnostic Trouble Code No.	Malfunction is detected when ...	Check Items (Possible Cause)
P0130 0303	<ul style="list-style-type: none"> <li>● An excessively high voltage from the sensor is sent to ECM.</li> <li>● The voltage from the sensor is constantly approx. 0.3V.</li> <li>● The maximum and minimum voltages from the sensor do not reach the specified voltages.</li> <li>● The sensor does not respond between rich and lean within the specified time.</li> </ul>	<ul style="list-style-type: none"> <li>● Harness or connectors (The sensor circuit is open or shorted.)</li> <li>● Front heated oxygen sensor</li> <li>● Fuel pressure</li> <li>● Injectors</li> <li>● Intake air leaks</li> </ul>

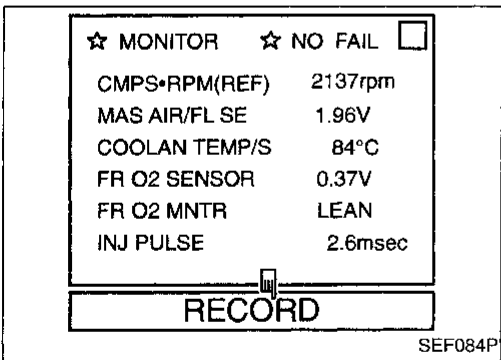

### OVERALL FUNCTION CHECK

Use this procedure to check the overall function of the front heated oxygen sensor circuit. During this check, a DTC might not be confirmed.

- 1) Start engine and warm it up sufficiently.
  - 2) Select "MANU TRIG" and "HI SPEED" in "DATA MONITOR" mode with CONSULT, and select "FR O2 SENSOR" and "FR O2 MNTR".
  - 3) Hold engine speed at 2,000 rpm under no load during the following steps.
  - 4) Touch "RECORD" on CONSULT screen.
  - 5) Check the following.
    - "FR O2 MNTR" in "DATA MONITOR" mode changes from "RICH" to "LEAN" to "RICH" 5 times in 10 seconds.
- 5 times (cycles) are counted as shown below:

cycle | 1 | 2 | 3 | 4 | 5 |  
FR O2 MNTR R-L-R-L-R-L-R-L-R

R = "FR O2 MNTR", "RICH"  
L = "FR O2 MNTR", "LEAN"

**Front Heated Oxygen Sensor (Front HO2S)  
(DTC: 0303) (Cont'd)**

- "FR O2 SENSOR" voltage goes above 0.6V at least once.
- "FR O2 SENSOR" voltage goes below 0.35V at least once.

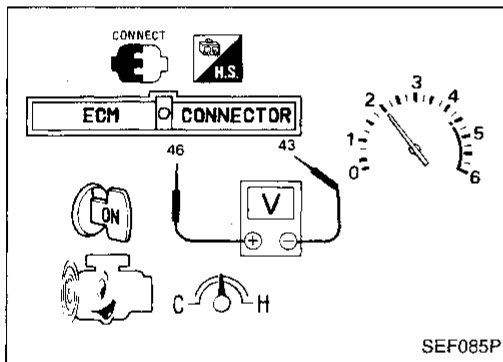
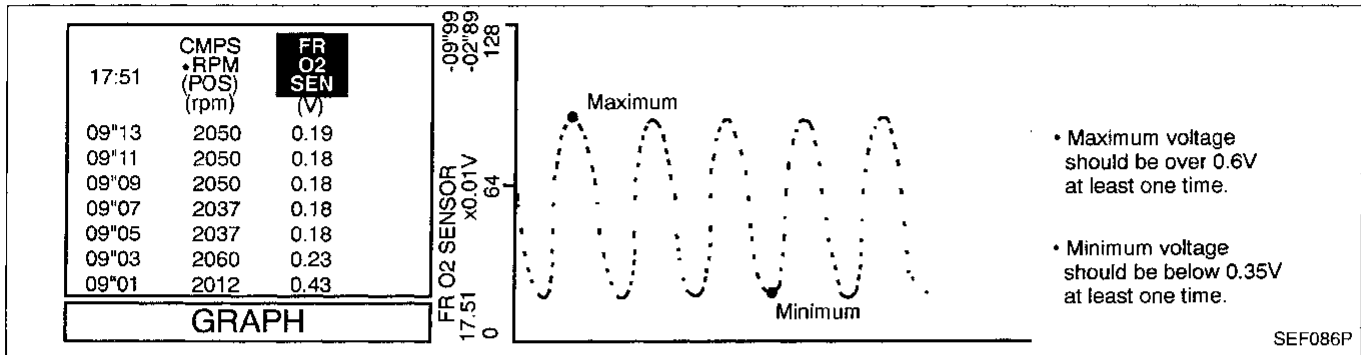

OR

- 1) Start engine and warm it up sufficiently.
- 2) Set voltmeter probes between ECM terminal ④⑥ (sensor signal) and ④③ (engine ground).
- 3) Check the following with engine speed held at 2,000 rpm constant under no load.
  - Malfunction indicator lamp goes on more than 5 times within 10 seconds in Diagnostic Test Mode II (FRONT HEATED OXYGEN SENSOR MONITOR).
  - The maximum voltage is over 0.6V at least one time.
  - The minimum voltage is below 0.35V at least one time.

Front Heated Oxygen Sensor (Front HO2S)  
(DTC: 0303) (Cont'd)

EC-FRO2-01

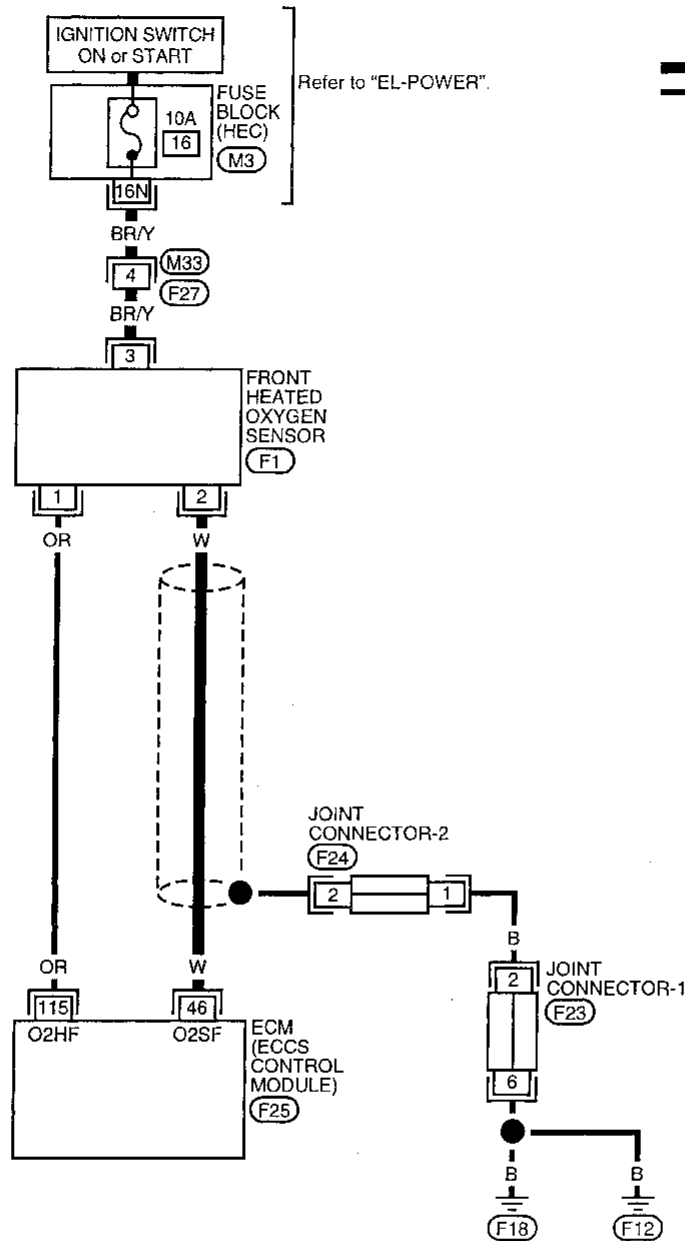

— : Detectable line for DTC  
— : Non-detectable line for DTC

CI  
MA  
EM  
LC  
**EC**  
FE  
CL  
MT  
AT  
FA  
RA  
BR  
ST  
RS  
BT  
HA  
EL  
IDX



Refer to last page (Foldout page).

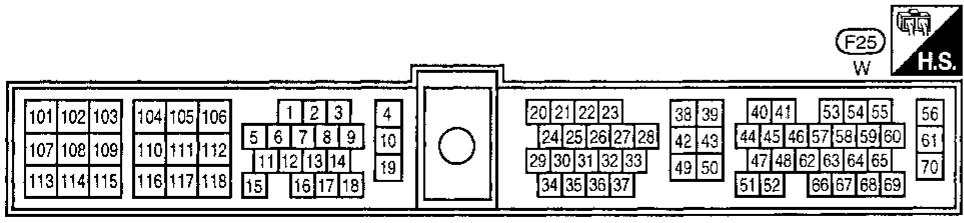

Front Heated Oxygen Sensor (Front HO2S)  
(DTC: 0303) (Cont'd)

DIAGNOSTIC PROCEDURE

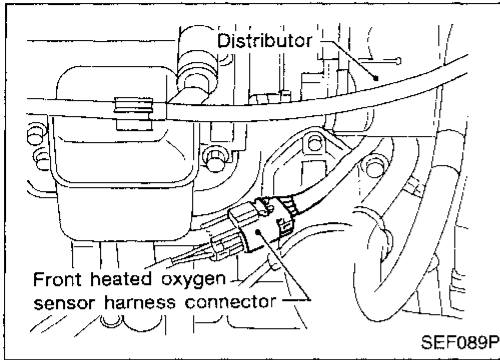

INSPECTION START

**A**

**CHECK INPUT SIGNAL CIRCUIT.**

1. Turn ignition switch "OFF".
2. Disconnect front heated oxygen sensor harness connector and ECM harness connector.
3. Check harness continuity between ECM terminal (46) and terminal (2).  
**Continuity should exist.**
4. Check harness continuity between ECM terminal (46) (or terminal (2)) and ground.  
**Continuity should not exist.**

NG → Repair harness or connectors.

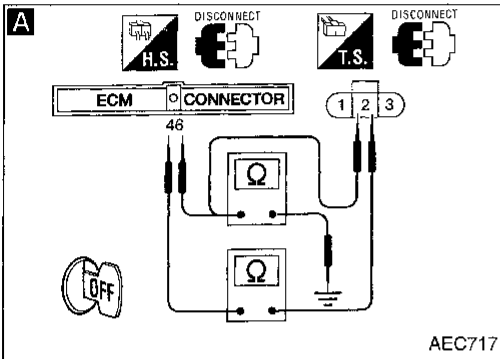

OK

Loosen and retighten engine ground screws.

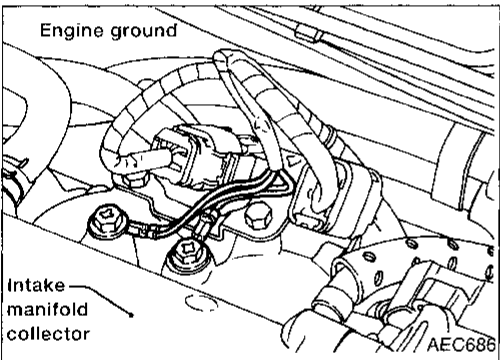

**B**

**CLEAR THE SELF-LEARNING DATA.**

1. Start engine and warm it up sufficiently.
2. Select "SELF-LEARNING CONTROL" in "ACTIVE TEST" mode with CONSULT.
3. Clear the self-learning control coefficient by touching "CLEAR".
4. Run engine for at least 10 minutes at idle speed.  
**Is the DTC P0170 detected?  
Is it difficult to start engine?**

OR

2. Turn ignition switch "OFF" and wait at least 5 seconds.
3. Disconnect mass air flow sensor harness connector, and restart and run engine for at least 3 seconds at idle speed.
4. Stop engine and reconnect mass air flow sensor harness connector.
5. Make sure diagnostic trouble code No. 0102 is displayed in Diagnostic Test Mode II.
6. Erase the Diagnostic Test Mode II (Self-diagnostic results) memory. Make sure diagnostic trouble code No. 0505 is displayed in Diagnostic Test Mode II.
7. Run engine for at least 10 minutes at idle speed.  
**Is the DTC 0706 detected?  
Is it difficult to start engine?**

Yes → Go to "TROUBLE DIAGNOSIS FOR DTC P0170 (0706)", EC-131.

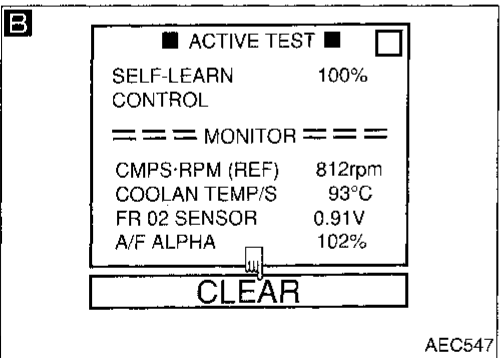

No



(Go to next page.)

Front Heated Oxygen Sensor (Front HO2S)  
(DTC: 0303) (Cont'd)

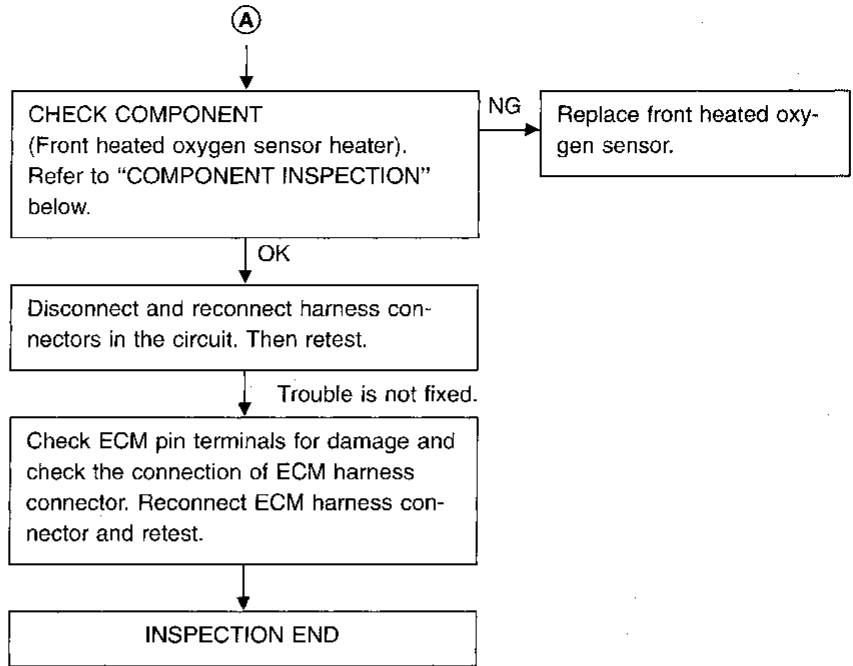

CI  
MA  
EM  
LC  
EC  
FE  
CL  
MT  
AT  
FA  
RA  
BR  
ST  
RS  
BT  
HA  
EL  
IDX

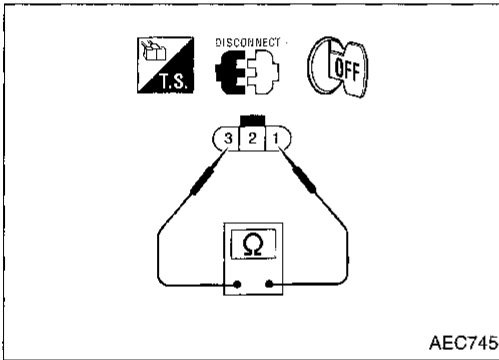

COMPONENT INSPECTION

Front heated oxygen sensor heater

Check resistance between terminals ① and ③.

**Resistance: 3.3 - 6.3Ω at 25°C (77°F)**

If NG, replace front heated oxygen sensor.

**CAUTION:**

Discard any heated oxygen sensor which has been dropped from a height of more than 0.5 m (19.7 in) onto a hard surface such as a concrete floor; use a new one.



**Closed Loop Control (DTC: 0307)**

- The closed loop control has one trip detection logic.

Diagnostic Trouble Code No.	Malfunction is detected when ...	Check Items (Possible Cause)
P0130 0307	<ul style="list-style-type: none"> <li>• The closed loop control function does not operate even when vehicle is driving in the specified condition.</li> </ul>	<ul style="list-style-type: none"> <li>• The front heated oxygen sensor circuit is open or short.</li> <li>• Front heated oxygen sensor.</li> <li>• Front heated oxygen sensor heater.</li> </ul>

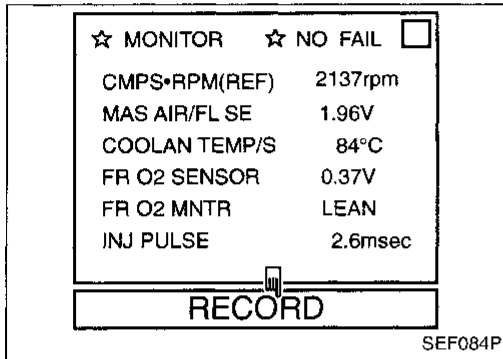

**OVERALL FUNCTION CHECK**

Use this procedure to check the overall function of the closed loop control. During this check, a DTC might not be confirmed.

- 1) Start engine and warm it up sufficiently.
  - 2) Select "MANU TRIG" and "HI SPEED" in "DATA MONITOR" mode with CONSULT, and select "FR O2 SENSOR" and "FR O2 MNTR".
  - 3) Hold engine speed at 2,000 rpm under no load during the following steps.
  - 4) Touch "RECORD" on CONSULT screen.
  - 5) Check the following.
    - "FR O2 MNTR" in "DATA MONITOR" mode changes from "RICH" to "LEAN" to "RICH" 5 times in 10 seconds.
- 5 times (cycles) are counted as shown below:

cycle | 1 | 2 | 3 | 4 | 5 |  
FR O2 MNTR R-L-R-L-R-L-R-L-R-L-R

R = "FR O2 MNTR", "RICH"  
L = "FR O2 MNTR", "LEAN"  
OR

- 1) Start engine and warm it up sufficiently.
- 2) Check that malfunction indicator lamp goes on more than 5 times in 10 seconds while keeping at 2,000 rpm in Diagnostic Test Mode II.

**DIAGNOSTIC PROCEDURE**

Refer to TROUBLE DIAGNOSIS FOR DTC P0130 (0303) for front heated oxygen sensor. (See page EC-117.)  
Refer to TROUBLE DIAGNOSIS FOR DTC P0135 (0901) for front heated oxygen sensor heater. (See next page.)

### Front Heated Oxygen Sensor Heater (DTC: 0901)

#### SYSTEM DESCRIPTION

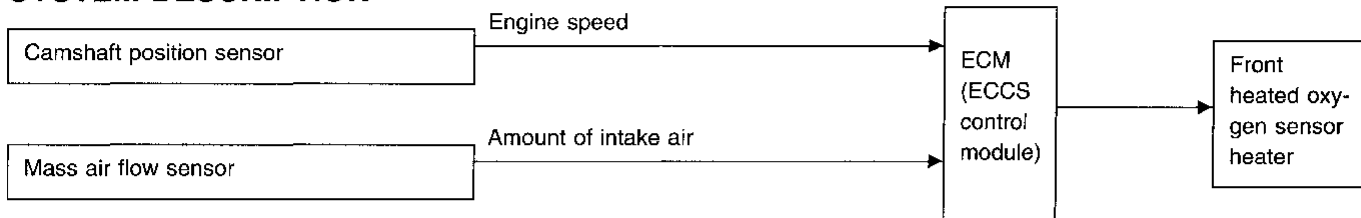

The ECM performs ON/OFF control of the front heated oxygen sensor heater corresponding to the engine conditions.

Engine speed rpm	Engine condition	Front heated oxygen sensor heater
Above 3,200	—	OFF
Below 3,200	Heavy load after warmed up	OFF
	Except above	ON

Diagnostic Trouble Code No.	Malfunction is detected when ....	Check items (Possible cause)
P0135 0901	<ul style="list-style-type: none"> <li>The current amperage in the front heated oxygen sensor heater circuit is out of the normal range. (An improper voltage drop signal is sent to ECM through the front heated oxygen sensor heater.)</li> </ul>	<ul style="list-style-type: none"> <li>Harness or connectors (The front heated oxygen sensor heater circuit is open or shorted.)</li> <li>Front heated oxygen sensor heater</li> </ul>

#### DIAGNOSTIC TROUBLE CODE DETECTING CONDITION

- 
 1) Turn ignition switch "ON" and select "DATA MONITOR" mode with CONSULT.  
 2) Start engine and run it for at least 35 seconds at idle speed.

OR

- 
 1) Start engine and run it for at least 35 seconds at idle speed.  
 2) Select "MODE 3" with GST.

OR

- 
 1) Start engine and run it for at least 35 seconds at idle speed.  
 2) Turn ignition switch "OFF", wait at least 5 seconds and then turn "ON".  
 3) Perform "Diagnostic Test Mode II" (Self-diagnostic results) with ECM.

Front Heated Oxygen Sensor Heater (DTC: 0901) (Cont'd)

EC-FRO2/H-01

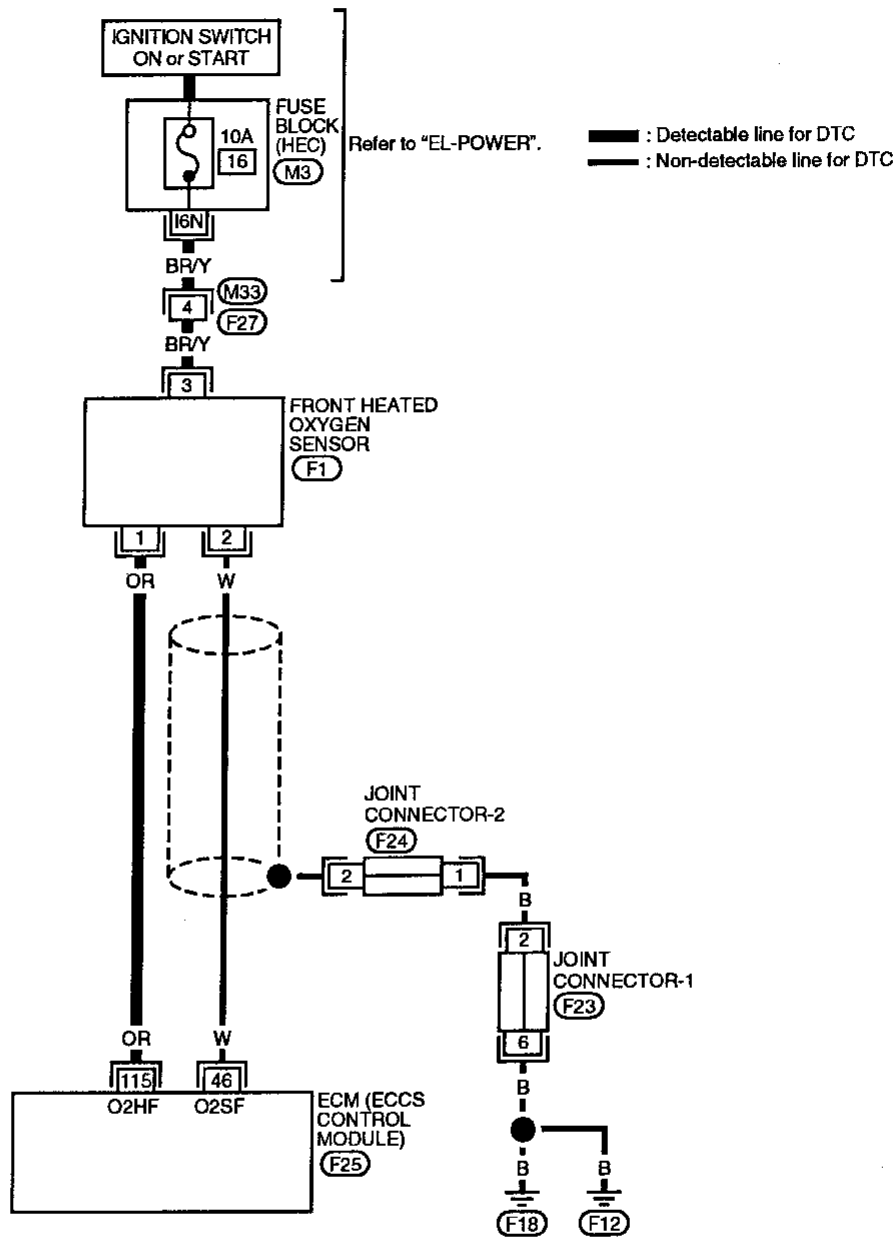

Refer to last page (Foldout page).

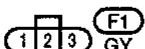

- (M3)
- (F23)
- (F24)

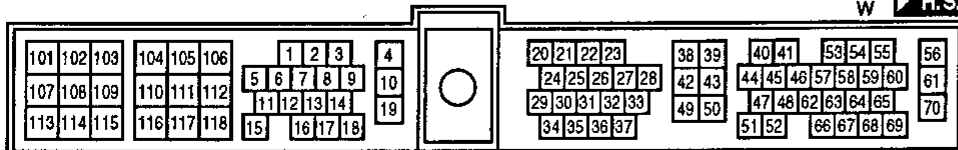

Front Heated Oxygen Sensor Heater (DTC: 0901) (Cont'd)

DIAGNOSTIC PROCEDURE

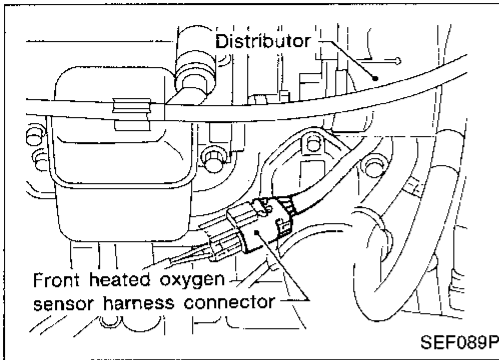

INSPECTION START

**A**

**CHECK POWER SUPPLY.**

1. Disconnect front heated oxygen sensor harness connector.
2. Turn ignition switch "ON".
3. Check voltage between terminal ③ and ground.

**Voltage: Battery voltage**

NG

Check the following.

- Harness connectors (F27, M33)
- 10A fuse
- Harness for open or short between front heated oxygen sensor and fuse

If NG, repair harness or connectors.

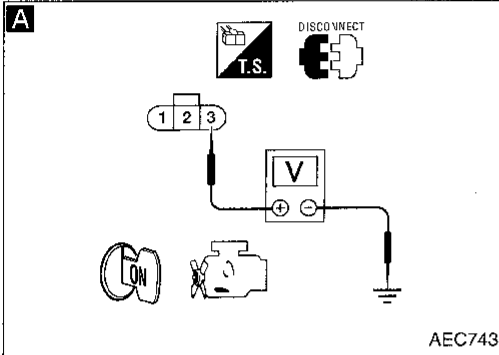

**B**

**CHECK GROUND CIRCUIT.**

1. Turn ignition switch "OFF".
2. Disconnect ECM harness connector.
3. Check harness continuity between terminal ① and ECM terminal ⑪⑤.

**Continuity should exist.**

If OK, check harness for short.

NG

Repair harness or connectors.

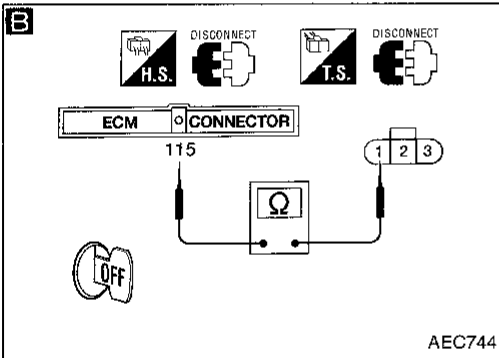

**CHECK COMPONENT**  
(Front heated oxygen sensor heater).  
Refer to "COMPONENT INSPECTION" below.

NG

Replace front heated oxygen sensor.

OK

Disconnect and reconnect harness connectors in the circuit, and retest.

Trouble is not fixed.

Check ECM pin terminals for damage and check the connection of ECM harness connector. Reconnect ECM harness connector and retest.

INSPECTION END

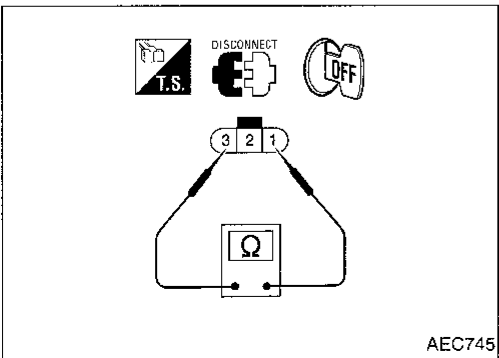

COMPONENT INSPECTION

Front heated oxygen sensor heater

Check resistance between terminals ① and ③.

**Resistance: 3.3 - 6.3Ω at 25°C (77°F)**

If NG, replace front heated oxygen sensor.

**CAUTION:**

Discard any heated oxygen sensor which has been dropped from a height of more than 0.5 m (19.7 in) onto a hard surface such as a concrete floor; use a new one.

CI  
MA  
EM  
LC  
EC  
FE  
CL  
WT  
AT  
FA  
RA  
BR  
ST  
RS  
BT  
HA  
EL  
IDX

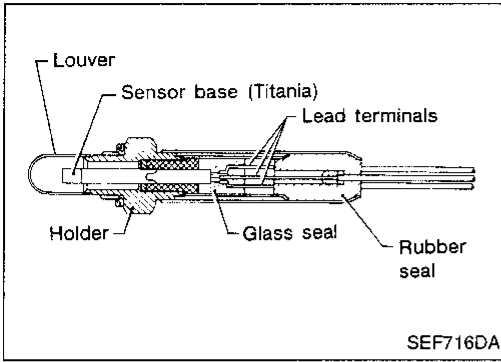

**Rear Heated Oxygen Sensor (Rear HO2S)  
(DTC: 0707)**

The rear heated oxygen sensor (Rear HO2S), after the three way catalyst, monitors the oxygen level in the exhaust gas. Even if the switching characteristics of the front heated oxygen sensor shift, the air-fuel ratio is controlled to stoichiometric by the signal from the rear heated oxygen sensor.

This sensor is made of ceramic titania. The electric resistance of ceramic titania drastically changes at the ideal air-fuel ratio. The output voltage of the sensor, depending on its resistance, is approximately 0 to 2.2V.

Under normal conditions, the rear heated oxygen sensor is not used for engine control operation.

It is used only for the on-board diagnosis of three way catalyst.

**ON-BOARD DIAGNOSIS LOGIC**

The rear heated oxygen sensor has a much longer switching time between rich and lean than the front heated oxygen sensor. The oxygen storage capacity before the three way catalyst causes the longer switching time. To judge the malfunctions of rear heated oxygen sensor, ECM monitors the sensor's voltage value and the switching response during the various driving condition such as fuel-cut.

Diagnostic Trouble Code No.	Malfunction is detected when ...	Check Items (Possible Cause)
P0136 0707	<ul style="list-style-type: none"> <li>● An excessively high voltage from the sensor is sent to ECM.</li> </ul> <hr style="border-top: 1px dotted black;"/> <ul style="list-style-type: none"> <li>● The specified maximum and minimum voltages from the sensor are not reached.</li> <li>● It takes more than the specified time for the sensor to respond between rich and lean.</li> </ul>	<ul style="list-style-type: none"> <li>● Harness or connectors (The sensor circuit is open.)</li> <li>● Rear heated oxygen sensor</li> </ul> <hr style="border-top: 1px dotted black;"/> <ul style="list-style-type: none"> <li>● Harness or connectors (The sensor circuit is shorted.)</li> <li>● Rear heated oxygen sensor</li> <li>● Fuel pressure</li> <li>● Injectors</li> <li>● Intake air leaks</li> </ul>

## Rear Heated Oxygen Sensor (Rear HO2S) (DTC: 0707) (Cont'd)

### OVERALL FUNCTION CHECK

Use this procedure to check the overall function of the rear heated oxygen sensor circuit. During this check, a DTC might not be confirmed.

- 1) Start engine and warm it up sufficiently.
- 2) Select "FUEL INJECTION" in "ACTIVE TEST" mode, and select "RR O2 SENSOR" as the monitor item with CONSULT.
- 3) Check "RR O2 SENSOR" at idle speed when adjusting "FUEL INJECTION" to  $\pm 25\%$ .  
 "RR O2 SENSOR" should be above 0.6V at least once when the "FUEL INJECTION" is +25%.  
 "RR O2 SENSOR" should be below 0.55V at least once when the "FUEL INJECTION" is -25%.

OR

- 1) Start engine and warm it up sufficiently.
- 2) Set voltmeter probes between ECM terminals ⑤② (sensor signal) and ④③ (engine ground).
- 3) Check the voltage when racing up to 4,000 rpm under no load at least 10 times.  
 (depress and release accelerator pedal as soon as possible)  
**The voltage should be above 0.6V and below 0.55V at least once during this procedure.**  
**If the voltage can be confirmed in step 3, step 4 is not necessary.**
- 4) Keep vehicle at idling for 10 minutes, then check the voltage. Or check the voltage when coasting from 80 km/h (50 MPH) in 3rd gear position.  
**The voltage should be above 0.6V and below 0.55V at least once during this procedure.**

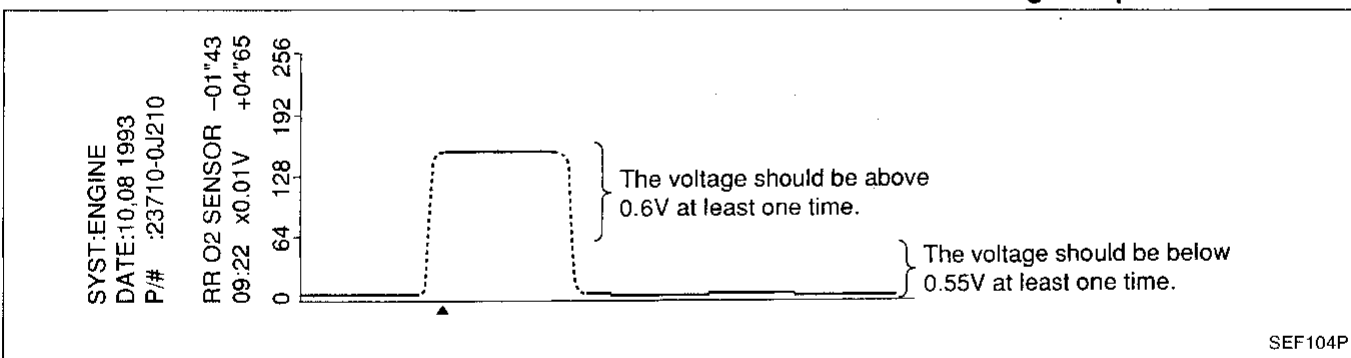
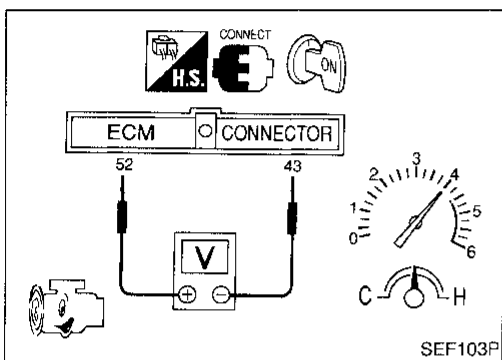
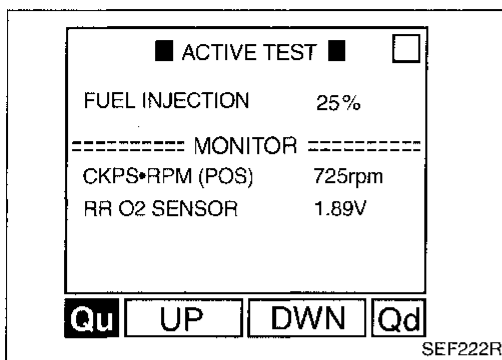

**Note:** After starting the engine, the output voltage of the rear heated oxygen sensor indicates higher voltage (approx. 5V at highest) than the normal operating range for about 7 seconds. This is due to checking for open circuits in rear heated oxygen sensor by on-board diagnosis. Therefore, if you measure the voltage (at ECM terminal ⑤②) during this diagnosis, the higher voltage will appear. (CONSULT will also show the higher voltage, GST may show approx. 0V.) This is not a malfunction even though it is out of the normal range.

Rear Heated Oxygen Sensor (Rear HO2S)  
(DTC: 0707) (Cont'd)

EC-RRO2-01

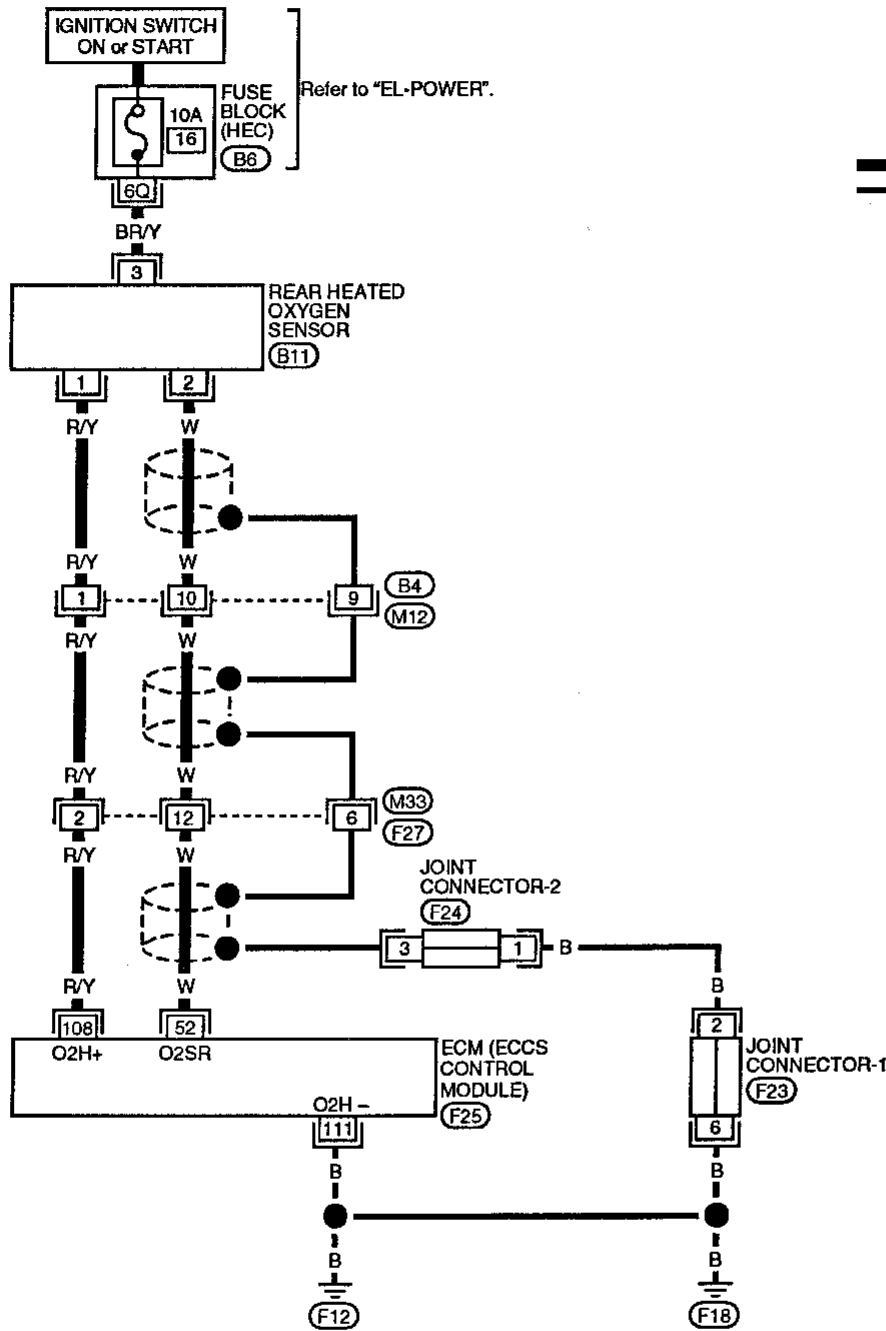

— : Detectable line for DTC  
— : Non-detectable line for DTC

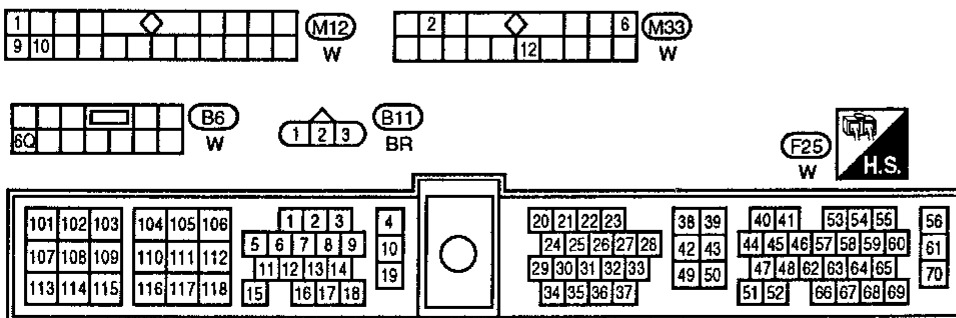

Refer to last page (Foldout page).

F23  
F24

Rear Heated Oxygen Sensor (Rear HO2S)  
(DTC: 0707) (Cont'd)

DIAGNOSTIC PROCEDURE

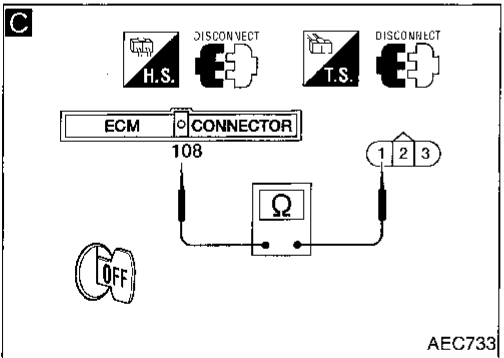
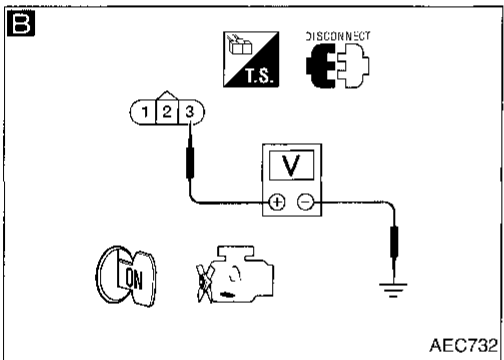
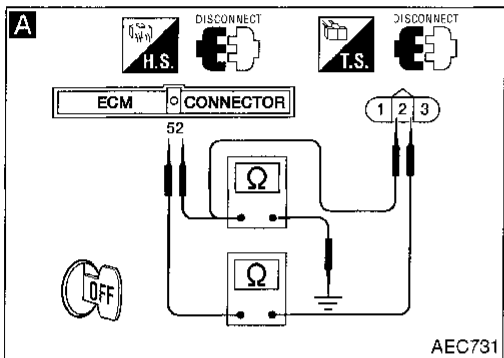
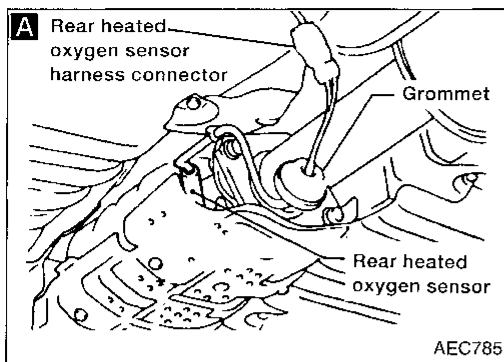

INSPECTION START

**A**  
**CHECK INPUT SIGNAL CIRCUIT.**  
1. Turn ignition switch "OFF".  
2. Remove grommet from underbody near three way catalyst to remove rear heated oxygen sensor harness connector.  
3. Disconnect rear heated oxygen sensor harness connector and ECM harness connector.  
4. Check harness continuity between ECM terminal (52) and terminal (2).  
**Continuity should exist.**  
5. Check harness continuity between ECM terminal (52) (or terminal (2)) and ground.  
**Continuity should not exist.**  
If OK, check harness for short.

NG → Repair harness or connectors.

OK → Loosen and retighten engine ground screws.

**B**  
**CHECK POWER SUPPLY.**  
1. Disconnect rear heated oxygen sensor harness connector.  
2. Turn ignition switch "ON".  
3. Check voltage between terminal (3) and ground.  
**Voltage: Battery voltage**

NG → Check the following.  
● 10A fuse  
● Harness for open or short between fuse and rear heated oxygen sensor  
If NG, repair harness or connectors.

**C**  
**CHECK GROUND CIRCUIT.**  
1. Turn ignition switch "OFF".  
2. Disconnect ECM harness connector.  
3. Check harness continuity between terminal (1) and ECM terminal (108).  
**Continuity should exist.**  
If OK, check harness for short.

NG → Check the following.  
● Harness connectors (B4), (M12)  
● Harness connectors (M33), (F27)  
● Harness for open or short between rear heated oxygen sensor and ECM  
If NG, repair harness or connectors.

OK → (Go to next page.)

CI  
MA  
EM  
LC  
EC  
FE  
CL  
MT  
AT  
FA  
RA  
BR  
ST  
RS  
BT  
HA  
EL  
IDX

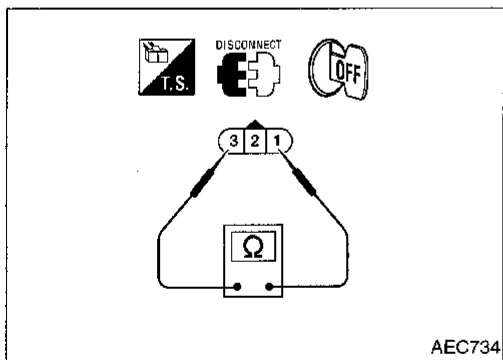
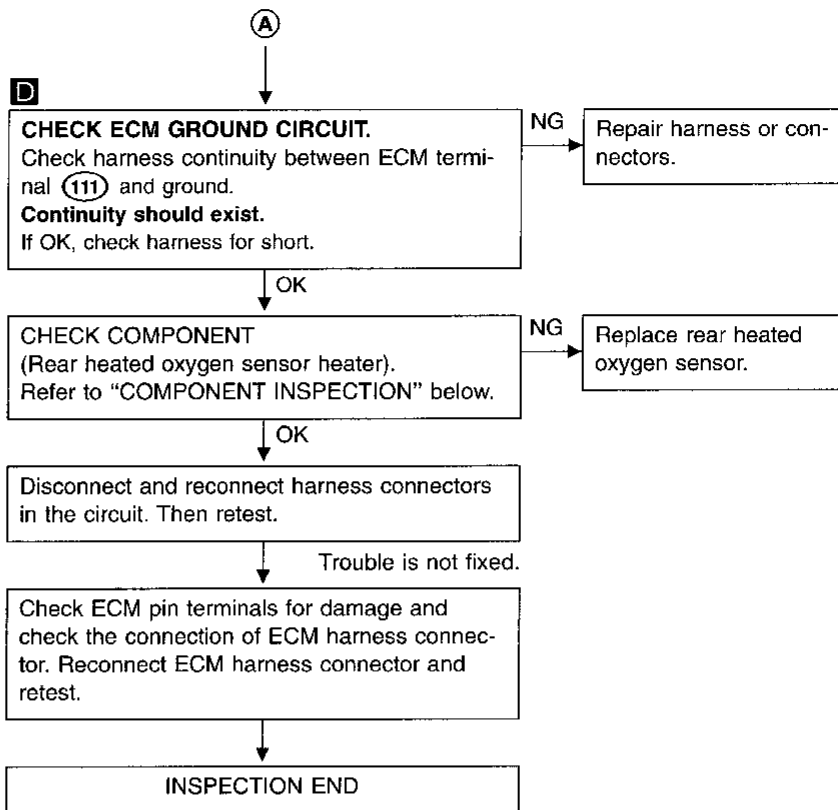
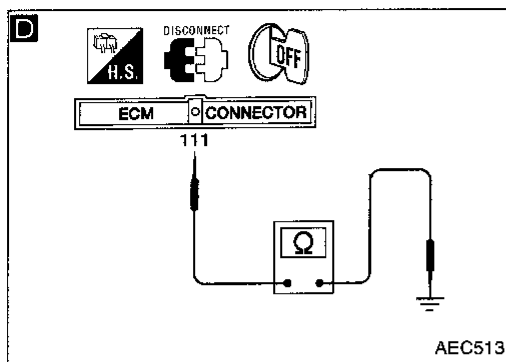

Rear Heated Oxygen Sensor (Rear HO2S)  
(DTC: 0707) (Cont'd)**COMPONENT INSPECTION****Rear heated oxygen sensor heater**

Check resistance between terminals ① and ③.

**Resistance: 5.2 - 8.2Ω [at 25°C (77°F)]**

If NG, replace the rear heated oxygen sensor.

**CAUTION:**

Discard any heated oxygen sensor which has been dropped from a height of more than 0.5 m (19.7 in) onto a hard surface such as a concrete floor; use a new one.

Fuel Injection System Function (DTC: 0706)

ON-BOARD DIAGNOSIS LOGIC

With Mixture Ratio Self-Learning Control, the actual mixture ratio can be brought closely to the theoretical mixture ratio based on the mixture ratio feedback signal from the front heated oxygen sensor. The ECM calculates the necessary compensation to correct the offset between the actual and the theoretical ratios.

In case the amount of the compensation value is extremely large, the ECM judges the condition as the fuel system malfunction and light up the MIL (two trip detection logic).

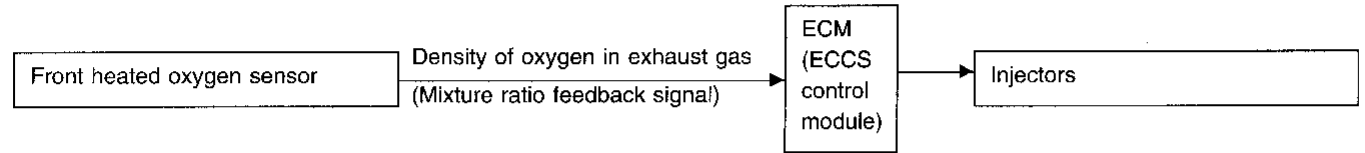

Diagnostic Trouble Code No.	Malfunction is detected when ...	Check Items (Possible Cause)
P0170 0706	<ul style="list-style-type: none"> <li>● Fuel injection system does not operate properly.</li> <li>● The amount of mixture ratio compensation is excessive. (The mixture ratio is too lean or too rich.)</li> </ul>	<ul style="list-style-type: none"> <li>● Intake air leak</li> <li>● Front heated oxygen sensor</li> <li>● Injectors</li> <li>● Exhaust gas leak</li> <li>● Incorrect fuel pressure</li> <li>● Lack of fuel</li> <li>● Mass air flow sensor</li> </ul>

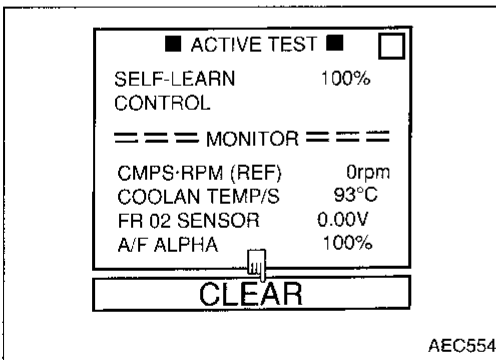

DIAGNOSTIC TROUBLE CODE CONFIRMATION PROCEDURE (Overall)

- 1) Start engine and warm it up sufficiently.
- 2) Turn ignition switch "OFF" and wait at least 3 seconds.
- 3) Turn ignition switch "ON" and select "SELF-LEARN CONTROL" in "ACTIVE TEST" mode with CONSULT.
- 4) Clear the self-learning control coefficient by touching "CLEAR".
- 5) Select "DATA MONITOR" mode with CONSULT.
- 6) Start engine again and run it for at least 10 minutes at idle speed.  
The DTC should be detected at this stage, if a malfunction exists.
- 7) If it is difficult to start engine at step 6, the fuel injection system has a malfunction, too.

OR

**Fuel Injection System Function (DTC: 0706)  
(Cont'd)**

- 1) Start engine and warm it up sufficiently.
- 2) Turn ignition switch "OFF" and wait at least 5 seconds.
- 3) Disconnect mass air flow sensor harness connector. Then restart and run engine for at least 3 seconds at idle speed.
- 4) Stop engine and reconnect mass air flow sensor harness connector.
- 5) Perform Diagnostic Test Mode II (Self-diagnostic results) with ECM. Make sure DTC 0102 is detected.
- 6) Erase the DTC 0102 by changing from Diagnostic Test Mode II to Diagnostic Test Mode I.
- 7) Perform Diagnostic Test Mode II (Self-diagnostic results) with ECM. Make sure DTC 0505 is detected.
- 8) Start engine again and run it for at least 10 minutes at idle speed.  
The DTC 0706 should be detected at this stage, if a malfunction exists.
- 9) If it is difficult to start engine at step 8, the fuel injection system has a malfunction.

Fuel Injection System Function (DTC: 0706)  
(Cont'd)

EC-FUEL-01

GI  
MA  
EM  
LC  
EC  
FE  
CL  
MT  
AT  
FA  
RA  
BR  
ST  
RS  
BT

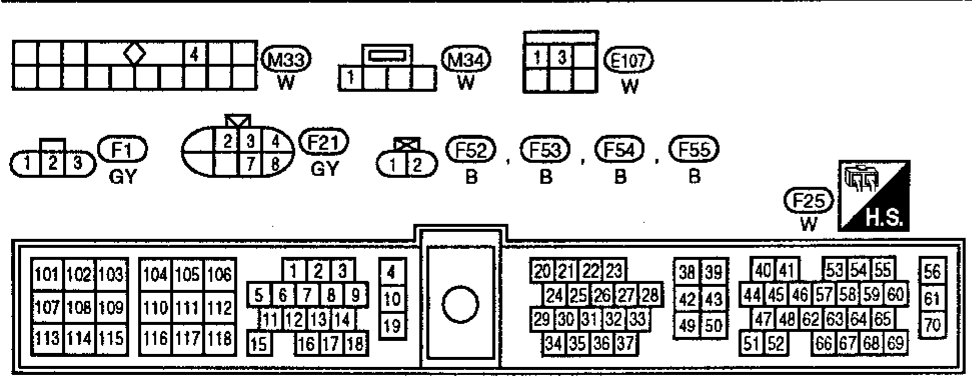
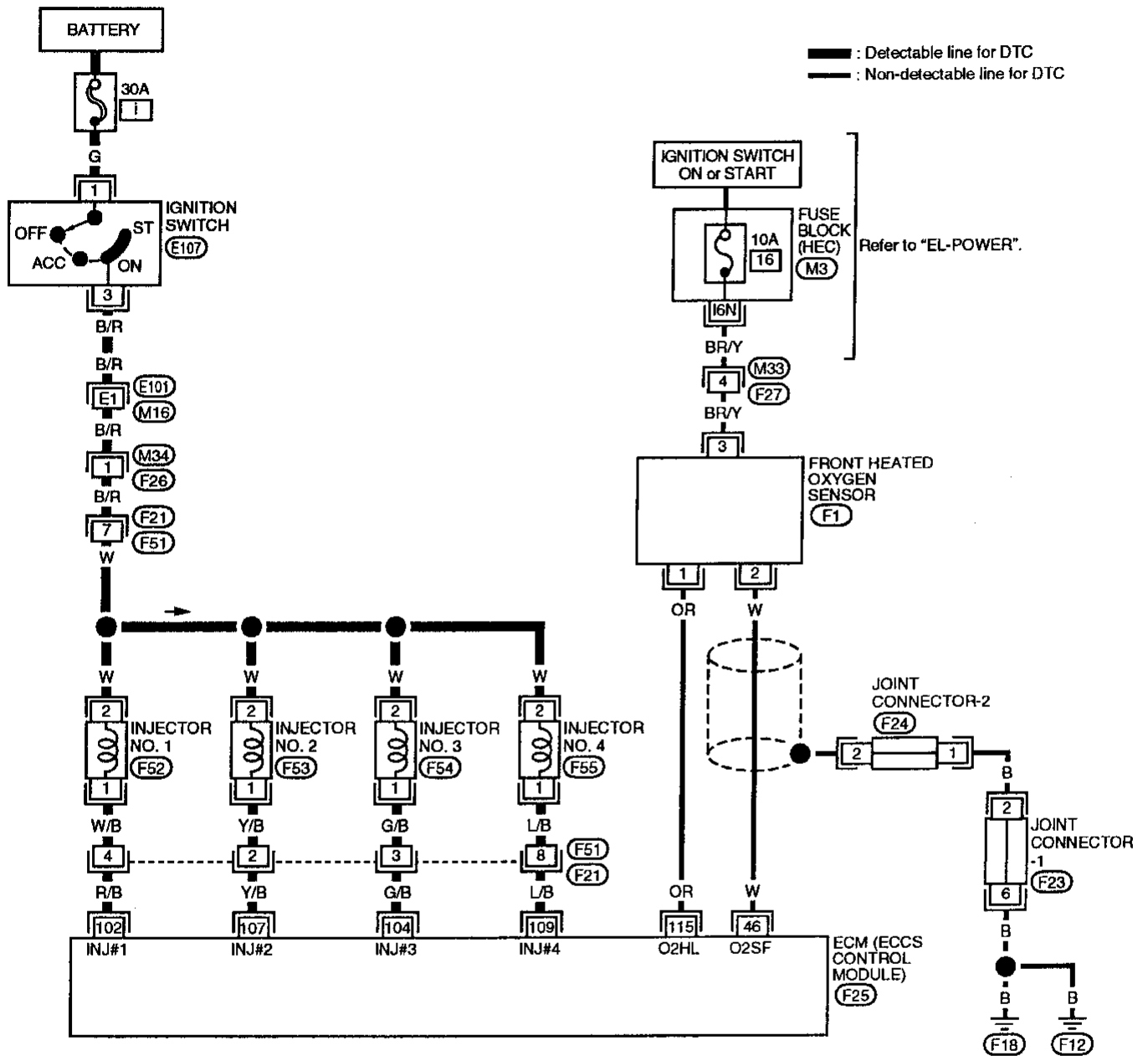

Refer to last page (Foldout page).  
 (M3)  
 (M16), (E101)  
 (F23)  
 (F24)

HA  
EL  
IDX

**Fuel Injection System Function (DTC: 0706)  
(Cont'd)**

**DIAGNOSTIC PROCEDURE**

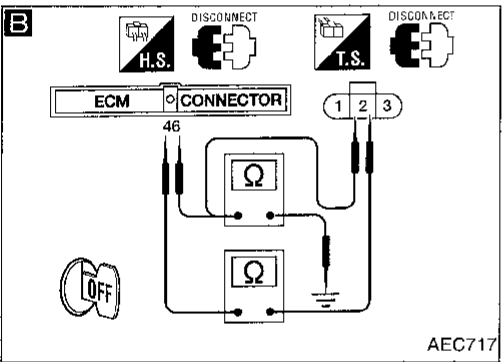
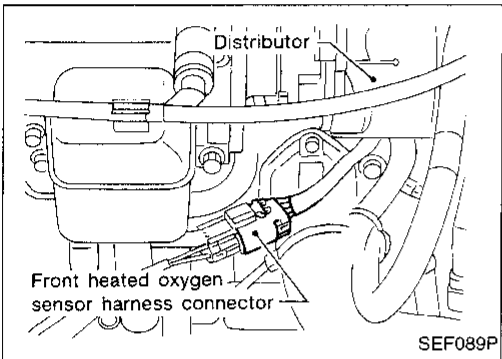
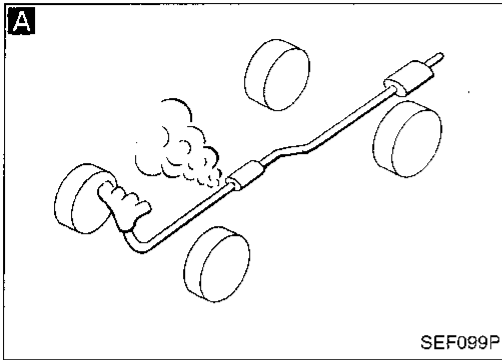

INSPECTION START

**A**  
**CHECK EXHAUST AIR LEAK.**  
Start engine and run it at idle. Listen for an exhaust air leak before the three way catalyst.

NG → Repair or replace.

OK  
**CHECK INTAKE AIR LEAK.**  
Start engine and run it at idle. Listen for an intake air leak after the mass air flow sensor.

NG → Repair or replace.

**B**  
**CHECK FRONT HEATED OXYGEN SENSOR.**  
1. Turn ignition switch "OFF".  
2. Disconnect front heated oxygen sensor harness connector and ECM harness connector.  
3. Check harness continuity between ECM terminal (46) and terminal (2).  
**Continuity should exist.**  
4. Check harness continuity between ECM terminal (46) (or terminal (2)) and ground.  
**Continuity should not exist.**  
If OK, check harness for short.

NG → Repair harness or connectors.

OK  
**CHECK FUEL PRESSURE.**  
1. Release fuel pressure to zero. Refer to EC-24.  
2. Install fuel pressure gauge and check fuel pressure.  
**At idle:**  
**Approx. 235 kPa**  
**(2.4 kg/cm<sup>2</sup>, 34 psi)**  
**A few seconds after ignition switch is turned OFF to ON:**  
**Approx. 294 kPa**  
**(3.0 kg/cm<sup>2</sup>, 43 psi)**

NG → Check fuel pump and circuit. Refer to EC-219.

OK  
**CHECK MASS AIR FLOW SENSOR.**  
Check "MASS AIR FLOW" in "DATA MONITOR" mode with CONSULT.  
**2.5 - 5.0 gm/sec: at idling**  
**7.1 - 12.5 gm/sec: at 2,500 rpm**  
OR  
Check "MASS AIR FLOW" in MODE 1 with GST.  
**2.5 - 5.0 gm/sec: at idling**  
**7.1 - 12.5 gm/sec: at 2,500 rpm**

NG → Check connectors for rusted terminals or loose connections in the mass air flow sensor circuit or engine grounds. Refer to EC-93.

OK  
Ⓐ  
(Go to next page.)

Fuel Injection System Function (DTC: 0706)  
(Cont'd)

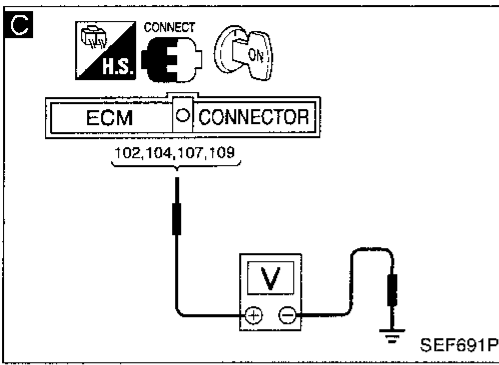

A

**C**

**CHECK INJECTORS.**

1. Turn ignition switch "ON".
2. Check voltage between ECM terminals (102), (104), (107), and (109) and ground with CONSULT or tester.

**Battery voltage should exist.**

3. Turn ignition switch "OFF".

OK

Remove injector assembly.  
Refer to EC-25.  
Keep fuel hose and all injectors connected to injector gallery.

Drips

1. Disconnect camshaft position sensor harness connector.
2. Turn ignition switch "ON". Make sure fuel does not drip from injector.

Does not drip.

Check ECM pin terminals for damage and check the connection of ECM harness connector. Reconnect ECM harness connector and retest.

INSPECTION END

NG

Perform TROUBLE DIAGNOSIS FOR NON-DETECTABLE ITEMS, "Injector", EC-214.  
Repair harness or connectors.

Drips

Replace the injector(s) from which fuel is dripping.

GI  
MA  
EM  
LC  
**EC**  
FE  
CL  
MT  
AT  
FA  
RA  
BR  
ST  
RS  
BT  
HA  
EL  
IDX

## No. 4 - 1 Cylinder Misfire, Multiple Cylinder Misfire (DTC: 0701 - 0605)

### ON-BOARD DIAGNOSIS LOGIC

If a misfire occurs, the engine speed will fluctuate. If the fluctuation is detected by the crankshaft position sensor (OBD), the misfire is diagnosed.

The misfire detection logic consists of the following two conditions.

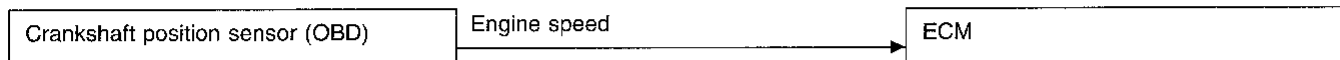

#### 1. One Trip Detection Logic (Three Way Catalyst Damage)

When a misfire is detected which will overheat and damage the three way catalyst, the malfunction indicator lamp (MIL) will start blinking; even during the first trip. In this condition, ECM monitors the misfire every 200 revolutions.

If the misfire frequency decreases to a level that will not damage the three way catalyst, the MIL will change from blinking to lighting up.

(After the first trip detection, the MIL will light up from engine starting. If a misfire is detected that will cause three way catalyst damage, the MIL will start blinking.)

#### 2. Two Trip Detection Logic (Exhaust quality deterioration)

When a misfire that will not damage the three way catalyst (but will affect exhaust emission) occurs, the malfunction indicator lamp will light up based on the second consecutive trip detection logic. In this condition, ECM monitors the misfire for each 1,000 revolutions of the engine.

Diagnostic Trouble Code No.	Malfunction is detected when ...	Check Items (Possible Cause)
P0304 (0605)	● Multiple cylinders misfire.	● Improper spark plug ● Insufficient compression
P0300 (0701)	● No. 1 cylinder misfires.	● Incorrect fuel pressure ● EGR valve
P0301 (0608)	● No. 2 cylinder misfires.	● Injector circuit is open or shorted ● Injectors
P0302 (0607)	● No. 3 cylinder misfires.	● Intake air leak ● Ignition secondary circuit is open or shorted
P0303 (0606)	● No. 4 cylinder misfires.	● Lack of fuel ● Magnetized flywheel (drive plate)

### DIAGNOSTIC TROUBLE CODE CONFIRMATION PROCEDURE (Overall)

-  1) Turn ignition switch "ON", and select "DATA MONITOR" mode with CONSULT.  
 2) Start engine and warm it up sufficiently.  
 3) Turn ignition switch "OFF" and wait at least 3 seconds.  
 4) Start engine again and drive at 1,500 - 4,000 rpm for at least 10 minutes.

OR

-  1) Start engine and warm it up sufficiently.  
 2) Turn ignition switch "OFF" and wait at least 3 seconds.  
 3) Start engine again and drive at 1,500 - 4,000 rpm for at least 10 minutes.  
 4) Select "MODE 3" with GST.

OR

-  1) Start engine and warm it up sufficiently.  
 2) Turn ignition switch "OFF" and wait at least 3 seconds.  
 3) Start engine again and drive at 1,500 - 4,000 rpm for at least 10 minutes.  
 4) Perform "Diagnostic Test Mode II (Self-diagnostic results)" with ECM.

No. 4 - 1 Cylinder Misfire, Multiple Cylinder Misfire (DTC: 0701 - 0605) (Cont'd)

DIAGNOSTIC PROCEDURE

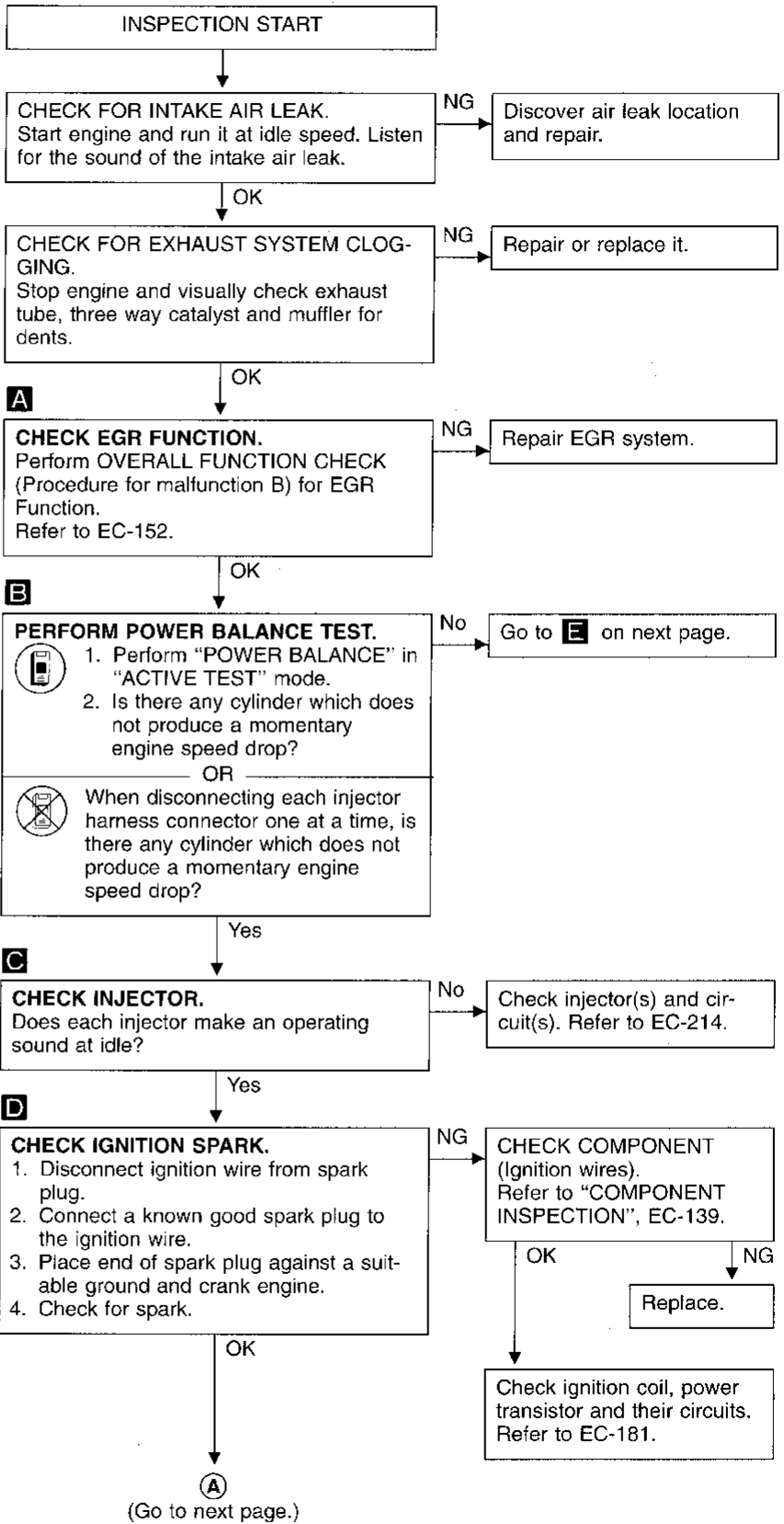
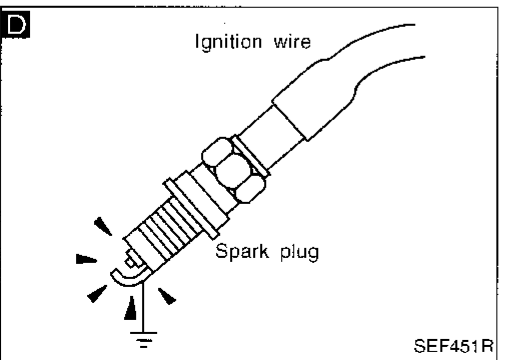
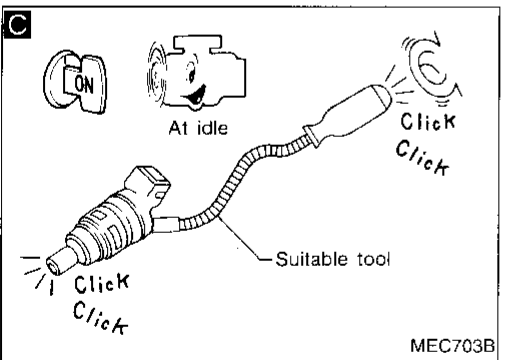
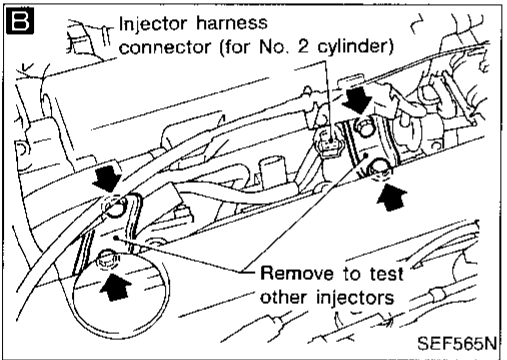
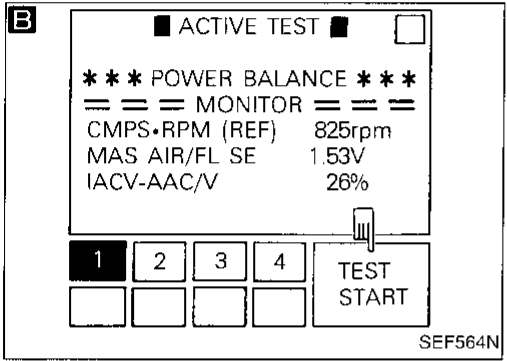
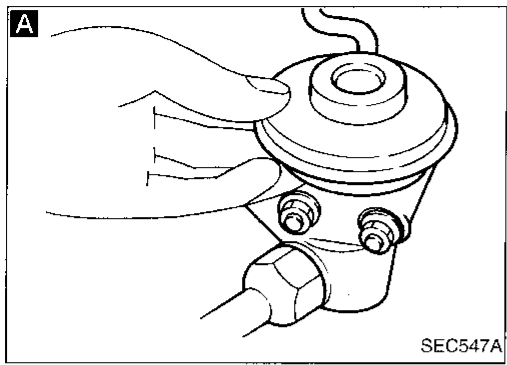

GI  
MA  
EM  
LC  
EC  
FE  
CL  
MT  
AT  
FA  
BA  
BR  
ST  
RS  
BT  
HA  
EL  
IDX



No. 4 - 1 Cylinder Misfire, Multiple Cylinder Misfire (DTC: 0701 - 0605) (Cont'd)

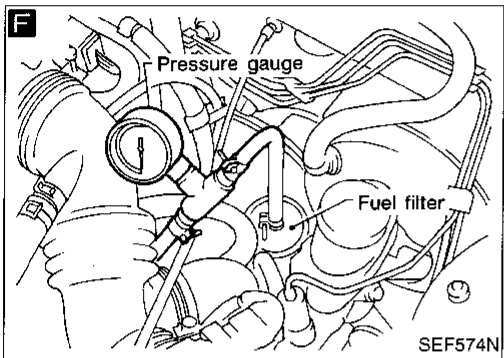
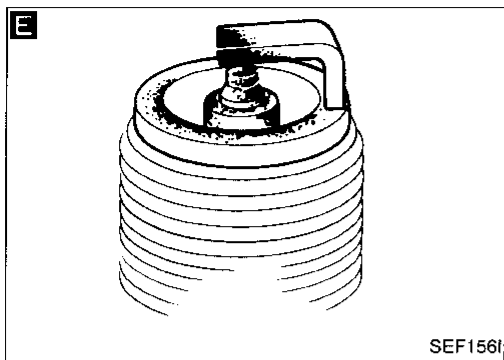

(A)

**E**  
**CHECK SPARK PLUGS.**  
 Remove the spark plugs and check for fouling, etc.

NG → Repair or replace spark plug(s).

OK

**F**  
**CHECK FUEL PRESSURE.**  
 1. Release fuel pressure to zero. Refer to EC-24.  
 2. Install fuel pressure gauge and check fuel pressure.  
**At idle:**  
**Approx. 235 kPa**  
**(2.4 kg/cm<sup>2</sup>, 34 psi)**

NG → Check fuel pump and circuit.

OK

**CHECK COMPRESSION PRESSURE.**  
 Refer to EM section.  
 ● Check compression pressure.  
**Standard:**  
**kPa (kg/cm<sup>2</sup>, psi)/300 rpm**  
**1,226 (12.5, 178)**  
**Minimum:**  
**kPa (kg/cm<sup>2</sup>, psi)/300 rpm**  
**1,030 (10.5, 149)**  
**Difference between each cylinder:**  
**kPa (kg/cm<sup>2</sup>, psi)/300 rpm**  
**98 (1.0, 14)**



NG → Check pistons, piston rings, valves, valve seats and cylinder head gaskets.

OK

**CHECK IGNITION TIMING.**  
 Perform "Basic Inspection", EC-62.

NG → Adjust ignition timing.

OK

**CHECK MASS AIR FLOW SENSOR.**  
 Check "MASS AIR FLOW" in "DATA MONITOR" mode with CONSULT.  
**2.5 - 5.0 gm/sec: at idling**  
**7.1 - 12.5 gm/sec: at 2,500 rpm**  
 OR  
 Check "MASS AIR FLOW" in MODE 1 with GST.  
**2.5 - 5.0 gm/sec: at idling**  
**7.1 - 12.5 gm/sec: at 2,500 rpm**

NG → Check connectors for rusted terminals or loose connections in the mass air flow sensor circuit or engine grounds. Refer to EC-93. If NG, repair or replace it.

OK

(B)

(Go to next page.)

## No. 4 - 1 Cylinder Misfire, Multiple Cylinder Misfire (DTC: 0701 - 0605) (Cont'd)

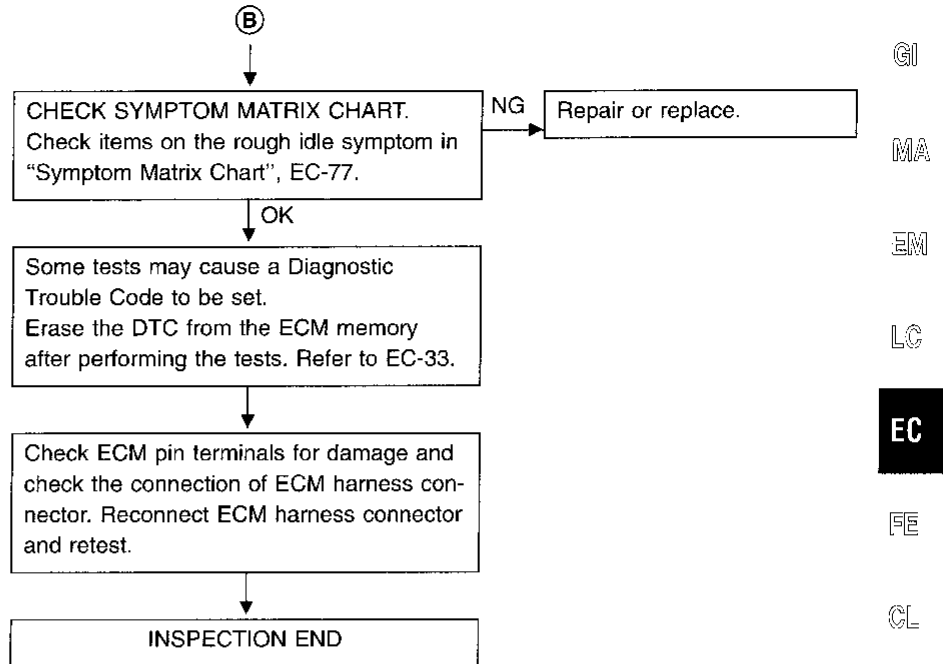

GI

MA

EM

LC

EC

FE

CL

MT

AT

FA

RA

BR

ST

RS

BT

HA

EL

IDX

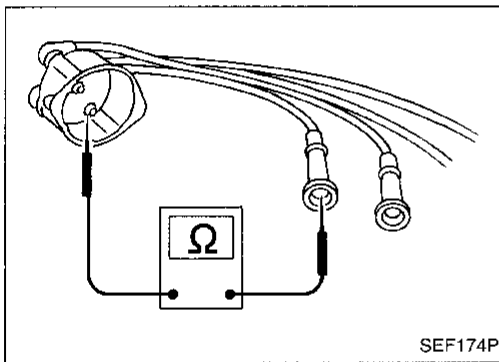

### COMPONENT INSPECTION

#### Ignition wires

1. Inspect wires for cracks, damage, burned terminals and for improper fit.
2. Measure the resistance of wires to their distributor cap terminal. Move each wire while testing to check for intermittent breaks.

#### Resistance:

**13.6 - 18.4 kΩ/m (4.15 - 5.61 kΩ/ft)**  
**[at 25°C (77°F)]**

If the resistance exceeds the above specification, inspect ignition wire to distributor cap connection. Clean connection or replace the ignition wire with a new one.

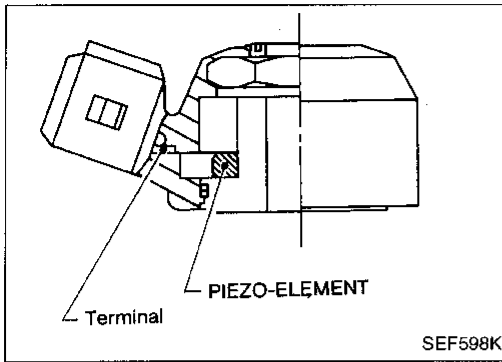

**Knock Sensor (KS) (DTC: 0304)**

The knock sensor is attached to the cylinder block. It senses engine knocking using a piezoelectric element. A knocking vibration from the cylinder block is sensed as vibrational pressure. This pressure is converted into a voltage signal and sent to the ECM.

\* Freeze frame data will not be stored in the ECM for the knock sensor. The MIL will not light for knock sensor malfunction.

Diagnostic Trouble Code No.	Malfunction is detected when ....	Check Items (Possible Cause)
P0325 0304	<ul style="list-style-type: none"> <li>An excessively low or high voltage from the knock sensor is sent to ECM.</li> </ul>	<ul style="list-style-type: none"> <li>Harness or connectors (The knock sensor circuit is open or shorted.)</li> <li>Knock sensor</li> </ul>

**DIAGNOSTIC TROUBLE CODE CONFIRMATION PROCEDURE**



- 1) Turn ignition switch "ON" and select "DATA MONITOR" mode with CONSULT.
- 2) Start engine and run it for at least 5 seconds at idle speed.

OR



- 1) Start engine and run it for at least 5 seconds at idle speed.
- 2) Select "MODE 3" with GST.

OR



- 1) Start engine and run it for at least 5 seconds at idle speed.
- 2) Turn ignition switch "OFF", wait at least 5 seconds and then turn "ON".
- 3) Perform "Diagnostic Test Mode II" (Self-diagnostic results) with ECM.

Knock Sensor (KS) (DTC: 0304) (Cont'd)

EC-KS-01 GI

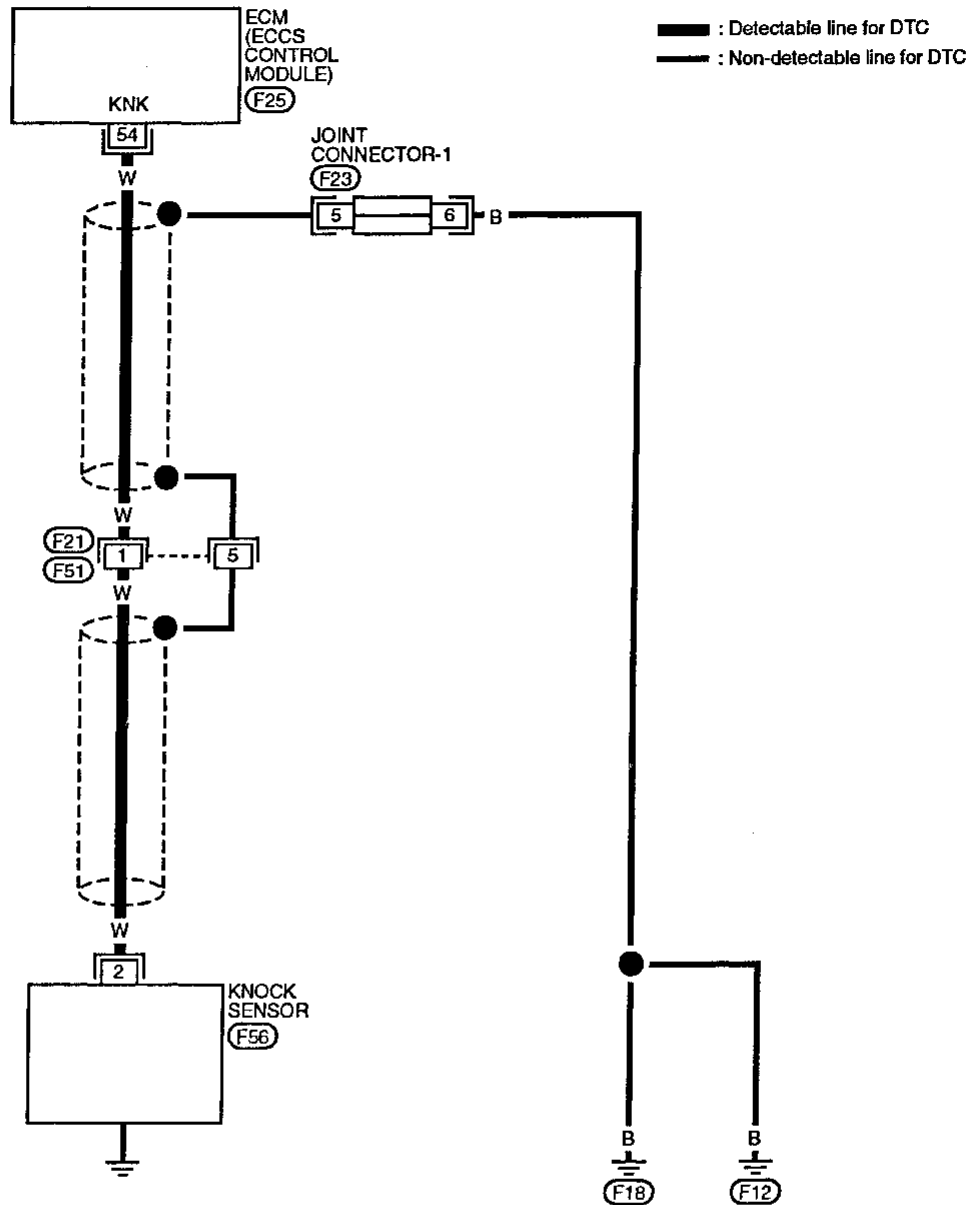

MA  
EM  
LC  
**EC**  
FE  
CL  
MT  
AT  
FA  
RA  
BR  
ST  
RS  
BT

Refer to last page (Foldout page).

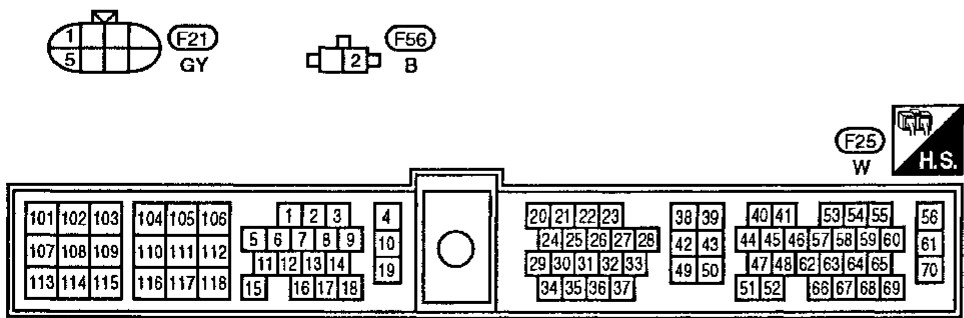

F23

## Knock Sensor (KS) (DTC: 0304) (Cont'd)

### DIAGNOSTIC PROCEDURE

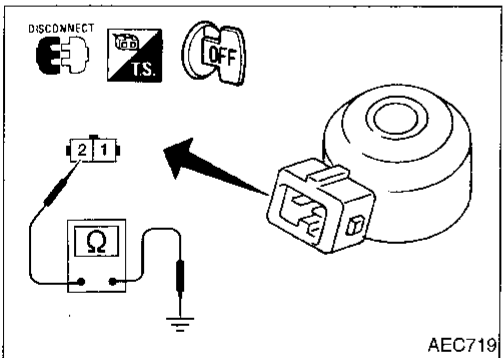
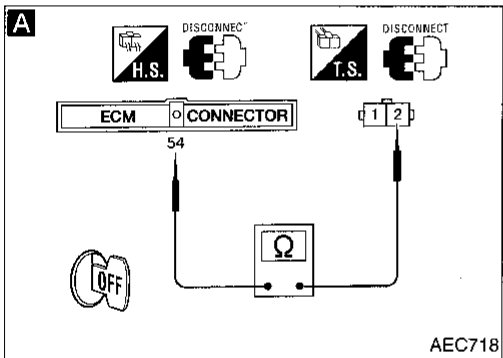
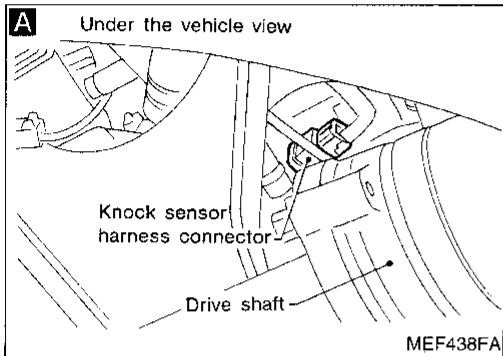
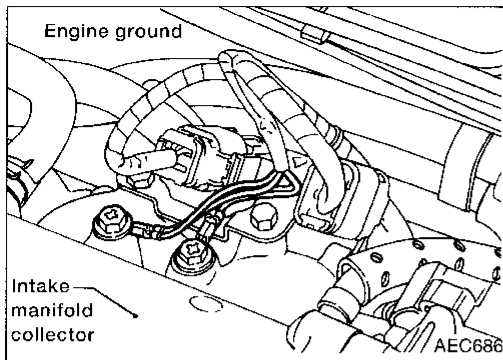

INSPECTION START

Loosen and retighten engine ground screws.

**A**

**CHECK INPUT SIGNAL CIRCUIT.**

1. Turn ignition switch "OFF".
2. Disconnect ECM harness connector and knock sensor harness connector.
3. Check harness continuity between terminal ② and ECM terminal ⑤4 .

**Continuity should exist.**  
If OK, check harness for short.

NG → Check the following.

- Harness connectors, (F21), (F51)

If NG, repair harness or connectors.

OK

**CHECK COMPONENT**  
(Knock sensor).  
Refer to "COMPONENT INSPECTION" below.

NG → Replace knock sensor.

OK

Disconnect and reconnect harness connectors in the circuit. Then retest.

Trouble is not fixed.

Check ECM pin terminals for damage and check the connection of ECM harness connector. Reconnect ECM harness connector and retest.

INSPECTION END

### COMPONENT INSPECTION

#### Knock sensor

- Use an ohmmeter which can measure more than 10 MΩ.

1. Disconnect knock sensor harness connector.
2. Check resistance between terminal ② and ground.

**Resistance: 500 - 620 kΩ [at 25°C (77°F)]**

#### CAUTION:

Discard any knock sensor which has been dropped or undergone shocks; use a new one.

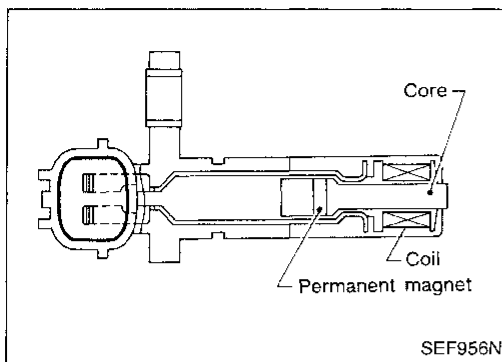

SEF956N

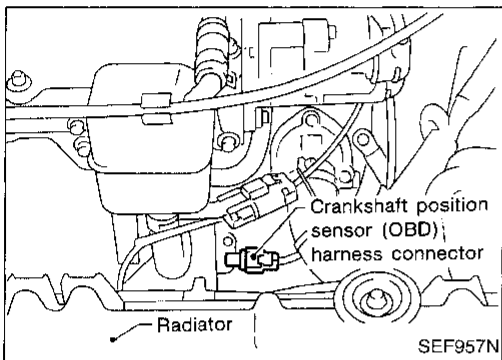

SEF957N

### Crankshaft Position Sensor (CKPS) (OBD) (DTC: 0802)

The crankshaft position sensor (OBD) is located on the transaxle housing facing the gear teeth (cogs) of the flywheel or drive plate. It detects the fluctuation of the engine revolution. The sensor consists of a permanent magnet, core and coil. When the engine is running, the high and low parts of the teeth cause the gap with the sensor to change. The changing gap causes the magnetic field near the sensor to change.

Due to the changing magnetic field, the voltage from the sensor changes.

The ECM receives the voltage signal and detects the fluctuation of the engine revolution.

This sensor is not directly used to control the engine system. It is used only for the on-board diagnosis of misfire.

Diagnostic Trouble Code No.	Malfunction is detected when ....	Check Items (Possible Cause)
P0335 0802	<ul style="list-style-type: none"> <li>The proper pulse signal from the crankshaft position sensor (OBD) is not sent to ECM while the engine is running at the specified engine speed.</li> </ul>	<ul style="list-style-type: none"> <li>Harness or connectors (The crankshaft position sensor (OBD) circuit is open.)</li> <li>Crankshaft position sensor (OBD)</li> </ul>

### DIAGNOSTIC TROUBLE CODE CONFIRMATION PROCEDURE

- 1) Turn ignition switch "ON" and select "DATA MONITOR" mode with CONSULT.  
 2) Start engine and run it for at least 15 seconds at idle speed.

OR

- 1) Start engine and run it for at least 15 seconds at idle speed.  
 2) Select "MODE 3" with GST.

OR

- 1) Start engine and run it for at least 15 seconds at idle speed.  
 2) Turn ignition switch "OFF", wait at least 5 seconds and then turn "ON".  
 3) Perform "Diagnostic Test Mode II" (Self-diagnostic results) with ECM.

Crankshaft Position Sensor (CKPS) (OBD)  
(DTC: 0802) (Cont'd)

EC-CKPS-01

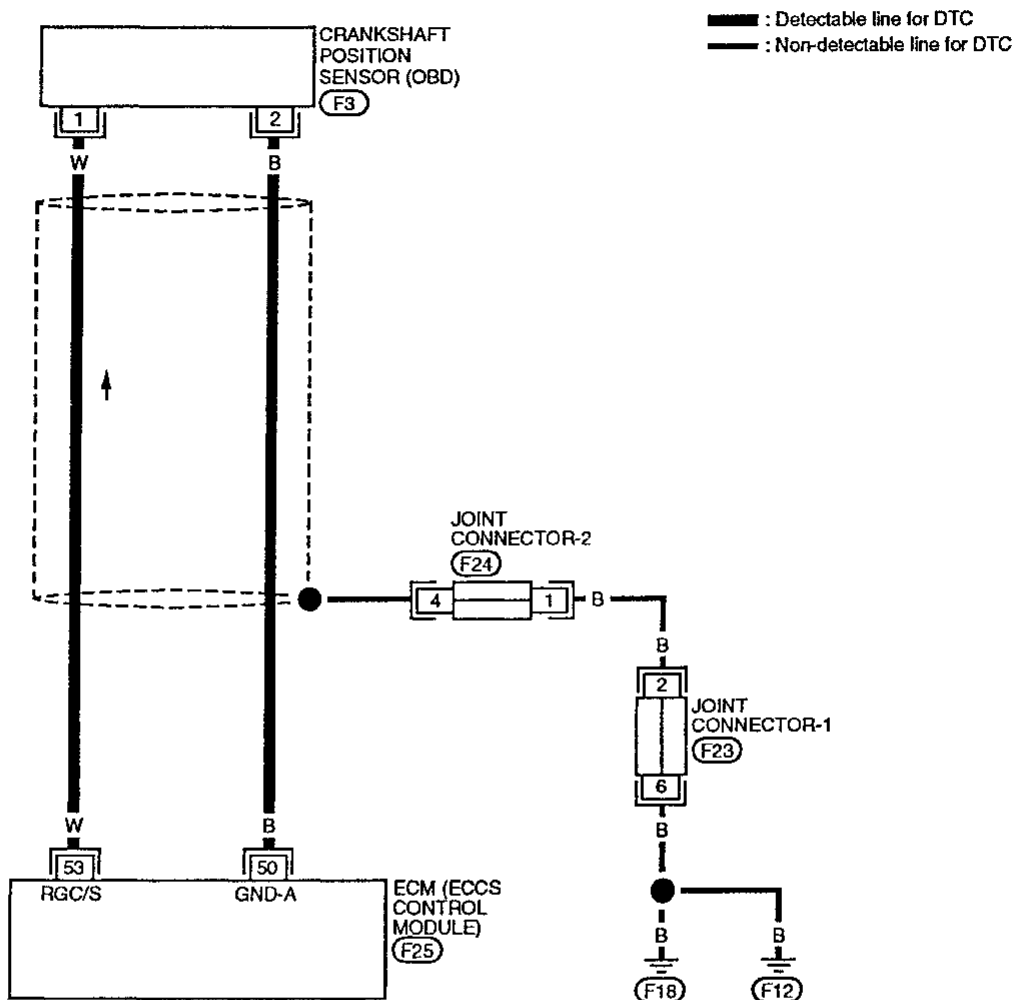

Refer to last page (Foldout page).

(F23)  
(F24)

(1) (2)  
GY

(F25)  
W H.S.

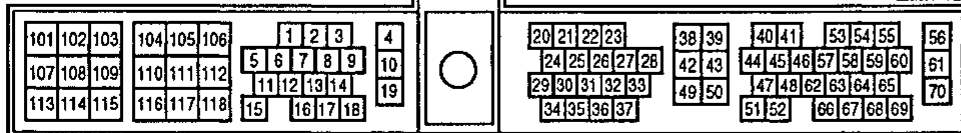

**Crankshaft Position Sensor (CKPS) (OBD)  
(DTC: 0802) (Cont'd)  
DIAGNOSTIC PROCEDURE**

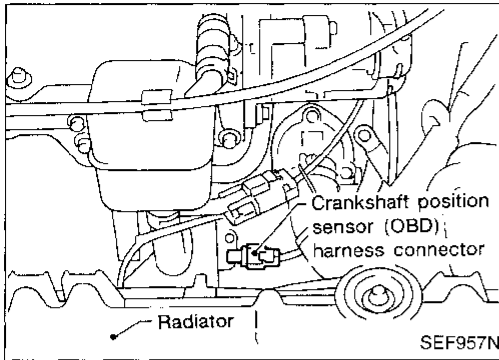

INSPECTION START

**A**  
**CHECK INPUT SIGNAL CIRCUIT.**  
1. Turn ignition switch "OFF".  
2. Disconnect crankshaft position sensor (OBD) and ECM harness connectors.  
3. Check continuity between ECM terminal ⑤ and terminal ①.  
**Continuity should exist.**  
If OK, check harness for short.

NG → Repair harness or connectors.

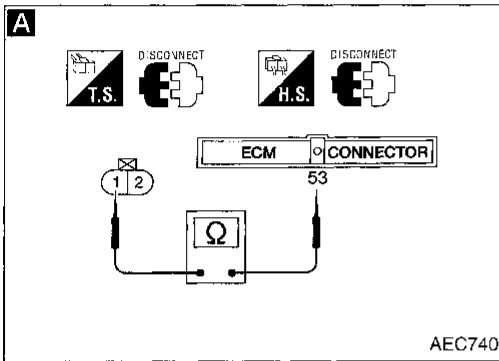

**B**  
**CHECK GROUND CIRCUIT.**  
1. Turn ignition switch "OFF".  
2. Check harness continuity between terminal ② and engine ground.  
**Continuity should exist.**  
If OK, check harness for short.

NG → Check the following.  
● Harness for open or short between ECM and crankshaft position sensor (OBD) harness connector  
If NG, repair harness or connectors.

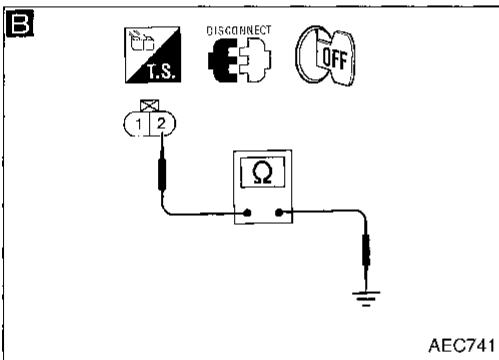

**CHECK COMPONENT**  
[Crankshaft position sensor (OBD)].  
Refer to "COMPONENT INSPECTION" on next page.

NG → Replace crankshaft position sensor (OBD).

Disconnect and reconnect harness connectors in the circuit. Then retest.

Trouble is not fixed.  
Check ECM pin terminals for damage and check the connection of ECM harness connector. Reconnect ECM harness connector and retest.

INSPECTION END

CI  
MA  
EM  
LC  
EC  
FE  
CL  
MT  
AT  
FA  
RA  
BR  
ST  
RS  
BT  
HA  
EL  
IDX



**Crankshaft Position Sensor (CKPS) (OBD)  
(DTC: 0802) (Cont'd)****COMPONENT INSPECTION****Crankshaft position sensor (OBD)**

1. Disconnect crankshaft position sensor (OBD) harness connector.
2. Loosen the fixing bolt of the sensor.
3. Remove the sensor.
4. Visually check the sensor for chipping.
5. Check resistance as shown in the figure.  
**Resistance: Approximately 166 - 204 $\Omega$**   
**[at 25°C (77°F)]**

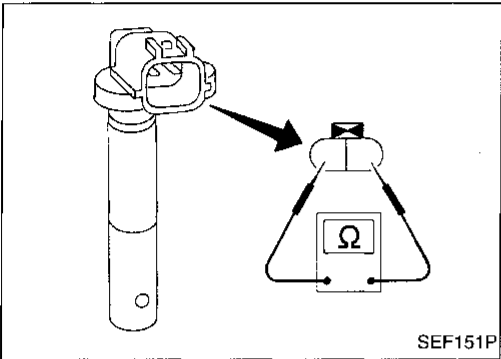
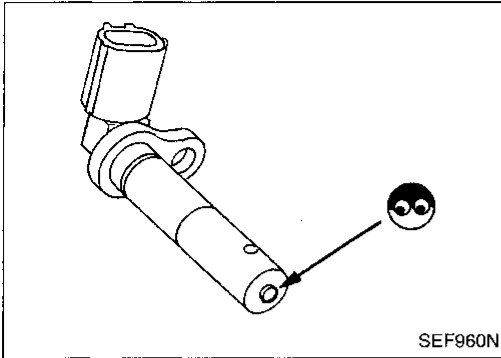

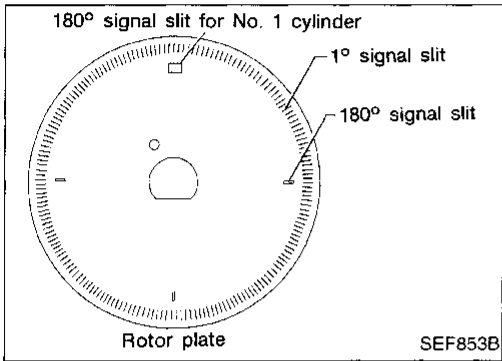
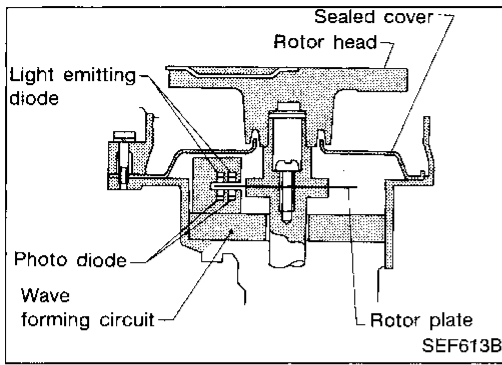

### Camshaft Position Sensor (CMPS)(DTC: 0101)

The camshaft position sensor is a basic component of the ECCS. It monitors engine speed and piston position. These input signals to the ECM are used to control fuel injection, ignition timing and other functions.

The camshaft position sensor has a rotor plate and a wave-forming circuit. The rotor plate has 360 slits for a 1° (POS) signal and 4 slits for a 180° (REF) signal. The wave-forming circuit consists of Light Emitting Diodes (LED) and photo diodes. The rotor plate is positioned between the LED and the photo diode. The LED transmits light to the photo diode. As the rotor plate turns, the slits cut the light to generate rough-shaped pulses. These pulses are converted into on-off signals by the wave-forming circuit and sent to the ECM.

GI

MA

EM

LC

EC

FE

CL

MT

Diagnostic Trouble Code No.	Malfunction is detected when ....	Check Items (Possible Cause)
P0340 0101	<ul style="list-style-type: none"> <li>Either 1° or 180° signal is not sent to ECM for the first few seconds during engine cranking.</li> <li>Either 1° or 180° signal is not sent to ECM often enough while the engine speed is higher than the specified engine speed.</li> <li>The relation between 1° and 180° signal is not in the normal range during the specified engine speed.</li> </ul>	<ul style="list-style-type: none"> <li>Harness or connectors (The camshaft position sensor circuit is open or shorted.)</li> <li>Camshaft position sensor</li> <li>Starter motor (Refer to EL section.)</li> <li>Starting system circuit (Refer to EL section.)</li> <li>Dead (Weak) battery</li> </ul>

AT

FA

RA

BR

### DIAGNOSTIC TROUBLE CODE CONFIRMATION PROCEDURE

Before performing the following procedure, confirm that battery voltage is more than 10.5 V.

- 1) Turn ignition switch "ON" and select "DATA MONITOR" mode with CONSULT.
- 2) Crank engine for at least 2 seconds.

OR

- 1) Crank engine for at least 2 seconds.
- 2) Select "MODE 3" with GST.

OR

- 1) Crank engine for at least 2 seconds.
- 2) Turn ignition switch "OFF", wait at least 5 seconds and then turn "ON".
- 3) Perform "Diagnostic Test Mode II" (Self-diagnostic results) with ECM.

ST

RS

BT

HA

EL

IDX

Camshaft Position Sensor (CMPS)(DTC: 0101)  
(Cont'd)

EC-CMPS-01

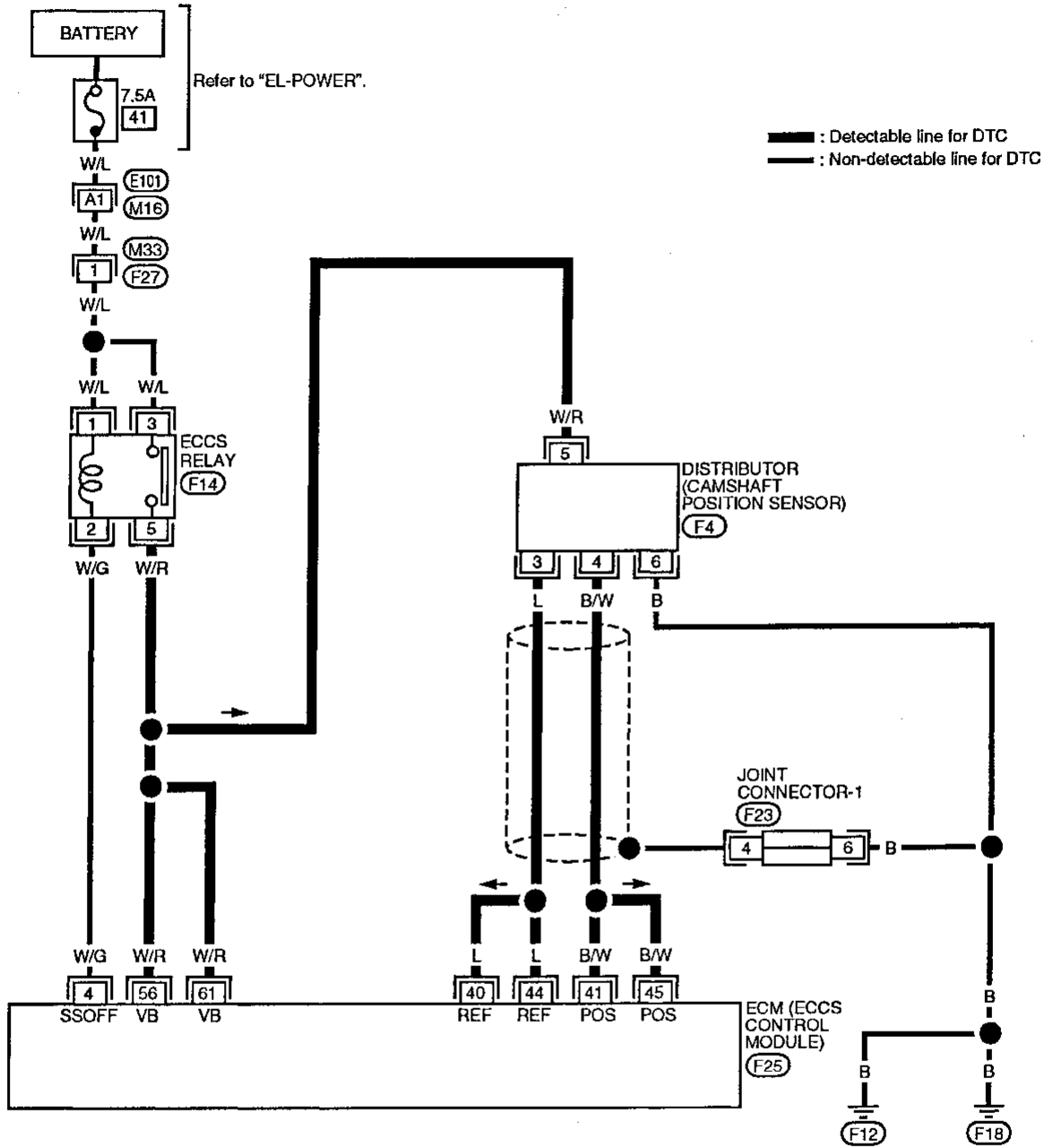

Refer to last page (Foldout page).

(M16), (E101)  
(F23)

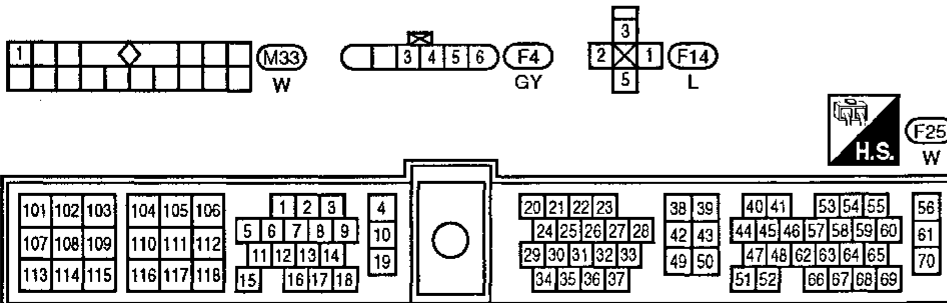

Camshaft Position Sensor (CMPS)(DTC: 0101)  
(Cont'd)

DIAGNOSTIC PROCEDURE (DETECTABLE CIRCUIT)

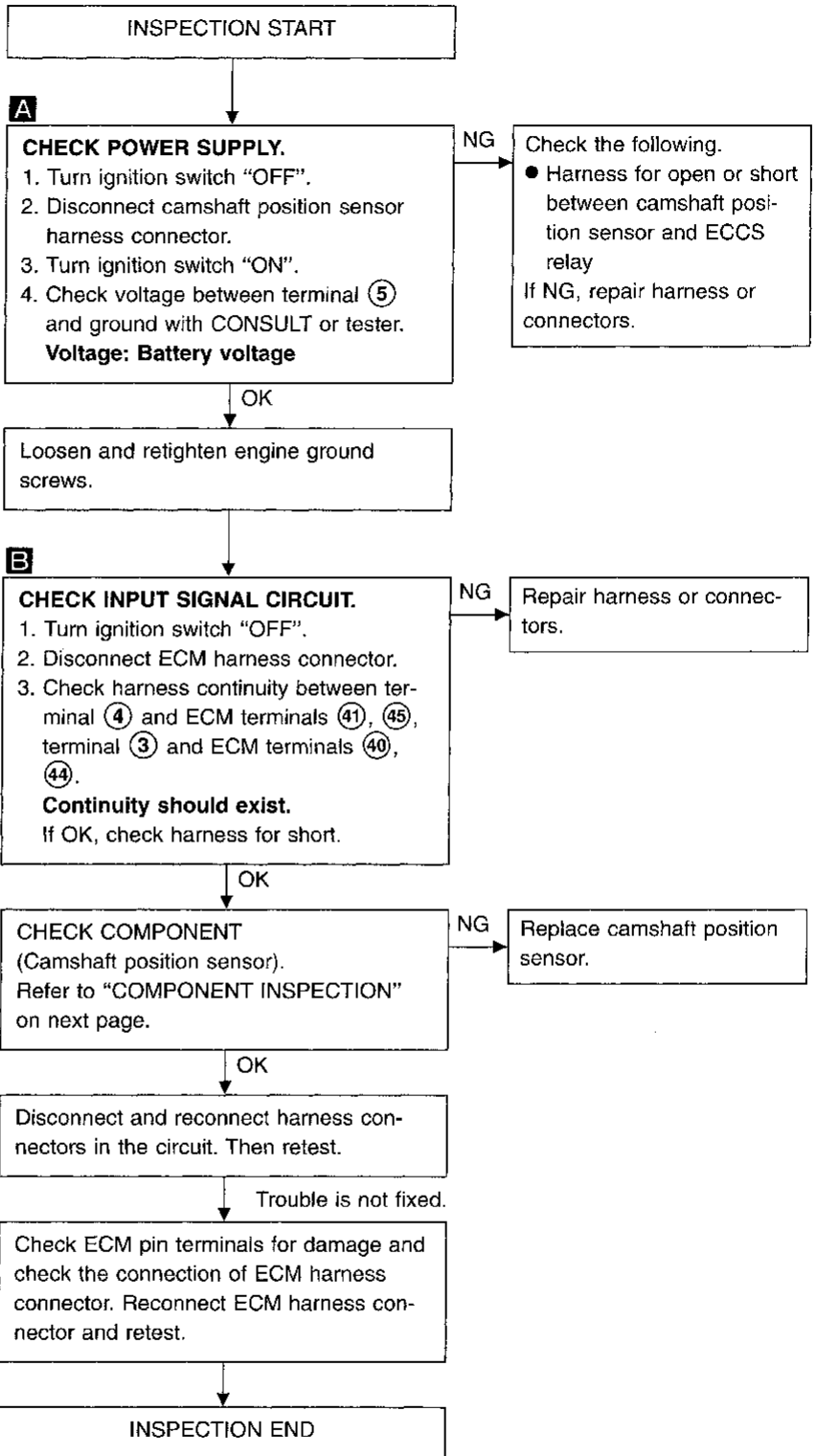
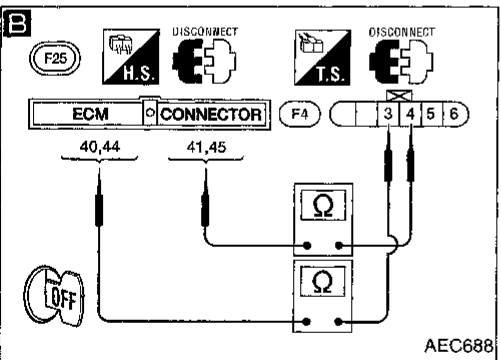
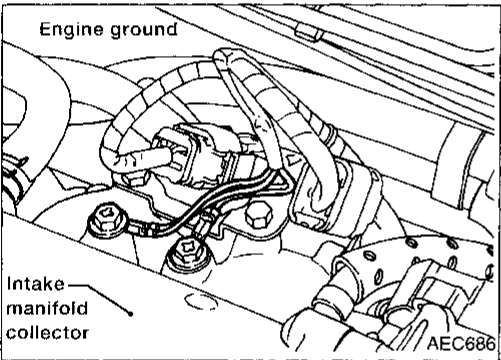
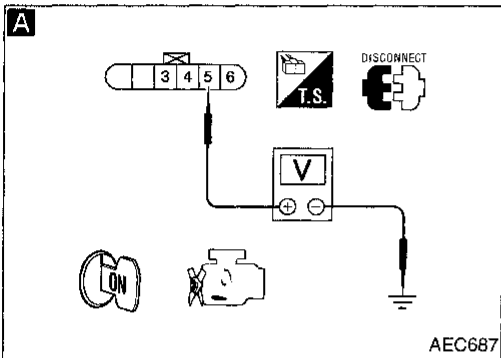
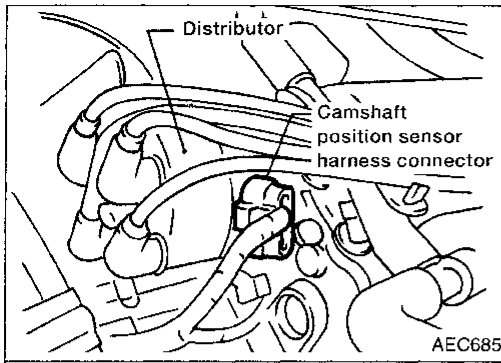

GI  
MA  
EM  
LC  
EC  
FE  
CL  
MT  
AT  
FA  
RA  
BR  
ST  
RS  
BT  
HA  
EL  
IDX

**Camshaft Position Sensor (CMPS)(DTC: 0101)  
(Cont'd)**

**DIAGNOSTIC PROCEDURE (NON-DETECTABLE  
CIRCUIT)**

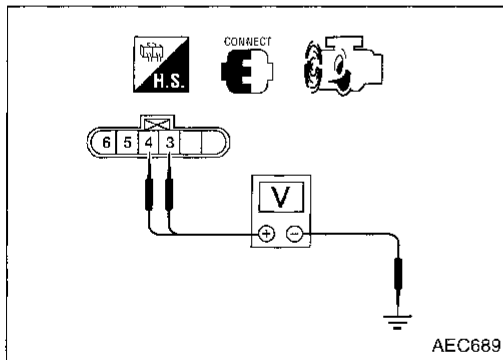
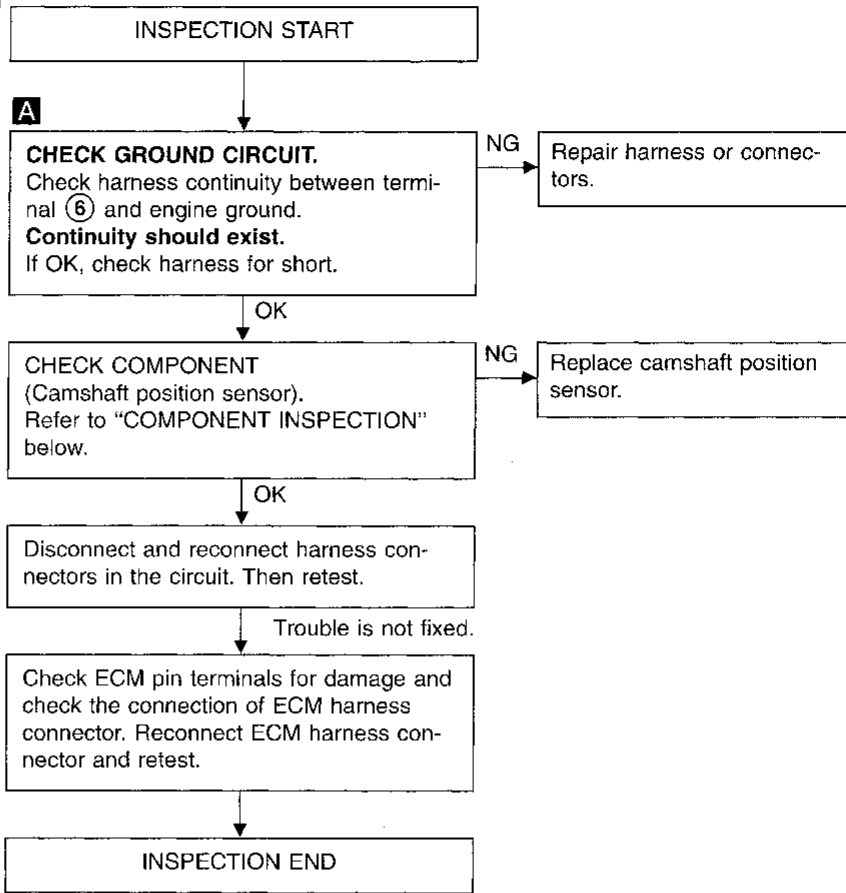
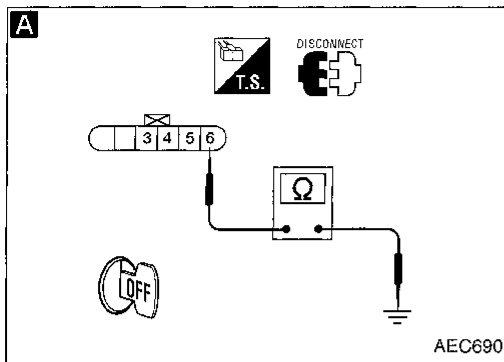

**COMPONENT INSPECTION**

**Camshaft position sensor**

1. Start engine.
2. Check voltage between camshaft position sensor terminals (3), (4) and ground with AC range.

Condition	Terminal	Voltage
Engine running at idle	(3) and ground	Approximately 2.7V* (AC)
	(4) and ground	

\*: Average voltage for pulse signal (Actual pulse signal can be confirmed by oscilloscope.)

If NG, replace distributor assembly with camshaft position sensor.

**Camshaft Position Sensor (CMPS)(DTC: 0101)  
(Cont'd)**

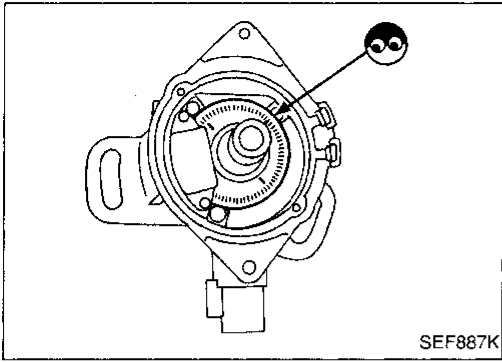

3. Remove distributor cap. Visually check signal plate for damage or dust.

**After this inspection, diagnostic trouble code No. 11 might be displayed with camshaft position sensor functioning properly. Erase the stored memory.**

GI

MA

EM

LC

**EC**

FE

CL

MT

AT

FA

RA

BR

ST

RS

BT

HA

EL

IDX

EGR Function (DTC: 0302)

SYSTEM DESCRIPTION

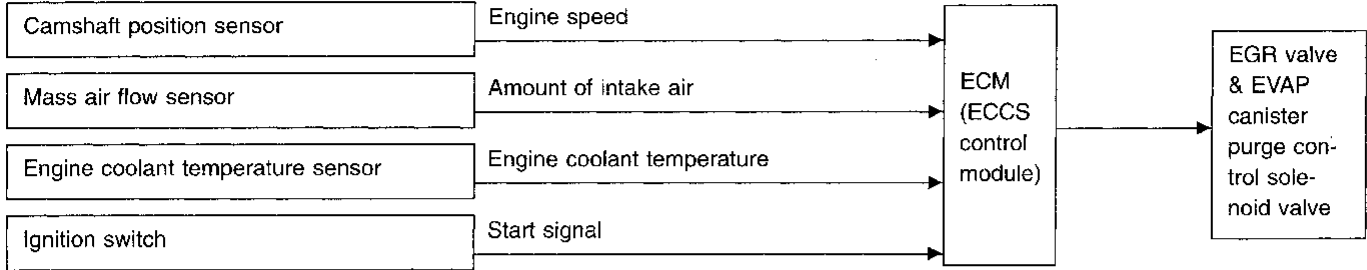

This system cuts and controls vacuum applied to the EGR valve and EVAP canister to suit engine operating conditions. This cut-and-control operation is accomplished through the ECM and the EGR valve & EVAP canister purge control solenoid valve. When the ECM detects any of the following conditions, current flows through the solenoid valve. This causes the port vacuum to be discharged into the atmosphere. The EGR valve and EVAP canister remain closed.

- Low engine coolant temperature
- Engine starting
- High-speed engine operation
- Engine idling
- Excessively high engine coolant temperature
- Mass air flow sensor malfunction

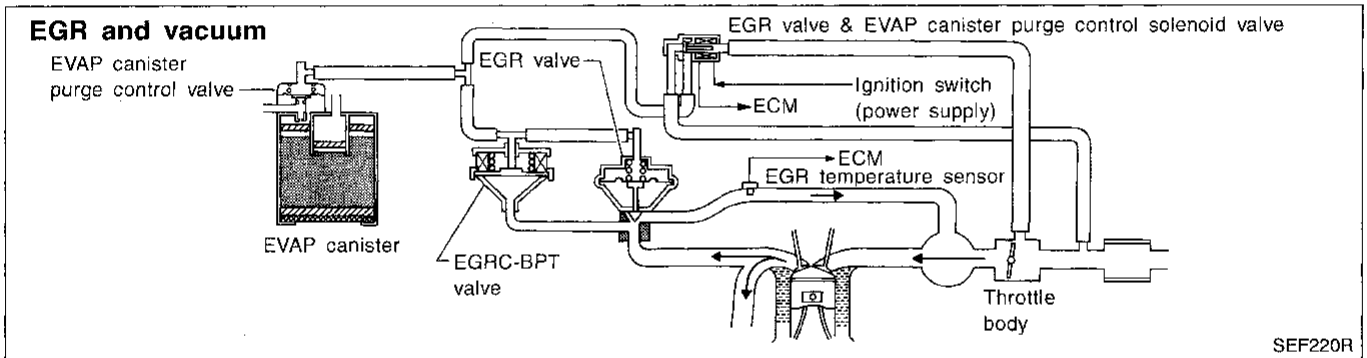

SEF220R

COMPONENT DESCRIPTION

Exhaust gas recirculation (EGR) valve

The EGR valve controls the amount of exhaust gas routed to the intake manifold. Vacuum is applied to the EGR valve in response to throttle valve opening. The vacuum controls the movement of a taper valve connected to the vacuum diaphragm in the EGR valve.

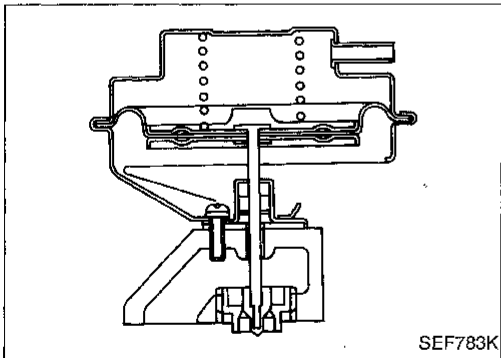

SEF783K

EGR valve and EVAP canister purge control solenoid valve

The EGR valve and EVAP canister purge control solenoid valve responds to signals from the ECM. When the ECM sends an ON (ground) signal, the coil in the solenoid valve is energized. A plunger will then move to cut the vacuum signal (from the throttle body to the EGR valve and EVAP canister purge control valve).

When the ECM sends an OFF signal, the vacuum signal passes through the solenoid valve. The signal then reaches the EGR valve and EVAP canister.

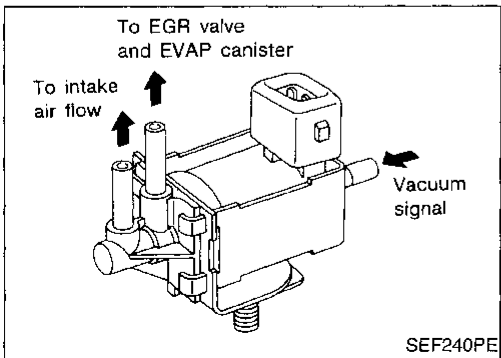

SEF240PE

EGR Function (DTC: 0302) (Cont'd)

ON-BOARD DIAGNOSIS LOGIC

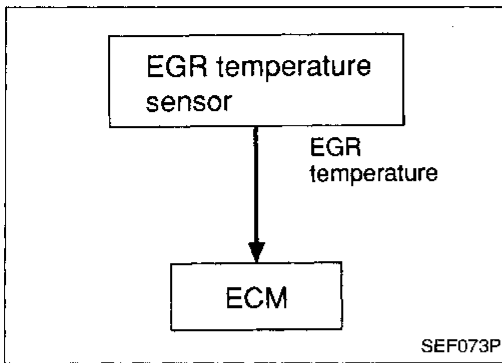

If the absence of EGR flow is detected by EGR temperature sensor under the condition that calls for EGR, a low-flow malfunction is diagnosed.

If EGR temperature sensor detects EGR flow under the condition that does not call for EGR, a high-flow malfunction is diagnosed.

Diagnostic Trouble Code No.	Malfunction is detected when ...	Check Items (Possible Cause)
P0400 0302	A) The exhaust gas recirculation (EGR) flow is excessively low during the specified driving condition.	<ul style="list-style-type: none"> <li>● EGR valve stuck closed</li> <li>● EGRC-BPT valve leaking</li> <li>● Passage blocked</li> <li>● EGR valve &amp; EVAP canister purge control solenoid valve</li> <li>● Tube leaking for EGR valve</li> <li>● EGR temperature sensor</li> </ul>
	B) The exhaust gas recirculation (EGR) flow is excessively high during the specified driving condition.	<ul style="list-style-type: none"> <li>● EGR valve &amp; EVAP canister purge control solenoid valve</li> <li>● EGR valve leaking or stuck open</li> <li>● EGR temperature sensor</li> </ul>

OVERALL FUNCTION CHECK

Use this procedure to check the overall EGR function. During this check, a DTC might not be confirmed.

Before starting with the following procedure, check the engine coolant temperature of the freeze frame data with CONSULT or Generic Scan Tool.

If the engine coolant temperature is higher than or equal to 71°C (160°F), perform only "Procedure for malfunction A".

If the engine coolant temperature is lower than 71°C (160°F), perform both "Procedure for malfunction A" and "Procedure for malfunction B".



EGR Function (DTC: 0302) (Cont'd)

Procedure for malfunction A

- 1) Start engine and warm it up sufficiently.
- 2) Check the EGR valve lifting when revving from 2,000 rpm up to 4,000 rpm under no load.

**EGR valve should lift up and down without sticking.**

If EGR valve does not lift up and down, try again with either of the following methods:

- ① • Select "EGRC SOLENOID VALVE" in "ACTIVE TEST" mode with CONSULT and turn the solenoid valve "OFF".
- ⌚ • Disconnect EGR valve & EVAP canister purge control solenoid valve harness connector.

(The DTC for EGR valve & EVAP canister purge control solenoid valve will be displayed, however, ignore it.)

- 3) Check voltage between EGR temperature sensor harness connector terminal ① and ground at idle speed.  
**Less than 4.5V should exist.**
- 4) Turn ignition switch "OFF".  
Check harness continuity between EGR temperature sensor harness connector terminal ② and ECM terminal ⑤0.  
**Continuity should exist.**
- 5) Perform "COMPONENTS INSPECTION", "EGR temperature sensor". Refer to EC-159.

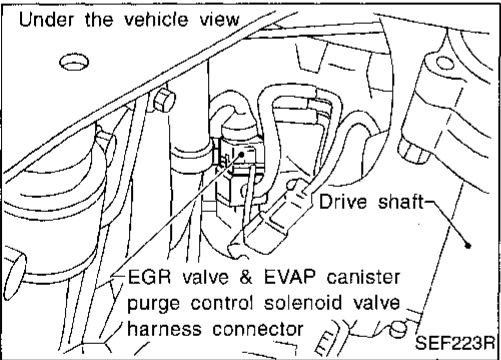
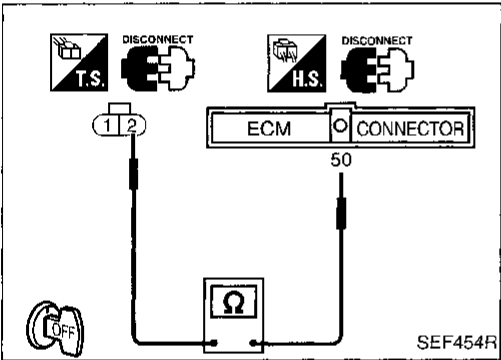
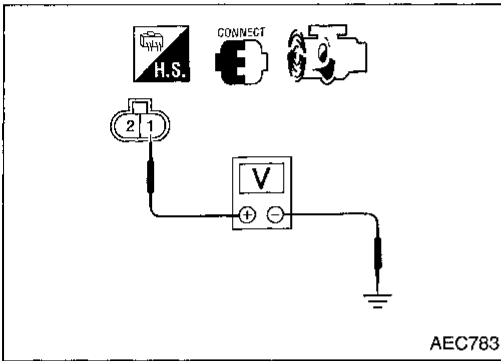
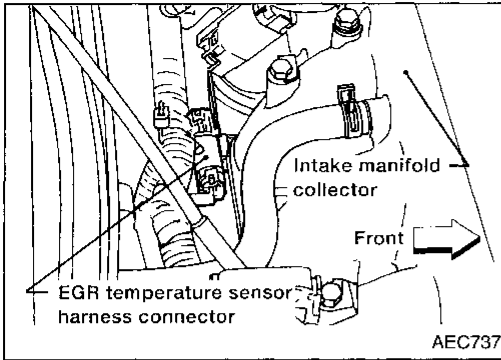

Overall function check

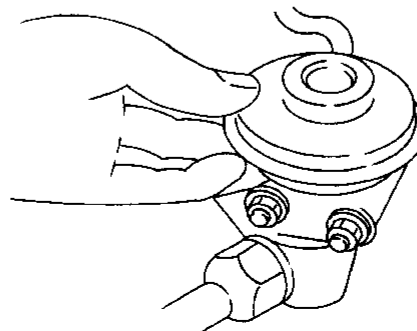
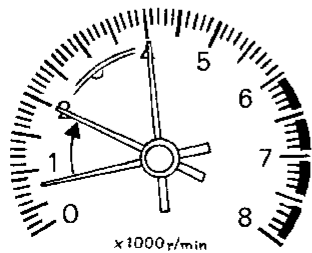

Check the EGR valve lifting when revving engine from 2,000 rpm up to 4,000 rpm.

SEF642Q

EGR Function (DTC: 0302) (Cont'd)

Procedure for malfunction B

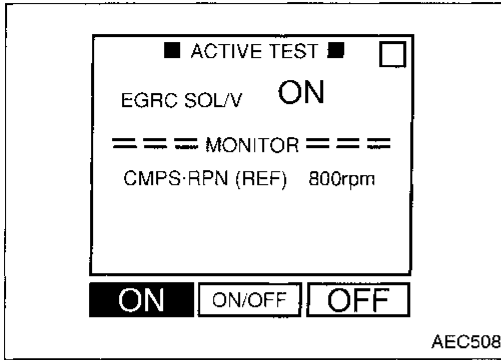

- 1) Start engine.
- 2) Select "EGRC SOLENOID VALVE" in "ACTIVE TEST" mode with CONSULT and turn the solenoid valve "ON".
- 3) Check for the EGR valve lifting when revving from 2,000 rpm up to 4,000 rpm under no load.

**EGR valve should be closed and should not lift up.**

OR

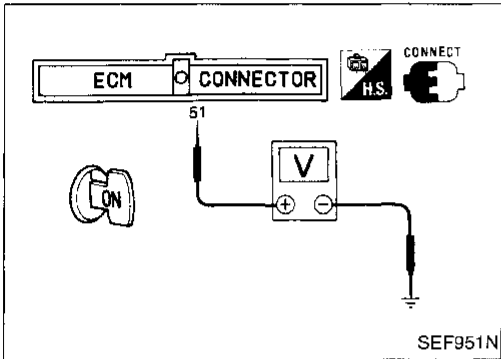

- 1) Confirm the engine coolant temperature is lower than 71°C (160°F) in "Mode 1" with generic scan tool. Perform the following steps before its temperature becomes higher than 71°C (160°F).
- 2) Start engine.
- 3) Check for the EGR valve lifting when revving from 2,000 rpm up to 4,000 rpm under no load.

**EGR valve should be closed and should not lift up.**

OR

- 1) Confirm the voltage between ECM terminal 51 and ground is higher than 1.48V. Perform the following steps before the voltage becomes lower than 1.48V.
- 2) Start engine.
- 3) Check for the EGR valve lifting when revving from 2,000 rpm up to 4,000 rpm under no load.

**EGR valve should be closed and should not lift up.**

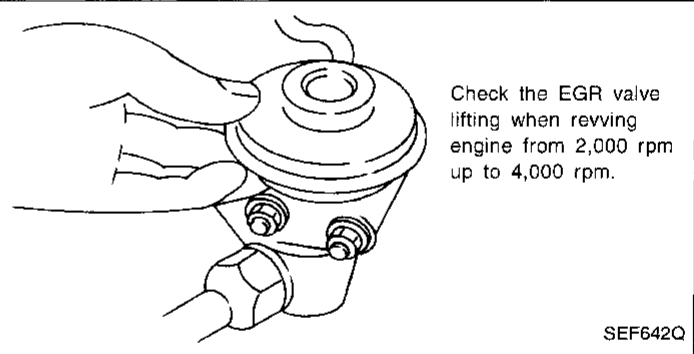
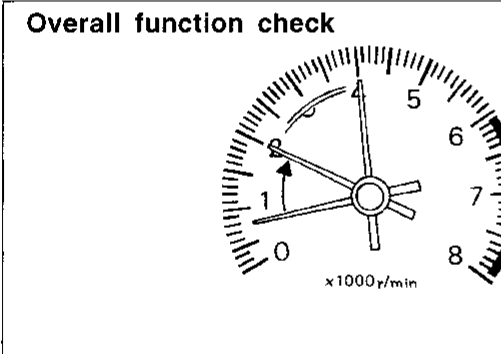

GI  
MA  
EM  
LC  
EC  
FE  
CL  
MT  
AT  
FA  
RA  
BR  
ST  
RS  
BT  
HA  
EL  
IDX

EGR Function (DTC: 0302) (Cont'd)

EC-EGRC1-01

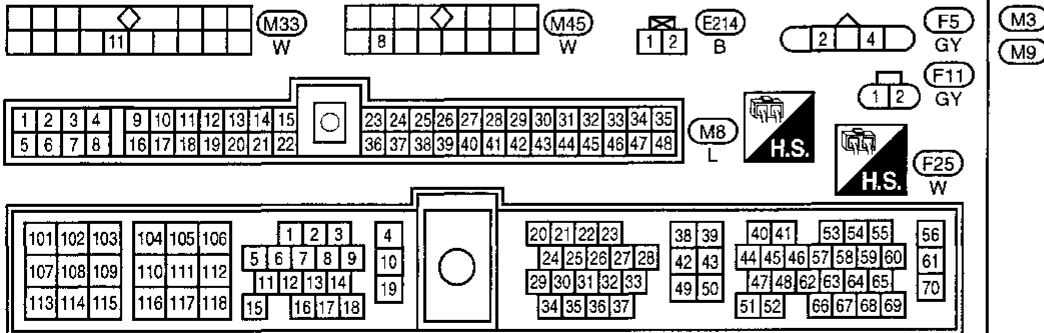
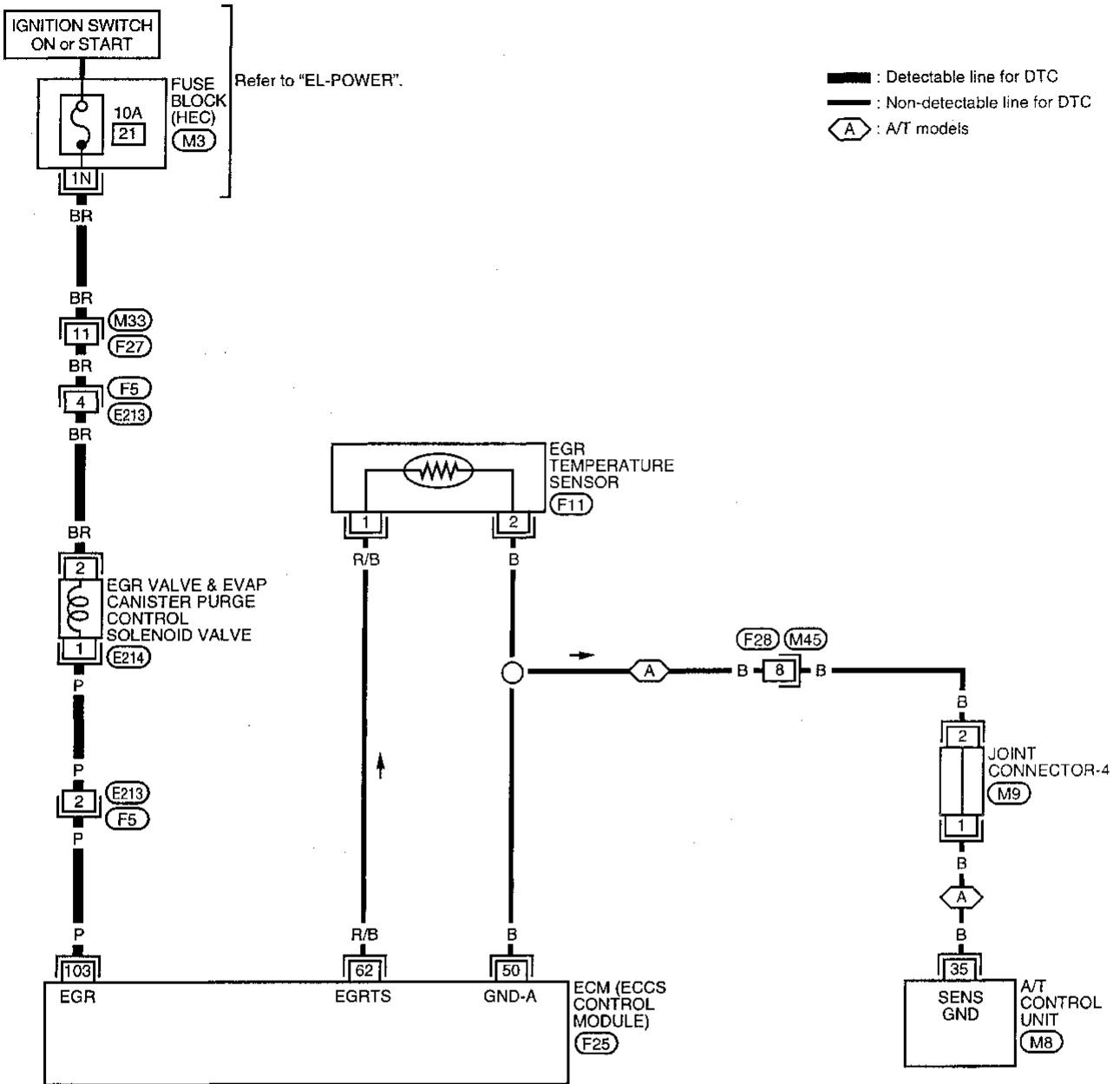

**EGR Function (DTC: 0302) (Cont'd)**  
**DIAGNOSTIC PROCEDURE**

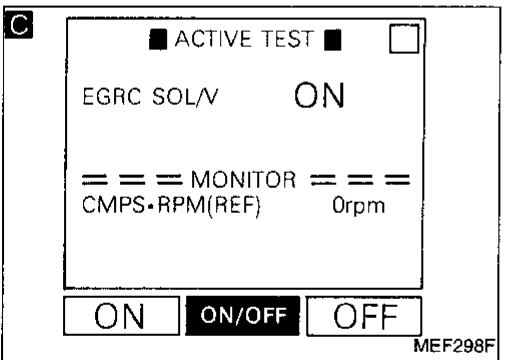
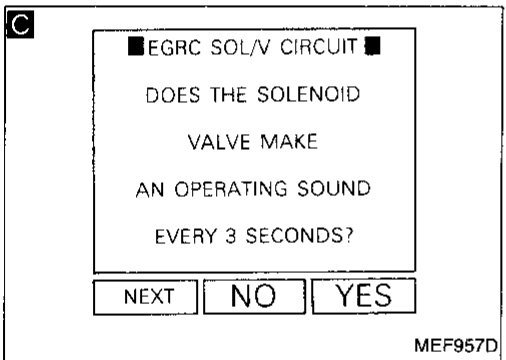
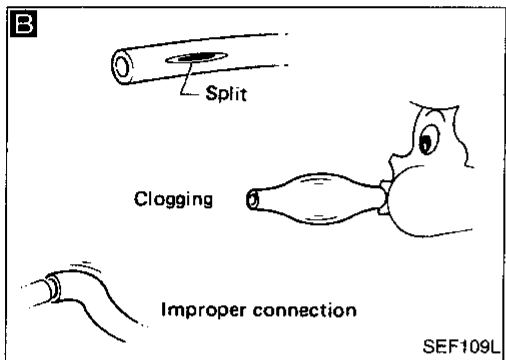
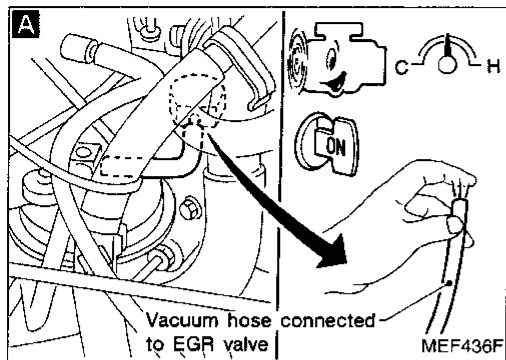

INSPECTION START

**A**  
**CHECK VACUUM SOURCE TO EGR VALVE.**  
1. Start engine and warm it up sufficiently.  
2. Rev engine speed at about 2,000 - 4,000 rpm.  
3. Disconnect vacuum hose to EGR valve.  
4. Make sure that vacuum exists.  
**Vacuum should exist.**

OK → **CHECK COMPONENTS (EGR valve).**  
Refer to "COMPONENTS INSPECTION", EC-159.  
NG ↓  
**Replace EGR valve.**

**B**  
**CHECK VACUUM HOSE.**  
Check vacuum hose for clogging, cracks or improper connection.

NG → **Repair or replace vacuum hose.**

**C**  
**CHECK COMPONENT (EGR valve & EVAP canister purge control solenoid valve).**  
1. Turn ignition switch "ON".  
2. Perform "EGRC SOL/V CIRCUIT" in "FUNCTION TEST" mode with CONSULT.

NG → **Repair or replace EGR valve & EVAP canister purge control solenoid valve circuit.**

OR  
1. Turn ignition switch "ON".  
2. Turn EGR valve & EVAP canister purge control solenoid valve "ON" and "OFF" in "ACTIVE TEST" mode with CONSULT and check operating sound.

OR  
1. Warm up engine sufficiently.  
2. Turn ignition switch "OFF" and wait at least 5 seconds.  
3. Turn ignition switch "ON".  
4. Check operating sound of the solenoid valve when disconnecting and reconnecting EGR valve & EVAP canister purge control solenoid valve harness connector.

OK ↓  
**(A)**  
**(Go to next page.)**

GI  
MA  
EM  
LC  
EC  
FE  
CL  
MT  
AT  
FA  
RA  
BR  
ST  
RS  
BT  
HA  
EL  
IDX

## EGR Function (DTC: 0302) (Cont'd)

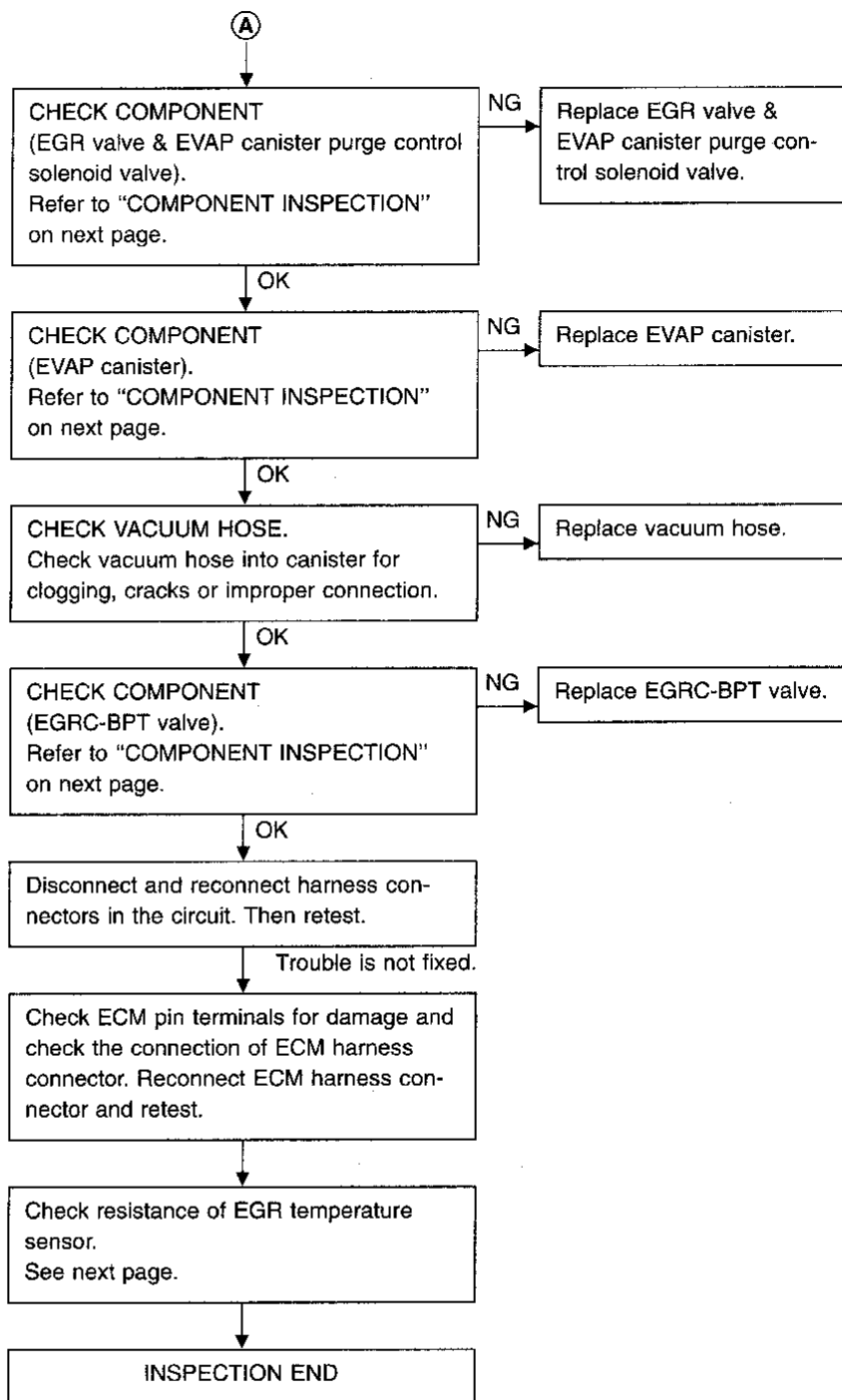

**EGR Function (DTC: 0302) (Cont'd)  
COMPONENT INSPECTION**

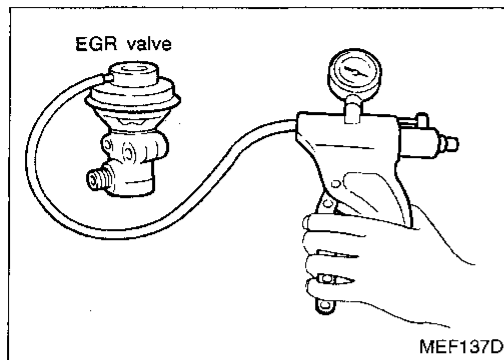

**EGR valve**

Apply vacuum to EGR vacuum port with a hand vacuum pump.  
**EGR valve spring should lift.**  
If NG, replace EGR valve.

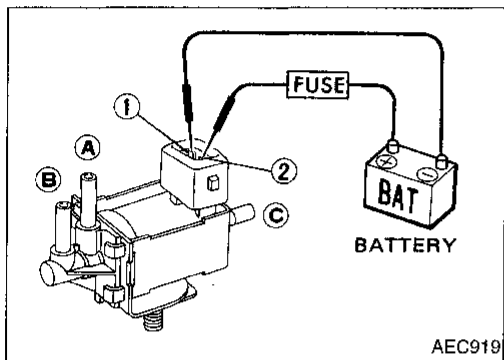

**EGR valve & EVAP canister purge control solenoid valve**

Check solenoid valve, following the table as shown below:

Conditions	Air passage continuity between (A) and (B)	Air passage continuity between (A) and (C)
12V direct current supply between terminals ① and ②	Yes	No
No supply	No	Yes

If NG, replace EGR valve & EVAP canister purge control solenoid valve.

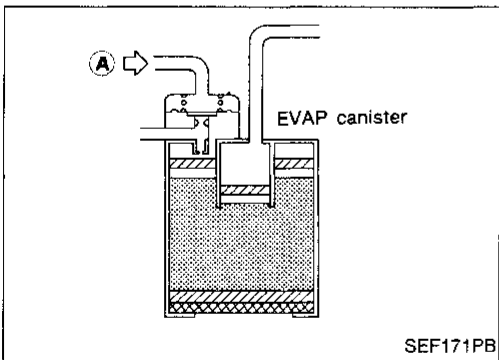

**EVAP canister**

Gently blow air from (A).  
**No leakage should exist.**

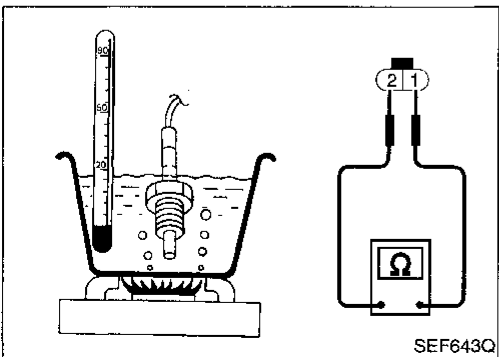

**EGR temperature sensor**

Check resistance change and resistance value.

EGR temperature °C (°F)	Voltage (V)	Resistance (MΩ)
0 (32)	4.81	7.9 - 9.7
50 (122)	2.82	0.57 - 0.70
100 (212)	0.8	0.08 - 0.10

If NG, replace EGR temperature sensor.

CI  
MA  
EM  
LC  
EC  
FE  
CL  
MT  
AT  
FA  
RA  
BR  
ST  
RS  
BT  
HA  
EL  
IDX

**EGR Function (DTC: 0302) (Cont'd)****EGRC-BPT valve**

1. Plug one of two ports of EGRC-BPT valve.
2. Vacuum from the other port and check for leakage while applying a pressure above 0.981 kPa (100 mmH<sub>2</sub>O, 3.94 inH<sub>2</sub>O) from under EGRC-BPT valve.
3. If a leakage is noted, replace the valve.

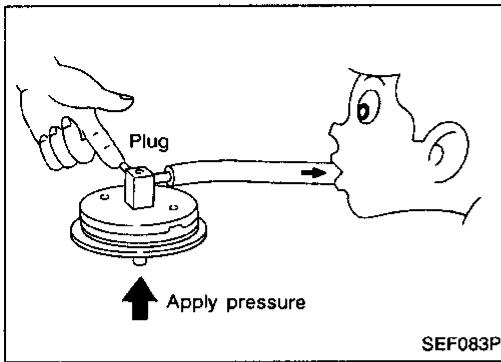

## EGRC-BPT Valve Function (DTC: 0306)

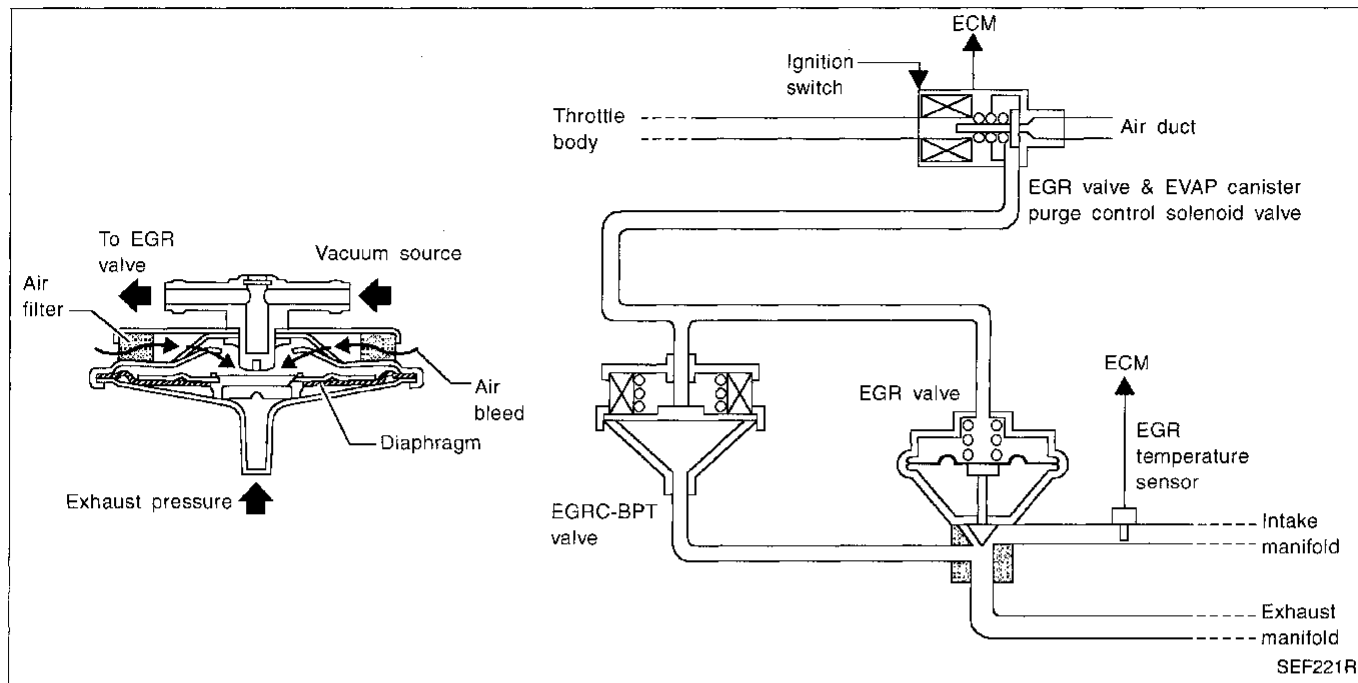

GI

MA

EM

LC

EC

FE

CL

MT

AT

FA

RA

BR

ST

RS

BT

HA

EL

IDX

## SYSTEM DESCRIPTION

The EGRC-BPT valve monitors exhaust pressure to activate the diaphragm, controlling throttle body vacuum applied to the EGR valve. In other words, recirculated exhaust gas is controlled in response to positioning of the EGR valve or to engine operation.

## ON-BOARD DIAGNOSIS LOGIC

If too much EGR flow exists due to an EGRC-BPT valve malfunction, off idle engine roughness will increase. If the roughness is large, then the vacuum to the EGR valve is interrupted through the EGR & EVAP canister purge control solenoid valve. If the engine roughness is reduced at that time, the EGRC-BPT valve malfunction is indicated.

Diagnostic Trouble Code No.	Malfunction is detected when ...	Check Items (Possible Cause)
P0402 0306	<ul style="list-style-type: none"> <li>The EGRC-BPT valve does not operate properly.</li> </ul>	<ul style="list-style-type: none"> <li>EGRC-BPT valve</li> <li>Misconnected rubber tube</li> <li>Blocked rubber tube</li> </ul>

## OVERALL FUNCTION CHECK

Use this procedure to check the overall function of the EGRC-BPT valve. During this check, a DTC might not be confirmed.

1. Disconnect the rubber tube to the fuel pressure regulator at the intake manifold.
2. Disconnect the rubber tube to the EGR valve & EVAP canister purge control solenoid valve at the EGRC-BPT valve.  
Connect the intake manifold and the EGRC-BPT valve with a rubber tube that has 1 mm (0.04 in) dia. orifice installed. (The intake manifold vacuum will be directly applied to the EGRC-BPT valve.)
3. Start engine.
4. Check for the EGR valve lifting with engine at less than 1,500 rpm under no load.  
**EGR valve should remain closed.**
5. Check the EGR valve lifting when revving from 2,000 rpm up to 4,000 rpm under no load.  
**EGR valve should lift up, and go down without sticking when the engine is returned to idle.**
6. Check rubber tube between EGR valve & EVAP canister purge control solenoid valve and throttle body for misconnection, cracks or blockages.



## EGRC-BPT Valve Function (DTC: 0306) (Cont'd)

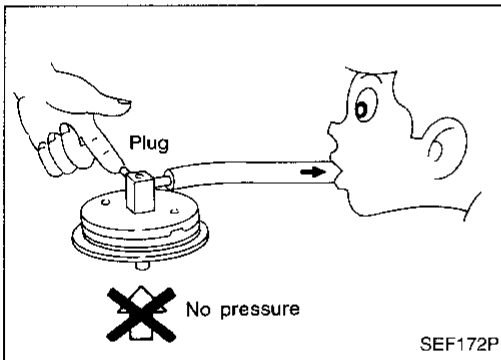
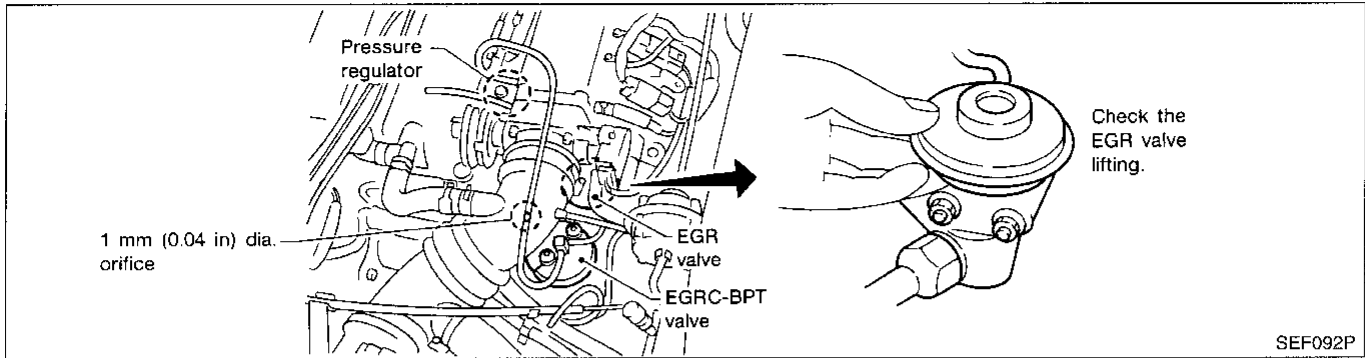

### COMPONENT INSPECTION

#### EGRC-BPT valve

1. Plug one of two ports of EGRC-BPT valve.
2. Vacuum from the other port and check leakage without applying any pressure from under EGR-BPT valve.  
**Leakage should exist.**

Three Way Catalyst Function (DTC: 0702)

ON-BOARD DIAGNOSIS LOGIC

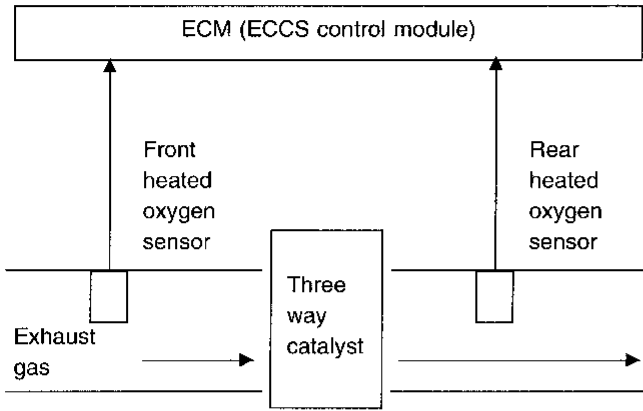

The ECM monitors the switching frequency ratio of front heated oxygen sensor and rear heated oxygen sensor.

A three way catalyst with high oxygen storage capacity will indicate a low switching frequency of rear heated oxygen sensor. As oxygen storage capacity decreases, the rear heated oxygen sensor switching frequency will increase.

When the frequency ratio of front heated oxygen sensor and rear heated oxygen sensor approaches a specified limit value, the second stage diagnosis is applied.

The second stage diagnosis switches the mixture ratio feedback control using front heated oxygen sensor to rear heated oxygen sensor.

Then ECM measures the switching lag time between front heated oxygen sensor and rear heated oxygen sensor.

The longer lag time indicates the greater oxygen storage capacity. If the lag time is within the specified level, the three way catalyst malfunction is diagnosed.

- The three way catalyst function has one trip detection logic.

Diagnostic Trouble Code No.	Malfunction is detected when ...	Check Items (Possible Cause)
P0420 0702	<ul style="list-style-type: none"> <li>• Three way catalyst does not operate properly.</li> <li>• Three way catalyst does not have enough oxygen storage capacity.</li> </ul>	<ul style="list-style-type: none"> <li>• Three way catalyst</li> <li>• Exhaust tube</li> <li>• Intake air leak</li> <li>• Injectors</li> <li>• Injector leak</li> </ul>

OVERALL FUNCTION CHECK

Use this procedure to check the overall function of the three way catalyst. During this check, a DTC might not be confirmed.

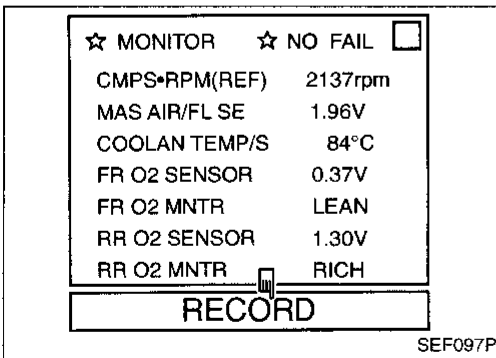

- 1) Start engine and warm it up sufficiently.
- 2) Set "MANU TRIG" and "HI SPEED", then select "FR O2 SENSOR", "RR O2 SENSOR", "FR O2 MNTR", "RR O2 MNTR" in "DATA MONITOR" mode with CONSULT.
- 3) Touch "RECORD" on CONSULT screen with engine speed held at 2,000 rpm constant under no load.
- 4) Make sure that the switching frequency between "RICH" and "LEAN" of "RR O2 SENSOR" is very less than that of "FR O2 SENSOR".

Switching frequency ratio =

$$\frac{\text{Rear heated oxygen sensor switching frequency}}{\text{Front heated oxygen sensor switching frequency}}$$

### Three Way Catalyst Function (DTC: 0702) (Cont'd)

This ratio should be less than 0.40 for A/T models and 0.37 for M/T models.

If the ratio is greater than the above value, the three way catalyst is not operating properly.

OR



- 1) Start engine and warm it up sufficiently.
- 2) Set voltmeter probes between ECM terminals ④⑥ (front heated oxygen sensor signal) and ④③ (engine ground), and ECM terminals ⑤② (rear heated oxygen sensor signal) and ④③ (engine ground).
- 3) Keep engine speed at 2,000 rpm constant under no load.
- 4) Make sure that the voltage switching frequency (high & low) between ECM terminals ⑤② and ④③ is much less than that of ECM terminals ④⑥ and ④③.

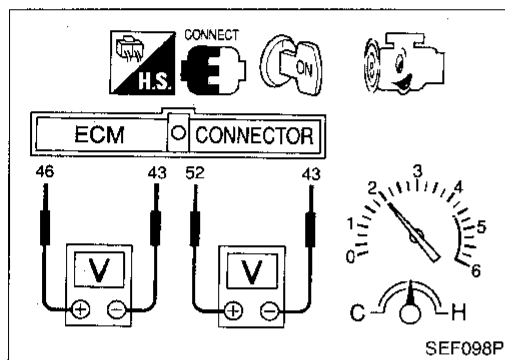

Switching frequency ratio =

Rear heated oxygen sensor voltage switching frequency

Front heated oxygen sensor voltage switching frequency

This ratio should be less than 0.40 for A/T models and 0.37 for M/T models.

If the ratio is greater than the above value, it means three way catalyst does not operate properly.

**Note:** If the voltage at terminal ④⑥ does not switch periodically more than 5 times within 10 seconds at step 3, perform TROUBLE DIAGNOSIS FOR DTC P0130 (0303) first. Refer to EC-117.

Three Way Catalyst Function (DTC: 0702)  
(Cont'd)

DIAGNOSTIC PROCEDURE

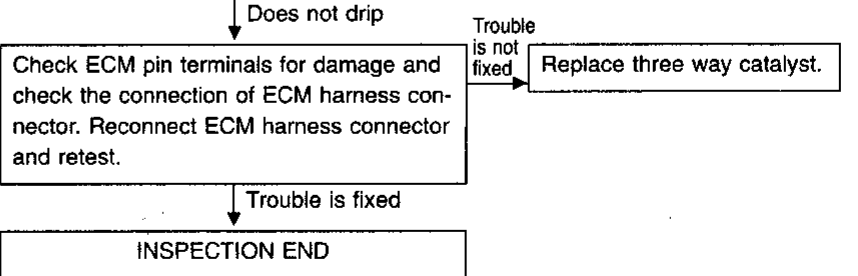
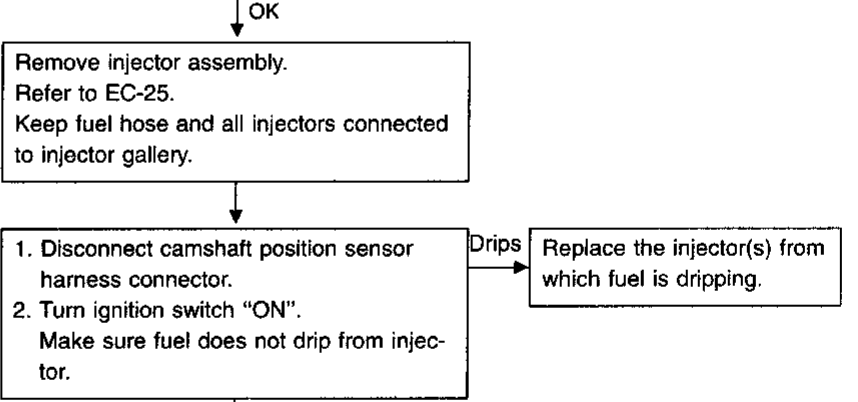
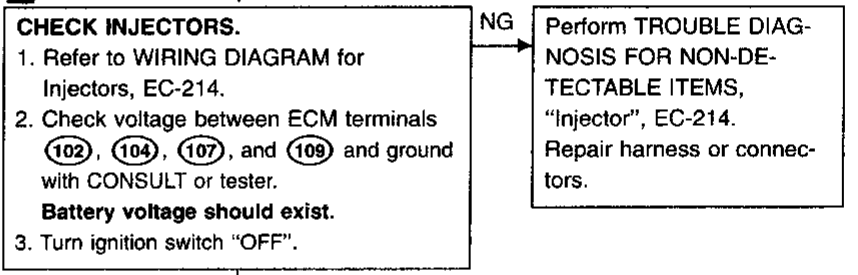
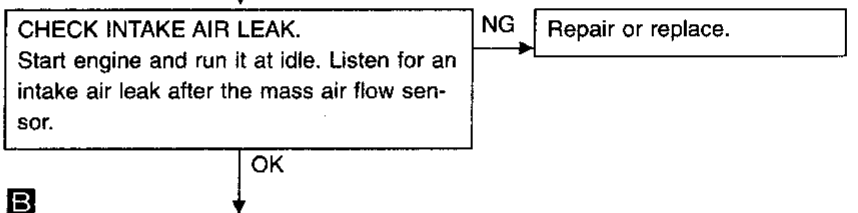
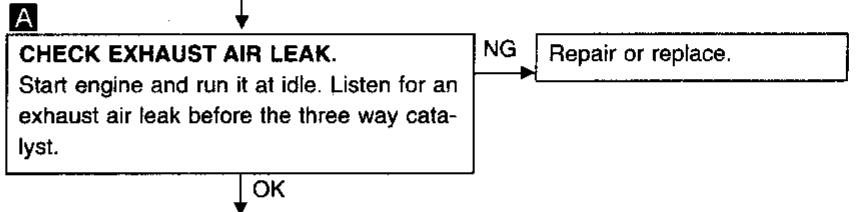
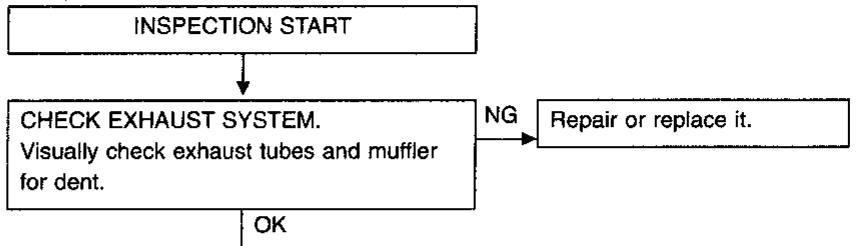
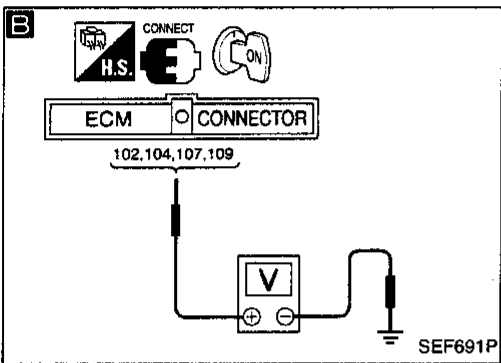
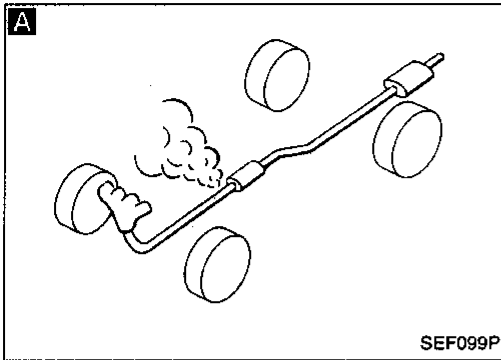

GI  
MA  
EM  
LC  
EC  
FE  
CL  
MT  
AT  
FA  
RA  
BR  
ST  
RS  
BT  
HA  
EL  
IDX

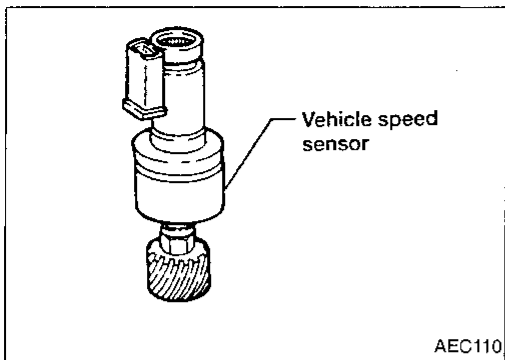

**Vehicle Speed Sensor (VSS) (DTC: 0104)**

The vehicle speed sensor is installed in the transaxle. It contains a pulse generator which provides a vehicle speed signal to the speedometer. The speedometer then sends a signal to the ECM.

Diagnostic Trouble Code No.	Malfunction is detected when ....	Check Items (Possible Cause)
P0500 0104	<ul style="list-style-type: none"> <li>The almost 0 km/h (0 MPH) signal from vehicle speed sensor is sent to ECM even when vehicle is being driven.</li> </ul>	<ul style="list-style-type: none"> <li>Harness or connector (The vehicle speed sensor circuit is open or shorted.)</li> <li>Vehicle speed sensor</li> </ul>

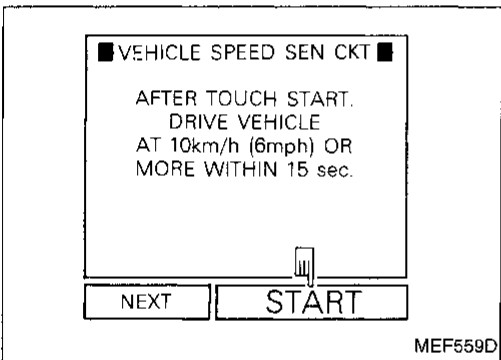

**OVERALL FUNCTION CHECK**

Use this procedure to check the overall function of the vehicle speed sensor circuit. During this check, a DTC might not be confirmed.

- 1) Jack up drive wheels.
- 2) Start engine.
- 3) Perform "VEHICLE SPEED SEN CKT" in "FUNCTION TEST" mode with CONSULT.

OR

- 1) Jack up drive wheels.
- 2) Start engine.
- 3) Read vehicle speed sensor signal in "DATA MONITOR" mode with CONSULT.

**The vehicle speed on CONSULT should be able to exceed 10 km/h (6 MPH) when rotating wheels with suitable gear position.**

OR

- 1) Jack up drive wheels.
- 2) Start engine.
- 3) Read vehicle speed sensor signal in "MODE 1" with GST.

**The vehicle speed on GST should be able to exceed 10 km/h (6 MPH) when rotating wheels with suitable gear position.**

OR

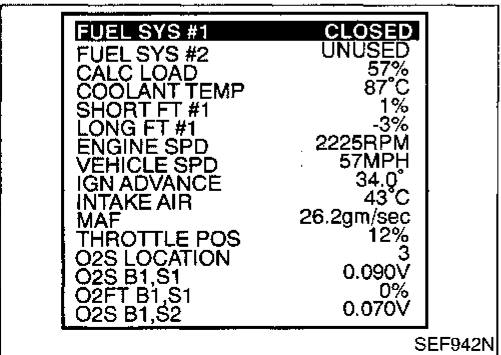
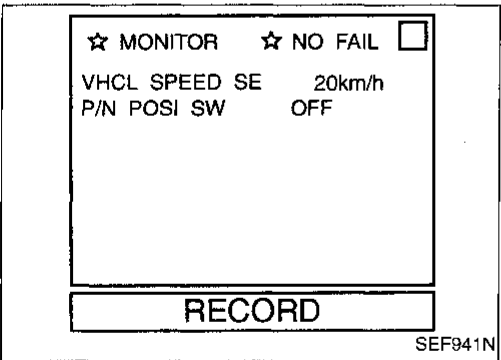

## Vehicle Speed Sensor (VSS) (DTC: 0104) (Cont'd)

### DIAGNOSTIC TROUBLE CODE CONFIRMATION PROCEDURE

-  1) Start engine and warm it up sufficiently.
- 2) Perform test drive for at least 10 seconds continuously under the following recommended condition.
- Engine speed : (A/T models) 2,000 - 3,200 rpm
  - (M/T models) 1,950 - 2,900 rpm
  - Intake manifold vacuum: -40.0 to -26.7 kPa (-300 to -200 mmHg, -11.81 to -7.87 inHg)
  - Gear position : Suitable position (except "N" or "P" position)
- 3) Stop the vehicle, turn ignition switch "OFF", wait at least 5 seconds and then turn "ON".
- 4) Perform "Diagnostic Test Mode II" (Self-diagnostic results) with ECM.

**Even though Diagnostic Trouble Code is not detected, perform the above test drive at least one more time.**

GI

MA

EM

LC

EC

FE

CL

MT

AT

FA

RA

BR

ST

RS

BT

HA

EL

IDX

Vehicle Speed Sensor (VSS) (DTC: 0104)  
(Cont'd)

EC-VSS-01

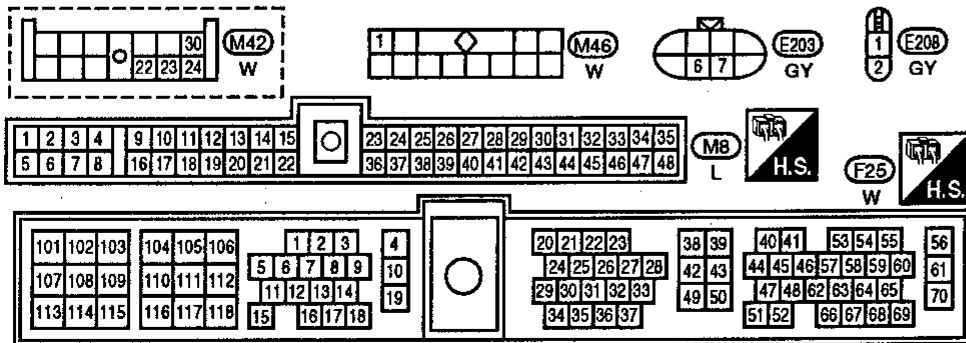
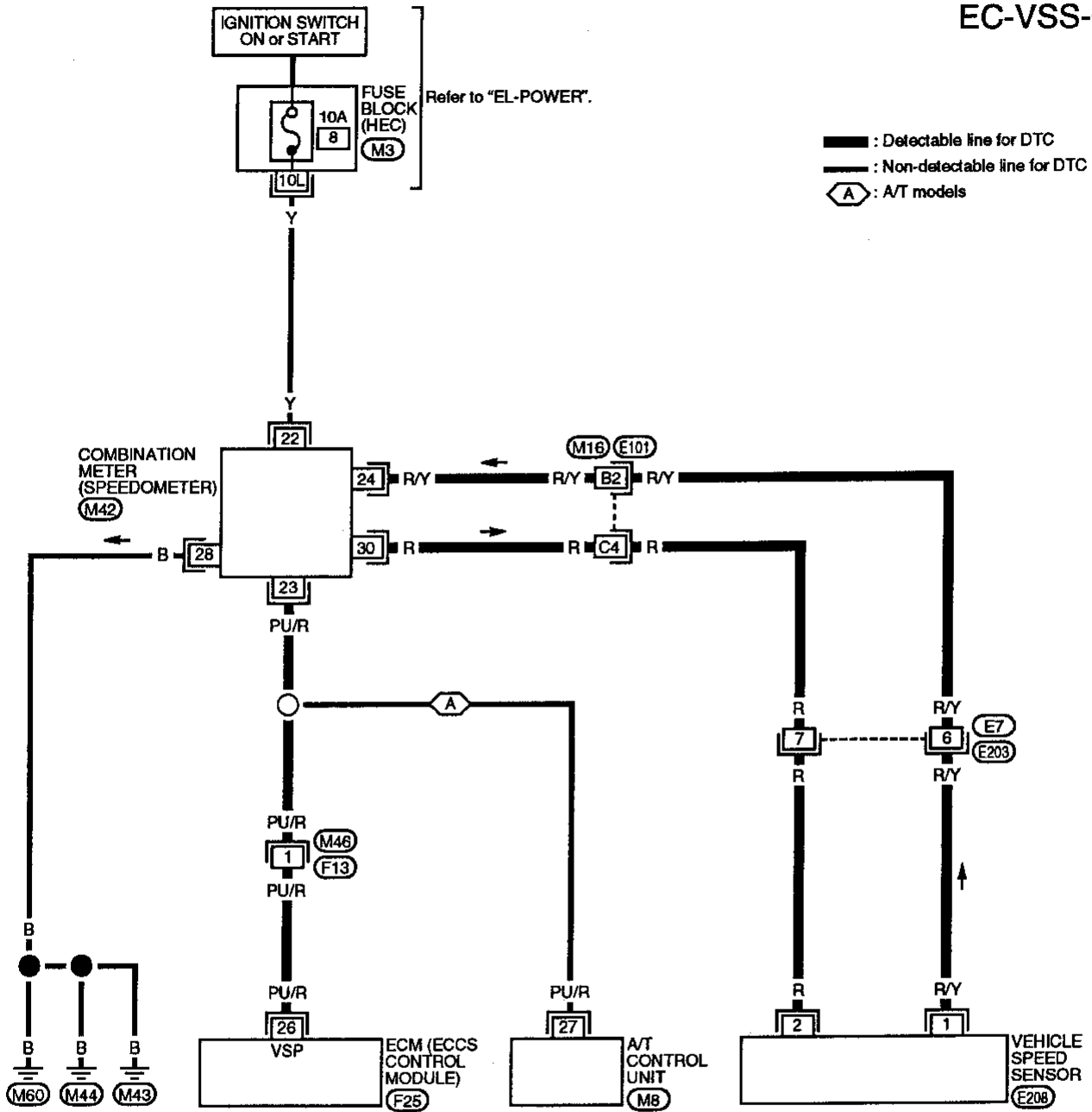

Refer to last page (Foldout page).

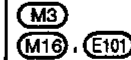

Vehicle Speed Sensor (VSS) (DTC: 0104)  
(Cont'd)

DIAGNOSTIC PROCEDURE

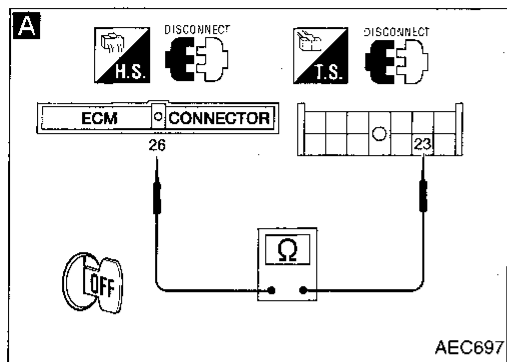

INSPECTION START

**A**  
**CHECK INPUT SIGNAL CIRCUIT.**  
1. Turn ignition switch "OFF".  
2. Disconnect ECM harness connector and combination meter harness connector.  
3. Check harness continuity between ECM terminal (26) and terminal (23).  
**Continuity should exist.**  
If OK, check harness for short.

NG  
Check the following.  
● Harness connectors (F13), (M46)  
● Harness for open or short between ECM and combination meter  
If NG, repair harness or connectors.

OK  
**CHECK SPEEDOMETER FUNCTION.**  
Make sure that speedometer functions properly.

NG  
Check the following.  
● Harness connectors (M16), (E101)  
● Harness connectors (E7), (E203)  
● Harness for open or short between combination meter and vehicle speed sensor  
If NG, repair harness or connectors.  
Check vehicle speed sensor and its circuit.  
Refer to EL section.

OK  
Disconnect and reconnect harness connectors in the circuit. Then retest.

Trouble is not fixed.  
Check ECM pin terminals for damage and check the connection of ECM harness connector. Reconnect ECM harness connector and retest.

INSPECTION END

CI  
MA  
EM  
LC  
EC  
FE  
CL  
MT  
AT  
FA  
RA  
BR  
ST  
RS  
BT  
HA  
EL  
DX



## Idle Air Control Valve (IACV) — Auxiliary Air Control (AAC) Valve (DTC: 0205)

### SYSTEM DESCRIPTION

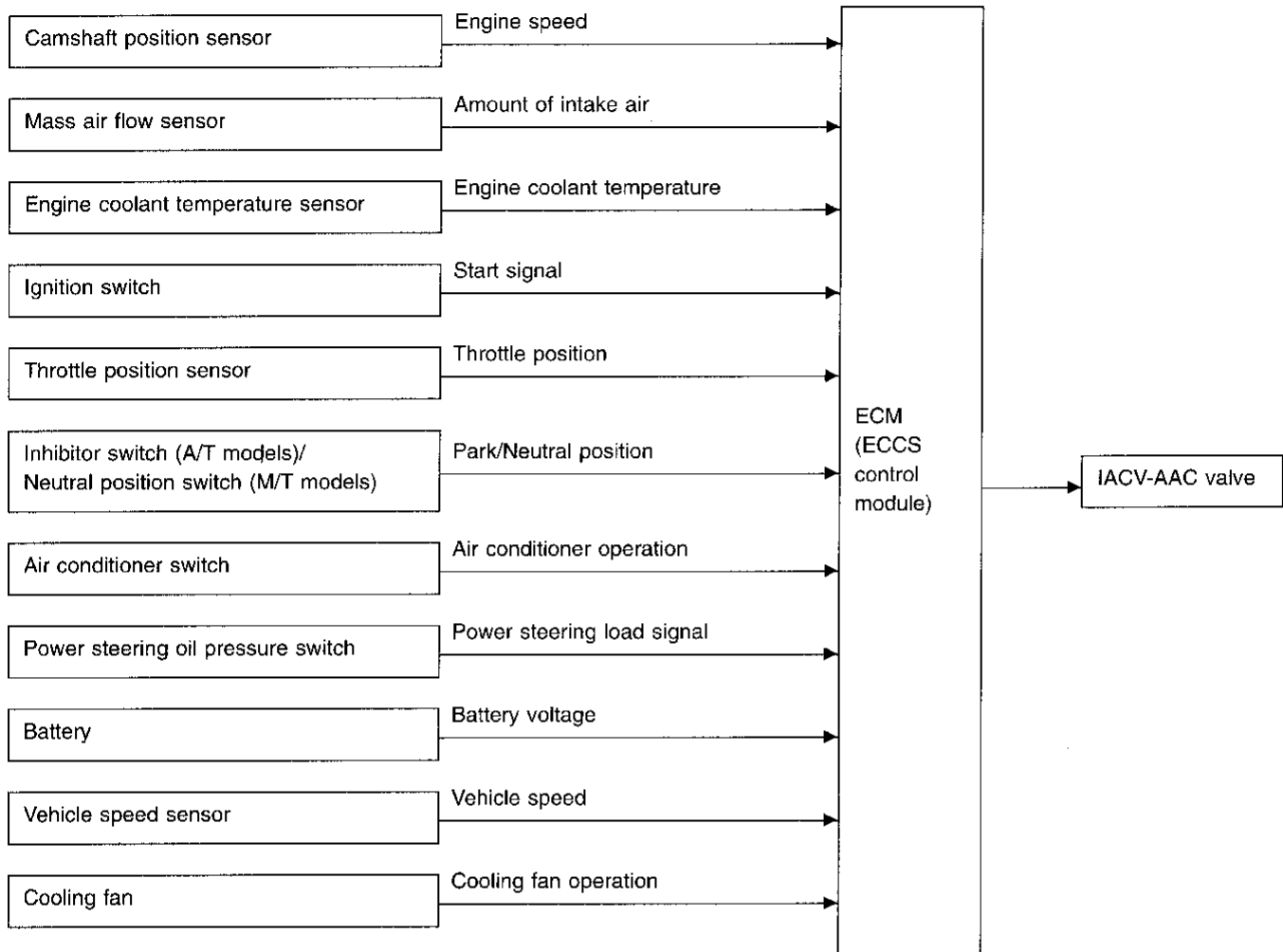

This system automatically controls engine idle speed to a specified level. Idle speed is controlled through fine adjustment of the amount of air which bypasses the throttle valve via IACV-AAC valve. The IACV-AAC valve repeats ON/OFF operation according to the signal sent from the ECM. The camshaft position sensor detects the actual engine speed and sends a signal to the ECM. The ECM then controls the ON/OFF time of the IACV-AAC valve so that engine speed coincides with the target value memorized in ECM. The target engine speed is the lowest speed at which the engine can operate steadily. The optimum value stored in the ECM is determined by taking into consideration various engine conditions, such as during warm up, deceleration, and engine load (air conditioner, power steering and cooling fan operation).

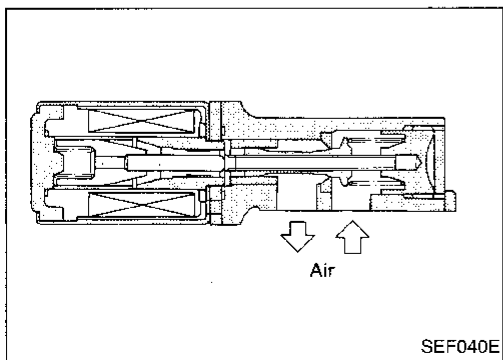

### COMPONENT DESCRIPTION

#### IACV-AAC valve

The IAC valve-AAC valve is moved by ON/OFF pulses from the ECM. The longer the ON pulse, the greater the amount of air that will flow through the valve. The more air that flows through the valve, the higher the idle speed.

## Idle Air Control Valve (IACV) — Auxiliary Air Control (AAC) Valve (DTC: 0205) (Cont'd)

Diagnostic Trouble Code No.	Malfunction is detected when ....	Check items (Possible cause)
P0505 0205	A) The IACV-AAC valve does not operate properly.	<ul style="list-style-type: none"> <li>● Harness or connectors (The IACV-AAC valve circuit is open.)</li> <li>● IACV-AAC valve</li> </ul>
	B) The IACV-AAC valve does not operate properly.	<ul style="list-style-type: none"> <li>● Harness or connectors (The IACV-AAC valve circuit is shorted.)</li> <li>● IACV-AAC valve</li> </ul>

### DIAGNOSTIC TROUBLE CODE CONFIRMATION PROCEDURE

#### Procedure for malfunction A

-  1) Turn ignition switch "ON".  
2) Select "DATA MONITOR" mode with CONSULT.  
3) Wait at least 2 seconds.

OR

-  1) Turn ignition switch "ON" and wait at least 2 seconds.  
2) Select "MODE 3" with GST.

OR

-  1) Turn ignition switch "ON" and wait at least 2 seconds.  
2) Perform "Diagnostic Test Mode II" (Self-diagnostic results) with ECM.

#### Procedure for malfunction B

-  1) Start engine and warm it up sufficiently.  
2) Turn ignition switch "OFF" and wait at least 5 seconds.  
3) Turn ignition switch "ON" again and select "DATA MONITOR" mode with CONSULT.  
4) Start engine and run it for at least 30 seconds at idle speed.

OR

-  1) Start engine and warm it up sufficiently.  
2) Turn ignition switch "OFF" and wait at least 5 seconds.  
3) Start engine again and run it for at least 30 seconds at idle speed.  
4) Select "MODE 3" with GST.

OR

-  1) Start engine and warm it up sufficiently.  
2) Turn ignition switch "OFF" and wait at least 5 seconds.  
3) Start engine again and run it for at least 30 seconds at idle speed.  
4) Turn ignition switch "OFF", wait at least 5 seconds and then turn "ON".  
5) Perform "Diagnostic Test Mode II" (Self-diagnostic results) with ECM.

Idle Air Control Valve (IACV) — Auxiliary Air Control (AAC) Valve (DTC: 0205) (Cont'd)

EC-AAC/V-01

— : Detectable line for DTC  
 - - - : Non-detectable line for DTC

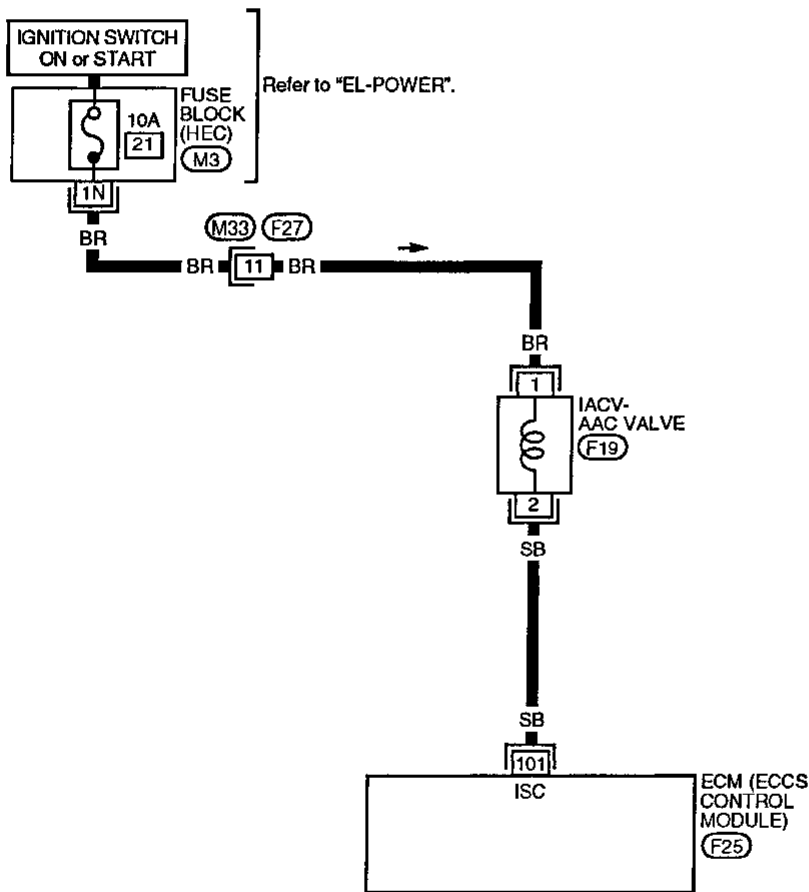

Refer to last page (Foldout page).

(M3)

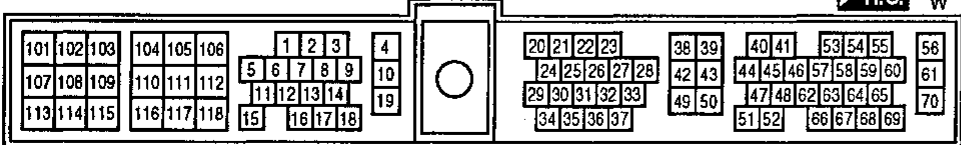
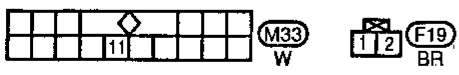

Idle Air Control Valve (IACV) — Auxiliary Air Control (AAC) Valve (DTC: 0205) (Cont'd)  
DIAGNOSTIC PROCEDURE

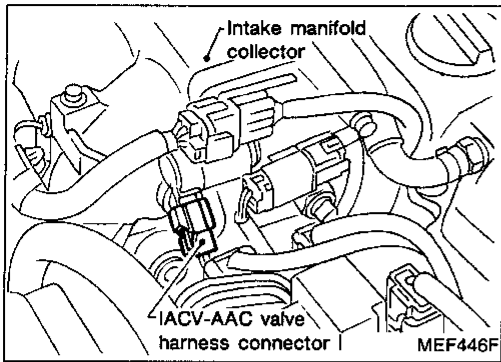

INSPECTION START

**A**  
**CHECK POWER SUPPLY.**  
1. Stop engine.  
2. Disconnect IACV-AAC valve harness connector.  
3. Turn ignition switch "ON".  
4. Check voltage between terminal ① and ground with CONSULT or tester.  
**Voltage: Battery voltage**

NG → Check the following.  
● Harness connectors  
● M33, F27  
● 10A fuse  
● Harness for open or short between IACV-AAC valve harness connector and fuse  
If NG, repair harness or connectors.

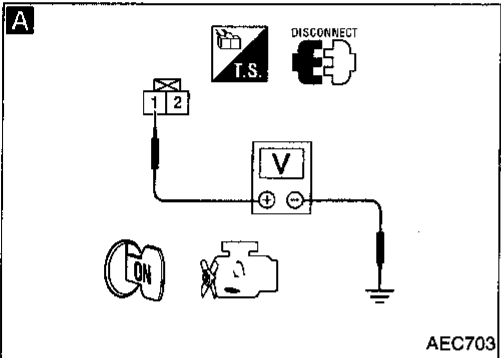

**B**  
**CHECK OUTPUT SIGNAL CIRCUIT.**  
1. Disconnect ECM harness connector.  
2. Check harness continuity between ECM terminal ① and terminal ②.  
**Continuity should exist.**  
If OK, check harness for short.

NG → Repair harness or connectors.

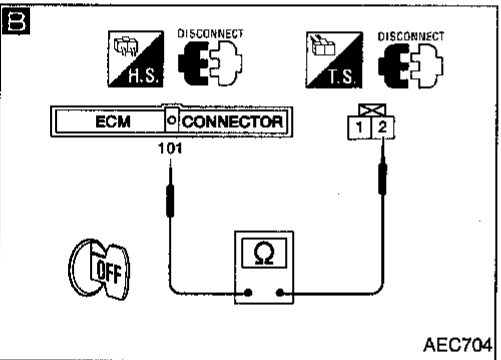

**CHECK COMPONENT (IACV-AAC valve).**  
Refer to "COMPONENT INSPECTION" below.

NG → Replace IACV-AAC valve.

OK → Disconnect and reconnect harness connectors in the circuit. Then retest.

Trouble is not fixed.  
Check ECM pin terminals for damage and check the connection of ECM harness connector. Reconnect ECM harness connector and retest.

INSPECTION END

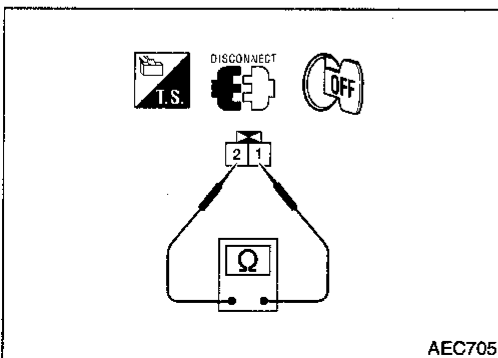

**COMPONENT INSPECTION**

**IACV-AAC valve**

Disconnect IACV-AAC valve harness connector.

- Check IACV-AAC valve resistance.  
**Resistance:**  
**Approximately 10Ω [at 25°C (77°F)]**
- Check plunger for seizing or sticking.
- Check for broken spring.

GI  
MA  
EM  
LC  
EC  
FE  
CL  
MT  
AT  
FA  
RA  
BR  
ST  
RS  
BT  
HA  
EL  
IDX

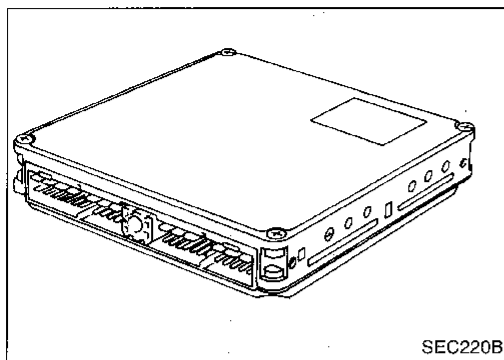

### Engine Control Module (ECM)-ECCS Control Module (DTC: 0301)

The ECM consists of a microcomputer, diagnostic test mode selector, and connectors for signal input and output and for power supply. The unit controls the engine.

Diagnostic Trouble Code No.	Malfunction is detected when ....	Check Items (Possible Cause)
P0605 0301	<ul style="list-style-type: none"> <li>● ECM calculation function is malfunctioning.</li> </ul>	<ul style="list-style-type: none"> <li>● ECM (ECCS control module)</li> </ul>

### DIAGNOSTIC TROUBLE CODE CONFIRMATION PROCEDURE



- 1) Turn ignition switch "ON".
- 2) Select "DATA MONITOR" mode with CONSULT.
- 3) Start engine and run it for at least 30 seconds at idle speed.

OR



- 1) Turn ignition switch "ON".
- 2) Select "Mode 3" with GST.
- 3) Start engine and run it for at least 30 seconds at idle speed.

OR



- 1) Turn ignition switch "ON".
- 2) Start engine and run it for at least 30 seconds at idle speed.
- 3) Turn ignition "OFF" and wait at least 5 seconds.
- 4) Perform "Diagnostic Test Mode II" (Self-diagnostic results) with ECM.

## Engine Control Module (ECM)-ECCS Control Module (DTC: 0301) (Cont'd)

### DIAGNOSTIC PROCEDURE

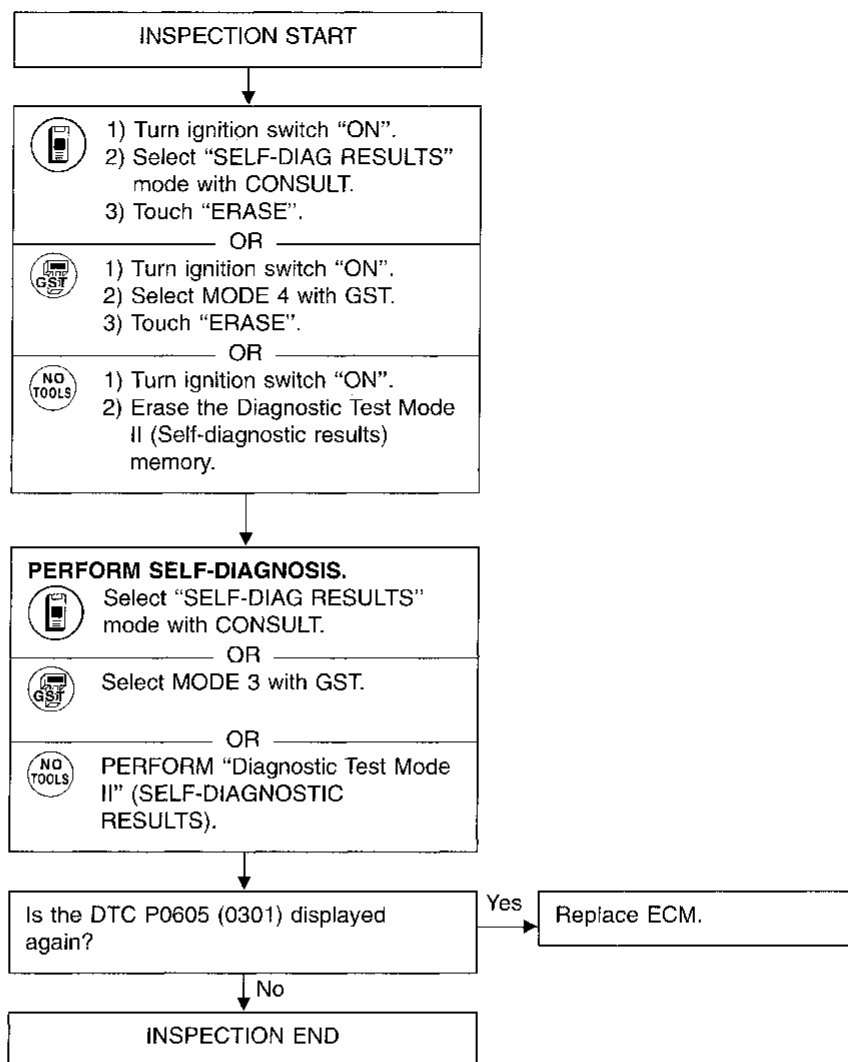

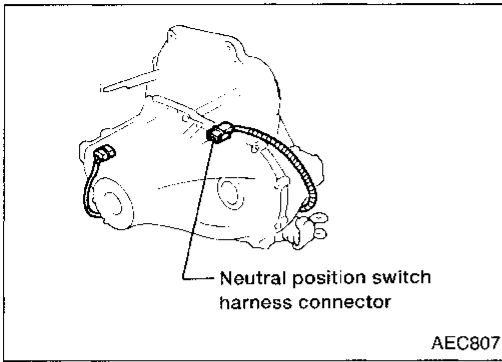

**Park/Neutral Position Switch (DTC: 1003)**

When the gear position is "P" (A/T models only) or "N", park/neutral position switch is "ON".

ECM detects the park/neutral position when continuity with ground exists.

Diagnostic Trouble Code No.	Malfunction is detected when ....	Check Items (Possible Cause)
P0705 1003	<ul style="list-style-type: none"> <li>The signal of the park/neutral position switch is not changed in the process of engine starting and driving.</li> </ul>	<ul style="list-style-type: none"> <li>Harness or connectors (The neutral position switch or inhibitor switch circuit is open or shorted.)</li> <li>Neutral position switch (M/T models)</li> <li>Inhibitor switch (A/T models)</li> </ul>

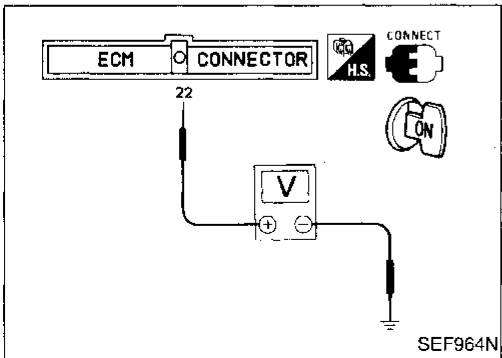
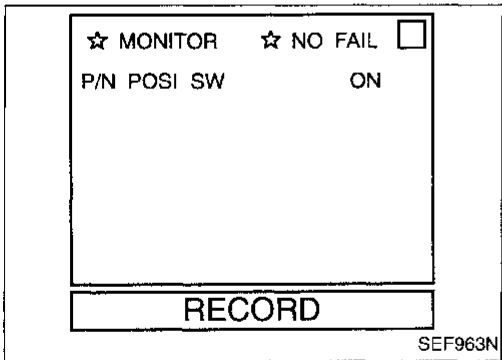
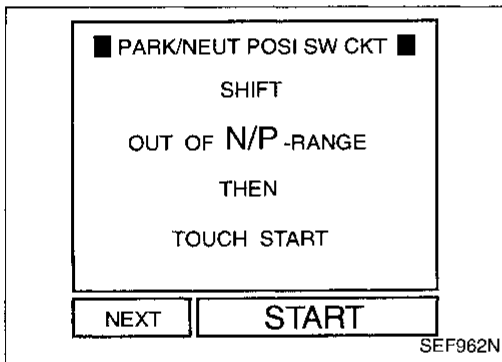

**OVERALL FUNCTION CHECK**

Use this procedure to check the overall function of the park/neutral position switch circuit. During this check, a DTC might not be confirmed.

- Turn ignition switch "ON".
- Perform "PARK/NEUT POSI SW CKT" in "FUNCTION TEST" mode with CONSULT.

OR

- Select "P/N POSI SW" in "DATA MONITOR" mode with CONSULT.
- Check the "P/N POSI SW" signal under the following conditions.

Condition (Gear position)	Signal
"P" (A/T only) and "N" position	ON
Except the above position	OFF

OR

- Turn ignition switch "ON".
- Check voltage between ECM terminal ② and body ground under the following conditions.

Condition (Gear position)	Voltage (V)
"P" (A/T only) and "N" position	Approx. 0
Except the above position	Battery voltage

Park/Neutral Position Switch (DTC: 1003)  
(Cont'd)

EC-PNP/SW-01

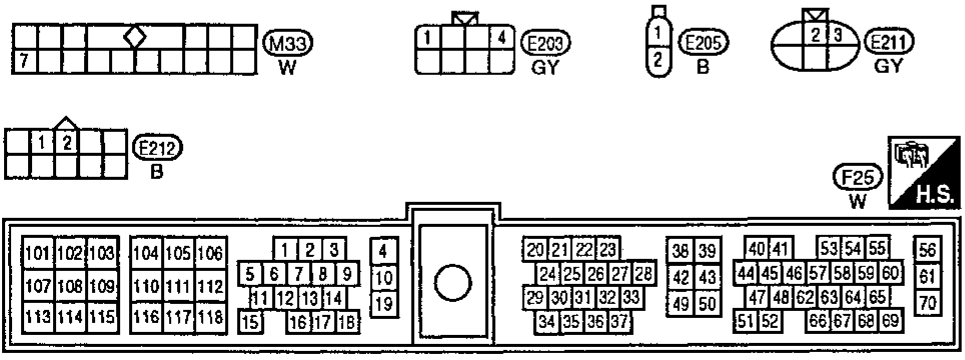
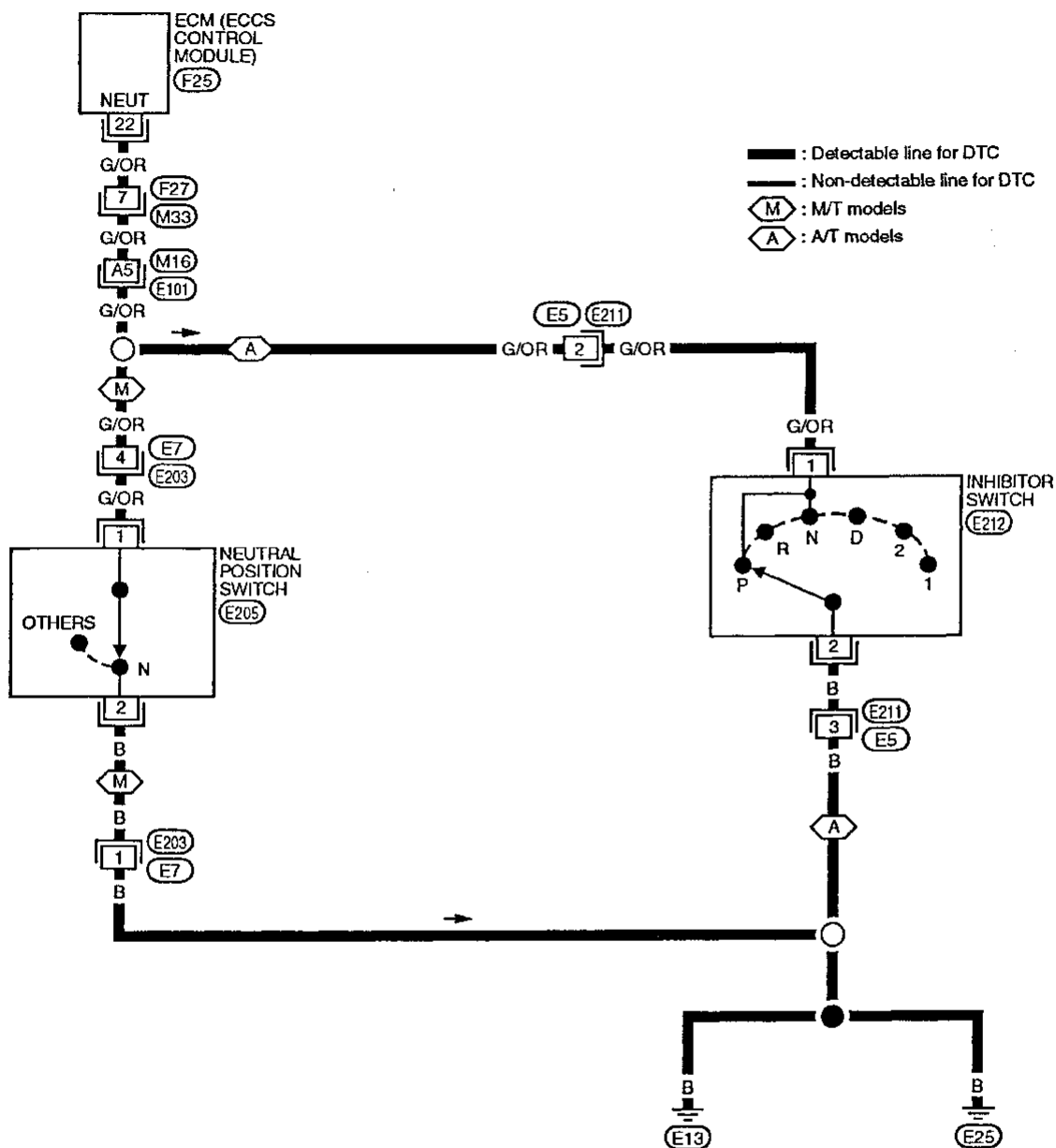

Refer to last page (Foldout page).  
(M16, E101)



**Park/Neutral Position Switch (DTC: 1003)  
(Cont'd)**

**DIAGNOSTIC PROCEDURE**

**Neutral position switch (M/T models)**

INSPECTION START

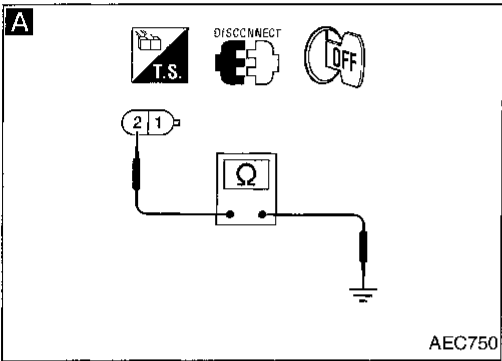
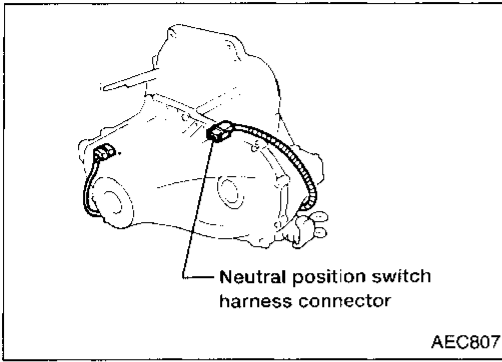

**A**

**CHECK GROUND CIRCUIT.**

1. Turn ignition switch "OFF".
2. Disconnect neutral position switch harness connector.
3. Check harness continuity between terminal ② and body ground.  
**Continuity should exist.**  
If OK, check harness for short.

NG → Check the following.

- Harness connectors (E203), (E7)
- Harness for open or short between neutral position switch and body ground

If NG, repair harness or connectors.

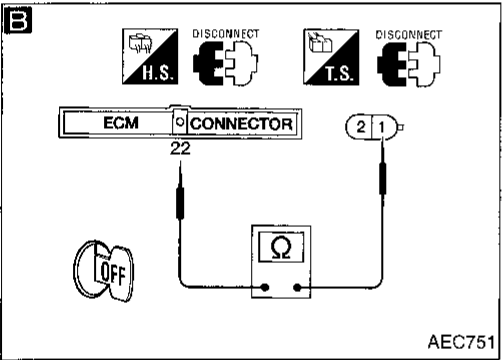

**B**

**CHECK INPUT SIGNAL CIRCUIT.**

1. Turn ignition switch "OFF".
2. Disconnect ECM harness connector.
3. Check harness continuity between ECM terminal ② and terminal ①.  
**Continuity should exist.**  
If OK, check harness for short.

NG → Check the following.

- Harness connectors (F27), (M33)
- Harness connectors (E7), (E203)
- Harness connectors (M16), (E101)
- Harness for open or short between ECM and neutral position switch

If NG, repair harness or connectors.

**CHECK COMPONENT**  
(Neutral position switch).  
Refer to MT section

NG → Replace neutral position switch.

Disconnect and reconnect harness connectors in the circuit. Then retest.

Trouble is not fixed.

Check ECM pin terminals for damage and check the connection of ECM harness connector. Reconnect ECM harness connector and retest.

INSPECTION END

Park/Neutral Position Switch (DTC: 1003)  
(Cont'd)

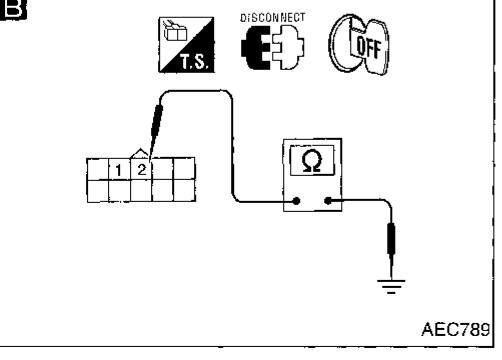
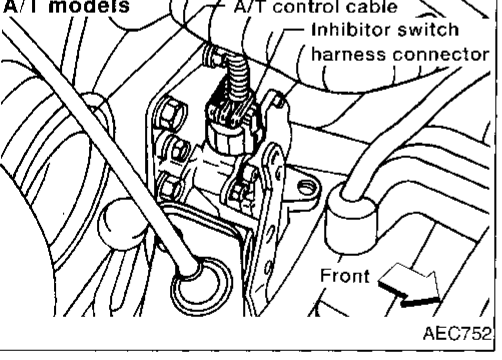
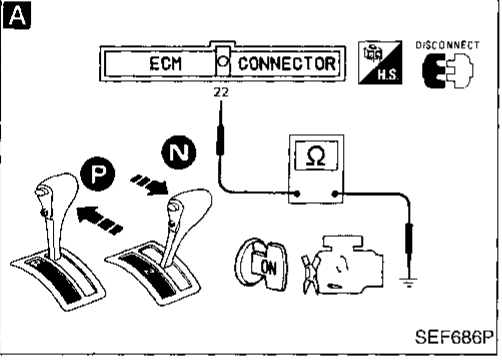
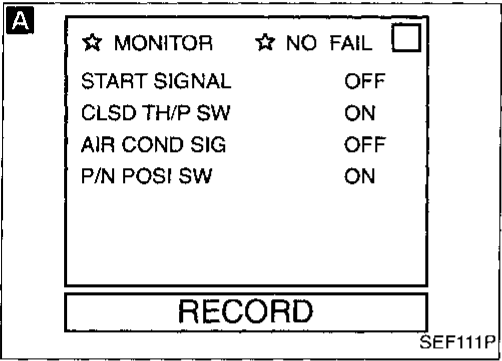
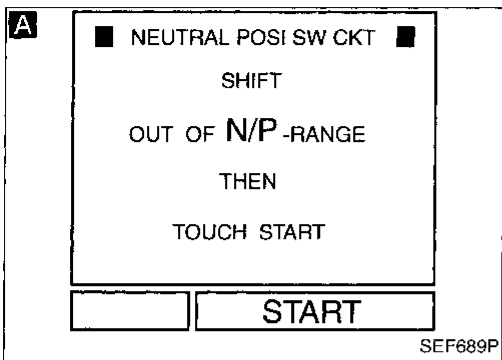

Inhibitor switch (A/T models)

INSPECTION START

**A**

**CHECK OVERALL FUNCTION.**

1. Turn ignition switch "ON".
2. Perform "NEUTRAL POSI SW CKT" in "FUNCTION TEST" mode with CONSULT.

OR

1. Turn ignition switch "ON".
2. Check neutral position switch signal in "DATA MONITOR" mode with CONSULT.

**"N" or "P" position: ON**  
**Except above: OFF**

OR

1. Make sure that inhibitor switch circuit functions properly. (Refer to AT section.)
2. Disconnect ECM harness connector.
3. Shift selector lever to "P" position.
4. Turn ignition switch "ON".
5. Check harness continuity between ECM terminal ② and body ground.  
**Continuity should exist.**  
If OK, check harness for short.
6. Shift selector lever to "N" position.
7. Check harness continuity between ECM terminal ② and body ground.  
**Continuity should exist.**  
If OK, check harness for short.

OK → INSPECTION END

NG

**B**

**CHECK GROUND CIRCUIT.**

1. Disconnect inhibitor switch harness connector.
2. Check harness continuity between terminals ② and body ground.  
**Continuity should exist.**  
If OK, check harness for short.

NG → Check the following.

- Harness connectors (E211), (E5)
- Harness for open or short between inhibitor switch and body ground

If NG, repair harness or connectors.

OK

**C**

**CHECK INPUT SIGNAL CIRCUIT.**

1. Disconnect ECM harness connector.
2. Check harness continuity between ECM terminal ② and terminal ①.  
**Continuity should exist.**  
If OK, check harness for short.

NG → Check the following.

- Harness connectors (E211), (E5)
- Harness for open or short between ECM and inhibitor switch

If NG, repair harness or connectors.

OK

(Go to next page.)

CI  
MA  
EM  
LC  
EC  
FE  
CL  
MT  
AT  
FA  
RA  
BR  
ST  
RS  
BT  
HA  
EL  
DX

Park/Neutral Position Switch (DTC: 1003)  
(Cont'd)

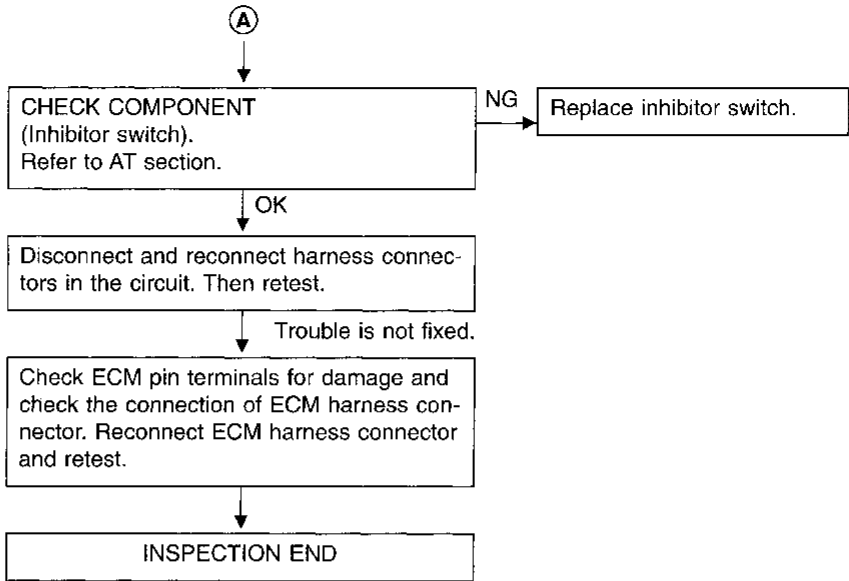
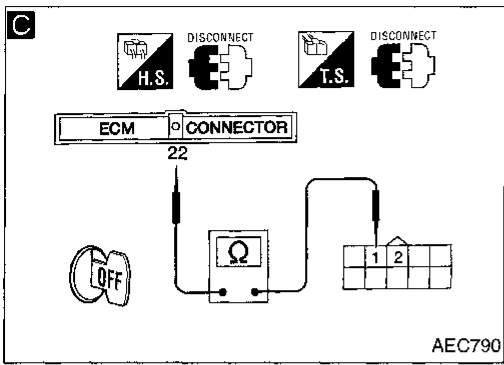

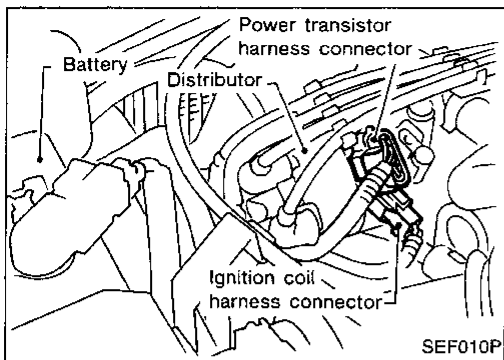

**Ignition Signal (DTC: 0201)**

**COMPONENT DESCRIPTION**

**Ignition coil & power transistor (Built into distributor)**

The ignition coil is a small molded type. The ignition signal from the ECM is sent to the power transistor. The power transistor switches on and off the ignition coil primary circuit. As the primary circuit is turned on and off, the proper high voltage is induced in the coil secondary circuit.

Diagnostic Trouble Code No.	Malfunction is detected when ...	Check Items (Possible Cause)
P1320 0201	<ul style="list-style-type: none"> <li>● The ignition signal in the primary circuit is not sent to ECM during engine cranking or running.</li> </ul>	<ul style="list-style-type: none"> <li>● Harness or connectors (The ignition primary circuit is open or shorted.)</li> <li>● Power transistor unit.</li> <li>● Resistor</li> <li>● Camshaft position sensor</li> <li>● Camshaft position sensor circuit</li> </ul>

**DIAGNOSTIC TROUBLE CODE CONFIRMATION PROCEDURE**

**Note:** If both DTC P0340 (0101) and P1320 (0201) are displayed, perform TROUBLE DIAGNOSIS FOR DTC P0340 first. Refer to EC-0.

- ①
- 1) Turn ignition switch "ON".
  - 2) Select "DATA MONITOR" mode with CONSULT.
  - 3) Start engine. (If engine does not run, turn ignition switch to "START" for at least 5 seconds.)

OR

- ②
- 1) Turn ignition switch "ON".
  - 2) Start engine. (If engine does not run, turn ignition switch to "START" for at least 5 seconds.)
  - 3) Select MODE 3 with GST.

OR

- ③
- 1) Turn ignition switch "ON".
  - 2) Start engine. (If engine does not run, turn ignition switch to "START" for at least 5 seconds.)
  - 3) Turn ignition switch "OFF" and wait at least 5 seconds, then turn "ON".
  - 4) Perform "Diagnostic Test Mode II" (Self-diagnostic results) with ECM.

Ignition Signal (DTC: 0201) (Cont'd)

EC-IGN/SG-01

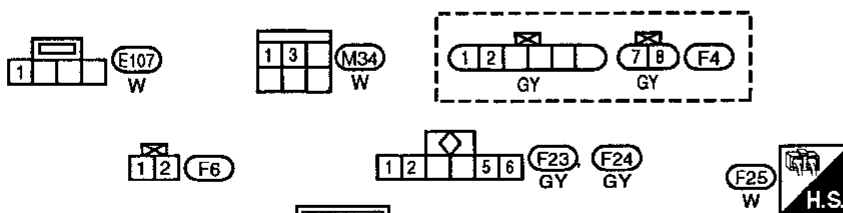
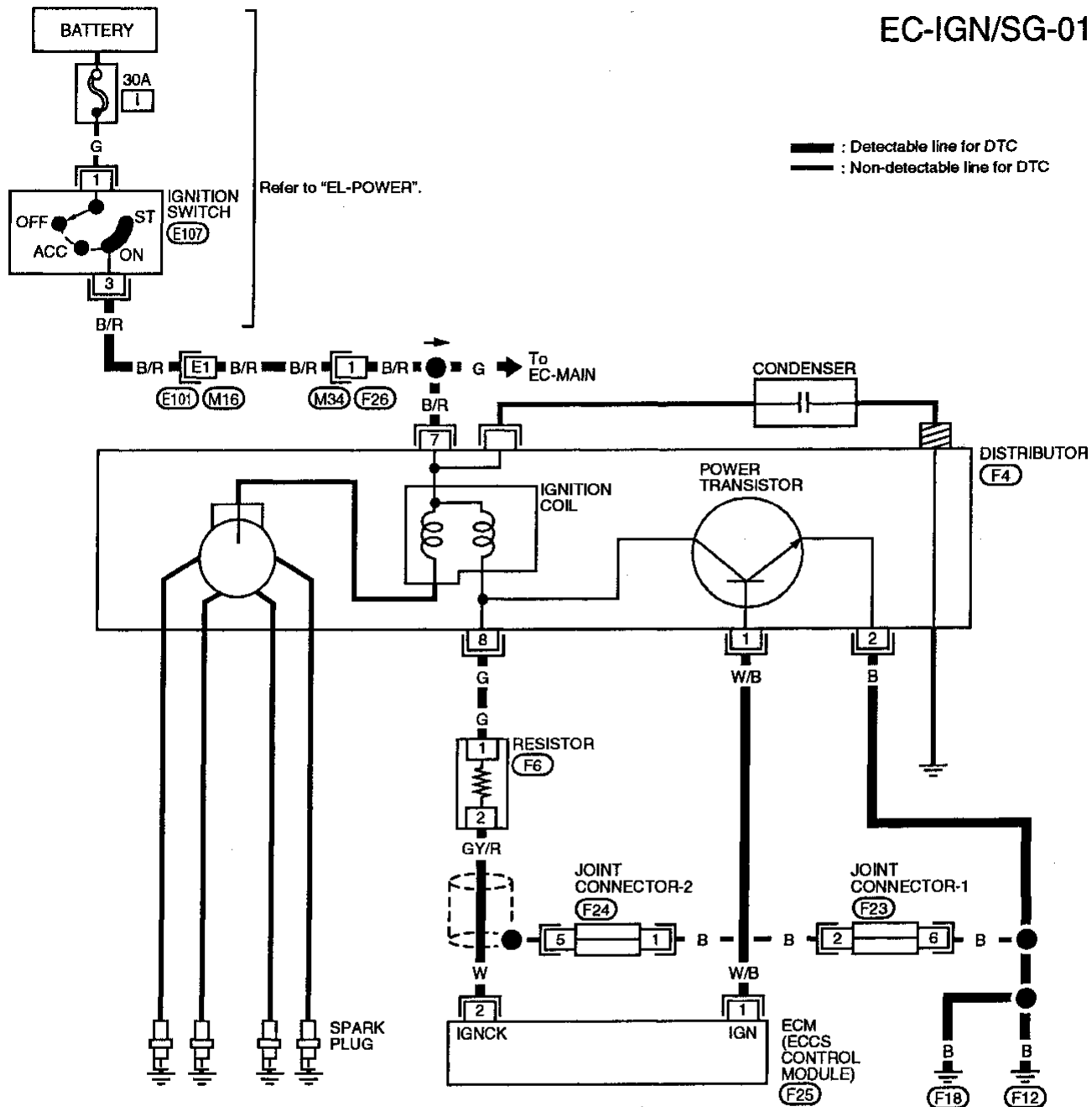

Refer to last page (Foldout page).

(M16), (E101)

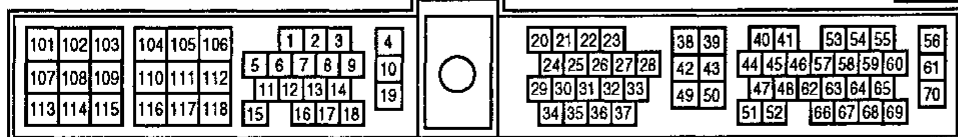

Ignition Signal (DTC: 0201) (Cont'd)  
DIAGNOSTIC PROCEDURE

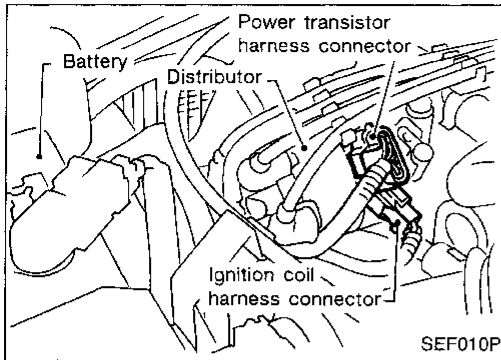

INSPECTION START

Turn ignition switch "OFF", and restart engine.  
**Is engine running?**

Yes → (A) (Go to next page.)

No

**A**  
**CHECK POWER SUPPLY.**  
1. Turn ignition switch "OFF".  
2. Disconnect ignition coil harness connector.  
3. Turn ignition switch "ON".  
4. Check voltage between terminal ⑦ and ground with CONSULT or tester.  
**Voltage: Battery voltage**

NG → Check the following.  
● Harness connectors  
● **E101**, **M16**  
● Harness connectors  
● **M34**, **F26**  
● Harness for open or short between ignition coil and ignition switch  
If NG, repair harness or connectors.

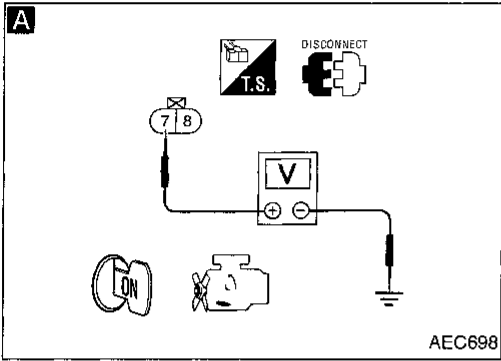

OK

**B**  
**CHECK GROUND CIRCUIT.**  
1. Turn ignition switch "OFF".  
2. Disconnect power transistor harness connector.  
3. Check harness continuity between terminal ② and engine ground.  
**Continuity should exist.**  
If OK, check harness for short.

NG → Repair harness or connectors.

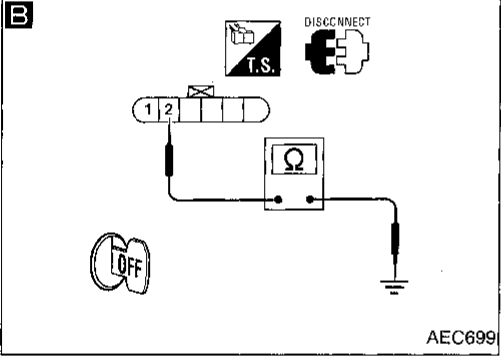

OK

**C**  
**CHECK INPUT SIGNAL CIRCUIT.**  
1. Disconnect ECM harness connector.  
2. Check harness continuity between ECM terminal ① and power transistor terminal ①.  
**Continuity should exist.**  
If OK, check harness for short.

NG → Repair harness or connectors.

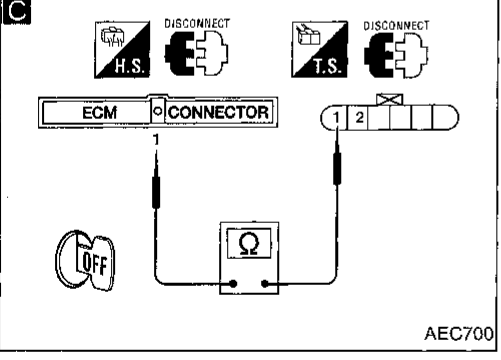

OK

**CHECK COMPONENTS**  
(Ignition coil, power transistor).  
Refer to "COMPONENT INSPECTION", EC-185.

NG → Replace malfunctioning component(s).

OK

Disconnect and reconnect harness connectors in the circuit. Then retest.

Trouble is not fixed.

Check ECM pin terminals for damage and check the connection of ECM harness connector. Reconnect ECM harness connector and retest.

INSPECTION END

GI  
MA  
EM  
LC  
EC  
FE  
CL  
MT  
AT  
FA  
RA  
BR  
ST  
RS  
BT  
HA  
EL  
IDX

Ignition Signal (DTC: 0201) (Cont'd)

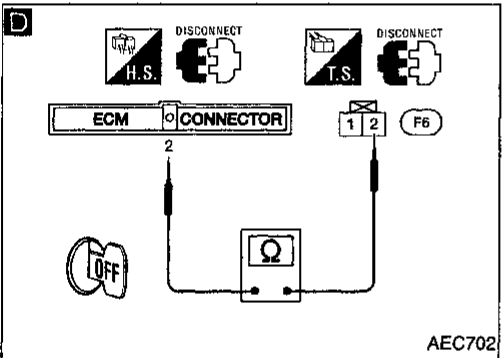
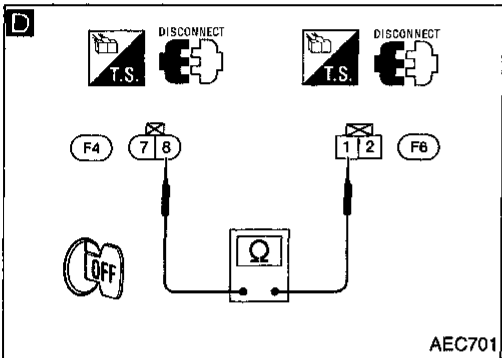
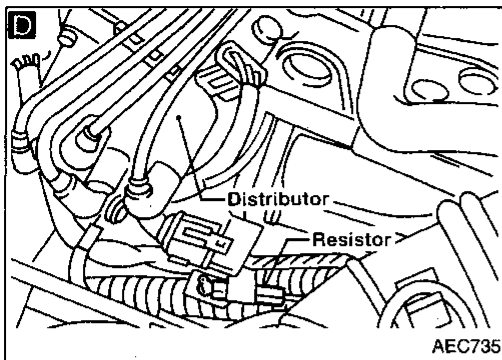

A

**D**

**CHECK INPUT SIGNAL CIRCUIT.**

1. Stop engine.
2. Disconnect ignition coil harness connector.
3. Strip tape covering resistor.
4. Disconnect ECM harness connector.
5. Check harness continuity between ignition coil terminal ⑧ and resistor terminal ①, resistor terminal ② and ECM terminal ②.

**Continuity should exist.**  
If OK, check harness for short.

NG → Repair harness or connectors.

OK

**CHECK COMPONENTS (Resistor).**  
Refer to "COMPONENT INSPECTION" on next page.

NG → Replace resistor.

OK

Disconnect and reconnect harness connectors in the circuit. Then retest.

Trouble is not fixed.

Check ECM pin terminals for damage and check the connection of ECM harness connector. Reconnect ECM harness connector and retest.

INSPECTION END

**Ignition Signal (DTC: 0201) (Cont'd)  
COMPONENT INSPECTION**

**Ignition coil**

1. Disconnect ignition coil harness connector.
2. Check resistance as shown in the figure.

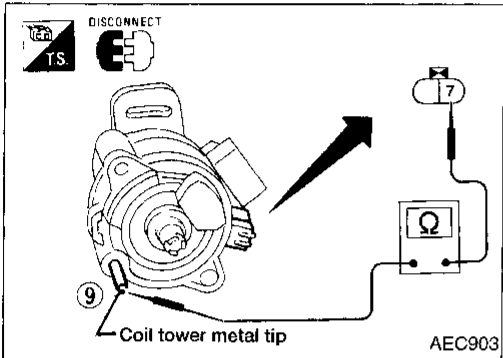
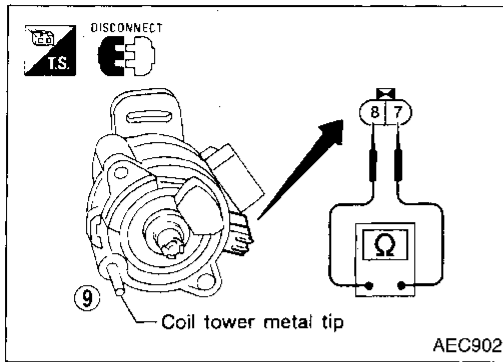

Terminal	Resistance [at 25°C (77°F)]
⑦ - ⑧ (Primary coil)	0.5 - 1.0 Ω
⑦ - ⑨ (Secondary coil)	Approximately 25 kΩ

For checking secondary coil, remove distributor cap and measure resistance between coil tower metal tip ⑨ and terminal ⑦.

If NG, replace distributor assembly as a unit.

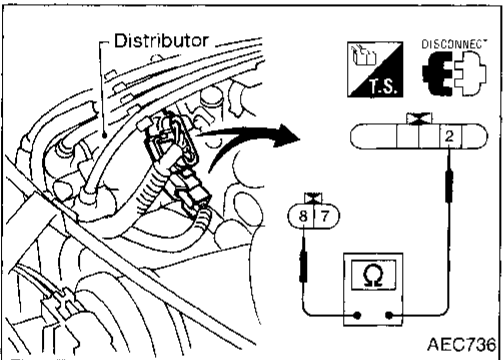

**Power transistor**

1. Disconnect camshaft position sensor & power transistor harness connector and ignition coil harness connector.
2. Check power transistor resistance between terminals ② and ⑧.

Terminals	Resistance	Result
② and ⑧	Except 0Ω	OK
	0Ω	NG

If NG, replace distributor assembly.

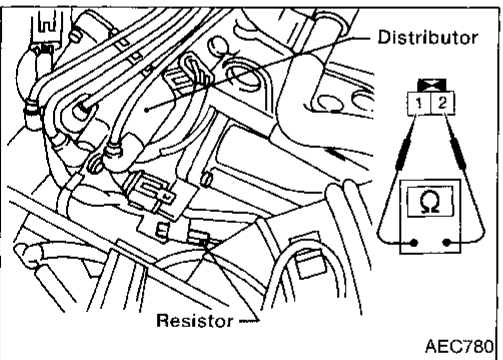

**Resistor**

1. Disconnect resistor harness connector.
2. Check resistance between terminals ① and ②  
**Resistance: Approximately 2.2 kΩ [at 25°C (77°F)]**  
If NG, replace resistor.

GI  
MA  
EM  
LC  
EC  
FE  
CL  
MT  
AT  
FA  
RA  
BR  
ST  
RS  
BT  
HA  
EL  
IDX



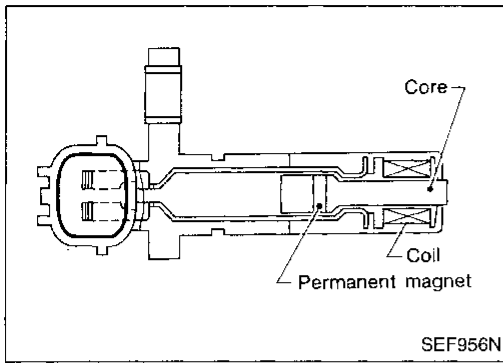

**Crankshaft Position Sensor (CKPS) (OBD) (COG) (DTC: 0905)**

The crankshaft position sensor (OBD) is located on the transmission housing facing the gear teeth (cogs) of the flywheel or drive plate. It detects the fluctuation of the engine revolution. The sensor consists of a permanent magnet, core and coil. When the engine is running, the high and low parts of the teeth cause the gap with the sensor to change. The changing gap causes the magnetic field near the sensor to change.

Due to the changing magnetic field, the voltage from the sensor changes.

The ECM receives the voltage signal and detects the fluctuation of the engine revolution.

This sensor is not directly used to control the engine system. It is used only for the on-board diagnosis of misfire.

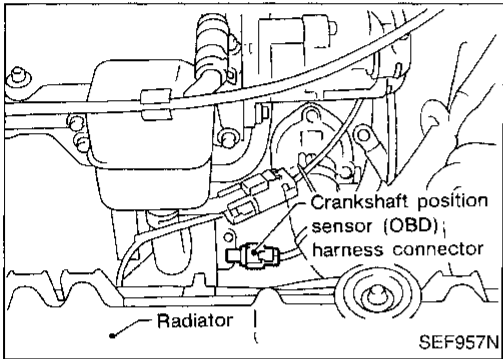

Diagnostic Trouble Code No.	Malfunction is detected when ....	Check Items (Possible Cause)
P1336 0905	<ul style="list-style-type: none"> <li>● A chipping of the flywheel or drive plate gear tooth (cog) is detected by the ECM.</li> </ul>	<ul style="list-style-type: none"> <li>● Harness or connectors</li> <li>● Crankshaft position sensor (OBD)</li> <li>● Flywheel (Drive plate)</li> </ul>

**DIAGNOSTIC TROUBLE CODE CONFIRMATION PROCEDURE**



- 1) Turn ignition switch "ON" and select "DATA MONITOR" mode with CONSULT.
- 2) Start engine and run it for at least 4 minutes at idle speed.

OR



- 1) Start engine and run it for at least 4 minutes at idle speed.
- 2) Select "MODE 3" with GST.

OR



- 1) Start engine and run it for at least 4 minutes at idle speed.
- 2) Turn ignition switch "OFF", wait at least 5 seconds and then turn "ON".
- 3) Perform "Diagnostic Test Mode II" (Self-diagnostic results) with ECM.

Crankshaft Position Sensor (CKPS) (OBD)  
(COG) (DTC: 0905) (Cont'd)

EC-CKPS-01

GI

MA

EM

LC

**EC**

FE

CL

MT

AT

FA

RA

BR

ST

RS

BT

HA

EL

IDX

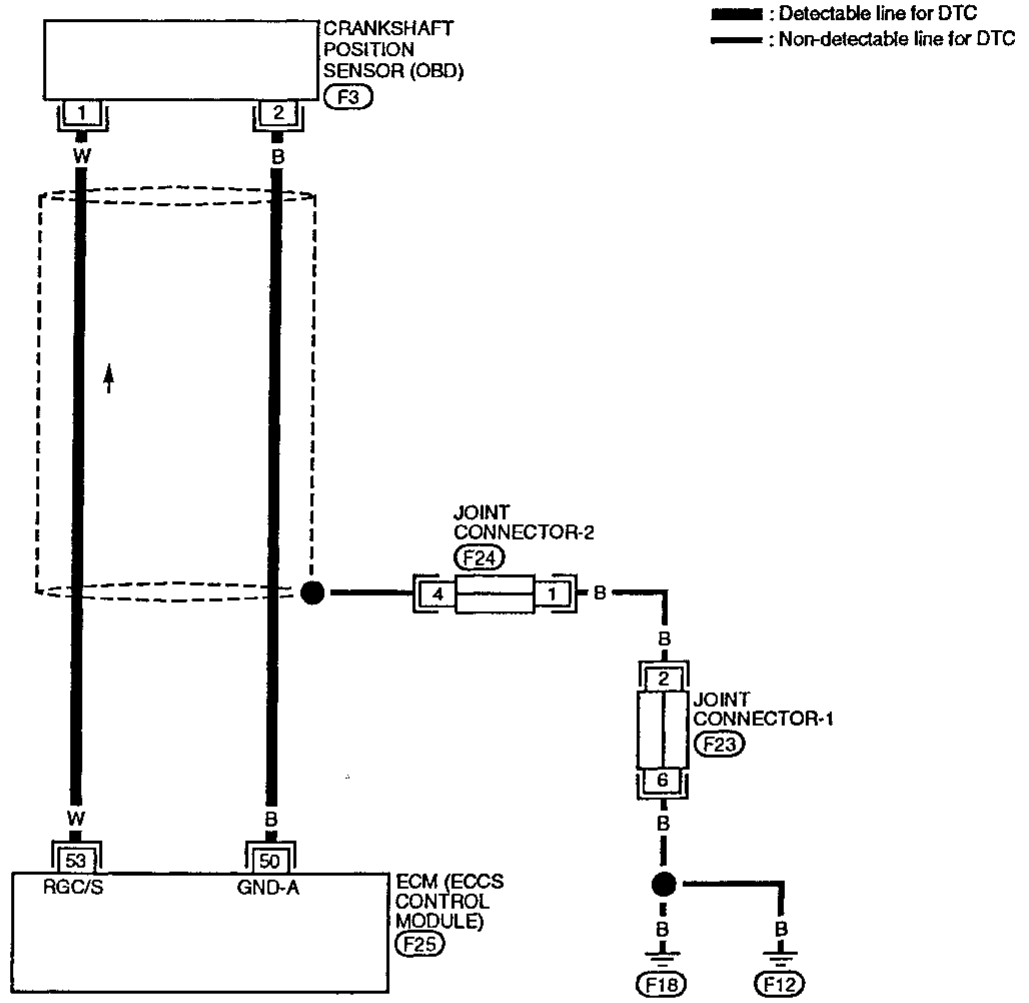

Refer to last page (Foldout page).

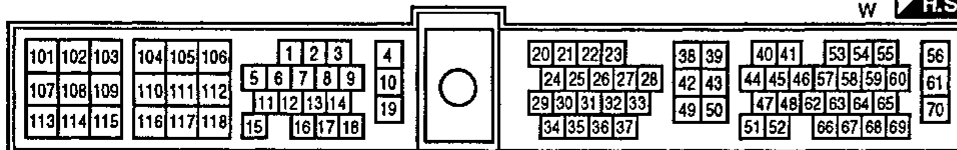
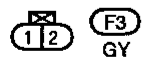

**Crankshaft Position Sensor (CKPS) (OBD) (COG) (DTC: 0905) (Cont'd)**

**DIAGNOSTIC PROCEDURE**

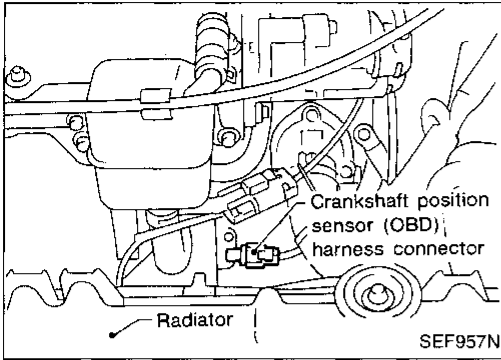

INSPECTION START

**A**

**CHECK INPUT SIGNAL.**

1. Turn ignition switch "OFF".
2. Disconnect crankshaft position sensor (OBD) and ECM harness connectors.
3. Check continuity between ECM terminal 53 and terminal 1.

**Continuity should exist.**  
If OK, check harness for short.

NG → Repair harness or connectors.

OK

**B**

**CHECK GROUND CIRCUIT.**

1. Turn ignition switch "OFF".
2. Check harness continuity between terminal 2 and engine ground.

**Continuity should exist.**  
If OK, check harness for short.

NG → Check the following.  
● Harness for open or short between ECM and crankshaft position sensor (OBD) harness connector  
If NG, repair harness or connectors.

OK

Loosen and retighten the fixing bolt of the crankshaft position sensor (OBD). Then retest.

Trouble is not fixed.

**CHECK COMPONENT** [Crankshaft position sensor (OBD)]. Refer to "COMPONENT INSPECTION" on next page.

NG → Replace crankshaft position sensor (OBD).

OK

Disconnect and reconnect harness connectors in the circuit. Then retest.

Trouble is not fixed.

Check ECM pin terminals for damage and check the connection of ECM harness connector. Reconnect ECM harness connector and retest.

Trouble is not fixed.

Visually check for chipping flywheel or drive plate gear tooth (cog).

NG → Replace the flywheel or drive plate.

OK

INSPECTION END

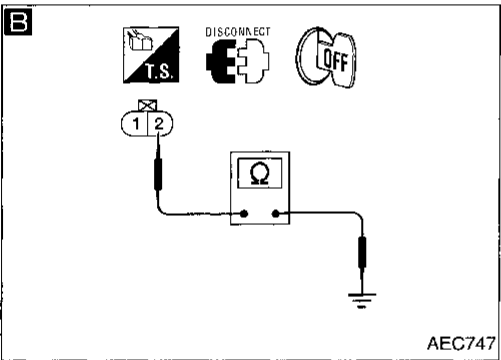
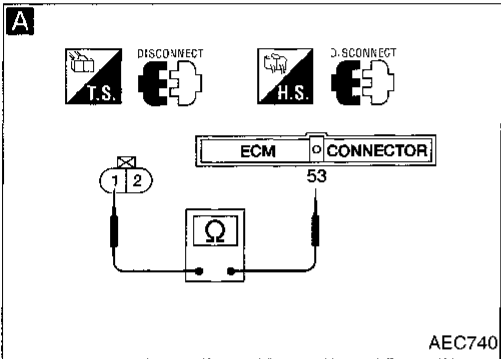

## Crankshaft Position Sensor (CKPS) (OBD) (COG) (DTC: 0905) (Cont'd)

### COMPONENT INSPECTION

#### Crankshaft position sensor (OBD)

1. Disconnect crankshaft position sensor (OBD) harness connector.
2. Loosen the fixing bolt of the sensor.
3. Remove the sensor.
4. Visually check the sensor for chipping.

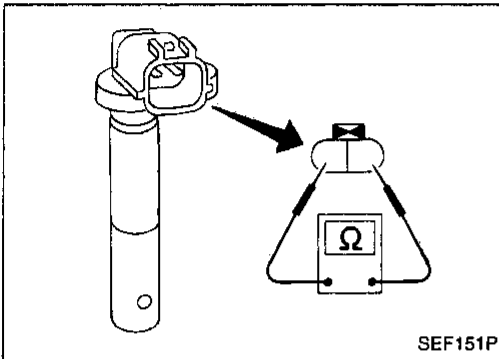
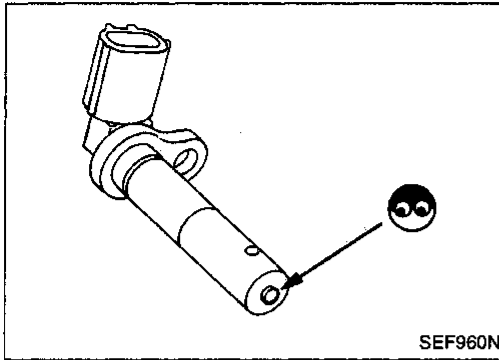

5. Check resistance as shown in the figure.  
**Resistance: Approximately 166 - 204Ω**  
**[at 25°C (77°F)]**

GI

MA

EM

LC

EC

FE

CL

MT

AT

FA

RA

BR

ST

RS

BT

HA

EL

IDX

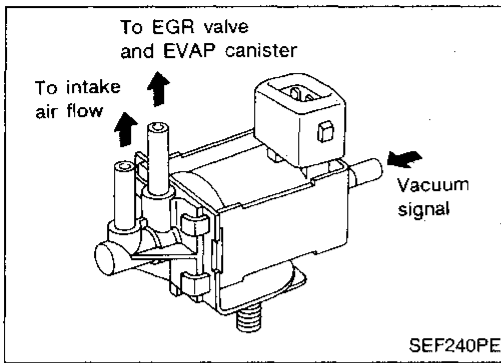

### EGR Valve and EVAP Canister Purge Control Solenoid Valve (DTC: 1005)

The EGR valve and EVAP canister purge control solenoid valve responds to signals from the ECM. When the ECM sends an ON (ground) signal, the coil in the solenoid valve is energized. A plunger will then move to cut the vacuum signal from the throttle body to the EGR valve and EVAP canister purge valve. When the ECM sends an OFF signal, the vacuum signal passes through the solenoid valve. The signal then reaches the EGR valve and EVAP canister.

Diagnostic Trouble Code No.	Malfunction is detected when ....	Check Items (Possible Cause)
P1400 1005	<ul style="list-style-type: none"> <li>The improper voltage signal is sent to ECM through EGR valve &amp; EVAP canister purge control solenoid valve.</li> </ul>	<ul style="list-style-type: none"> <li>Harness or connectors (The EGR valve &amp; EVAP canister purge control solenoid valve circuit is open or shorted.)</li> <li>EGR valve &amp; EVAP canister purge control solenoid valve</li> </ul>

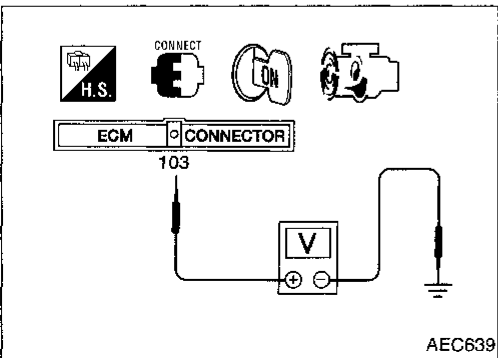
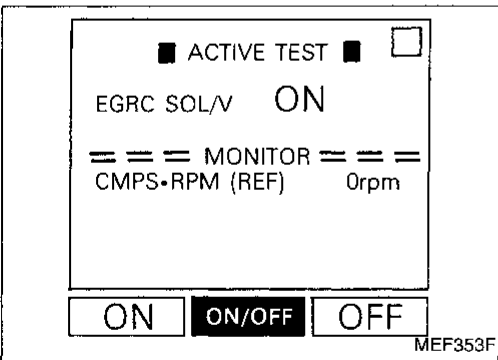
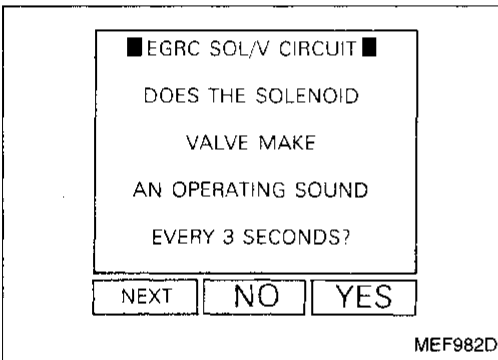

### OVERALL FUNCTION CHECK

Use this procedure to check the overall function of the EGR valve & EVAP canister purge control solenoid valve circuit. During this check, a DTC might not be confirmed.

- 1) Turn ignition switch "ON".
  - 2) Perform "EGRC SOL/V CIRCUIT" in "FUNCTION TEST" mode with CONSULT.
- OR
- 1) Turn ignition switch "ON".
  - 2) Perform "EGRC SOLENOID VALVE" in "ACTIVE TEST" mode with CONSULT and check the operating sound, according to ON/OFF switching.
- OR
- 1) Start engine and warm it up sufficiently.
  - 2) Turn ignition switch "OFF" and wait at least 5 seconds.
  - 3) Start engine again.
  - 4) Check the voltage between ECM terminal **103** and ground at idle speed.  
**Voltage: 0.06 - 0.11V**
  - 5) Check that the voltage changes to battery voltage and returns to 0.06 - 0.11V when the engine speed increases to about 3,600 rpm.

EGR Valve and EVAP Canister Purge Control Solenoid Valve (DTC: 1005) (Cont'd)

EC-EGRC/V-01

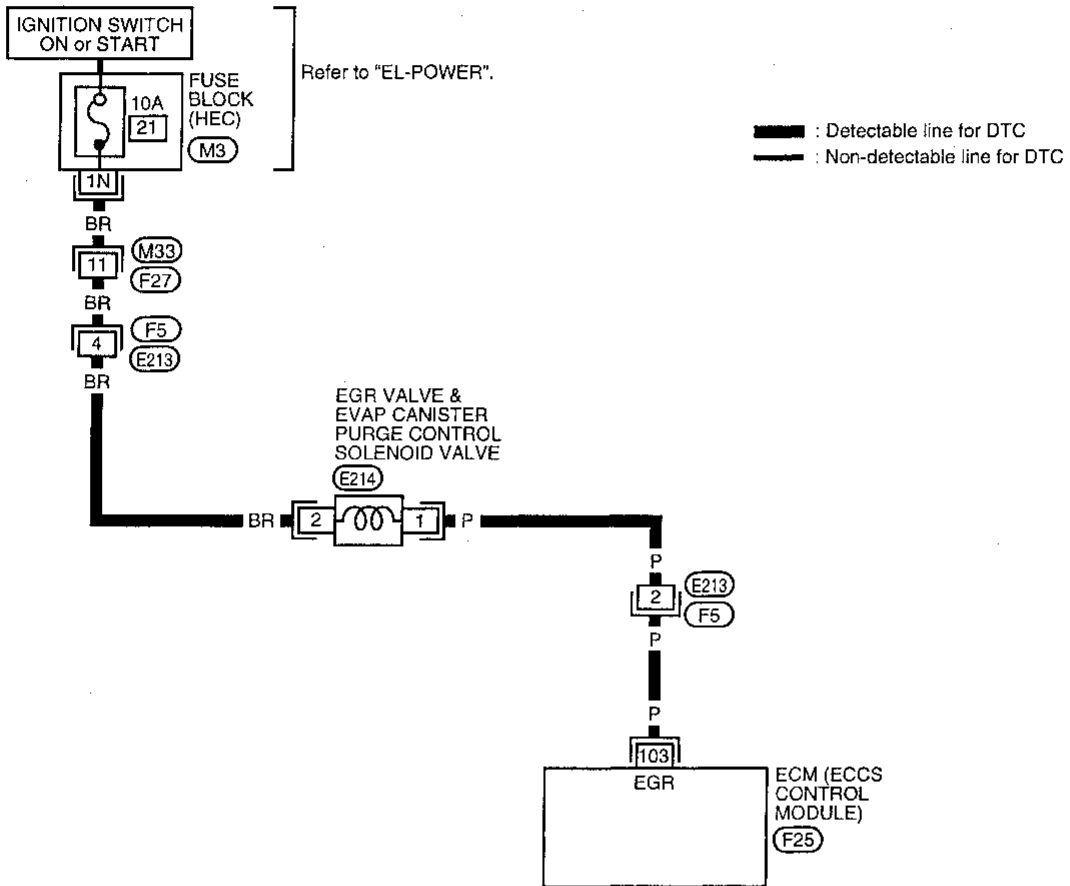

Refer to last page (Foldout page).

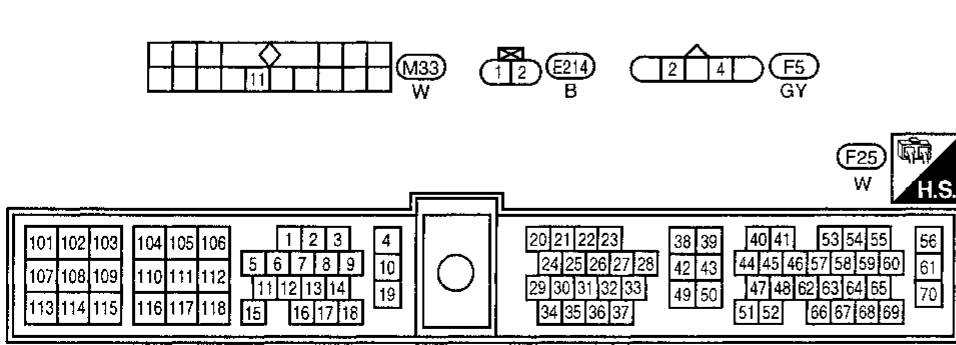

GI  
MA  
EM  
LC  
**EC**  
FE  
CL  
MT  
AT  
FA  
RA  
BR  
ST  
RS  
BT  
HA  
EL  
IDX

**EGR Valve and EVAP Canister Purge Control Solenoid Valve (DTC: 1005) (Cont'd)**

**DIAGNOSTIC PROCEDURE**

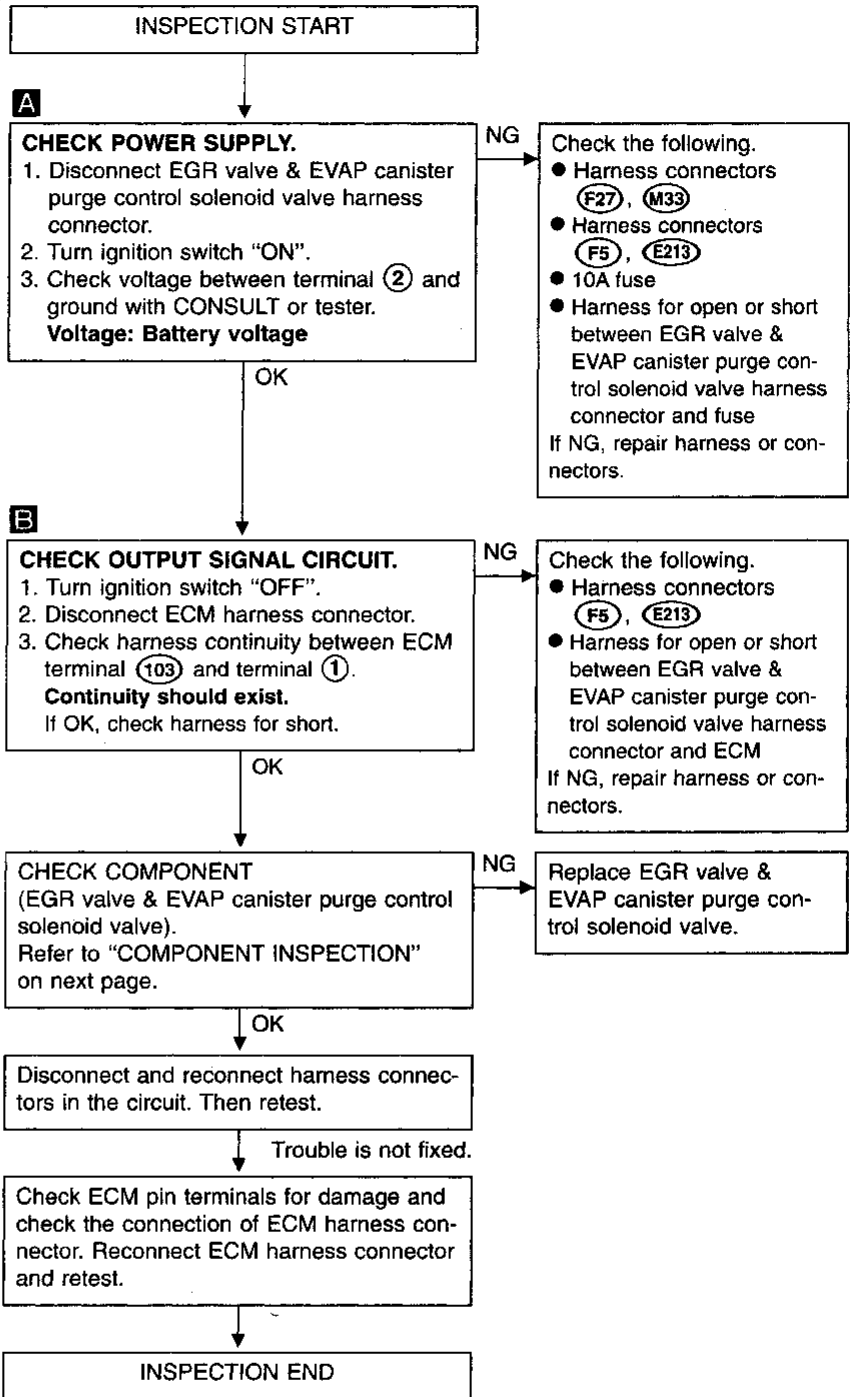
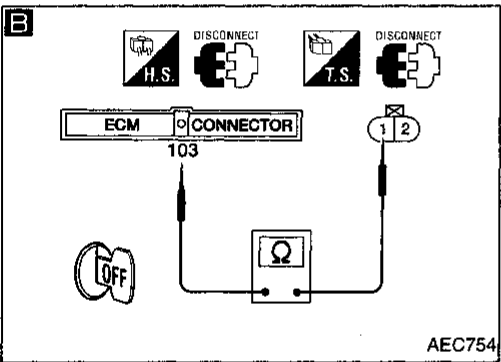
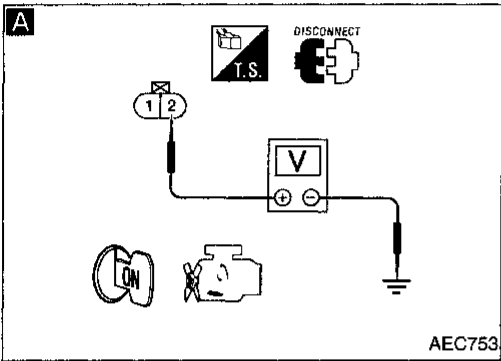
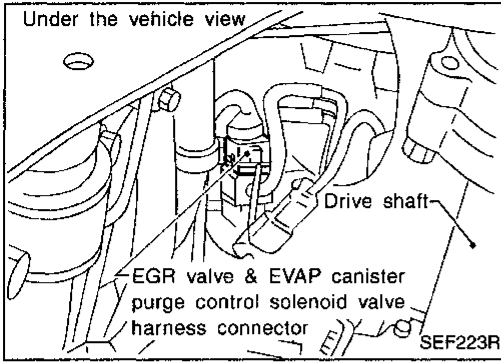

**EGR Valve and EVAP Canister Purge Control Solenoid Valve (DTC: 1005) (Cont'd)**

**COMPONENT INSPECTION**

**EGR valve and EVAP canister purge control solenoid valve**

Check air passage continuity.

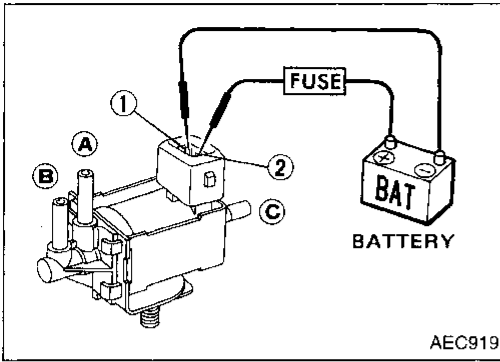

Condition	Air passage continuity between (A) and (B)	Air passage continuity between (A) and (C)
12V direct current supply between terminals ① and ②	Yes	No
No supply	No	Yes

If NG, replace solenoid valve.

GI  
MA  
EM  
LC  
EC  
FE  
CL  
MT  
AT  
FA  
RA  
BR  
ST  
RS  
BT  
HA  
EL  
IDX



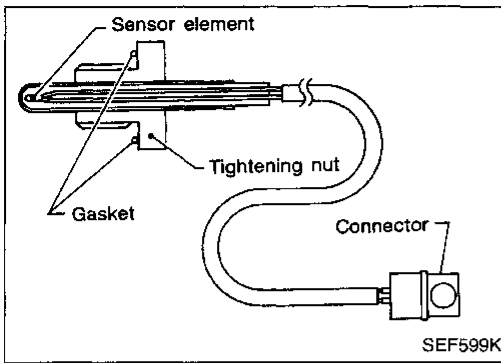

### EGR Temperature Sensor (DTC: 0305)

The EGR temperature sensor detects temperature changes in the EGR passage way. When the EGR valve opens, hot exhaust gases flow, and the temperature in the passage way changes. The EGR temperature sensor is a thermistor that modifies a voltage signal sent from the ECM. This modified signal then returns to the ECM as an input signal. As the temperature increases, EGR temperature sensor resistance decreases. This sensor is not directly used to control the engine system.

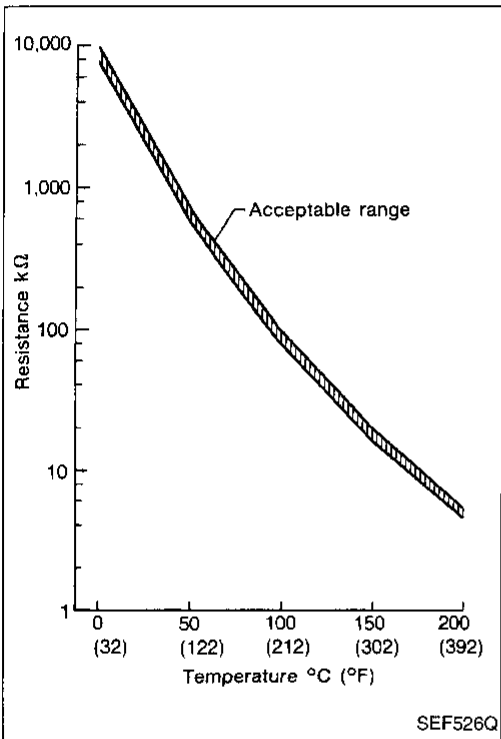

(Reference data)

EGR temperature °C (°F)	Voltage (V)	Resistance (MΩ)
0 (32)	4.81	7.9 - 9.7
50 (122)	2.82	0.57 - 0.70
100 (212)	0.8	0.08 - 0.10

Diagnostic Trouble Code No.	Malfunction is detected when ....	Check Items (Possible Cause)
P1401 0305	A) An excessively low voltage from the EGR temperature sensor is sent to ECM even when engine coolant temperature is low.	<ul style="list-style-type: none"> <li>● Harness or connectors (The EGR temperature sensor circuit is shorted.)</li> <li>● EGR temperature sensor</li> <li>● Malfunction of EGR function, EGRC-BPT valve or EGR valve &amp; EVAP canister purge control solenoid valve</li> </ul>
	B) An excessively high voltage from the EGR temperature sensor is sent to ECM even when engine coolant temperature is high.	<ul style="list-style-type: none"> <li>● Harness or connectors (The EGR temperature sensor circuit is open.)</li> <li>● EGR temperature sensor</li> <li>● Malfunction of EGR function, EGRC-BPT valve or EGR valve &amp; EVAP canister purge control solenoid valve</li> </ul>

**EGR Temperature Sensor (DTC: 0305)  
(Cont'd)**

**DIAGNOSTIC TROUBLE CODE CONFIRMATION  
PROCEDURE**

**Procedure for malfunction A**

- 1) Turn ignition switch "ON" and select "DATA MONITOR" mode with CONSULT.
- 2) Confirm that the engine coolant temperature is lower than 50°C (122°F). (If necessary, wait until the engine coolant temperature is the same as atmosphere temperature.)
- 3) Start engine and run it for at least 8 seconds at idle speed. [With the engine coolant temperature lower than 50°C (122°F)].

OR

- 1) Turn ignition switch "ON" and select "MODE 1" with GST.
- 2) Confirm that the engine coolant temperature is lower than 50°C (122°F). (If necessary, wait until the engine coolant temperature is the same as atmosphere temperature.)
- 3) Start engine and run it for at least 8 seconds at idle speed. [With the engine coolant temperature lower than 50°C (122°F)].
- 4) Select "MODE 3" with GST.

OR

- 1) Turn ignition switch "ON" and confirm that voltage between ECM terminal ⑤1 and ground is more than 2.35V. (If necessary, wait until the engine coolant temperature is the same as atmosphere temperature.)
- 2) Start engine and run it for at least 8 seconds at idle speed. (With the voltage between ECM terminal ⑤1 and ground should stay at more than 2.35V)
- 3) Turn ignition switch "OFF", wait at least 3 seconds and then turn "ON".
- 4) Perform "Diagnostic Test Mode II" (Self-diagnostic results) with ECM.

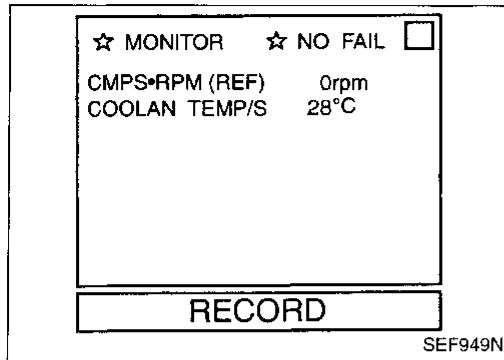

SEF949N

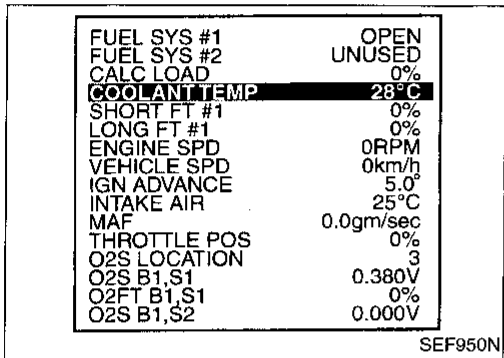

SEF950N

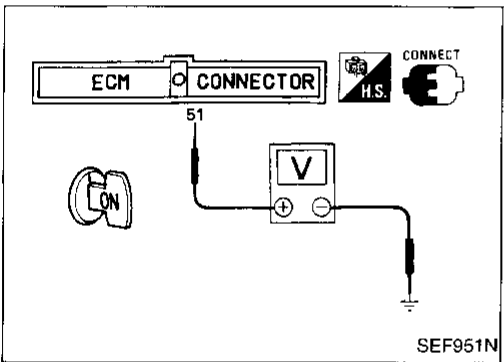

SEF951N

**Procedure for malfunction B**

- 1) Start engine and warm it up sufficiently.
- 2) Turn ignition switch "OFF", wait at least 3 seconds and then start engine again.
- 3) Select "DATA MONITOR" mode with CONSULT.
- 4) Run engine for at least 5 seconds at idle speed.

OR

- 1) Start engine and warm it up sufficiently.
- 2) Turn ignition switch "OFF", wait at least 3 seconds and then start engine again.
- 3) Run engine for at least 5 seconds at idle speed.
- 4) Select "MODE 3" with GST.

OR



- 1) Start engine and warm it up sufficiently.
- 2) Turn ignition switch "OFF", wait at least 3 seconds and then start engine again.
- 3) Run engine for at least 5 seconds at idle speed.
- 4) Turn ignition switch "OFF", wait at least 5 seconds and then turn "ON".
- 5) Perform "Diagnostic Test Mode II" (Self-diagnostic results) with ECM.



GI  
MA  
EM  
LC  
EC  
FE  
CL  
MT  
AT  
FA  
RA  
BR  
ST  
RS  
BT  
HA  
EL  
IDX

EGR Temperature Sensor (DTC: 0305)  
(Cont'd)

EC-EGR/TS-01

-  : Detectable line for DTC
-  : Non-detectable line for DTC
-  : A/T models

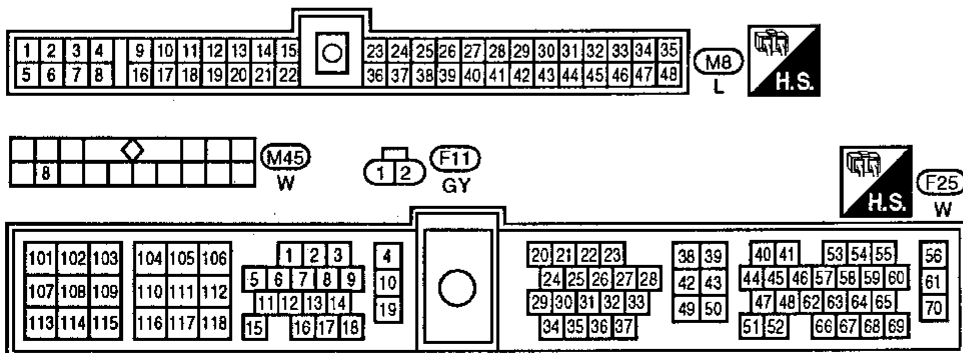
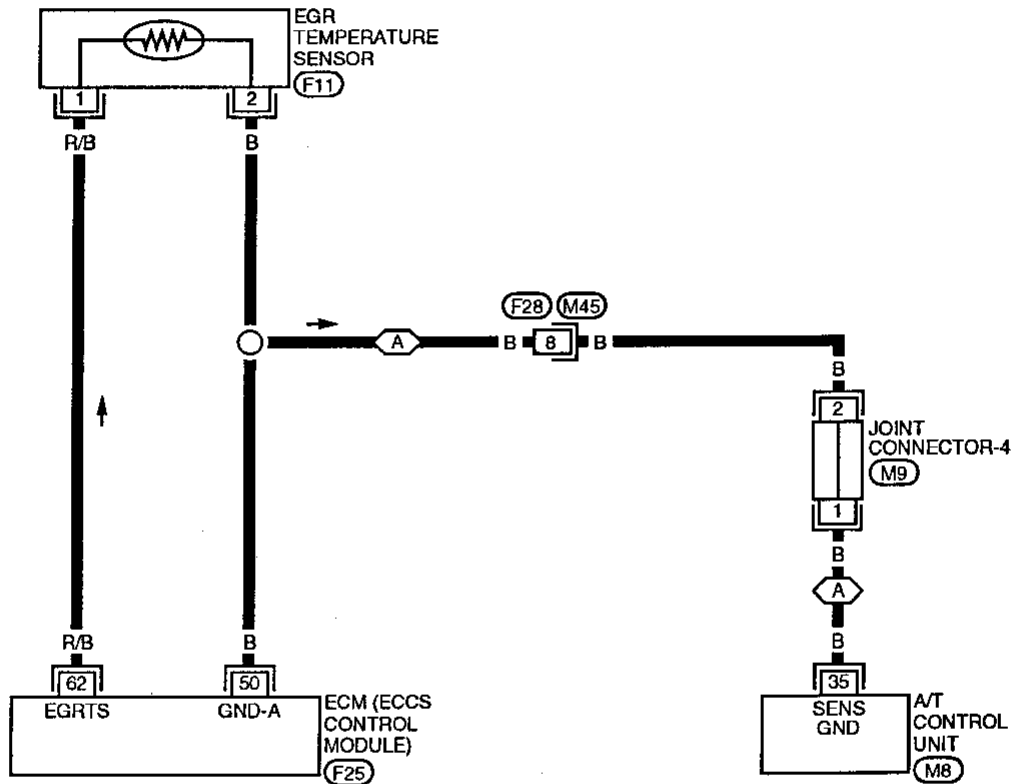

Refer to last page (Foldout page).

M9

EGR Temperature Sensor (DTC: 0305)  
(Cont'd)

DIAGNOSTIC PROCEDURE

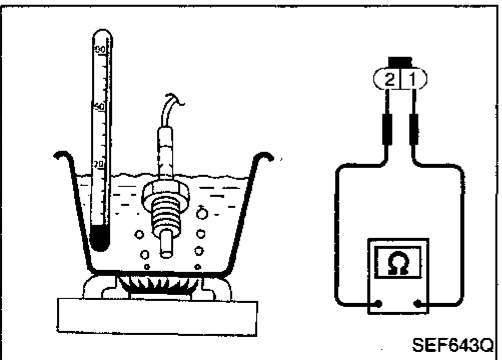
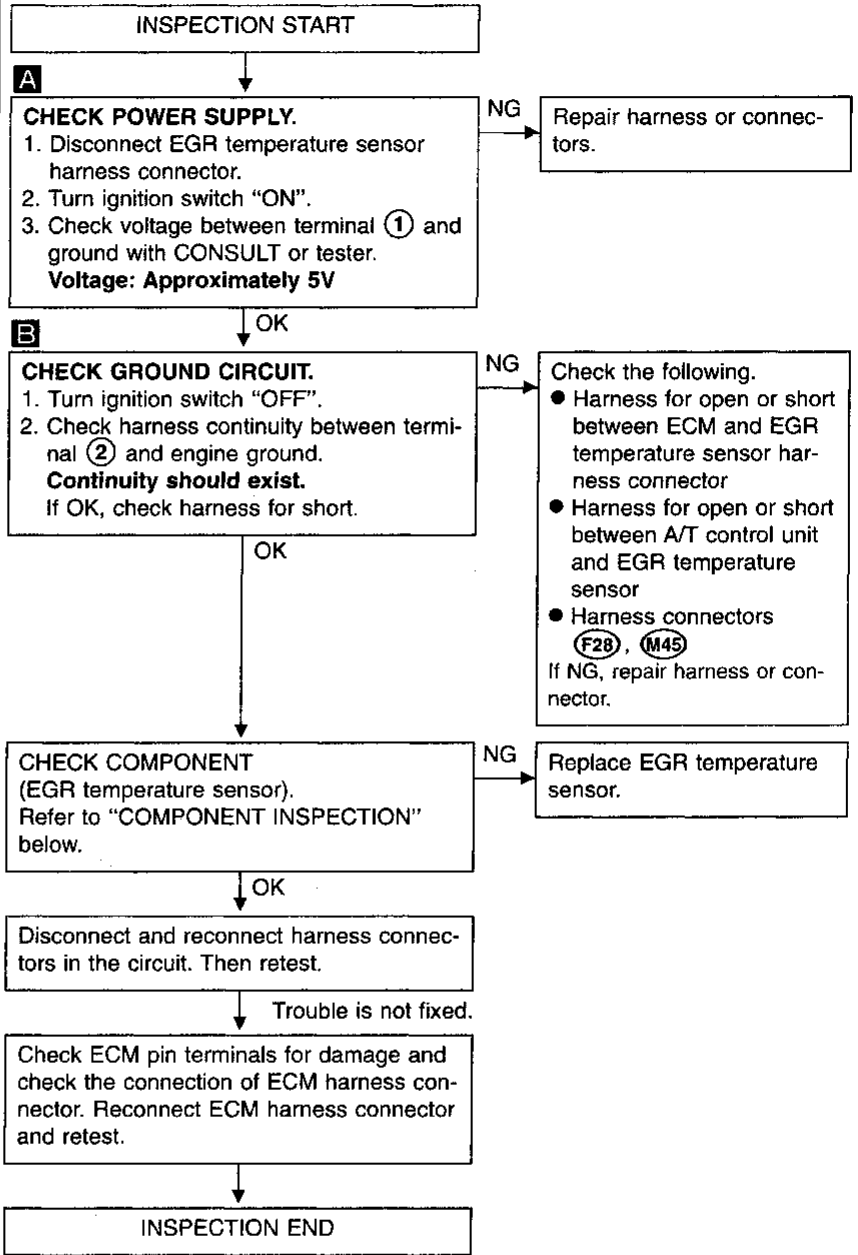
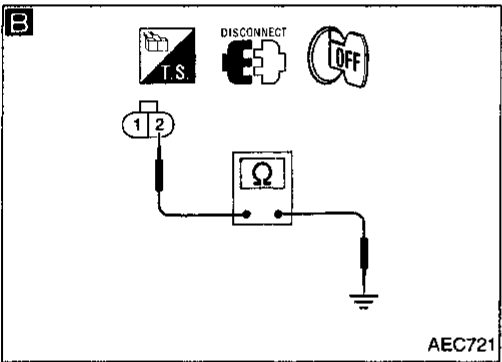
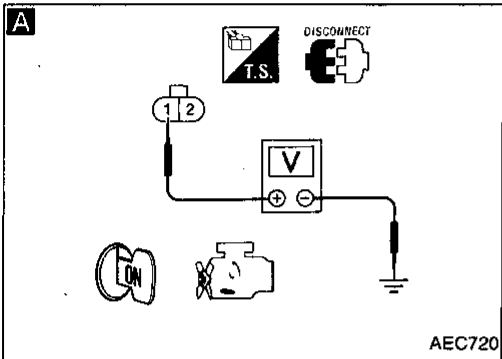
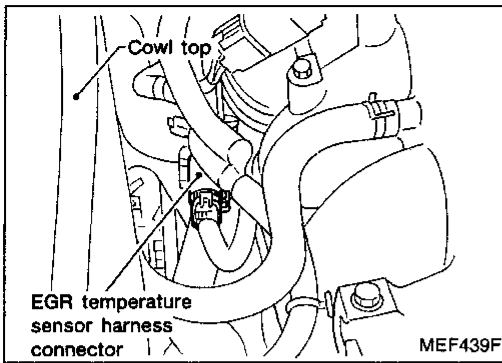

COMPONENT INSPECTION

EGR temperature sensor

Check resistance change and resistance value.

EGR temperature °C (°F)	Voltage (V)	Resistance (MΩ)
0 (32)	4.81	7.9 - 9.7
50 (122)	2.82	0.57 - 0.70
100 (212)	0.8	0.08 - 0.10

If NG, replace EGR temperature sensor.

CI  
MA  
EM  
LC  
EC  
FE  
CL  
MT  
AT  
FA  
RA  
BR  
ST  
RS  
BT  
HA  
EL  
IDX

### A/T Diagnosis Communication Line (DTC: 0804)

The malfunction information related to A/T (Automatic Transaxle) is transferred through the line (circuit) from A/T control unit to ECM. Therefore, be sure to erase the malfunction information such as DTC not only in A/T control unit but also ECM after the A/T related repair.

Diagnostic Trouble Code No.	Malfunction is detected when ...	Check Items (Possible Cause)
P1605 0804	<ul style="list-style-type: none"> <li>● An incorrect signal from A/T control units is sent to ECM.</li> </ul>	<ul style="list-style-type: none"> <li>● Harness or connectors (The communication line circuit between ECM and A/T control unit is open or shorted.)</li> <li>● Dead (Weak) battery</li> <li>● A/T control unit</li> </ul>

### DIAGNOSTIC TROUBLE CODE CONFIRMATION PROCEDURE



- 1) Turn ignition switch "ON".
- 2) Select "DATA MONITOR" mode with CONSULT.
- 3) Start engine and let it idle for at least 40 seconds.

OR



- 1) Start engine and let it idle for at least 40 seconds.
- 2) Select "MODE 3" with GST.

OR



- 1) Start engine and let it idle for at least 40 seconds.
- 2) Turn ignition switch "OFF", wait at least 5 seconds and then turn "ON".
- 3) Perform "Diagnostic Test Mode II" (Self-diagnostic results) with ECM.

A/T Diagnosis Communication Line (DTC: 0804) (Cont'd)

EC-ATDIAG-01

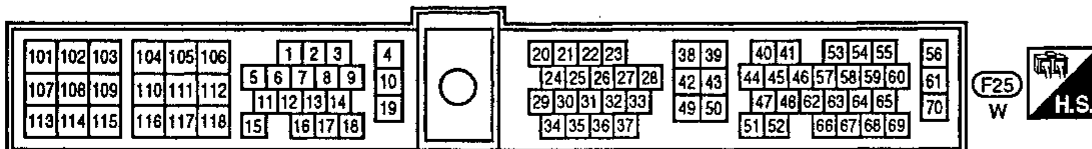
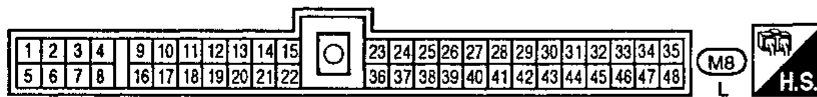
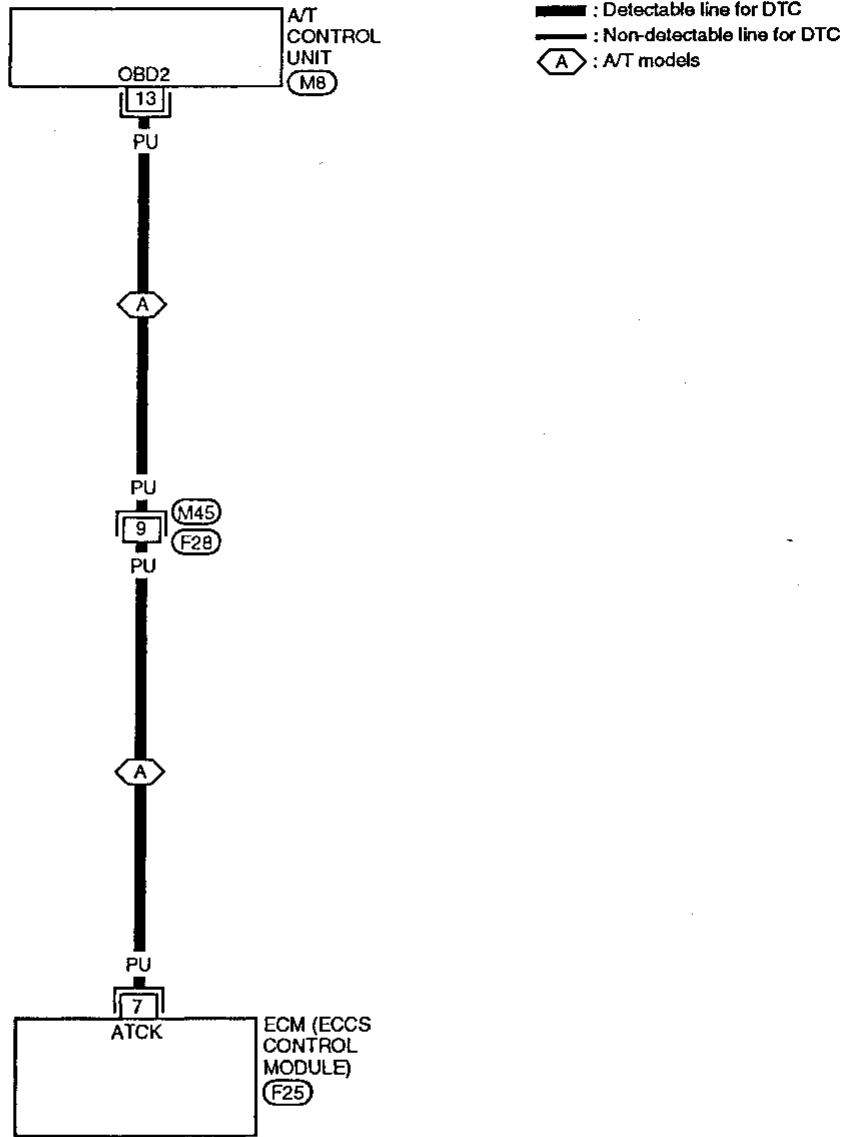

GI  
MA  
EM  
LC  
**EC**  
FE  
CL  
MT  
AT  
FA  
RA  
BR  
ST  
RS  
BT  
HA  
EL  
IDX

## A/T Diagnosis Communication Line (DTC: 0804) (Cont'd)

## DIAGNOSTIC PROCEDURE

INSPECTION START

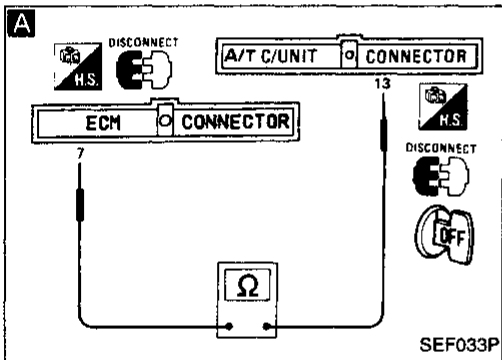
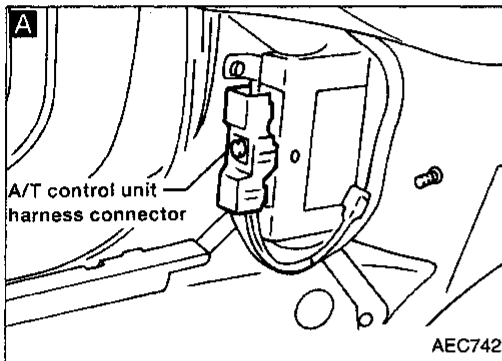
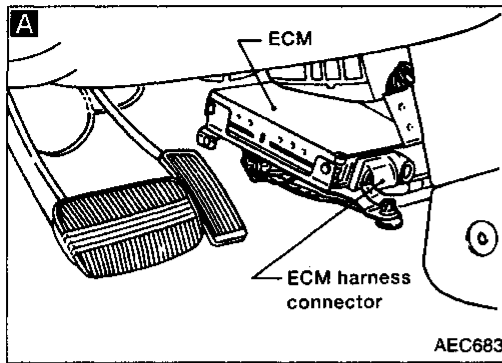

**A**

**CHECK INPUT SIGNAL CIRCUIT.**

1. Turn ignition switch "OFF".
2. Disconnect ECM harness connector and A/T control unit harness connector.
3. Check harness continuity between ECM terminal ⑦ and A/T control unit terminal ⑬.

**Continuity should exist.**  
If OK, check harness for short.

NG

Check the following.

- Harness connectors (F28, M45)
- Harness for open or short between ECM and A/T control unit.

If NG, repair harness or connectors.

OK

Disconnect and reconnect harness connectors in the circuit. Then retest.

Trouble is not fixed.

Check ECM pin terminals and A/T control unit pin terminals for damage and check the connection of ECM harness connector. Reconnect ECM harness connector and retest.

INSPECTION END

Cooling Fan (Overheat) (DTC: 0208)

SYSTEM DESCRIPTION

Cooling fan control

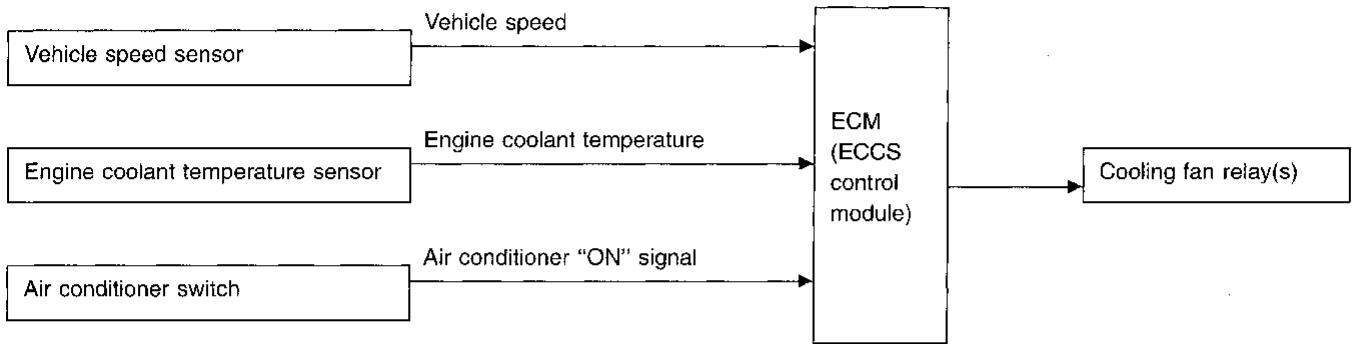

The ECM controls the cooling fan corresponding to the vehicle speed, engine coolant temperature, and air conditioner ON signal. The control system has 3-step control [HIGH/LOW/OFF] on A/T models and 2-step control [HIGH/OFF] on M/T models.

Operation

For A/T models

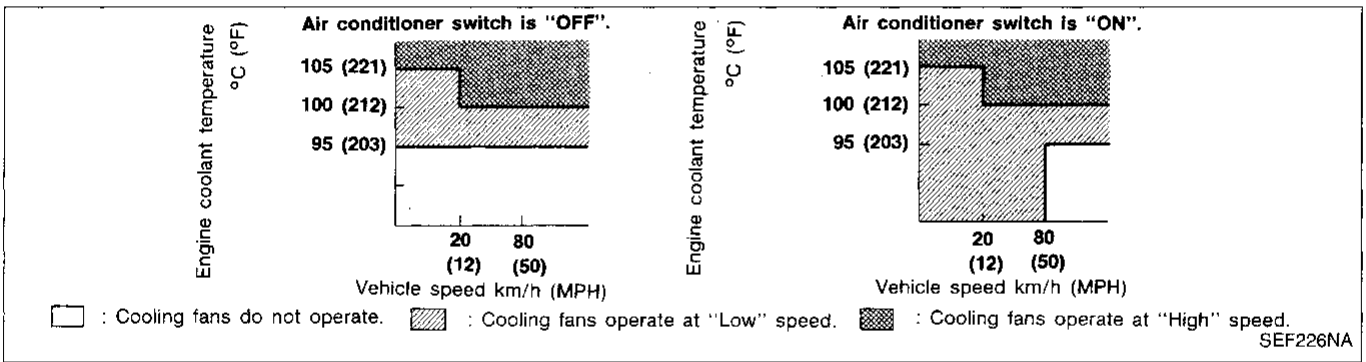

For M/T models

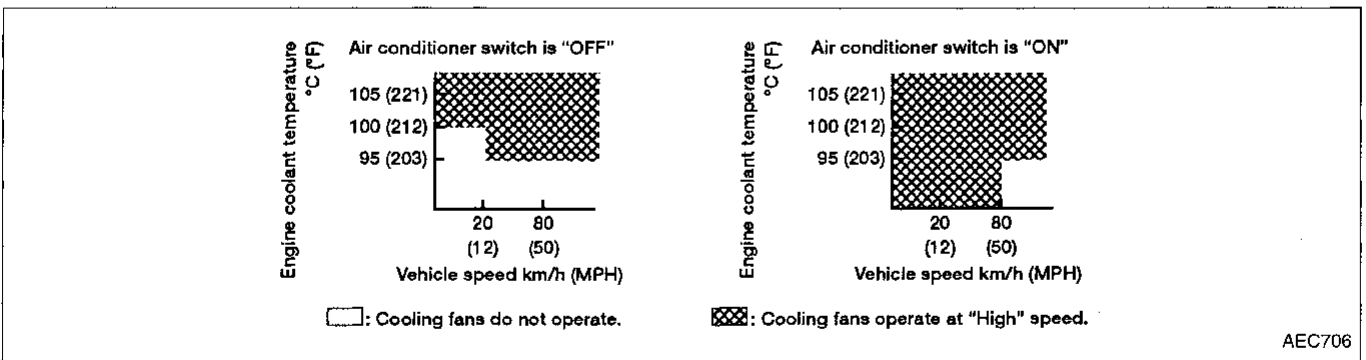



**Cooling Fan (Overheat) (DTC: 0208) (Cont'd)**

**ON-BOARD DIAGNOSIS LOGIC**

This diagnosis continuously monitors the engine coolant temperature.

If the cooling fan or another component in the cooling system malfunctions, engine coolant temperature will rise.

When the engine coolant temperature reaches an abnormally high temperature condition, a malfunction is indicated.

Diagnostic Trouble Code No.	Malfunction is detected when ...	Check Items (Possible Cause)
P1900* 0208	<ul style="list-style-type: none"> <li>● Cooling fan does not operate properly (Overheat).</li> <li>● Cooling fan system does not operate properly (Overheat).</li> <li>● Engine coolant was not added to the system using the proper filling method.</li> </ul>	<ul style="list-style-type: none"> <li>● Harness or connectors (The cooling fan circuit is open or shorted.)</li> <li>● Cooling fan</li> <li>● Radiator hose</li> <li>● Radiator</li> <li>● Radiator cap</li> <li>● Water pump</li> <li>● Thermostat</li> </ul> <p>For more information, refer to "MAIN 12 CAUSES OF OVERHEATING", EC-212.</p>

\* Diagnostic trouble code No. P1900 is not displayed in SELF-DIAGNOSTIC RESULTS mode with CONSULT.

**CAUTION:**

When a malfunction is indicated, be sure to replace the coolant following the procedure in the MA section ("Changing Engine Coolant", "ENGINE MAINTENANCE"). Also, replace the engine oil.

- a. Fill radiator with coolant up to specified level with a filling speed of 2 liters per minute. Be sure to use coolant with the proper mixture ratio. Refer to MA section ("Anti-freeze Coolant Mixture Ratio", "RECOMMENDED FLUIDS AND LUBRICANTS").
- b. After refilling coolant, run engine to ensure that no water-flow noise is emitted.

## Cooling Fan (Overheat) (DTC: 0208) (Cont'd) OVERALL FUNCTION CHECK

Use this procedure to check the overall function of the cooling fan. During this check, a DTC might not be confirmed.

### WARNING:

**Never remove the radiator cap when the engine is hot. Serious burns could be caused by high pressure fluid escaping from the radiator.**

**Wrap a thick cloth around cap. Carefully remove the cap by turning it a quarter turn to allow built-up pressure to escape. Then turn the cap all the way off.**

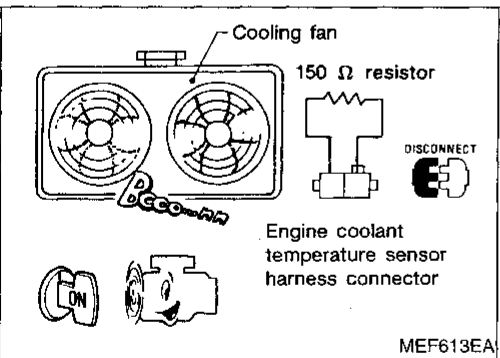
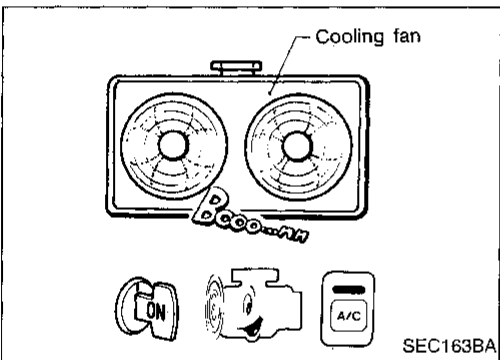
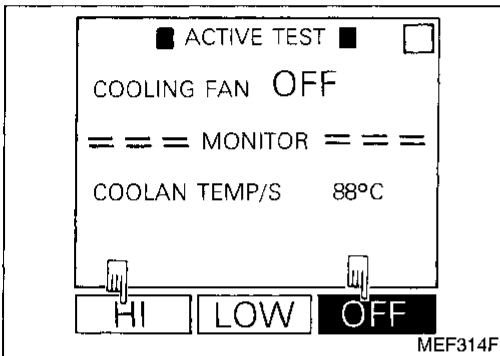
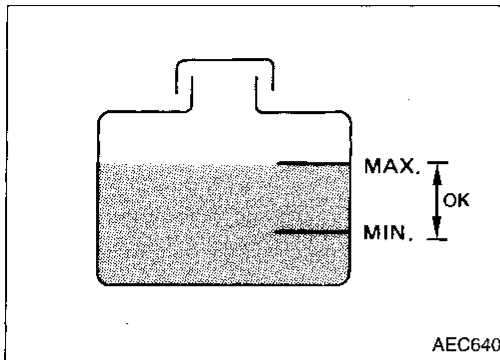

- 1) Check the coolant level in the reservoir tank and radiator. **Allow engine to cool before checking coolant level.** If the coolant level in the reservoir tank and/or radiator is below the proper range, skip the following steps and go to "DIAGNOSTIC PROCEDURE" (EC-206).
- 2) Confirm whether customer filled the coolant or not. If customer filled the coolant, skip the following steps and go to "DIAGNOSTIC PROCEDURE" (EC-206).



- 3) Turn ignition switch "ON".
- 4) Perform "COOLING FAN" in "ACTIVE TEST" mode with CONSULT (LOW speed and HI speed).

OR



- 3) Start engine. **Be careful not to overheat engine.**
- 4) Set temperature control lever to full cold position.
- 5) Turn air conditioner switch "ON".
- 6) Turn blower fan switch "ON".
- 7) Run engine at idle for a few minutes with air conditioner operating. **Be careful not to overheat engine.**
- 8) Make sure that cooling fan operates at low speed for A/T models and high speed for M/T models.
- 9) Turn ignition switch "OFF".
- 10) Turn air conditioner switch and blower fan switch "OFF".

### —A/T models only—

- 11) Disconnect engine coolant temperature sensor harness connector.
- 12) Connect 150Ω resistor to engine coolant temperature sensor harness connector.
- 13) Restart engine and make sure that cooling fan operates at higher speed than low speed. **Be careful not to overheat engine.**

Cooling Fan (Overheat) (DTC: 0208) (Cont'd)

FOR A/T MODELS

EC-COOL/F-01

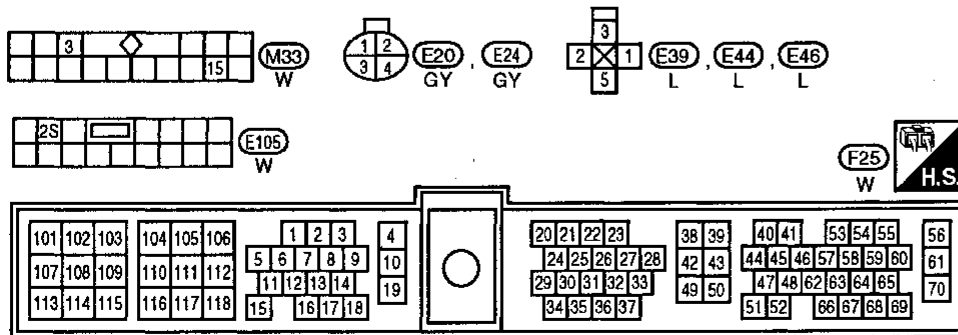
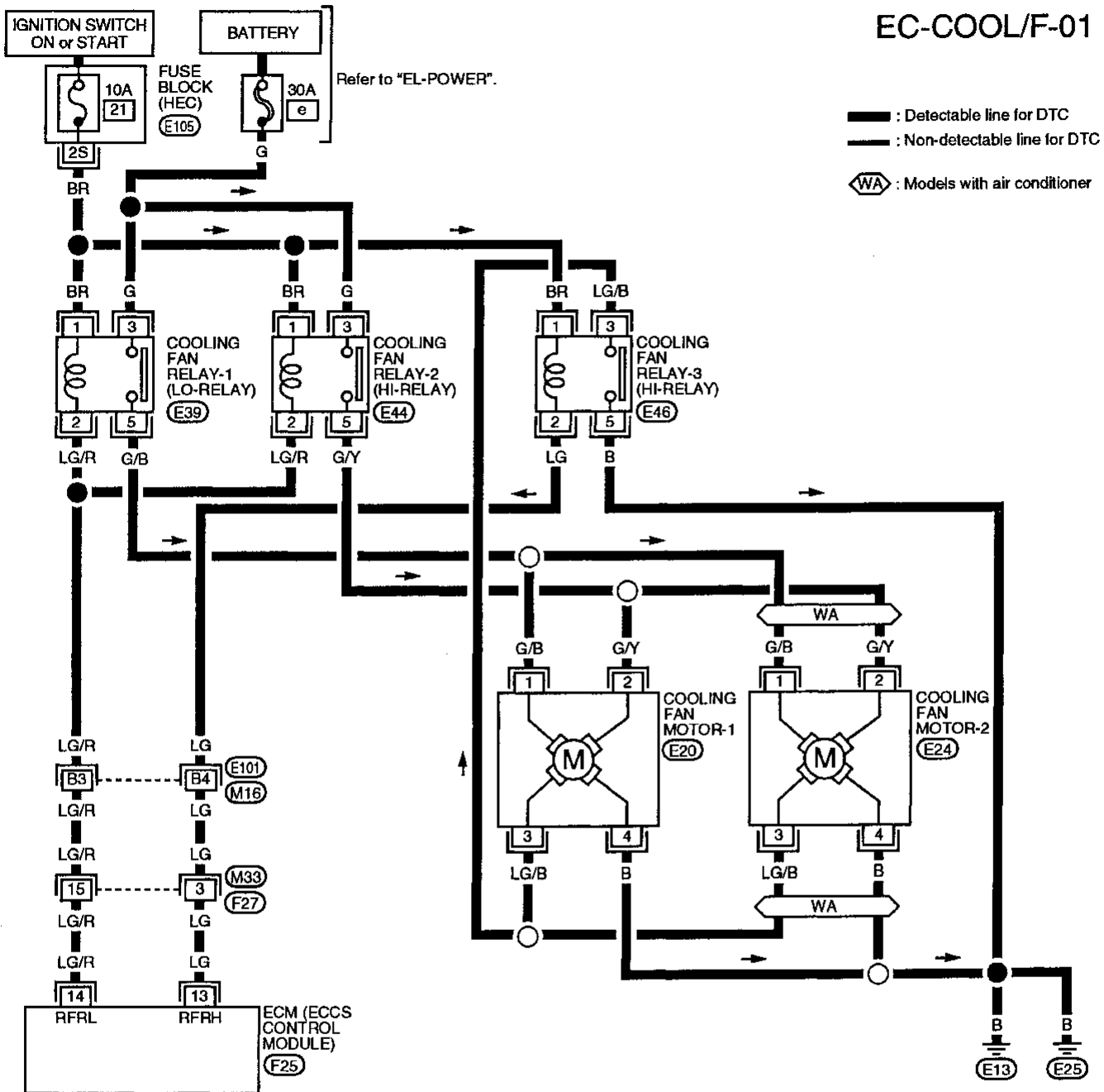

Refer to last page (Foldout page).  
M16, E101

Cooling Fan (Overheat) (DTC: 0208) (Cont'd)

FOR M/T MODELS

EC-COOL/F-02

GI

MA

EM

LC

EC

FE

CL

MT

AT

FA

RA

BR

ST

RS

BT

HA

EL

IDX

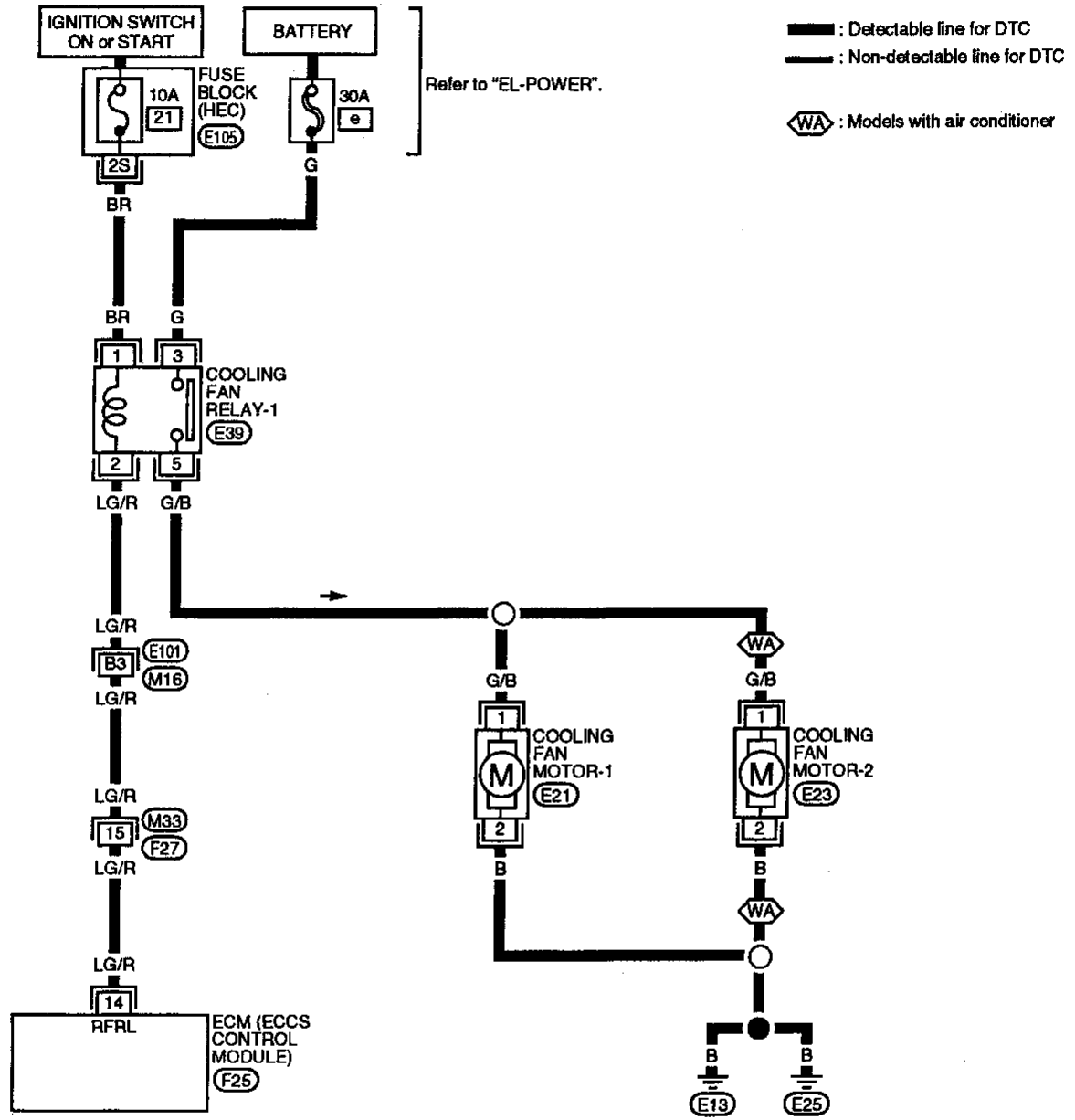

Refer to last page (Foldout page).

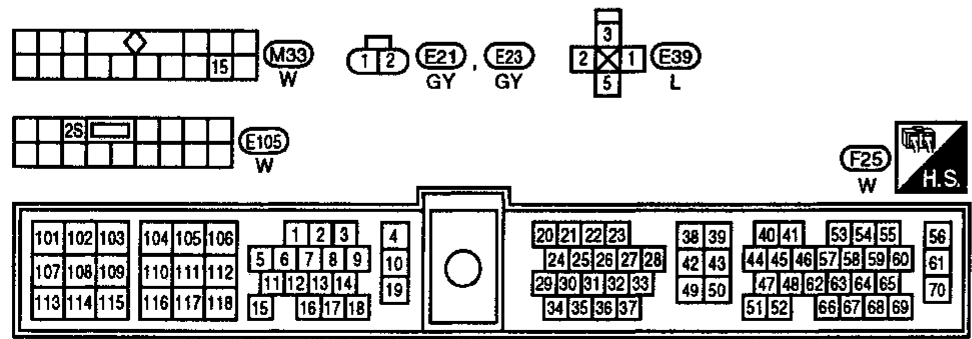

**Cooling Fan (Overheat) (DTC: 0208) (Cont'd)  
DIAGNOSTIC PROCEDURE**

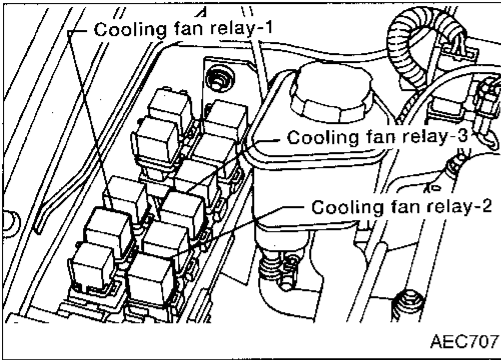

INSPECTION START

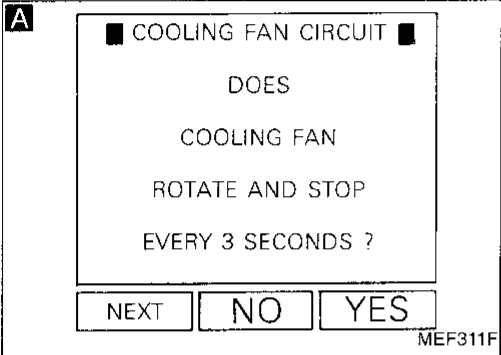

**A** CHECK COOLING FAN LOW SPEED OPERATION (A/T MODELS) AND HIGH SPEED OPERATION (M/T MODELS).  
1. Disconnect cooling fan relays-2 and -3 for A/T models.  
2. Turn ignition switch "ON".  
3. Perform "COOLING FAN CIRCUIT" in "FUNCTION TEST" mode with CONSULT.

NG Check cooling fan low speed control circuit (A/T models) and high speed control circuit (M/T models). (Go to PROCEDURE A.)

OR  
2. Turn ignition switch "ON".  
3. Perform "COOLING FAN" in "ACTIVE TEST" mode with CONSULT.

OR  
2. Start engine.  
3. Set temperature lever at full cold position.  
4. Turn air conditioner switch "ON".  
5. Turn blower fan switch "ON".  
6. Run engine at idle for a few minutes with air conditioner operating.  
7. Make sure that cooling fan operates at low speed for A/T models and at high speed for M/T models.

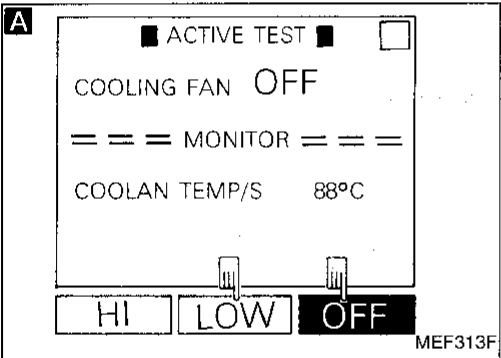

OK

(Go to next page.)

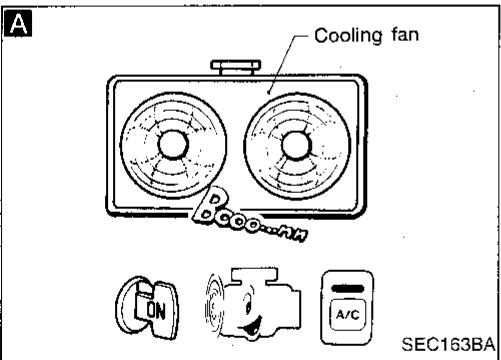

Cooling Fan (Overheat) (DTC: 0208) (Cont'd)

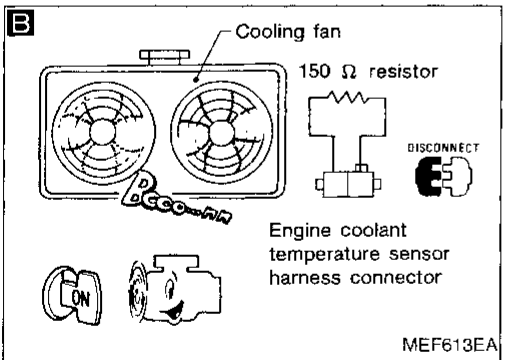
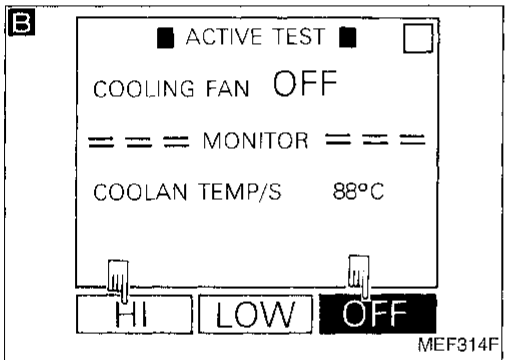
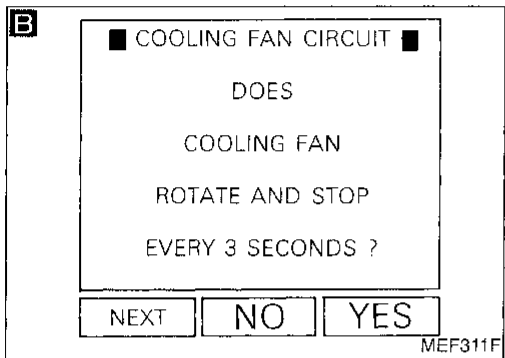
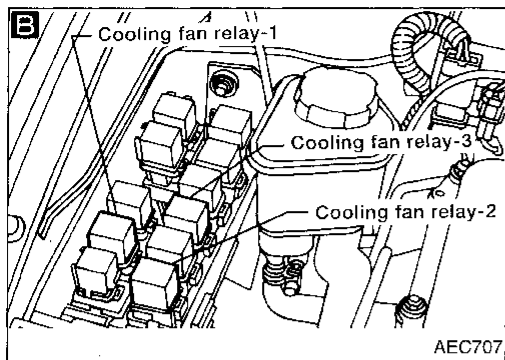

**B**

**CHECK COOLING FAN HIGH SPEED OPERATION (A/T MODELS).**

1. Turn ignition switch "OFF".
2. Reconnect cooling fan relays-2 and -3.
3. Disconnect cooling fan relay-1.
4. Turn ignition switch "ON".
5. Perform "COOLING FAN CIRCUIT" in "FUNCTION TEST" mode with CONSULT.

OR

4. Turn ignition switch "ON".
5. Perform "COOLING FAN" in "ACTIVE TEST" mode with CONSULT.

OR

4. Turn air conditioner switch and blower fan switch "OFF".
5. Disconnect engine coolant temperature sensor harness connector.
6. Connect 150Ω resistor to engine coolant temperature sensor harness connector.
7. Restart engine and make sure that cooling fan operates at higher speed than low speed.

NG → Check cooling fan high speed control circuit. (Go to PROCEDURE B.)

OK  
**B**  
 (Go to EC-211).

GI  
 MA  
 EM  
 LC  
**EC**  
 FE  
 CL  
 MT  
 AT  
 FA  
 RA  
 BR  
 ST  
 PS  
 BT  
 HA  
 EL  
 IDX

Cooling Fan (Overheat) (DTC: 0208) (Cont'd)

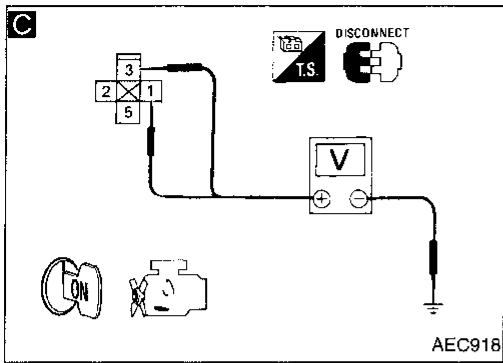

PROCEDURE A

INSPECTION START

- C**
- CHECK POWER SUPPLY.**
1. Turn ignition switch "OFF".
  2. Disconnect cooling fan relay-1.
  3. Turn ignition switch "ON".
  4. Check voltage between terminals ①, ③ and ground with CONSULT or tester.  
**Voltage: Battery voltage**

NG → Check the following.

- 10A fuse
- 30A fusible link
- Harness for open or short between cooling fan relay-1 and fuse
- Harness for open or short between cooling fan relay-1 and battery

If NG, repair harness or connectors.

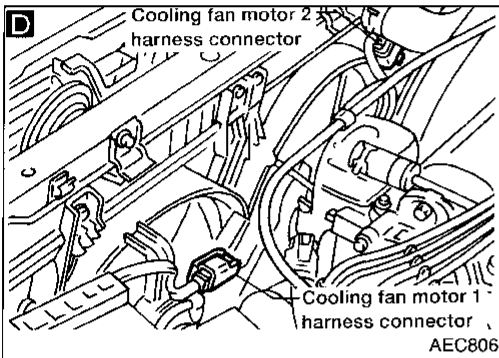

- D**
- CHECK GROUND CIRCUIT.**
1. Turn ignition switch "OFF".
  2. Disconnect cooling fan motor-1 harness connector and cooling fan motor-2 harness connector.
  3. Check harness continuity between terminal ① and terminal ⑤.  
**Continuity should exist.**  
If OK, check harness for short.
  4. Check harness continuity between terminal ④ (A/T models), ② (M/T models) and body ground.  
**Continuity should exist.**  
If OK, check harness for short.

NG → Repair harness or connectors.

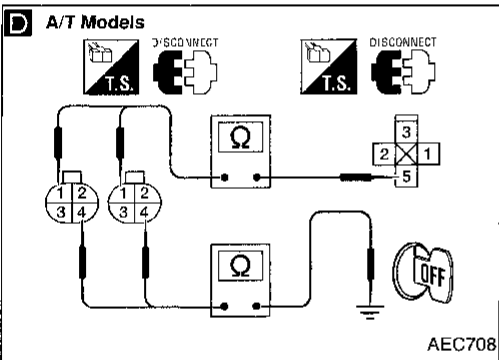

- E**
- CHECK OUTPUT SIGNAL CIRCUIT.**
1. Disconnect ECM harness connector.
  2. Check harness continuity between ECM terminal ⑭ and terminal ②.  
**Continuity should exist.**  
If OK, check harness for short.

NG → Check the following.

- Harness connectors (M16, E101)
- Harness connectors (F27, M33)
- Harness for open or short between cooling fan relay-1 and ECM

If NG, repair harness or connectors.

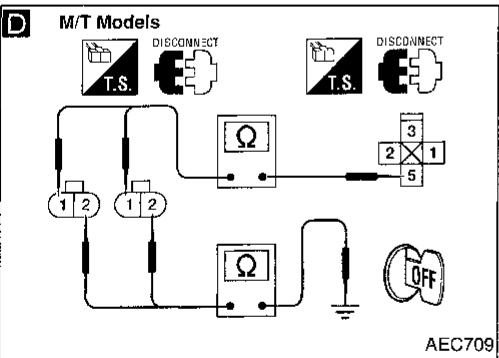

- CHECK COMPONENT**  
(Cooling fan relay-1).  
Refer to "COMPONENT INSPECTION", EC-213.

NG → Replace cooling fan relay.

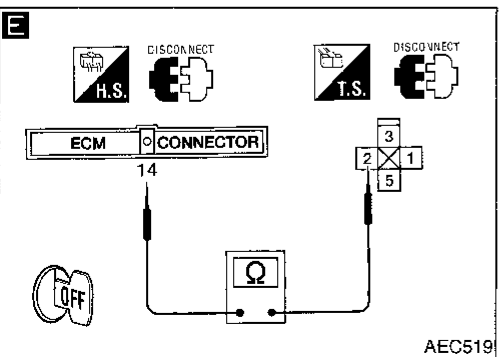

OK → (Go to next page.)

Cooling Fan (Overheat) (DTC: 0208) (Cont'd)

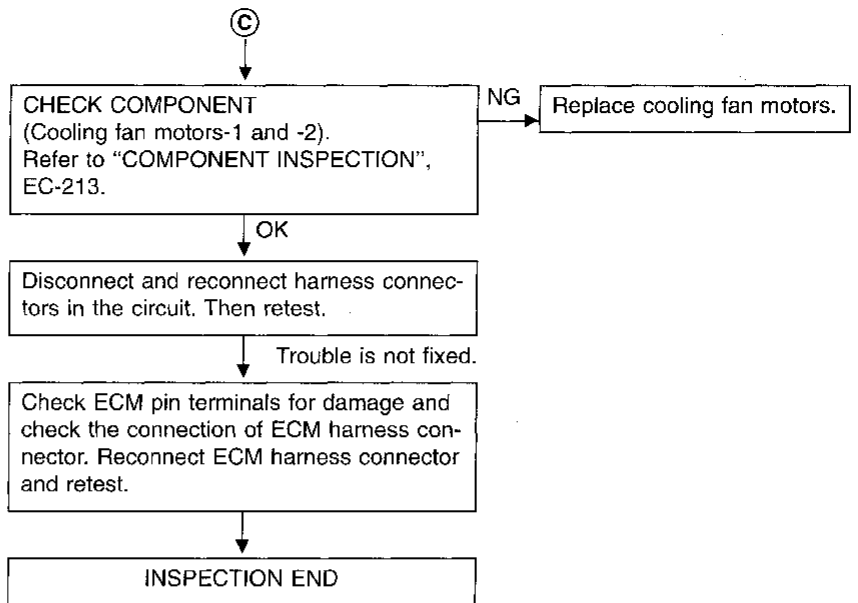

GI  
MA  
EM  
LC  
EC  
FE  
CL  
MT  
AT  
FA  
RA  
BR  
ST  
RS  
ET  
HA  
EL  
IDX

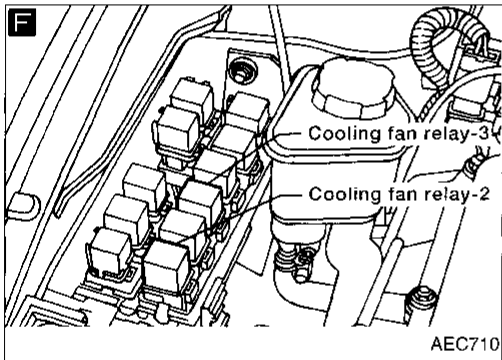

PROCEDURE B (For A/T models)

INSPECTION START

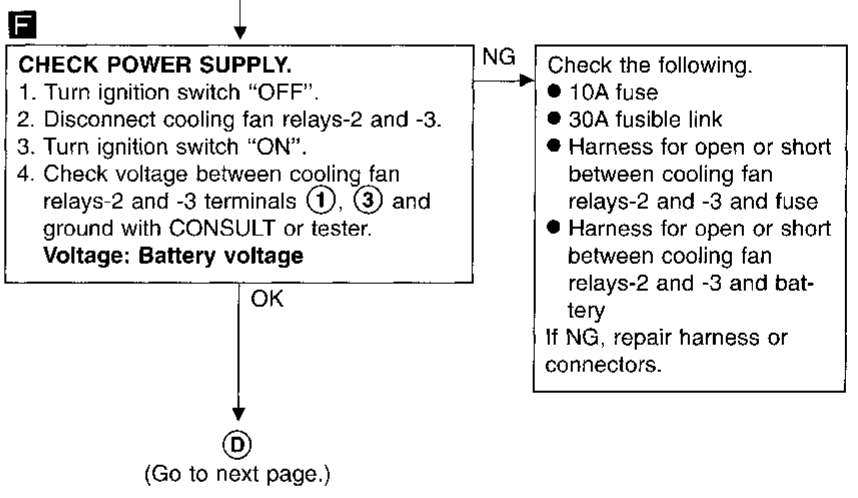
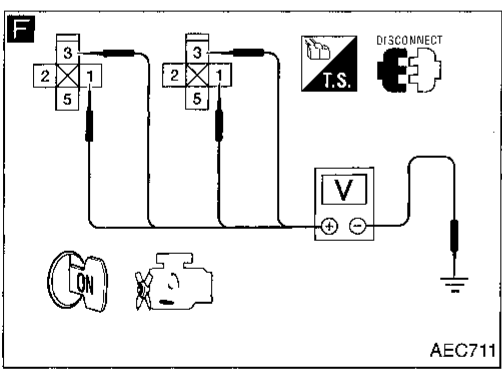



Cooling Fan (Overheat) (DTC: 0208) (Cont'd)

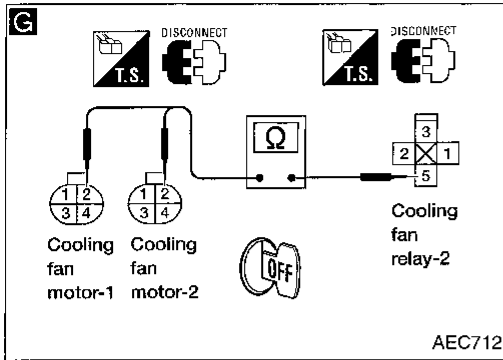

**D**

**CHECK POWER AND GROUND CIRCUIT.**

1. Turn ignition switch "OFF".
2. Disconnect cooling fan motors-1 and -2 harness connectors.
- G** 3. Check harness continuity between cooling fan relay-2 terminal ⑤ and cooling fan motors-1 and -2 terminal ②. **Continuity should exist.** If OK, check harness for short.
- H** 4. Check harness continuity between cooling fan relay-3 terminal ③ and cooling fan motors-1 and -2 terminal ③, cooling fan relay-3 terminal ⑤ and body ground. **Continuity should exist.** If OK, check harness for short.

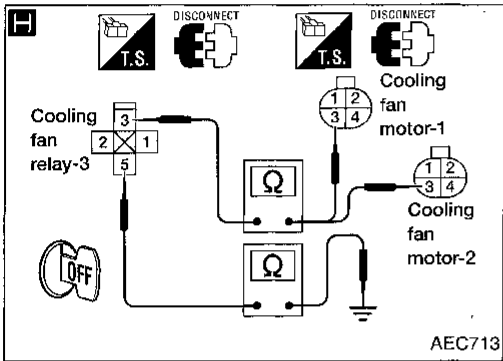

**I**

**CHECK OUTPUT SIGNAL CIRCUIT.**

1. Disconnect ECM harness connector.
2. Check harness continuity between ECM terminal ⑬ and cooling fan relay-3 terminal ②, ECM terminal ⑭ and cooling fan relay-2 terminal ②. **Continuity should exist.** If OK, check harness for short.

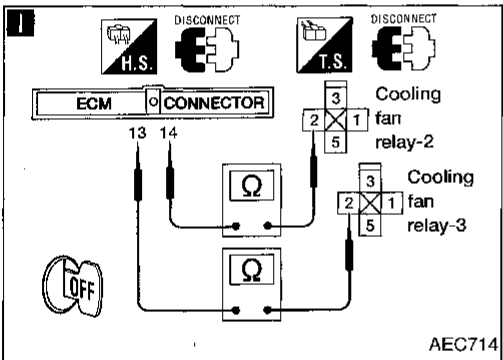

**CHECK COMPONENTS**  
(Cooling fan relays-2 and -3).  
Refer to "COMPONENT INSPECTION", EC-213.

**CHECK COMPONENTS**  
(Cooling fan motors).  
Refer to "COMPONENT INSPECTION", EC-213.

Disconnect and reconnect harness connectors in the circuit. Then retest.

Trouble is not fixed.

Check ECM pin terminals for damage and check the connection of ECM harness connector. Reconnect ECM harness connector and retest.

INSPECTION END

NG → Repair harness or connectors.

NG → Check the following.

- Harness connectors (M16, E101)
- Harness connectors (F27, M33)
- Harness for open or short between cooling fan relays-2 and -3 and ECM

If NG, repair harness or connectors.

NG → Replace cooling fan relays.

NG → Replace cooling fan motors.

Cooling Fan (Overheat) (DTC: 0208) (Cont'd)

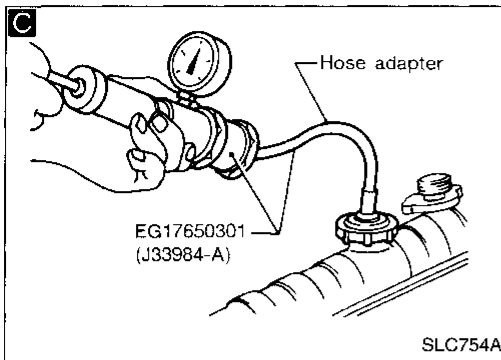

**C**

**CHECK COOLING SYSTEM FOR LEAK.**  
Apply pressure to the cooling system with a tester, and check if the pressure drops.  
**Testing pressure:**  
157 kPa (1.6 kg/cm<sup>2</sup>, 23 psi)  
**Pressure should not drop.**  
**CAUTION:**  
Higher than the specified pressure may cause radiator damage.

NG → Check the following for leak.  
● Hose  
● Radiator  
● Water pump  
Refer to LC section ("Water Pump").

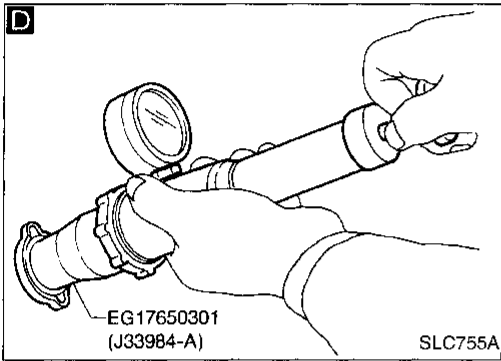

**D**

**CHECK RADIATOR CAP.**  
Apply pressure to cap with a tester.  
**Radiator cap relief pressure:**  
59 - 98 kPa (0.6 - 1.0 kg/cm<sup>2</sup>, 9 - 14 psi)

NG → Replace radiator cap.

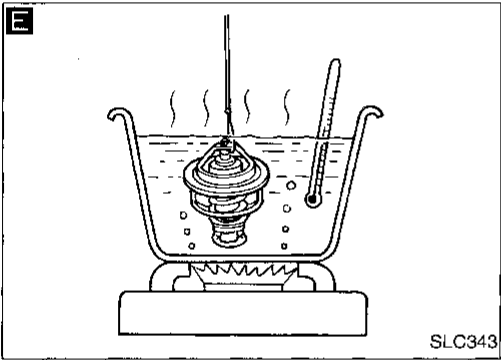

**E**

**CHECK THERMOSTAT.**  
1. Check valve seating condition at normal room temperatures. It should seat tightly.  
2. Check valve opening temperature and valve lift.  
**Valve opening temperature:**  
76.5°C (170°F) [standard]  
**Valve lift:**  
More than 8.0 mm/90°C (0.31 in/194°F)  
3. Check if valve is closed at 5°C (9°F) below valve opening temperature. For details, refer to LC section ("Thermostat").

NG → Replace thermostat

OK → Check engine coolant temperature sensor. Refer to "COMPONENT INSPECTION", EC-213.

NG → Replace engine coolant temperature sensor.

If the cause can not be isolated, go to "MAIN 12 CAUSES OF OVERHEATING" on next page.

INSPECTION END

**Perform FINAL CHECK by the following procedure after repair is completed.**

1. Warm up engine. Run the vehicle for at least 20 minutes. Pay attention to engine coolant temperature gauge on the instrument panel. If the reading shows an abnormally high temperature, another part may be malfunctioning.
2. Stop vehicle and let engine idle. Check the intake and exhaust systems for leaks by listening for noise or visually inspecting the components.
3. Allow engine to cool and visually check for oil and coolant leaks. Then, perform "OVERALL FUNCTION CHECK".

CI  
MA  
EM  
LC  
EC  
FE  
CL  
MT  
AT  
FA  
RA  
BR  
ST  
RS  
BT

## Cooling Fan (Overheat) (DTC: 0208) (Cont'd)

## MAIN 12 CAUSES OF OVERHEATING

Engine	Step	Inspection item	Equipment	Condition	Reference page
OFF	1	<ul style="list-style-type: none"> <li>Blocked radiator</li> <li>Blocked condenser</li> <li>Blocked radiator grille</li> <li>Blocked bumper</li> </ul>	<ul style="list-style-type: none"> <li>Visual</li> </ul>	No blocking	—
	2	<ul style="list-style-type: none"> <li>Coolant mixture</li> </ul>	<ul style="list-style-type: none"> <li>Coolant tester</li> </ul>	50 - 50% coolant mixture	See "RECOMMENDED FLUIDS AND LUBRICANTS" in MA section
	3	<ul style="list-style-type: none"> <li>Coolant level</li> </ul>	<ul style="list-style-type: none"> <li>Visual</li> </ul>	Coolant up to MAX level in reservoir tank and radiator filler neck	See "Changing Engine Coolant", "ENGINE MAINTENANCE" in MA section
	4	<ul style="list-style-type: none"> <li>Radiator cap</li> </ul>	<ul style="list-style-type: none"> <li>Pressure tester</li> </ul>	59 - 98 kPa (0.6-1.0 kg/cm <sup>2</sup> , 9 - 14 psi)	See "System Check" "ENGINE COOLING SYSTEM" in LC section
ON*2	5	<ul style="list-style-type: none"> <li>Coolant leaks</li> </ul>	<ul style="list-style-type: none"> <li>Visual</li> </ul>	No leaks	See "System Check" "ENGINE COOLING SYSTEM" in LC section
ON*2	6	<ul style="list-style-type: none"> <li>Thermostat</li> </ul>	<ul style="list-style-type: none"> <li>Touch the upper and lower radiator hoses</li> </ul>	Both hoses should be hot	See "Thermostat" and "Radiator", "ENGINE COOLING SYSTEM" in LC section
ON*1	7	<ul style="list-style-type: none"> <li>Cooling fan</li> </ul>	<ul style="list-style-type: none"> <li>CONSULT</li> </ul>	Operating	See "TROUBLE DIAGNOSIS FOR DTC P1900 (0208)" (EC-201)
OFF	8	<ul style="list-style-type: none"> <li>Combustion gas leak</li> </ul>	<ul style="list-style-type: none"> <li>Color checker chemical tester 4 Gas analyzer</li> </ul>	Negative	—
ON*3	9	<ul style="list-style-type: none"> <li>Coolant temperature gauge</li> </ul>	<ul style="list-style-type: none"> <li>Visual</li> </ul>	Gauge less than 3/4 when driving	—
		<ul style="list-style-type: none"> <li>Coolant overflow to reservoir tank</li> </ul>	<ul style="list-style-type: none"> <li>Visual</li> </ul>	No overflow during driving and idling	See "Changing Engine Coolant", "ENGINE MAINTENANCE" in MA section
OFF*4	10	<ul style="list-style-type: none"> <li>Coolant return from reservoir tank to radiator</li> </ul>	<ul style="list-style-type: none"> <li>Visual</li> </ul>	Should be initial level in reservoir tank	See "ENGINE MAINTENANCE" in MA section
OFF	11	<ul style="list-style-type: none"> <li>Cylinder head</li> </ul>	<ul style="list-style-type: none"> <li>Straight gauge feeler gauge</li> </ul>	0.1mm (0.004 in) Maximum distortion (warping)	See "Inspection", "CYLINDER HEAD" in EM section
	12	<ul style="list-style-type: none"> <li>Cylinder block and pistons</li> </ul>	<ul style="list-style-type: none"> <li>Visual</li> </ul>	No scuffing on cylinder walls or piston	See "Inspection", "CYLINDER BLOCK" in EM section

\*1: Turn the ignition switch ON.

\*2: Engine running at 3,000 rpm for 10 minutes.

\*3: Drive at 90 km/h (55MPH) for 30 minutes and then let idle for 10 minutes.

\*4: After 60 minutes of cool down time.

For more information, refer to "OVERHEATING CAUSE ANALYSIS" in LC section.

**Cooling Fan (Overheat) (DTC: 0208) (Cont'd)  
COMPONENT INSPECTION**

**Cooling fan relays-1, -2 and -3**

Check continuity between terminals ③ and ⑤

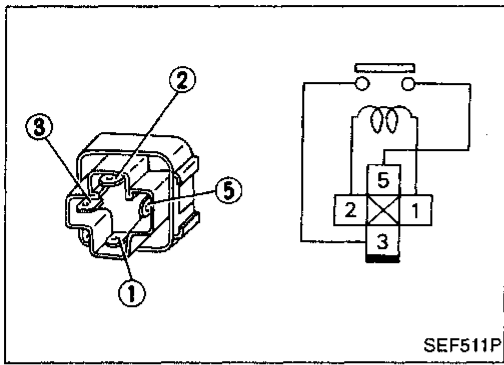

SEF511P

Conditions	Continuity
12V direct current supply between terminals ① and ②	Yes
No current supply	No

If NG, replace relay.

GI  
MA  
EM  
LC

**EC**

FE  
CL  
MT

**Cooling fan motors-1 and -2**

1. Disconnect cooling fan motor harness connectors.
2. Supply cooling fan motor terminals with battery voltage and check operation.

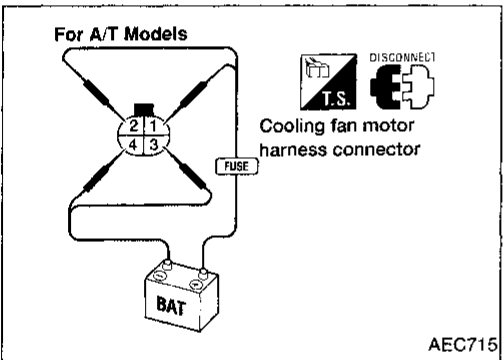

AEC715

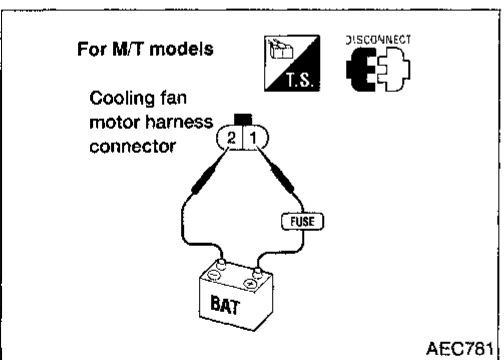

AEC781

	Speed	Terminals	
		(⊕)	(⊖)
Cooling fan motor	Low (A/T models)	①	④
	High (A/T models)	②	③
	High (M/T models)	①	②

AT  
FA  
RA  
BR  
ST

**Cooling fan motor should operate.**

If NG, replace cooling fan motor.

RS  
BT  
HA  
EL  
IDX

Injector

EC-INJECT-01

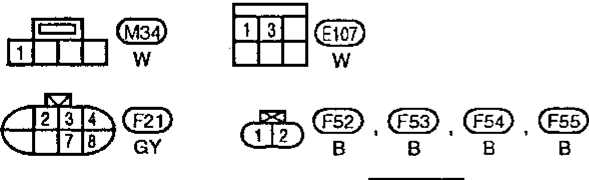
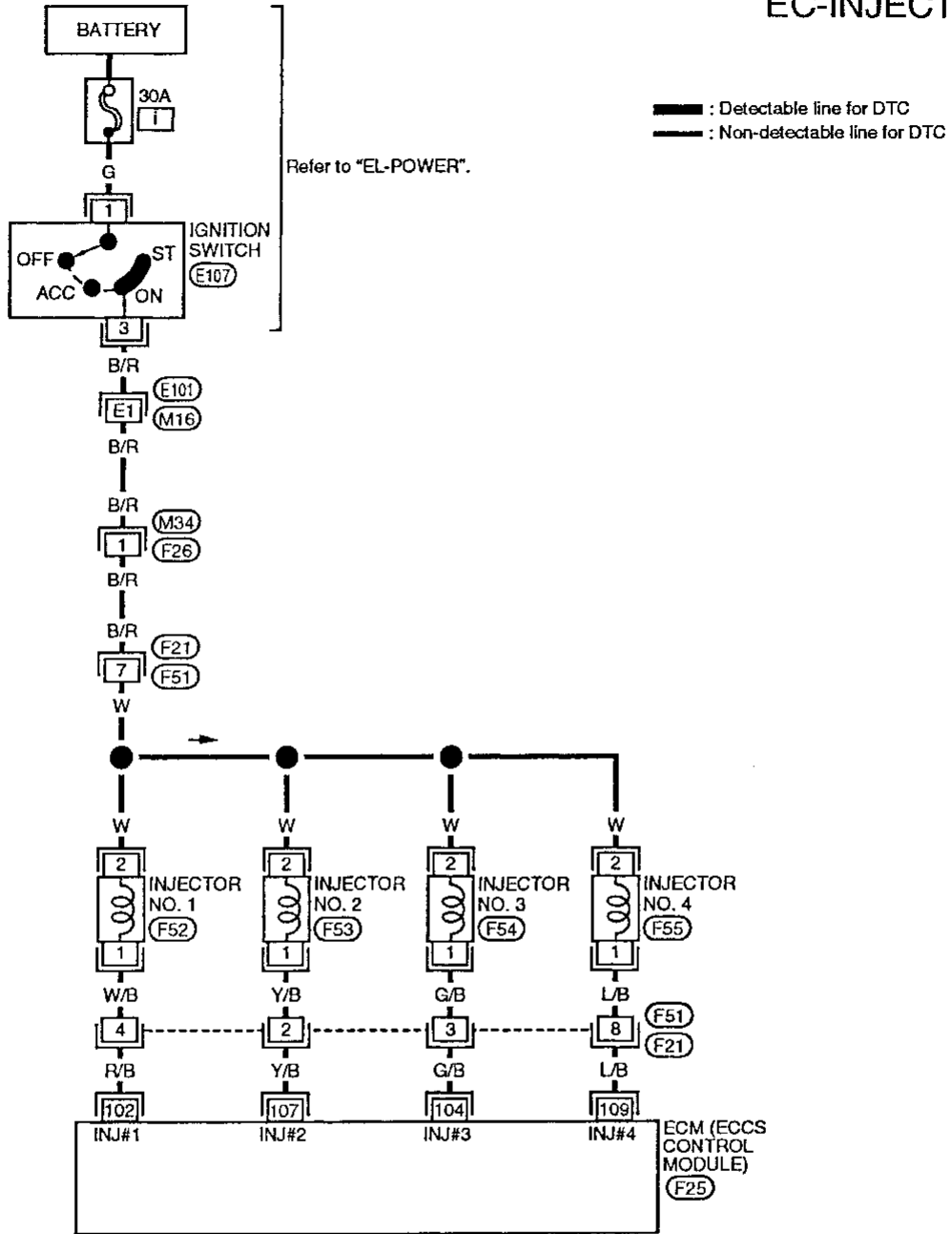

Refer to last page (Foldout page).

(M16), (E101)

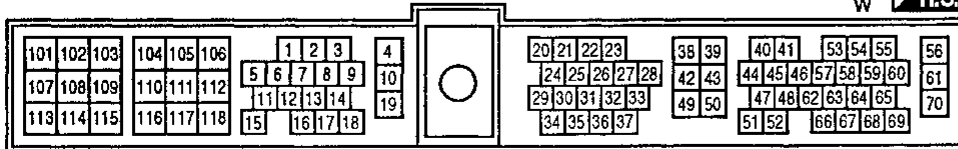

Injector (Cont'd)

COMPONENT DESCRIPTION

The fuel injector is a small, precise solenoid valve. When the ECM supplies a ground to the injector circuit, the coil in the injector is energized. The energized coil pulls the needle valve back and allows fuel to flow through the injector into the intake manifold. The amount of fuel injected depends upon the injection pulse duration. Pulse duration is the length of time the injector remains open. The ECM controls the injection pulse duration based on engine fuel needs.

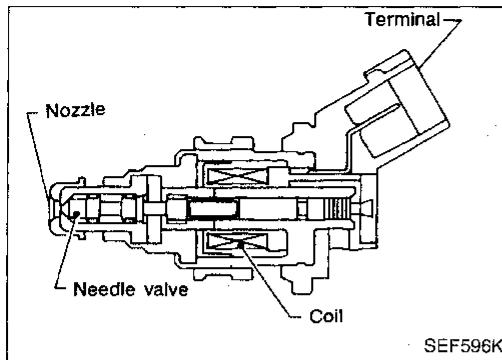

DIAGNOSTIC PROCEDURE

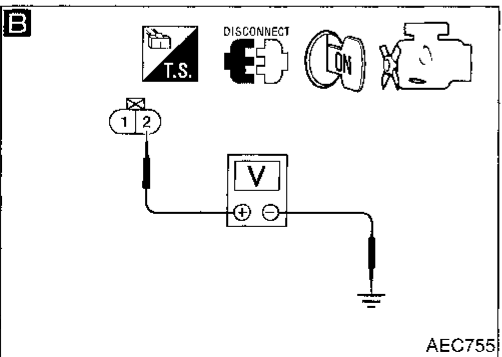
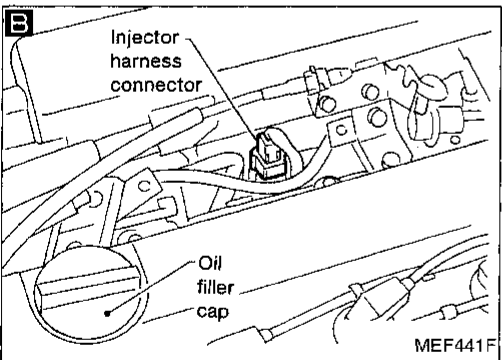
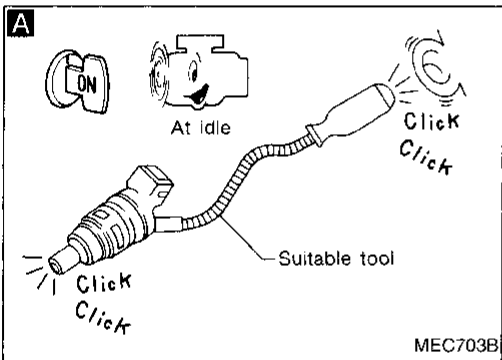
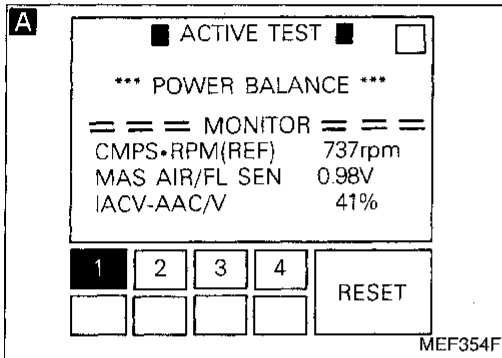
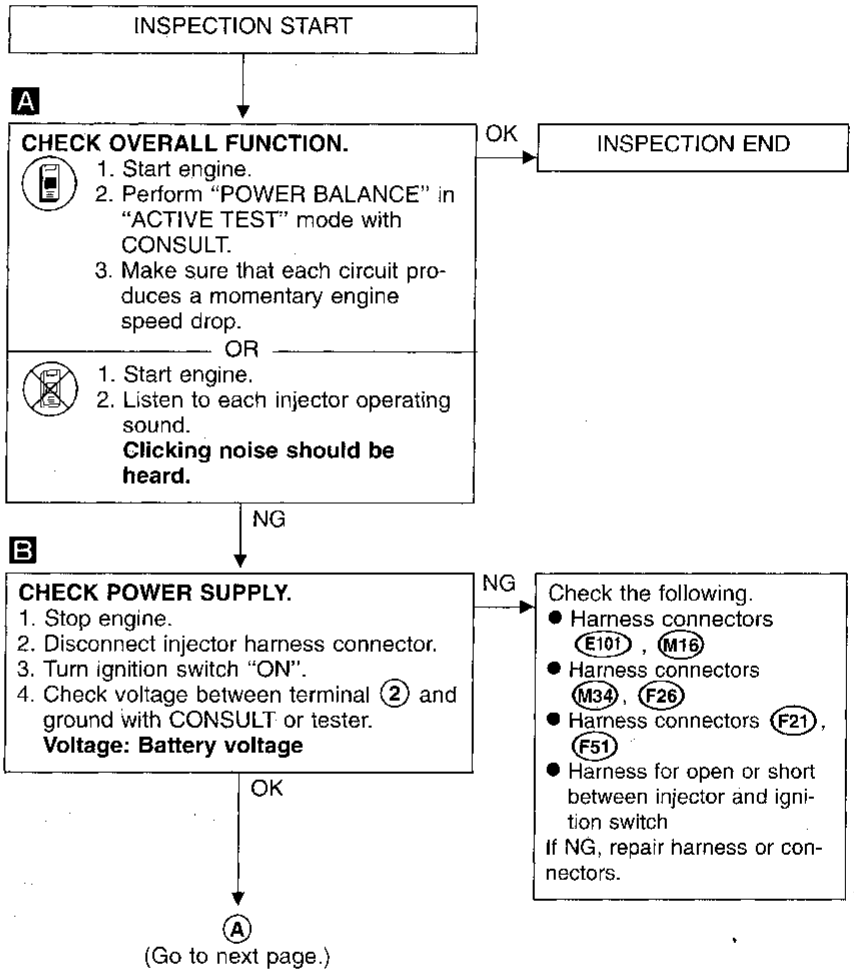

Injector (Cont'd)

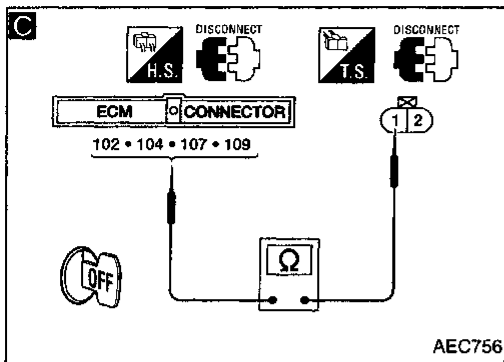

**CHECK OUTPUT SIGNAL CIRCUIT.**

1. Turn ignition switch "OFF".
2. Disconnect ECM harness connector.
3. Check harness continuity between injector harness connector terminal (1) and ECM terminals (102), (104), (107), (109). **Continuity should exist.** If OK, check harness for short.

NG → Check the following.  
● Harness for open or short between ECM and injector  
If NG, repair harness or connectors.

OK →

**CHECK COMPONENT (Injector).**  
Refer to "COMPONENT INSPECTION" below.

NG → Replace injector.

OK →

Disconnect and reconnect harness connectors in the circuit. Then retest.

Trouble is not fixed.

Check ECM pin terminals for damage and check the connection of ECM harness connector. Reconnect ECM harness connector and retest.

INSPECTION END

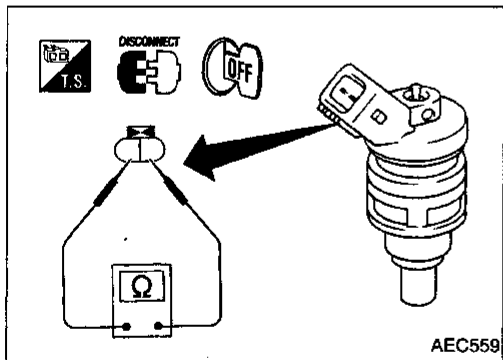

**COMPONENT INSPECTION**

**Injector**

1. Disconnect injector harness connector.
2. Check resistance between terminals as shown in the figure.  
**Resistance: 10 - 14Ω [at 25° (77°F)]**  
If NG, replace injector.

Start Signal

EC-S/SIG-01

: Detectable line for DTC  
 : Non-detectable line for DTC

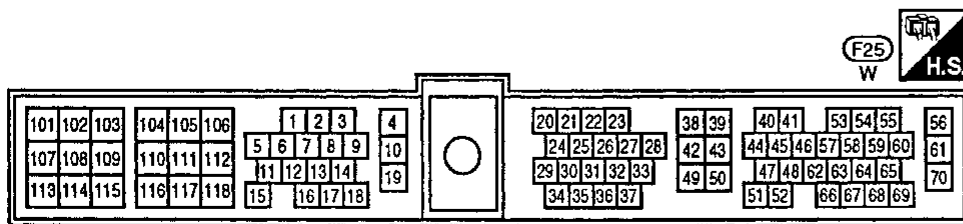
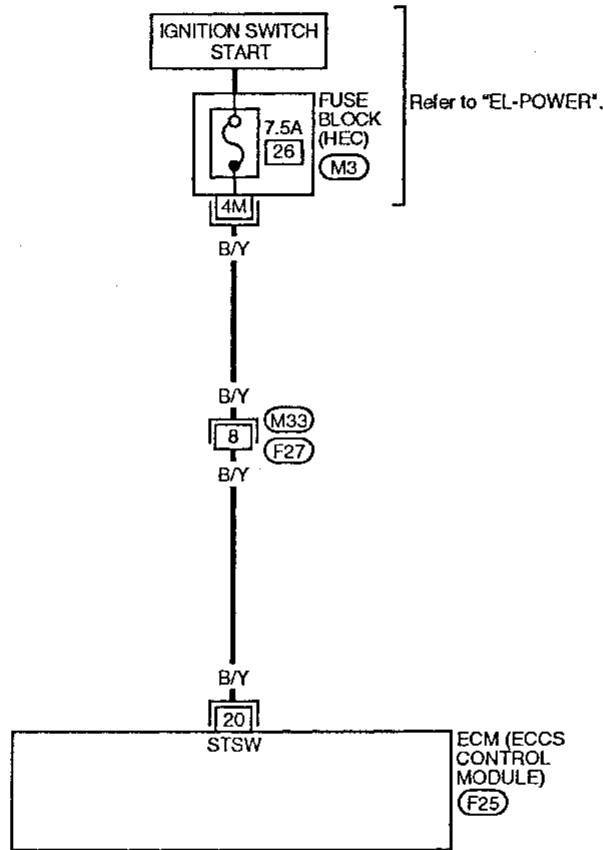

Refer to last page (Foldout page).  
M3

CI  
 MA  
 EM  
 LC  
**EC**  
 FE  
 CL  
 MT  
 AT  
 FA  
 RA  
 BR  
 ST  
 RS  
 BT  
 HA  
 EL  
 DX



Start Signal (Cont'd)  
DIAGNOSTIC PROCEDURE

**A**

■ START SIGNAL CKT ■

1. CLOSE THROTTLE, SHIFT TO P OR N RANGE.
2. TOUCH START AND START ENGINE IMMEDIATELY.

NEXT      START

SEF191L

**A**

☆ MONITOR      ☆ NO FAIL

START SIGNAL	OFF
CLSD TH/P SW	ON
AIR COND SIG	OFF
P/N POSI SW	ON

RECORD

SEF111P

**A**

ECM CONNECTOR

20

V

CONNECT H.S.

SEF109P

**B**

DISCONNECT T.S.

M33

8

V

DISCONNECT T.S.

AEC757

INSPECTION START

**A**

**CHECK OVERALL FUNCTION.**

1. Turn ignition switch "ON".
2. Perform "START SIGNAL CKT" in "FUNCTION TEST" mode with CONSULT.

OR

OK → INSPECTION END

1. Turn ignition switch "ON".
2. Check "START SIGNAL" in "DATA MONITOR" mode with CONSULT.

IGN "ON"	OFF
IGN "START"	ON

OR

1. Turn ignition switch to "START".
2. Check voltage between ECM terminal (20) and ground.

**Voltage:**  
Ignition switch "START"  
Battery voltage  
Except above  
Approximately 0V

NG

**B**

**CHECK POWER SUPPLY.**

1. Turn ignition switch "OFF".
2. Disconnect harness connectors (M33), (F27).
3. Turn ignition switch to "START".
4. Check voltage between harness connector (M33) terminal (8) and ground.

**Voltage:**  
Ignition switch "START"  
Battery voltage  
Except above  
Approximately 0V

NG → Check the following.

- Harness connector (M33)
- 7.5A fuse
- Harness for open or short between (M33) and ignition switch

If NG, repair harness or connectors.

OK

Disconnect and reconnect harness connectors in the circuit. Then retest.

Trouble is not fixed.

Check ECM pin terminals for damage and check the connection of ECM harness connector. Reconnect ECM harness connector and retest.

INSPECTION END

### Fuel Pump

#### SYSTEM DESCRIPTION

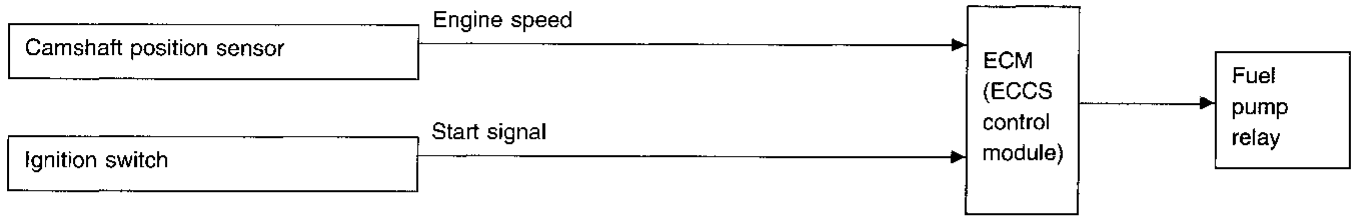

The ECM activates the fuel pump for several seconds after the ignition switch is turned on to improve engine startability. If the ECM receives a 180° signal from the camshaft position sensor, it knows that the engine is rotating, and causes the pump to perform. If the 180° signal is not received when the ignition switch is on, the engine stalls. The ECM stops pump operation and prevents battery discharging, thereby improving safety. The ECM does not directly drive the fuel pump. It controls the ON/OFF fuel pump relay, which in turn controls the fuel pump.

Condition	Fuel pump operation
Ignition switch is turned to ON.	Operates for 5 seconds
Engine running and cranking	Operates
When engine is stopped	Stops in 1 second
Except as shown above	Stops

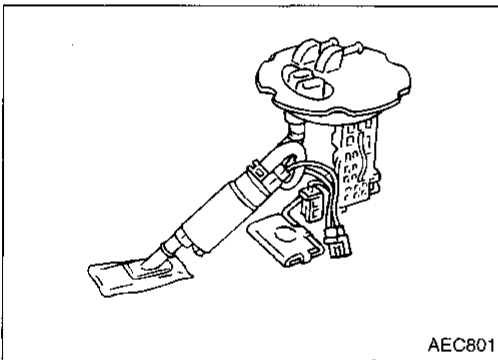

#### COMPONENT DESCRIPTION

The fuel pump with a fuel damper is an in-tank type (the pump and damper are located in the fuel tank).

GI  
MA  
EM  
LC  
EC  
FE  
CL  
MT  
AT  
FA  
RA  
BR  
ST  
RS  
BT  
HA  
EL  
IDX

Fuel Pump (Cont'd)

EC-F/PUMP-01

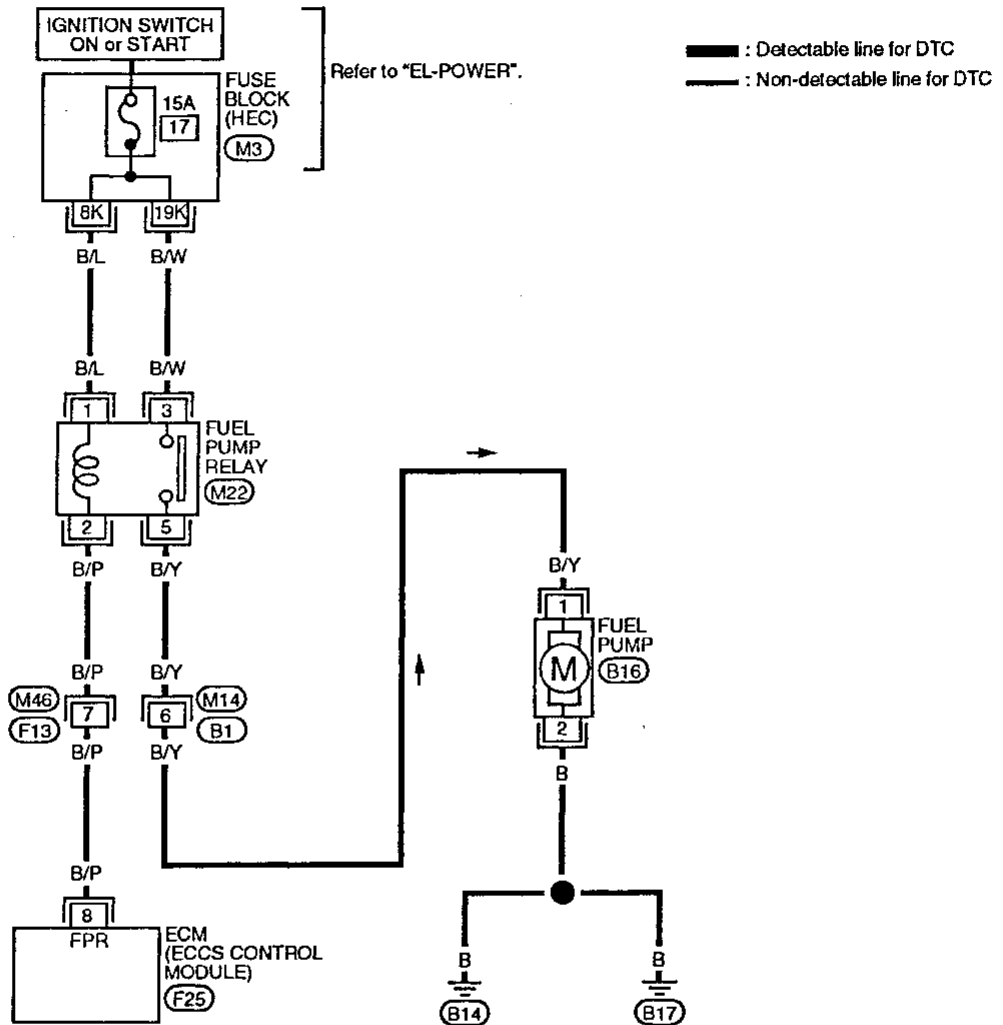

Refer to last page (Foldout page).

(M3)

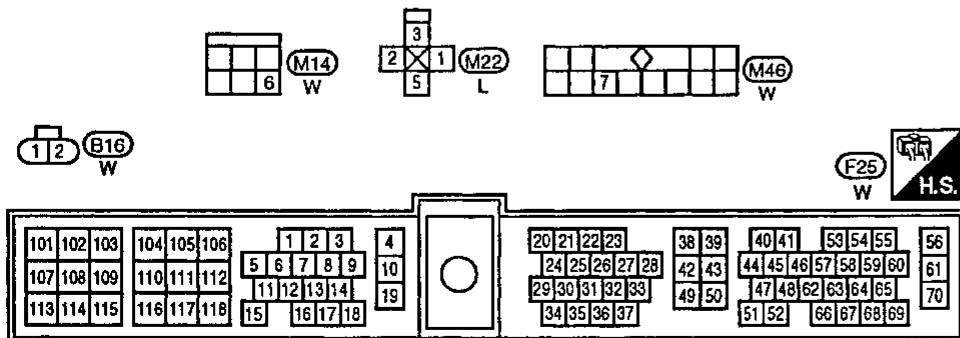

Fuel Pump (Cont'd)  
DIAGNOSTIC PROCEDURE

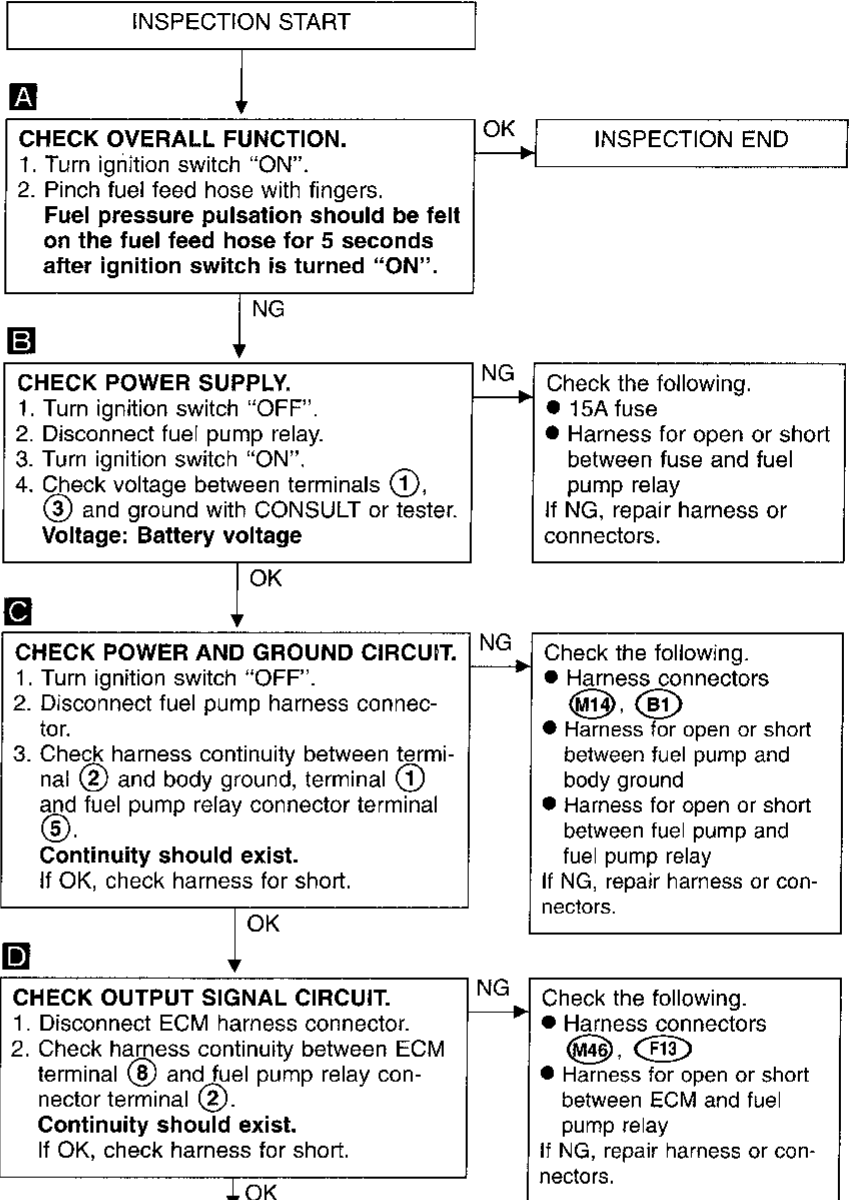
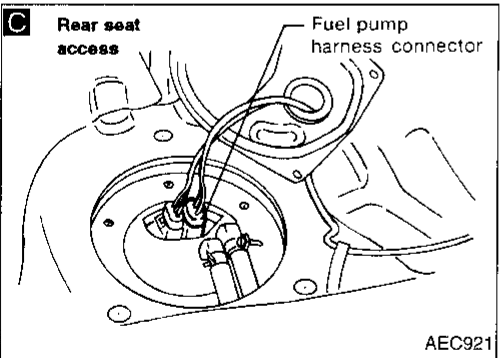
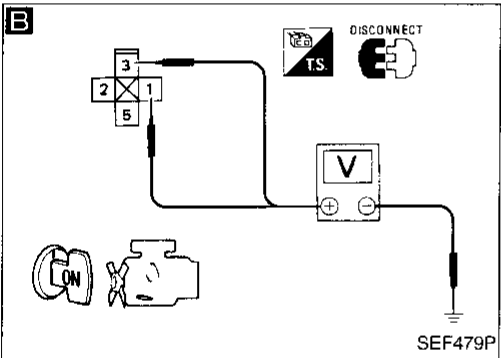
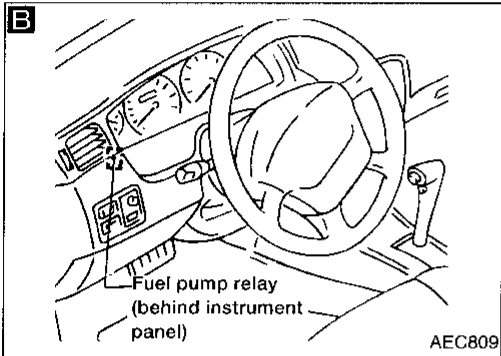
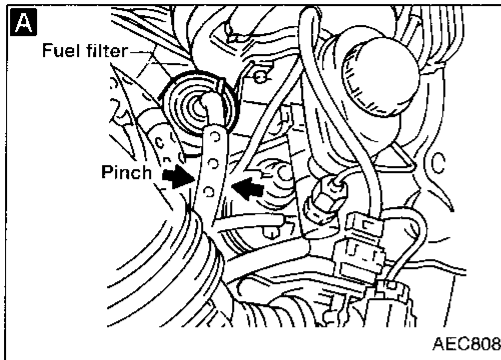

(Go to next page.)

GI  
MA  
EM  
LC  
EC  
FE  
CL  
MT  
AT  
FA  
RA  
BR  
ST  
RS  
BT  
HA  
EL  
IDX

Fuel Pump (Cont'd)

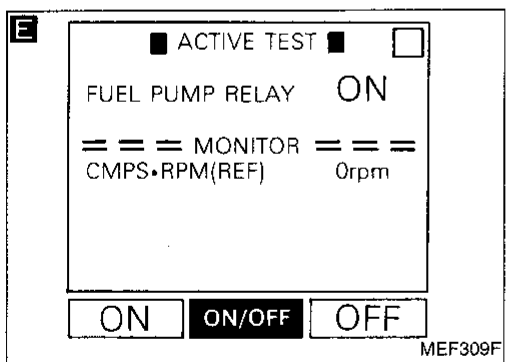
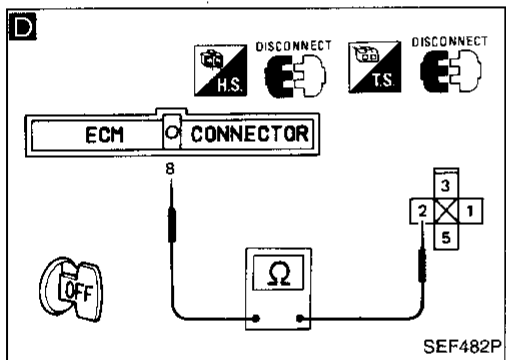
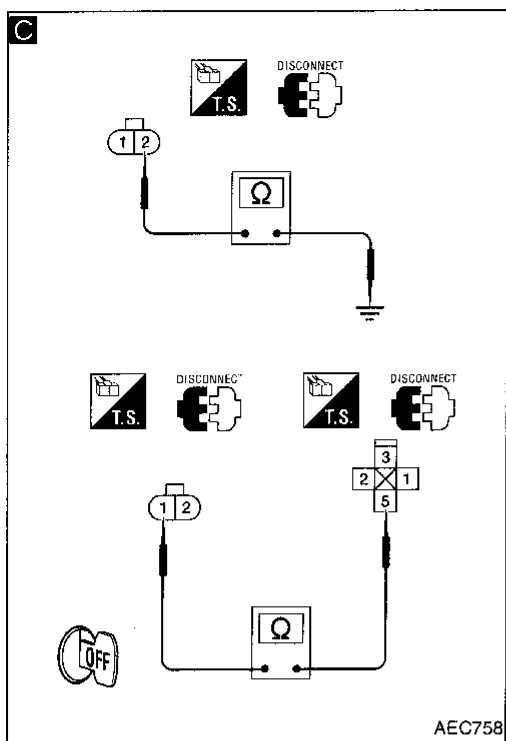

(A)

**E**

**CHECK COMPONENT**  
(Fuel pump relay).

1. Reconnect fuel pump relay, fuel pump harness connector and ECM harness connector.
2. Turn ignition switch "ON".
3. Turn fuel pump relay "ON" and "OFF" in "ACTIVE TEST" mode with CONSULT and check operating sound.

OR

Refer to "COMPONENT INSPECTION" on next page.

NG → Replace fuel pump relay.

OK ↓

**CHECK COMPONENT**  
(Fuel pump).  
Refer to "COMPONENT INSPECTION" on next page.

NG → Replace fuel pump.

OK ↓

Disconnect and reconnect harness connectors in the circuit. Then retest.

Trouble is not fixed. ↓

Check ECM pin terminals for damage and check the connection of ECM harness connector. Reconnect ECM harness connector and retest.

↓

INSPECTION END

**Fuel Pump (Cont'd)**  
**COMPONENT INSPECTION**

**Fuel pump relay**

Check continuity between terminals ③ and ⑤.

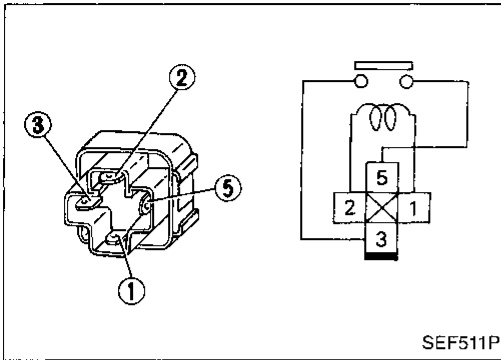

SEF511P

Conditions	Continuity
12V direct current supply between terminals ① and ②	Yes
No current supply	No

If NG, replace relay.

**Fuel pump**

1. Disconnect fuel pump harness connector.
2. Check resistance between terminals ① and ②.  
**Resistance: 0.2 - 5.0Ω [at 25°C (77°F)]**  
If NG, replace fuel pump.

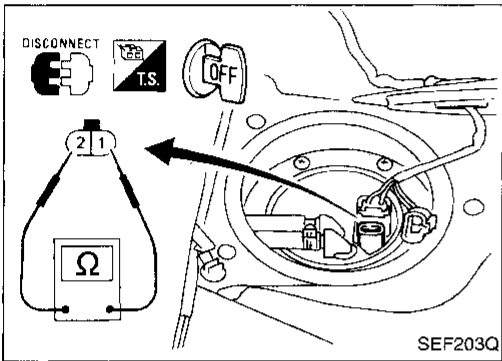

SEF203Q

GI

MA

EM

LC

EC

FE

CL

MT

AT

FA

RA

BR

ST

RS

BT

HA

EL

IDX

Power Steering Oil Pressure Switch

EC-PST/SW-01

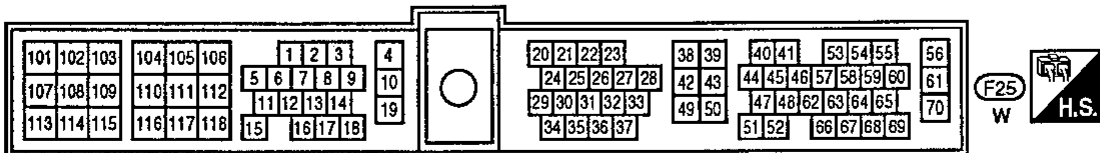
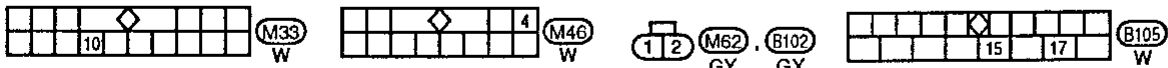
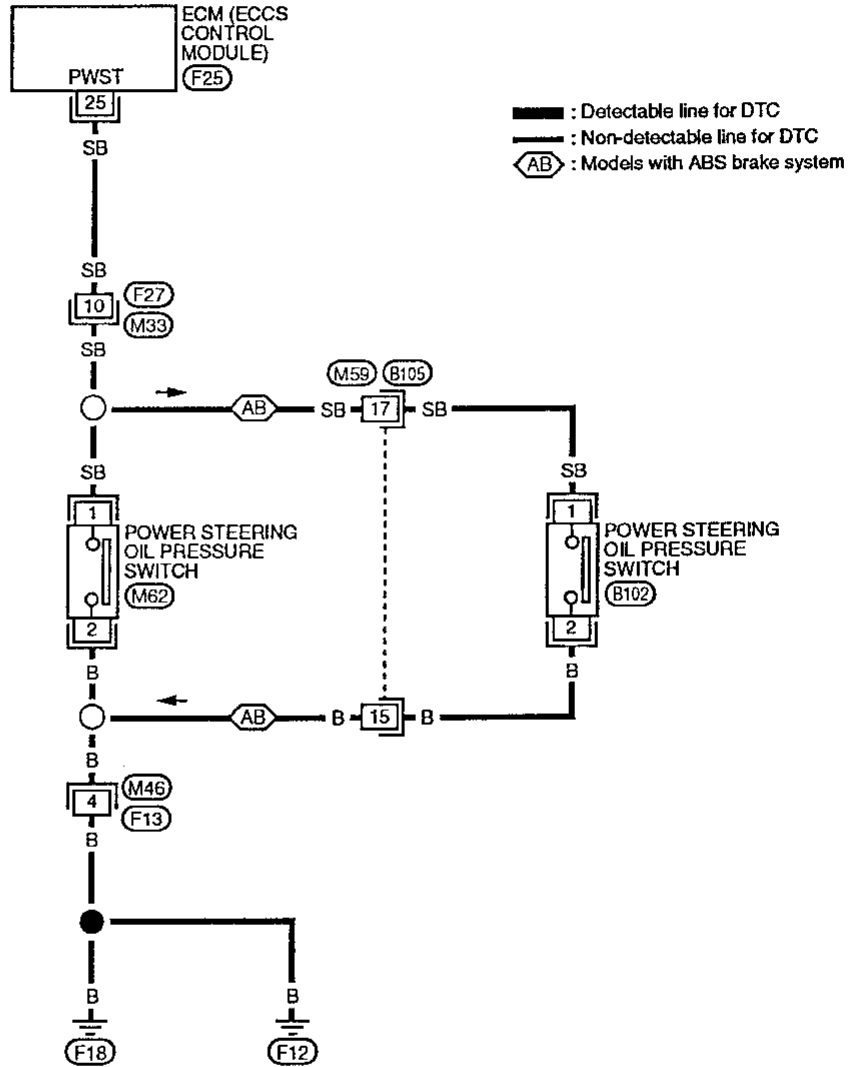

**Power Steering Oil Pressure Switch (Cont'd)**  
**COMPONENT DESCRIPTION**

The power steering oil pressure switch is attached to the power steering high-pressure tube and detects a power steering load. When a power steering load is detected, it signals the ECM. The ECM adjusts the IACV-AAC valve to increase the idle speed and adjust for the increased load.

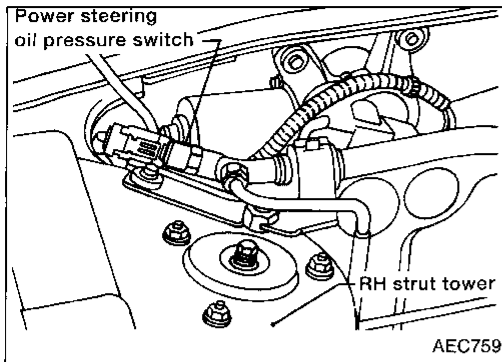

**DIAGNOSTIC PROCEDURE**

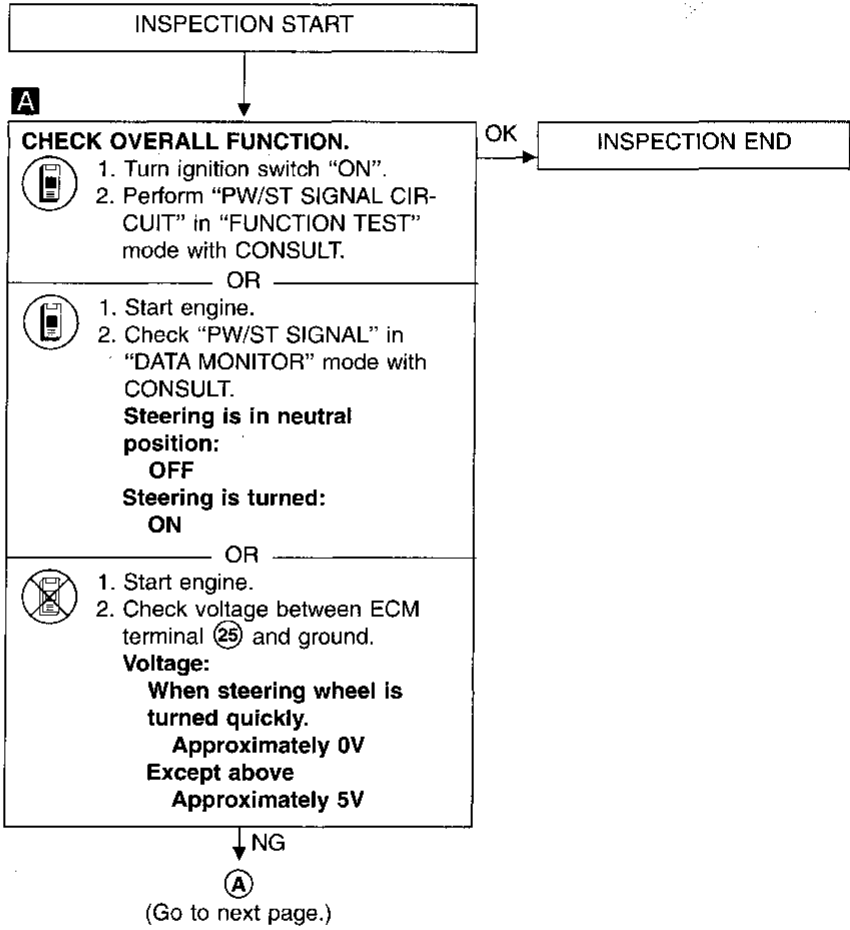

**A**

■ PW/ST SIGNAL CIRCUIT ■

HOLD STEERING WHEEL  
 IN A FULL  
 LOCKED POSITION  
 THEN  
 TOUCH START

NEXT    START

MEF023E

**A**

☆ MONITOR ☆ NO FAIL

PW/ST SIGNAL      OFF

RECORD

SEF591I

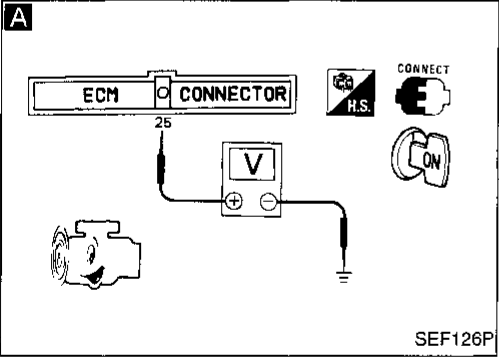

GI  
 MA  
 EM  
 LC  
**EC**  
 FE  
 CL  
 MT  
 AT  
 FA  
 RA  
 BR  
 ST  
 RS  
 BT  
 HA  
 EL  
 IDX



Power Steering Oil Pressure Switch (Cont'd)

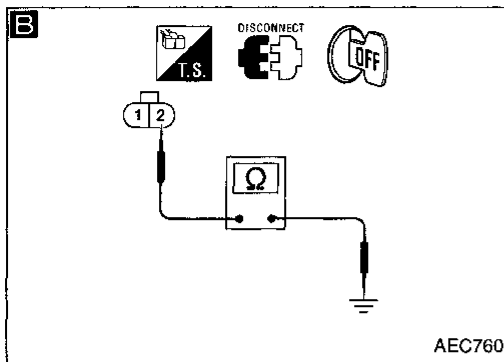

**B**  
**CHECK GROUND CIRCUIT.**  
 1. Turn ignition switch "OFF".  
 2. Disconnect power steering oil pressure switch harness connector.  
 3. Check harness continuity between terminal ② and engine ground.  
**Continuity should exist.**  
 If OK, check harness for short.

NG → Check the following.  
 ● Harness connectors  
 (M46), (F13) (and (M59), (B105) for ABS models)  
 ● Harness for open or short between power steering oil pressure switch and engine ground  
 If NG, repair harness or connectors.

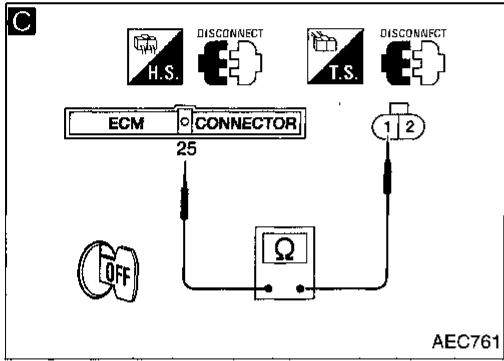

**C**  
**CHECK INPUT SIGNAL CIRCUIT.**  
 1. Disconnect ECM harness connector.  
 2. Check harness continuity between ECM terminal ②⑤ and terminal ①.  
**Continuity should exist.**  
 If OK, check harness for short.

NG → Check the following.  
 ● Harness connectors  
 (F27), (M33) (and (M59), (B105) for ABS models)  
 ● Harness for open or short between ECM and power steering oil pressure switch  
 If NG, repair harness or connectors.

**CHECK COMPONENT**  
 (Power steering oil pressure switch).  
 Refer to "COMPONENT INSPECTION" below.

NG → Replace power steering oil pressure switch.

OK → Disconnect and reconnect harness connectors in the circuit. Then retest.

Trouble is not fixed.  
 Check ECM pin terminals for damage and check the connection of ECM harness connector. Reconnect ECM harness connector and retest.

INSPECTION END

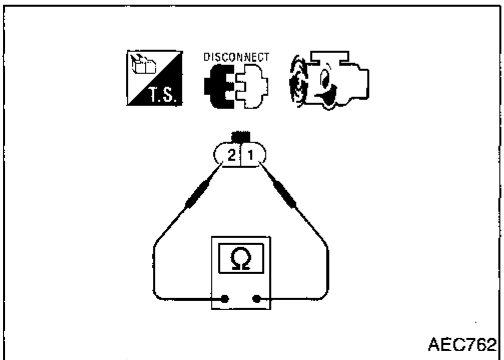

**COMPONENT INSPECTION**

**Power steering oil pressure switch**

1. Disconnect power steering oil pressure switch harness connector then start engine.
2. Check continuity between terminals ① and ②.

Conditions	Continuity
Steering wheel is being turned	Yes
Steering wheel is not being turned	No

If NG, replace power steering oil pressure switch.

IACV-Air Regulator

EC-AIRREG-01

CI  
MA  
EM  
LC  
**EC**  
FE  
CL  
MT  
AT  
FA  
RA  
BR  
ST  
RS  
BT  
HA  
EL  
IDX

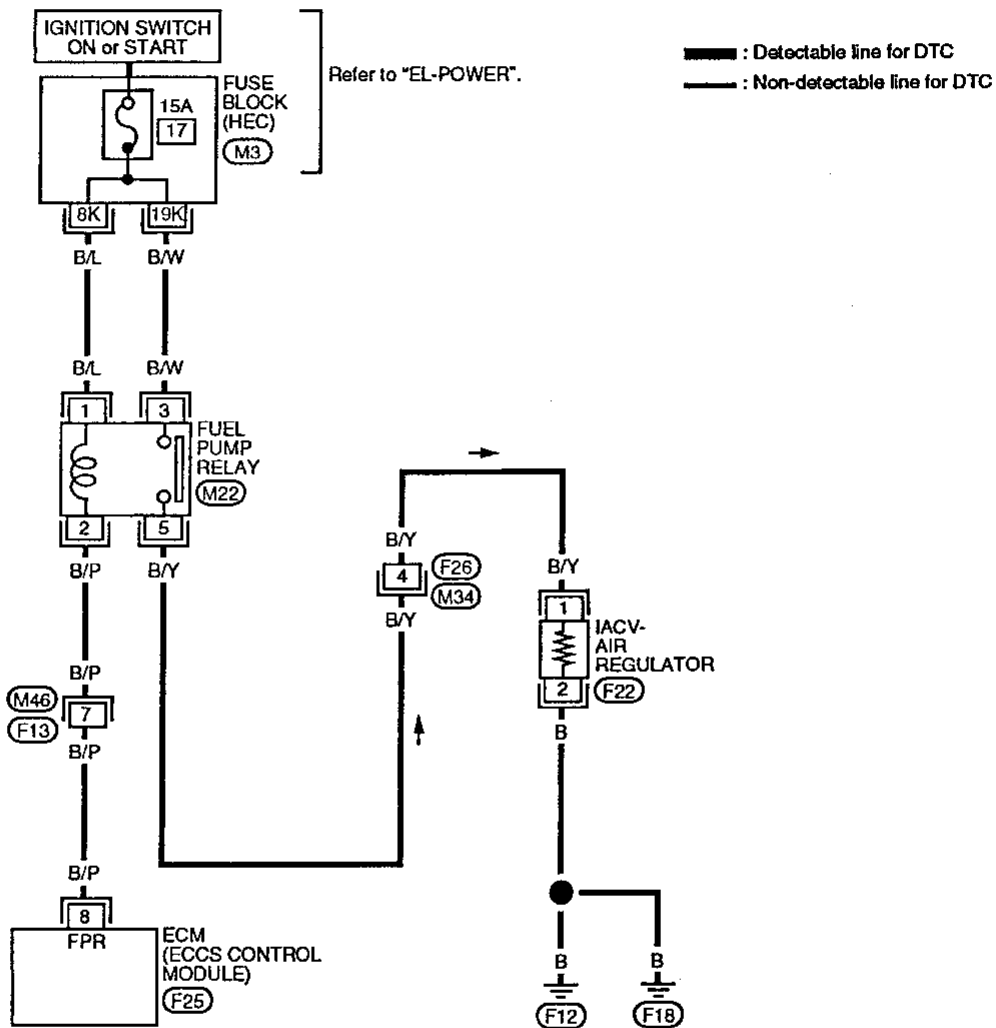

Refer to last page (Foldout page).

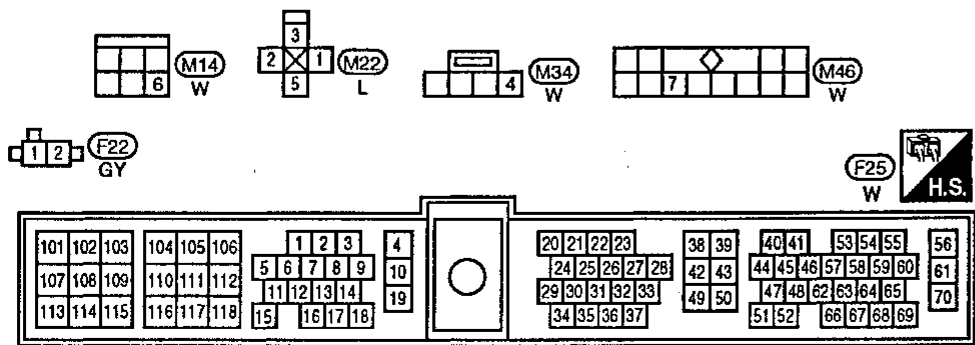

IACV-Air Regulator (Cont'd)

DESCRIPTION

The idle air control valve (IACV)-air regulator provides an air bypass when the engine is cold for a fast idle during warm-up. A bimetal, heater and rotary shutter are built into the IACV-air regulator. When the bimetal temperature is low, the air bypass port opens. As the engine starts and electric current flows through a heater, the bimetal begins to turn the shutter to close the bypass port. The air passage remains closed until the engine stops and the bimetal temperature drops.

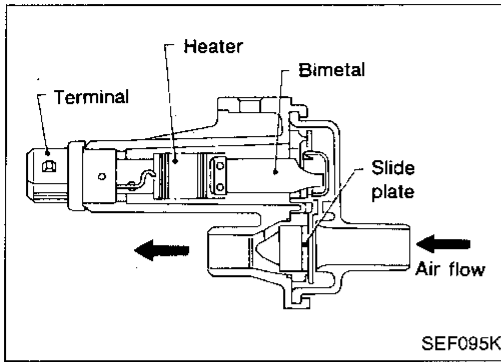

SEF095K

**A**

■ FUEL PUMP CIRCUIT ■  
 PINCH FUEL FEED HOSE WITH FINGERS IS THERE ANY PRESSURE PULSATION ON THE FUEL FEED HOSE?  
 OR  
 DOES THE FUEL PUMP RELAY MAKE AN OPERATING SOUND EVERY 3 SECONDS?

NEXT NO YES

MEF591B

**A**

■ ACTIVE TEST ■

FUEL PUMP RELAY ON

== == MONITOR == ==  
 CMPS•RPM(REF) 0rpm

ON ON/OFF OFF

MEF309F

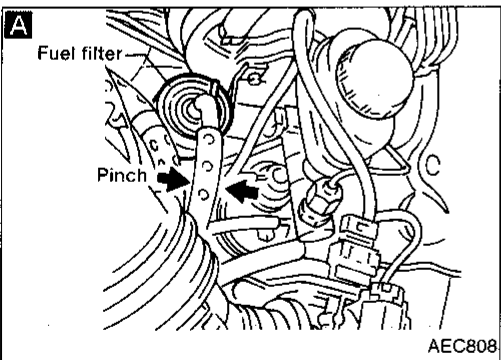

AEC808

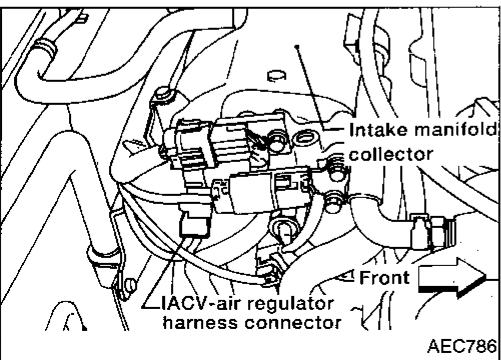

AEC786

DIAGNOSTIC PROCEDURE

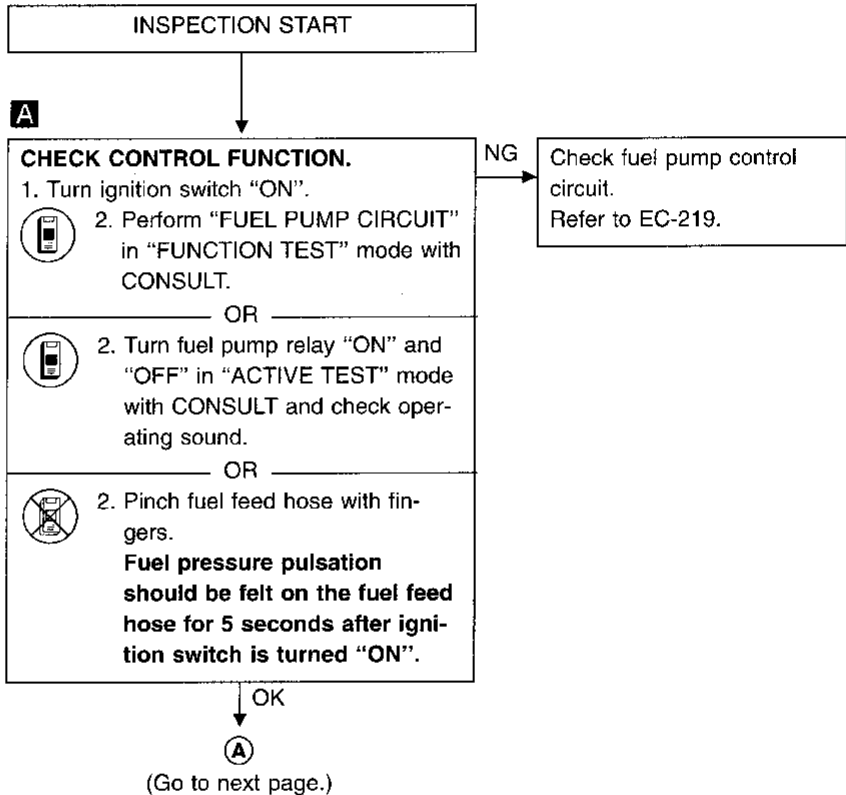

## IACV-Air Regulator (Cont'd)

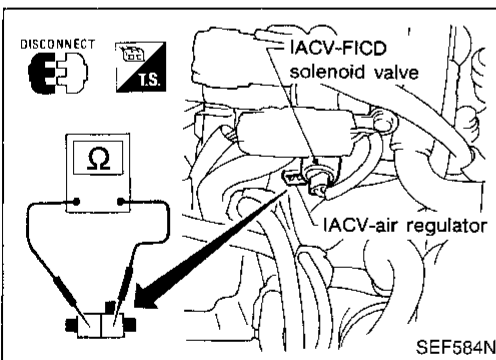
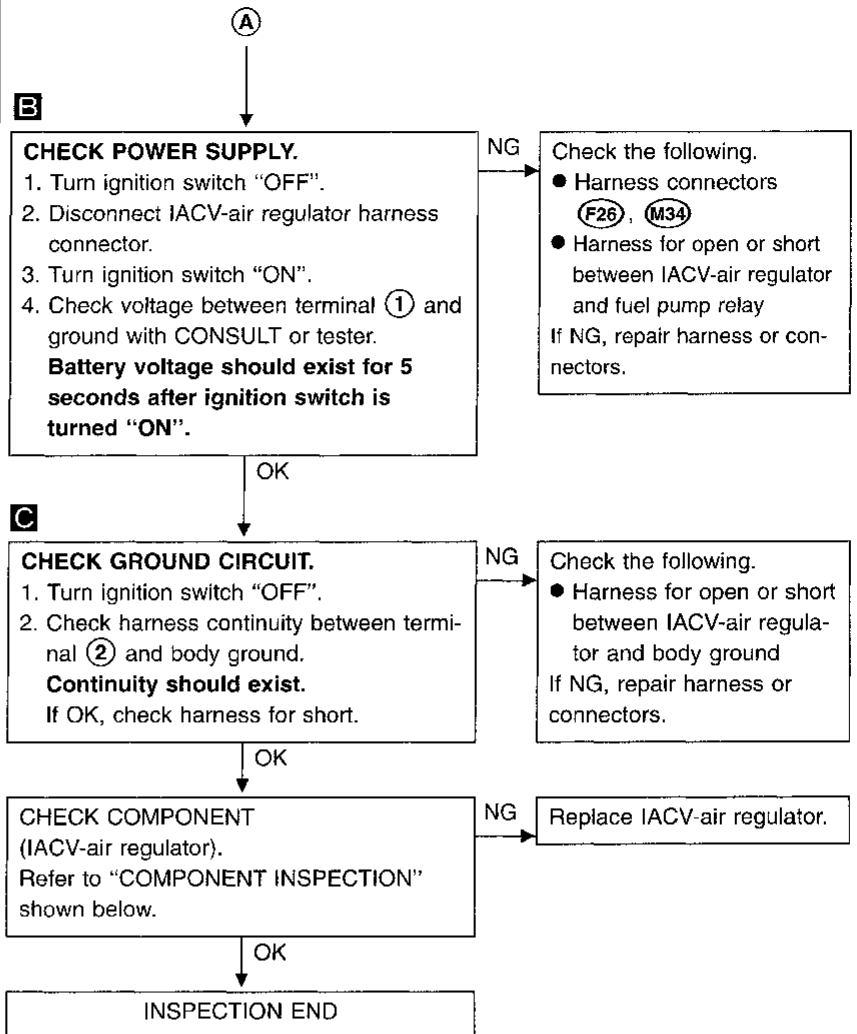
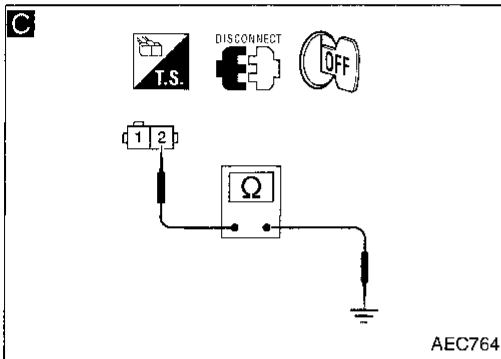
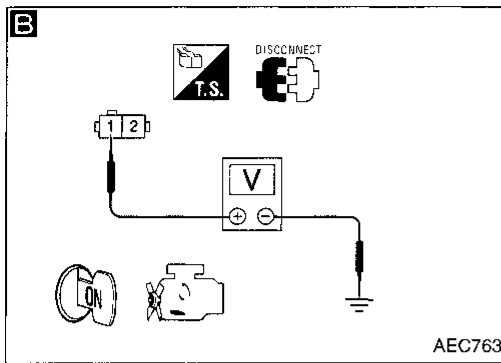
**COMPONENT INSPECTION****IACV-air regulator**

Disconnect IACV-air regulator harness connector.

- Check IACV-air regulator resistance.

**Resistance:**

**Approximately 70 - 80Ω [at 25°C (77°F)]**

- Check IACV-air regulator for clogging.

IACV-FICD Solenoid Valve

EC-FICD-01

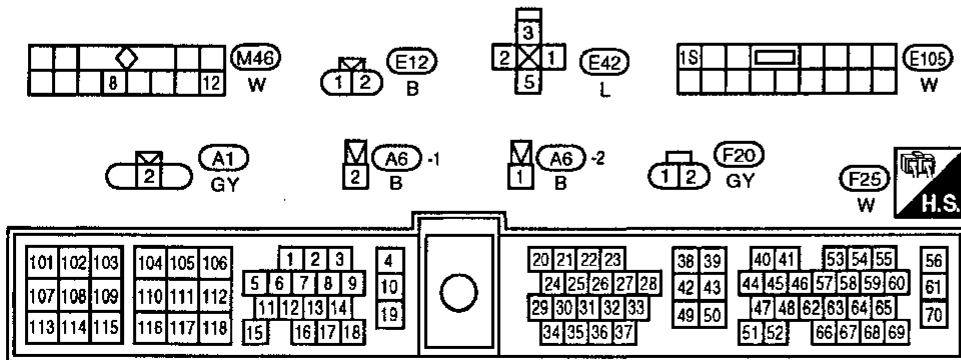
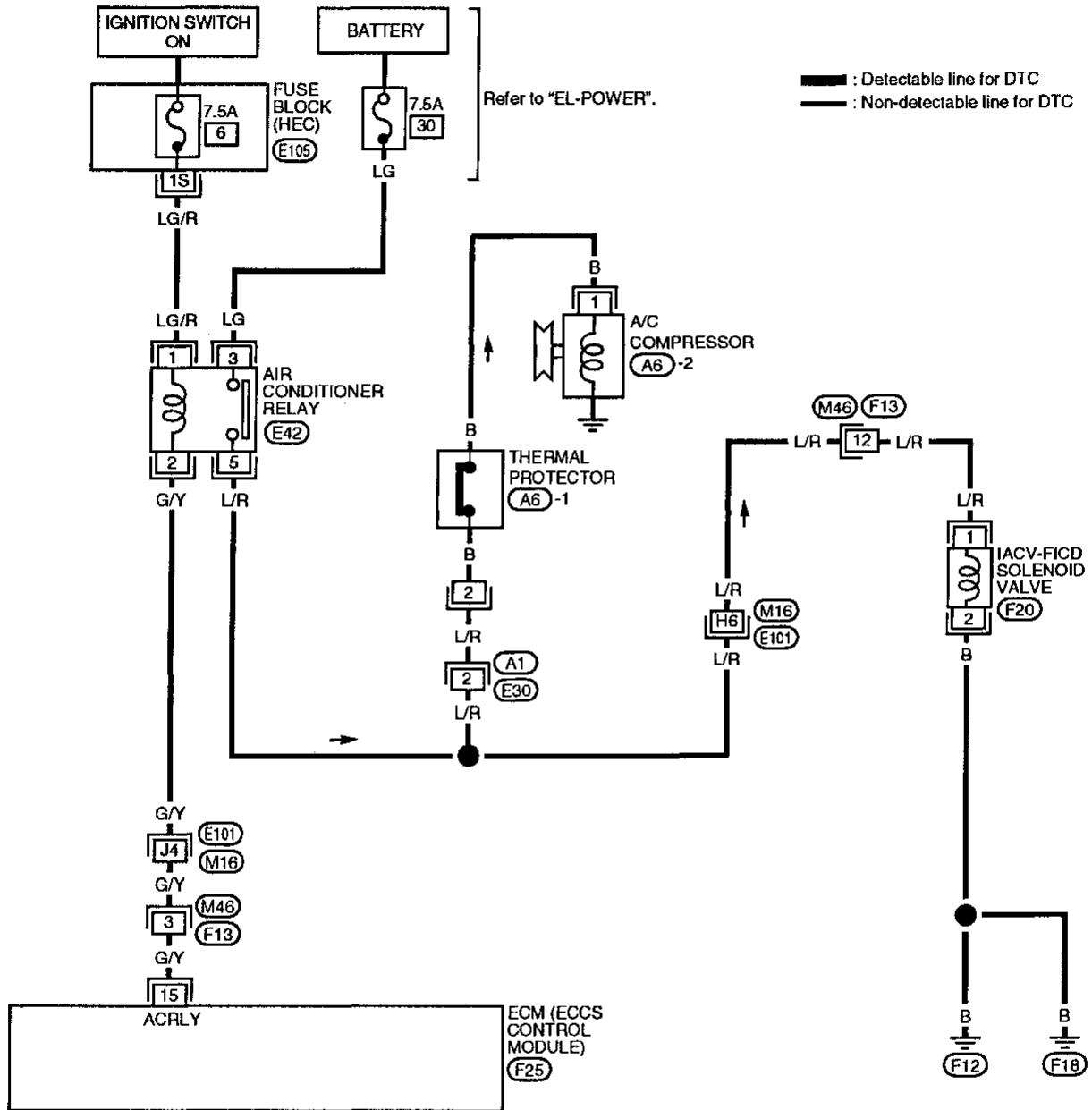

Refer to last page (Foldout page).  
 (M16), (E101)

IACV-FICD Solenoid Valve (Cont'd)

COMPONENT DESCRIPTION

When the air conditioner is on, the IAC valve-FICD solenoid valve supplies additional air to adjust to the increased load.

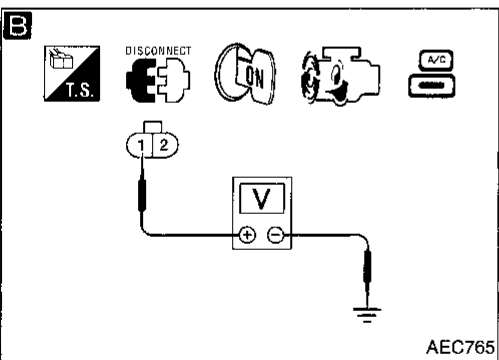
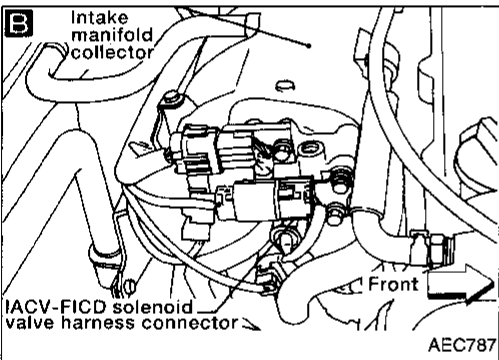
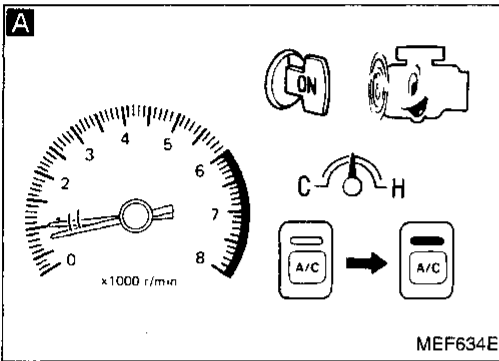
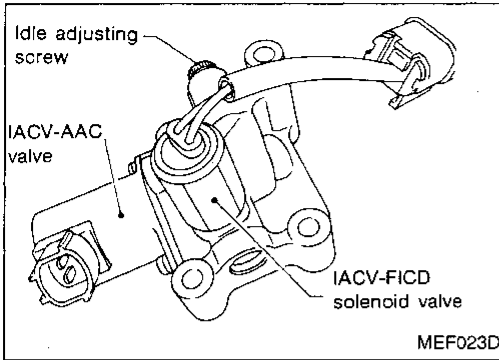

DIAGNOSTIC PROCEDURE

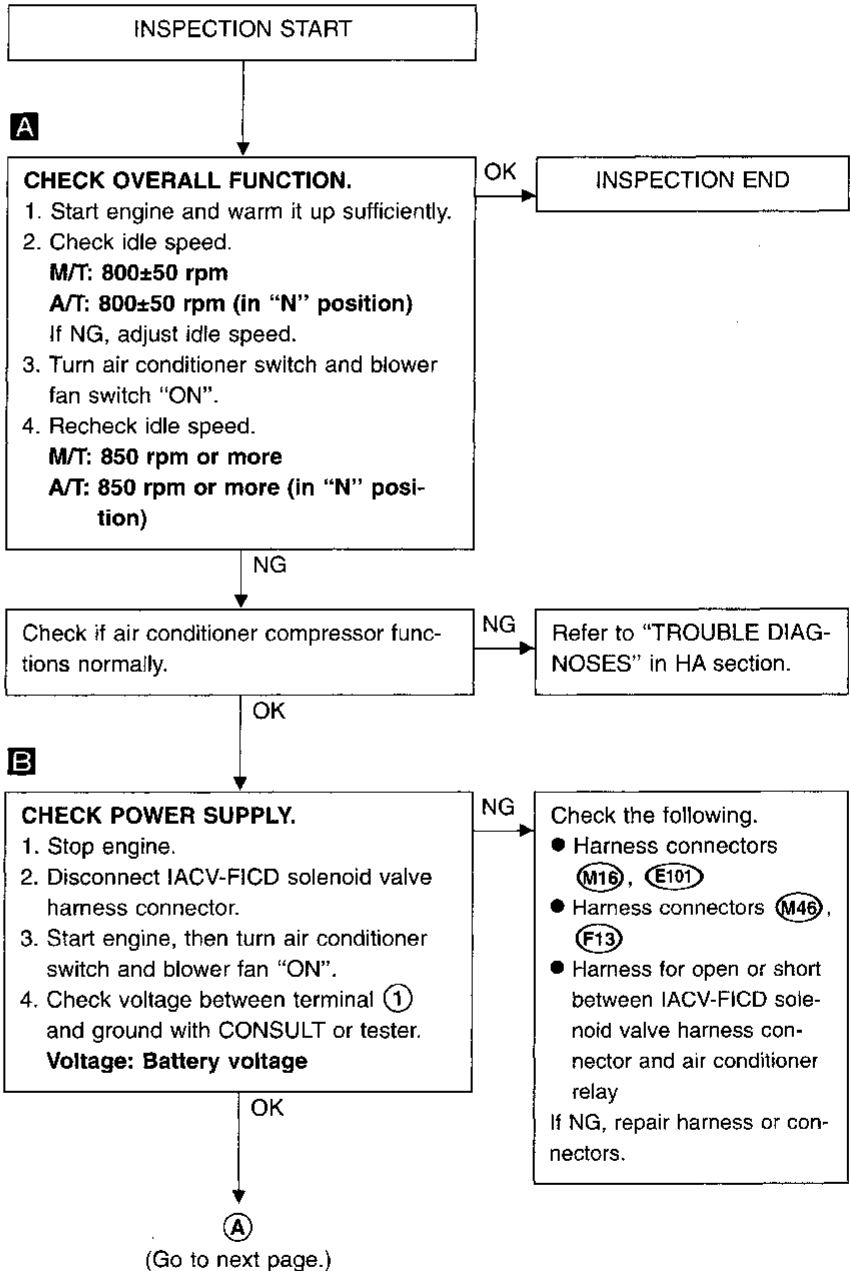

GI  
MA  
EM  
LC  
EC  
FE  
CL  
MT  
AT  
FA  
RA  
BR  
ST  
RS  
BT  
HA  
EL  
IDX

**IACV-FICD Solenoid Valve (Cont'd)**

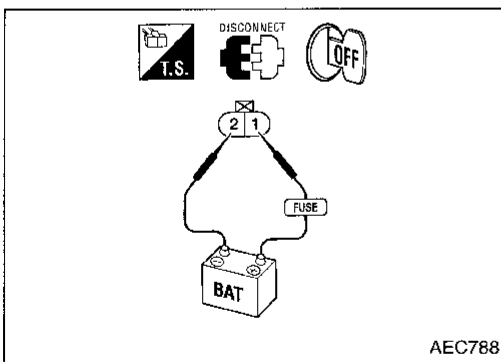
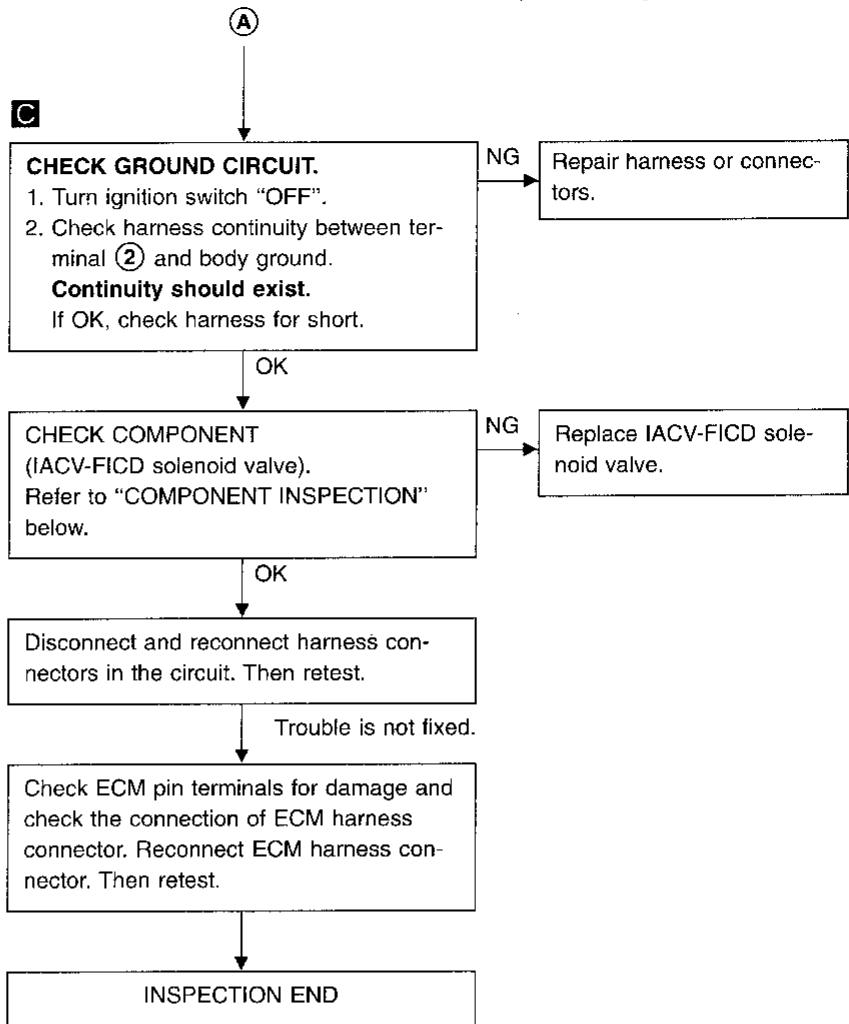
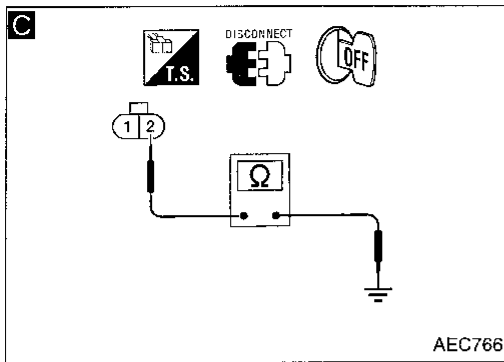

**COMPONENT INSPECTION**

**IACV-FICD solenoid valve**

Disconnect IACV-FICD solenoid valve harness connector.

- Check for clicking sound when applying 12V direct current to terminals.

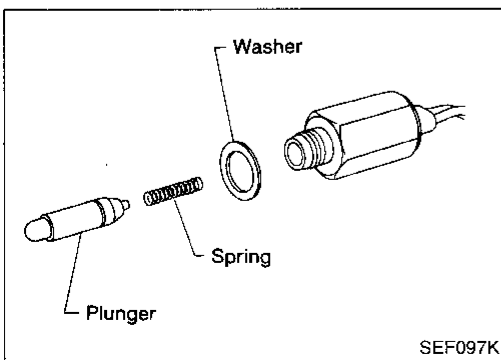

- Check plunger for seizing or sticking.
- Check for broken spring.

MIL & Data Link Connectors

EC-MIL-01

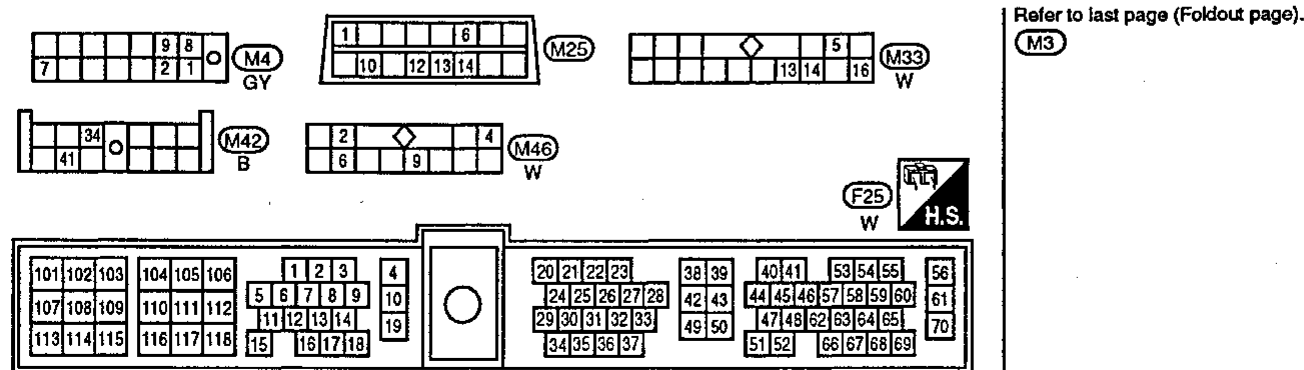
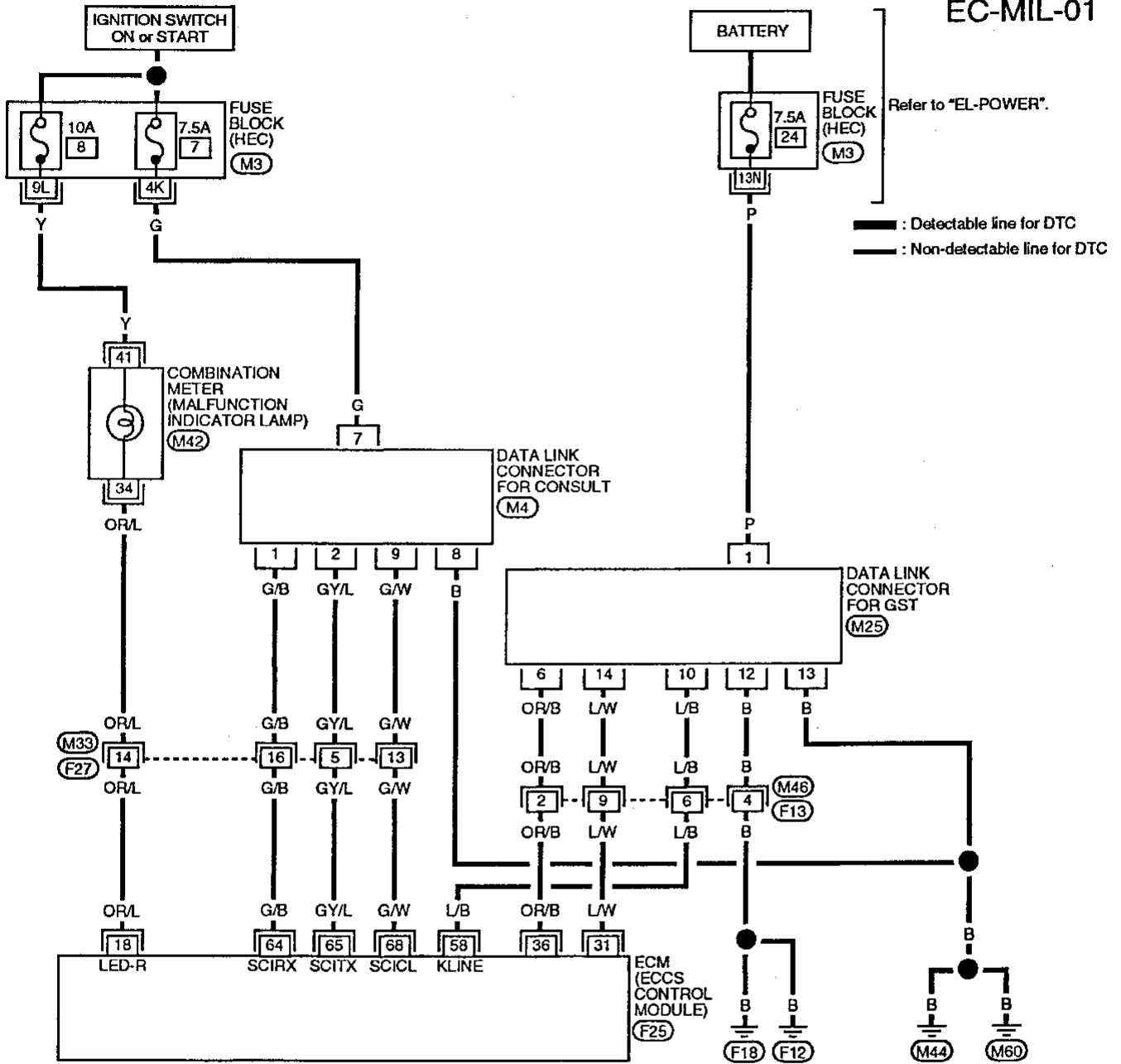

GI  
 MA  
 EM  
 LC  
**EC**  
 FE  
 CL  
 MT  
 AT  
 FA  
 RA  
 BR  
 ST  
 RS  
 BT  
 HA  
 EL  
 IDX



## Circuit Diagram

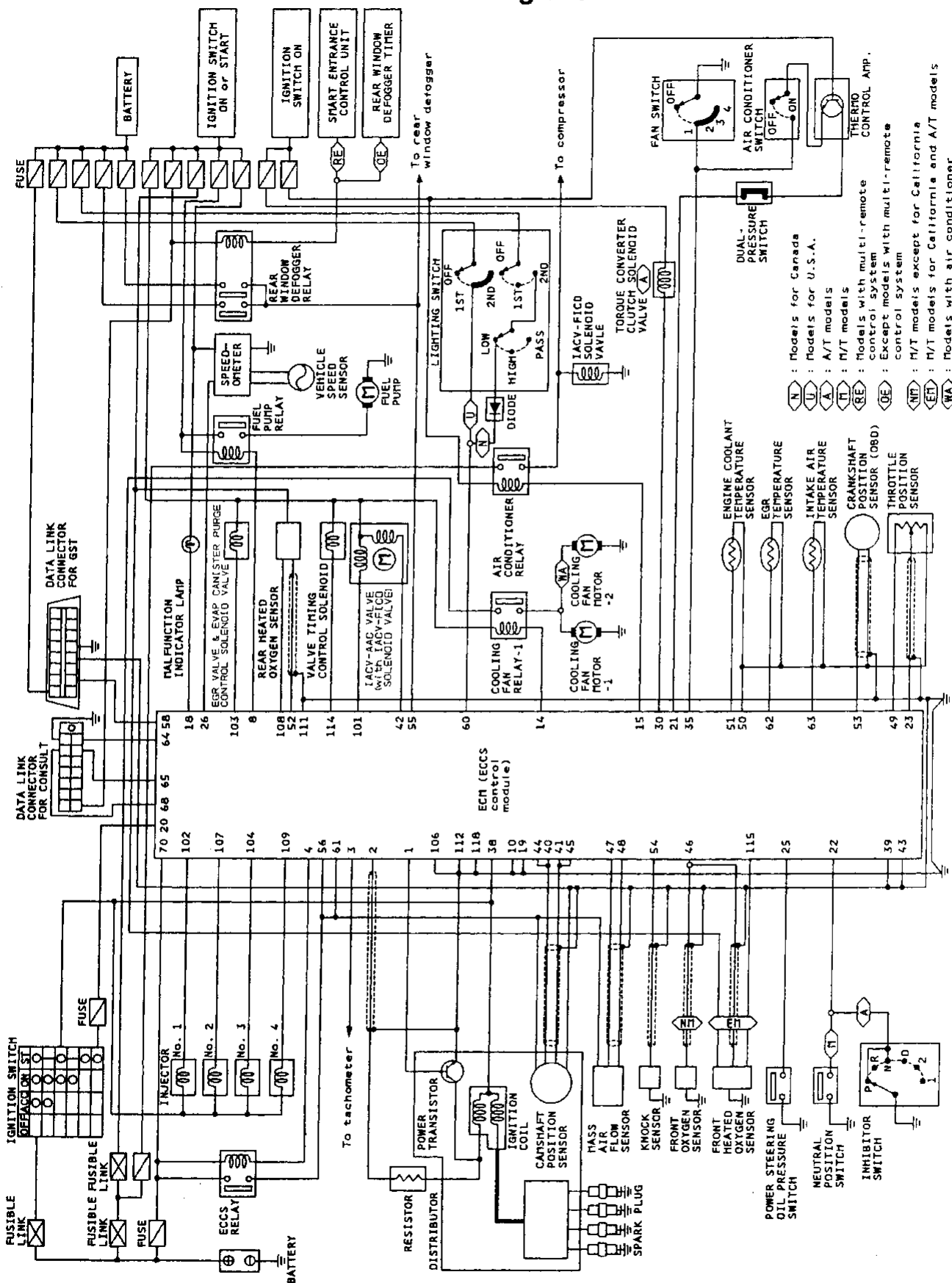

System Diagram

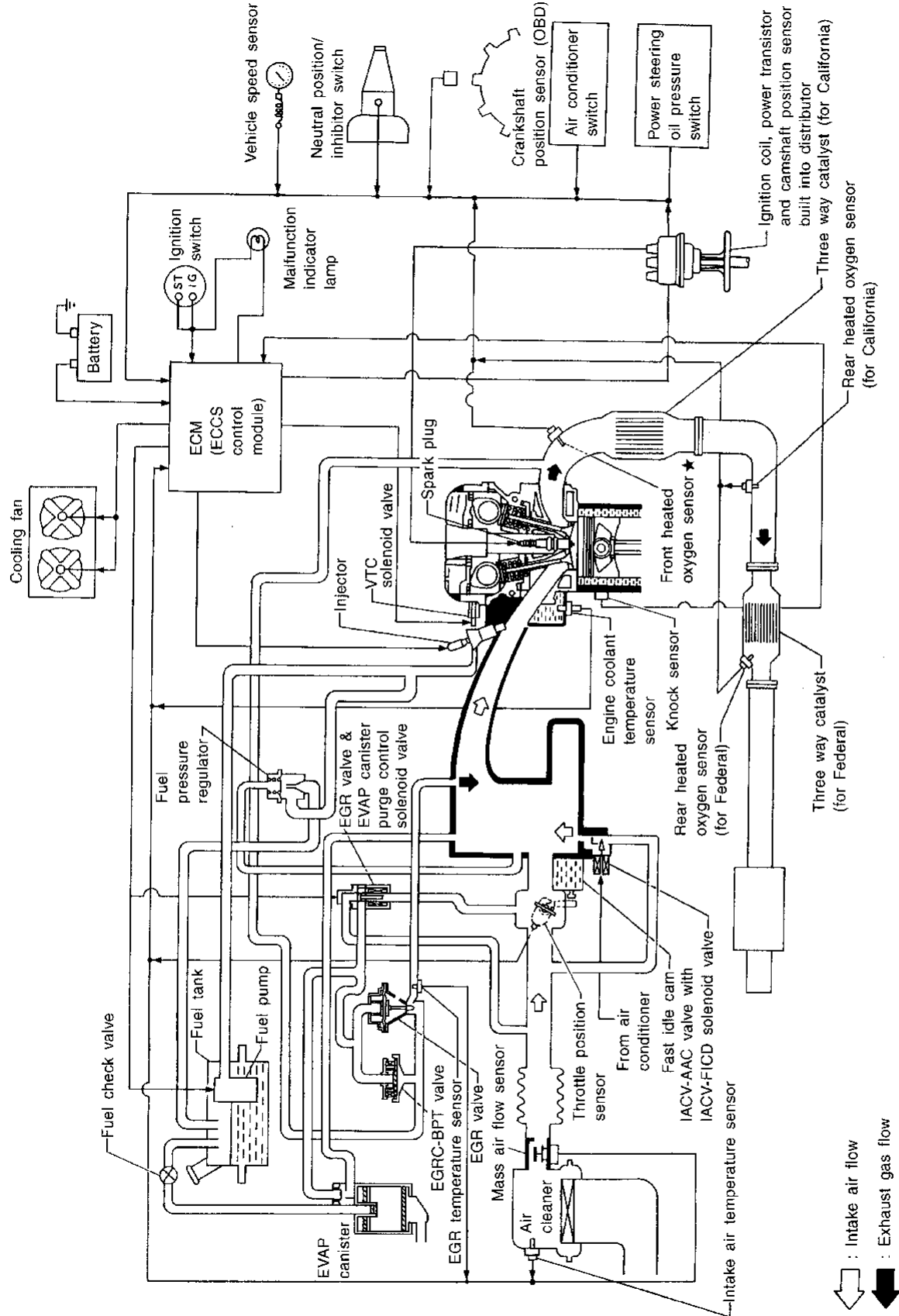

GA  
 MA  
 EM  
 LC  
**EC**  
 FE  
 CL  
 MT  
 AT  
 FA  
 RA  
 BR  
 ST  
 PC  
 BT  
 HA  
 EL  
 IDX

ECCS Component Parts Location

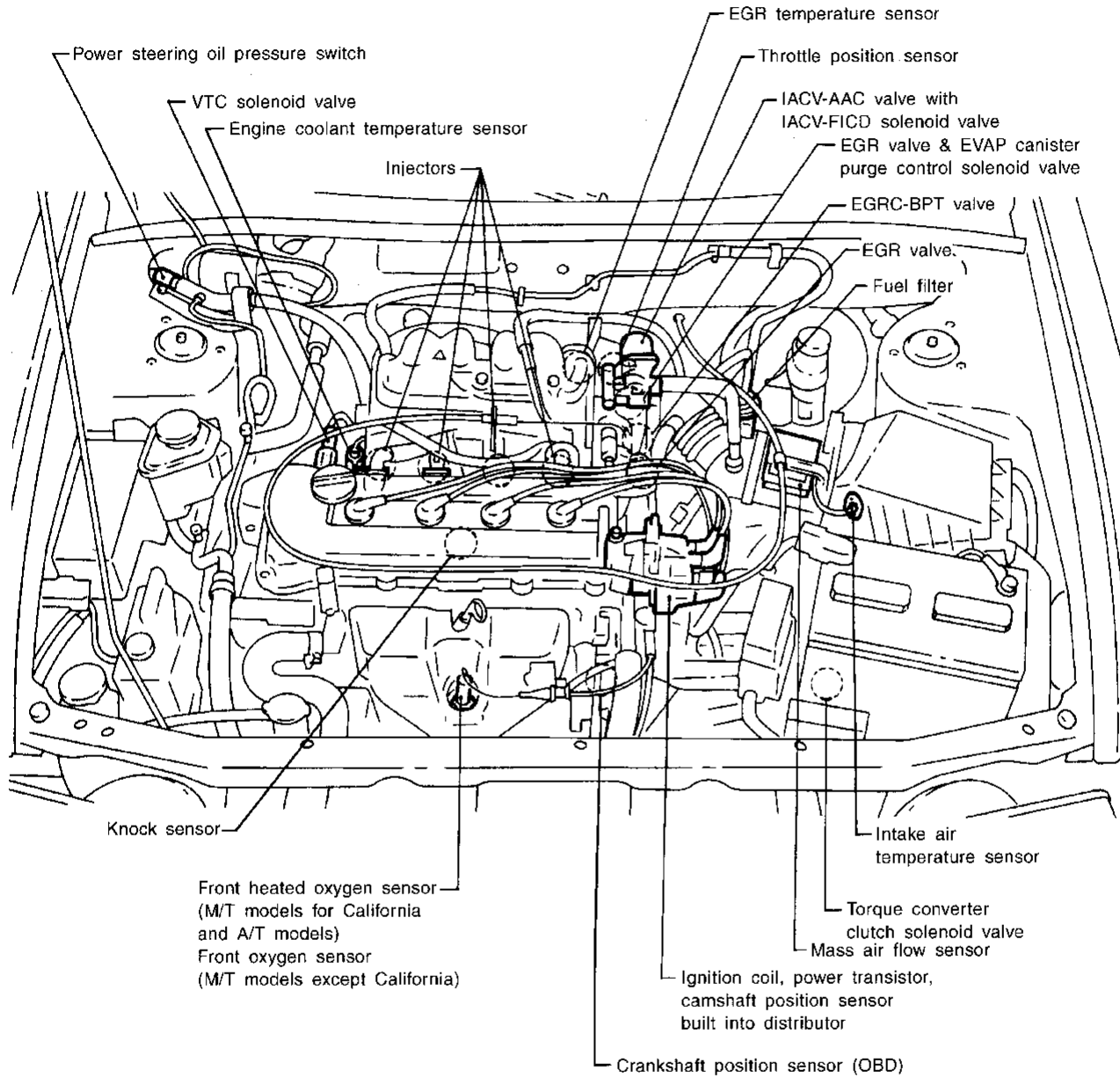

ECCS Component Parts Location (Cont'd)

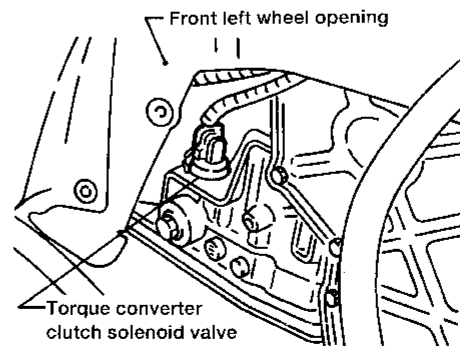
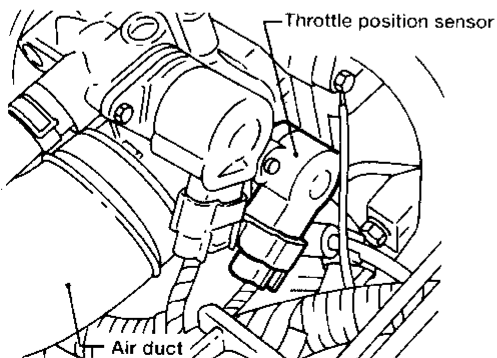
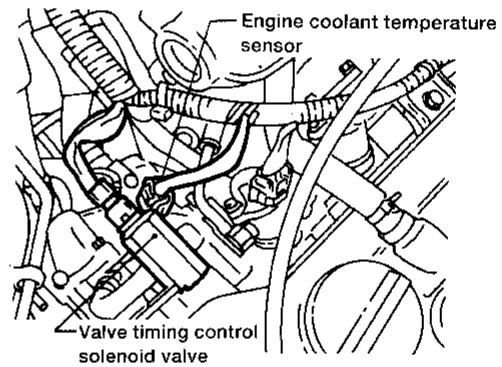
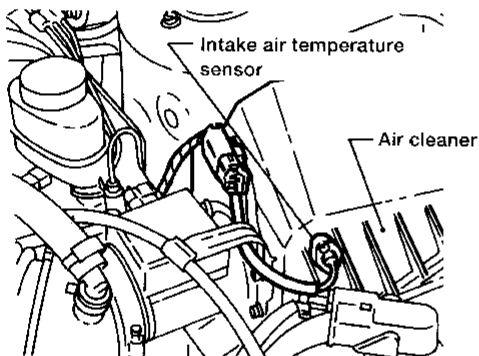
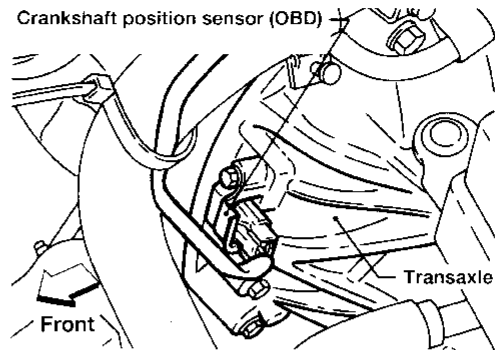
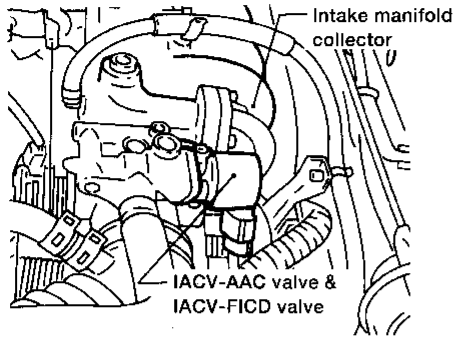

- GI
- MA
- EM
- LC
- EC**
- FE
- CL
- MT
- AT
- FA
- RA
- BR
- ST
- RS
- BT
- HA
- EL
- IDX

ECCS Component Parts Location (Cont'd)

Except for California models

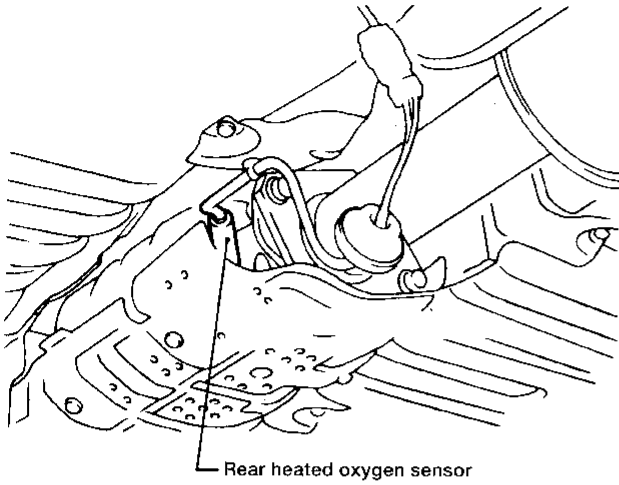

Models for California

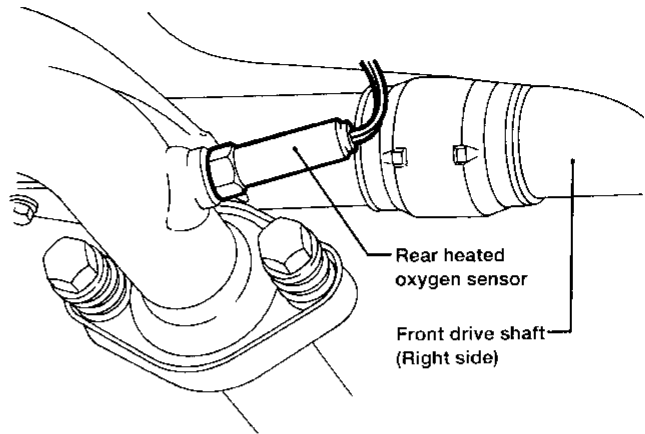

AEC910

Left side view

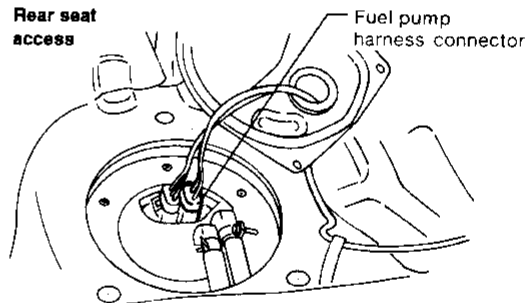
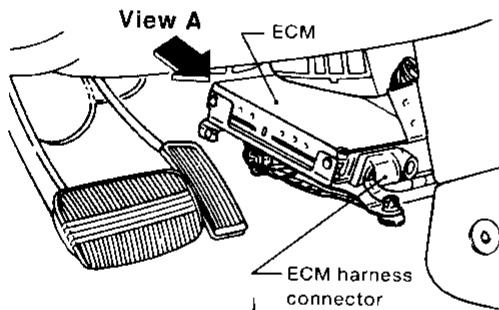

View A

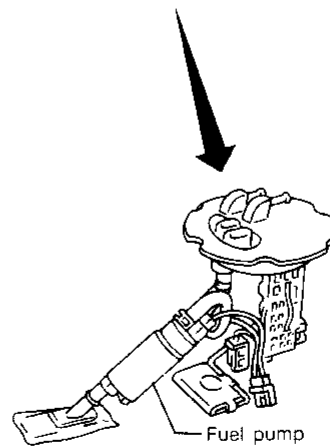
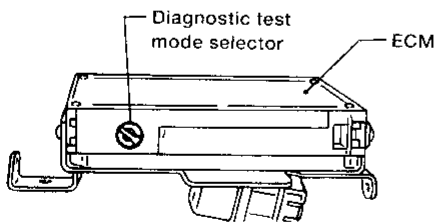

AEC803

Vacuum Hose Drawing

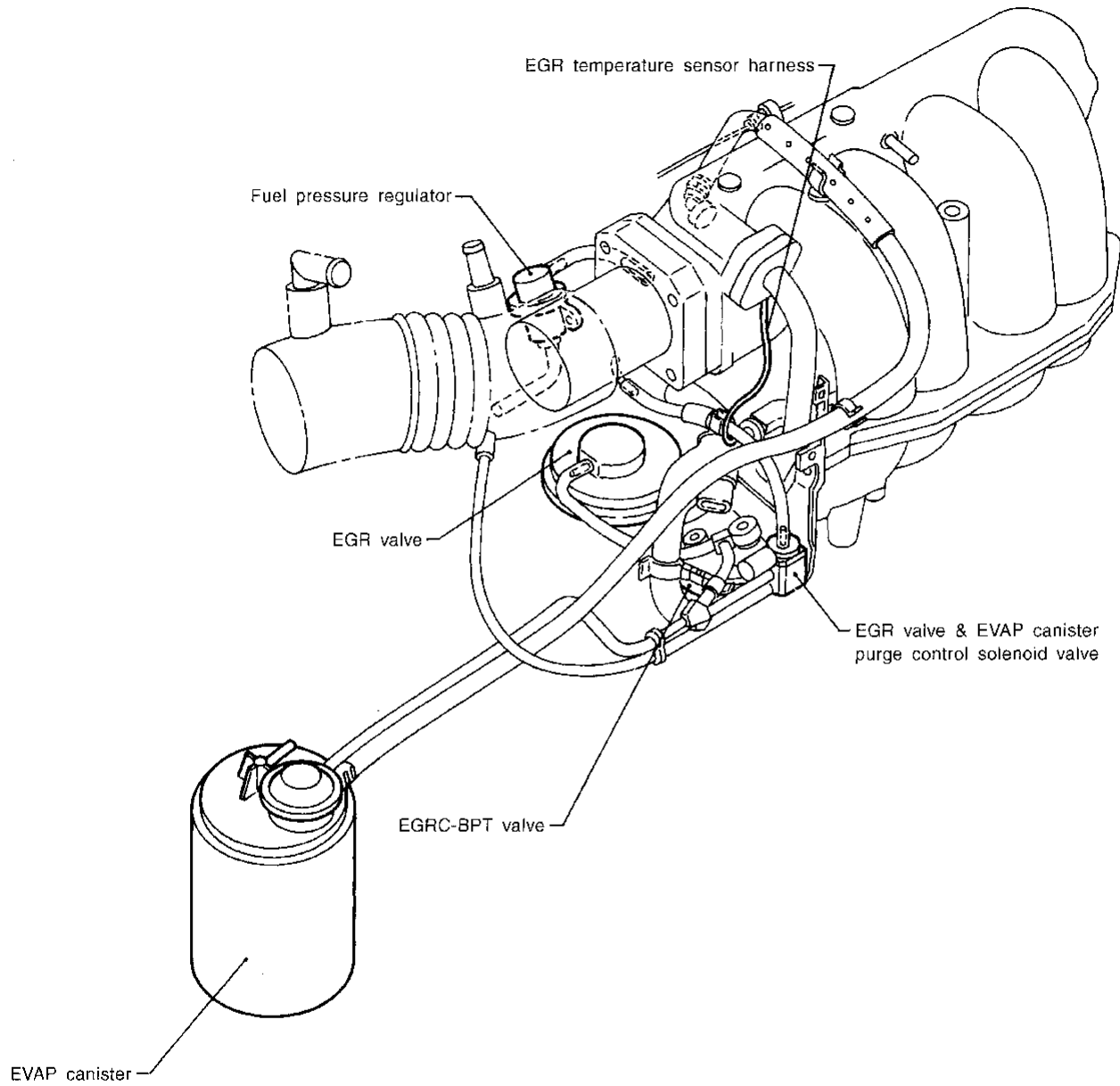

GI

MA

EM

LC

**EC**

FE

CL

MT

AT

FA

RA

BR

ST

RS

BT

HA

EL

SEF202R

Refer to "System Diagram" in ENGINE AND EMISSION CONTROL SYSTEM for vacuum control system.

IDX

System Chart

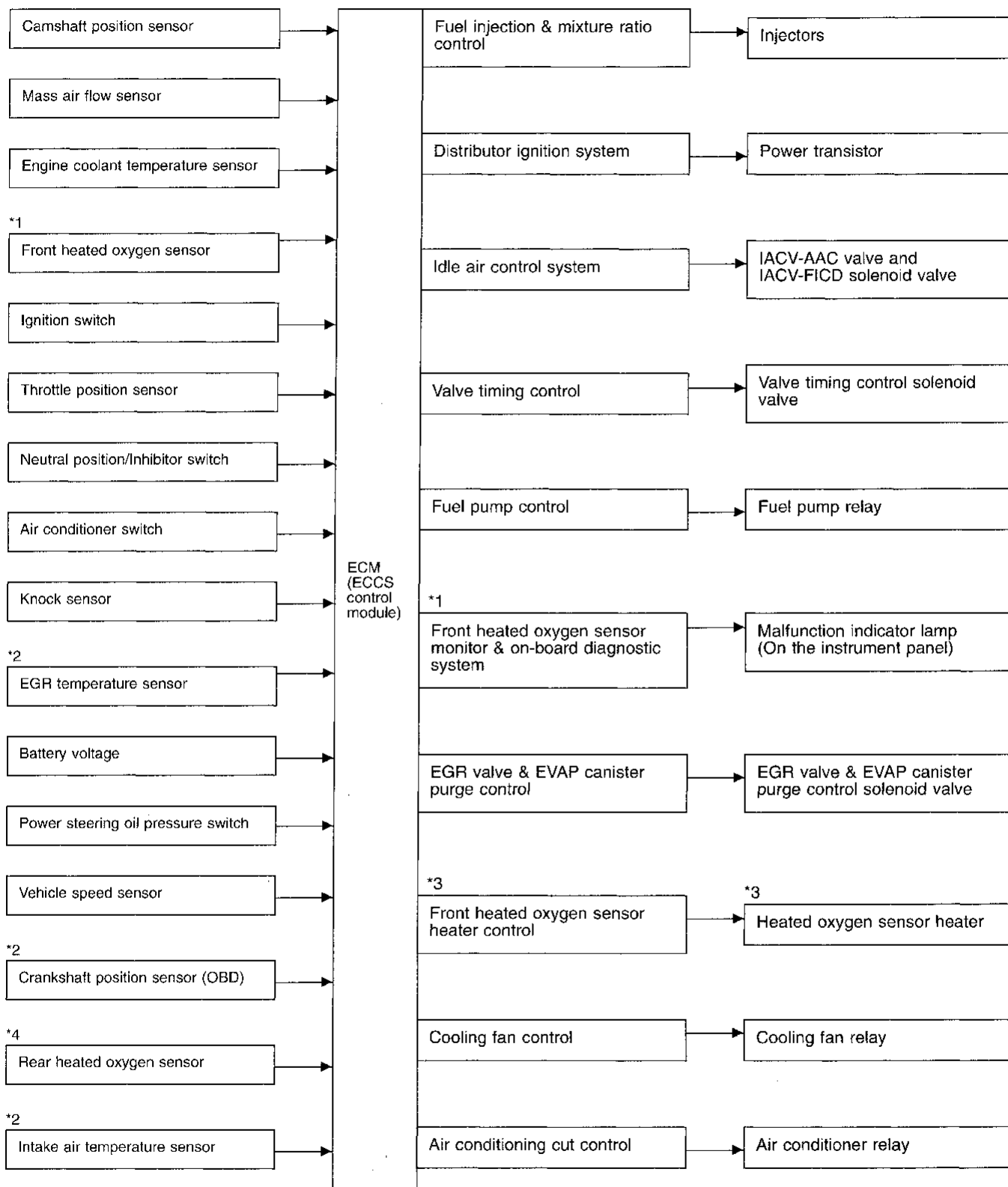

\*1: Oxygen sensor (M/T models except for California)

Heated oxygen sensor (M/T models for California and A/T models)

\*2: These sensors are not used to control the engine system. They are used only for the on-board diagnosis.

\*3: For A/T models and California M/T models.

\*4: Under normal conditions, this sensor is not for engine control operation.

## Multipoint Fuel Injection (MFI) System

### INPUT/OUTPUT SIGNAL LINE

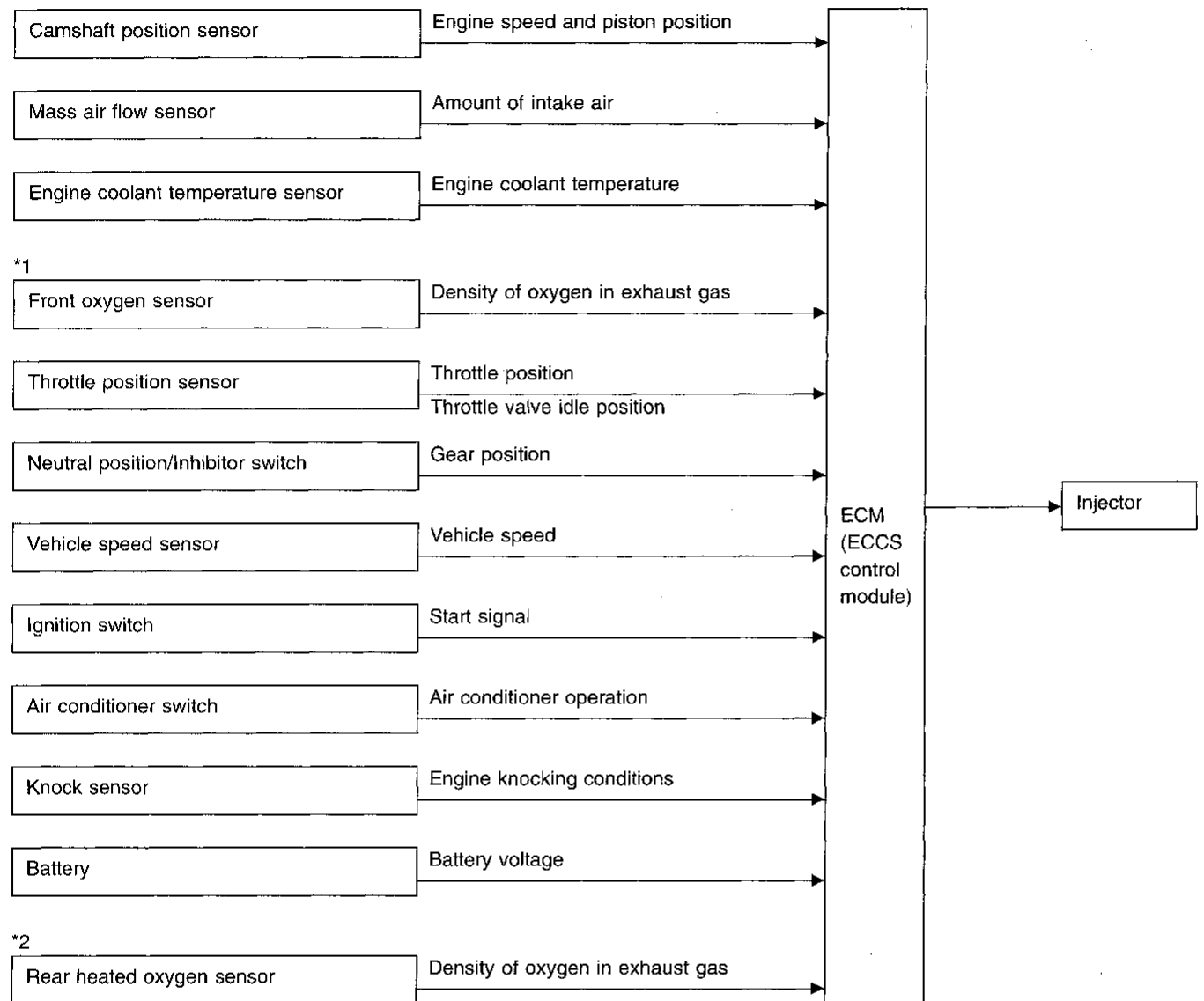

\*1: Oxygen sensor (M/T models except for California)

Heated oxygen sensor (M/T models for California and A/T models)

\*2: Under normal conditions, this sensor is not for engine control operation.

### BASIC MULTIPOINT FUEL INJECTION SYSTEM

The amount of fuel injected from the fuel injector is determined by the ECM. The ECM controls the length of time the valve remains open (injection pulse duration). The amount of fuel injected is a program value in the ECM memory. The program value is preset by engine operating conditions. These conditions are determined by input signals (for engine speed and intake air) from both the camshaft position sensor and the mass air flow sensor.

### VARIOUS FUEL INJECTION INCREASE/DECREASE COMPENSATION

In addition, the amount of fuel injected is compensated to improve engine performance under various operating conditions as listed below.

<Fuel increase>

- During warm-up
- When starting the engine
- During acceleration
- Hot-engine operation
- When selector lever is changed from "N" to "D" (A/T models only)
- High-load, high-speed operation

<Fuel decrease>

- During deceleration



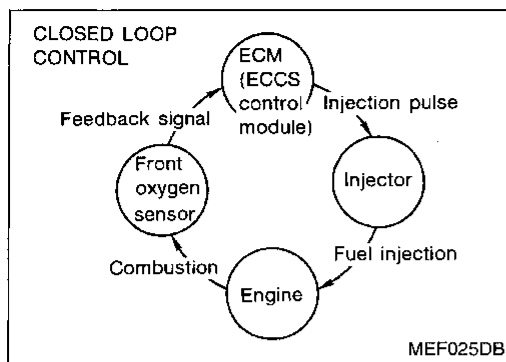

**Multiport Fuel Injection (MFI) System (Cont'd)  
MIXTURE RATIO FEEDBACK CONTROL (CLOSED LOOP CONTROL)**

The mixture ratio feedback system provides the best air-fuel mixture ratio for driveability and emission control. The three way catalyst can then better reduce CO, HC and NOx emissions. This system uses a front oxygen sensor\* in the exhaust manifold to monitor if the engine operation is rich or lean. The ECM adjusts the injection pulse width according to the sensor voltage signal. For more information about the front oxygen sensor\*, refer to EC-342. This maintains the mixture ratio within the range of stoichiometric (ideal air-fuel mixture).

This stage is referred to as the closed loop control condition. Rear heated oxygen sensor is located downstream of the three way catalyst. Even if the switching characteristics of the front heated oxygen sensor\* shift, the air-fuel ratio is controlled to stoichiometric by the signal from the rear heated oxygen sensor.

**OPEN LOOP CONTROL**

The open loop system condition refers to when the ECM detects any of the following conditions. Feedback control stops in order to maintain stabilized fuel combustion.

- Deceleration and acceleration
- High-load, high-speed operation
- Engine idling
- Malfunction of front oxygen sensor\* or its circuit
- Insufficient activation of front oxygen sensor\* at low engine coolant temperature
- High-engine coolant temperature
- After shifting from "N" to "D"
- During warm-up
- When starting the engine

**MIXTURE RATIO SELF-LEARNING CONTROL**

The mixture ratio feedback control system monitors the mixture ratio signal transmitted from the front oxygen sensor\*. This feedback signal is then sent to the ECM. The ECM controls the basic mixture ratio as close to the theoretical mixture ratio as possible. However, the basic mixture ratio is not necessarily controlled as originally designed. Both manufacturing differences (i.e., mass air flow sensor hot film) and characteristic changes during operation (i.e., injector clogging) directly affect mixture ratio.

Accordingly, the difference between the basic and theoretical mixture ratios is monitored in this system. This is then computed in terms of "injection pulse duration" to automatically compensate for the difference between the two ratios.

"Fuel trim" refers to the feedback compensation value compared against the basic injection duration. Fuel trim includes short-term fuel trim and long-term fuel trim.

"Short-term fuel trim" is the short-term fuel compensation used to maintain the mixture ratio at its theoretical value. The signal from the front oxygen sensor\* indicates whether the mixture ratio is RICH or LEAN compared to the theoretical value. The signal then triggers a reduction in fuel volume if the mixture ratio is rich, and an increase in fuel volume if it is lean.

"Long-term fuel trim" is overall fuel compensation carried out long-term to compensate for continual deviation of the short-term fuel trim from the central value. Such deviation will occur

**Multiport Fuel Injection (MFI) System (Cont'd)**

due to individual engine differences, wear over time and changes in the usage environment.

- \*: Oxygen sensor (M/T models except for California)
- Heated oxygen sensor (M/T models for California and A/T models)

GI  
MA  
EM  
LC  
EC  
FE  
CL  
MT  
AT  
FA  
RA  
BR  
ST  
RS  
BT  
HA  
EL  
IDX

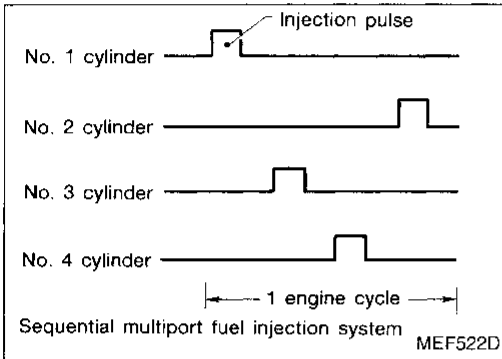

**FUEL INJECTION TIMING**

Two types of systems are used.

**Sequential multiport fuel injection system**

Fuel is injected into each cylinder during each engine cycle according to the firing order. This system is used when the engine is running.

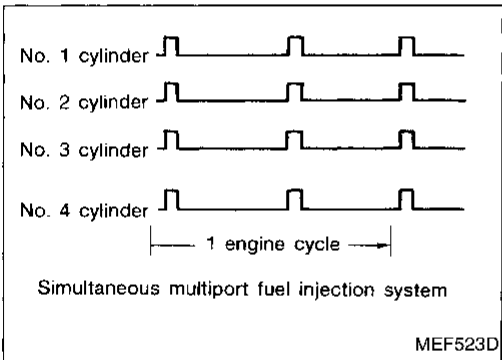

**Simultaneous multiport fuel injection system**

Fuel is injected simultaneously into all four cylinders twice each engine cycle. In other words, pulse signals of the same width are simultaneously transmitted from the ECM.

The four injectors will then receive the signals two times for each engine cycle.

This system is used when the engine is being started and/or if the fail-safe system (CPU) is operating.

**FUEL SHUT-OFF**

Fuel to each cylinder is cut off during deceleration or operation of the engine at excessively high speeds.

## Distributor Ignition (DI) System

### INPUT/OUTPUT SIGNAL LINE

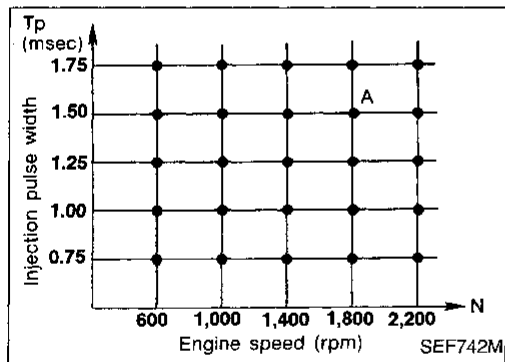
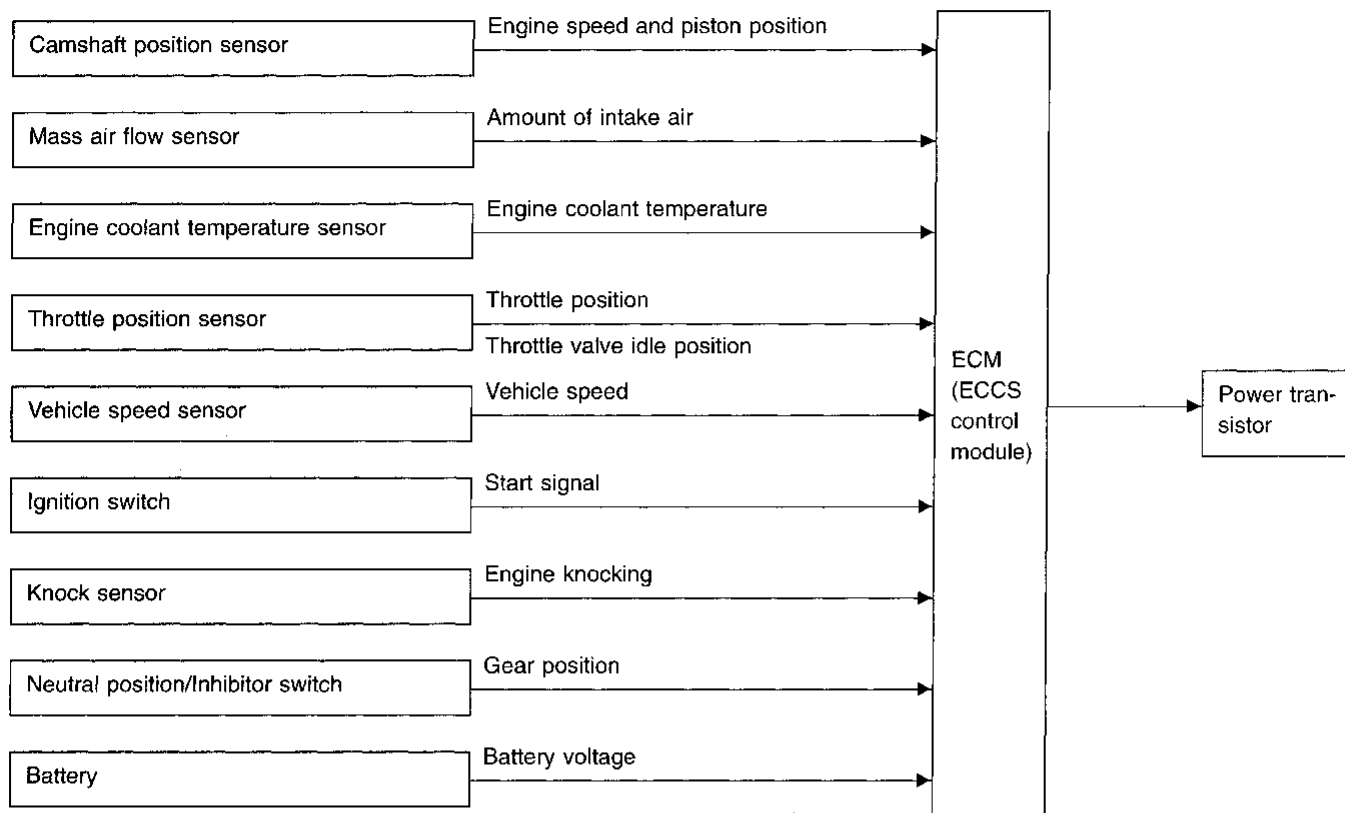

### SYSTEM DESCRIPTION

The ignition timing is controlled by the ECM to maintain the best air-fuel ratio for every running condition of the engine.

The ignition timing data is stored in the ECM. This data forms the map shown.

The ECM receives information such as the injection pulse width and camshaft position sensor signal. Computing this information, ignition signals are transmitted to the power transistor.

e.g., N: 1,800 rpm, Tp: 1.50 msec  
A °BTDC

During the following conditions, the ignition timing is revised by the ECM according to the other data stored in the ECM.

- At starting
- During warm-up
- At idle
- Hot engine operation
- During acceleration
- During high-load operation (VTC on)

The knock sensor retard system is designed only for emergencies. The basic ignition timing is programmed within the anti-knocking zone, if recommended fuel is used under dry conditions. The retard system does not operate under normal driving conditions.

If engine knocking occurs, the knock sensor monitors the condition. The signal is transmitted to the ECM (ECCS control module). The ECM retards the ignition timing to eliminate the knocking condition.

### Air Conditioning Cut Control

**INPUT/OUTPUT SIGNAL LINE**

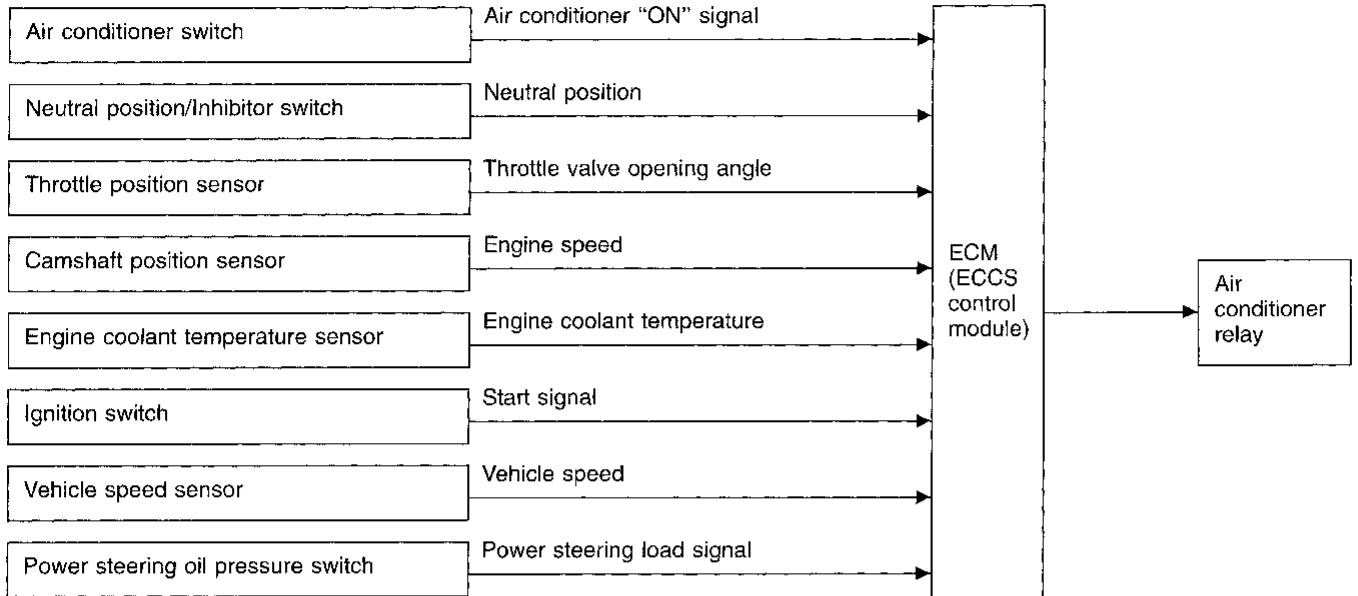

**SYSTEM DESCRIPTION**

This system improves acceleration when the air conditioner is used. When the accelerator pedal is fully depressed, the air conditioner is turned off for a few seconds.

### Fuel Cut Control (at no load & high engine speed)

**INPUT/OUTPUT SIGNAL LINE**

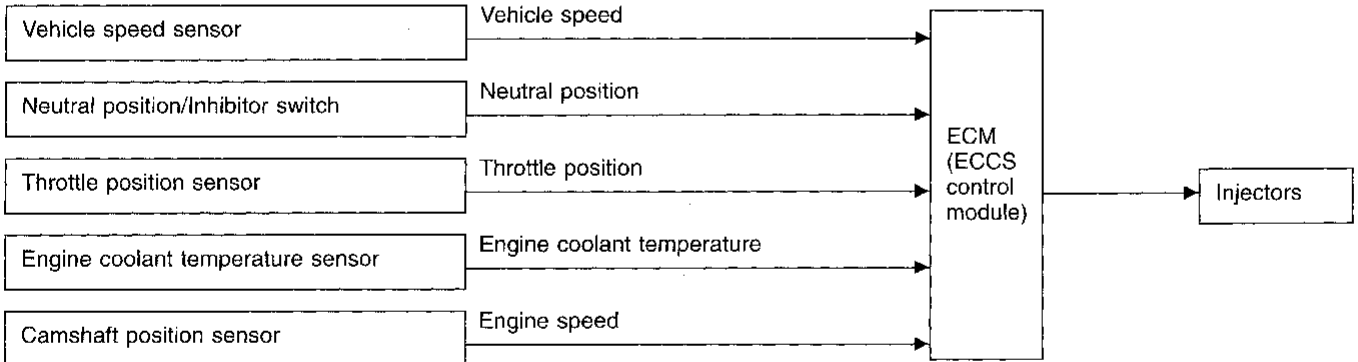

If the engine speed is above 4,000 rpm with no load (for example, in neutral and engine speed over 4,000 rpm) fuel will be cut off after some time. The exact time when the fuel is cut off varies based on engine speed. Fuel cut will operate until the engine speed reaches 1,500 rpm, then fuel cut is cancelled.

**NOTE:**  
 This function is different than deceleration control listed under "Multiport Fuel Injection (MFI) System" on EC-241.

Description

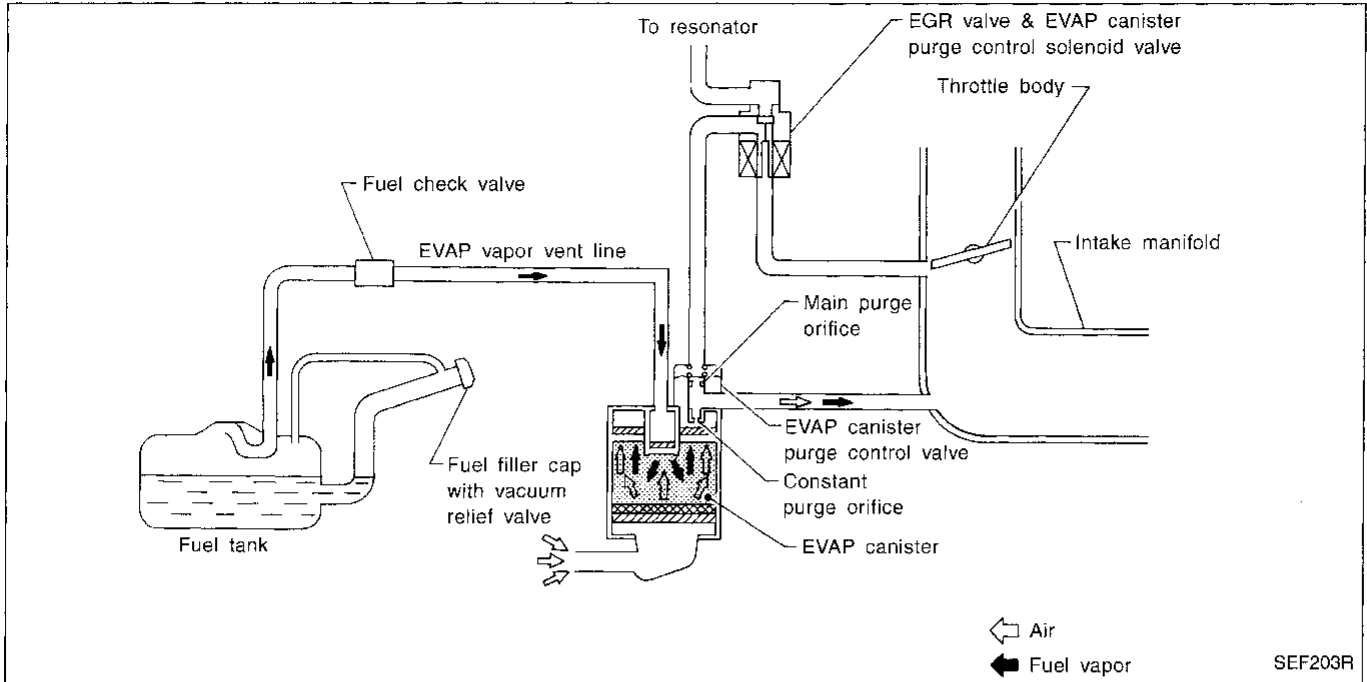

The evaporative emission system is used to reduce hydrocarbons emitted into the atmosphere from the fuel system. This reduction of hydrocarbons is accomplished by activated charcoals in the EVAP canister.

The fuel vapor from sealed fuel tank is led into the EVAP canister when the engine is off. The fuel vapor is then stored in the EVAP canister. The EVAP canister retains the fuel vapor until the EVAP canister is purged by air.

When the engine is running, the air is drawn through the bottom of the EVAP canister. The fuel vapor will then be led to the intake manifold.

When the engine runs at idle, the EVAP canister purge control valve is closed. Only a small amount of vapor flows into the intake manifold through the constant purge orifice.

As the engine speed increases and the throttle vacuum rises, the EVAP canister purge control valve opens. The vapor is sucked through both main purge and constant purge orifices.

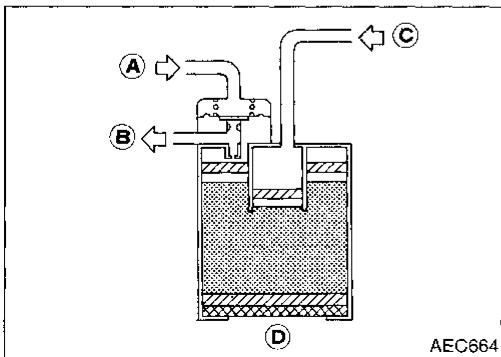

Inspection

EVAP CANISTER

Check EVAP canister as follows:

1. Blow air in port (A) and check that there is no leakage.
2. Apply vacuum to port (A). [Approximately -13.3 to -20.0 kPa (-100 to -150 mmHg, -3.94 to -5.91 inHg)]
3. Cover port (D) by hand.
4. Blow air in port (C) and check that it flows freely out of port (B).

**Inspection (Cont'd)**

**FUEL CHECK VALVE**

**Check valve operation**

1. Blow air through connector on fuel tank side.  
A considerable resistance should be felt and a portion of air flow should be directed toward the EVAP canister side.
2. Blow air through connector on EVAP canister side.  
Air flow should be smoothly directed toward fuel tank side.
3. If fuel check valve is suspected of not properly functioning in steps 1 and 2 above, replace it.

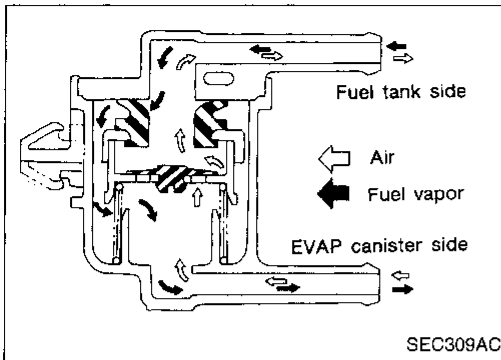

**FUEL TANK VACUUM RELIEF VALVE**

1. Wipe clean valve housing.
2. Suck air through the cap. A slight resistance accompanied by valve clicks indicates that valve A is in good mechanical condition. Note also that, by further sucking air, the resistance should disappear with valve clicks.
3. Blow air on fuel tank side and ensure that continuity of air passage exists through valve B.
4. If valve is clogged or if no resistance is felt, replace cap as an assembly.

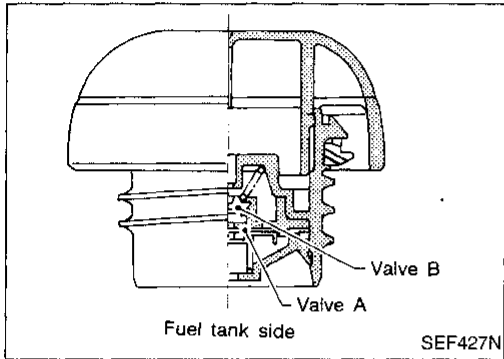

**Use only a genuine filler cap as a replacement.**

GI

MA

EM

LC

EC

FE

CL

MT

AT

FA

RA

BR

ST

RS

BT

HA

EL

IDX

**Description**

This system returns blow-by gas to the intake manifold collector.

The positive crankcase ventilation (PCV) valve is provided to conduct crankcase blow-by gas to the intake manifold.

During partial throttle operation of the engine, the intake manifold sucks the blow-by gas through the PCV valve.

Normally, the capacity of the valve is sufficient to handle any blow-by and a small amount of ventilating air.

The ventilating air is then drawn from the air duct

into the crankcase. In this process the air passes through the hose connecting air inlet tubes to rocker cover.

Under full-throttle condition, the manifold vacuum is insufficient to draw the blow-by flow through the valve. The flow goes through the hose connection in the reverse direction.

On vehicles with an excessively high blow-by, the valve does not meet the requirement. This is because some of the flow will go through the hose connection to the intake manifold collector under all conditions.

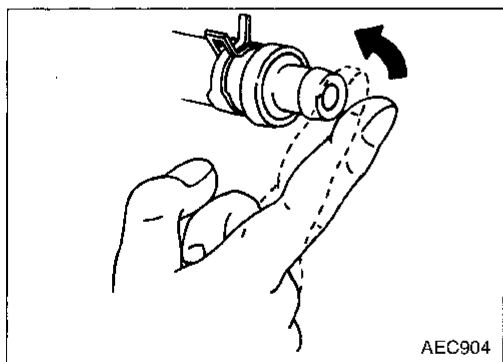
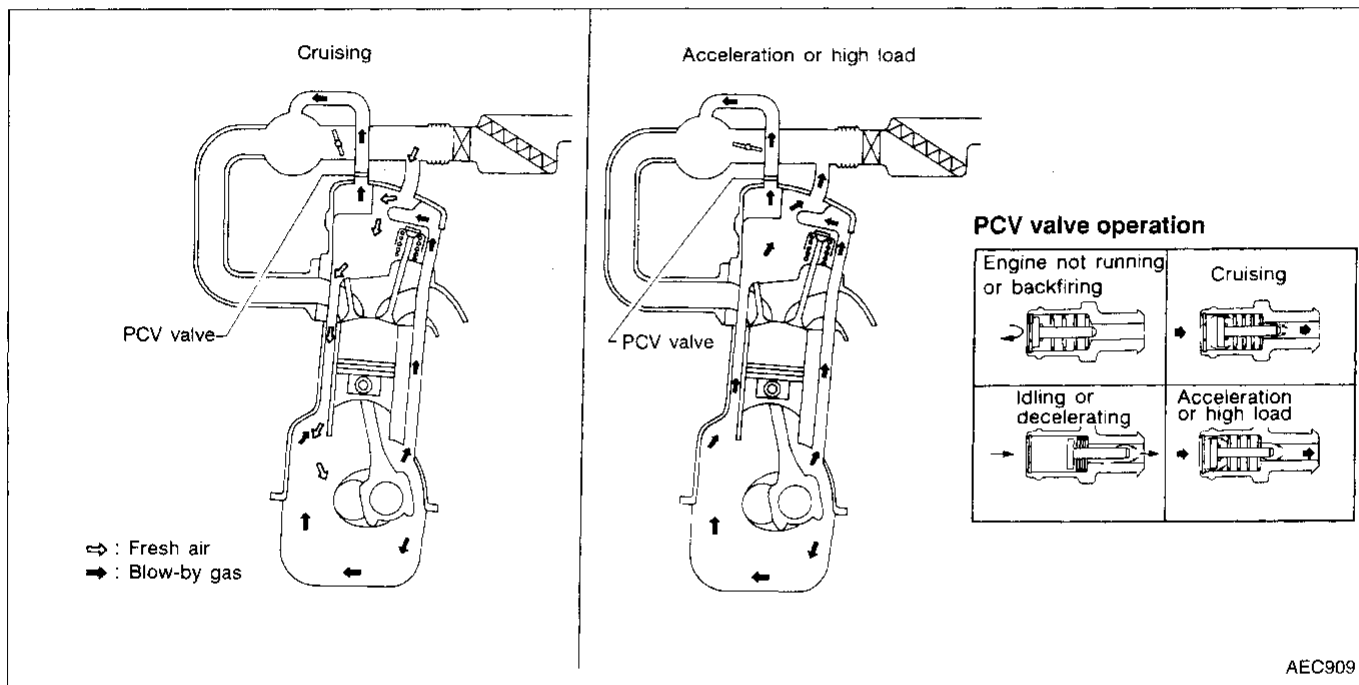

**Inspection**

**PCV (Positive Crankcase Ventilation) VALVE**

With engine running at idle, remove PCV valve from rocker cover. A properly working valve makes a hissing noise as air passes through it. A strong vacuum should be felt immediately when a finger is placed over the valve inlet.

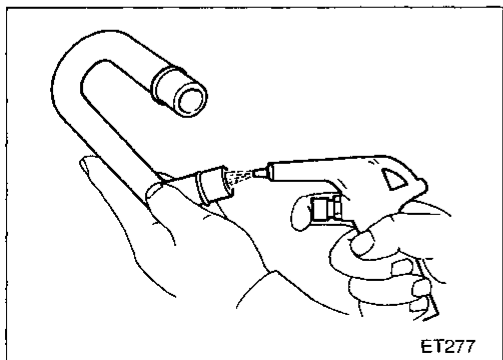

**PCV HOSE**

1. Check hoses and hose connections for leaks.
2. Disconnect all hoses and clean with compressed air. If any hose cannot be freed of obstructions, replace.

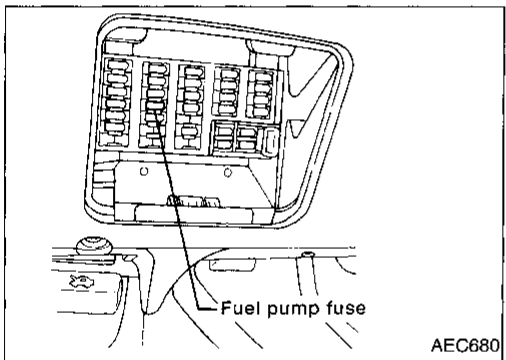
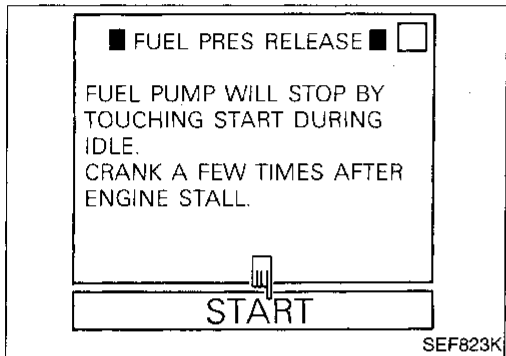
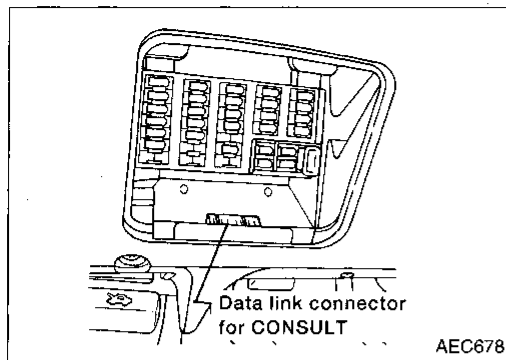

### Fuel Pressure Release

Before disconnecting fuel line, release fuel pressure from fuel line to eliminate danger.

1. Turn ignition switch "ON".
2. Perform "FUEL PRESSURE RELEASE" in "WORK SUPPORT" mode with CONSULT.
3. Start engine.
4. After engine stalls, crank it two or three times to release all fuel pressure.
5. Turn ignition switch "OFF".

1. Remove fuse for fuel pump.
2. Start engine.
3. After engine stalls, crank it two or three times to release all fuel pressure.
4. Turn ignition switch off and reconnect fuel pump fuse.

### Fuel Pressure Check

- When reconnecting fuel line, always use new clamps.
- Make sure that clamp screw does not contact adjacent parts.
- Use a torque driver to tighten clamps.
- Use Pressure Gauge to check fuel pressure.
- Do not perform fuel pressure check with system operating. Fuel pressure gauge may indicate false readings.

1. Release fuel pressure to zero.
2. Disconnect fuel hose between fuel filter and fuel tube (engine side).
3. Install pressure gauge between fuel filter and fuel tube.
4. Start engine and check for fuel leakage.
5. Read the indication of fuel pressure gauge.

At idling:

With vacuum hose connected  
 Approximately 235 kPa (2.4 kg/cm<sup>2</sup>, 34 psi)

With vacuum hose disconnected  
 Approximately 294 kPa (3.0 kg/cm<sup>2</sup>, 43 psi)

If results are unsatisfactory, perform Fuel Pressure Regulator Check.

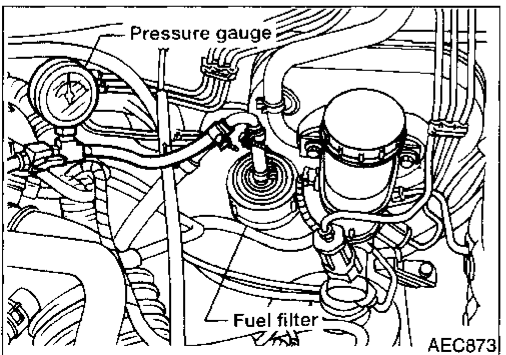

GI  
 MA  
 EM  
 LC  
 EC  
 FE  
 CL  
 MT  
 AT  
 FA  
 RA  
 BR  
 ST  
 RS  
 BT  
 HA  
 EL  
 IDX



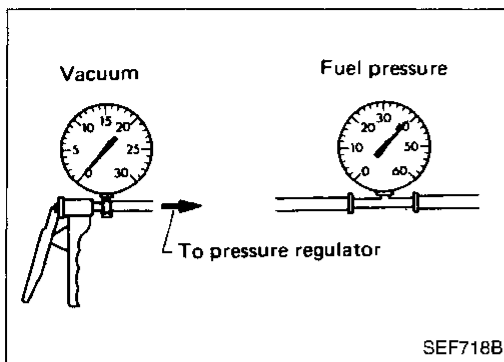

### Fuel Pressure Regulator Check

1. Stop engine and disconnect fuel pressure regulator vacuum hose from intake manifold.
2. Plug intake manifold with a rubber cap.
3. Connect variable vacuum source to fuel pressure regulator.
4. Start engine and read indication of fuel pressure gauge as vacuum is changed.

**Fuel pressure should decrease as vacuum increases. If results are unsatisfactory, replace fuel pressure regulator.**

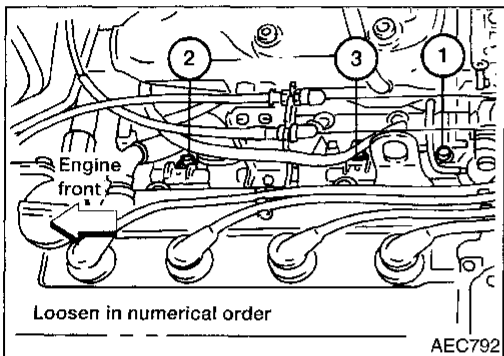

### Injector Removal and Installation

1. Release fuel pressure to zero.
2. Remove injector tube assembly with injectors from intake manifold.
3. Remove injectors from injector tube assembly.
  - Push injector tail piece.
  - Do not pull on the connector.

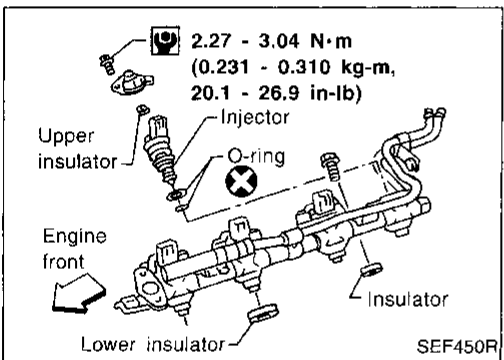

4. Install injectors.
  - Clean exterior of injector tail piece.
  - Use new O-rings.
  - Face metal plate of upper insulator to injector.

**CAUTION:**

**After properly connecting injectors to fuel tube assembly, check connections for fuel leakage.**

5. Assemble injectors to injector tube assembly.
6. Install injector tube assembly to intake manifold.

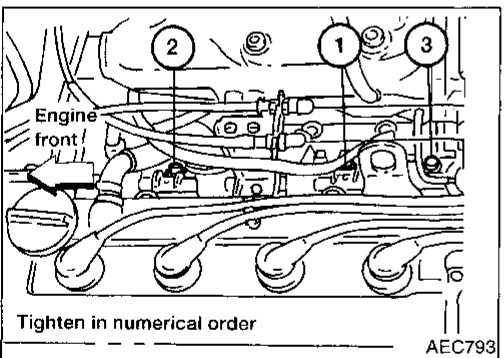

7. Tighten fuel tube bolts to 7.86 to 10.8 N-m (0.801 to 1.10 kg-m, 5.80 to 7.97 ft-lb) as shown in the figure. Then tighten the bolts to 15.7 to 20.6 N-m (1.60 to 2.10 kg-m, 11.58 to 15.19 ft-lb).

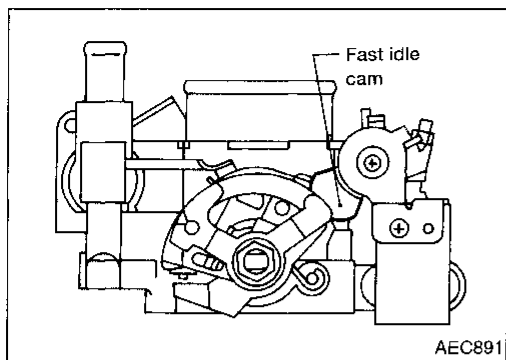

### Fast Idle Cam (FIC)

#### COMPONENT DESCRIPTION

The FIC is installed on the throttle body to maintain adequate engine speed while the engine is cold. It is operated by a volumetric change in wax located inside the thermo-element. The thermo-element is operated by engine coolant temperature.

#### COMPONENT INSPECTION AND ADJUSTMENT

1. If engine is not completely cold, remove throttle body from engine. Then, wait for at least 3 hours.  
(This step is necessary to bring the temperature of the thermo-element to the room temperature.)

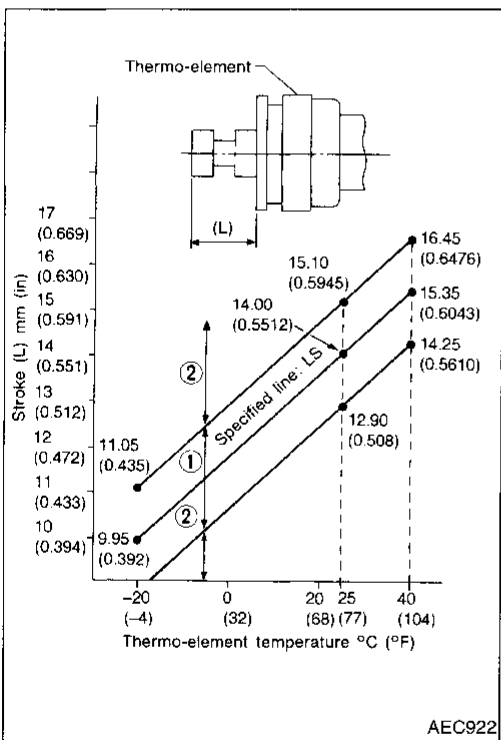

2. Measure thermo-element stroke (L) and room temperature.
3. Check thermo-element stroke (L) as shown in the figure.  
If the stroke is not within the range ①, replace thermo-element with new one. Then return to step 1 again.

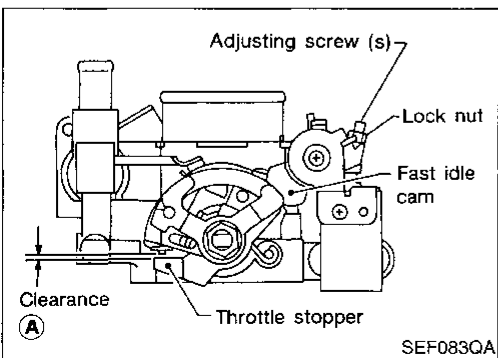

4. Adjust clearance (A) between throttle stopper and throttle adjusting screw to specification by turning adjusting screw (S).

Models	Clearance (A) mm (in)
M/T	0.72 - 1.18 (0.0283 - 0.0465)
A/T	0.95 - 1.43 (0.0374 - 0.0563)

GI  
MA  
EM  
LC  
EC  
FE  
CL  
MT  
AT  
FA  
RA  
BR  
ST  
RS  
BT  
HA  
EL

IDX

**Fast Idle Cam (FIC) (Cont'd)**

- 5. Rotate adjusting screw (S) clockwise or counterclockwise by Z turns according to the following equation, then tighten the adjusting screw lock nut.

$$Z = \frac{L - LS^*}{Y}$$

\*: Value of the specified line (Ls) at the temperature of thermo-element actually measured.

Y = 0.8 mm (0.031 in)

- Direction of adjusting screw (S) rotation
  - (1) Positive (+) Z: Counterclockwise
  - (2) Negative (-) Z: Clockwise

**For example:**

	Case I	Case II
Thermo-element temperature °C (°F)	25 (77)	40 (104)
Thermo-element specified stroke (Ls) mm (in)	14.0 (0.551)	15.35 (0.6043)
Thermo-element stroke (L) mm (in)	14.8 (0.583)	14.15 (0.5571)
Revolutions of adjusting screw (Z) mm/in	$Z = \frac{14.8 - 14.0}{0.8} = 1.0 /$ $\frac{0.583 - 0.551}{0.031} = 1.0$	$Z = \frac{14.15 - 15.35}{0.8} = -1.5 /$ $\frac{0.5571 - 0.6043}{0.031} = -1.5$
Direction of revolution	Counterclockwise	Clockwise

## Idle Speed/Ignition Timing/Idle Mixture Ratio Adjustment

### PREPARATION

• Make sure that the following parts are in good order.

- (1) Battery
- (2) Ignition system
- (3) Engine oil and coolant levels
- (4) Fuses
- (5) ECM harness connector
- (6) Vacuum hoses
- (7) Air intake system  
(Oil filler cap, oil level gauge, etc.)
- (8) Fuel pressure
- (9) Engine compression
- (10) EGR valve operation
- (11) Throttle valve
- (12) Evaporative emission system

- On models equipped with air conditioner, checks should be carried out while the air conditioner is "OFF".
- On models equipped with automatic transaxle, when checking idle speed, ignition timing and mixture ratio, checks should be carried out while shift lever is in "N" position.
- When measuring "CO" percentage, insert probe more than 40 cm (15.7 in) into tail pipe.
- Turn off headlamps, heater blower, rear defogger.
- Keep front wheels pointed straight ahead.
- Make the check after the cooling fan has stopped.

### Overall inspection sequence

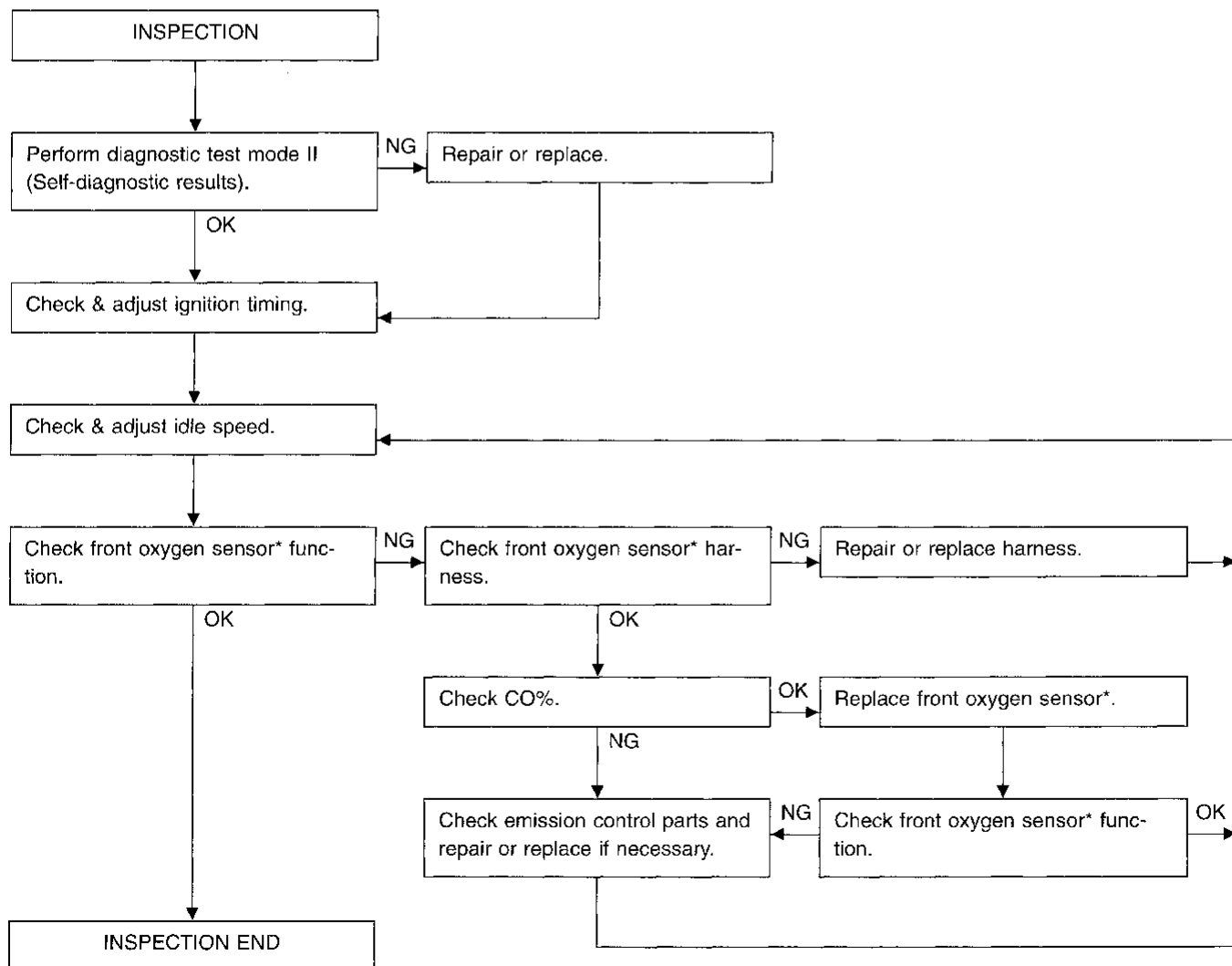

\*: Oxygen sensor (M/T models except for California)  
Heated oxygen sensor (M/T models for California and A/T models)

**Idle Speed/Ignition Timing/Idle Mixture Ratio Adjustment (Cont'd)**

START

Visually check the following:

- Air cleaner clogging
- Hoses and duct for leaks
- EGR valve operation
- Electrical connectors
- Gasket (intake manifold, cylinder head, exhaust system)
- Throttle valve and throttle position sensor operation

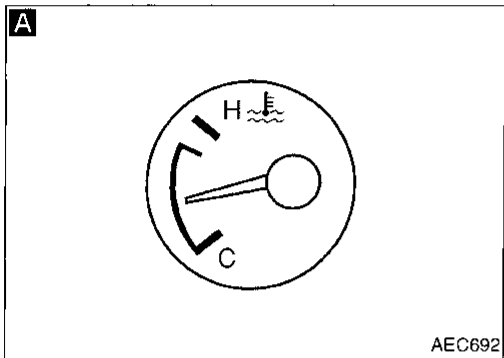

**A** Start engine and warm it up until engine coolant temperature indicator points to the middle of gauge. Ensure that engine speed is below 1,000 rpm.

Open engine hood and run engine at about 2,000 rpm for about 2 minutes under no-load.

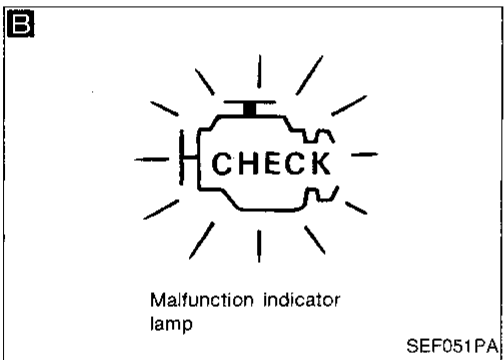

**B** Perform the Diagnostic Test Mode II (Self-diagnostic results).

OK → NG → Repair or replace components as necessary.

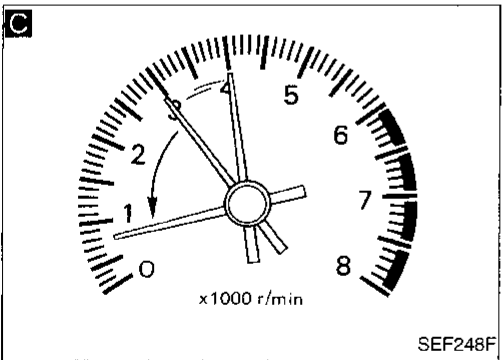

**C** Run engine at about 2,000 rpm for about 2 minutes under no-load. Rev engine two or three times under no-load, then run engine at idle speed for about 1 minute.

**D**

1. Select "IGNITION TIMING ADJ" in WORK SUPPORT mode.
2. Touch "START".

1. Turn off engine and disconnect throttle position sensor harness connector.
2. Start engine.

Rev engine (2,000 - 3,000 rpm) 2 or 3 times under no-load, then run engine at idle speed.

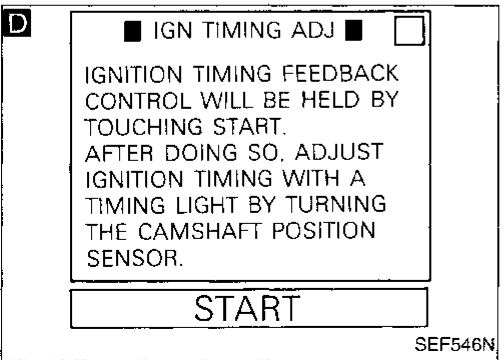

(Go to next page.)

Idle Speed/Ignition Timing/Idle Mixture Ratio Adjustment (Cont'd)

GI  
MA  
EM  
LC  
EC  
FE  
CL  
MT  
AT  
FA  
RA  
BR  
ST  
RS  
BT  
HA  
EL  
IDX

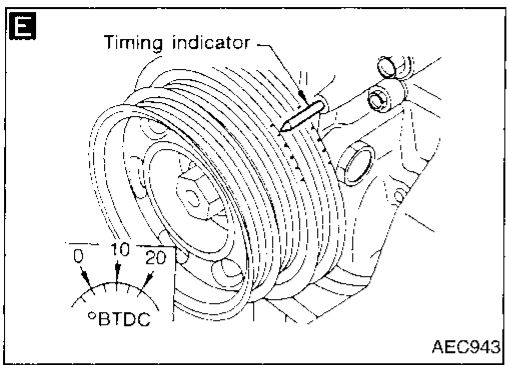

**F** ■ IGN TIMING ADJ ■ □

IGNITION TIMING FEEDBACK CONTROL WILL BE HELD BY TOUCHING START. AFTER DOING SO, ADJUST IGNITION TIMING WITH A TIMING LIGHT BY TURNING THE CAMSHAFT POSITION SENSOR.

START

SEF546N

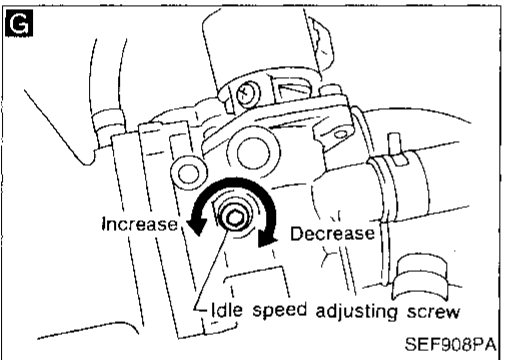

**H**

BACK	←	→	↑	↓	
MODE	LIGHT ON	LIGHT OFF	↑	↓	ENTER

SEF913J

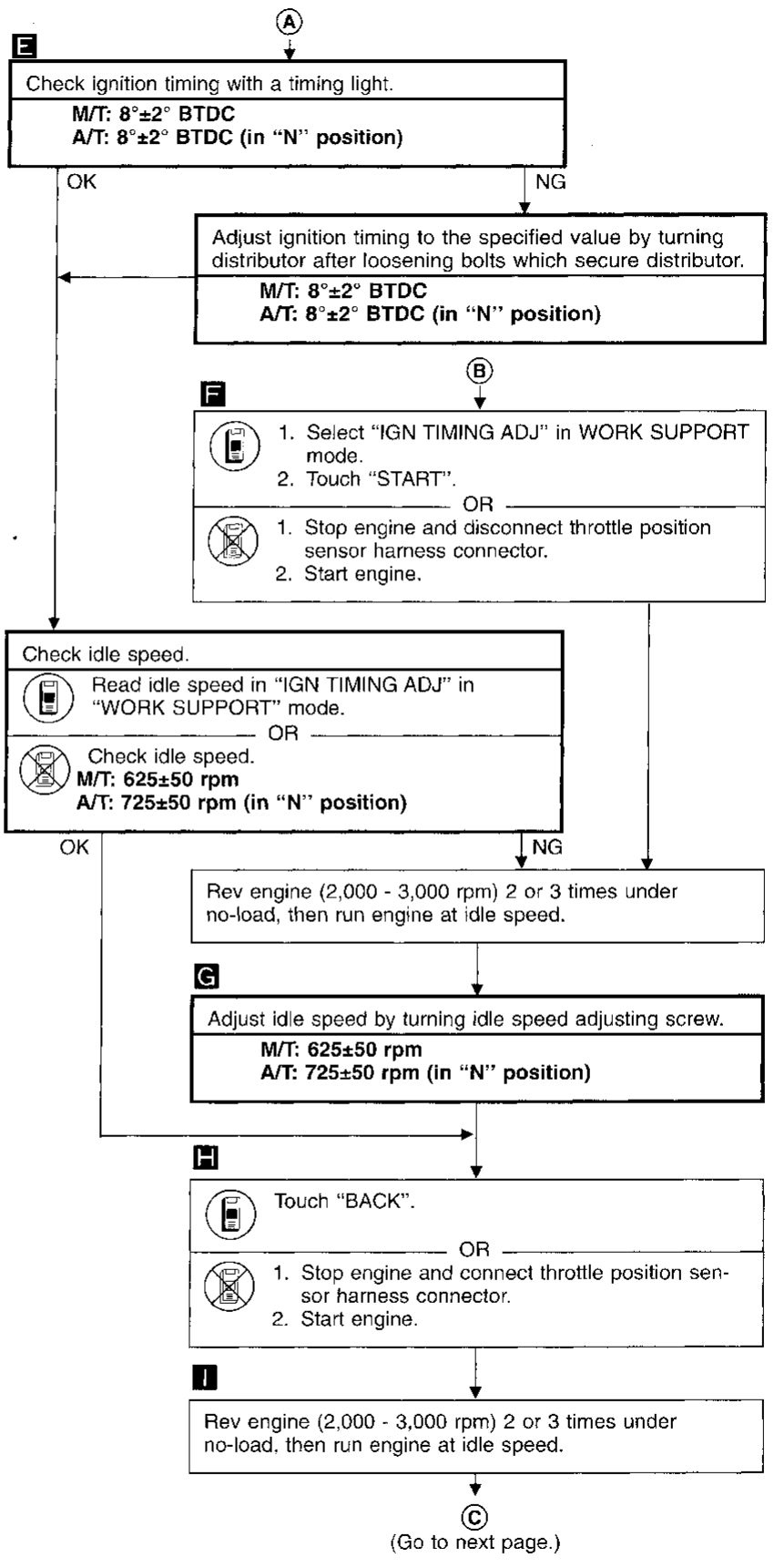
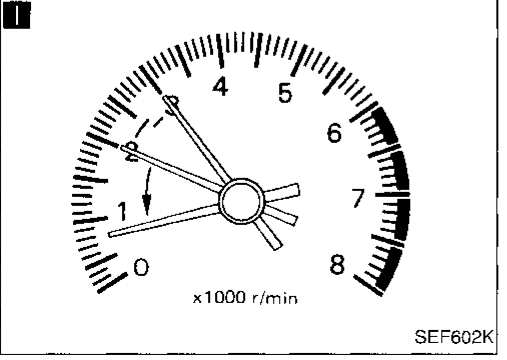

Idle Speed/Ignition Timing/Idle Mixture Ratio Adjustment (Cont'd)

**J**

☆ MONITOR ☆ NO FAIL

CMPS•RPM(REF) 700rpm

**RECORD**

SEF190P

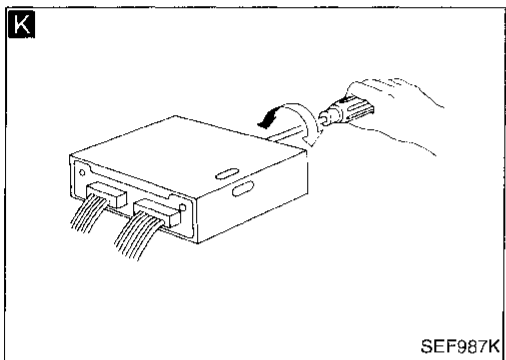

**L**

☆ MONITOR ☆ NO FAIL

CMPS•RPM (REF) 2000rpm  
FR O2 MNTR RICH

**RECORD**

SEF054P

**M**

SEF051P

**J**

Check idle speed.

Read idle speed in "DATA MONITOR" mode with CONSULT.

OR

Check idle speed.

M/T models except for Canada: 675±50 rpm  
M/T models for Canada: 750±50 rpm  
A/T models: 800±50 rpm (in "N" position)

OK

NG

Check IACV-AAC valve and replace if necessary.

Check IACV-AAC valve harness and repair if necessary.

Check ECM function\*1 by substituting another known good ECM.

**K**

Set the Diagnostic Test Mode II (front oxygen sensor monitor\*2).

Run engine at about 2,000 rpm for about 2 minutes under no-load.

**L M**

Check front oxygen sensor\*2 signal.

1. See "FR O2 MNTR" in "DATA MONITOR" mode.

2. Maintain engine at 2,000 rpm under no-load (engine is warmed up sufficiently). Check that the monitor fluctuates between "LEAN" and "RICH" more than 5 times during 10 seconds.

**1 cycle: RICH → LEAN → RICH**  
**2 cycles: RICH → LEAN → RICH → LEAN → RICH**

OR

Make sure that malfunction indicator lamp goes on and off more than 5 times during 10 seconds at 2,000 rpm.

OK

**END**

\*1: ECM may be the cause of a problem, but this is rarely the case.

\*2: Oxygen sensor (M/T models except for California)  
Heated oxygen sensor (M/T models for California and A/T models)

NG → **D**  
(Go to next page.)

Idle Speed/Ignition Timing/Idle Mixture Ratio Adjustment (Cont'd)

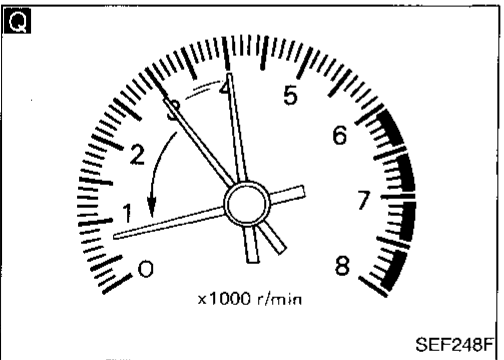
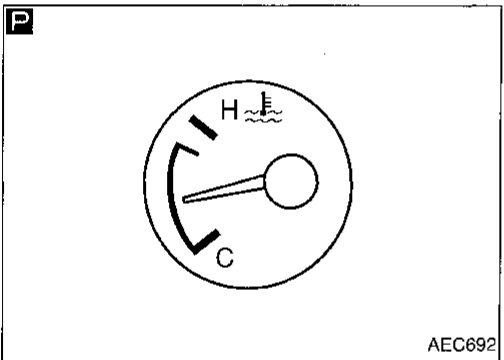
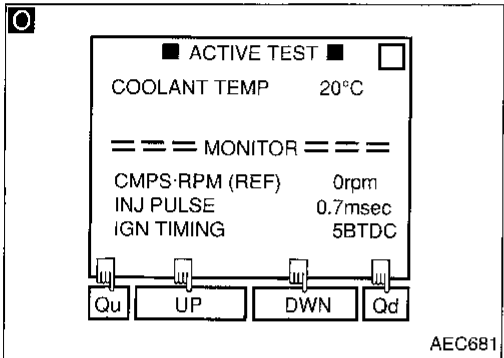
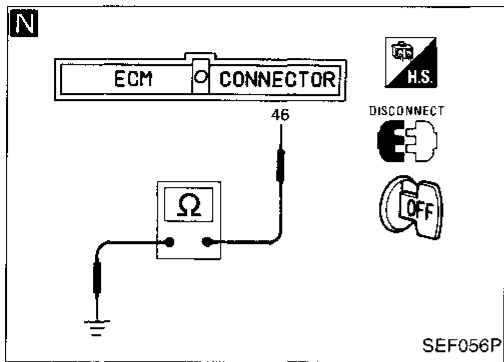

**N**  
 Check front oxygen sensor harness:

1. Turn off engine and disconnect battery ground cable.
2. Disconnect ECM harness connector from ECM
3. Disconnect front oxygen sensor harness connector. Then connect harness side terminal for front oxygen sensor to ground with a jumper wire.
4. Check for continuity between terminal (46) of ECM harness connector and body ground.

Continuity exists .....OK  
 Continuity does not exist.....NG

OK  
 Connect ECM harness connector to ECM.

NG  
 Repair harness. (Go to EC-255.)

- O**
1. Connect battery ground cable.
  2. Select "ENG COOLANT TEMP" in "ACTIVE TEST" mode.
  3. Set "COOLANT TEMP" at 20°C (68°F) by touching "Qu" and "Qd" and "UP", "DOWN".

- OR
1. Disconnect engine coolant temperature sensor harness connector.
  2. Connect a resistor (2.5 kΩ) between terminals of engine coolant temperature sensor harness connector.
  3. Connect battery ground cable.

**P**  
 Start engine and warm it up until engine coolant temperature indicator points to the middle of gauge. (Be sure to start engine after setting "COOLANT TEMP" or installing a 2.5 kΩ resistor.)

**Q**  
 Rev engine two or three times under no-load, then run engine at idle speed.

**E**  
 (Go to next page.)

GI  
 MA  
 EM  
 LC  
**EC**  
 FE  
 CL  
 MT  
 AT  
 FA  
 RA  
 BR  
 ST  
 RS  
 BT  
 HA  
 EL  
 IDX



Idle Speed/Ignition Timing/Idle Mixture Ratio Adjustment (Cont'd)

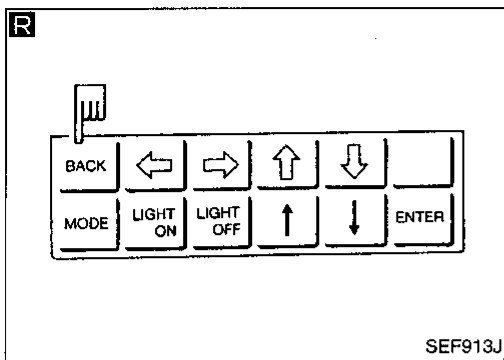

SEF913J

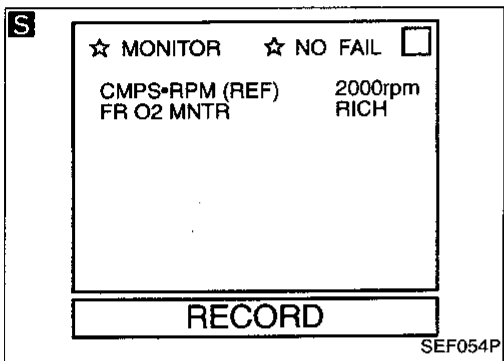

SEF054P

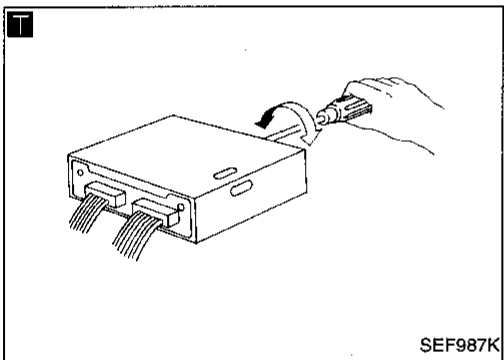

SEF987K

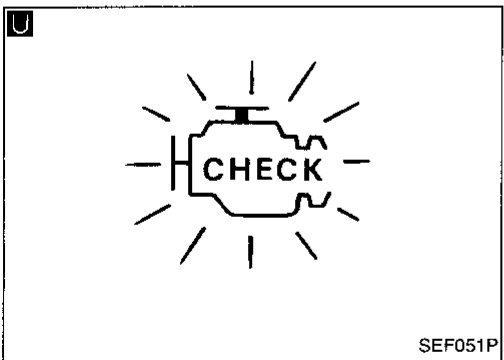

SEF051P

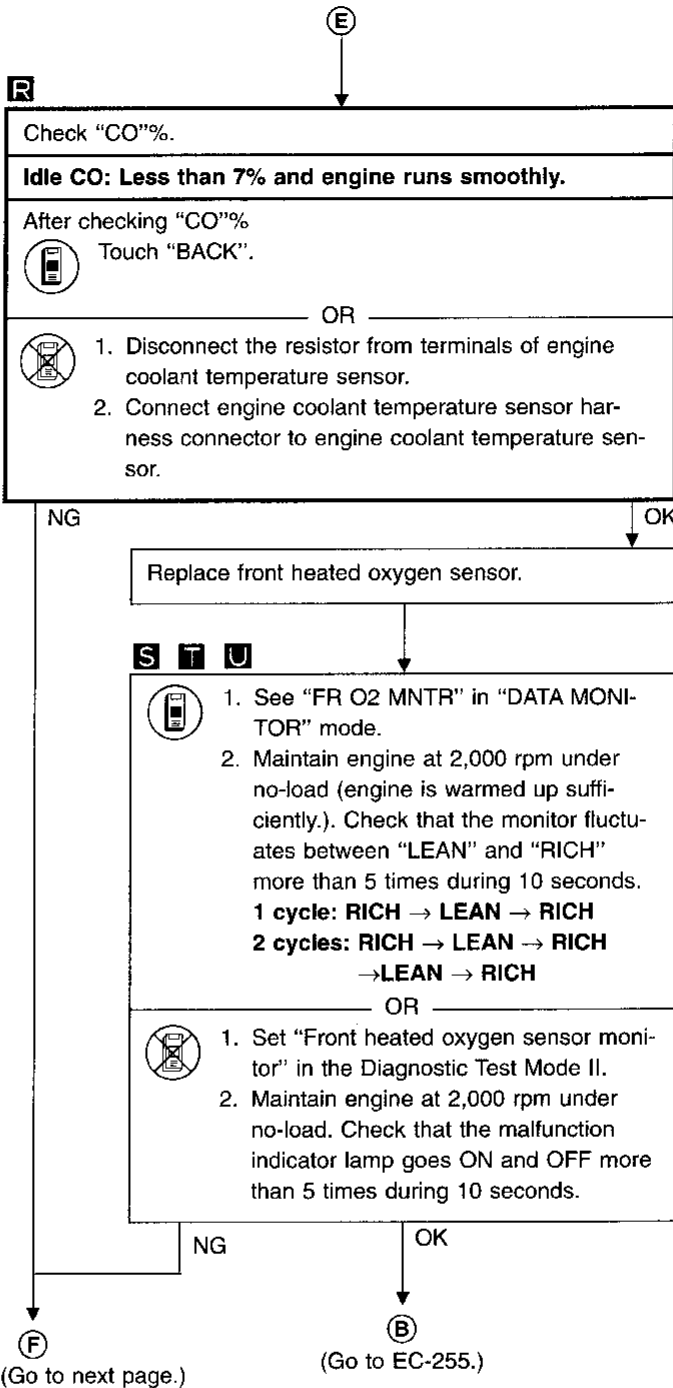

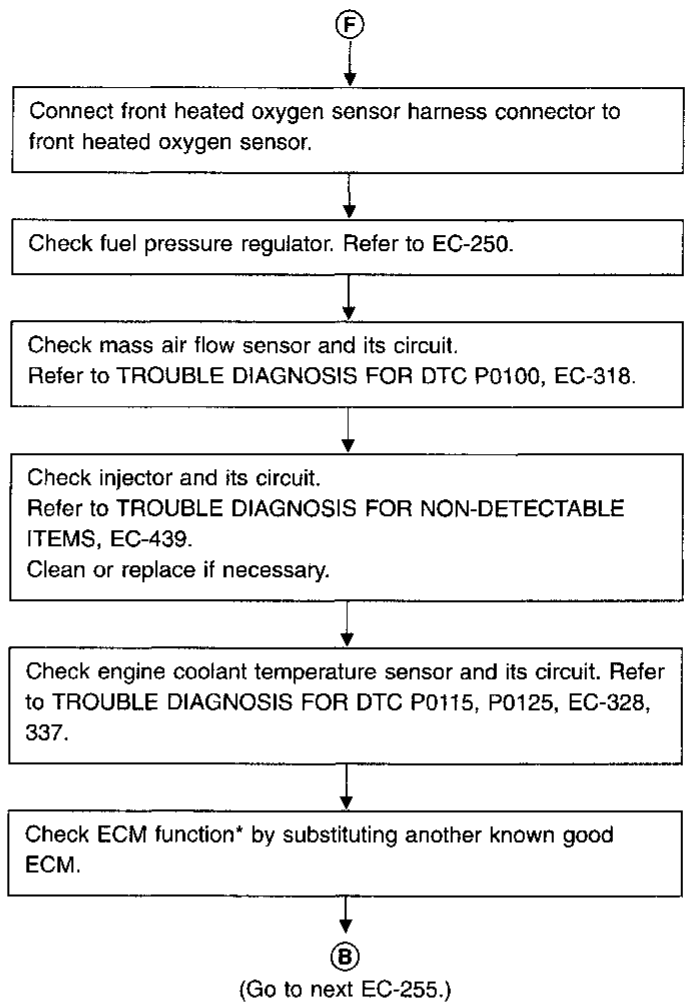

\*: ECM may be the cause of a problem, but this is rarely the case.

- GI
- MA
- EM
- LC
- EC**
- FE
- CL
- MT
- AT
- FA
- RA
- BR
- ST
- RS
- BT
- HA
- EL
- IDX

### Introduction

The ECM (ECCS control module) has an on-board diagnostic system, which detects engine system malfunctions related to sensors or actuators. The malfunction indicator lamp (MIL) on the instrument panel lights up when the same malfunction is detected in two consecutive trips (Two Trip Detection Logic).

### Two Trip Detection Logic

When a malfunction is detected for the first time, the malfunction (DTC and freeze frame data) is stored in the ECM memory. (1st trip) The malfunction indicator lamp will not light up at this stage.

If the same malfunction is detected during the next drive, this second detection causes the malfunction indicator lamp to light up. (2nd trip) Specific on-board diagnostic items will light up or blink the MIL even in the 1st trip as below.

Items	MIL		
	1st trip		2nd trip lighting up
	Blinking	Lighting up	
Misfire (Possible three way catalyst damage)— DTC: P0300-P0304 (0701-0605) is being detected	X		
Misfire (Possible three way catalyst damage)— DTC: P0300-P0304 (0701-0605) has been detected		X	
Three way catalyst function — DTC: P0420 (0702)		X	
Closed loop control — DTC: P0130 (0307)		X	
Except above			X

The “trip” in the “Two Trip Detection Logic” means performing of the “DTC Confirmation Procedure”.

### Diagnostic Trouble Code (DTC)



#### HOW TO READ DTC

The diagnostic trouble code can be read by the following methods.  
(Either code for the 1st trip or the 2nd trip can be read.)

1. The number of blinks of the malfunction indicator lamp in the Diagnostic Test Mode II (Self-Diagnostic Results) Examples: 0101, 0201, 1003, 1104, etc.  
These DTCs are controlled by NISSAN.
  2. CONSULT or GST (Generic Scan Tool) Examples: P0340, P1320, P0705, etc.  
These DTCs are prescribed by SAE J2012.
- **Output of the trouble code means that the indicated circuit has a malfunction. However, in case of the Mode II and GST they do not indicate whether the malfunction is still occurring or occurred in the past and returned to normal.**  
**CONSULT can identify them. Therefore, using CONSULT (if available) is recommended.**

#### HOW TO ERASE DTC

The diagnostic trouble code can be erased by the following methods.

-  Changing the diagnostic test mode from Diagnostic Test Mode II to Mode I by turning the mode selector on the ECM. (Refer to page EC-263.)
-  Selecting “ERASE” in the “SELF DIAG RESULTS” mode with CONSULT.
-  Selecting Mode 4 with GST (Generic Scan Tool).
- **If the battery terminal is disconnected, the diagnostic trouble code will be lost within 24 hours.**
- **When you erase the DTC, using CONSULT or GST is easier and quicker than switching the mode selector on the ECM.**

#### HOW TO ERASE DTC

1. If the ignition switch stays “ON” (engine stopped) after repair work, be sure to turn ignition switch “OFF” once. Wait for at least 3 seconds and then turn it “ON” again.
2. Turn CONSULT “ON” and touch “ENGINE”.
3. Touch “SELF-DIAG RESULTS”.
4. Touch “ERASE”. (The DTC in the ECM will be erased.)

Diagnostic Trouble Code (DTC) (Cont'd)

**How to erase DTC (With CONSULT)**

1. If the ignition switch stays "ON" after repair work, be sure to turn ignition switch "OFF" once. Wait for at least 5 seconds and then turn it "ON" again.

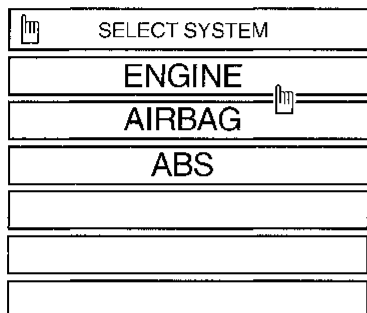

2. Turn CONSULT "ON" and touch "ENGINE".

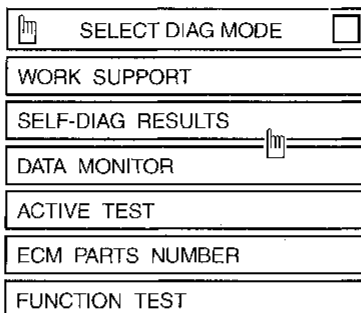

3. Touch "SELF-DIAG RESULTS".

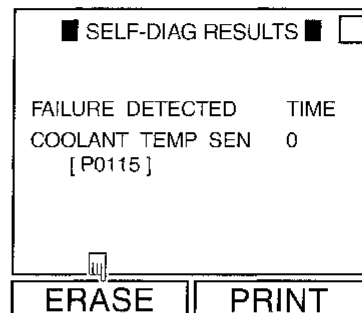

4. Touch "ERASE". (The DTC in the ECM will be erased.)

MEC814B



**HOW TO ERASE DTC**

1. If the ignition switch stays "ON" after repair work, be sure to turn ignition switch "OFF" once. Wait for at least 5 seconds and then turn it "ON" (engine stopped) again.
2. Perform "SELF-DIAGNOSTIC PROCEDURE (Without CONSULT)" in AT section titled "TROUBLE DIAGNOSIS", "Self-diagnosis". (The engine warm-up step can be skipped when performing the diagnosis only to erase the DTC.)
3. Select Mode 4 with GST (Generic Scan Tool).



**HOW TO ERASE DTC**

1. If the ignition switch stays "ON" after repair work, be sure to turn ignition switch "OFF" once. Wait for at least 3 seconds and then turn it "ON" again.
2. Change the diagnostic test mode from Mode II to Mode I by turning the mode selector on the ECM. (See page EC-263.)

**Freeze Frame Data**

The ECM has a memory function which stores the driving condition at the moment the ECM detects a malfunction. This includes fuel system status, calculated load value, engine coolant temperature, short fuel trim, long fuel trim, engine speed, vehicle speed.

Stored data is called Freeze Frame Data.

The data is useful for tracking down conditions at the time of the malfunction. Such conditions include whether vehicle was running or stopped, engine warm up, air-fuel ratio, etc.

This data can be utilized to duplicate the malfunction and to diagnose the trouble.

The data will be erased along with the diagnostic trouble code by the above-mentioned method.

The data can be stored only for the 1st trip. It can not be renewed even at the 2nd trip. The freeze frame data can be stored for only one item. Therefore, the ECM has the following priorities to update the data.

Priority	Detected items
1	Misfires — DTC: P0300-P0304 (0701-0605) Fuel Injection System Function — DTC: P0170 (0706)
2	Except the above items

For example, an EGR malfunction (Priority: 2) was detected and the freeze frame data was stored at the 1st trip. After that, misfire (Priority: 1) is detected in another trip, and freeze frame data is updated from the EGR malfunction for the misfire.

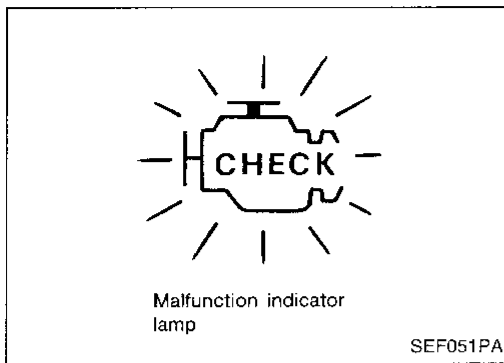

**Malfunction Indicator Lamp (MIL)**



1. The malfunction indicator lamp will light up when the ignition switch is turned ON without the engine running. This is a bulb check.
  - If the malfunction indicator lamp does not light up, refer to EL section (“WARNING LAMPS AND CHIME”) or see EC-457.
2. When the engine is started, the malfunction indicator lamp should go off. If the lamp remains on, the on-board diagnostic system has detected an engine system malfunction.

**ON-BOARD DIAGNOSTIC SYSTEM FUNCTION**

The on-board diagnostic system has the following four functions.

1. **BULB CHECK** : This function checks the MIL bulb for damage (blown, open circuit, etc.).
2. **MALFUNCTION WARNING** : This is a usual driving condition. When a malfunction is detected twice (two trip detection logic), the MIL will light up to inform the driver that a malfunction has been detected. Only the following malfunctions will light up or blink the MIL even in the 1st trip.
  - “Misfire (Possible three way catalyst damage)”
  - “Three way catalyst function”
  - “Closed loop control”
3. **SELF-DIAGNOSTIC RESULTS** : This function allows diagnostic trouble codes to be read.
4. **FRONT OXYGEN SENSOR MONITOR\*** : This function allows the fuel mixture condition (lean or rich), monitored by front oxygen sensor,\* to be read.

Refer to “HOW TO SWITCH DIAGNOSTIC TEST MODES” on next page.

Condition		Diagnostic Test Mode I	Diagnostic Test Mode II
Ignition switch in “ON” position 	Engine stopped 	BULB CHECK	SELF-DIAGNOSTIC RESULTS
	Engine running 	MALFUNCTION WARNING	FRONT OXYGEN SENSOR MONITOR*

\*: Oxygen sensor (M/T models except for California)  
Heated oxygen sensor (M/T models for California and A/T models)

Malfunction Indicator Lamp (MIL) (Cont'd)  
HOW TO SWITCH DIAGNOSTIC TEST MODES

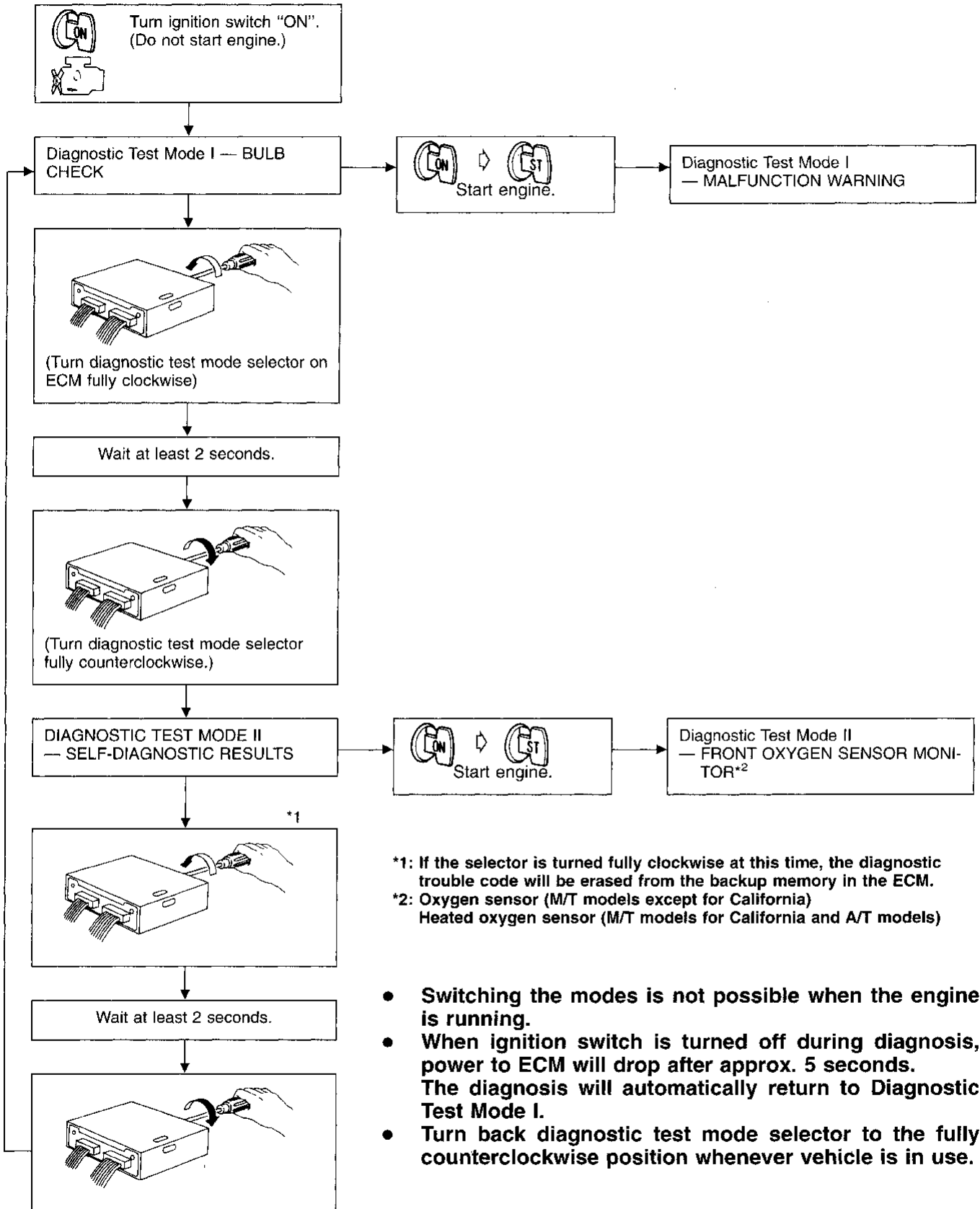

\*1: If the selector is turned fully clockwise at this time, the diagnostic trouble code will be erased from the backup memory in the ECM.  
\*2: Oxygen sensor (M/T models except for California)  
Heated oxygen sensor (M/T models for California and A/T models)

- Switching the modes is not possible when the engine is running.
- When ignition switch is turned off during diagnosis, power to ECM will drop after approx. 5 seconds. The diagnosis will automatically return to Diagnostic Test Mode I.
- Turn back diagnostic test mode selector to the fully counterclockwise position whenever vehicle is in use.

GI  
MA  
EM  
LC  
EC  
FE  
CL  
MT  
AT  
FA  
RA  
BR  
ST  
RS  
BT  
HA  
EL  
DX

## Malfunction Indicator Lamp (MIL) (Cont'd)

### DIAGNOSTIC TEST MODE I—BULB CHECK

In this mode, the MALFUNCTION INDICATOR LAMP on the instrument panel should stay ON. If it remains OFF, check the bulb. Refer to EL section (“WARNING LAMPS AND CHIME”) or see EC-457.

### DIAGNOSTIC TEST MODE I—MALFUNCTION WARNING

MALFUNCTION INDICATOR LAMP	Condition
ON	When the malfunction is detected or the ECM's CPU is malfunctioning. (The “1 trip” or “2 trip” is shown in the “MIL Illumination” of the “DTC Chart”.) Refer to EC-293.
OFF	No malfunction.

- These Diagnostic Trouble Code Numbers are clarified in Diagnostic Test Mode II (SELF-DIAGNOSTIC RESULTS).

### DIAGNOSTIC TEST MODE II—SELF-DIAGNOSTIC RESULTS

In this mode, a diagnostic trouble code is indicated by the number of blinks of the MALFUNCTION INDICATOR LAMP as shown below.

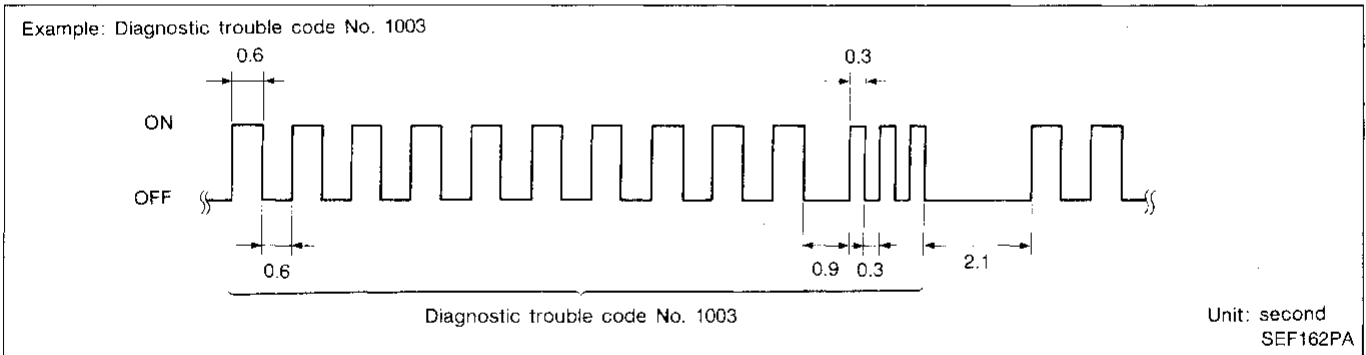
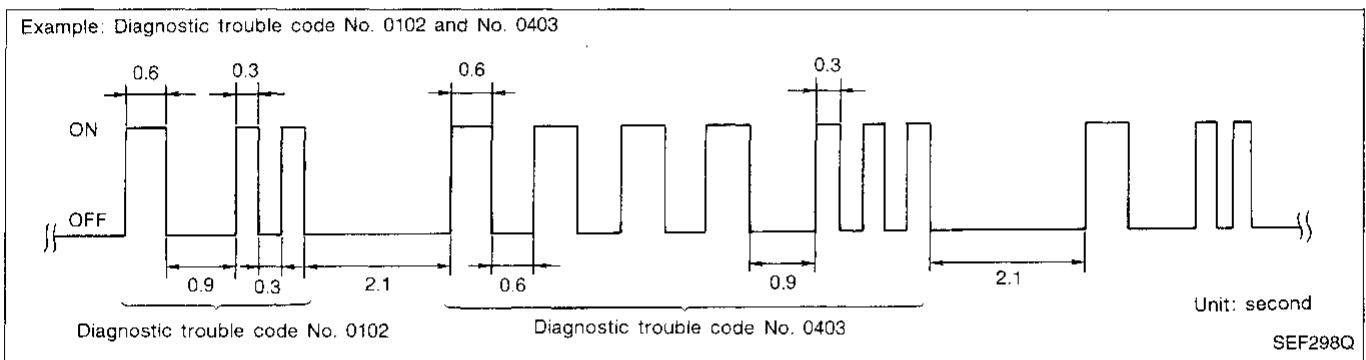

Long (0.6 second) blinking indicates the number of ten digits, and short (0.3 second) blinking indicates the number of single digits. For example, the malfunction indicator lamp blinks 10 times for 6 seconds (0.6 sec x 10 times) and then it blinks three times for about 1 second (0.3 sec x 3 times). This indicates the DTC “1003” and refers to the malfunction of the park/neutral position switch.

In this way, all the detected malfunctions are classified by their diagnostic trouble code numbers. The DTC “0505” refers to no malfunction. (See DIAGNOSTIC TROUBLE CODE CHART, refer to EC-293.)

### HOW TO ERASE DIAGNOSTIC TEST MODE II (Self-diagnostic results)

The diagnostic trouble code can be erased from the backup memory in the ECM when the diagnostic test mode is changed from Diagnostic Test Mode II to Diagnostic Test Mode I. (Refer to “HOW TO SWITCH DIAGNOSTIC TEST MODES” on previous page.)

- If the battery terminal is disconnected, the diagnostic trouble code will be lost from the backup memory within 24 hours.
- Be careful not to erase the stored memory before starting trouble diagnoses.

**Malfunction Indicator Lamp (MIL) (Cont'd)**

**DIAGNOSTIC TEST MODE II—FRONT OXYGEN SENSOR\*<sup>1</sup> MONITOR**

In this mode, the MALFUNCTION INDICATOR LAMP displays the condition of the fuel mixture (lean or rich) which is monitored by the front oxygen sensor\*<sup>1</sup>.

MALFUNCTION INDICATOR LAMP	Fuel mixture condition in the exhaust gas	Air fuel ratio feedback control condition
ON	Lean	Closed loop system
OFF	Rich	
* <sup>2</sup> Remains ON or OFF	Any condition	Open loop system

\*<sup>2</sup>: Maintains conditions just before switching to open loop.

To check the front oxygen sensor\*<sup>1</sup> function, start engine in Diagnostic Test Mode II. Then warm it up until engine coolant temperature indicator points to middle of gauge.

Next run engine at about 2,000 rpm for about 2 minutes under no-load conditions. Make sure that the MALFUNCTION INDICATOR LAMP comes ON more than 5 times within 10 seconds with engine running at 2,000 rpm under no-load.

\*<sup>1</sup>: Oxygen sensor (M/T models except for California)  
 Heated oxygen sensor (M/T models for California and A/T models)

**OBD System Operation Chart**

**RELATIONSHIP BETWEEN MIL, DTC, CONSULT AND DETECTABLE ITEMS**

- When a malfunction is detected for the first time, the DTC and the freeze frame data are stored in the ECM memory.
- When the same malfunction is detected in two consecutive trips, the MIL will come on. For details, refer to "Two Trip Detection Logic" on EC-260.
- The MIL will go off after the vehicle is driven three times with no malfunction. The drive is counted only when the recorded driving pattern is met (as stored in the ECM). If another malfunction occurs while counting, the counter will reset. The MIL will remain on until the vehicle is driven (in the recorded driving pattern) three times with no malfunction.
- The DTC and the freeze frame data can be displayed until the vehicle is driven 40 times (except for Misfire and Fuel Injection System). For Misfire and Fuel Injection System, the DTC and freeze frame data can be displayed until the vehicle is driven 80 times. The "TIME" IN "SELF-DIAGNOSTIC RESULTS" mode of CONSULT will count in response to the number of times the vehicle is driven.

**SUMMARY CHART**

Items	MIL (goes off)	DTC, Freeze Frame Data (no display)
Fuel Injection System	3 (pattern C)	80 (pattern B)
Misfire	3 (pattern C)	80 (pattern B)
Except the aboves	3 (pattern B)	40 (pattern A)

Details about patterns "A", "B", and "C" are on EC-267.



OBd System Operation Chart (Cont'd)

RELATIONSHIP BETWEEN MIL, DTC, CONSULT AND DRIVING PATTERNS FOR "MISFIRE" <EXHAUST QUALITY DETERIORATION>, "FUEL INJECTION SYSTEM"

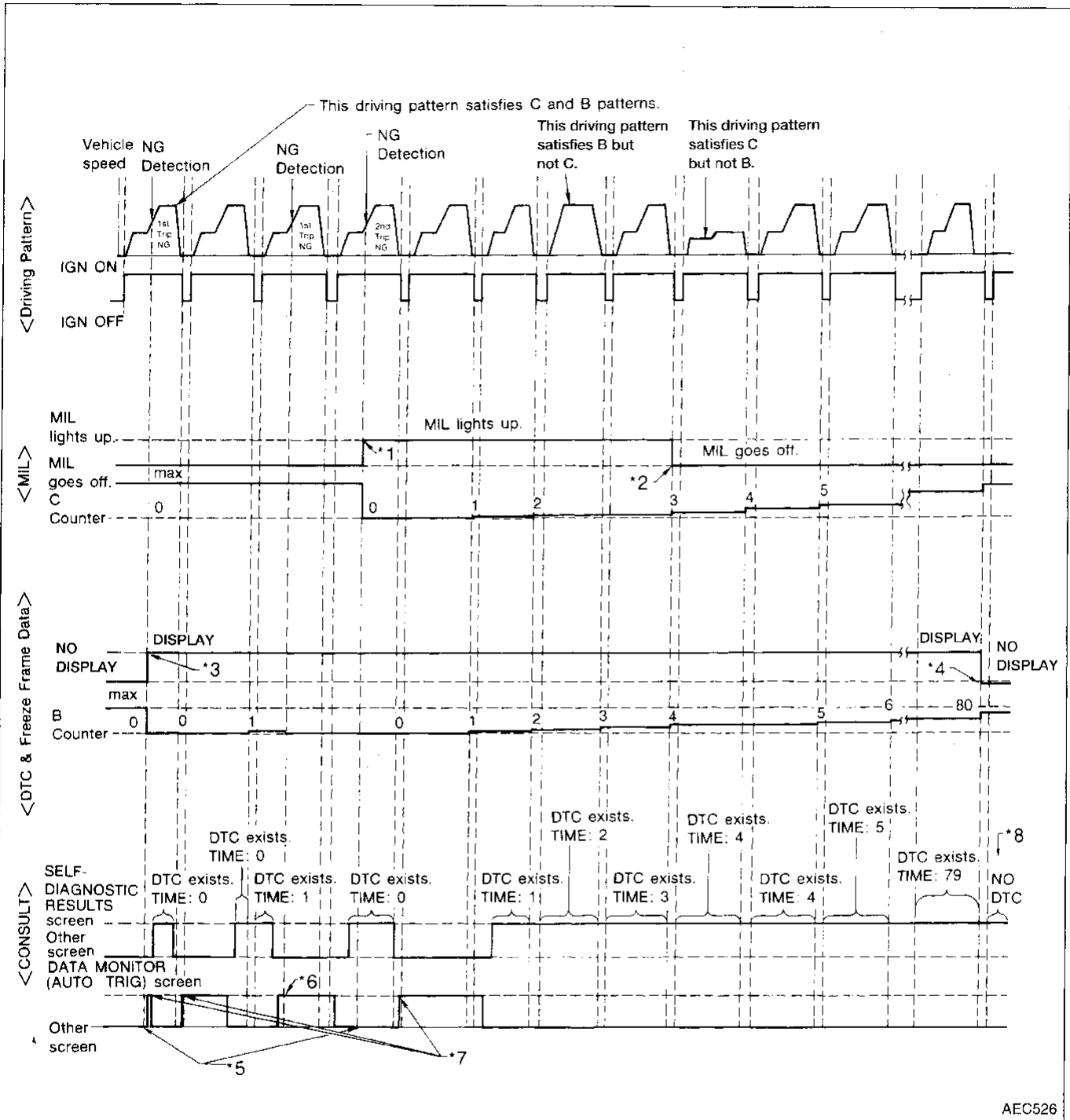

AEC526

- \*1: When the same malfunction is detected in two consecutive trips, MIL will light up.
- \*2: MIL will go off after vehicle is driven three times (pattern C) without any malfunctions.
- \*3: When a malfunction is detected for the first time, the DTC and the freeze frame data will be stored in ECM.
- \*4: The DTC and the freeze frame data will not be displayed any longer after vehicle is driven 80 times (pattern B) without the same malfunction. (The DTC and the freeze frame data still remain in ECM.)

- \*5: Other screen except DATA MONITOR (AUTO TRIG) can not display the malfunction.
- \*6: DATA MONITOR (AUTO TRIG) can display the malfunction at the moment it is detected.
- \*7: The malfunction can not be displayed because the timing to set DATA MONITOR (AUTO TRIG) screen was missed against the NG detection.
- \*8: The DTC and the freeze frame data will not be displayed any longer after vehicle is driven 80 times (pattern B) without the same malfunction. (The DTC and the freeze frame data still remain in ECM.)

OBD System Operation Chart (Cont'd)

EXPLANATION FOR DRIVING PATTERNS FOR "MISFIRE <EXHAUST QUALITY DETERIORATION>", "FUEL INJECTION SYSTEM"

<Driving pattern A>

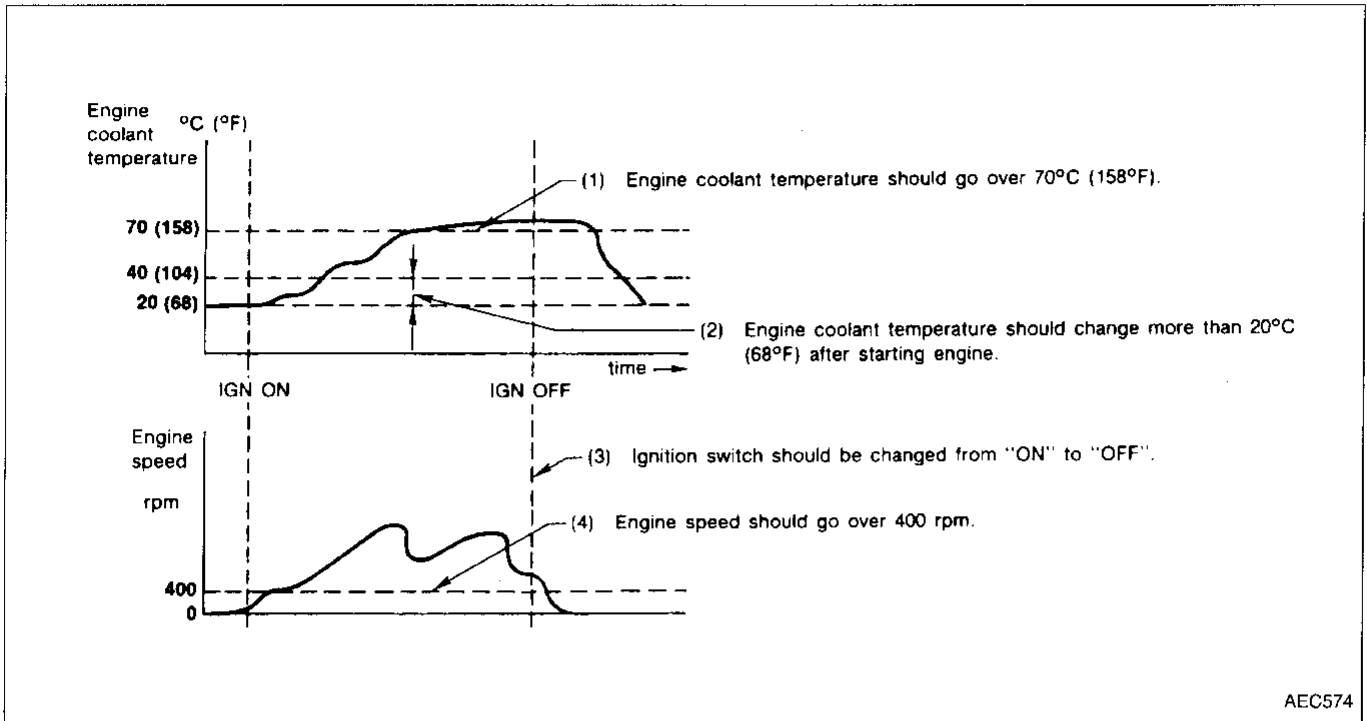

<Driving pattern B>

Driving pattern B means vehicle operation is as follows:

All components and systems should be monitored at least once by the OBD system.

- The B counter will reset when the malfunction is detected twice regardless of the driving pattern.
- The B counter will count the number of times driving pattern B is satisfied without the malfunction.
- The DTC will not be displayed after the B counter reaches 80.

<Driving pattern C>

Driving pattern C means vehicle operation is as follows:

(1) Driving pattern A should be satisfied.

(2) The following conditions should be satisfied at the same time:

Engine speed: (Engine speed in the freeze frame data) ±375 rpm

Calculated load value: (Calculated load value in the freeze frame data) x (1±0.1) [%]

Engine coolant temperature (T) condition:

- When the freeze frame data shows lower than 70°C (158°F), "T" should be lower than 70°C (158°F).
- When the freeze frame data shows higher than or equal to 70°C (158°F), "T" should be higher than or equal to 70°C (158°F).

Example:

If the stored freeze frame data is as follows:

Engine speed: 850 rpm, Calculated load value: 30%, Engine coolant temperature: 80°C (176°F)

To be satisfied with driving pattern C, the vehicle should run under the following conditions:

Engine speed: 475 - 1,225 rpm, Calculated load value: 27 - 33%, Engine coolant temperature: more than 70°C (158°F)

- The C counter will be cleared when the malfunction is detected regardless of (1), (2). (\*1 in "OBD SYSTEM OPERATION CHART")
- The C counter will be counted up when (1), (2) are satisfied without the same malfunction.
- The MIL will go off when the C counter reaches 3. (\*2 in "OBD SYSTEM OPERATION CHART")

OBd System Operation Chart (Cont'd)

RELATIONSHIP BETWEEN MIL, DTC, CONSULT AND DRIVING PATTERNS EXCEPT FOR "MISFIRE <EXHAUST QUALITY DETERIORATION>", "FUEL INJECTION SYSTEM"

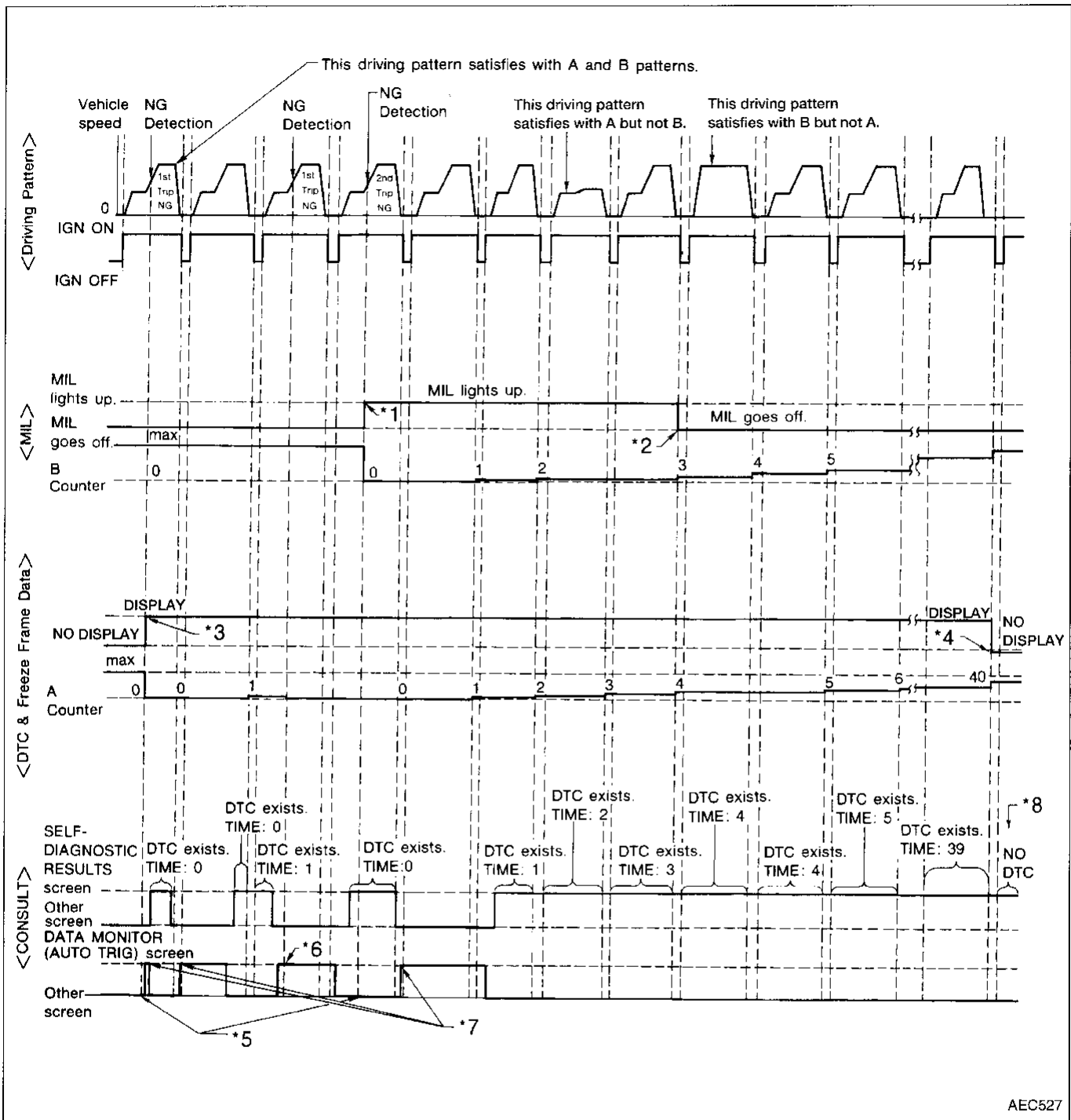

AEC527

- \*1: When the same malfunction is detected in two consecutive trips, MIL will light up.
- \*2: MIL will go off after vehicle is driven three times (pattern B) without any malfunctions.
- \*3: When a malfunction is detected for the first time, the DTC and the freeze frame data will be stored in ECM.
- \*4: The DTC and the freeze frame data will not be displayed after vehicle is driven 40 times (pattern A) without the same malfunction.  
(The DTC and the freeze frame data still remain in ECM.)

- \*5: Other screen except DATA MONITOR (AUTO TRIG) can not display the malfunction.
- \*6: DATA MONITOR (AUTO TRIG) can display the malfunction at the moment it is detected.
- \*7: The malfunction can not be displayed because the timing to set DATA MONITOR (AUTO TRIG) screen was missed against the NG detection.
- \*8: The DTC and the freeze frame data will not be displayed after vehicle is driven 40 times (pattern A) without the same malfunction.  
(The DTC and the freeze frame data still remain in ECM.)

OBd System Operation Chart (Cont'd)

EXPLANATION FOR DRIVING PATTERNS EXCEPT FOR "MISFIRE <EXHAUST QUALITY DETERIORATION>", "FUEL INJECTION SYSTEM"

<Driving pattern A>

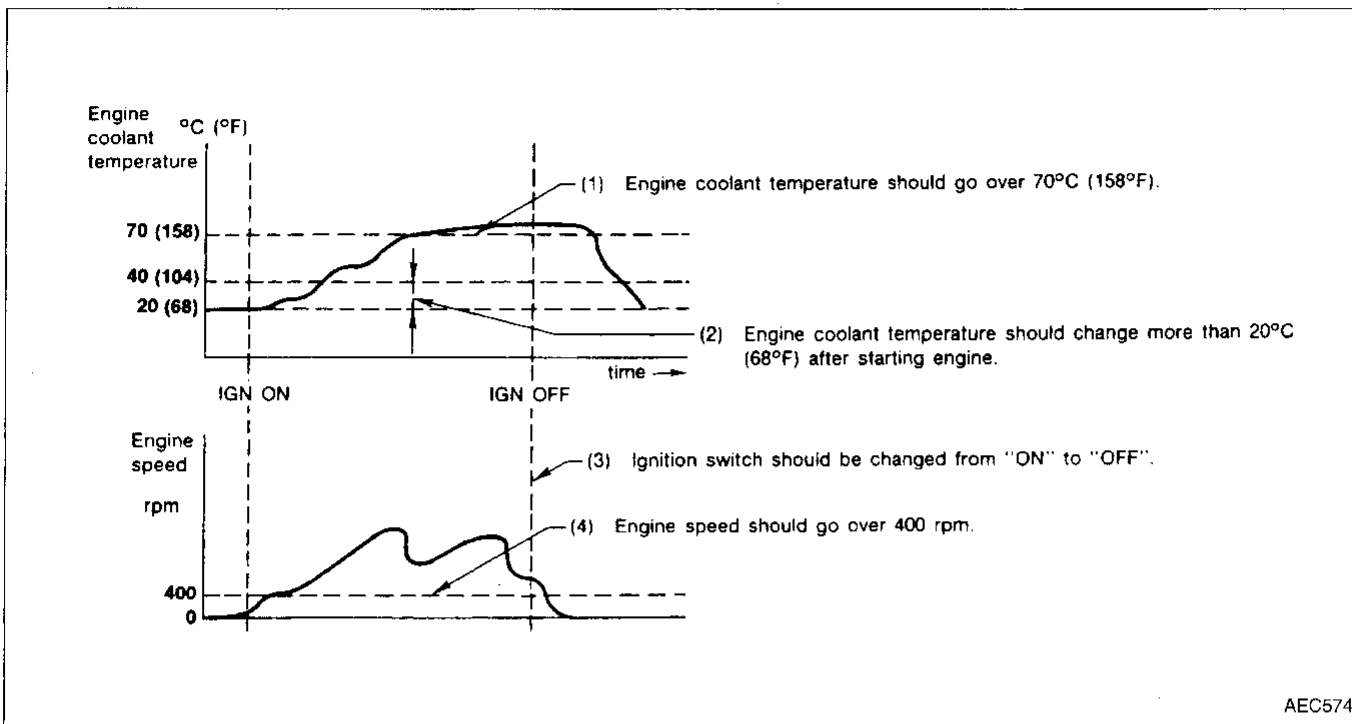

- The A counter will be cleared when the malfunction is detected regardless of (1) - (4).
- The A counter will be counted up when (1) - (4) are satisfied without the same malfunction.
- The DTC will not be displayed after the A counter reaches 40.

<Driving pattern B>

Driving pattern B means vehicle operation is as follows:

All components and systems should be monitored at least once by the OBD system.

- The B counter will be cleared when the malfunction is detected twice regardless of the driving pattern (\*1 in "OBD SYSTEM OPERATION CHART").
- The B counter will be counted up when driving pattern B is satisfied without any malfunctions.
- The MIL will go off when the B counter reaches 3 (\*2 in "OBD SYSTEM OPERATION CHART").

GI  
MA  
EM  
LC  
EC  
FE  
CL  
MT  
AT  
FA  
RA  
BR  
ST  
RS  
BT  
HA  
EL  
IDX

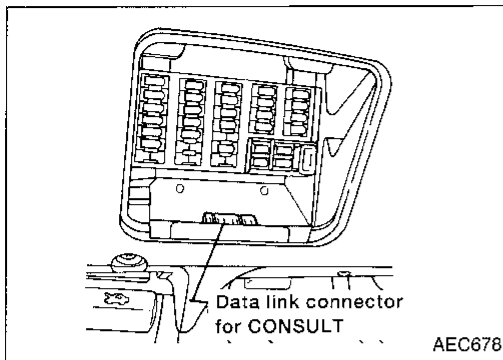

**CONSULT**

**CONSULT INSPECTION PROCEDURE**

1. Turn off ignition switch.
2. Connect "CONSULT" to data link connector for CONSULT. (Data link connector for CONSULT is located behind the fuse box cover.)

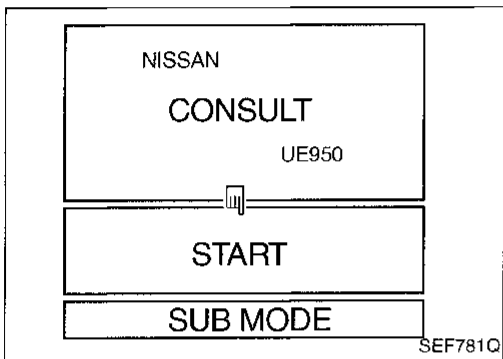

3. Turn on ignition switch.
4. Touch "START".

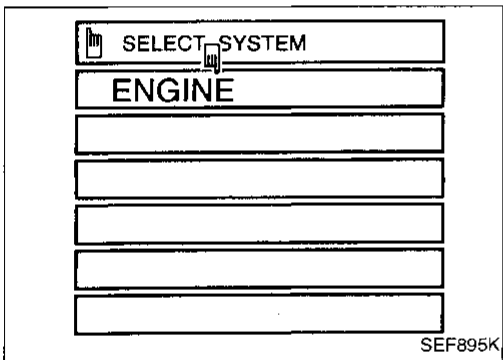

5. Touch "ENGINE".

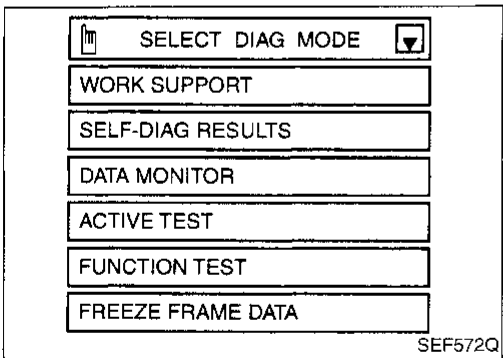

6. Perform each diagnostic test mode according to each service procedure.

**For further information, see the CONSULT Operation Manual.**

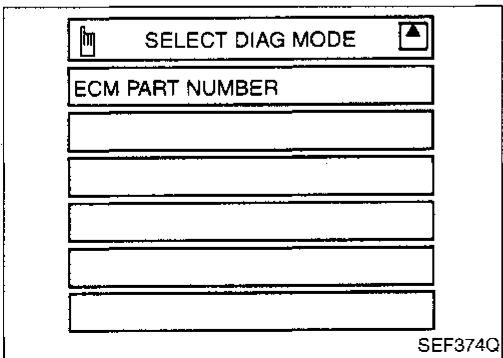

CONSULT (Cont'd)

ECCS COMPONENT PARTS/CONTROL SYSTEMS APPLICATION

		Item	DIAGNOSTIC TEST MODE					
			WORK SUP-PORT	SELF-DIAG-NOSTIC RESULTS	DATA MONITOR	ACTIVE TEST	FUNC-TION TEST	FREEZE FRAME DATA*2
ECCS COMPONENT PARTS	INPUT	Camshaft position sensor		X	X			X
		Mass air flow sensor		X	X			
		Engine coolant temperature sensor		X	X	X		X
		Front oxygen sensor*1		X	X		X	
		Rear heated oxygen sensor		X	X			
		Vehicle speed sensor		X	X		X	X
		Throttle position sensor	X	X	X		X	
		EGR temperature sensor		X	X			
		Intake air temperature sensor		X	X			
		Crankshaft position sensor (OBD)		X				
		Knock sensor		X				
		Ignition switch (start signal)			X		X	
		Closed throttle position (throttle position sensor signal)			X		X	
		Air conditioner switch			X			
		Park/Neutral position switch		X	X		X	
		Power steering oil pressure switch			X		X	
	Electrical load signal			X				
	Heater fan switch			X				
	Battery voltage			X				
	OUTPUT	Injectors			X	X	X	
		Power transistor (Ignition timing)	X	X (Igni-tion sig-nal)	X	X	X	
		IACV-AAC valve	X	X	X	X	X	
		Valve timing control solenoid valve		X	X	X	X	
		Air conditioner relay			X			
		Fuel pump relay	X		X	X	X	
		Cooling fan		X	X	X	X	
EGR valve & EVAP canister purge control solenoid valve			X	X	X	X		
Calculated load value				X			X	
Torque converter clutch solenoid valve			X	X				
Front heated oxygen sensor heater*3			X					

X: Applicable

\*1: Oxygen sensor (M/T models except for California)  
Heated oxygen sensor (M/T models for California and A/T models)

\*2: The items appear on CONSULT screen in FREEZE FRAME DATA mode only if a diagnostic trouble code (DTC) is detected. For details refer to EC-261

\*3: For A/T models and California M/T models

**CONSULT (Cont'd)**

**FUNCTION**

Diagnostic test mode	Function
Work support	A technician can adjust some devices faster and more accurately by following indications on CONSULT.
Self-diagnostic results	Self-diagnostic results can be read and erased quickly.
Data monitor	Input/Output data in the ECM can be read.
Active test	CONSULT drives some actuators apart from the ECM's and also shifts some parameters in a specified range.
ECM part numbers	ECM part numbers can be read.
Function test	Conducted by CONSULT instead of a technician to determine whether each system is "OK" or "NG".
Freeze frame data	ECM stores the driving condition at the moment a malfunction is detected, and stored data can be read. For details, refer to "Freeze Frame Data" (EC-280).

**WORK SUPPORT MODE**

WORK ITEM	CONDITION	USAGE
THRTL POS SEN ADJ	CHECK THE THROTTLE POSITION SENSOR SIGNAL. ADJUST IT TO THE SPECIFIED VALUE BY ROTATING THE SENSOR BODY UNDER THE FOLLOWING CONDITIONS. <ul style="list-style-type: none"> <li>● IGN SW "ON"</li> <li>● ENG NOT RUNNING</li> <li>● ACC PEDAL NOT PRESSED</li> </ul>	When adjusting throttle position sensor initial position
IGNITION TIMING ADJ	● IGNITION TIMING FEEDBACK CONTROL WILL BE HELD BY TOUCHING "START". AFTER DOING SO, ADJUST IGNITION TIMING WITH A TIMING LIGHT BY TURNING THE CAMSHAFT POSITION SENSOR.	When adjusting initial ignition timing
IACV-AAC VALVE ADJ	SET ENGINE SPEED AT THE SPECIFIED VALUE UNDER THE FOLLOWING CONDITIONS. <ul style="list-style-type: none"> <li>● ENGINE WARMED UP</li> <li>● NO-LOAD</li> </ul>	When adjusting idle speed
FUEL PRESSURE RELEASE	● FUEL PUMP WILL STOP BY TOUCHING "START" DURING IDLING. CRANK A FEW TIMES AFTER ENGINE STALLS.	When releasing fuel pressure from fuel line

**CONSULT (Cont'd)**

**SELF-DIAGNOSTIC MODE**

Regarding items detected in "SELF-DIAG RESULTS" mode, refer to "Diagnostic Trouble Code (DTC) Chart" (Refer to EC-291.)

**DATA MONITOR MODE**

Monitored item [Unit]	ECM input signals	Main signals	Description	Remarks
CMPS-RPM (REF) [rpm]	○	○	<ul style="list-style-type: none"> <li>Indicates the engine speed computed from the REF signal (180° signal) of the camshaft position sensor.</li> </ul>	<ul style="list-style-type: none"> <li>Accuracy becomes poor if engine speed drops below the idle rpm.</li> <li>If the signal is interrupted while the engine is running, an abnormal value may be indicated.</li> </ul>
MAS AIR/FL SE [V]	○	○	<ul style="list-style-type: none"> <li>The signal voltage of the mass air flow sensor is displayed.</li> </ul>	<ul style="list-style-type: none"> <li>When the engine is stopped, a certain value is indicated.</li> </ul>
COOLAN TEMP/S [°C] or [°F]	○	○	<ul style="list-style-type: none"> <li>The engine coolant temperature (determined by the signal voltage of the engine coolant temperature sensor) is displayed.</li> </ul>	<ul style="list-style-type: none"> <li>When the engine coolant temperature sensor is open or short-circuited, ECM enters fail-safe mode. The engine coolant temperature determined by the ECM is displayed.</li> </ul>
FR O2 SENSOR [V]	○	○	<ul style="list-style-type: none"> <li>The signal voltage of the front oxygen sensor* is displayed.</li> </ul>	
RR O2 SENSOR [V]	○	○	<ul style="list-style-type: none"> <li>The signal voltage of the rear heated oxygen sensor is displayed.</li> </ul>	
FR O2 MNTR [RICH/LEAN]	○	○	<ul style="list-style-type: none"> <li>Display of front oxygen sensor* signal during air-fuel ratio feedback control: RICH ... means the mixture became "rich", and control is being affected toward a leaner mixture. LEAN ... means the mixture became "lean", and control is being affected toward a rich mixture.</li> </ul>	<ul style="list-style-type: none"> <li>After turning ON the ignition switch, "RICH" is displayed until air-fuel mixture ratio feedback control begins.</li> <li>When the air-fuel ratio feedback is clamped, the value just before the clamping is displayed continuously.</li> </ul>
RR O2 MNTR [RICH/LEAN]	○		<ul style="list-style-type: none"> <li>Display of rear heated oxygen sensor signal: RICH ... means the amount of oxygen after three way catalyst is relatively large. LEAN ... means the amount of oxygen after three way catalyst is relatively small.</li> </ul>	<ul style="list-style-type: none"> <li>When the engine is stopped, a certain value is indicated.</li> </ul>
VHCL SPEED SE [km/h] or [mph]	○	○	<ul style="list-style-type: none"> <li>The vehicle speed computed from the vehicle speed sensor signal is displayed.</li> </ul>	
BATTERY VOLT [V]	○	○	<ul style="list-style-type: none"> <li>The power supply voltage of ECM is displayed.</li> </ul>	
THRTL POS SEN [V]	○	○	<ul style="list-style-type: none"> <li>The throttle position sensor signal voltage is displayed.</li> </ul>	
EGR TEMP SEN [V]	○		<ul style="list-style-type: none"> <li>The signal voltage of the EGR temperature sensor is displayed.</li> </ul>	

**NOTE:**

Any monitored item that does not match the vehicle being diagnosed is deleted from the display automatically.

\*: Oxygen sensor (M/T models except for California)  
Heated oxygen sensor (M/T for California and A/T models)



**CONSULT (Cont'd)**

Monitored item [Unit]	ECM input signals	Main signals	Description	Remarks
INT/A TEMP SE [°C] or [°F]	○		<ul style="list-style-type: none"> <li>The intake air temperature determined by the signal voltage of the intake air temperature sensor is indicated.</li> </ul>	
START SIGNAL [ON/OFF]	○	○	<ul style="list-style-type: none"> <li>Indicates [ON/OFF] condition from the starter signal.</li> </ul>	<ul style="list-style-type: none"> <li>After starting the engine, [OFF] is displayed regardless of the starter signal.</li> </ul>
CLSD THL/P SW [ON/OFF]	○	○	<ul style="list-style-type: none"> <li>Indicates the closed throttle position [ON/OFF] determined by the throttle position sensor signal. ON: Closed throttle position OFF: Other than closed throttle position</li> </ul>	
AIR COND SIG [ON/OFF]	○	○	<ul style="list-style-type: none"> <li>Indicates [ON/OFF] condition of the air conditioner switch as determined by the air conditioning signal.</li> </ul>	
P/N POSI SW [ON/OFF]	○	○	<ul style="list-style-type: none"> <li>Indicates [ON/OFF] condition from the park/neutral position switch signal.</li> </ul>	
PW/ST SIGNAL [ON/OFF]	○	○	<ul style="list-style-type: none"> <li>Indicates [ON/OFF] condition of the power steering oil pressure switch determined by the power steering oil pressure signal.</li> </ul>	
LOAD SIGNAL [ON/OFF]	○	○	<ul style="list-style-type: none"> <li>Indicates [ON/OFF] condition from the rear defogger signal and/or lighting switch. ON: Rear defogger is operating and/or lighting switch* is on. OFF: Rear defogger is not operating and lighting switch is not on.</li> </ul>	
IGNITION SW [ON/OFF]	○		<ul style="list-style-type: none"> <li>Indicates [ON/OFF] condition from the ignition switch.</li> </ul>	
HEATER FAN SE [ON/OFF]	○		<ul style="list-style-type: none"> <li>Indicates [ON/OFF] condition from the heater fan switch.</li> </ul>	
INJ PULSE [msec]		○	<ul style="list-style-type: none"> <li>Indicates the actual fuel injection pulse width compensated by ECM according to the input signals.</li> </ul>	<ul style="list-style-type: none"> <li>When the engine is stopped, a certain computed value is indicated.</li> </ul>
B/FUEL SCHDL [msec]		○	<ul style="list-style-type: none"> <li>"Base fuel schedule" indicates the fuel injection pulse width programmed into ECM, prior to any learned on-board correction.</li> </ul>	
IGN TIMING [BTDC]		○	<ul style="list-style-type: none"> <li>Indicates the ignition timing computed by ECM according to the input signals.</li> </ul>	
IACV-AAC/V [%]		○	<ul style="list-style-type: none"> <li>Indicates the idle air control valve (AAC valve) control value computed by ECM according to the input signals.</li> </ul>	
A/F ALPHA [%]		○	<ul style="list-style-type: none"> <li>Indicates the mean value of the air-fuel ratio feedback correction factor per cycle.</li> </ul>	<ul style="list-style-type: none"> <li>When the engine is stopped, a certain value is indicated.</li> <li>This data also includes the data for the air-fuel ratio learning control.</li> </ul>
AIR COND RLY [ON/OFF]			<ul style="list-style-type: none"> <li>Indicates the air conditioner relay control condition (determined by ECM according to the input signal).</li> </ul>	

\*: 1st position for USA models, 2nd position for Canada models

CONSULT (Cont'd)

Monitored item [Unit]	ECM input signals	Main signals	Description	Remarks
COOLING FAN [ON/OFF]			<ul style="list-style-type: none"> <li>Indicates the control condition of the cooling fans (determined by ECM according to the input signal). ON ... Operating OFF ... Stopped</li> </ul>	GI MA EM LC
FUEL PUMP RLY [ON/OFF]			<ul style="list-style-type: none"> <li>Indicates the fuel pump relay control condition determined by ECM according to the input signals.</li> </ul>	EC
VALVE TIM SOL [ON/OFF]			<ul style="list-style-type: none"> <li>The control condition of the valve timing solenoid valve (determined by ECM according to the input signal) is indicated. ON ... VTC operating OFF ... VTC not operating</li> </ul>	FE CL MT
EGR SOL/V [ON/OFF]			<ul style="list-style-type: none"> <li>Indicates the control condition of the EGR valve &amp; EVAP canister control solenoid valve (determined by ECM according to the input signal). ON ... EGR and EVAP canister purge operation cut-off OFF ... EGR and EVAP canister purge operation not cut-off</li> </ul>	AT FA BA
TCC SOL/V [ON/OFF]			<ul style="list-style-type: none"> <li>The control condition of the torque converter clutch solenoid valve (determined by ECM according to the input signals) is indicated. ON ... Lock-up is canceled OFF ... Lock-up is operational</li> </ul>	BR ST
O2 SEN HEATER* [ON/OFF]			<ul style="list-style-type: none"> <li>Indicates [ON/OFF] condition of front heated oxygen sensor heater determined by ECM according to the input signals.</li> </ul>	RS
CAL/LD VALUE [%]			<ul style="list-style-type: none"> <li>"Calculated load value" indicates the value of the current airflow divided by peak airflow.</li> </ul>	BT
ABSOL TH-P/S [%]			<ul style="list-style-type: none"> <li>"Absolute throttle position sensor" indicates the throttle opening computed by ECM according to the signal voltage of the throttle position sensor.</li> </ul>	HA
MASS AIRFLOW [gm/s]			<ul style="list-style-type: none"> <li>Indicates the mass air flow computed by ECM according to the signal voltage of the mass air flow sensor.</li> </ul>	EL
VOLTAGE [V]			<ul style="list-style-type: none"> <li>Voltage measured by the voltage probe.</li> </ul>	IDX
PULSE [msec] or [Hz] or [%]			<ul style="list-style-type: none"> <li>Pulse width, frequency or duty cycle measured by the pulse probe.</li> </ul>	<ul style="list-style-type: none"> <li>Only "#" is displayed if item is unable to be measured.</li> <li>Figures with "#"s are temporary ones. They are the same figures as an actual piece of data which was just previously measured.</li> </ul>

\*: For A/T models and California M/T models.

**CONSULT (Cont'd)**

**ACTIVE TEST MODE**

TEST ITEM	CONDITION	JUDGEMENT	CHECK ITEM (REMEDY)
FUEL INJECTION	<ul style="list-style-type: none"> <li>● Engine: Return to the original trouble condition</li> <li>● Change the amount of fuel injection using CONSULT.</li> </ul>	If trouble symptom disappears, see CHECK ITEM.	<ul style="list-style-type: none"> <li>● Harness and connector</li> <li>● Fuel injectors</li> <li>● Front oxygen sensor*</li> </ul>
IACV-AAC/V OPENING	<ul style="list-style-type: none"> <li>● Engine: After warming up, idle the engine.</li> <li>● Change the IACV-AAC valve opening percent using CONSULT.</li> </ul>	Engine speed changes according to the opening percent.	<ul style="list-style-type: none"> <li>● Harness and connector</li> <li>● IACV-AAC valve</li> </ul>
ENG COOLANT TEMP	<ul style="list-style-type: none"> <li>● Engine: Return to the original trouble condition</li> <li>● Change the engine coolant temperature indication using CONSULT.</li> </ul>	If trouble symptom disappears, see CHECK ITEM.	<ul style="list-style-type: none"> <li>● Harness and connector</li> <li>● Engine coolant temperature sensor</li> <li>● Fuel injectors</li> </ul>
IGNITION TIMING	<ul style="list-style-type: none"> <li>● Engine: Return to the original trouble condition</li> <li>● Timing light: Set</li> <li>● Retard the ignition timing using CONSULT.</li> </ul>	If trouble symptom disappears, see CHECK ITEM.	<ul style="list-style-type: none"> <li>● Adjust initial ignition timing</li> </ul>
POWER BALANCE	<ul style="list-style-type: none"> <li>● Engine: After warming up, idle the engine.</li> <li>● A/C switch "OFF"</li> <li>● Shift lever "N"</li> <li>● Cut off each injector signal one at a time using CONSULT.</li> </ul>	Engine runs rough or dies.	<ul style="list-style-type: none"> <li>● Harness and connector</li> <li>● Compression</li> <li>● Injectors</li> <li>● Power transistor</li> <li>● Spark plugs</li> <li>● Ignition coils</li> </ul>
COOLING FAN	<ul style="list-style-type: none"> <li>● Ignition switch: ON</li> <li>● Turn the cooling fan "ON" and "OFF" using CONSULT.</li> </ul>	Cooling fan moves and stops.	<ul style="list-style-type: none"> <li>● Harness and connector</li> <li>● Cooling fan motor</li> </ul>
FUEL PUMP RELAY	<ul style="list-style-type: none"> <li>● Ignition switch: ON (Engine stopped)</li> <li>● Turn the fuel pump relay "ON" and "OFF" using CONSULT and listen to operating sound.</li> </ul>	Fuel pump relay makes the operating sound.	<ul style="list-style-type: none"> <li>● Harness and connector</li> <li>● Fuel pump relay</li> </ul>
EGRC SOLENOID VALVE	<ul style="list-style-type: none"> <li>● Ignition switch: ON</li> <li>● Turn solenoid valve "ON" and "OFF" with the CONSULT and listen to operating sound.</li> </ul>	Solenoid valve makes an operating sound.	<ul style="list-style-type: none"> <li>● Harness and connector</li> <li>● Solenoid valve</li> </ul>
VALVE TIMING SOL	<ul style="list-style-type: none"> <li>● Ignition switch: ON</li> <li>● Turn solenoid valve "ON" and "OFF" using CONSULT and listen to operating sound.</li> </ul>	Solenoid valve makes an operating sound.	<ul style="list-style-type: none"> <li>● Harness and connector</li> <li>● Solenoid valve</li> </ul>
SELF-LEARNING CONT	<ul style="list-style-type: none"> <li>● In this test, the coefficient of self-learning control mixture ratio returns to the original coefficient by touching "CLEAR" on the screen.</li> </ul>		

\*: Oxygen sensor (M/T models except for California)  
 Heated oxygen sensor (A/T models and M/T models for California)

CONSULT (Cont'd)

FUNCTION TEST MODE

FUNCTION TEST ITEM	CONDITION	JUDGEMENT		CHECK ITEM (REMEDY)
SELF-DIAG RESULTS	<ul style="list-style-type: none"> <li>● Ignition switch: ON (Engine stopped)</li> <li>● Displays the results of on-board diagnostic system.</li> </ul>	—		Objective system
CLOSED THROTTLE POSI	<ul style="list-style-type: none"> <li>● Ignition switch: ON (Engine stopped)</li> <li>● Closed throttle position is tested when throttle is opened and closed fully. (Closed throttle position is selected by throttle position sensor.)</li> </ul>	Throttle valve: opened	OFF	<ul style="list-style-type: none"> <li>● Harness and connector</li> <li>● Throttle position sensor</li> <li>● Throttle position sensor adjustment</li> <li>● Throttle linkage</li> <li>● Verify operation in DATA MONITOR mode.</li> </ul>
		Throttle valve: closed	ON	
THROTTLE POSI SEN CKT	<ul style="list-style-type: none"> <li>● Ignition switch: ON (Engine stopped)</li> <li>● Throttle position sensor circuit is tested when throttle is opened and closed fully.</li> </ul>	Range (Throttle valve fully opened — Throttle valve fully closed)	More than 3.0V	<ul style="list-style-type: none"> <li>● Harness and connector</li> <li>● Throttle position sensor</li> <li>● Throttle position sensor adjustment</li> <li>● Throttle linkage</li> <li>● Verify operation in DATA MONITOR mode.</li> </ul>
PARK/NEUT POSI SW CKT	<ul style="list-style-type: none"> <li>● Ignition switch: ON (Engine stopped)</li> <li>● Inhibitor/Neutral position switch circuit is tested when shift lever is manipulated.</li> </ul>	Out of N/P positions	OFF	<ul style="list-style-type: none"> <li>● Harness and connector</li> <li>● Neutral position switch or inhibitor switch</li> <li>● Linkage or inhibitor switch adjustment</li> </ul>
		In N/P positions	ON	
FUEL PUMP CIRCUIT	<ul style="list-style-type: none"> <li>● Ignition switch: ON (Engine stopped)</li> <li>● Fuel pump circuit is tested by checking the pulsation in fuel pressure when fuel tube is pinched.</li> </ul>	There is pressure pulsation on the fuel feed hose.		<ul style="list-style-type: none"> <li>● Harness and connector</li> <li>● Fuel pump</li> <li>● Fuel pump relay</li> <li>● Fuel filter clogging</li> <li>● Fuel level</li> </ul>
EGRC SOL/V CIRCUIT	<ul style="list-style-type: none"> <li>● Ignition switch: ON (Engine stopped)</li> <li>● EGR valve &amp; EVAP canister purge control solenoid valve circuit is tested by checking solenoid valve operating noise.</li> </ul>	The solenoid valve makes an operating sound every 3 seconds.		<ul style="list-style-type: none"> <li>● Harness and connector</li> <li>● EGR valve &amp; EVAP canister purge control solenoid valve</li> </ul>
VALVE TIMING S/V CKT	<ul style="list-style-type: none"> <li>● Ignition switch: ON (Engine stopped)</li> <li>● Valve timing S/V circuit is tested by checking solenoid valve operating sound</li> </ul>	The solenoid valve makes an operating sound periodically.		<ul style="list-style-type: none"> <li>● Harness and connector</li> <li>● Valve timing solenoid valve</li> </ul>
COOLING FAN CIRCUIT	<ul style="list-style-type: none"> <li>● Ignition switch: ON (Engine stopped)</li> <li>● Cooling fan circuit is tested when cooling fan is rotated.</li> </ul>	The cooling fan rotates and stops every 3 seconds.		<ul style="list-style-type: none"> <li>● Harness and connector</li> <li>● Cooling fan motor</li> <li>● Cooling fan relay</li> </ul>

GI  
MA  
EM  
LC  
EC  
FE  
CL  
MT  
AT  
FA  
RA  
BR  
ST  
ES  
BT  
JA  
EL  
IDX

**CONSULT (Cont'd)**

FUNCTION TEST ITEM	CONDITION	JUDGEMENT		CHECK ITEM (REMEDY)
START SIGNAL CIRCUIT	<ul style="list-style-type: none"> <li>● Ignition switch: ON → START</li> <li>● Start signal circuit is tested when engine is started by operating the starter. Before cranking, battery voltage and engine coolant temperature are displayed. During cranking, average battery voltage, mass air flow sensor output voltage and cranking speed are displayed.</li> </ul>	Start signal: OFF → ON		<ul style="list-style-type: none"> <li>● Harness and connector</li> <li>● Ignition switch</li> </ul>
PW/ST SIGNAL CIRCUIT	<ul style="list-style-type: none"> <li>● Ignition switch: ON (Engine running)</li> <li>● Power steering circuit is tested when steering wheel is rotated fully and then set to a straight line running position.</li> </ul>	Locked position	ON	<ul style="list-style-type: none"> <li>● Harness and connector</li> <li>● Power steering oil pressure switch</li> <li>● Power steering pump</li> </ul>
		Neutral position	OFF	
VEHICLE SPEED SEN CKT	<ul style="list-style-type: none"> <li>● Vehicle speed sensor circuit is tested when vehicle is running at a speed of 10 km/h (6 MPH) or higher.</li> </ul>	Vehicle speed sensor input signal is greater than 4 km/h (2 MPH)		<ul style="list-style-type: none"> <li>● Harness and connector</li> <li>● Vehicle speed sensor</li> <li>● Electric speedometer</li> </ul>
IGN TIMING ADJ	<ul style="list-style-type: none"> <li>● After warming up, idle the engine.</li> <li>● Ignition timing adjustment is checked by reading ignition timing with a timing light and checking whether it agrees with specifications.</li> </ul>	The timing light indicates the same value on the screen.		<ul style="list-style-type: none"> <li>● Adjust ignition timing (by moving camshaft position sensor or distributor)</li> <li>● Camshaft position sensor drive mechanism</li> </ul>
MIXTURE RATIO TEST	<ul style="list-style-type: none"> <li>● Air-fuel ratio feedback circuit (injection system, ignition system, vacuum system, etc.) is tested by examining the front oxygen sensor* output at 2,000 rpm under non-loaded state.</li> </ul>	Front oxygen sensor* COUNT: More than 5 times during 10 seconds		<ul style="list-style-type: none"> <li>● INJECTION SYS (Injector, fuel pressure regulator, harness or connector)</li> <li>● IGNITION SYS (Spark plug, power transistor, ignition coil, harness or connector)</li> <li>● VACUUM SYS (Intake air leaks)</li> <li>● Front oxygen sensor* circuit</li> <li>● Front oxygen sensor* operation</li> <li>● Fuel pressure high or low</li> <li>● Mass air flow sensor</li> </ul>

\*: Oxygen sensor (M/T models except for California)  
 Heated oxygen sensor (M/T models for California and A/T models)

CONSULT (Cont'd)

FUNCTION TEST ITEM	CONDITION	JUDGEMENT	CHECK ITEM (REMEDY)
POWER BALANCE	<ul style="list-style-type: none"> <li>● After warming up, idle the engine.</li> <li>● Injector operation of each cylinder is stopped one after another, and resultant change in engine rotation is examined to evaluate combustion of each cylinder. (This is only displayed for models where a sequential multiport fuel injection system is used.)</li> </ul>	Difference in engine speed is greater than 25 rpm before and after cutting off the injector of each cylinder.	<ul style="list-style-type: none"> <li>● Injector circuit (Injector, harness or connector)</li> <li>● Ignition circuit (Spark plug, power transistor, ignition coil, harness or connector)</li> <li>● Compression</li> <li>● Valve timing</li> </ul>
IACV-AAC/V SYSTEM	<ul style="list-style-type: none"> <li>● After warming up, idle the engine.</li> <li>● IACV-AAC valve system is tested by detecting change in engine speed when IACV-AAC valve opening is changed to 0%, 20% and 80%.</li> </ul>	Difference in engine speed is greater than 150 rpm between when valve opening is at 80% and at 20%.	<ul style="list-style-type: none"> <li>● Harness and connector</li> <li>● IACV-AAC valve</li> <li>● Air passage restriction between air inlet and IACV-AAC valve</li> <li>● IAS (Idle adjusting screw) adjustment</li> </ul>

GI

MA

EM

LC

**EC**

FE

CL

MT

AT

FA

RA

BR

ST

RS

BT

HA

EL

IDX

**CONSULT (Cont'd)**

**FREEZE FRAME DATA**

Freeze frame data item	Description
DIAG TROUBLE CODE [PXXXX]	<ul style="list-style-type: none"> <li>● ECCS component part/control system has a trouble code, it is displayed as "PXXXX". [Refer to "Alphabetical &amp; P No. Index for DTC" (EC-459).]</li> </ul>
FUEL SYS DATA	<ul style="list-style-type: none"> <li>● "Fuel injection system status" at the moment a malfunction is detected is displayed.</li> <li>● One mode in the following is displayed.                      "MODE 2": Open loop due to detected system malfunction                      "MODE 3": Open loop due to driving conditions (power enrichment, deceleration enrichment)                      "MODE 4": Closed loop - using oxygen sensor*(s) as feedback for fuel control                      "MODE 5": Open loop - has not yet satisfied condition to go to closed loop</li> </ul>
CAL/LD VALUE [%]	<ul style="list-style-type: none"> <li>● The calculated load value at the moment a malfunction is detected is displayed.</li> </ul>
COOLANT TEMP [°C] or [°F]	<ul style="list-style-type: none"> <li>● The engine coolant temperature at the moment a malfunction is detected is displayed.</li> </ul>
S-FUEL TRIM [%]	<ul style="list-style-type: none"> <li>● "Short-term fuel trim" at the moment a malfunction is detected is displayed.</li> <li>● The short-term fuel trim indicates dynamic or instantaneous feedback compensation to the base fuel schedule.</li> </ul>
L-FUEL TRIM [%]	<ul style="list-style-type: none"> <li>● "Long-term fuel trim" at the moment a malfunction is detected is displayed.</li> <li>● The long-term fuel trim indicates much more gradual feedback compensation to the base fuel schedule than short-term fuel trim.</li> </ul>
ENGINE SPEED [rpm]	<ul style="list-style-type: none"> <li>● The engine speed at the moment a malfunction is detected is displayed.</li> </ul>
VHCL SPEED [km/h] or [mph]	<ul style="list-style-type: none"> <li>● The vehicle speed at the moment a malfunction is detected is displayed.</li> </ul>

\*: Oxygen sensor (M/T models except for California)  
 Heated oxygen sensor (M/T models for California and A/T models)

CONSULT (Cont'd)

REAL TIME DIAGNOSIS IN DATA MONITOR MODE

CONSULT has two kinds of triggers and they can be selected by touching "SETTING" in "DATA MONITOR" mode.

1. "AUTO TRIG" (Automatic trigger):
  - The malfunction will be identified on the CONSULT screen in real time. In other words, DTC and malfunction item will be displayed at the moment the malfunction is detected by ECM.
  - DATA MONITOR can be performed continuously until a malfunction is detected. However, DATA MONITOR cannot continue any longer after the malfunction detection.
2. "MANU TRIG" (Manual trigger):
  - DTC and malfunction item will not be displayed automatically on CONSULT screen even though a malfunction is detected by ECM.
  - DATA MONITOR can be performed continuously even though a malfunction is detected.

Use these triggers as follows:

1. "AUTO TRIG"
  - While trying to detect the DTC by performing the "DTC CONFIRMATION PROCEDURE", be sure to select to "DATA MONITOR (AUTO TRIG)" mode. You can confirm the malfunction at the moment it is detected.
  - While narrowing down the possible causes, CONSULT should be set in "DATA MONITOR (AUTO TRIG)" mode, especially in case the incident is intermittent. Inspect the circuit by gently shaking (or twisting) suspicious connectors, components and harness in the "DTC CONFIRMATION PROCEDURE". The moment a malfunction is found the DTC will be displayed. (Refer to GI section, "Incident Simulation Tests" in "HOW TO PERFORM EFFICIENT DIAGNOSIS FOR AN ELECTRICAL INCIDENT".)
2. "MANU TRIG"
  - If the malfunction is displayed as soon as "DATA MONITOR" is selected, reset CONSULT to "MANU TRIG". By selecting "MANU TRIG" you can monitor and store the data. The data can be utilized for further diagnosis, such as a comparison with the value for the normal operating condition.

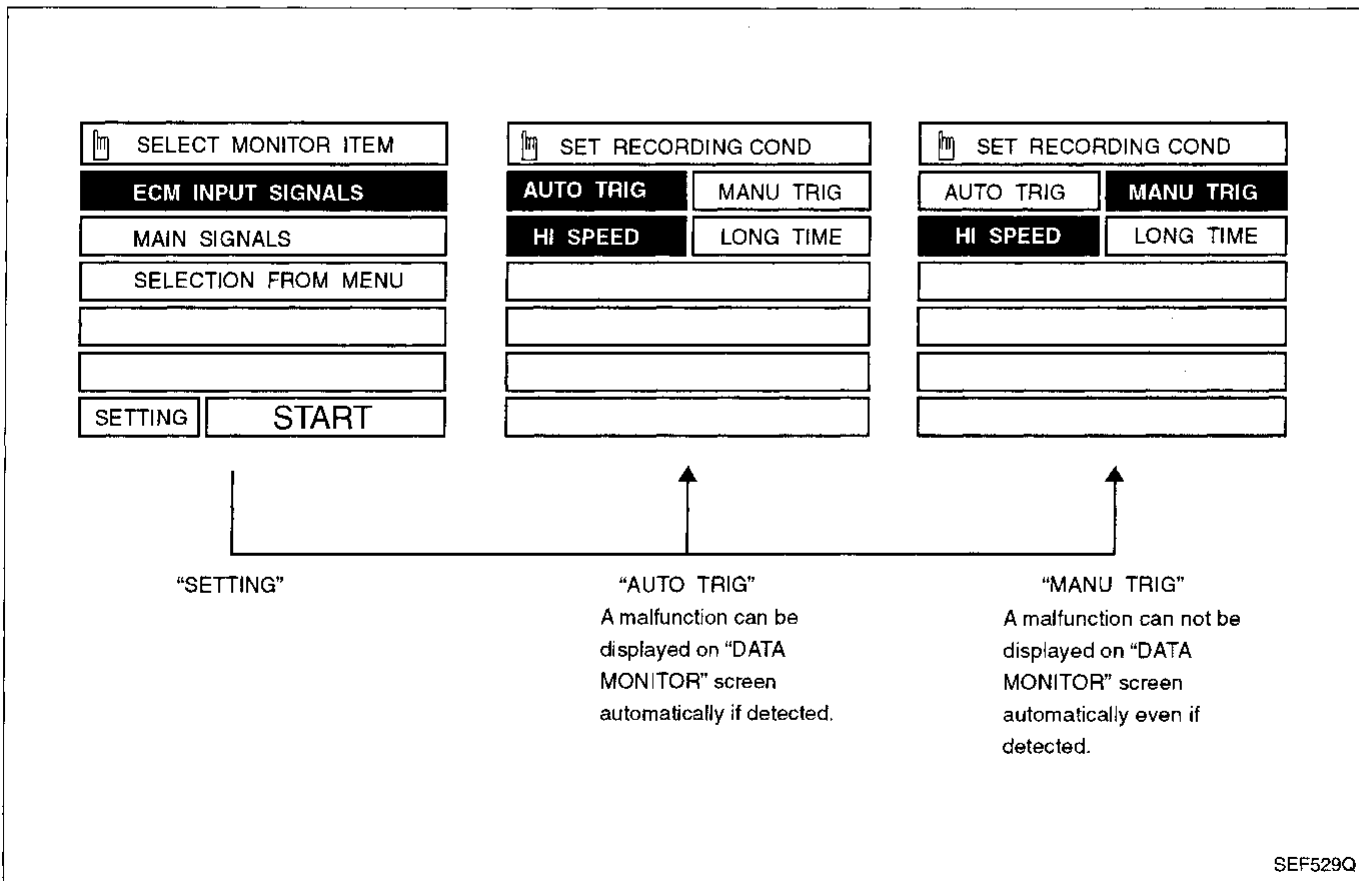



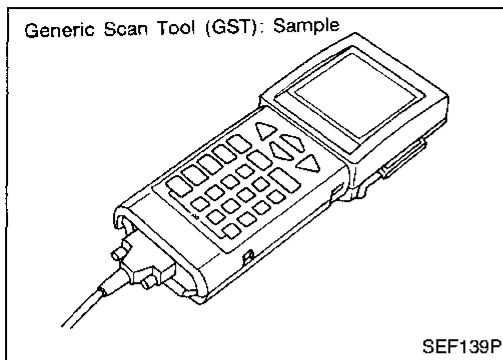

## Generic Scan Tool (GST)

### DESCRIPTION

Generic Scan Tool (OBDII scan tool) complying with SAE J1978 has five different functions explained on the next page. ISO9141 is used as the protocol. The name "GST" or "Generic Scan Tool" is used in this service manual.

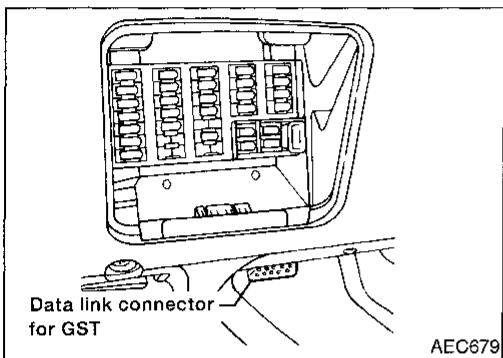

### GST INSPECTION PROCEDURE

1. Turn off ignition switch.
2. Connect "GST" to data link connector for GST. (Data link connector for GST is located under LH dash panel near the fuse box cover.)

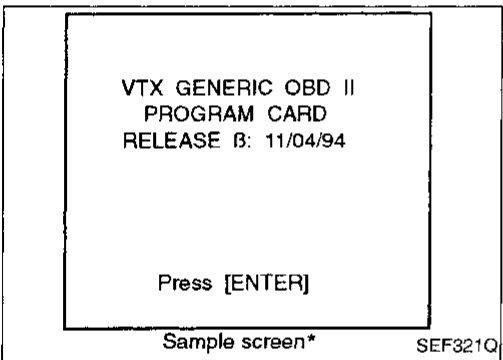

3. Turn on ignition switch.
4. Enter the program according to instruction on the screen or in the operation manual.

(\*: Regarding GST screens in this section, sample screens are shown.)

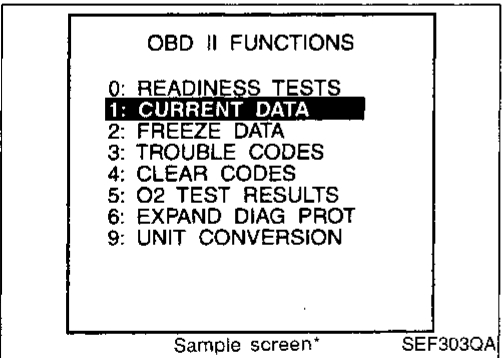

5. Perform each diagnostic mode according to each service procedure.

**For further information, see the GST Operation Manual of the tool maker.**

**Generic Scan Tool (GST) (Cont'd)**

**FUNCTION**

Diagnostic test mode		Function
MODE 1	(Current data)	This mode gains access to current emission-related data values, including analog inputs and outputs, digital inputs and outputs, and system status information.
MODE 2	(Freeze data)	This mode gains access to emission-related data value which were stored by ECM during the freeze frame. Refer to "Freeze Frame Data" (EC-280).
MODE 3	(Trouble codes)	This mode gains access to emission-related powertrain trouble codes which were stored by ECM.
MODE 4	(Clear codes)	This mode can clear all emission-related diagnostic information. This includes: <ul style="list-style-type: none"> <li>● Clear number of diagnostic trouble codes (MODE 1)</li> <li>● Clear diagnostic trouble codes (MODE 3)</li> <li>● Clear trouble code for freeze frame data (MODE 1)</li> <li>● Clear freeze frame data (MODE 2)</li> <li>● Clear heated oxygen sensor* test data (MODE 5)</li> <li>● Reset status of system monitoring test (MODE 1)</li> </ul>
MODE 5	(O2 test results)	This mode gains access to the on-board heated oxygen sensor* monitoring test results.

\*: Oxygen sensor (M/T models except for California)  
 Heated oxygen sensor (M/T models for California and A/T models)

GI  
 MA  
 EM  
 LC  
**EC**  
 FE  
 CL  
 MT  
 AT  
 FA  
 RA  
 BR  
 ST  
 RS  
 BT  
 HA  
 EL  
 IDX

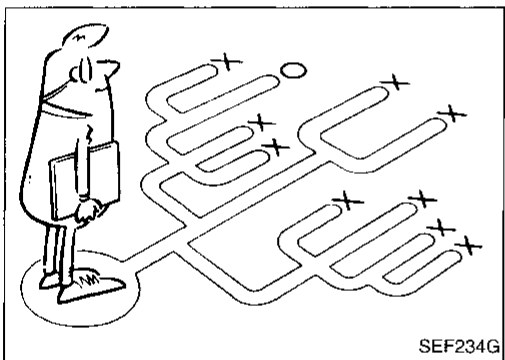
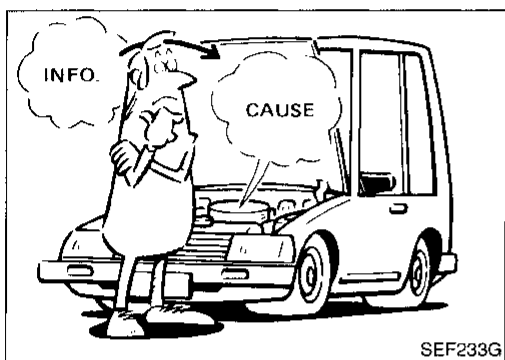
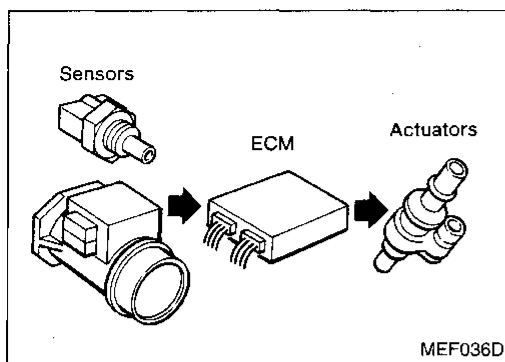

## Introduction

The engine has an ECM to control major systems such as fuel control, ignition control, idle air control system, etc. The ECM accepts input signals from sensors and instantly drives actuators. It is essential that both input and output signals are proper and stable. At the same time, it is important that there are no problems such as vacuum leaks, fouled spark plugs, or other problems with the engine.

It is much more difficult to diagnose a problem that occurs intermittently rather than continuously. Most intermittent problems are caused by poor electric connections or improper wiring. In this case, careful checking of suspected circuits may help prevent the replacement of good parts.

A visual check only may not find the cause of the problems. A road test with CONSULT (or GST) or a circuit tester connected should be performed. Follow the "Work Flow" on the next page. Before undertaking actual checks, take a few minutes to talk with a customer who approaches with a driveability complaint. The customer can supply good information about such problems, especially intermittent ones. Find out what symptoms are present and under what conditions they occur. A "Diagnostic Worksheet" like the example on next page should be used. Start your diagnosis by looking for "conventional" problems first. This will help troubleshoot driveability problems on an electronically controlled engine vehicle.



Work Flow

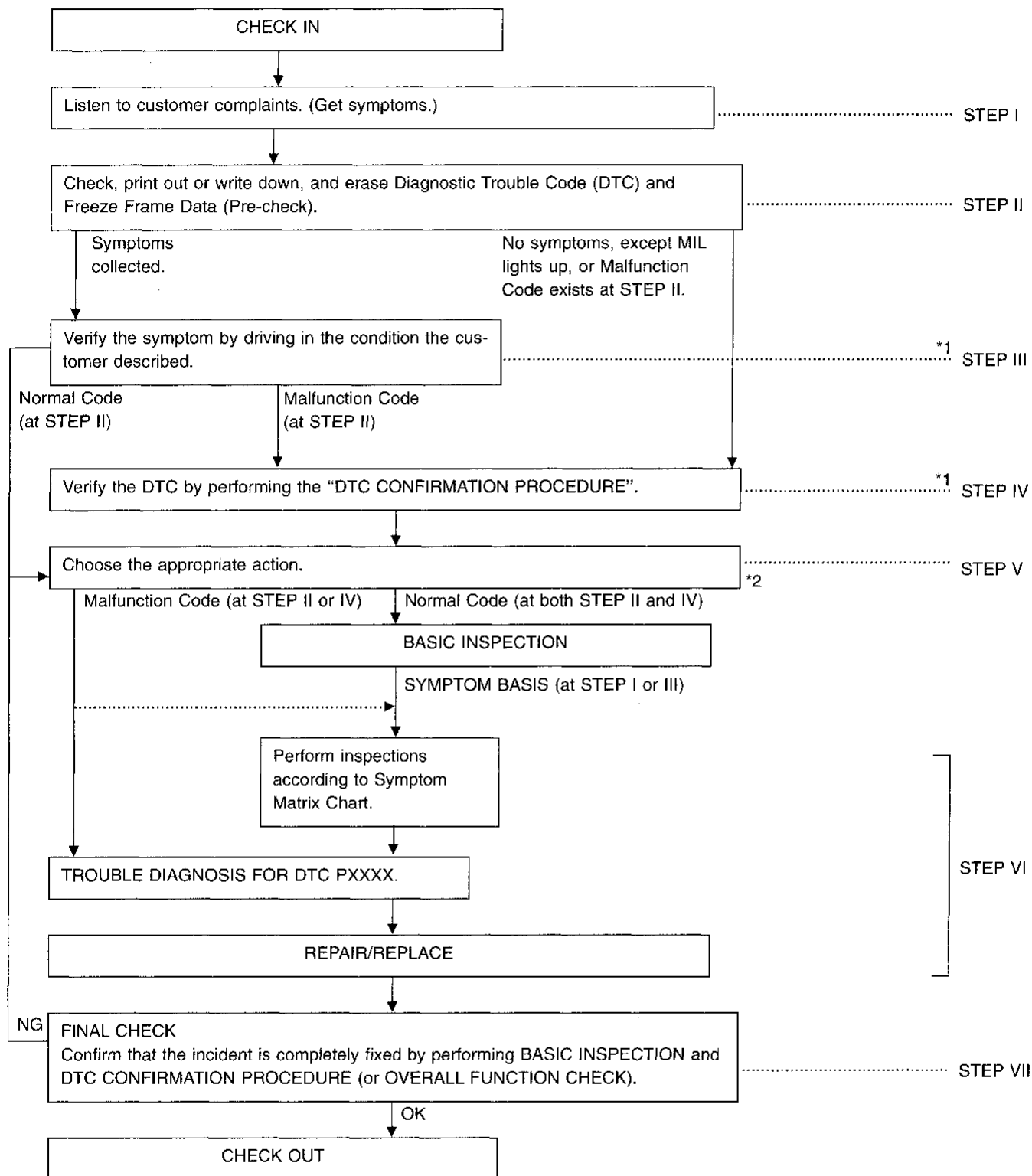

\*1: If the incident cannot be duplicated, refer to GI section (“Incident Simulation Tests”, “HOW TO PERFORM EFFICIENT DIAGNOSIS FOR AN ELECTRICAL INCIDENT”).

\*2: If the on-board diagnostic system cannot be performed, check main power supply and ground circuit. Refer to “TROUBLE DIAGNOSIS FOR POWER SUPPLY”, EC-315.

Description for Work Flow

STEP	DESCRIPTION
STEP I	Get detailed information about the conditions and the environment when the incident/symptom occurred using the "DIAGNOSTIC WORKSHEET" as shown on the next page.
STEP II	Before confirming the concern, check and write down (print out using CONSULT or Generic Scan Tool) the Diagnostic Trouble Code (DTC) and the freeze frame data, then erase the code and the data. Refer to EC-260. The DTC and the freeze frame data can be used when duplicating the incident at STEP III & IV. Study the relationship between the cause, specified by DTC, and the symptom described by the customer. (The "Symptom Matrix Chart" will be useful. Refer to EC-301.)
STEP III	Try to confirm the symptom and under what conditions the incident occurs. The "DIAGNOSTIC WORK SHEET" and the freeze frame data are useful to verify the incident. Connect CONSULT to the vehicle in DATA MONITOR (AUTO TRIG) mode and check real time diagnosis results. If the incident cannot be verified, perform INCIDENT SIMULATION TESTS. Refer to GI section. If the malfunction code is detected, skip STEP IV and perform STEP V.
STEP IV	Try to detect the Diagnostic Trouble Code (DTC) by driving in (or performing) the "DTC CONFIRMATION PROCEDURE". Check and read the DTC and freeze frame data by using CONSULT or Generic Scan Tool. During the DTC verification, be sure to connect CONSULT to the vehicle in DATA MONITOR (AUTO TRIG) mode and check real time diagnosis results. If the incident cannot be verified, perform INCIDENT SIMULATION TESTS. Refer to GI section. In case the "DTC CONFIRMATION PROCEDURE" is not available, perform the "OVERALL FUNCTION CHECK" instead. The DTC cannot be displayed by this check, however, this simplified "check" is an effective alternative. The "NG" result of the "OVERALL FUNCTION CHECK" is the same as the DTC detection.
STEP V	Take the appropriate action based on the results of STEP I through IV. If the malfunction code is indicated, proceed to TROUBLE DIAGNOSIS FOR DTC PXXXX. If the normal code is indicated, proceed to the BASIC INSPECTION. Refer to EC-288. Then perform inspections according to the Symptom Matrix Chart. Refer to EC-301.
STEP VI	Identify where to begin diagnosis based on the relationship study between symptom and possible causes. Inspect the system for mechanical binding, loose connectors or wiring damage using (tracing) "Harness Layouts". Gently shake the related connectors, components or wiring harness with CONSULT set in "DATA MONITOR (AUTO TRIG)" mode. Check the voltage of the related ECM terminals or monitor the output data from the related sensors with CONSULT. Refer to EC-304. The "DIAGNOSTIC PROCEDURE" in EC section contains a description based on open circuit inspection. A short circuit inspection is also required for the circuit check in the DIAGNOSTIC PROCEDURE. For details, refer to GI section ("Circuit Inspection", "HOW TO PERFORM EFFICIENT DIAGNOSIS FOR AN ELECTRICAL INCIDENT"). Repair or replace the malfunction parts.
STEP VII	Once you have repaired the circuit or replaced a component, you need to run the engine in the same conditions and circumstances which resulted in the customer's initial complaint. Perform the "DTC CONFIRMATION PROCEDURE" and confirm the normal code (Diagnostic trouble code No. 0505 or P0000) is detected. If the incident is still detected in the final check, perform STEP VI by using a different method from the previous one. Before returning the vehicle to the customer, be sure to erase the unnecessary (already fixed) DTC in ECM. Refer to EC-260.

GI  
MA  
EM  
LC  
EC  
FE  
CL  
MT  
AT  
FA  
RA  
BR  
ST  
RS  
BT  
HA  
EL  
IDX

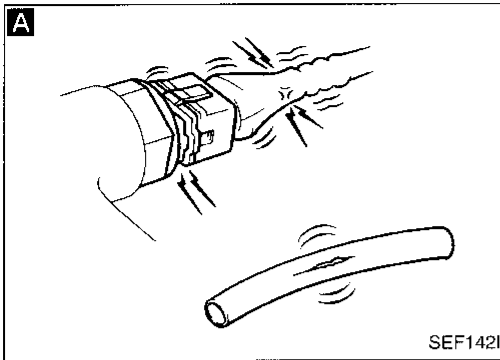

**Basic Inspection**

**Precaution:**

Perform Basic Inspection without electrical or mechanical loads applied;

- Headlamp switch is OFF,
- Air conditioner switch is OFF,
- Rear defogger switch is OFF,
- Steering wheel is in the straight-ahead position, etc.

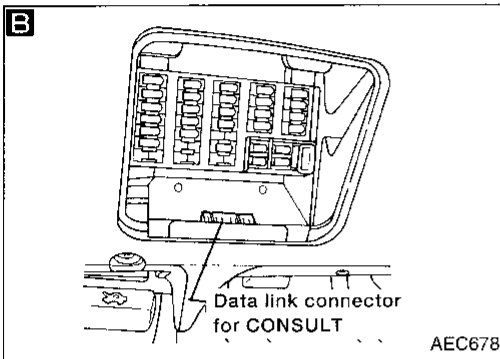

**A**

**BEFORE STARTING**

1. Check service records for any recent repairs that may indicate a related problem, or the current need for scheduled maintenance.
2. Open engine hood and check the following:
  - Harness connectors for improper connections
  - Vacuum hoses for splits, kinks, or improper connections
  - Wiring for improper connections, pinches, or cuts

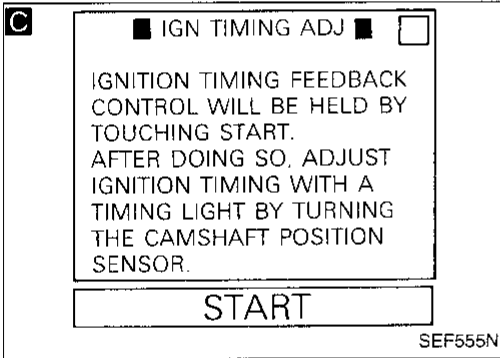

**B**

**CONNECT CONSULT TO THE VEHICLE.**  
Connect "CONSULT" to the data link connector for CONSULT and select "ENGINE" from the menu. Refer to EC-270.

**DOES ENGINE START?**

No → Go to **E**.

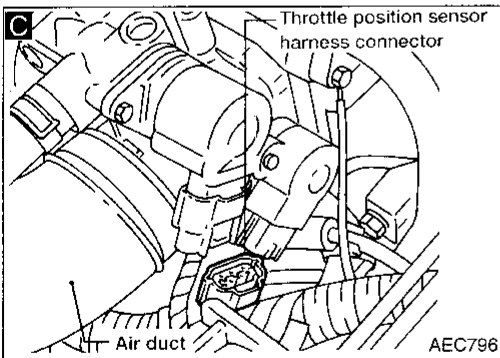

**C**

**CHECK IGNITION TIMING.**

1. Warm up engine sufficiently.
2. Select "IGN TIMING ADJ" in "WORK SUPPORT" mode.
3. Touch "START".
4. Check ignition timing at idle using timing light.

**Ignition timing:**  
**8°±2° BTDC**

---

1. Warm up engine sufficiently.
2. Stop engine and disconnect throttle position sensor harness connector.
3. Start engine.
4. Check ignition timing at idle using timing light.

**Ignition timing:**  
**8°±2° BTDC**

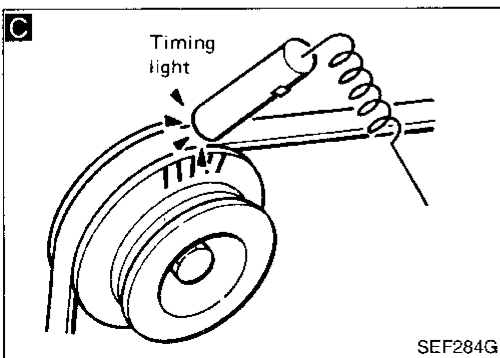

NG → Adjust ignition timing by turning camshaft position sensor.

OK

**A**

(Go to next page.)

Basic Inspection (Cont'd)

**D**  IGN TIMING ADJ

IGNITION TIMING FEEDBACK CONTROL WILL BE HELD BY TOUCHING START. AFTER DOING SO, ADJUST IGNITION TIMING WITH A TIMING LIGHT BY TURNING THE CAMSHAFT POSITION SENSOR.

**START**

SEF546N

**E**  THRTL POS SEN ADJ

\*\*\* ADJ MONITOR \*\*\*

THRTL POS SEN 0.52V

===== MONITOR =====

CMPS•RPM (REF)	0rpm
CLSD THL/P	ON

SEF165P

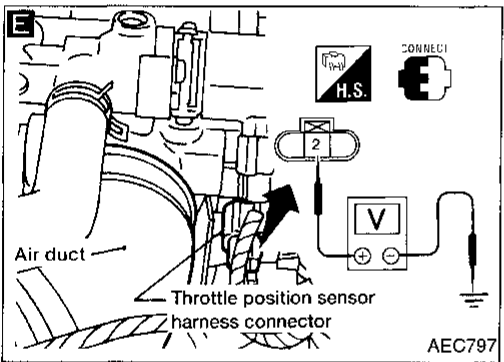

**D**

**CHECK IDLE ADJ. SCREW INITIAL SET RPM.**

- Select "IGN TIMING ADJ" in "WORK SUPPORT" mode.
- When touching "START", does engine speed fall to the following speed?  
**M/T 625±50 rpm**  
**A/T 725±50 rpm (in "N" position)**

OR

Does engine run at the following speed?  
**M/T: 625±50 rpm**  
**A/T: 725±50 rpm (in "N" position)**

Adjust engine speed by turning idle adjusting screw.

**E**

**CHECK THROTTLE POSITION SENSOR IDLE POSITION.**

- Perform "THRTL POS SEN ADJ" in "WORK SUPPORT" mode.
- Check that output voltage of throttle position sensor is approx. 0.35 to 0.65V (Throttle valve fully closes.) and "CLSD THL/P SW" stays "ON".

OR

Measure output voltage of throttle position sensor using voltmeter, and check that it is approx. 0.35 to 0.65V. (Throttle valve fully closed.)

Adjust output voltage to  $0.51 \pm 0.1V$  by rotating throttle position sensor body.

**RESET IDLE POSITION MEMORY.**

- Warm up engine sufficiently.
- Turn ignition switch "OFF" and wait at least 5 seconds.
- Disconnect throttle position sensor harness connector.
- Start engine and wait at least 5 seconds in "N" position.
- Reconnect throttle position sensor harness connector while running engine.

**B**  
(Go to next page.)

GI  
MA  
EM  
LC  
EC  
FE  
CL  
MT  
AT  
FA  
RA  
BR  
ST  
RS  
BT  
HA  
EL  
IDX



Basic Inspection (Cont'd)

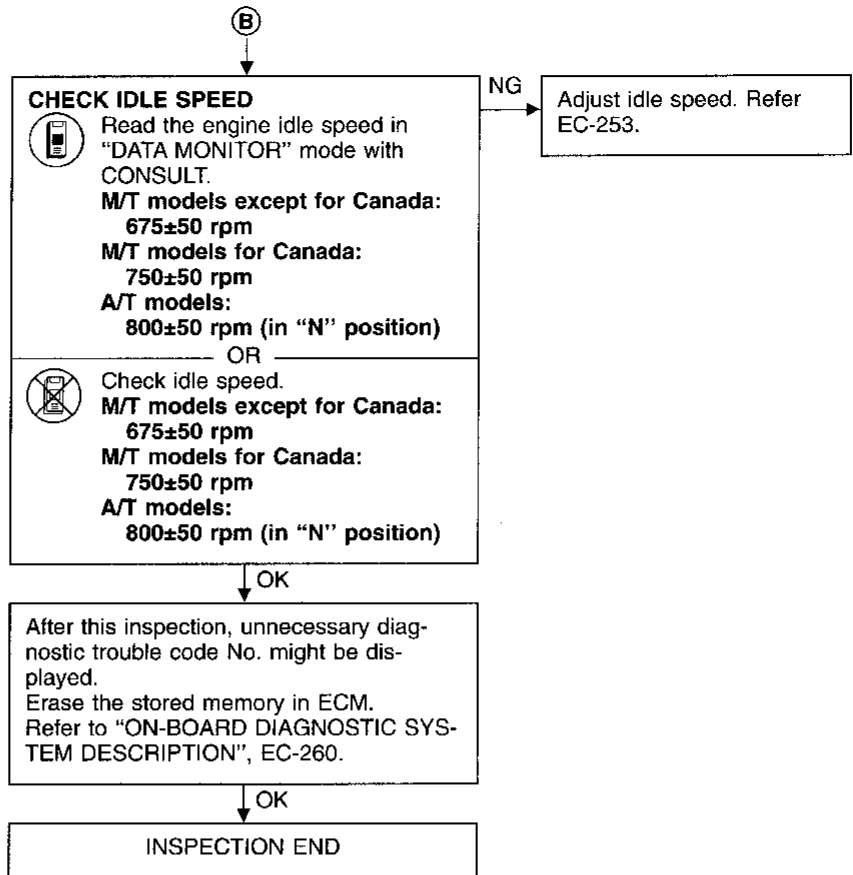

Diagnostic Trouble Code (DTC) Chart

ENGINE RELATED ITEMS

Diagnostic trouble code No.		Detected items (Screen terms for CONSULT, "SELF-DIAG RESULTS" mode)	Malfunction is detected when ...
CONSULT GST	MIL		
(P0000)	0505	No failure (NO SELF DIAGNOSTIC FAILURE INDICATED...)	<ul style="list-style-type: none"> <li>No malfunction related to OBD system is detected by either ECM or A/T control unit.</li> </ul>
P0100	0102	Mass air flow sensor circuit (MASS AIR FLOW SEN)	<ul style="list-style-type: none"> <li>An excessively high or low voltage is sent to ECM.</li> <li>Voltage sent to ECM is not practical when compared with the camshaft position sensor signal and throttle position sensor signal.</li> </ul>
P0110	0401	Intake air temperature sensor circuit (INT AIR TEMP SEN)	<ul style="list-style-type: none"> <li>An excessively low or high voltage from the sensor is sent to ECM.</li> <li>Voltage sent to ECM is not practical when compared with the engine coolant temperature sensor signal.</li> </ul>
P0115	0103	Engine coolant temperature sensor circuit (COOLANT TEMP SEN)	<ul style="list-style-type: none"> <li>An excessively high or low voltage from the sensor is sent to ECM.</li> </ul>
P0120	0403	Throttle position sensor circuit (THROTTLE POSI SEN)	<ul style="list-style-type: none"> <li>An excessively low or high voltage from the sensor is sent to ECM.</li> <li>Voltage sent to ECM is not practical when compared with the mass air flow sensor and camshaft position sensor signals.</li> </ul>
P0125	0908	Engine coolant temperature sensor function (*COOLANT TEMP SEN)	<ul style="list-style-type: none"> <li>Voltage sent to ECM from the sensor is not practical, even when some time has passed after starting the engine.</li> <li>Engine coolant temperature is insufficient for closed loop fuel control.</li> </ul>
P0130	0303	Front oxygen sensor*3 circuit (FRONT O2 SENSOR)	<ul style="list-style-type: none"> <li>An excessively high voltage from the sensor is sent to ECM.</li> <li>The voltage from the sensor is constantly approx. 0.3V.</li> <li>The maximum and minimum voltages from the sensor do not reach the specified voltages.</li> <li>The sensor does not respond between rich and lean within the specified time.</li> </ul>
P0130	0307	Closed loop control (CLOSED LOOP)	<ul style="list-style-type: none"> <li>The closed loop control function does not operate even when vehicle is driving in the specified condition.</li> </ul>

Abbreviations for Quick Reference of "DTC CONFIRMATION PROCEDURE"

IGN: ON : Turning the ignition switch ON is required for the ECM to detect a malfunction (if one exists).

RUNNING: Running engine is required for the ECM to detect a malfunction (if one exists).

LIFTING : Lifting up the vehicle, running engine and spinning wheels are required for the ECM.

DRIVING : Driving the vehicle in the specified pattern is required for the ECM.

Abbreviations for Quick Reference of "OVERALL FUNCTION CHECK"

IGN: ON : Turning the ignition switch ON is required for checking the function of the sensor, switch, solenoid and circuit.

RUNNING: Running engine is required for checking the function of the sensor, switch, solenoid and circuit.

LIFTING : Lifting up the vehicle, running engine and spinning wheels are required.

DRIVING : Driving the vehicle in the specified pattern is required.

\*3: Oxygen sensor (M/T models except for California), Heated oxygen sensor (M/T models for California and A/T models)

**Diagnostic Trouble Code (DTC) Chart (Cont'd)**

X: Applicable  
—: Not applicable

Check Items (Possible Cause)	"DTC CONFIRMATION PROCEDURE" Quick Ref. *1	"OVERALL FUNCTION CHECK" Quick Ref. *2	Fail Safe System	MIL Illumination	Reference Page
● No failure	—	—	—	—	—
● Harness or connectors (The sensor circuit is open or shorted.) ● Mass air flow sensor	RUNNING	RUNNING	X	2 trip	EC-318
● Harness or connectors (The sensor circuit is open or shorted.) ● Intake air temperature sensor	IGN: ON	—	—	2 trip	EC-323
● Harness or connectors (The sensor circuit is open or shorted.) ● Engine coolant temperature sensor	IGN: ON	—	X	2 trip	EC-328
● Harness or connectors (The sensor circuit is open or shorted.) ● Throttle position sensor	LIFTING	IGN: ON	X	2 trip	EC-332
● Harness or connectors (High resistance in the sensor circuit.) ● Engine coolant temperature sensor ● Thermostat	—	RUNNING	—	2 trip	EC-337
● Harness or connectors (The sensor circuit is open or shorted.) ● Front oxygen sensor*3 ● Fuel pressure ● Injectors ● Intake air leaks	—	RUNNING	—	2 trip	EC-342
● The front oxygen sensor*3 circuit is open or shorted. ● Front oxygen sensor*3 ● Front heated oxygen sensor heater (M/T models for California and A/T models)	—	RUNNING	—	1 trip	EC-347

\*1: This is Quick Reference of "DTC CONFIRMATION PROCEDURE".

Details are described in each TROUBLE DIAGNOSIS FOR DTC PXXXX.

\*2: ● The "OVERALL FUNCTION CHECK" is a simplified and effective way to inspect a component or circuit.

In some cases, the "OVERALL FUNCTION CHECK" is used rather than a "DIAGNOSTIC TROUBLE CODE CONFIRMATION PROCEDURE".

When no DTC CONFIRMATION PROCEDURE is available, the "NG" result of the OVERALL FUNCTION CHECK can be considered to mean the same as a DTC detection.

● During an "NG" OVERALL FUNCTION CHECK, the DTC might not be confirmed.

● This is Quick Reference of "OVERALL FUNCTION CHECK".

Details are described in each TROUBLE DIAGNOSIS FOR DTC PXXXX.

**Diagnostic Trouble Code (DTC) Chart (Cont'd)**

**ENGINE RELATED ITEMS**

Diagnostic trouble code No.		Detected items (Screen terms for CONSULT, "SELF-DIAG RESULTS" mode)	Malfunction is detected when ...	
CONSULT GST	MIL			
P0135	0901	Front heated oxygen sensor heater circuit (FR O2 SEN HEATER)	<ul style="list-style-type: none"> <li>● The current amperage in the heater circuit is out of the normal range. (An improper voltage drop signal is sent to ECM through the heater.)</li> </ul>	
P0136	0707	Rear heated oxygen sensor circuit (REAR O2 SENSOR)	<ul style="list-style-type: none"> <li>● An excessively high voltage from the sensor is sent to ECM.</li> <li>● The specified maximum and minimum voltages from the sensor are not reached.</li> <li>● It takes more than the specified time for the sensor to respond between rich and lean.</li> </ul>	
P0170	0706	Fuel injection system function (FUEL INJ SYSTEM)	<ul style="list-style-type: none"> <li>● Fuel injection system does not operate properly.</li> <li>● The amount of mixture ratio compensation is excessive. (The mixture ratio is too lean or too rich.)</li> </ul>	
P0300	0701	Multiple cylinders' misfire (MULTI CYL MISFIRE)	(Three way catalyst damage) The misfire occurs, which will damage three way catalyst by overheating.	(Exhaust quality deterioration) The misfire occurs, which will not damage three way catalyst but will affect emission deterioration.
P0301	0608	No. 1 cylinder's misfire (CYL 1 MISFIRE)		
P0302	0607	No. 2 cylinder's misfire (CYL 2 MISFIRE)		
P0303	0606	No. 3 cylinder's misfire (CYL 3 MISFIRE)		
P0304	0605	No. 4 cylinder's misfire (CYL 4 MISFIRE)		

**Abbreviations for Quick Reference of "DTC CONFIRMATION PROCEDURE"**

IGN: ON : Turning the ignition switch ON is required for the ECM to detect a malfunction (if one exists).

RUNNING: Running engine is required for the ECM to detect a malfunction (if one exists).

LIFTING : Lifting up the vehicle, running engine and spinning wheels are required for the ECM.

DRIVING : Driving the vehicle in the specified pattern is required for the ECM.

**Abbreviations for Quick Reference of "OVERALL FUNCTION CHECK"**

IGN: ON : Turning the ignition switch ON is required for checking the function of the sensor, switch, solenoid and circuit.

RUNNING: Running engine is required for checking the function of the sensor, switch, solenoid and circuit.

LIFTING : Lifting up the vehicle, running engine and spinning wheels are required.

DRIVING : Driving the vehicle in the specified pattern is required.

GI

HA

EM

LC

**EC**

FE

CL

MT

AT

FA

RA

BR

ST

RS

BT

HA

EL

IDX

**Diagnostic Trouble Code (DTC) Chart (Cont'd)**

X: Applicable  
—: Not applicable

Check Items (Possible Cause)	"DTC CONFIRMATION PROCEDURE" Quick Ref. *1	"OVERALL FUNCTION CHECK" Quick Ref. *2	Fail Safe System	MIL Illumination	Reference Page
<ul style="list-style-type: none"> <li>● Harness and connectors (The heater circuit is open or shorted.)</li> <li>● Front heated oxygen sensor heater</li> </ul>	RUNNING	—	—	2 trip	EC-348
<ul style="list-style-type: none"> <li>● Harness or connectors (The sensor circuit is open or shorted.)</li> <li>● Rear heated oxygen sensor</li> <li>● Fuel pressure</li> <li>● Injectors</li> <li>● Intake air leaks</li> </ul>	—	RUNNING (DRIVING)	—	2 trip	EC-351
<ul style="list-style-type: none"> <li>● Intake air leaks</li> <li>● Front oxygen sensor</li> <li>● Injectors</li> <li>● Exhaust gas leaks</li> <li>● Incorrect fuel pressure</li> <li>● Mass air flow sensor</li> <li>● Lack of fuel</li> </ul>	RUNNING	—	—	2 trip	EC-356
<ul style="list-style-type: none"> <li>● Improper spark plug</li> <li>● Ignition secondary circuit is open or shorted</li> <li>● Insufficient compression</li> <li>● Incorrect fuel pressure</li> <li>● EGR valve</li> <li>● Injector circuit is open or shorted</li> <li>● Injectors</li> <li>● Intake air leaks</li> <li>● Lack of fuel</li> <li>● Magnetized flywheel (drive plate)</li> </ul>	DRIVING	—	—	(Three way catalyst damage)  1 trip  (Exhaust quality deterioration)  2 trip	EC-361

\*1: This is Quick Reference of "DTC CONFIRMATION PROCEDURE".

Details are described in each TROUBLE DIAGNOSIS FOR DTC PXXXX.

\*2: ● The "OVERALL FUNCTION CHECK" is a simplified and effective way to inspect a component or circuit.

In some cases, the "OVERALL FUNCTION CHECK" is used rather than a "DIAGNOSTIC TROUBLE CODE CONFIRMATION PROCEDURE".

When no DTC CONFIRMATION PROCEDURE is available, the "NG" result of the OVERALL FUNCTION CHECK can be considered to mean the same as a DTC detection.

● During an "NG" OVERALL FUNCTION CHECK, the DTC might not be confirmed.

● This is Quick Reference of "OVERALL FUNCTION CHECK".

Details are described in each TROUBLE DIAGNOSIS FOR DTC PXXXX.

\*3: Oxygen sensor (M/T models except for California), Heated oxygen sensor (M/T models for California and A/T models)

Diagnostic Trouble Code (DTC) Chart (Cont'd)

ENGINE RELATED ITEMS

Diagnostic trouble code No.		Detected items (Screen terms for CONSULT, "SELF-DIAG RESULTS" mode)	Malfunction is detected when ...
CONSULT GST	MIL		
P0325 (*4)	0304	Knock sensor circuit (KNOCK SENSOR)	<ul style="list-style-type: none"> <li>An excessively low or high voltage from the sensor is sent to ECM.</li> </ul>
P0335	0802	Crankshaft position sensor (OBD) circuit [CRANK POS SEN (OBD)]	<ul style="list-style-type: none"> <li>The proper pulse signal from the sensor is not sent to ECM while the engine is running at the specified rpm.</li> </ul>
P0340	0101	Camshaft position sensor circuit (CAMSHAFT POSI SEN)	<ul style="list-style-type: none"> <li>Either 1° or 180° signal is not sent to ECM for the first few seconds during engine cranking.</li> <li>Either 1° or 180° signal is not sent to ECM often enough while the engine speed is higher than the specified rpm.</li> <li>The relation between 1° and 180° signals is not in the normal range during the specified rpm.</li> </ul>
P0400	0302	EGR function (EGR SYSTEM)	<ul style="list-style-type: none"> <li>The EGR flow is excessively low or high during the specified driving condition.</li> </ul> <hr/> <ul style="list-style-type: none"> <li>The exhaust gas recirculation (EGR) flow is excessively under during the specified conditions.</li> </ul>
P0402	0306	EGRC-BPT valve function (EGRC-BPT VALVE)	<ul style="list-style-type: none"> <li>EGRC-BPT valve does not operate properly.</li> </ul>
P0420	0702	Three way catalyst function (TW CATALYST SYSTEM)	<ul style="list-style-type: none"> <li>Three way catalyst does not operate properly.</li> <li>Three way catalyst does not have enough oxygen storage capacity.</li> </ul>
P0500	0104	Vehicle speed sensor circuit (VEHICLE SPEED SEN)	<ul style="list-style-type: none"> <li>The almost 0 km/h (0 MPH) signal from the sensor is sent to ECM even when vehicle is driving.</li> </ul>
P0505	0205	Idle speed control function (IACV-AAC VALVE)	<ul style="list-style-type: none"> <li>The IACV-AAC valve does not operate properly.</li> </ul> <hr/> <ul style="list-style-type: none"> <li>The IACV-AAC valve does not operate properly.</li> </ul>
P0605	0301	ECM (ECM)	<ul style="list-style-type: none"> <li>ECM calculation function is malfunctioning.</li> </ul>

Abbreviations for Quick Reference of "DTC CONFIRMATION PROCEDURE"

- IGN: ON : Turning the ignition switch ON is required for the ECM to detect a malfunction (if one exists).
- RUNNING: Running engine is required for the ECM to detect a malfunction (if one exists).
- LIFTING : Lifting up the vehicle, running engine and spinning wheels are required for the ECM.
- DRIVING : Driving the vehicle in the specified pattern is required for the ECM.

Abbreviations for Quick Reference of "OVERALL FUNCTION CHECK"

- IGN: ON : Turning the ignition switch ON is required for checking the function of the sensor, switch, solenoid and circuit.
- RUNNING: Running engine is required for checking the function of the sensor, switch, solenoid and circuit.
- LIFTING : Lifting up the vehicle, running engine and spinning wheels are required.
- DRIVING : Driving the vehicle in the specified pattern is required.

\*4: Freeze frame data is not stored in the ECM for the "Knock sensor". The MIL will not light up for a "Knock sensor" malfunction.

**Diagnostic Trouble Code (DTC) Chart (Cont'd)**

X: Applicable  
—: Not applicable

Check Items (Possible Cause)	"DTC *1 CONFIRMA- TION PROCE- DURE" Quick Ref.	*2 "OVERALL FUNCTION CHECK" Quick Ref.	Fail Safe System	MIL Illumination	Reference Page
<ul style="list-style-type: none"> <li>● Harness or connectors (The sensor circuit is open or shorted.)</li> <li>● Knock sensor</li> </ul>	RUNNING	—	—	—	EC-365
<ul style="list-style-type: none"> <li>● Harness or connectors (The sensor circuit is open.)</li> <li>● Crankshaft position sensor (OBD)</li> </ul>	RUNNING	—	—	2 trip	EC-368
<ul style="list-style-type: none"> <li>● Harness or connectors (The sensor circuit is open or shorted.)</li> <li>● Camshaft position sensor</li> <li>● Starter motor</li> <li>● Starting system circuit (EL section)</li> <li>● Dead (Weak) battery</li> </ul>	RUNNING	—	—	2 trip	EC-372
<ul style="list-style-type: none"> <li>● EGR valve stuck closed</li> <li>● Passage blocked</li> <li>● EGR and EVAP canister purge control solenoid valve</li> <li>● Tube leaking for EGR valve</li> <li>● EGRC-BPT valve leaking</li> <li>● EGR temperature sensor</li> </ul>	—	RUNNING	—	2 trip	EC-377
<ul style="list-style-type: none"> <li>● EGR valve &amp; EVAP canister purge control solenoid valve</li> <li>● EGR valve leaking or stuck open</li> <li>● EGR temperature sensor</li> </ul>	—	RUNNING	—	2 trip	EC-386
<ul style="list-style-type: none"> <li>● EGRC-BPT valve</li> <li>● Rubber tube (blocked or misconnected)</li> </ul>	—	RUNNING	—	2 trip	EC-388
<ul style="list-style-type: none"> <li>● Three way catalyst</li> <li>● Exhaust tube</li> <li>● Intake air leaks</li> <li>● Injectors</li> <li>● Injector leaks</li> </ul>	—	RUNNING	—	1 trip	EC-391
<ul style="list-style-type: none"> <li>● Harness or connectors (The sensor circuit is open or shorted.)</li> <li>● Vehicle speed sensor</li> </ul>	DRIVING	LIFTING	—	2 trip	EC-395
<ul style="list-style-type: none"> <li>● Harness or connectors (The valve circuit is open or shorted.)</li> <li>● IACV-AAC valve</li> </ul>	IGN: ON ..... RUNNING	—	—	2 trip	EC-399
<ul style="list-style-type: none"> <li>● ECM (ECCS control module)</li> </ul>	RUNNING	—	X	2 trip	EC-399

\*1: This is Quick Reference of "DTC CONFIRMATION PROCEDURE".

Details are described in each TROUBLE DIAGNOSIS FOR DTC PXXXX.

\*2: ● The "OVERALL FUNCTION CHECK" is a simplified and effective way to inspect a component or circuit.

In some cases, the "OVERALL FUNCTION CHECK" is used rather than a "DIAGNOSTIC TROUBLE CODE CONFIRMATION PROCEDURE".

When no DTC CONFIRMATION PROCEDURE is available, the "NG" result of the OVERALL FUNCTION CHECK can be considered to mean the same as a DTC detection.

● During an "NG" OVERALL FUNCTION CHECK, the DTC might not be confirmed.

● This is Quick Reference of "OVERALL FUNCTION CHECK".

Details are described in each TROUBLE DIAGNOSIS FOR DTC PXXXX.

**Diagnostic Trouble Code (DTC) Chart (Cont'd)**

**ENGINE RELATED ITEMS**

Diagnostic trouble code No.		Detected items (Screen terms for CONSULT, "SELF-DIAG RESULTS" mode)	Malfunction is detected when ...
CONSULT GST	MIL		
P0705	1003	Park/Neutral position switch circuit (PARK/NEUT POSI SW)	<ul style="list-style-type: none"> <li>The signal of the park/neutral position switch is not changed in the process of engine starting and driving.</li> </ul>
P1110	0805	VTC function (VTC SOLENOID VALVE)	<ul style="list-style-type: none"> <li>An improper voltage signal is sent to ECM through the solenoid valve.</li> <li>The basic injection pulse width does not change when VTC solenoid valve is activated to ON under the specified conditions.</li> </ul>
P1320	0201	Ignition signal circuit (IGN SIGNAL-PRIMARY)	<ul style="list-style-type: none"> <li>The ignition signal in the primary circuit is not sent to ECM during engine cranking or running.</li> </ul>
P1336	0905	Crankshaft position sensor (OBD) [CRANK P/S (OBD)-COG]	<ul style="list-style-type: none"> <li>Chipping of a flywheel or drive plate gear tooth (cog) is detected by ECM.</li> </ul>
P1400	1005	EGR valve and EVAP canister purge control solenoid valve circuit (EGRC SOLENOID/V)	<ul style="list-style-type: none"> <li>An improper voltage signal is sent to the ECM through the solenoid valve.</li> </ul>
P1401	0305	EGR temperature sensor circuit (EGR TEMP SENSOR)	<ul style="list-style-type: none"> <li>An excessively low or high voltage from the sensor is sent to ECM, even when engine coolant temperature is low or high.</li> </ul>
P1550	0904	T/C clutch solenoid valve (TOR CONV CLUTCH SV)	<ul style="list-style-type: none"> <li>An excessively low voltage from the solenoid is sent to ECM.</li> <li>A/T torque converter slips when in lock-up condition.</li> </ul>
P1900 (*5)	0208	Cooling fan circuit (OVER HEAT)	<ul style="list-style-type: none"> <li>Cooling fan does not operate properly. (Overheat)</li> <li>Cooling system does not operate properly. (Overheat)</li> <li>Engine coolant was not added to the system using the proper filling method.</li> </ul>

**Abbreviations for Quick Reference of "DTC CONFIRMATION PROCEDURE"**

- IGN: ON : Turning the ignition switch ON is required for the ECM to detect a malfunction (if one exists).
- RUNNING: Running engine is required for the ECM to detect a malfunction (if one exists).
- LIFTING : Lifting up the vehicle, running engine and spinning wheels are required for the ECM.
- DRIVING : Driving the vehicle in the specified pattern is required for the ECM.

**Abbreviations for Quick Reference of "OVERALL FUNCTION CHECK"**

- IGN: ON : Turning the ignition switch ON is required for checking the function of the sensor, switch, solenoid and circuit.
- RUNNING: Running engine is required for checking the function of the sensor, switch, solenoid and circuit.
- LIFTING : Lifting up the vehicle, running engine and spinning wheels are required.
- DRIVING : Driving the vehicle in the specified pattern is required.



Diagnostic Trouble Code (DTC) Chart (Cont'd)

X: Applicable  
—: Not applicable

Check Items (Possible Cause)	"DTC CONFIRMATION PROCEDURE" Quick Ref. *1	"OVERALL FUNCTION CHECK" Quick Ref. *2	Fail Safe System	MIL Illumination	Reference Page
<ul style="list-style-type: none"> <li>● Harness or connectors (The switch circuit is open or shorted.)</li> <li>● Neutral position switch</li> <li>● Inhibitor switch</li> </ul>	—	IGN: ON	—	2 trip	EC-401
<ul style="list-style-type: none"> <li>● Harness or connectors (The VTC solenoid valve circuit is open or shorted.)</li> <li>● VTC solenoid valve</li> </ul>	IGN: ON	—	—	2 trip	EC-404
<ul style="list-style-type: none"> <li>● Harness or connectors (The VTC solenoid valve circuit is open.)</li> <li>● VTC</li> <li>● Engine oil (The oil is deteriorated.)</li> <li>● Intake air system</li> <li>● VTC solenoid valve</li> </ul>	—	RUNNING			
<ul style="list-style-type: none"> <li>● Harness or connectors (The ignition primary circuit is open or shorted.)</li> <li>● Power transistor unit</li> <li>● Resistor</li> <li>● Camshaft position sensor</li> <li>● Camshaft position sensor circuit</li> </ul>	RUNNING	—	—	2 trip	EC-411
<ul style="list-style-type: none"> <li>● Harness or connectors</li> <li>● Crankshaft position sensor (OBD)</li> <li>● Flywheel (Drive plate)</li> <li>● Dead (Weak) battery</li> </ul>	RUNNING	—	—	2 trip	EC-416
<ul style="list-style-type: none"> <li>● Harness or connectors (The valve circuit is open or shorted.)</li> <li>● EGR valve and EVAP canister purge control solenoid valve</li> </ul>	—	IGN: ON (RUNNING)	—	2 trip	EC-420
<ul style="list-style-type: none"> <li>● Harness or connectors (The sensor circuit is open or shorted.)</li> <li>● EGR temperature sensor</li> </ul>	RUNNING	—	—	2 trip	EC-424
<ul style="list-style-type: none"> <li>● Harness or connectors (The valve circuit is open or shorted.)</li> <li>● T/C clutch solenoid valve</li> <li>● A/T hydraulic control system</li> </ul>	DRIVING	—	—	2 trip	EC-428
<ul style="list-style-type: none"> <li>● Harness or connectors (The cooling fan circuit is open or shorted.)</li> <li>● Cooling fan</li> <li>● Radiator hose</li> <li>● Radiator</li> <li>● Radiator cap</li> <li>● Water pump</li> <li>● Thermostat</li> </ul> <p>For more information, refer to "MAIN 12 CAUSES OF OVERHEATING", (EC-437).</p>	—	IGN: ON (RUNNING)	—	2 trip	EC-430

**Note: A dead (weak) battery will reduce the accuracy of the on-board diagnosis and may cause the MIL to light up without any malfunctions.**

\*1: This is Quick Reference of "DTC CONFIRMATION PROCEDURE".

Details are described in each TROUBLE DIAGNOSIS FOR DTC PXXXX.

\*2: ● The "OVERALL FUNCTION CHECK" is a simplified and effective way to inspect a component or circuit.

In some cases, the "OVERALL FUNCTION CHECK" is used rather than a "DIAGNOSTIC TROUBLE CODE CONFIRMATION PROCEDURE".

When no DTC CONFIRMATION PROCEDURE is available, the "NG" result of the OVERALL FUNCTION CHECK can be considered to mean the same as a DTC detection.

● During an "NG" OVERALL FUNCTION CHECK, the DTC might not be confirmed.

● This is Quick Reference of "OVERALL FUNCTION CHECK".

Details are described in each TROUBLE DIAGNOSIS FOR DTC PXXXX.

\*5: Diagnostic trouble code No. P1900 is not displayed in SELF-DIAGNOSTIC RESULTS mode with CONSULT.

**Diagnostic Trouble Code (DTC) Chart (Cont'd)**

**INSPECTION PRIORITY (ENGINE RELATED ITEMS)**

If some DTCs are displayed at the same time, perform inspections one by one based on the following priority chart.

Priority	Detected items (DTC)		
1	● ECM (P0605, 0301)	● Camshaft position sensor circuit (P0340, 0101)	● Engine coolant temperature sensor circuit (P0115, 0103) (P0125, 0908)
	● Mass air flow sensor circuit (P0100, 0102)	● Vehicle speed sensor circuit (P0500, 0104)	● Ignition signal circuit (P1320, 0201)
	● Throttle position sensor circuit (P0120, 0403)	● Intake air temperature sensor circuit (P0110, 0401)	● Park/Neutral position switch circuit (P0705, 1003)
	● EGR valve & EVAP canister purge control solenoid valve circuit (P1400, 1005)	● Knock sensor circuit (P0325, 0304)	
2	● EGR temperature sensor circuit (P1401, 0305)	● Crankshaft position sensor circuit (P0335, 0802) (P1336, 0905)	● Front oxygen sensor* circuit (P0130, 0303)
	● T/C clutch solenoid valve (P1550, 0904)	● Cooling fan circuit (P1900, 0208)	● Rear heated oxygen sensor circuit (P0136, 0707)
3	● EGR function (P0400, 0302)	● Misfire (P0304 - P0300, 0605 - 0701)	● Fuel injection system function (P0170, 0706)
	● EGRC-BPT valve function (P0402, 0306)	● Closed loop control (P0130, 0307)	● Three way catalyst function (P0420, 0702)
	● IACV-AAC valve circuit (P0505, 0205)	● VTC function (P1110, 0805)	

\*: Oxygen sensor (M/T models except for California)  
 Heated oxygen sensor (M/T models for California and A/T models)

GI

MA

EM

LC

**EC**

FE

CL

MT

AT

FA

RA

BR

ST

RS

BT

HA

EL

IDX

**Fail-Safe Chart**

The ECM enters fail-safe mode, if any of the following DTCs is recorded due to the open or short circuit.

DTC No.		Detected items	Engine operating condition in fail-safe mode														
CONSULT GST	MIL																
P0100	0102	Mass air flow sensor circuit	Engine speed will not rise more than 2,400 rpm due to the fuel cut.														
P0115	0103	Engine coolant temperature sensor circuit	<p>Engine coolant temperature will be determined based on the time after turning ignition switch "ON" or "START".</p> <table border="1"> <thead> <tr> <th>Condition</th> <th>Engine coolant temperature decided</th> </tr> </thead> <tbody> <tr> <td>Just as ignition switch is turned ON or Start</td> <td>40°C (104°F)</td> </tr> <tr> <td>More than 4 minutes after ignition ON or Start</td> <td>80°C (176°F)</td> </tr> <tr> <td>Except as shown above</td> <td>40 - 80°C (104 - 176°F) (Depends on the time)</td> </tr> </tbody> </table> <p>When the fail-safe system for engine coolant temperature sensor is activated, the cooling fan operates while engine is running.</p>	Condition	Engine coolant temperature decided	Just as ignition switch is turned ON or Start	40°C (104°F)	More than 4 minutes after ignition ON or Start	80°C (176°F)	Except as shown above	40 - 80°C (104 - 176°F) (Depends on the time)						
Condition	Engine coolant temperature decided																
Just as ignition switch is turned ON or Start	40°C (104°F)																
More than 4 minutes after ignition ON or Start	80°C (176°F)																
Except as shown above	40 - 80°C (104 - 176°F) (Depends on the time)																
P0120	0403	Throttle position sensor circuit	<p>Throttle position will be determined based on the injected fuel amount and the engine speed. Therefore, acceleration will be poor.</p> <table border="1"> <thead> <tr> <th>Condition</th> <th>Driving condition</th> </tr> </thead> <tbody> <tr> <td>When engine is idling</td> <td>Normal</td> </tr> <tr> <td>When accelerating</td> <td>Poor acceleration</td> </tr> </tbody> </table>	Condition	Driving condition	When engine is idling	Normal	When accelerating	Poor acceleration								
Condition	Driving condition																
When engine is idling	Normal																
When accelerating	Poor acceleration																
—	—	Start signal circuit	<p>If the ECM always receives a start signal, the ECM will judge the start signal "OFF" when engine speed is above 1,000 rpm. This prevents extra enrichment. After the engine speed is below 200 rpm, start-up enrichment will be allowed until the engine speed reaches 1,000 rpm.</p>														
—	—	ECM	<p><b>Fail-safe system activating condition when ECM is malfunctioning</b> The computing function of the ECM was judged to be malfunctioning. When the fail-safe system activates (i.e., if the ECM detects a malfunction condition in the CPU of ECM), the MALFUNCTION INDICATOR LAMP on the instrument panel lights to warn the driver.</p> <p><b>Engine control, with fail-safe system, operates when ECM is malfunctioning</b> When the fail-safe system is operating, fuel injection, ignition timing, fuel pump operation, IACV-AAC valve operation and cooling fan operation are controlled under certain limitations.</p> <table border="1"> <thead> <tr> <th></th> <th>Operation</th> </tr> </thead> <tbody> <tr> <td>Engine speed</td> <td>Engine speed will not rise more than 3,000 rpm</td> </tr> <tr> <td>Fuel injection</td> <td>Simultaneous multiport fuel injection system</td> </tr> <tr> <td>Ignition timing</td> <td>Ignition timing is fixed at the preset valve</td> </tr> <tr> <td>Fuel pump</td> <td>Fuel pump relay is "ON" when engine is running and "OFF" when engine stalls</td> </tr> <tr> <td>IACV-AAC valve</td> <td>Full open</td> </tr> <tr> <td>Cooling fans</td> <td>Cooling fan relay "ON" when engine is running, and "OFF" when engine stalls</td> </tr> </tbody> </table>		Operation	Engine speed	Engine speed will not rise more than 3,000 rpm	Fuel injection	Simultaneous multiport fuel injection system	Ignition timing	Ignition timing is fixed at the preset valve	Fuel pump	Fuel pump relay is "ON" when engine is running and "OFF" when engine stalls	IACV-AAC valve	Full open	Cooling fans	Cooling fan relay "ON" when engine is running, and "OFF" when engine stalls
	Operation																
Engine speed	Engine speed will not rise more than 3,000 rpm																
Fuel injection	Simultaneous multiport fuel injection system																
Ignition timing	Ignition timing is fixed at the preset valve																
Fuel pump	Fuel pump relay is "ON" when engine is running and "OFF" when engine stalls																
IACV-AAC valve	Full open																
Cooling fans	Cooling fan relay "ON" when engine is running, and "OFF" when engine stalls																

Symptom Matrix Chart

SYSTEM — Basic engine control system		SYMPTOM											Reference page		
		HARD/NO START/RESTART (EXCP. HA)	ENGINE STALL	HESITATION/SURGING/FLAT SPOT	SPARK KNOCK/DETONATION	LACK OF POWER/POOR ACCELERATION	HIGH IDLE/LOW IDLE	ROUGH IDLE/HUNTING	IDLING VIBRATION	SLOW/NO RETURN TO IDLE	OVERHEATS/WATER TEMPERATURE HIGH	EXCESSIVE FUEL CONSUMPTION		EXCESSIVE OIL CONSUMPTION	BATTERY DEAD (UNDER CHARGE)
		AA	AB	AC	AD	AE	AF	AG	AH	AJ	AK	AL		AM	HA
Fuel	Fuel pump circuit	●	●	●	○	●	○	●	●	○		●	○	EC-444	
	Fuel pressure regulator system	●	●	●	○	●	○	●	●	○		●		EC-249	
	Injector circuit	●	●	●	○	●		●	●			●		EC-439	
	Evaporative emission system	○	○	○	○	○	○	○	○	○		○		EC-246	
Air	Positive crankcase ventilation system	○	○	●	○	○	○	●	●	○		○		EC-248	
	Incorrect idle speed adjustment	○	○				○	○	○	○		○		EC-253	
	IACV-AAC valve circuit	●	●	●	○	●	●	●	●	●		●	○	EC-395	
	IACV-FICD solenoid valve circuit	○	○	○	○	○	○	○	○	○		○		EC-451	
Ignition	Incorrect ignition timing adjustment	○	○	●	●	●		●	●			●		EC-253	
	Ignition circuit	●	●	●	●	●		●	●			●		EC-411	
EGR	EGR valve & EVAP canister purge control solenoid valve circuit		●	●	●	○						●		EC-420	
	EGR system	○	●	●	●	○	○	●	●	○		○		EC-377	
Main power supply and ground circuit		○	○	○	○	○		○	○		○	○	○	EC-315	
Cooling	Cooling fan circuit	○	○	○	○	○	○	○	○	○	○	○	○	EC-430	
Air conditioner circuit		○	○	○	○	○	○	○	○	○	○	○	○	HA section	

● : High Possibility Item  
○ : Low Possibility Item

(continued on next page)

GI  
MA  
EM  
LC  
**EC**  
FE  
CL  
MT  
AT  
FA  
RA  
BR  
ST  
RS  
BT  
HA  
EL  
IDX

Symptom Matrix Chart (Cont'd)

SYSTEM — ECCS system		SYMPTOM													Reference page
		HARD/NO START/RESTART (EXCP. HA)	ENGINE STALL	HESITATION/SURGING/FLAT SPOT	SPARK KNOCK/DETONATION	LACK OF POWER/POOR ACCELERATION	HIGH IDLE/LOW IDLE	ROUGH IDLE/HUNTING	IDLING VIBRATION	SLOW/NO RETURN TO IDLE	OVERHEATS/WATER TEMPERATURE HIGH	EXCESSIVE FUEL CONSUMPTION	EXCESSIVE OIL CONSUMPTION	BATTERY DEAD (UNDER CHARGE)	
		AA	AB	AC	AD	AE	AF	AG	AH	AJ	AK	AL	AM	HA	
ECCS	Camshaft position sensor circuit	●	●	●	○	○		○	○			○		EC-372	
	Mass air flow sensor circuit	●	●	●	○	●		●	●			●		EC-318	
	Front heated oxygen sensor circuit		●	●	○	●		●	●			●		EC-342	
	Engine coolant temperature sensor circuit	●	●	●	○	●	●	●	●	●		●		EC-328, 337	
	Throttle position sensor circuit		●	●		●	●	●	●	●		●		EC-332	
	Incorrect throttle position sensor adjustment		●	○		○	●	○	○	●		○		EC-288	
	Vehicle speed sensor circuit		○	○		○						○		EC-391	
	Knock sensor circuit			○	○	○						○		EC-365	
	ECM	○	○	○	○	○	○	○	○	○	○	○		EC-399, 300	
	Start signal circuit	○												EC-442	
	Park/Neutral position switch circuit			○		○		○	○			○		EC-401	
	Power steering oil pressure switch circuit		○					○	○					EC-448	

● : High Possibility Item  
○ : Low Possibility Item

(continued on next page)

Symptom Matrix Chart (Cont'd)

SYSTEM — Engine mechanical & other		SYMPTOM													Reference page							
		HARD/NO START/RESTART (EXCP. HA)	ENGINE STALL	HESITATION/SURGING/FLAT SPOT	SPARK KNOCK/DETONATION	LACK OF POWER/POOR ACCELERATION	HIGH IDLE/LOW IDLE	ROUGH IDLE/HUNTING	IDLING VIBRATION	SLOW/NO RETURN TO IDLE	OVERHEATS/WATER TEMPERATURE HIGH	EXCESSIVE FUEL CONSUMPTION	EXCESSIVE OIL CONSUMPTION	BATTERY DEAD (UNDER CHARGE)								
		AA	AB	AC	AD	AE	AF	AG	AH	AJ	AK	AL	AM	HA								
Fuel	Fuel tank	○	○												—	EC						
	Fuel piping	○	○	○	○	○		○	○			○					—	FE				
	Vapor lock		○																—	CL		
	Valve deposit	○	○	○	○	○		○	○			○									—	MT
	Poor fuel (Heavy weight gasoline, Low octane)	○	○	○	○	○		○	○			○										
Air	Air duct		○	○				○	○			○		—	RA							
Air cleaner		○	○					○	○			○				—	BR					
Air leakage from air duct (Mass air flow sensor — throttle body)	○	○	○	○	○	○	○	○	○			○						—	ST			
Throttle body, Throttle wire	●	●	●		●	●	●	●	●			●								CL section	RS	
Air leakage from intake manifold/Collector/Gasket	○	●	○	○	○	○	○	○	○			○										AT section
Cranking	Battery	○	○	○				○	○			○	○	EL section	HA							
Alternator circuit	○	○	○					○	○			○	○			—	EL					
Starter circuit	●																	CL section	IDX			
Flywheel or drive plate	●																			AT section	RS	
Clutch interlock switch	○																					—
Inhibitor switch	○													—	BT							
Engine	Cylinder head	●	●	●	●	●		●	●			○				—	BT					
Cylinder head gasket	●	●	○	○	●			○	○			○	○					—	BT			
Cylinder block	●	○	○	○	○			○	○			○	○							—	BT	
Piston	●	●	○	●	○			○	○			○	○									—
Piston ring	●	○	○	○	○			○	○			○	○	—	BT							
Connecting rod	○	○	○	○	○			○	○			○	○			—	BT					
Bearing	○	○	○	○	○			○	○			○	○					—	BT			
Crankshaft	○	○	○	○	○			○	○			○	○							—	BT	
Valve mechanism	Timing chain	●	●	●	○	●		○	○			○	○									—
Camshaft	●	●	●	○	○			●	●			○	○	—	BT							
Intake valve	●	○	○	●	○			○	○			○	○			—	BT					
Exhaust valve	●	○	○	○	○			○	○			○	○					—	BT			
Exhaust	Exhaust manifold/Tube/Muffler/Gasket	○	○	○	○	○		○	○			○	○							—	BT	
Three way catalyst	●	●	○	○	○			○	○			○	○									—
Lubrication	Oil pan/Oil strainer/Oil pump/Oil filter/Oil gallery	●	○	○	○	○		●	●			○	○	—	BT							
Oil level (Low)/Filthy oil	○	○	○	○	○			○	○			○	○			—	BT					
Cooling	Radiator/Hose/Radiator filler cap	○	○	○	○	○		○	○			○	○					—	BT			
Thermostat	○	○	○	○	○	○		○	○			○	○							—	BT	
Water pump	○	○	○	○	○	○		○	○			○	○									—
Water gallery	○	○	○	○	○	○		○	○			○	○	—	BT							
Cooling fan	○	○	○	○	○	○		○	○			○	○			—	BT					
Coolant level (low)/Contaminated coolant	○	○	○	○	○	○		○	○			○	○					—	BT			

● : High Possibility Item  
○ : Low Possibility Item

### CONSULT Reference Value in Data Monitor Mode

Remarks:

- Specification data are reference values.
- Specification data are output/input values which are detected or supplied by the ECM at the connector.
- \* Specification data may not be directly related to their components signals/values/operations.  
(i.e., Adjust ignition timing with a timing light before monitoring IGN TIMING. Specification data might be displayed even when ignition timing is not adjusted to specification. This IGN TIMING monitors the data calculated by the ECM according to the input signals from the camshaft position sensor and other ignition timing related sensors.)
- If the real-time diagnosis results are NG, and the on-board diagnostic system results are OK, when diagnosing the mass air flow sensor, first check to see if the fuel pump control circuit is normal.

MONITOR ITEM	CONDITION		SPECIFICATION
CMPS-RPM (REF)	<ul style="list-style-type: none"> <li>● Tachometer: Connect</li> <li>● Run engine and compare tachometer indication with the CONSULT value.</li> </ul>		Almost the same speed as the CONSULT value.
MAS AIR/FL SE	<ul style="list-style-type: none"> <li>● Engine: After warming up</li> <li>● Air conditioner switch: OFF</li> <li>● Shift lever: "N"</li> <li>● No-load</li> </ul>	Idle	1.0 - 1.7V
		2,000 rpm	1.5 - 2.1V
COOLAN TEMP/S	<ul style="list-style-type: none"> <li>● Engine: After warming up</li> </ul>		More than 70°C (158°F)
FR O2 SENSOR	<ul style="list-style-type: none"> <li>● Engine: After warming up</li> </ul>	Maintaining engine speed at 2,000 rpm	0 - 0.3V ↔ 0.6 - 1.0V
FR O2 MNTR			LEAN ↔ RICH Changes more than 5 times during 10 seconds.
RR O2 SENSOR	<ul style="list-style-type: none"> <li>● Engine: After warming up</li> </ul>	Maintaining engine speed at 2,000 rpm	0 ↔ Approx. 2.2V
RR O2 MNTR			LEAN ↔ RICH
VHCL SPEED SE	<ul style="list-style-type: none"> <li>● Turn drive wheels and compare speedometer indication with the CONSULT value</li> </ul>		Almost the same speed as the CONSULT value
BATTERY VOLT	<ul style="list-style-type: none"> <li>● Ignition switch: ON (Engine stopped)</li> </ul>		11 - 14V
THRTL POS SEN	<ul style="list-style-type: none"> <li>● Ignition switch: ON (Engine stopped)</li> </ul>	Throttle valve fully closed	0.35 - 0.65V
		Throttle valve fully opened	Approx. 4.0V
EGR TEMP SEN	<ul style="list-style-type: none"> <li>● Engine: After warming up</li> </ul>		Less than 4.5V
START SIGNAL	<ul style="list-style-type: none"> <li>● Ignition switch: ON → START → ON</li> </ul>		OFF → ON → OFF
CLSD THL/P SW	<ul style="list-style-type: none"> <li>● Ignition switch: ON (Engine stopped)</li> </ul>	Throttle valve: Idle position	ON
		Throttle valve: Slightly open	OFF
AIR COND SIG	<ul style="list-style-type: none"> <li>● Engine: After warming up, idle the engine</li> </ul>	A/C switch "OFF"	OFF
		A/C switch "ON" (Compressor operates)	ON
P/N POSI SW	<ul style="list-style-type: none"> <li>● Ignition switch: ON</li> </ul>	Shift lever "P" or "N"	ON
		Except above	OFF

**CONSULT Reference Value in Data Monitor Mode (Cont'd)**

MONITOR ITEM	CONDITION		SPECIFICATION
PW/ST SIGNAL	● Engine: After warming up, idle the engine	Steering wheel in neutral position (forward direction)	OFF
		The steering wheel is turned	ON
IGNITION SW	● Ignition switch: ON → OFF		ON → OFF
HEATER FAN SE	● Heater fan switch: ON → OFF		ON → OFF
LOAD SIGNAL	● Ignition switch: ON	Rear window defogger is operating and/or lighting switch* is on	ON
		Rear window defogger is not operating and lighting switch is not on	OFF
INJ PULSE	● Engine: After warming up ● Air conditioner switch: OFF ● Shift lever: "N" ● No-load	Idle	2.4 - 3.2 msec.
		2,000 rpm	1.9 - 3.2 msec.
B/FUEL SCHDL	ditto	Idle	0.7 - 1.5 msec
		2,000 rpm	0.7 - 1.5 msec
IGN TIMING	ditto	Idle	6 -10° BTDC
		2,000 rpm	More than 25° BTDC
IACV-AAC/V	ditto	Idle	20 - 50%
		2,000 rpm	—
A/F ALPHA	● Engine: After warming up	Maintaining engine speed at 2,000 rpm	56 - 155%
AIR COND RLY	● Air conditioner switch: OFF → ON		OFF → ON
FUEL PUMP RLY	● Ignition switch is turned to ON (Operates for 5 seconds) ● Engine running and cranking ● When engine is stopped (stops in 1.0 seconds)		ON
	● Except as shown above		OFF
COOLING FAN	● After warming up engine, idle the engine. ● Air conditioner switch: OFF	Engine coolant temperature is 90°C (194°F) or less	OFF
		Engine coolant temperature is 91°C (196°F) or more	ON
VALVE TIM SOL	● Engine: After warming up	Idle	OFF
		2,000 rpm	ON
EGRC SOL/V	● Engine: After warming up ● Air conditioner switch: OFF ● Shift lever: N ● No-load ● M/T models: Jack up drive wheels and shift to 1st gear position	Idle	ON
		A/T models: 2,000 rpm M/T models: 2,000 rpm and more than 16 km/h (10 mph)	OFF

\*: 1st position for USA models, 2nd position for Canada models

GI

MA

EM

LC

EC

FE

CL

MT

AT

FA

RA

BR

ST

RS

BT

HA

EL

IDX



**CONSULT Reference Value in Data Monitor Mode (Cont'd)**

MONITOR ITEM	CONDITION		SPECIFICATION
TCC SOL/V	● Engine: After warming up	Idle	ON
		Vehicle speed is 64 km/h (40 MPH) or more in "D" position	OFF
O2 SEN HEATER*	● Engine speed: Idle		ON
	● Engine speed: Above 3,200 rpm		OFF
CAL/LD VALUE	● Engine: After warming up ● Air conditioner switch: OFF ● Shift lever: "N" ● No-load	Idle	15.0 - 30.0%
		2,500 rpm	13.0 - 28.0%
ABSOL TH/P/S	● Ignition switch: ON (Engine stopped)	Throttle valve fully closed	0.0%
		Throttle valve fully opened	Approx. 89%
MASS AIRFLOW	● Engine: After warming up ● Air conditioner switch: OFF ● Shift lever: N ● No-load	Idle	1.0 - 4.0 g·m/s
		2,500 rpm	5.0 - 10.0 g·m/s

\*: For A/T models and California M/T models.

### Major Sensor Reference Graph in Data Monitor Mode

The following are the major sensor reference graphs in "DATA MONITOR" mode. (Select "HI SPEED" in "DATA MONITOR" with CONSULT.)

#### THRTL POS SEN, ABSOL TH·P/S, CLSD THL/P SW

Below is the data for "THRTL POS SEN", "ABSOL TH·P/S" and "CLSD THL/P SW" when depressing the accelerator pedal with the ignition switch "ON".

The signal of "THRTL POS SEN" and "ABSOL TH·P/S" should rise gradually without any intermittent drop or rise after "CLSD THL/P SW" is changed from "ON" to "OFF".

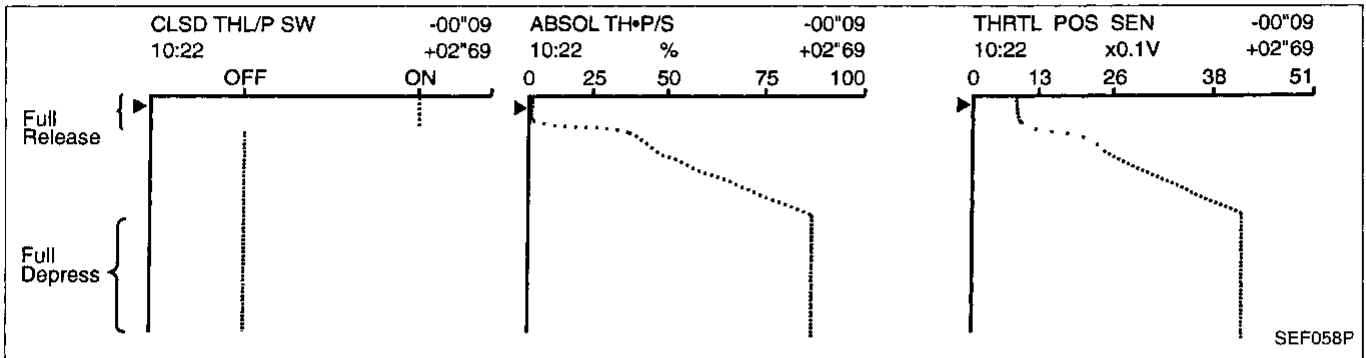

#### CMPS·RPM (REF), MAS AIR/FL SE, THRTL POS SEN, RR O2 SENSOR, FR O2 SENSOR, INJ PULSE

Below is the data for "CMPS·RPM (REF)", "MAS AIR/FL SE", "THRTL POS SEN", "RR O2 SENSOR", "FR O2 SENSOR" and "INJ PULSE" when revving quickly up to 4,800 rpm under no load after warming up engine sufficiently.

Each value is for reference, the exact value may vary.

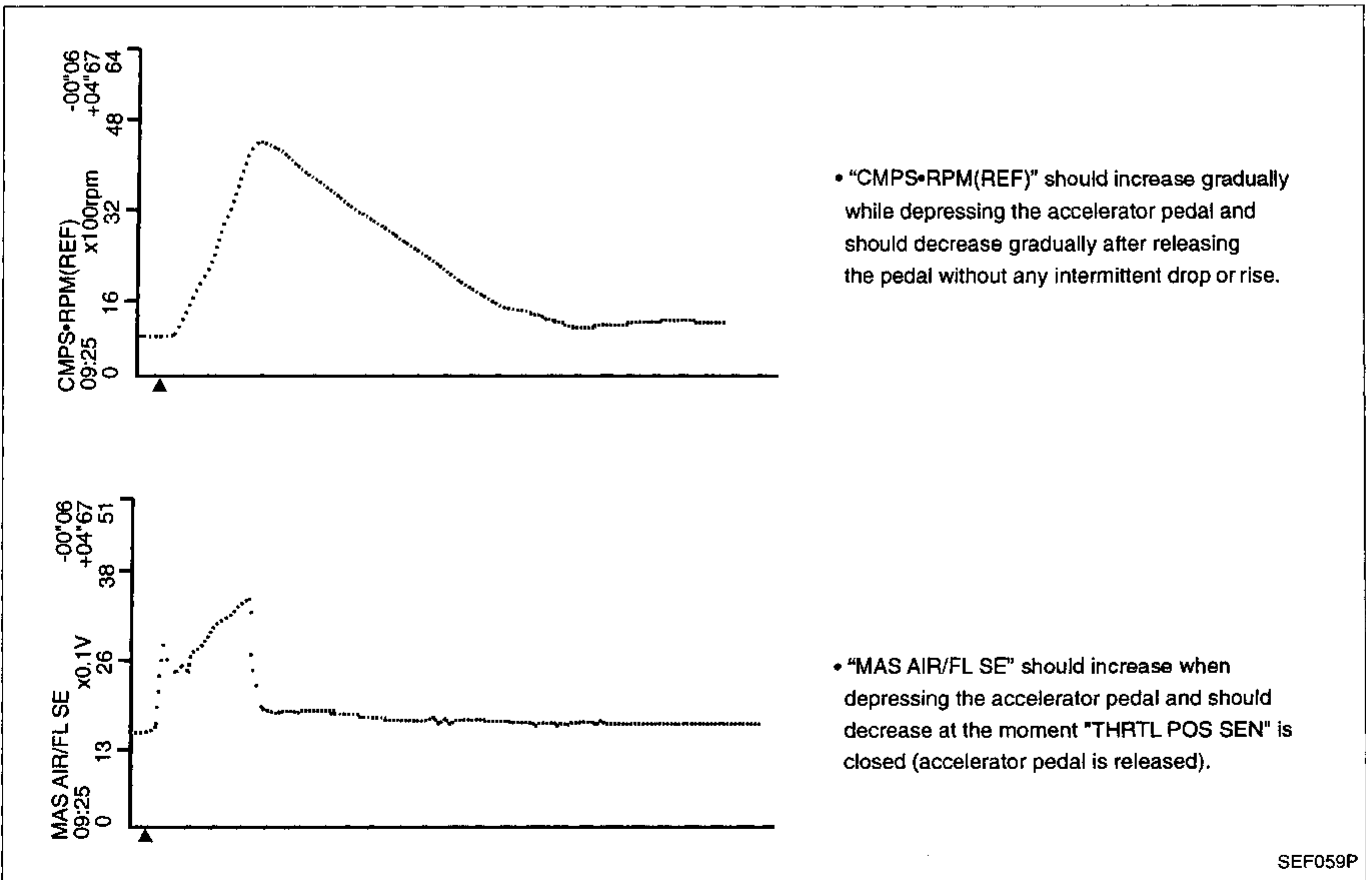

Major Sensor Reference Graph in Data Monitor Mode (Cont'd)

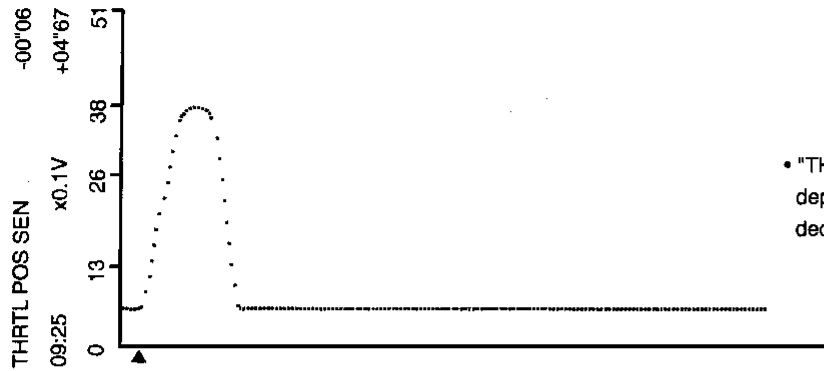

- "THRTL POS SEN" should increase while depressing the accelerator pedel and should decrease while releasing it.

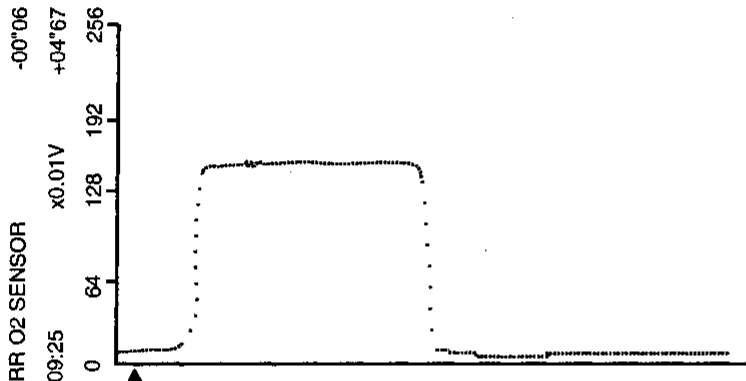

- "RR O2 SENSOR" may increase immediately after depressing the accelerator pedel and may decrease after releasing the pedal.

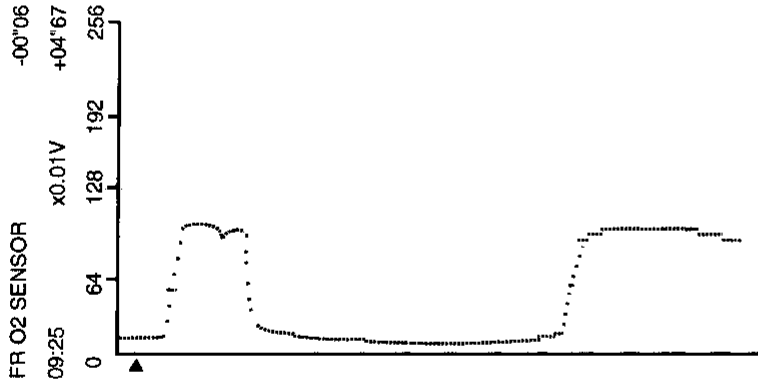

- "FR O2 SENSOR" may increase immediately after depressing the accelerator pedel and may decrease after releasing the pedal.

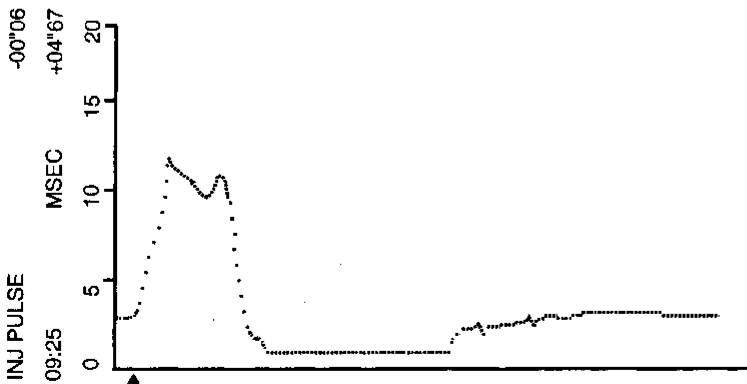

- "INJ PULSE" should increase when depressing the accelerator pedel and should decrease when the pedel is released.

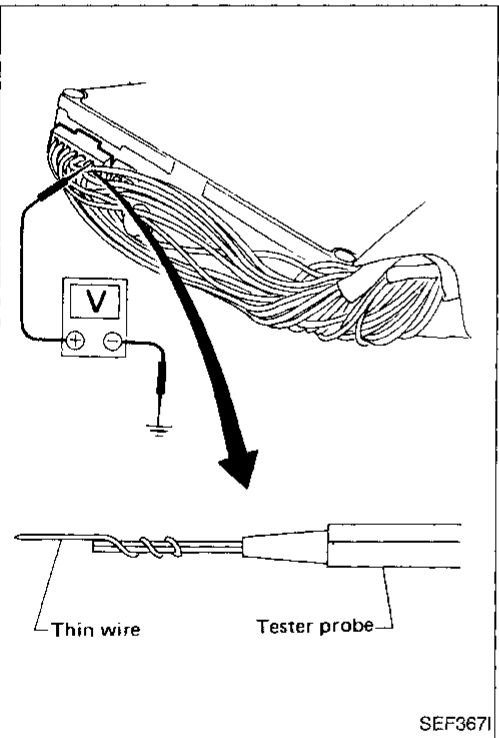
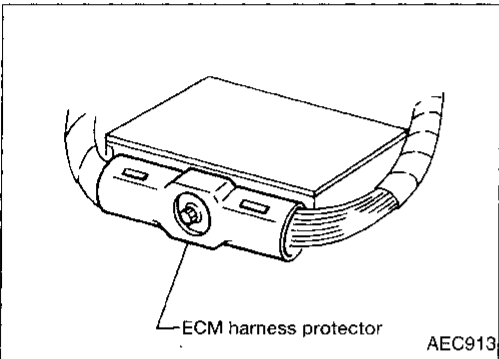
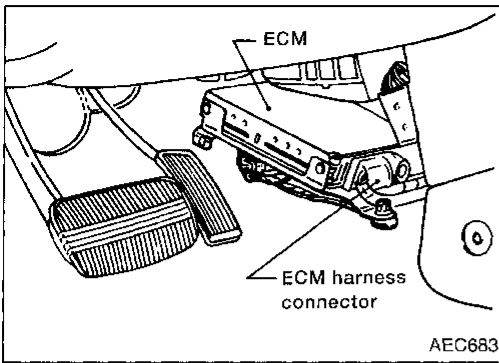

## ECM Terminals and Reference Value

### PREPARATION

1. ECM is located behind the center console. For this inspection, remove the front passenger center console panel.
2. Remove ECM harness protector.
3. Perform all voltage measurements with the connectors connected. Extend tester probe as shown to perform tests easily.

GI

MA

EM

LC

**EC**

FE

CL

MT

AT

FA

RA

BR

ST

RS

BT

HA

EL

IDX

### ECM HARNESS CONNECTOR TERMINAL LAYOUT

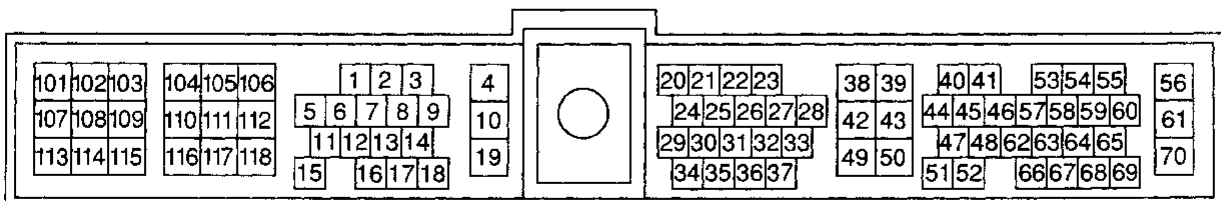

SEF064P

**ECM Terminals and Reference Value (Cont'd)**

**ECM INSPECTION TABLE**

Specification data are reference values and are measured between each terminal and Ⓞ (ECCS ground).

TER-MINAL NO.	WIRE COLOR	ITEM	CONDITION	DATA (DC voltage)
1	W/B	Ignition signal	Engine is running. └ Idle speed	0.3 - 0.6V*
			Engine is running. └ Engine speed is 2,000 rpm	Approximately 0.9V*
2	W	Ignition check	Engine is running. └ Idle speed	Approximately 12V*
3	L/B	Tachometer	Engine is running. └ Idle speed	Approximately 7V*
4	W/G	ECCS relay (Self-shutoff)	Engine is running. Ignition switch "OFF" └ For a few seconds after turning ignition switch "OFF"	0 - 1V
			Ignition switch "OFF" └ A few seconds passed after turning ignition switch "OFF"	BATTERY VOLTAGE (11 - 14V)
8	B/P	Fuel pump relay	Ignition switch "ON" └ For 5 seconds after turning ignition switch "ON"	0.07 - 0.20V
			Engine is running. Ignition switch "ON" └ More than 5 seconds after turning ignition switch "ON"	BATTERY VOLTAGE (11 - 14V)
10	B	ECCS ground	Engine is running. └ Idle speed	Engine ground
14	LG/R	Cooling fan relay	Engine is running. └ Cooling fan is not operating	BATTERY VOLTAGE (11 - 14V)
			Engine is running. └ Cooling fan is operating	0.07 - 0.30V
15	G/Y	Air conditioner relay	Engine is running. └ Both A/C switch and blower switch are "ON"	0.08 - 0.2V
			Engine is running. └ A/C switch is "OFF"	BATTERY VOLTAGE (11 - 14V)
18	OR/L	Malfunction indicator lamp	Ignition switch "ON"	Approximately 50mV
			Engine is running. └ Idle speed	BATTERY VOLTAGE (11 - 14V)

\*Average voltage for pulse signal (Actual pulse signal can be confirmed by oscilloscope.)

ECM Terminals and Reference Value (Cont'd)

TER-MINAL NO.	WIRE COLOR	ITEM	CONDITION	DATA (DC voltage)	
19	B	ECCS ground	Engine is running. └ Idle speed	Engine ground	GI
20	B/Y	Start signal	Ignition switch "ON" Ignition switch "START"	Approximately 0V BATTERY VOLTAGE (11 - 14V)	MA EM
21	LG/B	Air conditioner switch	Engine is running. └ Both air conditioner switch and blower switch are "ON" (Compressor operates) Engine is running. └ Air conditioner switch is "OFF"	Approximately 0V BATTERY VOLTAGE (11 - 14V)	LC EC
22	G/OR	Neutral position switch (M/T models) Inhibitor switch (A/T models)	Ignition switch "ON" └ Gear position is "Neutral position" (M/T models) └ Gear position is "N" or "P" (A/T models) Ignition switch "ON" └ Except the above gear position	Approximately 0V A/T models: BATTERY VOLTAGE (11 - 14V) M/T models: Approximately 5V	FE CL MT AT
23	Y	Throttle position sensor	Ignition switch "ON" └ Accelerator pedal released Ignition switch "ON" └ Accelerator pedal fully depressed	0.35 - 0.65V Approximately 4V	FA RA
25	SB	Power steering oil pressure switch	Engine is running. └ Steering wheel is being turned Engine is running. └ Steering wheel is not being turned	Approximately 0V Approximately 5V	BR
26	PU/R	Vehicle speed sensor	Engine is running. └ Front of vehicle raised and front wheels are rotating	Approximately 1.8 - 2.4V* (AC voltage)	ST RS
30	P/B	Torque converter clutch solenoid valve (A/T models only)	Engine is running └ Idle speed Engine is running (Warm-up condition) └ Vehicle speed is 64 km/h (40 MPH) or more in "D" position	Approximately 0V BATTERY VOLTAGE (11 - 14V)	BT HA
35	LG/B	Blower fan switch	Ignition switch "ON" └ Blower fan switch is "ON"	Approximately 0V	EL
38	B/R	Ignition switch	Ignition switch "OFF" Ignition switch "ON"	0V BATTERY VOLTAGE (11 - 14V)	IDX

\*Average voltage pulse signal (Actual pulse signal can be confirmed by oscilloscope.)

**ECM Terminals and Reference Value (Cont'd)**

TER-MINAL NO.	WIRE COLOR	ITEM	CONDITION	DATA (DC voltage)
39	B	ECCS ground	Engine is running. └ Idle speed	Engine ground
40 44	L L	Camshaft position sensor (Reference signal)	Engine is running. └ Idle speed	Approximately 2.7V* (AC voltage)
42	PU/W	IACV-AAC valve (Close)	Ignition switch "ON"	Approximately 0V
			Engine is running. (Warm-up condition) └ Engine speed is 2,000 rpm	BATTERY VOLTAGE (11 - 14V)
43	B	ECCS ground	Engine is running. └ Idle speed	Engine ground (Probe this terminal with ⊖ tester probe when measuring.)
41 45	B/W B/W	Camshaft position sensor (Position signal)	Engine is running. └ Idle speed	Approximately 2.7V* (AC voltage)
46	W	Front oxygen sensor or Front heated oxygen sensor	Engine is running. └ After warming up sufficiently and engine speed is 2,000 rpm	0 - Approximately 1.0V (periodically change)
47	G	Mass air flow sensor	Engine is running. (Warm-up condition) └ Idle speed	1.0 - 1.7V
			Engine is running. (Warm-up condition) └ Engine speed is 2,000 rpm	1.5 - 2.1V
48	R	Mass air flow sensor ground	Engine is running. (Warm-up condition) └ Idle speed	0.005 - 0.02V
49	P/L	Throttle position sensor power supply	Ignition switch "ON"	Approximately 5V
50	B	Sensors' ground	Engine is running. (Warm-up condition) └ Idle speed	0.001 - 0.02V
51	BR/Y	Engine coolant temperature sensor	Engine is running.	0 - 4.84V Output voltage varies with engine coolant temperature.
52	W	Rear heated oxygen sensor	Engine is running. └ After warming up sufficiently and engine speed is 2,000 rpm	0 - Approximately 2.2V**
53	W	Crankshaft position sensor (OBD)	Engine is running. (A/T: N range, M/T: Neutral) └ Idle speed (Air conditioner switch "OFF")	More than 0.4V* (AC voltage)
54	W	Knock sensor	Engine is running. └ Idle speed	2.0 - 3.0V

\*Average voltage for pulse signal (Actual pulse signal can be confirmed by oscilloscope.)

\*\*During the on-board diagnosis for the open circuit, approx. 1.5 - 5V will appear. This is not a malfunction. (Refer to page EC-351.)

ECM Terminals and Reference Value (Cont'd)

TER-MINAL NO.	WIRE COLOR	ITEM	CONDITION	DATA (DC voltage)	
55	L/R	Rear defogger relay	Ignition switch "ON" └ Rear defogger is "OFF"	Approximately 0V	GI
			Ignition switch "ON" └ Rear defogger is "ON"	BATTERY VOLTAGE (11 - 14V)	MA
56 61	W/R W/R	Power supply for ECM	Ignition switch "ON"	BATTERY VOLTAGE (11 - 14V)	EM
58	L/B	Data link connector for GST	Engine is running. └ Idle speed (GST is disconnected)	6 - 10V	LC
60	R/L	Headlamp switch	Lighting switch "ON"	BATTERY VOLTAGE (11 - 14V)	EC
			Lighting switch "OFF"	Approximately 0V	FE
62	R/B	EGR temperature sensor	Engine is running. (Warm-up condition) └ Idle speed	Less than 4.5V	CL
			Engine is running. (Warm-up condition) └ EGR system is operating	0 - 3.0V	MT
63	R/Y	Intake air temperature sensor	Engine is running.	0 - 5.0V Output voltage varies with intake air temperature.	AT
64	G/B	Data link connector for CONSULT	Engine is running.	Approximately 0V	
65	GY/L		└ Idle speed (CONSULT is connected and turned on)	Approximately 4 - 9V	FA
68	G/W			Approximately 3.5V*	
70	W/L	Power supply (Back-up)	Ignition switch "OFF"	BATTERY VOLTAGE (11 - 14V)	PA
101	SB	IACV-AAC valve (Open)	Ignition switch "ON"	BATTERY VOLTAGE (11 - 14V)	BR
			Engine is running. (Warm-up condition) └ Engine speed is 2,000 rpm	0 - 4V	ST
102	R/B	Injector No. 1	Engine is running	BATTERY VOLTAGE (11 - 14V)	
104	G/B	Injector No. 3			
107	Y/B	Injector No. 2			
109	L/B	Injector No. 4			
103	P	EGR & EVAP canister purge control solenoid valve	Engine is running. (Warm-up condition) └ M/T models: Jack up front wheels and drive wheels at 16km/h (10 mph) └ Engine speed is 2,000 rpm	BATTERY VOLTAGE (11 - 14V)	BT
			Engine is running. (Warm-up condition) └ Idle speed	Approximately 0V	HA
106	B	ECCS ground	Engine is running.	Engine ground	
			└ Idle speed		

\*Average voltage for pulse signal (Actual pulse signal can be confirmed by oscilloscope.)



**ECM Terminals and Reference Value (Cont'd)**

TER-MINAL NO.	WIRE COLOR	ITEM	CONDITION	DATA (DC voltage)
108	R/W	Rear heated oxygen sensor heater	Ignition switch "ON" Engine is running.	0 - Approximately 0.3V
111	B	Rear heated oxygen sensor heater ground	Engine is running. └ Idle speed	0.02 - 0.10V
112	B	ECCS ground	Engine is running. └ Idle speed	Engine ground
114	Y/R	VTC solenoid valve	Engine is running. └ Idle speed	BATTERY VOLTAGE (11 - 14V)
			Engine is running. └ Engine speed is 2,000 rpm	Approximately 0V
115	OR	Front heated oxygen sensor heater ground (M/T models for California and A/T models)	Engine is running. └ Engine speed is above 3,200 rpm	BATTERY VOLTAGE (11 - 14V)
			Engine is running. └ Engine speed is below 3,200 rpm	Approximately 0V
118	B	ECCS ground	Engine is running. └ Idle speed	Engine ground

Main Power Supply and Ground Circuit

EC-MAIN-01

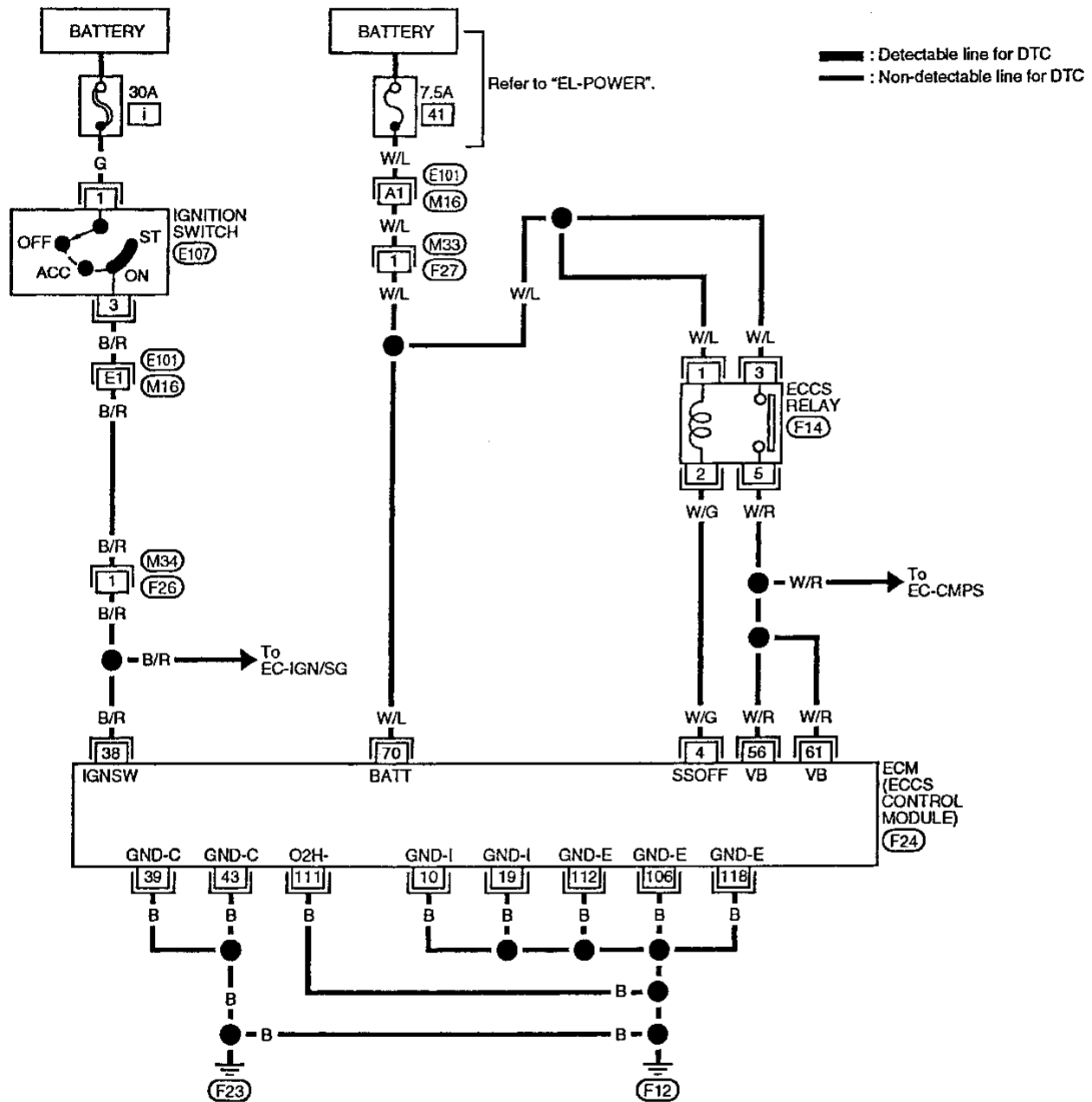

Refer to last page (Foldout page).  
 (M16), (E101)

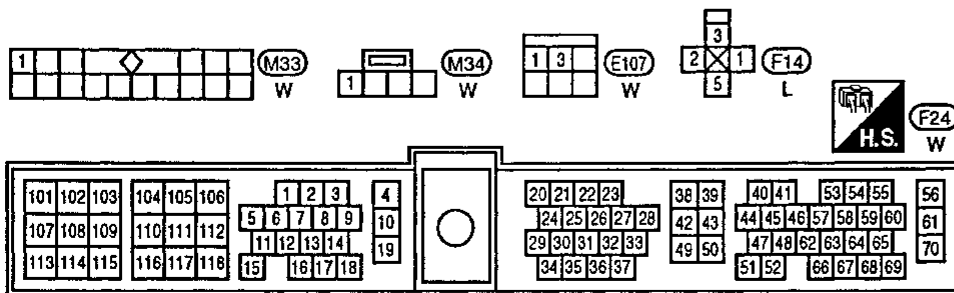

GI  
 MA  
 EM  
 LC  
**EC**  
 FE  
 CL  
 MT  
 AT  
 FA  
 RA  
 BR  
 ST  
 RS  
 BT  
 HA  
 EL  
 IDX

Main Power Supply and Ground Circuit (Cont'd)

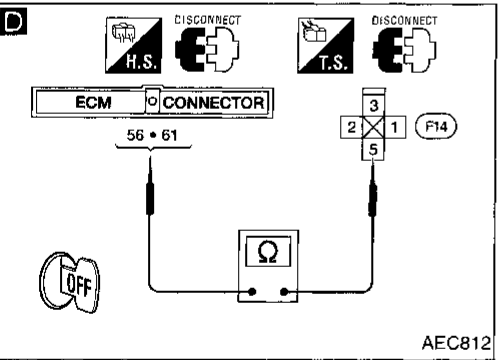
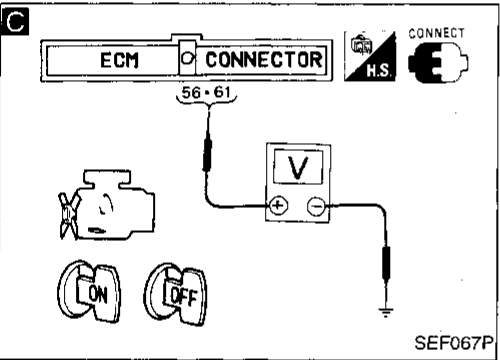
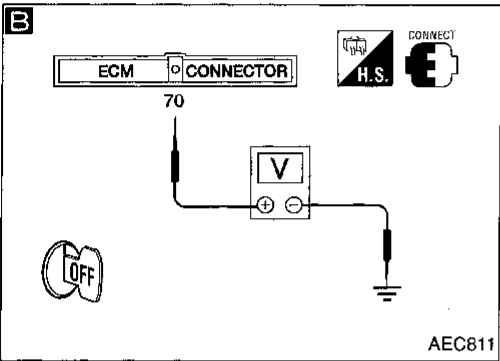
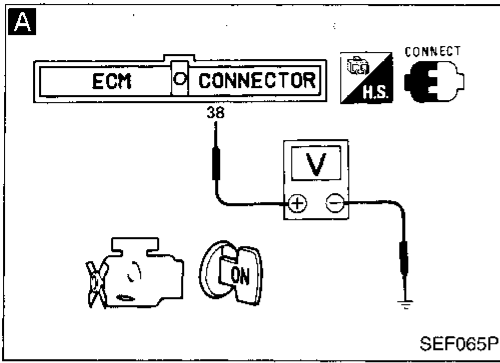

```

    graph TD
        Start[INSPECTION START] --> Q1{Start engine.  
Is engine running?}
        Q1 -- No --> A[CHECK POWER SUPPLY-I.  
1. Turn ignition switch "ON".  
2. Check voltage between ECM terminal 38 and ground with CONSULT or tester.  
Voltage: Battery voltage  
If NG, check the following.  
• Harness connectors M16, E101  
• Harness connectors F26, M34  
• Harness for open or short between ECM and ignition switch  
If NG, repair harness or connectors.]
        Q1 -- Yes --> B[CHECK POWER SUPPLY-II.  
1. Stop engine.  
2. Check voltage between ECM terminal 70, and ground with CONSULT or tester.  
Voltage: Battery voltage]
        A -- OK --> H[Go to H "CHECK GROUND CIRCUIT" on next page.]
        B -- NG --> NG_Box[Check the following.  
• Harness connectors M16, E101  
• Harness connectors F27, M33  
• 7.5A fuse  
• Harness for open or short between ECM and battery  
If NG, repair harness or connectors.]
        B -- OK --> C[CHECK POWER SUPPLY-III.  
1. Turn ignition switch "ON" and then "OFF".  
2. Check voltage between ECM terminals 56, 61 and ground with CONSULT or tester.  
After turning ignition switch "OFF", battery voltage will exist for a few seconds, then drop to approximately 0V.]
        NG_Box --> H
        C -- Case-1 --> A
        C -- Case-2 --> G[Go to G "CHECK ECCS RELAY" on next page.]
        C -- NG --> A
    
```

Main Power Supply and Ground Circuit (Cont'd)

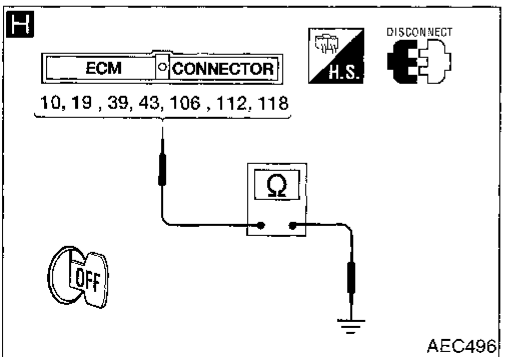
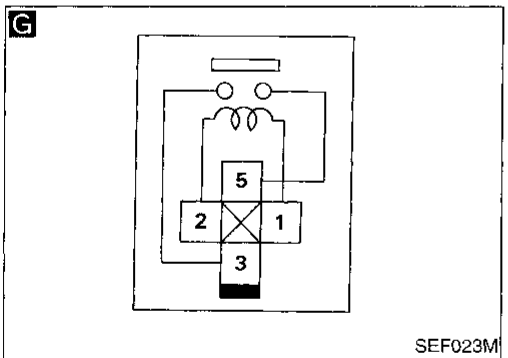
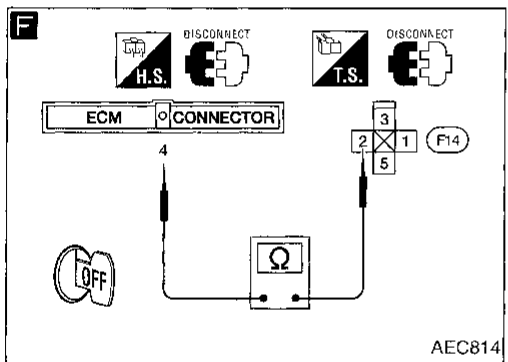
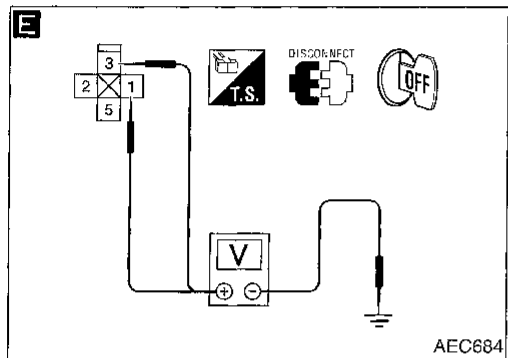
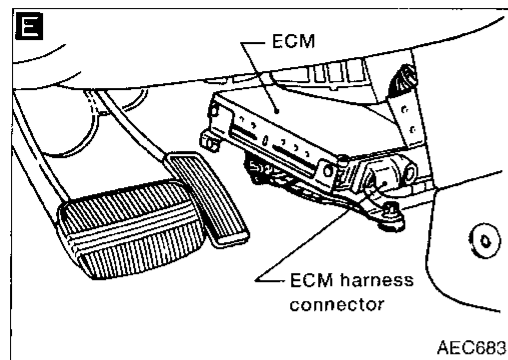

```

    graph TD
        A((A)) --> D
        subgraph D [D]
            D1[CHECK HARNESS CONTINUITY BETWEEN ECCS RELAY AND ECM]
            D2[1. Disconnect ECM harness connector.  
2. Disconnect ECCS relay.  
3. Check harness continuity between ECM terminals (56), (61) and terminal (5).  
Continuity should exist.  
If OK, check harness for short.]
        end
        D -- NG --> D1NG[Repair harness or connectors.]
        D -- OK --> E
        subgraph E [E]
            E1[CHECK VOLTAGE BETWEEN ECCS RELAY AND GROUND.]
            E2[1.) Check voltage between terminals (1), (3) and ground with CONSULT or tester.  
Voltage: Battery voltage]
        end
        E -- NG --> E1NG[Check the following.  
• Harness for open or short between ECCS relay and battery  
If NG, repair harness or connectors.]
        E -- OK --> F
        subgraph F [F]
            F1[CHECK OUTPUT SIGNAL CIRCUIT.]
            F2[1. Check harness continuity between ECM terminal (4) and terminal (2).  
Continuity should exist.  
If OK, check harness for short.]
        end
        F -- NG --> F1NG[Repair harness or connectors.]
        F -- OK --> G
        subgraph G [G]
            G1[CHECK ECCS RELAY.]
            G2[1. Apply 12V direct current between relay terminals (1) and (2).  
2. Check continuity between relay terminals (3) and (5).  
12V (1 - 2) applied:  
Continuity exists.  
No voltage applied:  
No continuity]
        end
        G -- NG --> G1NG[Replace ECCS relay.]
        G -- OK --> H
        subgraph H [H]
            H1[CHECK GROUND CIRCUIT.]
            H2[1. Turn ignition switch "OFF".  
2. Disconnect ECM harness connector.  
3. Check harness continuity between ECM terminals (10), (19), (39), (43), (106), (112), (118) and engine ground.  
Continuity should exist.  
If OK, check harness for short.]
        end
        H -- NG --> H1NG[Repair harness or connectors.]
        H -- OK --> I
        subgraph I [I]
            I1[Check ECM pin terminals for damage and check the connection of ECM harness connector.]
        end
        I --> J[INSPECTION END]
    
```

GI  
MA  
EM  
LC  
EC  
FE  
CL  
MT  
AT  
FA  
RA  
BR  
ST  
RS  
BT  
HA  
EL  
IDX

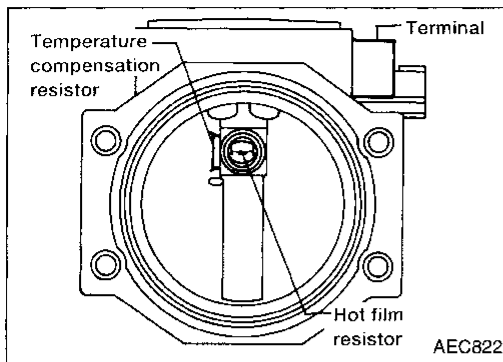

### Mass Air Flow Sensor (MAFS) (DTC: 0102)

The mass air flow sensor is placed in the stream of intake air. It measures the intake flow rate by measuring a part of the entire intake flow. It consists of a hot film resistor that is supplied with electric current from the ECM. The temperature of the hot film resistor is controlled by the ECM a certain amount. The heat generated by the hot film resistor is reduced as the intake air flows around it. The more air, the greater the heat loss. Therefore, the ECM must supply more electric current to maintain the temperature of the hot film resistor as air flow increases. The ECM detects the air flow by means of this current change.

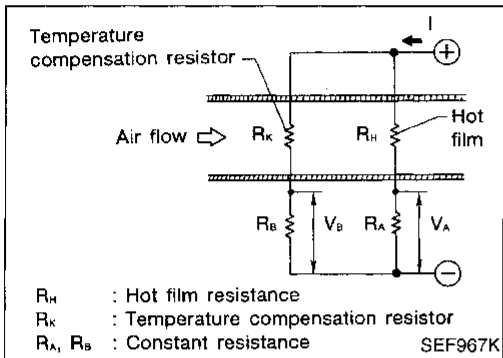

Diagnostic Trouble Code No.	Malfunction is detected when ...	Check Items (Possible Cause)
P0100 0102	A) An excessively high or low voltage from the sensor is sent to ECM. ..... B), C) Voltage sent to ECM is not practical when compared with the camshaft position sensor and throttle position sensor signals.	<ul style="list-style-type: none"> <li>● Harness or connectors (The sensor circuit is open or shorted.)</li> <li>● Mass air flow sensor</li> </ul>

### DIAGNOSTIC TROUBLE CODE CONFIRMATION PROCEDURE

#### Procedure for malfunction A

- 1) Turn ignition switch "ON", and wait at least 6 seconds.
  - 2) Select "DATA MONITOR" mode with CONSULT.
  - 3) Start engine and wait at least 3 seconds.
- OR
- 1) Turn ignition switch "ON", and wait at least 6 seconds.
  - 2) Start engine and wait at least 3 seconds.
  - 3) Select "MODE 3" with GST.
- OR
- 1) Turn ignition switch "ON", and wait at least 6 seconds.
  - 2) Start engine and wait at least 3 seconds.
  - 3) Turn ignition switch "OFF", wait at least 5 seconds and then turn "ON".
  - 4) Perform "Diagnostic Test Mode II" (Self-diagnostic results) with ECM.

Mass Air Flow Sensor (MAFS) (DTC: 0102)  
(Cont'd)

Procedure for malfunction B

- 1) Turn ignition switch "ON".
  - 2) Select "DATA MONITOR" mode with CONSULT.
  - 3) Start engine and warm it up sufficiently.
  - 4) Run engine for at least 10 seconds at idle speed.
- OR
- 1) Turn ignition switch "ON".
  - 2) Start engine and warm it up sufficiently.
  - 3) Run engine for at least 10 seconds at idle speed.
  - 4) Select "MODE 3" with GST.
- OR
- 1) Turn ignition switch "ON".
  - 2) Start engine and warm it up sufficiently.
  - 3) Run engine for at least 10 seconds at idle speed.
  - 4) Turn ignition switch "OFF", wait at least 5 seconds and then turn "ON".
  - 5) Perform "Diagnostic Test Mode II" (Self-diagnostic results) with ECM.

GI  
MA  
EM  
LC  
EC  
FE  
CL  
MT  
AT  
FA  
RA  
BR  
ST  
RS  
BT  
HA  
EL  
IDX

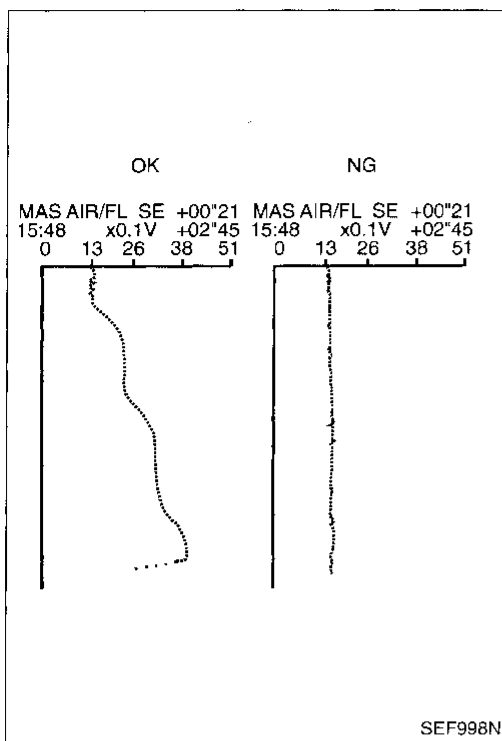

FUEL SYS #1	OPEN
FUEL SYS #2	UNUSED
CALC LOAD	22%
COOLANT TEMP	30°C
SHORT FT #1	0%
LONG FT #1	2%
ENGINE SPD	1000RPM
VEHICLE SPD	0km/h
IGN ADVANCE	20.0°
INTAKE AIR	26°C
MAF	0.0gm/sec
THROTTLE POS	0%
O2S LOCATION	3
O2S B1,S1	0.680V
O2FT B1,S1	0%
O2S B1,S2	0.080V

SEF003P

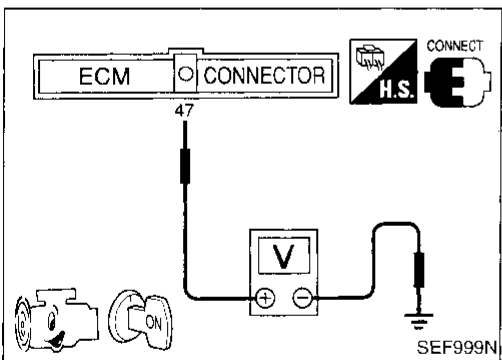

OVERALL FUNCTION CHECK

Use this procedure to check the overall function of the mass air flow sensor circuit. During this check, a DTC might not be confirmed.

Procedure for malfunction C

- 1) Turn ignition switch "ON".
  - 2) Start engine and warm it up sufficiently.
  - 3) Select "DATA MONITOR" mode with CONSULT.
  - 4) Check the voltage of mass air flow sensor with "DATA MONITOR".
  - 5) Check for linear voltage rise in response to increases to about 4,000 rpm in engine speed.
- OR
- 1) Turn ignition switch "ON".
  - 2) Start engine and warm it up sufficiently.
  - 3) Select "MODE 1" with GST.
  - 4) Check the mass air flow with "MODE 1".
  - 5) Check for linear mass air flow rise in response to increases to about 4,000 rpm in engine speed.
- OR
- 1) Turn ignition switch "ON".
  - 2) Start engine and warm it up sufficiently.
  - 3) Check the voltage between ECM terminal (47) and ground.
  - 4) Check for linear voltage rise in response to increases to about 4,000 rpm in engine speed.

Mass Air Flow Sensor (MAFS) (DTC: 0102)  
(Cont'd)

EC-MAFS-01

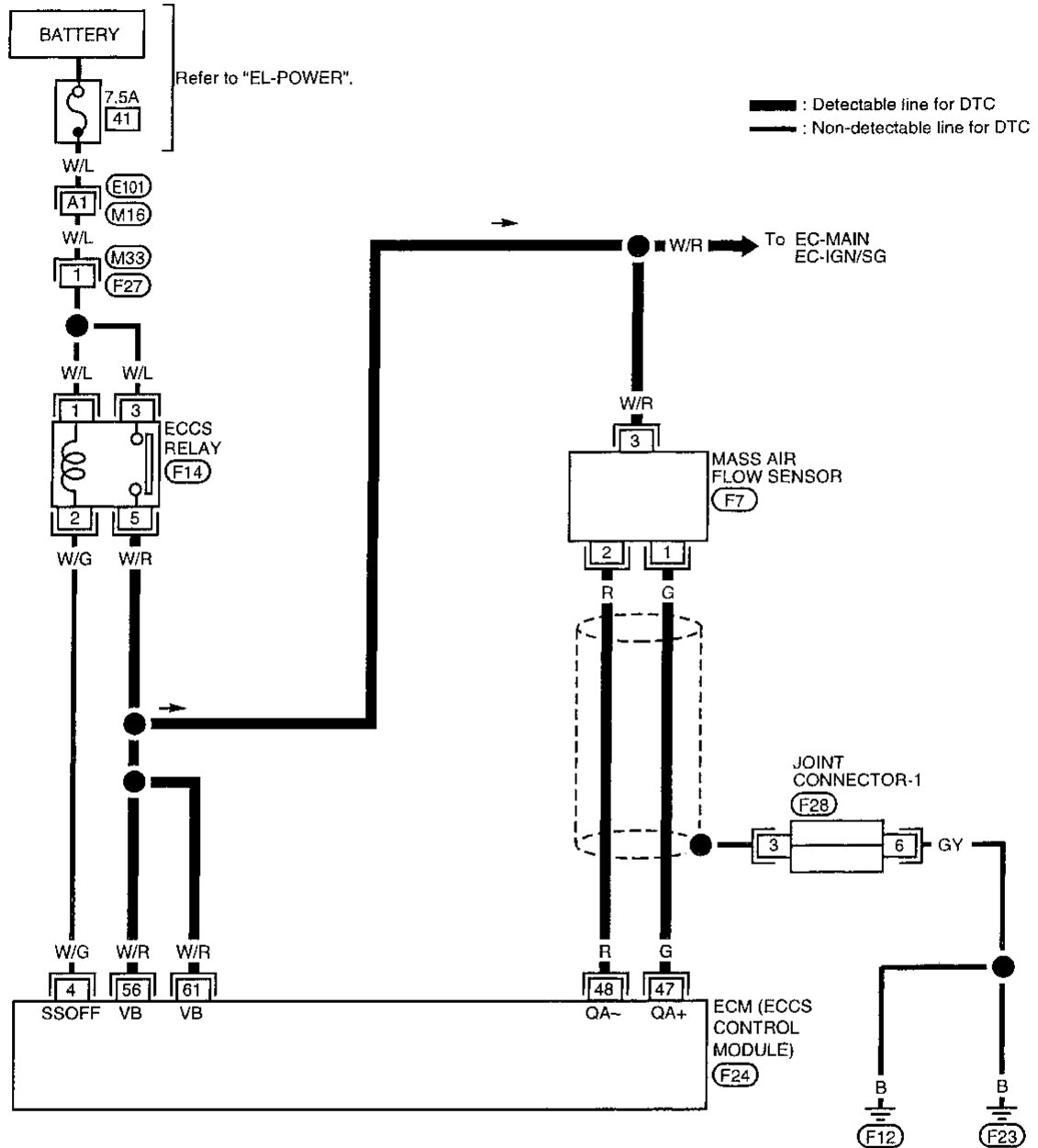

Refer to last page (Foldout page).

(M16) . (E101)

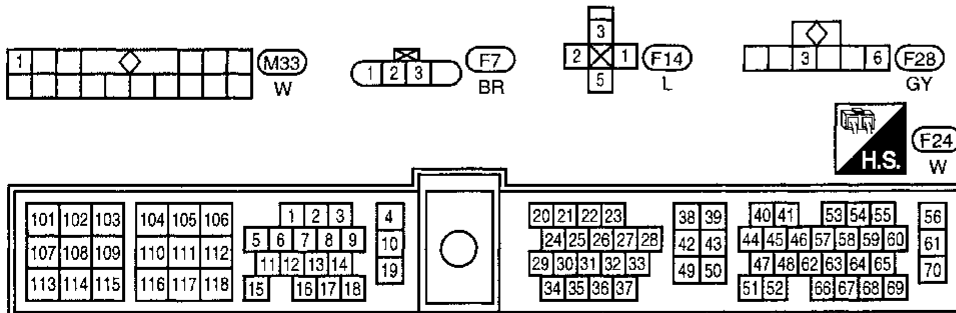

Mass Air Flow Sensor (MAFS) (DTC: 0102)  
(Cont'd)

DIAGNOSTIC PROCEDURE

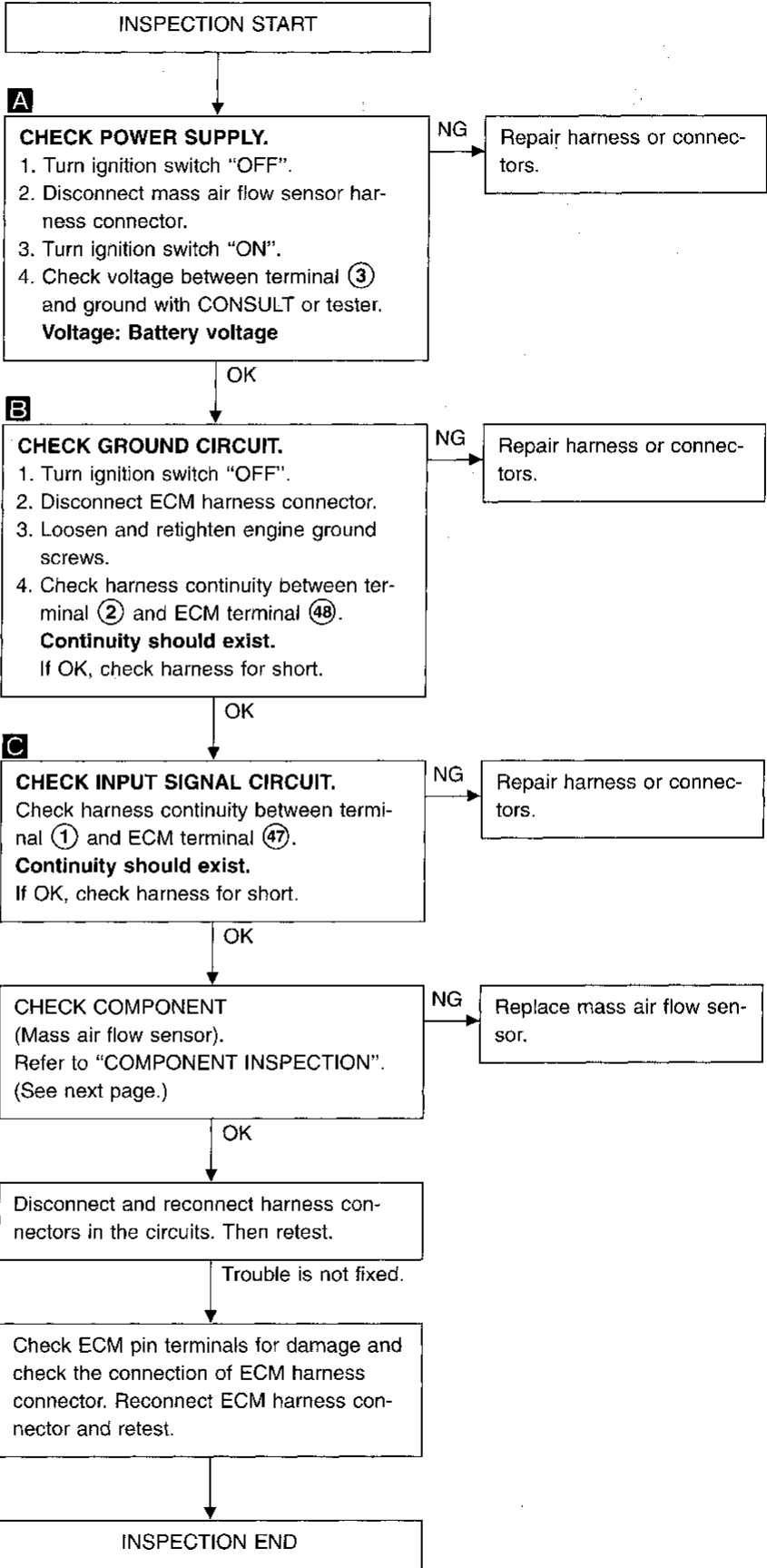
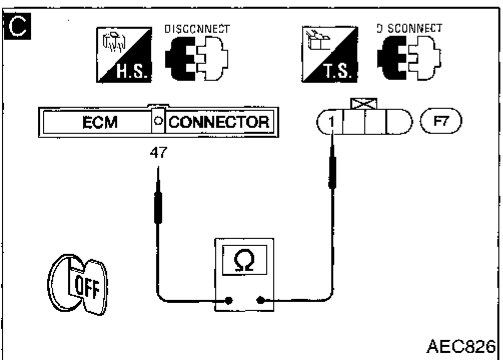
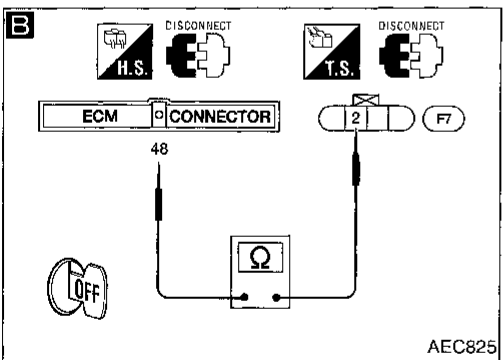
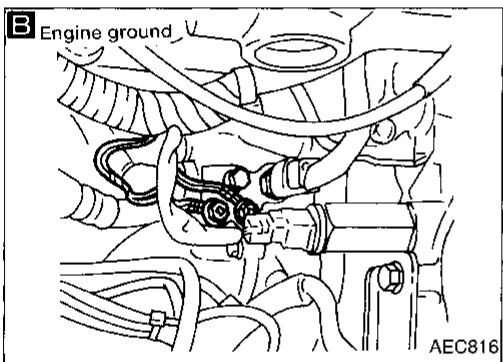
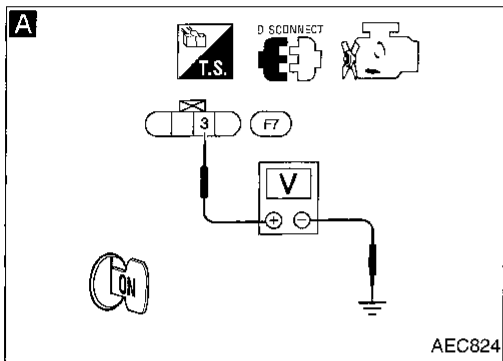
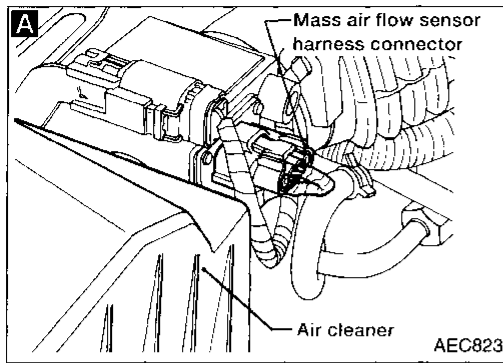

GI  
MA  
EM  
LC  
EC  
FE  
CL  
MT  
AT  
FA  
RA  
BR  
ST  
RS  
BT  
HA  
EL  
IDX



**Mass Air Flow Sensor (MAFS) (DTC: 0102)  
(Cont'd)**

**COMPONENT INSPECTION**

**Mass air flow sensor**

1. Turn ignition switch "ON".
2. Start engine and warm it up sufficiently.
3. Check voltage between terminal ① and ground.

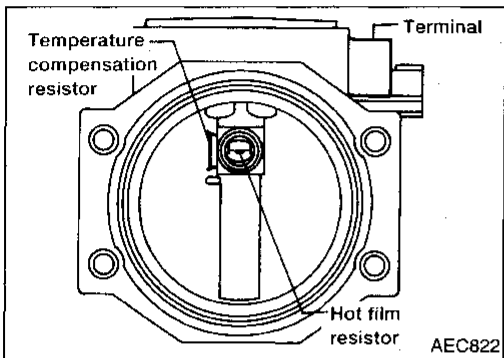
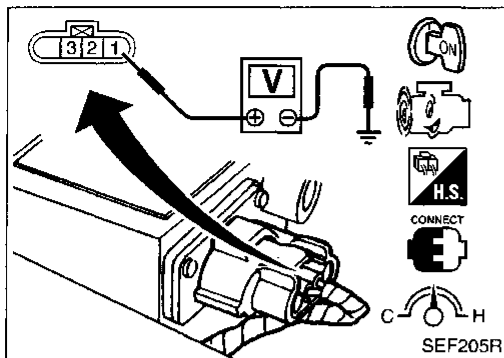

Conditions	Voltage V
Ignition switch "ON" (Engine stopped.)	Less than 1.0
Idle (Engine is warmed-up sufficiently.)	1.0 - 1.7
Idle to about 4,000 rpm*	1.0 - 1.7 to Approx. 4.0

- \*: Check for linear voltage rise in response to increases to about 4,000 rpm in engine speed.
4. If NG, remove mass air flow sensor from air duct. Check hot film for damage or dust.

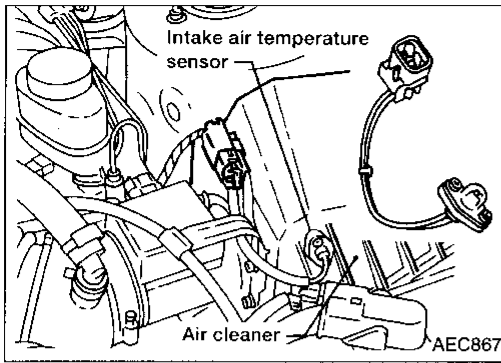

### Intake Air Temperature Sensor (DTC: 0401)

The intake air temperature sensor mounted to the air cleaner housing, detects intake air temperature and transmits a signal to the ECM.

The temperature sensing unit uses a thermistor which is sensitive to the change in temperature. Electrical resistance of the thermistor decreases in response to the temperature rise.

This sensor is not used to control the engine system. It is used only for the on-board diagnosis.

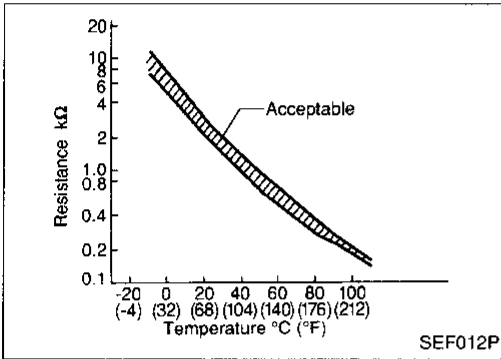

Intake air temperature °C (°F)	Resistance kΩ
20 (68)	2.1 - 2.9
80 (176)	0.27 - 0.38

Diagnostic Trouble Code No.	Malfunction is detected when ...	Check Items (Possible Cause)
P0110 0401	<p>A) An excessively low or high voltage from the sensor is sent to ECM.</p> <p>B) Voltage sent to ECM is not practical when compared with the engine coolant temperature sensor signal.</p>	<ul style="list-style-type: none"> <li>● Harness or connectors (The sensor circuit is open or shorted.)</li> <li>● Intake air temperature sensor.</li> </ul>

## Intake Air Temperature Sensor (DTC: 0401) (Cont'd)

### DIAGNOSTIC TROUBLE CODE CONFIRMATION PROCEDURE

#### Procedure for malfunction A and B

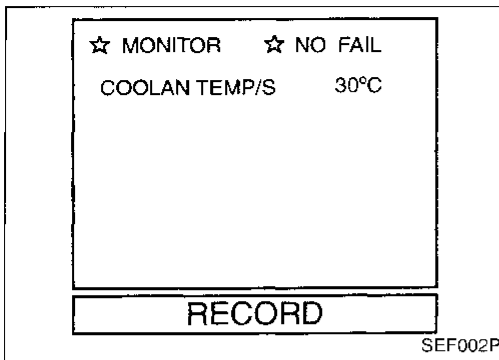

FUEL SYS #1	OPEN
FUEL SYS #2	UNUSED
CALC LOAD	0%
<b>COOLANT TEMP</b>	<b>28°C</b>
SHORT FT #1	0%
LONG FT #1	0%
ENGINE SPD	0RPM
VEHICLE SPD	0km/h
IGN ADVANCE	5.0°
INTAKE AIR	25°C
MAF	0.0gm/sec
THROTTLE POS	0%
O2S LOCATION	3
O2S B1,S1	0.380V
O2FT B1,S1	0%
O2S B1,S2	0.000V

SEF950N

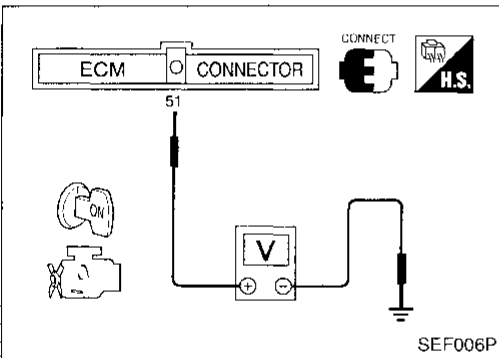

- 1) Wait until engine coolant temperature is less than 90°C (194°F).
  - (a) Turn ignition switch "ON".
  - (b) Select "DATA MONITOR" mode with CONSULT.
  - (c) Check the engine coolant temperature.
  - (d) If the engine coolant temperature is not less than 90°C (194°F), turn ignition switch "OFF" and cool down engine.
- 2) Turn ignition switch "ON".
- 3) Select "DATA MONITOR" mode with CONSULT.
- 4) Wait at least 5 seconds.

OR

- 1) Wait until engine coolant temperature is less than 90°C (194°F).
  - (a) Turn ignition switch "ON".
  - (b) Select MODE 1 with GST.
  - (c) Check the engine coolant temperature.
  - (d) If the engine coolant temperature is not less than 90°C (194°F), turn ignition switch "OFF" and cool down engine.
- 2) Turn ignition switch "ON" and wait at least 5 seconds.
- 3) Select MODE 3 with GST.

OR

- 1) Wait until engine coolant temperature is less than 90°C (194°F).
  - (a) Turn ignition switch "ON".
  - (b) Check voltage between ECM terminal 51 and ground.
 

**Voltage: More than 1.2 (V)**
  - (c) If the voltage is not more than 1.2V, turn ignition switch "OFF" and cool down engine.
- 2) Turn ignition switch "ON" wait at least 5 seconds.
- 3) Turn ignition switch "OFF", wait at least 5 seconds and then turn "ON".
- 4) Perform "Diagnostic Test Mode II" (Self-diagnostic results) with ECM.

Intake Air Temperature Sensor (DTC: 0401)  
(Cont'd)

EC-IATS-01

— : Detectable line for DTC  
— : Non-detectable line for DTC

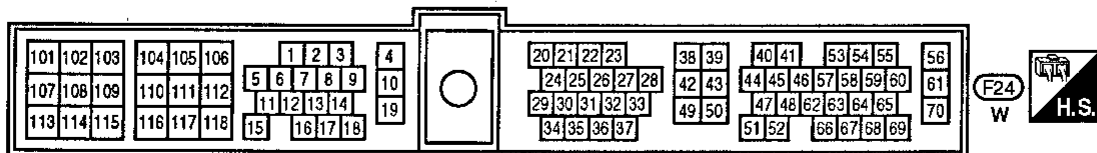
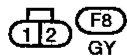
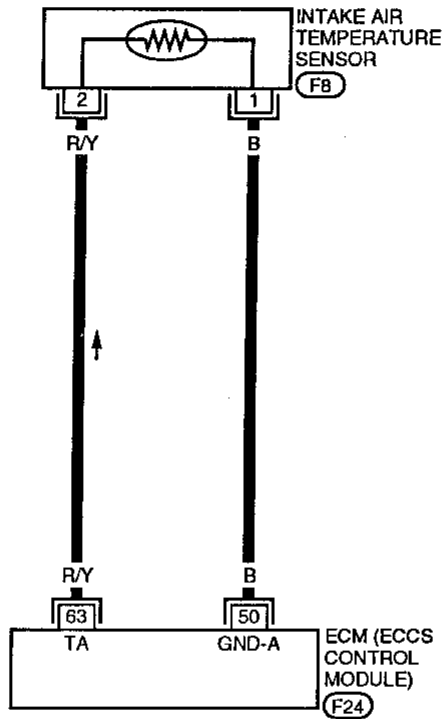

GI  
MA  
EM  
LC  
EC  
FE  
CL  
MT  
AT  
FA  
RA  
BR  
ST  
RS  
BT  
HA  
EL  
IDX

## Intake Air Temperature Sensor (DTC: 0401) (Cont'd)

### DIAGNOSTIC PROCEDURE

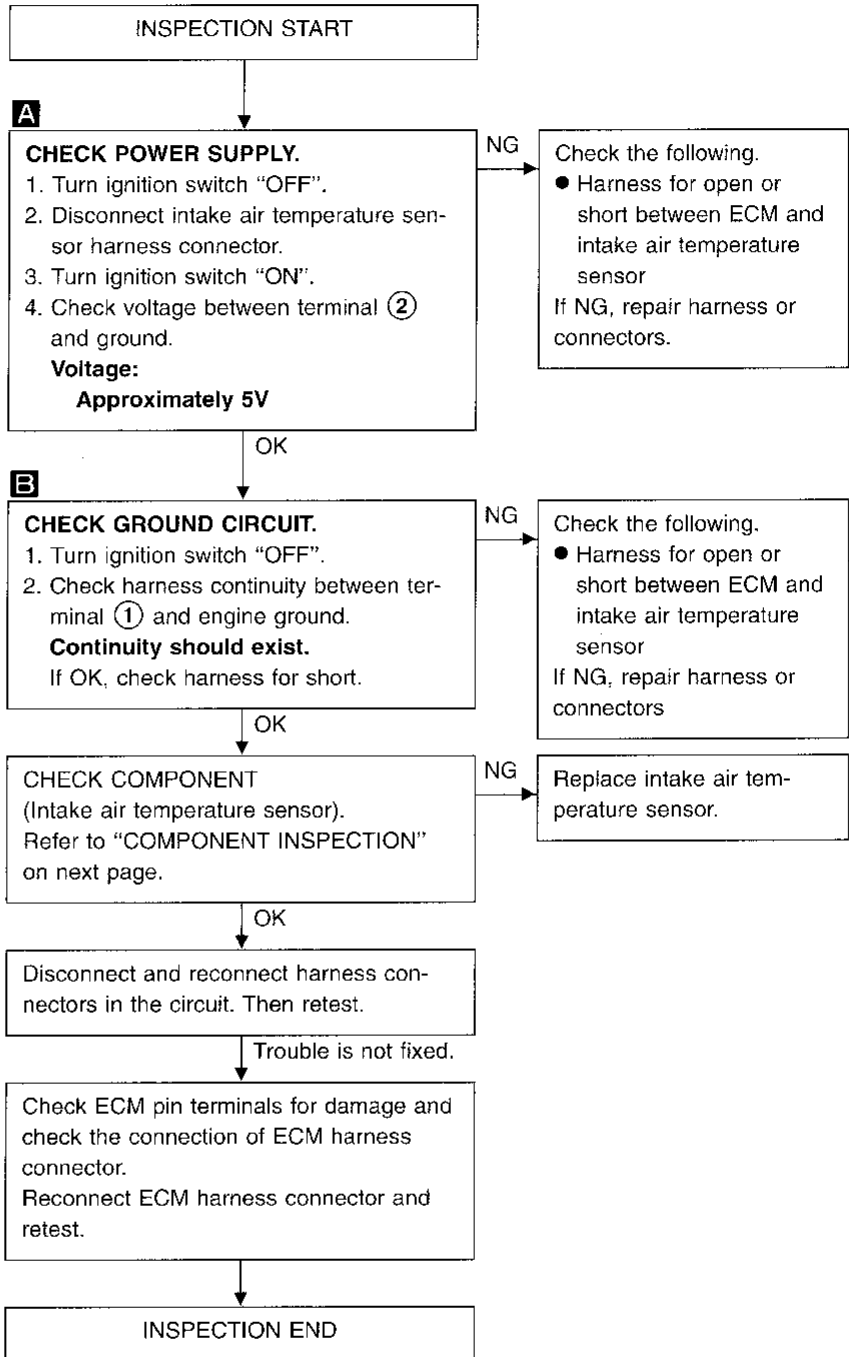
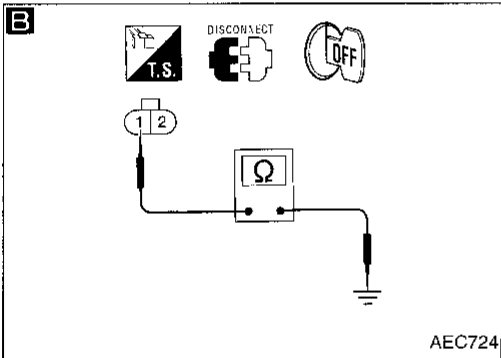
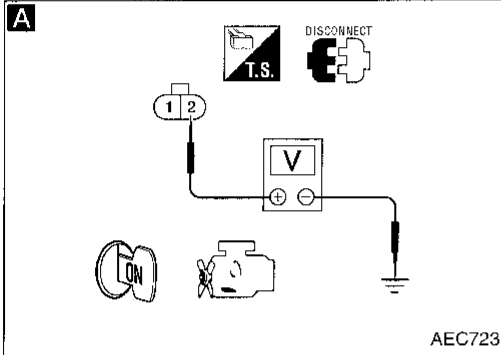
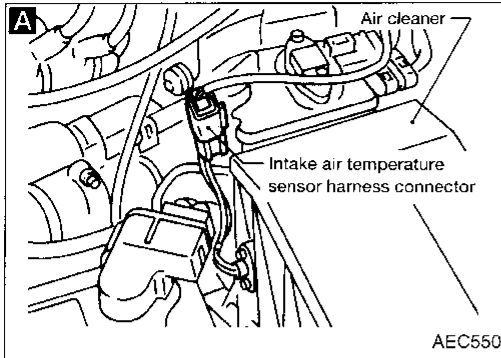

**Intake Air Temperature Sensor (DTC: 0401)  
(Cont'd)**

**COMPONENT INSPECTION**

**Intake air temperature sensor**

Check resistance as shown in the figure.

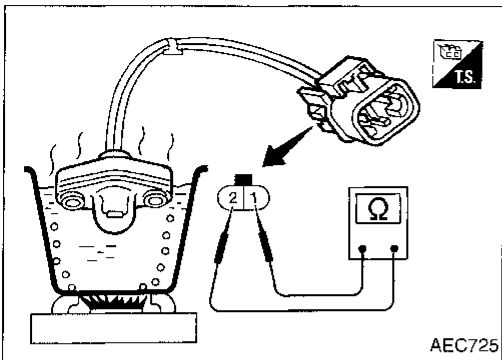

AEC725

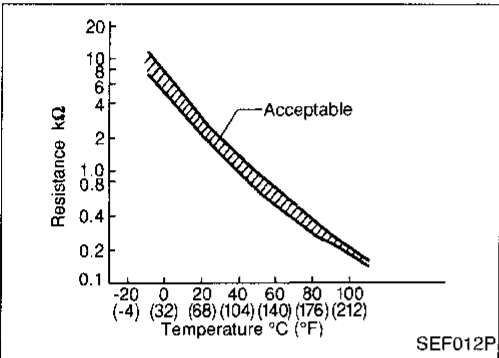

SEF012P

Intake air temperature °C (°F)	Resistance kΩ
20 (68)	2.1 - 2.9
80 (176)	0.27 - 0.38

If NG, replace intake air temperature sensor.

- GI
- MA
- EM
- LC
- EC**
- FE
- CL
- MT
- AT
- FA
- RA
- BR
- ST
- RS
- BT
- HA
- EL
- IDX

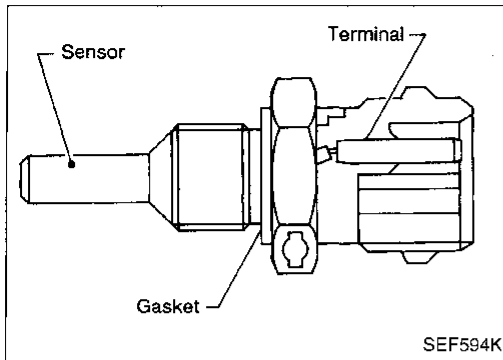

### Engine Coolant Temperature Sensor (ECTS) (DTC: 0103)

The engine coolant temperature sensor is used to detect the engine coolant temperature. The sensor modifies a voltage signal from the ECM. The modified signal returns to the ECM as the engine coolant temperature input. The sensor uses a thermistor which is sensitive to the change in temperature. The electrical resistance of the thermistor decreases as temperature increases.

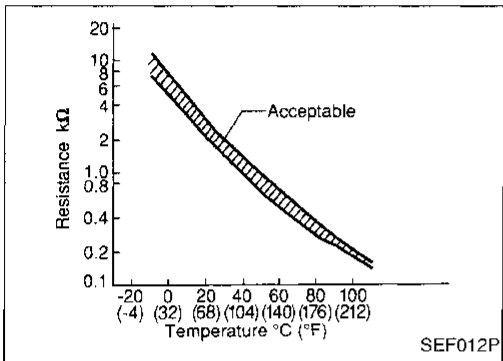



⟨Reference data⟩

Engine coolant temperature °C (°F)	Voltage (V)	Resistance (kΩ)
-10 (14)	4.4	7.0 - 11.4
20 (68)	3.5	2.1 - 2.9
50 (122)	2.2	0.68 - 1.00
90 (194)	1.0	0.236 - 0.260

Diagnostic Trouble Code No.	Malfunction is detected when ...	Check Items (Possible Cause)
P0115 0103	<ul style="list-style-type: none"> <li>An excessively high or low voltage from the sensor is sent to ECM.</li> </ul>	<ul style="list-style-type: none"> <li>Harness or connectors (The sensor circuit is open or shorted.)</li> <li>Engine coolant temperature sensor</li> </ul>

### DIAGNOSTIC TROUBLE CODE CONFIRMATION PROCEDURE

- 
  - Turn ignition switch "ON".
  - Select "DATA MONITOR" mode with CONSULT.
  - Wait at least 5 seconds.
- OR
- 
  - Turn ignition switch "ON" and wait at least 5 seconds.
  - Select "MODE 3" with GST.
- OR
- 
  - Turn ignition switch "ON" and wait at least 5 seconds.
  - Turn ignition switch "OFF", wait at least 5 seconds and then turn "ON".
  - Perform "Diagnostic Test Mode II" (Self-diagnostic results) with ECM.

Engine Coolant Temperature Sensor (ECTS)  
(DTC: 0103) (Cont'd)

EC-ECTS-01

**—** : Detectable line for DTC  
**—** : Non-detectable line for DTC

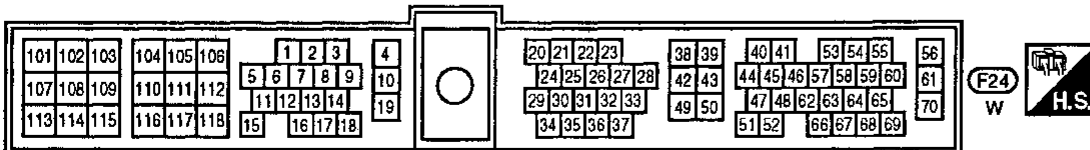
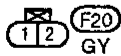
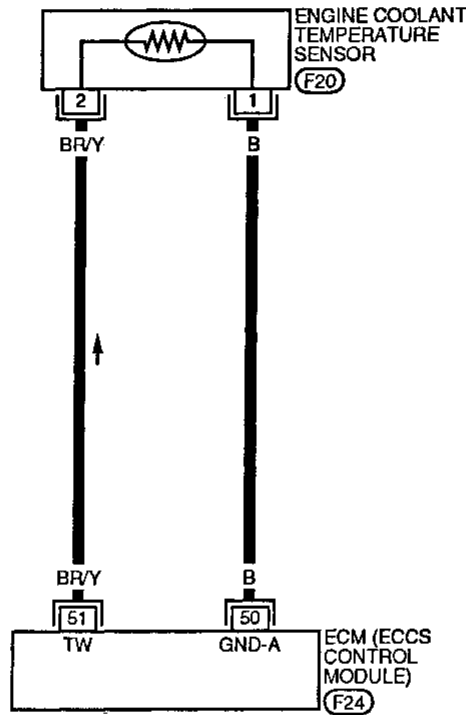

GI  
MA  
EM  
LC  
**EC**  
FE  
CL  
MT  
AT  
FA  
RA  
BR  
ST  
RS  
BT  
HA  
EL  
IDX



## Engine Coolant Temperature Sensor (ECTS) (DTC: 0103) (Cont'd)

### DIAGNOSTIC PROCEDURE

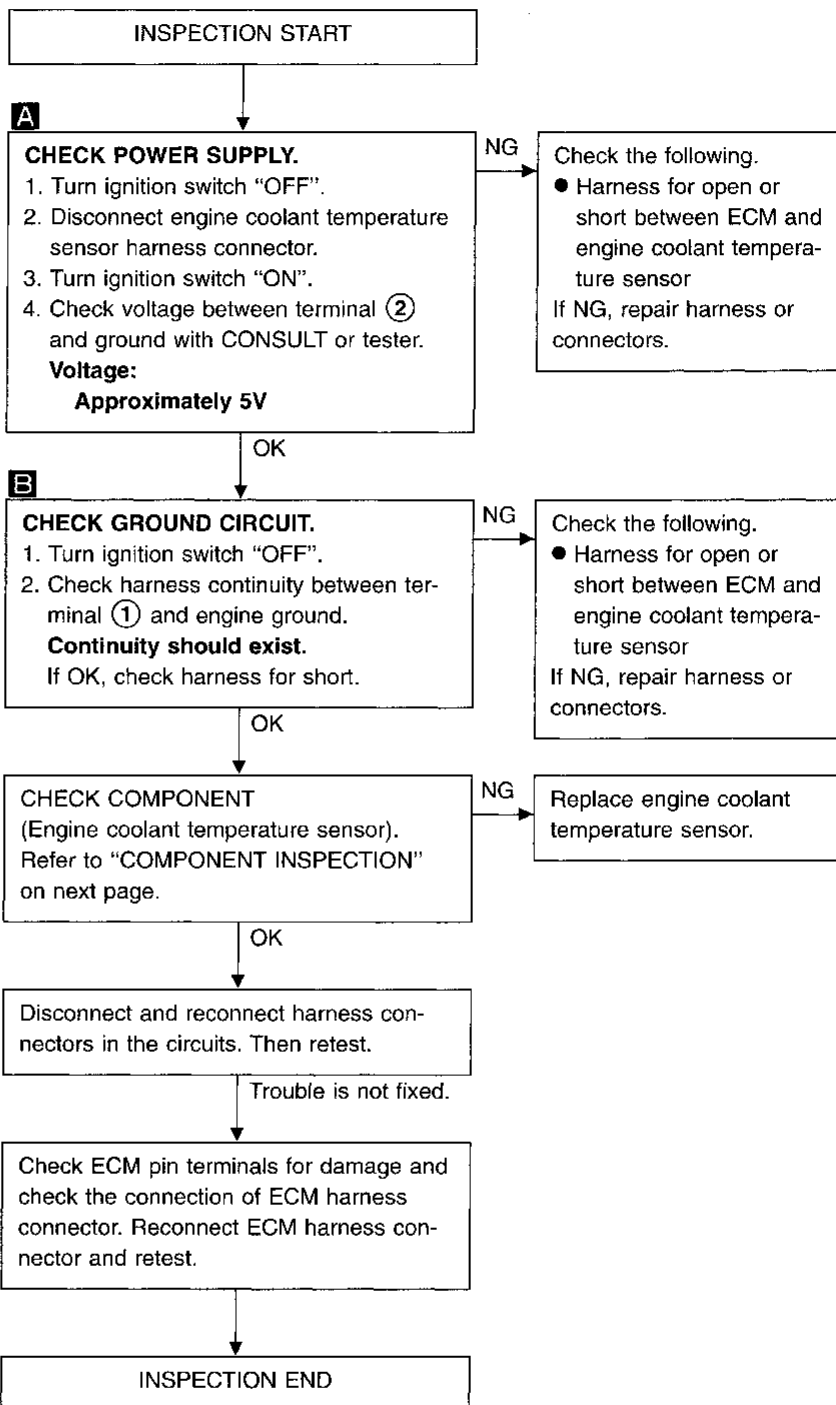
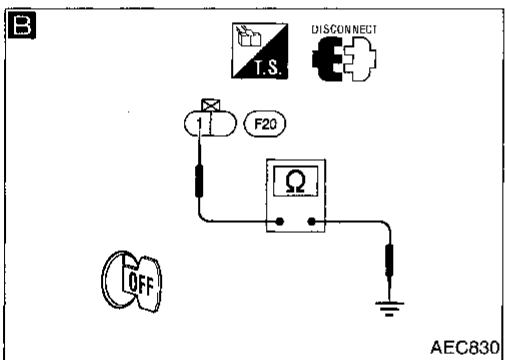
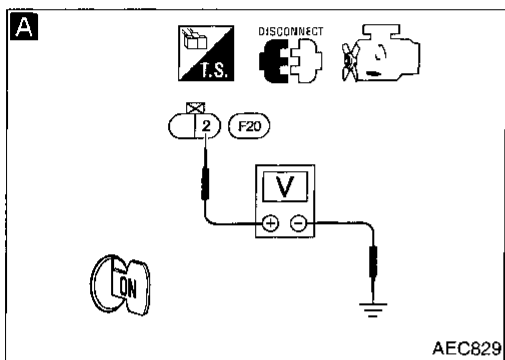
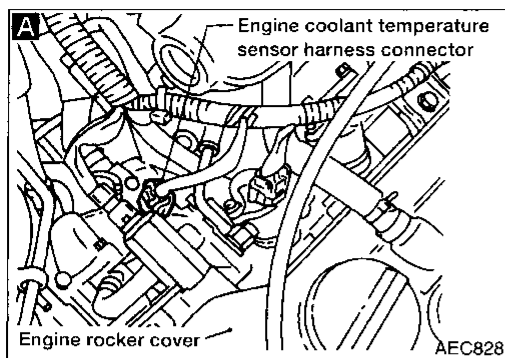

**Engine Coolant Temperature Sensor (ECTS)  
(DTC: 0103) (Cont'd)**

**COMPONENT INSPECTION**

**Engine coolant temperature sensor**

Check resistance as shown in the figure.

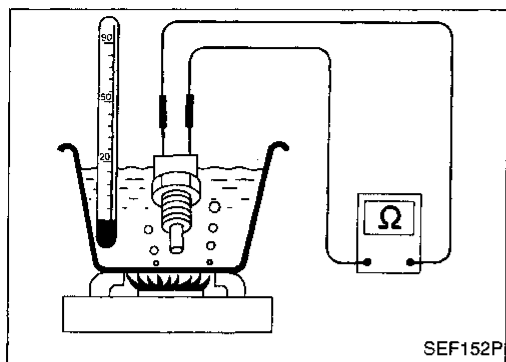

Temperature °C (°F)	Resistance kΩ
20 (68)	2.1 - 2.9
50 (122)	0.68 - 1.00
90 (194)	0.236 - 0.260

If NG, replace engine coolant temperature sensor.

GI

MA

EM

LC

**EC**

FE

CL

MT

AT

FA

RA

BR

ST

RS

BT

HA

EL

IDX

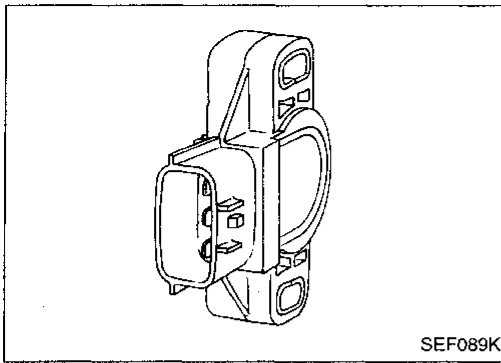

### Throttle Position Sensor (DTC: 0403)

The throttle position sensor responds to the accelerator pedal movement. This sensor is a kind of potentiometer which transforms the throttle position into output voltage, and emits the voltage signal to the ECM. In addition, the sensor detects the opening and closing speed of the throttle valve and feeds the voltage signal to the ECM.

Idle position of the throttle valve is determined by the ECM receiving the signal from the throttle position sensor. This one controls engine operation such as fuel cut.

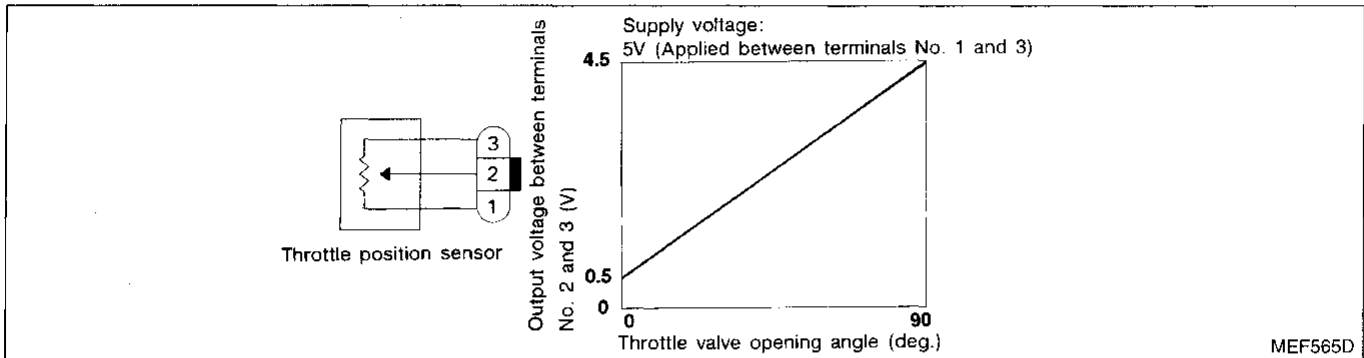

Diagnostic Trouble Code No.	Malfunction is detected when ...	Check Items (Possible Cause)
P0120 0403	<ul style="list-style-type: none"> <li>● An excessively low or high voltage from the sensor is sent to ECM.</li> <li>● Voltage sent to ECM is not practical when compared with mass air flow sensor and camshaft position sensor signals.</li> </ul>	<ul style="list-style-type: none"> <li>● Harness or connectors (The sensor circuit is open or shorted.)</li> <li>● Throttle position sensor</li> </ul>

**Throttle Position Sensor (DTC: 0403) (Cont'd)  
OVERALL FUNCTION CHECK**

Use this procedure to check the overall function of the throttle position sensor. During this check, a DTC might not be confirmed.

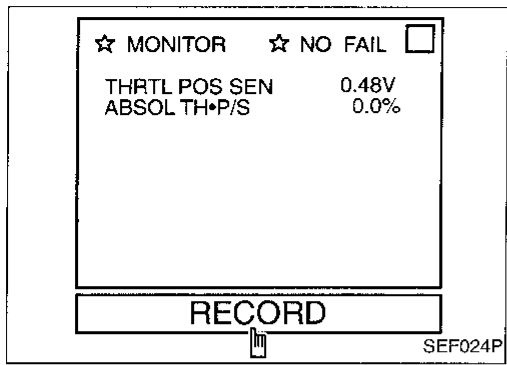

- 1) Turn ignition switch "ON".
- 2) Select "MANU TRIG" and "HI SPEED" in "DATA MONITOR" mode with CONSULT.
- 3) Select "THRTL POS SEN" and "ABSOL TH+PS" in "DATA MONITOR" mode with CONSULT.
- 4) Press RECORD on CONSULT SCREEN at the same time accelerator pedal is depressed.
- 5) Print out the recorded data and check the following:
  - The voltage when accelerator pedal fully released is approximately 0.35 - 0.65V.
  - The voltage rise is linear in response to accelerator pedal depression.
  - The voltage when accelerator pedal fully depressed is approximately 4V.

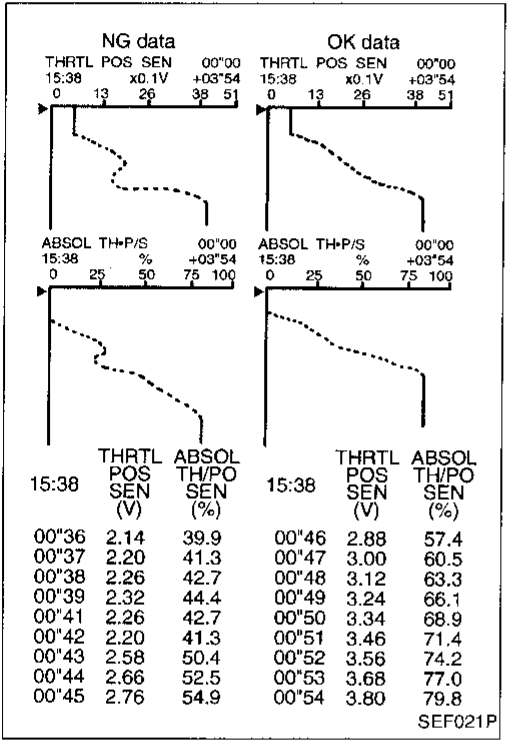

- OR
- 1) Turn ignition switch "ON".
  - 2) Check the voltage between ECM terminal ②③ and ④③ (ground) and check the following:
    - The voltage when accelerator pedal fully released is approximately 0.35 - 0.65V.
    - The voltage rise is linear in response to accelerator pedal depression.
    - The voltage when accelerator pedal fully depressed is approximately 4V.

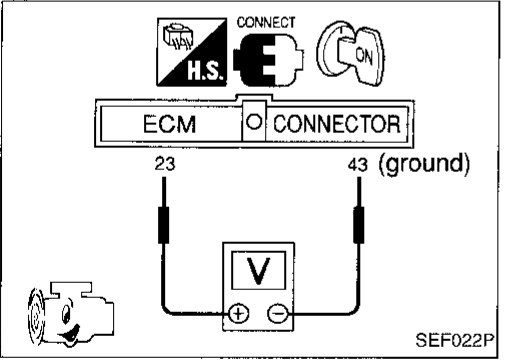

Throttle Position Sensor (DTC: 0403) (Cont'd)

EC-TPS-01

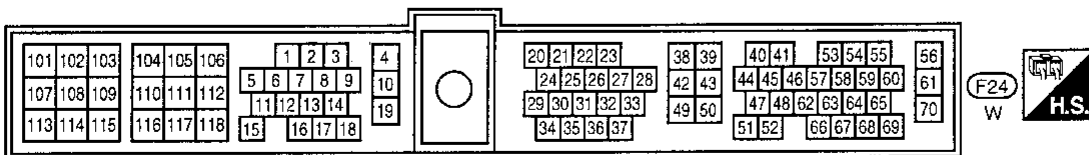
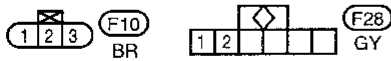
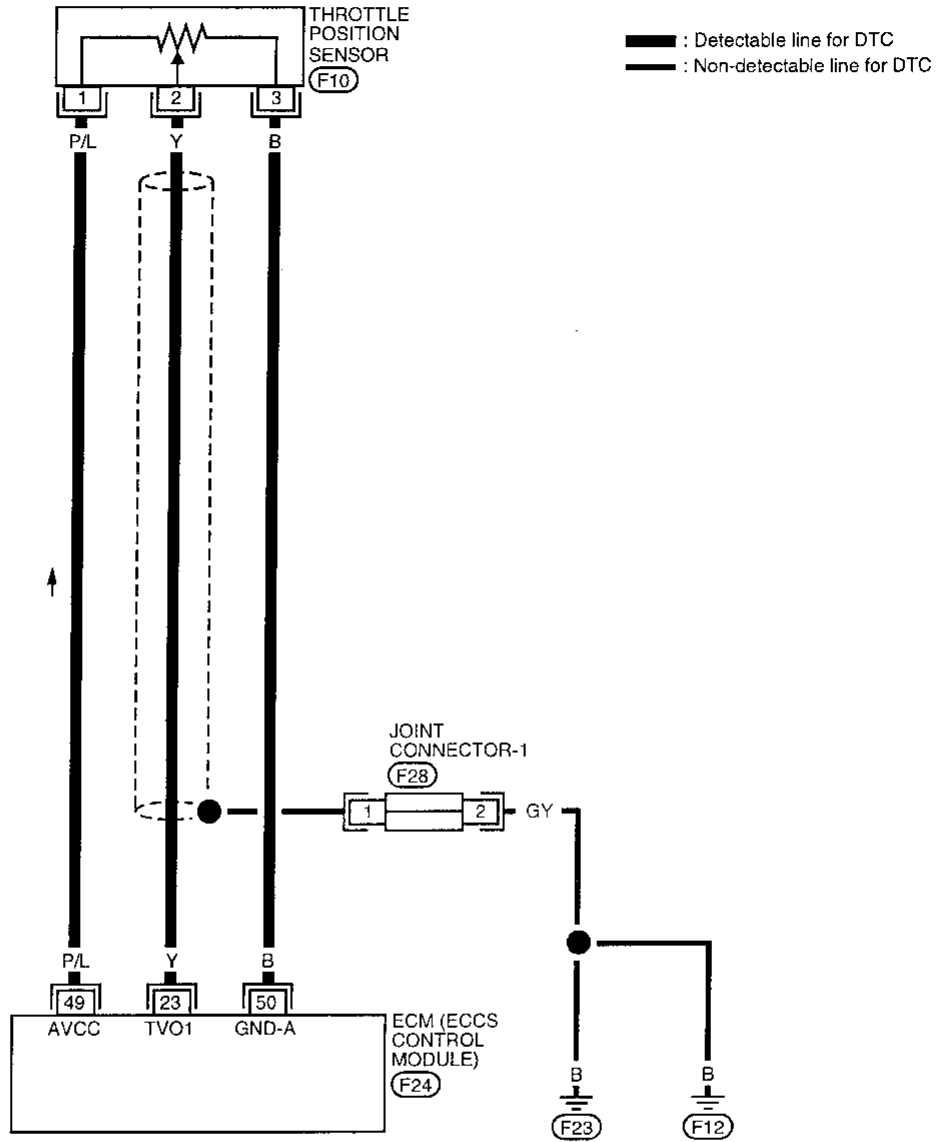

Throttle Position Sensor (DTC: 0403) (Cont'd)

DIAGNOSTIC PROCEDURE

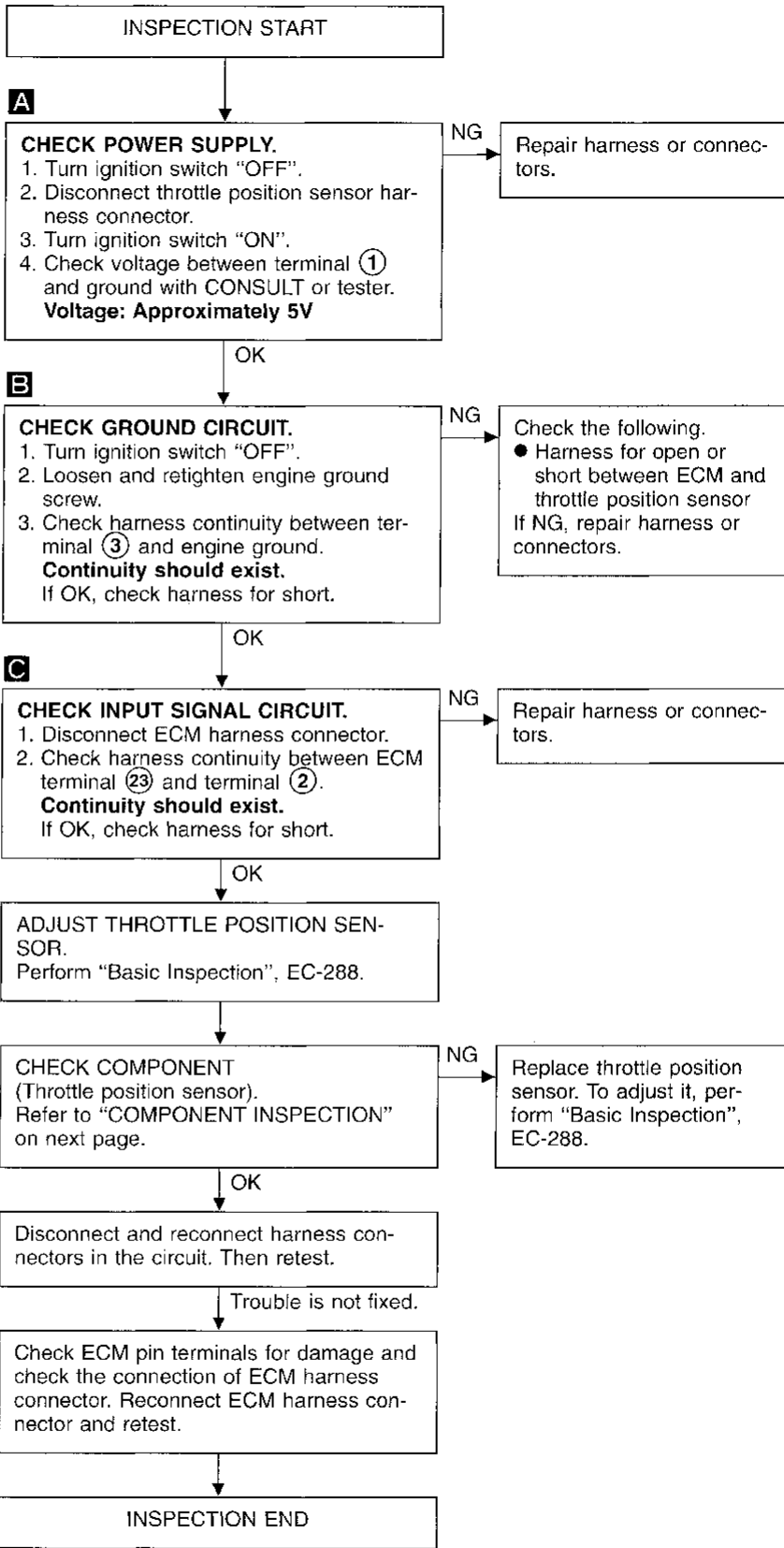
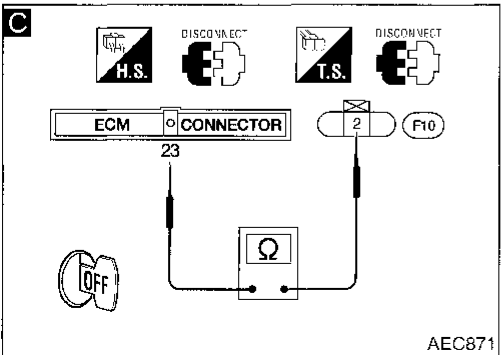
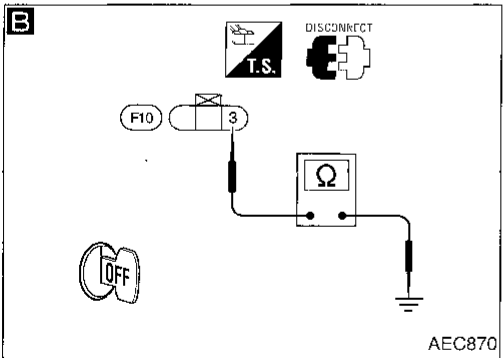
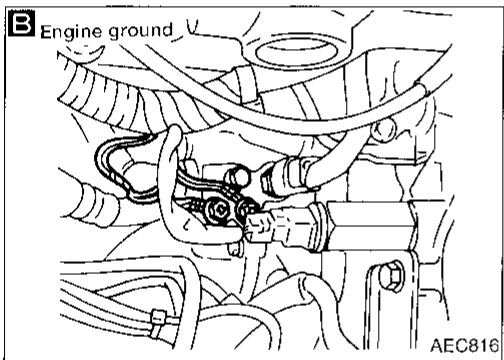
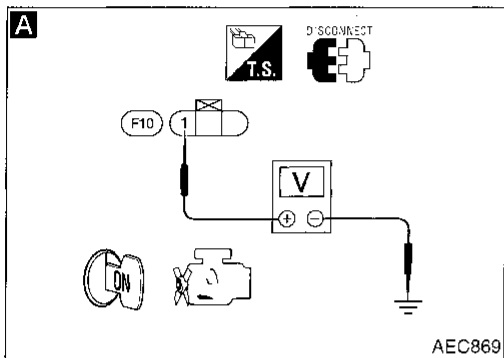
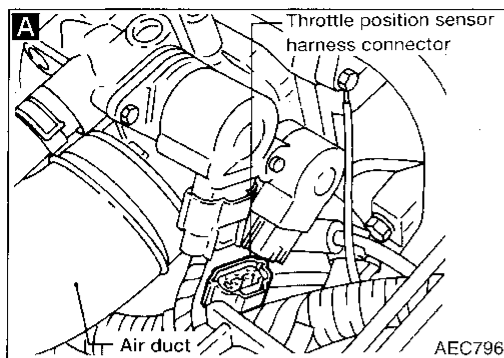

GI  
MA  
EM  
LC  
EC  
PE  
CL  
MT  
AT  
FA  
RA  
BR  
ST  
RS  
BT  
HA  
EL  
IDX

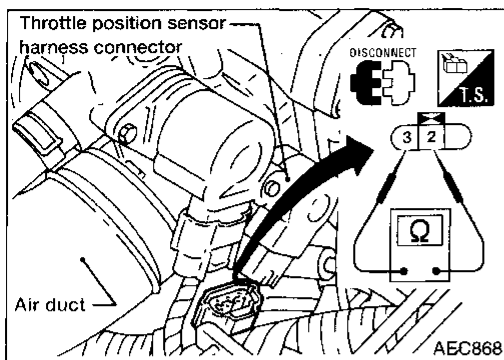

## Throttle Position Sensor (DTC: 0403) (Cont'd)

### COMPONENT INSPECTION

#### Throttle position sensor

1. Disconnect throttle position sensor harness connector.
2. Make sure that resistance between terminals ② and ③ changes when opening throttle valve manually.

Throttle valve conditions	Resistance [at 25°C (77°F)]
Completely closed	Approximately 0.6 kΩ
Partially open	0.6 - 4.0 kΩ
Completely open	Approximately 4.0 kΩ

If NG, replace throttle position sensor. To adjust it, perform "Basic Inspection", EC-288.

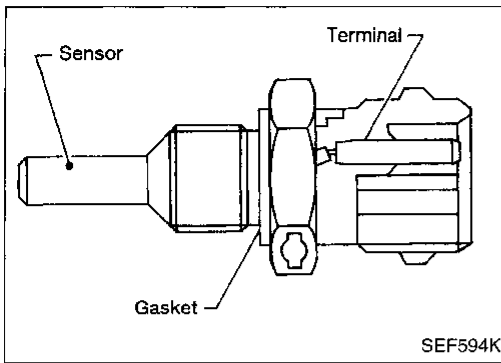

### Engine Coolant Temperature (ECT) Sensor (DTC: 0908)

The engine coolant temperature sensor is used to detect the engine coolant temperature. The sensor modifies a voltage signal from the ECM. The modified signal returns to the ECM as the engine coolant temperature input. The sensor uses a thermistor which is sensitive to the change in temperature. The electrical resistance of the thermistor decreases as temperature increases.

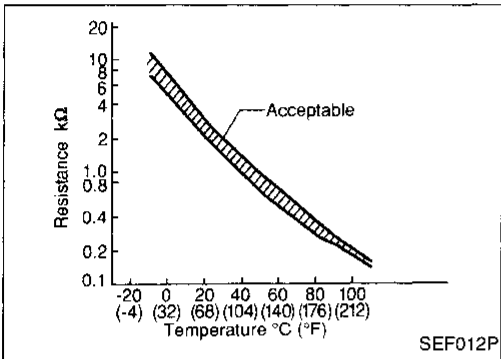

<Reference data>

Engine coolant temperature °C (°F)	Voltage (V)	Resistance (kΩ)
-10 (14)	4.4	7.0 - 11.4
20 (68)	3.5	2.1 - 2.9
50 (122)	2.2	0.68 - 1.00
90 (194)	1.0	0.236 - 0.260

Diagnostic Trouble Code No.	Malfunction is detected when ...	Check Items (Possible Cause)
P0125 0908	<ul style="list-style-type: none"> <li>● Voltage sent to ECM from the sensor is not practical, even when some time has passed after starting the engine.</li> <li>● Engine coolant temperature is insufficient for closed loop fuel control.</li> </ul>	<ul style="list-style-type: none"> <li>● Harness or connectors (High resistance in the circuit)</li> <li>● Engine coolant temperature sensor</li> <li>● Thermostat</li> </ul>

GI  
MA  
EM  
LC  
EC  
FE  
CL  
MT  
AT  
FA  
RA  
BR  
ST  
RS  
BT  
HA  
EL  
IDX



## Engine Coolant Temperature (ECT) Sensor (DTC: 0908) (Cont'd)

### OVERALL FUNCTION CHECK

Use this procedure to check the overall function of the engine coolant temperature sensor circuit. During this check, a DTC might not be confirmed.

**Note:** If both DTC P0115 (0103) and P0125 (0908) are displayed, first perform TROUBLE DIAGNOSIS FOR DTC P0115 (0103). (See EC-328.)

☆ MONITOR ☆ NO FAIL  
COOLANT TEMP/S 30°C

RECORD

SEF002P

FUEL SYS #1	OPEN
FUEL SYS #2	UNUSED
CALC LOAD	22%
COOLANT TEMP	30°C
SHORT FT #1	0%
LONG FT #1	2%
ENGINE SPD	1000RPM
VEHICLE SPD	0km/h
IGN ADVANCE	20.0°
INTAKE AIR	26°C
MAF	0.0gm/sec
THROTTLE POS	0%
O2S LOCATION	3
O2S B1,S1	0.680V
O2FT B1,S1	0%
O2S B1,S2	0.080V

SEF003P

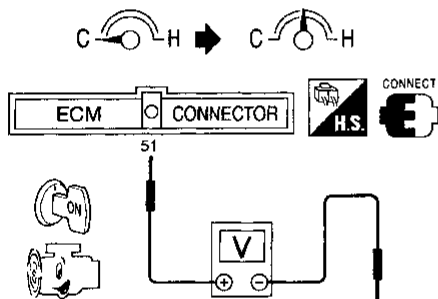

SEF004P



- 1) Turn ignition switch "ON".
- 2) Select "COOLANT TEMP/S" in "DATA MONITOR" mode with CONSULT.
- 3) Start engine and run it at idle speed.
- 4) Check that the engine coolant temperature rises to 25°C (77°F) or more within 15 minutes. (Be careful not to overheat engine.)

OR



- 1) Turn ignition switch "ON".
- 2) Select "MODE 1" with GST.
- 3) Start engine and run it at idle speed.
- 4) Check that the engine coolant temperature rises to 25°C (77°F) or more within 15 minutes. (Be careful not to overheat engine.)

OR



- 1) Turn ignition switch "ON".
- 2) Probe voltage meter between ECM terminal ⑤1 and ground.
- 3) Start engine and run it at idle speed.
- 4) Check that voltage of engine coolant temperature changes to less than 3.3 (V) within 15 minutes. (Be careful not to overheat engine.)

Engine Coolant Temperature (ECT) Sensor  
(DTC: 0908) (Cont'd)

EC-ECTS-01

— : Detectable line for DTC  
— : Non-detectable line for DTC

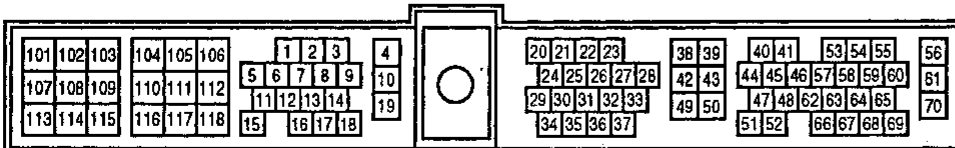
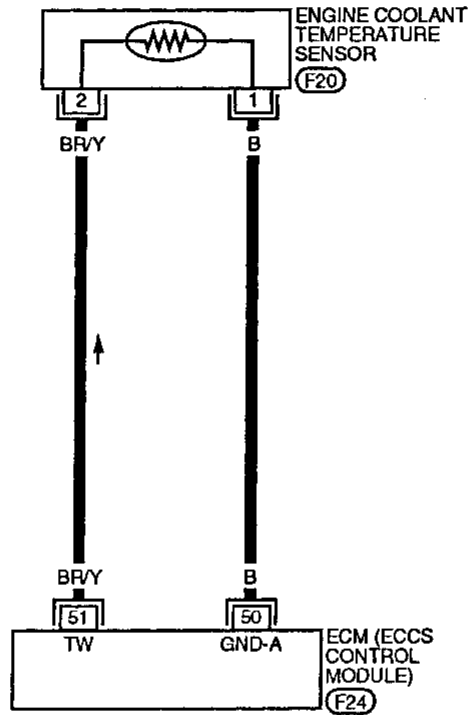

CI  
MA  
EM  
LC  
EC  
FE  
CL  
MT  
AT  
FA  
RA  
BR  
ST  
RS  
BT  
HA  
EL  
IDX

Engine Coolant Temperature (ECT) Sensor (DTC: 0908) (Cont'd)

DIAGNOSTIC PROCEDURE

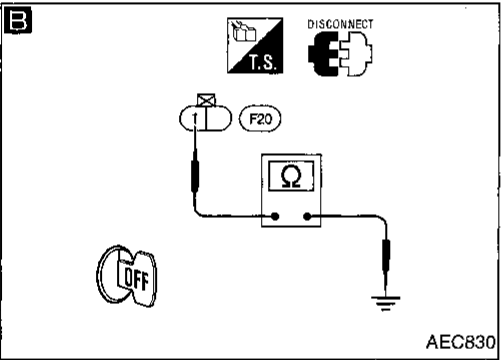
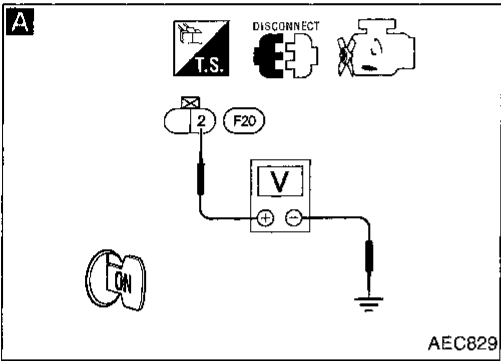
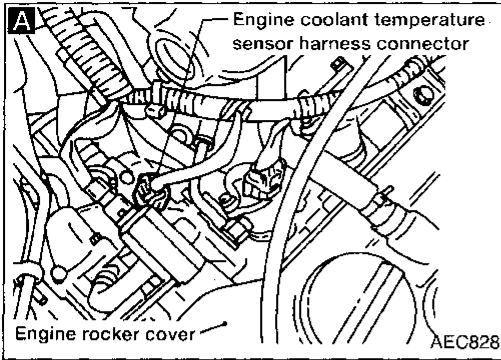

INSPECTION START

**A**  
**CHECK POWER SUPPLY.**  
 1. Turn ignition switch "OFF".  
 2. Disconnect engine coolant temperature sensor harness connector.  
 3. Turn ignition switch "ON".  
 4. Check voltage between terminal ② and ground with CONSULT or tester.  
**Voltage:**  
 Approximately 5V

NG → Check the following.  
 ● Harness for open or short between ECM and engine coolant temperature sensor  
 If NG, repair harness or connectors.

**B**  
**CHECK GROUND CIRCUIT.**  
 1. Turn ignition switch "OFF".  
 2. Check harness continuity between terminal ① and engine ground.  
**Continuity should exist.**  
 If OK, check harness for short.

NG → Check the following.  
 ● Harness for open or short between ECM and engine coolant temperature sensor  
 If NG, repair harness or connectors.

**CHECK COMPONENT**  
 (Engine coolant temperature sensor). Refer to "COMPONENT INSPECTION", on next page.

NG → Replace engine coolant temperature sensor.

**CHECK THERMOSTAT OPERATION.**  
 When the engine is cold [lower than 70°C (158°F)] condition, grasp lower radiator hose and confirm the engine coolant does not flow.

NG → **CHECK COMPONENT**  
 (Thermostat). Refer to LC section ("Thermostat", "ENGINE COOLING SYSTEM"). If NG, replace it.

Disconnect and reconnect harness connectors in the circuit. Then retest.

Trouble is not fixed.

Check ECM pin terminals for damage and check the connection of ECM harness connector. Reconnect ECM harness connector and retest.

INSPECTION END

**Engine Coolant Temperature (ECT) Sensor (DTC: 0908) (Cont'd)**

**COMPONENT INSPECTION**

**Engine coolant temperature sensor**

Check resistance as shown in the figure.

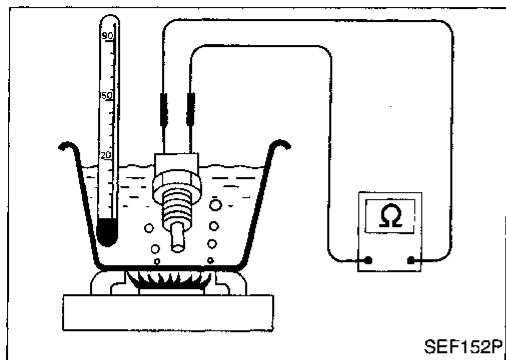

Temperature °C (°F)	Resistance (kΩ)
20 (68)	2.1 - 2.9
50 (122)	0.68 - 1.0
90 (194)	0.236 - 0.260

If NG, replace engine coolant temperature sensor.

GI

MA

EM

LC

**EC**

FE

CL

MT

AT

FA

RA

BR

ST

RS

BT

HA

EL

IDX

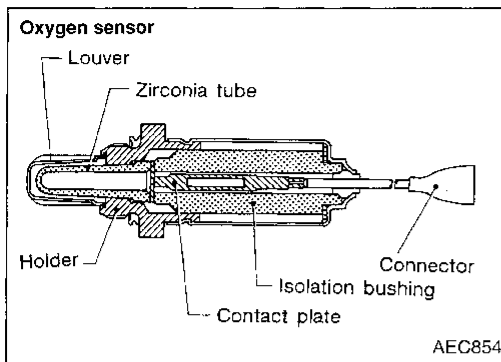

### Front Oxygen Sensor\* (Front O2S) (DTC: 0303)

The front O2S\* is placed into the exhaust manifold. It detects the amount of oxygen in the exhaust gas compared to the outside air. The sensor has a closed-end tube made of ceramic zirconia. The zirconia generates voltage from approximately 1V in richer conditions to 0V in leaner conditions. The sensor signal is sent to the ECM. The ECM adjusts the injection pulse duration to achieve the ideal air-fuel ratio. The ideal air-fuel ratio occurs near the radical change from 1V to 0V.

A heater is used to activate the sensor on M/T models for California and A/T models.

\*: Oxygen sensor (M/T models except for California)  
Heated oxygen sensor (M/T models for California and A/T models)

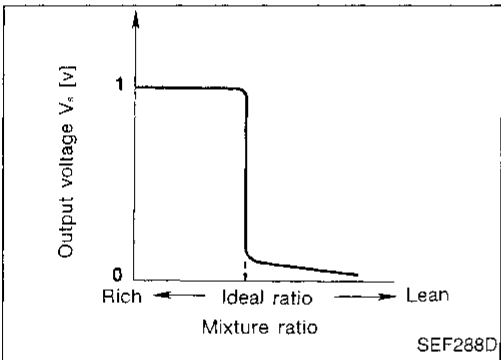
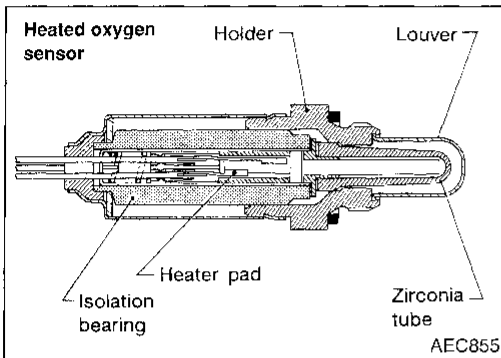

Diagnostic Trouble Code No.	Malfunction is detected when ...	Check Items (Possible Cause)
P0130 0303	<ul style="list-style-type: none"> <li>● An excessively high voltage from the sensor is sent to ECM.</li> <li>● The voltage from the sensor is constantly approx. 0.3V.</li> <li>● The maximum and minimum voltages from the sensor do not reach the specified voltages.</li> <li>● The sensor does not respond between rich and lean within the specified time.</li> </ul>	<ul style="list-style-type: none"> <li>● Harness or connectors (The sensor circuit is open or shorted.)</li> <li>● Front oxygen sensor*</li> <li>● Fuel pressure</li> <li>● Injectors</li> <li>● Intake air leaks</li> </ul>

\*: Oxygen sensor (M/T models except for California)  
Heated oxygen sensor (M/T models for California and A/T models)

☆ MONITOR    ☆ NO FAIL   

CMPS•RPM(REF)	2137rpm
MAS AIR/FL SE	1.96V
COOLAN TEMP/S	84°C
FR O2 SENSOR	0.37V
FR O2 MNTR	LEAN
INJ PULSE	2.6msec

RECORD

SEF084P

### OVERALL FUNCTION CHECK

Use this procedure to check the overall function of the front oxygen sensor circuit. During this check, a DTC might not be confirmed.

- 1) Start engine and warm it up sufficiently.
- 2) Select "MANU TRIG" and "HI SPEED" in "DATA MONITOR" mode with CONSULT, and select "FR O2 SENSOR" and "FR O2 MNTR".
- 3) Hold engine speed at 2,000 rpm under no load during the following steps.
- 4) Touch "RECORD" on CONSULT screen.

Front Oxygen Sensor\* (Front O2S) (DTC: 0303) (Cont'd)

- 5) Check the following.
- "FR O2 MNTR" in "DATA MONITOR" mode changes from "RICH" to "LEAN" to "RICH" 5 times in 10 seconds.
- 5 times (cycles) are counted as shown below:

cycle | 1 | 2 | 3 | 4 | 5 |  
FR O2 MNTR R-L-R-L-R-L-R-L-R

R = "FR O2 MNTR", "RICH"  
L = "FR O2 MNTR", "LEAN"

- "FR O2 SENSOR" voltage goes above 0.6V at least once.
- "FR O2 SENSOR" voltage goes below 0.35V at least once.

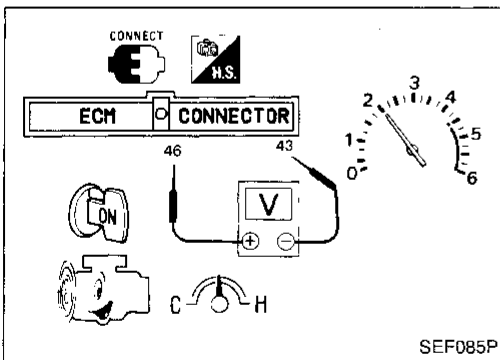
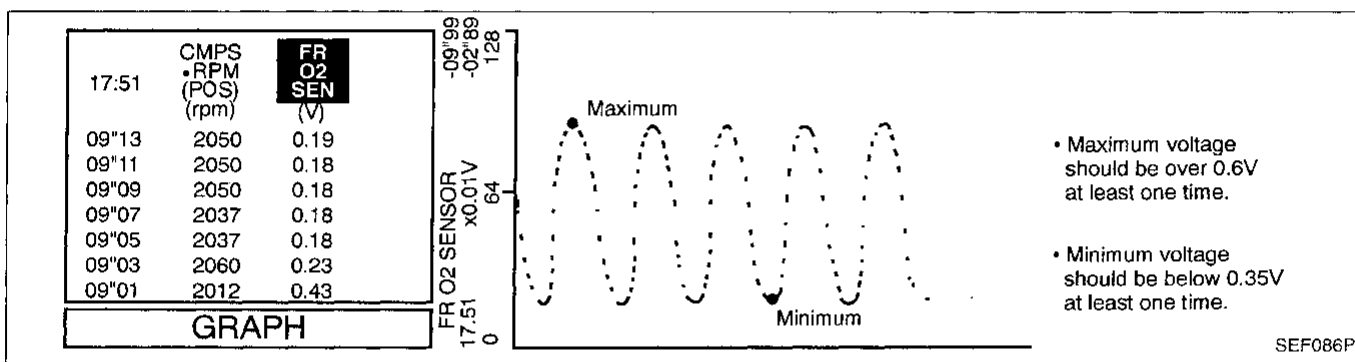

OR

- 1) Start engine and warm it up sufficiently.
- 2) Set voltmeter probes between ECM terminal ④⑥ (sensor signal) and ④③ (engine ground).
- 3) Check the following with engine speed held at 2,000 rpm constant under no load.
  - Malfunction indicator lamp goes on more than 5 times within 10 seconds in Diagnostic Test Mode II (FRONT OXYGEN SENSOR MONITOR).
  - The maximum voltage is over 0.6V at least one time.
  - The minimum voltage is below 0.35V at least one time.

Front Oxygen Sensor\* (Front O2S) (DTC: 0303) (Cont'd)

EC-FRO2-01

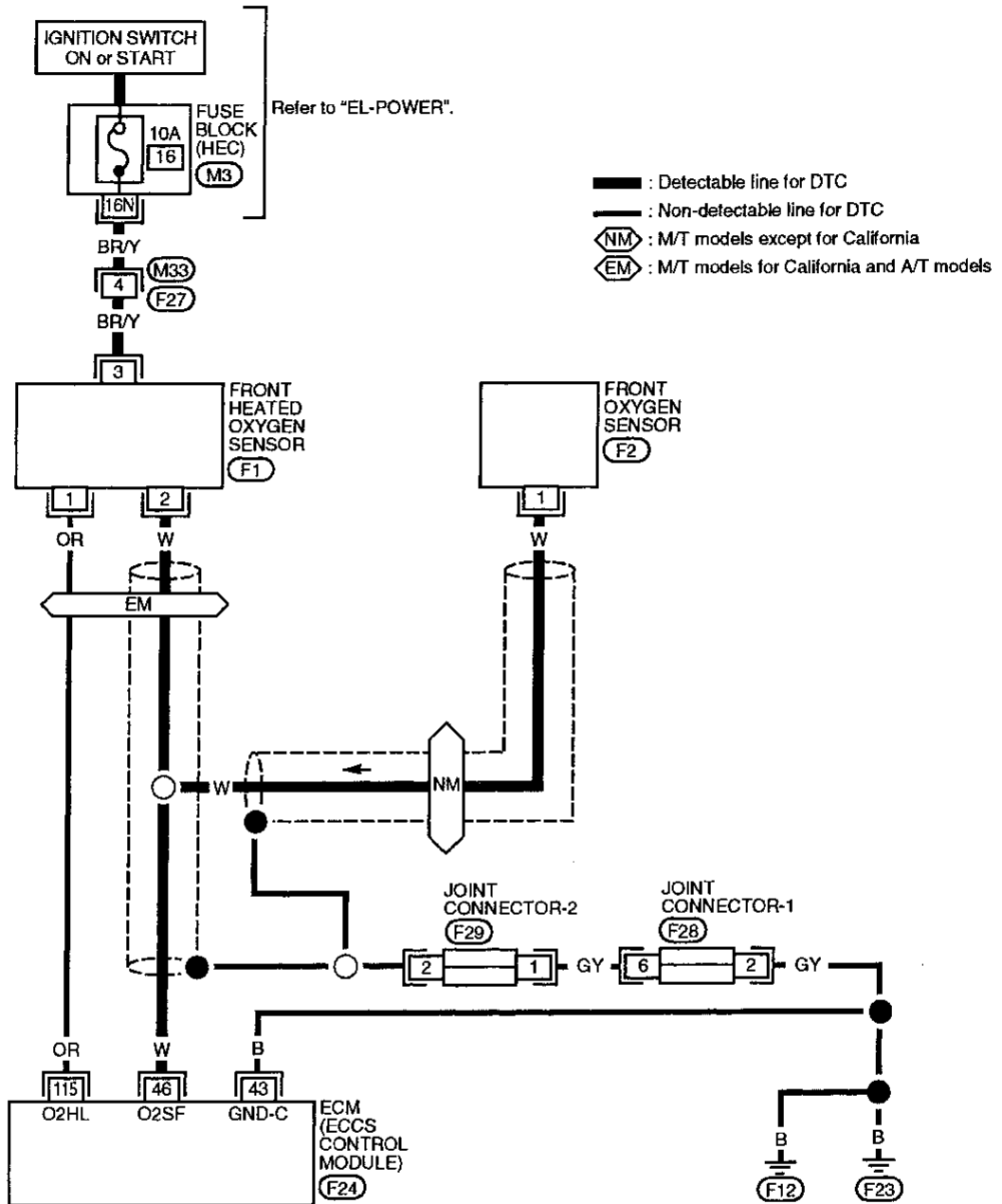

Refer to last page (Foldout page).

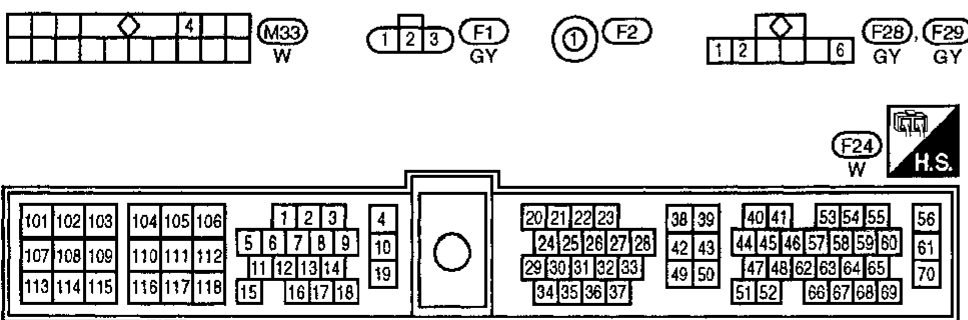

Front Oxygen Sensor\* (Front O2S) (DTC: 0303) (Cont'd)

DIAGNOSTIC PROCEDURE

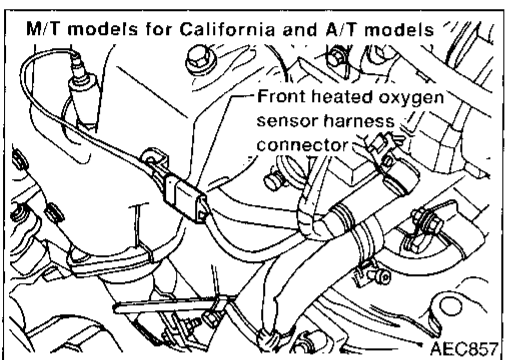
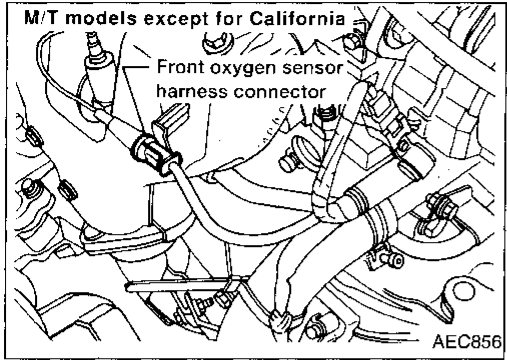

INSPECTION START

**A**

**CHECK INPUT SIGNAL CIRCUIT.**

1. Turn ignition switch "OFF".
2. Disconnect front oxygen sensor harness connector and ECM harness connector.
3. Check harness continuity between ECM terminal (46) and terminal (1) (M/T models except for California), terminal (2) (M/T models for California and A/T models).  
**Continuity should exist.**
4. Check harness continuity between ECM terminal (46) and ground.  
**Continuity should not exist.**  
If OK, check harness for short.

NG → Repair harness or connectors.

OK

Loosen and retighten engine ground screws.

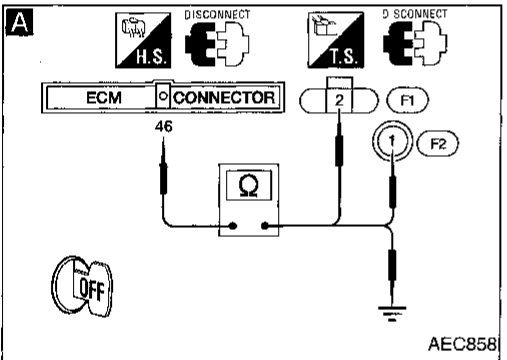

**B**

**CLEAR THE SELF-LEARNING DATA.**

1. Start engine and warm it up sufficiently.
2. Select "SELF-LEARNING CONTROL" in "ACTIVE TEST" mode with CONSULT.
3. Clear the self-learning control coefficient by touching "CLEAR".
4. Run engine for at least 10 minutes at idle speed.  
**Is the DTC P0170 detected?  
Is it difficult to start engine?**

OR

2. Turn ignition switch "OFF" and wait for at least 3 seconds.
3. Disconnect mass air flow sensor harness connector, and restart and run engine for at least 3 seconds at idle speed.
4. Stop engine and reconnect mass air flow sensor harness connector.
5. Make sure diagnostic trouble code No. 0102 is displayed in Diagnostic Test Mode II.
6. Erase the Diagnostic Test Mode II (Self-diagnostic results) memory. Make sure diagnostic trouble code No. 0505 is displayed in Diagnostic Test Mode II.
7. Run engine for at least 10 minutes at idle speed.  
**Is the DTC 0706 detected?  
Is it difficult to start engine?**

Yes → Go to "TROUBLE DIAGNOSIS FOR DTC P0170 (0706)", EC-356.

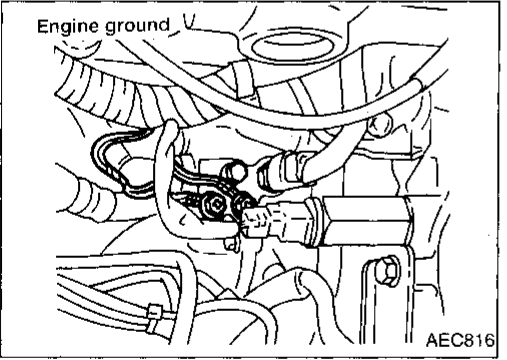

**B**

■ ACTIVE TEST ■	
SELF-LEARN CONTROL	100%
=== MONITOR ===	
CMPS-RPM (REF)	812rpm
COOLAN TEMP/S	93°C
FR O2 SENSOR	0.91V
A/F ALPHA	102%
CLEAR	

No

(Go to next page.)

GI  
MA  
EM  
LC  
EC  
FE  
CL  
MT  
AT  
FA  
RA  
BR  
ST  
RS  
BT  
HA  
EL  
IDX



## Front Oxygen Sensor\* (Front O2S) (DTC: 0303) (Cont'd)

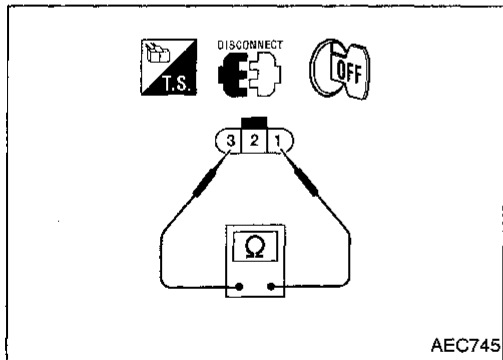
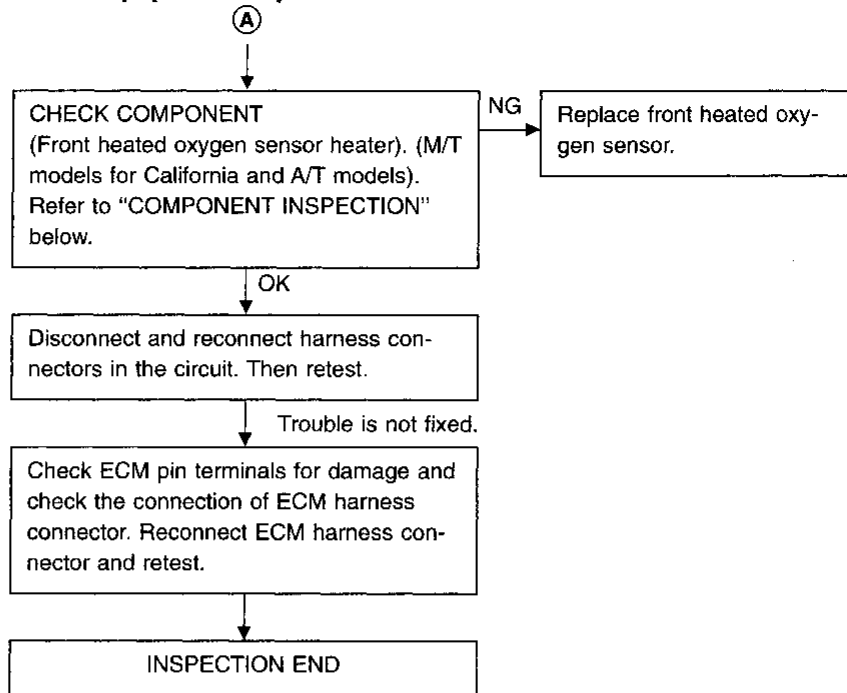

### COMPONENT INSPECTION

#### Front heated oxygen sensor heater

Check resistance between terminals ① and ③.

**Resistance: 3.3 - 6.3Ω [at 25°C (77°F)]**

If NG, replace front heated oxygen sensor.

#### CAUTION:

Discard any heated oxygen sensor which has been dropped from a height of more than 0.5 m (19.7 in) onto a hard surface such as a concrete floor; use a new one.

**Closed Loop Control (DTC: 0307)**

- The closed loop control has one trip detection logic.

Diagnostic Trouble Code No.	Malfunction is detected when ...	Check Items (Possible Cause)
P0130 0307	<ul style="list-style-type: none"> <li>• The closed loop control function does not operate even when vehicle is driving in the specified condition.</li> </ul>	<ul style="list-style-type: none"> <li>• The front heated oxygen sensor* circuit is open or short.</li> <li>• Front heated oxygen sensor*.</li> <li>• Front heated oxygen sensor heater (M/T models for California and A/T models)</li> </ul>

\*: Oxygen sensor (M/T models except for California)  
Heated oxygen sensor (M/T models for California and A/T models)

GI  
MA  
EM  
LC  
EC  
FE  
CL  
MT

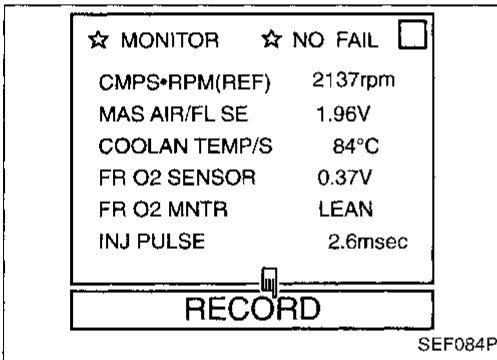

**OVERALL FUNCTION CHECK**

Use this procedure to check the overall function of the closed loop control. During this check, a DTC might not be confirmed.

- 1) Start engine and warm it up sufficiently.
  - 2) Select "MANU TRIG" and "HI SPEED" in "DATA MONITOR" mode with CONSULT, and select "FR O2 SENSOR" and "FR O2 MNTR".
  - 3) Hold engine speed at 2,000 rpm under no load during the following steps.
  - 4) Touch "RECORD" on CONSULT screen.
  - 5) Check the following.
    - "FR O2 MNTR" in "DATA MONITOR" mode changes from "RICH" to "LEAN" to "RICH" 5 times in 10 seconds.
- 5 times (cycles) are counted as shown below:

cycle | 1 | 2 | 3 | 4 | 5 |  
FR O2 MNTR R-L-R-L-R-L-R-L-R

R = "FR O2 MNTR", "RICH"  
L = "FR O2 MNTR", "LEAN"

- OR
- 1) Start engine and warm it up sufficiently.
  - 2) Check that malfunction indicator lamp goes on more than 5 times in 10 seconds while keeping at 2,000 rpm in Diagnostic Test Mode II.

AT  
FA  
RA  
BR  
ST  
RS  
BT  
HA  
EL

**DIAGNOSTIC PROCEDURE**

Refer to TROUBLE DIAGNOSIS FOR DTC P0130, EC-342.  
Refer to TROUBLE DIAGNOSIS FOR DTC P0135, EC-348 (M/T models for California and A/T models).

IDX

**Front Heated Oxygen Sensor Heater (DTC: 0901) (M/T models for California and A/T models)**

**SYSTEM DESCRIPTION**

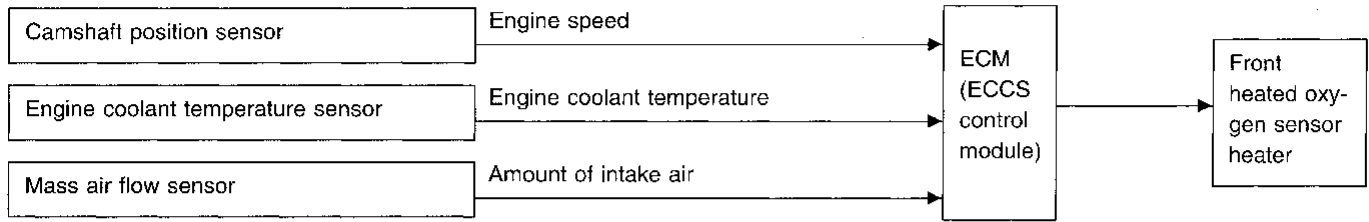



The ECM performs ON/OFF control of the front heated oxygen sensor heater corresponding to the engine conditions.

Engine speed (rpm)	Engine condition	Front heated oxygen sensor heater
Above 3,200	---	OFF
Below 3,200	Heavy load after warmed up	OFF
	Except above	ON

Diagnostic Trouble Code No.	Malfunction is detected when ....	Check Items (Possible Cause)
P0135 0901	<ul style="list-style-type: none"> <li>The current amperage in the front heated oxygen sensor heater circuit is out of the normal range. (An improper voltage drop signal is sent to ECM through the front heated oxygen sensor heater.)</li> </ul>	<ul style="list-style-type: none"> <li>Harness or connectors (The front heated oxygen sensor heater circuit is open or shorted.)</li> <li>Front heated oxygen sensor heater</li> </ul>

**DIAGNOSTIC TROUBLE CODE DETECTING CONDITION**

- 
  - Turn ignition switch "ON" and select "DATA MONITOR" mode with CONSULT.
  - Start engine and run it for at least 35 seconds at idle speed.
- OR
- 
  - Start engine and run it for at least 35 seconds at idle speed.
  - Select "MODE 3" with GST.
- OR
- 
  - Start engine and run it for at least 35 seconds at idle speed.
  - Turn ignition switch "OFF", wait at least 5 seconds and then turn "ON".
  - Perform "Diagnostic Test Mode II" (Self-diagnostic results) with ECM.

Front Heated Oxygen Sensor Heater (DTC: 0901) (M/T models for California and A/T models) (Cont'd)

EC-FRO2/H-01

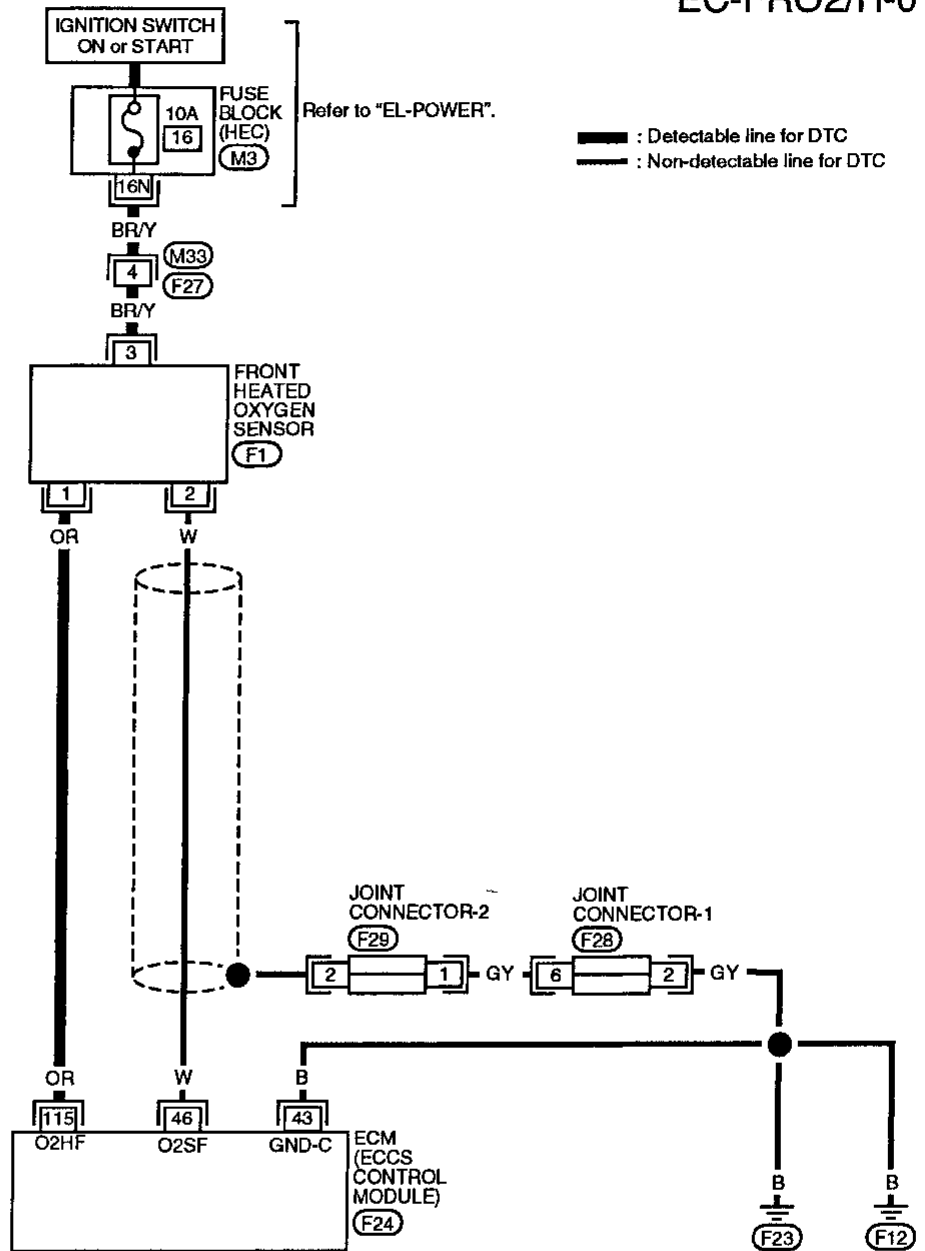

Refer to last page (Foldout page).

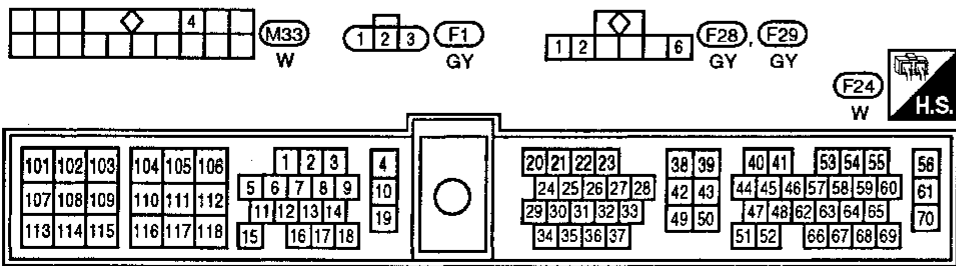

GI  
MA  
EM  
LC  
**EC**  
FE  
CL  
MT  
AT  
FA  
RA  
BR  
ST  
RS  
BT

## Front Heated Oxygen Sensor Heater (DTC: 0901) (M/T models for California and A/T models) (Cont'd)

### DIAGNOSTIC PROCEDURE

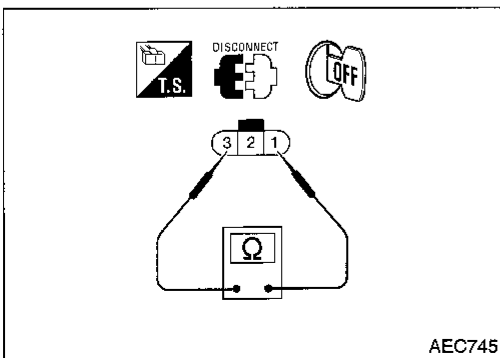
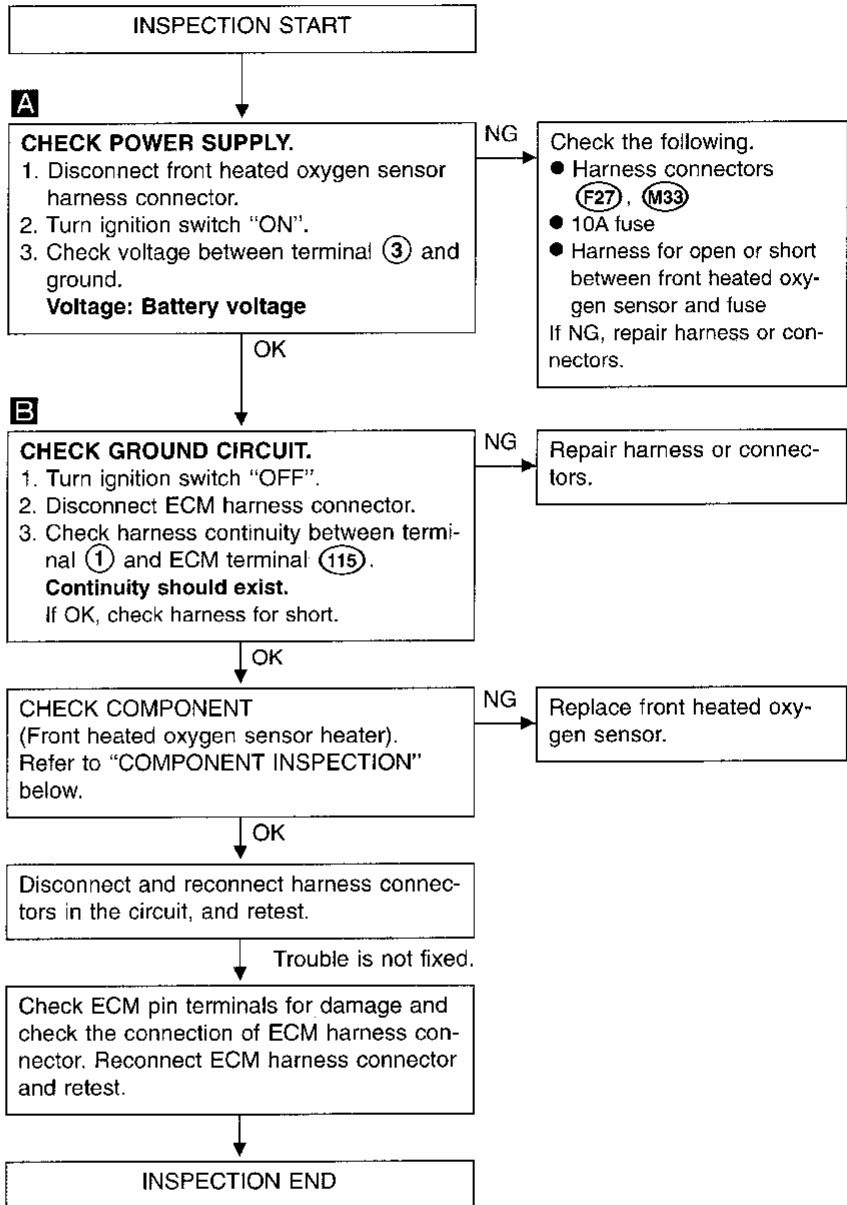
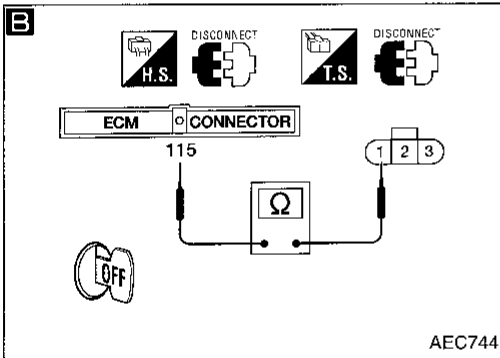
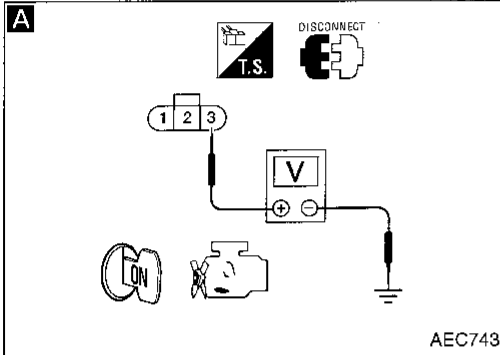
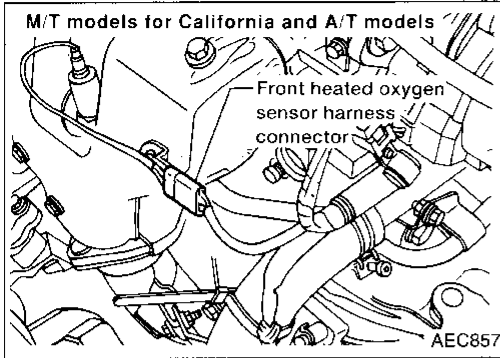

### COMPONENT INSPECTION

#### Front heated oxygen sensor heater

Check resistance between terminals ① and ③.

**Resistance: 3.3 - 6.3Ω at 25°C (77°F)**

If NG, replace front heated oxygen sensor.

#### CAUTION:

Discard any heated oxygen sensor which has been dropped from a height of more than 0.5 m (19.7 in) onto a hard surface such as a concrete floor; use a new one.

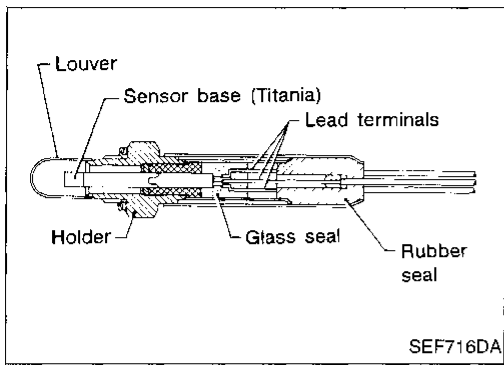

### Rear Heated Oxygen Sensor (Rear HO2S) (DTC: 0707)

The rear heated oxygen sensor (Rear HO2S), after the three way catalyst, monitors the oxygen level in the exhaust gas. Even if the switching characteristics of the front heated oxygen sensor\* shift, the air-fuel ratio is controlled to stoichiometric by the signal from the rear heated oxygen sensor.

This sensor is made of ceramic titania. The electric resistance of ceramic titania drastically changes at the ideal air-fuel ratio. The output voltage of the sensor, depending on its resistance, is approximately 0 to 2.2V.

The ECM supplies the sensor with approximately 2V and then measures the output voltage. About 0V means lean and about 2V means rich.

Under normal conditions, the rear heated oxygen sensor is not used for engine control operation.

It is used only for the on-board diagnosis of three way catalyst.

\*: Oxygen sensor (M/T models except for California)  
Heated oxygen sensor (M/T models for California and A/T models)

### ON-BOARD DIAGNOSIS LOGIC

The rear heated oxygen sensor has a much longer switching time between rich and lean than the front oxygen sensor. The oxygen storage capacity before the three way catalyst causes the longer switching time. To judge the malfunctions of rear heated oxygen sensor, ECM monitors the sensor's voltage value and the switching response during the various driving condition such as fuel-cut.

Diagnostic Trouble Code No.	Malfunction is detected when ...	Check Items (Possible Cause)
P0136 0707	<ul style="list-style-type: none"> <li>An excessively high voltage from the sensor is sent to ECM.</li> </ul>	<ul style="list-style-type: none"> <li>Harness or connectors (The sensor circuit is open.)</li> <li>Rear heated oxygen sensor</li> </ul>
	<ul style="list-style-type: none"> <li>The specified maximum and minimum voltages from the sensor are not reached.</li> <li>It takes more than the specified time for the sensor to respond between rich and lean.</li> </ul>	<ul style="list-style-type: none"> <li>Harness or connectors (The sensor circuit is shorted.)</li> <li>Rear heated oxygen sensor</li> <li>Fuel pressure</li> <li>Injectors</li> <li>Intake air leaks</li> </ul>

## Rear Heated Oxygen Sensor (Rear HO2S) (DTC: 0707) (Cont'd)

### OVERALL FUNCTION CHECK

Use this procedure to check the overall function of the rear heated oxygen sensor circuit. During this check a DTC might not be confirmed.

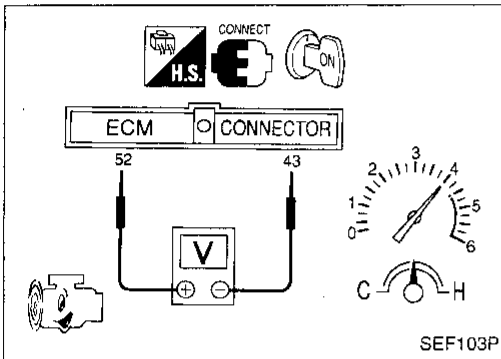
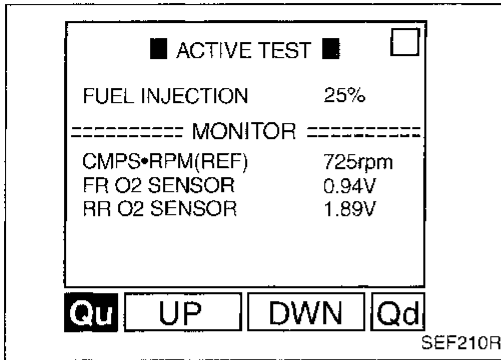

- 1) Start engine and warm it up sufficiently.
- 2) Select "FUEL INJECTION" in "ACTIVE TEST" mode, and select "RR O2 SENSOR" as the monitor item with CONSULT.
- 3) Check "RR O2 SENSOR" at idle speed when adjusting "FUEL INJECTION" to  $\pm 25\%$ .  
**"RR O2 SENSOR" should be above 0.6V at least once when the "FUEL INJECTION" is +25%.**  
**"RR O2 SENSOR" should be below 0.55V at least once when the "FUEL INJECTION" is -25%.**

OR

- 1) Start engine and warm it up sufficiently.
- 2) Set voltmeter probes between ECM terminals ⑤② (sensor signal) and ④③ (engine ground).
- 3) Check the voltage when revving up to 4,000 rpm under no load at least 10 times.  
(Depress and release accelerator pedal as soon as possible.)

**The voltage should be above 0.6V at least once.**  
**If the voltage is above 0.6V at step 3, skip step 4.**

- 4) Check the voltage when revving up to 6,000 rpm under no load. Or keep vehicle at idling for 10 minutes, then check the voltage. Or check the voltage when coasting from 80 km/h (50 MPH) in 3rd gear position.

**The voltage should be below 0.55V at least once.**

**Note:** After starting the engine, the output voltage of the rear heated oxygen sensor indicates higher voltage (approx. 5V at highest) than the normal operating range for about 7 seconds. This is due to checking for open circuits in rear heated oxygen sensor by on-board diagnosis. Therefore, if you measure the voltage (at ECM terminal ⑤②) during this diagnosis, the higher voltage will appear. (CONSULT will also show the higher voltage, GST may show approx. 0V.) This is not a malfunction even though it is out of the normal range.

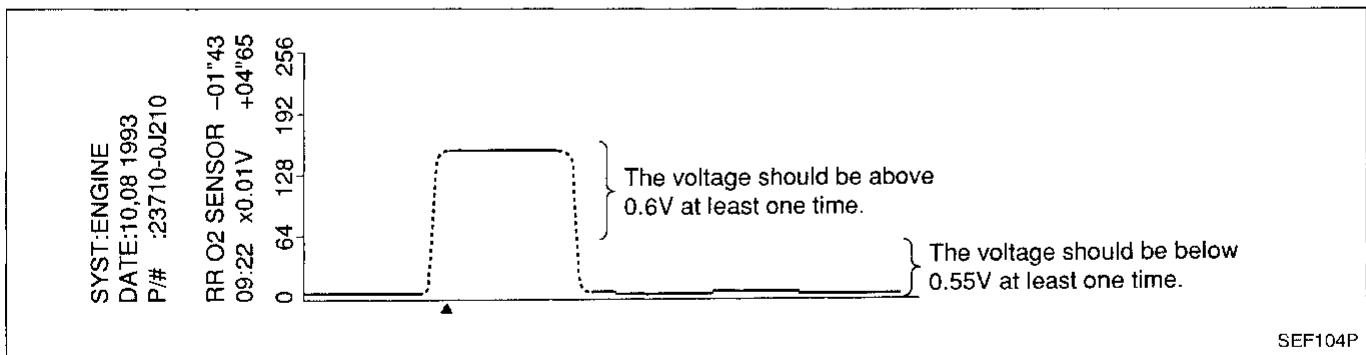

Rear Heated Oxygen Sensor (Rear HO2S)  
(DTC: 0707) (Cont'd)

EC-RRO2-01

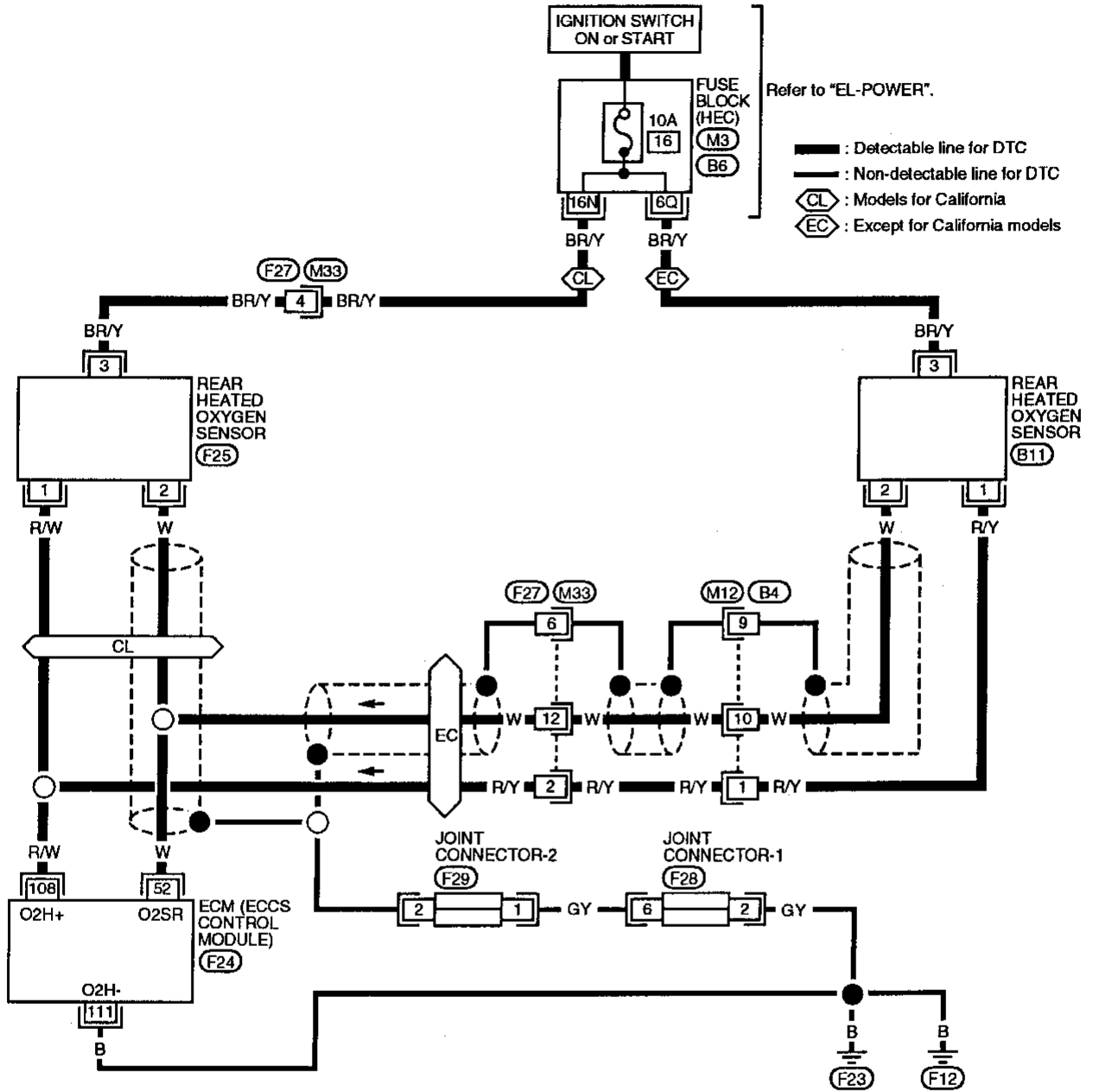

Refer to "EL-POWER".

— : Detectable line for DTC  
 - - - : Non-detectable line for DTC  
 CL : Models for California  
 EC : Except for California models

Refer to last page (Foldout page).

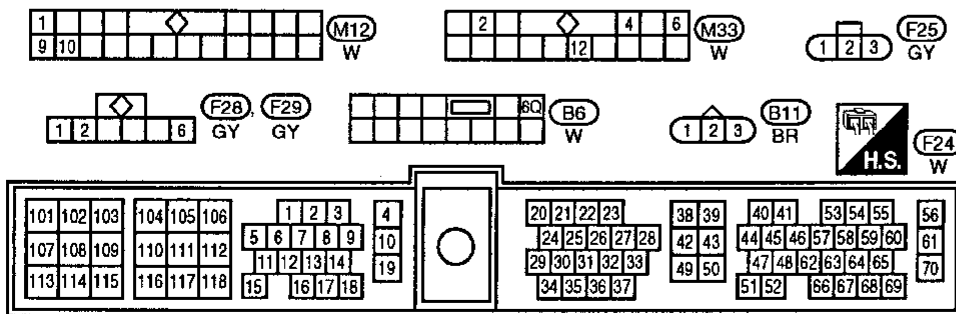

GI  
 NA  
 EM  
 LC  
**EC**  
 FE  
 CL  
 MT  
 AT  
 FA  
 RA  
 BR  
 ST  
 RS  
 BT  
 HA  
 EL  
 IDX



# Rear Heated Oxygen Sensor (Rear HO2S) (DTC: 0707) (Cont'd)

## DIAGNOSTIC PROCEDURE

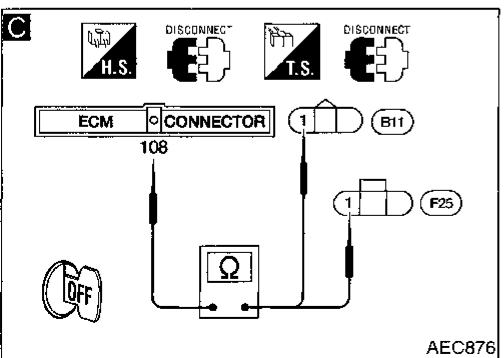
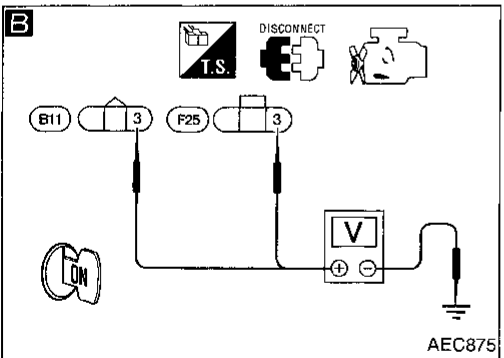
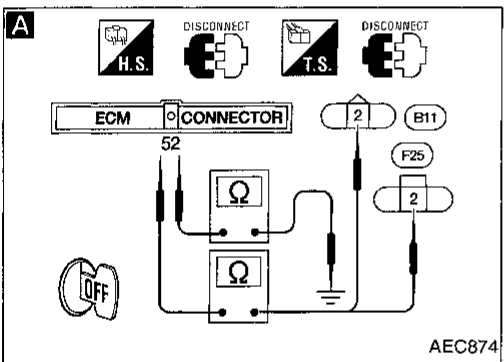
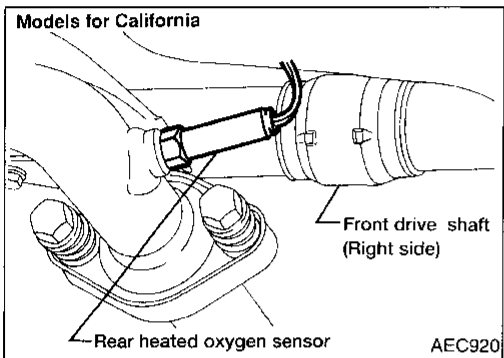
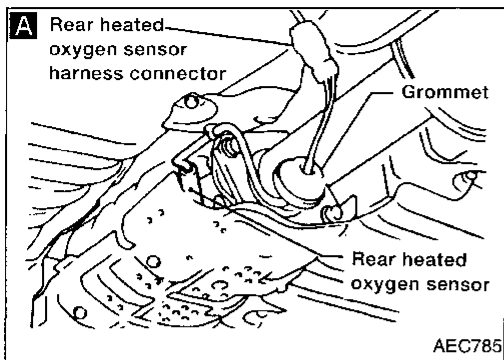

INSPECTION START

**A**  
**CHECK INPUT SIGNAL CIRCUIT.**  
1. Turn ignition switch "OFF".  
2. Remove grommet from underbody near three way catalyst to remove rear heated oxygen sensor harness connector.  
3. Disconnect rear heated oxygen sensor harness connector and ECM harness connector.  
4. Check harness continuity between ECM terminal 52 and terminal 2.  
**Continuity should exist.**  
5. Check harness continuity between ECM terminal 52 and ground.  
**Continuity should not exist.**  
If OK, check harness for short.

NG → Check the following.  
● Harness connectors (F27), (M33) (Except for California models)  
● Harness connectors (M12), (B14) (Except for California models)  
● Harness for open or short between rear heated oxygen sensor and ECM  
If NG, repair harness or connectors.

OK → Loosen and retighten engine ground screws.

**B**  
**CHECK POWER SUPPLY.**  
1. Turn ignition switch "ON".  
2. Check voltage between terminal 3 and ground.  
**Voltage: Battery voltage**

NG → Repair harness or connectors.

**C**  
**CHECK GROUND CIRCUIT.**  
1. Turn ignition switch "OFF".  
2. Disconnect ECM harness connector.  
3. Check harness continuity between terminal 1 and ECM terminal 108.  
**Continuity should exist.**  
If OK, check harness for short.

NG → Check the following.  
● Harness connectors (except for California) (B4), (M12)  
● Harness connectors (except for California) (M33), (F27)  
● Harness for open or short between rear heated oxygen sensor and ECM  
If NG, repair harness or connectors.

OK → (Go to next page.)

Rear Heated Oxygen Sensor (Rear HO2S)  
(DTC: 0707) (Cont'd)

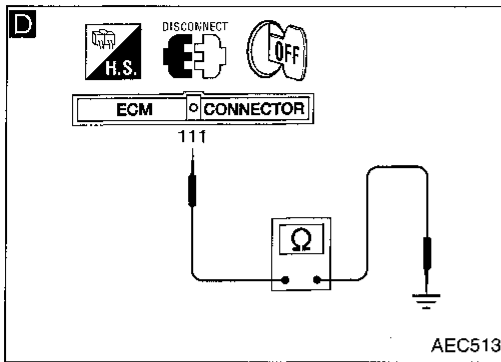

**D**

**CHECK ECM GROUND CIRCUIT.**  
Check harness continuity between ECM terminal (111) and ground.  
**Continuity should exist.**  
If OK, check harness for short.

NG → Repair harness or connectors.

OK →

**D**

**CHECK COMPONENT**  
(Rear heated oxygen sensor heater).  
Refer to "COMPONENT INSPECTION" below.

NG → Replace rear heated oxygen sensor.

OK →

Disconnect and reconnect harness connectors in the circuit. Then retest.

Trouble is not fixed.

Check ECM pin terminals for damage and check the connection of ECM harness connector. Reconnect ECM harness connector and retest.

INSPECTION END

GI  
MA  
EM  
LC  
EC  
FE  
CL  
MT  
AT  
FA  
RA  
BR  
ST  
RS  
BT  
HA  
EL  
IDX

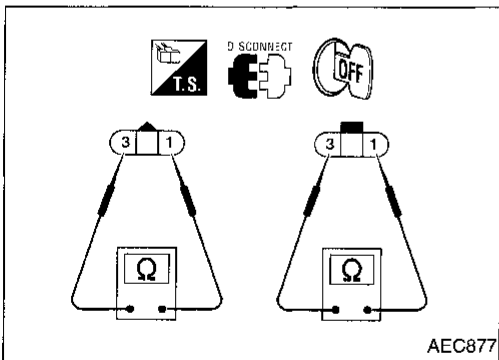

**COMPONENT INSPECTION**

**Rear heated oxygen sensor heater**

Check resistance between terminals ① and ③.

**Resistance: 5.2 - 8.2Ω [at 25°C (77°F)]**

If NG, replace the rear heated oxygen sensor.

**CAUTION:**

Discard any heated oxygen sensor which has been dropped from a height of more than 0.5 m (19.7 in) onto a hard surface such as a concrete floor; use a new one.

**Fuel Injection System Function (DTC: 0706)**

**ON-BOARD DIAGNOSIS LOGIC**

With the Air/Fuel Mixture Ratio Self-Learning Control, the actual mixture ratio can be brought closely to the theoretical mixture ratio based on the mixture ratio feedback signal from the front oxygen sensor\*. The ECM calculates the necessary compensation to correct the offset between the actual and the theoretical ratios.

In case the amount of the compensation value is extremely large, the ECM judges the condition as the fuel injection system malfunction and lights up the MIL (2 trip detection logic).

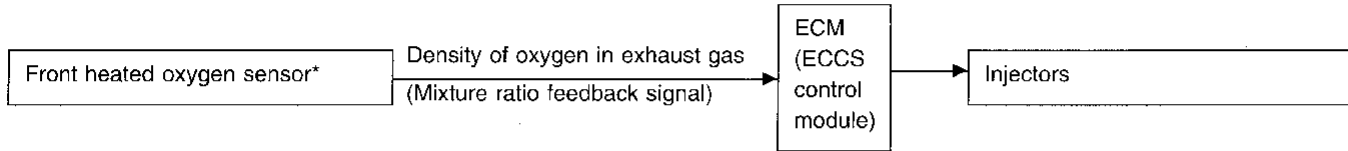

Diagnostic Trouble Code No.	Malfunction is detected when ...	Check Items (Possible Cause)
P0170 0706	<ul style="list-style-type: none"> <li>● Fuel injection system does not operate properly.</li> <li>● The amount of mixture ratio compensation is excessive. (The mixture ratio is too lean or too rich.)</li> </ul>	<ul style="list-style-type: none"> <li>● Intake air leaks</li> <li>● Front oxygen sensor*</li> <li>● Injectors</li> <li>● Exhaust gas leaks</li> <li>● Incorrect fuel pressure</li> <li>● Lack of fuel</li> <li>● Mass air flow sensor</li> </ul>

\*: Oxygen sensor (M/T models except for California)  
Heated oxygen sensor (M/T models for California and A/T models)

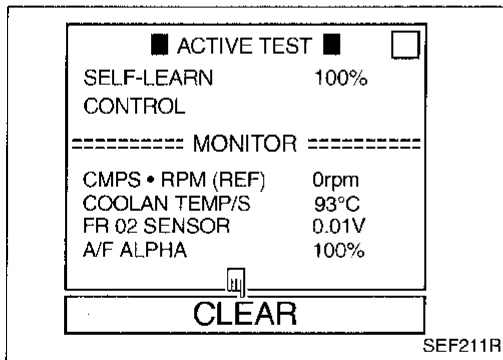

**DIAGNOSTIC TROUBLE CODE CONFIRMATION PROCEDURE (Overall)**

- 1) Start engine and warm it up sufficiently.
- 2) Turn ignition switch "OFF" and wait at least 5 seconds.
- 3) Turn ignition switch "ON" and select "SELF-LEARN CONTROL" in "ACTIVE TEST" mode with CONSULT.
- 4) Clear the self-learning control coefficient by touching "CLEAR".
- 5) Select "DATA MONITOR" mode with CONSULT.
- 6) Start engine again and run it for at least 10 minutes at idle speed.  
The DTC P0170 should be detected at this stage, if a malfunction exists.
- 7) If it is difficult to start engine at step 6, the fuel injection system has a malfunction, too.

OR

## Fuel Injection System Function (DTC: 0706) (Cont'd)

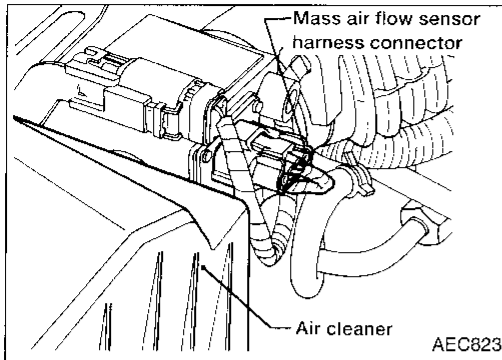

- 1) Disconnect mass air flow sensor harness connector.
- 2) Start engine and run it for at least 3 seconds at idle speed.
- 3) Stop engine and reconnect mass air flow sensor harness connector.
- 4) Turn ignition switch "ON".
- 5) Perform Diagnostic Test Mode II (Self-diagnostic results) with ECM. Make sure DTC 0102 is detected.
- 6) Erase the DTC 0102 by changing from Diagnostic Test Mode II to Diagnostic Test Mode I.
- 7) Perform Diagnostic Test Mode II (Self-diagnostic results) with ECM. Make sure DTC 0505 is detected.
- 8) Start engine again and run it for at least 10 minutes at idle speed.  
The DTC 0706 should be detected at this stage, if a malfunction exists.
- 9) If it is difficult to start engine at step 8, the fuel injection system also has a malfunction.

GI

MA

EM

LC

**EC**

FE

CL

MT

AT

FA

RA

BR

ST

RS

BT

HA

EL

DX

Fuel Injection System Function (DTC: 0706)  
(Cont'd)

EC-FUEL-01

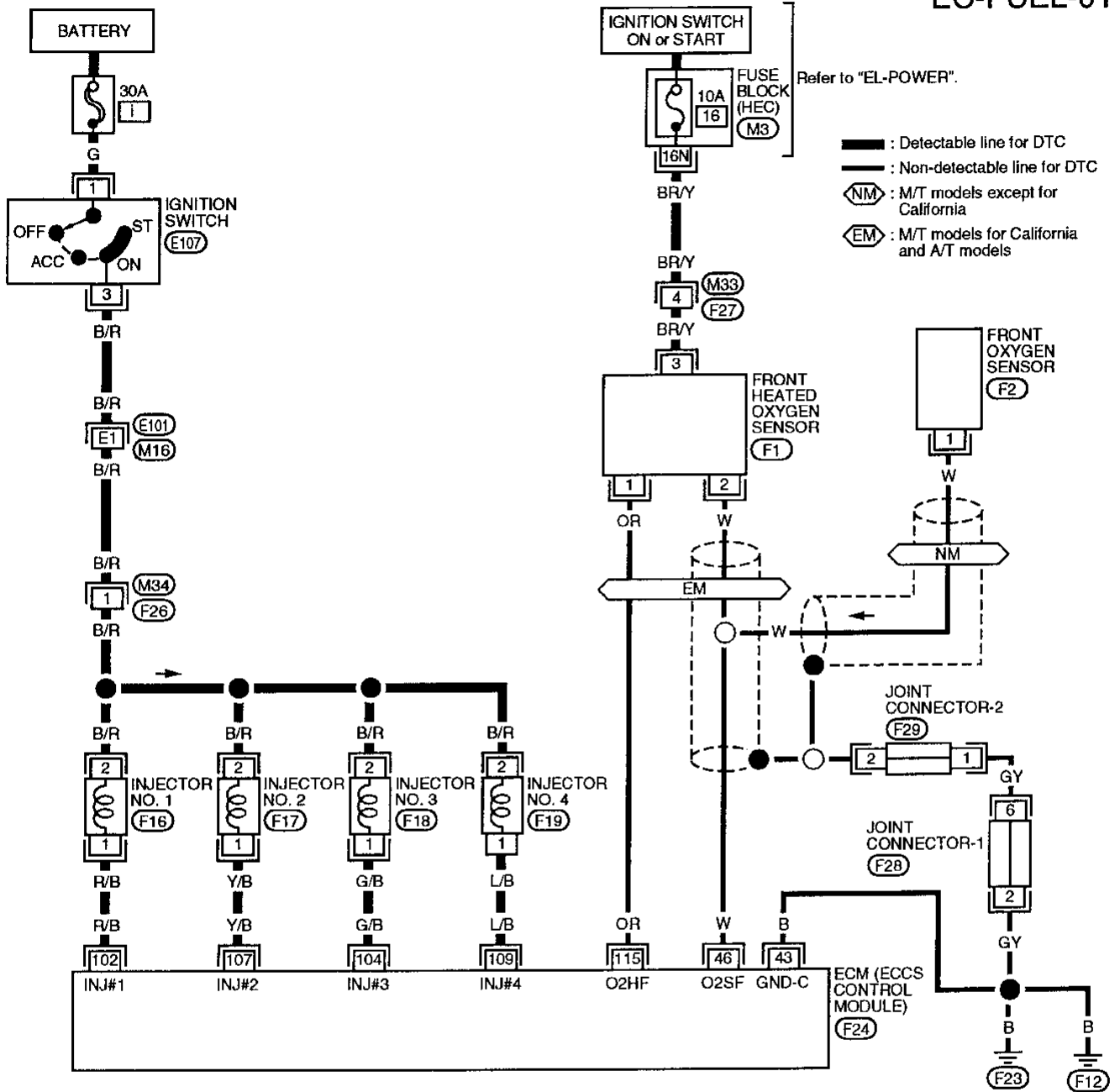

Refer to last page (Foldout page).

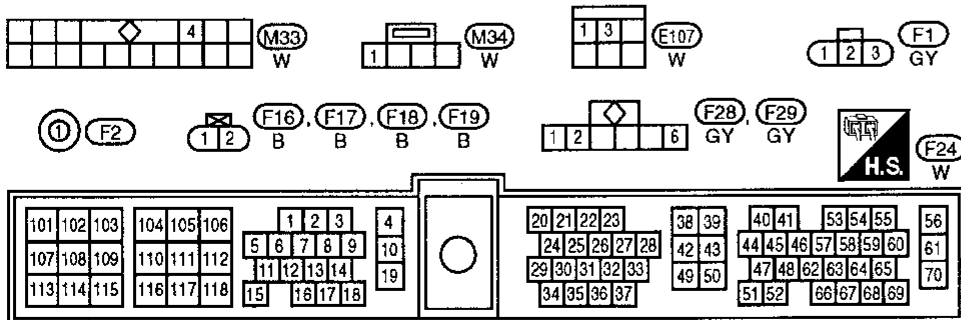

Fuel Injection System Function (DTC: 0706)  
(Cont'd)

DIAGNOSTIC PROCEDURE

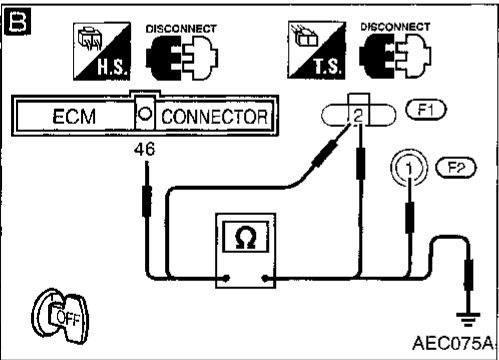
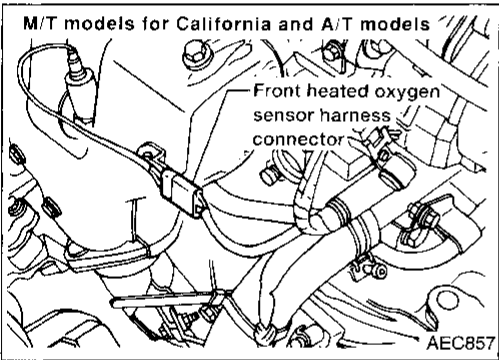
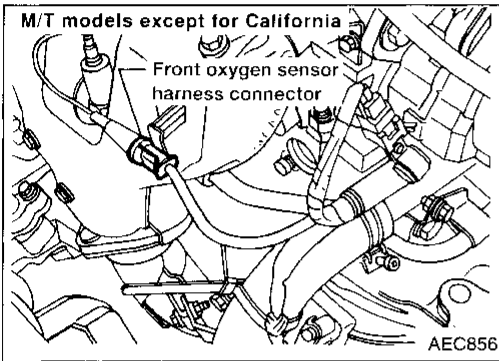
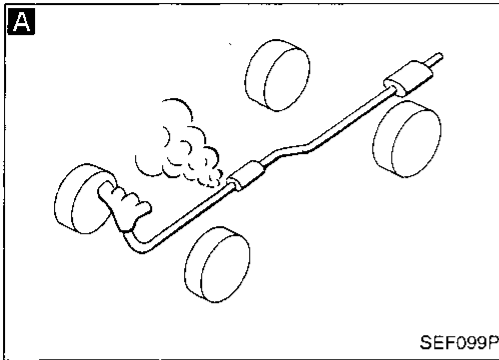

INSPECTION START

**A**  
**CHECK EXHAUST AIR LEAK.**  
Start engine and run it at idle. Listen for an exhaust air leak before three way catalyst.

NG → Repair or replace.

OK ↓

**CHECK FOR INTAKE AIR LEAK.**  
Start engine and run it at idle. Listen for an intake air leak after mass air flow sensor.

NG → Repair or replace.

OK ↓

**B**  
**CHECK FRONT OXYGEN SENSOR.**

1. Turn ignition switch "OFF".
2. Disconnect front oxygen sensor\* harness connector and ECM harness connector.
3. Check harness continuity between ECM terminal ④⑥ and terminal ① (M/T models except for California) or terminal ② (M/T models for California and A/T models).  
**Continuity should exist.**
4. Check harness continuity between ECM terminal ④⑥ (or terminal ②) and ground.  
**Continuity should not exist.**  
If OK, check harness for short.

NG → Repair harness or connectors.

OK ↓

**CHECK FUEL PRESSURE.**

1. Release fuel pressure to zero. (Refer to EC-0.)
2. Install fuel pressure gauge and check fuel pressure.

**At idle:**  
Approx. 235 kPa (2.4 kg/cm<sup>2</sup>, 34 psi)

**A few seconds after ignition switch is turned OFF to ON:**  
Approx. 294 kPa (3.0 kg/cm<sup>2</sup>, 43 psi)

NG → Check fuel pump and circuit. Refer to EC-444.

OK ↓

\*: Oxygen sensor (M/T models except for California)  
Heated oxygen sensor (M/T models for California and A/T models)

**CHECK MASS AIR FLOW SENSOR.**

Check "MASS AIR FLOW" in "DATA MONITOR" mode with CONSULT.

**1.0 - 4.0 g<sub>m</sub>/sec: at idling**  
**5.0 - 10.0 g<sub>m</sub>/sec: at 2,500 rpm**

OR

Check "mass air flow" in MODE 1 with GST.

**1.0 - 4.0 g<sub>m</sub>/sec: at idling**  
**5.0 - 10.0 g<sub>m</sub>/sec: at 2,500 rpm**

NG → Check connectors for rusted terminals or loose connections in the mass air flow sensor circuit or engine grounds. Refer to EC-318.

OK ↓

(Go to next page.)

GI  
MA  
EM  
LC  
EC  
FE  
CL  
MT  
AT  
FA  
RA  
BR  
ST  
RS  
BT  
HA  
EL  
IDX

Fuel Injection System Function (DTC: 0706)  
(Cont'd)

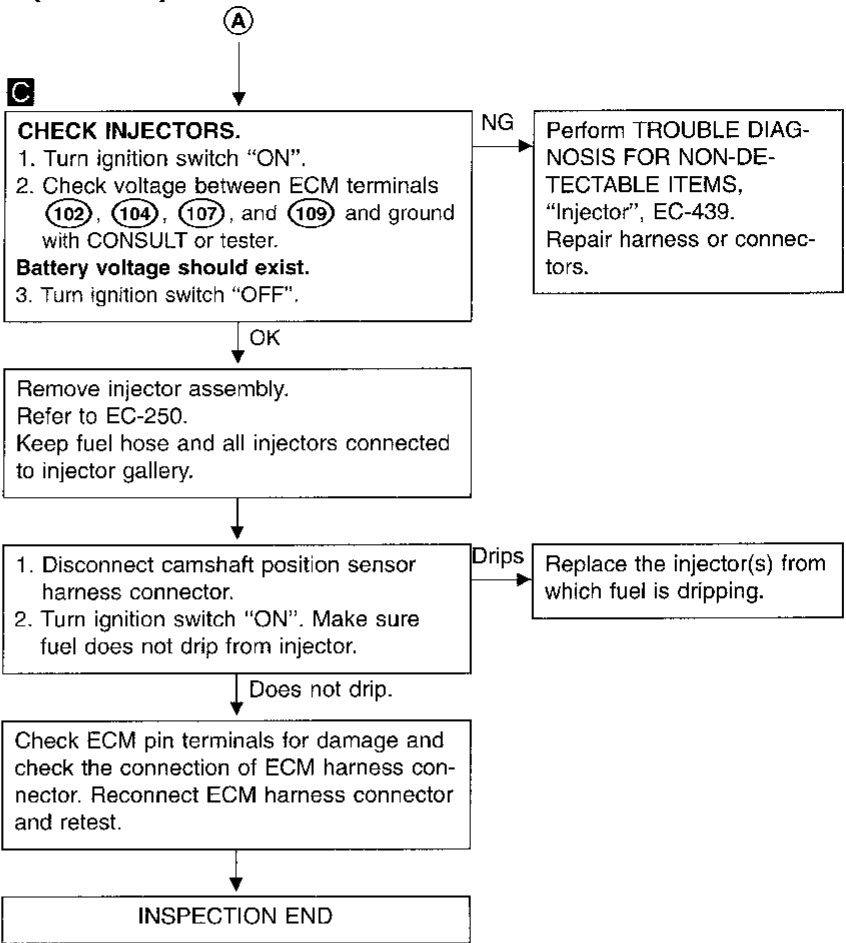
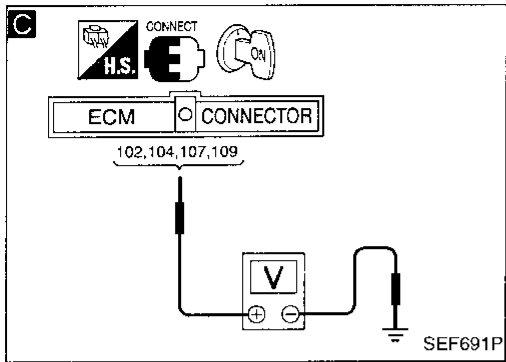

## No. 4 - 1 Cylinder Misfire, Multiple Cylinder Misfire (DTC: 0701 - 0605)

### ON-BOARD DIAGNOSIS LOGIC

If a misfire occurs, the engine speed will fluctuate. If the fluctuation is detected by the crankshaft position sensor (OBD), the misfire is diagnosed.

The misfire detection logic consists of the following two conditions.

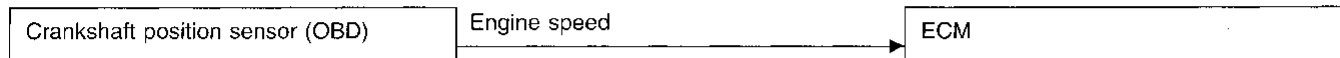

#### 1. One Trip Detection Logic (Three Way Catalyst Damage)

When a misfire is detected which will overheat and damage the three way catalyst, the malfunction indicator lamp (MIL) will start blinking; even during the first trip. In this condition, ECM monitors the misfire every 200 revolutions.

If the misfire frequency decreases to a level that will not damage the three way catalyst, the MIL will change from blinking to lighting up.

(After the first trip detection, the MIL will light up from engine starting. If a misfire is detected that will cause three way catalyst damage, the MIL will start blinking.)

#### 2. Two Trip Detection Logic (Exhaust quality deterioration)

When a misfire that will not damage the three way catalyst (but will affect exhaust emission) occurs, the malfunction indicator lamp will light up based on the second consecutive trip detection logic. In this condition, ECM monitors the misfire for each 1,000 revolutions of the engine.

Diagnostic Trouble Code No.	Malfunction is detected when ...	Check Items (Possible Cause)
P0300 (0701)	● Multiple cylinders misfire.	● Improper spark plug ● Insufficient compression
P0301 (0608)	● No. 1 cylinder misfires.	● Incorrect fuel pressure ● EGR valve
P0302 (0607)	● No. 2 cylinder misfires.	● Injector circuit is open or shorted ● Injectors
P0303 (0606)	● No. 3 cylinder misfires.	● Intake air leak ● Ignition secondary circuit is open or shorted
P0304 (0605)	● No. 4 cylinder misfires.	● Lack of fuel ● Magnetized flywheel (drive plate)

### DIAGNOSTIC TROUBLE CODE CONFIRMATION PROCEDURE (Overall)

- 1) Turn ignition switch "ON", and select "DATA MONITOR" mode with CONSULT.
- 2) Start engine and warm it up sufficiently.
- 3) Turn ignition switch "OFF" and wait at least 5 seconds.
- 4) Start engine again and drive at 1,500 - 4,000 rpm for at least 10 minutes.

OR

- 1) Start engine and warm it up sufficiently.
- 2) Turn ignition switch "OFF" and wait at least 5 seconds.
- 3) Start engine again and drive at 1,500 - 4,000 rpm for at least 10 minutes.
- 4) Select "MODE 3" with GST.

OR

- 1) Start engine and warm it up sufficiently.
- 2) Turn ignition switch "OFF" and wait at least 5 seconds.
- 3) Start engine again and drive at 1,500 - 4,000 rpm for at least 10 minutes.
- 4) Perform "Diagnostic Test Mode II (Self-diagnostic results)" with ECM.



**No. 4 - 1 Cylinder Misfire, Multiple Cylinder Misfire (DTC: 0701 - 0605) (Cont'd)**

**DIAGNOSTIC PROCEDURE**

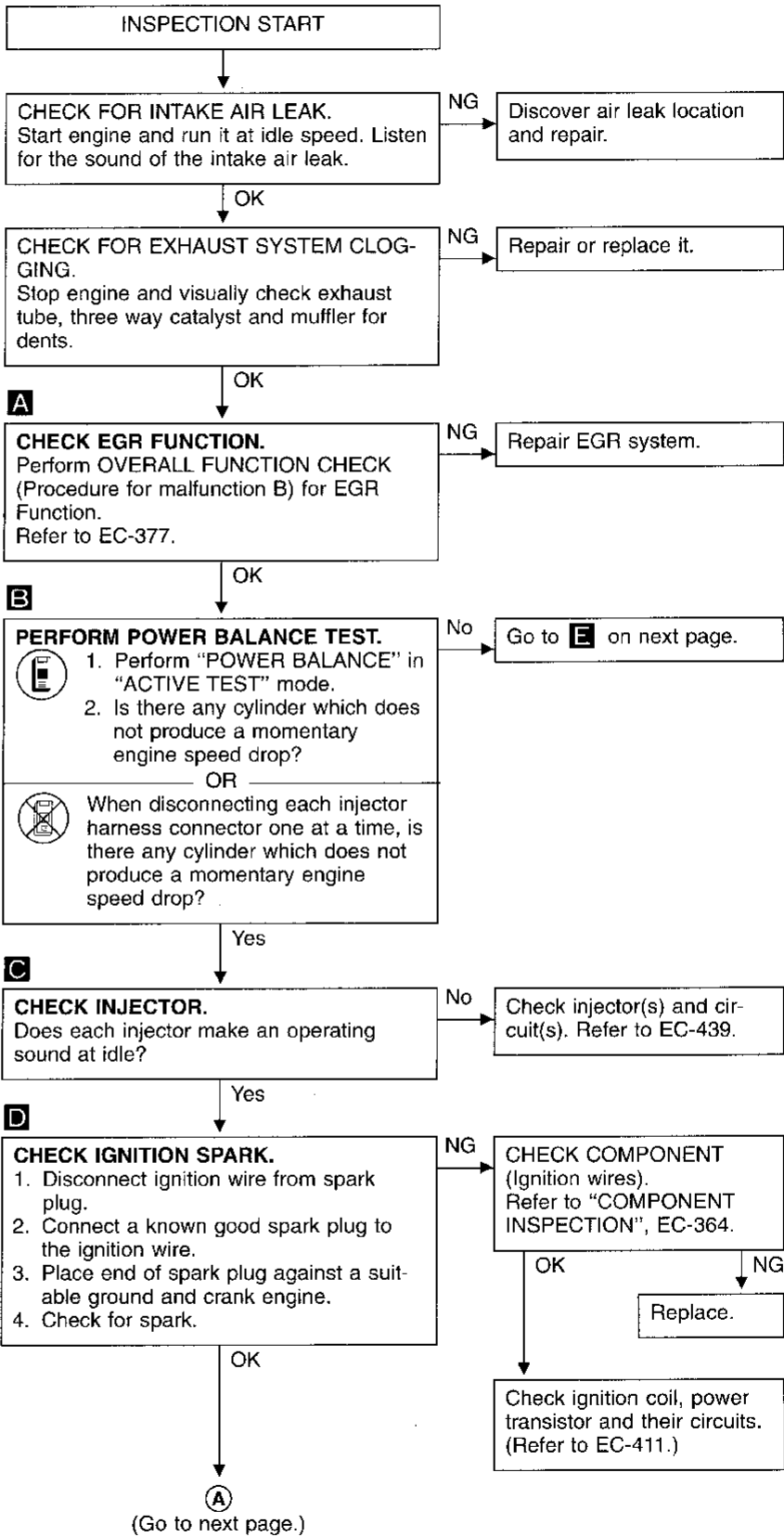
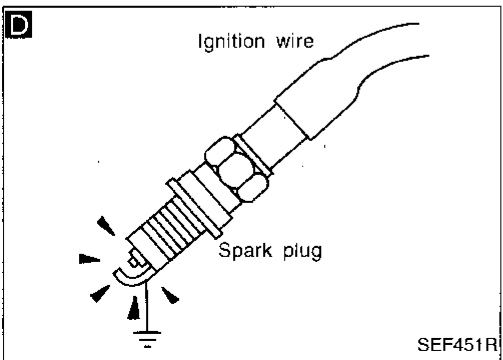
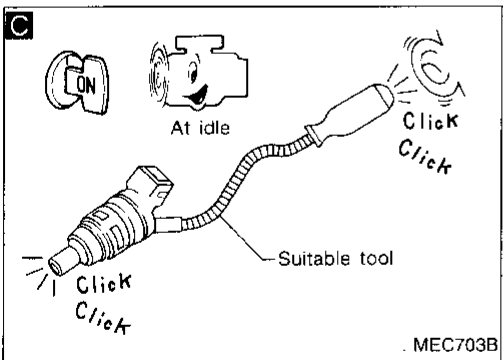
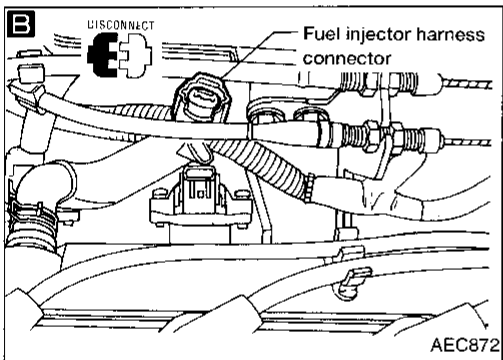
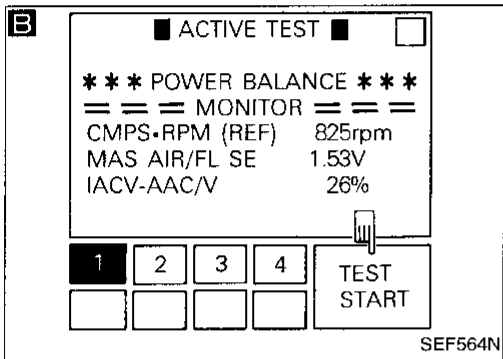
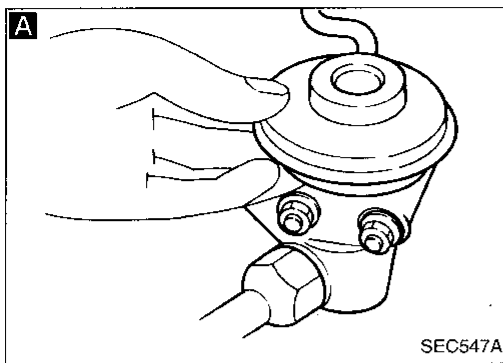

No. 4 - 1 Cylinder Misfire, Multiple Cylinder Misfire (DTC: 0701 - 0605) (Cont'd)

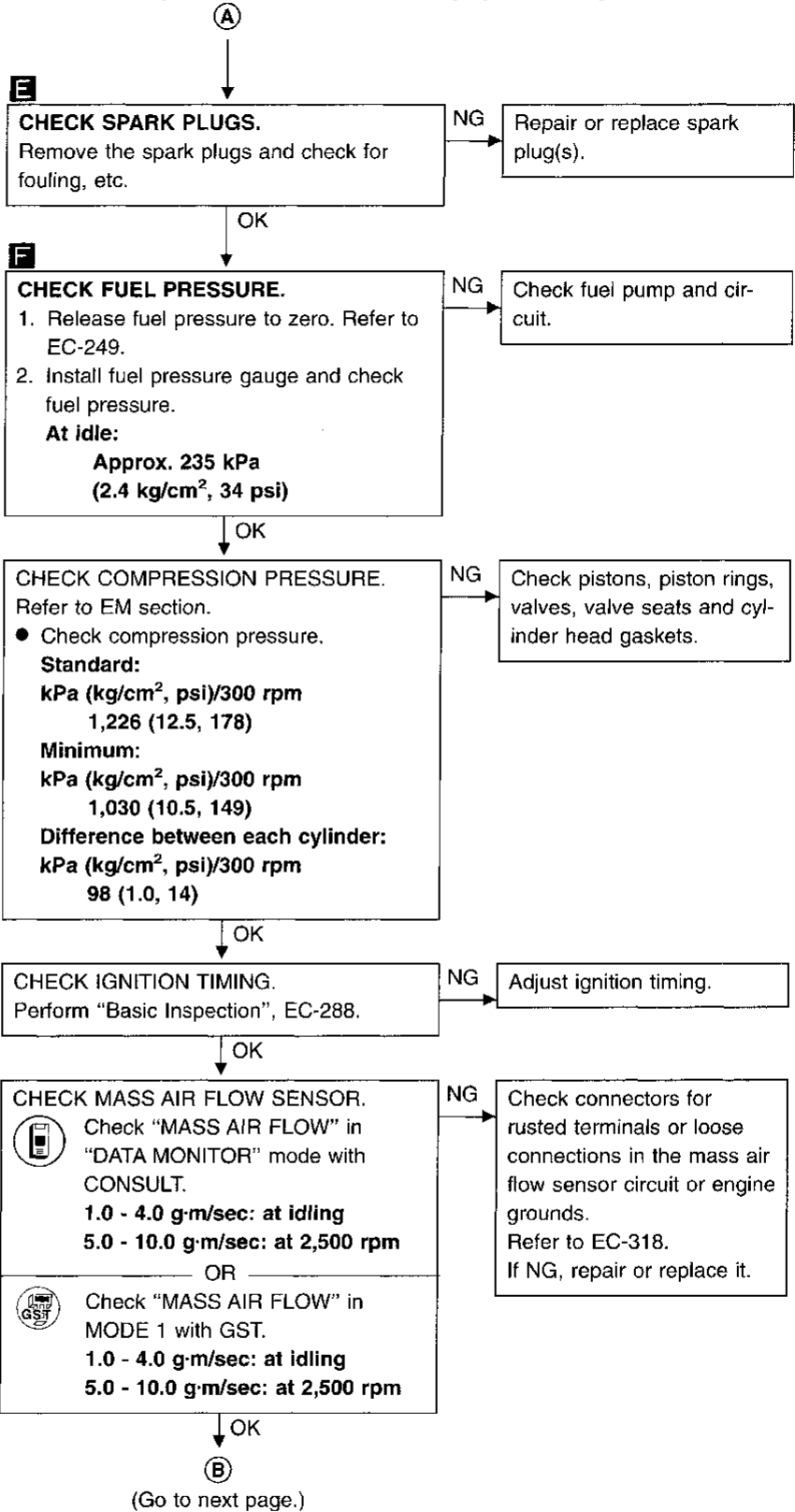
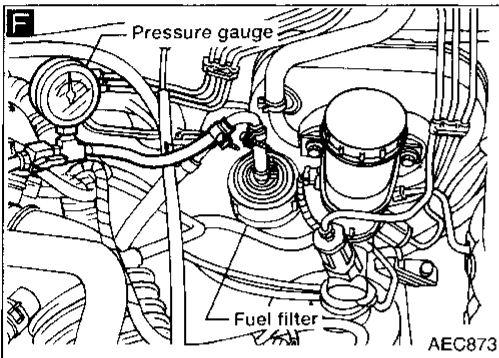
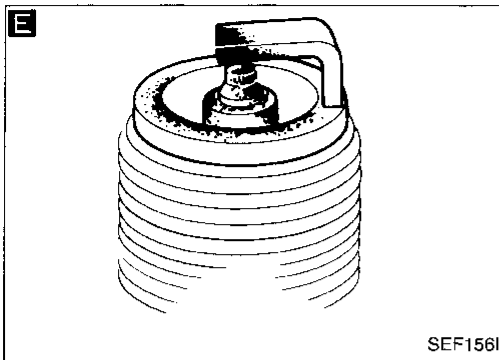

GI  
MA  
EM  
LC  
EC  
FE  
CL  
MT  
AT  
FA  
RA  
BR  
ST  
RS  
BT  
HA  
EL  
IDX

## No. 4 - 1 Cylinder Misfire, Multiple Cylinder Misfire (DTC: 0701 - 0605) (Cont'd)

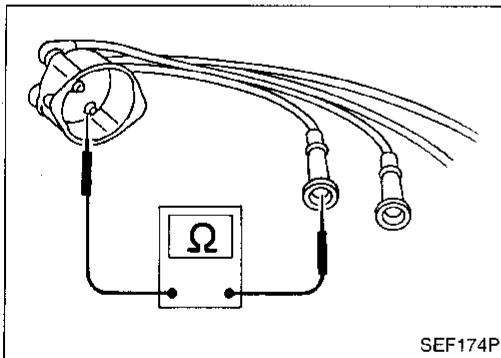
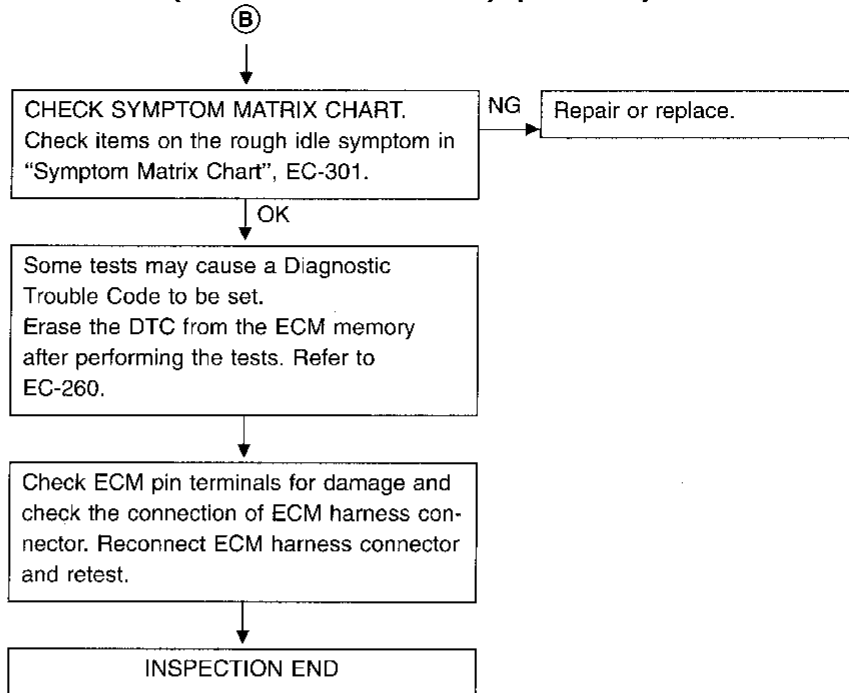

### COMPONENT INSPECTION

#### Ignition wires

1. Inspect wires for cracks, damage, burned terminals and for improper fit.
2. Measure the resistance of wires to their distributor cap terminal. Move each wire while testing to check for intermittent breaks.

#### Resistance:

**13.6 - 18.4 kΩ/m (4.15 - 5.61 kΩ/ft)**  
[at 25°C (77°F)]

If the resistance exceeds the above specification, inspect ignition wire to distributor cap connection. Clean connection or replace the ignition wire with a new one.

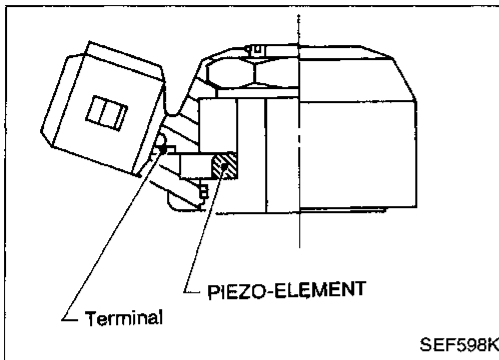



**Knock Sensor (KS) (DTC: 0304)**

The knock sensor is attached to the cylinder block. It senses engine knocking using a piezoelectric element. A knocking vibration from the cylinder block is sensed as vibrational pressure. This pressure is converted into a voltage signal and sent to the ECM.

\* Freeze frame data will not be stored in the ECM for the knock sensor. The MIL will not light for knock sensor malfunction.

Diagnostic Trouble Code No.	Malfunction is detected when ....	Check Items (Possible Cause)
P0325 0304	<ul style="list-style-type: none"> <li>An excessively low or high voltage from the knock sensor is sent to ECM.</li> </ul>	<ul style="list-style-type: none"> <li>Harness or connectors (The knock sensor circuit is open or shorted.)</li> <li>Knock sensor</li> </ul>

**DIAGNOSTIC TROUBLE CODE CONFIRMATION PROCEDURE**

- 
  - Turn ignition switch "ON" and select "DATA MONITOR" mode with CONSULT.
  - Start engine and run it for at least 5 seconds at idle speed.
- OR
- 
  - Start engine and run it for at least 5 seconds at idle speed.
  - Select "MODE 3" with GST.
- OR
- 
  - Start engine and run it for at least 5 seconds at idle speed.
  - Turn ignition switch "OFF", wait at least 5 seconds and then turn "ON".
  - Perform "Diagnostic Test Mode II" (Self-diagnostic results) with ECM.

Knock Sensor (KS) (DTC: 0304) (Cont'd)

EC-KS-01

— : Detectable line for DTC  
 - - - : Non-detectable line for DTC

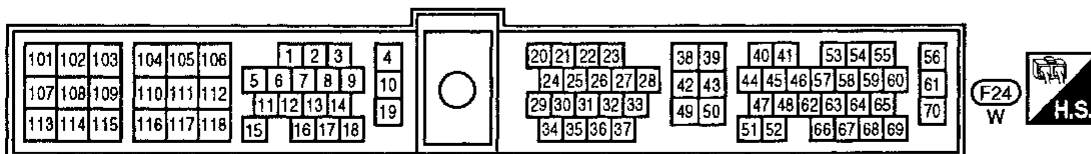
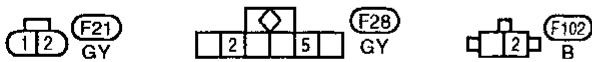
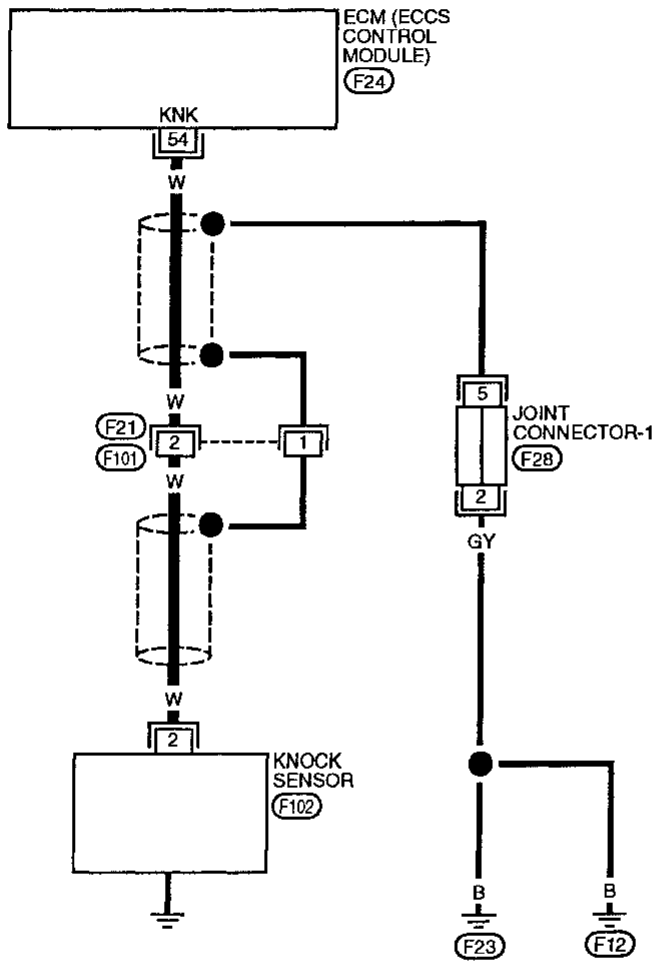

Knock Sensor (KS) (DTC: 0304) (Cont'd)

DIAGNOSTIC PROCEDURE

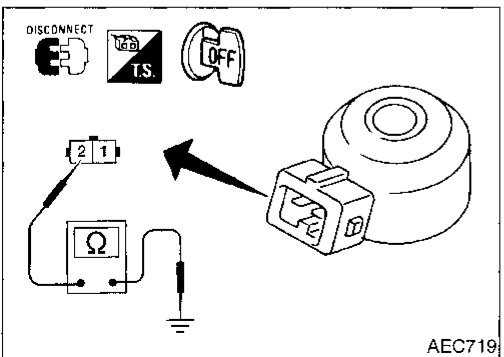
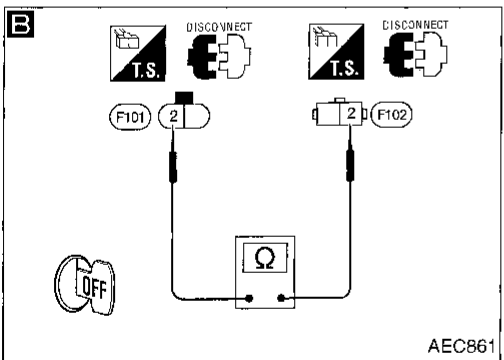
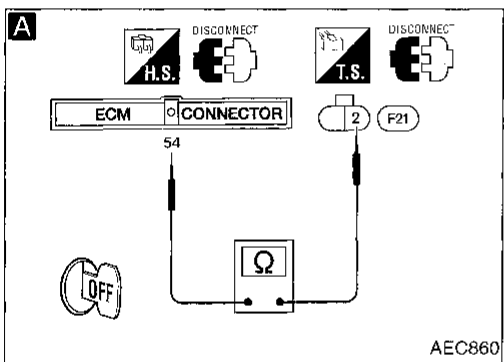
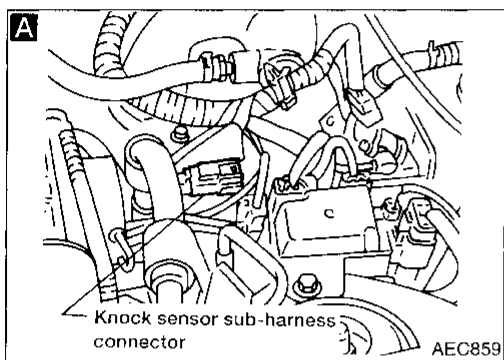
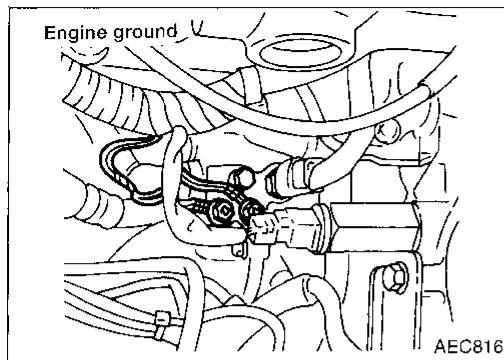

INSPECTION START

Loosen and retighten engine ground screws.

**A**  
**CHECK INPUT SIGNAL CIRCUIT.**  
 1. Turn ignition switch "OFF".  
 2. Disconnect ECM harness connector and knock sensor sub-harness connector.  
 3. Check harness continuity between terminal ② and ECM terminal ⑤4.  
**Continuity should exist.**  
 If OK, check harness for short.

NG → Repair harness or connectors.

**B**  
**CHECK SUB-HARNESS CIRCUIT.**  
 1. Disconnect knock sensor harness connector.  
 2. Check harness continuity between knock sensor harness connector terminal ② and knock sensor sub-harness connector terminal ②.  
**Continuity should exist.**  
 If OK, check harness for short.

NG → Repair harness or connectors.

**CHECK COMPONENT**  
 (Knock sensor).  
 Refer to "COMPONENT INSPECTION" below.

NG → Replace knock sensor.

Disconnect and reconnect harness connectors in the circuit. Then retest.

Trouble is not fixed.

Check ECM pin terminals for damage and check the connection of ECM harness connector. Reconnect ECM harness connector and retest.

INSPECTION END

COMPONENT INSPECTION

Knock sensor

- Use an ohmmeter which can measure more than 10 MΩ.
- 1. Disconnect knock sensor harness connector.
- 2. Check resistance between terminal ② and ground.  
**Resistance: 500 - 620 kΩ [at 25°C (77°F)]**

CAUTION:

Discard any knock sensors that have been dropped or physically damaged. Use only new ones.

GI  
 MA  
 EM  
 LC  
**EC**  
 FE  
 CL  
 WT  
 AT  
 FA  
 RA  
 BR  
 ST  
 RS  
 BT  
 HA  
 EL  
 IDX

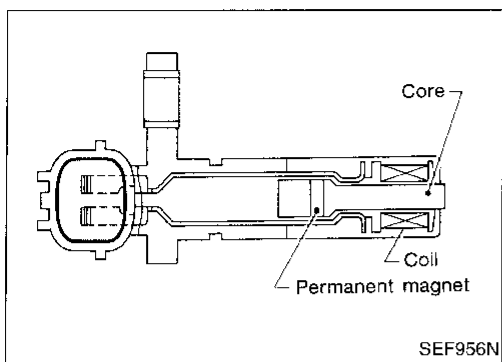

### Crankshaft Position Sensor (CKPS) (OBD) (DTC: 0802)

The crankshaft position sensor (OBD) is located on the transaxle housing facing the gear teeth (cogs) of the flywheel or drive plate. It detects the fluctuation of the engine revolution. The sensor consists of a permanent magnet, core and coil. When the engine is running, the high and low parts of the teeth cause the gap with the sensor to change. The changing gap causes the magnetic field near the sensor to change.

Due to the changing magnetic field, the voltage from the sensor changes.

The ECM receives the voltage signal and detects the fluctuation of the engine revolution.

This sensor is not directly used to control the engine system. It is used only for the on-board diagnosis of misfire.

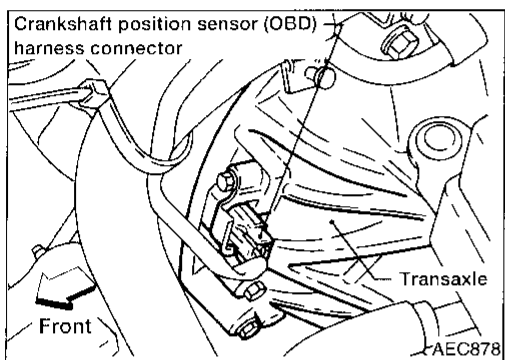

Diagnostic Trouble Code No.	Malfunction is detected when ....	Check Items (Possible Cause)
P0335 0802	<ul style="list-style-type: none"> <li>The proper pulse signal from the crankshaft position sensor (OBD) is not sent to ECM while the engine is running at the specified engine speed.</li> </ul>	<ul style="list-style-type: none"> <li>Harness or connectors (The crankshaft position sensor (OBD) circuit is open.)</li> <li>Crankshaft position sensor (OBD)</li> </ul>

### DIAGNOSTIC TROUBLE CODE CONFIRMATION PROCEDURE

- 
 1) Turn ignition switch "ON" and select "DATA MONITOR" mode with CONSULT.  
 2) Start engine and run it for at least 15 seconds at idle speed.

OR

- 
 1) Start engine and run it for at least 15 seconds at idle speed.  
 2) Select "MODE 3" with GST.

OR

- 
 1) Start engine and run it for at least 15 seconds at idle speed.  
 2) Turn ignition switch "OFF", wait at least 5 seconds and then turn "ON".  
 3) Perform "Diagnostic Test Mode II" (Self-diagnostic results) with ECM.

Crankshaft Position Sensor (CKPS) (OBD)  
(DTC: 0802) (Cont'd)

EC-CKPS-01

GI

MA

EM

LC

EC

FE

CL

MT

AT

FA

RA

BR

ST

RS

BT

HA

EL

IDX

— : Detectable line for DTC  
— : Non-detectable line for DTC

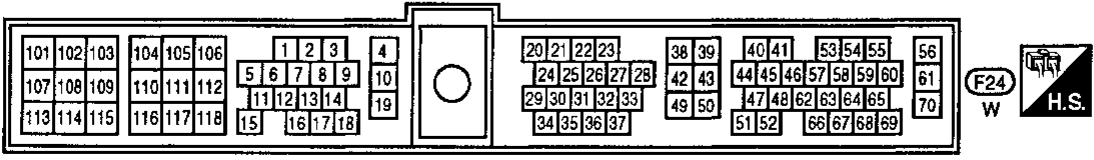
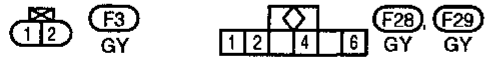
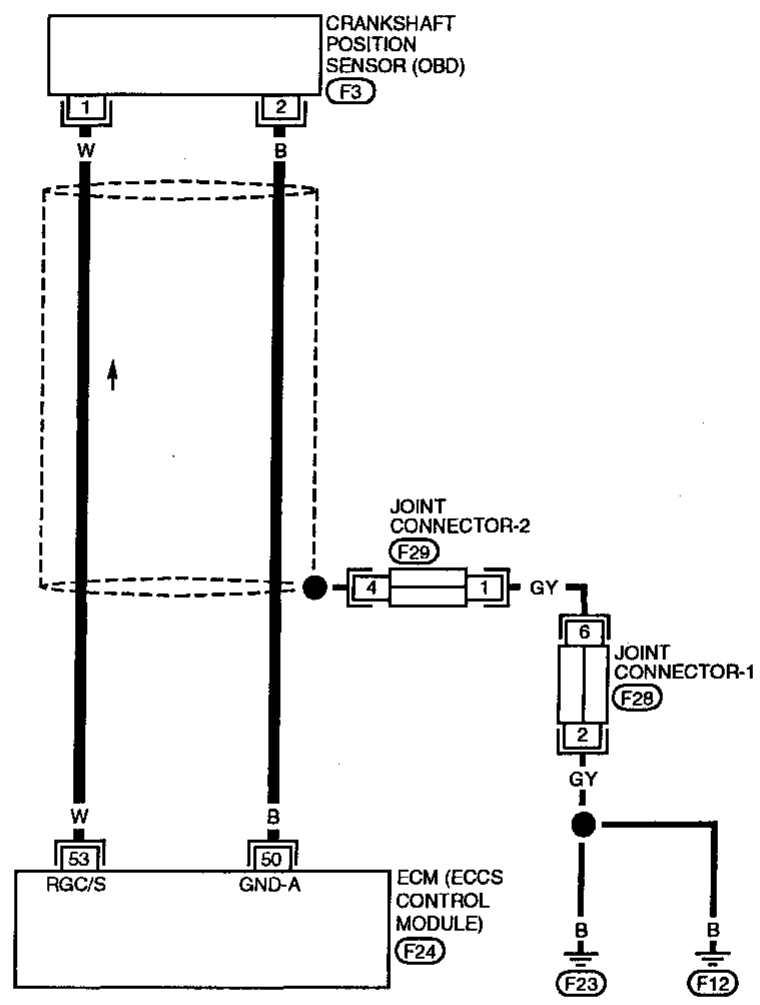



## Crankshaft Position Sensor (CKPS) (OBD) (DTC: 0802) (Cont'd)

### DIAGNOSTIC PROCEDURE

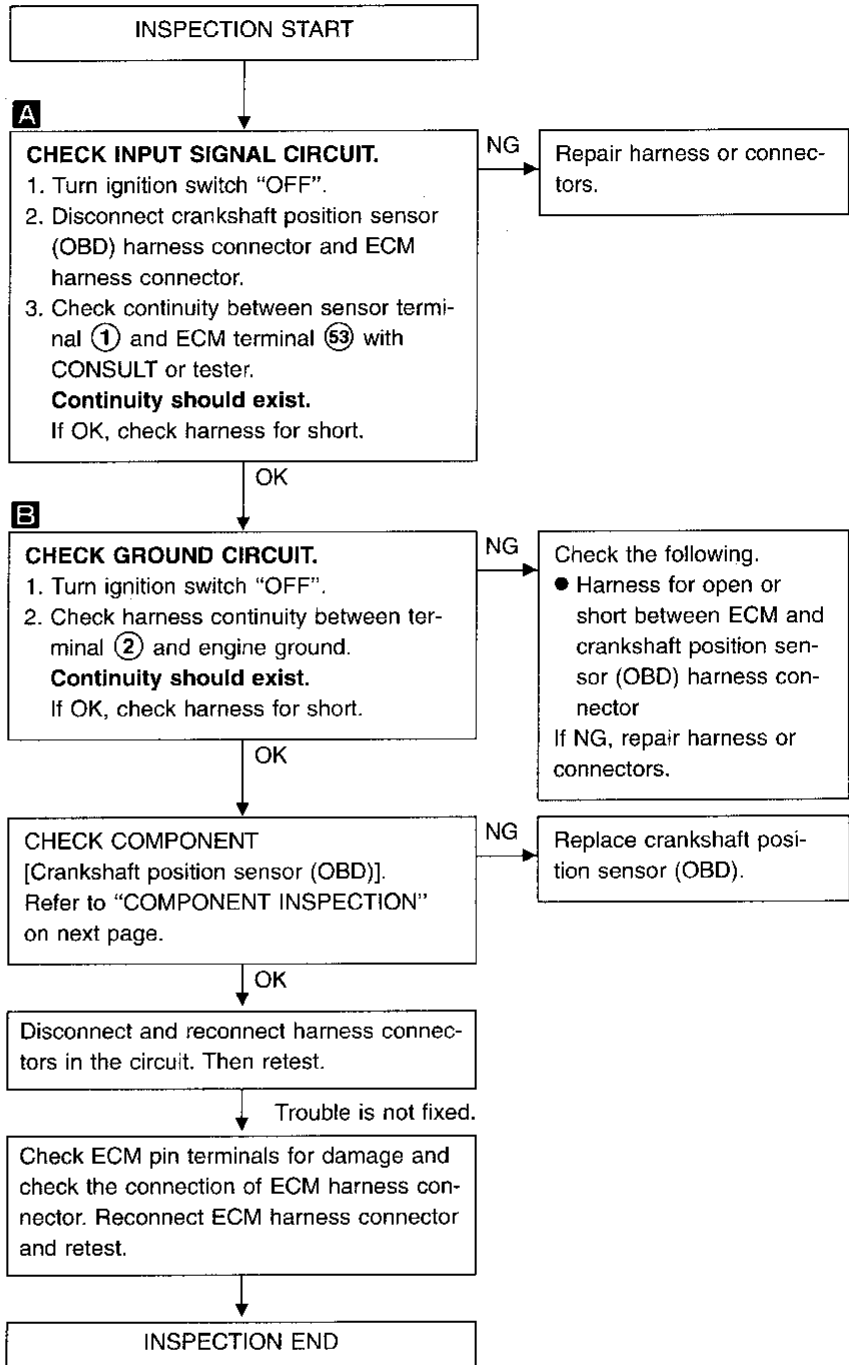
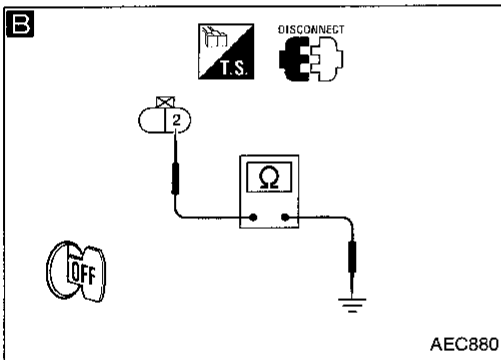
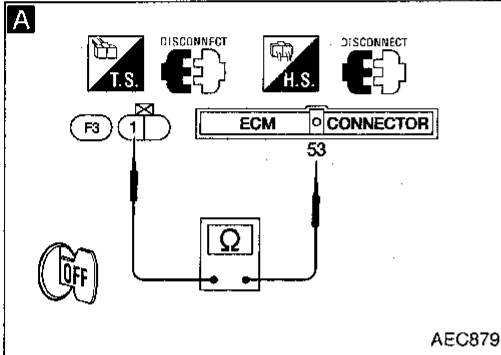
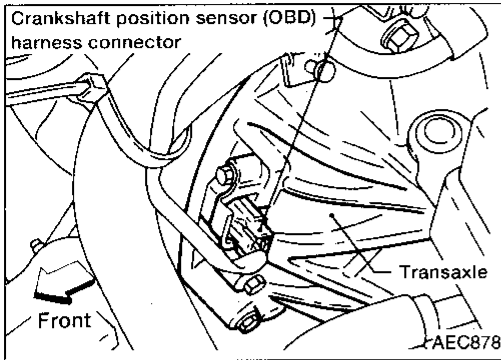

## Crankshaft Position Sensor (CKPS) (OBD) (DTC: 0802) (Cont'd)

### COMPONENT INSPECTION

#### Crankshaft position sensor (OBD)

1. Disconnect crankshaft position sensor (OBD) harness connector.
2. Loosen the fixing bolt of the sensor.
3. Remove the sensor.
4. Visually check the sensor for chipping.

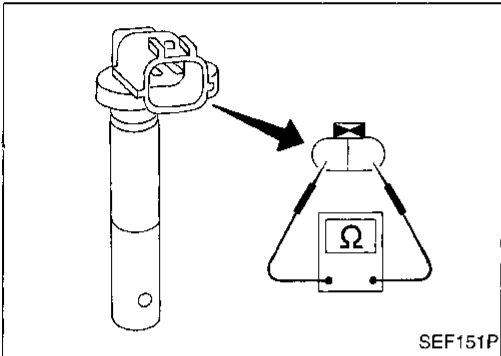
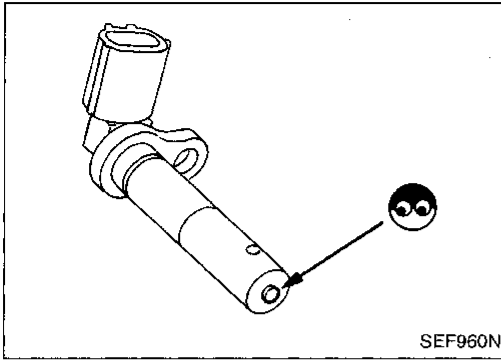

5. Check resistance as shown in the figure.

#### Resistance:

##### M/T models

432 - 528 $\Omega$  [at 25°C (77°F)]

##### A/T models

166.5 - 203.5 $\Omega$  [at 25°C (77°F)]

GI

MA

EM

LC

EC

FE

CL

MT

AT

FA

RA

BR

ST

RS

BT

HA

EL

DX

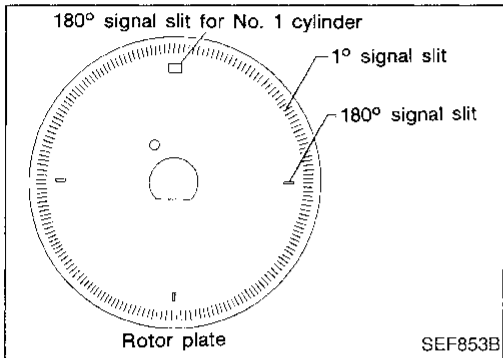
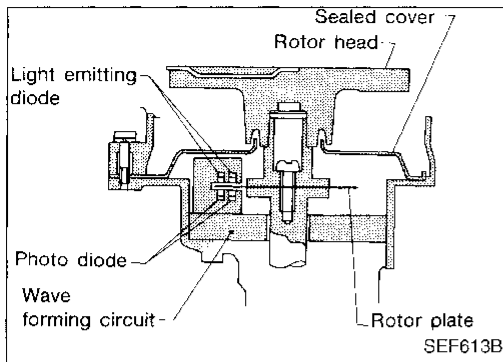

### Camshaft Position Sensor (CMPS)(DTC: 0101)

The camshaft position sensor is a basic component of the ECCS. It monitors engine speed and piston position. These input signals to the ECM are used to control fuel injection, ignition timing and other functions.



The camshaft position sensor has a rotor plate and a wave-forming circuit. The rotor plate has 360 slits for a 1° (POS) signal and 4 slits for a 180° (REF) signal. The wave-forming circuit consists of Light Emitting Diodes (LED) and photo diodes.

The rotor plate is positioned between the LED and the photo diode. The LED transmits light to the photo diode. As the rotor plate turns, the slits cut the light to generate rough-shaped pulses. These pulses are converted into on-off signals by the wave-forming circuit and sent to the ECM.

Diagnostic Trouble Code No.	Malfunction is detected when ....	Check Items (Possible Cause)
P0340 0101	<ul style="list-style-type: none"> <li>Either 1° or 180° signal is not sent to ECM for the first few seconds during engine cranking.</li> <li>Either 1° or 180° signal is not sent to ECM often enough while the engine speed is higher than the specified engine speed.</li> <li>The relation between 1° and 180° signal is not in the normal range during the specified engine speed.</li> </ul>	<ul style="list-style-type: none"> <li>Harness or connectors (The camshaft position sensor circuit is open or shorted.)</li> <li>Camshaft position sensor</li> <li>Starter motor (Refer to EL section.)</li> <li>Starting system circuit (Refer to EL section.)</li> <li>Dead (Weak) battery</li> </ul>

### DIAGNOSTIC TROUBLE CODE CONFIRMATION PROCEDURE

Before performing the following procedure, confirm that battery voltage is more than 10.5 V.

- 
 1) Turn ignition switch "ON" and select "DATA MONITOR" mode with CONSULT.
- 2) Crank engine for at least 2 seconds.
- OR
- 
 1) Crank engine for at least 2 seconds.
- 2) Select "MODE 3" with GST.
- OR
- 
 1) Crank engine for at least 2 seconds.
- 2) Turn ignition switch "OFF", wait at least 5 seconds and then turn "ON".
- 3) Perform "Diagnostic Test Mode II" (Self-diagnostic results) with ECM.

Camshaft Position Sensor (CMPS)(DTC: 0101)  
(Cont'd)

EC-CMPS-01

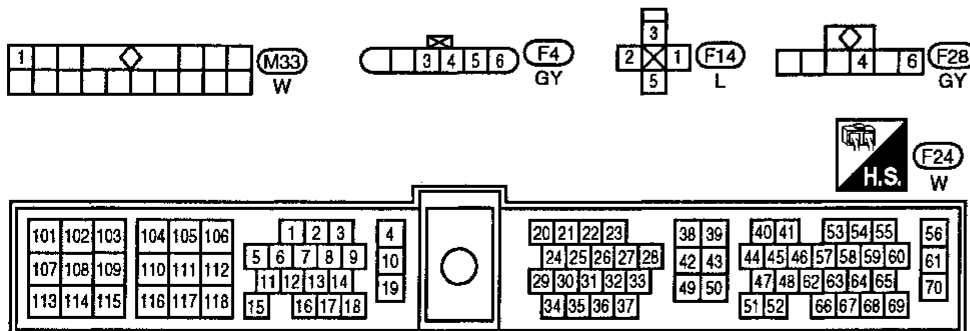
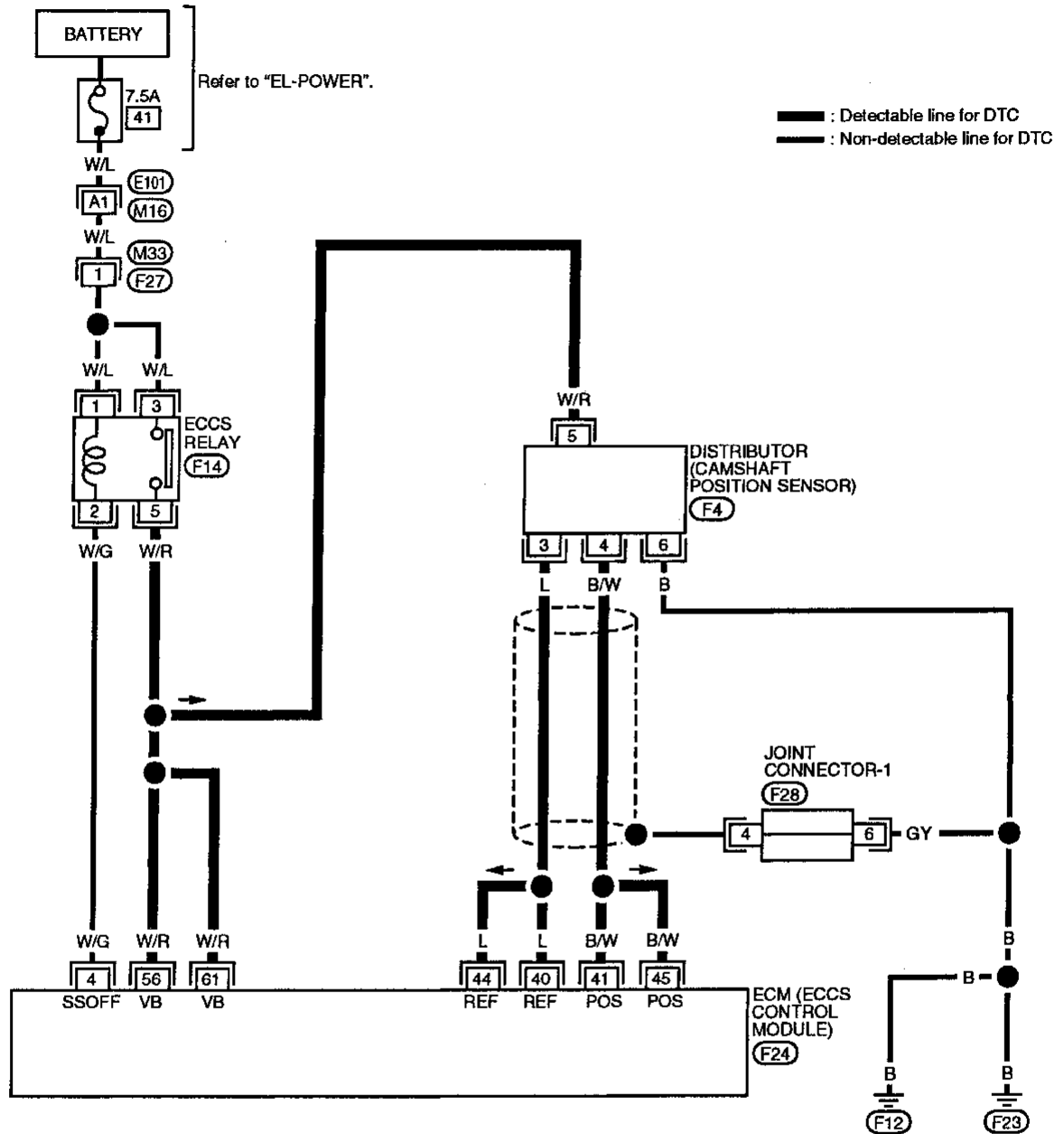

Refer to last page (Foldout page).

(M16), (E101)

GI  
MA  
EM  
LC  
EC  
FE  
CL  
MT  
AT  
FA  
RA  
BR  
ST  
RS  
BT

HA  
EL  
IDX

Camshaft Position Sensor (CMPS)(DTC: 0101)  
(Cont'd)

DIAGNOSTIC PROCEDURE (DETECTABLE CIRCUIT)

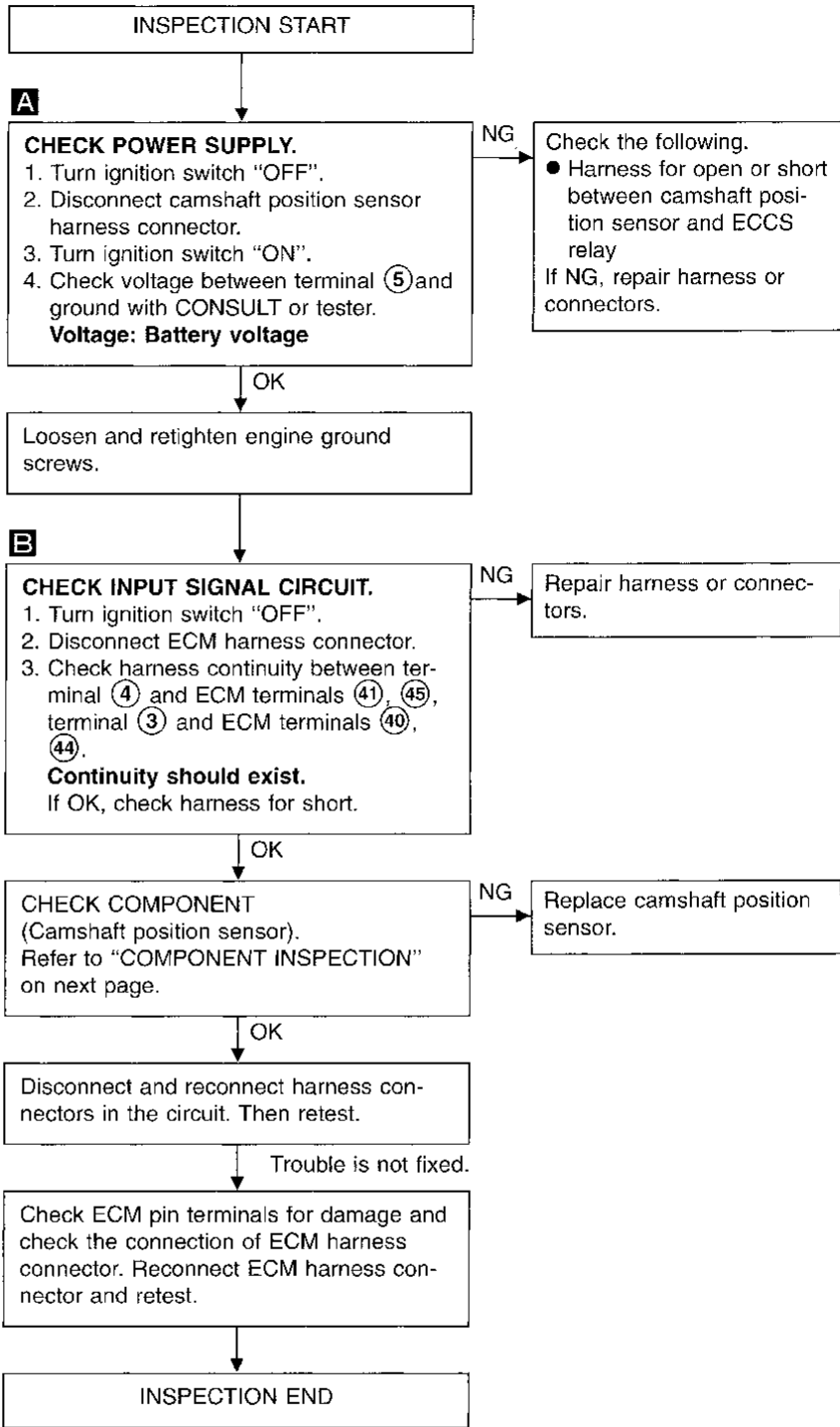
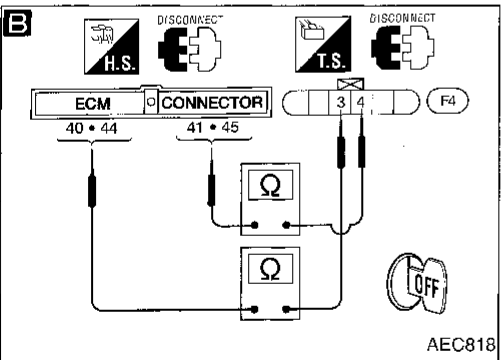
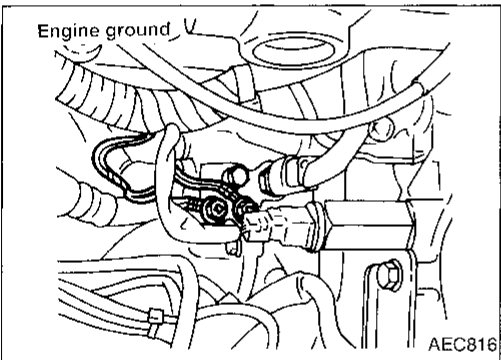
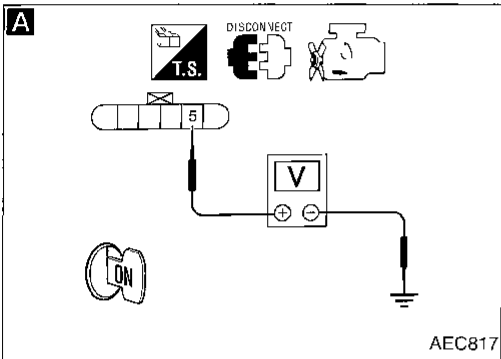
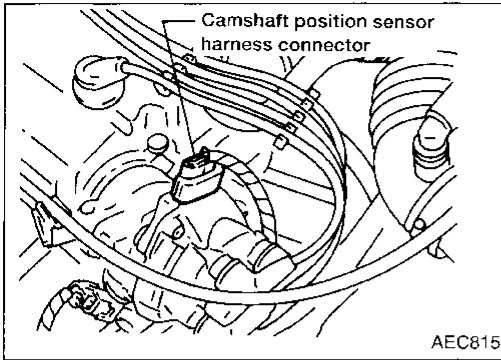

**Camshaft Position Sensor (CMPS)(DTC: 0101)  
(Cont'd)**

**DIAGNOSTIC PROCEDURE (NON-DETECTABLE  
CIRCUIT)**

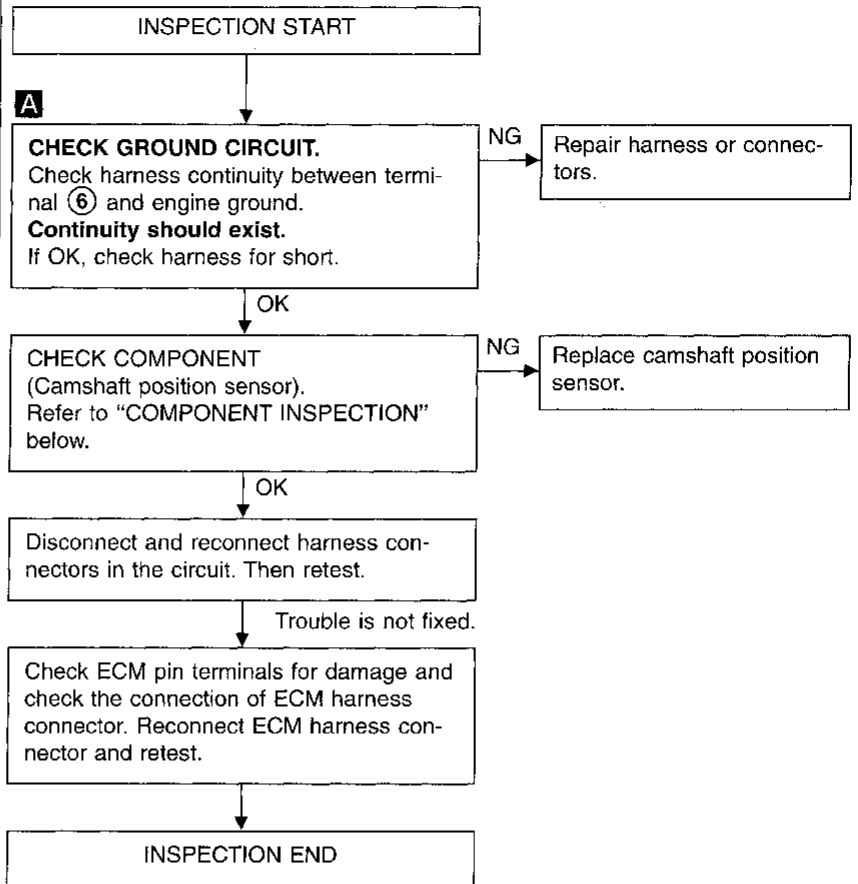
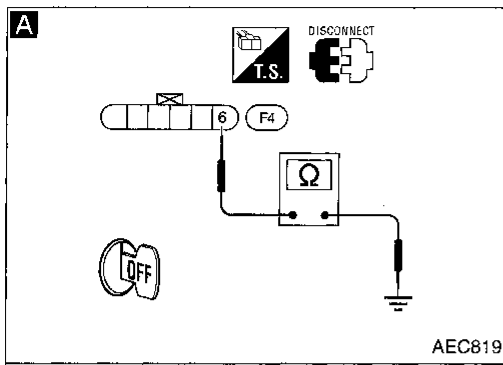

GI  
MA  
EM  
LC  
EC  
FE  
CL  
MT  
AT  
FA  
RA  
BR  
ST  
RS  
BT  
HA  
EL  
IDX

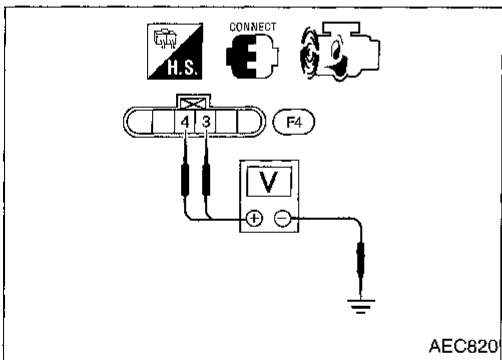

**COMPONENT INSPECTION  
Camshaft position sensor**

1. Start engine
2. Check voltage between terminals ③, ④ and ground with AC range.

Condition	Terminals	Voltage
Engine running at idle	③ and ground	Approximately 2.7V* (AC)
	④ and ground	

\*: Average voltage for pulse signal (Actual pulse signal can be confirmed by oscilloscope.)

If NG, replace distributor assembly with camshaft position sensor.

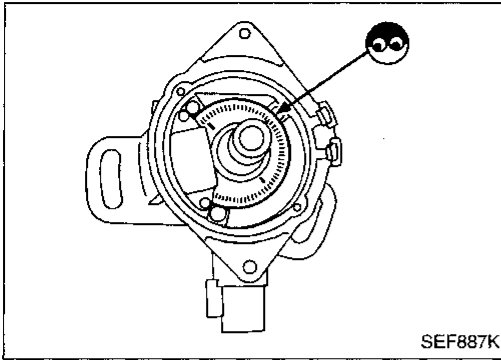
**Camshaft Position Sensor (CMPS)(DTC: 0101)  
(Cont'd)**

3. Remove distributor cap. Visually check signal plate for damage or dust.

**After this inspection, diagnostic trouble code No. P0340 might be displayed with camshaft position sensor functioning properly. Erase the stored memory.**

EGR Function (DTC: 0302)

SYSTEM DESCRIPTION

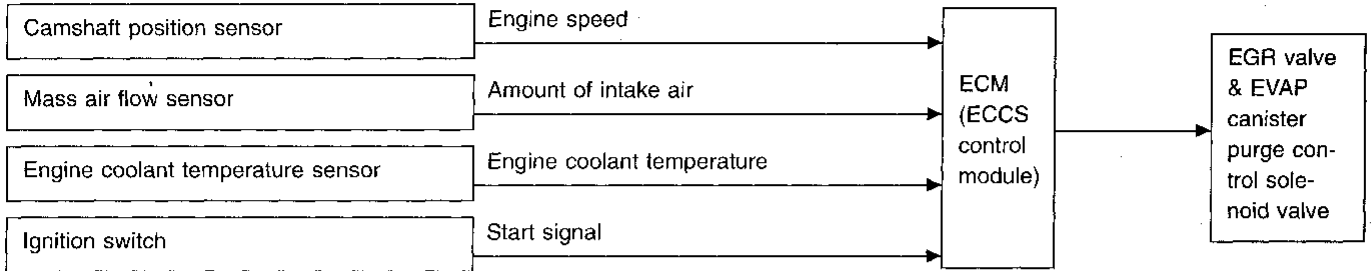

This system cuts and controls vacuum applied to EGR valve and EVAP canister to suit engine operating conditions. This cut-and-control operation is accomplished through the ECM and the EGR valve & EVAP canister purge control solenoid valve. When the ECM detects any of the following conditions, current flows through the solenoid valve. This causes the port vacuum to be discharged into the atmosphere. The EGR valve and EVAP canister remain closed.

- Low engine coolant temperature
- Engine starting
- High-speed engine operation
- Engine idling
- Excessively high engine coolant temperature
- Mass air flow sensor malfunction

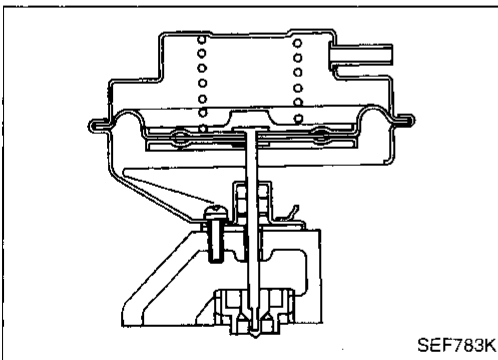
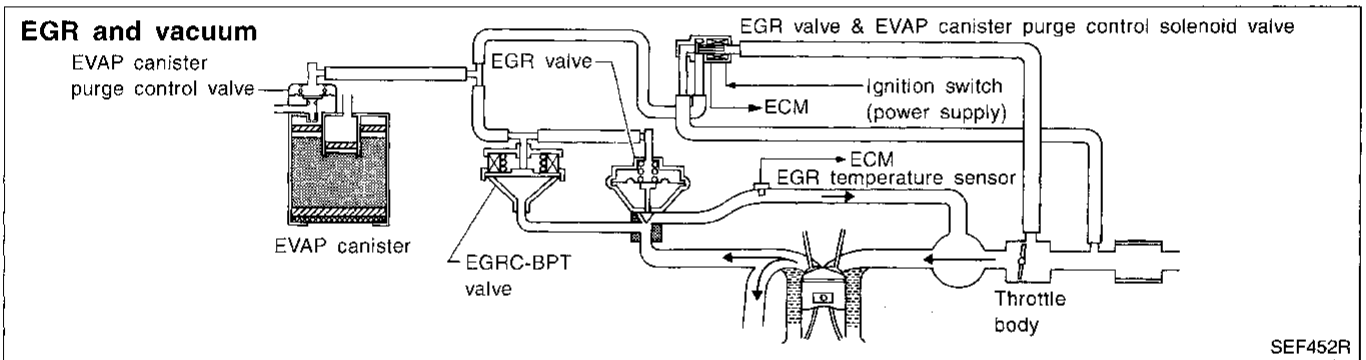

COMPONENT DESCRIPTION

Exhaust gas recirculation (EGR) valve

The EGR valve controls the amount of exhaust gas routed to the intake manifold. Vacuum is applied to the EGR valve in response to throttle valve opening. The vacuum controls the movement of a taper valve connected to the vacuum diaphragm in the EGR valve.

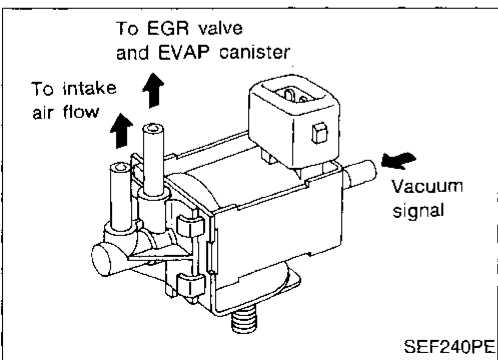

EGR valve & EVAP canister purge control solenoid valve

The EGR valve & EVAP canister purge control solenoid valve responds to signals from the ECM. When the ECM sends an ON (ground) signal, the coil in the solenoid valve is energized. A plunger will then move to cut the vacuum signal (from the throttle body to the EGR valve & EVAP canister purge control valve).

When the ECM sends an OFF signal, the vacuum signal passes through the solenoid valve. The signal then reaches the EGR valve and EVAP canister.



**EGR Function (DTC: 0302) (Cont'd)  
ON-BOARD DIAGNOSIS LOGIC**

If the absence of EGR flow is detected by EGR temperature sensor under the condition that calls for EGR, a low-flow malfunction is diagnosed.

If EGR temperature sensor detects EGR flow under the condition that does not call for EGR, a high-flow malfunction is diagnosed.

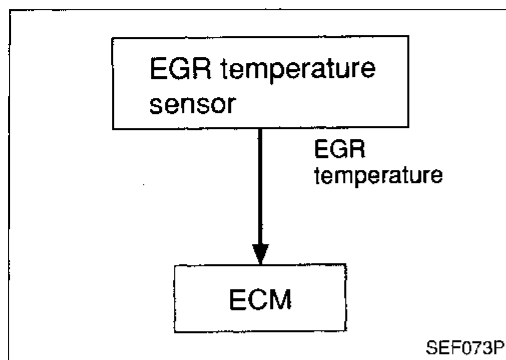

Diagnostic Trouble Code No.	Malfunction is detected when ...	Check Items (Possible Cause)
P0400 0302	A) The exhaust gas recirculation (EGR) flow is excessively low during the specified driving condition.	<ul style="list-style-type: none"> <li>● EGR valve stuck closed</li> <li>● EGRC-BPT valve leaking</li> <li>● Passage blocked</li> <li>● EGR valve &amp; EVAP canister purge control solenoid valve</li> <li>● Tube leaking for EGR valve</li> <li>● EGR temperature sensor</li> </ul>
	B) The exhaust gas recirculation (EGR) flow is excessively high during the specified driving condition.	<ul style="list-style-type: none"> <li>● EGR valve &amp; EVAP canister purge control solenoid valve</li> <li>● EGR valve leaking or stuck open</li> <li>● EGR temperature sensor</li> </ul>

**OVERALL FUNCTION CHECK**

Use this procedure to check the overall EGR function. During this check, a DTC might not be confirmed.

Before starting with the following procedure, check the engine coolant temperature of the freeze frame data with CONSULT or Generic Scan Tool.

If the engine coolant temperature is higher than or equal to 71°C (160°F), perform only "Procedure for malfunction A".

If the engine coolant temperature is lower than 71°C (160°F), perform both "Procedure for malfunction A" and "Procedure for malfunction B".

EGR Function (DTC: 0302) (Cont'd)

Procedure for malfunction A

- 1) Start engine and warm it up sufficiently.
- 2) Check the EGR valve lifting when revving from 2,000 rpm up to 4,000 rpm under no load.

**EGR valve should lift up and down without sticking.**

If EGR valve does not lift up and down, try again with either of the following methods:

- Select "EGRC SOLENOID VALVE" in "ACTIVE TEST" mode with CONSULT and turn the solenoid valve "OFF".
- Disconnect EGR valve & EVAP canister purge control solenoid valve harness connector.

(The DTC for EGR valve & EVAP canister purge control solenoid valve will be displayed, however, ignore it.)

- 3) Check voltage between EGR temperature sensor harness connector terminal ② and ground at idle speed.

**Less than 4.5V should exist.**

- 4) Turn ignition switch "OFF".

Check harness continuity between EGR temperature sensor harness connector terminal ① and ECM terminal ⑤0.

**Continuity should exist.**

- 5) Perform "COMPONENT INSPECTION", "EGR temperature sensor". Refer to EC-384.

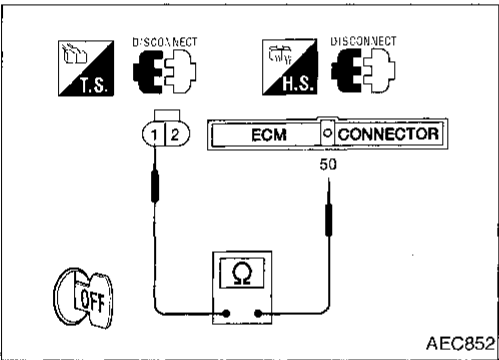
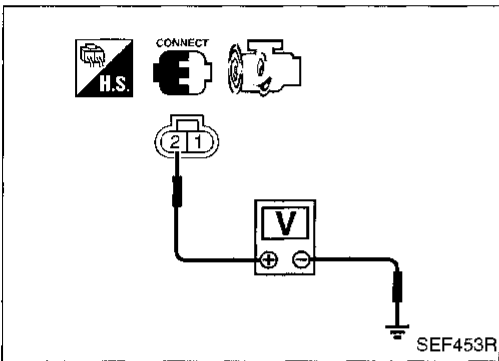
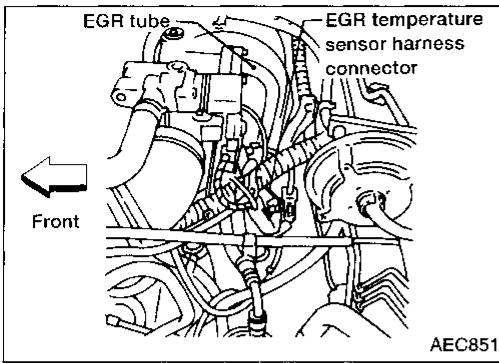

Overall function check

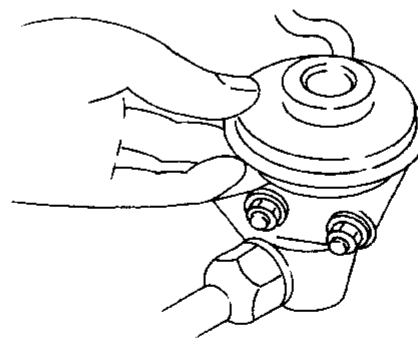
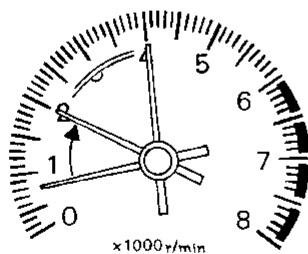

Check the EGR valve lifting when revving engine from 2,000 rpm up to 4,000 rpm.

SEF642Q

GI  
MA  
EM  
LC  
EC  
FE  
CL  
MT  
AT  
FA  
RA  
BR  
ST  
RS  
BT  
HA  
EL  
IDX

EGR Function (DTC: 0302) (Cont'd)

Procedure for malfunction B

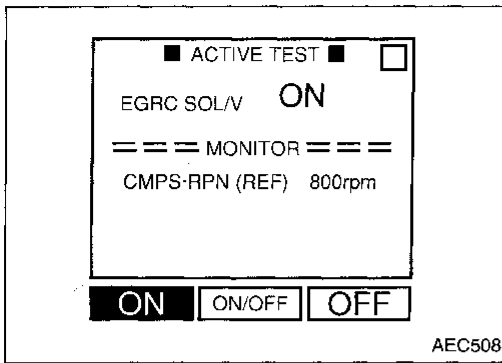

- 1) Start engine.
- 2) Select "EGRC SOLENOID VALVE" in "ACTIVE TEST" mode with CONSULT and turn the solenoid valve "ON".
- 3) Check for the EGR valve lifting when revving from 2,000 rpm up to 4,000 rpm under no load.

**EGR valve should be closed and should not lift up.**

OR

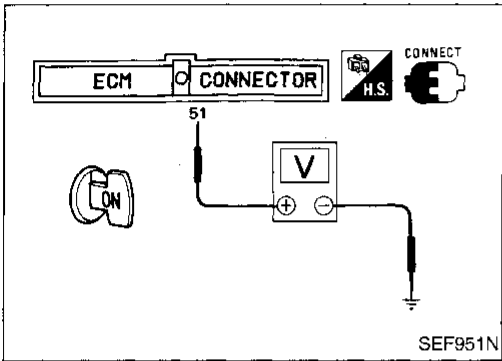

- 1) Confirm the engine coolant temperature is lower than 71°C (160°F) in "Mode 1" with generic scan tool. Perform the following steps before its temperature becomes higher than 71°C (160°F).
- 2) Start engine.
- 3) Check for the EGR valve lifting when revving from 2,000 rpm up to 4,000 rpm under no load.

**EGR valve should be closed and should not lift up.**

OR

- 1) Confirm the voltage between ECM terminal ⑤1 and ground is higher than 1.48V. Perform the following steps before the voltage becomes lower than 1.48V.
- 2) Start engine.
- 3) Check for the EGR valve lifting when revving from 2,000 rpm up to 4,000 rpm under no load.

**EGR valve should be closed and should not lift up.**

Overall function check

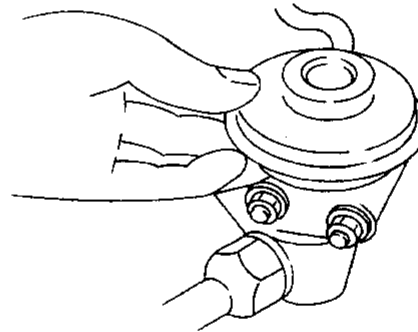
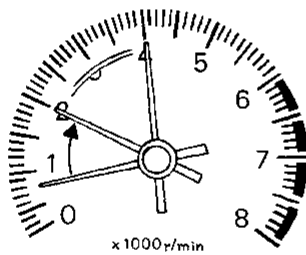

Check the EGR valve lifting when revving engine from 2,000 rpm up to 4,000 rpm.

SEF642Q

EGR Function (DTC: 0302) (Cont'd)

EC-EGRC1-01

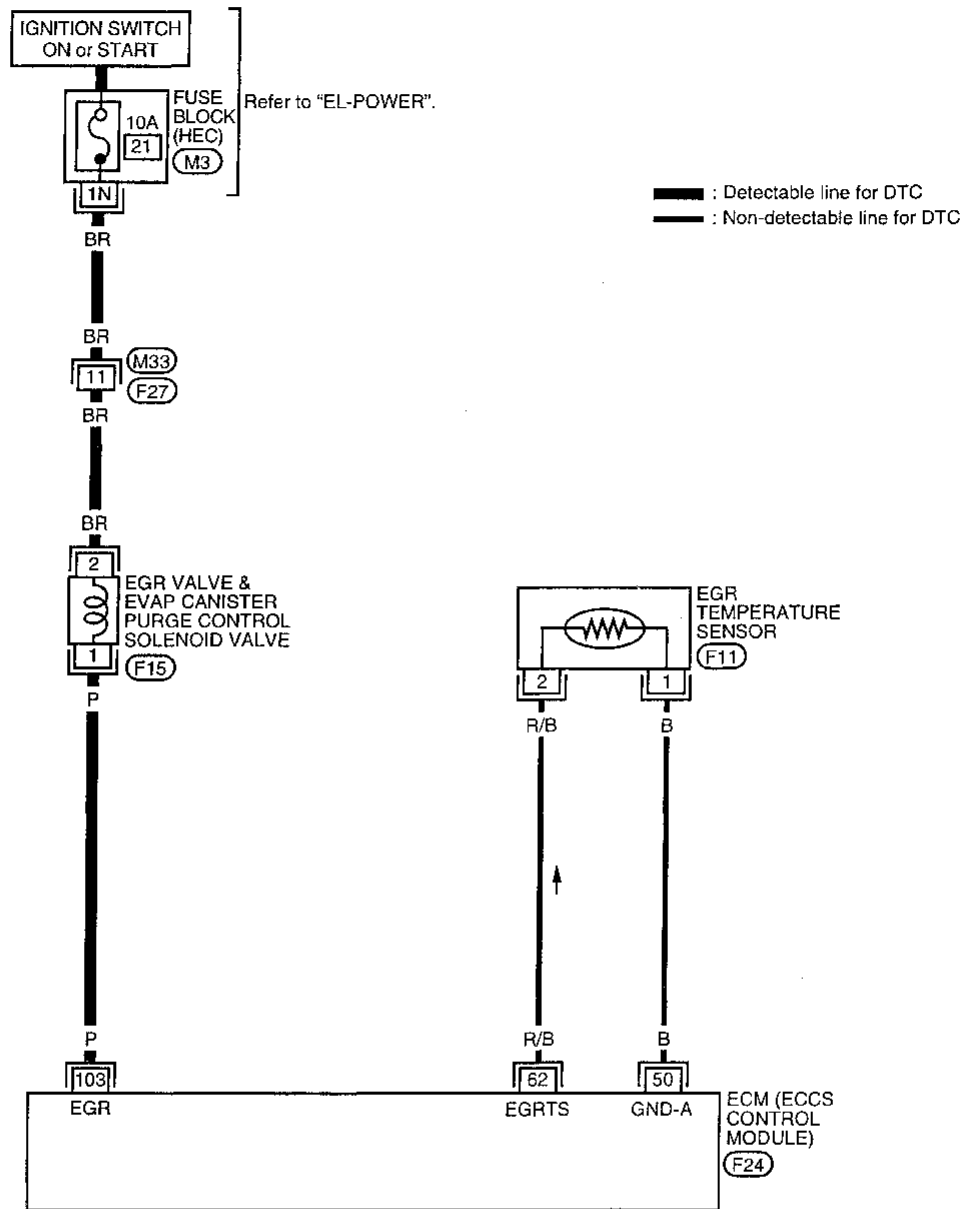

GI  
 MA  
 EM  
 LC  
**EC**  
 FE  
 CL  
 MT  
 AT  
 FA  
 RA  
 BR  
 ST  
 RS  
 BT  
 HA  
 EL  
 IDX

Refer to last page (Foldout page).

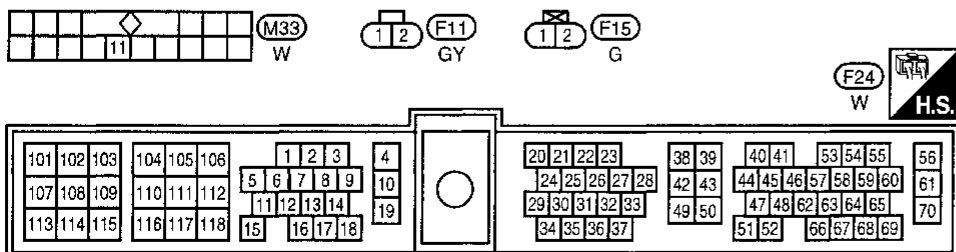

**EGR Function (DTC: 0302) (Cont'd)  
DIAGNOSTIC PROCEDURE**

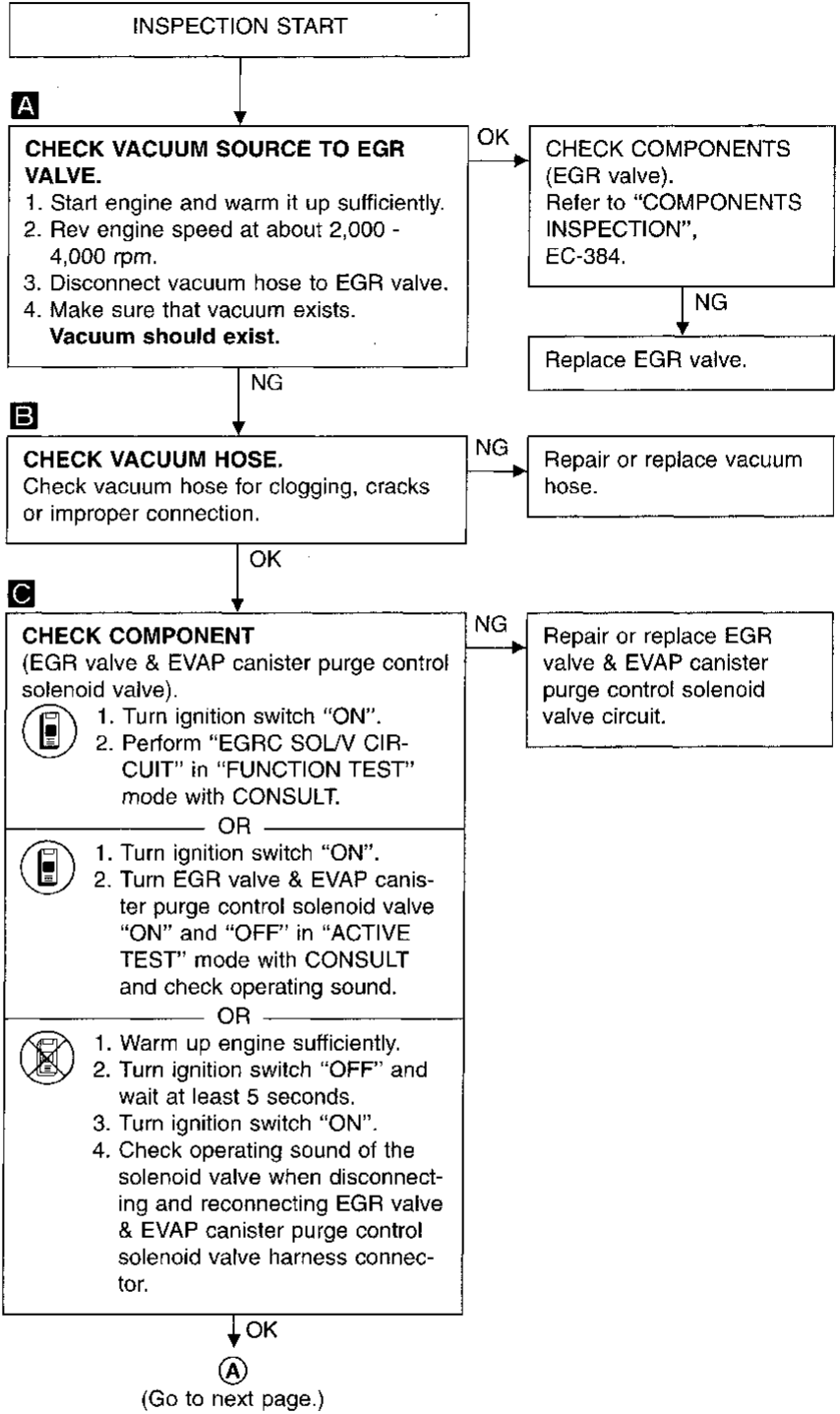
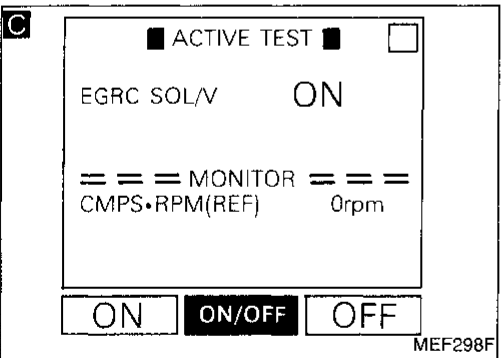
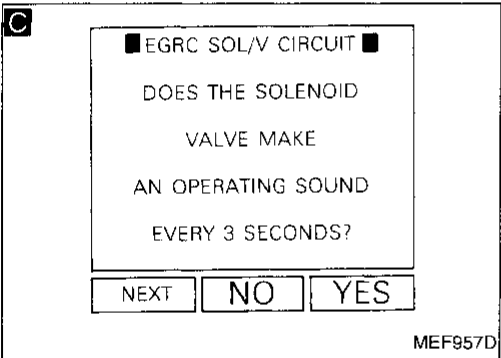
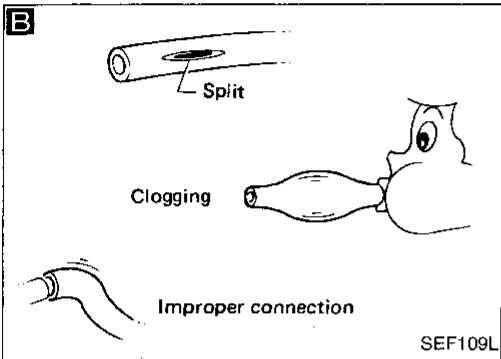
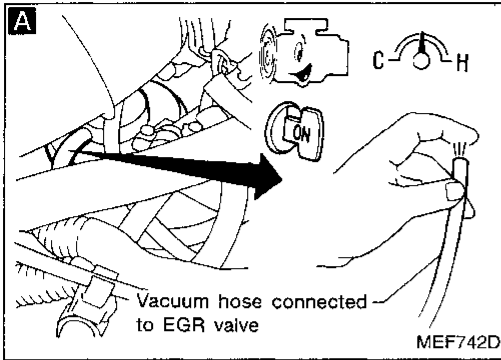

EGR Function (DTC: 0302) (Cont'd)

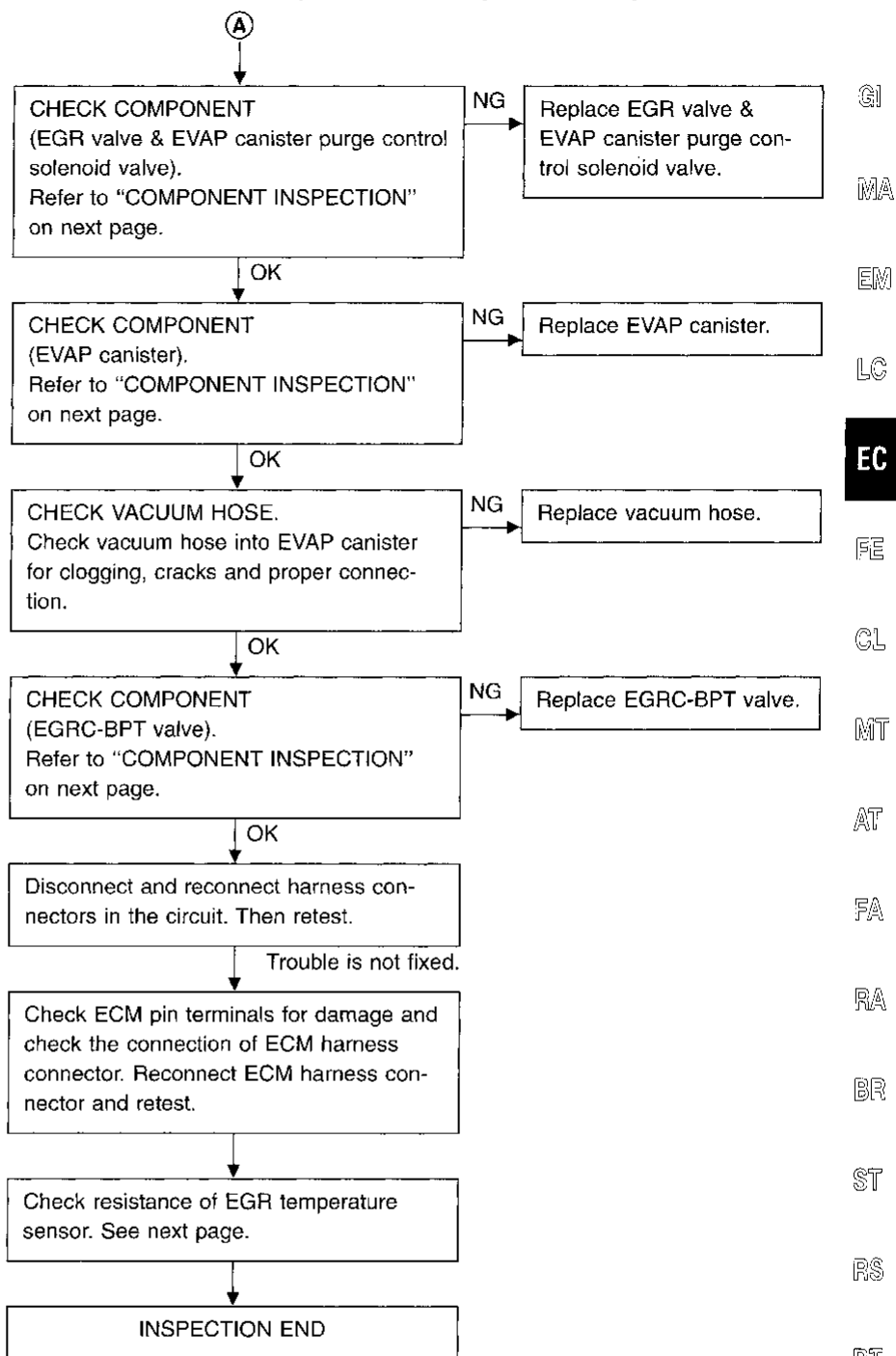

GI  
MA  
EM  
LC  
**EC**  
FE  
CL  
MT  
AT  
FA  
RA  
BR  
ST  
RS  
BT  
HA  
EL  
IDX

**EGR Function (DTC: 0302) (Cont'd)**

**COMPONENT INSPECTION**

**EGR valve**

Apply vacuum to EGR vacuum port with a hand vacuum pump.  
**EGR valve spring should lift.**  
 If NG, replace EGR valve.

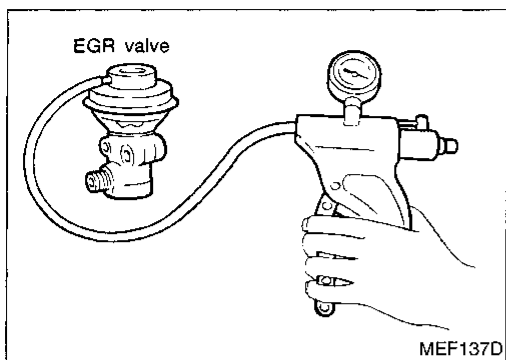

**EGR valve & EVAP canister purge control solenoid valve**

Check solenoid valve, following the table as shown below:

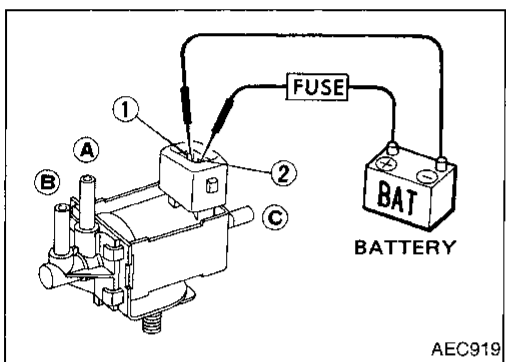

Conditions	Air passage continuity between (A) and (B)	Air passage continuity between (A) and (C)
12V direct current supply between terminals (1) and (2)	Yes	No
No supply	No	Yes

If NG, replace EGR valve & EVAP canister purge control solenoid valve.

**EVAP canister**

Gently blow air from (A).  
**No leakage should exist.**

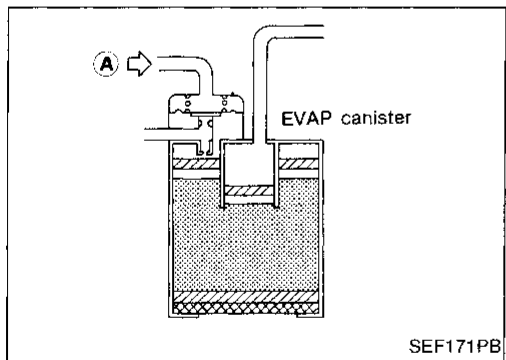

**EGR temperature sensor**

Check resistance change and resistance value.

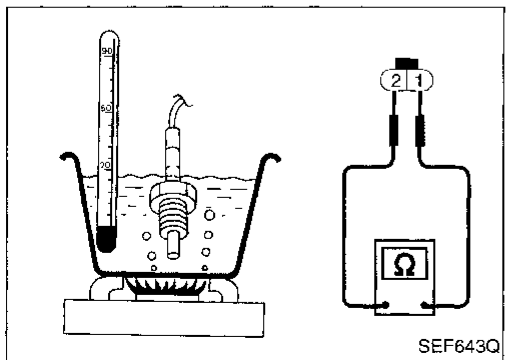

EGR temperature °C (°F)	Voltage (V)	Resistance (MΩ)
0 (32)	4.81	7.9 - 9.7
50 (122)	2.82	0.57 - 0.70
100 (212)	0.8	0.08 - 0.10

If NG, replace EGR temperature sensor.

**EGR Function (DTC: 0302) (Cont'd)****EGRC-BPT valve**

1. Plug one of two ports of EGRC-BPT valve.
2. Vacuum from the other port and check for leakage while applying a pressure above 0.981 kPa (100 mmH<sub>2</sub>O, 3.94 inH<sub>2</sub>O) from under EGRC-BPT valve.
3. If a leakage is noted, replace the valve.

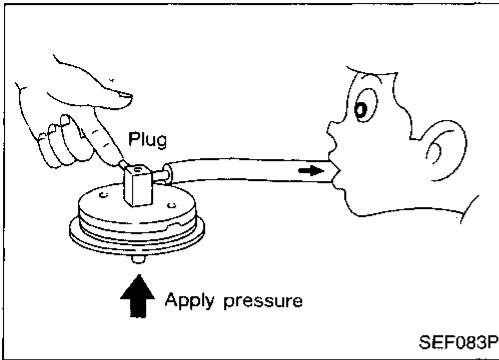

GI

MA

EM

LC

**EC**

FE

CL

MT

AT

FA

RA

BR

ST

RS

BT

HA

EL

DX



## EGRC-BPT Valve Function (DTC: 0306)

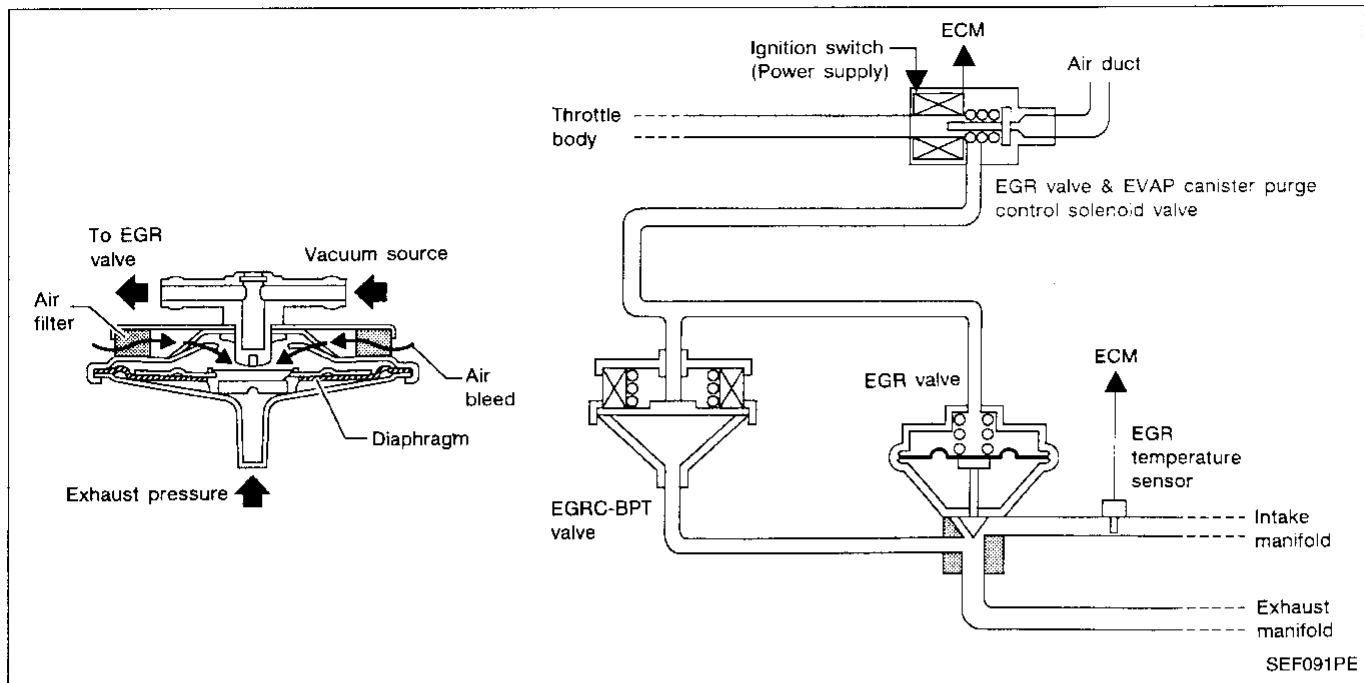

## SYSTEM DESCRIPTION

The EGRC-BPT valve monitors exhaust pressure to activate the diaphragm, controlling throttle body vacuum applied to the EGR valve. In other words, recirculated exhaust gas is controlled in response to positioning of the EGR valve or to engine operation.

## ON-BOARD DIAGNOSIS LOGIC

If too much EGR flow exists due to an EGRC-BPT valve malfunction, off idle engine roughness will increase. If roughness is large, then vacuum to the EGR valve is interrupted through the EGR valve & EVAP canister purge control solenoid valve. If the engine roughness is reduced at that time, the EGRC-BPT valve malfunction is indicated.

Diagnostic Trouble Code No.	Malfunction is detected when ...	Check Items (Possible Cause)
P0402 0306	<ul style="list-style-type: none"> <li>The EGRC-BPT valve does not operate properly.</li> </ul>	<ul style="list-style-type: none"> <li>EGRC-BPT valve</li> <li>Misconnected rubber tube</li> <li>Blocked rubber tube</li> </ul>

## OVERALL FUNCTION CHECK

Use this procedure to check the overall function of the EGRC-BPT valve. During this check, a DTC might not be confirmed.

- Disconnect the vacuum hose to the fuel pressure regulator at the intake manifold.
- Disconnect the vacuum hose to the EGR valve & EVAP canister purge control solenoid valve at the EGRC-BPT valve.  
Connect the intake manifold and the EGRC-BPT valve with a rubber tube that has 1 mm (0.04 in) dia. orifice installed. (The intake manifold vacuum will be directly applied to the EGRC-BPT valve.)
- Start engine.
- Check for the EGR valve lifting with engine at less than 1,500 rpm under no load.  
**EGR valve should remain closed.**
- Check the EGR valve lifting when revving from 2,000 rpm up to 4,000 rpm under no load.  
**EGR valve should lift up, and go down without sticking when the engine is returned to idle.**
- Check rubber tube between EGR valve & EVAP canister purge control solenoid valve and throttle body for misconnection, cracks or blockages.

EGRC-BPT Valve Function (DTC: 0306)  
(Cont'd)

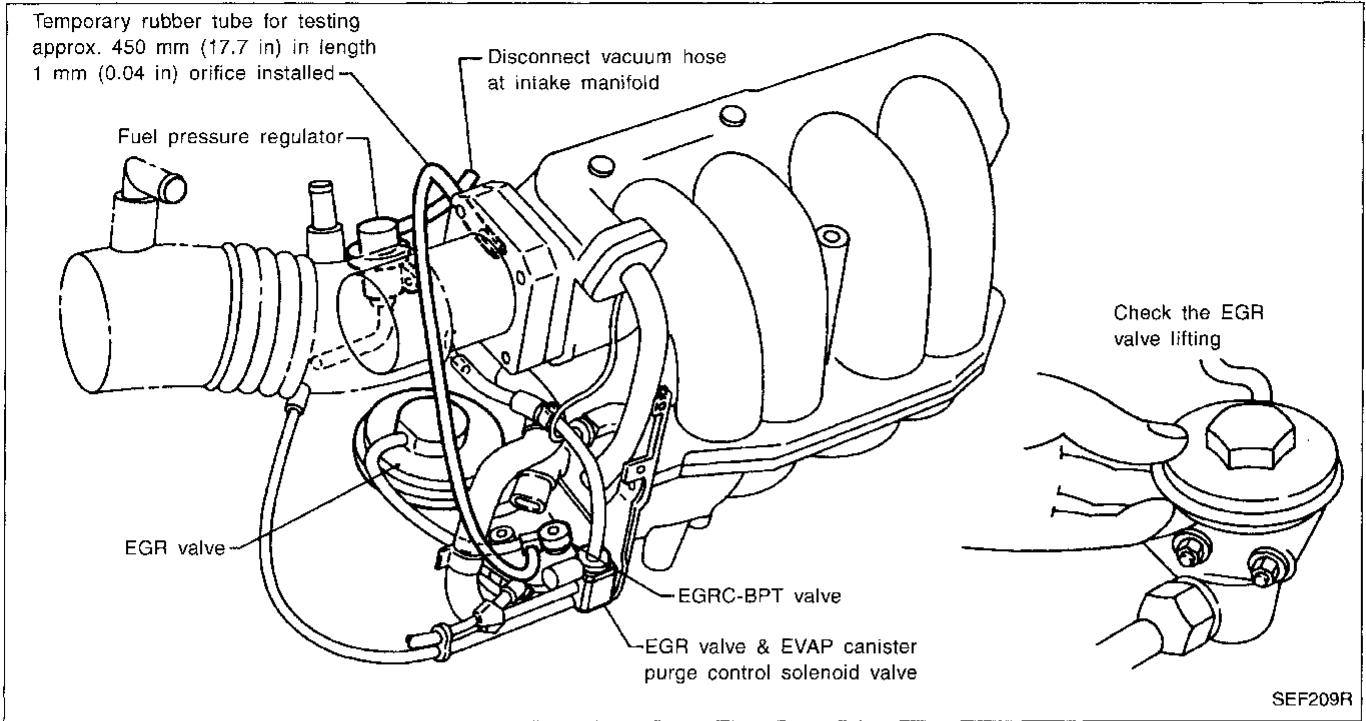

GI

MA

EM

LC

**EC**

FE

CL

MT

AT

FA

RA

BR

ST

RS

BT

HA

EL

IDX

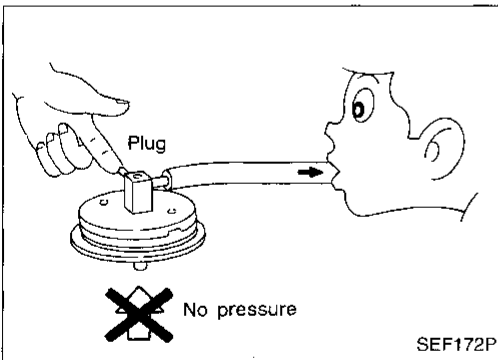

**COMPONENT INSPECTION**

**EGRC-BPT valve**

1. Plug one of two ports of EGRC-BPT valve.
2. Vacuum from the other port and check leakage without applying any pressure from under EGR-BPT valve. **Leakage should exist.**

### Three Way Catalyst Function (DTC: 0702)

#### ON-BOARD DIAGNOSIS LOGIC

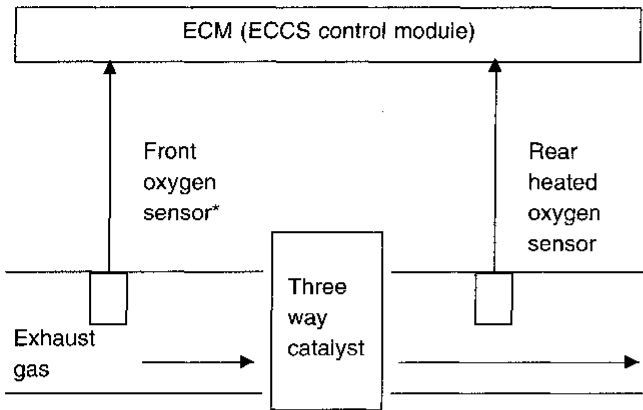

\*: Oxygen sensor (M/T models except for California)  
Heated oxygen sensor (M/T models for California and A/T models)

The ECM monitors the switching frequency ratio of front oxygen sensor\* and rear heated oxygen sensor.

A three way catalyst with high oxygen storage capacity will indicate a low switching frequency of rear heated oxygen sensor. As oxygen storage capacity decreases, the rear heated oxygen sensor switching frequency will increase.

When the frequency ratio of front oxygen sensor\* and rear heated oxygen sensor approaches a specified limit value, the second stage diagnosis is applied.

The second stage diagnosis switches the mixture ratio feedback control using front oxygen sensor\* to rear heated oxygen sensor.

Then ECM measures the switching lag time between front oxygen sensor\* and rear heated oxygen sensor.

The longer lag time indicates the greater oxygen storage capacity. If the lag time is within the specified level, the three way catalyst malfunction is diagnosed.

- The three way catalyst function has one trip detection logic.

Diagnostic Trouble Code No.	Malfunction is detected when ...	Check Items (Possible Cause)
P0420 0702	<ul style="list-style-type: none"> <li>• Three way catalyst does not operate properly.</li> <li>• Three way catalyst does not have enough oxygen storage capacity.</li> </ul>	<ul style="list-style-type: none"> <li>• Three way catalyst</li> <li>• Exhaust tube</li> <li>• Intake air leak</li> <li>• Injectors</li> <li>• Injector leak</li> </ul>

#### OVERALL FUNCTION CHECK

Use this procedure to check the overall function of the three way catalyst. During this check, a DTC might not be confirmed.

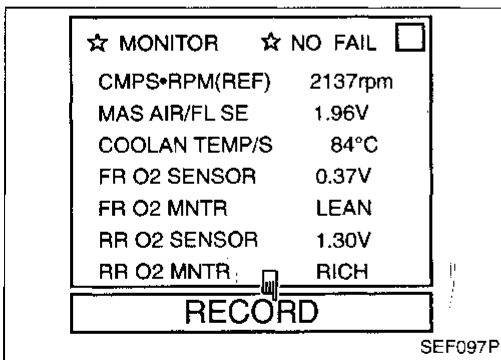

- 1) Start engine and warm it up sufficiently.
- 2) Set "MANU TRIG" and "HI SPEED", then select "FR O2 SENSOR", "RR O2 SENSOR", "FR O2 MNTR", "RR O2 MNTR" in "DATA MONITOR" mode with CONSULT.
- 3) Touch "RECORD" on CONSULT screen with engine speed held at 2,000 rpm constant under no load.
- 4) Make sure that the switching frequency between "RICH" and "LEAN" of "RR O2 SENSOR" is very less than that of "FR O2 SENSOR".

**Switching frequency ratio =**

$$\frac{\text{Rear heated oxygen sensor switching frequency}}{\text{Front oxygen sensor switching frequency}}$$

**This ratio should be less than 0.86.**

If the ratio is greater than 0.86, the three way catalyst is not operating properly.

OR

### Three Way Catalyst Function (DTC: 0702) (Cont'd)

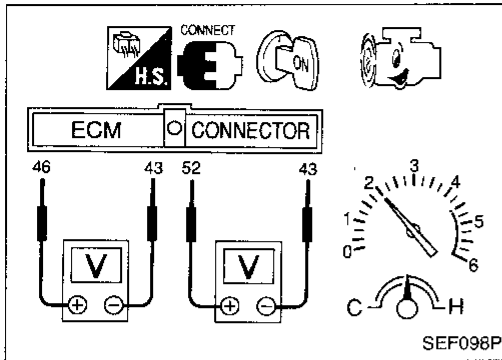

- 1) Start engine and warm it up sufficiently.
- 2) Set voltmeter probes between ECM terminals ④⑥ (front oxygen sensor signal) and ④③ (engine ground), and ECM terminals ⑤② (rear heated oxygen sensor signal) and ④③ (engine ground).
- 3) Keep engine speed at 2,000 rpm constant under no load.
- 4) Make sure that the voltage switching frequency (high & low) between ECM terminals ⑤② and ④③ is much less than that of ECM terminals ④⑥ and ④③.

**Switching frequency ratio =**

**Rear heated oxygen sensor voltage switching frequency**

**Front oxygen sensor voltage switching frequency**

**This ratio should be less than 0.86.**

If the ratio is greater than 0.86, it means three way catalyst does not operate properly.

**Note: If the voltage at terminal ④⑥ does not switch periodically more than 5 times within 10 seconds at step 3, perform TROUBLE DIAGNOSIS FOR DTC P0130 first. Refer to EC-342.**

CI

MA

EM

LC

EC

FE

CL

MT

AT

FA

RA

BR

ST

RS

BT

HA

EL

IDX

Three Way Catalyst Function (DTC: 0702)  
(Cont'd)

DIAGNOSTIC PROCEDURE

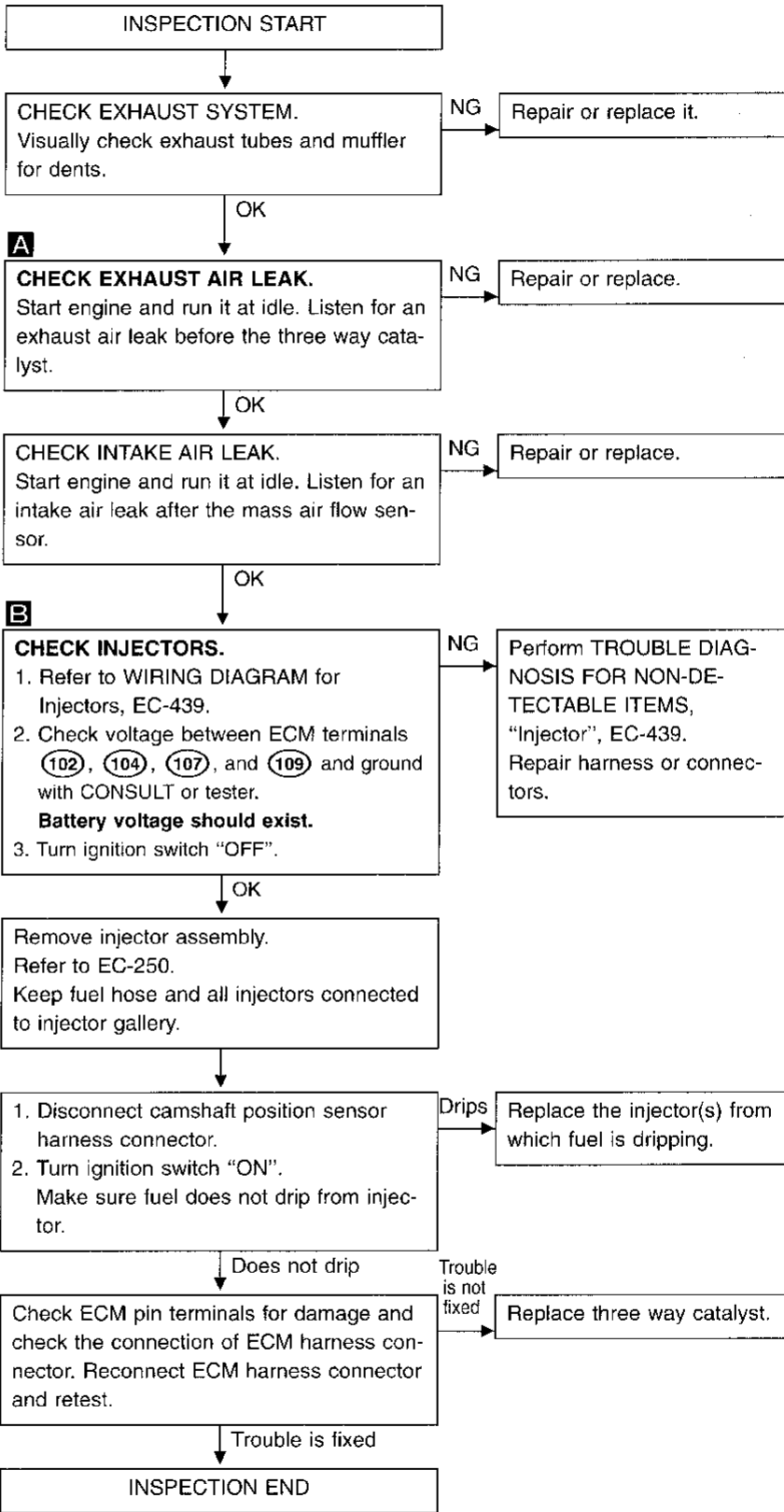
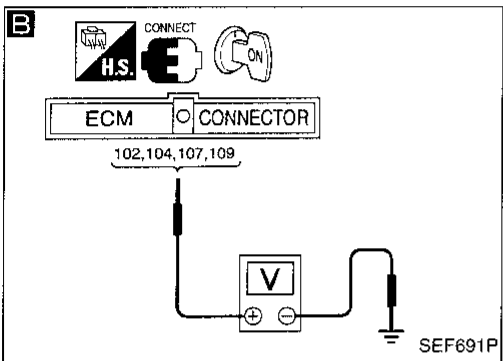
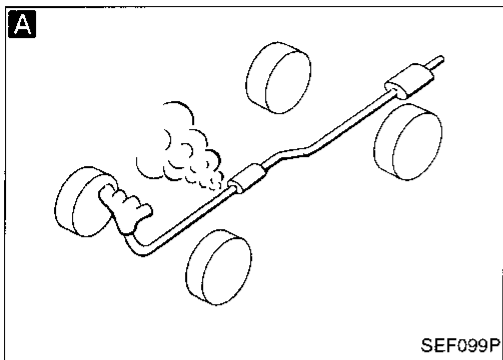

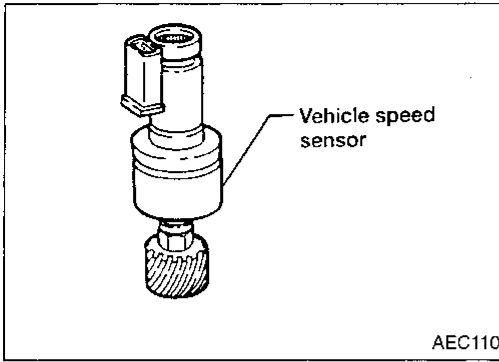

### Vehicle Speed Sensor (VSS) (DTC: 0104)

The vehicle speed sensor is installed in the transaxle. It contains a pulse generator which provides a vehicle speed signal to the speedometer. The speedometer then sends a signal to the ECM.

GI  
MA  
EM  
LC  
EC  
FE  
CL  
MT  
AT  
FA  
RA  
BR  
ST  
RS  
BT  
HA  
EL  
IDX

Diagnostic Trouble Code No.	Malfunction is detected when ....	Check Items (Possible Cause)
P0500 0104	<ul style="list-style-type: none"> <li>The almost 0 km/h (0 MPH) signal from vehicle speed sensor is sent to ECM even when vehicle is being driven.</li> </ul>	<ul style="list-style-type: none"> <li>Harness or connector (The vehicle speed sensor circuit is open or shorted.)</li> <li>Vehicle speed sensor</li> </ul>

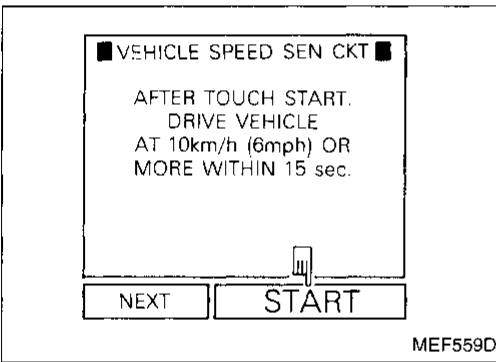

### OVERALL FUNCTION CHECK

Use this procedure to check the overall function of the vehicle speed sensor circuit. During this check, a DTC might not be confirmed.

- 1) Jack up drive wheels.
- 2) Start engine.
- 3) Perform "VEHICLE SPEED SEN CKT" in "FUNCTION TEST" mode with CONSULT.

OR

- 1) Jack up drive wheels.
- 2) Start engine.
- 3) Read vehicle speed sensor signal in "DATA MONITOR" mode with CONSULT.

**The vehicle speed on CONSULT should be able to exceed 10 km/h (6 MPH) when rotating wheels with suitable gear position.**

OR

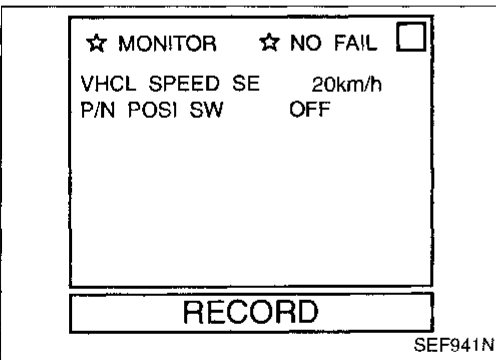

## Vehicle Speed Sensor (VSS) (DTC: 0104) (Cont'd)

FUEL SYS #1	CLOSED
FUEL SYS #2	UNUSED
CALC LOAD	57%
COOLANT TEMP	87°C
SHORT FT #1	1%
LONG FT #1	-3%
ENGINE SPD	2225RPM
VEHICLE SPD	57MPH
IGN ADVANCE	34.0°
INTAKE AIR	43°C
MAF	26.2gm/sec
THROTTLE POS	12%
O2S LOCATION	3
O2S B1,S1	0.090V
O2FT B1,S1	0%
O2S B1,S2	0.070V

SEF942N



- 1) Jack up drive wheels.
- 2) Start engine.
- 3) Read vehicle speed sensor signal in "MODE 1" with GST.

**The vehicle speed on GST should be able to exceed 10 km/h (6 MPH) when rotating wheels with suitable gear position.**

OR

## DIAGNOSTIC TROUBLE CODE CONFIRMATION PROCEDURE



- 1) Start engine and warm it up sufficiently.
- 2) Perform test drive continuously under the following recommended condition.

Testing time : (A/T models) at least 5 seconds  
(M/T models) at least 10 seconds

Engine speed : (A/T models) 2,100 - 2,800 rpm  
(M/T models) 1,700 - 2,800 rpm

Intake manifold vacuum: (A/T models) -46.7 to -20.0 kPa  
(-350 to -150 mmHg, -13.78 to -5.91 inHg)  
(M/T models) -46.7 to -33.3 kPa  
(-350 to -250 mmHg, -13.78 to -9.84 inHg)

Gear position : Suitable position (except "N" or "P" position)

- 3) Stop the vehicle, turn ignition switch "OFF", wait at least 5 seconds and then turn "ON".
- 4) Perform "Diagnostic Test Mode II" (Self-diagnostic results) with ECM.

**Even though Diagnostic Trouble Code is not detected, perform the above test drive at least one more time.**

Vehicle Speed Sensor (VSS) (DTC: 0104)  
(Cont'd)

EC-VSS-01

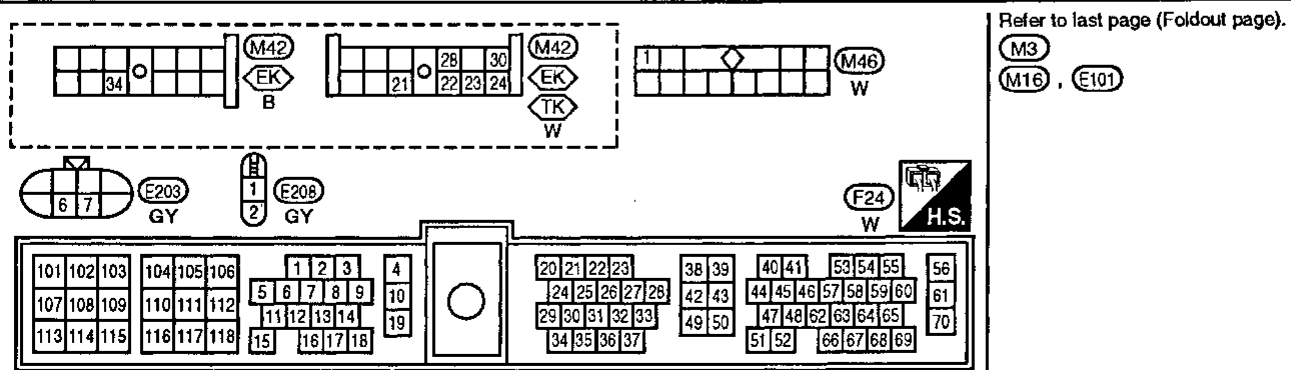
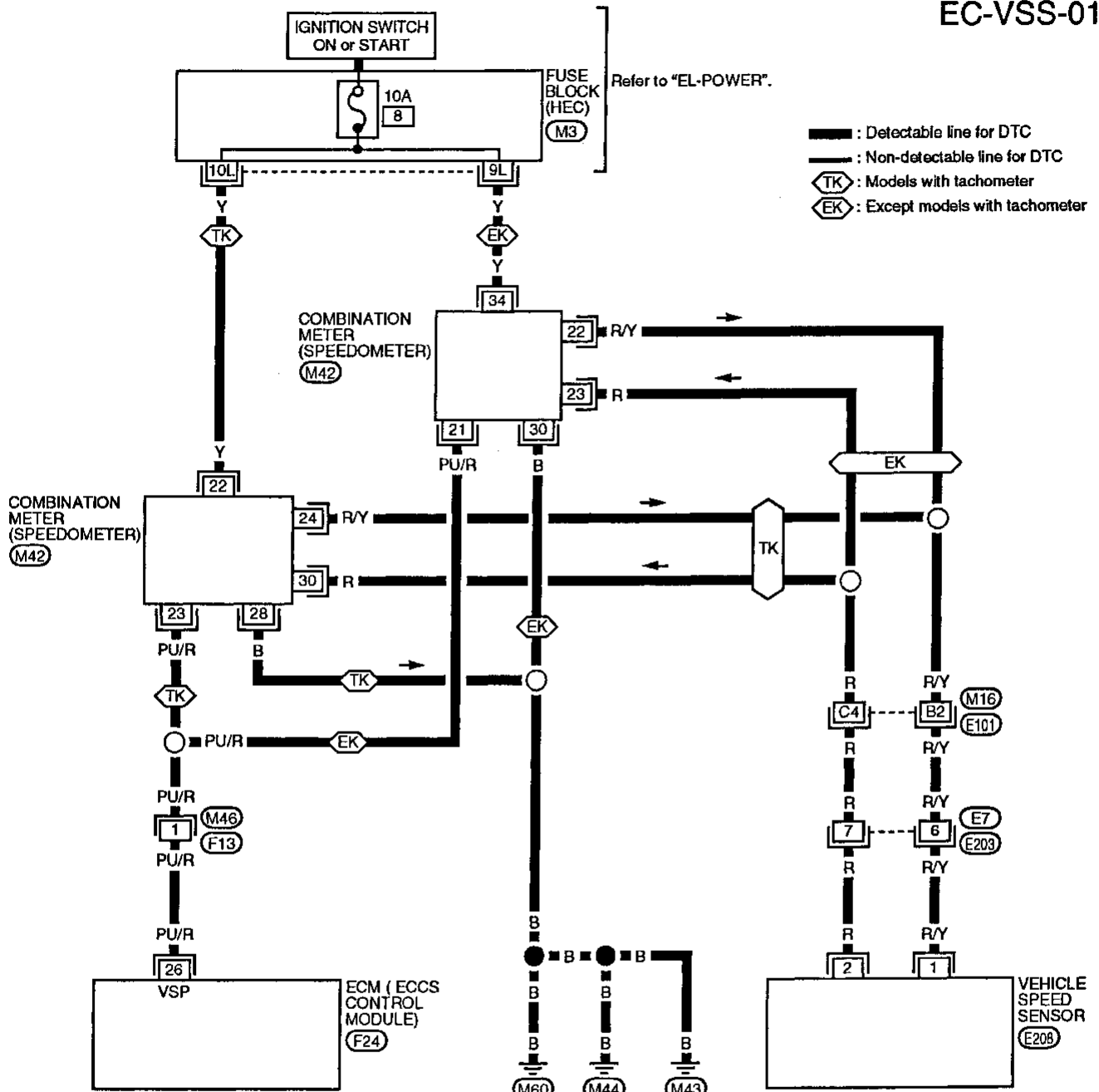



Vehicle Speed Sensor (VSS) (DTC: 0104)  
(Cont'd)

DIAGNOSTIC PROCEDURE

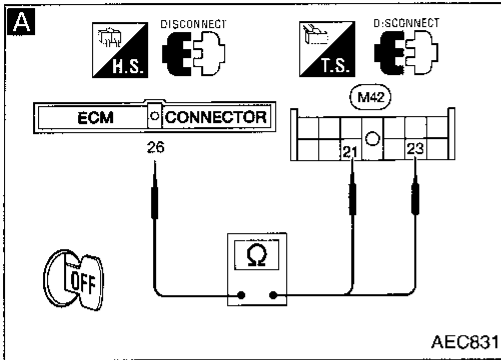

INSPECTION START

**A**

**CHECK INPUT SIGNAL CIRCUIT.**

1. Turn ignition switch "OFF".
2. Disconnect ECM harness connector and combination meter harness connector.
3. Check harness continuity.

Model	Terminals	
	ECM	Meter
With tachometer	(26)	(23)
Without tachometer	(26)	(21)

**Continuity should exist.**  
If OK, check harness for short.

NG

Check the following.

- Harness connectors (F13), (M46)
- Harness for open or short between ECM and combination meter

If NG, repair harness or connectors.

OK

**CHECK SPEEDOMETER FUNCTION.**  
Make sure that speedometer functions properly.

NG

Check the following.

- Harness connectors (M16), (E101)
- Harness connectors (E7), (E203)
- Harness for open or short between combination meter and vehicle speed sensor

If NG, repair harness or connectors.  
Check vehicle speed sensor and its circuit.  
Refer to EL section.

OK

Disconnect and reconnect harness connectors in the circuit. Then retest.

Trouble is not fixed.

Check ECM pin terminals for damage and check the connection of ECM harness connector. Reconnect ECM harness connector and retest.

INSPECTION END

## Idle Air Control Valve (IACV) — Auxiliary Air Control (AAC) Valve (DTC: 0205)

### SYSTEM DESCRIPTION

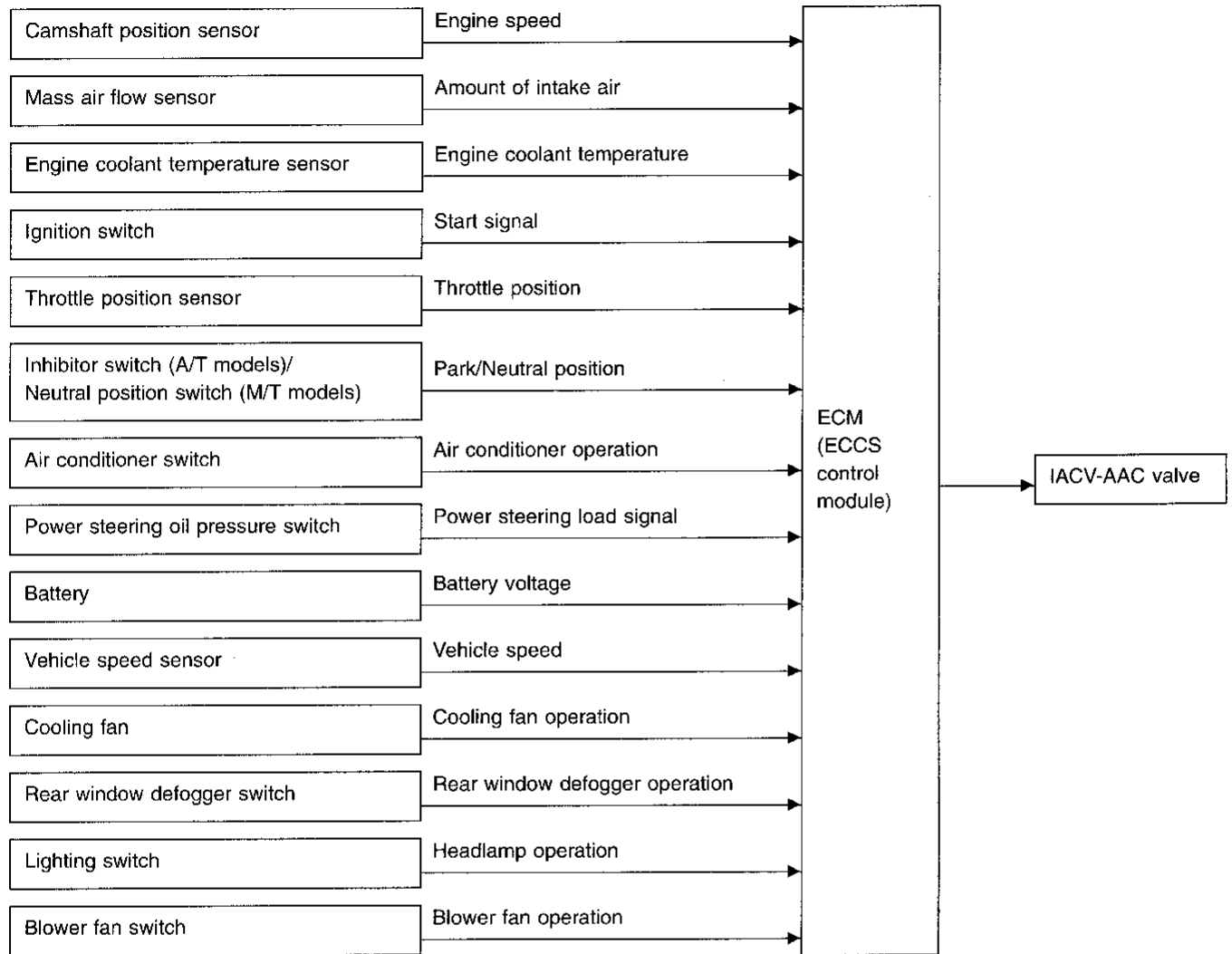

This system automatically controls engine idle speed to a specified level. Idle speed is controlled through fine adjustment of the amount of air which bypasses the throttle valve via IACV-AAC valve. The IACV-AAC valve opens and closes according to the signal sent from the ECM. The camshaft position sensor detects the actual engine speed and sends a signal to the ECM. The ECM then controls the IACV-AAC valve so that engine speed coincides with the target value memorized in ECM. The target engine speed is the lowest speed at which the engine can operate steadily. The optimum value stored in the ECM is determined by taking into consideration various engine conditions, such as during warm up, deceleration, and engine load (air conditioner, power steering and cooling fan operation).

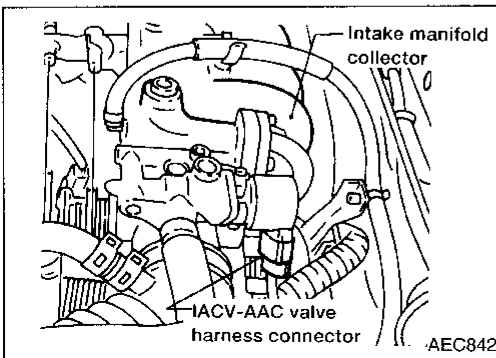

### COMPONENT DESCRIPTION

#### IACV-AAC valve

The IAC valve-AAC valve is moved by open and close signals from the ECM. When the open signal is sent to the valve, the amount of air that will flow through the valve increases. The more air that flows through the valve, the higher the idle speed. When the close signal is sent to the valve, the amount of air decreases.

GI  
MA  
EM  
LC  
EC  
FE  
CL  
MT  
AT  
FA  
RA  
BR  
ST  
RS  
BT  
HA  
EL  
IDX  
623

## Idle Air Control Valve (IACV) — Auxiliary Air Control (AAC) Valve (DTC: 0205) (Cont'd)

Diagnostic Trouble Code No.	Malfunction is detected when ....	Check Items (Possible Cause)
P0505 0205	A) The IACV-AAC valve does not operate properly.	<ul style="list-style-type: none"> <li>● Harness or connectors (The IACV-AAC valve circuit is open.)</li> <li>● IACV-AAC valve</li> </ul>
	B) The IACV-AAC valve does not operate properly.	<ul style="list-style-type: none"> <li>● Harness or connectors (The IACV-AAC valve circuit is shorted.)</li> <li>● IACV-AAC valve</li> </ul>

### DIAGNOSTIC TROUBLE CODE CONFIRMATION PROCEDURE

#### Procedure for malfunction A



- 1) Turn ignition switch "ON".
- 2) Select "DATA MONITOR" mode with CONSULT.
- 3) Start engine and run it at idle for at least 2 seconds.

OR



- 1) Start engine and run it at idle for at least 2 seconds.
- 2) Select "MODE 3" with GST.

OR



- 1) Start engine and run it at idle for at least 2 seconds.
- 2) Perform "Diagnostic Test Mode II" (Self-diagnostic results) with ECM.

#### Procedure for malfunction B



- 1) Start engine and warm it up sufficiently.
- 2) Turn ignition switch "OFF" and wait at least 5 seconds.
- 3) Turn ignition switch "ON" again and select "DATA MONITOR" mode with CONSULT.
- 4) Start engine and run it for at least 30 seconds at idle speed.

OR



- 1) Start engine and warm it up sufficiently.
- 2) Turn ignition switch "OFF" and wait at least 5 seconds.
- 3) Start engine again and run it for at least 30 seconds at idle speed.
- 4) Select "MODE 3" with GST.

OR



- 1) Start engine and warm it up sufficiently.
- 2) Turn ignition switch "OFF" and wait at least 5 seconds.
- 3) Start engine again and run it for at least 30 seconds at idle speed.
- 4) Turn ignition switch "OFF", wait at least 5 seconds and then turn "ON".
- 5) Perform "Diagnostic Test Mode II" (Self-diagnostic results) with ECM.

Idle Air Control Valve (IACV) — Auxiliary Air Control (AAC) Valve (DTC: 0205) (Cont'd)

EC-AAC/V-01

GI  
MA  
EM  
LC  
**EC**  
FE  
CL  
MT  
AT  
FA  
RA  
BR  
ST  
RS  
BT  
HA  
EL  
DX

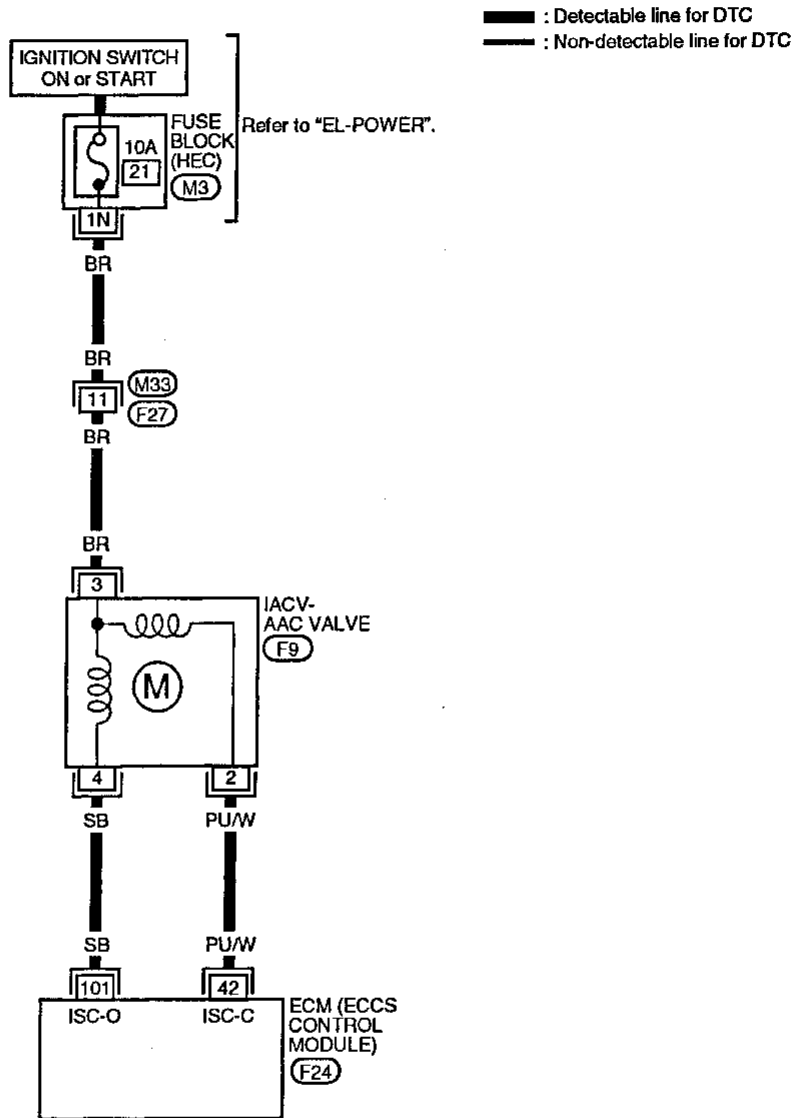

Refer to last page (Foldout page).

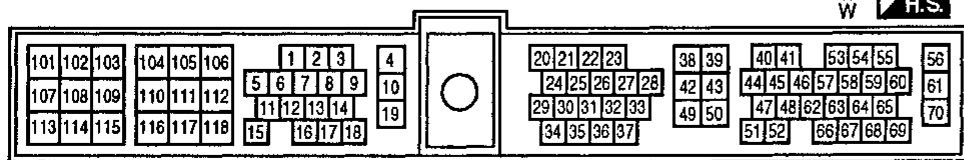
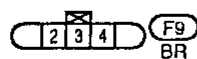

## Idle Air Control Valve (IACV) — Auxiliary Air Control (AAC) Valve (DTC: 0205) (Cont'd)

### DIAGNOSTIC PROCEDURE

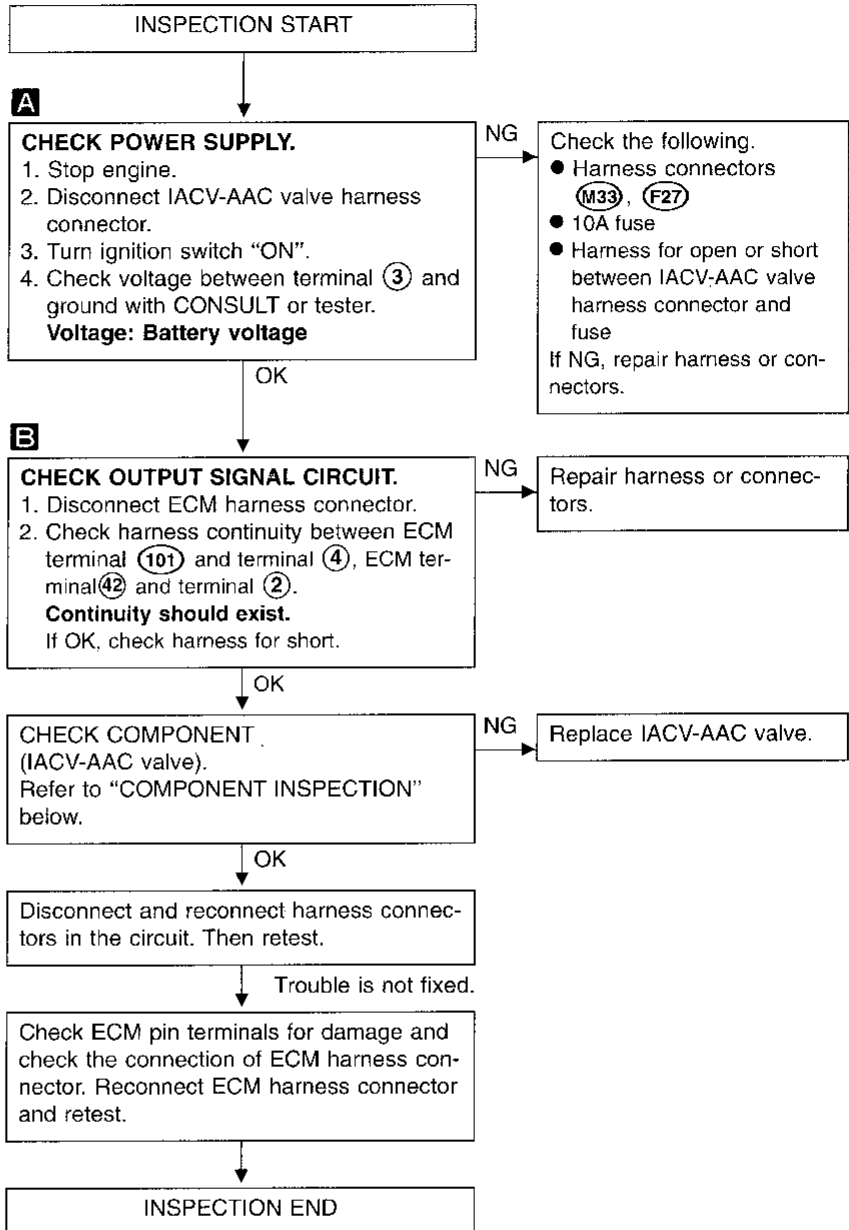
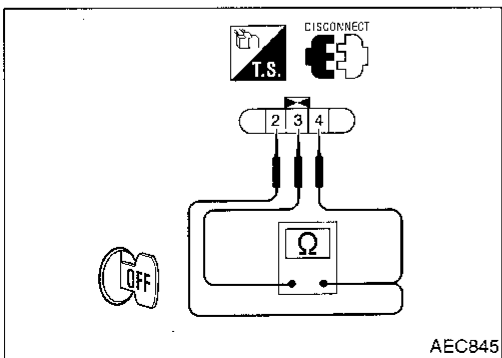
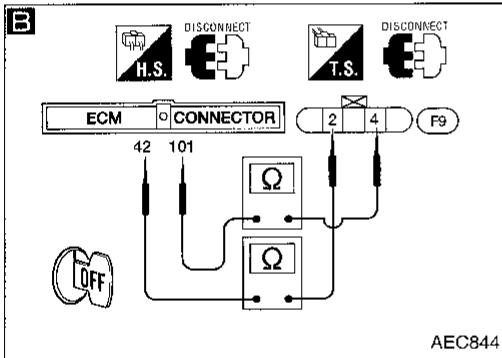
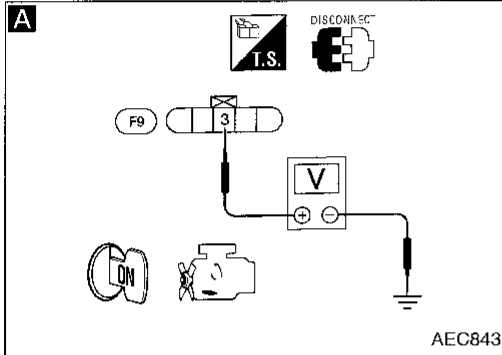
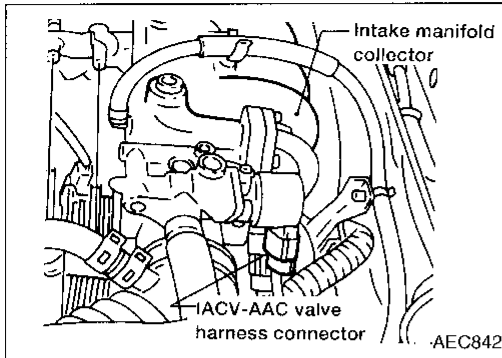

### COMPONENT INSPECTION

#### IACV-AAC valve

Disconnect IACV-AAC valve harness connector.

- Check resistance between terminals ② and ③, ③ and ④.

#### Resistance:

50 - 100Ω [at 25°C (77°F)]

If NG, replace IACV-AAC valve.

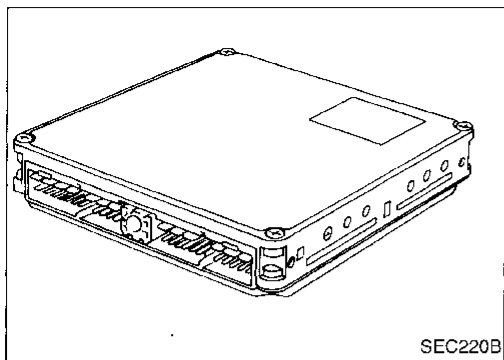

**Engine Control Module (ECM)-ECCS Control Module (DTC: 0301)**

The ECM consists of a microcomputer, diagnostic test mode selector, and connectors for signal input and output and for power supply. The unit controls the engine.

GI  
MA  
EM  
LC  
EC  
FE  
CL  
MT  
AT  
FA  
RA  
BR  
ST  
RS  
BT  
HA  
EL  
DX

Diagnostic Trouble Code No.	Malfunction is detected when ...	Check Items (Possible Cause)
P0605 0301	<ul style="list-style-type: none"> <li>ECM calculation function is malfunctioning.</li> </ul>	<ul style="list-style-type: none"> <li>ECM (ECCS control module)</li> </ul>

**DIAGNOSTIC TROUBLE CODE CONFIRMATION PROCEDURE**

- 1) Turn ignition switch "ON".  
 2) Select "DATA MONITOR" mode with CONSULT.  
 3) Start engine and run it for at least 30 seconds at idle speed.

OR

- 1) Turn ignition switch "ON".  
 2) Select "Mode 3" with GST.  
 3) Start engine and run it for at least 30 seconds at idle speed.

OR

- 1) Turn ignition switch "ON".  
 2) Start engine and run it for at least 30 seconds at idle speed.  
 3) Turn ignition switch "OFF" and wait at least 5 seconds.  
 4) Perform "Diagnostic Test Mode II" (Self-diagnostic results) with ECM.

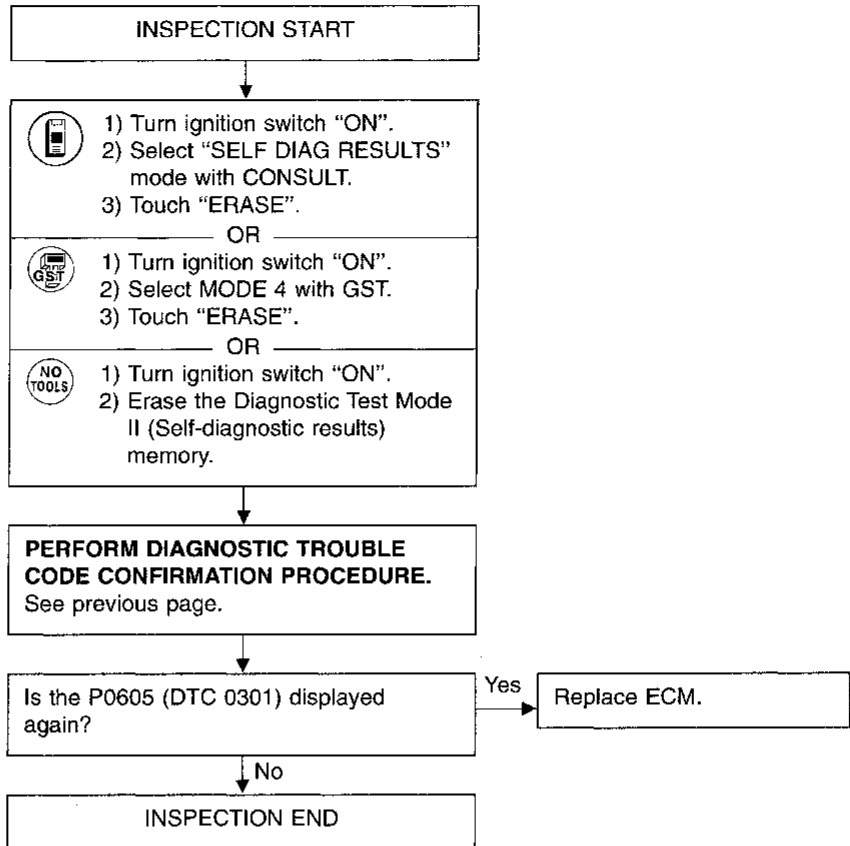
**Engine Control Module (ECM)-ECCS Control Module (DTC: 0301) (Cont'd)****DIAGNOSTIC PROCEDURE**

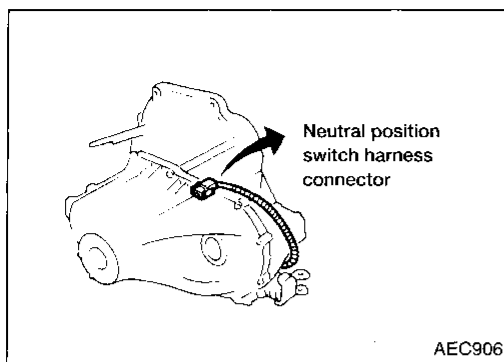

### Park/Neutral Position Switch (DTC: 1003)

When the gear position is "P" (A/T models only) or "N", park/neutral position switch is "ON".

ECM detects the park/neutral position when continuity with ground exists.

Diagnostic Trouble Code No.	Malfunction is detected when ....	Check Items (Possible Cause)
P0705 1003	<ul style="list-style-type: none"> <li>The signal of the park/neutral position switch is not changed in the process of engine starting and driving.</li> </ul>	<ul style="list-style-type: none"> <li>Harness or connectors (The neutral position switch or inhibitor switch circuit is open or shorted.)</li> <li>Neutral position switch (M/T models)</li> <li>Inhibitor switch (A/T models)</li> </ul>

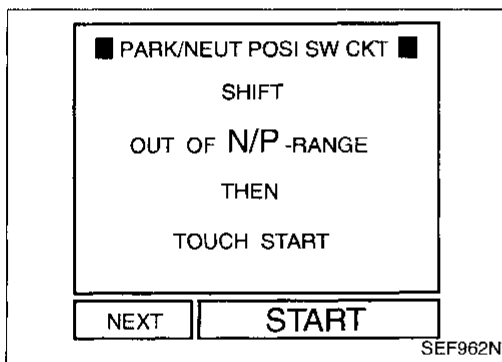

### OVERALL FUNCTION CHECK

Use this procedure to check the overall function of the park/neutral position switch circuit. During this check, a DTC might not be confirmed.

- Turn ignition switch "ON".
- Perform "PARK/NEUT POSI SW CKT" in "FUNCTION TEST" mode with CONSULT.

OR

- Select "P/N POSI SW" in "DATA MONITOR" mode with CONSULT.
- Check the "P/N POSI SW" signal under the following conditions.

Condition (Gear position)	Signal
"P" (A/T only) and "N" position	ON
Except the above position	OFF

OR

- Turn ignition switch "ON".
- Check voltage between ECM terminal ②② and body ground under the following conditions.

Condition (Gear position)	Voltage (V)
"P" (A/T only) and "N" position	Approx. 0
Except the above position	M/T models: Approx. 5 A/T models: Battery voltage

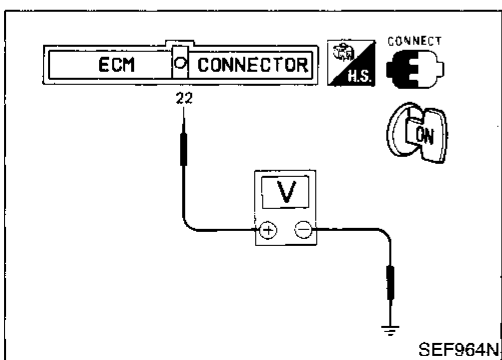
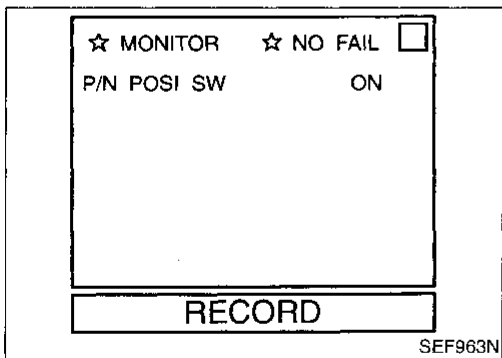



Park/Neutral Position Switch (DTC: 1003)  
(Cont'd)

EC-PNP/SW-01

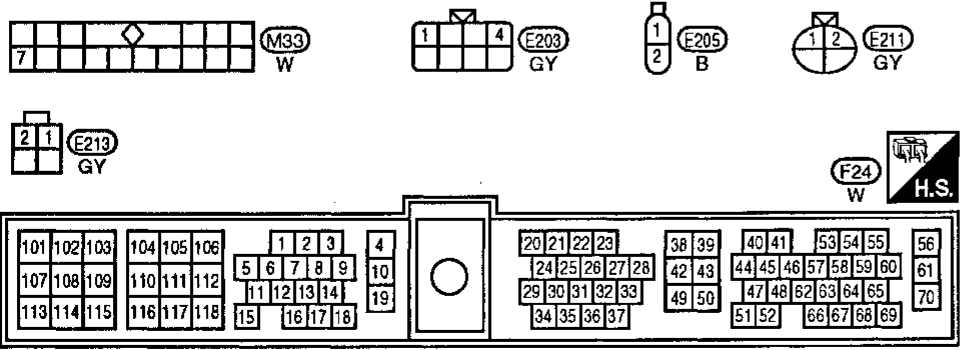
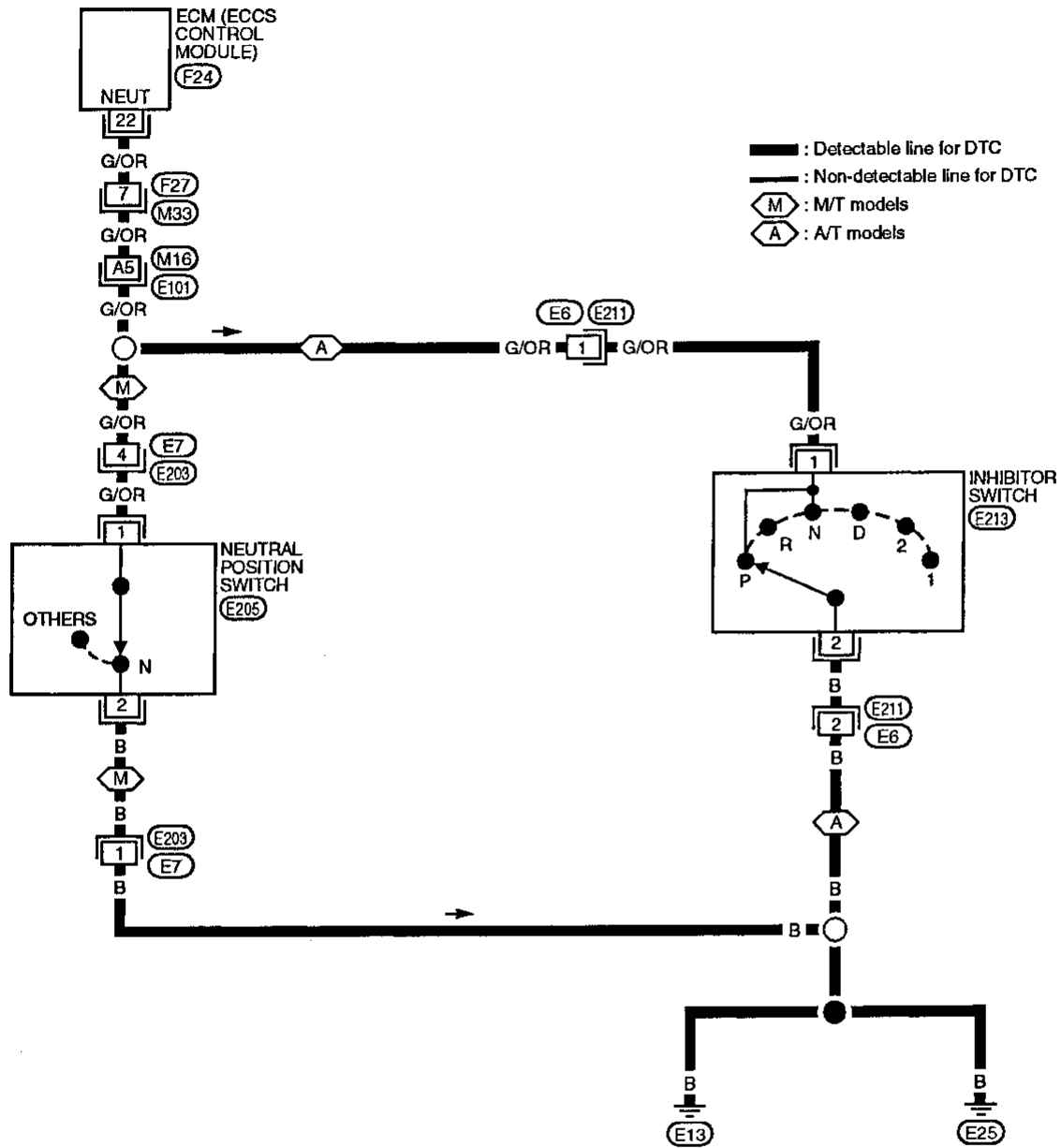

Refer to last page (Foldout page).  
(M16), (E101)

Park/Neutral Position Switch (DTC: 1003)  
(Cont'd)

DIAGNOSTIC PROCEDURE

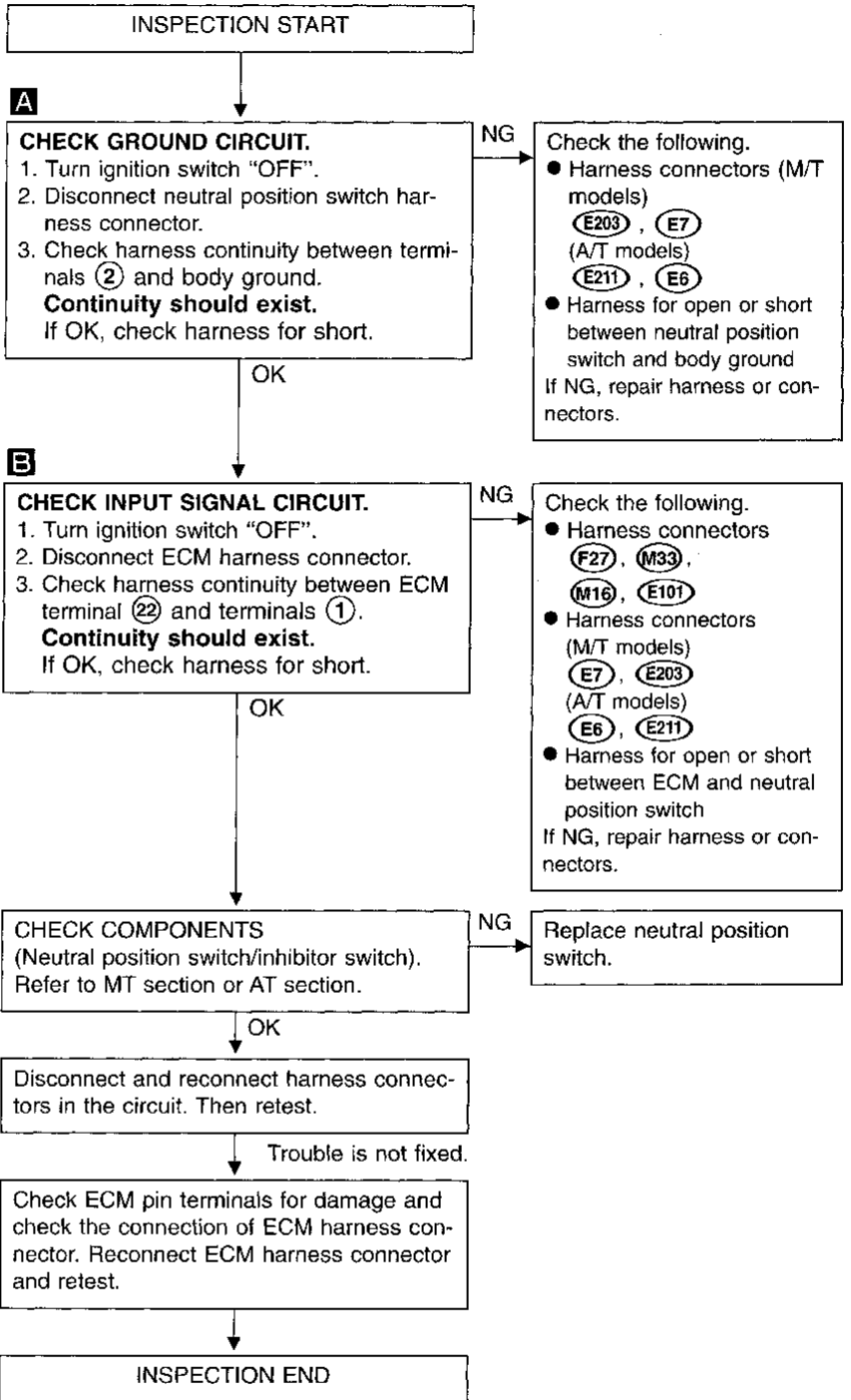
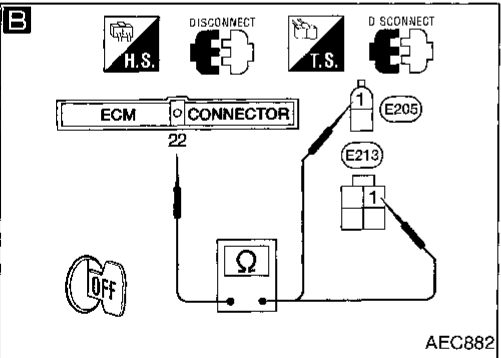
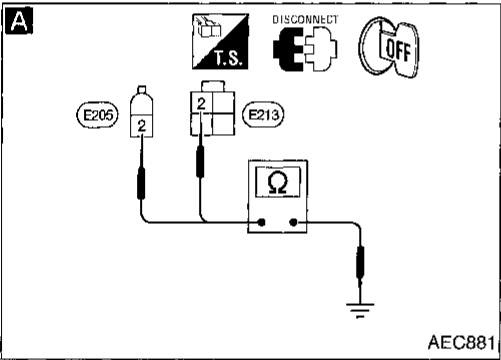
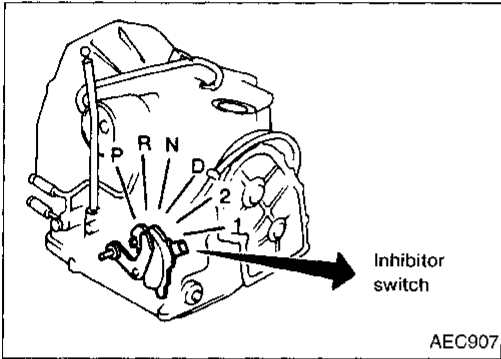
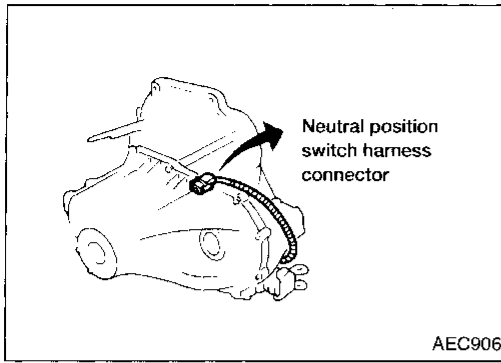

GI  
MA  
EM  
LC  
EC  
FE  
CL  
MT  
AT  
FA  
RA  
BR  
ST  
RS  
BT  
HA  
EL  
IDX

Valve Timing Control (VTC) (DTC: 0805)

SYSTEM DESCRIPTION

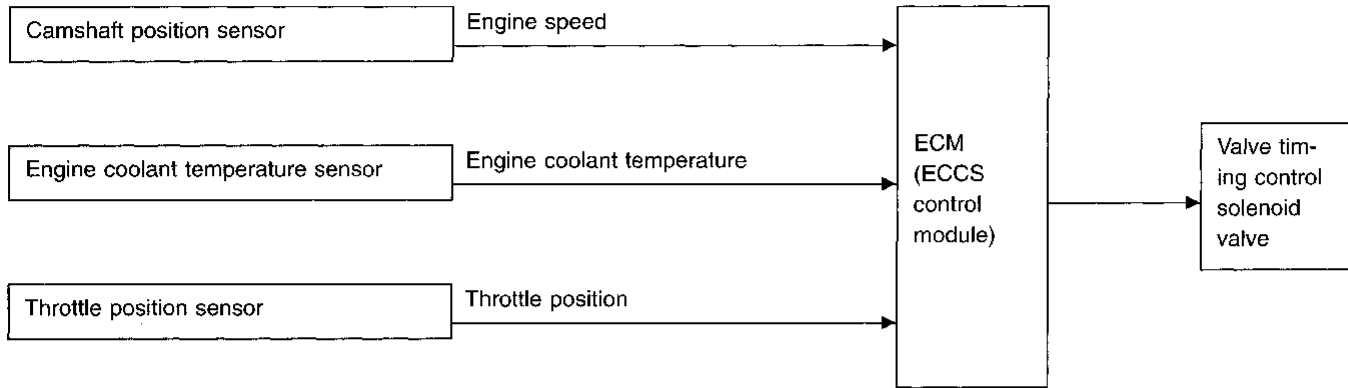

The valve timing control (VTC) system is utilized to control intake valve opening and closing timing. Engine coolant temperature signals, engine speed and throttle position are used to determine intake valve timing. The intake camshaft sprocket position is regulated by oil pressure controlled by the VTC.

When ECM sends ON signal to VTC solenoid valve, oil pressure is transmitted to camshaft sprocket. Then, intake side camshaft is advanced.

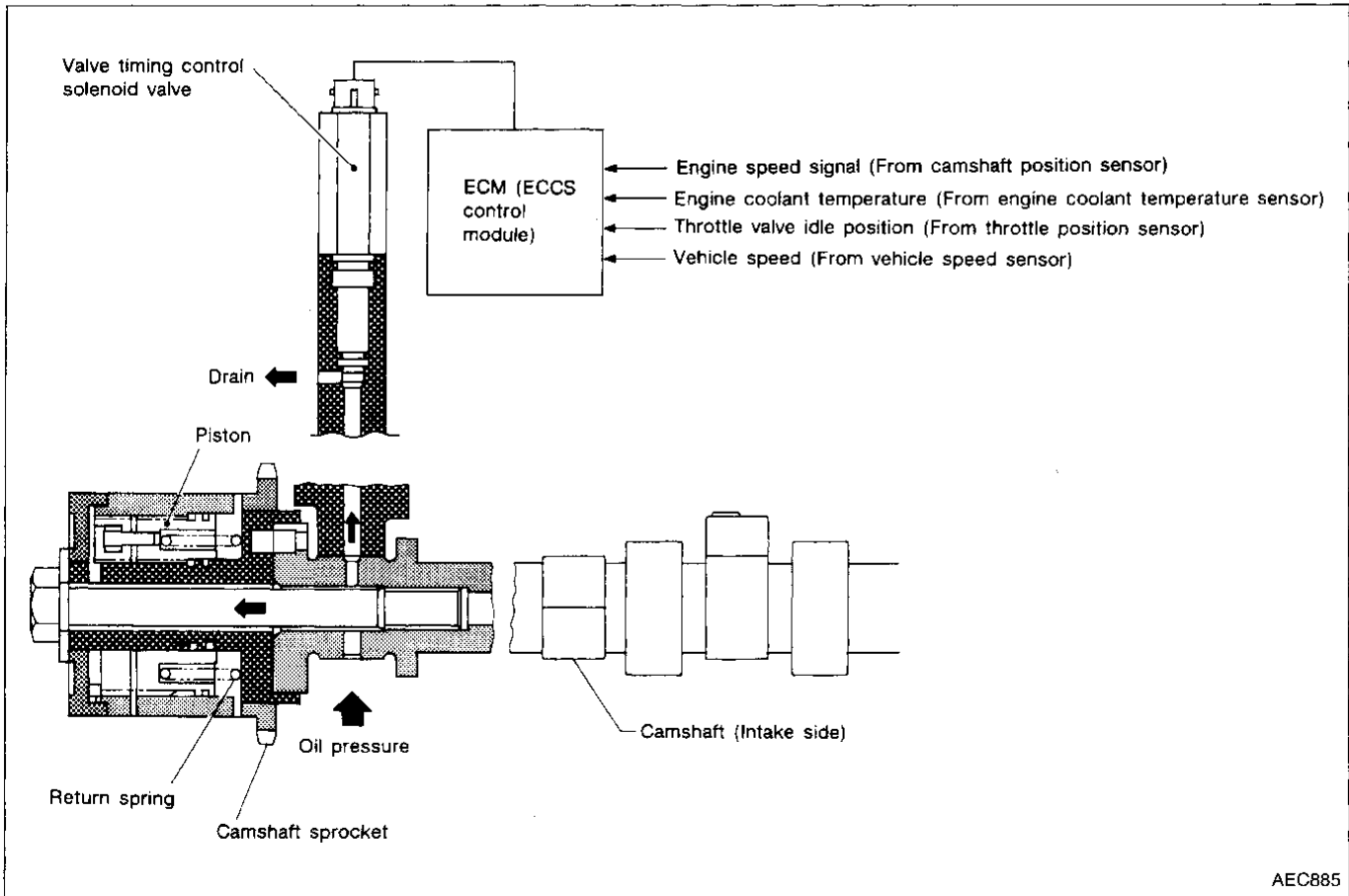

AEC885

Valve Timing Control (VTC) (DTC: 0805)  
(Cont'd)

OPERATION

Engine operating condition	Valve timing control solenoid valve	Intake valve opening and closing time	Valve overlap	Engine valve timing
<ul style="list-style-type: none"> <li>● Engine coolant temperature is 70°C (158°F) or more.</li> <li>● Engine speed is between 1,150 rpm and 5,400 rpm.</li> </ul>	ON	Advance	Increased	Ⓓ
<ul style="list-style-type: none"> <li>● Engine speed is 6,600 rpm or more.</li> </ul>	ON	Advance	Increased	Ⓓ
Those other than above	OFF	Normal	Normal	Ⓘ

Ⓘ Valve timing control (VTC) solenoid valve is OFF. Ⓓ Valve timing control (VTC) solenoid valve is ON.

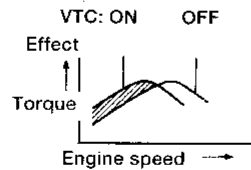
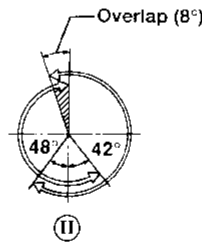
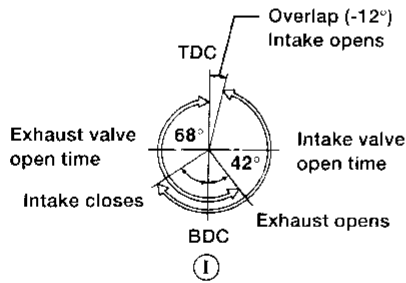
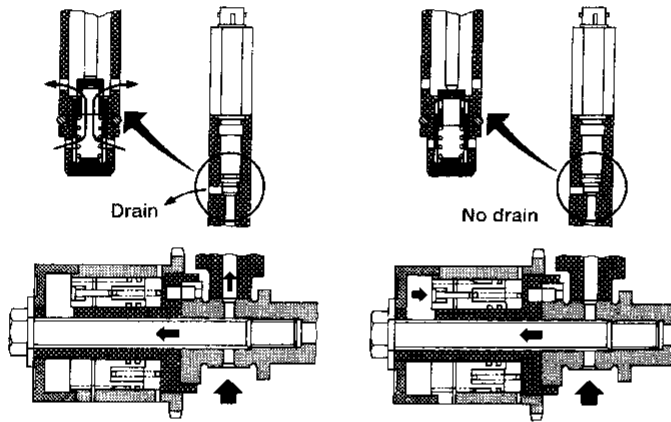

AEC886

## Valve Timing Control (VTC) (DTC: 0805) (Cont'd)

Diagnostic Trouble Code No.	Malfunction is detected when ....	Check Items (Possible Cause)
P1110 0805	A) An improper voltage signal is entered to ECM through VTC solenoid valve.	<ul style="list-style-type: none"> <li>● Harness or connectors (The VTC solenoid valve circuit is open or shorted.)</li> <li>● VTC solenoid valve</li> </ul>
	B) The basic injection pulse width does not change when VTC solenoid valve is activated to ON under the specified conditions.	<ul style="list-style-type: none"> <li>● Harness or connectors (The VTC solenoid valve circuit is open.)</li> <li>● VTC</li> <li>● Engine oil (The oil is deteriorated.)</li> <li>● Intake air system</li> <li>● VTC solenoid valve</li> </ul>

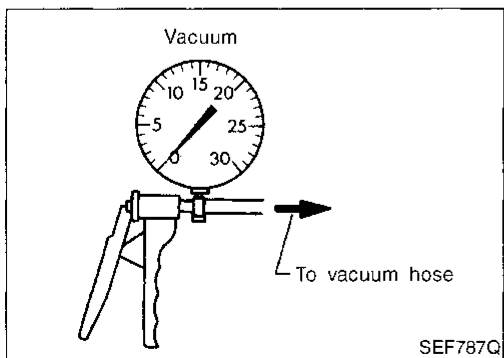
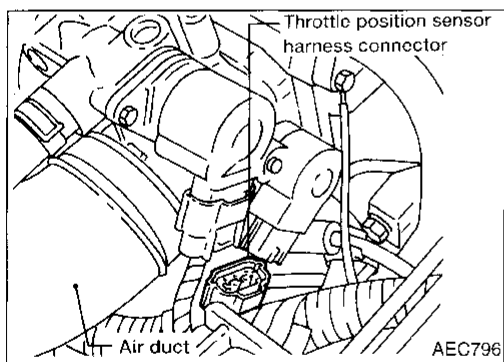
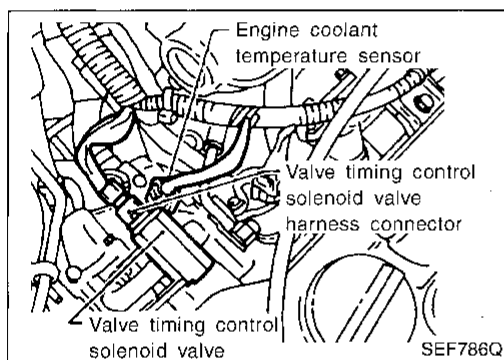

### DIAGNOSTIC TROUBLE CODE CONFIRMATION PROCEDURE

#### Procedure for malfunction A

- 1) Turn ignition switch "ON".
- 2) Select "DATA MONITOR" mode with CONSULT.
- 3) Wait at least 5 seconds.

OR

- 1) Turn ignition switch "ON" and wait at least 5 seconds.
- 2) Select "MODE 3" with GST.

OR

- 1) Turn ignition switch "ON", wait at least 5 seconds.
- 2) Perform "Diagnostic Test Mode II" (Self-diagnostic results) with ECM.

#### OVERALL FUNCTION CHECK

Use this procedure to check the overall function of the VTC. During this check, a DTC might not be confirmed.

#### Procedure for malfunction B

- 1) Start engine and warm it up sufficiently.
- 2) Turn ignition switch "OFF".
- 3) Disconnect throttle position sensor harness connector.
- 4) Disconnect vacuum hose from fuel pressure regulator and then connect the hose to vacuum gauge.
- 5) Turn ignition switch "ON" and select "VALVE TIMING SOL" in "ACTIVE TEST" mode with CONSULT.
- 6) Start engine and race it to 2,000 - 3,000 rpm 2 or 3 times.
- 7) Raise the idle speed (base idle) by turning the idle adjusting screw until intake manifold vacuum pressure becomes stable (Approx. 1,200 rpm).
- 8) Make sure that the difference of vacuum pressure is more than 1.3 kPa (10 mmHg, 0.39 inHg) when alternating "ON" and "OFF" with CONSULT.

Valve Timing Control (VTC) (DTC: 0805)  
(Cont'd)

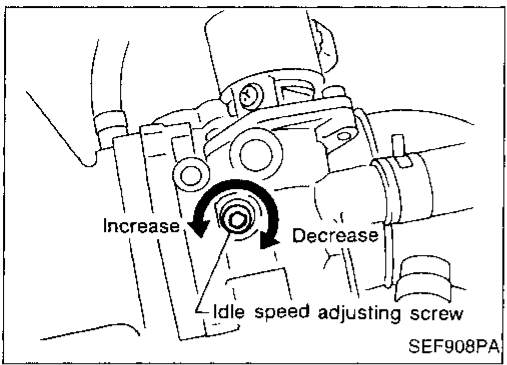

Reference value

VTC "ON":

Approximately -73.3 kPa (-550 mmHg, -21.65 inHg)

VTC "OFF":

Approximately -76.0 kPa (-570 mmHg, -22.44 inHg)

OR

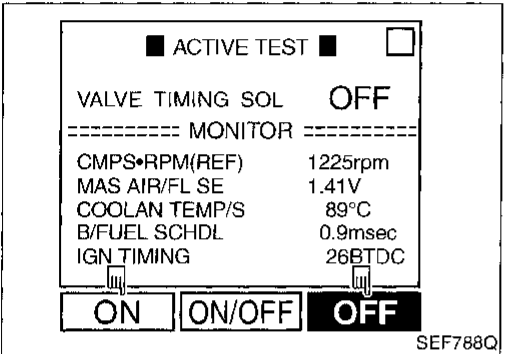

- 1) Start engine and warm it up sufficiently.
- 2) Turn ignition switch "OFF".
- 3) Disconnect throttle position sensor harness connector.
- 4) Disconnect vacuum hose from fuel pressure regulator and then connect the hose to vacuum gauge.
- 5) Disconnect VTC solenoid valve harness connector.
- 6) Start engine and race it to 2,000 - 3,000 rpm 2 or 3 times.
- 7) Raise the idle speed (base idle) by turning the idle adjusting screw until intake manifold vacuum pressure becomes stable (Approx. 1,200 rpm).
- 8) Make sure that the vacuum pressure changes more than 1.3 kPa (10 mmHg, 0.39 inHg) when supplying the solenoid valve terminals with battery voltage.

Reference value

Battery voltage supplied:

Approx. -73.3 kPa (-550 mmHg, -21.65 inHg)

No battery voltage supplied:

Approx. -76.0 kPa (-570 mmHg, -22.44 inHg)

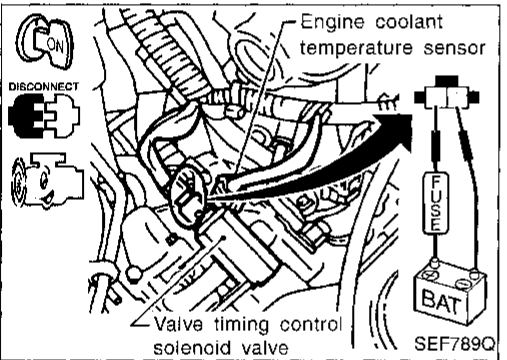

GI  
MA  
EM  
LC  
EC  
FE  
CL  
MT  
AT  
FA  
RA  
BR  
ST  
RS  
BT  
HA  
EL  
IDX

Valve Timing Control (VTC) (DTC: 0805)  
(Cont'd)

EC-VTC-01

— : Detectable line for DTC  
— : Non-detectable line for DTC

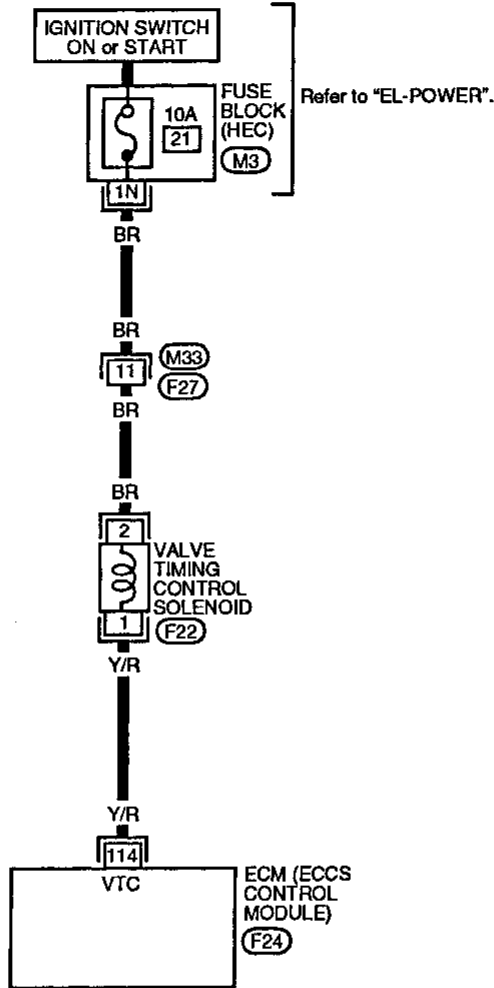

Refer to last page (Foldout page).

M3

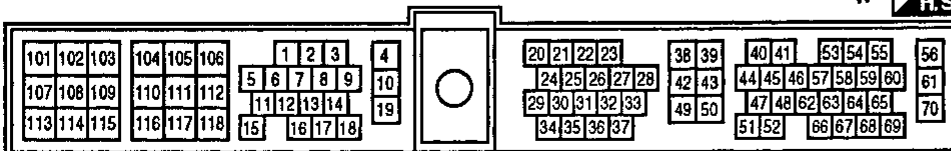

Valve Timing Control (VTC) (DTC: 0805)  
(Cont'd)

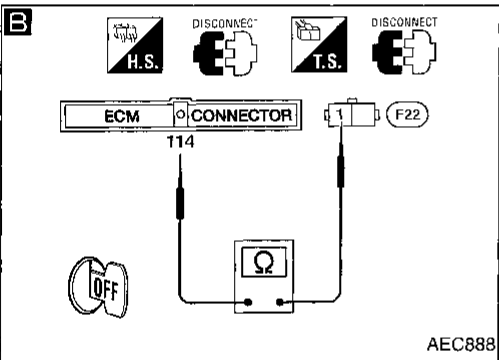
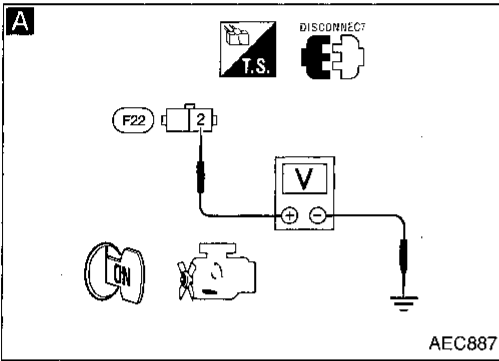
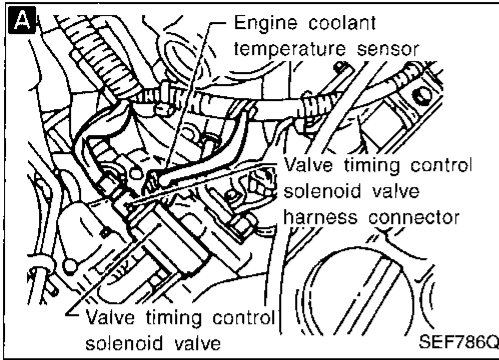

DIAGNOSTIC PROCEDURE

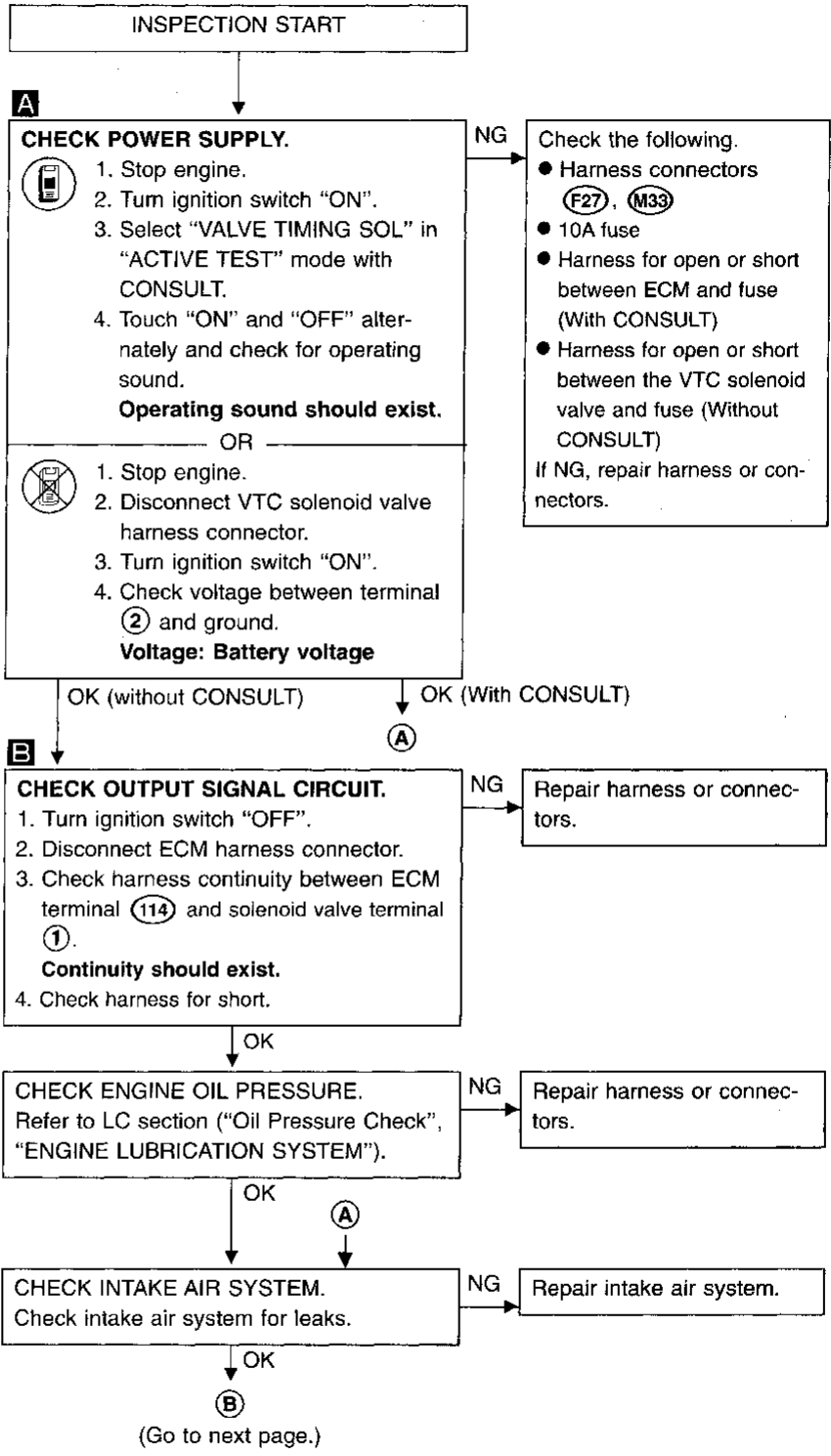

GI  
MA  
EM  
LC  
EC  
FE  
CL  
MT  
AT  
FA  
RA  
BR  
ST  
RS  
BT  
HA  
EL  
IDX



## Valve Timing Control (VTC) (DTC: 0805) (Cont'd)

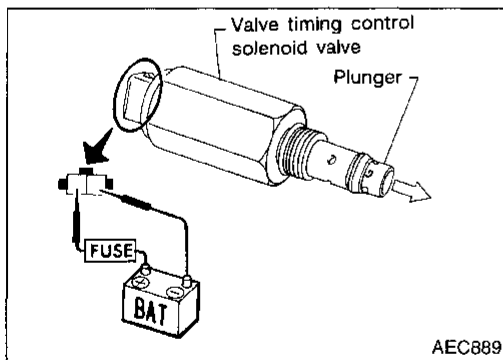
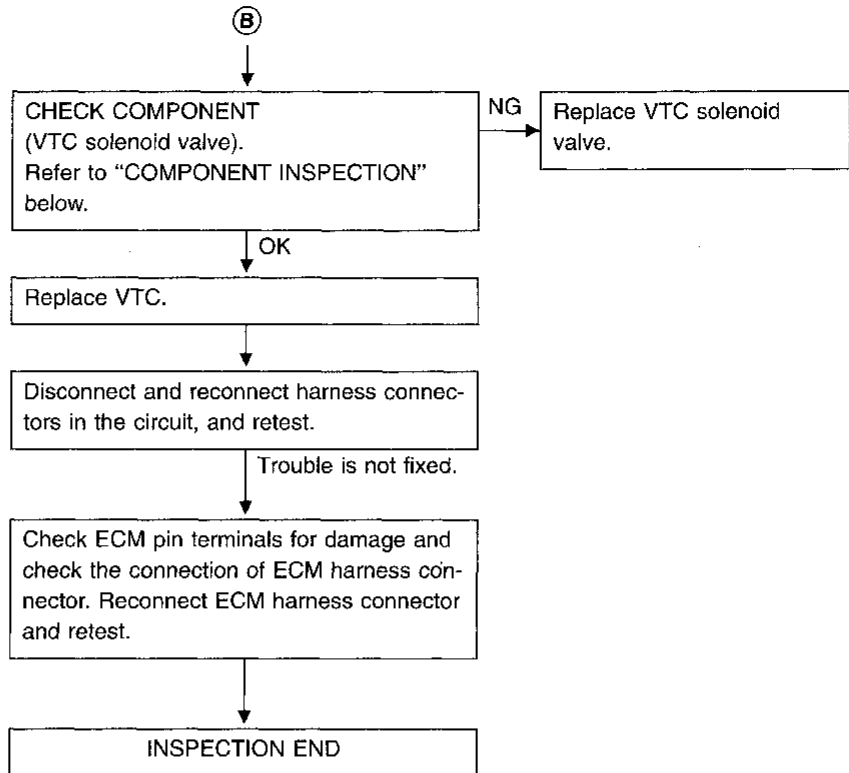

### COMPONENT INSPECTION

#### VTC solenoid valve

1. Supply VTC solenoid valve terminals with battery voltage.
2. Make sure that inside plunger protrudes.  
If NG, replace VTC solenoid valve.

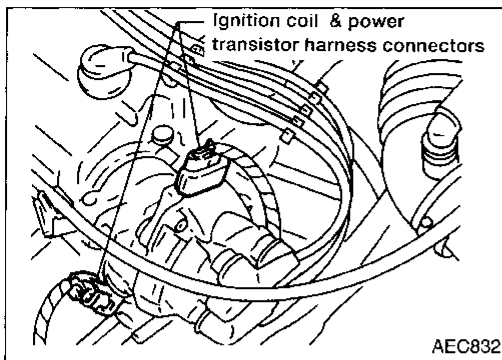

### Ignition Signal (DTC: 0201)

#### COMPONENT DESCRIPTION

#### Ignition coil & power transistor (Built into distributor)

The ignition coil is built into distributor. The ignition signal from the ECM is sent to the power transistor. The power transistor switches on and off the ignition coil primary circuit. As the primary circuit is turned on and off, the proper high voltage is induced in the coil secondary circuit.

Diagnostic Trouble Code No.	Malfunction is detected when ...	Check Items (Possible Cause)
P1320 0201	<ul style="list-style-type: none"> <li>● The ignition signal in the primary circuit is not sent to ECM during engine cranking or running.</li> </ul>	<ul style="list-style-type: none"> <li>● Harness or connectors (The ignition primary circuit is open or shorted.)</li> <li>● Power transistor unit.</li> <li>● Resistor</li> <li>● Camshaft position sensor</li> <li>● Camshaft position sensor circuit</li> </ul>

#### DIAGNOSTIC TROUBLE CODE CONFIRMATION PROCEDURE

**Note:** If both DTC P0340 (0101) and P1320 (0201) are displayed, perform TROUBLE DIAGNOSIS FOR DTC P0340 first. Refer to EC-372.

- ① 1) Turn ignition switch "ON".  
 2) Select "DATA MONITOR" mode with CONSULT.  
 3) Start engine. (If engine does not run, turn ignition switch to "START" for at least 5 seconds.)

- OR
- ② 1) Turn ignition switch "ON".  
 2) Start engine. (If engine does not run, turn ignition switch to "START" for at least 5 seconds.)  
 3) Select MODE 3 with GST.

- OR
- ③ 1) Turn ignition switch "ON".  
 2) Start engine. (If engine does not run, turn ignition switch to "START" for at least 5 seconds.)  
 3) Turn ignition switch "OFF" and wait at least 5 seconds, and then turn "ON".  
 4) Perform "Diagnostic Test Mode II" (Self-diagnostic results) with ECM.

Ignition Signal (DTC: 0201) (Cont'd)

EC-IGN/SG-01

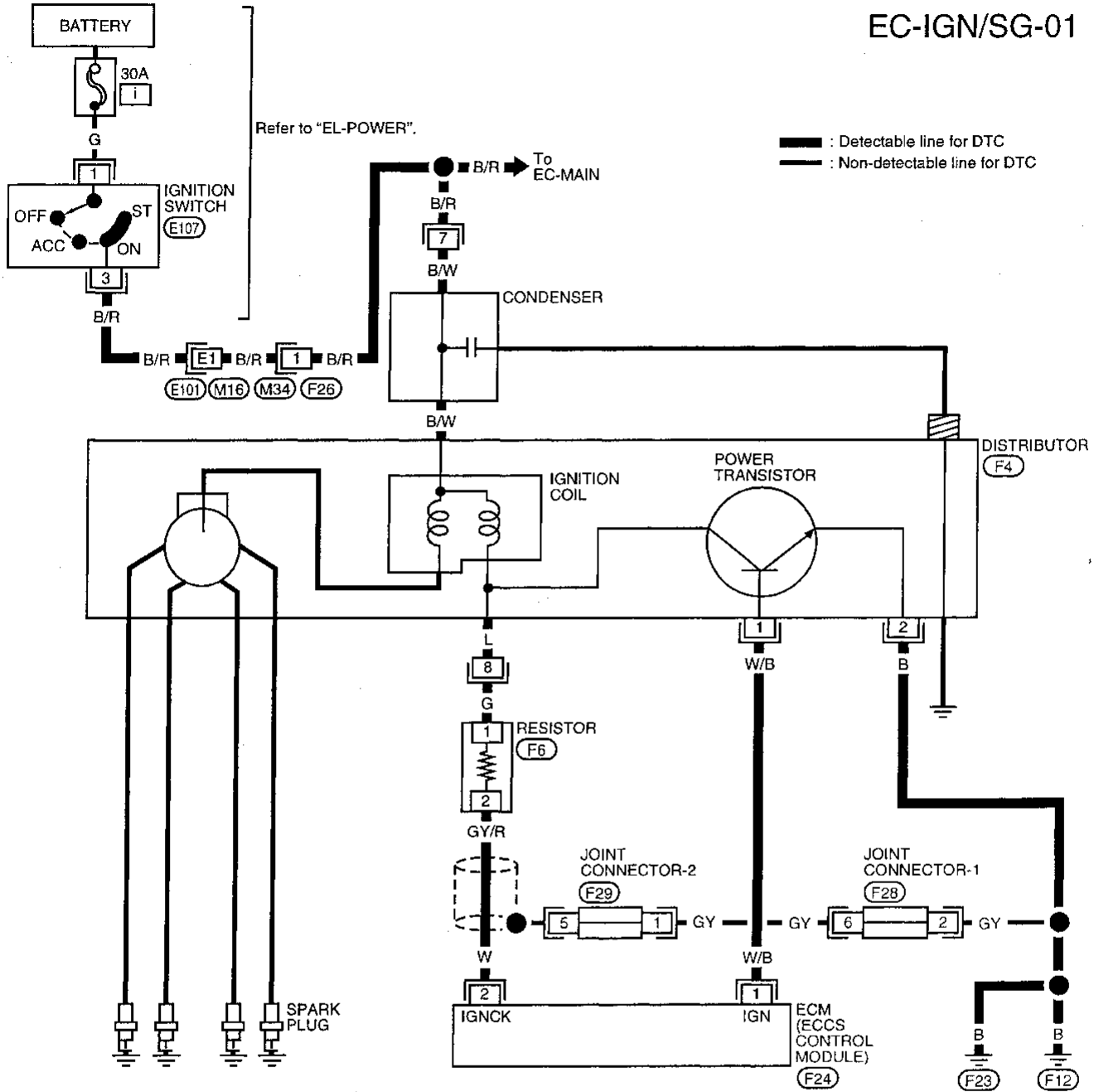

Refer to last page (Foldout page).

(M16), (E101)

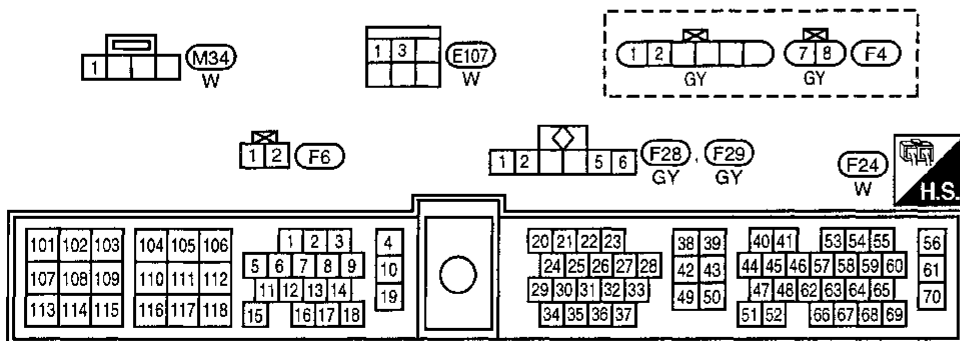

Ignition Signal (DTC: 0201) (Cont'd)  
DIAGNOSTIC PROCEDURE

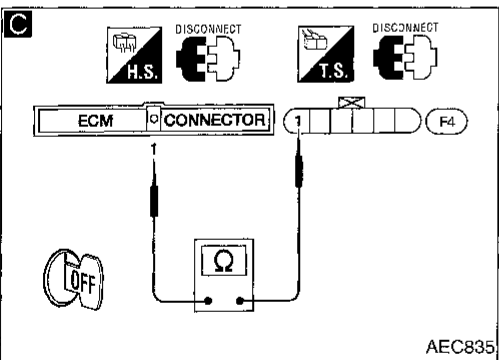
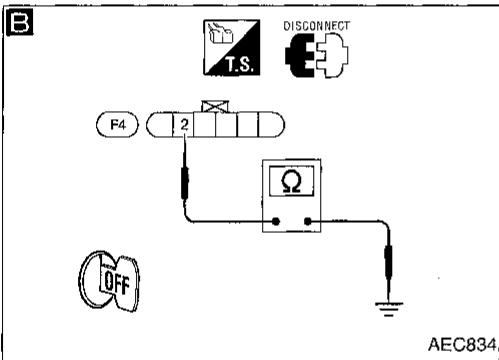
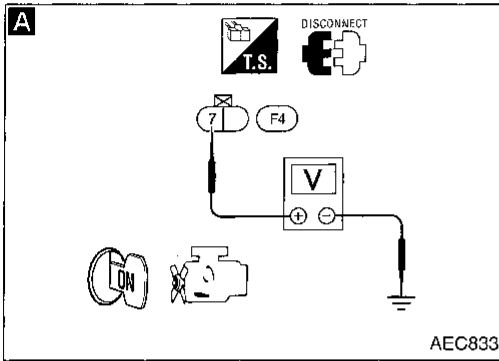
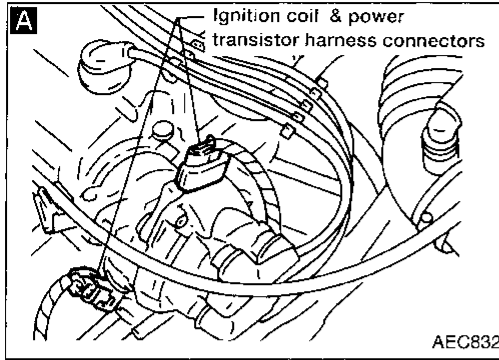

```

    graph TD
        Start[INSPECTION START] --> Q1{Turn ignition switch "OFF", and restart engine.  
Is engine running?}
        Q1 -- Yes --> A1((A))
        A1 --> End[INSPECTION END]
        Q1 -- No --> A2[A]
        subgraph A [CHECK POWER SUPPLY.]
            A2 --> A2_1[1. Turn ignition switch "OFF".]
            A2 --> A2_2[2. Disconnect ignition coil harness connector.]
            A2 --> A2_3[3. Turn ignition switch "ON".]
            A2 --> A2_4[4. Check voltage between terminal 7 and ground with CONSULT or tester.  
Voltage: Battery voltage]
        end
        A2 -- OK --> B[B]
        A2 -- NG --> A2_NG[Check the following.  
• Harness connectors (E101, M16)  
• Harness connectors (M34, F26)  
• Harness for open or short between ignition coil and ignition switch  
If NG, repair harness or connectors.]
        subgraph B [CHECK GROUND CIRCUIT.]
            B --> B_1[1. Turn ignition switch "OFF".]
            B --> B_2[2. Disconnect power transistor harness connector.]
            B --> B_3[3. Check harness continuity between terminal 2 and engine ground.  
Continuity should exist.  
If OK, check harness for short.]
        end
        B -- OK --> C[C]
        B -- NG --> B_NG[Repair harness or connectors.]
        subgraph C [CHECK INPUT SIGNAL CIRCUIT.]
            C --> C_1[1. Disconnect ECM harness connector.]
            C --> C_2[2. Check harness continuity between ECM terminal 1 and power transistor terminal 1.  
Continuity should exist.  
If OK, check harness for short.]
        end
        C -- OK --> D[D]
        C -- NG --> C_NG[Repair harness or connectors.]
        subgraph D [CHECK COMPONENTS  
(Ignition coil, power transistor).  
Refer to "COMPONENT INSPECTION", EC-415.]
            D --> D_1[Disconnect and reconnect harness connectors in the circuit. Then retest.]
            D --> D_2[Check ECM pin terminals for damage and check the connection of ECM harness connector. Reconnect ECM harness connector and retest.]
        end
        D -- OK --> End
        D -- NG --> D_NG[Replace malfunctioning component(s).]
        D -- Trouble is not fixed --> D_2
    
```

GI  
MA  
EM  
LC  
EC  
FE  
CL  
MT  
AT  
FA  
RA  
BR  
ST  
RS  
BT  
HA  
EL  
IDX

Ignition Signal (DTC: 0201) (Cont'd)

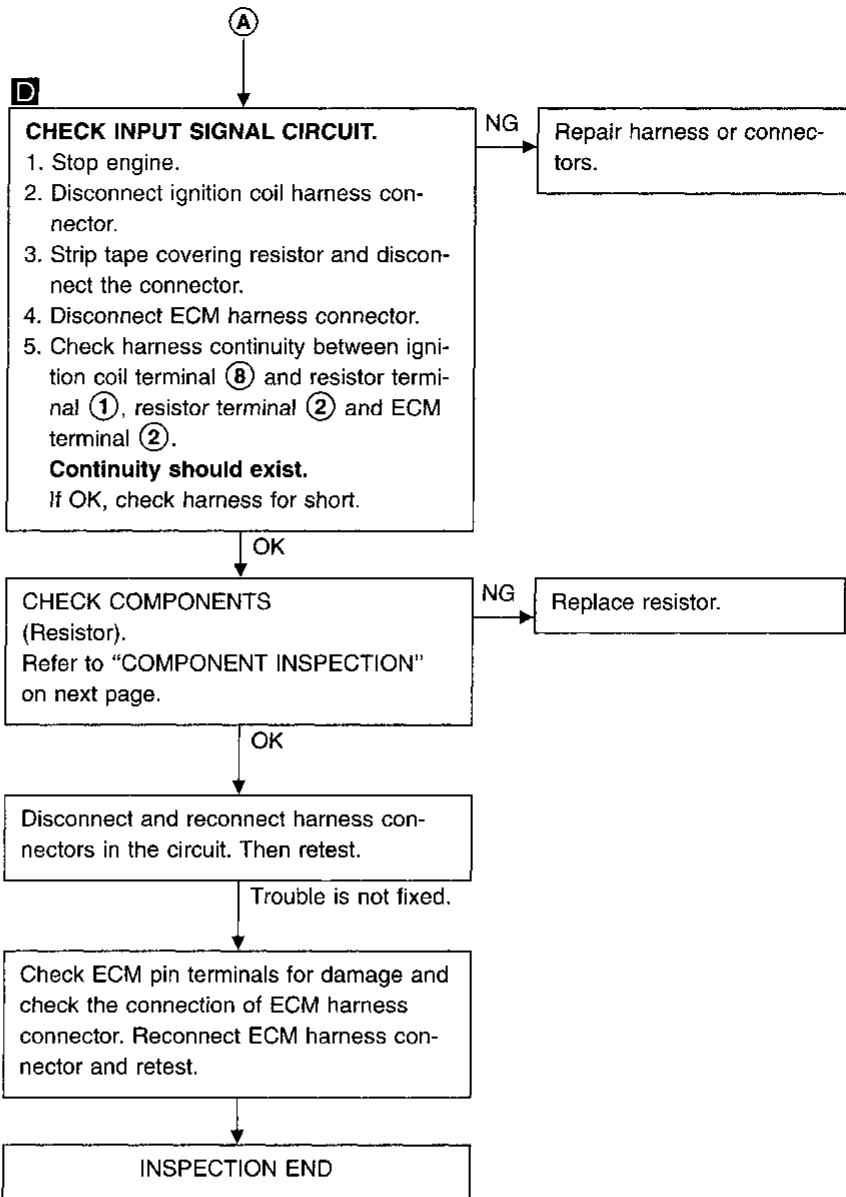
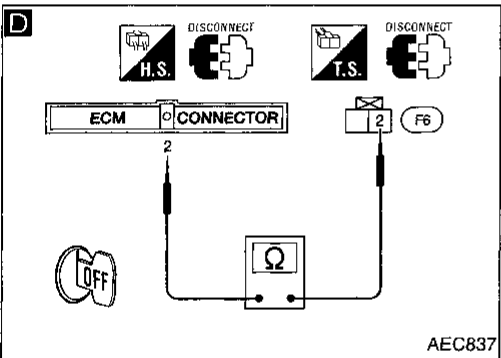
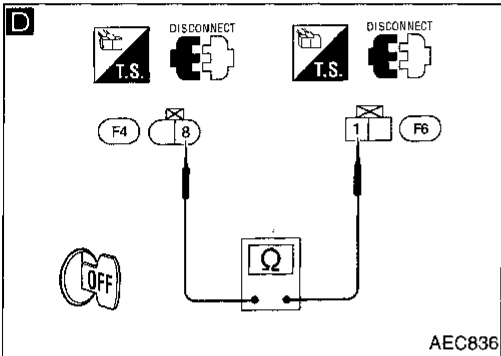
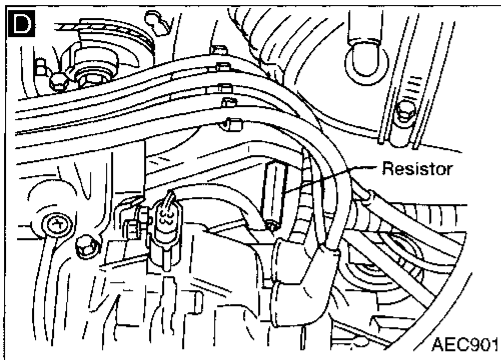

**Ignition Signal (DTC: 0201) (Cont'd)  
COMPONENT INSPECTION**

**Ignition coil**

1. Disconnect ignition coil harness connector.
2. Check resistance as shown in the figure.

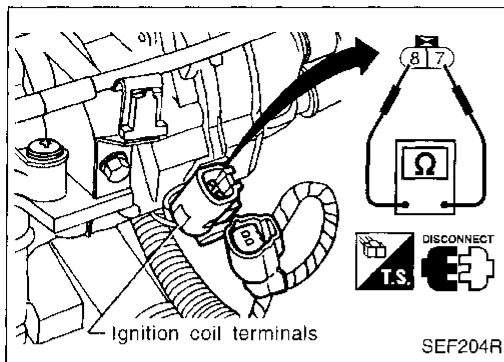

Terminal	Resistance [at 25°C (77°F)]
⑦ - ⑧ (Primary coil)	Approximately 1 Ω
⑦ - secondary terminal on distributor head (Secondary coil)	Approximately 10 kΩ

If NG, replace ignition coil.

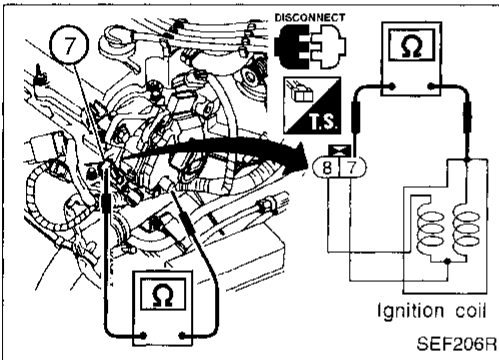

3. For checking secondary coil, remove distributor cap.
4. Check resistance between ignition coil harness connector terminal ⑦ and the secondary terminal on the distributor head.  
If NG, replace distributor.

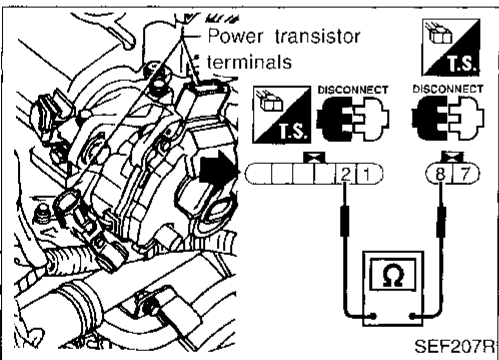

**Power transistor**

1. Disconnect power transistor harness connector.
2. Check power transistor resistance between terminals ② and ⑧.

Terminals	Resistance	Result
② and ⑧	Except 0Ω	OK
	0Ω	NG

If NG, replace distributor.

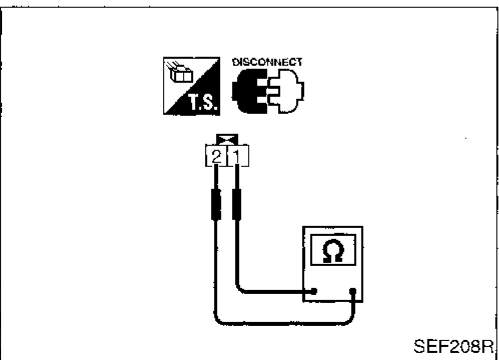

**Resistor**

1. Disconnect resistor harness connector.
2. Check resistance between terminals ① and ②.  
**Resistance: Approximately 2.2 kΩ [at 25°C (77°F)]**  
If NG, replace resistor.

GI  
MA  
EM  
LC  
EC  
FE  
CL  
MT  
AT  
FA  
RA  
BR  
ST  
RS  
BT  
HA  
EL  
IDX

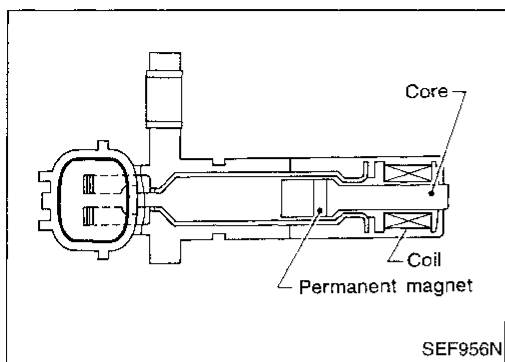

### Crankshaft Position Sensor (CKPS) (OBD) (COG) (DTC: 0905)

The crankshaft position sensor (OBD) is located on the transmission housing facing the gear teeth (cogs) of the flywheel or drive plate. It detects the fluctuation of the engine revolution. The sensor consists of a permanent magnet, core and coil. When the engine is running, the high and low parts of the teeth cause the gap with the sensor to change. The changing gap causes the magnetic field near the sensor to change.

Due to the changing magnetic field, the voltage from the sensor changes.

The ECM receives the voltage signal and detects the fluctuation of the engine revolution.

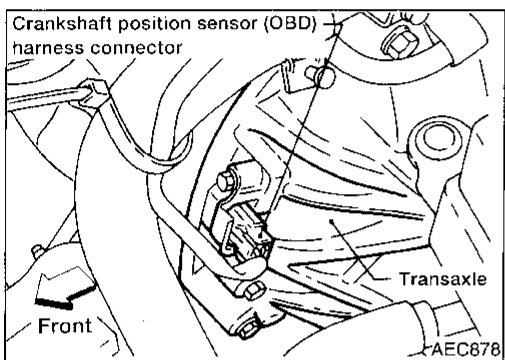

This sensor is not directly used to control the engine system. It is used only for the on-board diagnosis of misfire.



Diagnostic Trouble Code No.	Malfunction is detected when ....	Check Items (Possible Cause)
P1336 0905	<ul style="list-style-type: none"> <li>● A chipping of the flywheel or drive plate gear tooth (cog) is detected by the ECM.</li> </ul>	<ul style="list-style-type: none"> <li>● Harness or connectors</li> <li>● Crankshaft position sensor (OBD)</li> <li>● Flywheel (Drive plate)</li> <li>● Dead (Weak) battery</li> </ul>

### DIAGNOSTIC TROUBLE CODE CONFIRMATION PROCEDURE

Before performing the following procedure, confirm that battery voltage is more than 10.5V.

- 
  - 1) Turn ignition switch "ON" and select "DATA MONITOR" mode with CONSULT.
  - 2) Start engine and run it for at least 4 minutes at idle speed.
- OR
- 
  - 1) Start engine and run it for at least 4 minutes at idle speed.
  - 2) Select "MODE 3" with GST.
- OR
- 
  - 1) Start engine and run it for at least 4 minutes at idle speed.
  - 2) Turn ignition switch "OFF", wait at least 5 seconds and then turn "ON".
  - 3) Perform "Diagnostic Test Mode II" (Self-diagnostic results) with ECM.

Crankshaft Position Sensor (CKPS) (OBD)  
(COG) (DTC: 0905) (Cont'd)

EC-CKPS-01

— : Detectable line for DTC  
- - - : Non-detectable line for DTC

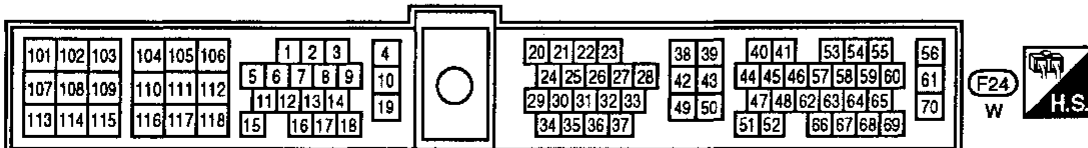
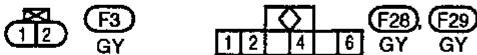
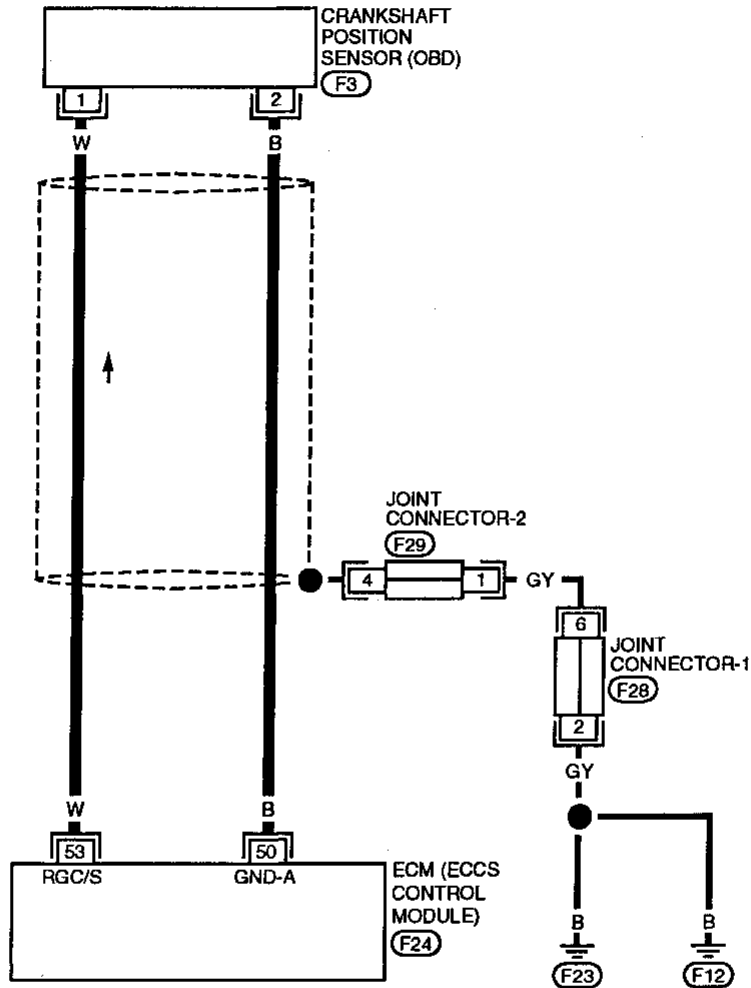



**Crankshaft Position Sensor (CKPS) (OBD) (COG) (DTC: 0905) (Cont'd)**  
**DIAGNOSTIC PROCEDURE**

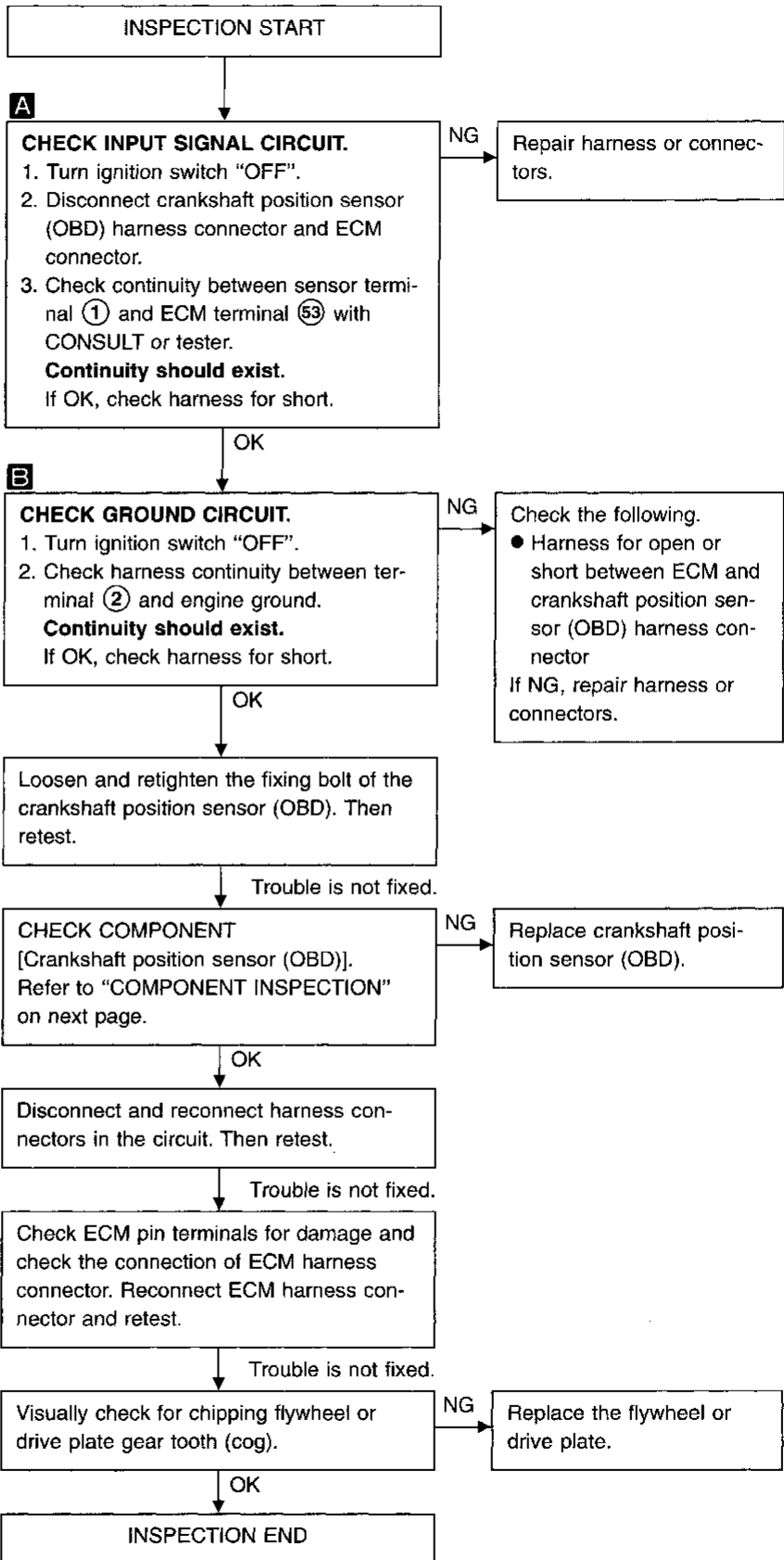
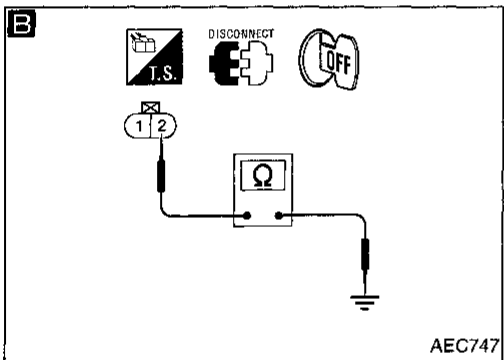
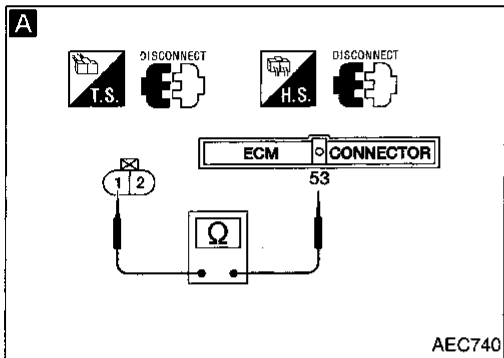
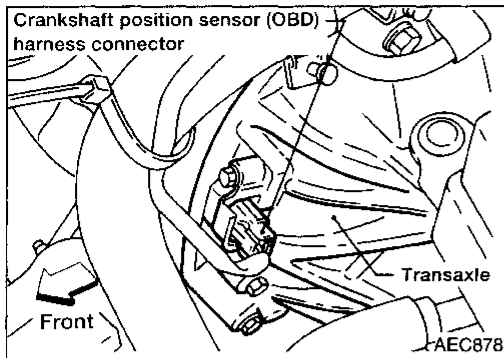

## Crankshaft Position Sensor (CKPS) (OBD) (COG) (DTC: 0905) (Cont'd)

### COMPONENT INSPECTION

#### Crankshaft position sensor (OBD)

1. Disconnect crankshaft position sensor (OBD) harness connector.
2. Loosen the fixing bolt of the sensor.
3. Remove the sensor.
4. Visually check the sensor for chipping.

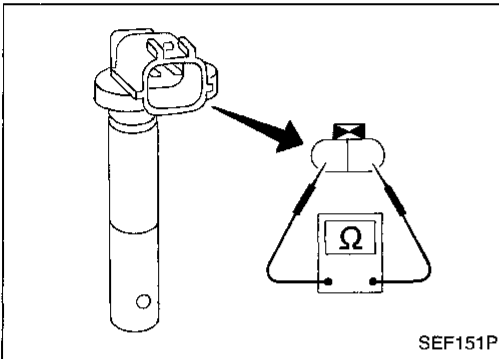
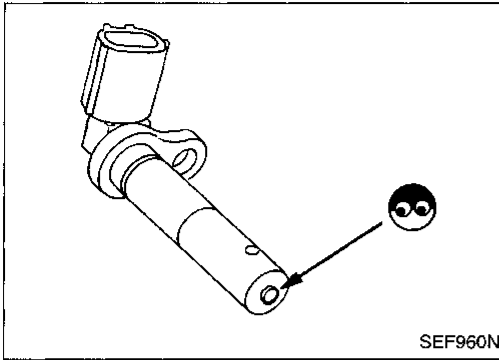

5. Check resistance as shown in the figure.

#### Resistance:

##### M/T models

432 - 528 $\Omega$  [at 25°C (77°F)]

##### A/T models

166.5 - 203.5 $\Omega$  [at 25°C (77°F)]

GI

MA

EM

LC

EC

FE

CL

MT

AT

FA

RA

BR

ST

RS

BT

HA

EL

IDX

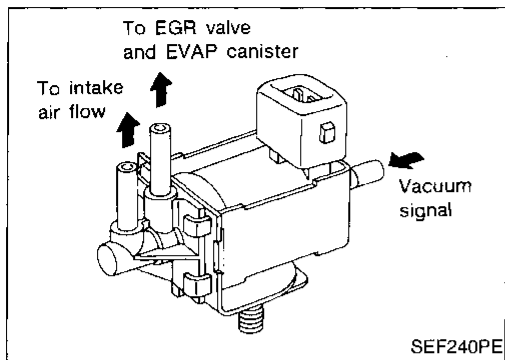

### EGR Valve and EVAP Canister Purge Control Solenoid Valve (DTC: 1005)

The EGR valve & EVAP canister purge control solenoid valve responds to signals from the ECM. When the ECM sends an ON (ground) signal, the coil in the solenoid valve is energized. A plunger will then move to cut the vacuum signal from the throttle body to the EGR valve and EVAP canister purge valve. When the ECM sends an OFF signal, the vacuum signal passes through the solenoid valve. The signal then reaches the EGR valve and EVAP canister.

Diagnostic Trouble Code No.	Malfunction is detected when ....	Check Items (Possible Cause)
P1400 1005	<ul style="list-style-type: none"> <li>An improper voltage signal is sent to ECM through EGR valve &amp; EVAP canister purge control solenoid valve.</li> </ul>	<ul style="list-style-type: none"> <li>Harness or connectors (The EGR valve &amp; EVAP canister purge control solenoid valve circuit is open or shorted.)</li> <li>EGR valve &amp; EVAP canister purge control solenoid valve</li> </ul>

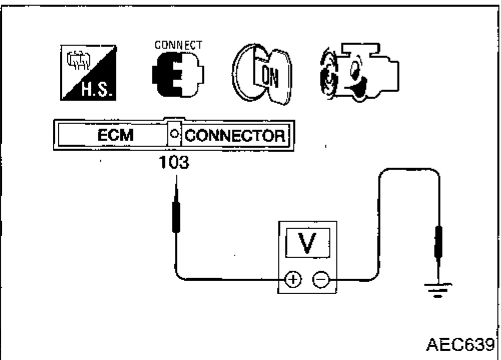
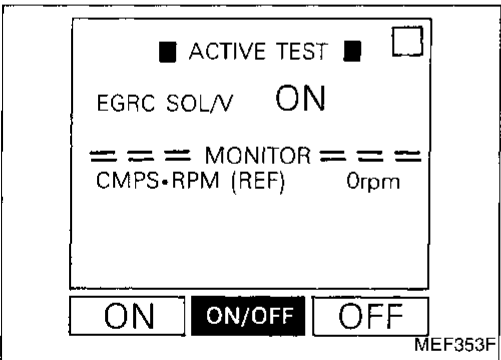
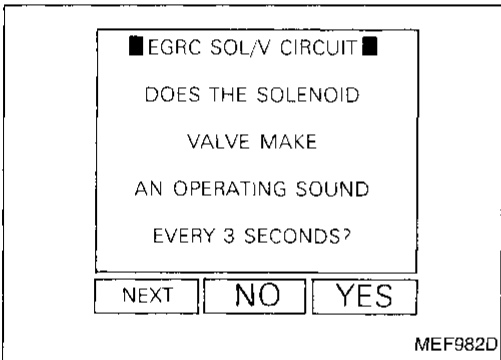

### OVERALL FUNCTION CHECK

Use this procedure to check the overall function of the EGR valve & EVAP canister purge control solenoid valve circuit. During this check, a DTC might not be confirmed.

- 1) Turn ignition switch "ON".
  - 2) Perform "EGRC SOL/V CIRCUIT" in "FUNCTION TEST" mode with CONSULT.
- OR
- 1) Turn ignition switch "ON".
  - 2) Perform "EGRC SOLENOID VALVE" in "ACTIVE TEST" mode with CONSULT and check the operating sound, according to ON/OFF switching.
- OR
- 1) Start engine and warm it up sufficiently.
  - 2) Turn ignition switch "OFF" and wait at least 5 seconds.
  - 3) For M/T models, jack up front wheels. Start engine again.
  - 4) Check the voltage between ECM terminal **103** and ground at idle speed.  
**Voltage: 0.04 - 0.08V**
  - 5) For M/T models, shift into 1st gear. Check that the voltage changes to battery voltage and returns to 0.04 - 0.08V when the engine speed increases to about 2,500 rpm.

EGR Valve and EVAP Canister Purge Control Solenoid Valve (DTC: 1005) (Cont'd)

EC-EGRC/V-01

GI  
MA  
EM  
LG  
**EC**  
FE  
CL  
MT  
AT  
FA  
RA  
BR  
ST  
RS  
BT  
HA  
EL  
IDX

— : Detectable line for DTC  
— : Non-detectable line for DTC

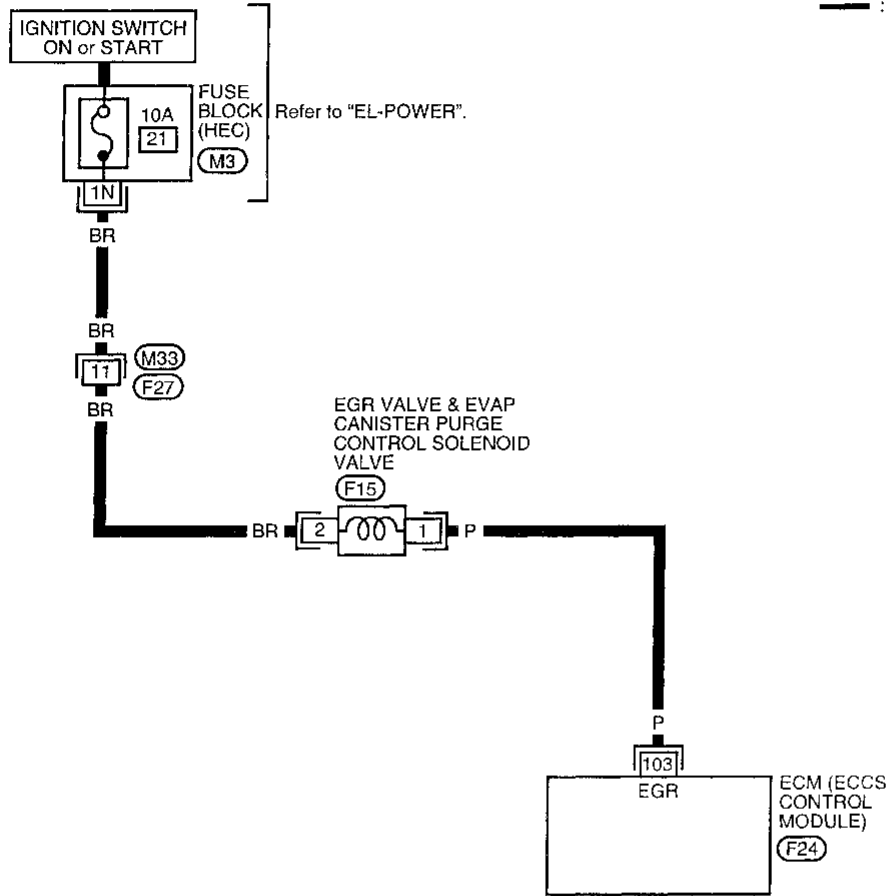

Refer to last page (Foldout page).

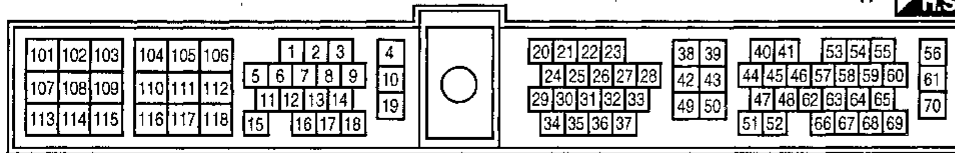
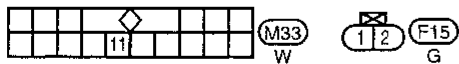

EGR Valve and EVAP Canister Purge Control Solenoid Valve (DTC: 1005) (Cont'd)

DIAGNOSTIC PROCEDURE

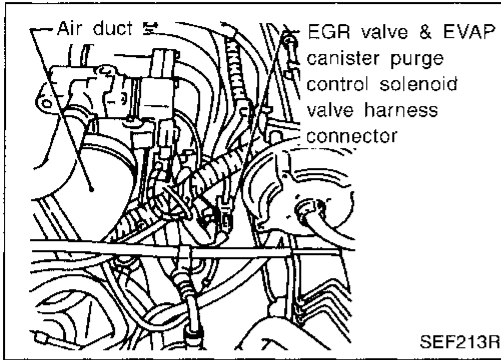

INSPECTION START

**A**  
**CHECK POWER SUPPLY.**  
 1. Disconnect EGR valve & EVAP canister purge control solenoid valve harness connector.  
 2. Turn ignition switch "ON".  
 3. Check voltage between terminal (2) and ground with CONSULT or tester.  
**Voltage: Battery voltage**

NG → Check the following.  
 • Harness connectors (M33, F27)  
 • 10A fuse  
 • Harness continuity between EGR valve & EVAP canister purge control solenoid valve sub-harness connector and fuse  
 If NG, repair harness or connectors.

OK

**B**  
**CHECK OUTPUT SIGNAL CIRCUIT.**  
 2. Disconnect ECM harness connector.  
 3. Check harness continuity between ECM terminal (103) and terminal (1).  
**Continuity should exist.**  
 If OK, check harness for short.

NG → Check the following.  
 • Harness continuity between EGR valve & EVAP canister purge control solenoid valve sub-harness connector and ECM  
 If NG, repair harness or connectors.

OK

**CHECK COMPONENT**  
 (EGR valve & EVAP canister purge control solenoid valve).  
 Refer to "COMPONENT INSPECTION" on next page.

NG → Replace EGR valve & EVAP canister purge control solenoid valve.

OK  
 Disconnect and reconnect harness connectors in the circuit. Then retest.

Trouble is not fixed.

Check ECM pin terminals for damage and check the connection of ECM harness connector. Reconnect ECM harness connector and retest.

INSPECTION END

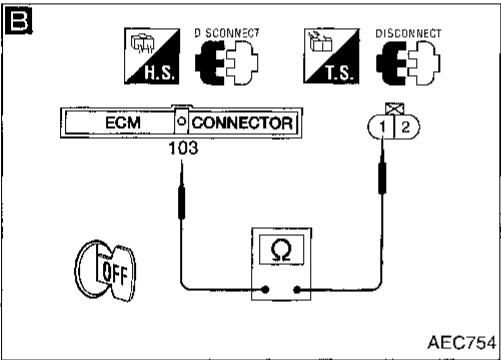
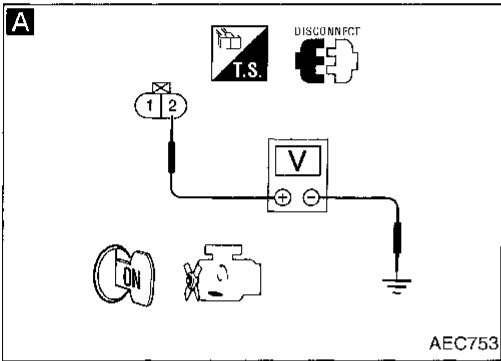

**EGR Valve and EVAP Canister Purge Control Solenoid Valve (DTC: 1005) (Cont'd)**

**COMPONENT INSPECTION**

**EGR valve and EVAP canister purge control solenoid valve**

Check air passage continuity.

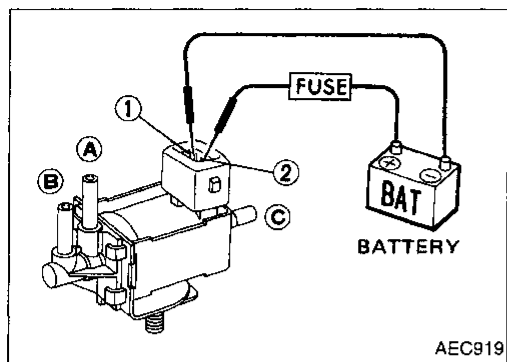

Condition	Air passage continuity between (A) and (B)	Air passage continuity between (A) and (C)
12V direct current supply between terminals ① and ②	Yes	No
No supply	No	Yes

If NG, replace solenoid valve.

GI

MA

EM

LC

**EC**

FE

CL

MT

AT

FA

RA

BR

ST

RS

BT

HA

EL

IDX

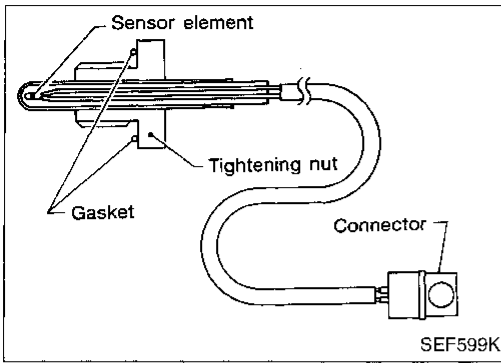

### EGR Temperature Sensor (DTC: 0305)

The EGR temperature sensor detects temperature changes in the EGR passage way. When the EGR valve opens, hot exhaust gases flow, and the temperature in the passage way changes. The EGR temperature sensor is a thermistor that modifies a voltage signal sent from the ECM. This modified signal then returns to the ECM as an input signal. As the temperature increases, EGR temperature sensor resistance decreases. This sensor is not directly used to control the engine system.

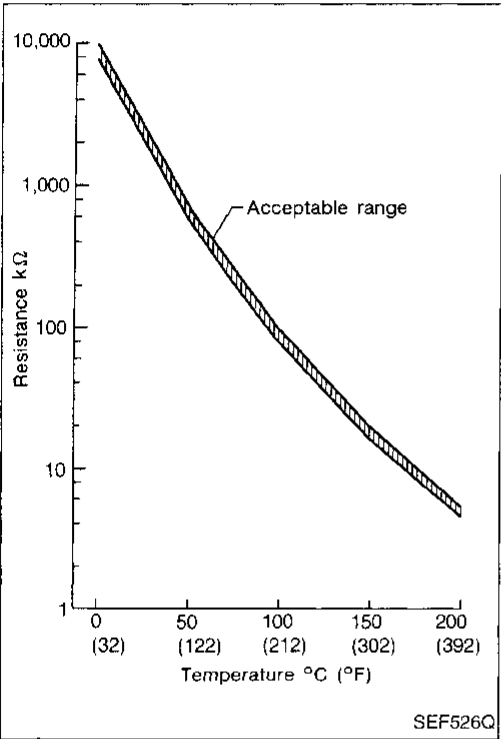

(Reference data)

EGR temperature °C (°F)	Voltage (V)	Resistance (MΩ)
0 (32)	4.81	7.9 - 9.7
50 (122)	2.82	0.57 - 0.70
100 (212)	0.8	0.08 - 0.10

Diagnostic Trouble Code No.	Malfunction is detected when ....	Check Items (Possible Cause)
P1401 0305	A) An excessively low voltage from the EGR temperature sensor is sent to ECM even when engine coolant temperature is low.	<ul style="list-style-type: none"> <li>● Harness or connectors (The EGR temperature sensor circuit is shorted.)</li> <li>● EGR temperature sensor</li> <li>● Malfunction of EGR function, EGRC-BPT valve or EGR valve &amp; EVAP canister purge control solenoid valve</li> </ul>
	B) An excessively high voltage from the EGR temperature sensor is sent to ECM even when engine coolant temperature is high.	<ul style="list-style-type: none"> <li>● Harness or connectors (The EGR temperature sensor circuit is open.)</li> <li>● EGR temperature sensor</li> <li>● Malfunction of EGR function, EGRC-BPT valve or EGR valve &amp; EVAP canister purge control solenoid valve</li> </ul>

**EGR Temperature Sensor (DTC: 0305)  
(Cont'd)**

**DIAGNOSTIC TROUBLE CODE CONFIRMATION  
PROCEDURE**

**Procedure for malfunction A**

- 1) Turn ignition switch "ON" and select "DATA MONITOR" mode with CONSULT.
- 2) Confirm that the engine coolant temperature is lower than 50°C (122°F). (If necessary, wait until the engine coolant temperature is the same as atmosphere temperature.)
- 3) Start engine and run it for at least 8 seconds at idle speed. [With the engine coolant temperature lower than 50°C (122°F)].

OR

- 1) Turn ignition switch "ON" and select "MODE 1" with GST.
- 2) Confirm that the engine coolant temperature is lower than 50°C (122°F). (If necessary, wait until the engine coolant temperature is the same as atmosphere temperature.)
- 3) Start engine and run it for at least 8 seconds at idle speed. [With the engine coolant temperature lower than 50°C (122°F)].
- 4) Select "MODE 3" with GST.

OR

- 1) Turn ignition switch "ON" and confirm that voltage between ECM terminal 51 and ground is more than 2.35V. (If necessary, wait until the engine coolant temperature is the same as atmosphere temperature.)
- 2) Start engine and run it for at least 8 seconds at idle speed. (With the voltage between ECM terminal 51 and ground should stay at more than 2.35V)
- 3) Turn ignition switch "OFF", wait at least 5 seconds and then turn "ON".
- 4) Perform "Diagnostic Test Mode II" (Self-diagnostic results) with ECM.

**Procedure for malfunction B**

- 1) Start engine and warm it up sufficiently.
- 2) Turn ignition switch "OFF", wait at least 3 seconds and then start engine again.
- 3) Select "DATA MONITOR" mode with CONSULT.
- 4) Run the engine for at least 8 seconds at idle speed.

OR

- 1) Start engine and warm it up sufficiently.
- 2) Turn ignition switch "OFF", wait at least 3 seconds and then start engine again.
- 3) Run the engine for at least 8 seconds at idle speed.
- 4) Select "MODE 3" with GST.

OR

- 1) Start engine and warm it up sufficiently.
- 2) Turn ignition switch "OFF", wait at least 3 seconds and then start engine again.
- 3) Run the engine for at least 8 seconds at idle speed.
- 4) Turn ignition switch "OFF", wait at least 5 seconds and then turn "ON".
- 5) Perform "Diagnostic Test Mode II" (Self-diagnostic results) with ECM.

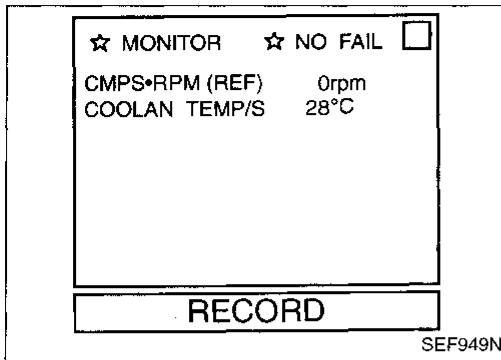

SEF949N

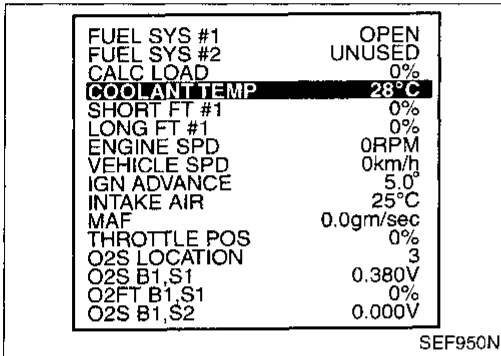

SEF950N

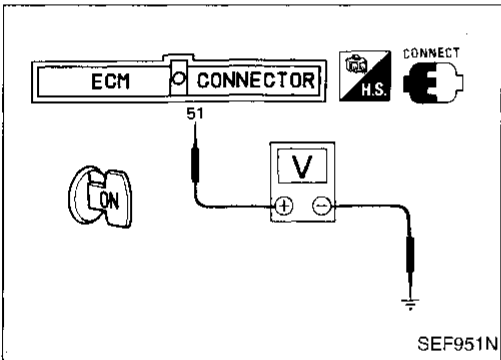

SEF951N

GI  
MA  
EM  
LC  
EC  
FE  
CL  
MT  
AT  
FA  
RA  
BR  
ST  
RS  
BT  
HA  
EL  
IDX



EGR Temperature Sensor (DTC: 0305)  
(Cont'd)

EC-EGR/TS-01

— : Detectable line for DTC  
— : Non-detectable line for DTC

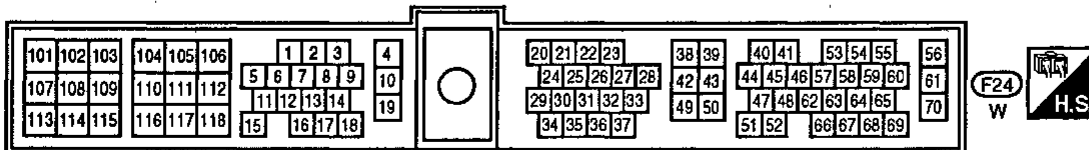
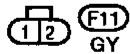
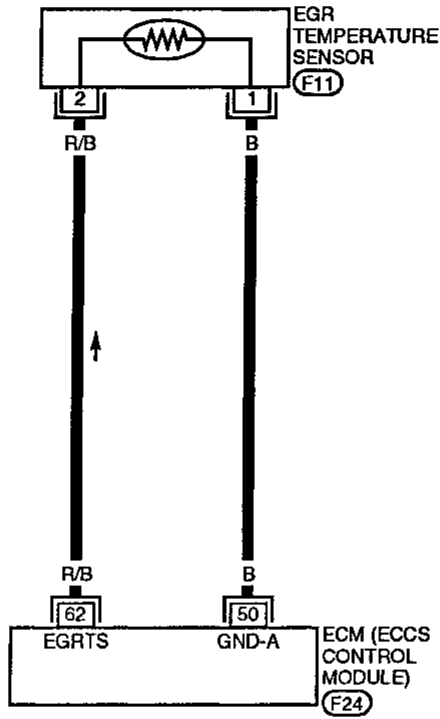

EGR Temperature Sensor (DTC: 0305)  
(Cont'd)

DIAGNOSTIC PROCEDURE

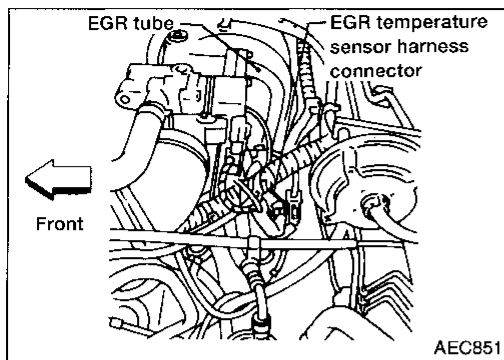

INSPECTION START

**A**  
**CHECK POWER SUPPLY.**  
1. Disconnect EGR temperature sensor harness connector.  
2. Turn ignition switch "ON".  
3. Check voltage between terminal ② and ground with CONSULT or tester.  
**Voltage: Approximately 5V**

NG → Repair harness or connectors.

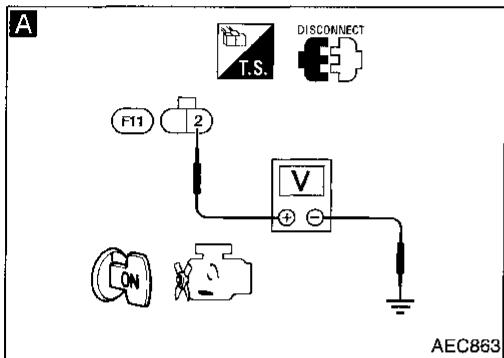

**B**  
**CHECK GROUND CIRCUIT.**  
1. Turn ignition switch "OFF".  
2. Check harness continuity between terminal ① and engine ground.  
**Continuity should exist.**  
If OK, check harness for short.

NG → Check the following.  
● Harness for open or short between ECM and EGR temperature sensor harness connector  
If NG, repair harness or connector.

**CHECK COMPONENT**  
(EGR temperature sensor).  
Refer to "COMPONENT INSPECTION" below.

NG → Replace EGR temperature sensor.

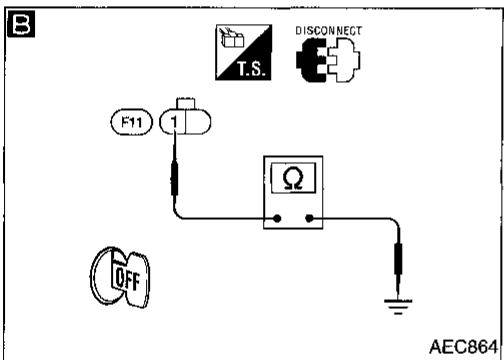

Disconnect and reconnect harness connectors in the circuit. Then retest.

↓ Trouble is not fixed.

Check ECM pin terminals for damage and check the connection of ECM harness connector. Reconnect ECM harness connector and retest.

INSPECTION END

COMPONENT INSPECTION

EGR temperature sensor

Check resistance change and resistance value.

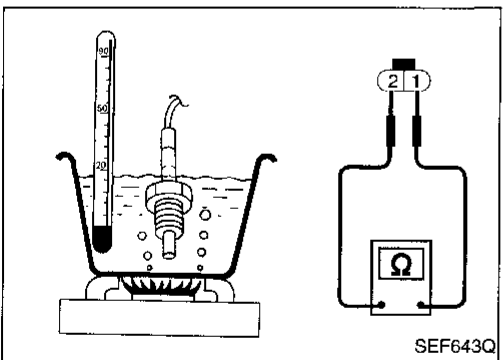

EGR temperature °C (°F)	Voltage (V)	Resistance (MΩ)
0 (32)	4.81	7.9 - 9.7
50 (122)	2.82	0.57 - 0.70
100 (212)	0.8	0.08 - 0.10

If NG, replace EGR temperature sensor.

GI  
MA  
EM  
LC  
EC  
FE  
CL  
MT  
AT  
FA  
RA  
BR  
ST  
RS  
BT  
HA  
EL  
IDX

## Torque Converter Clutch Solenoid Valve (DTC: 0904)

### SYSTEM DESCRIPTION

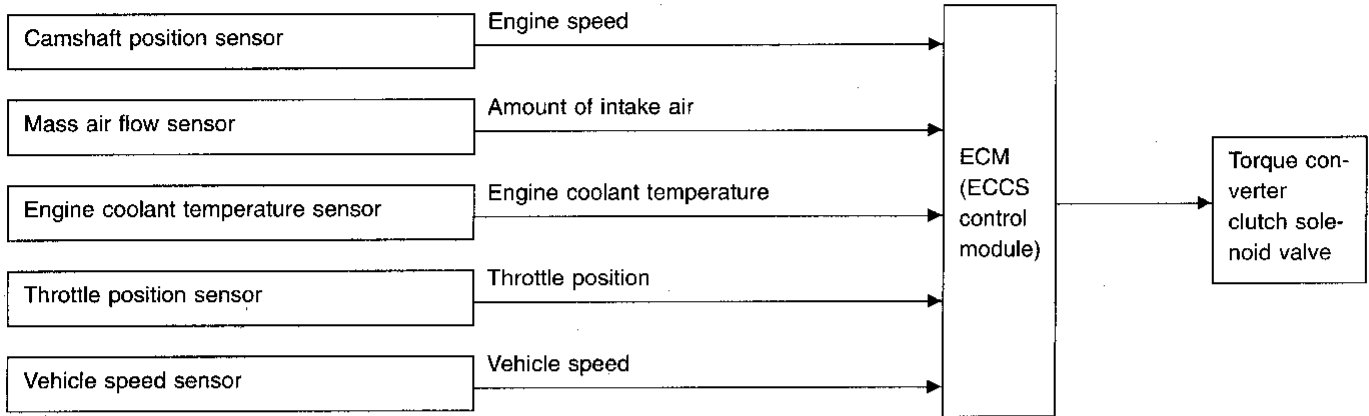

The ECM controls torque converter clutch solenoid valve to cancel the lock-up condition of A/T. When the solenoid valve is turned on, lock-up is cancelled. When the solenoid valve is turned off, A/T lock-up is operational.

- During high-load operation

**Conditions for lock-up cancel:**

- Throttle valve is fully closed (idling or deceleration)
- Engine coolant temperature is below 60°C (140°F)
- Vehicle speed is less than 64 km/h (40 MPH)

Diagnostic Trouble Code No.	Malfunction is detected when ....	Check Items (Possible Cause)
P1550 0904	<ul style="list-style-type: none"> <li>• An excessively low voltage from the solenoid is sent to ECM.</li> <li>• A/T torque converter slip is occurred in lock-up condition.</li> </ul>	<ul style="list-style-type: none"> <li>• Harness or connectors (The circuit is open or shorted.)</li> <li>• Torque converter clutch solenoid valve</li> <li>• A/T hydraulic control system</li> </ul>

## Torque Converter Clutch Solenoid Valve (DTC: 0904) (Cont'd)

### DIAGNOSTIC TROUBLE CODE CONFIRMATION PROCEDURE

-  1) Turn ignition switch "ON".
- 2) Select "DATA MONITOR" mode with CONSULT.
- 3) Start engine and warm it up sufficiently.
- 4) Perform test drive in "D" position for at least 12 seconds continuously under the following conditions.
- Engine speed: 1900 - 2500 rpm  
Vehicle speed: 76 - 100 km/h (47 - 62 MPH)

OR

-  1) Start engine and warm it up sufficiently.
- 2) Select MODE 3 with GST.
- 3) Perform test drive in "D" position for at least 12 seconds continuously under the following conditions.
- Engine speed: 1900 - 2500 rpm  
Vehicle speed: 76 - 100 km/h (47 - 62 MPH)

OR

-  1) Start engine and warm it up sufficiently.
- 2) Perform test drive in "D" position for at least 12 seconds continuously under the following conditions.
- Engine speed: 1900 - 2500 rpm  
Vehicle speed: 76 - 100 km/h (47 - 62 MPH)
- 3) Stop the vehicle, turn ignition switch "OFF", wait at least 3 seconds and then turn "ON".
- 4) Perform "Diagnostic Test Mode II (Self-diagnostic results)" with ECM.

**For diagnostic procedure, refer to AT section ("TORQUE CONVERTER CLUTCH SOLENOID VALVE", "Electrical Components Inspection", "TROUBLE DIAGNOSES").**

GI

MA

EM

LG

EC

FE

GL

MT

AT

FA

RA

BR

ST

RS

BT

HA

EL

IDX

### Cooling Fan (Overheat) (DTC: 0208)

#### SYSTEM DESCRIPTION

##### Cooling fan control

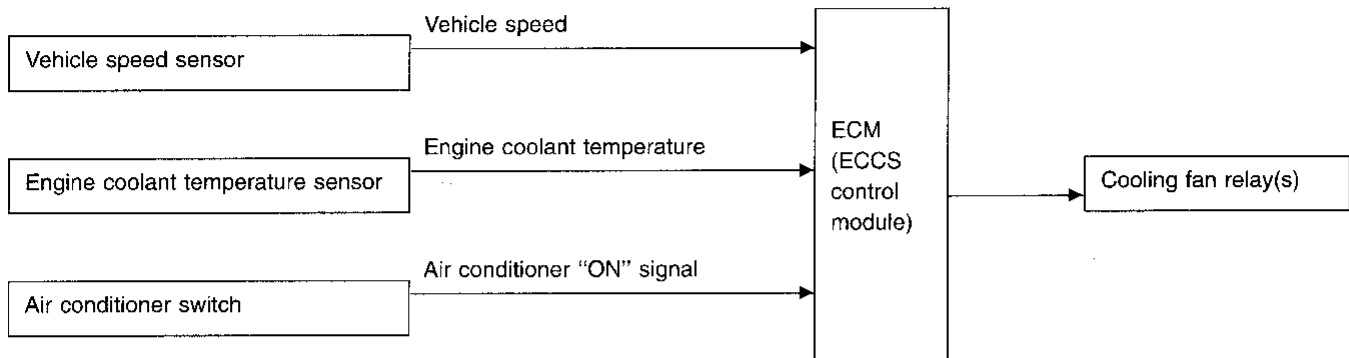

The ECM controls the cooling fan corresponding to the vehicle speed, engine coolant temperature, and air conditioner ON signal. The control system has 2-step control [ON/OFF].

#### Operation

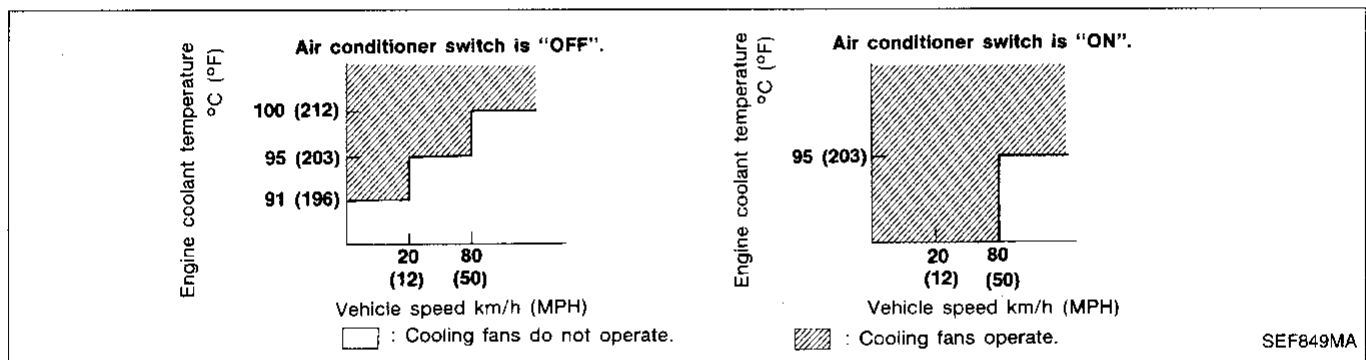

Cooling Fan (Overheat) (DTC: 0208) (Cont'd)

ON-BOARD DIAGNOSIS LOGIC

This diagnosis continuously monitors the engine coolant temperature.

If the cooling fan or another component in the cooling system malfunctions, engine coolant temperature will rise.

When the engine coolant temperature reaches an abnormally high temperature condition, a malfunction is indicated.

Diagnostic Trouble Code No.	Malfunction is detected when ...	Check Items (Possible Cause)
P1900* 0208	<ul style="list-style-type: none"> <li>● Cooling fan does not operate properly (Overheat).</li> <li>● Cooling fan system does not operate properly (Overheat).</li> <li>● Engine coolant was not added to the system using the proper filling method.</li> </ul>	<ul style="list-style-type: none"> <li>● Harness or connectors (The cooling fan circuit is open or shorted.)</li> <li>● Cooling fan</li> <li>● Radiator hose</li> <li>● Radiator</li> <li>● Radiator cap</li> <li>● Water pump</li> <li>● Thermostat</li> </ul> <p>For more information, refer to "MAIN 12 CAUSES OF OVERHEATING", EC-437.</p>

\* Diagnostic trouble code No. P1900 is not displayed in SELF-DIAGNOSTIC RESULTS mode with CONSULT.

**CAUTION:**

When a malfunction is indicated, be sure to replace the coolant following the procedure in the MA section ("Changing Engine Coolant", "ENGINE MAINTENANCE"). Also, replace the engine oil.

a. Fill radiator with coolant up to specified level with a filling speed of 2 liters per minute. Be sure to use coolant with the proper mixture ratio. Refer to MA section ("Anti-freeze Coolant Mixture Ratio", "RECOMMENDED FLUIDS AND LUBRICANTS").

b. After refilling coolant, run engine to ensure that no water-flow noise is emitted.

CI  
MA  
EM  
LC  
EC  
FE  
CL  
MT  
AT  
FA  
RA  
BR  
ST  
RS  
BT  
HA  
EL  
IDX

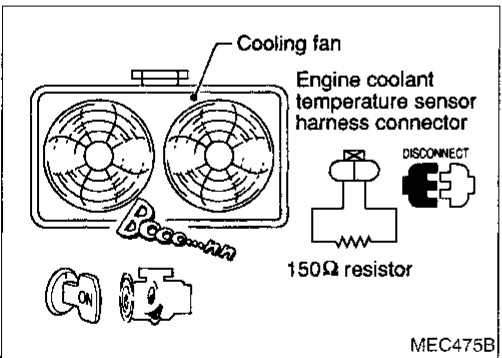
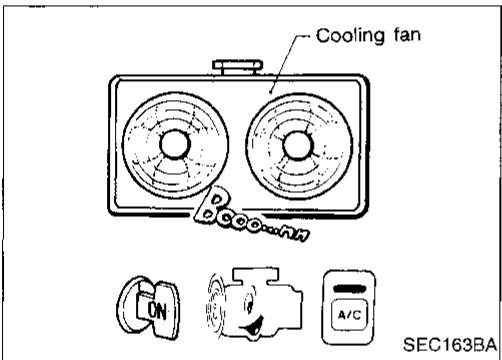
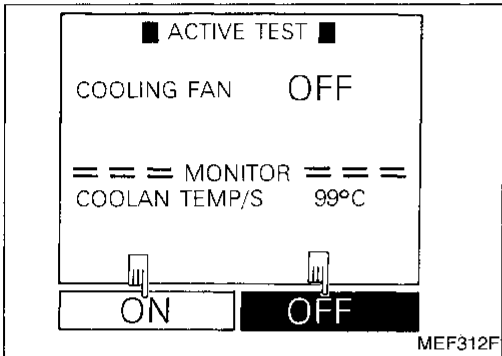
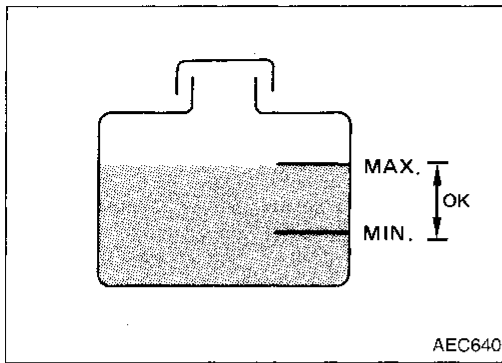

## Cooling Fan (Overheat) (DTC: 0208) (Cont'd)

### OVERALL FUNCTION CHECK

Use this procedure to check the overall function of the cooling fan. During this check, a DTC might not be confirmed.

#### WARNING:

**Never remove the radiator cap when the engine is hot. Serious burns could be caused by high pressure fluid escaping from the radiator.**

**Wrap a thick cloth around cap. Carefully remove the cap by turning it a quarter turn to allow built-up pressure to escape. Then turn the cap all the way off.**

- 1) Check the coolant level in the reservoir tank and radiator.  
**Allow engine to cool before checking coolant level.**  
If the coolant level in the reservoir tank and/or radiator is below the proper range, skip the following steps and go to "DIAGNOSTIC PROCEDURE" (EC-434).
- 2) Confirm whether customer filled the coolant or not. If customer filled the coolant, skip the following steps and go to "DIAGNOSTIC PROCEDURE" (EC-434).
- 3) Turn ignition switch "ON".
- 4) Perform "COOLING FAN" in "ACTIVE TEST" mode with CONSULT.

OR

- 3) Start engine.  
**Be careful not to overheat engine.**
- 4) Turn air conditioner switch "ON".
- 5) Turn blower fan switch "ON".
- 6) Make sure that cooling fan operates.
- 7) Turn ignition switch "OFF".
- 8) Turn air conditioner switch and blower fan switch "OFF".
- 9) Disconnect engine coolant temperature sensor harness connector.
- 10) Connect 150Ω resistor to engine coolant temperature sensor harness connector.
- 11) Restart engine and make sure that cooling fan operates.

**Be careful not to overheat engine.**

Cooling Fan (Overheat) (DTC: 0208) (Cont'd)

EC-COOL/F-01

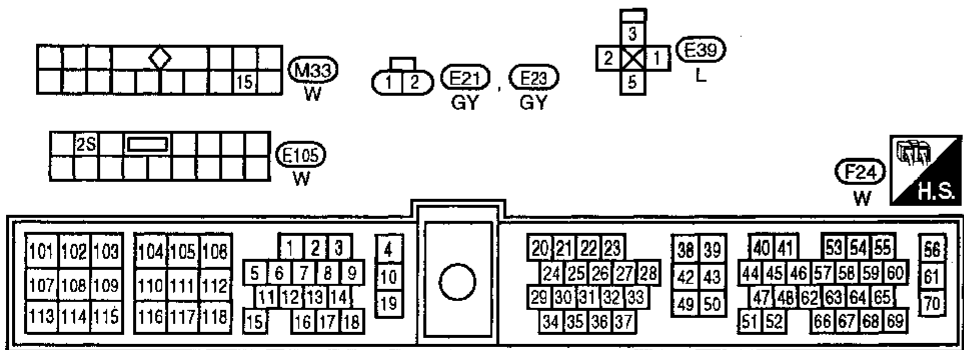
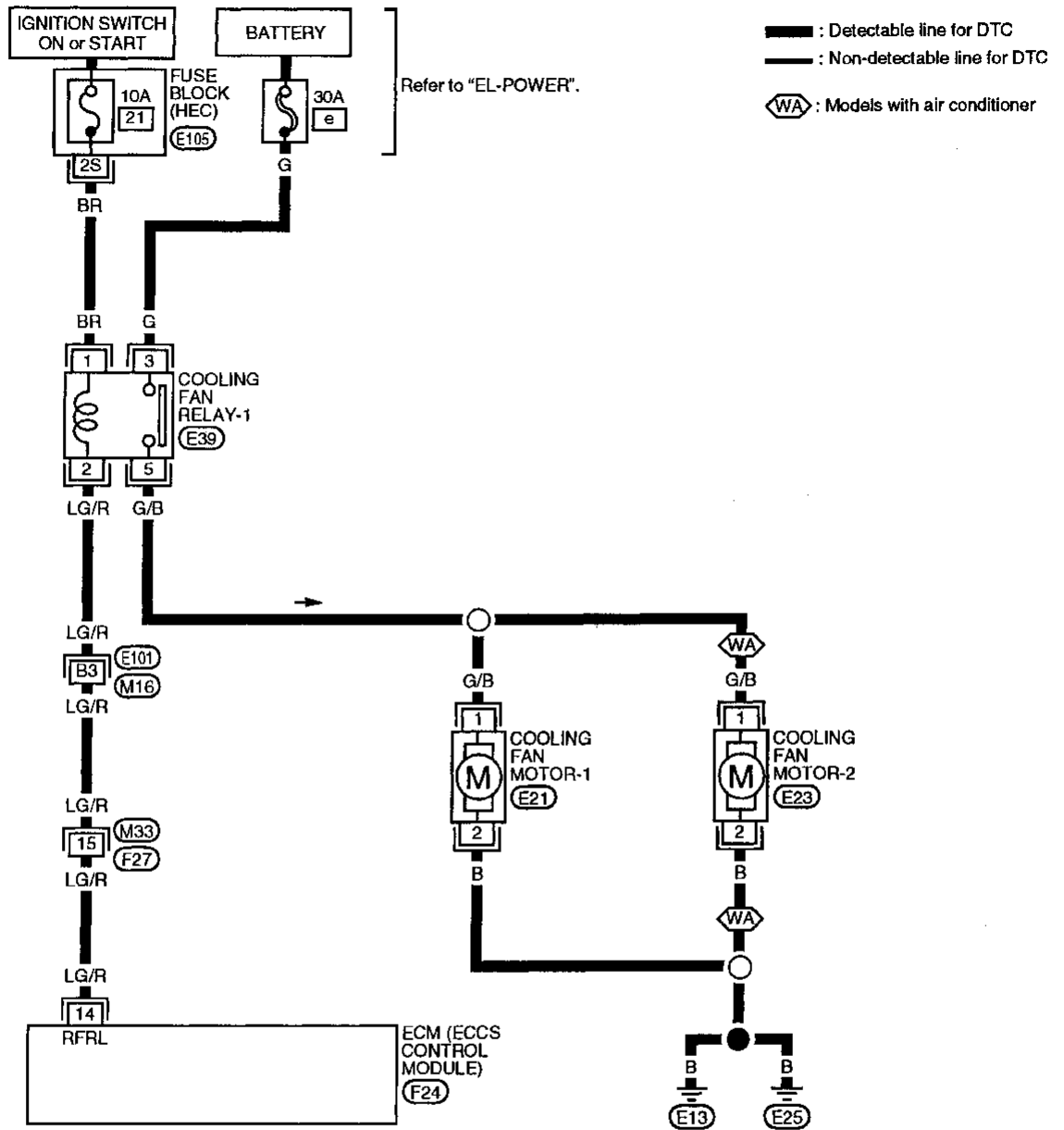

GI  
 MA  
 EM  
 LC  
**EC**  
 FE  
 CL  
 MT  
 AT  
 FA  
 RA  
 BR  
 ST  
 RS  
 BT  
 HA  
 EL  
 IDX



## Cooling Fan (Overheat) (DTC: 0208) (Cont'd) DIAGNOSTIC PROCEDURE

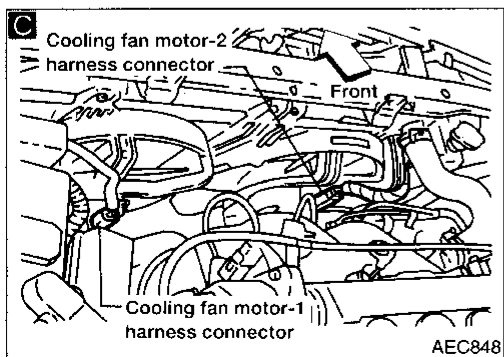
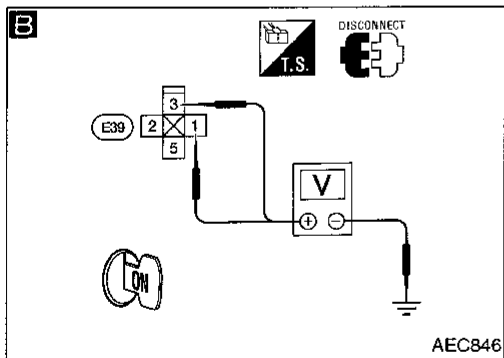
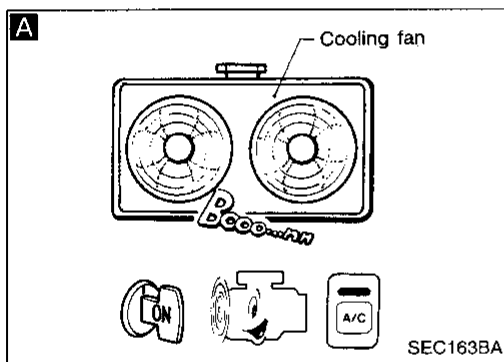
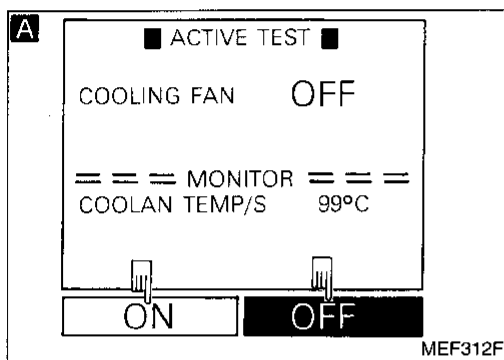
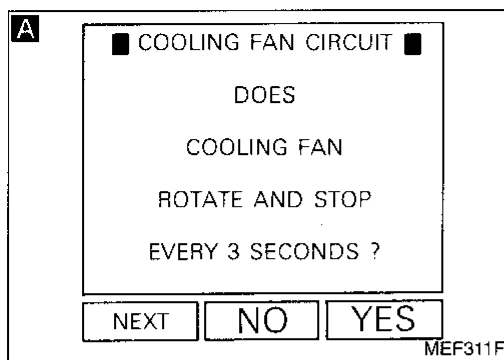

INSPECTION START

**A**

**CHECK COOLING FAN OPERATION.** OK → **B** (Go to EC-436.)

1. Turn ignition switch "ON".  
2. Perform "COOLING FAN CIRCUIT" in "FUNCTION TEST" mode with CONSULT.

OR

1. Turn ignition switch "ON".  
2. Perform "COOLING FAN" in "ACTIVE TEST" mode with CONSULT.

OR

1. Start engine.  
2. Turn air conditioner switch "ON".  
3. Turn blower fan switch "ON".  
4. Make sure that cooling fan operates.

NG

**B**

**CHECK POWER SUPPLY.** NG →

1. Turn ignition switch "ON".  
2. Disconnect cooling fan relay-1.  
3. Check voltage between terminals ①, ③ and ground with CONSULT or tester.  
**Voltage: Battery voltage**

Check the following.

- 10A fuse
- 30A fusible link
- Harness for open or short between cooling fan relay-1 and fuse
- Harness for open or short between cooling fan relay-1 and battery

If NG, repair harness or connectors.

OK

**C**

**CHECK GROUND CIRCUIT.** NG → Repair harness or connectors.

1. Turn ignition switch "ON".  
2. Disconnect cooling fan motor-1 harness connector and cooling fan motor-2 harness connector.  
3. Check harness continuity between cooling fan motor terminals ① and cooling fan relay-1 terminal ⑤.  
**Continuity should exist.**  
If OK, check harness for short.  
4. Check harness continuity between terminal ② and body ground.  
**Continuity should exist.**  
If OK, check harness for short.

OK

**A**  
(Go to next page.)

Cooling Fan (Overheat) (DTC: 0208) (Cont'd)

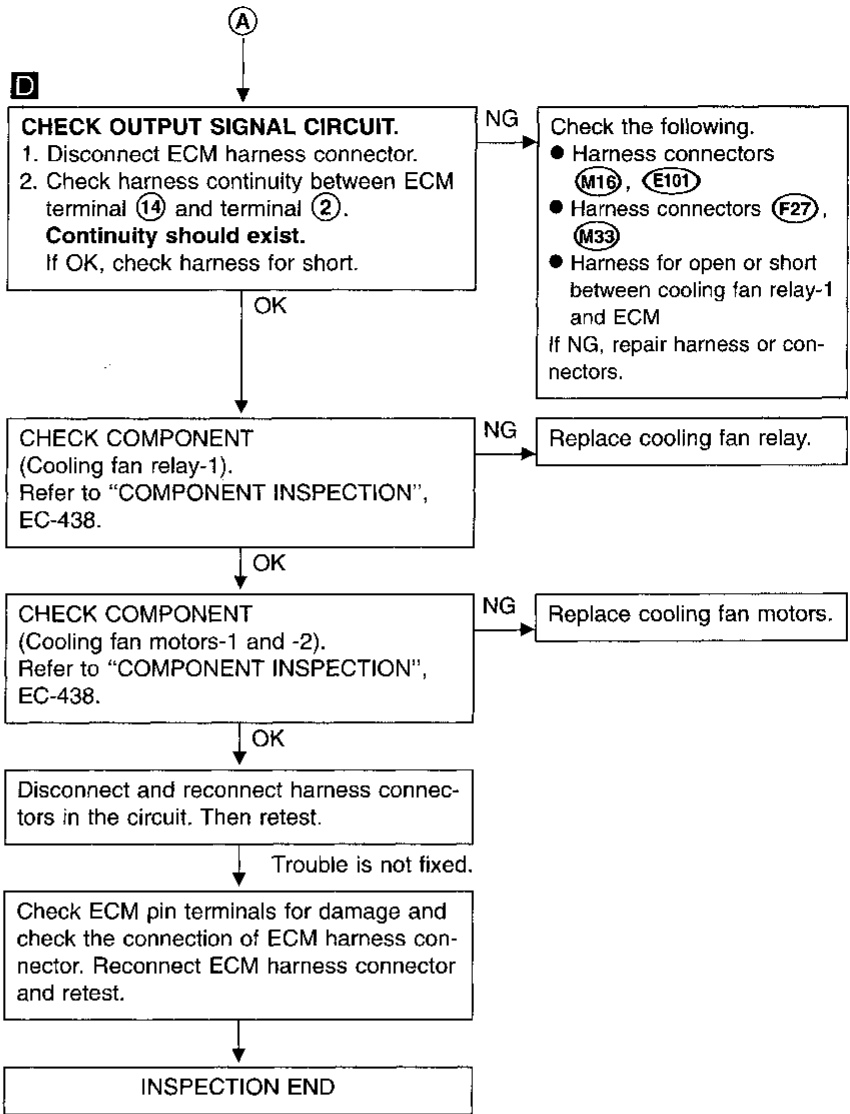
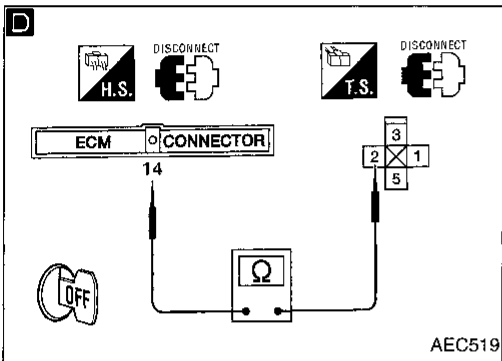
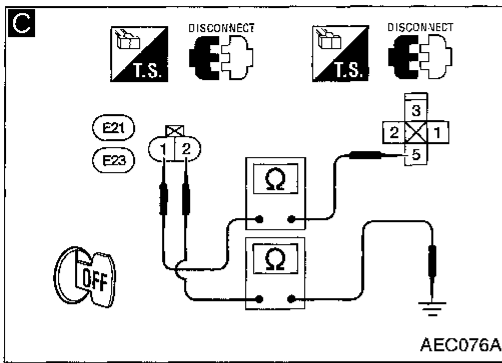

GI  
MA  
EM  
LC  
EC  
FE  
CL  
MT  
AT  
FA  
RA  
BR  
ST  
RS  
BT  
HA  
EL  
IDX

## Cooling Fan (Overheat) (DTC: 0208) (Cont'd)

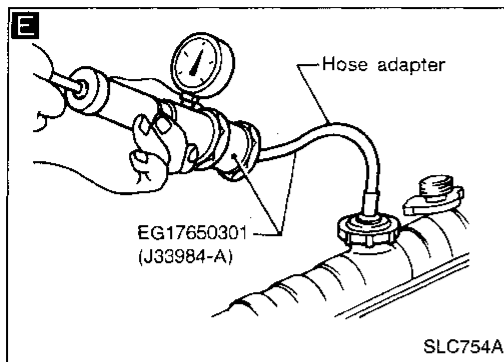

**E**

**CHECK COOLING SYSTEM FOR LEAK.**  
Apply pressure to the cooling system with a tester, and check if the pressure drops.  
**Testing pressure:**  
157 kPa (1.6 kg/cm<sup>2</sup>, 23 psi)  
**Pressure should not drop.**  
**CAUTION:**  
Higher than the specified pressure may cause radiator damage.

NG → Check the following for leak.

- Hose
- Radiator
- Water pump

Refer to LC section ("Water Pump").

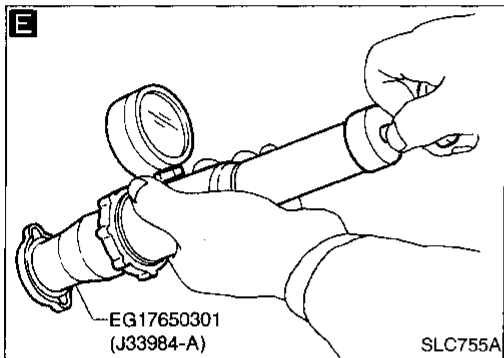

**E**

**CHECK RADIATOR CAP.**  
Apply pressure to cap with a tester.  
**Radiator cap relief pressure:**  
59 - 98 kPa (0.6 - 1.0 kg/cm<sup>2</sup>, 9 - 14 psi)

NG → Replace radiator cap.

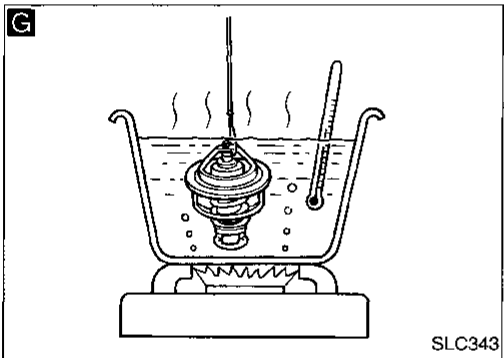

**G**

**CHECK THERMOSTAT.**

1. Check valve seating condition at normal room temperatures. It should seat tightly.
2. Check valve opening temperature and maximum valve lift.  
**Valve opening temperature:**  
76.5°C (170°F) [standard]  
**Valve lift:**  
More than 8.0 mm/90°C  
(0.31 in/194°F)
3. Check if valve is closed at 5°C (9°F) below valve opening temperature. For details, refer to LC section ("Thermostat").

NG → Replace thermostat

OK

Check engine coolant temperature sensor. Refer to "COMPONENT INSPECTION", EC-438.

NG → Replace engine coolant temperature sensor.

If the cause can not be isolated, go to "MAIN 12 CAUSES OF OVERHEATING" on next page.

INSPECTION END

**Perform FINAL CHECK by the following procedure after repair is completed.**

1. Warm up engine. Run the vehicle for at least 20 minutes. Pay attention to engine coolant temperature gauge on the instrument panel. If the reading shows an abnormally high temperature, another part may be malfunctioning.
2. Stop vehicle and let engine idle. Check the intake and exhaust systems for leaks by listening for noise or visually inspecting the components.
3. Allow engine to cool and visually check for oil and coolant leaks. Then, perform "OVERALL FUNCTION CHECK".

## Cooling Fan (Overheat) (DTC: 0208) (Cont'd)

## MAIN 12 CAUSES OF OVERHEATING

Engine	Step	Inspection item	Equipment	Condition	Reference page
OFF	1	<ul style="list-style-type: none"> <li>● Blocked radiator</li> <li>● Blocked condenser</li> <li>● Blocked radiator grille</li> <li>● Blocked bumper</li> </ul>	● Visual	No blocking	—
	2	● Coolant mixture	● Coolant tester	50 - 50% coolant mixture	See "RECOMMENDED FLUIDS AND LUBRICANTS" in MA section
	3	● Coolant level	● Visual	Coolant up to MAX level in reservoir tank and radiator filler neck	See "Changing Engine Coolant", "ENGINE MAINTENANCE" in MA section
	4	● Radiator cap	● Pressure tester	59 - 98 kPa (0.6 - 1.0 kg/cm <sup>2</sup> , 9 - 14 psi)	See "System Check" "ENGINE COOLING SYSTEM" in LC section
ON*2	5	● Coolant leaks	● Visual	No leaks	See "System Check" "ENGINE COOLING SYSTEM" in LC section
ON*2	6	● Thermostat	● Touch the upper and lower radiator hoses	Both hoses should be hot	See "Thermostat" and "Radiator", "ENGINE COOLING SYSTEM" in LC section
ON*1	7	● Cooling fan	● CONSULT	Operating	See "TROUBLE DIAGNOSIS FOR DTC P1900" (EC-430)
OFF	8	● Combustion gas leak	● Color checker chemical tester 4 Gas analyzer	Negative	—
ON*3	9	● Coolant temperature gauge	● Visual	Gauge less than 3/4 when driving	—
		● Coolant overflow to reservoir tank	● Visual	No overflow during driving and idling	See "Changing Engine Coolant", "ENGINE MAINTENANCE" in MA section
OFF*4	10	● Coolant return from reservoir tank to radiator	● Visual	Should be initial level in reservoir tank	See "ENGINE MAINTENANCE" in MA section
OFF	11	● Cylinder head	● Straight gauge feeler gauge	0.1mm (0.004 in) Maximum distortion (warping)	See "Inspection", "CYLINDER HEAD" in EM section
	12	● Cylinder block and pistons	● Visual	No scuffing on cylinder walls or piston	See "Inspection", "CYLINDER BLOCK" in EM section

\*1: Turn the ignition switch ON.

\*2: Engine running at 3,000 rpm for 10 minutes.

\*3: Drive at 90 km/h (55MPH) for 30 minutes and then let idle for 10 minutes.

\*4: After 60 minutes of cool down time.

For more information, refer to "OVERHEATING CAUSE ANALYSIS" in LC section.

**Cooling Fan (Overheat) (DTC: 0208) (Cont'd)  
COMPONENT INSPECTION**

**Cooling fan relay-1**

Check continuity between terminals ③ and ⑤

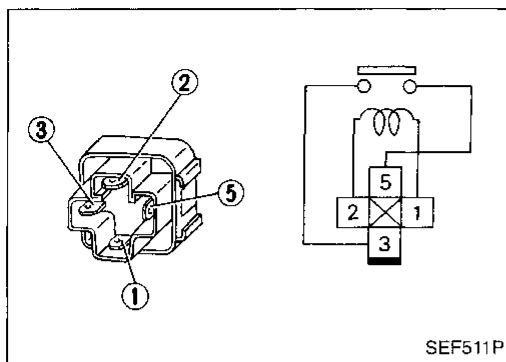

Conditions	Continuity
12V direct current supply between terminals ① and ②	Yes
No current supply	No

If NG, replace relay.

**Cooling fan motors-1 and -2**

1. Disconnect cooling fan motor harness connectors.
2. Supply cooling fan motor terminals with battery voltage and check operation.

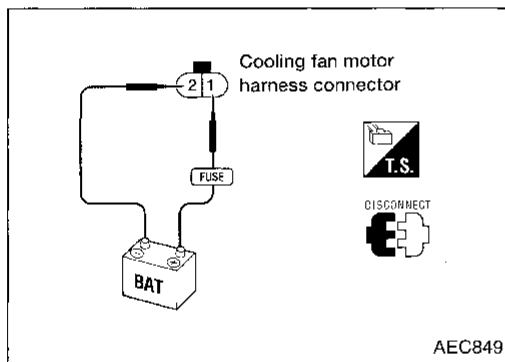

	Terminals	
	(⊕)	(⊖)
Cooling fan motor	①	②

**Cooling fan motor should operate.**

If NG, replace cooling fan motor.

Injector

EC-INJECT-01

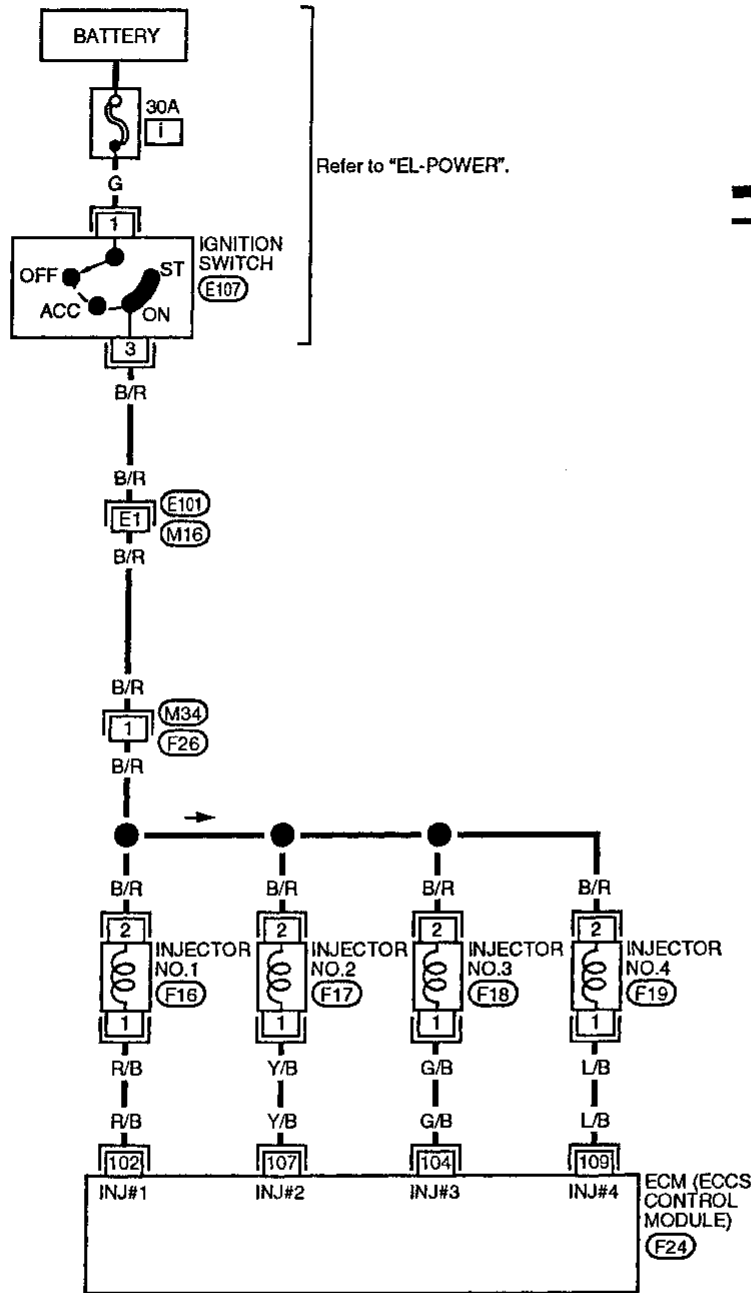

Refer to last page (Foldout page).

(M16), (E101)

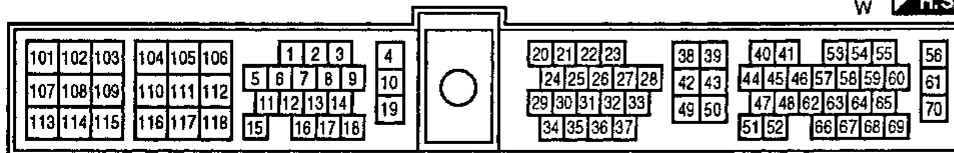
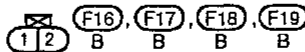

GI  
MA  
EM  
LC  
EC  
FE  
CL  
MT  
AT  
FA  
RA  
BR  
ST  
RS  
BT  
HA  
EL  
IDX

## Injector (Cont'd)

### COMPONENT DESCRIPTION

The fuel injector is a small, precise solenoid valve. When the ECM supplies a ground to the injector circuit, the coil in the injector is energized. The energized coil pulls the needle valve back and allows fuel to flow through the injector into the intake manifold. The amount of fuel injected depends upon the injection pulse duration. Pulse duration is the length of time the injector remains open. The ECM controls the injection pulse duration based on engine fuel needs.

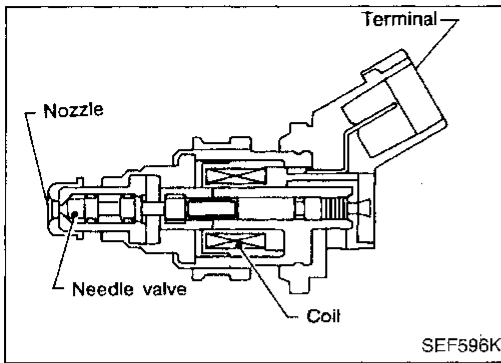

### DIAGNOSTIC PROCEDURE

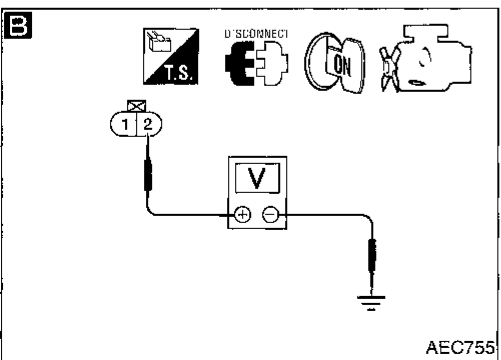
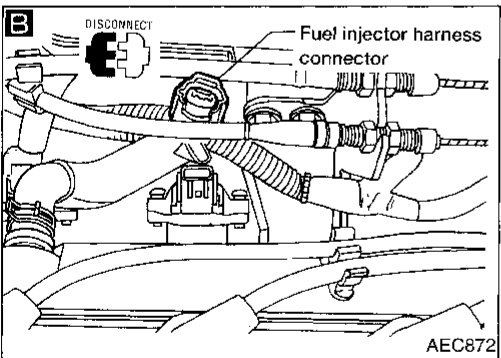
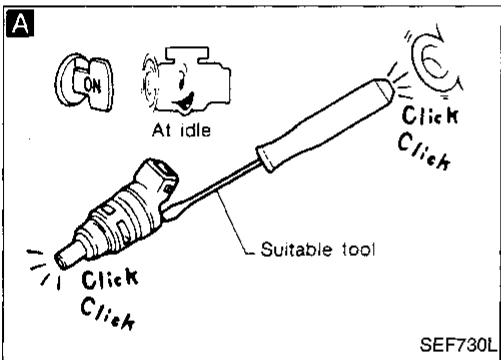
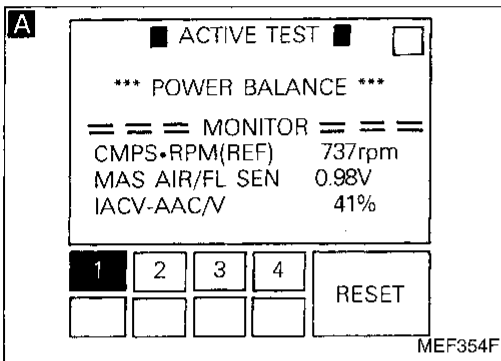
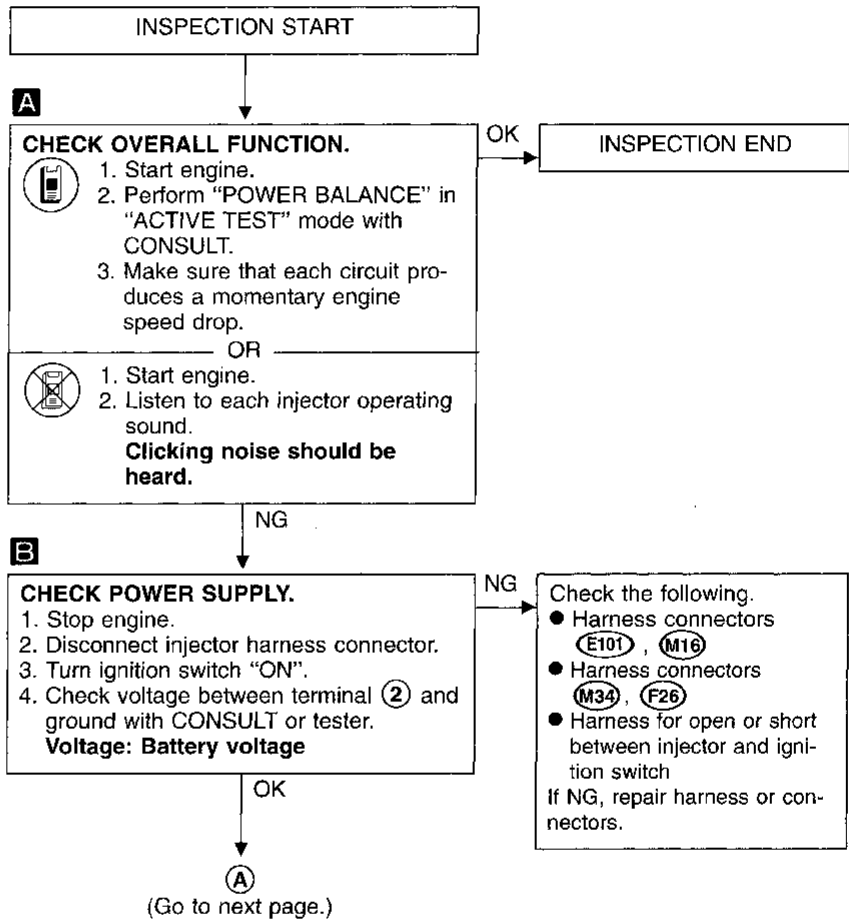

Injector (Cont'd)

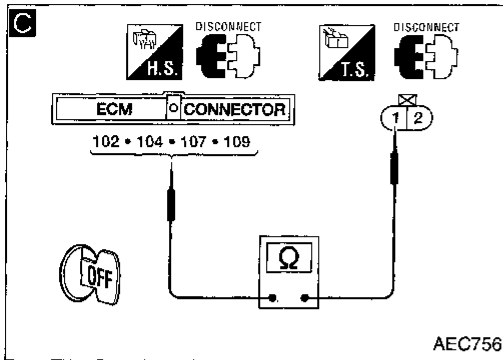

**C**

**①**

**C**

**CHECK OUTPUT SIGNAL CIRCUIT.**  
 1. Turn ignition switch "OFF".  
 2. Disconnect ECM harness connector.  
 3. Check harness continuity between injector harness connector terminal ① and ECM terminals ①②, ①④, ①⑦, ①⑨.  
**Continuity should exist.**

NG → Check the following.  
 ● Harness for open or short between ECM and injector  
 If NG, repair harness or connectors.

OK →

**CHECK COMPONENT (Injector).**  
 Refer to "COMPONENT INSPECTION" below.

NG → Replace injector.

OK →

Disconnect and reconnect harness connectors in the circuit. Then retest.

Trouble is not fixed.

Check ECM pin terminals for damage and check the connection of ECM harness connector. Reconnect ECM harness connector and retest.

INSPECTION END

GI  
MA  
EM  
LC  
EC  
FE  
CL  
MT  
AT  
FA  
RA  
BR  
ST  
RS  
BT  
HA  
EL  
IDX

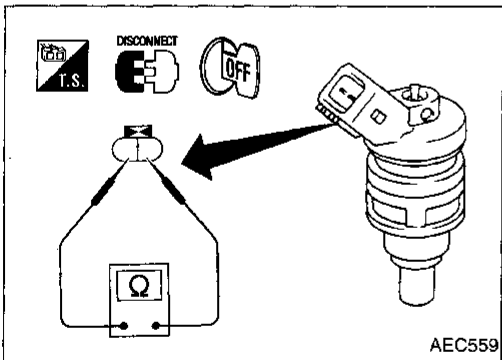

**COMPONENT INSPECTION**

**Injector**

1. Disconnect injector harness connector.
2. Check resistance between terminals as shown in the figure.  
**Resistance: 10 - 14Ω [at 25°C (77°F)]**  
 If NG, replace injector.



Start Signal

EC-S/SIG-01

— : Detectable line for DTC  
 — : Non-detectable line for DTC

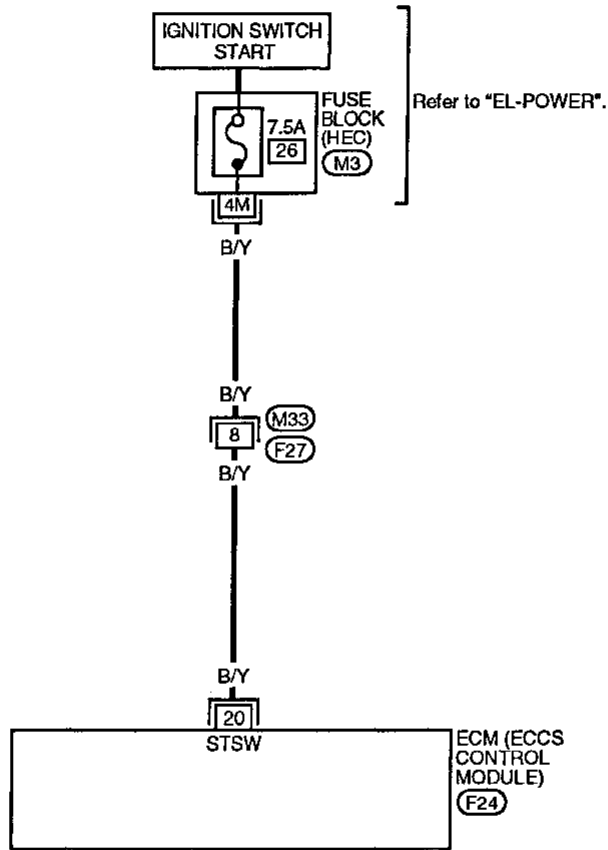

Refer to last page (Foldout page).

M3

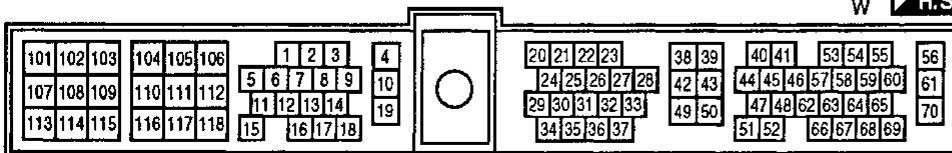

Start Signal (Cont'd)  
DIAGNOSTIC PROCEDURE

**A**

■ START SIGNAL CKT ■

1. CLOSE THROTTLE. SHIFT TO P OR N RANGE.
2. TOUCH START AND START ENGINE IMMEDIATELY.

NEXT      START

SEF191L

**A**

☆ MONITOR      ☆ NO FAIL

START SIGNAL      OFF

CLSD TH/P SW      ON

AIR COND SIG      OFF

P/N POSI SW      ON

RECORD

SEF111P

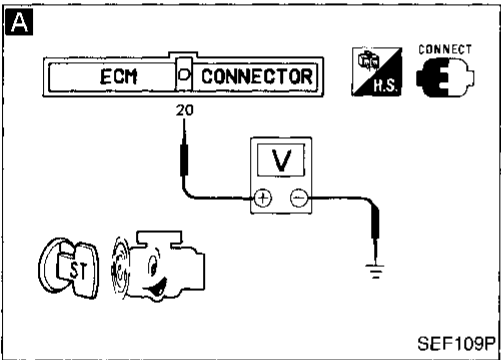

```

    graph TD
      Start[INSPECTION START] --> Check[CHECK OVERALL FUNCTION.]
      Check -- OK --> End1[INSPECTION END]
      Check --> OR1[OR]
      OR1 --> Check2[1. Turn ignition switch "ON".  
2. Check "START SIGNAL" in "DATA MONITOR" mode with CONSULT.]
      Check2 --> Table
      Table --> OR2[OR]
      OR2 --> Check3[1. Turn ignition switch to "START".  
2. Check voltage between ECM terminal 20 and ground.  
Voltage:  
Ignition switch "START"  
Battery voltage  
Except above  
Approximately 0V]
      Check3 -- NG --> Check4[Check the following.  
• Harness connectors (M33, F27)  
• 7.5A fuse  
• Harness for open or short between ECM harness connector and ignition switch  
If NG, repair harness or connectors.]
      Check4 --> Disconnect[Disconnect and reconnect harness connectors in the circuit. Then retest.]
      Disconnect -- Trouble is not fixed. --> Check5[Check ECM pin terminals for damage and check the connection of ECM harness connector. Reconnect ECM harness connector and retest.]
      Check5 --> End2[INSPECTION END]
    
```

INSPECTION START

**A** CHECK OVERALL FUNCTION.

1. Turn ignition switch "ON".
2. Perform "START SIGNAL CKT" in "FUNCTION TEST" mode with CONSULT.

OR

1. Turn ignition switch "ON".
2. Check "START SIGNAL" in "DATA MONITOR" mode with CONSULT.

IGN "ON"	OFF
IGN "START"	ON

OR

1. Turn ignition switch to "START".
2. Check voltage between ECM terminal 20 and ground.

**Voltage:**  
Ignition switch "START"  
Battery voltage  
Except above  
Approximately 0V

NG

Check the following.

- Harness connectors (M33, F27)
- 7.5A fuse
- Harness for open or short between ECM harness connector and ignition switch

If NG, repair harness or connectors.

Disconnect and reconnect harness connectors in the circuit. Then retest.

Trouble is not fixed.

Check ECM pin terminals for damage and check the connection of ECM harness connector. Reconnect ECM harness connector and retest.

INSPECTION END

GI  
MA  
EM  
LC  
EC  
FE  
CL  
MT  
AT  
FA  
RA  
BR  
ST  
RS  
BT  
HA  
EL  
IDX

### Fuel Pump

#### SYSTEM DESCRIPTION

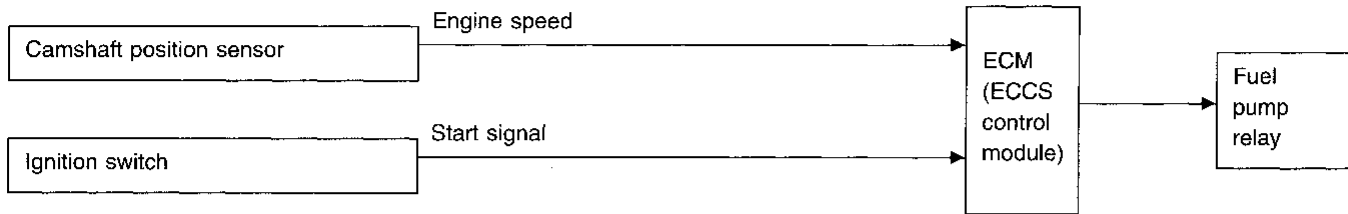

The ECM activates the fuel pump for several seconds after the ignition switch is turned on to improve engine startability. If the ECM receives a 180° signal from the camshaft position sensor, it knows that the engine is rotating, and causes the pump to perform. If the 180° signal is not received when the ignition switch is on, the engine stalls. The ECM stops pump operation and prevents battery discharging, thereby improving safety. The ECM does not directly drive the fuel pump. It controls the ON/OFF fuel pump relay, which in turn controls the fuel pump.

Condition	Fuel pump operation
Ignition switch is turned to ON.	Operates for 5 seconds
Engine running and cranking	Operates
When engine is stopped	Stops in 1 second
Except as shown above	Stops

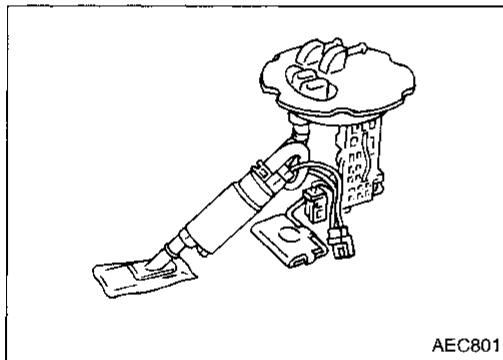

#### COMPONENT DESCRIPTION

A turbine type design fuel pump is used in the fuel tank.

Fuel Pump (Cont'd)

EC-F/PUMP-01

GI

MA

EM

LC

EC

FE

CL

MT

AT

FA

RA

BR

ST

RS

BT

HA

EL

IDX

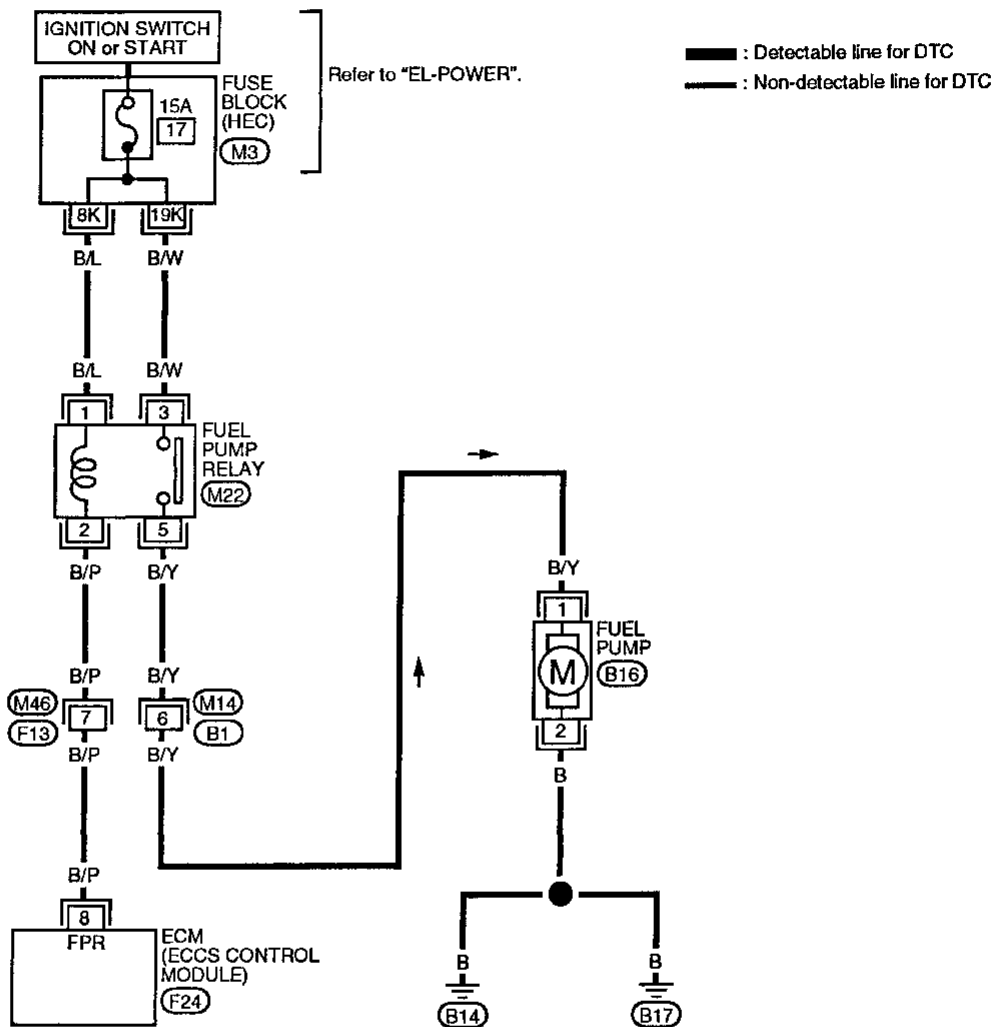

Refer to last page (Foldout page).

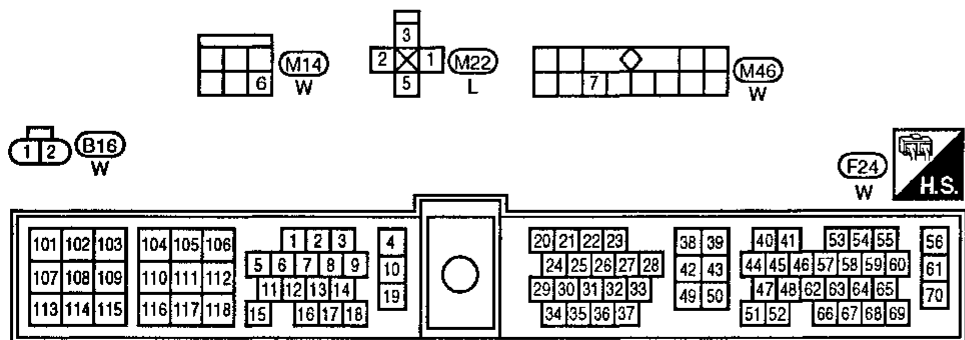

Fuel Pump (Cont'd)  
DIAGNOSTIC PROCEDURE

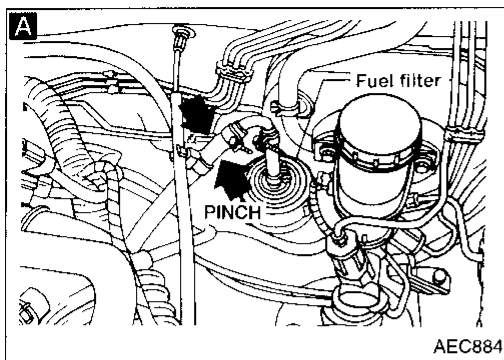

AEC884

INSPECTION START

**A**  
**CHECK OVERALL FUNCTION.**  
1. Turn ignition switch "ON".  
2. Pinch fuel feed hose with fingers.  
**Fuel pressure pulsation should be felt on the fuel feed hose for 5 seconds after ignition switch is turned "ON".**

OK → INSPECTION END

NG ↓

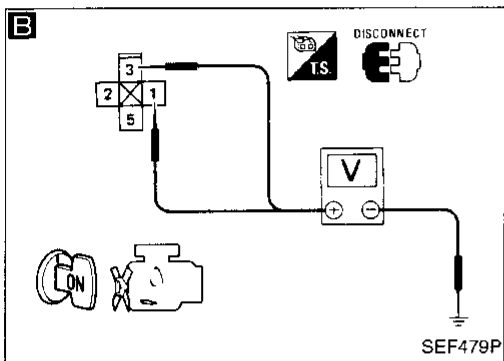

SEF479P

**B**  
**CHECK POWER SUPPLY.**  
1. Turn ignition switch "OFF".  
2. Disconnect fuel pump relay from relay box.  
3. Turn ignition switch "ON".  
4. Check voltage between terminals ①, ③ and ground with CONSULT or tester.  
**Voltage: Battery voltage**

NG → Check the following.  
● 15A fuse  
● Harness for open or short between fuse and fuel pump relay  
If NG, repair harness or connectors.

OK ↓

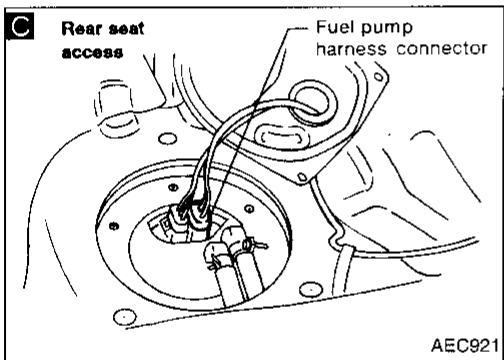

AEC921

**C**  
**CHECK POWER GROUND CIRCUIT.**  
1. Turn ignition switch "OFF".  
2. Disconnect fuel pump harness connector.  
3. Check harness continuity between terminal ② and body ground, terminal ① and fuel pump relay connector terminal ⑤.  
**Continuity should exist.**  
If OK, check harness for short.

NG → Check the following.  
● Harness connectors (M14, B1)  
● Harness for open or short between fuel pump and body ground  
● Harness for open or short between fuel pump and fuel pump relay  
If NG, repair harness or connectors.

OK ↓

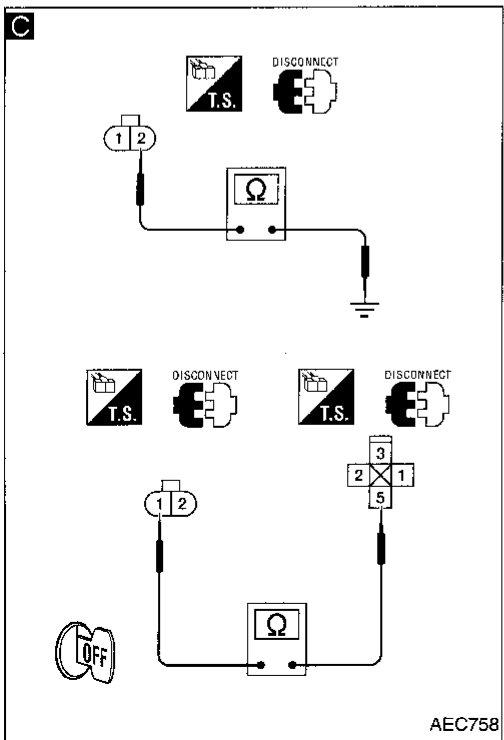

AEC758

**D**  
**CHECK OUTPUT SIGNAL CIRCUIT.**  
1. Disconnect ECM harness connector.  
2. Check harness continuity between ECM terminal ⑧ and fuel pump relay connector terminal ②.  
**Continuity should exist.**  
If OK, check harness for short.

NG → Check the following.  
● Harness connectors (M46, F13)  
● Harness for open or short between ECM and fuel pump relay  
If NG, repair harness or connectors.

OK ↓

Ⓐ  
(Go to next page.)

Fuel Pump (Cont'd)

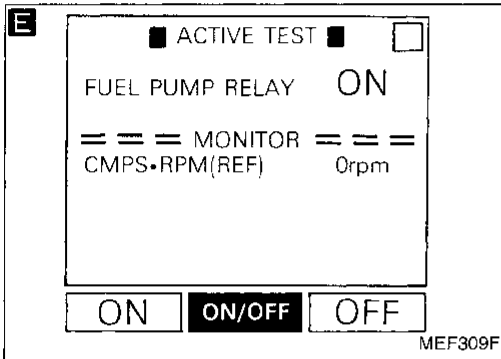
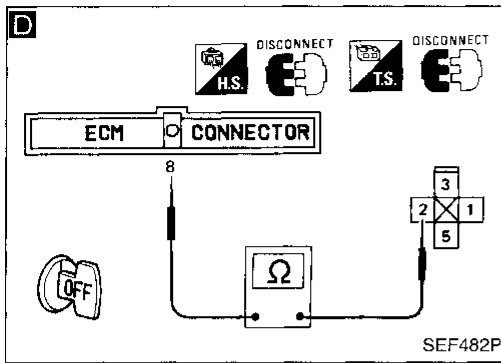

**E**

**CHECK COMPONENT**  
(Fuel pump relay).  
Refer to "Component Inspection" below.

NG → Replace fuel pump relay.

OK →

**CHECK COMPONENT**  
(Fuel pump).  
Refer to "COMPONENT INSPECTION"  
below.

NG → Replace fuel pump.

OK →

Disconnect and reconnect harness connectors in the circuit. Then retest.

↓ Trouble is not fixed.

Check ECM pin terminals for damage and check the connection of ECM harness connector. Reconnect ECM harness connector and retest.

↓

INSPECTION END

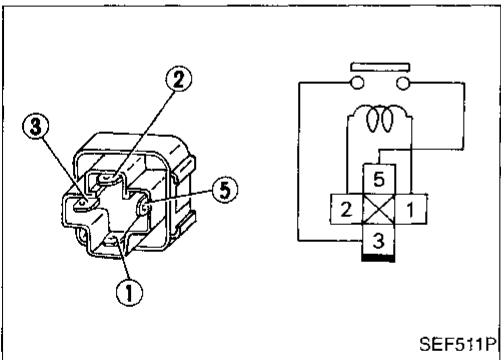

COMPONENT INSPECTION

Fuel pump relay

Check continuity between terminals ③ and ⑤.

Conditions	Continuity
12V direct current supply between terminals ① and ②	Yes
No current supply	No

If NG, replace relay.

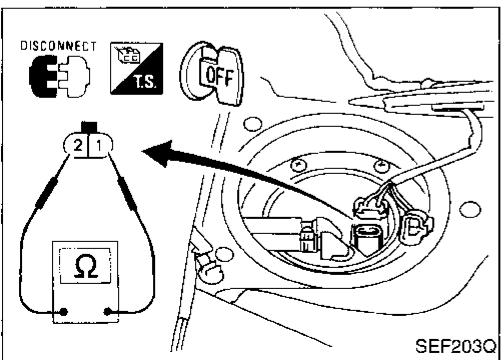

Fuel pump

1. Disconnect fuel pump harness connector.
2. Check resistance between terminals ① and ②.  
**Resistance: 0.2 - 5.0Ω [at 25°C (77°F)]**  
If NG, replace fuel pump.

GI  
MA  
EM  
LC  
EC  
FE  
CL  
MT  
AT  
FA  
RA  
BR  
ST  
PS  
BT  
HA  
EL  
IDX

Power Steering Oil Pressure Switch

EC-PST/SW-01

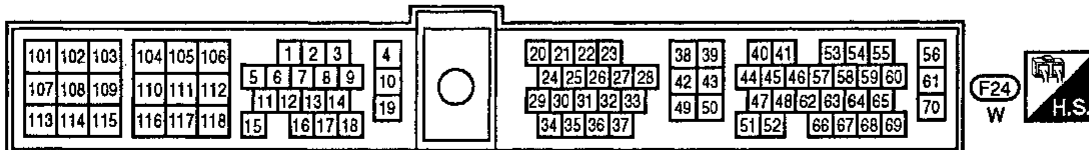
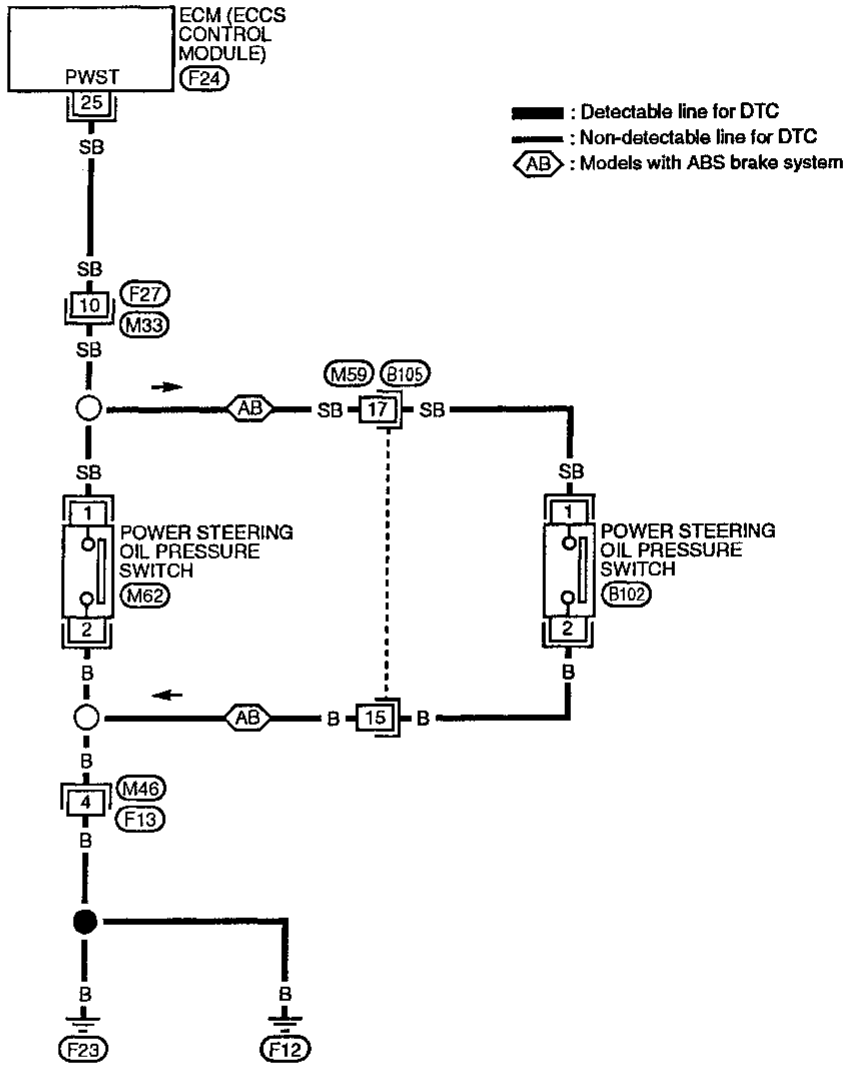

**Power Steering Oil Pressure Switch (Cont'd)**  
**COMPONENT DESCRIPTION**

The power steering oil pressure switch is attached to the power steering high-pressure tube and detects a power steering load. When a power steering load is detected, it signals the ECM. The ECM adjusts the IACV-AAC valve to increase the idle speed and adjust for the increased load.

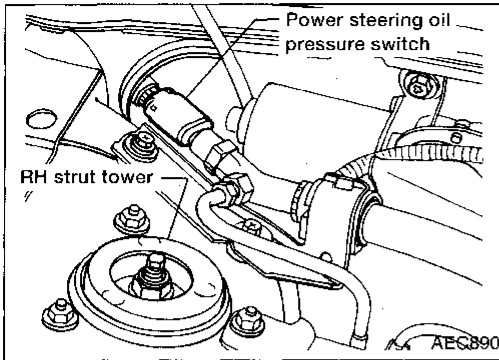

**DIAGNOSTIC PROCEDURE**

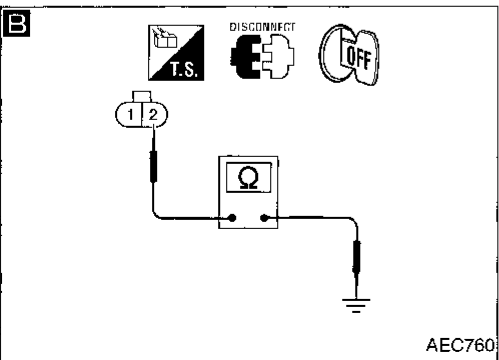
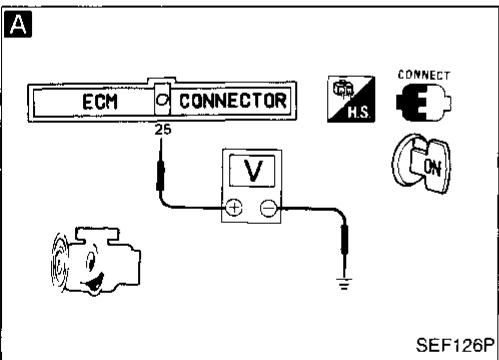
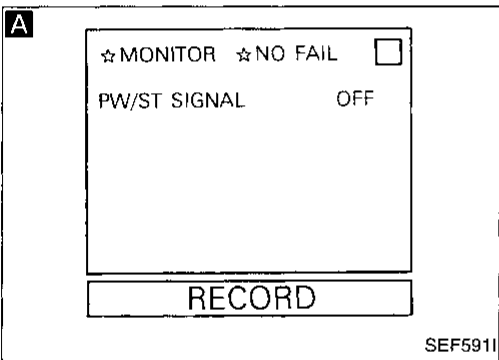
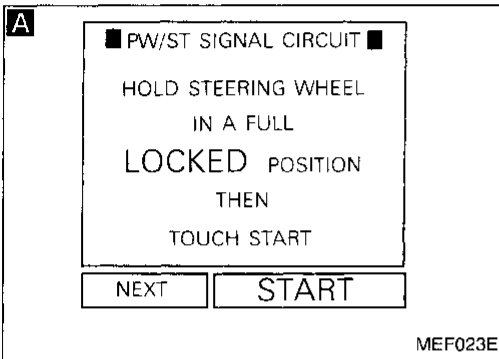
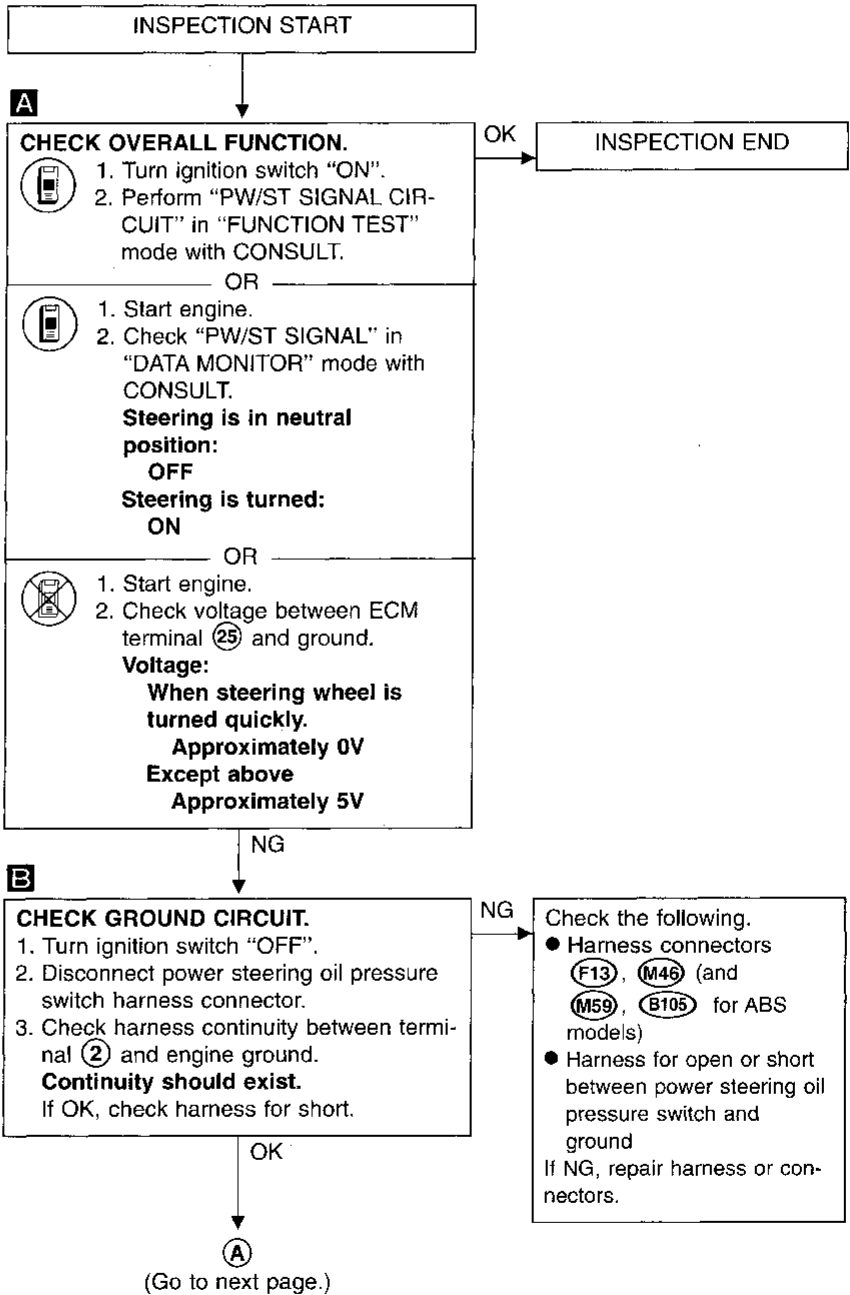



Power Steering Oil Pressure Switch (Cont'd)

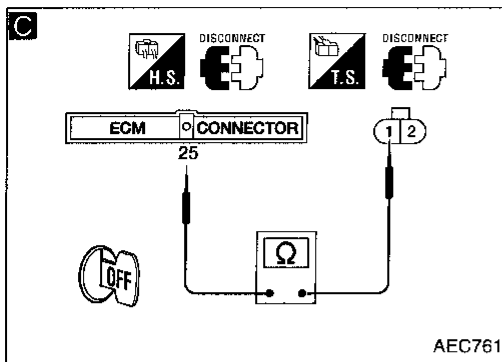

**C**

**①**

**C**

**CHECK INPUT SIGNAL CIRCUIT.**  
 1. Disconnect ECM harness connector.  
 2. Check harness continuity between ECM terminal ②⑤ and terminal ①.  
**Continuity should exist.**  
 If OK, check harness for short.

NG → Check the following.  
 ● Harness connectors  
 (F27), (M33) (and (M59), (B105) for ABS models)  
 ● Harness for open or short between ECM and power steering oil pressure switch  
 If NG, repair harness or connectors.

OK →

**CHECK COMPONENT**  
 (Power steering oil pressure switch).  
 Refer to "COMPONENT INSPECTION" below.

NG → Replace power steering oil pressure switch.

OK →

Disconnect and reconnect harness connectors in the circuit. Then retest.

↓ Trouble is not fixed.

Check ECM pin terminals for damage and check the connection of ECM harness connector. Reconnect ECM harness connector and retest.

↓

INSPECTION END

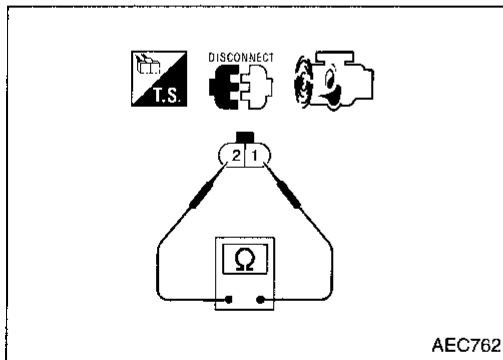

**COMPONENT INSPECTION**

**Power steering oil pressure switch**

1. Disconnect power steering oil pressure switch harness connector then start engine.
2. Check continuity between terminals ① and ②.

Conditions	Continuity
Steering wheel is being turned	Yes
Steering wheel is not being turned	No

If NG, replace power steering oil pressure switch.

IACV-FICD Solenoid Valve

EC-FICD-01

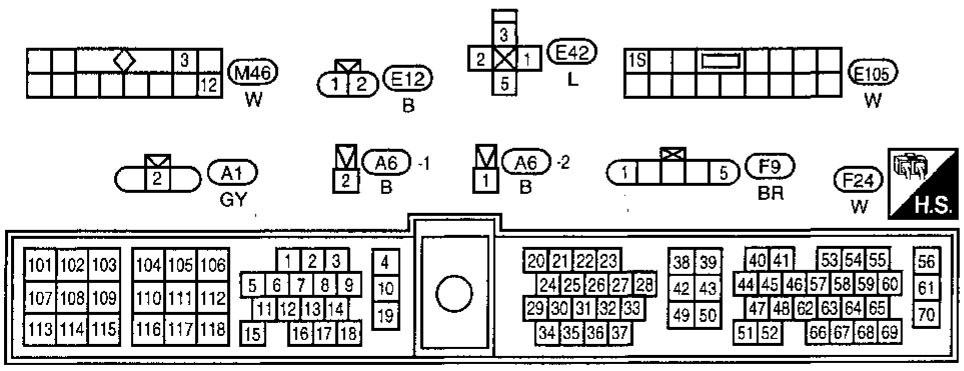
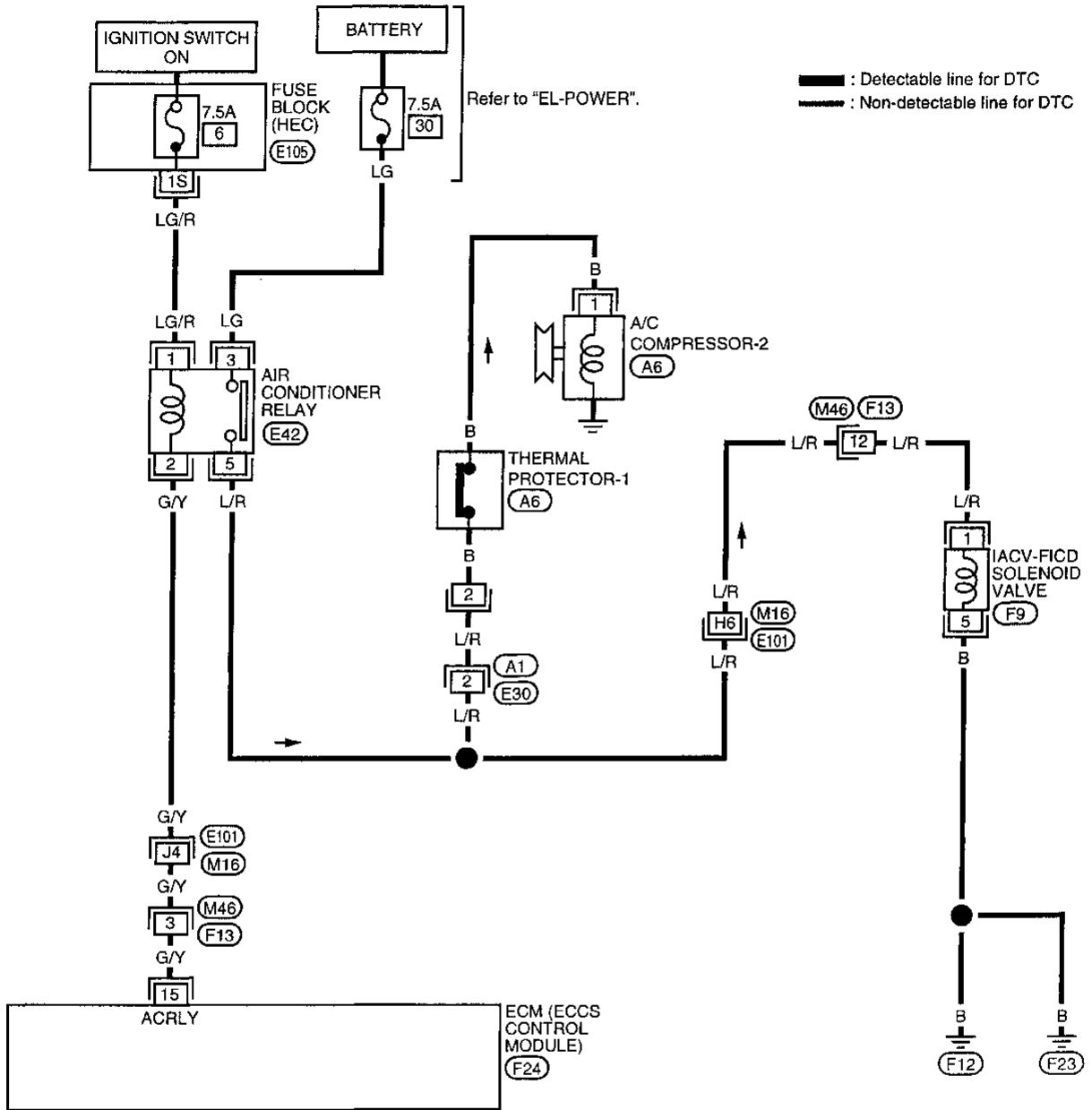

GI  
 MA  
 EM  
 LC  
**EC**  
 FE  
 CL  
 MT  
 AT  
 FA  
 RA  
 BR  
 ST  
 RS  
 BT  
 HA  
 EL  
 IDX

IACV-FICD Solenoid Valve (Cont'd)

COMPONENT DESCRIPTION

The IACV-FICD solenoid valve is built into the IACV-AAC valve body. When the air conditioner is on, the IACV-FICD solenoid valve supplies additional air to adjust to the increased load.

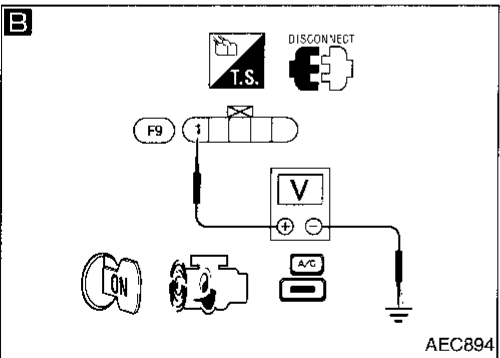
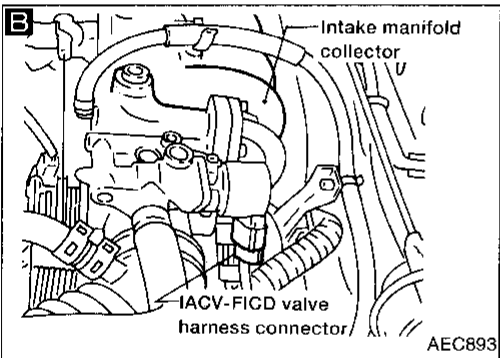
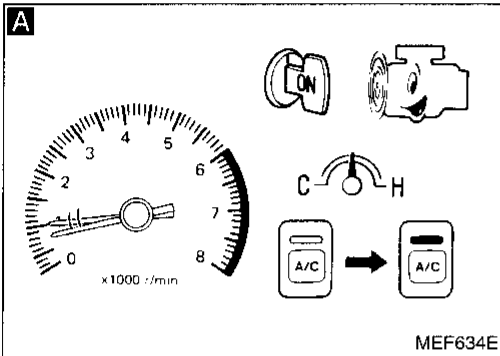
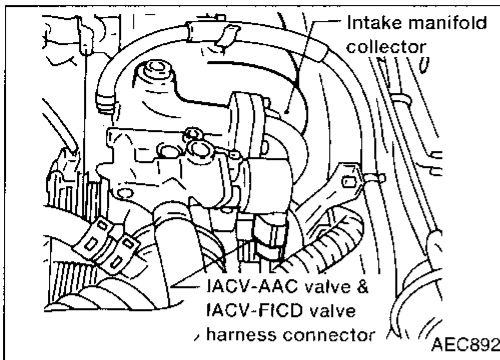

DIAGNOSTIC PROCEDURE

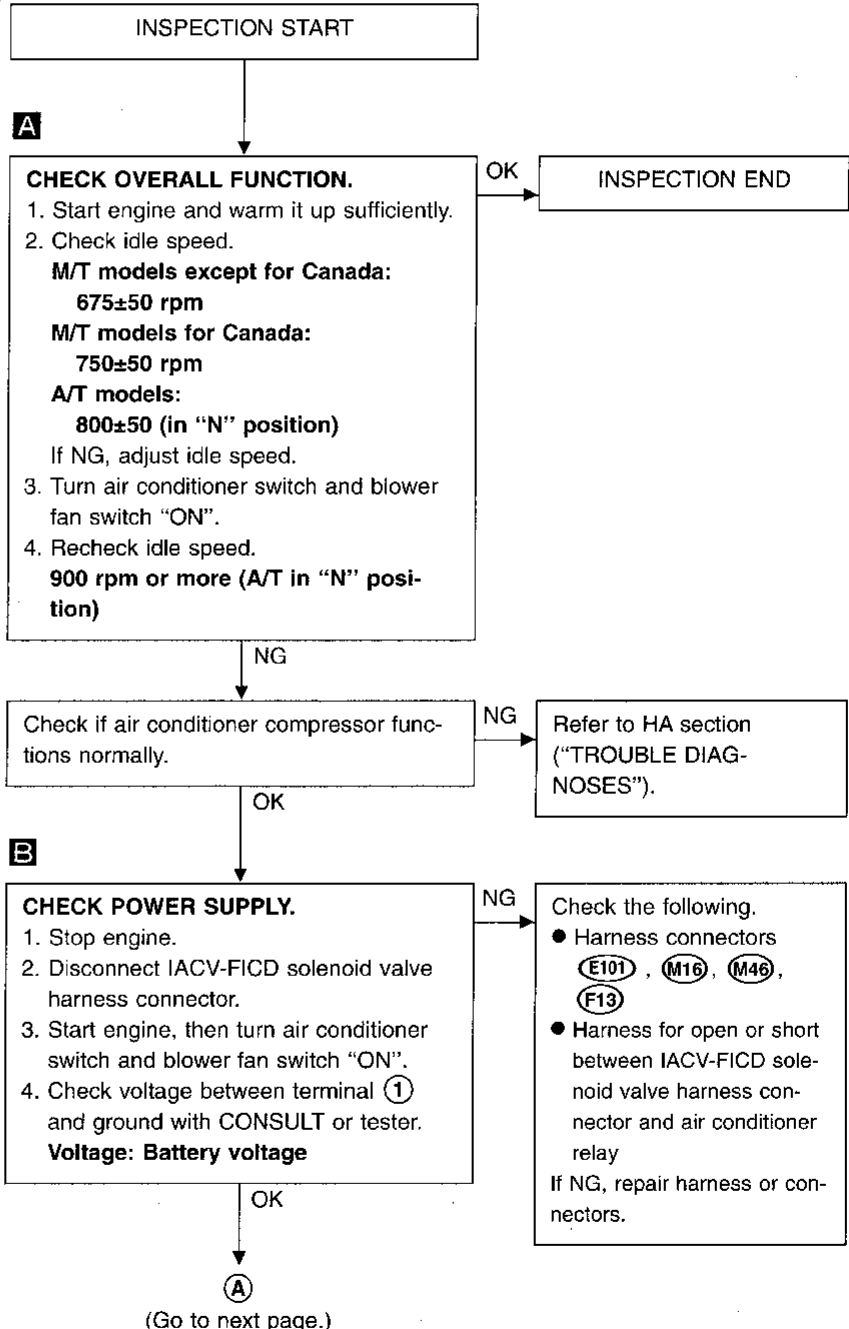

IACV-FICD Solenoid Valve (Cont'd)

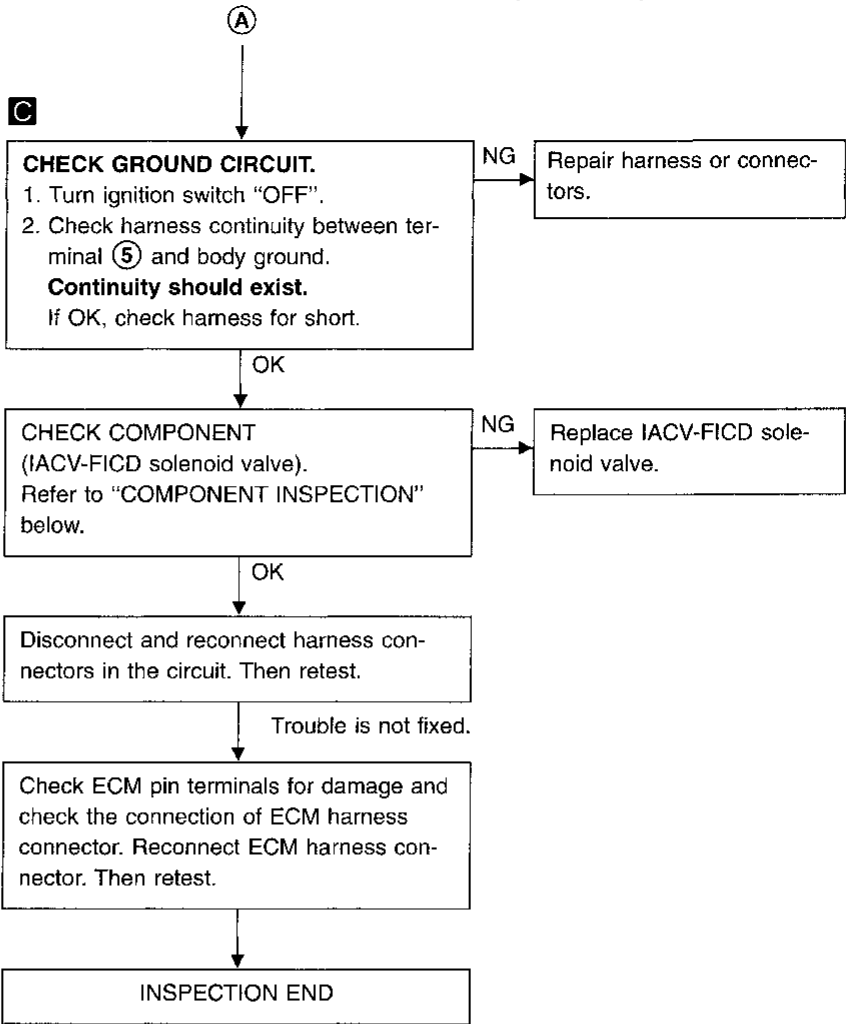
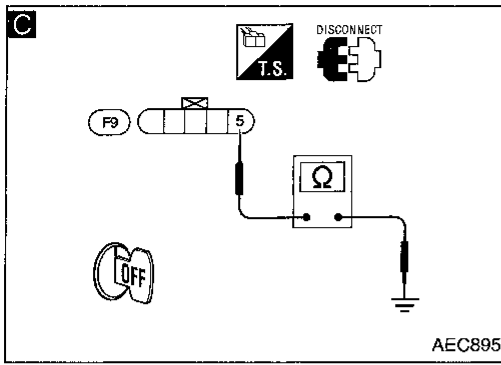

GI  
MA  
EM  
LC  
EC  
FE  
CL  
MT  
AT  
FA  
RA  
BR  
ST  
RS  
BT  
HA  
EL  
IDX

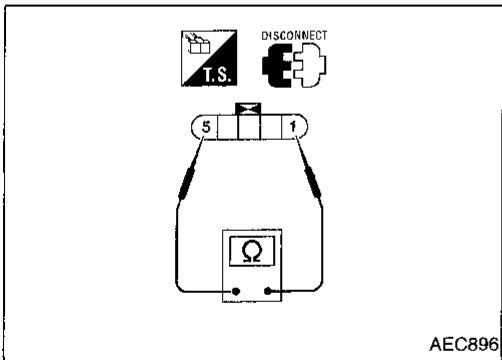

**COMPONENT INSPECTION**  
**IACV-FICD solenoid valve**

1. Disconnect IACV-FICD solenoid valve harness connector.
2. Check resistance between terminals ① and ⑤.  
**Resistance: 75 - 125Ω [at 25°C (77°F)]**  
If NG, replace the solenoid valve.

Electrical Load Signal

EC-LD/SIG-01

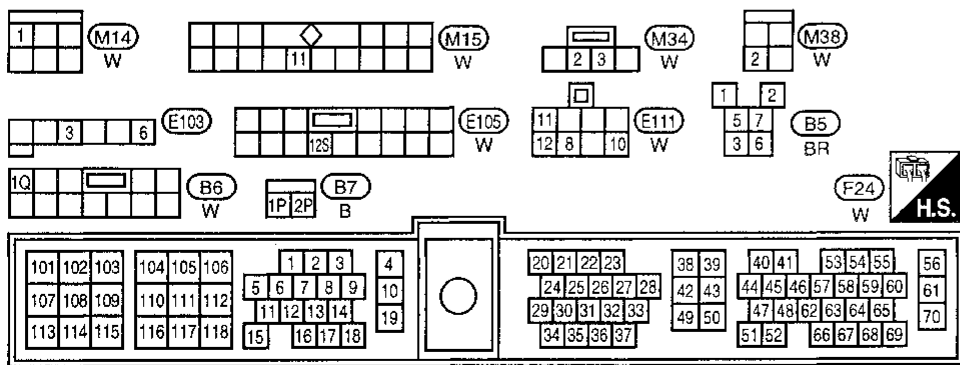
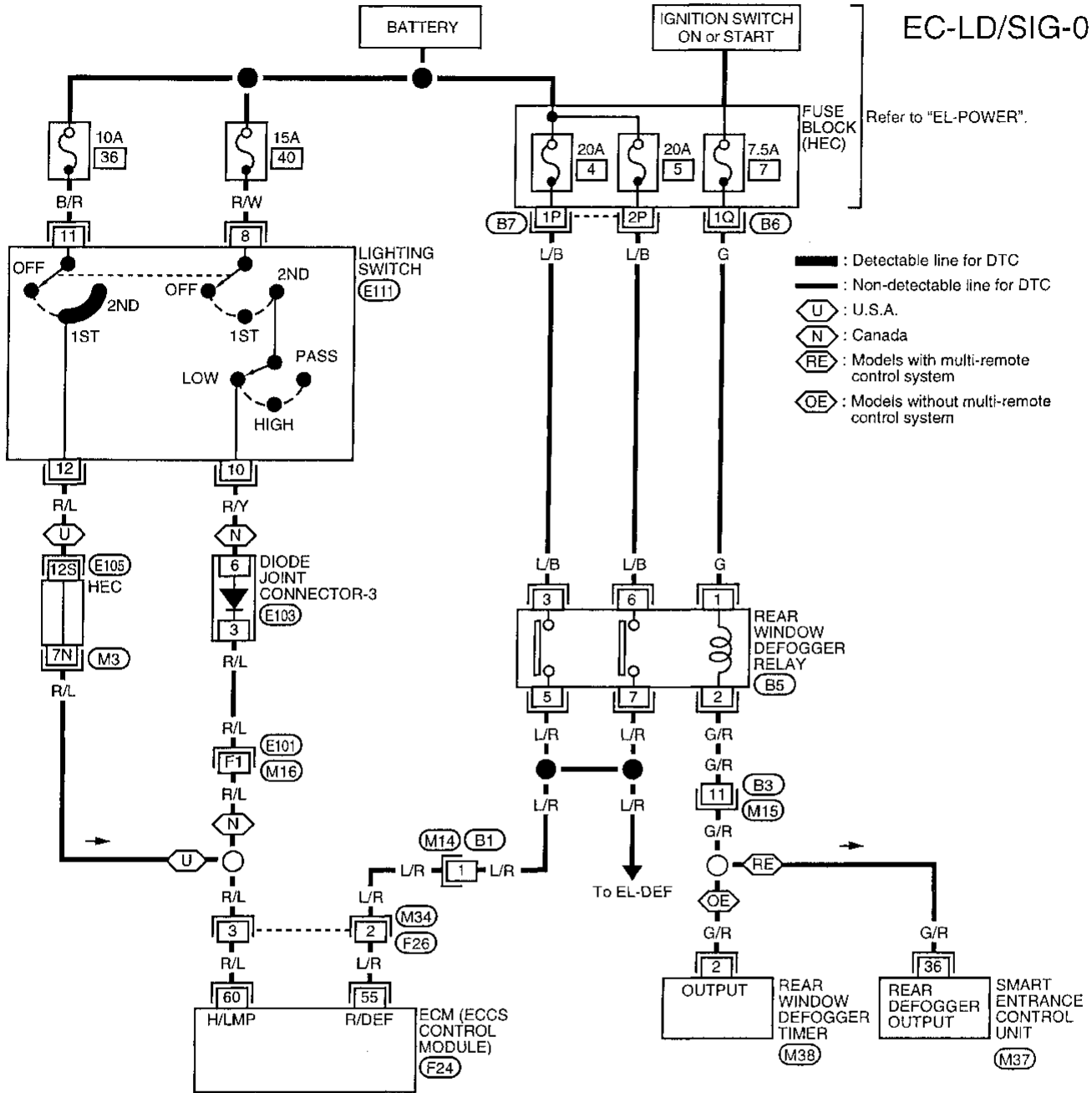

Refer to last page (Foldout page).

- M3
- M37
- M16, E101

Electrical Load Signal (Cont'd)

EC-LD/SIG-02

GI

MA

EM

LC

**EC**

FE

CL

MT

AT

FA

RA

BR

ST

RS

BT

HA

EL

IDX

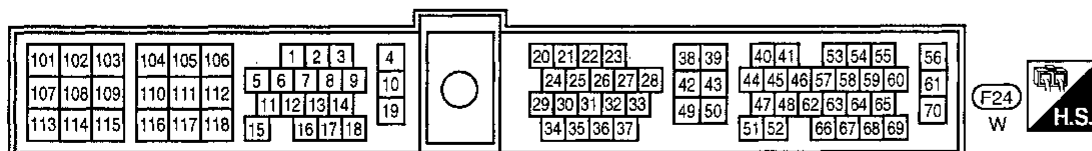
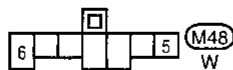
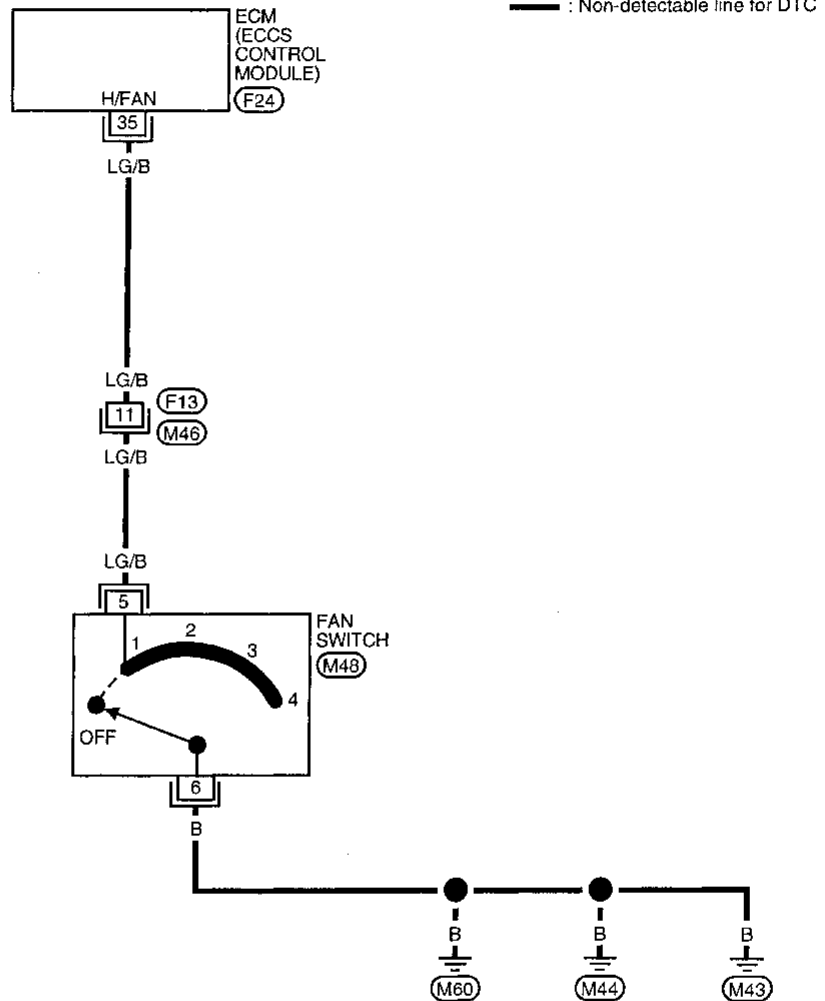

**Electrical Load Signal (Cont'd)  
DIAGNOSTIC PROCEDURE**

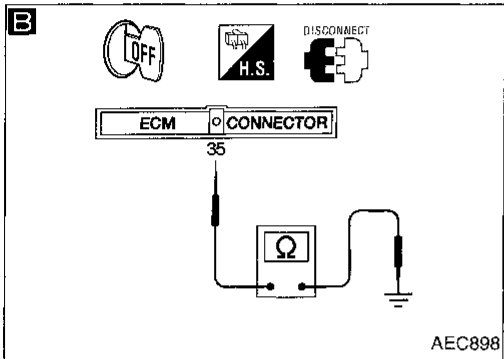
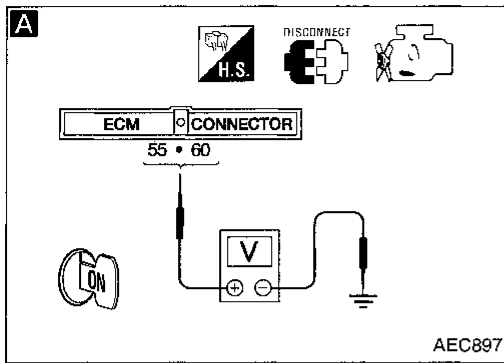

INSPECTION START

**A**  
**CHECK OVERALL FUNCTION.**  
1. Turn ignition switch "OFF".  
2. Disconnect ECM harness connector.  
3. Turn ignition switch "ON".  
4. Check voltage between ECM terminal ⑤⑤, ⑥⑥ and ground with CONSULT or tester.

**Voltage between ⑤⑤ and ground:**  
Rear window defogger "ON"  
Battery positive voltage  
Rear window defogger "OFF"  
0V

**Voltage between ⑥⑥ and ground:**  
Lighting switch "ON" or daytime running light "ON"  
Battery positive voltage  
Lighting switch "OFF" or daytime running light "OFF"  
0V

NG → Check the following.

For terminal ⑤⑤

- Harness connectors (M34, F26, M14, B1)
- Harness for open or short between ECM and rear window defogger relay
- Harness for open or short between timer and rear window defogger relay

Refer to EL section ("REAR WINDOW DEFOGGER")

For terminal ⑥⑥

- Harness connectors (M16, E101, M3, E105)
- Harness continuity between ECM and lighting switch
- Diode joint connector-3 (E103) for Canada models

If NG, repair harness or connectors.

**B**  
**CHECK POWER AND GROUND CIRCUIT**  
1. Turn ignition switch "OFF".  
2. Check continuity between ECM terminal ③⑤ and ground.

**Blower fan switch "ON"**  
Continuity should exist.

**Blower fan switch "OFF"**  
Continuity should not exist.

NG → Check the following.

- Harness connectors (M46, F13)
- Harness for open or short between ECM and fan switch, fan switch and ground

If NG, repair harness or connectors.

OK → Disconnect and reconnect harness connectors in the circuit. Then retest.

Trouble is not fixed. → Check ECM pin terminals for damage and check loose connection of ECM harness connector. Reconnect ECM harness connector and retest.

INSPECTION END

MIL & Data Link Connectors

EC-MIL-01

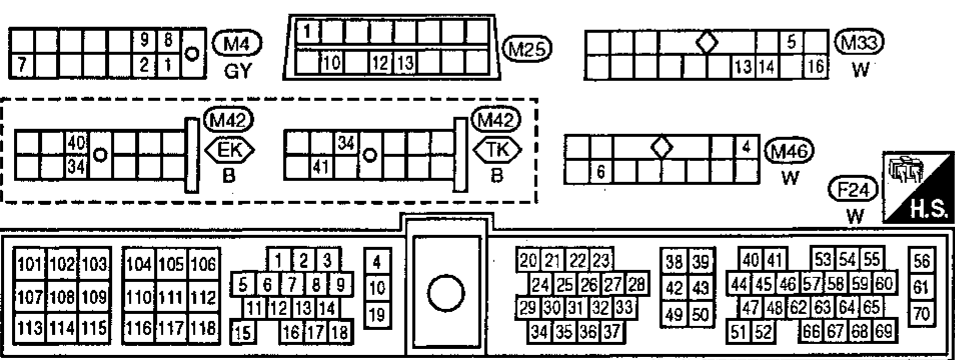
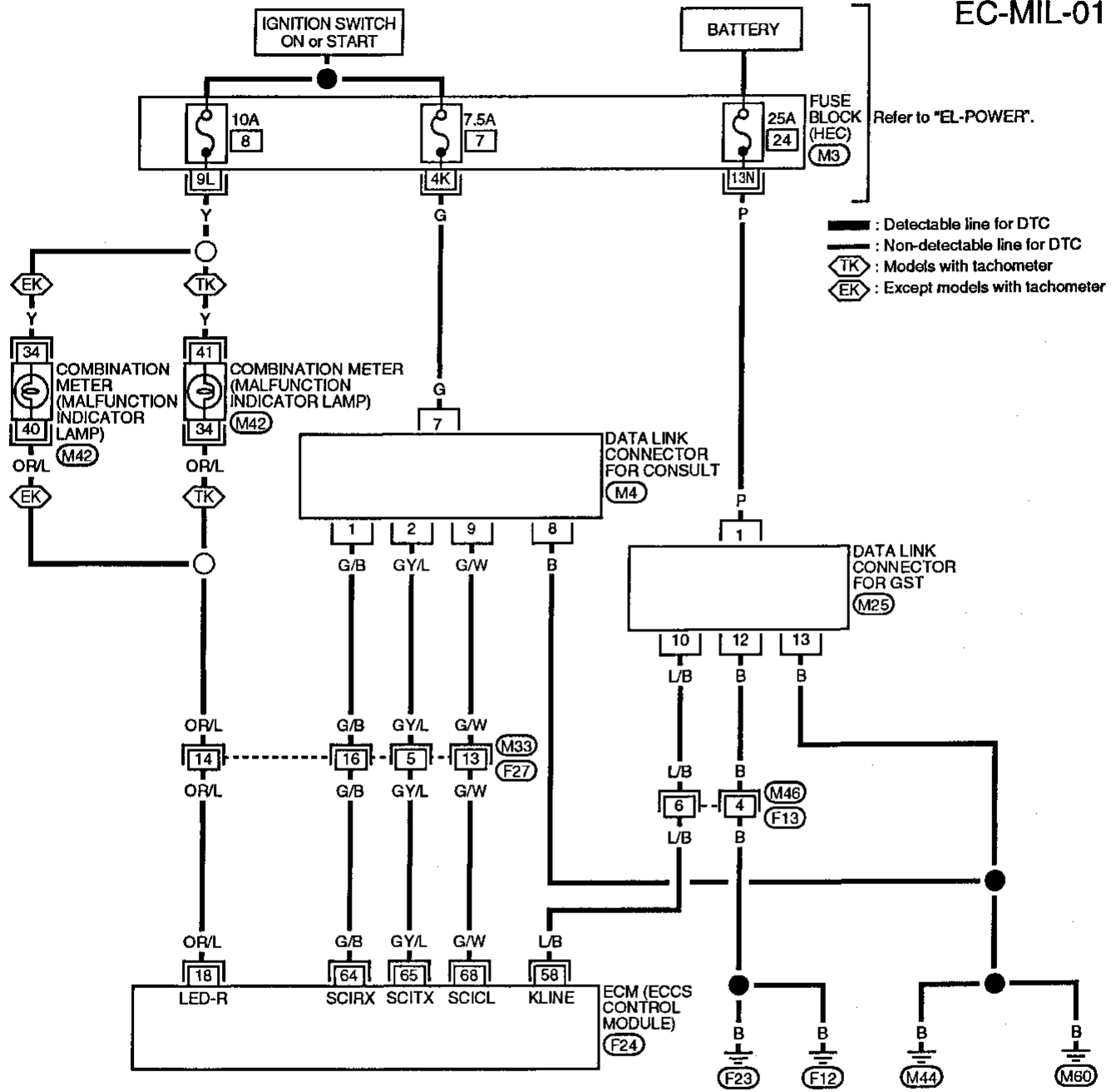

Refer to last page (Foldout page).



## Alphabetical &amp; P No. Index for DTC

## ALPHABETICAL INDEX FOR DTC

Items (CONSULT screen terms)	DTC		Reference page
	MIL*1	CONSULT GST*2	
A/T 1ST SIGNAL	1103	P0731	AT section
A/T 2ND SIGNAL	1104	P0732	AT section
A/T 3RD SIGNAL	1105	P0733	AT section
A/T 4TH SIG OR TCC	1106	P0734	AT section
A/T DIAG COMM LINE	0804	P1605	EC-198
CAMSHAFT POSI SEN	0101	P0340	EC-147
CLOSED LOOP	0307	P0130	EC-122
COOLANT TEMP SEN	0103	P0115	EC-103
*COOLANT TEMP SEN	0908	P0125	EC-112
CRANK P/S (OBD) COG	0905	P1336	EC-186
CRANK POS SEN (OBD)	0802	P0335	EC-143
CYL 1 MISFIRE	0608	P0301	EC-136
CYL 2 MISFIRE	0607	P0302	EC-136
CYL 3 MISFIRE	0606	P0303	EC-136
CYL 4 MISFIRE	0605	P0304	EC-136
ECM	0301	P0605	EC-174
EGR SYSTEM	0302	P0400	EC-152
EGR TEMP SENSOR	0305	P1401	EC-194
EGRC SOLENOID/V	1005	P1400	EC-190
EGRC-BPT VALVE	0306	P0402	EC-161
ENGINE SPEED SIG	1207	P0725	AT section
FLUID TEMP SENSOR	1208	P0710	AT section
FR O2 SEN HEATER	0901	P0135	EC-123
FRONT O2 SENSOR	0303	P0130	EC-117
FUEL INJ SYSTEM	0706	P0170	EC-131
IACV-AAC VALVE	0205	P0505	EC-170
IGN SIGNAL-PRIMARY	0201	P1320	EC-181
INHIBITOR SWITCH	1101	P0705	AT section
INT AIR TEMP SEN	0401	P0110	EC-98
KNOCK SENSOR	0304	P0325	EC-140
LINE PRESSURE S/V	1205	P0745	AT section
MASS AIR FLOW SEN	0102	P0100	EC-93
MULTI CYL MISFIRE	0701	P0300	EC-136
OVER HEAT	0208	P1900	EC-201
OVERRUN CLUTCH S/V	1203	P1760	AT section
PARK/NEUT POSI SW	1003	P0705	EC-176
REAR O2 SENSOR	0707	P0136	EC-126
SHIFT SOLENOID/V A	1108	P0750	AT section
SHIFT SOLENOID/V B	1201	P0755	AT section
THROTTLE POSI SEN	0403	P0120	EC-107
THRTL POSI SEN A/T	1206	P1705	AT section
TOR CONV CLUTCH SV	1204	P0740	AT section
TW CATALYST SYSTEM	0702	P0420	EC-163
VEHICLE SPEED SEN	0104	P0500	EC-166
VHCL SPEED SEN A/T	1102	P0720	AT section

\*1: These are controlled by NISSAN.

## P NO. INDEX FOR DTC

DTC		Items (CONSULT screen terms)	Reference page
CONSULT GST*2	MIL*1		
<b>P0000</b>	<b>0505</b>	<b>NO SELF DIAGNOSTIC FAILURE INDICATED</b>	—
P0100	0102	MASS AIR FLOW SEN	EC-93
P0110	0401	INT AIR TEMP SEN	EC-98
P0115	0103	COOLANT TEMP SEN	EC-103
P0120	0403	THROTTLE POSI SEN	EC-107
P0125	0908	*COOLANT TEMP SEN	EC-112
P0130	0307	CLOSED LOOP	EC-122
P0130	0303	FRONT O2 SENSOR	EC-117
P0135	0901	FR O2 SEN HEATER	EC-123
P0136	0707	REAR O2 SENSOR	EC-126
P0170	0706	FUEL INJ SYSTEM	EC-131
P0300	0701	MULTI CYL MISFIRE	EC-136
P0301	0608	CYL 1 MISFIRE	EC-136
P0302	0607	CYL 2 MISFIRE	EC-136
P0303	0606	CYL 3 MISFIRE	EC-136
P0304	0605	CYL 4 MISFIRE	EC-136
P0325	0304	KNOCK SENSOR	EC-140
P0335	0802	CRANK POS SEN (OBD)	EC-143
P0340	0101	CAMSHAFT POSI SEN	EC-147
P0400	0302	EGR SYSTEM	EC-152
P0402	0306	EGRC-BPT VALVE	EC-161
P0420	0702	TW CATALYST SYSTEM	EC-163
P0500	0104	VEHICLE SPEED SEN	EC-166
P0505	0205	IACV-AAC VALVE	EC-170
P0605	0301	ECM	EC-174
P0705	1003	PARK/NEUT POSI SW	EC-176
P0705	1101	INHIBITOR SWITCH	AT section
P0710	1208	FLUID TEMP SENSOR	AT section
P0720	1102	VHCL SPEED SEN A/T	AT section
P0725	1207	ENGINE SPEED SIG	AT section
P0731	1103	A/T 1ST SIGNAL	AT section
P0732	1104	A/T 2ND SIGNAL	AT section
P0733	1105	A/T 3RD SIGNAL	AT section
P0734	1106	A/T 4TH SIG OR TCC	AT section
P0740	1204	TOR CONV CLUTCH SV	AT section
P0745	1205	LINE PRESSURE S/V	AT section
P0750	1108	SHIFT SOLENOID/V A	AT section
P0755	1201	SHIFT SOLENOID/V B	AT section
P1320	0201	IGN SIGNAL-PRIMARY	EC-181
P1336	0905	CRANK P/S (OBD) COG	EC-186
P1400	1005	EGRC SOLENOID/V	EC-190
P1401	0305	EGR TEMP SENSOR	EC-194
P1605	0804	A/T DIAG COMM LINE	EC-198
P1705	1206	THRTL POSI SEN A/T	AT section
P1760	1203	OVERRUN CLUTCH S/V	AT section
P1900	0208	OVER HEAT	EC-201

\*2: These are prescribed by SAE J2012.

Alphabetical & P No. Index for DTC

ALPHABETICAL INDEX FOR DTC

Items (CONSULT screen terms)	DTC		Reference page
	MIL*1	CONSULT GST*2	
CAMSHAFT POSI SEN	0101	P0340	EC-372
CLOSED LOOP	0307	P0130	EC-347
COOLANT TEMP SEN	0103	P0115	EC-328
*COOLANT TEMP SEN	0908	P0125	EC-337
CRANK P/S (OBD) COG	0905	P1336	EC-416
CRANK POS SEN (OBD)	0802	P0335	EC-368
CYL 1 MISFIRE	0608	P0301	EC-361
CYL 2 MISFIRE	0607	P0302	EC-361
CYL 3 MISFIRE	0606	P0303	EC-361
CYL 4 MISFIRE	0605	P0304	EC-361
ECM	0301	P0605	EC-399
EGR SYSTEM	0302	P0400	EC-377
EGR TEMP SENSOR	0305	P1401	EC-424
EGRC SOLENOID/V	1005	P1400	EC-420
EGRC-BPT VALVE	0306	P0402	EC-386
FR O2 SEN HEATER	0901	P0135	EC-348
FRONT O2 SENSOR	0303	P0130	EC-342
FUEL INJ SYSTEM	0706	P0170	EC-356
IACV-AAC VALVE	0205	P0505	EC-395
IGN SIGNAL-PRIMARY	0201	P1320	EC-411
INT AIR TEMP SEN	0401	P0110	EC-323
KNOCK SENSOR	0304	P0325	EC-365
MASS AIR FLOW SEN	0102	P0100	EC-318
MULTI CYL MISFIRE	0701	P0300	EC-361
OVER HEAT	0208	P1900	EC-430
PARK/NEUT POSI SW	1003	P0705	EC-401
REAR O2 SENSOR	0707	P0136	EC-351
THROTTLE POSI SEN	0403	P0120	EC-332
TOR CONV CLUTCH SV	0904	P1550	EC-428
TW CATALYST SYSTEM	0702	P0420	EC-388
VEHICLE SPEED SEN	0104	P0500	EC-391
VTC SOLENOID VALVE	0805	P1110	EC-404

\*1: These are controlled by NISSAN.

P NO. INDEX FOR DTC

DTC		Items (CONSULT screen terms)	Reference page
CONSULT GST*2	MIL*1		
<b>P0000</b>	<b>0505</b>	<b>NO SELF DIAGNOSTIC FAILURE INDICATED</b>	—
P0100	0102	MASS AIR FLOW SEN	EC-318
P0110	0401	INT AIR TEMP SEN	EC-323
P0115	0103	COOLANT TEMP SEN	EC-328
P0120	0403	THROTTLE POSI SEN	EC-332
P0125	0908	*COOLANT TEMP SEN	EC-337
P0130	0307	CLOSED LOOP	EC-347
P0130	0303	FRONT O2 SENSOR	EC-342
P0135	0901	FR O2 SEN HEATER	EC-348
P0136	0707	REAR O2 SENSOR	EC-351
P0170	0706	FUEL INJ SYSTEM	EC-356
P0300	0701	MULTI CYL MISFIRE	EC-361
P0301	0608	CYL 1 MISFIRE	EC-361
P0302	0607	CYL 2 MISFIRE	EC-361
P0303	0606	CYL 3 MISFIRE	EC-361
P0304	0605	CYL 4 MISFIRE	EC-361
P0325	0304	KNOCK SENSOR	EC-365
P0335	0802	CRANK POS SEN (OBD)	EC-368
P0340	0101	CAMSHAFT POSI SEN	EC-372
P0400	0302	EGR SYSTEM	EC-377
P0402	0306	EGRC-BPT VALVE	EC-386
P0420	0702	TW CATALYST SYSTEM	EC-388
P0500	0104	VEHICLE SPEED SEN	EC-391
P0505	0205	IACV-AAC VALVE	EC-395
P0605	0301	ECM	EC-399
P0705	1003	PARK/NEUT POSI SW	EC-401
P1110	0805	VTC SOLENOID VALVE	EC-404
P1320	0201	IGN SIGNAL-PRIMARY	EC-411
P1336	0905	CRANK P/S (OBD) COG	EC-416
P1400	1005	EGRC SOLENOID/V	EC-420
P1401	0305	EGR TEMP SENSOR	EC-424
P1550	0904	TOR CONV CLUTCH SV	EC-428
P1900	0208	OVER HEAT	EC-430

\*2: These are prescribed by SAE J2012.

GI

MA

EM

LC

EC

FE

CL

MT

AT

FA

RA

BR

ST

RS

BT

HA

EL

IDX

**General Specifications**

<b>PRESSURE REGULATOR</b> Fuel pressure at idling kPa (kg/cm <sup>2</sup> , psi)	
Vacuum hose is connected	Approximately 235 (2.4, 34)
Vacuum hose is disconnected	Approximately 294 (3.0, 43)

**Inspection and Adjustment**

Idle speed*1	rpm	
No-load*2 (in "N" position)		800±50
Air conditioner: ON (in "N" position)		850 or more
Ignition timing		15°±2° BTDC
Throttle position sensor idle position	V	0.35 - 0.65

\*1: Feedback controlled and needs no adjustments

\*2: Under the following conditions:

- Air conditioner switch: OFF
- Electric load: OFF (Lights, heater fan & rear defogger)

**IGNITION COIL**

Primary voltage	V	12
Primary resistance [at 20°C (68°F)]	Ω	0.5 - 1.0
Secondary resistance [at 20°C (68°F)]	kΩ	Approximately 25

**MASS AIR FLOW SENSOR**

Supply voltage	V	Battery voltage (11 - 14)
Output voltage	V	1.3 - 1.7*
Mass air flow (Using CONSULT or GST) g/cm <sup>3</sup> /sec		2.5 - 5.0 at idle* 7.1 - 12.5 at 2,500 rpm*

\*: Engine is warmed up sufficiently and idling under no-load.

**ENGINE COOLANT TEMPERATURE SENSOR**

Temperature °C (°F)	Resistance kΩ
20 (68)	2.1 - 2.9
50 (122)	0.68 - 1.00
90 (194)	0.236 - 0.260

**EGR TEMPERATURE SENSOR**

EGR temperature °C (°F)	Voltage (V)	Resistance (MΩ)
0 (32)	4.81	7.9 - 9.7
50 (122)	2.82	0.57 - 0.70
100 (212)	0.8	0.08 - 0.10

**FRONT HEATED OXYGEN SENSOR HEATER**

Resistance [at 25°C (77°F)]	Ω	3.3 - 6.3
-----------------------------	---	-----------

**FUEL PUMP**

Resistance [at 25°C (77°F)]	Ω	Approximately 0.2 - 5.0
-----------------------------	---	-------------------------

**IACV-AAC VALVE**

Resistance [at 25°C (77°F)]	Ω	Approximately 10.0
-----------------------------	---	--------------------

**INJECTOR**

Resistance [at 25°C (77°F)]	Ω	10 - 14
-----------------------------	---	---------

**RESISTOR**

Resistance [at 25°C (77°F)]	kΩ	Approximately 2.2
-----------------------------	----	-------------------

**THROTTLE POSITION SENSOR**

Throttle valve conditions	Resistance kΩ [at 25°C (77°F)]
Completely closed	Approximately 1
Partially open	1 - 10
Completely open	Approximately 10

**Inspection and Adjustment (Cont'd)**

**CALCULATED LOAD VALUE**

	Calculated load value % (Using CONSULT or GST)
At idle	20.0 - 35.5
At 2,500 rpm	17.0 - 30.0

**INTAKE AIR TEMPERATURE SENSOR**

Temperature °C (°F)	Resistance kΩ
20 (68)	2.1 - 2.9
80 (176)	0.27 - 0.38

**REAR HEATED OXYGEN SENSOR HEATER**

Resistance [at 25°C (77°F)]	Ω	5.2 - 8.2
-----------------------------	---	-----------

**CRANKSHAFT POSITION SENSOR (OBD)**

Resistance [at 25°C (77°F)]	Ω	166 - 204
-----------------------------	---	-----------

GI

MA

EM

LC

**EC**

FE

CL

MT

AT

FA

RA

BR

ST

RS

BT

HA

EL

IDX

**General Specifications**

<b>PRESSURE REGULATOR</b>	
Fuel pressure at idling kPa (kg/cm <sup>2</sup> , psi)	
Vacuum hose is connected	Approximately 235 (2.4, 34)
Vacuum hose is disconnected	Approximately 294 (3.0, 43)

**Inspection and Adjustment**

Idle speed*1	rpm	
No-load*2	(in "N" position)	M/T models except for Canada: 675±50 rpm M/T models for Canada: 750±50 rpm A/T models: 800±50 (in "N" position)
Air conditioner: ON	(in "N" position)	900 or more
Ignition timing		8°±2° BTDC
Throttle position sensor idle position	V	0.35 - 0.65

\*1: Feedback controlled and needs no adjustments

\*2: Under the following conditions:

- Air conditioner switch: OFF
- Electric load: OFF (Lights, heater fan & rear defogger)

**IGNITION COIL**

Primary voltage	V	Battery voltage (11 - 14)
Primary resistance [at 25°C (77°F)]	Ω	Approximately 1.0
Secondary resistance [at 25°C (77°F)]	kΩ	Approximately 10.0

**MASS AIR FLOW SENSOR**

Supply voltage	V	Battery voltage (11 - 14)
Output voltage	V	1.0 - 1.7
Mass air flow (Using CONSULT or GST)	g·m/sec	1.0 - 4.0 at idle* 5.0 - 10.0 at 2,500 rpm*

\*: Engine is warmed up sufficiently and idling under no-load.

**ENGINE COOLANT TEMPERATURE SENSOR**

Temperature °C (°F)	Resistance kΩ
20 (68)	2.1 - 2.9
50 (122)	0.68 - 1.00
90 (194)	0.236 - 0.260

**EGR TEMPERATURE SENSOR**

EGR temperature °C (°F)	Voltage (V)	Resistance (MΩ)
0 (32)	4.81	7.9 - 9.7
50 (122)	2.82	0.57 - 0.70
100 (212)	0.8	0.08 - 0.10

**FUEL PUMP**

Resistance [at 25°C (77°F)]	Ω	0.2 - 5.0
-----------------------------	---	-----------

**IACV-AAC VALVE**

Resistance [at 25°C (77°F)]	Ω	50 - 100
-----------------------------	---	----------

**INJECTOR**

Resistance [at 25°C (77°F)]	Ω	10 - 14
-----------------------------	---	---------

**RESISTOR**

Resistance [at 25°C (77°F)]	kΩ	Approximately 2.2
-----------------------------	----	-------------------

**THROTTLE POSITION SENSOR**

Throttle valve conditions	Resistance [at 25°C (77°F)]
Completely closed	Approximately 0.6 kΩ
Partially open	0.6 - 4.0 kΩ
Completely open	Approximately 4.0 kΩ

**FRONT HEATED OXYGEN SENSOR HEATER**

Resistance [at 25°C (77°F)]	Ω	3.3 - 6.3
-----------------------------	---	-----------

**Inspection and Adjustment (Cont'd)**

**CALCULATED LOAD VALUE**

	Calculated load value % (Using CONSULT or GST)
At idle	15.0 - 30.0
At 2,500 rpm	13.0 - 28.0

**INTAKE AIR TEMPERATURE SENSOR**

Temperature °C (°F)	Resistance kΩ
20 (68)	2.1 - 2.9
80 (176)	0.27 - 0.38

**REAR HEATED OXYGEN SENSOR HEATER**

Resistance [at 25°C (77°F)]	Ω	
		5.2 - 8.2

**CRANKSHAFT POSITION SENSOR (OBD)**

Resistance [at 25°C (77°F)]	Ω	M/T	432 - 528
		A/T	166.5 - 203.5

GI  
MA  
EM  
LC  
**EC**  
FE  
CL  
MT  
AT  
FA  
RA  
BR  
ST  
RS  
BT  
HA  
EL  
IDX