

FRONT AXLE & FRONT SUSPENSION

SECTION **FA**

GI
MA
EM
LC
EC
FE
CL
MT
AT
FA
RA
BR
ST
RS
BT
HA
EL
IDX

CONTENTS

PRECAUTIONS AND PREPARATION	2	Components	15
Precautions	2	Disassembly	17
Special Service Tools.....	2	Inspection	19
Commercial Service Tools	3	Assembly	20
FRONT AXLE AND FRONT SUSPENSION	4	FRONT SUSPENSION	24
ON-VEHICLE SERVICE	5	Coil Spring and Strut Assembly.....	25
Front Axle and Front Suspension Parts	5	Removal And Installation	25
Front Wheel Bearing.....	6	Disassembly	25
Front Wheel Alignment	6	Inspection	25
Drive Shaft.....	7	Assembly	26
FRONT AXLE	8	Stabilizer Bar.....	26
Wheel Hub and Knuckle.....	8	Removal And Installation.....	26
Removal.....	8	Inspection	27
Installation.....	10	Transverse Link and Lower Ball Joint	27
Disassembly	10	Removal And Installation.....	27
Inspection	11	Inspection	28
Assembly	11	SERVICE DATA AND SPECIFICATIONS (SDS)	29
Drive Shaft	13	General Specifications.....	29
Removal.....	13	Inspection and Adjustment.....	29
Installation.....	14		

PRECAUTIONS AND PREPARATION

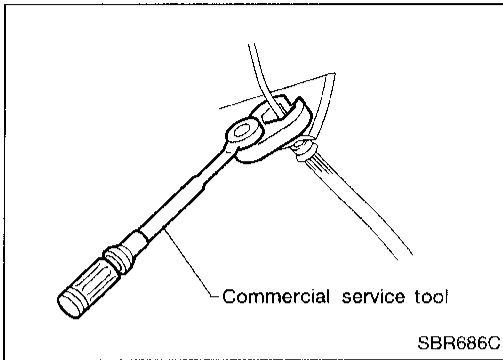

Precautions

- When installing rubber parts, final tightening must be carried out under unladen condition* with tires on ground.
- *: Fuel, radiator coolant and engine oil full. Spare tire, jack, hand tools and mats in designated positions.
- When installing suspension components, check wheel alignment and adjust if necessary.
- Use flare nut wrench when removing or installing brake tubes.
- Always torque brake lines when installing.

Special Service Tools

The actual shapes of Kent-Moore tools may differ from those of special service tools illustrated here.

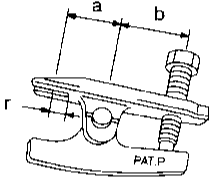
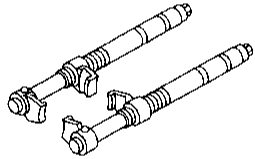
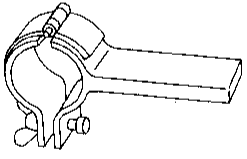
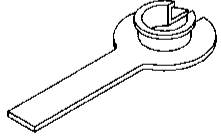
Tool number (Kent-Moore No.) Tool name	Description
HT72520000 (J25730-B) Ball joint remover NT546	 <p style="text-align: right;">Removing tie-rod and lower ball joint</p> <p style="text-align: right;">a: 33 mm (1.30 in) b: 50 mm (1.97 in) r: R11.5 mm (0.453 in)</p>
HT71780000 (—) Spring compressor NT144	 <p style="text-align: right;">Removing and installing coil spring</p>
ST35652000 (—) Strut attachment NT145	 <p style="text-align: right;">Fixing strut assembly</p>
KV38106700 (J34296-1) KV38106800 (J34297-1) Differential side oil seal protector NT147	 <p style="text-align: right;">Installing drive shaft</p> <p style="text-align: right;">LH: KV38106700 RH: KV38106800</p>

PRECAUTIONS AND PREPARATION

Commercial Service Tools

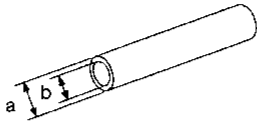
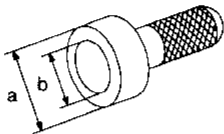
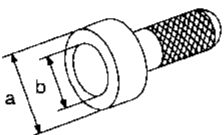
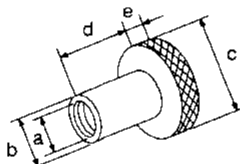
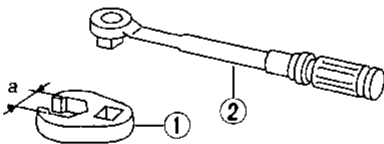
Tool name	Description	
Front wheel hub drift	 <p data-bbox="440 451 503 472">NT065</p>	<p data-bbox="1076 279 1307 300">Removing wheel hub</p> <p data-bbox="1076 430 1323 472">a: 42 mm (1.65 in) dia. b: 33 mm (1.30 in) dia.</p>
Front wheel bearing outer race drift	 <p data-bbox="440 676 503 697">NT115</p>	<p data-bbox="1076 501 1485 556">Removing and installing wheel bearing outer race</p> <p data-bbox="1076 655 1323 697">a: 76 mm (2.99 in) dia. b: 72 mm (2.83 in) dia.</p>
Grease seal drift	 <p data-bbox="440 898 503 919">NT115</p>	<p data-bbox="1076 724 1364 745">Installing outer grease seal</p> <p data-bbox="1076 877 1323 919">a: 81 mm (3.19 in) dia. b: 76 mm (2.99 in) dia.</p>
Attachment Wheel alignment	 <p data-bbox="440 1121 503 1142">NT148</p>	<p data-bbox="1076 947 1364 968">Measuring wheel alignment</p> <p data-bbox="1076 1003 1274 1113">a: Screw M22 x 1.5 b: 35 (1.38) dia. c: 65 (2.56) dia. d: 56 (2.20) e: 12 (0.47)</p> <p data-bbox="1076 1119 1226 1140">Unit: mm (in)</p>
<p data-bbox="159 1169 389 1190">① Flare nut crowfoot</p> <p data-bbox="159 1197 349 1218">② Torque wrench</p>	 <p data-bbox="440 1339 503 1360">NT360</p>	<p data-bbox="1076 1169 1453 1190">Removing and installing brake tubes</p> <p data-bbox="1076 1339 1266 1360">a: 10 mm (0.39 in)</p>

GI

MA

EM

LC

EC

FE

CL

MT

AT

FA

RA

BR

ST

RS

BT

HA

EL

IDX

FRONT AXLE AND FRONT SUSPENSION

SEC. 391 • 400 • 401

When installing rubber parts, final tightening must be carried out under unladen condition* with tires on ground.

* Fuel, radiator coolant and engine oil full. Spare tire, jack, hand tools and mats in designated positions.

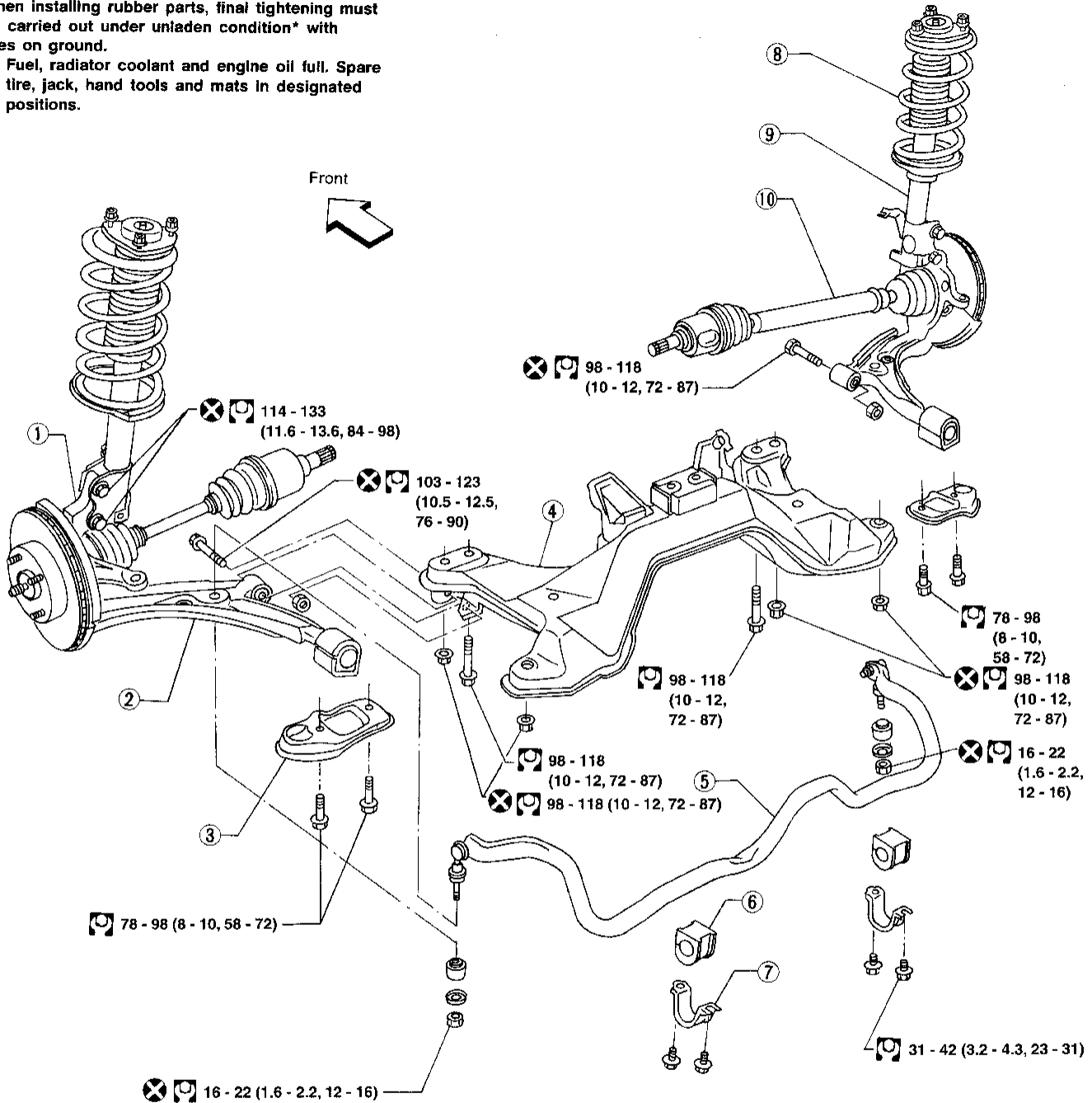

: N·m (kg-m, ft-lb)

AFA107

- ① Knuckle assembly
- ② Transverse link
- ③ Compression rod clamp
- ④ Front suspension member

- ⑤ Stabilizer bar
- ⑥ Bushing
- ⑦ Bracket

- ⑧ Coil spring
- ⑨ Strut assembly
- ⑩ Drive shaft

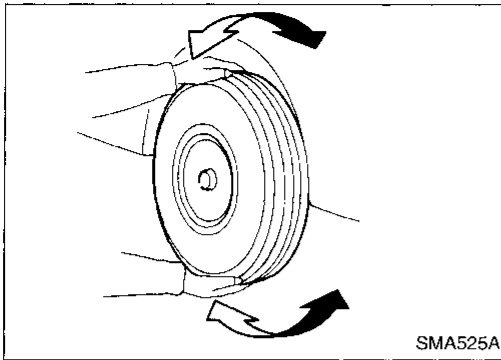

Front Axle and Front Suspension Parts

Check front axle and front suspension parts for excessive play, cracks, wear or other damage.

- Shake each front wheel to check for excessive play.
- Make sure that cotter pin is inserted.
- Retighten all nuts and bolts to the specified torque.

Tightening torque:

Refer to FA-24.

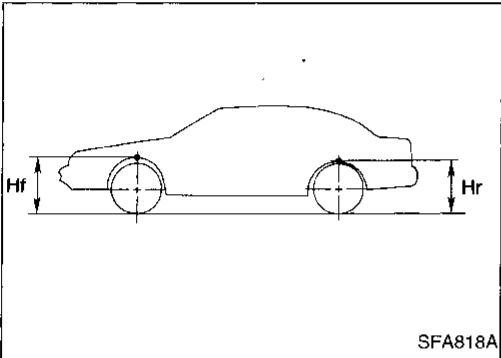

- Check spring height from top of wheelarch to ground using the following procedure.

a. Park vehicle on a level surface with vehicle unladen* .
*: Fuel, radiator coolant and engine oil full. Spare tire, jack, hand tools and mats in designated positions.

b. Check tires for proper inflation and wear (tread wear indicator must not be showing).

c. Bounce vehicle up and down several times and measure dimensions Hf and Hr. Refer to SDS, FA-30.

Spring height is not adjustable. If out of specification, check for worn springs or suspension parts.

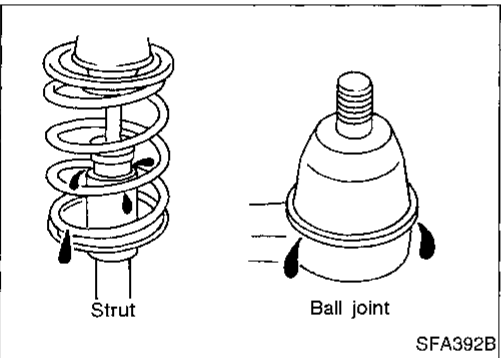

- Check strut for oil leakage or other damage.
- Check suspension ball joint for grease leakage and ball joint dust cover for cracks or other damage.

If ball joint dust cover is cracked or damaged, replace transverse link.

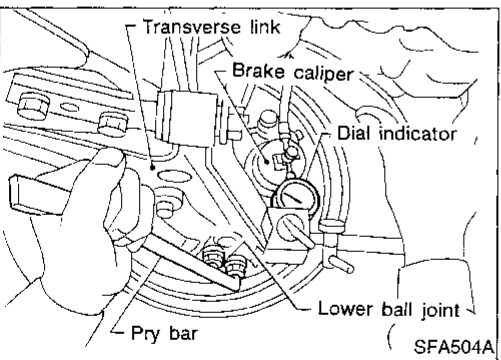

- Check suspension ball joint end play.
 - a. Jack up front of vehicle and set the stands.
 - b. Clamp dial indicator onto transverse link and place indicator tip on lower edge of brake caliper.
 - c. Make sure front wheels are straight and brake pedal is depressed.
 - d. Place a pry bar between transverse link and inner rim of road wheel.
 - e. While raising and releasing pry bar, observe maximum dial indicator value.

Vertical end play:

0 mm (0 in)

If ball joint vertical end play exists, remove transverse link and recheck the ball joint. Refer to FA-27.

GI

MA

EM

LC

EG

FE

CL

MT

AT

FA

RA

BR

ST

RS

BT

HA

EL

IDX

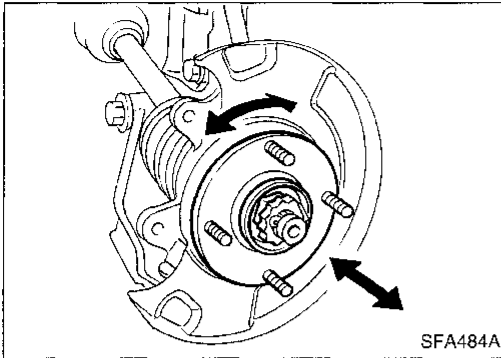

Front Wheel Bearing

- Check that wheel bearings operate smoothly.
- Check axial end play.
Axial end play:
0.05 mm (0.0020 in) or less
- If out of specification or wheel bearing does not turn smoothly, replace wheel bearing assembly. Refer to FA-8.

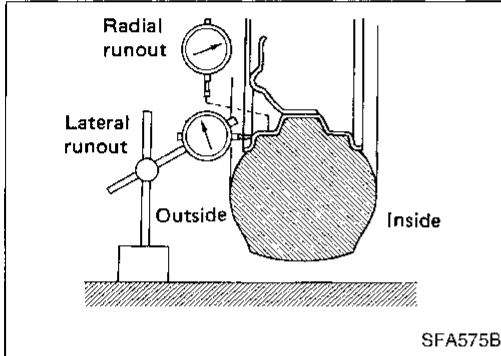

Front Wheel Alignment

Before checking front wheel alignment, be sure to make a preliminary inspection with vehicle unladen*.

*: Fuel, radiator coolant and engine oil full. Spare tire, jack, hand tools and mats in designated positions.

PRELIMINARY INSPECTION

1. Check tires for wear and improper inflation.
2. Check wheel runout.
Wheel runout:
Refer to SDS, FA-30.
3. Check front wheel bearings for looseness.
4. Check front suspension for looseness.
5. Check steering linkage for looseness.
6. Check that front struts work properly by using the standard bounce test.
7. Check vehicle posture (unladen).

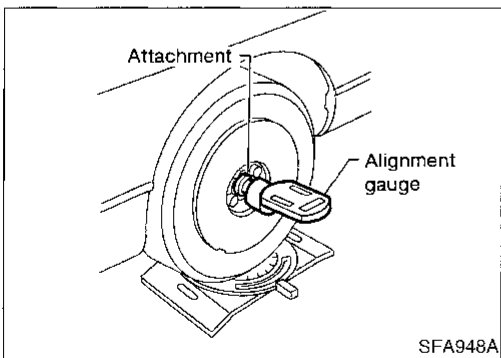

CAMBER, CASTER AND KINGPIN INCLINATION

- **Camber, caster and kingpin inclination are preset at factory and cannot be adjusted.**
1. Measure camber, caster and kingpin inclination of both right and left wheels with a suitable alignment gauge.
Camber, Caster and Kingpin inclination:
Refer to SDS, FA-29.
 2. If camber, caster and kingpin inclination are not within specification, inspect front suspension parts. Replace any damaged or worn out parts.

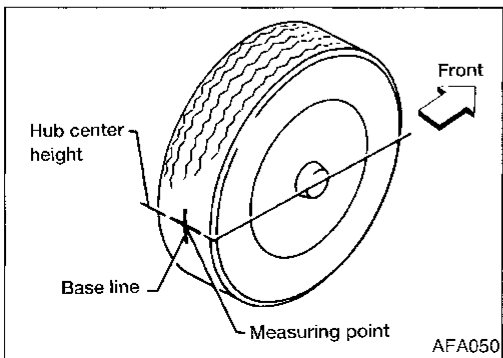

TOE-IN

- **Measure toe-in using the following procedure.**
- WARNING:**
- **Always perform the following procedure on a flat surface.**
 - **Make sure that no one is in front of the vehicle before pushing it.**
1. Bounce front of vehicle up and down to stabilize the posture.
 2. Push the vehicle straight ahead about 5 m (16 ft).
 3. Put a mark on base line of tread (rear side) of both front tires at the same height as hub center. These are measuring points.

ON-VEHICLE SERVICE

Front Wheel Alignment (Cont'd)

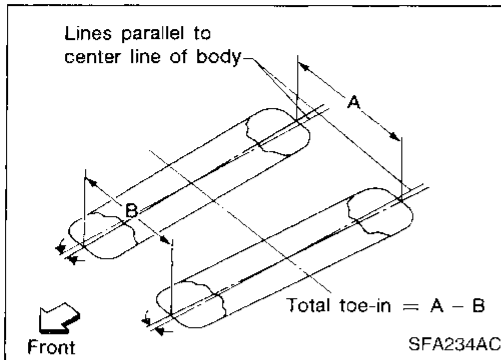

4. Measure distance "A" (rear side).
5. Push the vehicle slowly ahead to rotate the wheels 180 degrees (1/2 turn).
- If the wheels have rotated more than 180 degrees (1/2 turn), try the above procedure again from the beginning. Never push vehicle backward.
6. Measure distance "B" (front side).

Total toe-in:

Refer to SDS, FA-30.

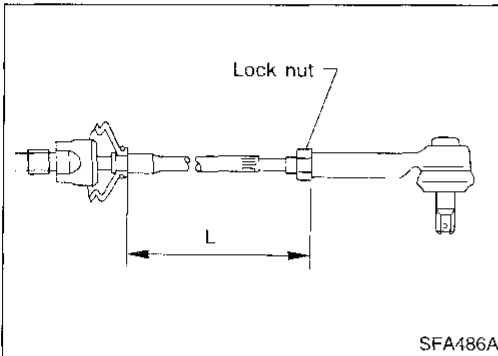

7. Adjust toe-in by varying the length of steering tie-rods.
 - a. Loosen lock nuts.
 - b. Adjust toe-in by screwing tie-rods in or out.

Standard length "L":

Refer to ST section ("General Specifications", "SDS").

- c. Tighten lock nuts to specified torque.

Ⓜ: 37 - 46 N·m (3.8 - 4.7 kg·m, 27 - 34 ft·lb)

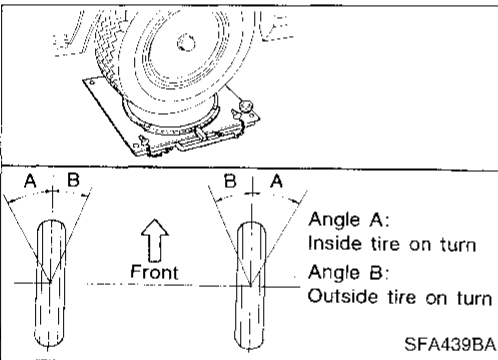

FRONT WHEEL TURNING ANGLE

1. Set wheels in straight-ahead position. Move vehicle forward until front wheels rest on turning radius gauge.
2. Rotate steering wheel all the way right and left; measure turning angle.
- On power steering models, turn steering wheel to full lock and apply force (at circumference of steering wheel) of 98 to 147 N (10 to 15 kg, 22 to 33 lb) with engine at idle.
- **Do not hold the steering wheel at full lock for more than 15 seconds.**

Wheel turning angle (Full turn):

Refer to SDS, FA-29.

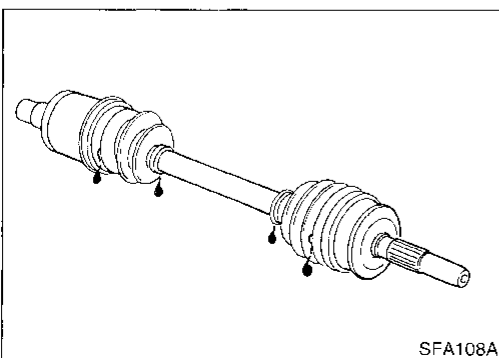

Drive Shaft

Check for grease leakage and other damage.

GI
MA
EM
LC
EC
FE
CL
MT
AT
FA
RA
BR
ST
RS
BT
HA
EL
DX

FRONT AXLE

SEC. 400

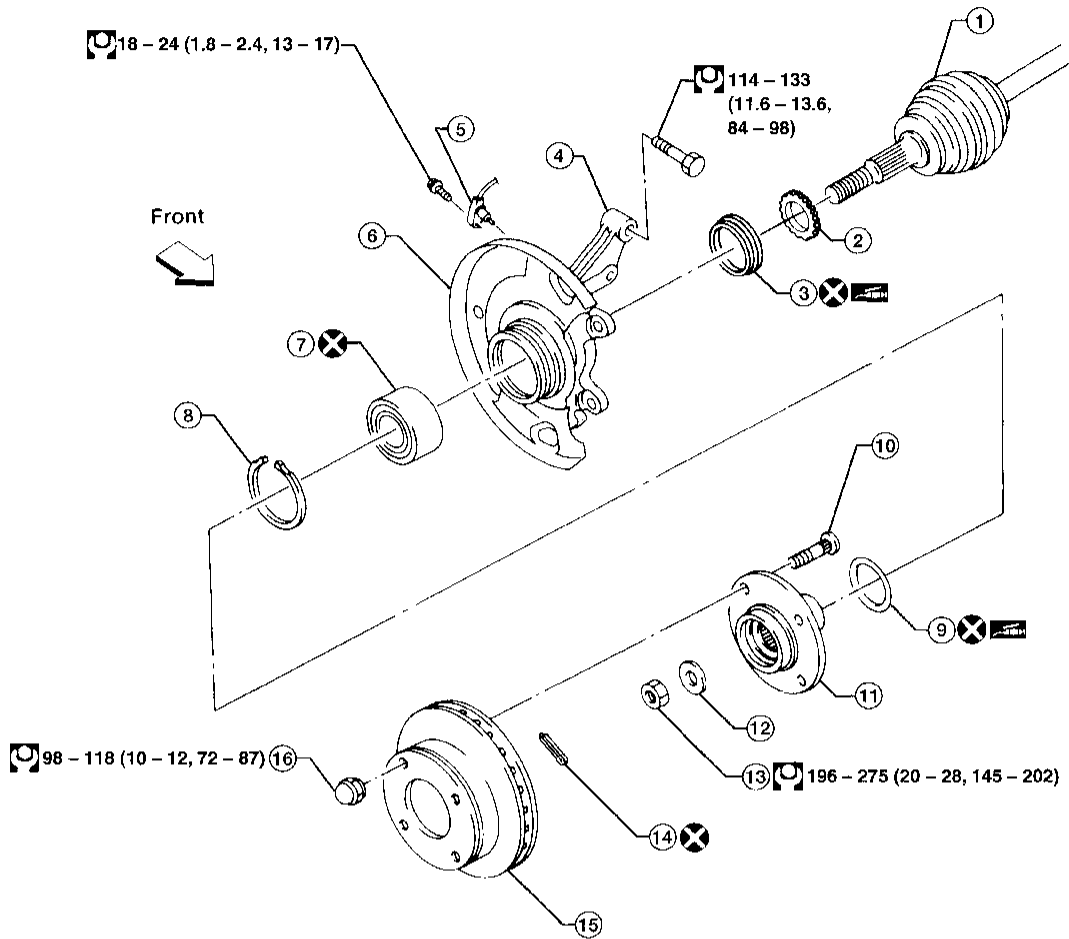

: N·m (kg-m, ft-lb)

AFA108

- | | | |
|---------------------|--------------------------|--------------------------|
| ① Drive shaft | ⑦ Wheel bearing assembly | ⑬ Wheel bearing lock nut |
| ② ABS sensor rotor | ⑧ Snap ring | ⑭ Cotter pin |
| ③ Inner grease seal | ⑨ Outer grease seal | ⑮ Disc rotor |
| ④ Knuckle | ⑩ Wheel bolt | ⑯ Wheel nut |
| ⑤ ABS sensor | ⑪ Wheel hub | |
| ⑥ Baffle plate | ⑫ Plain washer | |

Wheel Hub and Knuckle

REMOVAL

CAUTION:

Before removing front axle assembly, disconnect the ABS wheel sensor from the assembly. Move it away from the front axle assembly area.

Failure to do so may result in damage to sensor wires and the sensor becoming inoperative.

1. Remove wheel bearing lock nut.

FRONT AXLE

Wheel Hub and Knuckle (Cont'd)

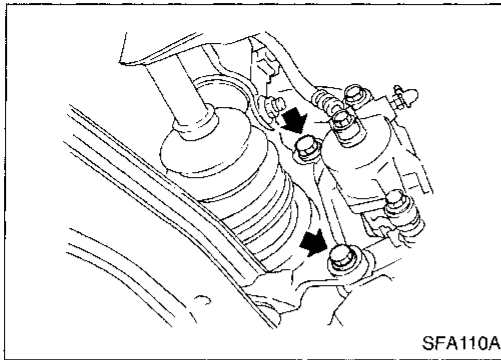

2. Remove brake caliper assembly and rotor.
 - **Brake hose need not be disconnected from brake caliper.**
Suspend brake caliper with wire so as not to stretch brake hose.
 - **Be careful not to depress brake pedal, or caliper piston will pop out.**
 - **Make sure brake hose is not twisted.**

GI

MA

EM

LC

EC

FE

CL

MT

AT

FA

RA

BR

ST

RS

BT

HA

EL

IDX

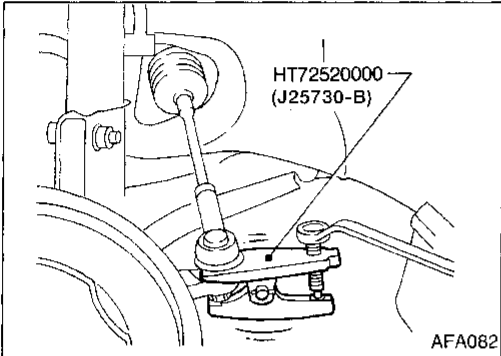

3. Separate tie-rod from knuckle with Tool.
 - **Install stud nut on stud bolt to prevent damage to stud bolt.**

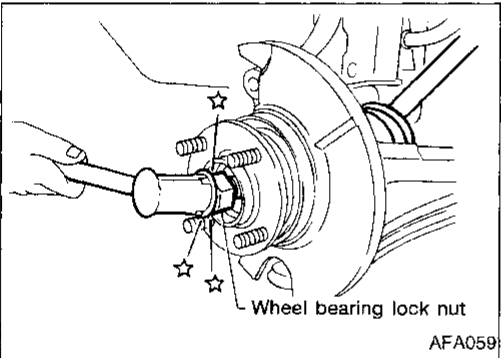

4. Separate drive shaft from knuckle by lightly tapping it. If it is hard to remove, use a puller.
 - **When removing drive shaft, cover boots with a shop towel to prevent damage to them.**

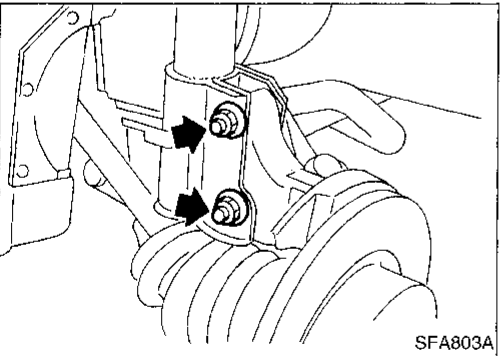

5. Remove strut lower mounting bolts.

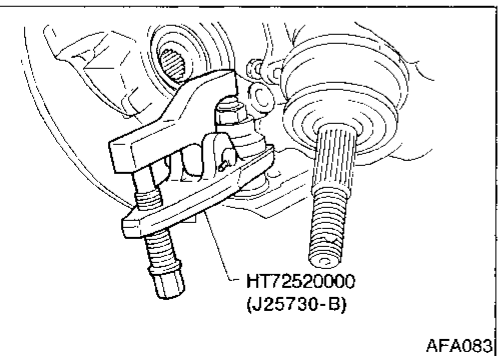

6. Loosen lower ball joint tightening nut.
7. Separate knuckle from lower ball joint stud with Tool.
8. Remove knuckle from transverse link.

FRONT AXLE

Wheel Hub and Knuckle (Cont'd)

INSTALLATION

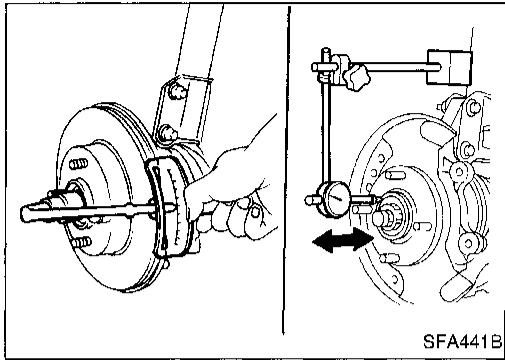

1. Install knuckle with wheel hub.
 - Replace strut lower mounting nuts.
 - **When installing knuckle to strut, be sure to hold bolts while tightening nuts.**
 - ☞: 114 - 133 N·m
(11.6 - 13.6 kg-m, 84 - 98 ft-lb)
 - **Apply oil to threaded portion of drive shaft and both sides of plain washer.**
2. Tighten wheel bearing lock nut.
 - ☞: 196 - 275 N·m
(20 - 28 kg-m, 145 - 202 ft-lb)
3. Check wheel bearing axial end play.
Axial end play:
0.05 mm (0.0020 in) or less

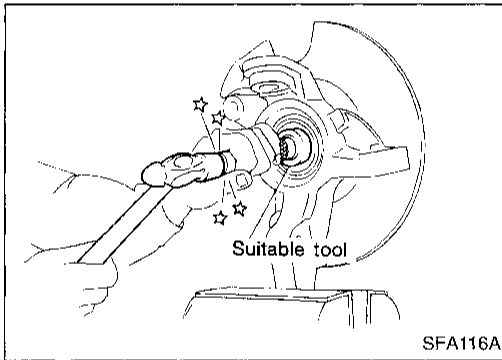

DISASSEMBLY

CAUTION:

- When removing wheel hub or wheel bearing from knuckle, replace wheel bearing assembly (outer race, inner race and grease seals) with a new one.
- **Wheel bearing does not require maintenance. If any of the following symptoms are noted, replace wheel bearing assembly.**
- Growling noise is emitted from wheel bearing during operation.
- Wheel bearing drags or turns roughly. This occurs when turning hub by hand after bearing lock nut is tightened to specified torque.

Wheel hub

Drive out wheel hub with inner race from knuckle with a suitable tool.

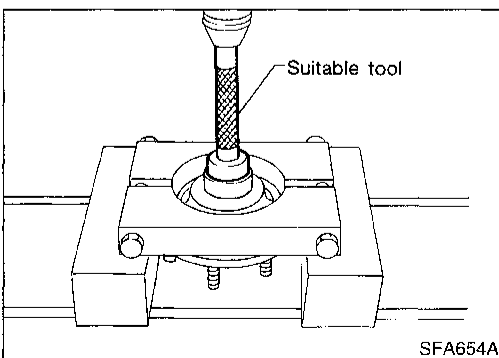

Wheel bearing

- **When replacing wheel bearing, replace wheel bearing assembly (including inner and outer races).**
1. Remove bearing inner race, then remove outer grease seal.

Wheel Hub and Knuckle (Cont'd)

2. Remove inner grease seal from knuckle.

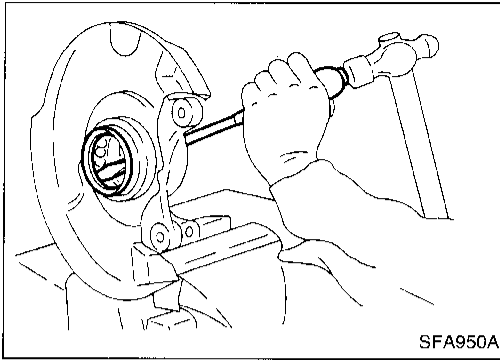

3. Remove snap ring.

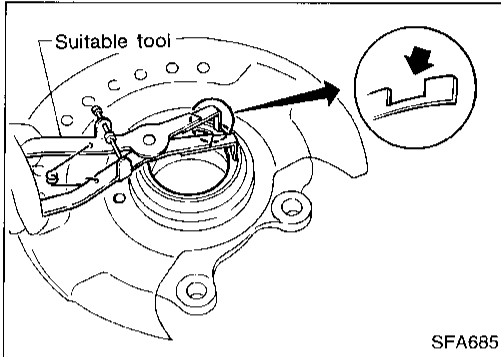

4. Press out bearing outer race.

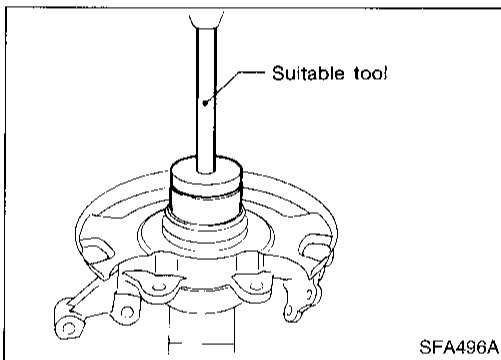

INSPECTION

Wheel hub and knuckle

Check wheel hub and knuckle for cracks by using a magnetic exploration or dyeing test.

Snap ring

Check snap ring for wear or cracks. Replace if necessary.

ASSEMBLY

1. Press new wheel bearing assembly into knuckle.

Maximum load P:

29 kN (3 ton, 3.3 US ton, 3.0 Imp ton)

CAUTION:

- Do not press on inner race of wheel bearing assembly.
- Do not apply oil or grease to mating surfaces of wheel bearing outer race and knuckle.

2. Install snap ring into groove of knuckle.

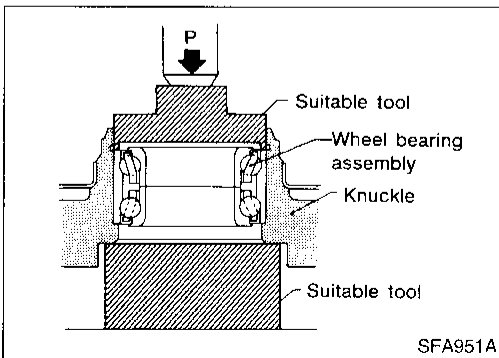

GI

MA

EM

LC

EC

FE

CL

MT

AT

FA

RA

BR

ST

RS

BT

HA

EL

IDX

FRONT AXLE

Wheel Hub and Knuckle (Cont'd)

3. Pack grease seal lip with multi-purpose grease.

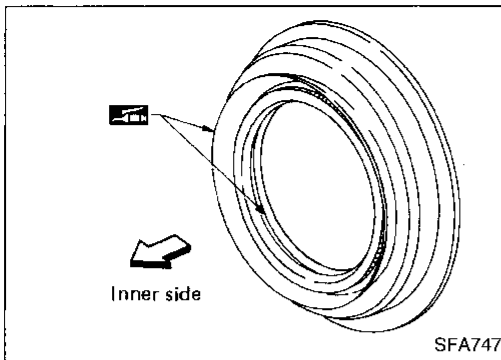

4. Install outer grease seal.
Maximum load P:
10 kN (1 ton, 1.1 US ton, 1.0 Imp ton)

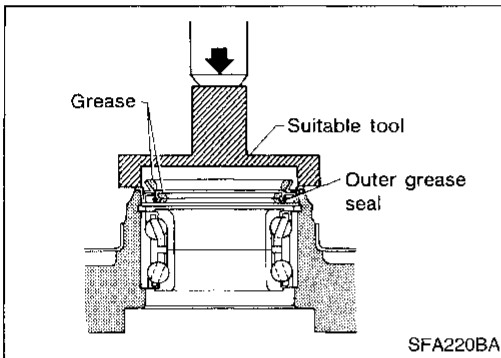

5. Install inner grease seal.
Maximum load P:
10 kN (1 ton, 1.1 US ton, 1.0 Imp ton)

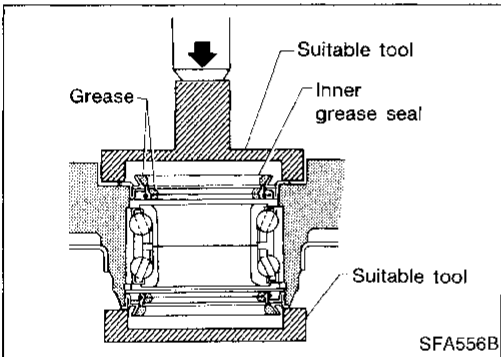

6. Press wheel hub into knuckle.
Maximum load P:
29 kN (3 ton, 3.3 US ton, 3.0 Imp ton)

 - Be careful not to damage grease seal.

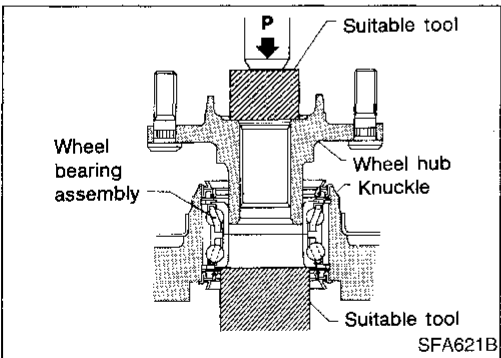

7. Check bearing operation.
 - a. Add load P with press.
Load P:
34.3 - 49.0 kN
(3.5 - 5.0 ton, 3.9 - 5.5 US ton, 3.44 - 4.92 Imp ton)

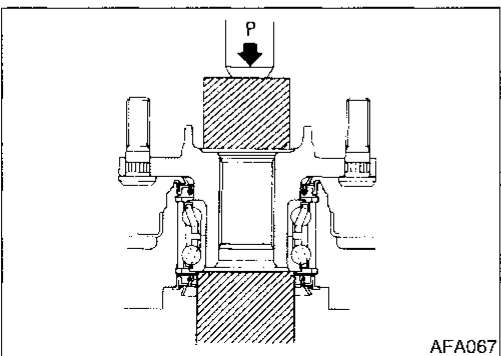

FRONT AXLE

Wheel Hub and Knuckle (Cont'd)

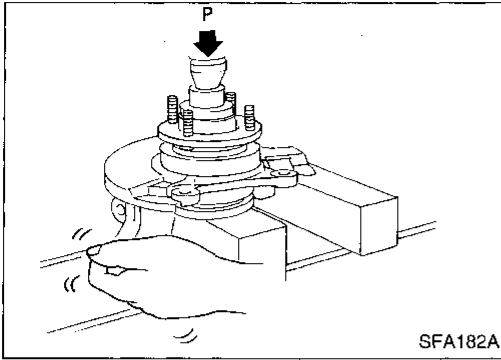

- b. Spin knuckle several turns in both directions.
- c. Make sure that wheel bearing operates smoothly.

GI

MA

EM

LC

EC

FE

CL

MT

AT

FA

RA

BR

ST

RS

BT

HA

EL

IDX

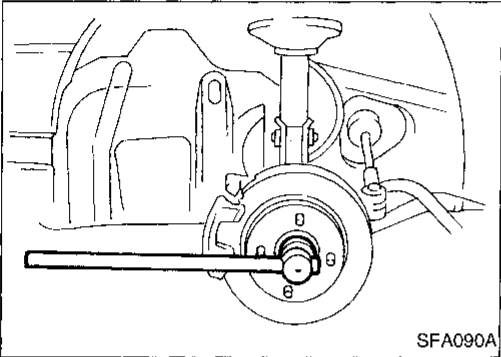

Drive Shaft

REMOVAL

1. Remove wheel bearing lock nut.
 - Tie-rod does not need to be disconnected from knuckle.
 - Suspend knuckle with wire so as not to stretch brake hose.
 - Do not pull or twist brake hose.
2. Remove clip and separate brake hose from strut.
3. Remove strut lower mounting bolts.
4. Separate drive shaft from knuckle by lightly tapping it. If it is hard to remove, use a puller.
 - When removing drive shaft, cover boots with shop towel to prevent damage to them.

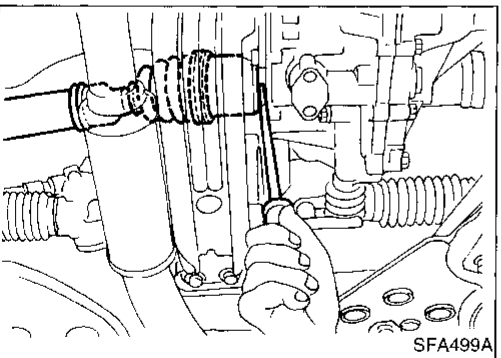
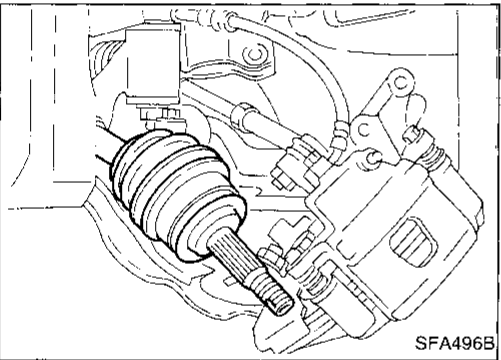

5. Remove right drive shaft from transaxle.
 - Models without support bearing —
 - Pry drive shaft from transaxle as shown.

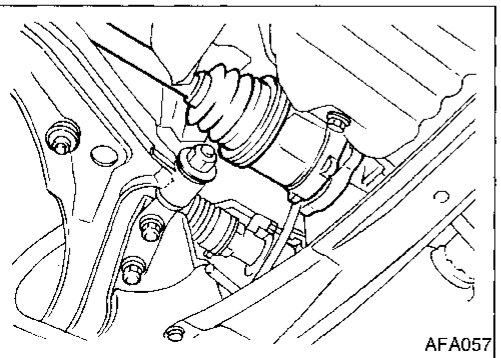

- Models with support bearing —
 - Remove support bearing bolts and pull drive shaft from transaxle.

FRONT AXLE

Drive Shaft (Cont'd)

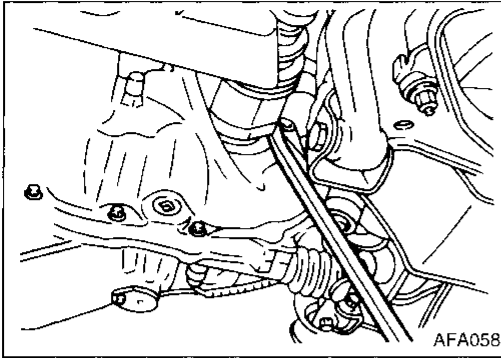

6. Remove left drive shaft from transaxle.
— **For M/T models** —
 - Pry drive shaft from transaxle as shown.

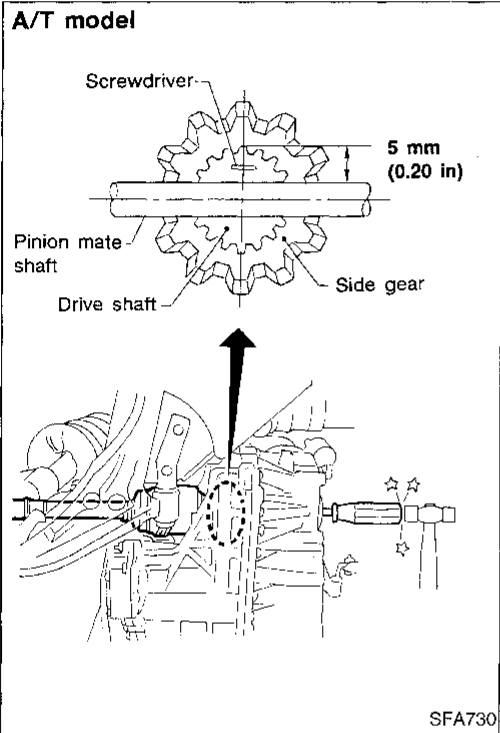

— For A/T models —

- Insert screwdriver into transaxle opening for right drive shaft and strike with a hammer.
- **Be careful not to damage pinion mate shaft and side gear.**

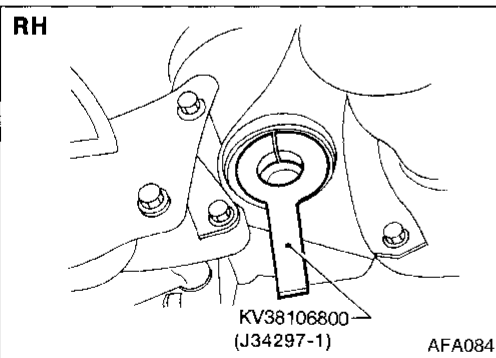

INSTALLATION

Transaxle side

1. Drive a new oil seal to transaxle. Refer to MT or AT section ("Differential Side Oil Seal Replacement", "ON-VEHICLE SERVICE").
2. Set Tool along the inner circumference of oil seal.

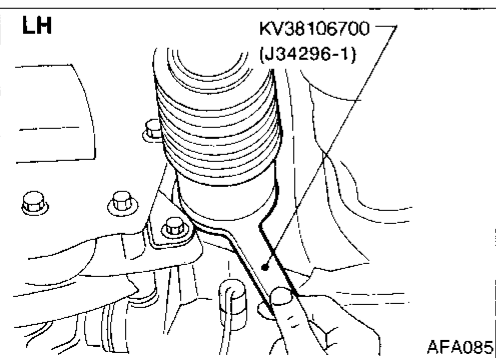

3. Insert drive shaft into transaxle. Be sure to properly align the serrations and then withdraw Tool.
4. Push drive shaft, then press-fit circular clip on the drive shaft into circular clip groove of side gear.
5. After its insertion, try to pull the slide joint out of the transaxle by hand. If it pulls out, the circular clip is not properly meshed with the side gear.

Wheel side

1. Install drive shaft into knuckle.
2. Tighten wheel bearing lock nut. Refer to FA-8.

FRONT AXLE

Drive Shaft (Cont'd)

COMPONENTS

CAUTION:

- Circular clips should be properly meshed with differential side gear (transaxle side) and with joint assembly (wheel side). Make sure they will not come out.
- Be careful not to damage boots. Use suitable protector or cloth during removal and installation.

GA16DE model

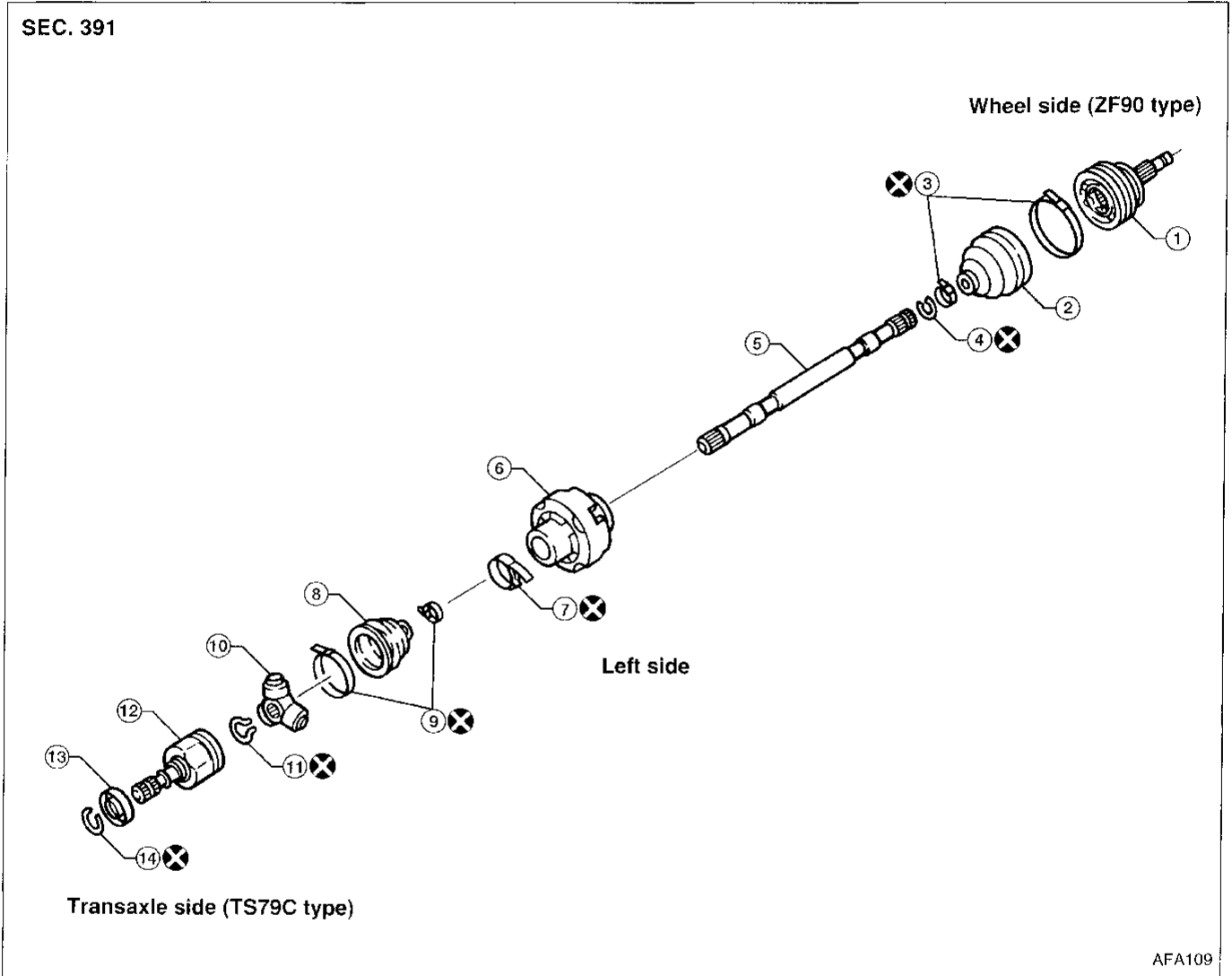

- | | | |
|------------------|-----------------------|-----------------------|
| ① Joint assembly | ⑥ Dynamic damper | ⑪ Snap ring |
| ② Boot | ⑦ Dynamic damper band | ⑫ Slide joint housing |
| ③ Boot band | ⑧ Boot | ⑬ Dust shield |
| ④ Circular clip | ⑨ Boot band | ⑭ Circular clip |
| ⑤ Drive shaft | ⑩ Spider assembly | |

FRONT AXLE

Drive Shaft (Cont'd)

SR20DE model

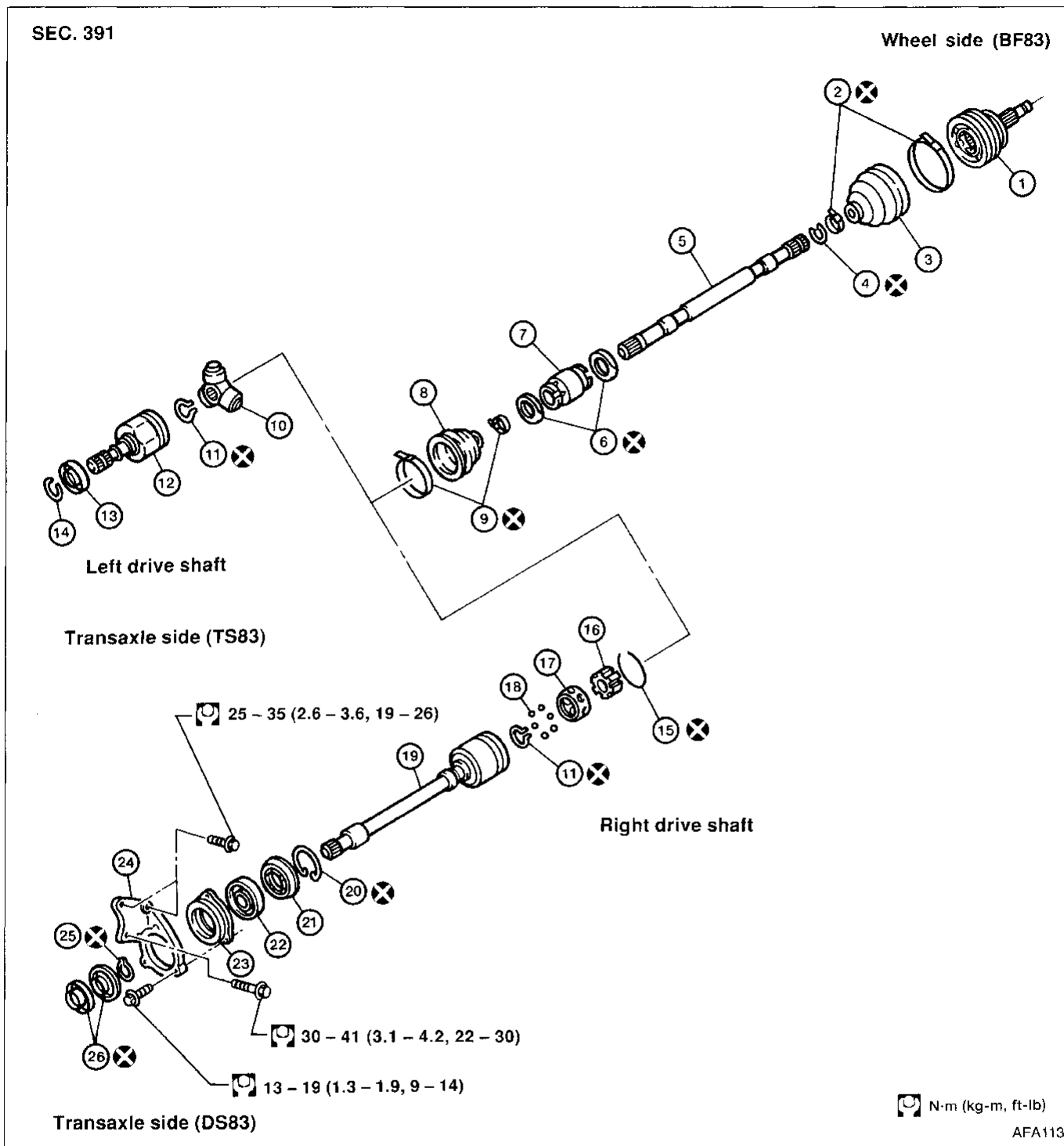

- ① Joint assembly
- ② Boot band
- ③ Boot
- ④ Circular clip B
- ⑤ Drive shaft
- ⑥ Band
- ⑦ Dynamic damper
- ⑧ Boot
- ⑨ Boot band

- ⑩ Spider assembly
- ⑪ Snap ring C
- ⑫ Slide joint housing
- ⑬ Dust shield
- ⑭ Circular clip A
- ⑮ Snap ring A
- ⑯ Inner race
- ⑰ Cage
- ⑱ Ball

- ⑲ Slide joint housing with extension shaft
- ⑳ Snap ring E
- ㉑ Dust shield
- ㉒ Support bearing
- ㉓ Support bearing retainer
- ㉔ Bracket
- ㉕ Snap ring D
- ㉖ Dust shield

FRONT AXLE

Drive Shaft (Cont'd)

DISASSEMBLY

Transaxle side (TS79C, TS83 type)

1. Remove boot bands.
2. Put matching marks on slide joint housing and drive shaft before separating joint assembly.
3. Put matching marks on spider assembly and drive shaft.

GI

MA

EM

LC

EC

FE

CL

MT

AT

FA

RA

BR

ST

RS

BT

HA

EL

IDX

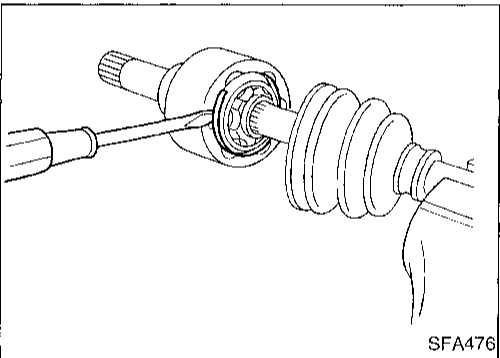
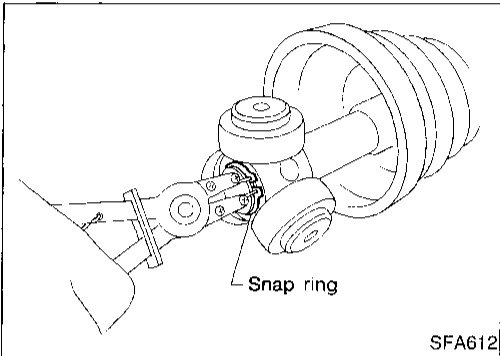
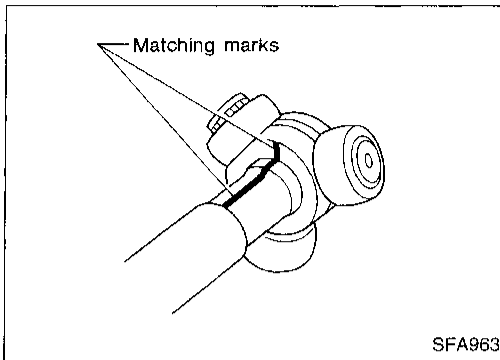

4. Remove snap ring, then remove spider assembly.

CAUTION:

Do not disassemble spider assembly.

5. Draw out boot.
- Cover drive shaft serration with tape to prevent damage to the boot.

Transaxle side (DS83 type)

1. Remove boot bands.
2. Put matching marks on slide joint housing and inner race, before separating joint assembly.
3. Pry off snap ring "A" with a screwdriver, and pull out slide joint housing.

4. Put matching marks on inner race and drive shaft.
 5. Remove snap ring "C", then remove ball cage, inner race and balls as a unit.
 6. Draw out boot.
- Cover drive shaft serrations with tape to prevent damage to the boot.

Wheel side

CAUTION:

The joint on the wheel side cannot be disassembled.

1. Before separating joint assembly, put matching marks on drive shaft and joint assembly.
 2. Separate joint assembly with a suitable tool.
- Be careful not to damage threads on drive shaft.
3. Remove boot bands.

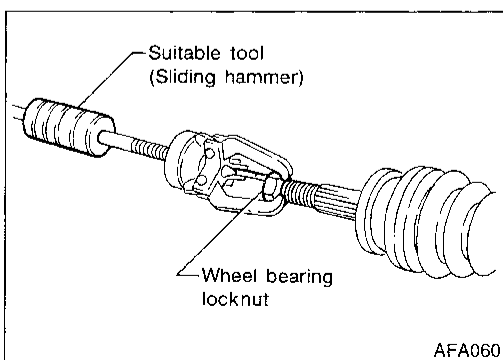

FRONT AXLE

Drive Shaft (Cont'd)

Support bearing

1. Remove dust shield.

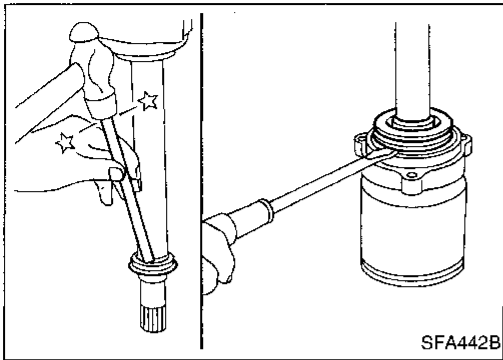

2. Remove snap ring.

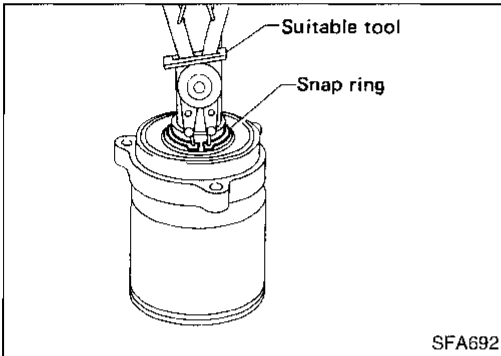

3. Press support bearing assembly off of drive shaft.

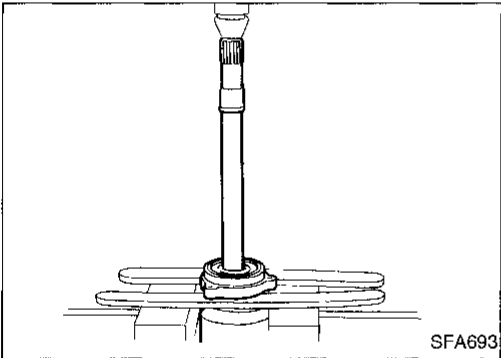

4. Remove snap ring.
5. Remove dust shield.
6. Separate support bearing from retainer.

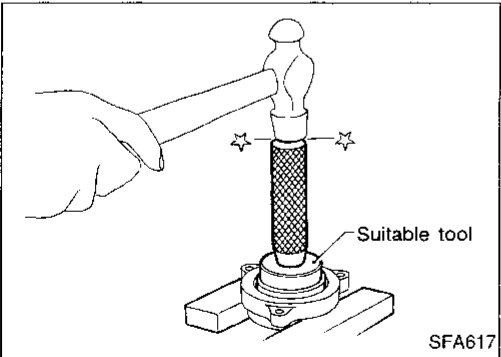

FRONT AXLE

Drive Shaft (Cont'd)

INSPECTION

Thoroughly clean all parts in cleaning solvent, then dry with compressed air. Check parts for evidence of deformation and other damage.

Drive shaft

Replace drive shaft if it is twisted or cracked.

Boot

Check boot for fatigue, cracks and wear. Replace boot with new boot bands.

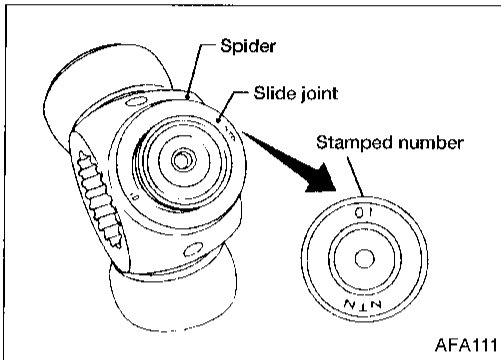

Joint assembly (Transaxle side)

TS790 type

- Check spider assembly for needle bearing and washer damage. Replace if necessary.
- Check roller surfaces for scratches, wear and other damage. Replace if necessary.
- Check serration for deformation. Replace if necessary.
- Check slide joint housing for any damage. Replace if necessary.
- When replacing only spider assembly, select a new spider assembly from among those listed in table below. Ensure that the number stamped on slide joint is the same as that stamped on new part.

Housing alone cannot be replaced. It must be replaced together with spider assembly.

Stamped number	Part No.
01	39720-61E01
02	39720-61E02
03	39720-61E03
04	39720-61E04
05	39720-61E05
06	39720-61E06
07	39720-61E07

TS83 type

- Check slide joint assembly for needle bearing, slide joint spider and washer damage. Replace if necessary.
- Check roller surfaces for scratches, wear and other damage. Replace slide joint assembly if necessary.

DS83 type

- Replace any parts of double offset joint which show signs of scorching, rust, wear or excessive play.
- Check serration for deformation. Replace if necessary.
- Check slide joint housing for any damage. Replace if necessary.

Joint assembly (Wheel side)

Replace joint assembly if it is deformed or damaged.

Support bearing

Make sure support bearing rolls freely and is free from noise, cracks, pitting and wear.

FRONT AXLE

Drive Shaft (Cont'd)

Support bearing bracket

Check support bearing bracket for cracks with a magnetic exploration or dyeing test.

ASSEMBLY

- After drive shaft has been assembled, ensure that it moves smoothly over its entire range without binding.
- Use **NISSAN GENUINE GREASE** or equivalent after every overhaul.

Support bearing

1. Install bearing into retainer.

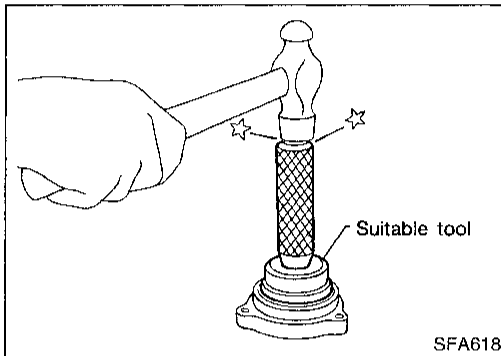

2. Install dust shield.
3. Install snap ring.
4. Press drive shaft into bearing.

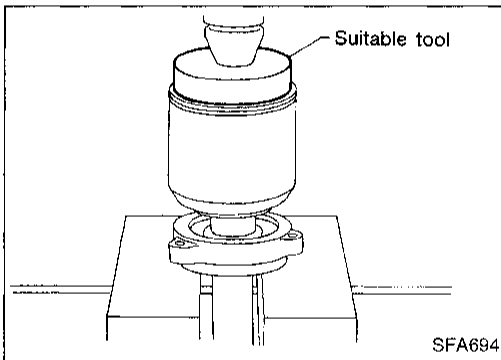

5. Install snap ring.
6. Install new dust shield.

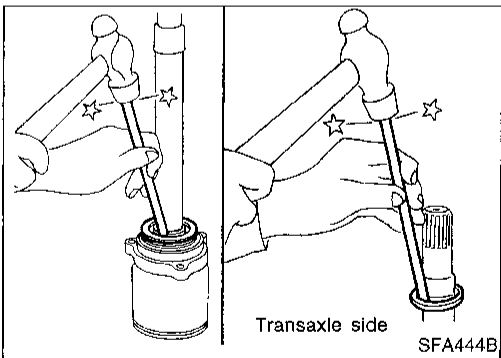

Wheel side

1. Install boot and new small boot band on drive shaft.
- **Cover drive shaft serration with tape to prevent damage to boot during installation.**

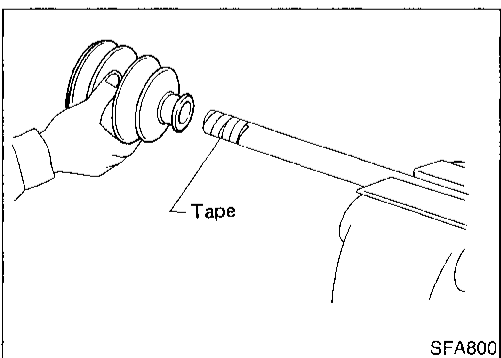

FRONT AXLE

Drive Shaft (Cont'd)

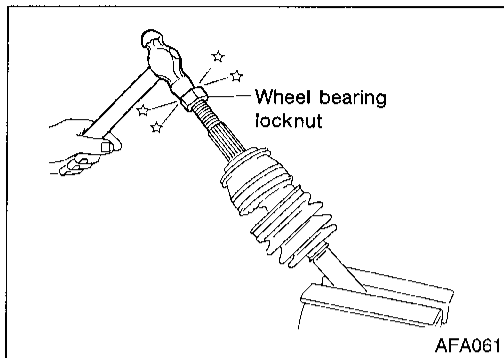

- Set joint assembly onto drive shaft by lightly tapping it. Ensure that marks which were made during disassembly are properly aligned.

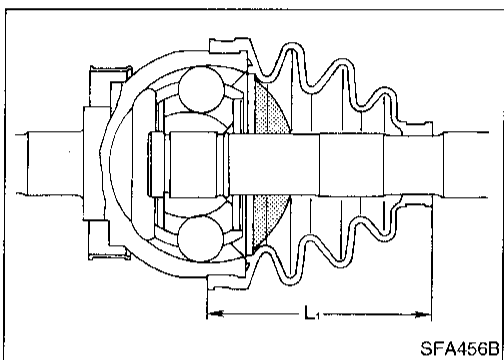

- Pack drive shaft with specified amount of grease.

Specified amount of grease:

ZF90 115 - 125 g (4.06 - 4.41 oz)

BF83 85 - 105 g (3.00 - 3.70 oz)

- Make sure that boot is properly installed on the drive shaft groove.

Set boot so that it does not swell and deform when its length is "L₁".

Length "L₁":

ZF90 96 - 98 mm (3.78 - 3.86 in)

BF83 95 mm (3.74 in)

- Lock new larger and smaller boot bands securely with a suitable tool.

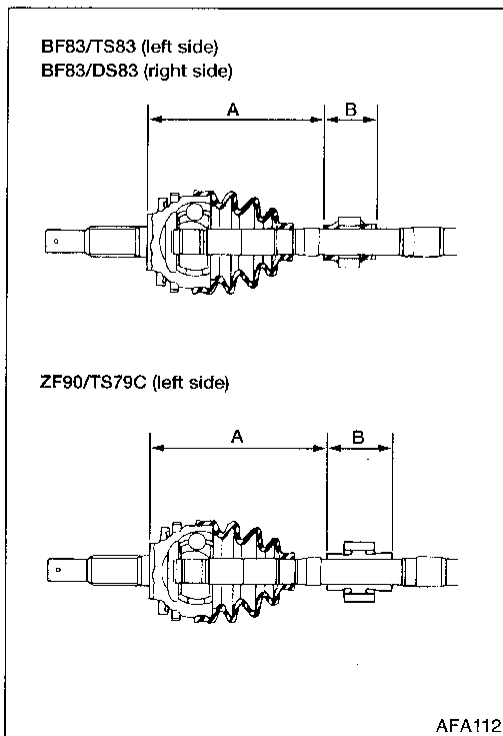
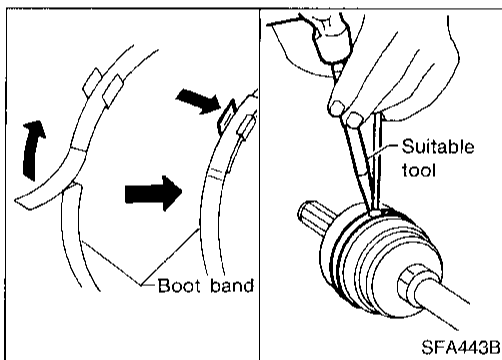

Dynamic damper

- Use a new damper band when reinstalling.
- Install dynamic damper from stationary-joint side while holding it securely:

Length:

Unit: mm (in)

	ZF90/TS79C	BF83/TS83, DS83		
	LH	RH	LH	
			A/T	M/T
"A"	175.3 - 185.3 (6.90 - 7.30)	169 - 175 (6.65 - 6.89)	154.8 - 160.8 (6.09 - 6.33)	
"B"	58 (2.28)	70 (2.76)	50 (1.97)	70 (2.76)

FRONT AXLE

Drive Shaft (Cont'd)

Transaxle side (TS79C, TS83 type)

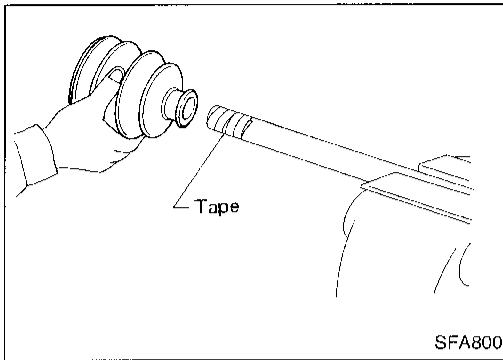

1. Install boot and new small boot band on drive shaft.
 - **Cover drive shaft serration with tape to prevent damage to boot during installation.**

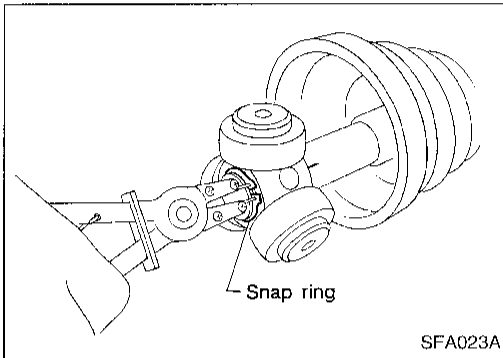

2. Install spider assembly securely, making sure the matching marks which were made during disassembly are properly aligned.
3. Install new snap ring.

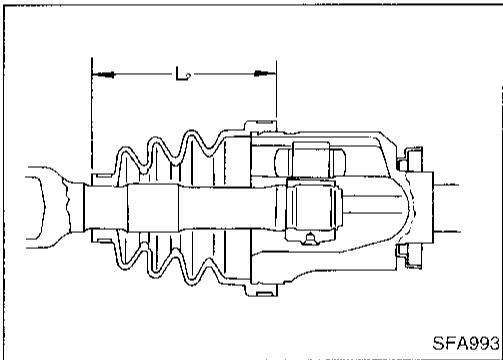

4. Pack drive shaft with specified amount of grease.
 - Specified amount of grease:**
 - TS79C 155 - 165 g (5.47 - 5.82 oz)**
 - TS83 130 - 150 g (4.59 - 5.29 oz)**
5. Install slide joint housing.
6. Set boot so that it does not swell and deform when its length is "L₂".
 - Length "L₂":**
 - TS79C 101.5 - 103.5 mm (4.00 - 4.07 in)**
 - TS83 99 mm (3.90 in)**
 - **Make sure that boot is properly installed on the drive shaft groove.**

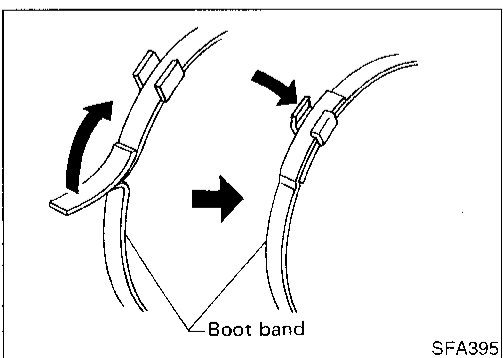

7. Lock new larger and smaller boot bands securely with a suitable tool.

FRONT AXLE

Drive Shaft (Cont'd)

Transaxle side (DS83 type)

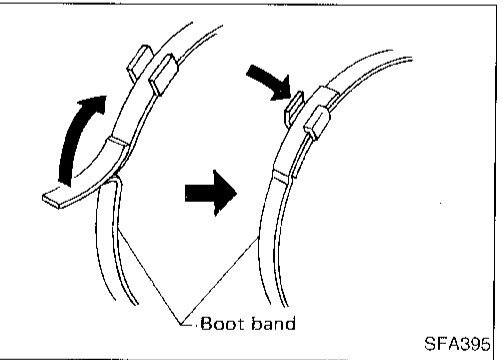
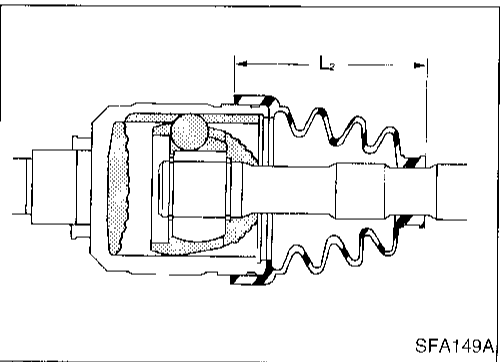
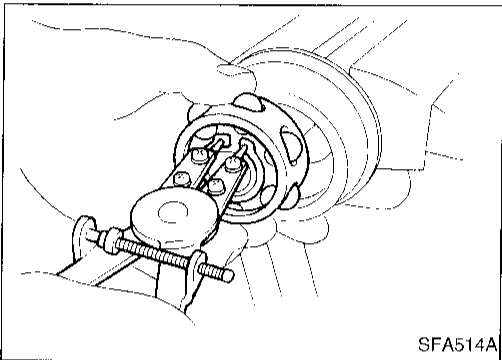
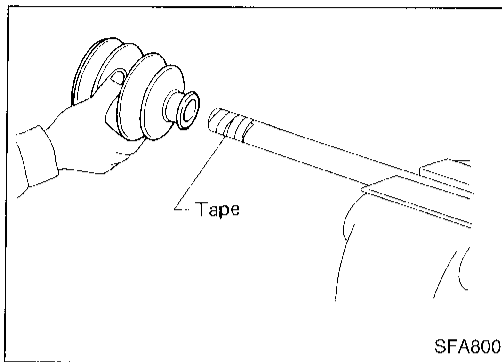

1. Install boot and new small boot band on drive shaft.
 - **Cover drive shaft serration with tape to prevent damage to boot during installation.**

2. Install ball cage, inner race and balls as a unit, making sure the matching marks which were made during disassembly are properly aligned.
3. Install new snap ring "C".

4. Pack drive shaft with specified amount of grease.

Specified amount of grease:

115 - 135 g (4.06 - 4.76 oz)

5. Install slide joint housing, then install new snap ring "A".
6. Make sure that boot is properly installed on the drive shaft groove.
Set boot so that it does not swell and deform when its length is "L₂".

Length "L₂":

98 mm (3.86 in)

7. Lock new larger and smaller boot bands securely with a suitable tool.

GI

MA

EM

LC

EC

FE

CL

MT

AT

FA

RA

BR

ST

RS

BT

HA

EL

IDX

FRONT SUSPENSION

SEC. 391-400-401

When installing rubber parts, final tightening must be carried out under unladen condition* with tires on ground.

* Fuel, radiator coolant and engine oil full.
Spare tire, jack, hand tools and mats in designated positions.

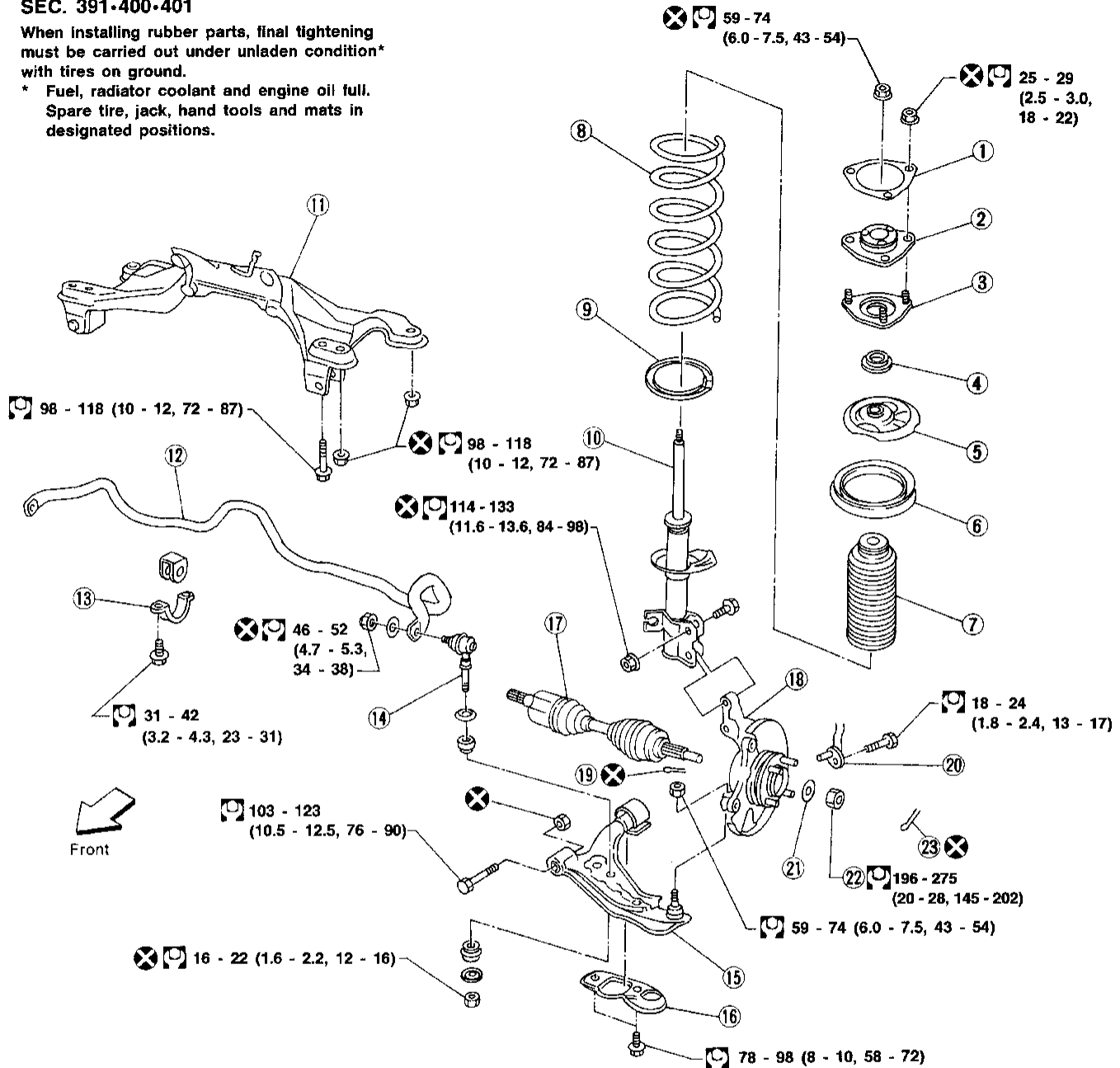

- ① Spacer
- ② Strut mounting insulator
- ③ Strut mounting insulator bracket
- ④ Thrust bearing
- ⑤ Upper spring seat
- ⑥ Upper spring rubber seat
- ⑦ Bumper rubber
- ⑧ Coil spring

- ⑨ Lower spring rubber seat
- ⑩ Strut assembly
- ⑪ Suspension member
- ⑫ Stabilizer bar
- ⑬ Stabilizer clamp
- ⑭ Connecting rod
- ⑮ Transverse link
- ⑯ Compression rod clamp

- ⑰ Drive shaft
- ⑱ Knuckle
- ⑲ Cotter pin
- ⑳ ABS sensor
- ㉑ Plain washer
- ㉒ Wheel bearing lock nut
- ㉓ Cotter pin

FRONT SUSPENSION

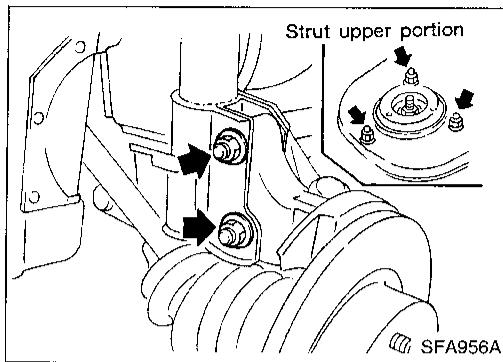

Coil Spring and Strut Assembly

REMOVAL AND INSTALLATION

- Remove strut assembly fixing bolts and nuts (to hood ledge).

WARNING:

Do not remove piston rod lock nut on vehicle.

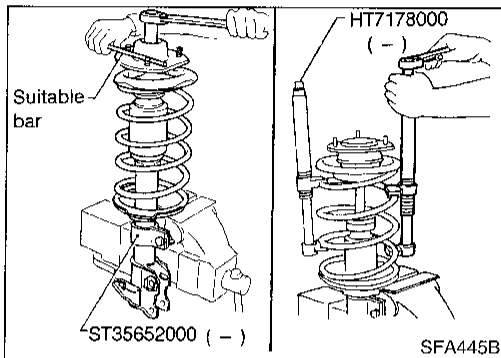

DISASSEMBLY

1. Set strut assembly on vise with Tool, then **loosen** piston rod lock nut.

WARNING:

Do not remove piston rod lock nut at this time.

2. Compress spring with Tool so that the strut mounting insulator can be turned by hand.
3. Remove piston rod lock nut.

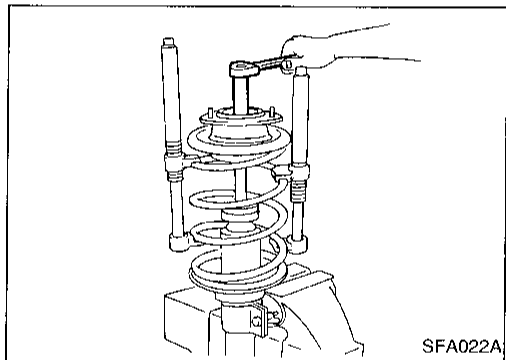

INSPECTION

Strut assembly

- Check both compression and extension for smooth operation through a full stroke.
- Check for oil leakage occurring on welded or gland packing portion.
- Check piston rod for cracks, deformation and other damage.
- Replace if necessary.

Strut mounting insulator

- Check cemented rubber-to-metal portion for separation and cracks.
- Check rubber parts for deterioration.

Thrust bearing

- Check thrust bearing parts for abnormal noise or excessive rattle in axial direction.
- Replace if necessary.

Coil spring and insulator

- Check for cracks, deformation and other damage. Replace if necessary.

CI
MA
EM
LC
EC
FE
CL
MT
AT
FA
RA
BR
ST
RS
BT
HA
EL
IDX

FRONT SUSPENSION

Coil Spring and Strut Assembly (Cont'd)

ASSEMBLY

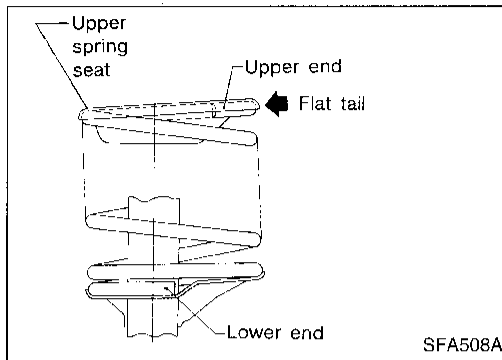

- When installing coil spring on strut, it must be positioned as shown in the figure at left.

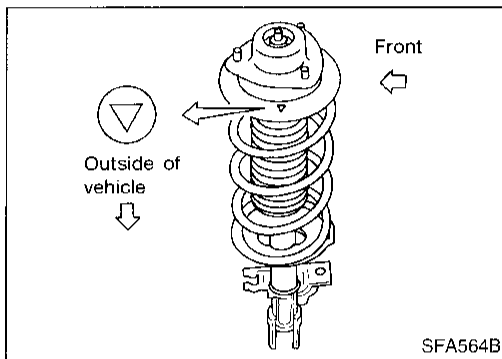

- Install upper spring seat with alignment mark facing outside of vehicle, in line with strut-to-knuckle attachment points.

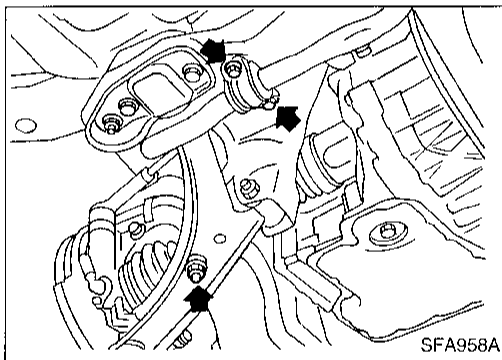

Stabilizer Bar

REMOVAL AND INSTALLATION

- Remove stabilizer bar.

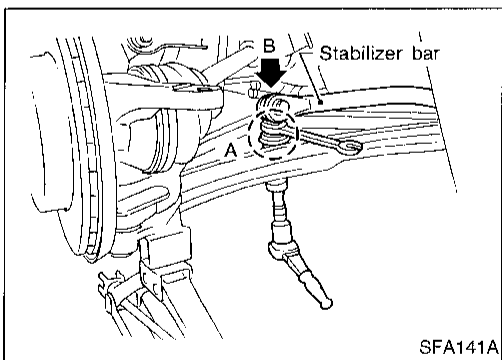

- When removing or installing stabilizer bar, secure portion A with wrench as shown.

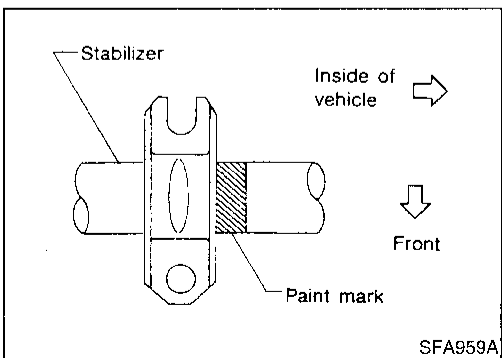

- When installing stabilizer, make sure the paint mark and clamp are in the correct positions.

FRONT SUSPENSION

Stabilizer Bar (Cont'd)

- Install stabilizer bar with ball joint socket properly placed.

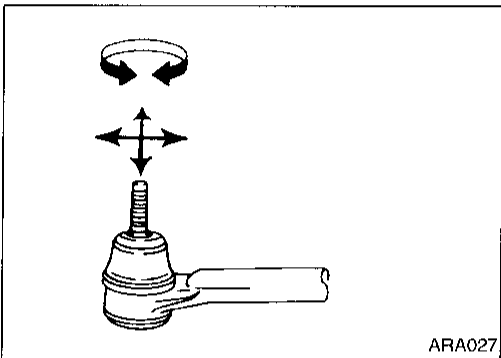
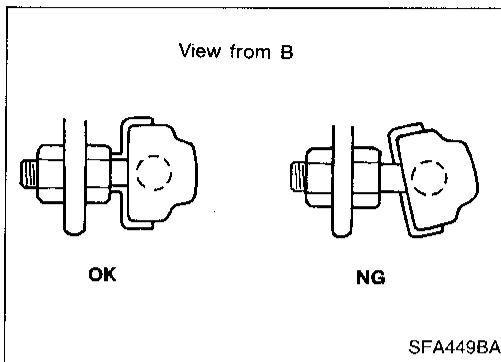

INSPECTION

- Check stabilizer for deformation or cracks. Replace if necessary.
- Check rubber bushings for deterioration or cracks. Replace if necessary.
- Check ball joint rotation in all directions. If movement is not smooth and free, replace stabilizer bar link.

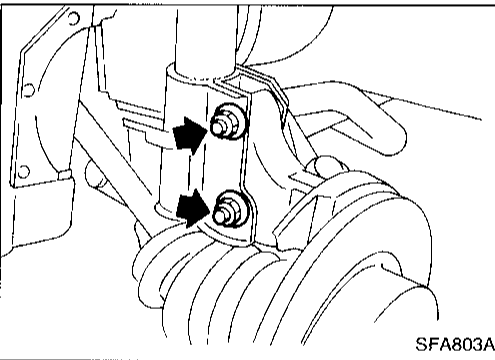

Transverse Link and Lower Ball Joint

REMOVAL AND INSTALLATION

1. Remove wheel bearing lock nut.
2. Remove strut lower mounting bolts.

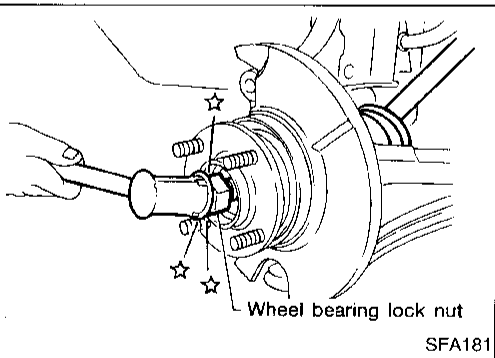

3. Separate drive shaft from knuckle by lightly tapping it. If it is hard to remove, use a puller.
- **Cover boots with shop towel to prevent damage to them when removing drive shaft.**

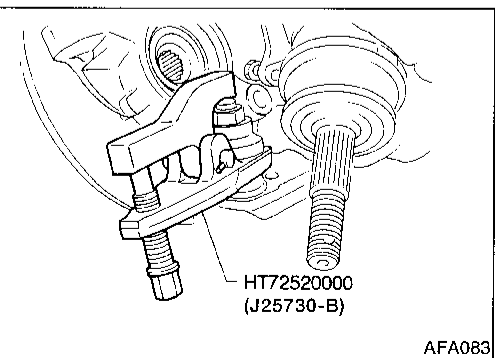

4. Separate lower ball joint stud from knuckle with Tool.

FRONT SUSPENSION

Transverse Link and Lower Ball Joint (Cont'd)

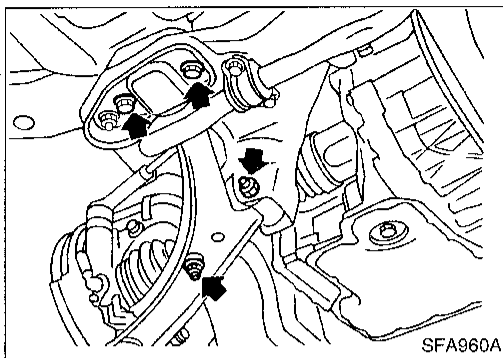

5. Remove bolts and nuts as shown at left.
6. During installation, final tightening must be carried out at curb weight with tires on the ground.

Tightening torque:

Refer to FA-24.

7. After installation, check wheel alignment. Refer to FA-6.

INSPECTION

- Check transverse link for damage, cracks and deformation. Replace if necessary.
- Check rubber bushing for damage, cracks and deformation. Replace transverse link if necessary.

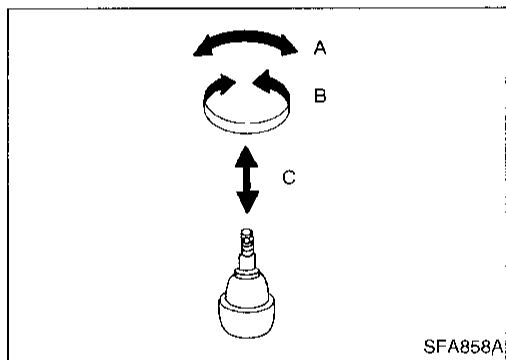

- Check ball joint for play. Replace transverse link assembly if any of the following exists:
 - Ball stud is worn.
 - Joint is hard to swing.
 - Play in axial direction is excessive.Before checking, turn ball joint at least 10 revolutions so that ball joint is properly broken in.

Swinging force "A":

(measuring point: cotter pin hole of ball stud)

7.8 - 57.9 N (0.8 - 5.9 kg, 1.8 - 13.0 lb)

Turning torque "B":

0.5 - 3.4 N·m (5 - 35 kg-cm, 4.3 - 30.4 in-lb)

Vertical end play "C":

0 mm (0 in)

- Check dust cover for damage. Replace it and cover clamp if necessary.

SERVICE DATA AND SPECIFICATIONS (SDS)

General Specifications

Suspension type	Strut type independent suspension
Strut type	Double-acting hydraulic

STABILIZER BAR

Applied model	2-door	
	GA16DE SE	SR20DE SE-R
	Optional with 14" tire	Standard
Stabilizer diameter	mm (in)	25.4 (1.000)
Identification color	Orange	

Inspection and Adjustment

WHEEL ALIGNMENT (Unladen*1)

Applied model		Manual steering	Power steering		
Camber	Degree minute (Decimal degree)	Minimum	-1°20' (-1.33°)		
		Nominal	-0°35' (-0.58°)		
		Maximum	0°10' (0.17°)		
		Left and right difference	1°00' (1.00°)		
Caster	Degree minute (Decimal degree)	Minimum	0°40' (0.67°)		
		Nominal	1°25' (1.42°)		
		Maximum	2°10' (2.17°)		
		Left and right difference	1°00' (1.00°)		
Kingpin inclination	Degree minute (Decimal degree)	Minimum	14°00' (14.00°)		
		Nominal	14°45' (14.75°)		
		Maximum	15°30' (15.50°)		
Total toe-in	mm (in)	Minimum	0 (0)		
		Nominal	2 (0.08)		
		Maximum	4 (0.16)		
Angle (left plus right)	Degree minute (Decimal degree)	Minimum	0' (0°)		
		Nominal	12' (0.20°)		
		Maximum	24' (0.40°)		
Wheel turning angle	Inside	Degree minute (Decimal degree)	Minimum	38°00' (38.00°)	34°00' (34.00°)
			Nominal	41°00' (41.00°)	37°00' (37.00°)
	Full turn*2	Degree minute (Decimal degree)	Maximum	42°00' (42.00°)	38°00' (38.00°)
			Nominal	34°00' (34.00°)	31°00' (31.00°)
	Outside				

*1: Fuel, radiator coolant and engine oil full. Spare tire, jack, hand tools and mats in designated positions.

*2: On power steering models, wheel turning force (at circumference of steering wheel) of 98 to 147 N (10 to 15 kg, 22 to 33 lb) with engine idle.

SERVICE DATA AND SPECIFICATIONS (SDS)

Inspection and Adjustment (Cont'd)

DRIVE SHAFT

Applied model	GA16DE	SR20DE	
		RH	LH
Joint type			
Transaxle side	TS79C	DS83	TS83
Wheel side	ZF90	BF83	
Applied grease			
Quality	Nissan genuine grease or equivalent		
Capacity g (oz)			
Transaxle side	155 - 165 (5.47 - 5.82)	115 - 135 (4.06 - 4.76)	130 - 150 (4.59 - 5.29)
Wheel side	115 - 125 (4.06 - 4.41)	85 - 105 (3.00 - 3.70)	
Boot length mm (in)			
Transaxle side "L ₂ "	101.5 - 103.5 (4.00 - 4.07)	98 (3.86)	99 (3.90)
Wheel side "L ₁ "	96 - 98 (3.78 - 3.86)	95 (3.74)	

Transaxle side

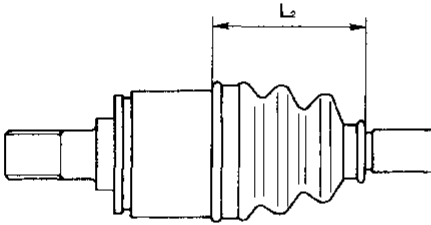

SFA961A

Wheel side

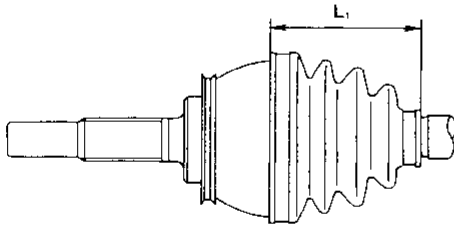

SFA962A

WHEEL BEARING

Axial end play	mm (in)	Less than 0.05 (0.0020)
Lock nut tightening torque	N·m (kg·m, ft·lb)	196 - 275 (20 - 28, 145 - 202)
Preload	N·m (kg·cm, in·lb)	1.4 (14.2, 12.3)
At hub bolt	N (kg, lb)	27.8 (2.8, 6.3)

WHEELARCH HEIGHT (Unladen*)

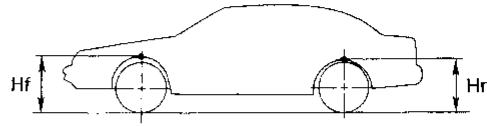

SFA818A

Applied model	155SR13	175/70R13	175/65/R14	195/55R15
Front (Hf) mm (in)	659 (25.94)		666 (26.22)	669 (26.34)
Rear (Hr) mm (in)	640 (25.20)	642 (25.28)	648 (25.51)	650 (25.59)

*: Fuel, radiator coolant and engine oil full. Spare tire, jack, hand tools and mats in designated positions.

LOWER BALL JOINT

Swinging force "A"	N (kg, lb)	8.2 - 57.3 (0.8 - 5.9, 1.8 - 12.9)
At cotter pin hole		
Turning torque "B"	N·m (kg·cm, in·lb)	0.5 - 3.4 (5 - 35, 4.3 - 30.4)
Vertical end play "C"	mm (in)	0 (0)

WHEEL RUNOUT

Unit: mm (in)

Wheel type	Aluminum	Steel wheel
Maximum radial runout limit	0.3 (0.012)	0.5 (0.020)
Maximum lateral runout limit	0.3 (0.012)	0.8 (0.031)