



# QUICK REFERENCE SPECIFICATIONS



AUTOMOTIVE SERVICE INFORMATION SUPPORT TERMINAL  
COPYRIGHT © NISSAN NORTH AMERICA, INC.

200SX 1997

Quick Reference

SR Engine

## SR20DE

Mark Actual  
to Confirm

Notes

**Engine Oil** SAE 5W-30 API SG, Energy Conserving Oil  
 With Oil Filter 3 5/8 qt  
 Without Oil Filter 3 3/8 qt

### Tune up

#### Spark Plugs (Platinum)

Plug Gap 0.039 - 0.043 in (1.0 - 1.1mm)

#### Standard

#### Platinum

Standard Type	BKR6E	PFR5B-11
Hot Type	BKR5E	PFR6B-11
Cold Type	BKR7E	PFR7B-11

**Ignition Timing** 15° ± 2° BTDC

**Base Idle** 750 ± 50 rpm

**Curb Idle (Target)** 800 ± 50 rpm

**Idle Mixture Ratio** Less Than 11 % CO

#### Throttle Position Sensor

T/V Closed Approx. 0.15 - 0.85 v

T/V Open Approx. 3.5 - 4.7 v

Idle Voltage Between Open & Closed

#### Radiator Fill

Coolant Type Ethylene Glycol

Coolant Capacity 6 1/2 qts

#### Compression

Standard 178 psi

Minimum 149 psi

Diff Between Cyl 14 psi

#### Fuel System

**Recommended Fuel** 87 Octane

#### Fuel Pressure @ Idle

Vacuum applied at fuel pressure regulator 34 psi

Vacuum released at fuel pressure regulator 43 psi

**Fuel Pump Ω** 0.2 - 5.0 Ω

**Fuel Injector Ω** 10 - 14 Ω

#### Sensors

#### Crank Position Sensor

71°F(25°C) 166 - 204Ω

#### Mass Air Flow Sensor

Supply Voltage 11 - 14 v

Output Volt. Idle 1.3 - 1.7 v

**Mass Air Flow**

At Idle	2.5 - 5.0 gm/sec	<input type="text"/>
2500 RPM	7.1 - 12.5 gm/sec	<input type="text"/>

**Coolant Temp Sensor**

68°F (20°C)	2.1 - 2.9 kΩ	<input type="text"/>
122°F (50°C)	0.68 - 1.0 kΩ	<input type="text"/>
194°F (90°C)	0.236 - 0.260 kΩ	<input type="text"/>

**EGR Temp Sensor**

32°F (0°C)	7.9 - 9.7 mΩ	<input type="text"/>
122°F (50°C)	0.57 - 0.70 mΩ	<input type="text"/>
212°F (100°C)	0.08 - 0.10 mΩ	<input type="text"/>

**IACV-AAC Valve**10.0 Ω **Intake Air Temperature Sensor**

68°F (20°C)	2.1 - 2.9 kΩ	<input type="text"/>
176°F (80°C)	0.27 - 0.38 kΩ	<input type="text"/>

**Ft O2 Sensor Heat**77°F (25°C) 3.3 - 6.3 Ω **Rr O2 Sensor Heat**77°F (25°C) 5.2 - 8.2 Ω **Electrical****Ignition System**

Firing Order 1-3-4-2

**Ignition Coil**

Primary Volt	12 V	<input type="text"/>
Primary Ω	0.5 - 1.0 Ω	<input type="text"/>
Secondary Ω	approx. 25.0 kΩ	<input type="text"/>
Ignition Coil Resistor	2.2 kΩ	<input type="text"/>

**Battery Specs.**

	<b>USA</b>	<b>Canada</b>
Group	21F	24F
Capacity	12V / 60AH	12v / 65AH
Cold Crank Amps	490 A	550 A
Reserve Capacity	88 min	113 min
Discharge Amps	245 A	275 A

**Charging System**

Alternator Type	LR180-741H	
Nom. Rated Out	12V / 80A	
Regulated Volts	14.1 - 14.7 V	
Hot Output Amps	More than 23A/1300rpm	<input type="text"/>
	More than 63A/2500rpm	<input type="text"/>
	More than 77A/5000rpm	<input type="text"/>

**EPA Mileage Estimate (SR Engine)**

(city/highway)	23/31 (MT)	23/30 (AT)
----------------	------------	------------



# QUICK REFERENCE DESCRIPTION

**ASIST**<sup>TM</sup>  
AUTOMOTIVE SERVICE INFORMATION SUPPORT TERMINAL  
COPYRIGHT © NISSAN NORTH AMERICA, INC.

200SX 1997

Quick Reference

SR Engine

## PREPARATION

**Make sure that the following parts are in order.**

1. Battery
2. Ignition system
3. Engine oil and coolant levels
4. Fuse
5. ECM harness connector
6. Vacuum hoses
7. Air intake system (Oil filler cap, oil level, etc.)
8. Fuel pressure
9. Engine compression
10. EGR valve operation (if equipped)
11. Throttle valve
12. Evaporative emission canister purge control valve.

### Note:

- On A/C equipped vehicles, turn A/C "Off" for testing.
- Transmission should be in "Park" or "Neutral".
- "CO" probe should be inserted into exhaust approximately 16 inches.
- Turn off headlamps, heater blower, rear defogger, etc.
- Front wheels pointed straight.
- Perform inspection with cooling fans "Off".



# QUICK REFERENCE SPECIFICATIONS



AUTOMOTIVE SERVICE INFORMATION SUPPORT TERMINAL  
COPYRIGHT © NISSAN NORTH AMERICA, INC.

200SX 1997

Quick Reference

GA Engine

## GA16DE

Mark Actual to Confirm

Notes

<b>Engine Oil</b>	SAE 5W-30 API SG, Energy Conserving Oil
With Oil Filter	3 3/8 qt
Without Oil Filter	3 qt

### Tune up

#### Spark Plugs

Plug Gap	0.039 - 0.043 in (1.0 - 1.1 mm)
Standard Type	BKR5E-11
Hot Type	BKR4E-11
Cold Type	BKR6E-11
Cold Type	BKR7E-11

#### Ignition Timing

8° ± 2° BTDC

#### Base Idle

M/T

A/T

625 ± 50 RPM

725 ± 50 RPM

#### Curb Idle (Target)

USA

Canada

Auto Trans 800 ± 50 rpm

800 ± 50 rpm

Manual Trans 675 ± 50 rpm

750 ± 50 rpm

#### Idle Mixture Ratio

2 - 11 % CO

#### Valve Clearance

Intake

Exhaust

Cold Approx 68°F (20°C) 0.010 - 0.013 in (0.25 - 0.33 mm)

0.013 - 0.016 in (0.32 - 0.40 mm)

Hot Approx 176°F (80°C) 0.008 - 0.019 in (0.21 - 0.49 mm)

0.012 - 0.023 in (0.30 - 0.58 mm)

#### Throttle Position Sensor

T/V Closed Approx. 0.15 - 0.85 v

T/V Open Approx. 3.5 - 4.7 v

Idle Voltage Between Open & Closed

#### Radiator Fill

Coolant Type Ethylene Glycol

Coolant Capacity

M/T

A/T

5 1/2 qts

6 qts

#### Compression

Standard 199 psi

Minimum 171 psi

Diff Between Cyl 14 psi

#### Fuel System

##### Fuel Pressure @ Idle

Vacuum applied at fuel pressure regulator

34 psi

Vacuum released at fuel pressure regulator

43 psi

**Recommended Fuel** 87 Octane

**Fuel Pump Ω** 0.2 - 5.0 Ω

**Fuel Injector Ω** 10 - 14 Ω

**Sensors**

**Mass Air Flow Sensor**

Supply Volt.	11 - 14v		<input type="text"/>
Output Volt. Idle	1.0 - 1.7v		<input type="text"/>

**Mass Air Flow**

At Idle	1.0 - 4.0 gm/sec		<input type="text"/>
2500 RPM	5.0 - 10.0 gm/sec		<input type="text"/>

**Coolant Temp Sensor**

68°F (20°C)	2.1 - 2.9 kΩ		<input type="text"/>
122°F (50°C)	0.68 - 1.0 kΩ		<input type="text"/>
194°F (90°C)	0.236 - 0.260 kΩ		<input type="text"/>

**Ft/Rr O2 Sensor Heat Ω**

	2.3 - 4.3 Ω		<input type="text"/>
--	-------------	--	----------------------

**EGR Temp Sensor Ω**

32°F (0°C)	7.9 - 9.7 mΩ		<input type="text"/>
122°F (50°C)	0.57 - 0.70 mΩ		<input type="text"/>
212°F (100°C)	0.08 - 0.10 mΩ		<input type="text"/>

**Intake Air Temp. Sensor**

68°F (20°C)	2.1 - 2.9 kΩ		<input type="text"/>
176°F (80°C)	0.27 - 0.38 kΩ		<input type="text"/>

**Crank P/Sen (OBD) M/T 432 - 528 Ω**

	A/T 166 - 204 Ω		<input type="text"/>
--	-----------------	--	----------------------

<b>F/Tank Temp Sen</b>	68°F (20°C)	2.3 - 2.7 kΩ	<input type="text"/>
	122°F (50°C)	0.79 - 0.90 kΩ	<input type="text"/>

<b>IACV-AAC Valve Ω</b>	50 - 100 Ω		<input type="text"/>
-------------------------	------------	--	----------------------

**Electrical**

**Ignition System**

Firing Order	1-3-4-2		
<b>Ignition Coil</b>			
Primary Volt	11 - 14V		<input type="text"/>
Primary Ω	1.0Ω		<input type="text"/>
Secondary Ω	10.0 kΩ		<input type="text"/>
Ignition Coil Resistor	2.2 kΩ		<input type="text"/>

**Battery Specs.**

	<b>USA</b>	<b>Canada</b>	
Group	21F	24F	
Capacity	12 / 60 V/AH	12 / 65 V/AH	
Cold Crank Amps	490 A	550 A	<input type="text"/>
Reserve Capacity	88 minutes	113 minutes	
Discharge Amps	245 A	275 A	<input type="text"/>

**Charging System**

Alternator Type	LR180-751		
Nom. Rated Out	12V / 80 A		
Regulated Volt	14.1 - 14.7V		
Hot Output Amps (Amps/rpm)	More than 23A/1300 rpm		<input type="text"/>
	More than 65A/2500 rpm		<input type="text"/>
	More than 77A/5000 rpm		<input type="text"/>

**EPA Mileage Estimate (GA Engine)**

(city/highway)	27/35 (MT)	26/33 (AT)
----------------	------------	------------



# QUICK REFERENCE DESCRIPTION

**ASIST**<sup>TM</sup>  
AUTOMOTIVE SERVICE INFORMATION SUPPORT TERMINAL  
COPYRIGHT © NISSAN NORTH AMERICA, INC.

200SX 1997

Quick Reference

GA Engine

## PREPARATION

**Make sure that the following parts are in order.**

1. Battery
2. Ignition system
3. Engine oil and coolant levels
4. Fuse
5. ECM harness connector
6. Vacuum hoses
7. Air intake system (Oil filler cap, oil level, etc.)
8. Fuel pressure
9. Engine compression
10. EGR valve operation (if equipped)
11. Throttle valve
12. Evaporative emission canister purge control valve.

### Note:

- On A/C equipped vehicles, turn A/C "Off" for testing.
- Transmission should be in "Park" or "Neutral".
- "CO" probe should be inserted into exhaust approximately 16 inches.
- Turn off headlamps, heater blower, rear defogger, etc.
- Front wheels pointed straight.
- Perform inspection with cooling fans "Off".



# QUICK REFERENCE SPECIFICATIONS



AUTOMOTIVE SERVICE INFORMATION SUPPORT TERMINAL  
COPYRIGHT © NISSAN NORTH AMERICA, INC.

200SX 1997

Quick Reference

SR-A/T

## RE4F03V

Mark Actual  
to Confirm

Notes

**A/T Fluid Type** Nissan Matic 'D'  
**Oil Capacity** 7 3/8 qt  
**A/T Cooler Type** Fin Type Structure

### Up-Shift Schedule Range (at normal operating temp.) MPH(km/h)

	Half Throttle	Full Throttle		
D <sub>1</sub> → D <sub>2</sub>	18 - 23 (29 - 37)	35 - 40 (56 - 64)	<input type="text"/>	<input type="text"/>
D <sub>2</sub> → D <sub>3</sub>	40 - 45 (64 - 72)	66 - 71 (107 - 115)	<input type="text"/>	<input type="text"/>
D <sub>3</sub> → D <sub>4</sub>	68 - 73 (110 - 118)	105 - 110 (169 - 177)	<input type="text"/>	<input type="text"/>

### Lock-Up Clutch (Approx. 1/4 Throttle) MPH(km/h)

	Lock-up ON	Lock-up OFF	
Gear Pos. D4 OD/on	65 - 70 (104 - 112)	57 - 62 (92 - 100)	<input type="text"/>
Gear Pos. D4 OD/off	53 - 58 (86 - 94)	52 - 57 (83 - 91)	

### Stall RPM

R, D, 2, 1 position	1,850 - 2,150 rpm	<input type="text"/>
---------------------	-------------------	----------------------

### Line Pressure

	PSI (kg/cm <sup>2</sup> ) At Curb Idle	At Stall rpm		
R - Position	131 (9.2)	247 (17.4)	<input type="text"/>	<input type="text"/>
D - Position	84 (5.9)	159 (11.2)	<input type="text"/>	<input type="text"/>
2, 1 - Position	87 (6.1)	159 (11.2)	<input type="text"/>	<input type="text"/>

### Shift Solenoids

Gear	Solenoid A	Solenoid B		
1st	ON	ON	<input type="text"/>	<input type="text"/>
2nd	OFF	ON	<input type="text"/>	<input type="text"/>
3rd	OFF	OFF	<input type="text"/>	<input type="text"/>
4th	ON	OFF	<input type="text"/>	<input type="text"/>

### Solenoid Valves

	Resistance	Pin Number	
Shift Solenoid A	20 - 30 Ω	6	<input type="text"/>
Shift Solenoid B	20 - 30 Ω	7	
Ovr. Clutch Solenoid	20 - 30 Ω	8	<input type="text"/>
Line Pres. Solenoid	2.5 - 5 Ω	1	<input type="text"/>
T/Conv. Clutch Sol	10 - 16 Ω	5	<input type="text"/>

### ATF Temperature Sensor

68°F (20°C)	2.5 kΩ	<input type="text"/>
176°F (80°C)	0.3 kΩ	<input type="text"/>
<b>Rev Sensor</b>	500 - 650 Ω	<input type="text"/>

<b>Drop Resistor</b>	11.2 - 12.8 Ω	<input type="text"/>
----------------------	---------------	----------------------

### Brake Band

Anchor end pin torq. 35 - 52 in lbs.  
 Num of return turns 2.5  
 Lock nut torque 23 - 27 ft lbs.



# QUICK REFERENCE DESCRIPTION

**ASIST**<sup>TM</sup>  
AUTOMOTIVE SERVICE INFORMATION SUPPORT TERMINAL  
COPYRIGHT © NISSAN NORTH AMERICA, INC.

200SX 1997

Quick Reference

SR-A/T

## PRECAUTIONS

- Before performing any diagnostic test, vehicle should be driven for approximately 10 minutes to raise transmission to the proper operating temperature of 122° to 176°.
- During stall testing, never hold throttle wide open for more than 5 seconds at a time. Extended stall testing can overheat transmission and cause serious damage.
- Nissan Matic 'D' ATF is the only fluid accepted for warranty, service contracts and goodwill repairs.
- Before performing any internal repairs, thoroughly clean the outside of the transmission case to prevent contamination.
- Use lint free cloth or towels for wiping parts. Common shop towels can leave contaminating fibers on the transmission parts and cause improper transmission operation.
- When servicing the valve body, valves, sleeves, plugs, etc. should slide along the bores in the valve body under their own weight.
- Before assembly, apply a coat of ATF to all internal transmission parts. Use petroleum jelly to protect o-rings and seals, or to hold bearings and washers in place during assembly.

**Important Note:** Nissan Matic 'D' must be used in performing repairs paid by Nissan/Infiniti, such as warranty, service contract, or good-will repairs. There will not be reimbursement for repairs when non-genuine Nissan Matic 'D' is used.





# QUICK REFERENCE SPECIFICATIONS



AUTOMOTIVE SERVICE INFORMATION SUPPORT TERMINAL  
COPYRIGHT © NISSAN NORTH AMERICA, INC.

200SX 1997

Quick Reference

GA-A/T

## RL4F03A

Mark Actual to Confirm

Notes

<b>A/T Fluid Type</b>	Nissan Matic 'D'	
<b>Oil Capacity</b>	7 3/8 qt	
<b>A/T Cooler Type</b>	Fin Type Structure	
<b>Up-Shift Schedule Range (at normal operating temp.)</b>	<b>mph(km/h)</b>	
	<b>Half Throttle</b>	<b>Full Throttle</b>
<b>D<sub>1</sub> → D<sub>2</sub></b>	18 - 23 (29 - 37)	32 - 37 (51 - 59)
<b>D<sub>2</sub> → D<sub>3</sub></b>	32 - 37 (52 - 60)	60 - 65 (97 - 105)
<b>D<sub>3</sub> → D<sub>4</sub></b>	63 - 68 (101 - 109)	85 - 90 (136 - 145)

<b>Lock-Up Clutch</b> (Approx. 1/4 Throttle)	<b>MPH(km/h)</b>	<b>Lock-up ON</b>	<b>Lock-up OFF</b>
Gear Position D4	66 - 71 (106 - 114)	42 - 47 (68 - 76)	

<b>Stall RPM</b> R, D, 2, 1 position	2,450 - 2,750 rpm
<b>Line Pressure</b>	<b>PSI (kg/cm<sup>2</sup>)</b>

	<b>At Curb Idle</b>	<b>At Stall rpm</b>
R - Position	128 (9.0)	256 (18.0)
D - Position	92 (6.5)	185 (13.0)
2, 1 - Position	166 (11.7)	185 (13.0)

<b>Governor Pres</b>	<b>MPH (km/h)</b>	<b>PSI (kg/km<sup>2</sup>)</b>
	0 (0)	0 (0)
	10 (16)	9 - 10 (0.6 - 0.7)
	20 (32)	16 - 18 (1.1 - 1.3)
	50 (80)	41 - 50 (2.9 - 3.5)

<b>Solenoid Valves</b>	<b>Resistance</b>
O/D Cancel Solenoid	Approx. 25 Ω
Torq. Conv. Clutch Sol.	Approx. 25 Ω

<b>Throttle Wire Adjustment</b>	
Throttle Wire Stroke	1.57 - 1.65 in (40 - 42 mm)

<b>Brake Band</b>	
Anchor end pin torq.	35 - 52 in lbs.
Num of return turns	2.5 +/- 0.125
Lock nut torque	23 - 27 ft lbs.



# QUICK REFERENCE DESCRIPTION

# ASIST™

AUTOMOTIVE SERVICE INFORMATION SUPPORT TERMINAL  
COPYRIGHT © NISSAN NORTH AMERICA, INC.

200SX 1997

Quick Reference

GA-A/T

## PRECAUTIONS

- Before performing any diagnostic test, vehicle should be driven for approximately 10 minutes to raise transmission to the proper operating temperature of 122° to 176°.
- During stall testing, never hold throttle wide open for more than 5 seconds at a time. Extended stall testing can overheat transmission and cause serious damage.
- Nissan Matic 'D' ATF is the only fluid accepted for warranty, service contracts and goodwill repairs.
- Before performing any internal repairs, thoroughly clean the outside of the transmission case to prevent contamination.
- Use lint free cloth or towels for wiping parts. Common shop towels can leave contaminating fibers on the transmission parts and cause improper transmission operation.
- When servicing the valve body, valves, sleeves, plugs, etc. should slide along the bores in the valve body under their own weight.
- Before assembly, apply a coat of ATF to all internal transmission parts. Use petroleum jelly to protect o-rings and seals, or to hold bearings and washers in place during assembly.

**Important Note:** Nissan Matic 'D' must be used in performing repairs paid by Nissan/Infiniti, such as warranty, service contract, or good-will repairs. There will not be reimbursement for repairs when non-genuine Nissan Matic 'D' is used.



# QUICK REFERENCE SPECIFICATIONS



AUTOMOTIVE SERVICE INFORMATION SUPPORT TERMINAL  
COPYRIGHT © NISSAN NORTH AMERICA, INC.

200SX 1997

Quick Reference

SR-M/T

## RS5F32V

Mark Actual to Confirm

Notes

### Clutch

Pedal height "H"	6.02 - 6.42 in (153 - 163 mm)
Pedal free play "A"	0.433 - 0.591 in (11 - 15 mm)
Flywheel Run-out	Less than 0.0059 in (0.15 mm)
Clutch Disc Run-out	0.039 in (1.00 mm)
Clutch Cover Torque	7 - 14 ft/lbs (1 - 2 kg/m)
(Two Stages)	16 - 22 ft/lbs (2.2 - 3.0 kg/m)

### Refill Capacity

(80W-90 API GL-4)	7 7/8 – 8 1/4 pt
<b>Oil Level Check</b>	1.34 - 1.57 in (34 - 40 mm)

### Gear End Play

1st gear	0.0071 - 0.0122 in (0.18 - 0.31 mm)
2nd gear	0.0079 - 0.0118 in (0.20 - 0.30 mm)
3rd gear	0.0079 - 0.0118 in (0.20 - 0.30 mm)
4th gear	0.0079 - 0.0118 in (0.20 - 0.30 mm)
5th gear	0.0071 - 0.0122 in (0.18 - 0.31 mm)

### Clearance Between Baulk Ring And Gear

	Standard	Wear Limit	
1st Gear	0.0374- 0.0571 in (0.95 - 1.45 mm)	0.028 in (0.7 mm)	<input type="text"/>
4th Gear	0.0354 - 0.0571 in (0.9 - 1.45 mm)	0.028 in (0.7 mm)	<input type="text"/>
5th Gear	0.035 - 0.059 in (0.9 - 1.5 mm)	0.028 in (0.7 mm)	<input type="text"/>
2nd & 3rd Outer (A)	0.028 - 0.035 in (0.7 - 0.9 mm)	0.008 in (0.2 mm)	<input type="text"/>
2nd & 3rd Inner (B)	0.024 - 0.043 in (0.6 - 1.1 mm)	0.008 in (0.2 mm)	<input type="text"/>

### Reverse Check Plugs

Turning Torque	43 - 65 in/lb (50 - 75 kg/cm)	<input type="text"/>
----------------	-------------------------------	----------------------

### Input Shaft Front Bearing Snap Ring

Specified Clearance	0 - 0.004 in (0 - 0.1mm)	<input type="text"/>
---------------------	--------------------------	----------------------

### Input Shaft 5<sup>th</sup> Synchronizer Hub Snap Ring

Specified Clearance	0 - 0.004 in (0 - 0.1mm)	<input type="text"/>
---------------------	--------------------------	----------------------

### Mainshaft Bearing Adjusting Spacer

Bearing Distance "C"	9.0610 - 9.0649 in (230.15 - 230.25 mm)	<input type="text"/>
----------------------	-----------------------------------------	----------------------

### Mainshaft C Ring

Specified Clearance	0 - 0.004 in (0 - 0.1 mm)	<input type="text"/>
---------------------	---------------------------	----------------------

### Differential Side Gear Thrust Washer

Specified Clearance	0.004 - 0.008 in (0.1 - 0.2 mm)	<input type="text"/>
---------------------	---------------------------------	----------------------

### Differential Side Bearing Preload

Preload Dimension	0.0098 - 0.0118 in (0.25 - 0.30 mm)	<input type="text"/>
-------------------	-------------------------------------	----------------------

**Final Drive Turning Torque**

Final drive only 26 - 61 in/lb (30 - 70 kg/cm)

Torq. variation per rev. 8.7 in/lb (10 kg/cm)

**Input Shaft Braking Mechanism**

Maximum height "H" 2.6441 - 2.6630 in (67.16 - 67.64 mm)

Clearance "C" 0.0020 - 0.0049 in (0.05 - 0.125 mm)

**Mainshaft Bearing End Play**

Allowable End play 0 - 0.004 in (0 - 0.1 mm)

--

**Total Turning Torque**

Total Torque 26 - 61 in/lb (30 - 70 kg/cm)



# QUICK REFERENCE DESCRIPTION

**ASIST**<sup>TM</sup>  
AUTOMOTIVE SERVICE INFORMATION SUPPORT TERMINAL  
COPYRIGHT © NISSAN NORTH AMERICA, INC.

200SX 1997

Quick Reference

SR-M/T

## PRECAUTIONS

- Nissan does not recommend flywheel resurfacing. If flywheel is not within specification, replacement is recommended.
- Refill transmission with the proper viscosity and amount of gear lube for the anticipated temperatures.
- To help prevent clutch judder, avoid excessive grease to clutch disc splines, input shaft and throwout bearing. Be sure to clean off any excessive grease.
- On rear wheel drive vehicles, inspect the shift control lever bushing for wear and proper alignment prior to reinstallation of a removed transmission.
- To avoid transmission contamination, inspect the shift lever dust boot for cracks or damage, and replace if needed. Install plastic wire ties to insure a tight fit of the boot to the shifter and housing.
- Before reinstallation of a removed transmission, inspect the engine to transmission alignment dowels for damage. Damaged dowels can cause misalignment of the engine to transmission, and this can cause the transmission to jump out of gear.



# QUICK REFERENCE SPECIFICATIONS



AUTOMOTIVE SERVICE INFORMATION SUPPORT TERMINAL  
COPYRIGHT © NISSAN NORTH AMERICA, INC.

200SX 1997

Quick Reference

GA-M/T

## RS5F31A

Mark Actual to Confirm

Notes

### Clutch

Pedal height "H"	6.02 - 6.42 in (153 - 163 mm)	<input type="checkbox"/>
Pedal free play "A"	0.433 - 0.591 in (11.0 - 15.0 mm)	<input type="checkbox"/>
Flywheel Run-out	Less than 0.0059 in (0.15 mm)	<input type="checkbox"/>
Clutch Disc Run-out	0.039 in (1.00 mm)	<input type="checkbox"/>
Clutch Cover Torque (Two Stages)	7.0 - 14 ft/lbs (1 - 2 kg/m) 16 - 22 ft/lbs (2.2 - 3.0 kg/m)	<input type="checkbox"/>

### Refill Capacity

(80W-90 API GL-4) 6 1/8 - 6 3/4 pt

### Oil Level Check

2.24 - 2.60 in (57 - 66 mm)

### Gear End Play

1st gear	0.0071 - 0.0122 in (0.18 - 0.31 mm)	<input type="checkbox"/>
2nd gear	0.0079 - 0.0118 in (0.20 - 0.30 mm)	<input type="checkbox"/>
3rd gear	0.0079 - 0.0118 in (0.20 - 0.30 mm)	<input type="checkbox"/>
4th gear	0.0079 - 0.0118 in (0.20 - 0.30 mm)	<input type="checkbox"/>
5th gear	0.0071 - 0.0122 in (0.18 - 0.31 mm)	<input type="checkbox"/>

### Clearance Between Baulk Ring And Gear

	Standard	Wear Limit	
1st - 5th Gear	0.0394 - 0.0531 in (1.0 - 1.35 mm)	0.028 in (0.7 mm)	<input type="checkbox"/>

### Reverse Check Plugs

Turning Torque 43 - 65 in/lb (50 - 75 kg/cm)

### Input Shaft Front Bearing Snap Ring

Specified Clearance 0 - 0.004 in (0 - 0.1mm)

### Input Shaft 5<sup>th</sup> Synchronizer Hub Snap Ring

Specified Clearance 0 - 0.004 in (0 - 0.1mm)

### Mainshaft C Ring

Specified Clearance 0 - 0.004 in (0 - 0.1 mm)

### Differential Side Gear Thrust Washer

Specified Clearance 0.004 - 0.008 in (0.1 - 0.2 mm)

### Differential Side Bearing Preload

Preload Dimension 0.0094 - 0.0126 in (0.24 - 0.32 mm)

### Final Drive Turning Torque

Final drive only 17 - 69 in/lb (20 - 80 kg/cm)

Torq. variation per rev. 8.7 in/lb (10 kg/cm)

### Mainshaft Bearing Preload

Preload dimension 0.0079 - 0.0098 in (0.20 - 0.25 mm)

### Total Turning Torque

Total Torque 35 - 122 in/lb (40 - 140 kg/cm)



# QUICK REFERENCE DESCRIPTION

**ASIST**<sup>TM</sup>  
AUTOMOTIVE SERVICE INFORMATION SUPPORT TERMINAL  
COPYRIGHT © NISSAN NORTH AMERICA, INC.

200SX 1997

Quick Reference

GA-M/T

## PRECAUTIONS

- Nissan does not recommend flywheel resurfacing. If flywheel is not within specification, replacement is recommended.
- Refill transmission with the proper viscosity and amount of gear lube for the anticipated temperatures.
- To help prevent clutch judder, avoid excessive grease to clutch disc splines, input shaft and throwout bearing. Be sure to clean off any excessive grease.
- On rear wheel drive vehicles, inspect the shift control lever bushing for wear and proper alignment prior to reinstallation of a removed transmission.
- To avoid transmission contamination, inspect the shift lever dust boot for cracks or damage, and replace if needed. Install plastic wire ties to insure a tight fit of the boot to the shifter and housing.
- Before reinstallation of a removed transmission, inspect the engine to transmission alignment dowels for damage. Damaged dowels can cause misalignment of the engine to transmission, and this can cause the transmission to jump out of gear.



# QUICK REFERENCE SPECIFICATIONS



AUTOMOTIVE SERVICE INFORMATION SUPPORT TERMINAL  
COPYRIGHT © NISSAN NORTH AMERICA, INC.

200SX 1997

Quick Reference

Heater & A/C

## AIR CONDITIONER

Mark Actual to Confirm

Notes

### Compressor

Model DKV-14D  
Type Vane Rotary

### Compressor Clutch Disc-to-Pulley Clearance

0.012 - 0.024 in (0.3 - 0.6 mm)

### Refrigerant

Type HFC-134a (R134a)  
Capacity 1.32 - 1.54 lb.

### Refrigerant Oil

Type Nissan Type "R" Lub.  
Capacity 6.8 fl oz  
Oil to AddPer  
Evaporator 2.5 oz (75 ml)  
Condenser 2.5 oz (75 ml)  
\*Liquid Tank 0.2 oz (5 ml)  
Large Refrig. Leak 1.0 oz (30 ml)  
Compressor  
(\*Add only if comp. is not replaced.)

### Engine Idle with A/C On

SR20DE Approx. 850 rpm  
GA16DE Approx. 900 rpm

### Performance Test

#### Recirculating-to-Discharge Air Temp

Relative Humidity	Recirc .Air Temp. at Blower Assy. Inlet	Discharge Air Temp. at Center Ventilator		
	F° (C°)	F° (C°)		
50 - 60 %	68° (20°)	40 - 45° (4 - 7°)	<input type="text"/>	<input type="text"/>
	77° (25°)	46 - 52° (8 - 11°)	<input type="text"/>	<input type="text"/>
	86° (30°)	53 - 60° (12 - 16°)	<input type="text"/>	<input type="text"/>
	95° (35°)	60 - 69° (15 - 20°)	<input type="text"/>	<input type="text"/>
	104° (40°)	67 - 79° (20 - 26°)	<input type="text"/>	<input type="text"/>
60 - 70 %	68° (20°)	45 - 49° (7 - 9°)	<input type="text"/>	<input type="text"/>
	77° (25°)	52 - 58° (11 - 15°)	<input type="text"/>	<input type="text"/>
	86° (30°)	60 - 68° (16 - 20°)	<input type="text"/>	<input type="text"/>
	95° (35°)	69 - 79° (20 - 26°)	<input type="text"/>	<input type="text"/>
	104° (40°)	79 - 92° (26 - 34°)	<input type="text"/>	<input type="text"/>



**Ambient Air Temp-to-Operating Pressure**

Air temperature F°(C°)	Relative Humidity 50-70%			
	High-pres.	Low-pres.		
68°(20°)	146 - 191 psi	16 - 30 psi	<input type="text"/>	<input type="text"/>
77°(25°)	179 - 232 psi	17 - 33 psi	<input type="text"/>	<input type="text"/>
86°(30°)	213 - 273 psi	20 - 38 psi	<input type="text"/>	<input type="text"/>
95°(35°)	274 - 314 psi	23 - 47 psi	<input type="text"/>	<input type="text"/>
104° (40°)	279 - 356 psi	28 - 57 psi	<input type="text"/>	<input type="text"/>

Thermo Control Amp	F°(C°)		
Decreasing	37-38 (3 - 4)	Off (12V)	<input type="text"/>
Increasing	39-41 (4 - 5)	On (0V)	<input type="text"/>

Thermal Protector	F°(C°)		
Increasing	293-311 (145-155)	Compressor Off	<input type="text"/>
Decreasing	266-284 (130-140)	Compressor On	<input type="text"/>

Dual Pressure Switch	On / Continuity	Off / No Continuity	
PSI			
Low Pres. Side	23 - 31 inc.	23 - 28 dec	<input type="text"/>
High Pres. Side	270 - 327 dec	384 - 412 inc.	<input type="text"/>

**A/C Drive Belt Deflection (Engine Cold)**

	Used Belt	New Belt	
<b>SR20DE</b>			
Deflection Limit	0.45 - 0.49 in (12 - 13 mm)		<input type="text"/>
Deflection After Adj.	0.28 - 0.31 in (7 - 8 mm)	0.26 - 0.30 in (7 - 8 mm)	<input type="text"/>
<b>GA16DE</b>			
Deflection Limit	0.374 in (9.5 mm)		<input type="text"/>
Deflection After Adj.	0.24 - 0.26 in (6 - 6.5 mm)	0.20 - 0.24 in (5 - 6 mm)	<input type="text"/>



# QUICK REFERENCE DESCRIPTION

**ASIST**<sup>TM</sup>  
AUTOMOTIVE SERVICE INFORMATION SUPPORT TERMINAL  
COPYRIGHT © NISSAN NORTH AMERICA, INC.

200SX 1997

Quick Reference

Heater & A/C

## PERFORMANCE TEST CONDITIONS

- Vehicle indoors or in the shade
- Doors closed
- Windows open
- Hood open
- Temperature on "Max" setting
- Discharge air on "Face Vent"
- Recirculation switch on "Recirc"
- Fan speed on "High"
- A/C switch "On" and verify A/C Clutch engagement
- Engine speed at 1500 RPM
- Verify heater cock is closed
- Operate the A/C system for 10 minutes before taking measurements

### Precautions:

1. When removing the compressor, store it in the same position as it is mounted in the vehicle. Failure to do so may cause lubricant to enter the low pressure chamber and cause compressor damage.
2. Allow components stored in cool areas to warm to area temperatures before removing seals. This prevents condensation from forming inside A/C components.



# QUICK REFERENCE SPECIFICATIONS



200SX 1997

Quick Reference

Suspension

## WHEEL ALIGNMENT (UNLADEN)

Mark Actual to Confirm

Notes

<b>Toe-in</b>	<b>Range</b>	<b>Nominal</b>		
Total toe-in (A - B)	0.00 - 0.16 in (0 - 4 mm)	0.08 in (2 mm)	<input type="text"/>	
Total toe-in angle (left plus right)	0.00° - 0.40° (0' - 24')	0.20° (12')	<input type="text"/>	
<b>Front Wheel Turning Angle (full turn)</b>				
	<b>Manual Steering</b>	<b>Power Steering</b>		
In/Wheel Range	38.00° - 42.00° (38° 00' - 42° 00')	34.00° - 38.00° (34° 00' - 38° 00')	<input type="text"/>	
In/Wheel Nominal	41.00° (41° 00')	37.00° (37° 00')	<input type="text"/>	
Out/Wheel Nominal	34.00° (34° 00')	31.00° (31° 00')	<input type="text"/>	
<b>Camber</b>				
Range	-1.33° to 0.17° (-1° 20' to 0° 10')		<input type="text"/>	<input type="text"/>
Nominal	-0.58° (-0° 35')			
Left/Right Difference	1.00° (1° 00')			
<b>Caster</b>				
Range	0.67° - 2.17° (0° 40' - 2° 10')		<input type="text"/>	<input type="text"/>
Nominal	1.42° (1° 25')			
Left/Right Difference	1.00° (1° 00')			
<b>Kingpin Inclination</b>				
Range	14.00° - 15.50° (14° 00' - 15° 30')		<input type="text"/>	<input type="text"/>
Nominal	14.75° (14° 45')			
<b>Set Back</b>	0.0 in +/- (0.0 mm +/-)		<input type="text"/>	<input type="text"/>
<b>Wheelbase</b>	99.8 in (2,535 mm)		<input type="text"/>	
<b>Rear Wheel Alignment</b>				
	<b>Toe-in</b>	<b>Range</b>	<b>Nominal</b>	
Total toe-in (A - B)	-0.12 in to 0.20 in (-3 to 5 mm)		0.04 in (1 mm)	<input type="text"/>
Total toe-in angle (left plus right)	-0.30° to 0.50° (-0° 18' to 0° 30')		0.10° (0° 6')	<input type="text"/>
<b>Camber</b>				
Range	-1.75° to -0.25° (-1° 45' to -0° 15')		<input type="text"/>	<input type="text"/>
Nominal	-1.00° (-1° 00')			
<b>Thrust Angle</b>	0.0° +/- (0°00' +/-)		<input type="text"/>	
<b>Ball Joint End Play</b>	Vertical End Play	0 in(0 mm)		<input type="text"/>
<b>Front Wheel Bearing</b>				
Axial End Play	0.0020 in (0.05 mm) or less		<input type="text"/>	<input type="text"/>
Lock nut torque	145 - 202 ft/lb (20 - 28 kg/m)			

**Rear Wheel Bearing**

Axial End Play 0.0020 in (0.05 mm) or less  
Lock nut torque 137 - 188 ft/lb (19 - 26 kg/m)

--	--

**Wheel Runout**

	<b>Aluminum Wheel</b>	<b>Steel Wheel</b>
Max. Lateral Run out:	0.012 in (0.3 mm)	0.031 in (0.8 mm)
Max. Radial Run out:	0.012 in (0.3 mm)	0.020 in (0.5 mm)

**Wheel arch Height (Unladen)**

<b>Tire Size</b>	<b>Front Height (Hf)</b>	<b>Rear Height (Hr)</b>
155SR13	25.94 in (659 mm)	25.20 in (640 mm)
175/70R13	25.94 in (659 mm)	25.28 in (642 mm)
175/65R14	26.22 in (666 mm)	25.51 in (648 mm)
195/55R15	26.34 in (669 mm)	25.59 in (650 mm)

--	--	--	--

**W/Lug Nut Torque** 72-87 ft/lb (10-12 kg/m)



# QUICK REFERENCE DESCRIPTION

# ASIST™

AUTOMOTIVE SERVICE INFORMATION SUPPORT TERMINAL  
COPYRIGHT © NISSAN NORTH AMERICA, INC.

200SX 1997

Quick Reference

Suspension

## PRELIMINARY INSPECTION

- Check tires for wear and proper inflation
- Check wheel runout
- Check front wheel bearings excessive play
- Check front suspension for excessive play
- Check steering linkage for excessive play
- Check struts for leakage and condition
- Check vehicle for proper ride height

## Precautions

1. When installing rubber parts, final tightening must be carried out under unladen conditions with the tires on the ground.
2. Recheck alignment after installing removed suspension components.



# QUICK REFERENCE SPECIFICATIONS



AUTOMOTIVE SERVICE INFORMATION SUPPORT TERMINAL  
COPYRIGHT © NISSAN NORTH AMERICA, INC.

200SX 1997

Quick Reference

Brakes

## BRAKE SYSTEM

Mark Actual to Confirm

Notes

<b>Brake Model Code</b>	<b>GA16DE</b> CL22VD	<b>SR20DE</b> AD22VE		
<b>Brake Fluid</b>	DOT 3 (Recommended)			
<b>Master Cyl. Bore Dia.</b>				
W/O ABS	13/16 in (20.64 mm)			
W/ABS		7/8 in (22.22 mm)	<input type="checkbox"/>	
<b>Frt Caliper Bore Dia.</b>	2.126 in (54.0 mm)	2.126 in (54.0 mm)		
<b>Frt Brake Pad Dimensions</b>				
Length	4.17 in (106 mm)	4.17 in (106 mm)	<input type="checkbox"/>	<input type="checkbox"/>
Width	1.555 in (39.5 mm)	1.555 in (39.5 mm)	<input type="checkbox"/>	<input type="checkbox"/>
Thickness	0.43 in (11.0 mm)	0.43 in (11.0 mm)	<input type="checkbox"/>	<input type="checkbox"/>
<b>Frt Brake Pad Wear Limit</b>				
Min. Thickness	0.079 in (2.0 mm)	0.079 in (2.0 mm)	<input type="checkbox"/>	<input type="checkbox"/>
<b>Frt Brake Rotor Dimensions</b>				
Outer Diameter	9.13 in (232.0 mm)	9.72 in (247.0)	<input type="checkbox"/>	<input type="checkbox"/>
Standard Thickness	0.71 in (18.0 mm)	0.71 in (18.0 mm)	<input type="checkbox"/>	<input type="checkbox"/>
<b>Frt Brake Rotor Repair/Wear Limits</b>				
Max. Runout	0.0028 in (0.07 mm)	0.0028 in (0.07 mm)	<input type="checkbox"/>	<input type="checkbox"/>
Min. Thickness	0.630 in (16.0 mm)	0.630 in (16.0 mm)	<input type="checkbox"/>	<input type="checkbox"/>
Max. Thk. Variation	0.0008 in (0.02 mm)	0.0008 in (0.02 mm)	<input type="checkbox"/>	<input type="checkbox"/>
<b>Rear Brake Code</b>	<b>LT18C</b>	<b>Rear Drum</b> <b>CL7HB</b>		
<b>Rear Cylinder/Caliper</b>	5/8 in (15.87 mm)	1 1/4 in (30.23mm)	<input type="checkbox"/>	
<b>Rear Pad/Shoe Dimensions</b>				
Length	6.80 in (172.8 mm)	3.7 in (94mm)	<input type="checkbox"/>	<input type="checkbox"/>
Width	1.18 in (30 mm)	1.14 in (29)	<input type="checkbox"/>	<input type="checkbox"/>
Thickness	0.16 in (4.0 mm)	0.39 in (10 mm)	<input type="checkbox"/>	<input type="checkbox"/>
<b>Rr Pad/Shoe Min Thk</b>	0.059 in (1.5mm)	0.059 in (1.5 mm)	<input type="checkbox"/>	<input type="checkbox"/>
<b>Rear Drum/Rotor Dimensions</b>				
Drum inside diameter	7.09 in(180mm)		<input type="checkbox"/>	<input type="checkbox"/>
Rotor Thickness		0.28 in (7 mm)	<input type="checkbox"/>	<input type="checkbox"/>
Rotor outside diameter		9.21 in (234 mm)	<input type="checkbox"/>	<input type="checkbox"/>

**Rear Brake Drum/Rotor Repair/Wear Limits**

Max. Inside Dia.	7.13 in (181 mm)	
Max Out-of-Round	0.0012 in (0.03 mm)	
Minimum Thickness		0.236 in (6.0 mm)
Maximum Runout		0.0028 in (0.07 mm)
Maximum Thickness Variation		0.0008 in (0.02 mm)

**Brake Pedal Dimen.**

	<b>Manual Trans</b>	<b>Auto Trans</b>
Free Height 'H'	5.83 - 6.22 in (148 - 158 mm)	6.18 - 6.57 in (157 - 167 mm)
Depressed Height 'D'	2.95 in (75 mm)	3.35 in (85 mm)
Switch Clearance 'C'	0.012 - 0.039 in (.3 - 1.0 mm)	
Pedal Free Play 'A'	0.039 - 0.118 in (1.0 - 3.0 mm)	

**Brake Booster**

	<b>S205 or C205 or M195T</b>
Output Rod Length	0.404 - 0.414 in (10.275 - 10.525 mm)
Clevis Length	4.9 in (125 mm)

**Proportioning Valve Pressure**

	<b>Applied Pressure (Front Brakes)</b>	<b>Output Pressure (Rear Brakes)</b>
GA16DE	1067 psi (75 kg/cm <sup>2</sup> )	739 - 796 psi (52-56 kg/cm <sup>2</sup> )
SR20DE	924 psi (65 kg/cm <sup>2</sup> )	597 - 654 psi (42-46 kg/cm <sup>2</sup> )

--	--

**Parking Brake Control**

	<b>Drum</b>	<b>Disc</b>
Number of Notches	7 - 8	8 - 9
	[Under force of 44 lb (20 kg)]	

--

**ABS Wheel Sensor**

Clearance Frt/Rr	0.004 - 0.043 in (0.1 -1.1 mm)
Resistance	0.6 - 3.25 kΩ
Sensor Rotor to hub	0.177 - 0.217 in (4.5 - 5.5 mm)

**Wheel Lug Nut**

72-87 ft lb (10-12 kg-m)



# QUICK REFERENCE DESCRIPTION

**ASIST**<sup>TM</sup>  
AUTOMOTIVE SERVICE INFORMATION SUPPORT TERMINAL  
COPYRIGHT © NISSAN NORTH AMERICA, INC.

200SX 1997

Quick Reference

Brakes

## PRECAUTIONS

1. Never reuse drained brake fluid.
2. Be careful not to splash brake fluid on painted surfaces.
3. Use clean brake fluid to clean or wash master cylinder wheel cylinders, and disc brake calipers parts.
4. Mineral oils such as gasoline and kerosene should not be used. They can cause damage to rubber parts of the hydraulic system.
5. Use flare nut wrench when removing or installing brake line fittings.
6. Always torque brake lines.
7. Always replace brake pad shims when replacing brake pads.

### Warning:

Clean brake pads and shoes with a dust collector to minimize the hazard of airborne particles or other materials.





# QUICK REFERENCE SPECIFICATIONS



200SX 1997

Quick Reference

Electrical

## ELECTRICAL

Mark Actual to Confirm

Notes

### Wire Color Code

B = Black	BR = Brown
W = White	OR = Orange
R = Red	P = Pink
G = Green	PU = Purple
L = Blue	GY = Gray
Y = Yellow	SB = Sky Blue
LG = Light Green	CH = Dark Brown
DG = Dark Green	

When a wire color is striped, the base color is given first, followed by the stripe color. Example L/W = Blue with white stripe

### Battery specification:

Group size	21F
Capacity	12 V / 60 AH
Cold cranking current	490 A
Reserve capacity	88 minutes
Load test at 3 × AH for 15 seconds.	

### Battery charging rates:

Amps	Time
50	1 hour
25	2 hours
10	5 hours
5	10 hours

Do not charge battery over 50 ampere rate.

Do not "quick charge" a full discharged battery.

If battery electrolyte temperature rises above 140°F, stop charging

### Starter: (Engine GA)

Type	M0T80281ZC	M2T49283ZC	S114-802A
	MITSUBISHI		HITACHI
Applied Model	Reduction	Non-reduction	Reduction
	M/T		A/T
	Federal	California	
No-load Current	90 A Max.	53 A Max.	90 A Max.
No-load RPM	2750 Min.	6000 Min.	2750 Min

### Starter: (Engine SR)

Type	M1T72985A	S114-701C
	MITSUBISHI	
	Reduction	Reduction
No-load Current	90 A Max.	90 A Max.
No-load RPM	3000 Min.	2950 Min

**Alternator:**

Type	HITACHI LR180-751 (engine GA) HITACHI LR180-741H (engine SR)
Nominal Rating	12 V / 80 A
Regulated Output Voltage	14.1 - 14.7
Output Current A/RPM	More Than 23 / 1,300
(with 13.5V applied)	More Than 65 / 2,500 More Than 77 / 5,000

**Thermal Transmitter (Water Temp. Sensor For Gauge)**

<b>Water Temperature</b>	<b>Resistance</b>
140°F (60°C)	Approx. 170 - 210 Ω (engine GA) Approx. 70 - 90 Ω (engine SR)
212°F (100°C)	Approx. 47 - 53 Ω (engine GA) Approx. 21 - 24 Ω (engine SR)

**Oil Pressure Switch:**

<b>Oil pressure PSI</b>	<b>Continuity</b>
More Than 10 - 20	NO
Less Than 10 - 20	YES

**Bulb Specifications:**

Item	Wattage (12V)	Bulb No.
Headlamp High/Low	65/45 (Sentra)	HB9004
	65/55 (200SX)	HB5 9007
Front Combination Lamp	27/8	1157NA
Front Fog Lamp	35	H3 (special)
Rear Turn Signal	27	1156
Stop/Tail Lamp	27/8	1157
Center Stop Lamp	13	912
Back-up Lamp	13 (Sentra)	921
	27 (200SX)	1156
License Plate Lamp	5	168

**How to perform voltage drop test: See Illustrations**

Symptom: Dim bulb or no operation

0 (zero) ohm resistance between switch and bulb

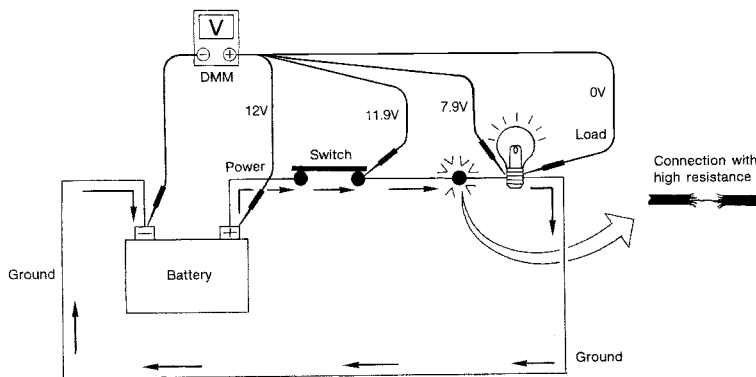

AGI069

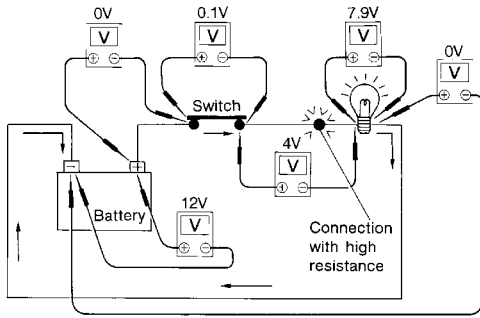

1. Connect the voltmeter as shown, starting at the battery and working your way around the circuit.
2. An unusually large voltage drop will indicate a component or wire that needs to be repaired. In the illustration, the poor connection causes a 4 volt drop.

The chart that follows illustrates some maximum allowable voltage drops. These values are given as a guideline, the exact value for each component may vary.

COMPONENT	VOLTAGE DROP
Wire	negligible <.001 volts
Ground Connections	Approx. 0.1 volts
Switch Contacts	Approx. 0.3 volts

AGI055



# QUICK REFERENCE DESCRIPTION



200SX 1997

Quick Reference

Electrical

## BATTERY CONDITION

### Battery Sulphation:

A battery will be completely discharged if it is left unattended for a long time and the specific gravity becomes less than 1.100. This may result in sulphation on the cell plates. To determine if a battery has been sulfated, note its voltage and current when charging. If low current and higher voltage are observed in the initial stages of charging a sulfated battery is likely. A sulfated battery may sometimes be brought back into service by means of a long slow charge, 12 hours or more.

### Checking Battery Specific Gravity With Hydrometer

Hydrometer temperature correction

Battery electrolyte temp. °C (°F)	Add to specific gravity reading
71 (160)	0.032
66 (150)	0.028
60 (140)	0.024
54 (129)	0.020
49 (120)	0.016
43 (110)	0.012
38 (100)	0.008
32 (90)	0.004
27 (80)	0
21 (70)	-0.004
16 (60)	-0.008
10 (50)	-0.012
4 (39)	-0.016
-1 (30)	-0.020
-7 (20)	-0.024
-12 (10)	-0.028
-18 (0)	-0.032

Corrected specific gravity	Approximate charge condition
1.260 - 1.280	Fully charged
1.230 - 1.250	3/4 charged
1.200 - 1.220	1/2 charged
1.170 - 1.190	1/4 charged
1.140 - 1.160	Almost discharged

- Do not quick charge a fully discharged battery.
- After charging, if the specific gravity of any two cells varies more than .050, the battery should be replaced.

