

REAR AXLE & REAR SUSPENSION

SECTION **RA**

GI

MA

EM

LC

EF &
EC

FE

CL

MT

AT

PD

FA

RA

BR

ST

BF

HA

EL

CONTENTS

PRECAUTIONS AND PREPARATION	2	Wheel Hub and Axle Housing	8
Precautions.....	2	Drive Shaft.....	11
Special Service Tools	2	REAR SUSPENSION	17
Commercial Service Tools	3	Coil Spring and Shock Absorber	18
REAR AXLE AND REAR SUSPENSION	4	Multi-link and Lower Ball Joint	19
ON-VEHICLE SERVICE	5	Stabilizer Bar	20
Rear Axle and Rear Suspension Parts.....	5	SUPER HICAS	21
Rear Wheel Bearing	5	Rear Wheel Alignment.....	21
Rear Wheel Alignment.....	5	Rear Axle Housing Ball Joint.....	21
Drive Shaft.....	6	SERVICE DATA AND SPECIFICATIONS (S.D.S.)	22
REAR AXLE AND REAR SUSPENSION		General Specifications.....	22
ASSEMBLY	7	Inspection and Adjustment.....	23
REAR AXLE	8		

PRECAUTIONS AND PREPARATION

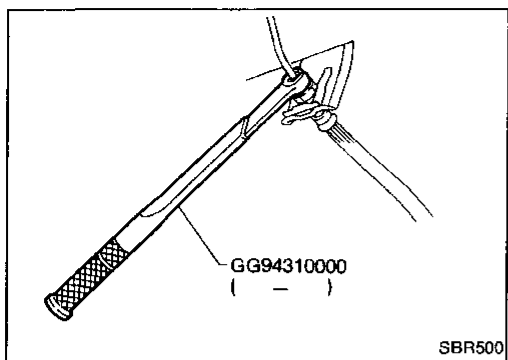

Precautions

- When installing rubber parts, final tightening must be carried out under unladen condition* with tires on ground.
- *: Fuel, radiator coolant and engine oil full. Spare tire, jack, hand tools and mats in designated positions.
- Use Tool when removing or installing brake tubes.
- When removing each suspension part, check wheel alignment and adjust if necessary.
- Do not jack up at the lower arm.

Special Service Tools

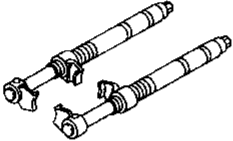
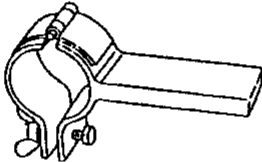
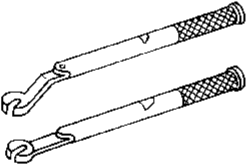
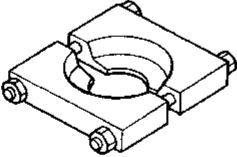
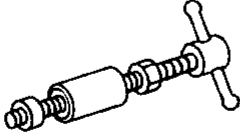
Tool number (Kent-Moore No.) Tool name	Description	
HT71780000 (—) Spring compressor		Removing and installing coil spring
ST35652000 (—) Strut attachment		Fixing strut assembly
GG94310000 (—) Flare nut torque wrench		Removing and installing brake piping
ST30031000 (J22912-01) Bearing puller		Removing inner race of wheel bearing
ST38280000 (—) Arm bushing remover		Removing and installing bushing of rear axle housing

PRECAUTIONS AND PREPARATION

Commercial Service Tools

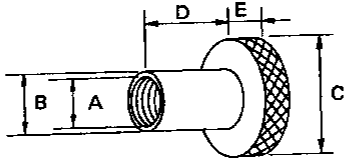
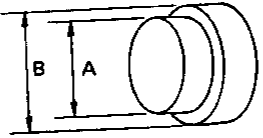
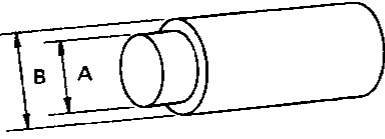
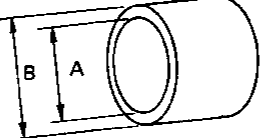
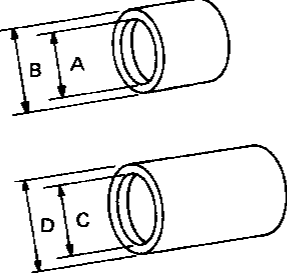
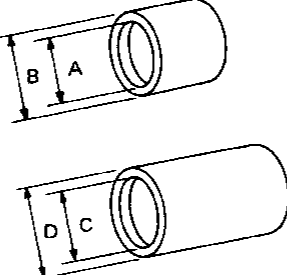
Tool name	Description
Attachment Wheel alignment	 <p>Measure rear wheel alignment A: Screw M24 x 1.5 B: 35 (1.38) dia. C: 65 (2.56) dia. D: 58 (2.20) E: 12 (0.47)</p> <p style="text-align: right;">Unit: mm (in)</p>
Rear wheel hub drift	 <p>Installing wheel bearing A: 41 mm (1.61 in) dia. B: 49 mm (1.93 in) dia.</p>
Wheel bearing drift	 <p>Removing rear wheel hub A: 26 mm (1.02 in) dia. B: 40 mm (1.57 in) dia.</p>
Rear drive shaft plug seal drift	 <p>Installing rear drive shaft plug seal A: 67 mm (2.64 in) dia. B: 85 mm (3.35 in) dia.</p>
Rear axle housing ball joint drift	 <p>Removing ball joint A: 20 (0.79) dia. B: 28 (1.10) dia. C: 40 (1.57) dia. D: 43 (1.69) dia.</p> <p style="text-align: right;">Unit: mm (in)</p>
Rear axle housing ball joint drift	 <p>Installing ball joint A: 33 (1.30) dia. B: 43 (1.69) dia. C: 30 (1.18) dia. D: 40 (1.57) dia.</p> <p style="text-align: right;">Unit: mm (in)</p>

GI

MA

EM

LC

EF &
EC

FE

CL

MT

AT

PD

FA

RA

BR

ST

BF

HA

EL

REAR AXLE AND REAR SUSPENSION

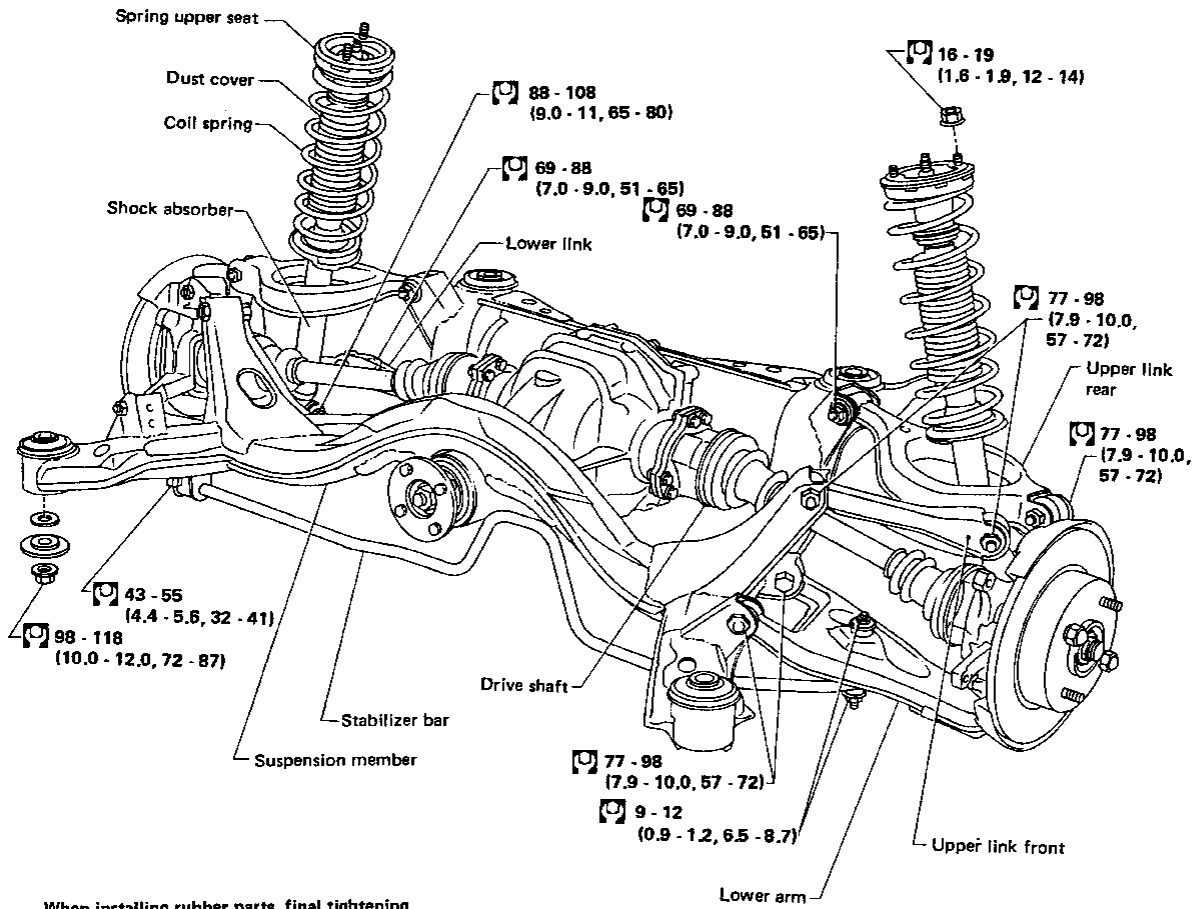

When installing rubber parts, final tightening must be carried out under unladen condition* with tires on ground.

* Fuel, radiator coolant and engine oil full. Spare tire, jack, hand tools and mats in designated positions.

: N·m (kg·m, ft·lb)

SRA093A

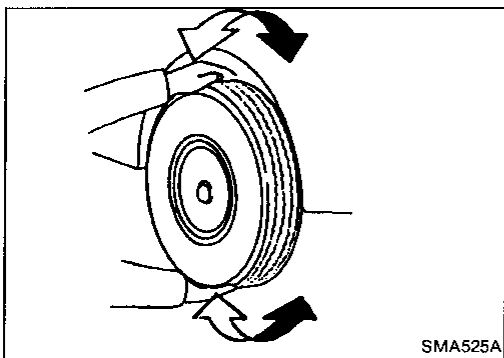

Rear Axle and Rear Suspension Parts

Check axle and suspension parts for looseness, wear or damage.

- Shake each rear wheel.
- Retighten all axle and suspension nuts and bolts to the

Tightening torque:

Refer to REAR SUSPENSION.

- Make sure that cotter pins are inserted.

GI

MA

EM

LC

EF &
EC

FE

CL

MT

AT

PD

FA

RA

BR

ST

BF

HA

EL

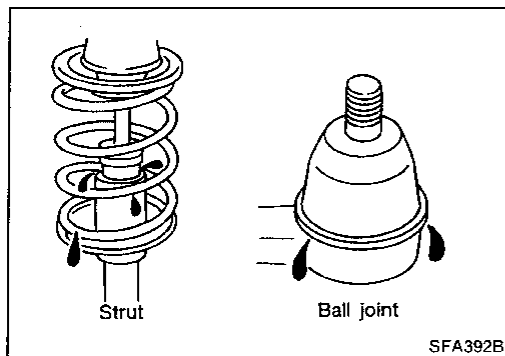

- Check shock absorber for oil leakage or other damage.
- Check wheelarch height. Refer to section FA.
- Check suspension lower ball joint for excessive play.
- Check suspension ball joint for grease leakage and ball joint dust cover for cracks or other damage.

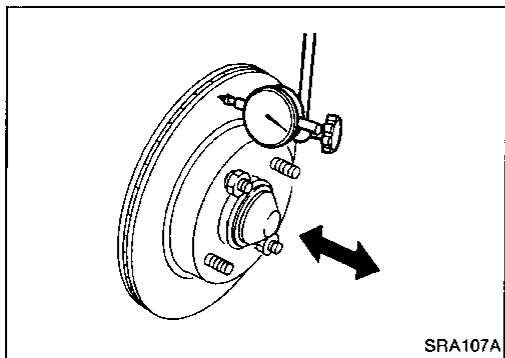

Rear Wheel Bearing

- Check that wheel bearings operate smoothly.
- Check axial end play.

Axial end play:

0.05 mm (0.0020 in) or less

- If axial end play is not within specification or wheel bearing does not turn smoothly, replace wheel bearing assembly.

Refer to REAR AXLE — Wheel Hub and Axle Housing.

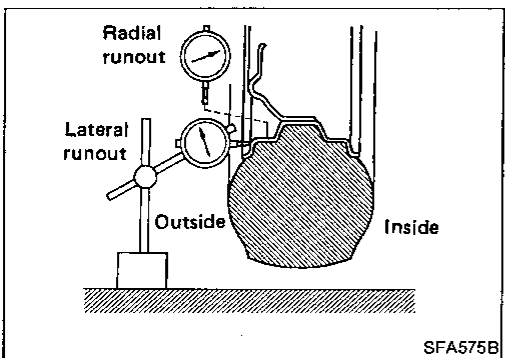

Rear Wheel Alignment

Before checking rear wheel alignment, be sure to make a preliminary inspection.

PRELIMINARY INSPECTION

Make following checks. Adjust, repair or replace if necessary.

- Check tires for wear and for improper inflation.
- Check rear wheel bearings for looseness and wheel runout. Refer to S.D.S.
- Check that rear shock absorber works properly.
- Check rear axle and rear suspension parts for looseness.
- Check vehicle posture at Unladen.

Fuel tank, radiator and engine oil full. Spare tire, jack, hand tools and mats in designated positions.

ON-VEHICLE SERVICE

Rear Wheel Alignment (Cont'd)

CAMBER

Measure camber of both right and left wheels with a suitable alignment gauge and adjust in accordance with the following procedures.

Camber:

Refer to S.D.S.

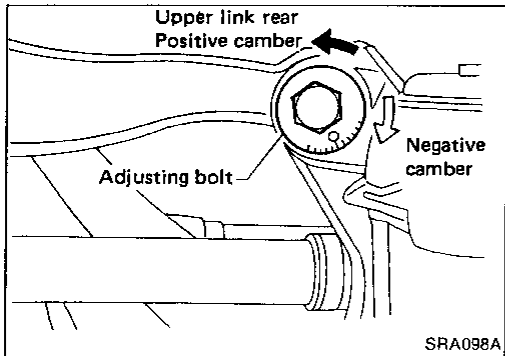
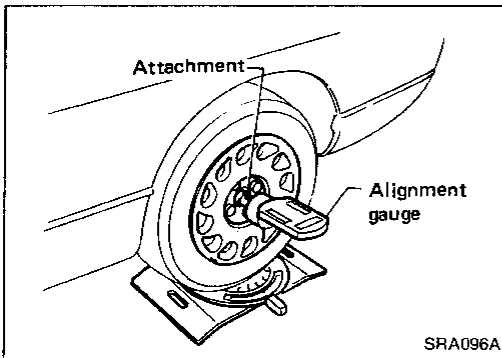

- If camber is not within specification, adjust by turning the adjusting bolt.

(1) Turn the adjusting bolt to adjust.

Camber changes about 5' with each graduation of the adjusting bolt.

(2) Tighten to the specified torque.

[]: 69 - 88 N·m

(7.0 - 9.0 kg-m, 51 - 65 ft-lb)

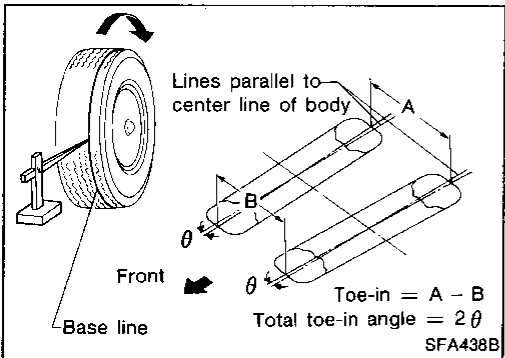

TOE-IN

1. Draw a base line across the tread.

After lowering rear of vehicle, move it up and down to eliminate friction.

2. Measure toe-in.

Measure distance "A" and "B" at the same height as hub center.

Toe-in:

Refer to S.D.S.

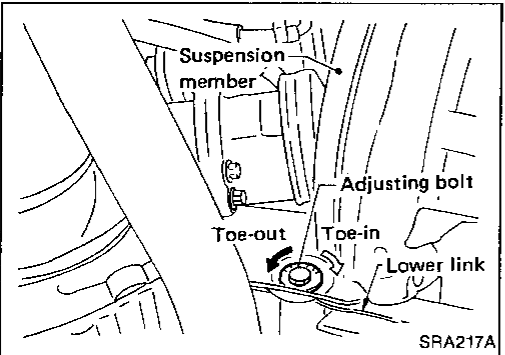

3. Adjust toe-in by turning adjusting bolts.

Toe changes about 1.5 mm (0.059 in) [One side] with each graduation of the adjusting bolt.

4. Tighten to the specified torque.

[]: 69 - 88 N·m

(7.0 - 9.0 kg-m, 51 - 65 ft-lb)

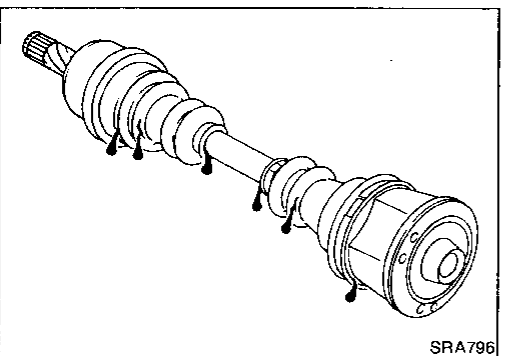

Drive Shaft

Check boot and drive shaft for cracks, wear, damage or grease leakage.

REAR AXLE AND REAR SUSPENSION ASSEMBLY

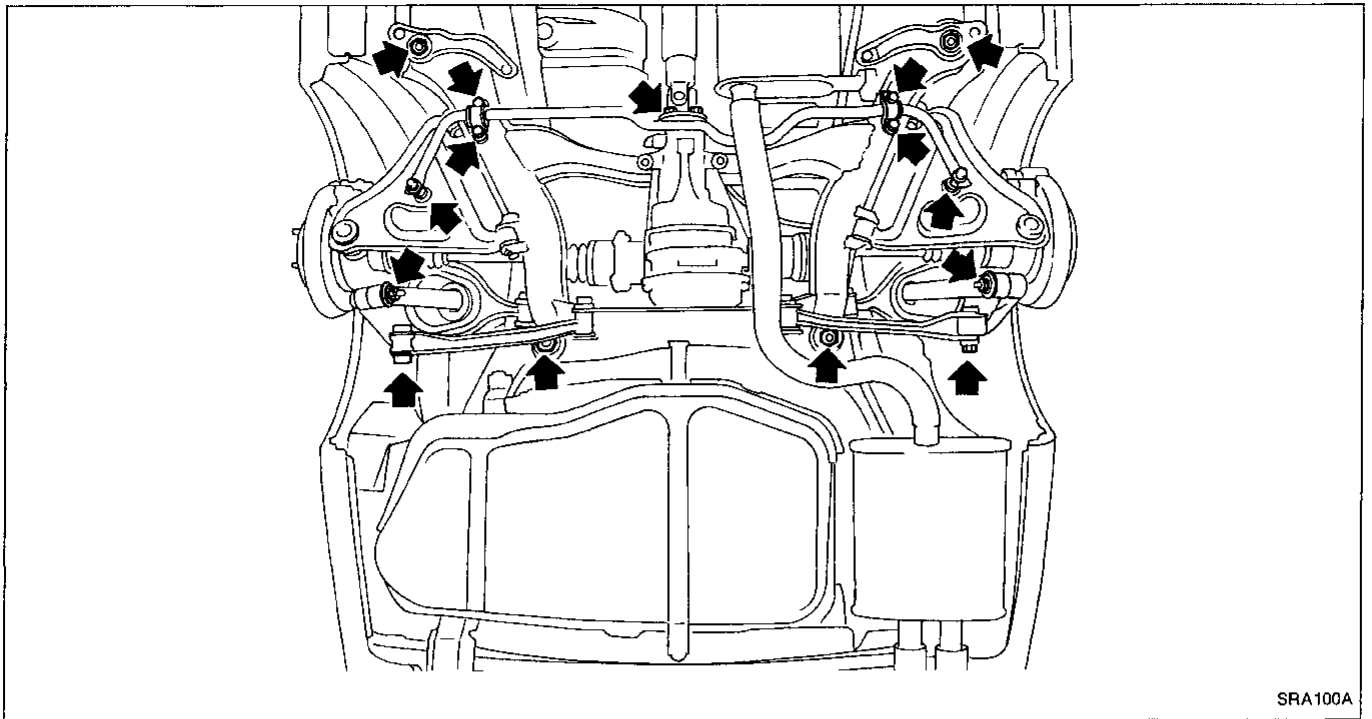

SRA100A

- Remove exhaust tube.
- Disconnect propeller shaft rear end.

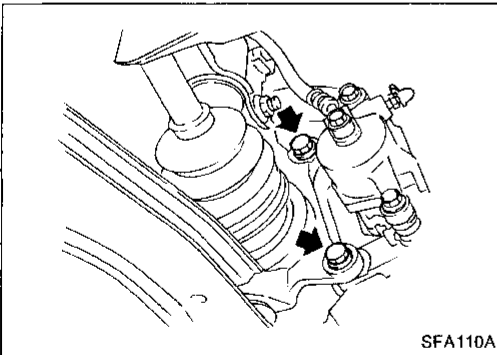

SFA110A

- Remove brake caliper assembly.
Brake hose need not be disconnected from brake caliper. Be careful not to depress brake pedal, or piston will pop out. Make sure brake hose is not twisted.

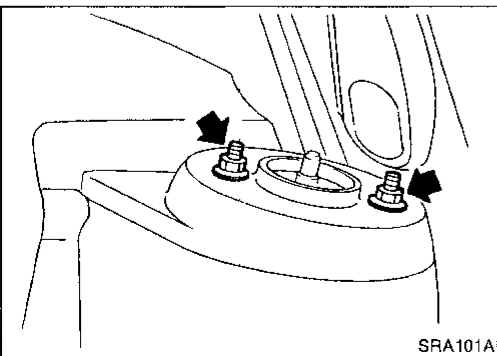

SRA101A

- Remove upper end nuts of shock absorber.
Do not remove piston rod lock nut.
- Remove suspension member fixing nuts. Then draw out rear axle and rear suspension assembly.

GI
MA
EM
LC
EF &
EC
FE
CL
MT
AT
PD
FA
RA
BR
ST
BF
HA
EL

REAR AXLE

Wheel Hub and Axle Housing

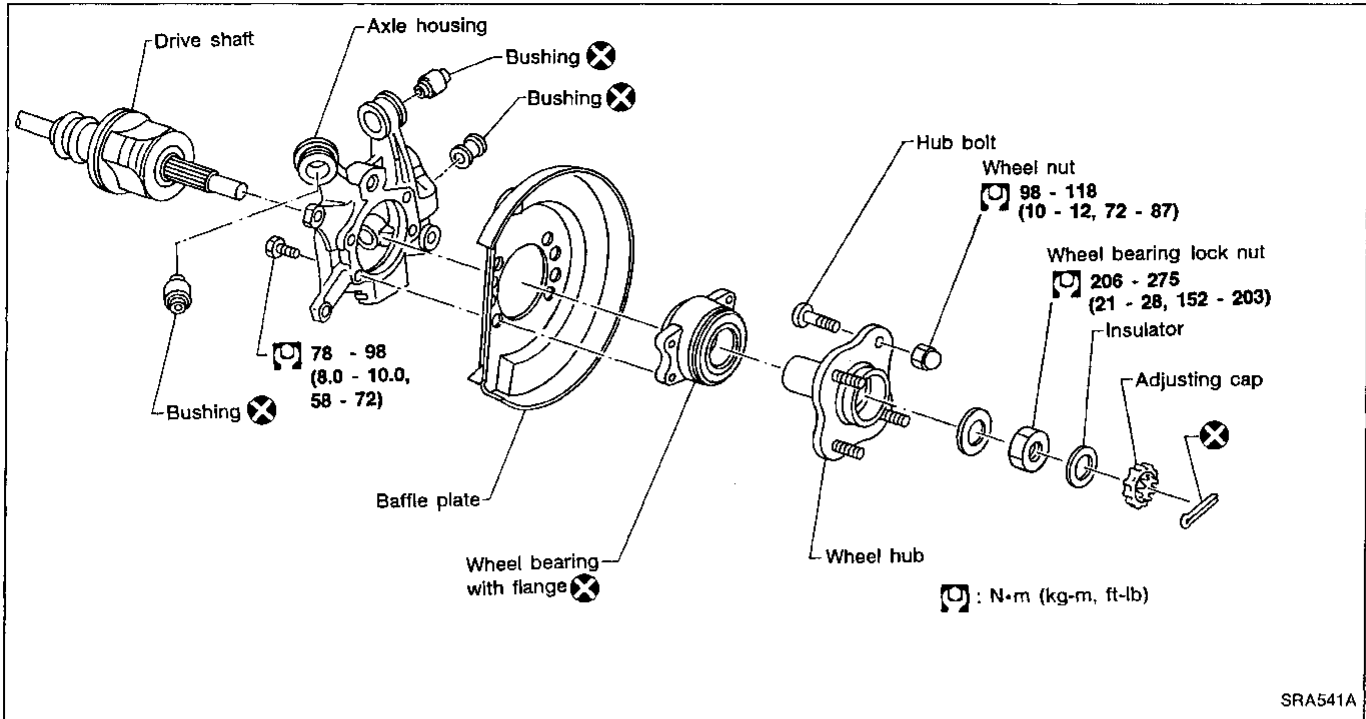

REMOVAL

- Remove wheel bearing lock nut.

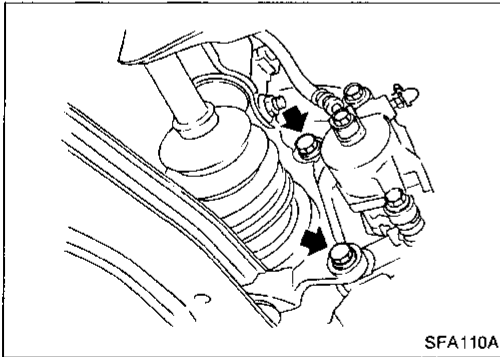

- Remove brake caliper assembly and rotor. **Brake hose need not be disconnected from brake caliper. Be careful not to depress brake pedal, or piston will pop out. Make sure brake hose is not twisted.**

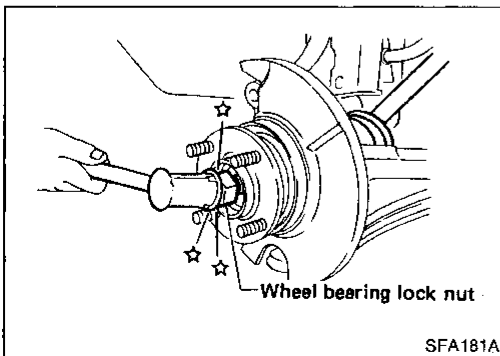

- Separate drive shaft from axle housing by slightly tapping it. **When removing drive shaft, cover boots with shop towel to prevent them from being damaged.**

REAR AXLE

Wheel Hub and Axle Housing (Cont'd)

- Remove axle housing.
- Remove wheel bearing with flange, and wheel hub from axle housing.

GI

MA

EM

LC

EF &
EC

FE

CL

MT

AT

PD

FA

RA

BR

ST

BF

HA

EL

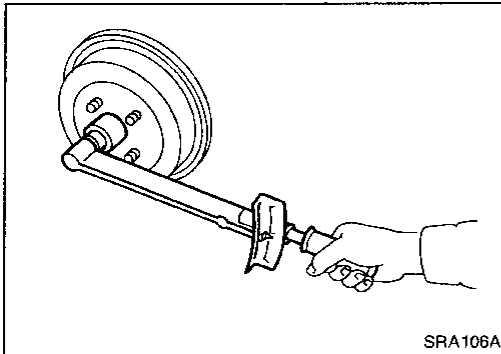

SRA106A

INSTALLATION

- Install axle housing with wheel hub.
- Tighten wheel bearing lock nut.
Ⓜ: 206 - 275 N·m
(21 - 28 kg-m, 152 - 203 ft-lb)

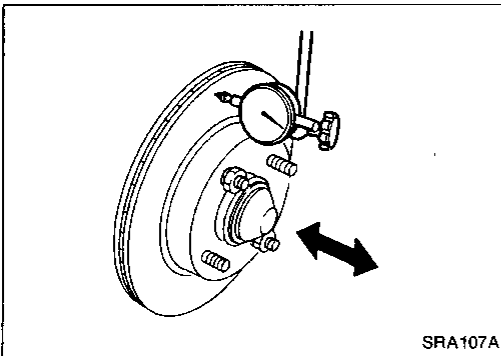

SRA107A

- Check wheel bearing axial end play.
Axial end play: 0.05 mm (0.0020 in) or less

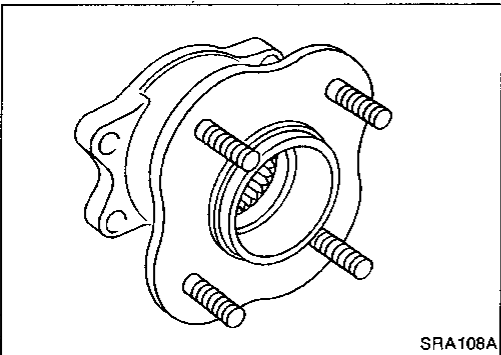

SRA108A

DISASSEMBLY

CAUTION:

Wheel bearing with flange usually does not require maintenance. If any of the following symptoms are noted, replace wheel bearing assembly (including flange, and inner and outer seals).

- Growling noise is emitted from wheel bearing during operation.
- Wheel bearing drags or turns roughly when hub is turned with your hand after bearing lock nut is tightened to specified torque.
- After wheel bearing is removed from hub.

Wheel hub

Remove wheel bearing (with flange) and wheel hub as one unit from axle housing before disassembling.

REAR AXLE

Wheel Hub and Axle Housing (Cont'd)

Wheel bearing

- Using a press and drift as shown in figure at left, press wheel bearing out.
- Discard old wheel bearing assembly. Replace with a new wheel assembly.

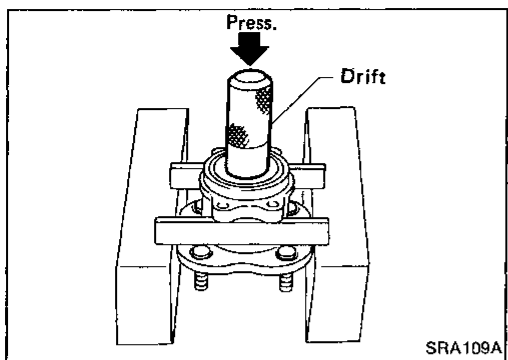

- Remove inner race from hub using a bearing replacer/puller.

CAUTION:

- a. Do not reuse old inner race although it is of the same brand as the bearing assembly.
- b. Do not replace grease seals as single parts.

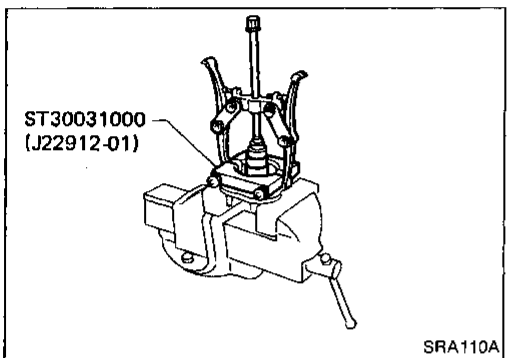

Axle housing

- Attach a drift on outer shell or bushing as shown in figure at left, remove bushing using arm bushing remover.

When placing axle housing in a vise, use wooden blocks or copper plates as pads.

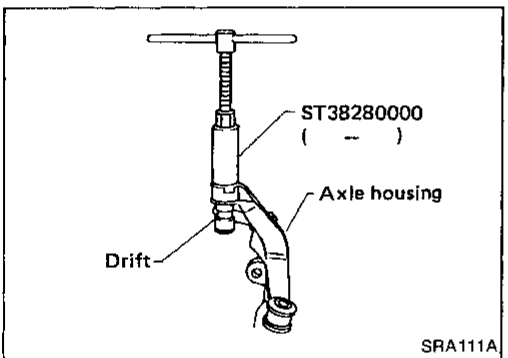

- Ensure axle housing bore is free from scratches or deformities before pressing bushing into it.
- Attach bushing to chamfered bore end of axle housing and press it until it is flush with end face of axle housing.

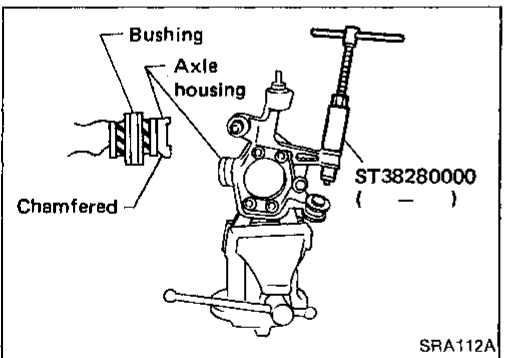

INSPECTION

Wheel hub and axle housing

- Check wheel hub and axle housing for cracks by using a magnetic exploration or dyeing test.
- Check wheel bearing for damage, seizure, rust or rough operation.
- Check rubber bushing for wear or other damage. Replace if necessary.

REAR AXLE

Wheel Hub and Axle Housing (Cont'd)

ASSEMBLY

Place hub on a block. Attach a drift to inner race of wheel bearing and press it into hub as shown in figure at left.

Be careful not to damage grease seal.

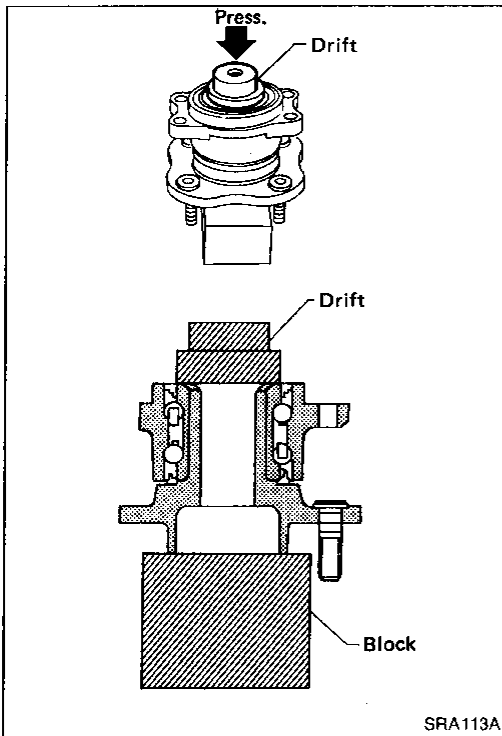

Drive Shaft

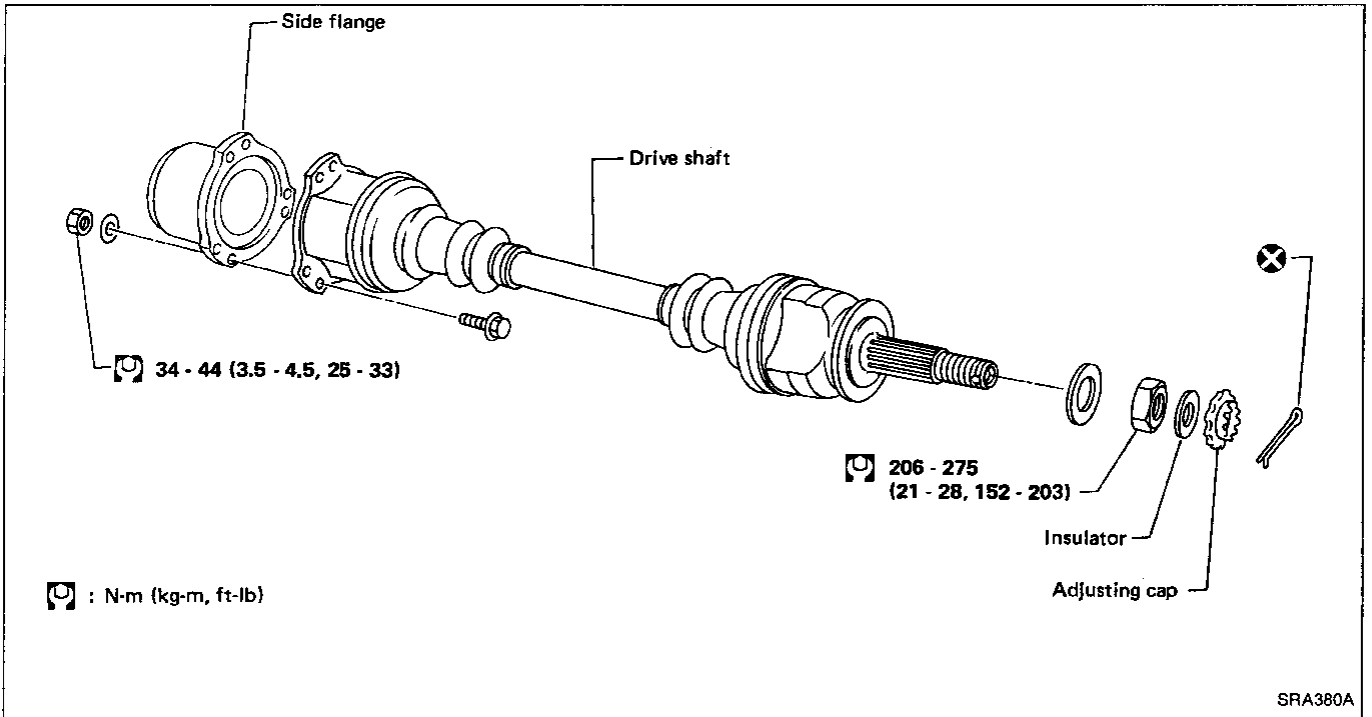

GI

MA

EM

LC

EF &
EC

FE

CL

MT

AT

PD

FA

RA

BR

ST

BF

HA

EL

REAR AXLE

Drive Shaft (Cont'd)

REMOVAL

When removing drive shaft, cover boots with shop towel to prevent damage to them.

Final drive side

Remove side flange mounting bolt and separate shaft.

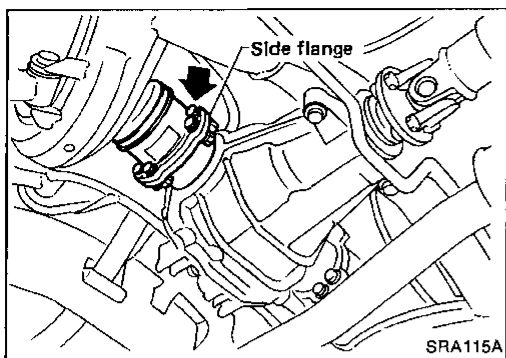

Wheel side

Remove drive shaft by lightly tapping it with a copper hammer. To avoid damaging threads of drive shaft, install a nut while removing drive shaft.

INSTALLATION

- Insert drive shaft from wheel hub and temporarily tighten wheel bearing lock nut.
- Tighten side flange mounting bolts to specified torque.
- Tighten wheel bearing lock nut to specified torque.

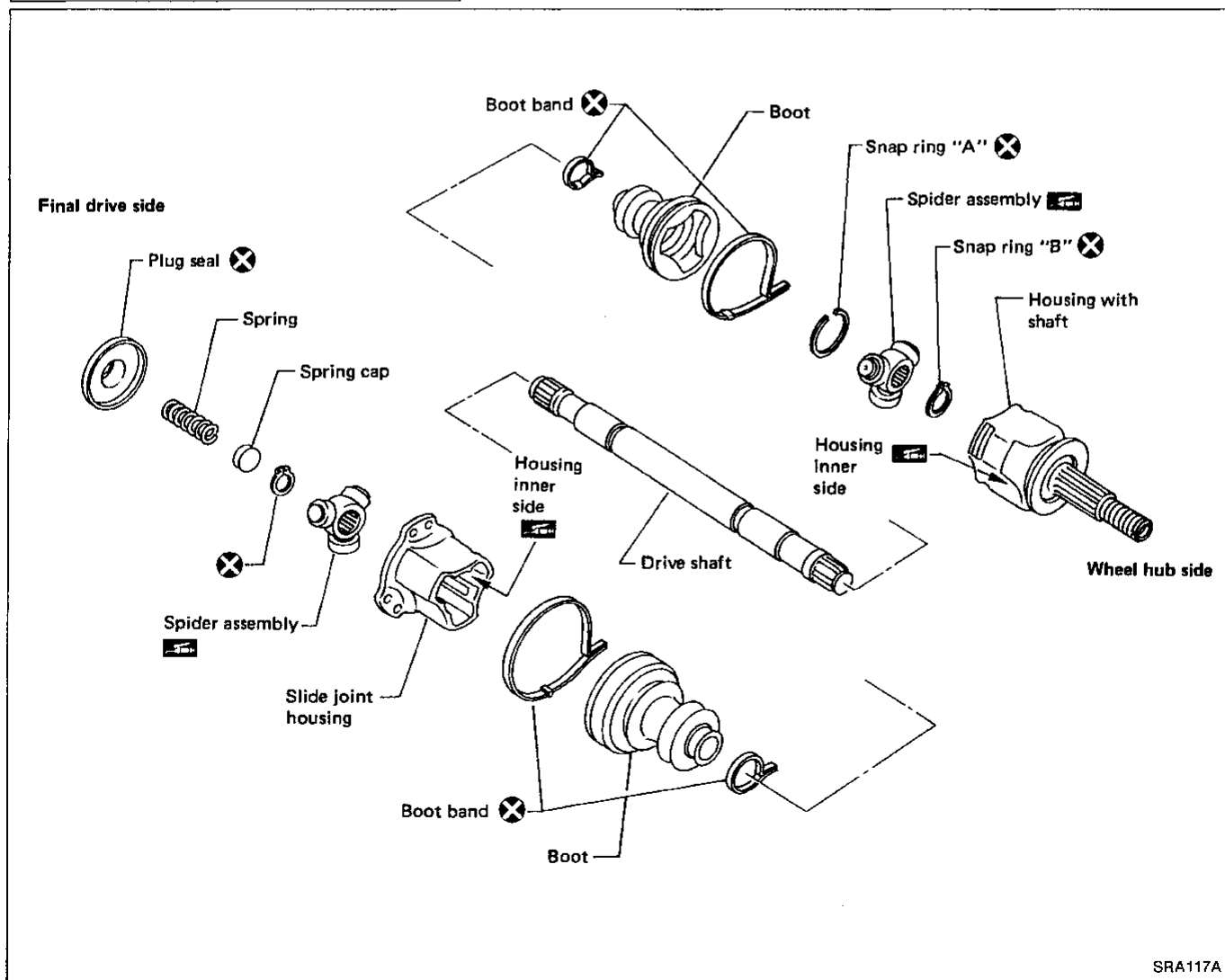
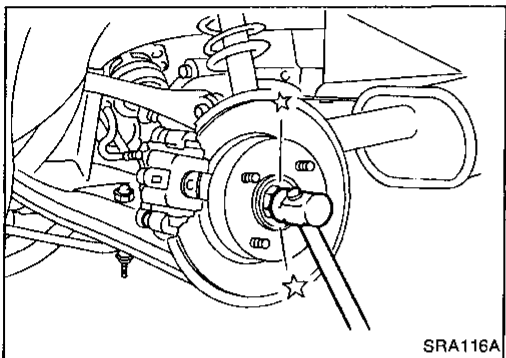

REAR AXLE

Drive Shaft (Cont'd)

DISASSEMBLY

Final drive side

1. Remove plug seal from slide joint housing by lightly tapping around slide joint housing.

GI

MA

EM

LC

EF &
EC

FE

CL

MT

AT

PD

FA

RA

BR

ST

BF

HA

EL

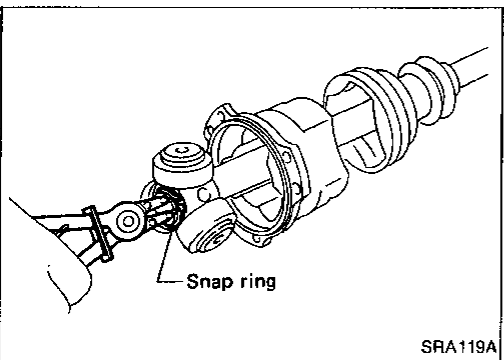
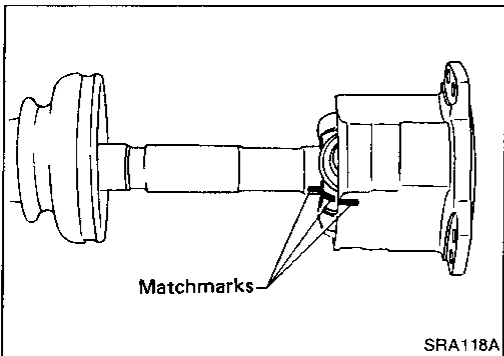
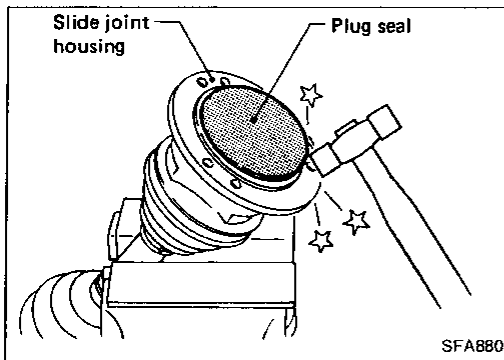

2. Remove boot bands.
3. Put matchmarks on slide joint housing and drive shaft before separating joint assembly.
4. Put matchmarks on spider assembly and drive shaft.

5. Pry off snap ring, then remove spider assembly.

CAUTION:

Do not disassemble spider assembly.

6. Draw out slide joint housing.
7. Draw out boot.

Cover drive shaft serration with tape to prevent damage to the boot.

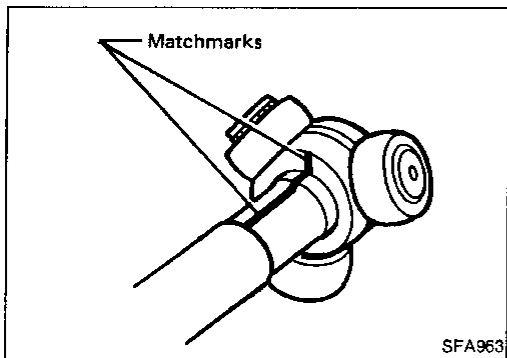

Wheel side

1. Remove boot bands.
2. Put matchmarks on housing together with shaft and drive shaft before separating joint assembly.
3. Put matchmarks on spider assembly and drive shaft.

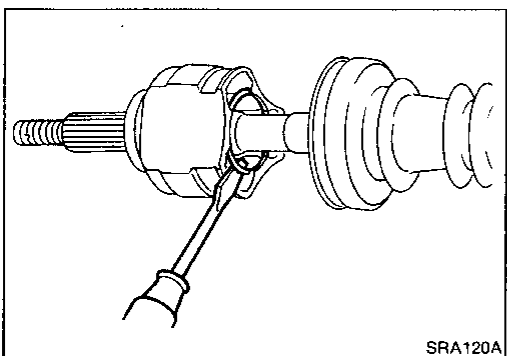

4. Pry off snap ring "A" with a screwdriver, and pull out slide joint housing.

REAR AXLE

Drive Shaft (Cont'd)

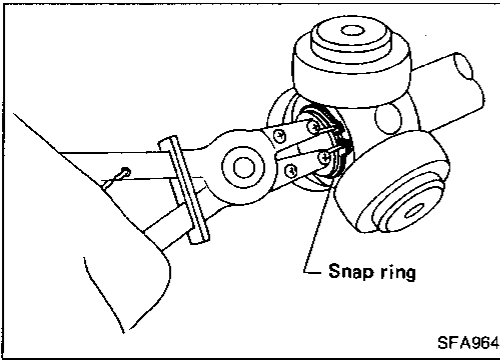

5. Pry off snap ring "B", then remove spider assembly.

CAUTION:

Do not disassemble spider assembly.

6. Draw out boot.

Cover drive shaft serration with tape to prevent damage to the boot.

INSPECTION

Thoroughly clean all parts in cleaning solvent, and dry with compressed air. Check parts for deformation or other damage.

Drive shaft

Replace drive shaft if it is twisted or cracked.

Boot

Check boot for fatigue, cracks, or wear. Replace boot with new boot bands.

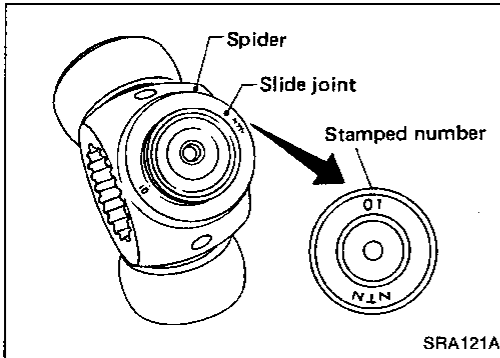

Joint assembly

- Check spider assembly for bearing, roller and washer damage. Replace spider assembly if necessary.
- Check housing for any damage. Replace housing set and spider assembly, if necessary.
- When replacing only spider assembly, select a new spider assembly from among those listed in table below. Ensure the number stamped on sliding joint is the same as that stamped on new part.

Housing alone cannot be replaced. It must be replaced together with spider assembly.

Stamped number	Part No.
00	39720 10V10
01	39720 10V11
02	39720 10V12

ASSEMBLY

- After drive shaft has been assembled, make sure it moves smoothly over its entire range without binding.
- Use Nissan Genuine Grease or equivalent after every overhaul.

REAR AXLE

Drive Shaft (Cont'd)

Final drive side

1. Install new small boot band, boot and slide joint housing to drive shaft.

Cover drive shaft serration with tape to prevent damage to boot during installation.

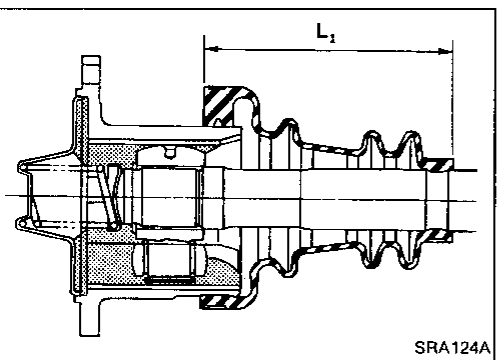
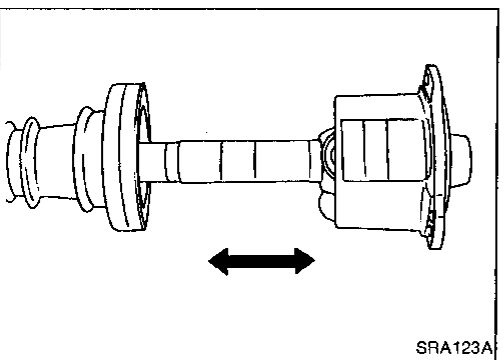
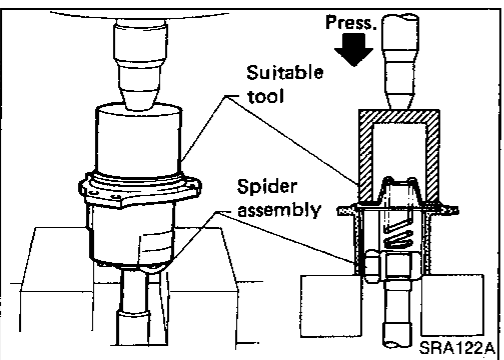
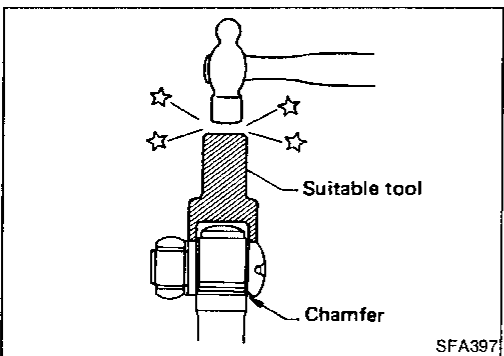
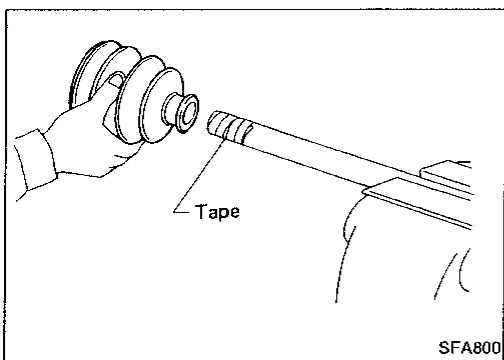

2. Install spider assembly securely, making sure marks are properly aligned.

Press-fit with spider assembly serration chamfer facing shaft.

3. Install new snap ring.

4. Install coil spring, spring cap and new plug seal to slide joint housing. Press plug seal.

Apply sealant to mating surface of plug seal.

CAUTION:

- a. When pressing plug seal into place, hold it horizontal so that spring inside it does not tilt or fall down.

- b. Move shaft in axial direction to ensure that spring is installed properly. If shaft drags or if spring is not installed properly, remove plug seal and install a new one. Discard plug seal after removal.

5. Pack drive shaft with specified amount of grease.

Specified amount of grease:

185 - 195 g (6.52 - 6.88 oz)

6. Set boot so that it does not swell and deform when its length is "L₁".

Length "L₁":

110.5 - 112.5 mm (4.35 - 4.43 in)

Make sure that boot is properly installed on the drive shaft groove.

GI

MA

EM

LC

EF &
EC

FE

CL

MT

AT

PD

FA

RA

BR

ST

BF

HA

EL

REAR AXLE

Drive Shaft (Cont'd)

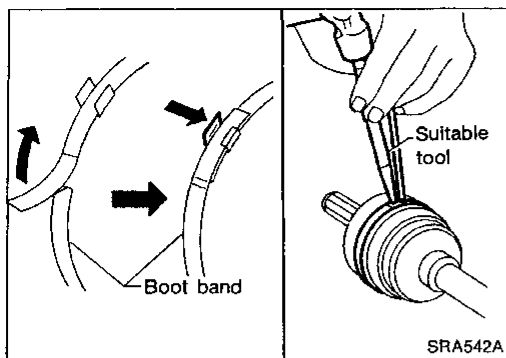

7. Lock new larger boot band securely with a suitable tool, then lock new smaller boot band.

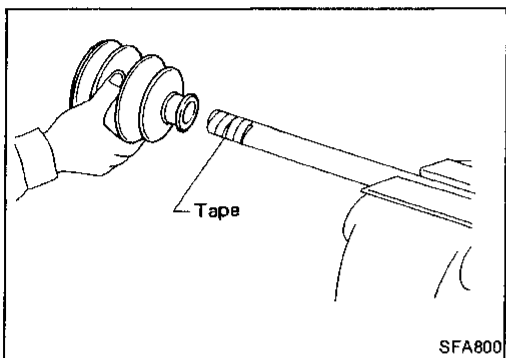

Wheel side

1. Install new small boot band and boot on drive shaft.
Cover drive shaft serration with tape to prevent damage to boot during installation.

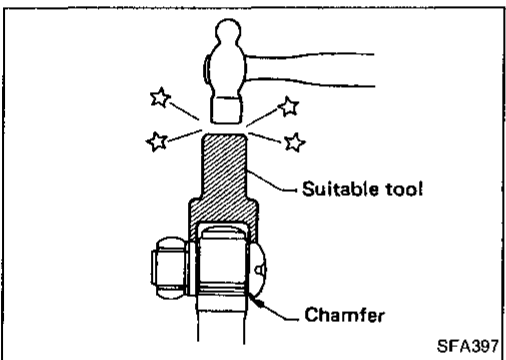

2. Install spider assembly securely, making sure marks are properly aligned.
Press-fit with spider assembly serration chamfer facing shaft.
3. Install new snap ring.

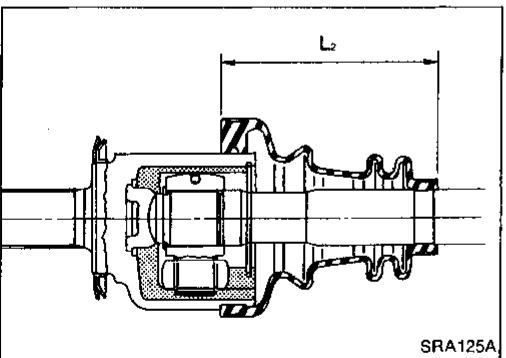

4. Pack drive shaft with specified amount of grease.
Specified amount of grease:
145 - 155 g (5.11 - 5.47 oz)
5. Install slide joint housing, then install new snap ring "A".
6. Set boot so that it does not swell and deform when its length is "L₂".
Length "L₂":
110.5 - 112.5 mm (4.35 - 4.43 in)

Make sure that boot is properly installed on the drive shaft groove.

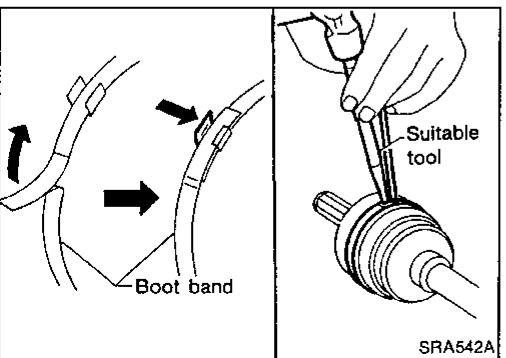

7. Lock new larger and smaller boot bands securely with a suitable tool.

REAR SUSPENSION

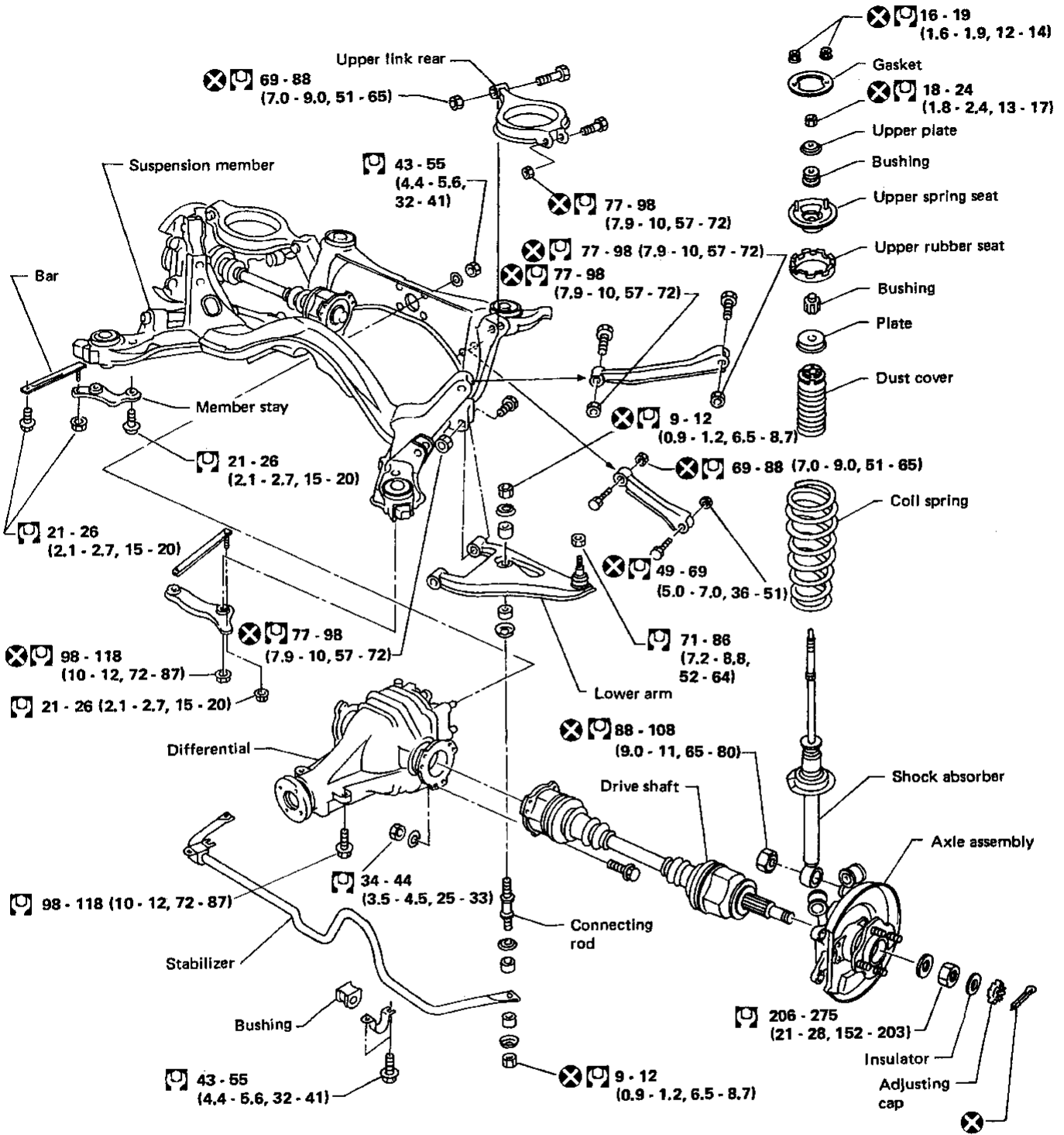

98 - 118
(10 - 12, 72 - 87)

21 - 26 (2.1 - 2.7, 15 - 20)

Differential

98 - 118 (10 - 12, 72 - 87)

Stabilizer

Bushing

43 - 55
(4.4 - 5.6, 32 - 41)

CAUTION:
Do not jack up at lower arm.
When installing rubber parts, final tightening must be carried out under unladen condition* with tires on ground.
* Fuel, radiator coolant and engine oil full.
Spare tire, jack, hand tools and mats in designated positions.

☐ : N·m (kg·m, ft·lb)

GI

MA

EM

LC

EF & EC

FE

CL

MT

AT

PD

FA

RA

BR

ST

BF

HA

EL

REAR SUSPENSION

Coil Spring and Shock Absorber

REMOVAL

Remove shock absorber upper and lower fixing nuts.

Do not remove piston rod lock nut on vehicle.

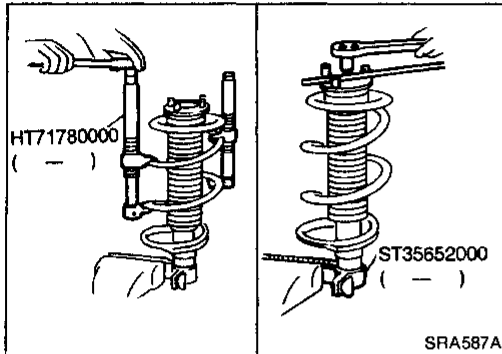

DISASSEMBLY

1. Set shock absorber on vise with attachment, then loosen piston rod lock nut.

Do not remove piston rod lock nut.

2. Compress spring with Tool so that the strut upper spring seat can be turned by hand.

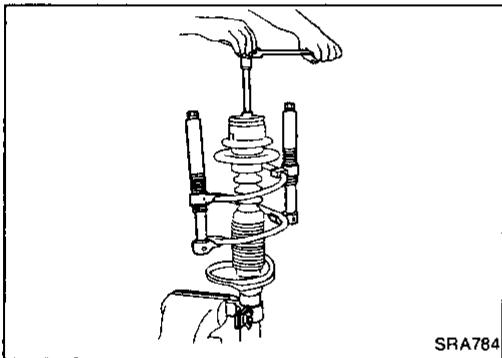

3. Remove piston rod lock nut.

INSPECTION

Shock absorber assembly

- Check for smooth operation through a full stroke, both compression and extension.
- Check for oil leakage occurring on welded or gland packing portion.
- Check piston rod for cracks, deformation or other damage. Replace if necessary.

Upper rubber seat and bushing

Check rubber parts for deterioration or cracks. Replace if necessary.

Coil spring

Check for cracks, deformation or other damage. Replace if necessary.

REAR SUSPENSION

Coil Spring and Shock Absorber (Cont'd)

ASSEMBLY

- When installing coil spring, be careful not to reverse top and bottom direction. (Top end is flat.)
- When installing coil spring on strut, it must be positioned as shown in figure at left.

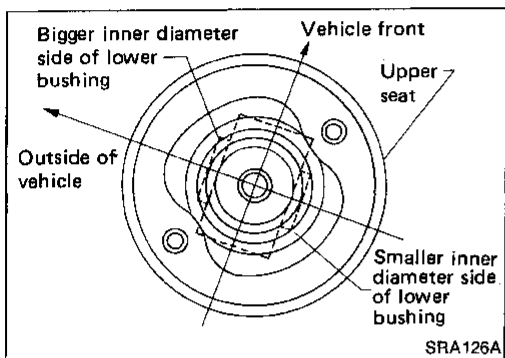
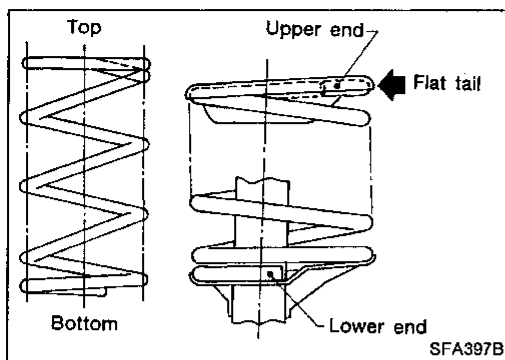

- When installing upper spring seat, make sure that it is positioned as shown.

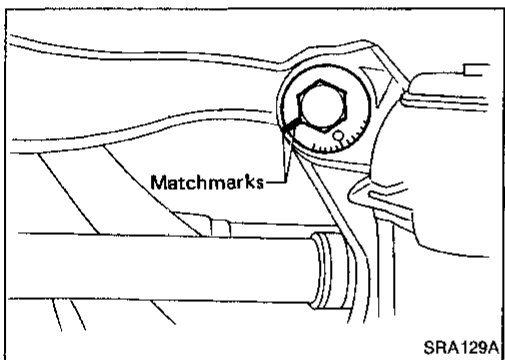

Multi-link and Lower Ball Joint

REMOVAL AND INSTALLATION

- Refer to "Removal and Installation" of REAR SUSPENSION. **Before removing, put matchmarks on adjusting pin.**
- When installing, final tightening must be carried out at curb weight with tires on ground.
- After installation, check wheel alignment. Refer to "Rear Wheel Alignment" of ON-VEHICLE SERVICE.

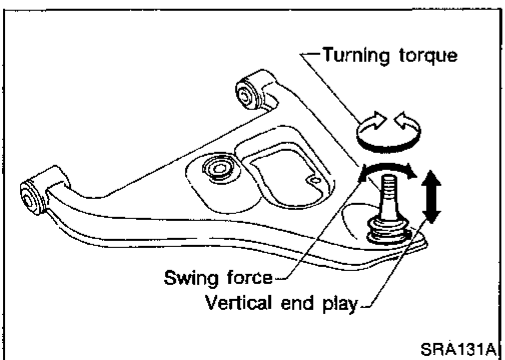
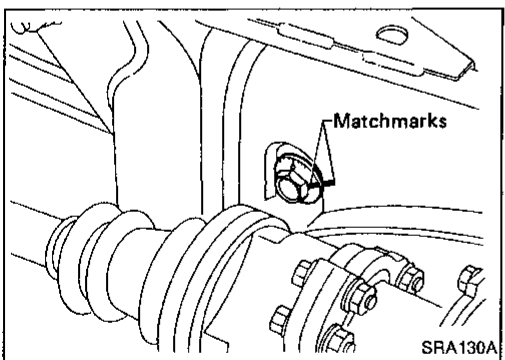

INSPECTION

Rear suspension member

Replace suspension member assembly if cracked or deformed or if any part (insulator, for example) is damaged.

Upper and lower links

Replace upper or lower link as required if cracked or deformed or if bushing is damaged.

GI

MA

EM

LC

EF &
EC

FE

CL

MT

AT

PD

FA

RA

BR

ST

BF

HA

EL

REAR SUSPENSION

Multi-link and Lower Ball Joint (Cont'd)

Suspension lower ball joint

- Measure swing force, turning torque and vertical end play in axial direction. (Use same measurement procedures as that of FA section.)
- If ball stud is worn, play in axial direction is excessive, or joint is hard to swing, replace lower arm.

Ball joint specifications	Swing force	12.7 - 90.2 N (1.3 - 9.2 kg, 2.9 - 20.3 lb)
	Turning torque	0.5 - 3.4 N·m (5 - 35 kg·cm, 4.3 - 30.4 in·lb)
	Vertical end play	0 mm (0 in)

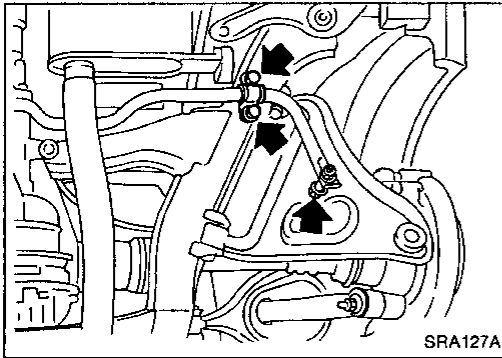

Stabilizer Bar

REMOVAL

- Remove connecting rod and clamp.

INSPECTION

- Check stabilizer bar for deformation or cracks. Replace if necessary.
- Check rubber bushings for deterioration or cracks. Replace if necessary.

INSTALLATION

When installing connecting rod, make sure direction is correct (as shown at left).

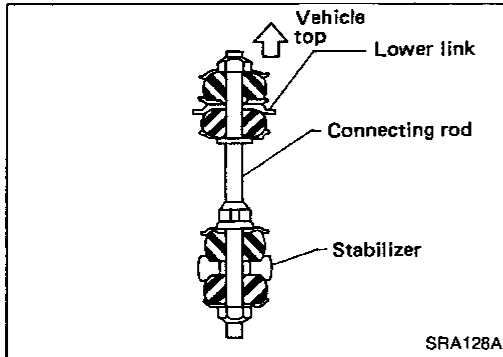

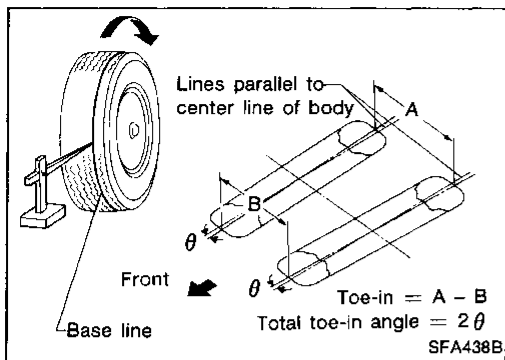

Rear Wheel Alignment

TOE-IN

1. Draw a base line across the tread.
After lowering rear of vehicle, move it up and down to eliminate friction.

2. Measure toe-in.

Measure distance "A" and "B" at the same height as hub center.

Toe-in:

Refer to S.D.S.

3. Adjust toe-in by varying length of power cylinder lower links.

- (1) Loosen lock nuts.
- (2) Adjust toe-in by turning lower links forward or backward.

Make sure both lower links are the same length.

Standard length "L":

185.5 mm (7.30 in)

(3) Tighten lock nuts to the specified torque.

□: 37 - 46 N·m

(3.8 - 4.7 kg·m, 27 - 34 ft·lb)

● Refer to ON-VEHICLE SERVICE for other procedures.

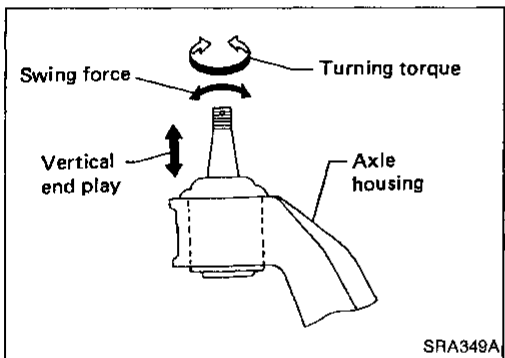
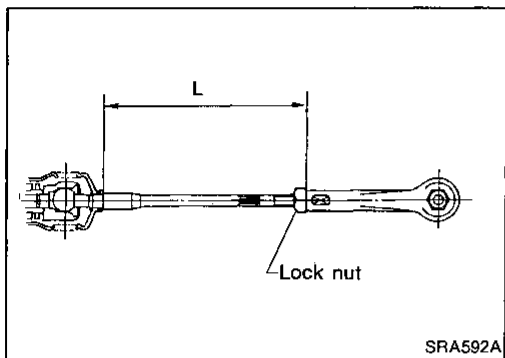

Rear Axle Housing Ball Joint

INSPECTION

- Measure swing force, turning torque and vertical end play in axial direction.
- If ball stud is worn, play in axial direction is excessive, or joint is hard to swing, replace ball joint.

Swing force, turning torque and vertical end play:

Refer to S.D.S

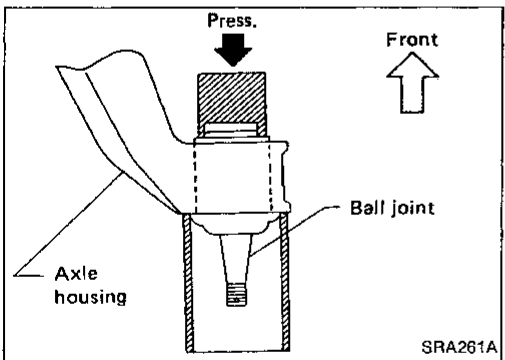

REMOVAL

- Remove ball joint snap ring.
- Press out ball joint from axle housing.

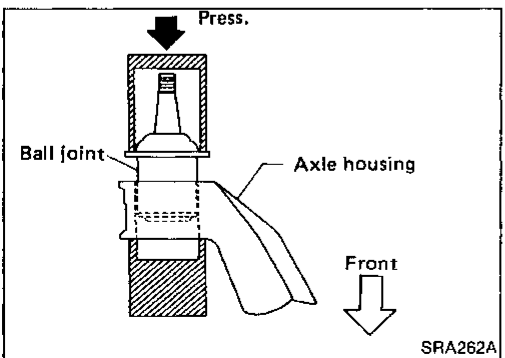

ASSEMBLY

- Press new ball joint assembly into axle housing.
- Install snap ring into groove of ball joint.
- Refer to REAR AXLE — Wheel Hub and Axle Housing for other procedures.
- Refer to ST section for power cylinder and SUPER HICAS — Trouble Diagnoses.

GI

MA

EM

LC

EF &
EC

FE

CL

MT

AT

PD

FA

RA

BR

ST

BF

HA

EL

SERVICE DATA AND SPECIFICATIONS (S.D.S.)

General Specifications

COIL SPRING

Applied model		Convertible	Coupe	Hatchback	
		Without HICAS			With HICAS
Wire diameter	mm (in)	10.7 (0.421)	10.6 (0.417)		11.0 (0.433)
Coil diameter	mm (in)	88.7 - 98.7 (3.492 - 3.886)			
Free length	mm (in)	397 (15.63)	375 (14.76)	385 (15.16)	367.5 (14.47)
Identification color		Yellow x 1	Pink x 1, Purple x 1	Pink x 1, Light blue x 1	Pink x 2

SHOCK ABSORBER

Applied model		Convertible	Coupe	Hatchback	
		Without HICAS			With HICAS
Piston rod diameter	mm (in)	12.5 (0.492)			

DRIVE SHAFT

Joint type		
Final drive side		TS82F
Wheel side		TS82C
Grease name		
Final drive side		Nissan genuine grease or equivalent
Wheel side		Nissan genuine grease or equivalent
Specified amount of grease	g (oz)	
Final drive side		185 - 195 (6.52 - 6.88)
Wheel side		145 - 155 (5.11 - 5.47)
Boot length	mm (in)	
Final drive side (L ₁)		110.5 - 112.5 (4.35 - 4.43)
Wheel side (L ₂)		

Final drive side

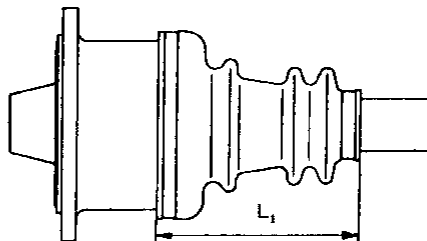

SRA133A

Wheel side

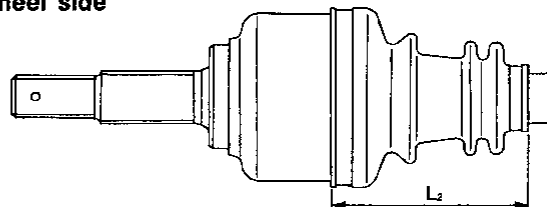

SRA543A

REAR STABILIZER BAR

Model		With HICAS	Without HICAS
Stabilizer diameter	mm (in)	21 (0.83)	15 (0.59)
Identification color		Red	Light green

SERVICE DATA AND SPECIFICATIONS (S.D.S.)

Inspection and Adjustment

WHEEL ALIGNMENT (Unladen*1)

Camber	degree	-1°36' to -0°36'
Toe-in		
A - B	mm (in)	0.5 - 4.5 (0.020 - 0.177)
Total angle 2θ	degree	3' - 25'

*1: Fuel, radiator coolant and engine oil full.
Spare tire, jack, hand tools and mats in designated positions.

WHEEL BEARING

Wheel bearing axial end play	mm (in)	0.05 (0.0020) or less
Wheel bearing lock nut		
Tightening torque	N·m (kg-m, ft-lb)	206 - 275 (21 - 28, 152 - 203)

WHEEL RUNOUT (Radial and lateral)

Wheel type		Radial runout	Lateral runout
Aluminum wheel	mm (in)	0.3 (0.012) or less	
Steel wheel	mm (in)	0.5 (0.020) or less	0.8 (0.031) or less

LOWER BALL JOINT

Swing force (Measuring point: cotter pin hole of ball stud)	N (kg, lb)	12.7 - 90.2 (1.3 - 9.2, 2.9 - 20.3)
Turning torque	N·m (kg-cm, in-lb)	0.5 - 3.4 (5 - 35, 4.3 - 30.4)
Vertical end play	mm (in)	0 (0)

LOWER LINK BALL JOINT (SUPER HICAS)

Swing force (at cotter pin hole)	N (kg, lb)	6.9 - 68.6 (0.7 - 7.0, 1.5 - 15.4)
Turning torque	N·m (kg-cm, in-lb)	0.3 - 2.9 (3 - 30, 2.6 - 26.0)
Vertical end play	mm (in)	0 (0)

GI

MA

EM

LC

EF &

EC

FE

CL

MT

AT

PD

FA

RA

BR

ST

BF

HA

EL