

DRIVE AXLE - REAR

1990 Nissan 240SX

1990 DRIVE AXLES
RWD Axle Shaft

240SX, 300ZX

NOTE: Information in this article applies to models with independent rear suspension. For other models, see appropriate DIFFERENTIAL & AXLE SHAFTS article.

DRIVE AXLE SHAFTS R & I

Removal

1) Raise and support vehicle. Cover boots with shop towel to prevent from damage. Remove the side flange-to-differential bolts and separate drive shaft.

2) To remove drive shaft from outboard/wheel side, loosen drive shaft lock nut, but do not remove completely. Tap lock nut lightly with soft hammer to drive out drive shaft.

DISASSEMBLY (240SX)

1) Remove boot bands. Paint matching marks on slide joint housing and drive shaft. Using a slide hammer, separate joint assembly.

2) Paint matching marks on spider assembly and drive shaft. Pry off snap ring from drive shaft, then remove spider assembly. DO NOT disassemble spider assembly. Cover drive shaft serration with tape and draw out boot.

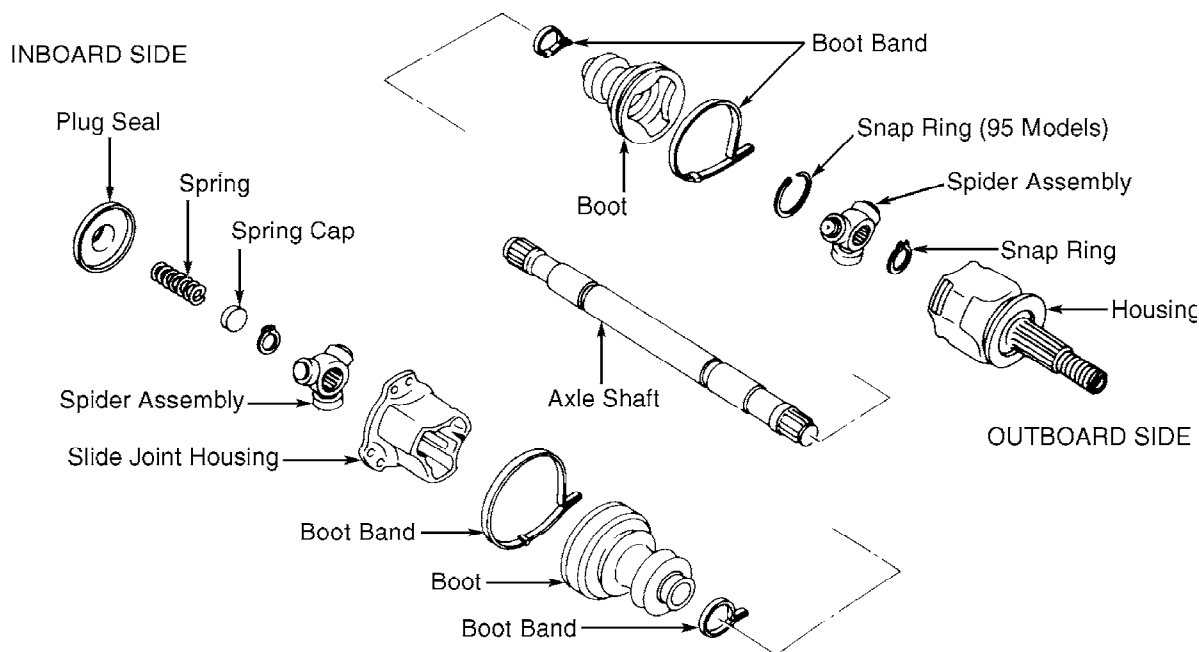

90C02340

Fig. 1: Exploded View of 240SX Drive Shaft
Courtesy of Nissan Motor Co., U.S.A.

DISASSEMBLY (300ZX)

CAUTION: On 300ZX, the joint on the outboard/wheel side cannot be disassembled.

1) Remove boot bands. Paint matching marks on slide joint housing and inner race. Separate joint assembly. Pry off snap ring and pull out joint housing.

2) Paint matching marks on inner bearing race and drive shaft. Pry off snap ring. Remove ball cage, inner race, and balls as a unit. Pry off inner snap ring and draw out boot.

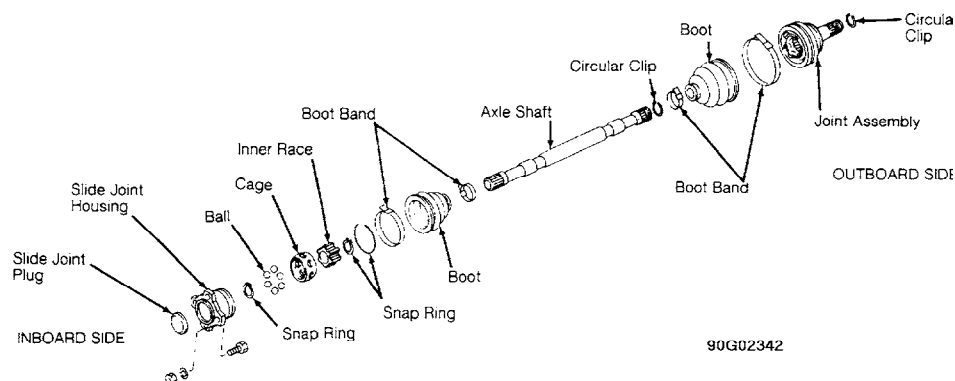

Fig. 2: Exploded View of 300ZX Drive Shaft
Courtesy of Nissan Motor Co., U.S.A.

REASSEMBLY (OUTBOARD/WHEEL SIDE)

1) Cover drive shaft serration with tape. Install boot and new boot band on drive shaft. Align matching marks and set joint assembly onto drive shaft by lightly tapping it.

2) Pack CV joint with grease. Set boot to specified length. See AXLE SHAFT BOOT LENGTH table. Ensure boot is fully installed on drive shaft groove. Lock boot bands securely with punch.

REASSEMBLY (INBOARD SIDE)

1) Cover drive shaft serration with tape. Install boot and new small boot band on drive shaft. Align matching marks and install spider assembly 240SX or bearing assembly (300ZX).

2) Install NEW snap ring. Pack CV joint with grease. Install slide joint housing. Set boot to specified length. See AXLE SHAFT BOOT LENGTH table. Ensure boot is properly installed on drive shaft groove. Lock boot bands securely with punch.

AXLE SHAFT BOOT LENGTH

Model	Outboard Boot		Inboard Boot	
	In. (mm)		In. (mm)	
240SX	4.35-4.43	(110.5-112.5)	4.35-4.43	(110.5-112.5)
300ZX	3.78-3.86	(96-98)	3.66-3.74	(93-95)

INSTALLATION

1) Install axle shafts into wheel hub and temporarily tighten

wheel hub lock nut. Install axle shaft onto differential side flange. Try to pull axle shaft out of differential by hand to ensure proper engagement of snap rings.

2) Tighten wheel hub lock nut to specification. See TORQUE SPECIFICATIONS table at end of article. Replace differential fluid (if required). To complete installation, reverse removal procedure.

REAR HUB ASSEMBLY R & I

Removal

Apply parking brake or depress brake pedal. Remove wheel bearing lock nut. Remove brake caliper and rotor. Remove drive shaft. See DRIVE AXLE SHAFTS in this article. Remove wheel bearing hub and wheel bearing from drive axle housing.

Disassembly

Press wheel bearing assembly out of hub. Using bearing puller, remove bearing race remaining in hub.

Reassembly

Press wheel bearing assembly into hub. Use care not to damage grease seal.

Installation

To install, reverse removal procedure.

TORQUE SPECIFICATIONS

TORQUE SPECIFICATIONS

Application	Ft. Lbs. (N.m)
Drive Shaft-to-Companion Flange Bolt ...	25-33 (34-44)
Strut-to-Axle Housing Bolt	
240SX	65-80 (88-108)
300SX	57-72 (78-98)
Wheel Bearing Hub-to-Axle Housing	58-72 (79-98)
Wheel Bearing Lock Nut	
240SX	174-231 (235-314)
300ZX	152-203 (206-275)