



# INSTRUMENT PANEL - STANDARD

1990 Nissan 240SX

1990 ACCESSORIES & EQUIPMENT  
Nissan Instrument Panels - Standard

240SX

## DESCRIPTION

The instrument cluster (combination meter) contains speedometer, tachometer, fuel gauge, temperature gauge and warning indicators. Combination meter can be removed with all gauges installed.

## TESTING BRAKE FLUID LEVEL LIGHT

Remove cap and brake level switch from brake fluid reservoir. Clean any foreign material from terminal connector. Using an ohmmeter, check brake level switch continuity. With brake fluid switch float raised, continuity should NOT exist. With brake fluid switch float lowered, continuity should exist.

## TESTING FUEL GAUGE

1) To check power source, turn ignition switch on. Check voltage between specified instrument panel terminal and ground. Refer to FUEL GAUGE TEST TERMINALS table. See Fig. 1. If battery voltage is present, go to step 3).

2) If battery voltage is NOT present, check for blown fuse or fusible link. Check harness continuity between battery terminal and combination meter. Check ignition relay and/or ignition switch for malfunction.

3) Turn ignition on. Connect a jumper wire with a 3.4 watt light bulb between fuel gauge terminal and ground for less than 10 seconds. Ensure fuel gauge moves smoothly from EMPTY to FULL.

4) If fuel gauge does not move smoothly from EMPTY to FULL, replace fuel gauge. If fuel gauge moves smoothly from EMPTY to FULL, test fuel gauge sending unit. See FUEL GAUGE SENDING UNIT. If sending unit is okay, repair or replace harness between combination meter and fuel gauge unit harness.

FUEL GAUGE TEST TERMINALS TABLE

Application	Test Terminals
240SX .....	No. 24 & Ground

## TESTING FUEL GAUGE SENDING UNIT

1) Remove sending unit from fuel tank. Measure resistance between terminals "G" (+) and "E" (-) of sending unit connector.

2) Resistance values should change as position of fuel sending unit is changed. Resistance values should approximately equal those on FUEL GAUGE SENDING UNIT RESISTANCE table.

FUEL GAUGE SENDING UNIT RESISTANCE TABLE (OHMS)

Full	Half	Empty



### TESTING OIL PRESSURE SWITCH

Check continuity between terminals of oil pressure switch and body ground. When engine is running, continuity should NOT exist. When engine is off, continuity should exist.

### TESTING PARKING BRAKE LIGHT

Disconnect electrical connector from under parking brake handle cover. Using an ohmmeter, check continuity of circuit through connector terminals. With parking brake lever pulled up, continuity should exist. With parking brake lever down, continuity should NOT exist.

### TESTING SPEED SENSOR SIGNAL CHECK

Remove speed sensor from transmission. Turn speedometer pinion quickly and measure voltage across sensor terminals. Voltage should be about .5 volt (AC). If reading is incorrect, replace speed sensor.

CAUTION: Ensure pinion shaft is properly seated when installing speed sensor. Speed sensor thrusting key should fit into groove of pinion shaft.

### TESTING TEMPERATURE GAUGE

1) To check power source, turn ignition switch on. Check voltage between specified temperature gauge terminal and ground. See TEMPERATURE GAUGE TEST TERMINALS table. See Fig. 1. Ensure battery voltage is present. If battery voltage is present, go to step 3).

2) If battery voltage is NOT present, check for blown fuse or fusible link. Check harness continuity between battery terminal and combination meter. Check for defective ignition relay and/or ignition switch.

3) Turn ignition on. Connect a jumper wire with a 3.4 watt light bulb between temperature gauge terminal and ground for less than 10 seconds. Temperature gauge should move smoothly to end of scale. If gauge does not move smoothly to end of scale, replace gauge. If gauge moves smoothly to end of scale, check temperature sending unit. See TESTING TEMPERATURE SENDING UNIT. If sending unit is okay, repair or replace sending unit harness.

TEMPERATURE GAUGE TEST TERMINALS TABLE

Application	Test Terminals
240SX .....	No. 24 & Ground

### TESTING TEMPERATURE SENDING UNIT

Check resistance between temperature sending unit terminals and body ground. At 140°F (60°C) resistance should be 70-90 ohms and at 212°F (100°C) resistance should be 21-24 ohms.

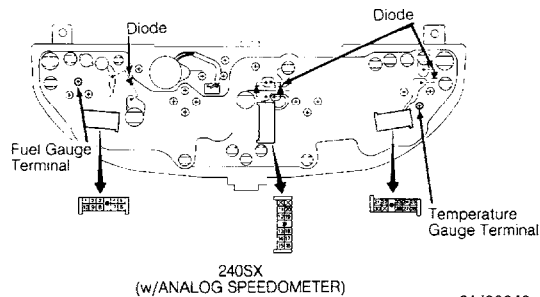

Fig. 1: Rear Views of Combination Meters  
 Courtesy of Nissan Motor Co., U.S.A.

**REMOVAL & INSTALLATION**

NOTE: When disassembling the instrument panel, DO NOT use excessive force to remove plastic parts from retainers or damage may occur.

**INSTRUMENT CLUSTER R & I**

NOTE: Always disconnect negative battery terminal before removing instrument cluster. On models equipped with Head-Up Display (HUD), cover HUD's reflective surface with cloth or vinyl sheet before removing instrument cluster.

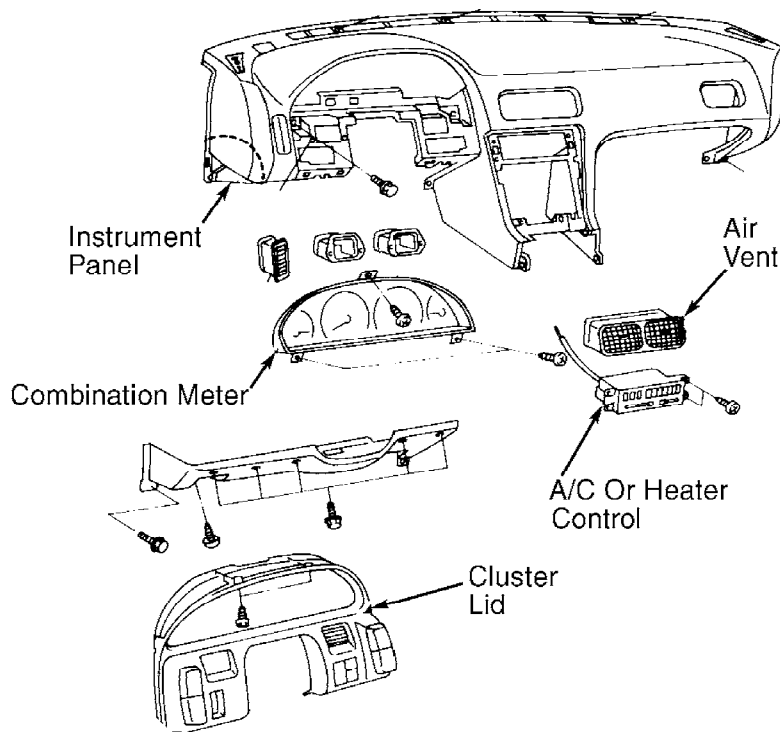

Fig. 2: Exploded View of Instrument Panel  
 Courtesy of Nissan Motor Co., U.S.A.

**WIRING DIAGRAMS**



See appropriate chassis wiring diagram in WIRING DIAGRAMS.

