

NISSAN 240SX

MODEL S13 SERIES

QUICK REFERENCE INDEX

GENERAL INFORMATION _____	GI
MAINTENANCE _____	MA
ENGINE MECHANICAL _____	EM
ENGINE LUBRICATION & COOLING SYSTEMS _____	LC
ENGINE FUEL & EMISSION CONTROL SYSTEM _____	EF & EC
ACCELERATOR CONTROL, FUEL & EXHAUST SYSTEMS _____	FE
CLUTCH _____	CL
MANUAL TRANSMISSION _____	MT
AUTOMATIC TRANSMISSION _____	AT
PROPELLER SHAFT & DIFFERENTIAL CARRIER _____	PD
FRONT AXLE & FRONT SUSPENSION _____	FA
REAR AXLE & REAR SUSPENSION _____	RA
BRAKE SYSTEM _____	BR
STEERING SYSTEM _____	ST
BODY _____	BF
HEATER & AIR CONDITIONER _____	HA
ELECTRICAL SYSTEM _____	EL

FOREWORD

This manual contains maintenance and repair procedures for the 1991 Nissan 240SX.

In order to assure your safety and the efficient functioning of the vehicle, this manual should be read thoroughly. It is especially important that the PRECAUTIONS in the GI section be completely understood before starting any repair task.

All information in this manual is based on the latest product information at the time of publication. The right is reserved to make changes in specifications and methods at any time without notice.

IMPORTANT SAFETY NOTICE

The proper performance of service is essential for both the safety of the technician and the efficient functioning of the vehicle.

The service methods in this Service Manual are described in such a manner that the service may be performed safely and accurately.

Service varies with the procedures used, the skills of the technician and the tools and parts available. Accordingly, anyone using service procedures, tools or parts which are not specifically recommended by NISSAN must first completely satisfy himself that neither his safety nor the vehicle's safety will be jeopardized by the service method selected.



NISSAN MOTOR CO., LTD.

Overseas Service Department

Tokyo, Japan

GENERAL INFORMATION

GI

SECTION **GI**

CONTENTS

PRECAUTIONS	GI- 2
HOW TO USE THIS MANUAL	GI- 5
HOW TO READ WIRING DIAGRAMS	GI- 7
HOW TO FOLLOW FLOW CHART IN TROUBLE DIAGNOSES	GI-10
IDENTIFICATION INFORMATION	GI-13
LIFTING POINTS AND TOW TRUCK TOWING	GI-17
TIGHTENING TORQUE OF STANDARD BOLTS	GI-20

PRECAUTIONS

Observe the following precautions to ensure safe and proper servicing. These precautions are not described in each individual section.

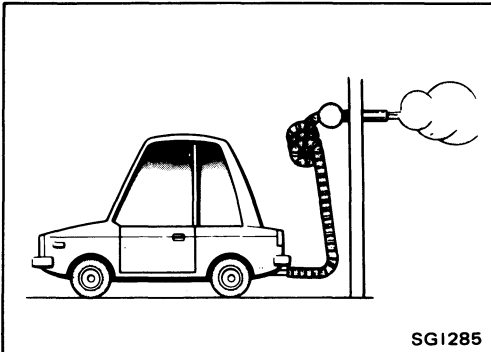

1. Do not operate the engine for an extended period of time without proper exhaust ventilation. Keep the work area well ventilated and free of any inflammable materials. Special care should be taken when handling any inflammable or poisonous materials, such as gasoline, refrigerant gas, etc. When working in a pit or other enclosed area, be sure to properly ventilate the area before working with hazardous materials. Do not smoke while working on the vehicle.

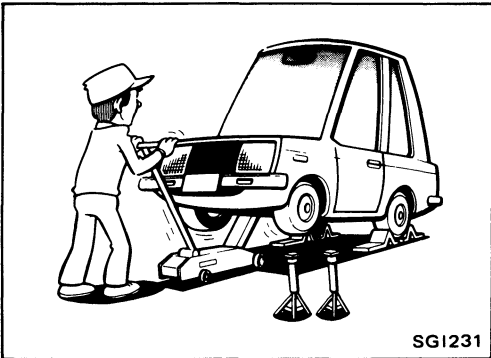

2. Before jacking up the vehicle, apply wheel chocks or other tire blocks to the wheels to prevent the vehicle from moving. After jacking up the vehicle, support the vehicle weight with safety stands at the points designated for proper lifting and towing before working on the vehicle. These operations should be done on a level surface.
3. When removing a heavy component such as the engine or transaxle/transmission, be careful not to lose your balance and drop them. Also, do not allow them to strike adjacent parts, especially the brake tubes and master cylinder.

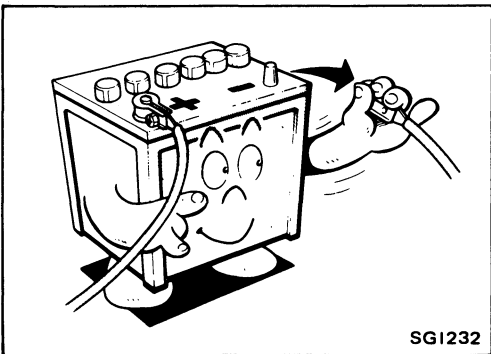

4. Before starting repairs which do not require battery power, always turn off the ignition switch, then disconnect the ground cable from the battery to prevent accidental short circuit.

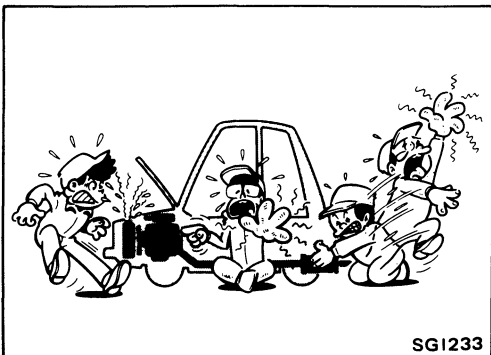

5. To prevent serious burns, avoid contact with hot metal parts such as the radiator, exhaust manifold, tail pipe and muffler. Do not remove the radiator cap when the engine is hot.

PRECAUTIONS

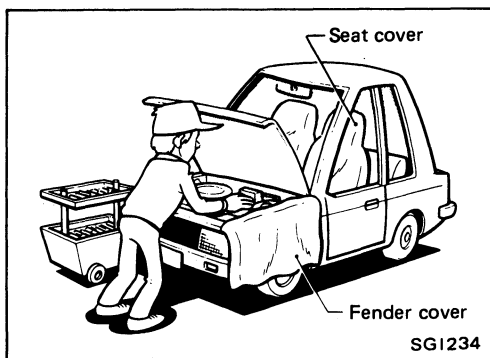

6. Before servicing the vehicle, protect fenders, upholstery and carpeting with appropriate covers. Take caution that keys, buckles or buttons on your person do not scratch the paint.

7. Clean all disassembled parts in the designated liquid or solvent prior to inspection or assembly.
8. Replace oil seals, gaskets, packings, O-rings, locking washers, cotter pins, self-locking nuts, etc. with new ones.
9. Replace inner and outer races of tapered roller bearings and needle bearings as a set.
10. Arrange the disassembled parts in accordance with their assembled locations and sequence.
11. Do not touch the terminals of electrical components which use microcomputers (such as electronic control units). Static electricity may damage internal electronic components.
12. After disconnecting vacuum or air hoses, attach a tag to indicate the proper connection.
13. Use only the lubricants specified in MA section.
14. Use approved bonding agent, sealants or their equivalents when required.
15. Use tools and recommended special tools where specified for safe and efficient service repairs.
16. When repairing the fuel, oil, water, vacuum or exhaust systems, check all affected lines for leaks.
17. Dispose of drained oil or the solvent used for cleaning parts in an appropriate manner.

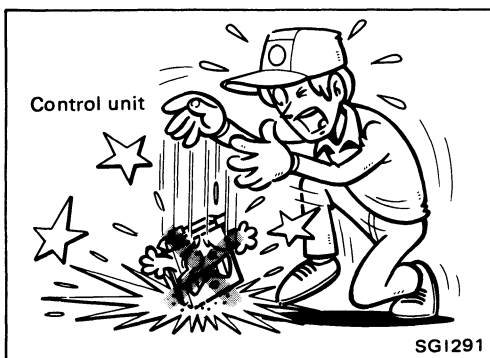

Precautions for E.F.I. or E.C.C.S. Engine

1. Before connecting or disconnecting E.F.I. or E.C.C.S. harness connector to or from any E.F.I. or E.C.C.S. control unit, be sure to turn the ignition switch to the "OFF" position and disconnect the negative battery terminal. Otherwise, there may be damage to control unit.
2. Before disconnecting pressurized fuel line from fuel pump to injectors, be sure to release fuel pressure to eliminate danger.
3. Be careful not to jar components such as control unit and air flow meter.

PRECAUTIONS

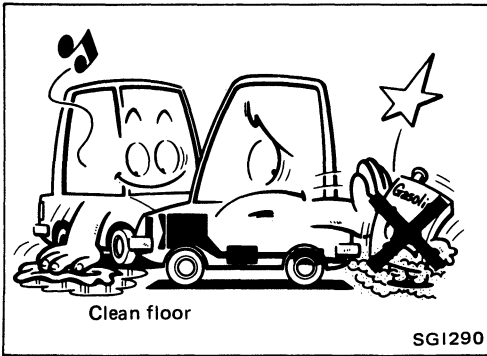

Precautions for Catalyst

If a large amount of unburned fuel flows into the converter, the converter temperature will be excessively high. To prevent this, follow the procedure below:

1. Use unleaded gasoline only. Leaded gasoline will seriously damage the catalytic converter.
2. When checking for ignition spark or measuring engine compression, make tests quickly and only when necessary.
3. Do not run engine when the fuel tank level is low, otherwise the engine may misfire causing damage to the converter.
4. Do not place the vehicle on inflammable material. Keep inflammable material off the exhaust pipe.

Precautions for Fuel

Use unleaded premium gasoline with an octane rating of at least 91 AKI (Anti-Knock Index) number (research octane number 96).

If unleaded premium gasoline is not available, unleaded regular gasoline with an octane rating of at least 87 AKI (research octane number 91) can be used.

However, for maximum vehicle performance, the use of unleaded premium gasoline is recommended.

CAUTION:

Do not use leaded gasoline. Using leaded gasoline will damage the catalytic converter.

HOW TO USE THIS MANUAL

1. **A QUICK REFERENCE INDEX**, a black tab (e.g. **BR**) is provided on the first page. You can quickly find the first page of each section by mating it to the section's black tab.
2. **THE CONTENTS** are listed on the first page of each section.
3. **THE TITLE** is indicated on the upper portion of each page and shows the part or system.
4. **THE PAGE NUMBER** of each section consists of two letters which designate the particular section and a number (e.g. "BR-5").
5. **THE LARGE ILLUSTRATIONS** are exploded views (See below) and contain tightening torques, lubrication points and other information necessary to perform repairs.
The illustrations should be used in reference to service matters only. When ordering parts, refer to the appropriate **PARTS CATALOG**.

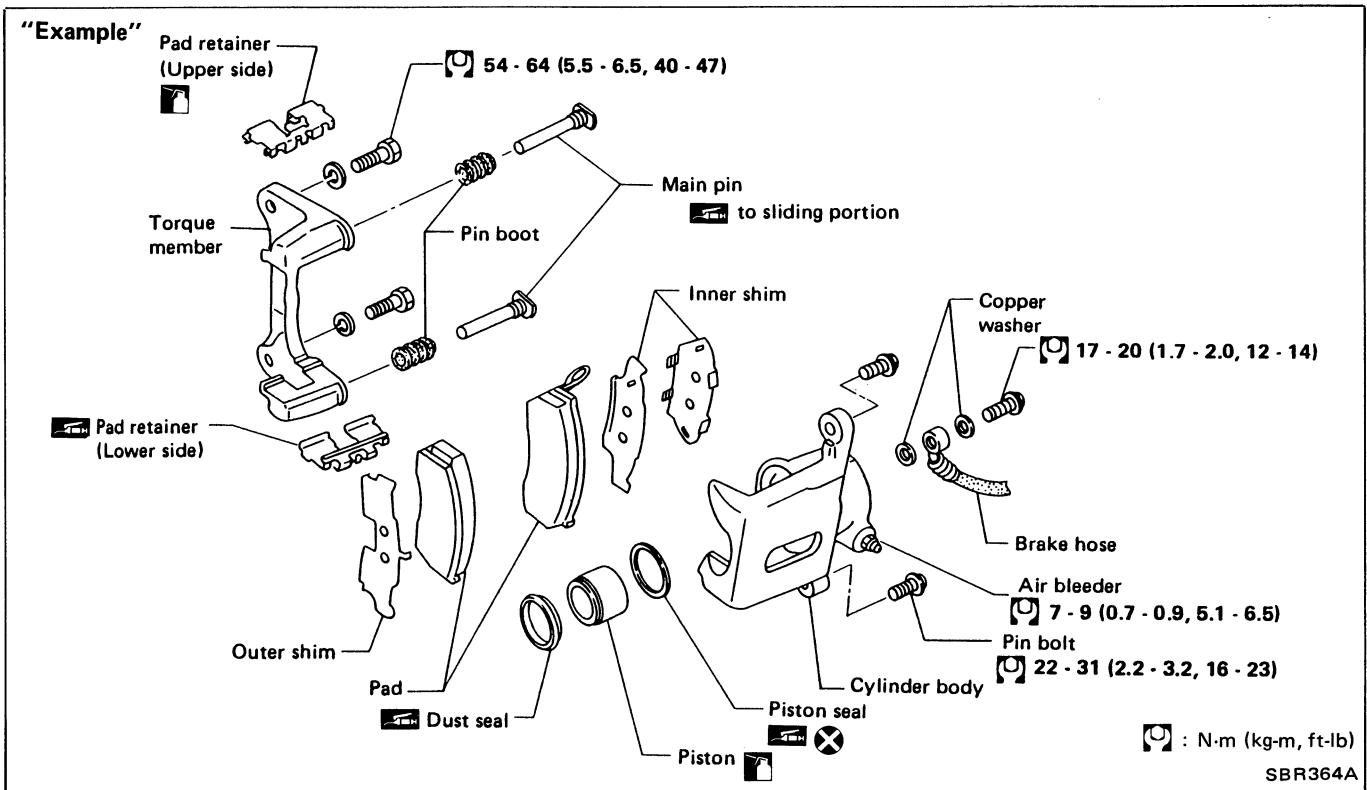

6. **THE SMALL ILLUSTRATIONS** show the important steps such as inspection, use of special tools, knacks of work and hidden or tricky steps which are not shown in the previous large illustrations. Assembly, inspection and adjustment procedures for the complicated units such as the automatic transaxle or transmission, etc. are presented in a step-by-step format where necessary.

7. The following **SYMBOLS AND ABBREVIATIONS** are used:

	: Tightening torque	M/T	: Manual Transaxle/Transmission
	: Should be lubricated with grease. Unless otherwise indicated, use recommended multi-purpose grease.	A/T	: Automatic Transaxle/Transmission
	: Should be lubricated with oil.	Tool	: Special Service Tools
	: Sealing point	L.H.D.	: Left-Hand Drive
	: Checking point	R.H.D.	: Right-Hand Drive
	: Always replace after every disassembly.	A.T.F.	: Automatic Transmission Fluid
	: Apply petroleum jelly.	D ₁	: Drive range 1st gear
	: Apply A.T.F.	D ₂	: Drive range 2nd gear
★	: Select with proper thickness.	D ₃	: Drive range 3rd gear
☆	: Adjustment is required.	D ₄	: Drive range 4th gear
S.D.S.	: Service Data and Specifications	O.D.	: Overdrive
L.H., R.H.	: Left-Hand, Right-Hand	2 ₂	: 2nd range 2nd gear
		2 ₁	: 2nd range 1st gear
		1 ₂	: 1st range 2nd gear
		1 ₁	: 1st range 1st gear

HOW TO USE THIS MANUAL

8. The **UNITS** given in this manual are primarily expressed as the SI UNIT (International System of Unit), and alternatively expressed in the metric system and in the yard/pound system.

“Example”

Tightening torque:

59 - 78 N·m (6.0 - 8.0 kg-m, 43 - 58 ft-lb)

9. **TROUBLE DIAGNOSES** are included in sections dealing with complicated components.
10. **SERVICE DATA AND SPECIFICATIONS** are contained at the end of each section for quick reference of data.
11. The captions **WARNING** and **CAUTION** warn you of steps that must be followed to prevent personal injury and/or damage to some part of the vehicle.
- **WARNING** indicates the possibility of personal injury if instructions are not followed.
 - **CAUTION** indicates the possibility of component damage if instructions are not followed.
 - **BOLD TYPED STATEMENTS** except **WARNING** and **CAUTION** give you helpful information.

HOW TO READ WIRING DIAGRAMS

WIRING DIAGRAM

Symbols used in WIRING DIAGRAM are shown below:

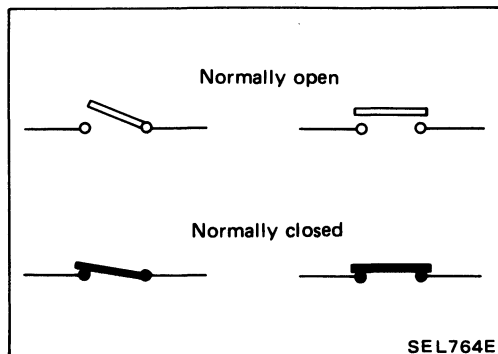
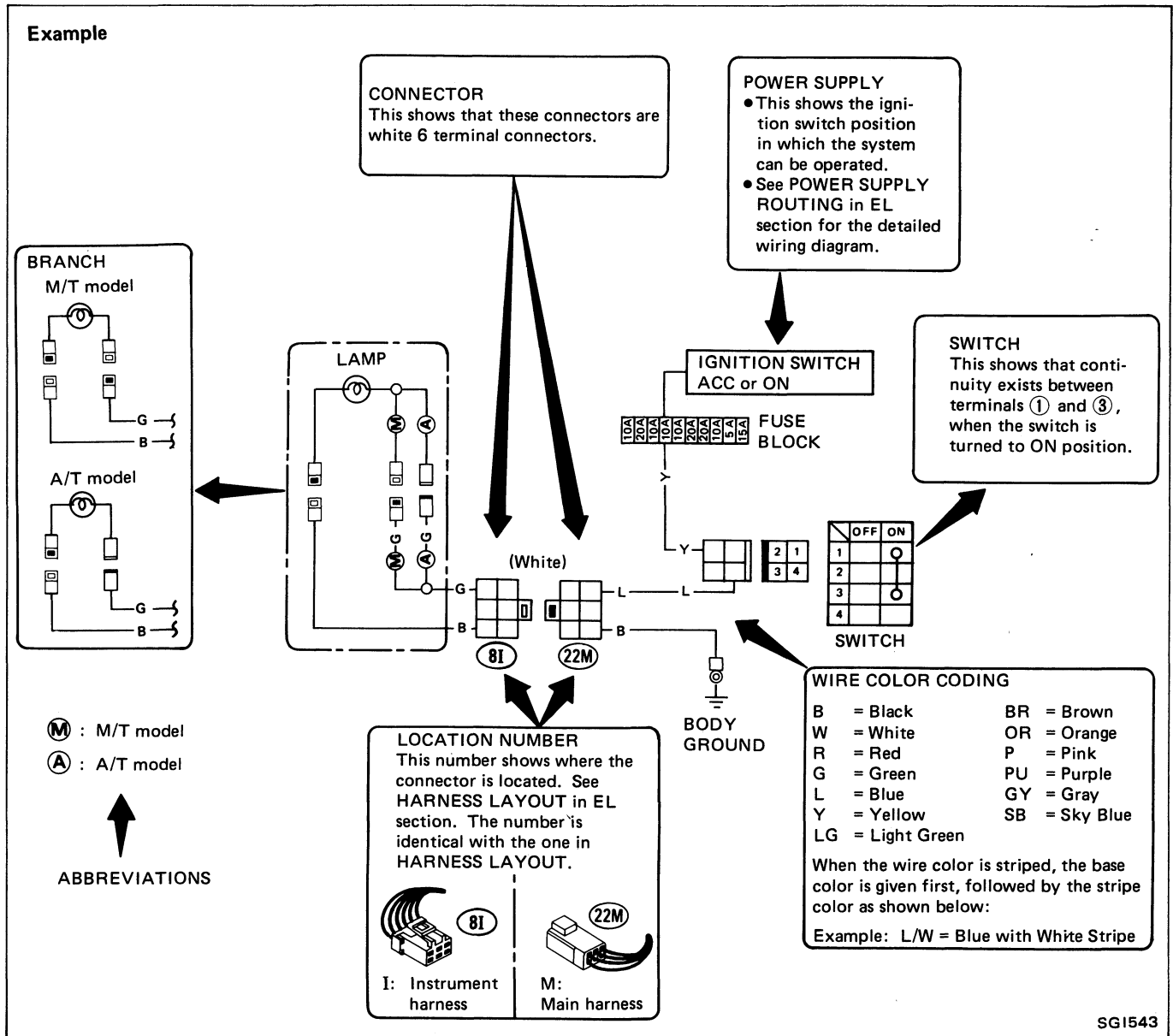

SWITCH POSITIONS

Wiring diagram switches are shown with the vehicle in the following condition.

- Ignition switch "OFF".
- Doors, hood and trunk lid/back door closed.
- Pedals are not depressed and parking brake is released.

HOW TO READ WIRING DIAGRAMS

Example

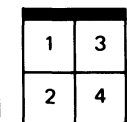

Connector symbol

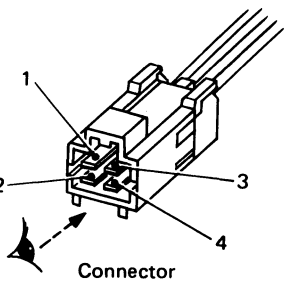

Connector

SG1362

CONNECTOR SYMBOLS

- All connector symbols in wiring diagrams are shown from the terminal side.

Example

Male terminal

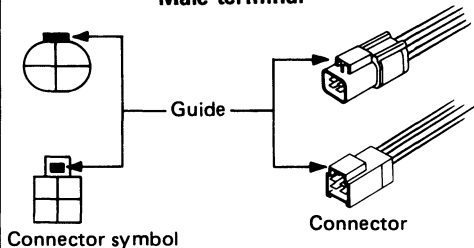

Connector symbol

Female terminal

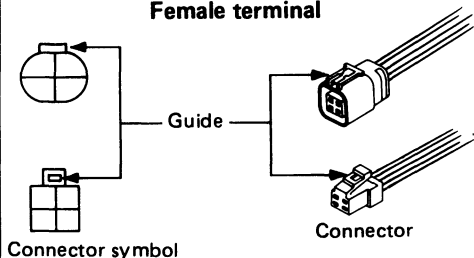

Connector symbol

SG1363

- Male and female terminals
Connector guides for male terminals are shown in black and female terminals in white in wiring diagrams.

MULTIPLE SWITCH

The continuity of the multiple switch is identified in the switch chart in wiring diagrams.

Example

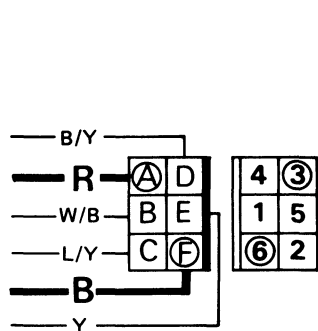

WIPER SWITCH

	OFF	INT	LO	HI	WASH
1					○
2				○	
③	○	○	●	○	
4	○	○	●	○	
5		○	○	○	
⑥		○	○	○	

Continuity circuit of wiper switch

SWITCH POSITION	CONTINUITY CIRCUIT
OFF	3 - 4
INT	3 - 4, 5 - 6
LO	3 - 6
HI	2 - 6
WASH	1 - 6

Example: Wiper switch in LO position

Continuity circuit: Red wire - (A) terminal - (③) terminal - Wiper switch (● - ●): LO) - (⑥) terminal - (F) terminal - Black wire

HOW TO READ WIRING DIAGRAMS

SUPER MULTIPLE JUNCTION (S.M.J.)

- The "S.M.J." indicated in wiring diagrams is shown in a simplified form. The terminal arrangement should therefore be referred to in the foldout at the end of the Service Manual.
- The foldout should be spread to read the entire wiring diagram.

Example

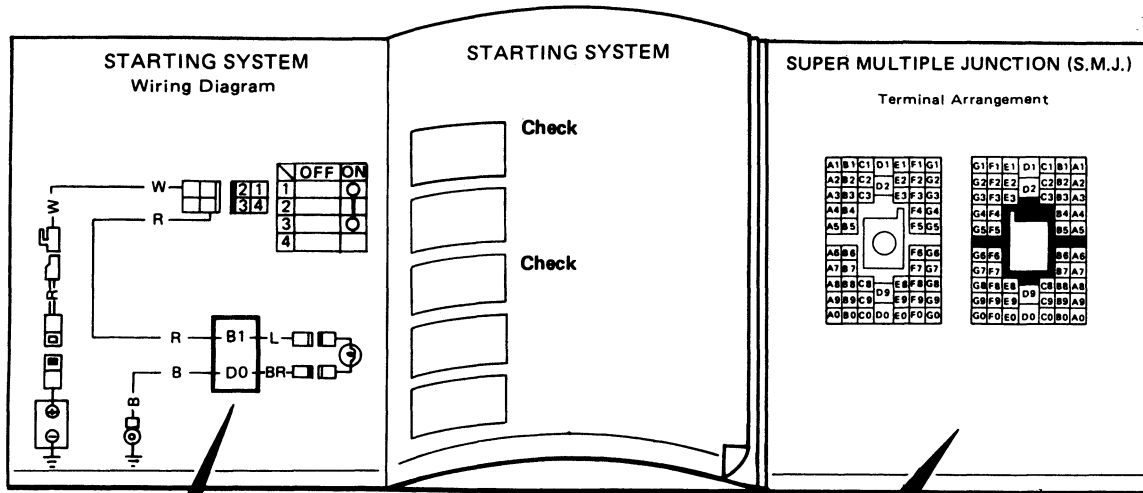

Super Multiple Junction (S.M.J.)

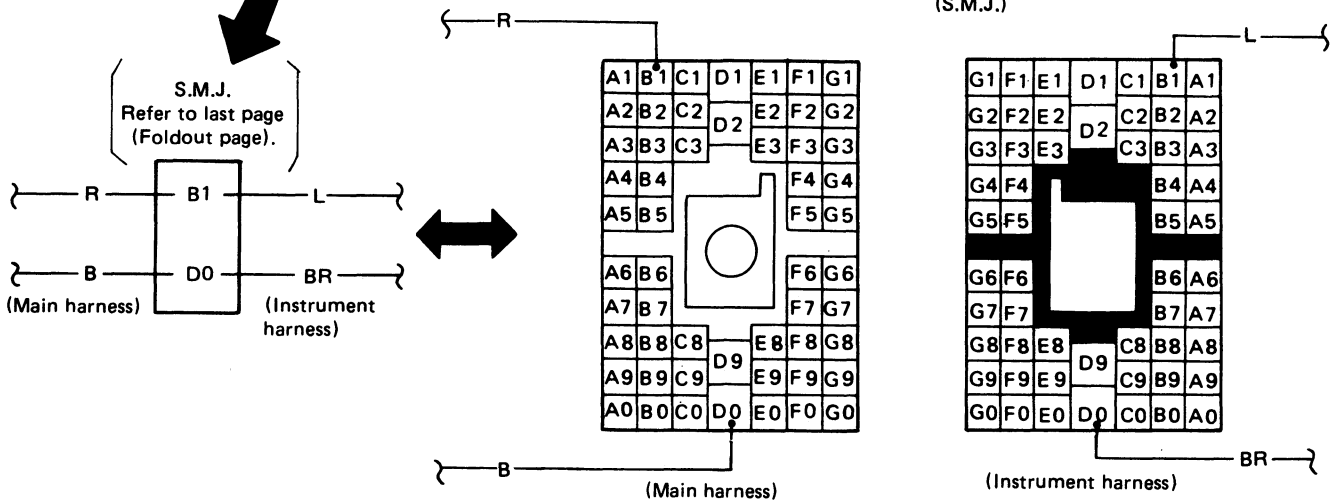

SEL653F

HOW TO FOLLOW FLOW CHART IN TROUBLE DIAGNOSES

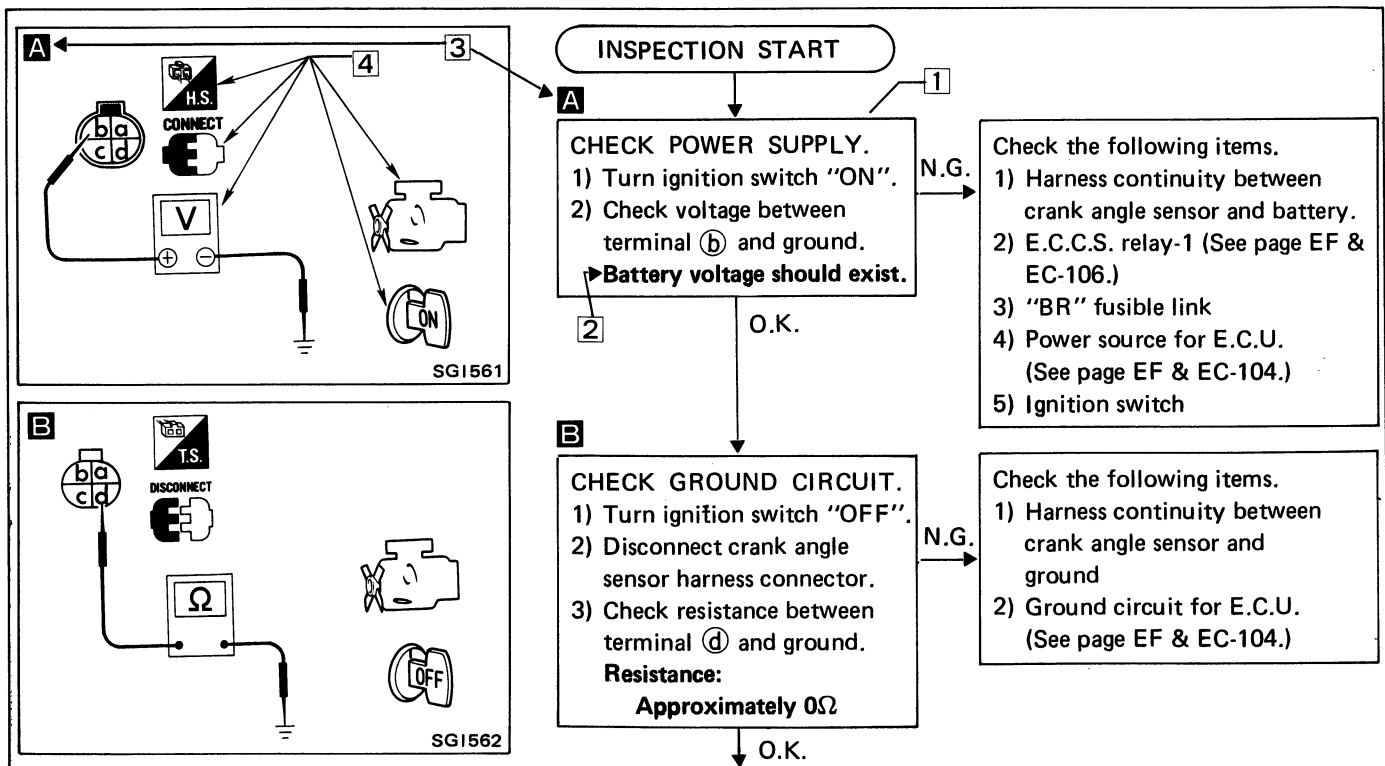

NOTICE

The flow chart indicates work procedures required to diagnose problems effectively. Observe the following instructions before diagnosing.

- 1) Use the flow chart after locating probable causes of a problem following the "Preliminary Check" or the "Symptom Chart".
- 2) After repairs, re-check that the problem has been completely eliminated.
- 3) Refer to Component Parts Location and Harness Layout for the Systems described in each section for identification/location of components and harness connectors.
- 4) Refer to the Circuit Diagram for Quick Pin Point Check. If you must perform circuit continuity between harness connectors more detail, such as in case of sub harness is used, refer to Wiring Diagram and Harness Layout in EL section for identification of harness connectors.
- 5) When checking circuit continuity, ignition switch should be "OFF".
- 6) Before checking voltage at connectors, check battery voltage.
- 7) After accomplishing the Diagnostic Procedures and Electrical Components Inspection, make sure that all harness connectors are reconnected as they were.

HOW TO FOLLOW FLOW CHART IN TROUBLE DIAGNOSES

HOW TO FOLLOW THIS FLOW CHART

1 Work and diagnostic procedure

Start to diagnose a problem using procedures indicated in enclosed blocks, as shown in the following example.

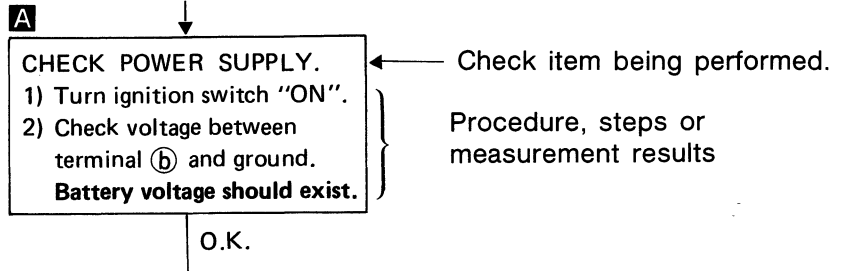

2 Measurement results

Required results are indicated in bold type in the corresponding block, as shown below.

These have the following meanings:

Battery voltage → 11 - 14V or approximately 12V
Voltage: Approximately 0V → Less than 1V

3 Cross reference of work symbols in the text and illustrations

Illustrations are provided as visual aids for work procedures. For example, symbol **A** indicated in the left upper portion of each illustration corresponds with the symbol in the flowchart for easy identification. More precisely, the procedure under the "CHECK POWER SUPPLY" outlined previously is indicated by an illustration **A**.

4 Symbols used in illustrations

Symbols included in illustrations refer to measurements or procedures. Before diagnosing a problem, familiarize yourself with each symbol.

Direction mark

A direction mark is shown to clarify the side of connector (terminal side or harness side).

Direction marks are mainly used in the illustrations indicating terminal inspection.



: View from terminal side ... T.S.

- All connector symbols shown from the terminal side are enclosed by a single line.







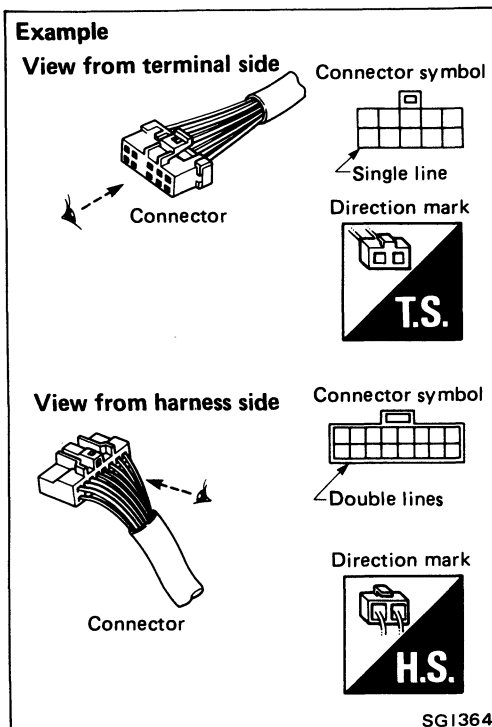









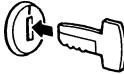







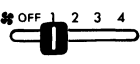

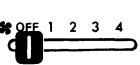

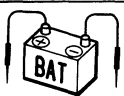





: View from harness side ... H.S.

- All connector symbols shown from the harness side are enclosed by a double line.

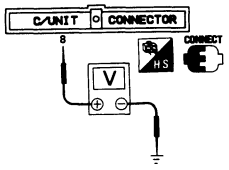

HOW TO FOLLOW FLOW CHART IN TROUBLE DIAGNOSES

Key to symbols signifying measurements or procedures

Symbol	Symbol explanation	Symbol	Symbol explanation
	Check after disconnecting the connector to be measured.		A/C switch is "OFF".
	Check after connecting the connector to be measured.		A/C switch is "ON".
	Insert key into ignition switch.		REC switch is "ON".
	Turn ignition switch to "OFF" position.		REC switch is "OFF".
	Turn ignition switch to "ON" position.		DEF switch is "ON".
	Turn ignition switch to "START" position.		VENT switch is "ON".
	Turn ignition switch from "OFF" to "ACC" position.		Fan switch is "ON". (At any position except for "OFF" position)
	Turn ignition switch from "ACC" to "OFF" position.		Fan switch is "OFF".
	Turn ignition switch from "OFF" to "ON" position.		Apply battery voltage directly to components.
	Turn ignition switch from "ON" to "OFF" position.		Drive vehicle.
	Do not start engine, or check with engine stopped.		Disconnect battery negative cable.
	Start engine, or check with engine running.		Depress brake pedal.
	Apply parking brake.		Release brake pedal.
	Release parking brake.		Depress accelerator pedal.
	Check after engine is warmed up sufficiently.		Release accelerator pedal.
	Voltage should be measured with a voltmeter.	<p>Pin terminal check for S.M.J. type E.C.U. and A/T control unit connectors. For details regarding the terminal arrangement, refer to the foldout page.</p> 	
	Circuit resistance should be measured with an ohmmeter.		
	Current should be measured with an ammeter.		

IDENTIFICATION INFORMATION

Model Variation

Destination			Body	Engine	Transmission	
					5-speed manual	4-speed automatic
					FS5W71C	RE4R01A
U.S.A.	Non-California	L.H.D.	Coupe	KA24DE	ML-FU	ML-AU
			Fastback		RML-FU	RML-AU
					RMLK-FU	RMLK-AU
	California		Coupe		ML-FV	ML-AV
			Fastback		RML-FV	RML-AV
					RMLK-FV	RMLK-AV
Canada			Coupe		ML-FN	ML-AN
			Fastback		RML-FN	RML-AN
					RMLK-FN	RMLK-AN

Prefix and suffix designations:

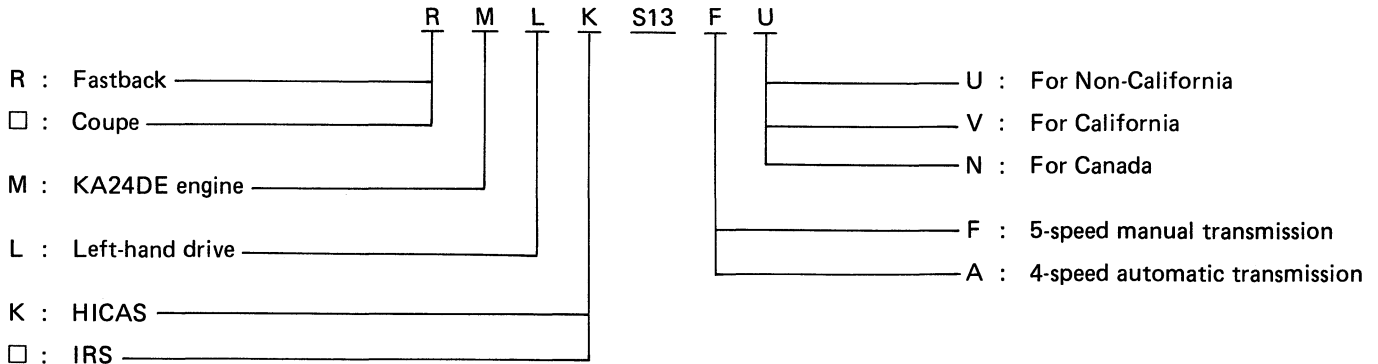

□ : means no indication.

IDENTIFICATION INFORMATION

Identification Number

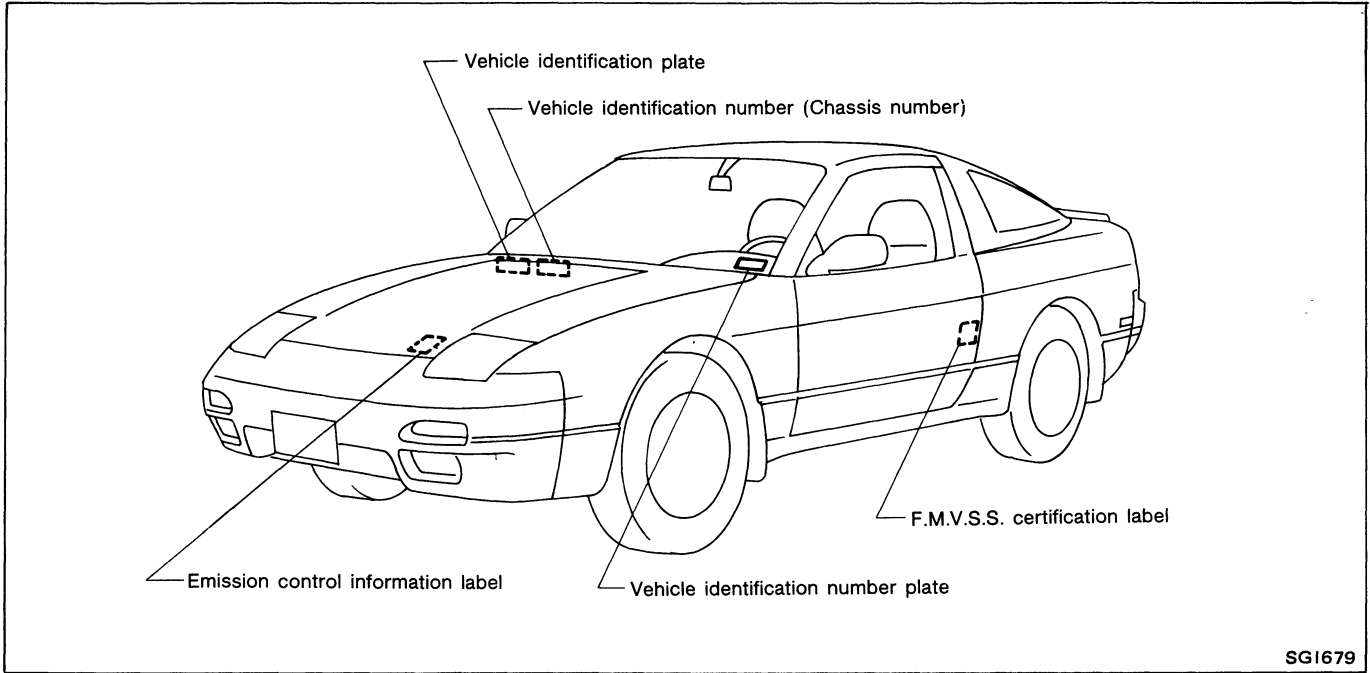

VEHICLE IDENTIFICATION NUMBER ARRANGEMENT

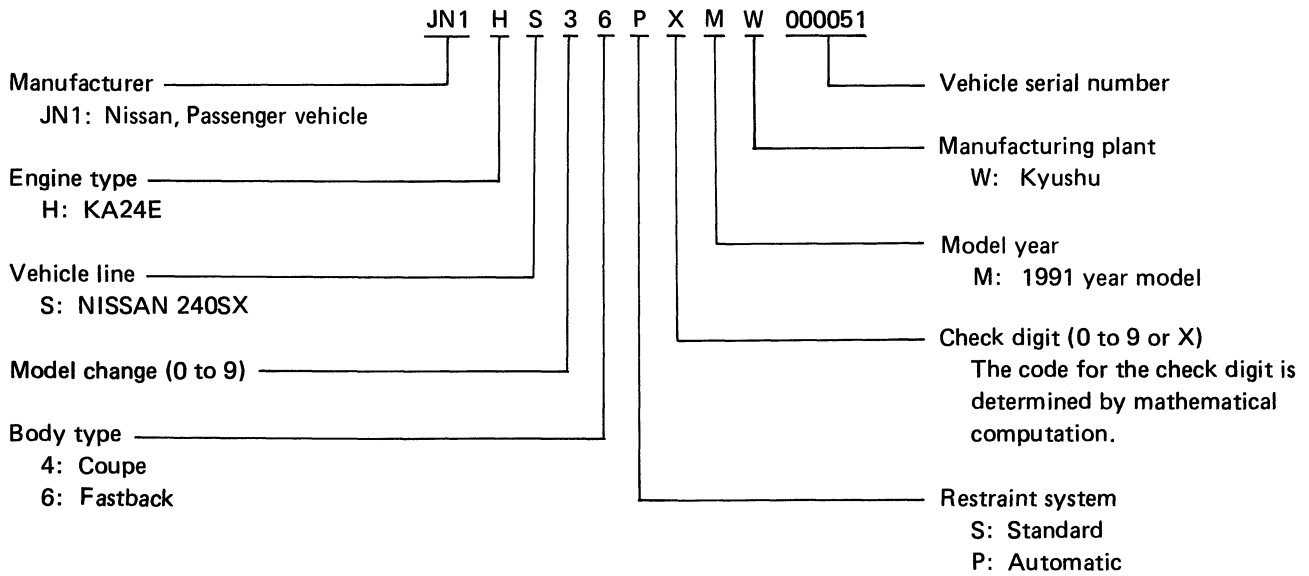

IDENTIFICATION INFORMATION

Identification Number (Cont'd) IDENTIFICATION PLATE

NISSAN MOTOR CO., LTD. JAPAN			
型式	TYPE	△	
	TIPO		
CHASSIS NO.		△	
NO. DE CHASIS			
MODEL		△	
MODELO			
○	カラー-COLOR TRIM	△	○
	トリム-COLOR GUARNICION	△	
エン	ENGINE	△	CC
ジン	MOTOR	△	
ミッション	TRANS. AXLE	△	
アクスル	TRANS. EJE	△	
	工場		PLANT
			PLANTA
日産自動車株式会社		MADE IN JAPAN	SGI315

- 1 Type
- 2 Vehicle identification number (Chassis number)
- 3 Model
- 4 Body color code
- 5 Trim color code
- 6 Engine model
- 7 Engine displacement
- 8 Transmission model
- 9 Axle model

ENGINE SERIAL NUMBER

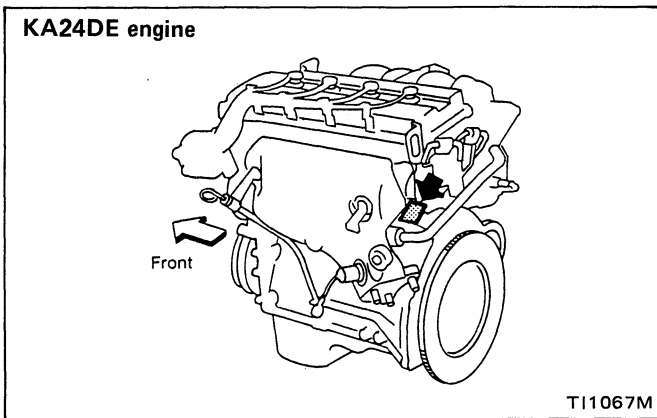

MANUAL TRANSMISSION NUMBER

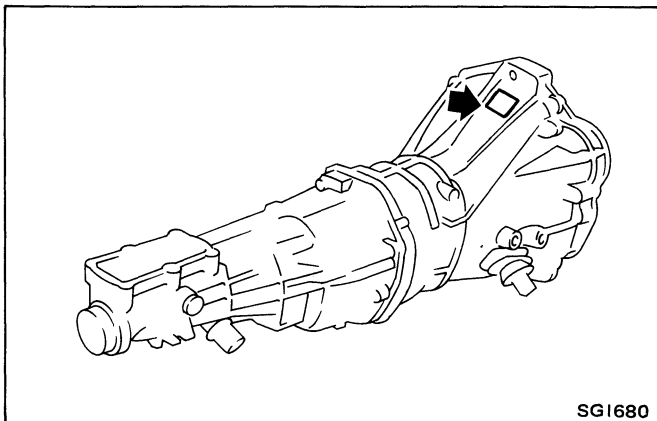

AUTOMATIC TRANSMISSION NUMBER

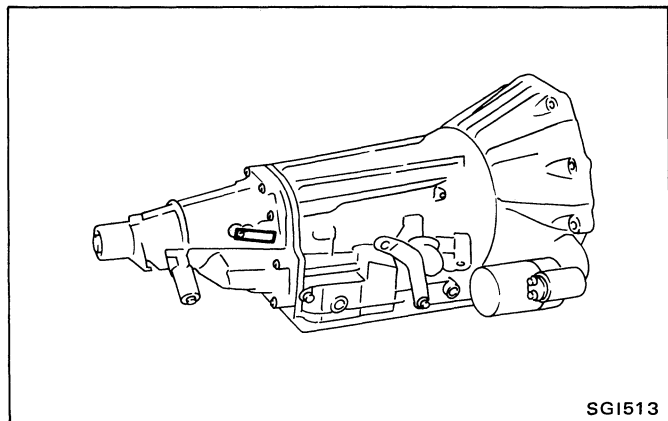

IDENTIFICATION INFORMATION

Dimensions

Unit: mm (in)

	Coupe	Fastback
Overall length	4,520 (178.0)	4,520 (178.0)
Overall width	1,690 (66.5)	1,690 (66.5)
Overall height	1,290 (50.8)	1,290 (50.8)
Front tread	1,465 (57.7)	1,465 (57.7)
Rear tread	1,460 (57.5)	1,460 (57.5)
Wheelbase	2,475 (97.4)	2,475 (97.4)

Wheels and Tires

Road wheel	Steel		6-JJx15, 4Tx15*1, 4Tx16*1
	Aluminum		6-JJx15
	Offset	mm (in)	40 (1.57)
Tire size	Conventional		P195/60R15 86H P205/60R15 89H*2
	Spare		T125/70D15 T135/70D16

*1: For spare tire

*2: Option

Garage Jack and Safety Stand

WARNING:

- Never get under the vehicle while it is supported only by the jack. Always use safety stands to support the frame when you have to get under the vehicle.
- Place wheel chocks at the front wheels when the rear wheels are raised and place wheel chocks at the rear wheels when the front wheels are raised.

CAUTION:

Place a wooden or rubber block between safety stand and vehicle body when the supporting body is flat.

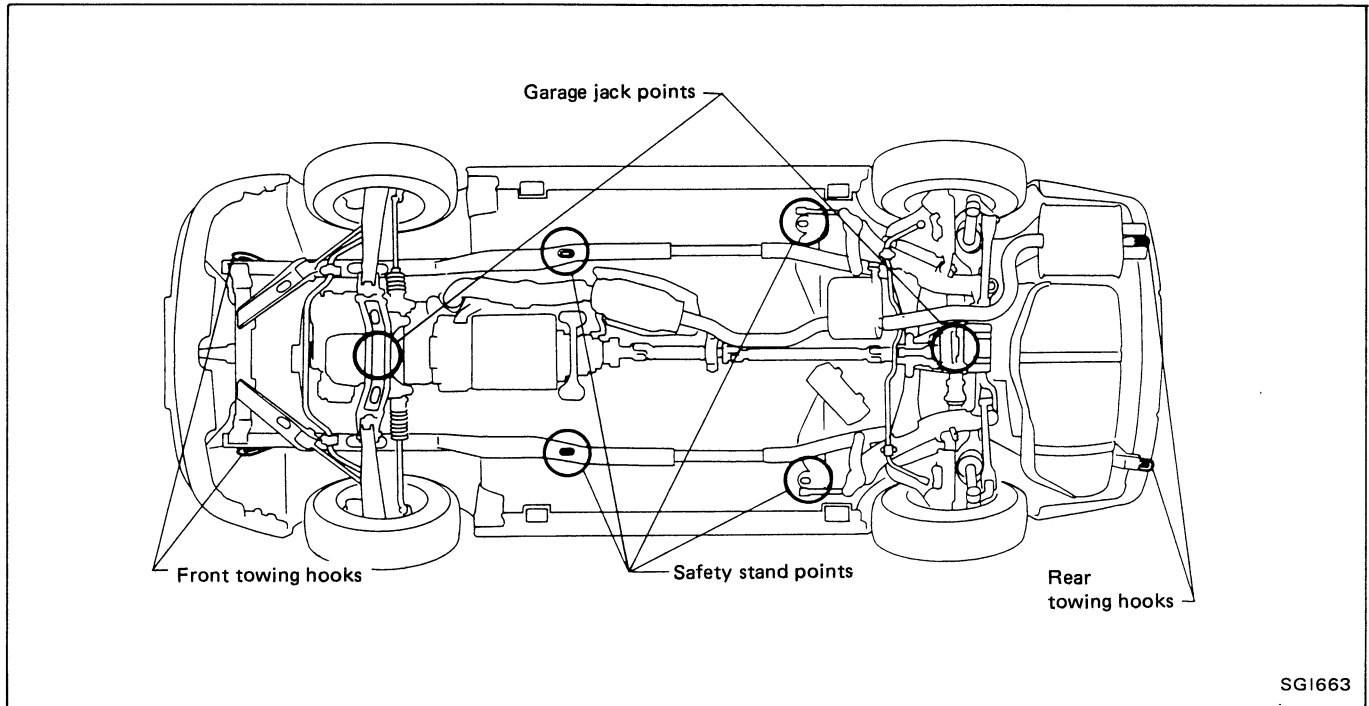

LIFTING POINTS AND TOW TRUCK TOWING

2-pole Lift

WARNING:

When lifting the vehicle, open the lift arms as wide as possible and ensure that the front and rear of the vehicle are well balanced.

When setting the lift arm, do not allow the arm to contact the brake tubes and fuel lines.

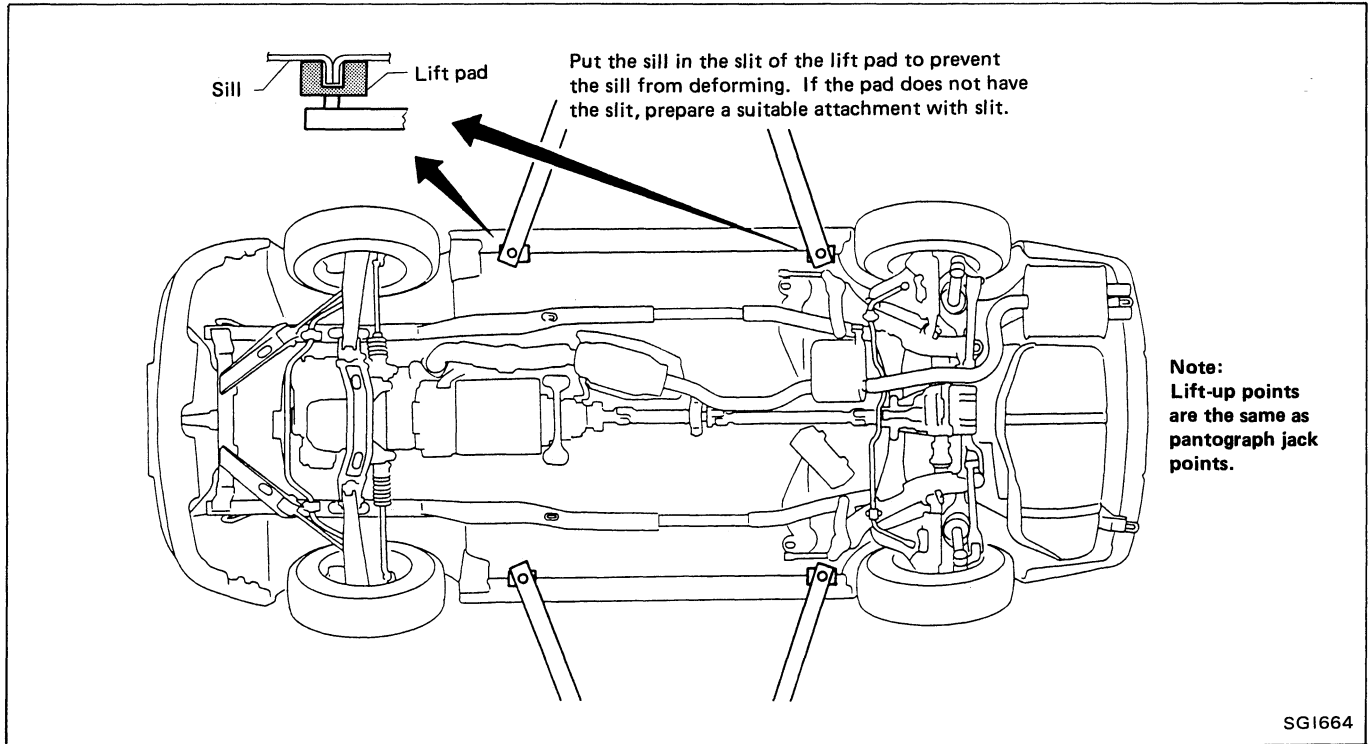

Tow Truck Towing

CAUTION:

- All applicable state or Provincial (in Canada) laws and local laws regarding the towing operation must be obeyed.
- It is necessary to use proper towing equipment to avoid possible damage to the vehicle during towing operation. Towing is in accordance with Towing Procedure Manual at dealer.
- When towing with the rear wheels on the ground, release the parking brake and move the gearshift lever to neutral ("N" position).

NISSAN recommends that vehicle be towed with the driving (rear) wheels off the ground as illustrated.

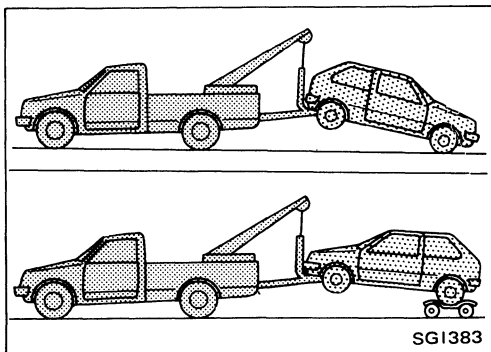

LIFTING POINTS AND TOW TRUCK TOWING

Tow Truck Towing (Cont'd)

TOWING AN AUTOMATIC TRANSMISSION MODEL WITH FOUR WHEELS ON GROUND OR TOWING WITH FRONT WHEELS RAISED (With rear wheels on ground)

Observe the following restricted towing speeds and distances.

Speed:

Below 50 km/h (30 MPH)

Distance:

Less than 65 km (40 miles)

If the speed or distance must necessarily be greater, remove the propeller shaft beforehand to prevent damage to the transmission.

TOWING POINT

Always pull the cable straight out from the vehicle. Never pull on the hook at a sideways angle.

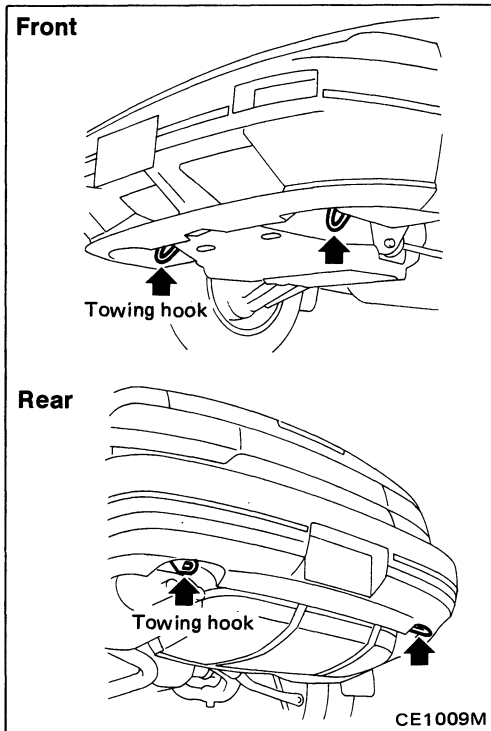

TIGHTENING TORQUE OF STANDARD BOLTS

Grade	Bolt size	Bolt diameter* mm	Pitch mm	Tightening torque (Without lubricant)						
				Hexagon head bolt			Hexagon flange bolt			
				N·m	kg·m	ft·lb	N·m	kg·m	ft·lb	
4T	M6	6.0	1.0	5.1	0.52	3.8	6.1	0.62	4.5	
	M8	8.0	1.25	13	1.3	9	15	1.5	11	
			1.0	13	1.3	9	16	1.6	12	
	M10	10.0	1.5	25	2.5	18	29	3.0	22	
			1.25	25	2.6	19	30	3.1	22	
	M12	12.0	1.75	42	4.3	31	51	5.2	38	
			1.25	46	4.7	34	56	5.7	41	
	M14	14.0	1.5	74	7.5	54	88	9.0	65	
	7T	M6	6.0	1.0	8.4	0.86	6.2	10	1.0	7
		M8	8.0	1.25	21	2.1	15	25	2.5	18
1.0				22	2.2	16	26	2.7	20	
M10		10.0	1.5	41	4.2	30	48	4.9	35	
			1.25	43	4.4	32	51	5.2	38	
M12		12.0	1.75	71	7.2	52	84	8.6	62	
			1.25	77	7.9	57	92	9.4	68	
M14		14.0	1.5	127	13.0	94	147	15.0	108	
9T		M6	6.0	1.0	12	1.2	9	15	1.5	11
		M8	8.0	1.25	29	3.0	22	35	3.6	26
	1.0			31	3.2	23	37	3.8	27	
	M10	10.0	1.5	59	6.0	43	70	7.1	51	
			1.25	62	6.3	46	74	7.5	54	
	M12	12.0	1.75	98	10.0	72	118	12.0	87	
			1.25	108	11.0	80	137	14.0	101	
	M14	14.0	1.5	177	18.0	130	206	21.0	152	

1. Special parts are excluded.
2. This standard is applicable to bolts having the following marks embossed on the bolt head.

*: Nominal diameter

Grade	Mark
4T	4
7T	7
9T	9

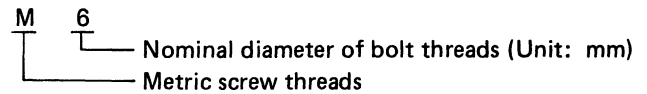

MAINTENANCE

SECTION MA

MA

CONTENTS

GENERAL MAINTENANCE	MA- 2
PERIODIC MAINTENANCE	MA- 4
RECOMMENDED LUBRICANTS AND FLUIDS	MA- 7
ENGINE MAINTENANCE	MA- 9
CHASSIS AND BODY MAINTENANCE	MA-15
SERVICE DATA AND SPECIFICATIONS (S.D.S.)	MA-22

GENERAL MAINTENANCE

General maintenance includes those items which should be checked during the normal day-to-day operation of the vehicle. They are essential if the vehicle is to continue operating properly. The owners can perform the checks and inspections themselves or they can have their NISSAN dealers do them for a nominal charge.

Item	Reference page
OUTSIDE THE VEHICLE	
The maintenance items listed here should be performed from time to time, unless otherwise specified.	
Tires Check the pressure with a gauge periodically when at a service station, including the spare, and adjust to the specified pressure if necessary. Check carefully for damage, cuts or excessive wear.	—
Wheel nuts When checking the tires, make sure no nuts are missing, and check for any loose nuts. Tighten if necessary.	—
Tire rotation Tires should be rotated every 12,000 km (7,500 miles.)	MA-19
Wheel alignment and balance If the vehicle should pull to either side while driving on a straight and level road, or if you detect uneven or abnormal tire wear, there may be a need for wheel alignment. If the steering wheel or seat vibrates at normal highway speeds, wheel balancing may be needed.	MA-18 FA-7
Windshield wiper blades Check for cracks or wear if they do not wipe properly.	—
Doors and engine hood Check that all doors and the engine hood operate smoothly as well as the trunk lid and back hatch. Also ensure, that all latches lock securely. Lubricate hinges, latches, rollers and links if necessary. Make sure that the secondary latch keeps the hood from opening when the primary latch is released. When driving in areas using road salt or other corrosive materials, check lubrication frequently.	MA-21
INSIDE THE VEHICLE	
The maintenance items listed here should be checked on a regular basis, such as when performing periodic maintenance, cleaning the vehicle, etc.	
Lights Make sure that the headlights, stop lights, tail lights, turn signal lights, and other lights are all operating properly and installed securely. Also check headlight aim.	—
Warning lights and buzzers/chimes Make sure that all warning lights and buzzers/chimes are operating properly.	—
Windshield wiper and washer Check that the wipers and washer operate properly and that the wipers do not streak.	—
Windshield defroster Check that the air comes out of the defroster outlets properly and in sufficient quantity when operating the heater or air conditioner.	—
Steering wheel Check that it has the specified free play. Be sure to check for changes in the steering condition, such as excessive free play, hard steering or strange noises. Free play: Less than 35 mm (1.38 in)	—
Seats Check seat position controls such as seat adjusters, seatback recliner, etc. to ensure they operate smoothly and that all latches lock securely in every position. Check that the head restraints move up and down smoothly and that the locks (if so equipped) hold securely in all latched positions. Check that the latches lock securely for folding-down rear seat-backs.	—
Seat belts Check that all parts of the seat belt system (e.g. buckles, anchors, adjusters and retractors) operate properly and smoothly, and are installed securely. Check the belt webbing for cuts, fraying, wear or damage.	MA-21

GENERAL MAINTENANCE

Item	Reference page
Clutch pedal Make sure the pedal operates smoothly and check that it has the proper free travel.	CL-5
Brakes Check that the brake does not pull the vehicle to one side when applied.	—
Brake pedal Check the pedal for smooth operation and make sure it has the proper distance under it when depressed fully. Check the brake booster function. Be certain to keep floor mats away from the pedal.	BR-7
Parking brake Check that the lever has the proper travel and confirm that your vehicle is held securely on a fairly steep hill with only the parking brake applied.	BR-24
Automatic transmission "Park" mechanism Check that the lock release button on the selector lever operates properly and smoothly. On a fairly steep hill check that your vehicle is held securely with the selector lever in the "P" position without applying any brakes.	—
UNDER THE HOOD AND VEHICLE	
The maintenance items listed here should be checked periodically (e.g. each time you check the engine oil or refuel).	
Windshield washer fluid Check that there is adequate fluid in the tank.	—
Engine coolant level Check the coolant level when the engine is cold.	MA-11
Radiator and hoses Check the front of the radiator and clean off any dirt, insects, leaves, etc., that may have accumulated. Make sure the hoses have no cracks, deformation, rot or loose connections.	—
Brake and clutch fluid levels Make sure that the brake and clutch fluid levels are between the "MAX" and "MIN" lines on the reservoir.	MA-15, 17
Battery Check the fluid level in each cell. It should be between the "MAX" and "MIN" lines.	—
Engine drive belts Make sure that no belt is frayed, worn, cracked or oily.	MA-9
Engine oil level Check the level on the dipstick after parking the vehicle on a level spot and turning off the engine.	MA-13
Power steering fluid level and lines Check the level when the fluid is cold and the engine is turned off. Check the lines for proper attachment, leaks, cracks, etc.	MA-19
Automatic transmission fluid level Check the level on the dipstick after putting the selector lever in "P" with the engine idling.	MA-16
Exhaust system Make sure there are no loose supports, cracks or holes. If the sound of the exhaust seems unusual or there is a smell of exhaust fumes, immediately locate the trouble and correct it.	MA-19
Underbody The underbody is frequently exposed to corrosive substances such as those used on icy roads or to control dust. It is very important to remove these substances, otherwise rust will form on the floor pan, frame, fuel lines and around the exhaust system. At the end of winter, the underbody should be thoroughly flushed with plain water, being careful to clean those areas where mud and dirt can easily accumulate.	—
Fluid leaks Check under the vehicle for fuel, oil, water or other fluid leaks after the vehicle has been parked for a while. Water dripping from the air conditioner after use is normal. If you should notice any leaks or gasoline fumes are evident, check for the cause and correct it immediately.	—

PERIODIC MAINTENANCE

Two different maintenance schedules are provided, and should be used, depending upon the conditions in which the vehicle is mainly operated. **After 60,000 miles (96,000 km) or 48 months, continue the periodic maintenance at the same mileage/time intervals.**

SCHEDULE 1

Follow Periodic Maintenance Schedule 1 if your driving habits frequently includes one or more of the following driving conditions:

- Repeated short trips of less than 5 miles (8 km).
- Repeated short trips of less than 10 miles (16 km) with outside temperatures remaining below freezing.
- Operating in hot weather in stop-and-go “rush hour” traffic.
- Extensive idling and/or low speed driving for long distances, such as police, taxi or door-to-door delivery use.
- Driving in dusty conditions.
- Driving on rough, muddy, or salt spread roads.
- Towing a trailer, using a camper or a car-top carrier.

SCHEDULE 2

Follow Periodic Maintenance Schedule 2 if none of the driving conditions shown in Schedule 1 apply to your driving habits.

PERIODIC MAINTENANCE

Schedule 1

Abbreviations: R = Replace I = Inspect. Correct or replace if necessary. [] : At the mileage intervals only

MAINTENANCE OPERATION	MAINTENANCE INTERVAL																Reference page	
Perform at number of miles, kilometers or months, whichever comes first.	3	6	9	12	15	18	21	24	27	30	33	36	39	42	45	48	(96)	
Emission control system maintenance																		
Drive belts	See NOTE (1)																I*	MA-9
Air cleaner filter	See NOTE (2)																[R]	MA-12
Vapor lines	I*																I*	MA-14
Fuel lines	I*																I*	MA-11
Fuel filter	See NOTE (3)*																MA-11	MA-11
Engine coolant	See NOTE (4)																R*	MA-10
Engine oil	R	R	R	R	R	R	R	R	R	R	R	R	R	R	R	R	R	MA-12
Engine oil filter (Use Nissan PREMIUM type or equivalent.)	R	R	R	R	R	R	R	R	R	R	R	R	R	R	R	R	R	MA-13
Spark plugs	[R]																[R]	MA-13
Intake & exhaust valve clearances	See NOTE (5)*																MA-14	MA-14
Chassis and body maintenance																		
Brake lines & cables	I	I	I	I	I	I	I	I	I	I	I	I	I	I	I	I	I	MA-17
Brake pads & discs	I	I	I	I	I	I	I	I	I	I	I	I	I	I	I	I	I	MA-18
Manual & automatic transmission oil, & differential gear oil	See NOTE (6)																I	MA-15, 16, 17
Steering gear & linkage, axle & suspension parts	I	I	I	I	I	I	I	I	I	I	I	I	I	I	I	I	I	MA-19, FA-5
Steering linkage ball joints & front suspension ball joints	I	I	I	I	I	I	I	I	I	I	I	I	I	I	I	I	I	MA-19, FA-5
SUPER HICAS linkage	I	I	I	I	I	I	I	I	I	I	I	I	I	I	I	I	I	MA-20
Exhaust system	I	I	I	I	I	I	I	I	I	I	I	I	I	I	I	I	I	MA-20

- NOTE:** (1) After 60,000 miles (96,000 km) or 48 months, inspect every 15,000 miles (24,000 km) or 12 months.
 (2) If operating mainly in dusty conditions, more frequent maintenance may be required.
 (3) If vehicle is operated under extremely adverse weather conditions or in areas where ambient temperatures are either extremely low or extremely high, the filters might become clogged. In such an event, replace them immediately.
 (4) After 60,000 miles (96,000 km) or 48 months, replace every 30,000 miles (48,000 km) or 24 months.
 (5) If valve noise increases, inspect valve clearances.
 (6) If towing a trailer, using a camper or a car-top carrier, or driving on rough or muddy roads, change (not just inspect) oil at every 30,000 miles (48,000 km) or 24 months.
 (7) Maintenance items and intervals with "*" are recommended by NISSAN for reliable vehicle operation. The owner need not perform such maintenance in order to maintain the emission warranty or manufacturer recall liability. Other maintenance items and intervals are required.

Schedule 2

Abbreviations: R = Replace I = Inspect. Correct or replace if necessary. [] : At the mileage intervals only

MAINTENANCE OPERATION		MAINTENANCE INTERVAL								Reference page
Perform at number of miles, kilometers or months, whichever comes first.	Miles x 1,000 (km x 1,000) Months	7.5 (12)	15 (24)	22.5 (36)	30 (48)	37.5 (60)	45 (72)	52.5 (84)	60 (96)	
Emission control system maintenance										
Drive belts	See NOTE (1)								I*	MA-9
Air cleaner filter					[R]				[R]	MA-12
Vapor lines					I*				I*	MA-14
Fuel lines					I*				I*	MA-11
Fuel filter	See NOTE (2)*									MA-11
Engine coolant	See NOTE (3)								R*	MA-10
Engine oil		R	R	R	R	R	R	R	R	MA-12
Engine oil filter (Use Nissan PREMIUM type or equivalent.)		R		R	R	R				MA-13
Spark plugs					[R]				[R]	MA-13
Intake & exhaust valve clearances	See NOTE (4)*									MA-14
Chassis and body maintenance										
Brake lines & cables		I		I	I	I	I	I	I	MA-17
Brake pads & discs		I		I	I	I	I	I	I	MA-18
Manual & automatic transmission oil, & differential gear oil		I		I	I	I	I	I	I	MA-15, 16, 17
Steering gear linkage, axle & suspension parts										MA-19, FA-5
SUPER HICAS linkage										MA-20
Exhaust system		I		I	I	I	I	I	I	MA-20

NOTE: (1) After 60,000 miles (96,000 km) or 48 months, inspect every 15,000 miles (24,000 km) or 12 months.
 (2) If vehicle is operated under extremely adverse weather conditions or in areas where ambient temperatures are either extremely low or extremely high, the filters might become clogged. In such an event, replace them immediately.
 (3) After 60,000 miles (96,000 km) or 48 months, replace every 30,000 miles (48,000 km) or 24 months.
 (4) If valve noise increases, inspect valve clearances.
 (5) Maintenance items and intervals with "*" are recommended by NISSAN for reliable vehicle operation. The owner need not perform such maintenance in order to maintain the emission warranty or manufacturer recall liability. Other maintenance items and intervals are required.

RECOMMENDED LUBRICANTS AND FLUIDS

Lubricants and Fluids

	Capacity (Approximate)			Recommended lubricants and fluids
	US measure	Imp measure	Liter	
Engine oil (Refill)				
With oil filter	3-3/4 qt	3-1/8 qt	3.5	Energy Conserving Oils of API SG*2, *3
Without oil filter	3-3/8 qt	2-7/8 qt	3.2	
Cooling system (with reservoir tank)	7-1/8 qt	5-7/8 qt	6.7	Anti-freeze coolant (Ethylene glycol base)
Manual transmission oil	5-1/8 pt	4-1/4 pt	2.4	API GL-4*2
Differential gear oil	2-3/4 pt	2-1/4 pt	1.3	API GL-5*2
Automatic transmission fluid	8-3/4 qt	7-1/4 qt	8.3	Genuine Nissan ATF*1 or equivalent Type DEXRON™
Power steering fluid	—	—	—	Type DEXRON™
Brake fluid	—	—	—	Genuine Nissan Brake Fluid*1 or equivalent DOT 3 (US FMVSS No. 116)
Multi-purpose grease	—	—	—	NLGI No. 2 (Lithium soap base)

*1: Available in mainland U.S.A. through you Nissan dealer.

*2: For further details, see "SAE Viscosity Number".

*3: Energy Conserving Oils

These oils can be identified by such labels as EC-I, EC-II, energy conserving, energy saving, improved fuel economy, etc.

RECOMMENDED LUBRICANTS AND FLUIDS

SAE Viscosity Number

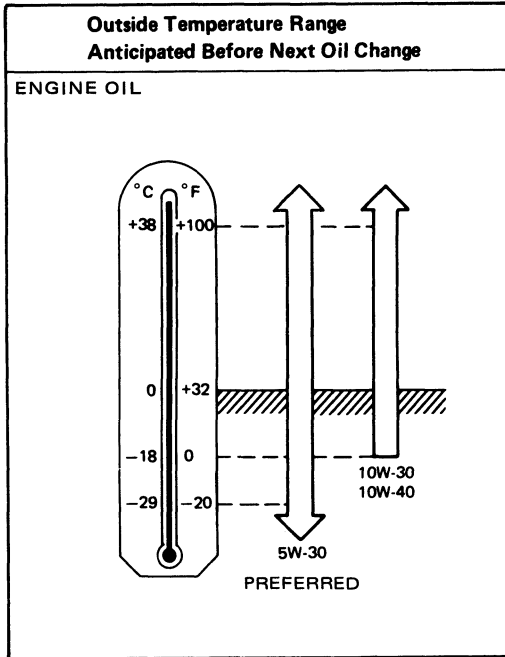

T10008

5W-30 is preferable for all ambient temperatures. 20W-40 and 20W-50 are usable if the ambient temperature is above 10°C (50°F) for all seasons.

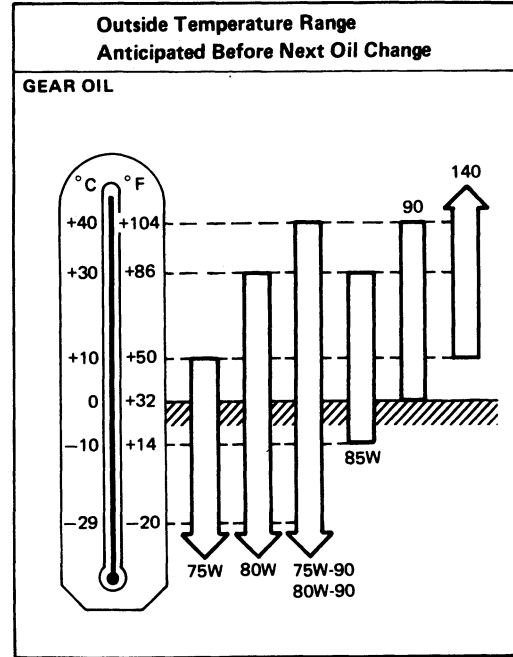

T10003

75W-90 for the transmission and 80W-90 for the differential are preferable if the ambient temperature is below 40°C (104°F).

ENGINE MAINTENANCE

Checking Drive Belts

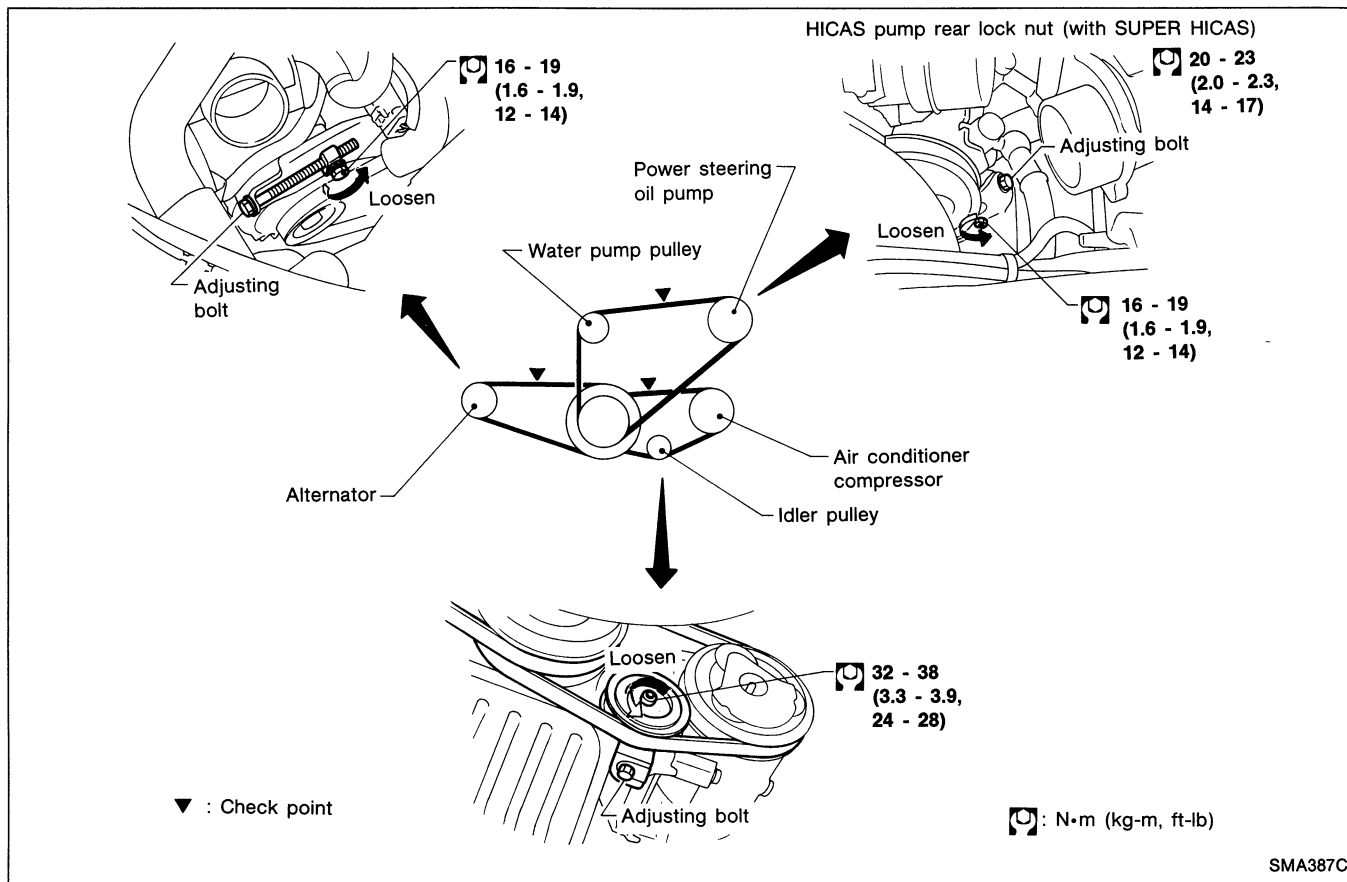

1. Inspect for cracks, fraying, wear or oil adhesion. If necessary, replace with a new one.
2. Inspect drive belt deflections by pushing on the belt midway between pulleys.

Adjust if belt deflections exceed the limit.

Belt deflection:

Inspect drive belt deflections when engine is cold.

Unit: mm (in)

	Used belt deflection		Deflection of new belt
	Limit	Deflection after adjustment	
Alternator	11 (0.43)	7 - 8 (0.28 - 0.31)	6 - 7 (0.24 - 0.28)
Air conditioner compressor	12 (0.47)	7.5 - 8.5 (0.295 - 0.335)	6.5 - 7.5 (0.256 - 0.295)
Power steering oil pump			
Without SUPER HICAS	13 (0.51)	7.5 - 8.5 (0.295 - 0.335)	6.5 - 7.5 (0.256 - 0.295)
With SUPER HICAS	9 (0.35)	6.5 - 7.5 (0.256 - 0.295)	5.5 - 6.5 (0.217 - 0.256)
Applied pushing force	98 N (10 kg, 22 lb)		

ENGINE MAINTENANCE

Changing Engine Coolant

WARNING:

To avoid being scalded, never change the coolant when the engine is hot.

1. Move heater "TEMP" control lever all the way to "HOT" position.

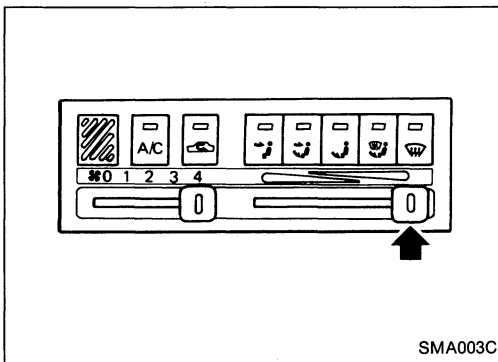

2. Open drain plug at the bottom of radiator, and remove radiator cap.

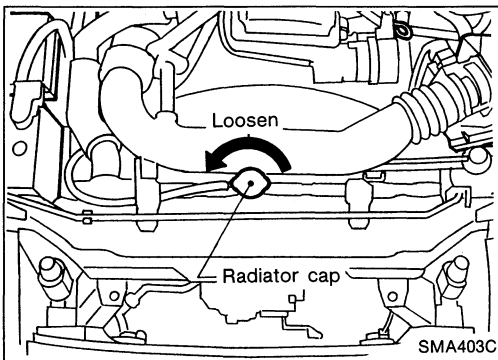
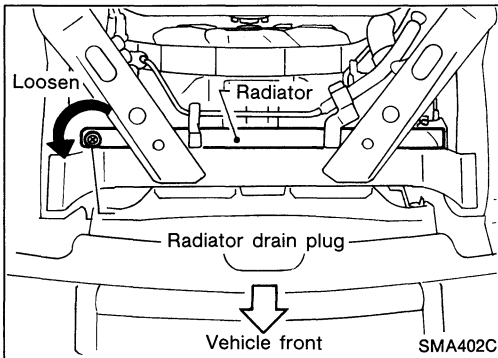

3. Remove drain plug on cylinder block.
4. Close drain plug and tighten drain plug securely.

- Apply sealant to the thread of drain plug.

⚙️: 34 - 44 N·m

(3.5 - 4.5 kg-m, 25 - 33 ft-lb)

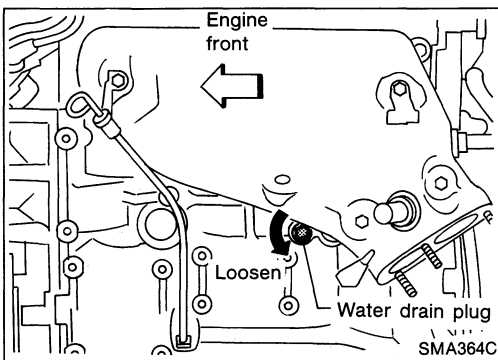

5. Open air relief plug.
6. Fill radiator with water and close air relief plug and radiator cap.
7. Run engine and warm it up sufficiently.
8. Race engine 2 or 3 times under no-load.
9. Stop engine and wait until it cools down.
10. Repeat step 2 through step 9 until clear water begins to drain from radiator.
11. Drain water.

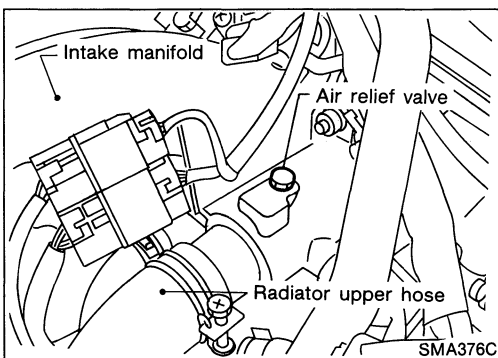

ENGINE MAINTENANCE

Changing Engine Coolant (Cont'd)

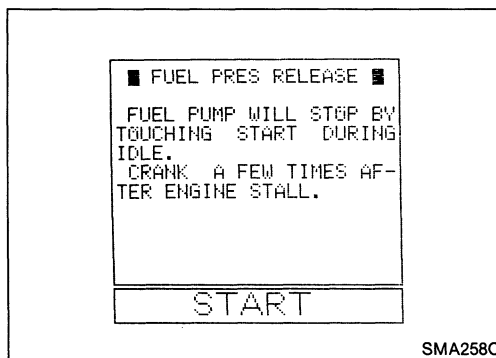
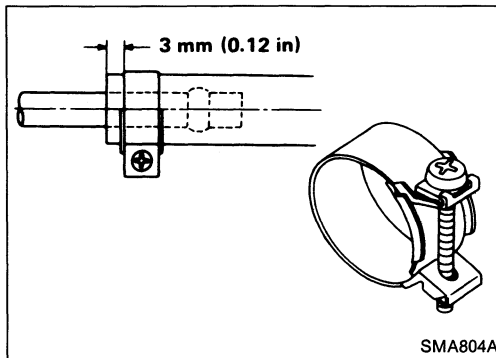
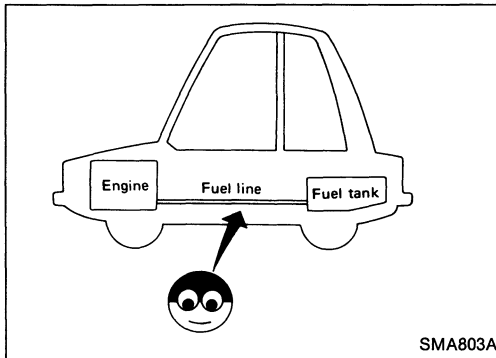
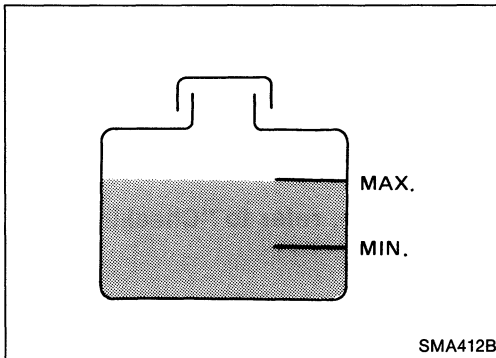
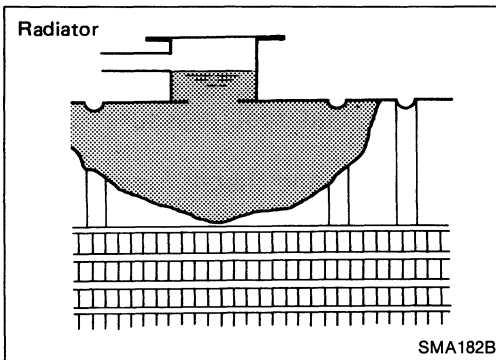

12. Open radiator cap and air relief plug.

13. Fill radiator with coolant up to specified level.

Follow instructions attached to anti-freeze container for mixing ratio of anti-freeze to water.

Coolant capacity (With reservoir tank):

6.7 l (7-1/8 US qt, 5-7/8 Imp qt)

Pour coolant through coolant filler neck slowly to allow air in system to escape.

14. Close air relief plug.

15. Remove reservoir tank, drain coolant, then clean reservoir tank.

16. Install reservoir tank and fill it with coolant up to "MAX" level and then install radiator cap.

17. Run engine and warm it up sufficiently.

18. Race engine 2 or 3 times under no-load.

19. Stop engine and cool it down, then add coolant as necessary.

Checking Fuel Lines

Inspect fuel lines and tank for improper attachment and for leaks, cracks, damage, loose connections, chafing and deterioration.

If necessary, repair or replace faulty parts.

Changing Fuel Filter

CAUTION:

Tighten high-pressure rubber hose clamp so that clamp end is 3 mm (0.12 in) from hose end.

Ensure that screw does not contact adjacent parts.

WARNING:

Before removing fuel filter, release fuel pressure from fuel line.



1. Perform "FUEL PRESSURE RELEASE" in "WORK SUPPORT" mode to release fuel pressure to zero.

2. Turn ignition switch off.

ENGINE MAINTENANCE

Changing Fuel Filter (Cont'd)

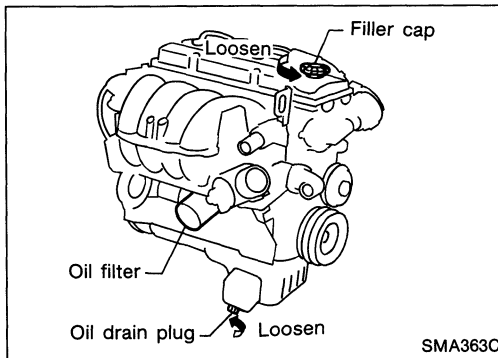
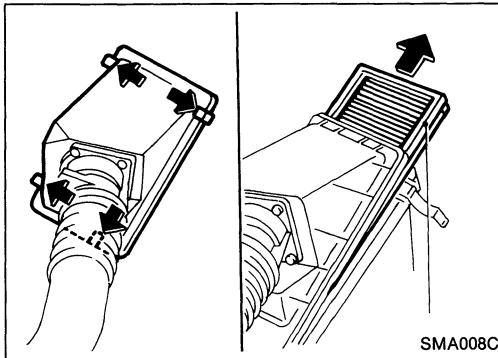
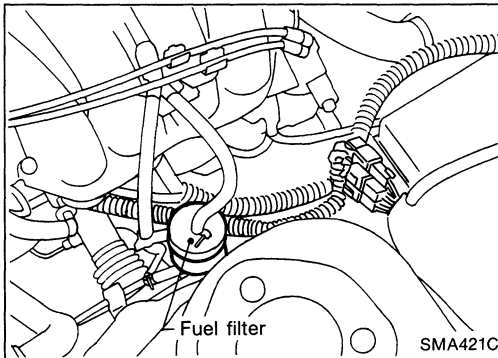
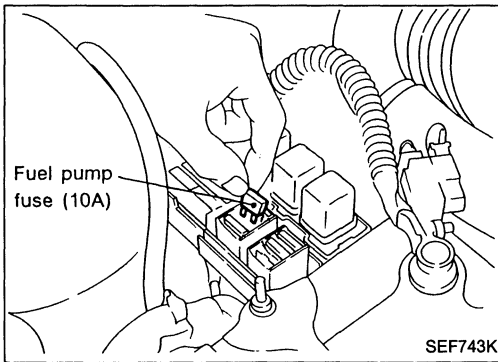

1. Remove fuse for fuel pump.
2. Start engine.
3. After engine stalls, crank engine two or three times to make sure that fuel pressure is released.
4. Turn ignition switch off and install fuse for fuel pump.

5. Loosen fuel hose clamps.
6. Replace fuel filter.

- Be careful not to spill fuel over engine compartment. Place a shop towel to absorb fuel.
- Use a high-pressure type fuel filter. Do not use a synthetic resinous fuel filter.
- When tightening fuel hose clamps, refer to "Checking Fuel Lines".

Changing Air Cleaner Filter

The viscous paper type filter does not need cleaning between renewals.

Changing Engine Oil

WARNING:

Be careful not to burn yourself, as the engine oil is hot.

1. Warm up engine, and check for oil leakage from engine components.
2. Remove drain plug and oil filler cap.
3. Drain oil and refill with new engine oil.

Refill oil capacity (Approximate):

Unit: liter (US qt, Imp qt)

With oil filter change	3.8 (4, 3-3/8)
Without oil filter change	3.5 (3-3/4, 3-1/8)

CAUTION:

- Be sure to clean drain plug and install with new washer.

Drain plug:

: 29 - 39 N·m

(3.0 - 4.0 kg-m, 22 - 29 ft-lb)

- Use recommended engine oil.
- The refill capacity changes depending on the oil temperature and drain time; use these values as a reference and be certain to check with the dipstick when changing the oil.

ENGINE MAINTENANCE

Changing Engine Oil (Cont'd)

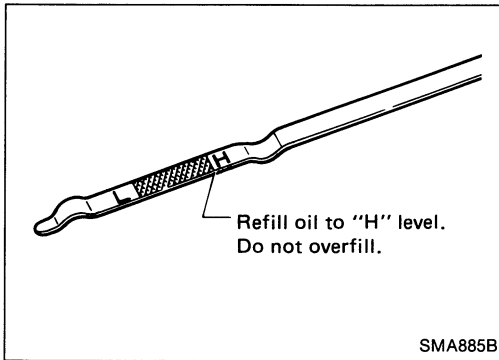

4. Check oil level.
5. Start engine and check area around drain plug and oil filter for oil leakage.
6. Run engine for a few minutes, then turn it off. After several minutes, check oil level.

Changing Oil Filter

1. Remove oil filter with a suitable tool.

WARNING:

Be careful not to burn yourself, as the engine and the engine oil are hot.

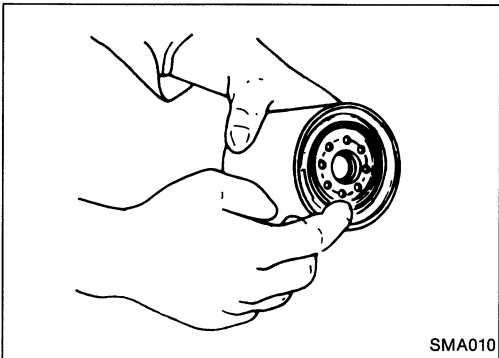

2. Before installing new oil filter, clean the oil filter mounting surface on cylinder block, and coat the rubber seal of oil filter with a little engine oil.

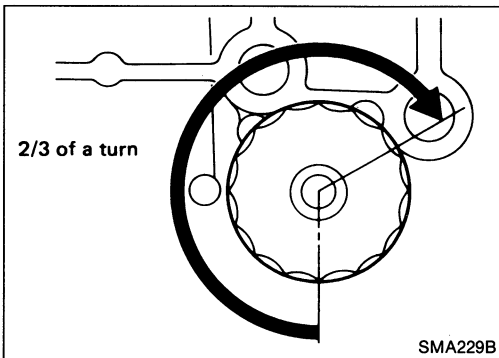

3. Screw in the oil filter until a slight resistance is felt, then tighten additionally more than 2/3 turn.
4. Add engine oil.

Refer to Changing Engine Oil.

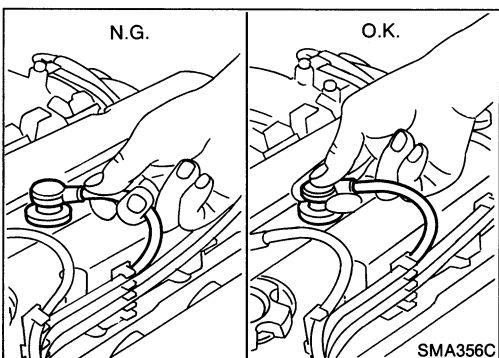

Changing Spark Plugs

1. Disconnect ignition wires from spark plugs at boot.
Do not pull on the wire.

ENGINE MAINTENANCE

Changing Spark Plugs (Cont'd)

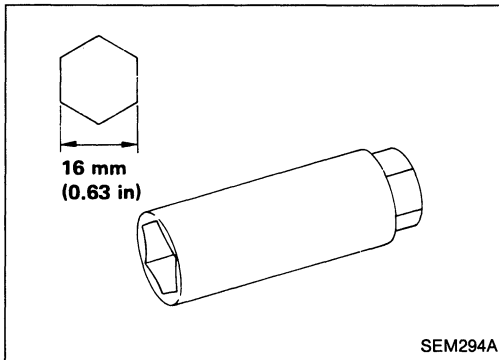

2. Remove spark plugs with spark plug wrench.

Spark plug:

Standard type

BKR5E-11

Cold type

BKR6E-11

BKR7E-11

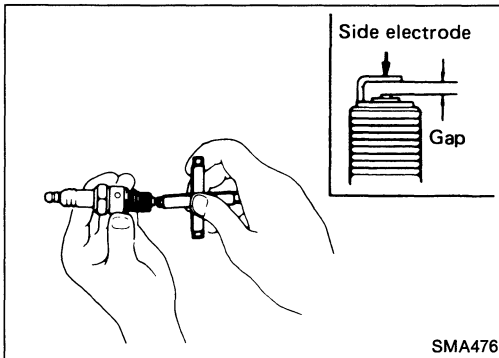

3. Check plug gap of each new spark plug.

Gap: 1.0 - 1.1 mm (0.039 - 0.043 in)

4. Install spark plugs. Reconnect ignition wires according to Nos. indicated on them.

Spark plug:

⚙️: 20 - 29 N·m

(2.0 - 3.0 kg-m, 14 - 22 ft-lb)

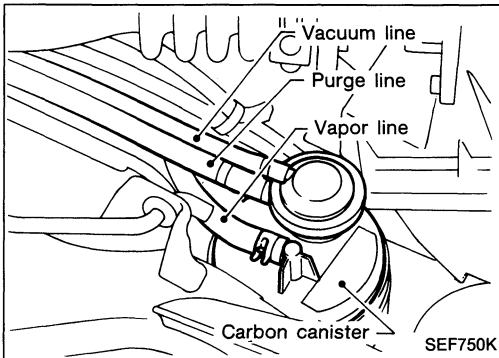

Checking Vapor Lines

1. Visually inspect vapor lines for improper attachment and for cracks, damage, loose connections, chafing and deterioration.
2. Inspect vacuum relief valve of fuel tank filler cap for clogging, sticking, etc.

Refer to EVAPORATIVE EMISSION CONTROL SYSTEM INSPECTION in section "EF & EC".

Checking Valve Clearance

Refer to "CYLINDER HEAD" in section "EM", if engine runs with unusual mechanical noise.

Checking Clutch Fluid Level and Leaks

- If fluid level is extremely low, check clutch system for leaks.

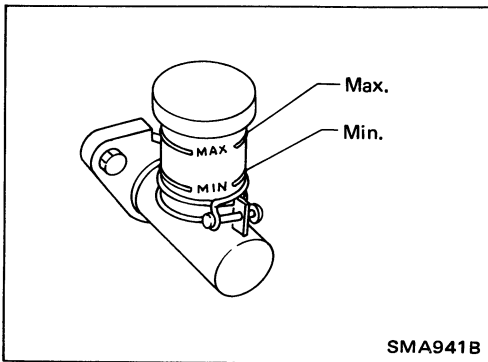

Checking M/T Oil

1. Check for oil leakage.

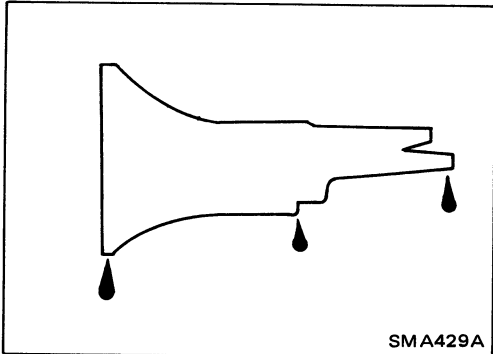

2. If leakage is found, check oil level.
Never start engine while checking oil level.

Filler plug:

⌘: 25 - 34 N·m (2.5 - 3.5 kg-m, 18 - 25 ft-lb)

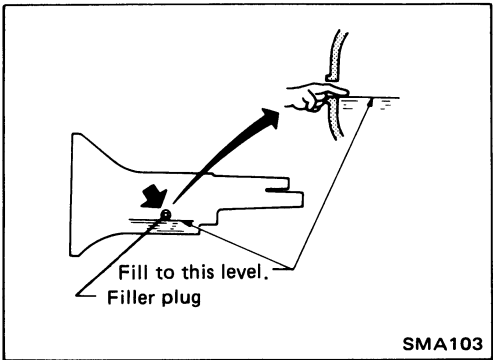

Changing M/T Oil

1. Drain oil and refill with new gear oil.
2. Check oil level.

Oil capacity:

2.4 ℓ (5-1/8 US pt, 4-1/4 Imp pt)

Drain plug:

⌘: 25 - 34 N·m (2.5 - 3.5 kg-m, 18 - 25 ft-lb)

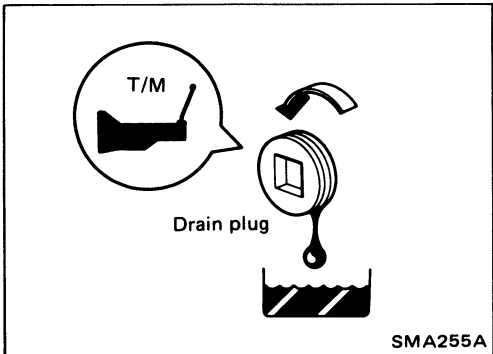

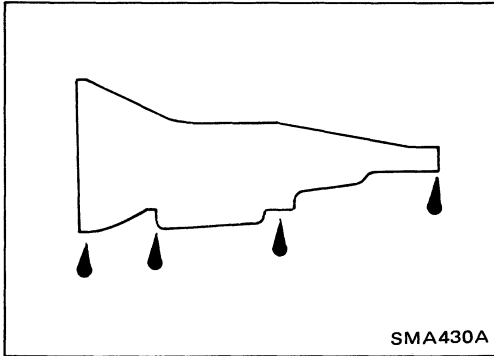

Checking A/T Fluid

1. Check for fluid leakage.

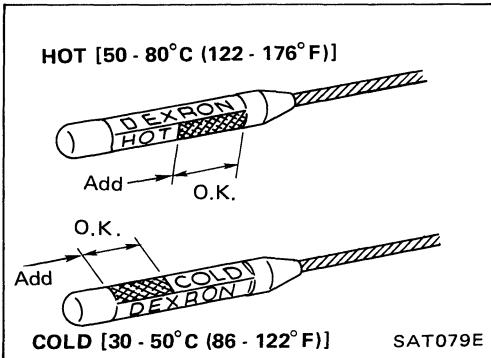

2. If leakage is found, check fluid level.

Fluid level should be checked using "HOT" range on dipstick at fluid temperatures of 50 to 80°C (122 to 176°F) after vehicle has been driven approximately 5 minutes in urban areas after engine is warmed up. But it can be checked at fluid temperatures of 30 to 50°C (86 to 122°F) using "COLD" range on dipstick for reference after engine is warmed up and before driving. However, fluid level must be rechecked using "HOT" range.

- 1) Park vehicle on level surface and set parking brake.
- 2) Start engine and then move selector lever through each gear range, ending in "P".
- 3) Check fluid level with engine idling.
- 4) Remove dipstick and wipe it clean with lint-free paper.
- 5) Reinsert dipstick into charging pipe as far as it will go.
- 6) Remove dipstick and note reading. If level is at low side of either range, add fluid to the charging pipe.

Do not overfill.

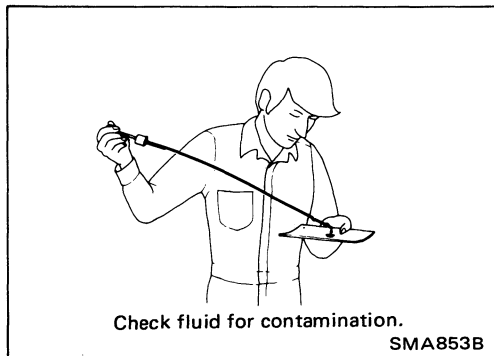

3. Check fluid condition.

Check fluid for contamination. If fluid is very dark or smells burned, or contains frictional material (clutches, band, etc.), check operation of A/T.

Refer to section AT for checking operation of A/T.

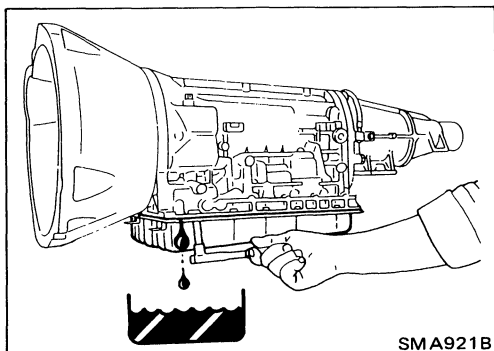

Changing A/T Fluid

1. Drain fluid by removing oil pan.
2. Replace gasket with new one.
3. Refill with fluid and then check fluid level.

Oil capacity (With torque converter):

8.3 ℓ (8-3/4 US qt, 7-1/4 Imp qt)

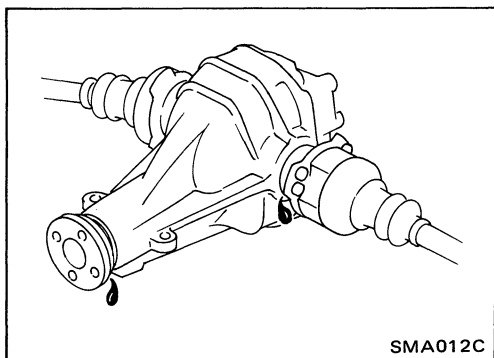

Checking Differential Gear Oil

1. Check differential carrier for oil leakage.

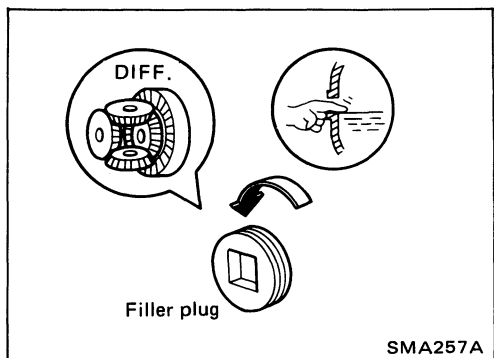

2. If leakage is found, check oil level.

Filler plug:

: 59 - 98 N·m (6 - 10 kg-m, 43 - 72 ft-lb)

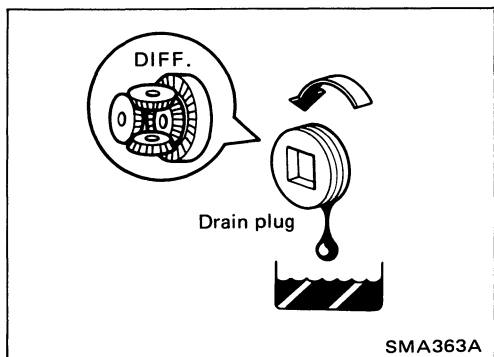

Changing Differential Gear Oil

1. Drain oil and refill with new gear oil.
2. Check oil level.

Oil capacity:

R200

1.3 ℓ (2-3/4 US pt, 2-1/4 Imp pt)

R200V

1.5 ℓ (3-1/8 US pt, 2-5/8 Imp pt)

Drain plug:

: 59 - 98 N·m (6 - 10 kg-m, 43 - 72 ft-lb)

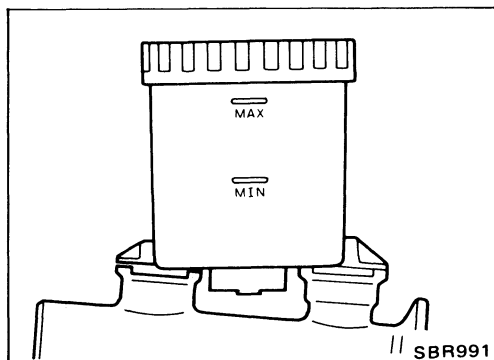

Checking Brake Fluid Level and Leaks

- If fluid level is extremely low, check brake system for leaks.

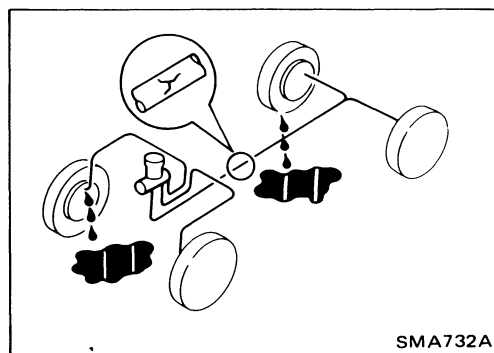

Checking Brake Lines and Cables

- Check brake fluid lines and parking brake cables for improper attachment and for leaks, chafing, abrasions, deterioration, etc.

CHASSIS AND BODY MAINTENANCE

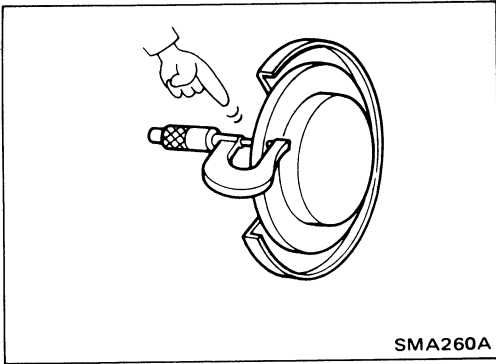

SMA260A

Checking Disc Brake

- Check condition of disc brake components.

ROTOR

- Check condition and thickness.

Unit: mm (in)

	Front		Rear
	CL22VB	CL25VA*	CL9H
Standard thickness	20.0 (0.787)	22.0 (0.866)	9.0 (0.354)
Minimum thickness	18.0 (0.709)	20.0 (0.787)	8.0 (0.315)

*: With A.B.S.

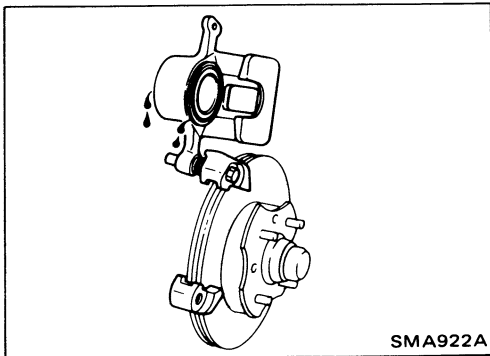

SMA922A

CALIPER

- Check operation and for leakage.

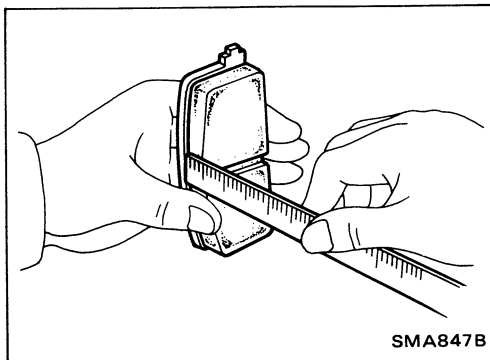

SMA847B

PAD

- Check for wear or damage.

Unit: mm (in)

	Front		Rear
	CL22VB	CL25VA*	CL9H
Standard thickness	10.0 (0.394)	11.0 (0.433)	9.5 (0.374)
Minimum thickness	2.0 (0.079)		1.5 (0.059)

*: With A.B.S.

Balancing Wheels

- Adjust wheel balance using road wheel center.

Wheel balance (Maximum allowable unbalance):

Refer to S.D.S.

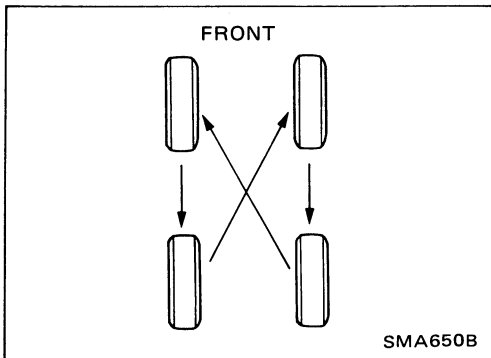

Tire Rotation

- Do not include the T-type spare tire when rotating the tires.
- Wheel nuts:
 □: 98 - 118 N·m
 (10.0 - 12.0 kg-m, 72 - 87 ft-lb)

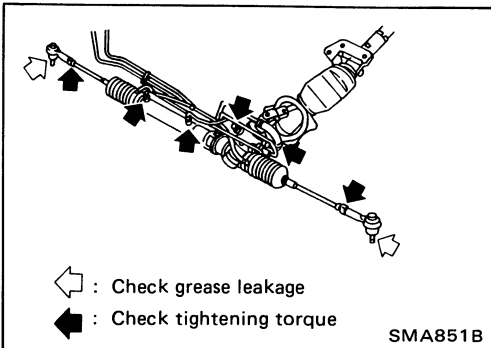

Checking Steering Gear and Linkage

STEERING GEAR

- Check gear housing and boots for looseness, damage or grease leakage.
- Check connection with steering column for looseness.

STEERING LINKAGE

- Check ball joint, dust cover and other component parts for looseness, wear, damage or grease leakage.

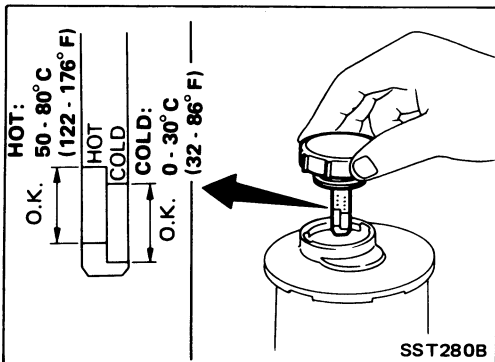

Checking Power Steering Fluid and Lines

CHECKING FLUID LEVEL (WITHOUT SUPER HICAS SYSTEM)

Fluid level should be checked using "HOT" range on dipstick at fluid temperatures of 50 to 80°C (122 to 176°F) or using "COLD" range on dipstick at fluid temperatures of 0 to 30°C (32 to 86°F).

CAUTION:

Do not overfill.

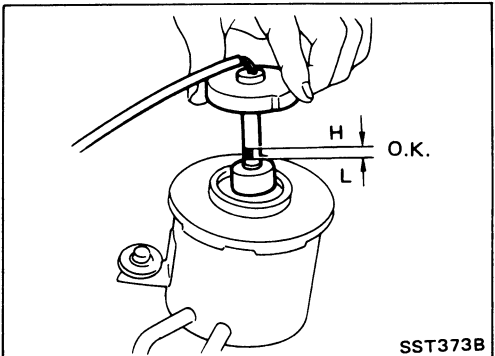

CHECKING FLUID LEVEL (WITH SUPER HICAS SYSTEM)

Maintain the fluid level so that the lower surface of the float is maintained between the "L" and "H" marks on the gauge rod. The fluid level should be checked when the engine is stopped and the fluid temperature is normal.

CAUTION:

Do not overfill.

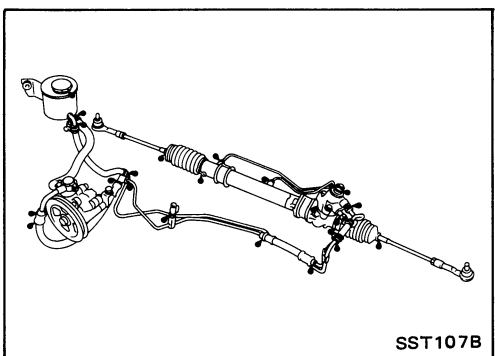

CHECKING LINES

Check lines for improper attachment, leaks, cracks, damage, loose connections, chafing and deterioration.

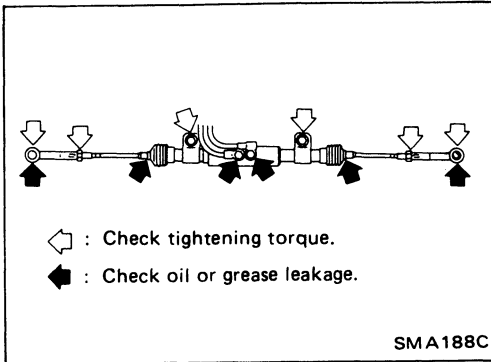

Checking SUPER HICAS Linkage (With SUPER HICAS system)

- Check power cylinder and linkage for damage, looseness and leakage of oil or grease.

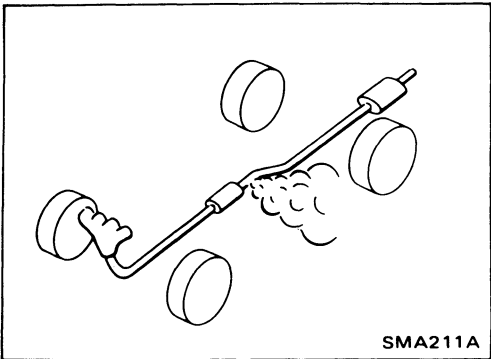

Checking Exhaust System

- Check exhaust pipes, muffler and mounting for improper attachment, leaks, cracks, damage, loose connections, chafing and deterioration.

CHASSIS AND BODY MAINTENANCE

LUBRICATING LOCKS, HINGES AND HOOD LATCHES

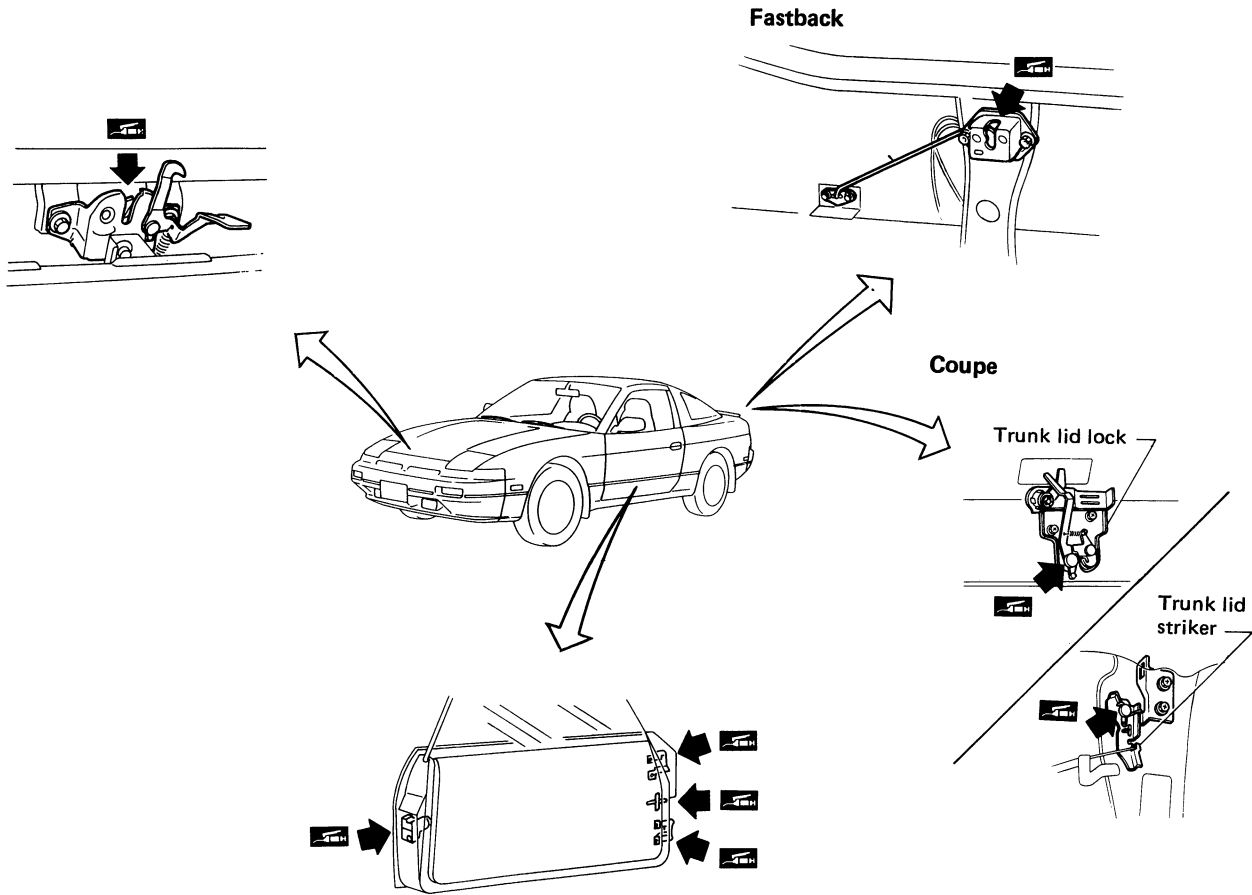

SMA999B

CHECKING SEAT BELTS, BUCKLES, RETRACTORS, ANCHORS AND ADJUSTERS

CAUTION:

1. All seat belt assemblies, including retractors and attaching hardware such as guide rail set, etc., should be inspected after any collision. Nissan recommends that all seat belt assemblies in use during a collision be replaced unless the collision was minor and the belts show no damage and continue to operate properly. Seat belt assemblies not in use during a collision should also be inspected and replaced if either damage or improper operation is noted.
2. If the condition of any component of a seat belt is questionable, do not have seat belt repaired, but replaced as a belt assembly.
3. If webbing is cut, frayed, or damaged, replace belt assembly.
4. Do not spill drinks, oil, etc. on inner lap belt buckle. Never oil tongue and buckle.
5. Use a NISSAN genuine seat belt assembly.

 Anchor bolt
 24 - 31 N·m
 (2.4 - 3.2 kg-m, 17 - 23 ft-lb)
 For automatic seat belt, refer to
 BF section.

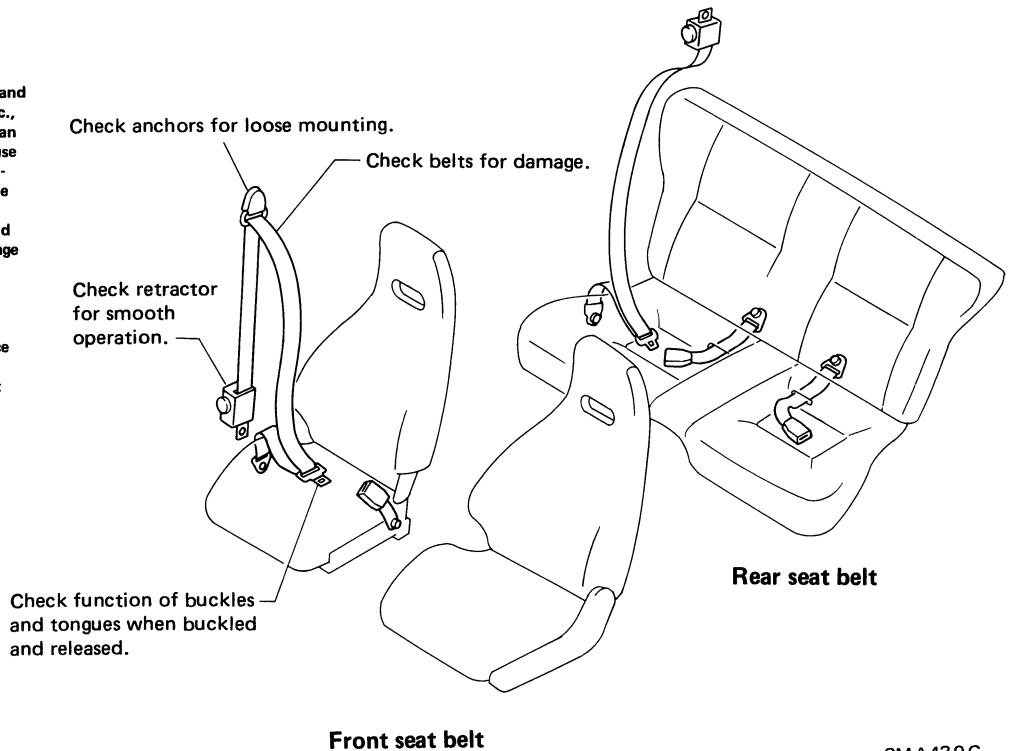

Front seat belt

Rear seat belt

SMA430C

SERVICE DATA AND SPECIFICATIONS (S.D.S.)

Engine Maintenance

INSPECTION AND ADJUSTMENT

Drive belt deflection

Unit: mm (in)

	Used belt deflection		Deflection of new belt
	Limit	Deflection after adjustment	
Alternator	11 (0.43)	7 - 8 (0.28 - 0.31)	6 - 7 (0.24 - 0.28)
Air conditioner compressor	12 (0.47)	7.5 - 8.5 (0.295 - 0.335)	6.5 - 7.5 (0.256 - 0.295)
Power steering oil pump			
Without SUPER HICAS	13 (0.51)	7.5 - 8.5 (0.295 - 0.335)	6.5 - 7.5 (0.256 - 0.295)
With SUPER HICAS	9 (0.35)	6.5 - 7.5 (0.256 - 0.295)	5.5 - 6.5 (0.217 - 0.256)
Applied pushing force	98 N (10 kg, 22 lb)		

Oil capacity (Refill)

Unit: ℓ (US qt, Imp qt)

With oil filter	3.8 (4, 3-3/8)
Without oil filter	3.5 (3-3/4, 3-1/8)

Coolant capacity

Unit: ℓ (US qt, Imp qt)

With reservoir tank	6.7 (7-1/8, 5-7/8)
---------------------	--------------------

Spark plug

Standard type	BKR5E-11
Cold type	BKR6E-11 BKR7E-11
Plug gap	1.0 - 1.1 mm (0.039 - 0.043 in)

Ignition wire

Resistance kΩ	Less than 30
---------------	--------------

TIGHTENING TORQUE

Unit	N·m	kg-m	ft-lb
Spark plug	20 - 29	2.0 - 3.0	14 - 22
Drain plug			
Engine block	34 - 44	3.5 - 4.5	25 - 33
Oil pan	29 - 39	3.0 - 4.0	22 - 29

SERVICE DATA AND SPECIFICATIONS (S.D.S.)

Chassis and Body Maintenance

INSPECTION AND ADJUSTMENT

Clutch

Unit: mm (in)

Pedal free height "H"	186 - 196 (7.32 - 7.72)
Pedal free play "A"	1.0 - 3.0 (0.039 - 0.118)

Front axle and front suspension (Unladen) *

Camber	degree	-1°30' to 0°
Caster	degree	6°00' - 7°30'
Kingpin inclination	degree	12°30' - 14°00'
Toe-in	mm (in)	0.3 - 2.3 (0.012 - 0.091)
(Total toe-in)	degree	1' - 13'
Front wheel turning angle		
Full turn	degree	39° - 43°/33°
Inside/outside		

*: Tankful of fuel, radiator coolant and engine oil full. Spare tire, jack, hand tools, mats in designated position.

Rear axle and rear suspension (Unladen) *

Camber	degree	-1°36' to -0°36'
Toe-in	mm (in)	0.5 - 4.5 (0.020 - 0.177)
(Total toe-in)	degree	3' - 25'

*: Tankful of fuel, radiator coolant and engine oil full. Spare tire, jack, hand tools, mats in designated position.

Wheel bearing

	Front	Rear
Wheel bearing axle end play mm (in)	0.03 (0.0012) or less	0.05 (0.0020) or less
Wheel bearing lock nut Tightening torque N·m (kg·m, ft·lb)	147 - 216 (15 - 22, 108 - 159)	206 - 275 (21 - 28, 152 - 203)

Brake

Unit: mm (in)

Disc brake		
Pad		
Standard thickness		
CL22VB		10.0 (0.394)
CL25VA		11.0 (0.433)
CL9H		9.5 (0.374)
Minimum thickness		
CL22VB		2.0 (0.079)
CL25VA		2.0 (0.079)
CL9H		1.5 (0.059)
Rotor		
Standard thickness		
CL22VB		20.0 (0.787)
CL25VA		22.0 (0.866)
CL9H		9.0 (0.354)
Minimum thickness		
CL22VB		18.0 (0.709)
CL25VA		20.0 (0.787)
CL9H		8.0 (0.315)
Pedal		
Free height		
M/T		177 - 187 (6.97 - 7.36)
A/T		186 - 196 (7.32 - 7.72)
Free play at clevis		1 - 3 (0.04 - 0.12)
Depressed height [under force of 490 N (50 kg, 110 lb) with engine running]		100 (3.94) or more
Parking brake		
Number of notches [at pulling force 196 N (20 kg, 44 lb)]		6 - 8

Wheel balance

Maximum allowable unbalance	Dynamic (at rim flange) g (oz)	10 (0.35) (One side)
	Static g (oz)	20 (0.71)

SERVICE DATA AND SPECIFICATIONS (S.D.S.)

Chassis and Body Maintenance (Cont'd)

TIGHTENING TORQUE

Unit	N·m	kg·m	ft·lb
Clutch			
Pedal stopper lock nut	16 - 22	1.6 - 2.2	12 - 16
Clutch switch lock nut	12 - 15	1.2 - 1.5	9 - 11
Manual transmission			
Drain and filler plugs	25 - 34	2.5 - 3.5	18 - 25
Final drive			
Drain plug	59 - 98	6 - 10	43 - 72
Filler plug	59 - 98	6 - 10	43 - 72
Front axle and front suspension			
Tie-rod lock nut	37 - 46	3.8 - 4.7	27 - 34
Rear axle and rear suspension			
Toe adjusting pin	69 - 88	7.0 - 9.0	51 - 65
Camber adjusting pin (Models without super HICAS)	69 - 88	7.0 - 9.0	51 - 65
Lower link lock nut (Models with super HICAS)	37 - 46	3.8 - 4.7	27 - 34
Brake system			
Air bleed valve	7 - 9	0.7 - 0.9	5.1 - 6.5
Brake lamp switch lock nut	12 - 15	1.2 - 1.5	9 - 11
Brake booster input rod lock nut	16 - 22	1.6 - 2.2	12 - 16
Wheel and tire			
Wheel nut	98 - 118	10.0 - 12.0	72 - 87

ENGINE MECHANICAL

SECTION **EM**

EM

CONTENTS

PRECAUTIONS	EM- 2
PREPARATION	EM- 3
OUTER COMPONENT PARTS	EM- 6
COMPRESSION PRESSURE	EM- 8
OIL PAN	EM- 9
TIMING CHAIN	EM-11
OIL SEAL REPLACEMENT	EM-21
CYLINDER HEAD	EM-23
ENGINE REMOVAL	EM-34
CYLINDER BLOCK	EM-37
SERVICE DATA AND SPECIFICATIONS (S.D.S.)	EM-49

PRECAUTIONS

Parts Requiring Angular Tightening

- Some important engine parts are tightened using an angular-tightening method rather than a torque setting method.
- If these parts are tightened using a torque setting method, dispersal of the tightening force (axial bolt force) will be two or three times that of the dispersal produced by using the correct angular tightening method.
- Although the torque setting values (described in this manual) are equivalent to those used when bolts and nuts are tightened with an angular-tightening method, they should be used for reference only.
- To assure the satisfactory maintenance of the engine, bolts and nuts must be tightened using an angular tightening method.
- Before tightening the bolts and nuts, ensure that the thread and seating surfaces are clean and then coated with engine oil.
- The bolts and nuts which require the angular-tightening method are as follows:
 - (1) Cylinder head bolts
 - (2) Connecting rod cap nuts.

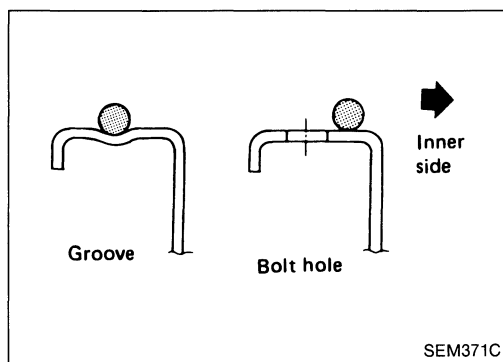



Liquid Gasket Application Procedure

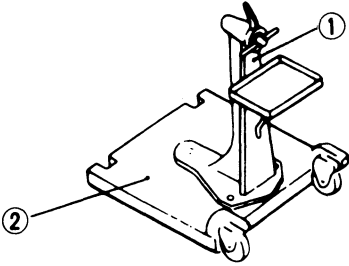
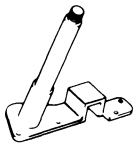
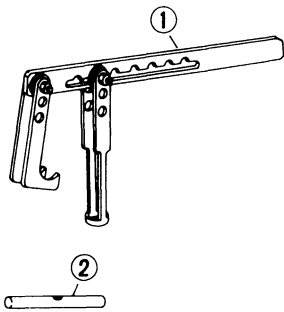

- Before applying liquid gasket, use a scraper to remove all traces of old liquid gasket from mating surface.**
- Apply a continuous bead of liquid gasket to mating surfaces. (Use Genuine Liquid Gasket or equivalent.)**
 - Be sure liquid gasket is 3.5 to 4.5 mm (0.138 to 0.177 in) wide (for oil pan).
 - Be sure liquid gasket is 2.0 to 3.0 mm (0.079 to 0.118 in) wide (in areas except oil pan).
- Apply liquid gasket to inner surface around hole perimeter area.**
(Assembly should be done within 5 minutes after coating.)
- Wait at least 30 minutes before refilling engine oil and engine coolant.**

PREPARATION

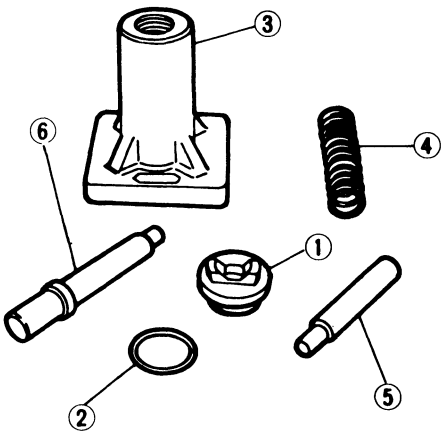
SPECIAL SERVICE TOOLS

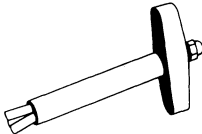
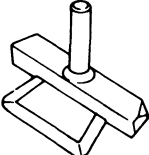
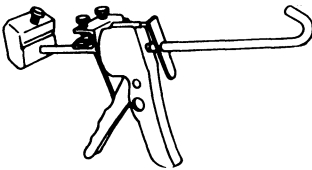

Tool number (Kent-Moore No.) Tool name	Description	
ST0501S000 (—) Engine stand assembly ① ST05011000 (—) Engine stand ② ST05012000 (—) Base		Disassembling and assembling
KV10105001 (—) Engine attachment		
KV101092S0 (—) Valve spring compressor ① KV10109210 (—) Compressor ② KV10109220 (—) Adapter		Disassembling and assembling valve components
KV10116300 (J-38955) Valve oil seal drift		Installing valve oil seal
KV10110300 (—) Piston pin press stand assembly ① KV10110310 (—) Cap ② KV10110330 (—) Spacer ③ ST13030020 (—) Press stand ④ ST13030030 (—) Spring ⑤ KV10110340 (—) Drift ⑥ KV10110320 (—) Center shaft		Disassembling and assembling piston with connecting rod

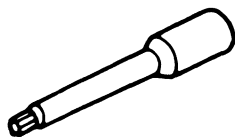
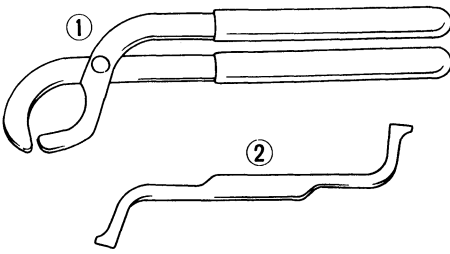
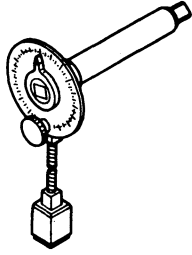
PREPARATION

Tool number (Kent-Moore No.) Tool name	Description
EM03470000 (J8037) Piston ring compressor	 <p data-bbox="1052 268 1448 325">Installing piston assembly into cylinder bore</p>
(J36467) Valve oil seal remover	 <p data-bbox="1052 443 1351 472">Displacement valve oil seal</p>
KV10111100 (—) Seal cutter	 <p data-bbox="1052 617 1242 646">Removing oil pan</p>
WS39930000 (—) Tube presser	 <p data-bbox="1052 791 1416 821">Pressing the tube of liquid gasket</p>
ST16610001 (J23907) Pilot bushing puller	
ST10120000 (J-24239-01) Cylinder head bolt wrench	 <p data-bbox="1052 1161 1416 1218">Loosening and tightening cylinder head bolt</p>
KV101151S0 Lifter stopper set ① KV10115110 Camshaft pliers ② KV10115120 Lifter stopper	 <p data-bbox="1052 1335 1226 1365">Changing shims</p>
KV10112100 Angle wrench	 <p data-bbox="1052 1629 1448 1686">Tightening bolts for bearing cap, cylinder head, etc.</p>

PREPARATION

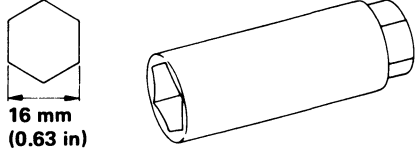
COMMERCIAL SERVICE TOOLS

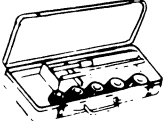
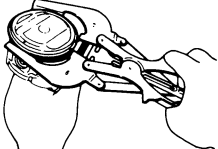
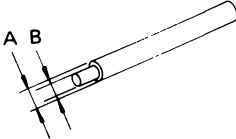
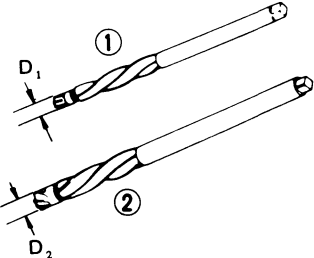
Tool name	Description									
Spark plug wrench	 <p>16 mm (0.63 in)</p> <p>Removing and installing spark plug</p>									
Pulley holder	 <p>Holding camshaft pulley while tightening or loosening camshaft bolt</p>									
Valve seat cutter set	 <p>Finishing valve seat dimensions</p>									
Piston ring expander	 <p>Removing and installing piston ring</p>									
Valve guide drift	 <p>Removing and installing valve guide</p> <p>Diameter: mm (in)</p> <table border="1" data-bbox="1052 1037 1424 1150"> <thead> <tr> <th></th> <th>Intake</th> <th>Exhaust</th> </tr> </thead> <tbody> <tr> <td>A</td> <td>10.5 (0.413)</td> <td>11.5 (0.453)</td> </tr> <tr> <td>B</td> <td>6.6 (0.260)</td> <td>7.6 (0.299)</td> </tr> </tbody> </table>		Intake	Exhaust	A	10.5 (0.413)	11.5 (0.453)	B	6.6 (0.260)	7.6 (0.299)
	Intake	Exhaust								
A	10.5 (0.413)	11.5 (0.453)								
B	6.6 (0.260)	7.6 (0.299)								
Valve guide reamer	 <p>Reaming valve guide (①) or hole for oversize valve guide (②)</p> <p>Diameter: mm (in)</p> <table border="1" data-bbox="1052 1310 1421 1423"> <thead> <tr> <th></th> <th>Intake</th> <th>Exhaust</th> </tr> </thead> <tbody> <tr> <td>D₁</td> <td>7 (0.28)</td> <td>8 (0.31)</td> </tr> <tr> <td>D₂</td> <td>11.2 (0.441)</td> <td>12.2 (0.480)</td> </tr> </tbody> </table>		Intake	Exhaust	D ₁	7 (0.28)	8 (0.31)	D ₂	11.2 (0.441)	12.2 (0.480)
	Intake	Exhaust								
D ₁	7 (0.28)	8 (0.31)								
D ₂	11.2 (0.441)	12.2 (0.480)								

OUTER COMPONENT PARTS

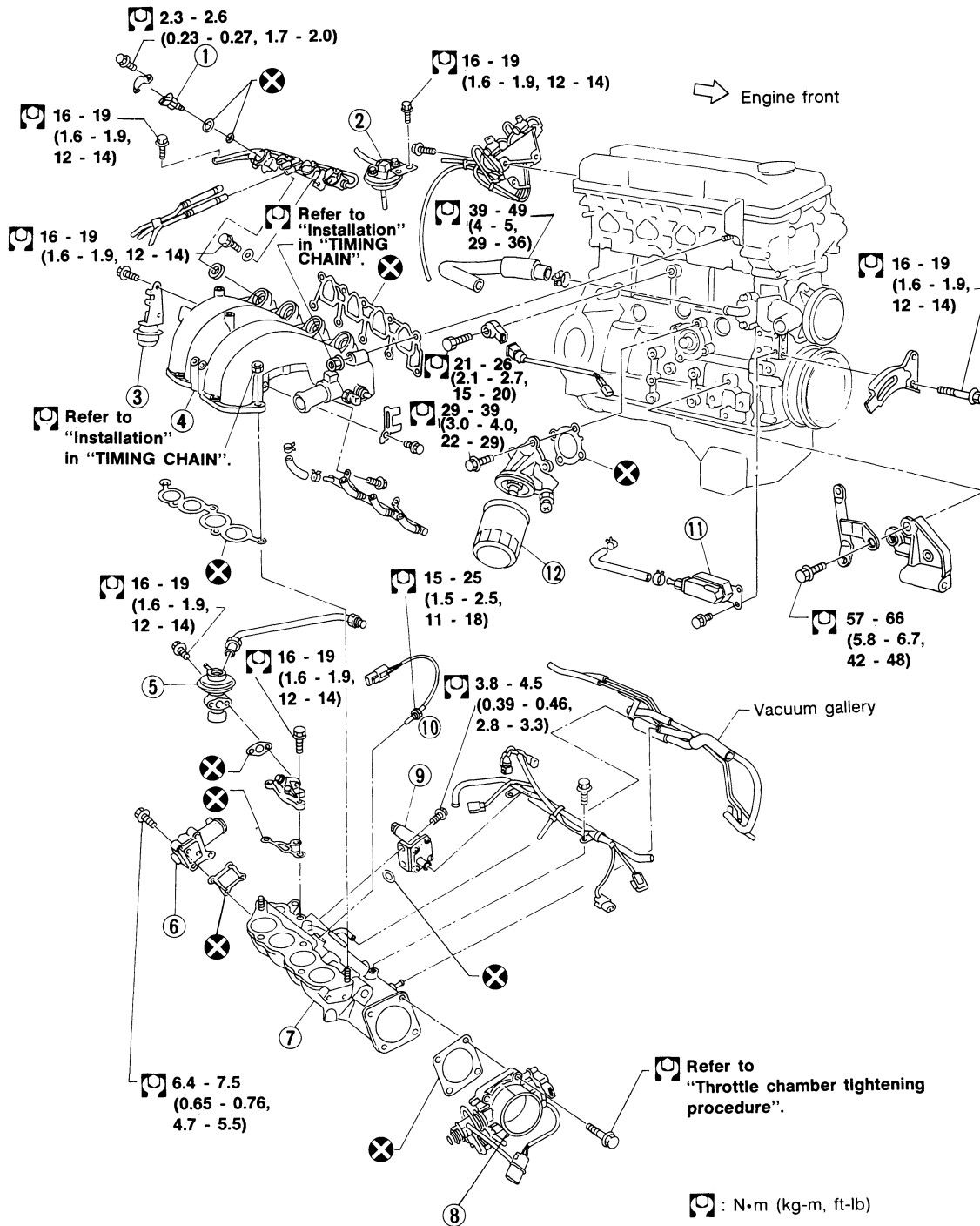

- ① Fuel injector
- ② B.P.T. valve
- ③ Swirl control valve
- ④ Intake manifold

- ⑤ E.G.R. control valve
- ⑥ I.A.A. unit
- ⑦ Intake manifold collector
- ⑧ Throttle chamber

- ⑨ Air regulator
- ⑩ Exhaust gas temperature sensor
- ⑪ Breather separator
- ⑫ Oil filter

SEM253D

OUTER COMPONENT PARTS

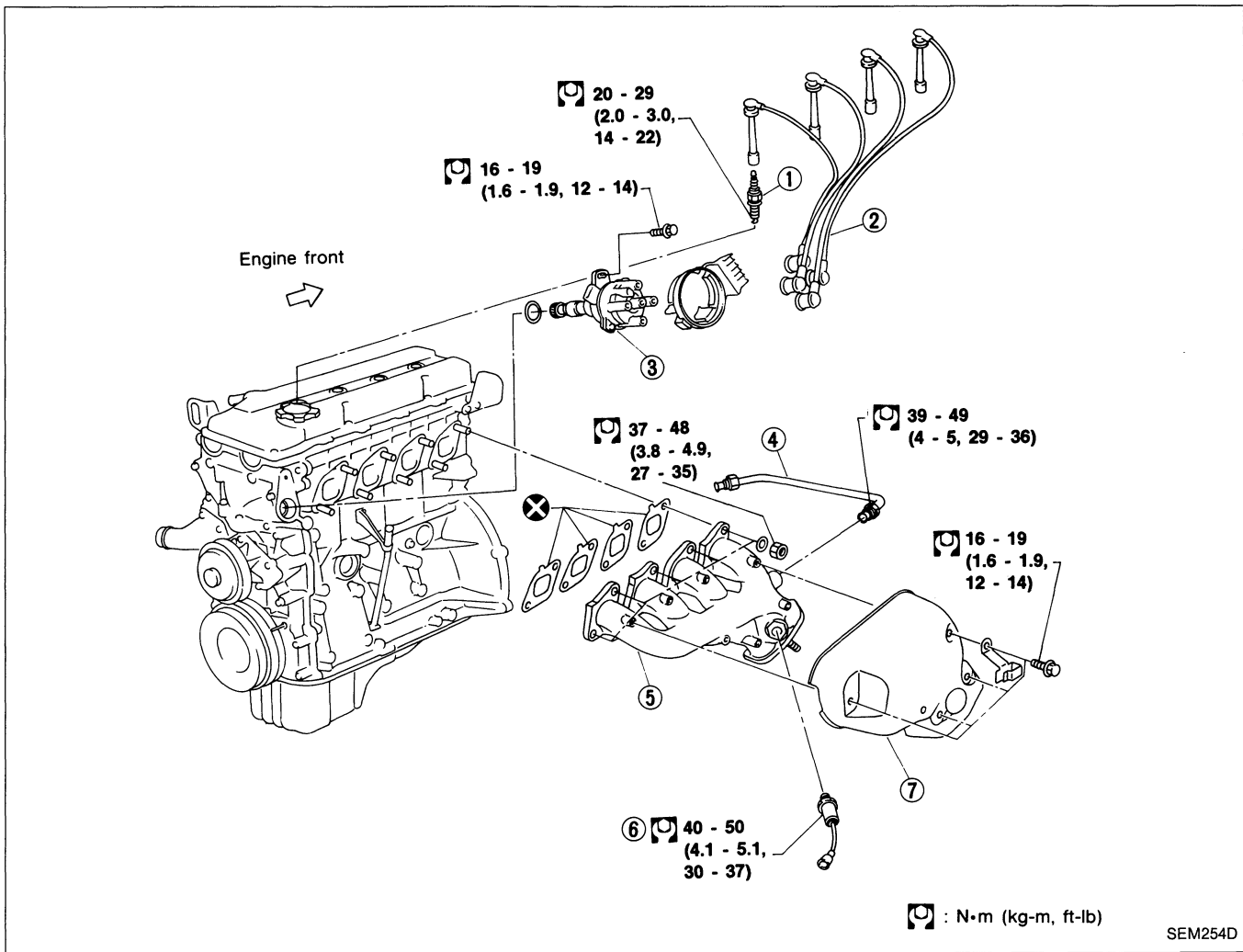

Intake manifold tightening procedure

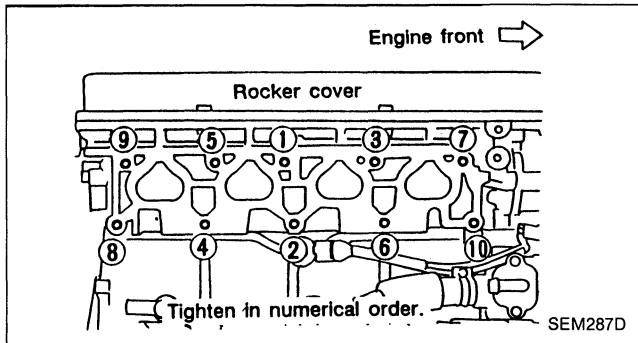

Intake manifold collector tightening procedure

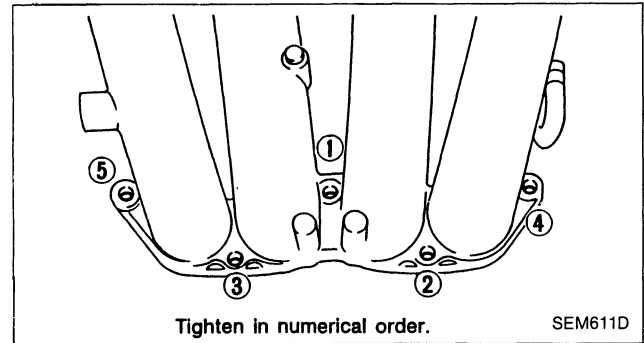

Exhaust manifold tightening procedure

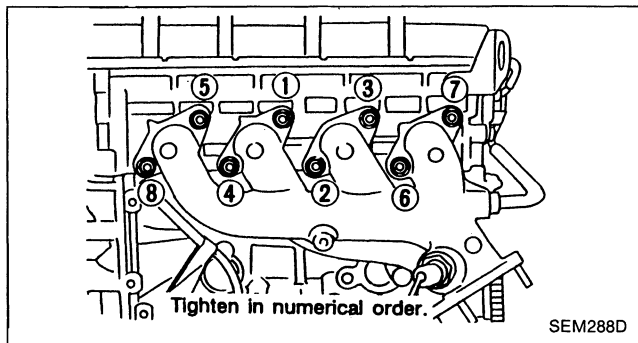

Throttle chamber tightening procedure

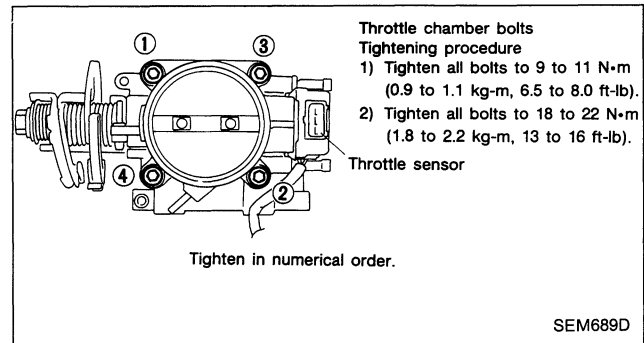

COMPRESSION PRESSURE

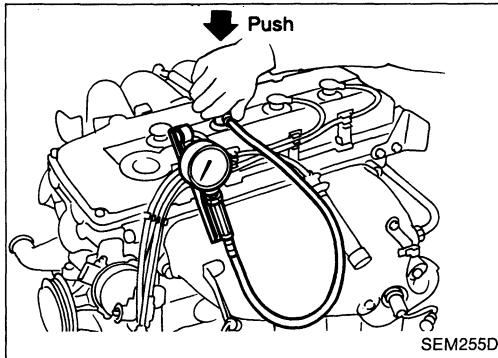
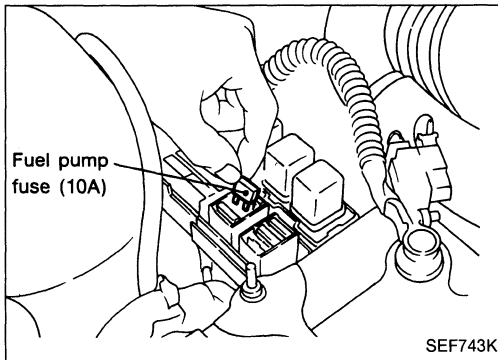

Measurement of Compression Pressure

1. Warm up engine.
 2. Turn ignition switch off.
 3. Release fuel pressure.
Refer to "Releasing Fuel Pressure" in section EF & EC.
 4. Remove all spark plugs.
 5. Disconnect distributor center cable.
 6. Attach a compression tester to No. 1 cylinder.
 7. Depress accelerator pedal fully to keep throttle valve wide open.
 8. Crank engine and record highest gauge indication.
 9. Repeat the measurement on each cylinder as shown above.
- **Always use a fully-charged battery to obtain specified engine revolution.**
- Compression pressure: kPa (kg/cm², psi)/rpm**
- Standard**
1,236 (12.6, 179)/300
- Minimum**
1,040 (10.6, 151)/300
- Difference limit between cylinders**
98 (1.0, 14)/300
10. If cylinder compression in one or more cylinders is low, pour a small amount of engine oil into cylinders through spark plug holes and retest compression.
- **If adding oil helps compression, piston rings may be worn or damaged. If so, replace piston rings after checking piston.**
 - **If pressure stays low, a valve may be sticking or seating improperly. Inspect and repair valve and valve seat. (Refer to S.D.S.) If valve or valve seat is damaged excessively, replace them.**
 - **If compression in any two adjacent cylinders is low and if adding oil does not help compression, there is leakage past the gasket surface. If so, replace cylinder head gasket.**

OIL PAN

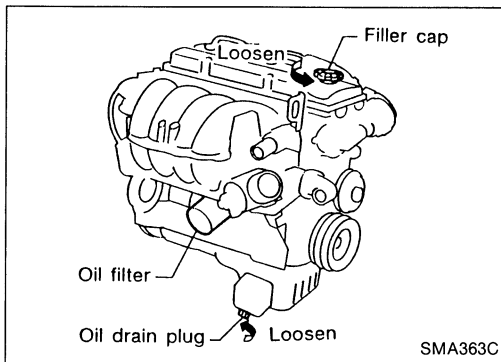

Removal

1. Raise vehicle and support it with safety stands.
2. Drain engine oil.

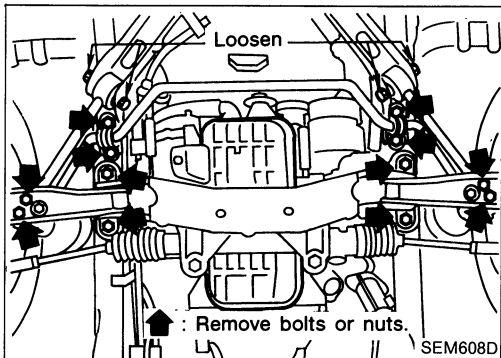

3. Remove the following parts.
 - Power steering tube
 - Front stabilizer bar securing bolts and nuts from side member.
 - Both left and right side engine mounting bolts. Refer to "ENGINE REMOVAL".
 - Gussets
4. Disconnect lower steering joint.
5. Remove front suspension member.

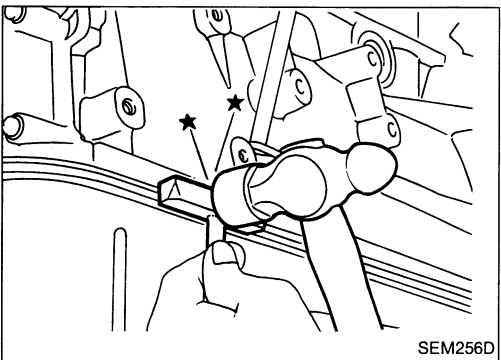
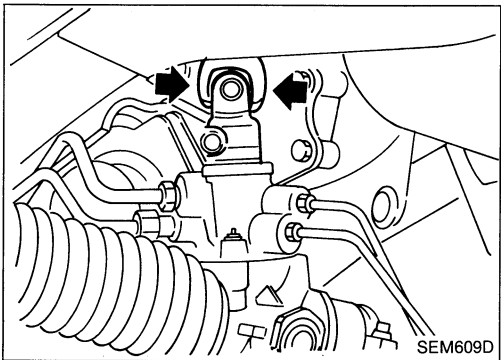

6. Remove oil pan.
 - (1) Insert Tool between cylinder block and oil pan.
 - **Do not drive seal cutter into oil pump or rear oil seal retainer portion, or aluminum mating face will be damaged.**
 - **Do not insert screwdriver, or oil pan flange will be deformed.**

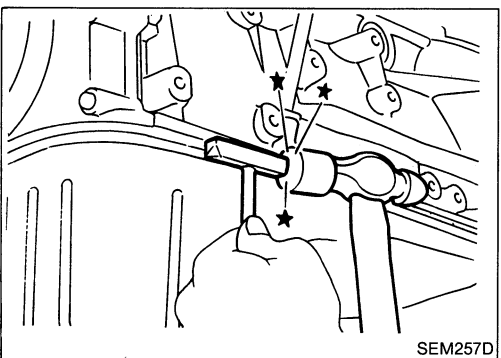

- (2) Slide Tool by tapping its side with a hammer, and remove oil pan.

OIL PAN

Removal (Cont'd)

7. Pull out oil pan from the front.

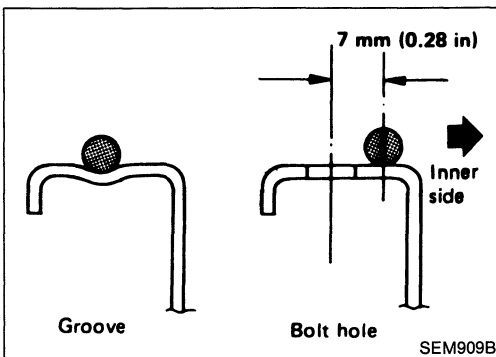
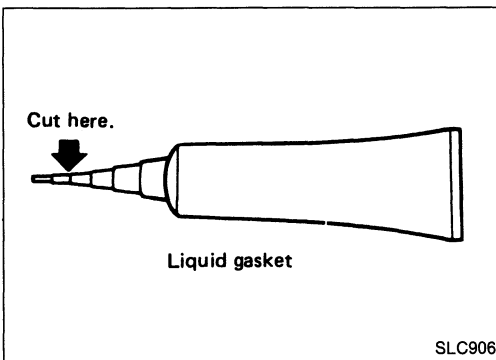
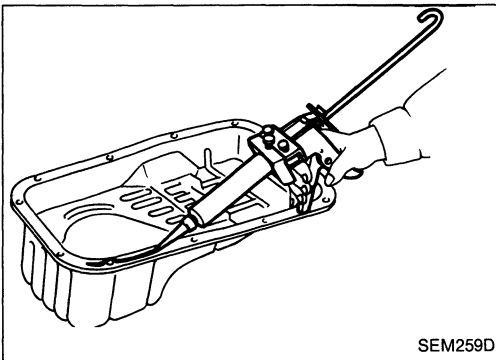
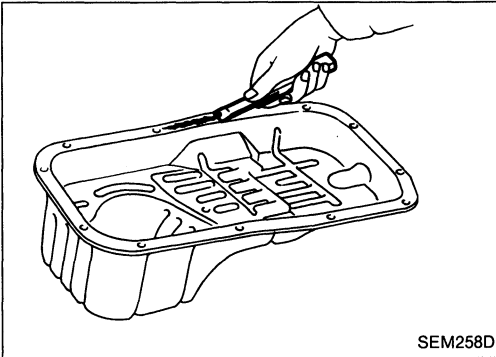
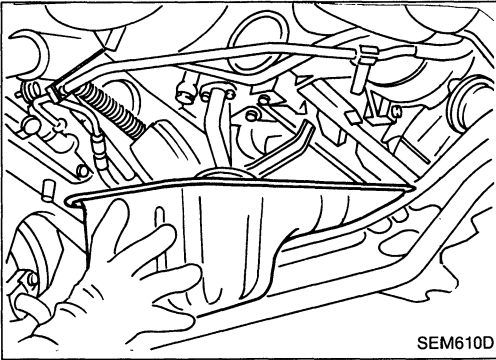

Installation

1. Before installing oil pan, remove all traces of liquid gasket from mating surface using a scraper.
 - Also remove traces of liquid gasket from mating surface of cylinder block.

2. Apply a continuous bead of liquid gasket to mating surface of oil pan.

- **Use Genuine Liquid Gasket or equivalent.**

- Be sure liquid gasket bead is 3.5 to 4.5 mm (0.138 to 0.177 in) wide.

3. Apply liquid gasket to inner sealing surface as shown in figure.

- **Attaching should be done within 5 minutes after coating.**

4. Install oil pan.

- **Wait at least 30 minutes before refilling engine oil.**

TIMING CHAIN

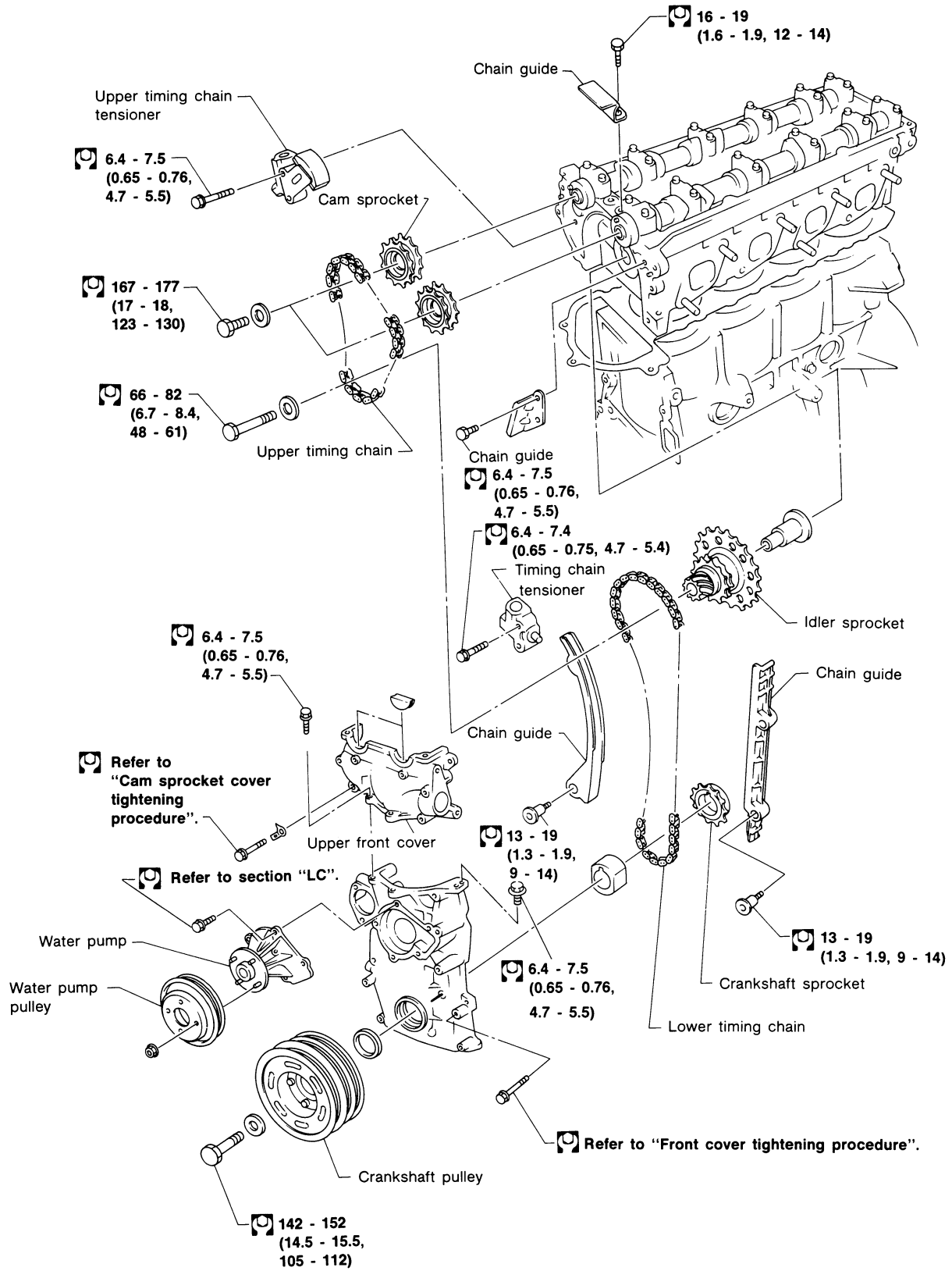

: N•m (kg-m, ft-lb)

TIMING CHAIN

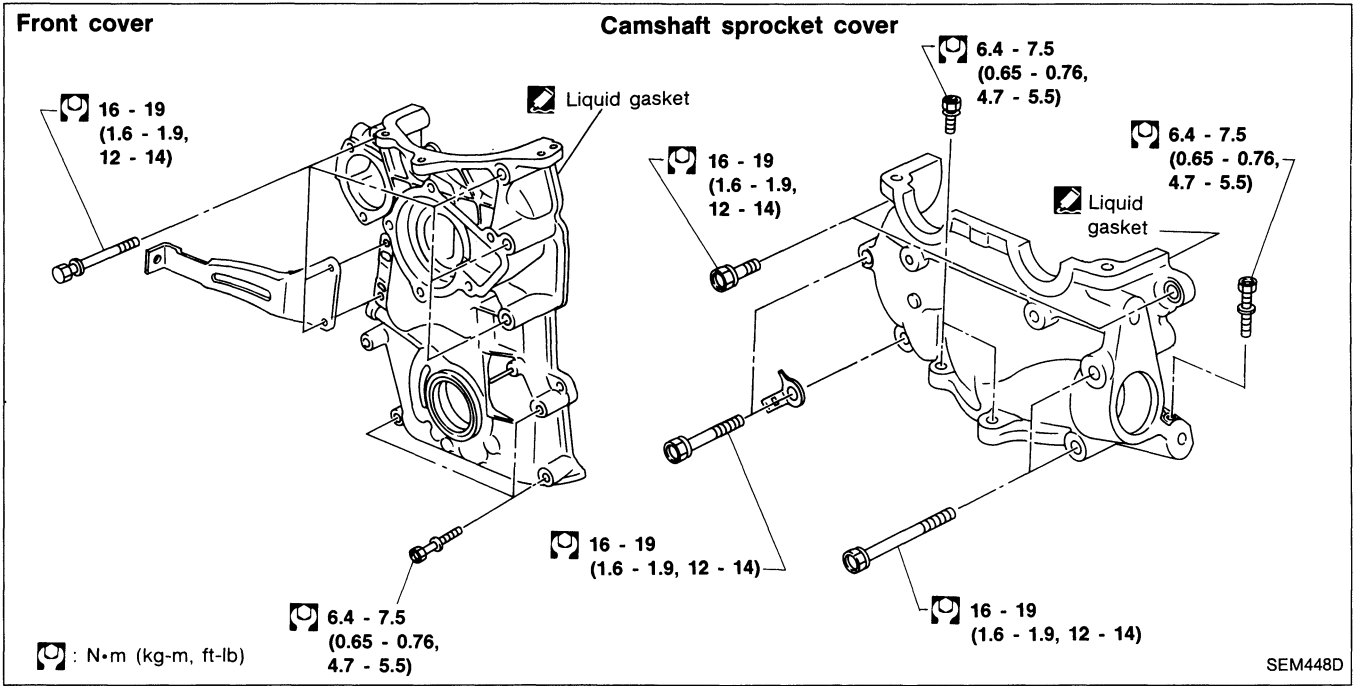

Liquid gasket application places

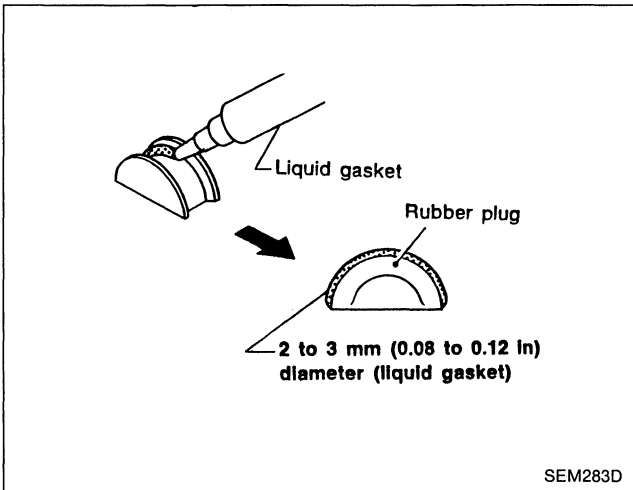
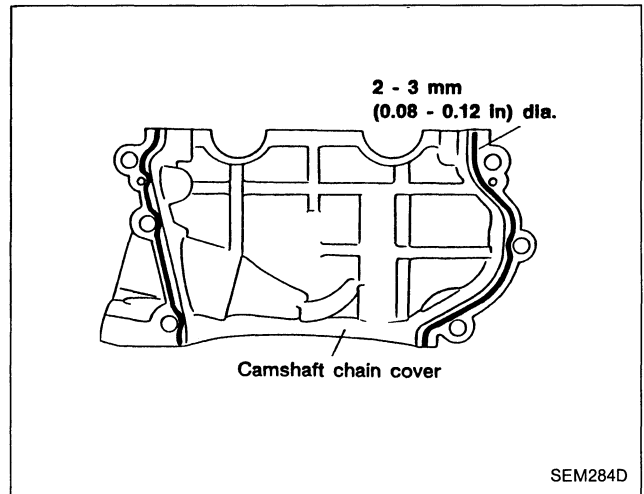
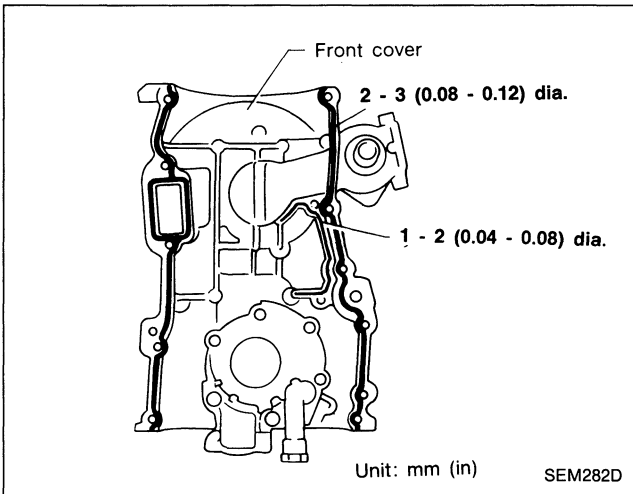

TIMING CHAIN

CAUTION:

- After removing timing chain, do not turn crankshaft and camshaft separately, or valves will strike piston heads.

Removal

UPPER TIMING CHAIN

1. Drain coolant from both cylinder block drain plug and radiator drain cock. Refer to MA section.
2. Drain engine oil from drain plug of oil pan.
3. Remove vacuum hoses, fuel tubes, wires, harness and connectors and so on.

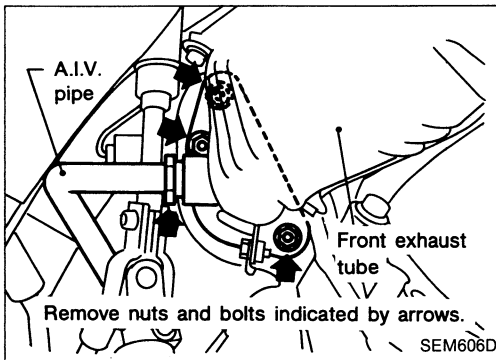

4. Remove front exhaust tube and A.I.V. pipe.
5. Remove the following parts.
 - Air duct
 - Cooling fan with coupling
 - Radiator shroud

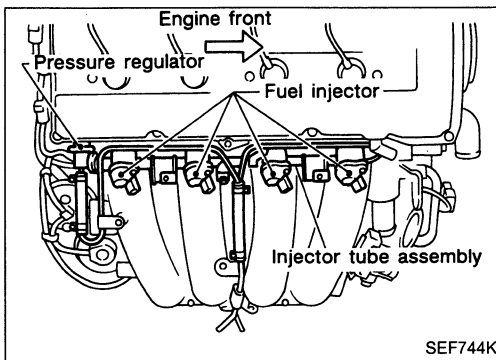

6. Disconnect injector harness connector and remove injector tube assembly with injectors.
7. Remove all spark plugs with high-tension cords.

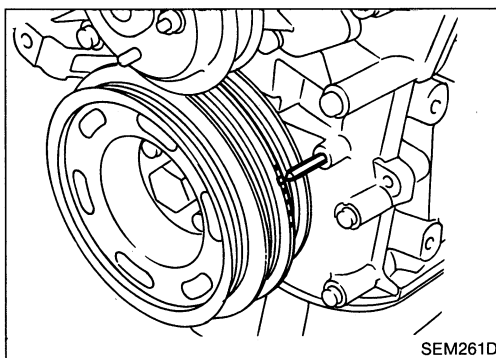

8. Set No. 1 piston at T.D.C. on its compression stroke.

TIMING CHAIN

Removal (Cont'd)

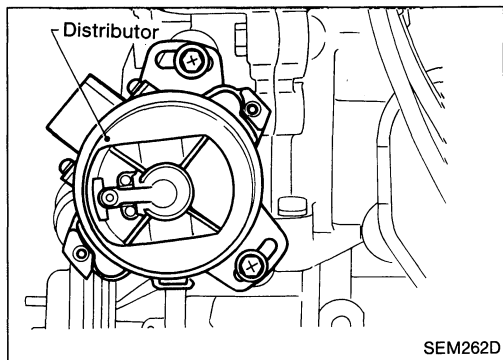

9. Remove rocker cover.
10. Remove distributor.

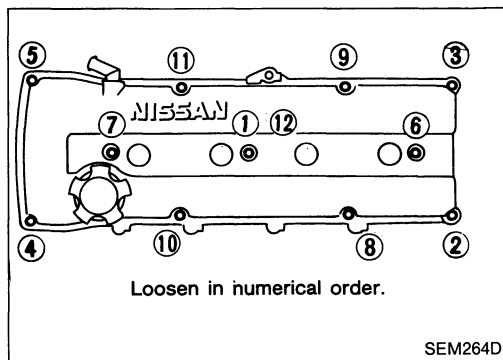

11. Remove cam sprocket.

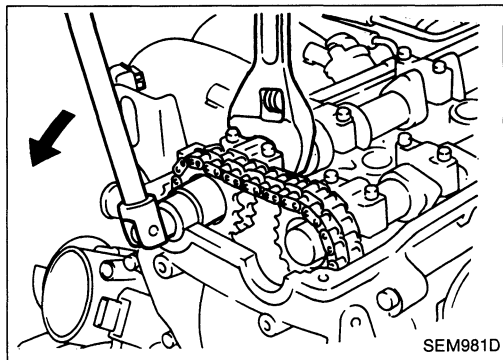

12. Remove cam brackets and camshafts.
 - These parts should be reassembled in their original positions.

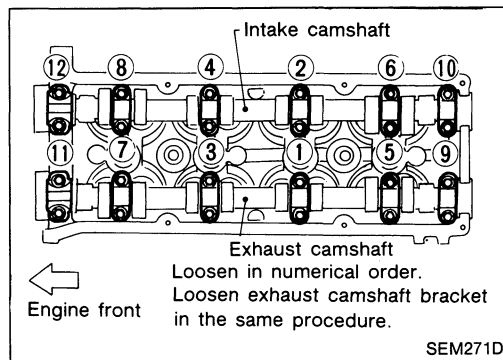

13. Loosen cylinder head bolts.
 - Head warpage or cracking could result from removing in incorrect order.
 - Cylinder head bolts should be loosened in two or three steps.

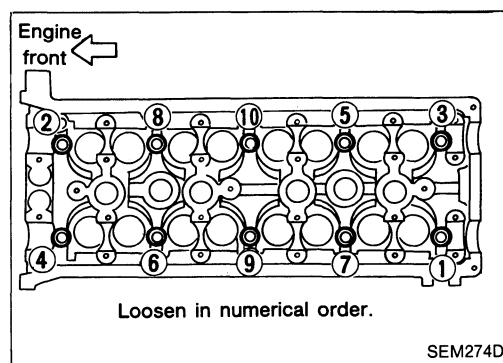

TIMING CHAIN

Removal (Cont'd)

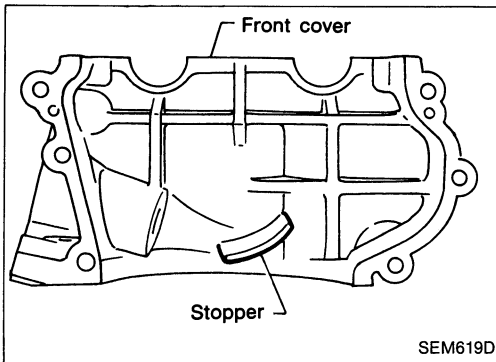

14. Remove cam sprocket cover

- Upper timing chain will not be disengaged from idler sprocket. For this reason, a stopper need not be used.

Cast portion of cam sprocket cover is located on lower side of idler sprocket so upper timing chain need not be disengaged from idler sprocket.

15. Remove upper chain tensioner and upper chain guides.

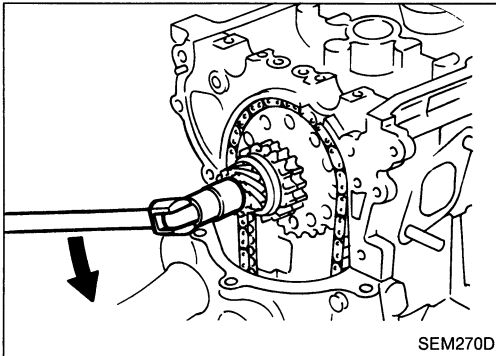

16. Remove upper timing chain.

17. Remove idler sprocket bolt.

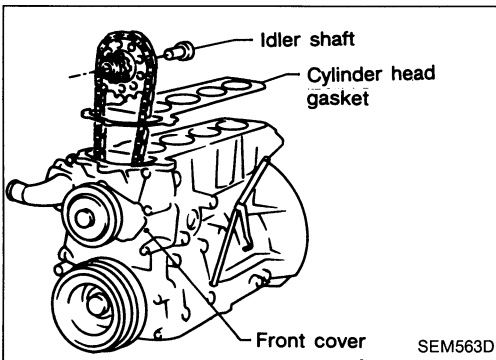

18. Remove cylinder head with intake manifold, intake manifold collector and exhaust manifold assembly.

19. Remove cylinder head gasket.

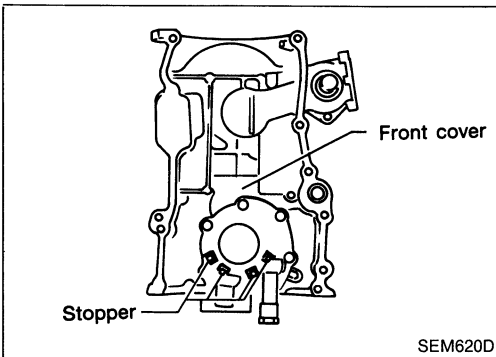

- Lower timing chain will not be disengaged from crankshaft sprocket. For this reason, a stopper need not be used.

Cast portion of front cover is located on lower side of crankshaft sprocket so lower timing chain need not be disengaged from idler sprocket.

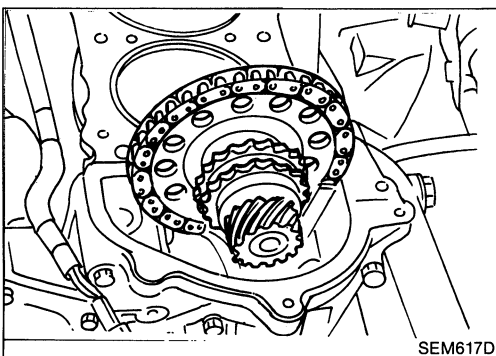

LOWER TIMING CHAIN

1. Remove upper timing chain.

Refer to "UPPER TIMING CHAIN "in" Removal.

TIMING CHAIN

Removal (Cont'd)

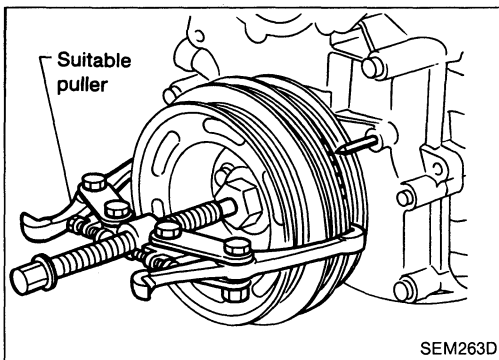

2. Remove oil pan.

Refer to "Removal" in "OIL PAN".

3. Remove oil strainer.

4. Remove the following parts.

- Power steering drive belt
- Alternator drive belt
- Air compressor drive belt
- Air compressor idler pulley

5. Remove crankshaft pulley.

6. Remove front cover

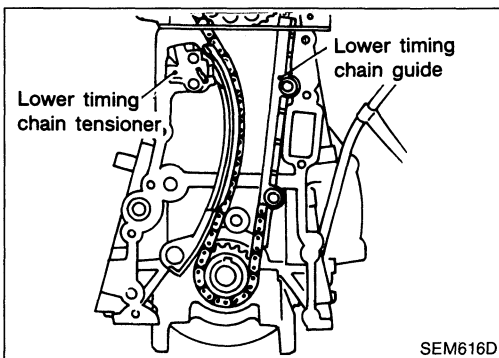

7. Remove the following parts.

- Lower timing chain tensioner
- Tension arm
- Lower timing chain guide

8. Remove lower timing chain and idler sprocket.

TIMING CHAIN

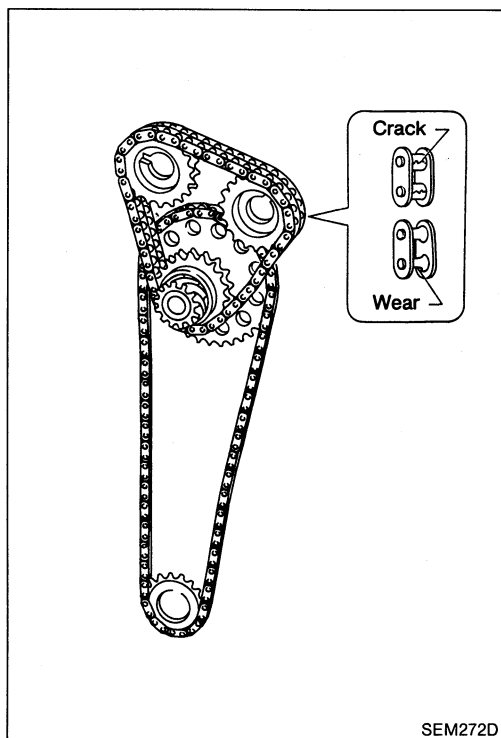

SEM272D

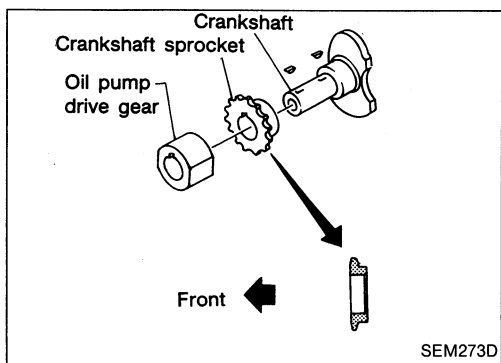

SEM273D

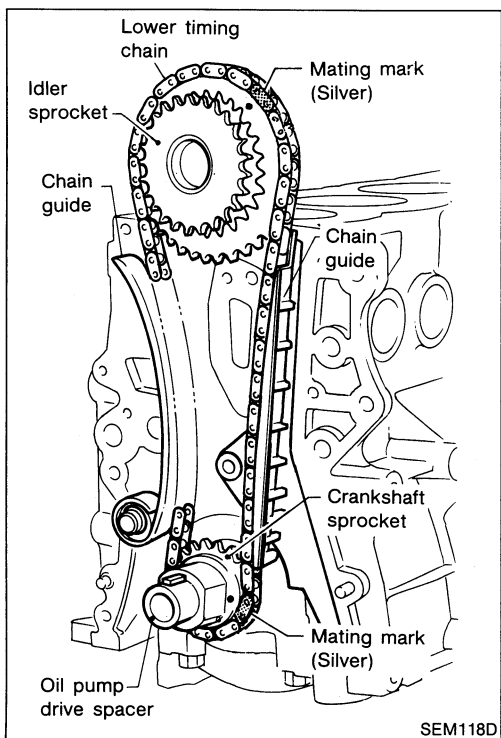

SEM118D

Inspection

Check for cracks and excessive wear at roller links. Replace chain if necessary.

Installation

LOWER TIMING CHAIN

1. Install crankshaft sprocket.
 - **Make sure that mating marks of crankshaft sprocket face front of engine.**
2. Position crankshaft so that No. 1 piston is set at T.D.C.
3. Install idler sprocket and lower timing chain.
 - **Set lower timing chain on the sprockets, aligning mating marks.**
 - **Be careful not to damage cylinder head gasket when installing lower timing chain.**
4. Install chain tension arm and chain guide.
5. Install lower timing chain tensioner.

TIMING CHAIN

Installation (Cont'd)

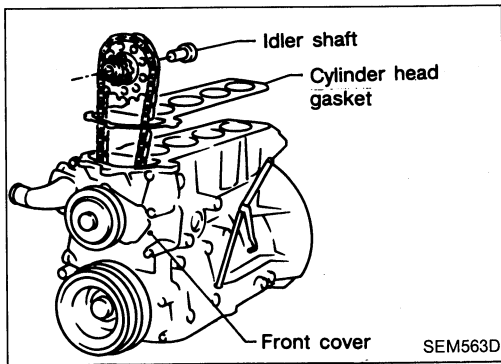

6. Install front cover.
 - **Apply a continuous bead of liquid gasket to front cover.**
 - **Be careful not to damage cylinder head gasket.**
 - **Be sure to install oil seal.**
7. Install the following parts:
 - Crankshaft pulley
 - Oil strainer
 - Oil pan
 - Component parts below the engine
 - Air compressor idler pulley
 - New cylinder head gasket
 - Idler shaft

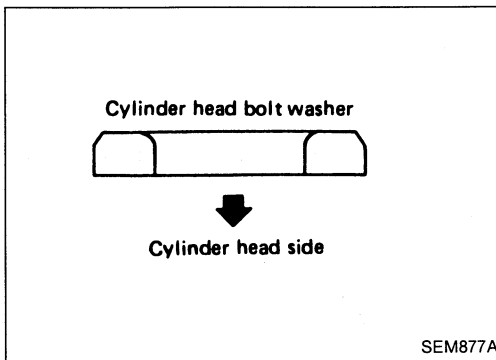

8. Install cylinder head and temporarily tighten cylinder head bolts when installing front cover.
 - **Temporarily tighten cylinder head bolts. This is necessary to avoid damaging cylinder head gasket.**
 - **Be sure to install washers between bolts and cylinder head.**

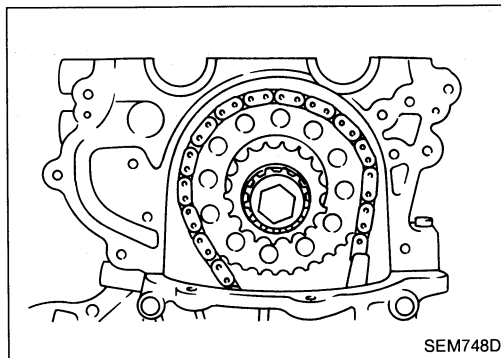

UPPER TIMING CHAIN

1. Install lower timing chain.
Refer to "LOWER TIMING CHAIN" in "Installation".
2. Install upper timing chain, chain tensioner and chain guide.
 - **Set upper timing chain on the idler sprockets, aligning mating marks.**

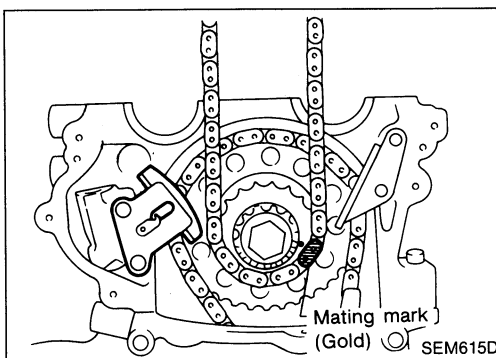

TIMING CHAIN

Installation (Cont'd)

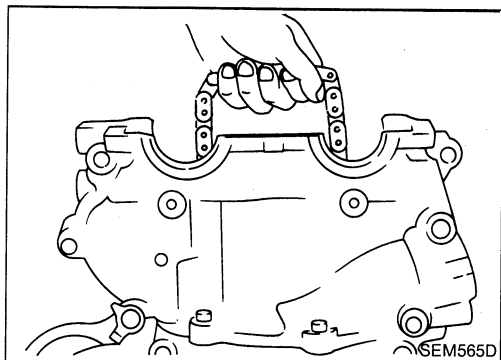

3. Install cam sprocket cover.
 - Apply a continuous bead of liquid gasket to front cover.
 - Be careful not to damage cylinder head gasket.
 - Be careful upper timing chain does not slip or jump when installing cam sprocket cover.

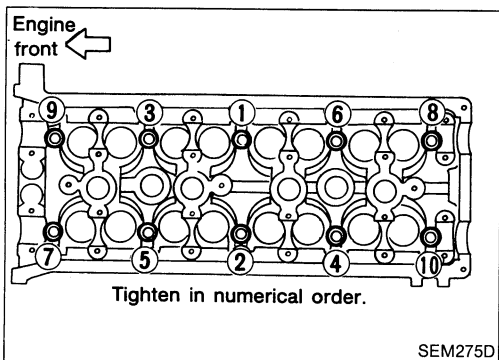

4. Tighten cylinder head bolts.
 - **Tightening procedure**
 - a Tighten all bolts to 29 N·m (3.0 kg-m, 22 ft-lb).
 - b Tighten all bolts to 79 N·m (8.1 kg-m, 59 ft-lb).
 - c Loosen all bolts completely
 - d Tighten all bolts to 25 to 34 N·m (2.5 to 3.5 kg-m, 18 to 25 ft-lb).
 - e Turn all bolts 86 to 91 degrees clockwise, or if an angle wrench is not available, tighten bolts to 75 to 84 N·m (7.6 to 8.6 kg-m, 55 to 62 ft-lb).

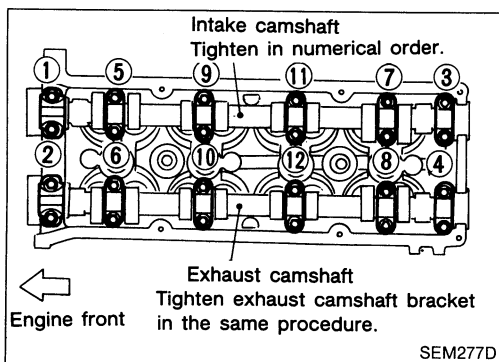
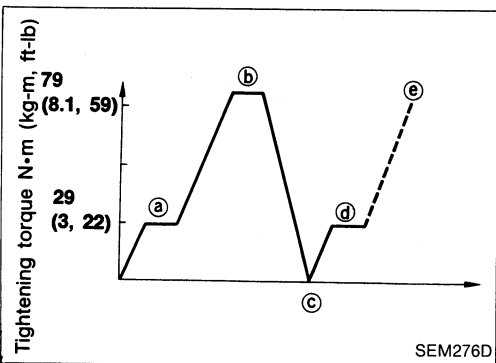

5. Install camshafts and camshaft brackets.

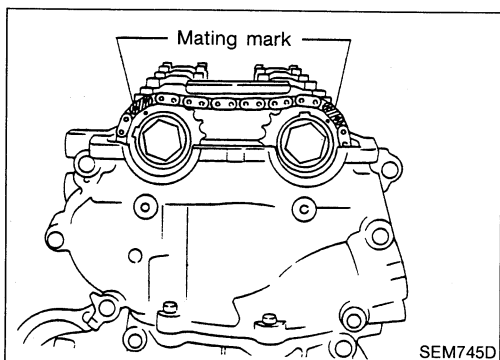

6. Install camshaft sprockets.
7. Install chain guide between both camshaft sprockets.

TIMING CHAIN

Installation (Cont'd)

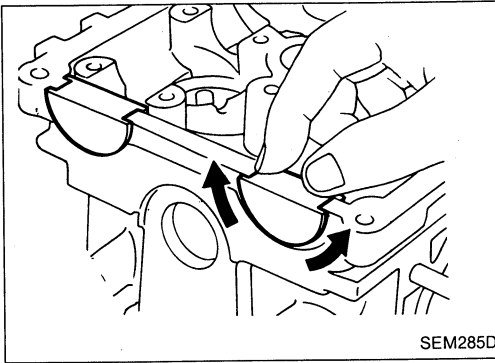

8. Install rubber plugs as follows.
 - (1) Apply liquid gasket to rubber plugs.
 - (2) Install rubber plugs, then move them by hand to uniformly spread the gasket on cam sprocket cover surface.
 - Rubber plugs should be installed flush with the cylinder head surface.
9. Install chain guide between both camshaft sprockets.

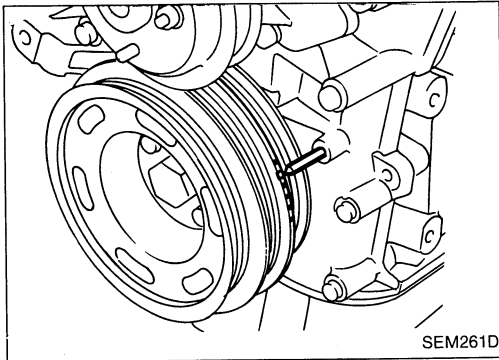
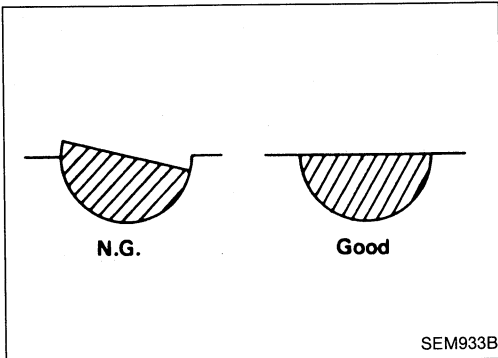

10. Install distributor.
 - Make sure that No. 1 piston is set at T.D.C. and that distributor rotor is set at No. 1 cylinder spark position.

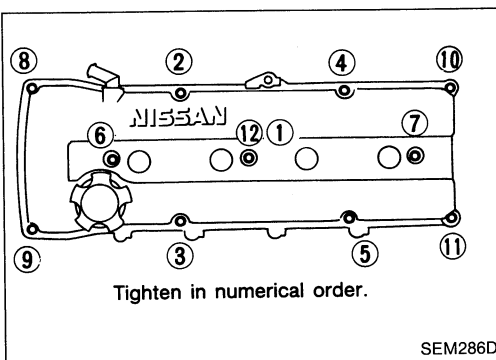
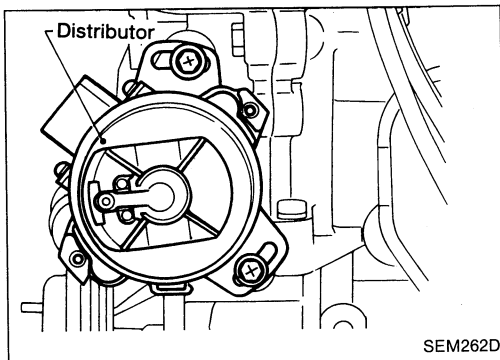

11. Install rocker cover.
12. Install all spark plugs with high-tension cords.
13. Connect injector harness connector and replace injector tube assembly with injectors.
14. Install the following parts.
 - Radiator shroud
 - Cooling fan with coupling
 - Air duct
15. Install vacuum hoses, fuel tubes, wires, harness and connectors and so on.

OIL SEAL REPLACEMENT

VALVE OIL SEAL

1. Remove rocker cover.
2. Remove camshaft. Refer to "TIMING CHAIN".
3. Remove valve spring and valve oil seal with Tool or a suitable tool.

Piston concerned should be set at T.D.C. to prevent valve from falling.

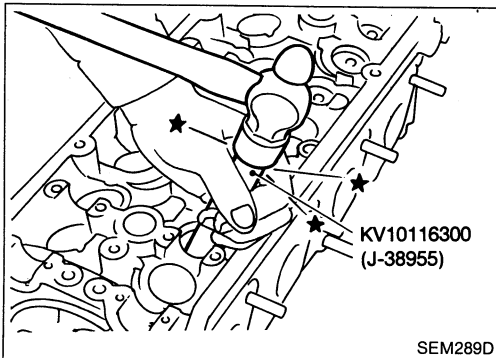

4. Apply engine oil to new valve oil seal and install it with Tool.

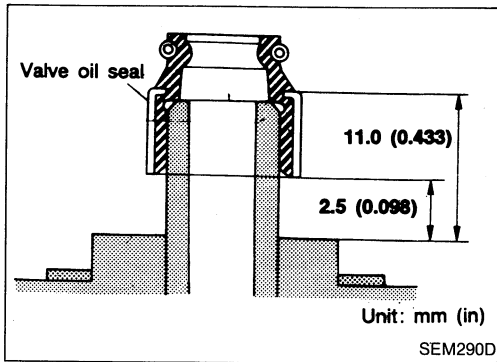

OIL SEAL INSTALLING DIRECTION

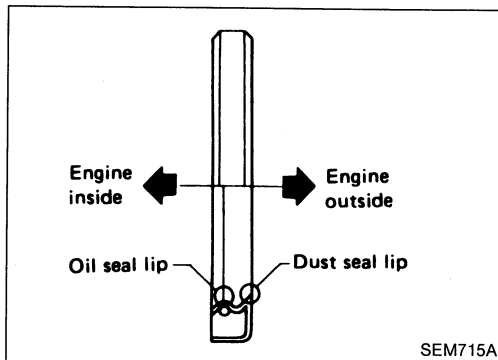

FRONT OIL SEAL

1. Remove radiator shroud and crankshaft pulley.
 2. Remove front oil seal
- **Be careful not to damage crankshaft.**

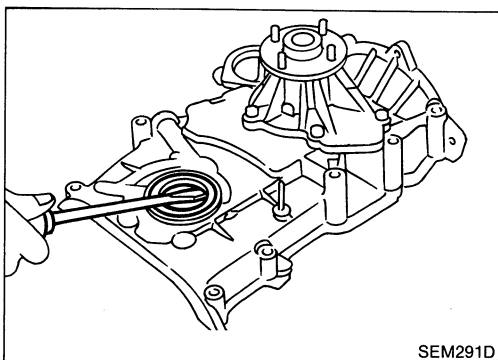

OIL SEAL REPLACEMENT

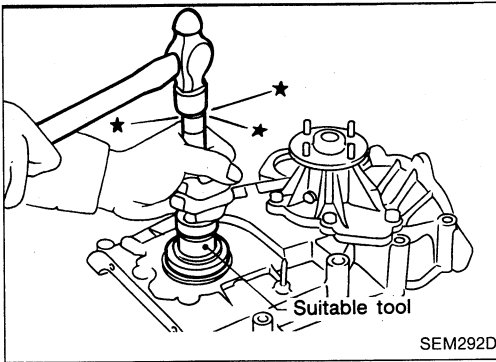

3. Apply engine oil to new oil seal and install it using a suitable tool.

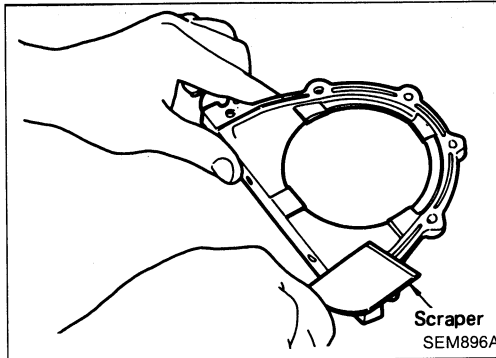

REAR OIL SEAL

1. Remove drive plate or flywheel.
2. Remove rear oil seal retainer.
3. Remove traces of liquid gasket using scraper.

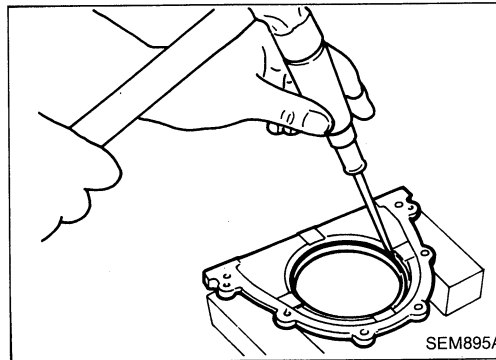

4. Remove rear oil seal from rear oil seal retainer.

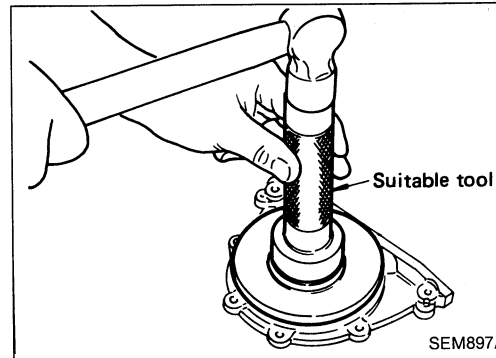

5. Apply engine oil to new oil seal and install it using a suitable tool.

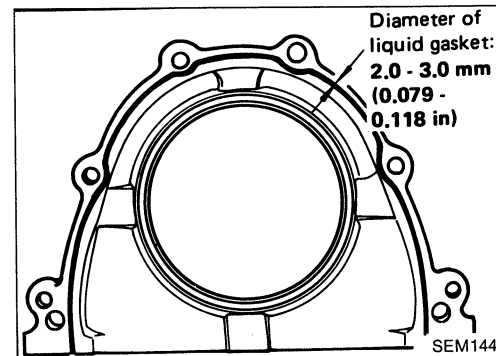

6. Apply a continuous bead of liquid gasket to rear oil seal retainer.

CYLINDER HEAD

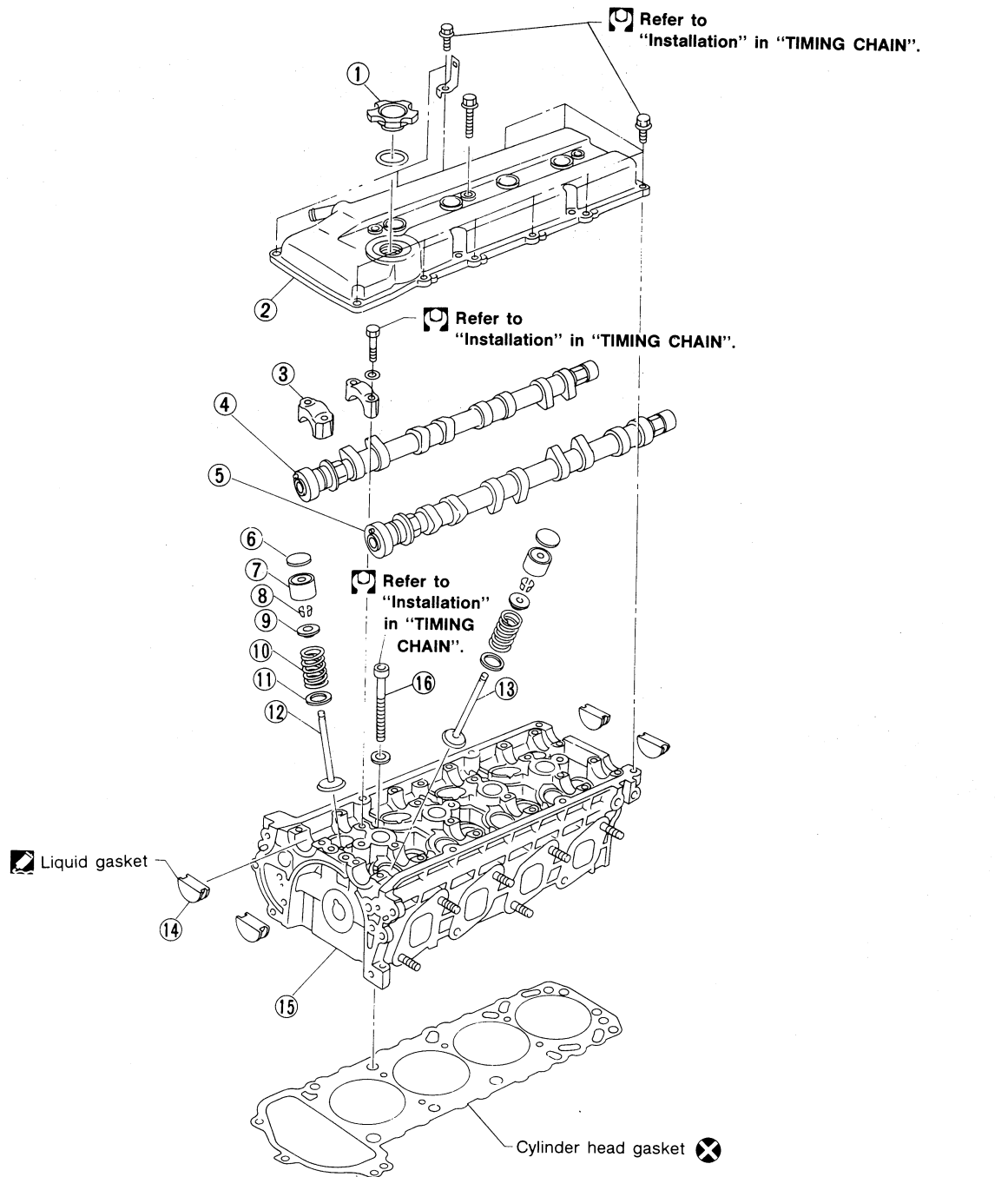

- ① Oil filler cap
- ② Rocker cover
- ③ Camshaft bracket
- ④ Intake camshaft
- ⑤ Exhaust camshaft
- ⑥ Shim

- ⑦ Valve lifter
- ⑧ Valve cotter
- ⑨ Spring retainer
- ⑩ Valve spring
- ⑪ Spring seat

- ⑫ Intake valve
- ⑬ Exhaust valve
- ⑭ Rubber plug
- ⑮ Cylinder head
- ⑯ Cylinder head bolt

SEM293D

CYLINDER HEAD

CAUTION:

- When installing sliding parts such as rocker arms, camshaft and oil seal, be sure to apply new engine oil on their sliding surfaces.
- When tightening cylinder head bolts, intake camshaft sprocket bolts and camshaft bracket bolts, apply new engine oil to thread portions and seat surfaces of bolts.
- Attach tags to valve lifters so as not to mix them up.

Removal

- This removal is the same procedure as those for timing chain. Refer to "Removal" in "TIMING CHAIN".

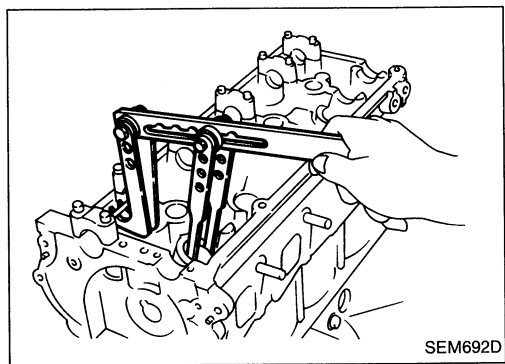

Disassembly

1. Remove intake manifold, collector assembly and exhaust manifold. Refer to "Outer Component Parts".
2. Remove valve components with Tool.
3. Remove valve oil seal with a suitable tool.

CYLINDER HEAD

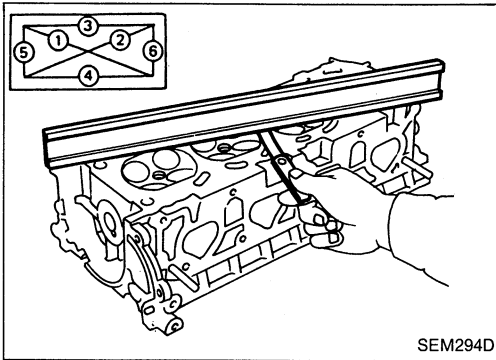

Inspection

CYLINDER HEAD DISTORTION

Head surface flatness:

Standard:

Less than 0.03 mm (0.0012 in)

Limit:

0.1 mm (0.004 in)

If beyond the specified limit, replace it or resurface it.

Resurfacing limit:

The resurfacing limit of cylinder head is determined by the cylinder block resurfacing in an engine.

Amount of cylinder head resurfacing is "A".

Amount of cylinder block resurfacing is "B".

The maximum limit is as follows:

A + B = 0.2 mm (0.008 in)

After resurfacing cylinder head, check that camshaft rotates freely by hand. If resistance is felt, cylinder head must be replaced.

Nominal cylinder head height:

126.3 - 126.5 mm (4.972 - 4.980 in)

CAMSHAFT VISUAL CHECK

Check camshaft for scratches, seizure and wear.

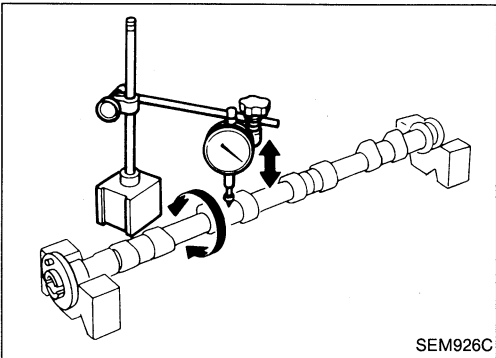

CAMSHAFT RUNOUT

1. Measure camshaft runout at the center journal.

Runout (Total indicator reading):

Standard:

Less than 0.02 mm (0.0008 in)

Limit:

0.04 mm (0.0016 in)

2. If it exceeds the limit, replace camshaft.

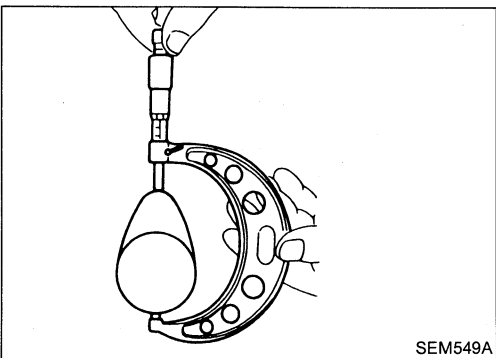

CAMSHAFT CAM HEIGHT

1. Measure camshaft cam height.

Standard cam height:

Intake

42.415 - 42.605 mm (1.6699 - 1.6774 in)

Exhaust

42.415 - 43.005 mm (1.6699 - 1.6931 in)

Cam wear limit:

Intake & Exhaust

0.2 mm (0.008 in)

2. If wear is beyond the limit, replace camshaft.

CYLINDER HEAD

Inspection (Cont'd)

CAMSHAFT JOURNAL CLEARANCE

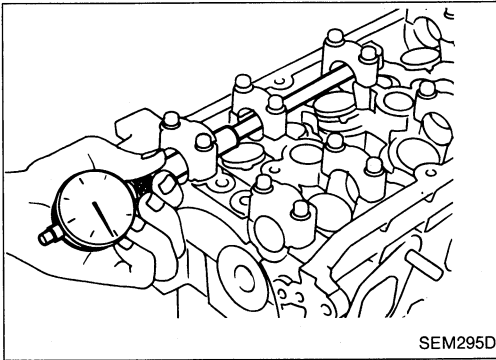

1. Install camshaft bracket and tighten bolts to the specified torque.
2. Measure inner diameter of camshaft bearing.
Standard inner diameter:
28.000 - 28.025 mm (1.1024 - 1.1033 in)

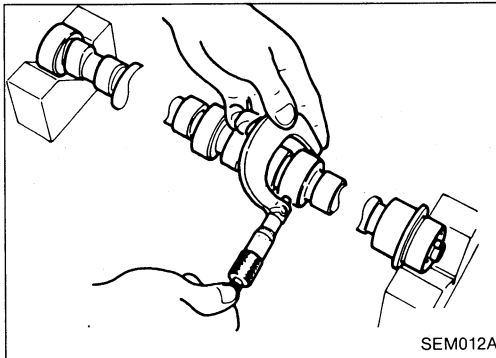

3. Measure outer diameter of camshaft journal.
Standard outer diameter:
#1 journal
27.935 - 27.955 mm (1.0998 - 1.1006 in)
#2 to #5 journals
23.935 - 23.955 mm (0.9423 - 0.9431 in)
4. If clearance exceeds the limit, replace camshaft and/or cylinder head.
Camshaft journal clearance:
Standard
0.045 - 0.090 mm (0.0018 - 0.0035 in)
Limit
0.15 mm (0.0059 in)

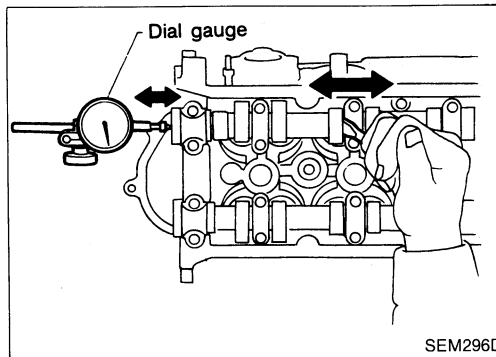

CAMSHAFT END PLAY

1. Install camshaft and thermostat housing in cylinder head.
2. Measure camshaft end play.
Camshaft end play:
Standard
0.070 - 0.148 mm (0.0028 - 0.0058 in)
Limit
0.20 mm (0.0079 in)

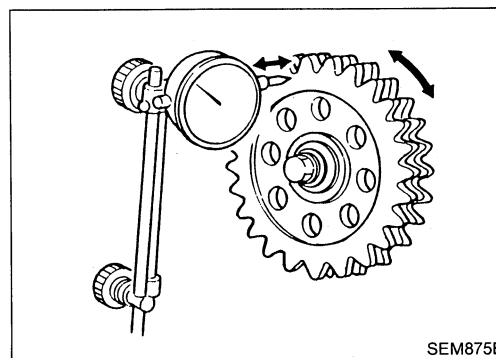

CAMSHAFT SPROCKET RUNOUT

1. Install sprocket on camshaft.
2. Measure camshaft sprocket runout.
Runout (Total indicator reading):
Limit 0.15 mm (0.0059 in)
3. If it exceeds the limit, replace camshaft sprocket.

CYLINDER HEAD

Inspection (Cont'd)

VALVE GUIDE CLEARANCE

1. Measure valve deflection in a parallel direction with rocker arm. (Valve and valve guide mostly wear in this direction.)

Valve deflection limit (Dial gauge reading):

Intake

0.16 mm (0.0063 in)

Exhaust

0.2 mm (0.008 in)

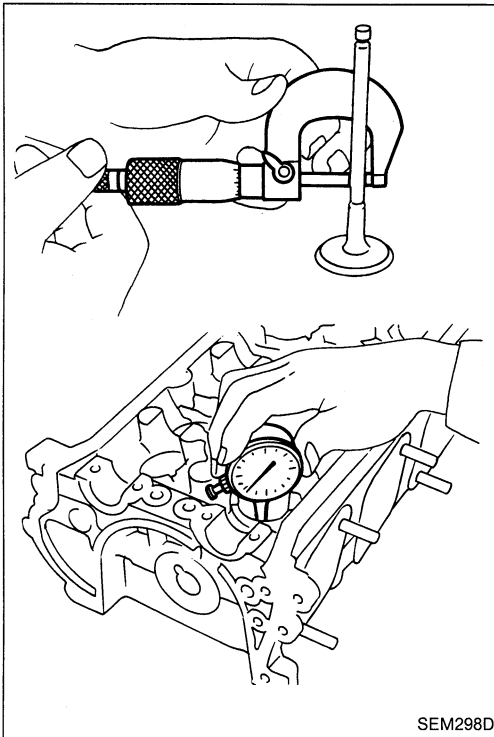
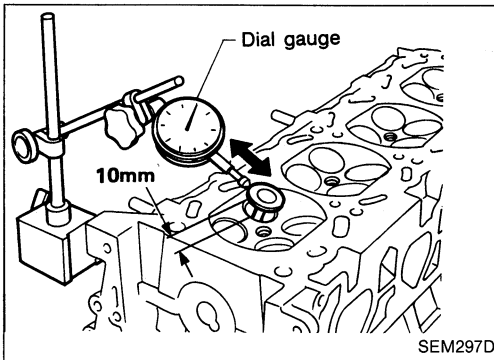

2. If it exceeds the limit, check valve to valve guide clearance.
 - a. Measure valve stem diameter and valve guide inner diameter.
 - b. Check that clearance is within specification.

Valve to valve guide clearance:

Unit: mm (in)

	Standard	Limit
Intake	0.020 - 0.053 (0.0008 - 0.0021)	0.08 (0.0031)
Exhaust	0.040 - 0.073 (0.0016 - 0.0029)	0.1 (0.004)

- c. If it exceeds the limit, replace valve or valve guide.

VALVE GUIDE REPLACEMENT

1. To remove valve guide, heat cylinder head to 120 to 140°C (248 to 284°F).

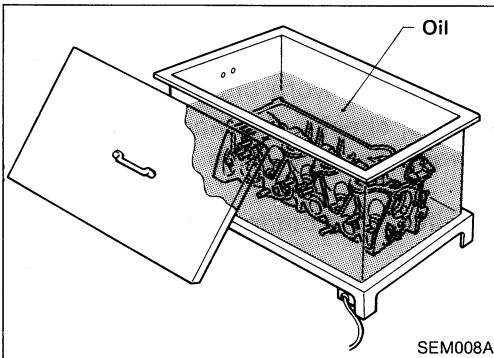

2. Drive out valve guide with a press [under a 20 kN (2 t, 2.2 US ton, 2.0 Imp ton) pressure] or hammer and suitable tool.

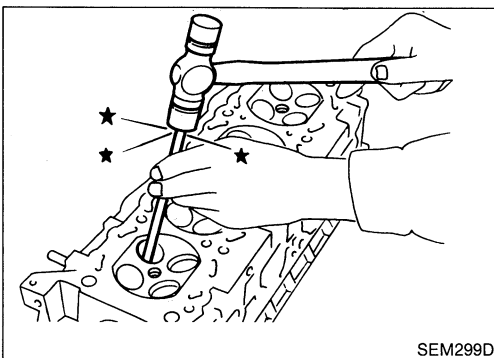

CYLINDER HEAD

Inspection (Cont'd)

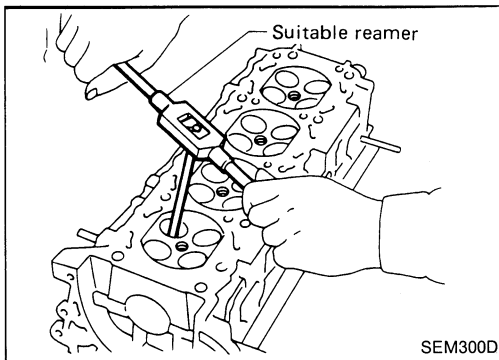

3. Ream cylinder head valve guide hole.

Valve guide hole diameter

(for service parts):

Intake

11.175 - 11.196 mm (0.4400 - 0.4408 in)

Exhaust

12.175 - 12.196 mm (0.4793 - 0.4802 in)

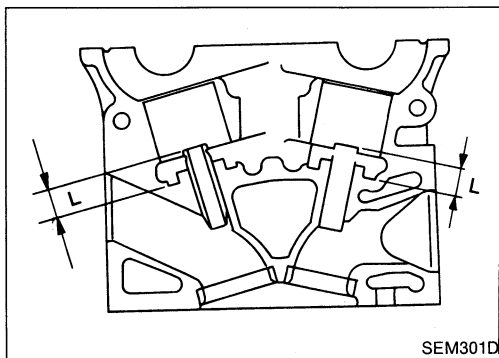

4. Heat cylinder head to 120 to 140°C (230 to 266°F) and press service valve guide onto cylinder head.

Projection "L":

13.3 - 13.9 mm (0.524 - 0.547 in)

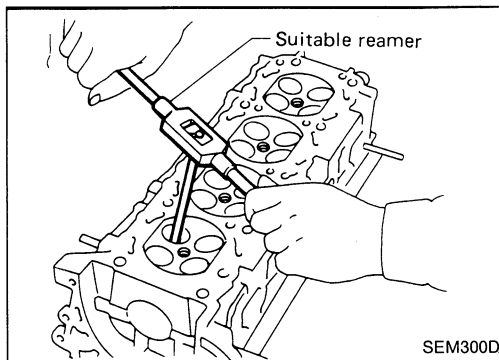

5. Ream valve guide.

Finished size:

Intake & Exhaust

7.000 - 7.018 mm (0.2756 - 0.2763 in)

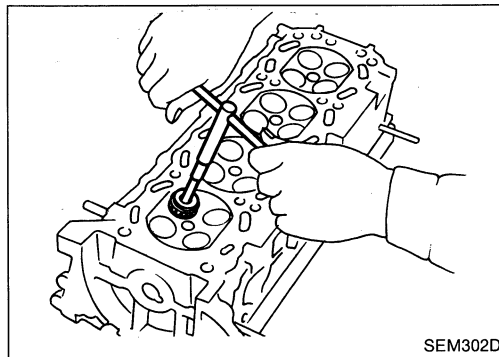

VALVE SEATS

Check valve seats for any evidence of pitting at valve contact surface, and reset or replace if it has worn out excessively.

- Before repairing valve seats, check valve and valve guide for wear. If they have worn, replace them. Then correct valve seat.
- Cut with both hands to uniform the cutting surface.

CYLINDER HEAD

Inspection (Cont'd)

REPLACING VALVE SEAT FOR SERVICE PARTS

1. Bore out old seat until it collapses. The machine depth stop should be set so that boring cannot continue beyond the bottom face of the seat recess in cylinder head.
2. Ream cylinder head recess.

Reaming bore for service valve seat

Oversize [0.5 mm (0.020 in)]:

Intake

38.000 - 38.016 mm (1.4961 - 1.4967 in)

Exhaust

32.700 - 32.716 mm (1.2874 - 1.2880 in)

Reaming should be done in circles concentric to the valve guide center so that valve seat will have the correct fit.

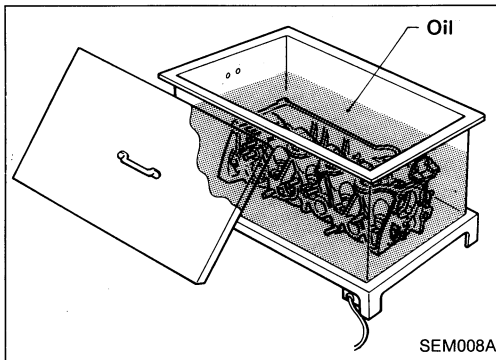
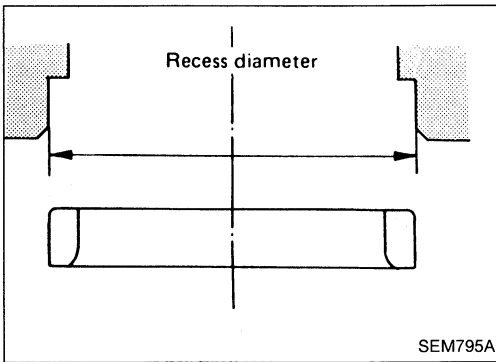

3. Heat cylinder head to 120 to 140°C (248 to 284°F).
4. Press fit valve seat until it seats on the bottom.

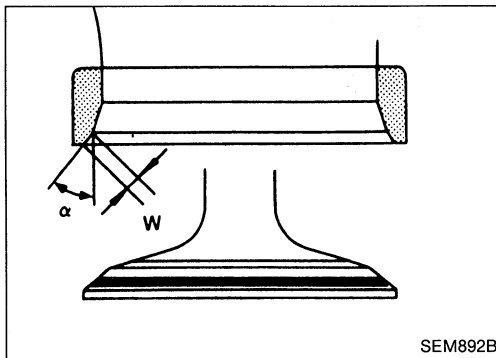

5. Cut or grind valve seat using suitable tool at the specified dimensions as shown in S.D.S.
6. After cutting, lap valve seat with abrasive compound.
7. Check valve seating condition.

Seat face angle " α ":

44°73' - 45°07' deg.

Contacting width "W":

Intake

1.48 - 1.63 mm (0.0583 - 0.0642 in)

Exhaust

1.77 - 1.90 mm (0.0697 - 0.0748 in)

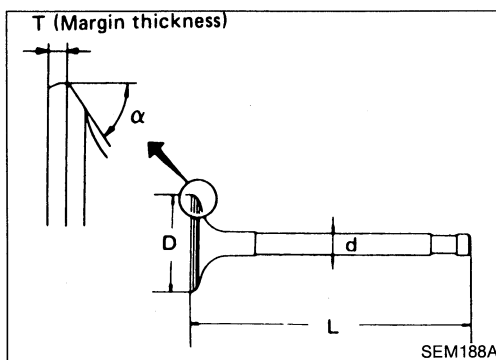

VALVE DIMENSIONS

Check dimensions in each valve. For dimensions, refer to S.D.S. When valve head has been worn down to 0.5 mm (0.020 in) in margin thickness, replace valve.

Grinding allowance for valve stem tip is 0.2 mm (0.008 in) or less.

CYLINDER HEAD

Inspection (Cont'd)

VALVE SPRING

Squareness

1. Measure "S" dimension.

Out-of-square:

Less than 1.9 mm (0.075 in)

2. If it exceeds the limit, replace spring.

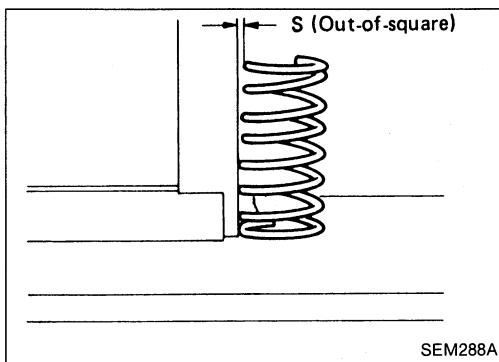

Pressure

Check valve spring pressure.

Pressure: N (kg, lb) at height mm (in)

Standard

548.70 (55.95, 123.37) at 26.0 (1.024)

Limit

More than 489.4 (49.9, 110.0) at 26.0 (1.024)

If it exceeds the limit, replace spring.

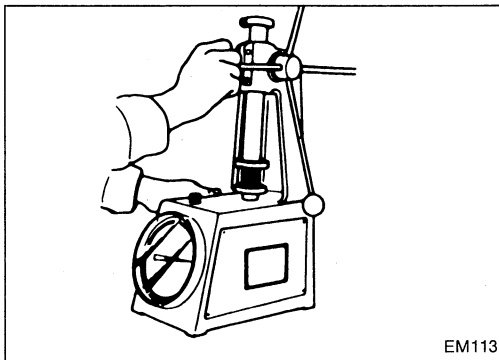

VALVE LIFTER AND VALVE SHIM

1. Visually check contact and sliding surfaces for wear or scratches.

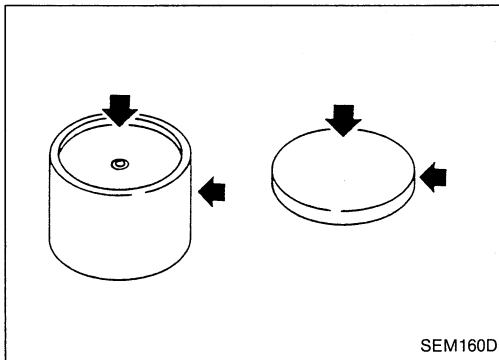

2. Check diameter of valve lifter and valve lifter guide bore.

Valve lifter diameter:

33.960 - 33.975 mm (1.3370 - 1.3376 in)

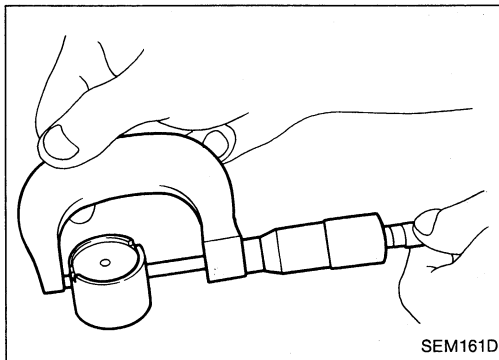

Lifter guide bore diameter:

34.000 - 34.021 mm (1.3386 - 1.3394 in)

Valve lifter to valve lifter guide clearance:

0.025 - 0.061 mm (0.0010 - 0.0024 in)

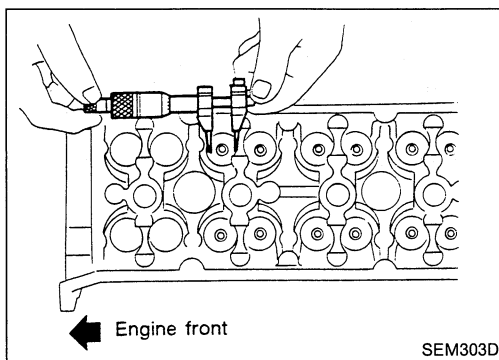

CYLINDER HEAD

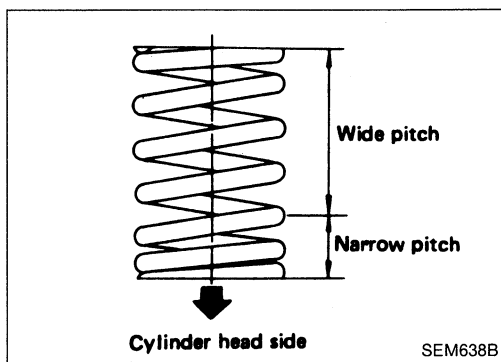

Assembly

1. Install valve component parts.
 - **Always use new valve oil seal. Refer to OIL SEAL REPLACEMENT.**
 - **Before installing valve oil seal, install valve spring seat.**
 - **Install outer valve spring (uneven pitch type) with its narrow pitch side toward cylinder head side.**
 - **After installing valve component parts, use plastic hammer to lightly tap valve stem tip to assure a proper fit.**

Installation

- This installation is the same procedure as those for timing chain. Refer to "Installation" in "TIMING CHAIN".

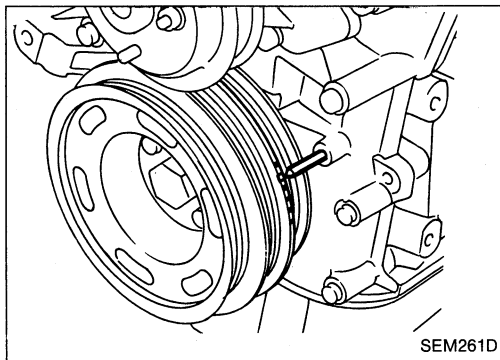

Valve Clearance

CHECKING

Check valve clearance while engine is warm but not running.

1. Remove rocker cover.
2. Remove all spark plugs.
3. Set No. 1 cylinder at T.D.C. on its compression stroke.
 - Align pointer with T.D.C. mark on crankshaft pulley.
 - Check that valve lifters on No. 1 cylinder are loose and valve lifters on No. 4 are tight.

If not, turn crankshaft one revolution (360°) and align as above.

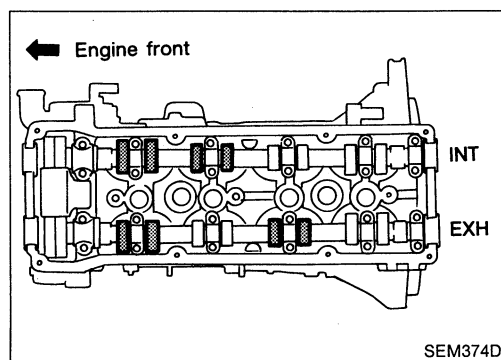

4. Check only those valves shown in the figure.

CYLINDER HEAD

Valve Clearance (Cont'd)

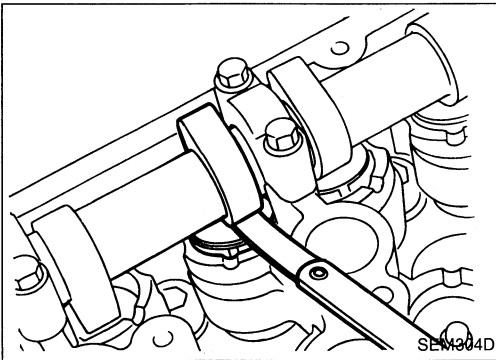

- Using a feeler gauge, measure clearance between valve lifter and camshaft.
- Record any valve clearance measurements which are out of specification. They will be used later to determine the required replacement adjusting shim.

Valve clearance (Hot):

Intake

0.31 - 0.39 mm (0.012 - 0.015 in)

Exhaust

0.33 - 0.41 mm (0.013 - 0.016 in)

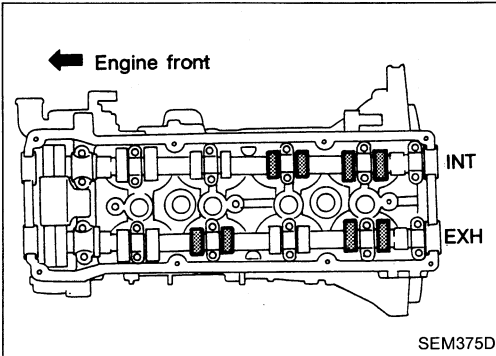

5. Turn crankshaft one revolution (360°) and align mark on crankshaft pulley with pointer.
6. Check those valves shown in the figure.
 - Use the same procedure as mentioned in step 4.
7. If all valve clearances are within specification, install the following parts.
 - Rocker cover
 - All spark plugs

ADJUSTING

Adjust valve clearance while engine is cold.

1. Turn crankshaft, to position cam lobe on camshaft of valve that must be adjusted upward.
2. Place Tool (A) around camshaft as shown in figure.
3. Rotate Tool (A) so that lifter is pushed down.

Before placing Tool (A), rotate notch toward center of cylinder head (See figure.), to simplify shim removal later.

CAUTION:

Be careful not to damage cam surface with Tool (A).

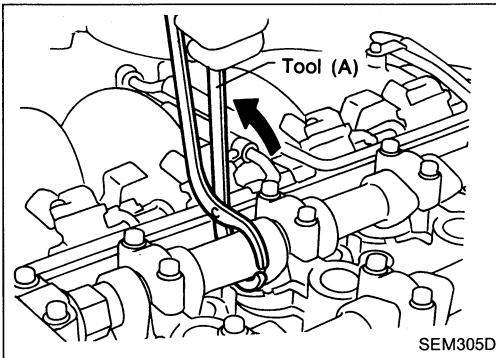

4. Place Tool (B) between camshaft and valve lifter to retain valve lifter.

CAUTION:

- Tool (B) must be placed as close to camshaft bracket as possible.
- Be careful not to damage cam surface with Tool (B).

5. Remove Tool (A).

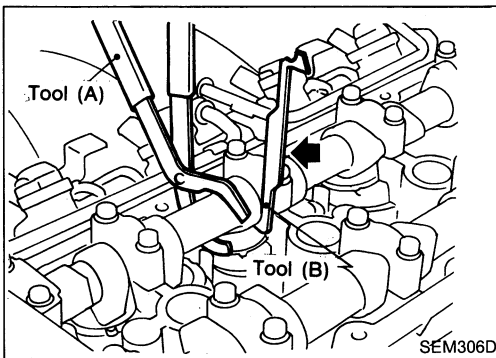

6. Remove adjusting shim using a small screwdriver and a magnetic finger.

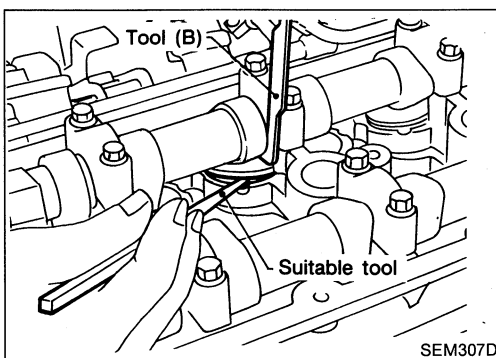

CYLINDER HEAD

Valve Clearance (Cont'd)

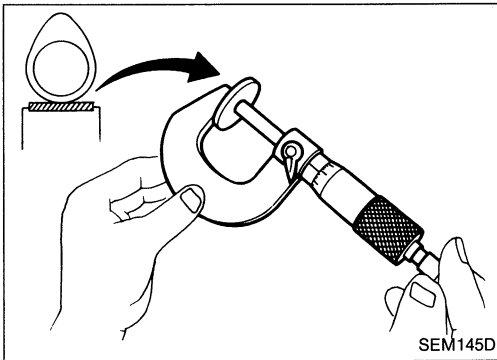

7. Determine replacement adjusting shim size following formula.

- Using a micrometer determine thickness of removed shim.
- Calculate thickness of new adjusting shim so valve clearance comes within specified values.

R = Thickness of removed shim

N = Thickness of new shim

M = Measured valve clearance

Intake:

$$N = R + [M - 0.35 \text{ mm (0.0138 in)}]$$

Exhaust:

$$N = R + [M - 0.37 \text{ mm (0.0146 in)}]$$

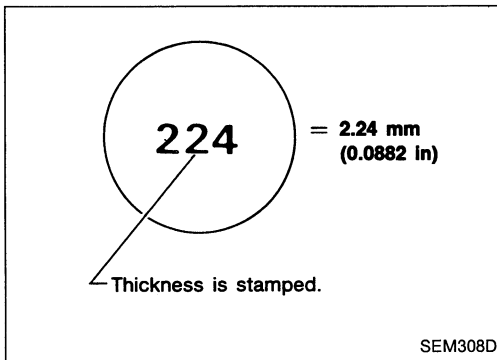

Shims are available in 37 sizes from 1.96 mm (0.0772 in) to 2.68 mm (0.1055 in), in steps of 0.02 mm (0.0008 in).

- Select new shim with thickness as close as possible to calculated value.

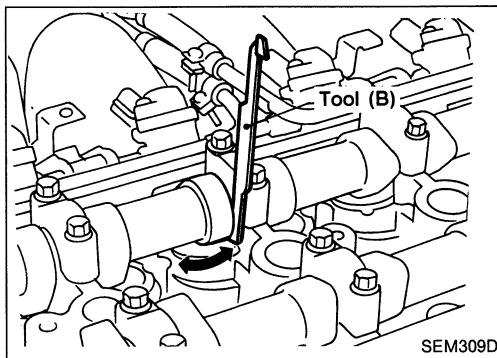

8. Install new shim using a suitable tool.

- **Install with the surface on which the thickness is stamped facing down.**

9. Place Tool (A) as mentioned in steps 2 and 3.

10. Remove Tool (B).

11. Remove Tool (A).

12. Recheck valve clearance.

Refer to "CHECKING".

ENGINE REMOVAL

M/T model

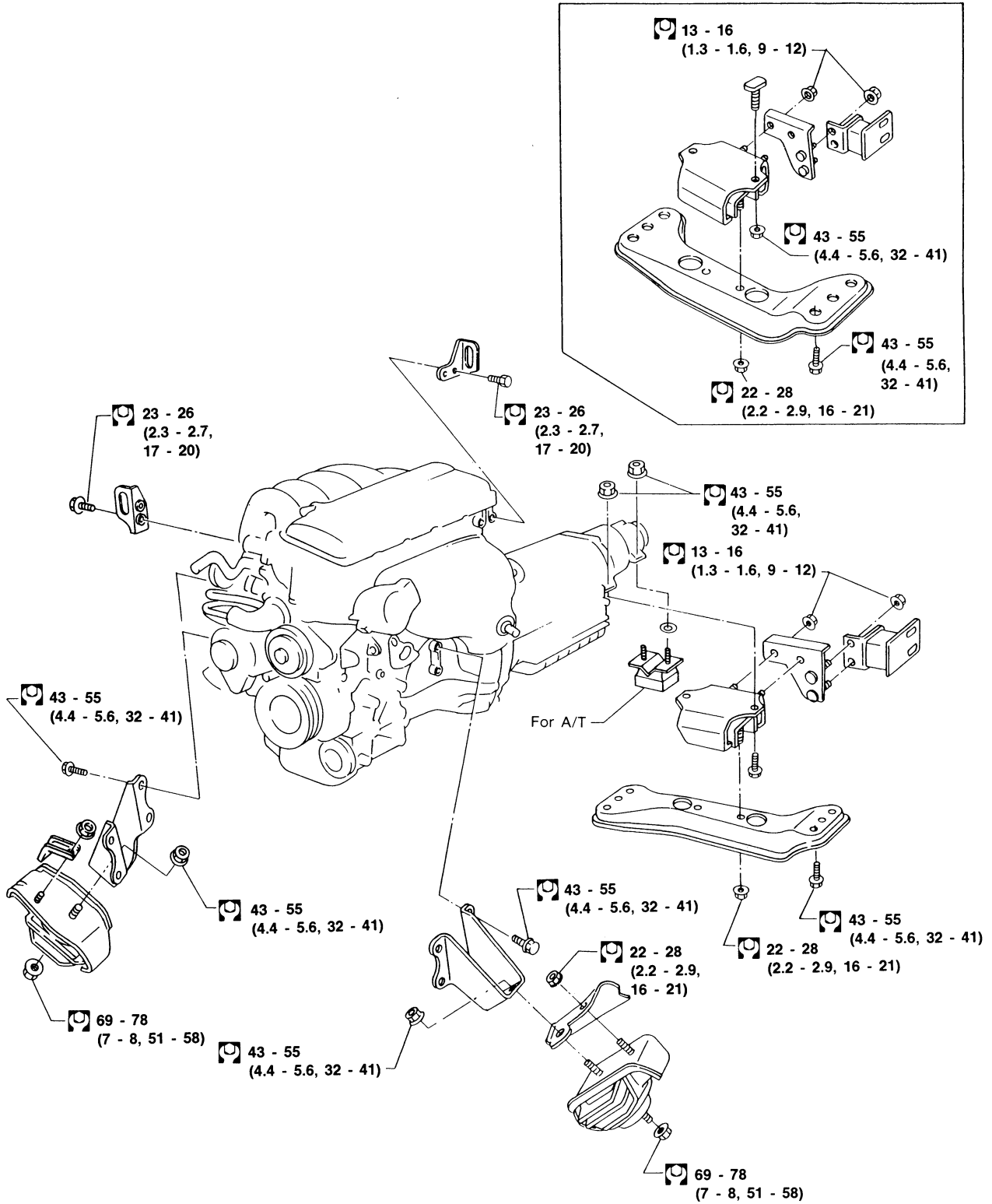

: N·m (kg-m, ft-lb)

ENGINE REMOVAL

WARNING:

- a. Situate vehicle on a flat and solid surface.
- b. Place chocks at front and back of rear wheels.
- c. Do not remove engine until exhaust system has completely cooled off.
Otherwise, you may burn yourself and/or fire may break out in fuel line.
- d. For safety during subsequent steps, the tension of wires should be slackened against the engine.
- e. Before disconnecting fuel hose, release fuel pressure from fuel line.
Refer to "Releasing Fuel Pressure" in section EF & EC.
- f. Be sure to hoist engine and transmission in a safe manner.
- g. For engines not equipped with engine slingers, attach proper slingers and bolts described in PARTS CATALOG.

CAUTION:

- When lifting engine, be careful not to strike adjacent parts, especially accelerator wire casing, brake lines, and brake master cylinder.
- In hoisting the engine, always use engine slingers in a safe manner.

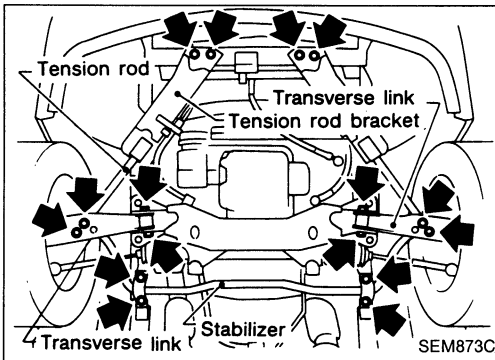

Removal

1. Remove transmission.

Refer to section AT or MT.

2. Remove engine under cover and hood.
3. Drain coolant from both cylinder block drain plug, and radiator drain cock.
4. Drain engine oil from drain plug of oil pan.
5. Remove vacuum hoses, fuel tubes, wires, harness and connectors and so on.
6. Remove front exhaust tubes.
7. Remove radiator and shroud.
8. Remove drive belts.
9. Remove, A/C pump and power steering oil pump from engine.
10. Install engine slingers to cylinder head.
11. Set a suitable hoist on engine slinger.
12. Remove engine mounting bolts from both sides and then slowly raise engine.

ENGINE REMOVAL

Removal (Cont'd)

13. Remove engine as shown.

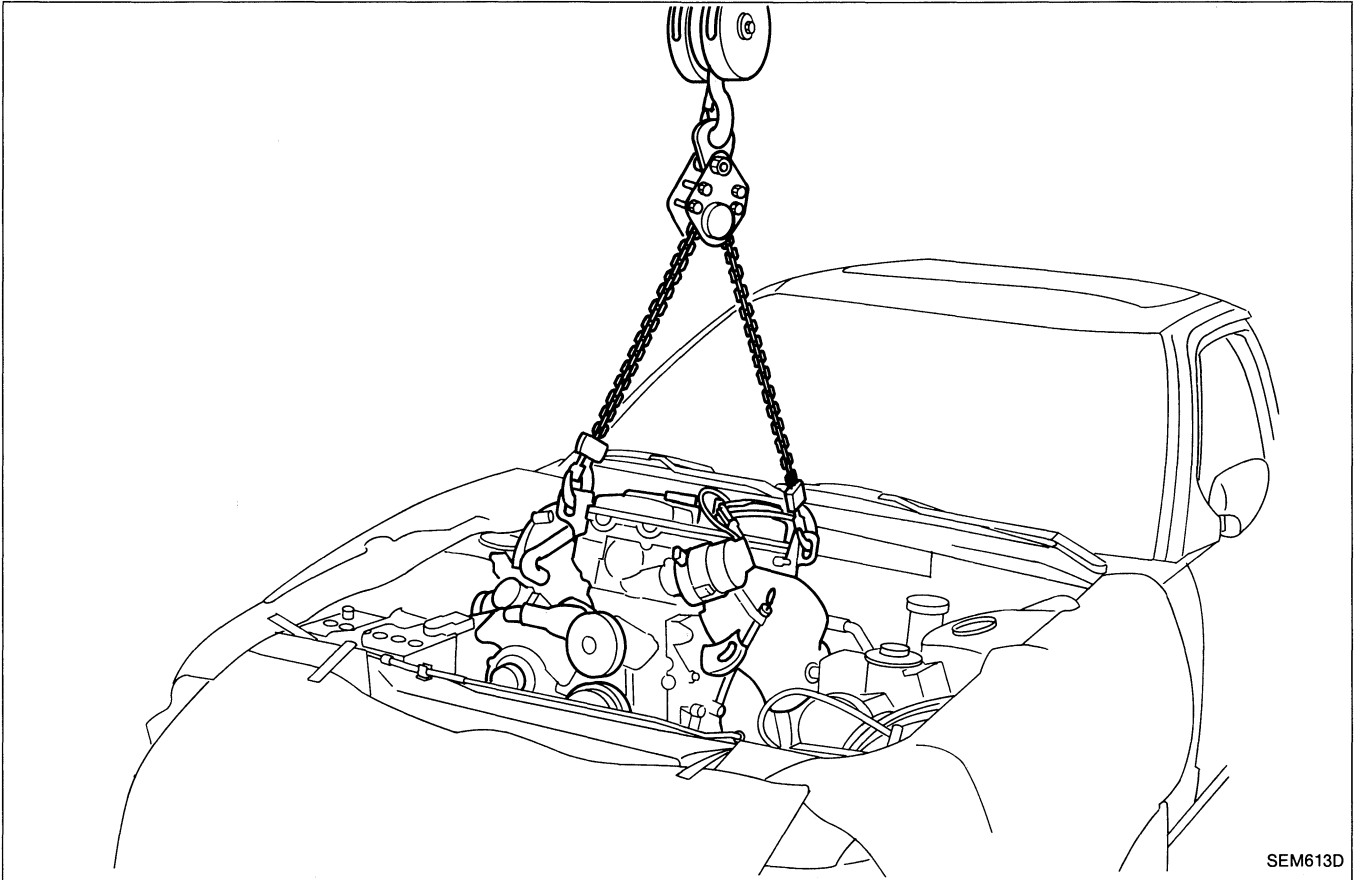

CYLINDER BLOCK

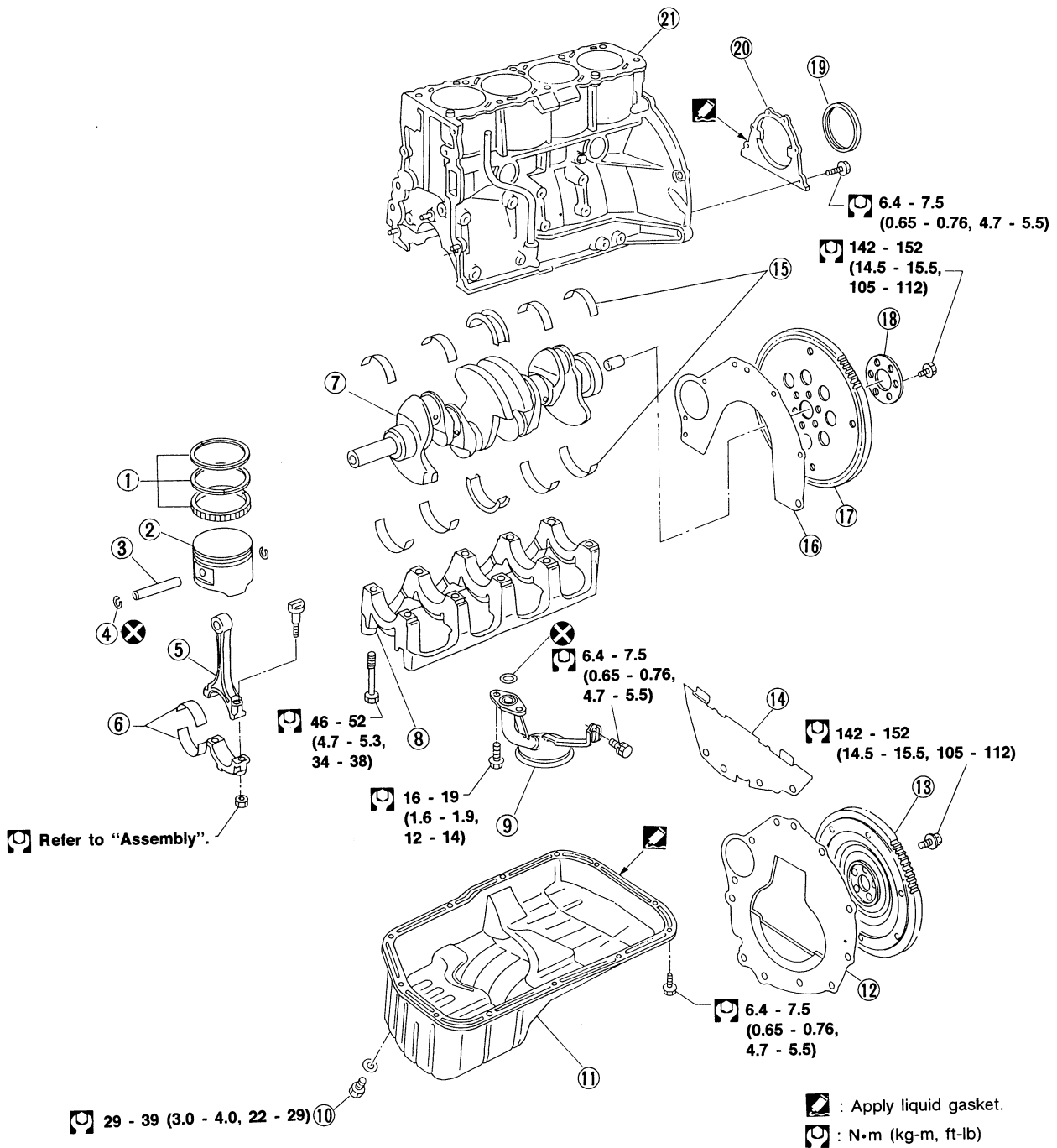

- ① Piston rings
- ② Piston
- ③ Piston pin
- ④ Snap ring
- ⑤ Connecting rod
- ⑥ Connecting rod bearing
- ⑦ Crankshaft

- ⑧ Main bearing cap
- ⑨ Oil strainer
- ⑩ Drain plug
- ⑪ Oil pan
- ⑫ Rear plate (M/T)
- ⑬ Flywheel (M/T)
- ⑭ Dust cover (A/T)

- ⑮ Main bearing
- ⑯ Rear plate (A/T)
- ⑰ Drive plate (A/T)
- ⑱ Drive plate reinforcement
- ⑲ Rear oil seal
- ⑳ Rear oil seal retainer
- ㉑ Cylinder block

SEM310D

CYLINDER BLOCK

CAUTION:

- When installing sliding parts such as bearings and pistons, be sure to apply engine oil on the sliding surfaces.
- Place removed parts such as bearings and bearing caps in their proper order and direction.
- When tightening connecting rod bolts and main bearing cap bolts, apply engine oil to thread portion of bolts and seating surface of nuts.

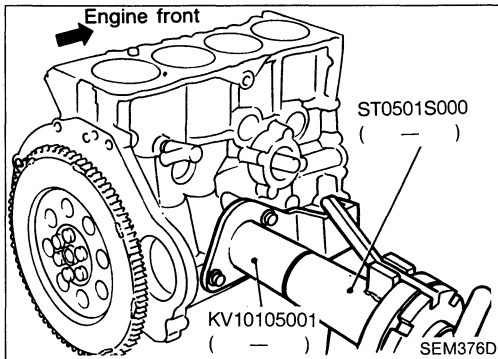

Disassembly

PISTON AND CRANKSHAFT

1. Place engine on a work stand.
2. Remove timing chain.
Refer to "Removal" in "TIMING CHAIN".

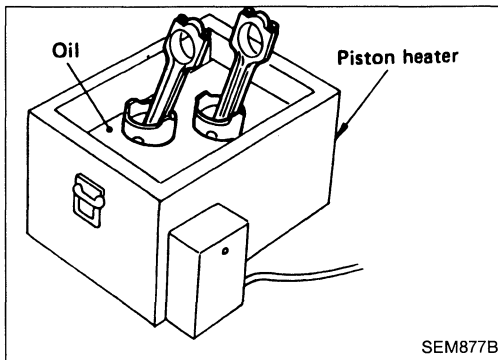

3. Remove pistons with connecting rods.
 - When disassembling piston and connecting rod, remove snap rings, then heat piston to 60 to 70°C (140 to 158°F) or use piston pin press stand at room temperature.

CAUTION:

- When piston rings are not replaced, make sure that piston rings are mounted in their original positions.
- When piston rings are being replaced and no punchmark is present, piston rings can be mounted with either side up.

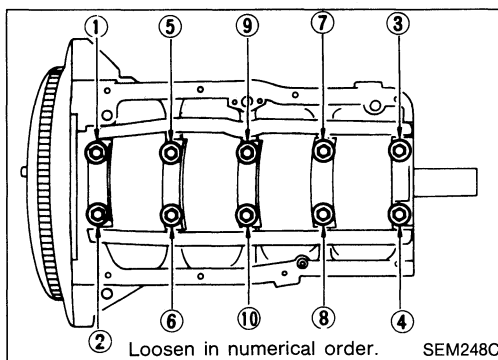
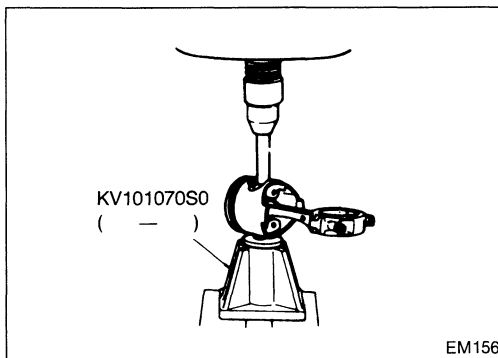

4. Remove main bearing beam and crankshaft.
 - Before removing main bearing beam, measure crankshaft end play.
 - Bolts should be loosened in two or three steps.

CYLINDER BLOCK

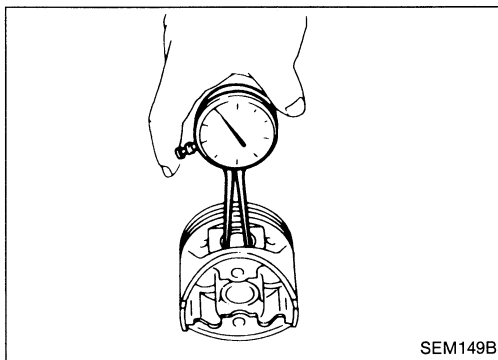

Inspection

PISTON AND PISTON PIN CLEARANCE

1. Measure inner diameter of piston pin hole "dp".

Standard diameter "dp":

20.987 - 20.999 mm (0.8263 - 0.8267 in)

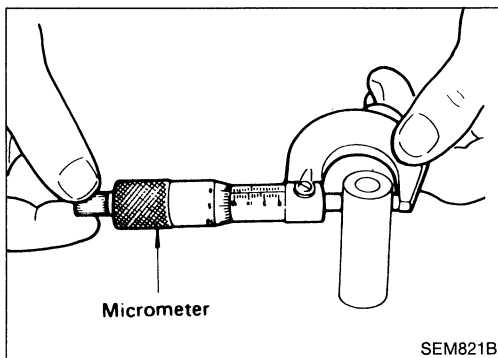

2. Measure outer diameter of piston pin "Dp".

Standard diameter "Dp":

20.989 - 21.001 mm (0.8263 - 0.8268 in)

3. Calculate interference fit of piston pin to piston.

$dp - Dp = 0 - 0.004 \text{ mm (0 - 0.0002 in)}$

If it exceeds the above value, replace piston assembly with pin.

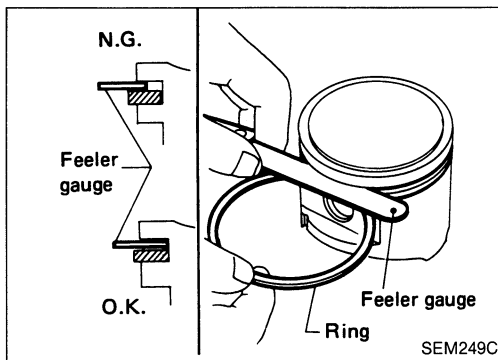

PISTON RING SIDE CLEARANCE

Side clearance:

Top ring

0.040 - 0.080 mm (0.0016 - 0.0031 in)

2nd ring

0.030 - 0.070 mm (0.0012 - 0.0028 in)

Max. limit of side clearance:

0.1 mm (0.004 in)

If out of specification, replace piston and/or piston ring assembly.

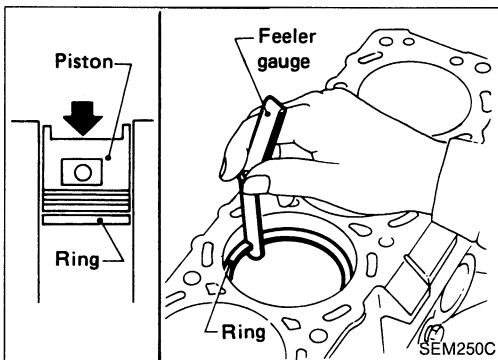

PISTON RING END GAP

End gap:

Top ring

0.28 - 0.52 mm (0.0110 - 0.0205 in)

2nd ring

0.45 - 0.69 mm (0.0177 - 0.0272 in)

Oil ring

0.20 - 0.69 mm (0.0079 - 0.0272 in)

Max. limit of ring gap:

1.0 mm (0.039 in)

If out of specification, replace piston ring. If gap still exceeds the limit even with a new ring, rebore cylinder and use oversized piston and piston rings.

Refer to S.D.S.

CYLINDER BLOCK

Inspection (Cont'd)

CONNECTING ROD BEND AND TORSION

Bend:

Limit 0.15 mm (0.0059 in)
per 100 mm (3.94 in) length

Torsion:

Limit 0.30 mm (0.0118 in)
per 100 mm (3.94 in) length

If it exceeds the limit, replace connecting rod assembly.

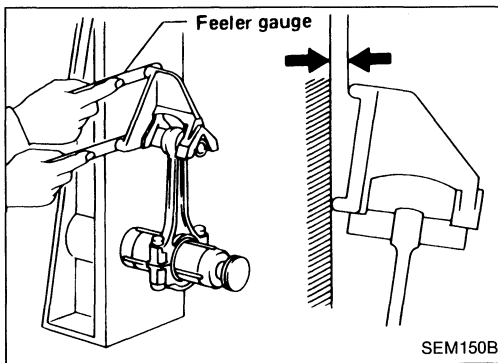

CYLINDER BLOCK DISTORTION AND WEAR

1. Clean upper face of cylinder block and measure the distortion.

Limit:

0.10 mm (0.0039 in)

2. If out of specification, resurface it.
The resurfacing limit is determined by cylinder head resurfacing in engine.

Amount of cylinder head resurfacing is "A"

Amount of cylinder block resurfacing is "B"

The maximum limit is as follows:

$A + B = 0.2 \text{ mm (0.008 in)}$

Nominal cylinder block height

from crankshaft center:

246.95 - 247.05 mm (9.7224 - 9.7264 in)

3. If necessary, replace cylinder block.

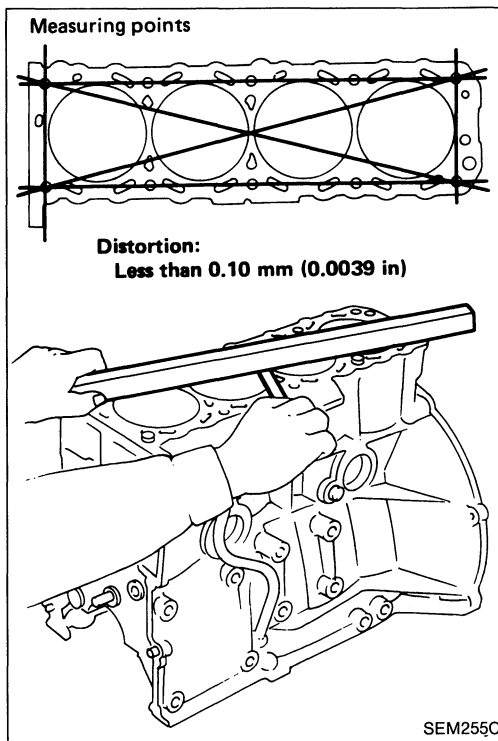

PISTON-TO-BORE CLEARANCE

1. Using a bore gauge, measure cylinder bore for wear, out-of-round and taper.

Standard inner diameter:

89.000 - 89.030 mm (3.5039 - 3.5051 in)

Wear limit:

0.2 mm (0.008 in)

Out-of-round (X - Y) limit:

0.015 mm (0.0006 in)

Taper (A - B) limit:

0.01 mm (0.0004 in)

If it exceeds the limit, rebore all cylinders. Replace cylinder block if necessary.

2. Check for scratches and seizure. If seizure is found, hone it.

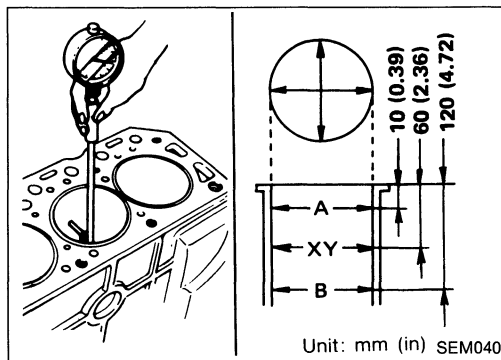

CYLINDER BLOCK

Inspection (Cont'd)

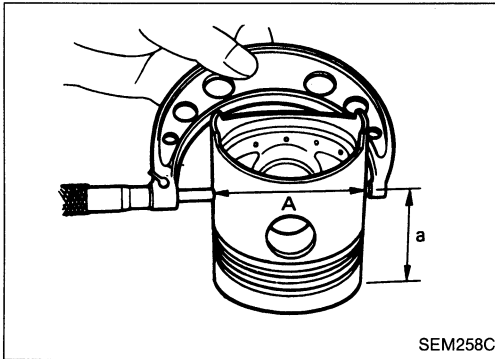
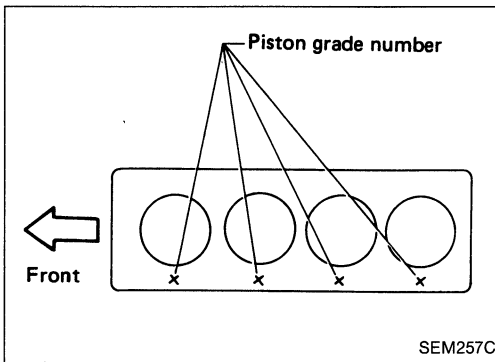

- If both cylinder block and piston are replaced with new ones, select piston of the same grade number punched on cylinder block upper surface.

3. Measure piston skirt diameter.

Piston diameter "A":

Refer to S.D.S.

Measuring point "a" (Distance from the top):

52 mm (2.05 in)

4. Check that piston-to-bore clearance is within specification.

Piston-to-bore clearance "B":

0.020 - 0.040 mm (0.0008 - 0.0016 in)

5. Determine piston oversize according to amount of cylinder wear.

Oversize pistons are available for service. Refer to S.D.S.

6. Cylinder bore size is determined by adding piston-to-bore clearance to piston diameter "A".

Rebored size calculation:

$$D = A + B - C$$

where,

D: Bored diameter

A: Piston diameter as measured

B: Piston-to-bore clearance

C: Honing allowance 0.02 mm (0.0008 in)

7. Install main bearing caps, and tighten to the specified torque to prevent distortion of cylinder bores in final assembly.

8. Cut cylinder bores.

- **When any cylinder needs boring, all other cylinders must also be bored.**

- **Do not cut too much out of cylinder bore at a time. Cut only 0.05 mm (0.0020 in) or so in diameter at a time.**

9. Hone cylinders to obtain specified piston-to-bore clearance.

10. Measure finished cylinder bore for out-of-round and taper.

- **Measurement should be done after cylinder bore cools down.**

CYLINDER BLOCK

Inspection (Cont'd)

CRANKSHAFT

1. Check crankshaft main and pin journals for score, wear or cracks.
2. With a micrometer, measure journals for taper and out-of-round.

Out-of-round (X - Y):

Less than 0.005 mm (0.0002 in)

Taper (A - B):

Less than 0.002 mm (0.0001 in)

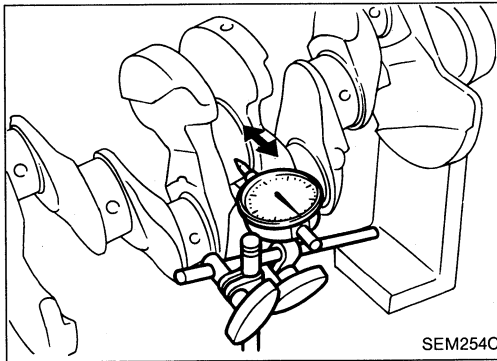
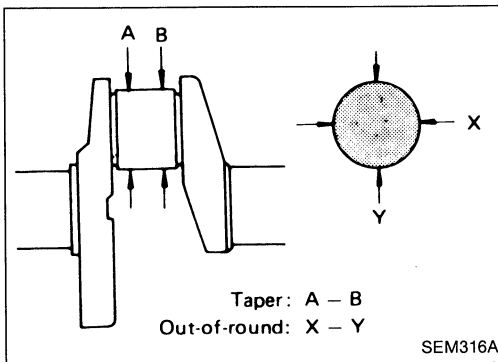

3. Measure crankshaft runout.

Runout (Total indicator reading):

Less than 0.04 mm (0.0016 in)

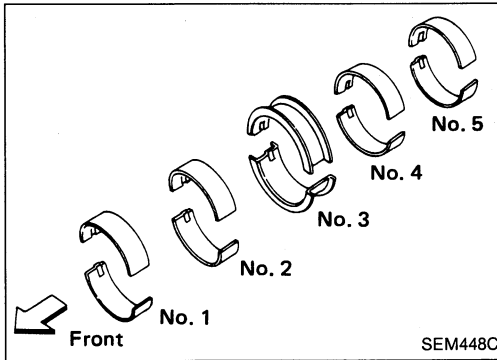

BEARING CLEARANCE

- Either of the following two methods may be used, however, method "A" gives more reliable results and is preferable.

Method A (Using bore gauge & micrometer)

Main bearing

1. Set main bearings in their proper positions on cylinder block and main bearing cap.

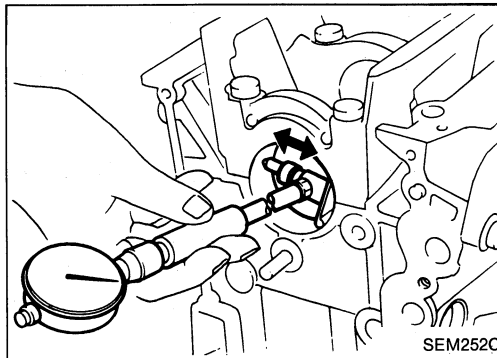

2. Install main bearing cap to cylinder block.

Tighten all bolts in correct order in two or three stages. Refer to "Assembly".

3. Measure inner diameter "A" of each main bearing.

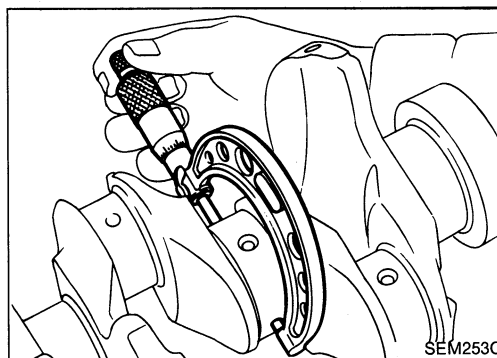

4. Measure outer diameter "Dm" of each crankshaft main journal.

5. Calculate main bearing clearance.

Main bearing clearance = A - Dm

Standard:

0.020 - 0.047 mm (0.0008 - 0.0019 in)

Limit: 0.1 mm (0.004 in)

6. If it exceeds the limit, replace bearing.

7. If clearance cannot be adjusted within the standard of any bearing, grind crankshaft journal and use undersized bearing.

CYLINDER BLOCK

Inspection (Cont'd)

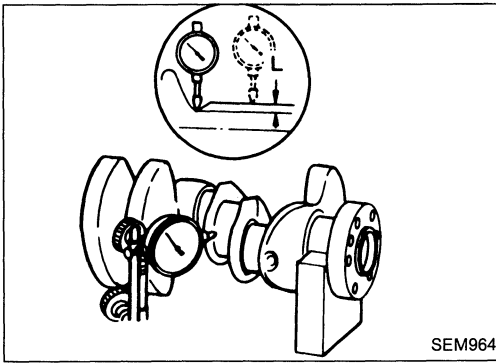

- a. When grinding crankshaft journal, confirm that "L" dimension in fillet roll is more than the specified limit.
"L": 0.1 mm (0.004 in)
- b. Refer to S.D.S. for grinding crankshaft and available service parts.

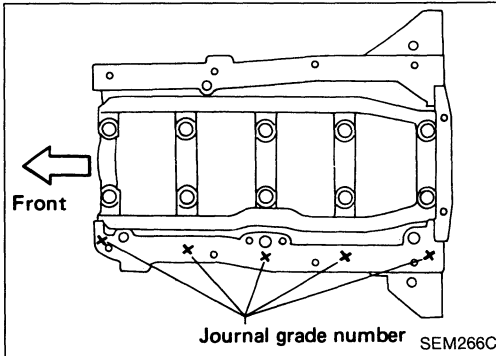

8. If crankshaft is reused, measure main bearing clearance and select thickness of main bearing.
If crankshaft is replaced with a new one, it is necessary to select thickness of main bearings as follows:
 - a. Grade number of each cylinder block main journal is punched on the respective cylinder block.

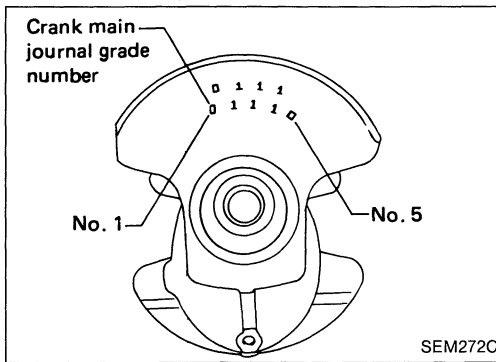

- b. Grade number of each crankshaft main journal is punched on crankshaft.

- c. Select main bearing with suitable thickness according to the following table.

Main bearing grade number:

Main journal grade number Crankshaft journal grade number	0	1	2
	0	1	2
1	1	2	3
2	2	3	4

For example:

Main journal grade number: 1

Crankshaft journal grade number: 2

Main bearing grade number = 1 + 2 = 3

CYLINDER BLOCK

Inspection (Cont'd)

Connecting rod bearing (Big end)

1. Install connecting rod bearing to connecting rod and cap.
2. Install connecting rod cap to connecting rod.

Tighten bolts to the specified torque.

3. Measure inner diameter "C" of each bearing.

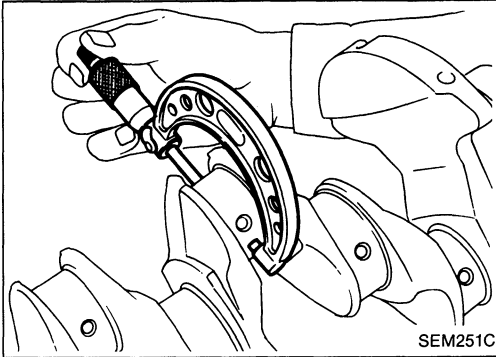
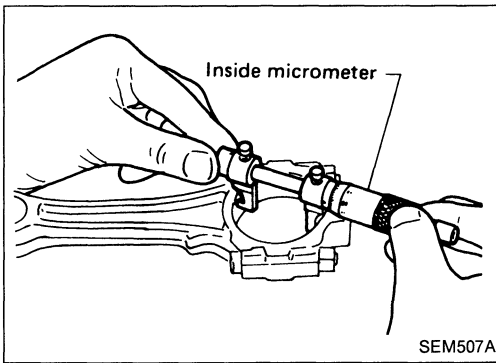

4. Measure outer diameter "Dp" of each crankshaft pin journal.

5. Calculate connecting rod bearing clearance.

$$\text{Connecting rod bearing clearance} = C - D_p$$

Standard:

0.010 - 0.035 mm (0.0004 - 0.0014 in)

Limit: 0.09 mm (0.0035 in)

6. If it exceeds the limit, replace bearing.
7. If clearance cannot be adjusted within the standard of any bearing, grind crankshaft journal and use undersized bearing.

Refer to step 7 of "BEARING CLEARANCE — Main bearing".

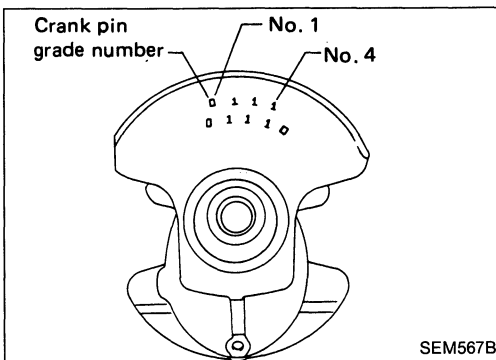

8. If crankshaft is replaced with a new one, select connecting rod bearing according to the following table.

Connecting rod bearing grade number:

Crank pin grade number	Connecting rod bearing grade number
0	0
1	1
2	2

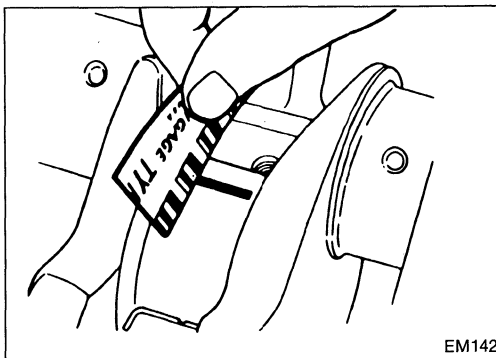

Method B (Using plastigage)

CAUTION:

- Do not turn crankshaft or connecting rod while plastigage is being inserted.
- When bearing clearance exceeds the specified limit, ensure that the proper bearing has been installed. Then if excessive bearing clearance exists, use a thicker main bearing or undersized bearing so that the specified bearing clearance is obtained.

CYLINDER BLOCK

Inspection (Cont'd)

CONNECTING ROD BUSHING CLEARANCE (Small end)

1. Measure inner diameter "C" of bushing.

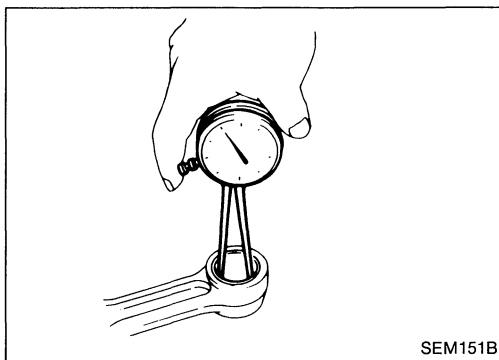

2. Measure outer diameter "Dp" of piston pin.
3. Calculate connecting rod bushing clearance.

$$C - D_p =$$

0.005 - 0.017 mm (0.0002 - 0.0007 in) (Standard)
0.023 mm (0.0009 in) (Limit)

If it exceeds the limit, replace connecting rod assembly and/or piston set with pin.

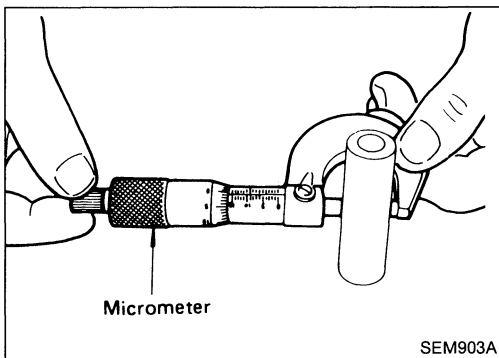

REPLACEMENT OF CONNECTING ROD BUSHING (Small end)

1. Drive in small end bushing until it is flush with end surface of rod.

Be sure to align the oil holes.

2. After driving in small end bushing, ream the bushing so that clearance between small end bushing and piston pin is specified value.

Clearance between small end bushing and piston pin:
0.005 - 0.017 mm (0.0002 - 0.0007 in)

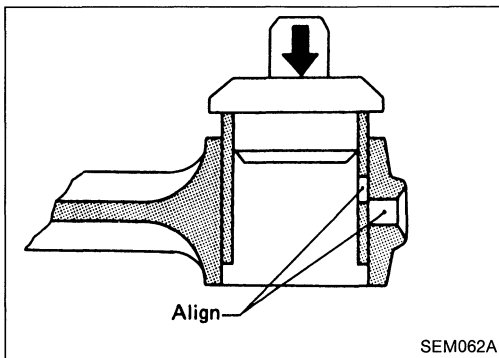

FLYWHEEL/DRIVE PLATE RUNOUT

Runout (Total indicator reading):

Flywheel (M/T model)

Less than 0.15 mm (0.0059 in)

Drive plate (A/T model)

Less than 0.5 mm (0.020 in)

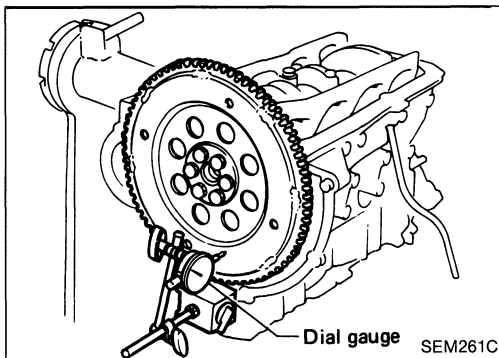

Assembly

PISTON

1. Install new snap ring on one side of piston pin hole.

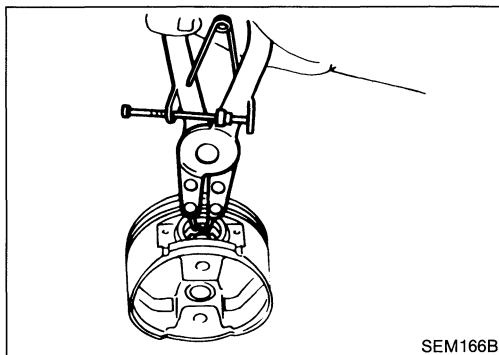

CYLINDER BLOCK

Assembly (Cont'd)

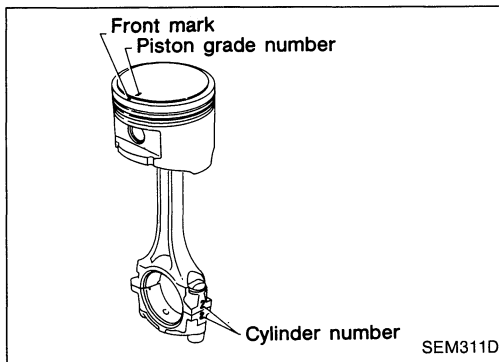

- Heat piston to 60 to 70°C (140 to 158°F) and assemble piston, piston pin, connecting rod and new snap ring.
 - Align the direction of piston and connecting rod.
 - Numbers stamped on connecting rod and cap correspond to each cylinder.
 - After assembly, make sure connecting rod swings smoothly.

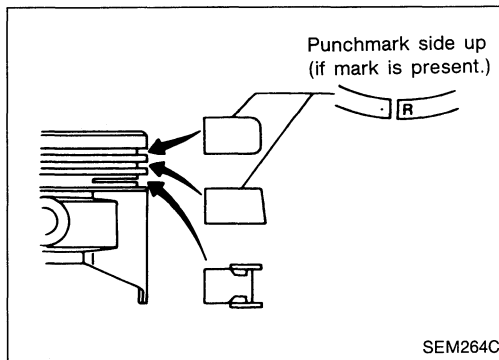

- Set piston rings as shown.

CAUTION:

- When piston rings are not being replaced, make sure that piston rings are mounted in their original positions.
- When piston rings are being replaced and no punchmark is present, piston rings can be mounted with either side up.

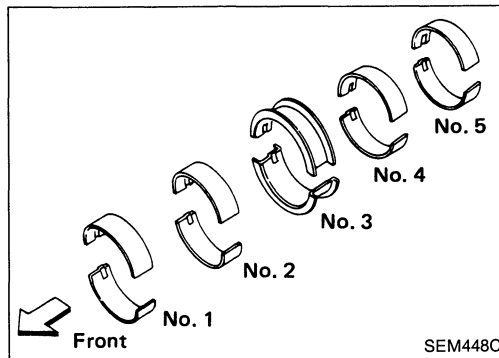
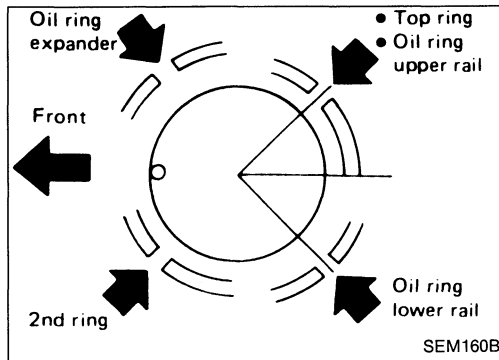

CRANKSHAFT

- Set main bearings in their proper positions on cylinder block and main bearing beam.
 - Confirm that correct main bearings are used. Refer to "Inspection" of this section.

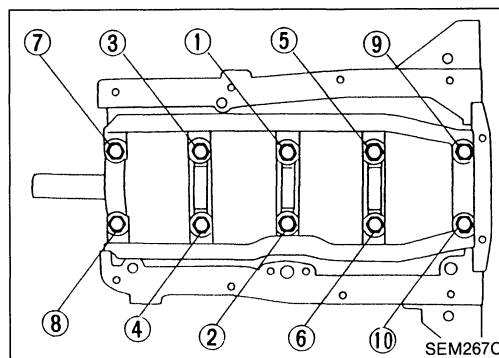

- Install crankshaft and main bearing beam and tighten bolts to the specified torque.
 - Prior to tightening bearing cap bolts, place bearing cap in its proper position by shifting crankshaft in the axial direction.
 - Tighten bearing cap bolts gradually in two or three stages. Start with center bearing and move outward sequentially.
 - After securing bearing cap bolts, make sure crankshaft turns smoothly by hand.

CYLINDER BLOCK

Assembly (Cont'd)

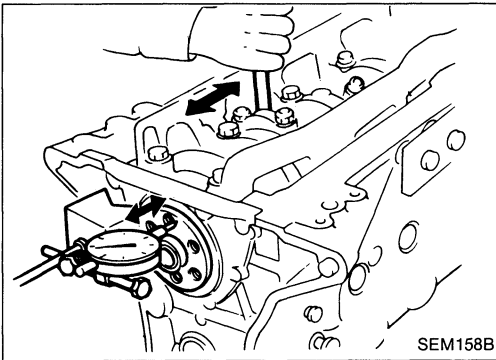

3. Measure crankshaft end play.

Crankshaft end play:

Standard

0.05 - 0.18 mm (0.0020 - 0.0071 in)

Limit

0.3 mm (0.012 in)

If beyond the limit, replace bearing with a new one.

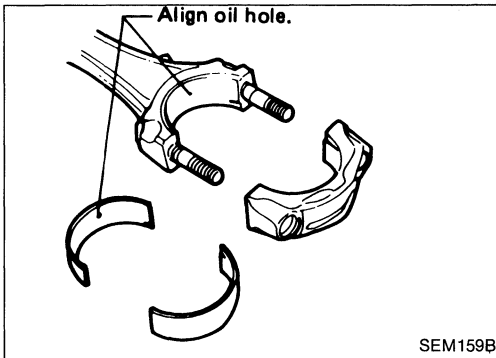

4. Install connecting rod bearings in connecting rods and connecting rod caps.

- Confirm that correct bearings are used. Refer to "Inspection".
- Install bearings so that oil hole in connecting rod aligns with oil hole of bearing.

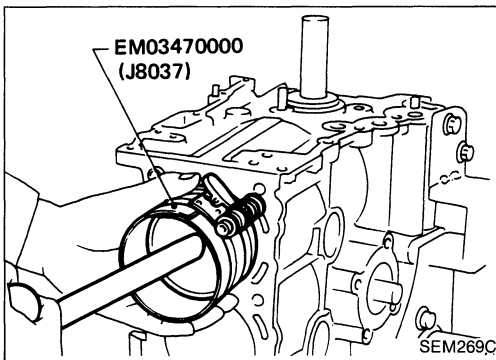

5. Install pistons with connecting rods.

- a. Install them into corresponding cylinders with Tool.

- **Be careful not to scratch cylinder wall by connecting rod.**
- **Arrange so that front mark on piston head faces toward front of engine.**

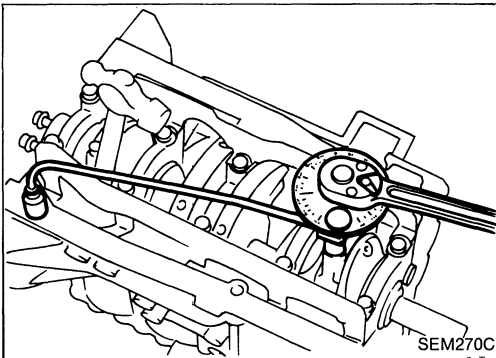

- b. Install connecting rod bearing caps.

Tighten connecting rod bearing cap nuts to the specified torque.

Connecting rod bearing nut:

- (1) Tighten to 14 to 16 N·m

(1.4 to 1.6 kg·m, 10 to 12 ft·lb).

- (2) Tighten bolts 60 to 65 degrees clockwise with an angle wrench, or if an angle wrench is not available, tighten them to 38 to 44 N·m (3.9 to 4.5 kg·m, 28 to 33 ft·lb).

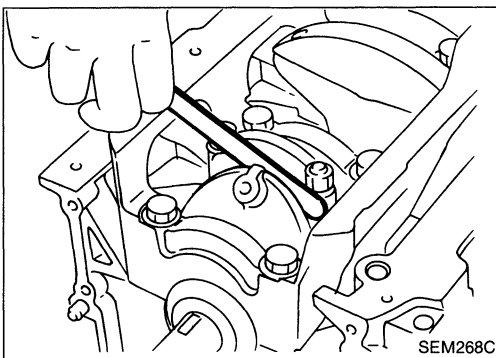

6. Measure connecting rod side clearance.

Connecting rod side clearance:

Standard

0.2 - 0.4 mm (0.008 - 0.016 in)

Limit

0.6 mm (0.024 in)

If beyond the limit, replace connecting rod and/or crankshaft.

CYLINDER BLOCK

Assembly (Cont'd)

REPLACING PILOT BUSHING

1. Remove pilot bushing (M/T) or pilot converter (A/T).

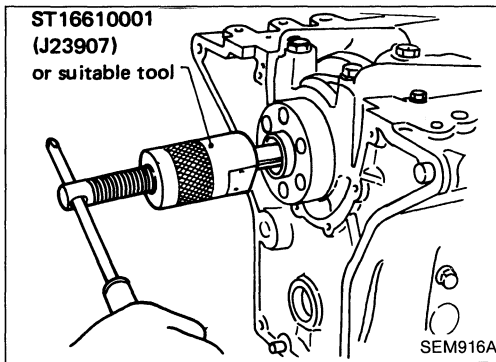

2. Install pilot bushing (M/T) or pilot converter (A/T).

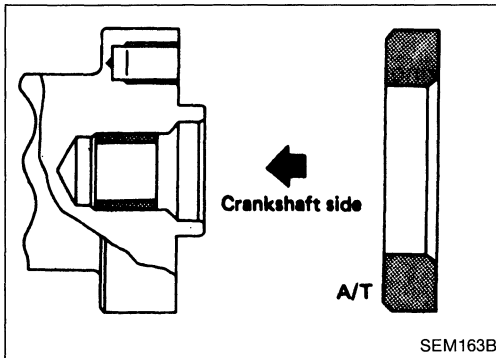

SERVICE DATA AND SPECIFICATIONS (S.D.S.)

General Specifications

Cylinder arrangement		In-line 4
Displacement	cm ³ (cu in)	2,389 (145.78)
Bore and stroke	mm (in)	89 x 96 (3.50 x 3.78)
Valve arrangement		D.O.H.C.
Firing order		1-3-4-2
Number of piston rings		
Compression		2
Oil		1
Number of main bearings		5
Compression ratio		9.5

COMPRESSION PRESSURE

Unit: kPa (kg/cm², psi)/300 rpm

Compression pressure		
Standard		1,236 (12.6, 179)
Minimum		1,040 (10.6, 151)
Differential limit between cylinders		98 (1.0, 14)

SERVICE DATA AND SPECIFICATIONS (S.D.S.)

Inspection and Adjustment VALVE

CYLINDER HEAD

Unit: mm (in)

	Standard	Limit
Head surface distortion	Less than 0.03 (0.0012)	0.1 (0.004)

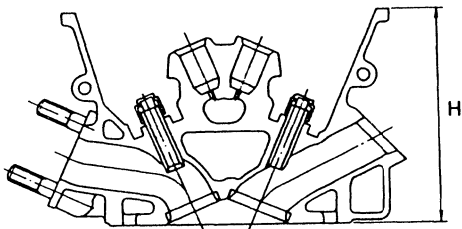

Nominal cylinder head height:
H = 126.3 - 126.5 (4.972 - 4.980)

SEM956C

Unit: mm (in)

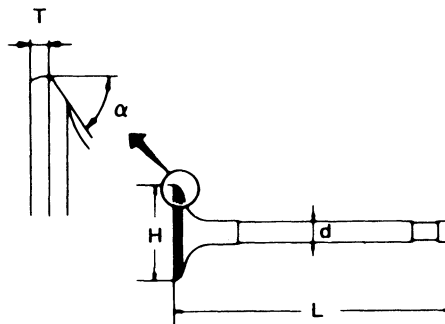

SEM188

Valve head diameter "D"

Intake	36.5 - 36.7 (1.437 - 1.445)
Exhaust	31.2 - 31.4 (1.228 - 1.236)

Valve length "L"

Intake	101.02 - 101.62 (3.9772 - 4.0008)
Exhaust	98.52 - 99.72 (3.8787 - 3.9260)

Valve stem diameter "d"

Intake	6.965 - 6.980 (0.2742 - 0.2748)
Exhaust	6.945 - 6.960 (0.2734 - 0.2740)

Valve seat angle "alpha"

Intake	45°15' - 45°45'
Exhaust	45°15' - 45°45'

Valve margin "T"

Intake	0.95 - 1.25 (0.0374 - 0.0492)
Exhaust	1.15 - 1.45 (0.0453 - 0.0571)

Valve margin "T" limit

Valve margin "T" limit	More than 0.5 (0.020)
Valve stem end surface grinding limit	Less than 0.2 (0.008)

SERVICE DATA AND SPECIFICATIONS (S.D.S.)

Inspection and Adjustment (Cont'd)

Valve spring

Free height	mm (in)	44.6 (1.756)
Pressure N (kg, lb) at height mm (in)	Standard	548.70 (55.95, 123.37) at 26.0 (1.024)
		Limit
Out-of-square	mm (in)	Less than 1.9 (0.075)

Valve lifter

Unit: mm (in)

Valve lifter outer diameter	33.960 - 33.975 (1.3370 - 1.3376)
Lifter guide inner diameter	34.000 - 34.021 (1.3386 - 1.3394)
Clearance between lifter and filter guide	0.025 - 0.061 (0.0010 - 0.0024)

Valve guide

Unit: mm (in)

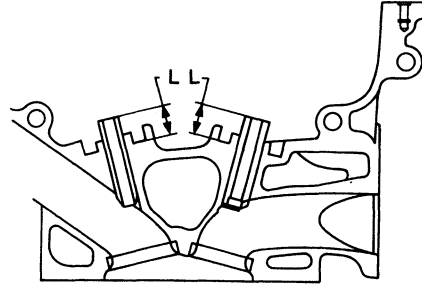

SEM301D

		Standard	Service
Valve guide	Outer diameter	Intake	11.023 - 11.034 (0.4340 - 0.4344)
		Exhaust	11.223 - 11.234 (0.4418 - 0.4423)
Valve guide	Inner diameter (Finished size)	Intake	12.223 - 12.234 (0.4812 - 0.4817)
		Exhaust	7.000 - 7.018 (0.2756 - 0.2763)
Cylinder head valve guide hole diameter	Intake	7.000 - 7.018 (0.2756 - 0.2763)	10.975 - 10.996 (0.4321 - 0.4329)
	Exhaust	11.175 - 11.196 (0.4400 - 0.4408)	11.975 - 11.996 (0.4715 - 0.4723)
Interference fit of valve guide		0.027 - 0.059 (0.0011 - 0.0023)	
Stem to guide clearance		Standard	Limit
		Intake	0.020 - 0.053 (0.0008 - 0.0021)
	Exhaust	0.040 - 0.073 (0.0016 - 0.0029)	0.1 (0.004)
Valve deflection limit		0.2 (0.008)	
Projection length "L"		13.3 - 13.9 (0.524 - 0.547)	

SERVICE DATA AND SPECIFICATIONS (S.D.S.)

Inspection and Adjustment (Cont'd)

Valve clearance adjustment

Unit: mm (in)

Valve clearance	
Intake	0.31 - 0.39 (0.012 - 0.015)
Exhaust	0.33 - 0.41 (0.013 - 0.016)

Available shims

Thickness mm (in)	Identification mark
1.96 (0.0772)	196
1.98 (0.0780)	198
2.00 (0.0787)	200
2.02 (0.0795)	202
2.04 (0.0803)	204
2.06 (0.0811)	206
2.08 (0.0819)	208
2.10 (0.0827)	210
2.12 (0.0835)	212
2.14 (0.0843)	214
2.16 (0.0850)	216
2.18 (0.0858)	218
2.20 (0.0866)	220
2.22 (0.0874)	222
2.24 (0.0882)	224
2.26 (0.0890)	226
2.28 (0.0898)	228
2.30 (0.0906)	230
2.32 (0.0913)	232
2.34 (0.0921)	234
2.36 (0.0929)	236
2.38 (0.0937)	238
2.40 (0.0945)	240
2.42 (0.0953)	242
2.44 (0.0961)	244
2.46 (0.0969)	246
2.48 (0.0976)	248
2.50 (0.0984)	250
2.52 (0.0992)	252
2.54 (0.1000)	254
2.56 (0.1008)	256
2.58 (0.1016)	258
2.60 (0.1024)	260
2.62 (0.1031)	262
2.64 (0.1039)	264
2.66 (0.1047)	266
2.68 (0.1055)	268

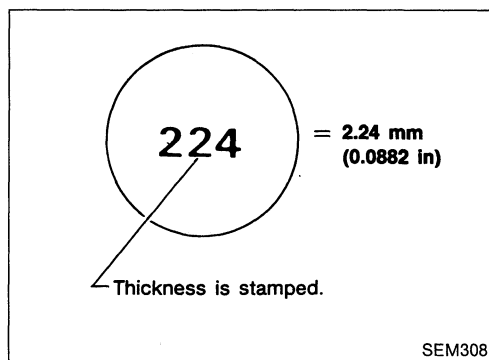

SERVICE DATA AND SPECIFICATIONS (S.D.S.)

Inspection and Adjustment (Cont'd)

Valve seat

Unit: mm (in)

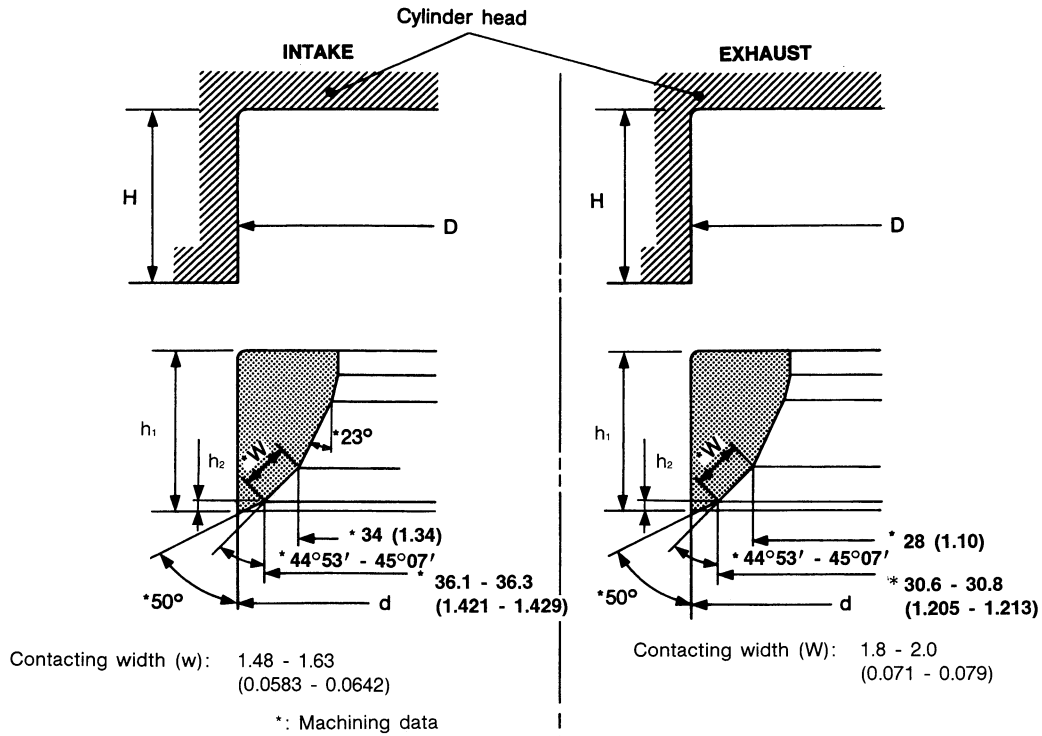

SEM651D

		Standard	Service
Cylinder head seat recess diameter (D)	In.	37.500 - 37.516 (1.4764 - 1.4770)	38.000 - 38.016 (1.4961 - 1.4967)
	Ex.	32.200 - 32.216 (1.2677 - 1.2683)	32.700 - 32.716 (1.2874 - 1.2880)
Valve seat interference fit	In.	0.064 - 0.096 (0.0025 - 0.0038)	
	Ex.	0.064 - 0.096 (0.0025 - 0.0038)	
Valve seat outer diameter (d)	In.	37.580 - 37.596 (1.4795 - 1.4802)	38.080 - 38.096 (1.4992 - 1.4998)
	Ex.	32.280 - 32.296 (1.2709 - 1.2715)	32.780 - 32.796 (1.2905 - 1.2912)
Depth (H)	In.	6.19 - 6.21 (0.2437 - 0.2445)	
	Ex.	6.1 - 6.3 (0.240 - 0.248)	
Height (h ₁)		5.9 - 6.0 (0.232 - 0.236)	
Height (h ₂)	In.	0.44 - 0.64 (0.0173 - 0.0252)	
	Ex.	0.53 - 0.73 (0.0209 - 0.0287)	

SERVICE DATA AND SPECIFICATIONS (S.D.S.)

Inspection and Adjustment

CYLINDER BLOCK

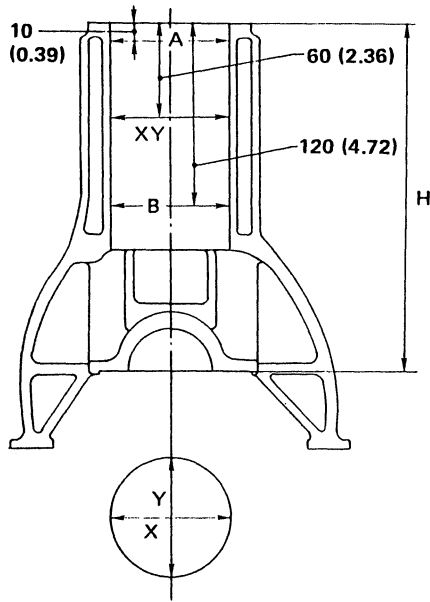

SEM447C

Unit: mm (in)

		Standard	Limit
Distortion		Less than 0.03 (0.0012)	0.1 (0.004)
Cylinder bore	Inner diameter	Grade 1	89.000 - 89.010 (3.5039 - 3.5043)
		Grade 2	89.010 - 89.020 (3.5043 - 3.5047)
		Grade 3	89.020 - 89.030 (3.5047 - 3.5051)
	Out-of-round (X - Y)	Less than 0.015 (0.0006)	—
Taper (A - B)		Less than 0.010 (0.0004)	—
Difference in inner diameter between cylinders		Less than 0.03 (0.0012)	0.2 (0.008)
Cylinder block height (From crankshaft center)		246.95 - 247.05 (9.7224 - 9.7264)	0.2 (0.008)*

* Total amount of cylinder head resurfacing and cylinder block resurfacing

SERVICE DATA AND SPECIFICATIONS (S.D.S.)

Inspection and Adjustment (Cont'd)

CAMSHAFT AND CAMSHAFT BEARING

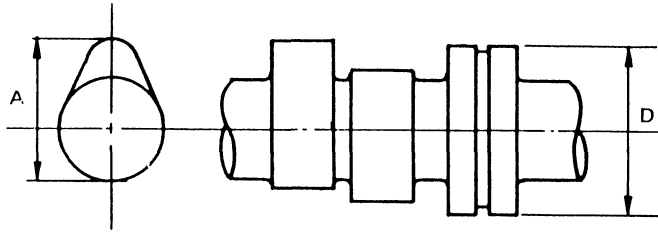

SEM568A

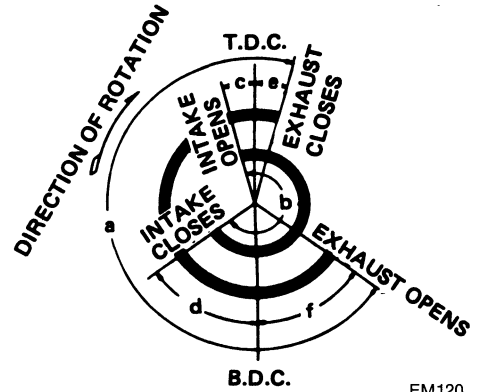

EM120

Unit: mm (in)

		Standard	Limit
Cam height (A)	Intake	42.415 - 42.605 (1.6699 - 1.6774)	—
	Exhaust	42.415 - 43.005 (1.6699 - 1.6931)	—
Wear limit of cam height		—	0.2 (0.008)
Camshaft journal to bearing clearance		0.045 - 0.090 (0.0018 - 0.0035)	0.12 (0.0047)
Inner diameter of camshaft bearing	#1 journal	28.000 - 28.025 (1.1024 - 1.1033)	—
	#2 to #5 journal	24.000 - 24.025 (0.9449 - 0.9459)	
Outer diameter of camshaft journal (D)	#1 journal	27.935 - 27.955 (1.0998 - 1.1006)	—
	#1 to #5 journal	23.935 - 23.955 (0.9423 - 0.9431)	
Camshaft runout*		—	0.04 (0.0016)
Camshaft and play		0.07 - 0.15 (0.0028 - 0.0059)	0.2 (0.008)
Valve timing (Degree on crankshaft)	a	240	—
	b	248	—
	c	-1	—
	d	61	—
	e	8	—
	f	60	—

* Total indicator reading

SERVICE DATA AND SPECIFICATIONS (S.D.S.)

Inspection and Adjustment (Cont'd)

PISTON, PISTON RING AND PISTON PIN

Piston ring

Unit: mm (in)

Piston

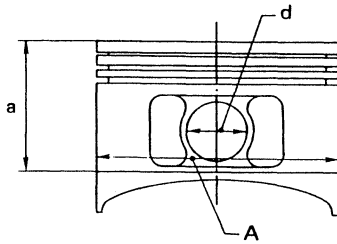

SEM444C

Unit: mm (in)

Piston skirt diameter (A)	Standard	Grade No. 1	88.970 - 88.980 (3.5027 - 3.5031)
		Grade No. 2	88.980 - 88.990 (3.5031 - 3.5035)
		Grade No. 3	88.990 - 89.000 (3.5035 - 3.5039)
	Service (Oversize)	0.5 (0.020)	89.470 - 89.500 (3.5224 - 3.5236)
		1.0 (0.039)	89.970 - 90.000 (3.5421 - 3.5433)
Dimension (a)	Approximately 52 (2.05)		
Piston pin hole diameter (d)	20.987 - 20.999 (0.8263 - 0.8267)		
Piston-to-cylinder bore clearance	0.020 - 0.040 (0.0008 - 0.0016)		

		Standard	Limit
Side clearance	Top	0.040 - 0.080 (0.0016 - 0.0031)	0.1 (0.004)
	2nd	0.030 - 0.070 (0.0012 - 0.0028)	0.1 (0.004)
Ring gap	Top	0.28 - 0.52 (0.0110 - 0.0205)	1.0 (0.039)
	2nd	0.45 - 0.69 (0.0177 - 0.0272)	1.0 (0.039)
	Oil (rail ring)	0.20 - 0.69 (0.0079 - 0.0272)	1.0 (0.039)

CONNECTING ROD

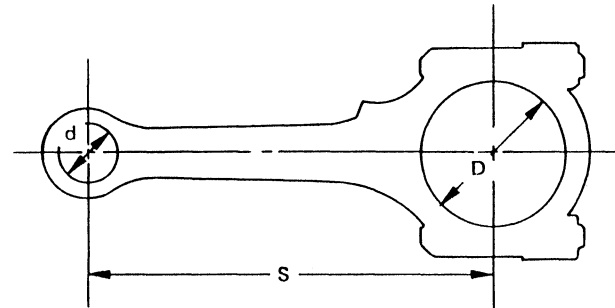

SEM570A

Unit: mm (in)

Piston pin

Unit: mm (in)

	Standard	Limit
Piston pin outer diameter	20.989 - 21.001 (0.8263 - 0.8268)	—
Interference fit of piston pin to piston pin hole	0 - 0.004 (0 - 0.0002)	—
Piston pin to connecting rod bearing clearance	0.005 - 0.017 (0.0002 - 0.0007)	0.023 (0.0009)

	Standard	Limit
Center distance (S)	164.95 - 165.05 (6.4941 - 6.4980)	—
Bend [per 100 mm (3.94 in)]	—	0.15 (0.0059)
Torsion [per 100 mm (3.94 in)]	—	0.30 (0.0118)
Piston pin bushing inner diameter (d)*	21.000 - 21.012 (0.8268 - 0.8272)	—
Connecting rod big end inner diameter (D)*	53.000 - 53.013 (2.0866 - 2.0871)	—
Side clearance	0.2 - 0.4 (0.008 - 0.016)	0.6 (0.024)

* Without bearing

SERVICE DATA AND SPECIFICATIONS (S.D.S.)

CRANKSHAFT

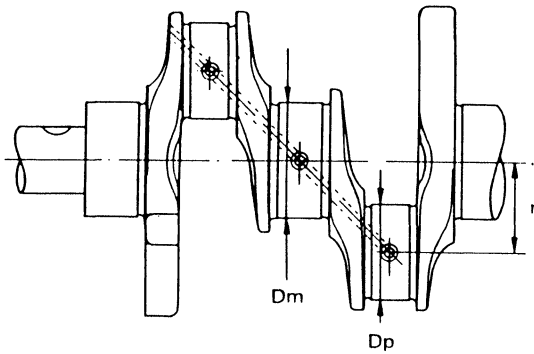

SEM394

Out-of-round X - Y
Taper A - B

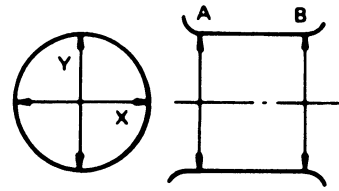

EM715

Unit: mm (in)

Main journal diameter (Dm)	Grade	No. 0	59.967 - 59.975 (2.3609 - 2.3612)
		No. 1	59.959 - 59.967 (2.3606 - 2.3609)
		No. 2	59.951 - 59.959 (2.3603 - 2.3606)
Pin journal diameter (Dp)	Grade	No. 0	49.968 - 49.974 (1.9672 - 1.9675)
		No. 1	49.962 - 49.968 (1.9670 - 1.9672)
		No. 2	49.956 - 49.962 (1.9668 - 1.9670)
Center distance (r)			47.97 - 48.05 (1.8886 - 1.8917)
		Standard	Limit
Taper of journal and pin [(A) - (B)]		—	0.002 (0.0001)
Out-of-round of journal and pin [(X) - (Y)]		—	0.005 (0.0002)
Runout [T.I.R.]*		—	0.04 (0.0016)
Free end play		0.05 - 0.18 (0.0020 - 0.0071)	0.3 (0.012)
Fillet roll		More than 0.1 (0.004)	

* Total indicator reading

BEARING CLEARANCE

Unit: mm (in)

	Standard	Limit
Main bearing clearance	0.020 - 0.047 (0.0008 - 0.0019)	0.1 (0.004)
Connecting rod bearing clearance	0.010 - 0.035 (0.0004 - 0.0014)	0.09 (0.0035)

ENGINE LUBRICATION & COOLING SYSTEMS

SECTION **LC**

LC

CONTENTS

PREPARATION.....	LC- 2
ENGINE LUBRICATION SYSTEM	LC- 3
ENGINE COOLING SYSTEM.....	LC- 7
SERVICE DATA AND SPECIFICATIONS (S.D.S.).....	LC-13

PREPARATION

SPECIAL SERVICE TOOLS

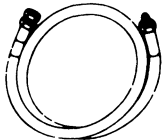
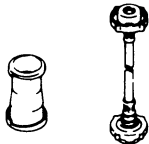
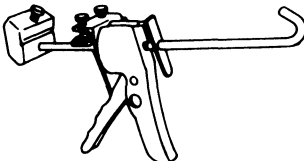
Tool number (Kent-Moore No.) Tool name	Description
ST25051001 (J25695-1) Oil pressure gauge	 An oil pressure gauge with a circular face, a needle, and a threaded inlet on the left side.
ST25052000 (J25695-2) Hose	 A circular metal flange with two hose fittings on opposite sides. <p data-bbox="1047 476 1450 533">Adapting oil pressure gauge to cylinder block</p>
EG17650301 (—) Radiator cap tester adapter	 A small cylindrical adapter and a radiator cap tester with a long handle and a hook. <p data-bbox="1047 653 1450 709">Adapting radiator cap tester to radiator filler neck</p>
WS39930000 (—) Tube presser	 A hand-operated tube presser with two handles and a curved end. <p data-bbox="1047 829 1414 856">Pressing the tube of liquid gasket</p>

ENGINE LUBRICATION SYSTEM

Lubrication Circuit

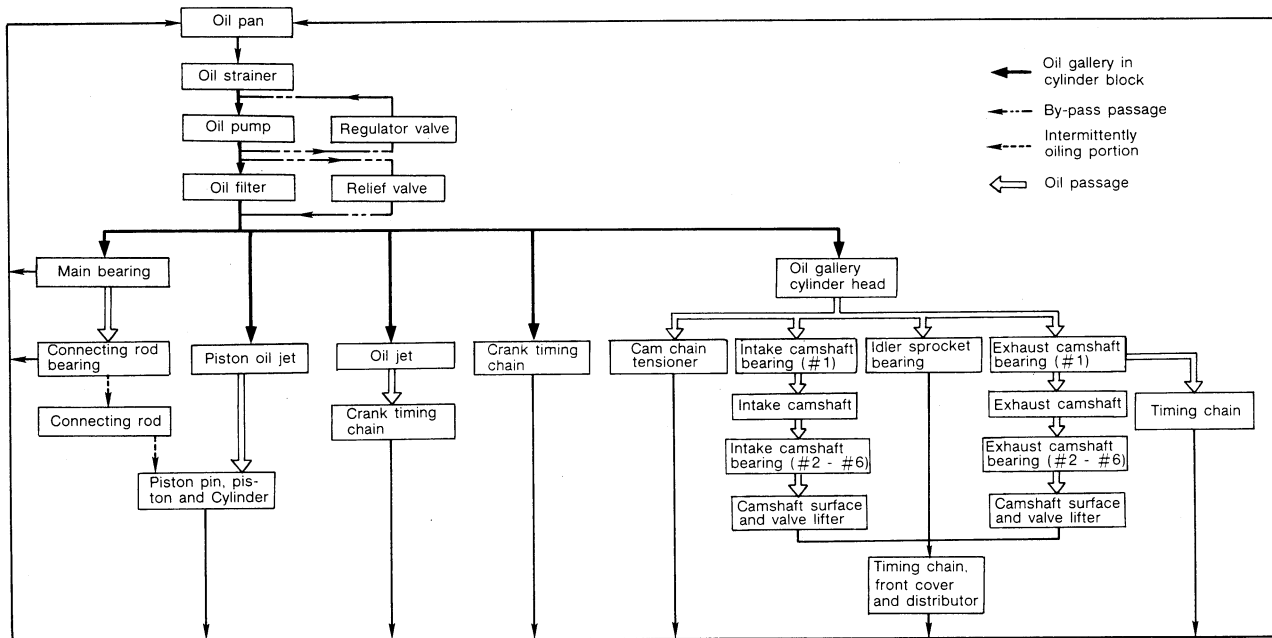
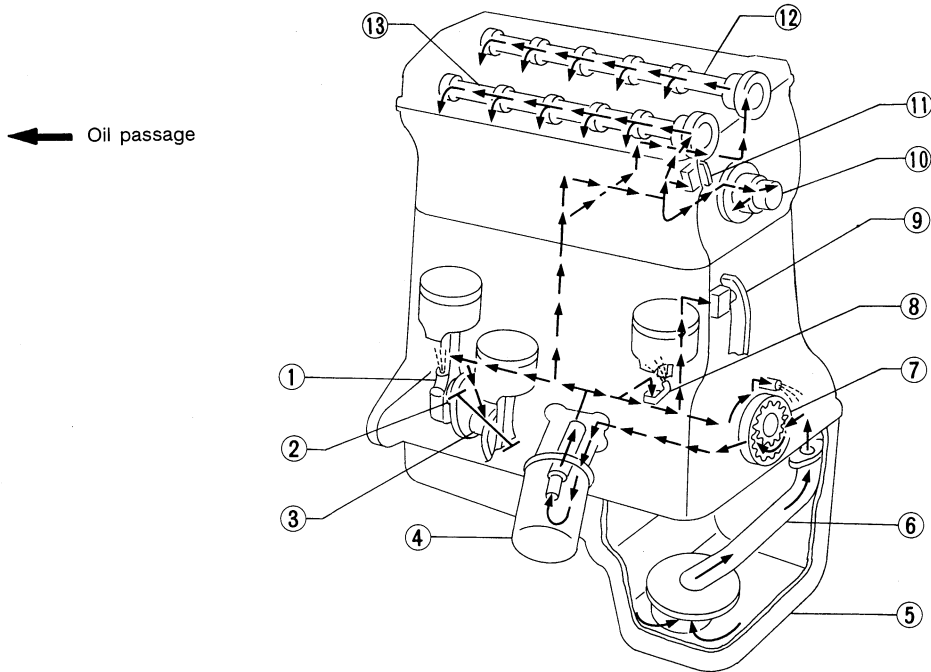

SLC517A

- | | | |
|--------------------------|--------------------------|--------------------------------|
| ① Connecting rod | ⑥ Oil strainer | ⑩ Idler sprocket |
| ② Connecting rod bearing | ⑦ Oil pump | ⑪ Upper timing chain tensioner |
| ③ Main bearing | ⑧ Piston oil jet | ⑫ Exhaust camshaft |
| ④ Oil filter | ⑨ Timing chain tensioner | ⑬ Intake camshaft |
| ⑤ Oil pan | | |

ENGINE LUBRICATION SYSTEM

Oil Pressure Check

WARNING:

- Be careful not to burn yourself, as the engine and oil may hot.
- Oil pressure check should be done in "Neutral" gear position.

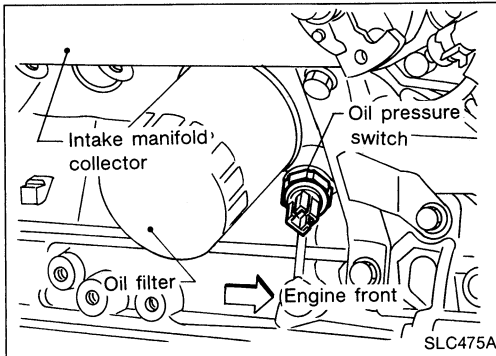

1. Check oil level.
2. Remove oil pressure switch.

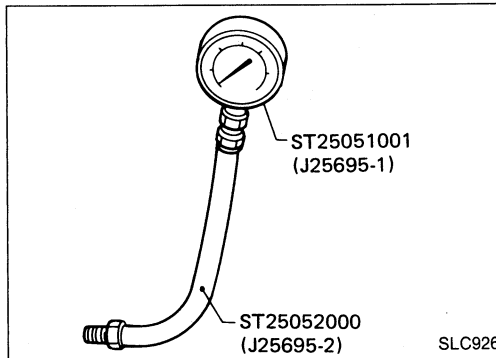

3. Install pressure gauge.
4. Start engine and warm it up to normal operating temperature.
5. Check oil pressure with engine running under no-load.

Engine rpm	Approximate discharge pressure kPa (kg/cm ² , psi)
Idle speed	More than 78 (0.8, 11)
3,000	412 - 481 (4.2 - 4.9, 60 - 70)

If difference is extreme, check oil passage and oil pump for oil leaks.

6. Install oil pressure switch with sealant.

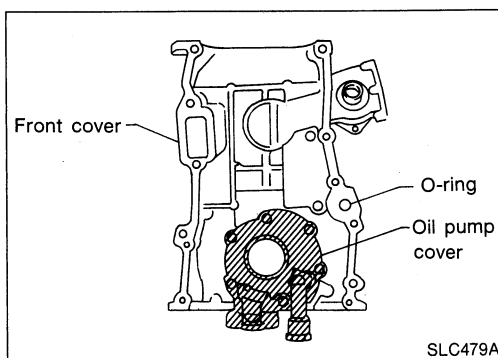

Oil Pump

REMOVAL

1. Remove front cover.
Refer to "TIMING CHAIN" in section EM.
2. Remove oil pump cover.

ENGINE LUBRICATION SYSTEM

Oil Pump (Cont'd)

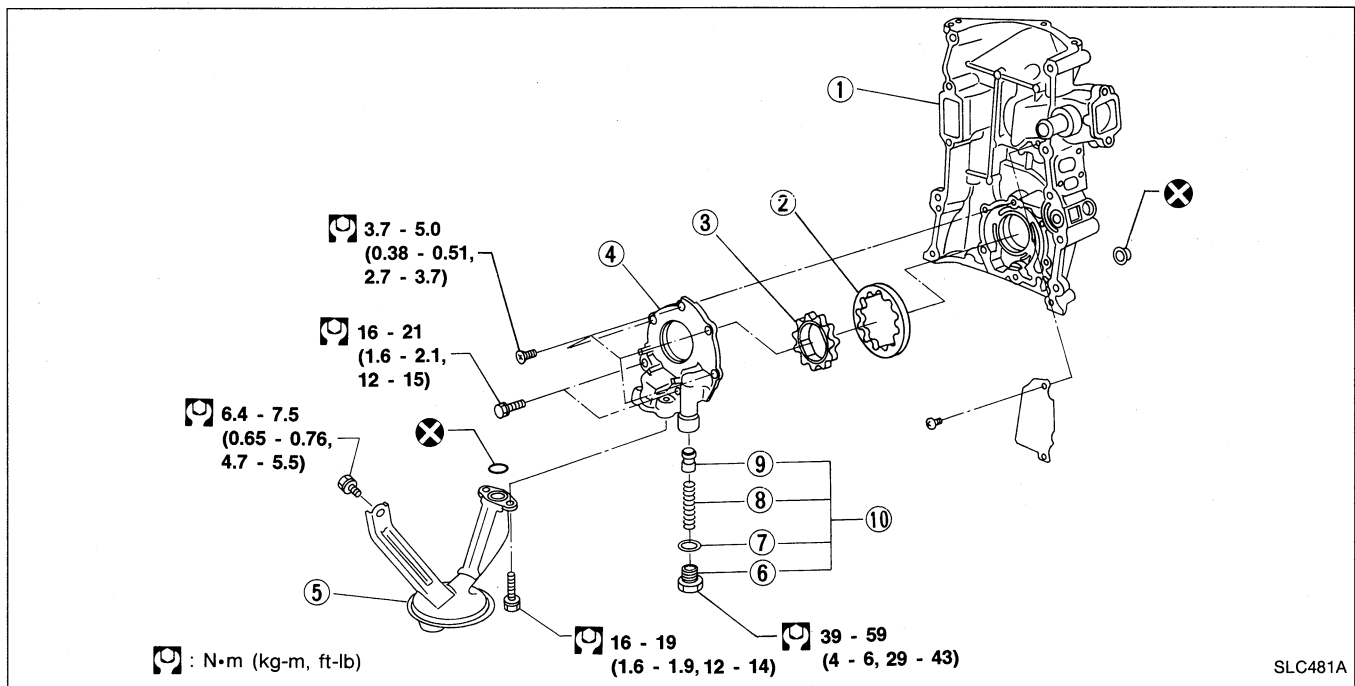

- | | |
|------------------|----------------------------|
| ① Front cover | ⑥ Cap |
| ② Outer gear | ⑦ Washer |
| ③ Inner gear | ⑧ Spring |
| ④ Oil pump cover | ⑨ Regulator valve |
| ⑤ Oil strainer | ⑩ Regulator valve assembly |

- Always replace oil seals and gaskets with new ones.
- When installing oil pump, apply engine oil to inner and outer gears.

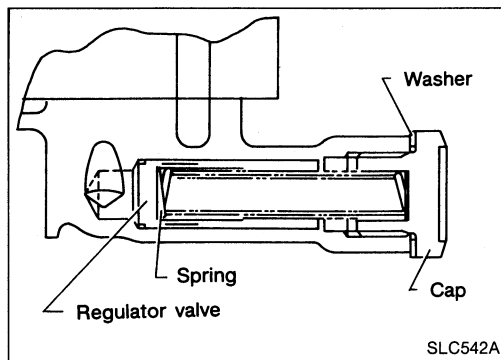

REGULATOR VALVE INSPECTION

1. Visually inspect components for wear and damage.
 2. Check oil pressure regulator valve sliding surface and valve spring.
 3. Coat regulator valve with engine oil and check that it falls smoothly into the valve hole by its own weight.
- If damaged, replace regulator valve set or oil pump assembly.

ENGINE LUBRICATION SYSTEM

Oil Pump (Cont'd)

OIL PRESSURE RELIEF VALVE INSPECTION

Inspect oil pressure relief valve for movement, cracks and breaks by pushing the ball. If replacement is necessary, remove valve by prying it out with a suitable tool. Install a new valve in place by tapping it.

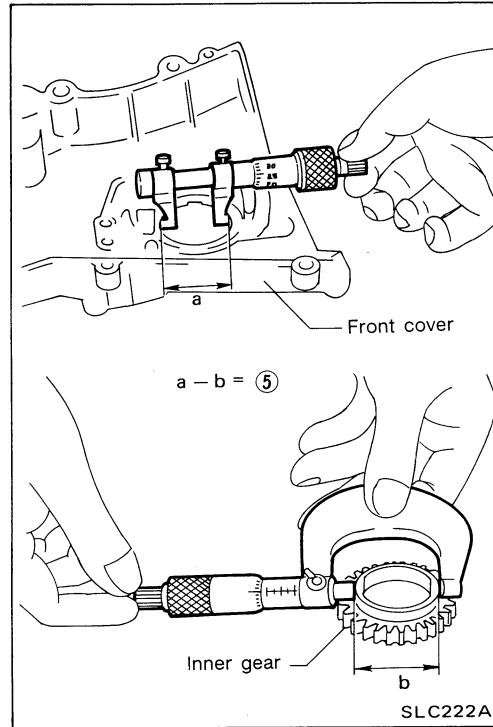
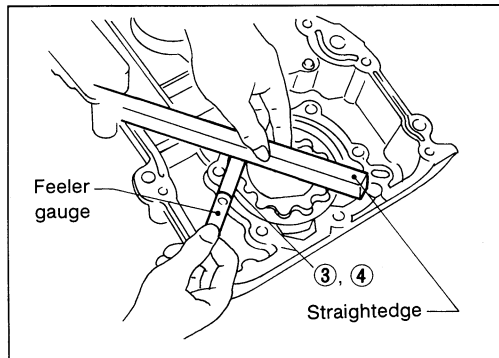
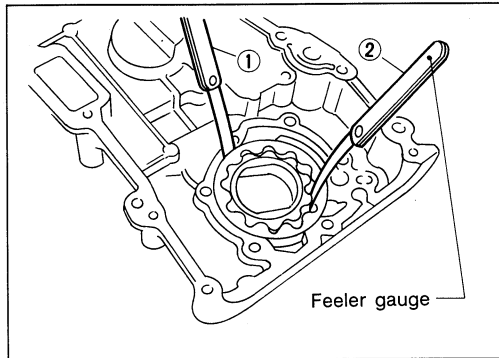
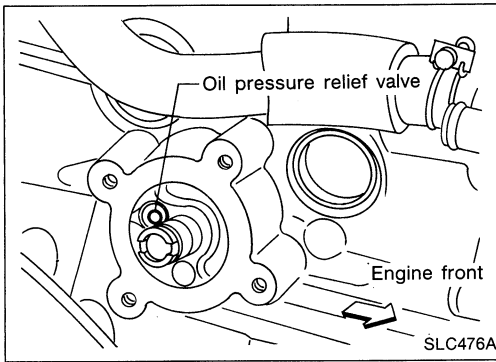

OIL PUMP INSPECTION

Using a feeler gauge, check the following clearances.

Standard clearance:

Unit: mm (in)

Body to outer gear clearance ①	0.114 - 0.20	(0.0045 - 0.0079)
Inner gear to outer gear tip clearance ②	0.04 - 0.18	(0.0016 - 0.0071)
Cover to inner gear clearance ③	0.05 - 0.09	(0.0020 - 0.0035)
Cover to outer gear clearance ④	0.05 - 0.11	(0.0020 - 0.0043)
Inner gear to brazen portion clearance ⑤	.	0.045 - 0.091	(0.0018 - 0.0036)

- If the tip clearance (②) exceeds the limit, replace gear set.
- If body to gear clearances (①, ③, ④, ⑤) exceed the limit, replace front cover assembly.

ENGINE COOLING SYSTEM

Cooling Circuit

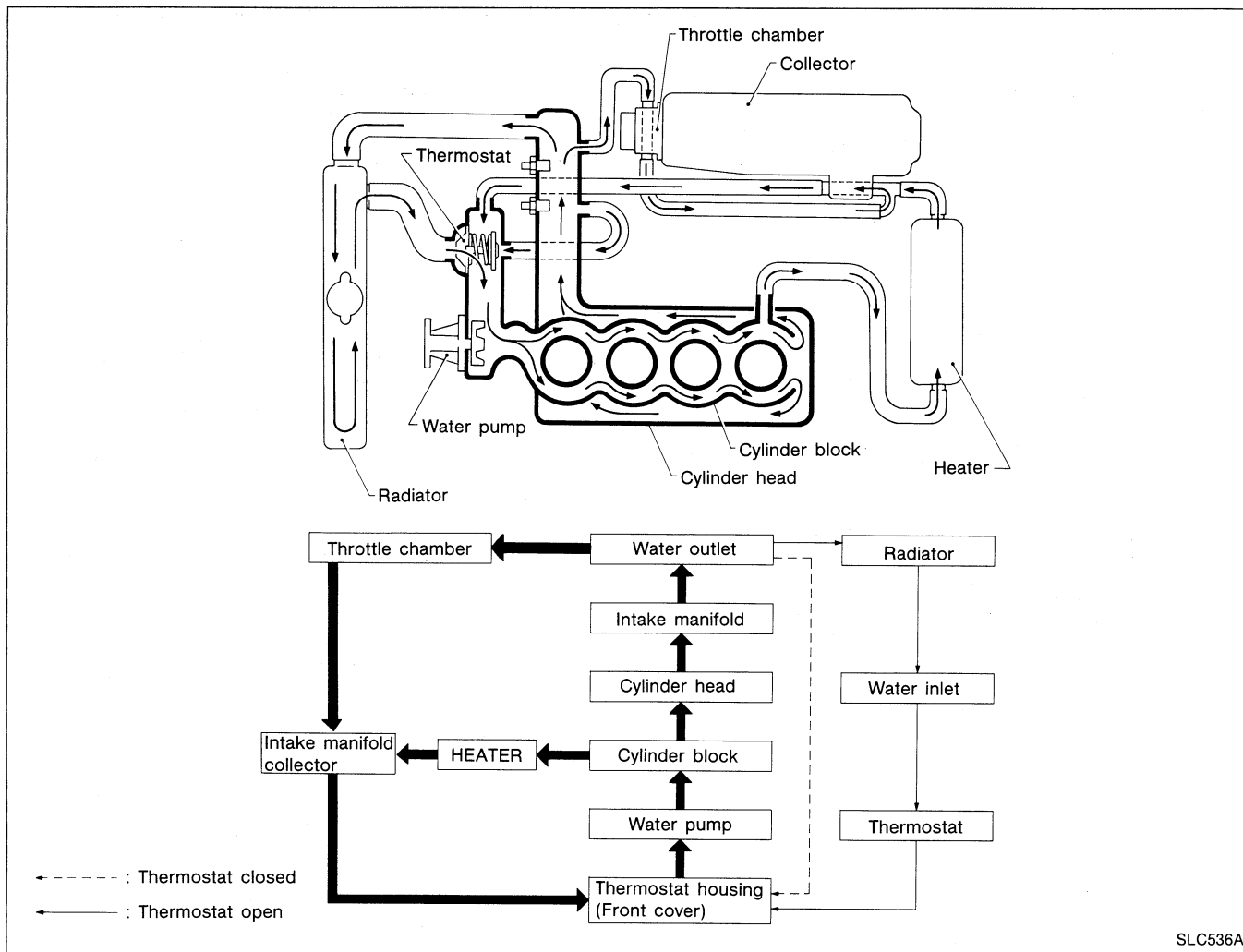

System Check

WARNING:

Never remove the radiator cap when the engine is hot; serious burns could be caused by high pressure fluid escaping from the radiator.

Wrap a thick cloth around cap and carefully remove the cap by turning it a quarter turn to allow built-up pressure to escape and then turn the cap all the way off.

CHECKING COOLING SYSTEM HOSES

Check hoses for improper attachment, leaks, cracks, damage, loose connections, chafing and deterioration.

ENGINE COOLING SYSTEM

System Check (Cont'd)

CHECKING COOLING SYSTEM FOR LEAKS

To check for leakage, apply pressure to the cooling system with a tester.

Testing pressure:

157 kPa (1.6 kg/cm², 23 psi)

CAUTION:

Higher than the specified pressure may cause radiator damage.

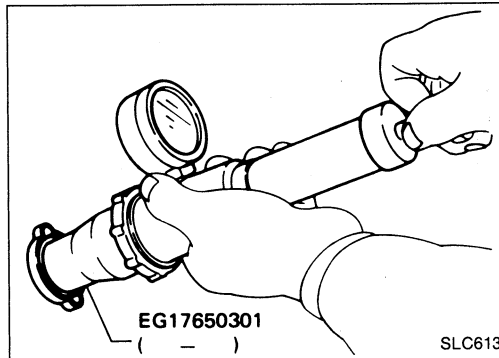
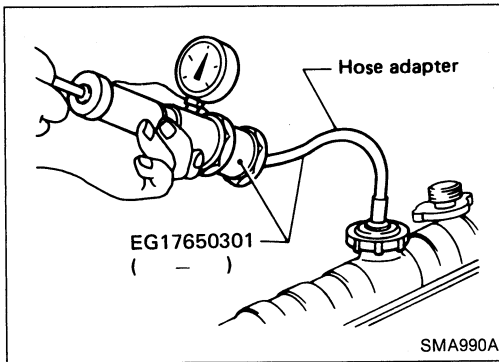

CHECKING RADIATOR CAP

To check radiator cap, apply pressure to cap with a tester.

Radiator cap relief pressure:

78 - 98 kPa (0.8 - 1.0 kg/cm², 11 - 14 psi)

ENGINE COOLING SYSTEM

Water Pump

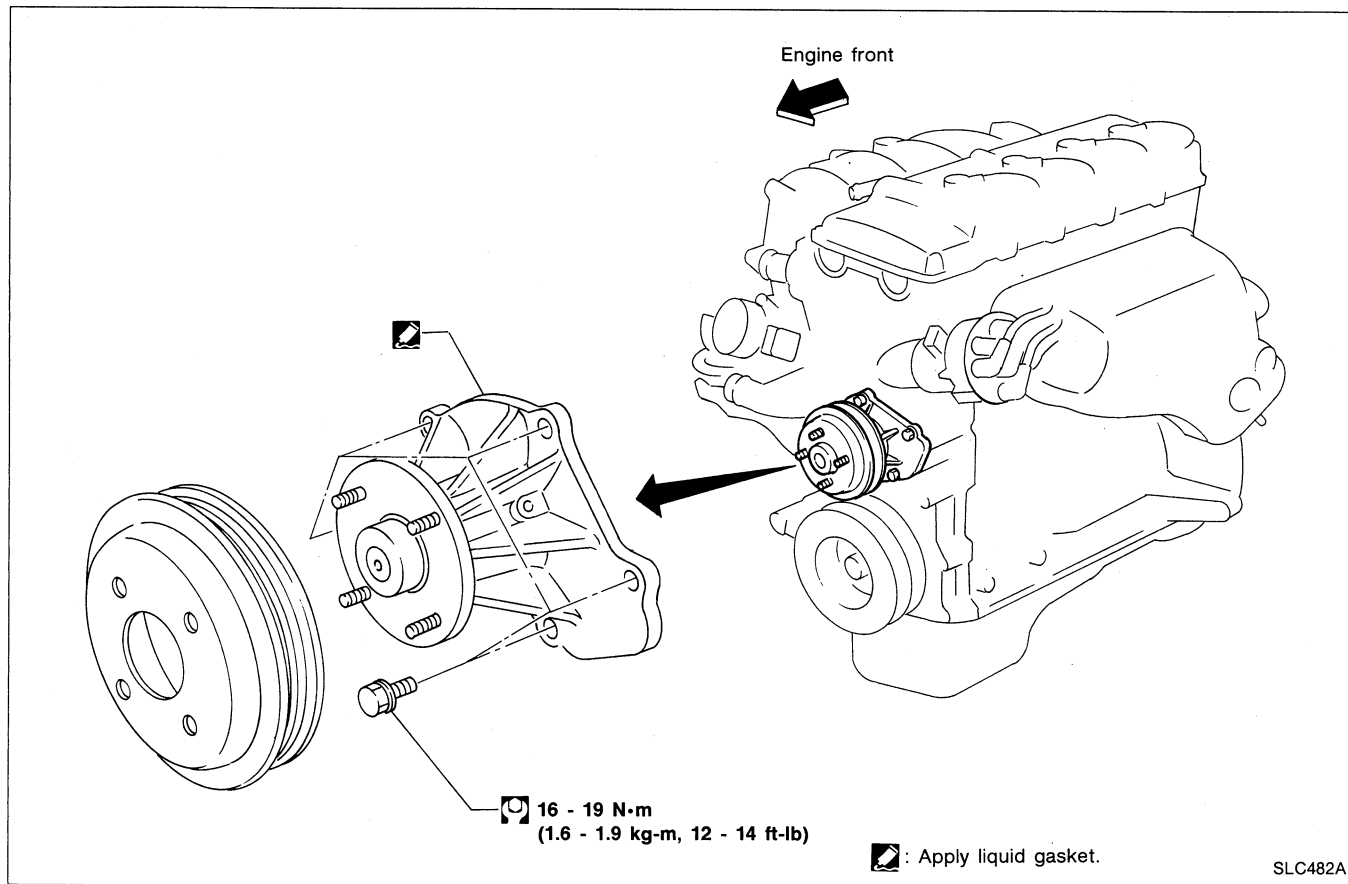

CAUTION:

- When removing water pump assembly, be careful not to get coolant on drive belt.
- Water pump cannot be disassembled and should be replaced as a unit.
- After installing water pump, connect hose and clamp securely, then check for leaks using radiator cap tester.

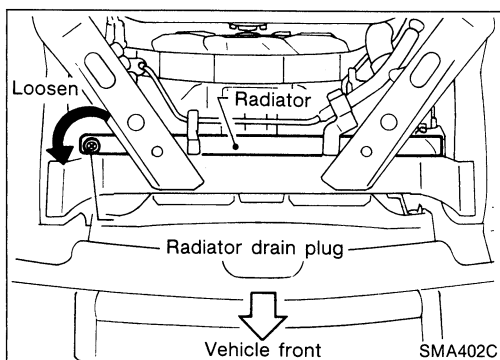

REMOVAL

1. Drain coolant from cylinder block and radiator.
2. Remove fan coupling with fan.
3. Remove power steering pump drive belt, alternator drive belt and air compressor drive belt.
4. Remove water pump.

ENGINE COOLING SYSTEM

Water Pump (Cont'd)

INSPECTION

1. Check for badly rusted or corroded vanes and body assembly.
2. Check for rough operation due to excessive end play.

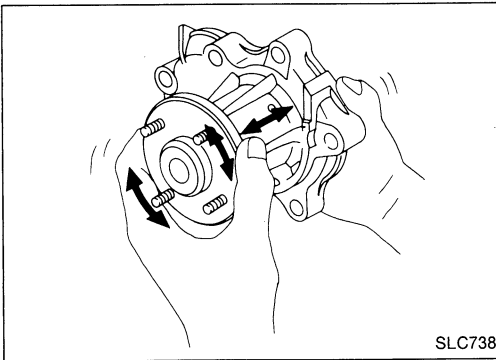

INSTALLATION

1. Before installing water pump, remove all traces of liquid gasket from mating surface using a scraper.
 - Also remove traces of liquid gasket from mating surface of cylinder block.

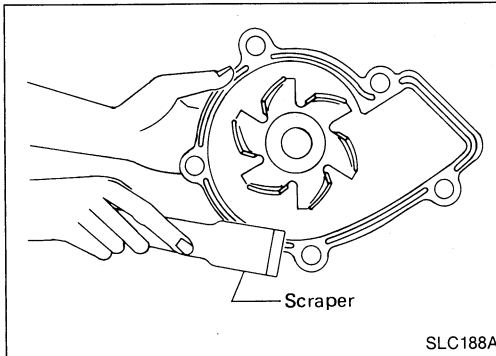

2. Apply a continuous bead of liquid gasket to mating surface of water pump.
 - Use genuine liquid gasket or equivalent.

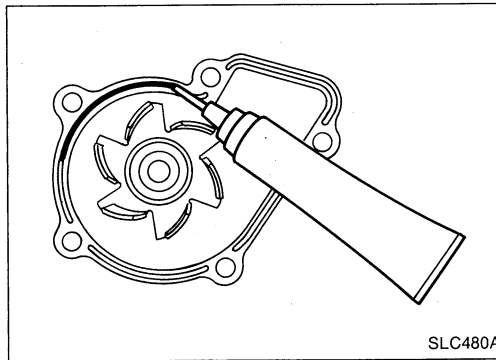

ENGINE COOLING SYSTEM

Thermostat

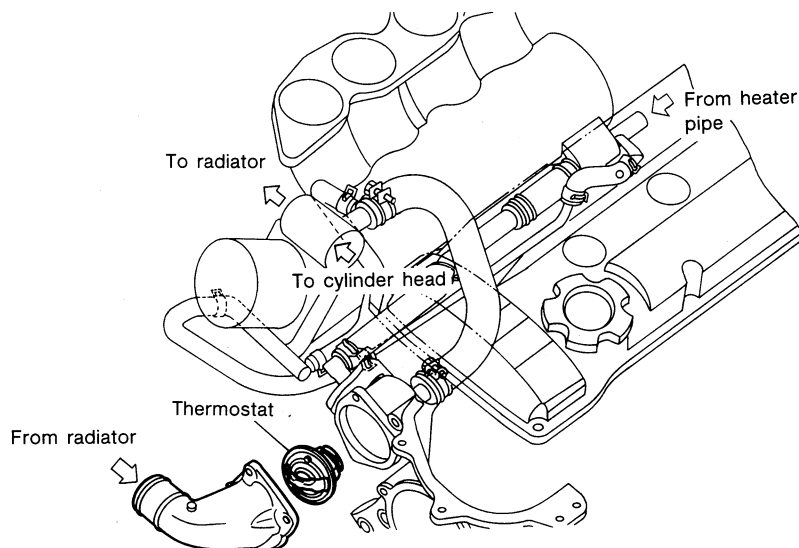

Liquid gasket application places

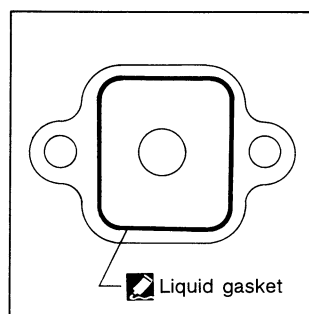
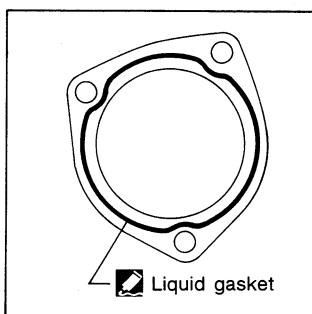

SLC537A

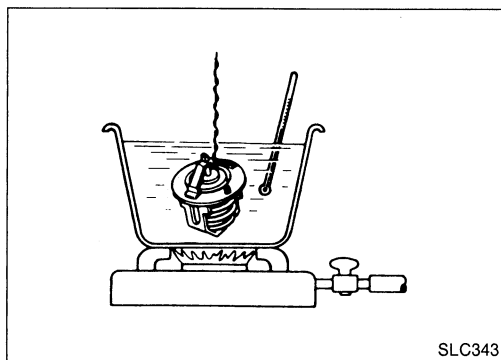

INSPECTION

1. Check valve seating condition at ordinary room temperatures. It should seat tightly.
2. Check valve opening temperature and maximum valve lift.

		Standard
Valve opening temperature	°C (°F)	76.5 (170)
Maximum valve lift	mm/°C (in/°F)	10/90 (0.39/194)

3. Then check if valve is closed at 5°C (9°F) below valve opening temperature.
 - Apply a continuous bead of liquid gasket to mating surface of water inlet. Refer to "Water Pump".
 - After installation, run engine for a few minutes, and check for leaks.
 - Be careful not to spill coolant over engine compartment. Use a rag to absorb coolant.

ENGINE COOLING SYSTEM

Radiator

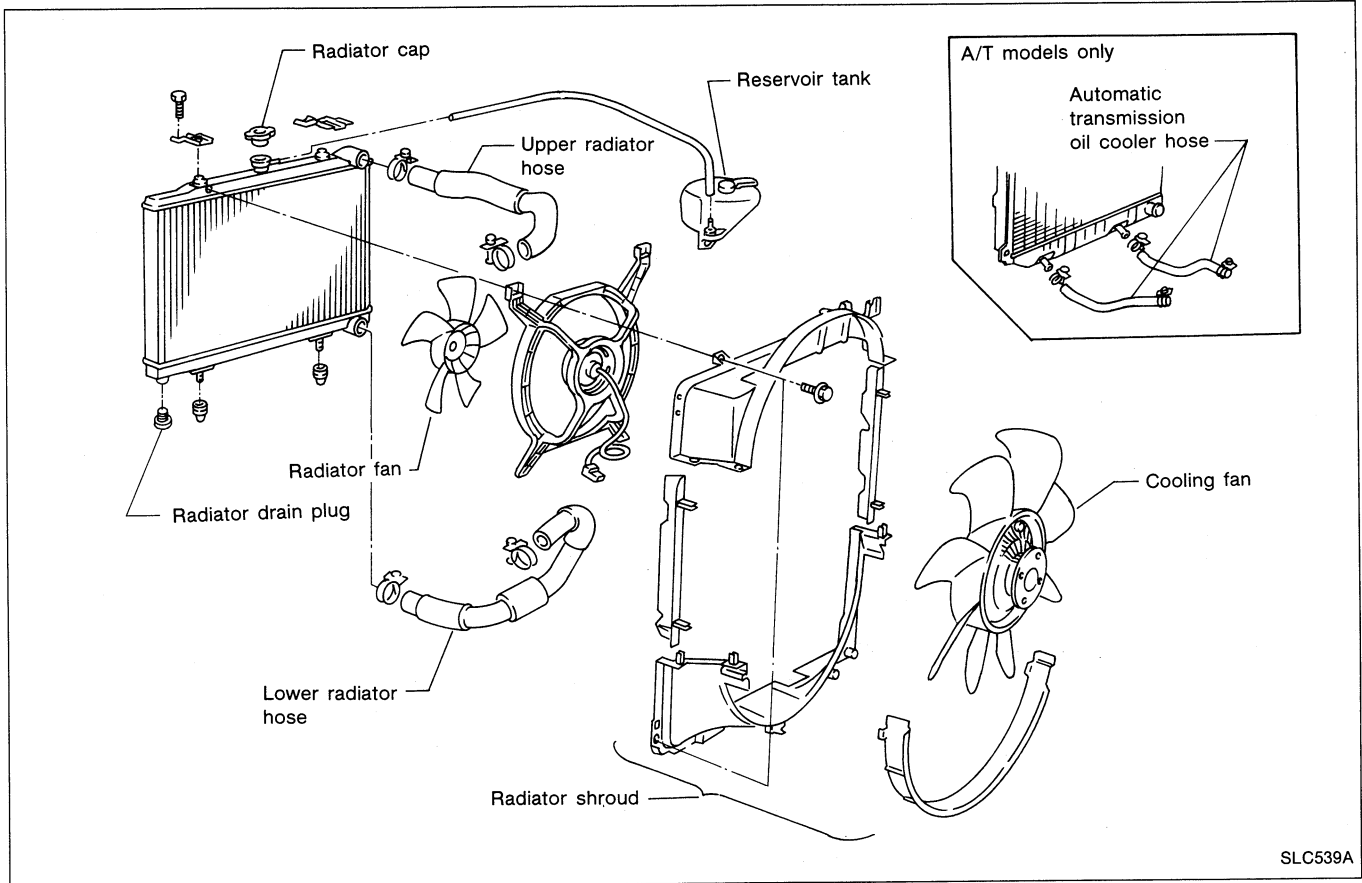

CAUTION:
When filling radiator with coolant, refer to MA section.

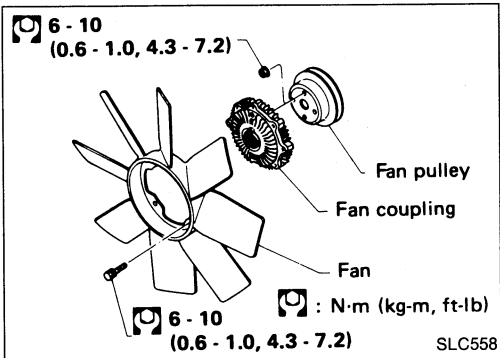

Cooling Fan

DISASSEMBLY AND ASSEMBLY

INSPECTION

Check fan coupling for rough operation, oil leakage or bent bimetal.

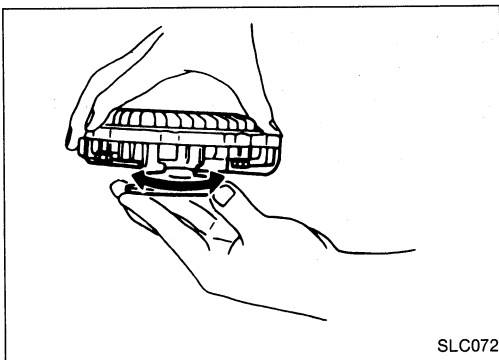

SERVICE DATA AND SPECIFICATIONS (S.D.S.)

Engine Lubrication System

Oil pressure check

Engine rpm	Approximate discharge pressure kPa (kg/cm ² , psi)
Idle speed	More than 78 (0.8, 11)
3,000	412 - 481 (4.2 - 4.9, 60 - 70)

Oil pump

		Unit: mm (in)
Body to outer gear clearance	0.114 - 0.20 (0.0045 - 0.0079)
Inner gear to outer gear tip clearance	0.04 - 0.18 (0.0016 - 0.0071)
Cover to inner gear clearance	0.05 - 0.09 (0.0020 - 0.0035)
Cover to outer gear clearance	0.05 - 0.11 (0.0020 - 0.0043)
Inner gear to brazed portion clearance	0.045 - 0.091 (0.0018 - 0.0036)

Engine Cooling System

Thermostat

Valve opening temperature	°C (°F)	76.5 (170)
Max. valve lift	mm/°C (in/°F)	10/90 (0.39/194)

Radiator

		Unit: kPa (kg/cm ² , psi)
Cap relief pressure		78 - 98 (0.8 - 1.0, 11 - 14)
Leakage test pressure		157 (1.6, 23)

ENGINE FUEL & EMISSION CONTROL SYSTEM

SECTION **EF & EC**

EF & EC

CONTENTS

PREPARATION.....	EF & EC- 2
PRECAUTIONS.....	EF & EC- 3
ENGINE AND EMISSION CONTROL OVERALL SYSTEM	EF & EC- 4
ENGINE AND EMISSION CONTROL PARTS DESCRIPTION	EF & EC- 10
ENGINE AND EMISSION CONTROL SYSTEM DESCRIPTION	EF & EC- 17
IDLE SPEED/IGNITION TIMING/IDLE MIXTURE RATIO INSPECTION.....	EF & EC- 28
TROUBLE DIAGNOSES	EF & EC- 33
FUEL INJECTION CONTROL SYSTEM INSPECTION	EF & EC-191
EVAPORATIVE EMISSION CONTROL SYSTEM	EF & EC-193
CRANKCASE EMISSION CONTROL SYSTEM.....	EF & EC-195
SERVICE DATA AND SPECIFICATIONS (S.D.S.)	EF & EC-196

Note: Refer to Foldout page for “E.C.C.S. WIRING DIAGRAM”.

When you read wiring diagrams:

- Read G1 section, “HOW TO READ WIRING DIAGRAMS”.
- See EL section, “POWER SUPPLY ROUTING” for power distribution circuit.

When you perform trouble diagnoses, read G1 section, “HOW TO FOLLOW FLOW CHART IN TROUBLE DIAGNOSES”.

PREPARATION

SPECIAL SERVICE TOOL

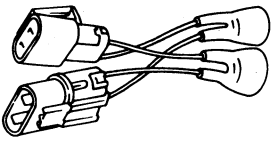
Tool number (Kent-Moore No.) Tool name	Description
EG11160000 (—) Ignition coil adapter harness	 <p data-bbox="1047 296 1315 331">Measuring engine speed</p>

PRECAUTIONS

E.C.U.

- Do not disassemble E.C.C.S. control unit. (E.C.U.)
- Do not turn diagnosis mode selector forcibly.
- If a battery terminal is disconnected, the memory will return to the ROM value. The E.C.C.S. will now start to self-control at its initial value. Engine operation can vary slightly when the terminal is disconnected. However, this is not an indication of a problem. Do not replace parts because of a slight variation.
- Do not apply undue force to mounting bracket.
- Before connecting or disconnecting E.C.U. connector, make sure red and green LEDs are off after turning ignition key off.
- Always install the properly specified E.C.U. on car; otherwise, erroneous engine operation may result.
- Disconnect connector by pulling it (not the harness) straight out.
- Before connecting connector, make sure all pins are straight.

WIRELESS EQUIPMENT

- When installing a C.B. ham radio or a mobile phone, be sure to observe the following, as installation location may affect the electronic control systems.
- 1) Keep antenna as far as possible away from electronic control units.
 - 2) Keep antenna feeder line more than 20 cm (7.9 in) away from harness of electronic controls. Do not let them run parallel for a long distance.
 - 3) Adjust antenna and feeder line so that standing-wave ratio can be kept smaller.
 - 4) Be sure to ground radio to vehicle body.

BATTERY

- Always use a 12 volt battery as a power source.
- Do not disconnect battery cables while the engine is running.
- Do not reverse polarity of battery when connecting it. Otherwise, E.C.U. and/or injectors may be burned.

INJECTOR

- Do not disconnect injector harness connectors with engine running.
- Do not apply battery power directly to injectors; otherwise injectors will be damaged.

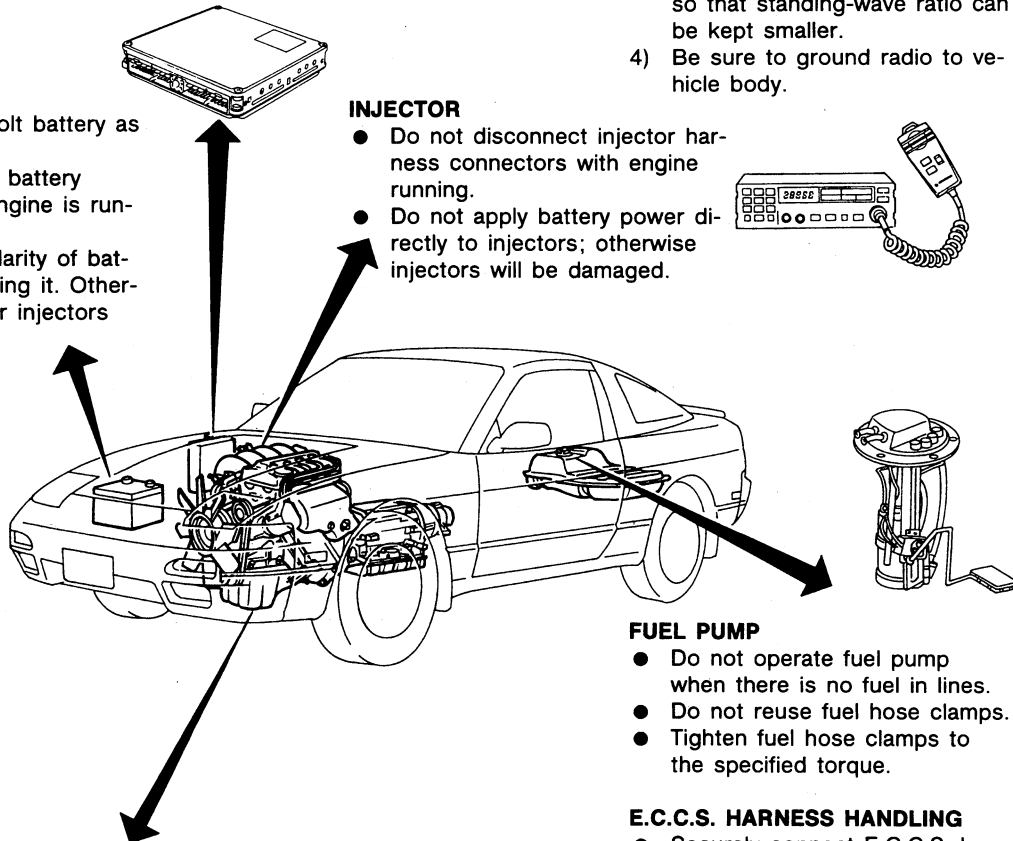

E.C.C.S. PARTS HANDLING

- Handle air flow meter carefully to avoid damage.
- Do not disassemble air flow meter.
- Do not clean air flow meter with detergent.
- Do not jolt or jar the crank angle sensor.

WHEN STARTING

- Do not depress accelerator pedal when starting.
- Immediately after starting, do not rev up engine unnecessarily.
- Do not rev up engine just prior to shutdown.

FUEL PUMP

- Do not operate fuel pump when there is no fuel in lines.
- Do not reuse fuel hose clamps.
- Tighten fuel hose clamps to the specified torque.

E.C.C.S. HARNESS HANDLING

- Securely connect E.C.C.S. harness connectors. A poor connection can cause extremely high voltage to develop in the coil and condenser, resulting in damage to ICs.
- Keep E.C.C.S. harness at least 10 cm (3.9 in) away from adjacent harnesses, to prevent an E.C.C.S. system malfunction due to receiving external noise, degraded operation of ICs, etc.
- Keep E.C.C.S. parts and harnesses dry.
- Before removing parts, turn off ignition switch and then disconnect battery ground cable.

ENGINE AND EMISSION CONTROL OVERALL SYSTEM

E.C.C.S. Component Parts Location

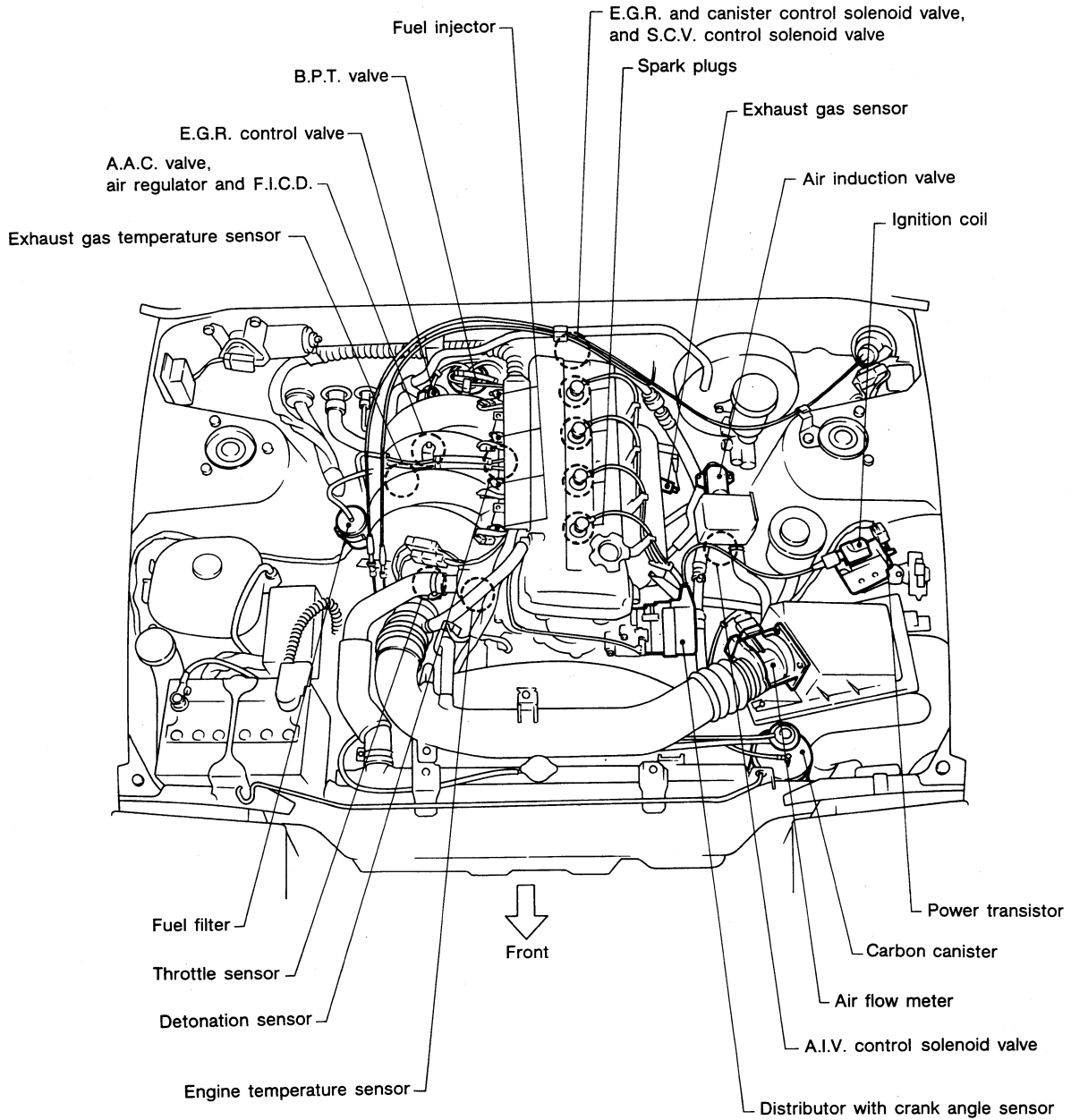

ENGINE AND EMISSION CONTROL OVERALL SYSTEM

E.C.C.S. Component Parts Location (Cont'd)

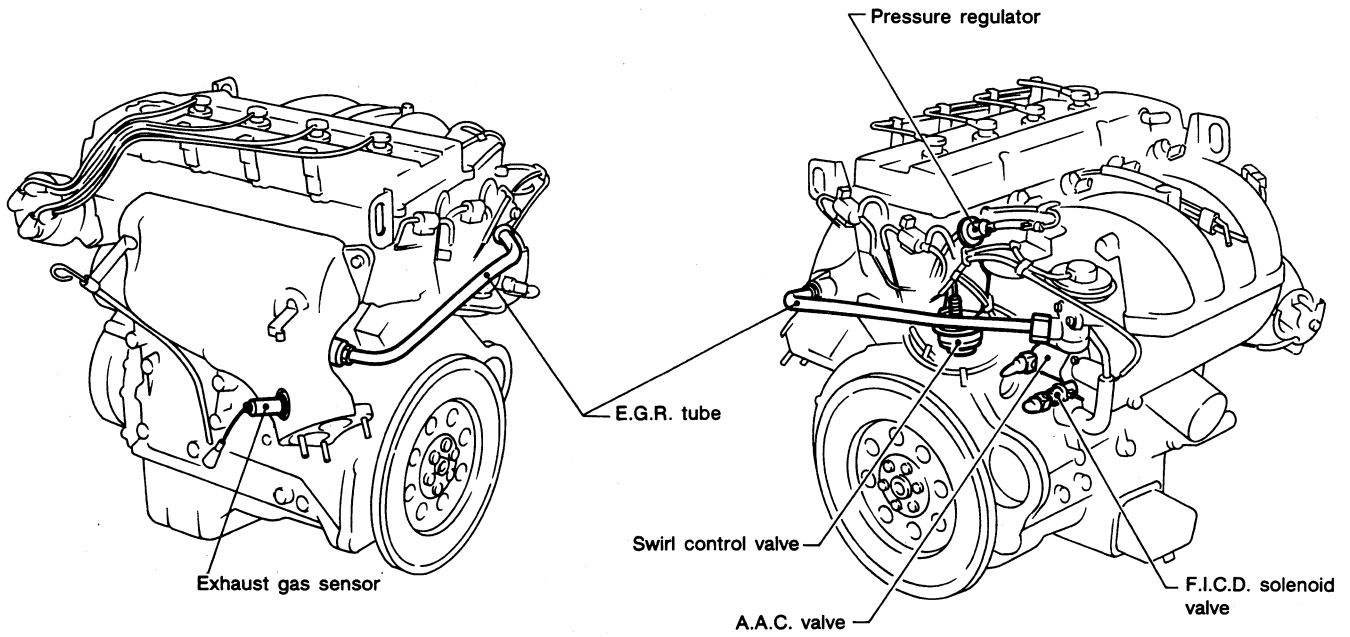

E.C.C.S. control unit location

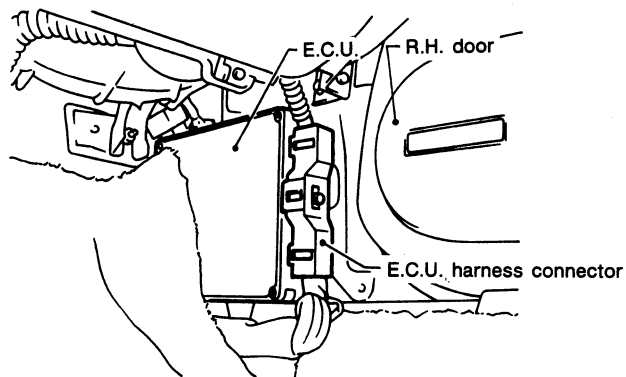

ENGINE AND EMISSION CONTROL OVERALL SYSTEM

System Diagram

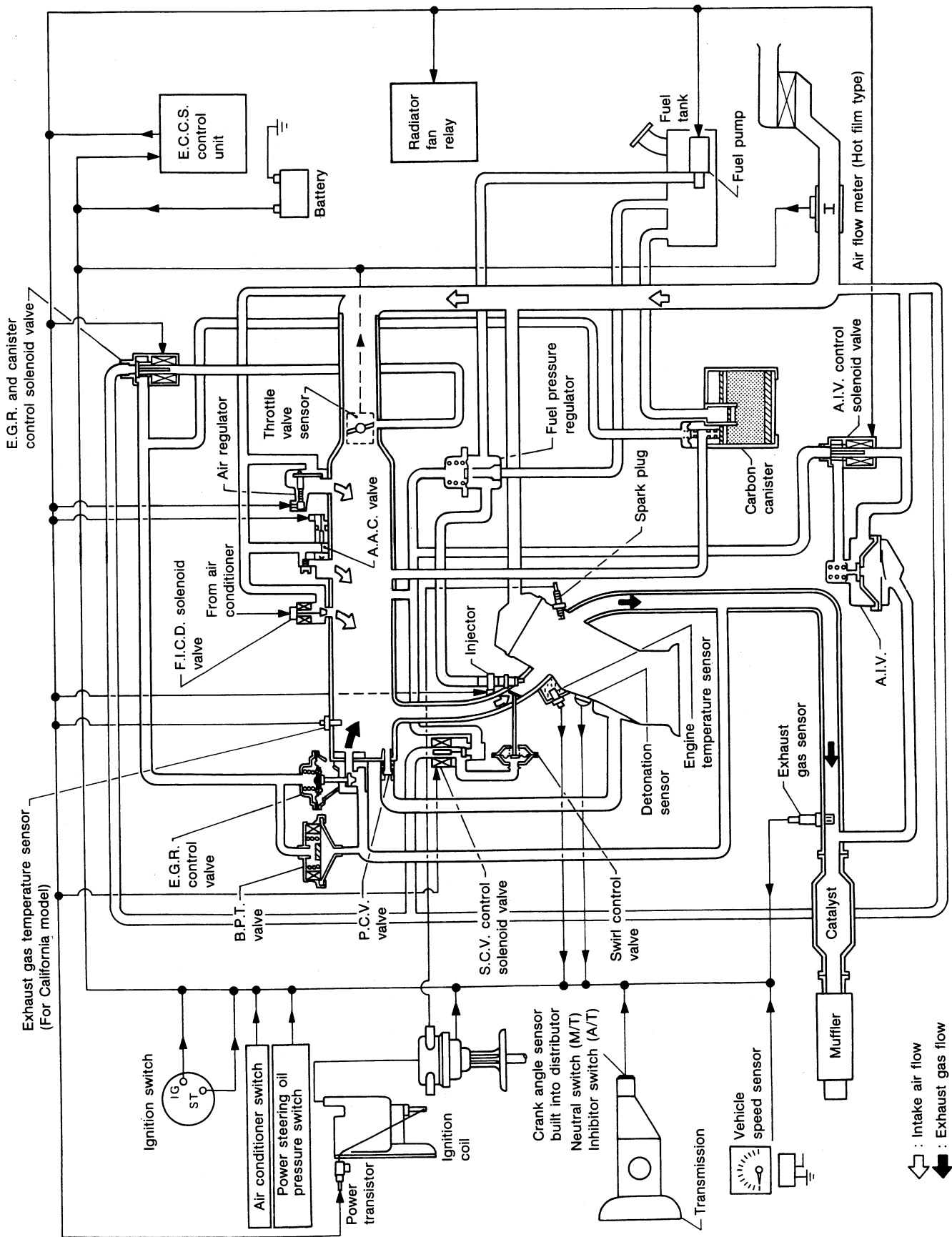

SEF844K

ENGINE AND EMISSION CONTROL OVERALL SYSTEM

System Chart

E.C.C.S. CONTROL SYSTEM

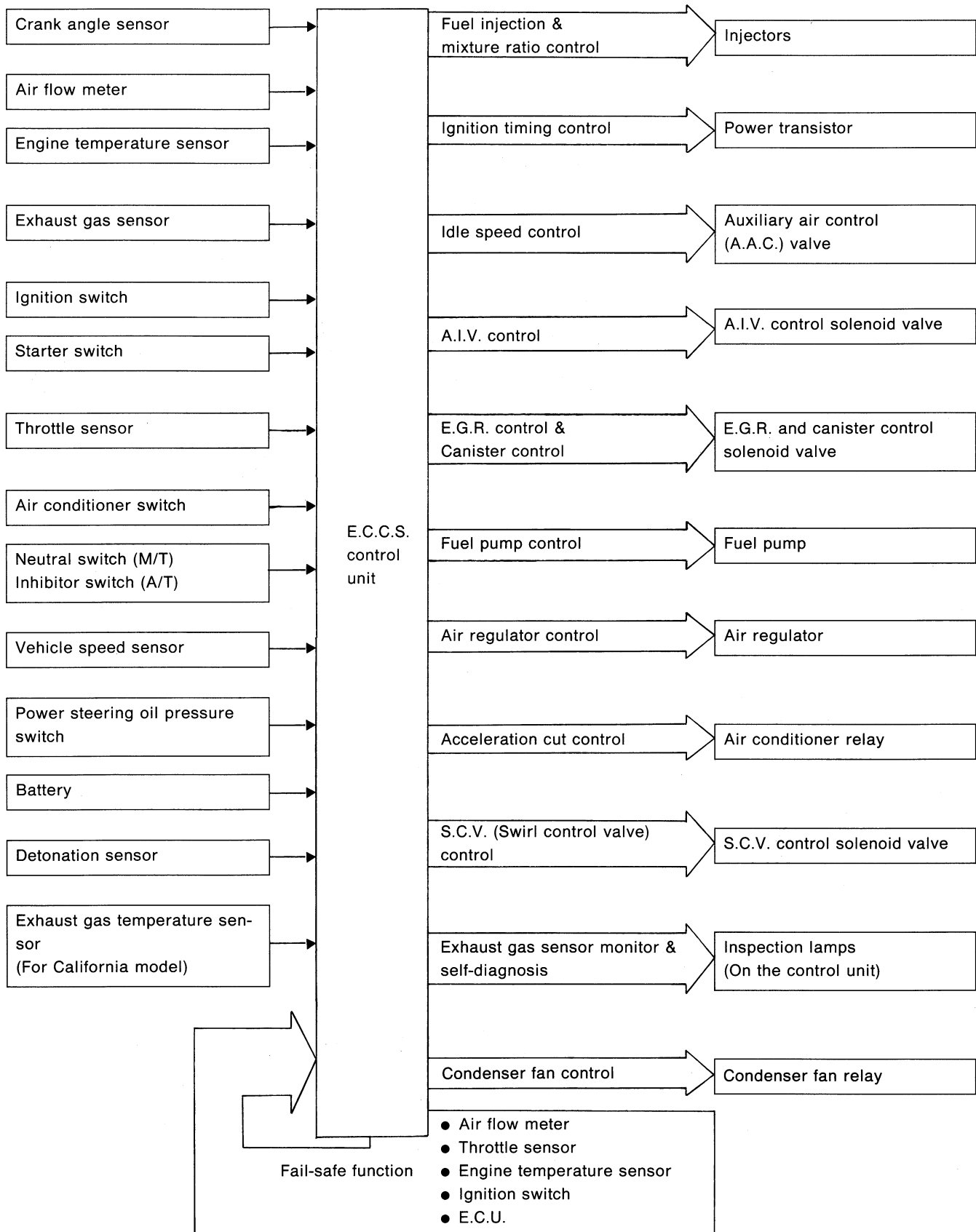

ENGINE AND EMISSION CONTROL OVERALL SYSTEM

Vacuum Hose Drawing

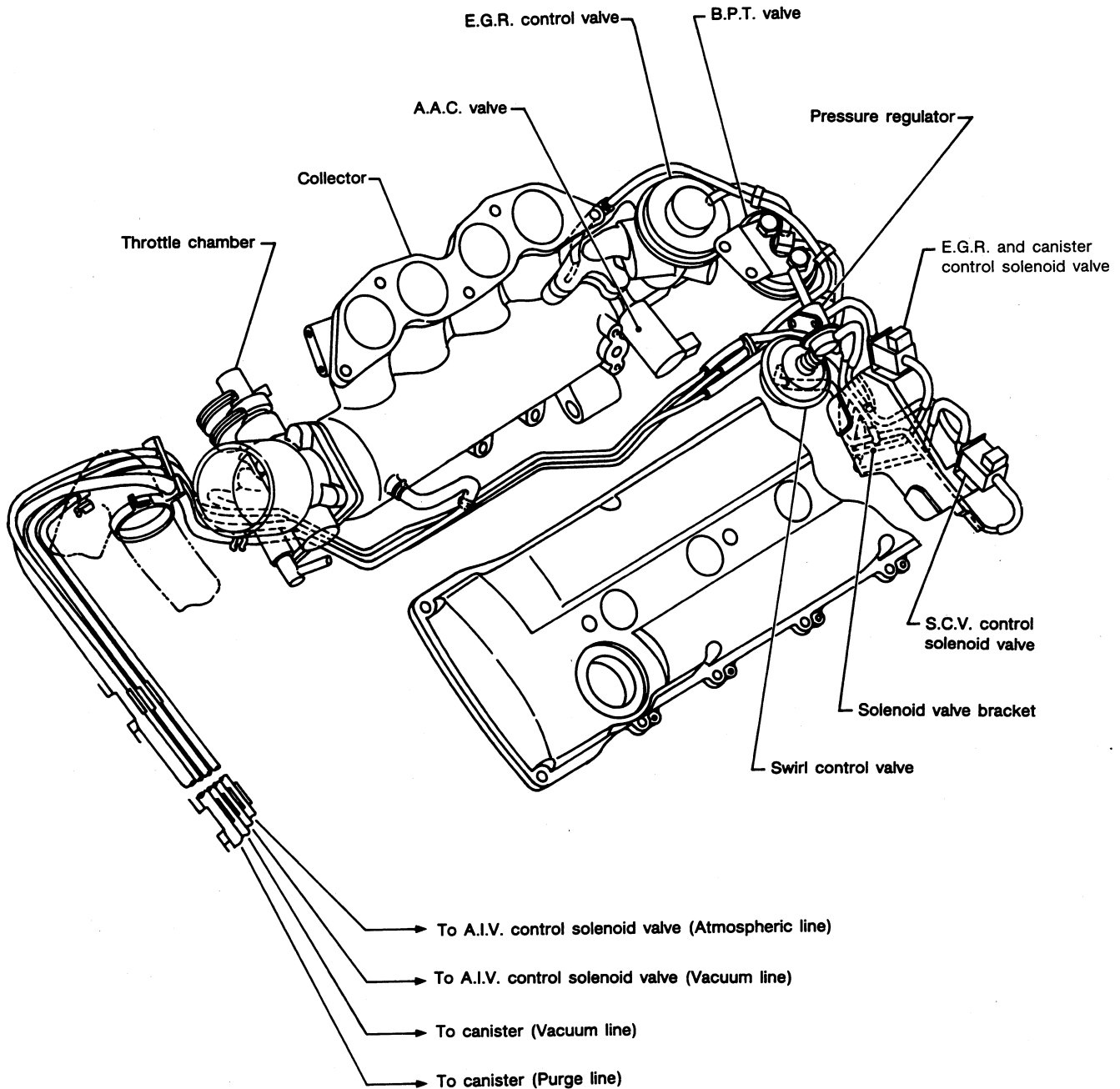

ENGINE AND EMISSION CONTROL OVERALL SYSTEM

Circuit Diagram

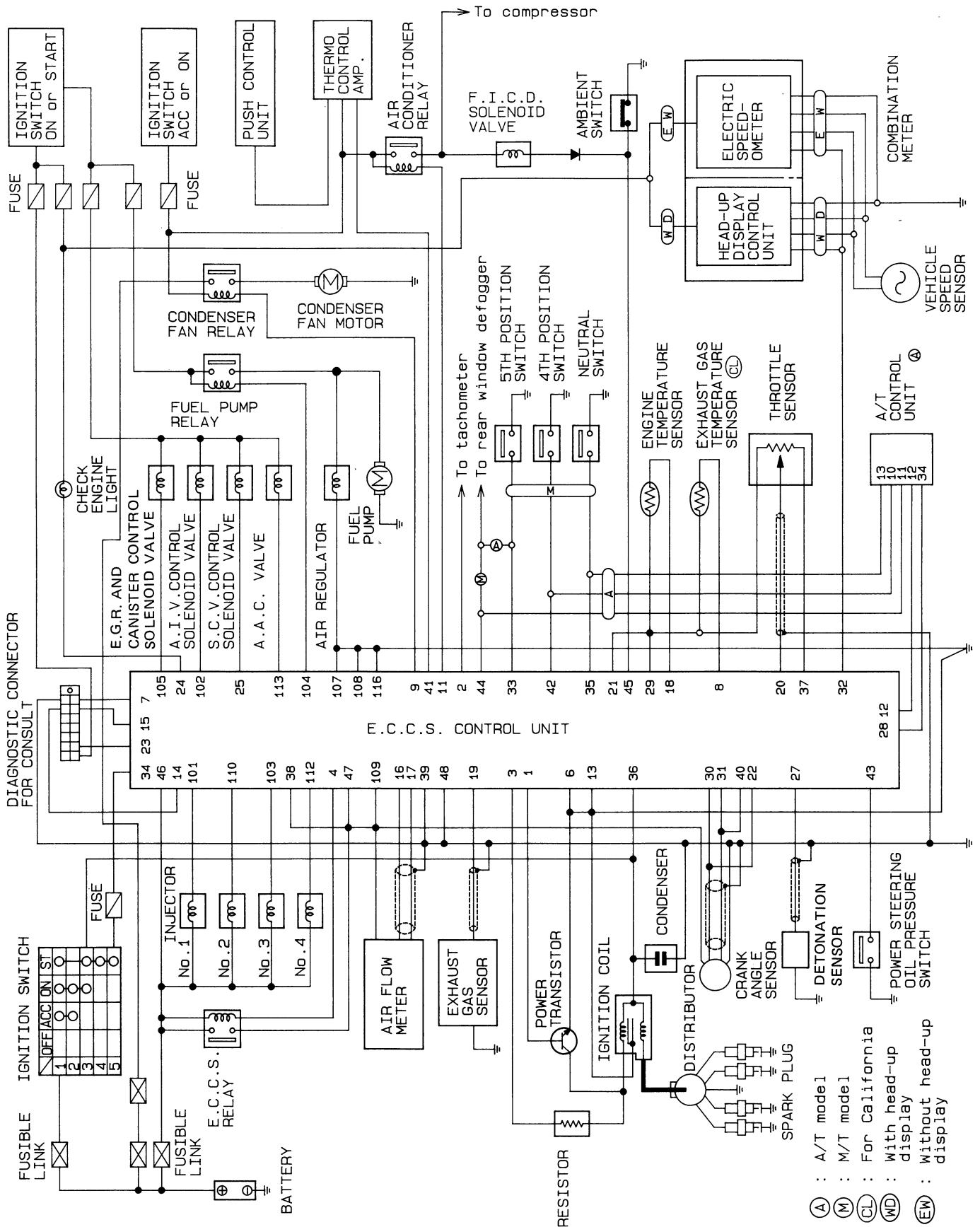

SEF004L

ENGINE AND EMISSION CONTROL PARTS DESCRIPTION

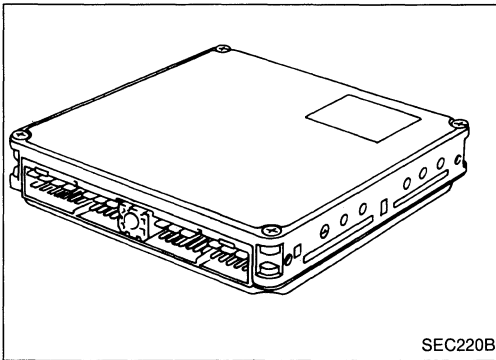

SEC220B

E.C.C.S. Control Unit (E.C.U.)

The E.C.U. consists of a microcomputer, inspection lamps, a diagnostic mode selector, and connectors for signal input and output and for power supply. The unit controls the engine.

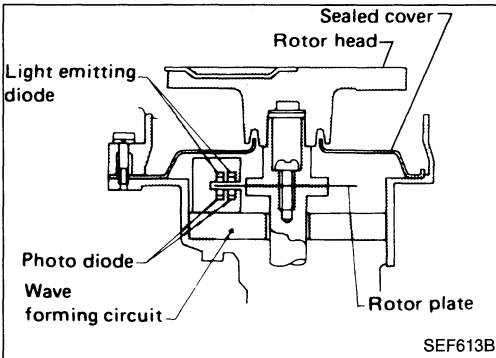

SEF613B

Crank Angle Sensor

The crank angle sensor is a basic component of the entire E.C.C.S. It monitors engine speed and piston position, and sends signals to the E.C.U. to control fuel injection, ignition timing and other functions.

The crank angle sensor has a rotor plate and a wave-forming circuit. The rotor plate has 360 slits for 1° signal and 4 slits for 180° signal. Light Emitting Diodes (L.E.D.) and photo diodes are built in the wave-forming circuit.

When the rotor plate passes between the L.E.D. and the photo diode, the slits in the rotor plate continually cut the light being transmitted to the photo diode from the L.E.D. This generates rough-shaped pulses which are converted into on-off signals by the wave-forming circuit, which are then sent to the E.C.U.

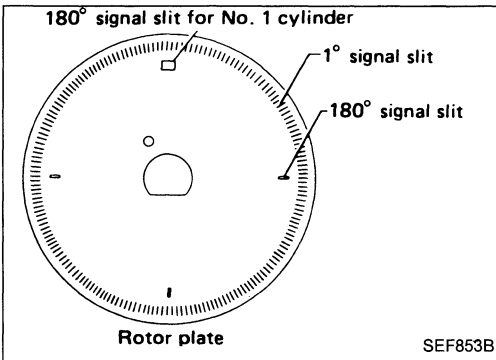

SEF853B

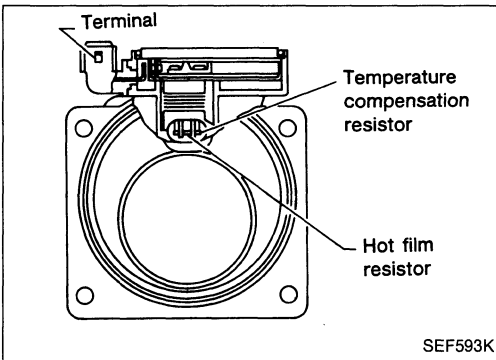

SEF593K

Air Flow Meter

The air flow meter measures the intake air flow rate by measuring a part of the entire flow. Measurements are made in such a way that the E.C.U. receives electrical output signals varied by the amount of heat emitting from the hot film placed in the stream of the intake air.

When intake air flows into the intake manifold through a route around the hot film, the heat generated from the hot film is taken away by the air. The amount of heat reduction depends on the air flow. The temperature of the hot film is automatically controlled to a certain number of degrees.

Therefore, it is necessary to supply the hot film with more electric current in order to maintain the temperature of the hot film. The E.C.U. detects the air flow by means of this current change.

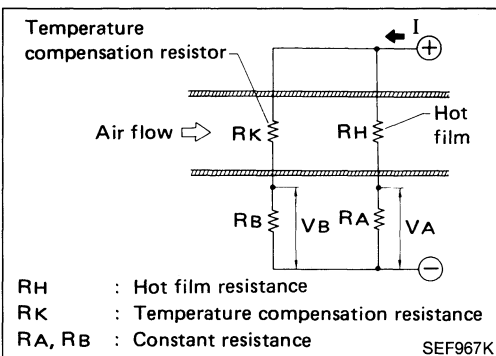

SEF967K

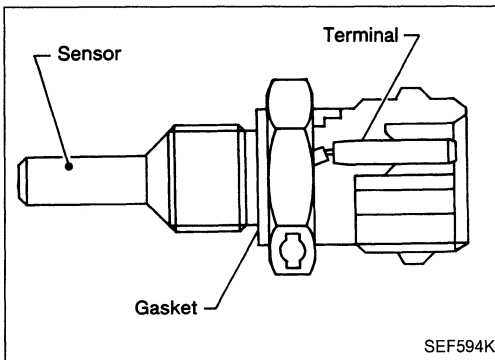

Engine Temperature Sensor

The engine temperature sensor detects the engine temperature, which is dependent on engine coolant temperature, and transmits a signal to the E.C.U.

The temperature sensing unit employs a thermistor which is sensitive to the change in temperature. Electrical resistance of the thermistor decreases in response to the temperature rise.

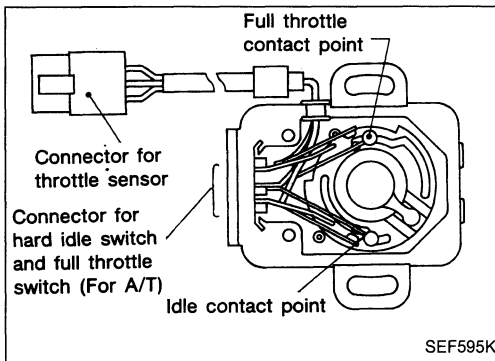

Throttle Sensor & Soft/Hard Idle Switch

The throttle sensor responds to the accelerator pedal movement. This sensor is a kind of potentiometer which transforms the throttle valve position into output voltage, and emits the voltage signal to the E.C.U. In addition, the sensor detects the opening and closing speed of the throttle valve and feeds the voltage signal to the E.C.U.

Idle position of the throttle valve is determined by the E.C.U. receiving the signal from the throttle sensor. This system is called "soft idle switch" and controls engine operation such as fuel cut. On the other hand, "hard idle switch", which is built into the throttle sensor unit on A/T equipped models, is used not for engine control.

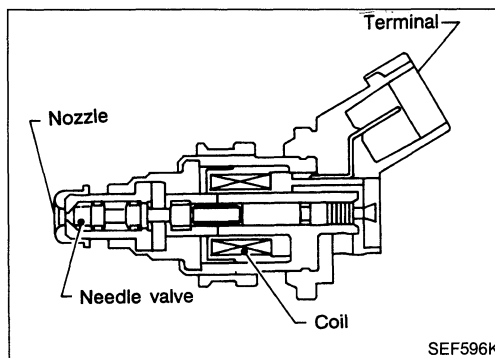
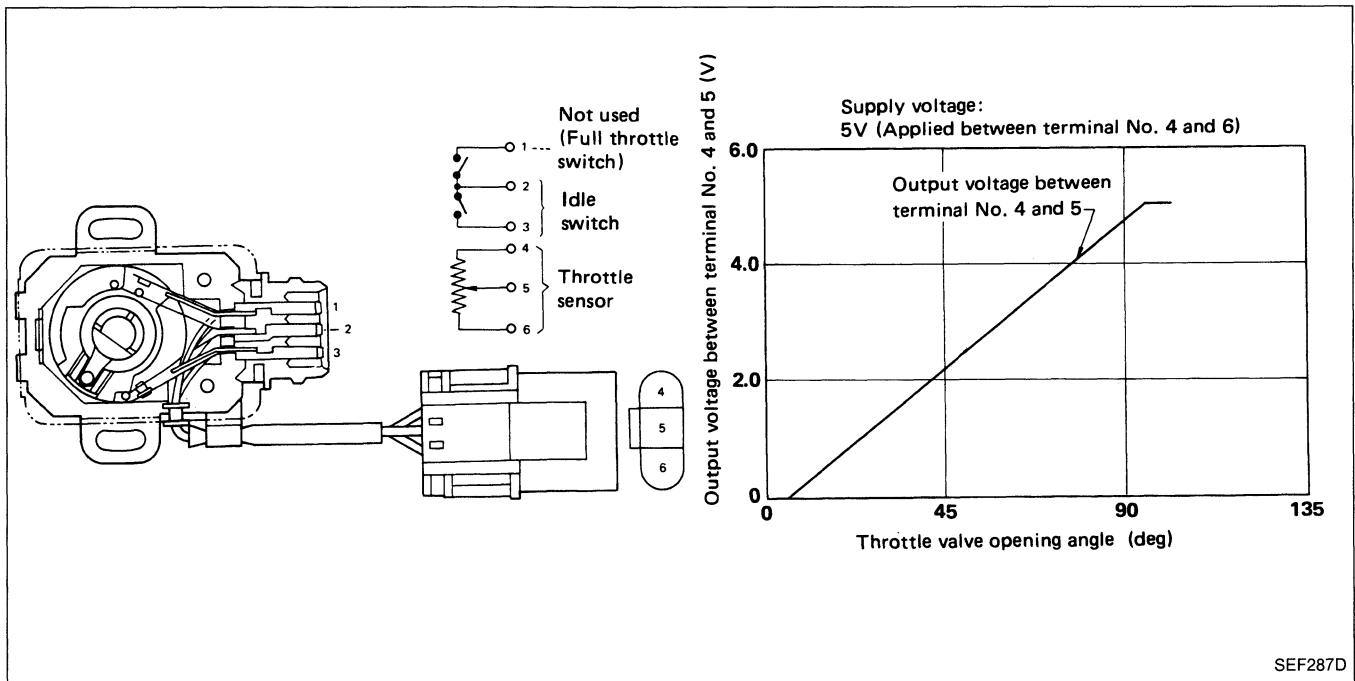

Fuel Injector

The fuel injector is a small, elaborate solenoid valve. As the E.C.U. sends injection signals to the injector, the coil in the injector pulls the needle valve back and fuel is released into the intake manifold through the nozzle. The injected fuel is controlled by the E.C.U. in terms of injection pulse duration.

ENGINE AND EMISSION CONTROL PARTS DESCRIPTION

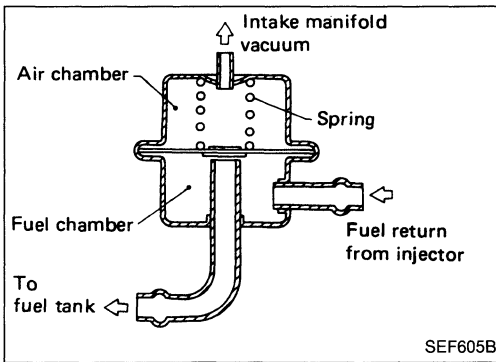

Pressure Regulator

The pressure regulator maintains the fuel pressure at 299.1 kPa (3.05 kg/cm², 43.4 psi). Since the injected fuel amount depends on injection pulse duration, it is necessary to maintain the pressure at the above value.

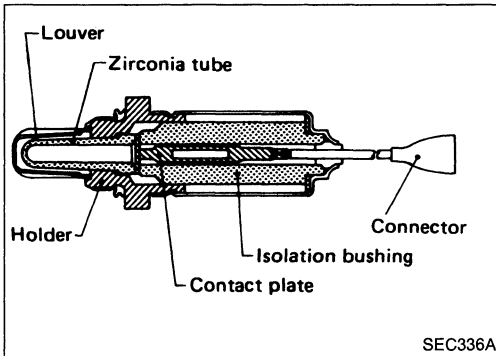

Exhaust Gas Sensor

The exhaust gas sensor, which is placed into the exhaust manifold, monitors the amount of oxygen in the exhaust gas. The sensor has a closed-end tube made of ceramic zirconia. The outer surface of the tube is exposed to exhaust gas, and the inner surface to atmosphere. The zirconia of the tube compares the oxygen density of exhaust gas with that of atmosphere, and generates electricity. In order to improve the generating power of the zirconia, its tube is coated with platinum. The voltage is approximately 1V in a richer condition of the mixture ratio than the ideal air-fuel ratio, while approximately 0V in leaner conditions. The radical change from 1V to 0V occurs at around the ideal mixture ratio. In this way, the exhaust gas sensor detects the amount of oxygen in the exhaust gas and sends the signal of approximately 1V or 0V to the E.C.U.

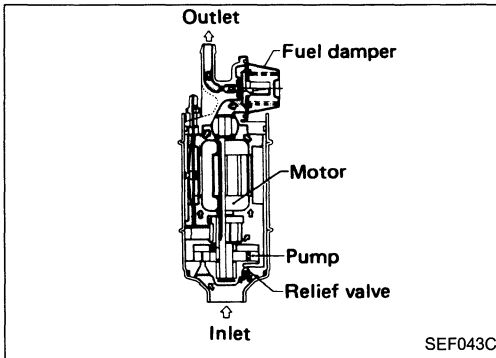
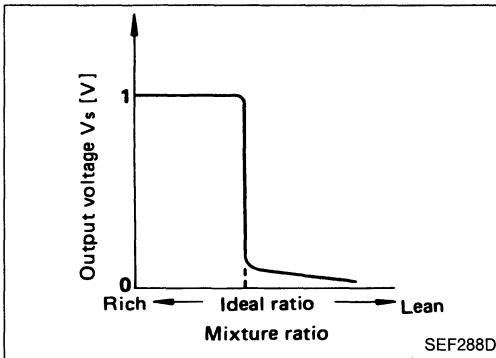

Fuel Pump

The fuel pump with a fuel damper is a submersible type, and are located in the fuel tank.

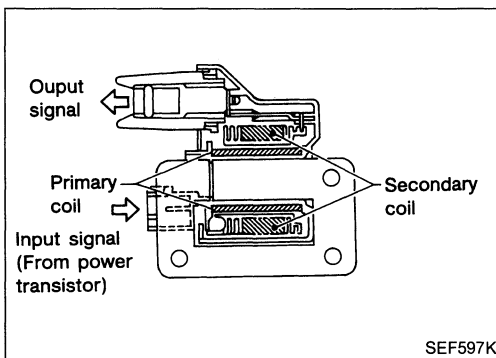

Ignition Coil with Power Transistor

The ignition signal from the E.C.U. is amplified by the power transistor, which turns the ignition coil primary circuit on and off, inducing the proper high voltage in the secondary circuit. The ignition coil is a small, molded type.

ENGINE AND EMISSION CONTROL PARTS DESCRIPTION

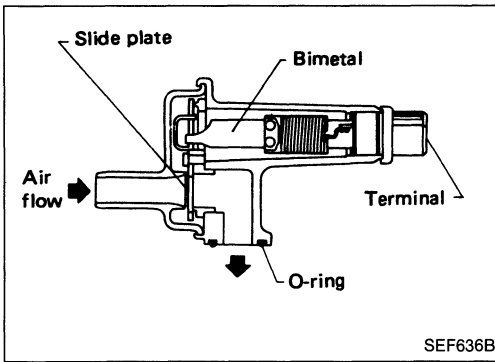

Air Regulator

The air regulator provides an air by-pass when the engine is cold for a fast idle during warm-up.

A bimetal, heater and rotary shutter are built into the air regulator. When the bimetal temperature is low, the air by-pass port opens. As the engine starts and electric current flows through a heater, the bimetal begins to turn the shutter to close the by-pass port. The air passage remains closed until the engine stops and the bimetal temperature drops.

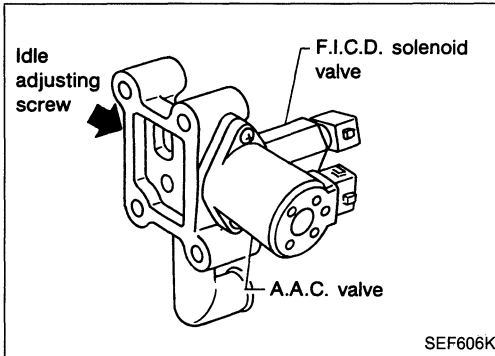

Idle Air Adjusting (I.A.A.) Unit

The I.A.A. unit is made up of the A.A.C. valve, F.I.C.D. solenoid valve and idle adjust screw. It receives the signal from the E.C.U. and controls the idle speed at the preset value.

The F.I.C.D. solenoid valve compensates for changes in idle speed caused by the operation of the air compressor. A vacuum control valve is also installed in this unit to prevent an abnormal rise in intake manifold vacuum pressure during deceleration.

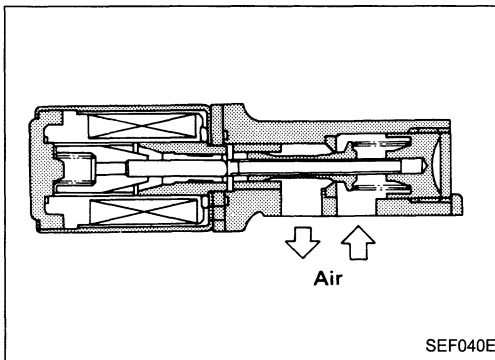

Auxiliary Air Control (A.A.C.) Valve

The E.C.U. actuates the A.A.C. valve by an ON/OFF pulse. The longer that ON pulse is received, the larger the amount of air that will flow through the A.A.C. valve.

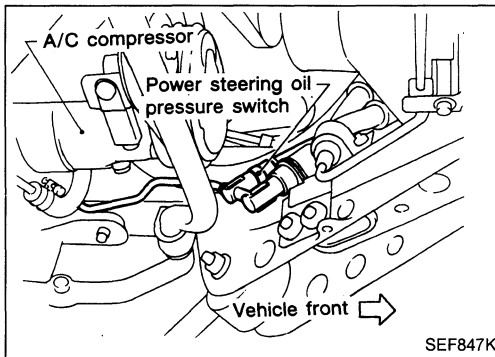

Power Steering Oil Pressure Switch

The power steering oil pressure switch is attached to the power steering high-pressure tube and detects the power steering load, sending the load signal to the E.C.U. The E.C.U. then sends the idle-up signal to the I.S.C. valve.

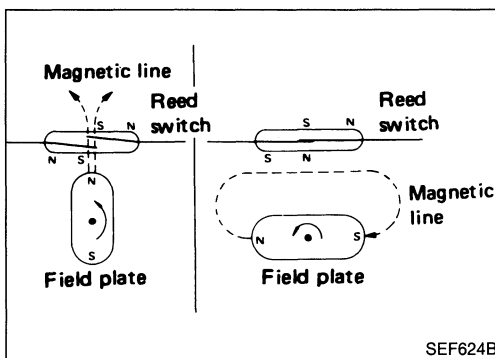

Vehicle Speed Sensor

The vehicle speed sensor provides a vehicle speed signal to the E.C.U.

The speed sensor consists of a reed switch, which is installed on the transmission unit and transforms vehicle speed into a pulse signal.

ENGINE AND EMISSION CONTROL PARTS DESCRIPTION

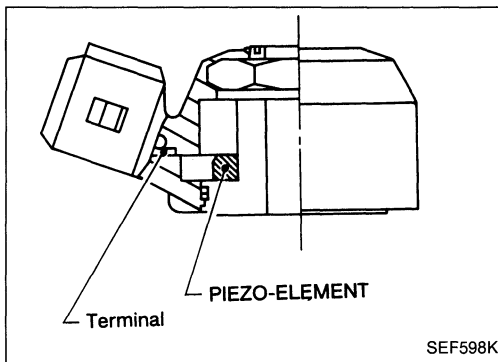

Detonation Sensor

The detonation sensor is attached to the cylinder block and senses engine knocking conditions. A knocking vibration from the cylinder block is applied as pressure to the piezoelectric element. This vibrational pressure is then converted into a voltage signal which is sent to the E.C.U.

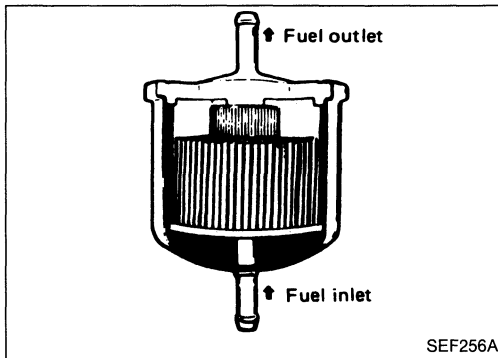

Fuel Filter

The specially designed fuel filter has a metal case in order to withstand high fuel pressure.

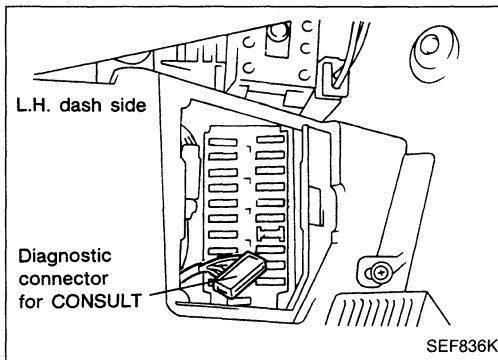

Diagnostic Connector for CONSULT

The diagnostic connector for CONSULT is located beside the fuse lid.

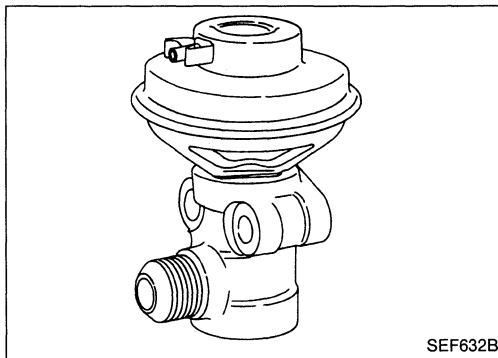

E.G.R. Control Valve

The E.G.R. control valve controls the quantity of exhaust gas to be led to the intake manifold through vertical movement of the taper valve connected to the diaphragm, to which vacuum is applied in response to the opening of the throttle valve.

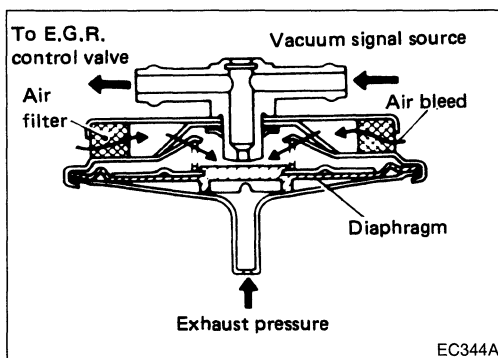

B.P.T. Valve

The B.P.T. valve monitors exhaust pressure to activate the diaphragm, controlling throttle chamber vacuum applied to the E.G.R. control valve. In other words, recirculated exhaust gas is controlled in response to positioning of the E.G.R. control valve or to engine operation.

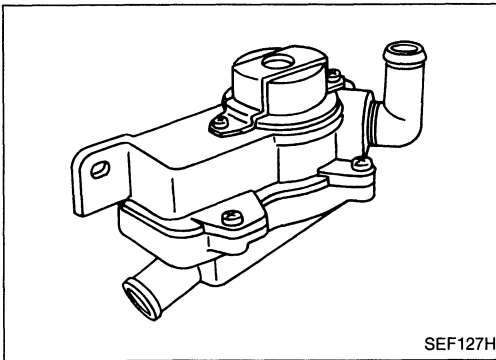

Air Induction Valve (A.I.V.)

The air induction valve sends secondary air to the exhaust manifold, using a vacuum created by exhaust pulsation in the exhaust manifold. When the exhaust pressure is below atmospheric pressure (negative pressure), secondary air is sent to the exhaust manifold. When the exhaust pressure is above atmospheric pressure, the reed valves prevent secondary air from being sent back to the air cleaner.

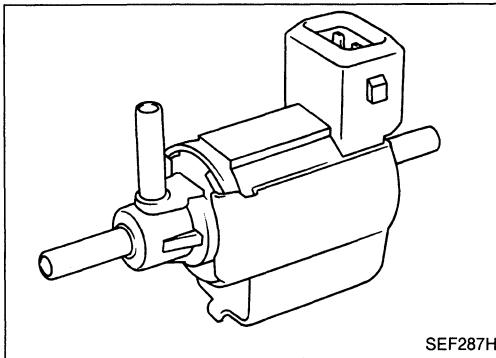

A.I.V. Control Solenoid Valve

The A.I.V. control solenoid valve cuts the intake manifold vacuum signal for A.I.V. control. It responds to the ON/OFF signal from the E.C.U. When the solenoid is off, the vacuum signal from the intake manifold is cut. When the control unit sends an ON signal, the coil pulls the plunger downward and feeds the vacuum signal to the A.I.V. control valve.

E.G.R. and Canister Control Solenoid Valve

The solenoid valve responds to the ON/OFF signal from the E.C.U. When it is off, a vacuum signal from the throttle chamber is fed into the E.G.R. control valve. When the control unit sends an ON signal, the coil pulls the plunger downward and cuts the vacuum signal.

S.C.V. Control Solenoid Valve

The S.C.V. control solenoid valve cuts the intake manifold vacuum signal for swirl control valve. It responds to the ON/OFF signal from the E.C.U. When the solenoid is off, the vacuum signal from the intake manifold is cut. When the control unit sends an ON signal the coil pulls the plunger and feeds the vacuum signal to the swirl control valve actuator.

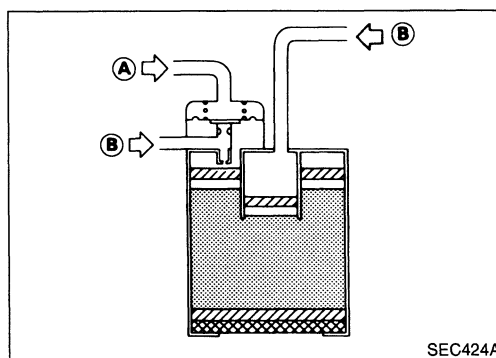

Carbon Canister

The carbon canister is filled with active charcoal to absorb evaporative gases produced in the fuel tank. These absorbed gases are then delivered to the intake manifold by manifold vacuum for combustion purposes.

The vacuum in the intake passage upstream of the throttle valve increases in response to the amount of the intake air.

When the vacuum of the intake passage is higher than a preset value, the 2nd purge control valve opens and the absorbed gases are sucked into the intake passage for combustion purposes.

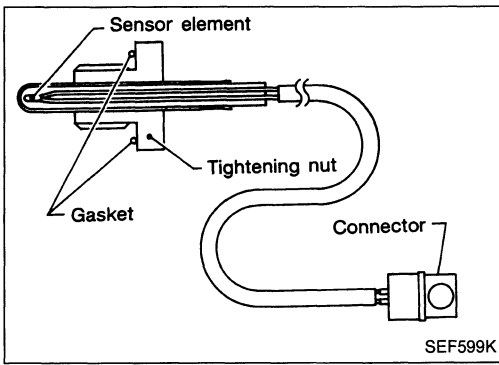

Exhaust Gas Temperature Sensor (For California models)

The exhaust gas temperature sensor monitors in exhaust gas temperature and transmits a signal to the E.C.U. The temperature sensing unit employs a thermistor which is sensitive to the change in temperature. Electric resistance of the thermistor decreases in response to the temperature rise.

Fuel Injection Control

INPUT/OUTPUT SIGNAL LINE

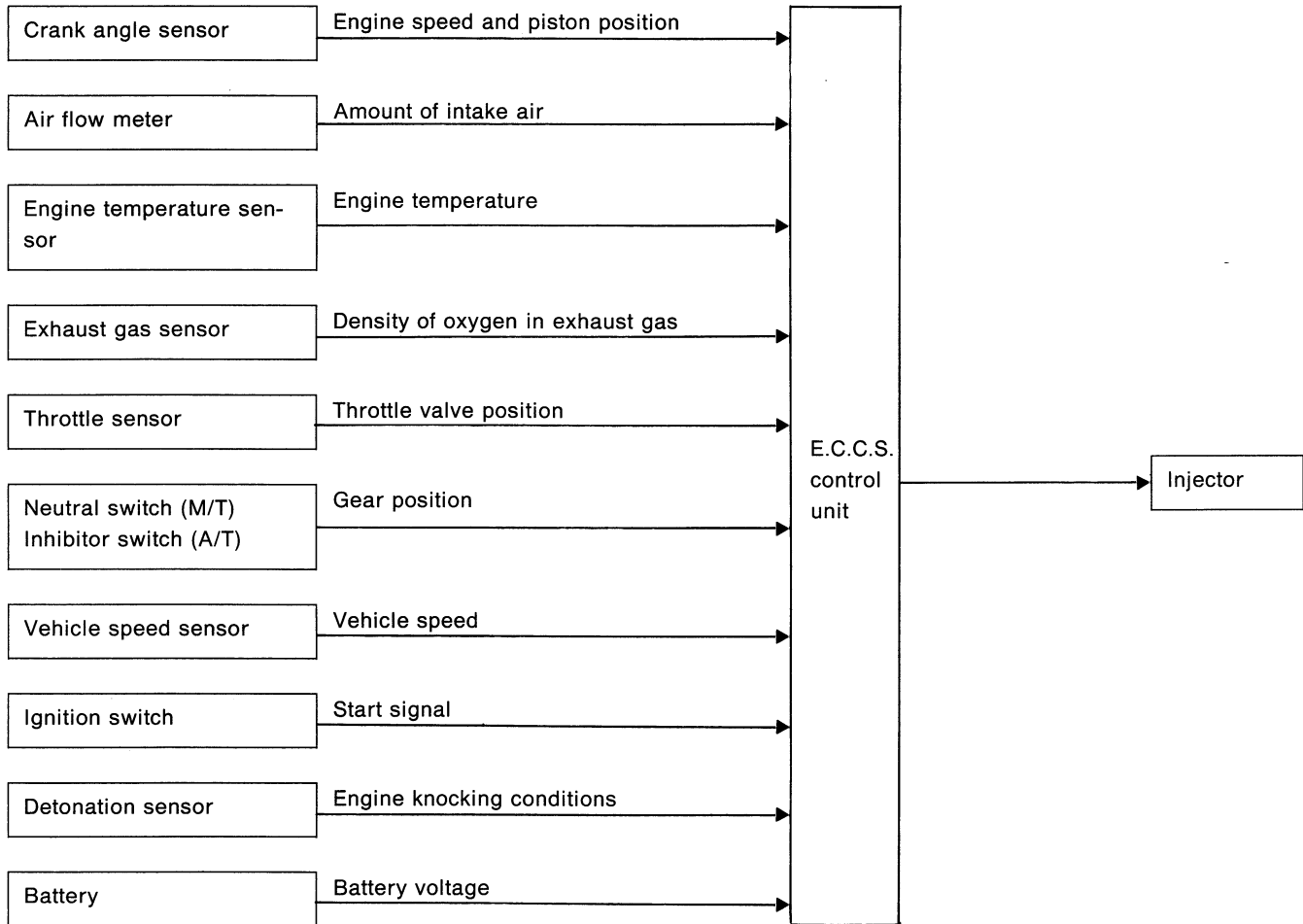

BASIC FUEL INJECTION CONTROL

The amount of fuel injected from the fuel injector, or the length of time the valve remains open, is determined by the E.C.U. The amount of fuel injected is a program value mapped in the E.C.U. ROM memory. In other words, the program value is preset by engine operating conditions determined by input signals (for engine speed and air intake) from both the crank angle sensor and the air flow meter.

VARIOUS FUEL INJECTION INCREASE/DECREASE COMPENSATION

In addition, the amount of fuel injection is compensated for to improve engine performance under various operating conditions as listed below.

< Fuel increase >

- 1) During warm-up
- 2) When starting the engine
- 3) During acceleration
- 4) Hot-engine operation

< Fuel decrease >

- 1) During deceleration

ENGINE AND EMISSION CONTROL SYSTEM DESCRIPTION

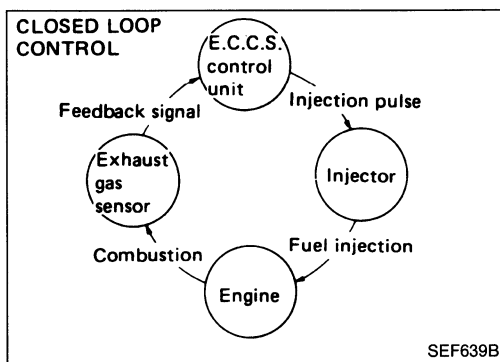

Fuel Injection Control (Cont'd)

MIXTURE RATIO FEEDBACK CONTROL

The mixture ratio feedback system is used for precise control of the mixture ratio to the stoichiometric point, so that the three-way catalyst can reduce CO, HC and NO_x emissions. This system uses an exhaust gas sensor in the exhaust manifold to check the air-fuel ratio. The control unit adjusts the injection pulse width according to the sensor voltage so the mixture ratio will be within the range of the stoichiometric air-fuel ratio.

This stage refers to the closed-loop control condition. The open-loop control condition refers to that under which the E.C.U. detects any of the following conditions and feedback control stops in order to maintain stabilized fuel combustion.

- 1) Deceleration and acceleration
- 2) High-load, high-speed operation
- 3) Engine idling
- 4) Malfunction of exhaust gas sensor or its circuit
- 5) Insufficient activation of exhaust gas sensor at low engine temperature
- 6) Engine starting
- 7) High-engine temperature
- 8) After shifting from "N" to "D"

MIXTURE RATIO SELF-LEARNING CONTROL

The mixture ratio feedback control system monitors the mixture ratio signal transmitted from the exhaust gas sensor. This feedback signal is then sent to the E.C.U. to control the amount of fuel injection to provide a basic mixture ratio as close to the theoretical mixture ratio as possible. However, the basic mixture ratio is not necessarily controlled as originally designed. This is due to manufacturing differences (e.g., air flow meter hot film) and changes to the E.C.C.S. parts during operation (injector clogging, etc.) which directly affect the mixture ratio.

Accordingly, the difference between the basic and theoretical mixture ratios is monitored in this system. This is then computed in terms of "fuel injection duration" to automatically compensate for the difference between the two ratios.

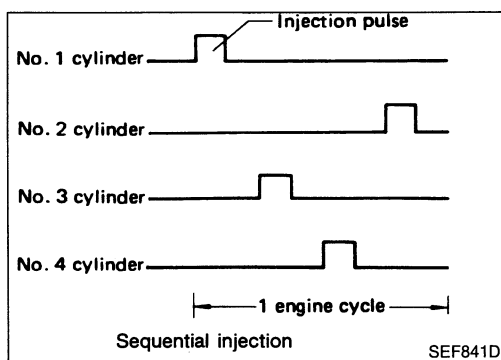

FUEL INJECTION TIMING

Two types of fuel injection systems are used — sequential injection and simultaneous injection. In the former, fuel is injected into each cylinder during each engine cycle according to the firing order.

ENGINE AND EMISSION CONTROL SYSTEM DESCRIPTION

Fuel Injection Control (Cont'd)

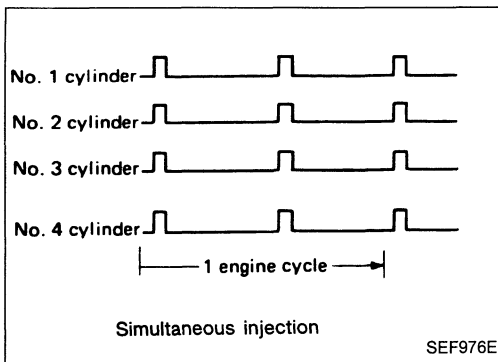

In the simultaneous injection system, fuel is injected into all four cylinders simultaneously twice each engine cycle. In other words, pulse signals of the same width are simultaneously transmitted from the E.C.U. to the four injectors two times for each engine cycle.

When the engine is being started and/or if the fail-safe system (C.P.U., crank angle sensor) is operating, simultaneous fuel injection is used. When the engine is running sequential fuel injection is used.

FUEL SHUT-OFF

Fuel to each cylinder is cut off during deceleration, operation of the engine at excessively high speeds or at high exhaust temperatures.

ENGINE AND EMISSION CONTROL SYSTEM DESCRIPTION

Ignition Timing Control

INPUT/OUTPUT SIGNAL LINE

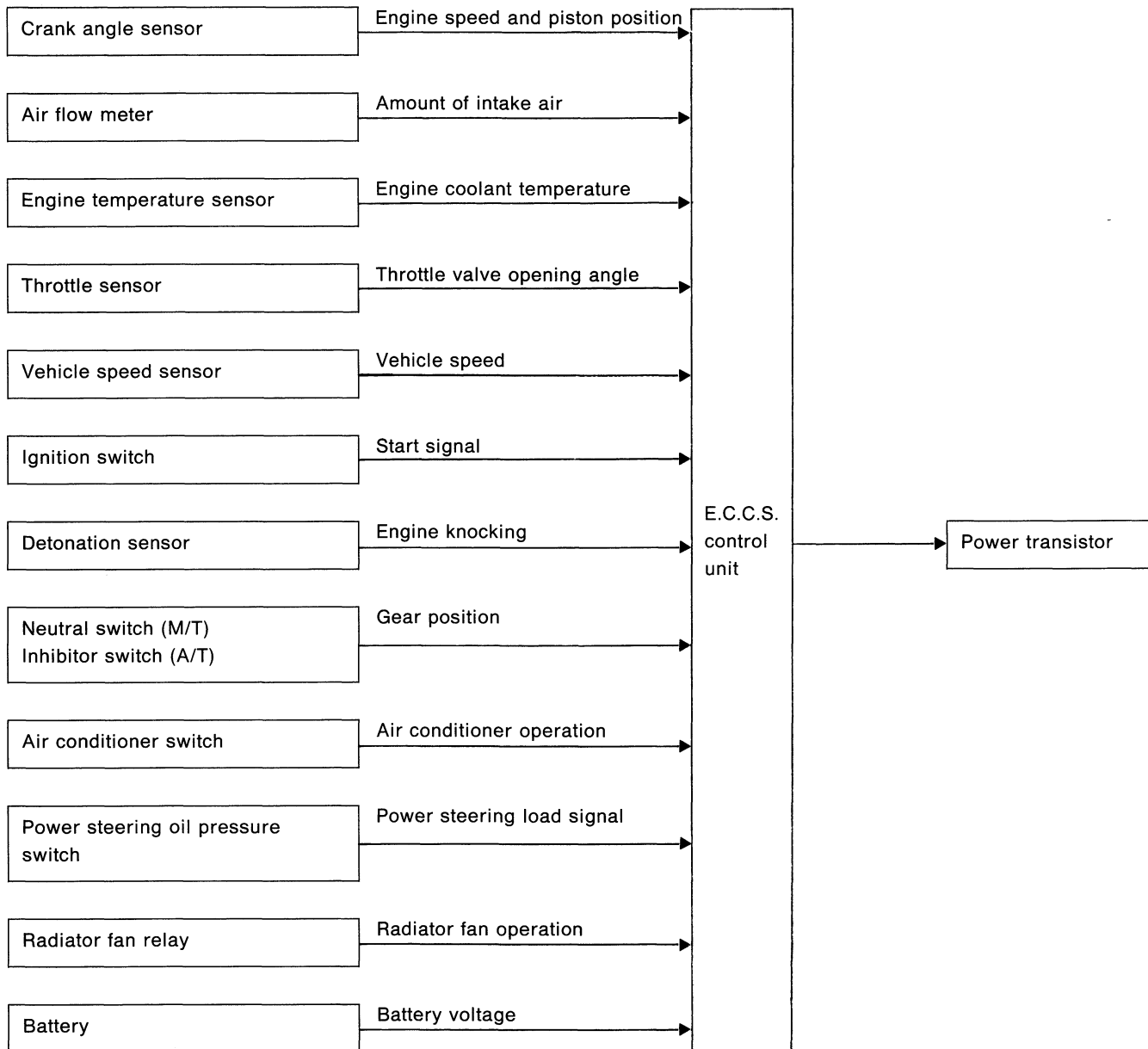

ENGINE AND EMISSION CONTROL SYSTEM DESCRIPTION

Ignition Timing Control (Cont'd)

SYSTEM DESCRIPTION

The ignition timing is controlled by the E.C.U. in order to maintain the best air-fuel ratio for every running condition of the engine.

The ignition timing data is stored in the ROM located in the E.C.U. This data forms the map shown below.

The E.C.U. detects information such as the injection pulse width and crank angle sensor signal which varies every moment. Then responding to this information, ignition signals are transmitted to the power transistor.

e.g. N: 1,800 rpm, Tp: 1.50 msec
A °B.T.D.C.

In addition to this,

- 1 At starting
- 2 During warm-up
- 3 At idle
- 4 During swirl control valve operates
- 5 Hot engine operation
- 6 At acceleration

the ignition timing is revised by the E.C.U. according to the other data stored in the ROM.

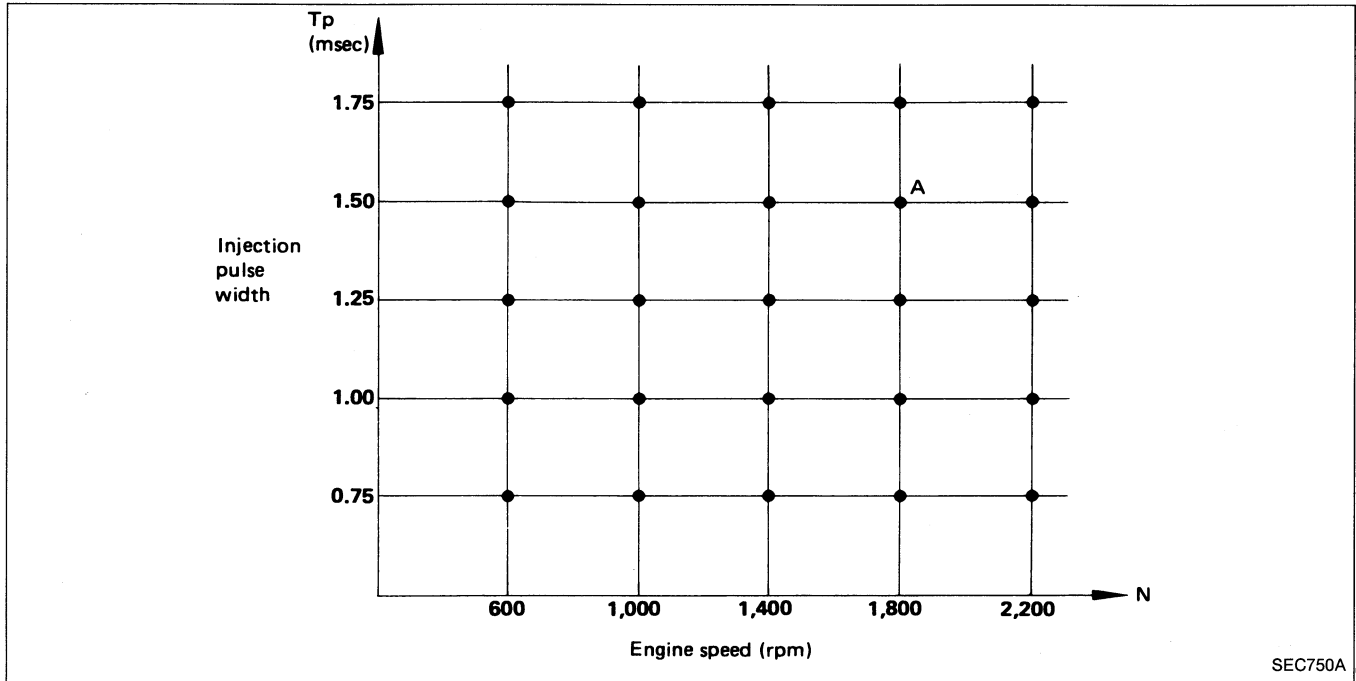

The retard system, actuated by the detonation sensor, is designed only for emergencies. The basic ignition timing is pre-programmed within the anti-knocking zone, if recommended fuel is used under dry conditions. Consequently, the retard system does not operate under normal driving conditions.

However, if engine knocking occurs, the detonation sensor monitors the condition and the signal is transmitted to the E.C.C.S. control unit. After receiving it, the control unit retards the ignition timing to eliminate the knocking condition.

Idle Speed Control

INPUT/OUTPUT SIGNAL LINE

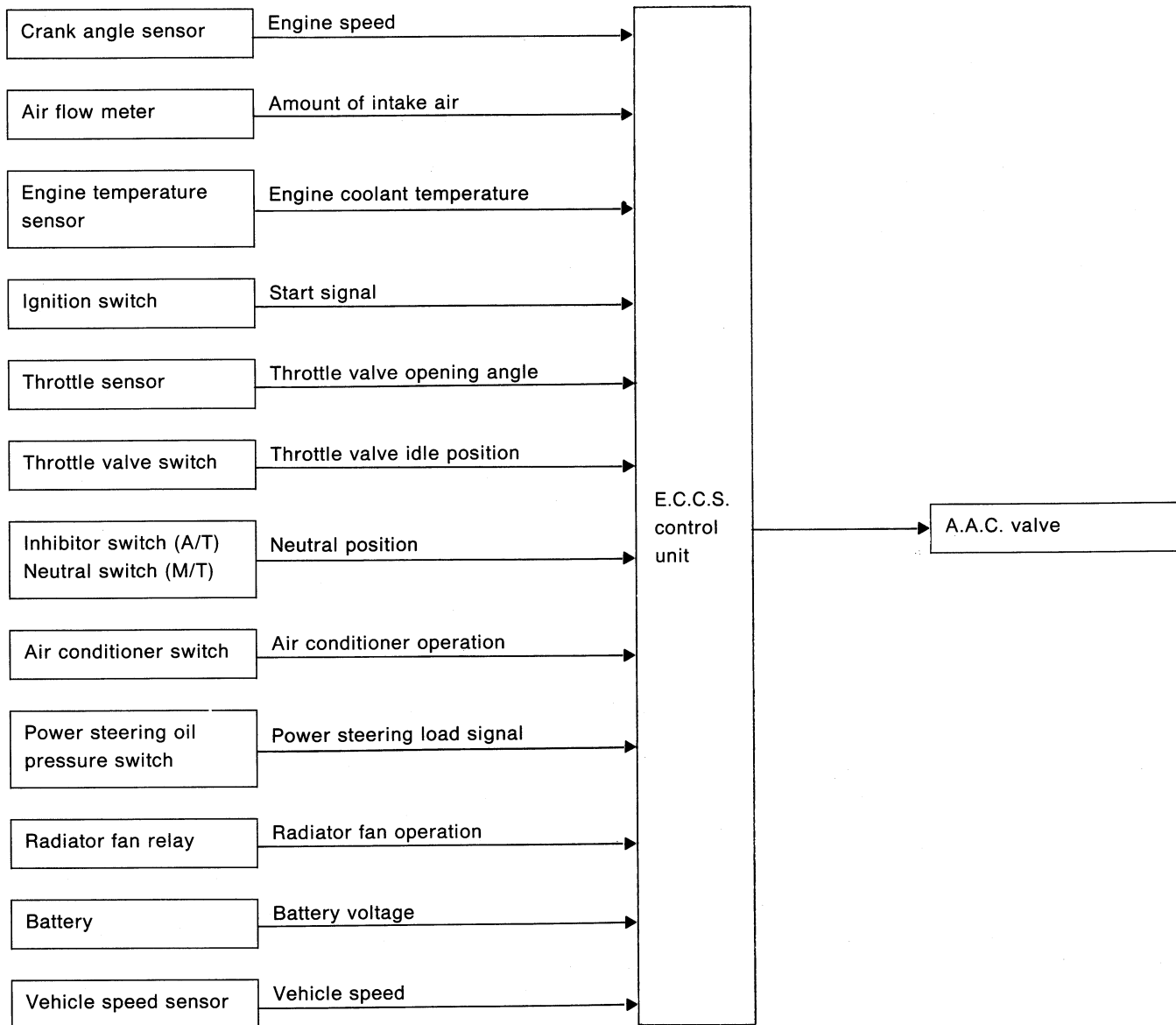

SYSTEM DESCRIPTION

This system automatically controls engine idle speed to a specified level. Idle speed is controlled through fine adjustment of the amount of air which by-passes the throttle valve via the A.A.C. valve. The A.A.C. valve repeats ON/OFF operation according to the signal sent from the E.C.U. The crank angle sensor detects the actual engine speed and sends a signal to the E.C.U.

The E.C.U. then controls the ON/OFF time of the A.A.C. valve so that engine speed coincides with the target value memorized in the ROM. The target engine speed is the lowest speed at which the engine can operate steadily. The optimum value stored in the ROM is determined by taking into consideration various engine conditions, such as noise and vibration transmitted to the vehicle interior, fuel consumption, and engine load.

Air Induction Valve (A.I.V.) Control

INPUT/OUTPUT SIGNAL LINE

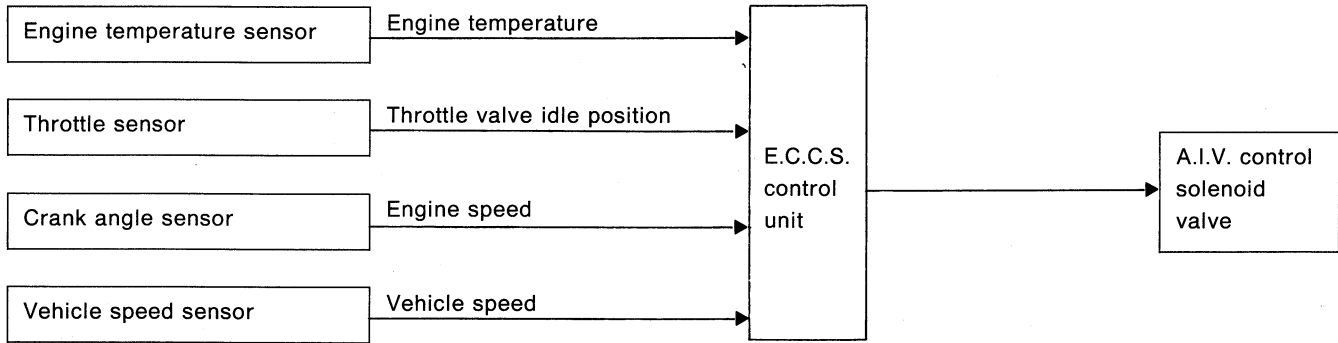

SYSTEM DESCRIPTION

The air induction system is designed to send secondary air to the exhaust manifold, utilizing the vacuum caused by exhaust pulsation in the exhaust manifold.

The exhaust pressure in the exhaust manifold usually pulsates in response to the opening and closing of the exhaust valve and decreases below atmospheric pressure periodically.

If a secondary air intake pipe is opened to the atmosphere under vacuum conditions, secondary

air can be drawn into the exhaust manifold in proportion to the vacuum.

The air induction valve is controlled by the E.C.C.s. control unit, corresponding to the engine temperature. When the engine is cold, the A.I.V. control system operates to reduce HC and CO.

In extremely cold conditions, A.I.V. control system does not operate to reduce after-burning.

This system also operates during deceleration for the purpose of blowing off water around the air induction valve.

E.G.R. (Exhaust Gas Recirculation) Control

INPUT/OUTPUT SIGNAL LINE

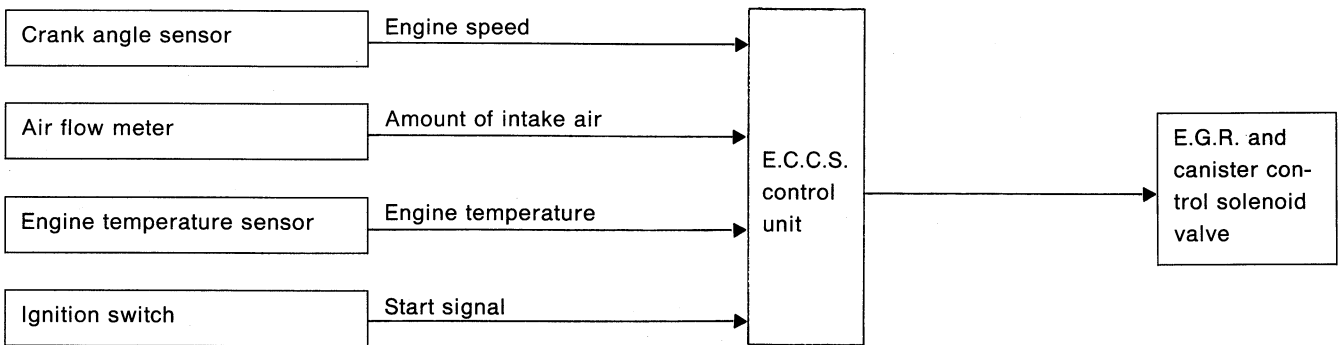

SYSTEM DESCRIPTION

In addition, a system is provided which precisely cuts and controls port vacuum applied to the E.G.R. valve to suit engine operating conditions. This cut-and-control operation is accomplished through the E.C.U. When the E.C.U. detects any of the following conditions, current flows through the solenoid valve in the E.G.R. control vacuum line. This causes the port vacuum to be discharged into the atmosphere so that the E.G.R. control valve remains closed.

- 1) Low engine temperature
- 2) Engine starting
- 3) High-speed engine operation
- 4) Engine idling
- 5) Excessively high engine temperature

ENGINE AND EMISSION CONTROL SYSTEM DESCRIPTION

Fuel Pump Control

INPUT/OUTPUT SIGNAL LINE

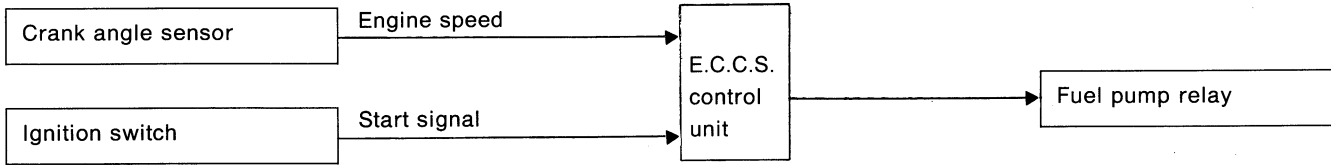

SYSTEM DESCRIPTION

The E.C.U. activates the fuel pump for several seconds after the ignition switch is turned on to improve engine start-up. If the E.C.U. receives a 1° signal from the crank angle sensor, it knows that the engine is rotating, and causes the pump to activate. If the 1° signal is not received when the ignition switch is on, the engine stalls. The E.C.U. stops pump operation and prevents the battery from discharging, thereby improving safety. The E.C.U. does not directly drive the fuel pump. It controls the ON/OFF fuel pump relay, which in turn controls the fuel pump.

Condition	Fuel pump operation
Ignition switch is turned to ON.	Operates for 5 seconds
Engine running and cranking	Operates
When engine is stopped	Stops in 1 second
Except as shown above	Stops

Air Regulator Control

INPUT/OUTPUT SIGNAL LINE

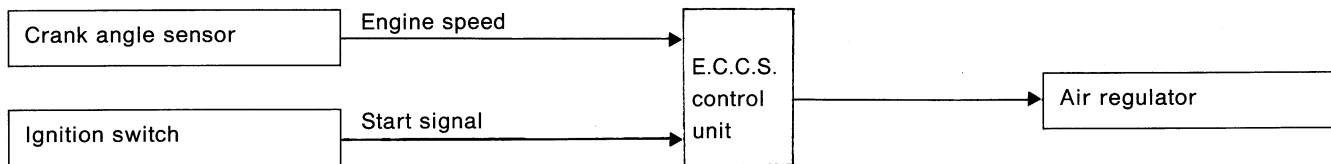

SYSTEM DESCRIPTION

The air regulator is controlled by the E.C.U. at the same time as fuel pump ON-OFF control.

Condition	Air regulator operation
Ignition switch is turned to ON	Operates for 5 seconds
While engine is running and cranking	Operates
When engine is stopped	OFF in 1 second
Except as shown above	OFF

ENGINE AND EMISSION CONTROL SYSTEM DESCRIPTION

Acceleration Cut Control

INPUT/OUTPUT SIGNAL LINE

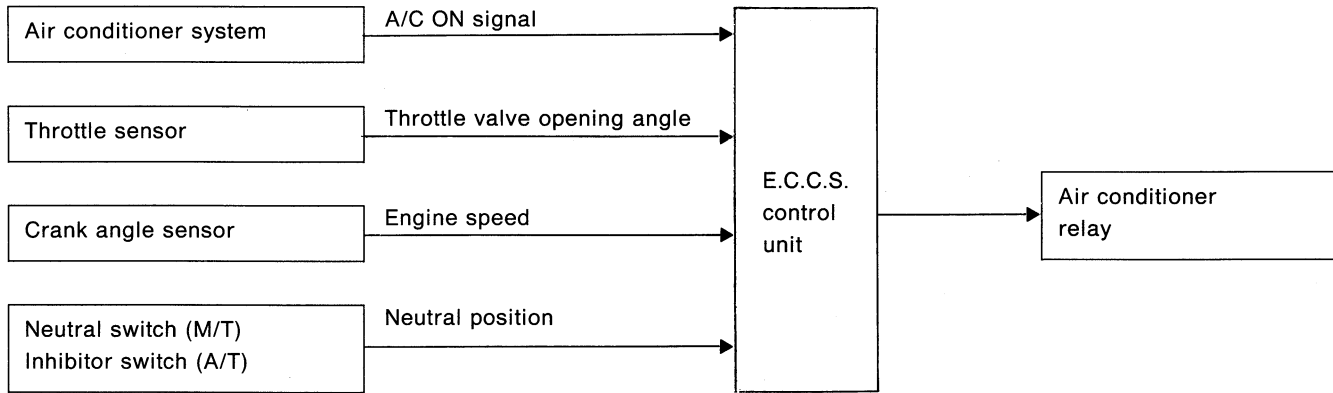

SYSTEM DESCRIPTION

When the accelerator pedal is fully depressed or the engine is running at high speed, the air conditioner is turned off for a few seconds.

This system improves acceleration when the air conditioner is used.

Swirl Control Valve (S.C.V.) Control

INPUT/OUTPUT SIGNAL LINE

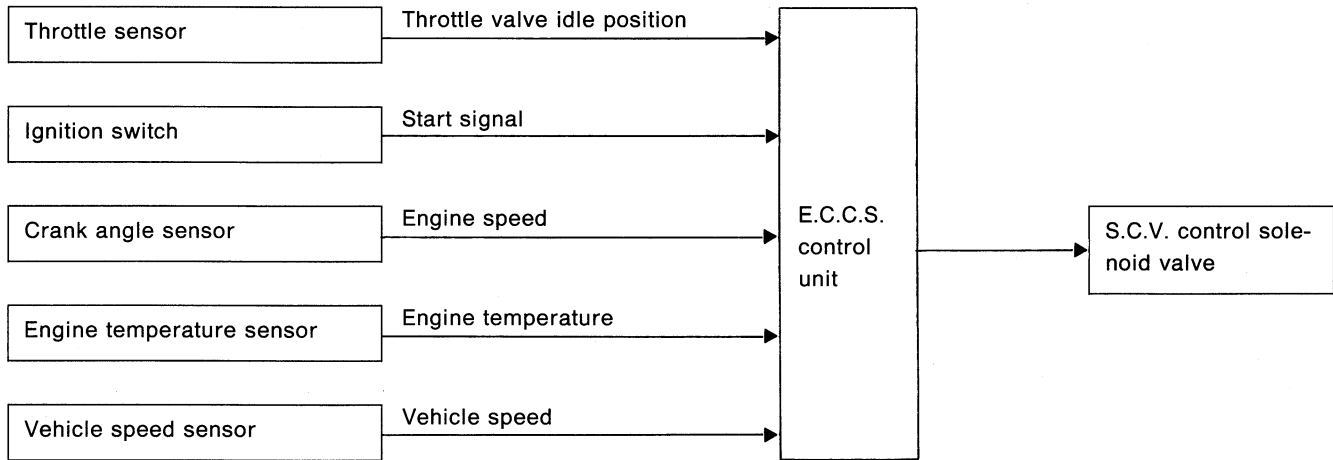

SYSTEM DESCRIPTION

This system has a swirl control valve (S.C.V.) in the intake passage of each cylinder. While idling the S.C.V. closes. Thus the velocity of the air in the intake passage increases, promoting the vaporization of the fuel and producing a swirl in the combustion chamber. Because of this operation, this system tends to increase the burning speed of the gas mixture,

improve fuel consumption, and increase the stability in running conditions. Also, except when idling, this system opens the S.C.V. In this condition, this system tends to increase power by improving intake efficiency via reduction of intake flow resistance, intake flow. The solenoid valve controls S.C.V.'s shut/open condition. This solenoid valve is operated by the E.C.U.

ENGINE AND EMISSION CONTROL SYSTEM DESCRIPTION

Condenser Fan Control

INPUT/OUTPUT SIGNAL LINE

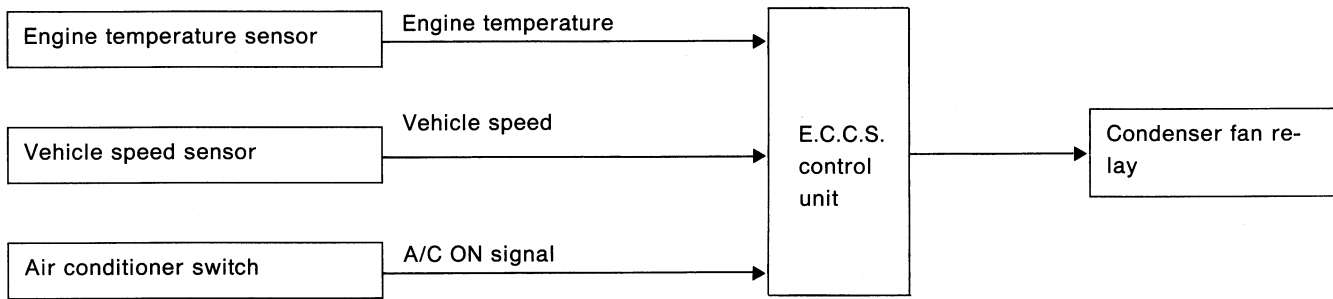

SYSTEM DESCRIPTION

The E.C.U. performs ON and OFF control of the radiator fan relay, corresponding to the engine temperature sensor, vehicle speed sensor and air conditioner switch operations.

Vehicle speed km/h (MPH)	Engine coolant temperature °C (°F)	A/C OFF	A/C ON
Below 20 (12)	Below 100 (212)	FAN OFF	FAN ON
	100 (212) or more	FAN ON	
Between 20 (12) and 79 (49)	Below 100 (212)	FAN OFF	
	100 (212) or more	FAN ON	
80 (50) or more	Below 100 (212)	FAN OFF	
	100 (212) or more	FAN ON	

Fail-safe System

C.P.U. MALFUNCTION

Input/output signal line

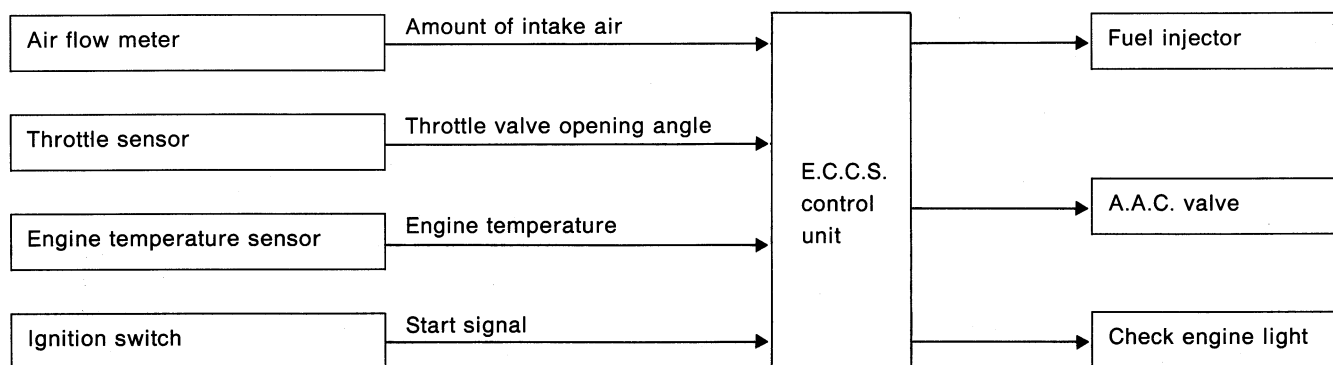

ENGINE AND EMISSION CONTROL SYSTEM DESCRIPTION

Fail-safe System (Cont'd)

Outline

The fail-safe system makes engine starting possible if there is something malfunctioning in the E.C.U.'s C.P.U. circuit.

In former models, engine starting was difficult under the previously mentioned conditions. But with the provisions in this fail-safe system, it is possible to start the engine.

Fail-safe system activating condition when E.C.U. is malfunctioning

The fail-safe mode operates when the computing function of the E.C.U. is judged to be malfunctioning.

When the fail-safe system activates, i.e. if a malfunction condition is detected in the C.P.U. of the E.C.U., the CHECK ENGINE LIGHT on the instrument panel lights to warn the driver.

Engine control with fail-safe system, operates when E.C.U. is malfunctioning

When the fail-safe system is operating, fuel injection, ignition timing, and so on are controlled under certain limitations.

Operation (Air flow meter malfunction)

Engine condition	Starter switch	Fail-safe system	Fail-safe functioning
Stopped	ANY	Does not operate	—
Cranking	ON		
Running	OFF	Operates	Engine speed will not rise above 2,400 rpm

ENGINE TEMPERATURE SENSOR MALFUNCTION

When the engine temperature sensor output voltage is below or above the specified value, engine coolant temperature is fixed at the preset value as follows:

Engine condition	Engine coolant temperature preset value °C (°F)
Start	40 (104)
Running	80 (176)

Cancellation of fail-safe system when E.C.U. is malfunctioning

Activation of the fail-safe system is canceled each time the ignition switch is turned OFF. The system is reactivated if all of the activating conditions are satisfied after turning the ignition switch from OFF to ON.

AIR FLOW METER MALFUNCTION

If the air flow meter output voltage is below the specified value when the starter switch is being turned OFF, the E.C.U. senses an air flow meter malfunction. In the case of a malfunction, the fuel injection operates without the air flow meter signal.

Although the air flow meter is malfunctioning, it is possible to start the engine and drive the vehicle. But engine speed will not rise more than 2,400 rpm in order to inform the driver of fail-safe system operation while driving.

THROTTLE SENSOR MALFUNCTION

When the throttle sensor output voltage is below or above the specified value, the throttle valve opening is fixed at a specified value. In this condition the E.C.U. does not use the throttle sensor output. The idle position is decided by the air flow meter, crank angle sensor output signals.

Operation	Driving condition
While idling	Low engine speed
While accelerating	Poor acceleration

START SIGNAL FOR MISOPERATION

Once the engine speed exceeds 1,000 rpm, no ill effect will be caused in the engine control during engine operation even if the ignition switch is set by mistake to the START position.

IDLE SPEED/IGNITION TIMING/IDLE MIXTURE RATIO INSPECTION

PREPARATION

1. Make sure that the following parts are in good order.

- Battery
- Ignition system
- Engine oil and coolant levels
- Fuses
- E.C.U. harness connector
- Vacuum hoses
- Air intake system
(Oil filler cap, oil level gauge, etc.)
- Fuel pressure
- Engine compression
- E.G.R. control valve operation
- Throttle valve

2. On air conditioner equipped models, checks should be carried out while the air conditioner is "OFF".
3. On automatic transmission equipped models, when checking idle rpm, ignition timing and mixture ratio, checks should be carried out while shift lever is in "N" position.
4. When measuring "CO" percentage, insert probe more than 40 cm (15.7 in) into tail pipe.
5. Turn off headlamps, heater blower, rear defogger.
6. Keep front wheels pointed straight ahead.
7. Make the check after the radiator fan has stopped.

Overall inspection sequence

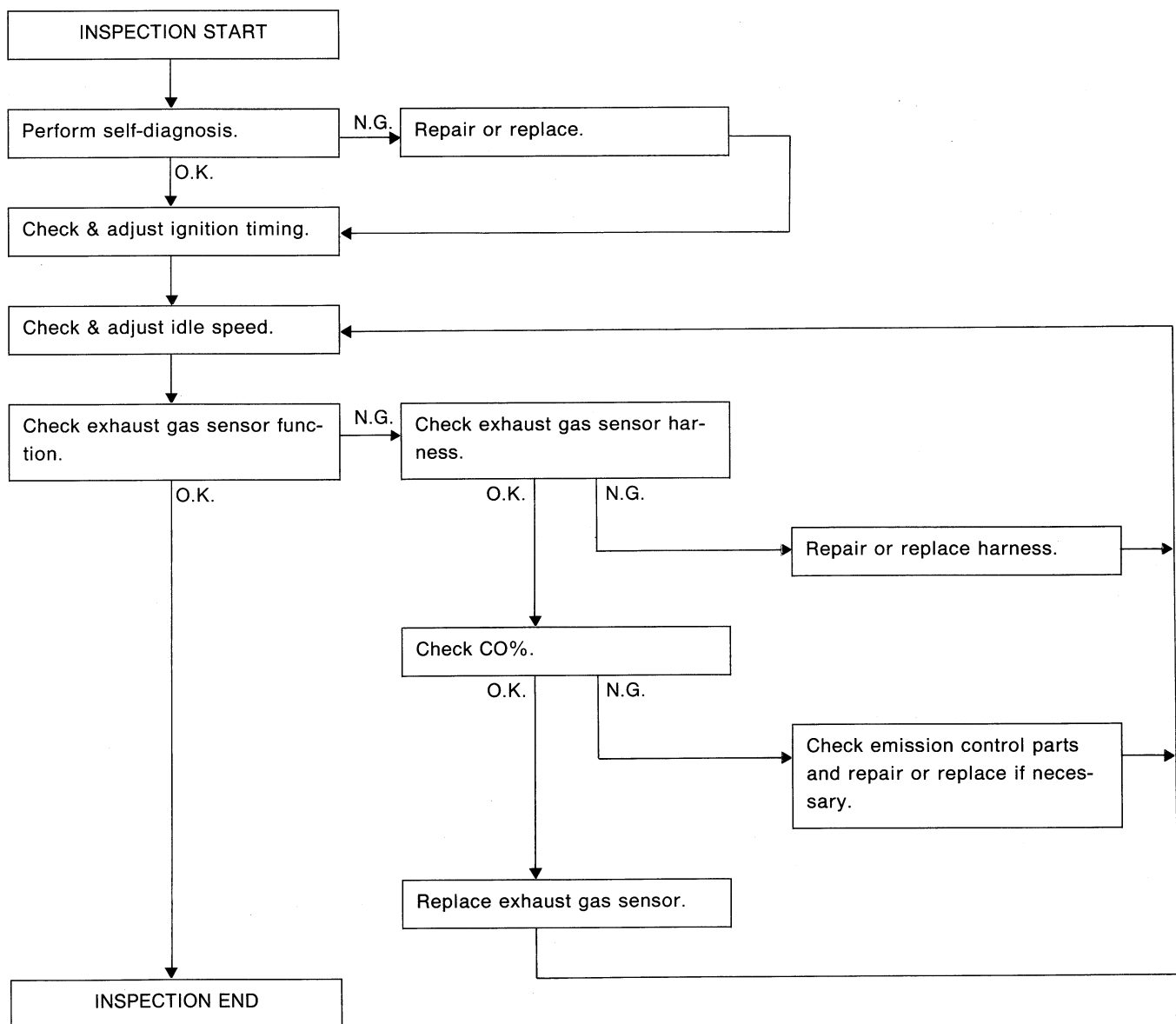

IDLE SPEED/IGNITION TIMING/IDLE MIXTURE RATIO INSPECTION

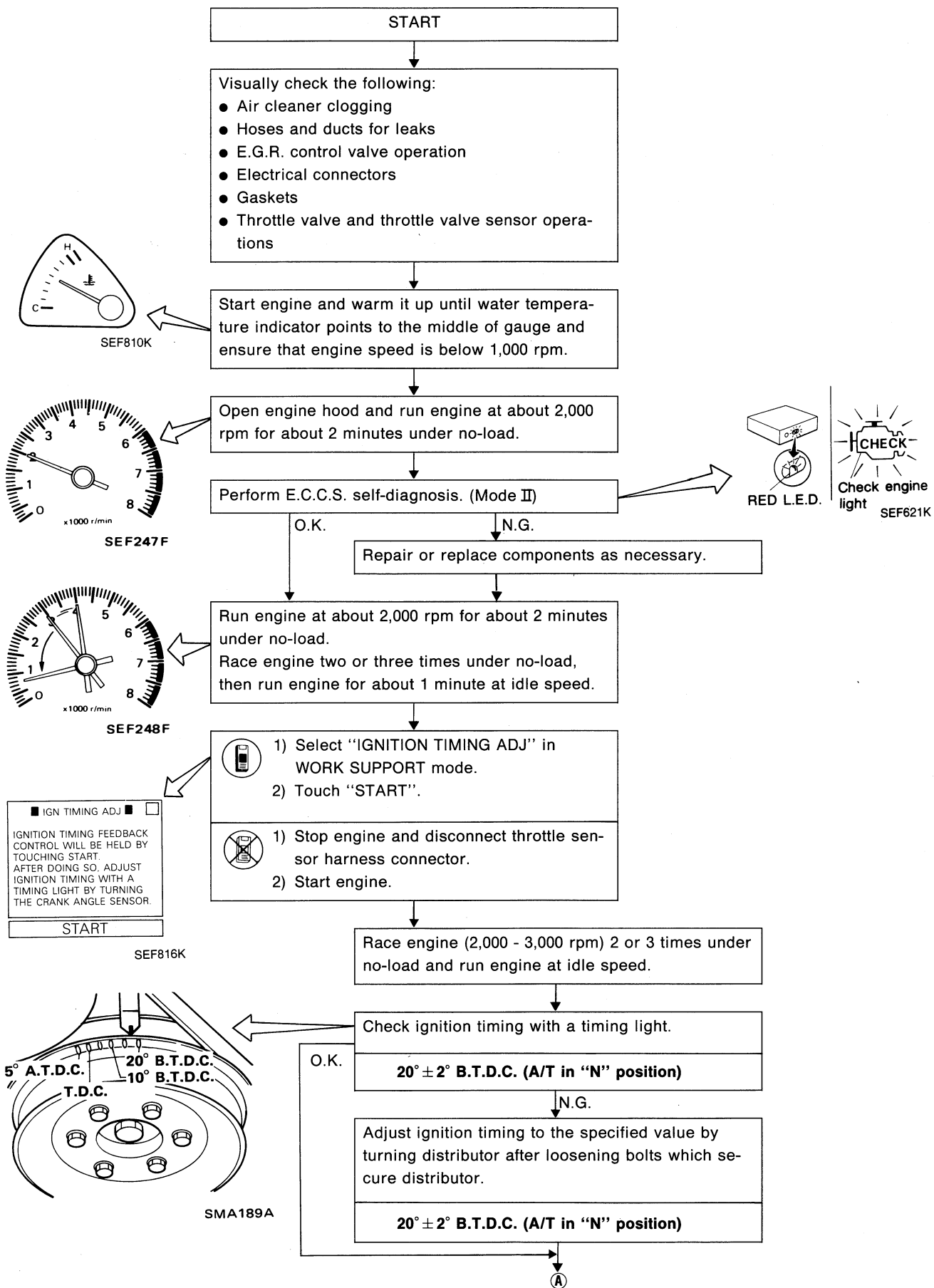

IDLE SPEED/IGNITION TIMING/IDLE MIXTURE RATIO INSPECTION

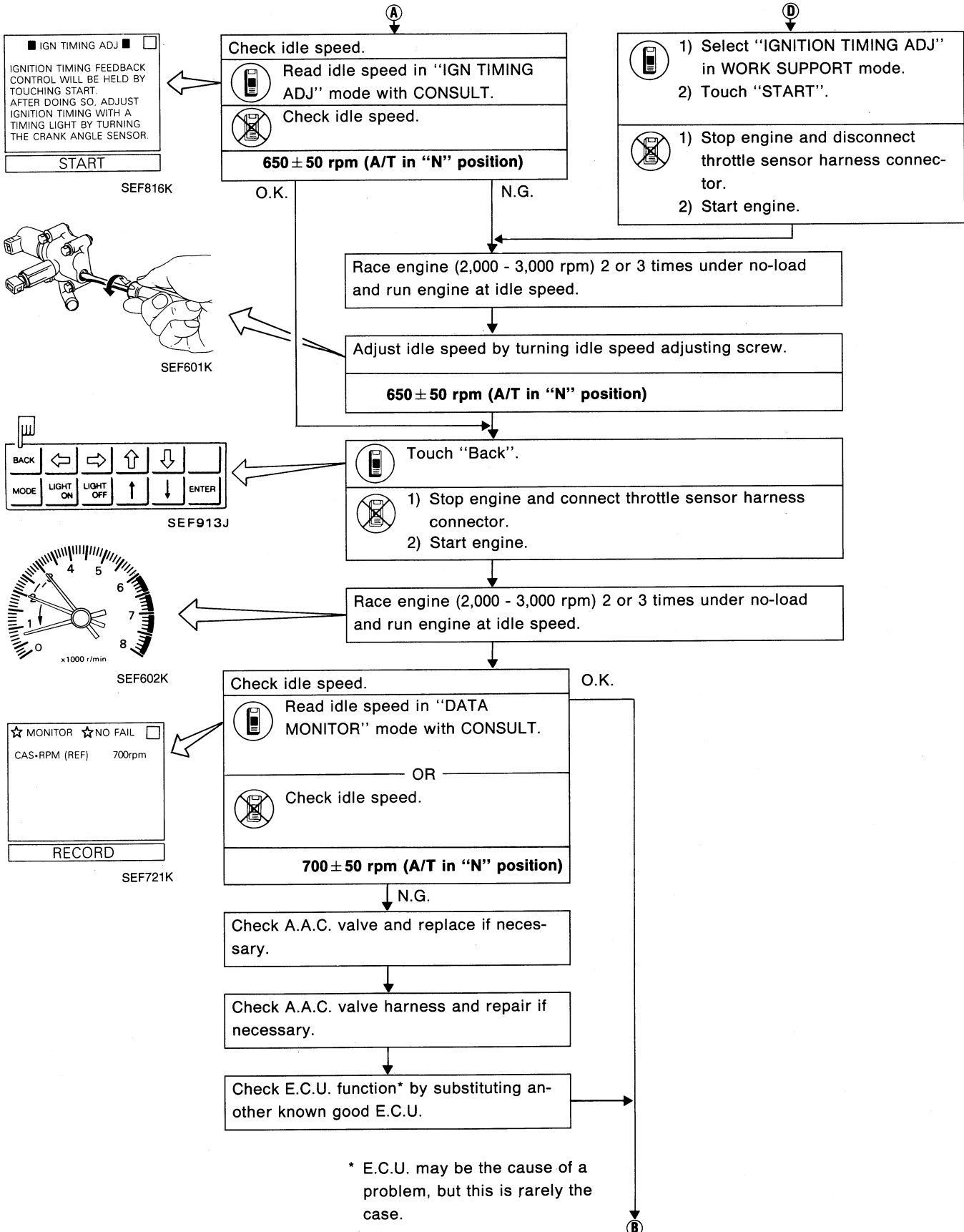

IDLE SPEED/IGNITION TIMING/IDLE MIXTURE RATIO INSPECTION

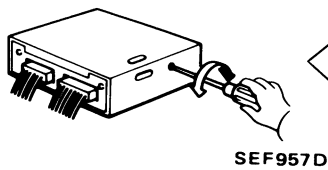

B

Set the diagnostic mode of E.C.U. to mode II.

Run engine at about 2,000 rpm for about 2 minutes under no-load.

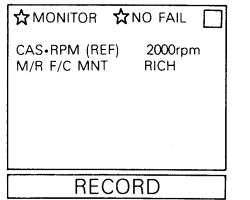

Check exhaust gas sensor signal.

1) See "M/R F/C MNT" in "DATA MONITOR" mode.
2) Maintaining engine at 2,000 rpm under no-load (engine is warmed up sufficiently), check that the monitor fluctuates between "LEAN" and "RICH" more than 5 times during 10 seconds.

RICH → LEAN → RICH →
1 time 2 times

LEAN → RICH OR

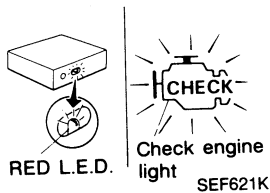

Make sure that inspection lamp goes on and off more than 5 times during 10 seconds at 2,000 rpm.

O.K. → INSPECTION END

N.G. →

Check exhaust gas sensor harness:

- 1) Turn off engine and disconnect battery ground cable.
- 2) Disconnect E.C.U. harness connector from E.C.U.
- 3) Disconnect exhaust gas sensor harness connector and connect terminal for exhaust gas sensor to ground with a jumper wire.
- 4) Check for continuity between terminal No. 19 of E.C.U. harness connector and ground metal on vehicle body.

Continuity exists ... O.K.
Continuity does not exist ... N.G.

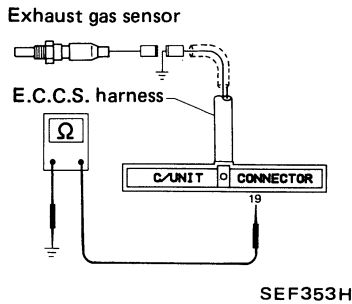

O.K. → Connect E.C.U. harness connector to E.C.U.

N.G. → Repair harness. → D

1) Select "ENGINE TEMP" in "ACTIVE TEST" mode.
2) Set "ENGINE TEMP" at 20°C (68°F).

● Disconnect engine temperature sensor harness connector.
● Connect a resistor (2.5 kΩ) between terminals of engine temperature sensor harness connector.

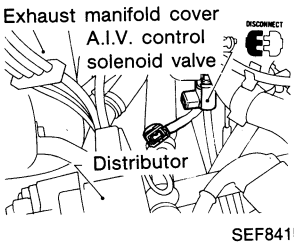

Disconnect A.I.V. control solenoid valve harness connector.

C

IDLE SPEED/IGNITION TIMING/IDLE MIXTURE RATIO INSPECTION

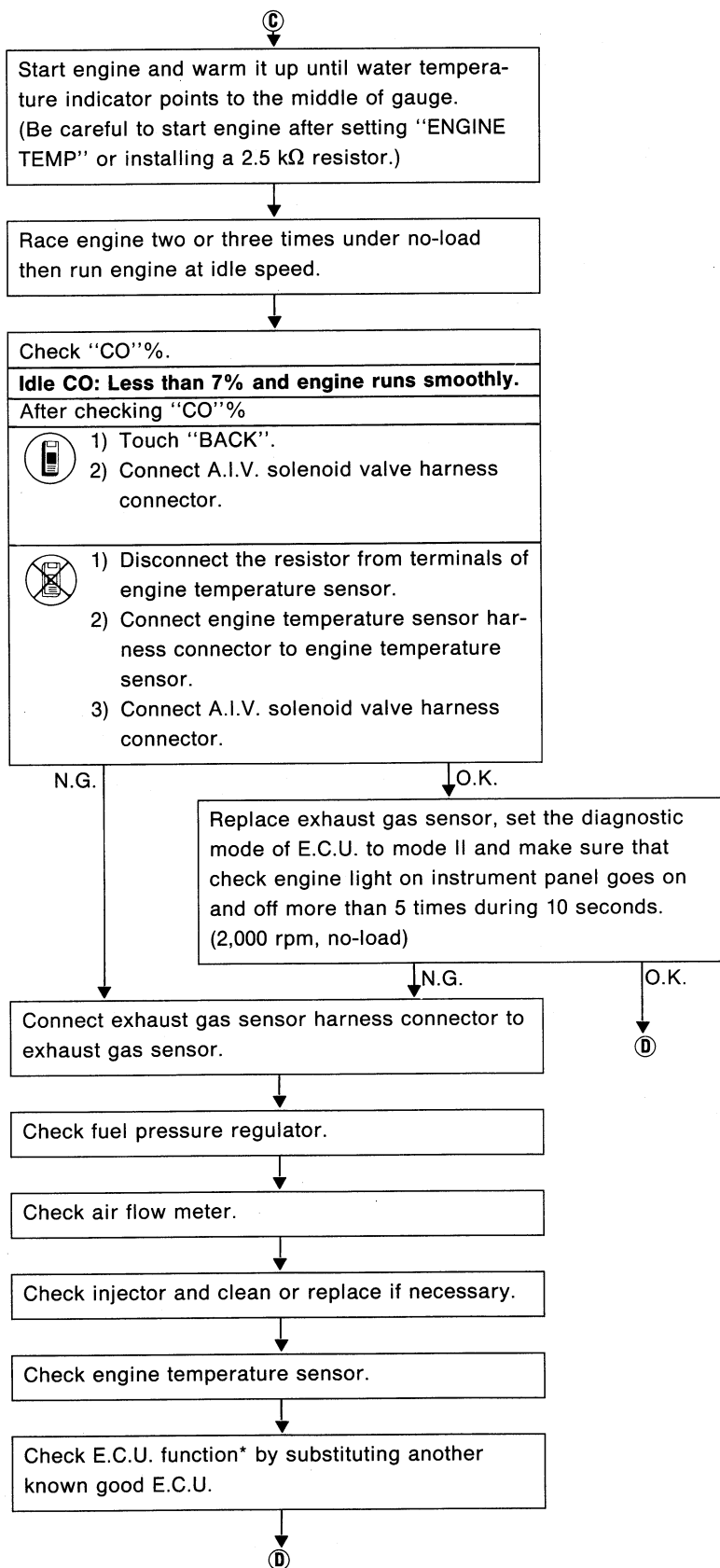

* E.C.U. may be the cause of a problem, but this is rarely the case.

TROUBLE DIAGNOSES

Contents

How to Perform Trouble Diagnoses for Quick and Accurate Repair	EF & EC- 35
Self-diagnosis	EF & EC- 39
Self-diagnosis — Mode I	EF & EC- 41
Self-diagnosis — Mode II (Self-diagnostic results)	EF & EC- 42
Self-diagnosis — Mode II (Exhaust gas sensor monitor)	EF & EC- 45
Consult	EF & EC- 46
Diagnostic Procedure	EF & EC- 53
Basic Inspection	EF & EC- 55
Diagnostic Procedure 1 — High Idling after Warm-up	EF & EC- 58
Diagnostic Procedure 2 — Hunting	EF & EC- 59
Diagnostic Procedure 3 — Unstable Idle	EF & EC- 61
Diagnostic Procedure 4 — Hard to Start or Impossible to Start when the Engine is Cold	EF & EC- 64
Diagnostic Procedure 5 — Hard to Start or Impossible to Start when the Engine is Hot	EF & EC- 66
Diagnostic Procedure 6 — Hard to Start or Impossible to Start under Normal Conditions	EF & EC- 68
Diagnostic Procedure 7 — Hesitation when the Engine is Hot	EF & EC- 70
Diagnostic Procedure 8 — Hesitation when the Engine is Cold	EF & EC- 71
Diagnostic Procedure 9 — Hesitation under Normal Conditions	EF & EC- 72
Diagnostic Procedure 10 — Engine Stalls when turning	EF & EC- 73
Diagnostic Procedure 11 — Engine Stalls when the Engine is Hot	EF & EC- 75
Diagnostic Procedure 12 — Engine Stalls when the Engine is Cold	EF & EC- 77
Diagnostic Procedure 13 — Engine Stalls when Stepping on the Accelerator Momentarily	EF & EC- 79
Diagnostic Procedure 14 — Engine Stalls after Decelerating	EF & EC- 81
Diagnostic Procedure 15 — Engine Stalls when Accelerating or when Driving at Constant Speed	EF & EC- 85
Diagnostic Procedure 16 — Engine Stalls when the Electrical Load is Heavy	EF & EC- 87
Diagnostic Procedure 17 — Lack of Power and Stumble	EF & EC- 89
Diagnostic Procedure 18 — Detonation	EF & EC- 90
Diagnostic Procedure 19 — Surge	EF & EC- 92
Diagnostic Procedure 20 — Backfire through the Intake	EF & EC- 93
Diagnostic Procedure 21 — Backfire through the Exhaust	EF & EC- 94
Diagnostic Procedure 22 MAIN POWER SUPPLY AND GROUND CIRCUIT	EF & EC- 96
Diagnostic Procedure 23 CRANK ANGLE SENSOR	EF & EC-100
Diagnostic Procedure 24 AIR FLOW METER	EF & EC-104
Diagnostic Procedure 25 ENGINE TEMPERATURE SENSOR	EF & EC-108
Diagnostic Procedure 26 VEHICLE SPEED SENSOR	EF & EC-112
Diagnostic Procedure 27 IGNITION SIGNAL	EF & EC-114
Diagnostic Procedure 28 E.C.C.S. CONTROL UNIT	EF & EC-118
Diagnostic Procedure 29 E.G.R. FUNCTION, E.G.R. CONTROL	EF & EC-120
Diagnostic Procedure 30 EXHAUST GAS SENSOR	EF & EC-126
Diagnostic Procedure 31 DETONATION SENSOR	EF & EC-130

TROUBLE DIAGNOSES

Contents (Cont'd)

Diagnostic Procedure 32	
EXHAUST GAS TEMPERATURE SENSOR	EF & EC-132
Diagnostic Procedure 33	
THROTTLE SENSOR	EF & EC-136
Diagnostic Procedure 34	
INJECTOR LEAK	EF & EC-140
Diagnostic Procedure 35	
A/T CONTROL	EF & EC-142
Diagnostic Procedure 36	
START SIGNAL	EF & EC-144
Diagnostic Procedure 37	
A.I.V. CONTROL	EF & EC-146
Diagnostic Procedure 38	
INJECTOR	EF & EC-150
Diagnostic Procedure 39	
FUEL PUMP	EF & EC-152
Diagnostic Procedure 40	
S.C.V. CONTROL	EF & EC-156
Diagnostic Procedure 41	
AIR REGULATOR	EF & EC-160
Diagnostic Procedure 42	
A.A.C. VALVE	EF & EC-162
Diagnostic Procedure 43	
CONDENSER FAN CONTROL	EF & EC-166
Diagnostic Procedure 44	
POWER STEERING OIL PRESSURE SWITCH	EF & EC-170
Diagnostic Procedure 45	
NEUTRAL SWITCH/A/T CONTROL UNIT	EF & EC-174
Electrical Components Inspection	EF & EC-178

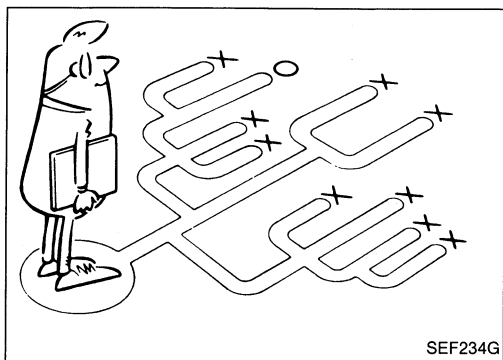
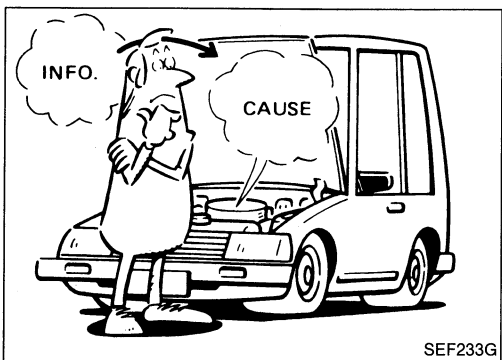
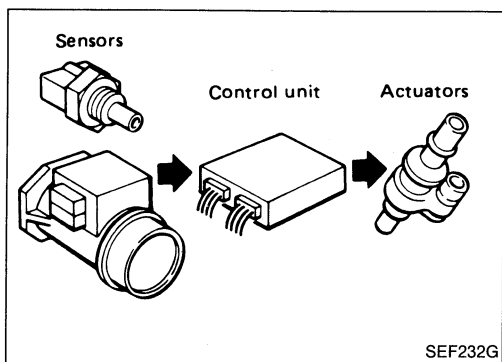

How to Perform Trouble Diagnoses for Quick and Accurate Repair

INTRODUCTION

The engine has an electronic control unit to control major systems such as fuel control, ignition control, idle speed control, etc. The control unit accepts input signals from sensors and instantly drives actuators. It is essential that both kinds of signals are proper and stable. At the same time, it is important that there are no conventional problems such as vacuum leaks, fouled spark plugs, or other problems with the engine.

It is much more difficult to diagnose a problem that occurs intermittently rather than continuously. Most intermittent problems are caused by poor electric connections or improper wiring. In this case, careful checking of suspected circuits may help prevent the replacement of good parts.

A visual check only may not find the cause of the problems, so a road test with a circuit tester connected to a suspected circuit should be performed.

Before undertaking actual checks, take just a few minutes to talk with a customer who approaches with a driveability complaint. The customer is a very good supplier of information on such problems, especially intermittent ones. Through interaction with the customer, find out what symptoms are present and under what conditions they occur.

Start your diagnosis by looking for "conventional" problems first. This is one of the best ways to troubleshoot driveability problems on an electronically controlled engine vehicle.

TROUBLE DIAGNOSES

How to Perform Trouble Diagnoses for Quick and Accurate Repair (Cont'd)

WORK FLOW

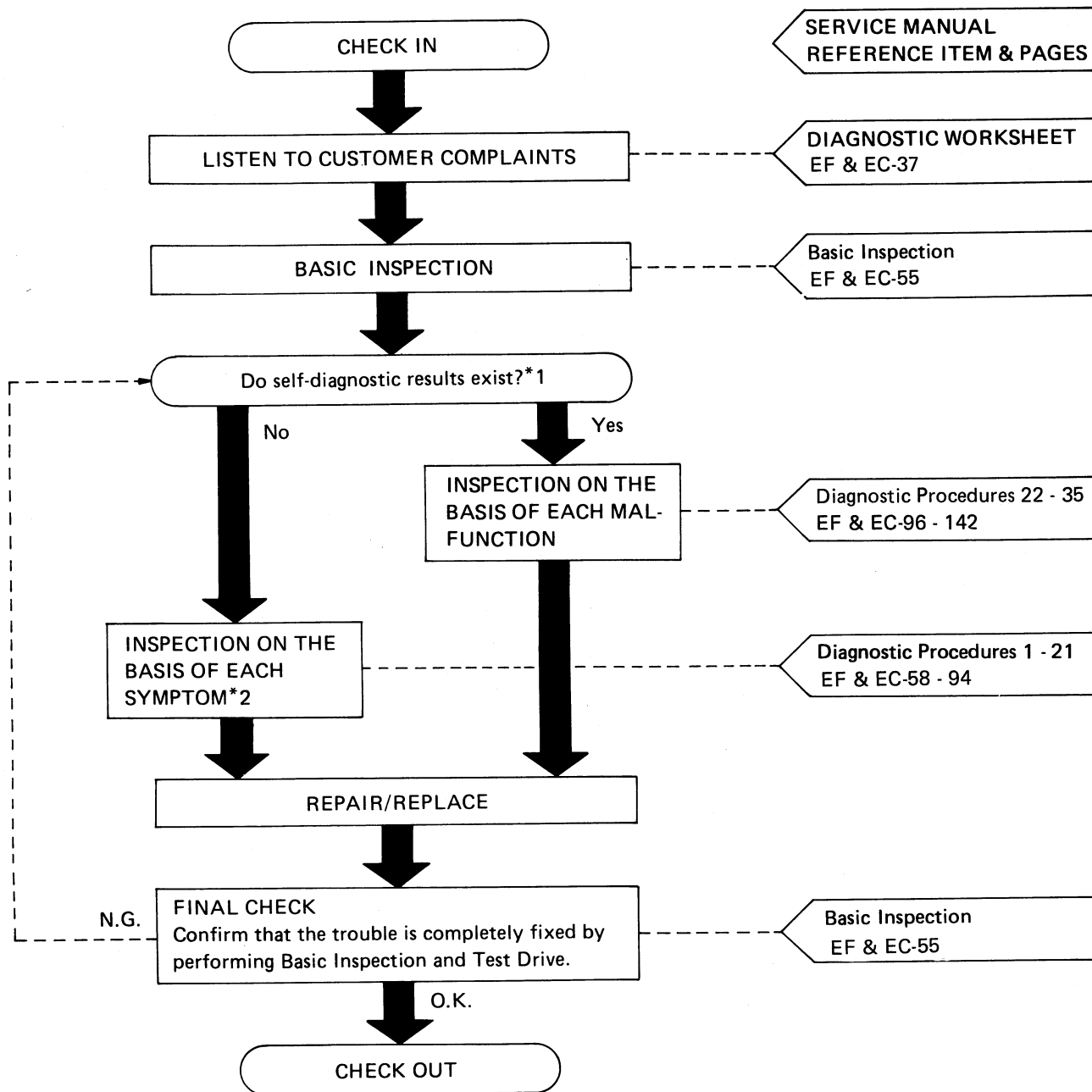

***1:** If the self-diagnosis cannot be performed, check main power supply and ground circuit. (See Diagnostic Procedure 22.)
***2:** If the trouble is not duplicated, see INTERMITTENT PROBLEM SIMULATION (EF & EC-38).

TROUBLE DIAGNOSES

How to Perform Trouble Diagnoses for Quick and Accurate Repair (Cont'd)

KEY POINTS

WHAT Vehicle & engine model
WHEN Date, Frequencies
WHERE Road conditions
HOW Operating conditions,
 Weather conditions,
 Symptoms

DIAGNOSTIC WORKSHEET

There are many kinds of operating conditions that lead to malfunctions on engine components.

A good grasp of such conditions can make trouble-shooting faster and more accurate.

In general, feelings for a problem depend on each customer. It is important to fully understand the symptoms or under what conditions a customer complains.

Make good use of a diagnostic worksheet such as the one shown below in order to utilize all the complaints for trouble-shooting.

Worksheet sample

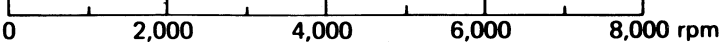
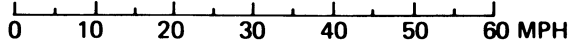
Customer name MR/MS		Model & Year	VIN
Engine #		Trans.	Mileage
Incident Date		Manuf. Date	In Service Date
Symptoms	<input type="checkbox"/> Startability	<input type="checkbox"/> Impossible to start <input type="checkbox"/> No combustion <input type="checkbox"/> Partial combustion <input type="checkbox"/> Partial combustion affected by throttle position <input type="checkbox"/> Partial combustion NOT affected by throttle position <input type="checkbox"/> Possible but hard to start <input type="checkbox"/> Others []	
	<input type="checkbox"/> Idling	<input type="checkbox"/> No fast idle <input type="checkbox"/> Unstable <input type="checkbox"/> High idle <input type="checkbox"/> Low idle <input type="checkbox"/> Others []	
	<input type="checkbox"/> Driveability	<input type="checkbox"/> Stumble <input type="checkbox"/> Surge <input type="checkbox"/> Detonation <input type="checkbox"/> Lack of power <input type="checkbox"/> Intake backfire <input type="checkbox"/> Exhaust backfire <input type="checkbox"/> Others []	
	<input type="checkbox"/> Engine stall	<input type="checkbox"/> At the time of start <input type="checkbox"/> While idling <input type="checkbox"/> While accelerating <input type="checkbox"/> While decelerating <input type="checkbox"/> Just after stopping <input type="checkbox"/> While loading	
Incident occurrence		<input type="checkbox"/> Just after delivery <input type="checkbox"/> Recently <input type="checkbox"/> In the morning <input type="checkbox"/> At night <input type="checkbox"/> In the daytime	
Frequency		<input type="checkbox"/> All the time <input type="checkbox"/> Under certain conditions <input type="checkbox"/> Sometimes	
Weather conditions		<input type="checkbox"/> Not affected	
Weather		<input type="checkbox"/> Fine <input type="checkbox"/> Raining <input type="checkbox"/> Snowing <input type="checkbox"/> Others []	
Temperature		<input type="checkbox"/> Hot <input type="checkbox"/> Warm <input type="checkbox"/> Cool <input type="checkbox"/> Cold <input type="checkbox"/> Humid °F	
Engine conditions		<input type="checkbox"/> Cold <input type="checkbox"/> During warm-up <input type="checkbox"/> After warm-up Engine speed 	
Road conditions		<input type="checkbox"/> In town <input type="checkbox"/> In suburbs <input type="checkbox"/> Highway <input type="checkbox"/> Off road (up/down)	
Driving conditions		<input type="checkbox"/> Not affected <input type="checkbox"/> At starting <input type="checkbox"/> While idling <input type="checkbox"/> At racing <input type="checkbox"/> While accelerating <input type="checkbox"/> While cruising <input type="checkbox"/> While decelerating <input type="checkbox"/> While turning (RH/LH) Vehicle speed 	
Check engine light		<input type="checkbox"/> Turned on <input type="checkbox"/> Not turned on	

TROUBLE DIAGNOSES

How to Perform Trouble Diagnoses for Quick and Accurate Repair (Cont'd)

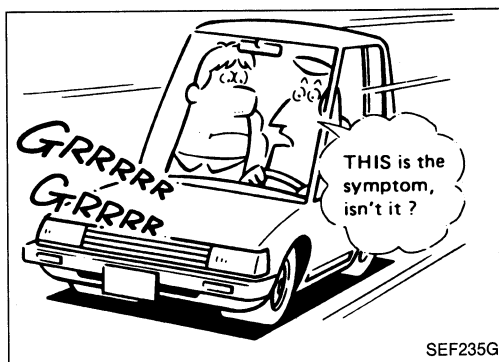

INTERMITTENT PROBLEM SIMULATION

In order to duplicate an intermittent problem, it is effective to create similar conditions for component parts, under which the problem might occur.

Perform the activity listed under

Service procedure and note the result.

	Variable factor	Influential part	Target condition	Service procedure
1	Mixture ratio	Pressure regulator	Made lean	Remove vacuum hose and apply vacuum.
			Made rich	Remove vacuum hose and apply pressure.
2	Ignition timing	Crank angle sensor	Advanced	Rotate distributor clockwise.
			Retarded	Rotate distributor counterclockwise.
3	Mixture ratio feedback control	Exhaust gas sensor	Suspended	Disconnect exhaust gas sensor harness connector.
		Control unit	Operation check	Perform self-diagnosis (Mode II) at 2,000 rpm.
4	Idle speed	A.A.C. valve	Raised	Turn idle adjusting screw counterclockwise.
			Lowered	Turn idle adjusting screw clockwise.
5	Electrical connection (Electric continuity)	Harness connectors and wires	Poor electrical connection or improper wiring	Tap or wiggle.
				Race engine rapidly. See if the torque reaction of the engine unit causes electric breaks.
6	Temperature	Control unit	Cooled	Cool with an icing spray or similar device.
			Warmed	Heat with a hair drier. [WARNING: Do not overheat the unit.]
7	Moisture	Electric parts	Damp	Wet. [WARNING: Do not directly pour water on components. Use a mist sprayer.]
8	Electric loads	Load switches	Loaded	Turn on headlamps, air conditioner, rear defogger, etc.
9	Idle switch condition	Control unit	ON-OFF switching	Rotate throttle sensor body.
10	Ignition spark	Timing light	Spark power check	Try to flash timing light for each cylinder using ignition coil adapter (S.S.T.).

TROUBLE DIAGNOSES

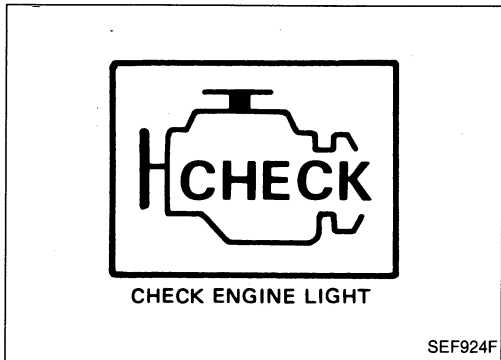

Self-diagnosis

CHECK ENGINE LIGHT

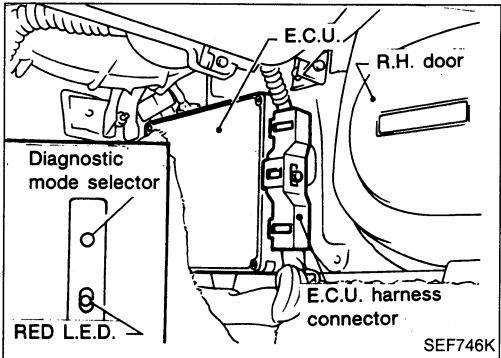

A check engine light has been adopted on all models. This light blinks simultaneously with the RED L.E.D. on the E.C.U.



E.C.U. L.E.D.

The E.C.U. has only one RED L.E.D.

SELF-DIAGNOSTIC FUNCTION

Condition		Mode	
		Mode I	Mode II
Ignition switch in "ON" position 	Engine stopped 	BULB CHECK	SELF-DIAGNOSTIC RESULTS
	Engine running 	MALFUNCTION WARNING	EXHAUST GAS SENSOR MONITOR

TROUBLE DIAGNOSES

Self-diagnosis (Cont'd) HOW TO SWITCH MODES

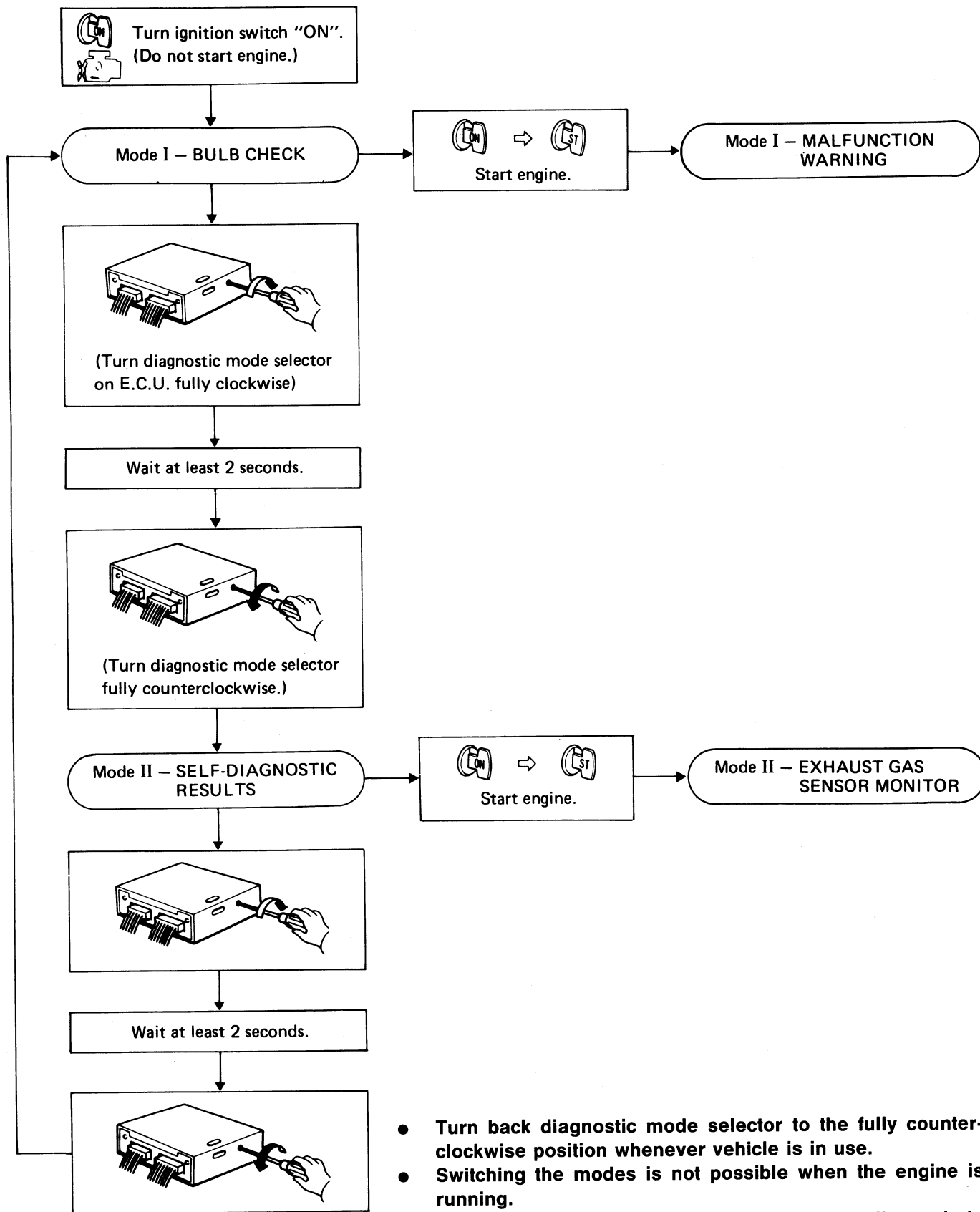

- Turn back diagnostic mode selector to the fully counterclockwise position whenever vehicle is in use.
- Switching the modes is not possible when the engine is running.
- When the ignition switch is turned off during diagnosis in each mode, and then turned back on again after power to the E.C.U. has dropped off completely, the diagnosis will automatically return to Mode I.

TROUBLE DIAGNOSES

Self-diagnosis — Mode I

MODE I — BULB CHECK

In this mode, the RED L.E.D. in the E.C.U. and the CHECK ENGINE LIGHT in the instrument panel stay "ON".

If either remain "OFF", check the bulb in the CHECK ENGINE LIGHT or the RED L.E.D.

MODE I — MALFUNCTION WARNING

FOR CALIFORNIA MODELS

CHECK ENGINE LIGHT and RED L.E.D.	Condition
ON	When the following malfunctions (check engine light item) are detected or the E.C.U.'s C.P.U. or crank angle sensor is malfunctioning.
OFF	O.K.

Code No.	Malfunction
12	Air flow meter circuit
13	Engine temperature sensor circuit
14	Vehicle speed sensor circuit
31	E.C.U. (E.C.C.S. control unit)
32	E.G.R. function
33	Exhaust gas sensor circuit
35	Exhaust gas temperature sensor circuit
43	Throttle sensor circuit
45	Injector leak

- **These Code Numbers are clarified in Mode II — SELF-DIAGNOSTIC RESULTS.**
- **The RED L.E.D. and the CHECK ENGINE LIGHT will turn off when normal condition is detected. At this time, the Mode II — SELF-DIAGNOSTIC RESULTS memory must be cleared as the contents remain stored.**

FOR NON-CALIFORNIA MODELS

CHECK ENGINE LIGHT and RED L.E.D.	Condition
ON	When the E.C.U.'s C.P.U. or crank angle sensor is malfunctioning.
OFF	O.K.

TROUBLE DIAGNOSES

Self-diagnosis — Mode II (Self-diagnostic results)

CAUTION:

The mode selector on the E.C.U. must be returned to the fully counterclockwise position, except when switching the modes.

DESCRIPTION

In this mode, a malfunction code is indicated by the number of flashes from the RED L.E.D. or the CHECK ENGINE LIGHT as shown below:

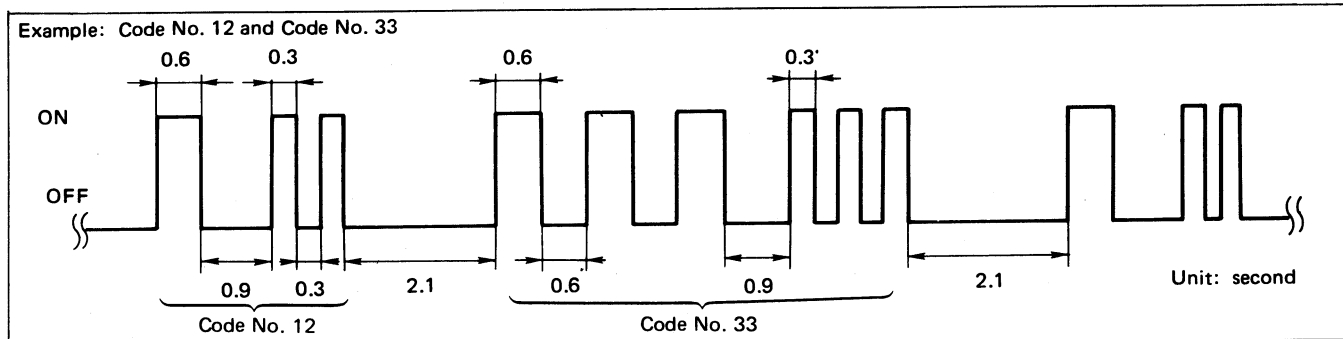

Long (0.6 second) blinking indicates the number of ten digits and short (0.3 second) blinking indicates the number of single digits.

For example, the red L.E.D. flashes once for 0.6 seconds and then it flashes twice for 0.3 seconds. This indicates the number "12" and refers to a malfunction in the air flow meter. In this way, all the problems are classified by their code numbers.

Display code table

Code No.	Detected items	California models	Non-California models
11*	Crank angle sensor circuit	X	X
12	Air flow meter circuit	X	X
13	Engine temperature sensor circuit	X	X
14	Vehicle speed sensor circuit	X	X
21*	Ignition signal circuit	X	X
31	E.C.U.	X	X
32	E.G.R. function	X	—
33	Exhaust gas sensor circuit	X	X
34	Detonation sensor circuit	X	X
35	Exhaust gas temperature sensor circuit	X	—
43	Throttle sensor circuit	X	X
45	Injector leak	X	—
54	Signal circuit from A/T control unit to E.C.U. (A/T only)	X	X
55	No malfunction in the above circuits	X	X

X: Available

—: Not available

: Check engine light item

*: Check items causing a malfunction of crank angle sensor circuit first, if both code No. 11 and 21 are displayed at the same time.

TROUBLE DIAGNOSES

Self-diagnosis — Mode II (Self-diagnostic results) (Cont'd)

Code No.	Detected items	Malfunction is detected when ...	Check item (remedy)
11*	Crank angle sensor circuit	<ul style="list-style-type: none"> ● Either 1° or 90° signal is not entered for the first few seconds during engine cranking. ● Either 1° or 90° signal is not input often enough while the engine speed is higher than the specified rpm. 	<ul style="list-style-type: none"> ● Harness and connector (If harness and connector are normal, replace crank angle sensor.)
12	Air flow meter circuit	<ul style="list-style-type: none"> ● The air flow meter circuit is open or shorted. (An abnormally high or low voltage is entered.) 	<ul style="list-style-type: none"> ● Harness and connector (If harness and connector are normal, replace air flow meter.)
13	Engine temperature sensor circuit	<ul style="list-style-type: none"> ● The engine temperature sensor circuit is open or shorted. (An abnormally high or low output voltage is entered.) 	<ul style="list-style-type: none"> ● Harness and connector ● Engine temperature sensor
14	Vehicle speed sensor circuit	<ul style="list-style-type: none"> ● The vehicle speed sensor circuit is open or shorted. 	<ul style="list-style-type: none"> ● Harness and connector ● Vehicle speed sensor (reed switch)
21*	Ignition signal circuit	<ul style="list-style-type: none"> ● The ignition signal in the primary circuit is not entered during engine cranking or running. 	<ul style="list-style-type: none"> ● Harness and connector ● Power transistor unit
31	E.C.U.	<ul style="list-style-type: none"> ● E.C.U. calculation function is malfunctioning. 	(Replace E.C.C.S. control unit.)
32	E.G.R. function	<ul style="list-style-type: none"> ● E.G.R. control valve does not operate. (E.G.R. control valve spring does not lift.) 	<ul style="list-style-type: none"> ● E.G.R. control valve ● E.G.R. and canister control solenoid valve
33	Exhaust gas sensor circuit	<ul style="list-style-type: none"> ● The exhaust gas sensor circuit is open or shorted. (An abnormally high or low output voltage is entered.) 	<ul style="list-style-type: none"> ● Harness and connector ● Exhaust gas sensor ● Fuel pressure ● Injectors ● Intake air leaks
34	Detonation sensor circuit	<ul style="list-style-type: none"> ● The detonation circuit is open or shorted. (An abnormally high or low voltage is entered.) 	<ul style="list-style-type: none"> ● Harness and connector ● Detonation sensor
35	Exhaust gas temperature sensor circuit	<ul style="list-style-type: none"> ● The exhaust gas temperature sensor circuit is open or shorted. (An abnormally high or low voltage is entered.) 	<ul style="list-style-type: none"> ● Harness and connector ● Exhaust gas temperature sensor
43	Throttle sensor circuit	<ul style="list-style-type: none"> ● The throttle sensor circuit is open or shorted. (An abnormally high or low voltage is entered.) 	<ul style="list-style-type: none"> ● Harness and connector ● Throttle sensor
45	Injector leak	<ul style="list-style-type: none"> ● Fuel leaks from injector. 	<ul style="list-style-type: none"> ● Injector
54	Signal circuit from A/T control unit to E.C.U. (A/T only)	<ul style="list-style-type: none"> ● The A/T communication line is open or shorted. 	<ul style="list-style-type: none"> ● Harness and connector

*: Check items causing a malfunction of crank angle sensor circuit first, if both "CRANK ANGLE SENSOR (No. 11)" and "IGN SIGNAL-PRIMARY (No. 21)" are displayed one after the other.

TROUBLE DIAGNOSES

Self-diagnosis — Mode II (Self-diagnostic results) (Cont'd)

RETENTION OF DIAGNOSTIC RESULTS

The diagnostic results will remain in E.C.U. memory until the starter is operated fifty times after a diagnostic item has been judged to be malfunctioning. The diagnostic result will then be canceled automatically. If a diagnostic item which has been judged to be malfunctioning and stored in memory is again judged to be malfunctioning before the starter is operated fifty times, the second result will replace the previous one. It will be stored in E.C.U. memory until the starter is operated fifty times more.

RETENTION TERM CHART (Example)

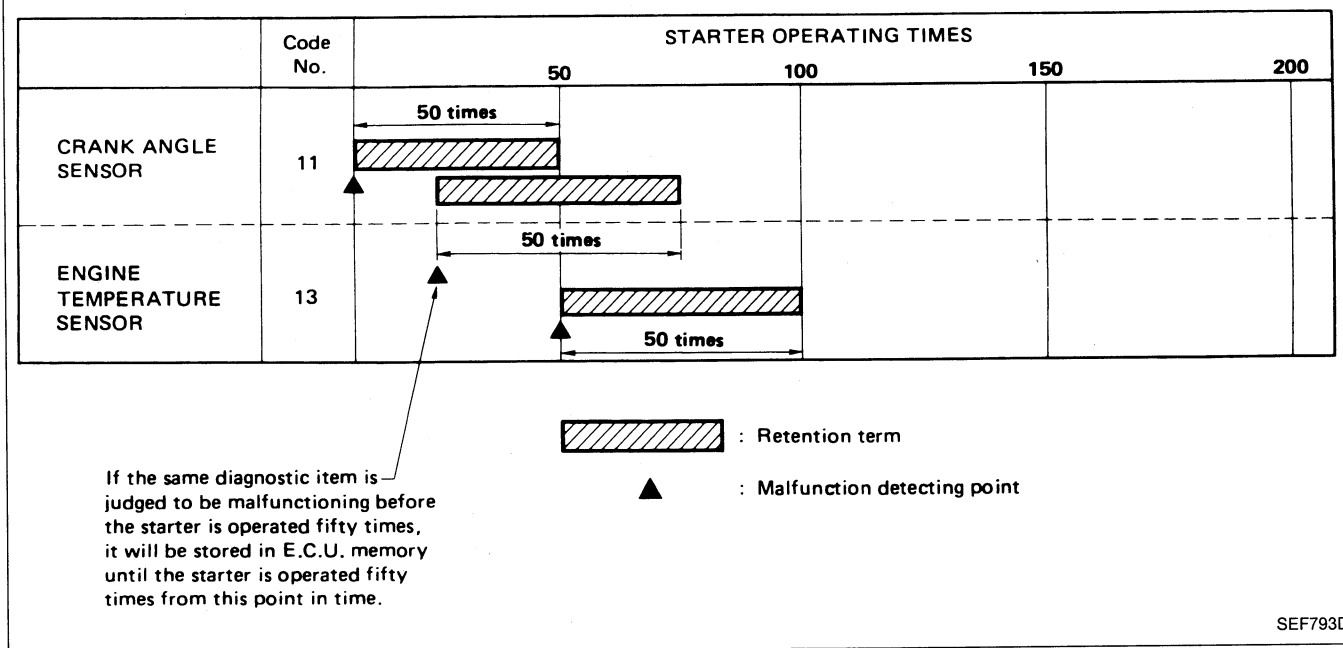

HOW TO ERASE SELF-DIAGNOSTIC RESULTS

The malfunction code is erased from the backup memory on the E.C.U. when the diagnostic mode is changed from Mode II to Mode I. (Refer to "HOW TO SWITCH MODES".)

- When the battery terminal is disconnected, the malfunction code will be lost from the backup memory within 24 hours.
- Before starting self-diagnosis, do not erase the stored memory before beginning self-diagnosis.

TROUBLE DIAGNOSES

Self-diagnosis — Mode II (Exhaust gas sensor monitor)

DESCRIPTION

In this mode, the CHECK ENGINE LIGHT and RED L.E.D. display the condition of the fuel mixture (lean or rich) which is monitored by the exhaust gas sensor.

CHECK ENGINE LIGHT and RED L.E.D.	Fuel mixture condition in the exhaust gas	Air fuel ratio feedback control condition
ON	Lean	Closed loop control
OFF	Rich	
*Remains ON or OFF	Any condition	Open loop control

*: Maintains conditions just before switching to open loop.

HOW TO CHECK EXHAUST GAS SENSOR

1. Set Mode II. (Refer to "HOW TO SWITCH MODES".)
2. Start engine and warm it up until engine coolant temperature indicator points to the middle of the gauge.
3. Run engine at about 2,000 rpm for about 2 minutes under no-load conditions.
4. Make sure RED L.E.D. or CHECK ENGINE LIGHT goes ON and OFF more than 5 times every 10 seconds; measured at 2,000 rpm under no-load.

TROUBLE DIAGNOSES

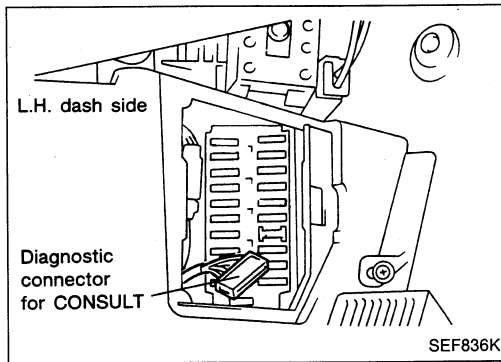

Consult

CONSULT INSPECTION PROCEDURE

1. Turn off ignition switch.
2. Connect "CONSULT" to diagnostic connector.
(Diagnostic connector is located in lower side instrument panel.)

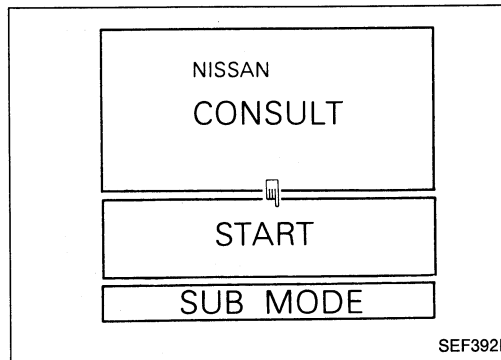

3. Turn on ignition switch.
4. Touch "START".

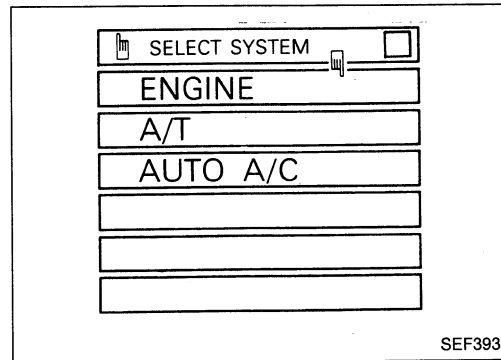

5. Touch "ENGINE".

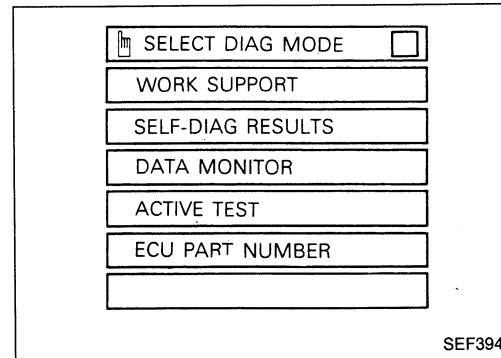

6. Perform each diagnostic mode according to the inspection sheet as follows:

For further information, see the CONSULT Operation Manual.

TROUBLE DIAGNOSES

Consult (Cont'd)

E.C.C.S. COMPONENT PARTS APPLICATION

MODE		WORK SUPPORT	SELF-DIAGNOSTIC RESULTS	DATA MONITOR	ACTIVE TEST
E.C.C.S. COMPONENT PARTS					
INPUT	Crank angle sensor (REF)		X	X	
	Air flow meter		X	X	
	Engine temperature sensor		X	X	X
	Exhaust gas sensor		X	X	
	Vehicle speed sensor		X	X	
	Throttle sensor	X	X	X	
	Exhaust gas temperature sensor*		X	X	
	Detonation sensor		X		
	Ignition switch (start signal)			X	
	Air conditioner switch			X	
	Neutral switch			X	
	Power steering oil pressure switch			X	
	Idle switch			X	
	Battery			X	
OUT-PUT	Injectors		X	X	X
	Power transistor (ignition timing)	X	X (Ignition signal)	X	X
	A.A.C. valve	X		X	X
	E.G.R. and canister control solenoid valve		X	X	X
	Air conditioner relay			X	
	Fuel pump relay	X		X	X
	A.I.V. control solenoid valve			X	X
	Swirl control solenoid valve			X	X
	Radiator fan relay			X	X

: The E.C.C.S. component part marked "" is applicable to vehicles for California only.

X: Applicable

FUNCTION

Diagnostic mode	Function
Work support	This mode enables a technician to adjust some devices faster and more accurately by following the indications on the CONSULT unit.
Self-diagnostic results	Self-diagnostic results can be read and erased quickly.
Data monitor	Input/Output data in the control unit can be read.
Active test	Mode in which CONSULT drives some actuators apart from the control units and also shifts some parameters in a specified range.
E.C.U. part number	E.C.U. part number can be read.

TROUBLE DIAGNOSES

Consult (Cont'd)

WORK SUPPORT MODE

WORK ITEM	CONDITION	USAGE
THROTTLE SENSOR ADJUSTMENT	CHECK THE THROTTLE SENSOR SIGNAL. ADJUST IT TO THE SPECIFIED VALUE BY ROTATING THE SENSOR BODY UNDER THE FOLLOWING CONDITIONS. <ul style="list-style-type: none">● IGN SW "ON"● ENG NOT RUNNING● ACC PEDAL NOT PRESSED	When adjusting throttle sensor initial position
IGNITION TIMING ADJUSTMENT*	<ul style="list-style-type: none">● IGNITION TIMING FEEDBACK CONTROL WILL BE HELD BY TOUCHING "START". AFTER DOING SO, ADJUST IGNITION TIMING WITH A TIMING LIGHT BY TURNING THE CRANK ANGLE SENSOR.	When adjusting initial ignition timing
AAC VALVE ADJUSTMENT	SET ENGINE RPM AT THE SPECIFIED VALUE UNDER THE FOLLOWING CONDITIONS. <ul style="list-style-type: none">● ENGINE WARMED UP● NO-LOAD	When adjusting idle speed
FUEL PRESSURE RELEASE	<ul style="list-style-type: none">● FUEL PUMP WILL STOP BY TOUCHING "START" WHEN IDLING. CRANK A FEW TIMES AFTER ENGINE STALLS.	When releasing fuel pressure from fuel line

TROUBLE DIAGNOSES

Consult (Cont'd)

SELF-DIAGNOSTIC RESULTS MODE

DIAGNOSTIC ITEM	DIAGNOSTIC ITEM IS DETECTED WHEN ...	CHECK ITEM (REMEDY)
CRANK ANGLE SENSOR*	<ul style="list-style-type: none"> ● Either 1° or 120° signal is not entered for the first few seconds during engine cranking. ● Either 1° or 120° signal is not input often enough while the engine speed is higher than the specified rpm. 	<ul style="list-style-type: none"> ● Harness and connector (If harness and connector are normal, replace crank angle sensor.)
AIR FLOW METER	<ul style="list-style-type: none"> ● The air flow meter circuit is open or shorted. (An abnormally high or low voltage is entered.) 	<ul style="list-style-type: none"> ● Harness and connector (If harness and connector are normal, replace air flow meter.)
ENGINE TEMP SENSOR	<ul style="list-style-type: none"> ● The engine temperature sensor circuit is open or shorted. (An abnormally high or low output voltage is entered.) 	<ul style="list-style-type: none"> ● Harness and connector ● Engine temperature sensor
CAR SPEED SENSOR	<ul style="list-style-type: none"> ● The vehicle speed sensor circuit is open or shorted. 	<ul style="list-style-type: none"> ● Harness and connector ● Vehicle speed sensor (reed switch)
IGN SIGNAL-PRIMARY*	<ul style="list-style-type: none"> ● The ignition signal in primary circuit is not entered during engine cranking or running. 	<ul style="list-style-type: none"> ● Harness and connector ● Power transistor unit
CONTROL UNIT	<ul style="list-style-type: none"> ● E.C.U. calculation function is malfunctioning. 	(Replace E.C.C.S. control unit.)
EGR SYSTEM**	<ul style="list-style-type: none"> ● E.G.R. control valve does not operate. (E.G.R. control valve spring does not lift.) 	<ul style="list-style-type: none"> ● E.G.R. control valve ● E.G.R. and canister control solenoid valve
EXH GAS SENSOR	<ul style="list-style-type: none"> ● The exhaust gas sensor circuit is open or shorted. (An abnormally high or low output voltage is entered.) 	<ul style="list-style-type: none"> ● Harness and connector ● Exhaust gas sensor ● Fuel pressure ● Injectors ● Intake air leaks
DETONATION SENSOR	<ul style="list-style-type: none"> ● The detonation circuit is open or shorted. (An abnormally high or low voltage is entered.) 	<ul style="list-style-type: none"> ● Harness and connector ● Detonation sensor
EXH GAS TEMP SENSOR**	<ul style="list-style-type: none"> ● The exhaust gas temperature sensor circuit is open or shorted. (An abnormally high or low voltage is entered.) 	<ul style="list-style-type: none"> ● Harness and connector ● Exhaust gas temperature sensor
THROTTLE SENSOR	<ul style="list-style-type: none"> ● The throttle sensor circuit is open or shorted. (An abnormally high or low voltage is entered.) 	<ul style="list-style-type: none"> ● Harness and connector ● Throttle sensor
INJECTOR LEAK**	<ul style="list-style-type: none"> ● Fuel leaks from injector. 	<ul style="list-style-type: none"> ● Injector

*: Check items causing a malfunction of crank angle sensor circuit first, if both "CRANK ANGLE SENSOR" and "IGN SIGNAL-PRIMARY" come out at the same time.

The diagnostic item marked "**" is applicable to vehicles for California only.

TROUBLE DIAGNOSES

Consult (Cont'd)

DATA MONITOR MODE

MONITOR ITEM	CONDITION		SPECIFICATION	CHECK ITEM WHEN OUTSIDE SPEC.
CAS, RPM (POS)	<ul style="list-style-type: none"> Tachometer: Connect Run engine and compare tachometer indication with the CONSULT value. 		Almost the same speed as the CONSULT value.	<ul style="list-style-type: none"> Harness and connector Crank angle sensor
AIR FLOW MTR	<ul style="list-style-type: none"> Engine: After warming up, idle the engine A/C switch "OFF" Shift lever "N" 	Idle	1.0 - 1.5V	<ul style="list-style-type: none"> Harness and connector Air flow meter
		2,000 rpm	1.4 - 1.9V	
ENG TEMP SEN	<ul style="list-style-type: none"> Engine: After warming up 		More than 70°C (158°F)	<ul style="list-style-type: none"> Harness and connector Engine temperature sensor
EXH GAS SEN	<ul style="list-style-type: none"> Engine: After warming up 	Maintaining engine speed at 2,000 rpm	0 ↔ Approx. 1.5V	<ul style="list-style-type: none"> Harness and connector Exhaust gas sensor Intake air leaks Injectors
M/R F/C MNT			LEAN ↔ RICH Changes more than 5 times during 10 seconds.	
CAR SPEED SEN	<ul style="list-style-type: none"> Turn drive wheels and compare speedometer indication with the CONSULT value 		Almost the same speed as the CONSULT value	<ul style="list-style-type: none"> Harness and connector Vehicle speed sensor
BATTERY VOLT	<ul style="list-style-type: none"> Ignition switch: ON (Engine stopped) 		11 - 14V	<ul style="list-style-type: none"> Battery E.C.U. power supply circuit
THROTTLE SEN	<ul style="list-style-type: none"> Ignition switch: ON (Engine stopped) 	Throttle valve fully closed	0.4 - 0.5V	<ul style="list-style-type: none"> Harness and connector Throttle sensor Throttle sensor adjustment
		Throttle valve fully opened	Approx. 4.0V	
EGR TEMP SEN*	<ul style="list-style-type: none"> Engine: After warming up 		Less than 4.5V	<ul style="list-style-type: none"> Harness and connector Exhaust gas temperature sensor
START SIGNAL	<ul style="list-style-type: none"> Ignition switch: ON → START 		OFF → ON	<ul style="list-style-type: none"> Harness and connector Starter switch
IDLE POSITION	<ul style="list-style-type: none"> Ignition switch: ON (Engine stopped) 	Throttle valve: Idle position	ON	<ul style="list-style-type: none"> Harness and connector Throttle sensor Throttle sensor adjustment
		Throttle valve: Slightly open	OFF	
AIR COND SIG	<ul style="list-style-type: none"> Engine: After warming up, idle the engine 	A/C switch "OFF"	OFF	<ul style="list-style-type: none"> Harness and connector Air conditioner switch
		A/C switch "ON"	ON	
NEUTRAL SW	<ul style="list-style-type: none"> Ignition switch: ON 	Shift lever "P" or "N"	ON	<ul style="list-style-type: none"> Harness and connector Neutral switch
		Except above	OFF	

Remarks: The monitor item marked "*" is applicable to vehicles for California only.
Specifications are reference values.

TROUBLE DIAGNOSES

Consult (Cont'd)

MONITOR ITEM	CONDITION	SPECIFICATION	CHECK ITEM WHEN OUTSIDE SPEC.	
INJ PULSE	<ul style="list-style-type: none"> ● Engine: After warming up ● A/C switch "OFF" ● Shift lever "N" ● No-load 	Idle	3.1 - 3.8 msec.	<ul style="list-style-type: none"> ● Harness and connector ● Injector ● Air flow meter ● Intake air system
		2,000 rpm	2.9 - 3.6 msec.	
IGN TIMING	ditto	Idle	20° B.T.D.C.	<ul style="list-style-type: none"> ● Harness and connector ● Crank angle sensor
		2,000 rpm	More than 25° B.T.D.C.	
AAC VALVE	ditto	Idle	15 - 40%	<ul style="list-style-type: none"> ● Harness and connector ● A.A.C. valve
		2,000 rpm	—	
AIR COND RLY	● Air conditioner switch OFF → ON	OFF → ON	<ul style="list-style-type: none"> ● Harness and connector ● Air conditioner switch ● Air conditioner relay 	
SWRL CONT SOL VALVE	<ul style="list-style-type: none"> ● Fuel temperature is above 35°C (95°F) 	Idle	ON	<ul style="list-style-type: none"> ● Harness and connector ● Pressure regulator control solenoid valve ● Fuel temperature sensor
		2,000 rpm	OFF	
EGR CONT S/V	<ul style="list-style-type: none"> ● Engine: After warming up ● A/C switch "OFF" ● Shift lever "N" ● No-load 	Idle	ON	<ul style="list-style-type: none"> ● Harness and connector ● E.G.R. and canister control solenoid valve
		2,000 rpm	OFF	
PW/ST SIGNAL	<ul style="list-style-type: none"> ● Engine: After warming up, idle the engine 	Steering wheel in neutral (forward direction)	OFF	<ul style="list-style-type: none"> ● Harness and connector ● Power steering oil pressure switch
		The steering wheel is turned.	ON	
LOAD SIGNAL	<ul style="list-style-type: none"> ● Ignition switch: ON 	Rear window defogger is operating.	ON	<ul style="list-style-type: none"> ● Harness and connector ● Rear window defogger system (Refer to section EL.)
		Rear window defogger is not operating.	OFF	
AMB TEMP SW	<ul style="list-style-type: none"> ● Ignition switch: ON ● Compare ambient temperature with the following: 	Below 19°C (66°F)	OFF	<ul style="list-style-type: none"> ● Harness and connector ● Ambient switch
		19 - 25°C (66 - 77°F)	—	
		Above 25°C (77°F)	ON	

Remarks: Specifications are reference values.

TROUBLE DIAGNOSES

Consult (Cont'd)

ACTIVE TEST MODE

TEST ITEM	CONDITION	JUDGMENT	CHECK ITEM (REMEDY)
FUEL INJECTION TEST	<ul style="list-style-type: none"> ● Engine: Return to the original trouble condition ● Change the amount of fuel injection with the CONSULT. 	If trouble symptom disappears, see CHECK ITEM.	<ul style="list-style-type: none"> ● Harness and connector ● Fuel injectors ● Exhaust gas sensors
AAC/V OPENING TEST	<ul style="list-style-type: none"> ● Engine: After warming up, idle the engine. ● Change the AAC valve opening percent with the CONSULT. 	Engine speed changes according to the opening percent.	<ul style="list-style-type: none"> ● Harness and connector ● AAC valve
ENGINE TEMP TEST	<ul style="list-style-type: none"> ● Engine: Return to the original trouble condition ● Change the engine coolant temperature with the CONSULT. 	If trouble symptom disappears, see CHECK ITEM.	<ul style="list-style-type: none"> ● Harness and connector ● Engine temperature sensor ● Fuel injectors
IGN TIMING TEST	<ul style="list-style-type: none"> ● Engine: Return to the original trouble condition ● Timing light: Set ● Retard the ignition timing with the CONSULT. 	If trouble symptom disappears, see CHECK ITEM.	<ul style="list-style-type: none"> ● Adjust initial ignition timing
POWER BALANCE TEST	<ul style="list-style-type: none"> ● Engine: After warming up, idle the engine. ● A/C switch "OFF" ● Shift lever "N" ● Cut off each injector signal one at a time with the CONSULT. 	Engine runs rough or dies.	<ul style="list-style-type: none"> ● Harness and connector ● Compression ● Injectors ● Power transistor ● Spark plugs ● Ignition coils
RADIATOR FAN TEST	<ul style="list-style-type: none"> ● Ignition switch: ON ● Turn the radiator fan "ON" and "OFF" with the CONSULT. 	Radiator fan moves and stops.	<ul style="list-style-type: none"> ● Harness and connector ● Radiator fan motor
FUEL PUMP RLY TEST	<ul style="list-style-type: none"> ● Ignition switch: ON (Engine stopped) ● Turn the fuel pump relay "ON" and "OFF" with the CONSULT and listen to operating sound. 	Fuel pump relay makes the operating sound.	<ul style="list-style-type: none"> ● Harness and connector ● Fuel pump relay
EGR CONT SOL/V TEST	<ul style="list-style-type: none"> ● Ignition switch: ON ● Turn solenoid valve "ON" and "OFF" with the CONSULT and listen to operating sound. 	Each solenoid valve makes an operating sound.	<ul style="list-style-type: none"> ● Harness and connector ● Solenoid valve
AIV CONT SOL/V TEST			
SWIRL CONT SOL/V TEST			
SELF-LEARN CONT TEST	<ul style="list-style-type: none"> ● In this test, the coefficient of self-learning control mixture ratio returns to the original coefficient by touching "CLEAR" on the screen. 		

TROUBLE DIAGNOSES

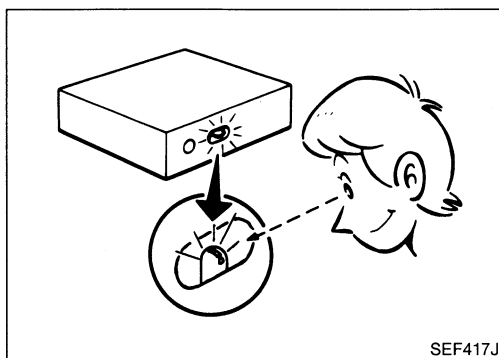
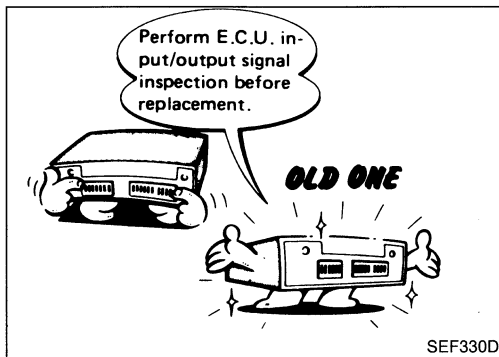
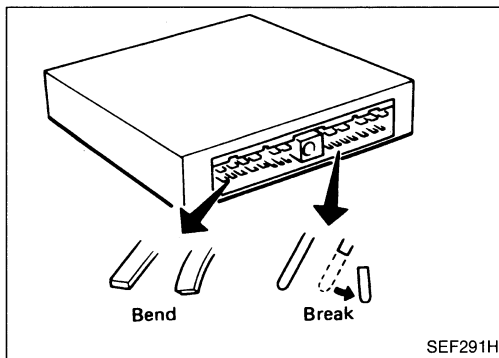
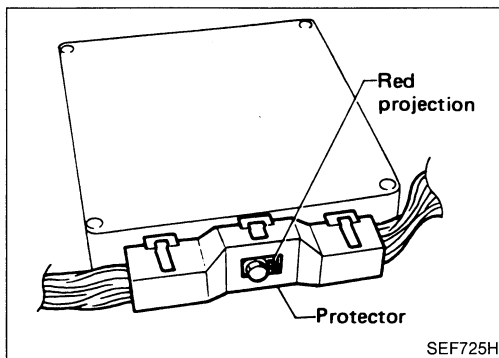
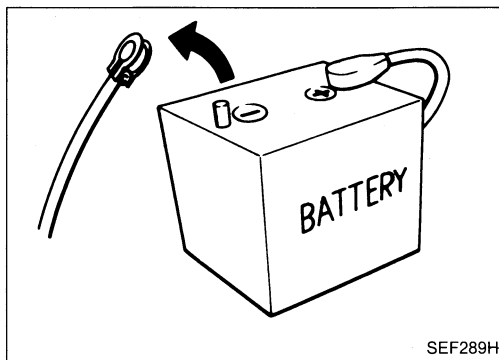

Diagnostic Procedure

CAUTION:

1. Before connecting or disconnecting the E.C.U. harness connector to or from any E.C.U., be sure to turn the ignition switch to the "OFF" position and disconnect the negative battery terminal in order not to damage E.C.U. as battery voltage is applied to E.C.U. even if ignition switch is turned off. Failure to do so may damage the E.C.U.

2. When connecting E.C.U. harness connector, tighten securing bolt until red projection is in line with connector face.

3. When connecting or disconnecting pin connectors into or from E.C.U., take care not to damage pin terminals (bend or break).

4. Make sure that there are not any bends or breaks on E.C.U. pin terminal, when connecting pin connectors.

5. Before replacing E.C.U., perform E.C.U. input/output signal inspection and make sure whether E.C.U. functions properly or not. (See page EF & EC-178.)

6. After performing this "Diagnostic Procedure", perform E.C.C.S. self-diagnosis and driving test.

TROUBLE DIAGNOSES

Diagnostic Procedure (Cont'd)

7. When measuring E.C.U. controlled components supply voltage with a circuit tester, separate one tester probe from the other.

If the two tester probes accidentally make contact with each other during measurement, the circuit will be shorted, resulting in damage to the control unit power transistor.

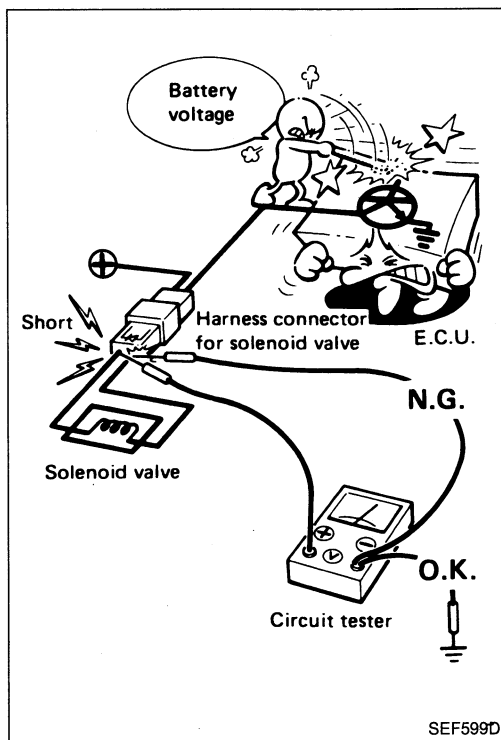

TROUBLE DIAGNOSES

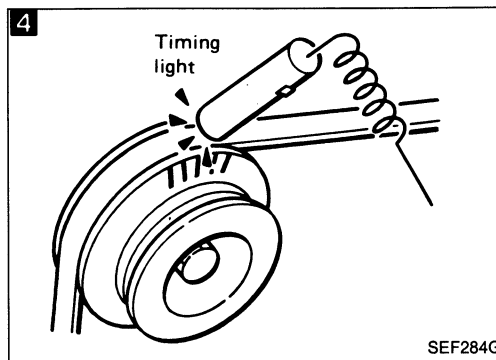
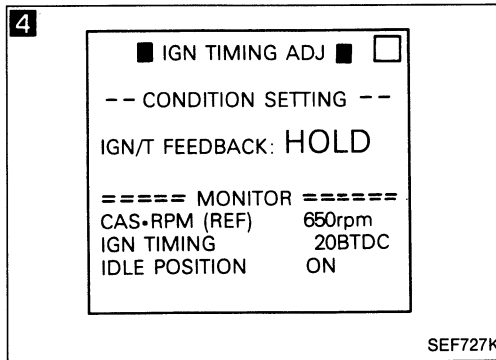
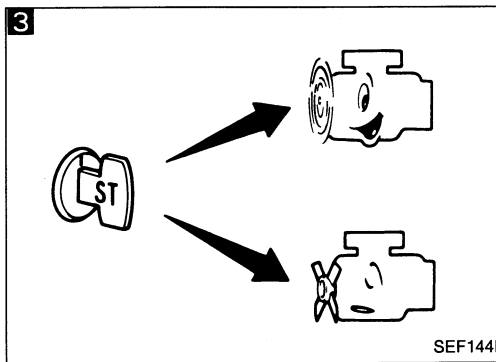
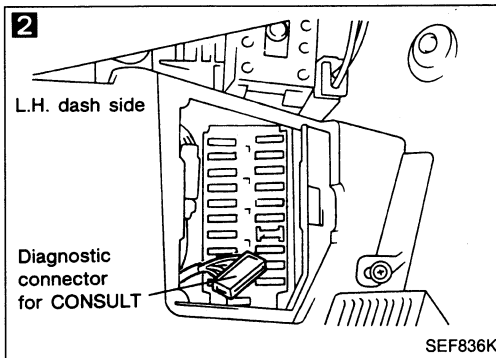
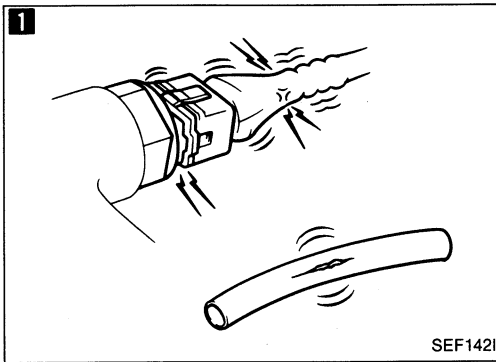

Basic Inspection

1

BEFORE STARTING

1. Check service records for any recent repairs that may indicate a related problem, or the current need for scheduled maintenance.
2. Open engine hood and check the following:
 - Harness connectors for proper connections
 - Vacuum hoses for splits, kinks, and proper connections
 - Wiring for proper connections, pinches, and cuts

2

CONNECT CONSULT TO THE VEHICLE.

Connect "CONSULT" to the diagnostic connector and select "ENGINE" from the menu. (Refer to page EF & EC-46.)

3

DOES ENGINE START?

No → Go to **6**

Yes ↓

4

CHECK IGNITION TIMING.

1. Warm up engine sufficiently.
2. Select "IGN TIMING ADJ" in "WORK SUPPORT" mode.
3. Touch "START".
4. Check ignition timing at idle using timing light.

Ignition timing:
20° ± 2° B.T.D.C.

N.G. → Adjust ignition timing by turning crank angle sensor. Refer to page EF & EC-28.

1. Warm up engine sufficiently.
2. Stop engine and disconnect throttle sensor harness connector.
3. Start engine.
4. Check ignition timing at idle using timing light.

Ignition timing:
20° ± 2° B.T.D.C.

O.K.

↓

(Go to **A** on next page.)

TROUBLE DIAGNOSES

Basic Inspection (Cont'd)

5

■ IGN TIMING ADJ ■ □

-- CONDITION SETTING --

IGN/T FEEDBACK: HOLD

===== MONITOR =====

CAS•RPM (REF)	650rpm
IGN TIMING	20BTDC
IDLE POSITION	ON

SEF727K

5

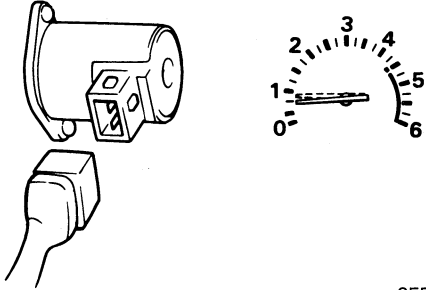

SEF146I

6

■ THROTTLE SEN ADJ ■ □

**** ADJ MONITOR ****

THROTTLE SEN 0.44V

===== MONITOR =====

CAS•RPM (REF)	687rpm
IDLE POSITION	ON

SEF725K

6

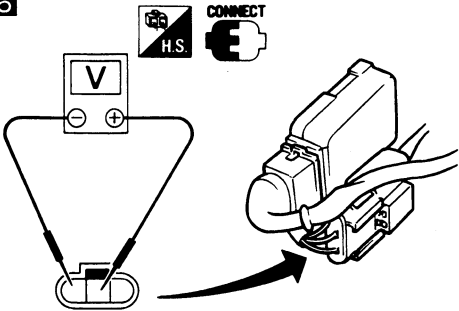

SEF148I

Ⓐ

5

CHECK IDLE ADJ. SCREW INITIAL SET RPM.

1. Select "IGN TIMING ADJ" in "WORK SUPPORT" mode.
2. When touching "START", does engine speed fall to 650 ± 50 rpm (A/T in "N" position)?

OR

Does engine run at 650 ± 50 rpm (A/T in "N" position)?

N.G. → Adjust engine speed by turning idle adjusting screw.

O.K.

6

CHECK THROTTLE SENSOR IDLE POSITION.

1. Perform "THROTTLE SEN. ADJ." in "WORK SUPPORT" mode.
2. Check that output voltage of throttle sensor is approx. 0.4 to 0.5V. (Throttle valve fully closes.) and "IDLE POSITION" stays "ON".

OR

Measure output voltage of throttle sensor using voltmeter, and check that it is approx. 0.4 to 0.5V. (Throttle valve fully closed.)

N.G. →

1. Adjust output voltage by rotating throttle sensor body.
2. Disconnect throttle sensor harness connector for a few seconds and then reconnect it.
3. Confirm that "IDLE POSITION" stays "ON".

O.K.

↓

(Go to Ⓑ on next page.)

TROUBLE DIAGNOSES

Basic Inspection (Cont'd)

7

☆ MONITOR ☆ NO FAIL

START SIGNAL OFF
 IDLE POSITION ON
 AIR COND SIG OFF
 NEUTRAL SW ON

RECORD

SEF723K

7



A/C



ST





N

SEF150I

7

ⓑ

CHECK SWITCH INPUT SIGNAL.

Select the following switches in "DATA MONITOR" mode,

- Start signal,
- Idle position,
- Air conditioner signal,
- Neutral (Parking) switch, and check the switches' ON-OFF operation.

— OR —

Remove E.C.U. from front floor panel and check the above switches' ON-OFF operation using voltmeter at each E.C.U. terminal.

N.G. → Repair or replace the malfunctioning switch or its circuit.

— OR —

Switch	Condition	Voltage (V)
Start signal	IGN	0 → Battery voltage
	IGN ON → START	
Idle position	Engine warmed up sufficiently	Battery voltage → 0V
	Idle position → Depress the accelerator pedal.	
A/C signal	A/C OFF → A/C ON (Engine running)	7.0 - 10.0 → 0.5 - 0.7
Neutral (Parking) switch	Shift lever is "N" or "P" position → Except "N" and "P"	0 → 8.0 - 10.0

8

■ SELF-DIAG RESULTS ■

FAILURE DETECTED TIME
 ENGINE TEMP SENSOR 0

ERASE

PRINT

SEF151I

O.K.

8

READ SELF-DIAGNOSTIC RESULTS.

- Perform "SELF-DIAG RESULTS" mode.
- Read out self-diagnostic results.
- Is a failure detected?

— OR —

- Set "Self-diagnostic results mode" in Mode II. (Refer to page EF & EC-42.)
- Count the number of RED L.E.D. or check engine light flashes and read out the codes.
- Are the codes being output?

Yes → Go to the relevant inspection procedure.

8

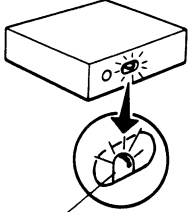

RED L.E.D.

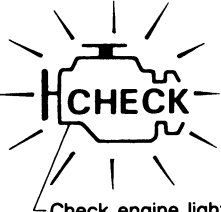

CHECK
Check engine light

SEF621K

No

INSPECTION END

TROUBLE DIAGNOSES

Diagnostic Procedure 1 — High Idling after Warm-up

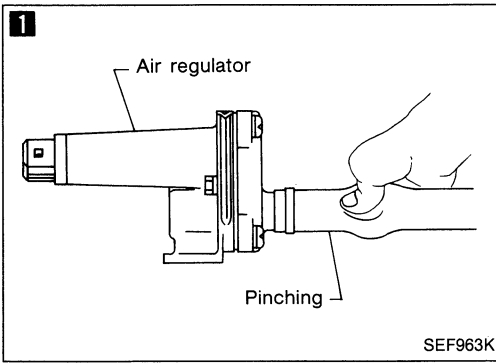

1
CHECK AIR REGULATOR.
When pinching the air regulator hose, does the engine speed drop?

Yes → Check air regulator. (See page EF & EC-160.)

No ↓

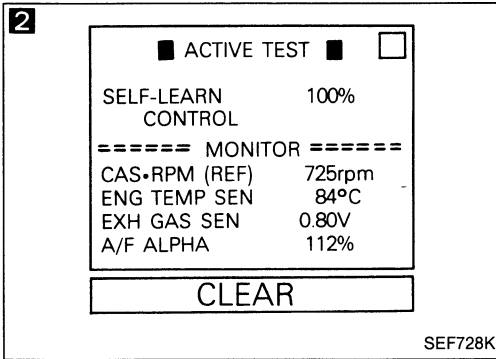

2
CHECK INTAKE AIR LEAK.

1. Select "SELF-LEARNING CONT" in "ACTIVE TEST" mode.
2. Clear the self-learning control coefficient by touching "CLEAR".
3. Does the engine speed drop?

Yes → Discover air leak location and repair.

OR

 1. Disconnect exhaust gas sensor harness connectors.
2. After racing engine at 2,000 rpm under no load for about 30 seconds, does the engine speed drop?

No ↓

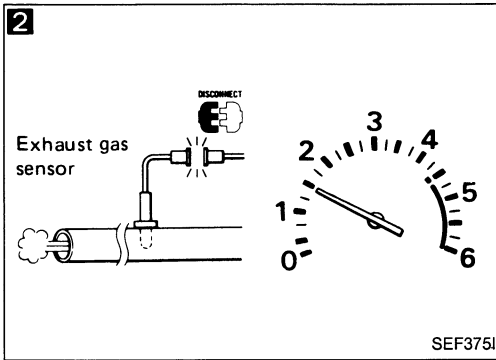

3
CHECK THROTTLE LINKAGE.

1. Check that throttle linkage moves smoothly.
2. Confirm that throttle valve both fully opens and fully closes.

N.G. → Repair throttle linkage or sticking of throttle valve.

O.K. ↓

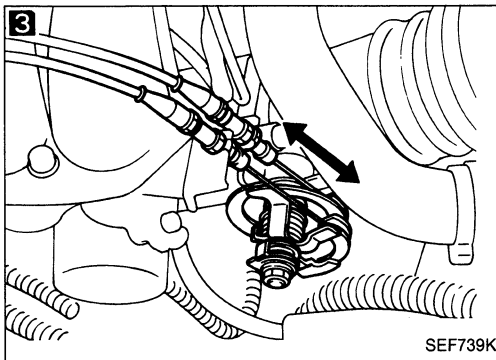

INSPECTION END

TROUBLE DIAGNOSES

Diagnostic Procedure 2 — Hunting

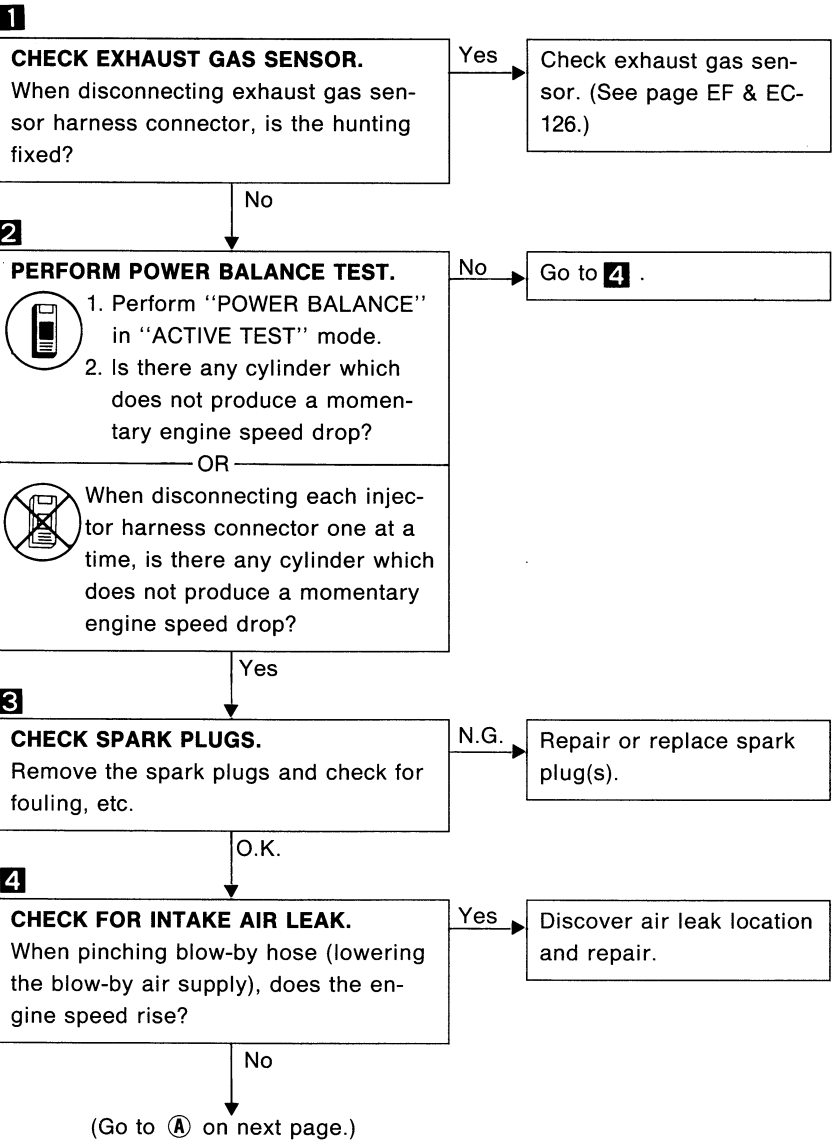
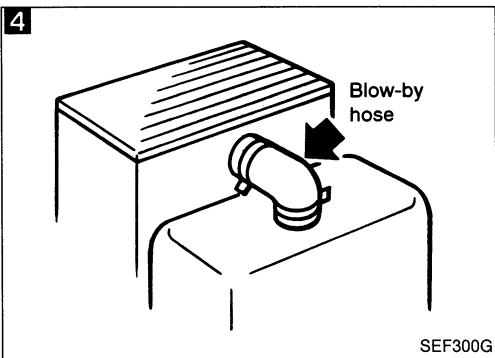
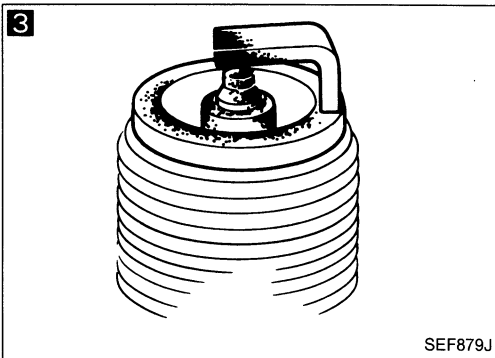
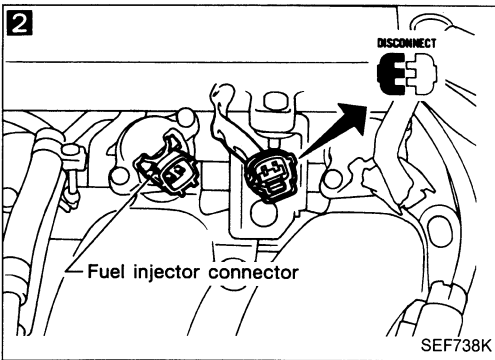
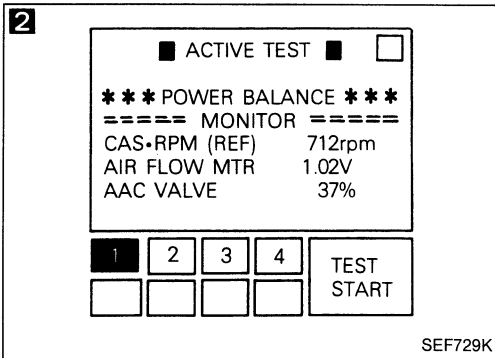
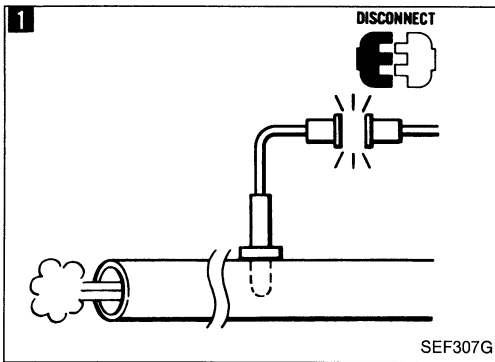

TROUBLE DIAGNOSES

Diagnostic Procedure 2 — Hunting (Cont'd)

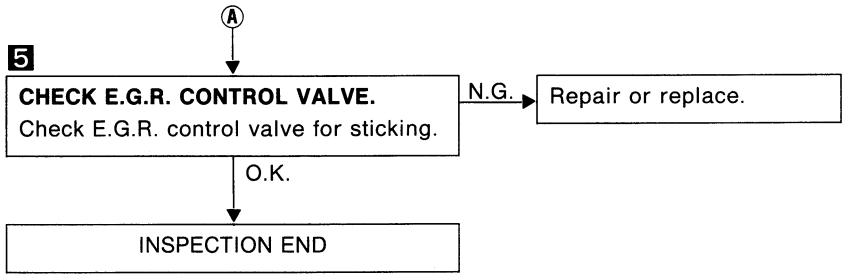
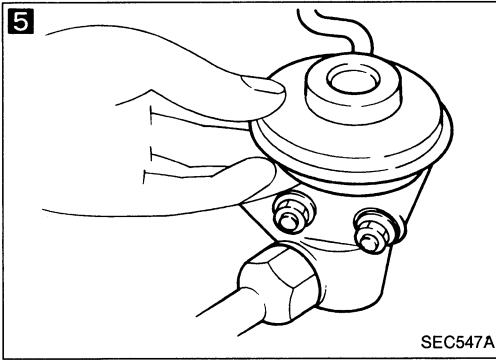

TROUBLE DIAGNOSES

Diagnostic Procedure 3 — Unstable Idle

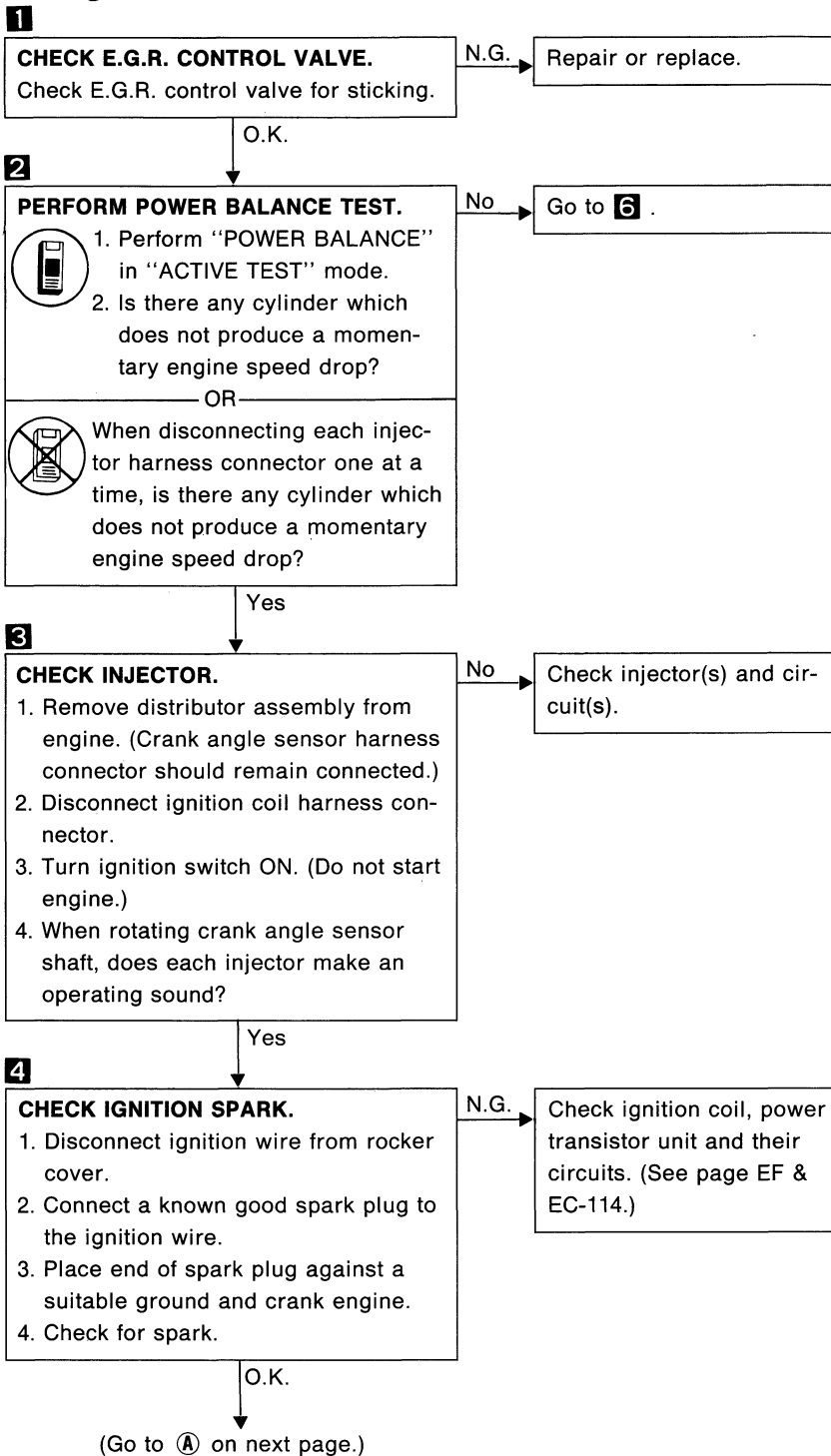
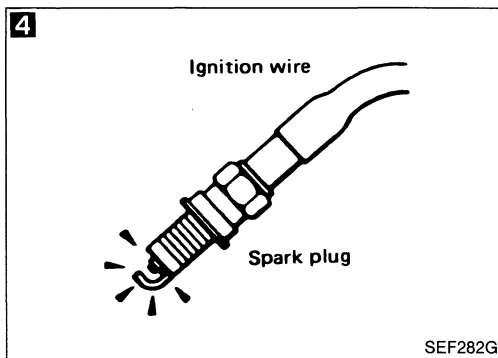
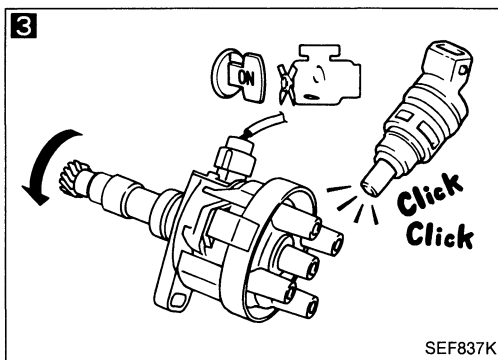
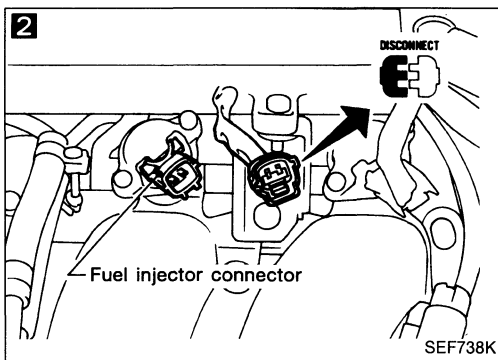
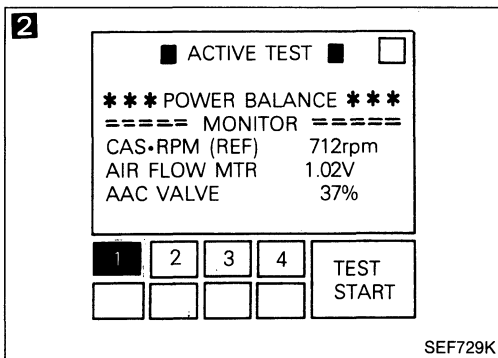
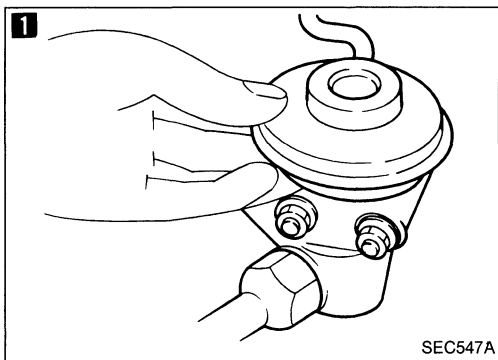

TROUBLE DIAGNOSES

Diagnostic Procedure 3 — Unstable Idle (Cont'd)

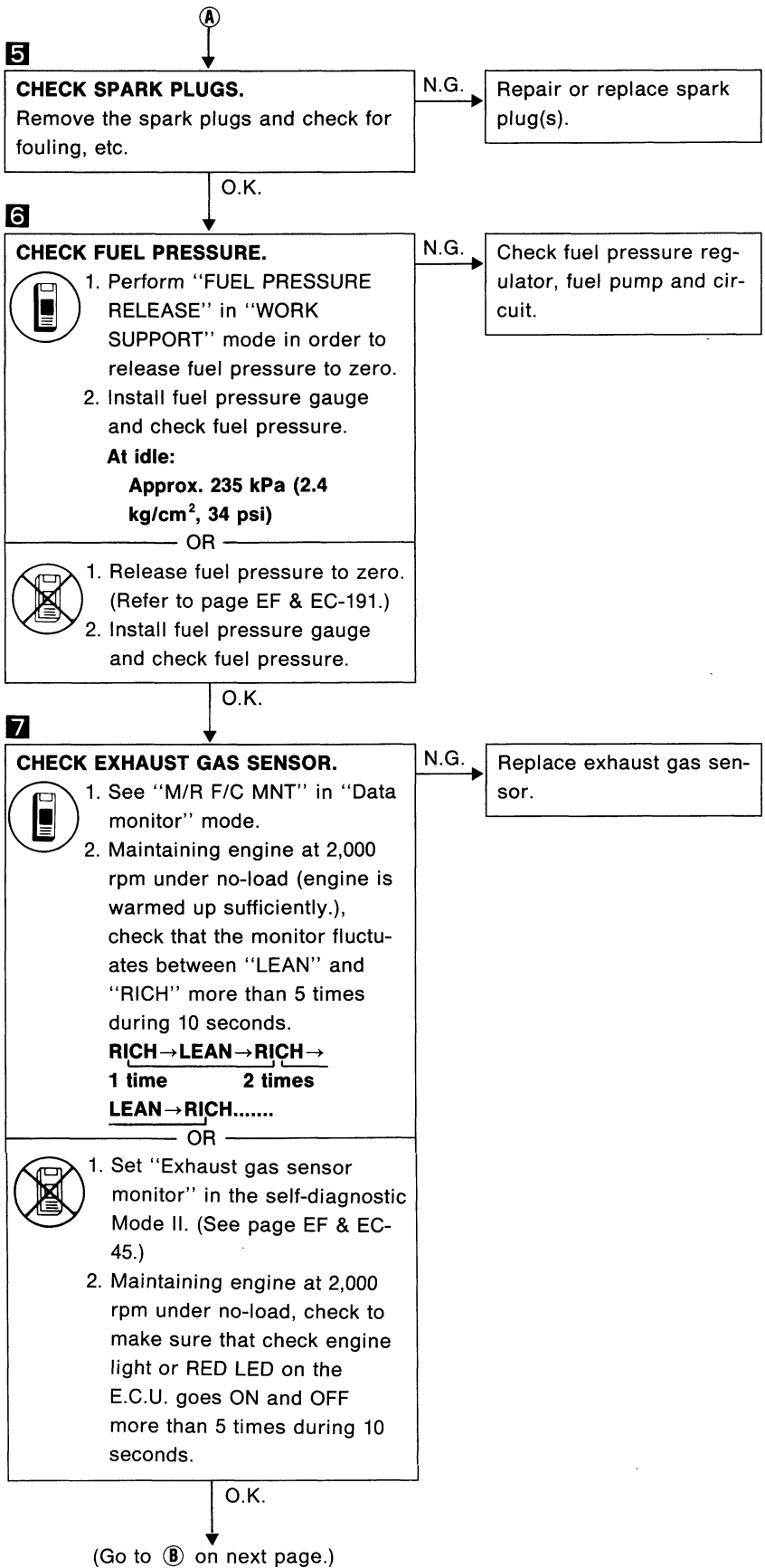
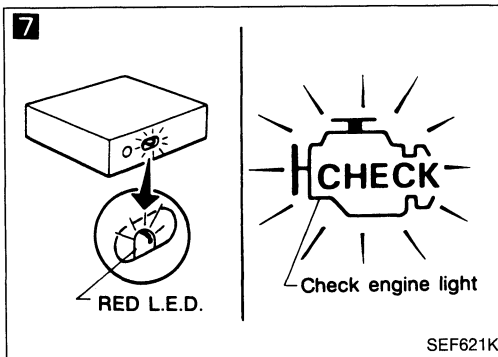
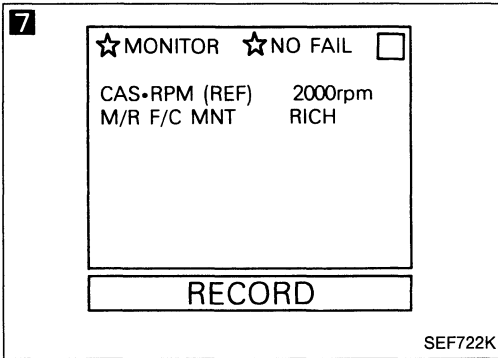
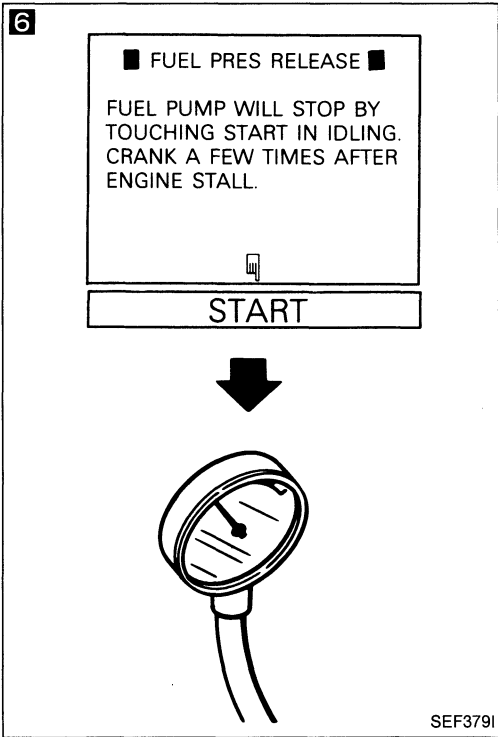
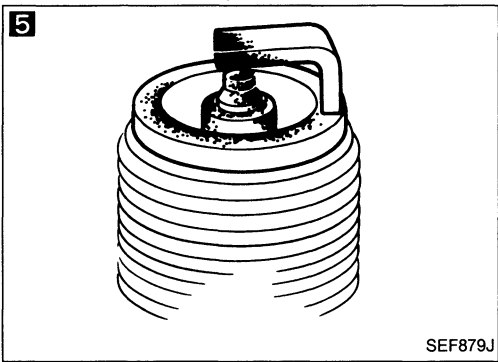

TROUBLE DIAGNOSES

Diagnostic Procedure 3 — Unstable Idle (Cont'd)

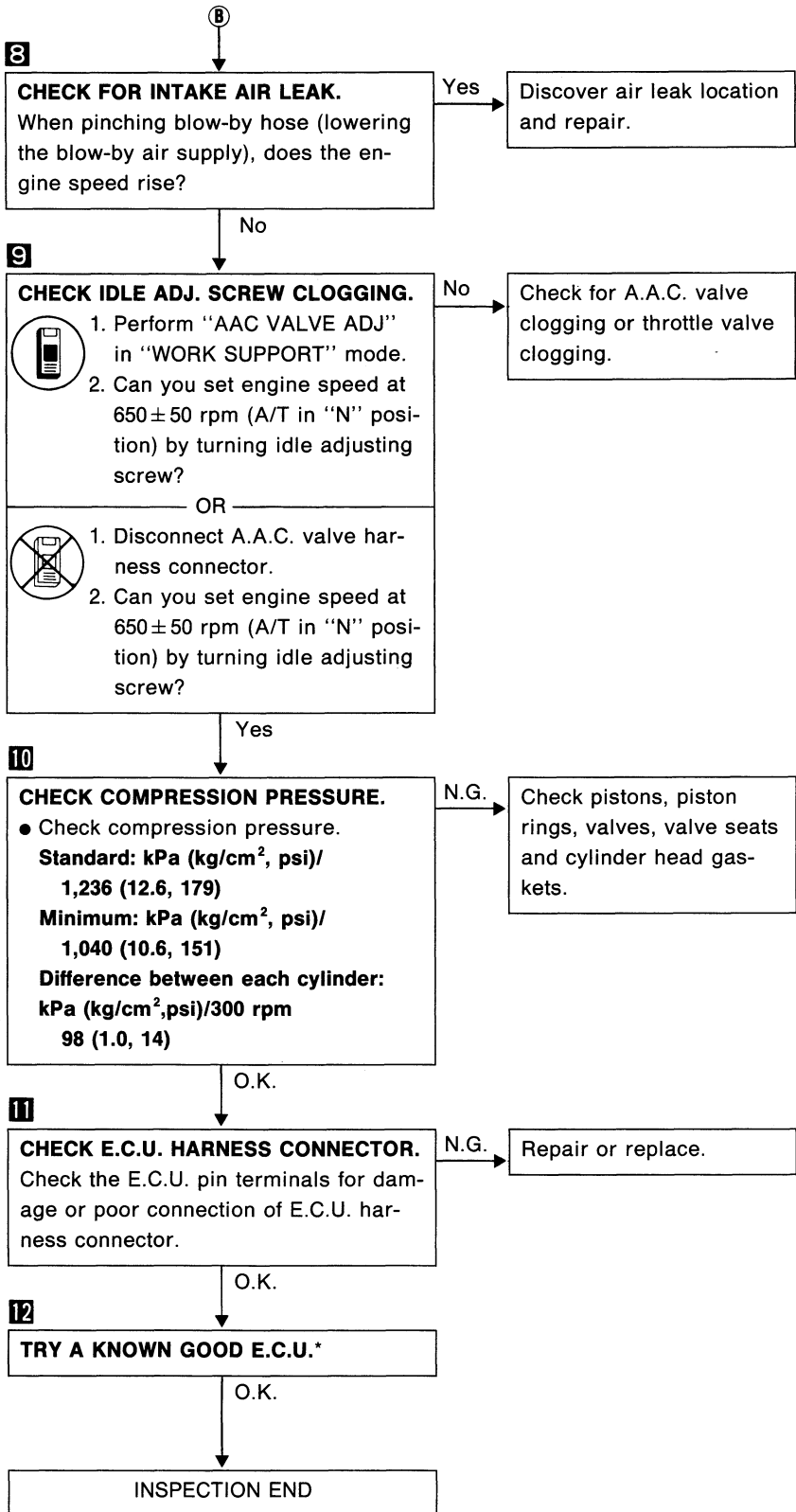
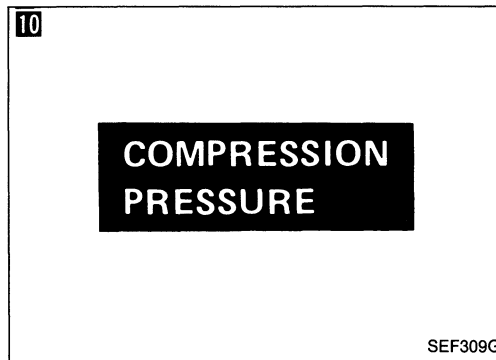
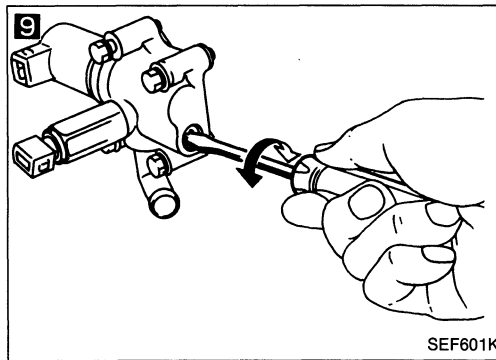
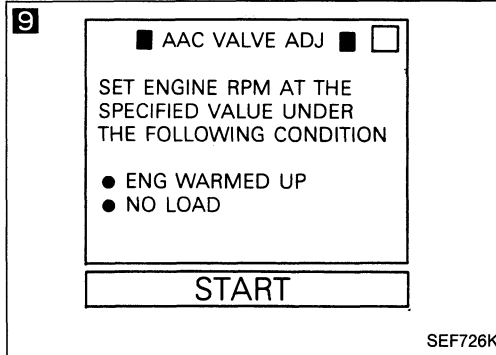
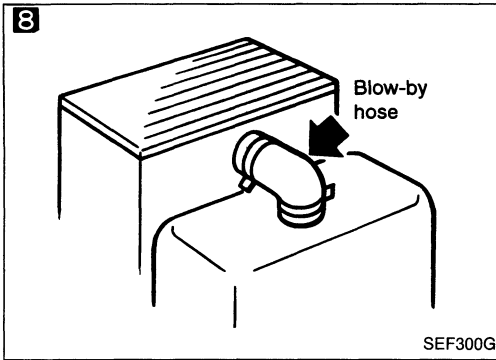

*: E.C.U. may be the cause of a problem, but this is rarely the case.

TROUBLE DIAGNOSES

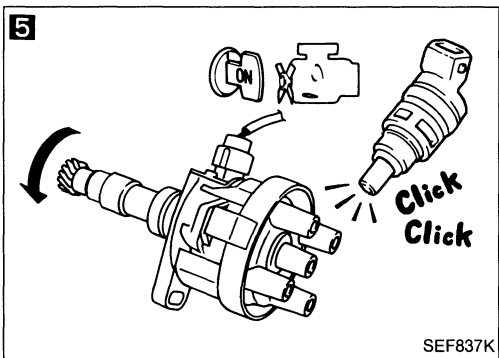
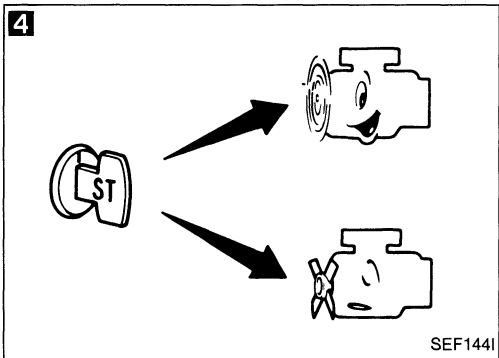
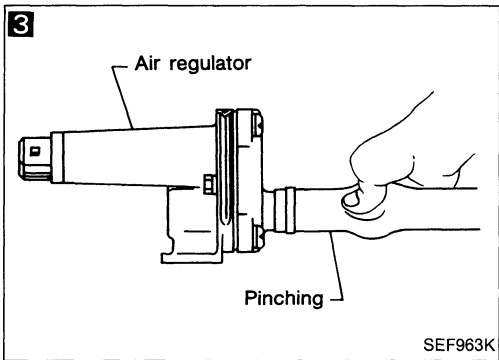
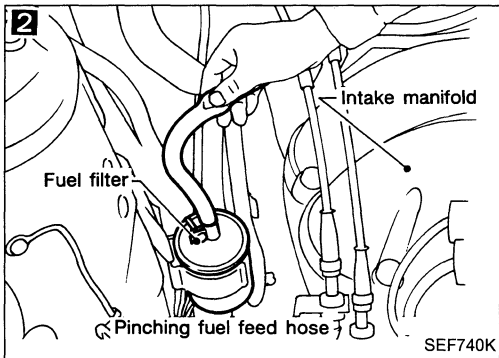
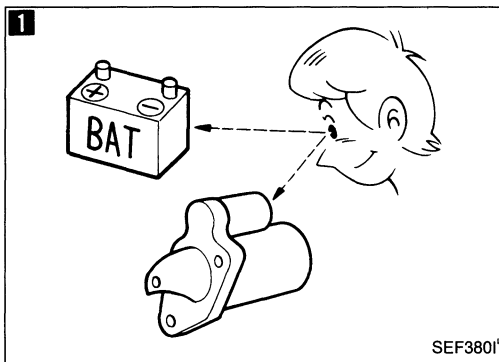

Diagnostic Procedure 4 — Hard to Start or Impossible to Start when the Engine is Cold

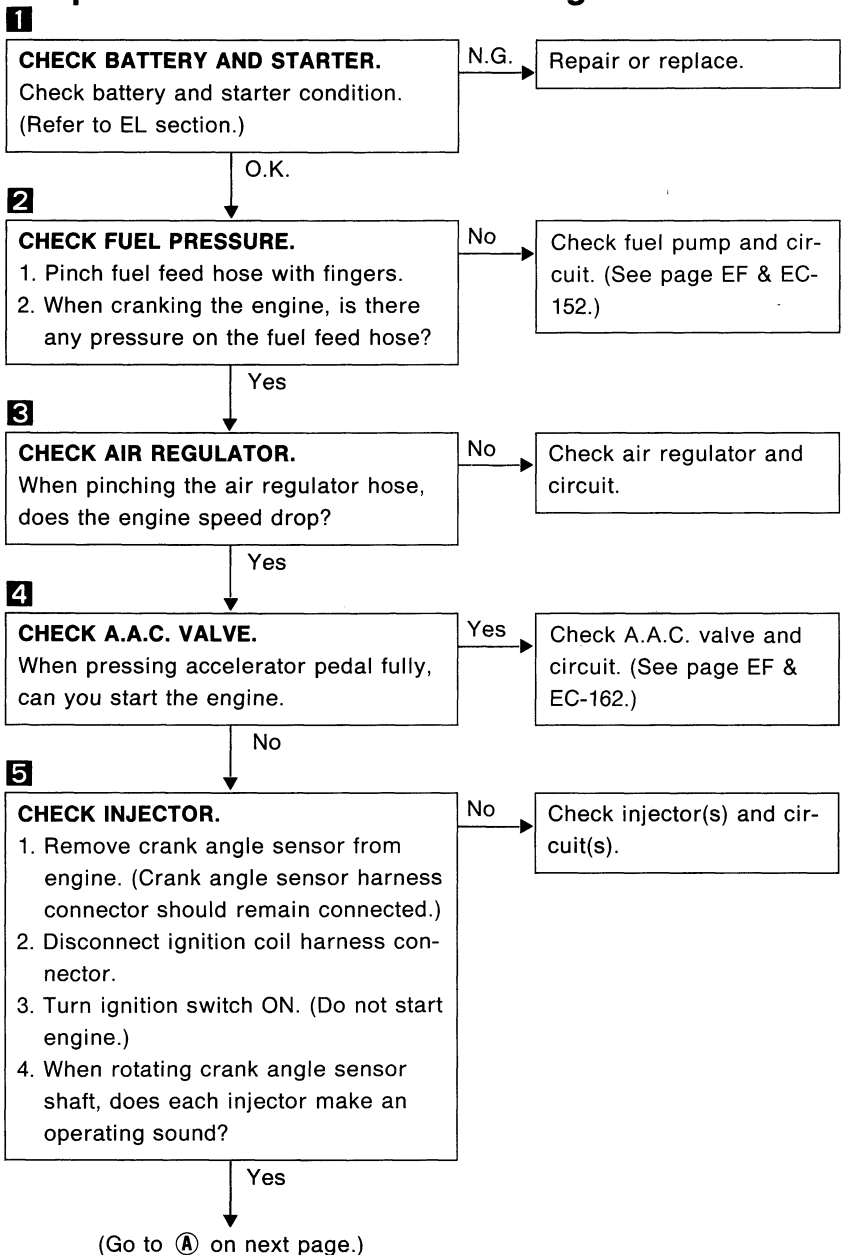

TROUBLE DIAGNOSES

Diagnostic Procedure 4 — Hard to Start or Impossible to Start when the Engine is Cold (Cont'd)

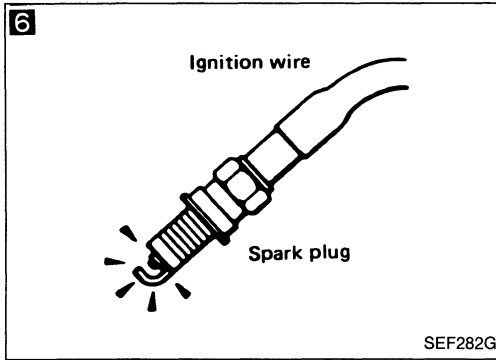

6

CHECK IGNITION SPARK.

1. Disconnect ignition wire from rocker cover.
2. Connect a known good spark plug to the ignition wire.
3. Place end of spark plug against a suitable ground and crank engine.
4. Check for spark.

N.G. → Check ignition coil, power transistor unit and their circuits. (See page EF & EC-114.)

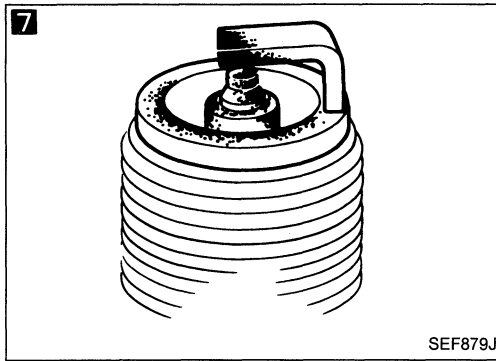

7

CHECK SPARK PLUGS.
Remove the spark plugs and check for fouling, etc.

N.G. → Repair or replace spark plug(s).

8

CHECK E.C.U. HARNESS CONNECTOR.
Check the E.C.U. pin terminals for damage or poor connection of E.C.U. harness connector.

N.G. → Repair or replace.

9

CHECK E.C.U. POWER SUPPLY AND GROUND CIRCUIT.
Refer to page EF & EC-96.

N.G. → Repair or replace.

10

TRY A KNOWN GOOD E.C.U.*

INSPECTION END

*: E.C.U. may be the cause of a problem, but this is rarely the case.

TROUBLE DIAGNOSES

Diagnostic Procedure 5 — Hard to Start or Impossible to Start when the Engine is Hot

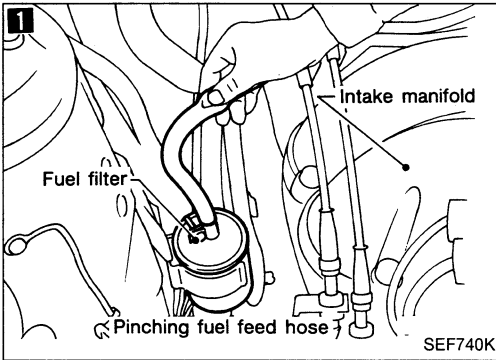

1
CHECK FUEL PRESSURE.
1. Pinch fuel feed hose with fingers.
2. When cranking the engine, is there any pressure on the fuel feed hose?

No → Check fuel pump and circuit. (See page EF & EC-152.)

Yes

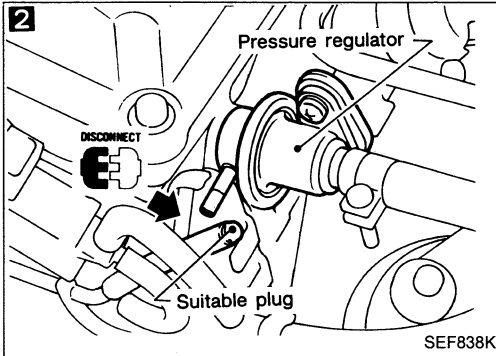

2
CHECK FUEL VAPOR.
1. Disconnect fuel pressure regulator vacuum hose and plug hose.
2. Can you start engine?

Yes → Check fuel properties.

No

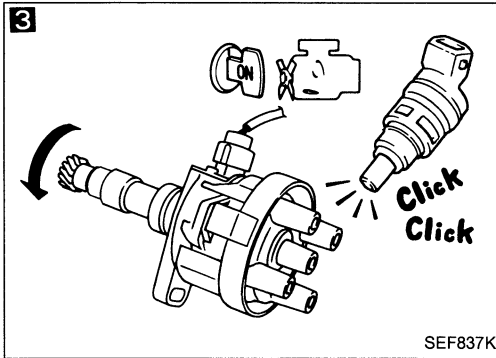

3
CHECK INJECTOR.
1. Remove crank angle sensor from engine. (Crank angle sensor harness connector should remain connected.)
2. Disconnect ignition coil harness connector.
3. Turn ignition switch ON. (Do not start engine.)
4. When rotating crank angle sensor shaft, does each injector make an operating sound?

No → Check injector(s) and circuit(s).

Yes

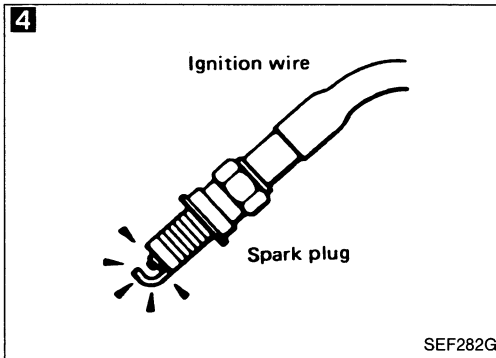

4
CHECK IGNITION SPARK.
1. Disconnect ignition wire from rocker cover.
2. Connect a known good spark plug to the ignition wire.
3. Place end of spark plug against a suitable ground and crank engine.
4. Check for spark.

N.G. → Check ignition coil, power transistor unit and circuits. (See page EF & EC-114.)

O.K.

(Go to **A** on next page.)

TROUBLE DIAGNOSES

Diagnostic Procedure 5 — Hard to Start or Impossible to Start when the Engine is Hot (Cont'd)

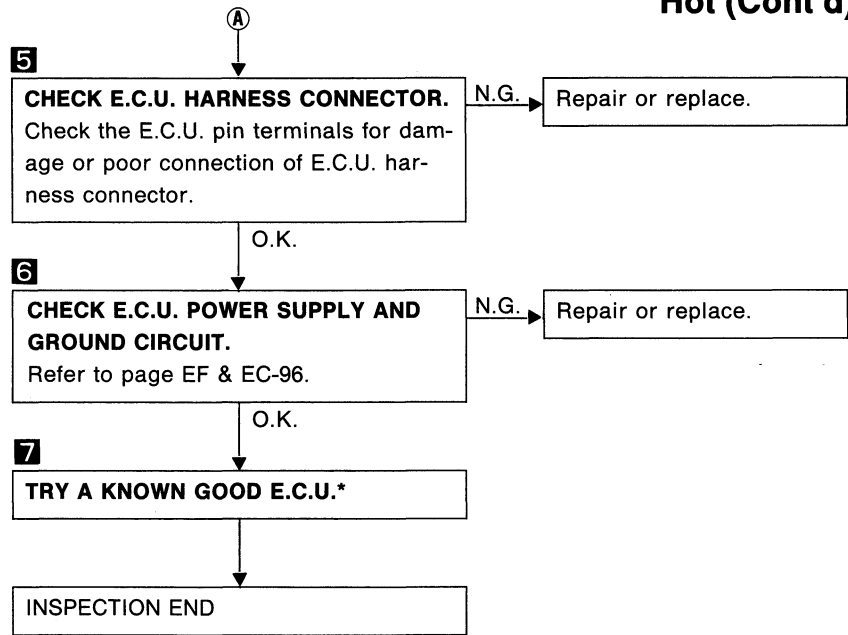

*: E.C.U. may be the cause of a problem, but this is rarely the case.

TROUBLE DIAGNOSES

Diagnostic Procedure 6 — Hard to Start or Impossible to Start under Normal Conditions

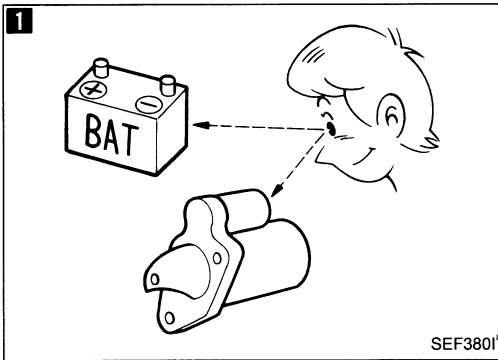

SEF380I

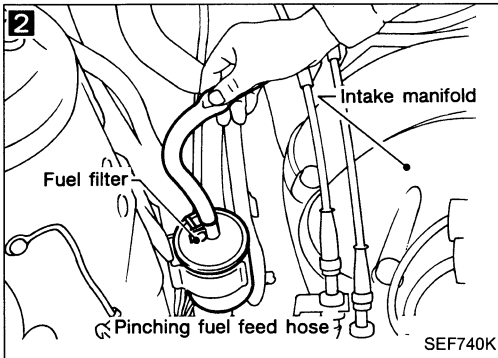

SEF740K

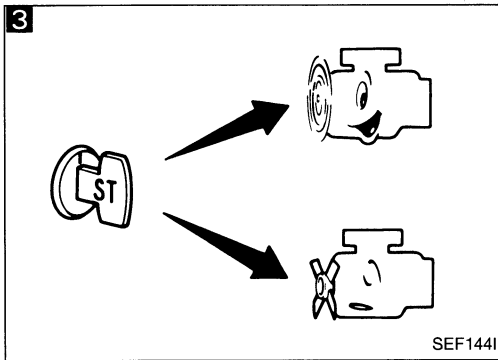

SEF144I

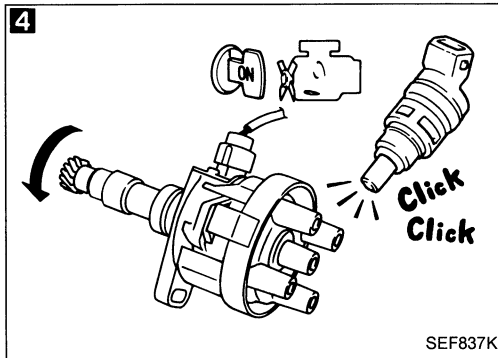

SEF837K

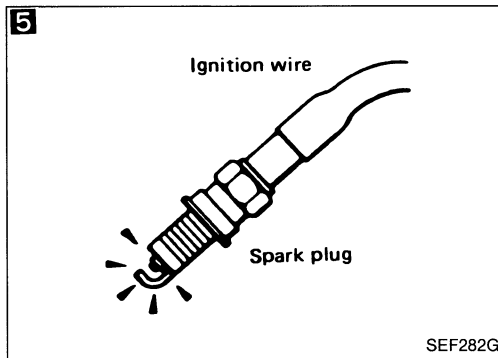

SEF282G

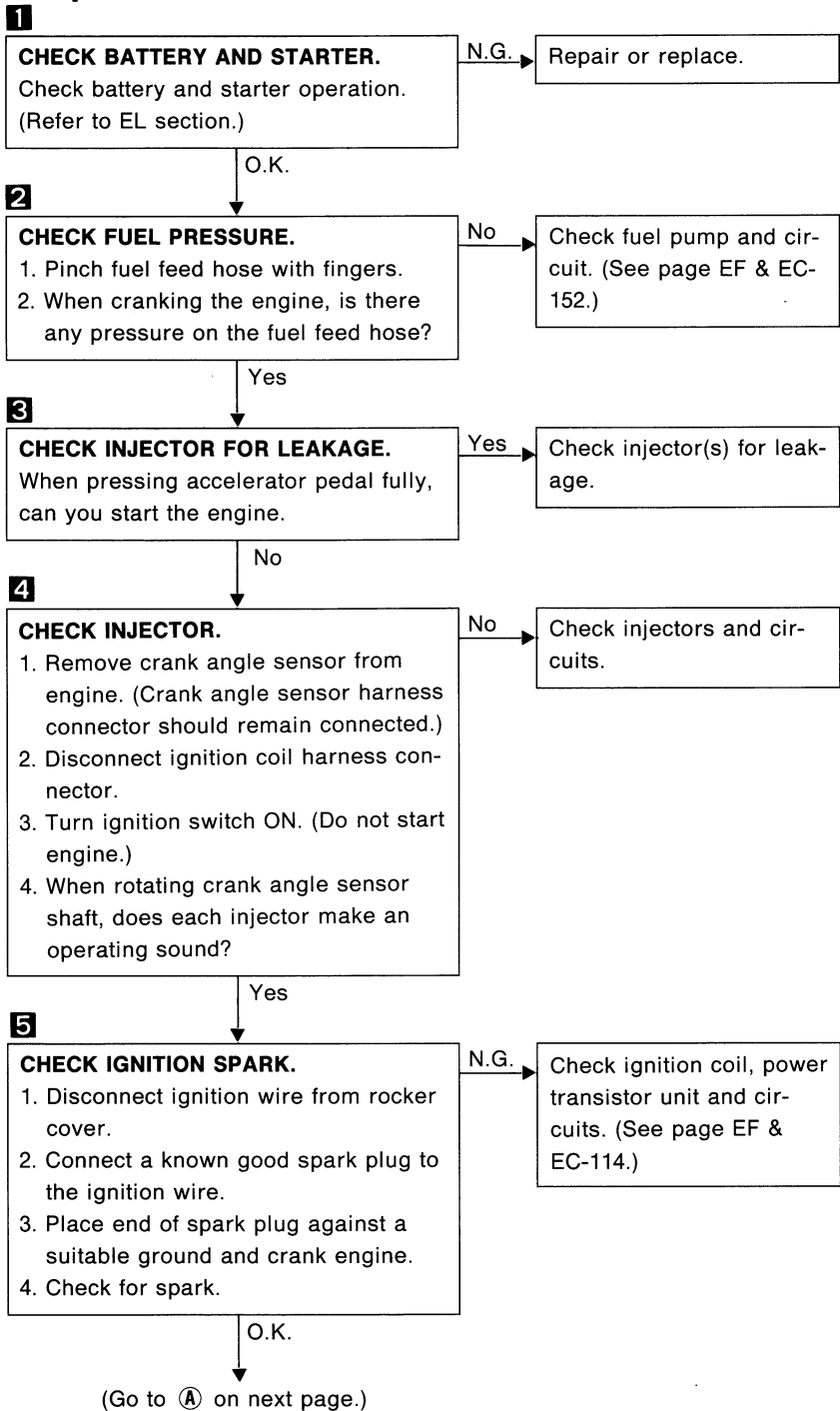

TROUBLE DIAGNOSES

Diagnostic Procedure 6 — Hard to Start or Impossible to Start under Normal Conditions (Cont'd)

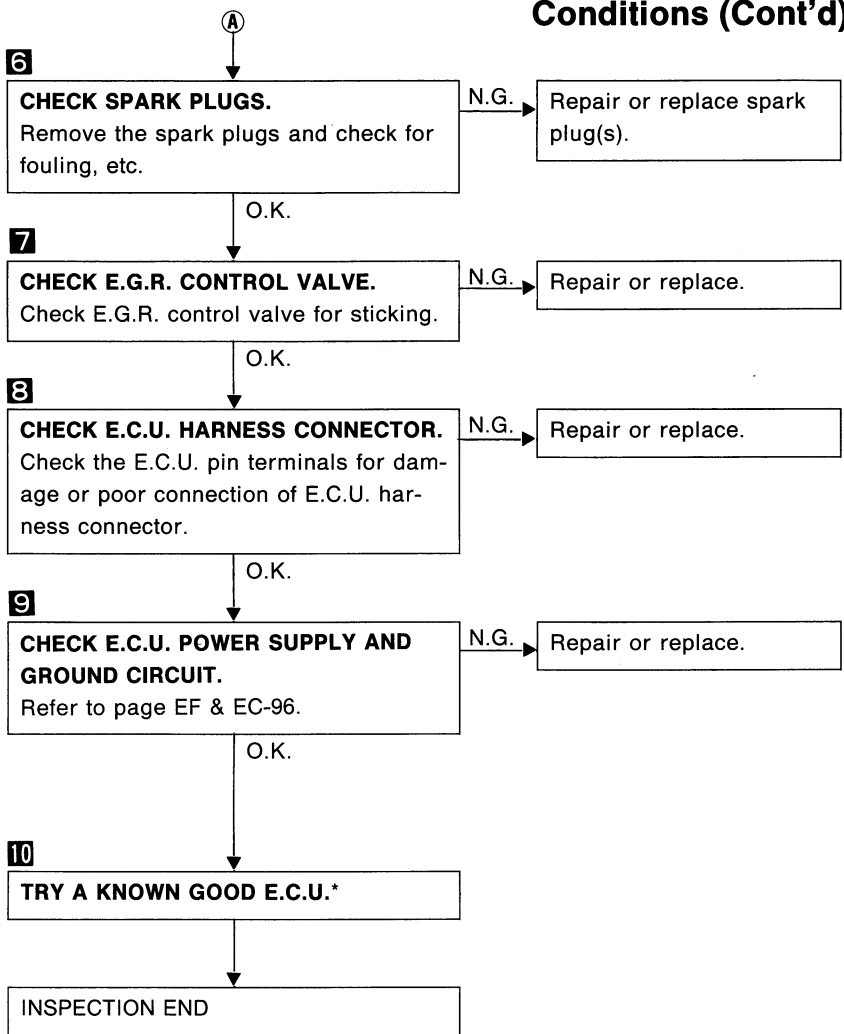
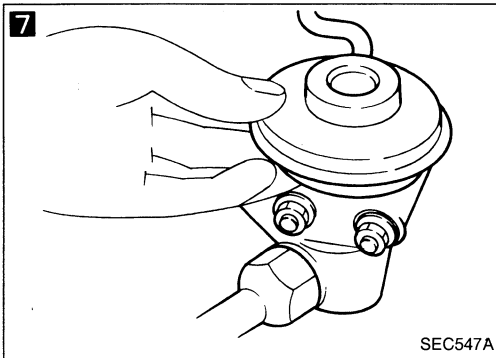
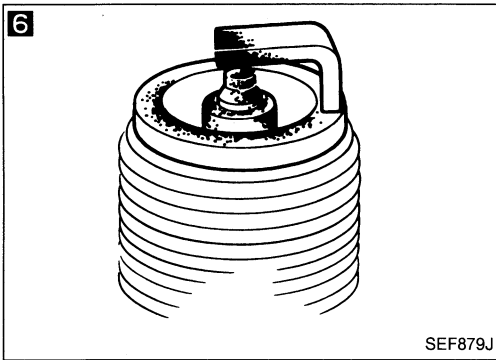

*: E.C.U. may be the cause of a problem, but this is rarely the case.

TROUBLE DIAGNOSES

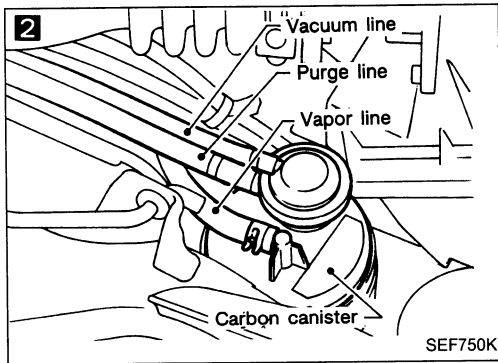
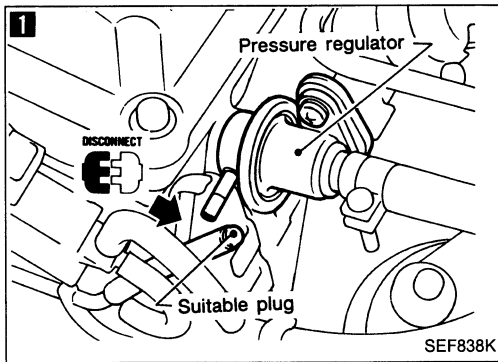

Diagnostic Procedure 7 — Hesitation when the Engine is Hot

1

CHECK FUEL VAPOR.

1. Disconnect fuel pressure regulator vacuum hose and plug hose.
2. Perform cruise test.
3. Does the hesitation disappear?

Yes → Check fuel properties.

No

2

CHECK CANISTER PURGE.

1. Disconnect canister purge line hose and plug hose.
2. Perform cruise test.
3. Does the hesitation disappear?

Yes → Check purge and vacuum lines.

No

INSPECTION END

TROUBLE DIAGNOSES

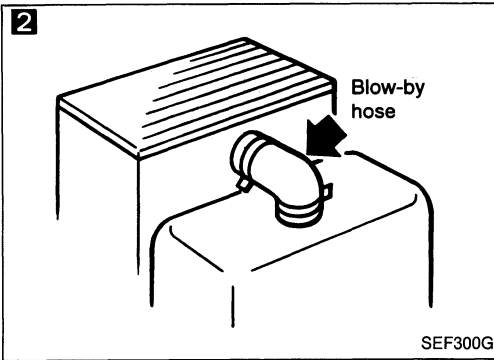
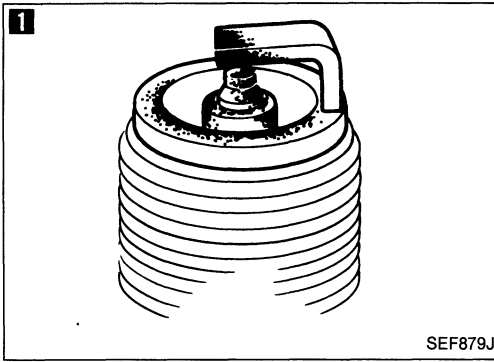

Diagnostic Procedure 8 — Hesitation when the Engine is Cold

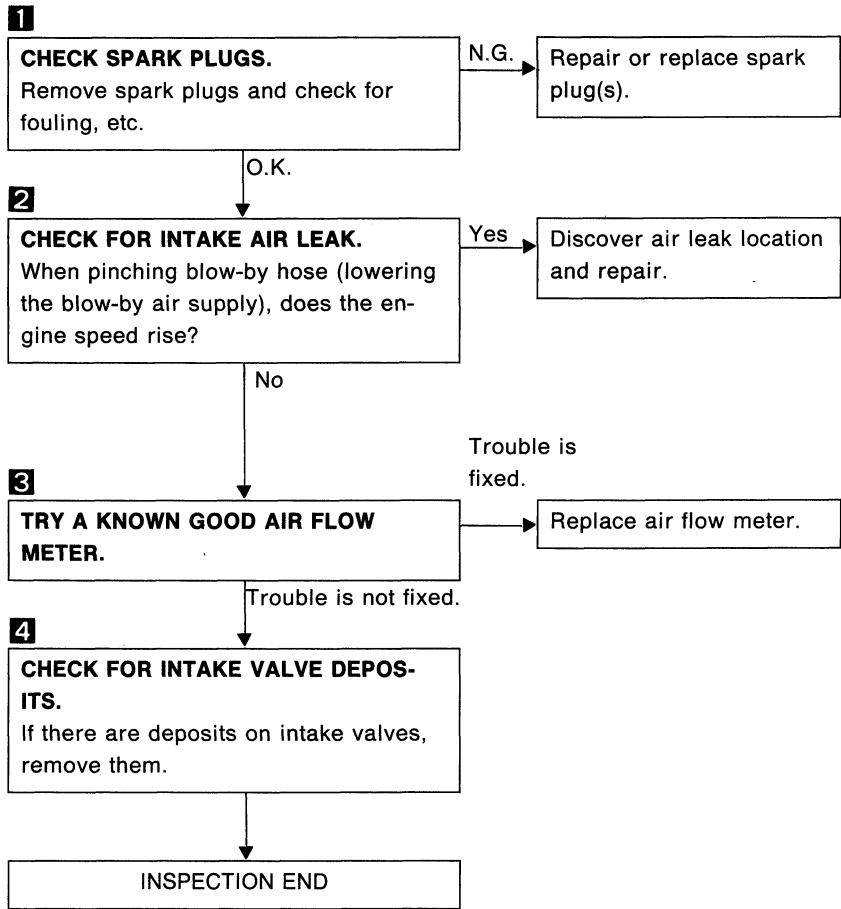

TROUBLE DIAGNOSES

Diagnostic Procedure 9 — Hesitation under Normal Conditions

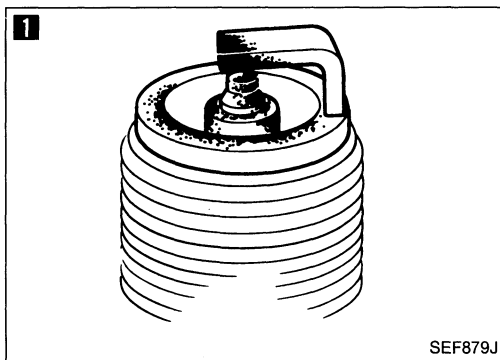

SEF879J

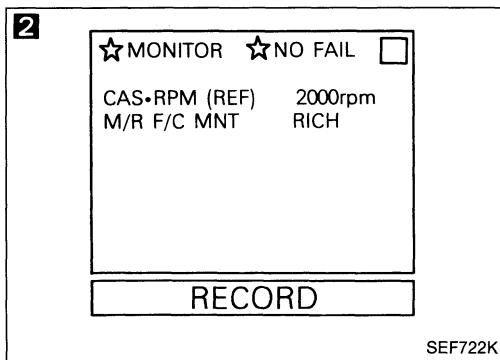

SEF722K

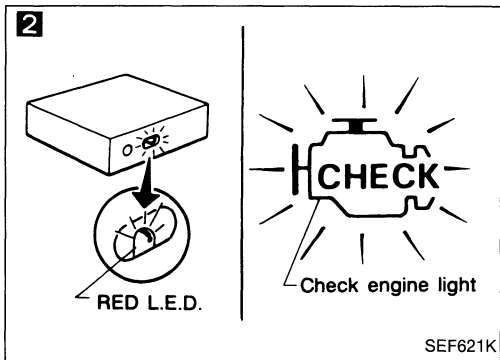

SEF621K

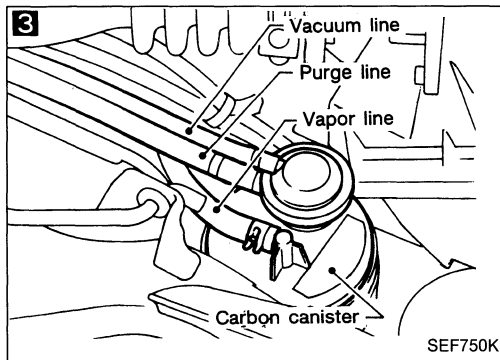

SEF750K

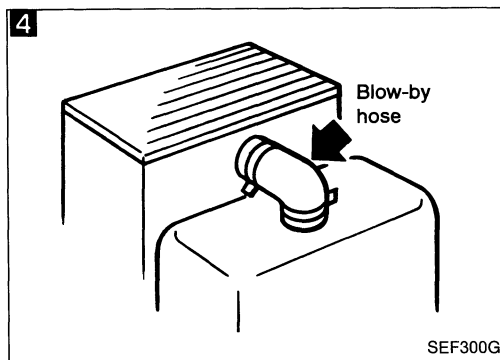

SEF300G

1

CHECK SPARK PLUGS.

Remove spark plugs and check for fouling, etc.

N.G.

Repair or replace spark plug(s).

O.K.

2

CHECK EXHAUST GAS SENSOR.



1. See "M/R F/C MNT" in "DATA MONITOR" mode.
2. Maintaining engine at 2,000 rpm under no-load (with engine warmed up sufficiently), check to make sure that the monitor fluctuates between "LEAN" and "RICH" more than 5 times during 10 seconds.

RICH → LEAN → RICH →
1 time 2 times
LEAN → RICH.....

OR



1. Set "Exhaust gas sensor monitor" in the self-diagnostic Mode II. (See page EF & EC-45.)
2. Maintaining engine at 2,000 rpm under no load, check that check engine light or RED LED on the E.C.U. goes ON and OFF more than 5 times during 10 seconds.

Yes

Replace exhaust gas sensor(s).

No

3

CHECK CANISTER PURGE.

1. Disconnect canister purge line hose and plug hose.
2. Perform cruise test.
3. Does the hesitation disappear?

Yes

Check purge and vacuum lines.

No

4

CHECK FOR INTAKE AIR LEAK.

When pinching blow-by hose (lowering the blow-by air supply), does the engine speed rise?

Yes

Discover air leak location and repair.

No

INSPECTION END

TROUBLE DIAGNOSES

Diagnostic Procedure 10 — Engine Stalls when Turning

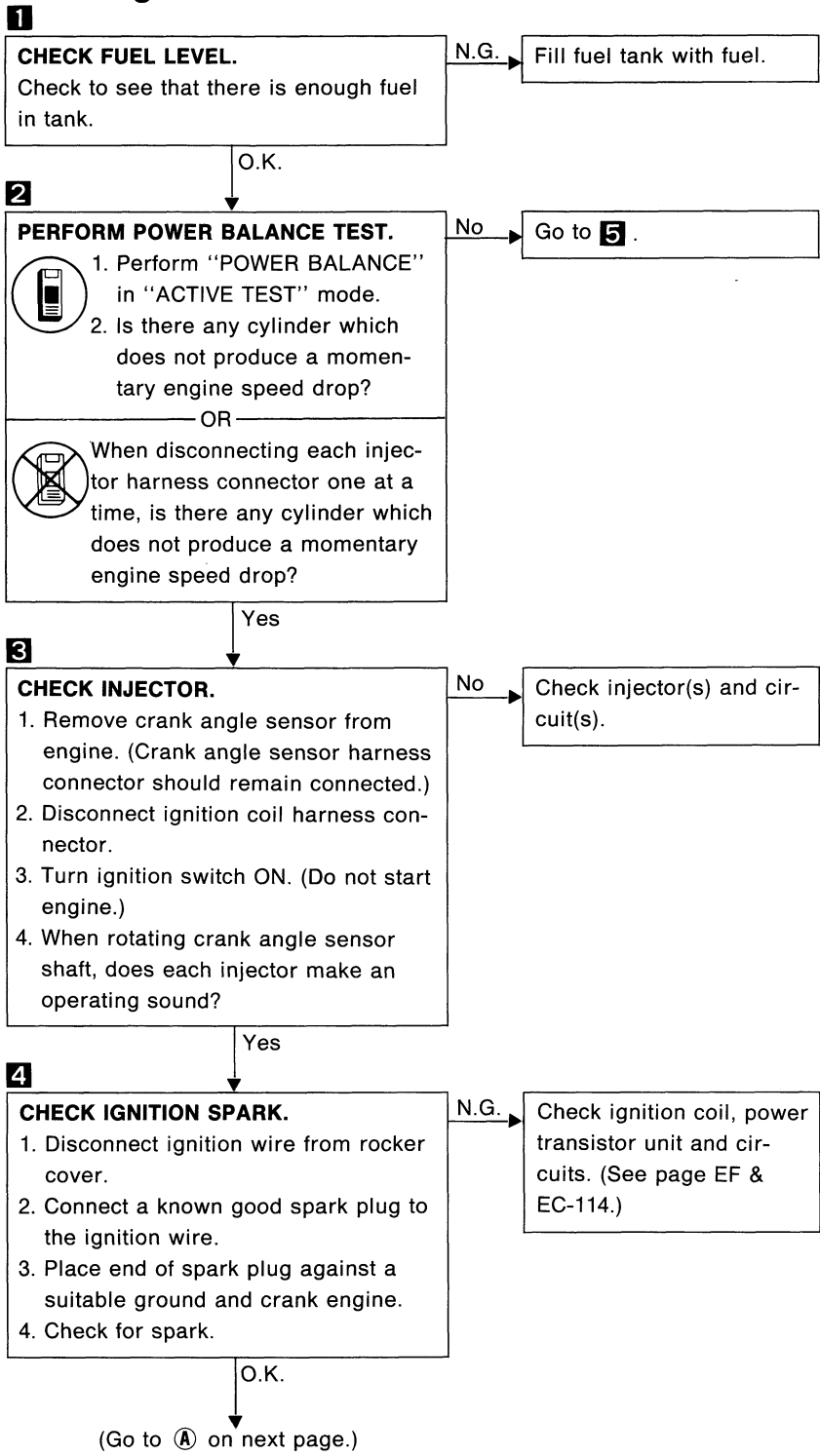
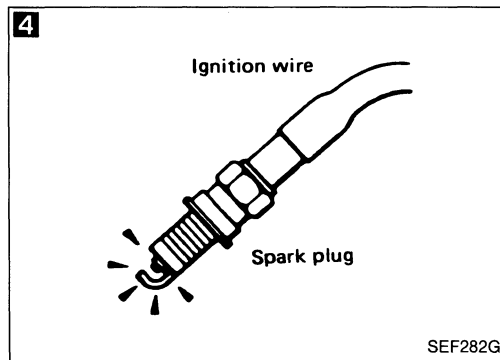
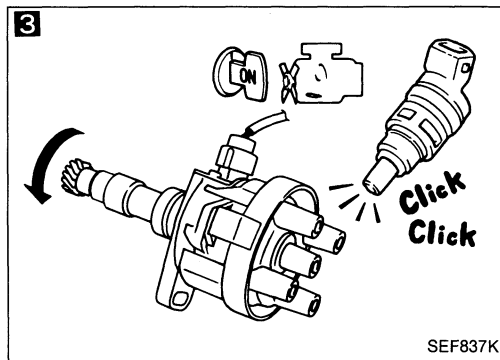
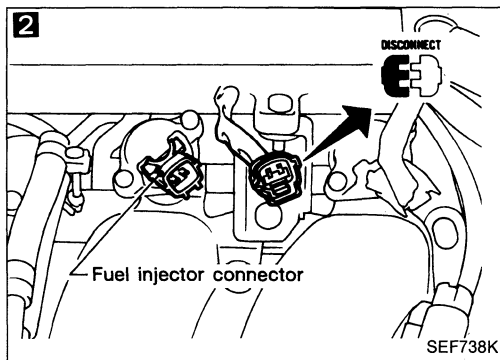
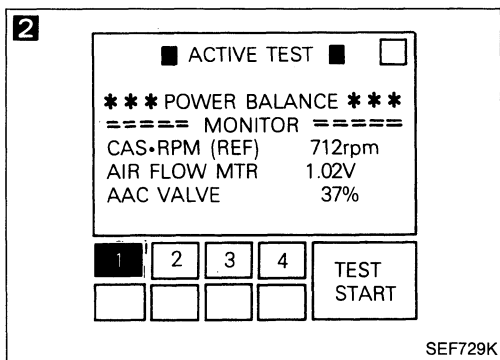
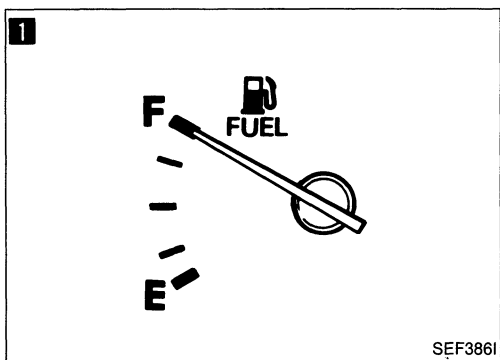

TROUBLE DIAGNOSES

Diagnostic Procedure 10 — Engine Stalls when Turning (Cont'd)

5

■ FUEL PRES RELEASE ■

FUEL PUMP WILL STOP BY TOUCHING START IN IDLING. CRANK A FEW TIMES AFTER ENGINE STALL.

START



SEF379I

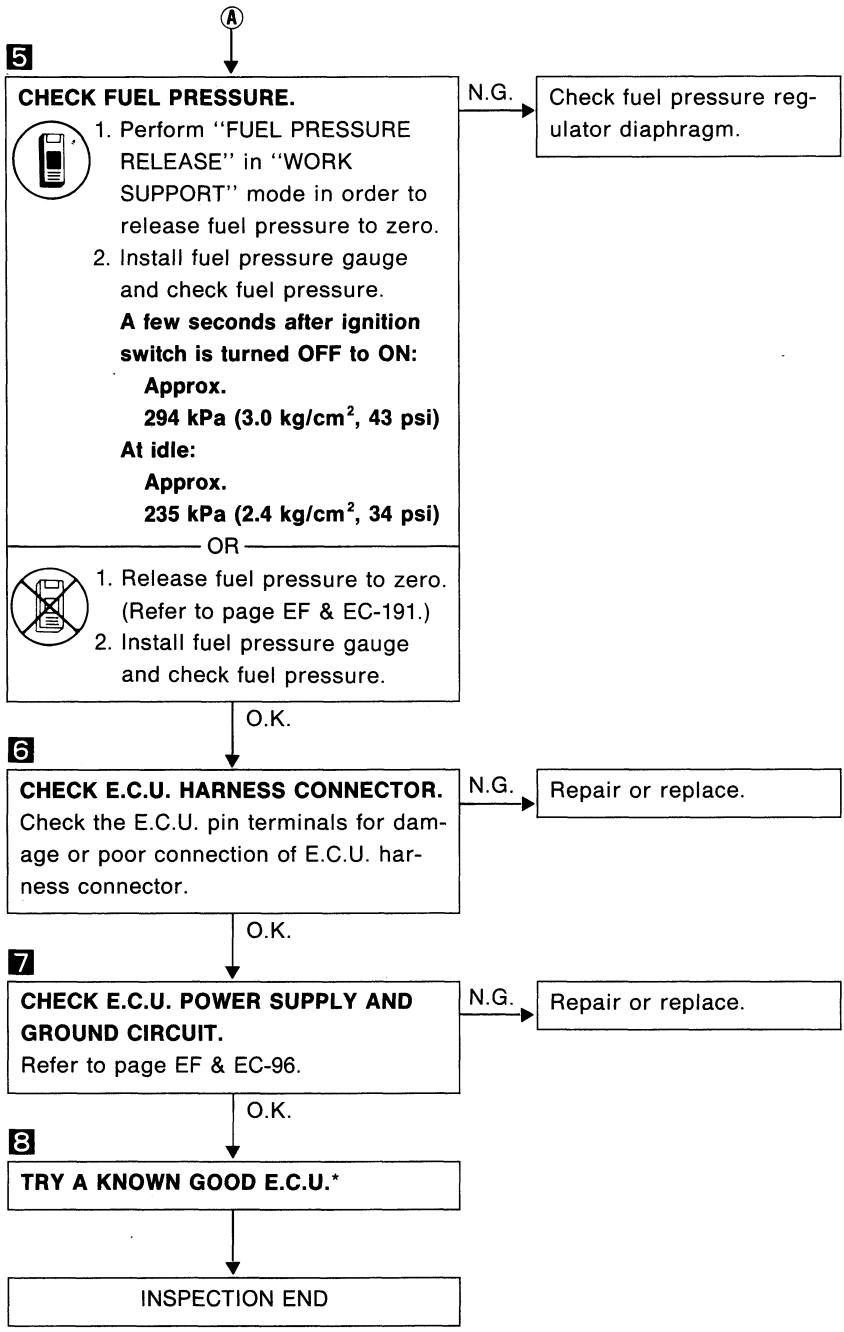

*: E.C.U. may be the cause of a problem, but this is rarely the case.

TROUBLE DIAGNOSES

Diagnostic Procedure 11 — Engine Stalls when the Engine is Hot

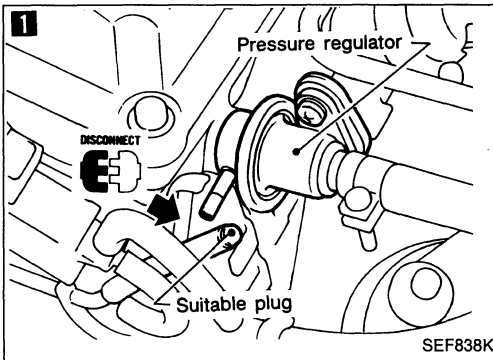

1
CHECK FUEL VAPOR.
1. Disconnect fuel pressure regulator vacuum hose and plug hose.
2. Perform cruise test.
3. Does the engine stall disappear?

Yes → Check fuel properties.

No

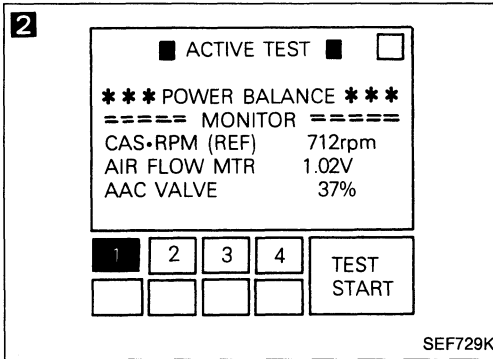

2
PERFORM POWER BALANCE TEST.
1. Perform "POWER BALANCE" in "ACTIVE TEST" mode.
2. Is there any cylinder which does not produce a momentary engine speed drop?

No → Go to 5.

OR

When disconnecting each injector harness connector one at a time, is there any cylinder which does not produce a momentary engine speed drop?

Yes

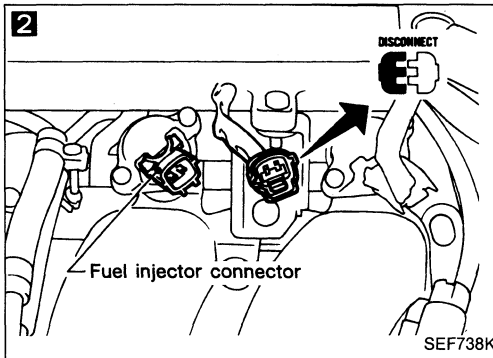

3
CHECK INJECTOR.
1. Remove distributor assembly from engine. (Crank angle sensor harness connector should remain connected.)
2. Disconnect ignition coil harness connector.
3. Turn ignition switch ON. (Do not start engine.)
4. When rotating crank angle sensor shaft, does each injector make an operating sound?

No → Check injector(s) and circuit(s).

Yes

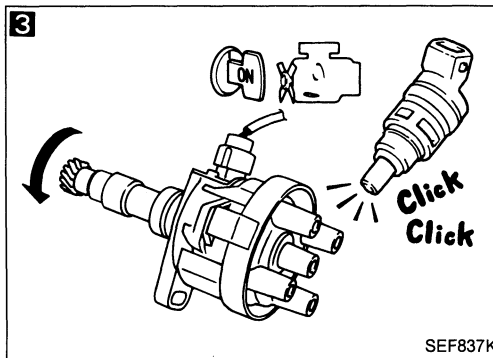

4
CHECK IGNITION SPARK.
1. Disconnect ignition wire from rocker cover.
2. Connect a known good spark plug to the ignition wire.
3. Place end of spark plug against a suitable ground and crank engine.
4. Check for spark.

N.G. → Check ignition coil, power transistor unit and their circuits. (See page EF & EC-114.)

O.K.

(Go to A on next page.)

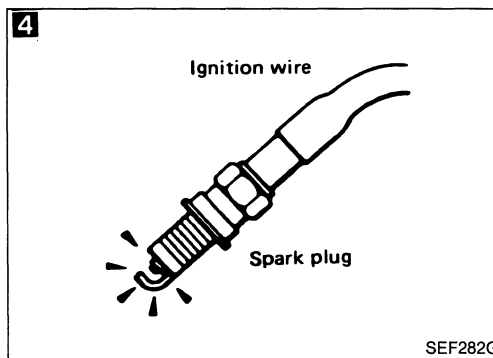

TROUBLE DIAGNOSES

Diagnostic Procedure 11 — Engine Stalls when the Engine is Hot (Cont'd)

5

■ FUEL PRES RELEASE ■

FUEL PUMP WILL STOP BY TOUCHING START IN IDLING. CRANK A FEW TIMES AFTER ENGINE STALL.

START



SEF3791

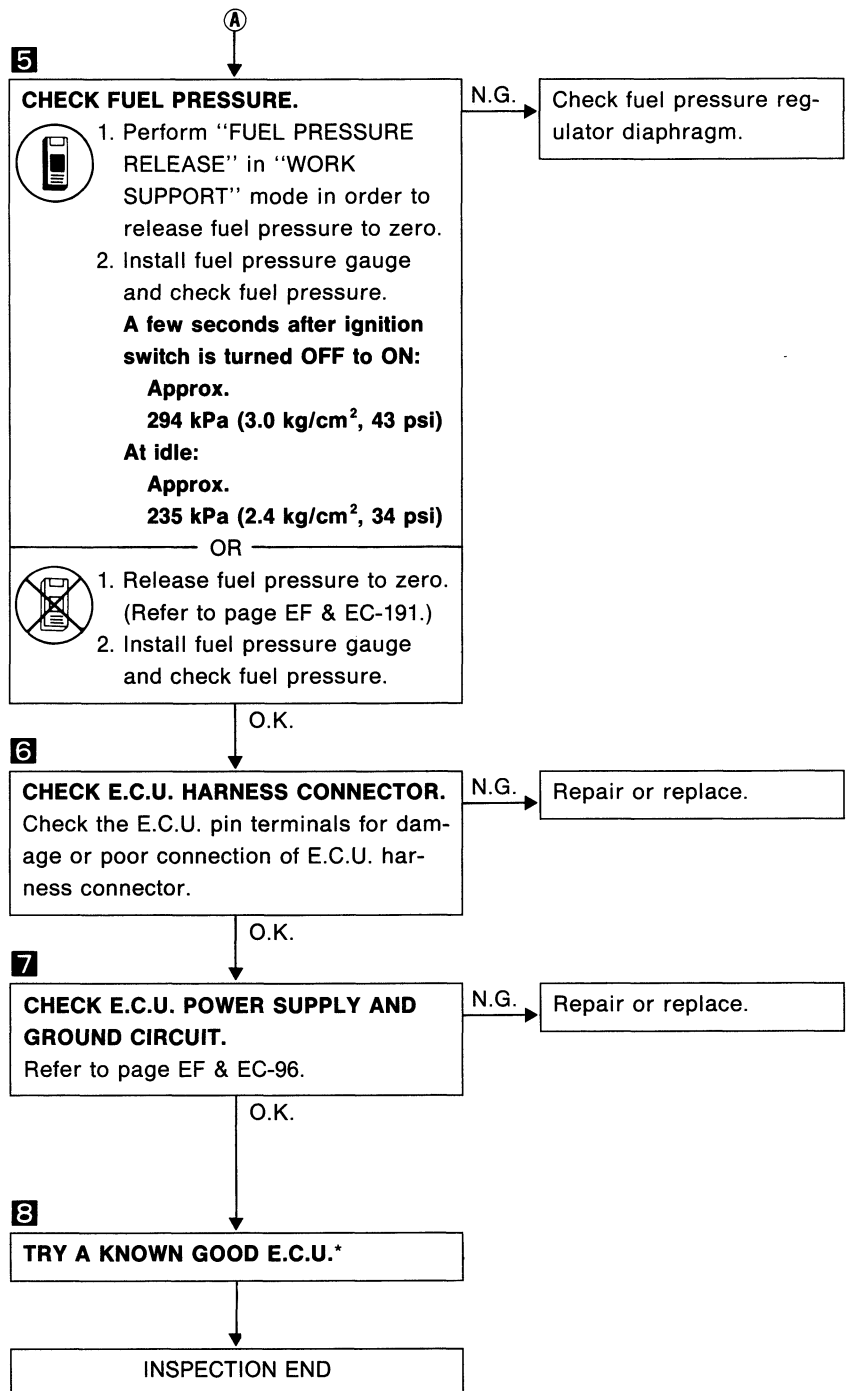

*: E.C.U. may be the cause of a problem, but this is rarely the case.

TROUBLE DIAGNOSES

Diagnostic Procedure 12 — Engine Stalls when the Engine is Cold

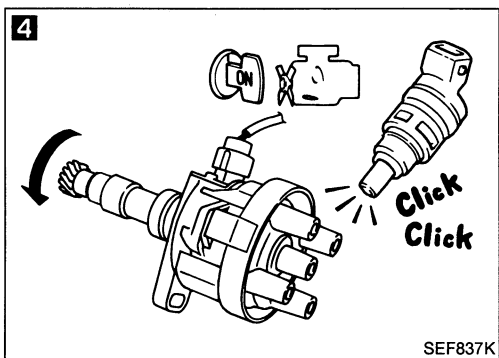
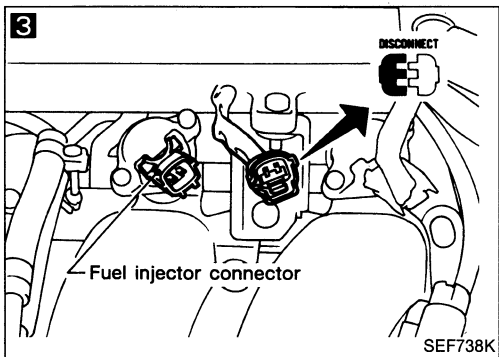
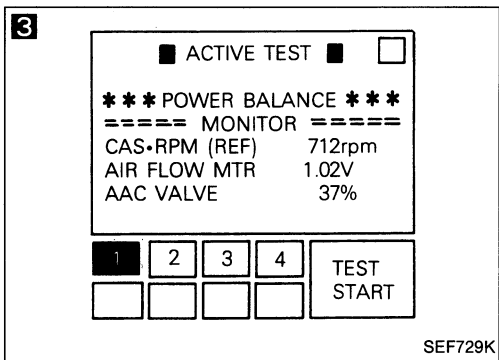
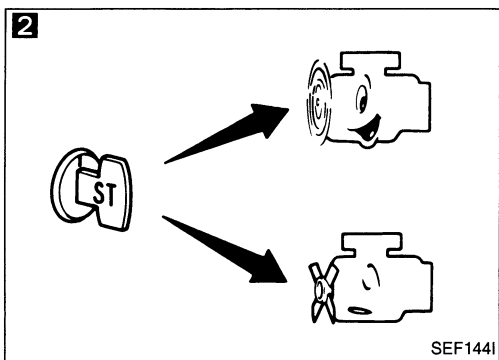
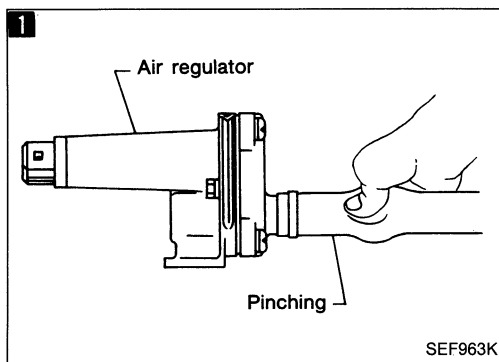

1
CHECK AIR REGULATOR.
When pinching the air regulator hose, does the engine speed drop?

No → Check air regulator and circuit.

Yes
2
CHECK A.A.C. VALVE.
When the engine is cold, can you start the engine when pressing accelerator pedal fully?

Yes → Check A.A.C. valve and circuits. (See page EF & EC-162.)

No
3
PERFORM POWER BALANCE TEST.
1. Perform "POWER BALANCE" in "ACTIVE TEST" mode.
2. Is there any cylinder which does not produce a momentary engine speed drop?

N.G. → Go to **7**.

OR
When disconnecting each injector harness connector one at a time, is there any cylinder which does not produce a momentary engine speed drop?

O.K.

4
CHECK INJECTOR.
1. Remove crank angle sensor assembly from engine. (Crank angle sensor harness connector should remain connected.)
2. Disconnect ignition coil harness connector.
3. Turn ignition switch ON. (Do not start engine.)
4. When rotating crank angle sensor shaft, does each injector make an operating sound?

N.G. → Check injector(s) and circuit(s).

O.K.

(Go to **A** on next page.)

TROUBLE DIAGNOSES

Diagnostic Procedure 12 — Engine Stalls when the Engine is Cold (Cont'd)

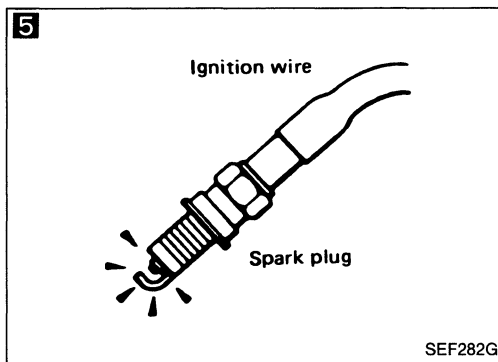

- 5**
- CHECK IGNITION SPARK.**
1. Disconnect ignition wire from rocker cover.
 2. Connect a known good spark plug to the ignition wire.
 3. Place end of spark plug against a suitable ground and crank engine.
 4. Check for spark.

N.G. → Check ignition coil, power transistor unit and circuits. (See page EF & EC-114.)

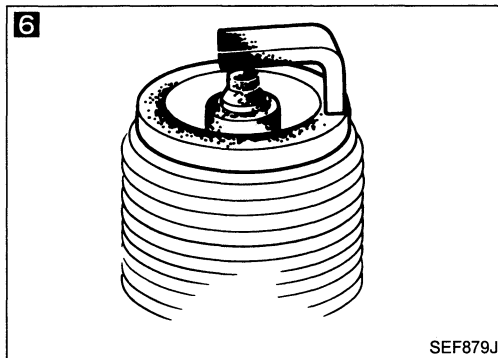

- 6**
- CHECK SPARK PLUGS.**
- Remove the spark plugs and check for fouling, etc.

N.G. → Repair or replace spark plug(s).

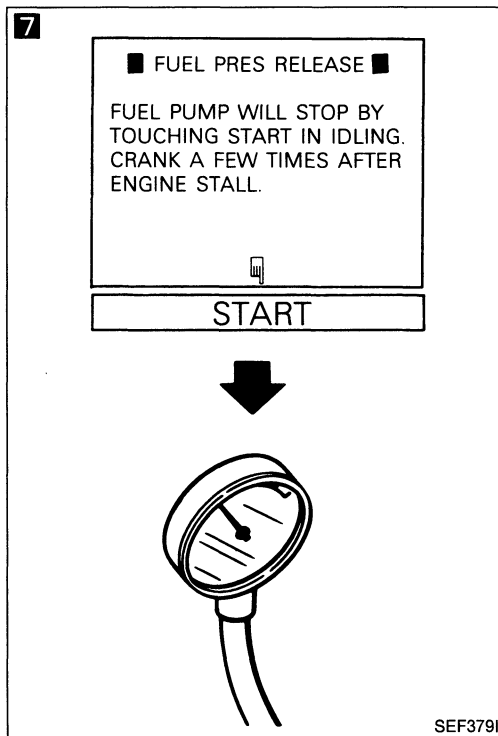

- 7**
- CHECK FUEL PRESSURE.**
1. Perform "FUEL PRESSURE RELEASE" in "WORK SUPPORT" mode in order to release fuel pressure to zero.
 2. Install fuel pressure gauge and check fuel pressure.
- A few seconds after ignition switch is turned OFF to ON:**
- Approx.**
294 kPa (3.0 kg/cm², 43 psi)
- At idle:**
Approx.
235 kPa (2.4 kg/cm², 34 psi)
- OR
1. Release fuel pressure to zero. (Refer to page EF & EC-191.)
 2. Install fuel pressure gauge and check fuel pressure.

N.G. → Check fuel pressure regulator diaphragm.

- 8**
- CHECK E.C.U. HARNESS CONNECTOR.**
- Check the E.C.U. pin terminals for damage or poor connection of E.C.U. harness connector.

N.G. → Repair or replace.

- 9**
- CHECK E.C.U. POWER SUPPLY AND GROUND CIRCUIT.**
- Refer to page EF & EC-96.

N.G. → Repair or replace.

- 10**
- TRY A KNOWN GOOD E.C.U.***

INSPECTION END

*: E.C.U. may be the cause of a problem, but this is rarely the case.

Diagnostic Procedure 13 — Engine Stalls when Stepping on the Accelerator Momentarily

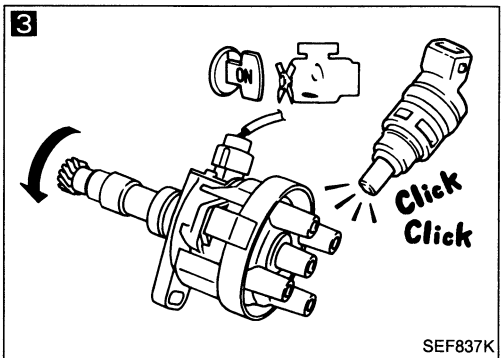
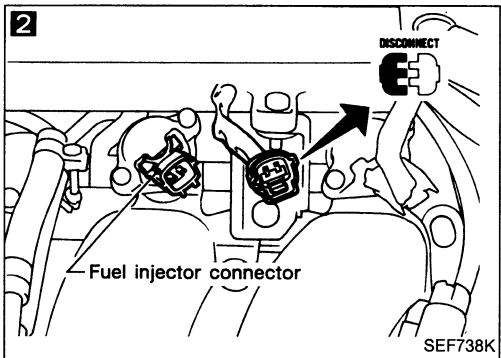
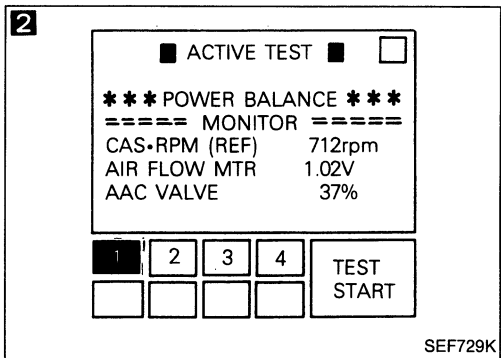
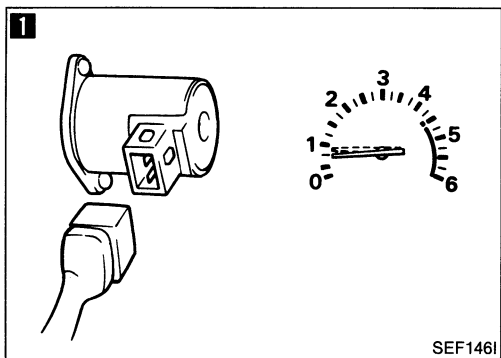
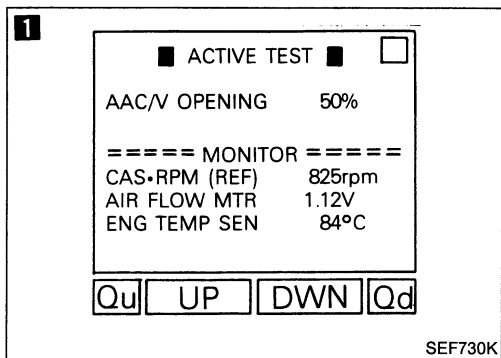

1

CHECK A.A.C. VALVE.

1. Select "A.A.C. VALVE OPENING" in "ACTIVE TEST" mode.
2. When touching "Qu" and "Qd", does the engine speed change according to the percent of A.A.C. valve opening?

OR

 When disconnecting A.A.C. valve harness connector, does the engine speed drop?

No → Check A.A.C. valve and circuit. (See page EF & EC-162.)

2

PERFORM POWER BALANCE TEST.

1. Perform "POWER BALANCE" in "ACTIVE TEST" mode.
2. Is there any cylinder which does not produce a momentary engine speed drop?

OR

 When disconnecting each injector harness connector one at a time, is there any cylinder which does not produce a momentary engine speed drop?

No → Go to **5**.

3

CHECK INJECTOR.

1. Remove distributor assembly from engine. (Crank angle sensor harness connector should remain connected.)
2. Disconnect ignition coil harness connector.
3. Turn ignition switch ON. (Do not start engine.)
4. When rotating crank angle sensor shaft, does each injector make an operating sound?

No → Check injector(s) and their circuit(s).

(Go to **A** on next page.)

TROUBLE DIAGNOSES

Diagnostic Procedure 13 — Engine Stalls when Stepping on the Accelerator Momentarily (Cont'd)

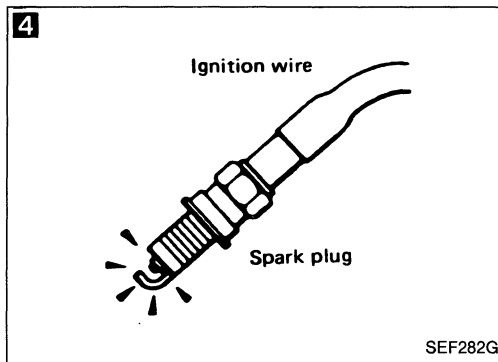

4

CHECK IGNITION SPARK.

1. Disconnect ignition wire from rocker cover.
2. Connect a known good spark plug to the ignition wire.
3. Place end of spark plug against an earth point with engine cranking.
4. Check for spark.

N.G. → Check ignition coil, power transistor unit and their circuits. (See page EF & EC-114.)

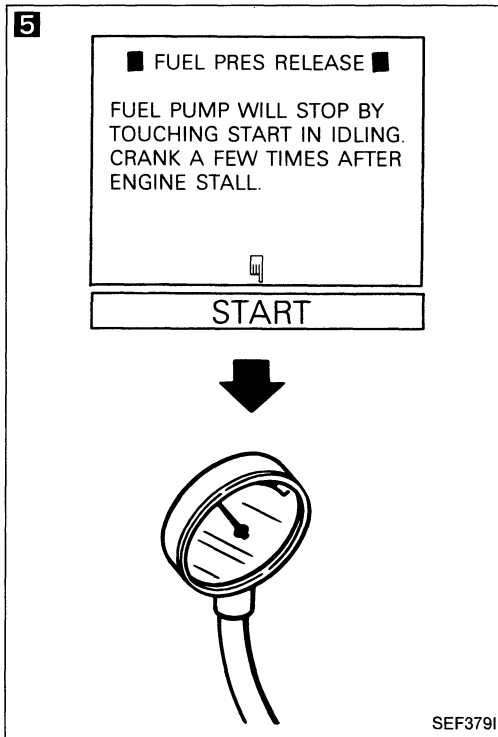

5

CHECK FUEL PRESSURE.

1. Perform "FUEL PRESSURE RELEASE" in "WORK SUPPORT" mode in order to release fuel pressure to zero.
2. Install fuel pressure gauge and check fuel pressure.

A few seconds after ignition switch is turned OFF to ON:

Approx.
294 kPa (3.0 kg/cm², 43 psi)

At idle:
Approx.
235 kPa (2.4 kg/cm², 34 psi)

OR

1. Release fuel pressure to zero. (Refer to page EF & EC-191.)
2. Install fuel pressure gauge and check fuel pressure.

N.G. → Check fuel pressure regulator diaphragm.

6

CHECK E.C.U. HARNESS CONNECTOR.

Check the E.C.U. pin terminals for damage or poor connection of E.C.U. harness connector.

N.G. → Repair or replace.

7

CHECK E.C.U. POWER SUPPLY AND GROUND CIRCUIT.

Refer to page EF & EC-96.

N.G. → Repair or replace.

8

TRY A KNOWN GOOD E.C.U.*

INSPECTION END

*: E.C.U. may be the cause of a problem, but this is rarely the case.

TROUBLE DIAGNOSES

Diagnostic Procedure 14 — Engine Stalls after Decelerating

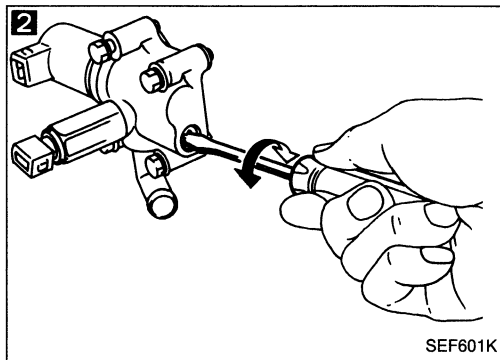
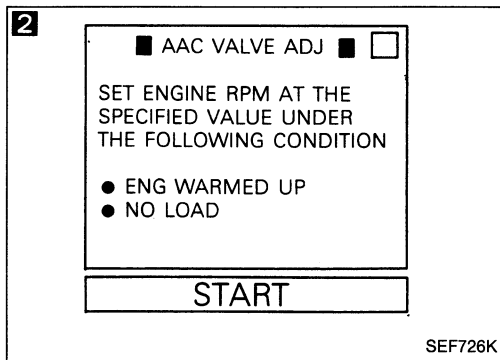
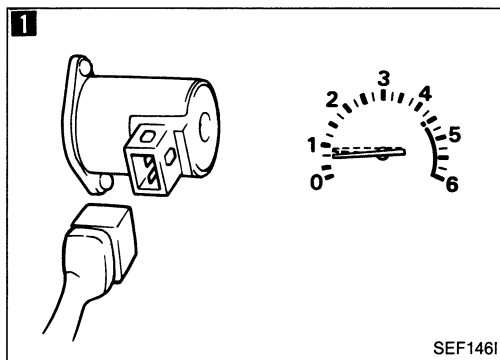
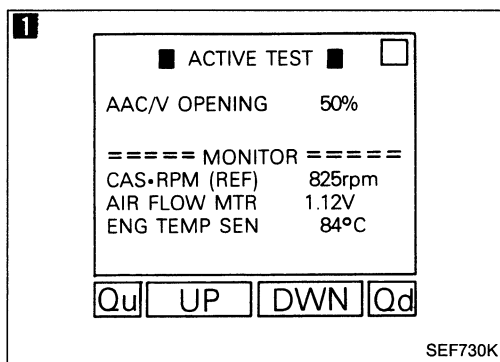

1
CHECK A.A.C. VALVE.
 1. Select "A.A.C. VALVE OPENING" in "ACTIVE TEST" mode.
 2. When touching "Qu" and "Qd", does the engine speed change according to the percent of A.A.C. valve opening?

No → Check A.A.C. valve and circuit. (See page EF & EC-162.)

OR
 When disconnecting A.A.C. valve harness connector, does the engine speed drop?

2
CHECK IDLE ADJ. SCREW CLOGGING.
 1. Perform "A.A.C. VALVE ADJ" in "WORK SUPPORT" mode.
 2. Can you set engine speed at 650 ± 50 rpm (A/T in "N" position) by turning idle adjusting screw?

No → Check for A.A.C. valve clogging or throttle chamber clogging.

OR
 1. Disconnect A.A.C. valve harness connector.
 2. Can you set engine speed at 650 ± 50 rpm (A/T in "N" position) by turning idle adjusting screw?

Yes
 ↓
 (Go to **A** on next page.)

TROUBLE DIAGNOSES

Diagnostic Procedure 14 — Engine Stalls after Decelerating (Cont'd)

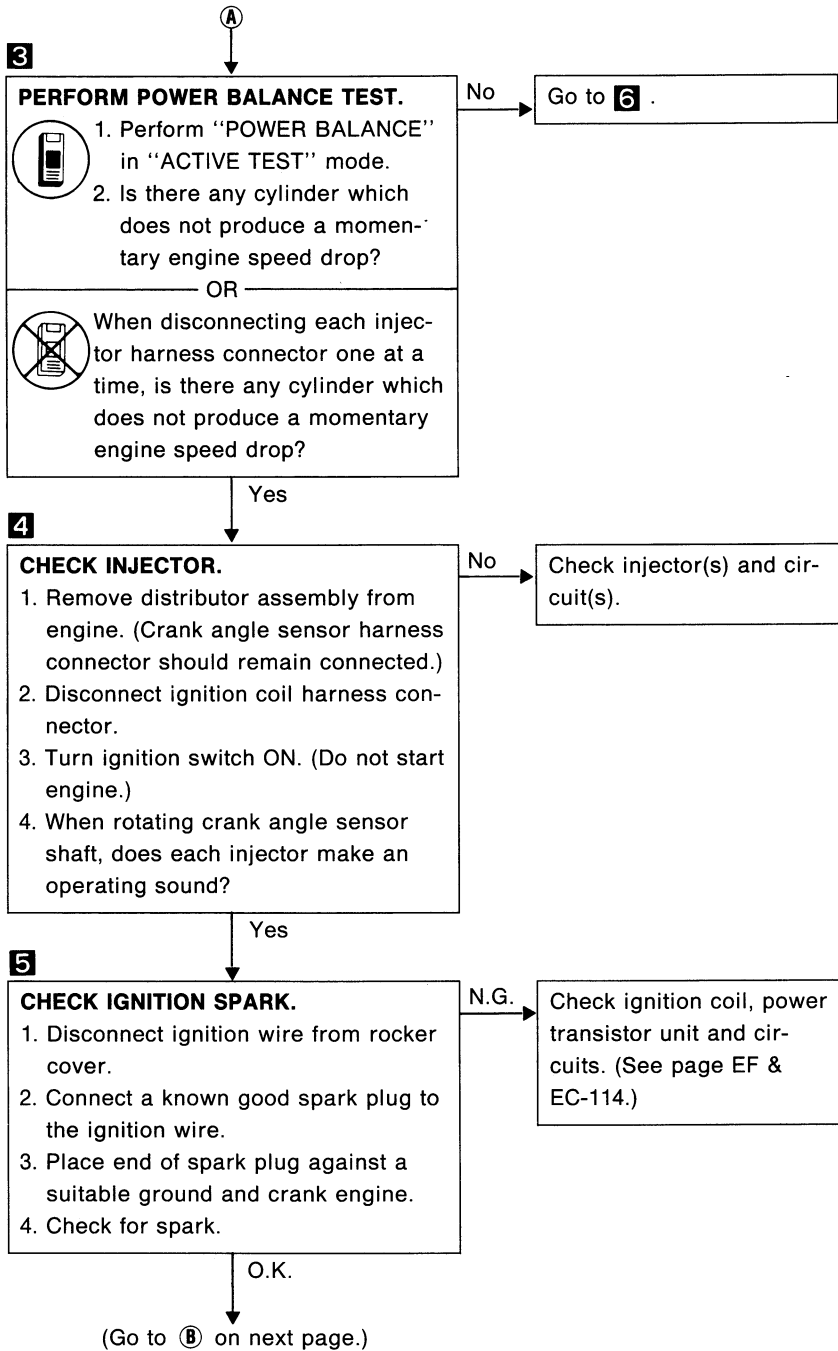
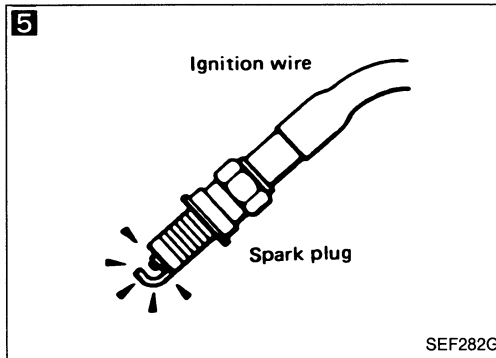
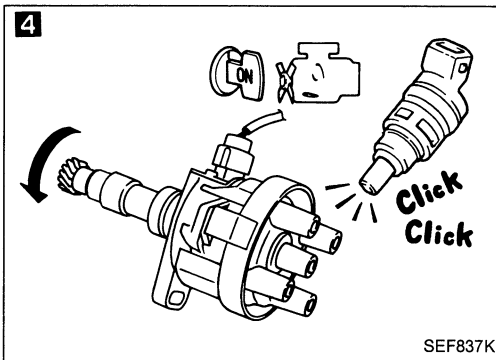
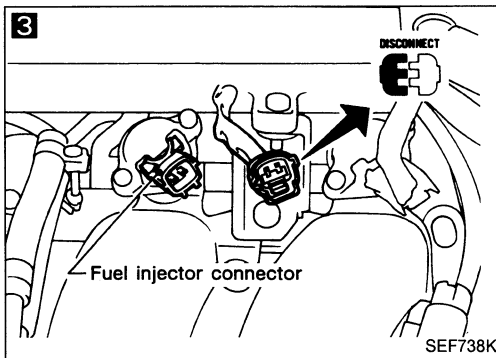
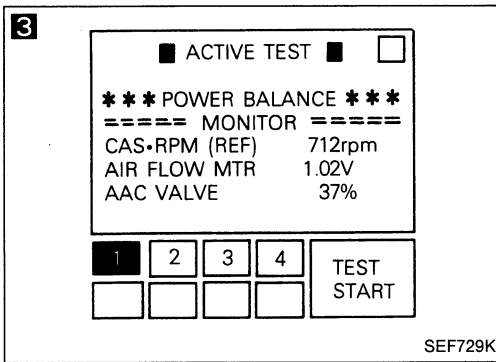

TROUBLE DIAGNOSES

Diagnostic Procedure 14 — Engine Stalls after Decelerating (Cont'd)

6

■ FUEL PRES RELEASE ■

FUEL PUMP WILL STOP BY TOUCHING START IN IDLING. CRANK A FEW TIMES AFTER ENGINE STALL.

START



SEF379I

B

6

CHECK FUEL PRESSURE.

1. Perform "FUEL PRESSURE RELEASE" in "WORK SUPPORT" mode in order to release fuel pressure to zero.
2. Install fuel pressure gauge and check fuel pressure.

A few seconds after ignition switch is turned OFF to ON:
Approx.
294 kPa (3.0 kg/cm², 43 psi)

At idle:
Approx.
235 kPa (2.4 kg/cm², 34 psi)

OR

1. Release fuel pressure to zero. (Refer to page EF & EC-191.)
2. Install fuel pressure gauge and check fuel pressure.

O.K.

N.G. → Check fuel pressure regulator diaphragm.

7

☆ MONITOR ☆ NO FAIL

CAS•RPM (REF) 2000rpm
M/R F/C MNT RICH

RECORD

SEF722K

7

CHECK EXHAUST GAS SENSOR.

1. See "M/R F/C MNT" in "DATA MONITOR" mode.
2. Maintaining engine at 2,000 rpm under no-load (with engine warmed up sufficiently.), check to make sure that the monitor fluctuates between "LEAN" and "RICH" more than 5 times during 10 seconds.

RICH → LEAN → RICH →
1 time 2 times

LEAN → RICH.....

OR

1. Set "Exhaust gas sensor monitor" in the self-diagnostic Mode II. (See page EF & EC-45.)
2. Maintaining engine at 2,000 rpm under no load, check that check engine light or RED LED on the E.C.U. goes ON and OFF more than 5 times during 10 seconds.

O.K.

N.G. → Replace exhaust gas sensor.

7

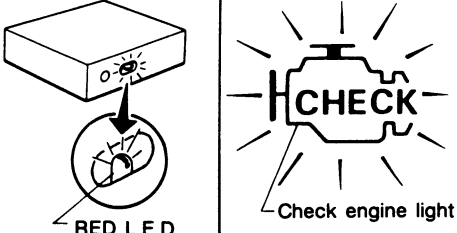

SEF621K

(Go to C on next page.)

TROUBLE DIAGNOSES

Diagnostic Procedure 14 — Engine Stalls after Decelerating (Cont'd)

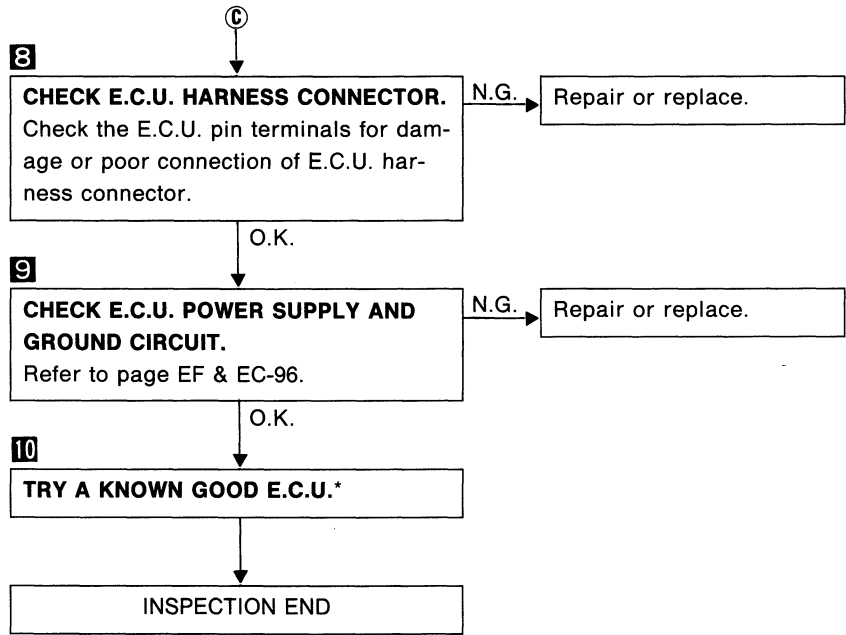

*: E.C.U. may be the cause of a problem, but this is rarely the case.

TROUBLE DIAGNOSES

Diagnostic Procedure 15 — Engine Stalls when Accelerating or when Driving at Constant Speed

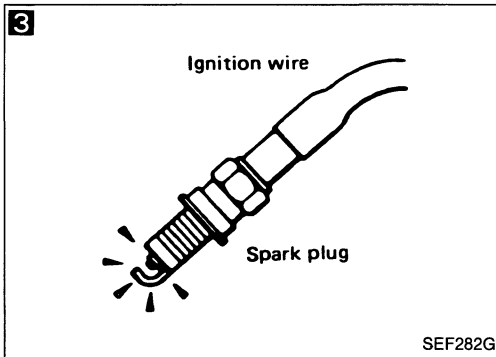
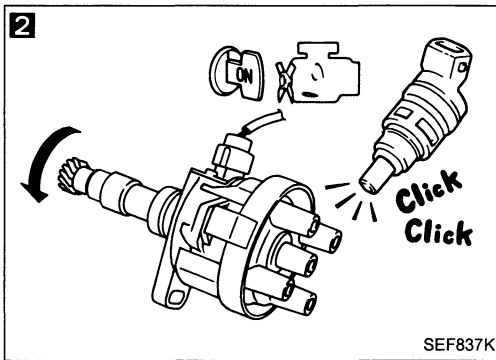
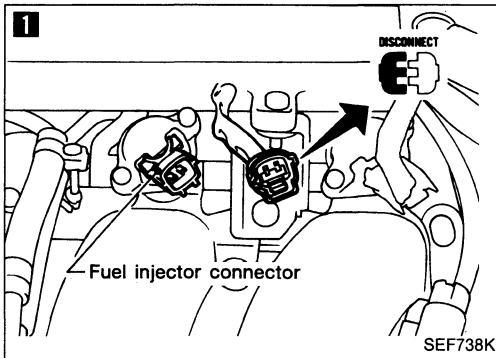
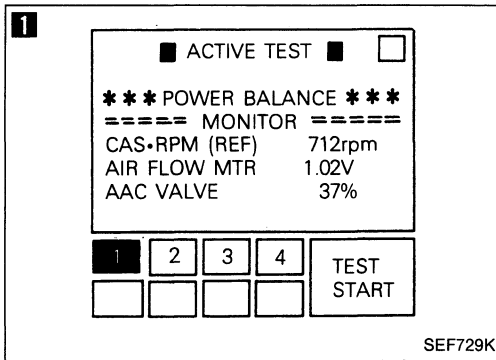

1 PERFORM POWER BALANCE TEST.

1. Perform "POWER BALANCE" in "ACTIVE TEST" mode.
2. Is there any cylinder which does not produce a momentary engine speed drop?

No → Go to **4**.

OR

-  When disconnecting each injector harness connector one at a time, is there any cylinder which does not produce a momentary engine speed drop?

Yes

2 CHECK INJECTOR.

1. Remove distributor assembly from engine. (Crank angle sensor harness connector should remain connected.)
2. Disconnect ignition coil harness connector.
3. Turn ignition switch ON. (Do not start engine.)
4. When rotating crank angle sensor shaft, does each injector make an operating sound?

No → Check injector(s) and circuit(s).

Yes

3 CHECK IGNITION SPARK.

1. Disconnect ignition wire from rocker cover.
2. Connect a known good spark plug to the ignition wire.
3. Place end of spark plug against a suitable ground and crank engine.
4. Check for spark.

N.G. → Check ignition coil, power transistor unit and circuits. (See page EF & EC-114.)

O.K.

(Go to **A** on next page.)

TROUBLE DIAGNOSES

Diagnostic Procedure 15 — Engine Stalls when Accelerating or when Driving at Constant Speed (Cont'd)

4

■ FUEL PRES RELEASE ■

FUEL PUMP WILL STOP BY TOUCHING START IN IDLING. CRANK A FEW TIMES AFTER ENGINE STALL.

START



SEF3791

4

CHECK FUEL PRESSURE.

1. Perform "FUEL PRESSURE RELEASE" in "WORK SUPPORT" mode in order to release fuel pressure to zero.

2. Install fuel pressure gauge and check fuel pressure.

A few seconds after ignition switch is turned OFF to ON:

Approx.
294 kPa (3.0 kg/cm², 43 psi)

At idle:
Approx.
235 kPa (2.4 kg/cm², 34 psi)

OR

1. Release fuel pressure to zero. (Refer to page EF & EC-191.)

2. Install fuel pressure gauge and check fuel pressure.

N.G. → Check fuel pump, circuit and fuel pressure regulator.

O.K. →

5

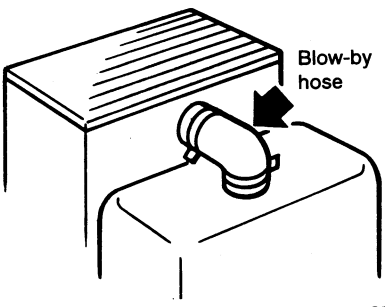

Blow-by hose

SEF300G

5

CHECK FOR INTAKE AIR LEAK.

When pinching blow-by hose (lowering the blow-by air supply), does the engine speed rise?

Yes → Discover air leak location and repair.

No →

6

CHECK E.C.U. HARNESS CONNECTOR.

Check the E.C.U. pin terminals for damage or poor connection of E.C.U. harness connector.

N.G. → Repair or replace.

O.K. →

7

CHECK E.C.U. POWER SUPPLY AND GROUND CIRCUIT.

Refer to page EF & EC-96.

Yes → Repair or replace.

No →

8

TRY A KNOWN GOOD E.C.U.*

INSPECTION END

*: E.C.U. may be the cause of a problem, but this is rarely the case.

TROUBLE DIAGNOSES

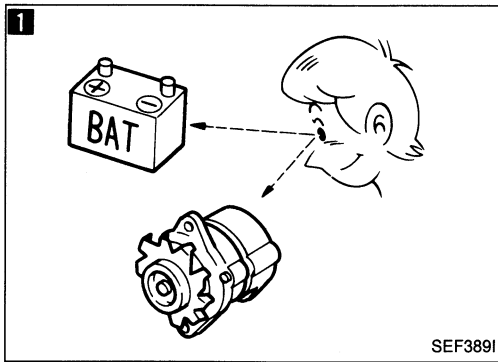

Diagnostic Procedure 16 — Engine Stalls when the Electrical Load is Heavy

1
CHECK BATTERY AND ALTERNATOR.
Check battery and alternator condition.
(Refer to EL section.)

N.G. → Repair or replace.

O.K.

2
PERFORM POWER BALANCE TEST.
1. Perform "POWER BALANCE" in "ACTIVE TEST" mode.
2. Is there any cylinder which does not produce a momentary engine speed drop?

No → Go to **5**.



OR
When disconnecting each injector harness connector one at a time, is there any cylinder which does not produce a momentary engine speed drop?

Yes

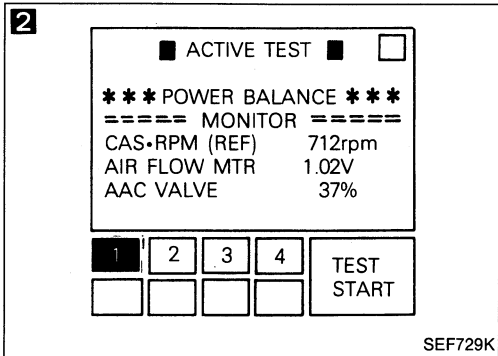

3
CHECK INJECTOR.
1. Remove distributor assembly from engine. (Crank angle sensor harness connector should remain connected.)
2. Disconnect ignition coil harness connector.
3. Turn ignition switch ON. (Do not start engine.)
4. When rotating crank angle sensor shaft, does each injector make an operating sound?

No → Check injector(s) and circuit(s).

Yes

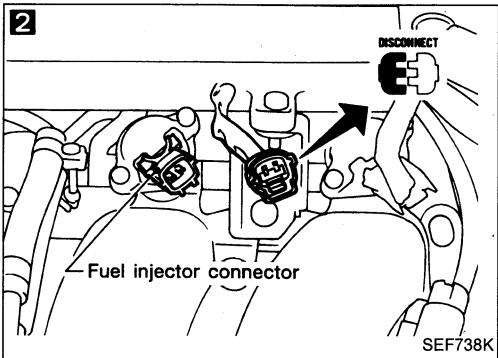

4
CHECK IGNITION SPARK.
1. Disconnect ignition wire from rocker cover.
2. Connect a known good spark plug to the ignition wire.
3. Place end of spark plug against a suitable ground and crank engine.
4. Check for spark.

N.G. → Check ignition coil, power transistor unit and circuits. (See page EF & EC-114.)

O.K.

(Go to **A** on next page.)

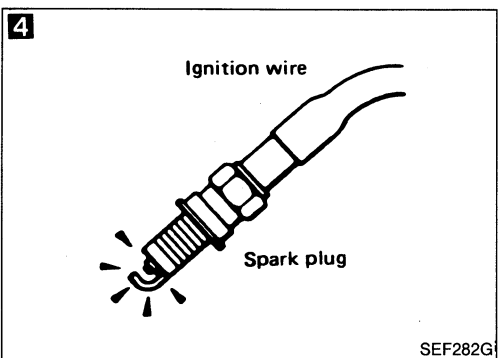
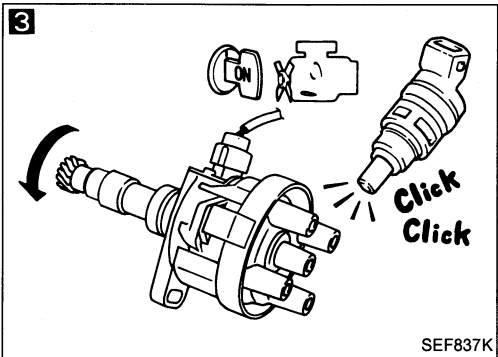

TROUBLE DIAGNOSES

Diagnostic Procedure 16 — Engine Stalls when the Electrical Load is Heavy (Cont'd)

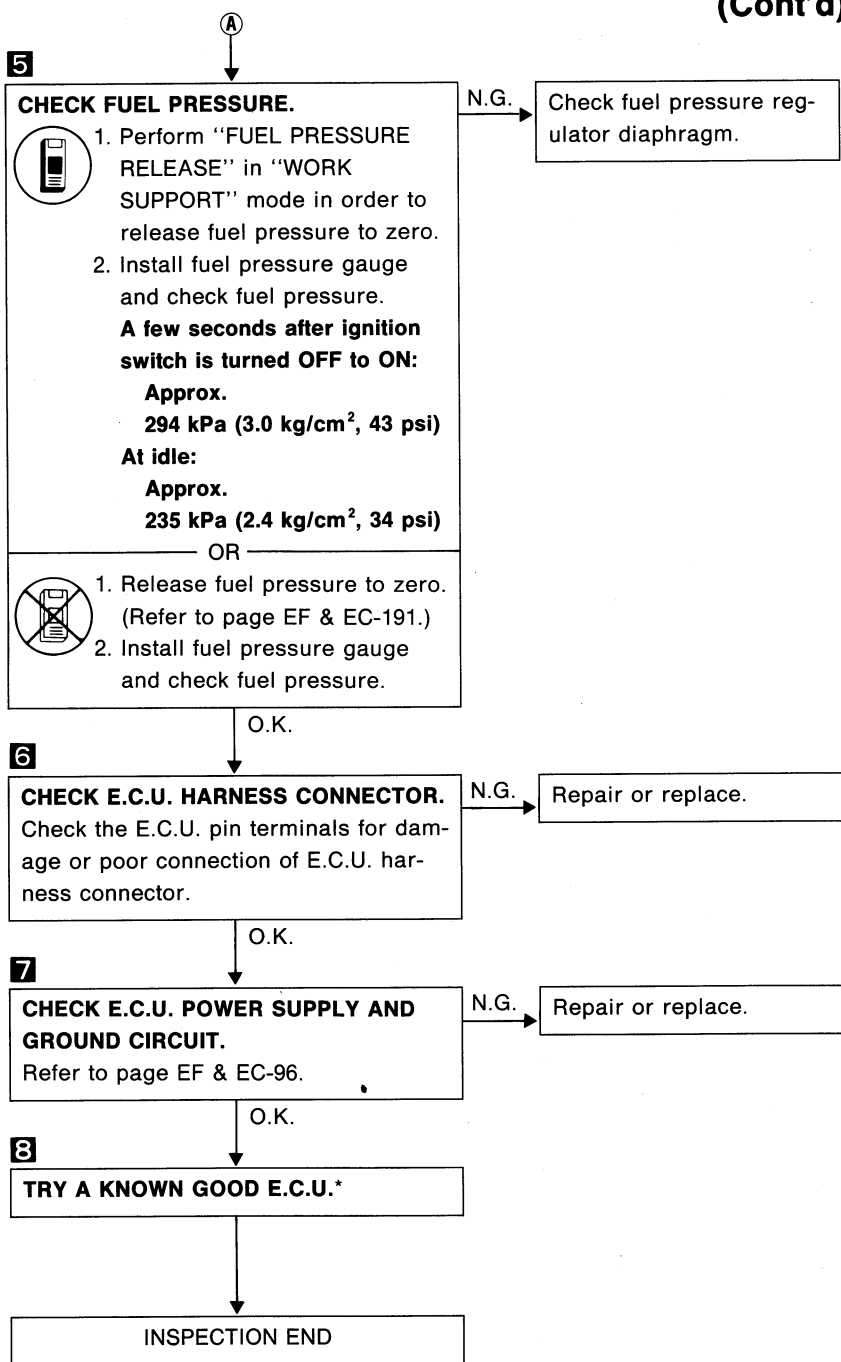
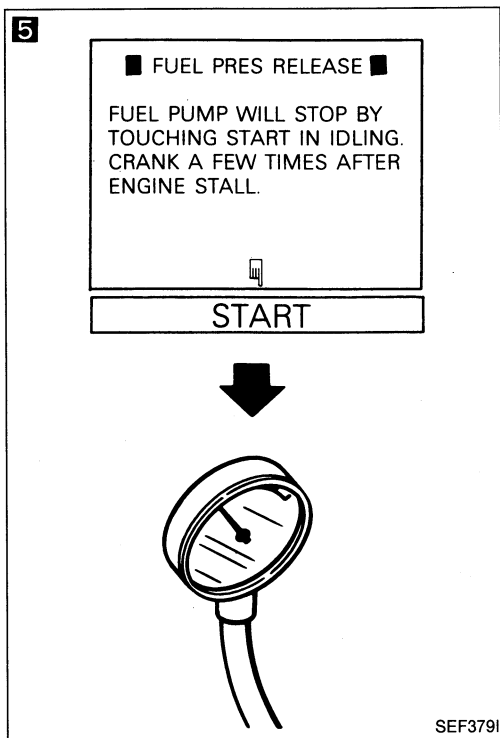

*: E.C.U. may be the cause of a problem, but this is rarely the case.

TROUBLE DIAGNOSES

Diagnostic Procedure 17 — Lack of Power and Stumble

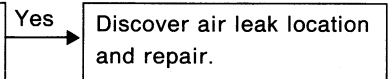
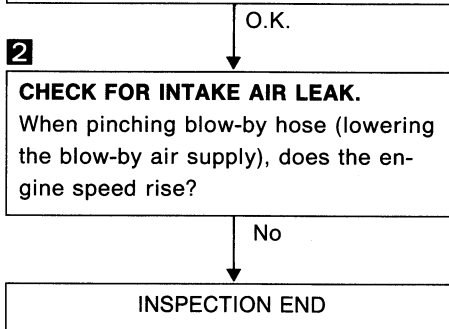
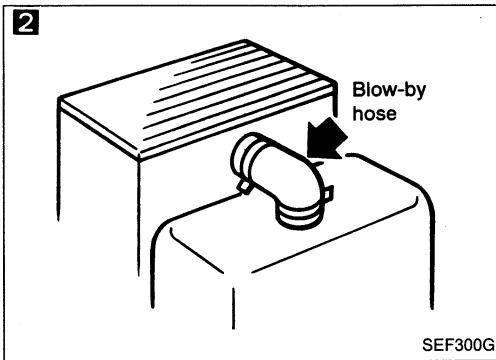
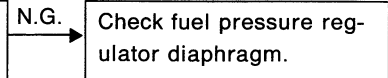
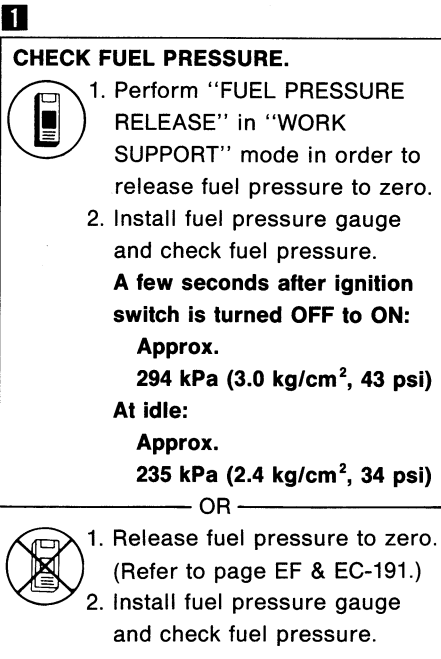
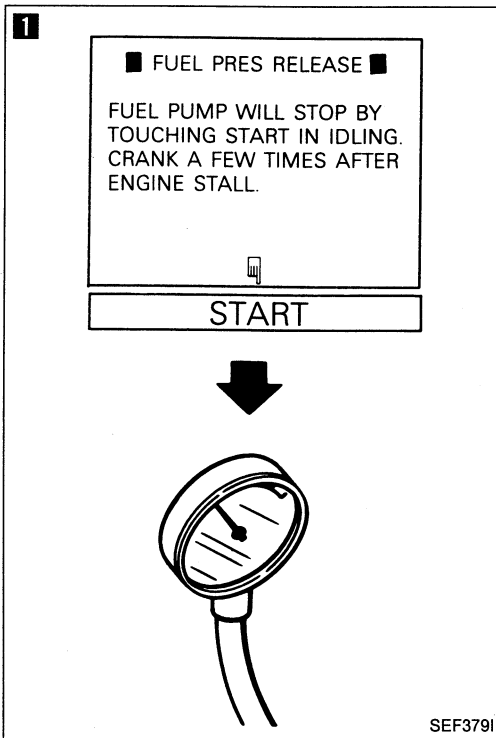

Diagnostic Procedure 18 — Detonation

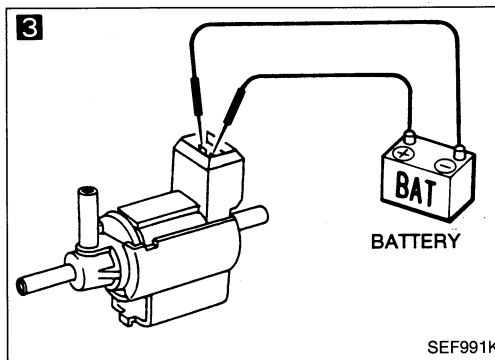
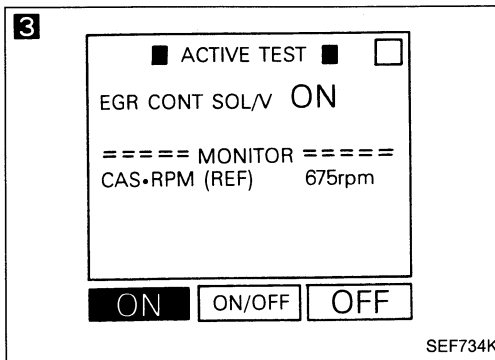
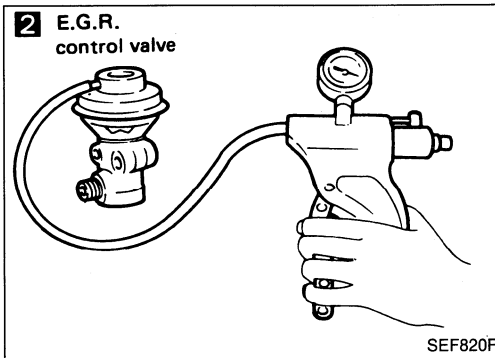
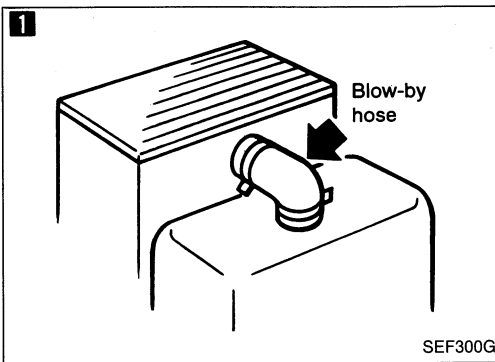

1

CHECK FOR INTAKE AIR LEAK.

When pinching blow-by hose (lowering the blow-by air supply), does the engine rpm rise?

Yes

Discover air leak location and repair.

No

2

CHECK E.G.R. OPERATION.

1. Apply vacuum directly to the E.G.R. control valve using a handy vacuum pump.
2. Check to see that the engine runs rough or dies.

No

Check E.G.R. control valve for sticking.

Yes

3

CHECK E.G.R. CONTROL SOLENOID VALVE.



1. Select "E.G.R. CONT SOL VALVE" in "ACTIVE TEST" mode.
2. Turn E.G.R. and canister control solenoid valve ON and OFF.
3. Check operating sound.

OR



1. Disconnect E.G.R. and canister control solenoid valve harness connector.
2. Supply E.G.R. and canister control solenoid valve terminals with battery current and check operating sound.

N.G.

Check solenoid valve and circuit.

O.K.

4

CHECK VACUUM HOSES.

Check the following vacuum hoses for clogging, cracks and poor connection.

- a) Vacuum hose between E.G.R. control valve and E.G.R. and canister control solenoid valve.
- b) Vacuum hose between E.G.R. and canister control solenoid valve and throttle chamber port.
- c) Vacuum hose between E.G.R. and canister control solenoid valve and air duct.

N.G.

Repair or replace.

O.K.

(Go to **A** on next page.)

TROUBLE DIAGNOSES

Diagnostic Procedure 18 — Detonation (Cont'd)

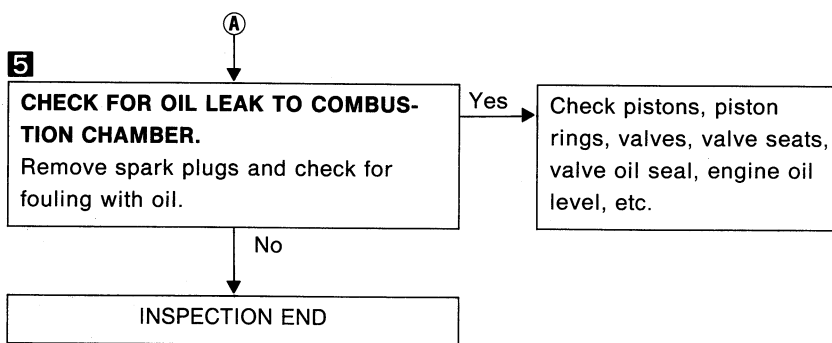
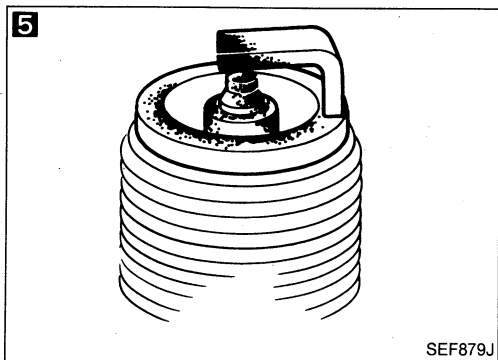

TROUBLE DIAGNOSES

Diagnostic Procedure 19 — Surge

1

☆ MONITOR ☆ NO FAIL

CAS•RPM (REF) 2000rpm
M/R F/C MNT RICH

RECORD

SEF722K

1

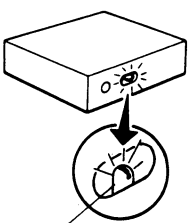

RED L.E.D.

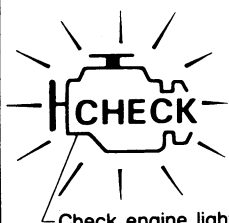

Check engine light

SEF621K

2

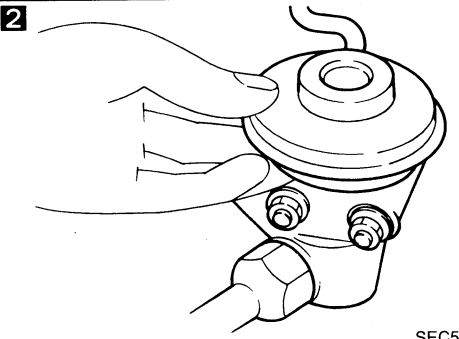

SEC547A

1

CHECK EXHAUST GAS SENSOR.

1. See "M/R F/C MNT" in "DATA MONITOR" mode.
2. Maintaining engine at 2,000 rpm under no-load (with engine warmed up sufficiently.), check to make sure that the monitor fluctuates between "LEAN" and "RICH" more than 5 times during 10 seconds.

RICH → LEAN → RICH →
1 time 2 times

LEAN → RICH.....
OR

1. Set "Exhaust gas sensor monitor" in the self-diagnostic Mode II. (See page EF & EC-45.)
2. Maintaining engine at 2,000 rpm under no load, check that check engine light or RED LED on the E.C.U. goes ON and OFF more than 5 times during 10 seconds.

N.G. → Replace exhaust gas sensor.

O.K.

2

CHECK E.G.R. CONTROL VALVE.
Check E.G.R. control valve for sticking.

N.G. → Repair or replace.

O.K.

3

TRY A KNOWN GOOD E.C.U.*

O.K.

INSPECTION END

*: E.C.U. may be the cause of a problem, but this is rarely the case.

TROUBLE DIAGNOSES

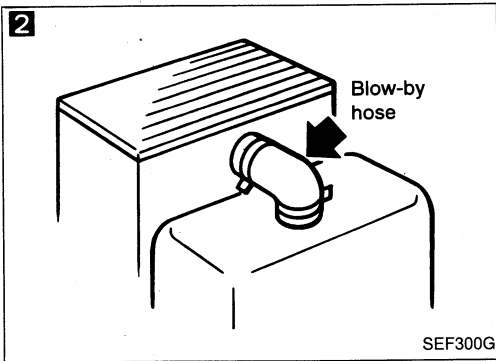
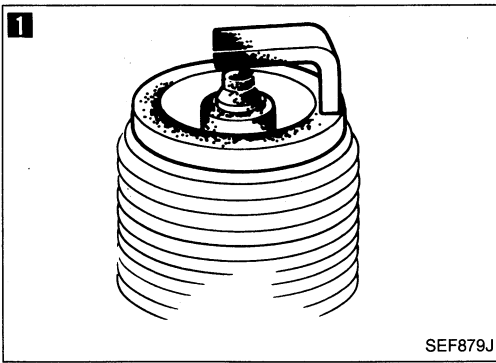

Diagnostic Procedure 20 — Backfire through the Intake

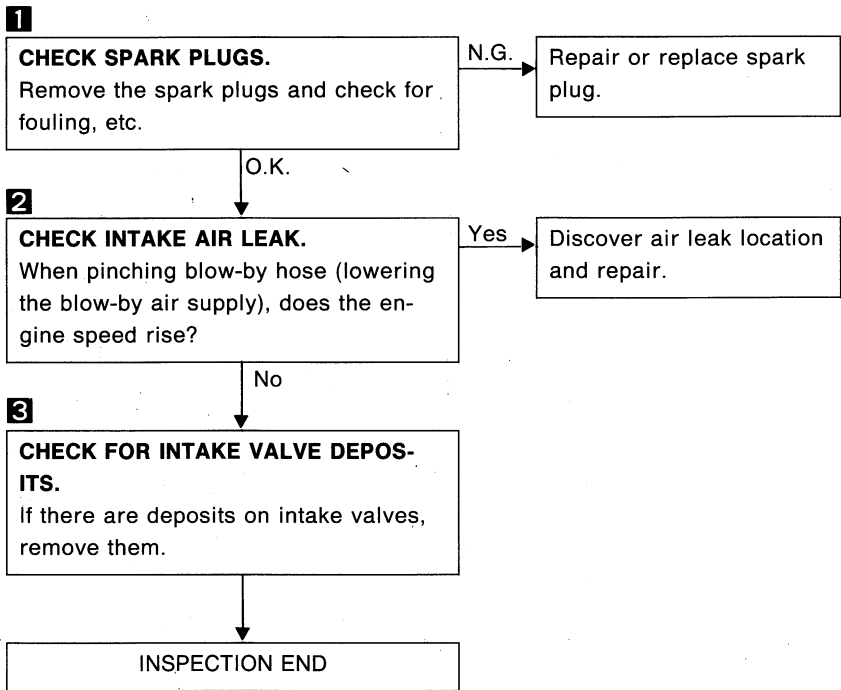

TROUBLE DIAGNOSES

Diagnostic Procedure 21 — Backfire through the Exhaust

1

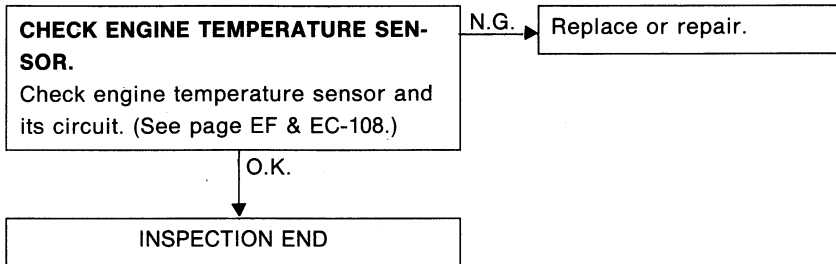

TROUBLE DIAGNOSES

NOTE

Diagnostic Procedure 22

MAIN POWER SUPPLY AND GROUND CIRCUIT (Not self-diagnostic item)

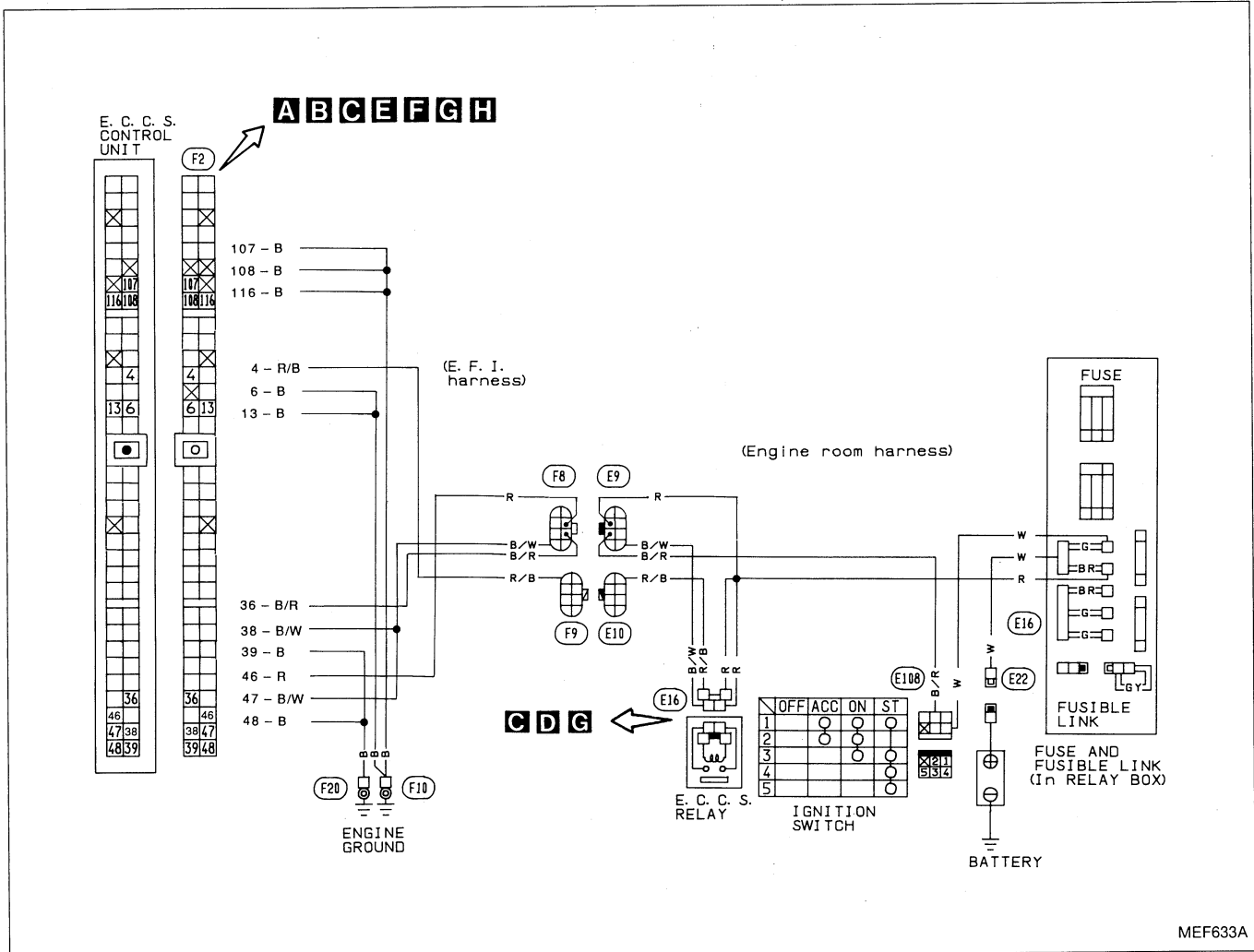

Harness layout

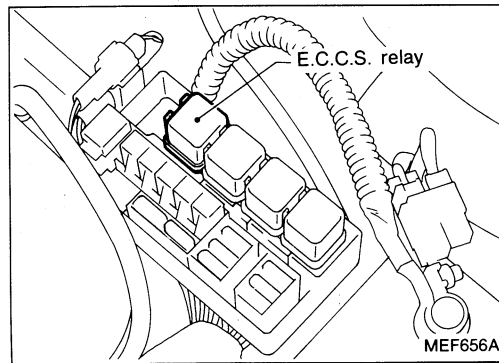
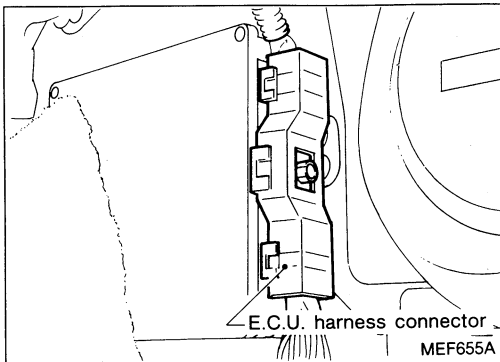

Diagnostic Procedure 22 (Cont'd)

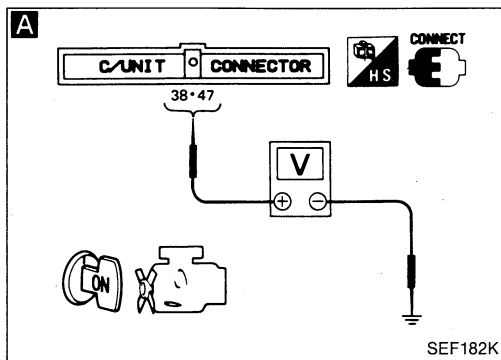

INSPECTION START

A

CHECK POWER SUPPLY.

- 1) Turn ignition switch "ON".
- 2) Check voltage between E.C.U. terminals ③⑧, ④⑦ and ground.

Voltage: Battery voltage

B

CHECK GROUND CIRCUIT.

- 1) Turn ignition switch "OFF".
- 2) Disconnect E.C.U. harness connector.
- 3) Check harness continuity between E.C.U. terminals ⑥, ⑬, ⑩⑦, ⑩⑧, ⑩⑨ and engine ground.

Continuity should exist.

If N.G., repair harness or connectors.

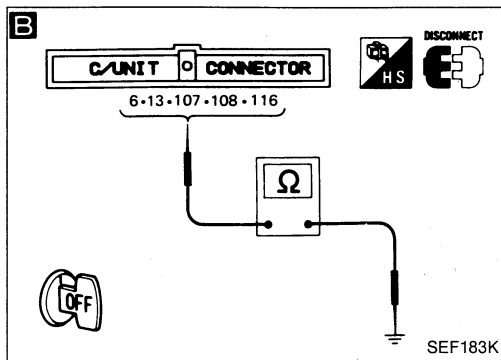

N.G.

C

CHECK HARNESS CONTINUITY BETWEEN E.C.C.S. RELAY AND E.C.U.

- 1) Turn ignition switch "OFF".
- 2) Disconnect E.C.U. harness connector.
- 3) Disconnect E.C.C.S. relay.
- 4) Check harness continuity between E.C.U. terminals ③⑧, ④⑦ and terminal ③.

Continuity should exist.

O.K.

O.K.

Check E.C.U. pin terminals for damage or the connection of E.C.U. harness connector.

N.G.

Check the following.

- Harness connectors ①⑧, ①⑨
- Harness continuity between E.C.U. and E.C.C.S. relay

If N.G., repair harness or connectors.

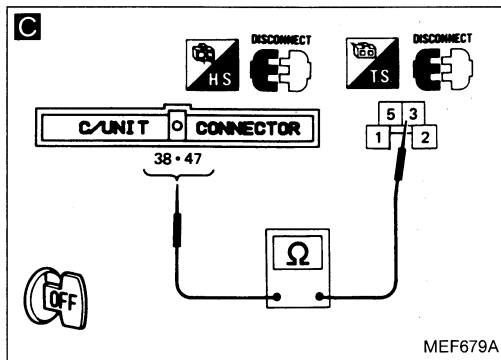

O.K.

D

CHECK VOLTAGE BETWEEN E.C.C.S. RELAY AND GROUND.

- 1) Check voltage between terminals ①, ⑤ and ground.

Voltage: Battery voltage

N.G.

Check the following.

- "BR" fusible link
- Harness continuity between E.C.C.S. relay and battery

If N.G., repair harness or connectors.

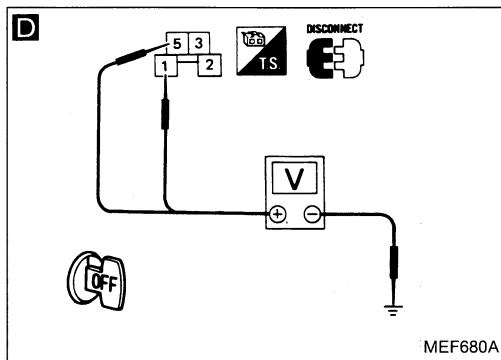

N.G.

E

CHECK VOLTAGE BETWEEN E.C.U. AND GROUND.

- 1) Check voltage between E.C.U. terminal ④⑥ and ground.

Voltage: Battery voltage

N.G.

Check the following.

- Harness connectors ①⑧, ①⑨
- "BR" fusible link
- Harness continuity between E.C.U. and battery

If N.G., repair harness or connectors.

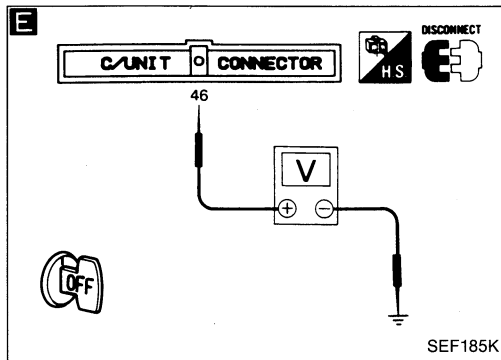

O.K.

①

Diagnostic Procedure 22 (Cont'd)

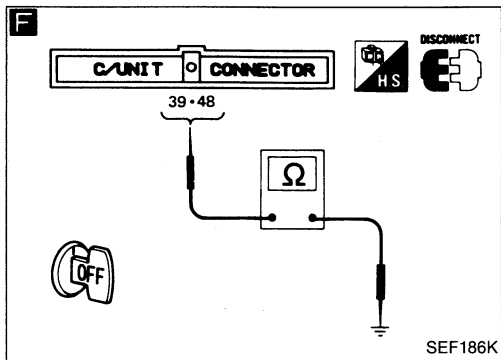

F

CHECK GROUND CIRCUIT.
 1) Check harness continuity between E.C.U. terminals ③⑨, ④⑧ and engine ground.
Continuity should exist.

N.G. → Repair harness or connectors.

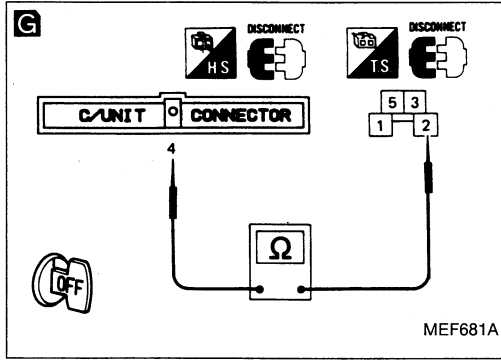

G

CHECK OUTPUT SIGNAL CIRCUIT.
 1) Check harness continuity between E.C.U. terminal ④ and terminal ②.
Continuity should exist.

N.G. → Check the following.
 ● Harness connectors (F9, E10)
 ● Harness continuity between E.C.U. and E.C.C.S. relay
 If N.G., repair harness or connectors.

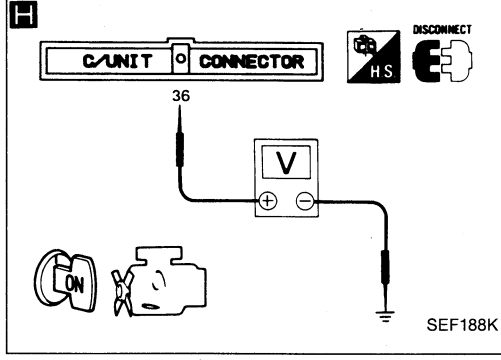

H

CHECK INPUT SIGNAL CIRCUIT.
 1) Turn ignition switch "ON".
 2) Check voltage between E.C.U. terminal ③⑥ and ground.
Voltage: Battery voltage

N.G. → Check the following.
 ● Harness connectors (F8, E9)
 ● Harness continuity between E.C.U. and ignition switch
 If N.G., repair harness or connectors.

CHECK COMPONENT (E.C.C.S. relay).
 Refer to "Electrical Components Inspection".
 (See page EF & EC-188.)

N.G. → Replace E.C.C.S. relay.

Check E.C.U. pin terminals for damage or the connection of E.C.U. harness connector.

NOTE

Diagnostic Procedure 23

CRANK ANGLE SENSOR (Code No. 11)

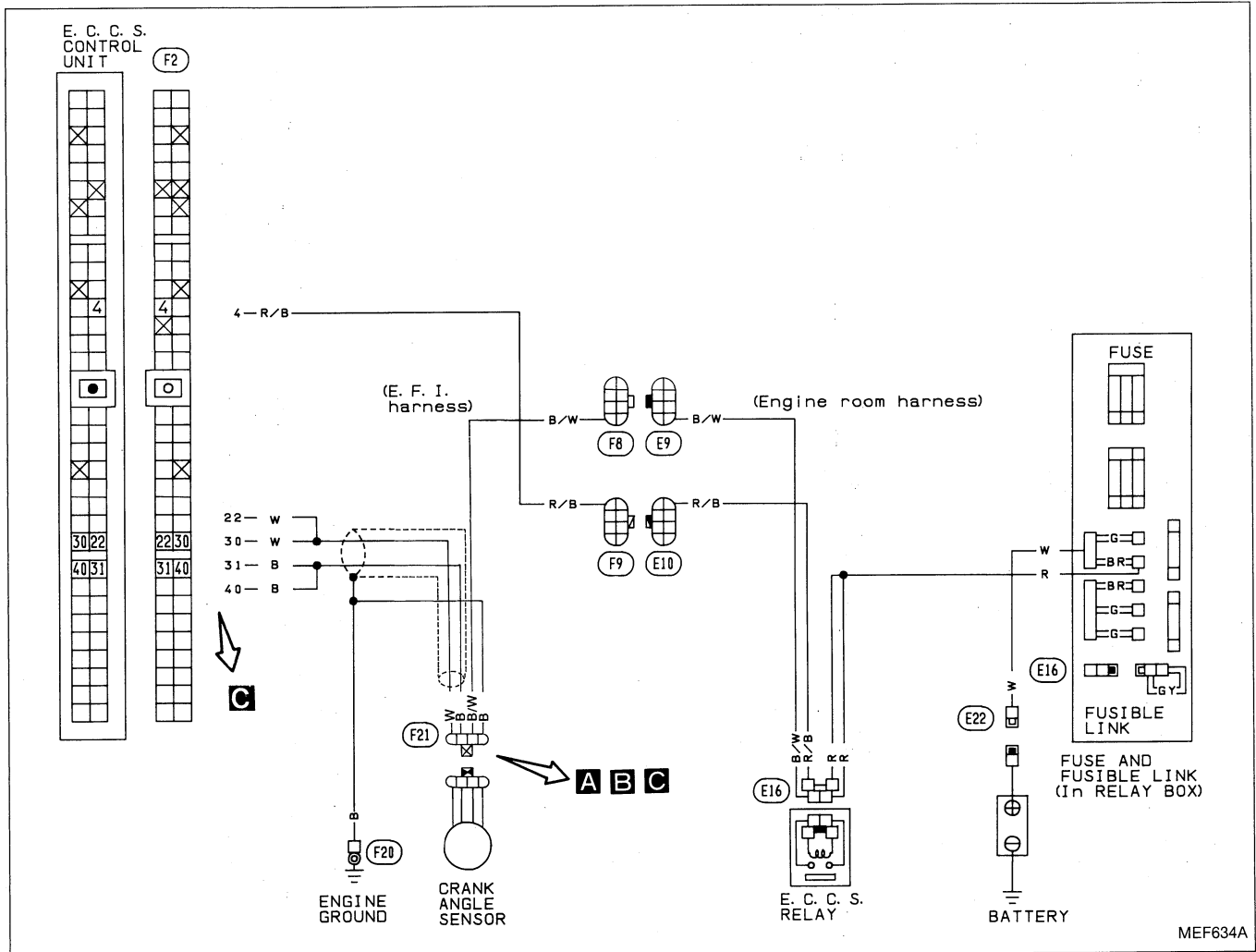

Harness layout

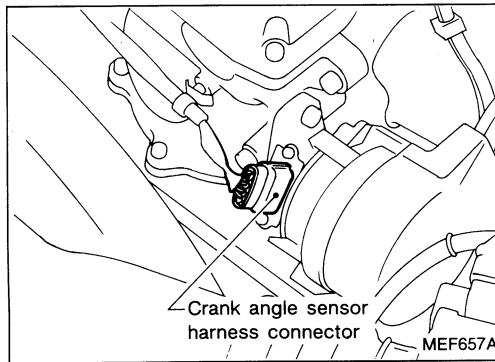
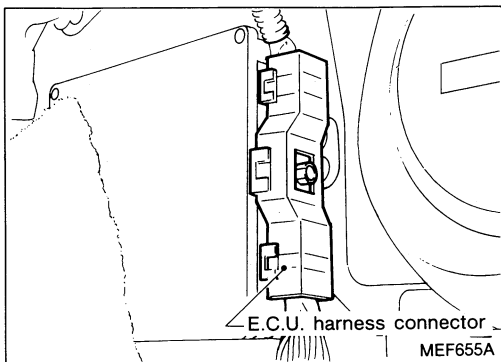

Diagnostic Procedure 23 (Cont'd)

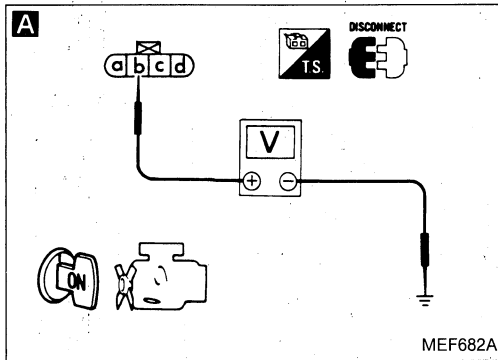

INSPECTION START

A
CHECK POWER SUPPLY.
 1) Disconnect crank angle sensor harness connector.
 2) Turn ignition switch "ON".
 3) Check voltage between terminal **b** and ground.
Voltage: Battery voltage

N.G. → Check the following.
 ● Harness connectors (F8, E9)
 ● Harness continuity between crank angle sensor and E.C.C.S. relay
 If N.G., repair harness or connectors.

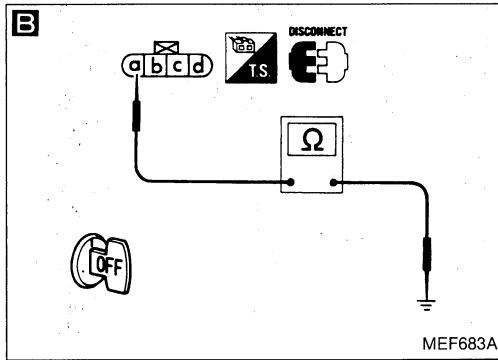

B
CHECK GROUND CIRCUIT.
 1) Turn ignition switch "OFF".
 2) Check harness continuity between terminal **c** and engine ground.
Continuity should exist.

N.G. → Repair harness or connectors.

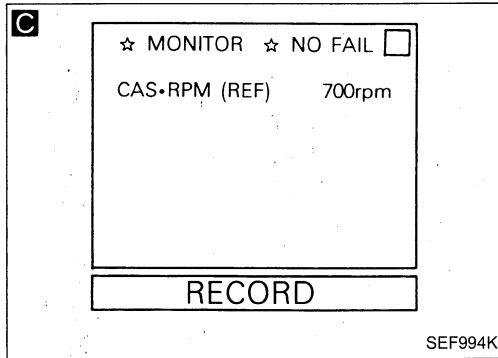

C
CHECK INPUT SIGNAL CIRCUIT.
 1) Reconnect crank angle sensor harness connector.
 2) Start engine.
 3) Read crank angle sensor signals in "DATA MONITOR" mode with CONSULT.
rpm: 700 ± 50

N.G. → Repair harness or connectors.

OR
 1) Disconnect E.C.U. harness connector.
 2) Check harness continuity between terminal **c** and E.C.U. terminals **31**, **40** (1° signal), terminal **d** and E.C.U. terminals **22**, **30** (180° signal).
Continuity should exist.

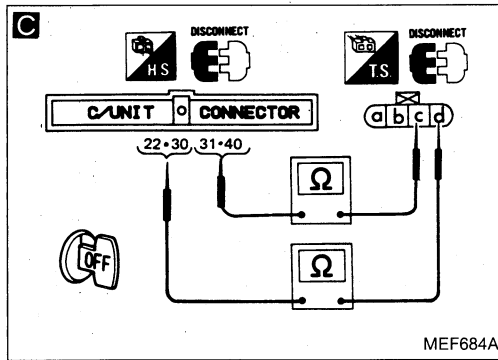

CHECK COMPONENT
 (Crank angle sensor).
 Refer to "Electrical Components Inspection".
 (See page EF & EC-183.)

N.G. → Replace crank angle sensor.

Check E.C.U. pin terminals for damage or the connection of E.C.U. harness connector.

Diagnostic Procedure 23 (Cont'd)

Perform FINAL CHECK by the following procedure after repair is completed.

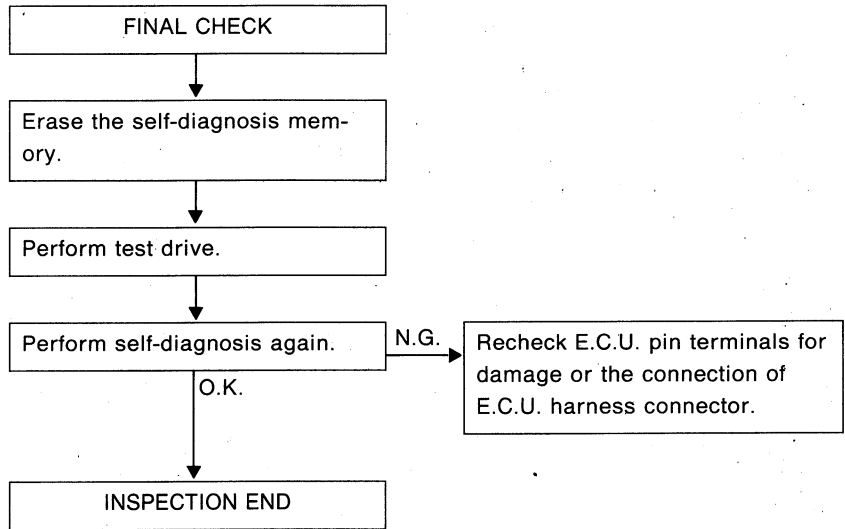

NOTE

Diagnostic Procedure 24

AIR FLOW METER (Code No. 12)  (CHECK ENGINE LIGHT ITEM)

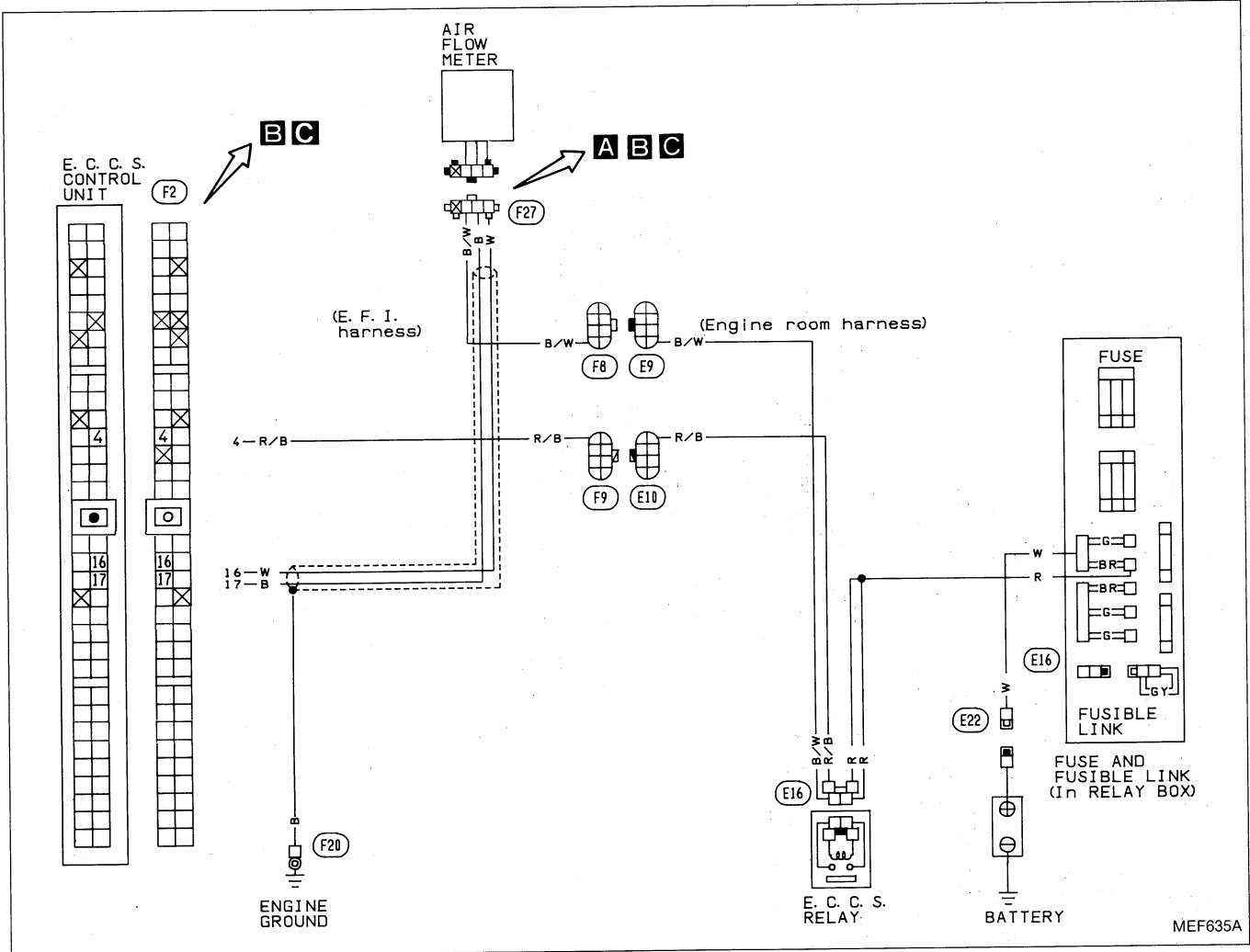

MEF635A

Harness layout

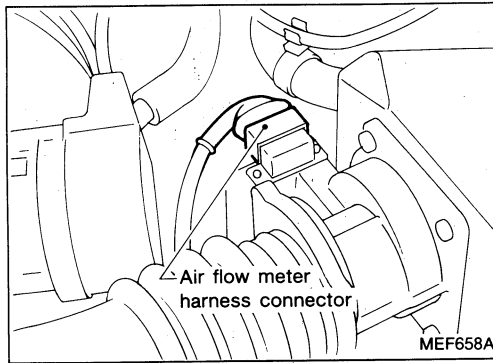
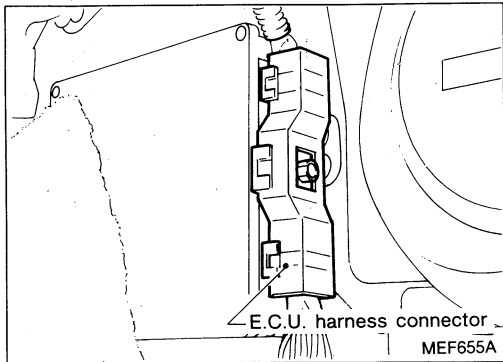

Diagnostic Procedure 24 (Cont'd)

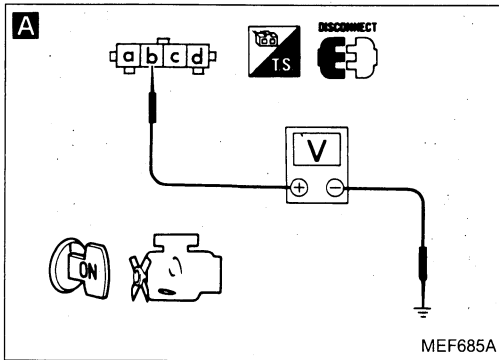

INSPECTION START

A

CHECK POWER SUPPLY.

- 1) Disconnect air flow meter harness connector.
- 2) Turn ignition switch "ON".
- 3) Check voltage between terminal ① and ground.

Voltage: Battery voltage

N.G. → Check the following.

- Harness connectors (F8), (E9)
- Harness continuity between air flow meter and E.C.S. relay

If N.G., repair harness or connectors.

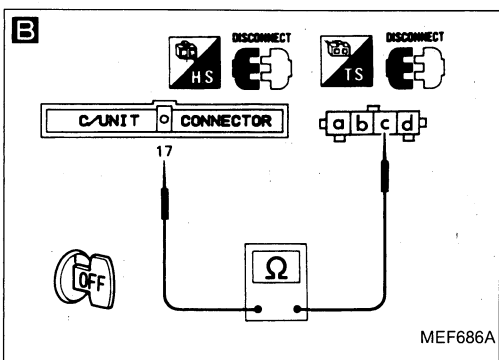

B

CHECK GROUND CIRCUIT.

- 1) Turn ignition switch "OFF".
- 2) Disconnect E.C.U. harness connector.
- 3) Check harness continuity between terminal ⑥ and E.C.U. terminal ⑰.

Continuity should exist.

N.G. → Repair harness or connectors.

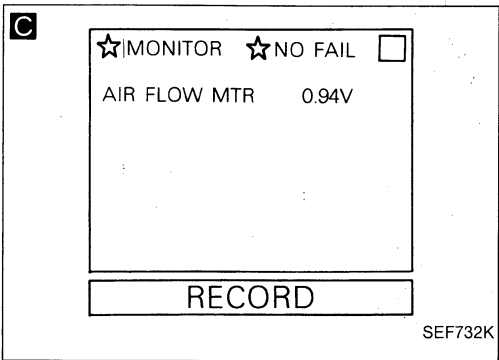

C

CHECK INPUT SIGNAL CIRCUIT.

- 1) Reconnect air flow meter harness connector and E.C.U. harness connector.
- 2) Start engine and warm it up sufficiently.
- 3) Read air flow meter signal in "DATA MONITOR" mode with CONSULT.

Voltage: 0.8 - 1.2V (At idle)

OR

N.G. → Repair harness or connectors.

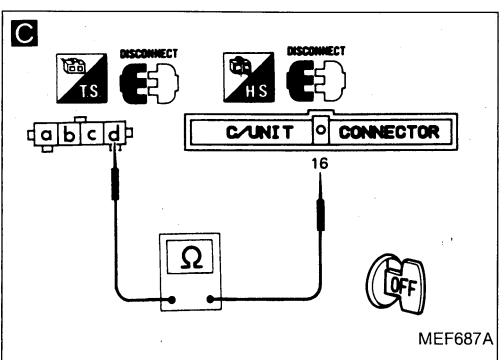

1) Check harness continuity between terminal ④ and E.C.U. terminal ⑰.

Continuity should exist.

CHECK COMPONENT (Air flow meter).

Refer to "Electrical Components Inspection". (See page EF & EC-183.)

N.G. → Replace air flow meter.

Check E.C.U. pin terminals for damage or the connection of E.C.U. harness connector.

Diagnostic Procedure 24 (Cont'd)

Perform FINAL CHECK by the following procedure after repair is completed.

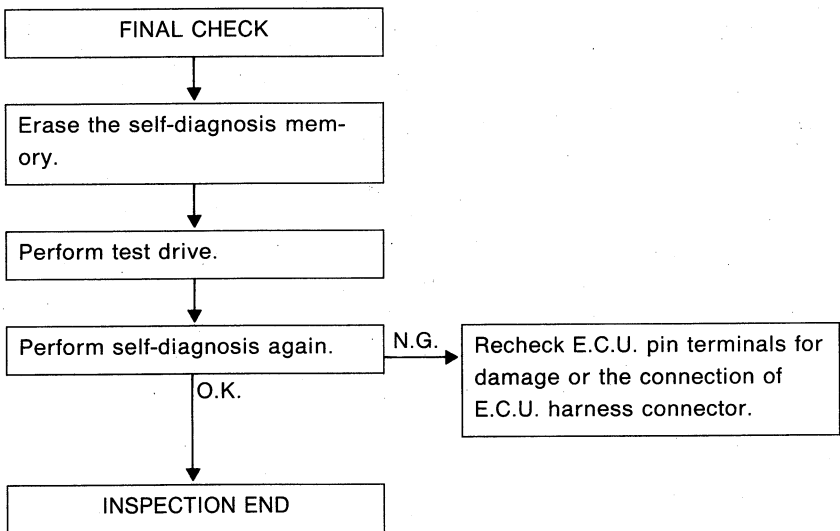

NOTE

Diagnostic Procedure 25

ENGINE TEMPERATURE SENSOR (Code No. 13)  (CHECK ENGINE LIGHT ITEM)

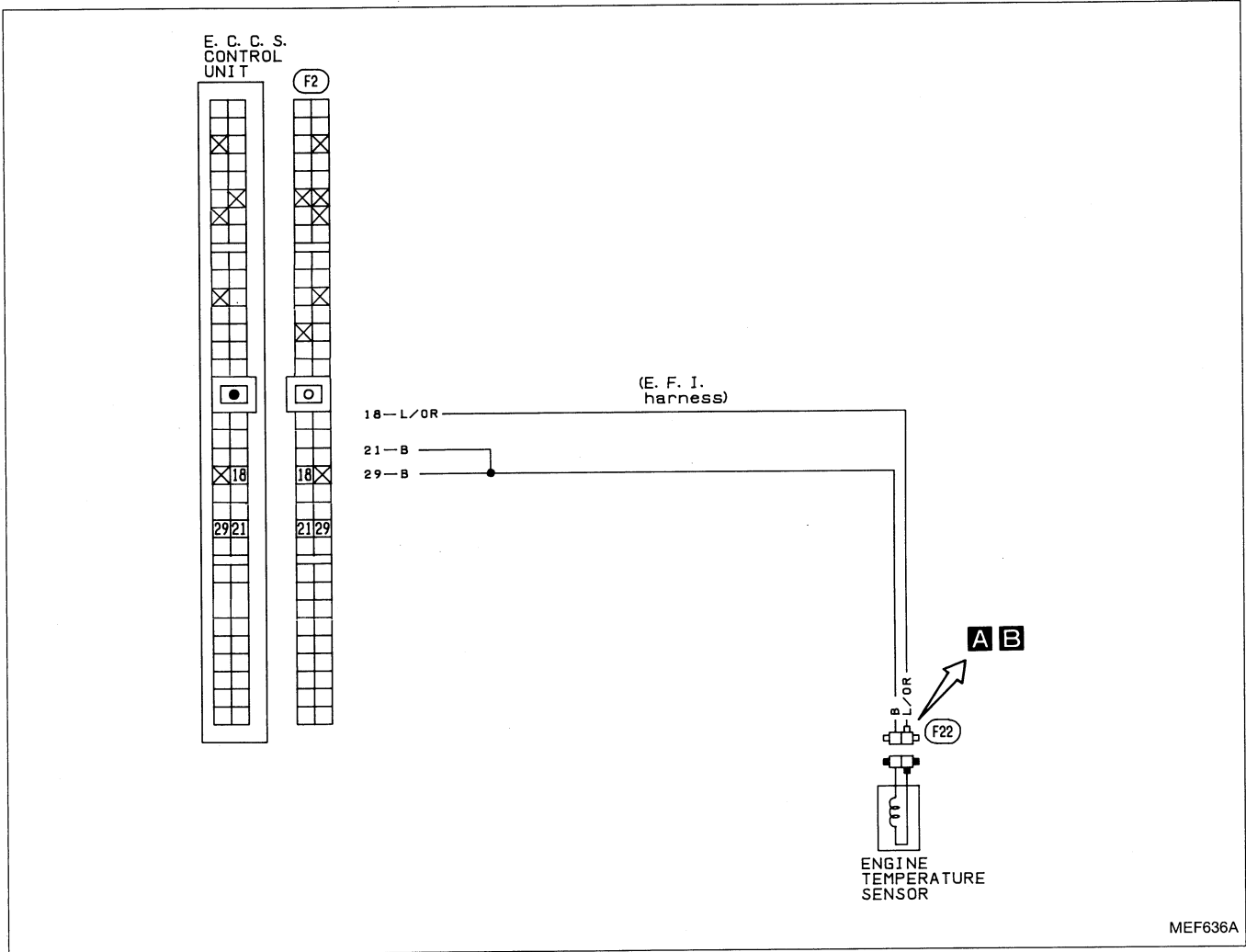

Harness layout

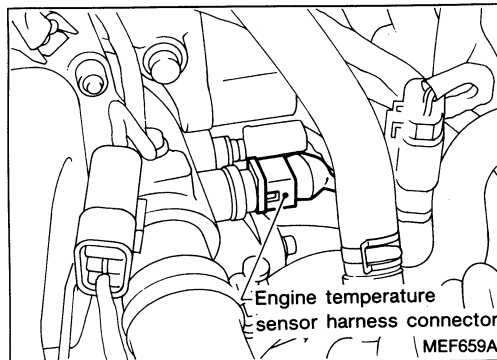
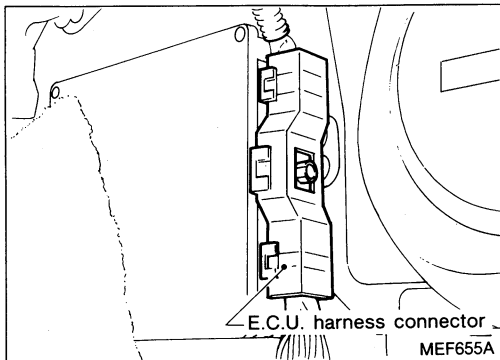

Diagnostic Procedure 25 (Cont'd)

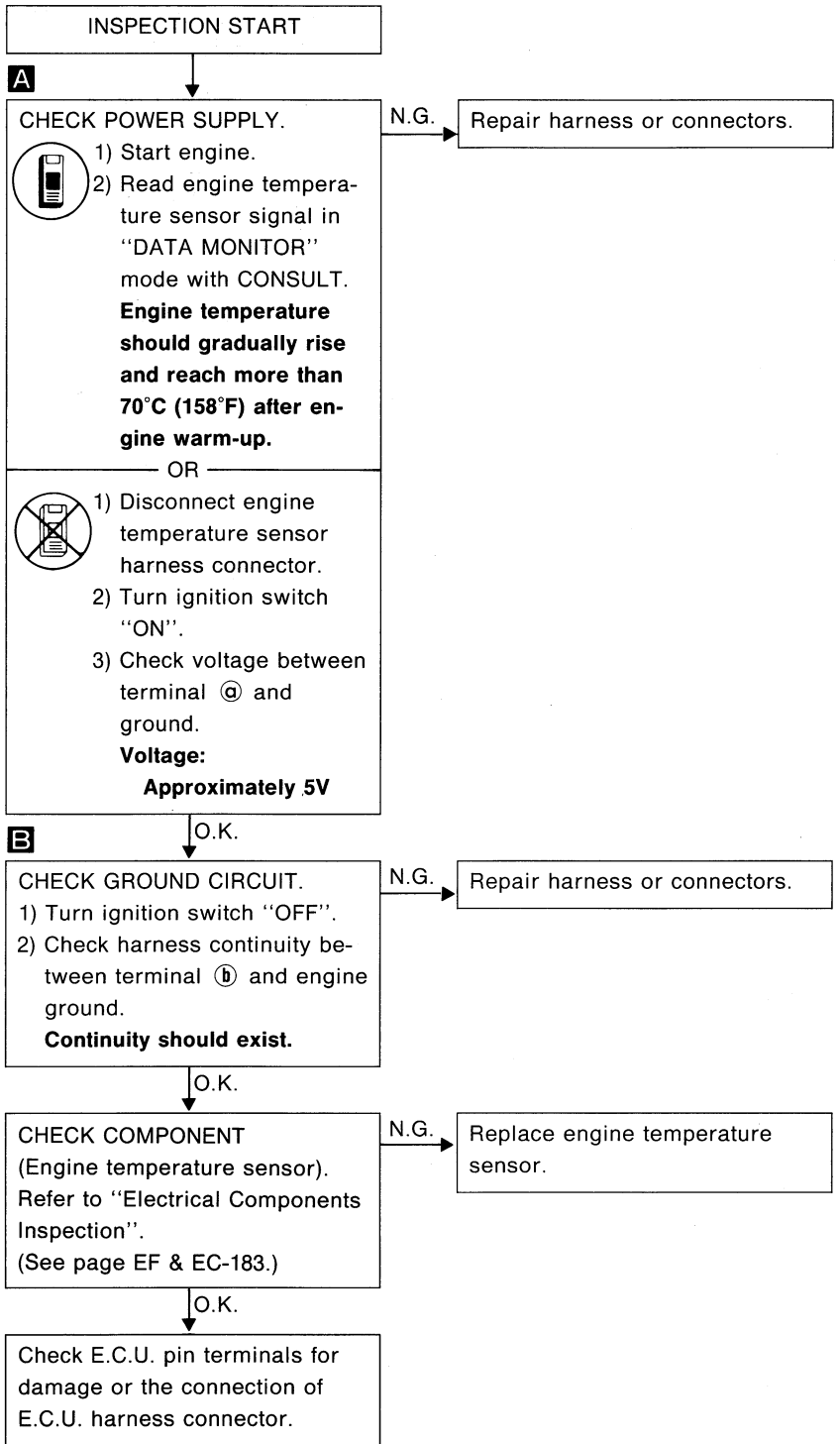
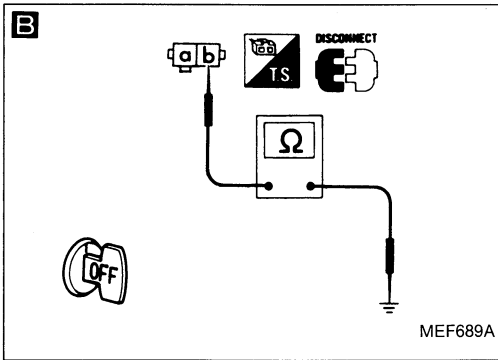
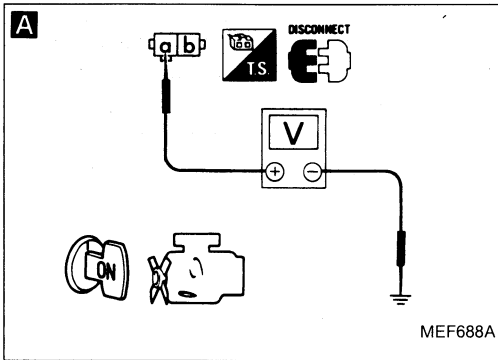
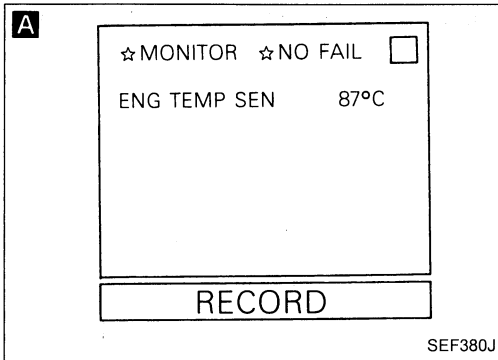

Diagnostic Procedure 25 (Cont'd)

Perform FINAL CHECK by the following procedure after repair is completed.

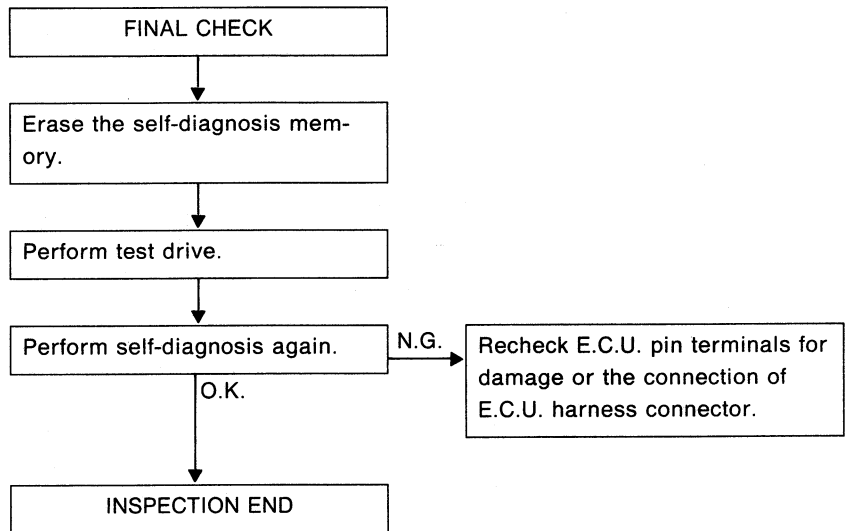

NOTE

Diagnostic Procedure 26

VEHICLE SPEED SENSOR (Code No. 14) H_{CHECK} (CHECK ENGINE LIGHT ITEM)

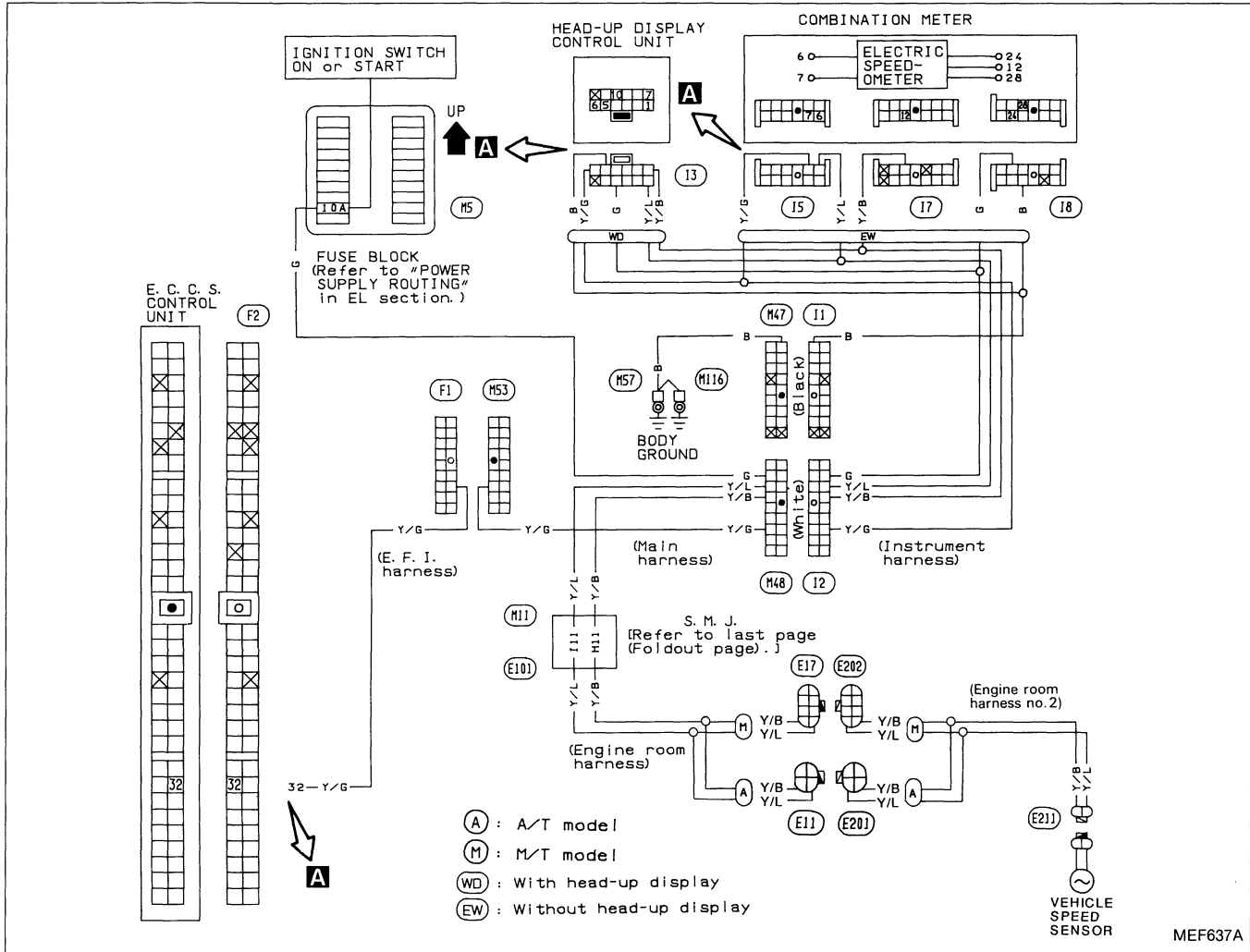

Harness layout

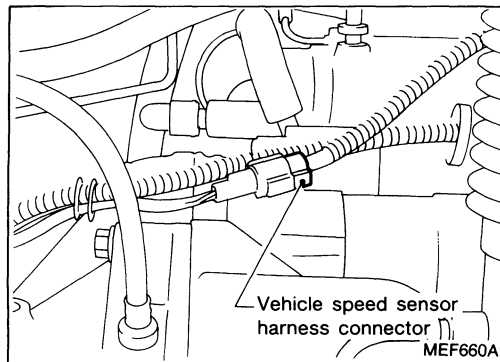
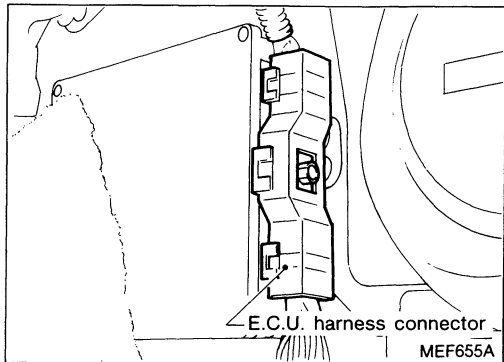

Diagnostic Procedure 26 (Cont'd)

A

☆ MONITOR ☆ NO FAIL

CAR SPEED SEN 10mph

RECORD

SEF995K

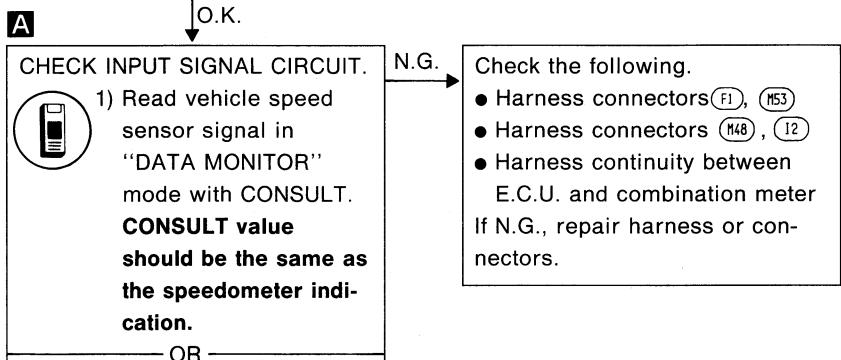
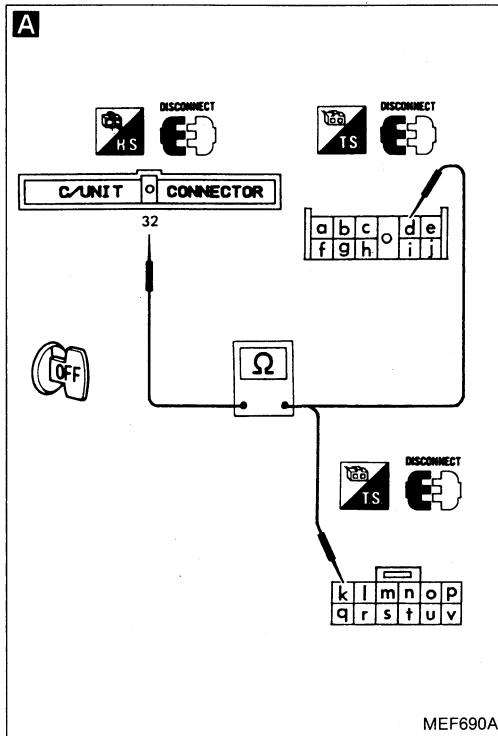
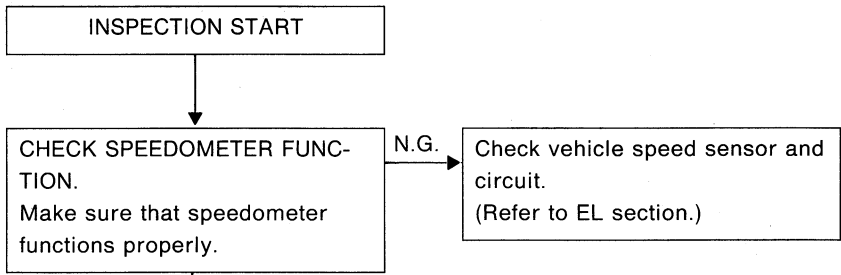

- OR
- 1) Turn ignition switch "OFF".
 - 2) Disconnect E.C.U. harness connector and combination meter harness connector.
 - 3) Check harness continuity between E.C.U. terminal ② and terminal ④ (Models without head-up display), ① (Models with head-up display).
- Continuity should exist.**

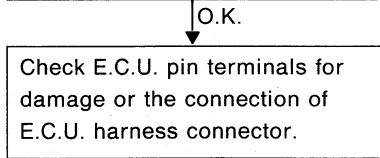

Perform FINAL CHECK by the following procedure after repair is completed.

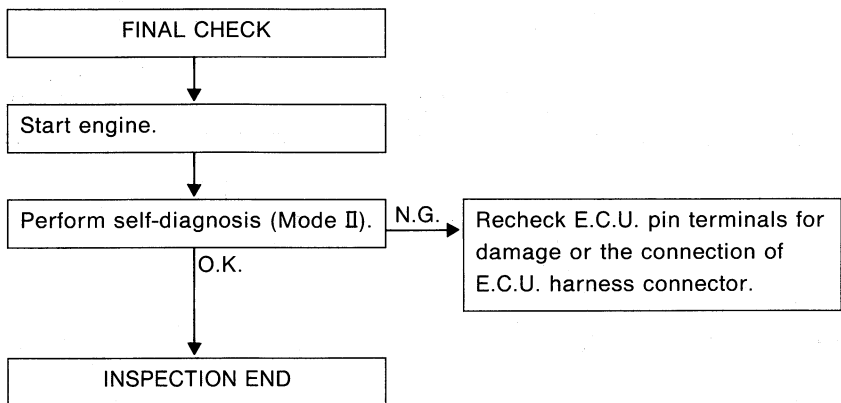

Diagnostic Procedure 27

IGNITION SIGNAL (Code No. 21)

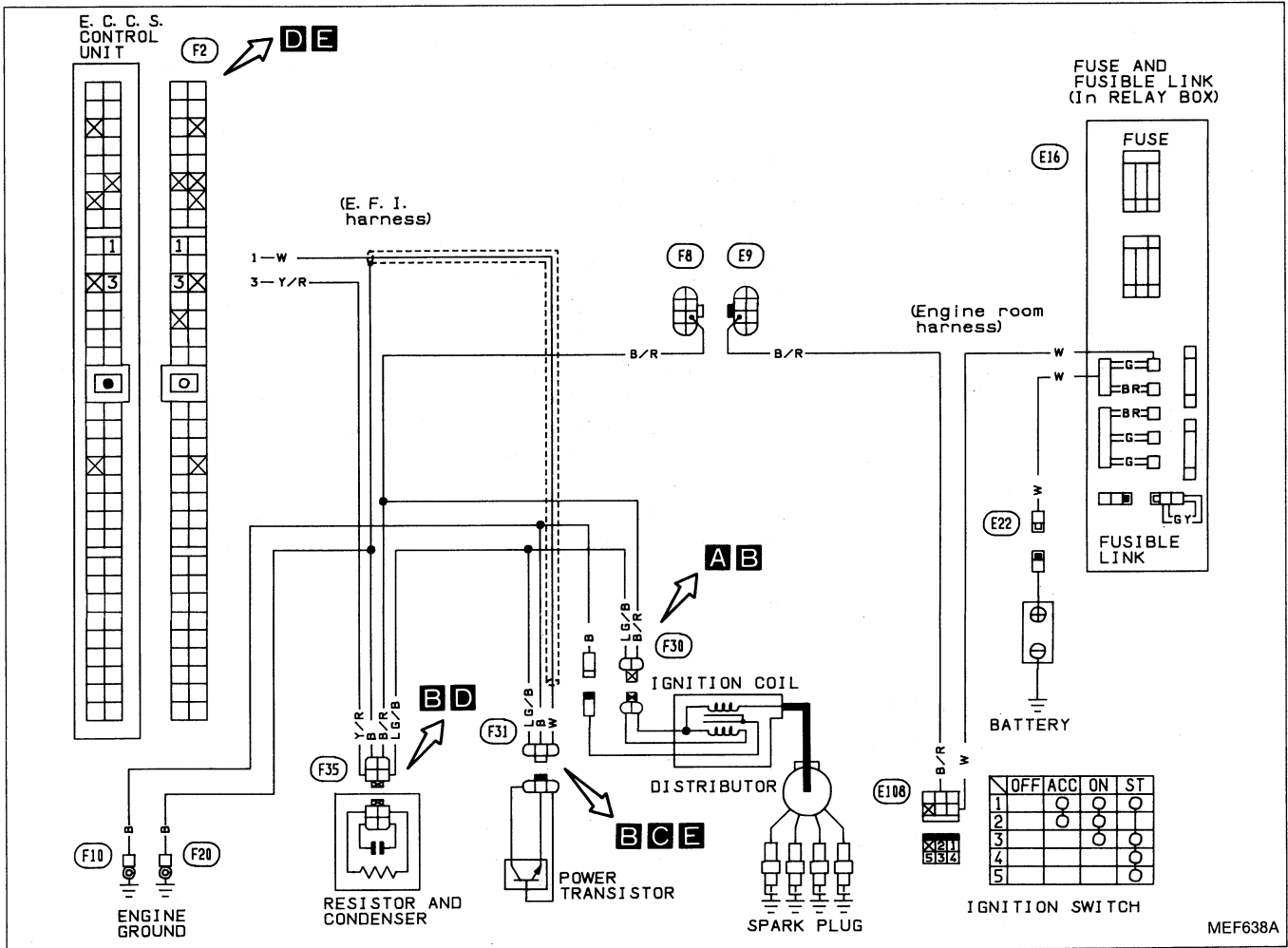

Harness layout

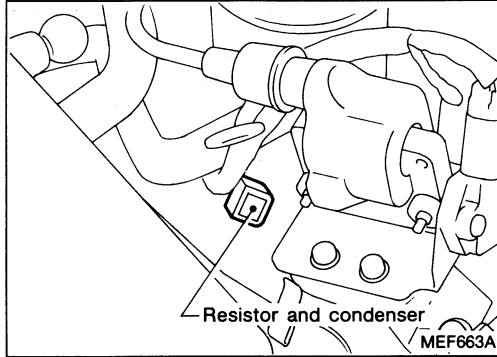
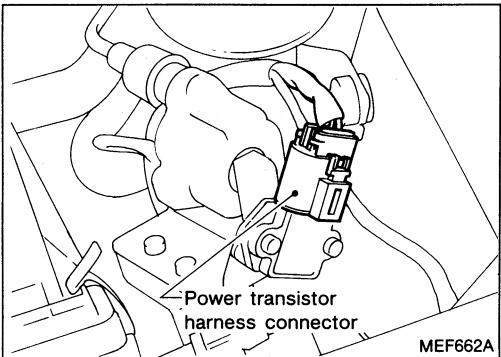
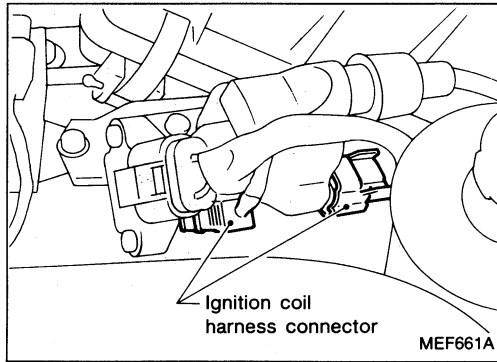
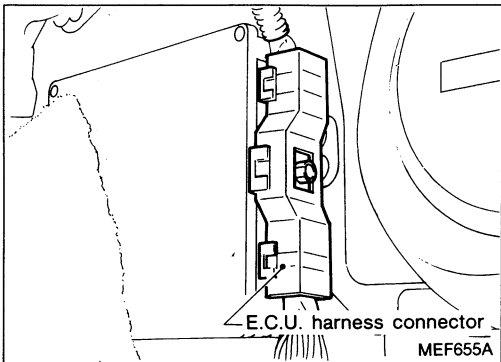

Diagnostic Procedure 27 (Cont'd)

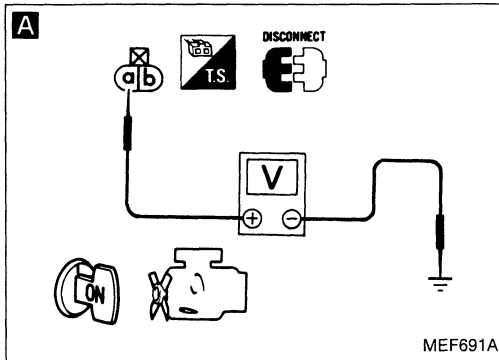

A INSPECTION START

A CHECK POWER SUPPLY.

- 1) Disconnect ignition coil harness connector.
- 2) Turn ignition switch "ON".
- 3) Check voltage between terminal ① and ground.

Voltage: Battery voltage

N.G. → Check the following.

- Harness connectors (FB, E9)
- Harness continuity between ignition coil and ignition switch

If N.G., repair harness or connectors.

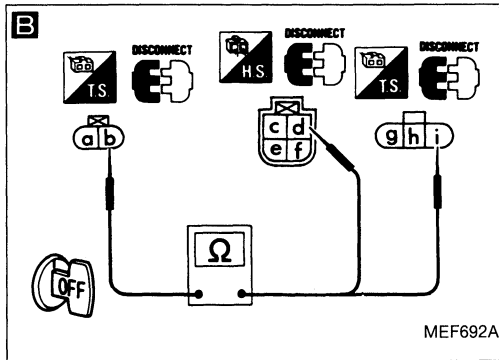

B CHECK GROUND CIRCUIT.

- 1) Turn ignition switch "OFF".
- 2) Disconnect resistor and condenser harness connector.
- 3) Disconnect power transistor harness connector.

B 4) Check harness continuity between terminal ② and terminals ④, ⑤.

Continuity should exist.

C 5) Check harness continuity between terminal ⑥ and engine ground.

Continuity should exist.

N.G. → Repair harness or connectors.

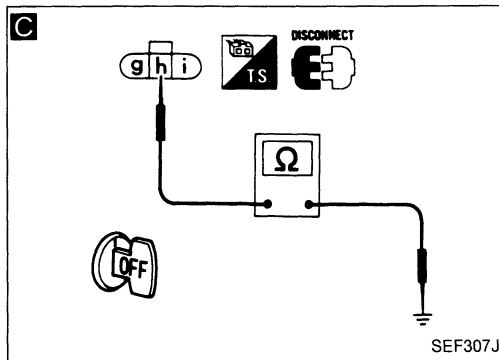

D CHECK INPUT SIGNAL CIRCUIT.

- 1) Disconnect E.C.U. harness connector.
- 2) Check harness continuity between terminal ⑥ and E.C.U. terminal ③.

Continuity should exist.

N.G. → Repair harness or connectors.

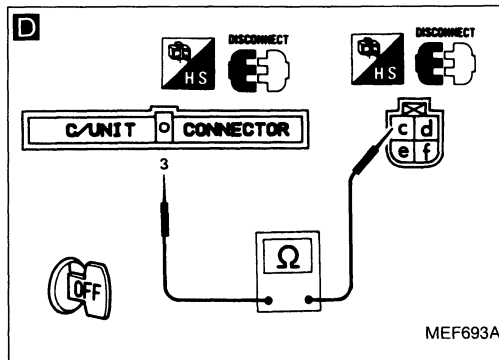

E CHECK OUTPUT SIGNAL CIRCUIT.

- 1) Check harness continuity between terminal ④ and E.C.U. terminal ①.

Continuity should exist.

N.G. → Repair harness or connectors.

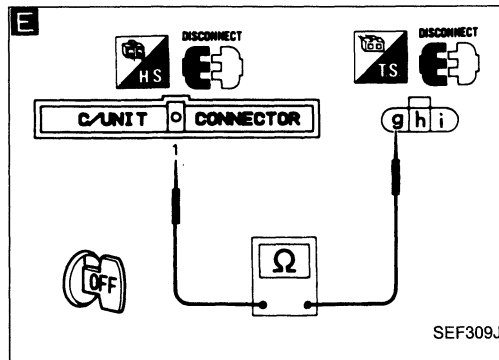

CHECK COMPONENTS (Ignition coil, resistor and power transistor). Refer to "Electrical Components Inspection". (See pages EF & EC-184, 190.)

N.G. → Replace malfunctioning component(s).

O.K. → **A**

Diagnostic Procedure 27 (Cont'd)

Ⓐ

Check E.C.U. pin terminals for damage or the connection of E.C.U. harness connector.

Perform FINAL CHECK by the following procedure after repair is completed.

FINAL CHECK

Erase the self-diagnosis memory.

Perform test drive.

Perform self-diagnosis again.

N.G.

Recheck E.C.U. pin terminals for damage or the connection of E.C.U. harness connector.

O.K.

INSPECTION END

NOTE

Diagnostic Procedure 28

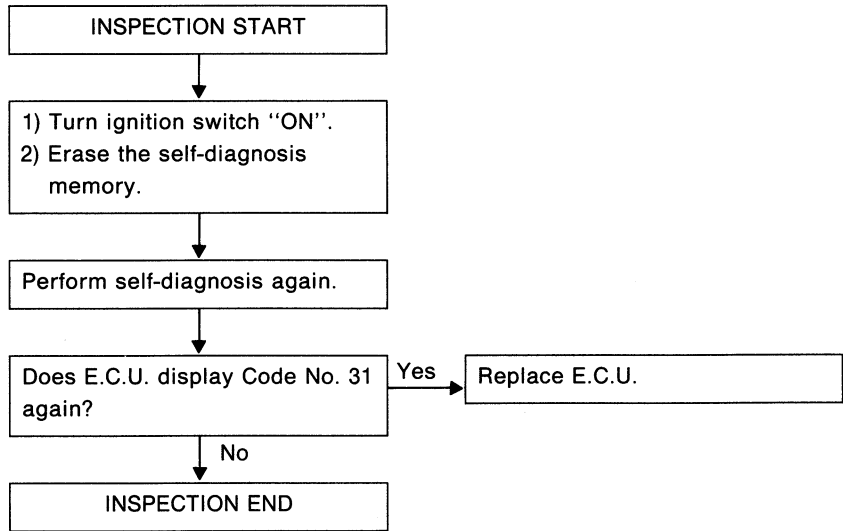
E.C.C.S. CONTROL UNIT (Code No. 31)  (CHECK ENGINE LIGHT ITEM)

NOTE

Diagnostic Procedure 29

E.G.R. FUNCTION (Code No. 32)  (CHECK ENGINE LIGHT ITEM): CALIFORNIA MODEL
 E.G.R. CONTROL (Not self-diagnostic item): NON-CALIFORNIA MODEL

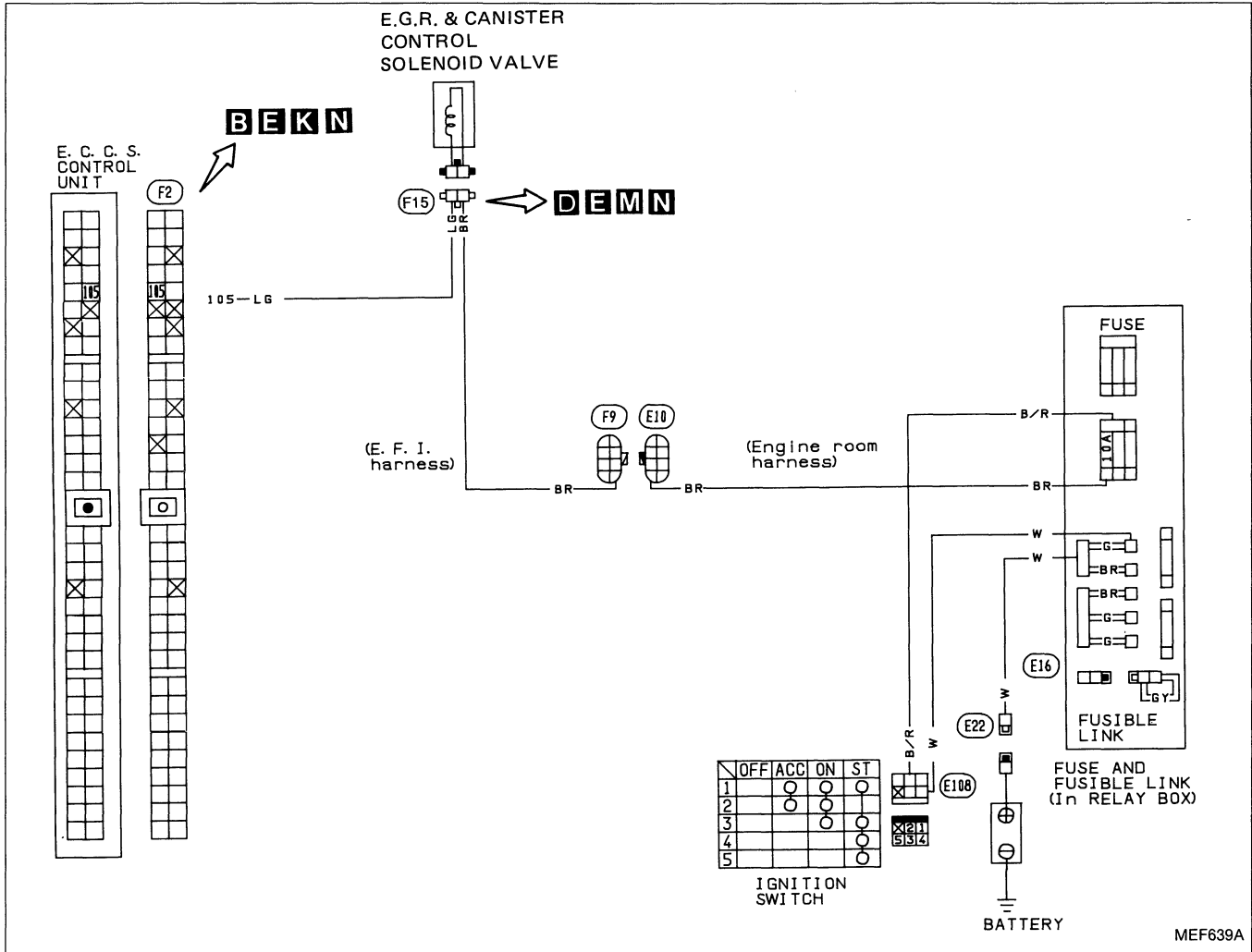

Harness layout

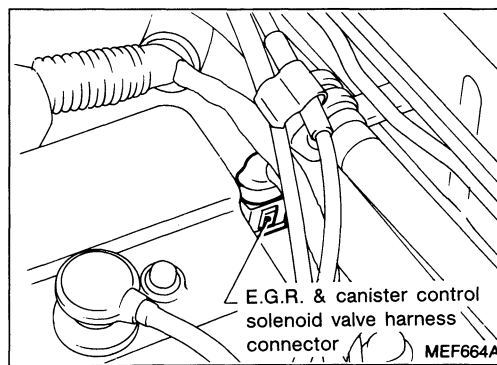
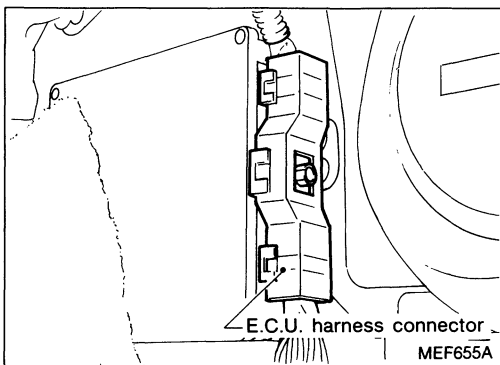

Diagnostic Procedure 29 (Cont'd)

California model

INSPECTION START

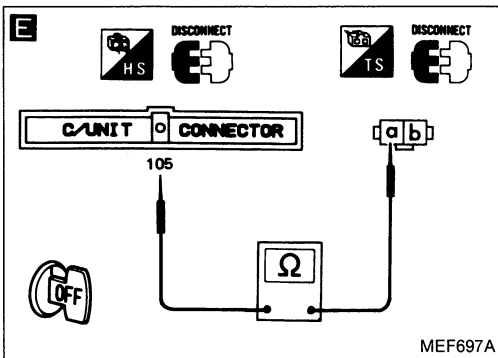
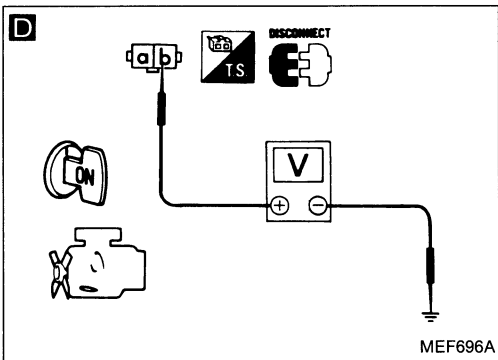
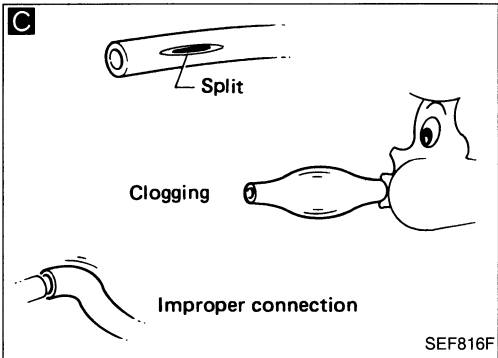
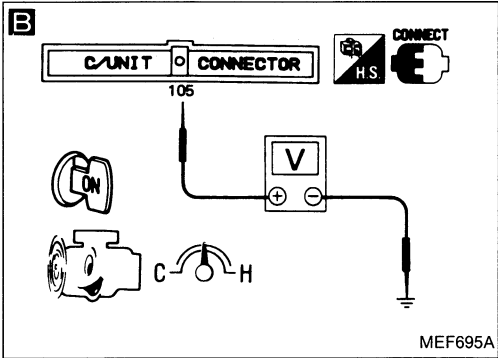
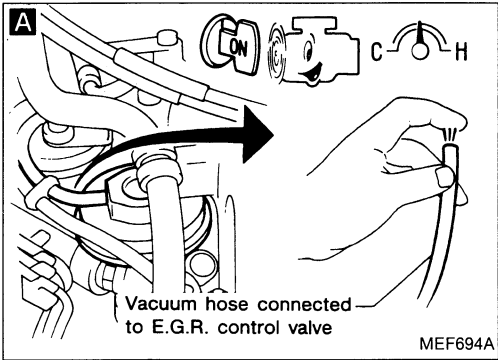

A

CHECK VACUUM SOURCE TO E.G.R. CONTROL VALVE.

- 1) Start engine and warm it up sufficiently.
- 2) Perform self-diagnosis. Make sure that none of the codes No. 12, No. 13, No. 35 or No. 43 are displayed.
- 3) Keep engine speed at about 2,000 rpm.
- 4) Disconnect vacuum hose to E.G.R. control valve.
- 5) Make sure that vacuum exists under the following conditions.

At idle:
Vacuum should not exist.

Engine speed is about 2,000 rpm.:
Vacuum should exist.

O.K. → CHECK COMPONENTS (E.G.R. control valve, B.P.T. valve and exhaust gas temperature sensor). Refer to "Electrical Components Inspection". (See page EF & EC-185, 186.)

N.G. → Replace malfunctioning component(s).

B

CHECK CONTROL FUNCTION.

- 1) Check voltage between E.C.U. terminal 105 and ground under the following conditions.

Voltage:

At idle
Approximately 0V

Engine speed is about 2,000 rpm.
Battery voltage

O.K. → CHECK VACUUM HOSE.

- 1) Check vacuum hose for clogging, cracks and proper connection.

D

CHECK POWER SUPPLY.

- 1) Stop engine.
- 2) Disconnect E.G.R. & canister control solenoid valve harness connector.
- 3) Turn ignition switch "ON".
- 4) Check voltage between terminal (b) and ground.

Voltage: Battery voltage

N.G. → Check the following.

- Harness connectors (F9), (E10)
- 10A fuse
- Harness continuity between E.G.R. & canister control solenoid valve and fuse

If N.G., repair harness or connectors.

O.K. → **A**

Diagnostic Procedure 29 (Cont'd)

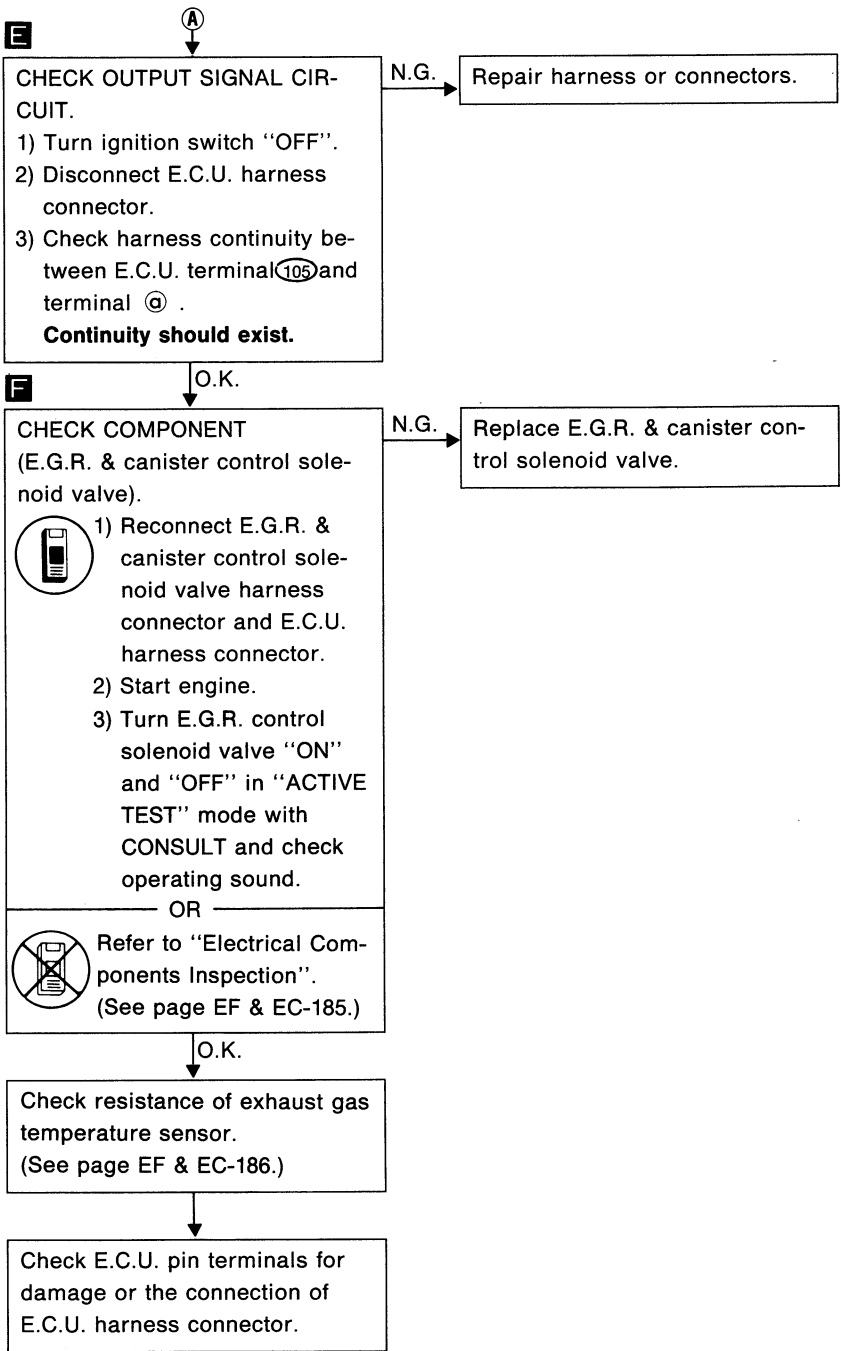
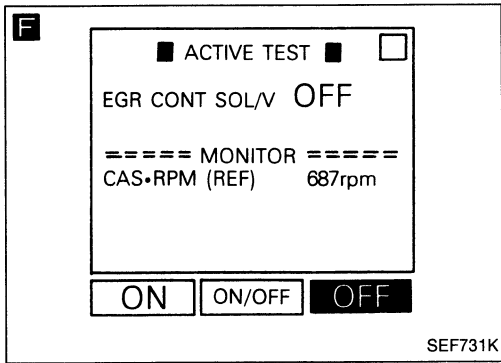

Diagnostic Procedure 29 (Cont'd)

G ROAD TEST

Test condition

Drive vehicle under the following conditions with suitable shift position.

- (1) Engine speed:
2,400±800 rpm
- (2) Intake manifold vacuum:
-40.0±13.3 kPa
(-300±100 mmHg, -11.81±3.94 inHg)

Driving mode

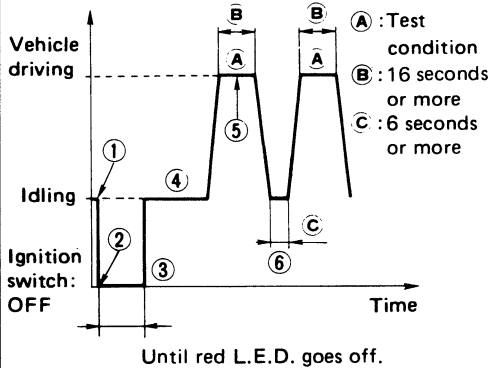

- ① Start engine and warm it up sufficiently.
- ② Turn off ignition switch and keep it off until red L.E.D. goes off.
- ③ Start engine and make sure that air conditioner switch and rear defogger are turned "OFF" during test drive.
- ④ Keep engine running for at least 4 minutes.
- ⑤ Shift to suitable gear position and drive in "Test condition" for at least 16 seconds.
- ⑥ Decrease engine revolutions to less than 1,500 rpm for at least 6 seconds.
- ⑦ Repeat steps ⑤ through ⑥ at least 1 more time.

SEF007L

Perform FINAL CHECK by the following procedure after repair is completed.

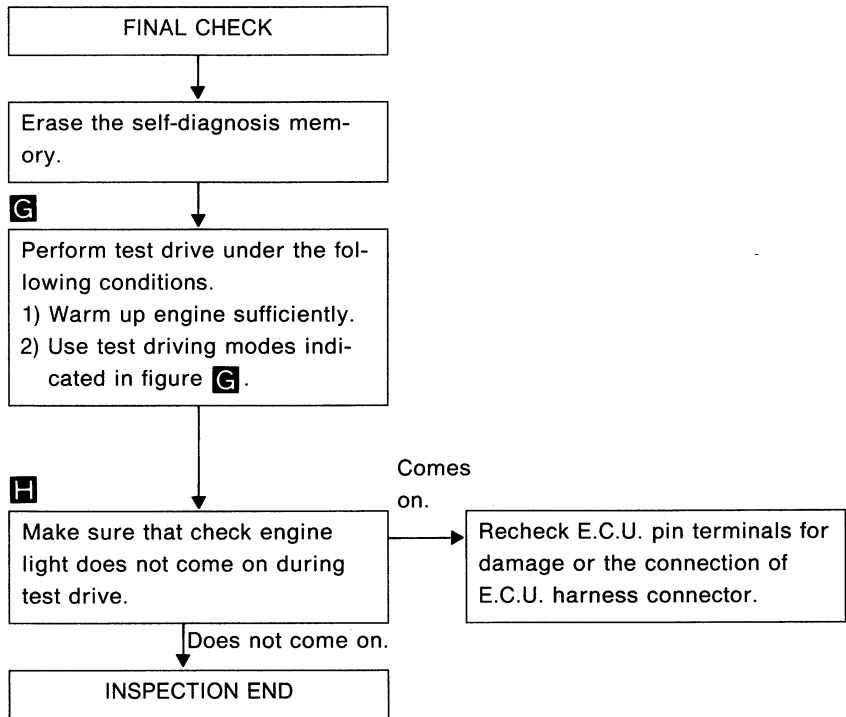

H

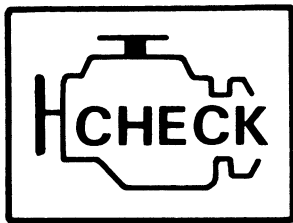

CHECK ENGINE LIGHT

SEF924F

Diagnostic Procedure 29 (Cont'd)

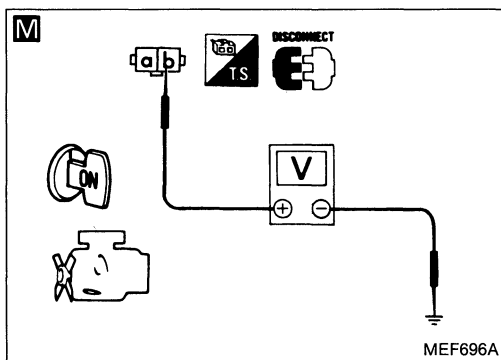
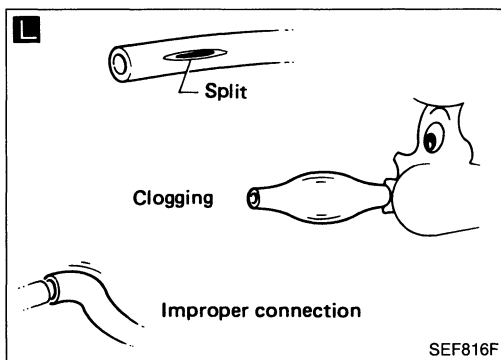
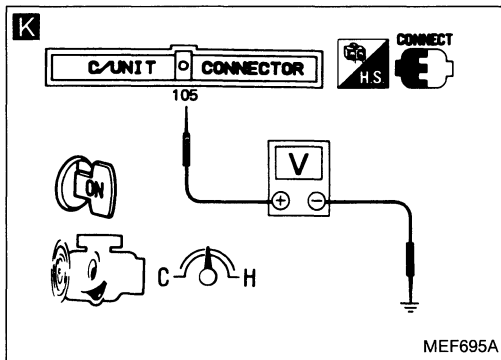
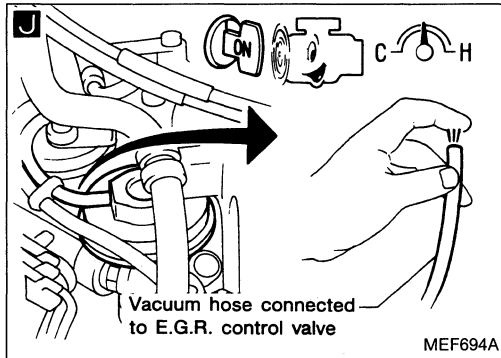
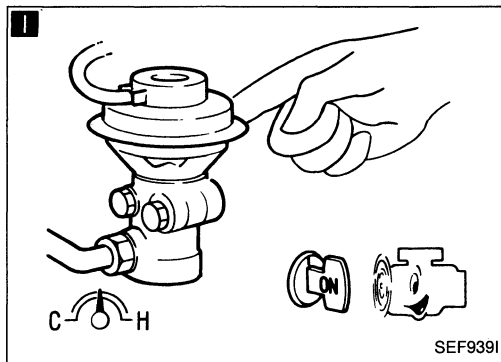

Non-California model

INSPECTION START

I
CHECK OVERALL FUNCTION.
 1) Start engine and warm it up sufficiently.
 2) Make sure that E.G.R. control valve spring is lifted up and down when racing engine (2,000 rpm). (Use your finger.)

Is lifted up and down. → **INSPECTION END**

Is not lifted up and down. → **J**
CHECK VACUUM SOURCE TO E.G.R. CONTROL VALVE.
 1) Disconnect vacuum hose to E.G.R. control valve.
 2) Make sure that vacuum exists under the following conditions.
At idle:
 Vacuum should not exist.
Engine speed is about 2,000 rpm:
 Vacuum should exist.

O.K. → **CHECK COMPONENTS** (E.G.R. control valve and B.P.T. valve). Refer to "Electrical Components Inspection". (See page EF & EC-185.)

N.G. → **Replace malfunctioning component(s).**

N.G. → **K**
CHECK CONTROL FUNCTION.
 1) Check voltage between E.C.U. terminal 105 and ground under the following conditions.
Voltage:
At idle
 Approximately 0V
Engine speed is about 2,000 rpm.
 Battery voltage

O.K. → **L**
CHECK VACUUM HOSE.
 1) Check vacuum hose for clogging, cracks and proper connection.

N.G. → **M**
CHECK POWER SUPPLY.
 1) Stop engine.
 2) Disconnect E.G.R. & canister control solenoid valve harness connector.
 3) Turn ignition switch "ON".
 4) Check voltage between terminal B and ground.
Voltage: Battery voltage

N.G. → **Check the following.**
 ● Harness connectors (F9, E11)
 ● 10A fuse
 ● Harness continuity between E.G.R. & canister control solenoid valve and fuse
 If N.G., repair harness or connectors.

O.K. → **A**

Diagnostic Procedure 29 (Cont'd)

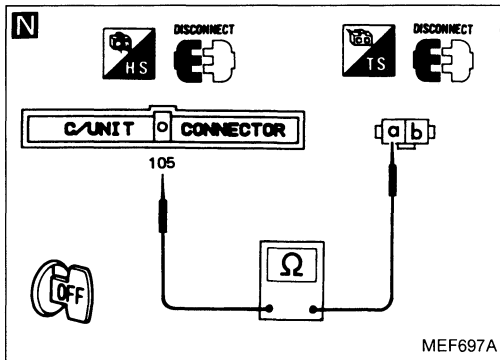

N

A

CHECK OUTPUT SIGNAL CIRCUIT.

- 1) Turn ignition switch "OFF".
- 2) Disconnect E.C.U. harness connector.
- 3) Check harness continuity between E.C.U. terminal 105 and terminal @.

Continuity should exist.

N.G. → Repair harness or connectors.

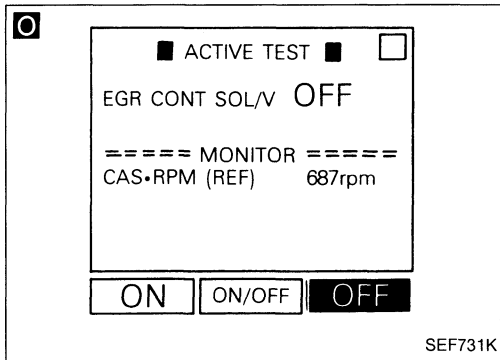

O

CHECK COMPONENT (E.G.R. & canister control solenoid valve).

- 1) Reconnect E.G.R. & canister control solenoid valve harness connector and E.C.U. harness connector.
- 2) Start engine.
- 3) Turn E.G.R. control solenoid valve "ON" and "OFF" in "ACTIVE TEST" mode with CONSULT and check operating sound.

N.G. → Replace E.G.R. & canister control solenoid valve.

OR

 Refer to "Electrical Components Inspection". (See page EF & EC-185.)

O.K.

Check E.C.U. pin terminals for damage or the connection of E.C.U. harness connector.

Diagnostic Procedure 30

EXHAUST GAS SENSOR (Code No. 33)  (CHECK ENGINE LIGHT ITEM): CALIFORNIA MODEL ONLY

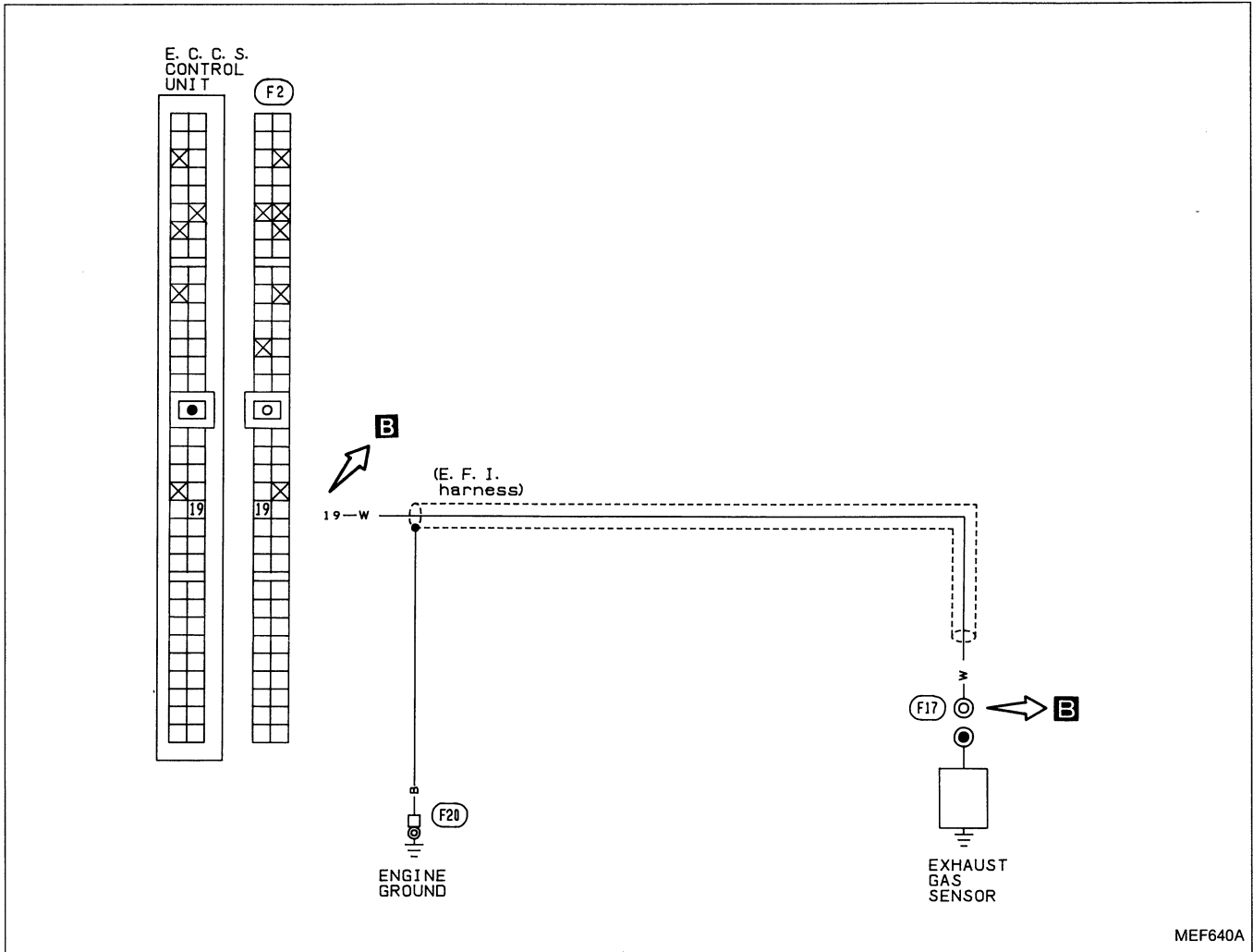

Harness layout

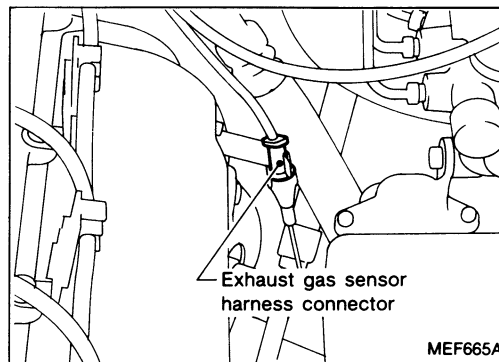
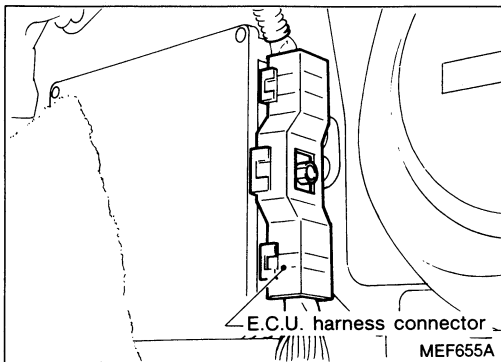

Diagnostic Procedure 30 (Cont'd)

A

☆ MONITOR ☆ NO FAIL

CAS-RPM(REF) 2087rpm

M/R F/C MNT LEAN

RECORD

SEF996K

A

RED L.E.D.

Check engine light

SEF621K

B

C/UNIT CONNECTOR

19 ⑩

Ω

OFF

SEF942I

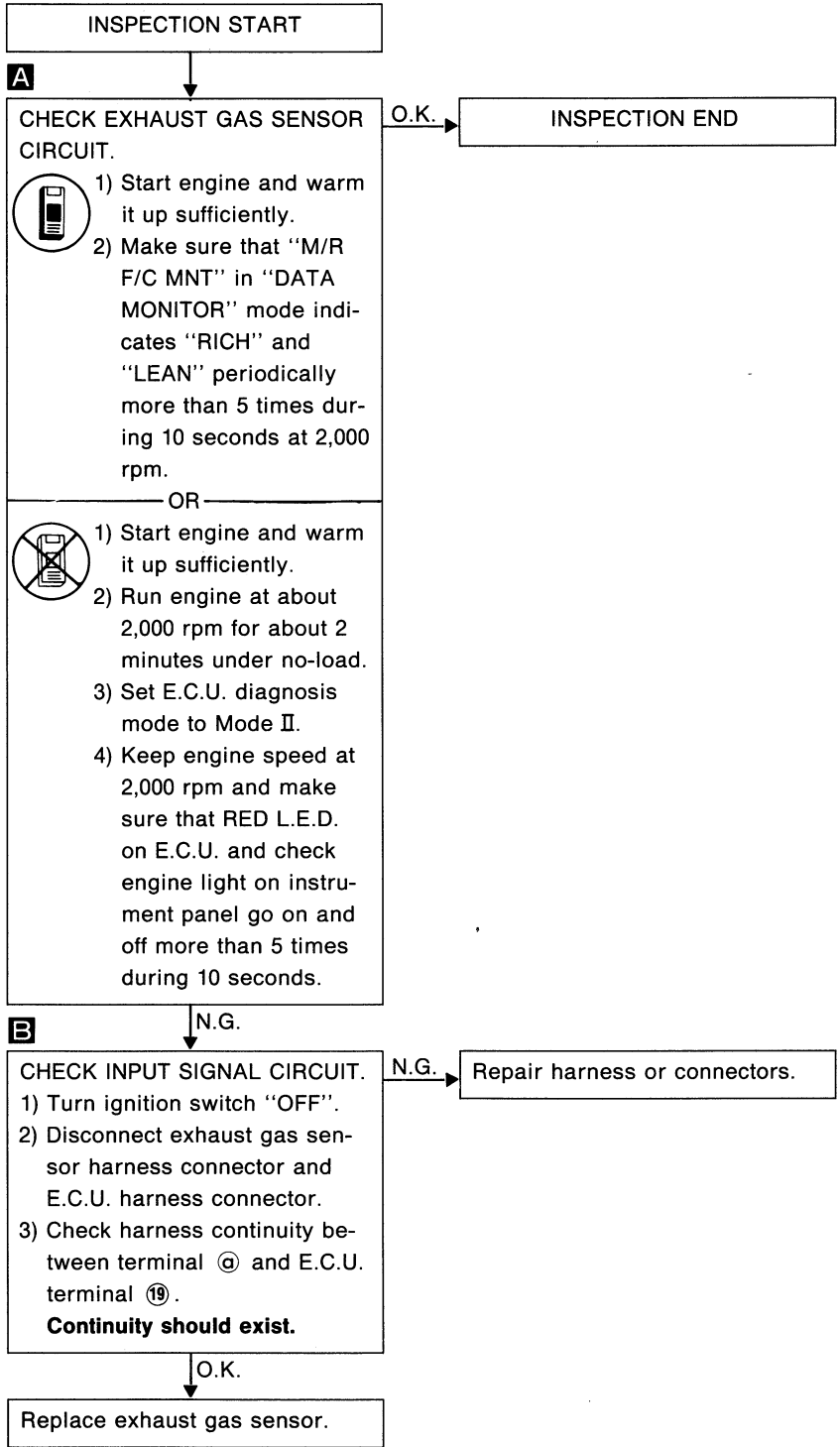

Diagnostic Procedure 30 (Cont'd)

Perform **FINAL CHECK** by the following procedure after repair is completed.

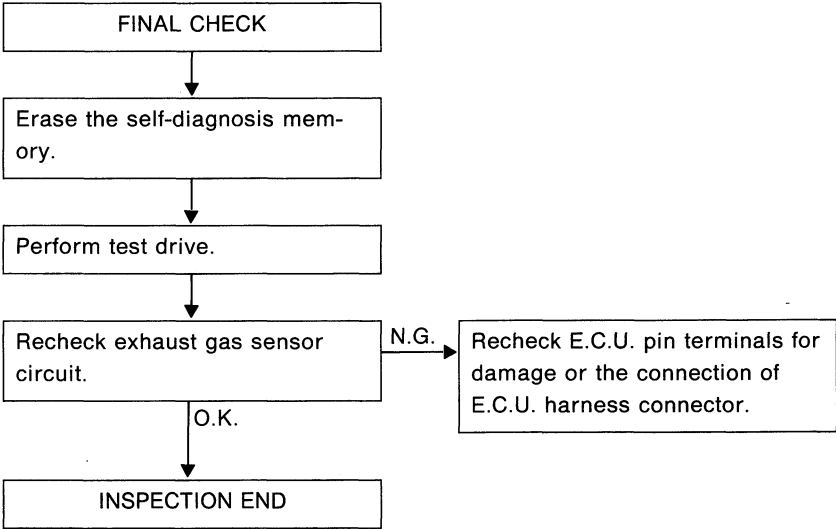

NOTE

Diagnostic Procedure 31

DETONATION SENSOR (Code No. 34)

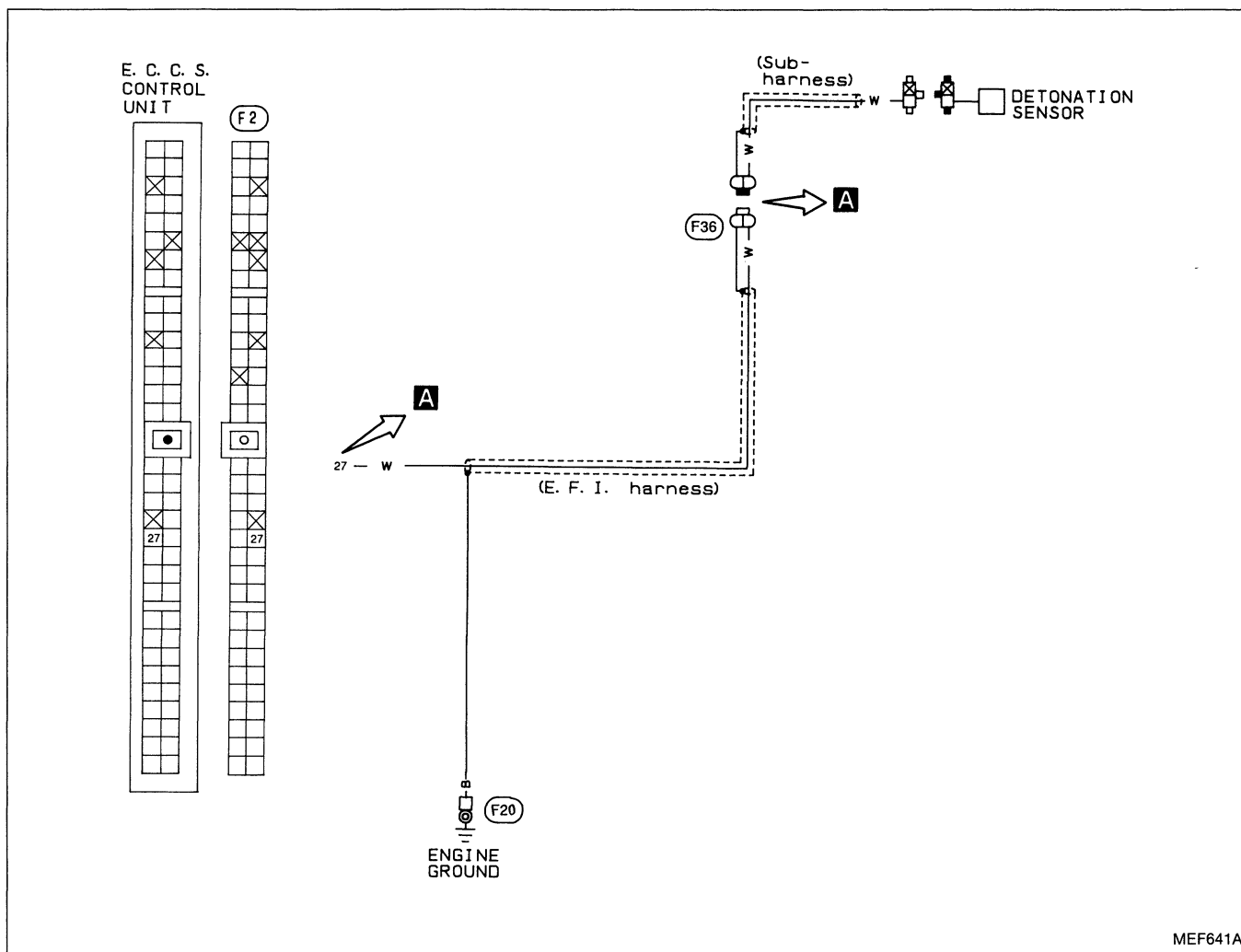

Harness layout

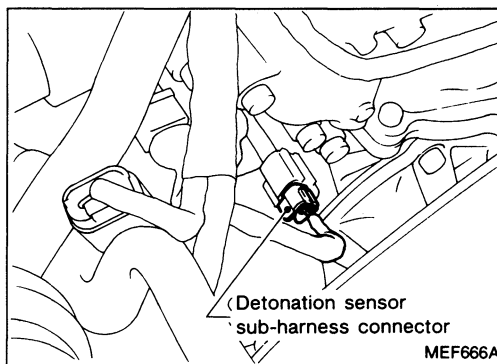
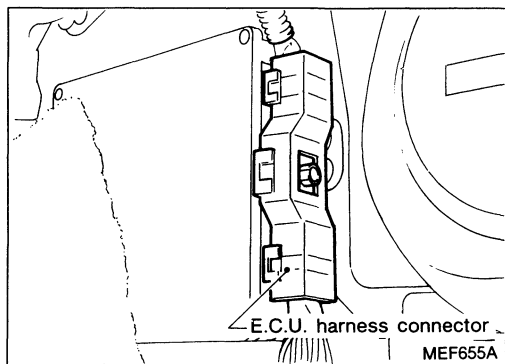

Diagnostic Procedure 31 (Cont'd)

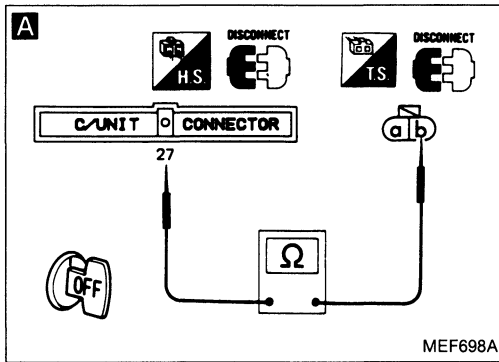

INSPECTION START

A CHECK INPUT SIGNAL CIRCUIT.

1) Disconnect E.C.U. harness connector and detonation sensor sub-harness connector.

2) Check harness continuity between terminal **b** and E.C.U. terminal **27**.

Continuity should exist.

N.G. → Repair harness or connectors.

O.K.

CHECK COMPONENT (Detonation sensor). Refer to "Electrical Components Inspection". (See page EF & EC-187.)

N.G. → Replace detonation sensor.

O.K.

Check E.C.U. pin terminals for damage or the connection of E.C.U. harness connector.

Perform FINAL CHECK by the following procedure after repair is completed.

FINAL CHECK

Erase the self-diagnosis memory.

Perform test drive.

Perform self-diagnosis again.

N.G. → Recheck E.C.U. pin terminals for damage or the connection of E.C.U. harness connector.

O.K.

INSPECTION END

Diagnostic Procedure 32

EXHAUST GAS TEMPERATURE SENSOR (Code No. 35)  (CHECK ENGINE LIGHT ITEM): CALIFORNIA MODEL ONLY

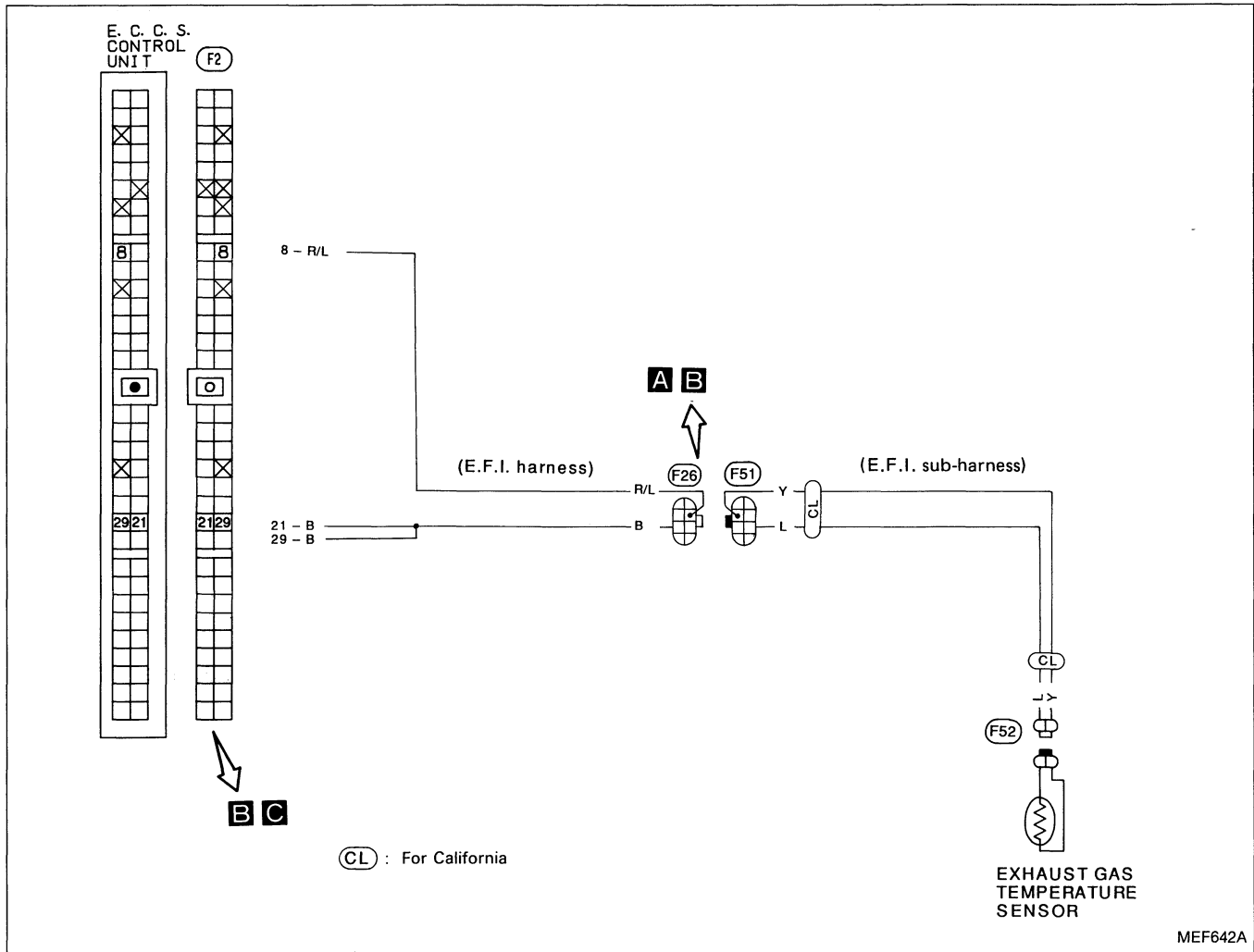

Harness layout

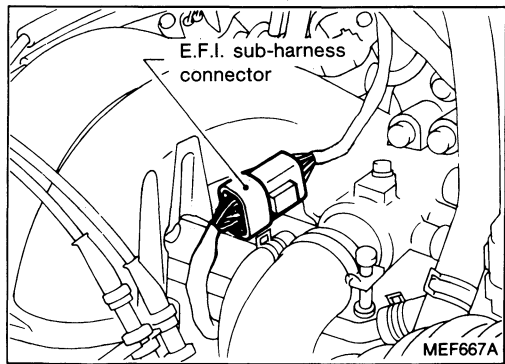
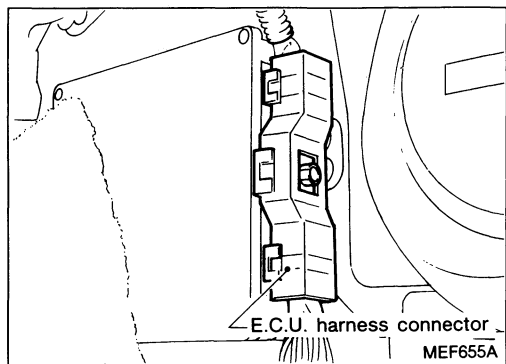

Diagnostic Procedure 32 (Cont'd)

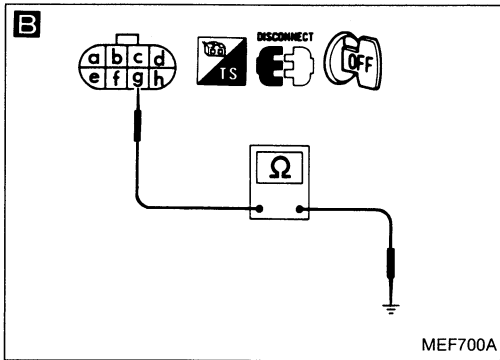
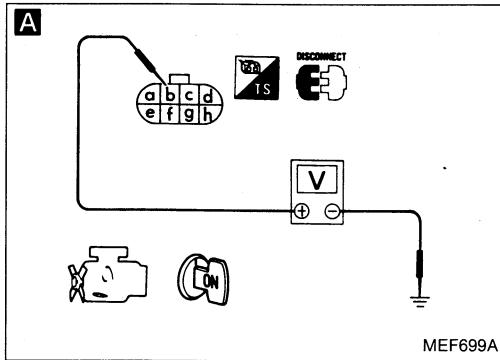
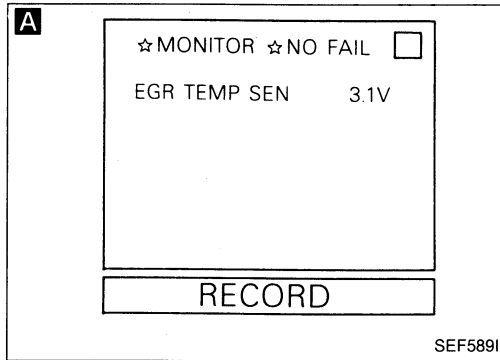

```

    graph TD
        Start[INSPECTION START] --> A[CHECK POWER SUPPLY.]
        A -- N.G. --> Repair1[Repair harness or connectors.]
        A -- O.K. --> B[CHECK GROUND CIRCUIT.]
        B -- N.G. --> Repair2[Repair harness or connectors.]
        B -- O.K. --> C[CHECK COMPONENT.]
        C -- N.G. --> Repair3[Replace exhaust gas temperature sensor.]
        C -- O.K. --> D[Check E.C.U. pin terminals for damage or the connection of E.C.U. harness connector.]
    
```

A

INSPECTION START

A

CHECK POWER SUPPLY.

1) Start engine and warm it up sufficiently.

2) Read exhaust gas temperature sensor signal in "DATA MONITOR" mode with CONSULT.

Voltage:
Less than 4.5V (at idle)

OR

2) Stop engine.

3) Disconnect exhaust gas temperature sensor sub-harness connector (F51).

4) Turn ignition switch "ON".

5) Check voltage between terminal (b) and ground.

Voltage:
Less than 4.5V (at idle)

B

CHECK GROUND CIRCUIT.

1) Turn ignition switch "OFF".

2) Check harness continuity between terminal (g) and engine ground.

Continuity should exist.

C

CHECK COMPONENT.
(Exhaust gas temperature sensor).
Refer to "Electrical Components Inspection".
(See page EF & EC-186.)

Check E.C.U. pin terminals for damage or the connection of E.C.U. harness connector.

Diagnostic Procedure 32 (Cont'd)

Perform FINAL CHECK by the following procedure after repair is completed.

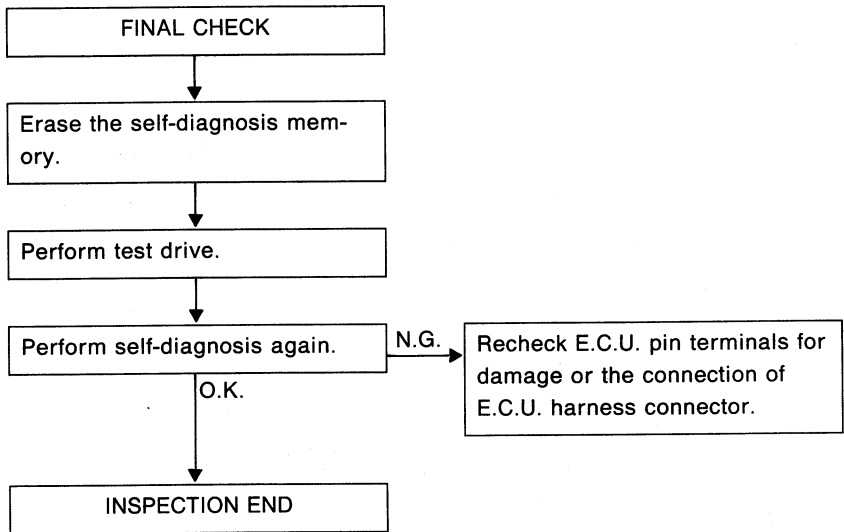

NOTE

Diagnostic Procedure 33

THROTTLE SENSOR (Code No. 43)  (CHECK ENGINE LIGHT ITEM)

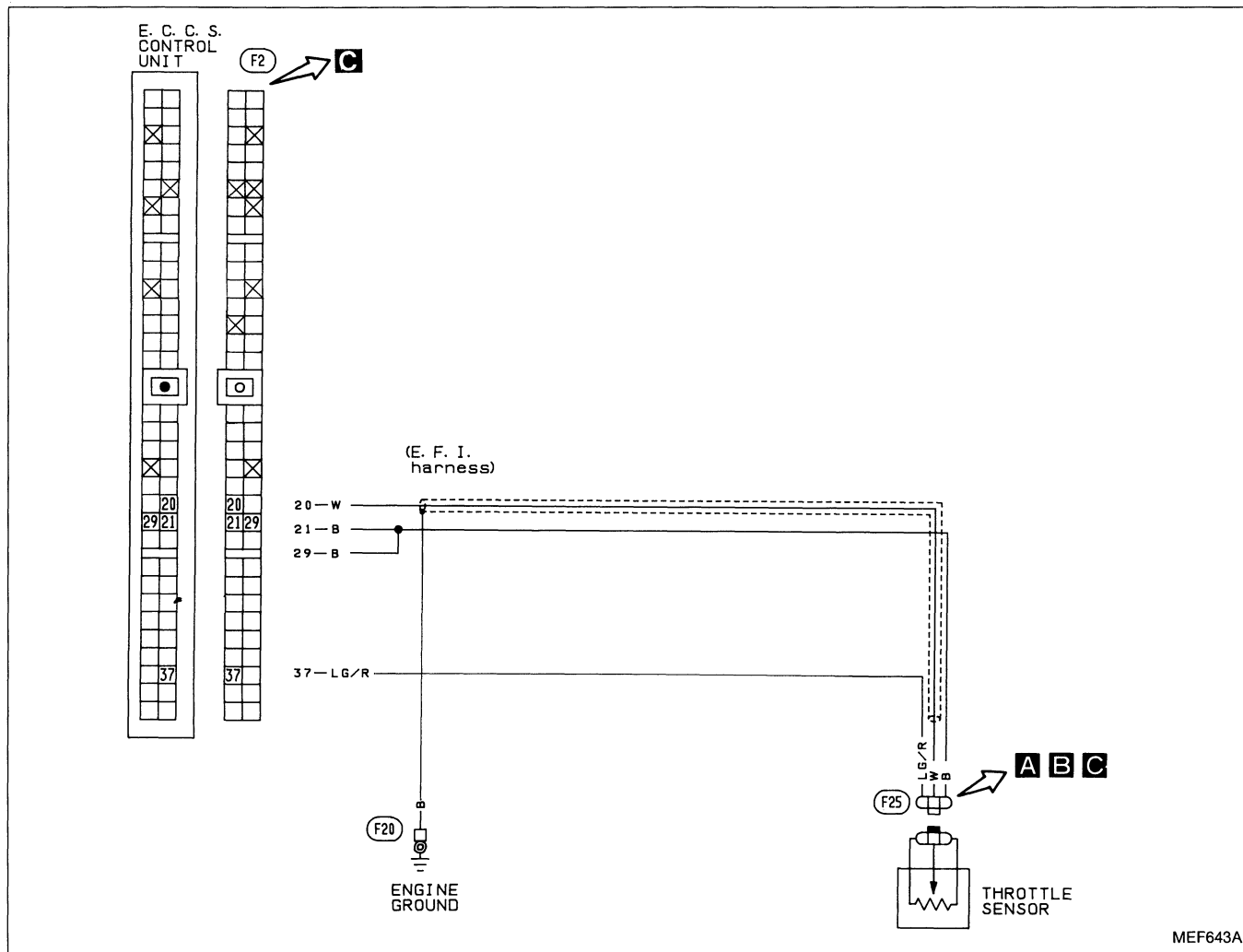

Harness layout

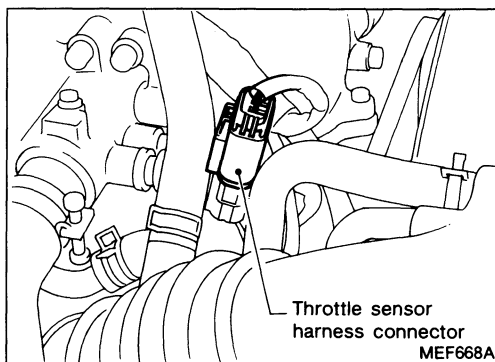
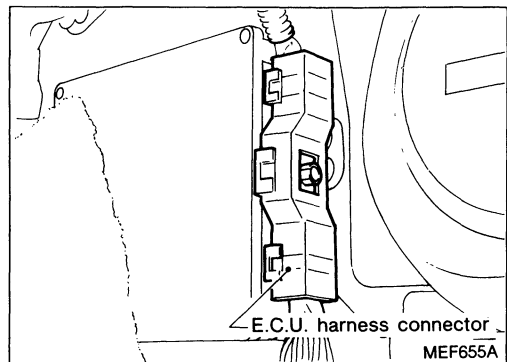

Diagnostic Procedure 33 (Cont'd)

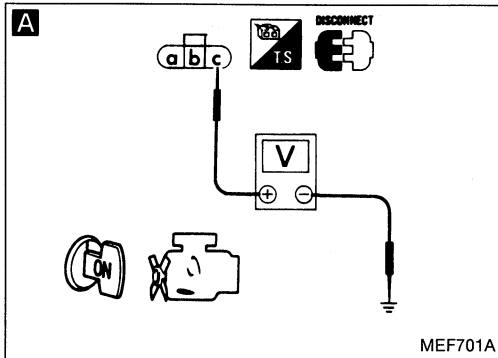

INSPECTION START

A

CHECK POWER SUPPLY.

- 1) Disconnect throttle sensor harness connector.
- 2) Turn ignition switch "ON".
- 3) Check voltage between terminal Ⓐ and ground.

Voltage: Approximately 5V

N.G. → Repair harness or connectors.

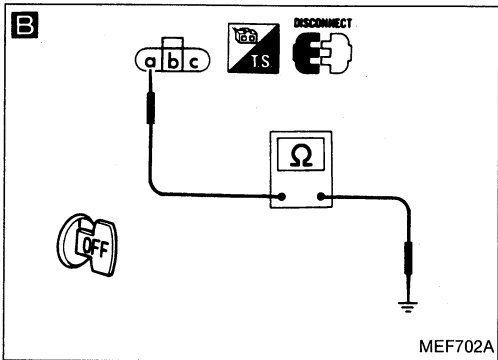

O.K.

B

CHECK GROUND CIRCUIT.

- 1) Turn ignition switch "OFF".
- 2) Check harness continuity between terminal Ⓐ and engine ground.

Continuity should exist.

N.G. → Repair harness or connectors.

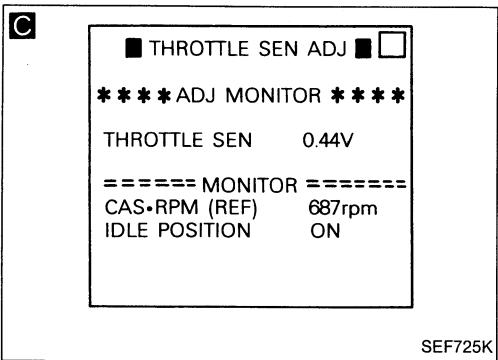

O.K.

C

CHECK INPUT SIGNAL CIRCUIT.

- 1) Reconnect throttle sensor harness connector.
- 2) Turn ignition switch "ON".
- 3) Read throttle sensor output voltage in "WORK SUPPORT" mode with CONSULT.

Throttle valve fully closed:

Approx. 0.4V

Throttle valve fully open:

Approx. 4.0V

N.G. → Repair harness or connectors.

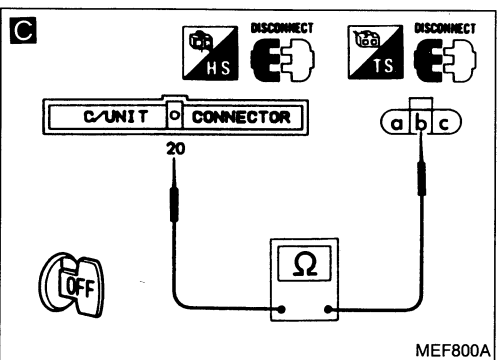

OR

- 1) Disconnect E.C.U. harness connector.
- 2) Check harness continuity between E.C.U. terminal 20 and terminal Ⓑ.

Continuity should exist.

N.G. → Replace throttle sensor.

O.K.

CHECK COMPONENT (Throttle sensor).

Refer to "Electrical Components Inspection".

(See page EF & EC-186.)

O.K.

Check E.C.U. pin terminals for damage or the connection of E.C.U. harness connector.

Diagnostic Procedure 33 (Cont'd)

Perform FINAL CHECK by the following procedure after repair is completed.

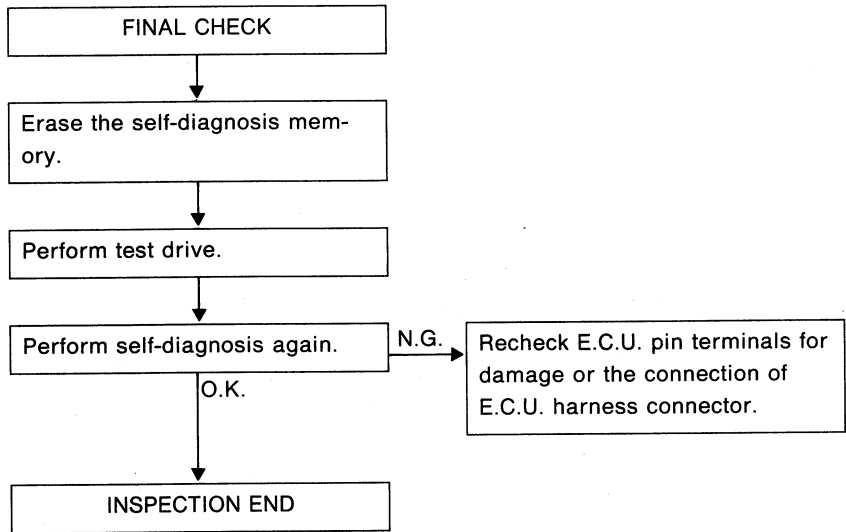

NOTE

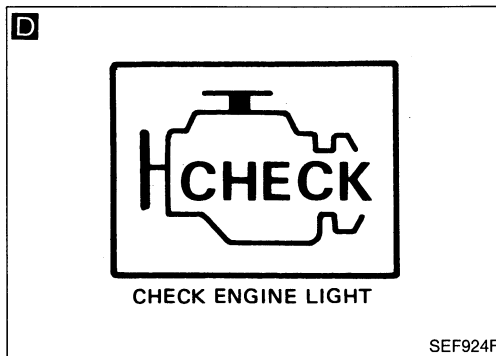
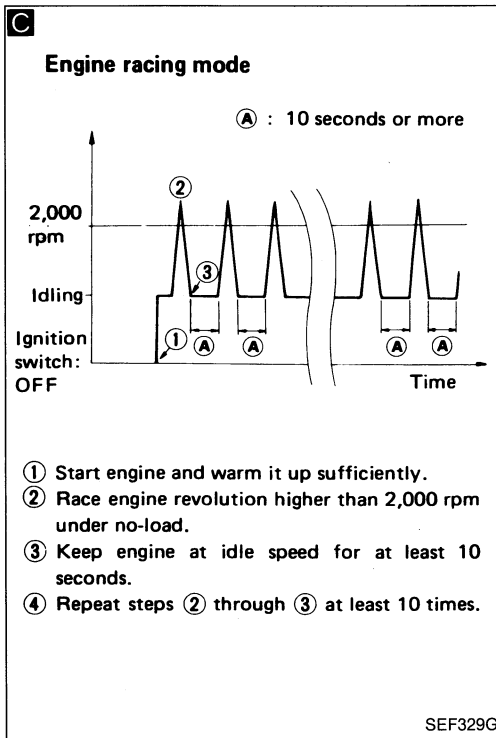
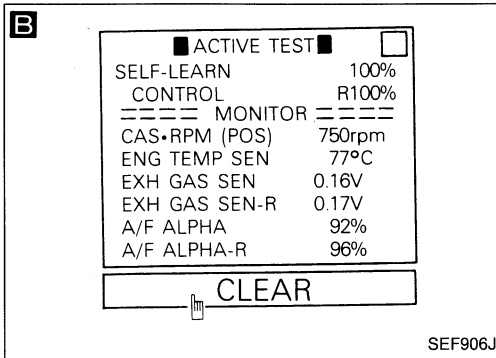
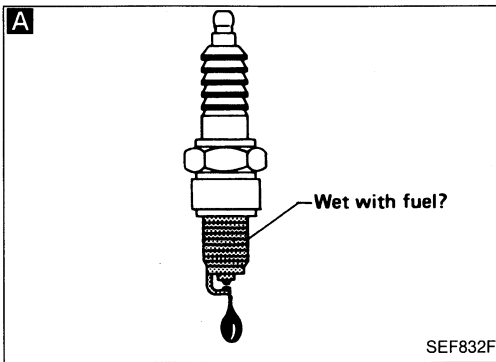

Diagnostic Procedure 34

INJECTOR LEAK (Code No. 45)  (CHECK ENGINE LIGHT ITEM); CALIFORNIA MODEL ONLY

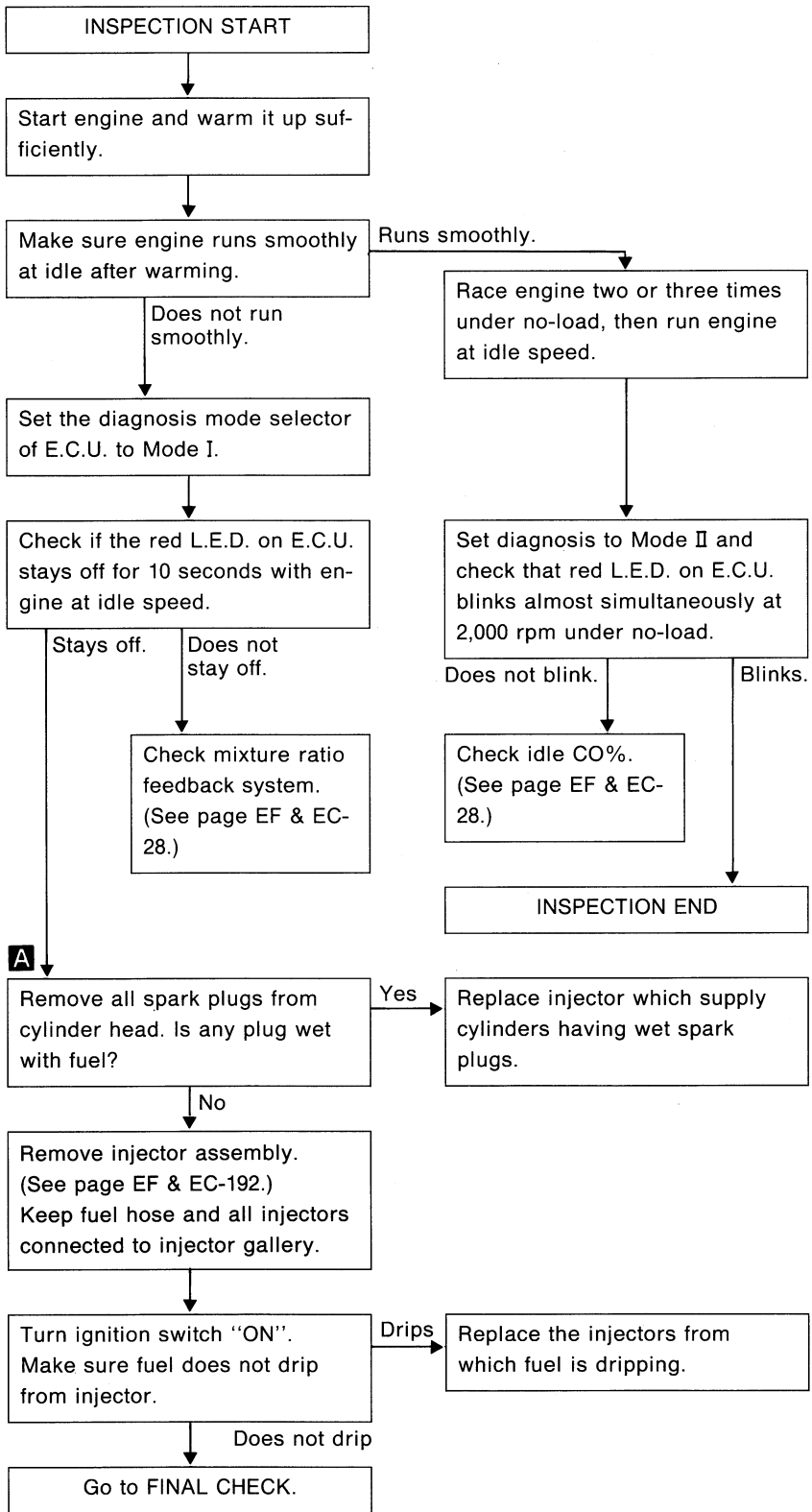

Diagnostic Procedure 34 (Cont'd)

Perform FINAL CHECK by the following procedure after repair is completed.

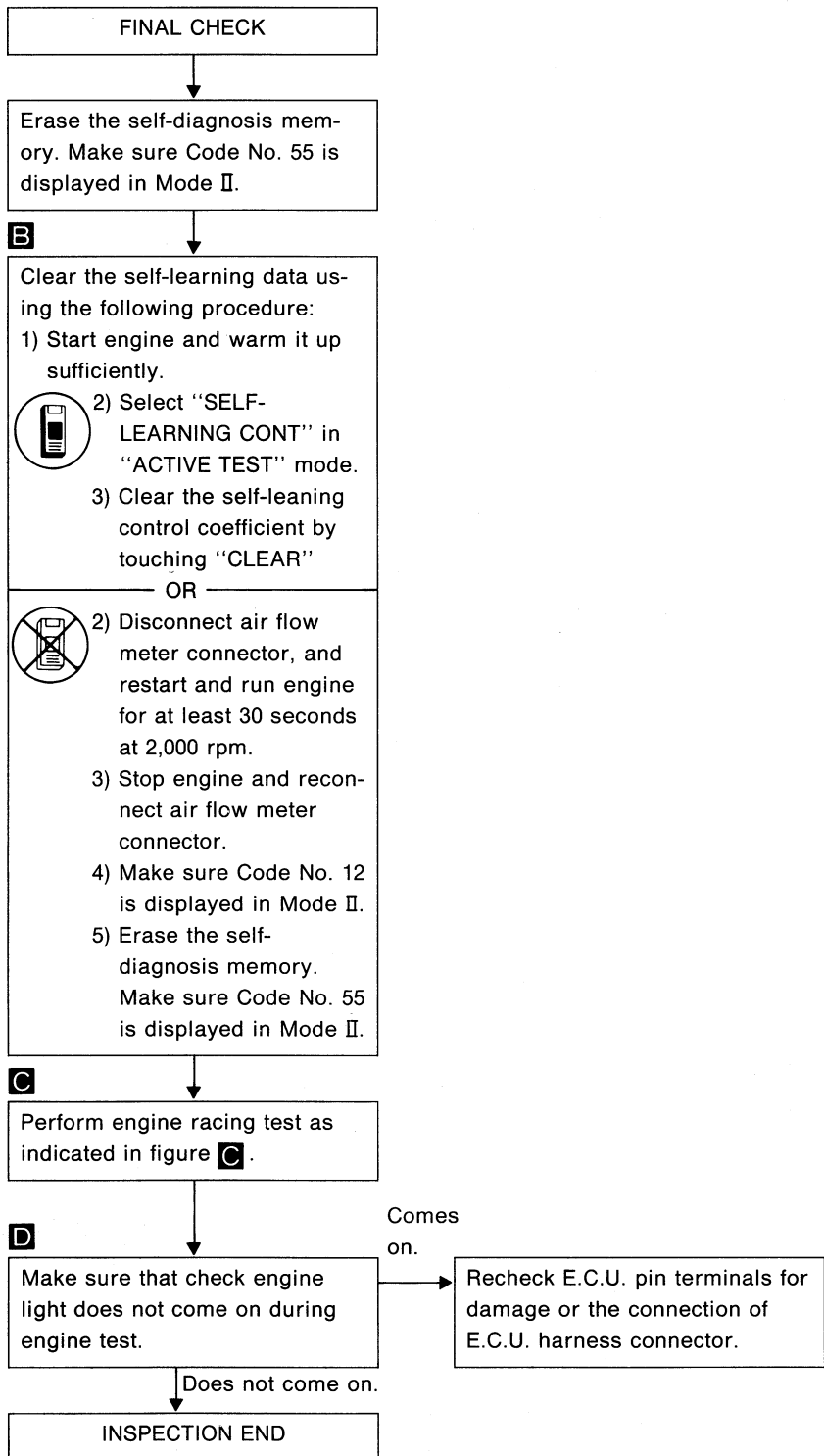

Diagnostic Procedure 35

A/T CONTROL (Code No. 54)

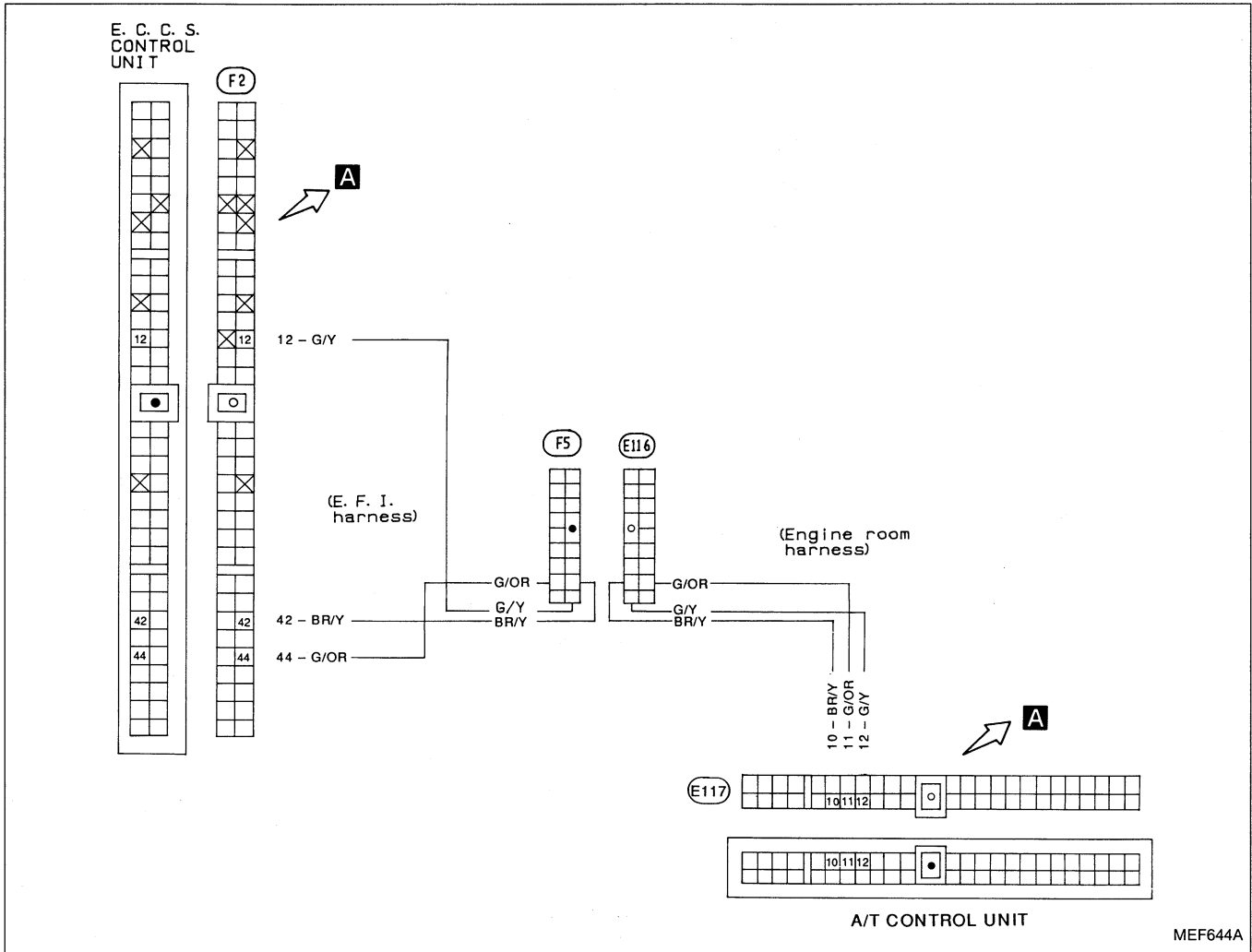

MEF644A

Harness layout

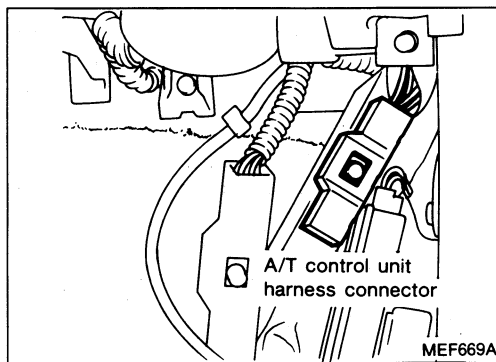
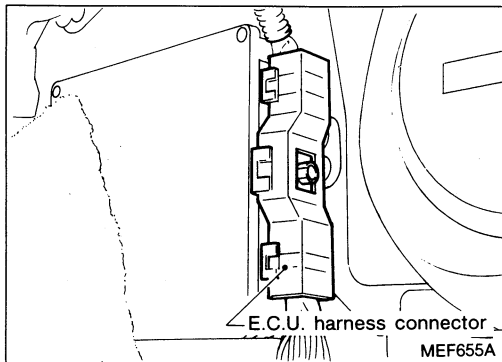

Diagnostic Procedure 35 (Cont'd)

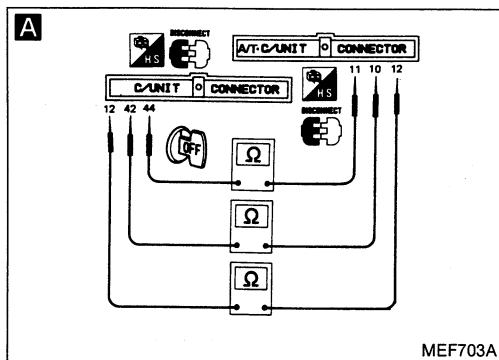

INSPECTION START

A
CHECK INPUT SIGNAL CIRCUIT.

- 1) Disconnect E.C.U. harness connector and A/T control unit harness connector.
- 2) Check harness continuity between E.C.U. terminal ⑫ and terminal ⑪, E.C.U. terminal ④② and terminal ⑩, E.C.U. terminal ④④ and terminal ①①. **Continuity should exist.**

N.G.

Check the following.

- Harness connectors (F5), (E116)
 - Harness continuity between E.C.U. and A/T control unit
- If N.G., repair harness or connectors.

O.K.

Check E.C.U. pin terminals for damage or the connection of E.C.U. harness connector.

Perform FINAL CHECK by the following procedure after repair is completed.

FINAL CHECK

Erase the self-diagnosis memory.

Perform test drive.

Perform self-diagnosis again.

N.G.

Recheck E.C.U. pin terminals for damage or the connection of E.C.U. harness connector.

O.K.

INSPECTION END

Diagnostic Procedure 36

START SIGNAL (Not self-diagnostic item)

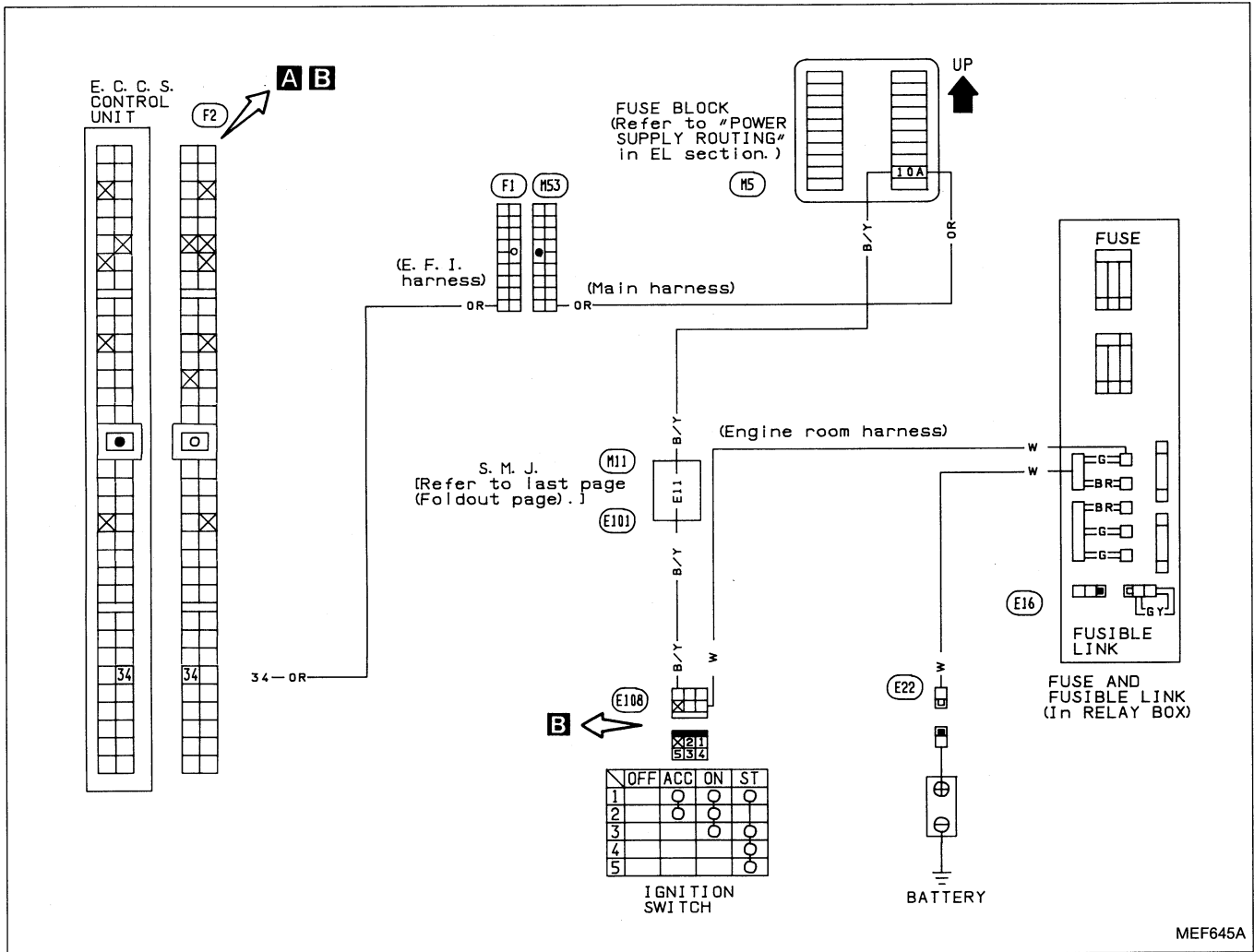

MEF645A

Harness layout

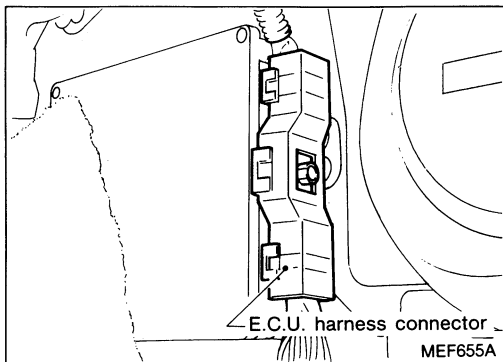

Diagnostic Procedure 36 (Cont'd)

A

☆ MONITOR	☆ NO FAIL	<input type="checkbox"/>
START SIGNAL	OFF	
IDLE POSITION	ON	
AIR COND SIG	OFF	
NEUTRAL SW	ON	

RECORD

SEF384J

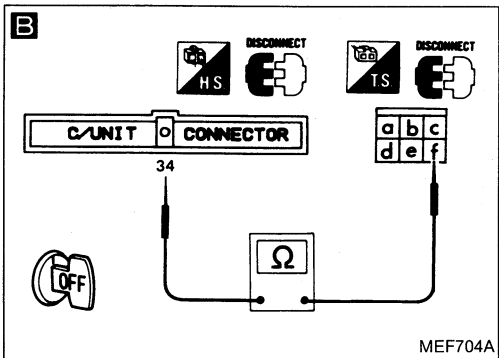
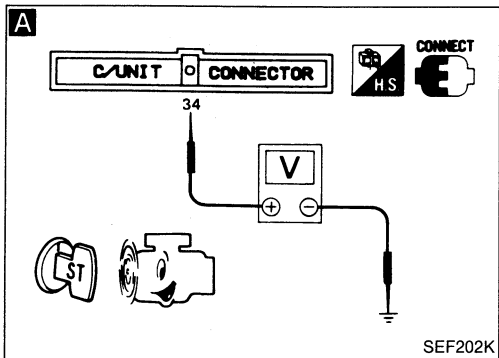

INSPECTION START

A

CHECK OVERALL FUNCTION.

- 1) Turn ignition switch "ON".
- 2) Check start signal in "DATA MONITOR" mode with CONSULT.

IGN "ON"	OFF
IGN "START"	ON

OR

- 1) Turn ignition switch to "START".
- 2) Check voltage between E.C.U. terminal ③④ and ground.

Voltage:

Ignition switch "START"

Battery voltage

Except above

Approximately 0V

O.K. → INSPECTION END

B N.G.

CHECK INPUT SIGNAL CIRCUIT.

- 1) Turn ignition switch "OFF".
- 2) Disconnect E.C.U. harness connector and ignition switch harness connector.
- 3) Check harness continuity between E.C.U. terminal ③④ and terminal ①.

Continuity should exist.

- N.G. → Check the following.
- Harness connectors (F1), (M53)
 - Harness connectors (M11), (E101)
 - 10A fuse
 - Harness continuity between E.C.U. and ignition switch
- If N.G., repair harness or connectors.

O.K.

Check E.C.U. pin terminals for damage or the connection of E.C.U. harness connector.

Diagnostic Procedure 37

A.I.V. CONTROL (Not self-diagnostic item)

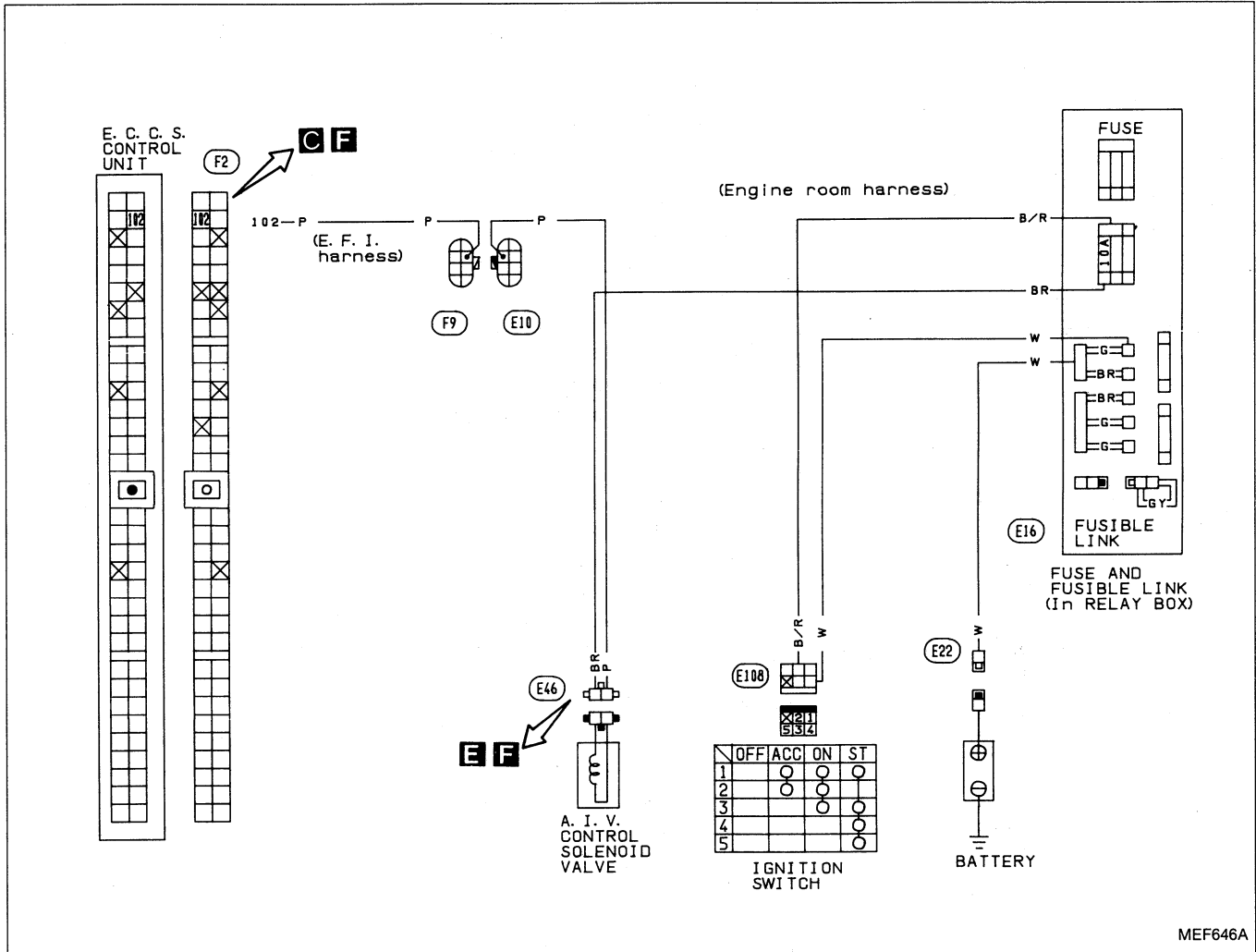

MEF646A

Harness layout

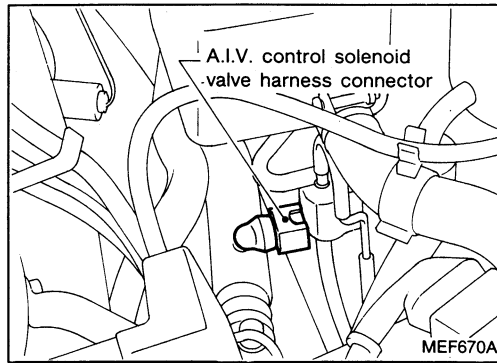
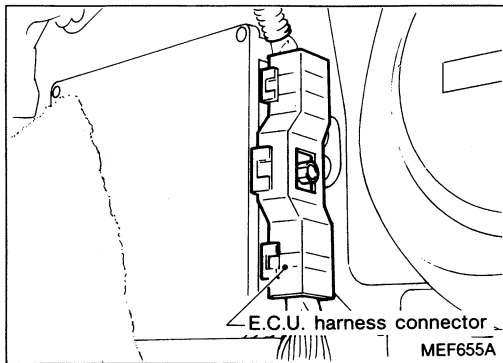

Diagnostic Procedure 37 (Cont'd)

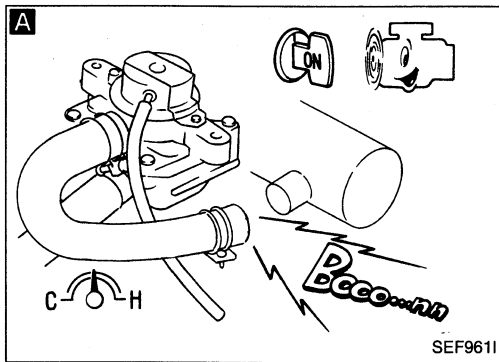

INSPECTION START

A

CHECK OVERALL FUNCTION.

- 1) Start engine and warm it up sufficiently.
- 2) Run engine at about 2,000 rpm for about 2 minutes under no-load.
- 3) Release accelerator pedal fully, and run engine at idle.
- 4) Listen to A.I.V. operating sound.

At idle and during deceleration:

A.I.V. should operate.

Except above:

A.I.V. should not operate.

O.K. → INSPECTION END

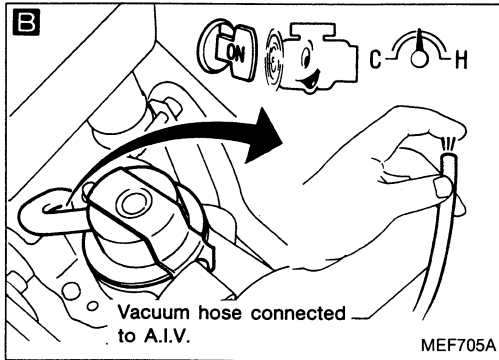

B

CHECK VACUUM SOURCE TO A.I.V.

- 1) Disconnect vacuum hose to A.I.V.
- 2) Make sure that vacuum exists under the following conditions.

At idle and during deceleration:

Vacuum should exist.

Except above:

Vacuum should not exist.

O.K. → CHECK COMPONENT (A.I.V.). Refer to "Electrical Components Inspection". (See page EF & EC-189.)

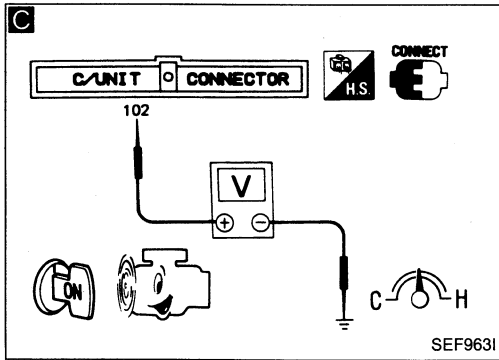

C

CHECK CONTROL FUNCTION.

- 1) Check voltage between E.C.U. terminal 102 and ground.

Voltage:

At idle and during deceleration

Approximately 0V

Except above

Battery voltage

O.K. → CHECK VACUUM HOSE. Check vacuum hose for clogging, cracks and proper connections.

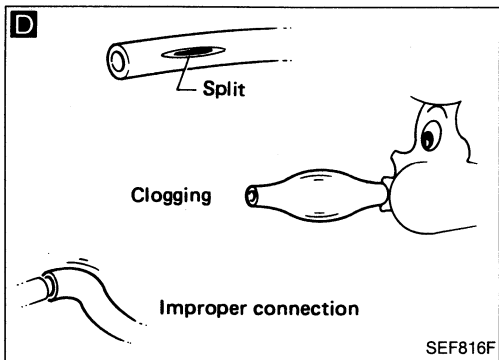

E

CHECK POWER SUPPLY.

- 1) Stop engine.
- 2) Disconnect A.I.V. control solenoid valve harness connector.
- 3) Turn ignition switch "ON".
- 4) Check voltage between terminal (b) and ground.

Voltage: Battery voltage

N.G. → Check the following.

- 10A fuse
- Harness continuity between fuse and A.I.V. control solenoid valve

If N.G., repair harness or connectors.

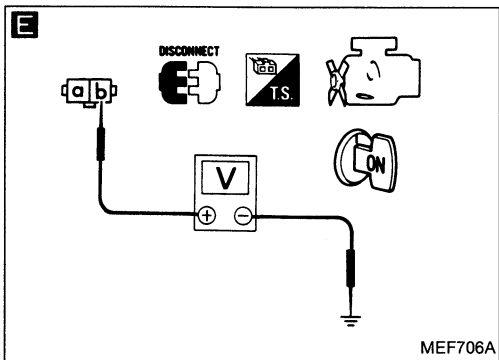

O.K. → A

Diagnostic Procedure 37 (Cont'd)

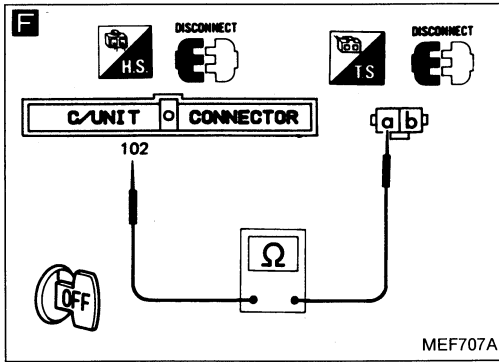

F

↓ **A**

CHECK OUTPUT SIGNAL CIRCUIT.

- 1) Turn ignition switch "OFF".
- 2) Disconnect E.C.U. harness connector.
- 3) Check harness continuity between E.C.U. terminal 102 and terminal **a**.

Continuity should exist.

N.G. → Repair harness or connectors.

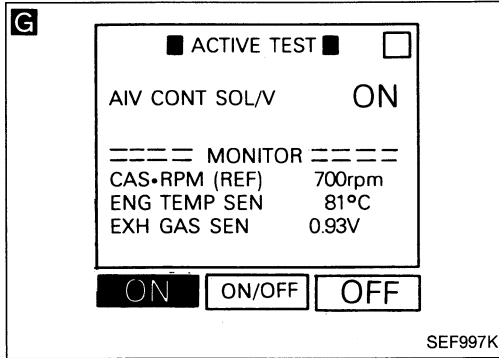

G

↓ **O.K.**

CHECK COMPONENT (A.I.V. control solenoid valve).

- 1) Reconnect E.C.U. harness connector and A.I.V. control solenoid valve harness connector.
- 2) Start engine.
- 3) Perform "A.I.V. CONTROL SOLENOID VALVE TEST" in "ACTIVE TEST" mode with CONSULT.

OR

 Refer to "Electrical Components Inspection". (See page EF & EC-189.)

N.G. → Replace A.I.V. control solenoid valve.

↓ **O.K.**

Check E.C.U. pin terminals for damage or the connection of E.C.U. harness connector.

NOTE

Diagnostic Procedure 38

INJECTOR (Not self-diagnostic item)

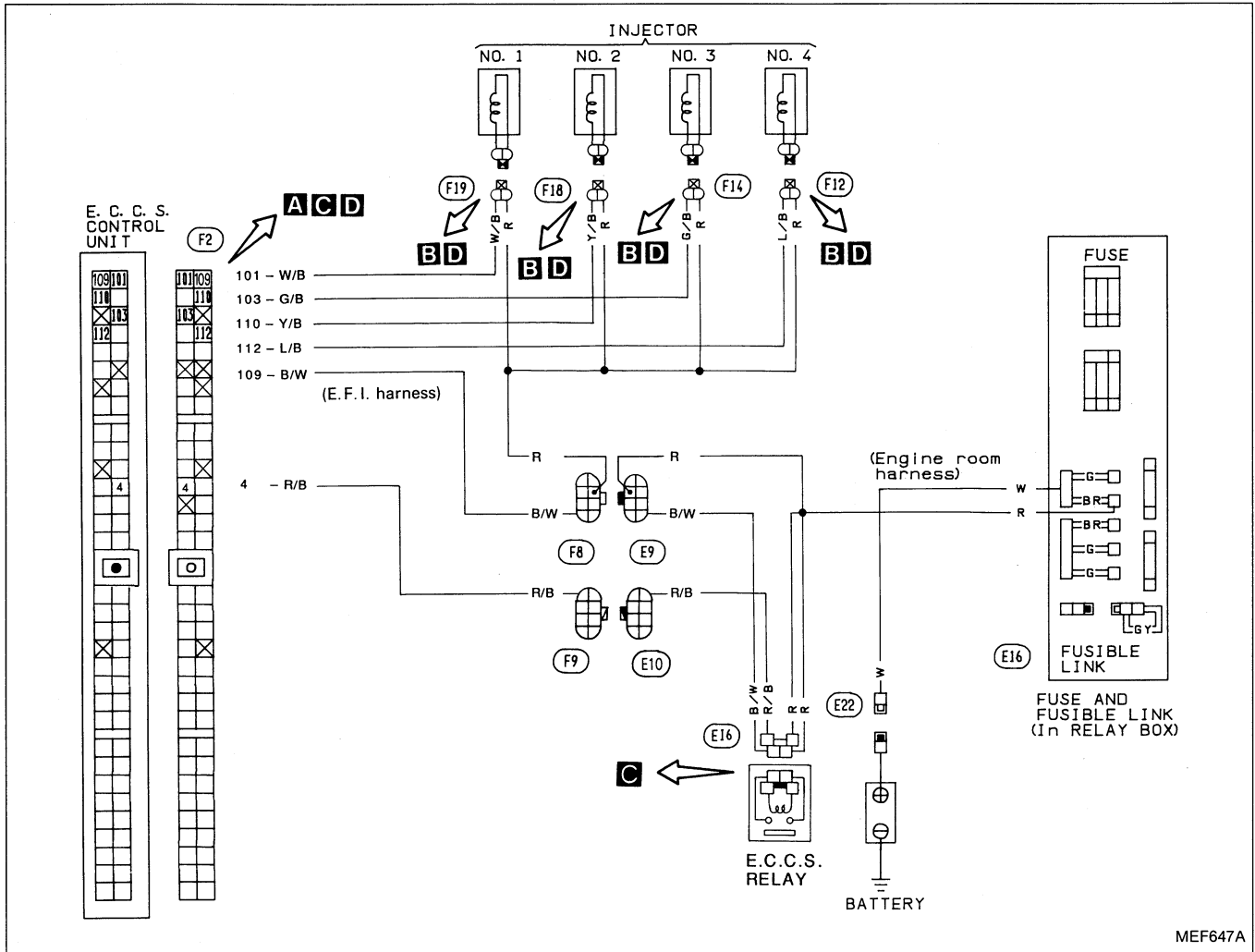

MEF647A

Harness layout

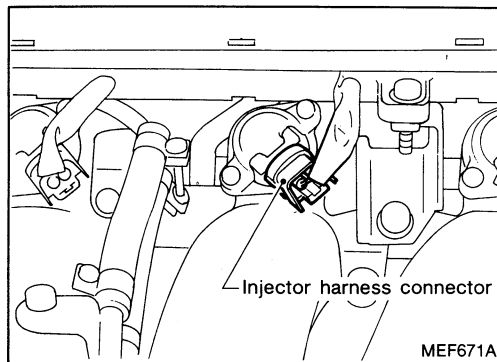
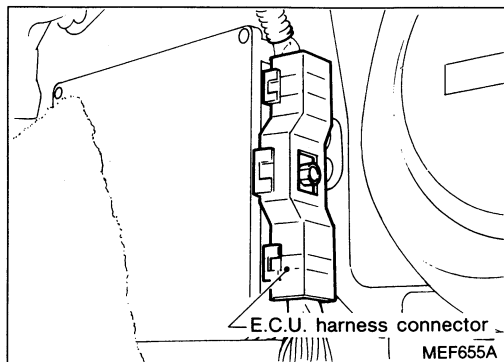

Diagnostic Procedure 38 (Cont'd)

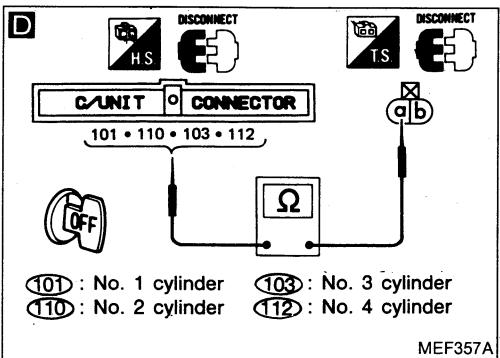
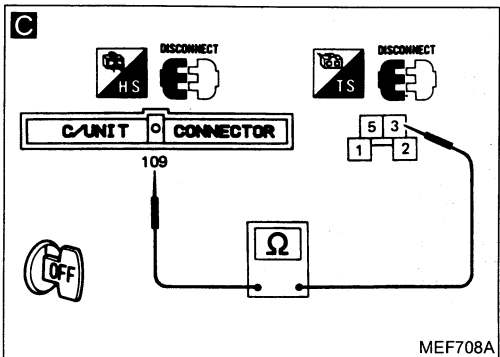
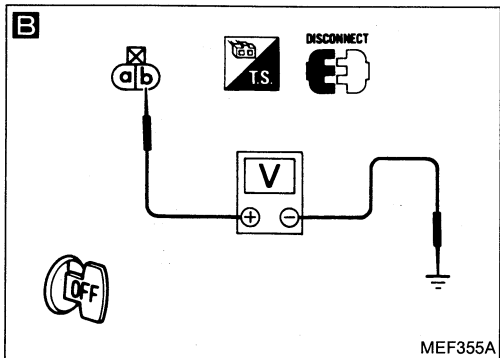
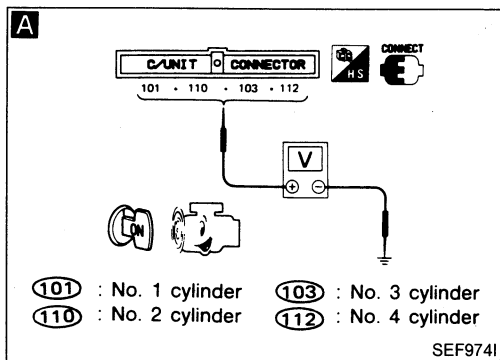

```

    graph TD
      Start[INSPECTION START] --> A[CHECK CONTROL FUNCTION.  
1) Start engine.  
2) Check voltage between E.C.U. terminals ⑩①, ⑩②, ⑩③, ⑩④ and ground.  
Voltage: Battery voltage]
      A -- O.K. --> End[INSPECTION END]
      A -- N.G. --> B[CHECK POWER SUPPLY.  
1) Stop engine.  
2) Disconnect injector harness connector and E.C.U. harness connector.  
3) Check voltage between terminal ⑩⑨ and ground.  
Voltage: Battery voltage  
4) Disconnect E.C.C.S. relay.  
5) Check harness continuity between E.C.U. terminal ⑩⑨ and terminal ③.  
Continuity should exist.]
      B -- N.G. --> B_NG[Check the following.  
• Harness connectors ⑩⑧, ⑩⑨  
• "BR" fusible link  
• Harness continuity between battery and injector  
• Harness continuity between E.C.U. and E.C.C.S. relay  
If N.G., repair harness or connectors.]
      B -- O.K. --> D[CHECK OUTPUT SIGNAL CIRCUIT.  
1) Check harness continuity between terminal ⑩ and E.C.U. terminals ⑩①, ⑩②, ⑩③, ⑩④.  
Continuity should exist.]
      D -- N.G. --> D_NG[Repair harness or connectors.]
      D -- O.K. --> C[CHECK COMPONENT (Injector).  
Refer to "Electrical Components Inspection".  
(See page EF & EC-187.)]
      C -- N.G. --> C_NG[Replace injector.]
      C -- O.K. --> C_OK[Check E.C.U. pin terminals for damage or the connection of E.C.U. harness connector.]
  
```

Diagnostic Procedure 39

FUEL PUMP (Not self-diagnostic item)

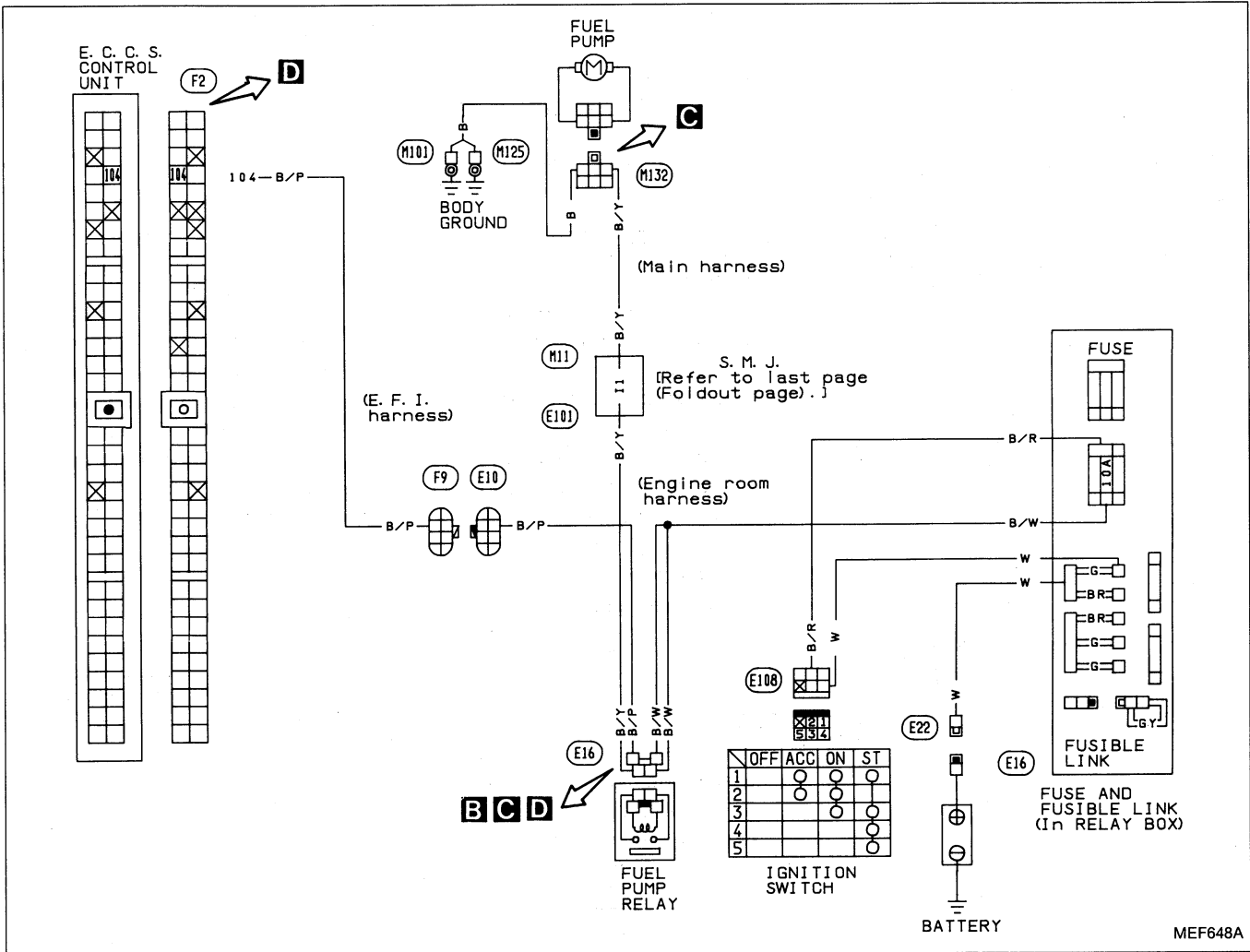

Harness layout

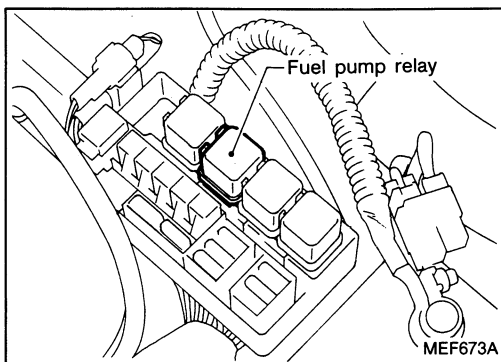
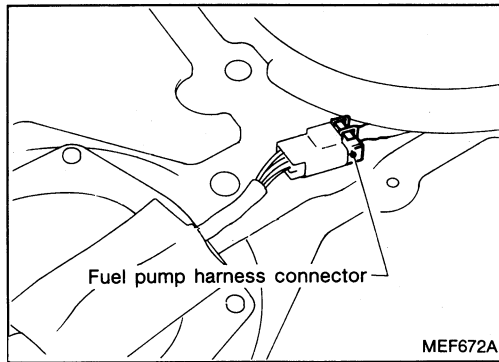
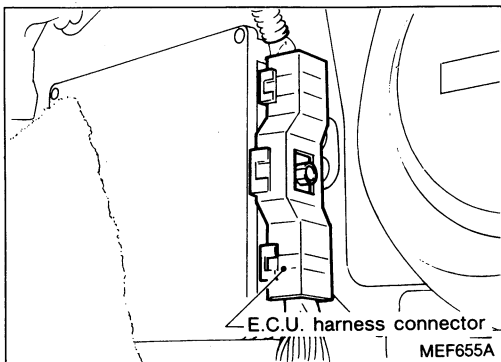

Diagnostic Procedure 39 (Cont'd)

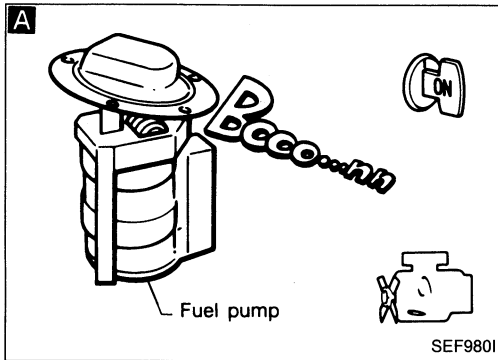

INSPECTION START

A

CHECK OVERALL FUNCTION.

- 1) Turn ignition switch "ON".
- 2) Listen to fuel pump operating sound.

Fuel pump should operate for 5 seconds after ignition switch is turned "ON".

O.K. → INSPECTION END

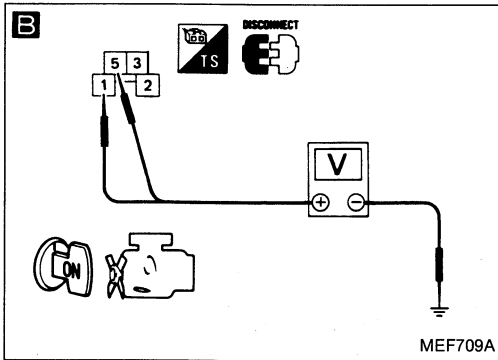

B

CHECK POWER SUPPLY.

- 1) Turn ignition switch "OFF".
- 2) Disconnect fuel pump relay.
- 3) Turn ignition switch "ON".
- 4) Check voltage between terminals ①, ⑤ and ground.

Voltage: Battery voltage

N.G. → Check the following.

- 10A fuse
- Harness continuity between fuse and fuel pump relay

If N.G., repair harness or connectors.

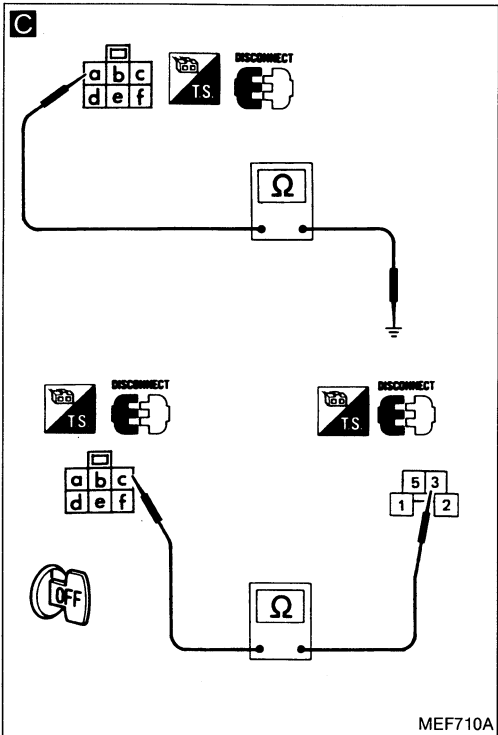

C

CHECK GROUND CIRCUIT.

- 1) Turn ignition switch "OFF".
- 2) Disconnect fuel pump harness connector.
- 3) Check harness continuity between terminal ① and body ground, terminal ⑥ and terminal ③.

Continuity should exist.

N.G. → Check the following.

- Harness connectors (M11), (E10)
- Harness continuity between fuel pump and body ground
- Harness continuity between fuel pump and fuel pump relay

If N.G., repair harness or connectors.

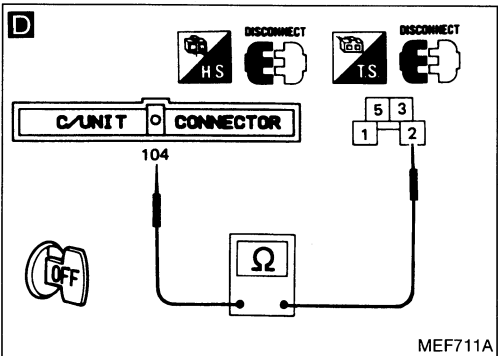

D

CHECK OUTPUT SIGNAL CIRCUIT.

- 1) Disconnect E.C.U. harness connector.
- 2) Check harness continuity between E.C.U. terminal ⑩ and terminal ②.

Continuity should exist.

N.G. → Check the following.

- Harness connectors (F9), (E10)
- Harness continuity between E.C.U. and fuel pump relay

If N.G., repair harness or connectors.

O.K. → A

Diagnostic Procedure 39 (Cont'd)

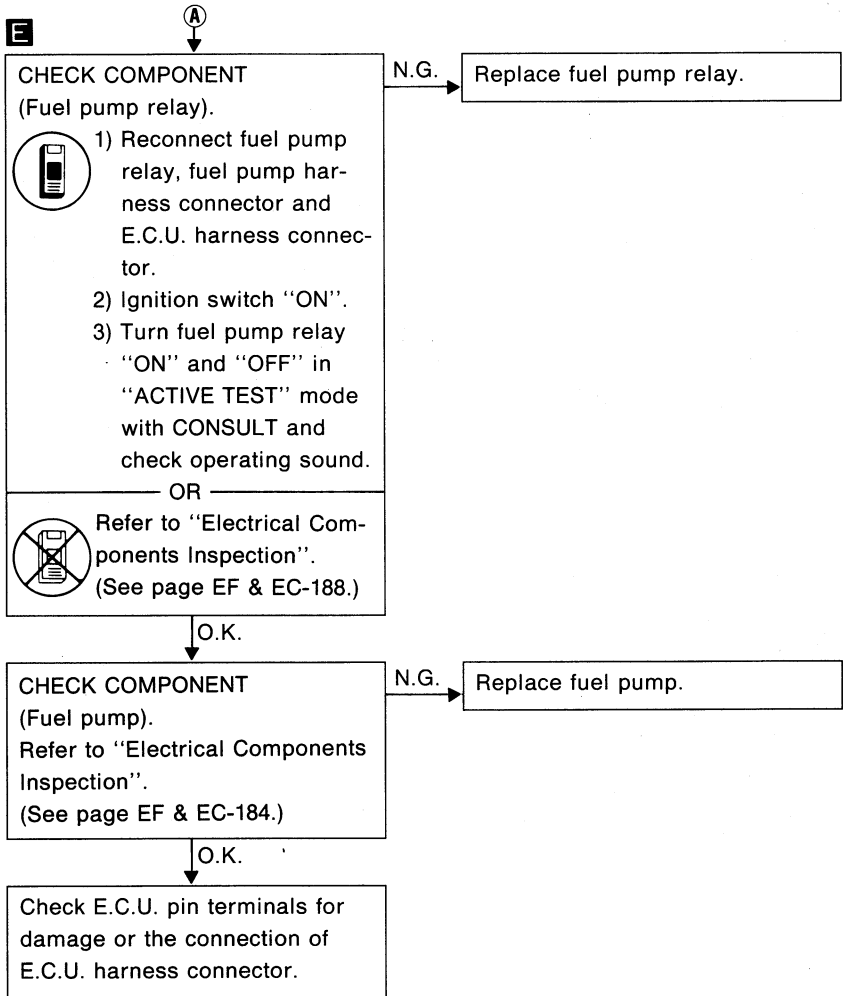
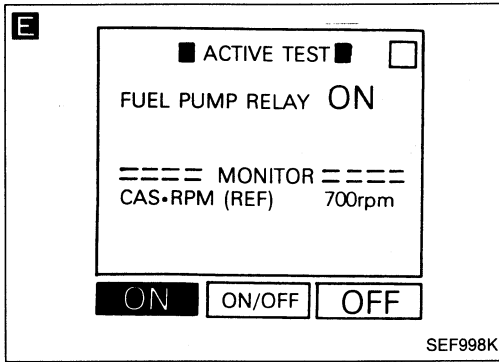

NOTE

Diagnostic Procedure 40

S.C.V. CONTROL (Not self-diagnostic item)

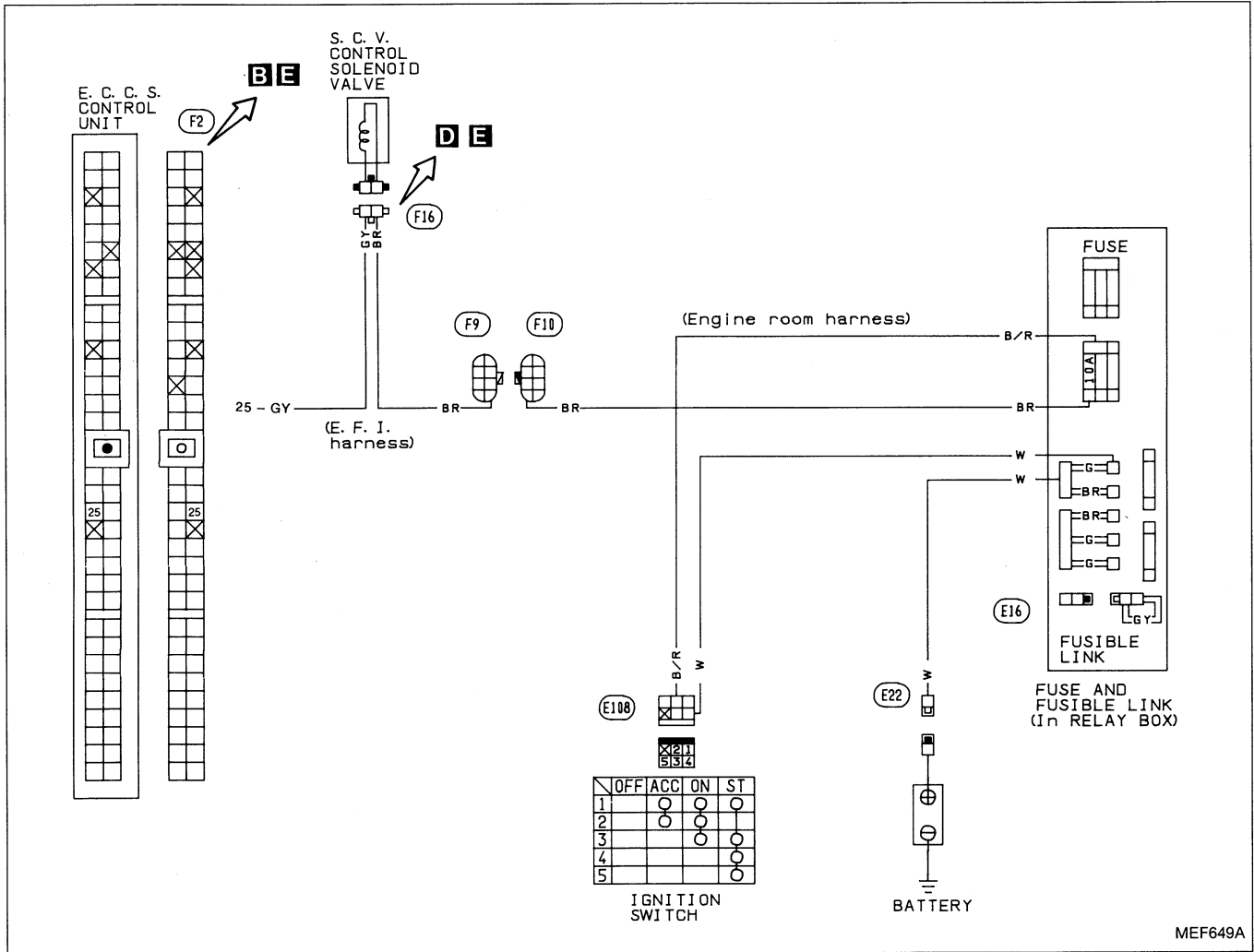

Harness layout

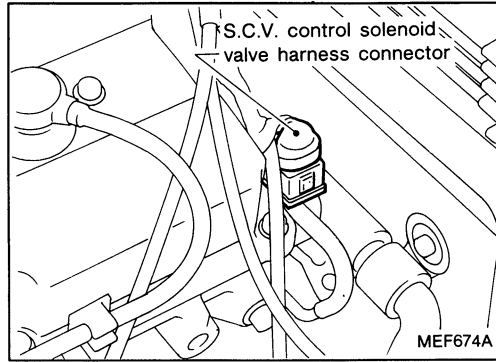
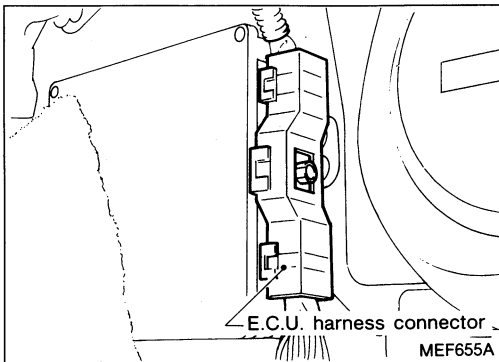

Diagnostic Procedure 40 (Cont'd)

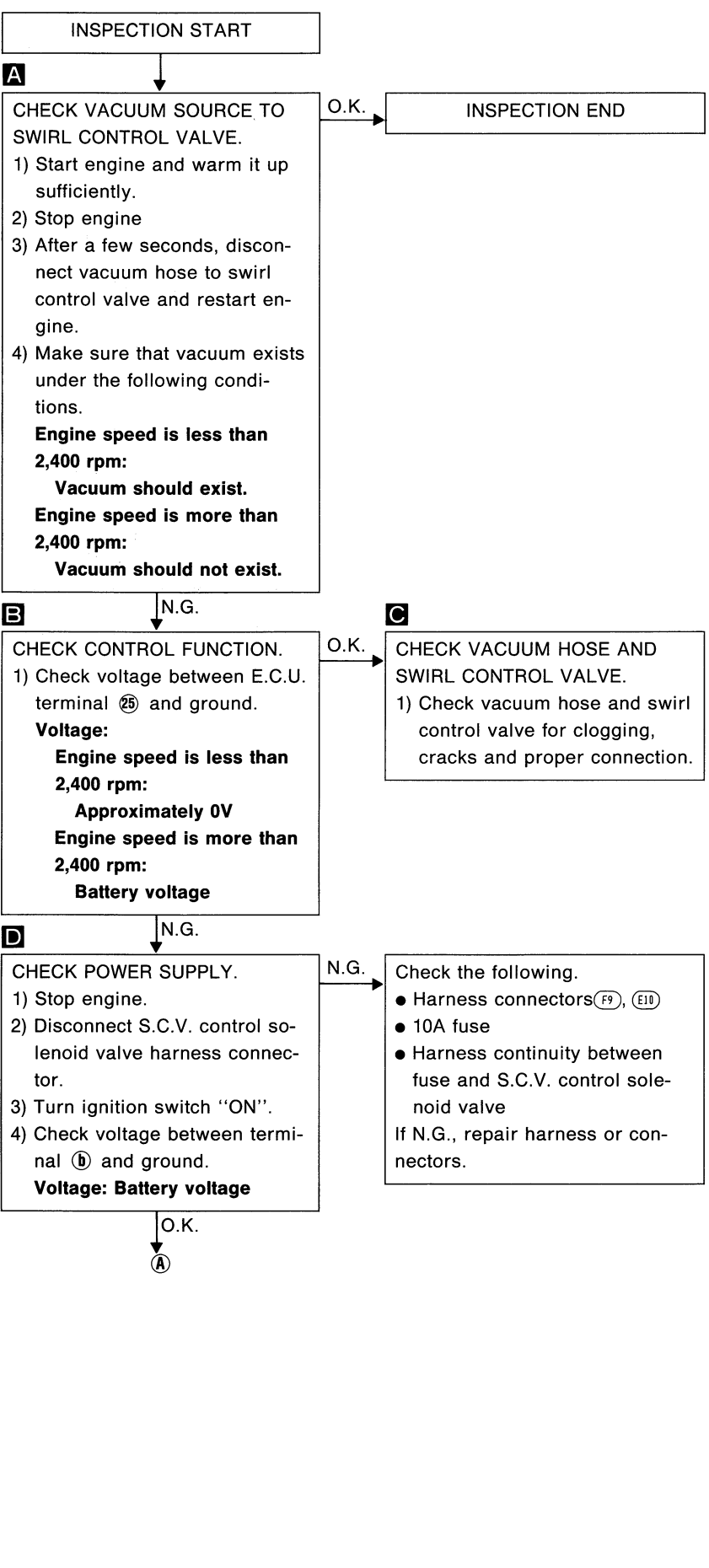
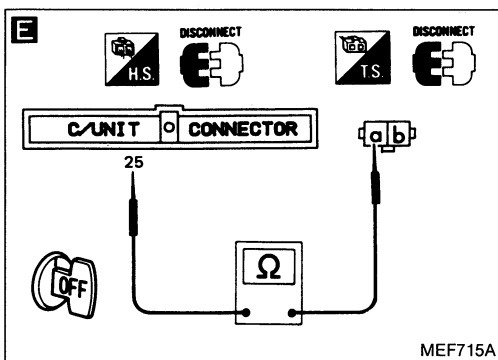
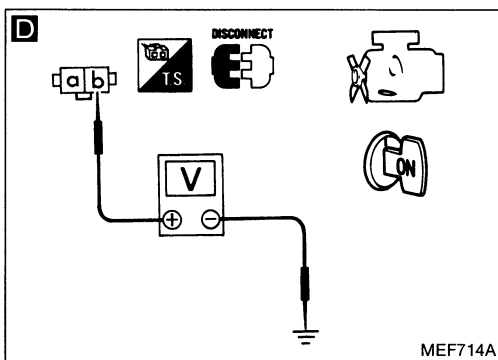
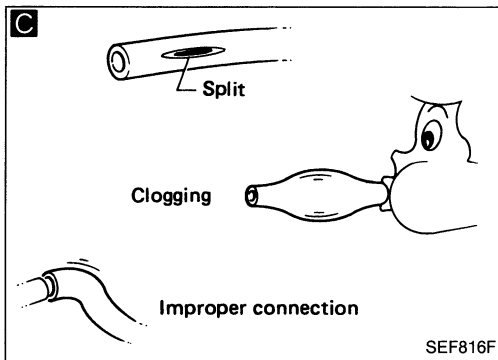
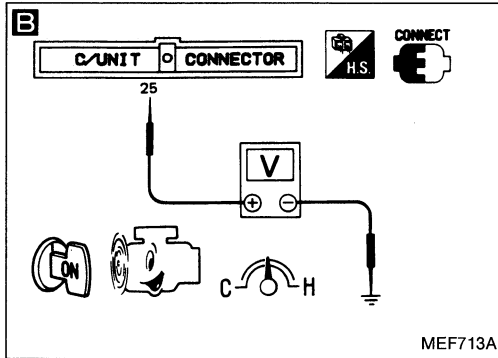
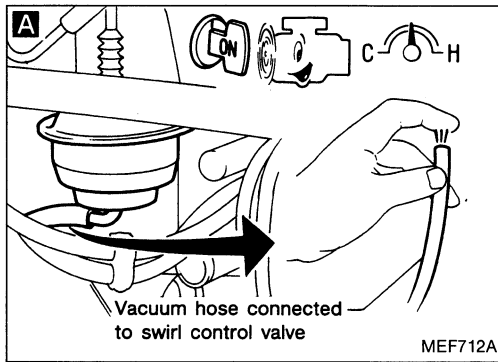

Diagnostic Procedure 40 (Cont'd)

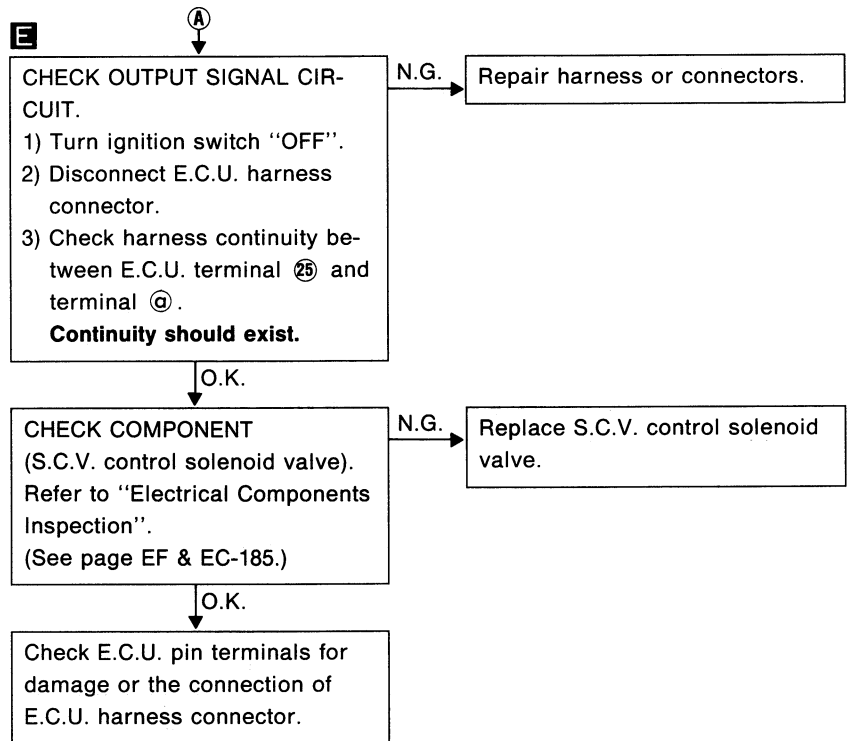

NOTE

Diagnostic Procedure 41

AIR REGULATOR (Not self-diagnostic item)

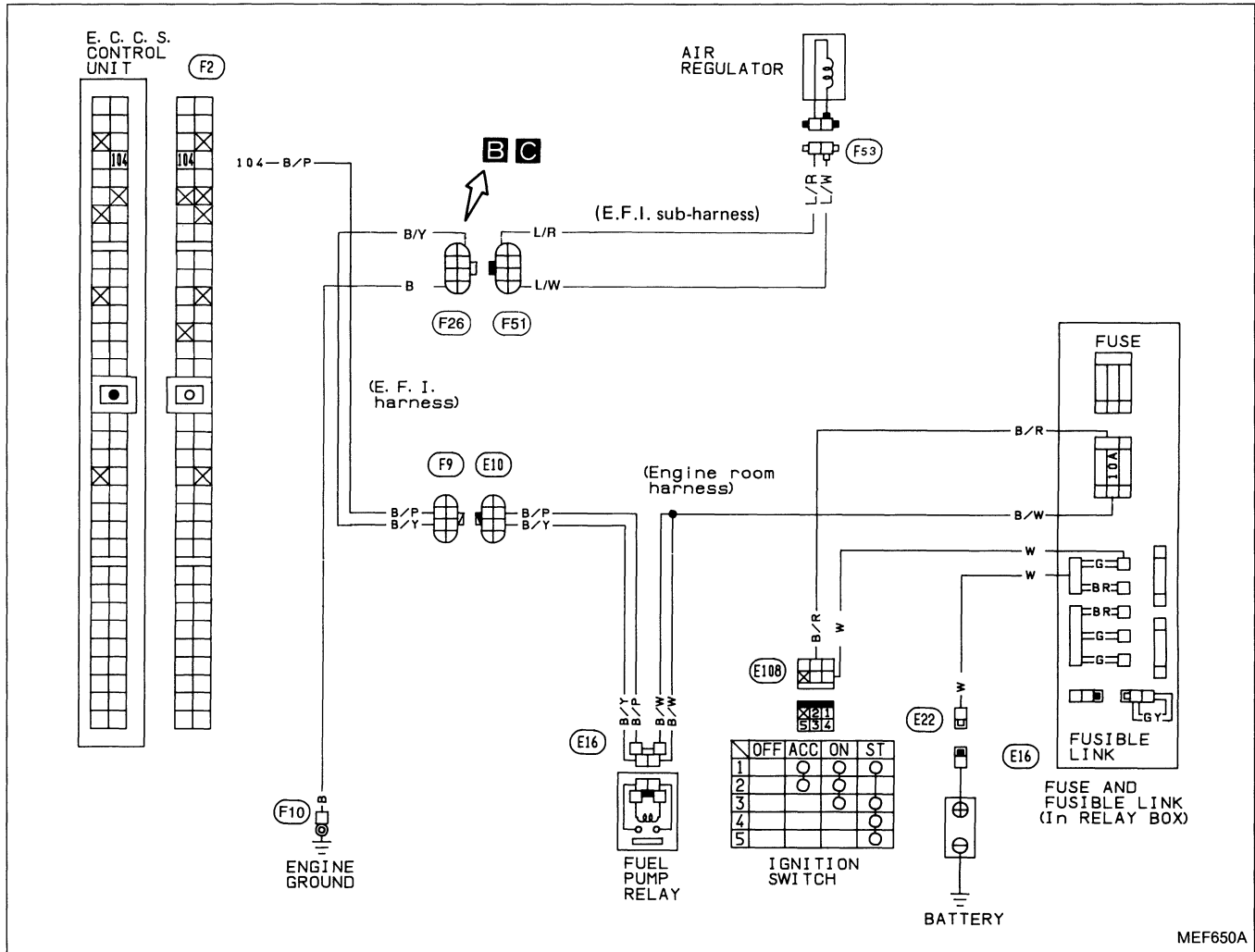

Harness layout

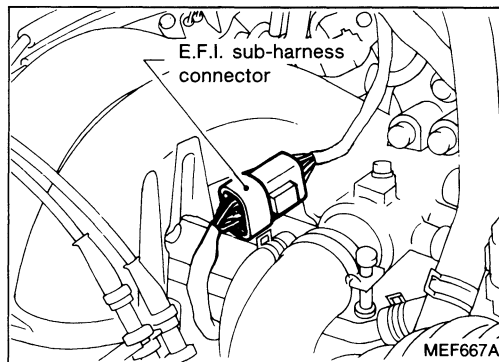
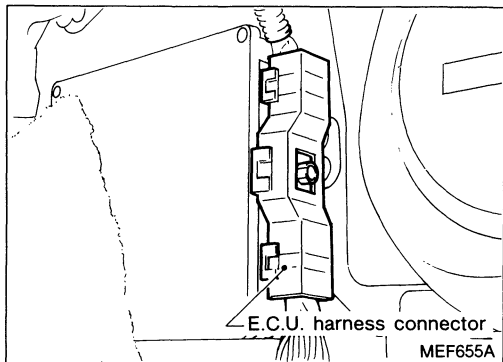

Diagnostic Procedure 41 (Cont'd)

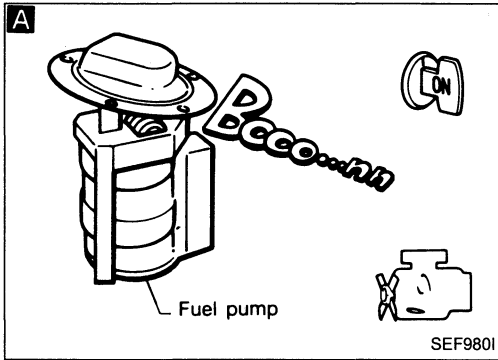

INSPECTION START

A
CHECK CONTROL FUNCTION.
 1) Turn ignition switch "ON".
 2) Listen to fuel pump operating sound.
Fuel pump should operate for 5 seconds after ignition switch is turned "ON".

N.G. → Check fuel pump control circuit. (See page EF & EC-152.)

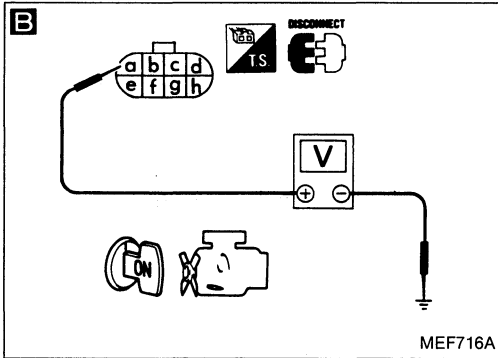

B
CHECK POWER SUPPLY.
 1) Turn ignition switch "OFF".
 2) Disconnect air regulator sub-harness connector (F51).
 3) Turn ignition switch "ON".
 4) Check voltage between terminal Ⓐ and ground.
Battery voltage should exist for 5 seconds after ignition switch is turned "ON".

N.G. → Check the following.
 ● Harness connectors (F9), (E10)
 ● Harness continuity between air regulator sub-harness connector and fuel pump relay
 If N.G., repair harness or connectors.

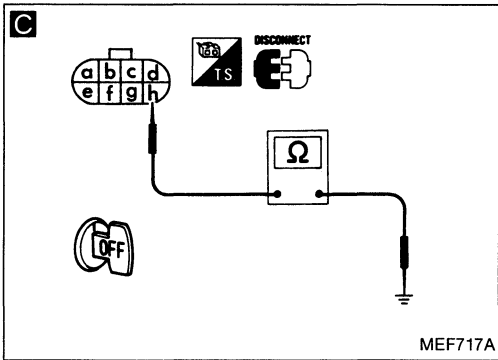

C
CHECK GROUND CIRCUIT.
 1) Turn ignition switch "OFF".
 2) Check harness continuity between terminal Ⓜ and body ground.
Continuity should exist.

N.G. → Repair harness or connectors.

CHECK COMPONENT (Air regulator).
 Refer to "Electrical Components Inspection". (See page EF & EC-189.)

N.G. → Replace air regulator.

INSPECTION END

Diagnostic Procedure 42

A.A.C. VALVE (Not self-diagnostic item)

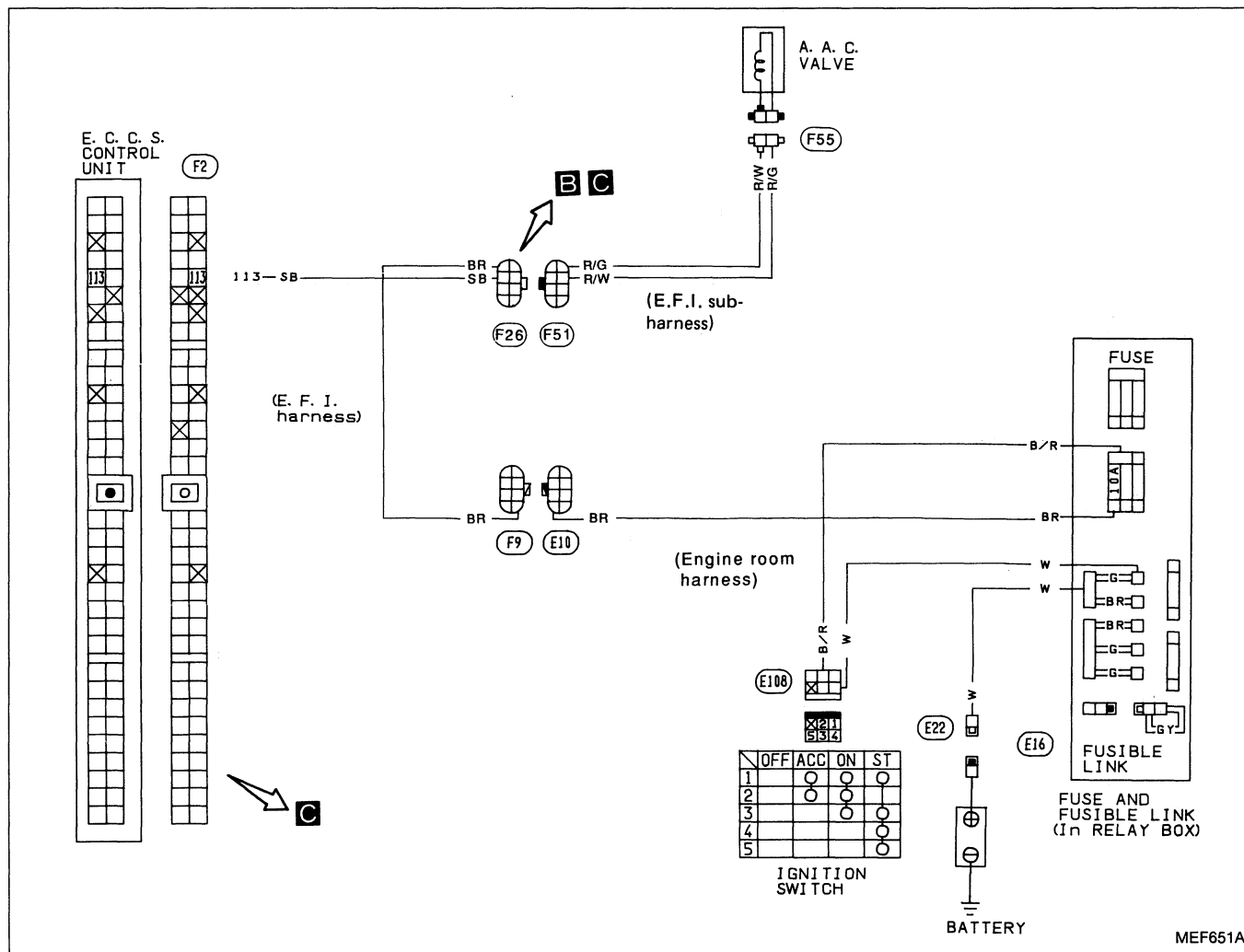

Harness layout

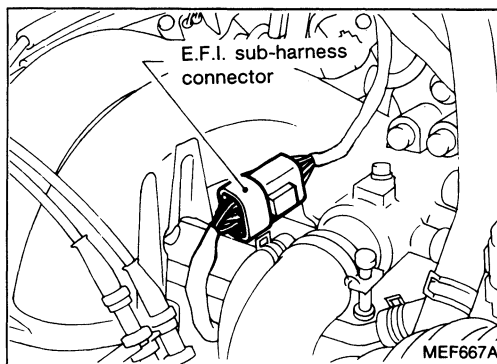
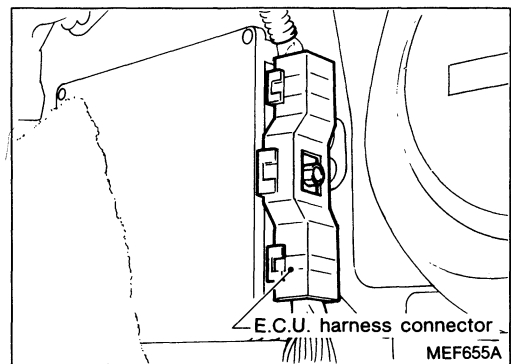

Diagnostic Procedure 42 (Cont'd)

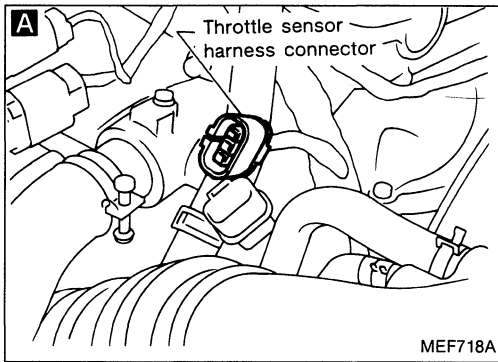

INSPECTION START

A

CHECK OVERALL FUNCTION.

- 1) Start engine and warm it up sufficiently.
- 2) Check idle speed.
700 ± 50 rpm
If N.G., adjust idle speed.
- 3) Perform self-diagnosis.
Make sure that code No. 43 is not displayed.
Make sure that throttle sensor is not in "fail-safe" state.
- 4) Disconnect throttle sensor harness connector.
- 5) Make sure that idle speed drops.

Drops → INSPECTION END

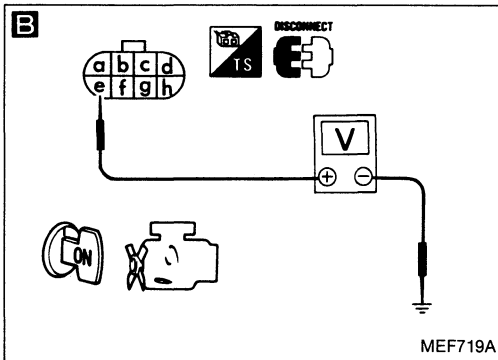

B

Does not drop

CHECK POWER SUPPLY.

- 1) Stop engine.
- 2) Disconnect A.A.C. valve sub-harness connector (F51).
- 3) Turn ignition switch "ON".
- 4) Check voltage between terminal (E) and ground.
Voltage: Battery voltage

N.G. → Check the following.

- Harness connectors (F9), (E10)
- 10A fuse
- Harness continuity between A.A.C. valve sub-harness connector and fuse

If N.G., repair harness or connectors.

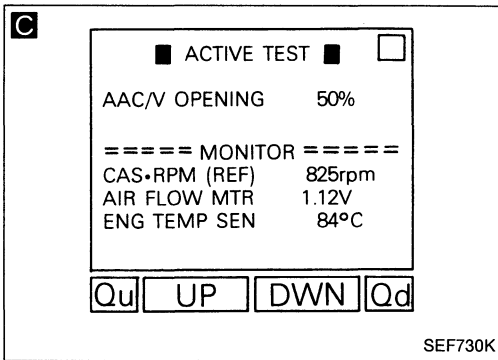

C

O.K.

CHECK OUTPUT SIGNAL CIRCUIT.

- 1) Reconnect throttle sensor harness connector and A.A.C. valve sub-harness connector.
- 2) Perform "AAC VALVE OPENING TEST" in "ACTIVE TEST" mode with CONSULT.

N.G. → Repair harness or connectors.

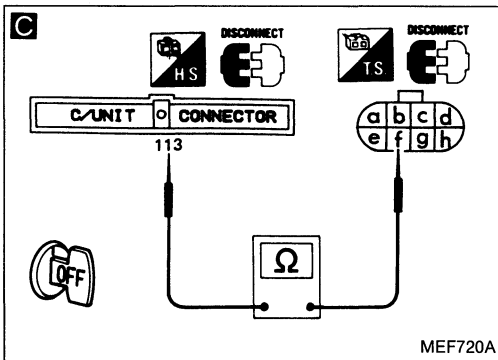

—OR—

- 1) Turn ignition switch "OFF".
- 2) Disconnect E.C.U. harness connector.
- 3) Check harness continuity between E.C.U. terminal (113) and terminal (f).
Continuity should exist.

O.K. → A

Diagnostic Procedure 42 (Cont'd)

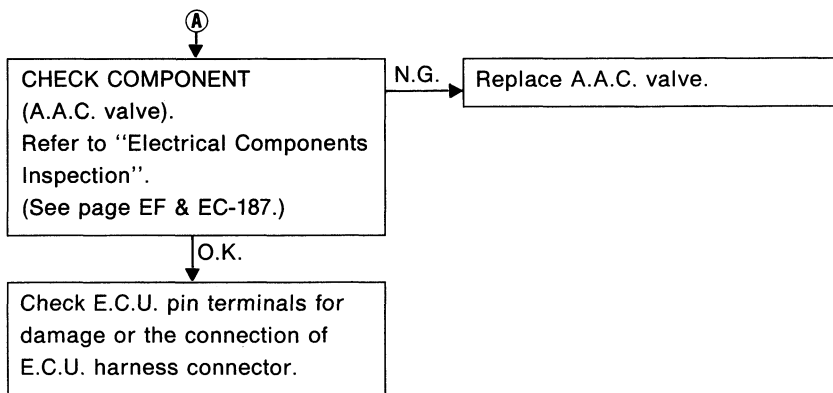

NOTE

Diagnostic Procedure 43

CONDENSER FAN CONTROL (Not self-diagnostic item)

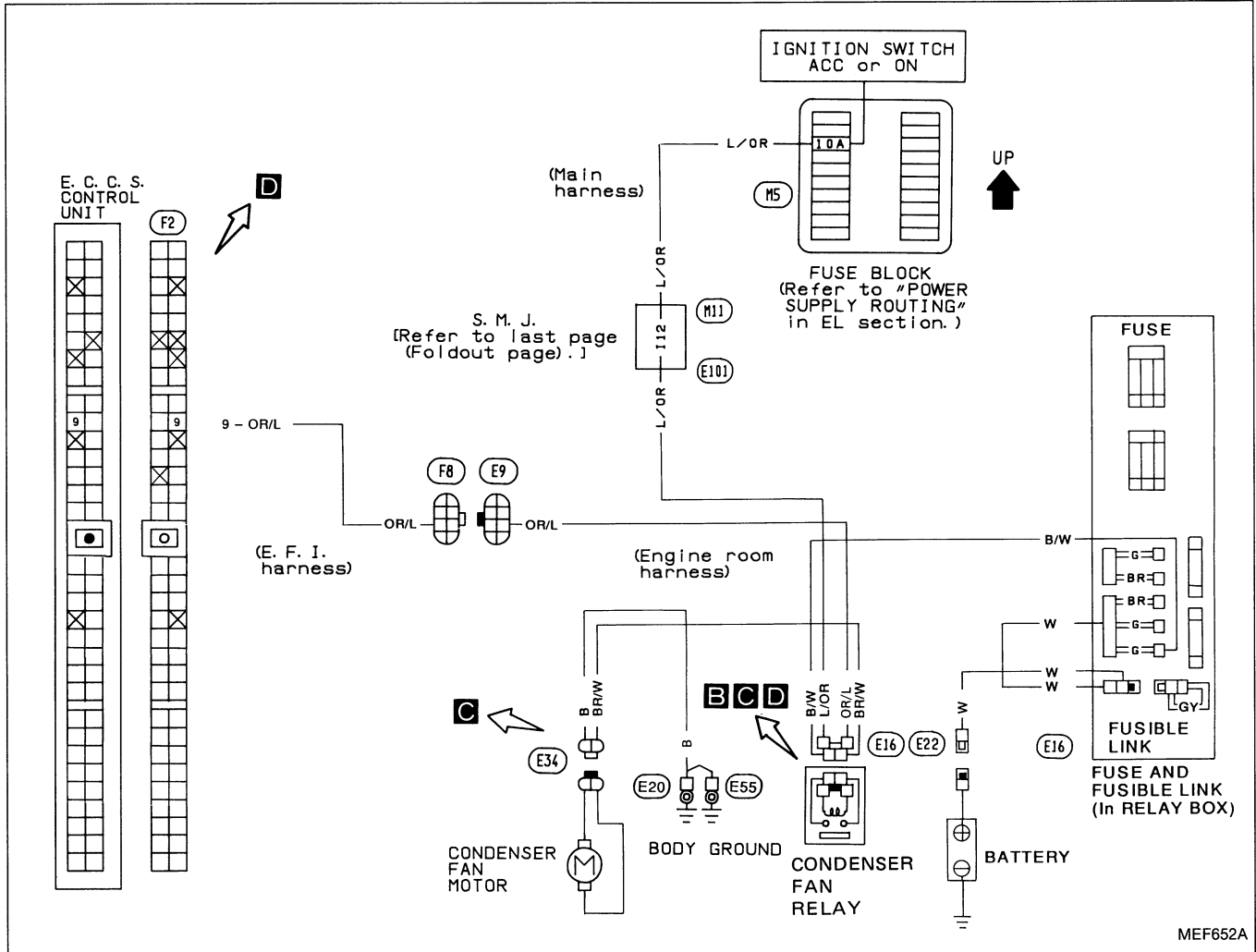

Harness layout

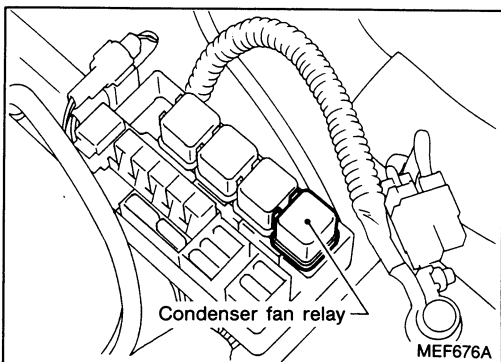
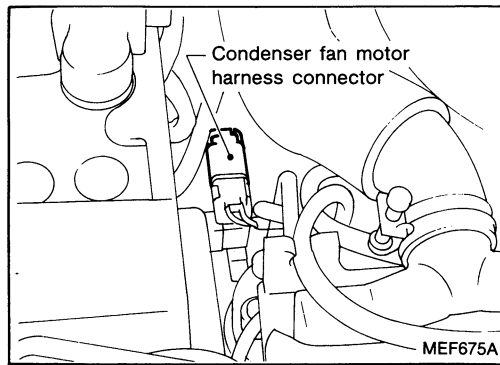
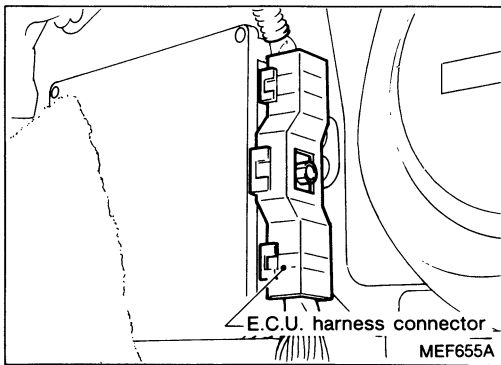

Diagnostic Procedure 43 (Cont'd)

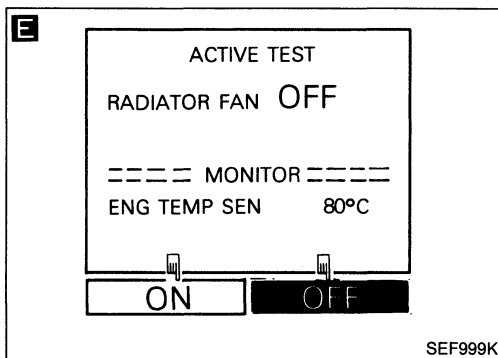
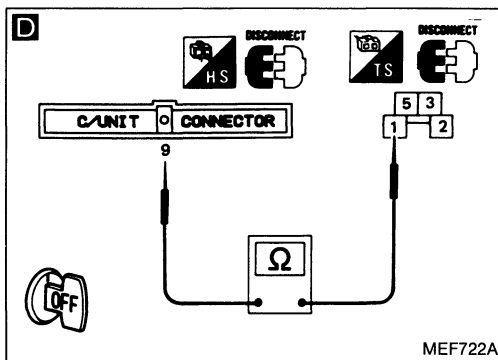
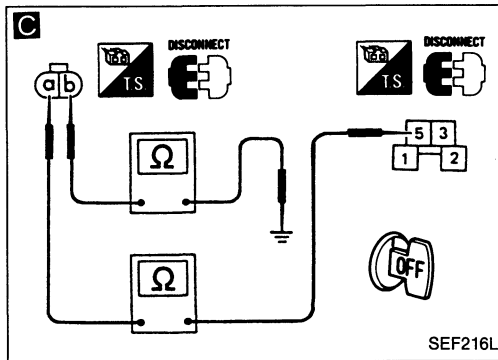
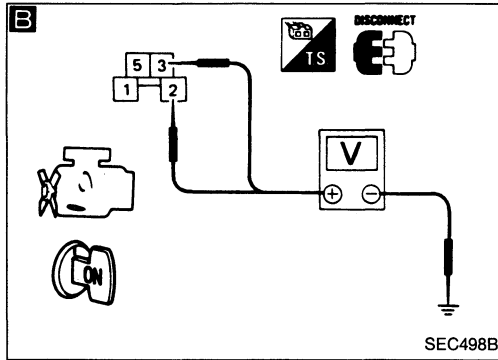
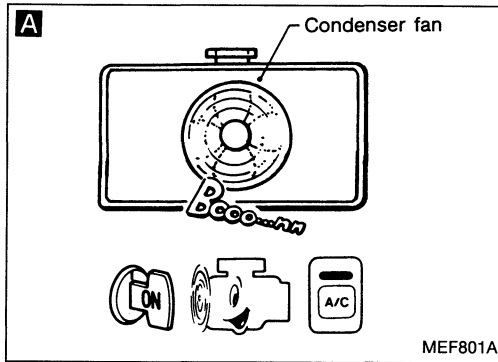

INSPECTION START

A
 CHECK CONDENSER FAN OPERATION.
 1) Start engine.
 2) Set temperature lever at full cold position.
 3) Turn air conditioner switch "ON".
 4) Turn blower fan switch "ON".
 5) Run engine at idle for a few minutes with air conditioner operating.
 6) Make sure that condenser fan operates.

O.K. → INSPECTION END

B
 CHECK POWER SUPPLY.
 1) Turn air conditioner switch "OFF".
 2) Turn blower fan switch "OFF".
 3) Stop engine.
 4) Disconnect condenser fan relay.
 5) Turn ignition switch "ON".
 6) Check voltage between terminals ②, ③ and ground.
Voltage: Battery voltage

N.G. → Check the following.
 ● Harness connectors (H11), (E10)
 ● "GY" fusible link
 ● "G" fusible link
 ● 10A fuse
 ● Harness continuity between battery and condenser fan relay
 ● Harness continuity between fuse and condenser fan relay
 If N.G., repair harness or connectors.

C
 CHECK GROUND CIRCUIT.
 1) Turn ignition switch "OFF".
 2) Disconnect condenser fan motor harness connector.
 3) Check harness continuity between terminal ① and terminal ⑤, terminal ① and body ground.
Continuity should exist.

N.G. → Repair harness or connectors.

D
 CHECK OUTPUT SIGNAL CIRCUIT.
 1) Disconnect E.C.U. harness connector.
 2) Check harness continuity between E.C.U. terminal ⑨ and terminal ①.
Continuity should exist.

N.G. → Check the following.
 ● Harness connectors F8, (E9)
 ● Harness continuity between E.C.U. and condenser fan relay
 If N.G., repair harness or connectors.

O.K. → **A**

Diagnostic Procedure 43 (Cont'd)

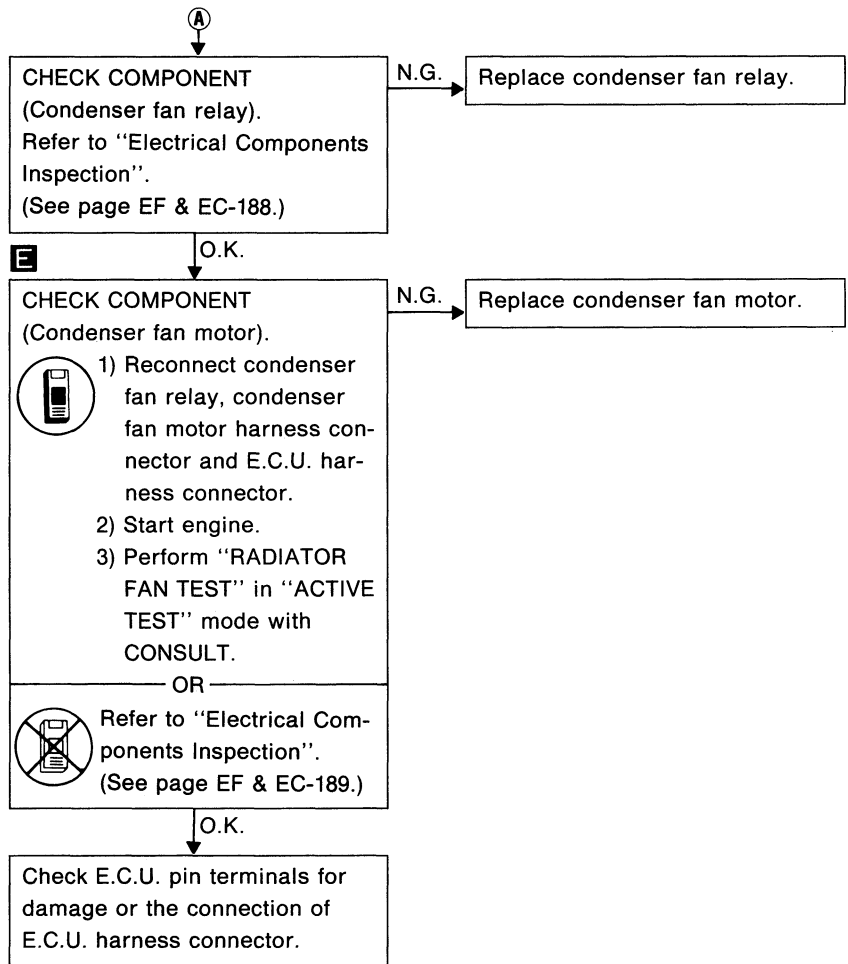

NOTE

Diagnostic Procedure 44

POWER STEERING OIL PRESSURE SWITCH (Not self-diagnostic item)

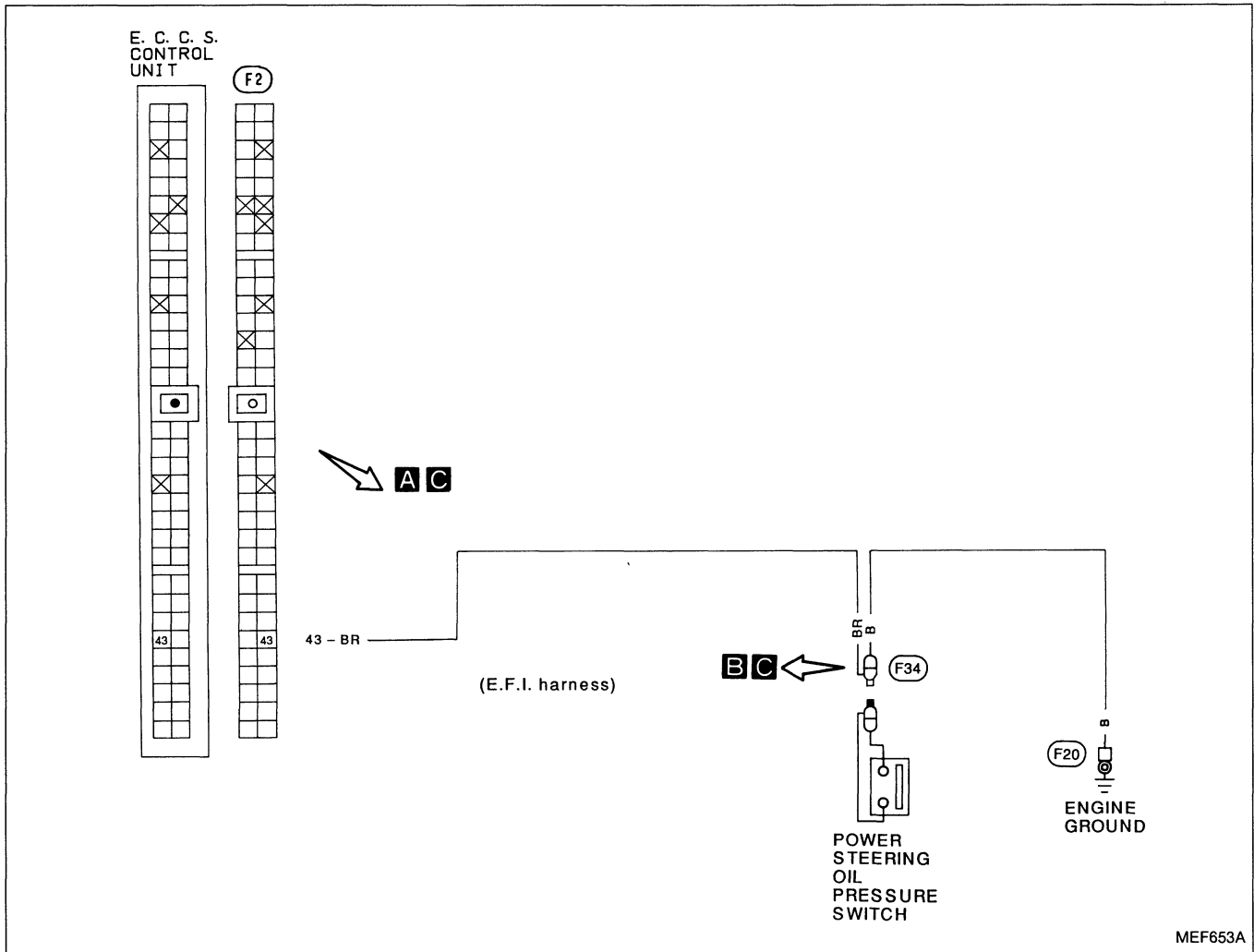

Harness layout

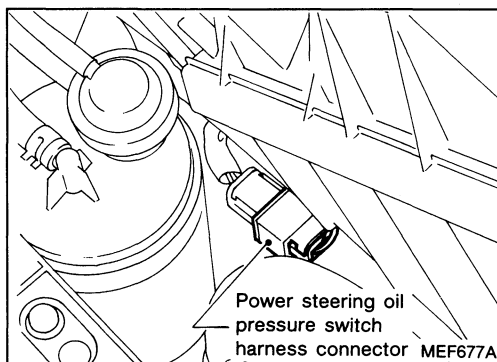
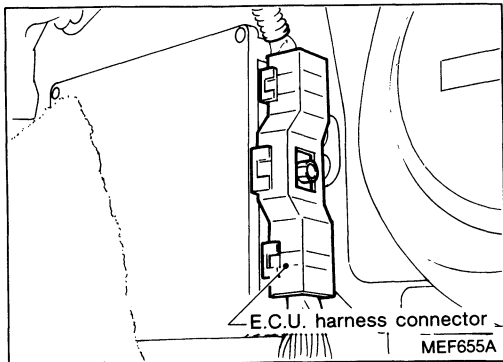

Diagnostic Procedure 44 (Cont'd)

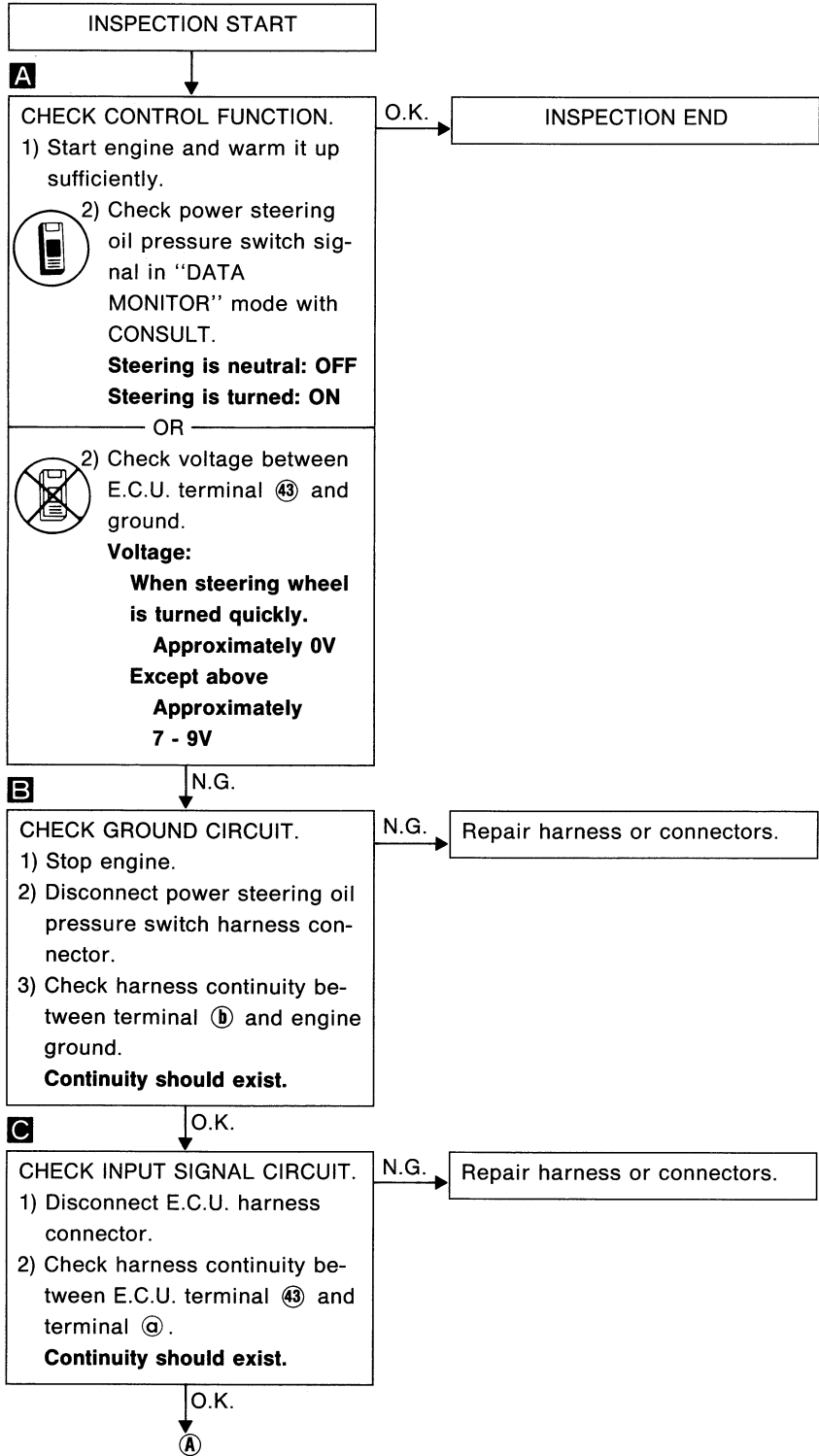
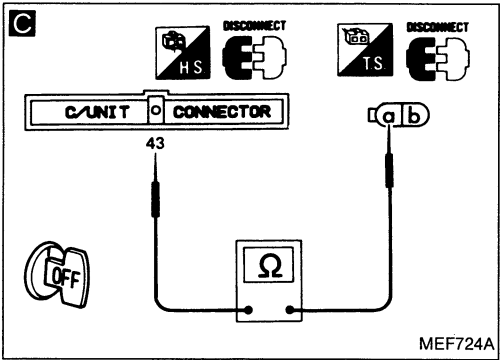
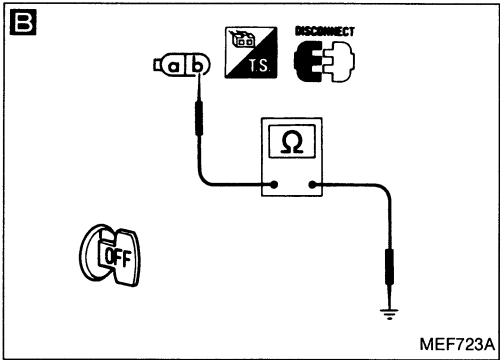
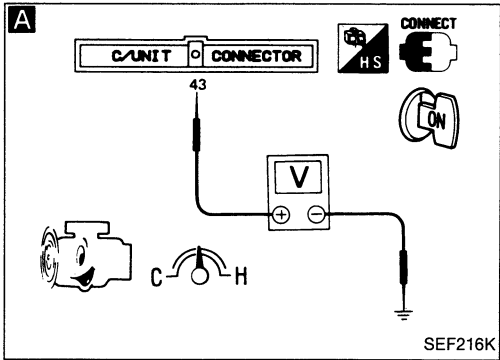
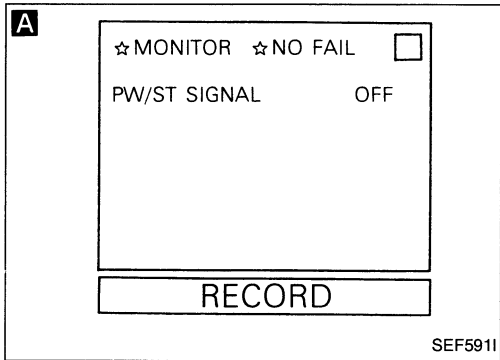

Diagnostic Procedure 44 (Cont'd)

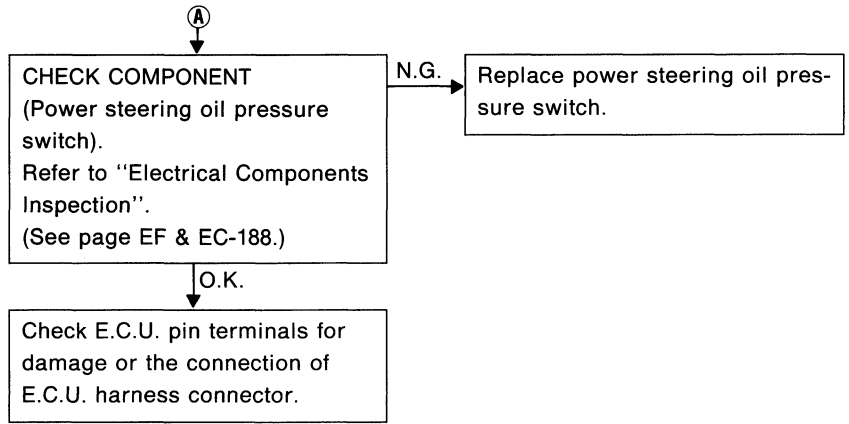

NOTE

Diagnostic Procedure 45

NEUTRAL SWITCH/A/T CONTROL UNIT (NEUTRAL SIGNAL) (Not self-diagnostic item)

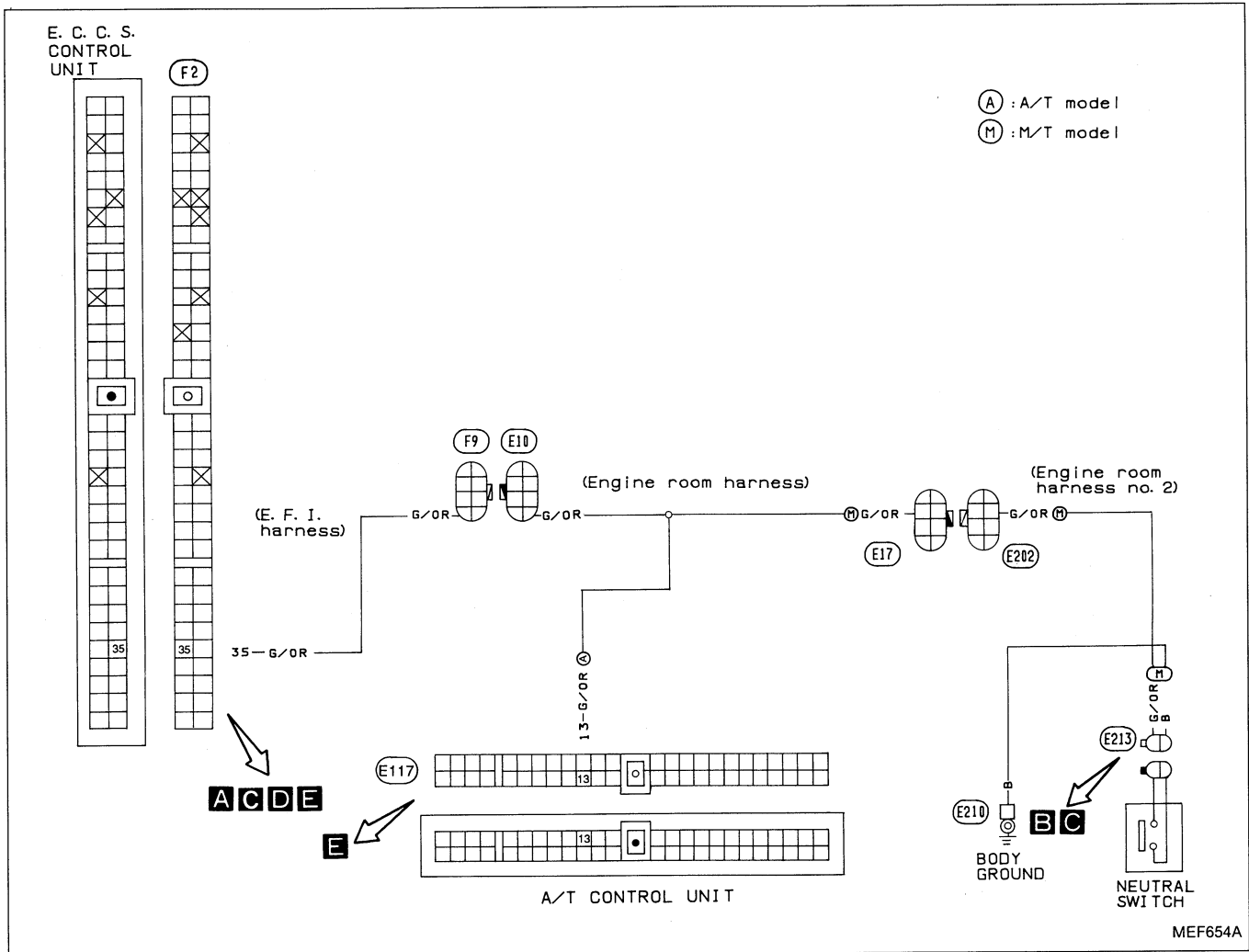

Harness layout

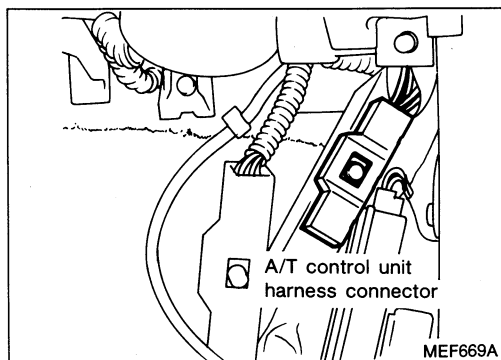
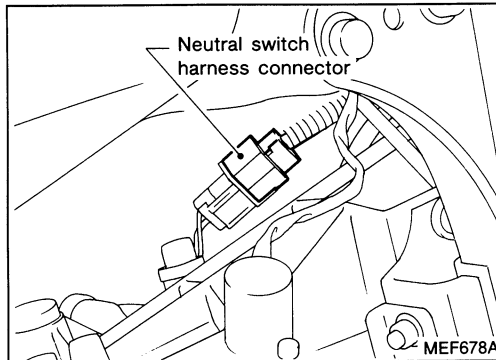
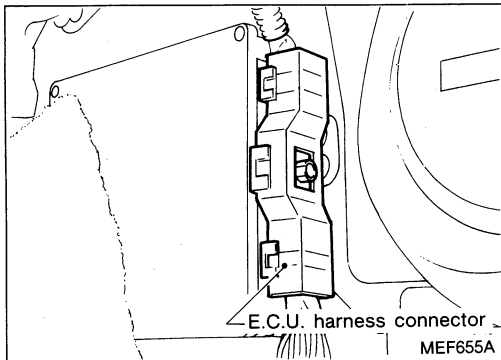

Diagnostic Procedure 45 (Cont'd)

A

☆ MONITOR	☆ NO FAIL	<input type="checkbox"/>
START SIGNAL		OFF
IDLE POSITION		ON
AIR COND SIG		OFF
NEUTRAL SW		ON

RECORD

SEF384J

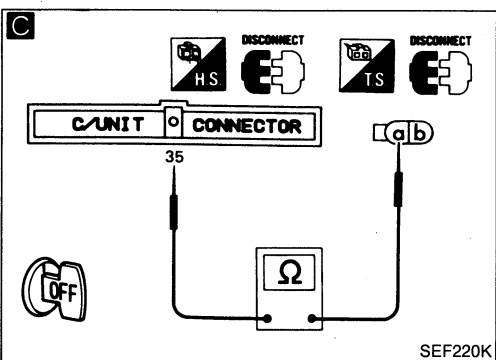
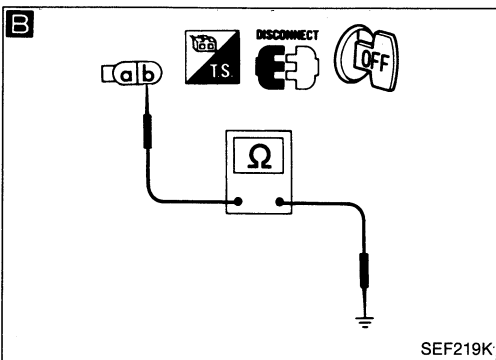
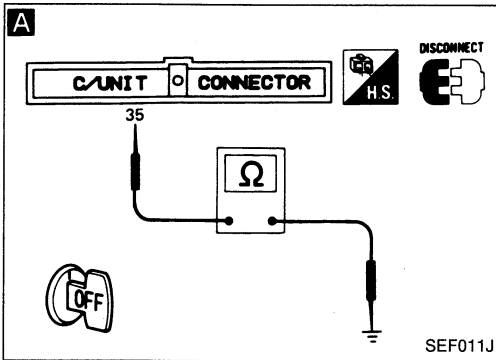

Neutral switch

INSPECTION START

A

CHECK OVERALL FUNCTION.

- 1) Turn ignition switch "ON".
- 2) Check neutral switch signal in "DATA MONITOR" mode with CONSULT.

O.K. → INSPECTION END

Neutral position: ON
Except above: OFF

OR

- 1) Set shift lever to the neutral position.
- 2) Disconnect E.C.U. harness connector.
- 3) Check harness continuity between E.C.U. terminal ③⑤ and body ground.

Continuity should exist.

N.G. ↓

Turn ignition switch "OFF".

B

CHECK GROUND CIRCUIT.

- 1) Disconnect neutral switch harness connector.
- 2) Check harness continuity between terminal ① and body ground.

Continuity should exist.

N.G. → Repair harness or connectors.

O.K. ↓

Disconnect E.C.U. harness connector.

C

CHECK INPUT SIGNAL CIRCUIT.

- 1) Check harness continuity between E.C.U. terminal ③⑤ and terminal ②.

Continuity should exist.

N.G. → Check the following.

- Harness connectors ①⑨, ①⑩
- Harness connectors ①⑪, ①⑫
- Harness continuity between E.C.U. and neutral switch

If N.G., repair harness or connectors.

①

Diagnostic Procedure 45 (Cont'd)

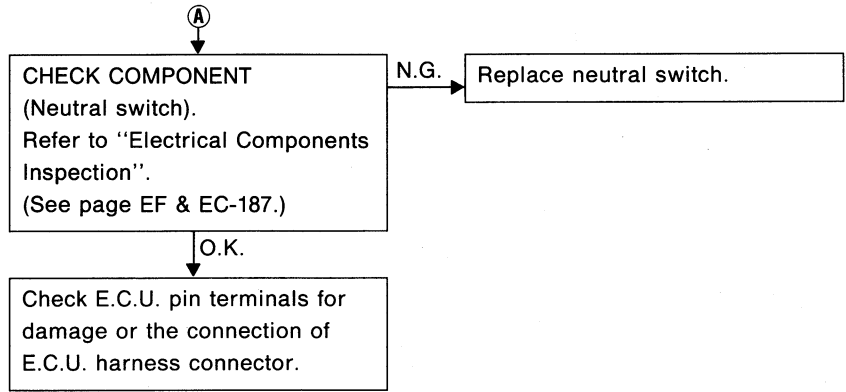

Diagnostic Procedure 45 (Cont'd)

D

☆ MONITOR	☆ NO FAIL	<input type="checkbox"/>
START SIGNAL		OFF
IDLE POSITION		ON
AIR COND SIG		OFF
NEUTRAL SW		ON

RECORD

SEF385J

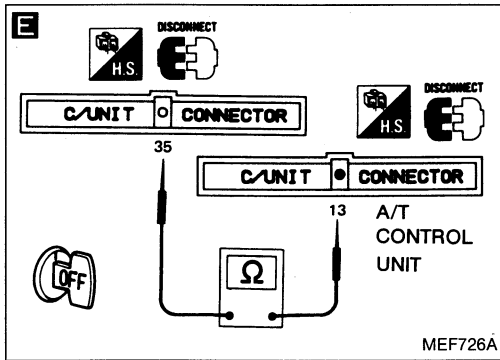
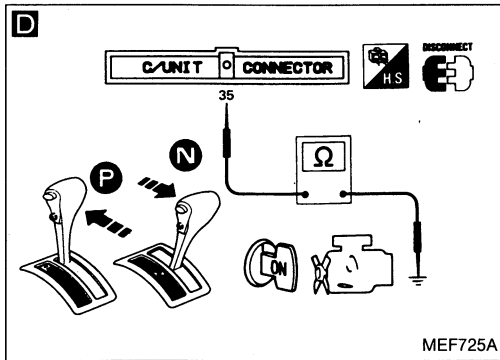

A/T control unit

INSPECTION START

D

CHECK OVERALL FUNCTION.



- 1) Turn ignition switch "ON".
- 2) Check neutral switch signal in "DATA MONITOR" mode with CONSULT.

"N" or "P": ON
Except above: OFF
OR



- 1) Make sure that inhibitor switch circuit functions properly. (Refer to AT section.)
- 2) Disconnect E.C.U. harness connector.
- 3) Shift selector lever to "P" range.
- 4) Turn ignition switch "ON".
- 5) Check harness continuity between E.C.U. terminal 35 and body ground.
Continuity should exist.
- 6) Shift selector lever to "N" range.
- 7) Check harness continuity between E.C.U. terminal 35 and body ground.
Continuity should exist.

O.K. → INSPECTION END

E N.G.

CHECK INPUT SIGNAL CIRCUIT.

- 1) Turn ignition switch "OFF".
- 2) Disconnect A/T control unit harness connector.
- 3) Check harness continuity between E.C.U. terminal 35 and terminal 13.
Continuity should exist.

N.G. →

Check the following.

- Harness connectors (F9, E10)
- Harness continuity between E.C.U. and A/T control unit

If N.G., repair harness or connectors.

O.K.

Check E.C.U. pin terminals for damage or the connection of E.C.U. harness connector.

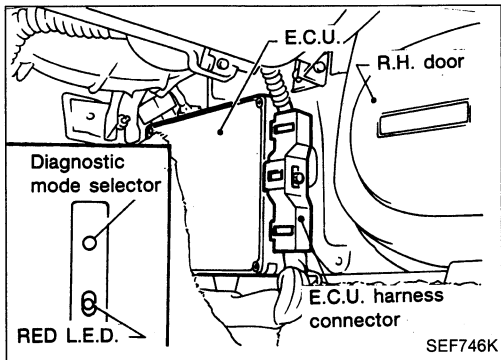

Electrical Components Inspection

E.C.U. INPUT/OUTPUT SIGNAL INSPECTION

1. E.C.U. is located behind front passenger side dash. For this inspection, remove the front passenger side dash.

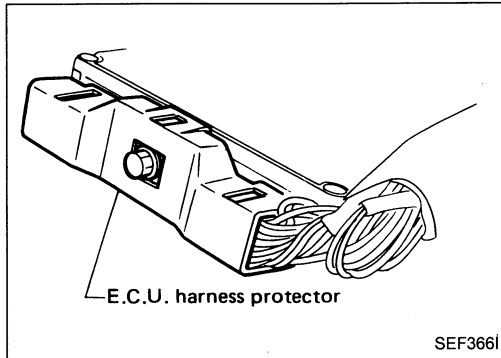

2. Remove E.C.U. harness protector.

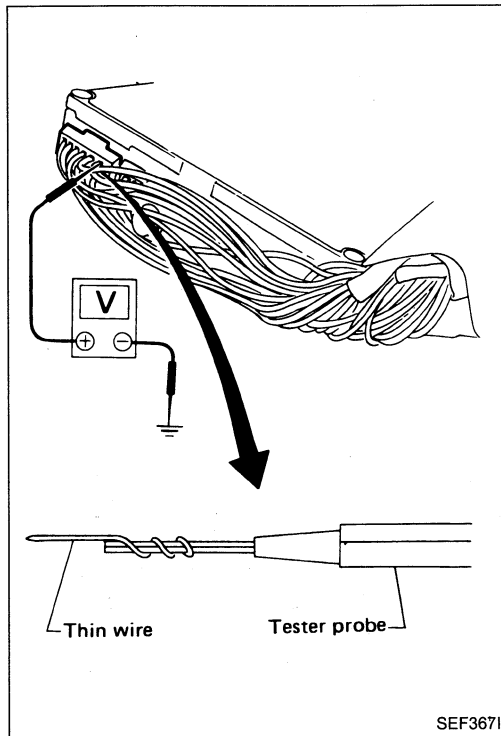

3. Perform all voltage measurements with the connectors connected. Extend tester probe as shown to perform tests easily.

Electrical Components Inspection (Cont'd)

E.C.U. inspection table

*Data are reference values.

TER-MINAL NO.	ITEM	CONDITION	*DATA
1	Ignition signal	Engine is running. └ Idle speed	0.2 - 0.3V
		Engine is running. └ Engine speed is 2,000 rpm.	Approximately 0.8V
3	Ignition check	Engine is running. └ Idle speed	BATTERY VOLTAGE (11 - 14V)
4	E.C.C.S. relay (Self-shutoff)	Engine is running. └ Ignition switch "OFF" └ For approximately 1 second after turning ignition switch "OFF"	0 - 1V
		Ignition switch "OFF" └ Approximately 1 second after turning ignition switch "OFF"	BATTERY VOLTAGE (11 - 14V)
8	Exhaust gas temperature sensor	Engine is running. └ E.G.R. system is not operating.	Less than 4.5V
		Engine is running. └ E.G.R. system is operating.	0 - 1.0V
9	Condenser fan relay	Engine is running. └ Condenser fan is not operating.	BATTERY VOLTAGE (11 - 14V)
		Engine is running. └ Condenser fan is operating.	Approximately 0.7V
11	Air conditioner relay	Engine is running. └ Both A/C switch and blower switch are "ON".	Approximately 0.7V
		Engine is running. └ A/C switch is "OFF".	BATTERY VOLTAGE (11 - 14V)
16	Air flow meter	Engine is running. └ Idle speed	0.8 - 3.0V Output voltage varies with engine revolution.
18	Engine temperature sensor	Engine is running.	0 - 5.0V Output voltage varies with engine water temperature.

TROUBLE DIAGNOSES

KA24DE

Electrical Components Inspection (Cont'd)

*Data are reference values.

TER-MINAL NO.	ITEM	CONDITION	*DATA
19	Exhaust gas sensor	<div style="border: 1px solid black; padding: 2px; display: inline-block;">Engine is running.</div> └ After warming up sufficiently	0 - Approximately 1.0V
20	Throttle sensor	<div style="border: 1px solid black; padding: 2px; display: inline-block;">Ignition switch "ON"</div>	0.4 - Approximately 5V Output voltage varies with the throttle valve opening angle.
22 30	Crank angle sensor (Reference signal)	<div style="border: 1px solid black; padding: 2px; display: inline-block;">Engine is running.</div> └ Do not run engine at high speed under no-load.	0.1 - 1.3V
25	S.C.V. control solenoid valve	<div style="border: 1px solid black; padding: 2px; display: inline-block;">Engine is running.</div> (Warm-up condition) └ Idle speed	Approximately 0.7V
		<div style="border: 1px solid black; padding: 2px; display: inline-block;">Engine is running.</div> └ Engine speed is about 2,000 rpm.	BATTERY VOLTAGE (11 - 14V)
27	Detonation sensor	<div style="border: 1px solid black; padding: 2px; display: inline-block;">Engine is running.</div> └ Idle speed	Approximately 2.5V
31 40	Crank angle sensor (Position signal)	<div style="border: 1px solid black; padding: 2px; display: inline-block;">Engine is running.</div> └ Do not run engine at high speed under no-load.	2.0 - 3.0V
34	Start signal	<div style="border: 1px solid black; padding: 2px; display: inline-block;">Ignition switch "ON"</div>	Approximately 0V
		<div style="border: 1px solid black; padding: 2px; display: inline-block;">Ignition switch "START"</div>	BATTERY VOLTAGE (11 - 14V)
35	Neutral switch	<div style="border: 1px solid black; padding: 2px; display: inline-block;">Ignition switch "ON"</div> └ Neutral	0V
		<div style="border: 1px solid black; padding: 2px; display: inline-block;">Ignition switch "ON"</div> └ Except the above gear position	Approximately 6V
36	Ignition switch	<div style="border: 1px solid black; padding: 2px; display: inline-block;">Ignition switch "OFF"</div>	0V
		<div style="border: 1px solid black; padding: 2px; display: inline-block;">Ignition switch "ON"</div>	BATTERY VOLTAGE (11 - 14V)
37	Throttle sensor power supply	<div style="border: 1px solid black; padding: 2px; display: inline-block;">Ignition switch "ON"</div>	Approximately 5V
38 47	Power supply for E.C.U.	<div style="border: 1px solid black; padding: 2px; display: inline-block;">Ignition switch "ON"</div>	BATTERY VOLTAGE (11 - 14V)

TROUBLE DIAGNOSES

KA24DE

Electrical Components Inspection (Cont'd)

*Data are reference values.

TER-MINAL NO.	ITEM	CONDITION	*DATA
41	Air conditioner switch	Engine is running. └ Both air conditioner switch and blower switch are "ON".	Approximately 0V
		Engine is running. └ Air conditioner switch is "OFF".	BATTERY VOLTAGE (11 - 14V)
43	Power steering oil pressure switch	Engine is running. └ Steering wheel is being turned.	0V
		Engine is running. └ Steering wheel is not being turned.	Approximately 8V
45	Fan switch	Engine is running. └ Fan switch is "ON".	Approximately 0V
		Engine is running. └ Fan switch is "OFF".	Approximately 7V
46	Power supply (Back-up)	Ignition switch "OFF"	BATTERY VOLTAGE (11 - 14V)
101	Injector No. 1	Engine is running.	BATTERY VOLTAGE (11 - 14V)
103	Injector No. 3		
110	Injector No. 2		
112	Injector No. 4		
102	A.I.V. control solenoid valve	Engine is running. (Warm-up condition) └ Idle speed └ During deceleration	Approximately 0.7V
		Engine is running. └ Accelerator pedal is depressed.	BATTERY VOLTAGE (11 - 14V)
104	Fuel pump relay	Ignition switch "ON" └ For 5 seconds after turning ignition switch "ON" Engine is running.	Approximately 0.8V
		Ignition switch "ON" └ 5 seconds after turning ignition switch "ON"	BATTERY VOLTAGE (11 - 14V)

TROUBLE DIAGNOSES

KA24DE

Electrical Components Inspection (Cont'd)

*Data are reference values.

TER-MINAL NO.	ITEM	CONDITION	*DATA
105	E.G.R. & canister control solenoid valve	<div style="border: 1px solid black; padding: 2px; display: inline-block;">Engine is running.</div> (Warm-up condition) ↳ Idle speed	Approximately 0.7V
		<div style="border: 1px solid black; padding: 2px; display: inline-block;">Engine is running.</div> (Warm-up condition) ↳ Engine speed is about 2,000 rpm.	BATTERY VOLTAGE (11 - 14V)
113	A.A.C. valve	<div style="border: 1px solid black; padding: 2px; display: inline-block;">Engine is running.</div> ↳ Idle speed	9 - 14V
		<div style="border: 1px solid black; padding: 2px; display: inline-block;">Engine is running.</div> ↳ Steering wheel is being turned. ↳ Air conditioner is operating. ↳ Rear defogger is "ON". ↳ Headlamp are in high position.	5 - 9V

E.C.U. HARNESS CONNECTOR TERMINAL LAYOUT

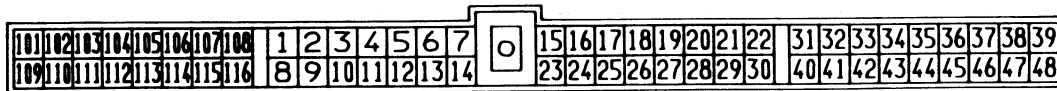

SEF419H

Electrical Components Inspection (Cont'd)

CRANK ANGLE SENSOR

1. Remove distributor assembly from engine. Disconnect ignition wires and center cable from distributor. (Crank angle sensor harness connector should remain connected.)
2. Turn ignition switch "ON".
3. Rotate crank angle sensor shaft slowly by hand and check voltage between terminals ①, ② and ground.

Terminal	Voltage
① (180° signal)	Voltage fluctuates between 5V and 0V.
② (1° signal)	

4. Rotate crank angle sensor shaft slowly by hand and check voltage between terminals ③ and ④ ground. Measure with circuit tester set in 100 mV range, AC.

Tester pointer deflects: O.K.
Tester pointer does not deflect: N.G.

If N.G., replace crank angle sensor.

After this inspection, malfunction code No. 11 might be displayed though the crank angle sensor is functioning properly. In this case erase the stored memory.

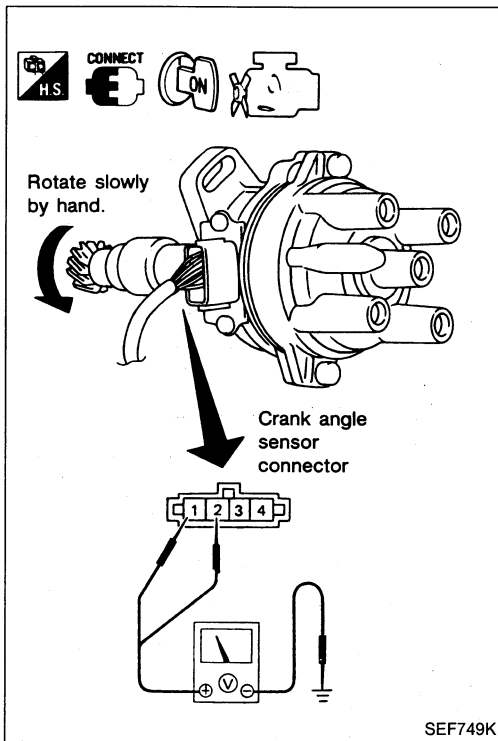

AIR FLOW METER

1. Fold back air flow meter harness connector rubber as shown in the figure if the harness connector is connected.
2. Turn ignition switch "ON".
3. Start engine and warm it up sufficiently.
4. Check voltage between terminal ① and ground.

Conditions	Voltage V
Ignition switch "ON" (Engine stopped.)	Approximately 0.2
Idle (Engine is warmed-up sufficiently.)	Approximately 1.0 - 1.4

5. If N.G., remove air flow meter from air duct. Check hot film for damage or dust.

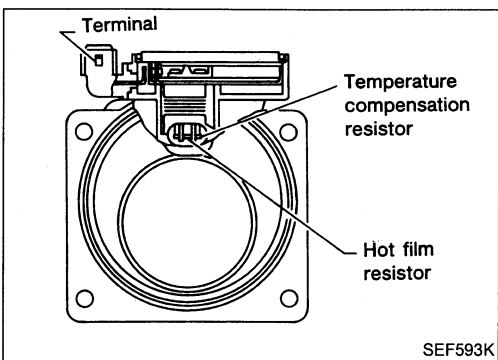
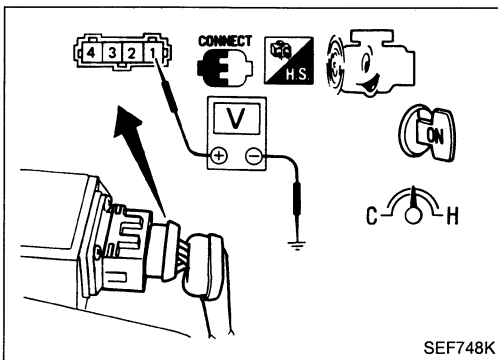

ENGINE TEMPERATURE SENSOR

1. Disconnect engine temperature sensor harness connector.
2. Check resistance as shown in the figure.

Temperature °C (°F)	Resistance kΩ
20 (68)	2.1 - 2.9
50 (122)	0.68 - 1.00
80 (176)	0.30 - 0.33

If N.G., replace engine temperature sensor.

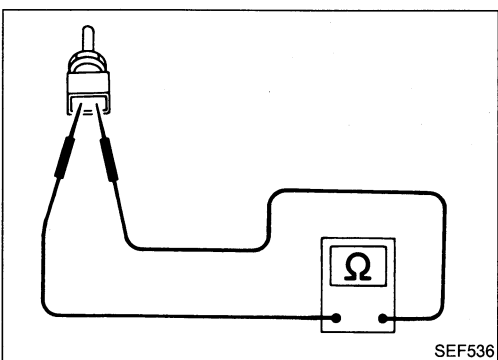

Electrical Components Inspection (Cont'd)

POWER TRANSISTOR

1. Disconnect power transistor harness connector.
2. Check power transistor continuity between terminals with a digital tester as shown in the figure.

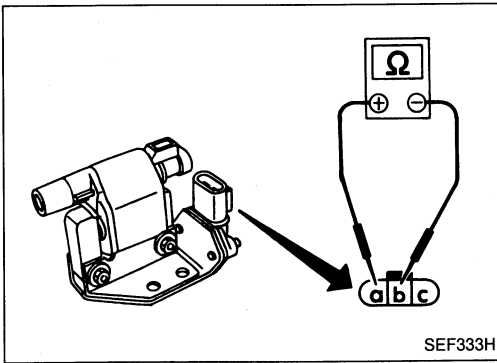

SEF333H

Terminal side	Terminal ㉑		Terminal ㉒		Terminal ㉓	
	Resistance Ω	Result	Resistance Ω	Result	Resistance Ω	Result
Terminal ㉑	—	—	∞	O.K.	∞	O.K.
	—	—	Not ∞ or 0	N.G.	Not ∞ or 0	N.G.
	—	—	0	N.G.	0	N.G.
Terminal ㉒	∞	N.G.	—	—	∞	N.G.
	Not ∞ or 0	O.K.	—	—	Not ∞ or 0	O.K.
	0	N.G.	—	—	0	N.G.
Terminal ㉓	∞	N.G.	∞	N.G.	—	—
	Not ∞ or 0	O.K.	Not ∞ or 0	O.K.	—	—
	0	N.G.	0	N.G.	—	—

If N.G., replace power transistor.

IGNITION COIL

1. Disconnect ignition coil harness connector.
2. Check resistance as shown in the figure.

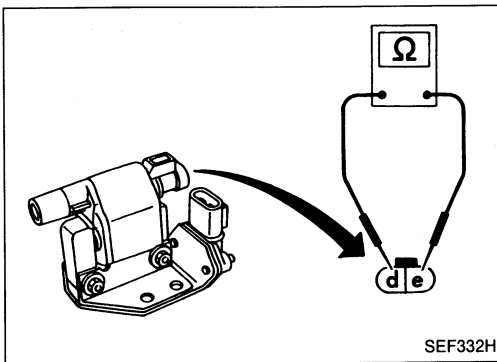

SEF332H

Terminal	Resistance
㉑ - ㉒	Approximately 0.7Ω

If N.G., replace power transistor.

FUEL PUMP

1. Disconnect fuel pump harness connector.
2. Check resistance between terminals ① and ③.

Resistance: Approximately 0.5Ω

If N.G., replace fuel pump.

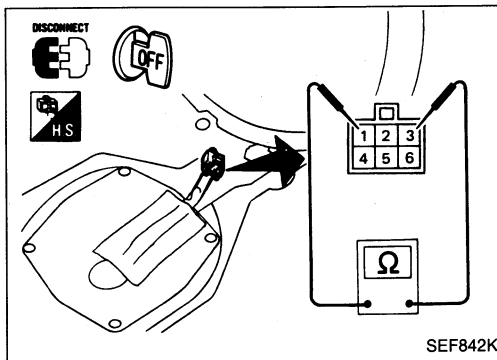

SEF842K

Electrical Components Inspection (Cont'd)

VEHICLE SPEED SENSOR

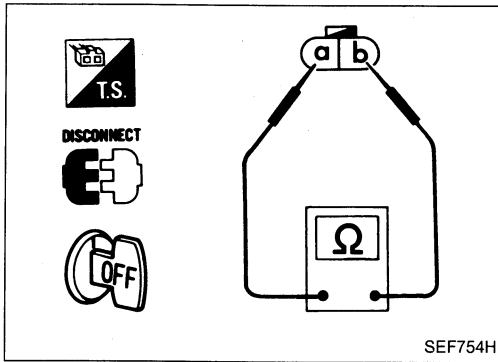

1. Jack up rear wheels. Use stands to support vehicle.
2. Disconnect vehicle speed sensor harness connector.
3. Check continuity between terminals Ⓐ and Ⓑ while rotating rear wheel by hand.

Continuity should come and go.

If N.G. replace vehicle speed sensor.

E.G.R. AND CANISTER CONTROL SOLENOID VALVE, S.C.V. CONTROL SOLENOID VALVE AND A.I.V. CONTROL SOLENOID VALVE

Check air passage continuity.

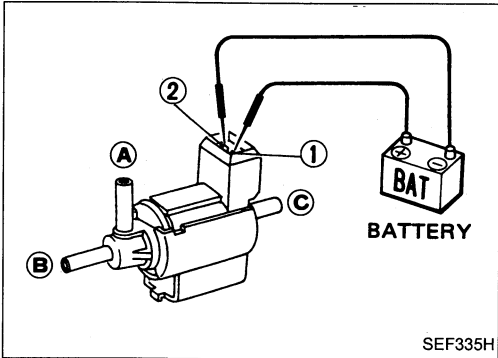

Condition	Air passage continuity between Ⓐ and Ⓑ	Air passage continuity between Ⓐ and Ⓒ
12V direct current supply between terminals ① and ②	Yes	No
No supply	No	Yes

If N.G., replace solenoid valve.

E.G.R. CONTROL VALVE

Apply vacuum to E.G.R. vacuum port with a hand vacuum pump.

E.G.R. control valve spring should lift.

If N.G., replace E.G.R. control valve.

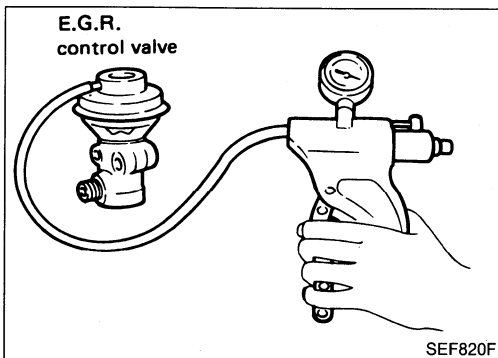

B.P.T. VALVE

Plug one of two ports of B.P.T. valve.

Apply a pressure above 0.490 kPa (50 mmH₂O, 1.97 inH₂O) to check for leakage. If a leak is noted, replace valve.

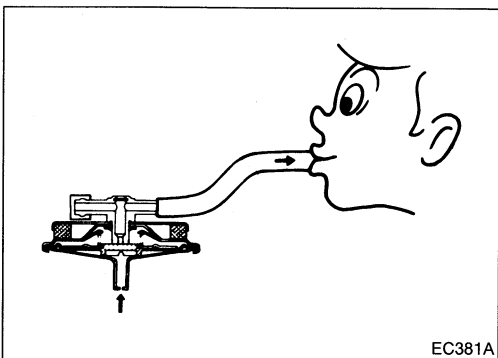

Electrical Components Inspection (Cont'd)

EXHAUST GAS TEMPERATURE SENSOR

Check resistance change and resistance value at 100°C (212°F).

- Resistance should decrease in response to temperature increase.

Resistance: 100°C (212°F)

85.3 ± 8.53 kΩ

If N.G., replace exhaust gas temperature sensor.

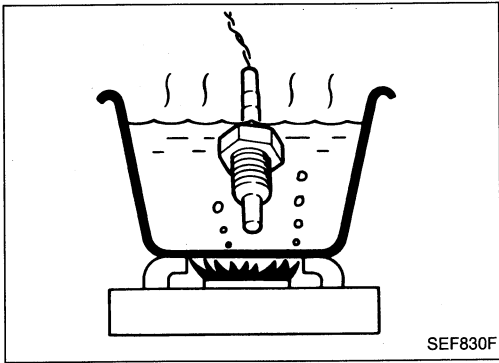

THROTTLE SENSOR

1. Disconnect throttle sensor harness connector.
2. Make sure that resistance between terminals ① and ② changes when opening throttle valve manually.

Accelerator pedal conditions	Resistance kΩ
Completely released	Approximately 2
Partially released	2 - 10
Completely depressed	Approximately 10

If N.G., replace throttle sensor.

Adjustment

If throttle sensor is replaced or removed, it is necessary to install in proper position, by following the procedure as shown below:

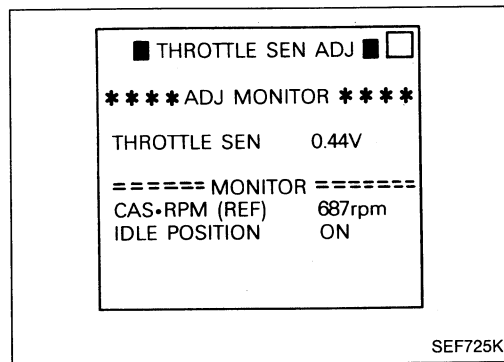
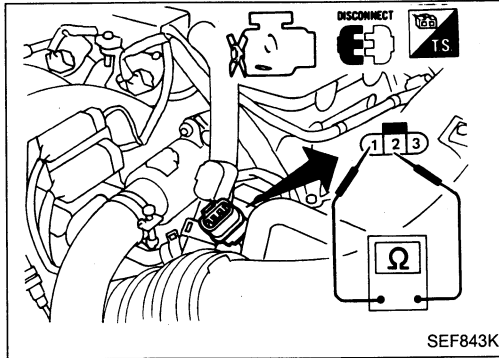

1. Install throttle sensor body in throttle chamber. Do not tighten bolts. Leave bolts loose.
2. Connect throttle sensor harness connector.
3. Start engine and warm it up sufficiently.



Perform "THROTTLE SEN ADJ" in "WORK SUPPORT" mode.



Measure output voltage of throttle sensor using voltmeter.

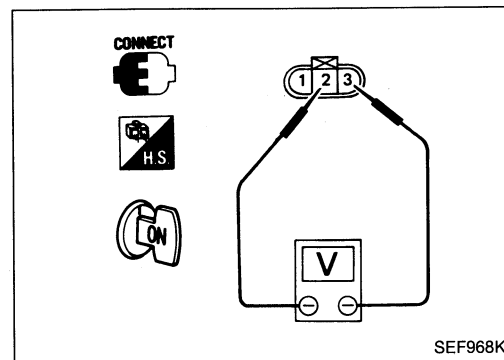

5. Adjust by rotating throttle sensor body so that output voltage is 0.45 to 0.55V.
6. Tighten mounting bolts.
7. Disconnect throttle sensor harness connector for a few seconds and then reconnect it.

Electrical Components Inspection (Cont'd)

A.A.C. VALVE

- Check A.A.C. valve resistance.

Resistance:
Approximately 10Ω

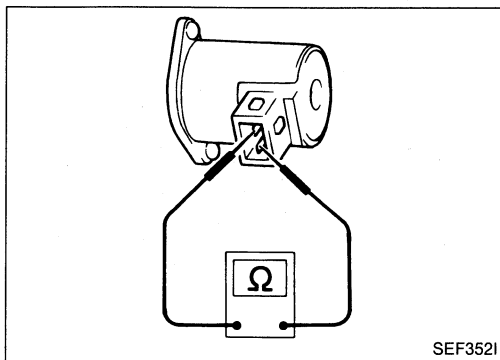

SEF352I

- Check plunger for seizing or sticking.
- Check for broken spring.

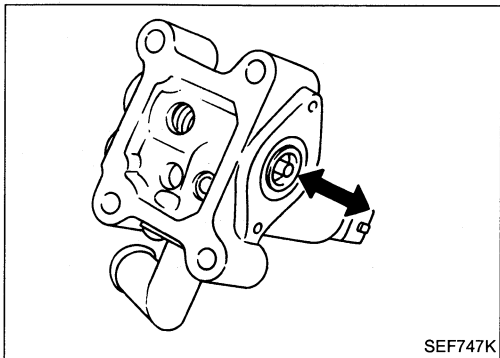

SEF747K

DETONATION SENSOR

1. Disconnect detonation sensor sub-harness connector.
2. Check continuity between terminal ⓐ and ground.

Continuity should exist.

- It is necessary to use an ohmmeter which can measure more than 10 MΩ.

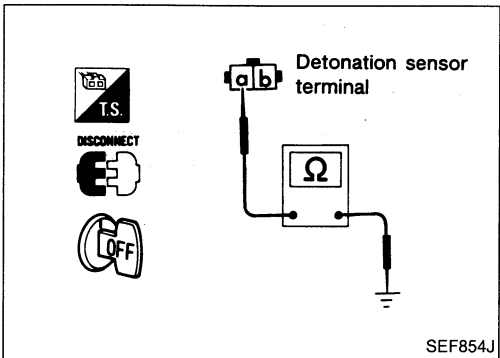

SEF854J

INJECTOR

1. Disconnect injector harness connector.
2. Check resistance between terminals as shown in the figure.

Resistance: Approximately 11Ω [at 20°C (68°F)]
If N.G., replace injector.

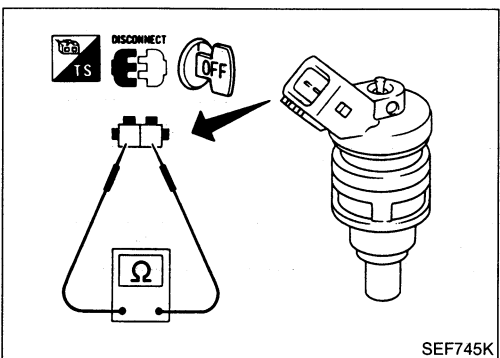

SEF745K

NEUTRAL SWITCH

Check continuity between terminals as shown in the figure.

Conditions	Continuity
Shift to neutral position	Yes
Shift to other position	No

If N.G., replace neutral switch.

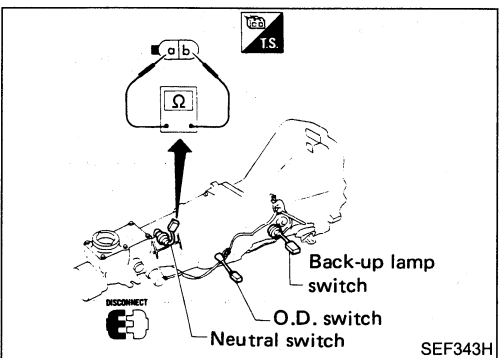

SEF343H

Electrical Components Inspection (Cont'd)

INHIBITOR SWITCH (A/T models)

Check continuity between terminals ① and ②.

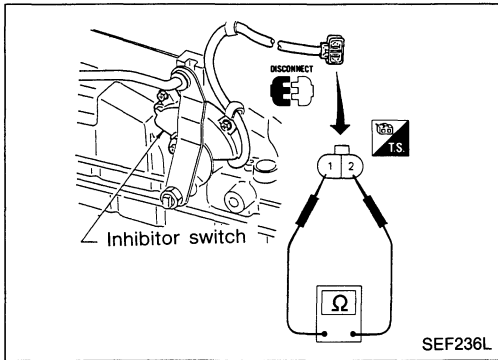

Conditions	Continuity
Shift to "P" or "N" position	Yes
Shift to other position	No

If N.G., replace inhibitor switch.

Refer to section AT.

swirl control valve

Supply vacuum to actuator and check swirl control valve operation.

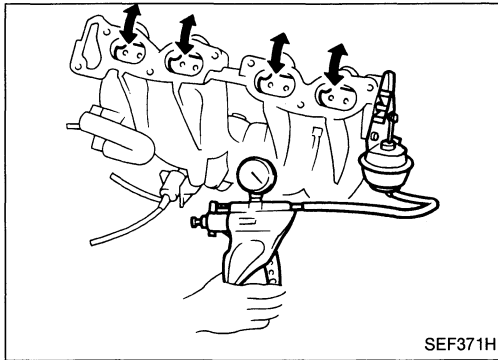

Conditions	Swirl control valve
Supply vacuum to actuator	Close
No supply	Open

E.C.C.S. RELAY, FUEL PUMP RELAY, CONDENSER FAN RELAY AND IGNITION COIL RELAY

Check continuity between terminals ③ and ⑤.

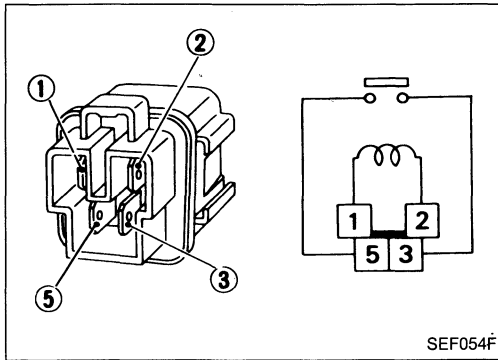

Conditions	Continuity
12V direct current supply between terminals ① and ②	Yes
No current supply	No

If N.G., replace relay.

N & P RELAY

Check continuity between terminals ③ and ④.

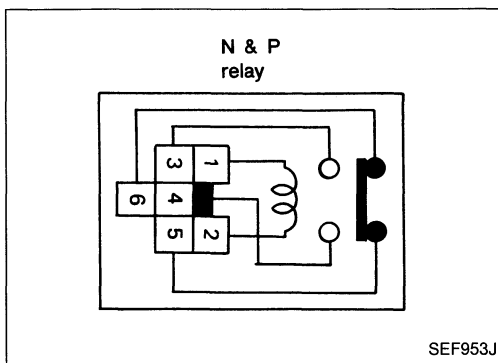

Conditions	Continuity
12V direct current supply between terminals ① and ②.	Yes
No current supply	No

If N.G., replace relay.

POWER STEERING OIL PRESSURE SWITCH

1. Disconnect power steering oil pressure switch harness connector.
2. Check continuity between terminals.

Conditions	Continuity
Steering wheel is being turned	Yes
Steering wheel is not being turned	No

Electrical Components Inspection (Cont'd)

AIR REGULATOR

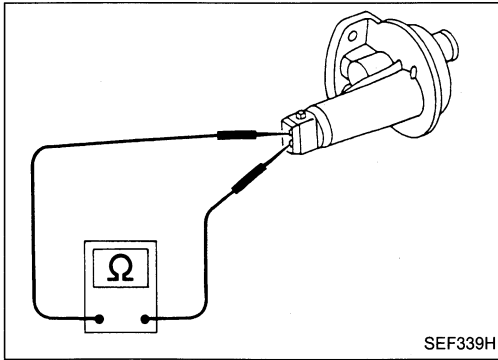

SEF339H

- Check air regulator resistance.
Resistance:
Approximately 75Ω
- Check air regulator for clogging.

F.I.C.D. SOLENOID VALVE

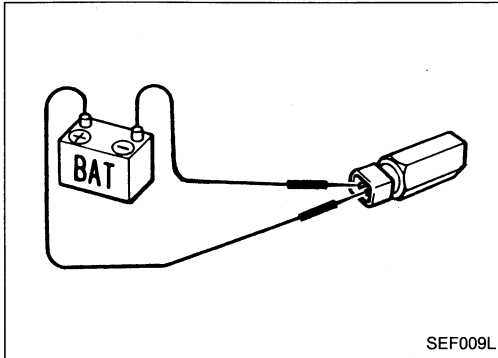

SEF009L

- Check that clicking sound is heard when applying 12V direct current to terminals.

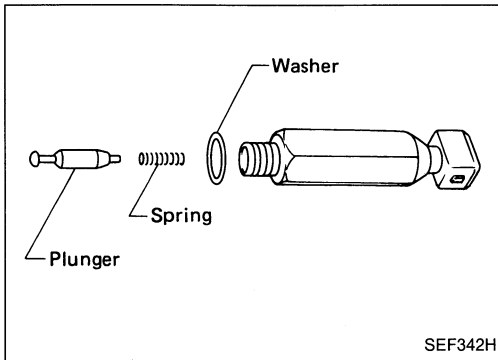

SEF342H

- Check plunger for seizure or sticking.
- Check for broken spring.

AIR INDUCTION VALVE

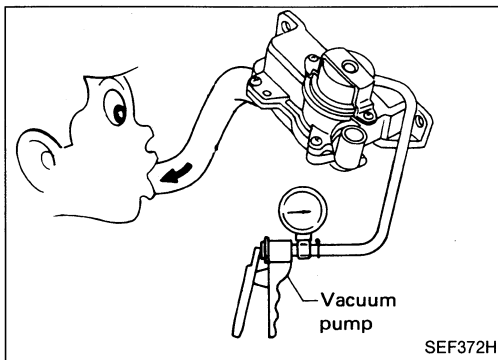

SEF372H

Apply vacuum to vacuum motor, suck or blow hose to make sure that air flows only towards the air induction side.

CONDENSER FAN MOTOR

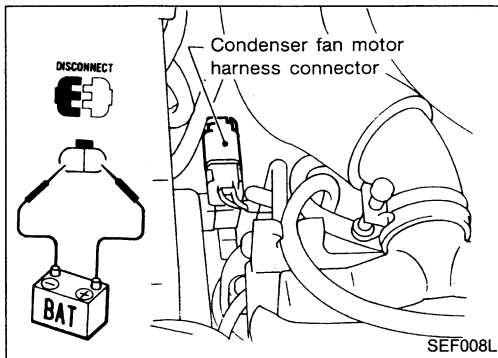

SEF008L

Check that condenser fan operates when applying 12V direct current to terminals as shown in figure.

Electrical Components Inspection (Cont'd)

RESISTOR

1. Disconnect resistor harness connector.
2. Check resistance between terminals Ⓐ and Ⓑ.

Resistance: Approximately 2.2k Ω

If N.G., replace resistor.

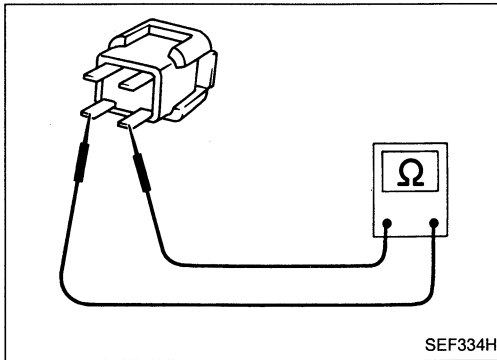

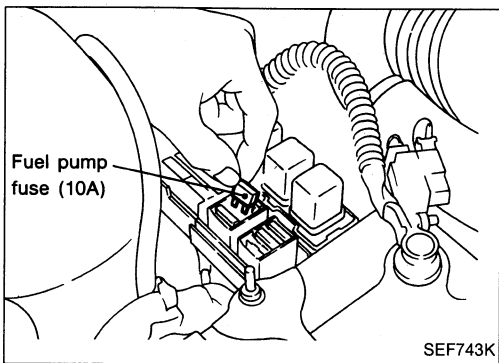
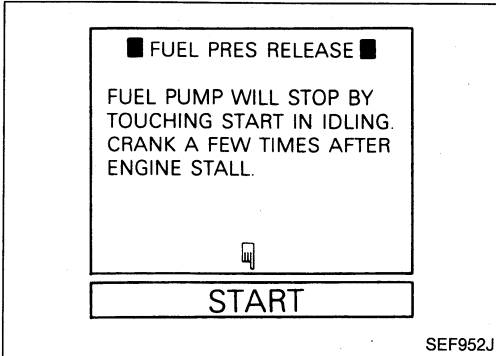
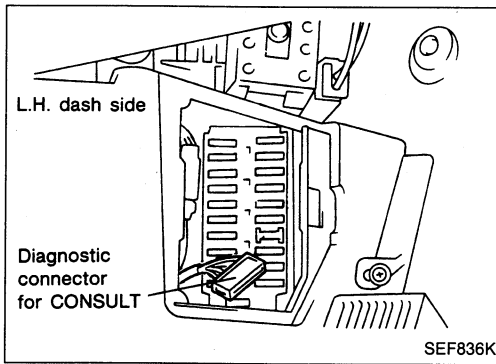

Releasing Fuel Pressure

Before disconnecting fuel line, release fuel pressure from fuel line to eliminate danger.



Perform "FUEL PRESSURE RELEASE" in "WORK SUPPORT" mode with CONSULT.



1. Remove fuel pump fuse.
2. Start engine.
3. After engine stalls, crank it two or three times to release all fuel pressure.
4. Turn ignition switch off and reconnect fuel pump fuse.

Fuel Pressure Check

- a. Make sure that clamp screw does not contact adjacent parts.
 - b. Use a torque driver to tighten clamps.
 - c. Use Pressure Gauge to check fuel pressure.
 - d. Do not perform fuel pressure check while fuel pressure regulator control system is operating; otherwise, fuel pressure gauge might indicate incorrect readings.
1. Release fuel pressure to zero.
 2. Disconnect fuel hose between fuel filter and fuel tube (engine side).
 3. Install pressure gauge between fuel filter and fuel tube.
 4. Start engine and check for fuel leakage.

Fuel Pressure Check (Cont'd)

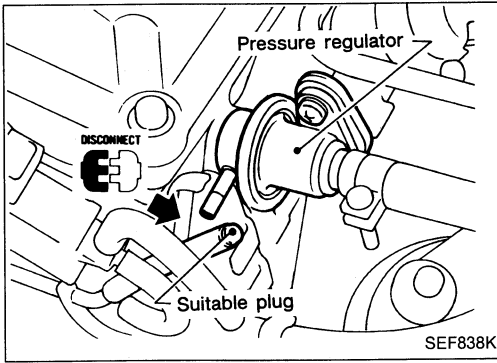

5. Read the indication of fuel pressure gauge.

At idling:

When fuel pressure regulator valve vacuum hose is connected.

Approximately 235 kPa (2.4 kg/cm², 34 psi)

When fuel pressure regulator valve vacuum hose is disconnected.

Approximately 294 kPa (3.0 kg/cm², 43 psi)

6. Stop engine and disconnect fuel pressure regulator vacuum hose from intake manifold.
7. Plug intake manifold with a rubber cap.
8. Connect variable vacuum source to fuel pressure regulator.

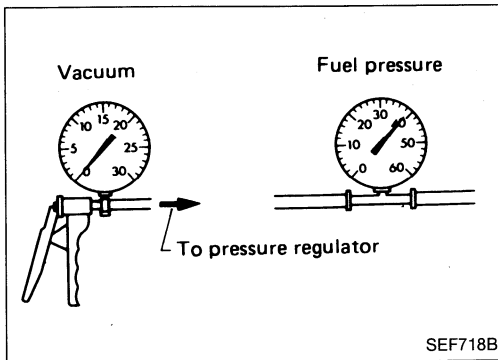

9. Start engine and read indication of fuel pressure gauge as vacuum is changed.

Fuel pressure should decrease as vacuum increases. If results are unsatisfactory, replace fuel pressure regulator.

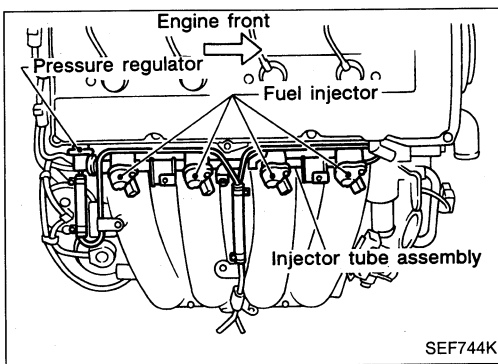

Injector Removal and Installation

1. Release fuel pressure to zero.
2. Remove related covers, harnesses, wires and tubes.
3. Remove injector tube assembly with injectors from intake manifold.
4. Remove injectors from injector tube assembly.
 - Push injector tail piece.
 - Do not pull on the connector.
5. Install injectors as follows:
 - 1) Clean exterior of injector tail piece.
 - 2) Use new O-rings

CAUTION:

After properly connecting injectors to fuel tube assembly, check connections for fuel leakage.

6. Assemble injectors to injector tube assembly.
7. Install injector tube assembly to intake manifold.

Description

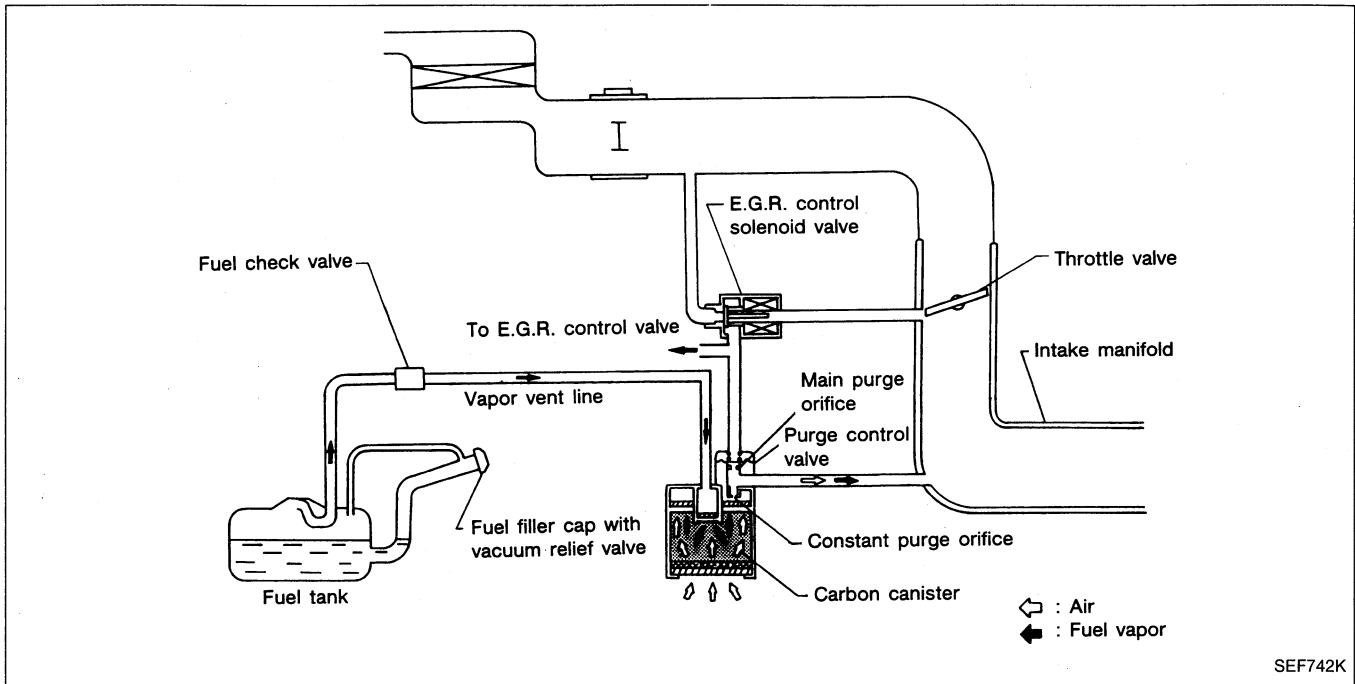

The evaporative emission control system is used to reduce hydrocarbons emitted into the atmosphere from the fuel system. This reduction of hydrocarbons is accomplished by activated charcoals in the carbon canister.

The fuel vapor from the sealed fuel tank is led into the canister which contains activated carbon and the vapor is stored there when the engine is not running.

The canister retains the fuel vapor until the canister is purged by the air drawn through the bottom of the canister to the intake manifold when the engine is running. When the engine runs at idle, the purge control valve is closed.

Only a small amount of stored vapor flows into the intake manifold through the constant purge orifice. As the engine speed increases, and the throttle vacuum rises higher, the purge control valve opens and the vapor is sucked into the intake manifold through both the main purge orifice and the constant purge orifice.

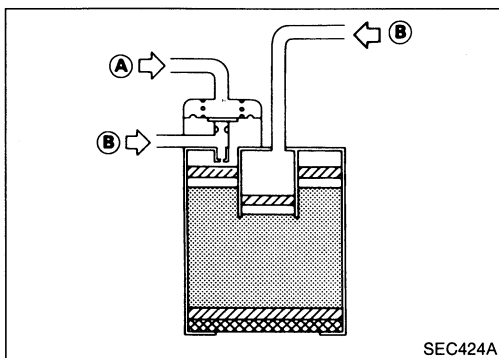

Inspection

CARBON CANISTER

Check carbon canister as follows:

- Ⓐ : Blow air and ensure that there is no leakage.
- Ⓑ : Blow air and ensure that there is leakage.

Inspection (Cont'd)

FUEL TANK VACUUM RELIEF VALVE

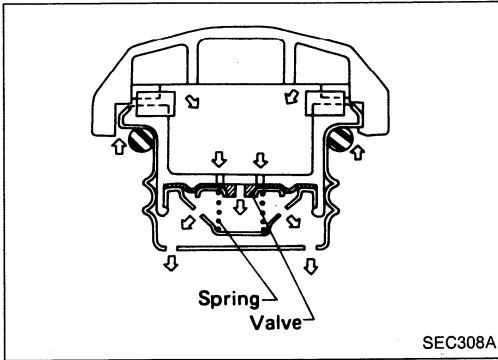

1. Wipe clean valve housing.
2. Suck air through the cap. A slight resistance accompanied by valve clicks indicates that valve is in good mechanical condition. Note also that, by further sucking air, the resistance should disappear with valve clicks.
3. If valve is clogged or if no resistance is felt, replace cap as an assembly.

FUEL CHECK VALVE

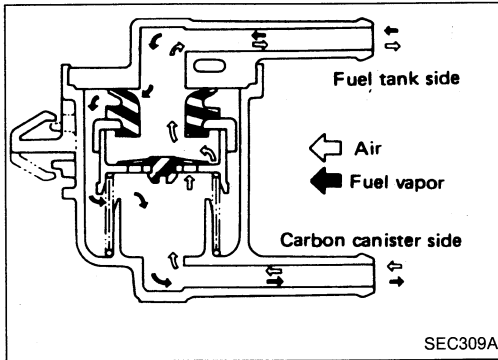

1. Blow air through connector on fuel tank side. A considerable resistance should be felt and a portion of air flow should be directed toward the canister.
2. Blow air through connector on canister side. Air flow should be smoothly directed toward fuel tank.
3. If fuel check valve is suspected of not properly functioning in steps 1 and 2 above, replace it.

Description

This system returns blow-by gas to the intake collector.

The positive crankcase ventilation (P.C.V.) valve is provided to conduct crankcase blow-by gas to the intake manifold.

During partial throttle operation of the engine, the intake manifold sucks the blow-by gas through the P.C.V. valve.

Normally, the capacity of the valve is sufficient to handle any blow-by and a small amount of ventilating air.

The ventilating air is then drawn from the air duct, through the hose connecting air inlet tubes to rocker cover, into the crankcase.

Under full-throttle condition, the manifold vacuum is insufficient to draw the blow-by flow through the valve, and its flow goes through the hose connection in the reverse direction.

On vehicles with an excessively high blow-by some of the flow will go through the hose connection to the intake collector under all conditions.

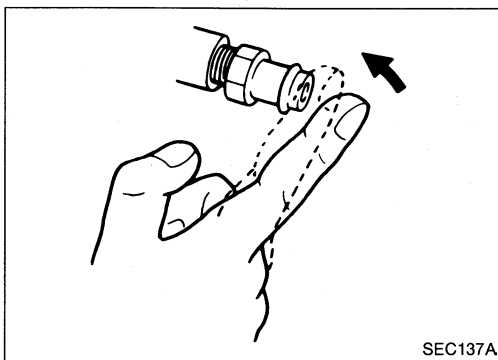
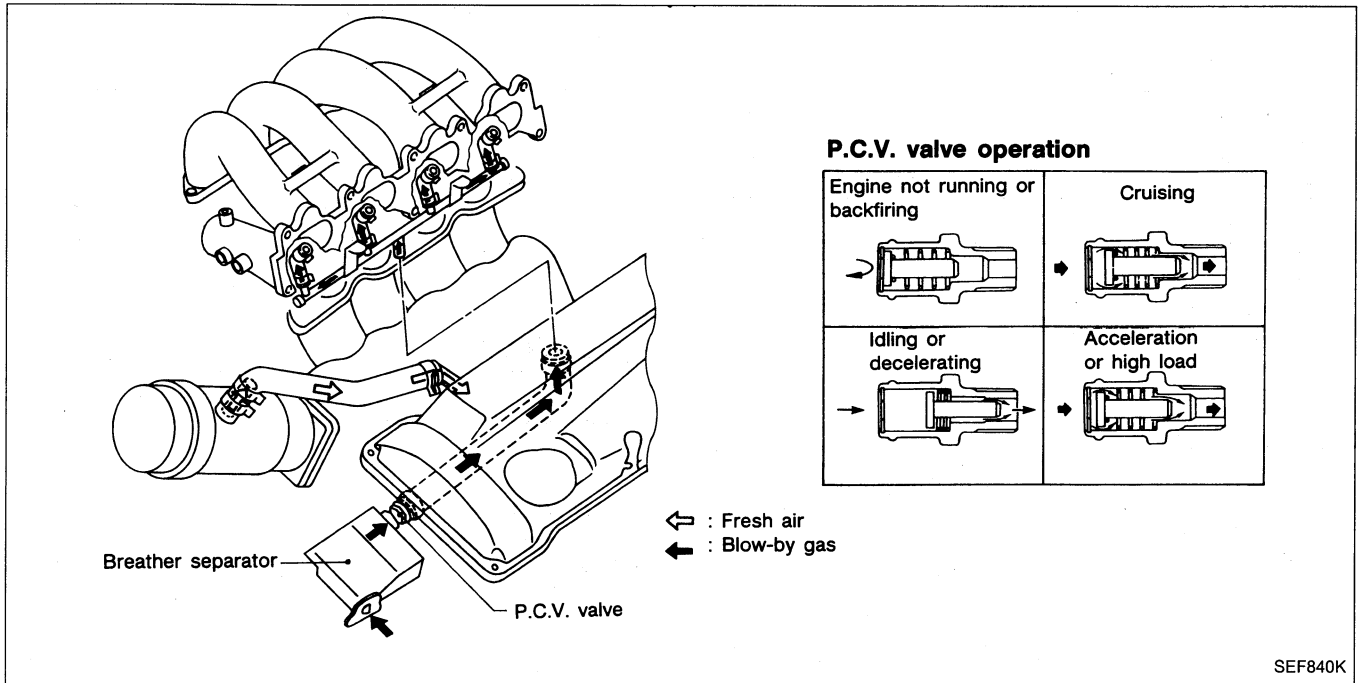

Inspection

P.C.V. (Positive Crankcase Ventilation)

With engine running at idle, remove ventilation hose from P.C.V. valve; if the valve is working properly, a hissing noise will be heard as air passes through it and a strong vacuum should be felt immediately when a finger is placed over valve inlet.

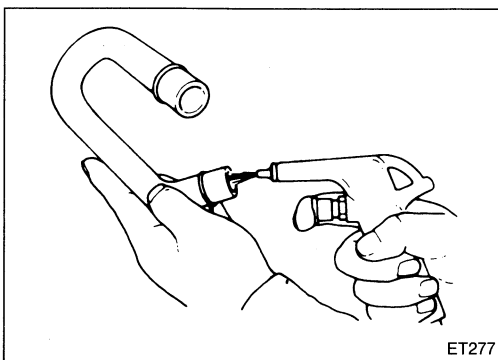

VENTILATION HOSE

1. Check hoses and hose connections for leaks.
2. Disconnect all hoses and clean with compressed air. If any hose cannot be freed of obstructions, replace.

General Specifications

PRESSURE REGULATOR	
Fuel pressure at idling kPa (kg/cm ² , psi)	
Vacuum hose is connected	Approximately 235 (2.4, 34)
Vacuum hose is disconnected	Approximately 294 (3.0, 43)

Inspection and Adjustment

Idle speed*1	rpm	
No-load*2 (in "N" position)		700 ± 50
Air conditioner: ON (in "N" position)		1,000 ± 50
Ignition timing		20° ± 2° B.T.D.C.
Throttle sensor idle position	V	0.4 - 0.5

*1: Feedback controlled and needs no adjustments

*2: Under the following conditions:

- Air conditioner switch: OFF
- Electric load: OFF (Lights, heater, fan & rear defogger)

IGNITION COIL

Primary voltage	V	Battery voltage (11 - 14)
Primary resistance [at 20°C (68°F)]	Ω	Approximately 1.0
Secondary resistance [at 20°C (68°F)]	kΩ	Approximately 10.0

AIR FLOW METER

Supply voltage	V	Battery voltage (11 - 14)
Output voltage	V	0.8 - 1.2

*: Engine is warmed up sufficiently and idling under no-load.

ENGINE TEMPERATURE SENSOR

Temperature °C (°F)	Resistance kΩ
20 (68)	2.1 - 2.9
50 (122)	0.68 - 1.00
80 (176)	0.30 - 0.33

EXHAUST GAS TEMPERATURE SENSOR

Resistance [at 100°C (212°F)]	kΩ	85.3 ± 8.53
----------------------------------	----	-------------

FUEL PUMP

Resistance	Ω	Approximately 0.5
------------	---	-------------------

A.A.C. VALVE

Resistance	Ω	Approximately 10.0
------------	---	--------------------

INJECTOR

Resistance	Ω	Approximately 11
------------	---	------------------

RESISTOR

Resistance	kΩ	Approximately 2.2
------------	----	-------------------

THROTTLE SENSOR

Accelerator pedal conditions	Resistance kΩ
Completely released	Approximately 2
Partially released	2 - 10
Completely depressed	Approximately 10

ACCELERATOR CONTROL, FUEL & EXHAUST SYSTEMS

SECTION **FE**

CONTENTS

ACCELERATOR CONTROL SYSTEM	FE-2
FUEL SYSTEM	FE-3
EXHAUST SYSTEM	FE-4

FE

ACCELERATOR CONTROL SYSTEM

- When removing accelerator cable, make a mark to indicate lock nut's initial position.
- Check that throttle valve fully opens when accelerator pedal is fully depressed and that it returns to idle position when pedal is released.
- Adjust accelerator cable according to the following procedure.
Tighten "adjusting nut" until "throttle drum" starts to move.
From that position turn back "adjusting nut" 1.5 to 2 turns, and fasten it with a lock nut.
- Check accelerator control parts for improper contact with any adjacent parts.
- When connecting accelerator cable, be careful not to twist or scratch its inner wire.

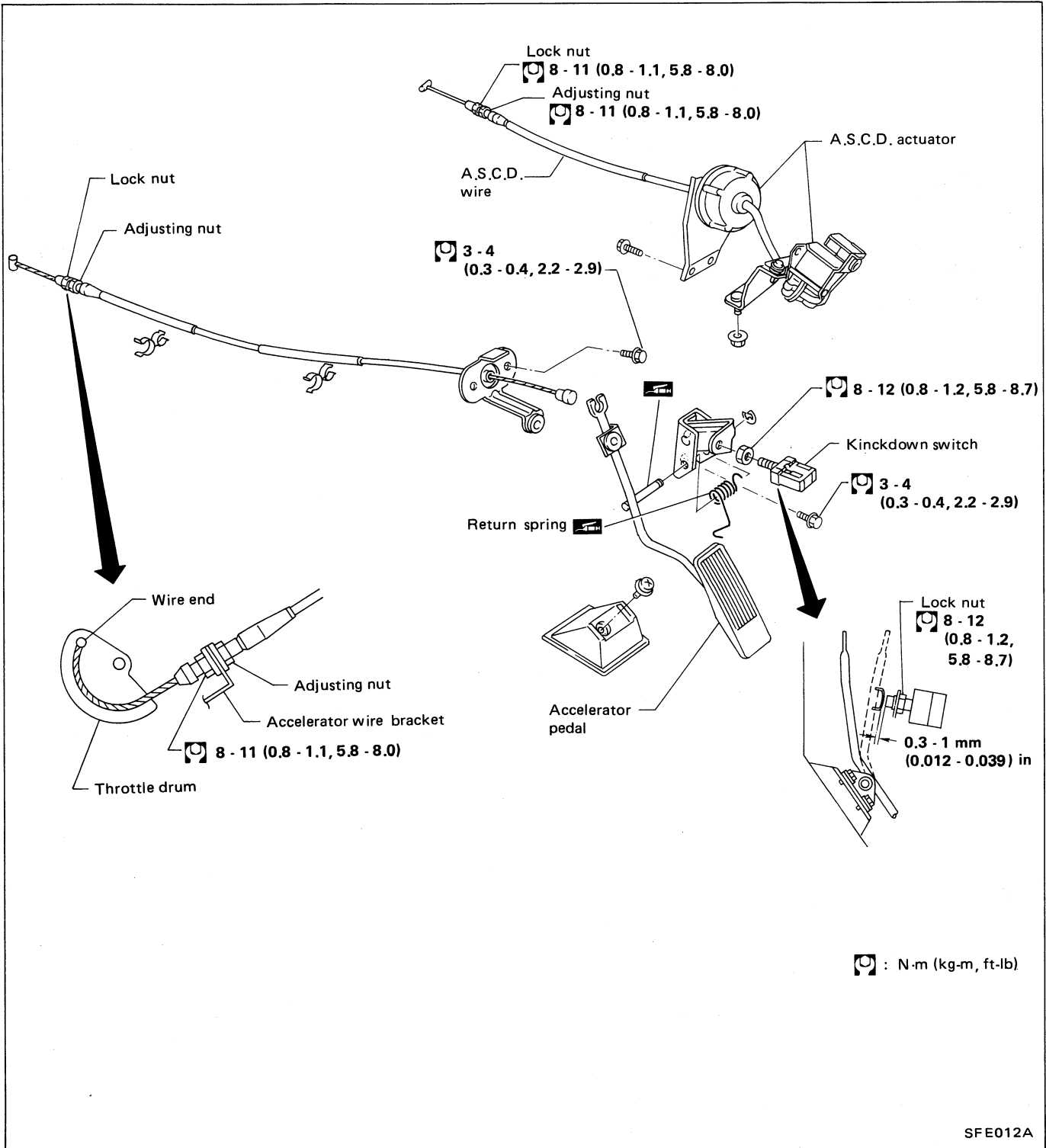

SFE012A

FUEL SYSTEM

WARNING:

When replacing fuel line parts, be sure to observe the following:

- Put a "CAUTION: INFLAMMABLE" sign in workshop.
- Do not smoke while servicing fuel system. Keep open flames and sparks away from work area.
- Be sure to disconnect battery ground cable before conducting operations.
- Be sure to furnish workshop with a CO₂ fire extinguisher.
- Put drained fuel in an explosion-proof container and put lid on securely.

CAUTION:

- For electric fuel pump model, before disconnecting fuel hose, release fuel pressure from fuel line. Refer to "Fuel Filter Replacement" in MA section.
- Do not disconnect any fuel line unless absolutely necessary.
- Plug hose and pipe openings to prevent entry of dust or dirt.
- Always replace O-ring and clamps with new ones.
- Do not kink or twist hose and tube when they are installed.
- Do not tighten hose clamps excessively to avoid damaging hoses.
- When installing fuel check valve, be careful of its designated direction. (Refer to section EF & EC.)
- Run engine and check for leaks at connections.

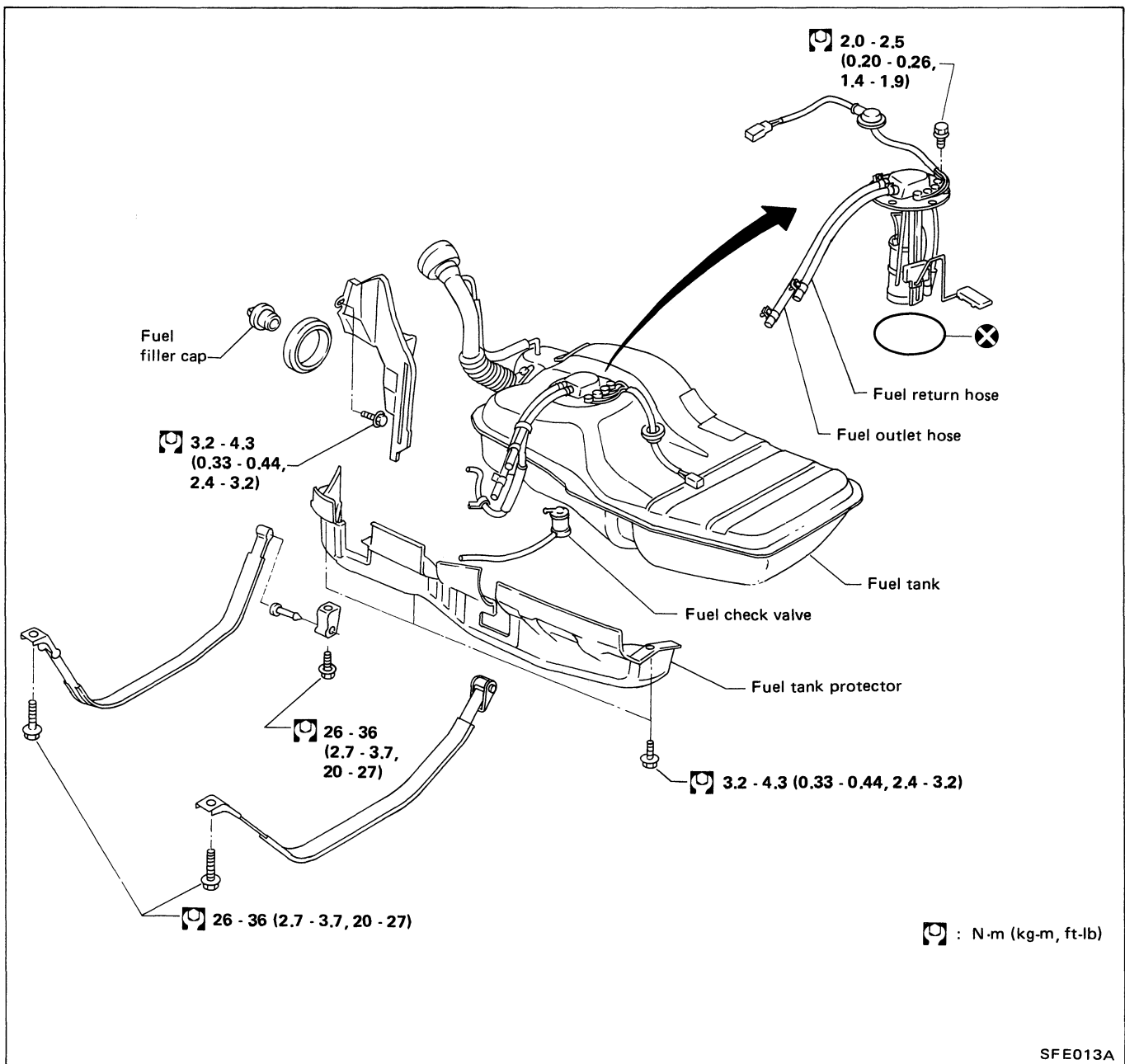

EXHAUST SYSTEM

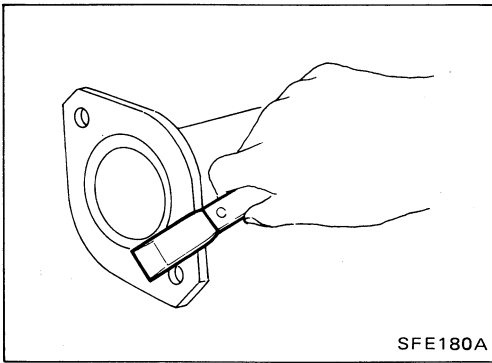

CAUTION:

- Always replace exhaust gaskets with new ones when reassembling.
If gasket is left on flange surface, scrape off completely as shown at left.
- With engine running, check all tube connections for exhaust gas leaks, and entire system for unusual noises.
- After installation, check to ensure that mounting brackets and mounting insulator are free from undue stress. If any of the above parts are not installed properly, excessive noise or vibration may be transmitted to the vehicle body.

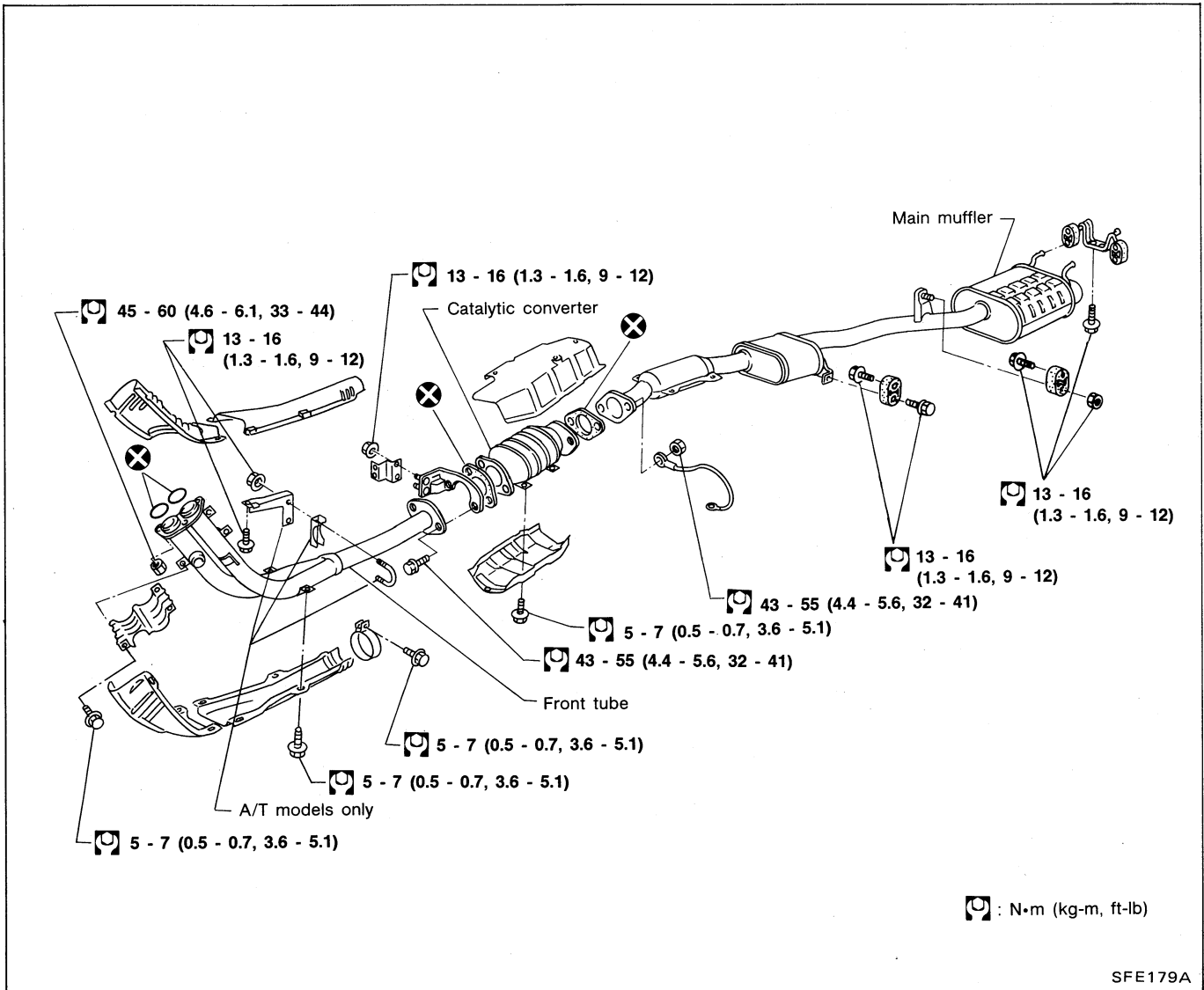

CLUTCH

SECTION **CL**

CONTENTS

PRECAUTIONS AND PREPARATION	CL- 2
CLUTCH SYSTEM	CL- 4
INSPECTION AND ADJUSTMENT	CL- 5
HYDRAULIC CLUTCH CONTROL	CL- 7
CLUTCH RELEASE MECHANISM	CL- 9
CLUTCH DISC AND CLUTCH COVER	CL-11
SERVICE DATA AND SPECIFICATIONS (S.D.S.)	CL-14



PRECAUTIONS AND PREPARATION

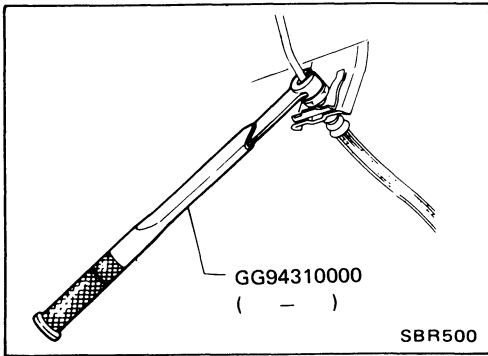

Precautions



- Recommended fluid is brake fluid "DOT 3".
- Never reuse drained brake fluid.
- Be careful not to splash brake fluid on painted areas.
- When removing and installing clutch piping, use Tool.
- Use new brake fluid to clean or wash all parts of master cylinder, operating cylinder and clutch damper.
- Never use mineral oils such as gasoline or kerosene. It will ruin the rubber parts of the hydraulic system.

WARNING:

After cleaning the clutch disc, wipe it with a dust collector. Do not use compressed air.

Preparation

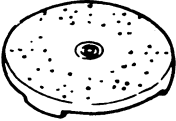
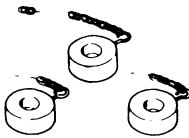
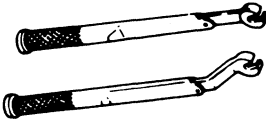
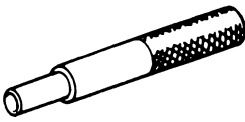
SPECIAL SERVICE TOOLS

Tool number (Kent-Moore No.) Tool name	Description	
ST20050010 (-) Base plate		Inspecting diaphragm spring of clutch cover
ST20050100 (-) Distance piece		Inspecting diaphragm spring of clutch cover
GG94310000 (-) Flare nut torque wrench		Removing and installing each clutch piping
ST20600000 (J26366) Clutch aligning bar		Installing clutch cover and clutch disc
ST20050240 (-) Diaphragm spring adjusting wrench		Adjusting unevenness of diaphragm spring of clutch cover

PRECAUTIONS AND PREPARATION

Preparation (Cont'd)

COMMERCIAL SERVICE TOOLS

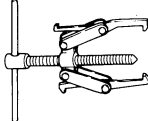
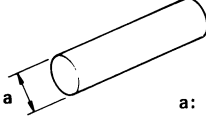
Tool name	Description
Bearing puller	 Removing release bearing
Bearing drift	 a: 50 mm (1.97 in) dia.

CLUTCH SYSTEM

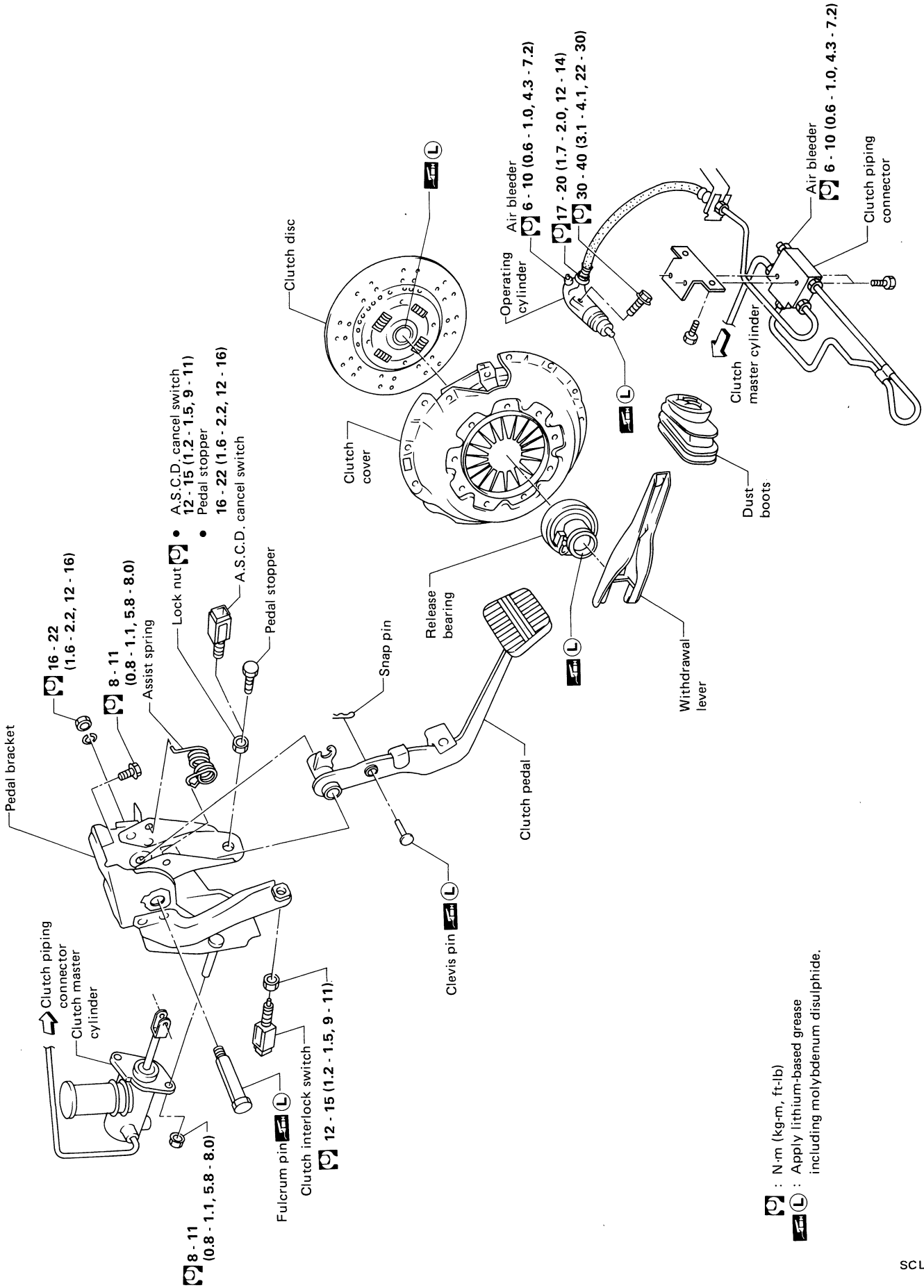

: N·m (kg-m, ft-lb)
 : Apply lithium-based grease including molybdenum disulphide.

INSPECTION AND ADJUSTMENT

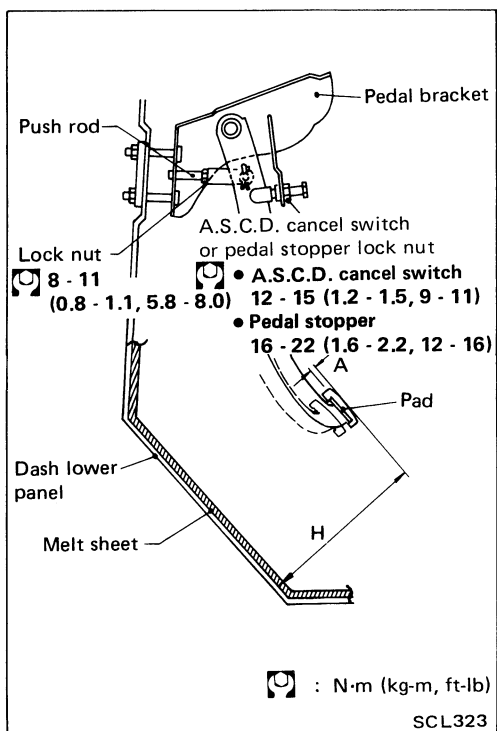

Adjusting Clutch Pedal

1. Adjust pedal height with pedal stopper or A.S.C.D. cancel switch.

Pedal height "H":

186 - 196 mm (7.32 - 7.72 in)

2. Adjust pedal free play with master cylinder push rod. Then tighten lock nut.

Pedal free play "A":

1.0 - 3.0 mm (0.039 - 0.118 in)

Pedal free play means the following total measured at position of pedal pad:

- Play due to clevis pin and clevis pin hole in clutch pedal.
3. Make sure that clevis pin can be rotated smoothly. If not, readjust pedal free play with master cylinder push rod.

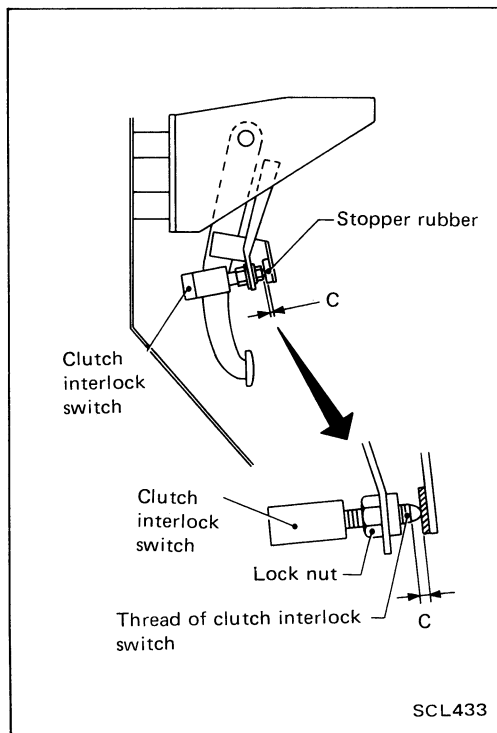

— U.S.A. model only —

3. Adjust clearance "C" between pedal stopper rubber and threaded end of clutch interlock switch while depressing clutch pedal fully.

Clearance C:

1.0 - 2.0 mm (0.039 - 0.079 in)

INSPECTION AND ADJUSTMENT

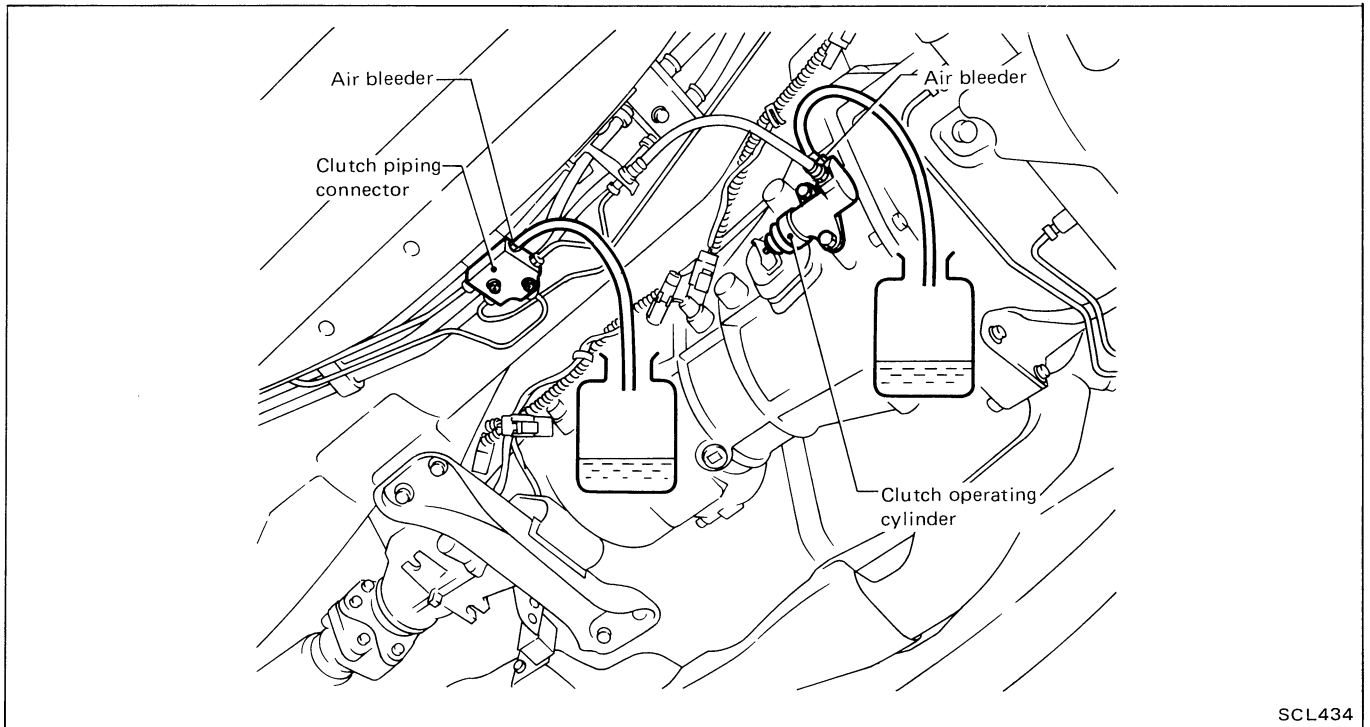

Bleeding Procedure

1. Bleed air from clutch operating cylinder according to the following procedure.

Carefully monitor fluid level at master cylinder during bleeding operation.

- a. Top up reservoir with recommended brake fluid.
 - b. Connect a transparent vinyl tube to air bleeder valve.
 - c. Fully depress clutch pedal several times.
 - d. With clutch pedal depressed, open bleeder valve to release air.
 - e. Close bleeder valve.
 - f. Repeat steps c through e above until brake fluid flows from air bleeder valve without air bubbles.
2. Bleed air from clutch piping connector according to the above same procedure.
 3. Repeat the above bleeding procedures 1 and 2 several times.

HYDRAULIC CLUTCH CONTROL

Clutch Master Cylinder

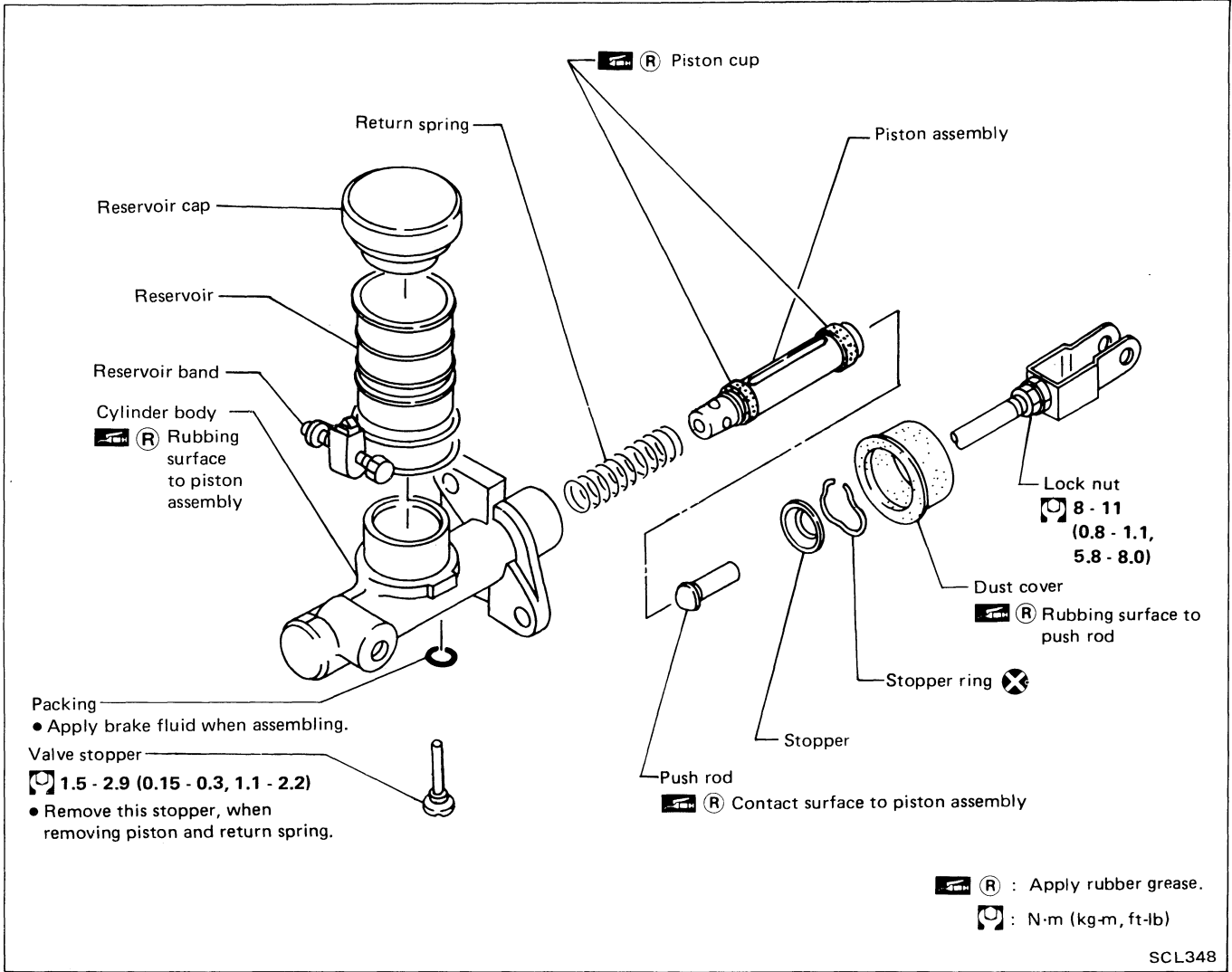

DISASSEMBLY AND ASSEMBLY

- Push piston into cylinder body with screwdriver when removing and installing valve stopper.

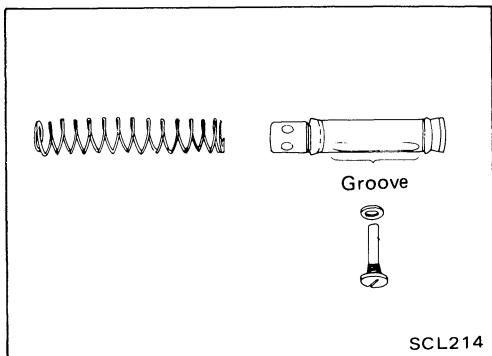

- Align groove of piston assembly and valve stopper when installing valve stopper.
- Check direction of piston cups.

HYDRAULIC CLUTCH CONTROL

Clutch Master Cylinder (Cont'd)

INSPECTION

- Check cylinder and piston rubbing surface for uneven wear, rust or damage. Replace if necessary.
- Check piston with piston cup for wear or damage. Replace if necessary.
- Check return spring for wear or damage. Replace if necessary.
- Check reservoir for deformation or damage. Replace if necessary.
- Check dust cover for cracks, deformation or damage. Replace if necessary.

Operating Cylinder

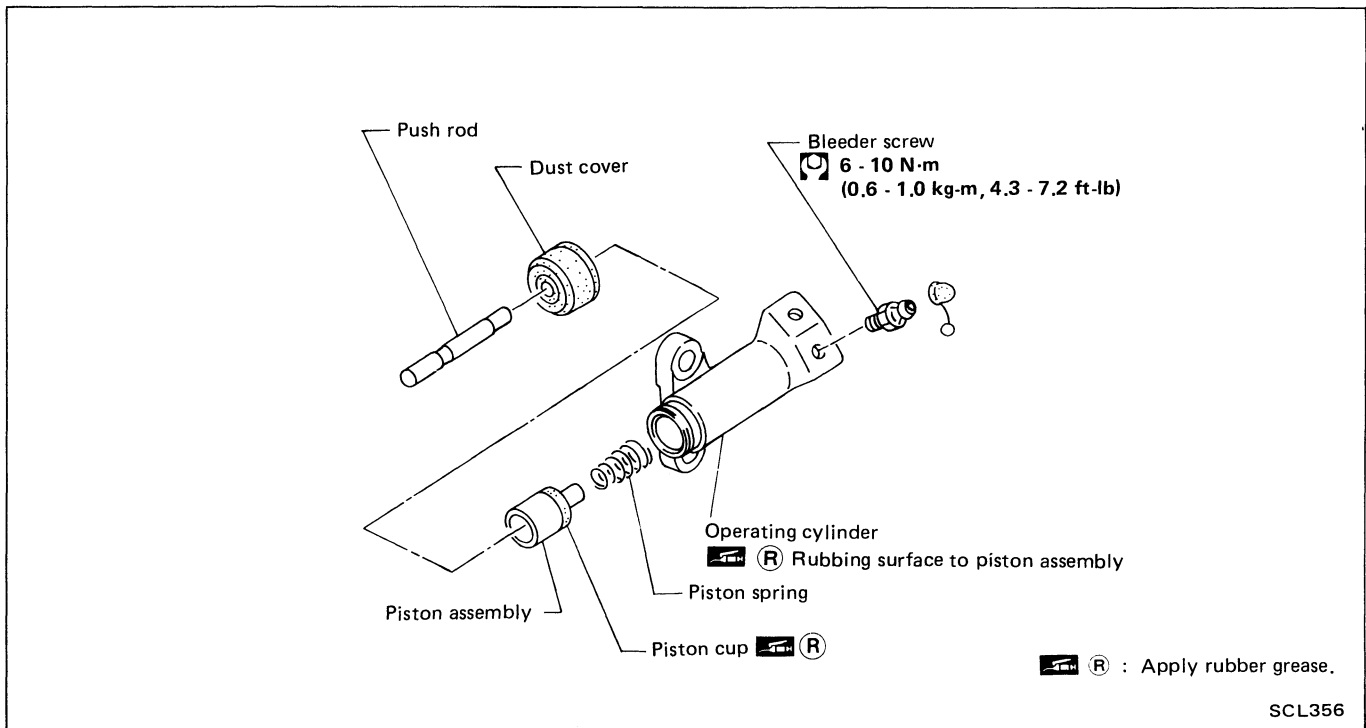

INSPECTION

- Check rubbing surface of cylinder for wear, rust or damage. Replace if necessary.
- Check piston with piston cup for wear or damage. Replace if necessary.
- Check piston spring for wear or damage. Replace if necessary.
- Check dust cover for cracks, deformation or damage. Replace if necessary.

CLUTCH RELEASE MECHANISM

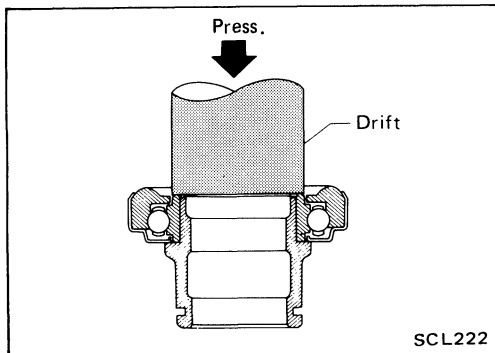
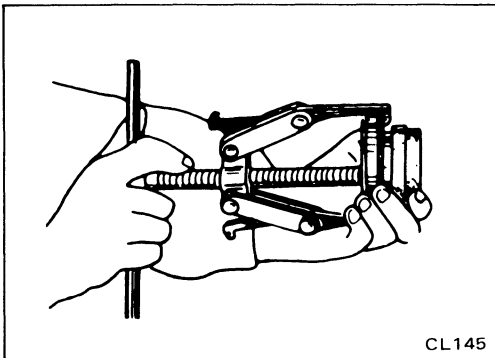
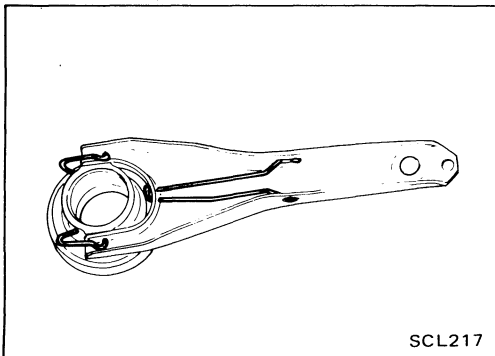
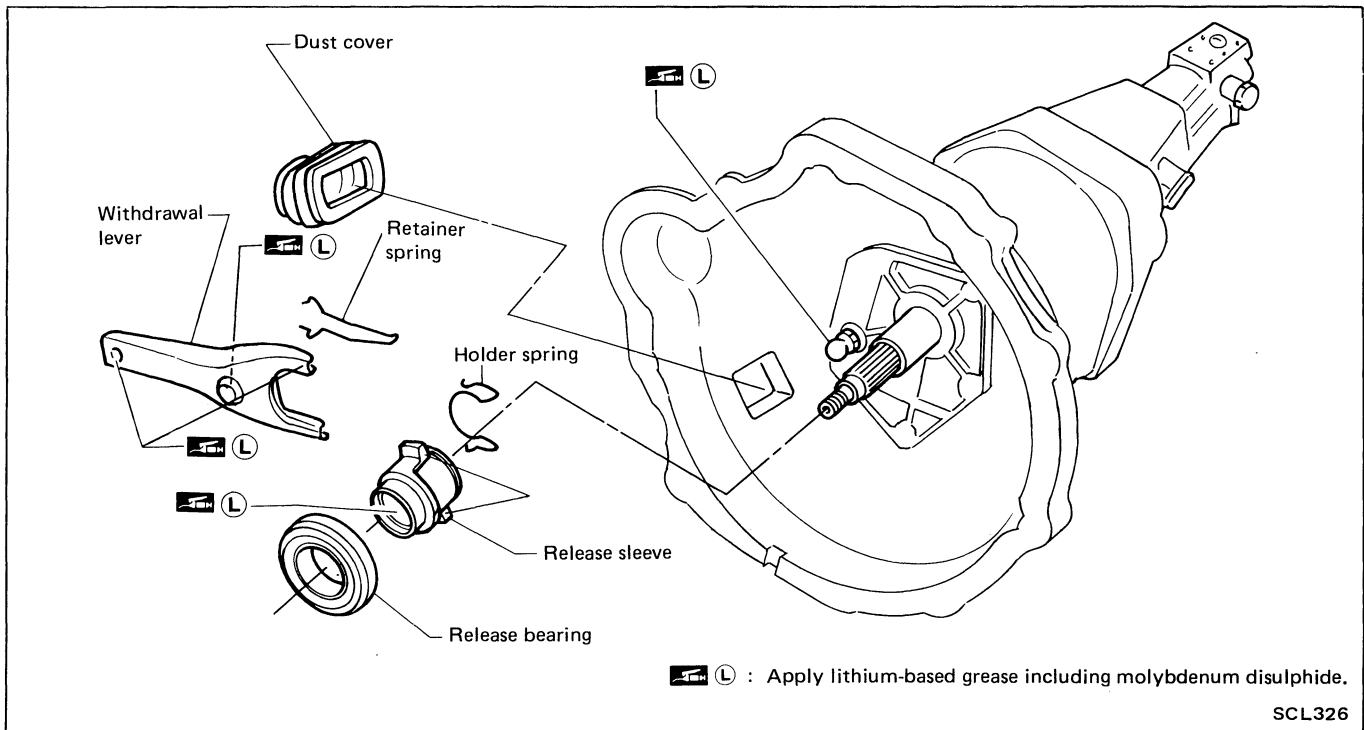

REMOVAL AND INSTALLATION

- Install retainer spring and holder spring.
- Remove release bearing.
- Install release bearing with suitable drift.

CLUTCH RELEASE MECHANISM

INSPECTION

- Check release bearing to see that it rolls freely and is free from noise, cracks, pitting or wear. Replace if necessary.
- Check release sleeve and withdrawal lever rubbing surface for wear, rust or damage. Replace if necessary.

LUBRICATION

- Apply recommended grease to contact surface and rubbing surface.

Too much lubricant might damage clutch disc facing.

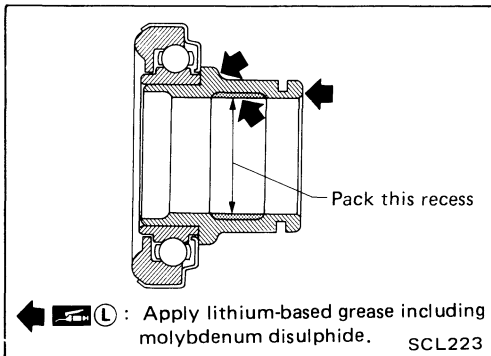

CLUTCH DISC AND CLUTCH COVER

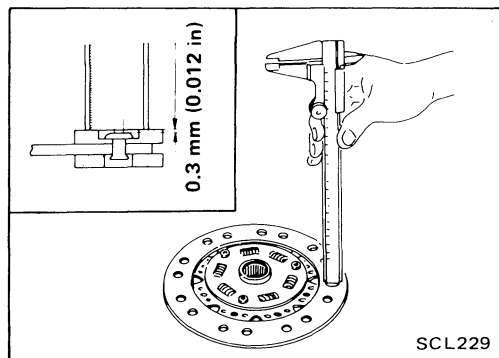
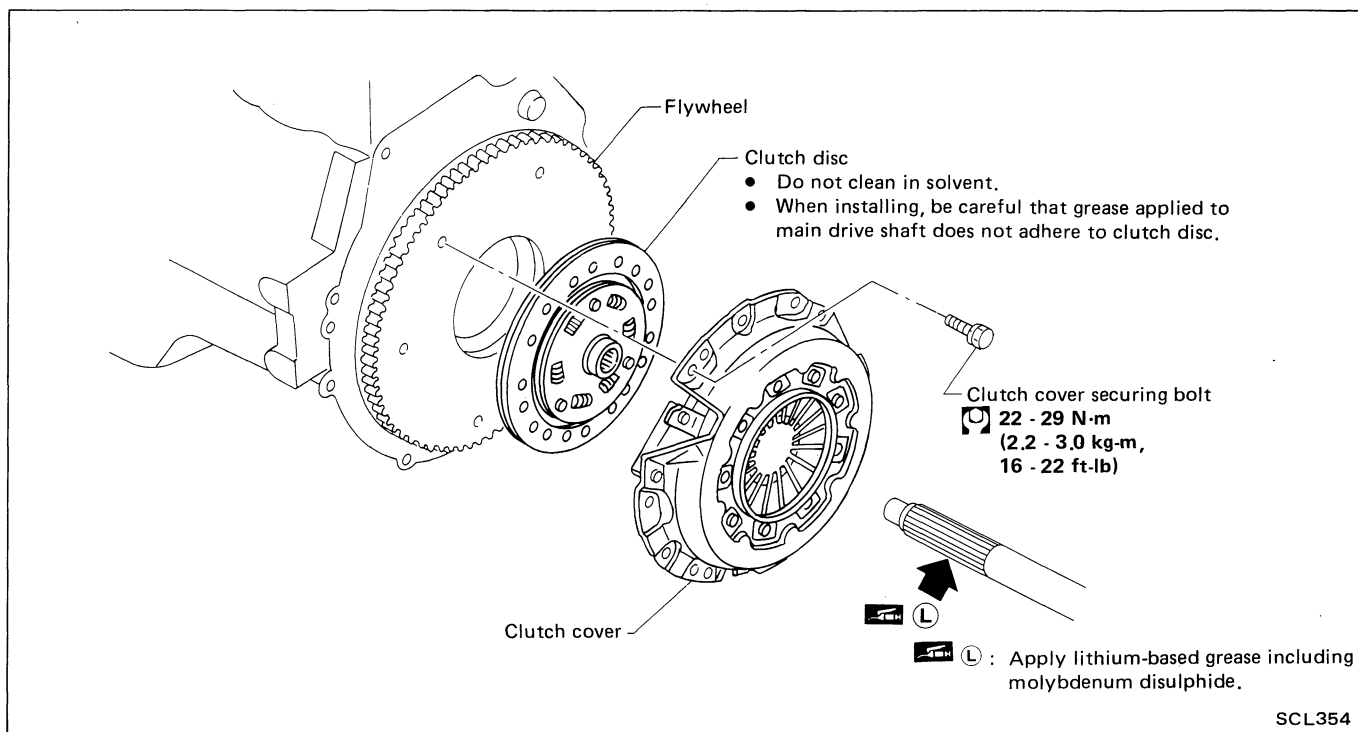

Clutch Disc INSPECTION

- Check clutch disc for wear of facing.
**Wear limit of facing surface to rivet head:
0.3 mm (0.012 in)**

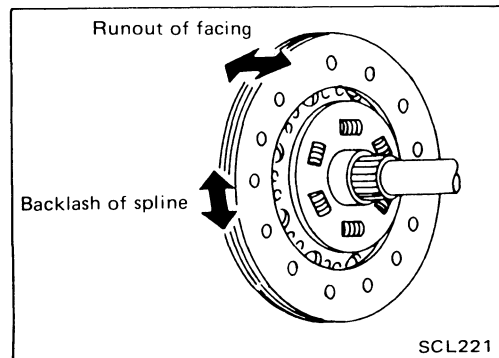

- Check clutch disc for backlash of spline and runout of facing.
**Maximum backlash of spline (at outer edge of disc):
0.9 mm (0.035 in)**
**Runout limit:
1.0 mm (0.039 in)**
**Distance of runout check point (from hub center):
107.5 mm (4.23 in)**
- Check clutch disc for burns, discoloration or oil or grease leakage. Replace if necessary.

INSTALLATION

- Apply recommended grease to contact surface of spring portion.
Too much lubricant might damage clutch disc facing.

CLUTCH DISC AND CLUTCH COVER

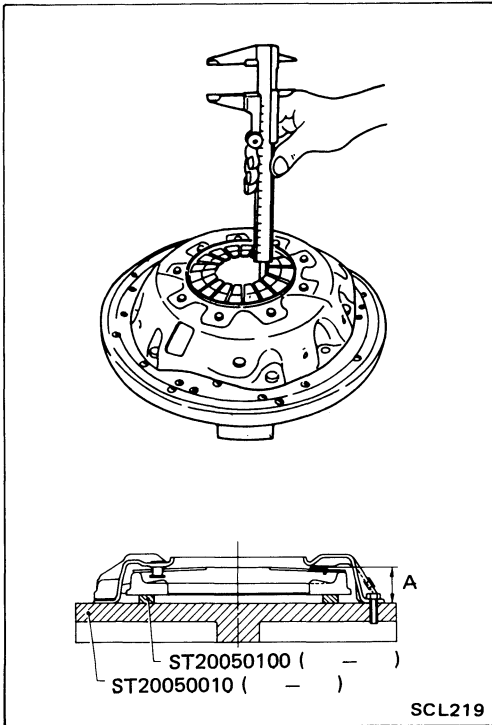

Clutch Cover and Flywheel

INSPECTION AND ADJUSTMENT

- Set Tool and check height and unevenness of diaphragm spring.

Diaphragm spring height "A":

33.0 - 35.0 mm (1.299 - 1.378 in)

- Check thrust rings for wear or damage by shaking cover assembly and listening for chattering noise, or lightly hammering on rivets for a slightly cracked noise. Replace clutch cover assembly if necessary.
- Check pressure plate and clutch disc contact surface for slight burns or discoloration. Repair pressure plate with emery paper.
- Check pressure plate and clutch disc contact surface for deformation or damage. Replace if necessary.

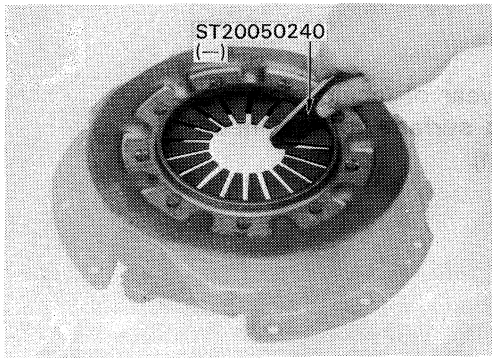

- Adjust unevenness of diaphragm spring with Tool.

Uneven limit:

0.7 mm (0.028 in)

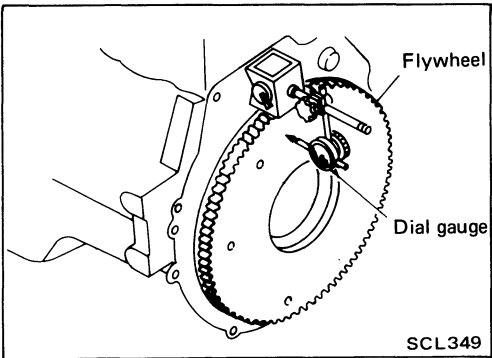

FLYWHEEL INSPECTION

- Check contact surface of flywheel for slight burns or discoloration. Repair flywheel with emery paper.
- Check flywheel runout.

Runout (Total indicator reading):

Less than 0.15 mm (0.0059 in)

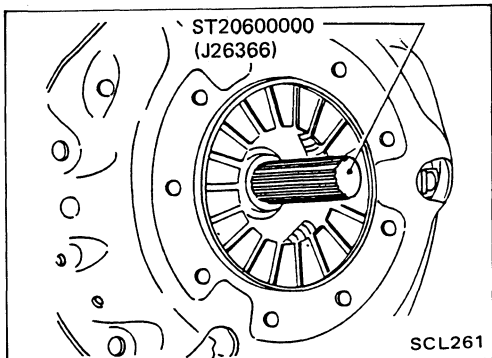

INSTALLATION

- Insert Tool into clutch disc hub when installing clutch cover and disc.

CLUTCH DISC AND CLUTCH COVER

Clutch Cover and Flywheel (Cont'd)

- Tighten clutch cover fixing bolts in numerical order by 2 steps.

Tightening torque:

First step 20 N·m (2.0 kg-m, 14 ft-lb)

Final step 22 - 29 N·m (2.2 - 3.0 kg-m, 16 - 22 ft-lb)

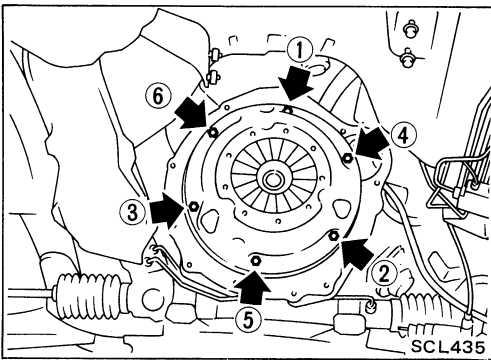

SERVICE DATA AND SPECIFICATIONS (S.D.S.)

General Specifications

CLUTCH CONTROL SYSTEM

Type of clutch control	Hydraulic
------------------------	-----------

CLUTCH MASTER CYLINDER

Inner diameter	mm (in)	15.87 (5/8)
----------------	---------	-------------

CLUTCH OPERATING CYLINDER

Inner diameter	mm (in)	17.46 (11/16)
----------------	---------	---------------

CLUTCH DISC

Model	225LTD
Facing size (Outer dia. x inner dia. x thickness) mm (in)	225 x 150 x 3.5 (8.86 x 5.91 x 0.138)
Thickness of disc assembly With load mm (in)	7.6 - 8.0 (0.299 - 0.315) with 5,394 N (550 kg, 1,213 lb)

CLUTCH COVER

Model	C225S
Full load N (kg, lb)	5,394 (550, 1,213)

Inspection and Adjustment

CLUTCH PEDAL

Unit: mm (in)

Pedal height "H"	186 - 196 (7.32 - 7.72)
Pedal free play (Backlash at clevis)	1.0 - 3.0 (0.039 - 0.118)
Clearance between pedal stopper rubber and threaded end of clutch interlock	1.0 - 2.0 (0.039 - 0.079)

*: Measured from surface of melt sheet to pedal pad

CLUTCH COVER

Unit: mm (in)

Model	C225S
Diaphragm spring height	33.0 - 35.0 (1.299 - 1.378)
Uneven limit of diaphragm spring toe height	0.7 (0.028)

CLUTCH DISC

Unit: mm (in)

Model	225LTD
Wear limit of facing surface to rivet head	0.3 (0.012)
Runout limit of facing	1.0 (0.039)
Distance of runout check point (from the hub center)	107.5 (4.23)
Maximum backlash of spline (at outer edge of disc)	0.9 (0.035)

MANUAL TRANSMISSION





CONTENTS

PREPARATION	MT- 2
ON-VEHICLE SERVICE	MT- 4
REMOVAL AND INSTALLATION	MT- 6
MAJOR OVERHAUL	MT- 8
DISASSEMBLY	MT-11
INSPECTION	MT-16
ASSEMBLY	MT-18
SERVICE DATA AND SPECIFICATIONS (S.D.S.)	MT-28



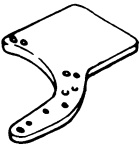
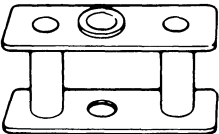
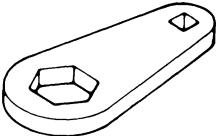

PREPARATION

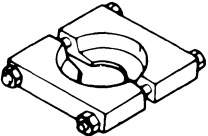
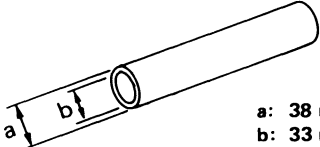
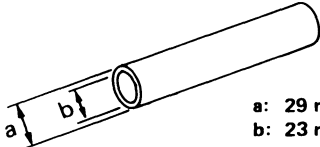
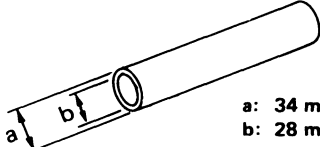
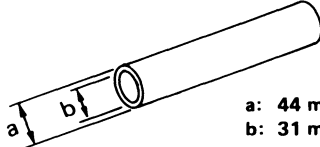
SPECIAL SERVICE TOOLS

Tool number (Kent-Moore No.) Tool name	Description	
ST23810001 (-) Adapter setting plate		Fixing adapter plate with gear assembly
KV31100401 (-) Transmission press stand		Pressing counter gear and mainshaft
ST22520000 (J26348) Wrench		Tightening mainshaft lock nut
ST23540000 (J25689-A) Pin punch		Removing and installing fork rod retaining pin
ST30031000 (J22912-01) Puller		Removing and installing 1st gear bushing Removing main drive gear bearing Measuring wear of baulk rings
ST23860000 (-) Drift	 <p style="margin-left: 100px;"> a: 38 mm (1.50 in) dia. b: 33 mm (1.30 in) dia. </p>	Installing counter drive gear
ST22360002 (J25679-01) Drift	 <p style="margin-left: 100px;"> a: 29 mm (1.14 in) dia. b: 23 mm (0.91 in) dia. </p>	Installing counter gear front and rear end bearings
ST22350000 (J25678-01) Drift	 <p style="margin-left: 100px;"> a: 34 mm (1.34 in) dia. b: 28 mm (1.10 in) dia. </p>	Installing O.D. gear bushing
ST23800000 (J25691-01) Drift	 <p style="margin-left: 100px;"> a: 44 mm (1.73 in) dia. b: 31 mm (1.22 in) dia. </p>	Installing front cover oil seal

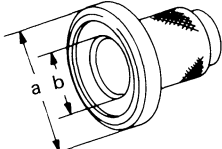
PREPARATION

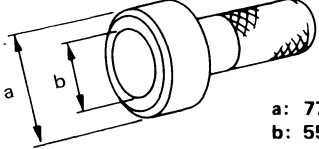
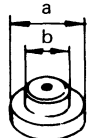
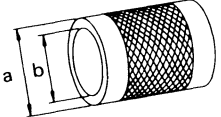
Tool number (Kent-Moore No.) Tool name	Description
ST3340001 (J26082) Drift	 <p>a: 60 mm (2.36 in) dia. b: 47 mm (1.85 in) dia.</p>
ST33290001 (J25810-A) Puller	
ST30720000 (-) Drift	 <p>a: 77 mm (3.03 in) dia. b: 55.5 mm (2.185 in) dia.</p>
ST30613000 (J25742-3) Drift	 <p>a: 71.5 mm (2.815 in) dia. b: 47.5 mm (1.870 in) dia.</p>
ST33200000 (J26082) Drift	 <p>a: 60 mm (2.36 in) dia. b: 44.5 mm (1.752 in) dia.</p>

COMMERCIAL SERVICE TOOL

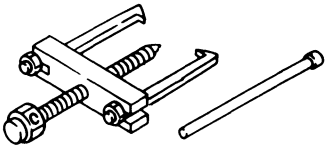
Tool name	Description
Puller	 <p>Removing counter bearings, counter drive and O.D. gears</p>

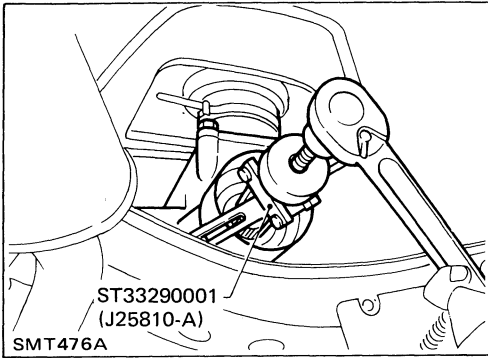

Replacing Rear Oil Seal
REMOVAL

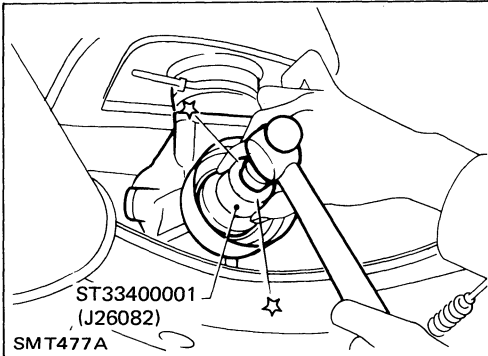

INSTALLATION

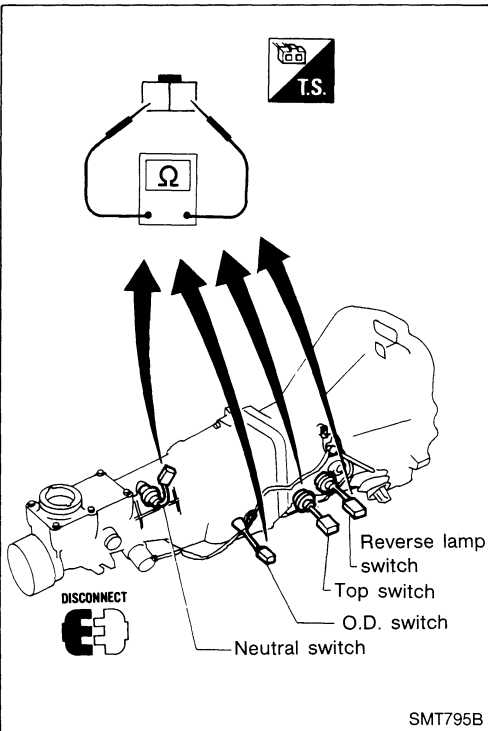

Check of Position Switch
REVERSE LAMP SWITCH

- Check continuity.

Gear position	Continuity
Reverse	Yes
Except reverse	No

NEUTRAL SWITCH

- Check continuity.

Gear position	Continuity
Neutral	Yes
Except neutral	No

TOP (4th) SWITCH

- Check continuity.

Gear position	Continuity
4th	Yes
Except 4th	No

ON-VEHICLE SERVICE

Check of Position Switch (Cont'd)

O.D. (5th) SWITCH

- Check continuity.

Gear position	Continuity
5th	Yes
Except 5th	No

REMOVAL AND INSTALLATION

Removal

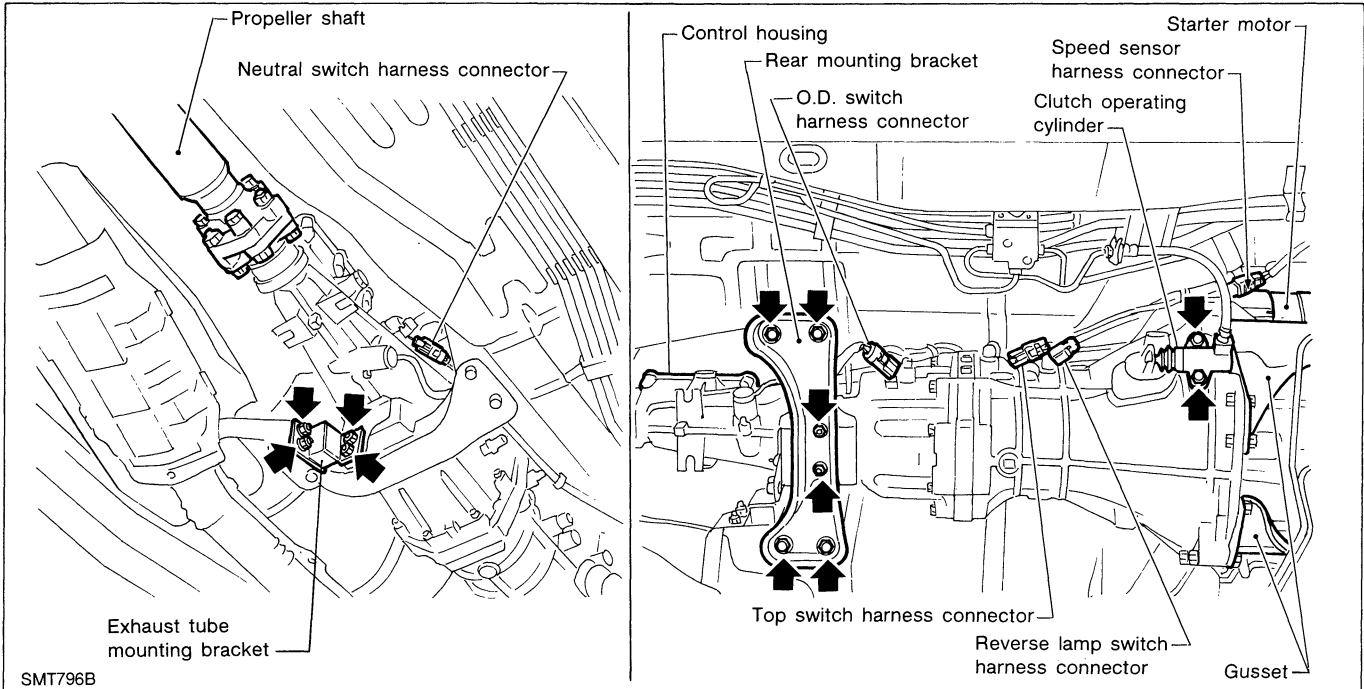

- Remove clutch operating cylinder from transmission.
- Disconnect speed sensor, O.D. switch top (4th) switch, reverse lamp switch and neutral switch harness connectors.
- Remove starter motor from transmission.
- Remove propeller shaft. — Refer to section PD.
- **Insert plug into rear oil seal after removing propeller shaft.**
- **Be careful not to damage spline, sleeve yoke and rear oil seal when removing propeller shaft.**
- Remove exhaust tube mounting bracket from transmission.
- Support manual transmission with a jack.
- Remove rear mounting bracket.
- Lower manual transmission as much as possible.
- Remove shift lever with control housing from transmission.

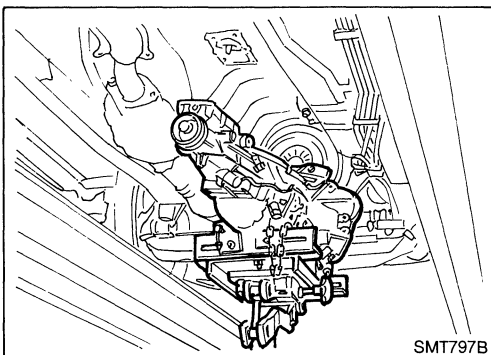

- Remove gussets and transmission fixing bolts.
- Remove transmission from engine.
- **Support manual transmission while removing it.**

REMOVAL AND INSTALLATION

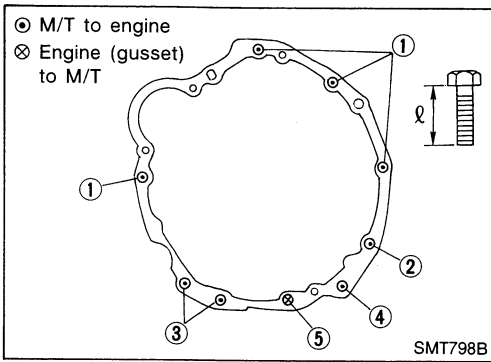

Installation

- Tighten transmission fixing bolts.

Bolt No.	Tightening torque N·m (kg·m, ft·lb)	ℓ mm (in)
①	39 - 49 (4.0 - 5.0, 29 - 36)	60 (2.36)
②	39 - 49 (4.0 - 5.0, 29 - 36)	70 (2.76)
③ *	29 - 39 (3.0 - 4.0, 22 - 29)	35 (1.38)
④ *	29 - 39 (3.0 - 4.0, 22 - 29)	65 (2.56)
⑤	29 - 39 (3.0 - 4.0, 22 - 29)	25 (0.98)
Gusset to engine	29 - 39 (3.0 - 4.0, 22 - 29)	20 (0.79)

*: With nut.

- Install any part removed.

MAJOR OVERHAUL

Case Components

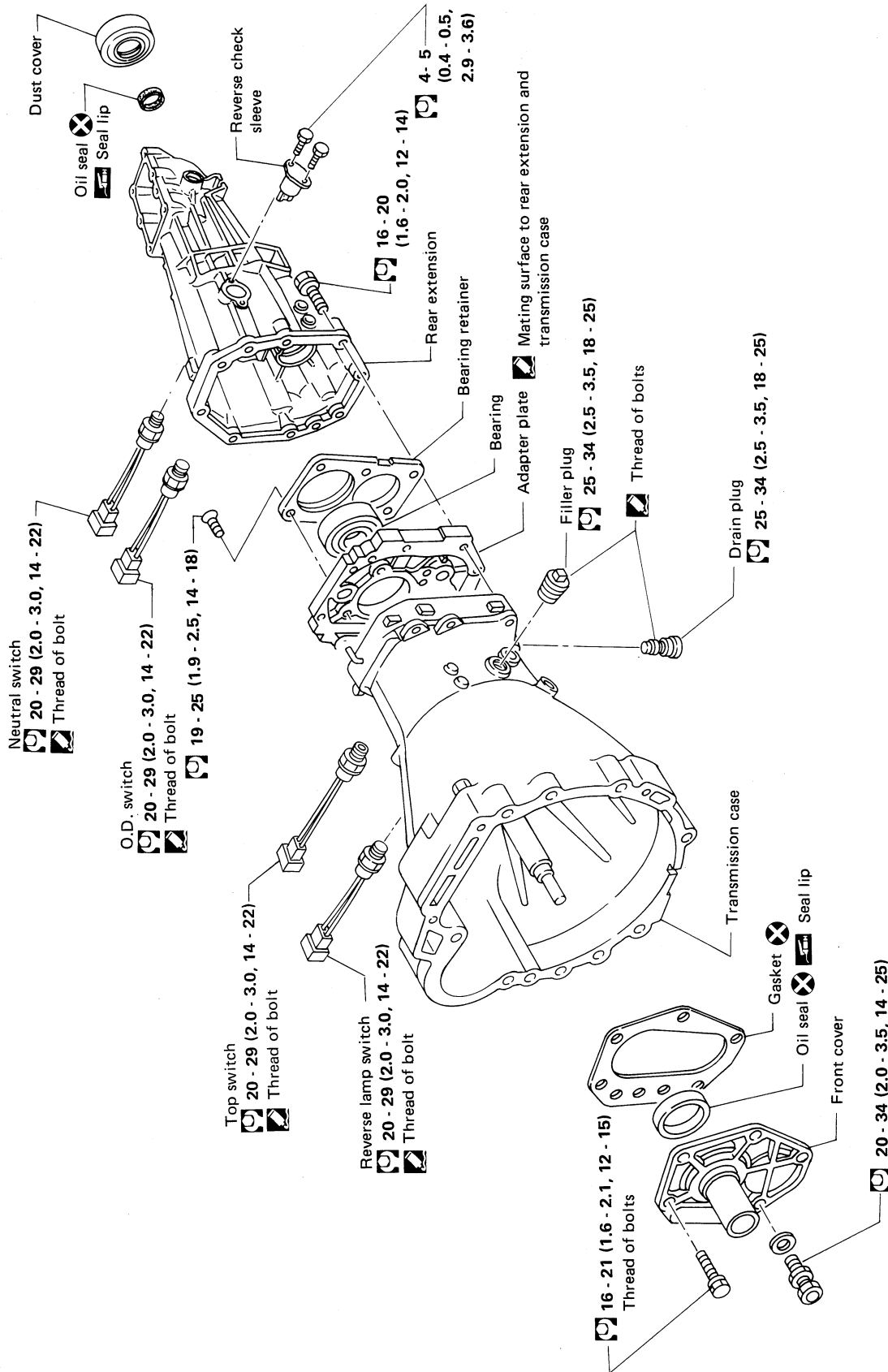

[Symbol] : N·m (kg·m, ft·lb)
 [Symbol] : Apply recommended sealant (Nissan genuine part: K-P610-00250) or equivalent.

MAJOR OVERHAUL

Gear Components

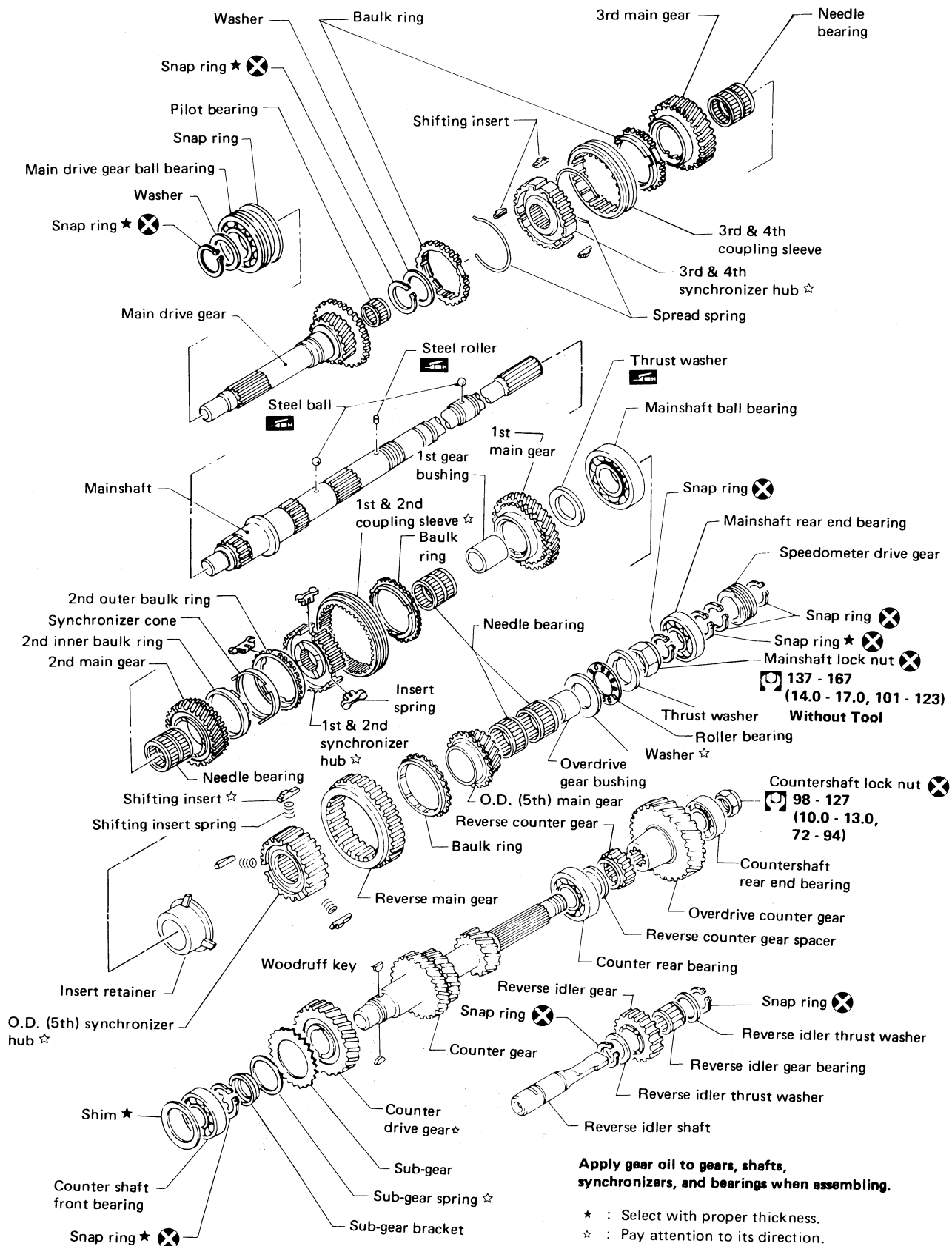

Apply gear oil to gears, shafts, synchronizers, and bearings when assembling.

★ : Select with proper thickness.

☆ : Pay attention to its direction.

⊗ : N·m (kg·m, ft·lb)

SMT037B

DISASSEMBLY

Case Components

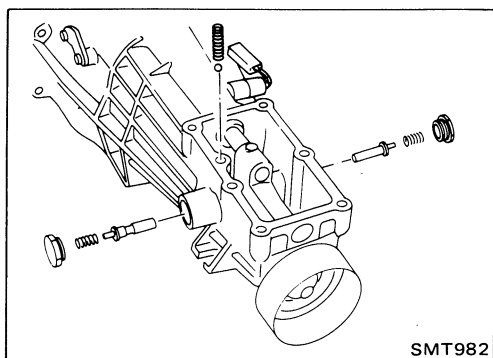

1. Remove rear extension.
 - a. Remove control housing, check ball, return spring plug, select check plunger and return springs.

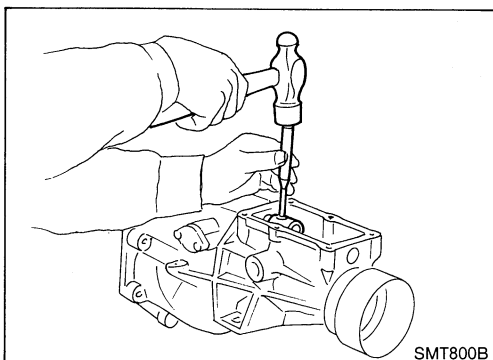

- b. Drive out striking arm retaining pin.
 - c. Remove striking arm from striking rod.

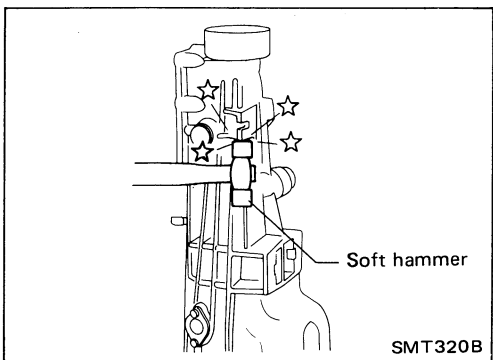

- d. Remove rear extension by lightly tapping it.

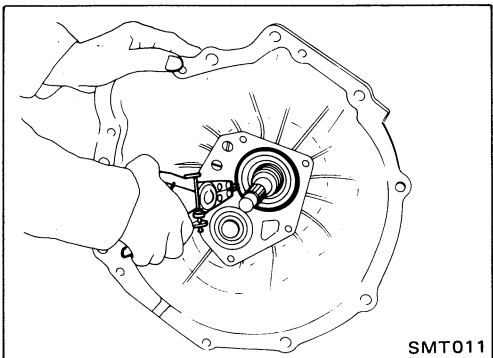

2. Remove front cover, gasket, shim of countershaft front bearing, and snap ring of main drive gear ball bearing.

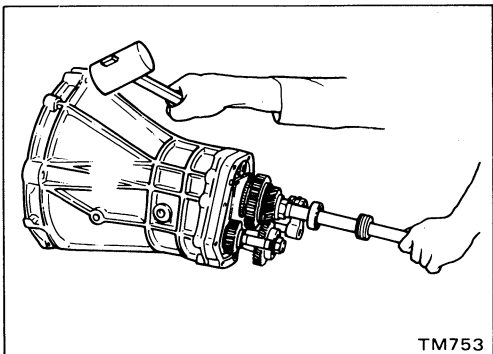

3. Remove transmission case by tapping lightly.

DISASSEMBLY

Case Components (Cont'd)

4. Remove front cover oil seal.

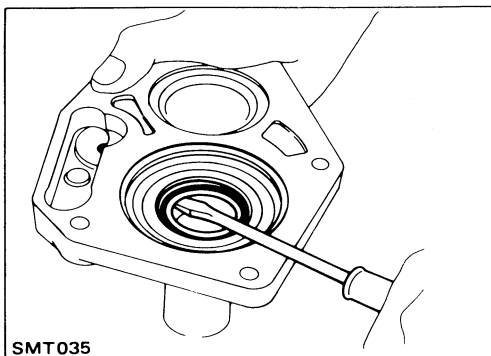

SMT035

Shift Control Components

1. Set up Tool on adapter plate.
2. Remove striking rod from adapter plate.
3. Remove check ball plugs, check springs, and check balls.

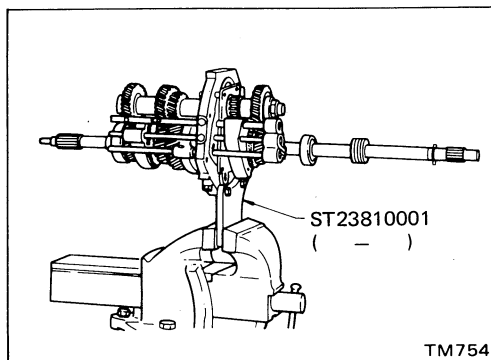

TM754

4. Drive out retaining pins. Then drive out fork rods and remove interlock balls.

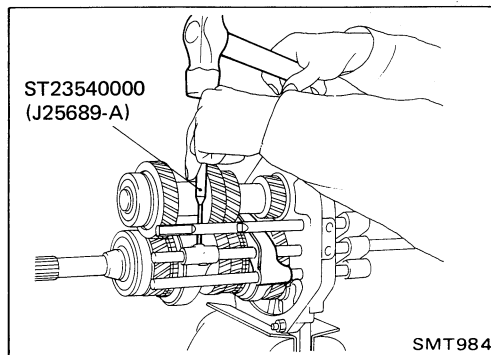

SMT984

5. Remove lever bracket securing bolt.

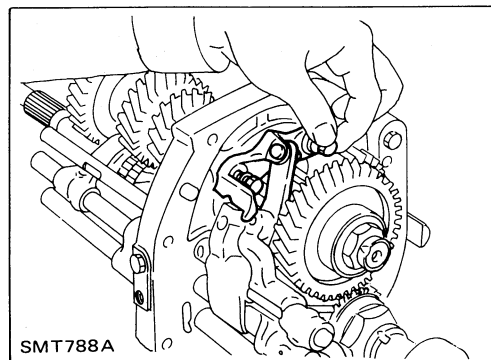

SMT788A

6. Draw out 3rd-4th fork rod.

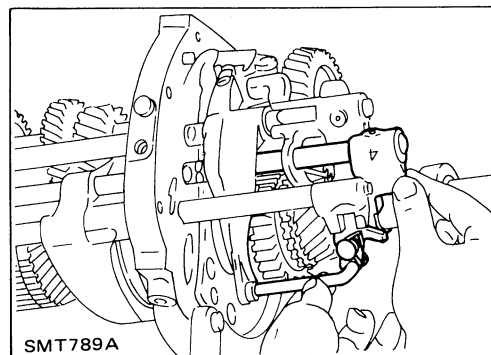

SMT789A

DISASSEMBLY

Shift Control Components (Cont'd)

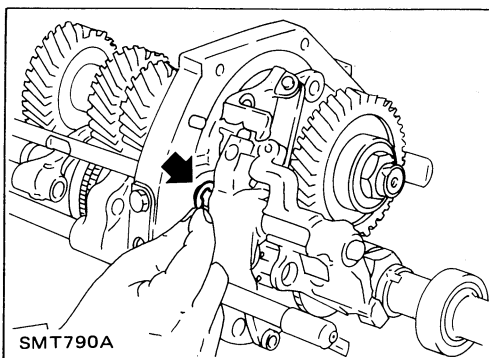

7. Remove E-ring from O.D. and reverse fork rod.

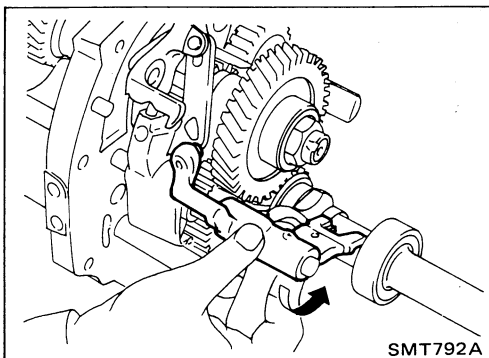

8. Draw out O.D. and reverse fork shaft by rotating O.D. and reverse bracket counterclockwise.

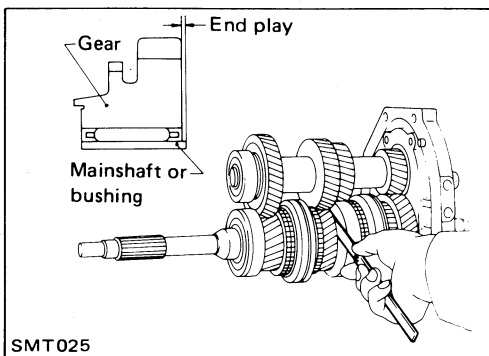

Gear Components

1. Before removing gears and shafts, measure each gear end play.

Gear end play: Refer to S.D.S.

If not within specification, disassemble and check contact surface of gear to hub, washer, bushing, needle bearing and shaft.

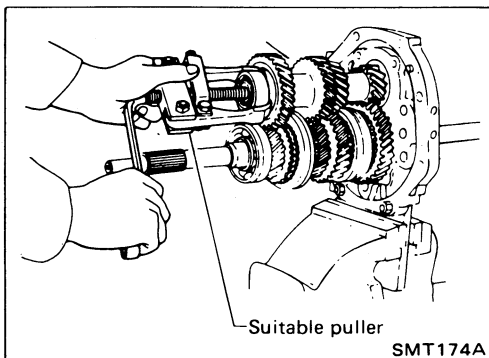

2. Mesh 2nd and reverse gear, then draw out counter front bearing with suitable puller.
3. Remove snap ring and then remove sub-gear bracket, sub-gear spring and sub-gear.

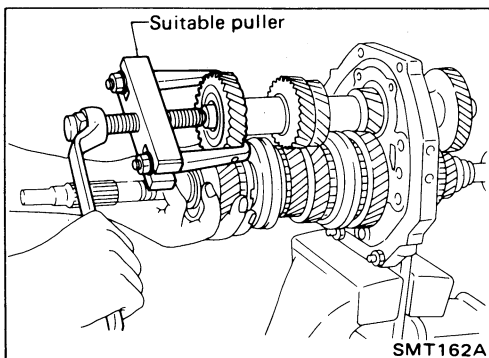

4. Draw out counter drive gear with main drive gear assembly with suitable puller.
- **When drawing out main drive gear assembly, be careful not to drop pilot bearing and baulk ring.**

DISASSEMBLY

Gear Components (Cont'd)

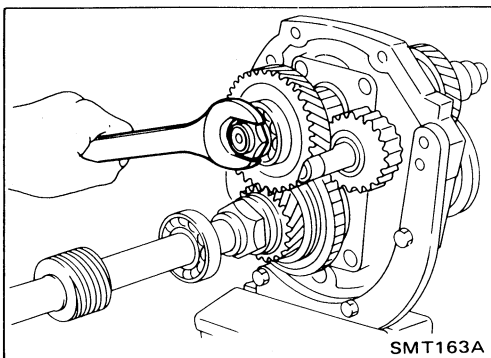

5. Remove rear side components on mainshaft and counter gear.
 - a. Release staking on countershaft nut and mainshaft nut and loosen these nuts.

Mainshaft nut: Left-hand thread

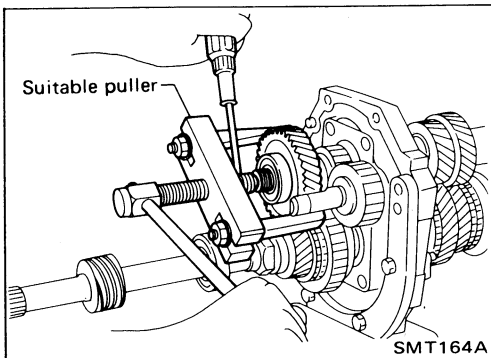

- b. Pull out O.D. counter gear with bearing with suitable puller.
 - c. Draw out reverse counter gear and spacer.
 - d. Remove snap rings from reverse idler shaft and draw out reverse idler gear, thrust washers and reverse idler gear bearing.
 - e. Remove speedometer drive gear and steel ball.

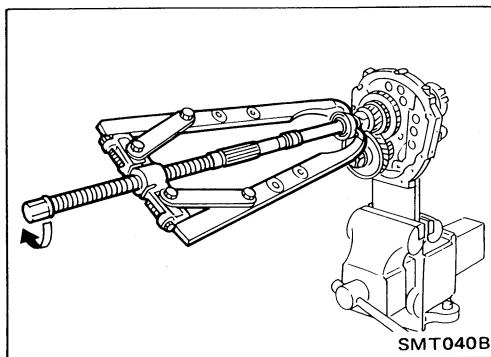

- f. Remove snap ring and pull out overdrive mainshaft bearing, then remove snap ring.
 - g. Remove mainshaft nut.
 - h. Remove steel roller and washer.
 - i. Remove roller bearing and washer.
 - j. Remove O.D. main gear, needle bearing and baulk ring (O.D.).
 - k. Remove O.D. coupling sleeve, shifting inserts and shifting insert springs.

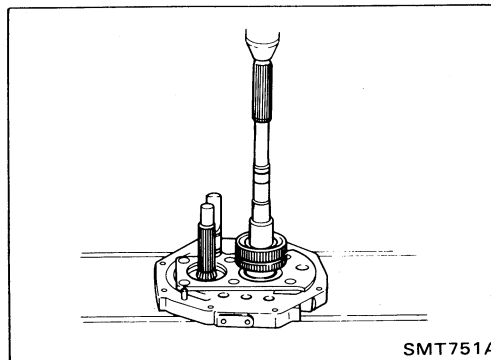

- l. Press out mainshaft and counter gear alternately.
 - **Make sure to alternate pressing of mainshaft and counter gear so as not to allow the front surface of one to contact the rear surface of the other.**

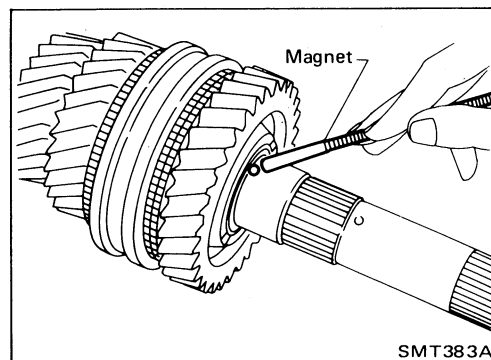

6. Remove front side components on mainshaft.
 - a. Remove 1st gear washer and steel ball.
 - b. Remove 1st main gear and 1st gear needle bearing.

DISASSEMBLY

Gear Components (Cont'd)

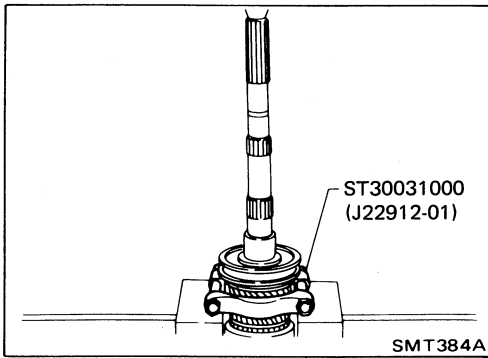

- c. Press out 2nd main gear together with 1st gear bushing and 1st & 2nd synchronizer assembly.
- d. Remove mainshaft front snap ring.

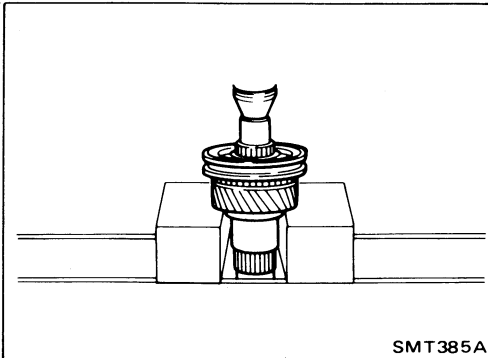

- e. Press out 3rd main gear together with 3rd & 4th synchronizer assembly and 3rd gear needle bearing.

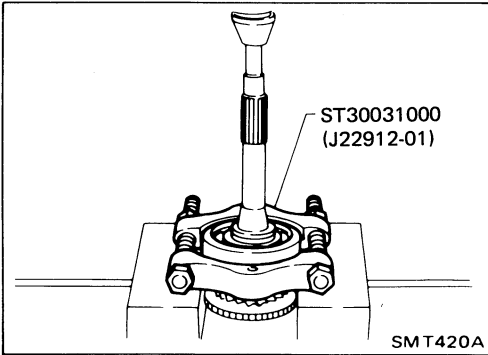

7. Remove main drive gear bearing.
 - a. Remove main drive gear snap ring and spacer.
 - b. Press out main drive gear bearing.

INSPECTION

Shift Control Components

- Check contact surface and sliding surface for wear, scratches, projections or other damage.

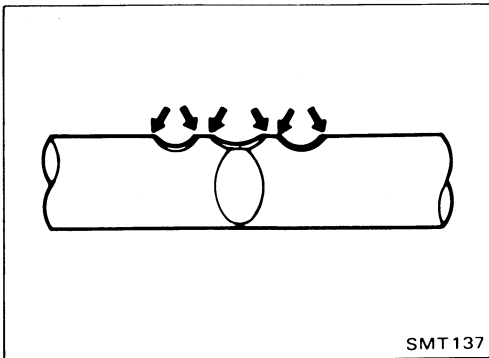

Gear Components

GEAR AND SHAFT

- Check shafts for cracks, wear or bending.
- Check gears for excessive wear, chips or cracks.

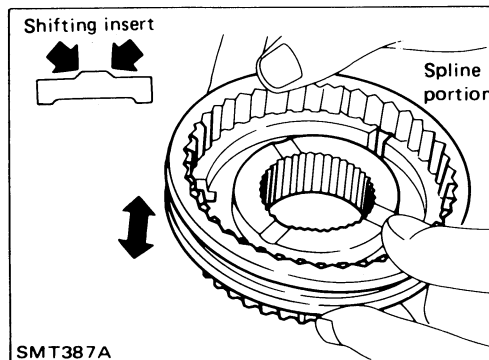
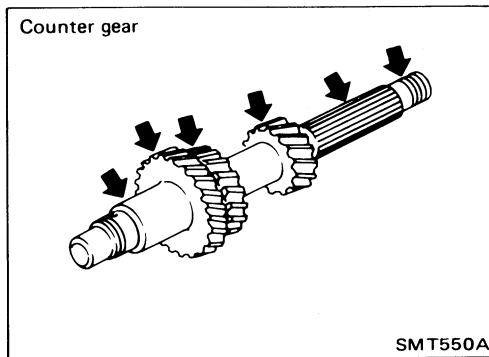
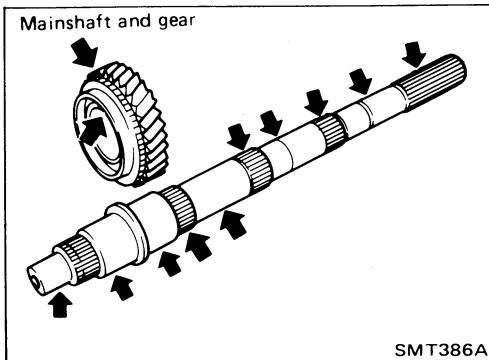

SYNCHRONIZERS

- Check spline portion of coupling sleeves, hubs and gears for wear or cracks.
- Check baulk rings for cracks or deformation.
- Check shifting inserts for wear or deformation.
- Check insert springs for deformation.

INSPECTION

Gear Components (Cont'd)

- Measure clearance between baulk ring and gear.

Clearance between baulk ring and gear (1st, 3rd, main drive and O.D. baulk ring):

Unit: mm (in)

Dimension	Standard	Wear limit
1st	1.2 - 1.6 (0.047 - 0.063)	0.8 (0.031)
3rd and main drive	1.2 - 1.6 (0.047 - 0.063)	
O.D.	1.2 - 1.4 (0.047 - 0.055)	

If the clearance is smaller than the wear limit, replace baulk ring.

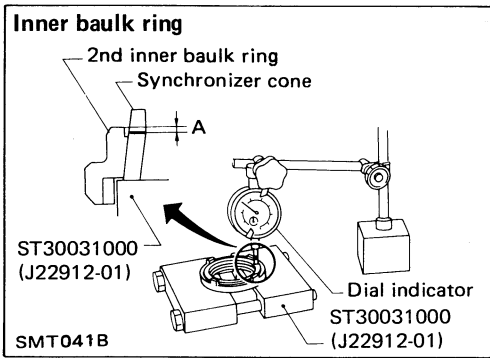
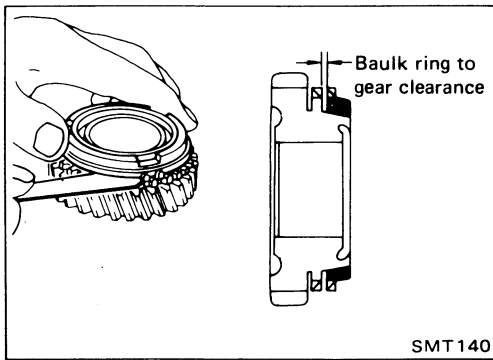

- Measure wear of 2nd baulk ring.

- Place baulk rings in position on synchronizer cone.
- While holding baulk rings against synchronizer cone as far as it will go, measure dimensions "A" and "B".

Unit: mm (in)

Dimension	Standard	Wear limit
A	0.6 - 1.1 (0.024 - 0.043)	0.2 (0.008)
B	0.7 - 0.9 (0.028 - 0.035)	

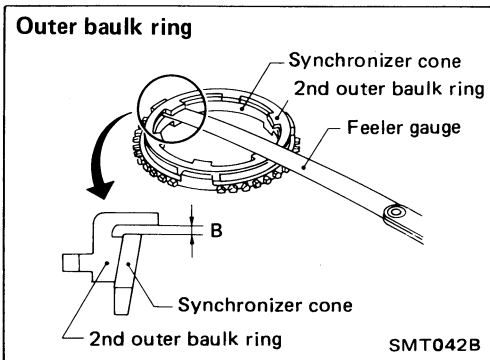

- If dimension "A" or "B" is smaller than the wear limit, replace baulk ring.

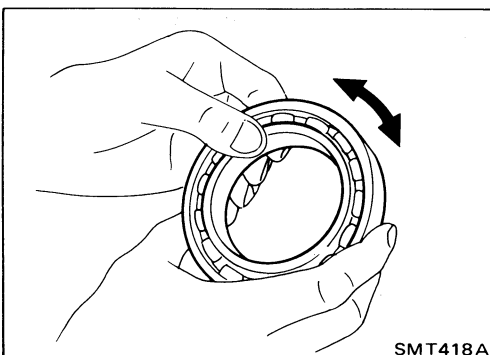

BEARINGS

- Make sure bearings roll freely and are free from noise, crack, pitting or wear.

ASSEMBLY

Gear Components

1. Install bearings into case components.

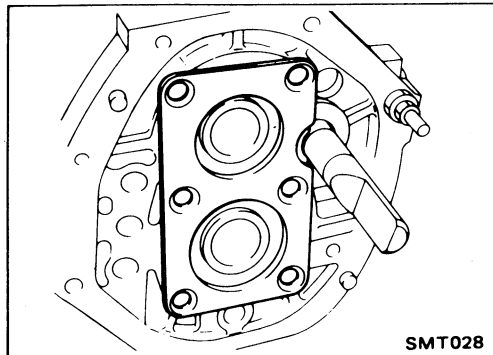
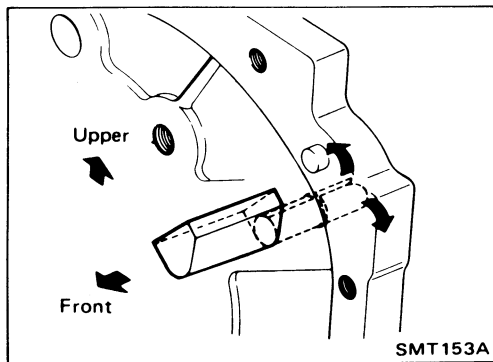
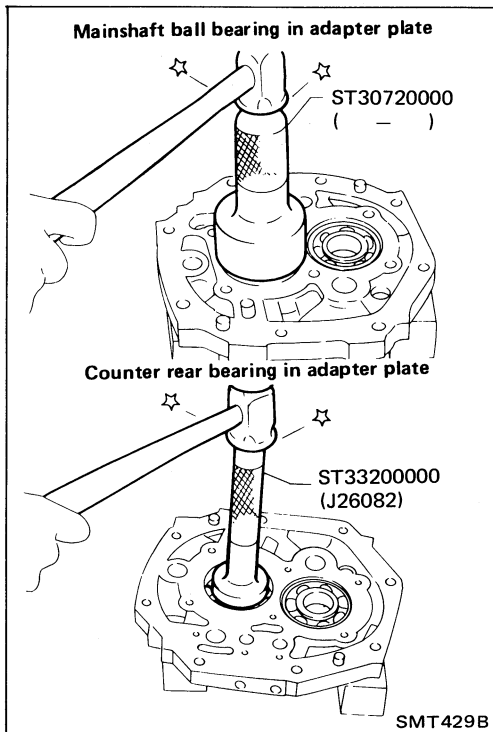

2. Assemble adapter plate parts.

- Install oil gutter on adapter plate and expand on rear side.

- Install bearing retainer.

a. Insert reverse shaft, then install bearing retainer.

b. Tighten each screw, then stake each at two points.

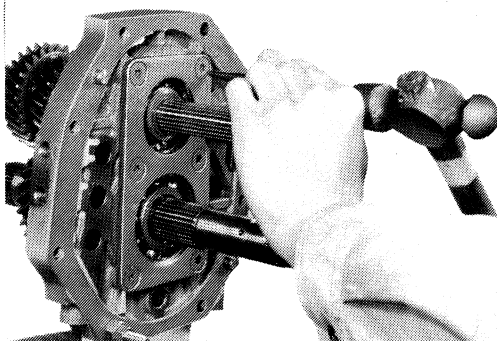

ASSEMBLY

Gear Components (Cont'd)

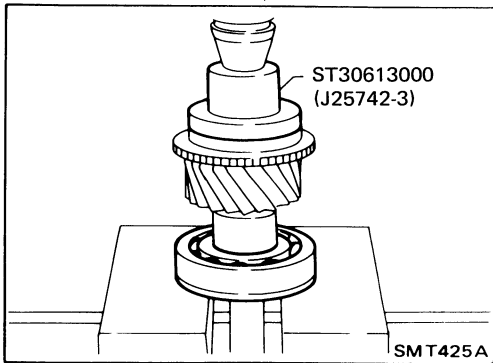

3. Install main drive gear bearing.
 - a. Press main drive gear bearing.
 - b. Install main drive gear spacer.

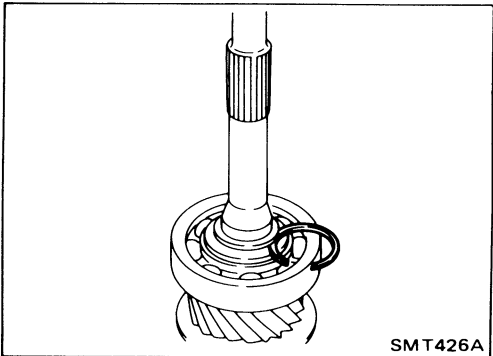

- c. Select proper main drive gear snap ring to minimize clearance of groove and install it.

Allowable clearance of groove:

0 - 0.13 mm (0 - 0.0051 in)

Main drive gear snap ring:

Refer to S.D.S.

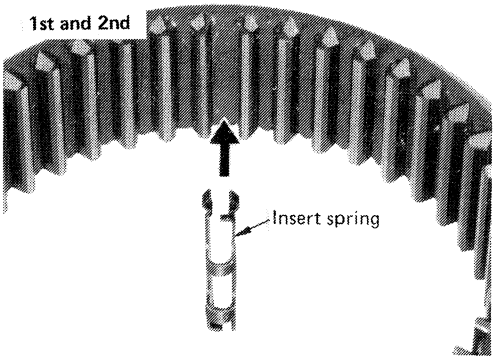

4. Assemble synchronizers.
 - 1st & 2nd synchronizer

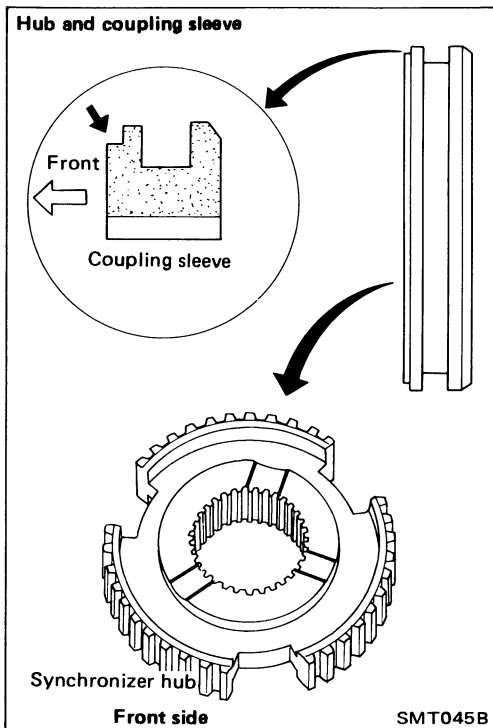

- Check coupling sleeve and synchronizer hub orientation.

ASSEMBLY

Gear Components (Cont'd)

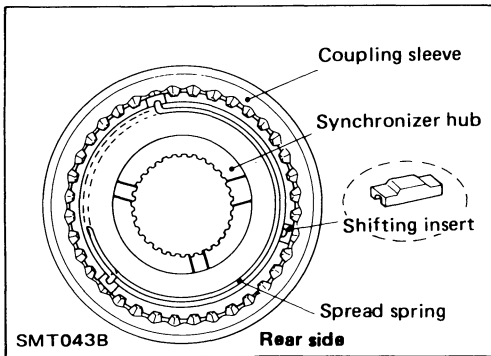
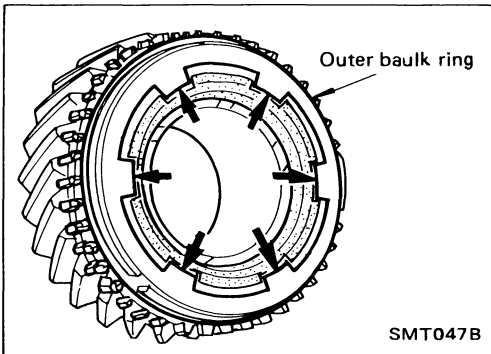
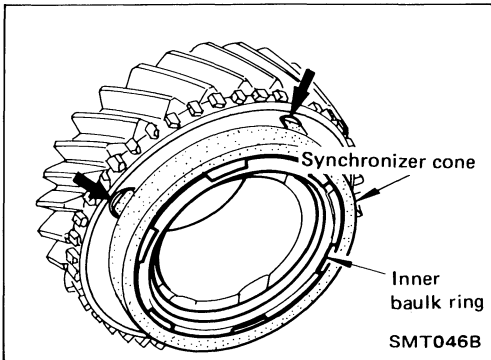

- 3rd & 4th synchronizer

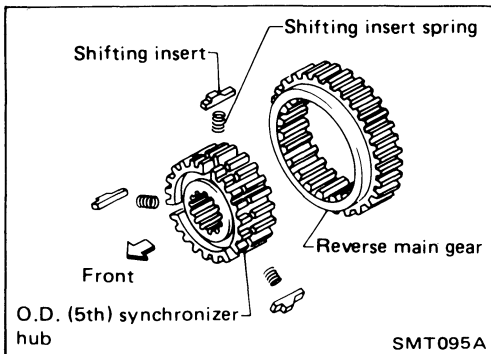

- O.D. synchronizer

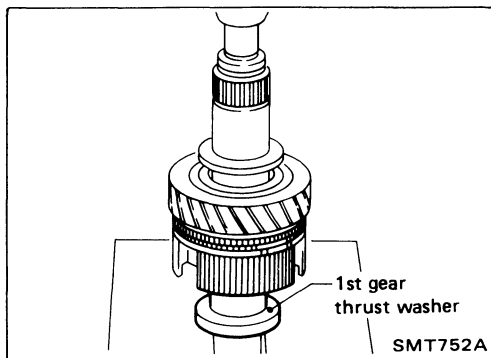

5. Install front side components on main shaft.
 - a. Assemble 2nd main gear, needle bearing and 1st & 2nd synchronizer assembly, then press 1st gear bushing on mainshaft.
 - b. Install 1st main gear.

ASSEMBLY

Gear Components (Cont'd)

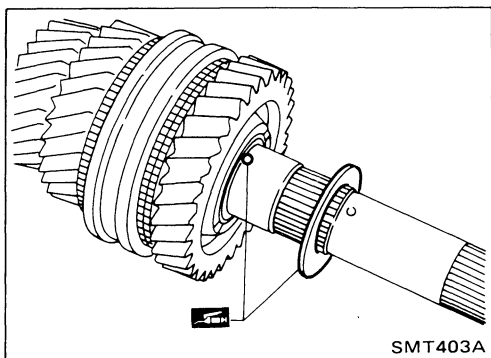

- c. Install steel ball and 1st gear washer.
Apply multi-purpose grease to steel ball and 1st gear washer before installing.

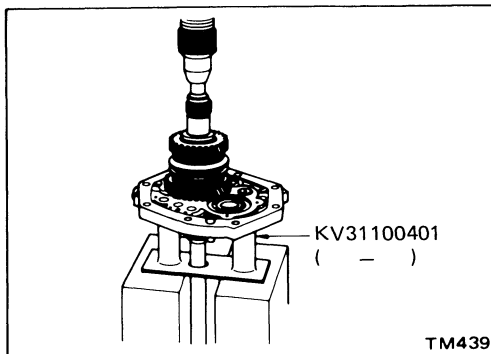

6. Install mainshaft and counter gear on adapter plate and main drive gear on mainshaft.
 a. Press mainshaft assembly to adapter plate with Tool.

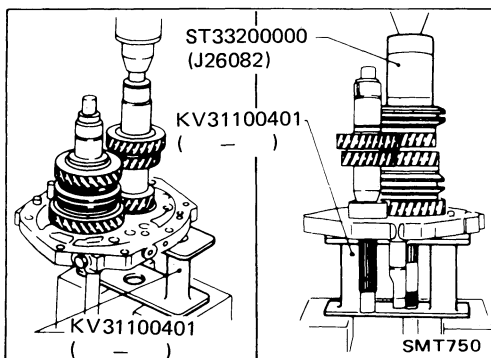

- b. Press counter gear into adapter plate with Tool.
 c. Install 3rd main gear and then press 3rd & 4th synchronizer assembly.

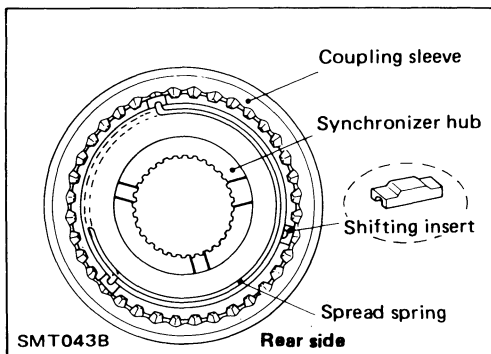

- Pay attention to direction of 3rd & 4th synchronizer.

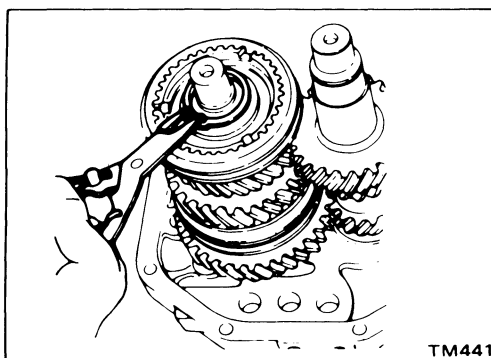

- d. Install thrust washer on mainshaft and secure it with mainshaft front snap ring.
 Select proper snap ring to minimize clearance of groove in mainshaft.

Allowable clearance of groove:
 0 - 0.18 mm (0 - 0.0071 in)

Mainshaft front snap ring:
 Refer to S.D.S.

- e. Apply gear oil to mainshaft pilot bearing and install it on mainshaft.

ASSEMBLY

Gear Components (Cont'd)

- f. Press counter drive gear with main drive gear with Tool.

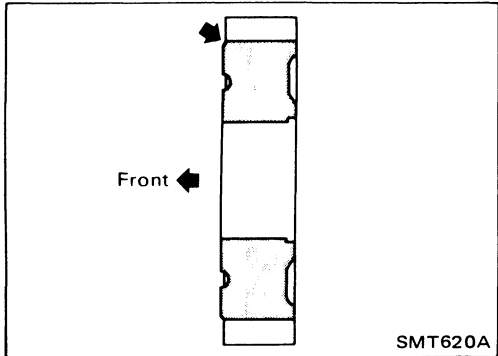
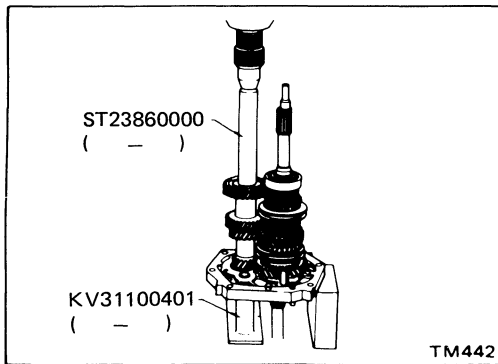

- Pay attention to direction of counter drive gear.

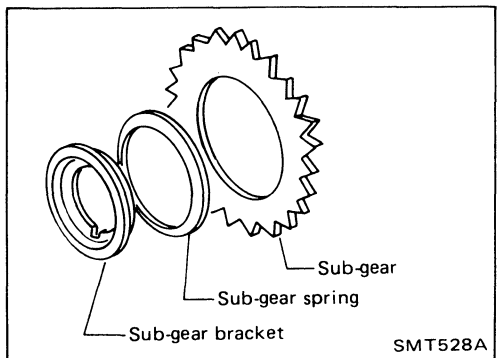

- g. Install sub-gear components.

- (1) Install sub-gear and sub-gear bracket on counter drive gear and then select proper snap ring to minimize clearance of groove in counter gear.

Allowable clearance of groove:

0 - 0.18 mm (0 - 0.0071 in)

Counter drive gear snap ring: Refer to S.D.S.

- (2) Remove snap ring, sub-gear bracket and sub-gear from counter gear.
- (3) Reinstall sub-gear, sub-gear spring and sub-gear bracket.

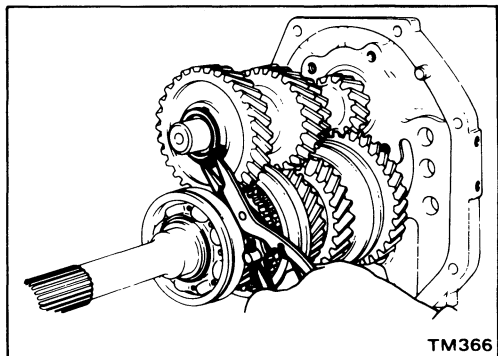

- h. Install selected counter drive gear snap ring.

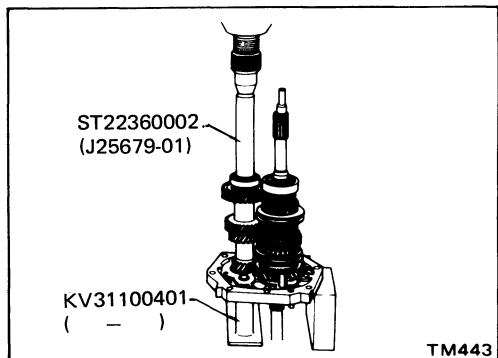

- i. Press counter gear front bearing onto counter gear.

ASSEMBLY

Gear Components (Cont'd)

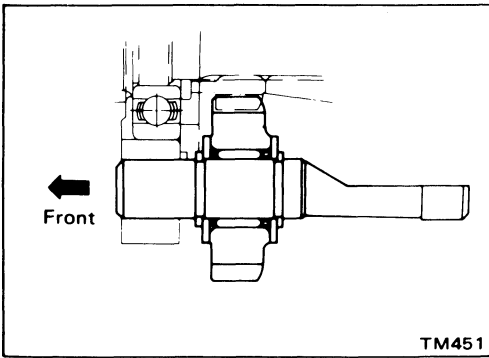

7. Install rear side components on mainshaft and counter gear.
 - a. Install reverse idler gear to reverse idler shaft with spacers, snap rings and needle bearing.

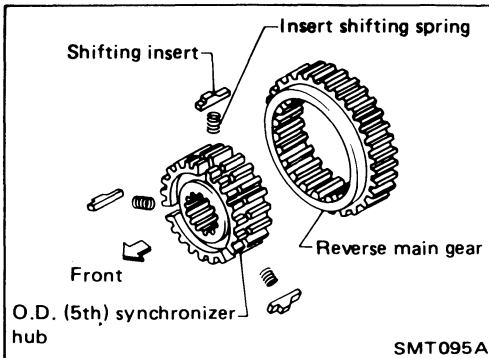

- b. Install insert retainer and O.D. synchronizer to mainshaft.
 - **Pay attention to direction of hub.**

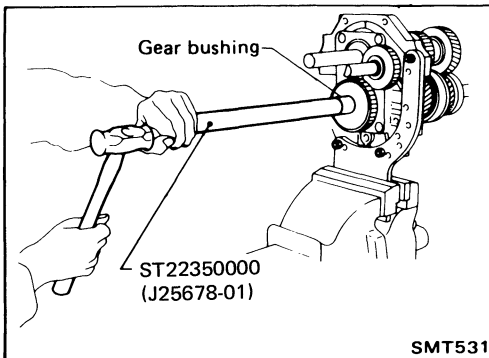

- c. Install O.D. gear bushing with Tool.
 - d. Install O.D. main gear and needle bearing.
 - e. Install spacer, reverse counter gear and O.D. counter gear.
 - **O.D. main gear and O.D. counter gear should be handled as a matched set.**
 - f. Install washer, roller bearing, steel roller and thrust washer.
 - g. Tighten mainshaft lock nut temporarily.
 - **Always use new lock nut.**

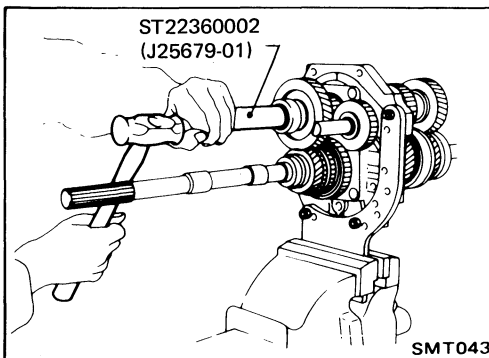

- h. Install countershaft rear end bearing with Tool.

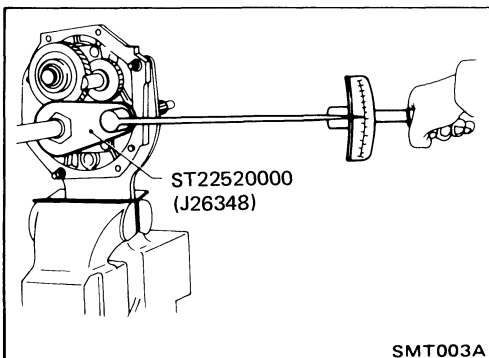

8. Mesh 2nd and reverse gears, then tighten mainshaft lock nut with Tool.

ASSEMBLY

Gear Components (Cont'd)

- Use the left chart when deciding the reading torque. (Length of torque wrench vs. setting or reading torque)
- 9. Tighten countershaft lock nut.
- **Always use new lock nut.**

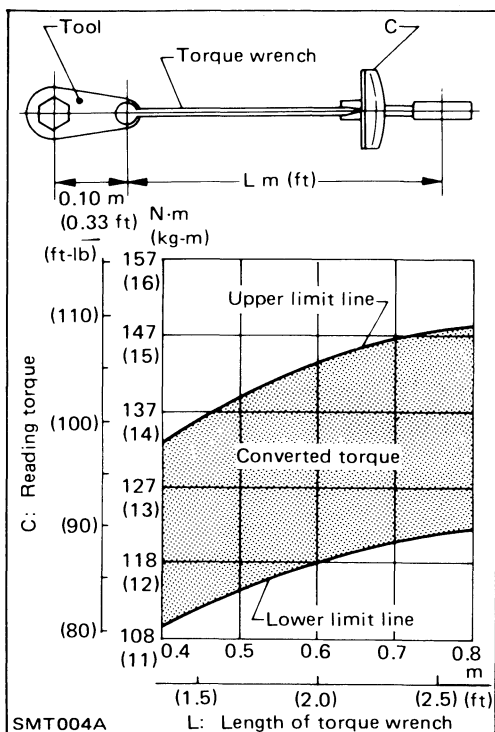

Mainshaft

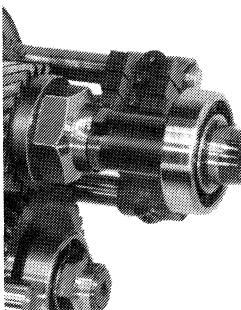

Countershaft

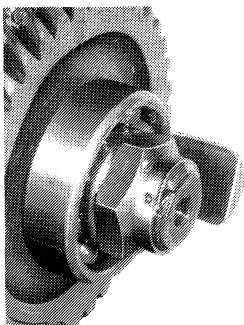

10. Stake mainshaft lock nut and countershaft lock nut with a punch.
11. Measure gear end play. For the description, refer to DIS-ASSEMBLY for Gear Components.

Shift Control Components

1. Install shift rods, interlock plunger, interlock balls and check balls.

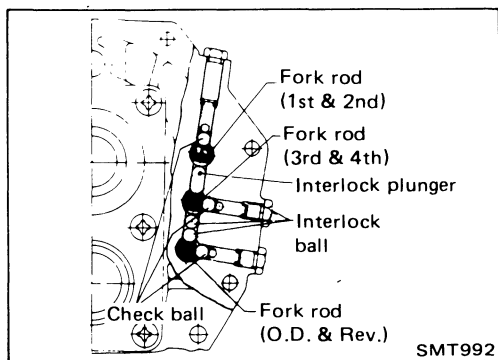

- a. 1st-2nd shift fork

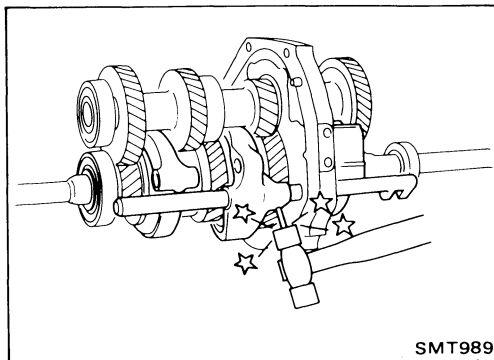

ASSEMBLY

Shift Control Components (Cont'd)

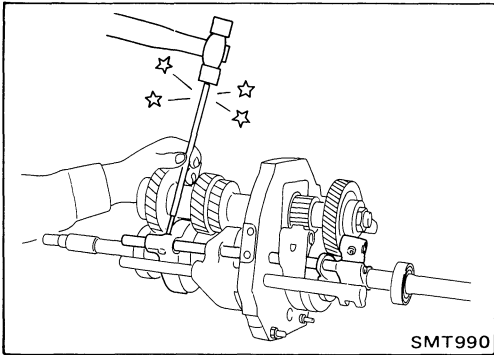

b. 3rd-4th shift fork

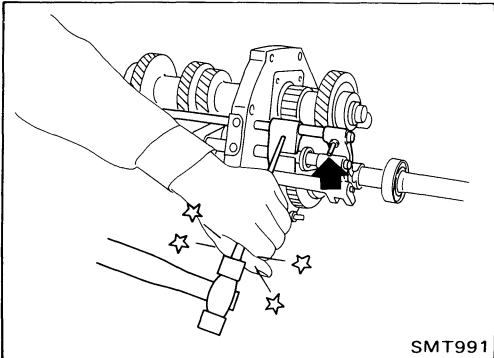

c. O.D.-reverse shift fork or reverse shift fork.

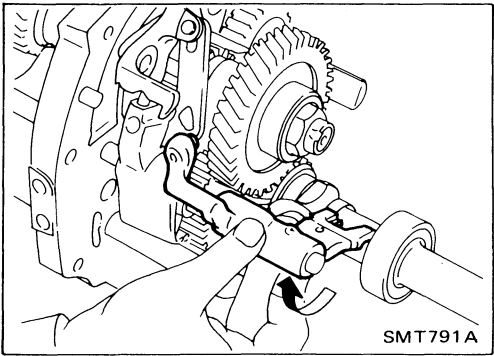

2. Install O.D. and reverse fork shaft by rotating O.D. and reverse bracket clockwise.

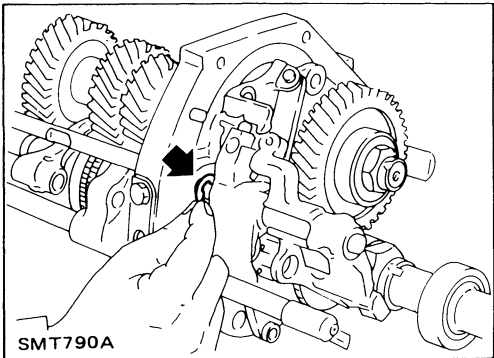

3. Install E-ring on O.D. and reverse fork rod.

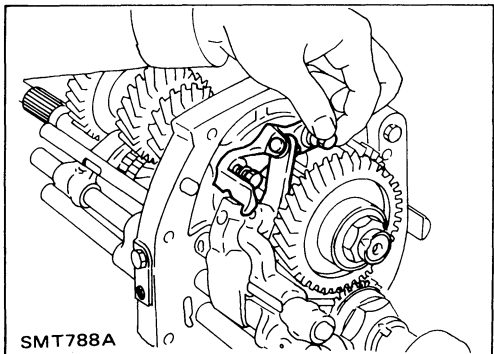

4. Install lever bracket securing bolt.

ASSEMBLY

Case Components

1. Install front cover oil seal.
 - Apply multi-purpose grease to seal lip of oil seal before installing.

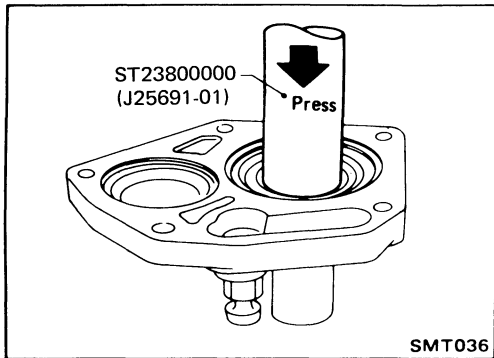

2. Apply sealant to mating surface of transmission case.

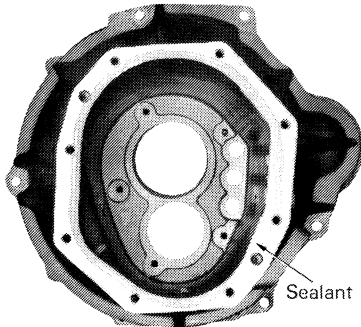

3. Install gear assembly onto transmission case.

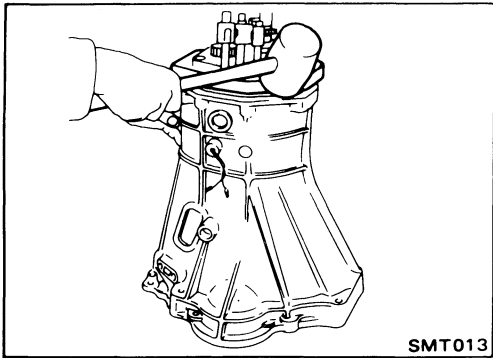

4. Install snap ring of main drive bearing.

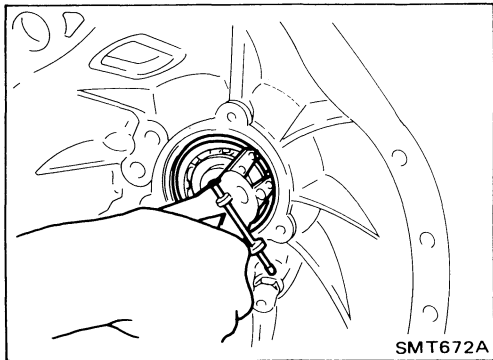

5. Set 1st & 2nd, 3rd & 4th and 5th & reverse shift forks in neutral position.
6. Install striking rod onto adapter plate while aligning striking lever with shift brackets.

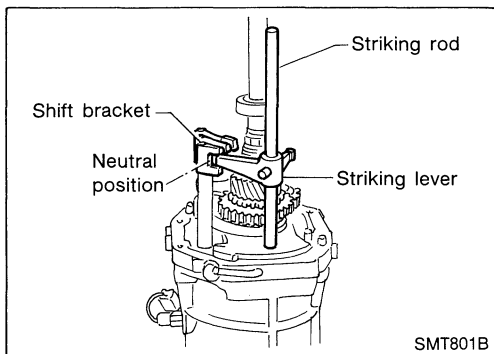

ASSEMBLY

Case Components (Cont'd)

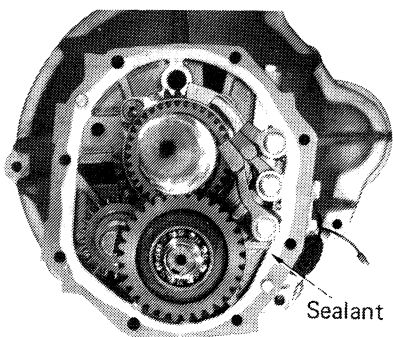

7. Apply sealant to mating surface of adapter plate.
8. Install rear extension while inserting striking arm into striking rod.

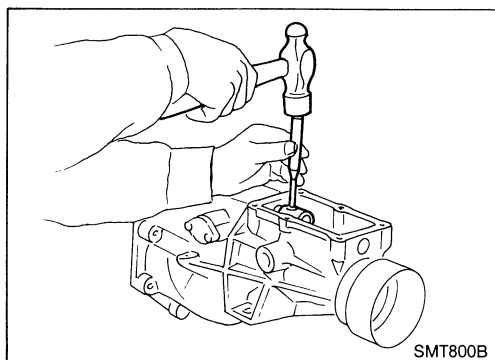

9. Install striking arm retaining pin.

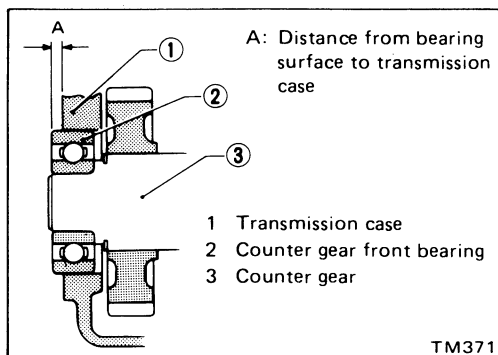

10. Select counter front bearing shim.
Counter front bearing shim: Refer to S.D.S.
11. Install gasket and front cover.

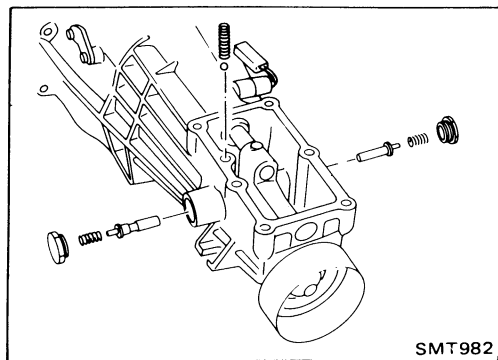

12. Install return spring plugs, check ball, return springs and select check plunger.
13. Install control housing and gasket.

SERVICE DATA AND SPECIFICATIONS (S.D.S)

General Specifications

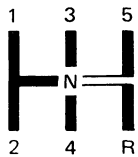
Transmission model		FS5W71C	
Number of speeds		5	
Shift pattern			
Synchronesh type		Warner	
Gear ratio	1st	3.321	
	2nd	1.902	
	3rd	1.308	
	4th	1.000	
	O.D.	0.759	
	Reverse	3.382	
Number of teeth	Mainshaft	Drive	22
		1st	33
		2nd	27
		3rd	26
		O.D.	21
		Reverse	36
		Countershaft	Drive
1st	14		
2nd	20		
3rd	28		
O.D.	39		
Reverse	15		
Reverse idler gear		21	
Oil capacity ℓ (US pt, Imp pt)		2.4 (5-1/8, 4-1/4)	
Remarks	Sub-gear	○	
	Mainshaft braking mechanism	○	
	Double baulk ring type synchronizer	2nd synchronizer	

SERVICE DATA AND SPECIFICATIONS (S.D.S)

Inspection and Adjustment

GEAR END PLAY

Gear	End play mm (in)
1st gear	0.31 - 0.41 (0.0122 - 0.0161)
2nd gear	0.11 - 0.21 (0.0043 - 0.0083)
3rd gear	0.11 - 0.21 (0.0043 - 0.0083)
O.D. gear	0.24 - 0.41 (0.0094 - 0.0161)

CLEARANCE BETWEEN BAULK RING AND GEAR

1st, 3rd, main drive and O.D. baulk ring

Unit: mm (in)

	Standard	Wear limit
1st	1.2 - 1.6 (0.047 - 0.063)	0.8 (0.031)
3rd and main drive	1.2 - 1.6 (0.047 - 0.063)	
O.D.	1.2 - 1.4 (0.047 - 0.055)	

2nd baulk ring

Unit: mm (in)

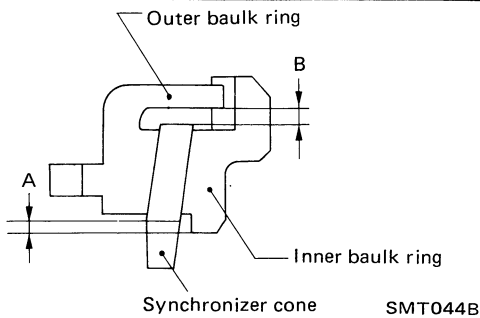

Dimension	Standard	Wear limit
A	0.6 - 1.1 (0.024 - 0.043)	0.2 (0.008)
B	0.7 - 0.9 (0.028 - 0.035)	

AVAILABLE SNAP RINGS

Main drive gear bearing

Allowable clearance 0 - 0.13 mm (0 - 0.0051 in)

Thickness mm (in)	Part number
1.73 (0.0681)	32204-78005
1.80 (0.0709)	32204-78000
1.87 (0.0736)	32204-78001
1.94 (0.0764)	32204-78002
2.01 (0.0791)	32204-78003
2.08 (0.0819)	32204-78004

Mainshaft front

Allowable clearance 0 - 0.18 mm (0 - 0.0071 in)

Thickness mm (in)	Part number
2.4 (0.094)	32263-V5200
2.5 (0.098)	32263-V5201
2.6 (0.102)	32263-V5202

Mainshaft rear end bearing

Allowable clearance 0 - 0.14 mm (0 - 0.0055 in)

Thickness mm (in)	Part number
1.1 (0.043)	32228-20100
1.2 (0.047)	32228-20101
1.3 (0.051)	32228-20102
1.4 (0.055)	32228-20103

Counter drive gear

Allowable clearance 0 - 0.18 mm (0 - 0.0071 in)

Thickness mm (in)	Part number
1.4 (0.055)	32215-E9000
1.5 (0.059)	32215-E9001
1.6 (0.063)	32215-E9002

AVAILABLE SHIMS

Counter front bearing

Unit: mm (in)

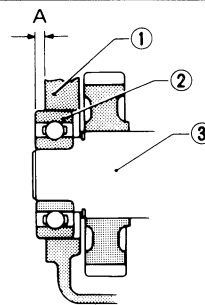

A: Distance from bearing surface to transmission case

- 1 Transmission case
- 2 Counter gear front bearing
- 3 Counter gear

TM371

"A"	Thickness of shim	Part number
4.52 - 4.71 (0.1780 - 0.1854)	Not necessary	
4.42 - 4.51 (0.1740 - 0.1776)	0.1 (0.004)	32218-V5000
4.32 - 4.41 (0.1701 - 0.1736)	0.2 (0.008)	32218-V5001
4.22 - 4.31 (0.1661 - 0.1697)	0.3 (0.012)	32218-V5002
4.12 - 4.21 (0.1622 - 0.1657)	0.4 (0.016)	32218-V5003
4.02 - 4.11 (0.1583 - 0.1618)	0.5 (0.020)	32218-V5004
3.92 - 4.01 (0.1543 - 0.1579)	0.6 (0.024)	32218-V5005

AUTOMATIC TRANSMISSION

SECTION **AT**

CONTENTS

PREPARATION	AT- 2
PRECAUTIONS	AT- 3
A/T CONTROL DIAGRAM	AT- 4
ON-VEHICLE SERVICE	AT- 7
TROUBLE DIAGNOSES	AT- 11
REMOVAL AND INSTALLATION	AT-103
MAJOR OVERHAUL	AT-106
DISASSEMBLY	AT-110
REPAIR FOR COMPONENT PARTS	AT-121
ASSEMBLY	AT-166
SERVICE DATA AND SPECIFICATIONS (S.D.S.)	AT-185

AT

When you read wiring diagrams:

- Read GI section, "HOW TO READ WIRING DIAGRAMS".
- See EL section, "POWER SUPPLY ROUTING" for power distribution circuit.

When you perform trouble diagnoses, read GI section, "HOW TO FOLLOW FLOW CHART IN TROUBLE DIAGNOSES".

PREPARATION

SPECIAL SERVICE TOOLS

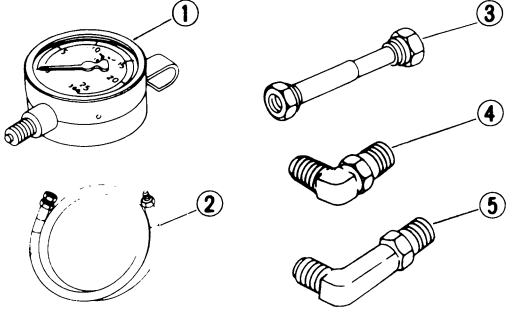
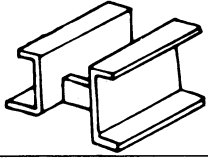
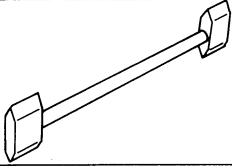
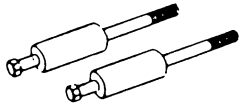
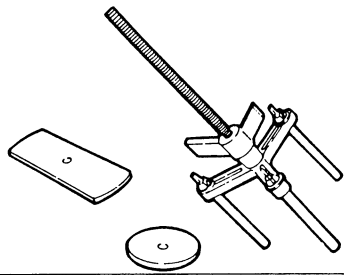
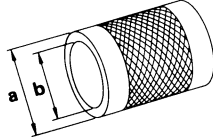
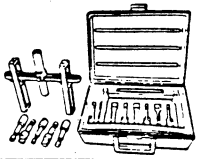
Tool number (Kent-Moore No.) Tool name	Description	
ST2505S001 (J25695-A) Oil pressure gauge set ① ST25051001 (-) Oil pressure gauge ② ST25052000 (-) Hose ③ ST25053000 (-) Joint pipe ④ ST25054000 (-) Adapter ⑤ ST25055000 (-) Adapter		Measuring line pressure
ST07870000 (J37068) Transmission case stand		Disassembling and assembling A/T
KV31102100 (J37065) Torque converter one-way clutch check tool		Checking one-way clutch in torque converter
ST25850000 (J25721-A) Sliding hammer		Removing oil pump assembly
KV31102400 (J34285 and J34285-87) Clutch spring compressor		Removing and installing clutch return springs
ST33200000 (J26082) Drift	 <p style="margin-left: 100px;"> a: 60 mm (2.36 in) dia. b: 44.5 mm (1.752 in) dia. </p>	Installing oil pump housing oil seal Installing rear oil seal
(J34291) Shim setting gauge set		Selecting oil pump cover bearing race and oil pump thrust washer

PRECAUTIONS

Service Notice

- Before proceeding with disassembly, thoroughly clean the outside of the transmission. It is important to prevent the internal parts from becoming contaminated by dirt or other foreign matter.
- Disassembly should be done in a clean work area.
- Use lint-free cloth or towels for wiping parts clean. Common shop rags can leave fibers that could interfere with the operation of the transmission.
- When disassembling parts, place them in order in a parts rack so that they can be put back into the unit in their proper positions.
- All parts should be carefully cleaned with a general purpose, non-flammable solvent before inspection or reassembly.
- Gaskets, seals and O-rings should be replaced any time the transmission is disassembled.
- It is very important to perform functional tests whenever they are indicated.
- The valve body contains precision parts and requires extreme care when parts are removed and serviced. Place removed parts in order on a parts rack so they can be put back in the valve body in the same positions and sequences. Care will also prevent springs and small parts from becoming scattered or lost.
- Properly installed valves, sleeves, plugs, etc. will slide along their bores in the valve body under their own weight.
- Before assembly, apply a coat of recommended A.T.F. to all parts. Petroleum jelly may be applied to O-rings and seals and used to hold small bearings and washers in place during re-assembly. Do not use grease.
- Extreme care should be taken to avoid damage to O-rings, seals and gaskets when assembling.
- After overhaul, refill the transmission with new A.T.F.

A/T CONTROL DIAGRAM

Hydraulic Control Circuits

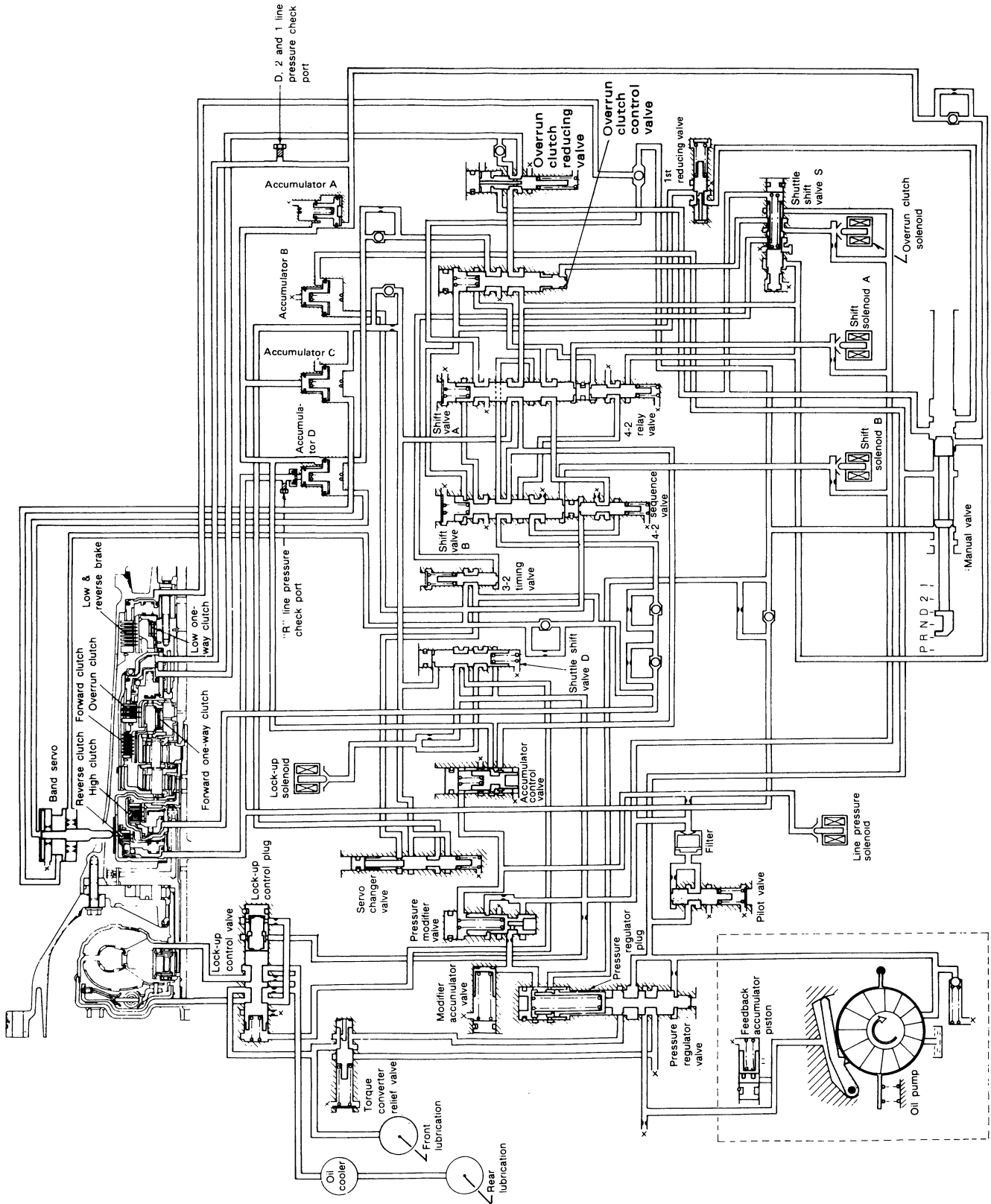

A/T CONTROL DIAGRAM

Electrical Control Chart

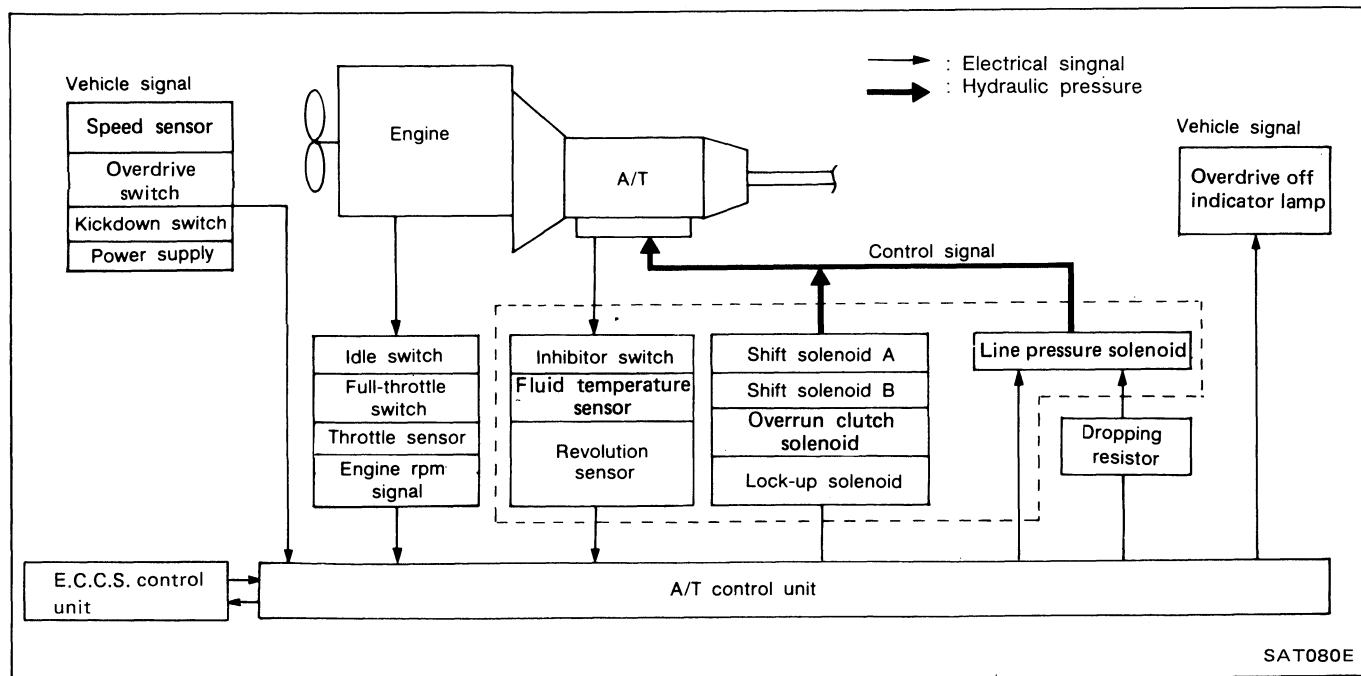

Mechanical Operation

Shift position	Reverse clutch	High clutch	Forward clutch	Overrun clutch	Band servo			Forward one-way clutch	Low one-way clutch	Low & reverse brake	Lock-up	Remarks
					2nd apply	3rd release	4th apply					
P												PARK
R	○									○		REVERSE
N												NEUTRAL
D *4	1st		○	⊗				●	●			Automatic shift 1 ↔ 2 ↔ 3 ↔ 4
	2nd		○	⊗	○			●				
	3rd		○	○	⊗	*2 ⊗	⊗	●				
	4th		○	⊗		*3 ⊗	⊗	○			○	
2	1st		○	⊗				●	●			Automatic shift 1 ↔ 2
	2nd		○	○	○			●				
1	1st		○	○	○			●		○		Locks (held stationary) in 1st speed 1 ← 2
	2nd		○	○	○	○		●				

*1. Operates when overdrive switch is set in "OFF" position.

*2. Oil pressure is applied to both 2nd "apply" side and 3rd "release" side of band servo piston. However, because oil pressure area on the "release" side is greater than that on the "apply" side, brake band does not contract.

*3. Oil pressure is applied to 4th "apply" side in condition *2 above, and brake band contracts.

*4. A/T will not shift to 4th when overdrive switch is set in "OFF" position.

○ : Operates.

⊗ : Operates when throttle opening is less than 1/16. Engine brake activates.

● : Operates during "progressive" acceleration.

⊗ : Operates but does not affect power transmission.

⊗ : Operates when throttle opening is less than 1/16 but does not affect engine brake.

A/T CONTROL DIAGRAM

Cross-Sectional View

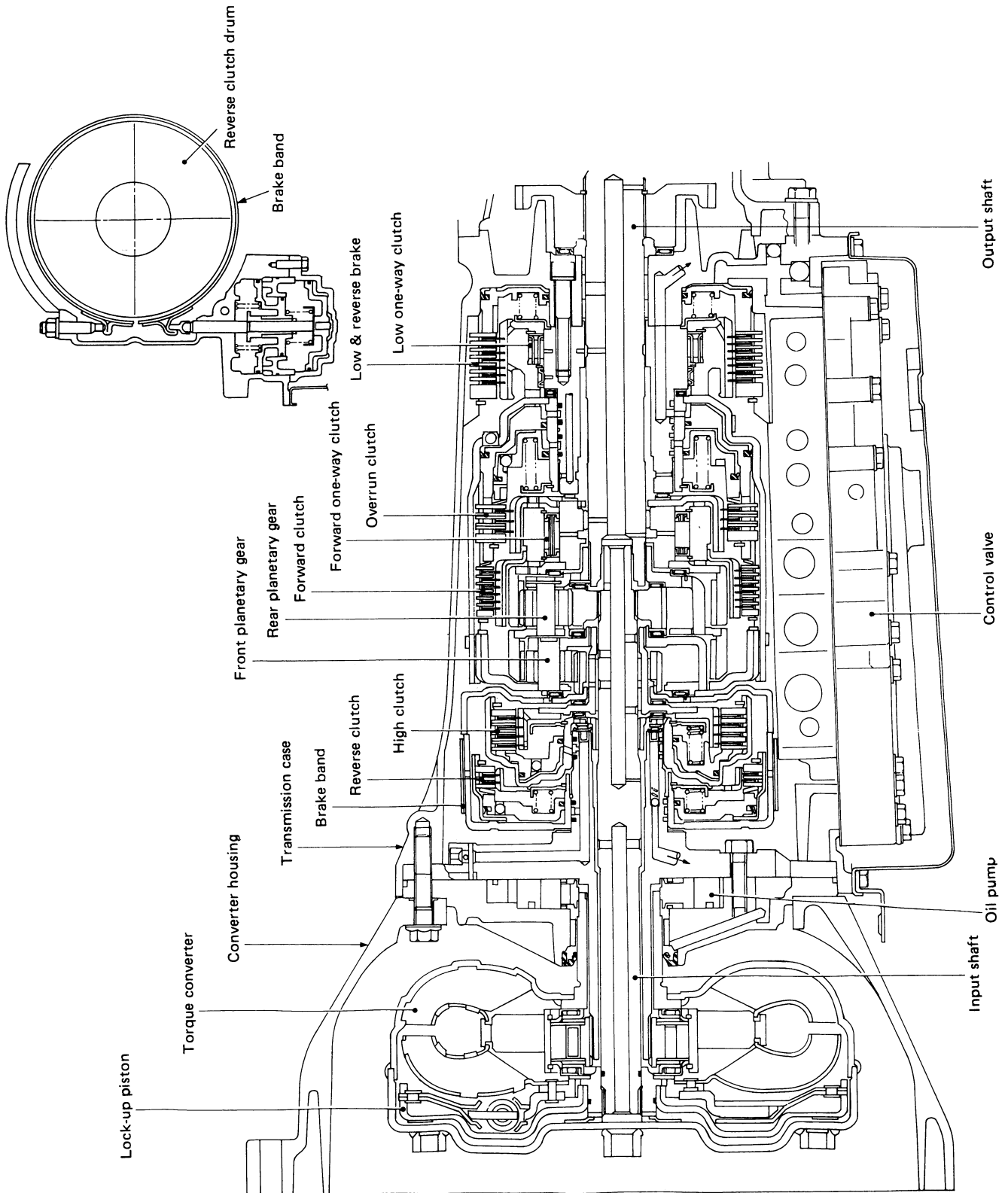

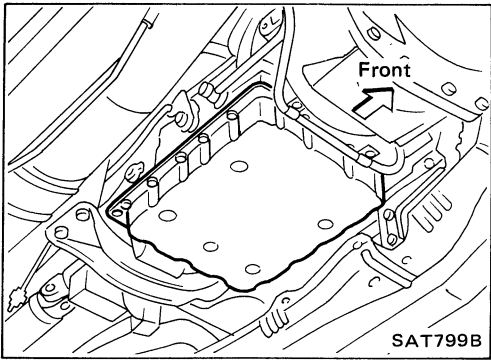

Control Valve Assembly and Accumulators Inspection

1. Remove oil pan and gasket and drain A.T.F.

2. Remove oil strainer.

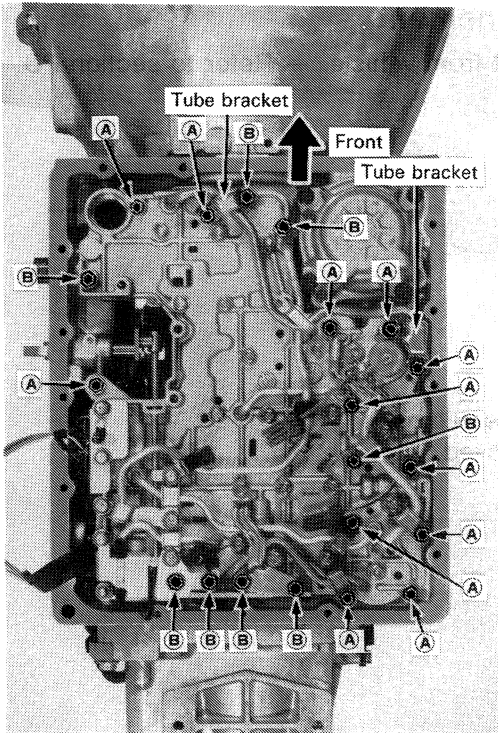

3. Remove control valve assembly by removing fixing bolts and disconnecting harness connector.

Bolt length and location

Bolt symbol	ℓ mm (in)	 ℓ
Ⓐ	33 (1.30)	
Ⓑ	45 (1.77)	

4. Remove solenoids and valves from valve body if necessary.

5. Remove terminal cord assembly if necessary.

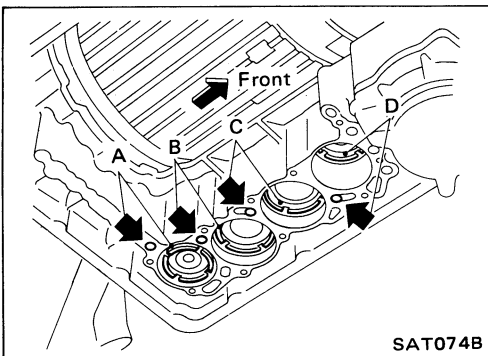

6. Remove accumulator A, B, C and D by applying compressed air if necessary.

- Hold each piston with rag.
- 7. Reinstall any part removed.
- Always use new sealing parts.

Revolution Sensor Replacement

1. Remove rear engine mounting member from body panel while supporting A/T with jack.
2. Lower A/T assembly as much as possible.

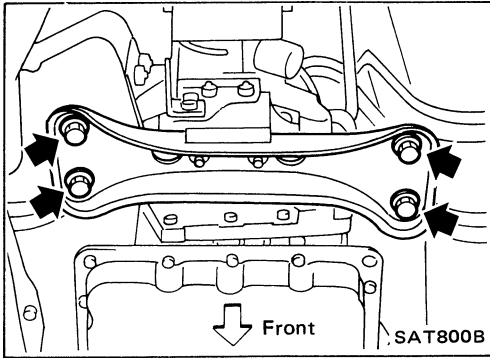

3. Remove revolution sensor from A/T assembly.
 4. Reinstall any part removed.
- **Always use new sealing parts.**

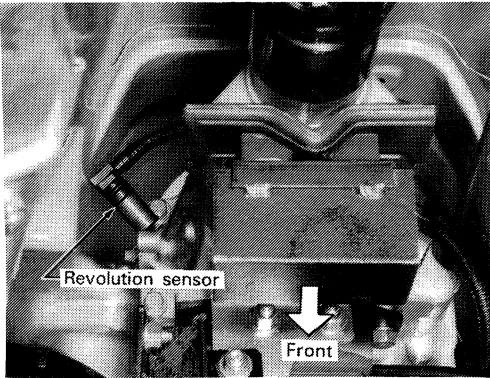

Rear Oil Seal Replacement

1. Remove propeller shaft from vehicle. — Refer to section PD.
2. Remove rear oil seal.

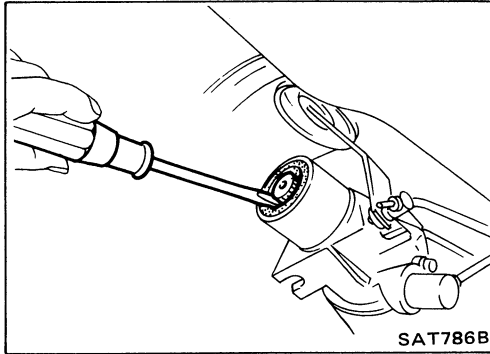

3. Install rear oil seal.
- **Apply A.T.F. before installing.**
4. Reinstall any part removed.

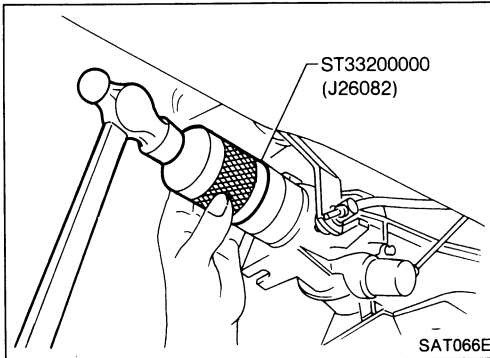

Parking Components Inspection

1. Remove propeller shaft from vehicle. — Refer to section PD.
2. Remove rear engine mounting member from A/T assembly.

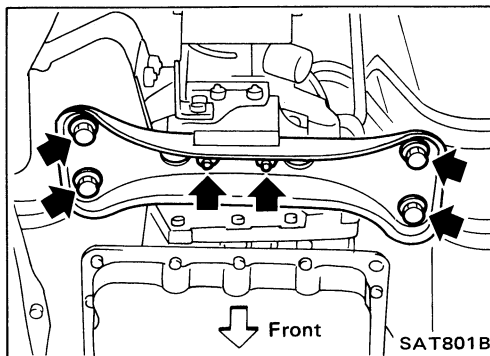

ON-VEHICLE SERVICE

Parking Components Inspection (Cont'd)

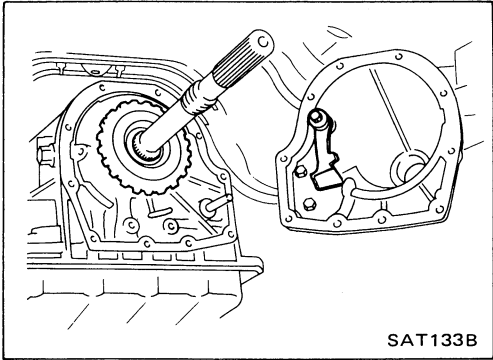

3. Remove rear extension from transmission case.
 4. Replace parking components if necessary.
 5. Reinstall any part removed.
- Always use new sealing parts.

Inhibitor Switch Adjustment

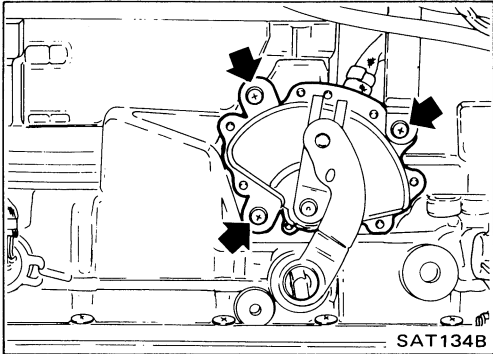

1. Remove manual control linkage from manual shaft of A/T assembly.
2. Set manual shaft of A/T assembly in "N" position.
3. Loosen inhibitor switch fixing bolts.

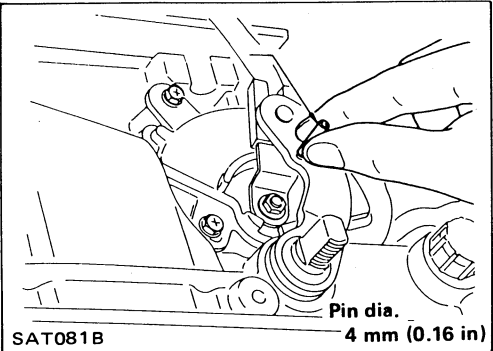

4. Insert pin into adjustment holes in both inhibitor switch and manual shaft of A/T assembly as near vertical as possible.
5. Reinstall any part removed.
6. Check continuity of inhibitor switch. — Refer to "Electrical Components Inspection".

Manual Control Linkage Adjustment

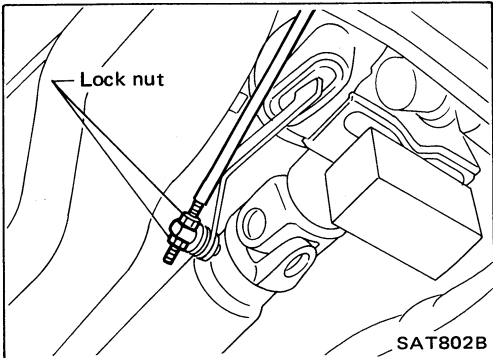

Move selector lever from "P" range to "1" range. You should be able to feel the detents in each range. If the detents cannot be felt or the pointer indicating the range is improperly aligned, the linkage needs adjustment.

1. Place selector lever in "P" range.
2. Loosen lock nuts.

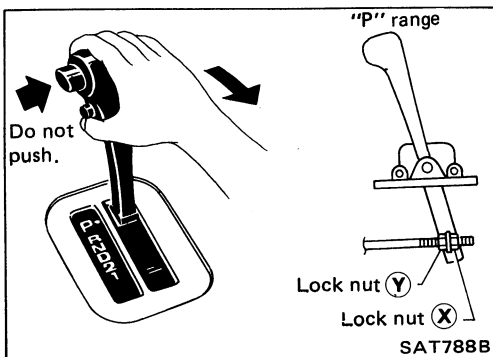

3. Tighten lock nut (X) until it touches trunnion pulling selector lever toward "R" range side without pushing button.
4. Back off lock nut (X) 1 turn and tighten lock nut (Y) to the specified torque.

Lock nut:

□: 11 - 15 N·m (1.1 - 1.5 kg·m, 8 - 11 ft·lb)

5. Move selector lever from "P" range to "1" range. Make sure that selector lever can move smoothly.

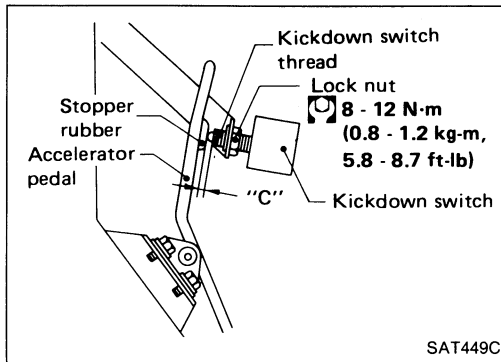

Kickdown Switch Adjustment

1. Adjust accelerator cable — Refer to section FE.
2. Adjust clearance "C" between stopper rubber and end of kickdown switch thread while depressing accelerator pedal fully.
Clearance "C": 0.3 - 1.0 mm (0.012 - 0.039 in)

TROUBLE DIAGNOSES

Contents

How to Perform Trouble Diagnoses for Quick and Accurate Repair	AT- 13
Preliminary Check	AT- 14
Diagnosis by CONSULT	AT- 31
A/T Electrical Parts Location	AT- 34
Circuit Diagram for Quick Pinpoint Check	AT- 35
Wiring Diagram	AT- 36
Self-diagnosis	AT- 38
SELF-DIAGNOSTIC PROCEDURE (With CONSULT)	AT- 38
SELF-DIAGNOSTIC PROCEDURE (Without CONSULT)	AT- 39
JUDGEMENT OF SELF-DIAGNOSIS CODE	AT- 41
REVOLUTION SENSOR CIRCUIT CHECK	AT- 45
SPEED SENSOR CIRCUIT CHECK	AT- 46
THROTTLE SENSOR CIRCUIT CHECK	AT- 47
SHIFT SOLENOID A CIRCUIT CHECK	AT- 48
SHIFT SOLENOID B CIRCUIT CHECK	AT- 49
OVERRUN CLUTCH SOLENOID CIRCUIT CHECK	AT- 50
LOCK-UP SOLENOID CIRCUIT CHECK	AT- 51
FLUID TEMPERATURE SENSOR CIRCUIT AND A/T CONTROL UNIT POWER SOURCE CIRCUIT CHECKS	AT- 52
ENGINE REVOLUTION SIGNAL CIRCUIT CHECK	AT- 54
LINE PRESSURE SOLENOID CIRCUIT CHECK	AT- 55
INHIBITOR, OVERDRIVE, KICKDOWN AND IDLE SWITCH CIRCUIT CHECKS	AT- 56
Diagnostic Procedure 1 (SYMPTOM: O.D. OFF indicator lamp does not come on for about 2 seconds when turning ignition switch to "ON".)	AT- 60
Diagnostic Procedure 2 (SYMPTOM: Engine cannot be started with selector lever in "P" or "N" range or engine can be started with selector lever in "D", "2", "1" or "R" range.)	AT- 61
Diagnostic Procedure 3 (SYMPTOM: Vehicle moves when it is pushed forward or backward with selector lever in "P" range.)	AT- 61
Diagnostic Procedure 4 (SYMPTOM: Vehicle moves forward or backward when selecting "N" range.)	AT- 62
Diagnostic Procedure 5 (SYMPTOM: There is large shock when changing from "N" to "R" range.)	AT- 63
Diagnostic Procedure 6 (SYMPTOM: Vehicle does not creep backward when selecting "R" range.)	AT- 64
Diagnostic Procedure 7 (SYMPTOM: Vehicle does not creep forward when selecting "D", "2" or "1" range.)	AT- 65
Diagnostic Procedure 8 (SYMPTOM: Vehicle cannot be started from D ₁ on Cruise test — Part 1.)	AT- 66
Diagnostic Procedure 9 (SYMPTOM: A/T does not shift from D ₁ to D ₂ at the specified speed. A/T does not shift from D ₄ to D ₂ when depressing accelerator pedal fully at the specified speed.)	AT- 67
Diagnostic Procedure 10 (SYMPTOM: A/T does not shift from D ₂ to D ₃ at the specified speed.)	AT- 68
Diagnostic Procedure 11 (SYMPTOM: A/T does not shift from D ₃ to D ₄ at the specified speed.)	AT- 69
Diagnostic Procedure 12 (SYMPTOM: A/T does not perform lock-up at the specified speed.)	AT- 70
Diagnostic Procedure 13 (SYMPTOM: A/T does not hold lock-up condition for more than 30 seconds.)	AT- 71
Diagnostic Procedure 14 (SYMPTOM: Lock-up is not released when accelerator pedal is released.)	AT- 71

TROUBLE DIAGNOSES

Contents (Cont'd)

Diagnostic Procedure 15

(SYMPTOM: Engine speed does not return to idle smoothly when A/T is shifted from D₄ to D₃ with accelerator pedal released.

Vehicle does not decelerate by engine brake when changing overdrive switch to "OFF" position with accelerator pedal released.

Vehicle does not decelerate by engine brake when changing selector lever from "D" to "2" range with accelerator pedal released.)

AT- 72

Diagnostic Procedure 16

(SYMPTOM: Vehicle does not start from D₁ on Cruise test — Part 2.)

AT- 73

Diagnostic Procedure 17

(SYMPTOM: A/T does not shift from D₄ on D₃ when changing overdrive switch to "OFF" position.)

AT- 73

Diagnostic Procedure 18

(SYMPTOM: A/T does not shift from D₃ on D₂ when changing selector lever from "D" to "2" range.)

AT- 74

Diagnostic Procedure 19

(SYMPTOM: A/T does not shift from 2₂ to 1₁ when changing selector lever from "2" to "1" range.)

AT- 74

Diagnostic Procedure 20

(SYMPTOM: Vehicle does not decelerate by engine brake when shifting from 2₂ (1₂) to 1₁.)

AT- 74

AT- 75

AT- 82

AT- 86

AT- 89

AT- 89

AT- 89

AT- 90

AT- 91

AT- 91

AT- 91

AT- 91

AT- 91

AT- 95

AT- 95

AT- 99

AT-100

AT-101

TROUBLE DIAGNOSES

How to Perform Trouble Diagnoses for Quick and Accurate Repair

WORK FLOW

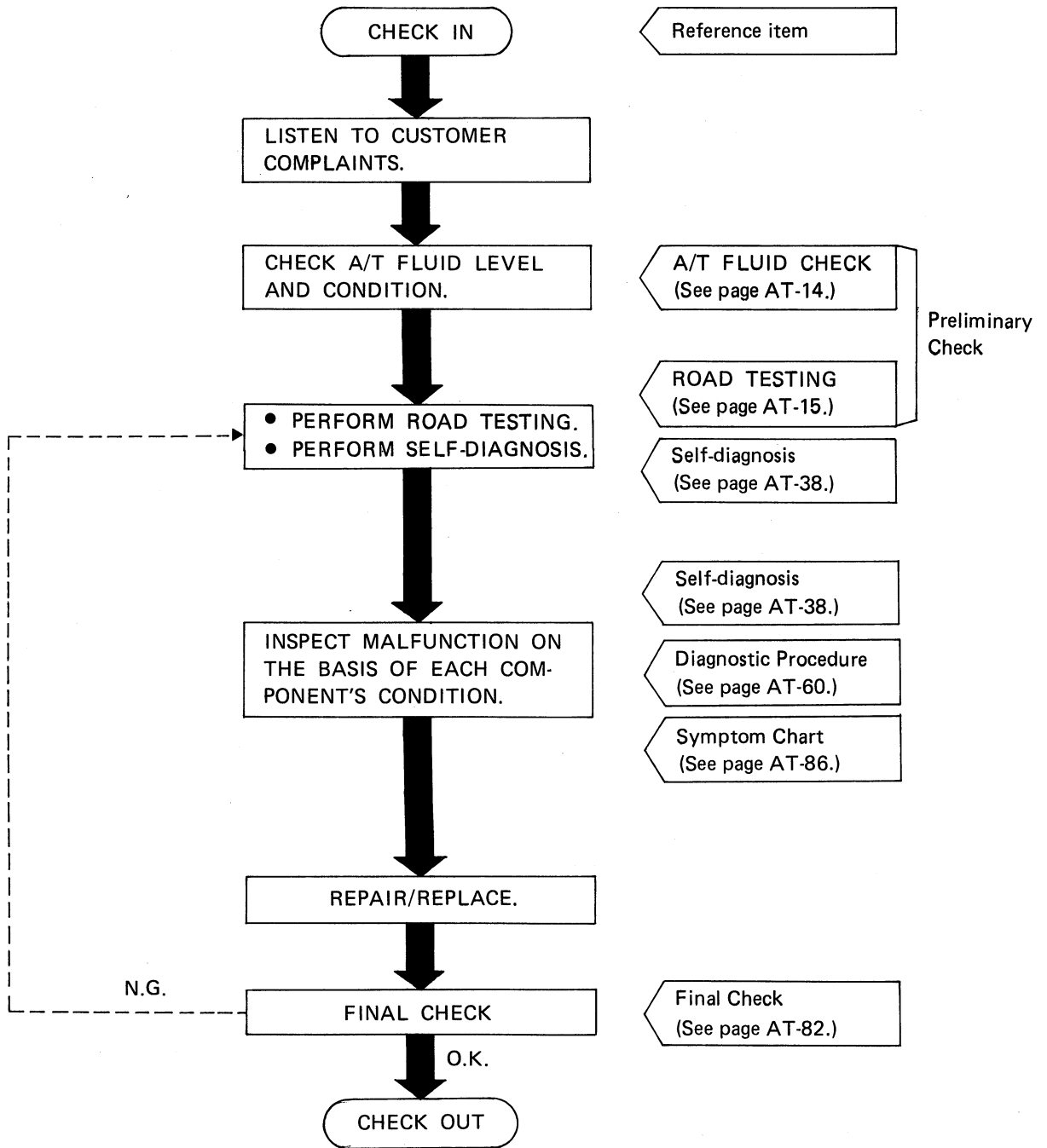

TROUBLE DIAGNOSES

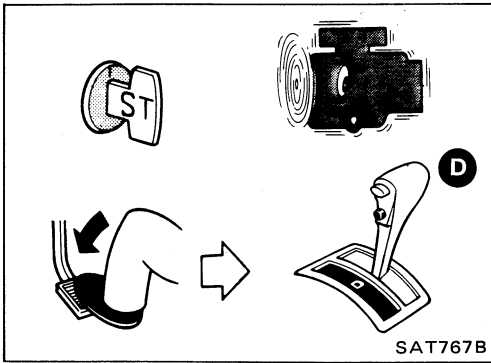

Preliminary Check

A/T FLUID CHECK

Fluid leakage check

1. Clean area suspected of leaking, — for example, mating surface of converter housing and transmission case.
2. Start engine, apply foot brake, place selector lever in "D" range and wait a few minutes.
3. Stop engine.
4. Check for fresh leakage.

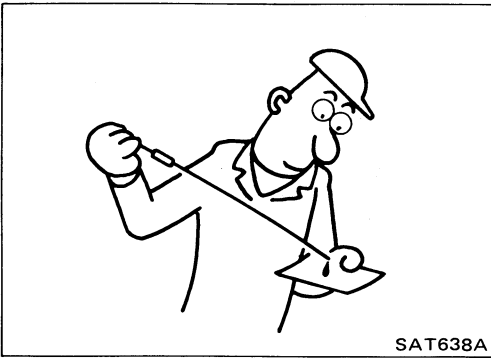
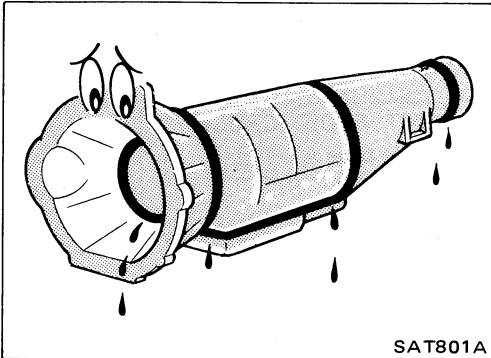

Fluid condition check

Fluid color	Suspected problem
Dark or black with burned odor	Wear of frictional material
Milky pink	Water contamination — Road water entering through filler tube or breather
Varnished fluid, light to dark brown and tacky	Oxidation — Over or under filling — Overheating

Fluid level check

Refer to section MA.

TROUBLE DIAGNOSES

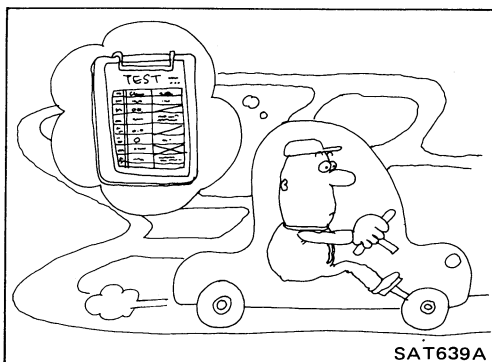
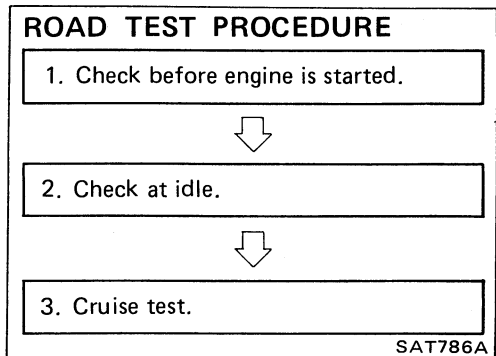

Preliminary Check (Cont'd)

ROAD TESTING

Description

- The purpose of this road test is to determine overall performance of automatic transmission and analyze causes of problems.
- The road test consists of the following three parts:
 1. Check before engine is started
 2. Check at idle
 3. Cruise test
- Before road test, familiarize yourself with all test procedures and items to check.
- Conduct tests on all items. Troubleshoot items which check out No Good after road test. Refer to "Self-diagnosis" and "Diagnostic Procedure".

TROUBLE DIAGNOSES

Preliminary Check (Cont'd)

1. Check before engine is started

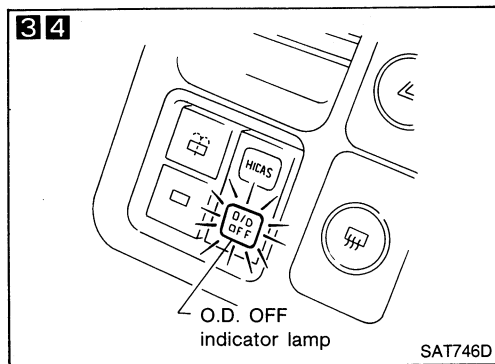
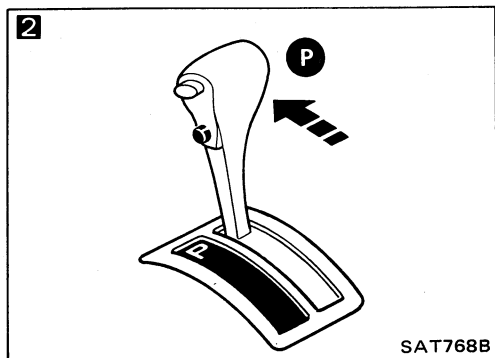
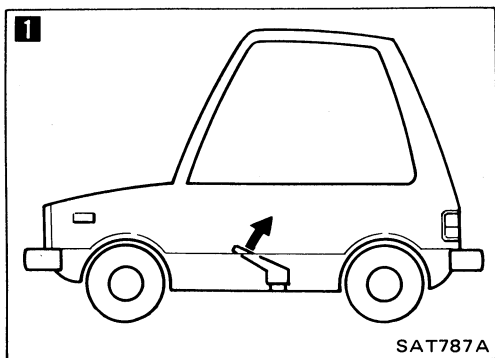

1
Park vehicle on flat surface.

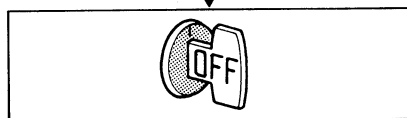

2
Move selector lever to "P" range.

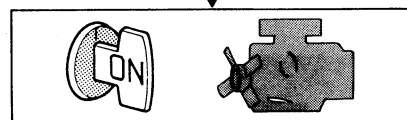

3
Does O.D. OFF indicator lamp come on for about 2 seconds?
No → Go to Diagnostic Procedure 1.

Yes
4
Does O.D. OFF indicator lamp flicker for about 8 seconds?
Yes → Perform self-diagnosis. — Refer to SELF-DIAGNOSIS PROCEDURE.

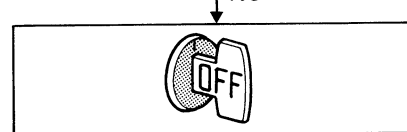

Perform self-diagnosis. — Refer to SELF-DIAGNOSIS PROCEDURE and note N.G. items.

Go to "ROAD TESTING — 2. Check at idle".

TROUBLE DIAGNOSES

Preliminary Check (Cont'd)

2. Check at idle

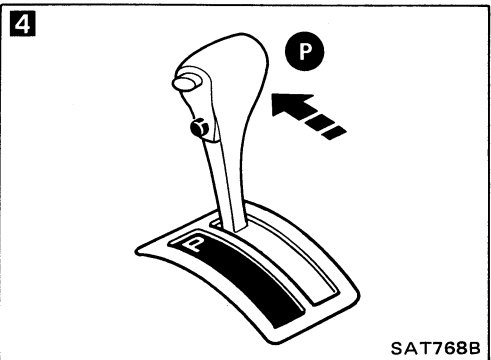
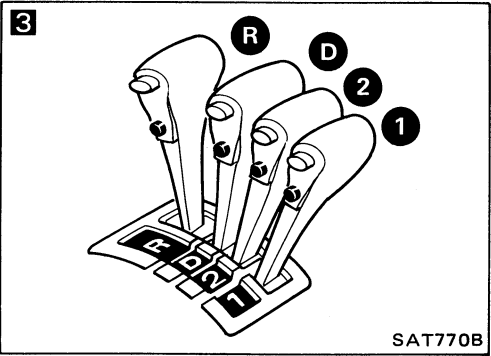
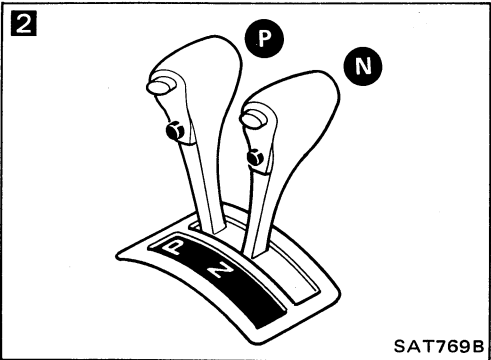
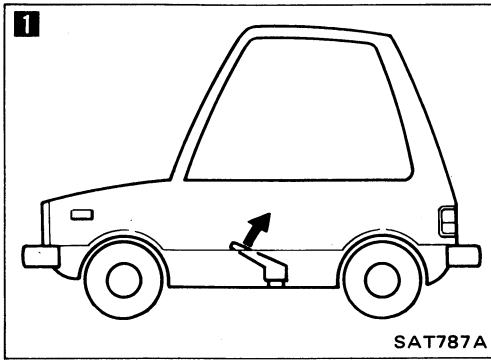

1
Park vehicle on flat surface.

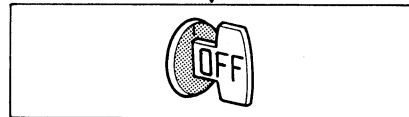

2
Move selector lever to "P" or "N" range.

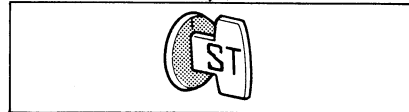

Is engine started?

No → Go to Diagnostic Procedure 2.

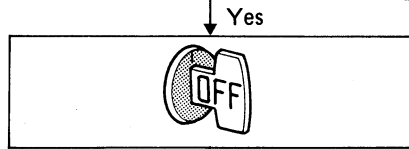

3
Move selector lever to "D", "1", "2" or "R" range.

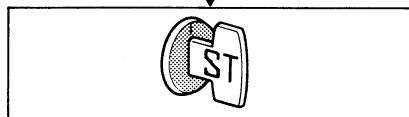

Is engine started?

Yes → Go to Diagnostic Procedure 2.

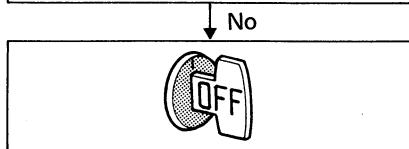

4
Move selector lever to "P" range.

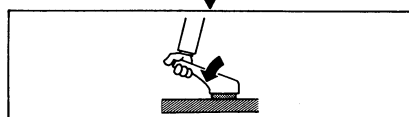

5
Push vehicle forward or backward.

Does vehicle move when it is pushed forward or backward?

Yes → Go to Diagnostic Procedure 3.

No
↓
A

TROUBLE DIAGNOSES

Preliminary Check (Cont'd)

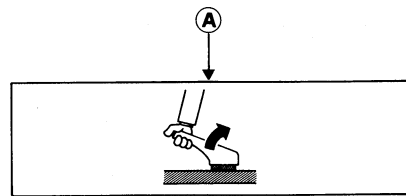
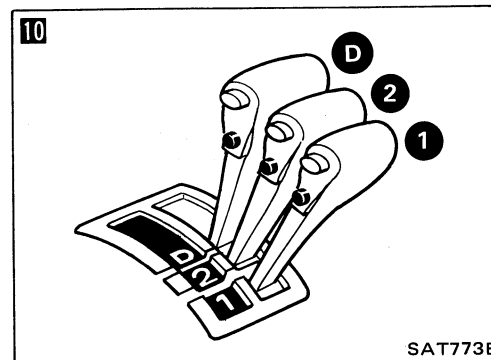
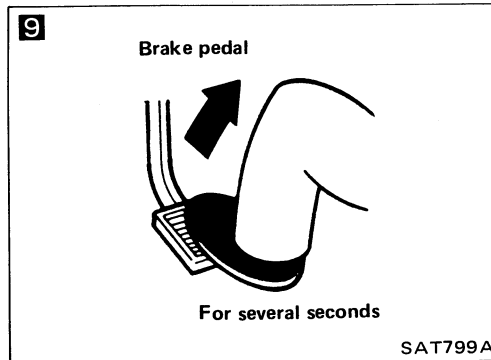
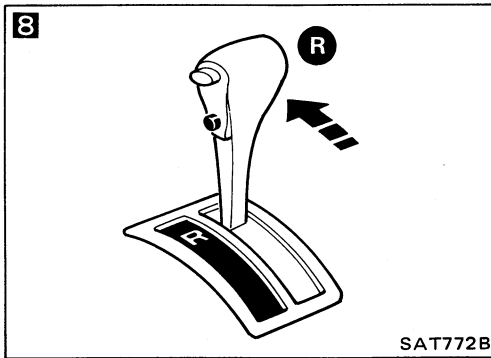
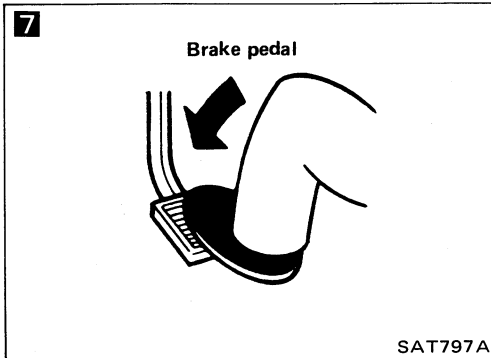
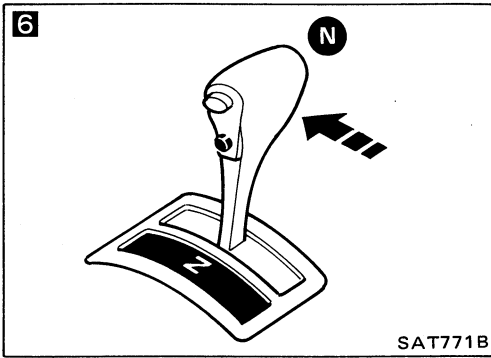

6 Move selector lever to "N" range.

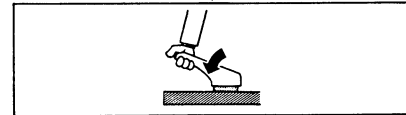
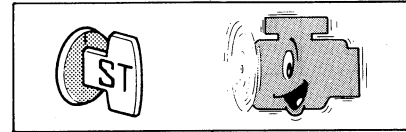

Does vehicle move forward or backward? Yes → Go to Diagnostic Procedure 4.

7 Apply foot brake.

8 Move selector lever to "R" range.

Is there large shock when changing from "N" to "R" range? Yes → Go to Diagnostic Procedure 5.

9 Release foot brake for several seconds.

Does vehicle creep backward when foot brake is released? No → Go to Diagnostic Procedure 6.

10 Move selector lever to "D", "1" and "2" range and check if vehicle creeps forward.

Does vehicle creep forward in all three ranges? Yes → Go to Cruise test.

No
Go to Diagnostic Procedure 7.

TROUBLE DIAGNOSES

Preliminary Check (Cont'd)

3. Cruise test

- Check all items listed in Parts 1 through 3.



With CONSULT

- Using CONSULT, conduct a cruise test and record the result.
- Print the result and ensure that shifts and lock-ups take place as per "Shift Schedule."

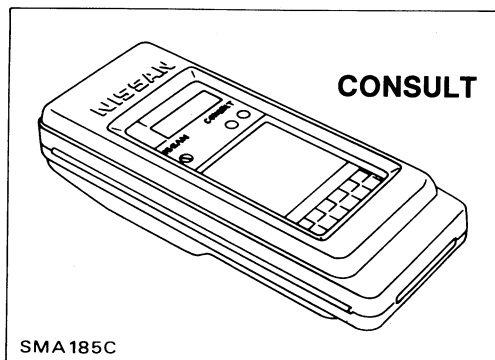

CONSULT setting procedure

1. Turn off ignition switch.
2. Connect "CONSULT" to diagnostic connector. (Diagnostic connector is located in left dash side panel.)

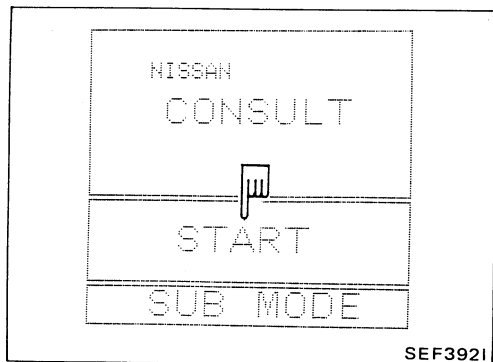
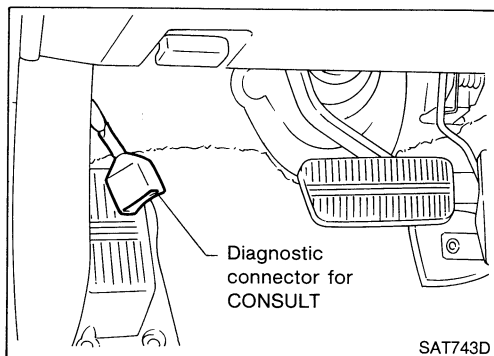

3. Turn on ignition switch.
4. Touch "START".

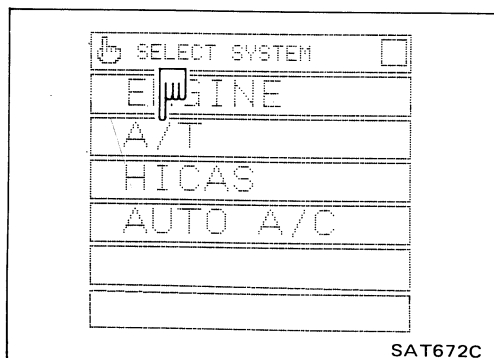

5. Touch "A/T".

TROUBLE DIAGNOSES

Preliminary Check (Cont'd)

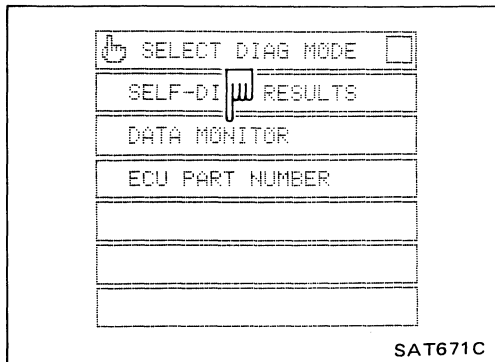

6. Touch "DATA MONITOR".

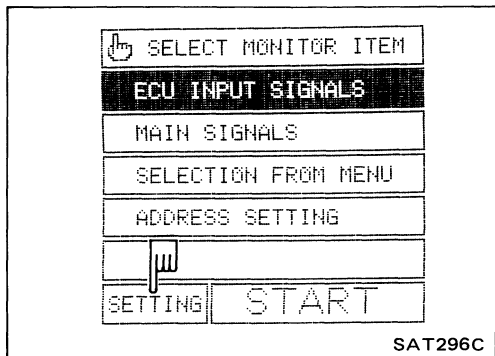

7. Touch "SETTING" to set recording condition.

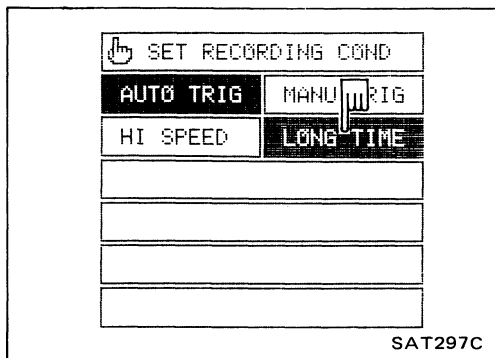

8. Touch "LONG TIME" and "ENTER" key.

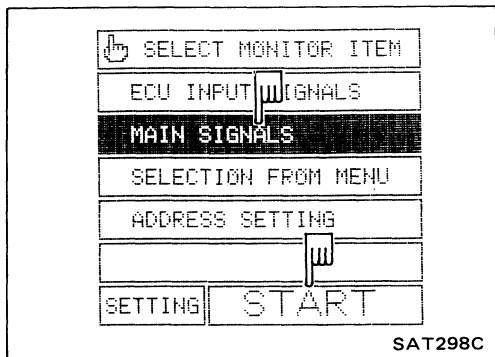

9. Go back to SELECT MONITOR ITEM and touch "MAIN SIGNALS".

10. Touch "START".

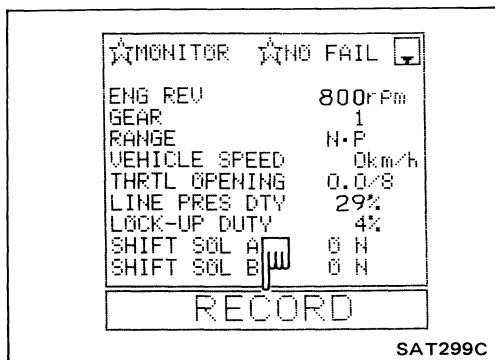

11. When performing cruise test, touch "RECORD".

TROUBLE DIAGNOSES

Preliminary Check (Cont'd)

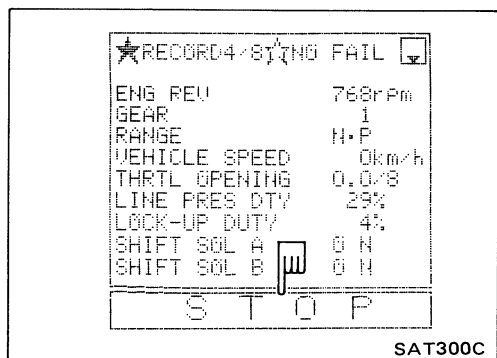

12. After finishing cruise test part 1, touch "STOP".

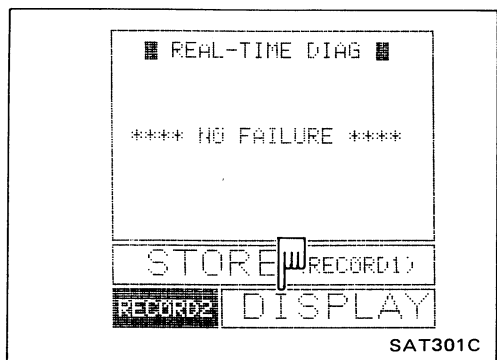

13. Touch "DISPLAY".

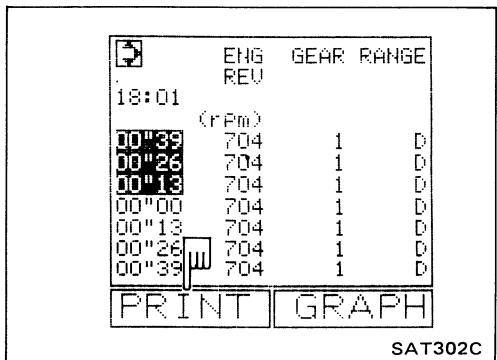

14. Touch "PRINT".

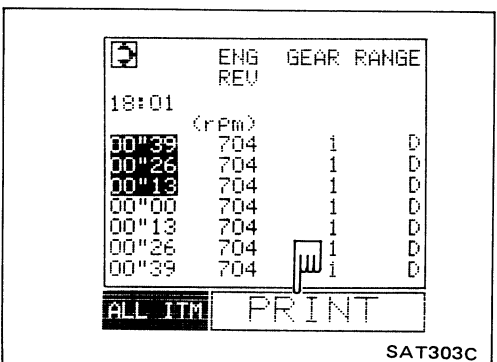

15. Touch "PRINT" again.

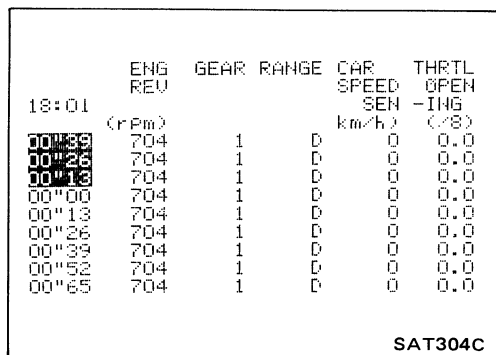

16. Check the monitor data printed out.

17. Continue cruise test part 2 and 3.

TROUBLE DIAGNOSES

Preliminary Check (Cont'd)

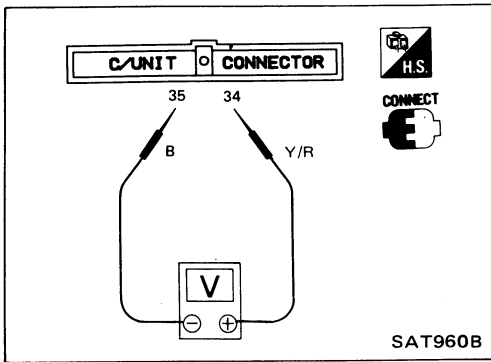

Without CONSULT

- Throttle position can be controlled by voltage across terminals ③④ and ③⑤ of A/T control unit.

TROUBLE DIAGNOSES

Preliminary Check (Cont'd)

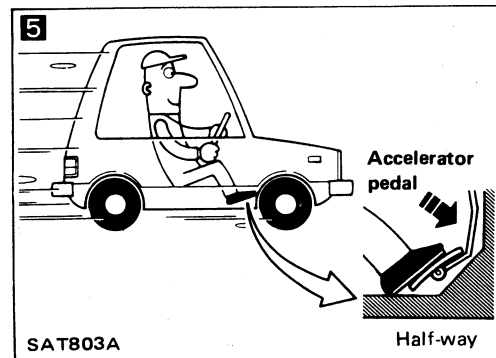
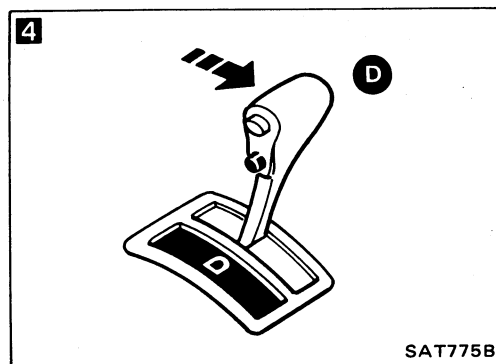
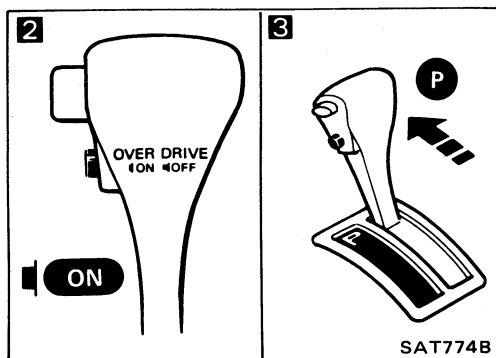
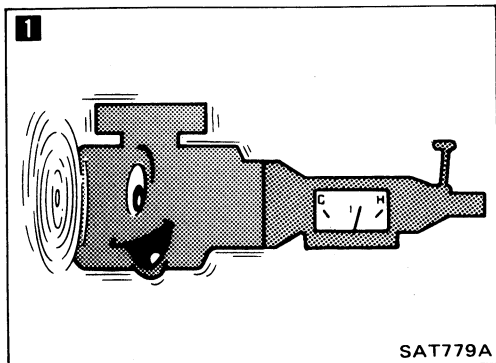

Cruise test – Part 1

1

Warm up engine until engine oil and A.T.F. reach operating temperature after vehicle has been driven approx. 10 minutes.

A.T.F. operating temperature:
50 - 80°C (122 - 176°F)

Park vehicle on flat surface.

2

Set overdrive switch in "ON" position.

3

Move selector lever to "P" range.

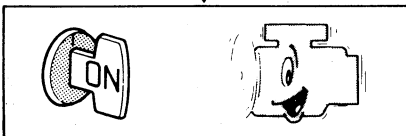

4

Move selector lever to "D" range.

5

Accelerate vehicle to half throttle.

Does vehicle start from D₁?



Read gear position.

No

Go to Diagnostic Procedure 8.

Yes

A

TROUBLE DIAGNOSES

Preliminary Check (Cont'd)

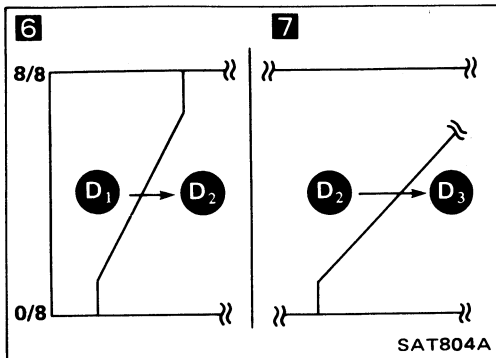

6 A

Does A/T shift from D₁ to D₂ at the specified speed?

Read gear position, throttle opening and vehicle speed.

Specified speed when shifting from D₁ to D₂: Refer to Shift schedule.

No → Go to Diagnostic Procedure 9.

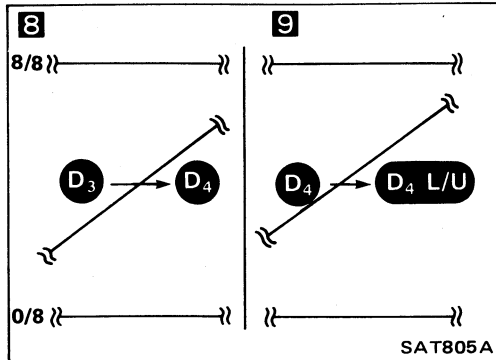

7

Does A/T shift from D₂ to D₃ at the specified speed?

Read gear position, throttle opening and vehicle speed.

Specified speed when shifting from D₂ to D₃: Refer to Shift schedule.

No → Go to Diagnostic Procedure 10.

8

Does A/T shift from D₃ to D₄ at the specified speed?

Read gear position, throttle opening and vehicle speed.

Specified speed when shifting from D₃ to D₄: Refer to Shift schedule.

No → Go to Diagnostic Procedure 11.

9

Does A/T perform lock-up at the specified speed?

Read vehicle speed, throttle opening when lock-up duty becomes 94%.

Specified speed when lock-up occurs: Refer to Shift schedule.

No → Go to Diagnostic Procedure 12.

Does A/T hold lock-up condition for more than 30 seconds?

No → Go to Diagnostic Procedure 13.

B

TROUBLE DIAGNOSES

Preliminary Check (Cont'd)

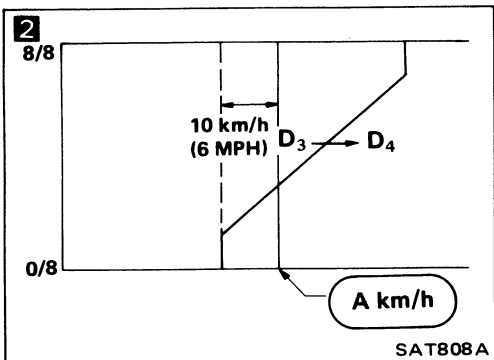
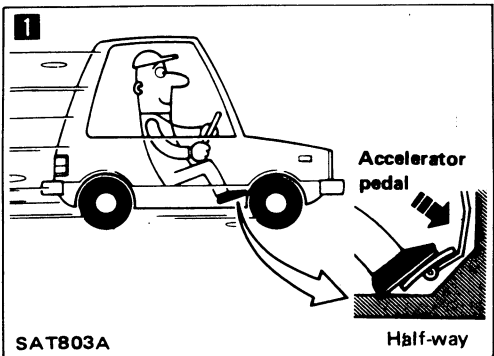
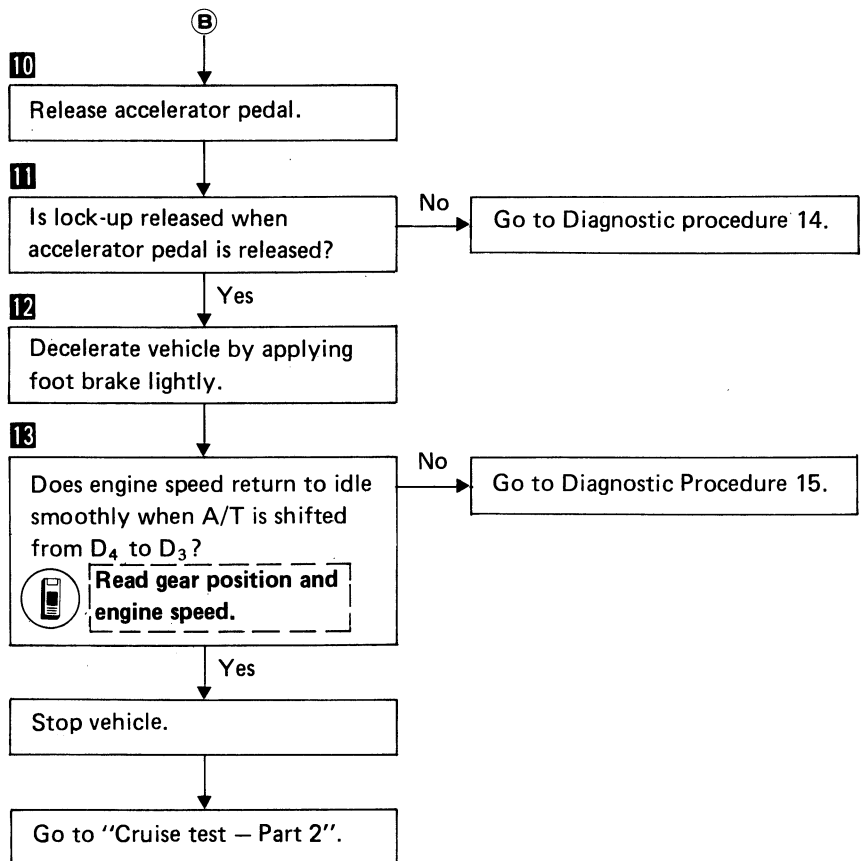
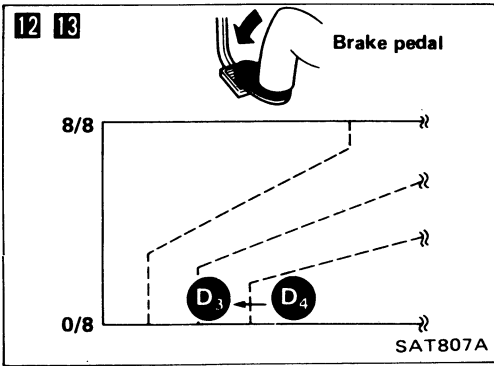
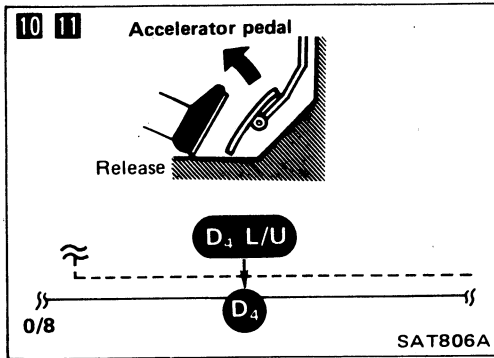

Cruise test — Part 2

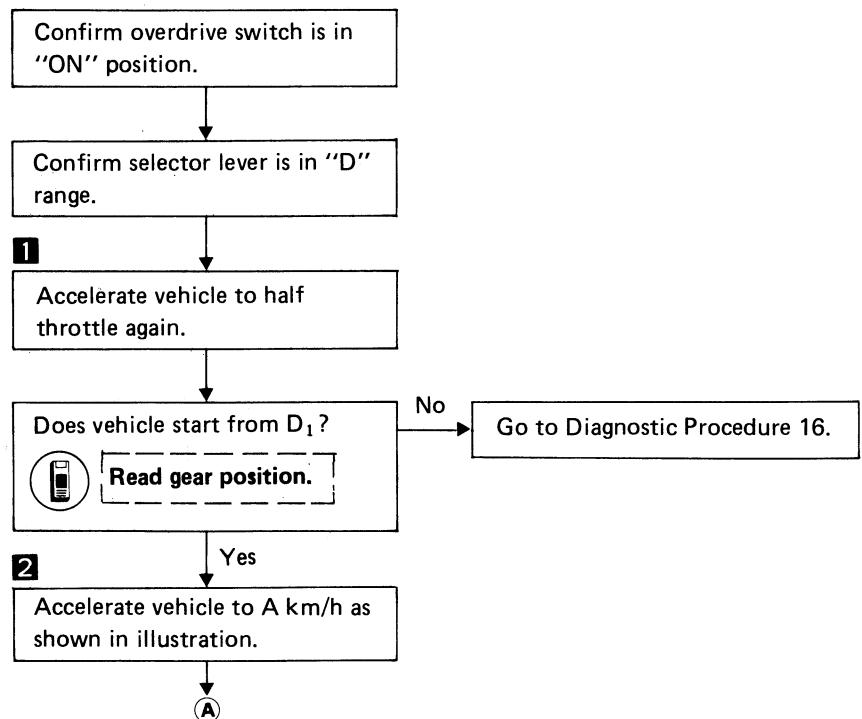

TROUBLE DIAGNOSES

Preliminary Check (Cont'd)

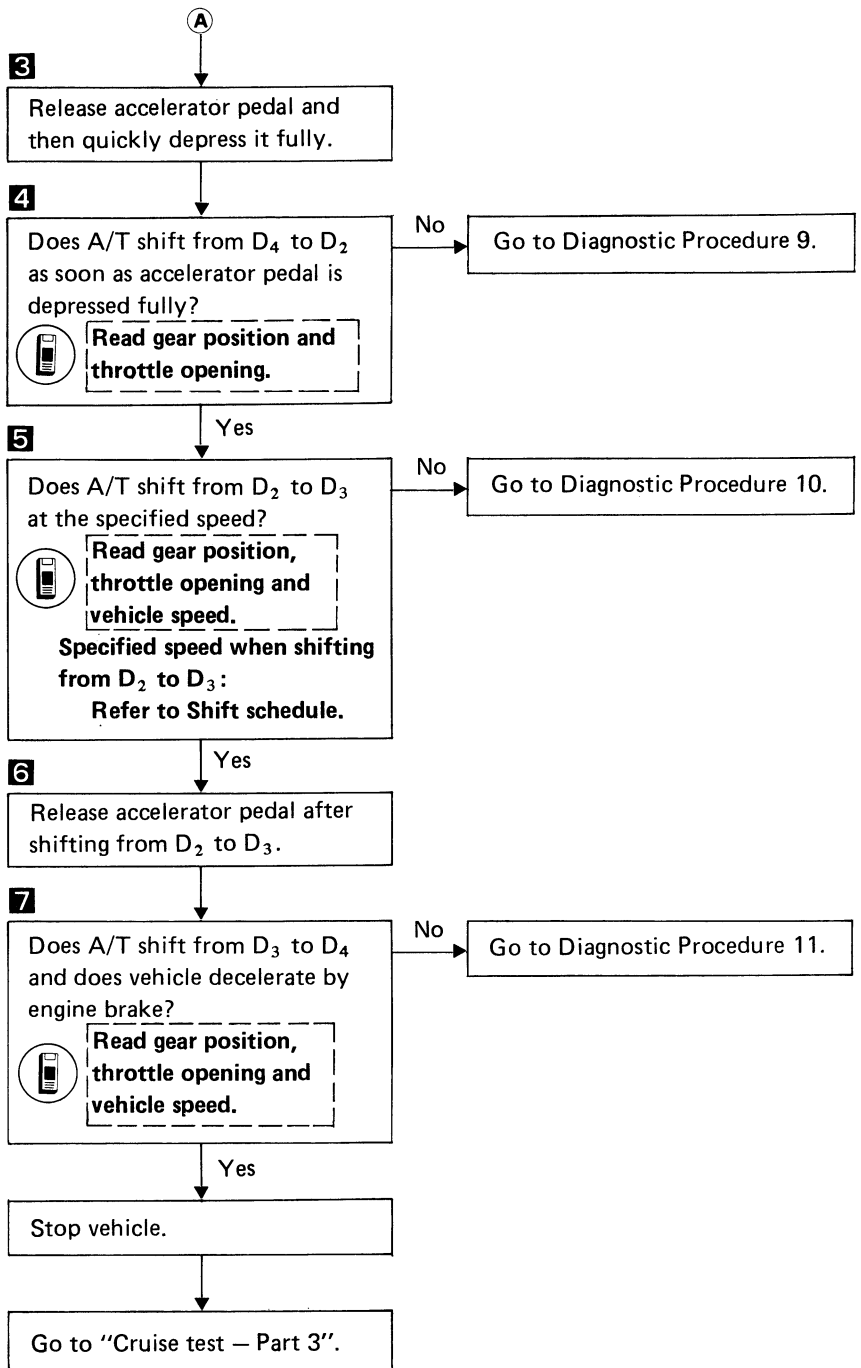
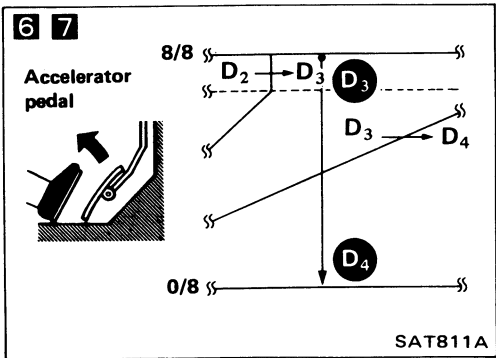
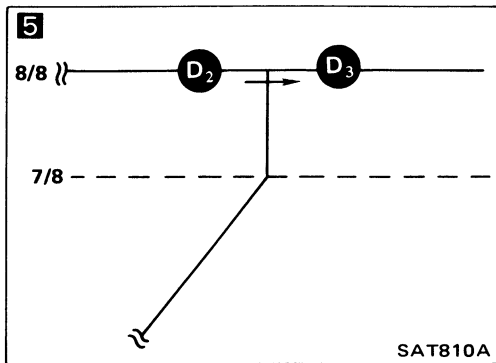
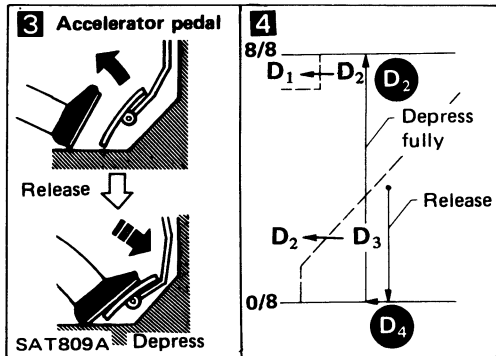

TROUBLE DIAGNOSES

Preliminary Check (Cont'd)

Cruise test — Part 3

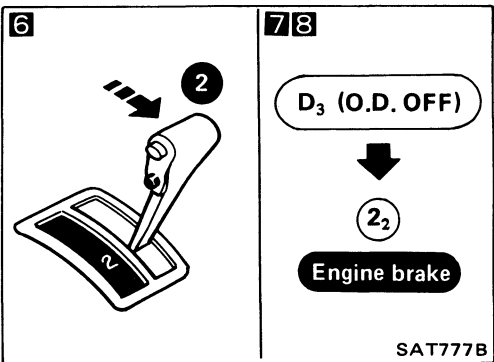
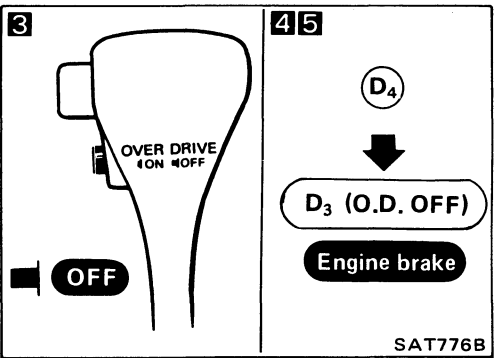
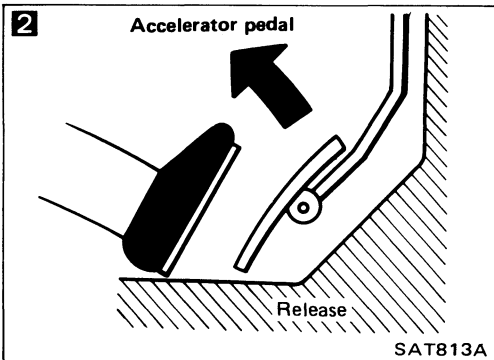
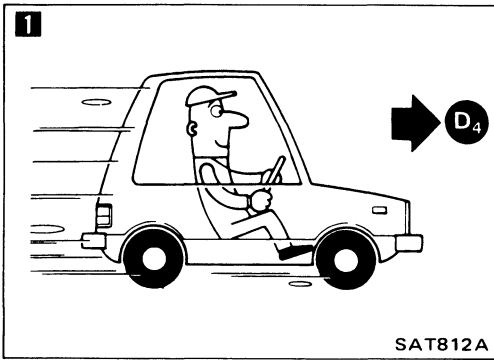

1 Confirm overdrive switch is in "ON" position.

Confirm selector lever is in "D" range.

1 Accelerate vehicle, using half-throttle, to D₄.

2 Release accelerator pedal.

3 Set overdrive switch in "OFF" position while driving in D₄ range.

4 Does A/T shift from D₄ to D₃?
 Read gear position and vehicle speed.

No → Go to Diagnostic Procedure 17.

5 Does vehicle decelerate by engine brake?
 Yes

No → Go to Diagnostic Procedure 15.

6 Move selector lever from "D" to "2" range while driving in D₃.

7 Does A/T shift from D₃ to 2₂?
 Read gear position.

No → Go to Diagnostic Procedure 18.

8 Does vehicle decelerate by engine brake?
 Yes

No → Go to Diagnostic Procedure 15.

A

TROUBLE DIAGNOSES

Preliminary Check (Cont'd)

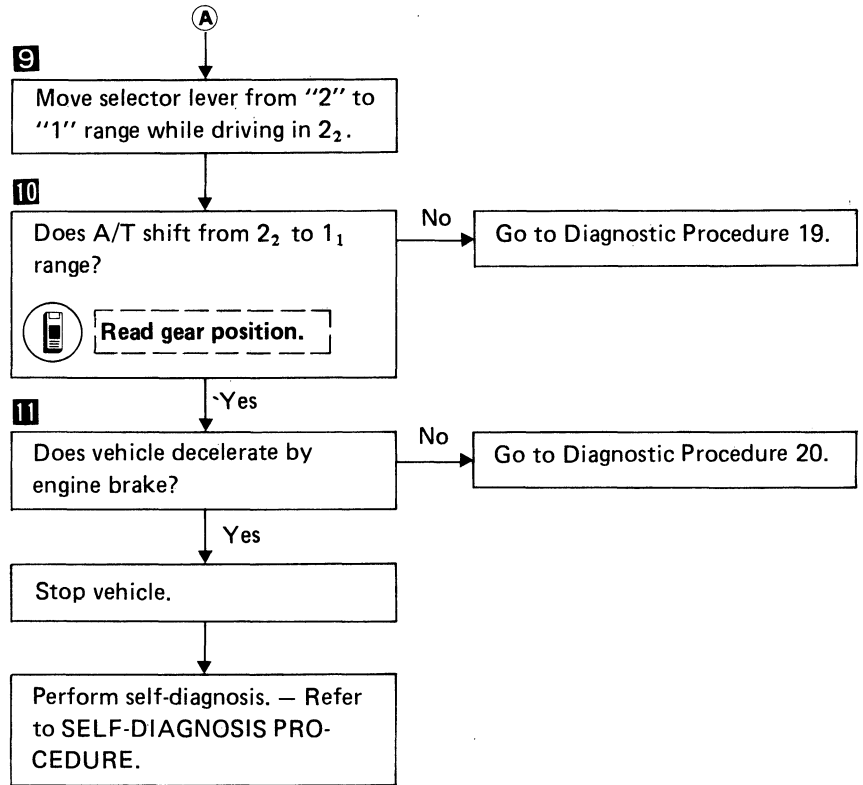
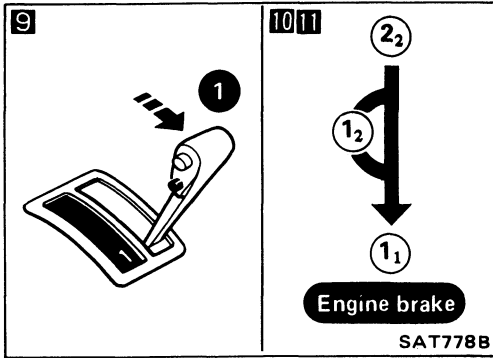

TROUBLE DIAGNOSES

Preliminary Check (Cont'd)

Vehicle speed when shifting gears

Throttle position	Vehicle speed km/h (MPH)						
	D ₁ → D ₂	D ₂ → D ₃	D ₃ → D ₄	D ₄ → D ₃	D ₃ → D ₂	D ₂ → D ₁	1 ₂ → 1 ₁
Full throttle	56 - 60 (35 - 37)	102 - 108 (63 - 67)	158 - 168 (98 - 104)	152 - 162 (94 - 101)	92 - 98 (57 - 61)	40 - 44 (25 - 27)	53 - 57 (33 - 35)
Half throttle	39 - 43 (24 - 27)	74 - 80 (46 - 50)	111 - 121 (69 - 75)	55 - 65 (34 - 40)	27 - 33 (17 - 21)	10 - 14 (6 - 9)	53 - 57 (33 - 35)

Vehicle speed when performing and releasing lock-up

Throttle position	O.D. switch [Shift range]	Vehicle speed km/h (MPH)	
		Lock-up "ON"	Lock-up "OFF"
Full throttle	ON [D ₄]	158 - 168 (98 - 104)	152 - 162 (94 - 101)
	OFF [D ₃]	102 - 108 (63 - 67)	92 - 98 (57 - 61)
Half throttle	ON [D ₄]	112 - 120 (70 - 75)	101 - 109 (63 - 68)
	OFF [D ₃]	91 - 99 (57 - 62)	86 - 94 (53 - 58)

TROUBLE DIAGNOSES

Preliminary Check (Cont'd)

Shift schedule (Overdrive ON)

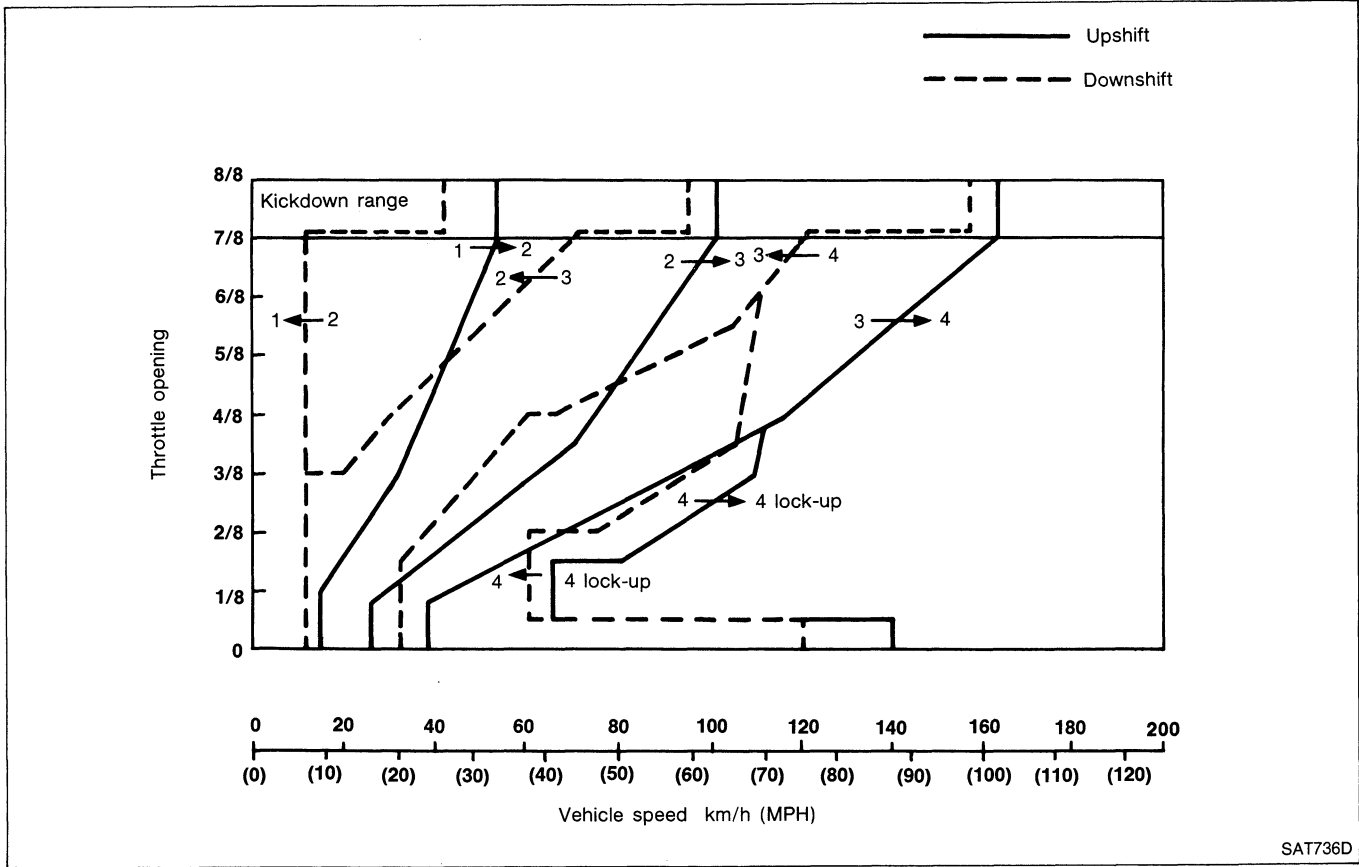

SAT736D

Shift schedule (Overdrive OFF)

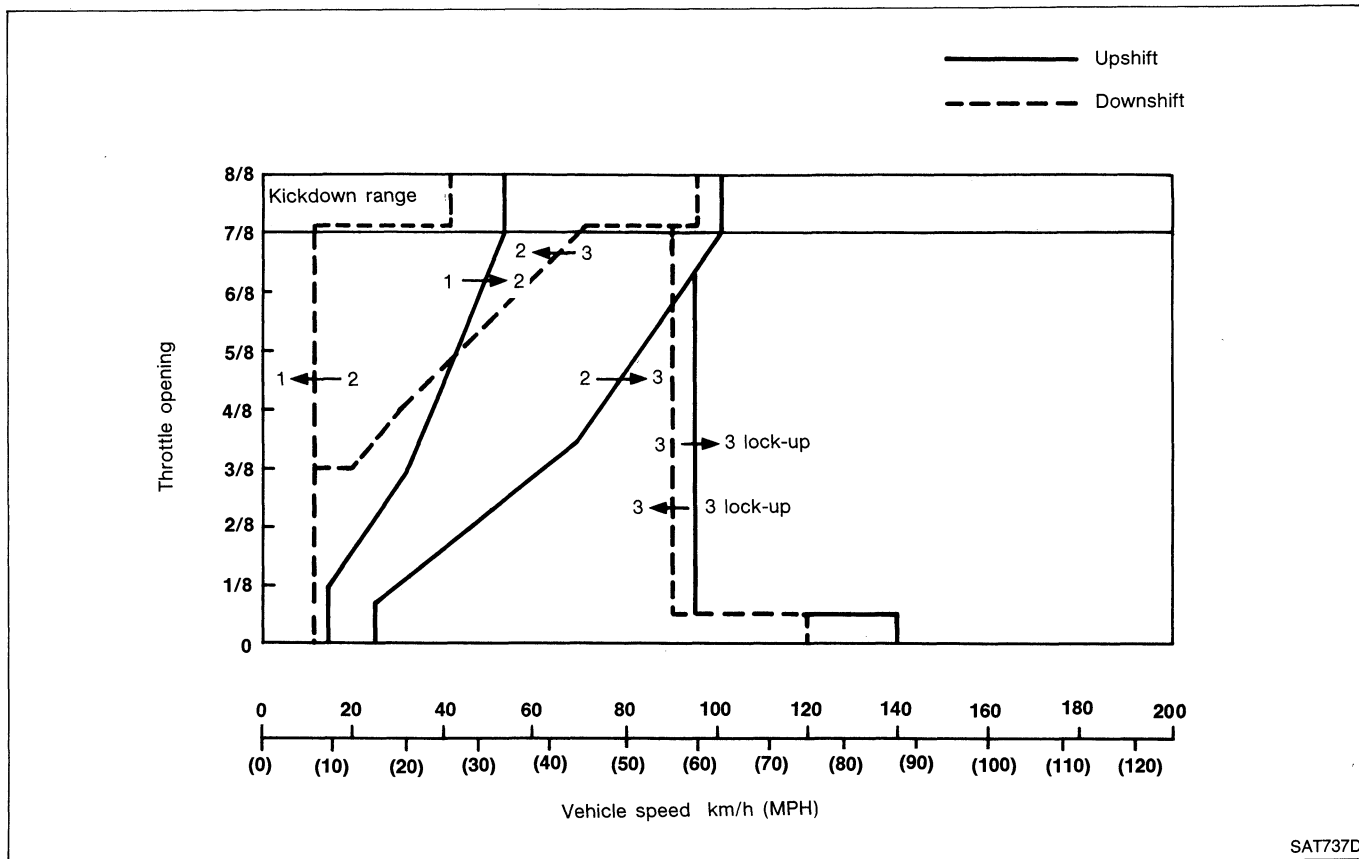

SAT737D

TROUBLE DIAGNOSES

Diagnosis by CONSULT

NOTICE

1. The CONSULT electrically displays shift timing and lock-up timing (that is, operation timing of each solenoid). When a noticeable time difference occurs between shift timing which is manifested by shift shock and the CONSULT display, mechanical parts (except solenoids, sensors, etc.) are considered to be malfunctioning. Check mechanical parts using applicable diagnostic procedures.
2. Shift schedule (which implies gear position) displayed on CONSULT and that indicated in Service Manual may differ slightly. This occurs because of the following reasons:
 - Actual shift schedule has more or less tolerance or allowance,
 - Shift schedule indicated in Service Manual refers to the point where shifts starts, and
 - Gear position displayed on CONSULT indicates the point where shifts are completed.
3. Shift solenoid "A" or "B" is displayed on CONSULT at the start of shifting while gear position is displayed upon completion of shifting (which is computed by A/T control unit).

TROUBLE DIAGNOSES

Diagnosis by CONSULT (Cont'd)

DATA MONITOR APPLICATION

Item	Application
Vehicle speed sensor 1 (A/T)	X
Vehicle speed sensor 2 (meter)	X
Throttle sensor	X
Fluid temperature sensor	X
Battery voltage	X
Engine rpm	X
Selector lever switch (O.D. switch)	X
A.S.C.D. – cruise signal	X
A.S.C.D. – O.D. cut signal	X
Kickdown switch	X
Power shift switch	–
Idle switch	X
Full throttle switch	X
Shift solenoid A	X
Shift solenoid B	X
Overrun clutch solenoid	X
*Shift solenoid A (feedback)	X
*Shift solenoid B (feedback)	X
*Overrun clutch solenoid (feedback)	X
Hold mode switch	–
1 range switch	X
2 range switch	X
D range switch	X
N range switch	X
R range switch	X
Gear position	X
Range position	X
Vehicle speed	X
Throttle opening	X
Line-pressure solenoid	X
Lock-up solenoid	X

X: Applicable –: Not applicable

TROUBLE DIAGNOSES

Diagnosis by CONSULT (Cont'd)

DATA ANALYSIS

Item	Display	Condition
Lock-up duty	Approximately 4%	Lock-up "OFF"
	↓ Approximately 94%	↓ Lock-up "ON"
Line pressure duty	Approximately 29%	Low line-pressure (Small throttle opening)
	↓ Approximately 94%	↓ High line-pressure (Large throttle opening)
Throttle sensor	Approximately 0.5V	Fully-closed throttle
	Approximately 4V	Fully-open throttle
Fluid temperature sensor	Approximately 1.5V	Cold [20°C (68°F)]
	↓ Approximately 0.5V	↓ Hot [80°C (176°F)]

Gear position	1	2	3	4
Shift solenoid A	ON	OFF	OFF	ON
Shift solenoid B	ON	ON	OFF	OFF

TROUBLE DIAGNOSES

A/T Electrical Parts Location

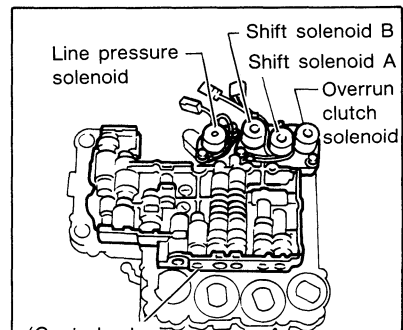
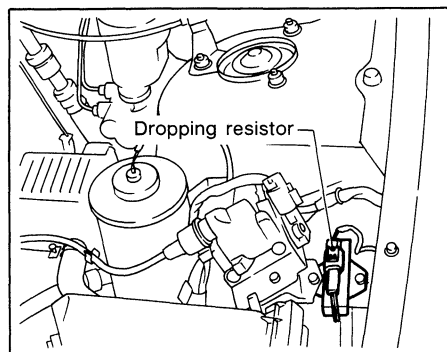
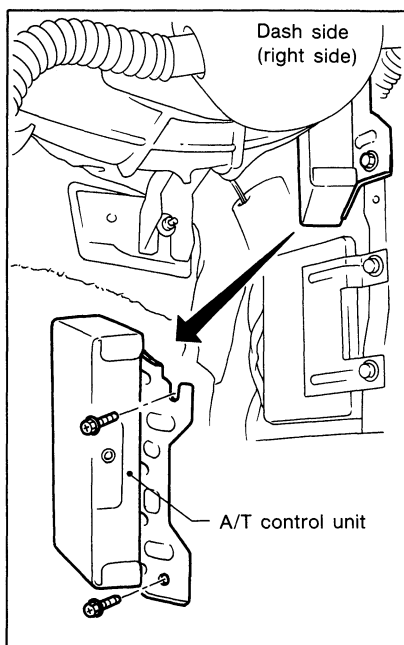
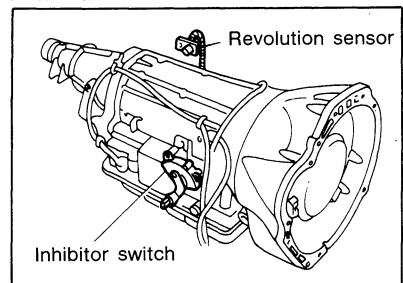
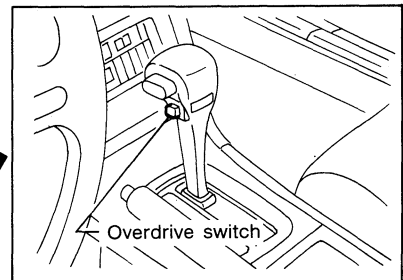
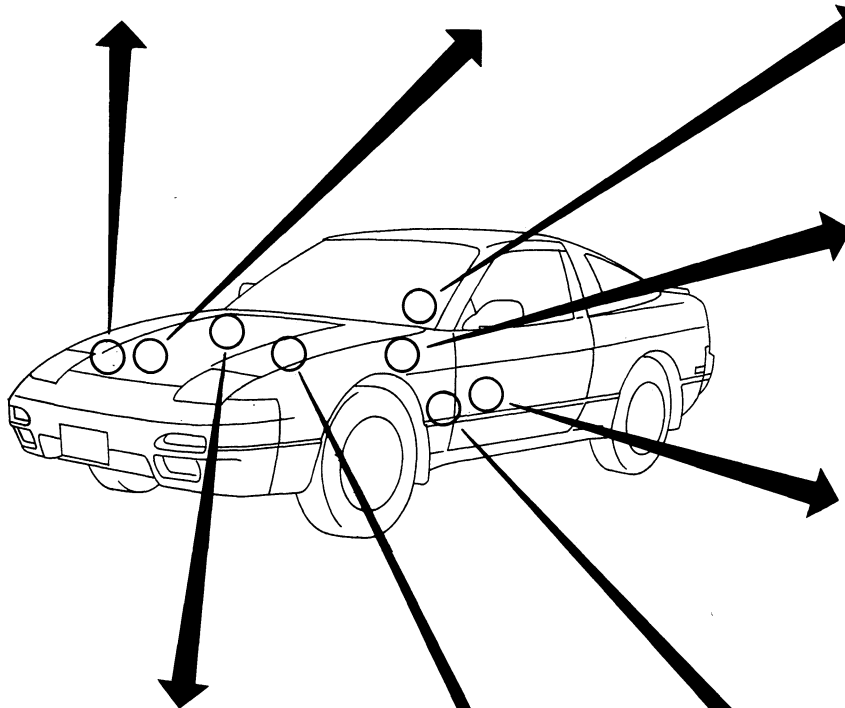
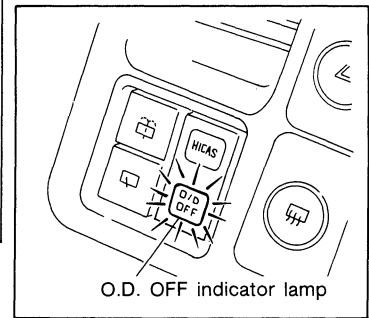
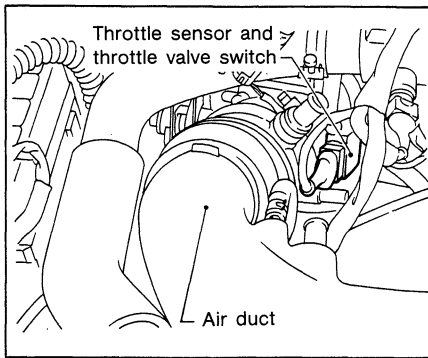
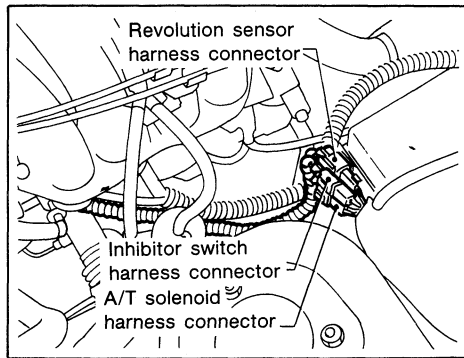

(Control valve upper body)

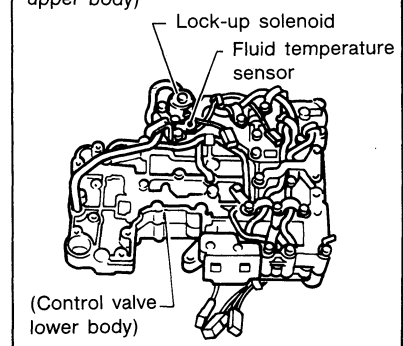

(Control valve lower body)

TROUBLE DIAGNOSES

Circuit Diagram for Quick Pinpoint Check

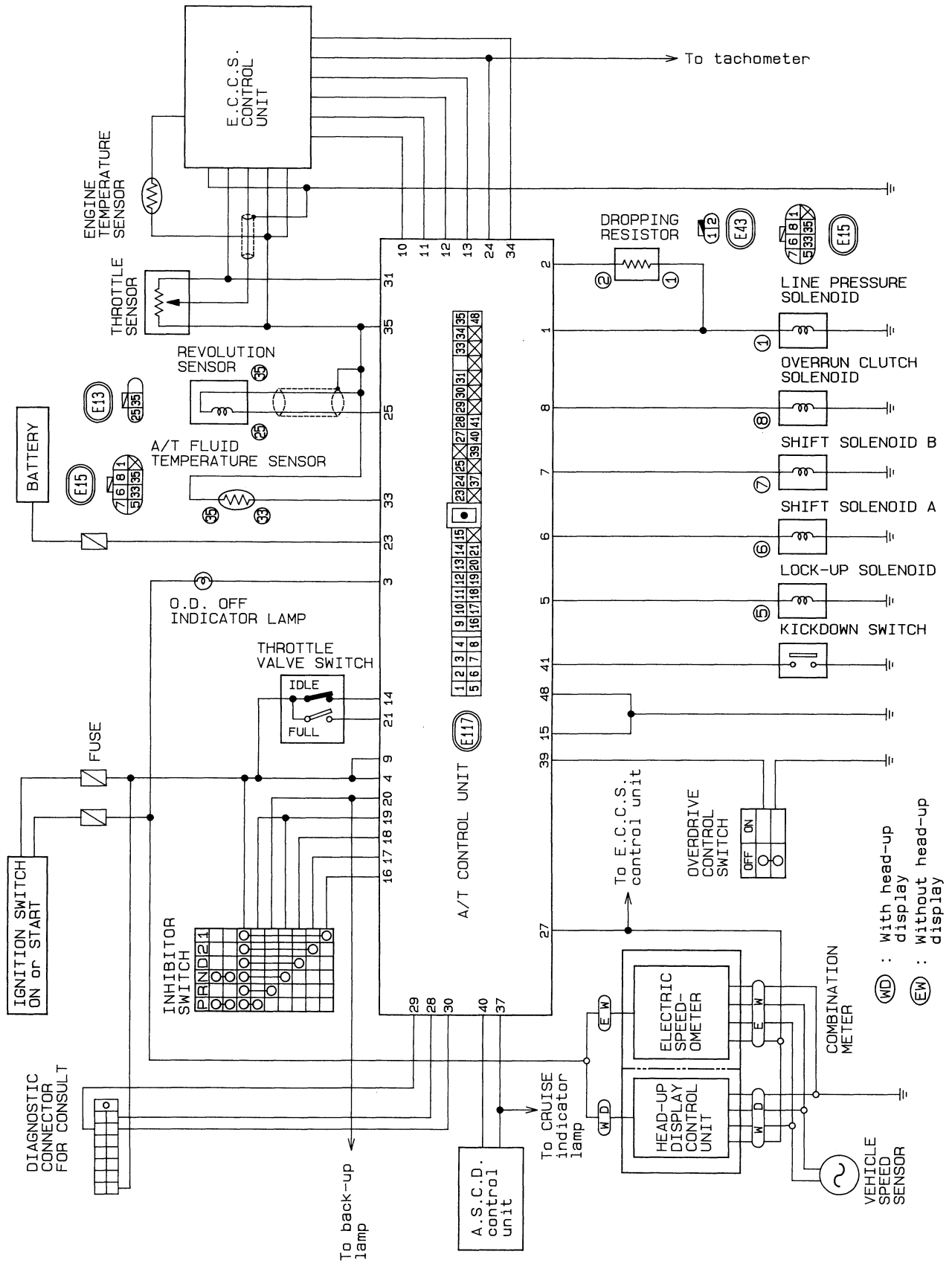

TROUBLE DIAGNOSES

Wiring Diagram

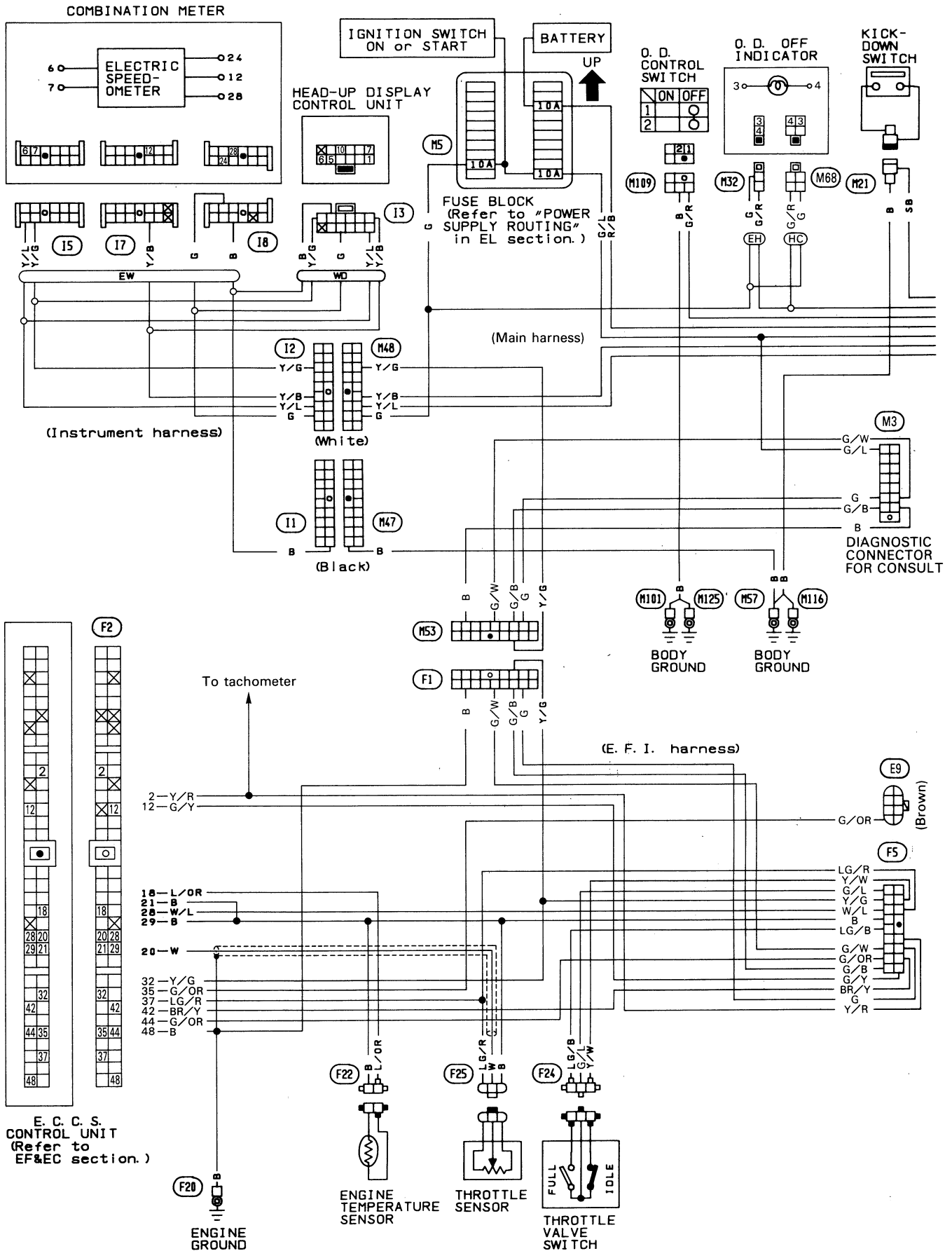

TROUBLE DIAGNOSES

Wiring Diagram (Cont'd)

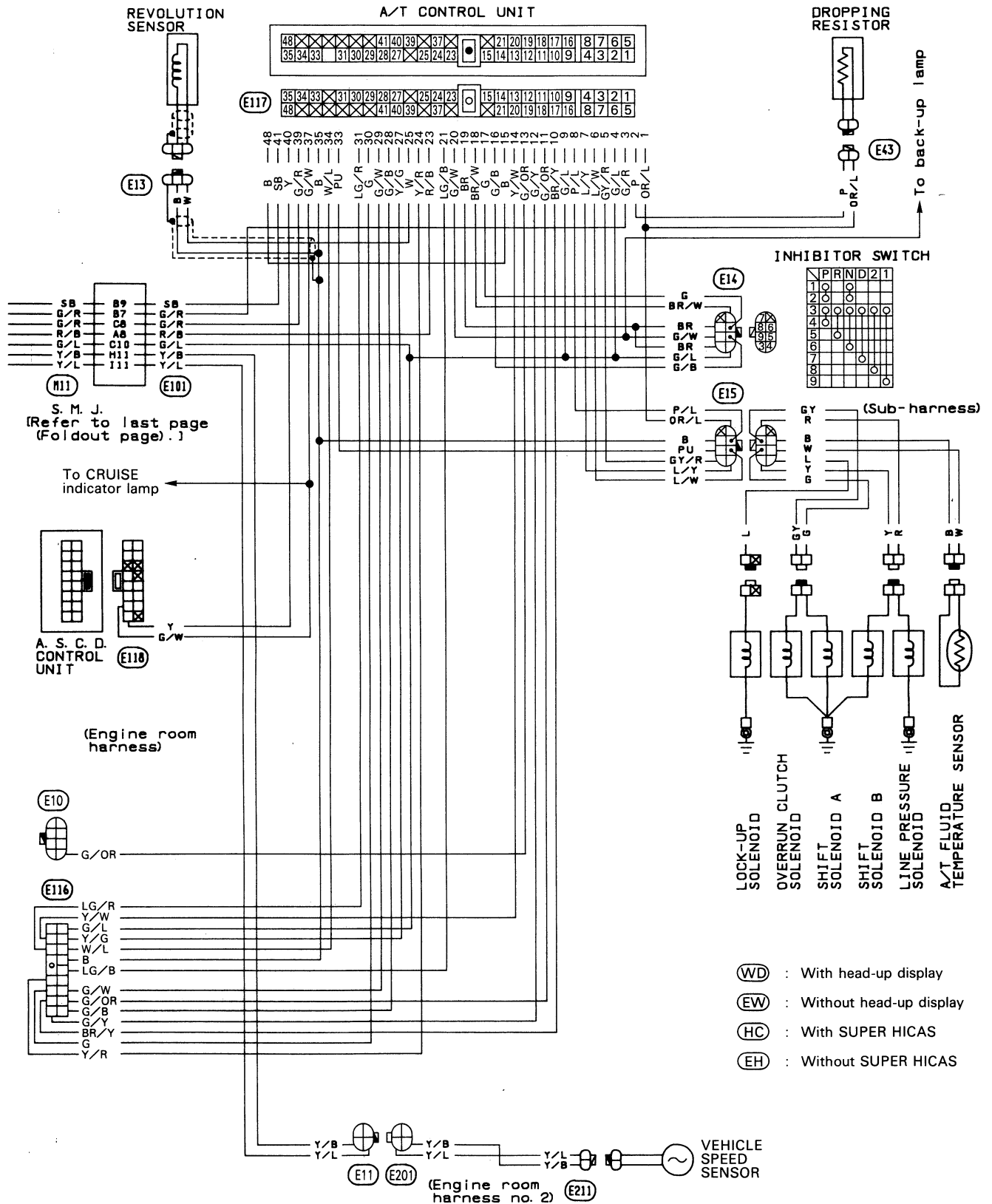

S. M. J.
[Refer to last page
(Foldout page).]

To CRUISE
indicator lamp

A. S. C. D.
CONTROL
UNIT

(Engine room
harness)

(Engine room
harness no. 2)

TROUBLE DIAGNOSES

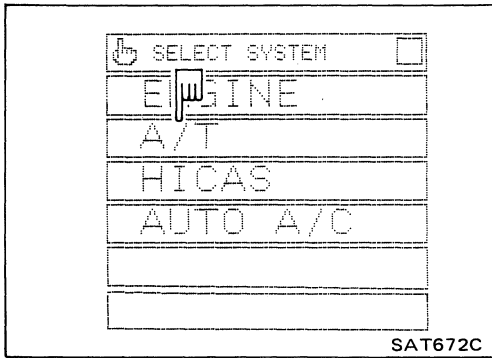

Self-diagnosis

SELF-DIAGNOSTIC PROCEDURE (With CONSULT)

1. Turn on CONSULT.
2. Touch "A/T".

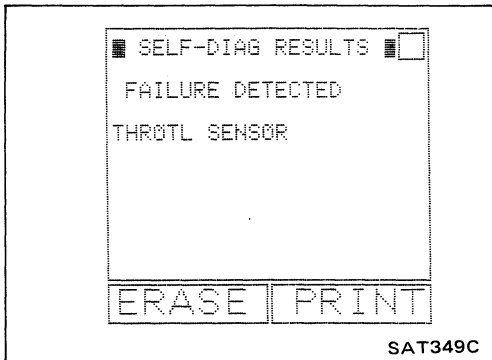

3. Touch "SELF-DIAGNOSIS".
CONSULT performs REAL-TIME SELF-DIAGNOSIS.

TROUBLE DIAGNOSES

Self-diagnosis (Cont'd)

SELF-DIAGNOSTIC PROCEDURE (⌚ Without CONSULT)

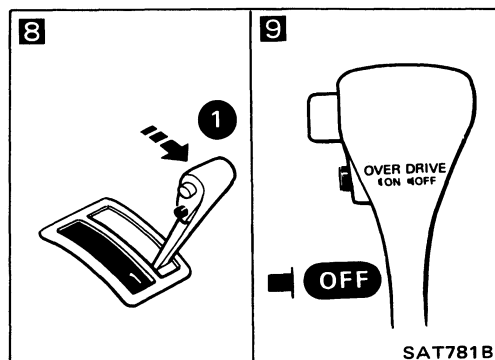
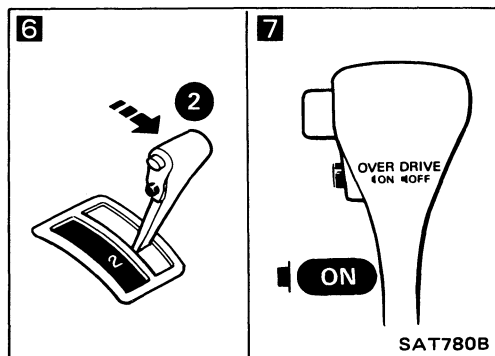
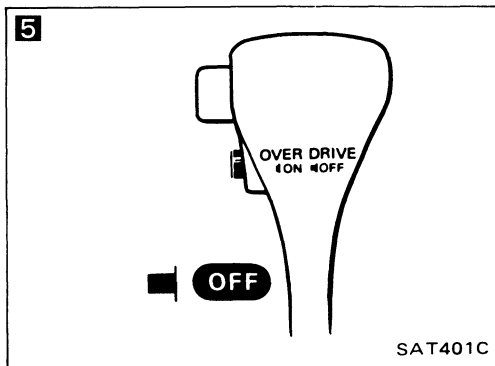
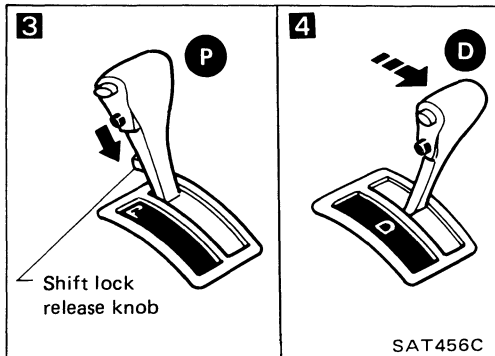
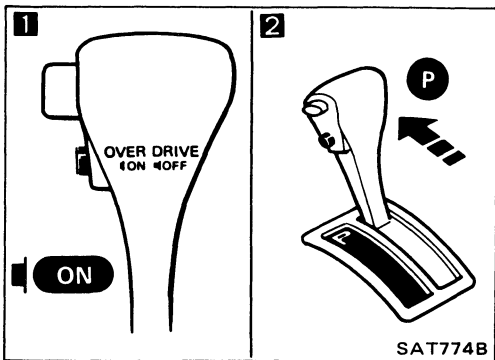

DIAGNOSIS START

Start engine and warm it up to normal engine operating temperature.

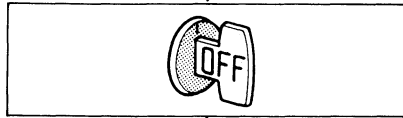

1 Set overdrive switch in "ON" position.

2 Move selector lever to "P" range.

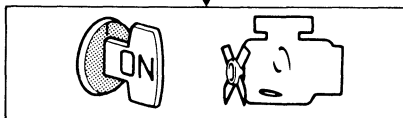

Does A/T check lamp come on for about 2 seconds?

Yes

No

Go to Diagnostic Procedure 1.

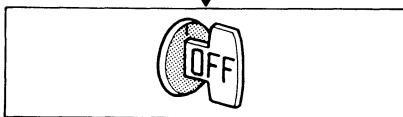

3 Push shift lock release knob (if equipped).

4 Move selector lever to "D" range.

5 Set overdrive switch in "OFF" position.

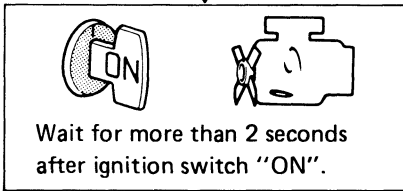

6 Move selector lever to "2" range.

7 Set overdrive switch in "ON" position.

8 Move selector lever to "1" range.

9 Set overdrive switch in "OFF" position.

A

TROUBLE DIAGNOSES

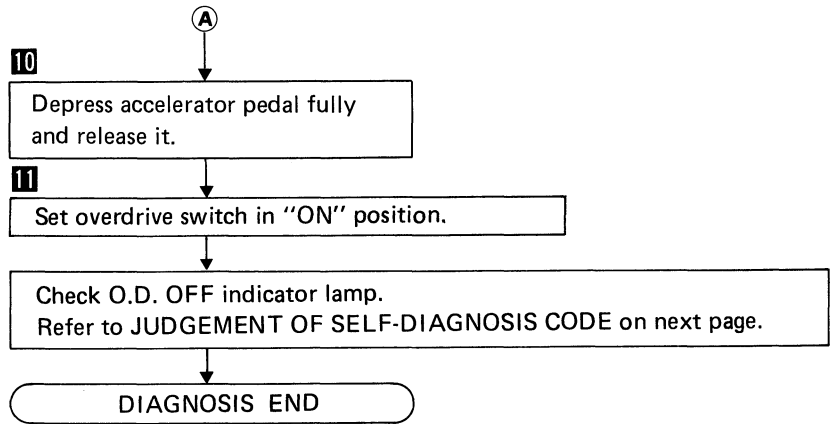
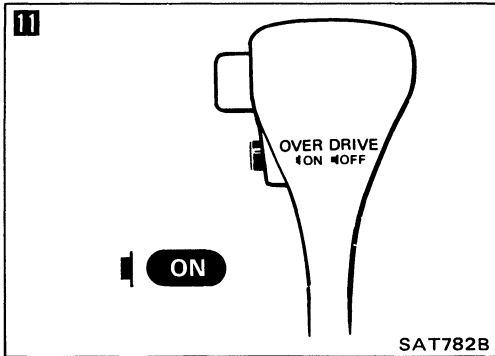
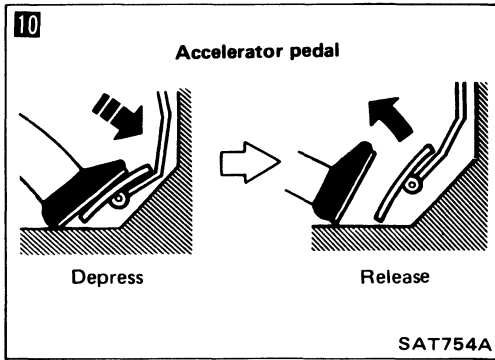

Self-diagnosis (Cont'd)



TROUBLE DIAGNOSES

Self-diagnosis (Cont'd)

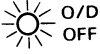
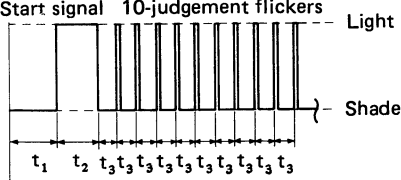
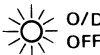
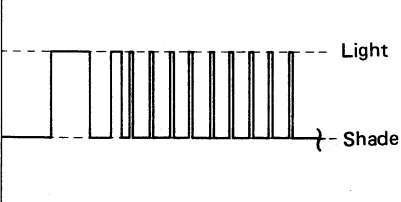
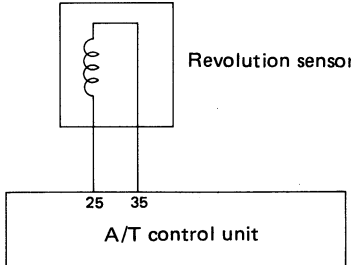
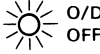
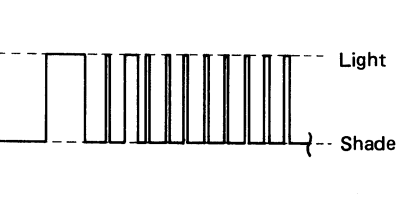
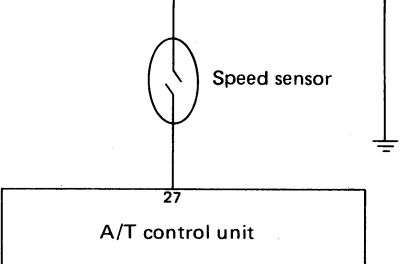

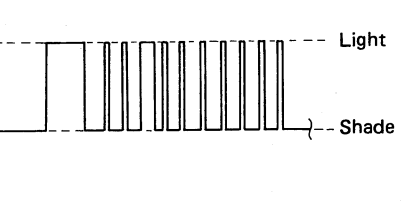
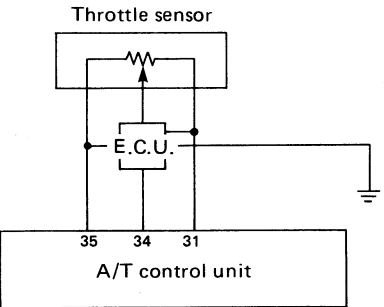



JUDGEMENT OF SELF-DIAGNOSIS CODE

O.D. OFF indicator lamp:	Damaged circuit
<p style="text-align: center;">All judgement flickers are same.</p> <div style="text-align: center;">  </div> <div style="border: 1px solid black; width: fit-content; margin: 5px auto; padding: 2px;">Self-diagnosis start</div> <div style="text-align: center;">  </div> <p style="text-align: right; font-size: small;">SAT723B</p>	<p>All circuits that can be confirmed by self-diagnosis are O.K.</p>
<p style="text-align: center;">1st judgement flicker is longer than others.</p> <div style="text-align: center;">  </div> <div style="text-align: center;">  </div> <p style="text-align: right; font-size: small;">SAT724B</p>	<p>Revolution sensor circuit is short-circuited or disconnected.</p> <div style="text-align: center;">  </div> <p style="text-align: center; font-weight: bold;">➡ Go to REVOLUTION SENSOR CIRCUIT CHECK.</p> <p style="text-align: right; font-size: small;">SAT954D</p>
<p style="text-align: center;">2nd judgement flicker is longer than others.</p> <div style="text-align: center;">  </div> <div style="text-align: center;">  </div> <p style="text-align: right; font-size: small;">SAT725B</p>	<p>Speed sensor circuit is short-circuited or disconnected.</p> <div style="text-align: center;">  </div> <p style="text-align: center; font-weight: bold;">➡ Go to SPEED SENSOR CIRCUIT CHECK.</p> <p style="text-align: right; font-size: small;">SAT955D</p>
<p style="text-align: center;">3rd judgement flicker is longer than others.</p> <div style="text-align: center;">  </div> <div style="text-align: center;">  </div> <p style="text-align: right; font-size: small;">SAT726B</p>	<p>Throttle sensor circuit is short-circuited or disconnected.</p> <div style="text-align: center;">  </div> <p style="text-align: center; font-weight: bold;">➡ Go to THROTTLE SENSOR CIRCUIT CHECK.</p> <p style="text-align: right; font-size: small;">SAT956D</p>

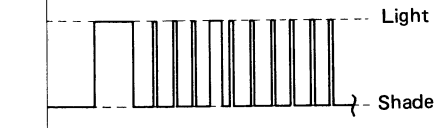
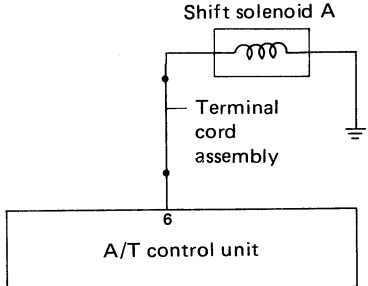
$t_1 = 2.5$ seconds $t_2 = 2.0$ seconds $t_3 = 1.0$ second

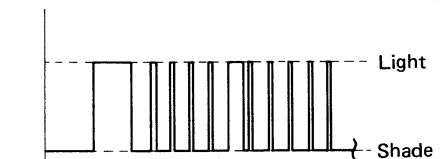
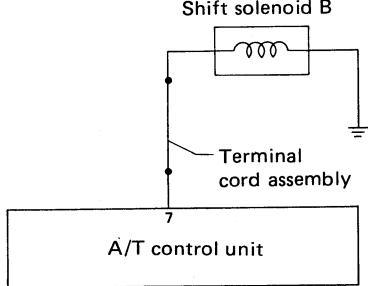

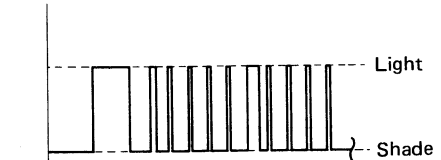
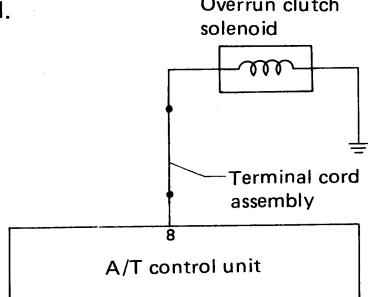

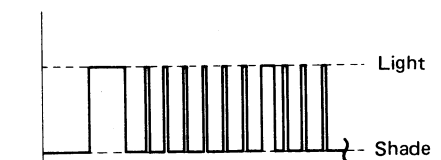
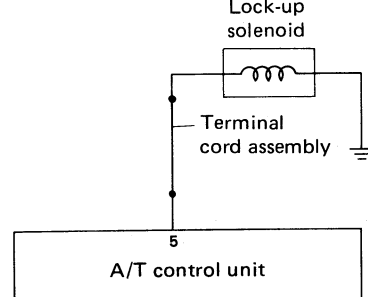
TROUBLE DIAGNOSES

Self-diagnosis (Cont'd)

O.D. OFF indicator lamp:	Damaged circuit
<p>4th judgement flicker is longer than others.</p>  <p>Self-diagnosis start</p>  <p style="text-align: right;">Light Shade</p> <p style="text-align: right;">SAT727B</p>	<p>Shift solenoid A circuit is short-circuited or disconnected.</p>  <p style="text-align: center;">6 A/T control unit</p> <p>➡ Go to SHIFT SOLENOID A CIRCUIT CHECK.</p> <p style="text-align: right;">SAT957D</p>
<p>5th judgement flicker is longer than others.</p>   <p style="text-align: right;">Light Shade</p> <p style="text-align: right;">SAT728B</p>	<p>Shift solenoid B circuit is short-circuited or disconnected.</p>  <p style="text-align: center;">7 A/T control unit</p> <p>➡ Go to SHIFT SOLENOID B CIRCUIT CHECK.</p> <p style="text-align: right;">SAT958D</p>
<p>6th judgement flicker is longer than others.</p>   <p style="text-align: right;">Light Shade</p> <p style="text-align: right;">SAT729B</p>	<p>Overrun clutch solenoid circuit is short-circuited or disconnected.</p>  <p style="text-align: center;">8 A/T control unit</p> <p>➡ Go to VERRUN CLUTCH SOLENOID CIRCUIT CHECK.</p> <p style="text-align: right;">SAT959D</p>
<p>7th judgement flicker is longer than others.</p>   <p style="text-align: right;">Light Shade</p> <p style="text-align: right;">SAT730B</p>	<p>Lock-up solenoid circuit is short-circuited or disconnected.</p>  <p style="text-align: center;">5 A/T control unit</p> <p>➡ Go to LOCK-UP SOLENOID CIRCUIT CHECK.</p> <p style="text-align: right;">SAT960D</p>

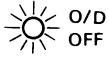
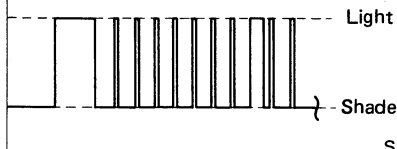
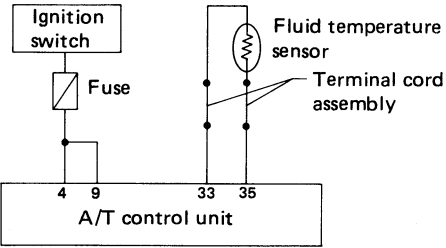
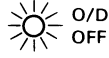
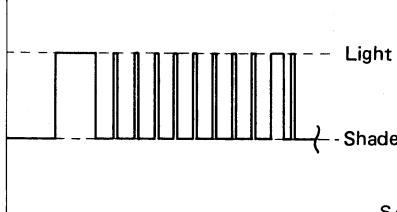
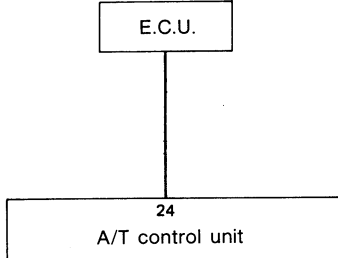
TROUBLE DIAGNOSES

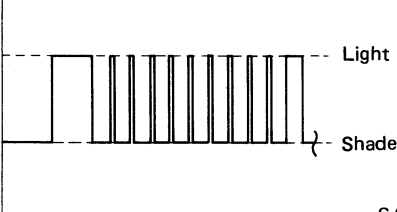
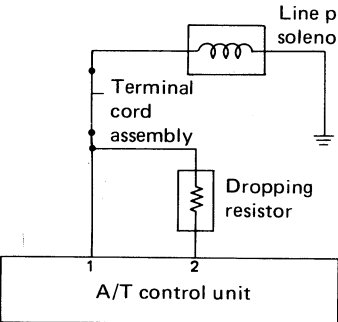
Self-diagnosis (Cont'd)

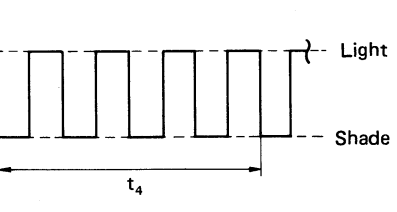
O.D. OFF indicator lamp:	Damaged circuit
<p>8th judgement flicker is longer than others.</p>  <p>Self-diagnosis start</p>  <p>SAT731B</p>	<p>Fluid temperature sensor is disconnected or A/T control unit power source circuit is damaged.</p>  <p>Go to FLUID TEMPERATURE SENSOR CIRCUIT AND A/T CONTROL UNIT POWER SOURCE CIRCUIT CHECK.</p> <p>SAT961D</p>
<p>9th judgement flicker is longer than others.</p>   <p>SAT733B</p>	<p>Engine revolution signal circuit is short-circuited or disconnected.</p>  <p>Go to ENGINE REVOLUTION SIGNAL CIRCUIT CHECK.</p> <p>SAT962D</p>
<p>10th judgement flicker is longer than others.</p>   <p>SAT732B</p>	<p>Line pressure solenoid circuit is short-circuited or disconnected.</p>  <p>Go to LINE PRESSURE SOLENOID CIRCUIT CHECK.</p> <p>SAT963D</p>
<p>Flickers as shown below:</p>   <p>SAT734B</p>	<p>Battery power is low. Battery has been disconnected for a long time. Battery is connected conversely. (When reconnecting A/T control unit connectors. – This is not a problem.)</p>

$t_4 = 1.0$ second

TROUBLE DIAGNOSES

Self-diagnosis (Cont'd)

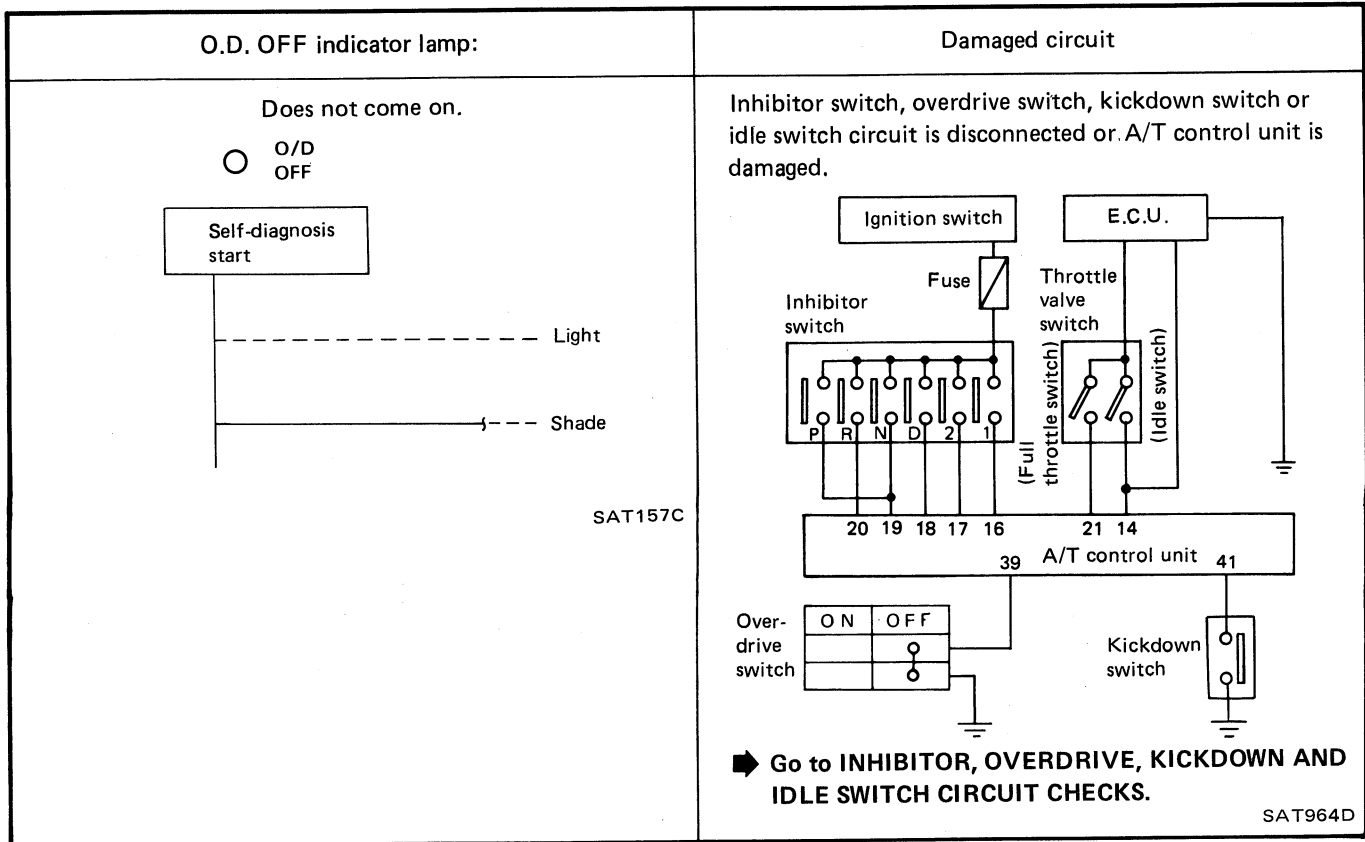

TROUBLE DIAGNOSES

Self-diagnosis (Cont'd)

REVOLUTION SENSOR CIRCUIT CHECK

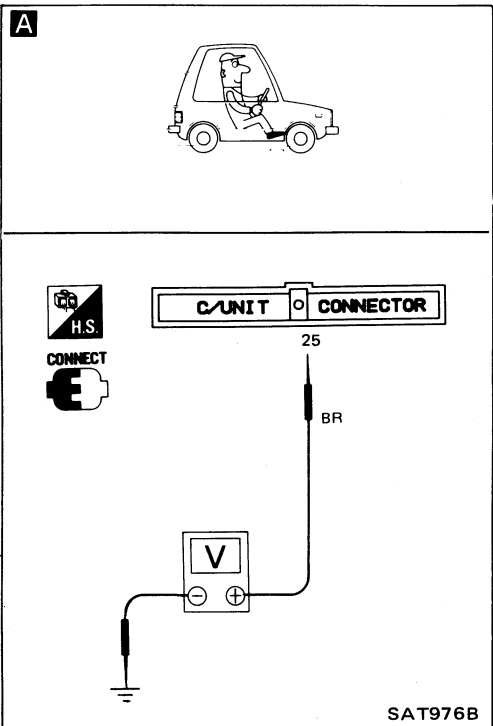
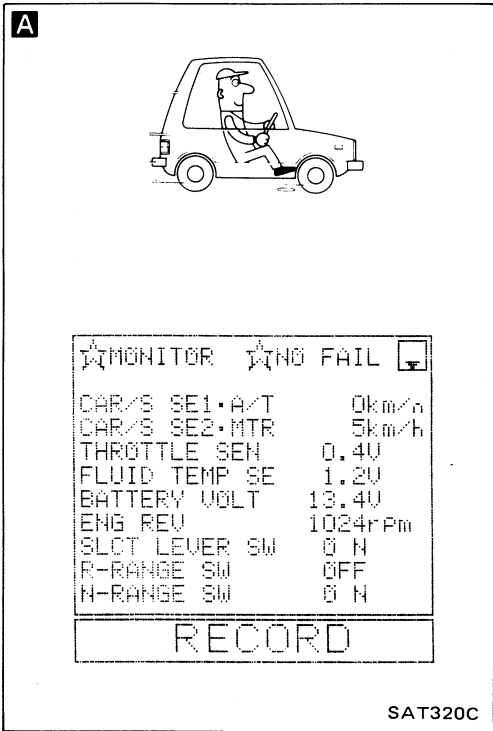
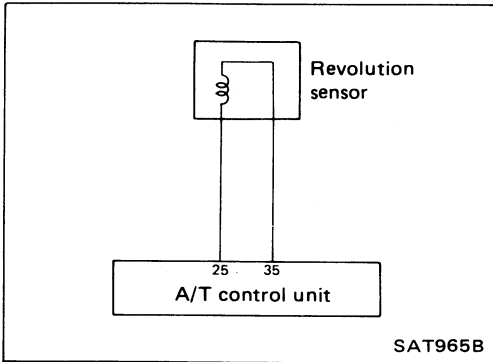

CHECK REVOLUTION SENSOR. — Refer to "Electrical Components Inspection".

N.G.

Repair or replace revolution sensor.

O.K.

A

CHECK INPUT SIGNAL.

N.G.

Check harness continuity between A/T control unit and revolution sensor.

1.

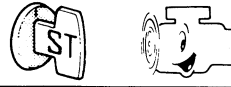

2.



- Select "E.C.U. INPUT SIGNALS".
- Read out the value of "CAR SPEED SENSOR 1" while driving.
- Check the value changes according to driving speed.

OR



Check voltage between A/T control unit terminal ②⑤ and ground while driving.

(Measure with A.C. range.)

Voltage:

At 0 km/h (0 MPH):

0V

At 30 km/h (19 MPH):

1V or more

(Voltage rises gradually in response to vehicle speed.)

O.K.

Perform self-diagnosis again after driving for a while.

N.G.

1. Perform A/T control unit input/output signal inspection.
2. If N.G., recheck A/T control unit pin terminals for damage or connection of A/T control unit harness connector.

O.K.

INSPECTION END

TROUBLE DIAGNOSES

Self-diagnosis (Cont'd)

SPEED SENSOR CIRCUIT CHECK

A



☆MONITOR	☆NO FAIL	
CAR/S SE1-A/T		0km/h
CAR/S SE2-MTR		5km/h
THROTTLE SEN		0.4V
FLUID TEMP SE		1.2V
BATTERY VOLT		13.4V
ENG REV		1024rPm
SLCT LEVER SW		0 N
R-RANGE SW		OFF
N-RANGE SW		0 N

RECORD

SAT320C

A

CHECK INPUT SIGNAL.

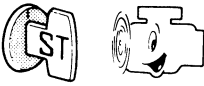
1. 

2. 

- Select "E.C.U. INPUT SIGNALS".
- Read out the value of "CAR SPEED SENSOR 2" while driving.
- Check the value changes according to driving speed.

OR



- Check voltage between A/T control unit terminal 27 and ground while driving at 2 to 3 km/h (1 to 2 MPH) for 1 m (3 ft) or more.
Voltage: Varies from 0V to 5V

O.K. →

Perform self-diagnosis again after driving for a while.

O.K. →

INSPECTION END

N.G. →

Check the following items.

- Speed sensor and ground circuit for speed sensor – Refer to section EL.
- Harness continuity between A/T control unit and speed sensor

N.G. →

1. Perform A/T control unit input/output signal inspection.

2. If N.G., recheck A/T control unit pin terminals for damage or connection of A/T control unit harness connector.

A

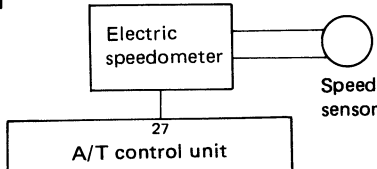

At 2 - 3 km/h (1 - 2 MPH)

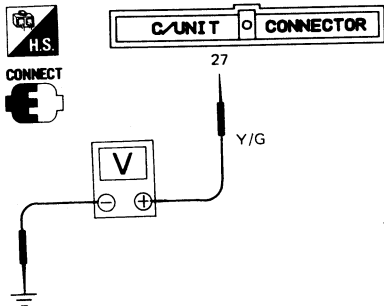



SAT967D

TROUBLE DIAGNOSES

Self-diagnosis (Cont'd)

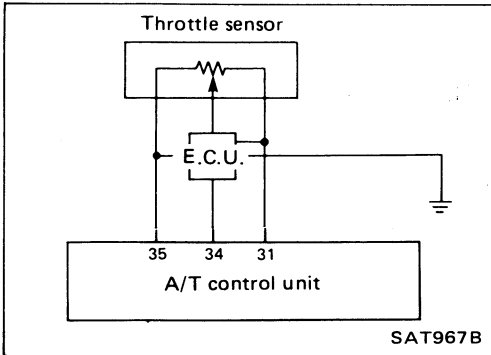
THROTTLE SENSOR CIRCUIT CHECK



A

Depress slowly.

```

MONITOR  *NO FAIL
CAR/S SE1-A/T      0km/h
CAR/S SE2-MTR     5km/h
THROTTLE SEN      0.4V
FLUID TEMP SE     1.2V
BATTERY VOLT     13.4V
ENG REV           1024rpm
SLCT LEVER SW     0 N
R-RANGE SW        OFF
N-RANGE SW        0 N
    
```

RECORD

SAT321C

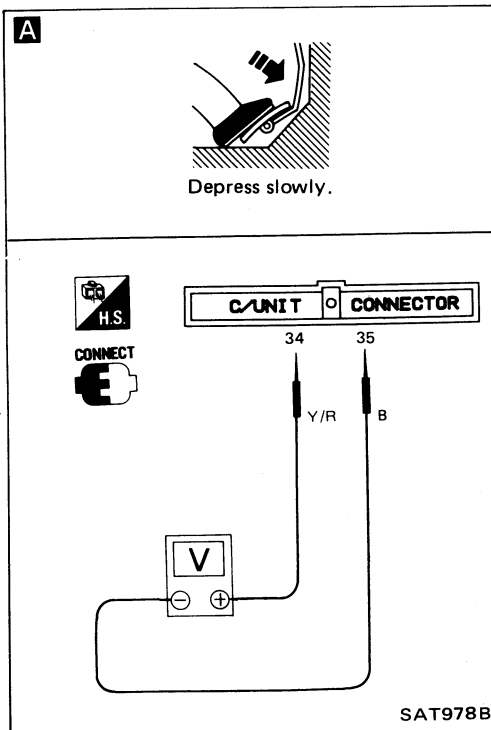

Perform self-diagnosis (Mode III) for engine control.

N.G. → Check throttle sensor circuit for engine control. — Refer to section EF & EC.

O.K. ↓

A

CHECK INPUT SIGNAL.

1.

N.G. → Check harness continuity between E.C.U. and A/T control unit regarding throttle sensor circuit.

2. • Select "E.C.U. INPUT SIGNALS".
• Read out the value of "THROTTLE SENSOR".

Voltage:
Fully-closed throttle: 0.2 - 0.6V
Fully-open throttle: 2.9 - 3.9V

OR

• Check voltage between A/T control unit terminals 34 and 35 while accelerator pedal is depressed slowly.

Voltage:
Fully-closed throttle: 0.2 - 0.6V
Fully-open throttle: 2.9 - 3.9V

(Voltage rises gradually in response to throttle valve opening.)

O.K. ↓

Perform self-diagnosis again after driving for a while.

N.G. → 1. Perform A/T control unit input/output signal inspection.
2. If N.G., recheck A/T control unit pin terminals for damage or connection of A/T control unit harness connector.

O.K. ↓

INSPECTION END

TROUBLE DIAGNOSES

Self-diagnosis (Cont'd)

SHIFT SOLENOID A CIRCUIT CHECK

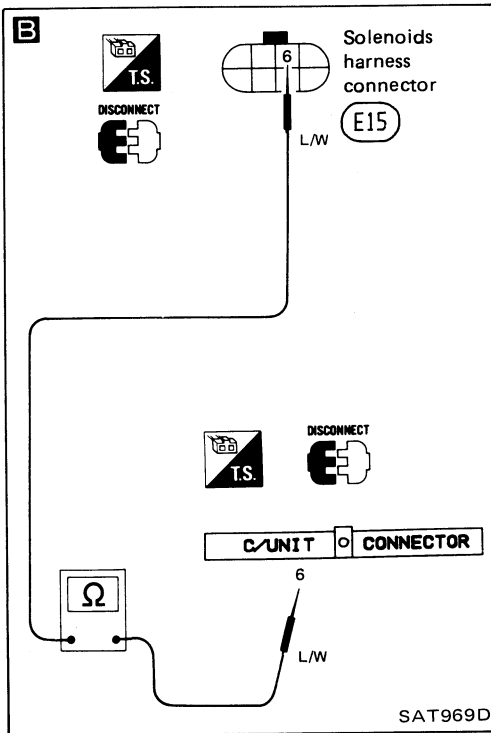
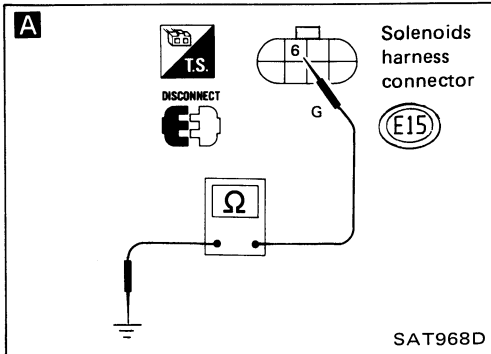
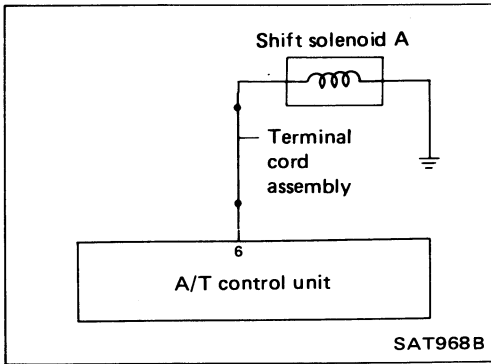

A

CHECK GROUND CIRCUIT.

1. 
2. Disconnect terminal cord assembly connector in engine compartment.
3. Check resistance between terminal ⑥ and ground.
Resistance: 20 - 30Ω

N.G.

1. Remove control valve assembly. — Refer to "ON-VEHICLE SERVICE".
2. Check the following items.
 - Shift solenoid A — Refer to "Electrical Components Inspection".
 - Harness continuity of terminal cord assembly

B

CHECK POWER SOURCE CIRCUIT.

1. 
2. Disconnect A/T control unit connector.
3. Check resistance between terminal ⑥ and A/T control unit terminal ⑥.
Resistance: Approximately 0Ω
4. Reinstall any part removed.

N.G.

Repair or replace harness between A/T control unit and terminal cord assembly.

Perform self-diagnosis after driving for a while.

O.K.

INSPECTION END

N.G.

1. Perform A/T control unit input/output signal inspection.
2. If N.G., recheck A/T control unit pin terminals for damage or connection of A/T control unit harness connector.

TROUBLE DIAGNOSES

Self-diagnosis (Cont'd)

SHIFT SOLENOID B CIRCUIT CHECK

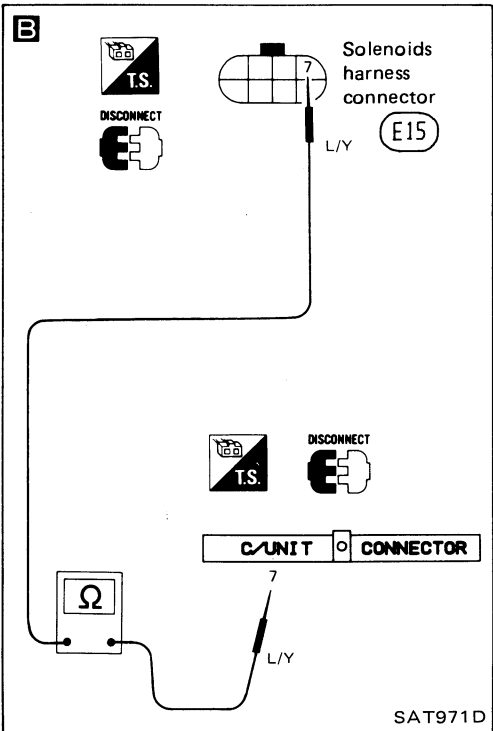
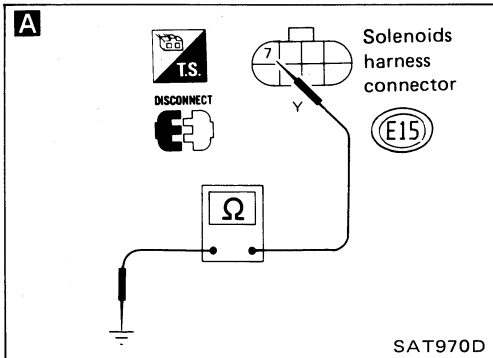
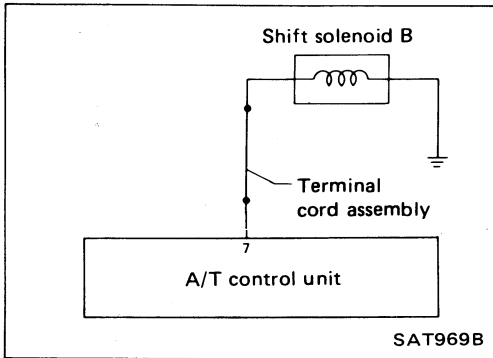

A

CHECK GROUND CIRCUIT.

- 1.
2. Disconnect terminal cord assembly connector in engine compartment.
3. Check resistance between terminal ⑦ and ground.
Resistance: 20 - 40Ω

N.G.

1. Remove control valve assembly. — Refer to "ON-VEHICLE SERVICE".
2. Check the following items.
 - Shift solenoid B — Refer to "Electrical Components Inspection".
 - Harness continuity of terminal cord assembly

B

CHECK POWER SOURCE CIRCUIT.

- 1.
2. Disconnect A/T control unit connector.
3. Check resistance between terminal ⑦ and A/T control unit terminal ⑦.
Resistance: Approximately 0Ω
4. Reinstall any part removed.

N.G.

Repair or replace harness between A/T control unit and terminal cord assembly.

O.K.

Perform self-diagnosis after driving for a while.

O.K.

INSPECTION END

N.G.

1. Perform A/T control unit input/output signal inspection.
2. If N.G., recheck A/T control unit pin terminals for damage or connection of A/T control unit harness connector.

TROUBLE DIAGNOSES

Self-diagnosis (Cont'd)

OVERRUN CLUTCH SOLENOID CIRCUIT CHECK

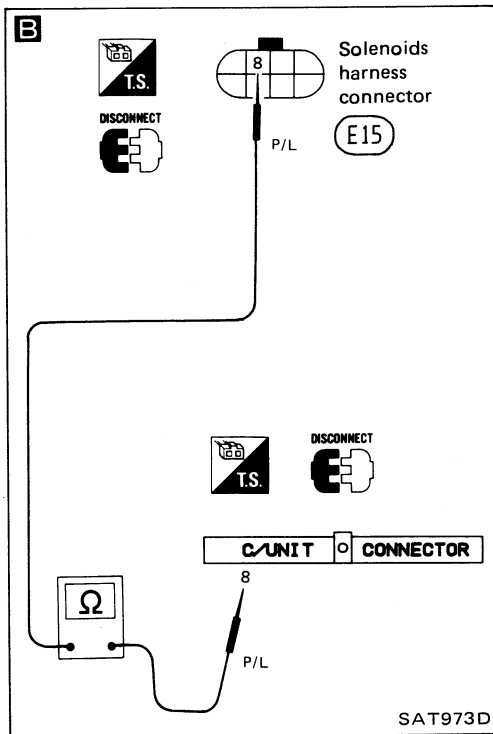
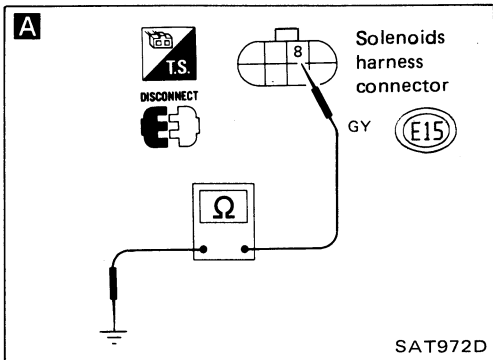
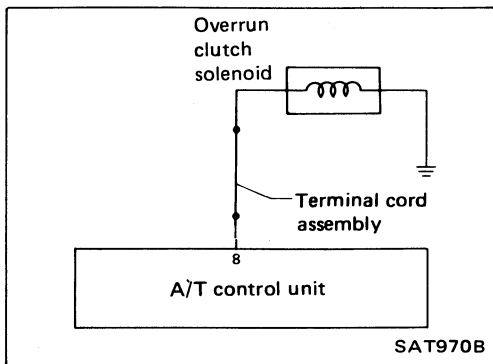

A CHECK GROUND CIRCUIT.

1. 
2. Disconnect terminal cord assembly connector in engine compartment.
3. Check resistance between terminal ⑧ and ground.
Resistance: 20 - 30Ω

N.G.

1. Remove control valve assembly. — Refer to "ON-VEHICLE SERVICE".
2. Check the following items.
 - Overrun clutch solenoid. — Refer to "Electrical Components Inspection".
 - Harness continuity of terminal cord assembly

O.K.

B CHECK POWER SOURCE CIRCUIT.

1. 
2. Disconnect A/T control unit connector.
3. Check resistance between terminal ⑧ and A/T control unit terminal ⑧.
Resistance: Approximately 0Ω
4. Reinstall any part removed.

N.G.

- Repair or replace harness between A/T control unit and terminal cord assembly.

O.K.

Perform self-diagnosis after driving for a while.

N.G.

1. Perform A/T control unit input/output signal inspection.
2. If N.G., recheck A/T control unit pin terminals for damage or connection of A/T control unit harness connector.

O.K.

INSPECTION END

TROUBLE DIAGNOSES

Self-diagnosis (Cont'd)

LOCK-UP SOLENOID CIRCUIT CHECK

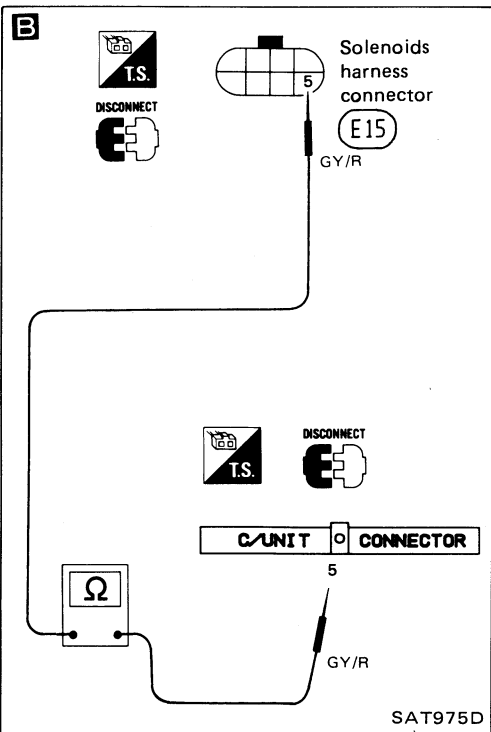
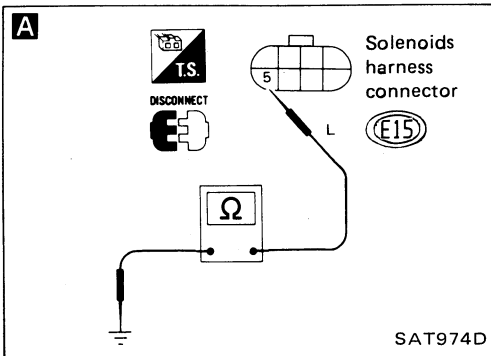
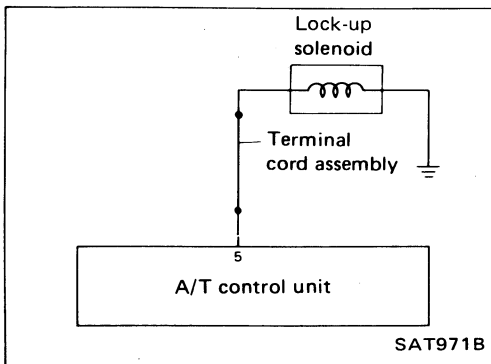

A

CHECK GROUND CIRCUIT.

1. 
2. Disconnect terminal cord assembly connector in engine compartment.
3. Check resistance between terminal ⑤ and ground.
Resistance: 10 - 20 Ω

N.G.

1. Remove oil pan.
– Refer to "ON-VEHICLE SERVICE".
2. Check the following items.
 - Lock-up solenoid – Refer to "Electrical Components Inspection".
 - Harness continuity of terminal cord assembly.

O.K.

B

CHECK POWER SOURCE CIRCUIT.

1. 
2. Disconnect A/T control unit connector.
3. Check resistance between terminal ⑤ and A/T control unit terminal ⑤.
Resistance: Approximately 0 Ω
4. Reinstall any part removed.

N.G.

Repair or replace harness between A/T control unit and terminal cord assembly.

O.K.

Perform self-diagnosis after driving for a while.

O.K.

INSPECTION END

N.G.

1. Perform A/T control unit input/output signal inspection.
2. If N.G., recheck A/T control unit pin terminals for damage or connection of A/T control unit harness connector.

TROUBLE DIAGNOSES

Self-diagnosis (Cont'd)

FLUID TEMPERATURE SENSOR CIRCUIT AND A/T CONTROL UNIT POWER SOURCE CIRCUIT CHECKS

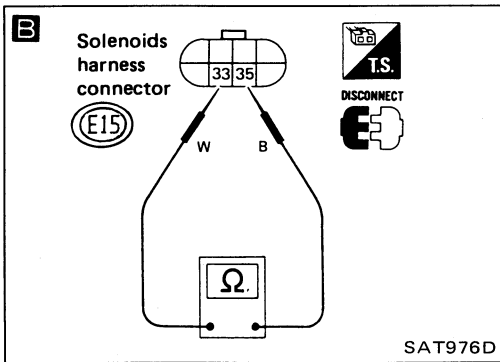
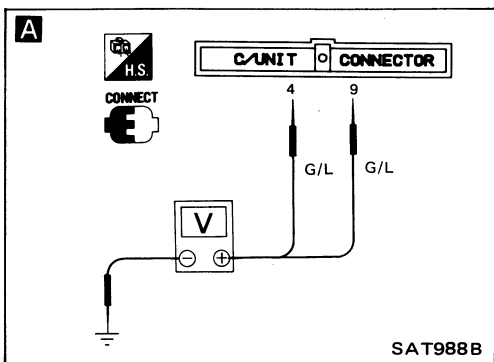
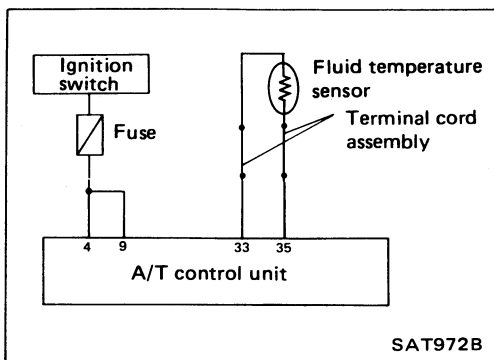

A

CHECK A/T CONTROL UNIT POWER SOURCE.

1.

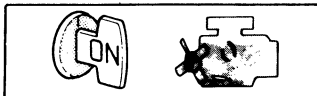

2. Check voltage between A/T control unit terminals ④, ⑨ and ground.

Battery voltage should exist.

N.G.

Check the following items.

- Harness continuity between ignition switch and A/T control unit
- Ignition switch and fuse – Refer to section EL.

B

CHECK FLUID TEMPERATURE SENSOR WITH TERMINAL CORD ASSEMBLY

1.



2. Disconnect terminal cord assembly connector in engine compartment.

3. Check resistance between terminals ③③ and ③⑤ when A/T is cold.

Resistance:

Cold [20°C (68°F)]

Approximately 2.5 kΩ

4. Reinstall any part removed.

N.G.

1. Remove control valve cover.

2. Check the following items.

- Fluid temperature sensor – Refer to "Electrical Components Inspection".
- Harness continuity of terminal cord assembly

O.K.

A

TROUBLE DIAGNOSES

Self-diagnosis (Cont'd)

C

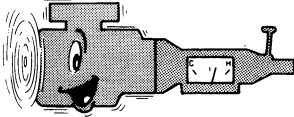

```

    ☆MONITOR ☆NO FAIL
    CAR/S SE1·A/T      0km/h
    CAR/S SE2·MTR      5km/h
    THROTTLE SEN       0.4V
    FLUID TEMP SE      1.2V
    BATTERY VOLT       13.4V
    ENG REV            1024rpm
    SLCT LEVER SW      0 N
    R-RANGE SW         OFF
    N-RANGE SW         0 N
    
```

RECORD

SAT330C

C

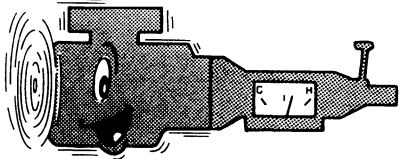
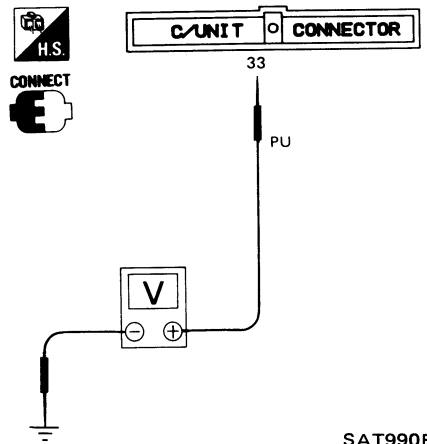



SAT990B

C

CHECK INPUT SIGNAL OF FLUID TEMPERATURE SENSOR.

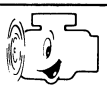
N.G. → Check harness continuity between A/T control unit and terminal cord assembly.

- 

- 
 - Select "E.C.U. INPUT SIGNALS".
 - Read out the value of "FLUID TEMPERATURE SENSOR".

Voltage:
 Cold [20°C (68°F)] →
 Hot [80°C (176°F)]:
 Approximately
 1.5V → 0.5V

— OR —

 - 
 Check voltage between A/T control unit terminal ③③ and ground while warming up A/T.

Voltage:
 Cold [20°C (68°F)] →
 Hot [80°C (176°F)]:
 Approximately
 1.5V → 0.5V

O.K. → Perform self-diagnosis after driving for a while.

N.G. → 1. Perform A/T control unit input/output signal inspection.
 2. If N.G., recheck A/T control unit pin terminals for damage or connection of A/T control unit harness connector.

O.K. → **INSPECTION END**

TROUBLE DIAGNOSES

Self-diagnosis (Cont'd)

ENGINE REVOLUTION SIGNAL CIRCUIT CHECK

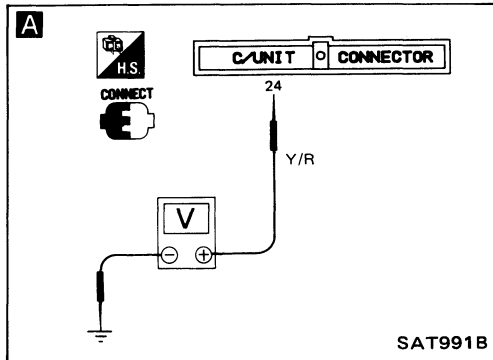
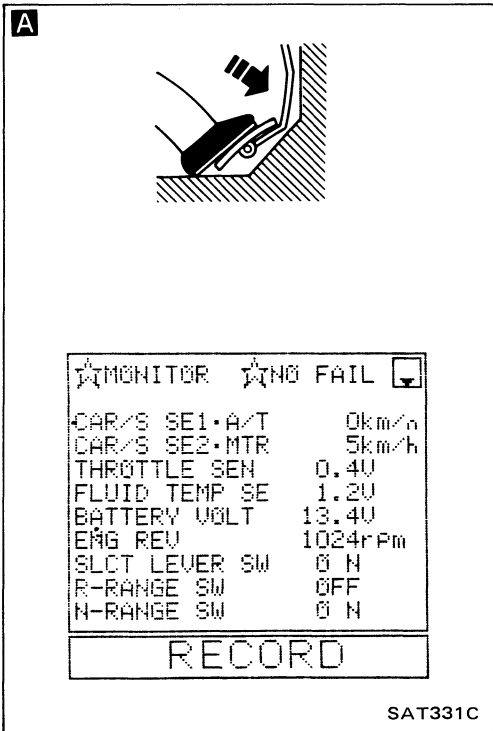
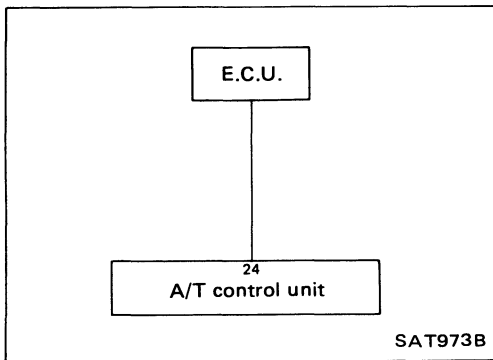

Check ignition circuit condition for engine.

N.G.

Repair or replace. — Refer to section EF & EC.

O.K.

A

CHECK INPUT SIGNAL.

1.

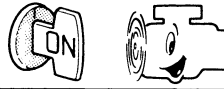

2.

- Select "E.C.U. INPUT SIGNALS".
- Read out the value of "ENGINE REVOLUTION".
- Check engine revolution changes according to throttle opening.

N.G.

Check harness continuity between A/T control unit and E.C.C.S. control unit.

OR



- Check voltage between A/T control unit terminal ②④ and ground.
Voltage: 0.9 - 4.5V

O.K.

Perform self-diagnosis again after driving for a while.

N.G.

1. Perform A/T control unit input/output signal inspection.
2. If N.G., recheck A/T control unit pin terminals for damage or connection of A/T control unit harness connector.

O.K.

INSPECTION END

TROUBLE DIAGNOSES

Self-diagnosis (Cont'd)

LINE PRESSURE SOLENOID CIRCUIT CHECK

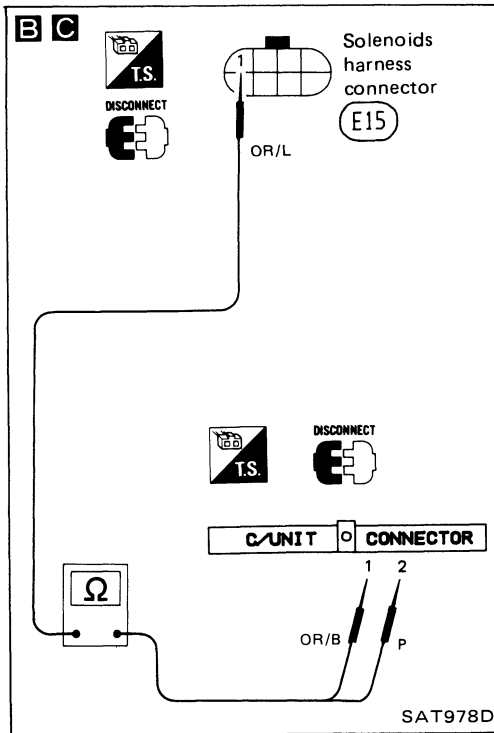
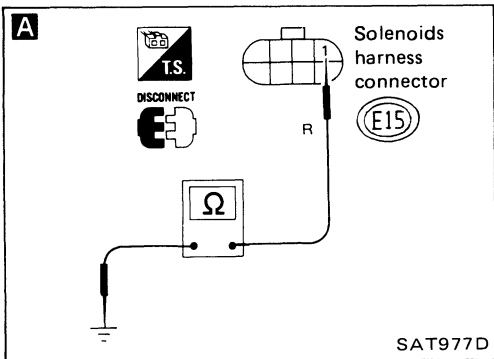
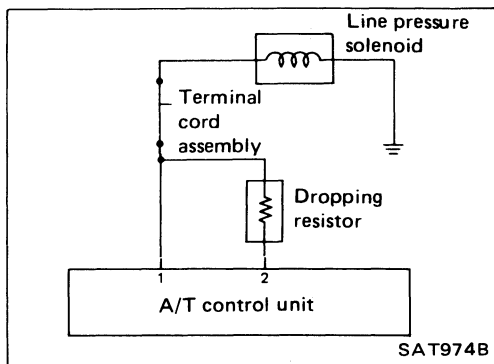

A

CHECK GROUND CIRCUIT.

1. Disconnect terminal cord assembly connector in engine compartment.
2. Check resistance between terminal ① and ground.
Resistance: 2.5 - 5Ω

- N.G.
1. Remove control valve assembly. — Refer to "ON-VEHICLE SERVICE".
 2. Check the following items.
 - Line pressure solenoid — Refer to "Electrical Components Inspection".
 - Harness continuity of terminal cord assembly

O.K.

B

CHECK POWER SOURCE CIRCUIT.

1. Disconnect A/T control unit connector.
2. Check resistance between terminal ① and A/T control unit terminal ②.
Resistance: 11.2 - 12.8Ω

- N.G.
- Check the following items.
- Dropping resistor — Refer to "Electrical Components Inspection".
 - Harness continuity between A/T control unit ② and terminal cord assembly

O.K.

C

CHECK POWER SOURCE CIRCUIT

1. Check resistance between terminal ① and A/T control unit terminal ①.
Resistance: Approximately 0Ω
2. Reinstall any part removed.

- N.G.
- Repair or replace harness between A/T control unit ① and terminal cord assembly.

O.K.

Perform self-diagnosis after driving for a while.

- N.G.
1. Perform A/T control unit input/output signal inspection.
 2. If N.G., recheck A/T control unit pin terminals for damage or connection of A/T control unit harness connector.

O.K.

INSPECTION END

TROUBLE DIAGNOSES

Self-diagnosis (Cont'd)

INHIBITOR, OVERDRIVE, KICKDOWN AND IDLE SWITCH CIRCUIT CHECKS

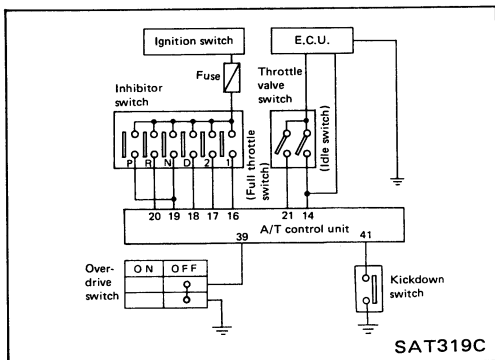

A

```

    ☆MONITOR ☆NO FAIL
    CAR/S SE1·A/T      0km/h
    CAR/S SE2·MTR     5km/h
    THROTTLE SEN      0.4V
    FLUID TEMP SE     1.2V
    BATTERY VOLT     13.4V
    ENG REV           1024rPm
    SLCT LEVER SW    0 N
    R-RANGE SW      OFF
    N-RANGE SW      0 N
    
```

RECORD

SAT334C

A

H.S. CONNECT

UNIT CONNECTOR

16 17 18 19 20

G/B G BR/W BR G/W

V

SAT994B

A

CHECK INHIBITOR SWITCH CIRCUIT.

1.

2. Select "E.C.U. INPUT signals".

- Read out "R, N, D, 1 and 2 range switches" moving selector lever to each range.
- Check the selector lever position is indicated properly.

N.G. →

Check the following items.

- Inhibitor switch – Refer to "Electrical Components Inspection".
- Harness continuity between ignition switch and inhibitor switch
- Harness continuity between inhibitor switch and A/T control unit

OR

Check voltage between A/T control unit terminals 16, 17, 18, 19, 20 and ground while moving selector lever through each range.

Voltage:

B: Battery voltage

0: 0V

Terminal No.	19	20	18	17	16
P, N	B	0	0	0	0
R	0	B	0	0	0
D	0	0	B	0	0
2	0	0	0	B	0
1	0	0	0	0	B

O.K.

A

TROUBLE DIAGNOSES

Self-diagnosis (Cont'd)

B

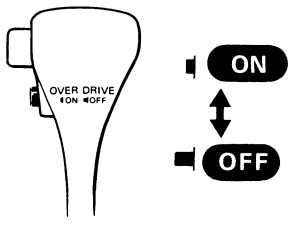

OVER DRIVE
ON OFF

ON

OFF

```

    ☆MONITOR ☆NO FAIL
    CAR/S SE1·A/T      0km/h
    CAR/S SE2·MTR      5km/h
    THROTTLE SEN       0.4U
    FLUID TEMP SE      1.2U
    BATTERY VOLT       13.4U
    ENG REV            1024rPm
    SLOT LEVER SW      0 N
    R-RANGE SW         OFF
    N-RANGE SW         0 N
    
```

RECORD

SAT335C

B

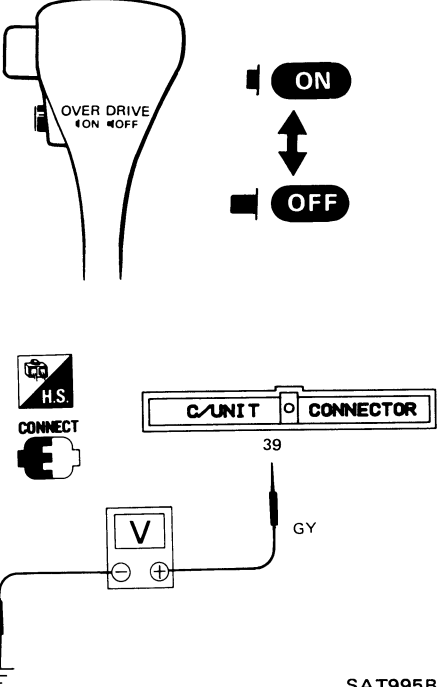

OVER DRIVE
ON OFF

ON

OFF

H.S.
CONNECT

C/UNIT o CONNECTOR

39

GY

V

SAT995B

B

CHECK OVERDRIVE SWITCH CIRCUIT.

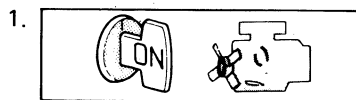

2.  • Select "E.C.U. INPUT SIGNALS".
- Read out "SELECTOR LEVER SWITCH (Overdrive switch)".
- Check the selector lever switch position is indicated properly. (Selector lever switch "ON" displayed on CONSULT means overdrive "OFF".)

N.G.

Check the following items.

- Overdrive switch — Refer to "Electrical Components Inspection".
- Harness continuity between A/T control unit and overdrive switch
- Harness continuity of ground circuit for overdrive switch

OR



- Check voltage between A/T control unit terminal 39 and ground when overdrive switch is in "ON" position and in "OFF" position.

Switch position	Voltage
ON	Battery voltage
OFF	1V or less

O.K.

B

TROUBLE DIAGNOSES

Self-diagnosis (Cont'd)

C



MONITOR	NO FAIL
0-RANGE SW	OFF
1-RANGE SW	OFF
2-RANGE SW	OFF
ASCD·CRUISE	OFF
ASCD·OD CUT	OFF
KICKDOWN SW	OFF
POWERSHIFT SW	OFF
IDLE SW	ON
FULL THRTL SW	OFF

RECORD

SAT336C

C

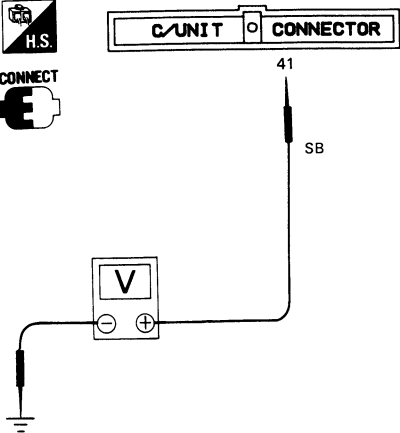



SAT337C

C

B

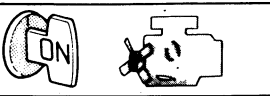
CHECK KICKDOWN SWITCH CIRCUIT.

1. 

2. 

- Select "E.C.U. INPUT SIGNALS".
- Read out "KICKDOWN SWITCH" depressing accelerator pedal fully.
- Check Kickdown switch position is indicated properly.

OR



- Check voltage between A/T control unit terminal (41) and ground while depressing accelerator pedal slowly. (after warming up engine)

Voltage:
 When releasing accelerator pedal: 3 - 8V
 When depressing accelerator pedal fully: 1V or less

N.G.

Check the following items.

- Kickdown switch
- Harness continuity between A/T control unit and kickdown switch
- Harness continuity of ground circuit for kickdown switch
- Adjust kickdown switch — Refer to "ON-VEHICLE SERVICE".

O.K.

C

TROUBLE DIAGNOSES

Self-diagnosis (Cont'd)

D



☆MONITOR	☆NO FAIL	
D-RANGE SW	OFF	
1-RANGE SW	OFF	
2-RANGE SW	OFF	
ASC-D·CRUISE	OFF	
ASC-D·OD CUT	OFF	
KICKDOWN SW	OFF	
POWERSHIFT SW	OFF	
IDLE SW	ON	
FULL THRTL SW	OFF	

RECORD

SAT338C

D

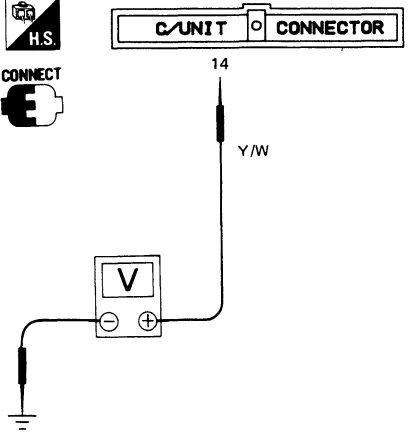



SAT979D

D

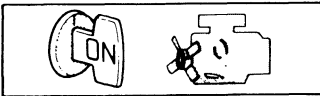
CHECK IDLE SWITCH CIRCUIT.

1. 

2.  • Select "E.C.U. INPUT SIGNALS".

• Read out "IDLE SWITCH" depressing and releasing accelerator pedal.

• Check idle switch changes ON or OFF.

— OR —

 • Check voltage between A/T control unit terminal ⑭ and ground while depressing accelerator pedal slowly.

Voltage:

When releasing accelerator pedal:
8 - 15V

When depressing accelerator pedal fully:
1V or less

O.K. → Perform self-diagnosis again after driving for a while.

O.K. → **INSPECTION END**

N.G. → Perform self-diagnosis (Mode IV) for engine control. Check idle switch circuit.

O.K. → Check harness continuity between A/T control unit and idle switch.

N.G. → Check idle switch circuit for engine control. — Refer to section EF & EC.

N.G. → 1. Perform A/T control unit input/output signal inspection.
2. If N.G., recheck A/T control unit pin terminals for damage or connection of A/T control unit harness connector.

TROUBLE DIAGNOSES

Diagnostic Procedure 1

SYMPTOM: O.D. OFF indicator lamp does not come on for about 2 seconds when turning ignition switch to "ON".

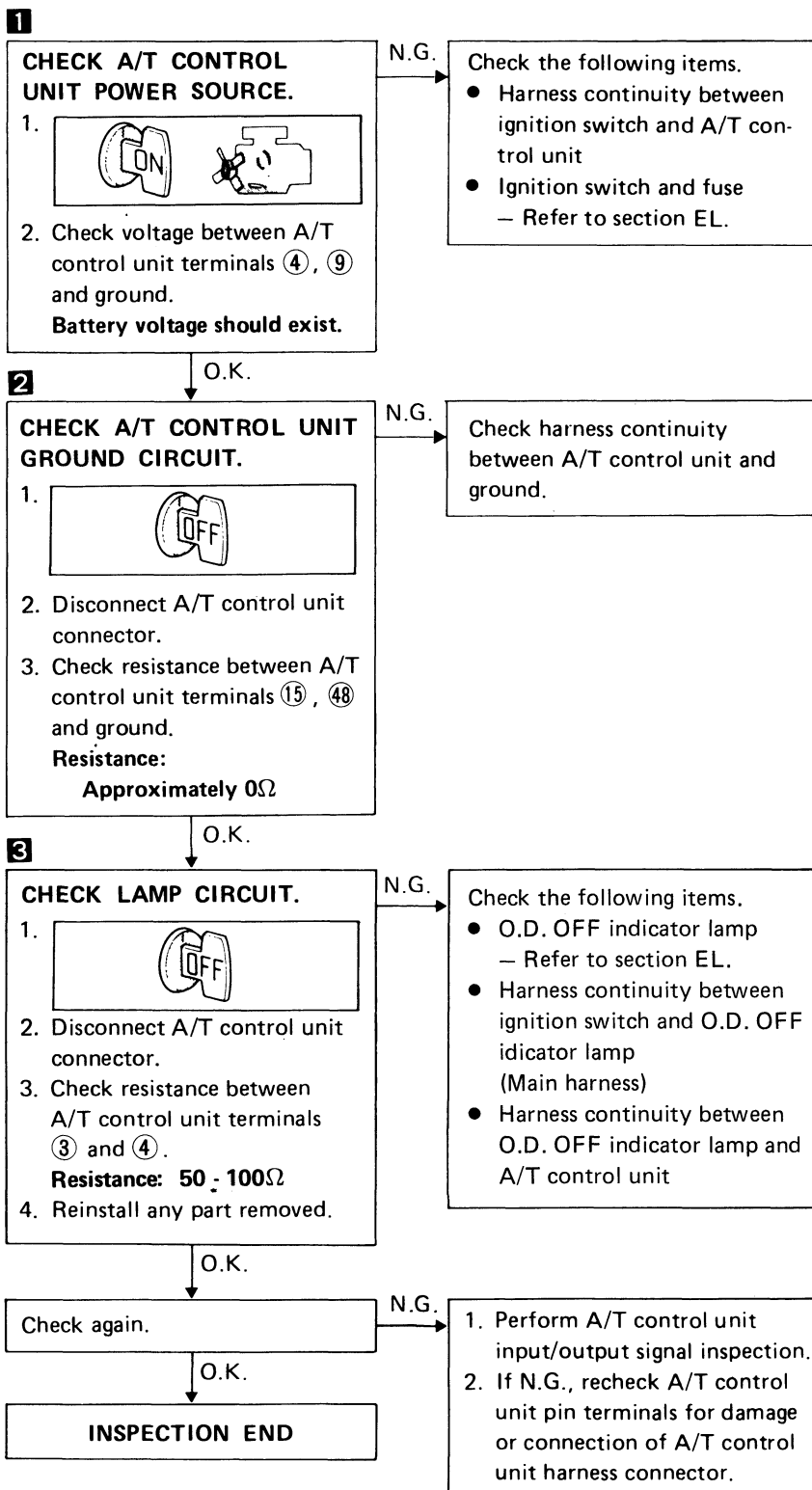
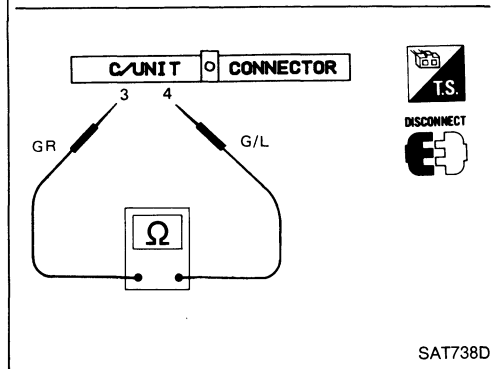
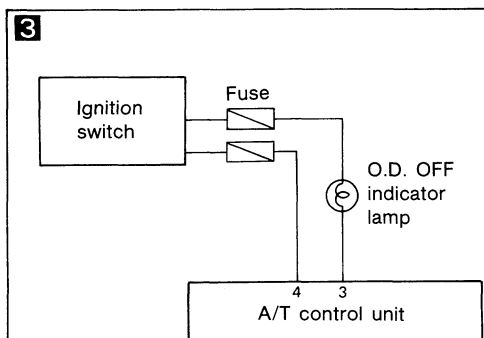
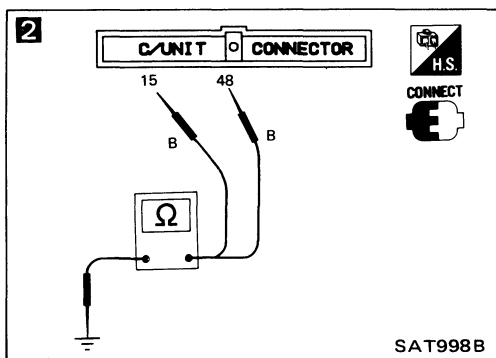
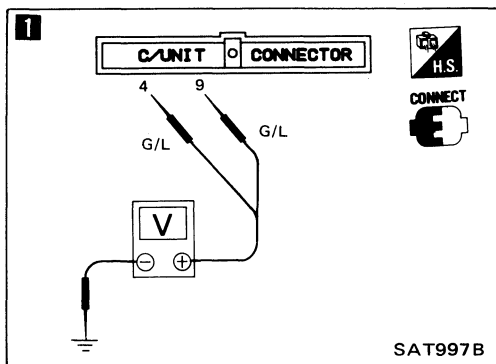

TROUBLE DIAGNOSES

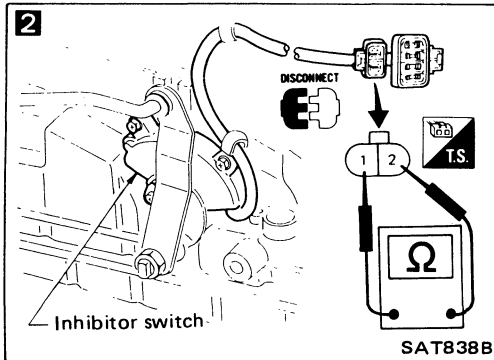
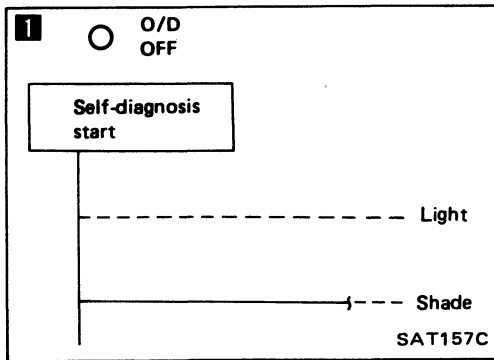

Diagnostic Procedure 2

SYMPTOM: Engine cannot be started with selector lever in "P" or "N" range or engine can be started with selector lever in "D", "2", "1" or "R" range.

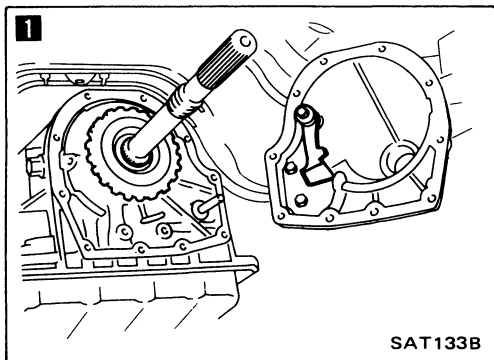
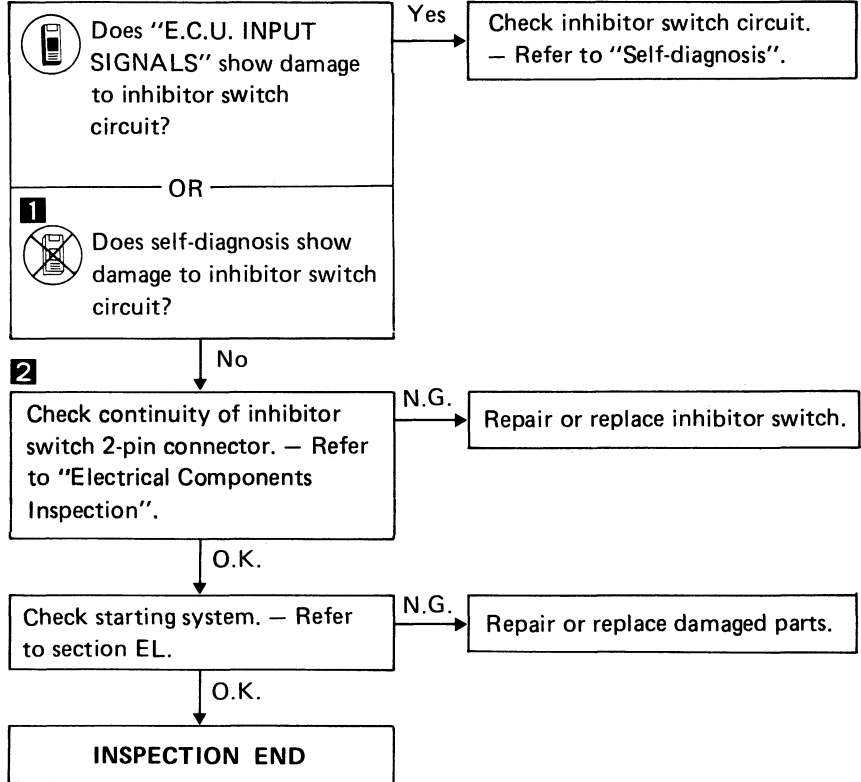

Diagnostic Procedure 3

SYMPTOM: Vehicle moves when it is pushed forward or backward with selector lever in "P" range.

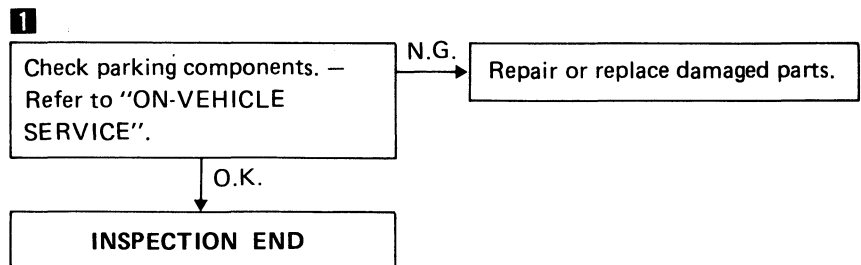

TROUBLE DIAGNOSES

Diagnostic Procedure 4

SYMPTOM: Vehicle moves forward or backward when selecting "N" range.

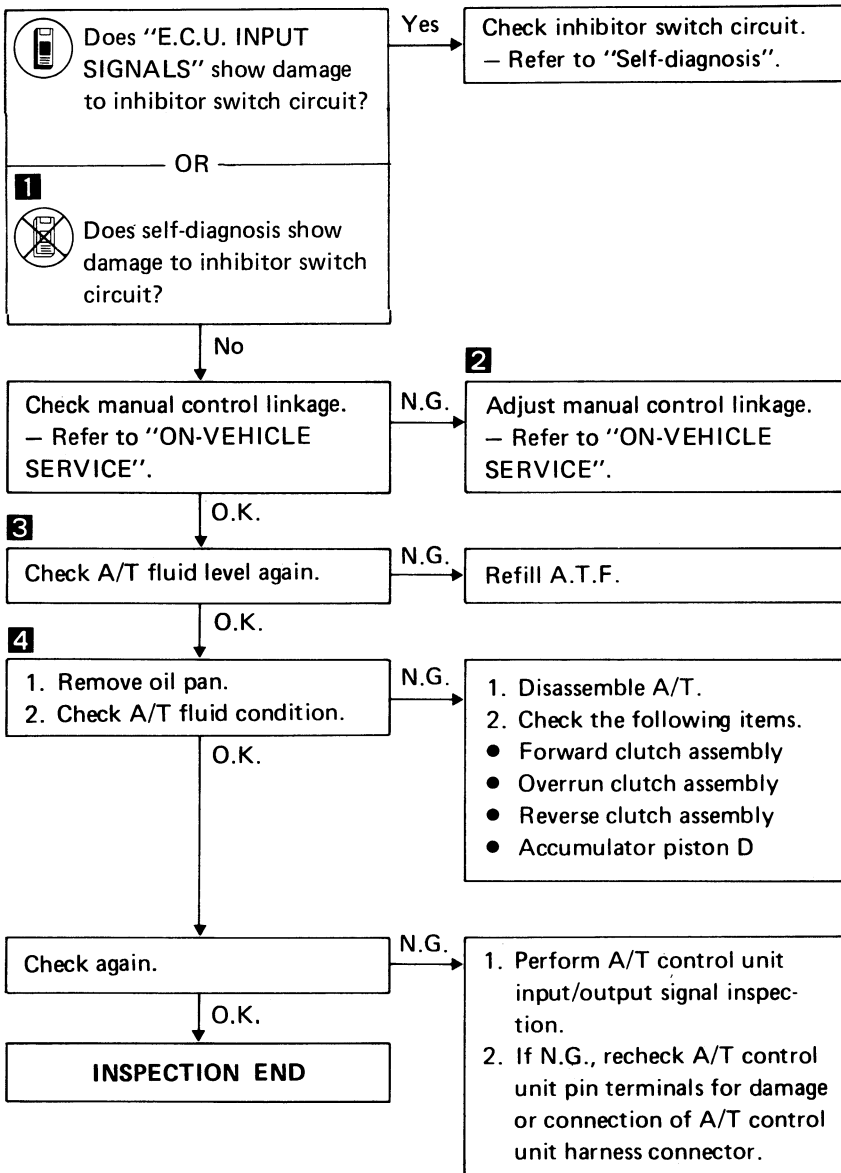
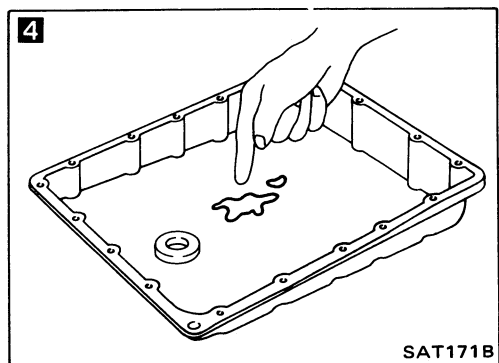
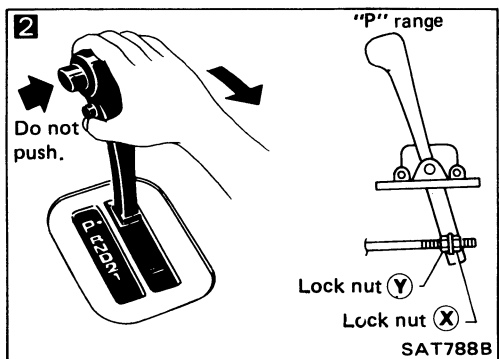
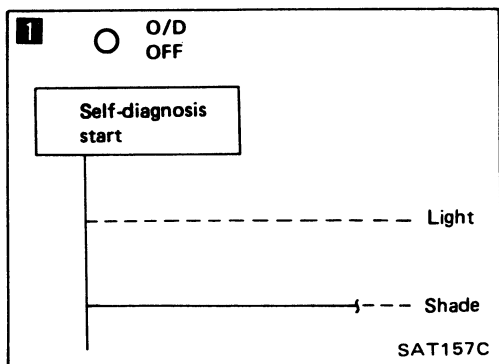

TROUBLE DIAGNOSES

Diagnostic Procedure 5

SYMPTOM: There is large shock when changing from "N" to "R" range.

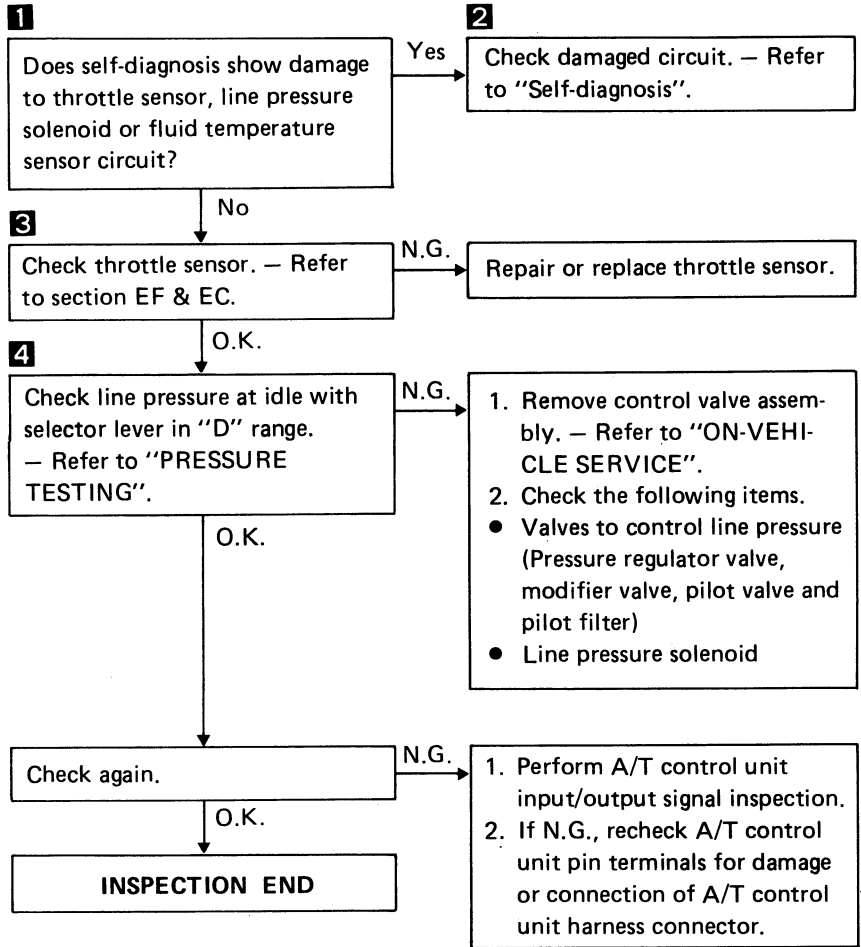
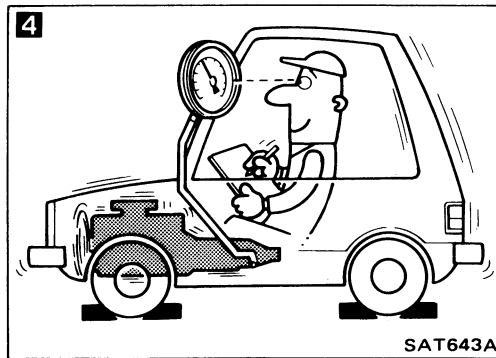
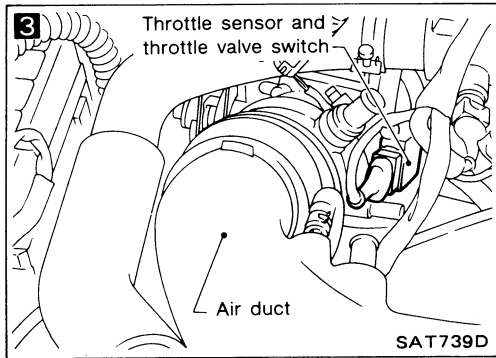
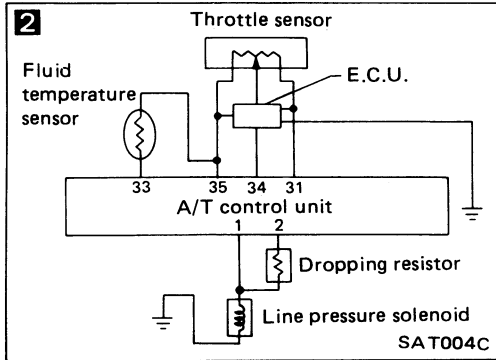
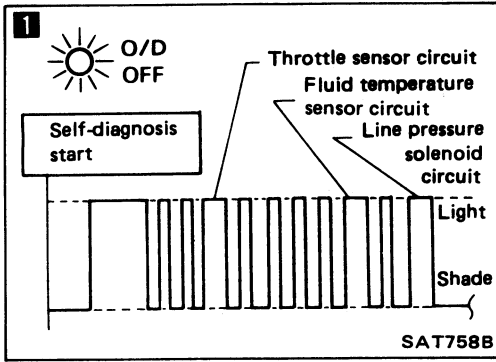

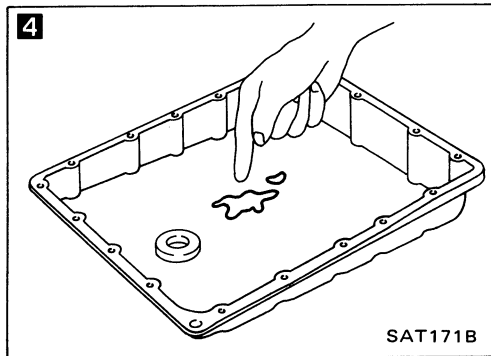
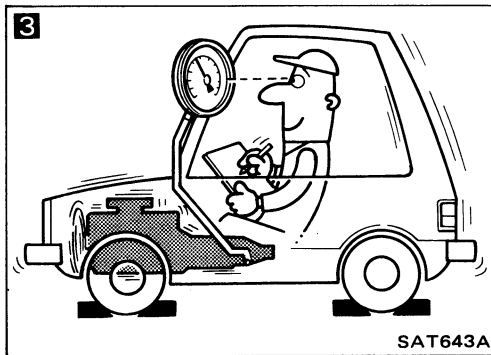
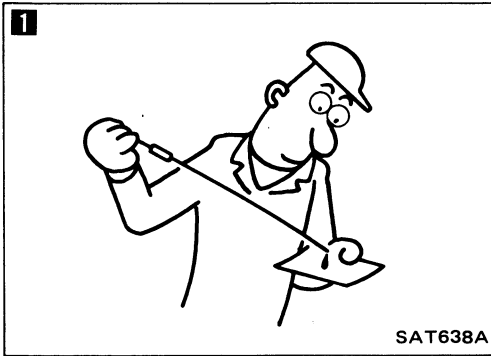

Diagnostic Procedure 6

SYMPTOM: Vehicle does not creep backward when selecting "R" range.

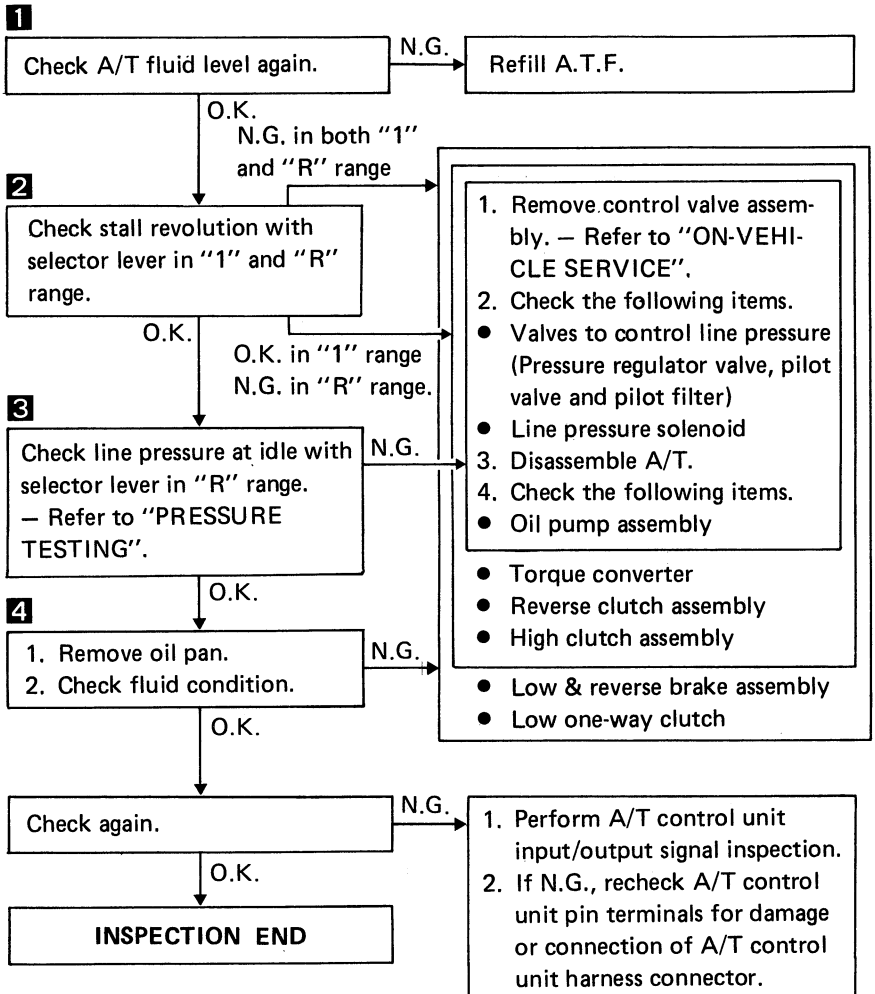

TROUBLE DIAGNOSES

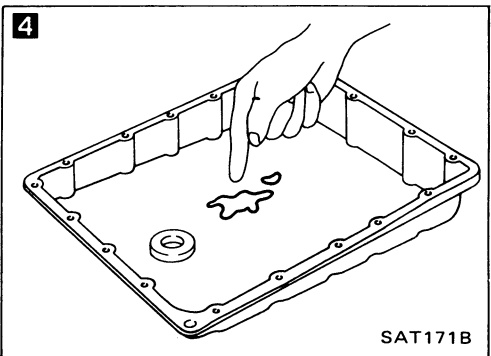
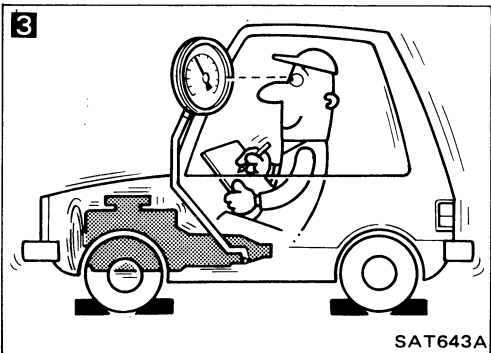
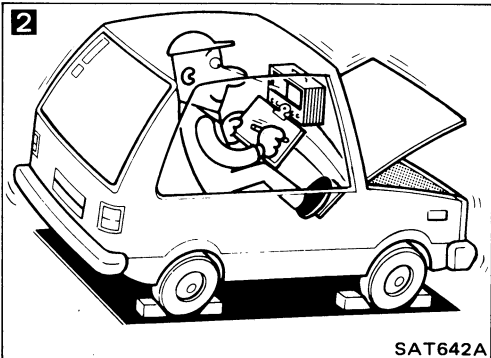
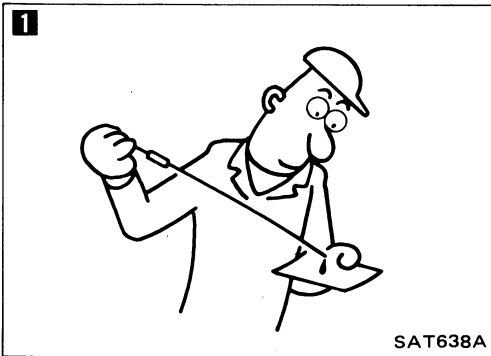

Diagnostic Procedure 7

SYMPTOM: Vehicle does not creep forward when selecting "D", "2" or "1" range.

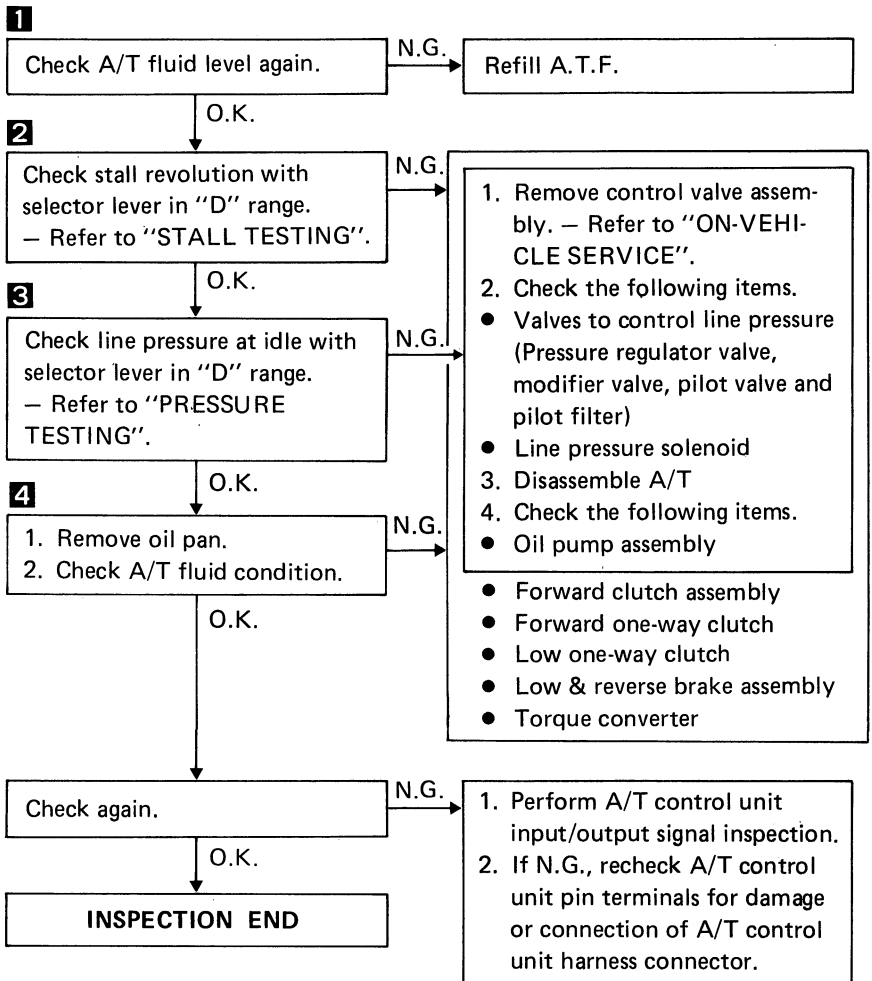

TROUBLE DIAGNOSES

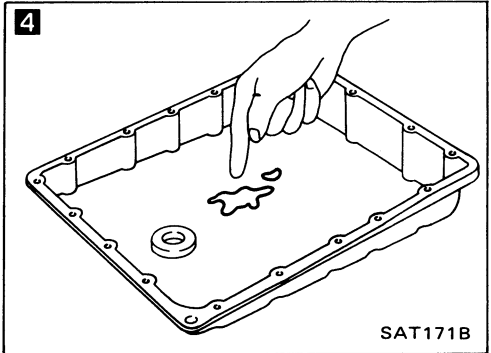
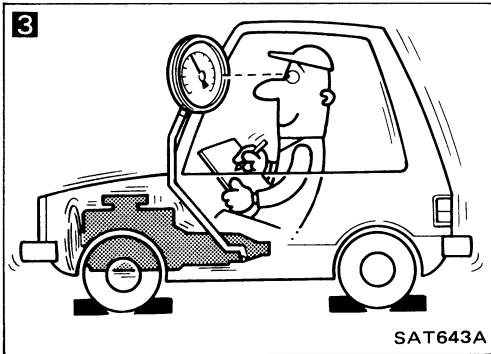
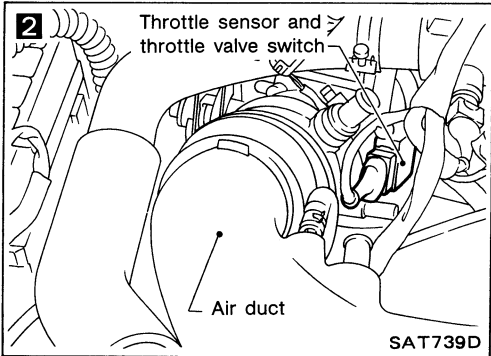
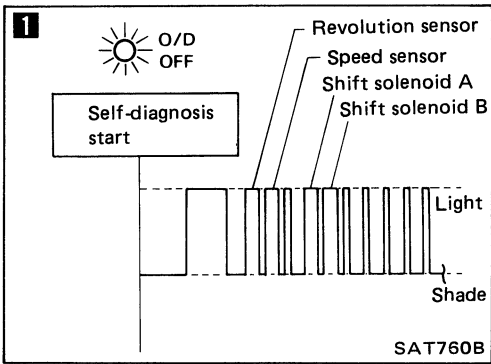

Diagnostic Procedure 8

SYMPTOM: Vehicle cannot be started from D₁ on Cruise test — Part 1.

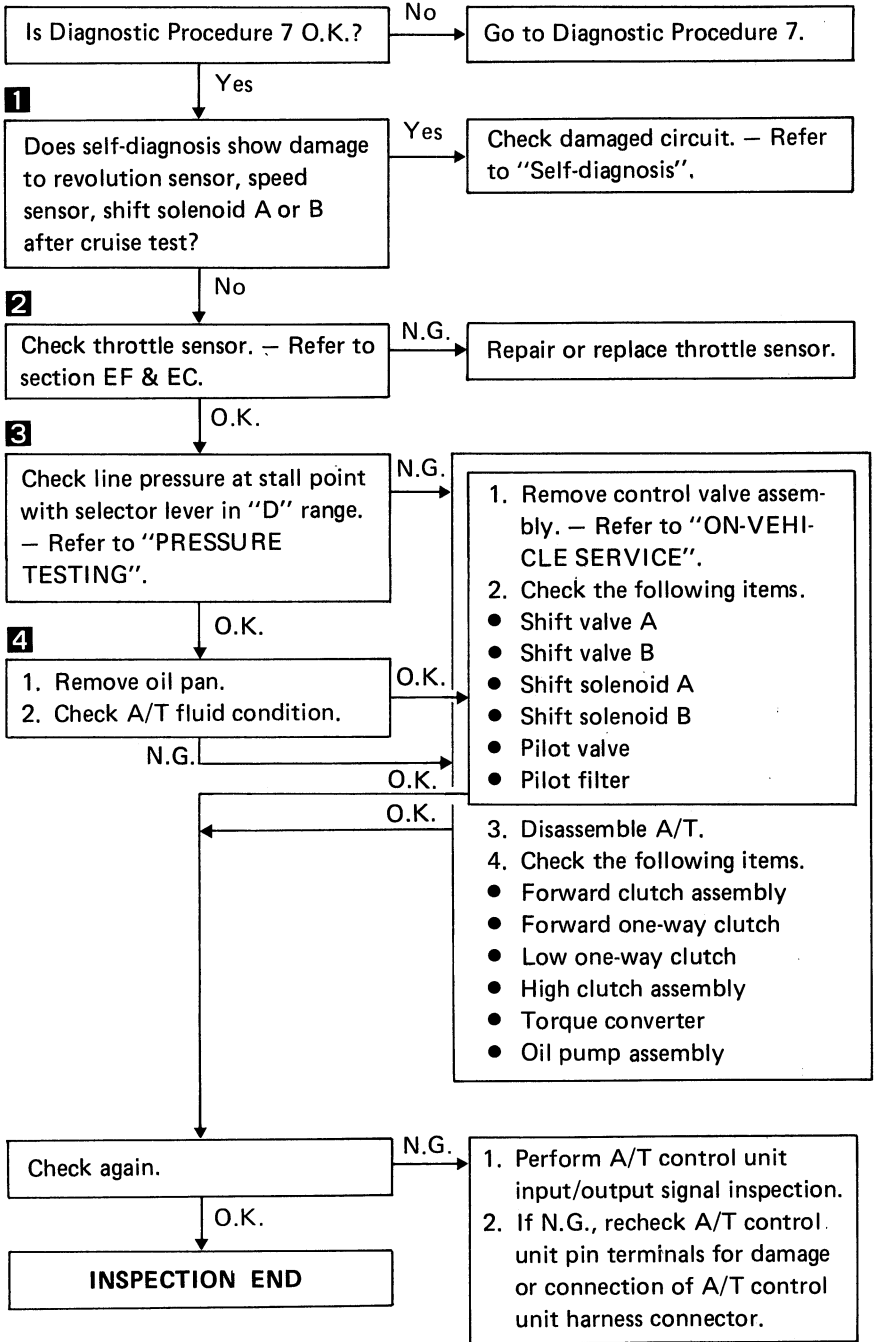

TROUBLE DIAGNOSES

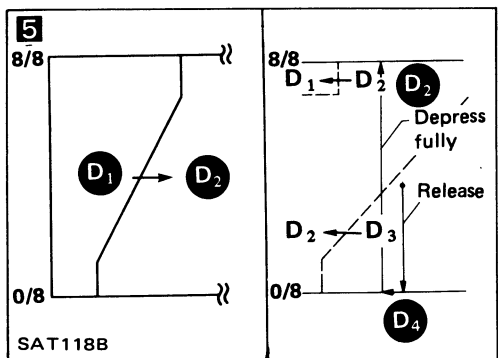
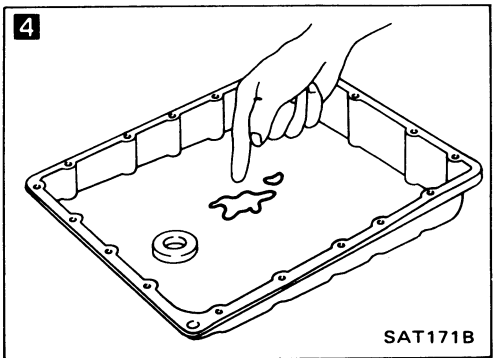
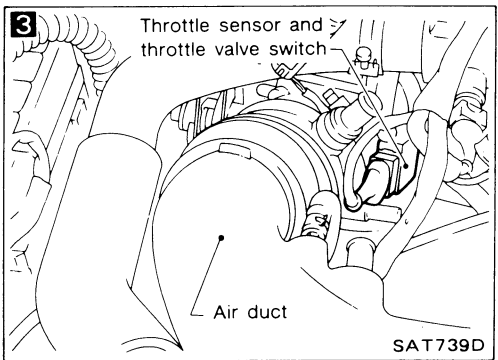
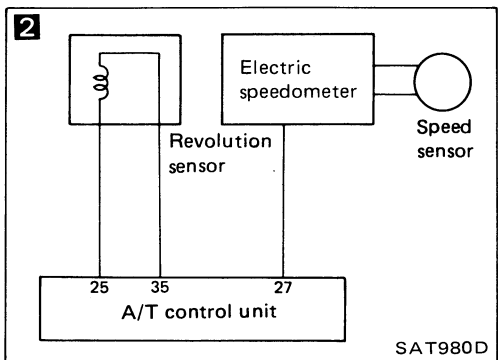
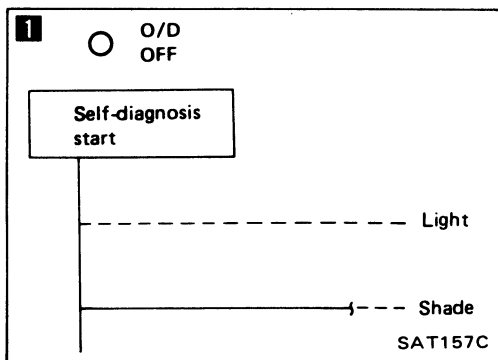

Diagnostic Procedure 9

SYMPTOM: A/T does not shift from D₁ to D₂ at the specified speed.
A/T does not shift from D₄ to D₂ when depressing accelerator pedal fully at the specified speed.

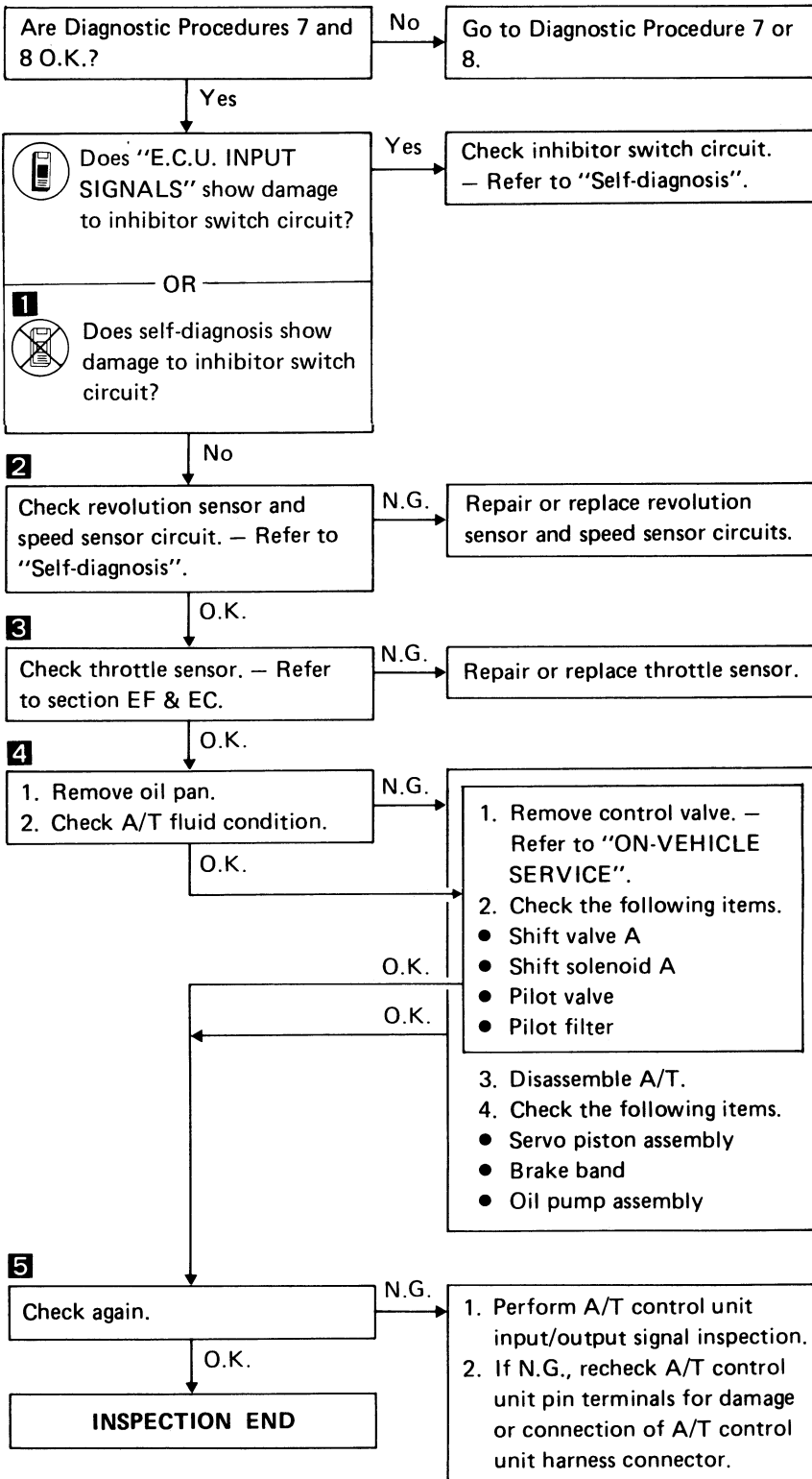

TROUBLE DIAGNOSES

Diagnostic Procedure 10

SYMPTOM: A/T does not shift from D₂ to D₃ at the specified speed.

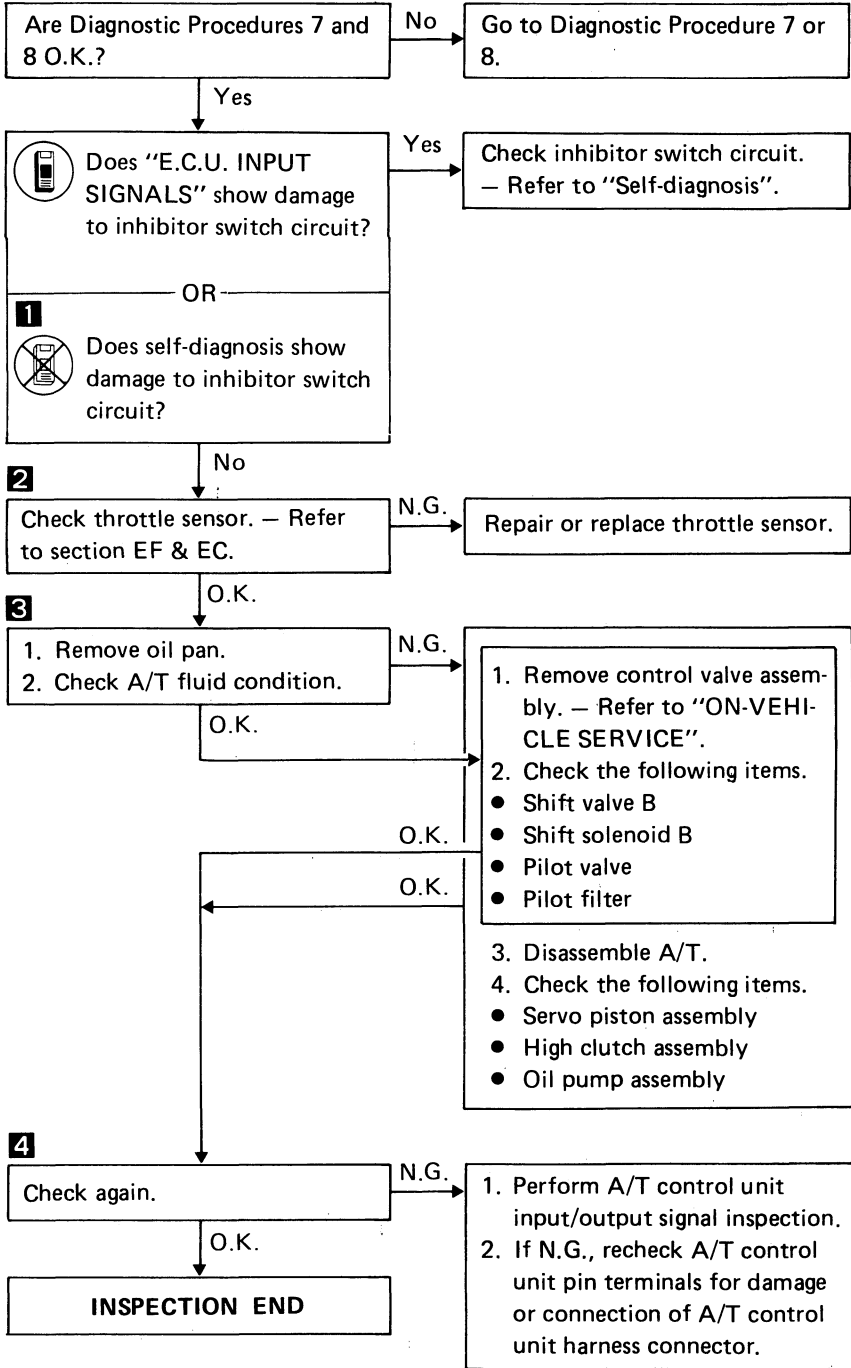
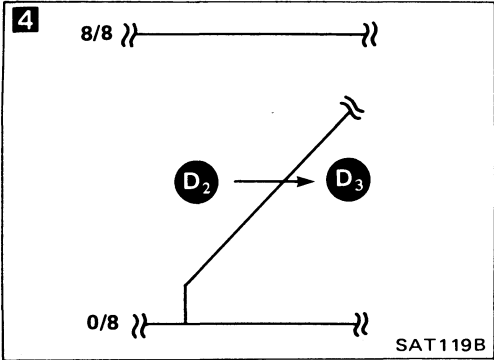
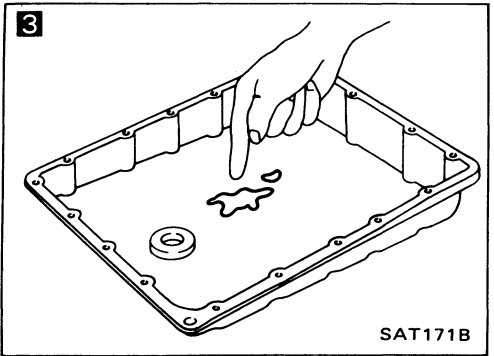
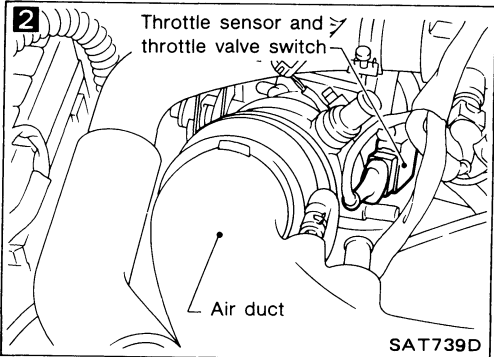
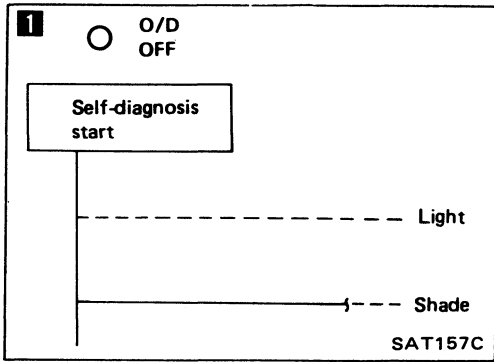

TROUBLE DIAGNOSES

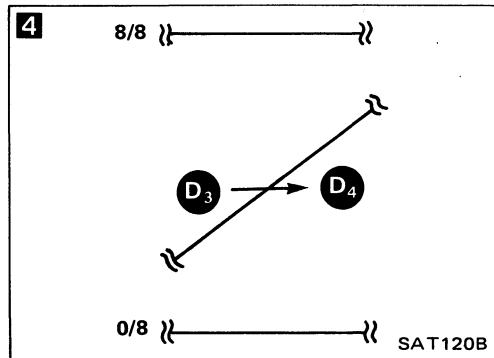
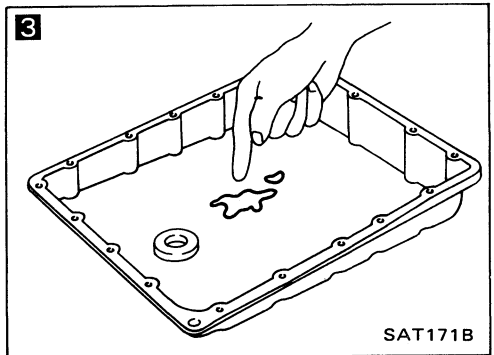
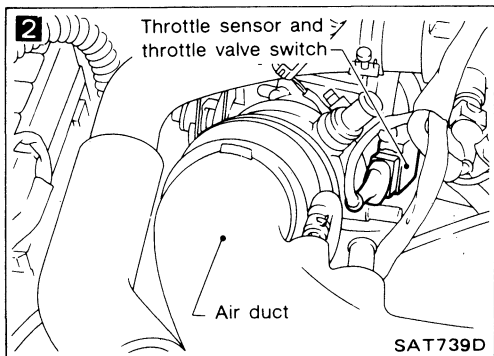
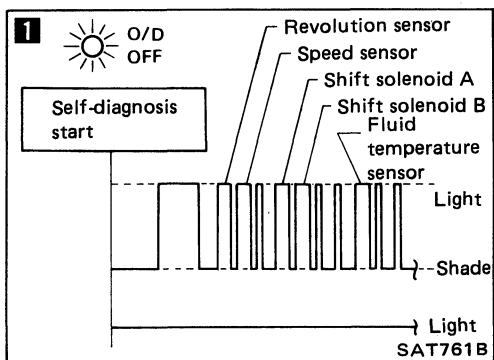

Diagnostic Procedure 11

SYMPTOM: A/T does not shift from D₃ to D₄ at the specified speed.

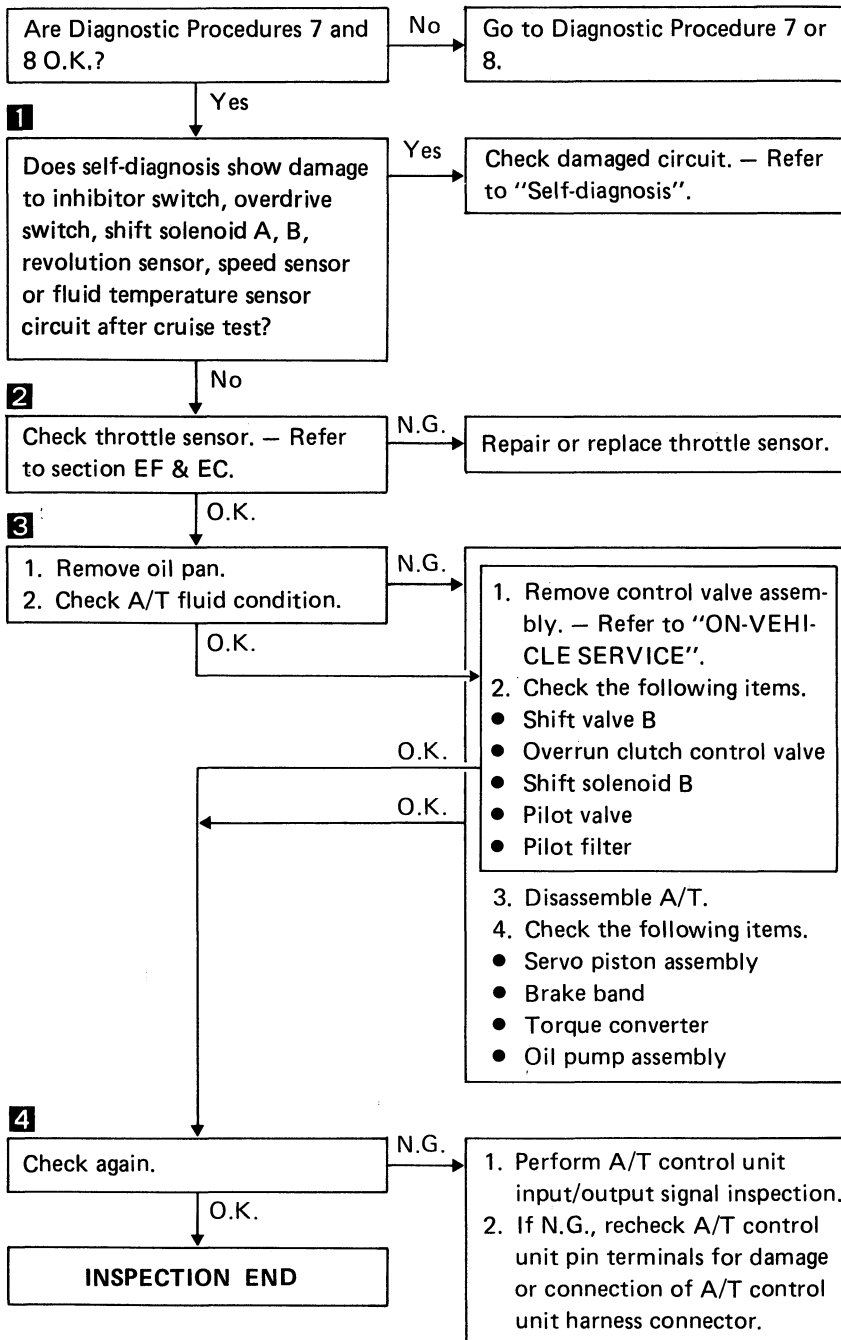

TROUBLE DIAGNOSES

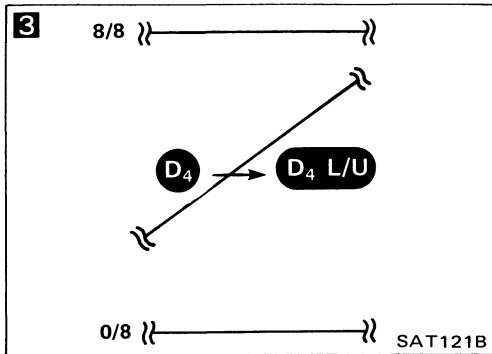
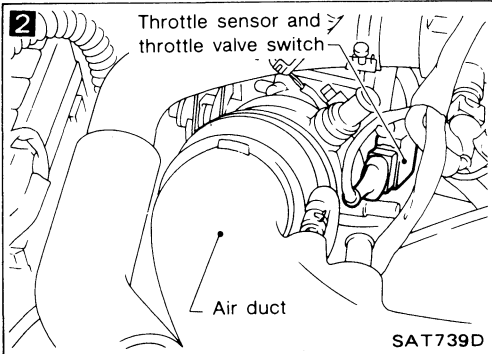
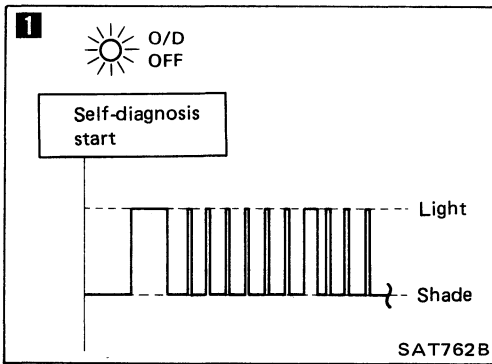

Diagnostic Procedure 12

SYMPTOM: A/T does not perform lock-up at the specified speed.

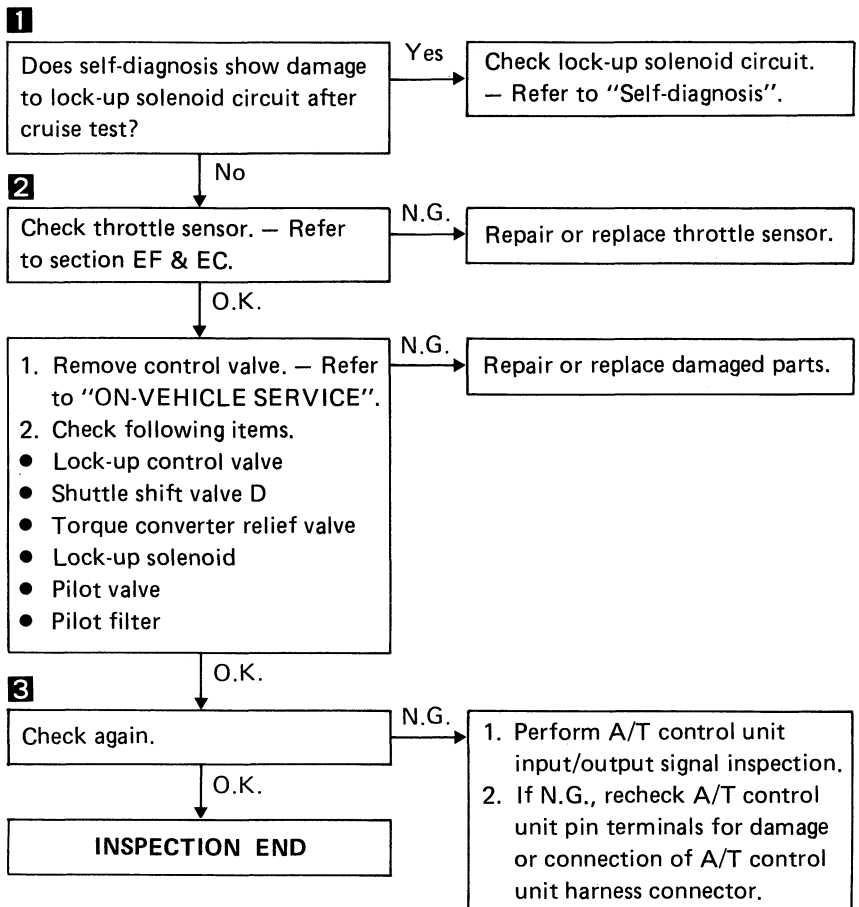

TROUBLE DIAGNOSES

Diagnostic Procedure 13

SYMPTOM: A/T does not hold lock-up condition for more than 30 seconds.

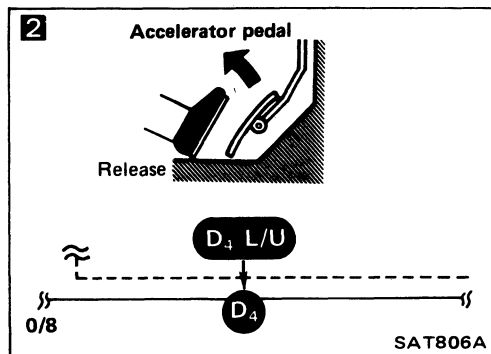
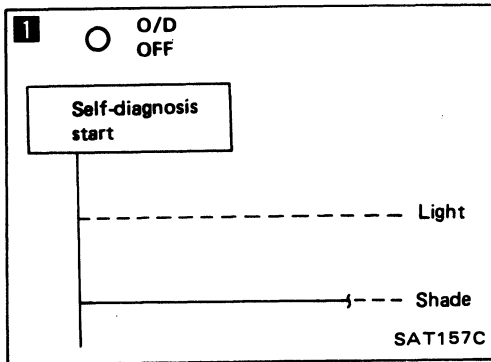
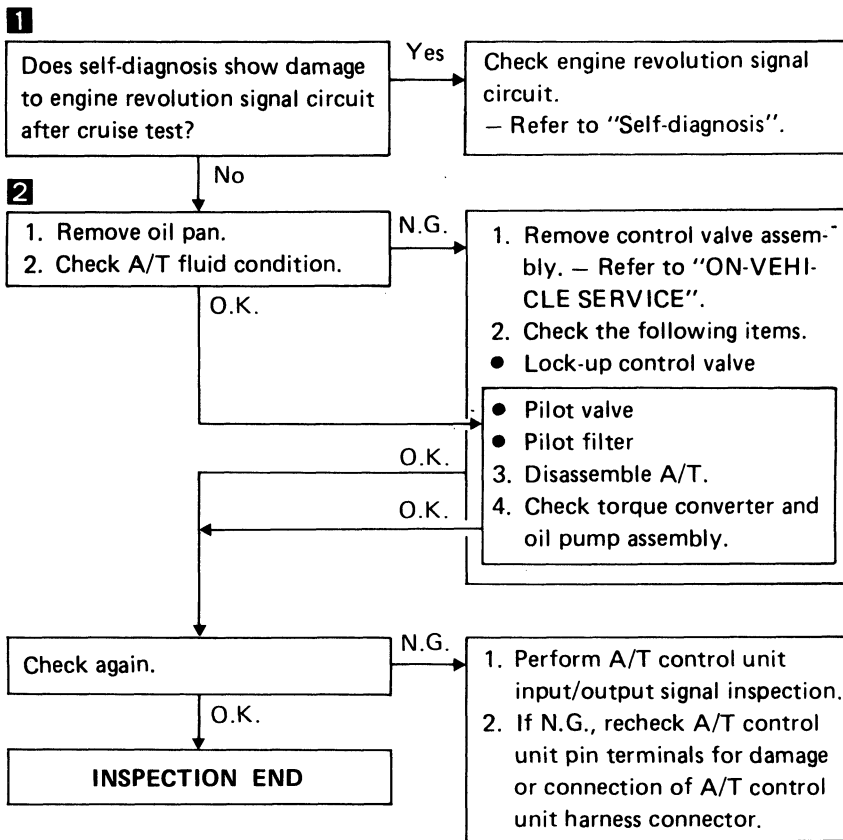
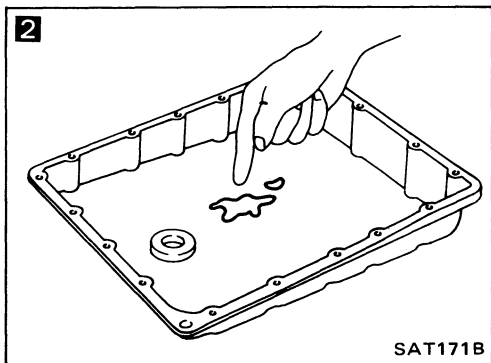
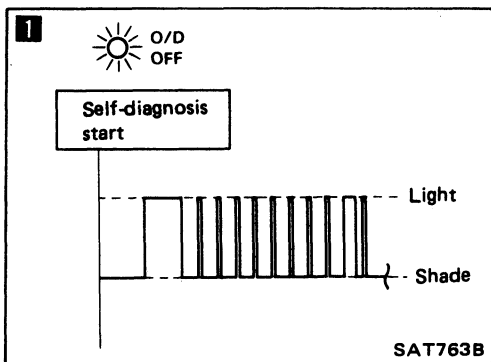

Diagnostic Procedure 14

SYMPTOM: Lock-up is not released when accelerator pedal is released.

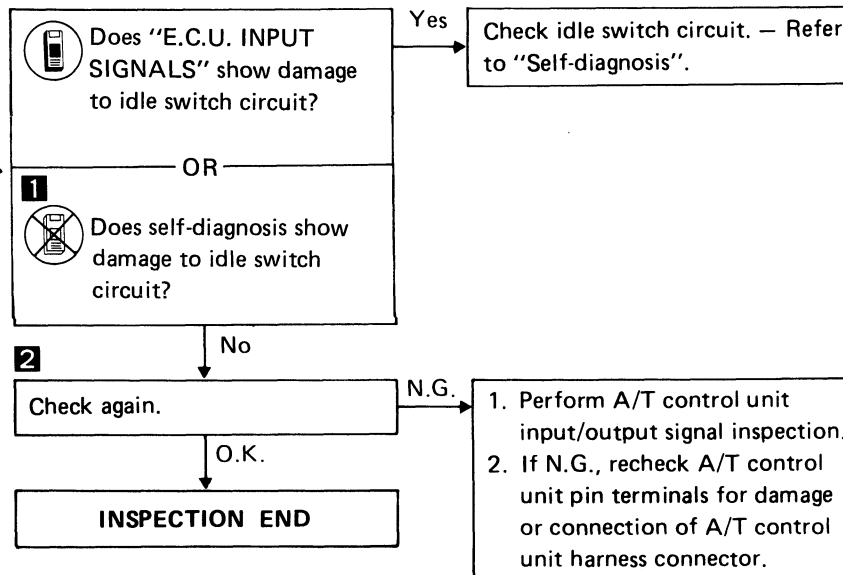

TROUBLE DIAGNOSES

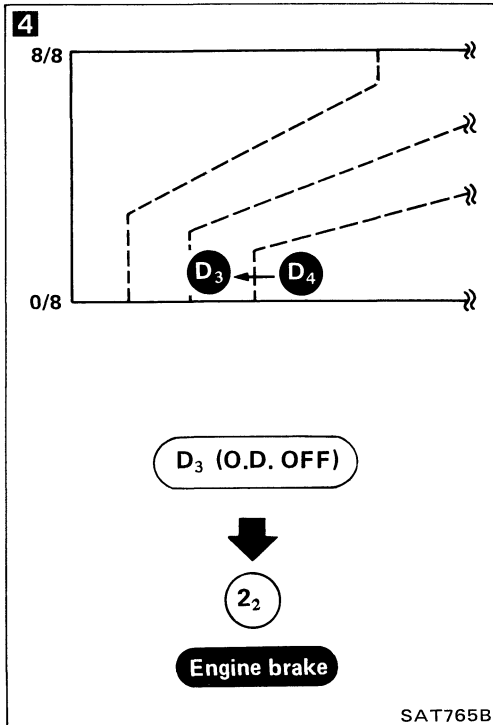
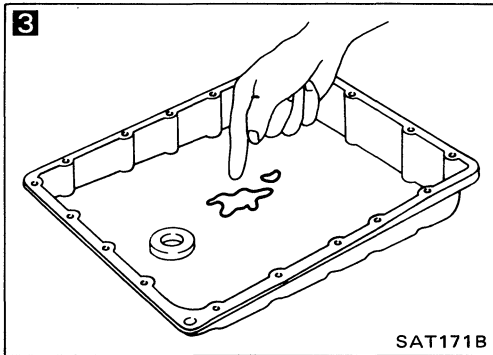
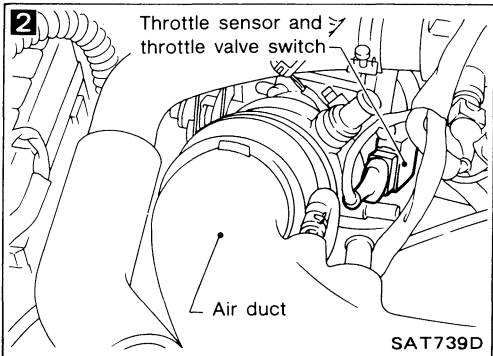
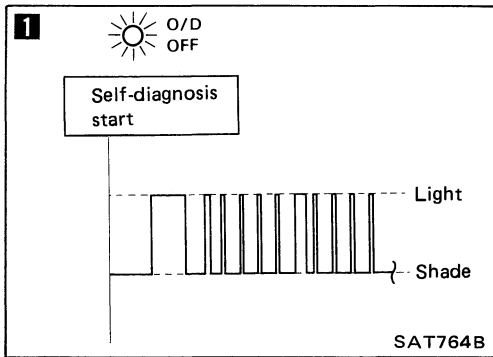

Diagnostic Procedure 15

SYMPTOM: Engine speed does not return to idle smoothly when A/T is shifted from D₄ to D₃ with accelerator pedal released.

Vehicle does not decelerate by engine brake when changing overdrive switch to "OFF" position with accelerator pedal released.

Vehicle does not decelerate by engine brake when changing selector lever from "D" to "2" range with accelerator pedal released.

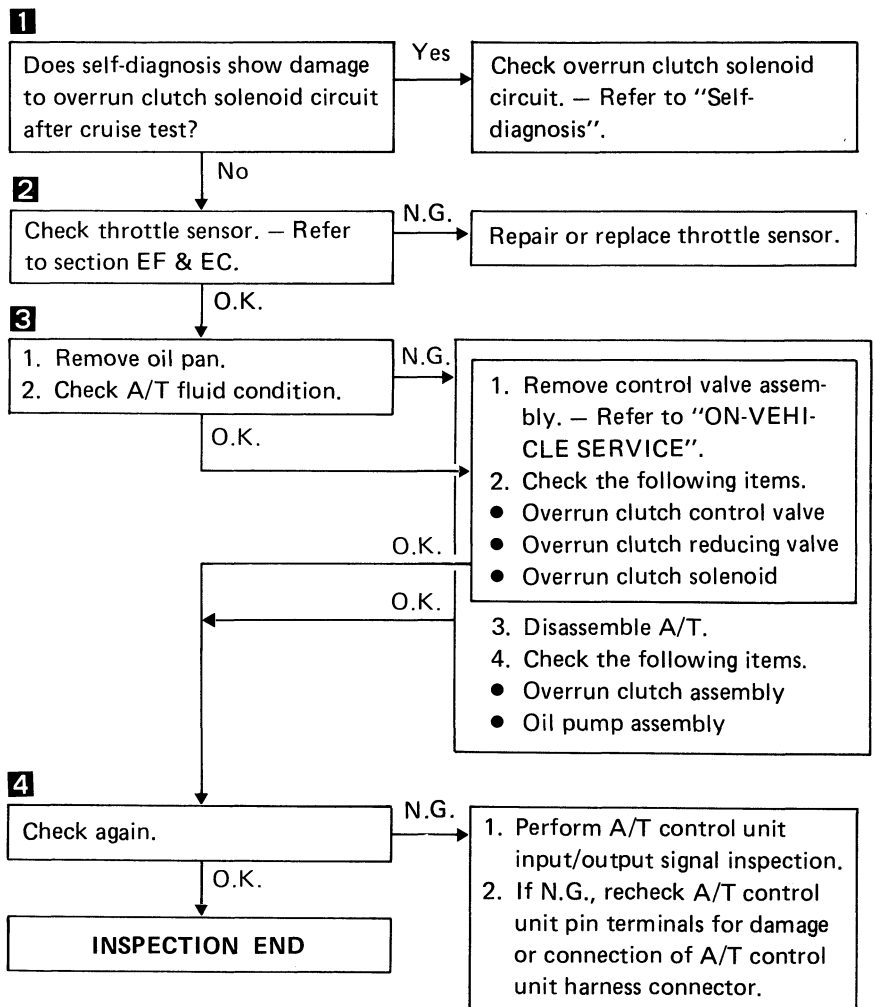

TROUBLE DIAGNOSES

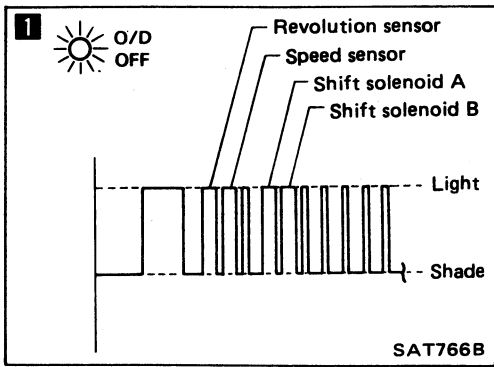

Diagnostic Procedure 16

SYMPTOM: Vehicle does not start from D₁ on Cruise test — Part 2.

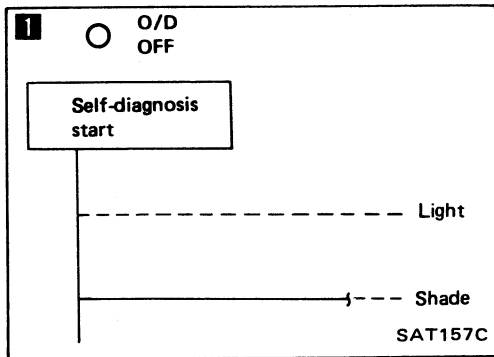
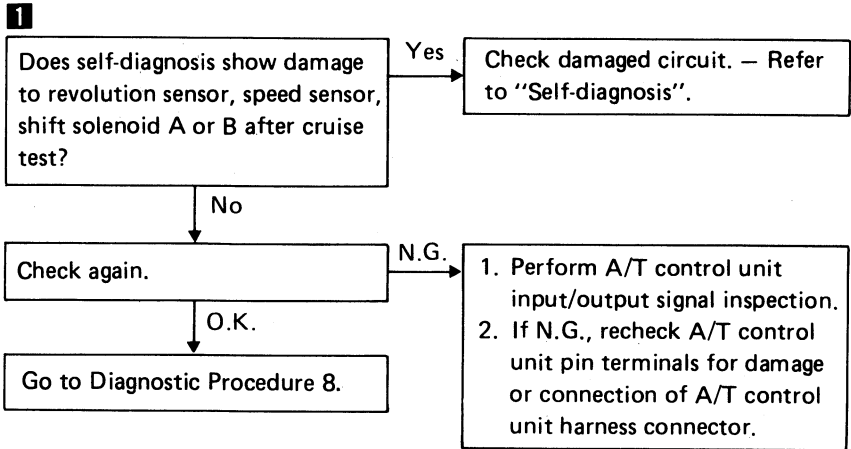

Diagnostic Procedure 17

SYMPTOM: A/T does not shift from D₄ to D₃ when changing overdrive switch to "OFF" position.

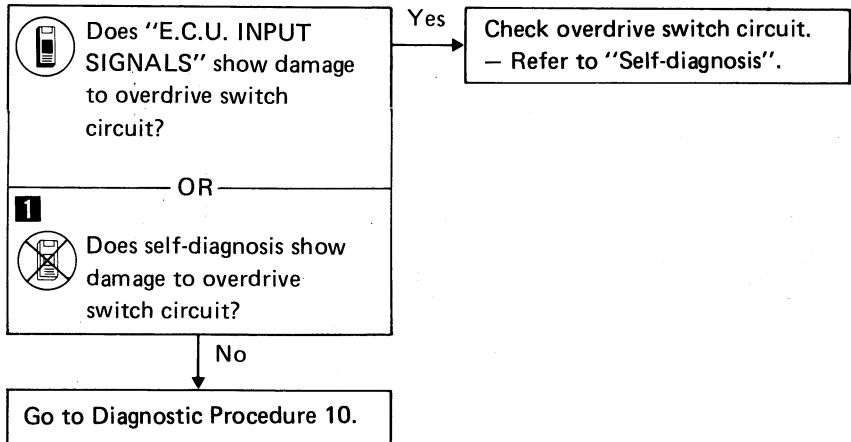

TROUBLE DIAGNOSES

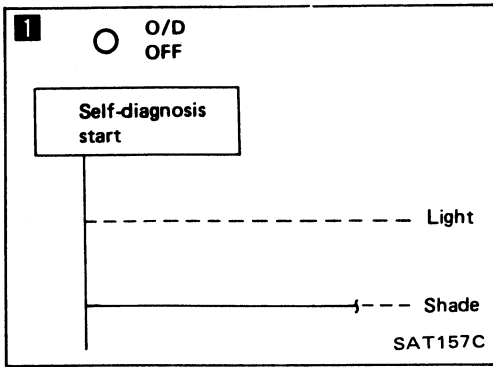

Diagnostic Procedure 18

SYMPTOM: A/T does not shift from D_3 to 2_2 when changing selector lever from "D" to "2" range.

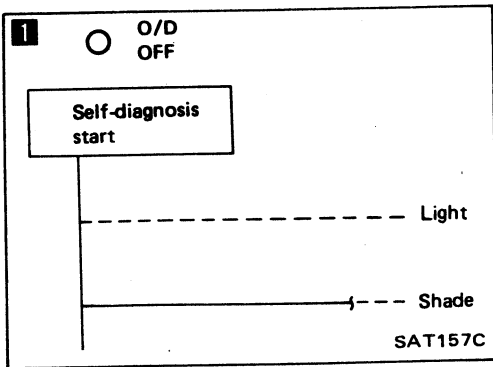
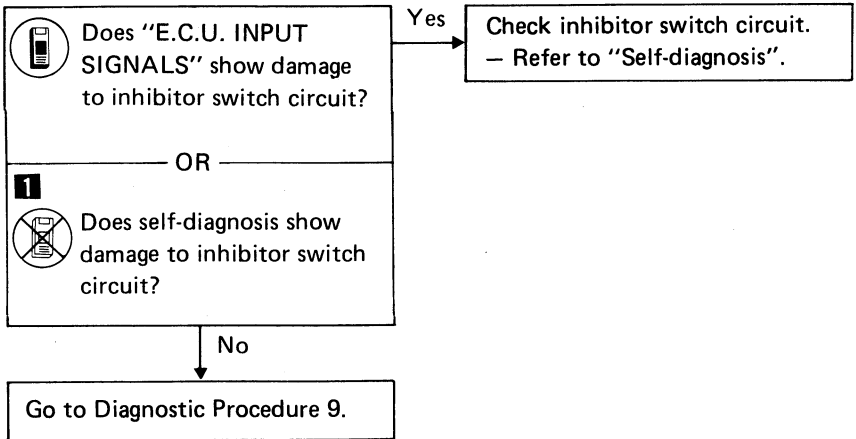

Diagnostic Procedure 19

SYMPTOM: A/T does not shift from 2_2 to 1_1 , when changing selector lever from "2" to "1" range.

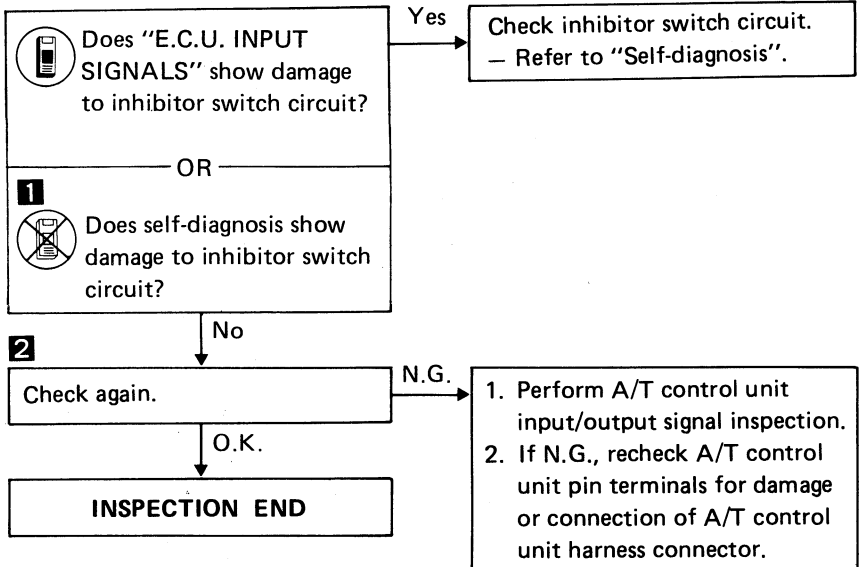
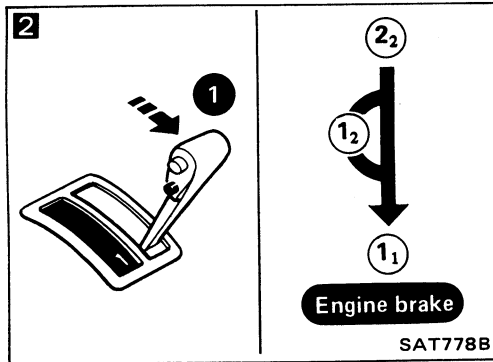

Diagnostic Procedure 20

SYMPTOM: Vehicle does not decelerate by engine brake when shifting from 2_2 (1_2) to 1_1 .

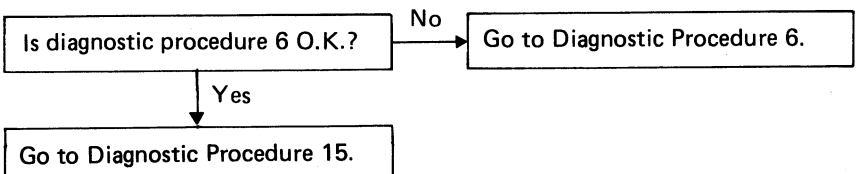

TROUBLE DIAGNOSES

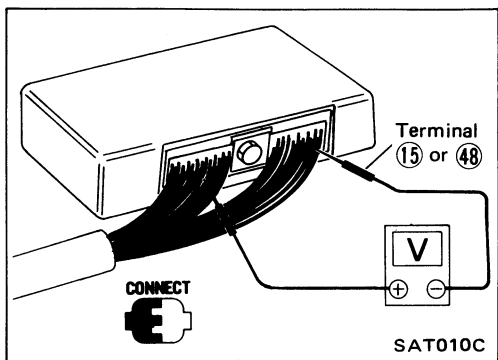

Electrical Components Inspection

INSPECTION OF A/T CONTROL UNIT

- Measure voltage between each terminal and terminal ⑮ or ④⑧ by following "A/T CONTROL UNIT INSPECTION TABLE".

- Pin connector terminal layout.

1	2	3	4	9	10	11	12	13	14	15	●	23	24	25	⊗	27	28	29	30	31	⊗	33	34	35
5	6	7	8	16	17	18	19	20	21	⊗	⊗	37	⊗	39	40	41	⊗	⊗	⊗	⊗	⊗	⊗	⊗	48



SAT981D

TROUBLE DIAGNOSES

Electrical Components Inspection (Cont'd)

A/T CONTROL UNIT INSPECTION TABLE
(Data are reference values.)

Terminal No.	Item	Condition	Judgement standard
1	Line pressure solenoid	When accelerator pedal is released after warming up engine.	1.5 - 2.5V
		When accelerator pedal is depressed fully after warming up engine.	0.5V or less
2	Line pressure solenoid (with dropping resistor)	When accelerator pedal is released after warming up engine.	5 - 14V
		When accelerator pedal is depressed fully after warming up engine.	0.5V or less
3	O.D. OFF indicator lamp	When A/T check lamp is on.	1V or less
		When A/T check lamp is not on.	Battery voltage
4	Power source	When ignition switch is turned to "ON".	Battery voltage
		When ignition switch is turned to "OFF".	1V or less
5	Lock-up solenoid	When A/T is performing lock-up.	8 - 15V
		When A/T is not performing lock-up.	1V or less
6	Shift solenoid A	When shift solenoid A is operating. (When driving in "D ₁ " or "D ₄ ".)	Battery voltage
		When shift solenoid A is not operating. (When driving in "D ₂ " or "D ₃ ".)	1V or less
7	Shift solenoid B	When shift solenoid B is operating. (When driving in "D ₁ " or "D ₂ ".)	Battery voltage
		When shift solenoid B is not operating. (When driving in "D ₃ " or "D ₄ ".)	1V or less
8	Overrun clutch solenoid	When timing solenoid is operating. (When driving in "D ₁ " or "D ₄ ".)	Battery voltage
		When timing solenoid is not operating. (When driving in "D ₂ " or "D ₃ ".)	1V or less

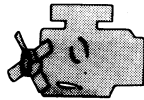

TROUBLE DIAGNOSES

Electrical Components Inspection (Cont'd)

Terminal No.	Item	Condition	Judgement standard
9	Power source	Same as No. 4	-
10*	-		
11	-		
12	-		
13	-		
14	Idle switch (in throttle valve switch)	When accelerator pedal is released after warming up engine.	8 - 15V
		When accelerator pedal is depressed after warming up engine.	1V or less
15	Ground	-	-
16	Inhibitor "1" range switch	When selector lever is set to "1" range.	Battery voltage
		When selector lever is set to other ranges.	1V or less
17	Inhibitor "2" range switch	When selector lever is set to "2" range.	Battery voltage
		When selector lever is set to other ranges.	1V or less
18	Inhibitor "D" range switch	When selector lever is set to "D" range.	Battery voltage
		When selector lever is set to other ranges.	1V or less
19	Inhibitor "N" or "P" range switch	When selector lever is set to "N" range.	Battery voltage
		When selector lever is set to other ranges.	1V or less
20	Inhibitor "R" range switch	When selector lever is set to "R" range.	Battery voltage
		When selector lever is set to other ranges.	1V or less
21	Full throttle switch (in throttle valve switch)	When accelerator pedal is depressed more than half-way after warming up engine.	8 - 15V
		When accelerator pedal is released after warming up engine.	1V or less
22	-	-	-







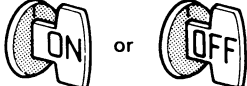
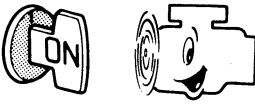

*: This terminal is connected to terminal No. 42 of E.C.C.S. control unit.

When code No. 54 appears during engine self-diagnosis, check line between above terminals for proper continuity.



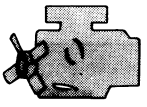
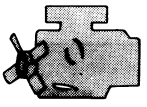

TROUBLE DIAGNOSES

Electrical Components Inspection (Cont'd)

Terminal No.	Item	Condition		Judgement standard
23	Power source (Back-up)		When ignition switch is turned to "OFF".	Battery voltage
			When ignition switch is turned to "ON".	Battery voltage
24	Engine revolution signal		When engine is running at idle speed.	0.9V
			When engine is running at 3,000 rpm.	Approximately 3.7V
25	Revolution sensor (Measure in AC range)		When vehicle is cruising at 30 km/h (19 MPH).	1V or more Voltage rises gradually in response to vehicle speed.
			When vehicle is parked.	0V
26	—		—	—
27	Speed sensor		When vehicle is moving at 2 to 3 km/h (1 to 2 MPH) for 1 m (3 ft) or more.	Vary from 0 to 5V
28	—		—	—
29	—		—	—
30	—		—	—
31	Throttle sensor (Power source)		—	4.5 - 5.5V
32	—		—	—
33	Fluid temperature sensor		When A.T.F. temperature is 20°C (68°F).	Approximately 1.5V
			When A.T.F. temperature is 80°C (176°F).	Approximately 0.5V
34	Throttle sensor		When accelerator pedal is depressed slowly after warming up engine.	Fully-closed throttle: Approximately 0.5V
			Voltage rises gradually in response to throttle opening angle.	Fully-open throttle: Approximately 4V
35	Throttle sensor (Ground)		—	—
36	—		—	—
37	A.S.C.D. cruise signal		When A.S.C.D. cruise is being performed. ("CRUISE" light comes on.)	Battery voltage
			When A.S.C.D. cruise is not being performed. ("CRUISE" light does not come on.)	1V or less

TROUBLE DIAGNOSES

Electrical Components Inspection (Cont'd)

Terminal No.	Item	Condition	Judgement standard	
38	—	—	—	
39	Overdrive switch	 	When overdrive switch is set in "ON" position.	Battery voltage
			When overdrive switch is set in "OFF" position.	1V or less
40	A.S.C.D. O.D. cut signal		When "ACCEL" set switch on A.S.C.D. cruise is released.	5 - 8V
			When "ACCEL" set switch on A.S.C.D. cruise is applied.	1V or less
41	Kickdown switch	 	When accelerator pedal is released after warming up engine.	3 - 8V
			When accelerator pedal is depressed fully after warming up engine.	1V or less
42	—	—	—	
43	—	—	—	
44	—	—	—	
45	—	—	—	
46	—	—	—	
47	—	—	—	
48	Ground	—	—	

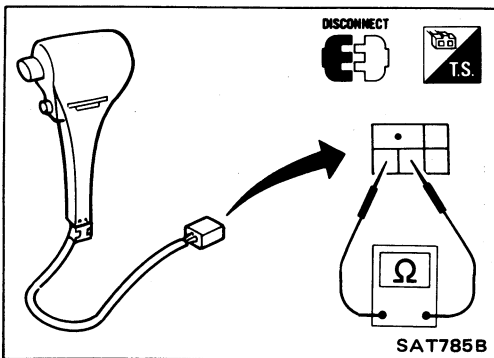

OVERDRIVE SWITCH

- Check continuity between two terminals.

O.D. switch position	Continuity
ON	No
OFF	Yes

TROUBLE DIAGNOSES

Electrical Components Inspection (Cont'd)

INHIBITOR SWITCH

1. Check continuity between terminals ① and ② and between terminals ③ and ④, ⑤, ⑥, ⑦, ⑧, ⑨ while moving selector lever through each range.

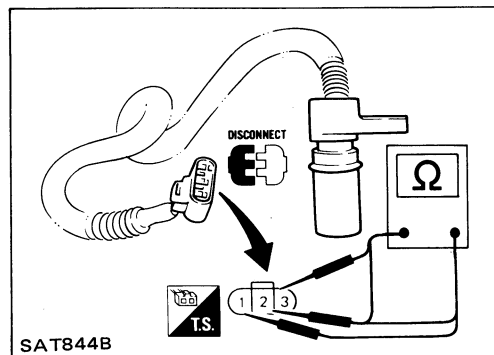
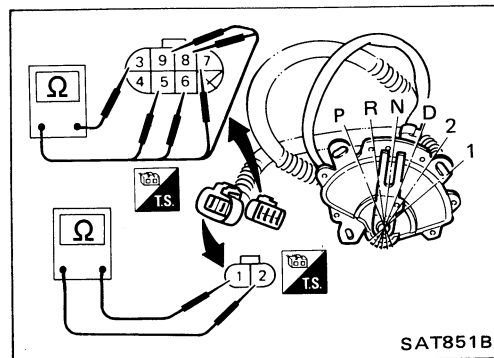
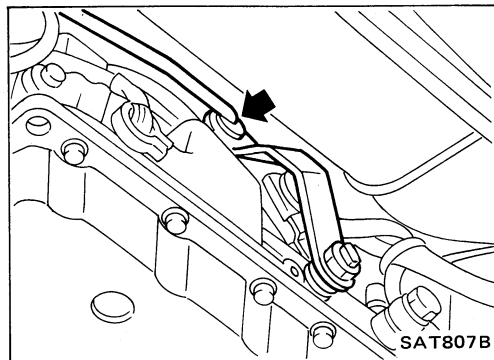
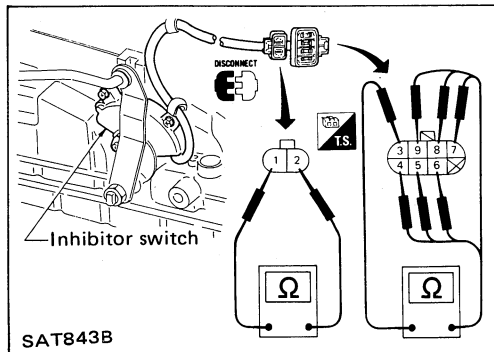
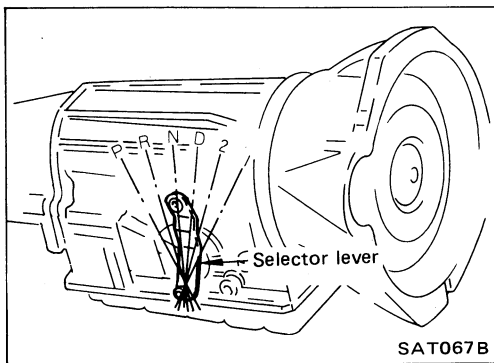

Terminal No.	①	②	③	④	⑤	⑥	⑦	⑧	⑨
Lever position									
P	○—○		○—○						
R			○—○	○—○					
N	○—○		○—○		○—○				
D			○—○				○—○		
2			○—○					○—○	
1			○—○						○—○

2. If N.G., check again with manual control linkage disconnected from manual shaft of A/T assembly. — Refer to step 1.
3. If O.K. on step 2, adjust manual control linkage. — Refer to "ON-VEHICLE SERVICE".
4. If N.G. on step 2, remove inhibitor switch from A/T and check continuity of inhibitor switch terminal. — Refer to step 1.
5. If O.K. on step 4, adjust inhibitor switch. — Refer to "ON-VEHICLE SERVICE".
6. If N.G. on step 4, replace inhibitor switch.

REVOLUTION SENSOR

- For removal and installation, refer to "ON-VEHICLE SERVICE".
- Check resistance between terminals ①, ② and ③.

Terminal No.	Resistance
① ②	500 - 650Ω
② ③	No continuity
① ③	No continuity

TROUBLE DIAGNOSES

Electrical Components Inspection (Cont'd)

FLUID TEMPERATURE SENSOR

- For removal and installation, refer to "ON-VEHICLE SERVICE".
- Check resistance between two terminals while changing temperature as shown at left.

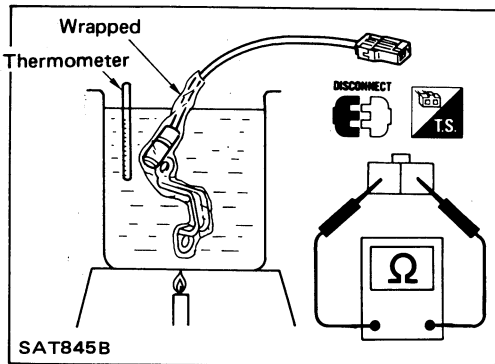

Temperature °C (°F)	Resistance
20 (68)	Approximately 2.5 kΩ
80 (176)	Approximately 0.3 kΩ

LOCK-UP SOLENOID

- For removal and installation, refer to "ON-VEHICLE SERVICE".
- Check resistance between two terminals.

Resistance:

Lock-up solenoid 10 - 20Ω

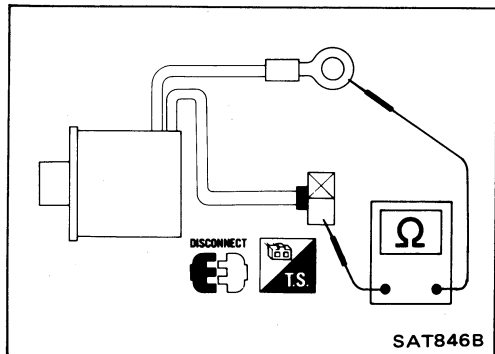

3-UNIT SOLENOID ASSEMBLY (Shift solenoids A, B and overrun clutch solenoid) AND LINE PRESSURE SOLENOID

- For removal and installation, refer to "ON-VEHICLE SERVICE".
- Check resistance between terminals of each solenoid.

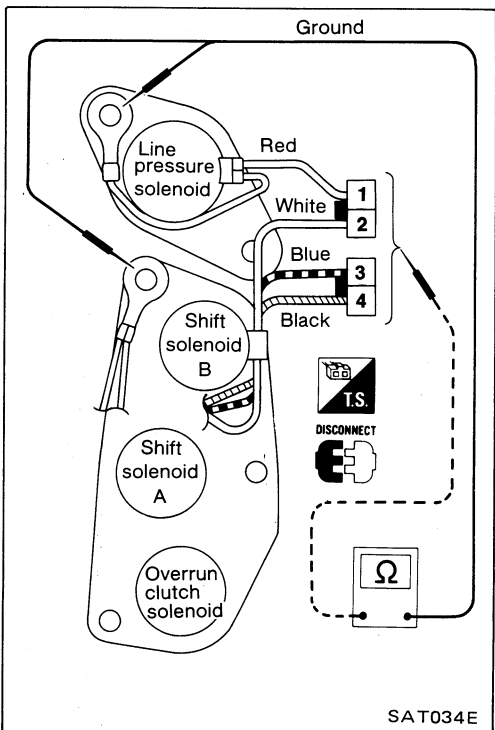

Solenoid	Terminal No.	Resistance
Shift solenoid A	③	20 - 40Ω'
Shift solenoid B	②	
Overrun clutch solenoid	④	
Line pressure solenoid	①	2.5 - 5Ω

DROPPING RESISTOR

- Check resistance between two terminals.

Resistance: 11.2 - 12.8Ω

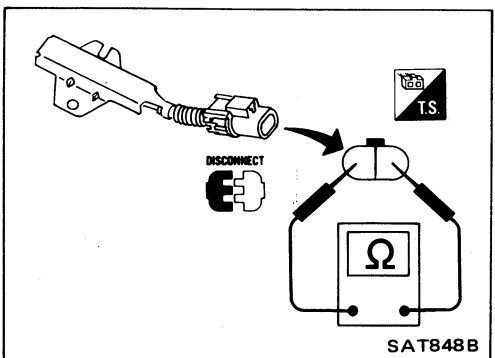

TROUBLE DIAGNOSES

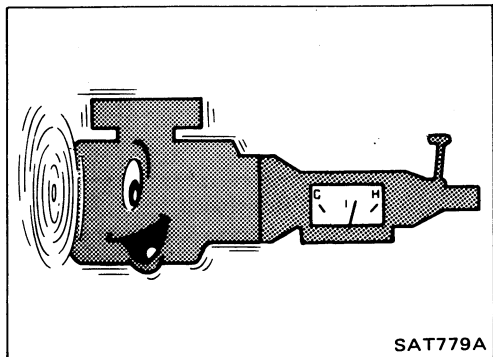

Final Check

STALL TESTING

Stall test procedure

1. Check A/T and engine fluid levels. If necessary, add.
2. Warm up engine until engine oil and A.T.F. reach operating temperature after vehicle has been driven approx. 10 minutes.

A.T.F. operating temperature:
50 - 80°C (122 - 176°F)

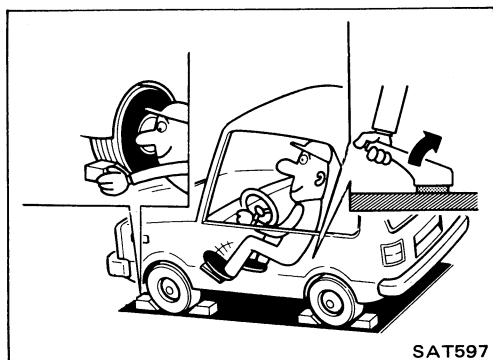

3. Set parking brake and block wheels.
 4. Install a tachometer where it can be seen by driver during test.
- It is good practice to put a mark on point of specified engine rpm on indicator.

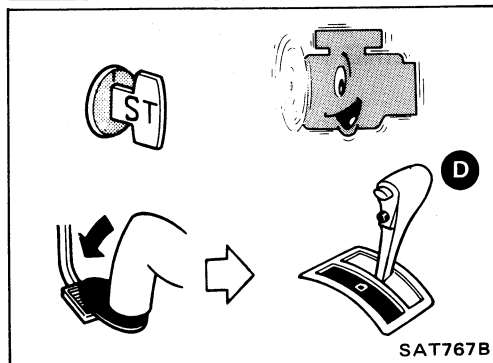

5. Start engine, apply foot brake, and place selector lever in "D" range.

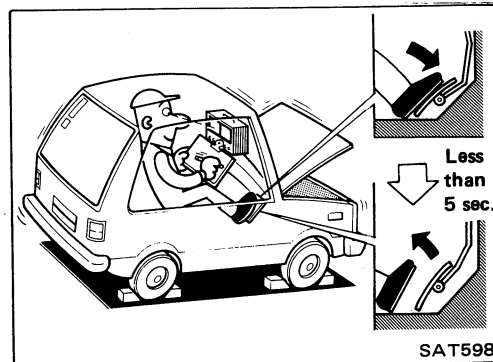

6. Accelerate to wide-open throttle gradually while applying foot brake.
 7. Quickly note the engine stall revolution and immediately release throttle.
- During test, never hold throttle wide-open for more than 5 seconds.

Stall revolution:
2,050 - 2,250 rpm

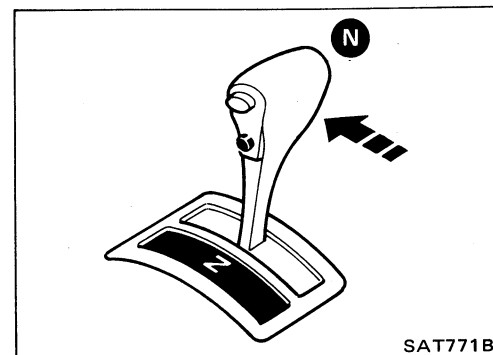

8. Shift selector lever to "N".
 9. Cool off A.T.F.
- Run engine at idle for at least one minute.
10. Perform stall tests in the same manner as in steps 5 through 9 with selector lever in "2", "1" and "R", respectively.

TROUBLE DIAGNOSES

Final Check (Cont'd)

Judgement of stall test

Selector lever position	Judgement		
D	L	O	H
2	L	O	H
1	L	O	O
R	L	H	H

O : Stall revolution is normal.
 H : Stall revolution is higher than specified.
 L : Stall revolution is lower than specified.

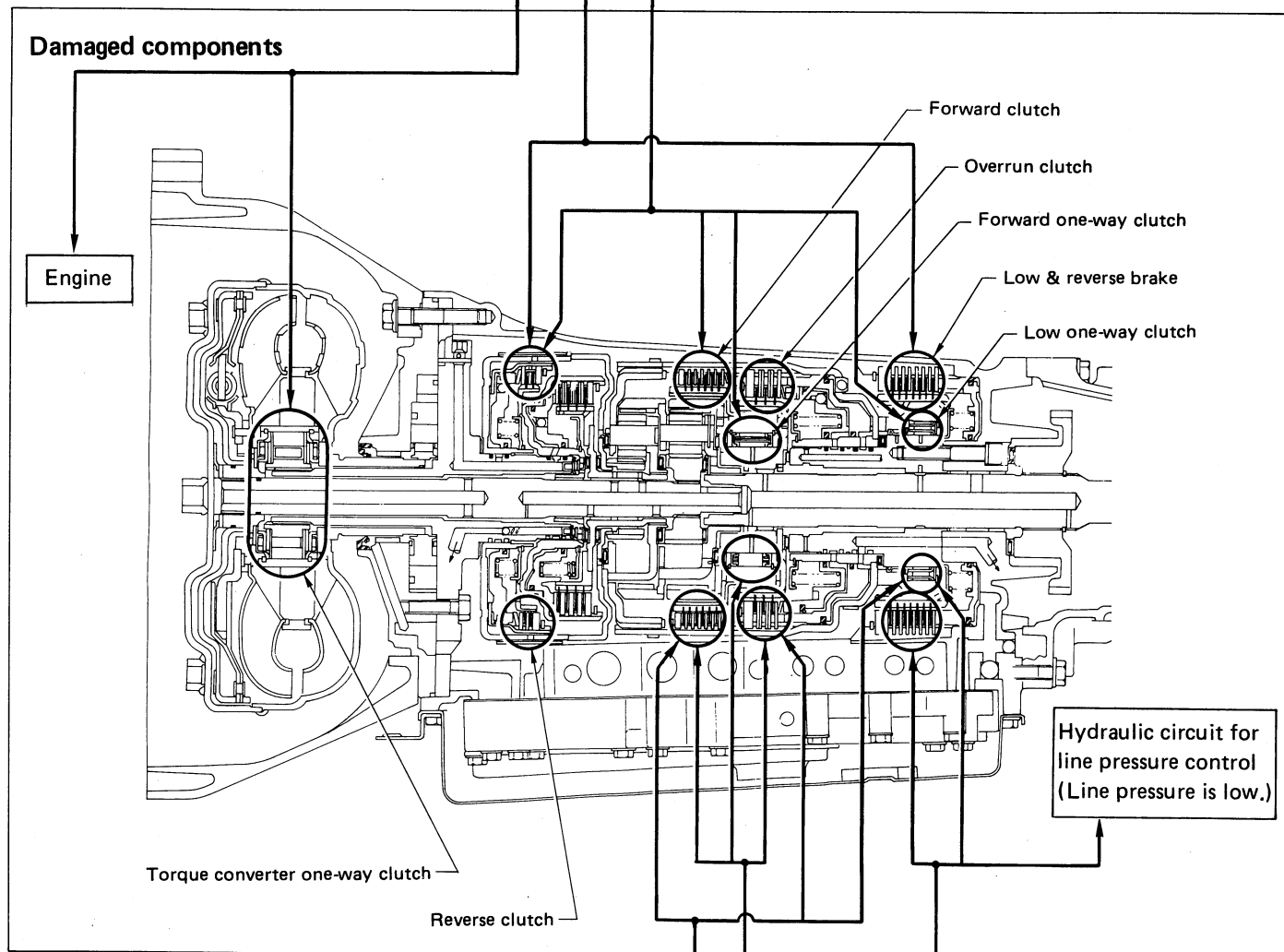

D	H	H	H	O
2	H	H	H	O
1	O	H	H	O
R	O	O	H	O
Selector lever position	Judgement			

TROUBLE DIAGNOSES

Final Check (Cont'd)

PRESSURE TESTING

- Location of line pressure test port
- Line pressure plugs are hexagon headed bolts.
- Always replace line pressure plugs as they are self-sealing bolts.

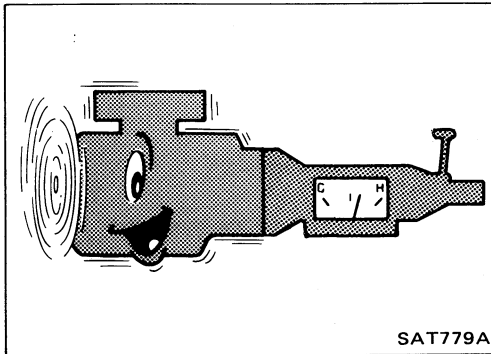
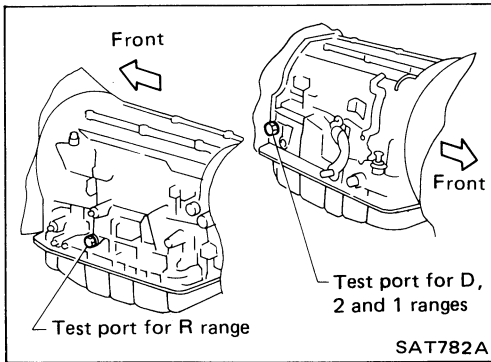

Line pressure test procedure

1. Check A/T and engine fluid levels. If necessary, add.
2. Warm up engine until engine oil and A.T.F. reach operating temperature after vehicle has been driven approx. 10 minutes.

A.T.F. operating temperature:
50 - 80°C (122 - 176°F)

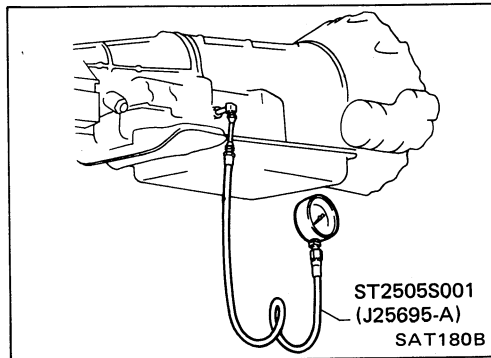

3. Install pressure gauge to line pressure port.
— D, 2 and 1 ranges —

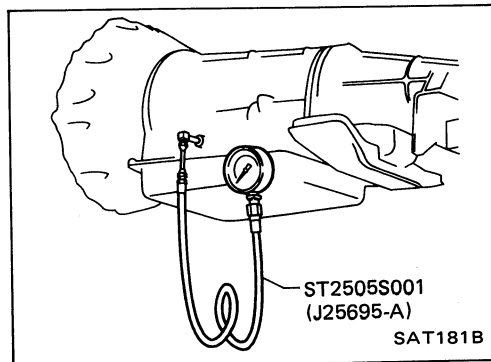

— R range —

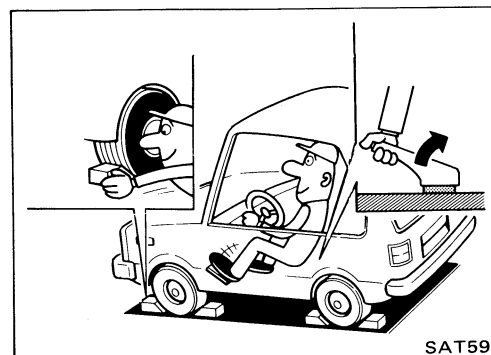

4. Set parking brake and block wheels.
 - Continue to depress brake pedal fully while line pressure test at stall speed is performed.

TROUBLE DIAGNOSES

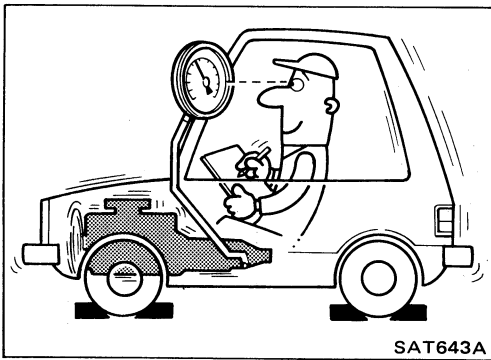

Final Check (Cont'd)

5. Start engine and measure line pressure at idle and stall speed.

- When measuring line pressure at stall speed, follow the stall test procedure.

Line pressure:

Engine speed rpm	Line pressure kPa (kg/cm ² , psi)	
	D, 2 and 1 ranges	R range
Idle	422 - 461 (4.3 - 4.7, 61 - 67)	667 - 706 (6.8 - 7.2, 97 - 102)
Stall	1,020 - 1,098 (10.4 - 11.2, 148 - 159)	1,422 - 1,500 (14.5 - 15.3, 206 - 218)

JUDGEMENT OF LINE PRESSURE TEST

Judgement		Suspected parts
At idle	Line pressure is low in all ranges.	<ul style="list-style-type: none"> ● Oil pump wear ● Control piston damage ● Pressure regulator valve or plug sticking ● Spring for pressure regulator valve damaged ● Fluid pressure leakage between oil strainer and pressure regulator valve
	Line pressure is low in particular range.	<ul style="list-style-type: none"> ● Fluid pressure leakage between manual valve and particular clutch. ● For example; If line pressure is low in "R" and "1" ranges but is normal in "D" and "2" range, fluid leakage exists at or around low & reverse brake circuit.
	Line pressure is high.	<ul style="list-style-type: none"> ● Mal-adjustment of throttle sensor ● Fluid temperature sensor damaged ● Line pressure solenoid sticking ● Short circuit of line pressure solenoid circuit ● Pressure modifier valve sticking ● Pressure regulator valve or plug sticking
At stall speed	Line pressure is low.	<ul style="list-style-type: none"> ● Mal-adjustment of throttle sensor ● Control piston damaged ● Line pressure solenoid sticking ● Short circuit of line pressure solenoid circuit ● Pressure regulator valve or plug sticking ● Pressure modifier valve sticking ● Pilot valve sticking

TROUBLE DIAGNOSES

Symptom Chart

Reference page (AT-)		ON vehicle										OFF vehicle																							
		9, 14	80	80	84	81, 126	81	81	7, 81	7	7	110, 121	140, 144	146, 157	146, 154	150	164																		
Reference page (AT-)	Reference page (AT-)	Fluid level	Control linkage	Inhibitor switch	Throttle sensor (Adjustment)	Revolution sensor and speed sensor	Engine revolution signal	Engine idling rpm	Line pressure	Control valve assembly	Shift solenoid A	Shift solenoid B	Line pressure solenoid	Lock-up solenoid	Overrun clutch solenoid	Fluid temperature sensor	Accumulator N-D	Accumulator 1-2	Accumulator 2-3	Accumulator 3-4 (N-R)	Ignition switch and starter	Torque converter	Oil pump	Reverse clutch	High clutch	Forward clutch	Forward one-way clutch	Overrun clutch	Low one-way clutch	Low & reverse brake	Brake band	Parking components			
61	Engine does not start in "N", "P" ranges.	.	2	3	1		
61	Engine starts in range other than "N" and "P".	.	1	2		
-	Transmission noise in "P" and "N" ranges.	1	.	.	3	4	5	.	2	7	6		
61	Vehicle moves when changing into "P" range or parking gear does not disengage when shifted out of "P" range.	.	1	2	.		
62	Vehicle runs in "N" range.	.	1	4	.	.	3	.	2	.	5		
64	Vehicle will not run in "R" range (but runs in "D", "2" and "1" ranges). Clutch slips. Very poor acceleration.	.	1	2	.	4	.	3	5	6	7	.	8	.	9	.	.	.		
-	Vehicle braked when shifting into "R" range.	1	2	3	5	.	4	6	.	8	.	9	.	.	7	.	.		
-	Sharp shock in shifting from "N" to "D" range.	.	.	.	2	.	5	1	3	7	.	6	.	.	4	8	9		
-	Vehicle will not run in "D" and "2" ranges (but runs in "1" and "R" range).	.	1	2		
65	Vehicle will not run in "D", "1", "2" ranges (but runs in "R" range). Clutch slips. Very poor acceleration.	1	2	.	4	.	3	6	7	.	8	9	.	10	.	.	.		
-	Clutches or brakes slip somewhat in starting.	1	2	.	3	.	.	4	.	6	.	5	7	.	8	.	13	12	.	10	.	9	.	.	11	.	
-	Excessive creep.	1	
64, 65	No creep at all.	1	2	.	3	6	5	.	.	4	
-	Failure to change gear from "D ₁ " to "D ₂ ".	.	2	1	.	5	.	.	4	3	6	.	.	
-	Failure to change gear from "D ₂ " to "D ₃ ".	.	2	1	.	5	.	.	4	3	6	7	.	.	
-	Failure to change gear from "D ₃ " to "D ₄ ".	.	2	1	.	4	.	.	.	3	5	6	.	.	
67, 68, 69	Too high a gear change point from "D ₁ " to "D ₂ ", from "D ₂ " to "D ₃ ", from "D ₃ " to "D ₄ ".	.	.	1	2	3	4
-	Gear change directly from "D ₁ " to "D ₃ " occurs.	1	2	3	.	.	
-	Engine stops when shifting lever into "R", "D", "2" and "1".	1	.	3	.	.	.	2	4	
-	Too sharp a shock in change from "D ₁ " to "D ₂ ".	.	.	1	.	.	.	2	4	5	.	3	6	.	.	
-	Too sharp a shock in change from "D ₂ " to "D ₃ ".	.	.	1	.	.	.	2	4	3	5	6	.	.	

TROUBLE DIAGNOSES

Symptom Chart (Cont'd)

	Reference page (AT-)	ON vehicle										OFF vehicle																				
		9, 14	80	80	84	81, 126	81	81	7, 81	7	7	110, 121	140, 144	146, 157	146, 154	150	164															
Reference page (AT-)	Numbers are arranged in order of probability. Perform inspections starting with number one and work up. Circled numbers indicate that the transmission must be removed from the vehicle.	Fluid level	Control linkage	Inhibitor switch	Throttle sensor (Adjustment)	Revolution sensor and speed sensor	Engine revolution signal	Engine idling rpm	Line pressure	Control valve assembly	Shift solenoid A	Shift solenoid B	Line pressure solenoid	Lock-up solenoid	Overrun clutch solenoid	Fluid temperature sensor	Accumulator N-D	Accumulator 1-2	Accumulator 2-3	Accumulator 3-4 (N-R)	Ignition switch and starter	Torque converter	Oil pump	Reverse clutch	High clutch	Forward clutch	Forward one-way clutch	Overrun clutch	Low one-way clutch	Low & reverse brake	Brake band	Parking components
-	Too sharp a shock in change from "D ₃ " to "D ₄ ".	.	.	1	.	.	2	4	3	⑥	.	⑤	.		
-	Almost no shock or clutches slipping in change from "D ₁ " to "D ₂ ".	1	.	2	.	.	3	5	4	⑥	.		
-	Almost no shock or slipping in change from "D ₂ " to "D ₃ ".	1	.	2	.	.	3	5	4	⑦	.		
-	Almost no shock or slipping in change from "D ₃ " to "D ₄ ".	1	.	2	.	.	3	5	4	⑦	.		
-	Vehicle braked by gear change from "D ₁ " to "D ₂ ".	1	②	④	.	.	⑤	③	.		
-	Vehicle braked by gear change from "D ₂ " to "D ₃ ".	1	②	.		
-	Vehicle braked by gear change from "D ₃ " to "D ₄ ".	1	④	.	③	②	.	.	.		
-	Maximum speed not attained. Acceleration poor.	1	.	2	.	.	.	5	3	4	⑪	⑩	⑥	⑦	.	.	.	⑨	⑧	.		
-	Failure to change gear from "D ₄ " to "D ₃ ".	1	.	2	.	.	.	6	4	5	3	⑧	⑦	.			
-	Failure to change gear from "D ₃ " to "D ₂ " or from "D ₄ " to "D ₂ ".	1	.	2	.	.	.	5	3	4	⑥	.	.	.	⑦	.			
-	Failure to change gear from "D ₂ " to "D ₁ " or from "D ₃ " to "D ₁ ".	1	.	2	.	.	.	5	3	4	⑦	.	.	⑥	⑧	.			
-	Gear change shock felt during deceleration by releasing accelerator pedal.	.	.	1	.	.	2	4	3			
-	Too high a change point from "D ₄ " to "D ₃ ", from "D ₃ " to "D ₂ ", from "D ₂ " to "D ₁ ".	.	.	1	2			
-	Kickdown does not operate when depressing pedal in "D ₄ " within kickdown vehicle speed.	.	.	1	2	.	.	3	4			
-	Kickdown operates or engine overruns when depressing pedal in "D ₄ " beyond kickdown vehicle speed limit.	.	.	2	1	.	.	3	4			
-	Races extremely fast or slips in changing from "D ₄ " to "D ₃ " when depressing pedal.	1	.	2	.	.	3	5	.	4	⑥	⑦			
-	Races extremely fast or slips in changing from "D ₄ " to "D ₂ " when depressing pedal.	1	.	2	.	.	3	6	5	4	⑧	.	.	⑦	.			
-	Races extremely fast or slips in changing from "D ₃ " to "D ₂ " when depressing pedal.	1	.	2	.	.	3	5	.	4	.	.	8	.	0	⑨	⑦	.	.	⑥	.			
-	Races extremely fast or slips in changing from "D ₄ " or "D ₃ " to "D ₁ " when depressing pedal.	1	.	2	.	.	3	5	.	4	⑤	⑦	⑧	.	.			
-	Vehicle will not run in any range.	1	2	.	.	.	3	.	.	4	⑨	⑤	⑥	⑧	⑦	⑩		
-	Transmission noise in "D", "2", "1" and "R" ranges.	1	②			

TROUBLE DIAGNOSES

Symptom Chart (Cont'd)

Reference page (AT-)	Reference page (AT-)	ON vehicle										OFF vehicle																					
		9, 14	80	80	84	81, 126	81	81	7, 81	7	7	110, 121	140, 144	146, 157	146, 154	150	164																
	Numbers are arranged in order of probability. Perform inspections starting with number one and work up. Circled numbers indicate that the transmission must be removed from the vehicle.	Fluid level	Control linkage	Inhibitor switch	Throttle sensor (Adjustment)	Revolution sensor and speed sensor	Engine revolution signal	Engine idling rpm	Line pressure	Control valve assembly	Shift solenoid A	Shift solenoid B	Line pressure solenoid	Lock-up solenoid	Overrun clutch solenoid	Fluid temperature sensor	Accumulator N-D	Accumulator 1-2	Accumulator 2-3	Accumulator 3-4 (N-R)	Ignition switch and starter	Torque converter	Oil pump	Reverse clutch	High clutch	Forward clutch	Forward one-way clutch	Overrun clutch	Low one-way clutch	Low & reverse brake	Brake band	Parking components	
74	Failure to change from "D ₃ " to "2 ₁ " when changing lever into "2" range.	.	7	1	2	6	5	4	.	.	3	⑨	.	.	⑧	.	
-	Gear change from "2 ₂ " to "2 ₃ " in "2" range.	.	.	1	
74	Engine brake does not operate in "1" range.	.	2	1	3	4	.	.	.	6	5	.	.	.	7	⑧	.	⑨	.	.	
-	Gear change from "1 ₁ " to "1 ₂ " in "1" range.	.	2	1	
-	Does not change from "1 ₂ " to "1 ₁ " in "1" range.	.	.	1	.	2	.	.	.	4	3	.	.	.	5	⑥	.	⑦	.	.	
-	Large shock changing from "1 ₂ " to "1 ₁ " in "1" range.	1	②	.	.	.	
-	Transmission overheats.	1	.	.	3	.	.	2	4	6	.	.	5	⑭	⑦	⑧	⑨	⑪	.	⑫	.	⑬	⑩	.	
-	A.T.F. shoots out during operation. White smoke emitted from exhaust pipe during operation.	1	②	③	⑤	.	⑥	.	⑦	④	.	
-	Offensive smell at fluid charging pipe.	1	②	③	④	⑤	⑦	.	⑧	.	⑨	⑥	.
-	Torque converter is not locked up.	.	.	3	1	2	4	.	6	8	.	.	.	7	.	5	⑨	
-	Lock-up piston slip	1	.	.	2	.	.	3	6	.	.	5	4	⑦	
70	Lock-up point is extremely high or low.	.	.	.	1	2	.	.	4	.	.	.	3	
-	A/T does not shift to "D ₄ " when driving with overdrive switch "ON".	.	.	2	1	3	.	8	6	4	.	.	5	7	⑩	.	⑨	.	.	
-	Engine is stopped at "R", "D", "2" and "1" ranges.	1	5	4	3	.	2	

TROUBLE DIAGNOSES

A/T Shift Lock System

SHIFT LOCK SYSTEM ELECTRICAL PARTS LOCATION

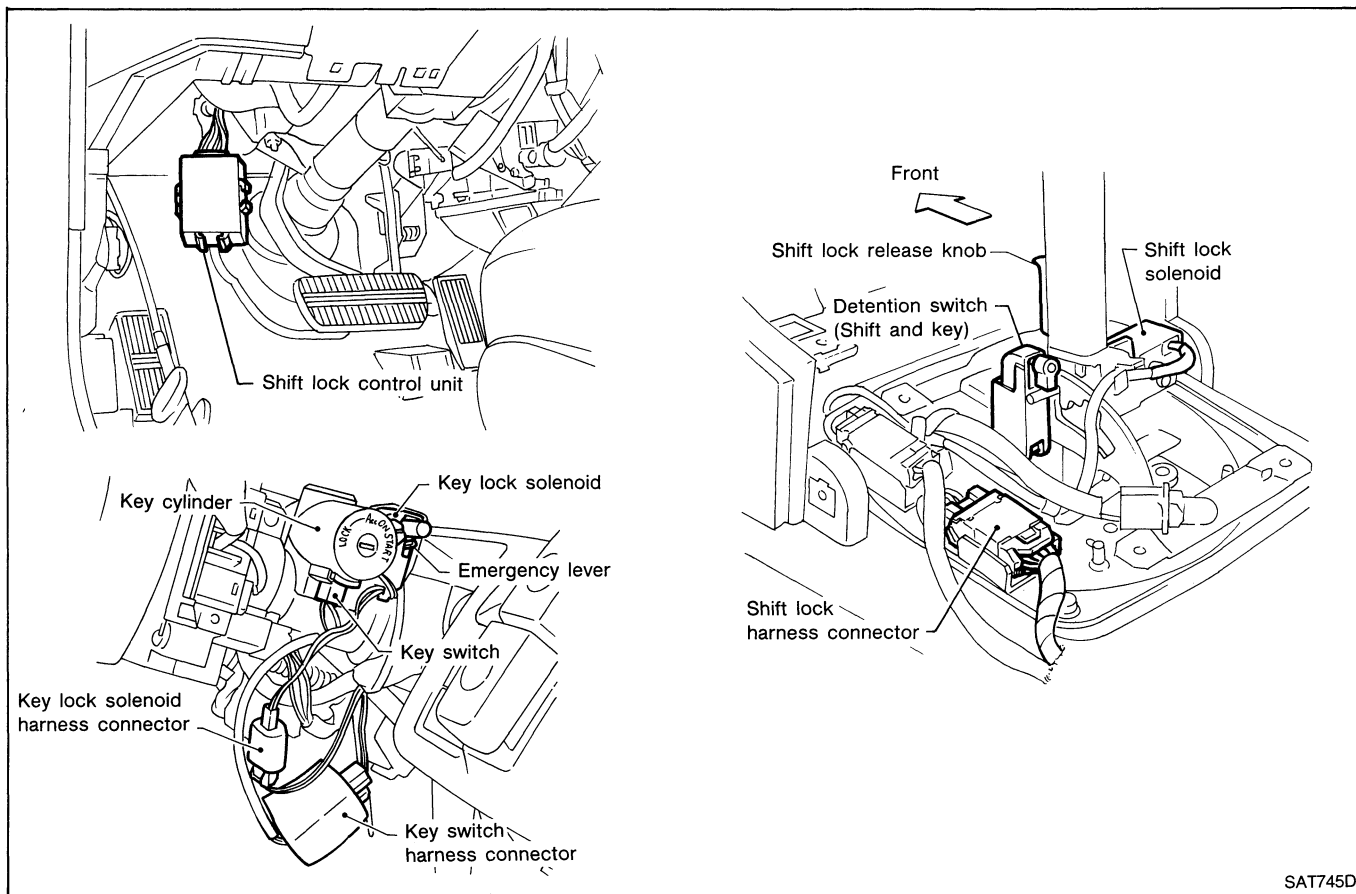

CIRCUIT DIAGRAM FOR QUICK PINPOINT CHECK

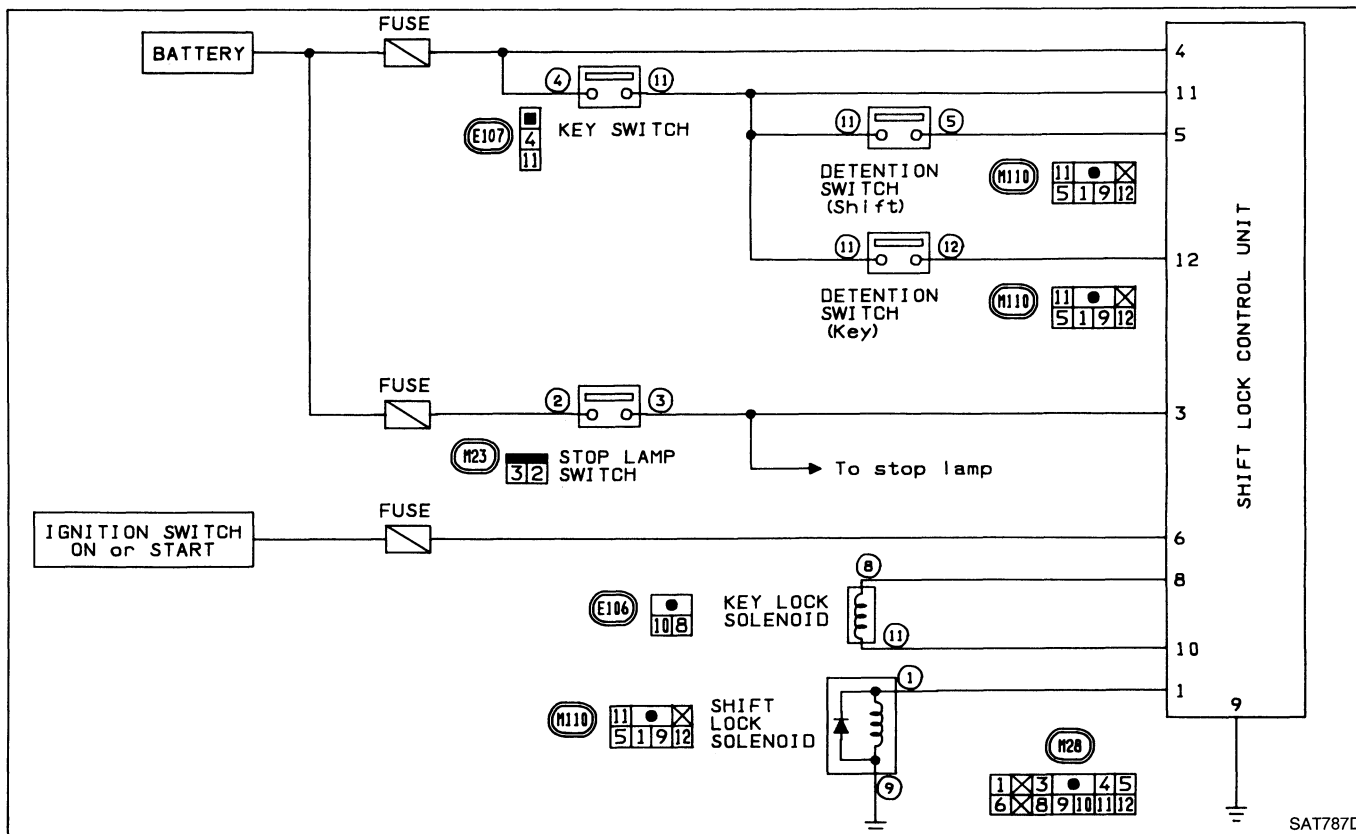

TROUBLE DIAGNOSES

A/T Shift Lock System (Cont'd)

WIRING DIAGRAM

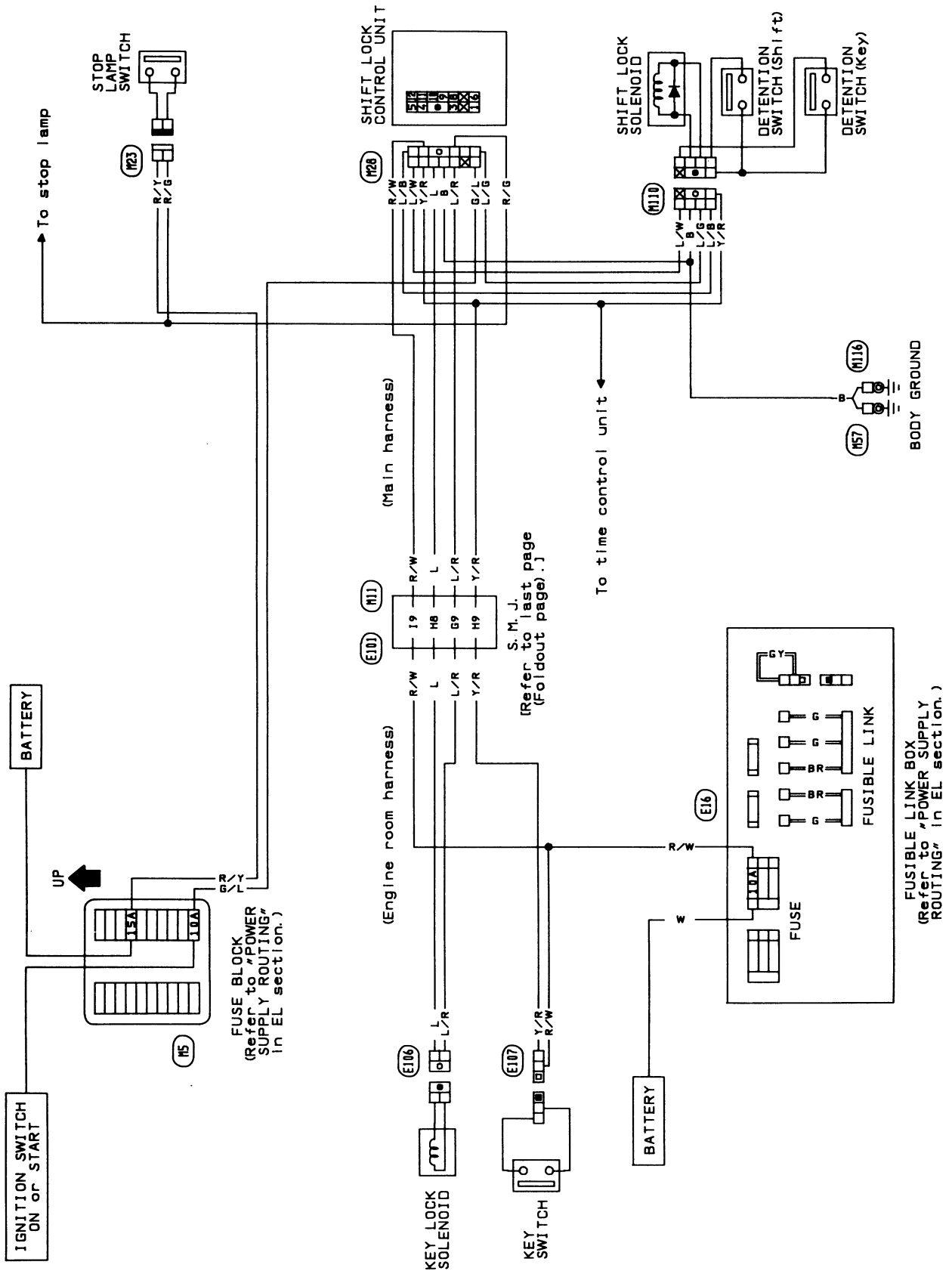

TROUBLE DIAGNOSES

A/T Shift Lock System (Cont'd)

DIAGNOSTIC PROCEDURE 1

SYMPTOM:

Selector lever cannot be moved from "P" range when applying brake pedal or can be moved when releasing brake pedal.

Selector lever can be moved from "P" range when key is removed from key cylinder.

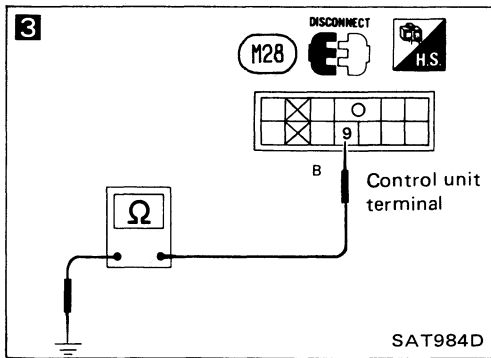
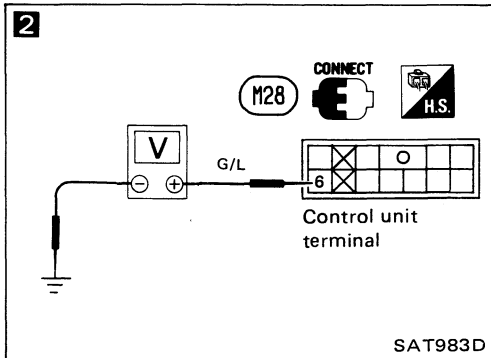
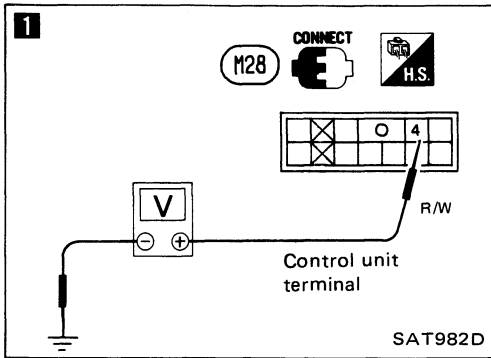

1

CHECK POWER SOURCE.

1. Check voltage between control unit harness terminals ④ and ground. **Battery voltage should exist.**

N.G.

- Check the following items:
1. Harness continuity between battery and control unit harness terminal ④
 2. Fuse

O.K.

2

CHECK IGNITION SIGNAL.

1. Check voltage between control unit harness terminal ⑥ and ground. **0V**
2. Check voltage between control unit harness terminal ⑥ and ground. **Battery voltage should exist.**

N.G.

- Check the following items:
1. Harness continuity between battery and control unit harness terminal ⑥
 2. Fuse
 3. Ignition switch

O.K.

3

CHECK GROUND CIRCUIT FOR CONTROL UNIT.

1. Disconnect control unit harness connector.
2. Check continuity between control unit harness terminal ⑨ and ground. **Continuity should exist.**

N.G.

Repair harness or connector.

O.K.

A

TROUBLE DIAGNOSES

A/T Shift Lock System (Cont'd)

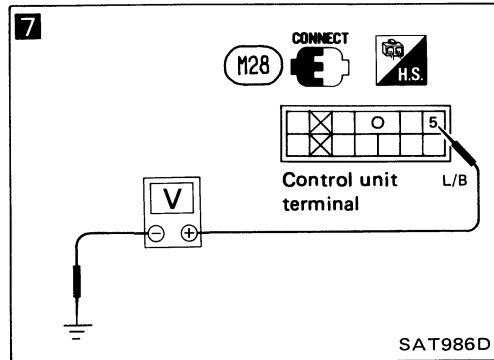
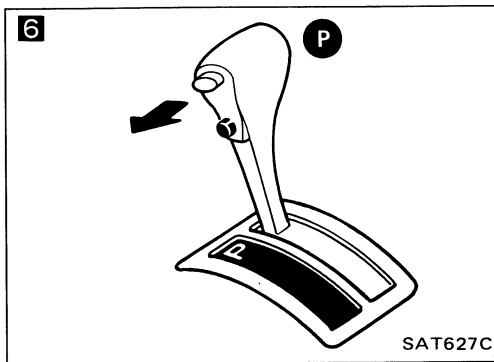
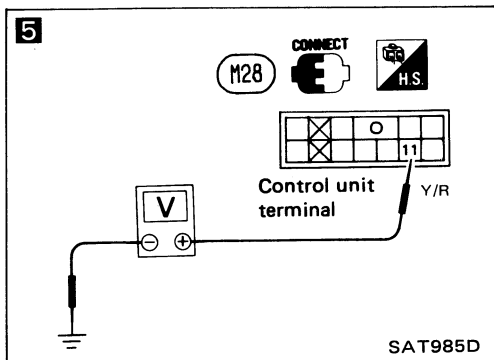
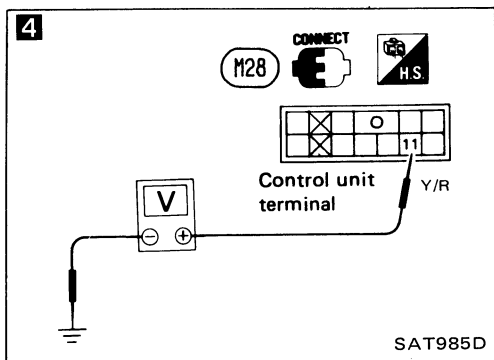

4

CHECK INPUT SIGNAL (KEY SWITCH).

1. Reconnect control unit harness connector.
- 2.
3. Check voltage between control unit terminal ① and ground.
0V

N.G. Check key switch. (Refer to "COMPONENT CHECK".)

5

- 1.
2. Check voltage between control unit harness terminal ① and ground.
Battery voltage should exist.

N.G. Check the following items:

1. Harness continuity between control unit harness terminal ① and key switch harness terminal ①.
2. Harness continuity between key switch harness terminal ④ and fuse
3. Key switch (Refer to "COMPONENT CHECK".)

6

CHECK INPUT SIGNAL (DETENTION SWITCH—SHIFT).

- 1.
2. Set selector lever in "P" position and release selector lever button.
3. Check voltage between control unit harness terminal ⑤ and ground.
0V

N.G. Check detention switch—shift. (Refer to "COMPONENT CHECK".)

O.K.

TROUBLE DIAGNOSES

A/T Shift Lock System (Cont'd)

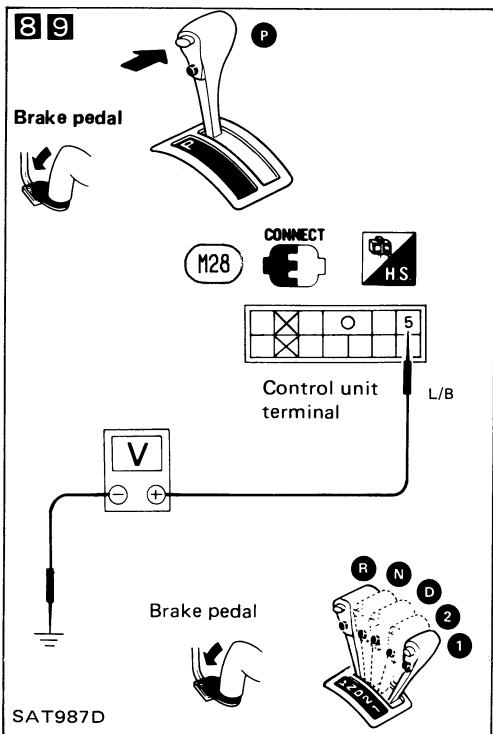

CHECK INPUT SIGNAL (DETENTION SWITCH—SHIFT).

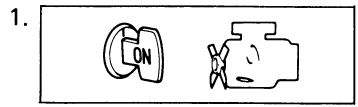

8 2. Check voltage between control unit harness terminal ⑤ and ground with brake pedal depressed and selector lever button pushed.
Battery voltage should exist.

9 3. Check voltage between control unit harness terminal ⑤ and ground with selector lever set in any position except "P".
When selector lever cannot be moved from "P" position with brake pedal depressed, push shift lock release knob.
Battery voltage should exist.

N.G.

- Check the following items:
1. Harness continuity between control unit harness terminal ⑤ and detention switch harness terminal ⑤
 2. Harness continuity between detention switch harness terminal ⑪ and key switch harness terminal ⑪
 3. Detention switch—shift (Refer to "COMPONENT CHECK".)

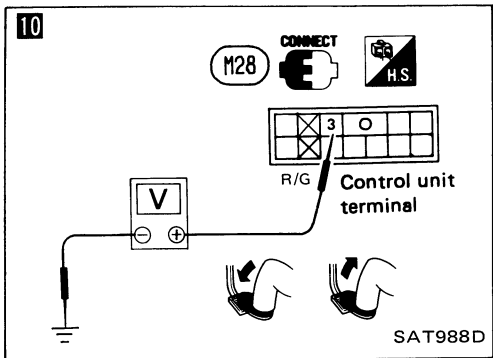

CHECK INPUT SIGNAL (STOP LAMP SWITCH).

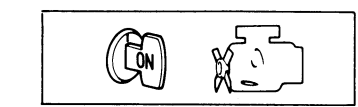

• Check voltage between control unit harness terminal ③ and ground.

Brake pedal	Voltage
Depressed	Battery voltage
Released	0V

N.G.

- Check the following items:
1. Harness continuity between control unit harness terminal ③ and stop lamp switch harness terminal ③
 2. Stop lamp switch (Refer to "COMPONENT CHECK".)

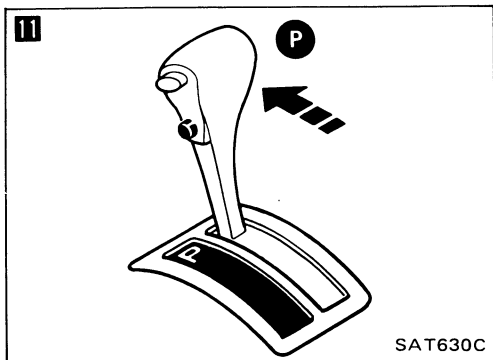

11 Set selector lever in "P" position.

©

TROUBLE DIAGNOSES

A/T Shift Lock System (Cont'd)

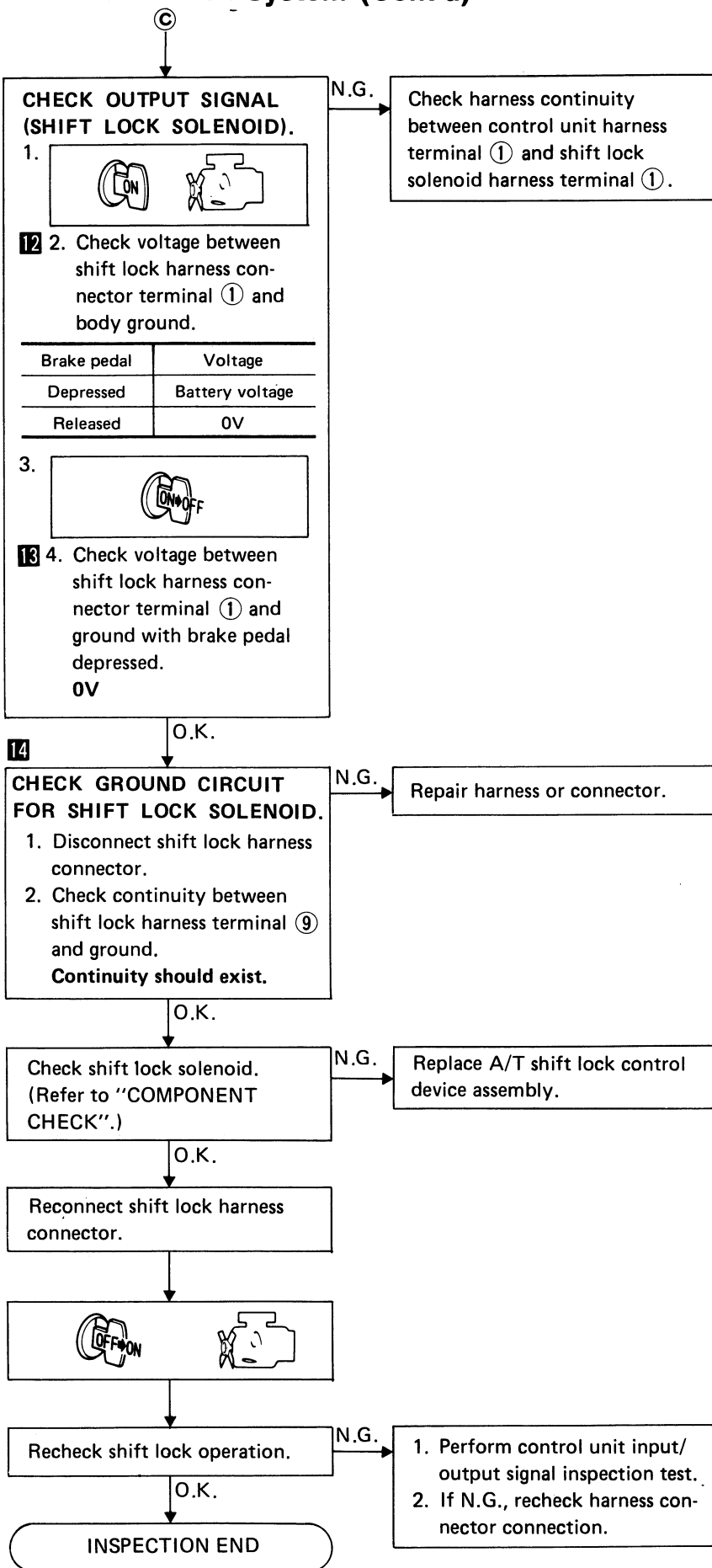
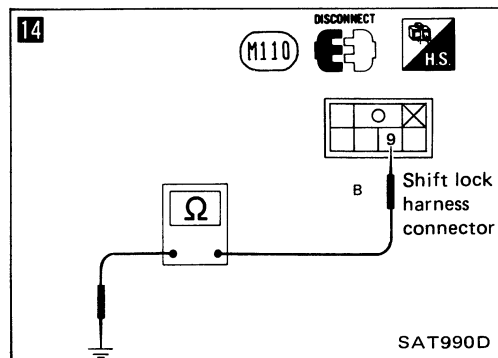
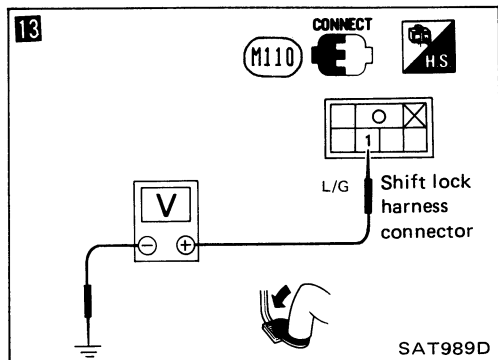
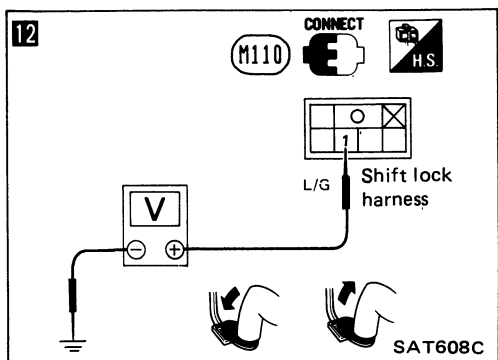

TROUBLE DIAGNOSES

A/T Shift Lock System (Cont'd)

DIAGNOSTIC PROCEDURE 2

SYMPTOM:

Ignition key cannot be removed when selector lever is set to "P" position or can be removed when selector lever is set to any position except "P".

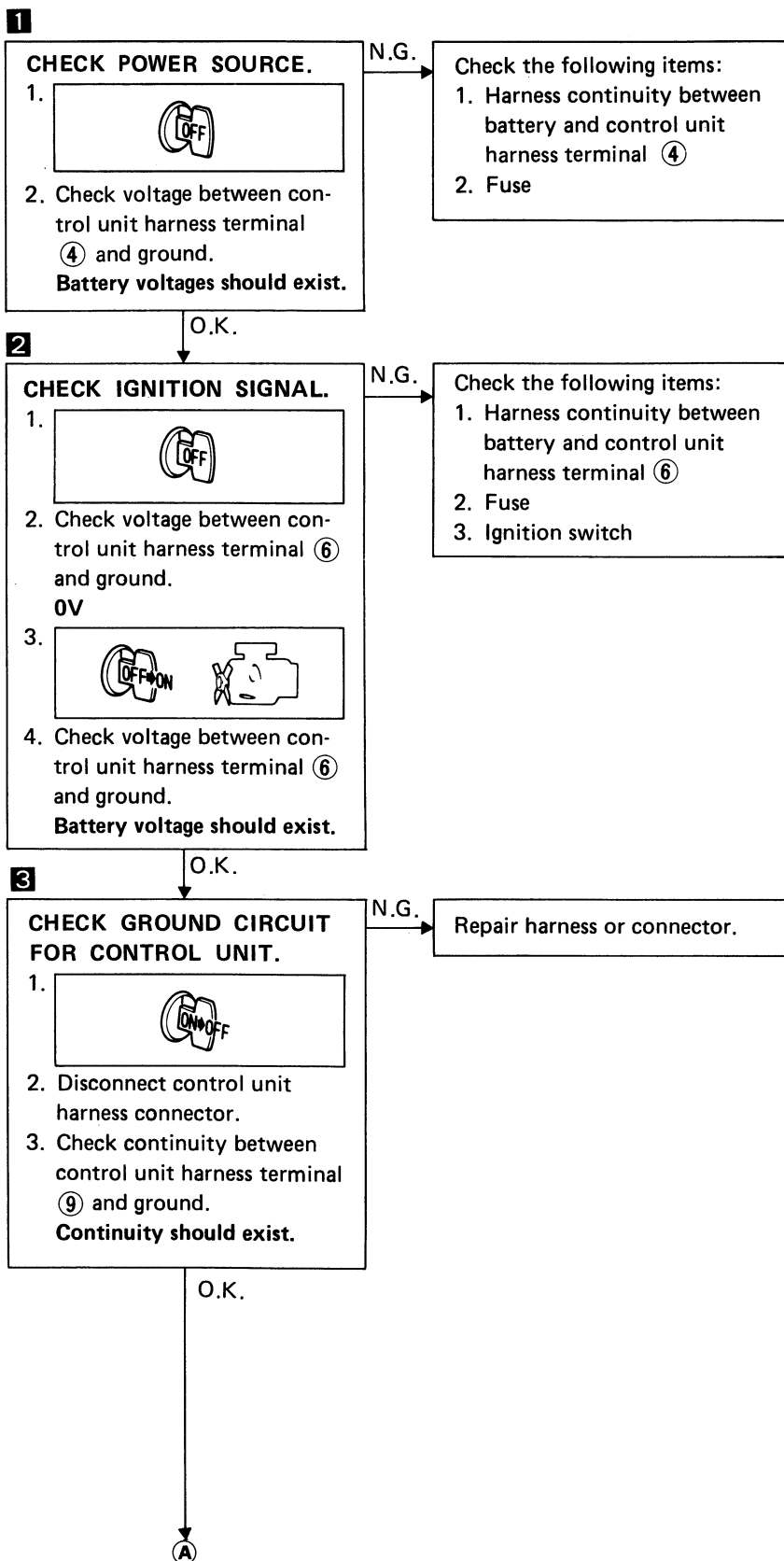
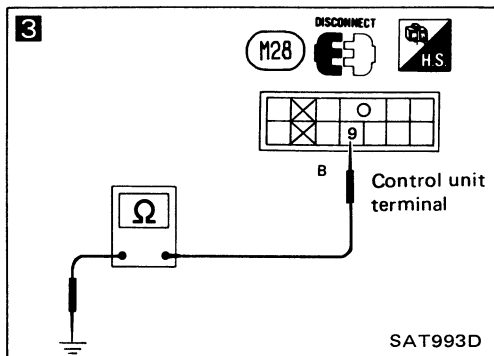
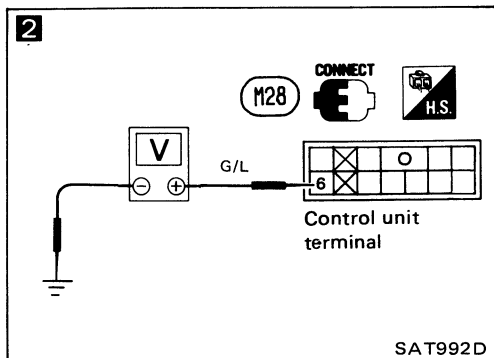
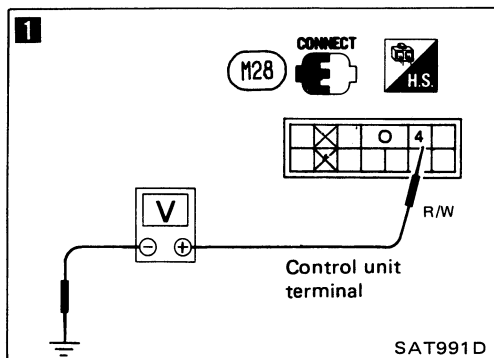

TROUBLE DIAGNOSES

A/T Shift Lock System (Cont'd)

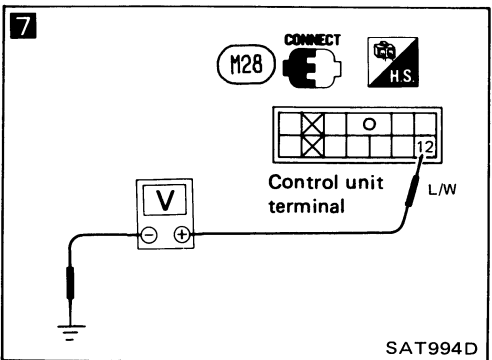
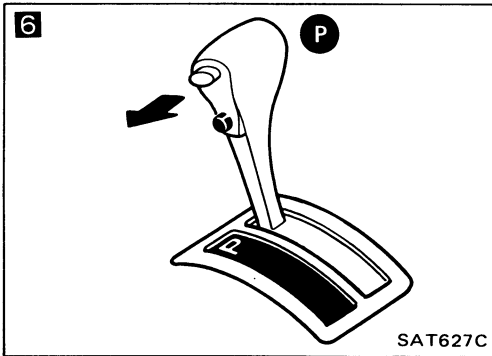
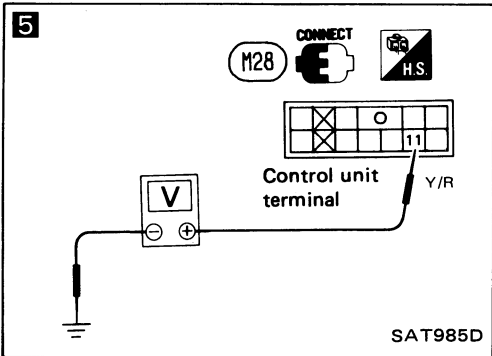
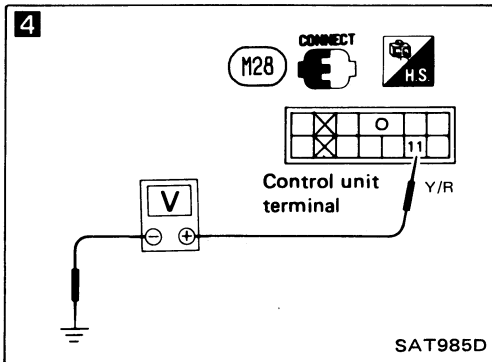

4

CHECK INPUT SIGNAL (KEY SWITCH).

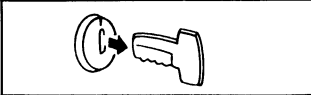
1. Reconnect control unit harness connector.
2. 

When ignition key cannot be removed, even if selector lever is in "P" position, use emergency lever.

3. Check voltage between control unit terminal ① and ground.
0V

N.G. → Check key switch. (Refer to "COMPONENT CHECK".)

5

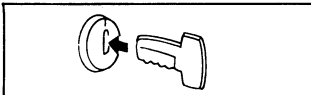
1. 
2. Check voltage between control unit harness terminal ① and ground.
Battery voltage should exist.

N.G. → Check the following items:

1. Harness continuity between control unit harness terminal ① and key switch harness terminal ①.
2. Harness continuity between key switch harness terminal ④ and fuse
3. Key switch (Refer to "COMPONENT CHECK".)

O.K. →

CHECK INPUT SIGNAL (DETENTION SWITCH-KEY).

1. 
2. Set selector lever in "P" position and release selector lever button.
3. Check voltage between control unit harness terminal ⑫ and ground.
0V

N.G. → Check detention switch-key. (Refer to "COMPONENT CHECK".)

O.K. →

B

TROUBLE DIAGNOSES

A/T Shift Lock System (Cont'd)

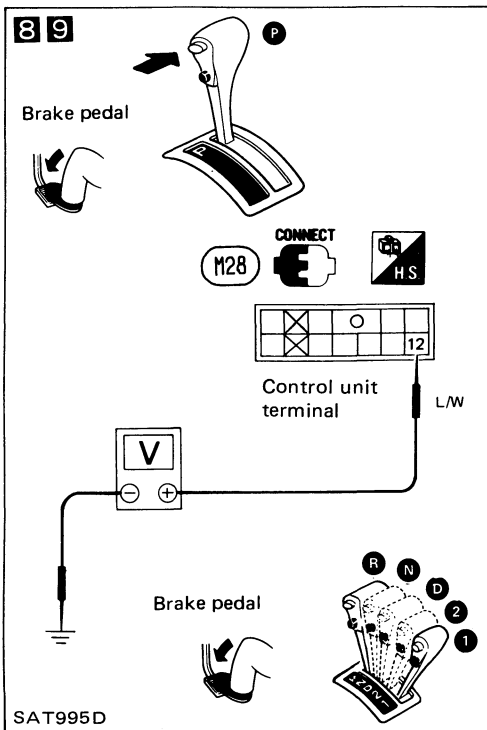

CHECK INPUT SIGNAL (DETENTION SWITCH—KEY).

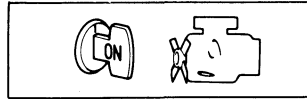

- 8** 1. Check voltage between control unit harness terminal ⑫ and ground with brake pedal depressed and selector lever button pushed.
Battery voltage should exist.
- 9** 2. Check voltage between control unit harness terminal ⑫ and ground with selector lever set in any position except "P".
Battery voltage should exist.

N.G.

Check the following items:

1. Harness continuity between control unit harness terminal ⑫ and detention switch harness terminal ⑫
2. Harness continuity between detention switch harness terminal ⑪ and key switch harness terminal ⑪
3. Detention switch—key (Refer to "COMPONENT CHECK".)

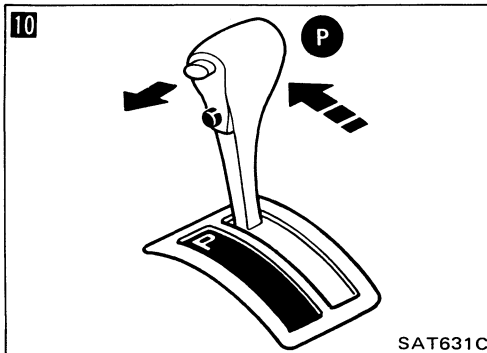

10

O.K.

Set selector lever in "P" position and release selector lever button.



11

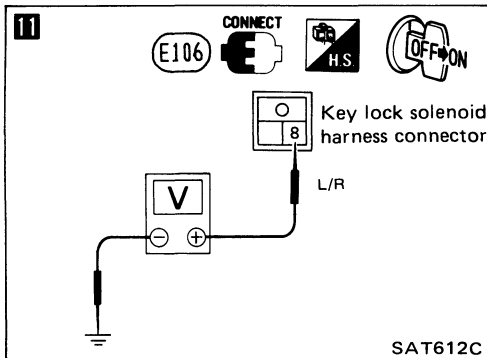

CHECK OUTPUT SIGNAL (KEY LOCK SIGNAL).



Check voltage between key lock solenoid harness terminal ⑧ and ground at the moment ignition key is turned from OFF to ON.
Battery voltage should exist for approximately 0.1 seconds.

N.G.

Check harness continuity between shift lock solenoid harness terminal ⑧ and control unit harness terminal ⑧.

O.K.

N.G.

Repair harness or connector.

Replace control unit.

O.K.

Ⓒ

TROUBLE DIAGNOSES

A/T Shift Lock System (Cont'd)

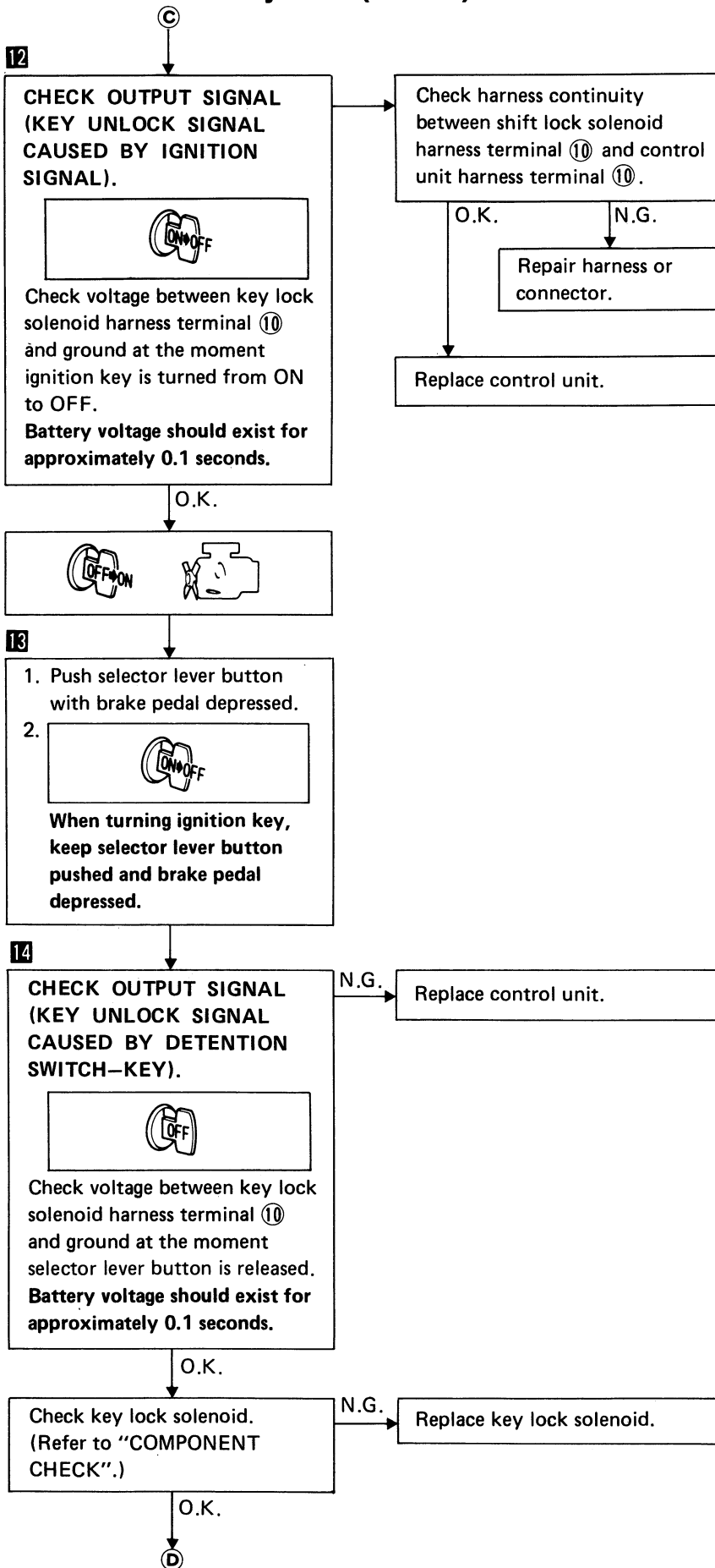
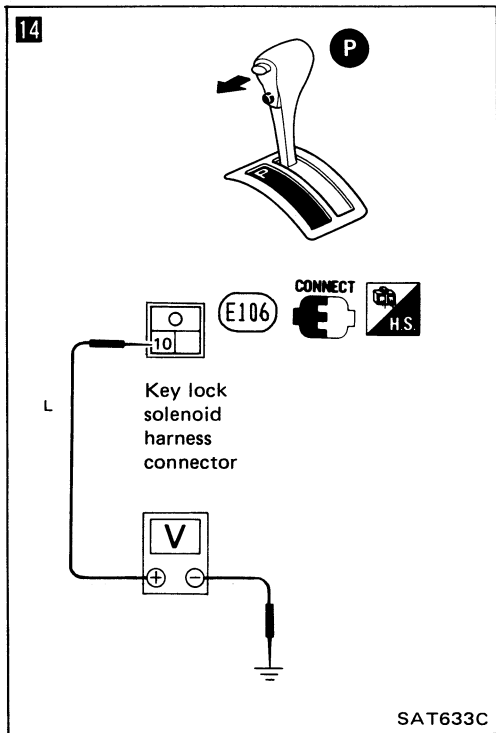
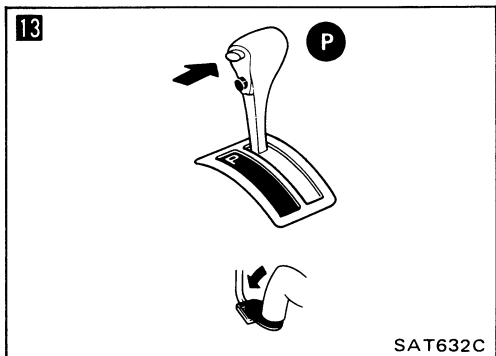
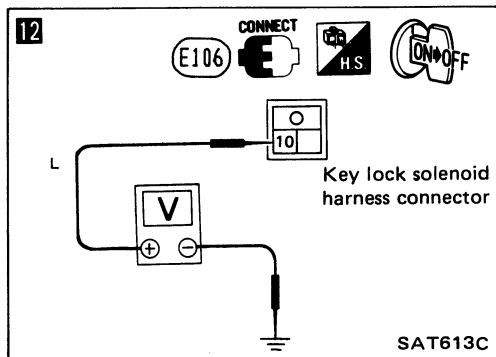

TROUBLE DIAGNOSES

A/T Shift Lock System (Cont'd)

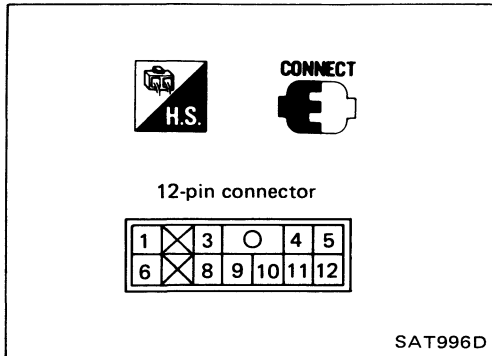
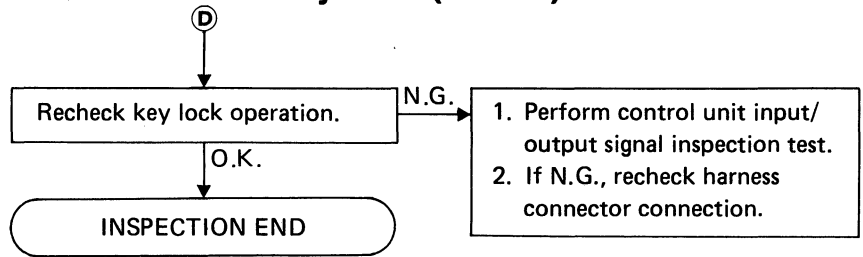



SHIFT LOCK CONTROL UNIT INSPECTION

- Measure voltage between each terminal and terminal ⑨ by following "SHIFT LOCK CONTROL UNIT INSPECTION TABLE".
- Pin connector terminal layout.

TROUBLE DIAGNOSES

A/T Shift Lock System (Cont'd)

SHIFT LOCK CONTROL UNIT INSPECTION TABLE (Data are reference values.)

Terminal No.		Item	Condition	Judgement standard	
⊕	⊖				
1	9	Shift lock signal	 When selector lever is set in "P" position and brake pedal is depressed	Battery voltage	
			Except above	0V	
3		Stop lamp switch	When brake pedal is depressed	Battery voltage	
			When brake pedal is released	0V	
4		Power source		Battery voltage	
5		Detention switch (Shift)	When key is inserted into key cylinder, selector lever is set in "P" position and selector lever button is released	0V	
			Except above	Battery voltage	
6		Ignition signal		Battery voltage	
8		10	Key lock signal	When ignition switch is turned from LOCK, OFF or ACC to ON	Battery voltage (Approximately 0.1 seconds)
				Except above	0V
9	—	Ground	—	—	
10	8	Key unlock signal	When ignition switch is turned from ON to LOCK, OFF, or ACC, selector lever is set in "P" position and selector lever button is released	Battery voltage (Approximately 0.1 seconds)	
			Except above	0V	
11	9	Key switch	When key is inserted into key cylinder	Battery voltage	
			When key is removed from key cylinder	0V	
Detention switch (Key)		When key is inserted into key cylinder, selector lever is set in "P" position and selector lever button is released	0V		
		Except above	Battery voltage		

TROUBLE DIAGNOSES

A/T Shift Lock System (Cont'd)

COMPONENT CHECK

Shift lock solenoid

- Check operation by applying battery voltage to shift lock harness connector.

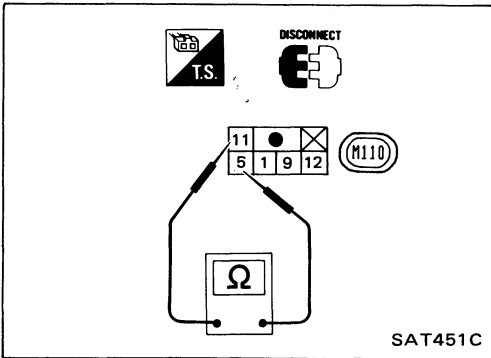
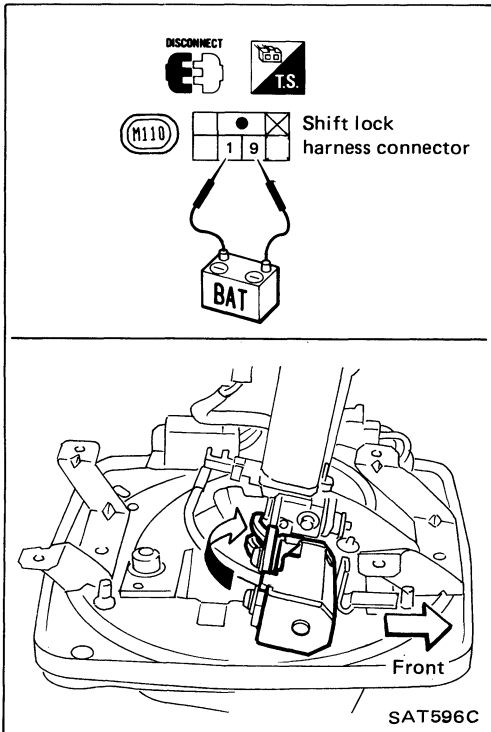

Detention switch—shift

- Check continuity between terminals ⑤ and ⑪ of shift lock harness connector.

Condition	Continuity
When selector lever is set in "P" position and selector lever button is released	No
Except the above	Yes

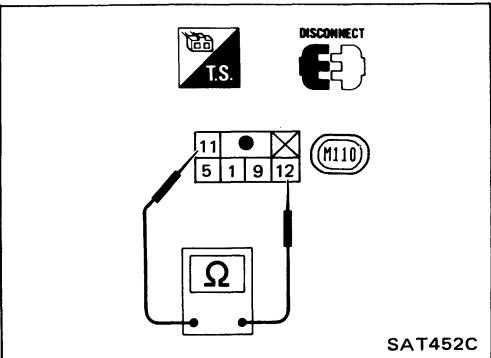

Detention switch—key

- Check continuity between terminals ⑪ and ⑫ of shift lock harness connector.

Condition	Continuity
When selector lever is set in "P" position and selector lever button is released	No
Except the above	Yes

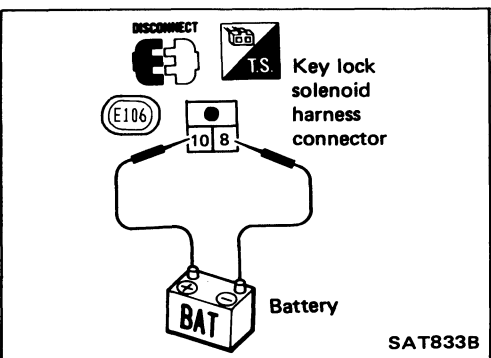

Key lock solenoid

- Check operation by applying battery voltage to key lock solenoid harness connector.

Operating sound must be emitted.

TROUBLE DIAGNOSES

A/T Shift Lock System (Cont'd)

Key switch

- Check continuity between terminals ④ and ⑪ of key switch harness connector.

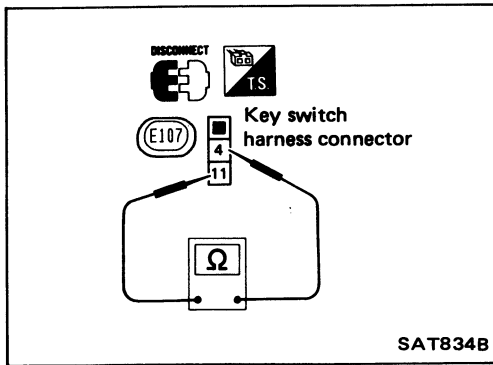

Condition	Continuity
When key is inserted into key cylinder	Yes
When key is removed from key cylinder	No

Stop lamp switch

- Check continuity between terminals ② and ③ of stop lamp switch harness connector.

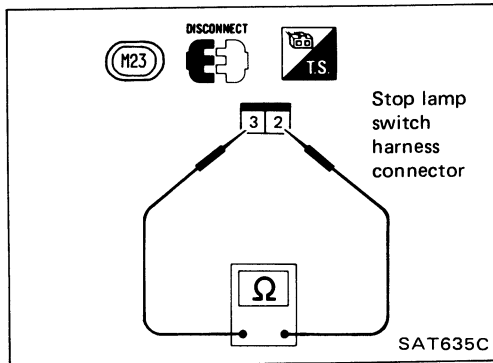

Condition	Continuity
When brake pedal is depressed	Yes
When brake pedal is released	No

Check stop lamp switch after adjusting brake pedal — refer to section BR.

REMOVAL AND INSTALLATION

Removal

- Disconnect A/T harness connector and clamps.

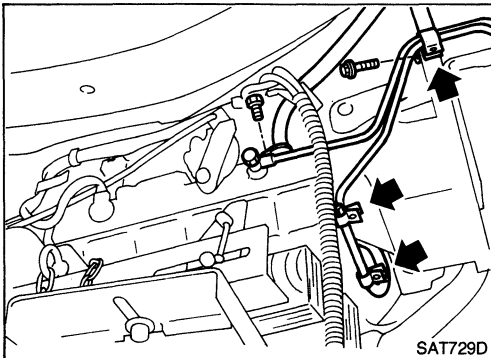
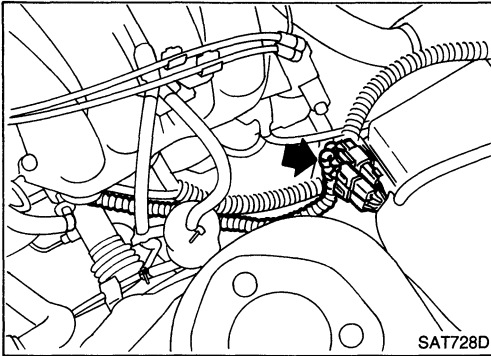

- Remove fluid charging pipe and oil cooler pipe at right side of A/T assembly. Plug up openings.
- Remove oil cooler pipe clamp at engine oil pan.
- Disconnect speed sensor harness connector.
- Remove control linkage from selector lever.

- Remove propeller shaft — Refer to section PD.
Insert plug into rear oil seal after removing propeller shaft. Be careful not to damage spline, sleeve yoke and rear oil seal, when removing propeller shaft.

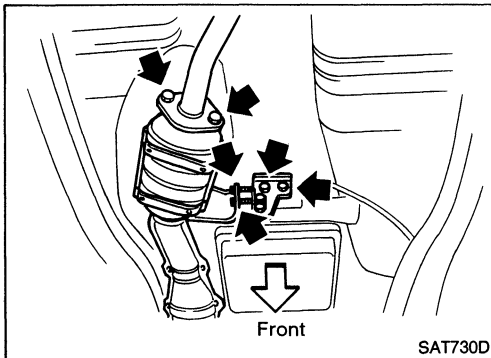

- Remove heat insulator from catalytic converter.
- Remove exhaust tube bracket and separate rear exhaust tube from converter.
- Remove starter motor.

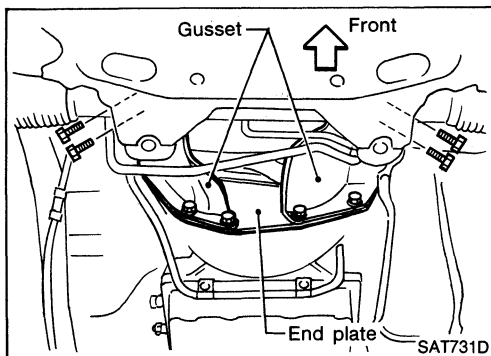

- Remove gussets and end plate.

REMOVAL AND INSTALLATION

Removal (Cont'd)

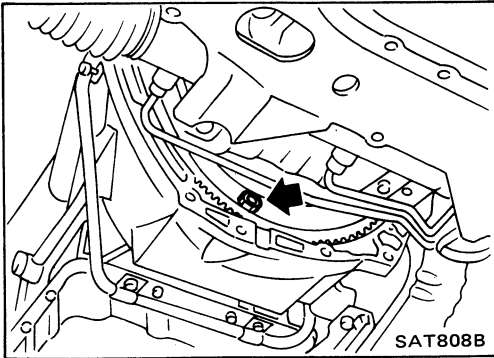

- Remove bolts securing torque converter to drive plate. Gain access to bolts by turning crankshaft.

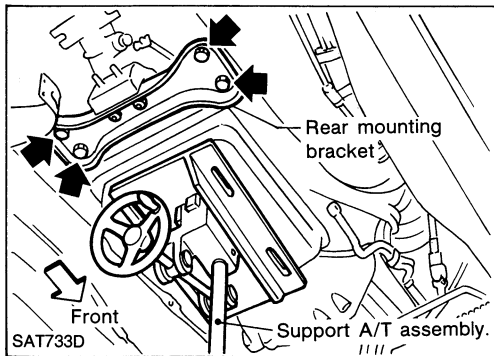
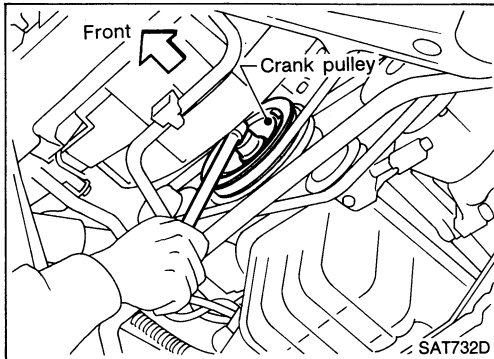

- Support A/T assembly by placing a jack under oil pan.
- Remove rear mounting bracket from body.

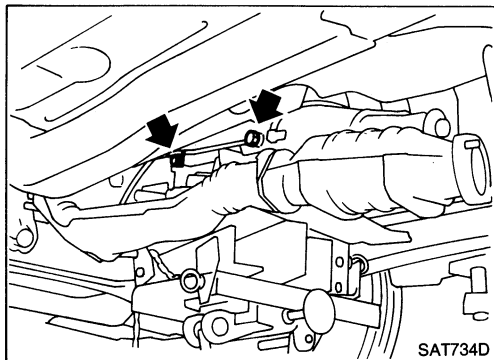

- Lower A/T assembly as much as possible.
- Remove oil cooler pipe from left side of A/T assembly. Plug up openings.

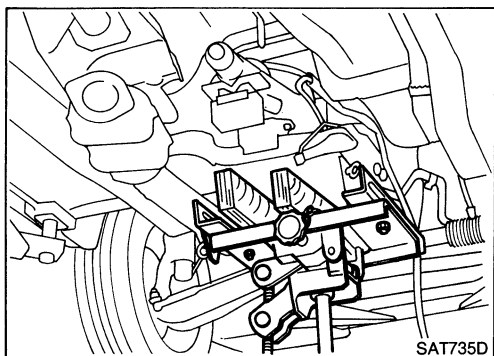

- Remove bolts securing A/T assembly to engine.
- Remove and lower A/T assembly. Be careful not to damage steering gear and tubes.

REMOVAL AND INSTALLATION

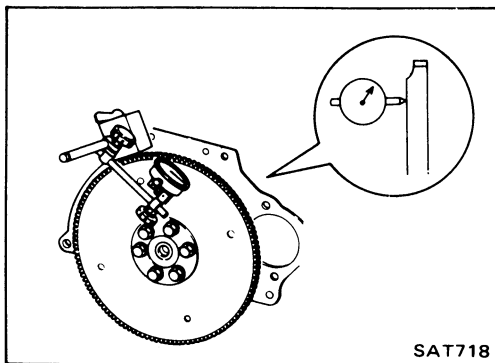

SAT718

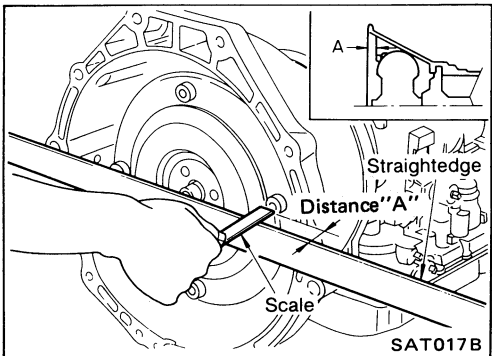

SAT017B

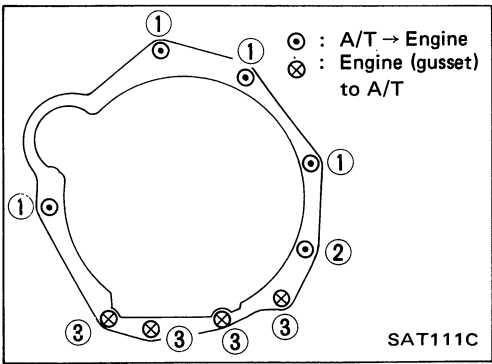

SAT111C



SAT638A

Installation

- Drive plate runout
 - Maximum allowable runout:**
0.5 mm (0.020 in)
 - If this runout is out of allowance, replace drive plate with ring gear.

- When connecting torque converter to transmission, measure distance "A" to be certain that they are correctly assembled.
 - Distance "A":**
26 mm (1.02 in) or more
- Install converter to drive plate.
- Reinstall any part removed.
- **After converter is installed to drive plate, rotate crankshaft several turns and check to be sure that transmission rotates freely without binding.**

- Tighten bolts securing transmission.

Bolt No.	Tightening torque N-m (kg-m, ft-lb)	Bolt length "L" mm (in)
1	39 - 49 (4.0 - 5.0, 29 - 36)	40 (1.57)
2	39 - 49 (4.0 - 5.0, 29 - 36)	50 (1.97)
3	29 - 39 (3.0 - 4.0, 22 - 29)	25 (0.98)
Gusset to engine (4 bolts)	29 - 39 (3.0 - 4.0, 22 - 29)	20 (0.79)

- Reinstall any part removed.
- Check fluid level in transmission.
- Move selector lever through all positions to be sure that transmission operates correctly.
 - With parking brake applied, rotate engine at idling. Move selector lever through "N" to "D", to "2", to "1" and to "R". A slight shock should be felt by hand gripping selector each time transmission is shifted.
- Perform road test. — Refer to "ROAD TESTING".

MAJOR OVERHAUL

Oil Channel

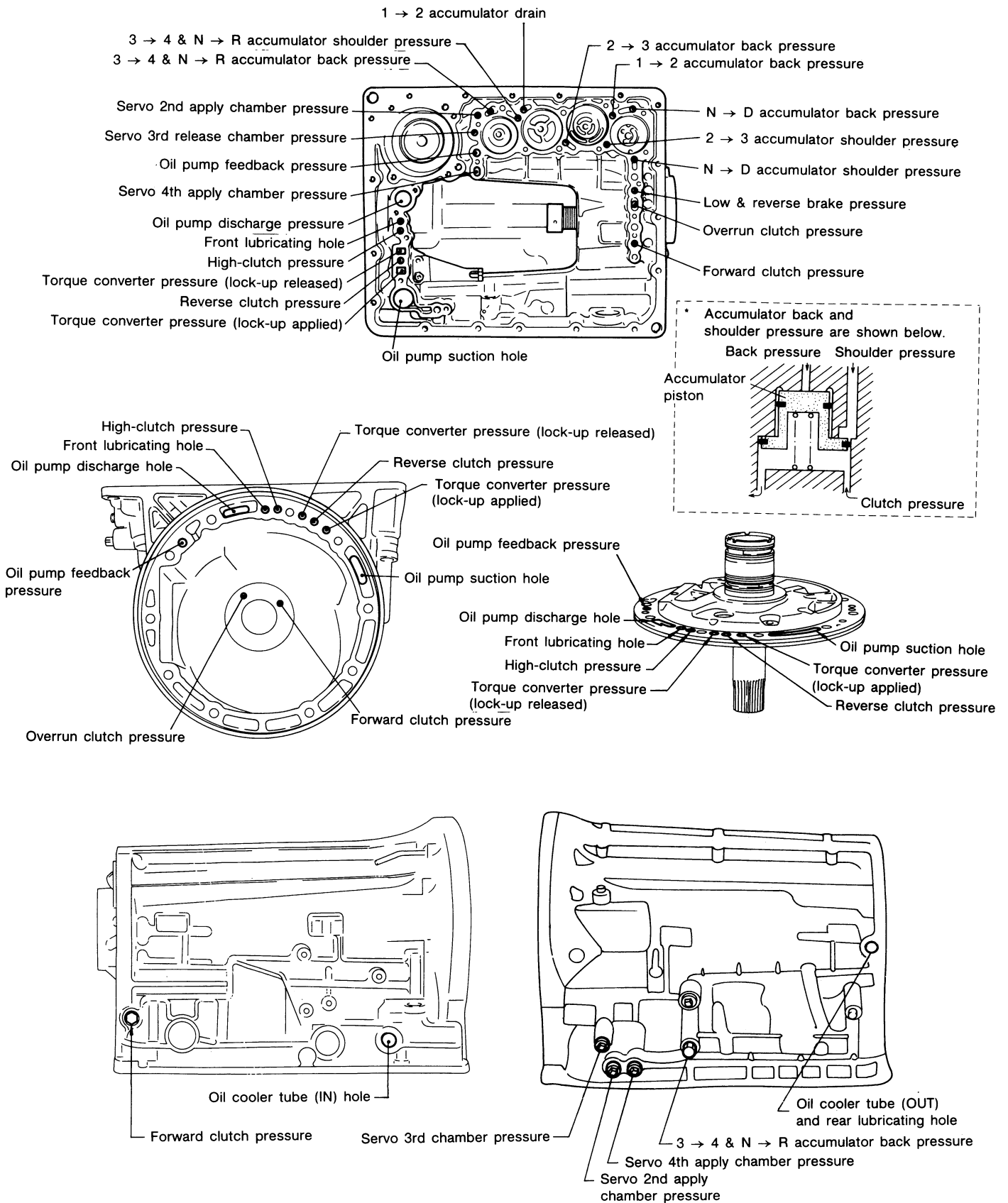

SAT185B

MAJOR OVERHAUL

Locations of Needle Bearings, Thrust Washers and Snap Rings

Outer diameter of snap rings

Item number	Outer diameter mm (in)
②	161.0 (6.34)
③	140.1 (5.52)
④	156.4 (6.16)
⑥	142.0 (5.59)
⑦	159.2 (6.27)

Thrust washers

Item number	Color
①	Black
⑤	White

Outer diameter of needle bearings

Item number	Outer diameter mm (in)
⑧	47 (1.85)
⑨	53 (2.09)
⑩	53 (2.09)
⑪	78 (3.07)
⑫	53 (2.09)
⑬	78 (3.07)
⑭	59 (2.32)
⑮	78 (3.07)
⑯	64 (2.52)

Inner diameter of bearing races

Item number	Outer diameter mm (in)
⑪	58 (2.28)
⑬	58.8 (2.315)

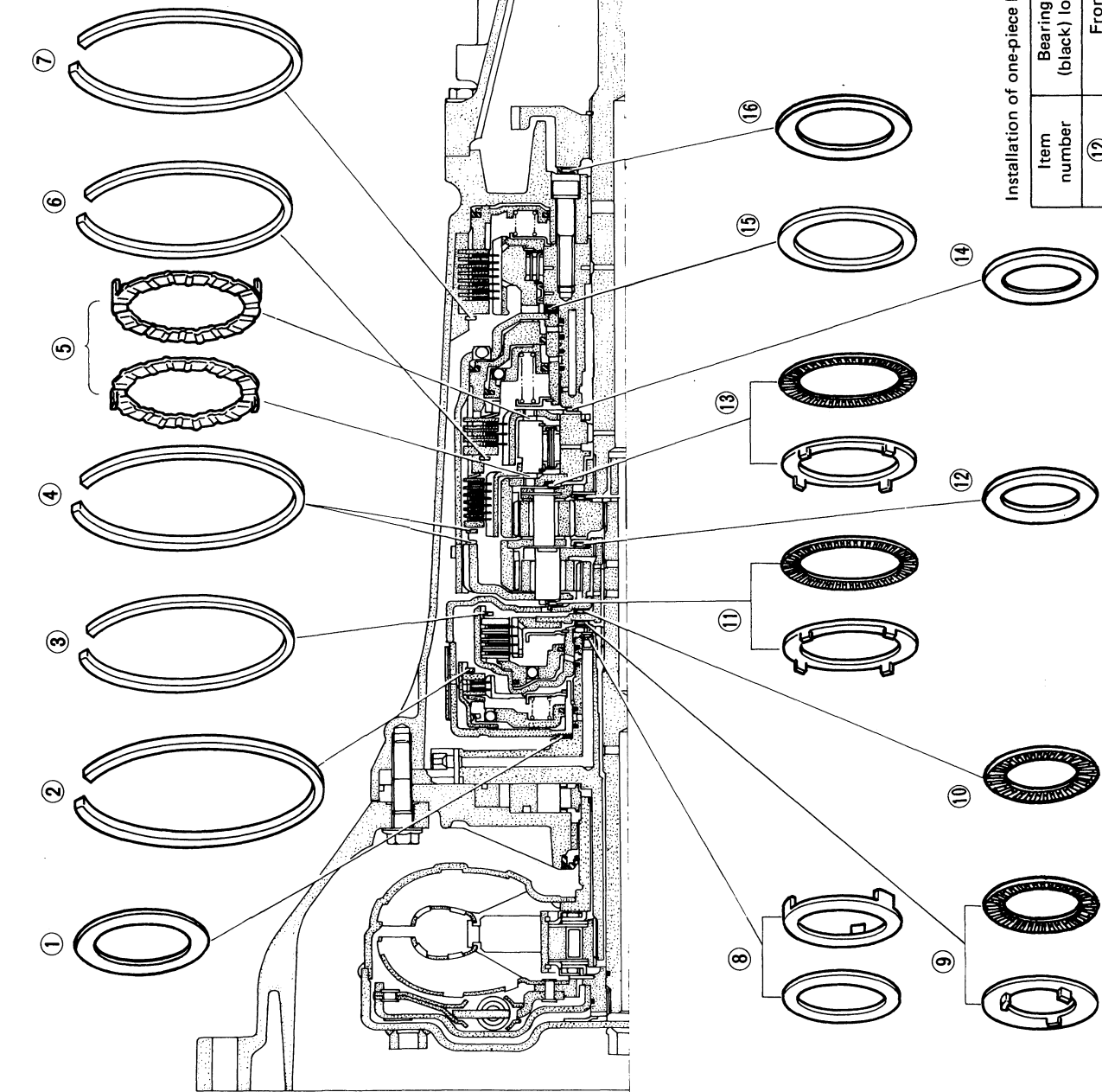

Installation of one-piece bearings

Item number	Bearing race (black) location
⑫	Front
⑮	Rear side
⑯	Rear side

DISASSEMBLY

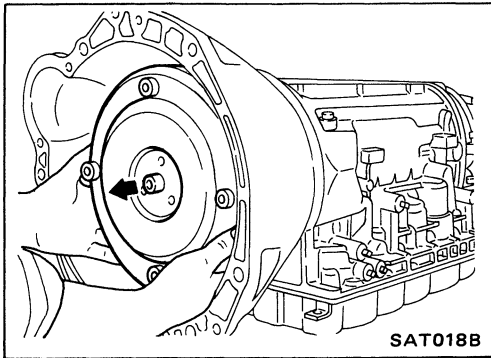

Disassembly

1. Remove torque converter by holding it firmly and turning while pulling straight out.

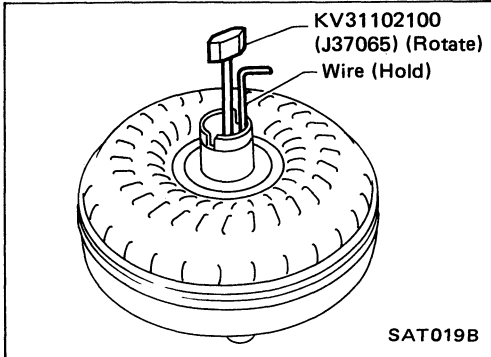

2. Check torque converter one-way clutch.
 - a. Insert Tool into spline of one-way clutch inner race.
 - b. Hook bearing support unitized with one-way clutch outer race with suitable wire.
 - c. Check that one-way clutch inner race rotates only clockwise with Tool while holding bearing support with wire.

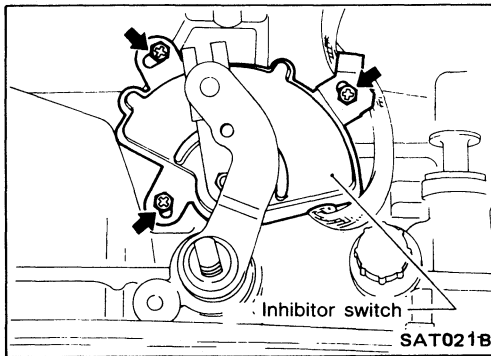

3. Remove inhibitor switch from transmission case.

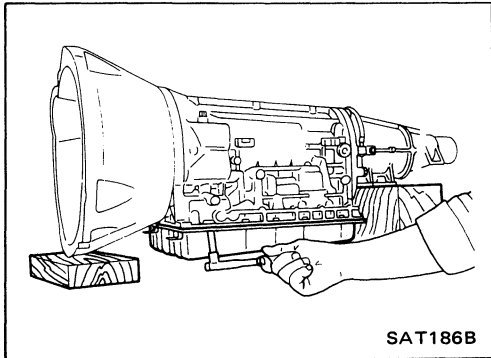

4. Remove oil pan.
 - a. Drain A.T.F. from rear extension.
 - b. Raise oil pan by placing wooden blocks under converter housing and rear extension.
 - c. Separate the oil pan and transmission case.
 - **Always place oil pan straight down so that foreign particles inside will not move.**

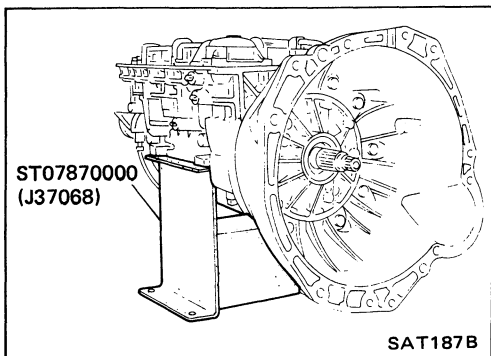

5. Place transmission into Tool with the control valve facing up.

DISASSEMBLY

Disassembly (Cont'd)

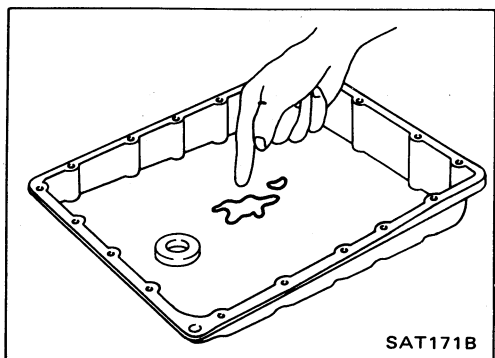

6. Check oil pan and oil strainer for accumulation of foreign particles.

- If materials of clutch facing are found, clutch plates may be worn.
- If metal filings are found, clutch plates, brake bands, etc. may be worn.
- If aluminum filings are found, bushings or aluminum cast parts may be worn.

In above cases, replace torque converter and check unit for cause of particle accumulation.

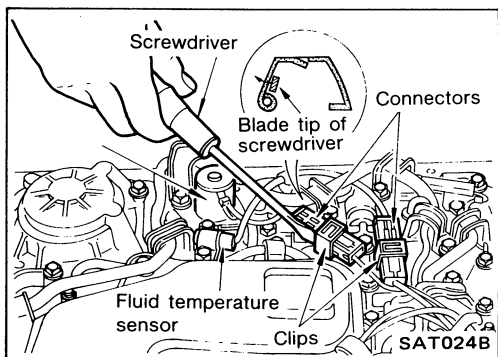

7. Remove lock-up solenoid and fluid temperature sensor connectors.

- **Be careful not to damage connector.**

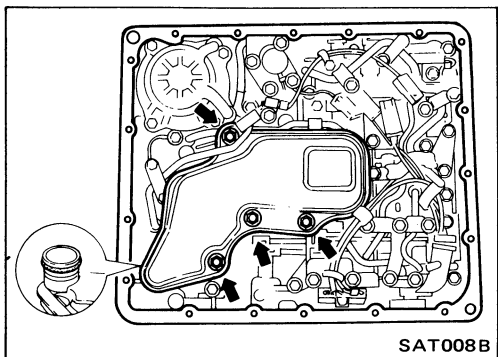

8. Remove oil strainer.

- a. Remove oil strainer from control valve assembly. Then remove O-ring from oil strainer.

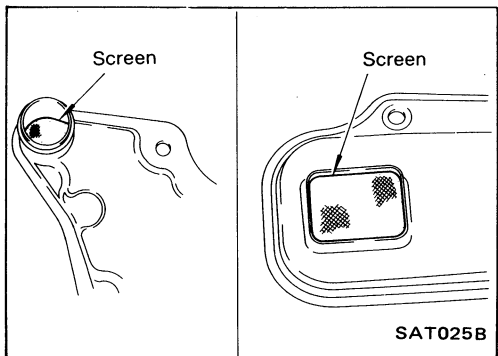

- b. Check oil strainer screen for damage.

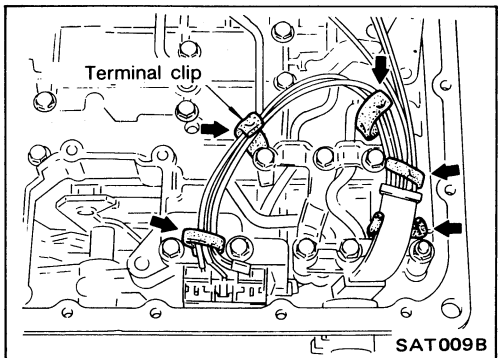

9. Remove control valve assembly.

- a. Straighten terminal clips to free terminal cords then remove terminal clips.

DISASSEMBLY

Disassembly (Cont'd)

- b. Remove bolts **(A)** and **(B)**, and remove control valve assembly from transmission.

Bolt symbol	ℓ mm (in)	 ℓ
(A)	33 (1.30)	
(B)	45 (1.77)	

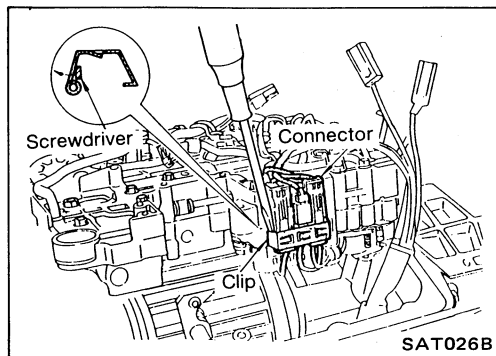
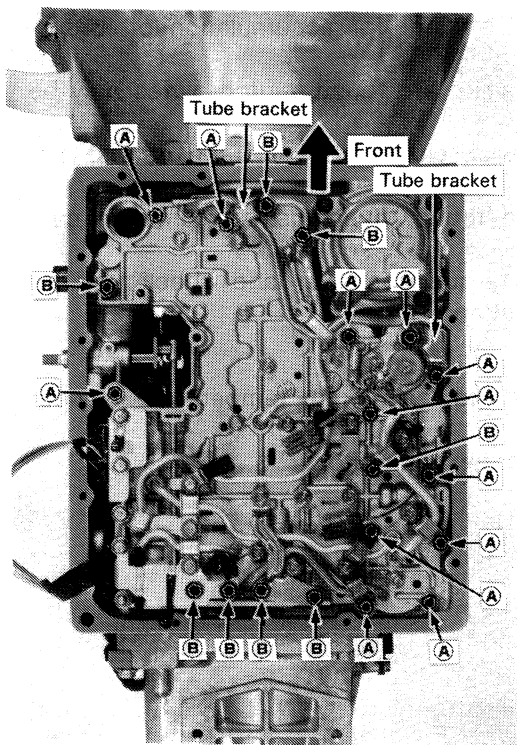

- c. Remove solenoid connector.

- Be careful not to damage connector.

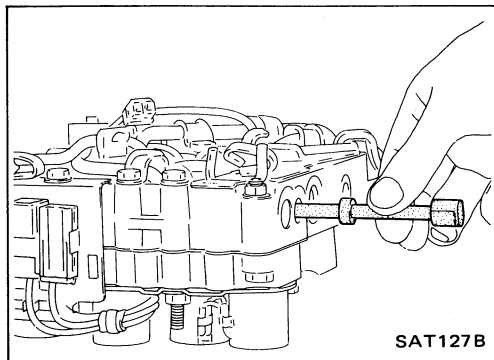

- d. Remove manual valve from control valve assembly.

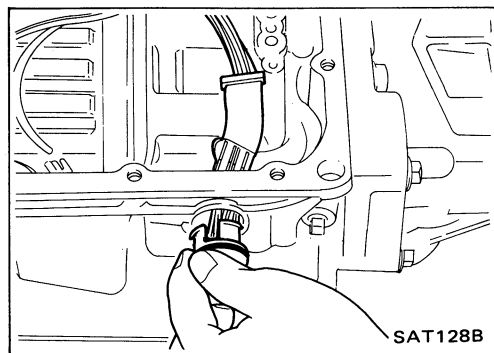

10. Remove terminal cord assembly from transmission case while pushing on stopper.

- Be careful not to damage cord.
- Do not remove terminal cord assembly unless it is damaged.

DISASSEMBLY

Disassembly (Cont'd)

11. Remove converter housing from transmission case.

- Be careful not to scratch converter housing.

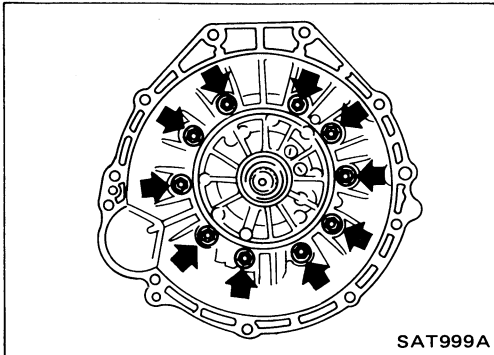

12. Remove O-ring from input shaft.

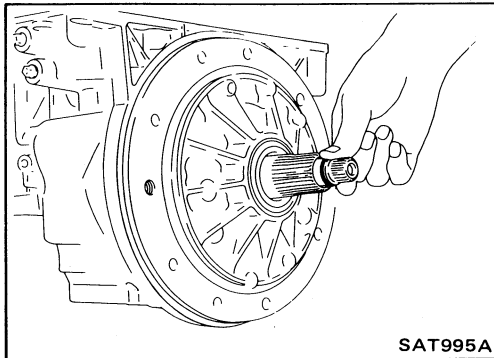

13. Remove oil pump assembly.

- a. Attach Tool to oil pump assembly and extract it evenly from transmission case.

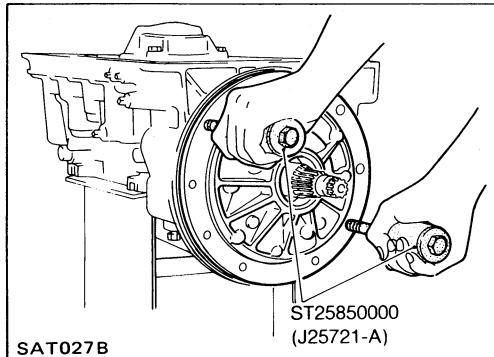

- b. Remove O-ring from oil pump assembly.

- c. Remove traces of sealant from oil pump housing.

- Be careful not to scratch pump housing.

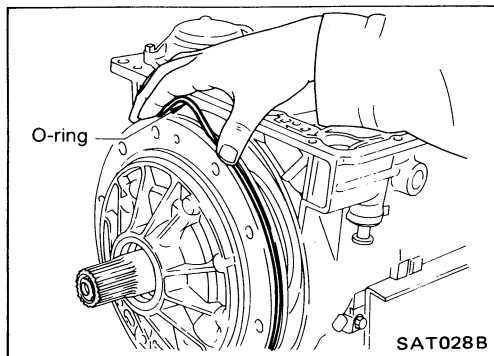

- d. Remove needle bearing and thrust washer from oil pump assembly.

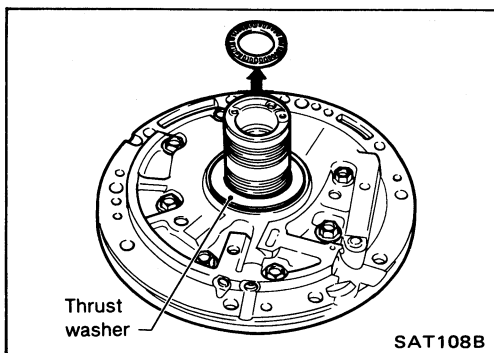

DISASSEMBLY

Disassembly (Cont'd)

14. Remove input shaft and oil pump gasket.

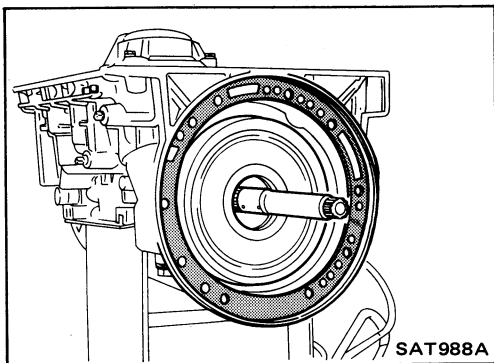

15. Remove brake band and band strut.

a. Loosen lock nut and remove band servo anchor end pin from transmission case.

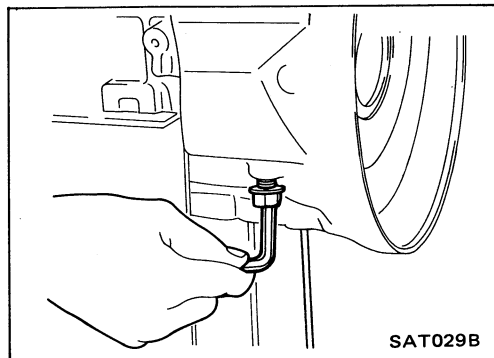

b. Remove brake band and band strut from transmission case.

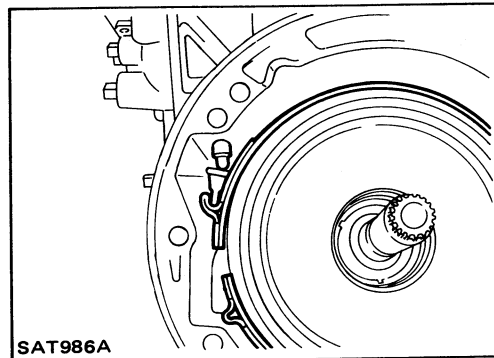

c. Hold brake band in a circular shape with clip.

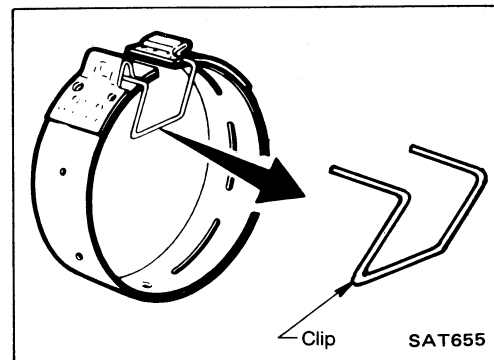

16. Remove front side clutch and gear components.

a. Remove clutch pack (reverse clutch, high clutch and front sun gear) from transmission case.

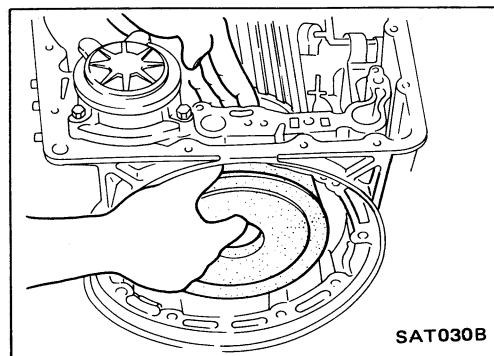

DISASSEMBLY

Disassembly (Cont'd)

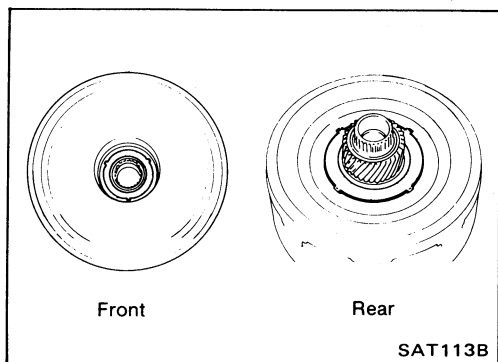

- b. Remove front bearing race from clutch pack.
- c. Remove rear bearing race from clutch pack.

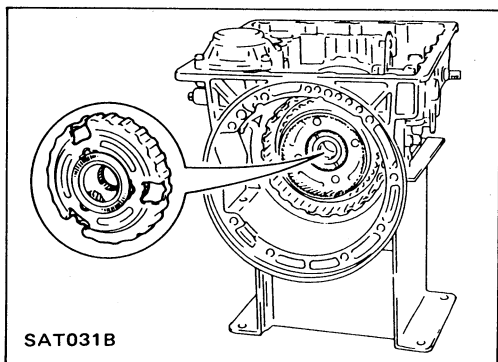

- d. Remove front planetary carrier from transmission case.

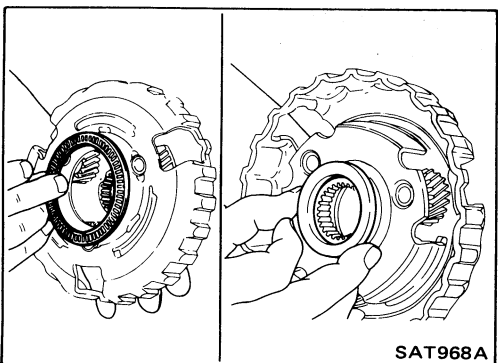

- e. Remove front needle bearing from front planetary carrier.
- f. Remove rear bearing from front planetary carrier.

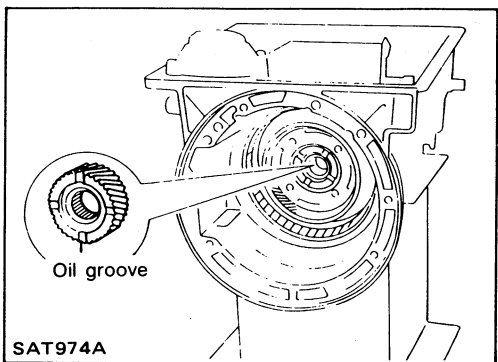

- g. Remove rear sun gear from transmission case.

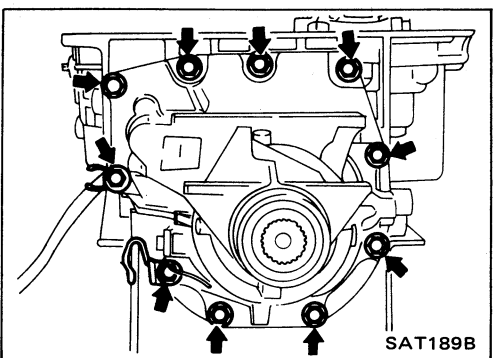

- 17. Remove rear extension.
 - a. Remove rear extension from transmission case.
 - b. Remove rear extension gasket from transmission case.

DISASSEMBLY

Disassembly (Cont'd)

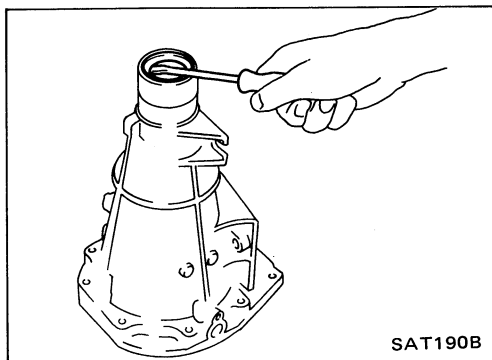

- c. Remove oil seal from rear extension.
- **Do not remove oil seal unless it is to be replaced.**

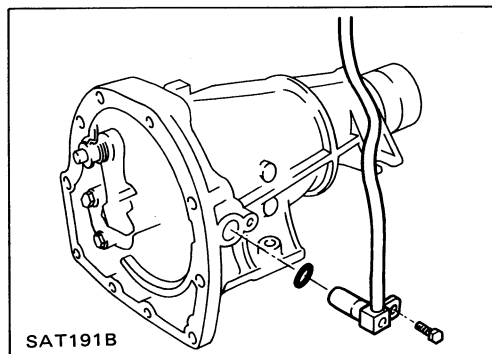

- d. Remove revolution sensor from rear extension.
- e. Remove O-ring from revolution sensor.

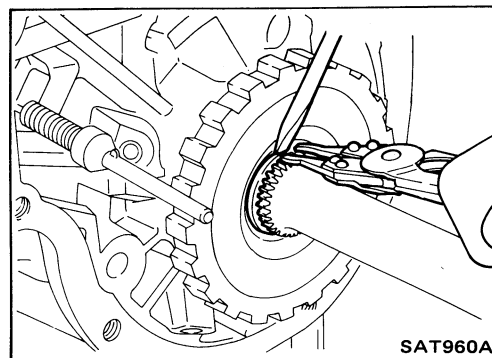

- 18. Remove output shaft and parking gear.
- a. Remove rear snap ring from output shaft.

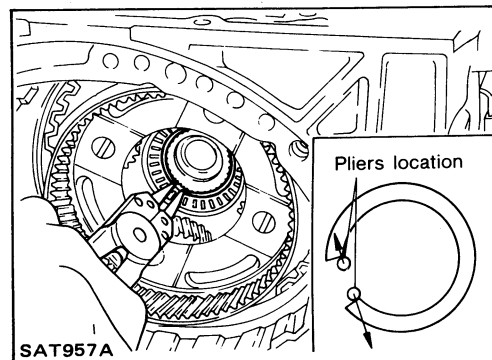

- b. Slowly push output shaft all the way forward.
- **Do not use excessive force.**
- c. Remove snap ring from output shaft.

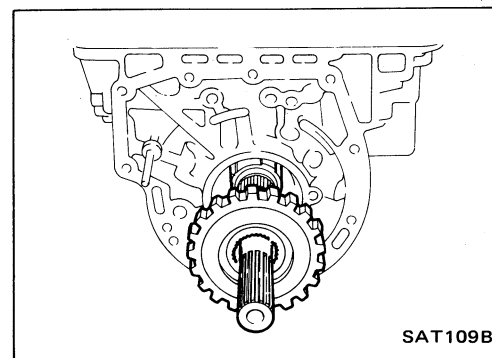

- d. Remove output shaft and parking gear as a unit from transmission case.
- e. Remove parking gear from output shaft.

DISASSEMBLY

Disassembly (Cont'd)

f. Remove needle bearing from transmission case.

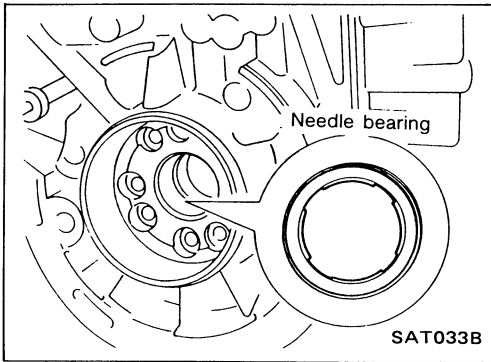

19. Remove rear side clutch and gear components.

a. Remove front internal gear.

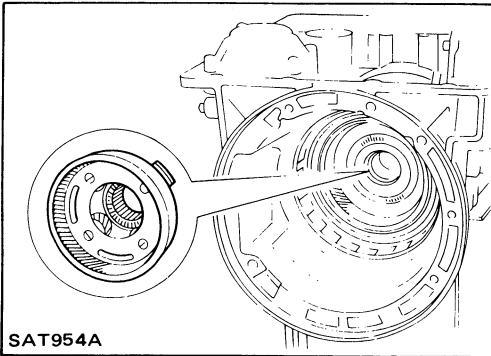

b. Remove bearing race from front internal gear.

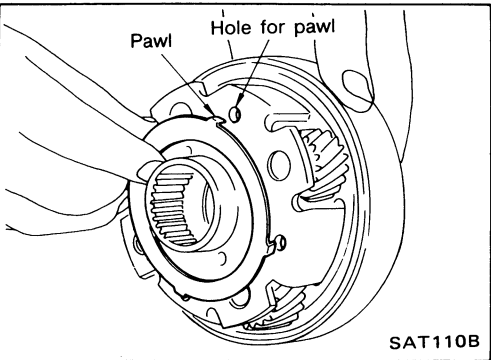

c. Remove needle bearing from rear internal gear.

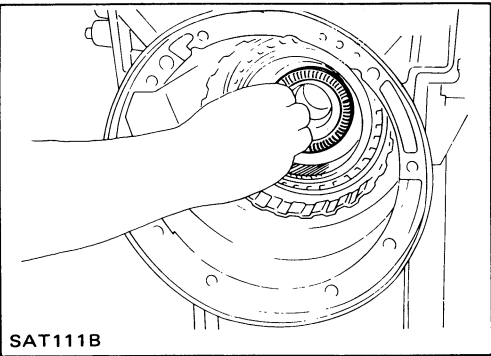

d. Remove rear internal gear, forward clutch hub and overrun clutch hub as a set from transmission case.

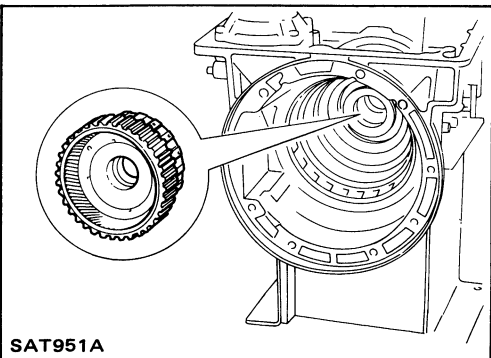

DISASSEMBLY

Disassembly (Cont'd)

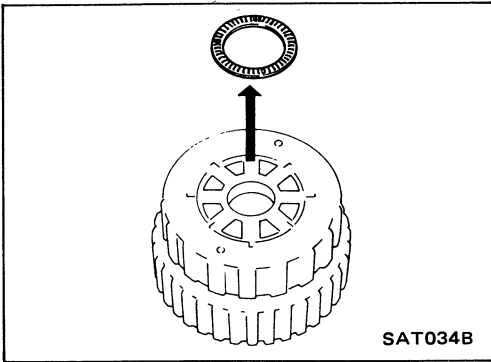

e. Remove needle bearing from overrun clutch hub.

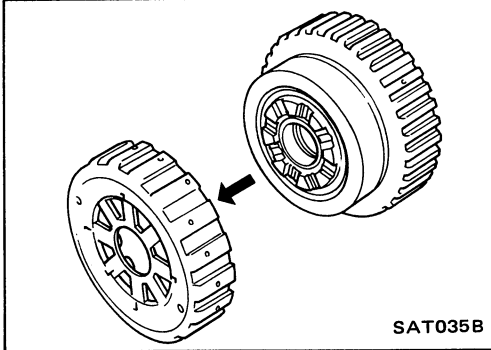

f. Remove overrun clutch hub from rear internal gear and forward clutch hub.

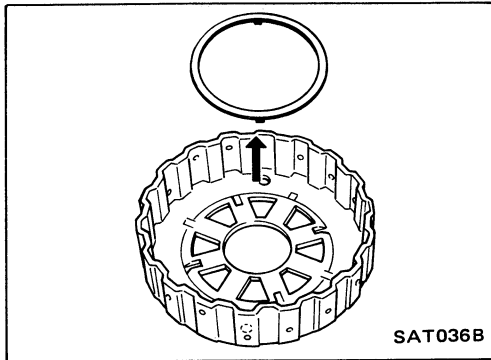

g. Remove thrust washer from overrun clutch hub.

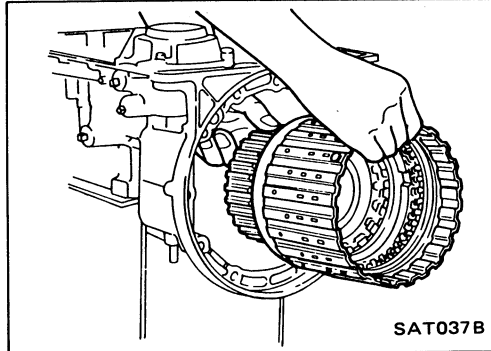

h. Remove forward clutch assembly from transmission case.

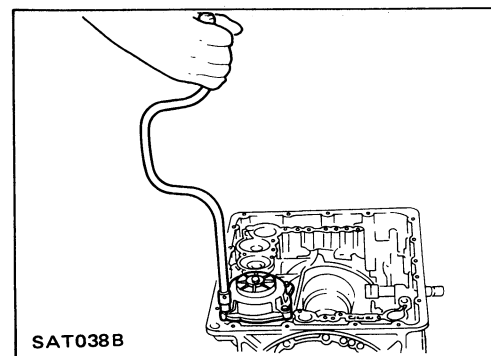

20. Remove band servo and accumulator components.
a. Remove band servo retainer from transmission case.

DISASSEMBLY

Disassembly (Cont'd)

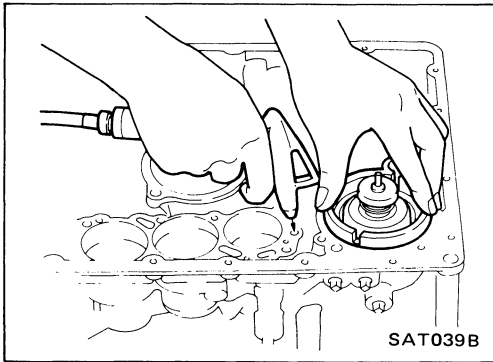

- b. Apply compressed air to oil hole until band servo piston comes out of transmission case.
- **Hold piston with a rag and gradually direct air to oil hole.**
- c. Remove return springs.

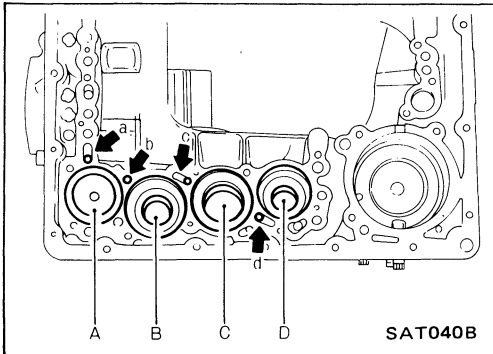

- d. Remove springs from accumulator pistons B, C and D.
- e. Apply compressed air to each oil hole until piston comes out.
- **Hold piston with a rag and gradually direct air to oil hole.**

Identification of accumulator pistons	A	B	C	D
Identification of oil holes	a	b	c	d

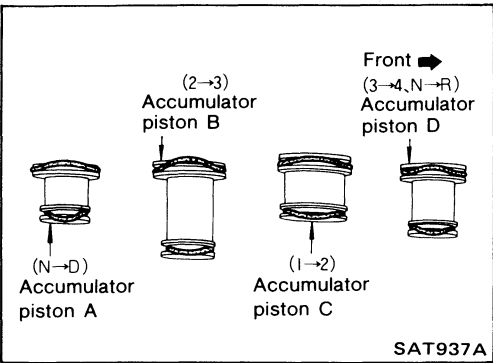

- f. Remove O-ring from each piston.

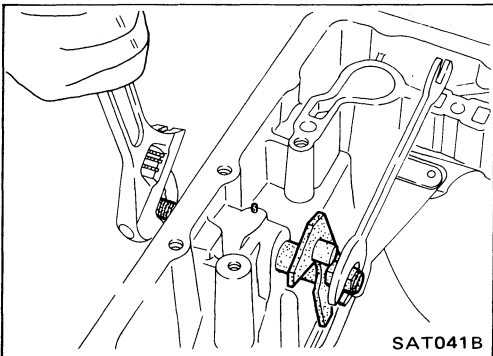

- 21. Remove manual shaft components, if necessary.
- a. Hold width across flats of manual shaft (outside the transmission case) and remove lock nut from shaft.

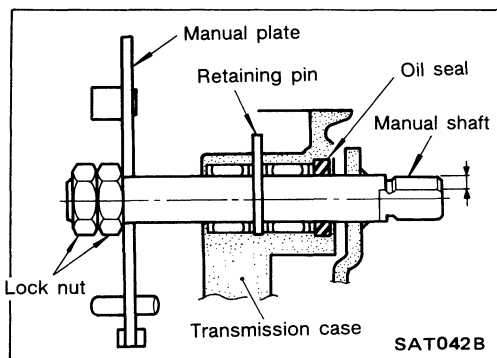

- b. Remove retaining pin from transmission case.

DISASSEMBLY

Disassembly (Cont'd)

- c. While pushing detent spring down, remove manual plate and parking rod from transmission case.

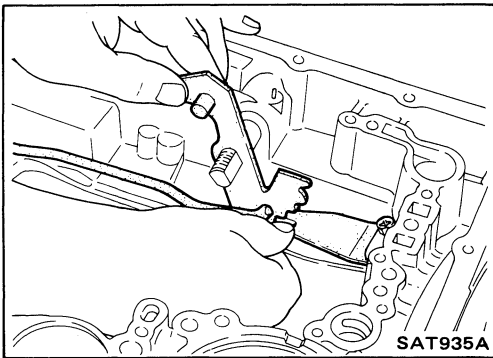

- d. Remove manual shaft from transmission case.

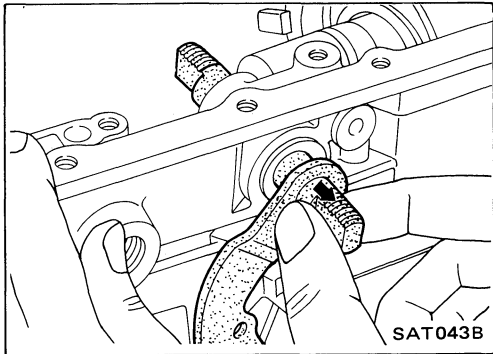

- e. Remove spacer and detent spring from transmission case.

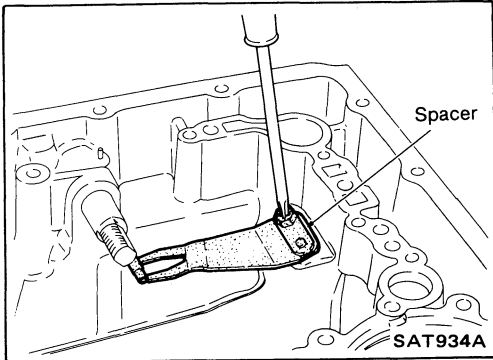

- f. Remove oil seal from transmission case.

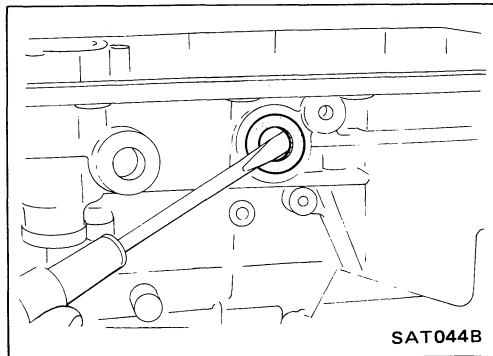

Oil Pump

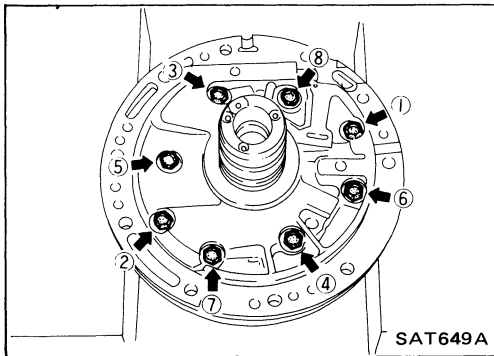
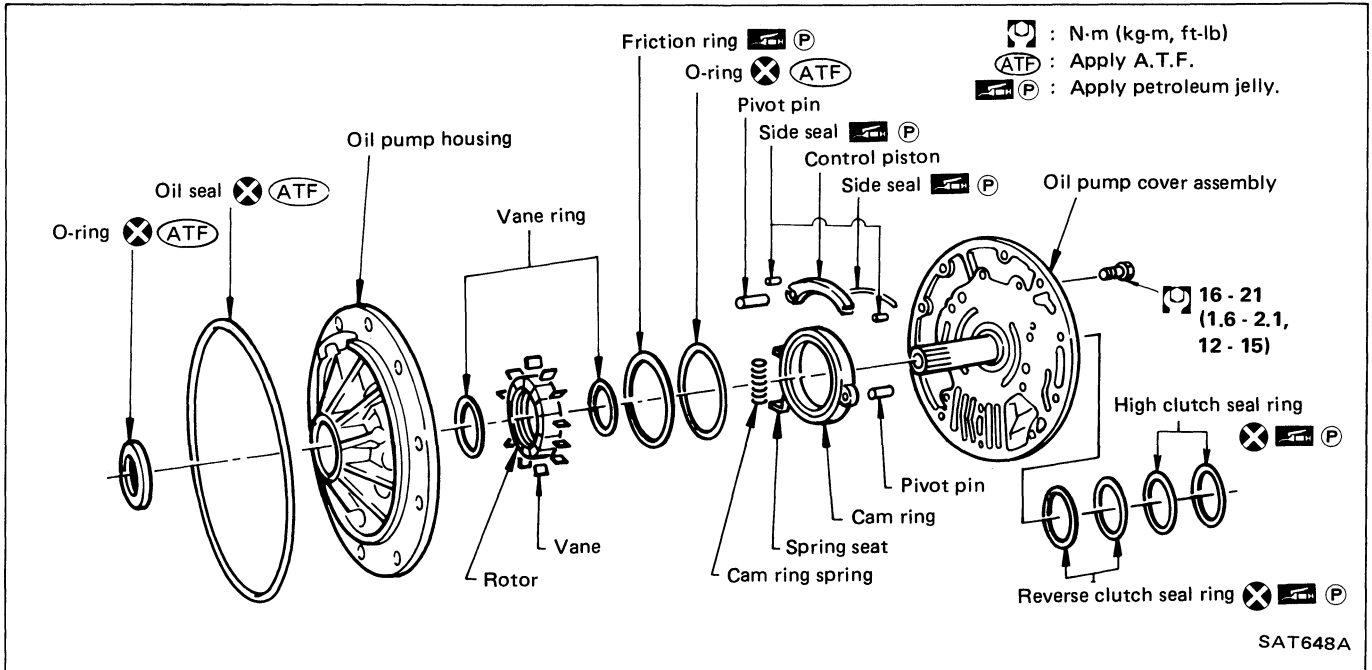

DISASSEMBLY

- Loosen bolts in numerical order and remove oil pump cover.

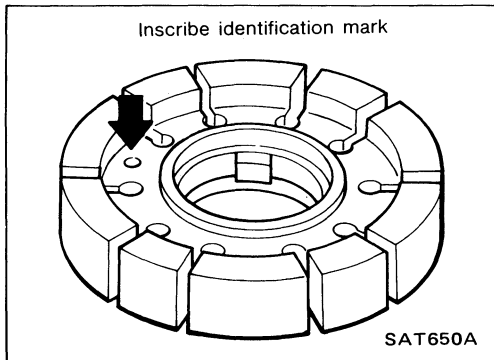

- Remove rotor, vane rings and vanes.
 - Inscribe a mark on back of rotor for identification of fore-aft direction when reassembling rotor. Then remove rotor.

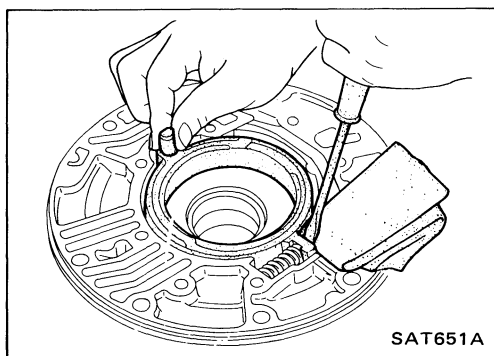

- While pushing on cam ring remove pivot pin.
 - Be careful not to scratch oil pump housing.

REPAIR FOR COMPONENT PARTS

Oil Pump (Cont'd)

4. While holding cam ring and spring lift out cam ring spring.

- Be careful not to damage oil pump housing.
- Hold cam ring spring to prevent it from jumping.

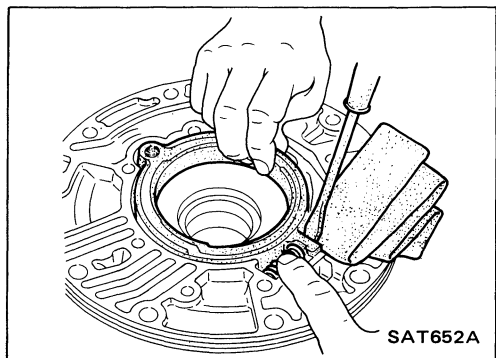

5. Remove cam ring and cam ring spring from oil pump housing.

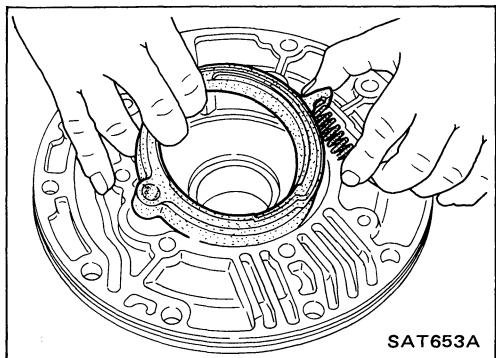

6. Remove pivot pin from control piston and remove control piston assembly.

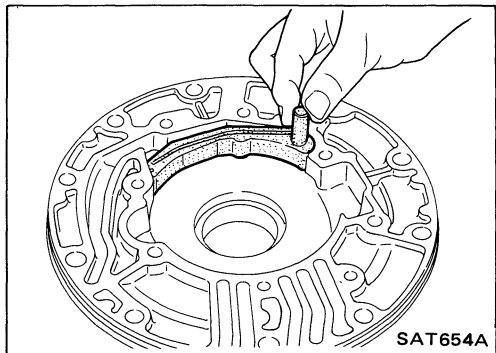

7. Remove oil seal from oil pump housing.

- Be careful not to scratch oil pump housing.

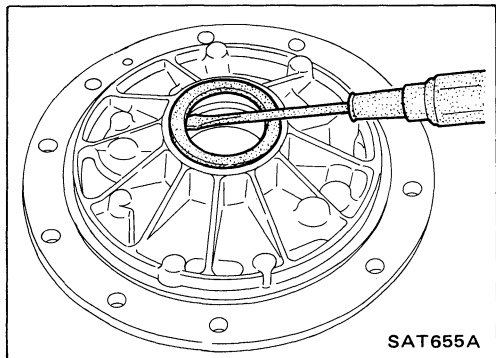

INSPECTION

Oil pump cover, rotor, vanes, control piston, side seals, cam ring and friction ring

- Check for wear or damage.

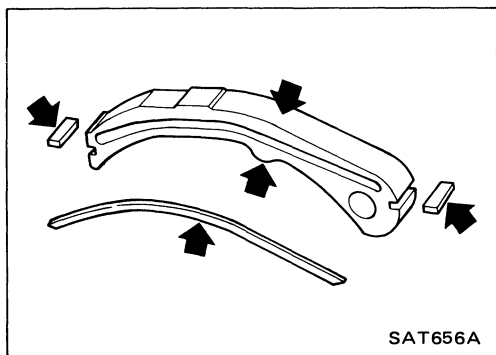

REPAIR FOR COMPONENT PARTS

Oil Pump (Cont'd)

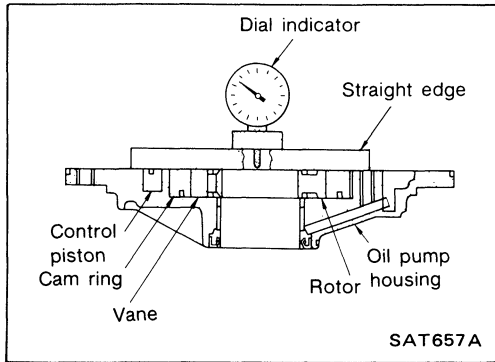

Side clearances

- Measure side clearances between end of oil pump housing and cam ring, rotor, vanes and control piston in at least four places along their circumferences. Maximum measured values should be within specified ranges.
- **Before measuring side clearance, check that friction rings, O-ring, control piston side seals and cam ring spring are removed.**

Standard clearance:

Cam ring

0.01 - 0.024 mm (0.0004 - 0.0009 in)

Rotor, vanes, control piston

0.03 - 0.044 mm (0.0012 - 0.0017 in)

- If not within standard clearance, replace oil pump assembly except oil pump cover assembly.

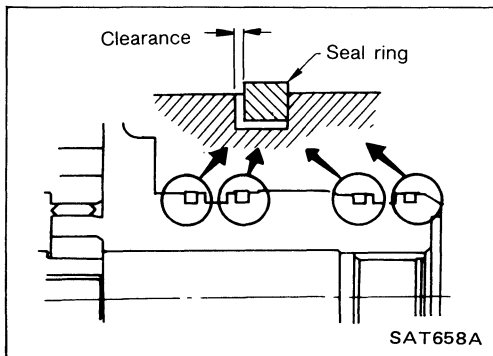

Seal ring clearance

- Measure clearance between seal ring and ring groove.

Standard clearance:

0.10 - 0.25 mm (0.0039 - 0.0098 in)

Wear limit:

0.25 mm (0.0098 in)

- If not within wear limit, replace oil pump cover assembly.

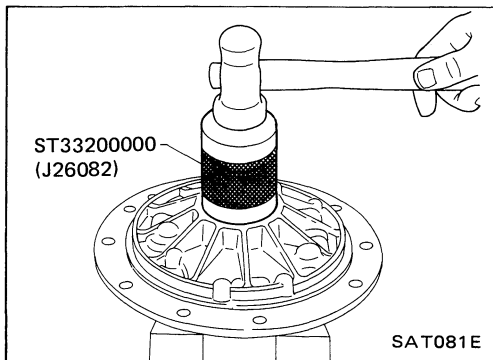

ASSEMBLY

1. Drive oil seal into oil pump housing.

- **Apply A.T.F. to outer periphery and lip surface.**

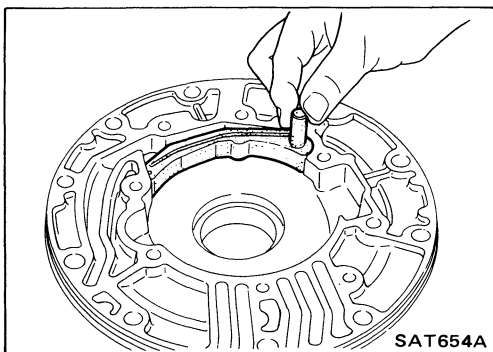

2. Install cam ring in oil pump housing by the following steps.

- a. Install side seal on control piston.

- **Pay attention to its direction — Black surface goes toward control piston.**

- **Apply petroleum jelly to side seal.**

- b. Install control piston on oil pump.

REPAIR FOR COMPONENT PARTS

Oil Pump (Cont'd)

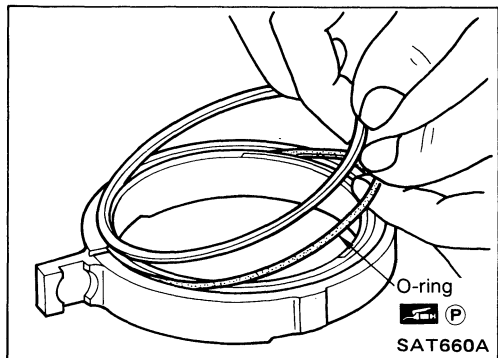

- c. Install O-ring and friction ring on cam ring.
● Apply petroleum jelly to O-ring.

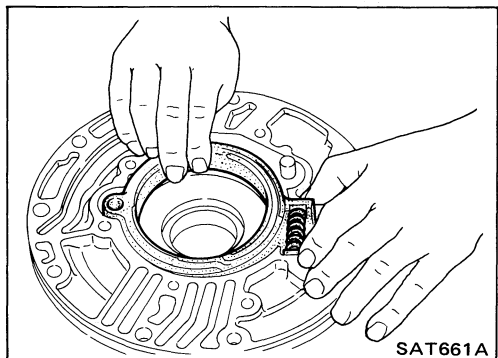

- d. Assemble cam ring, cam ring spring and spring seat. Install spring by pushing it against pump housing.

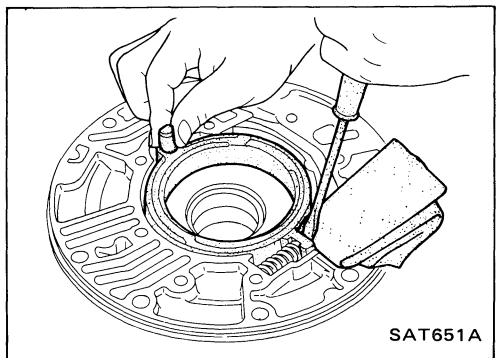

- e. While pushing on cam ring install pivot pin.

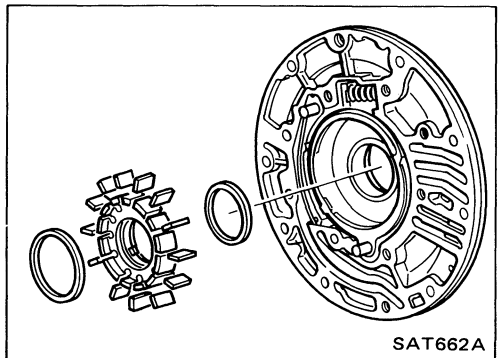

3. Install rotor, vanes and vane rings.
● Pay attention to direction of rotor.

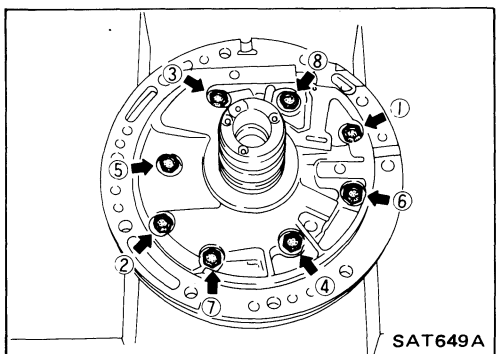

4. Install oil pump housing and oil pump cover.
a. Wrap masking tape around splines of oil pump cover assembly to protect seal. Position oil pump cover assembly in oil pump housing assembly, then remove masking tape.
b. Tighten bolts in a criss-cross pattern.

REPAIR FOR COMPONENT PARTS

Oil Pump (Cont'd)

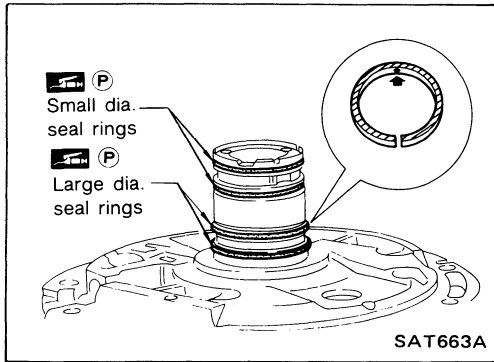

5. Install seal rings carefully after packing ring grooves with petroleum jelly. Press rings down into jelly to a close fit.

- Seal rings come in two different diameters. Check fit carefully in each groove.

Small dia. seal ring:

No mark

Large dia. seal ring:

Yellow mark in area shown by arrow

- Do not spread gap of seal ring excessively while installing. It may deform ring.

REPAIR FOR COMPONENT PARTS

Control Valve Assembly

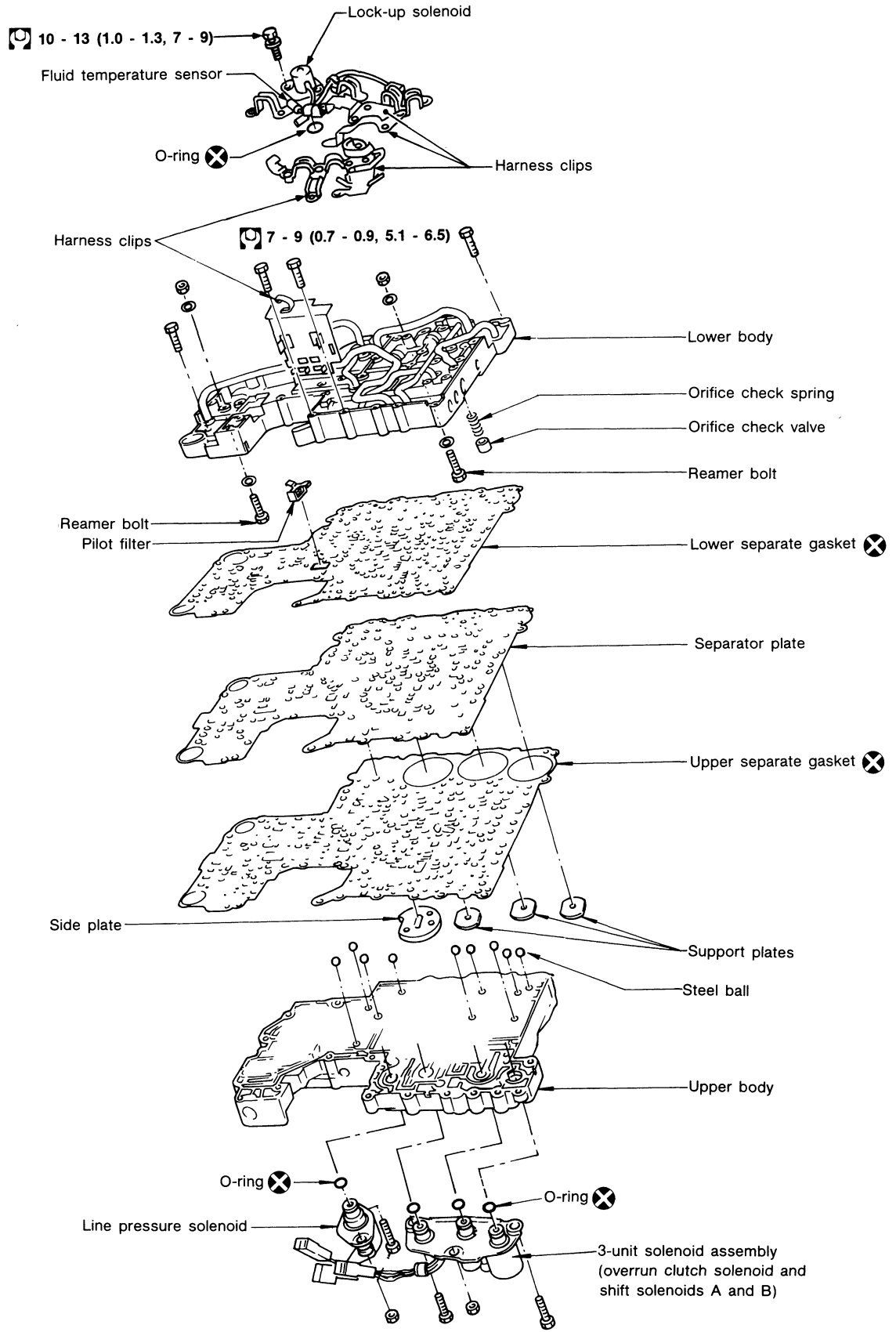

7 - 9 (0.7 - 0.9, 5.1 - 6.5)

: N·m (kg-m, ft-lb)

SAT193B

REPAIR FOR COMPONENT PARTS

Control Valve Assembly (Cont'd)

DISASSEMBLY

1. Remove solenoids.
 - a. Remove lock-up solenoid and side plate from lower body.
 - b. Remove O-ring from solenoid.

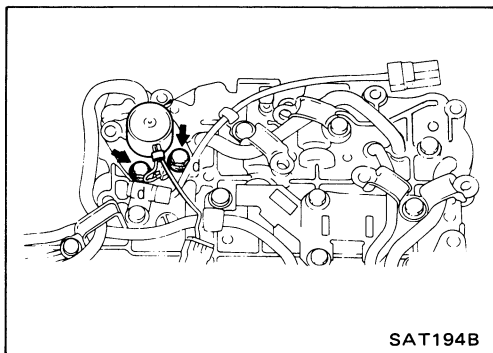

-
-
- c. Remove line pressure solenoid from upper body.
- d. Remove O-ring from solenoid.

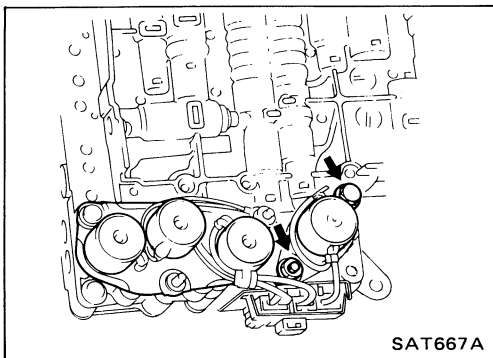

-
-
-
-
- e. Remove 3-unit solenoid assembly from upper body.
- f. Remove O-rings from solenoids.

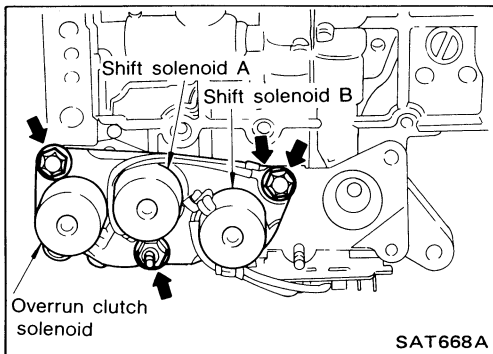

-
-
-
-
-
-
2. Disassemble upper and lower bodies.
 - a. Place upper body facedown, and remove bolts, reamer bolts and support plates.
 - b. Remove lower body, separator plate and separate gasket as a unit from upper body.
 - **Be careful not to drop pilot filter, orifice check valve, spring and steel balls.**

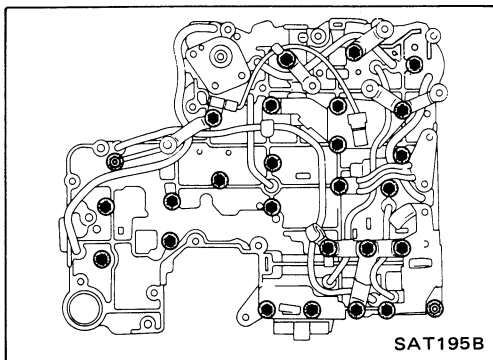

-
-
-
-
-
-
-
- c. Place lower body facedown, and remove separate gasket and separator plate.
- d. Remove pilot filter, orifice check valve and orifice check spring.

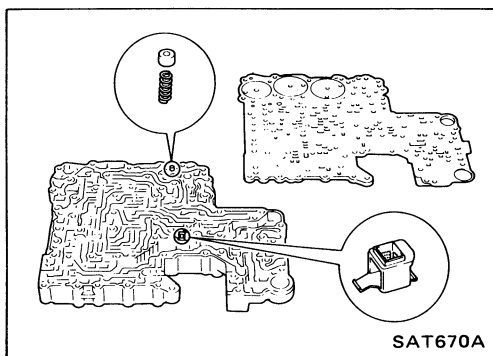

REPAIR FOR COMPONENT PARTS

Control Valve Assembly (Cont'd)

- e. Check to see that steel balls are properly positioned in upper body and then remove them from upper body.

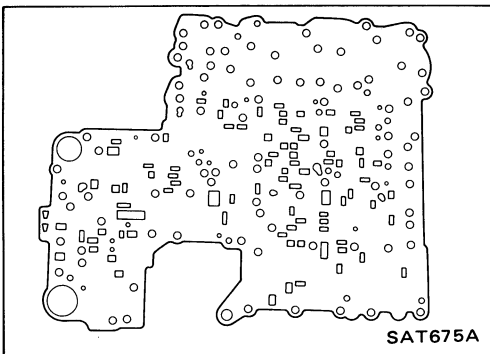
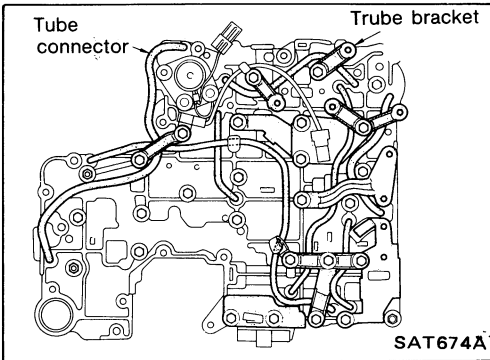
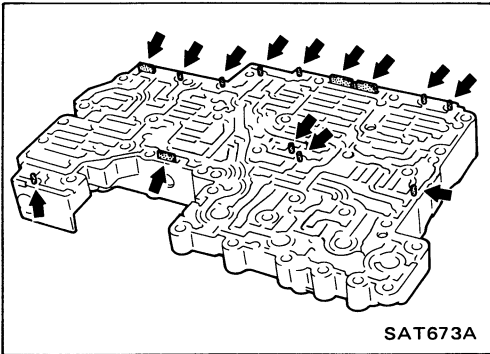
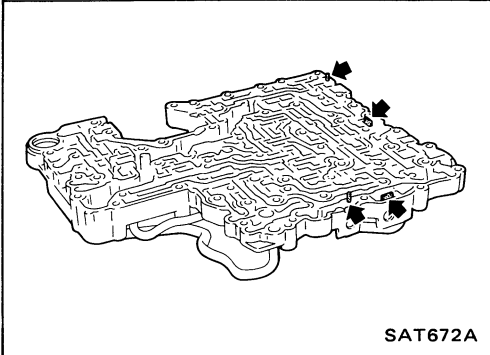
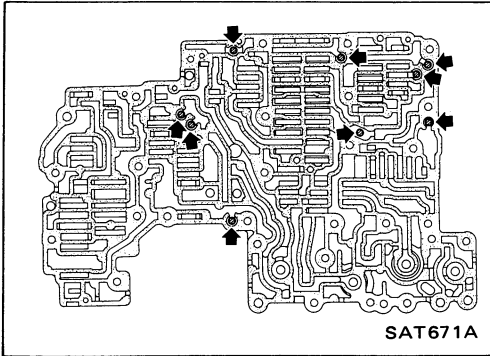

INSPECTION

Lower and upper bodies

- Check to see that there are pins and retainer plates in lower body.

- Check to see that there are pins and retainer plates in upper body.

- **Be careful not to lose these parts.**

- Check to make sure that oil circuits are clean and free from damage.

- Check tube brackets and tube connectors for damage.

Separator plates

- Check to make sure that separator plate is free of damage and not deformed and oil holes are clean.

REPAIR FOR COMPONENT PARTS

Control Valve Assembly (Cont'd)

Pilot filter

- Check to make sure that filter is not clogged or damaged.

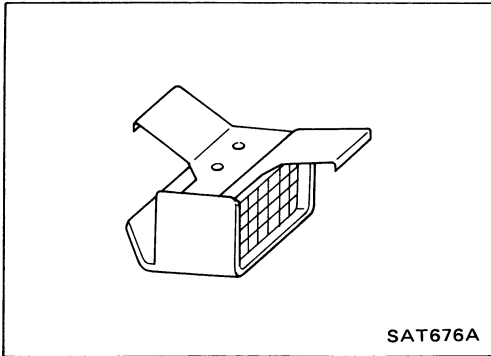

SAT676A

Lock-up solenoid

- Check that filter is not clogged or damaged.
- Measure resistance. — Refer to “Electrical Components Inspection”.

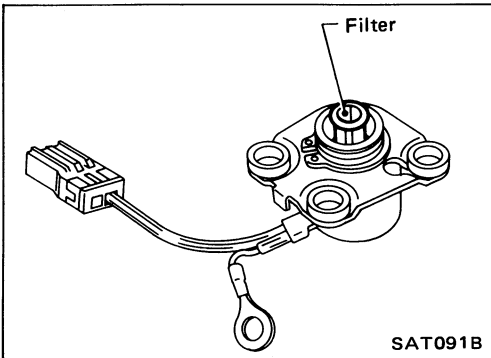

SAT091B

Line pressure solenoid

- Check that filter is not clogged or damaged.
- Measure resistance. — Refer to “Electrical Components Inspection”.

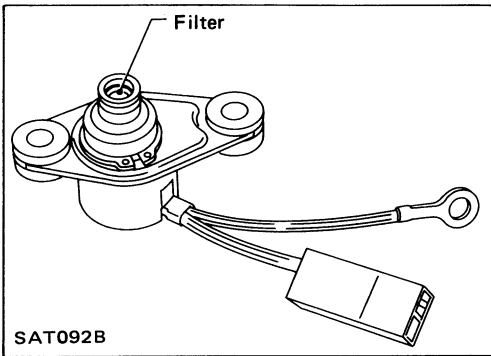

SAT092B

3-unit solenoid assembly (Overrun clutch solenoid and shift solenoids A and B)

- Measure resistance of each solenoid. — Refer to “Electrical Components Inspection”.

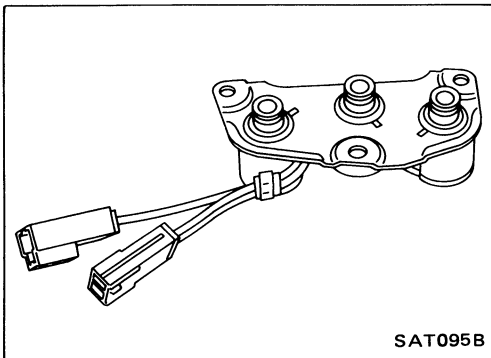

SAT095B

Fluid temperature sensor

- Measure resistance. — Refer to “Electrical Components Inspection”.

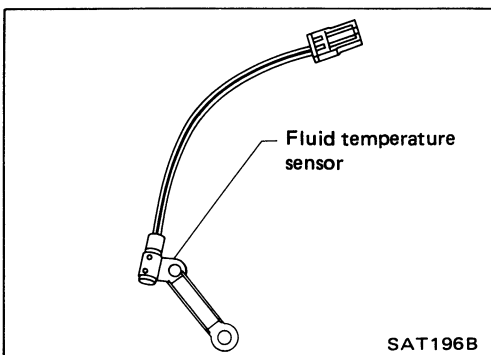

SAT196B

REPAIR FOR COMPONENT PARTS

Control Valve Assembly (Cont'd) ASSEMBLY

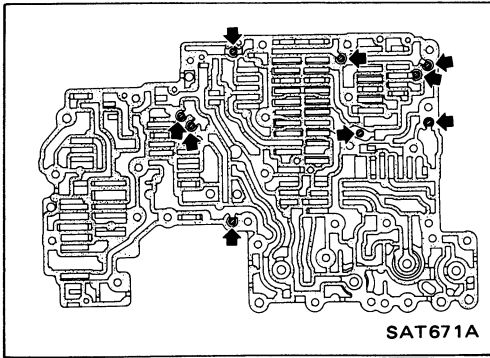

1. Install upper and lower bodies.
 - a. Place oil circuit of upper body face up. Install steel balls in their proper positions.

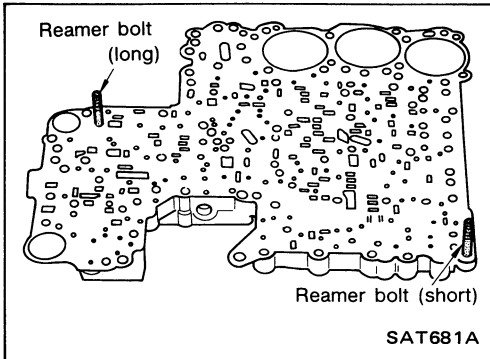

- b. Install reamer bolts from bottom of upper body and install separate gaskets.

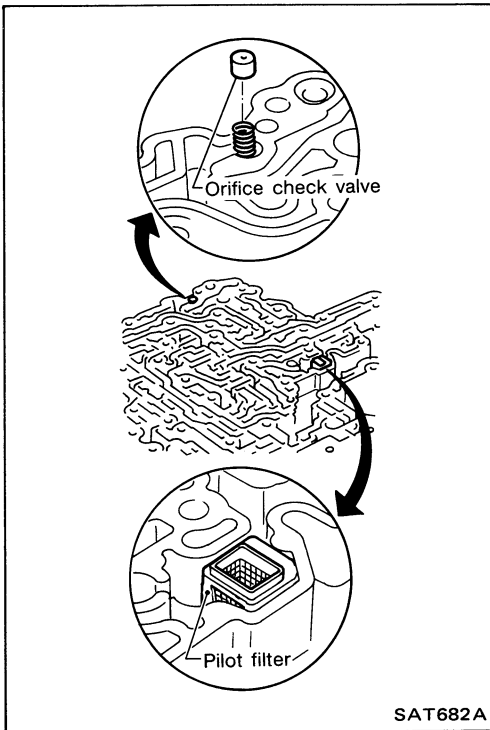

- c. Place oil circuit of lower body face up. Install orifice check spring, orifice check valve and pilot filter.

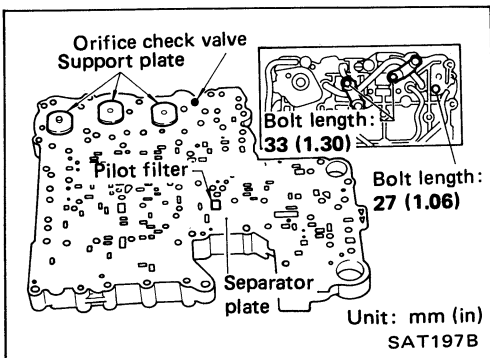

- d. Install lower separate gaskets and separator plates on lower body.
 - e. Install and temporarily tighten support plates, fluid temperature sensor and tube brackets.

REPAIR FOR COMPONENT PARTS

Control Valve Assembly (Cont'd)

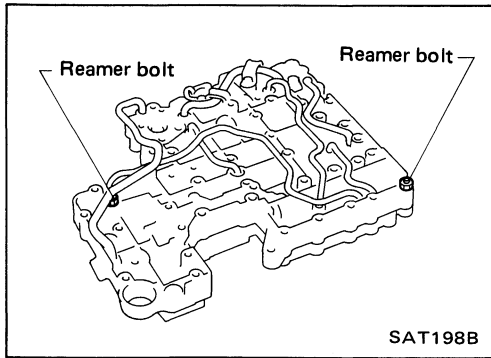

f. Temporarily assemble lower and upper bodies, using reamer bolt as a guide.

- Be careful not to dislocate or drop steel balls, orifice check spring, orifice check valve and pilot filter.

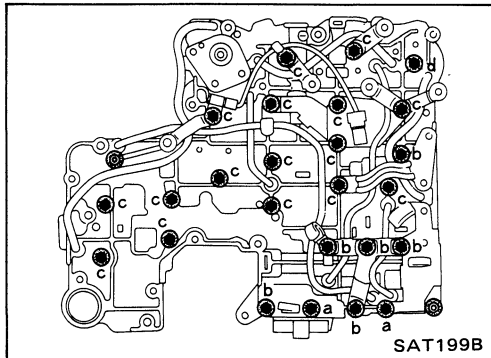

g. Install and temporarily tighten bolts and tube brackets in their proper locations.

Bolt length and location:

Item	Bolt symbol	Bolt length			
		a	b	c	d
Bolt length	mm (in)	70 (2.76)	50 (1.97)	33 (1.30)	27 (1.06)

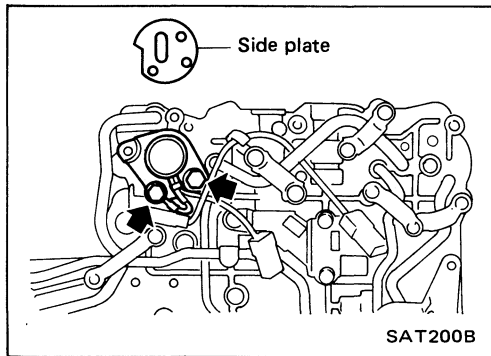

2. Install solenoids.

a. Attach O-ring and install lock-up solenoid and side plates onto lower body.

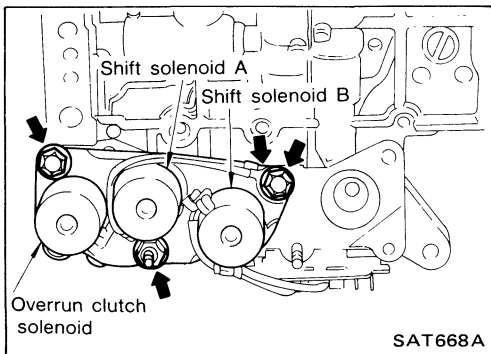

b. Attach O-rings and install 3-unit solenoids assembly onto upper body.

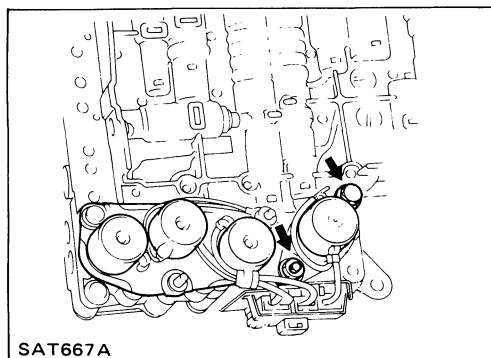

c. Attach O-ring and install line pressure solenoid onto upper body.

3. Tighten all bolts.

Control Valve Upper Body

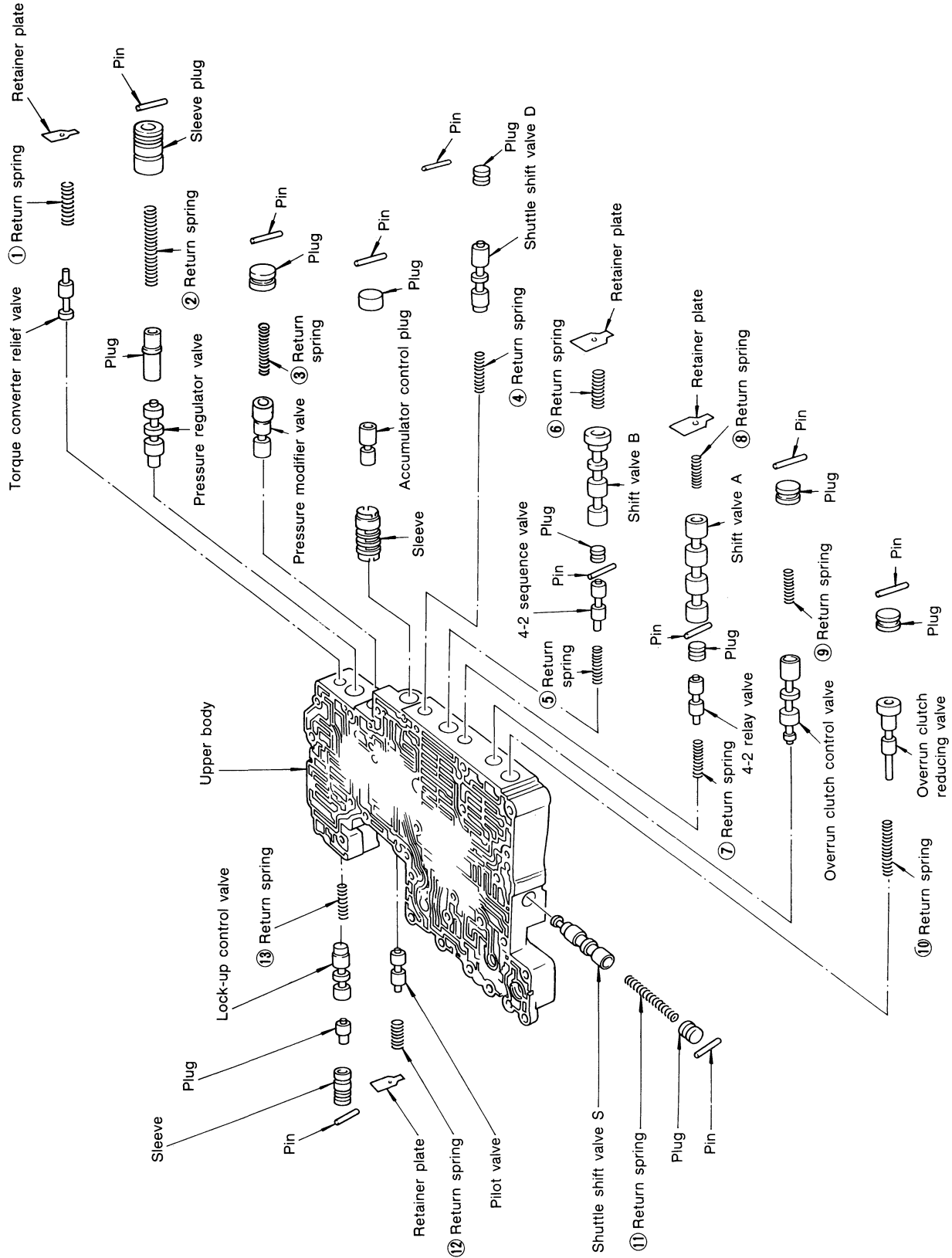

Numbers preceding valve springs correspond with those shown in Spring Chart on page AT-135.

Apply A.T.F. to all components before their installation.

REPAIR FOR COMPONENT PARTS

Control Valve Upper Body (Cont'd) DISASSEMBLY

1. Remove valves at parallel pins.
 - Do not use a magnetic hand.

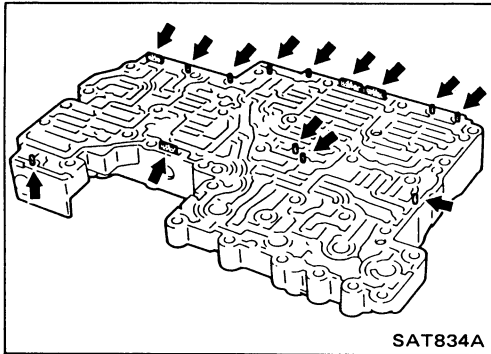

- a. Use a wire paper clip to push out parallel pins.

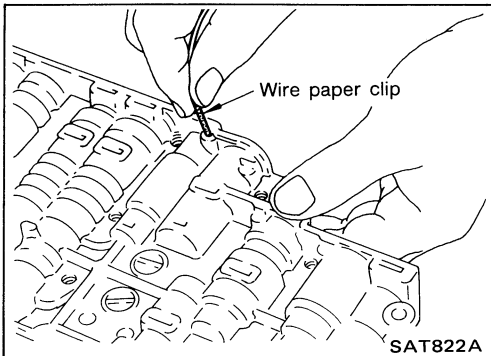

- b. Remove parallel pins while pressing their corresponding plugs and sleeves.
 - Remove plug slowly to prevent internal parts from jumping out.

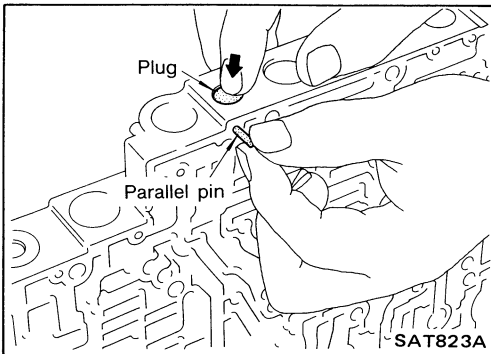

- c. Place mating surface of valve facedown, and remove internal parts.
 - If a valve is hard to remove, place valve body facedown and lightly tap it with a soft hammer.
 - Be careful not to drop or damage valves and sleeves.

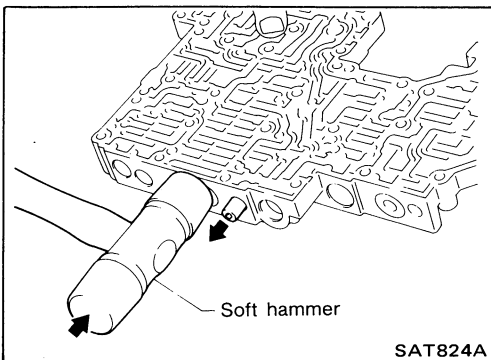

2. Remove valves at retainer plates.
 - a. Pry out retainer plate with wire paper clip.

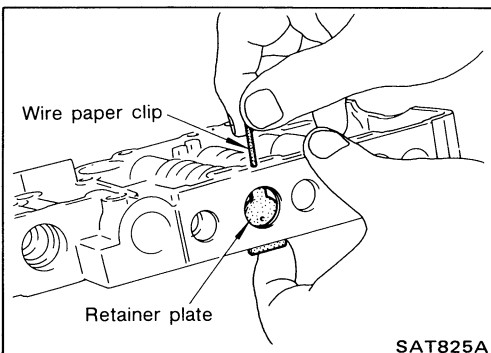

REPAIR FOR COMPONENT PARTS

Control Valve Upper Body (Cont'd)

b. Remove retainer plates while holding spring.

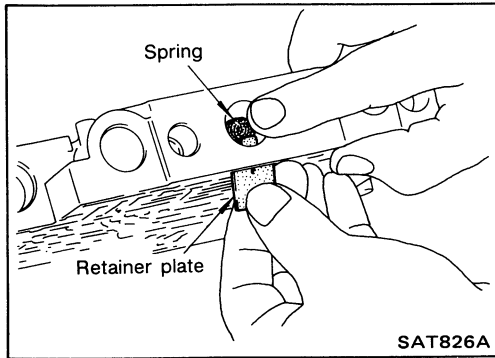

c. Place mating surface of valve facedown, and remove internal parts.

- If a valve is hard to remove, lightly tap valve body with a soft hammer.
- Be careful not to drop or damage valves, sleeves, etc.

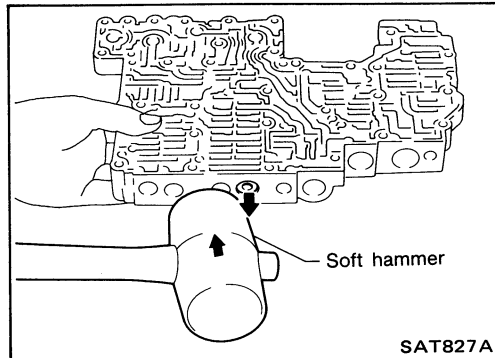

- 4-2 sequence valve and relay valve are located far back in upper body. If they are hard to remove, carefully push them out using stiff wire.
- Be careful not to scratch sliding surface of valve with wire.

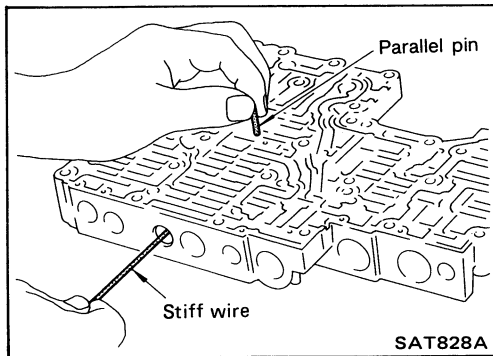

REPAIR FOR COMPONENT PARTS

Control Valve Upper Body (Cont'd)

INSPECTION

Valve springs

- Measure free length and outer diameter of each valve spring. Also check for damage or deformation.
- Numbers of each valve spring listed in table below are the same as those in the figure on AT-132.

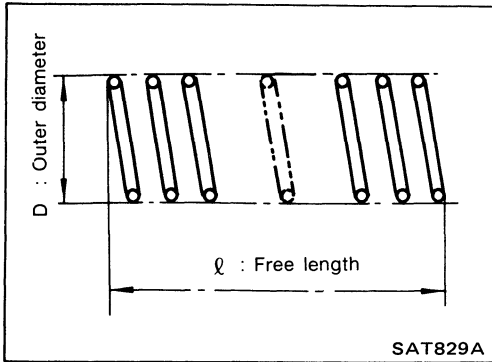

Inspection standard

Unit: mm (in)

Parts	Item	Part No.	l	D
①	Torque converter relief valve spring	31742-41X23	38.0 (1.496)	9.0 (0.354)
②	Pressure regulator valve spring	31742-41X24	44.0 (1.732)	14.0 (0.551)
③	Pressure modifier valve spring	31742-41X19	31.95 (1.2579)	6.8 (0.268)
④	Shuttle shift valve D spring	31762-41X00	26.5 (1.043)	6.0 (0.236)
⑤	4-2 sequence valve spring	31756-41X00	29.1 (1.146)	6.95 (0.2736)
⑥	Shift valve B spring	31762-41X01	25.0 (0.984)	7.0 (0.276)
⑦	4-2 relay valve spring	31756-41X00	29.1 (1.146)	6.95 (0.2736)
⑧	Shift valve A spring	31762-41X01	25.0 (0.984)	7.0 (0.276)
⑨	Overrun clutch control valve spring	31762-41X03	23.6 (0.929)	7.0 (0.276)
⑩	Overrun clutch reducing valve spring	31742-41X20	32.5 (1.280)	7.0 (0.276)
⑪	Shuttle shift valve S spring	31762-41X04	51.0 (2.008)	5.65 (0.2224)
⑫	Pilot valve spring	31742-41X13	25.7 (1.012)	9.1 (0.358)
⑬	Lock-up control valve spring	31742-41X22	18.5 (0.728)	13.0 (0.512)

- Replace valve springs if deformed or fatigued.

Control valves

- Check sliding surfaces of valves, sleeves and plugs.

REPAIR FOR COMPONENT PARTS

Control Valve Upper Body (Cont'd) ASSEMBLY

1. Lubricate the control valve body and all valves with A.T.F. Install control valves by sliding them carefully into their bores.

- Be careful not to scratch or damage valve body.

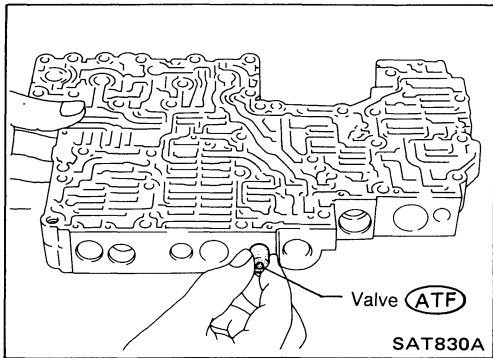

- Wrap a small screwdriver with vinyl tape and use it to insert the valves into proper position.

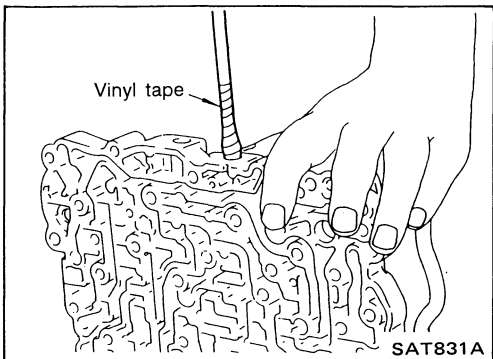

Pressure regulator valve

- If pressure regulator plug is not centered properly, sleeve cannot be inserted into bore in upper body. If this happens, use vinyl tape wrapped screwdriver to center sleeve until it can be inserted.
- Turn sleeve slightly while installing.

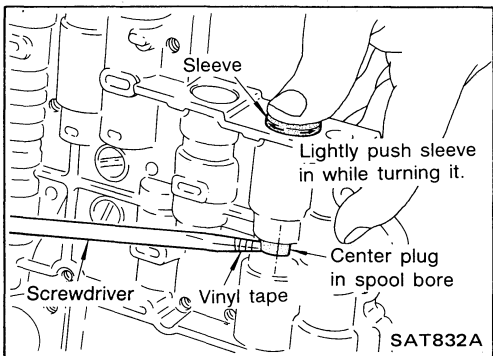

Accumulator control plug

- Align protrusion of accumulator control sleeve with notch in plug.
- Align parallel pin groove in plug with parallel pin, and install accumulator control valve.

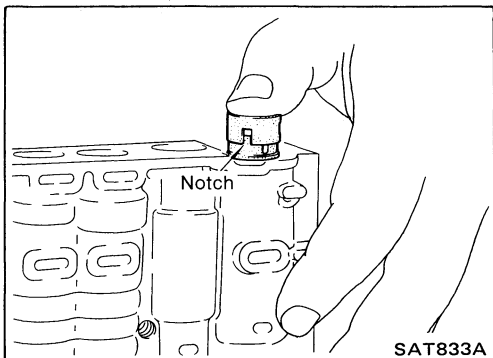

2. Install parallel pins and retainer plates.

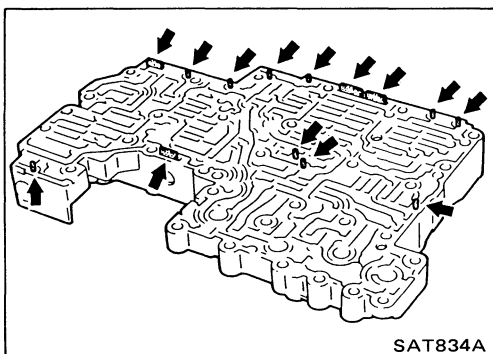

REPAIR FOR COMPONENT PARTS

Control Valve Upper Body (Cont'd)

- While pushing plug, install parallel pin.

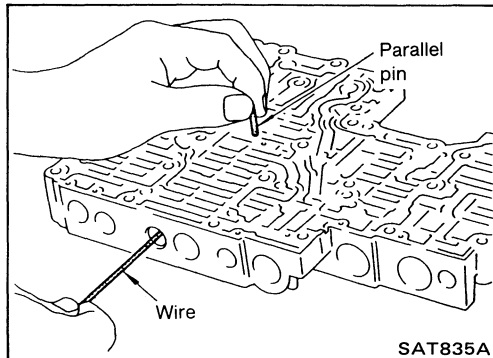
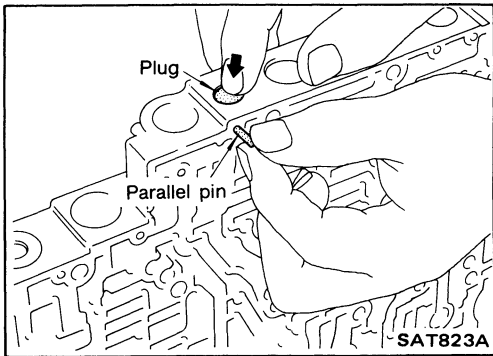

4-2 sequence valve and relay valve

- Push 4-2 sequence valve and relay valve with wire wrapped in vinyl tape to prevent scratching valve body. Install parallel pins.

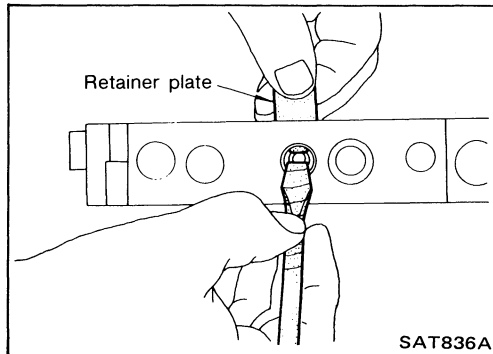

- Insert retainer plate while pushing spring.

Control Valve Lower Body

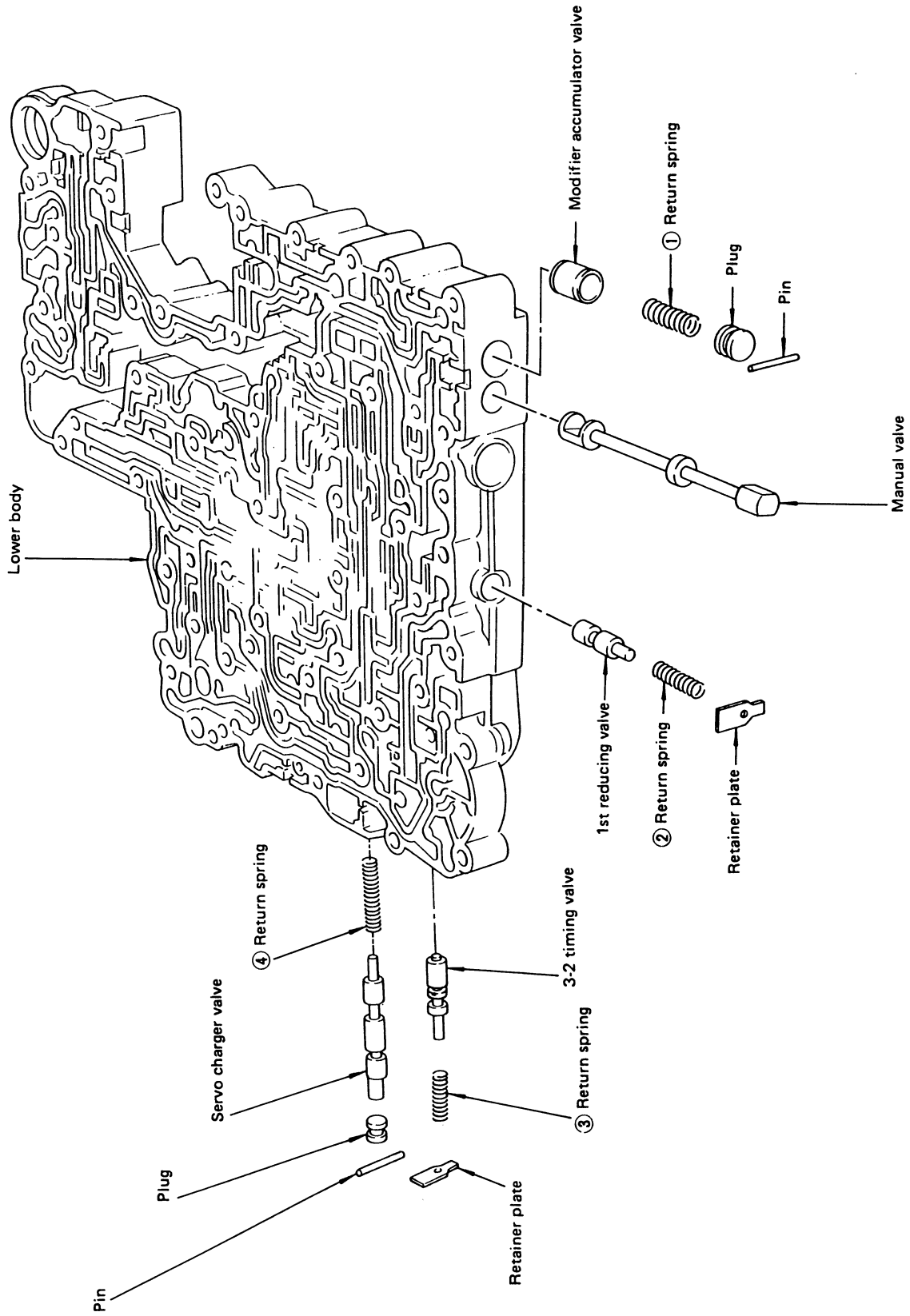

Numbers preceding valve springs correspond with those shown in Spring Chart on next page.

Apply A.T.F. to all components before their installation.

REPAIR FOR COMPONENT PARTS

Control Valve Lower Body (Cont'd)

DISASSEMBLY

1. Remove valves at parallel pins.
2. Remove valves at retainer plates.
For removal procedures, refer to "DISASSEMBLY" of Control Valve Upper Body.

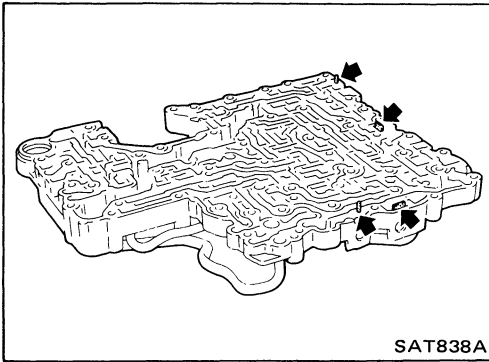

INSPECTION

Valve springs

- Check each valve spring for damage or deformation. Also measure free length and outer diameter.
- Numbers of each valve spring listed in table below are the same as those in the figure on AT-138.

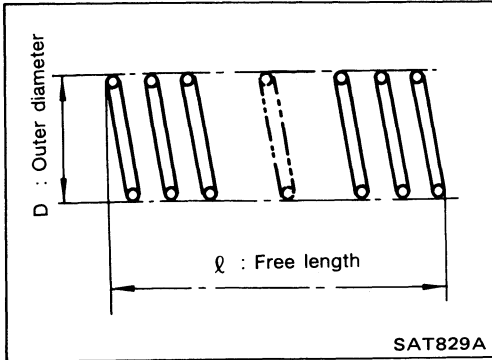

Inspection standard:

Unit: mm (in)

Parts	Item	Part No.	ℓ	D
①	Modifier accumulator piston spring	31742-41X15	30.5 (1.201)	9.8 (0.386)
②	1st reducing valve spring	31756-41X05	25.4 (1.000)	6.75 (0.2657)
③	3-2 timing valve spring	31742-41X08	20.55 (0.8091)	6.75 (0.2657)
④	Servo charger valve spring	31742-41X06	23.0 (0.906)	6.7 (0.264)

- Replace valve springs if deformed or fatigued.

Control valves

- Check sliding surfaces of control valves, sleeves and plugs for damage.

ASSEMBLY

- Install control valves.
For installation procedures, refer to "ASSEMBLY" of Control Valve Upper Body.

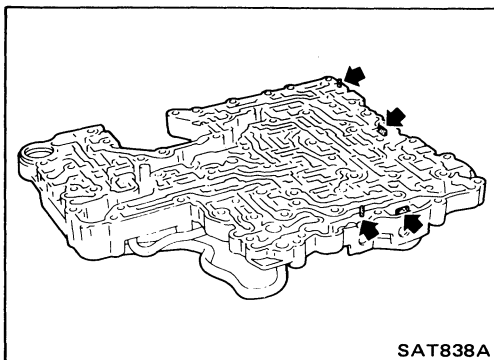

Reverse Clutch

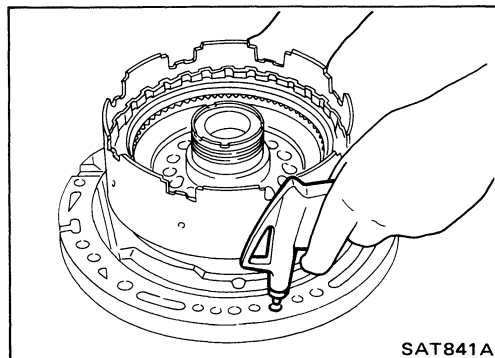
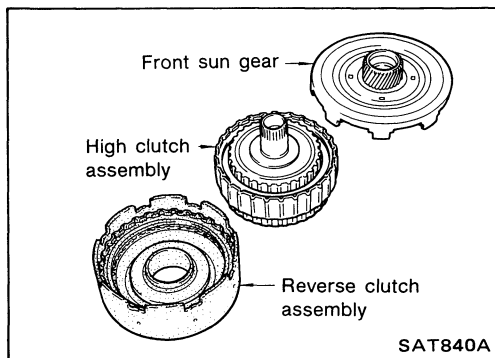
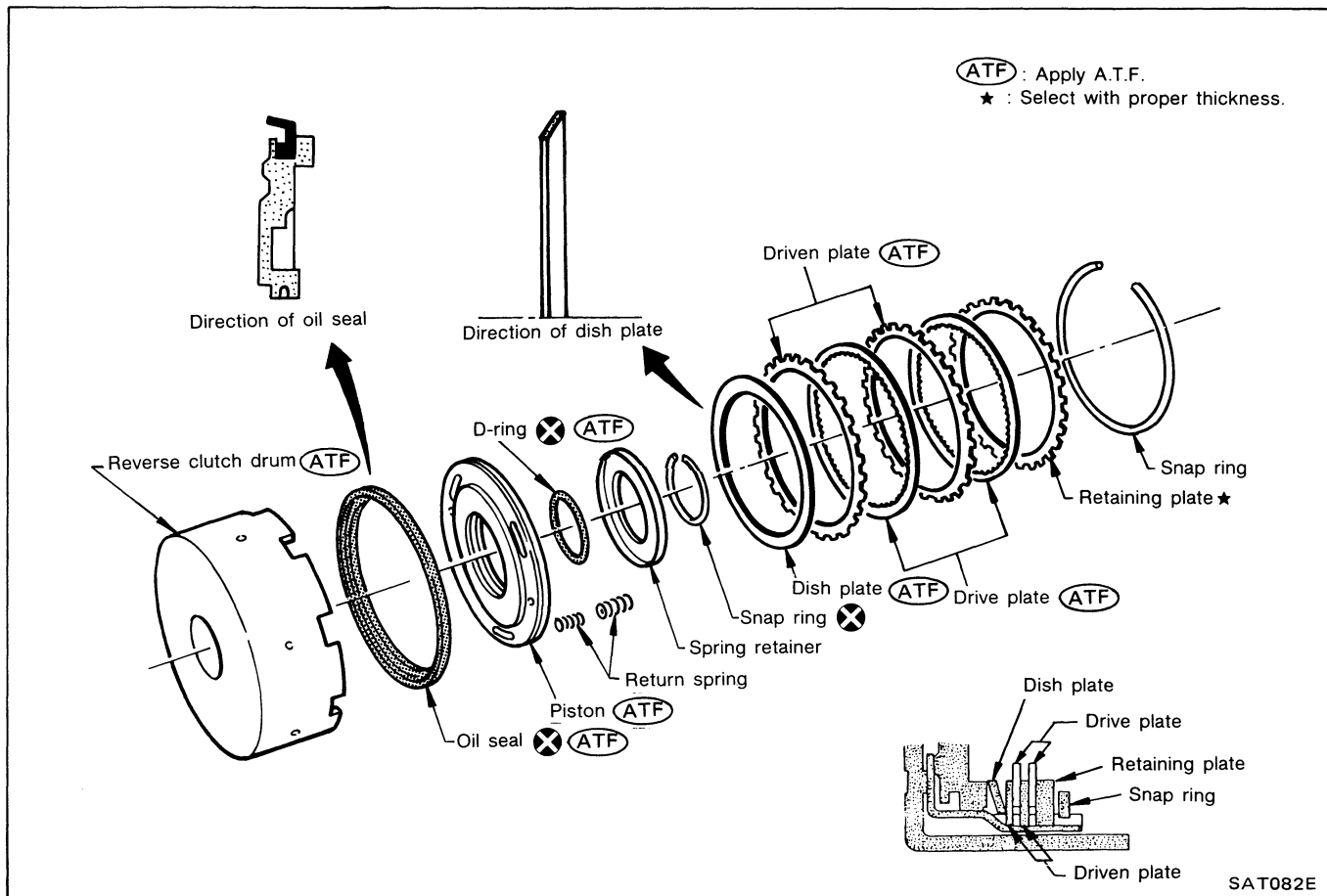

DISASSEMBLY

1. Remove reverse clutch assembly from clutch pack.

2. Check operation of reverse clutch.

- a. Install seal ring onto oil pump cover and install reverse clutch. Apply compressed air to oil hole.
- b. Check to see that retaining plate moves to snap ring.
- c. If retaining plate does not move to snap ring, D-ring or oil seal may be damaged or fluid may be leaking at piston check ball.

REPAIR FOR COMPONENT PARTS

Reverse Clutch (Cont'd)

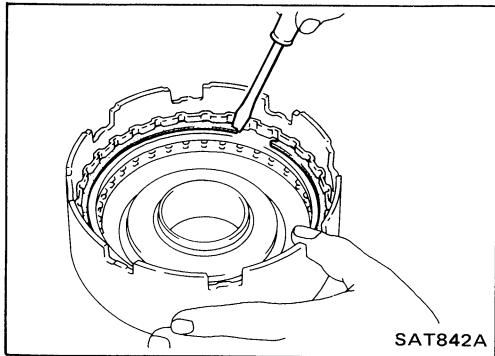

- Remove drive plates, driven plates, retaining plate, dish plate and snap ring.

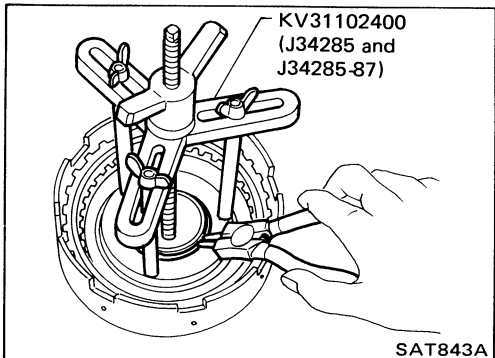

- Remove snap ring from clutch drum while compressing clutch springs.

- **Do not expand snap ring excessively.**
- Remove spring retainer and return spring.

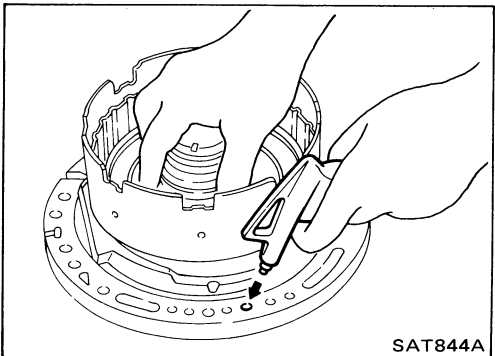

- Install seal ring onto oil pump cover and install reverse clutch drum. While holding piston, gradually apply compressed air to oil hole until piston is removed.

- **Do not apply compressed air abruptly.**

- Remove D-ring and oil seal from piston.

INSPECTION

Reverse clutch snap ring and spring retainer

- Check for deformation, fatigue or damage.

Reverse clutch return springs

- Check for deformation or damage. Also measure free length and outside diameter.

Inspection standard:

Unit: mm (in)

Parts	Part No.	ℓ	D
Spring	31505-41X02	19.69 (0.7752)	11.6 (0.457)

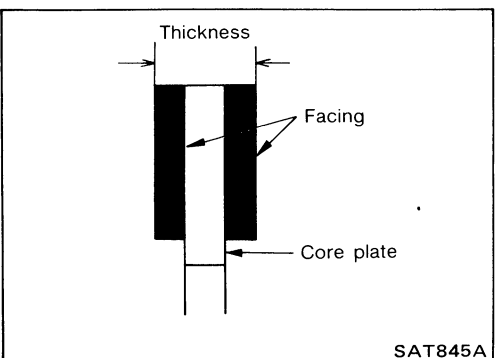
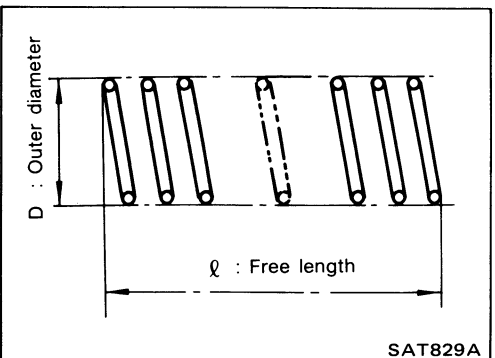

Reverse clutch drive plates

- Check facing for burns, cracks or damage.

- Measure thickness of facing.

Thickness of drive plate:

Standard value: 2.0 mm (0.079 in)

Wear limit: 1.8 mm (0.071 in)

- If not within wear limit, replace.

Reverse clutch dish plate

- Check for deformation or damage.

REPAIR FOR COMPONENT PARTS

Reverse Clutch (Cont'd)

Reverse clutch piston

- Shake piston to assure that balls are not seized.
- Apply compressed air to check ball oil hole opposite the return spring to assure that there is no air leakage.
- Also apply compressed air to oil hole on return spring side to assure that air leaks past ball.

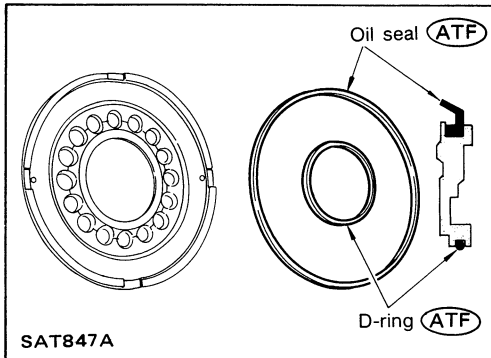
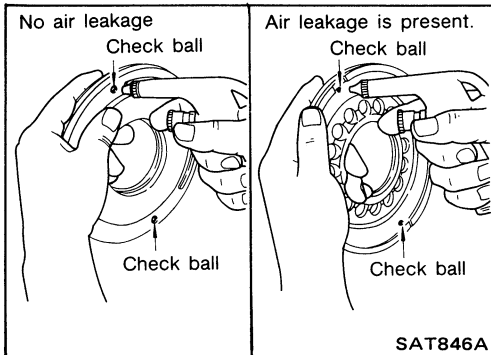

ASSEMBLY

1. Install D-ring and oil seal on piston.
 - Apply A.T.F. to both parts.

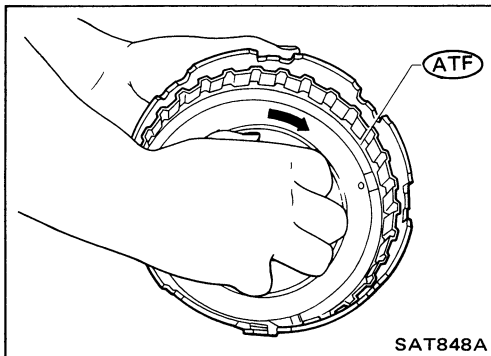

2. Install piston assembly by turning it slowly and evenly.
 - Apply A.T.F. to inner surface of drum.

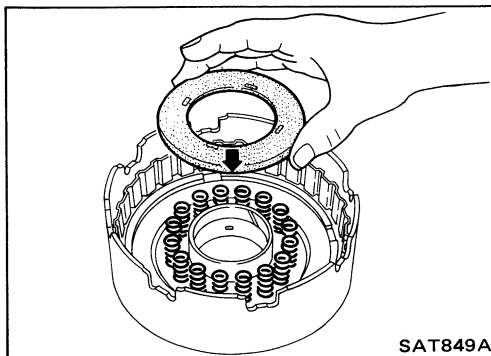

3. Install return springs and spring retainer.

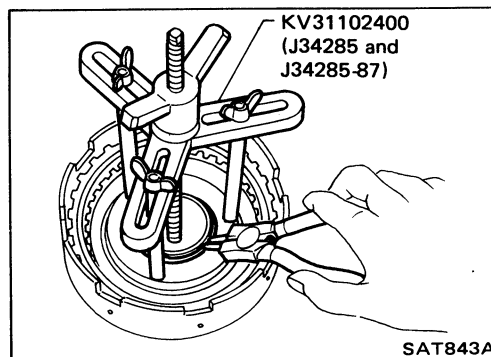

4. Install snap ring while compressing clutch springs.

REPAIR FOR COMPONENT PARTS

Reverse Clutch (Cont'd)

- Do not align snap ring gap with spring retainer stopper.

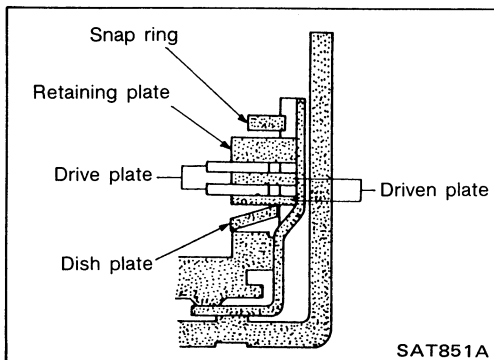
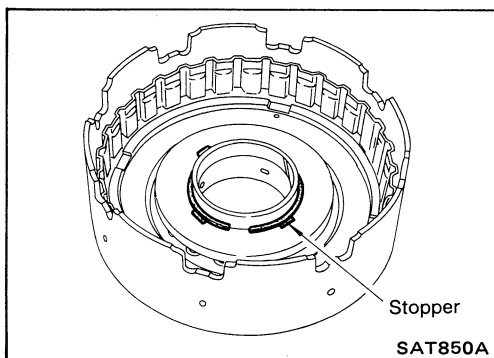

5. Install drive plates, driven plates, retaining plate and dish plate.

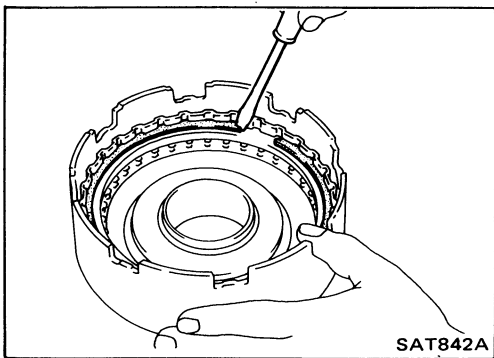

6. Install snap ring.

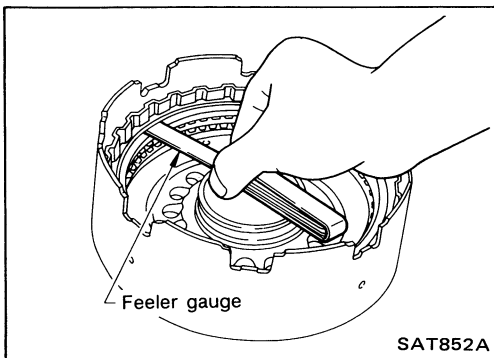

7. Measure clearance between retaining plate and snap ring. If not within allowable limit, select proper retaining plate.

Specified clearance:

Standard

0.5 - 0.8 mm (0.020 - 0.031 in)

Allowable limit

1.2 mm (0.047 in)

Retaining plate:

Refer to S.D.S.

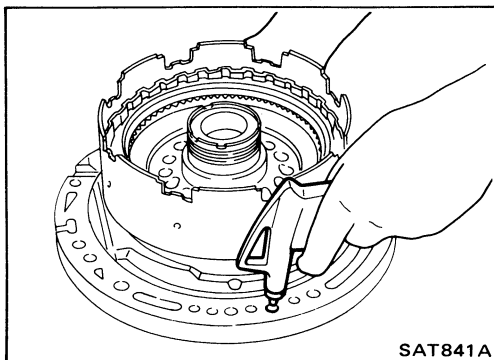

8. Check operation of reverse clutch.
Refer to "DISASSEMBLY" of Reverse Clutch.

REPAIR FOR COMPONENT PARTS

High Clutch

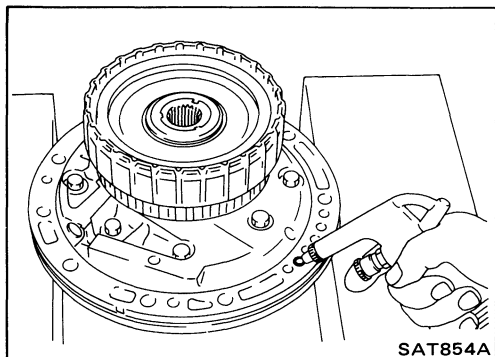
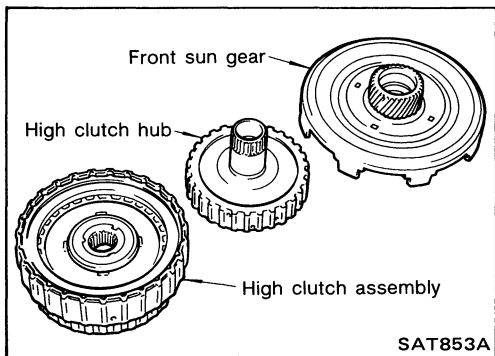
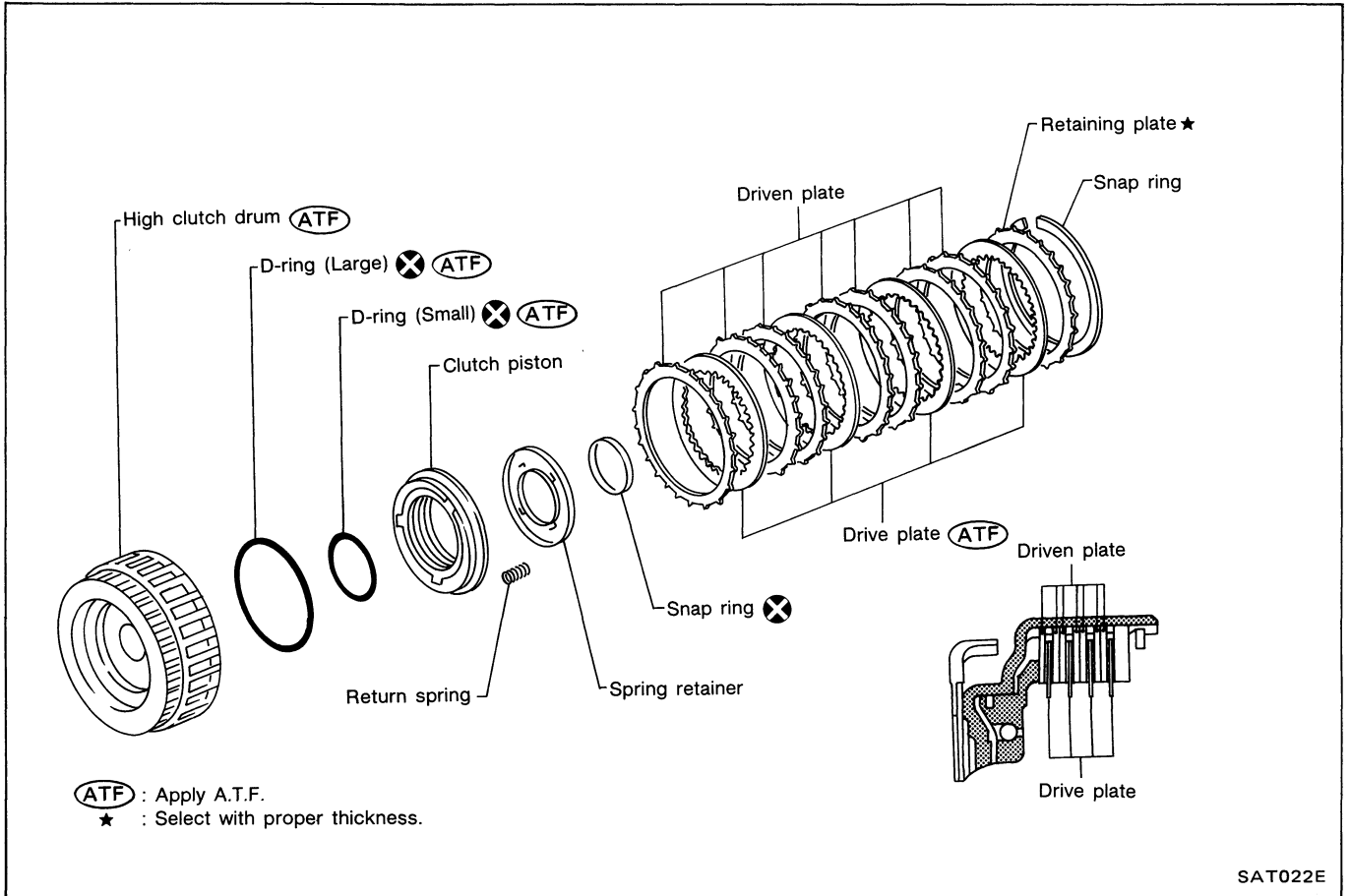

Service procedures for high clutch are essentially the same as those for reverse clutch, with the following exception:

- Check of high clutch operation

REPAIR FOR COMPONENT PARTS

High Clutch (Cont'd)

- Removal and installation of return spring

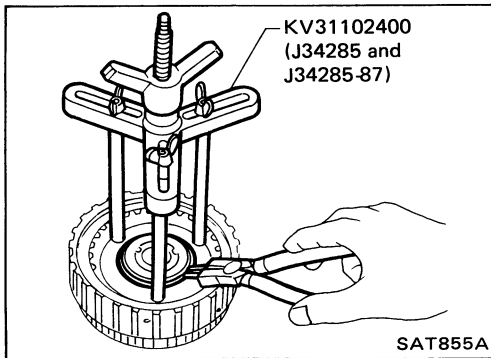

- Inspection of high clutch return springs

Inspection standard:

Unit: mm (in)

Part No.	ℓ	D
31505-21X03	22.06 (0.8685)	11.6 (0.457)

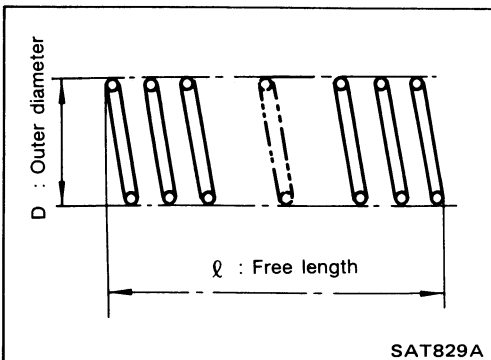

- Inspection of high clutch drive plate

Thickness of drive plate:

Standard

1.6 mm (0.063 in)

Wear limit

1.4 mm (0.055 in)

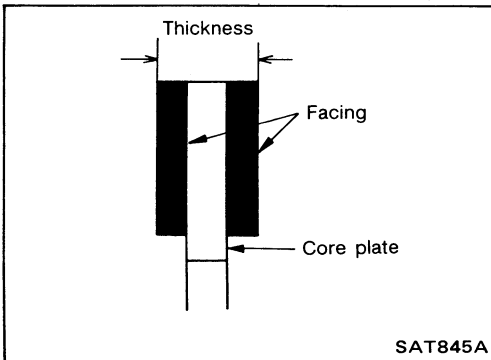

- Measurement of clearance between retaining plate and snap ring

Specified clearance:

Standard

1.8 - 2.2 mm (0.071 - 0.087 in)

Allowable limit

3.0 mm (0.118 in)

Retaining plate:

Refer to S.D.S.

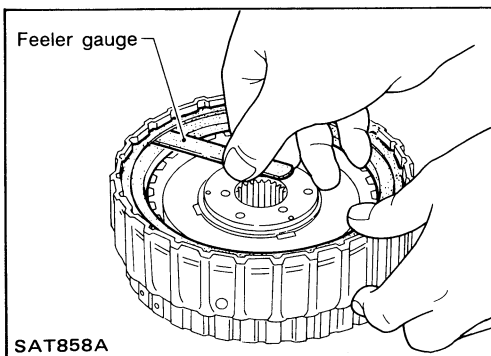

REPAIR FOR COMPONENT PARTS

Forward and Overrun Clutches

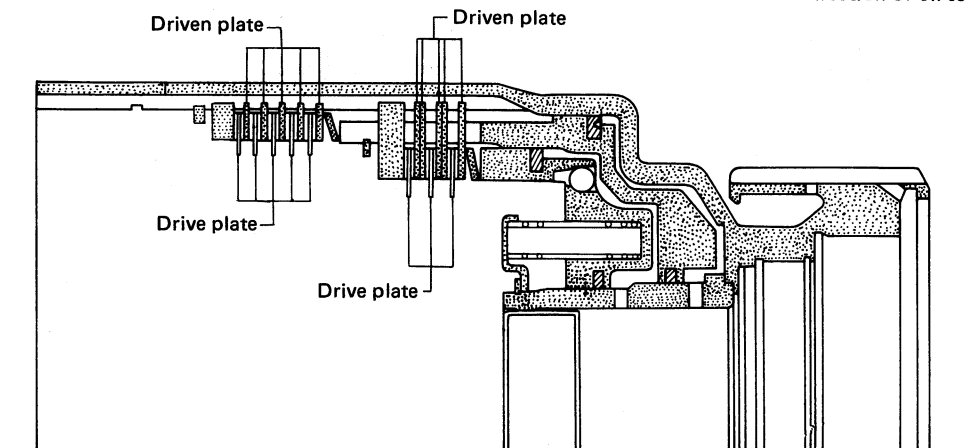
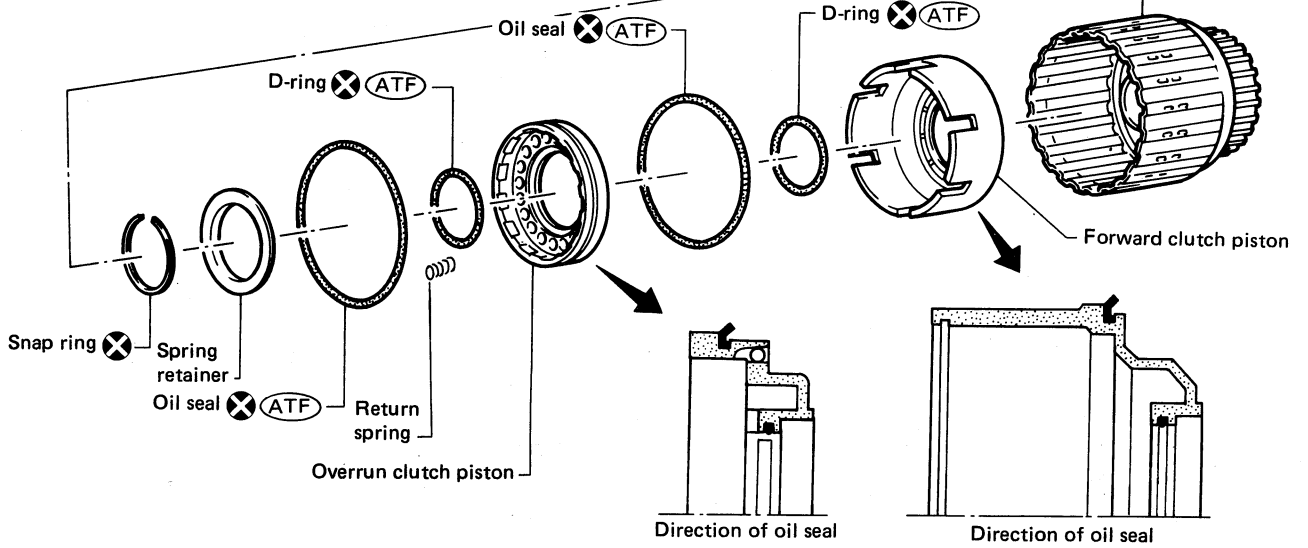
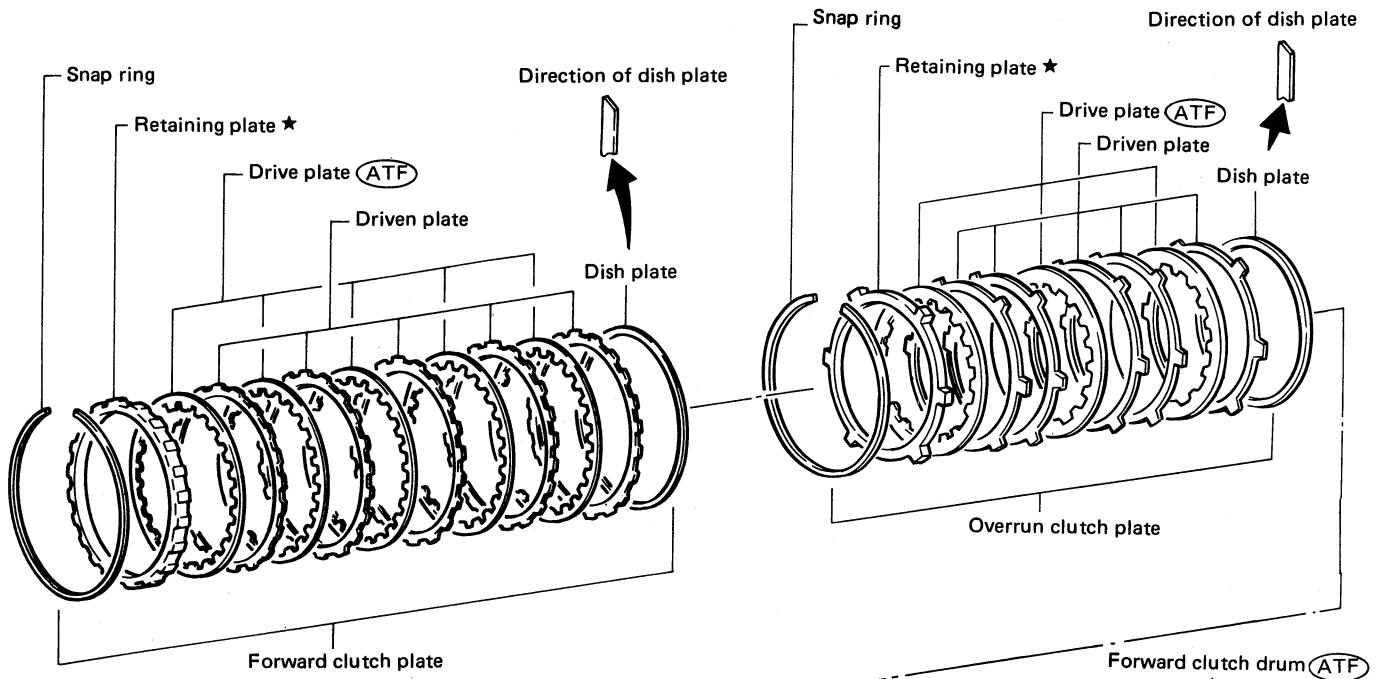

(ATF) : Apply A.T.F.

★ : Select with proper thickness.

SAT083E

REPAIR FOR COMPONENT PARTS

Forward and Overrun Clutches (Cont'd)

Service procedures for forward and overrun clutches are essentially the same as those for reverse clutch, with the following exception:

- Check of forward clutch operation.

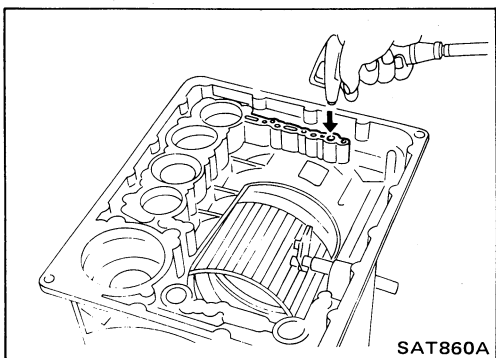

- Check of overrun clutch operation.

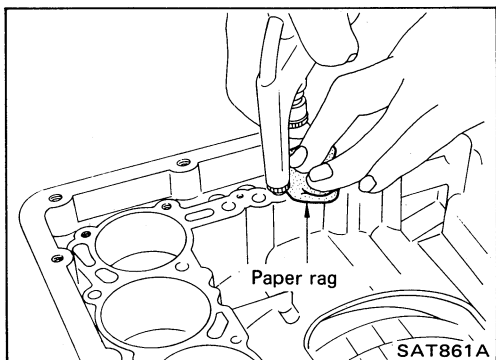

- Removal of forward clutch drum
Remove forward clutch drum from transmission case by holding snap ring.

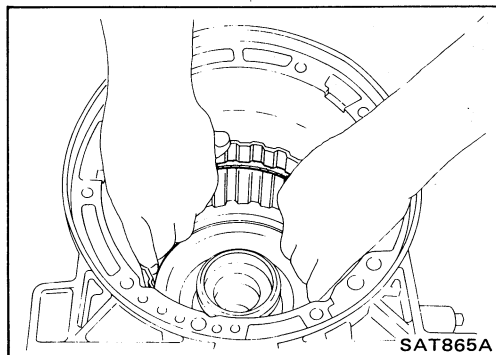

- Removal of forward clutch and overrun clutch pistons
1. While holding overrun clutch piston, gradually apply compressed air to oil hole.

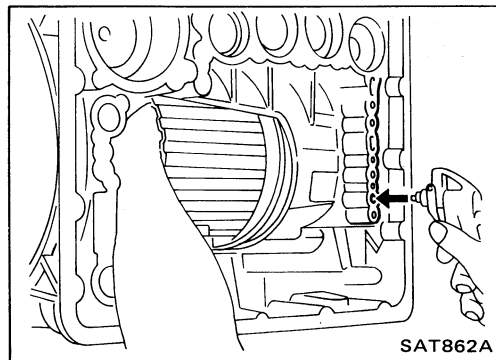

- 2. Remove overrun clutch from forward clutch.

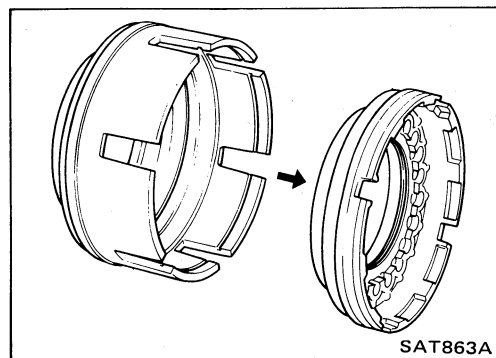

REPAIR FOR COMPONENT PARTS

Forward and Overrun Clutches (Cont'd)

- Removal and installation of return springs

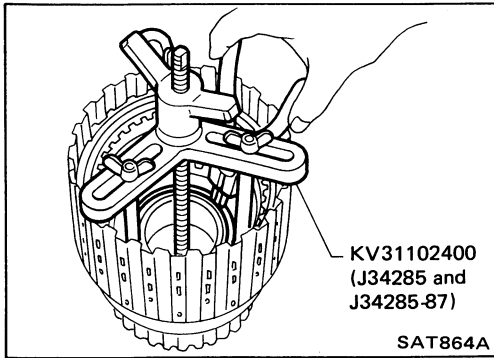

- Inspection of forward clutch and overrun clutch return springs

Inspection standard:

Unit: mm (in)

Part No.	ℓ	D
31505-41X01	35.77 (1.4083)	9.7 (0.382)

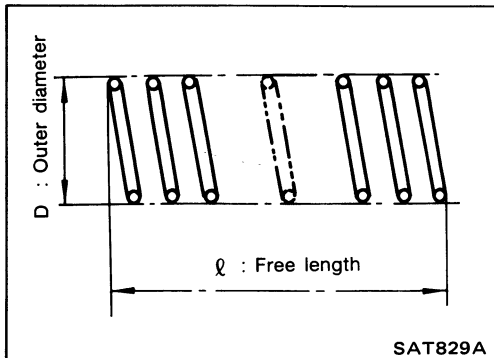

- Inspection of forward clutch drive plates

Thickness of drive plate:

Standard

2.0 mm (0.079 in)

Wear limit

1.8 mm (0.071 in)

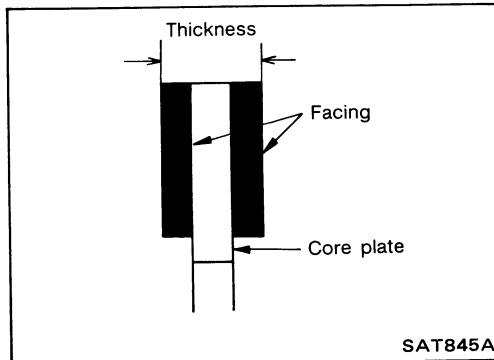

- Inspection of overrun clutch drive plates

Thickness of drive plate:

Standard

2.0 mm (0.079 in)

Wear limit

1.8 mm (0.071 in)

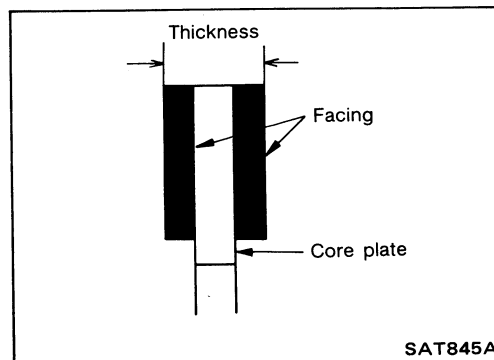

- Installation of forward clutch piston and overrun clutch piston

1. Install forward clutch piston by turning it slowly and evenly.

- **Apply A.T.F. to inner surface of clutch drum.**

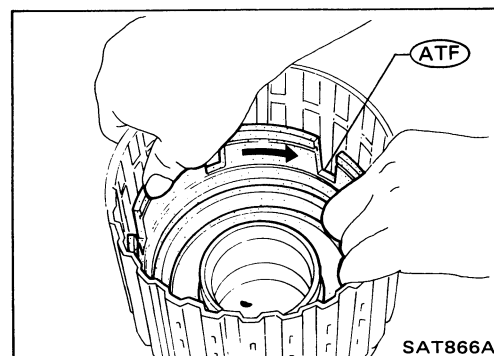

REPAIR FOR COMPONENT PARTS

Forward and Overrun Clutches (Cont'd)

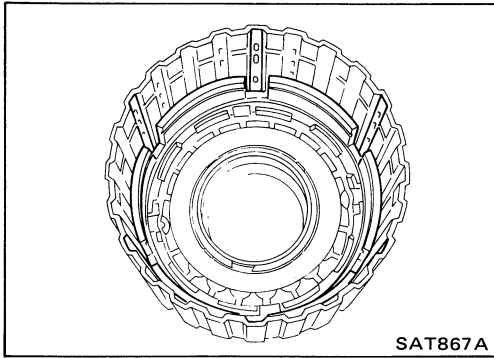

- Align notch in forward clutch piston with groove in forward clutch drum.

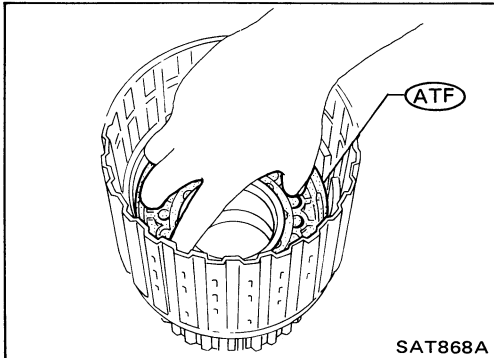

2. Install overrun clutch by turning it slowly and evenly.

- Apply A.T.F. to inner surface of forward clutch piston.

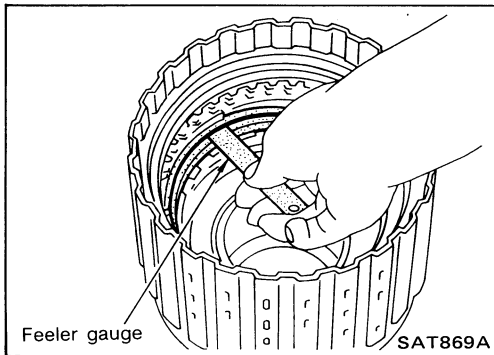

- Measurement of clearance between retaining plate and snap ring of overrun clutch

Specified clearance:

Standard

1.0 - 1.4 mm (0.039 - 0.055 in)

Allowable limit

2.0 mm (0.079 in)

Retaining plate:

Refer to S.D.S.

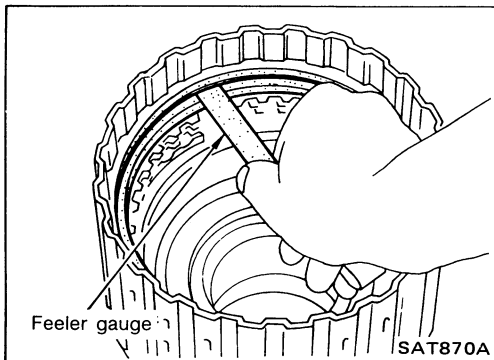

- Measurement of clearance between retaining plate and snap ring of forward clutch

Specified clearance:

Standard

0.45 - 0.85 mm (0.0177 - 0.0335 in)

Allowable limit

1.85 mm (0.0728 in)

Retaining plate:

Refer to S.D.S.

REPAIR FOR COMPONENT PARTS

Low & Reverse Brake

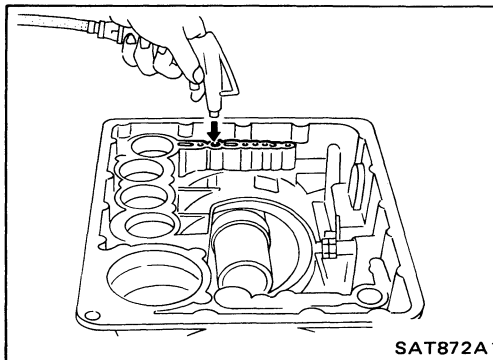
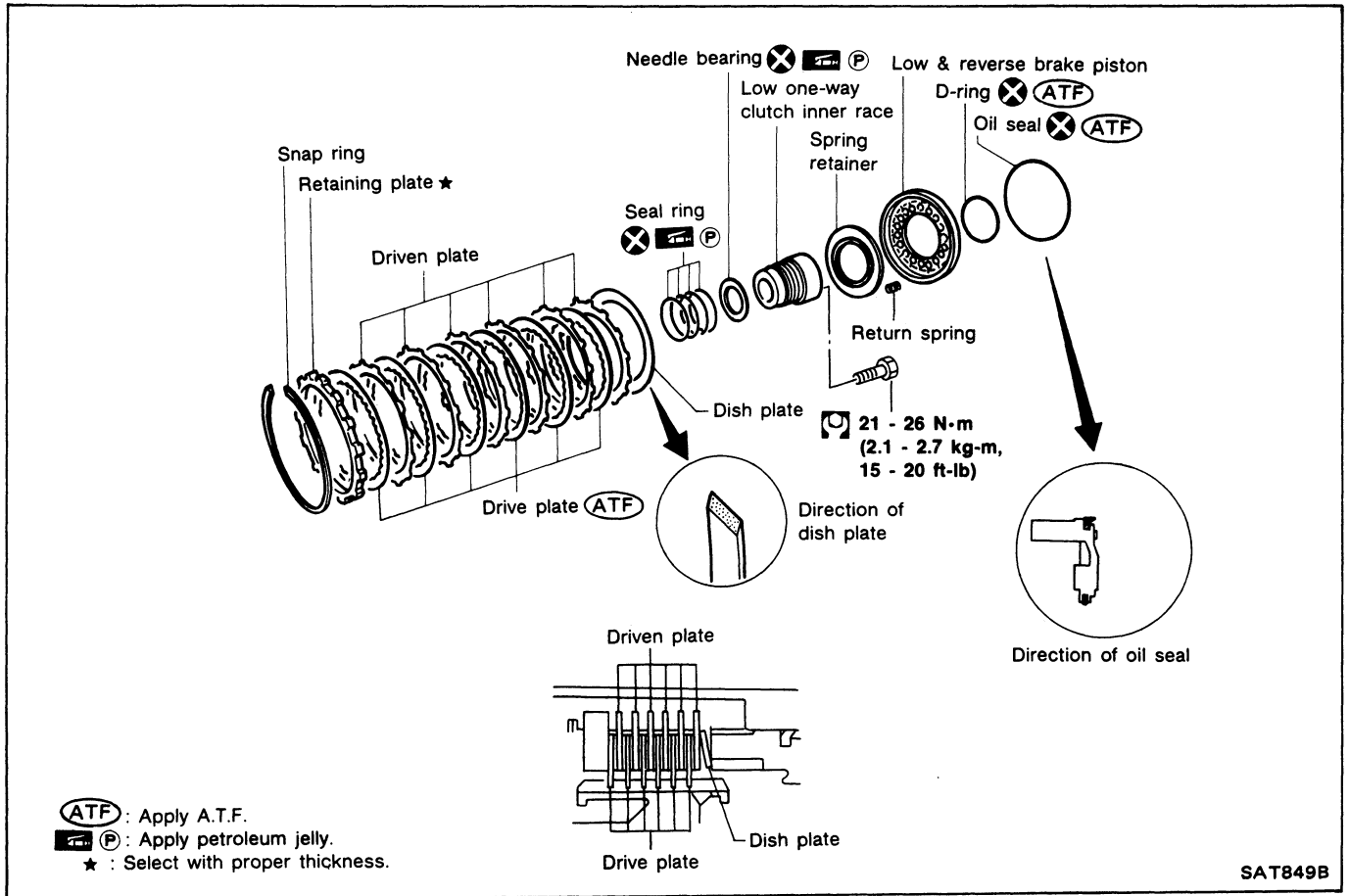

DISASSEMBLY

1. Check operation of low and reverse brake.
 - a. Install seal ring onto oil pump cover and install reverse clutch. Apply compressed air to oil hole.
 - b. Check to see that retaining plate moves to snap ring.
 - c. If retaining plate does not move to snap ring, D-ring or oil seal may be damaged or fluid may be leaking at piston check ball.

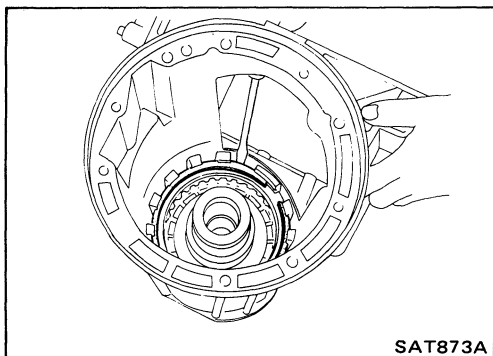

2. Remove snap ring, low and reverse brake drive plates, driven plates and dish plate.

REPAIR FOR COMPONENT PARTS

Low & Reverse Brake (Cont'd)

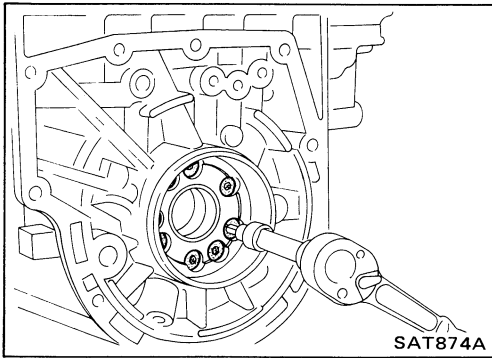

- Remove low one-way clutch inner race, spring retainer and return spring from transmission case.

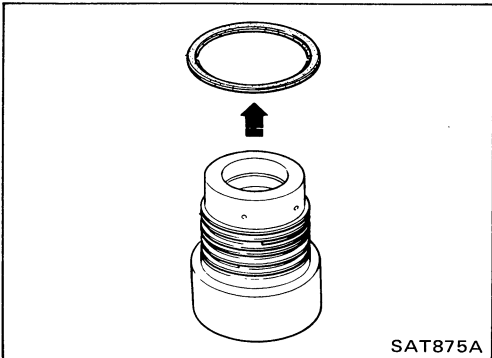

- Remove seal rings from low one-way clutch inner race.
- Remove needle bearing from low one-way clutch inner race.

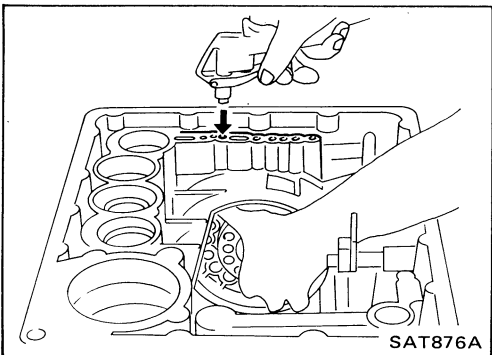

- Remove low and reverse brake piston using compressed air.
- Remove oil seal and D-ring from piston.

INSPECTION

Low and reverse brake snap ring and spring retainer

- Check for deformation, or damage.

Low and reverse brake return springs

- Check for deformation or damage. Also measure free length and outside diameter.

Inspection standard:

Unit: mm (in)

Part No.	ℓ	D
31521-21X00	23.7 (0.933)	11.6 (0.457)

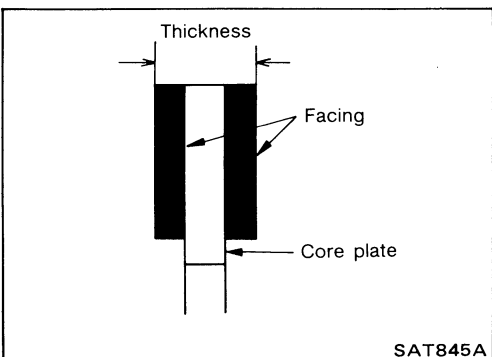
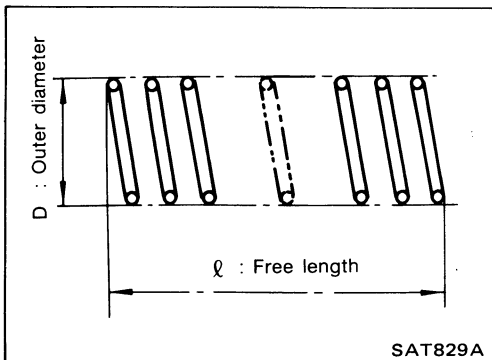

Low and reverse brake drive plates

- Check facing for burns, cracks or damage.

- Measure thickness of facing.

Thickness of drive plate:

Standard value

2.0 mm (0.079 in)

Wear limit

1.8 mm (0.071 in)

- If not within wear limit, replace.

REPAIR FOR COMPONENT PARTS

Low & Reverse Brake (Cont'd)

Low one-way clutch inner race

- Check frictional surface of inner race for wear or damage.

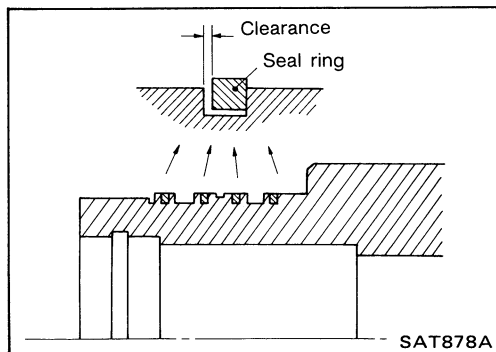
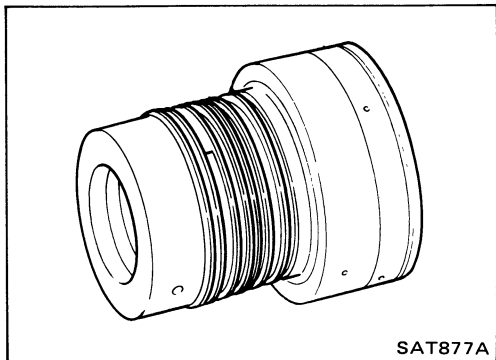

- Install a new seal rings onto low one-way clutch inner race.
- **Be careful not to expand seal ring gap excessively.**
- Measure seal ring-to-groove clearance.

Inspection standard:

Standard value: 0.10 - 0.25 mm (0.0039 - 0.0098 in)

Allowable limit: 0.25 mm (0.0098 in)

- If not within allowable limit, replace low one-way clutch inner race.

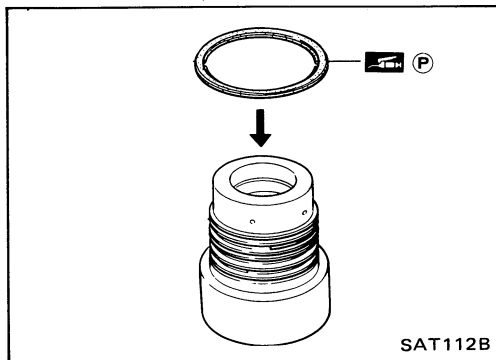

ASSEMBLY

1. Install bearing onto one-way clutch inner race.
 - Pay attention to its direction — **Black surface goes to rear side.**
 - Apply petroleum jelly to needle bearing.

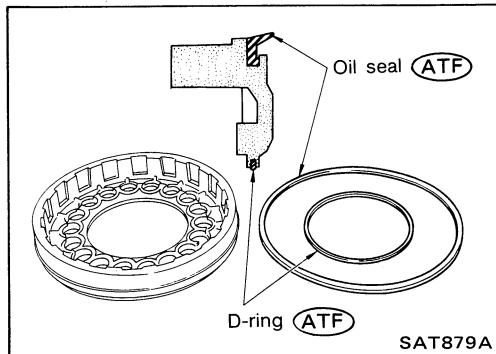

2. Install oil seal and D-ring onto piston.
 - Apply A.T.F. to oil seal and D-ring.

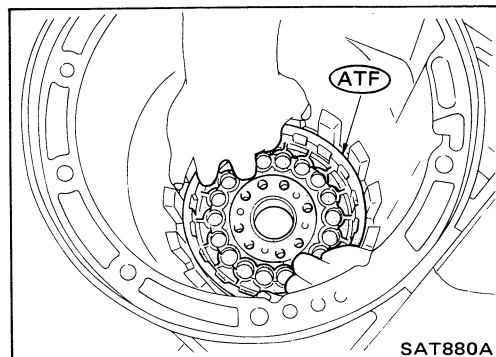

3. Install piston by rotating it slowly and evenly.
 - Apply A.T.F. to inner surface of transmission case.

REPAIR FOR COMPONENT PARTS

Low & Reverse Brake (Cont'd)

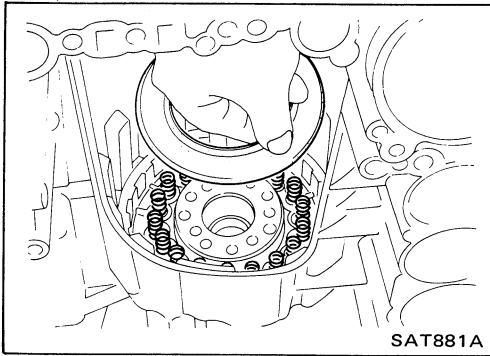

4. Install return springs, spring retainer and low one-way clutch inner race onto transmission case.

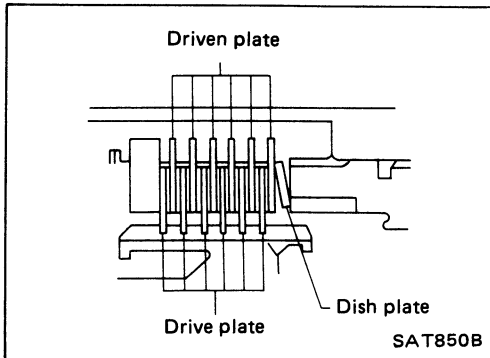

5. Install dish plate, low and reverse brake drive plates, driven plates and retaining plate.
6. Install snap ring on transmission case.

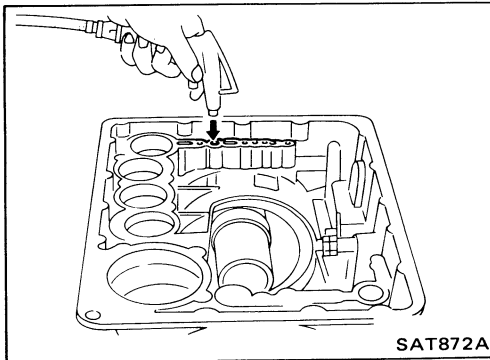

7. Check operation of low and reverse brake clutch piston. Refer to "DISASSEMBLY".

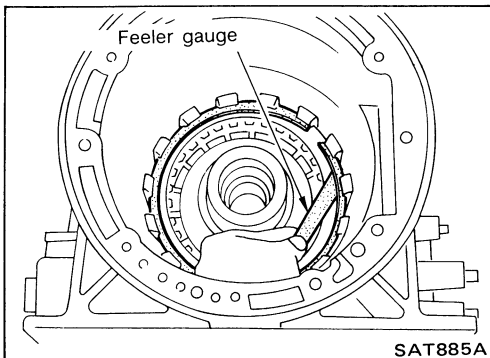

8. Measure clearance between retaining plate and snap ring. If not within allowable limit, select proper retaining plate.

Specified clearance:

Standard

0.7 - 1.1 mm (0.028 - 0.043 in)

Allowable limit

2.3 mm (0.091 in)

Retaining plate:

Refer to S.D.S.

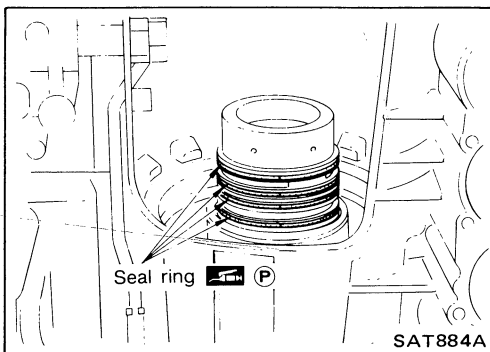

9. Install low one-way clutch inner race seal ring.
 - Apply petroleum jelly to seal ring.
 - Make sure seal rings are pressed firmly into place and held by petroleum jelly.

Forward Clutch Drum Assembly

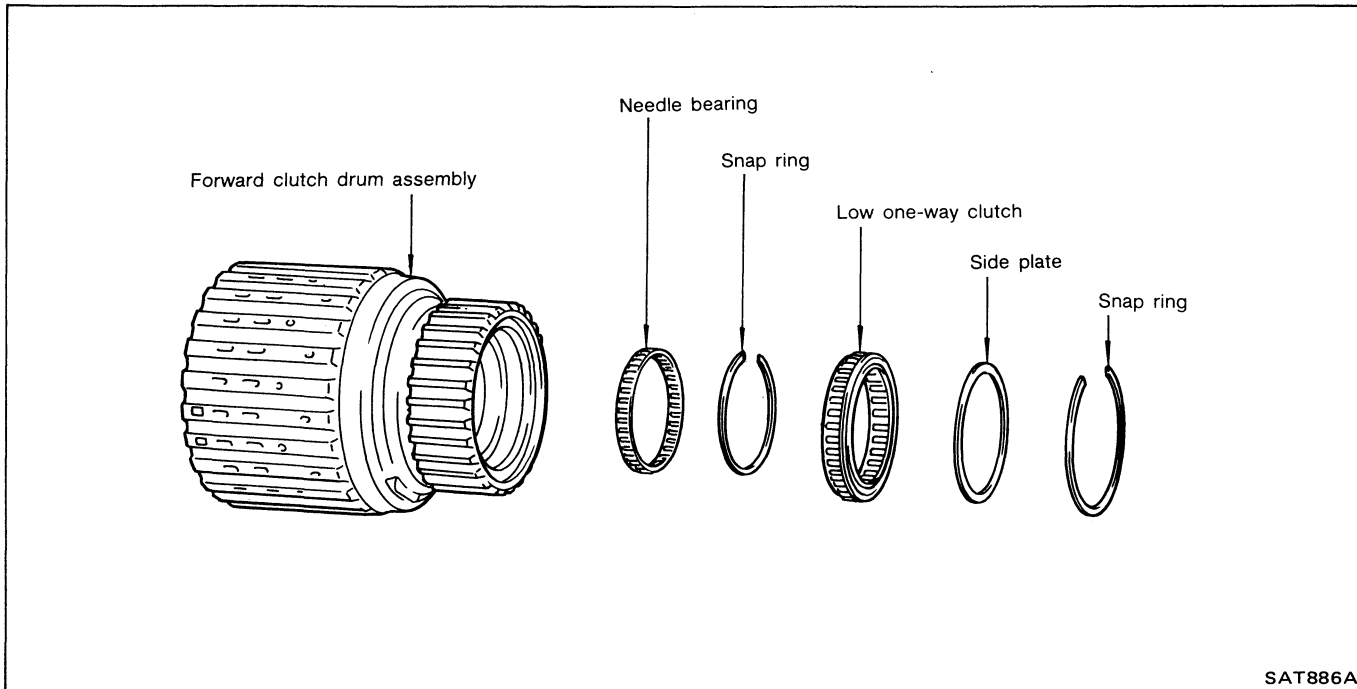

SAT886A

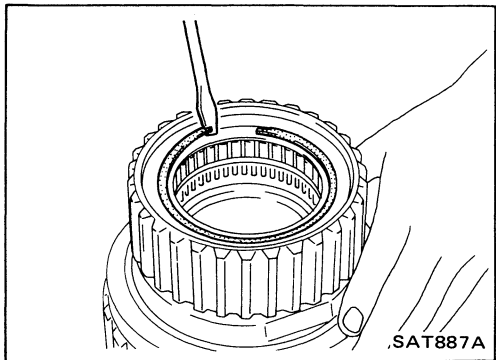

DISASSEMBLY

1. Remove snap ring from forward clutch drum.

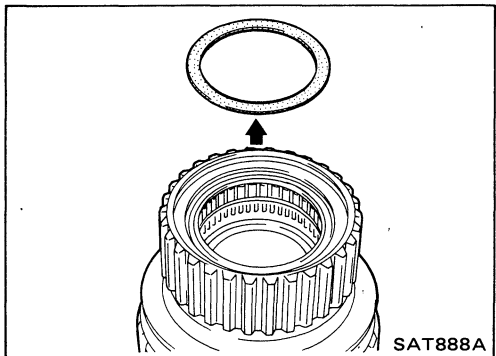

2. Remove side plate from forward clutch drum.

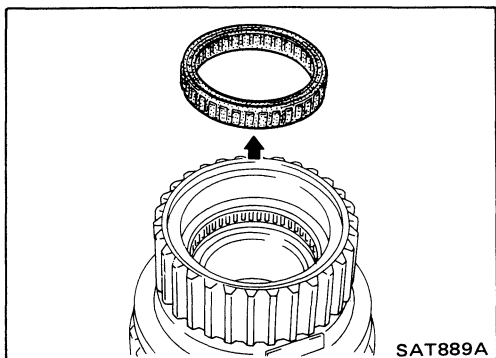

3. Remove low one-way clutch from forward clutch drum.

REPAIR FOR COMPONENT PARTS

Forward Clutch Drum Assembly (Cont'd)

4. Remove snap ring from forward clutch drum.

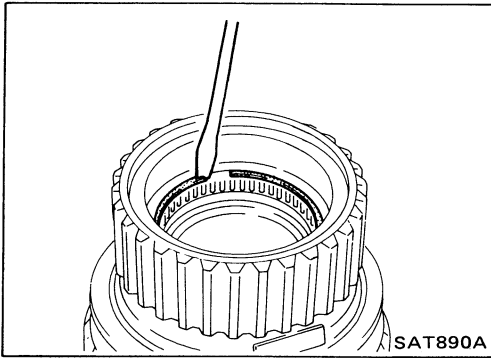

5. Remove needle bearing from forward clutch drum.

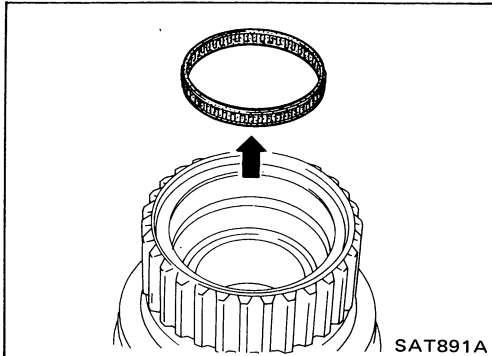

INSPECTION

Forward clutch drum

- Check spline portion for wear or damage.
- Check frictional surfaces of low one-way clutch and needle bearing for wear or damage.

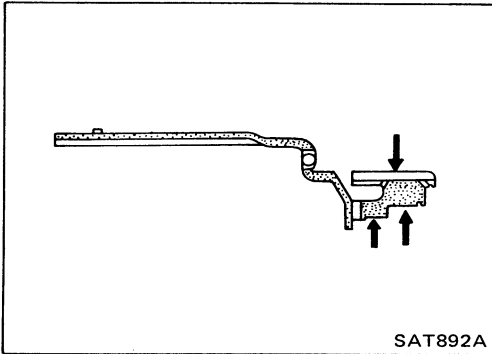

Needle bearing and low one-way clutch

- Check frictional surface for wear or damage.

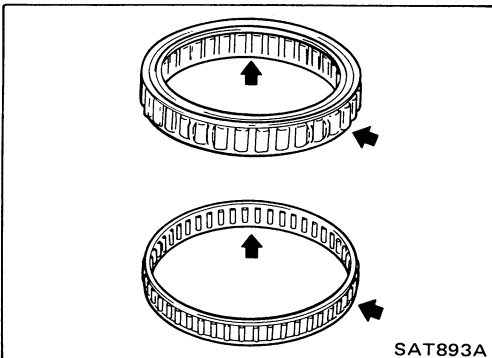

ASSEMBLY

1. Install needle bearing in forward clutch drum.

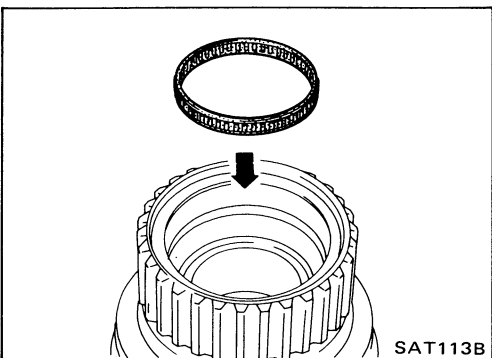

REPAIR FOR COMPONENT PARTS

Forward Clutch Drum Assembly (Cont'd)

2. Install snap ring onto forward clutch drum.

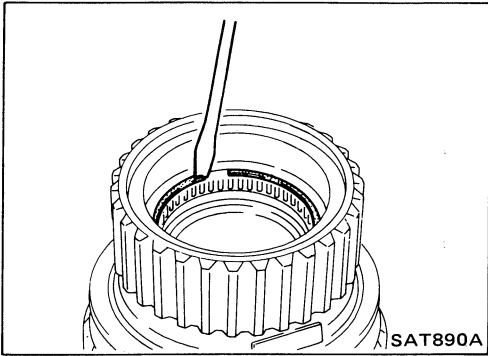

3. Install low one-way clutch onto forward clutch drum by pushing the roller in evenly.

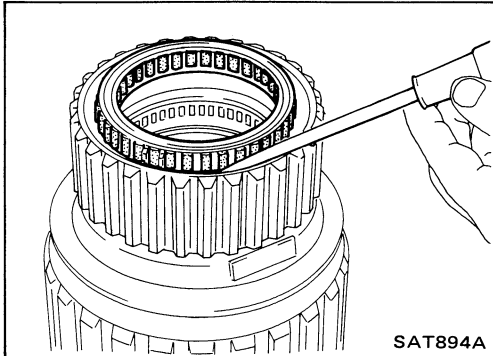

● Install low one-way clutch with flange facing rearward.

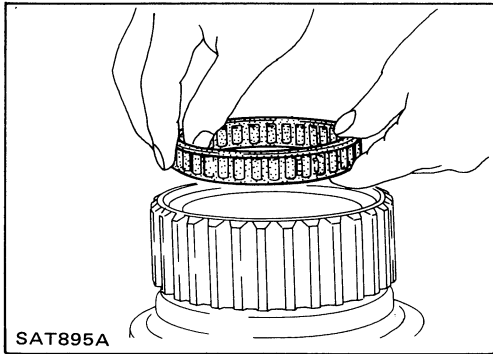

4. Install side plate onto forward clutch drum.
5. Install snap ring onto forward clutch drum.

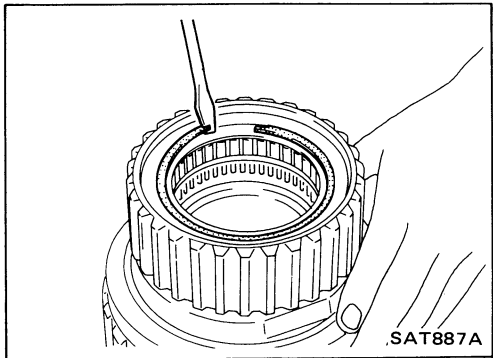

Rear Internal Gear and Forward Clutch Hub

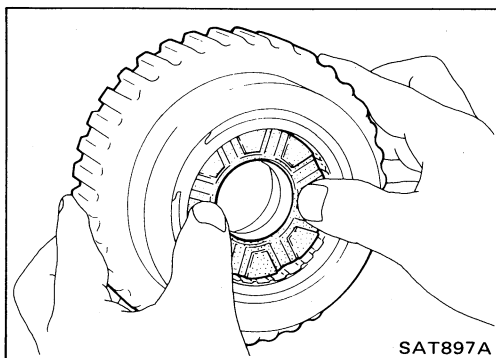
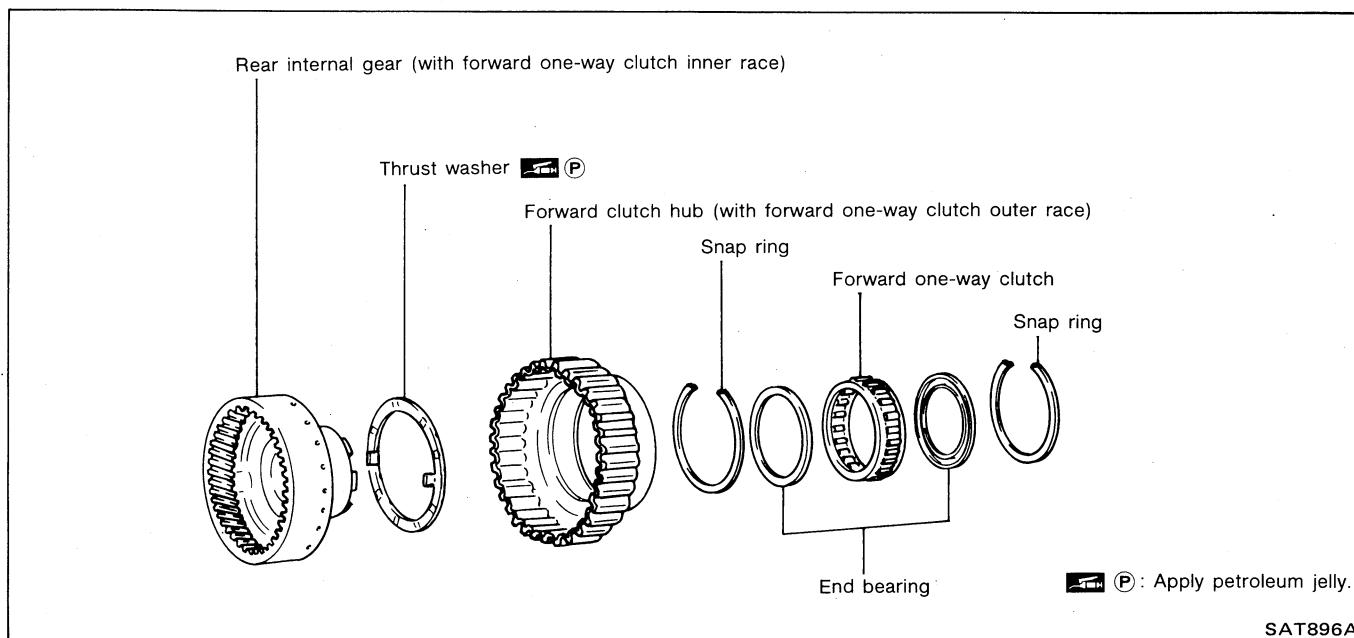

DISASSEMBLY

1. Remove rear internal gear by pushing forward clutch hub forward.

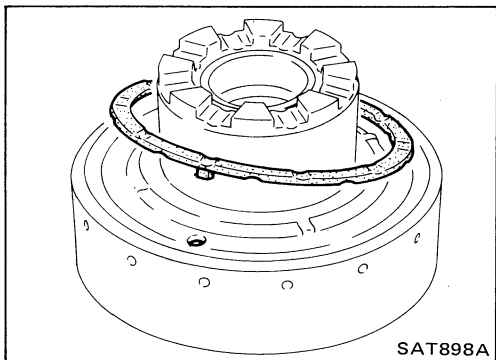

2. Remove thrust washer from rear internal gear.

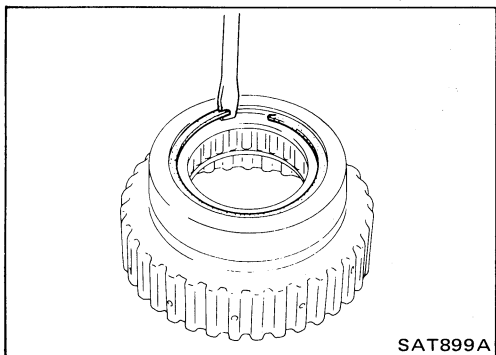

3. Remove snap ring from forward clutch hub.

REPAIR FOR COMPONENT PARTS

Rear Internal Gear and Forward Clutch Hub (Cont'd)

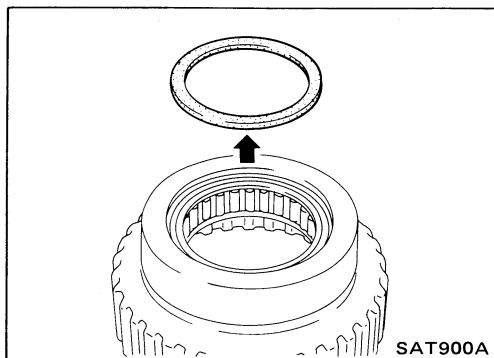

4. Remove end bearing.

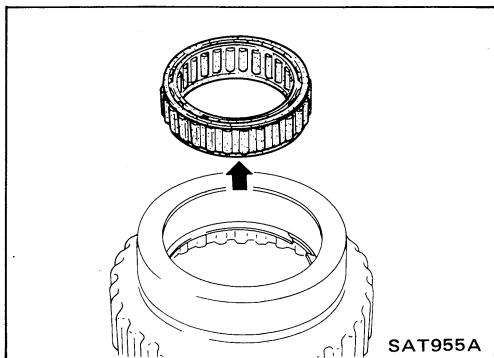

5. Remove forward one-way clutch and end bearing as a unit from forward clutch hub.

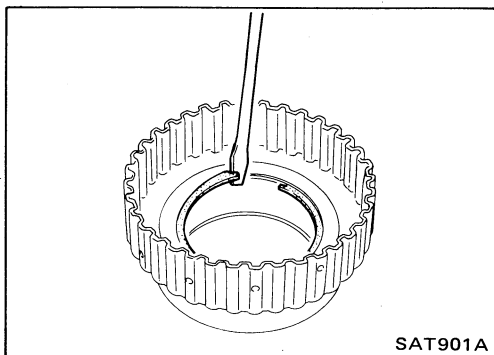

6. Remove snap ring from forward clutch hub.

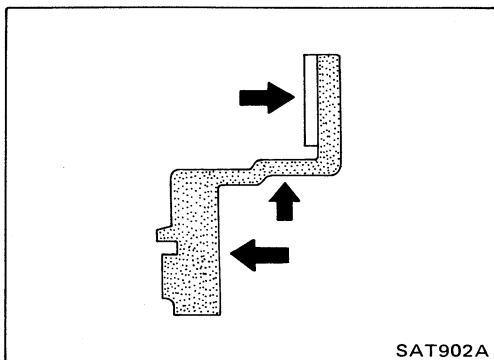

INSPECTION

Rear internal gear and forward clutch hub

- Check gear for excessive wear, chips or cracks.
- Check frictional surfaces of forward one-way clutch and thrust washer for wear or damage.
- Check spline for wear or damage.

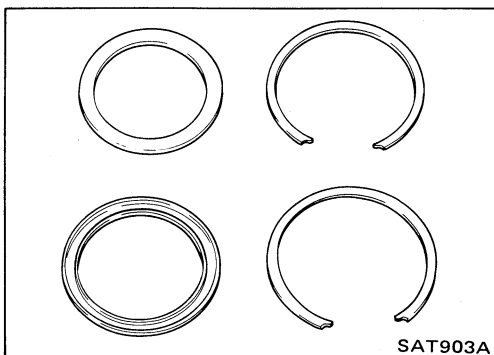

Snap ring and end bearing

- Check for deformation or damage.

REPAIR FOR COMPONENT PARTS

Rear Internal Gear and Forward Clutch Hub (Cont'd)

ASSEMBLY

1. Install snap ring onto forward clutch hub.
2. Install end bearing.

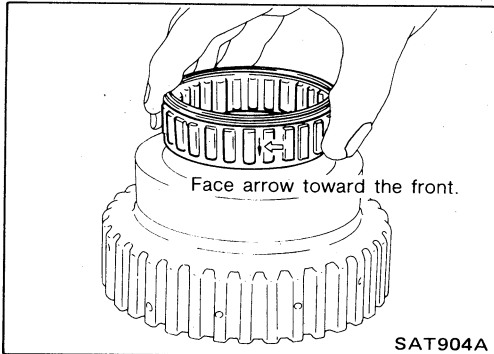
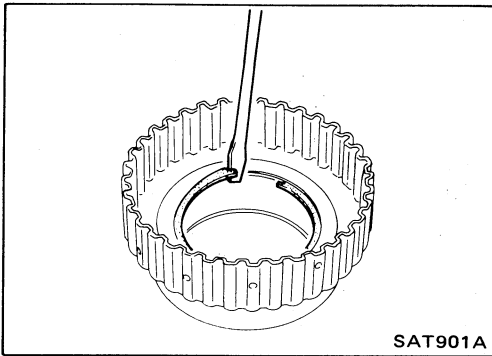

3. Install forward one-way clutch onto clutch hub.
 - Install forward one-way clutch with flange facing rearward.
4. Install end bearing.
5. Install snap ring onto forward clutch hub.

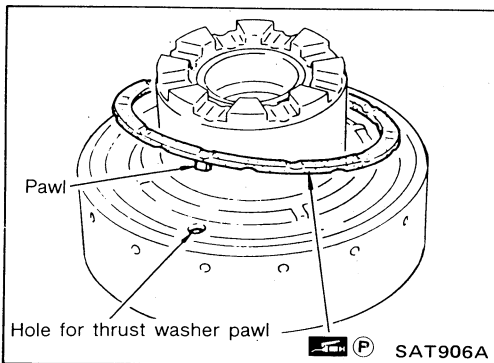

6. Install thrust washer onto rear internal gear.
 - Apply petroleum jelly to thrust washer.
 - Securely insert pawls of thrust washer into holes in rear internal gear.

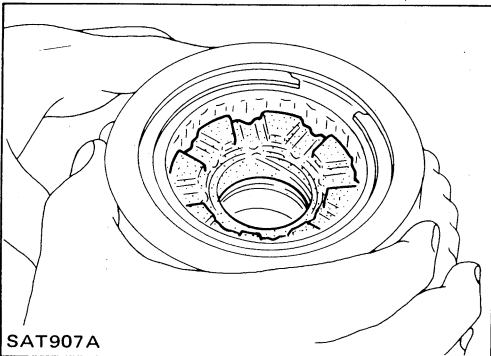

7. Position forward clutch hub in rear internal gear.

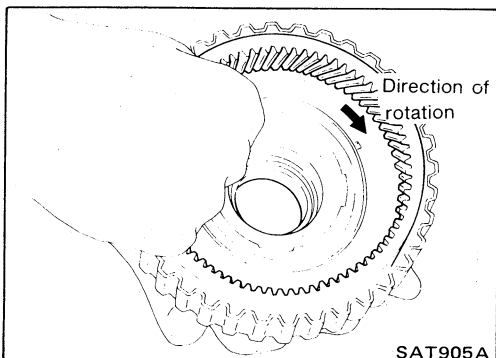

8. After installing, check to assure that forward clutch hub rotates clockwise.

Band Servo Piston Assembly

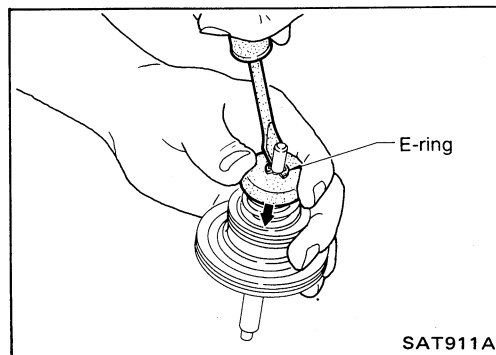
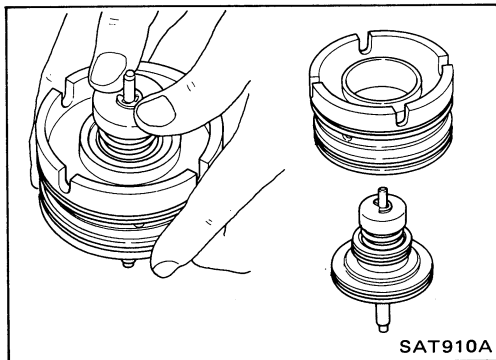
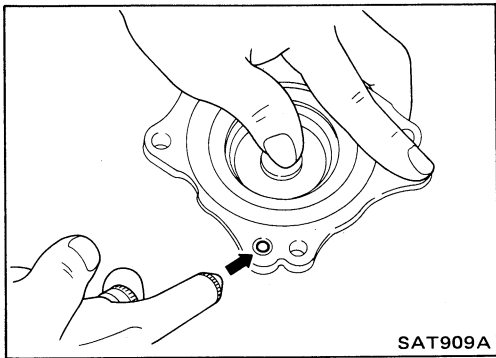
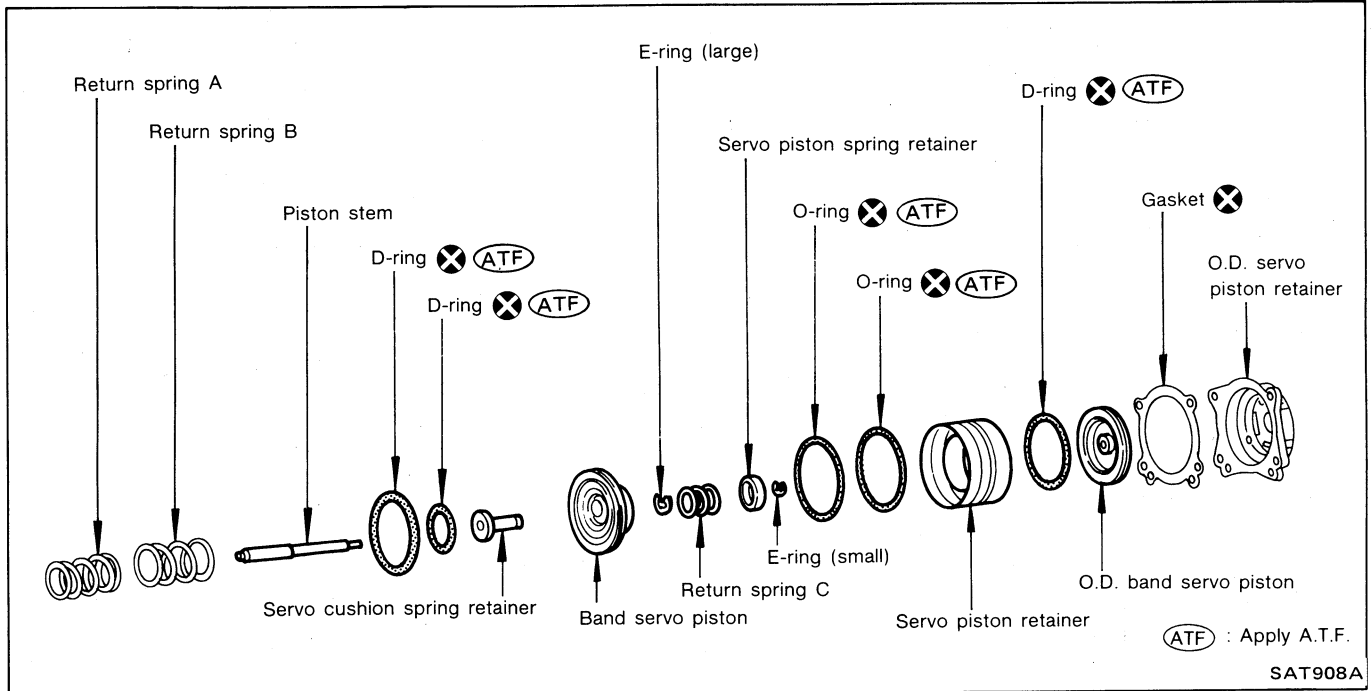

DISASSEMBLY

1. Block one oil hole in O.D. servo piston retainer and the center hole in O.D. band servo piston.
2. Apply compressed air to the other oil hole in piston retainer to remove O.D. band servo piston from retainer.
3. Remove D-ring from O.D. band servo piston.
4. Remove band servo piston assembly from servo piston retainer by pushing it forward.
5. Place piston stem end on a wooden block. While pushing servo piston spring retainer down, remove E-ring.

REPAIR FOR COMPONENT PARTS

Band Servo Piston Assembly (Cont'd)

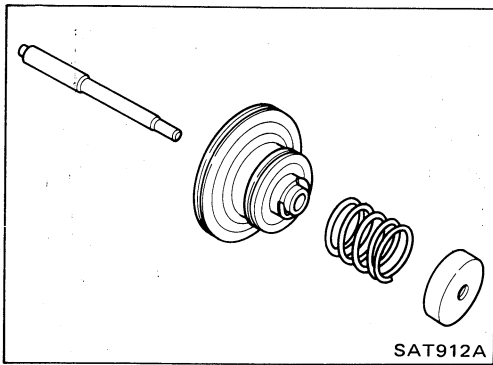

6. Remove servo piston spring retainer, return spring C and piston stem from band servo piston.

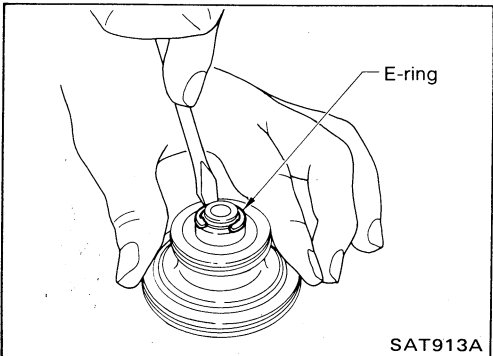

7. Remove E-ring from band servo piston.

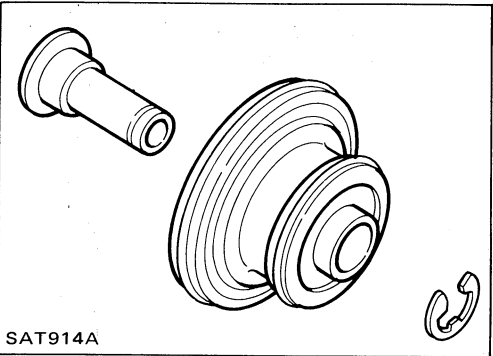

8. Remove servo cushion spring retainer from band servo piston.
9. Remove D-rings from band servo piston.
10. Remove O-rings from servo piston retainer.

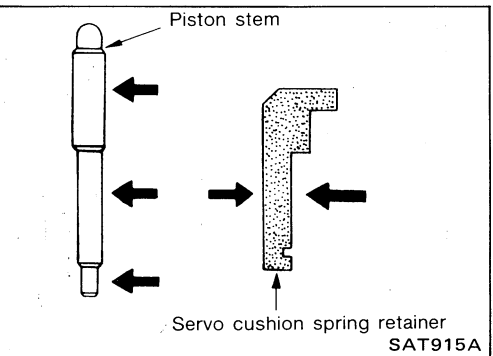

INSPECTION

Pistons, retainers and piston stem

- Check frictional surfaces for abnormal wear or damage.

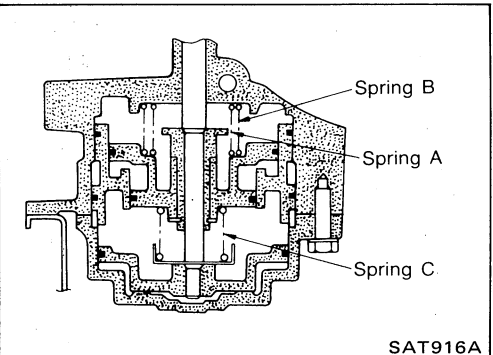

Return springs

- Check for deformation or damage. Measure free length and outer diameter.

Inspection standard:

Unit: mm (in)

Parts	Free length	Outer diameter
Spring A	45.6 (1.795)	34.3 (1.350)
Spring B	53.8 (2.118)	40.3 (1.587)
Spring C	29.7 (1.169)	27.6 (1.087)

REPAIR FOR COMPONENT PARTS

Band Servo Piston Assembly (Cont'd)

ASSEMBLY

1. Install O-rings onto servo piston retainer.
 - Apply A.T.F. to O-rings.
 - Pay attention to position of each O-ring.

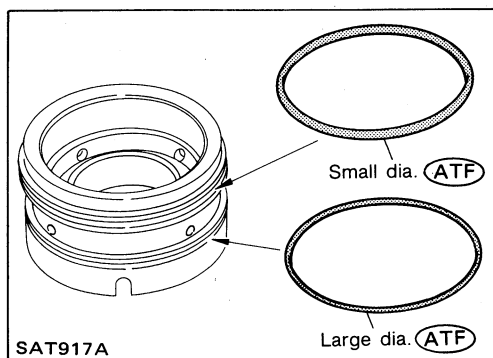

2. Install servo cushion spring retainer onto band servo piston.

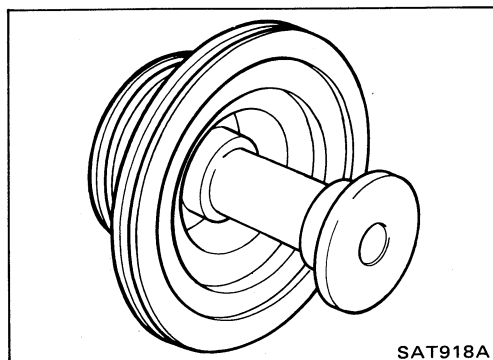

3. Install E-ring onto servo cushion spring retainer.

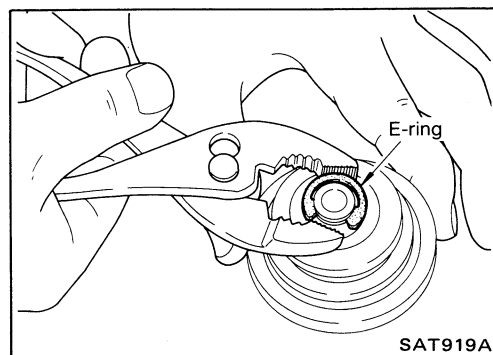

4. Install D-rings onto band servo piston.
 - Apply A.T.F. to D-rings.

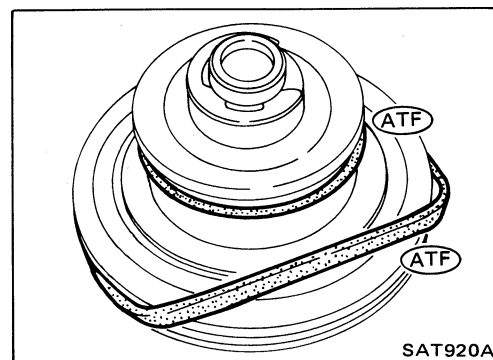

5. Install servo piston spring retainer, return spring C and piston stem onto band servo piston.

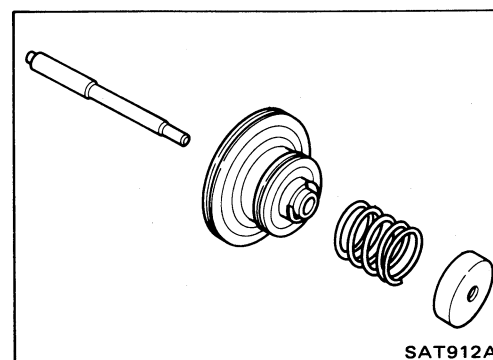

REPAIR FOR COMPONENT PARTS

Band Servo Piston Assembly (Cont'd)

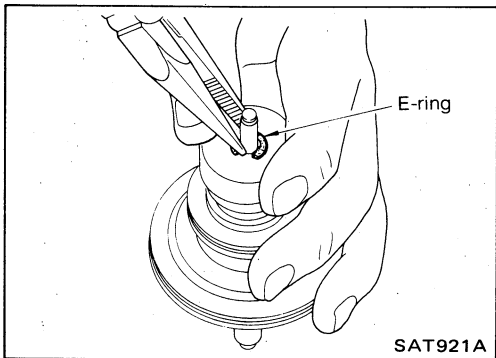

6. Place piston stem end on a wooden block. While pushing servo piston spring retainer down, install E-ring.

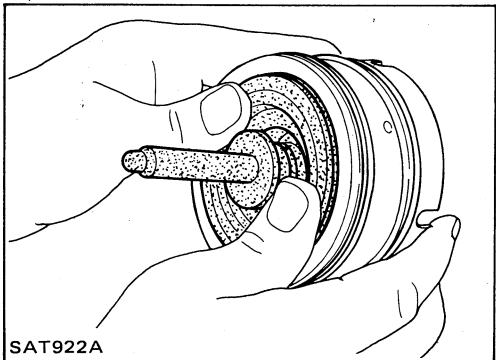

7. Install band servo piston assembly onto servo piston retainer by pushing it inward.

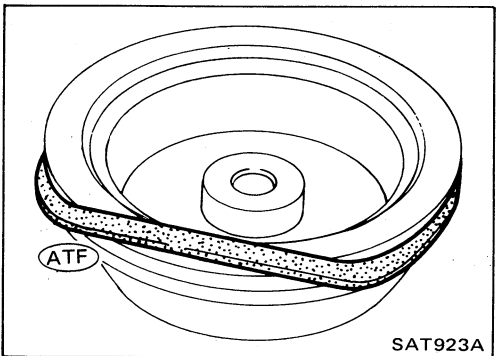

8. Install D-ring on O.D. band servo piston.
● **Apply A.T.F. to D-ring.**

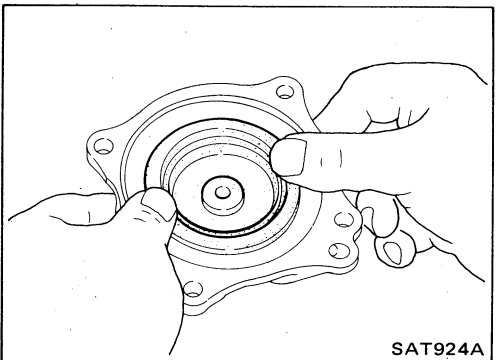

9. Install O.D. band servo piston onto servo piston retainer by pushing it inward.

Parking Pawl Components

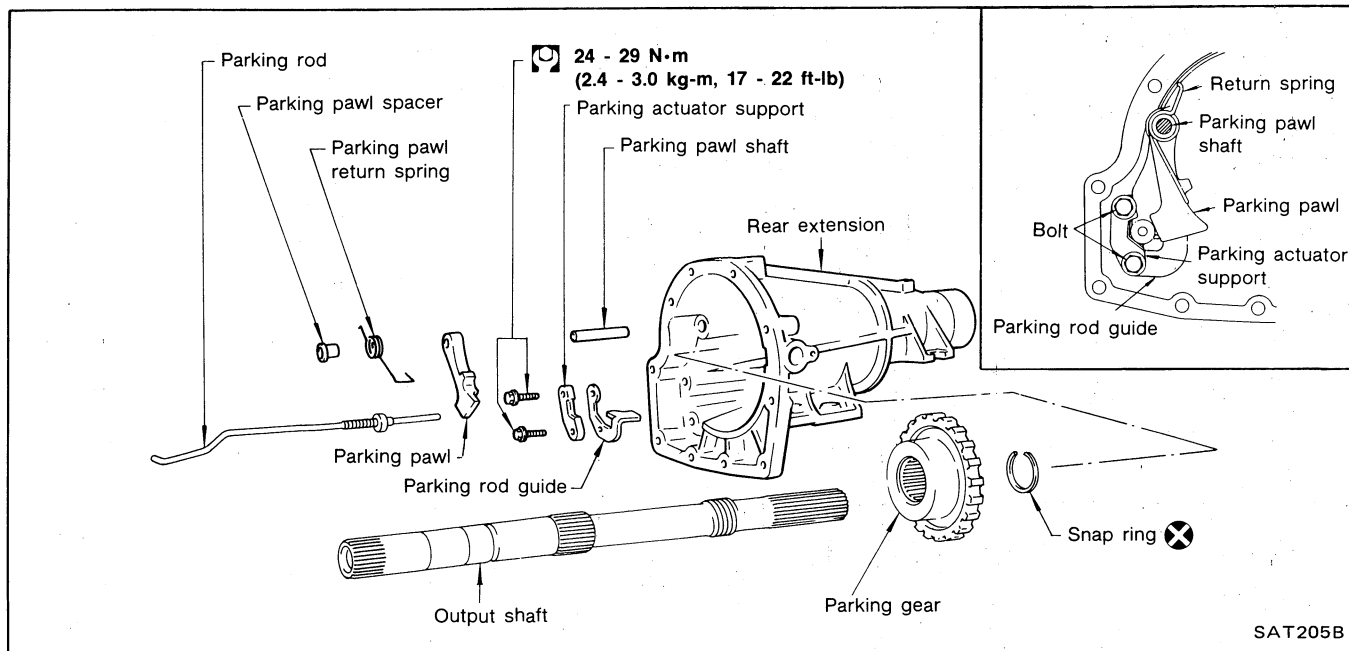

SAT205B

DISASSEMBLY

1. Slide return spring to the front of rear extension flange.

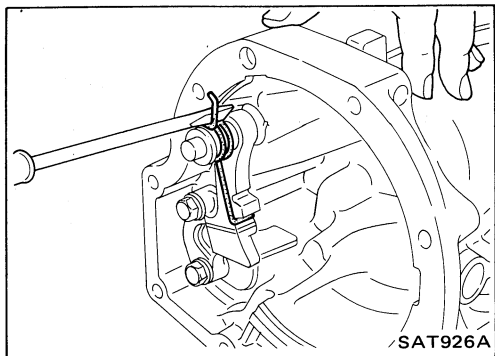

2. Remove return spring, pawl spacer and parking pawl from rear extension.
3. Remove parking pawl shaft from rear extension.

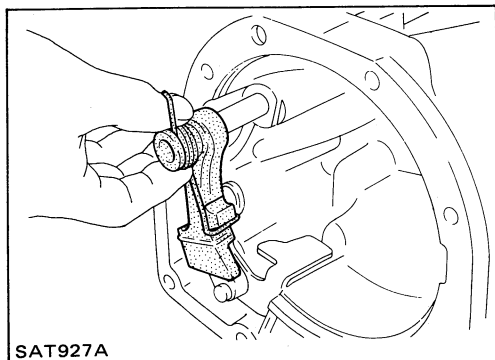

4. Remove parking actuator support and rod guide from rear extension.

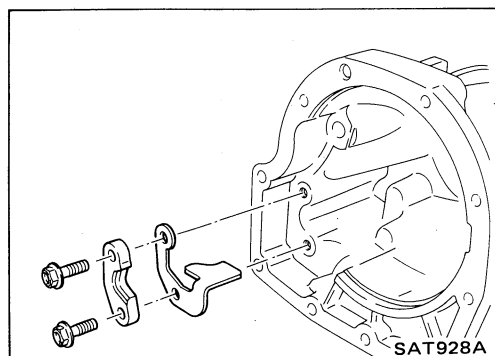

REPAIR FOR COMPONENT PARTS

Parking Pawl Components (Cont'd)

INSPECTION

Parking pawl and parking actuator support

- Check contact surface of parking rod for wear.

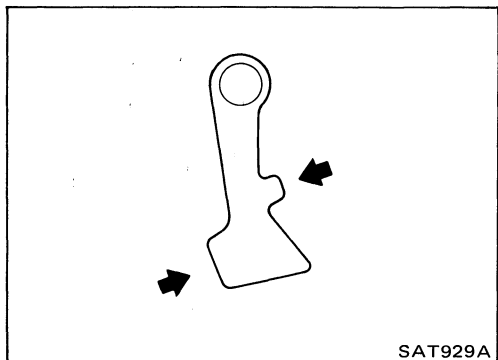

SAT929A

ASSEMBLY

1. Install rod guide and parking actuator support onto rear extension.
2. Insert parking pawl shaft into rear extension.

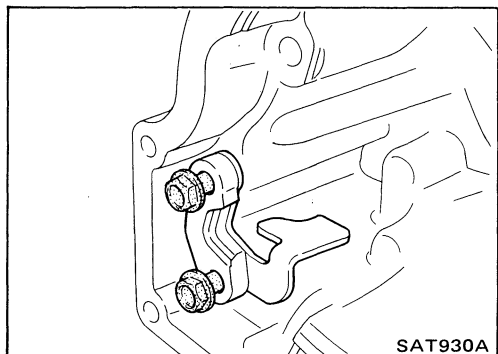

SAT930A

3. Install return spring, pawl spacer and parking pawl onto parking pawl shaft.

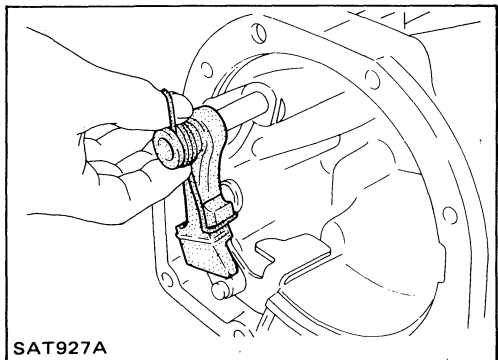

SAT927A

4. Bend return spring upward and install it onto rear extension.

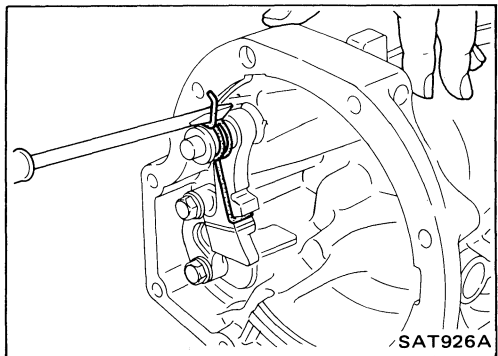

SAT926A

ASSEMBLY

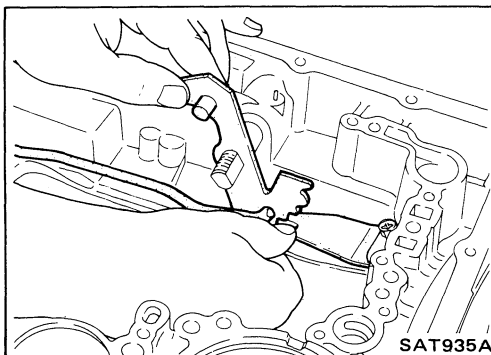
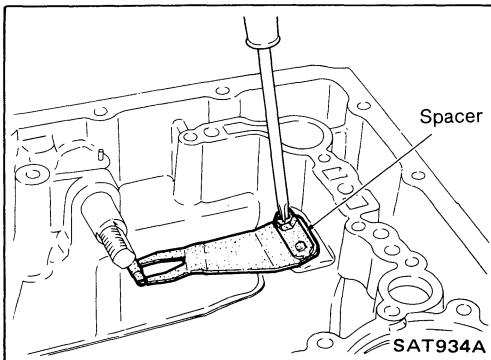
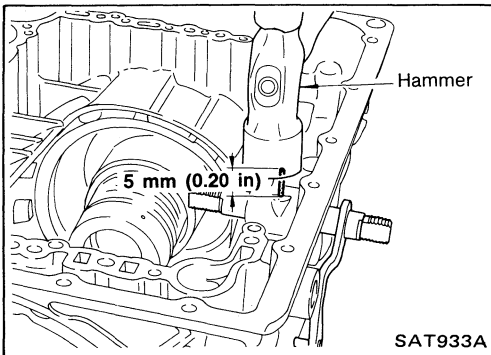
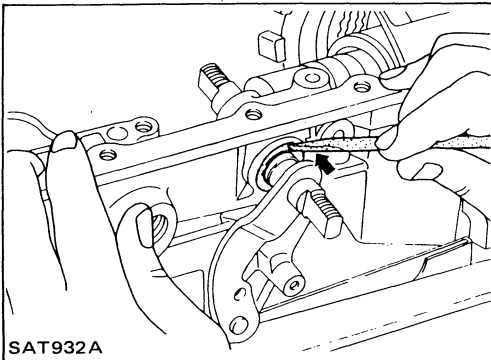
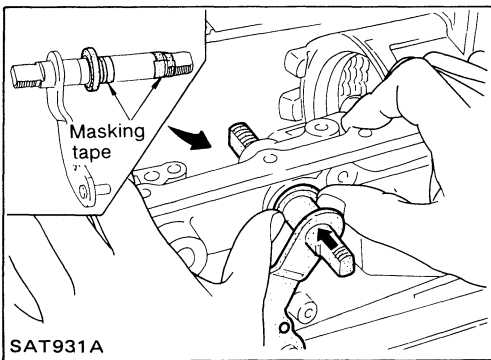

Assembly

1. Install manual shaft components.
 - a. Install oil seal onto manual shaft.
 - **Apply A.T.F. to oil seal.**
 - **Wrap threads of manual shaft with masking tape.**
 - b. Insert manual shaft and oil seal as a unit into transmission case.
 - c. Remove masking tape.
- d. Push oil seal evenly and install it onto transmission case.
- e. Align groove in shaft with drive pin hole, then drive pin into position as shown in figure at left.
- f. Install detent spring and spacer.
- g. While pushing detent spring down, install manual plate onto manual shaft.

ASSEMBLY

Assembly (Cont'd)

h. Install lock nuts onto manual shaft.

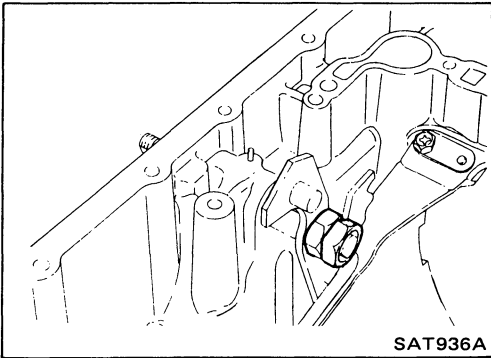

2. Install accumulator piston.
 - a. Install O-rings onto accumulator piston.
 - **Apply A.T.F. to O-rings.**

Accumulator piston O-rings:

Unit: mm (in)

Accumulator	A	B	C	D
Small diameter end	29 (1.14)	32 (1.26)	45 (1.77)	29 (1.14)
Large diameter end	45 (1.77)	50 (1.97)	50 (1.97)	45 (1.77)

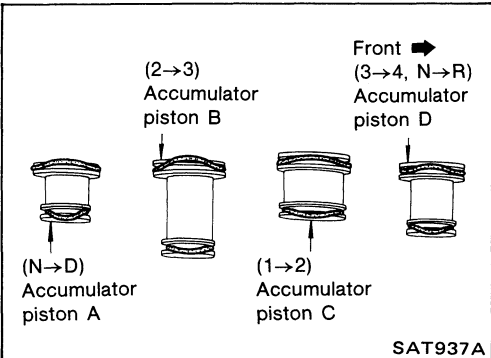

- b. Install return spring for accumulator A onto transmission case.

Free length of return spring:

Unit: mm (in)

Accumulator	A
Free length	43 (1.69)

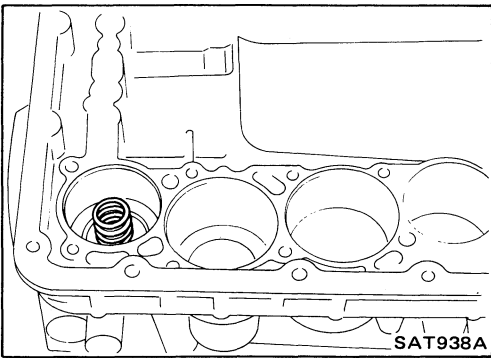

- c. Install accumulator pistons A, B, C and D.
 - **Apply A.T.F. to transmission case.**

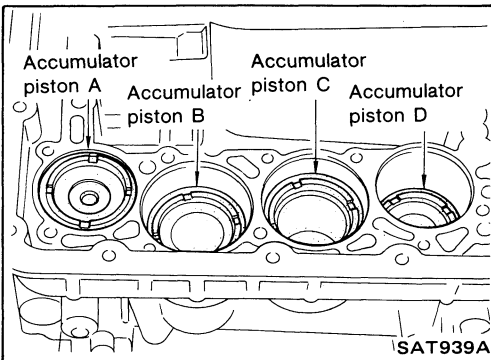

3. Install band servo piston.
 - a. Install return springs onto servo piston.

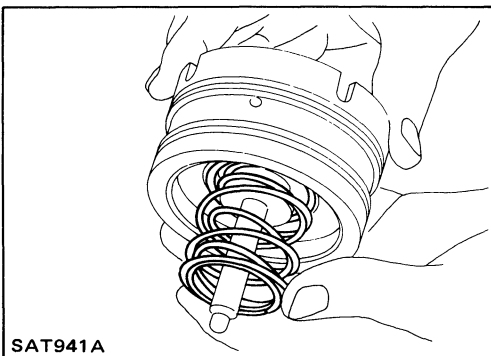

ASSEMBLY

Assembly (Cont'd)

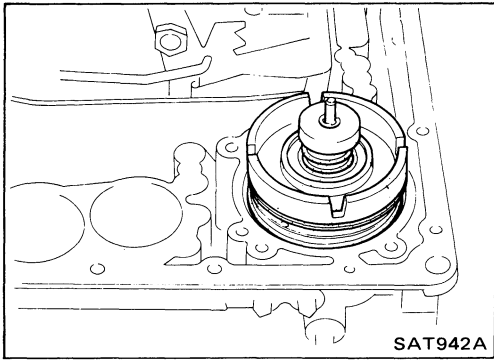

- b. Install band servo piston onto transmission case.
 - Apply A.T.F. to O-ring of band servo piston and transmission case.
- c. Install gasket for band servo onto transmission case.

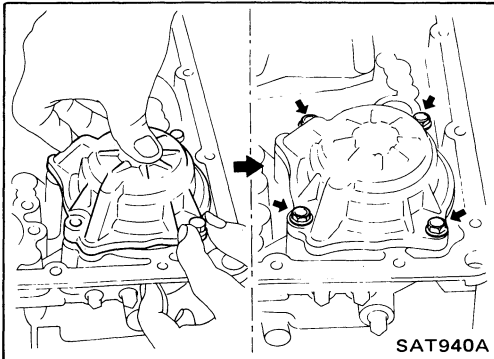

- d. Install band servo retainer onto transmission case.

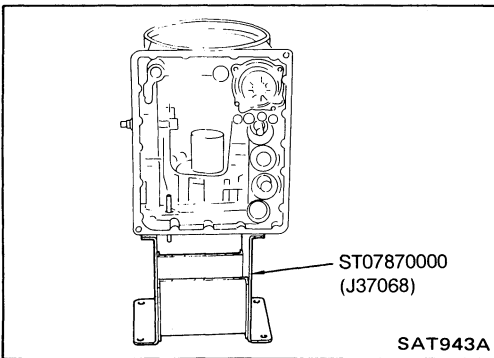

- 4. Install rear side clutch and gear components.
 - a. Place transmission case in vertical position.

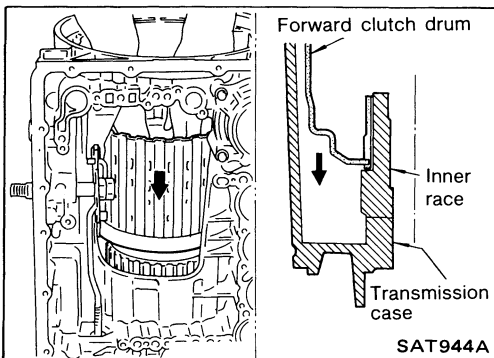

- b. Slightly lift forward clutch drum assembly and slowly rotate it clockwise until its hub passes fully over the clutch inner race inside transmission case.

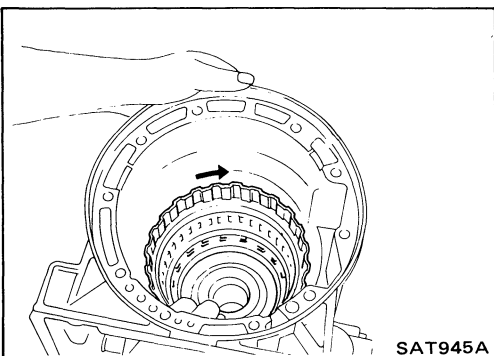

- c. Check to be sure that rotation direction of forward clutch assembly is correct.

ASSEMBLY

Assembly (Cont'd)

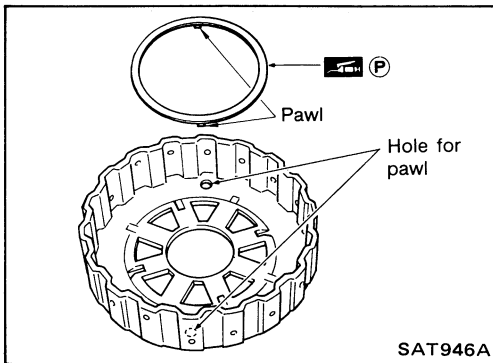

- d. Install thrust washer onto front of overrun clutch hub.
- Apply petroleum jelly to the thrust washer.
 - Insert pawls of thrust washer securely into holes in overrun clutch hub.

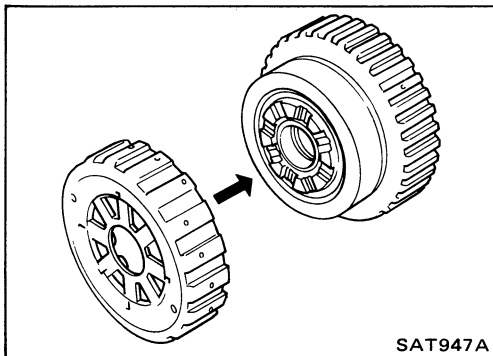

- e. Install overrun clutch hub onto rear internal gear assembly.

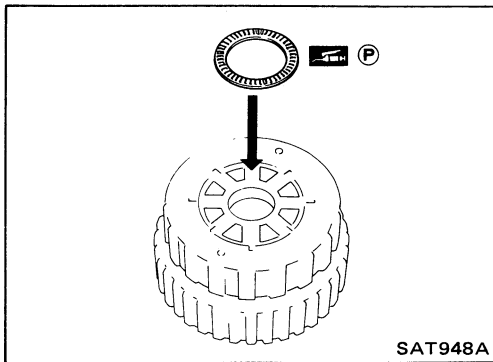

- f. Install needle bearing onto rear of overrun clutch hub.
- Apply petroleum jelly to needle bearing.

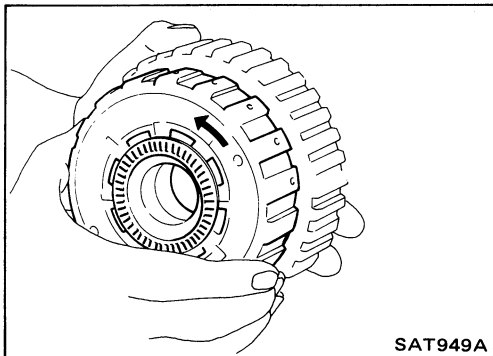

- g. Check that overrun clutch hub rotates as shown while holding forward clutch hub.

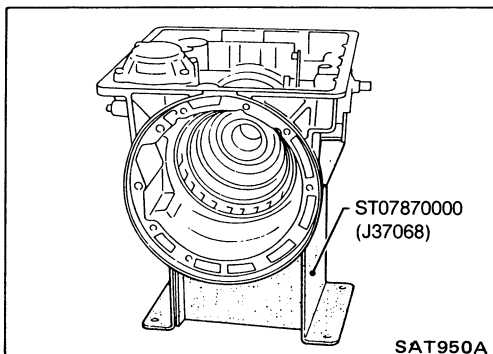

- h. Place transmission case into horizontal position.

ASSEMBLY

Assembly (Cont'd)

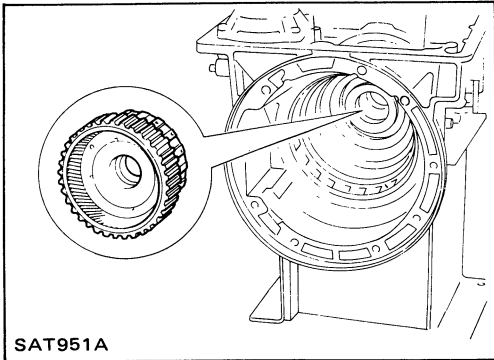

- i. Install rear internal gear, forward clutch hub and overrun clutch hub as a unit onto transmission case.

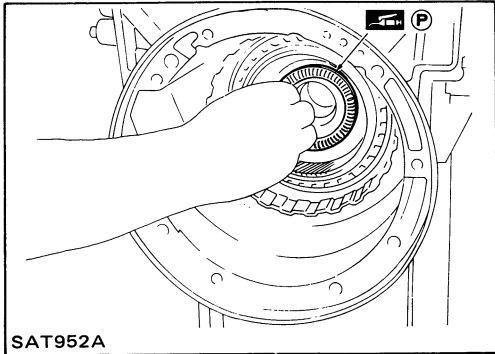

- j. Install needle bearing onto rear internal gear.
● **Apply petroleum jelly to needle bearing.**

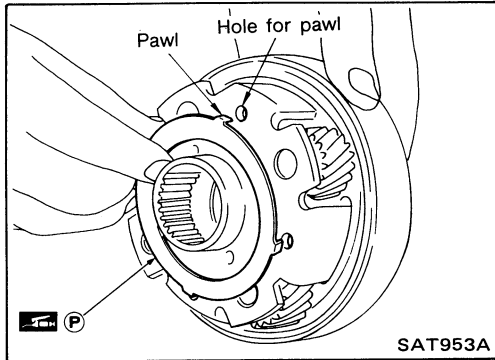

- k. Install bearing race onto rear of front internal gear.
● **Apply petroleum jelly to bearing race.**
● **Securely engage pawls of bearing race with holes in front internal gear.**

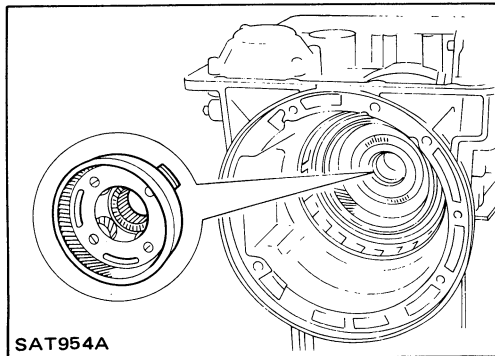

- l. Install front internal gear on transmission case.

ASSEMBLY

Adjustment

When any parts listed in the following table are replaced, total end play or reverse clutch end play must be adjusted.

Part name \ Item	Total end play	Reverse clutch end play
Transmission case	●	●
Low one-way clutch inner race	●	●
Overrun clutch hub	●	●
Rear internal gear	●	●
Rear planetary carrier	●	●
Rear sun gear	●	●
Front planetary carrier	●	●
Front sun gear	●	●
High clutch hub	●	●
High clutch drum	●	●
Oil pump cover	●	●
Reverse clutch drum	—	●

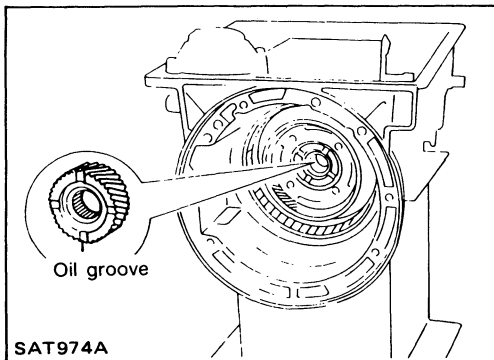

1. Install front side clutch and gear components.
 - a. Install rear sun gear on transmission case.
 - **Pay attention to its direction.**

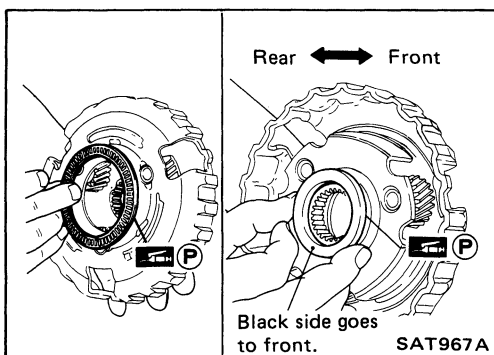

- b. Install needle bearing on front of front planetary carrier.
 - **Apply petroleum jelly to needle bearing.**
 - c. Install needle bearing on rear of front planetary carrier.
 - **Apply petroleum jelly to bearing.**
 - **Pay attention to its direction — Black side goes to front.**

ASSEMBLY

Adjustment (Cont'd)

- d. While rotating forward clutch drum clockwise, install front planetary carrier on forward clutch drum.

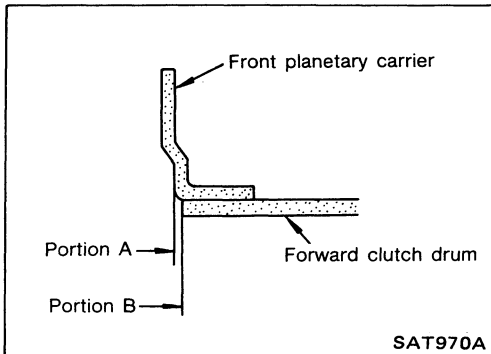
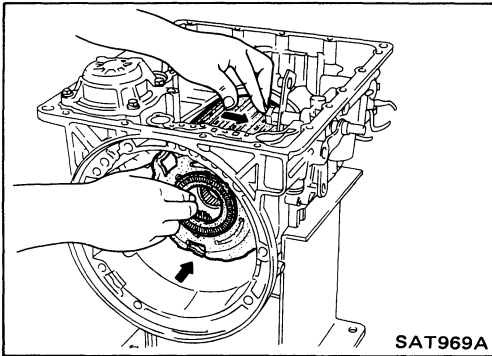

- Check that portion A of front planetary carrier protrudes approximately 2 mm (0.08 in) beyond portion B of forward clutch assembly.

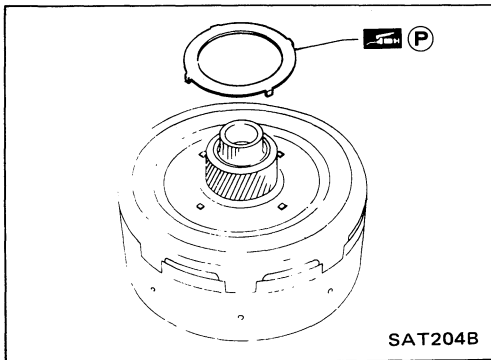

- e. Install bearing races on rear of clutch pack.
- Apply petroleum jelly to bearing races.
 - Securely engage pawls of bearing race with hole in clutch pack.

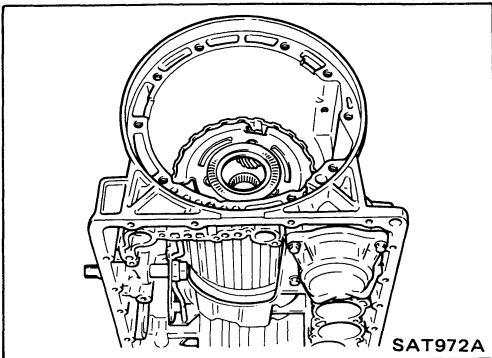

- f. Place transmission case in vertical position.

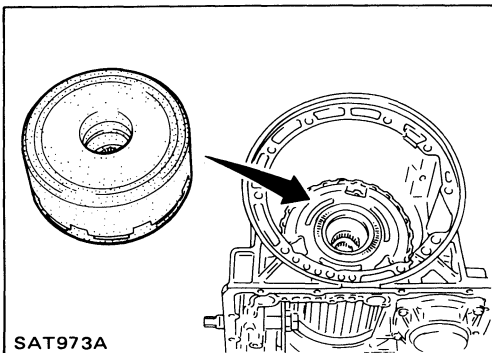

- g. Install clutch pack into transmission case.

ASSEMBLY

Adjustment (Cont'd)

2. Adjust total end play.

Total end play "T₁":

0.25 - 0.55 mm (0.0098 - 0.0217 in)

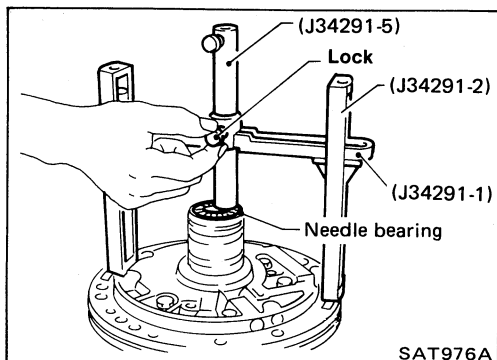
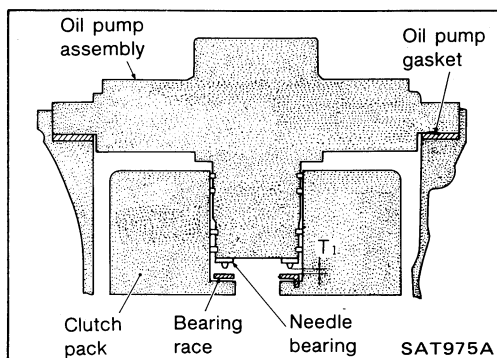

a. With needle bearing installed, place J34291-1 (bridge), J34291-2 (legs) and the J34291-5 (gauging cylinder) onto oil pump. The long ends of legs should be placed firmly on machined surface of oil pump assembly and gauging cylinder should rest on top of the needle bearing. Lock gauging cylinder in place with set screw.

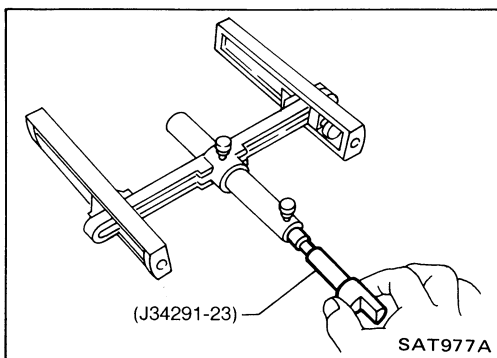

b. Install J34291-23 (gauging plunger) into gauging cylinder.

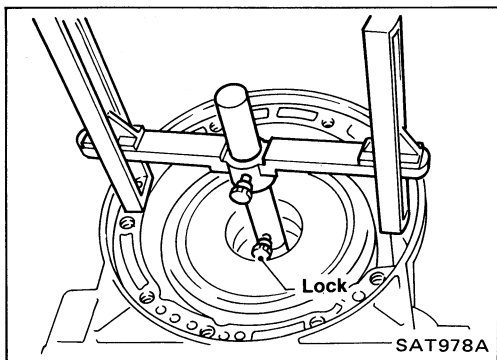

c. With original bearing race installed inside reverse clutch drum, place shim selecting gauge with its legs on machined surface of transmission case (no gasket) and allow gauging plunger to rest on bearing race. Lock gauging plunger in place with set screw.

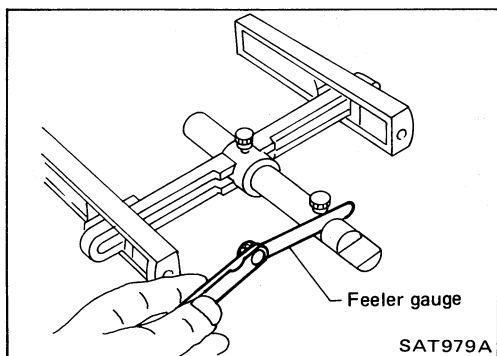

d. Remove Tool and use feeler gauge to measure gap between gauging cylinder and gauging plunger. This measurement should give exact total end play.

Total end play "T₁":

0.25 - 0.55 mm (0.0098 - 0.0217 in)

- If end play is out of specification, decrease or increase thickness of oil pump cover bearing race as necessary.

Available oil pump cover bearing race:

Refer to S.D.S.

ASSEMBLY

Adjustment (Cont'd)

3. Adjust reverse clutch drum end play.

Reverse clutch drum end play "T₂":

0.55 - 0.90 mm (0.0217 - 0.0354 in)

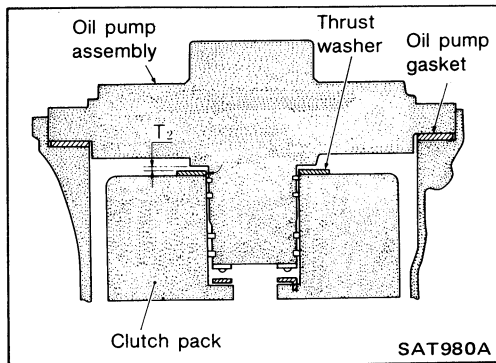

- a. Place J34291-1 (bridge), J34291-2 (legs) and J34291-5 (gauging cylinder) on machined surface of transmission case (no gasket) and allow gauging cylinder to rest on front thrust surface of reverse clutch drum. Lock cylinder in place with set screw.

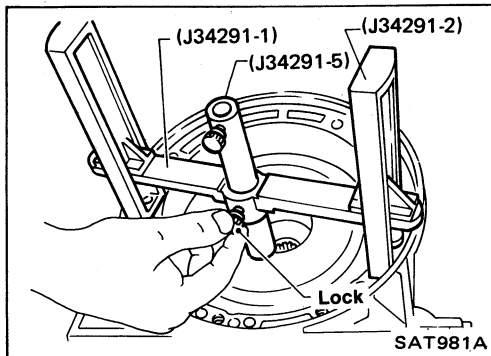

- b. Install J34291-23 (gauging plunger) into gauging cylinder.

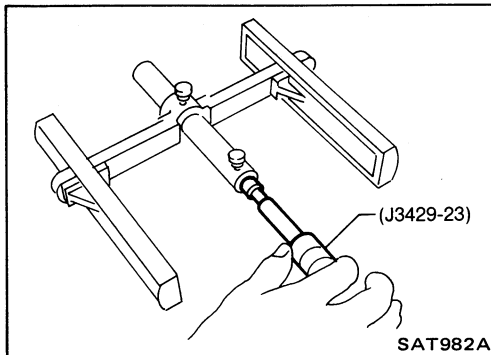

- c. With original thrust washer installed on oil pump, place shim setting gauge legs onto machined surface of oil pump assembly and allow gauging plunger to rest on thrust washer. Lock plunger in place with set screw.

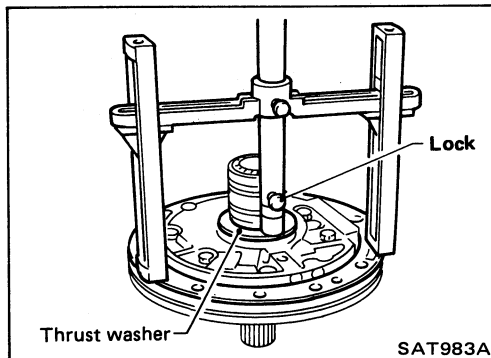

- d. Use feeler gauge to measure gap between gauging plunger and gauging cylinder. This measurement should give you exact reverse clutch drum end play.

Reverse clutch drum end play "T₂":

0.55 - 0.90 mm (0.0217 - 0.0354 in)

- If end play is out of specification, decrease or increase thickness of oil pump thrust washer as necessary.

Available oil pump thrust washer:

Refer to S.D.S.

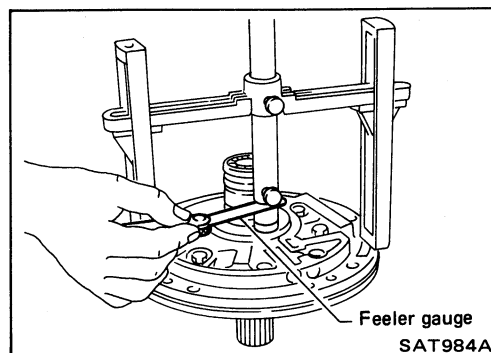

ASSEMBLY

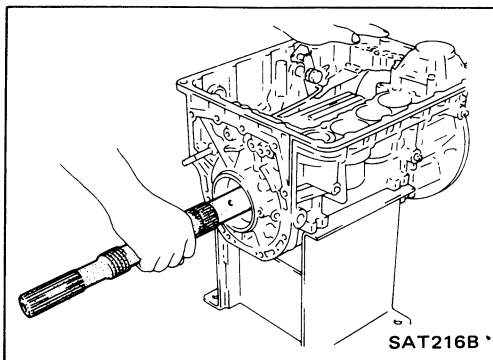

Assembly

1. Install output shaft and parking gear.
 - a. Insert output shaft from rear of transmission case while slightly lifting front internal gear.
 - **Do not force output shaft against front of transmission case.**

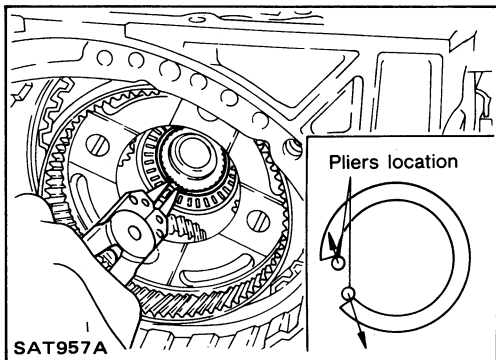

- b. Carefully push output shaft against front of transmission case. Install snap ring on front of output shaft.
 - **Check to be sure output shaft cannot be removed in rear direction.**

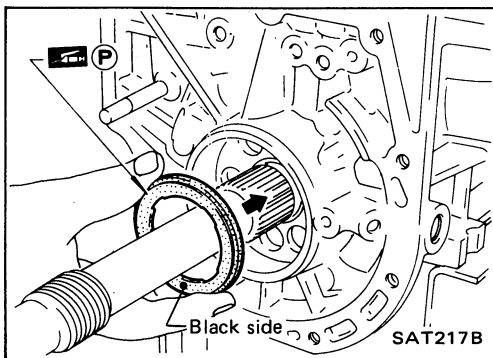

- c. Install needle bearing on transmission case.
 - **Pay attention to its direction — Black side goes to rear.**
 - **Apply petroleum jelly to needle bearing.**

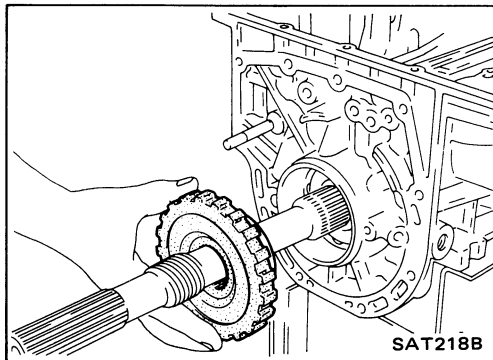

- d. Install parking gear on transmission case.

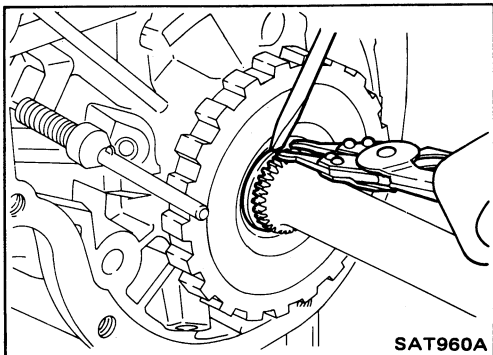

- e. Install snap ring on rear of output shaft.
 - **Check to be sure output shaft cannot be removed in forward direction.**

ASSEMBLY

Assembly (Cont'd)

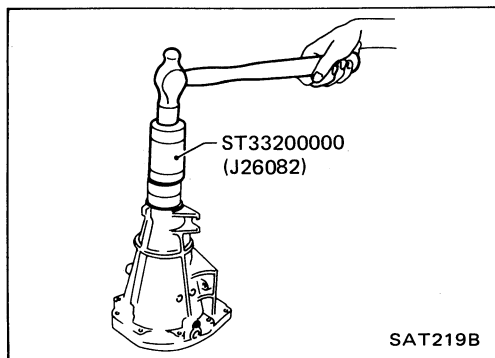

2. Install rear extension.
 - a. Install oil seal on rear extension.
 - Apply A.T.F. to oil seal.

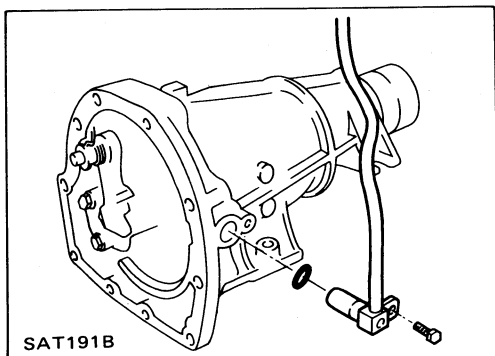

- b. Install O-ring on revolution sensor.
 - Apply A.T.F. to O-ring.
 - c. Install revolution sensor on rear extension.

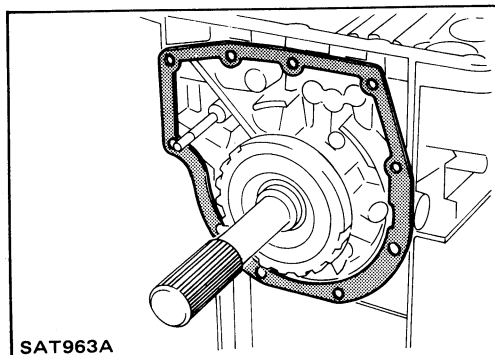

- d. Install rear extension gasket on transmission case.

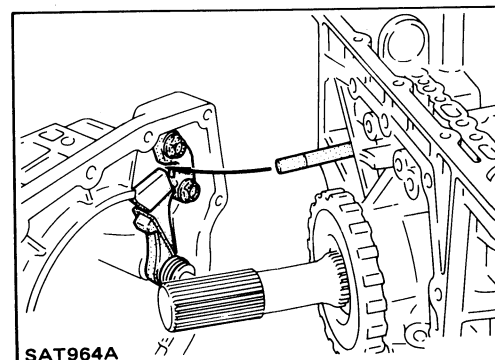

- e. Install parking rod on transmission case.

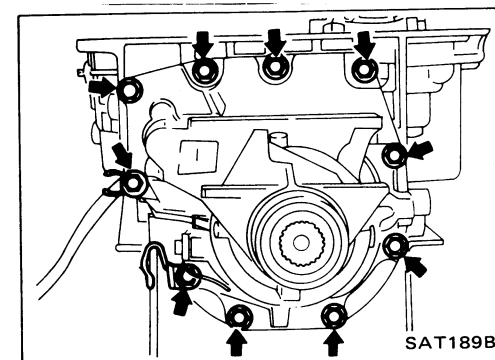

- f. Install rear extension on transmission case.

ASSEMBLY

Assembly (Cont'd)

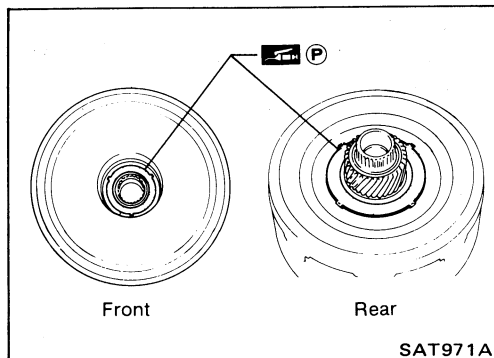
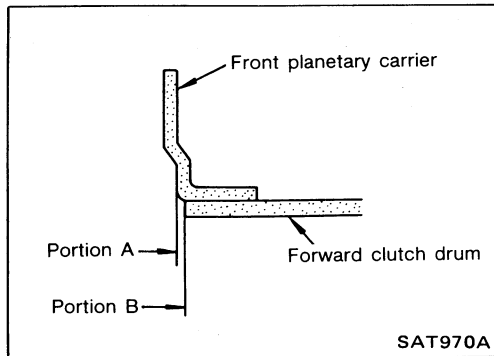
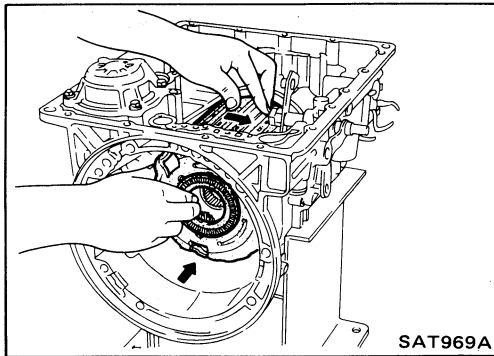
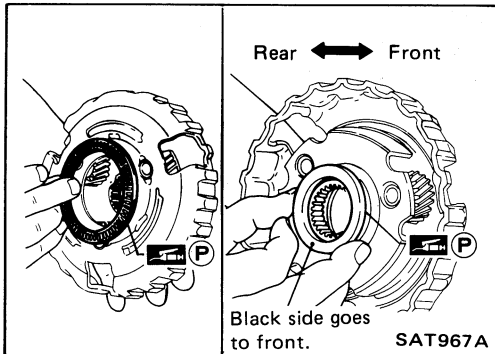
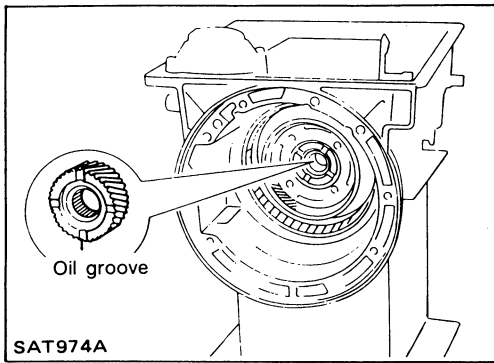

3. Install front side clutch and gear components.

a. Install rear sun gear on transmission case.

- Pay attention to its direction.

b. Make sure needle bearing is on front of front planetary carrier.

- Apply petroleum jelly to needle bearing.

c. Make sure needle bearing is on rear of front planetary carrier.

- Apply petroleum jelly to bearing.

- Pay attention to its direction — Black side goes to front.

d. While rotating forward clutch drum clockwise, install front planetary carrier on forward clutch drum.

- Check that portion A of front planetary carrier protrudes approximately 2 mm (0.08 in) beyond portion B of forward clutch assembly.

e. Make sure bearing races are on front and rear of clutch pack.

- Apply petroleum jelly to bearing races.

- Securely engage pawls of bearing races with holes in clutch pack.

ASSEMBLY

Assembly (Cont'd)

- f. Install clutch pack into transmission case.

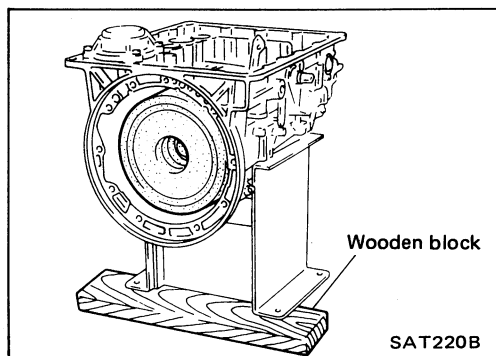

4. Install brake band and band strut.
a. Install band strut on brake band.
● Apply petroleum jelly to band strut.

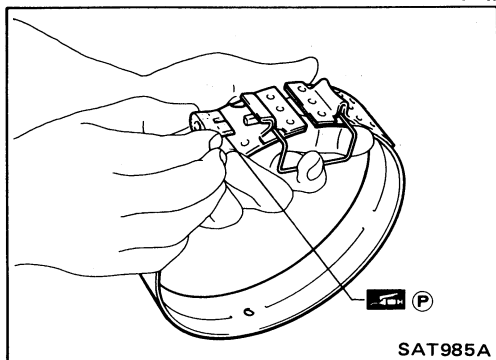

- b. Place brake band on periphery of reverse clutch drum, and insert band strut into end of band servo piston stem.

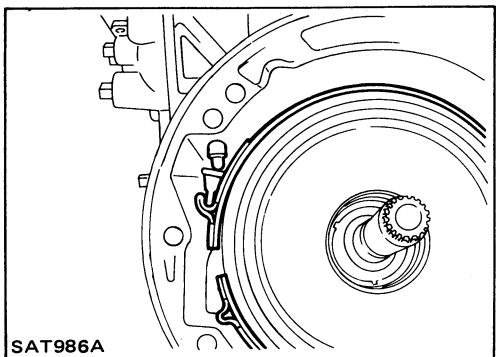

- c. Install anchor end bolt on transmission case. Then, tighten anchor end bolt just enough so that reverse clutch drum (clutch pack) will not tilt forward.

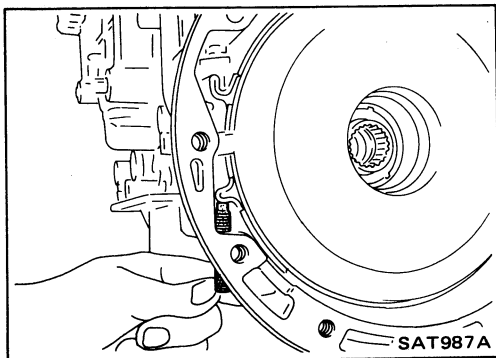

5. Install input shaft on transmission case.
● Pay attention to its direction — O-ring groove side is front.
6. Install gasket on transmission case.

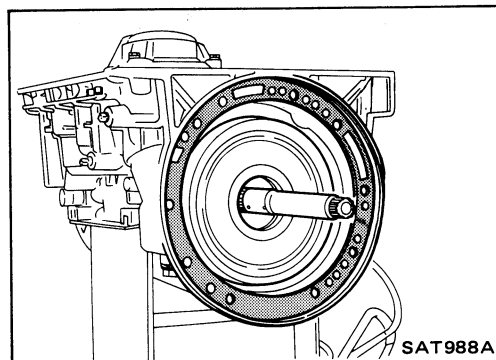

ASSEMBLY

Assembly (Cont'd)

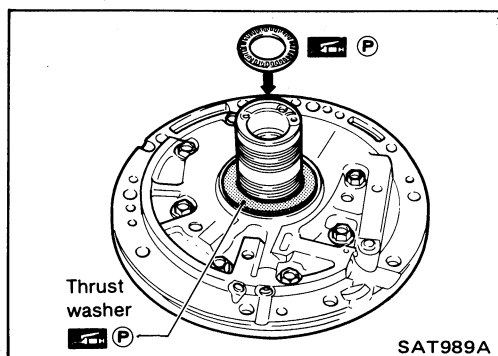

7. Install oil pump assembly.
 - a. Install needle bearing on oil pump assembly.
 - **Apply petroleum jelly to the needle bearing.**
 - b. Install selected thrust washer on oil pump assembly.
 - **Apply petroleum jelly to thrust washer.**

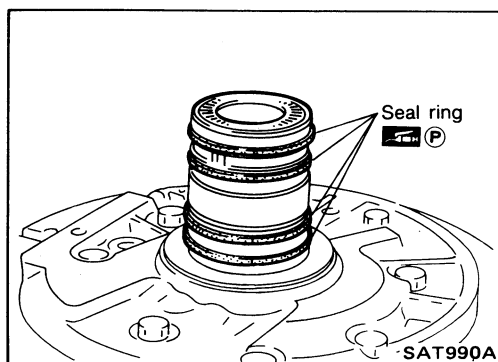

- c. Carefully install seal rings into grooves and press them into the petroleum jelly so that they are a tight fit.

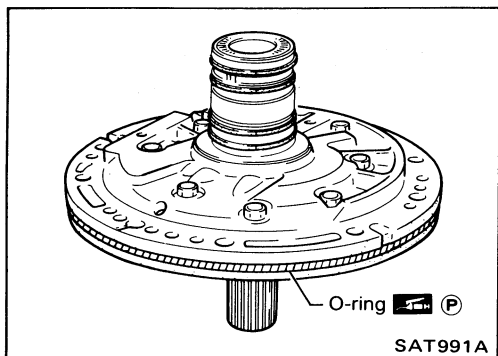

- d. Install O-ring on oil pump assembly.
 - **Apply petroleum jelly to O-ring.**

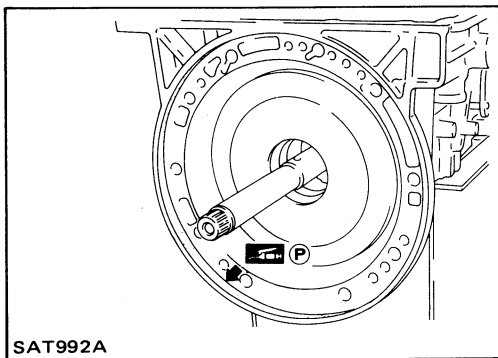

- e. Apply petroleum jelly to mating surface of transmission case and oil pump assembly.

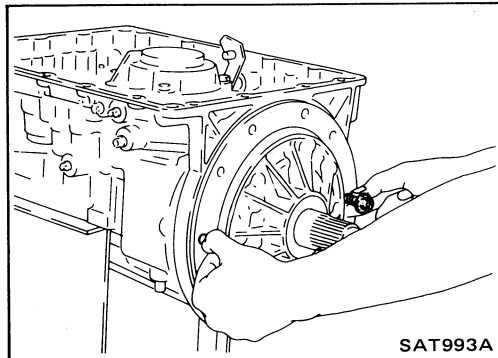

- f. Install oil pump assembly.
 - **Install two converter housing securing bolts in bolt holes in oil pump assembly as guides.**

ASSEMBLY

Assembly (Cont'd)

- Insert oil pump assembly to the specified position in transmission, as shown at left.

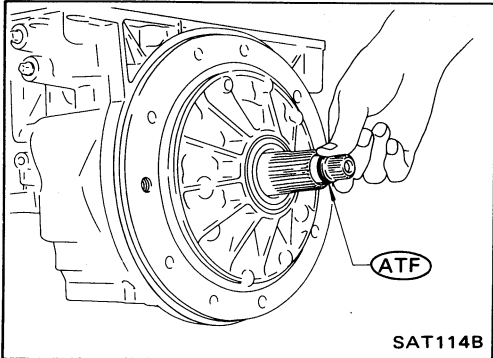
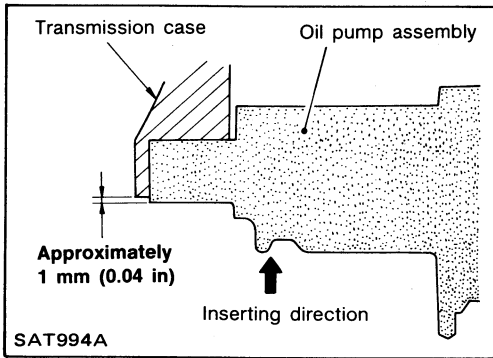

8. Install O-ring on input shaft.
- Apply A.T.F. to O-rings.

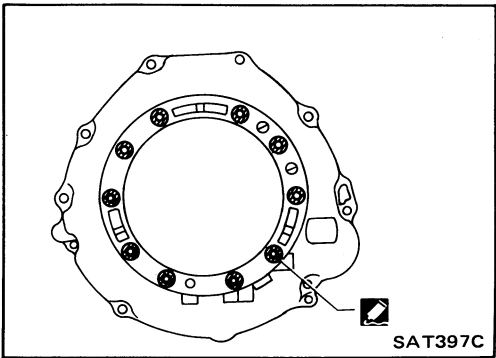

9. Install converter housing.
- a. Apply recommended sealant (Nissan genuine part: KP610-00250 or equivalent) to outer periphery of bolt holes in converter housing.
- Do not apply too much sealant.

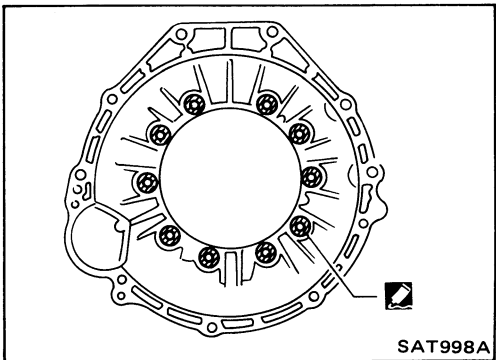

- b. Apply recommended sealant (Nissan genuine part: KP610-00250 or equivalent) to seating surfaces of bolts that secure front of converter housing.

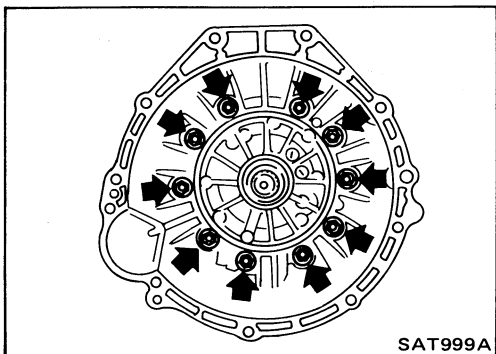

- c. Install converter housing on transmission case.

ASSEMBLY

Assembly (Cont'd)

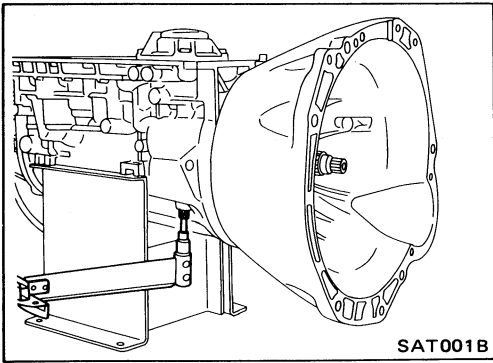

10. Adjust brake band.
 - a. Tighten anchor end bolt to specified torque.

Anchor end bolt:
 \square : 4 - 6 N·m
 (0.4 - 0.6 kg-m, 2.9 - 4.3 ft-lb)
 - b. Back off anchor end bolt two and a half turns.

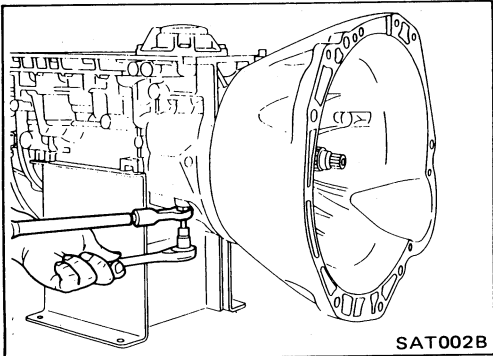

- c. While holding anchor end pin, tighten lock nut.

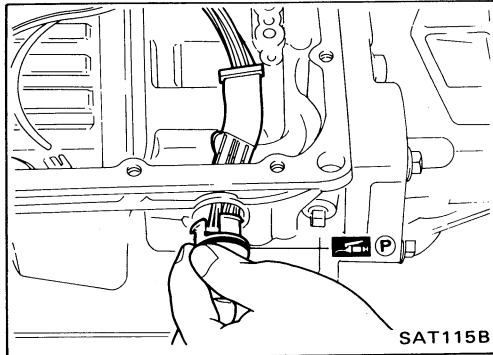

11. Install terminal cord assembly.
 - a. Install O-ring on terminal cord assembly.
 - **Apply petroleum jelly to O-ring.**
 - b. Compress terminal cord assembly stopper and install terminal cord assembly on transmission case.

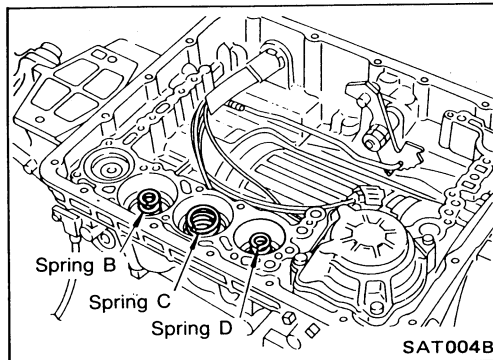

12. Install control valve assembly.
 - a. Install accumulator piston return springs B, C and D.

Free length of return springs:

Unit: mm (in)

Item	Accumulator		
	B	C	D
Free length	66 (2.60)	45 (1.77)	58.4 (2.299)

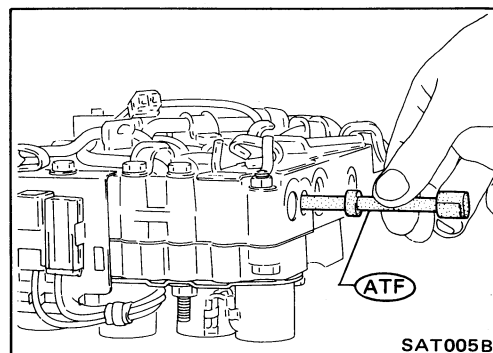

- b. Install manual valve on control valve.
 - **Apply A.T.F. to manual valve.**

ASSEMBLY

Assembly (Cont'd)

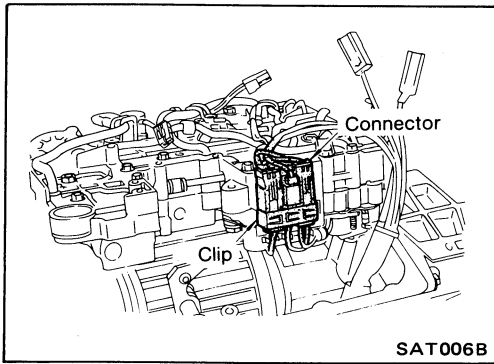

- c. Place control valve assembly on transmission case. Connect solenoid connector for upper body.
- d. Install connector clip.

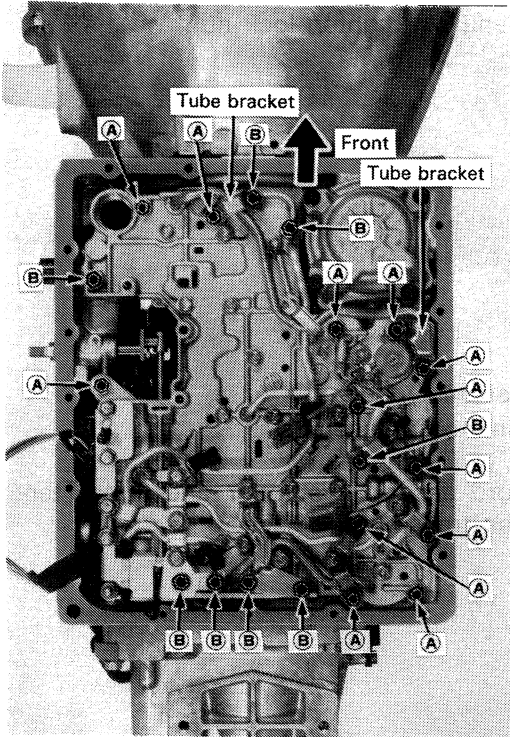

- e. Install control valve assembly on transmission case.
- f. Install connector tube brackets and tighten bolts **(A)** and **(B)**.
- **Check that terminal assembly harness does not catch.**

Bolt symbol	ℓ mm (in)	 ℓ
(A)	33 (1.30)	
(B)	45 (1.77)	

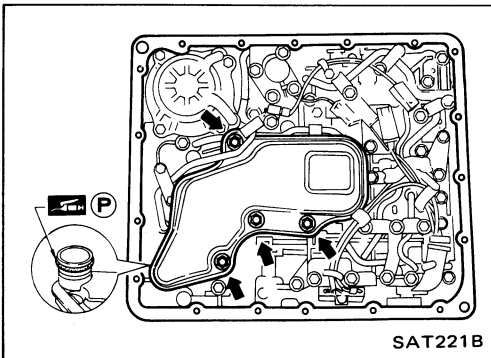

- g. Install O-ring on oil strainer.
- **Apply petroleum jelly to O-ring.**
- h. Install oil strainer on control valve.

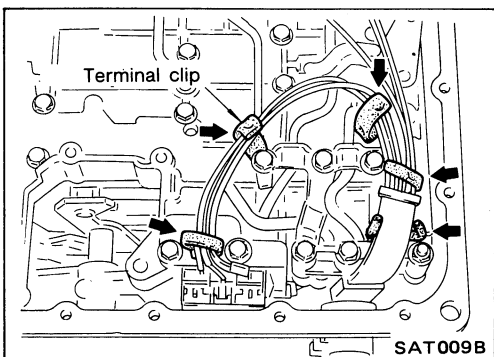

- i. Securely fasten terminal harness with clips.

ASSEMBLY

Assembly (Cont'd)

- j. Install lock-up solenoid and fluid temperature sensor connectors.

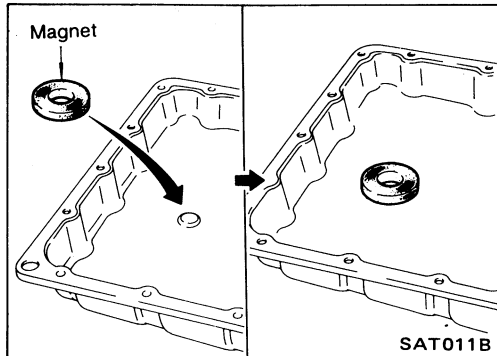
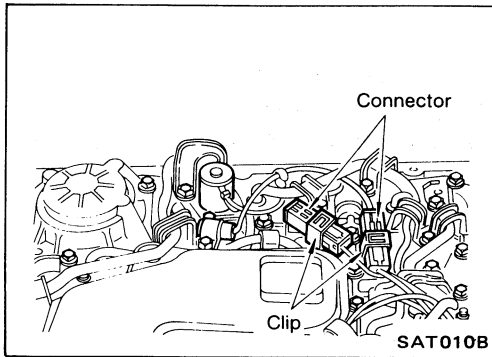

13. Install oil pan.
- a. Attach a magnet to oil pan.

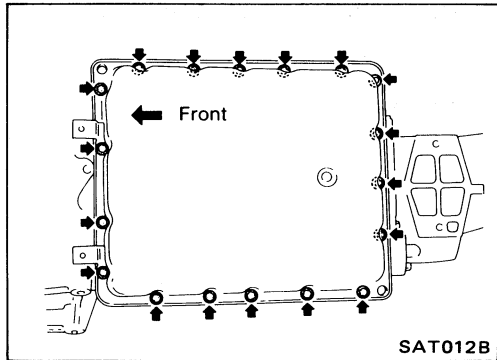

- b. Install oil pan gasket on transmission case.
- c. Install oil pan and bracket on transmission case.
- **Tighten four bolts in a criss-cross pattern to prevent dislocation of gasket.**

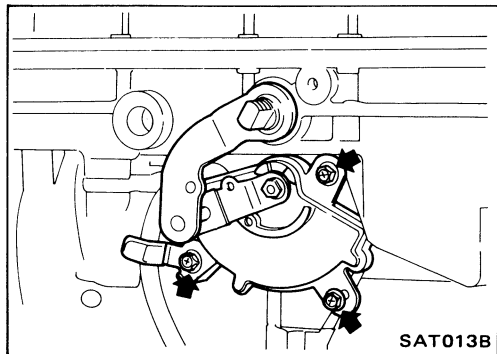

14. Install inhibitor switch.
- a. Check that manual shaft is in "1" range.
- b. Temporarily install inhibitor switch on manual shaft.
- c. Move manual shaft to "N".

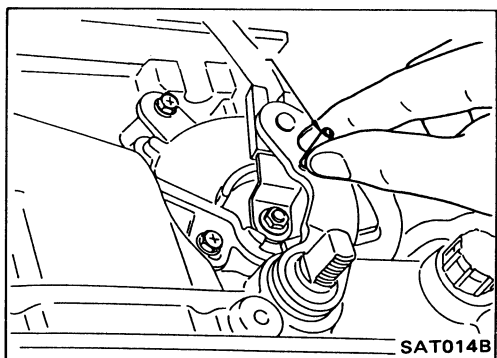

- d. Tighten bolts while inserting 4.0 mm (0.157 in) dia. pin vertically into locating holes in inhibitor switch and manual shaft.

ASSEMBLY

Assembly (Cont'd)

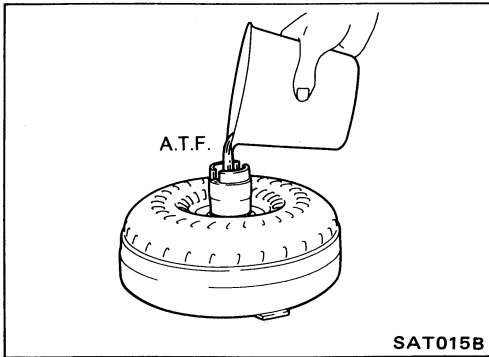

15. Install torque converter.

a. Pour A.T.F. into torque converter.

- Approximately 2 liters (2-1/8 US qt, 1-3/4 Imp qt) of fluid are required for a new torque converter.
- When reusing old torque converter, add the same amount of fluid as was drained.

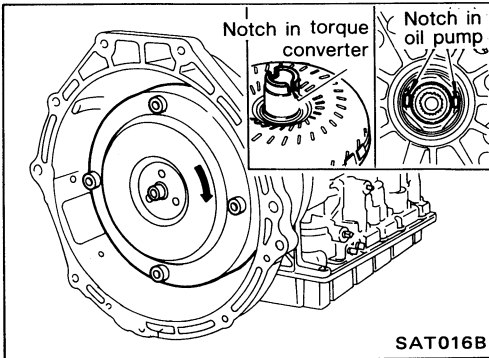

b. Install torque converter while aligning notches and oil pump.

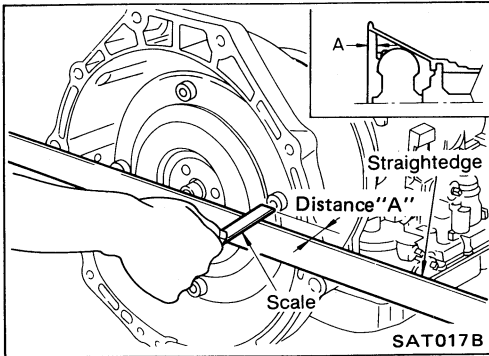

c. Measure distance A to check that torque converter is in proper position.

Distance "A":

26 mm (1.02 in) or more

SERVICE DATA AND SPECIFICATIONS (S.D.S.)

General Specifications

Engine	KA24DE
Automatic transmission model	RE4R01A
Transmission model code number	45X64
Stall torque ratio	2.0 : 1
Transmission gear ratio	
1st	2.785
2nd	1.545
Top	1.000
O.D.	0.694
Reverse	2.272
Recommended oil	Automatic transmission fluid Type DEXRON™
Oil capacity ℓ (US qt, Imp qt)	8.3 (8-3/4, 7-1/4)

Specifications and Adjustment

VEHICLE SPEED WHEN SHIFTING GEARS

Throttle position	Vehicle speed km/h (MPH)						
	D ₁ → D ₂	D ₂ → D ₃	D ₃ → D ₄	D ₄ → D ₃	D ₃ → D ₂	D ₂ → D ₁	1 ₂ → 1 ₁
Full throttle	56 - 60 (35 - 37)	102 - 108 (63 - 67)	158 - 168 (98 - 104)	152 - 162 (94 - 101)	92 - 98 (57 - 61)	40 - 44 (25 - 27)	53 - 57 (33 - 35)
Half throttle	39 - 43 (24 - 27)	74 - 80 (46 - 50)	111 - 121 (69 - 75)	55 - 65 (34 - 40)	27 - 33 (17 - 21)	10 - 14 (6 - 9)	53 - 57 (33 - 35)

VEHICLE SPEED WHEN PERFORMING AND RELEASING LOCK-UP

Throttle position	O.D. switch [Shift range]	Vehicle speed km/h (MPH)	
		Lock-up "ON"	Lock-up "OFF"
Full throttle	ON [D ₄]	158 - 168 (98 - 104)	152 - 162 (94 - 101)
	OFF [D ₃]	102 - 108 (63 - 67)	92 - 98 (57 - 61)
Half throttle	ON [D ₄]	112 - 120 (70 - 75)	101 - 109 (63 - 68)
	OFF [D ₃]	91 - 99 (57 - 62)	86 - 94 (53 - 58)

STALL REVOLUTION

Stall revolution rpm
2,050 - 2,250

LINE PRESSURE

Engine speed rpm	Line pressure kPa (kg/cm ² , psi)	
	D, 2 and 1 ranges	R range
Idle	422 - 461 (4.3 - 4.7, 61 - 67)	667 - 706 (6.8 - 7.2, 97 - 102)
Stall	1,020 - 1,098 (10.4 - 11.2, 148 - 159)	1,422 - 1,500 (14.5 - 15.3, 206 - 218)

SERVICE DATA AND SPECIFICATIONS (S.D.S.)

Specifications and Adjustment (Cont'd)

RETURN SPRINGS

Unit: mm (in)

Parts		Item	Part No.	Free length	Outer diameter
Control valve	Upper body	Torque converter relief valve spring	31742-41X23	38.0 (1.496)	9.0 (0.354)
		Pressure regulator valve spring	31742-41X24	44.0 (1.732)	14.0 (0.551)
		Pressure modifier valve spring	31742-41X19	31.95 (1.2579)	6.8 (0.268)
		Shuttle shift valve D spring	31762-41X00	26.5 (1.043)	6.0 (0.236)
		4-2 sequence valve spring	31756-41X00	29.1 (1.146)	6.95 (0.2736)
		Shift valve B spring	31762-41X01	25.0 (0.984)	7.0 (0.276)
		4-2 relay valve spring	31756-41X00	29.1 (1.146)	6.95 (0.2736)
		Shift valve A spring	31762-41X01	25.0 (0.984)	7.0 (0.276)
		Overrun clutch control valve spring	31762-41X03	23.6 (0.929)	7.0 (0.276)
		Overrun clutch reducing valve spring	31742-41X20	32.5 (1.280)	7.0 (0.276)
		Shuttle shift valve S spring	31762-41X04	51.0 (2.008)	5.65 (0.2224)
		Pilot valve spring	31742-41X13	25.7 (1.012)	9.1 (0.358)
		Lock-up control valve spring	31742-41X22	18.5 (0.728)	13.0 (0.512)
		Lower body	Modifier accumulator piston spring	31742-41X15	30.5 (1.201)
	1st reducing valve spring		31756-41X05	25.4 (1.000)	6.75 (0.2657)
	3-2 timing valve spring		31742-41X08	20.55 (0.8091)	6.75 (0.2657)
Servo charger valve spring	31742-41X06		23.0 (0.906)	6.7 (0.264)	
Reverse clutch	16 pcs	31505-41X02	19.69 (0.7752)	11.6 (0.457)	
High clutch	16 pcs	31505-21X03	22.06 (0.8685)	11.6 (0.457)	
Forward clutch (Overrun clutch)	20 pcs	31505-41X01	35.77 (1.4083)	9.7 (0.382)	
Low & reverse brake	18 pcs	31521-21X00	23.7 (0.933)	11.6 (0.457)	
Band servo	Spring A	31605-41X05	45.6 (1.795)	34.3 (1.350)	
	Spring B	31605-41X00	53.8 (2.118)	40.3 (1.587)	
	Spring C	31605-41X01	29.7 (1.169)	27.6 (1.087)	
Accumulator	Accumulator A	31605-41X02	43.0 (1.693)	11.6 (0.457)	
	Accumulator B	31605-41X10	66.0 (2.598)	11.6 (0.457)	
	Accumulator C	31605-41X09	45.0 (1.772)	11.6 (0.457)	
	Accumulator D	31605-41X06	58.4 (2.299)	11.6 (0.457)	

SERVICE DATA AND SPECIFICATIONS (S.D.S.)

Specifications and Adjustment (Cont'd)

ACCUMULATOR O-RING

Accumulator	Diameter mm (in)			
	A	B	C	D
Small diameter end	29 (1.14)	32 (1.26)	45 (1.77)	29 (1.14)
Large diameter end	45 (1.77)	50 (1.97)	50 (1.97)	45 (1.77)

CLUTCHES AND BRAKES

Reverse clutch			
Number of drive plates		2	
Number of driven plates		2	
Thickness of drive plate mm (in)			
Standard		2.0 (0.079)	
Wear limit		1.8 (0.071)	
Clearance mm (in)			
Standard		0.5 - 0.8 (0.020 - 0.031)	
Allowable limit		1.2 (0.047)	
Thickness of retaining plate	Thickness mm (in)	Part number	
	4.6 (0.181)	31537-21X00	
	4.8 (0.189)	31537-21X01	
	5.0 (0.197)	31537-21X02	
	5.2 (0.205)	31537-21X03	
	5.4 (0.213)	31537-21X04	
	5.6 (0.220)	31567-21X13	
	5.8 (0.228)	31567-21X14	
High clutch			
Number of drive plates		4	
Number of driven plates		7	
Thickness of drive plate mm (in)			
Standard		1.6 (0.063)	
Wear limit		1.4 (0.055)	
Clearance mm (in)			
Standard		1.8 - 2.2 (0.071 - 0.087)	
Allowable limit		3.0 (0.118)	
Thickness of retaining plate	Thickness mm (in)	Part number	
	3.0 (0.118)	31537-41X69	
	3.2 (0.126)	31537-41X70	
	3.4 (0.134)	31537-41X71	
	3.6 (0.142)	31537-41X61	
	3.8 (0.150)	31537-41X62	
	4.0 (0.157)	31537-41X63	
	4.2 (0.165)	31537-41X64	
4.4 (0.173)	31537-41X65		

Forward clutch			
Number of drive plates		5	
Number of driven plates		5	
Thickness of drive plate mm (in)			
Standard		2.0 (0.079)	
Wear limit		1.8 (0.071)	
Clearance mm (in)			
Standard		0.45 - 0.85 (0.0177 - 0.0335)	
Allowable limit		1.85 (0.0728)	
Thickness of retaining plate	Thickness mm (in)	Part number	
	8.0 (0.315)	31537-41X00	
	8.2 (0.323)	31537-41X01	
	8.4 (0.331)	31537-41X02	
	8.6 (0.339)	31537-41X03	
	8.8 (0.346)	31537-41X04	
	9.0 (0.354)	31537-41X05	
	9.2 (0.362)	31537-41X06	
Overrun clutch			
Number of drive plates		3	
Number of driven plates		5	
Thickness of drive plate mm (in)			
Standard		2.0 (0.079)	
Wear limit		1.8 (0.071)	
Clearance mm (in)			
Standard		1.0 - 1.4 (0.039 - 0.055)	
Allowable limit		2.0 (0.079)	
Thickness of retaining plate	Thickness mm (in)	Part number	
	4.0 (0.157)	31537-41X79	
	4.2 (0.165)	31537-41X80	
	4.4 (0.173)	31537-41X81	
	4.6 (0.181)	31537-41X82	
	4.8 (0.189)	31537-41X83	
	5.0 (0.197)	31537-41X84	
	5.2 (0.205)	31537-41X20	

SERVICE DATA AND SPECIFICATIONS (S.D.S.)

Specifications and Adjustment (Cont'd)

Low & reverse brake		
Number of drive plates	6	
Number of driven plates	6	
Thickness of drive plate mm (in)		
Standard	2.0 (0.079)	
Wear limit	1.8 (0.071)	
Clearance mm (in)		
Standard	0.7 - 1.1 (0.028 - 0.043)	
Allowable limit	2.3 (0.091)	
Thickness of retaining plate	Thickness mm (in)	
	Part number	
	9.0 (0.354)	31667-41X05
	9.2 (0.362)	31667-41X06
	9.4 (0.370)	31667-41X09
	9.6 (0.378)	31667-41X10
9.8 (0.386)	31667-41X18	
10.0 (0.394)	31667-41X19	
Brake band		
Anchor end bolt tightening torque N-m (kg-m, ft-lb)	4 - 6 (0.4 - 0.6, 2.9 - 4.3)	
Number of returning revolutions for anchor end bolt	2.5	

REVERSE CLUTCH DRUM END PLAY

Reverse clutch drum end play "T ₂ "	0.55 - 0.90 mm (0.0217 - 0.0354 in)	
Thickness of oil pump thrust washer	Thickness mm (in)	Part number
	0.7 (0.028)	31528-21X00
	0.9 (0.035)	31528-21X01
	1.1 (0.043)	31528-21X02
	1.3 (0.051)	31528-21X03
	1.5 (0.059)	31528-21X04
	1.7 (0.067)	31528-21X05
1.9 (0.075)	31528-21X06	

REMOVAL AND INSTALLATION

Manual control linkage Number of returning revolutions for lock nut	1
Lock nut tightening torque	11 - 15 N-m (1.1 - 1.5 kg-m, 8 - 11 ft-lb)
Distance between end of clutch housing and torque converter	26.0 mm (1.024 in) or more
Drive plate runout limit	0.5 mm (0.020 in)

OIL PUMP AND LOW ONE-WAY CLUTCH

Oil pump clearance mm (in)	
Cam ring — oil pump housing Standard	0.01 - 0.024 (0.0004 - 0.0009)
Rotor, vanes and control piston — oil pump housing Standard	0.03 - 0.044 (0.0012 - 0.0017)
Seal ring clearance mm (in)	
Standard	0.10 - 0.25 (0.0039 - 0.0098)
Allowable limit	0.25 (0.0098)

TOTAL END PLAY

Total end play "T ₁ "	0.25 - 0.55 mm (0.0098 - 0.0217 in)	
Thickness of oil pump cover bearing race	Thickness mm (in)	Part number
	0.8 (0.031)	31429-21X00
	1.0 (0.039)	31429-21X01
	1.2 (0.047)	31429-21X02
	1.4 (0.055)	31429-21X03
	1.6 (0.063)	31429-21X04
	1.8 (0.071)	31429-21X05
	2.0 (0.079)	31429-21X06

PROPELLER SHAFT & DIFFERENTIAL CARRIER

SECTION **PD**

CONTENTS

PREPARATION	PD- 2
PROPELLER SHAFT	PD- 5
ON-VEHICLE SERVICE (Final drive)	PD- 9
REMOVAL AND INSTALLATION	PD-11
FINAL DRIVE (Model R200)	PD-12
DISASSEMBLY (Model R200)	PD-13
INSPECTION (Model R200)	PD-17
ADJUSTMENT (Model R200)	PD-18
ASSEMBLY (Model R200)	PD-25
FINAL DRIVE (Model R200V)	PD-30
DISASSEMBLY (Model R200V)	PD-31
INSPECTION (Model R200V)	PD-35
ADJUSTMENT (Model R200V)	PD-36
ASSEMBLY (Model R200V)	PD-43
SERVICE DATA AND SPECIFICATIONS (S.D.S.)	PD-49



PD

PREPARATION

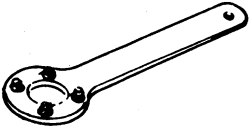
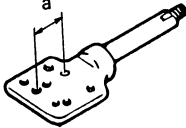
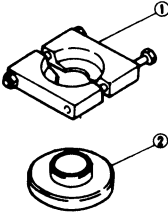
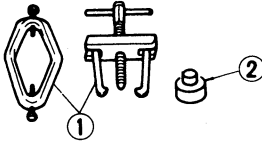
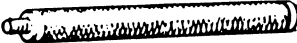
SPECIAL SERVICE TOOLS

Tool number (Kent-Moore No.) Tool name	Description	
ST38060002 (J34311) Drive pinion flange wrench		Removing and installing propeller shaft lock nut, and drive pinion lock nut.
KV38 100800 (-) Equivalent tool (J25604-01) Differential attachment	 a: 152 mm (5.98 in)	Mounting final drive (To use, make a new hole.)
ST3090S000 (-) Drive pinion rear inner race puller set ① ST30031000 (J22912-01) Puller ② ST30901000 (-) Equivalent tool (J26010-01) Base		Removing and installing drive pinion rear cone
ST3306S001 (-) Differential side bearing puller set ① ST33051001 (-) Equivalent tool (J22888) Body ② ST33061000 (J8107-2) Equivalent tool (J26010-01) Adapter		Removing and installing differential side bearing inner cone
ST30611000 (J25742-1) Drift		Installing pinion rear bearing outer race

PREPARATION

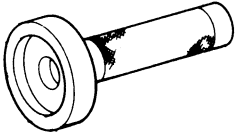
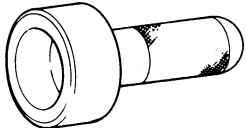
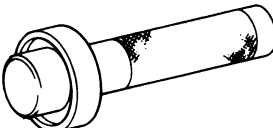
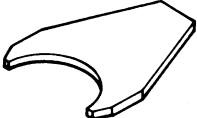
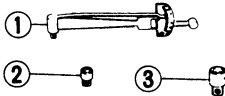
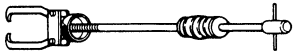
Tool number (Kent-Moore No.) Tool name	Description
ST30613000 (J25742-3) Drift	<div style="display: flex; justify-content: space-between;"> <div data-bbox="121 247 386 409"></div> <div data-bbox="698 283 795 367" style="text-align: center;">  </div> <div data-bbox="1019 254 1455 283" style="text-align: right;">Installing pinion front bearing outer race</div> </div>
ST30701000 (J25742-2) Drift	<div style="display: flex; justify-content: space-between;"> <div data-bbox="121 415 386 577"></div> <div data-bbox="727 472 776 514" style="text-align: center;">  </div> <div data-bbox="1019 422 1438 451" style="text-align: right;">Installing pinion rear bearing outer race</div> </div>
KV38100200 (J26233) Gear carrier side oil seal drift	<div style="display: flex; justify-content: space-between;"> <div data-bbox="121 583 386 756"></div> <div data-bbox="652 604 885 735" style="text-align: center;">  </div> <div data-bbox="1019 590 1247 619" style="text-align: right;">Installing side oil seal</div> </div>
KV38100500 (-) Gear carrier front oil seal drift	<div style="display: flex; justify-content: space-between;"> <div data-bbox="121 762 386 934"></div> <div data-bbox="657 787 901 913" style="text-align: center;">  </div> <div data-bbox="1019 774 1263 804" style="text-align: right;">Installing front oil seal</div> </div>
KV38100300 (J25523) Differential side bearing inner cone	<div style="display: flex; justify-content: space-between;"> <div data-bbox="121 940 386 1113"></div> <div data-bbox="662 976 933 1102" style="text-align: center;">  </div> <div data-bbox="1019 955 1373 984" style="text-align: right;">Installing side bearing inner cone</div> </div>
KV38100600 (J25267) Side bearing spacer drift	<div style="display: flex; justify-content: space-between;"> <div data-bbox="121 1119 386 1281"></div> <div data-bbox="690 1144 885 1260" style="text-align: center;">  </div> <div data-bbox="1019 1140 1325 1169" style="text-align: right;">Installing side bearing spacer</div> </div>
ST3127S000 (See J25765-A) Preload gauge ① GG91030000 (J25765) Torque wrench ② HT62940000 (-) Socket adapter ③ HT62900000 (-) Socket adapter	<div style="display: flex; justify-content: space-between;"> <div data-bbox="121 1287 386 1680"></div> <div data-bbox="662 1438 885 1533" style="text-align: center;">  </div> <div data-bbox="1019 1291 1373 1350" style="text-align: right;">Measuring pinion bearing preload and total preload</div> </div>
HT72400000 (-) Slide hammer	<div style="display: flex; justify-content: space-between;"> <div data-bbox="121 1686 386 1841"></div> <div data-bbox="641 1732 933 1785" style="text-align: center;">  </div> <div data-bbox="1019 1694 1406 1724" style="text-align: right;">Removing differential case assembly</div> </div>

PREPARATION

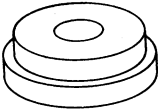
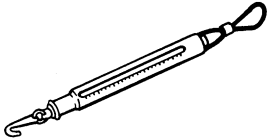
Tool number (Kent-Moore No.) Tool name	Description
(J34309) Differential shim selector	 <p data-bbox="1019 260 1268 317">Adjusting bearing preload and gear height</p>
(J25269-4) Side bearing discs (2 Req'd)	 <p data-bbox="1019 632 1268 688">Selecting pinion height adjusting washer</p>
(J8129) Spring gauge	 <p data-bbox="1019 800 1284 856">Measuring carrier turning torque</p>

PROPELLER SHAFT

3S63A-T

Washer

Apply a coat of multi-purpose lithium grease containing molybdenum disulfide to the end face of the center bearing and both sides of the washer.

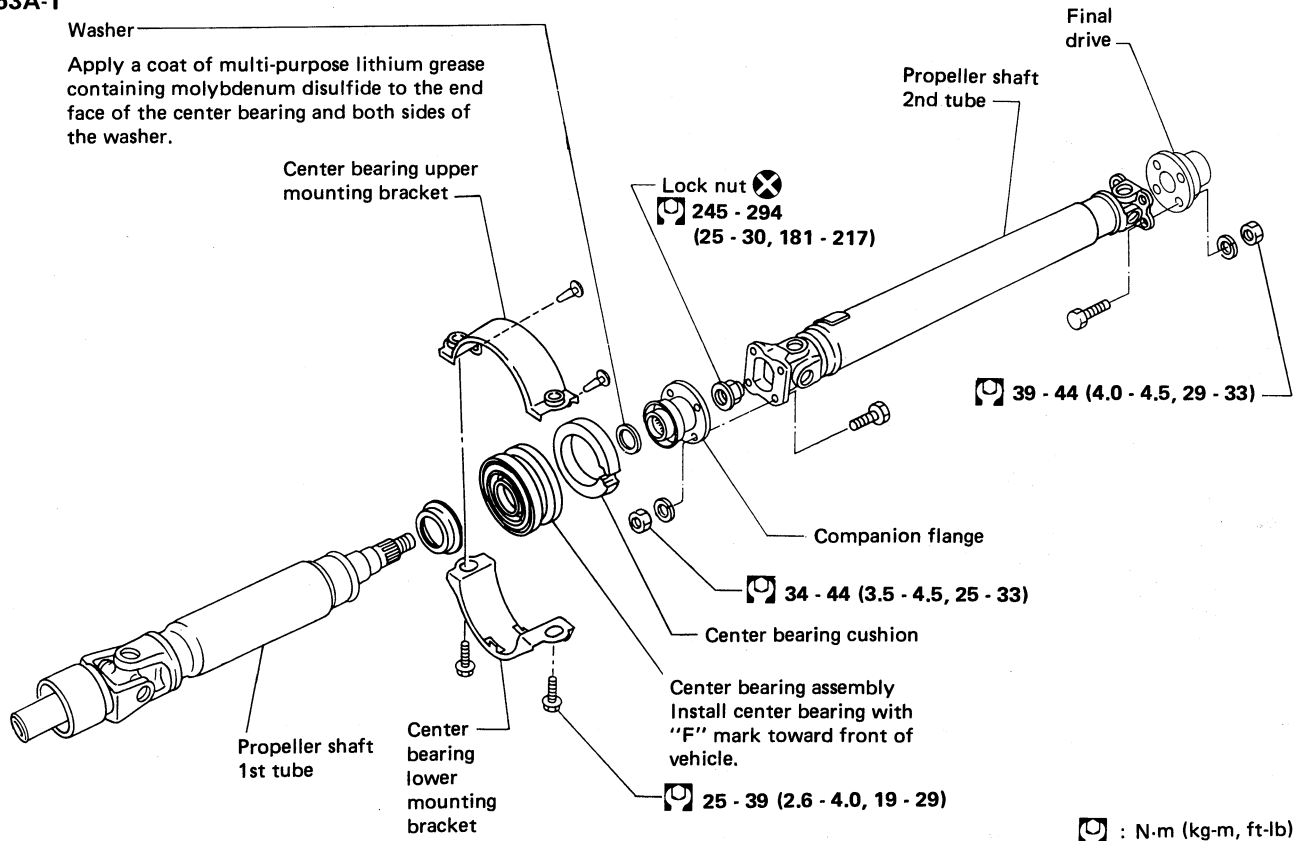

SPD047A

3S63A-R

Washer

Apply a coat of multi-purpose lithium grease containing molybdenum disulfide to the end face of the center bearing and both sides of the washer.

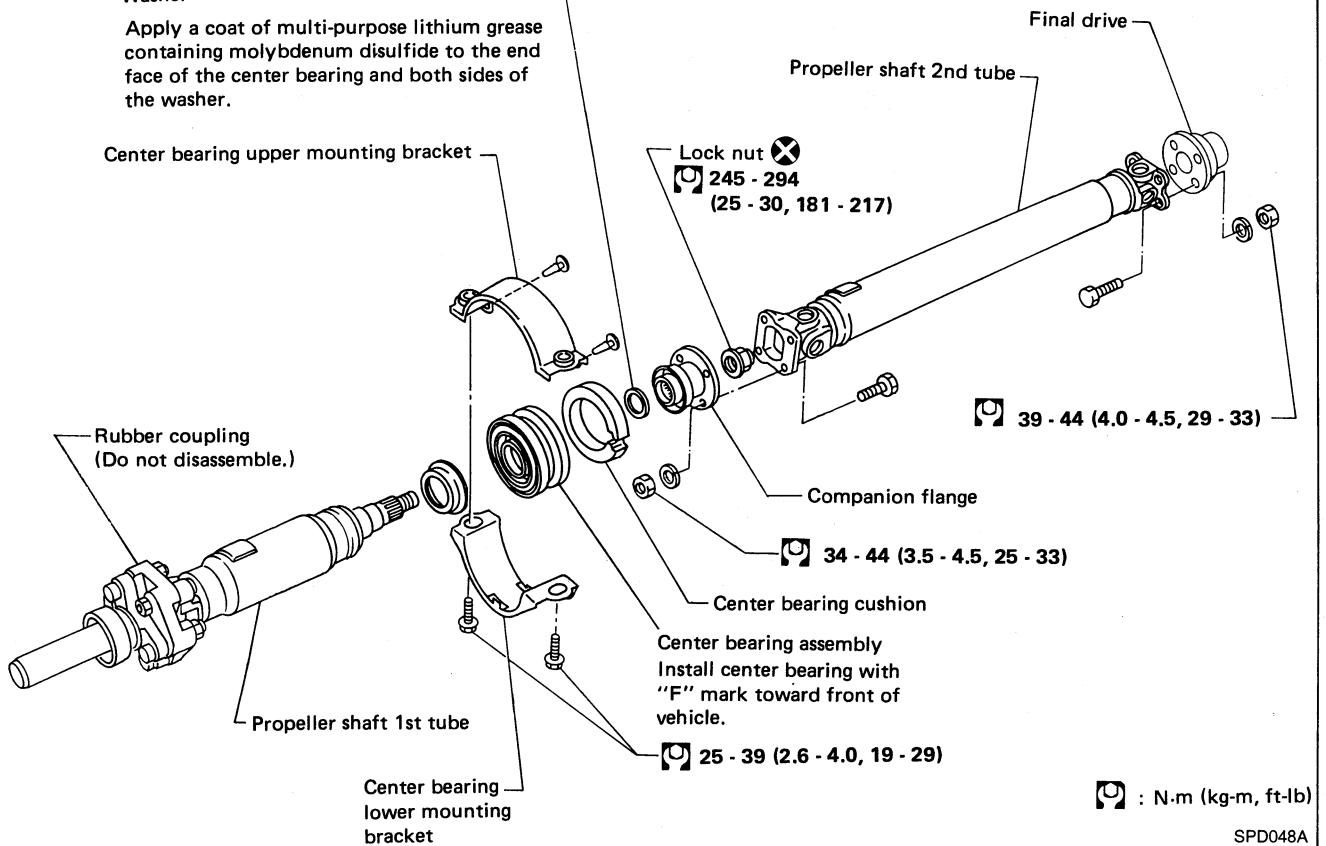

SPD048A

PROPELLER SHAFT

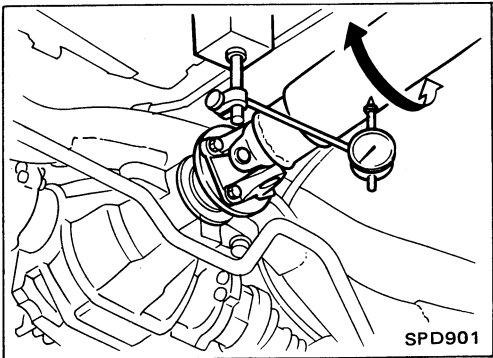

On-vehicle Service

PROPELLER SHAFT VIBRATION

If vibration is present at high speed, inspect propeller shaft runout first.

1. Raise rear wheels.
2. Measure propeller shaft runout at indicated points by rotating final drive companion flange with hands.

Runout limit: 0.6 mm (0.024 in)

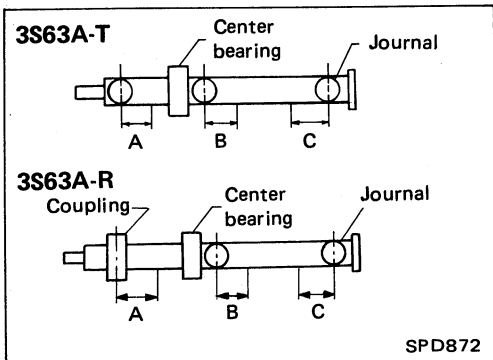

Propeller shaft runout measuring points:

Unit: mm (in)

Distance	Model	3S63A-T	3S63A-R
	A		155 (6.10)
B		165 (6.50)	165 (6.50)
C		185 (7.28)	185 (7.28)

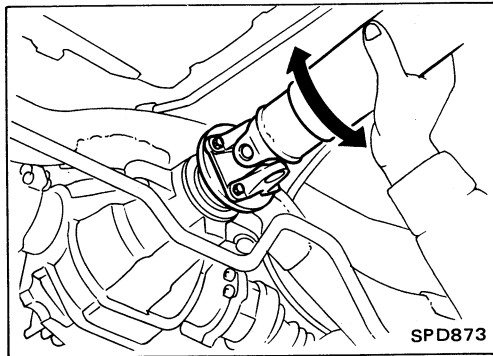

3. If runout exceeds specifications, disconnect propeller shaft at final drive companion flange; then rotate companion flange 180 degrees and reconnect propeller shaft.

Runout limit: 0.6 mm (0.024 in)

4. Check runout again. If runout still exceeds specifications, replace propeller shaft assembly.
5. Perform road test.

APPEARANCE CHECKING

- Inspect propeller shaft tube surface for dents or cracks. If damaged, replace propeller shaft assembly.
- If center bearing is noisy or damaged, replace center bearing.

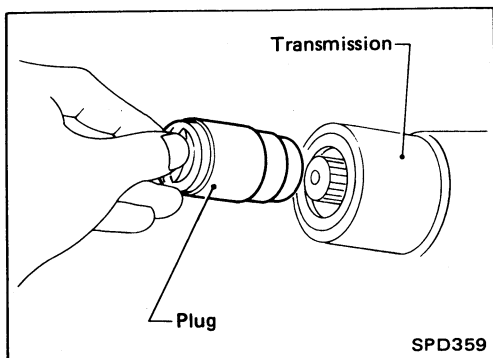

Removal

- Draw out propeller shaft from transmission and plug up rear end of transmission rear extension housing.

PROPELLER SHAFT

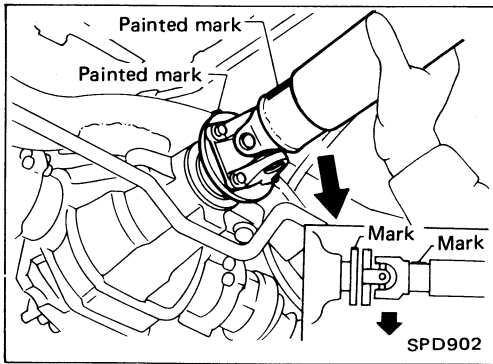

Installation

- Temporarily install differential companion flange and flange yoke so that their alignment marks are located as close to each other as possible.
- Turn propeller shaft until alignment marks face straight upward. Securely fasten propeller shaft so that lower side wall of concave flange yoke will touch lower side wall of convex companion flange.

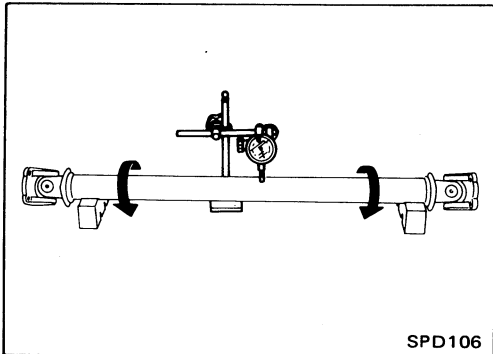

Inspection

- Inspect propeller shaft runout. If runout exceeds specifications, replace propeller shaft assembly.
Runout limit: 0.6 mm (0.024 in)

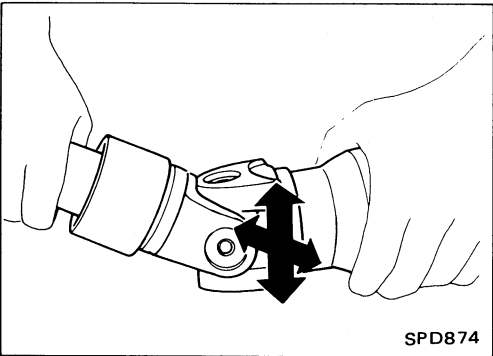

- Inspect journal axial play. If the play exceeds specifications, replace propeller shaft assembly.

Journal axial play:
0 mm (0 in)

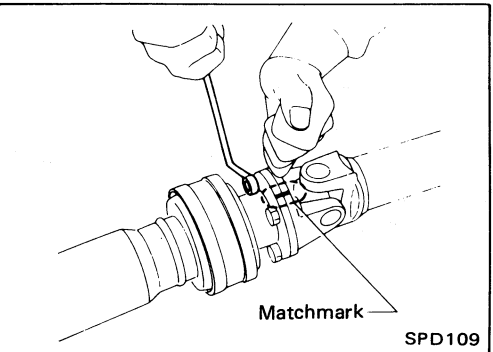

Disassembly

CENTER BEARING

1. Put matchmarks on flanges, and separate 2nd tube from 1st tube.

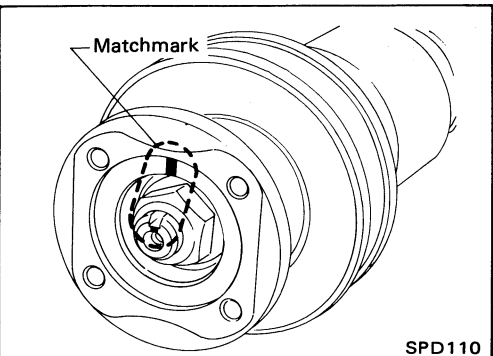

2. Put matchmarks on the flange and shaft.

PROPELLER SHAFT

Disassembly (Cont'd)

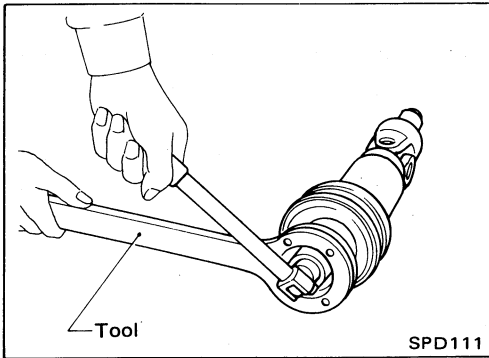

3. Remove locking nut with Tool.

Tool number:

ST38060002 (J34311)

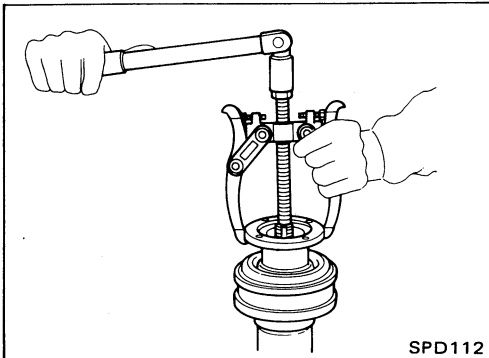

4. Remove companion flange with puller.

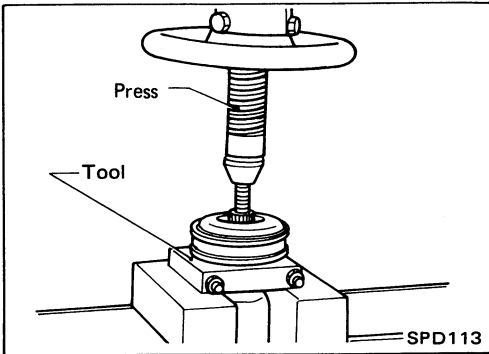

5. Remove center bearing with Tool and press.

Tool number: ST30031000 (J22912-01)

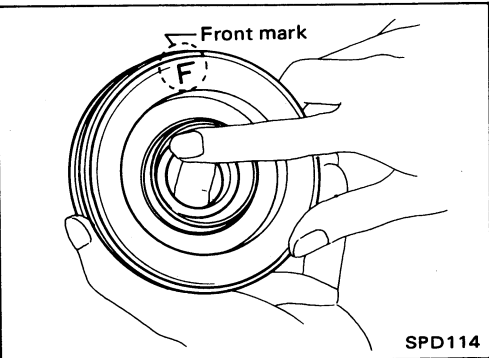

Assembly

CENTER BEARING

- When installing center bearing, position the "F" mark on center bearing toward front of vehicle.
- **Apply a coat of multi-purpose lithium grease containing molybdenum disulfide to the end face of the center bearing and both sides of the washer.**

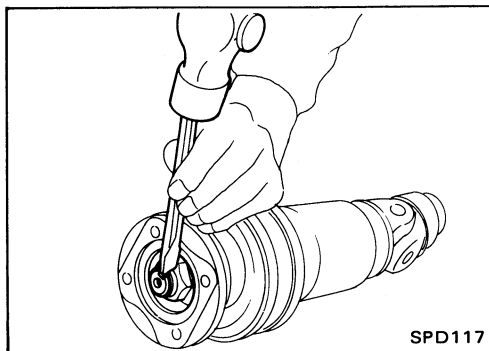

- Stake the nut. Always use new one.
- Align matchmarks when assembling tubes.

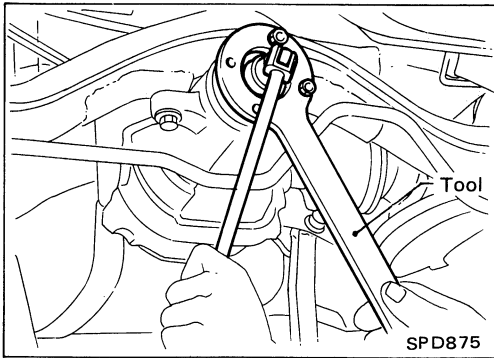

Front Oil Seal Replacement

1. Remove propeller shaft.
2. Loosen drive pinion nut with Tool.
Tool number: ST38060002 (J34311)

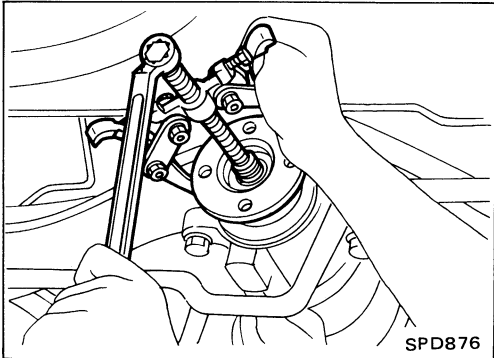

3. Remove companion flange.

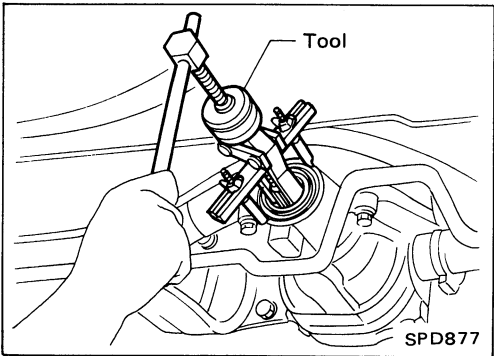

4. Remove front oil seal.

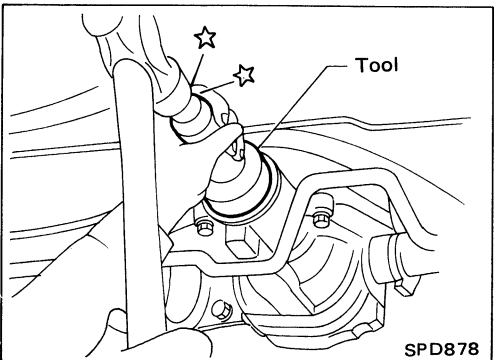

5. Apply multi-purpose grease to sealing lips of oil seal. Press front oil seal into carrier.
6. Install companion flange and drive pinion nut.
7. Install propeller shaft.

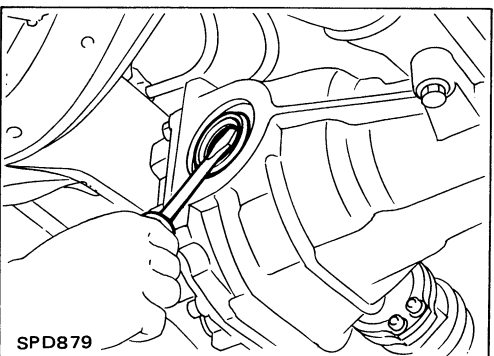

Side Oil Seal Replacement

1. Remove drive shafts.
Refer to RA section.
2. Remove oil seal.

ON-VEHICLE SERVICE (Final drive)

Side Oil Seal Replacement (Cont'd)

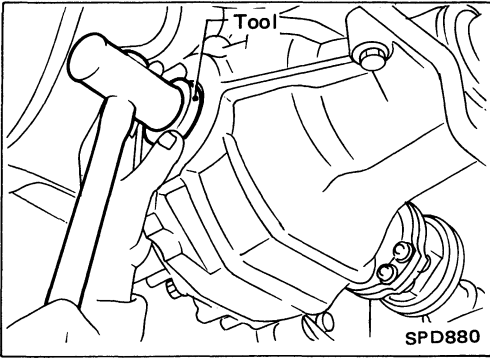

3. Apply multi-purpose grease to sealing lips of oil seal. Press-fit oil seal into carrier with Tool.
Tool number: KV38100200 (J26233)
4. Install drive shafts.

REMOVAL AND INSTALLATION

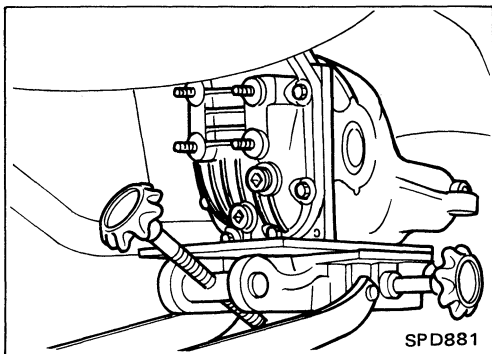

Removal

- Remove propeller shaft.
- Insert plug into rear oil seal after removing propeller shaft.**

- Remove drive shafts.
Refer to RA section.
- Pull off final drive backward together with jack.

CAUTION:

- Be careful not to damage spline, sleeve yoke and front oil seal, when removing propeller shaft.
- After final drive is removed, support suspension member on a stand to prevent its insulators from being twisted or damaged.

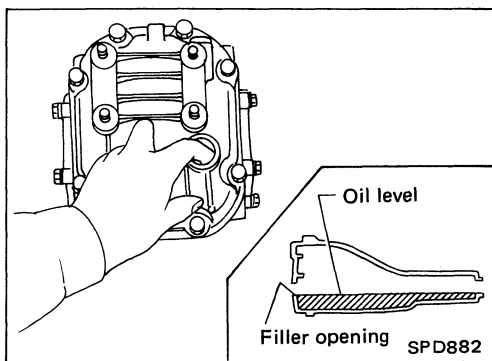

Installation

- Fill final drive with recommended gear oil.

FINAL DRIVE (Model R200)

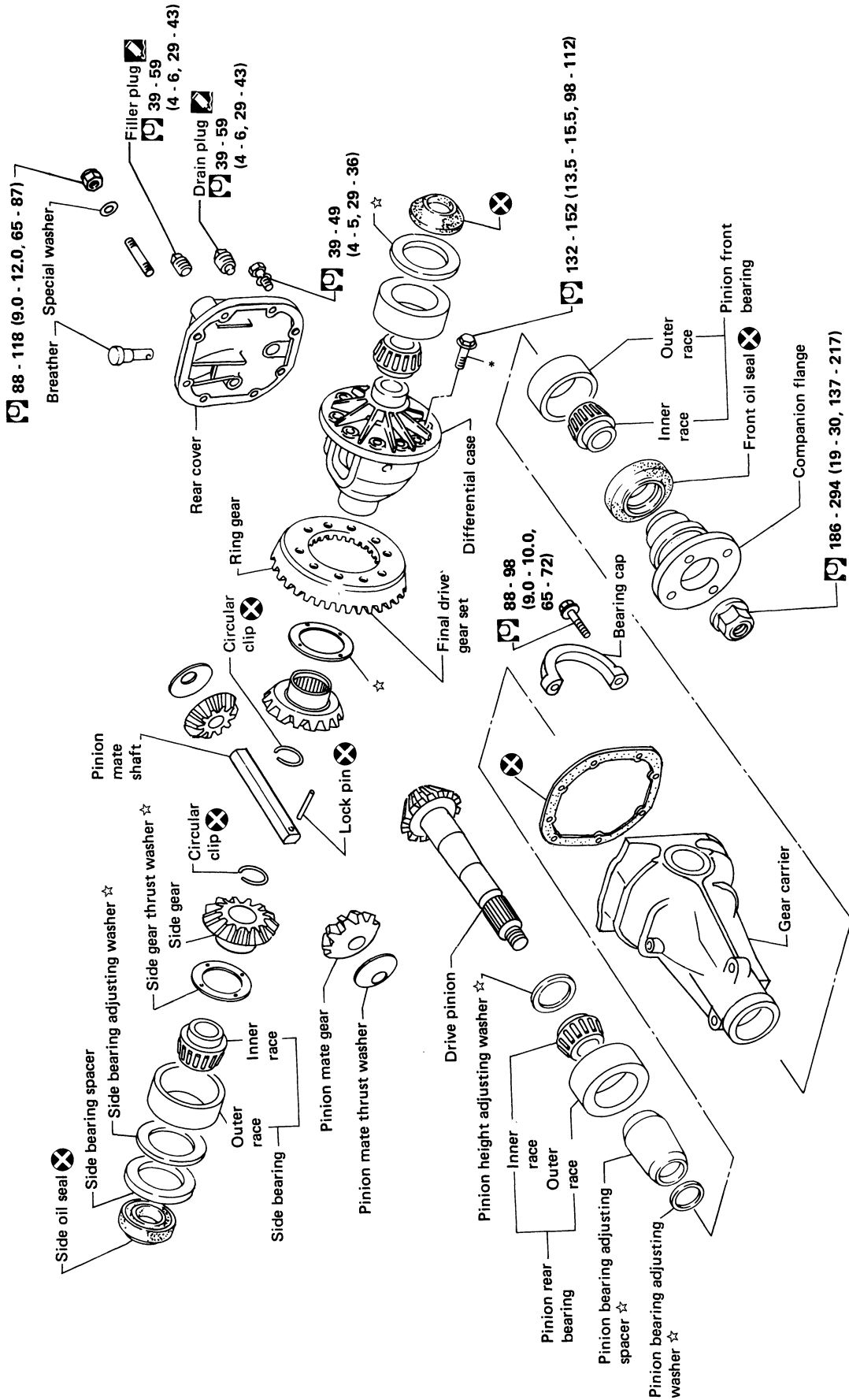

☆ : Adjustment is required.
 * : Using locking agent [Locktite (stud lock) or equivalent]
 [Symbol] : N.m (kg-m, ft-lb)

DISASSEMBLY (Model R200)

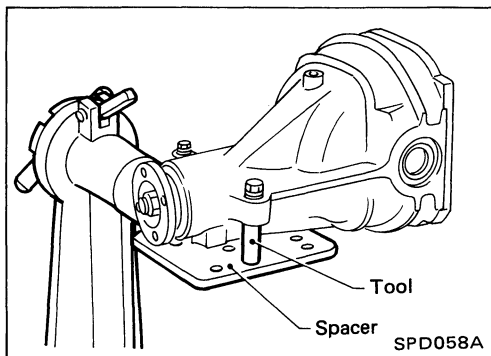
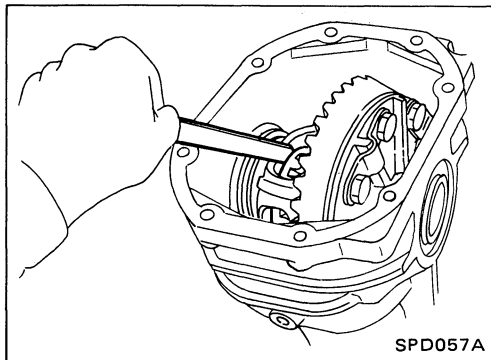
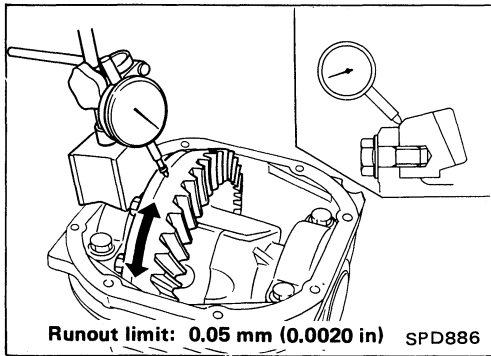
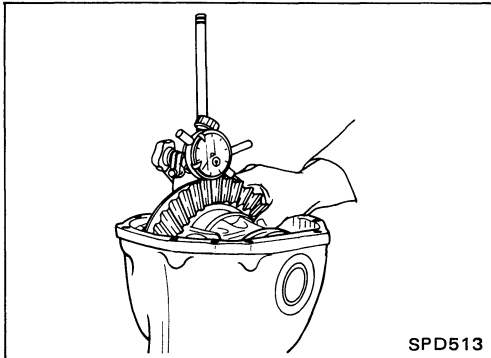
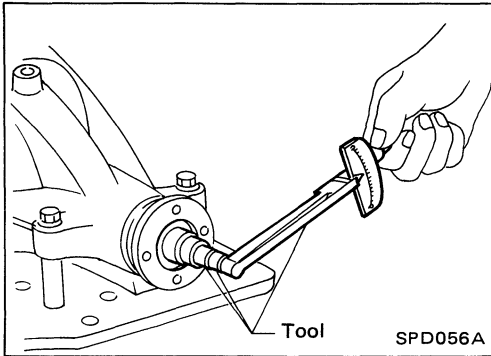

Pre-inspection

Before disassembling final drive, perform the following inspection.

- Total preload
 - 1) Turn drive pinion in both directions several times to set bearing rollers.
 - 2) Check total preload with Tool.

Tool number: ST3127S000 (See J25765-A.)

Total preload:

1.4 - 1.7 N·m

(14 - 17 kg-cm, 12 - 15 in-lb)

- Ring gear to drive pinion backlash
Check ring gear-to-drive pinion backlash with a dial indicator at several points.

Ring gear-to-drive pinion backlash:

0.10 - 0.15 mm (0.0039 - 0.0059 in)

- Ring gear runout
Check runout of ring gear with a dial indicator.

Runout limit:

0.05 mm (0.0020 in)

- Tooth contact
Check tooth contact. (Refer to Adjustment.)

- Side gear to pinion mate gear backlash
Measure clearance between side gear thrust washer and differential case with a feeler gauge.

Clearance between side gear thrust washer and differential case:

0.1 - 0.2 mm (0.004 - 0.008 in)

Differential Carrier

1. Using two 45 mm (1.77 in) spacers, mount carrier on Tool.

Tool number: KV38100800 (—)

DISASSEMBLY (Model R200)

Differential Carrier (Cont'd)

2. Paint or punch matchmarks on one side of the side bearing cap so it can be properly reinstalled.

Bearing caps are line-board during manufacture. Replace them in their proper positions.

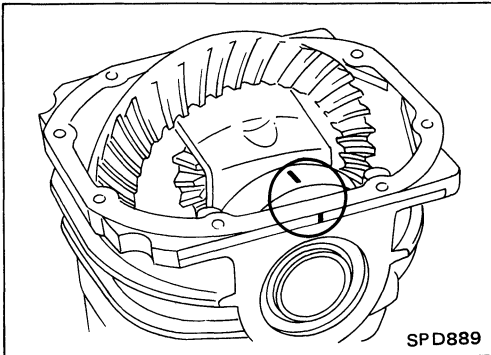

3. Remove side bearing caps.

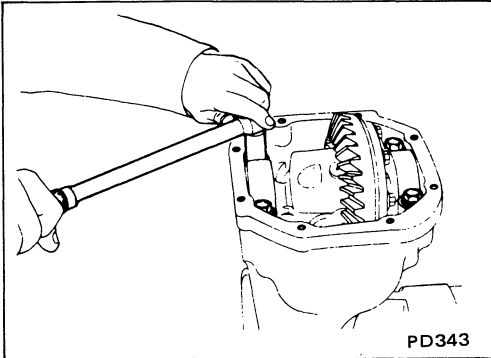

4. Lift differential case assembly out with Tool.
Tool number: HT72400000 (—)

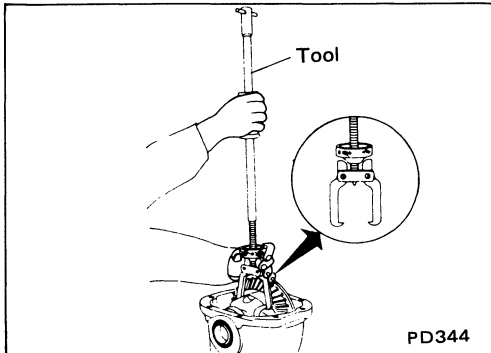

Keep the side bearing outer races together with inner cone — do not mix them up.

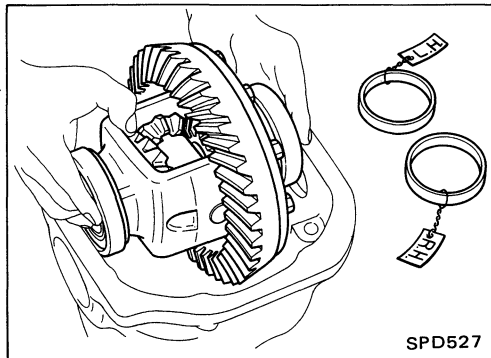

5. Loosen drive pinion nut and pull off companion flange.

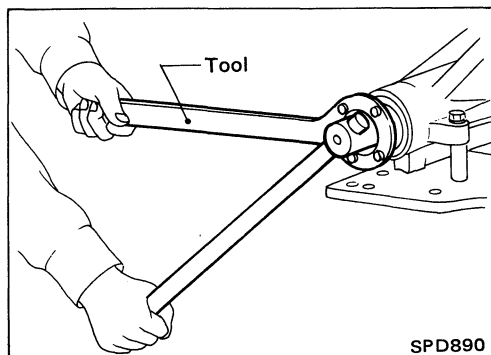

DISASSEMBLY (Model R200)

Differential Carrier (Cont'd)

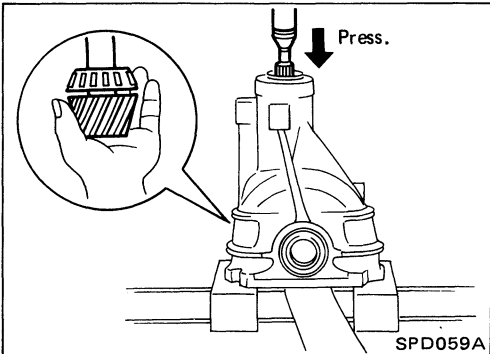
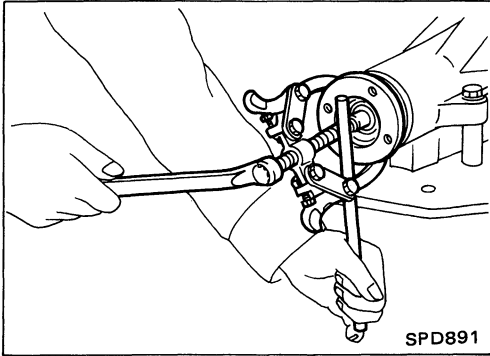

6. Take out drive pinion (together with rear bearing inner race, bearing spacer and adjusting washer).
7. Remove oil seal.
8. Remove front bearing inner race.
9. Remove side oil seal.

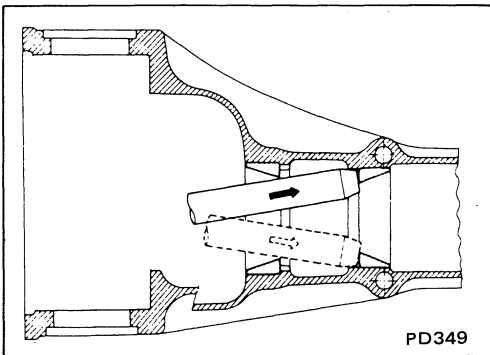

10. Remove pinion bearing outer races with a brass drift.

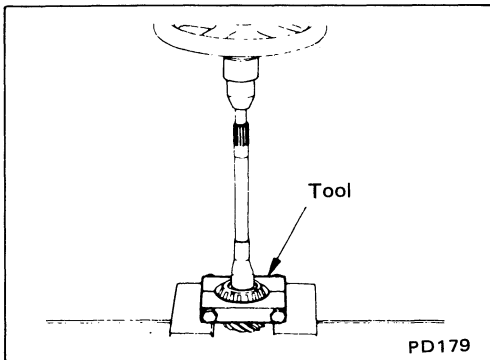

11. Remove pinion rear bearing inner race and drive pinion height adjusting washer with suitable tool.

DISASSEMBLY (Model R200)

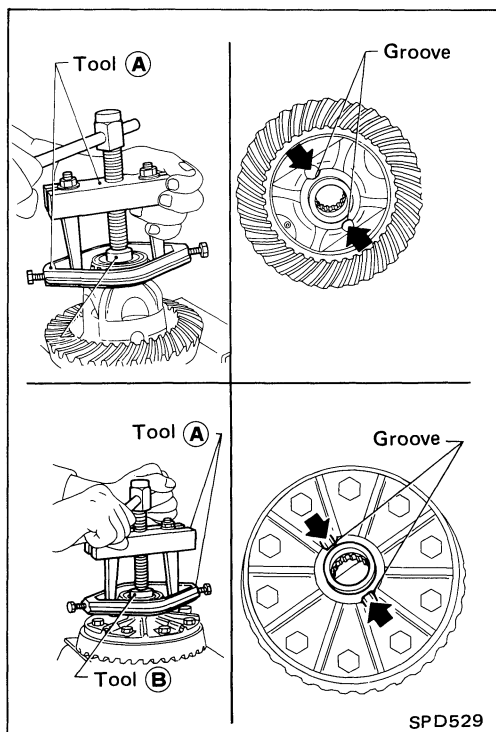

Differential Case

1. Remove side bearing inner cones.
To prevent damage to bearing, engage puller jaws in groove.

Tool number:

- Ⓐ ST33051001 (—)
Equivalent tool (J22888)
- Ⓑ ST33061000 (J8107-2)

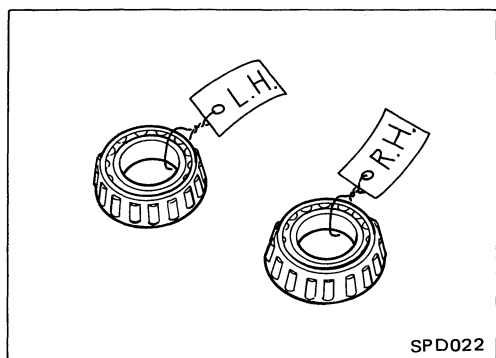

Be careful not to confuse left- and right-hand parts.

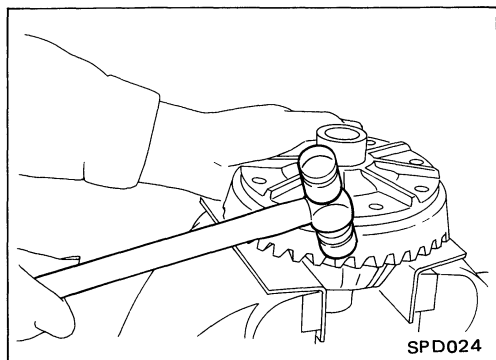

2. Loosen ring gear bolts in a criss-cross fashion.
3. Tap ring gear off the differential case with a soft hammer.
Tap evenly all around to keep ring gear from binding.

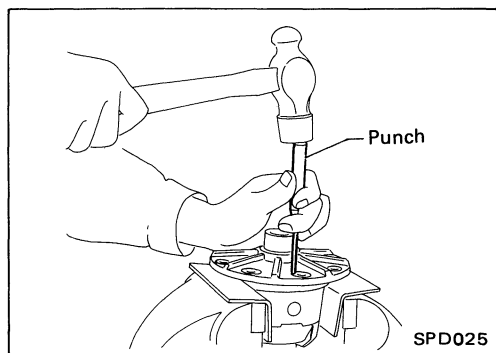

4. Drive out pinion mate shaft lock pin, with punch from ring gear side.
Lock pin is calked at pin hole mouth on differential case.

Ring Gear and Drive Pinion

Check gear teeth for scoring, cracking or chipping. If any part is damaged, replace ring gear and drive pinion as a set (hypoid gear set).

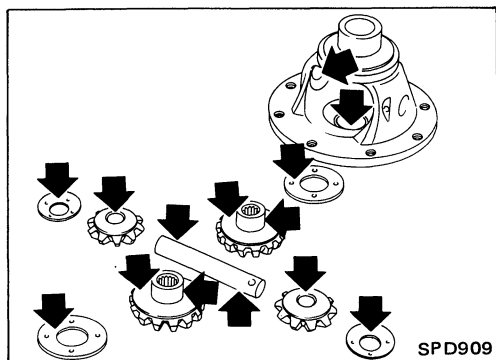

Differential Case Assembly

Check mating surfaces of differential case, side gears, pinion mate gears, pinion mate shaft and thrust washers.

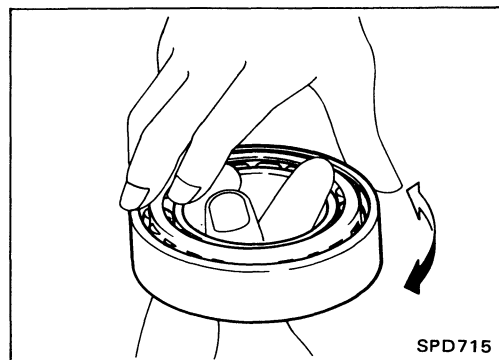

Bearing

1. Thoroughly clean bearing.
2. Check bearings for wear, scratches, pitting or flaking. Check tapered roller bearing for smooth rotation. If damaged, replace outer race and inner cone as a set.

ADJUSTMENT (Model R200)

For quiet and reliable final drive operation, the following five adjustments must be made correctly.

1. Side bearing preload
2. Pinion gear height
3. Pinion bearing preload
4. Ring gear-to-pinion backlash (Refer to ASSEMBLY.)
5. Ring and pinion gear tooth contact pattern

Side Bearing Preload

A selection of carrier side bearing preload shims is required for successful completion of this procedure.

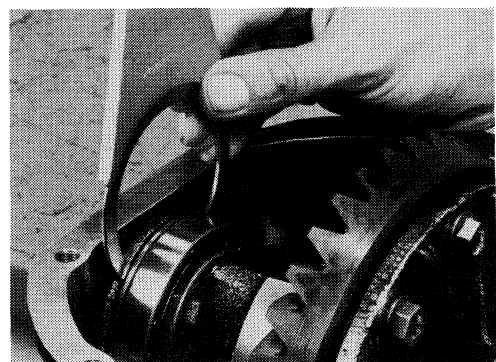
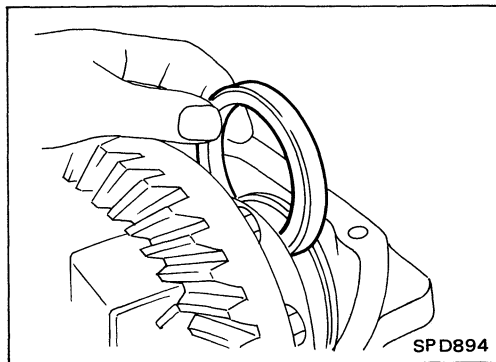
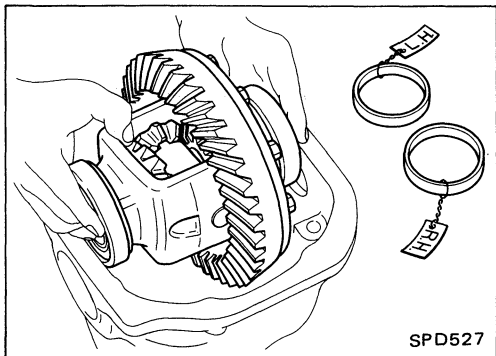

1. Make sure all parts are clean and that the bearings are well lubricated with light oil or Dexron™ type automatic transmission fluid.
2. Place the differential carrier, with side bearings and bearing races installed, into the final drive housing.
3. Put the side bearing spacer in place on the ring gear end of the carrier.
4. Using the J-25267 side bearing spacer drift, place both of the original carrier side bearing preload shims on the carrier end, opposite the ring gear.

ADJUSTMENT (Model R200)

Side Bearing Preload (Cont'd)

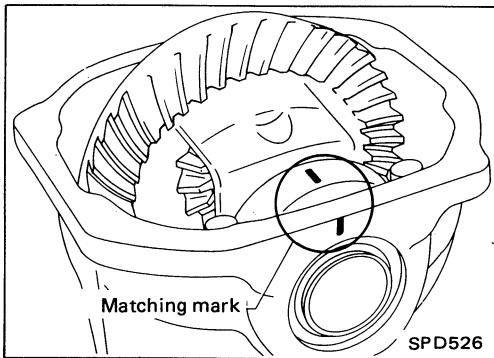

5. Install the side bearing caps in their correct locations and torque the bearing cap retaining bolts.

Specification:

88 - 98 N·m

(9 - 10 kg-m, 65 - 72 ft-lb)

6. Turn the carrier several times to seat the bearings.

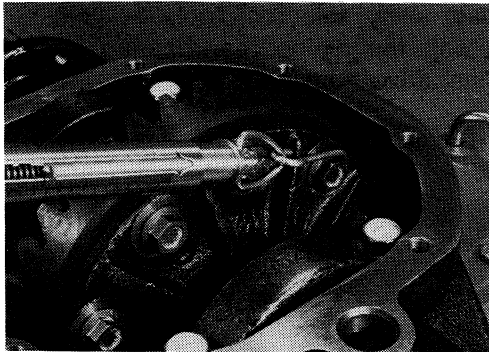

7. Measure the turning torque of the carrier at the ring gear retaining bolts with a spring gauge, J-8129.

Specification:

34.3 - 39.2 N

(3.5 - 4 kg, 7.7 - 8.8 lb)

of pulling force at the ring gear bolt.

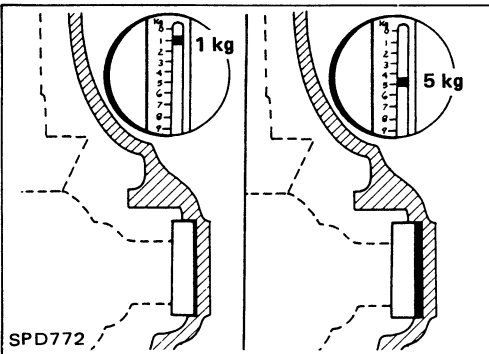

8. If the carrier turning torque is not within the specification range, increase or decrease the total thickness of the side bearing adjusting washers until the turning torque is correct. If the turning torque is less than the specified range, install washers of greater thickness; if the turning torque is greater than the specification, install thinner washers. See the S.D.S. section for washer dimensions and part numbers.

9. Record the total amount of washer thickness required for the correct carrier side bearing preload.

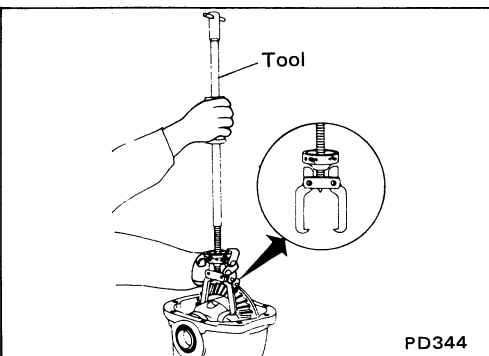

10. Remove the carrier from the final drive housing, saving the selected preload washers for later use during the assembly of the final drive unit.

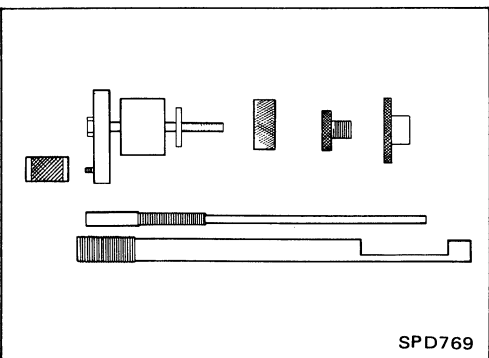

Pinion Gear Height and Pinion Bearing Preload

1. Make sure all parts are clean and that the bearings are well lubricated.
2. Assemble the pinion gear bearings into the pinion preload shim selector Tool, J-34309.

ADJUSTMENT (Model R200)

Pinion Gear Height and Pinion Bearing Preload (Cont'd)

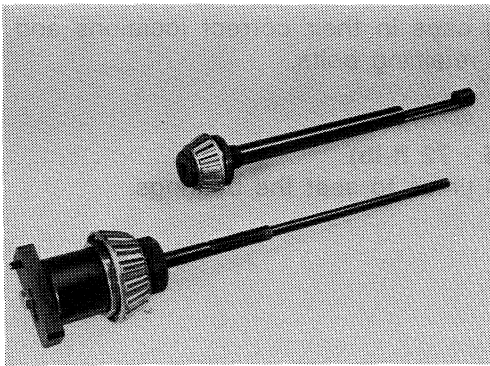

- **Front pinion bearing** — make sure the J-34309-3 front pinion bearing seat is secured tightly against the J-34309-2 gauge anvil. Then turn the front pinion bearing pilot, J-34309-5, to secure the bearing in its proper position.
- **Rear pinion bearing** — the rear pinion bearing pilot, J-34309-8, is used to center the rear pinion bearing only. The rear pinion bearing locking seat, J-34309-4, is used to lock the bearing to the assembly.

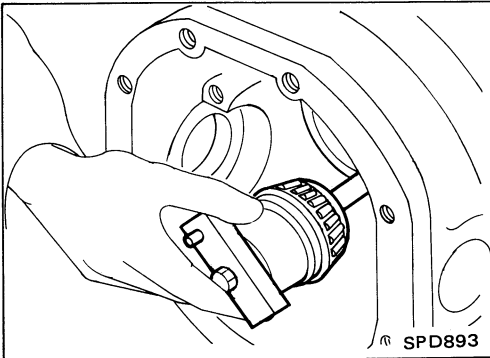

3. Place the pinion preload shim selector Tool, J-34309-1, gauge screw assembly with the pinion rear bearing inner cone installed into the final drive housing.

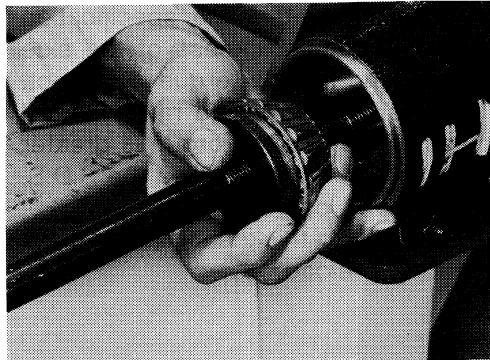

4. Assemble the front pinion bearing inner cone and the J-34309-2 gauge anvil together with the J-34309-1 gauge screw in the final drive housing. Make sure that the pinion height gauge plate, J-34309-16, will turn a full 360 degrees, and tighten the two sections together by hand.

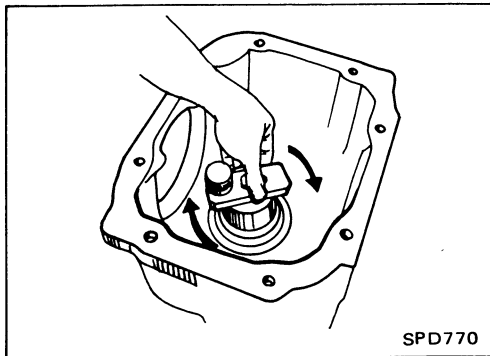

5. Turn the assembly several times to seat the bearings.

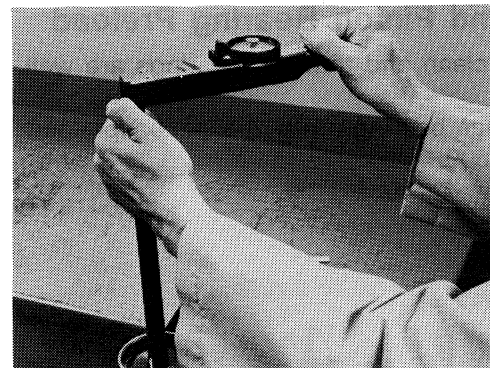

6. Measure the turning torque at the end of the J-34309-2 gauge anvil using torque wrench J-25765A.

Turning torque specification:

1.0 - 1.3 N·m

(10 - 13 kg-cm, 8.7 - 11.3 in-lb)

ADJUSTMENT (Model R200)



Pinion Gear Height and Pinion Bearing Preload (Cont'd)

- Place the J-34309-11 "R200A" pinion height adapter onto the gauge plate and tighten it by hand.

CAUTION:

Make sure all machined surfaces are clean.



— PINION BEARING PRELOAD WASHER SELECTION —

- Place the solid pinion bearing spacer, small end first, over the J-34309-2 gauge anvil and seat the small end squarely against the tip of the J-34309-1 gauge screw in the tool recessed portion.

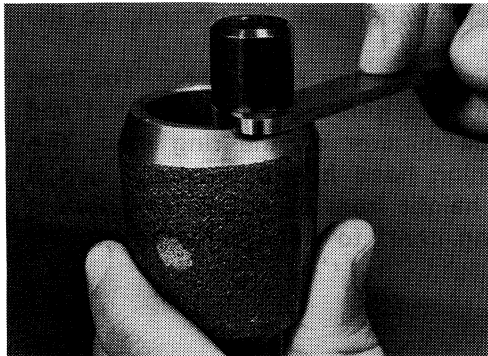
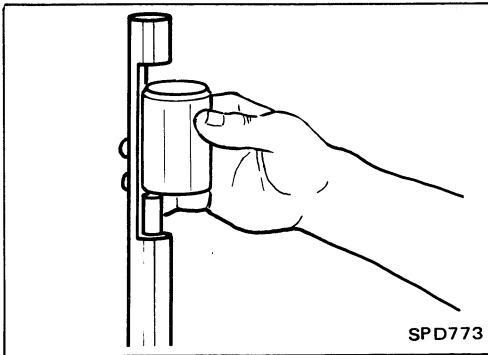

- Select the correct thickness of pinion bearing preload adjusting washer using a standard gauge of 3.5 mm (0.138 in) and your J-34309-101 feeler gauge. *The exact measure you get with your gauges is the thickness of the adjusting washer required.* Select the correct washer from the following chart.

**Drive pinion bearing preload adjusting washer:
Refer to S.D.S.**

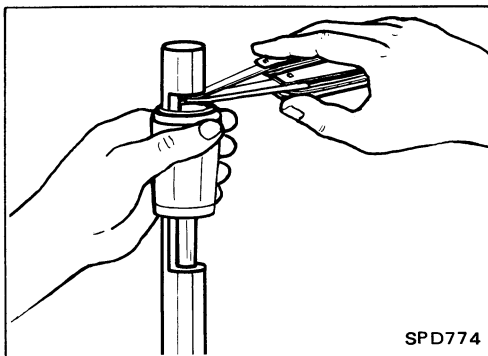

- Set your selected, correct pinion bearing preload adjusting washer aside for use when assembling the pinion gear and bearings into the final drive.

ADJUSTMENT (Model R200)

Pinion Gear Height and Pinion Bearing Preload (Cont'd)

— PINION HEIGHT ADJUSTING WASHER SELECTION —

11. Now, position the side bearing discs, J-25269-4, and arbor firmly into the side bearing bores.

Install the side bearing caps and tighten the cap bolts to proper torque.

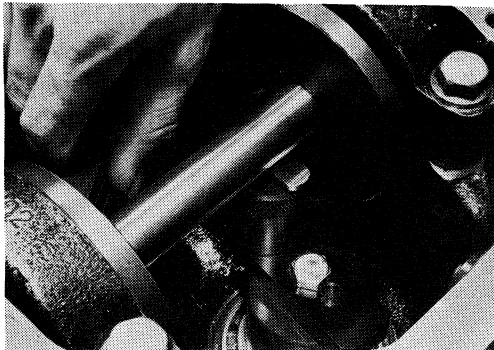
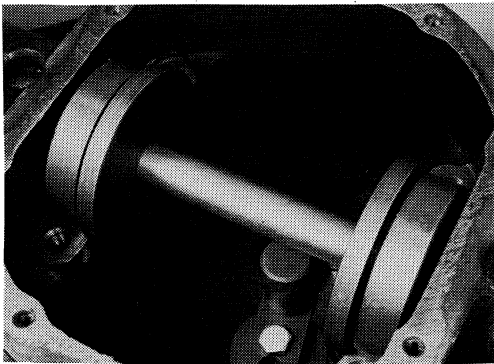

12. Select the correct *standard* pinion height adjusting washer thickness using a standard gauge of 3 mm (0.12 in) and your J-34309-101 feeler gauge. Measure the distance between the J-34309-10 pinion height adapter and the arbor.

13. Write down your exact total measurement.

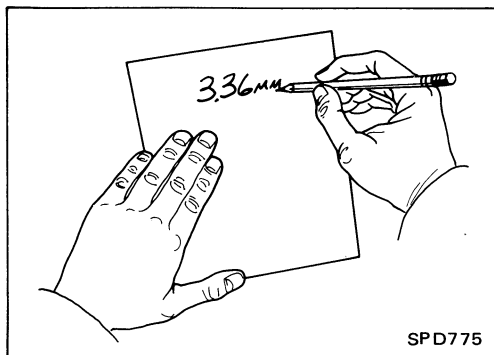

14. Correct the pinion height washer size by referring to the "pinion head number."

There are two numbers painted on the pinion gear. The first one refers to the pinion and ring gear as a matched set and should be the same as the number on the ring gear. The second number is the "pinion head height number," and it refers to the ideal pinion height from standard for quietest operation. Use the following chart to determine the correct pinion height washer.

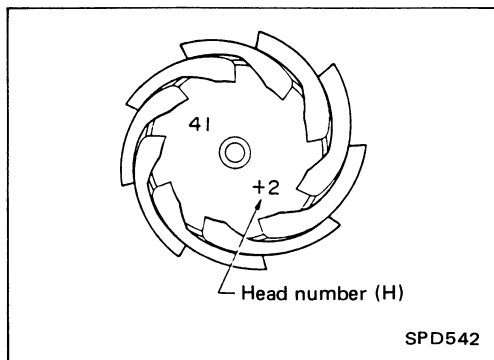

ADJUSTMENT (Model R200)

Pinion Gear Height and Pinion Bearing Preload (Cont'd)

Pinion head height number	Add or remove from the standard pinion height washer thickness measurement
-6	Add 0.06 mm (0.0024 in)
-5	Add 0.05 mm (0.0020 in)
-4	Add 0.04 mm (0.0016 in)
-3	Add 0.03 mm (0.0012 in)
-2	Add 0.02 mm (0.0008 in)
-1	Add 0.01 mm (0.0004 in)
0	Use the selected washer thickness
+1	Subtract 0.01 mm (0.0004 in)
+2	Subtract 0.02 mm (0.0008 in)
+3	Subtract 0.03 mm (0.0012 in)
+4	Subtract 0.04 mm (0.0016 in)
+5	Subtract 0.05 mm (0.0020 in)
+6	Subtract 0.06 mm (0.0024 in)

15. Select the correct pinion height washer from the following chart.

Drive pinion height adjusting washer (R200):

Thickness mm (in)	Part No.
3.09 (0.1217)	38154-P6017
3.12 (0.1228)	38154-P6018
3.15 (0.1240)	38154-P6019
3.18 (0.1252)	38154-P6020
3.21 (0.1264)	38154-P6021
3.24 (0.1276)	38154-P6022
3.27 (0.1287)	38154-P6023
3.30 (0.1299)	38154-P6024
3.33 (0.1311)	38154-P6025
3.36 (0.1323)	38154-P6026
3.39 (0.1335)	38154-P6027
3.42 (0.1346)	38154-P6028
3.45 (0.1358)	38154-P6029
3.48 (0.1370)	38154-P6030
3.51 (0.1382)	38154-P6031
3.54 (0.1394)	38154-P6032
3.57 (0.1406)	38154-P6033
3.60 (0.1417)	38154-P6034
3.63 (0.1429)	38154-P6035
3.66 (0.1441)	38154-P6036



16. Remove the J-34309 pinion preload shim selector Tool from the final drive housing and disassemble to retrieve the pinion bearings.

ADJUSTMENT (Model R200)

Tooth Contact

Gear tooth contact pattern check is necessary to verify correct relationship between ring gear and drive pinion. Hypoid gear sets which are not positioned properly may be noisy, or have short life, or both. Low noise and a long life can be assured with a pattern check.

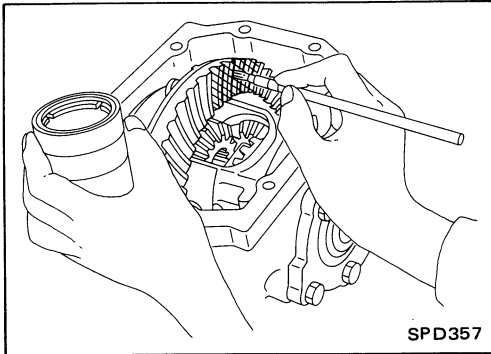

1. Thoroughly clean ring gear and drive pinion teeth.
2. Sparingly apply a mixture of powdered ferric oxide and oil or equivalent to 3 or 4 teeth of ring gear drive side.

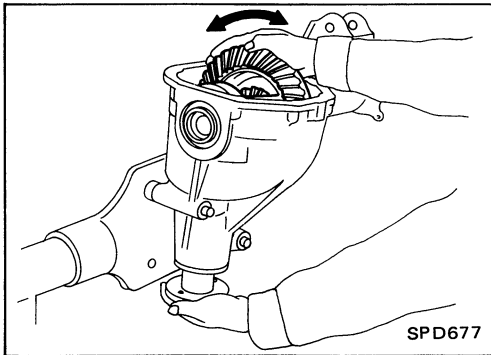

3. Hold companion flange steady and turn the ring gear in both directions.

Usually the pattern will be correct if you have calculated the shims correctly and the backlash is correct. However, in rare cases you may have to use trial-and-error processes until you get a good tooth contact pattern. The tooth pattern is the best indication of how well a differential has been set up.

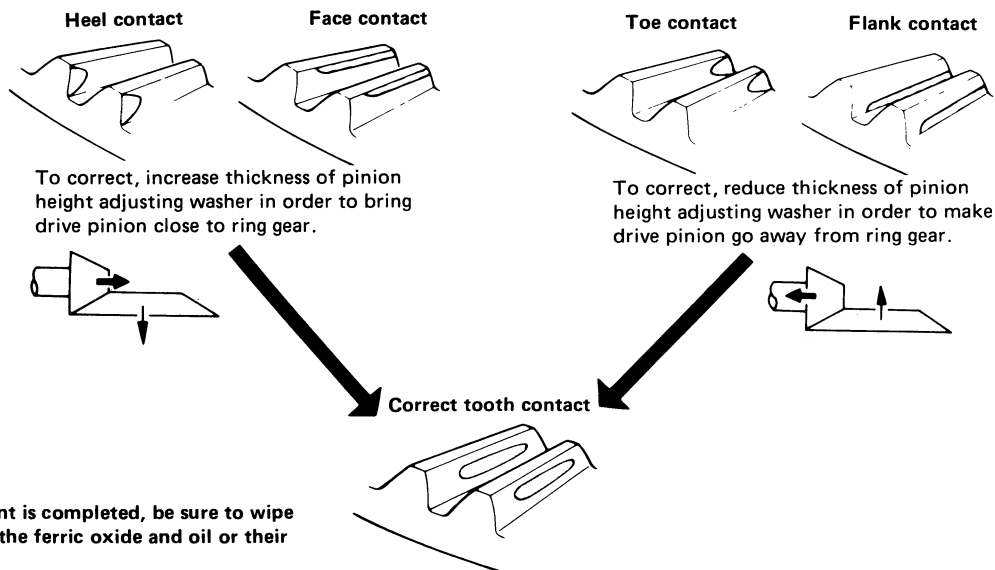

SPD007

ASSEMBLY (Model R200)

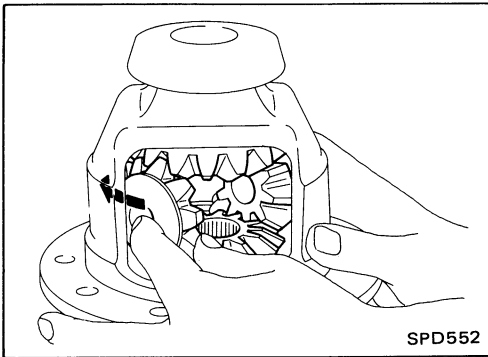

Differential Case

1. Install side gears, pinion mate gears, thrust washers and thrust block into differential case.

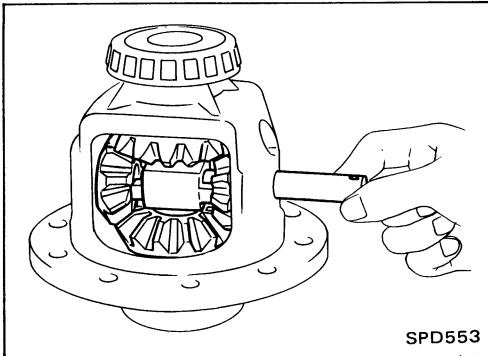

2. Fit pinion mate shaft to differential case so that it meets lock pin holes.

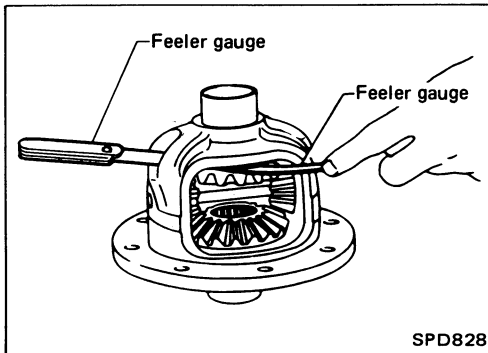

3. Adjust clearance between rear face of side gear and thrust washer by selecting side gear thrust washer. Refer to S.D.S.
Clearance between side gear thrust washer and differential case:
0.10 - 0.20 mm (0.0039 - 0.0079 in)

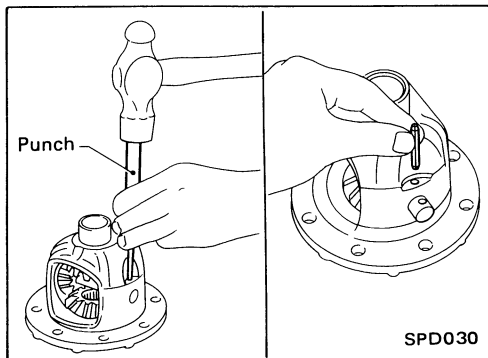

4. Install pinion mate shaft lock pin with a punch.
Make sure lock pin is flush with case.

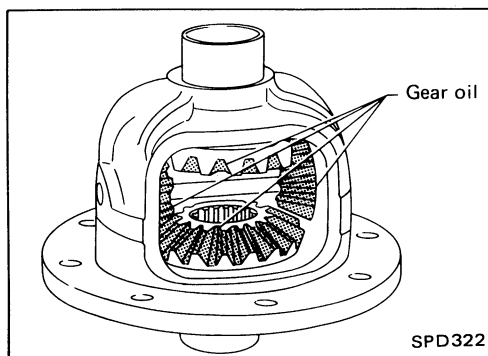

5. Apply oil to gear tooth surfaces and thrust surfaces and check that they turn properly.

ASSEMBLY (Model R200)

Differential Case (Cont'd)

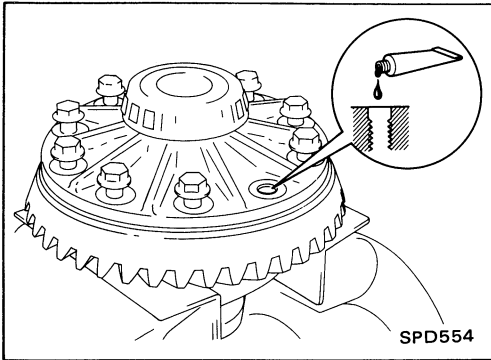

6. Apply locking sealant to ring gear bolts, and install them. Tighten bolts in a criss-cross fashion, lightly tapping bolt head with a hammer.

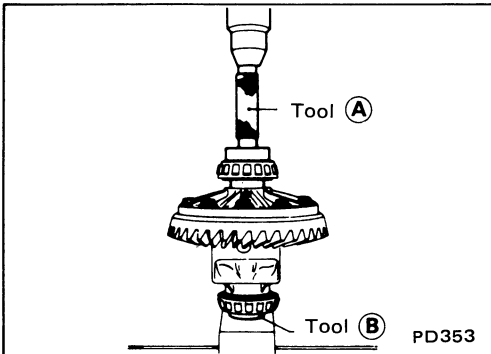

7. Press-fit side bearing inner cones on differential case with Tool.

Tool number:

- (A) KV38100300 (J25523)
- (B) ST33061000 (J8107-2)

Differential Carrier

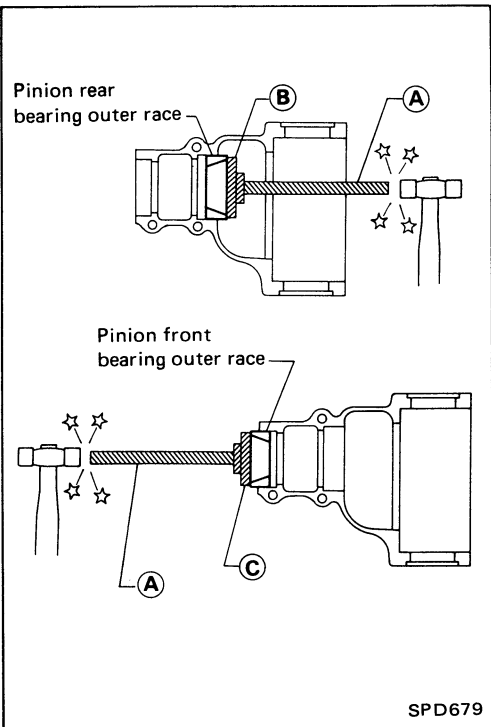

1. Press-fit front and rear bearing outer races with Tools.

Tool number:

- (A) ST30611000 (J25742-1)
- (B) ST30701000 (J25742-2)
- (C) ST30613000 (J25742-3)

2. Select pinion bearing adjusting washer and drive pinion bearing spacer, referring to Adjustment.

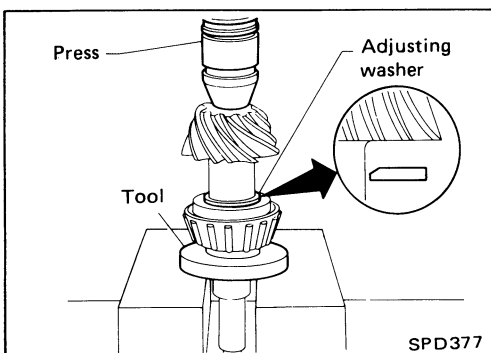

3. Install drive pinion height adjusting washer in drive pinion, and press-fit pinion rear bearing inner cone in it, using press and Tool.

Tool number: ST30901000 (—)

ASSEMBLY (Model R200)

Differential Carrier (Cont'd)

4. Place pinion front bearing inner cone in final drive housing.

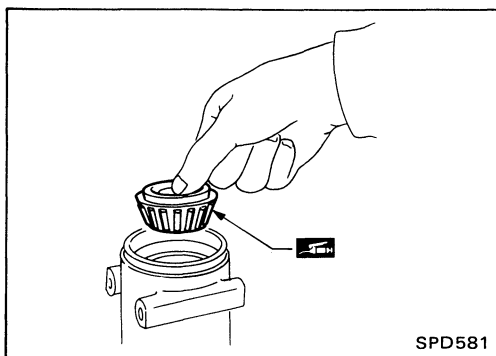

5. Set drive pinion assembly (as shown in figure at left) in differential carrier and install drive pinion, with press and suitable tool.

Stop when drive pinion touches bearing.

Apply multi-purpose grease to pinion rear bearing inner race, pinion front bearing inner race and front pilot bearing.

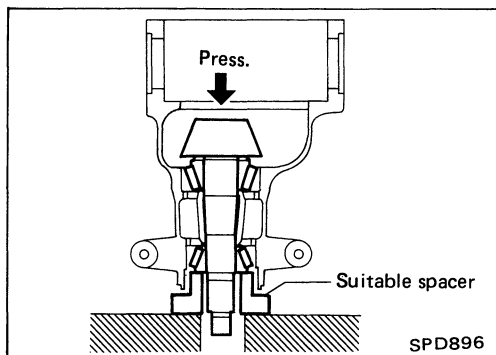
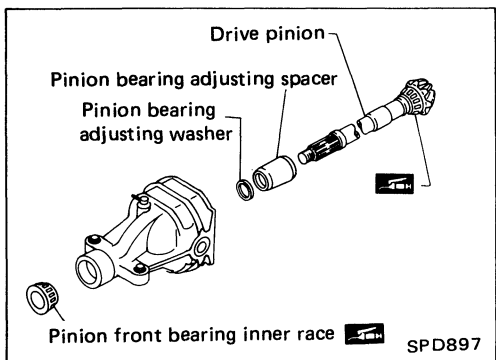

6. Apply multi-purpose grease to cavity at sealing lips of oil seal. Install front oil seal with Tool.

Tool number: KV38100500 (—)

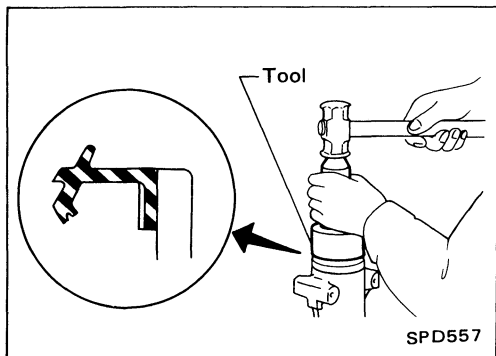

7. Install companion flange, and tighten pinion nut to specified torque with Tool.

Ascertain that threaded portion of drive pinion and pinion nut are free from oil or grease.

Tool number: ST38060002 (J34311)

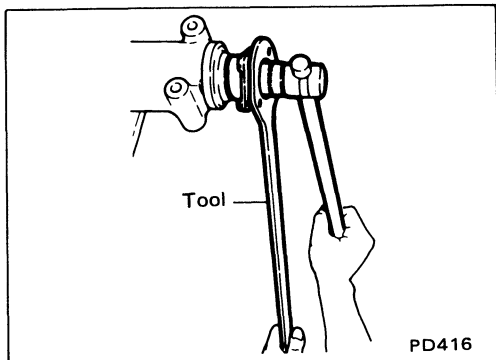

ASSEMBLY (Model R200)

Differential Carrier (Cont'd)

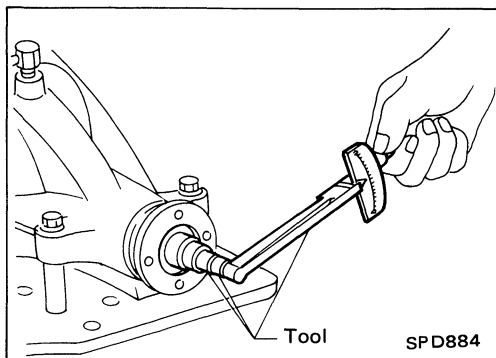

8. Turn drive pinion in both directions several times, and measure pinion bearing preload.

Pinion bearing preload:

1.1 - 1.4 N·m

(11 - 14 kg·cm, 9.5 - 12.2 in·lb)

- When pinion bearing preload is outside the specifications, replace pinion bearing adjusting washer and spacer with a different thickness.

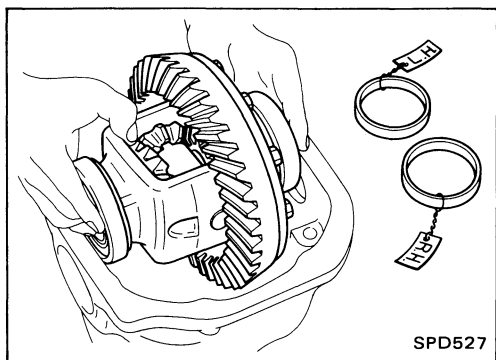

9. Select side bearing adjusting washer. Refer to Adjustment.
10. Install differential case assembly with side bearing outer races into gear carrier.

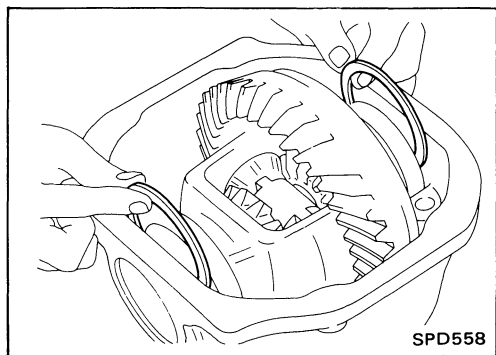

11. Insert left and right side bearing adjusting washers in place between side bearings and carrier.

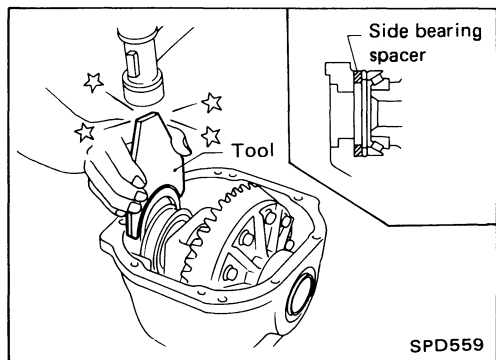

12. Drive in side bearing spacer with Tool.
Tool number: KV38100600 (J25267)

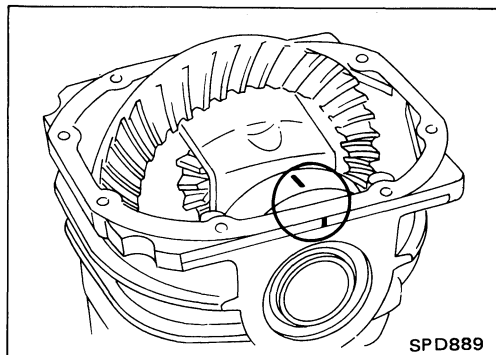

13. Align mark on bearing cap with that on gear carrier and install bearing cap on gear carrier.

ASSEMBLY (Model R200)

Differential Carrier (Cont'd)

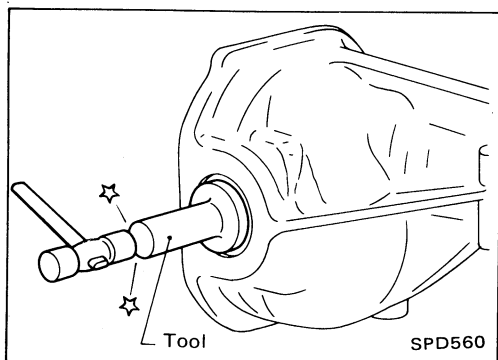

14. Apply multi-purpose grease to cavity at sealing lips of oil seal. Install side oil seal.

Tool number: KV38100200 (J26233)

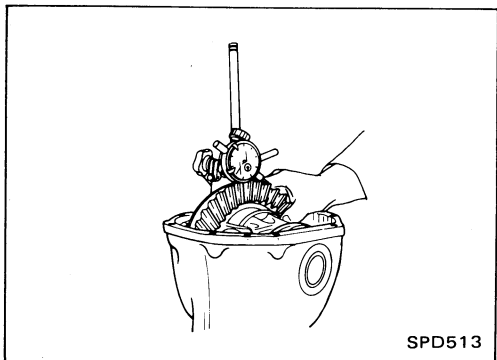

15. Measure ring gear-to-drive pinion backlash with a dial indicator.

Ring gear-to-drive pinion backlash:

0.10 - 0.15 mm

(0.0039 - 0.0059 in)

- If backlash is too small, decrease thickness of left shim and increase thickness of right shim by the same amount.

If backlash is too great, reverse the above procedure.

Never change the total amount of shims as it will change the bearing preload.

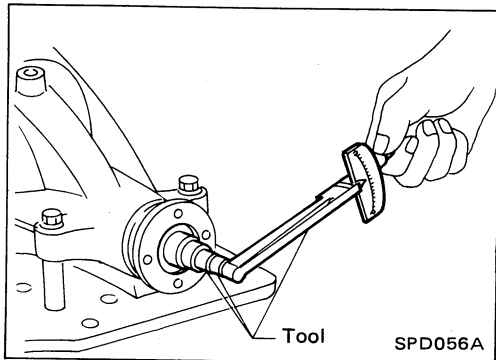

16. Check total preload with Tool.

When checking preload, turn drive pinion in both directions several times to seat bearing rollers correctly.

Total preload:

Value more than 0.29 N·m (3.0 kg-cm, 2.6 in-lb) added on measured value of drive pinion preload

- If preload is too great, remove the same amount of shim to each side.
- If preload is too small, add the same amount of shim to each side.

Never add or remove a different number of shims for each side as it will change ring gear-to-drive pinion backlash.

17. Recheck ring gear-to-drive pinion backlash because increase or decrease in thickness of shims will cause change of ring gear-to-pinion backlash.

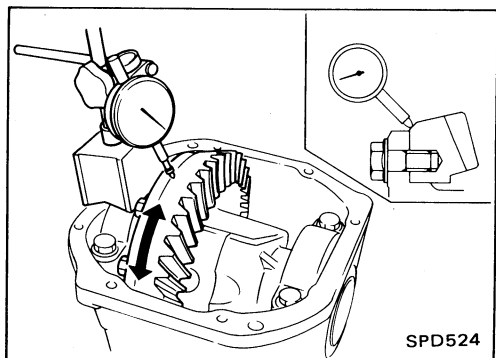

18. Check runout of ring gear with a dial indicator.

Runout limit:

0.05 mm (0.0020 in)

- If backlash varies excessively in different places, foreign matter may be caught between the ring gear and the differential case.
- If the backlash varies greatly when the ring gear runout is within a specified range, replace the hypoid gear set or differential case.

19. Check tooth contact.

Refer to Adjustment.

20. Install rear cover and gasket.

FINAL DRIVE (Model R200V)

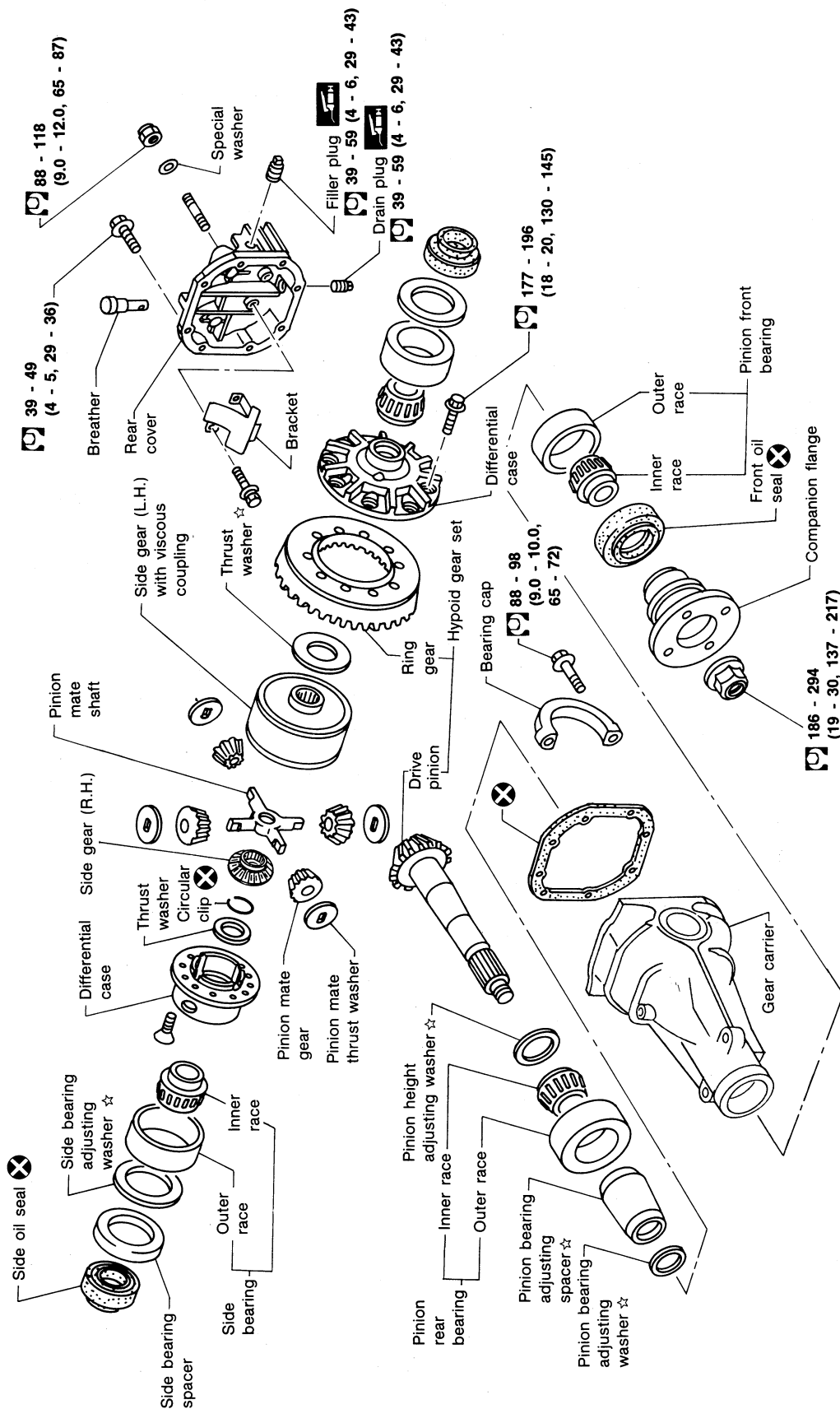

□ : N·m (kg-m, ft-lb)
 ☆ : Adjustment is required.

DISASSEMBLY (Model R200V)

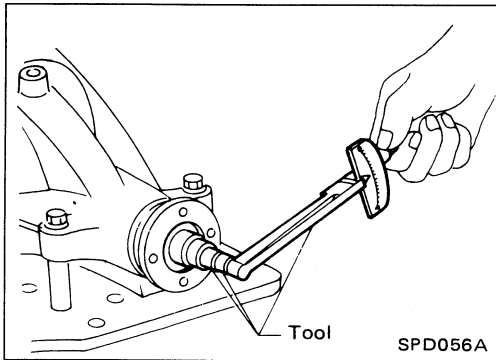

Pre-inspection

Before disassembling final drive, perform the following inspection.

- Total preload
 - 1) Turn drive pinion in both directions several times to set bearing rollers.
 - 2) Check total preload with Tool.

Tool number: ST3127S000 (See J25765-A)

Total preload:

1.4 - 1.7 N·m (14 - 17 kg-cm, 12 - 15 in-lb)

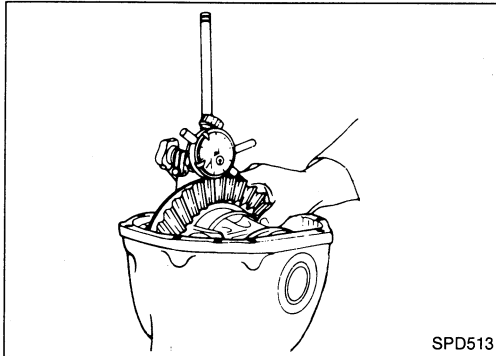

- Ring gear to drive pinion backlash
Check ring gear to drive pinion backlash with a dial indicator at several points.

Ring gear to drive pinion backlash:

0.10 - 0.15 mm (0.0039 - 0.0059 in)

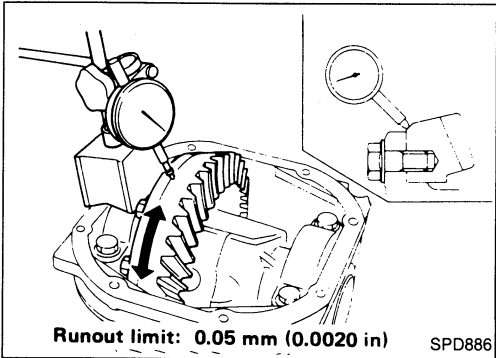

- Ring gear runout
Check runout of ring gear with a dial indicator.

Runout limit:

0.05 mm (0.0020 in)

- Tooth contact
Check tooth contact. (Refer to Adjustment.)

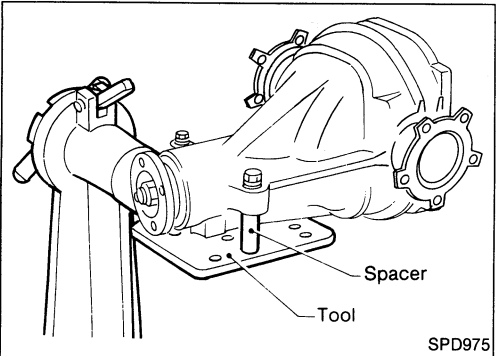

Differential Carrier

1. Using two 45 mm (1.77 in) spacers, mount carrier on Tool.
Tool number: KV38100800 (—)

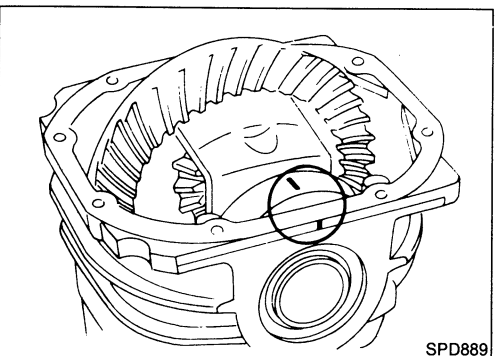

2. Paint or punch matchmarks on one side of the side bearing cap so it can be properly reinstalled.

Bearing caps are line-bored during manufacture. Replace them in their proper positions.

DISASSEMBLY (Model R200V)

Differential Carrier (Cont'd)

3. Remove side bearing caps.

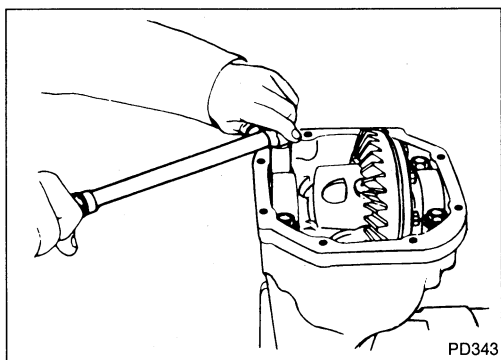

4. Lift differential case assembly out with Tool.
Tool number: HT72400000 (—)

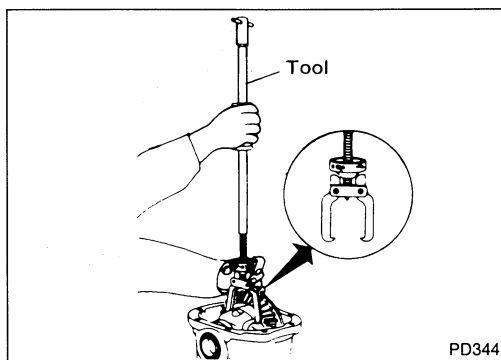

Keep the side bearing outer races together with inner cone — do not mix them up.

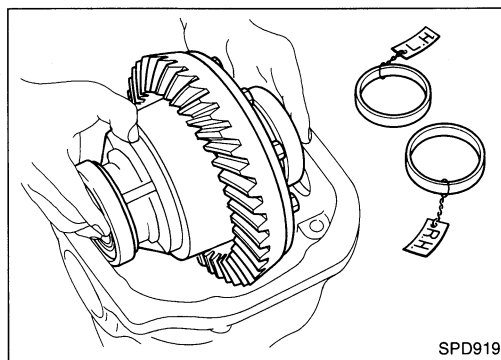

5. Loosen drive pinion nut and pull off companion flange.

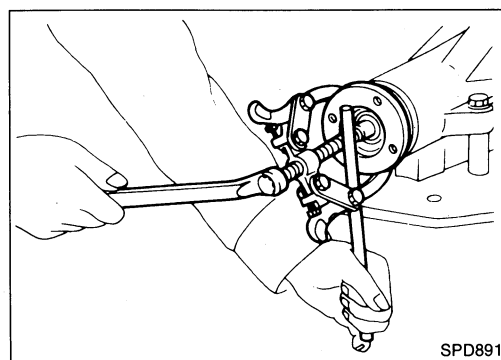
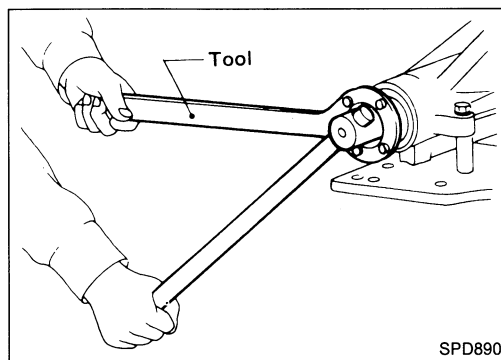

DISASSEMBLY (Model R200V)

Differential Carrier (Cont'd)

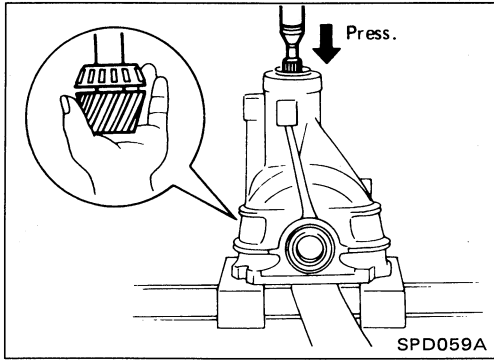

6. Take out drive pinion (together with rear bearing inner race, bearing spacer and adjusting washer).
7. Remove oil seal.
8. Remove front bearing inner race.
9. Remove side oil seal.

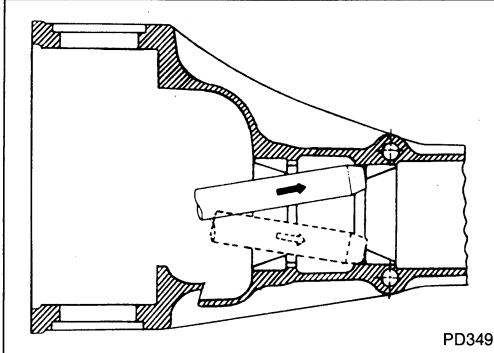

10. Remove pinion bearing outer races with a brass drift.

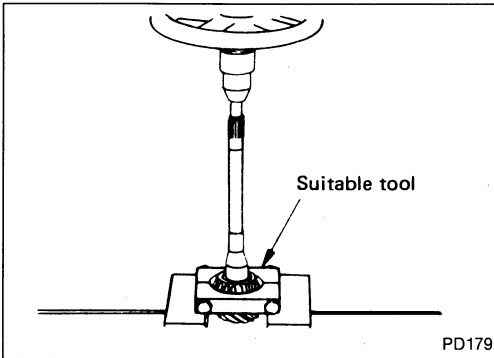

11. Remove pinion rear bearing inner race and drive pinion height adjusting washer with suitable tool.

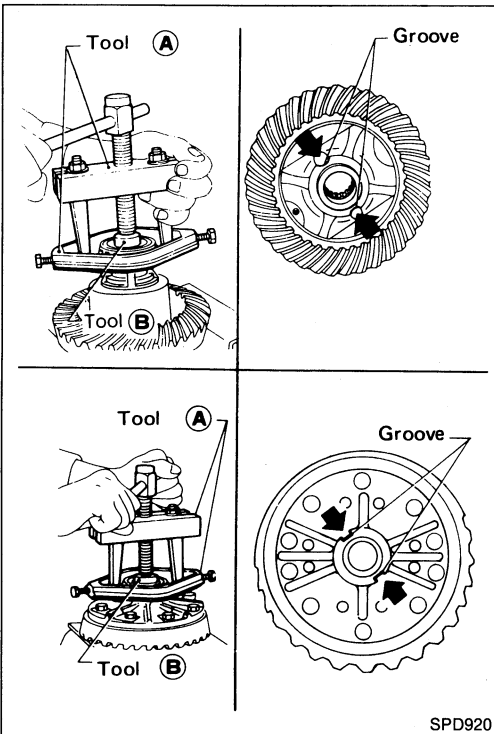

Differential Case

1. Remove side bearing inner cones.

To prevent damage to bearing, engage puller jaws in groove.

Tool number:

- (A) ST33051001 (—)
- (B) ST33061000 (J8107-2)

DISASSEMBLY (Model R200V)

Differential Case (Cont'd)

Be careful not to confuse left- and right-hand parts. Keep bearing and bearing race for each side together.

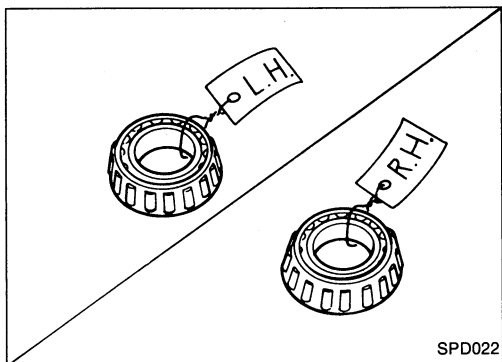

2. Loosen ring gear bolts in a criss-cross fashion.
 3. Tap ring gear off the differential case with a soft hammer.
- Tap evenly all around to keep ring gear from binding.**

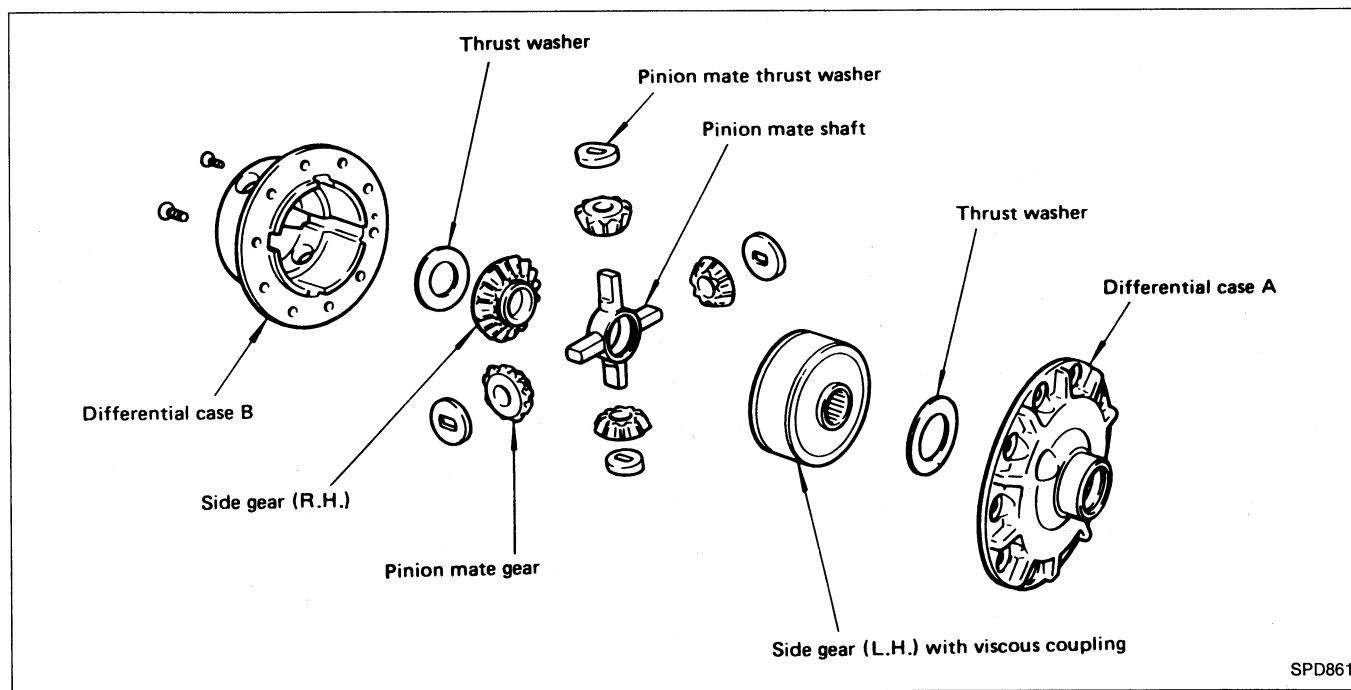
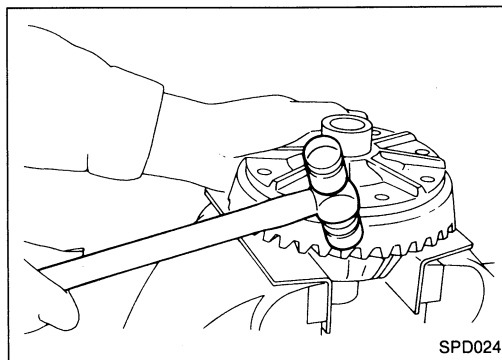

4. Loosen screws on differential cases A and B.
5. Separate differential cases A and B.

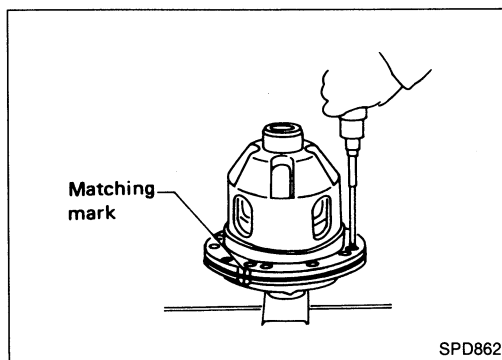

Contact Surfaces

1. Clean the disassembled parts in suitable solvent and blow dry with compressed air.
2. If following surfaces are found to be burred or scratched, smooth with oil stone.
 - Differential case A
 - Differential case B
 - Side gear
 - Pinion mate gear
 - Pinion mate shaft
3. Check viscous coupling for oil leakage. If necessary, replace it with new one.

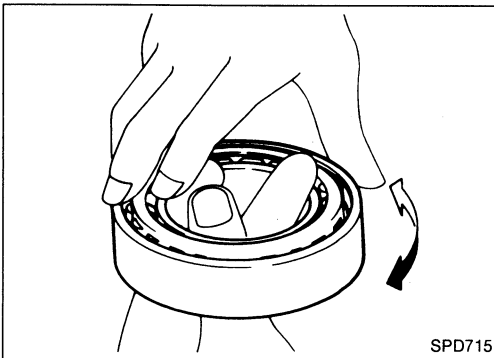

Bearing

1. Thoroughly clean bearing.
2. Check bearings for wear, scratches, pitting or flaking. Check tapered roller bearing for smooth rotation. If damaged, replace outer race and inner cone as a set.

ADJUSTMENT (Model R200V)

For quiet and reliable final drive operation, the following five adjustments must be made correctly.

1. Side bearing preload
2. Pinion gear height
3. Pinion bearing preload
4. Ring gear to pinion backlash (Refer to ASSEMBLY.)
5. Ring and pinion gear tooth contact pattern

Side Bearing Preload

A selection of carrier side bearing preload shims is required for successful completion of this procedure.

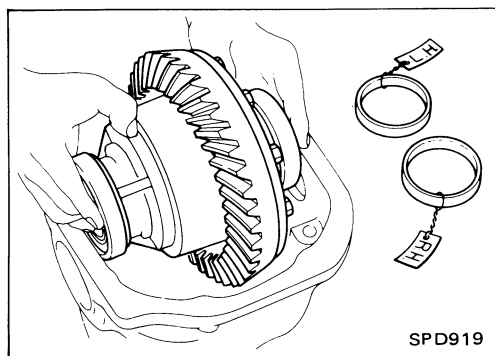

1. Make sure all parts are clean and that the bearings are well lubricated with light oil or Dexron™ type automatic transmission fluid.
2. Place the differential carrier, with side bearings and bearing races installed, into the final drive housing.

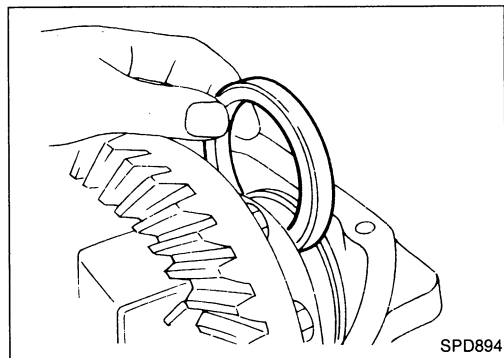

3. Put the side bearing spacer in place on the ring gear end of the carrier.

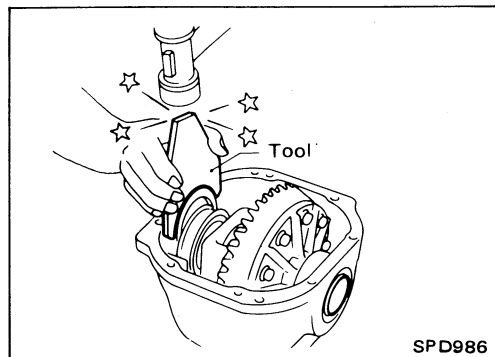

4. Using the J-25267 side bearing spacer drift, place both of the original carrier side bearing preload shims on the carrier end, opposite the ring gear.

ADJUSTMENT (Model R200V)

Side Bearing Preload (Cont'd)

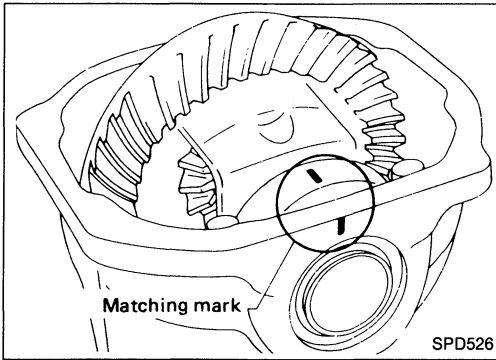

5. Install the side bearing caps in their correct locations and torque the bearing cap retaining bolts.

Specification:

88 - 98 N·m (9 - 10 kg-m, 65 - 72 ft-lb)

6. Turn the carrier several times to seat the bearings.

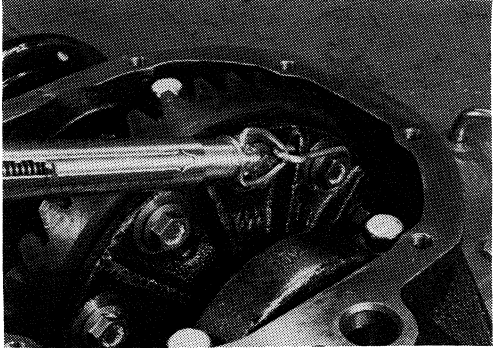

7. Measure the turning torque of the carrier at the ring gear retaining bolts with a spring gauge, J-8129.

Specification:

**34.3 - 39.2 N (3.5 - 4 kg, 7.7 - 8.8 lb)
of pulling force at the ring gear bolt**

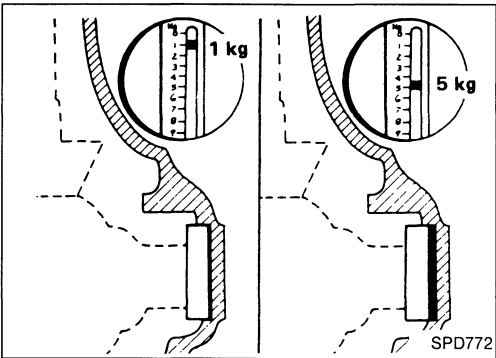

8. If the carrier turning torque is not within the specification range, increase or decrease the total thickness of the side bearing adjusting washers until the turning torque is correct. If the turning torque is less than the specified range, install washers of greater thickness; if the turning torque is greater than the specification, install thinner washers. See the S.D.S. section for washer dimensions and part numbers.

9. Record the total amount of washer thickness required for the correct carrier side bearing preload.

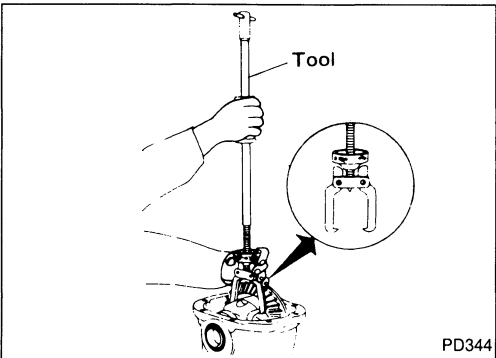

10. Remove the carrier from the final drive housing, saving the selected preload washers for later use during the assembly of the final drive unit.

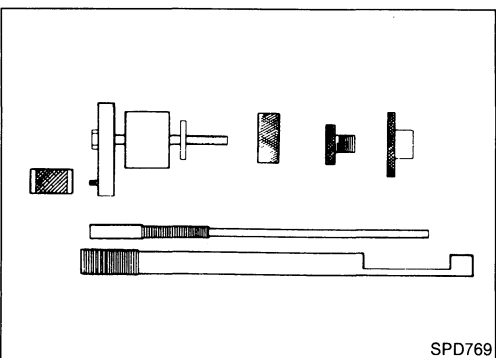

Pinion Gear Height and Pinion Bearing Preload

1. Make sure all parts are clean and that the bearings are well lubricated.
2. Assemble the pinion gear bearings into the pinion preload shim selector Tool, J-34309.

ADJUSTMENT (Model R200V)

Pinion Gear Height and Pinion Bearing Preload (Cont'd)

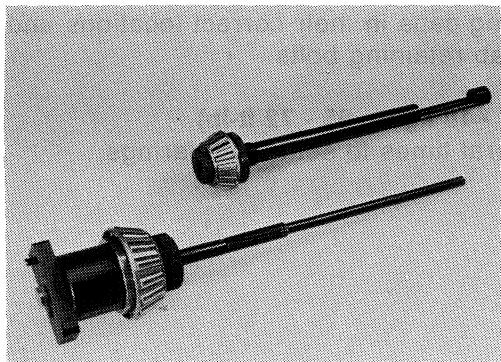

- **Front pinion bearing** — make sure the J-34309-3 front pinion bearing seat is secured tightly against the J-34309-2 gauge anvil. Then turn the front pinion bearing pilot, J-34309-5, to secure the bearing in its proper position.
- **Rear pinion bearing** — the rear pinion bearing pilot, J-34309-8, is used to center the rear pinion bearing only. The rear pinion bearing locking seat, J-34309-4, is used to lock the bearing to the assembly.
- **Installation of J-34309-9 and J-34309-16** — place a suitable 2.5 mm (0.098 in) thick plain washer between J-34309-9 and J-34309-16. Both surfaces of J-34309-9 and J-34309-16 must be parallel with a clearance of 2.5 mm (0.098 in).

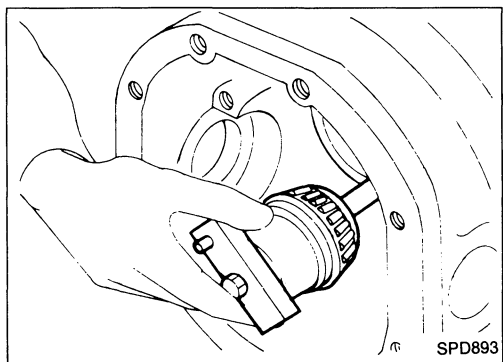

3. Place the pinion preload shim selector Tool, J-34309-1, gauge screw assembly with the pinion rear bearing inner cone installed into the final drive housing.

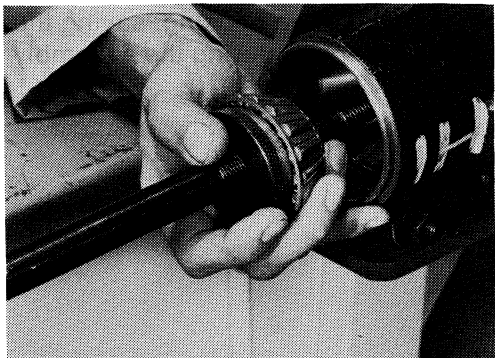

4. Assemble the front pinion bearing inner cone and the J-34309-2 gauge anvil together with the J-34309-1 gauge screw in the final drive housing. Make sure that the pinion height gauge plate, J-34309-16, will turn a full 360 degrees, and tighten the two sections together by hand.

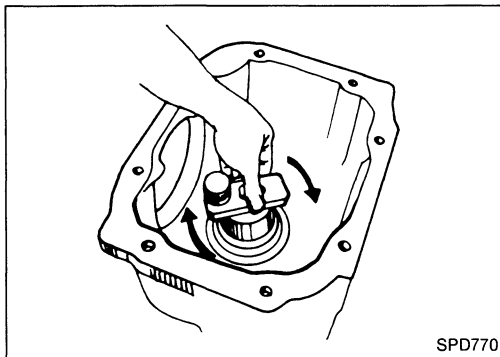

5. Turn the assembly several times to seat the bearings.

ADJUSTMENT (Model R200V)

Pinion Gear Height and Pinion Bearing Preload (Cont'd)

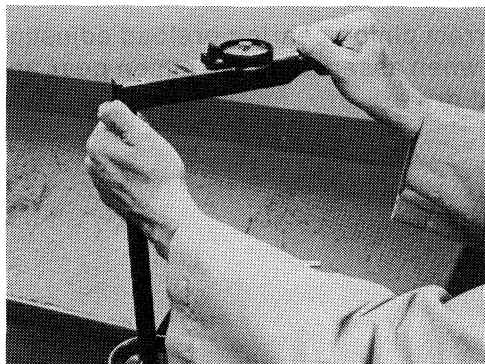

6. Measure the turning torque at the end of the J-34309-2 gauge anvil using torque wrench J-25765A.

Turning torque specification:

1.0 - 1.3 N-m (10 - 13 kg-cm, 8.7 - 11.3 in-lb)

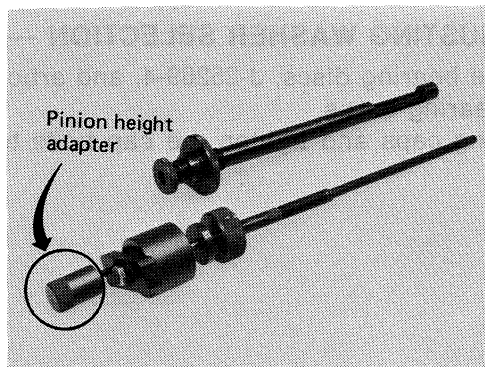

7. Place the J-34309-11 "R200A" pinion height adapter onto the gauge plate and tighten it by hand.

CAUTION:

Make sure all machined surfaces are clean.

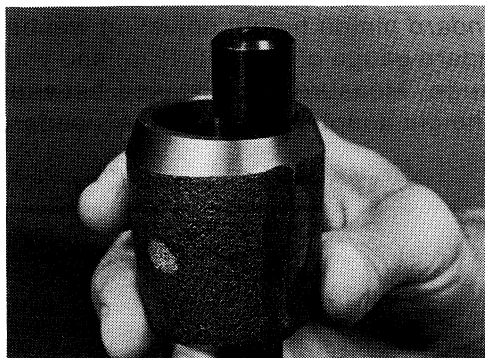

— PINION BEARING PRELOAD WASHER SELECTION —

8. Place the solid pinion bearing spacer, small end first, over the J-34309-2 gauge anvil and seat the small end squarely against the tip of the J-34309-1 gauge screw in the tool recessed portion.

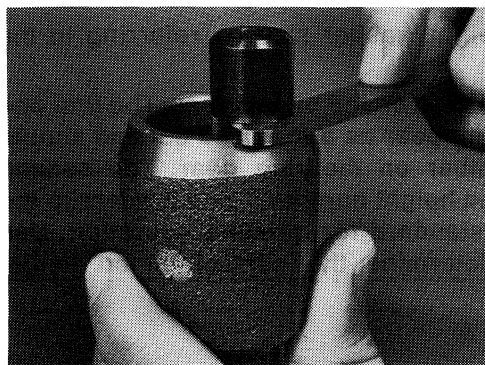
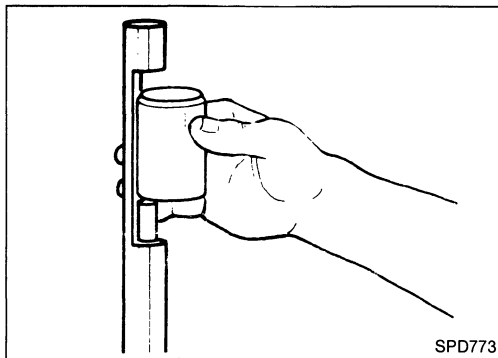

9. Select the correct thickness of pinion bearing preload adjusting washer using a standard gauge of 3.5 mm (0.138 in) and your J-34309-101 feeler gauge. *The exact measurement you get with your gauges is the thickness of the adjusting washer required.* Select the correct washer.

Drive pinion bearing preload adjusting washer:

Refer to S.D.S.

ADJUSTMENT (Model R200V)

Pinion Gear Height and Pinion Bearing Preload (Cont'd)

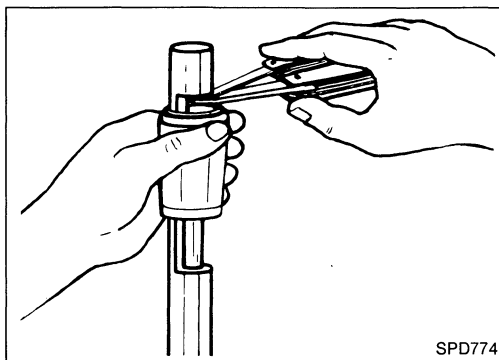

10. Set your selected, correct pinion bearing preload adjusting washer aside for use when assembling the pinion gear and bearings into the final drive.

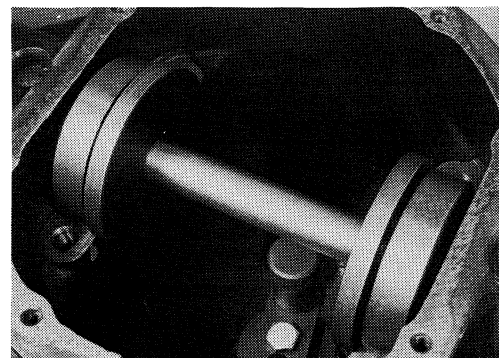

— PINION HEIGHT ADJUSTING WASHER SELECTION —

11. Now, position the side bearing discs, J-25269-4, and arbor firmly into the side bearing bores. Install the side bearing caps and tighten the cap bolts to proper torque.

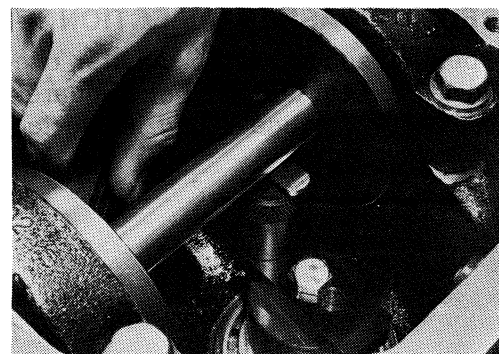

12. Select the correct *standard* pinion height adjusting washer thickness using a standard gauge of 3 mm (0.12 in) and your J-34309-101 feeler gauge. Measure the distance between the J-34309-11 pinion height adapter including the standard gauge and the arbor.

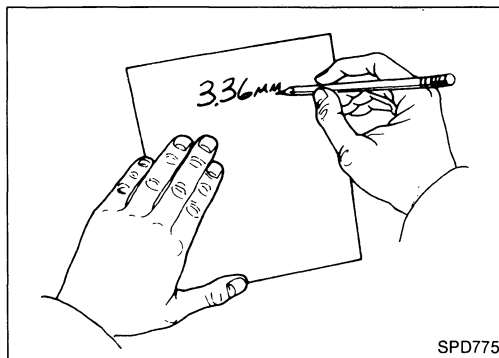

13. Write down your exact measurement (the value of feeler gauge).

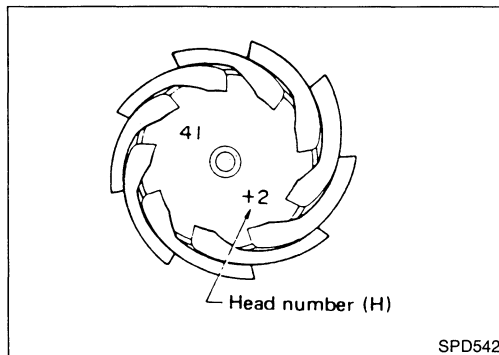

14. Correct the pinion height washer size by referring to the "pinion head number."

There are two numbers painted on the pinion gear. The first one refers to the pinion and ring gear as a matched set and should be the same as the number on the ring gear. The second number is the "pinion head height number," and it refers to the ideal pinion height from standard for quietest operation. Use the following chart to determine the correct pinion height washer.

ADJUSTMENT (Model R200V)

Pinion Gear Height and Pinion Bearing Preload (Cont'd)

Pinion head height number	Add or remove from the standard pinion height washer thickness measurement
- 6	Add 0.06 mm (0.0024 in)
- 5	Add 0.05 mm (0.0020 in)
- 4	Add 0.04 mm (0.0016 in)
- 3	Add 0.03 mm (0.0012 in)
- 2	Add 0.02 mm (0.0008 in)
- 1	Add 0.01 mm (0.0004 in)
0	Use the selected washer thickness
+ 1	Subtract 0.01 mm (0.0004 in)
+ 2	Subtract 0.02 mm (0.0008 in)
+ 3	Subtract 0.03 mm (0.0012 in)
+ 4	Subtract 0.04 mm (0.0016 in)
+ 5	Subtract 0.05 mm (0.0020 in)
+ 6	Subtract 0.06 mm (0.0024 in)

15. Select the correct pinion height washer from the following chart.

Drive pinion height adjusting washer (R200):

Thickness mm (in)	Part No.
3.09 (0.1217)	38154-P6017
3.12 (0.1228)	38154-P6018
3.15 (0.1240)	38154-P6019
3.18 (0.1252)	38154-P6020
3.21 (0.1264)	38154-P6021
3.24 (0.1276)	38154-P6022
3.27 (0.1287)	38154-P6023
3.30 (0.1299)	38154-P6024
3.33 (0.1311)	38154-P6025
3.36 (0.1323)	38154-P6026
3.39 (0.1335)	38154-P6027
3.42 (0.1346)	38154-P6028
3.45 (0.1358)	38154-P6029
3.48 (0.1370)	38154-P6030
3.51 (0.1382)	38154-P6031
3.54 (0.1394)	38154-P6032
3.57 (0.1406)	38154-P6033
3.60 (0.1417)	38154-P6034
3.63 (0.1429)	38154-P6035
3.66 (0.1441)	38154-P6036



16. Remove the J-34309 pinion preload shim selector Tool from the final drive housing and disassemble to retrieve the pinion bearings.

Tooth Contact

Checking gear tooth contact pattern is necessary to verify correct relationship between ring gear and drive pinion. Hypoid gears which are not positioned properly in relation to one another may be noisy, or have short life or both. With the checking of gear tooth contact pattern, the most desirable contact for low noise level and long life can be assured.

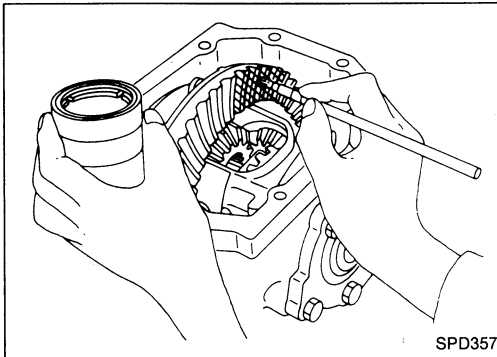

1. Thoroughly clean ring gear and drive pinion teeth.
2. Sparingly apply a mixture of powdered titanium oxide and oil or equivalent to 3 or 4 teeth of ring gear drive side.

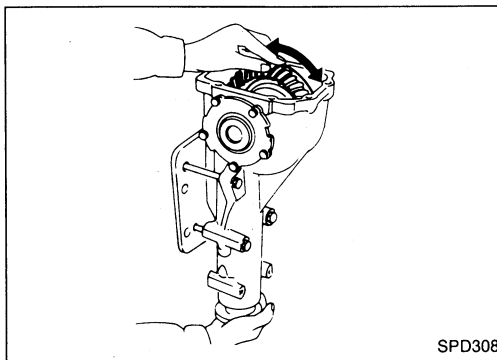

3. Hold companion flange steady by hand and rotate the ring gear in both directions.

Usually the pattern will be correct if you have calculated the shims correctly and the backlash is correct. However, in rare cases you may have to use trial-and-error processes until you get a good tooth contact pattern. The tooth pattern is the best indication of how well the final drive has been set up.

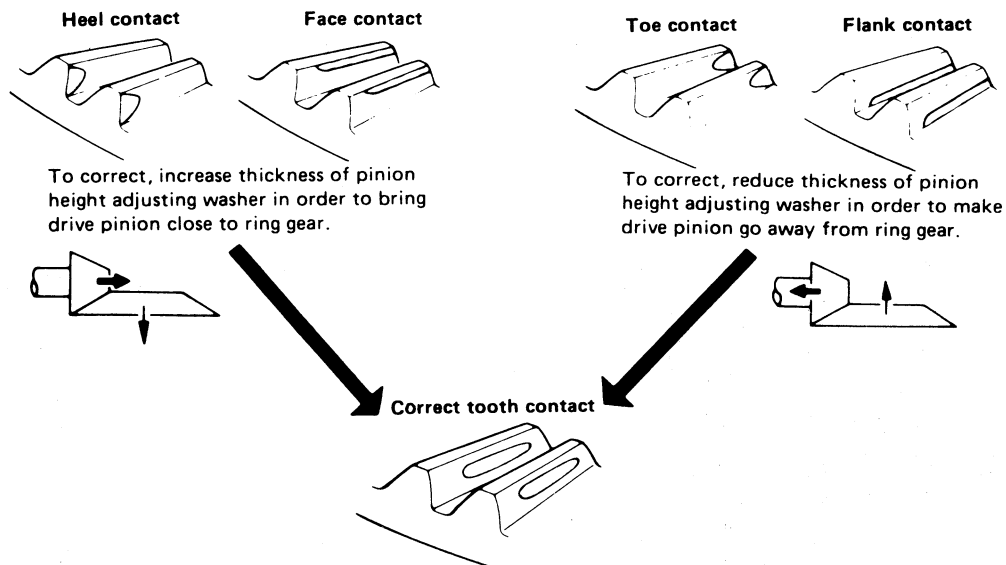

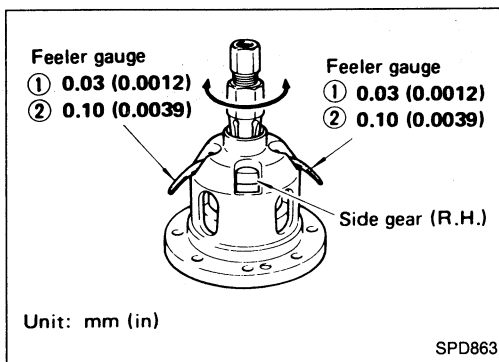

Differential Case

THRUST WASHER SELECTION

Whenever side gears or pinion mate gears are replaced, select suitable thrust washers as follows:

1. Clean side gears and pinion mate gears using a suitable solvent.
2. Before assembling gears, apply hypoid gear oil to frictional surfaces.
3. Install the previously removed thrust washer on right side gear. On left side gear, install a suitable thrust washer. Temporarily tighten differential cases using two screws.
4. Position differential assembly so that right side gear is on the upper side. Place a 0.03 mm (0.0012 in) feeler gauge (for example) between right side gear and thrust washer.

Do not insert feeler gauge in oil groove portion of differential case.

5. Also place a 0.03 mm (0.0012 in) additional feeler gauge between right side gear and thrust washer so that it is positioned diagonal to (180° apart from) the feeler gauge described previously.
6. Rotate right side gear with a suitable tool attached to splines.
If right side gear cannot be rotated, replace thrust washer used on left side gear with a thinner one.
7. Replace both 0.03 mm (0.0012 in) feeler gauges with 0.10 mm (0.0039 in) gauges. At this point, make sure right side gear does not rotate. If it does, replace thrust washer on left side gear with a thicker one so that right side gear does not rotate.
8. As explained in above example, select suitable thrust washers to ensure that:
 - a) Both side gears rotate. [0.03 mm (0.0012 in) feeler gauges are used in this case.]
 - b) Side gear is held stationary. [0.10 mm (0.0039 in) feeler gauges are used in this case.]
 (Refer to S.D.S.)

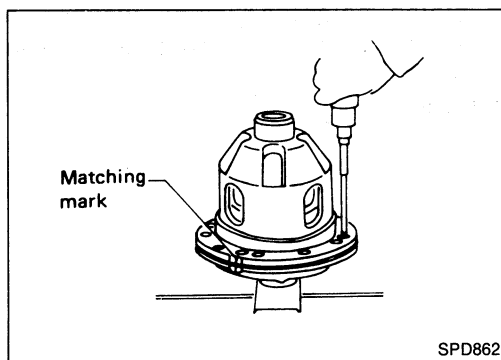

ASSEMBLY

1. Install differential case A and B.

ASSEMBLY (Model R200V)

Differential Case (Cont'd)

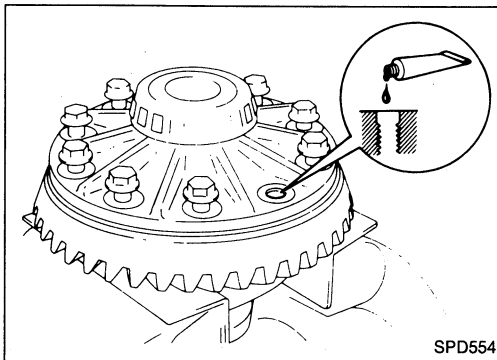

2. Place differential case on ring gear.
3. Apply locking sealant to ring gear bolts, and install them.
Tighten bolts in a criss-cross fashion, lightly tapping bolt head with a hammer.

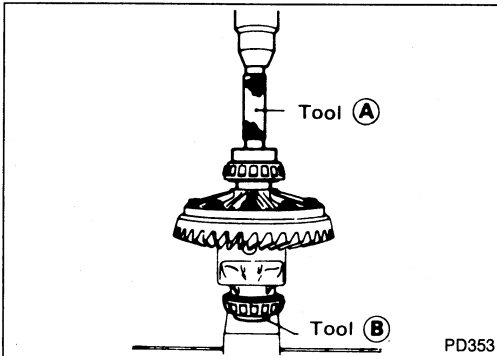

4. Press-fit side bearing inner cones on differential case with Tool.

Tool number:

- (A) KV38100300 (J25523)
- (B) ST33061000 (J8107-2)

Differential Carrier

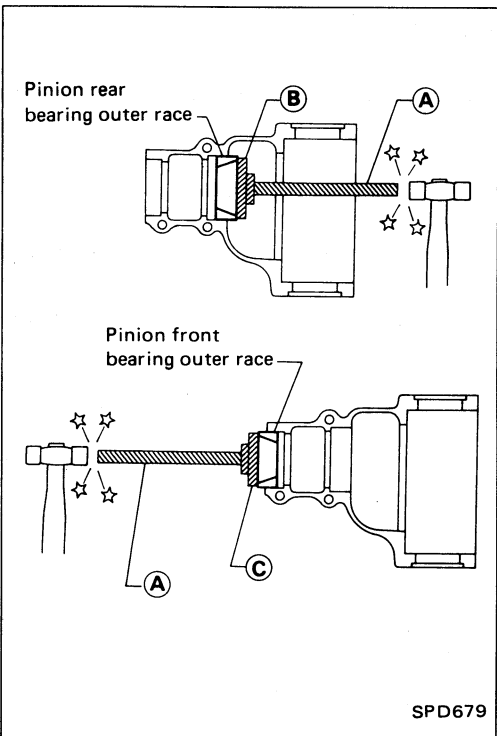

1. Press-fit front and rear bearing outer races with Tools.

Tool number:

- (A) ST30611000 (J25742-1)
- (B) ST30701000 (J25742-2)
- (C) ST30613000 (J25742-3)

2. Select pinion bearing adjusting washer and drive pinion bearing spacer, referring to ADJUSTMENT.

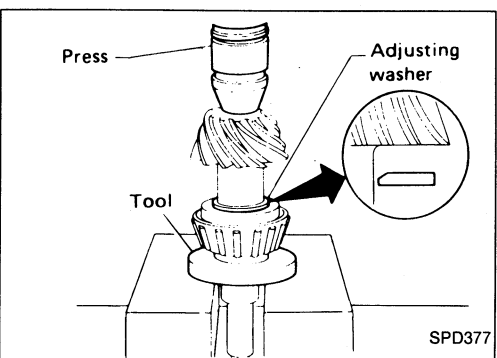

3. Install selected drive pinion height adjusting washer in drive pinion, and press-fit pinion rear bearing inner cone in it, using press and Tool.

Tool number: ST30901000 (—)

ASSEMBLY (Model R200V)

Differential Carrier (Cont'd)

4. Place pinion front bearing inner cone in final drive housing.

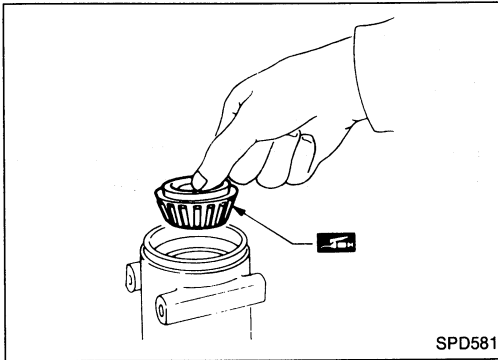

5. Set drive pinion assembly (as shown in figure at left) in differential carrier and install drive pinion, with press and suitable tool.

Stop when drive pinion touches bearing.

Apply multi-purpose grease to pinion rear bearing inner race, pinion front bearing inner race and front pilot bearing.

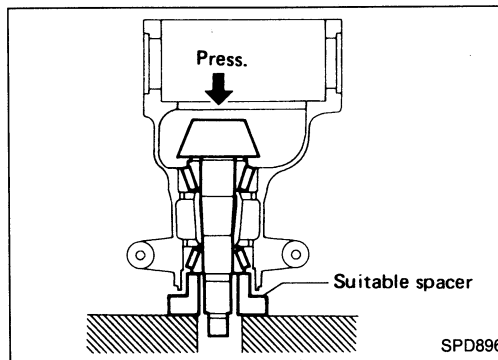
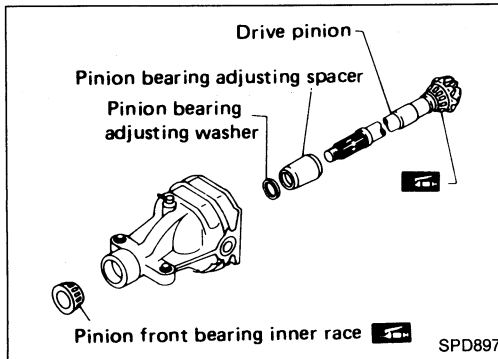

6. Apply multi-purpose grease to cavity at sealing lips of oil seal. Install front oil seal with Tool.

Tool number: KV38100500 (—)

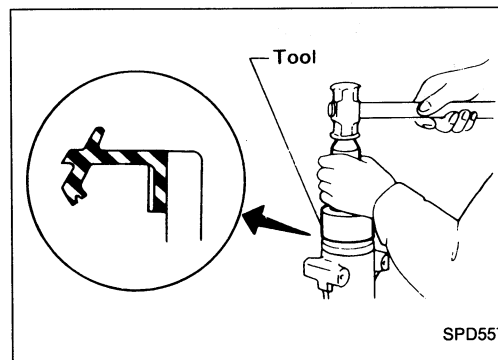

7. Install companion flange, and tighten pinion nut to specified torque with Tool.

Make sure that threaded portion of drive pinion and pinion nut are free from oil or grease.

Tool number: ST38060002 (J34311)

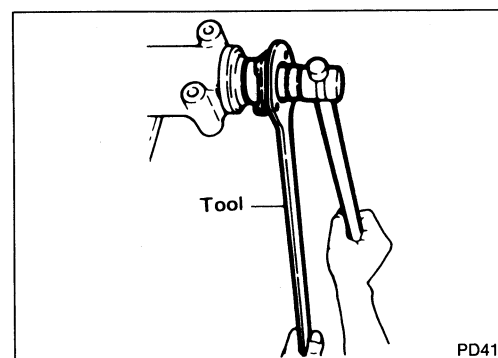

ASSEMBLY (Model R200V)

Differential Carrier (Cont'd)

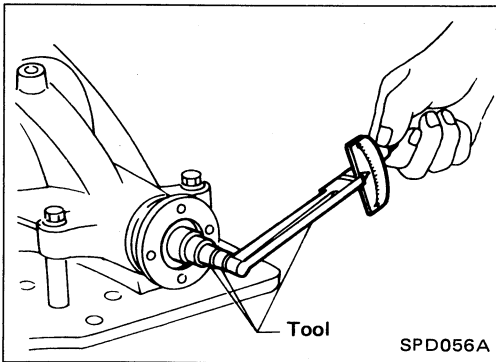

8. Turn drive pinion in both directions several times, and measure pinion bearing preload.

Pinion bearing preload:

1.1 - 1.4 N·m (11 - 14 kg-cm, 9.5 - 12.2 in-lb)

When pinion bearing preload is outside the specifications, replace pinion bearing adjusting washer and spacer with a different thickness.

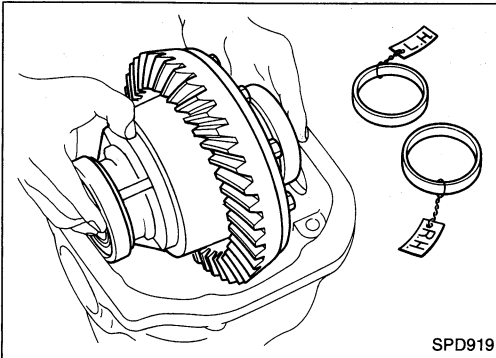

9. Select side bearing adjusting washer. Refer to ADJUSTMENT.
10. Install differential case assembly with side bearing outer races into gear carrier.

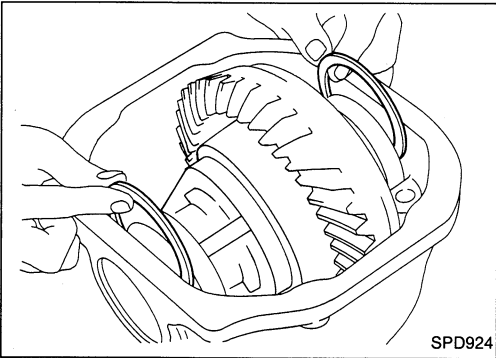

11. Insert left and right side bearing adjusting washers in place between side bearings and carrier.

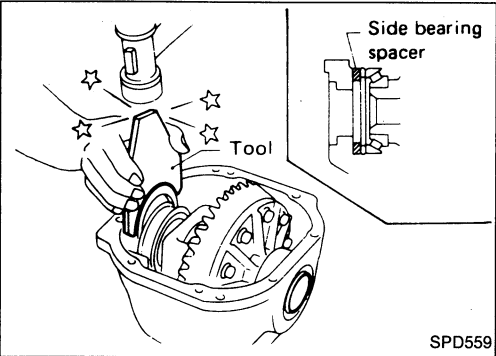

12. Drive in side bearing spacer with Tool.
Tool number: KV38100600 (J25267)
Spacer location: Right side

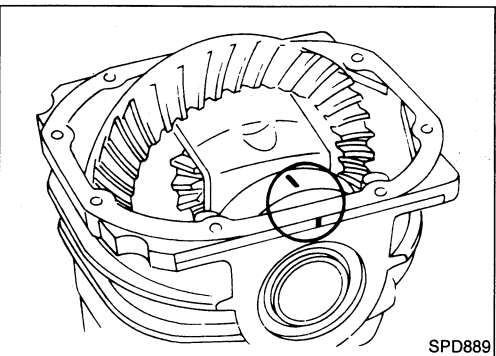

13. Align mark on bearing cap with that on gear carrier and install bearing cap on gear carrier.

ASSEMBLY (Model R200V)

Differential Carrier (Cont'd)

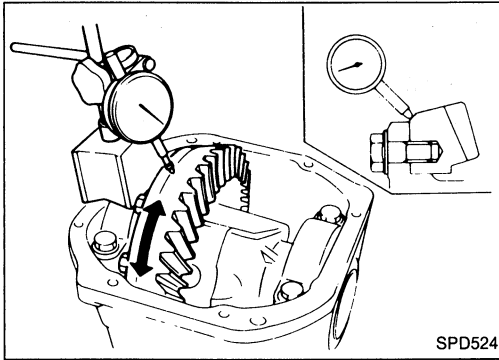

14. Check runout of ring gear with a dial indicator.

Runout limit:

0.05 mm (0.0020 in)

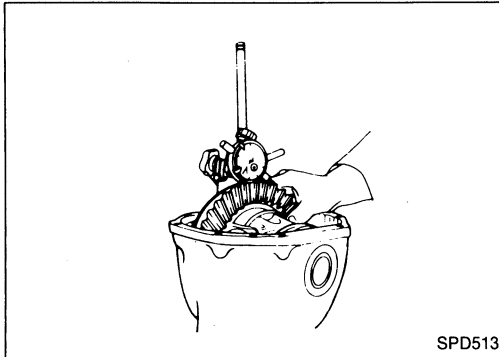

15. Measure ring gear to drive pinion backlash with a dial indicator.

Ring gear to drive pinion backlash:

0.10 - 0.15 mm (0.0039 - 0.0059 in)

- If backlash is too small, decrease thickness of left shim and increase thickness of right shim by the same amount.
- If backlash is too great, reverse the above procedure.

Never change the total amount of shims as it will change the bearing preload.

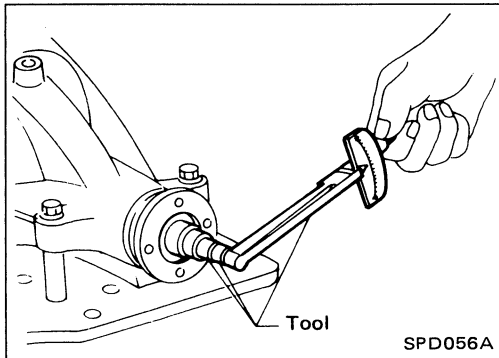

16. Check total preload with Tool.

When checking preload, turn drive pinion in both directions several times to seat bearing rollers correctly.

Total preload:

Value more than 0.29 N-m (3.0 kg-cm, 2.6 in-lb)

added on measured value of drive pinion preload

- If preload is too great, remove the same amount of shim from each side.
- If preload is too small, add the same amount of shim to each side.

Never add or remove a different number of shims for each side as it will change ring gear to drive pinion backlash.

17. Recheck ring gear to drive pinion backlash because increase or decrease in thickness of shims will cause change of ring gear to pinion backlash.

- If backlash varies excessively in different places, foreign matter may be caught between the ring gear and the differential case.
- If the backlash varies greatly when the ring gear runout is within a specified range, replace the hypoid gear set or differential case.

18. Check tooth contact.

Refer to ADJUSTMENT.

ASSEMBLY (Model R200V)

Differential Carrier (Cont'd)

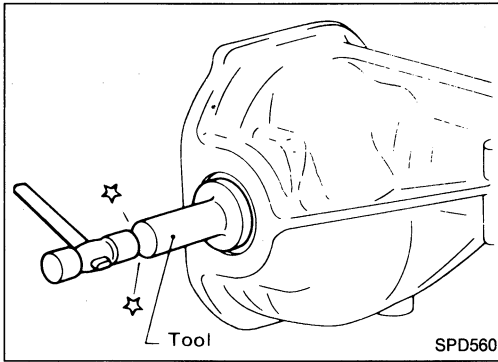

19. Apply multi-purpose grease to cavity at sealing lips of oil seal. Install side oil seal.

Tool number: KV38100200 (J26233)

20. Install rear cover and gasket.

SERVICE DATA AND SPECIFICATIONS (S.D.S.)

Propeller Shaft

GENERAL SPECIFICATIONS

Unit: mm (in)

Applied model Transmission type	M/T	A/T
Propeller shaft model	3S63A-R	3S63A-T
Number of joints	3	
Coupling method with transmission	Sleeve type	
Type of journal bearings	Shell type (Non-disassembly type)	
Distance between yokes	63.0 (2.480)	
Shaft length (Spider to spider)		
1st	395.0 (15.55)	432.0 (17.01)
2nd		
Without A.B.S.	605.0 (23.82)	
With A.B.S.	590 (23.23)	
Shaft outer diameter		
1st	75.0 (2.953)	
2nd	75.0 (2.953)	75.0 (2.953) ... Large side 63.5 (2.500) ... Small side

SPECIFICATIONS AND ADJUSTMENT

Unit: mm (in)

Propeller shaft model	3S63A-R	3S63A-T
Propeller shaft runout limit	0.6 (0.024)	
Journal axial play	0 (0)	

SERVICE DATA AND SPECIFICATIONS (S.D.S.)

Final Drive

GENERAL SPECIFICATIONS

Final drive model	R200V	R200
Ring gear pitch diameter mm (in)	205 (8.07)	
Gear ratio	4.083	
Number of teeth (Ring gear/Drive pinion)	49/12	
Oil capacity (approx.) ℓ (US pt, Imp pt)	1.5 (3-1/8, 2-5/8)	1.3 (2-3/4, 2-1/4)
Number of pinion gears	4	2
Side gear bearing spacer location	Right	

INSPECTION AND ADJUSTMENT

Ring gear runout

Ring gear runout limit mm (in)	0.05 (0.0020)
-----------------------------------	---------------

Side gear adjustment

Clearance between side gear and differential case mm (in)	0.03 - 0.09 (0.0012 - 0.0035)
---	----------------------------------

Available side gear thrust washers (R200V)

Thickness	mm (in)	Part number
0.80	(0.0315)	38424-40F60
0.83	(0.0327)	38424-40F61
0.86	(0.0339)	38424-40F62
0.89	(0.0350)	38424-40F63
0.92	(0.0362)	38424-40F64
0.95	(0.0374)	38424-40F65
0.98	(0.0386)	38424-40F66
1.01	(0.0398)	38424-40F67
1.04	(0.0409)	38424-40F68
1.07	(0.0421)	38424-40F69
1.10	(0.0433)	38424-40F70
1.13	(0.0445)	38424-40F71
1.16	(0.0457)	38424-40F72
1.19	(0.0469)	38424-40F73
1.22	(0.0480)	38424-40F74
1.25	(0.0492)	38424-40F75
1.28	(0.0504)	38424-40F76
1.31	(0.0516)	38424-40F77
1.34	(0.0528)	38424-40F78
1.37	(0.0539)	38424-40F79
1.40	(0.0551)	38424-40F80
1.43	(0.0563)	38424-40F81
1.46	(0.0575)	38424-40F82
1.49	(0.0587)	38424-40F83

Available side gear thrust washers (R200)

Thickness	mm (in)	Part number
0.75	(0.0295)	38424-N3110
0.78	(0.0307)	38424-N3111
0.81	(0.0319)	38424-N3112
0.84	(0.0331)	38424-N3113
0.87	(0.0343)	38424-N3114
0.90	(0.0354)	38424-N3115
0.93	(0.0366)	38424-N3116

Drive pinion height adjustment

Available pinion height adjusting washers

Thickness	mm (in)	Part number
3.09	(0.1217)	38154-P6017
3.12	(0.1228)	38154-P6018
3.15	(0.1240)	38154-P6019
3.18	(0.1252)	38154-P6020
3.21	(0.1264)	38154-P6021
3.24	(0.1276)	38154-P6022
3.27	(0.1287)	38154-P6023
3.30	(0.1299)	38154-P6024
3.33	(0.1311)	38154-P6025
3.36	(0.1323)	38154-P6026
3.39	(0.1335)	38154-P6027
3.42	(0.1346)	38154-P6028
3.45	(0.1358)	38154-P6029
3.48	(0.1370)	38154-P6030
3.51	(0.1382)	38154-P6031
3.54	(0.1394)	38154-P6032
3.57	(0.1406)	38154-P6033
3.60	(0.1417)	38154-P6034
3.63	(0.1429)	38154-P6035
3.66	(0.1441)	38154-P6036

SERVICE DATA AND SPECIFICATIONS (S.D.S.)

Final Drive (Cont'd)

Drive pinion preload adjustment

Drive pinion bearing adjusting method	Pinion bearing adjusting washer and spacer
Drive pinion preload with front oil seal N·m (kg-cm, in-lb)	1.1 - 1.4 (11 - 14, 9.5 - 12.2)

Available drive pinion bearing preload adjusting washers

Thickness	mm (in)	Part number
3.80 - 3.82	(0.1496 - 0.1504)	38125-61001
3.82 - 3.84	(0.1504 - 0.1512)	38126-61001
3.84 - 3.86	(0.1512 - 0.1520)	38127-61001
3.86 - 3.88	(0.1520 - 0.1528)	38128-61001
3.88 - 3.90	(0.1528 - 0.1535)	38129-61001
3.90 - 3.92	(0.1535 - 0.1543)	38130-61001
3.92 - 3.94	(0.1543 - 0.1551)	38131-61001
3.94 - 3.96	(0.1551 - 0.1559)	38132-61001
3.96 - 3.98	(0.1559 - 0.1567)	38133-61001
3.98 - 4.00	(0.1567 - 0.1575)	38134-61001
4.00 - 4.02	(0.1575 - 0.1583)	38135-61001
4.02 - 4.04	(0.1583 - 0.1591)	38136-61001
4.04 - 4.06	(0.1591 - 0.1598)	38137-61001
4.06 - 4.08	(0.1598 - 0.1606)	38138-61001
4.08 - 4.10	(0.1606 - 0.1614)	38139-61001

Available drive pinion bearing preload adjusting spacers

Length	mm (in)	Part number
54.50	(2.1457)	38165-B4000
54.80	(2.1575)	38165-B4001
55.10	(2.1693)	38165-B4002
55.40	(2.1811)	38165-B4003
55.70	(2.1929)	38165-B4004
56.00	(2.2047)	38165-61001

Total preload adjustment

Drive pinion to ring gear backlash	mm (in)	0.10 - 0.15 (0.0039 - 0.0059)
Total preload		Value more than 0.29 N·m (3.0 kg-cm, 2.6 in-lb) added on measured value of drive pinion preload
Side bearing adjusting method		Adjusting washer

Available side bearing adjusting washers

Thickness	mm (in)	Part number
2.00	(0.0787)	38453-N3100
2.05	(0.0807)	38453-N3101
2.10	(0.0827)	38453-N3102
2.15	(0.0846)	38453-N3103
2.20	(0.0866)	38453-N3104
2.25	(0.0886)	38453-N3105
2.30	(0.0906)	38453-N3106
2.35	(0.0925)	38453-N3107
2.40	(0.0945)	38453-N3108
2.45	(0.0965)	38453-N3109
2.50	(0.0984)	38453-N3110
2.55	(0.1004)	38453-N3111
2.60	(0.1024)	38453-N3112
2.65	(0.1043)	38453-N3113

FRONT AXLE & FRONT SUSPENSION

SECTION **FA**

CONTENTS

PRECAUTIONS AND PREPARATION	FA- 2
FRONT AXLE AND FRONT SUSPENSION	FA- 4
CHECK AND ADJUSTMENT — On-vehicle	FA- 5
FRONT AXLE	FA- 9
FRONT AXLE — Wheel Hub and Knuckle	FA-10
FRONT AXLE — Baffle Plate	FA-13
FRONT SUSPENSION	FA-14
FRONT SUSPENSION — Coil Spring and Strut Assembly	FA-15
FRONT SUSPENSION — Tension Rod and Stabilizer Bar	FA-17
FRONT SUSPENSION — Transverse Link and Lower Ball Joint	FA-18
SERVICE DATA AND SPECIFICATIONS (S.D.S.)	FA-19

PRECAUTIONS AND PREPARATION

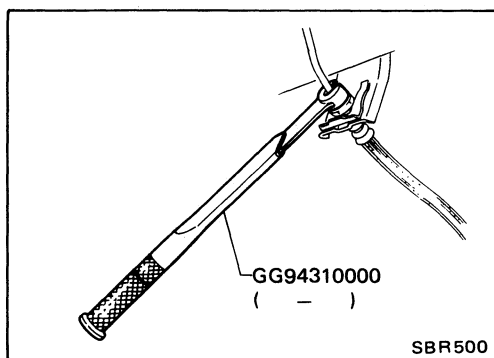

Precautions

- When installing each rubber part, final tightening must be carried out under unladen condition* with tires on ground.
 - * Fuel, radiator coolant and engine oil full. Spare tire, jack, hand tools and mats in designated positions.
- When removing each suspension part, check wheel alignment and adjust if necessary.
- Use Tool when removing or installing brake tubes.

Preparation

SPECIAL SERVICE TOOLS

Tool number (Kent-Moore No.) Tool name	Description	
HT72520000 (J25730-A) Ball joint remover	<p style="text-align: center;">PAT. P</p>	Removing tie-rod outer end and lower ball joint
HT71780000 (-) Spring compressor		Removing and installing coil spring
ST35652000 (-) Strut attachment		Fixing strut assembly
GG94310000 (-) Flare nut torque wrench		Removing and installing brake piping

PRECAUTIONS AND PREPARATION

Preparation (Cont'd) COMMERCIAL SERVICE TOOLS

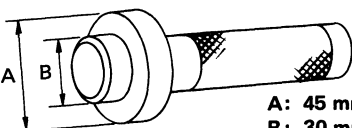
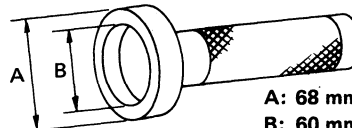
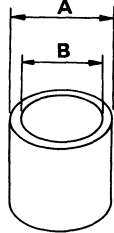
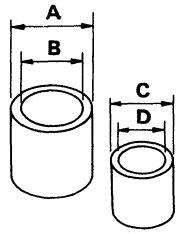
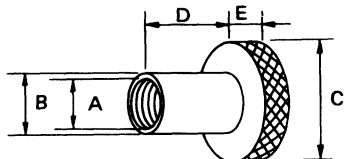
Tool name	Description
Wheel bearing drift	 <p style="text-align: right;">Removing wheel bearing</p> <p style="text-align: right;">A: 45 mm (1.77 in) dia. B: 30 mm (1.18 in) dia.</p>
Wheel bearing drift	 <p style="text-align: right;">Installing wheel bearing</p> <p style="text-align: right;">A: 68 mm (2.68 in) dia. B: 60 mm (2.36 in) dia.</p>
Baffle plate drift	 <p style="text-align: right;">Installing baffle plate</p> <p style="text-align: right;">A: 88 mm (3.46 in) dia. B: 68 mm (2.68 in) dia.</p>
Tension rod bushing drift	 <p style="text-align: right;">Removing and installing tension rod bushing</p> <p style="text-align: right;">A: 75 mm (2.95 in) dia. B: 66 mm (2.60 in) dia. C: 62 mm (2.44 in) dia. D: 25 - 55 mm (0.98 - 2.17 in) dia.</p>
Attachment Wheel alignment	 <p style="text-align: right;">Measure wheel alignment</p> <p style="text-align: right;">A: Screw M22 x 1.5 B: 35 (1.38) dia. C: 65 (2.56) dia. D: 56 (2.20) E: 12 (0.47)</p> <p style="text-align: right;">Unit: mm (in)</p>

FRONT AXLE AND FRONT SUSPENSION

When installing each rubber part, final tightening must be carried out under unladen condition* with tires on ground.

* Fuel, radiator coolant and engine oil full. Spare tire, jack, hand tools and mats in designated positions.

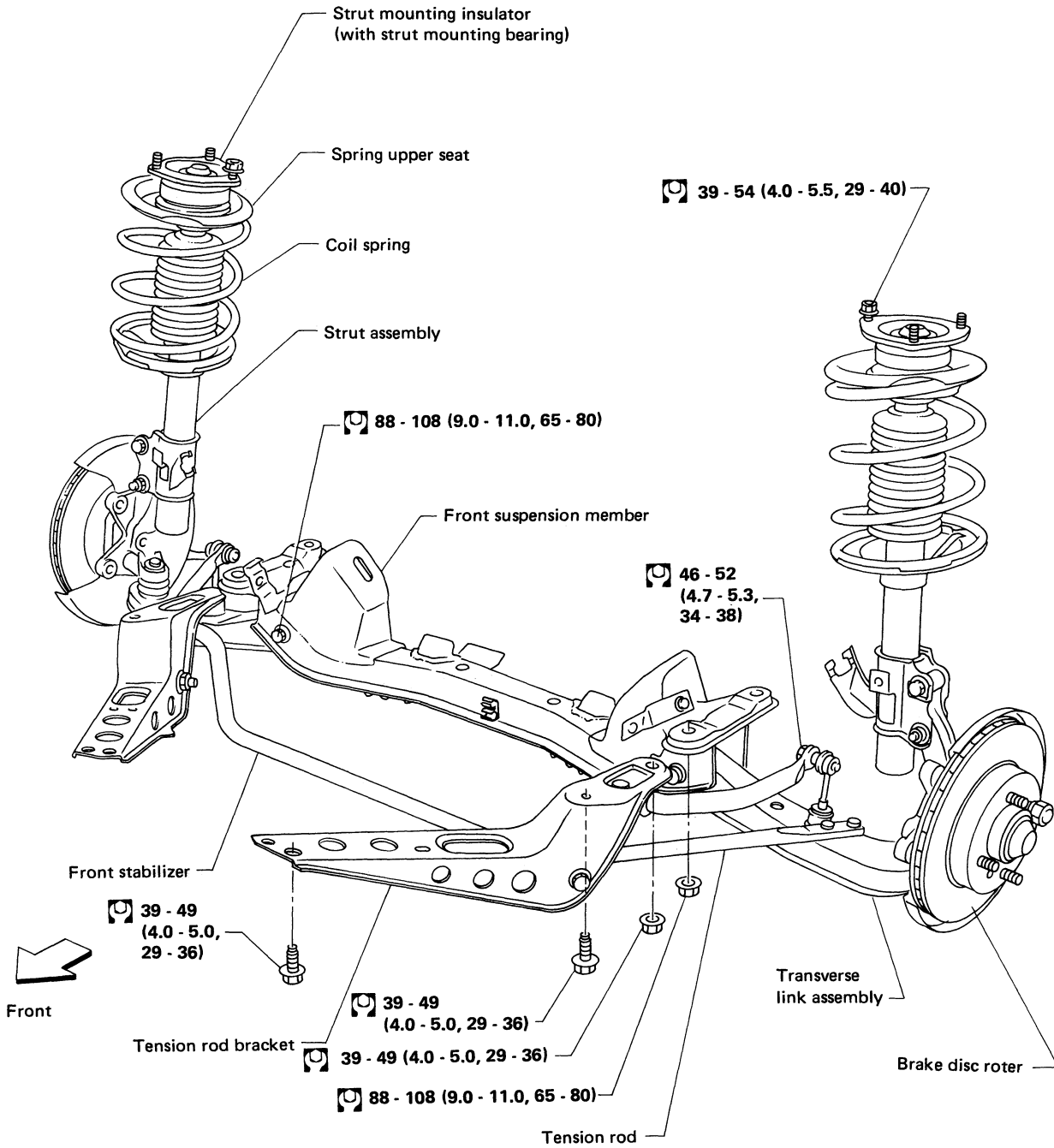

: N-m (kg-m, ft-lb)

SFA540A

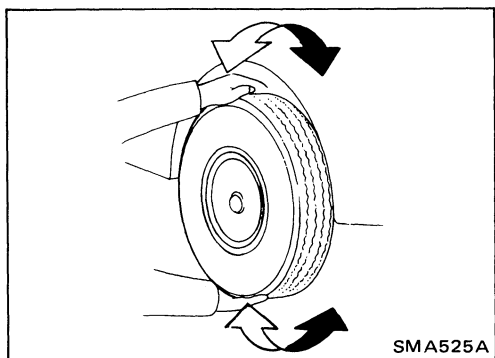

Front Axle and Front Suspension Parts

Check front axle and front suspension parts for looseness, cracks, wear or other damage.

- Shake each front wheel to check for excessive play.

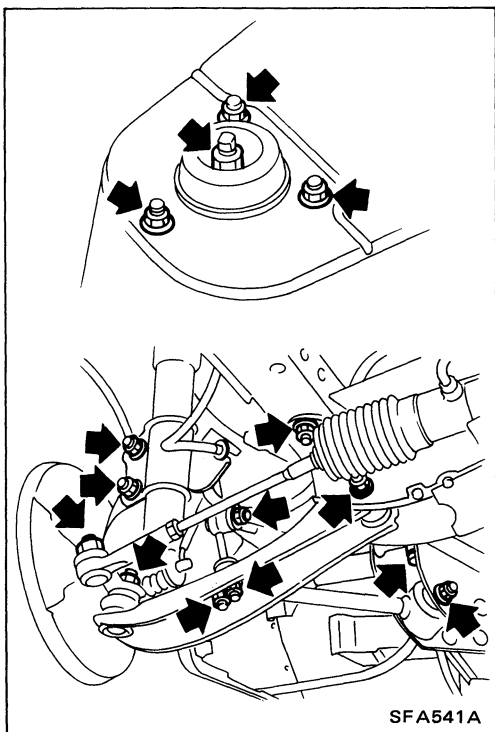

- Retighten all nuts and bolts to the specified torque.
Tightening torque: Refer to FRONT SUSPENSION.
- Make sure that cotter pin is inserted.

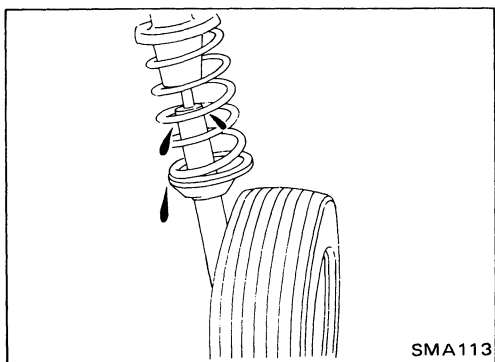

- Check strut (shock absorber) for oil leakage or other damage.

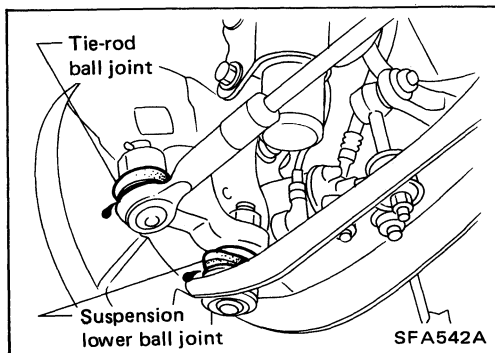

- Check suspension ball joint for grease leakage and ball joint dust cover for cracks or other damage.

CHECK AND ADJUSTMENT — On-vehicle

Front Axle and Front Suspension Parts (Cont'd)

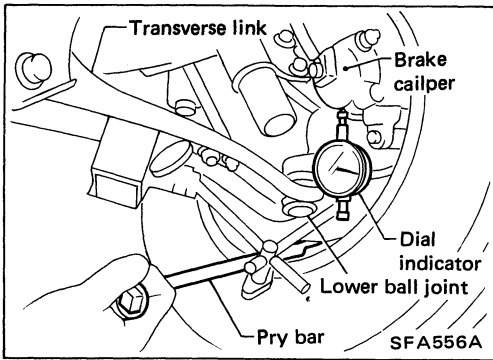

- Check suspension ball joint end play.
- (1) Jack up front of vehicle and set the stands.
 - (2) Clamp dial indicator onto transverse link and place indicator tip on lower edge of brake caliper.
 - (3) Make sure front wheels are straight and brake pedal is depressed.
 - (4) Place a pry bar between transverse link and inner rim of road wheel.
 - (5) While raising and releasing pry bar, observe maximum dial indicator value.

Vertical end play:

0 mm (0 in)

- (6) If ball joint movement is beyond specifications, remove and recheck it.

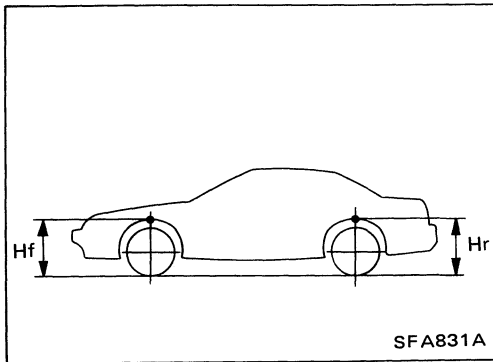

- Check spring height from the top of the wheelarch to the ground.

- (1) Vehicle must be unladen*, parked on a level surface, and tires checked for proper inflation and wear (tread wear indicator must not be showing).

*: Fuel, radiator coolant and engine oil full. Spare tire, jack, hand tools and mats in designated positions.

- (2) Bounce the vehicle up and down several times before measuring.

Wheelarch height:

Front (Hf): 694 mm (27.32 in)

Rear (Hr): 670 mm (26.38 in)

- (3) Spring height is not adjustable. If out of specification, check for worn springs or suspension parts.

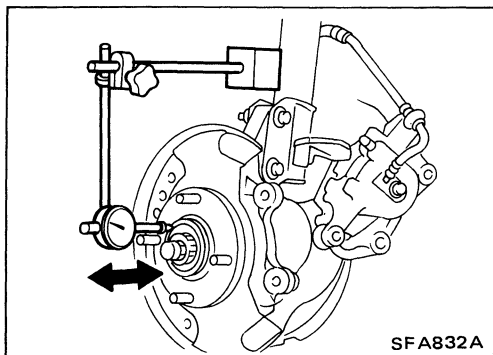

Front Wheel Bearing

- Check that wheel bearings operate smoothly.
- Check axial end play.

Axial end play:

0.03 mm (0.0012 in) or less

- If axial end play is not within specification or wheel bearing does not turn smoothly, replace wheel bearing assembly. Refer to FRONT AXLE — Wheel Hub and Knuckle.

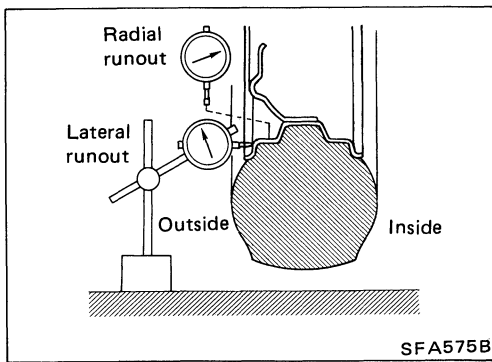

Front Wheel Alignment

Before checking front wheel alignment, be sure to make a preliminary inspection (Unladen*).

*: Fuel, radiator coolant and engine oil full. Spare tire, jack, hand tools and mats in designated positions.

PRELIMINARY INSPECTION

1. Check tires for wear and improper inflation.
2. Check wheel runout.

Wheel runout:

Refer to S.D.S.

3. Check front wheel bearings for looseness.
4. Check front suspension for looseness.
5. Check steering linkage for looseness.
6. Check that front shock absorbers work properly by using the standard bounce test.
7. Check vehicle posture (Unladen).

CAMBER, CASTER AND KINGPIN INCLINATION

Camber, caster and kingpin inclination are preset at factory and cannot be adjusted.

1. Measure camber, caster and kingpin inclination of both right and left wheels with a suitable alignment gauge.

Camber (Unladen):

$-1^{\circ}30'$ to 0°

Caster (Unladen):

$6^{\circ}00'$ - $7^{\circ}30'$

Kingpin inclination (Unladen):

$12^{\circ}30'$ - $14^{\circ}00'$

2. If camber, caster and kingpin inclination are not within specification, inspect and replace any damaged or worn front suspension parts.

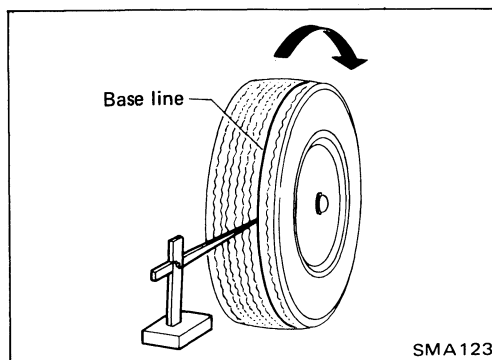
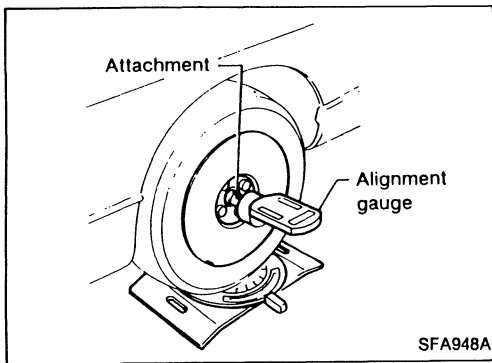

TOE-IN

1. Draw a base line across the tread.
 - After lowering front of vehicle, move it up and down to eliminate friction, and set steering wheel in straight-ahead position.

CHECK AND ADJUSTMENT — On-vehicle

Front Wheel Alignment (Cont'd)

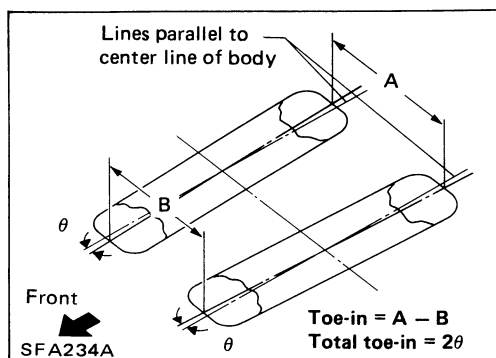

2. Measure toe-in.
Measure distance "A" and "B" at same height as hub center.

Toe-in:

$$A - B \quad 0.3 - 2.3 \text{ mm (0.012 - 0.091 in)}$$

$$2\theta \quad (\text{Total toe-in}) \quad 2' - 13'$$

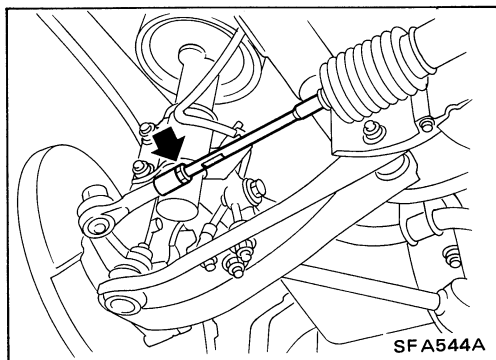

3. Adjust toe-in by varying length of steering tie-rods.
 - (1) Loosen lock nuts.
 - (2) Adjust toe-in by turning forward and reverse tie-rod.

Make sure both tie-rods are the same length.

Standard length "L":

Refer to ST section.

- (3) Tighten lock nuts to specified torque.

Lock nut tightening torque:

Refer to ST section.

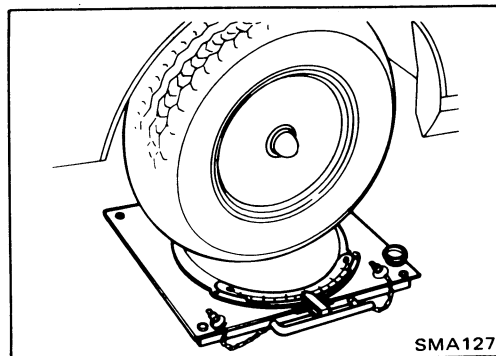
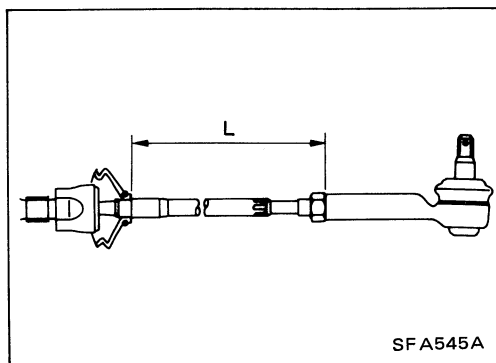

FRONT WHEEL TURNING ANGLE

1. Set wheels in straight-ahead position and then move vehicle forward until front wheels rest on turning radius gauge properly.

2. Rotate fully steering wheel to the right or left; measure turning angle.

Wheel turning angle:

Full turns	Inside wheel: A	39° - 43°
	Outside wheel: B	33°

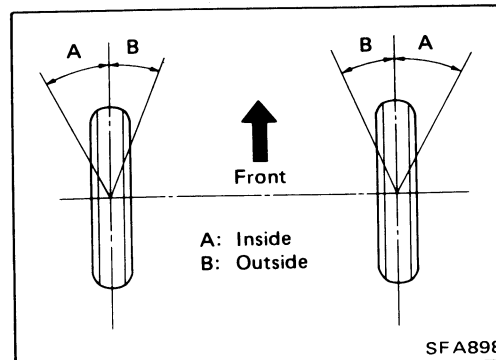

FRONT AXLE

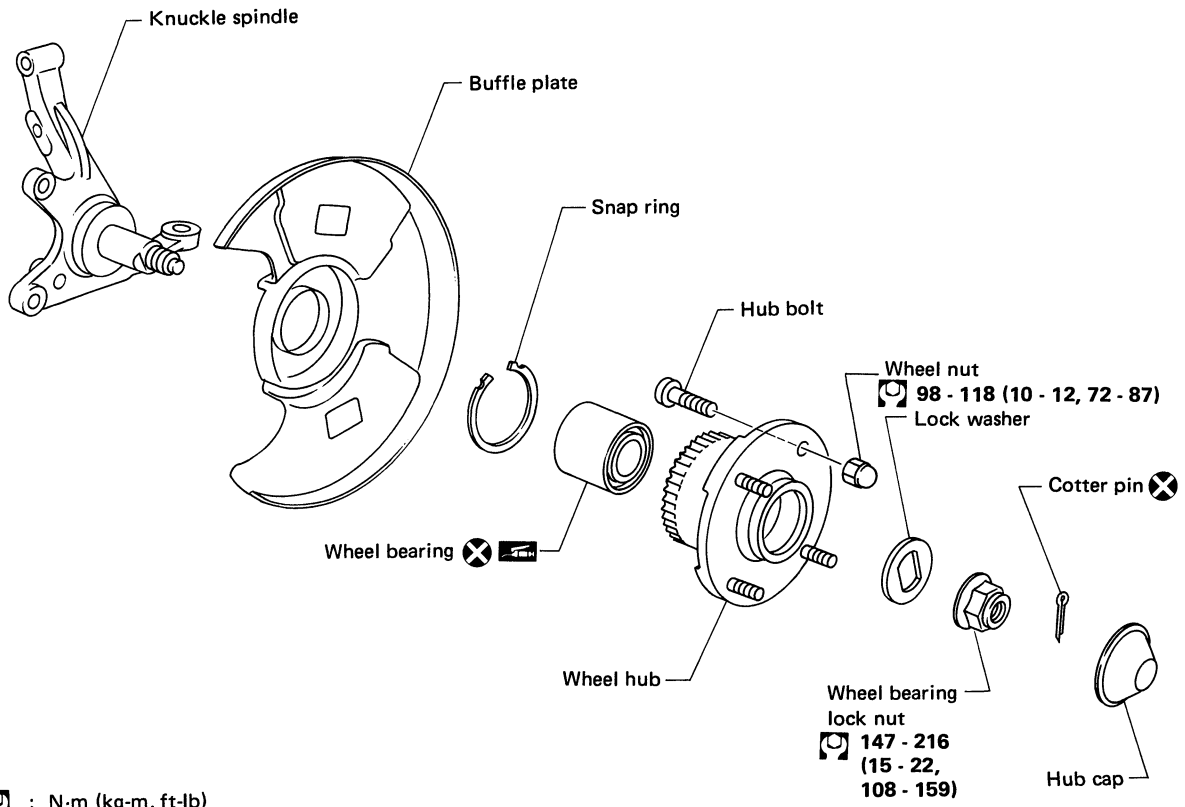

SFA546A

FRONT AXLE — Wheel Hub and Knuckle

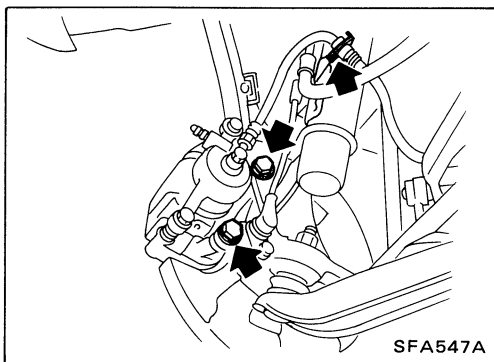

Removal

- Remove brake caliper assembly.
Brake hose need not be disconnected from brake caliper. Be careful not to depress brake pedal, or piston will pop out. Make sure brake hose is not twisted.
- Remove brake rotor.

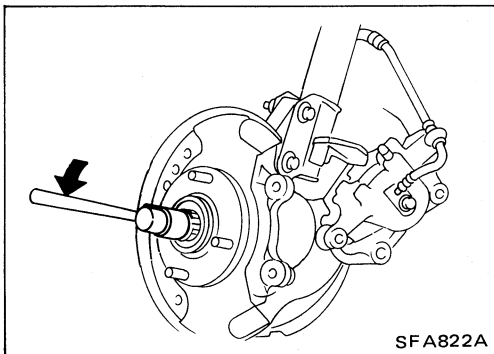

- Remove wheel bearing lock nut. Remove wheel hub from spindle.

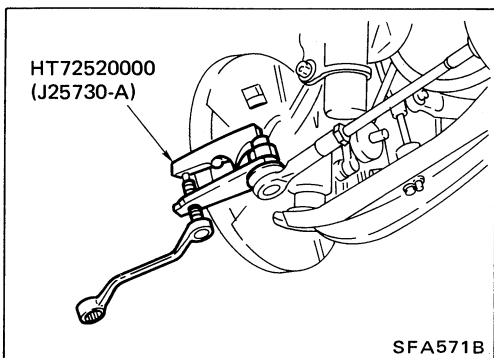

- Remove tie-rod ball joint and lower ball joint.

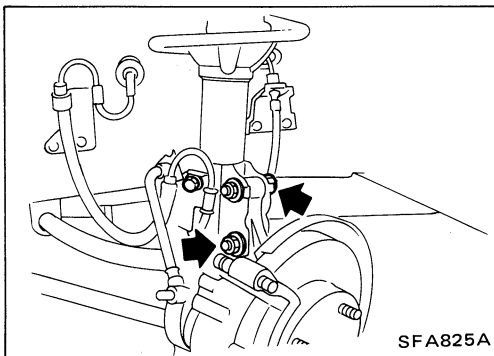

- Disconnect knuckle from strut.

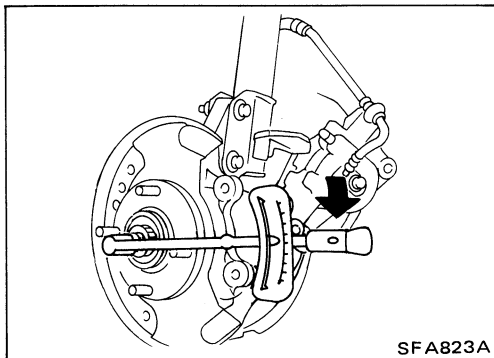

Installation

- Install wheel hub.
- Tighten wheel bearing lock nut.
☞: 147 - 216 N·m
(15 - 22 kg-m, 108 - 159 ft-lb)

FRONT AXLE — Wheel Hub and Knuckle

Installation (Cont'd)

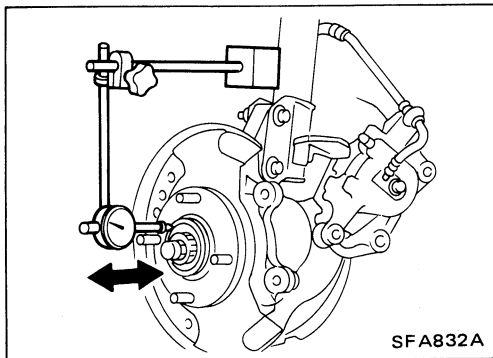

- Check wheel bearing axial end play.
Axial end play: 0.03 mm (0.0012 in) or less

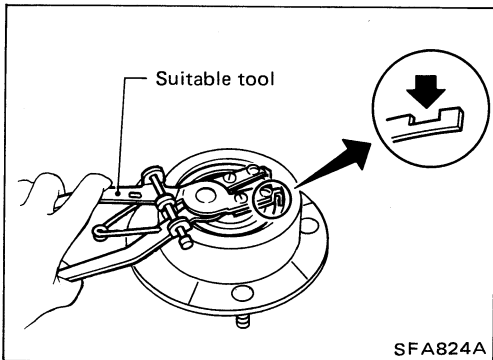

Disassembly

CAUTION:

When removing wheel bearing from wheel hub, replace wheel bearing assembly (outer race, inner races and grease seal) with a new one.

- Remove circular clip with suitable tool.
- Press out wheel bearing assembly from wheel hub.

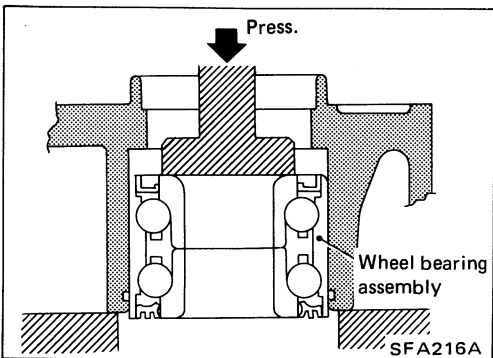

Inspection

WHEEL HUB

Check wheel hub for any cracks by using a magnetic exploration or dyeing test.

CIRCULAR CLIP

Check circular clip for wear or cracks.
Replace if necessary.

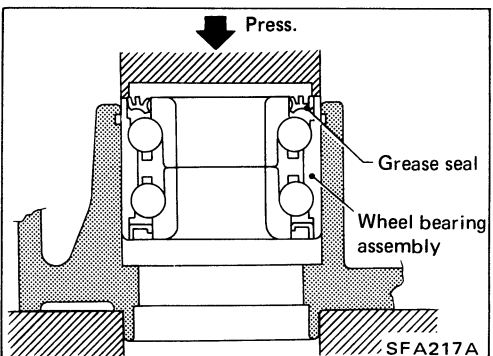

Assembly

1. Press new wheel bearing assembly into wheel hub from inside of wheel hub.

Maximum load P:

29 kN (3 t, 3.3 US ton, 3.0 Imp ton)

CAUTION:

- Do not press inner race of wheel bearing assembly.
- Do not apply oil or grease to mating surfaces of wheel bearing outer race and wheel hub.
Be careful not to damage grease seal.

FRONT AXLE — Wheel Hub and Knuckle

Assembly (Cont'd)

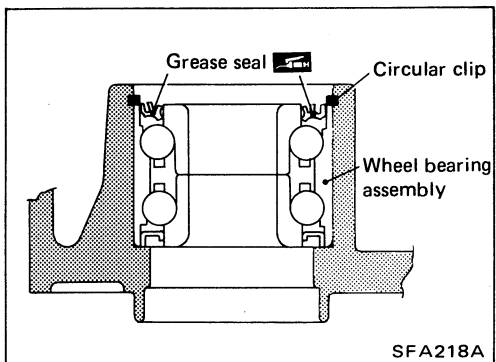

2. Install circular clip into groove of wheel hub.
3. Apply multi-purpose grease to sealing lip.

FRONT AXLE — Baffle Plate

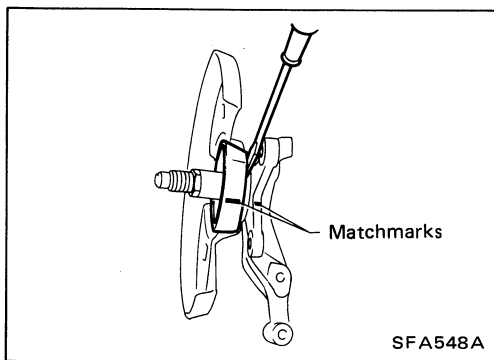

Removal

- Mark matchmarks on baffle plate before removing.
- If baffle plate replacement requires removal of knuckle spindle, separate it equally using a screwdriver.

Be careful not to scratch knuckle spindle.

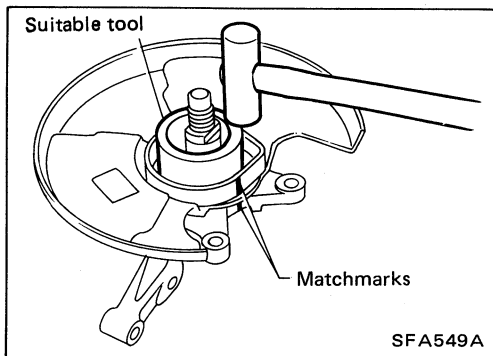

Installation

Align matchmarks previously marked on baffle plate and install baffle plate by lightly tapping with a copper hammer and suitable tool.

FRONT SUSPENSION

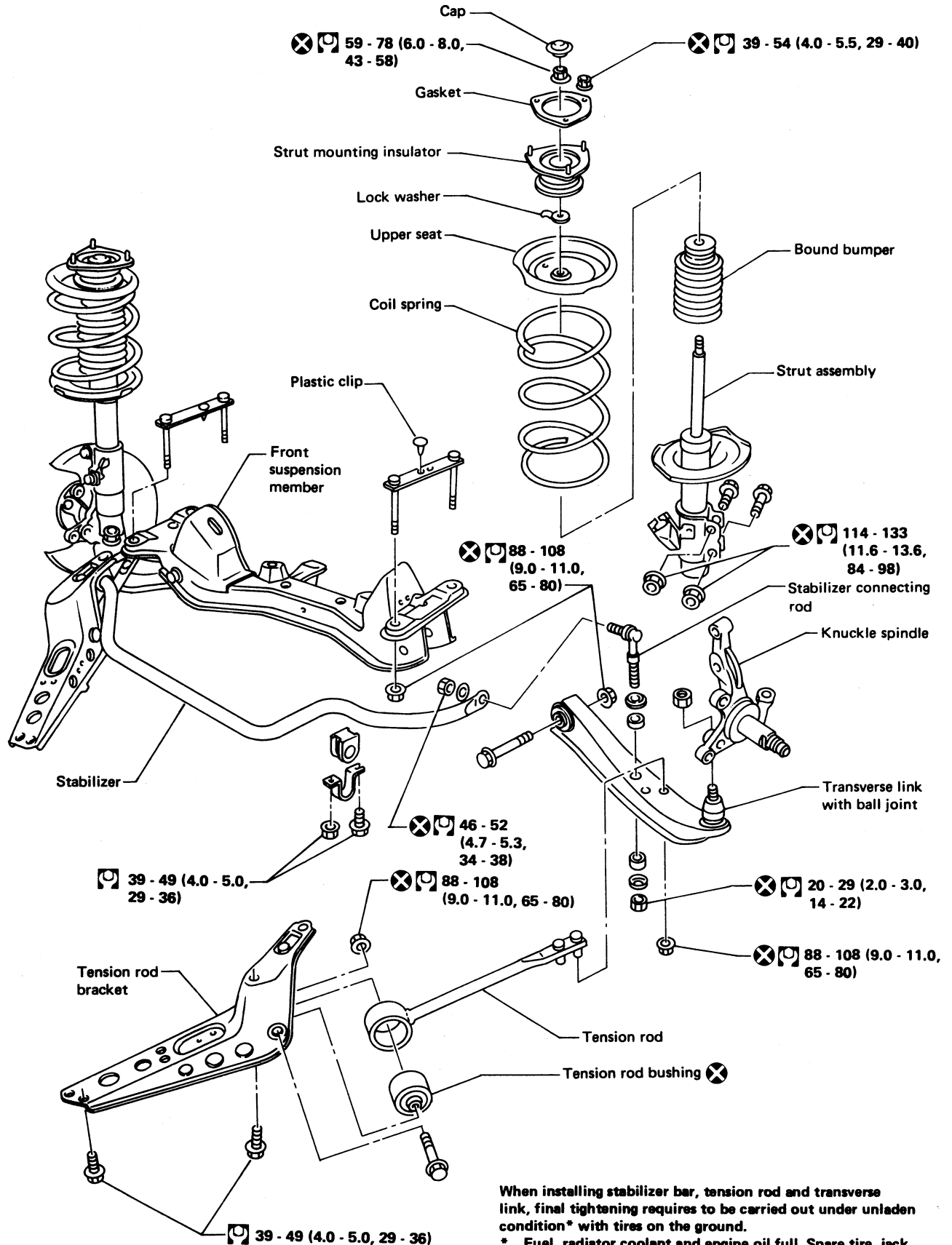

When installing stabilizer bar, tension rod and transverse link, final tightening requires to be carried out under unladen condition* with tires on the ground.

* Fuel, radiator coolant and engine oil full. Spare tire, jack, hand tools and mats in designated position.

: N-m (kg-m, ft-lb)

SFA550A

FRONT SUSPENSION — Coil Spring and Strut Assembly

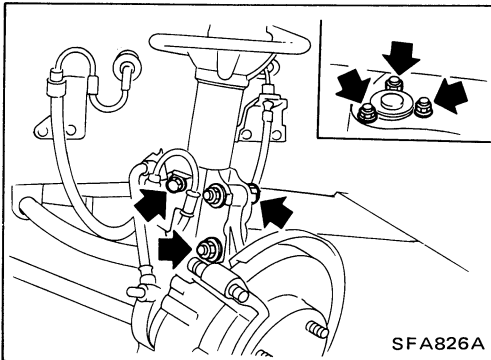

Removal

Remove strut assembly fixing bolts and nuts (to hoodledge).
Do not remove piston rod lock nut on vehicle.

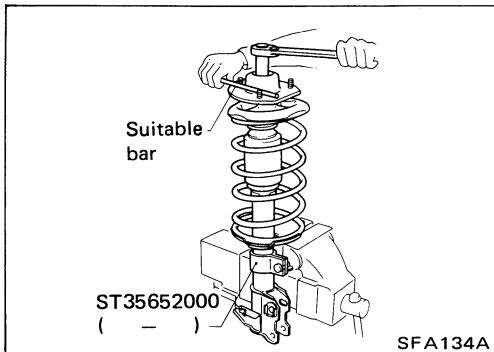

Disassembly

1. Set strut assembly on vise with Tool, then loosen piston rod lock nut.

Do not remove piston rod lock nut.

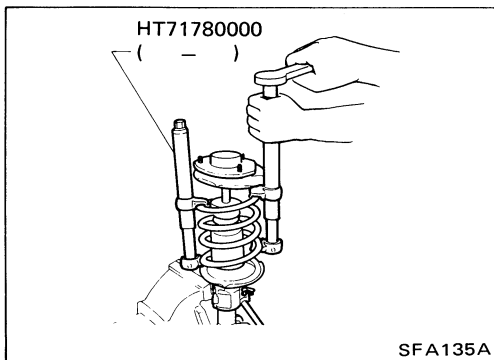

2. Compress spring with a Tool so that strut mounting insulator can be turned by hand.

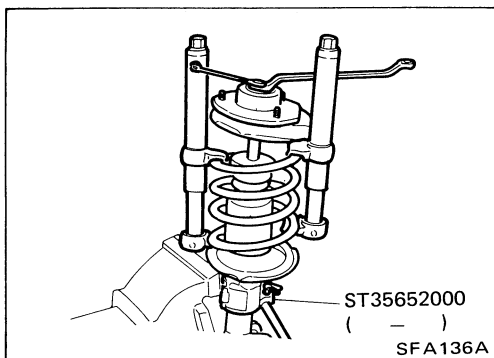

3. Remove piston rod lock nut.

Inspection

STRUT ASSEMBLY

- Check for smooth operation through a full stroke, both compression and extension.
- Check for oil leakage occurring on welded or gland packing portion.
- Check piston rod for cracks, deformation or other damage. Replace if necessary.

FRONT SUSPENSION — Coil Spring and Strut Assembly

Inspection (Cont'd)

STRUT MOUNTING INSULATOR

- Check cemented rubber-to-metal portion for separation or cracks. Check rubber parts for deterioration.
- Check thrust bearing parts for abnormal noise or excessive rattle in axial direction.
Replace if necessary.

LOCK WASHER

Check for cracks, deformation or other damage. Replace if necessary.

COIL SPRING

Check for cracks, deformation or other damage. Replace if necessary.

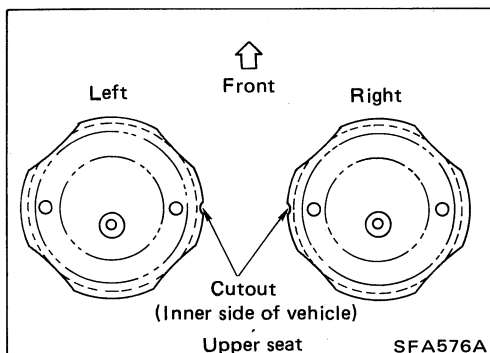
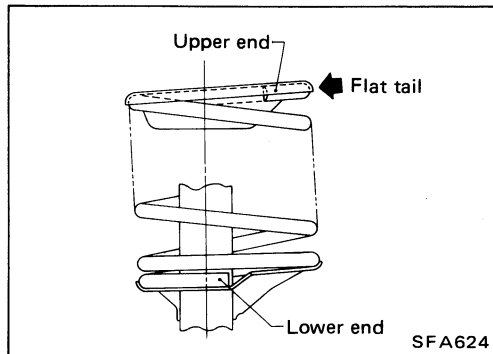
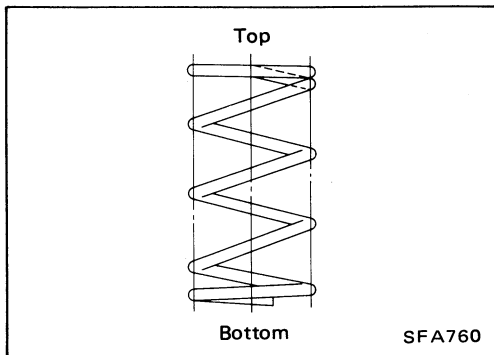

Assembly

- When installing coil spring, be careful not to reverse top and bottom direction. (Top end is flat.)
- When installing coil spring on strut, it must be positioned as shown in figure at left.
- Install upper spring seat with its cutout facing the inner side of vehicle.

FRONT SUSPENSION — Tension Rod and Stabilizer Bar

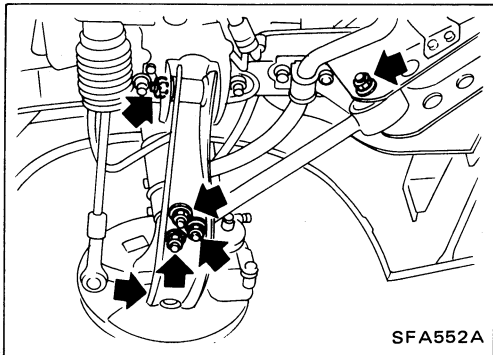

Removal and Installation

- Remove tension rod and stabilizer bar.

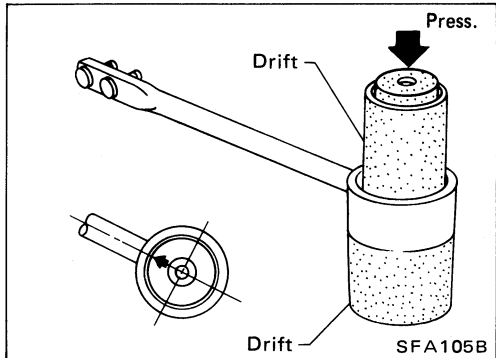

- When removing tension rod bushing, place one drift on lower side of bushing and the other on upper side, as shown at left, and press bushing out.
- Place arrow mark on bushing facing tension rod before installing bushing.

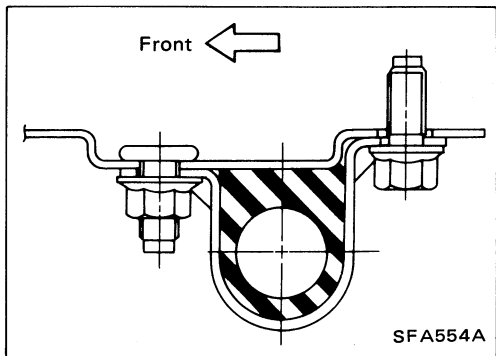

- Install stabilizer rear side bushings, then install front side bushings. When installing stabilizer bar clamp, make sure direction is correct (as shown at left).

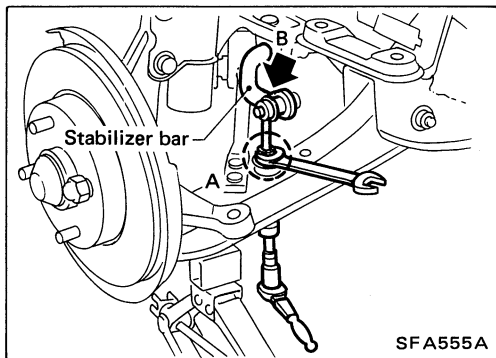

- When removing and installing stabilizer bar, fix portion A.

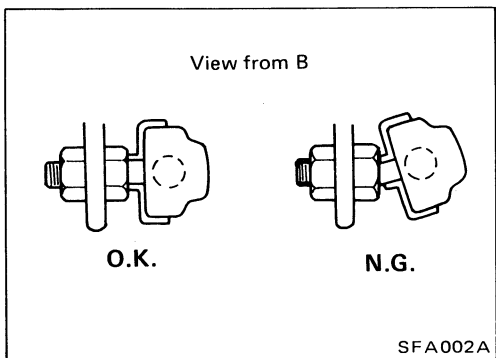

- Install stabilizer bar with ball joint socket properly placed.

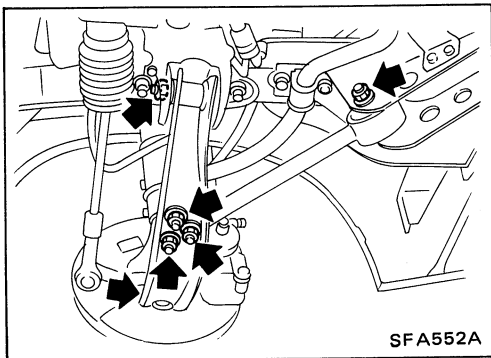

Removal and Installation

- Remove stabilizer, tension rod, ball joint and transverse link assembly.
- During installation, final tightening must be carried out at curb weight with tires on ground.
- After installation, check wheel alignment. Refer to "Front Wheel Alignment" of CHECK AND ADJUSTMENT — On-vehicle.

Inspection

TRANSVERSE LINK

- Check transverse link for damage, cracks or deformation. Replace it if necessary.
- Check rubber bushing for damage, cracks and deformation. Replace transverse link if necessary.

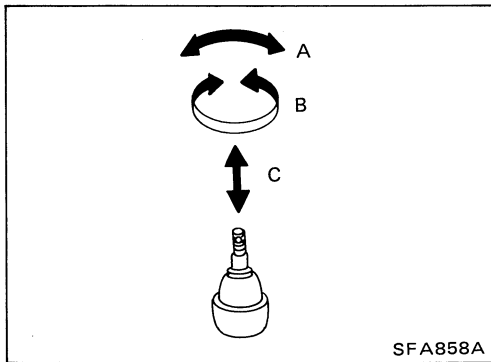

LOWER BALL JOINT

- Check ball joint for play. If ball stud is worn, play in axial direction is excessive or joint is hard to swing, replace lower ball joint. Before checking, turn ball joint at least 10 revolutions so that ball joint is properly broken in.
 - Swinging force "A":**
(measuring point: cotter pin hole of ball stud)
7.8 - 54.9 N (0.8 - 5.6 kg, 1.8 - 12.3 lb)
 - Turning torque "B":**
0.49 - 3.43 N·m (5.0 - 35 kg-cm, 4.3 - 30.4 in-lb)
 - Vertical end play "C":**
0 mm (0 in)
- Check dust cover for damage. Replace it and cover clamp if necessary.

SERVICE DATA AND SPECIFICATIONS (S.D.S.)

General Specifications

COIL SPRING

Item	Model	
	Without HICAS	With HICAS
Wire diameter mm (in)	13.4 (0.528)	13.3 (0.524)
Coil diameter mm (in)	170.4 (6.71)	170.3 (6.70)
Free length mm (in)	350 (13.78)	336 (13.23)
Spring constant N/mm (kg/mm, lb/in)	17.7 (1.8, 101)	19.6 (2.0, 112)
Identification color	Yellow x 1 Light green x 1	Yellow x 1 Orange x 1

FRONT STABILIZER BAR

Stabilizer diameter mm (in)	25 (0.98)
Identification color	Orange

WHEELARCH HEIGHT (Unladen*)

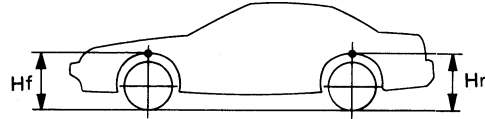

SFA831A

Applied model	All	
Front (Hf) mm (in)	694 (27.32)	
Rear (Hr) mm (in)	670 (26.38)	

*: Tankful of fuel, radiator coolant and engine oil full. Spare tire, jack, hand tools, mats in designated position.

STRUT

Item	Model	
	Without HICAS	With HICAS
Piston rod diameter mm (in)	20.0 (0.787)	
Damping force [at 0.1 m (0.3 ft)/sec.] N (kg, lb)	Expansion	412 - 608 (29 - 55, 64 - 121)
	Compression	206 - 304 (21 - 31, 46 - 68)
Damping force [at 0.3 m (1.0 ft)/sec.] N (kg, lb)	Expansion	912 - 1,245 (93 - 127, 205 - 280)
	Compression	392 - 588 (40 - 60, 88 - 132)

SERVICE DATA AND SPECIFICATIONS (S.D.S.)

Inspection and Adjustment

WHEEL ALIGNMENT (Unladen*1)

Camber	degree	-1° 30' to 0°
Caster	degree	6° 00' - 7° 30'
Toe-in	mm (in)	0.3 - 2.3 (0.012 - 0.091)
Total toe-in	degree	2' - 13'
Kingpin inclination	degree	12° 30' - 14° 00'
Front wheel turning angle		
Full turn*2	degree	39° - 43° / 33°
inside/outside		

*1: Tankful of fuel, radiator coolant and engine oil full. Spare tire, jack, hand tools, mats in designated position.

*2: On power steering models, wheel turning force (at circumference of steering wheel) of 98 to 147 N (10 to 15 kg, 22 to 33 lb) with engine idle.

WHEEL BEARING

Wheel bearing axial end play	mm (in)	0.03 (0.0012) or less
Wheel bearing lock nut		
Tightening torque	N·m (kg-m, ft-lb)	147 - 216 (15 - 22, 108 - 159)

LOWER BALL JOINT

Swinging force (Measuring point: cotter pin hole of ball stud)	N (kg, lb)	7.8 - 54.9 (0.8 - 5.6, 1.8 - 12.3)
Turning torque	N·m (kg-cm, in-lb)	0.49 - 3.43 (5.0 - 35, 4.3 - 30.4)
Vertical end play	mm (in)	0 (0)

WHEEL RUNOUT (Radial and lateral)

Wheel type	Radial runout	Lateral runout
Aluminum wheel mm (in)	0.3 (0.012) or less	
Steel wheel mm (in)	0.5 (0.020) or less	0.8 (0.031) or less

REAR AXLE & REAR SUSPENSION

SECTION **RA**

CONTENTS

PRECAUTIONS AND PREPARATION	RA- 2
REAR AXLE AND REAR SUSPENSION	RA- 4
CHECK AND ADJUSTMENT — On-vehicle	RA- 5
REAR AXLE AND REAR SUSPENSION ASSEMBLY	RA- 8
REAR AXLE — Wheel Hub and Axle Housing	RA- 9
REAR AXLE — Drive Shaft	RA-13
REAR SUSPENSION	RA-19
REAR SUSPENSION — Coil Spring and Shock Absorber	RA-20
REAR SUSPENSION — Stabilizer Bar	RA-22
SUPER HICAS	RA-23
REAR SUSPENSION — Multi-link and Lower Ball Joint	RA-25
SERVICE DATA AND SPECIFICATIONS (S.D.S.)	RA-26

PRECAUTIONS AND PREPARATION

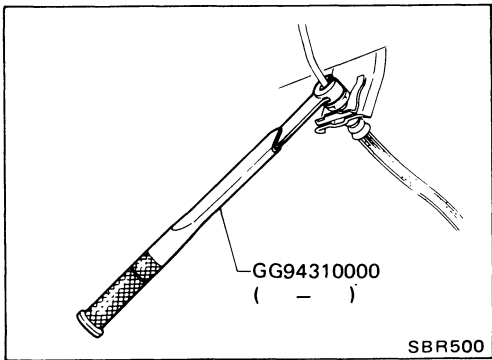

Precautions

- When installing each rubber part, final tightening must be carried out under unladen condition* with tires on ground.
- * Fuel, radiator coolant and engine oil full. Spare tire, jack, hand tools, and mats in designated positions.
- Use Tool when removing or installing brake tubes.
- When removing each suspension part, check wheel alignment and adjust if necessary.
- Do not jack up at the lower arm.

Preparation

SPECIAL SERVICE TOOLS

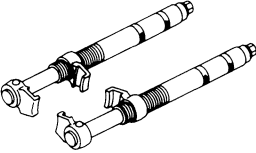
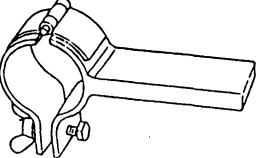
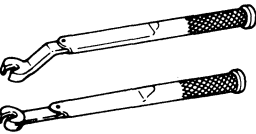
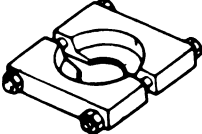
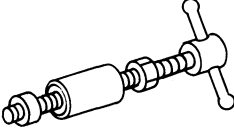
Tool number (Kent-Moore No.) Tool name	Description	
HT71780000 (-) Spring compressor		Removing and installing coil spring
ST35652000 (-) Strut attachment		Fixing strut assembly
GG94310000 (-) Flare nut torque wrench		Removing and installing brake piping
ST30031000 (J22912-01) Bearing puller		Removing inner race of wheel bearing
ST38280000 (-) Arm bushing remover		Removing and installing bushing of rear axle housing

PRECAUTIONS AND PREPARATION

Preparation (Cont'd)

COMMERCIAL SERVICE TOOLS

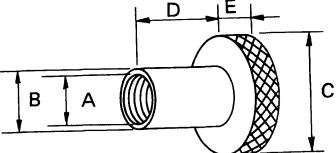
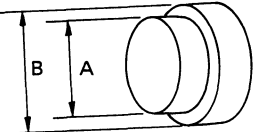
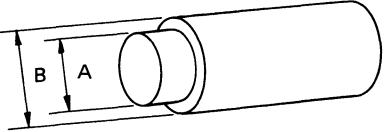
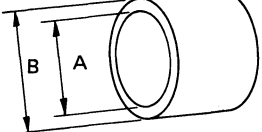
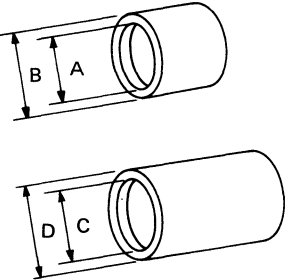
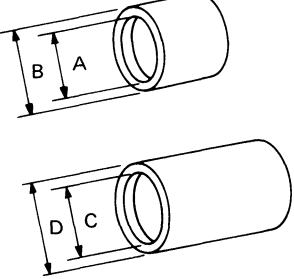
Tool name	Description
Attachment Wheel alignment	 <p>Measure rear wheel alignment</p> <p>A: Screw M24 x 1.5 B: 35 (1.38) dia. C: 65 (2.56) dia. D: 56 (2.20) E: 12 (0.47) Unit: mm (in)</p>
Rear wheel hub drift	 <p>Installing wheel bearing</p> <p>A: 41 mm (1.61 in) dia. B: 49 mm (1.93 in) dia.</p>
Wheel bearing drift	 <p>Removing rear wheel hub</p> <p>A: 26 mm (1.02 in) dia. B: 40 mm (1.57 in) dia.</p>
Rear drive shaft plug seal drift	 <p>Installing rear drive shaft plug seal</p> <p>A: 67 mm (2.64 in) dia. B: 85 mm (3.35 in) dia.</p>
Rear axle housing ball joint drift	 <p>Removing ball joint</p> <p>A: 20 (0.79) dia. B: 28 (1.10) dia. C: 40 (1.57) dia. D: 43 (1.69) dia.</p> <p>Unit: mm (in)</p>
Rear axle housing ball joint drift	 <p>Installing ball joint</p> <p>A: 33 (1.30) dia. B: 43 (1.69) dia. C: 30 (1.18) dia. D: 40 (1.57) dia.</p> <p>Unit: mm (in)</p>

REAR AXLE AND REAR SUSPENSION

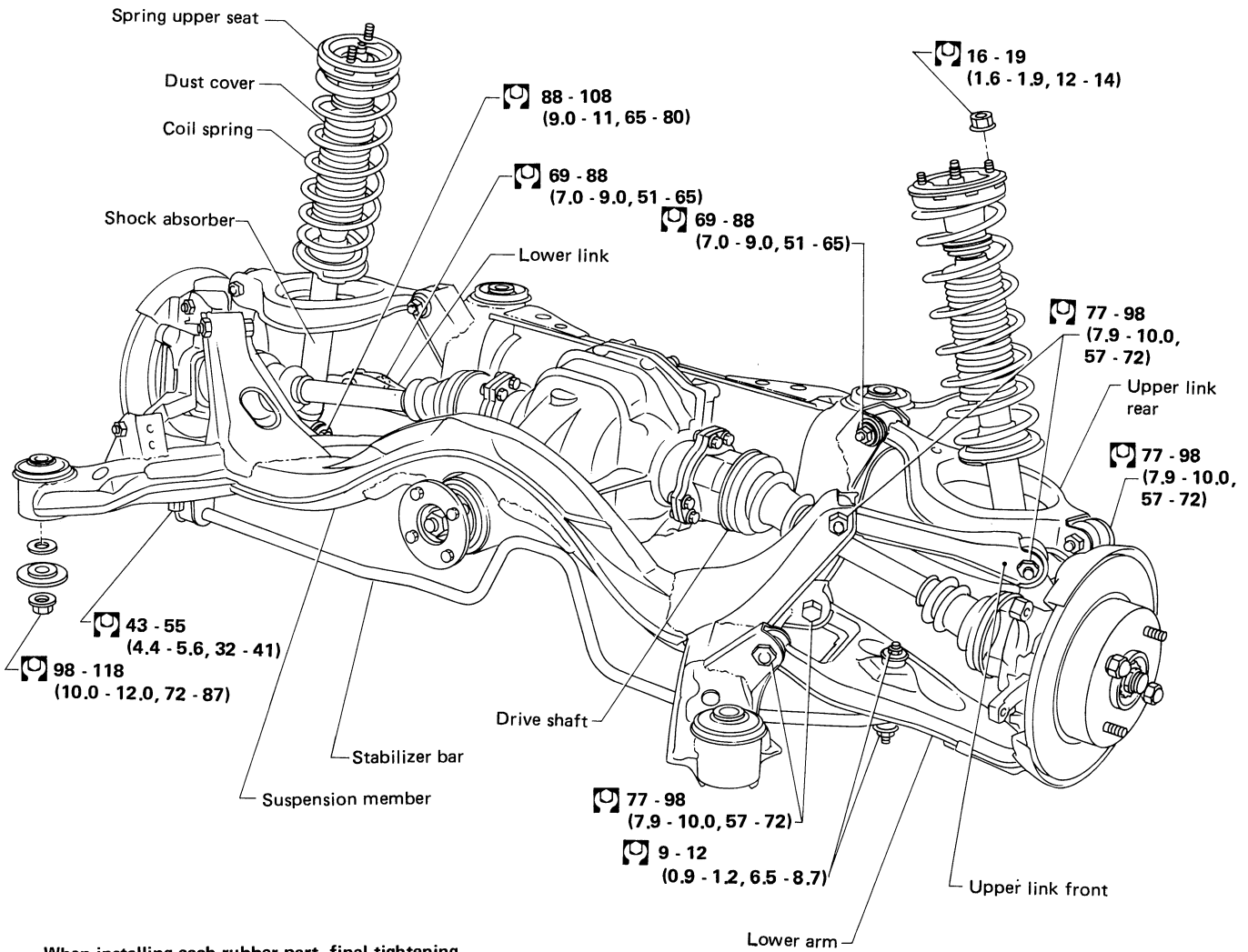

When installing each rubber part, final tightening must be carried out under unladen condition* with tires on ground.

* Fuel, radiator coolant and engine oil full.
Spare tire, jack, hand tools and mats in designated positions.

: N·m (kg·m, ft·lb)

SRA093A

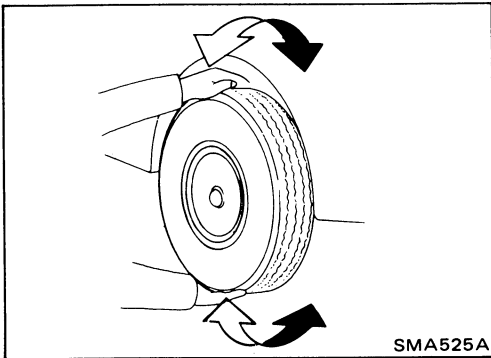

Rear Axle and Rear Suspension Parts

Check axle and suspension parts for looseness, wear or damage.

- Shake each rear wheel.

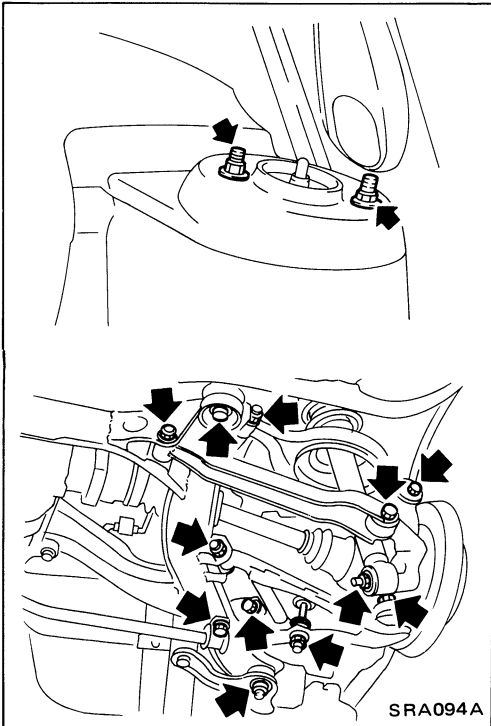

- Retighten all nuts and bolts to the specified torque.

Tightening torque:

Refer to REAR SUSPENSION.

- Make sure that cotter pin is inserted.

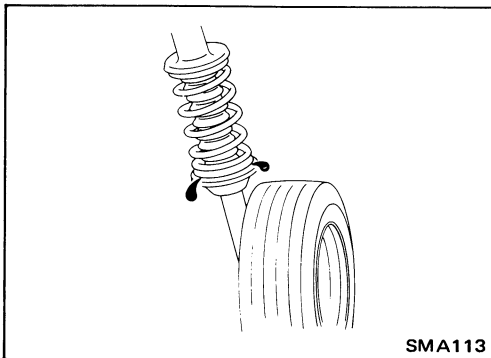

- Check shock absorber for oil leakage or other damage.
- Check wheelarch height. Refer to section FA.

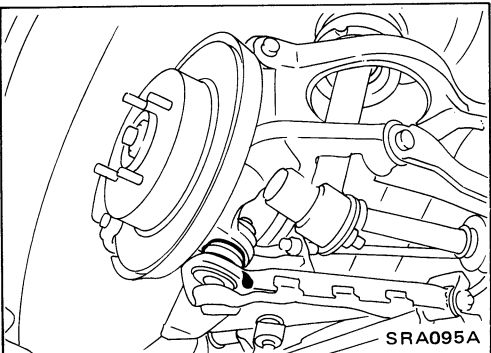

- Check suspension lower ball joint for excessive play.
- Check suspension ball joint for grease leakage and ball joint dust cover for cracks or other damage.

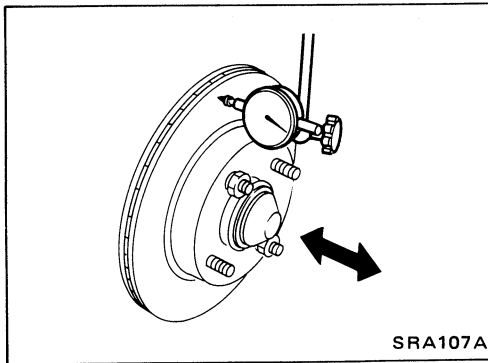

Rear Wheel Bearing

- Check that wheel bearings operates smoothly.
- Check axial end play.

Axial end play:

0.05 mm (0.0020 in) or less

If axial end play is not within specification or wheel bearing does not turn smoothly, replace wheel bearing assembly.
Refer to REAR AXLE — Wheel Hub and Axle Housing.

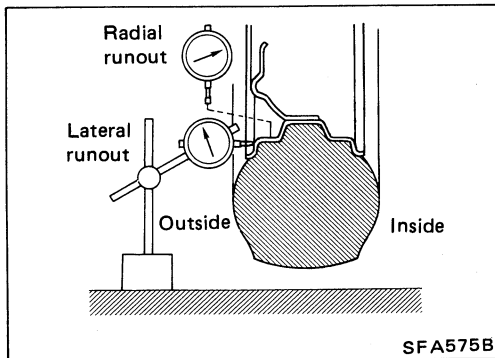

Rear Wheel Alignment

Before checking rear wheel alignment, be sure to make a preliminary inspection.

PRELIMINARY INSPECTION

Make following checks. Adjust, repair or replace if necessary.

- Check tires for wear and for improper inflation.
- Check rear wheel bearings for looseness.
- Check wheel runout.

Refer to S.D.S.

- Check that rear shock absorber works properly.
- Check rear axle and rear suspension parts for looseness.
- Check vehicle posture (Unladen).

“Unladen”:

Fuel tank, radiator and engine oil full. Spare tire, jack, hand tools and mats in designated positions.

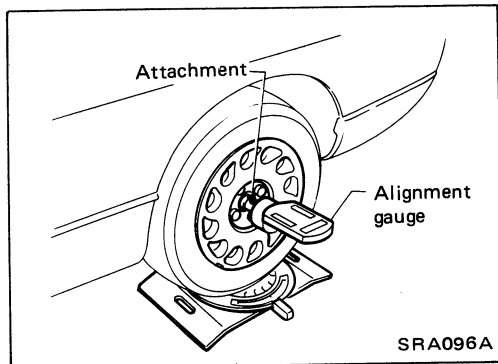

CAMBER

Measure camber of both right and left wheels with a suitable alignment gauge and adjust in accordance with the following procedures.

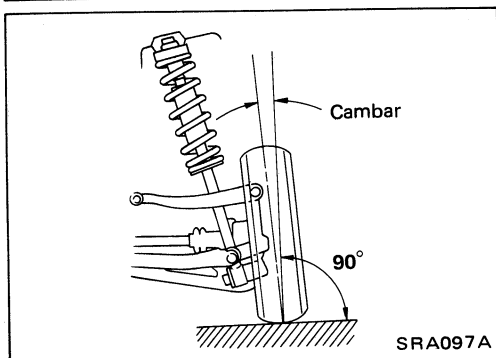

Camber:

-1°36' to -0°36'

CHECK AND ADJUSTMENT — On-vehicle

Rear Wheel Alignment (Cont'd)

If camber is not within specification, adjust by turning the adjusting pin.

(1) Turn the adjusting pin to adjust.

Camber changes about 5' with each graduation of the adjusting pin.

(2) Tighten to the specified torque.

\square : 69 - 88 N·m

(7.0 - 9.0 kg-m, 51 - 65 ft-lb)

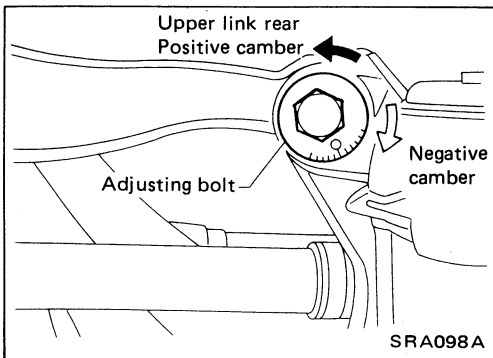

TOE-IN

1. Draw a base line across the tread.

After lowering rear of vehicle, move it up and down to eliminate friction.

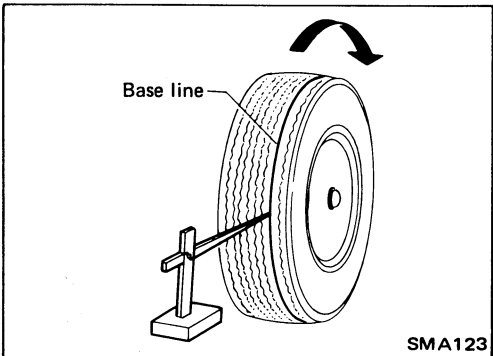

2. Measure toe-in.

Measure distance "A" and "B" at the same height as hub center.

Toe-in:

$A - B$

0.5 - 4.5 mm (0.020 - 0.177 in)

2θ (Total toe-in)

3' - 25'

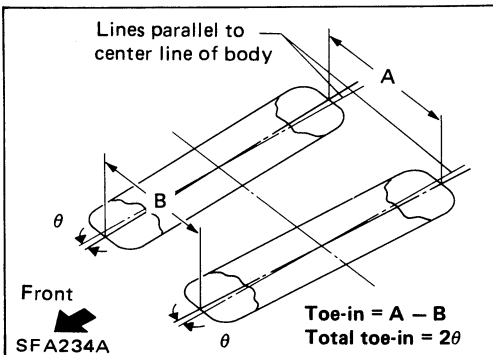

3. Adjust toe-in by turning adjusting pins.

Toe changes about 1.5 mm (0.059 in) [One side] with each graduation of the adjusting pin.

4. Tighten to the specified torque.

\square : 69 - 88 N·m

(7.0 - 9.0 kg-m, 51 - 65 ft-lb)

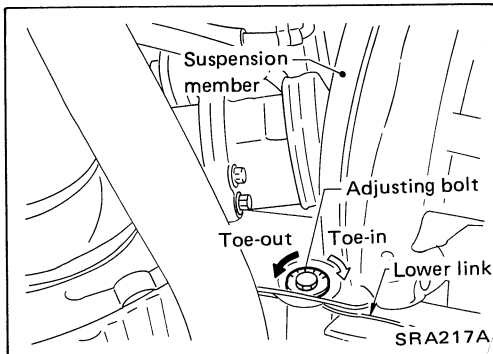

Drive Shaft

Check boot and drive shaft for cracks, wear, damage or grease leakage.

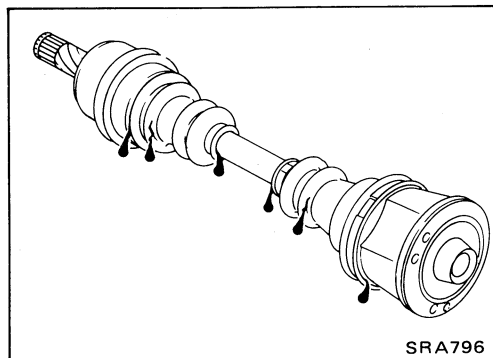

REAR AXLE AND REAR SUSPENSION ASSEMBLY

Removal and Installation

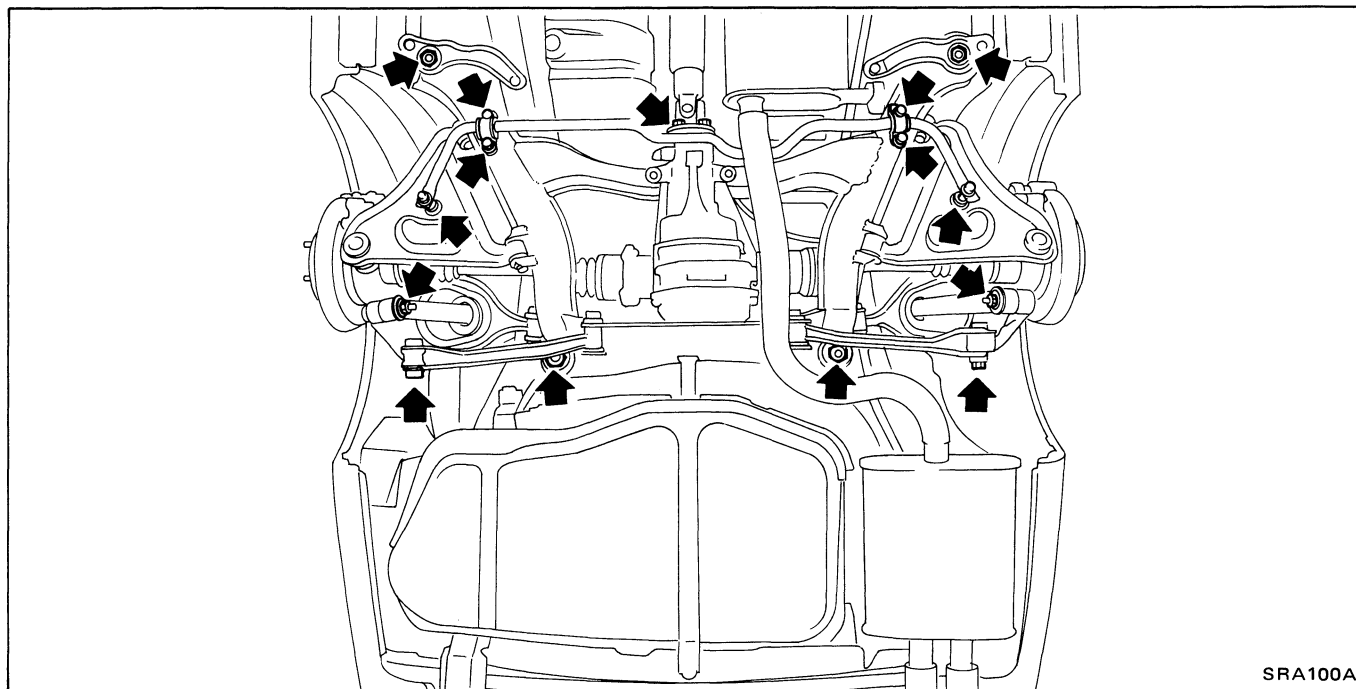

- Remove exhaust tube.
- Disconnect propeller shaft rear end.

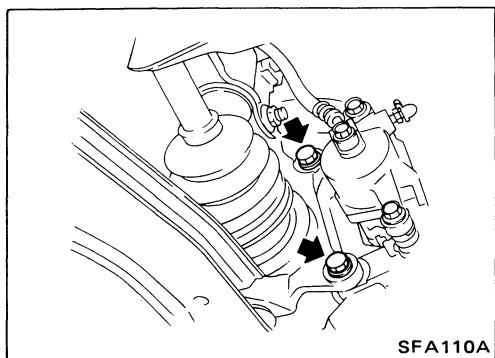

- Remove brake caliper assembly.
Brake hose need not be disconnected from brake caliper.
Be careful not to depress brake pedal, or piston will pop out.
Make sure brake hose is not twisted.

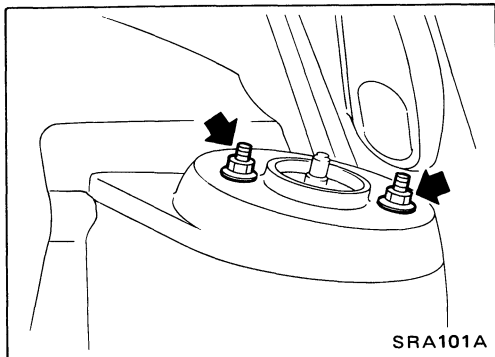

- Remove upper end nuts of shock absorber.
Do not remove piston rod lock nut.
- Remove suspension member fixing nuts. Then draw out rear axle and rear suspension assembly.

REAR AXLE — Wheel Hub and Axle Housing

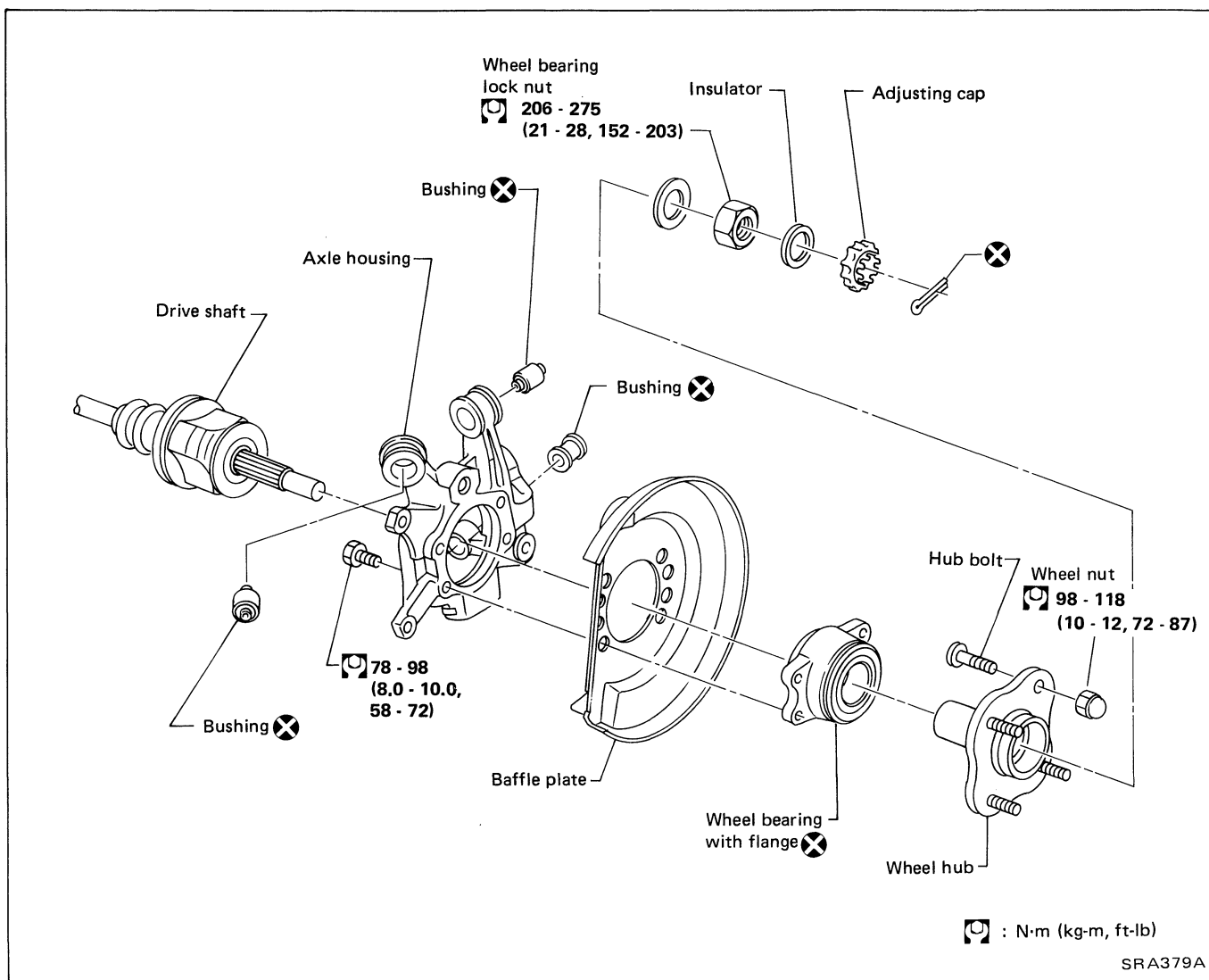

Removal

- Remove wheel bearing lock nut.

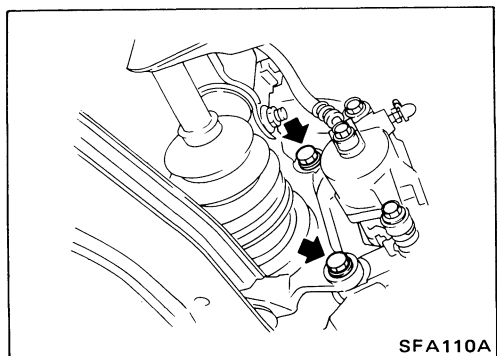

- Remove brake caliper assembly and rotor. Brake hose need not be disconnected from brake caliper. Be careful not to depress brake pedal, or piston will pop out. Make sure brake hose is not twisted.

REAR AXLE — Wheel Hub and Axle Housing

Removal (Cont'd)

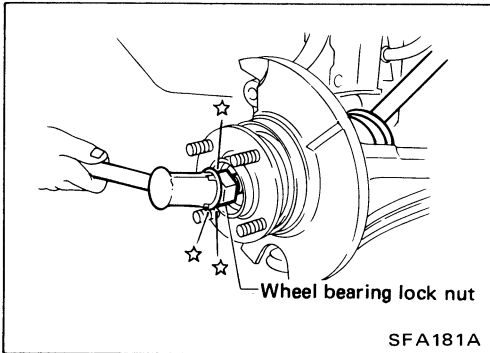

- Separate drive shaft from axle housing by slightly tapping it. When removing drive shaft, cover boots with waste cloth to prevent them from being damaged.

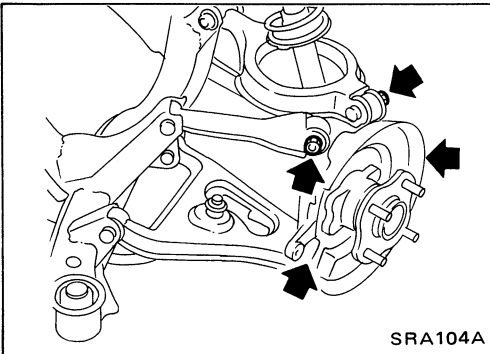

- Remove axle housing.

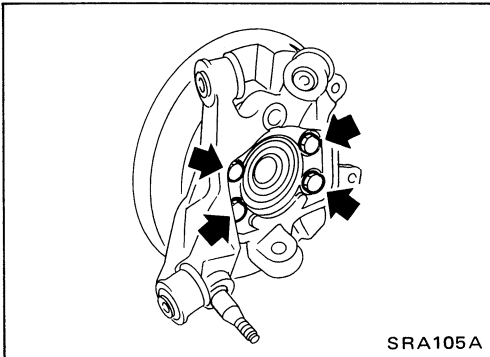

- Remove wheel bearing with flange, and wheel hub from axle housing.

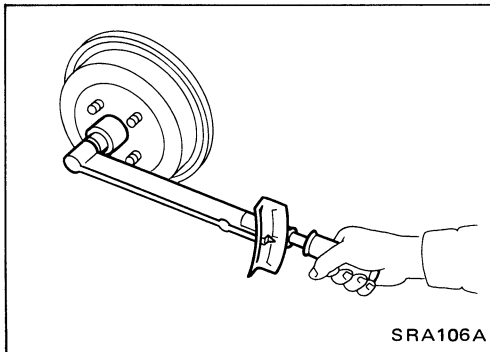

Installation

- Install axle housing with wheel hub.
- Tighten wheel bearing lock nut.
⌘: 206 - 275 N·m
(21 - 28 kg-m, 152 - 203 ft-lb)

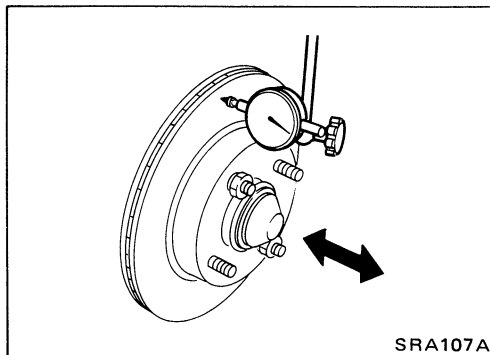

- Check wheel bearing axial end play.
Axial end play: 0.05 mm (0.0020 in) or less

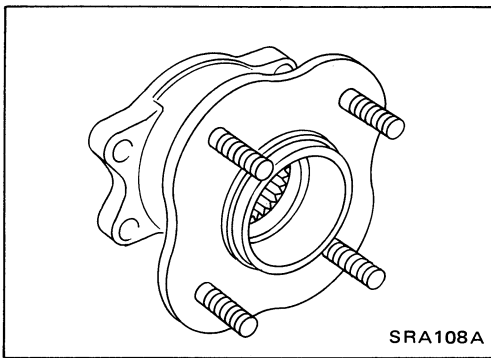

Disassembly

CAUTION:

Wheel bearing with flange usually does not require maintenance. If any of the following symptoms are noted, replace wheel bearing assembly (including flange, and inner and outer seals).

- Growling noise is emitted from wheel bearing during operation.
- Wheel bearing drags or turns roughly when hub is turned with your hand after bearing lock nut is tightened to specified torque.
- After wheel bearing is removed from hub.

WHEEL HUB

Remove wheel bearing (with flange) and wheel hub as one unit from axle housing before disassembling.

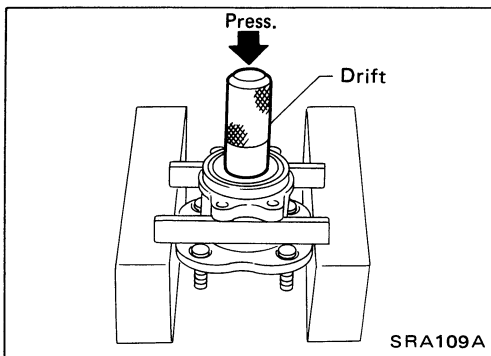

WHEEL BEARING

- Using a press and drift as shown in figure at left, press wheel bearing out.
- Discard old wheel bearing assembly. Replace with a new wheel assembly.

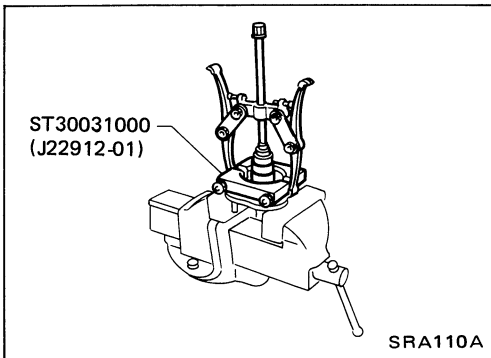

- Remove inner race from hub using a bearing replacer/puller.

CAUTION:

- Do not reuse old inner race although it is of the same brand as the bearing assembly.
- Do not replace grease seals as single parts.

REAR AXLE — Wheel Hub and Axle Housing

Disassembly (Cont'd)

AXLE HOUSING

- Attach a drift on outer shell of bushing as shown in figure at left, remove bushing using arm bushing remover.

When placing axle housing in a vise, use wooden blocks or copper plates as pads.

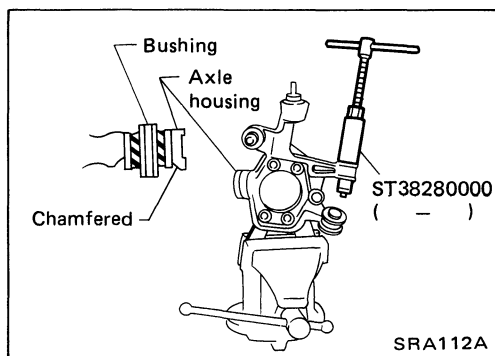
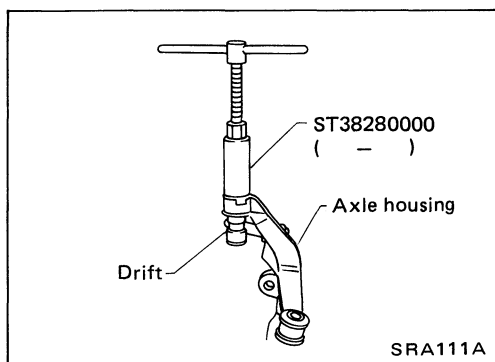

- Ensure axle housing bore is free from scratches or deformities before pressing bushing into it.
- Attach bushing to chamfered bore end of axle housing and press it until it is flush with end face of axle housing.

Inspection

WHEEL HUB AND AXLE HOUSING

- Check wheel hub and axle housing for cracks by using a magnetic exploration or dyeing test.
- Check wheel bearing for damage, seizure, rust or rough operation.
- Check rubber bushing for wear or other damage.
Replace if necessary.

Assembly

Place hub on a block. Attach a drift to inner race of wheel bearing and press it into hub as shown in figure at left.

Be careful not to damage grease seal.

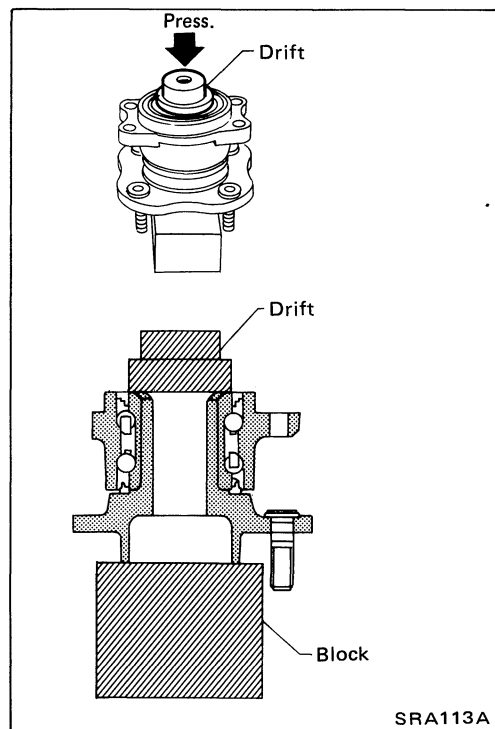

REAR AXLE — Drive Shaft

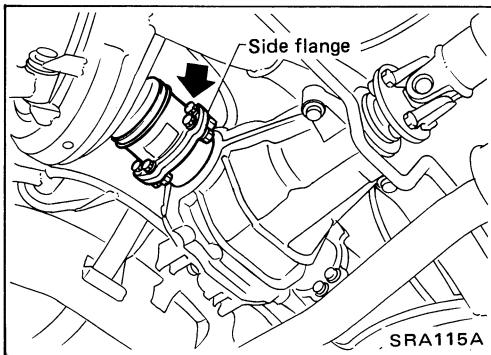
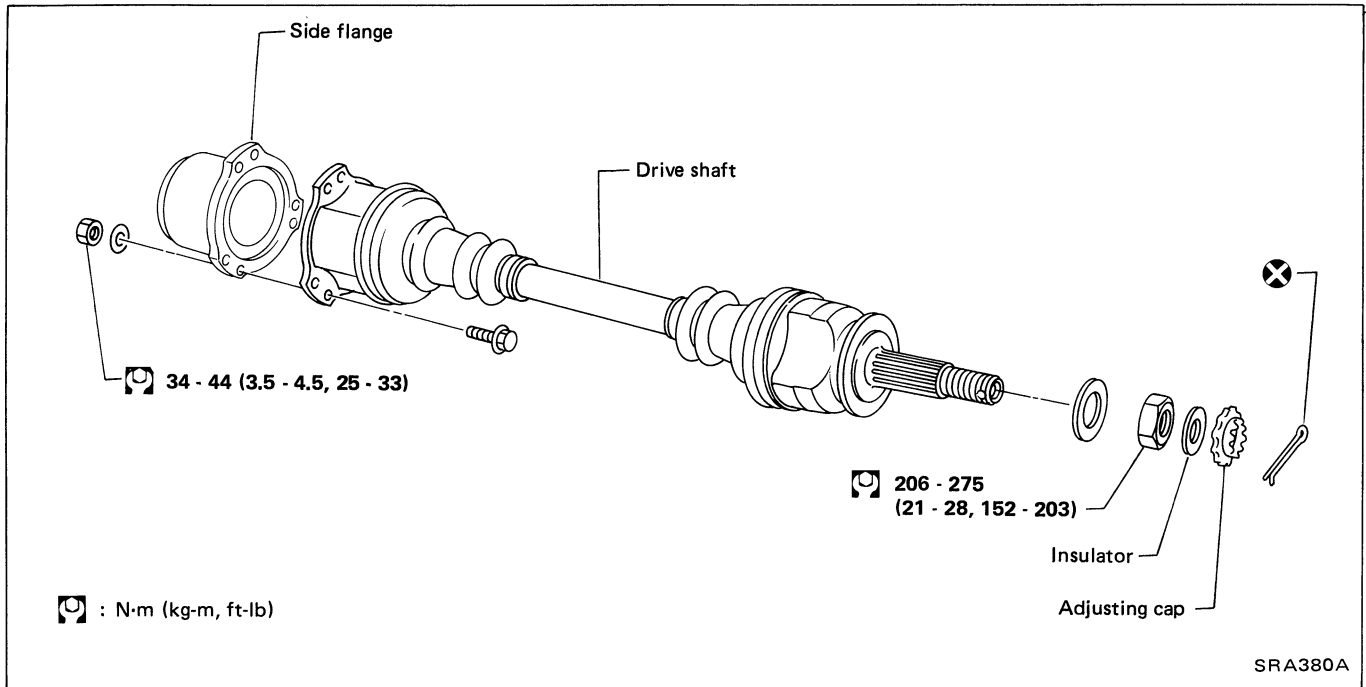

Removal

When removing drive shaft, cover boots with waste cloth to prevent damage to them.

FINAL DRIVE SIDE

Remove side flange mounting bolt and separate shaft.

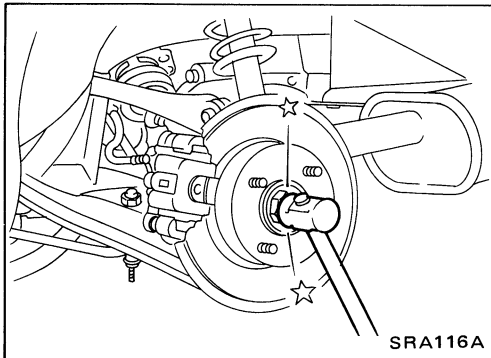

WHEEL SIDE

Remove drive shaft by lightly tapping it with a copper hammer. To avoid damaging threads of drive shaft, install a nut while removing drive shaft.

Installation

- Insert drive shaft from wheel hub and temporarily tighten wheel bearing lock nut.
- Tighten side flange mounting bolts to specified torque.
- Tighten wheel bearing lock nut to specified torque.

REAR AXLE — Drive Shaft

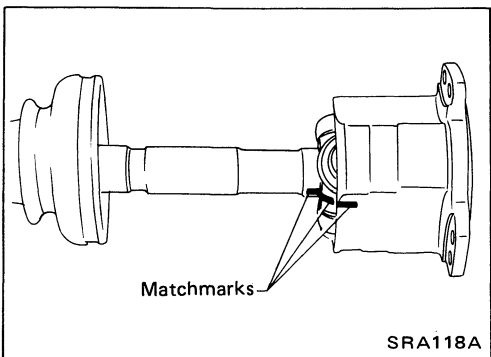
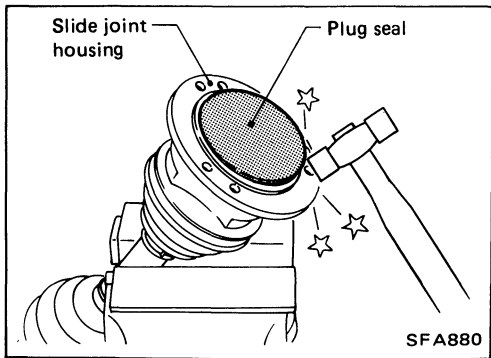
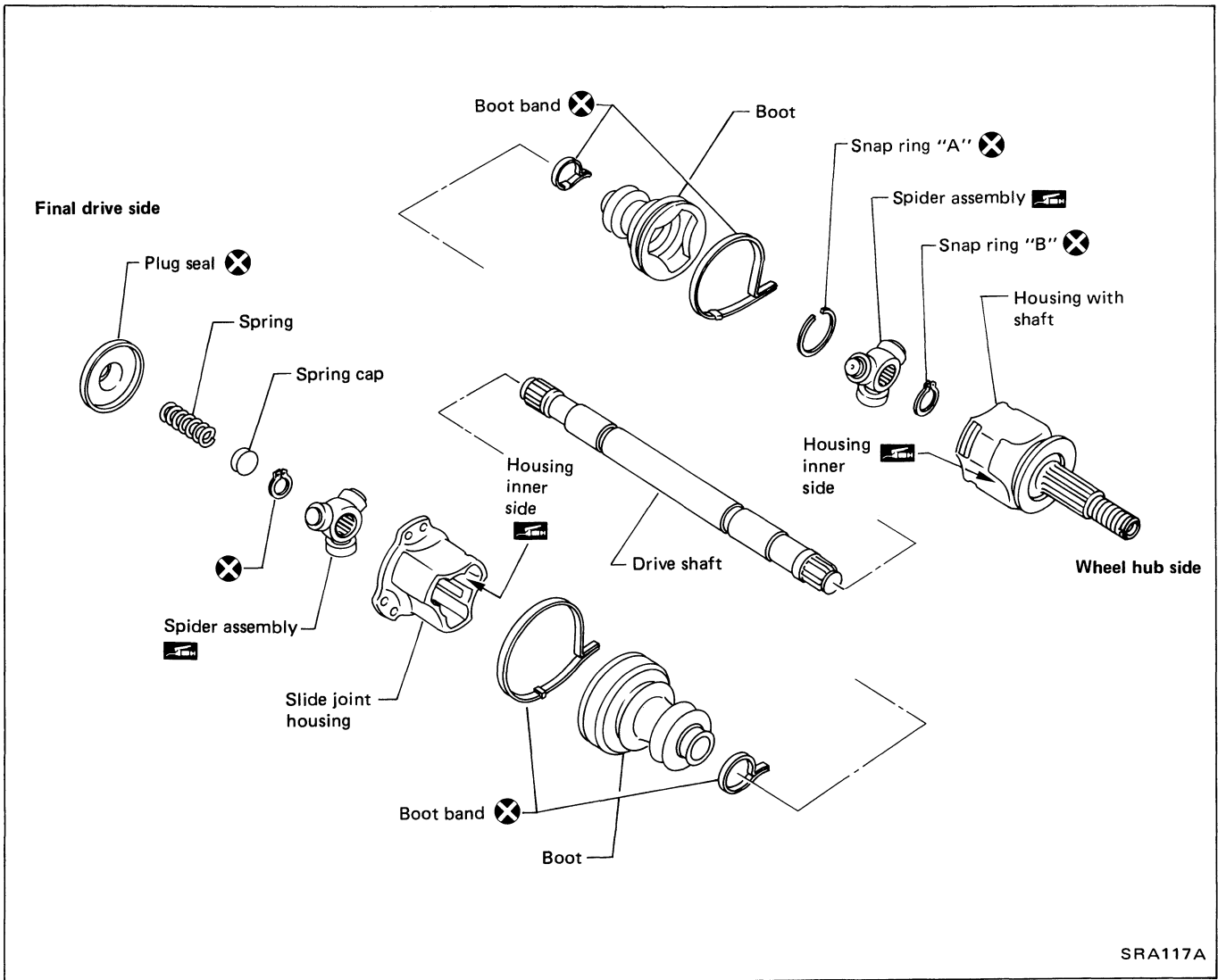

Disassembly

FINAL DRIVE SIDE

1. Remove plug seal from slide joint housing by lightly tapping around slide joint housing.

2. Remove boot bands.

3. Put matchmarks on slide joint housing and drive shaft before separating joint assembly.

4. Put matchmarks on spider assembly and drive shaft.

REAR AXLE — Drive Shaft

Disassembly (Cont'd)

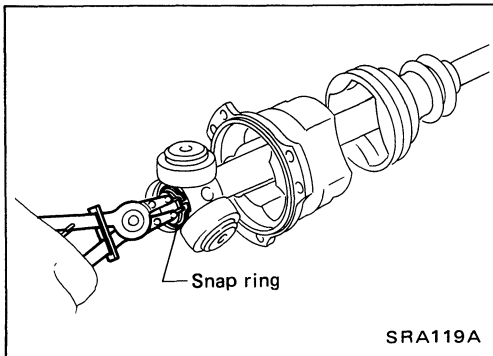

5. Pry off snap ring, then remove spider assembly.

CAUTION:

Do not disassemble spider assembly.

6. Draw out slide joint housing.

7. Draw out boot.

Cover drive shaft serration with tape to prevent damage to the boot.

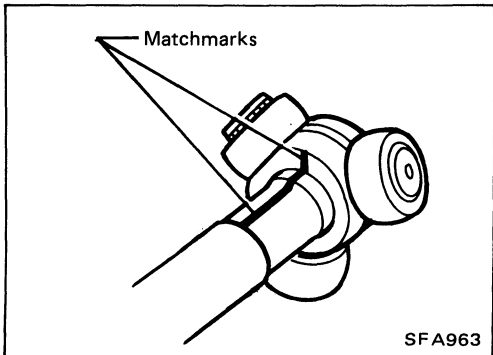

WHEEL SIDE

1. Remove boot bands.

2. Put matchmarks on housing together with shaft and drive shaft before separating joint assembly.

3. Put matchmarks on spider assembly and drive shaft.

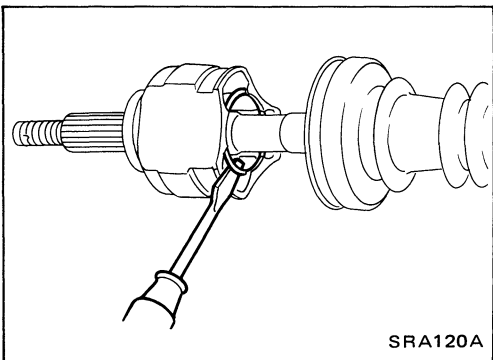

4. Pry off snap ring "A" with a screwdriver, and pull out slide joint housing.

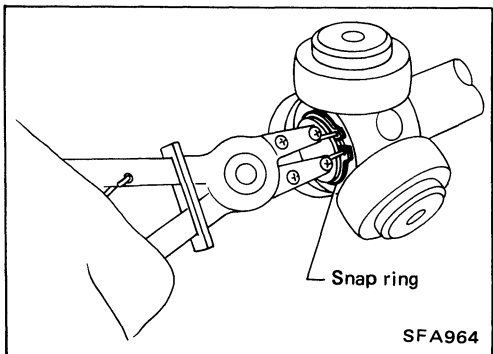

5. Pry off snap ring "B", then remove spider assembly.

CAUTION:

Do not disassemble spider assembly.

6. Draw out boot.

Cover drive shaft serration with tape to prevent damage to the boot.

Inspection

Thoroughly clean all parts in cleaning solvent, and dry with compressed air. Check parts for deformation or other damage.

DRIVE SHAFT

Replace drive shaft if it is twisted or cracked.

BOOT

Check boot for fatigue, cracks, or wear. Replace boot with new boot bands.

Inspection (Cont'd)

JOINT ASSEMBLY

- Check spider assembly for bearing, roller and washer damage. Replace spider assembly if necessary.
- Check housing for any damage. Replace housing set and spider assembly, if necessary.

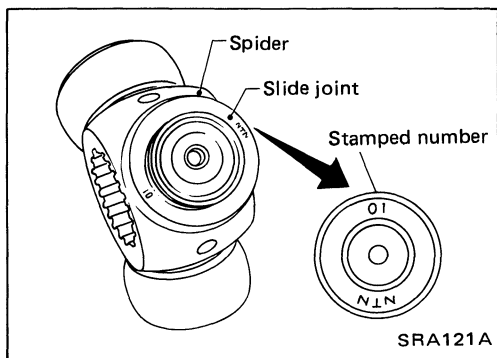

- When replacing only spider assembly, select a new spider assembly from among those listed in table below. Ensure the number stamped on sliding joint is the same as that stamped on new part.

Housing alone cannot be replaced. It must be replaced together with spider assembly.

Stamped number	Part No.
00	39720 10V10
01	39720 10V11
02	39720 10V12

Assembly

- After drive shaft has been assembled, make sure it moves smoothly over its entire range without binding.
- Use Nissan Genuine Grease or equivalent after every overhaul.

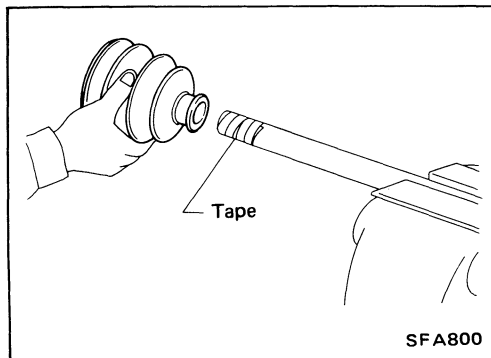

FINAL DRIVE SIDE

1. Install new small boot band, boot and slide joint housing to drive shaft.

Cover drive shaft serration with tape to prevent damage to boot during installation.

REAR AXLE — Drive Shaft

Assembly (Cont'd)

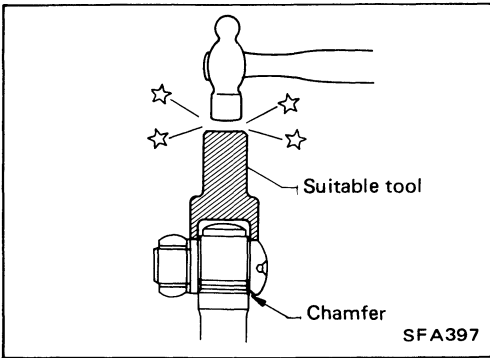

2. Install spider assembly securely, making sure marks are properly aligned.

Press-fit with spider assembly serration chamfer facing shaft.

3. Install new snap ring.

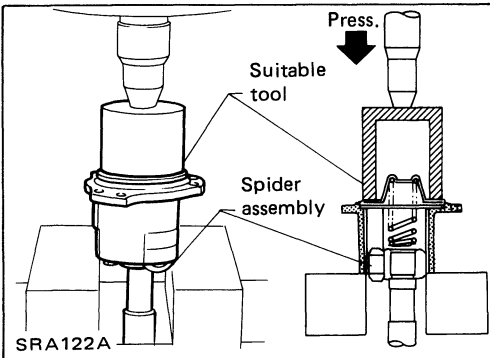

4. Install coil spring, spring cap and new plug seal to slide joint housing. Press plug seal.

Apply sealant to mating surface of plug seal.

CAUTION:

a. When pressing plug seal into place, hold it horizontal so that spring inside it does not tilt or fall down.

b. Move shaft in axial direction to ensure that spring is installed properly. If shaft drags or if spring is not installed properly, remove plug seal and install a new one. Discard plug seal after removal.

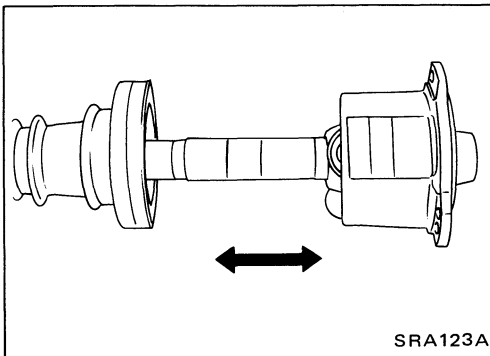

5. Pack drive shaft with specified amount of grease.

Specified amount of grease:

185 - 195 g (6.52 - 6.88 oz)

6. Set boot so that it does not swell and deform when its length is "L₁".

Length "L₁":

110.5 - 112.5 mm (4.35 - 4.43 in)

Make sure that boot is properly installed on the drive shaft groove.

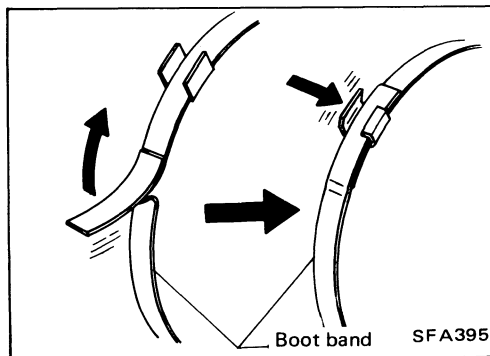
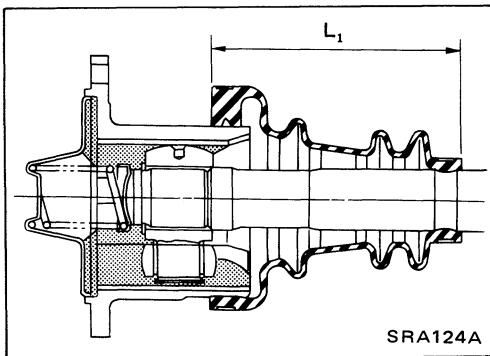

REAR AXLE — Drive Shaft

Assembly (Cont'd)

7. Lock new larger boot band securely with a suitable tool, then lock new smaller boot band.

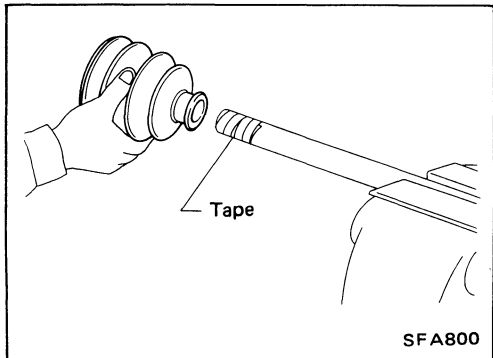
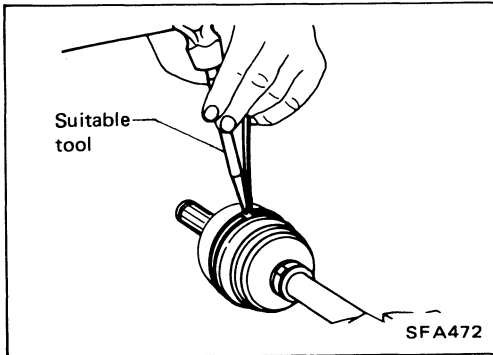

WHEEL SIDE

1. Install new small boot band and boot on drive shaft.
Cover drive shaft serration with tape to prevent damage to boot during installation.

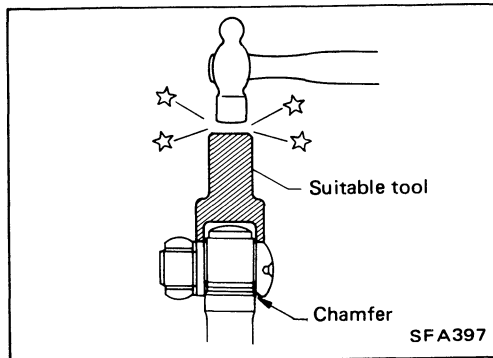

2. Install spider assembly securely, making sure marks are properly aligned.

Press-fit with spider assembly serration chamfer facing shaft.

3. Install new snap ring.

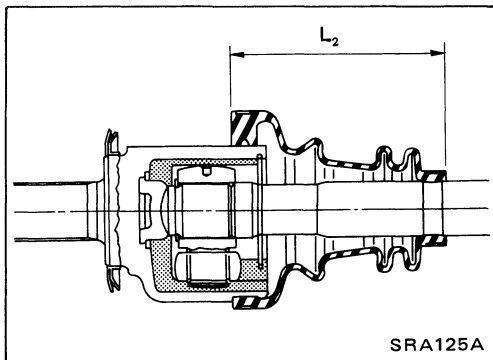

4. Pack drive shaft with specified amount of grease.

Specified amount of grease:

145 - 155 g (5.11 - 5.47 oz)

5. Install slide joint housing, then install new snap ring "A".
6. Set boot so that it does not swell and deform when its length is " L_2 ".

Length " L_2 ":

110.5 - 112.5 mm (4.35 - 4.43 in)

Make sure that boot is properly installed on the drive shaft groove.

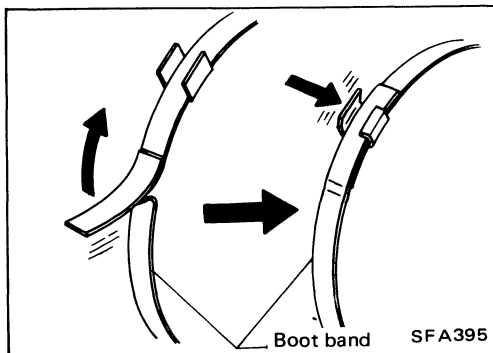

7. Lock new larger and smaller boot bands securely with a suitable tool.

REAR SUSPENSION

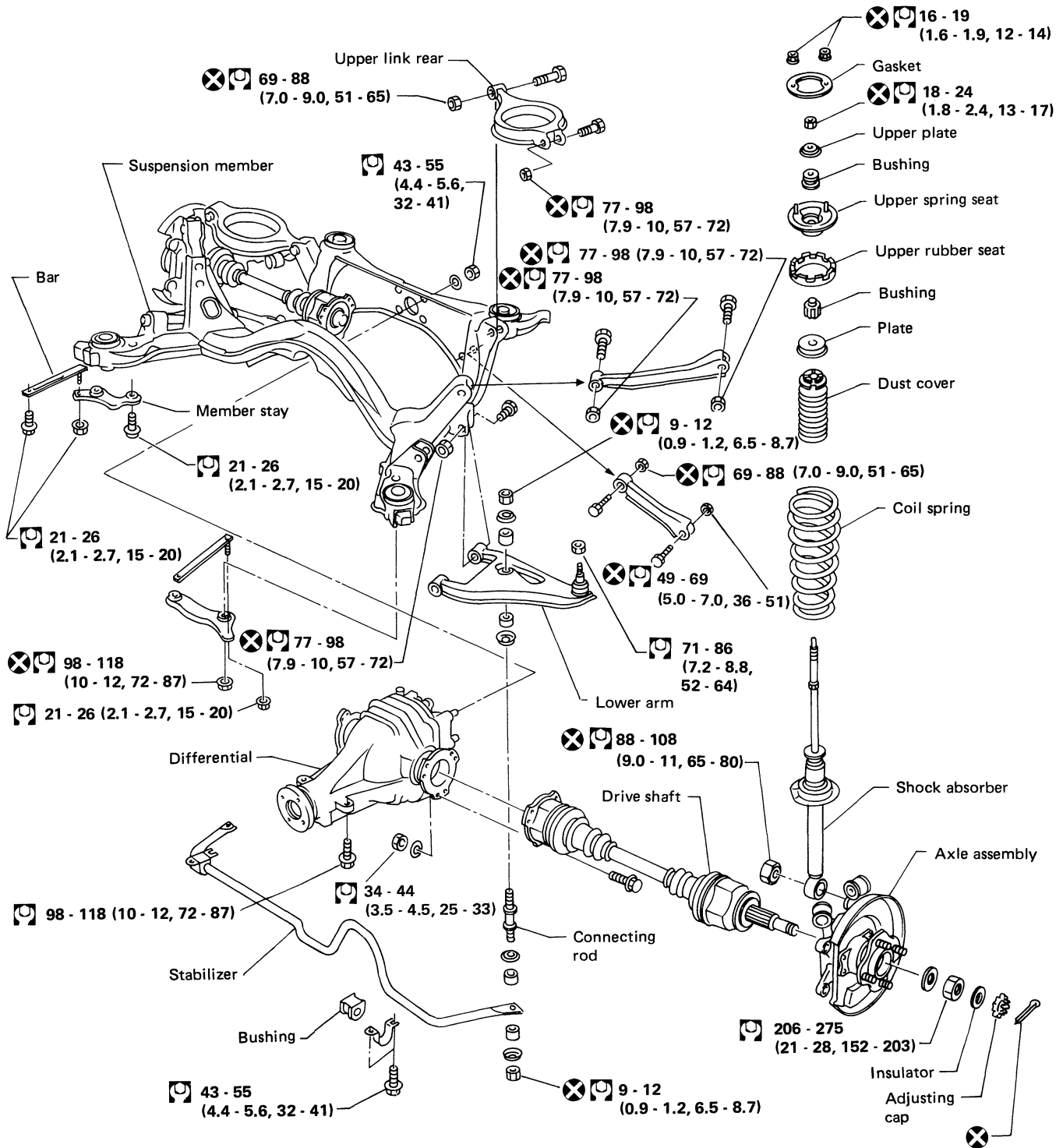

CAUTION:
Do not jack up at lower arm.
When installing each rubber part, final tightening must be carried out under unladen condition* with tires on ground.

* Fuel, radiator coolant and engine oil full.
Spare tire, jack, hand tools and mats in designated positions.

: N·m (kg·m, ft·lb)

Removal

Remove shock absorber upper and lower fixing nuts.
Do not remove piston rod lock nut on vehicle.

Disassembly

1. Set shock absorber on vise with attachment, then loosen piston rod lock nut.

Do not remove piston rod lock nut.

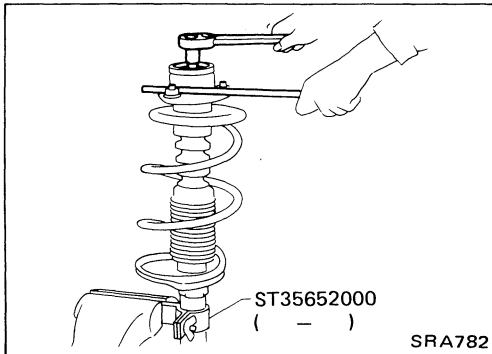

2. Compress spring with Tool so that the strut upper spring seat can be turned by hand.

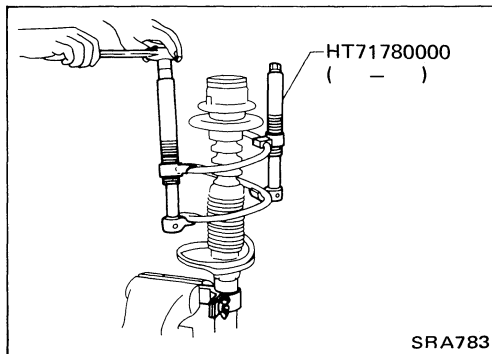

3. Remove piston rod lock nut.

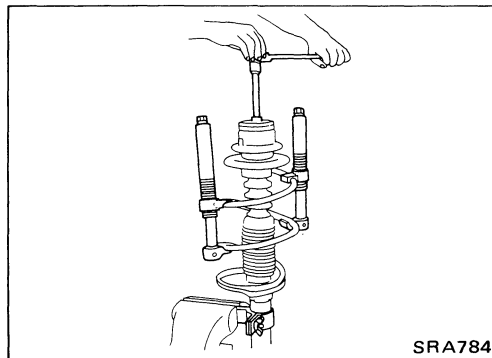

Inspection

SHOCK ABSORBER ASSEMBLY

- Check for smooth operation through a full stroke, both compression and extension.
- Check for oil leakage occurring on welded or gland packing portion.
- Check piston rod for cracks, deformation or other damage. Replace if necessary.

UPPER RUBBER SEAT AND BUSHING

Check rubber parts for deterioration or cracks.
Replace if necessary.

REAR SUSPENSION — Coil Spring and Shock Absorber

Inspection (Cont'd)

COIL SPRING

Check for cracks, deformation or other damage. Replace if necessary.

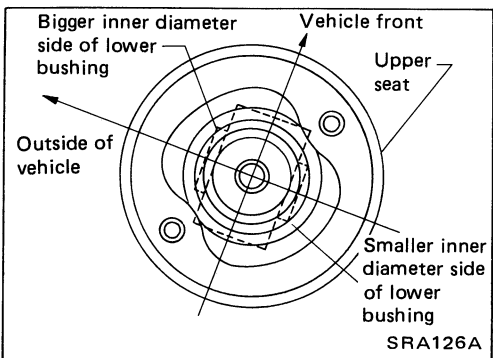
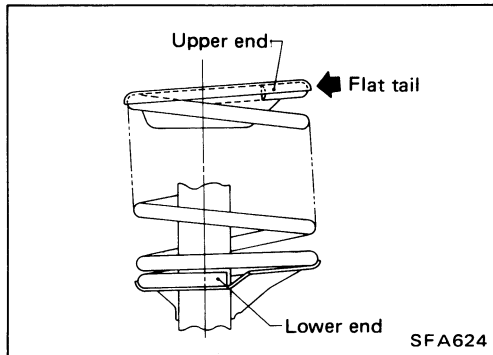
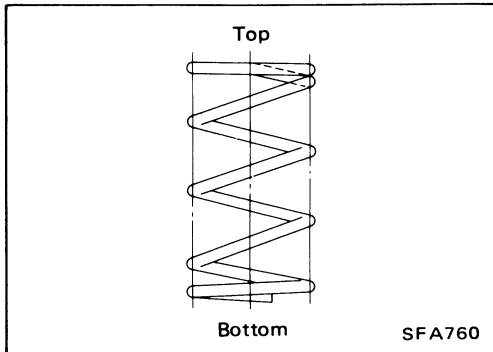

Assembly

- When installing coil spring, be careful not to reverse top and bottom direction. (Top end is flat.)

- When installing coil spring on strut, it must be positioned as shown in figure at left.

- When installing upper spring seat, make sure that it is positioned as shown.

REAR SUSPENSION — Stabilizer Bar

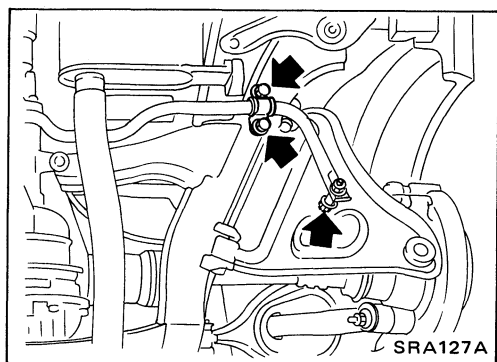

Removal

Remove connecting rod and clamp.

Inspection

- Check stabilizer bar for deformation or cracks. Replace if necessary.
- Check rubber bushings for deterioration or cracks. Replace if necessary.

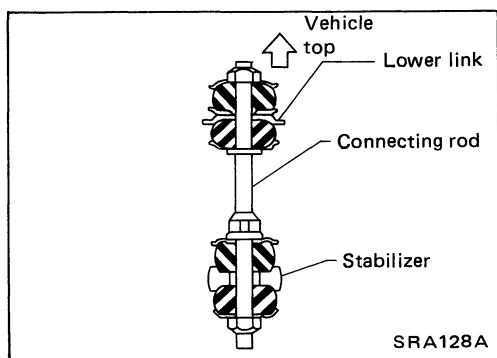

Installation

When installing connecting rod, make sure direction is correct (as shown at left).

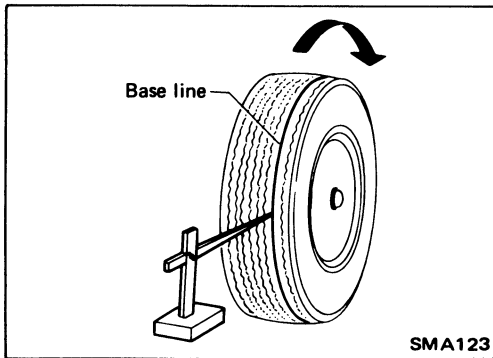

Rear Wheel Alignment

TOE-IN

1. Draw a base line across the tread.
After lowering rear of vehicle, move it up and down to eliminate friction.

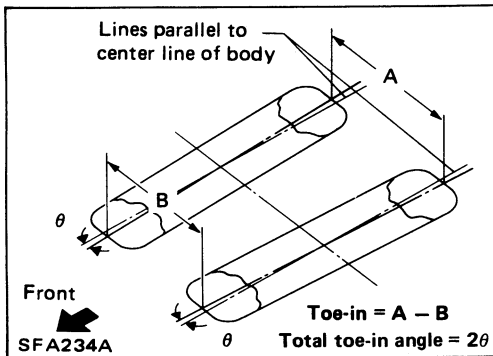

2. Measure toe-in.

Measure distance "A" and "B" at the same height as hub center.

Toe-in:

A - B

0.5 - 4.5 mm (0.020 - 0.177 in)

2θ (Total toe-in angle)

3' - 25'

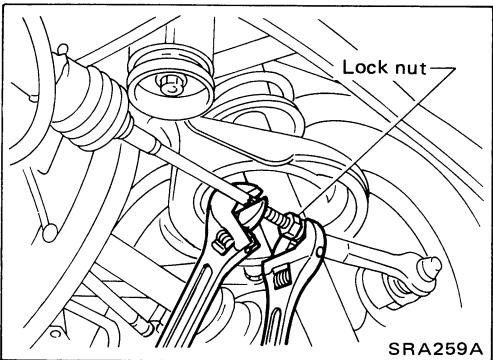

3. Adjust toe-in by varying length of power cylinder lower links.

(1) Loosen lock nuts.

(2) Adjust toe-in by turning lower links forward or backward.

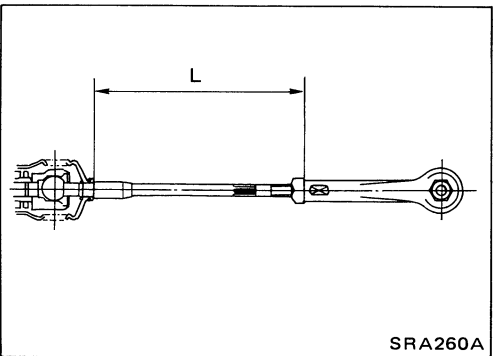

Make sure both lower links are the same length.

Standard length "L":

185.5 mm (7.30 in)

(3) Tighten lock nuts to the specified torque.

\square : 37 - 46 N·m

(3.8 - 4.7 kg-m, 27 - 34 ft-lb)

● Refer to CHECK AND ADJUSTMENT for other procedures.

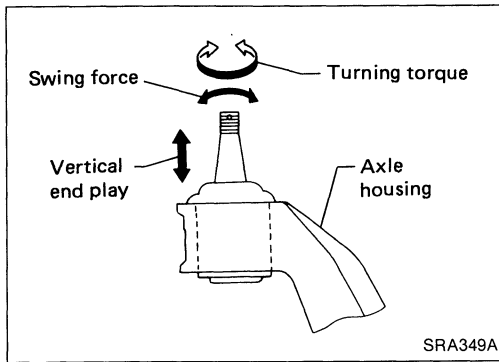

Rear Axle Housing Ball Joint

INSPECTION

- Measure swing force, turning torque and vertical end play in axial direction.
- If ball joint is worn, play in axial direction is excessive, or joint is hard to swing, replace ball joint.

Ball joint specifications	Swing force	6.9 - 68.6 N (0.7 - 7.0 kg, 1.5 - 15.4 lb)
	Turning torque	0.3 - 2.9 N·m (3 - 30 kg-cm, 2.6 - 26.0 in-lb)
	Vertical end play	0 mm (0 in)

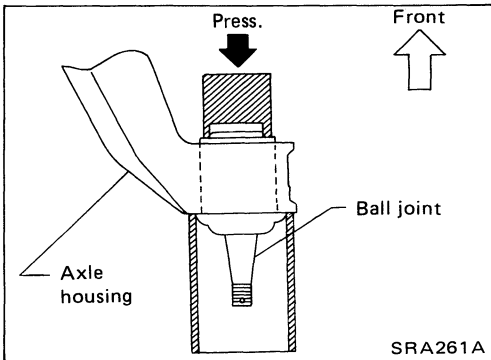

REMOVAL

- Remove ball joint snap ring.
- Press out ball joint from axle housing.

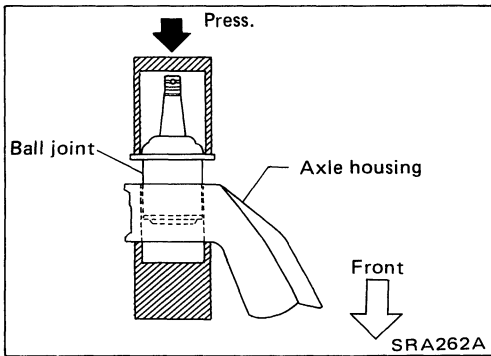

ASSEMBLY

- Press new ball joint assembly into axle housing.
- Install snap ring into groove of ball joint.
- Refer to REAR AXLE — Wheel Hub and Axle Housing for other procedures.
- Refer to ST section for power cylinder and SUPER HICAS — Trouble Diagnoses.

Removal and Installation

- Refer to "Removal and Installation" of REAR AXLE AND REAR SUSPENSION ASSEMBLY.

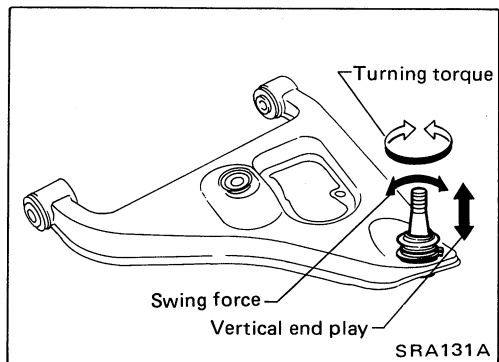
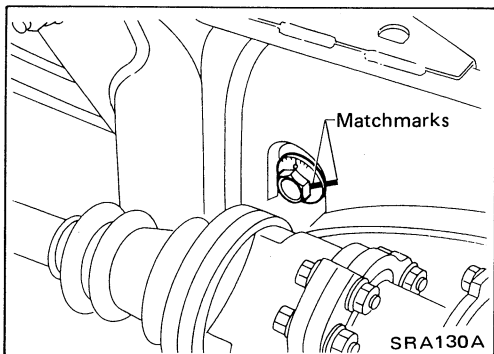
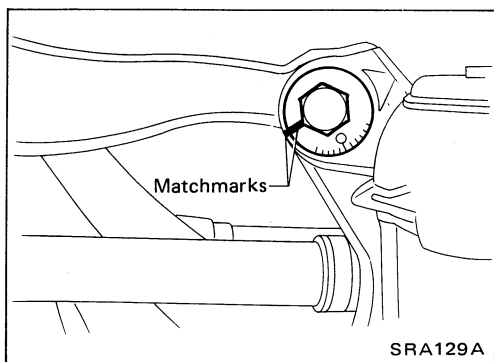

Before removing, put matchmarks on adjusting pin.

- When installing, final tightening must be carried out at curb weight with tires on ground.
- After installation, check wheel alignment. Refer to "Rear Wheel Alignment" of CHECK AND ADJUSTMENT — On vehicle.

Inspection

REAR SUSPENSION MEMBER

Replace suspension member assembly if cracked or deformed or if any part (insulator, for example) is damaged.

UPPER AND LOWER LINKS

Replace upper or lower link as required if cracked or deformed or if bushing is damaged.

SUSPENSION LOWER BALL JOINT

- Measure swing force, turning torque and vertical end play in axial direction. (Use same measurement procedures as that of FA section.)
- If ball stud is worn, play in axial direction is excessive, or joint is hard to swing, replace lower arm.

Ball joint specifications	Swing force	12.7 - 90.2 N (1.3 - 9.2 kg, 2.9 - 20.3 lb)
	Turning torque	0.5 - 3.4 N·m (5 - 35 kg·cm, 4.3 - 30.4 in·lb)
	Vertical end play	0 mm (0 in)

SERVICE DATA AND SPECIFICATIONS (S.D.S.)

General Specifications

COIL SPRING

Item	Model	Hatchback		Coupe
		With HICAS	Without HICAS	
Wire diameter	mm (in)	11.0 (0.433)	10.6 (0.417)	
Coil diameter	mm (in)	90 - 100 (3.54 - 3.94)		
Free length	mm (in)	367.5 (14.47)	385 (15.16)	375 (14.76)
Spring constant	N/mm (kg/mm, lb/in)	19.6 (2.0, 112)	17.7 (1.8, 101)	
Identification color		Pink x 2	Pink x 1 Light blue x 1	Pink x 1 Purple x 1

SHOCK ABSORBER

Item	Model	With HICAS	Without HICAS
		Piston rod diameter	mm (in)
Damping force	N (kg, lb)		
[at 0.1 m (0.3 ft)/sec.]			
Expansion		314 - 471 (32 - 48, 71 - 106)	392 - 588 (40 - 60, 88 - 132)
Compression		157 - 235 (16 - 24, 35 - 53)	196 - 294 (20 - 30, 44 - 66)
Damping force	N (kg, lb)		
[at 0.3 m (1.0 ft)/sec.]			
Expansion		588 - 804 (60 - 82, 132 - 181)	
Compression		265 - 402 (27 - 41, 60 - 90)	

DRIVE SHAFT

Joint type		TS82F
Final drive side		
Wheel side		TS82C
Diameter	mm (in)	
Wheel side D_1		30 (1.18)
Grease name		
Final drive side		Nissan genuine grease or equivalent
Wheel side		Nissan genuine grease or equivalent
Specified amount of grease	g (oz)	
Final drive side		185 - 195 (6.52 - 6.88)
Wheel side		145 - 155 (5.11 - 5.47)
Boot length	mm (in)	
Final drive side (L_1)		110.5 - 112.5 (4.35 - 4.43)
Wheel side (L_2)		

Final drive side

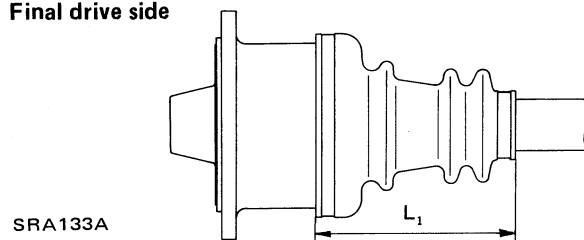

Wheel side

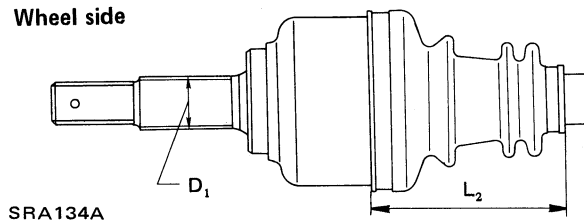

REAR STABILIZER BAR

Item	Model	With HICAS	Without HICAS
		Stabilizer diameter	mm (in)
Identification color		Red	Light green

SERVICE DATA AND SPECIFICATIONS (S.D.S.)

Inspection and Adjustment

WHEEL ALIGNMENT (Unladen*)

Camber	degree	-1°36' to -0°36'
Toe-in	mm (in)	0.5 - 4.5 (0.020 - 0.177)
(Total)	degree	3' - 25'

* Tankful of fuel, radiator coolant and engine oil full.
Spare tire, jack, hand tools, mats in designated position.

WHEEL BEARING

Wheel bearing axial end play	mm (in)	0.05 (0.0020) or less
Wheel bearing lock nut Tightening torque	N-m (kg-m, ft-lb)	206 - 275 (21 - 28, 152 - 203)

WHEEL RUNOUT (Radial and lateral)

Wheel type		Radial runout	Lateral runout
Aluminum wheel	mm (in)	0.3 (0.012) or less	
Steel wheel	mm (in)	0.5 (0.020) or less	0.8 (0.031) or less

LOWER BALL JOINT

Swing force (Measuring point: cotter pin hole of ball stud)	N (kg, lb)	12.7 - 90.2 (1.3 - 9.2, 2.9 - 20.3)
Turning torque	N-m (kg-cm, in-lb)	0.5 - 3.4 (5 - 35, 4.3 - 30.4)
Vertical end play	mm (in)	0 (0)

LOWER LINK BALL JOINT (SUPER HICAS)

Swing force (at cotter pin hole)	N (kg, lb)	6.9 - 68.6 (0.7 - 7.0, 1.5 - 15.4)
Turning torque	N-m (kg-cm, in-lb)	0.3 - 2.9 (3 - 30, 2.6 - 26.0)
Vertical end play	mm (in)	0 (0)

BRAKE SYSTEM

SECTION **BR**

CONTENTS

PRECAUTIONS AND PREPARATION	BR- 2
CHECK AND ADJUSTMENT	BR- 3
BRAKE HYDRAULIC LINE	BR- 4
BRAKE PEDAL AND BRACKET	BR- 6
BRAKE BOOSTER	BR- 8
VACUUM PIPING	BR-10
MASTER CYLINDER	BR-12
FRONT DISC BRAKE (CL22VB, CL25VA) — Caliper	BR-13
FRONT DISC BRAKE (CL22VB, CL25VA) — Rotor	BR-17
REAR DISC BRAKE (CL9H) — Caliper	BR-18
REAR DISC BRAKE (CL9H) — Rotor	BR-22
PARKING BRAKE CONTROL	BR-23
ANTI-LOCK BRAKING SYSTEM	BR-25
TROUBLE DIAGNOSES	BR-29
SERVICE DATA AND SPECIFICATIONS (S.D.S.)	BR-54

BR

PRECAUTIONS AND PREPARATION

Precautions

- Recommended fluid is brake fluid "DOT 3".
- Never reuse drained brake fluid.
- Be careful not to splash brake fluid on painted areas.
- To clean or wash all parts of master cylinder, disc brake caliper and wheel cylinder, use clean brake fluid.
- Never use mineral oils such as gasoline or kerosene. They will ruin rubber parts of hydraulic system.

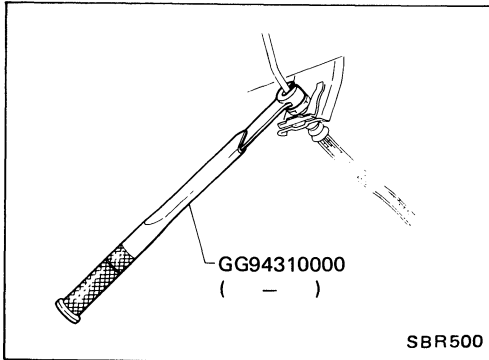

- Use Tool when removing and installing brake tube.

WARNING:

- Clean brake pads and shoes with a waste cloth, then collect dust with a dust collector.

Preparation SPECIAL SERVICE TOOL

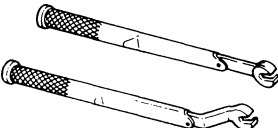
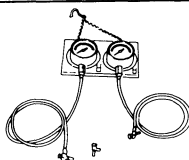
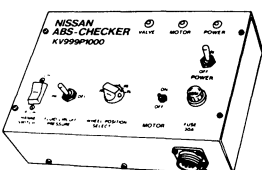
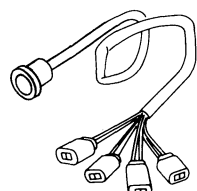
Tool number (Kent-Moore No.) Tool name	Description
GG94310000 (-) Flare nut torque wrench	
KV991V0010 (-) Brake fluid pressure gauge	
KV999P1000 (-) A.B.S. checker	
KV999P1010 (-) A.B.S. checker adapter harness	

CHECK AND ADJUSTMENT

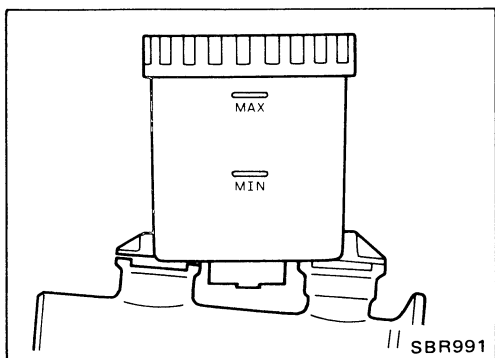

Checking Brake Fluid Level

- Check fluid level in reservoir tank. It should be between Max. and Min. lines on reservoir tank.
- If fluid level is extremely low, check brake system for leaks.

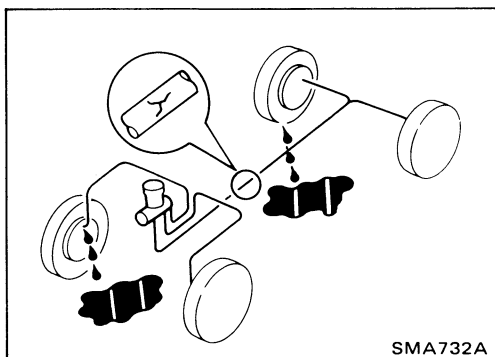

Checking Brake System

- Check brake lines (tubes and hoses) for cracks, deterioration or other damage. Replace any damaged parts. If leakage occurs around joints, retighten or, if necessary, replace damaged parts.
- Check for oil leakage by fully depressing brake pedal.

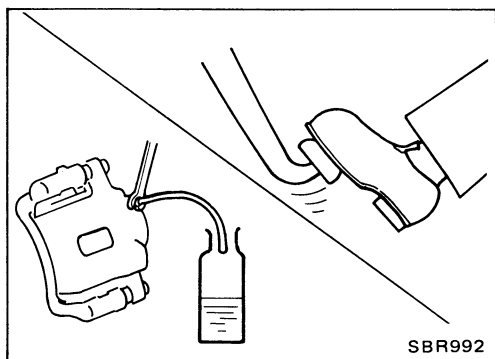

Changing Brake Fluid

1. Drain brake fluid in each air bleeder valve.
 2. Refill until new brake fluid comes out of each air bleeder valve.
Use same procedure as in bleeding hydraulic system to refill brake fluid.
Refer to Bleeding Procedure.
- **Refill with recommended brake fluid "DOT 3".**
 - **Never reuse drained brake fluid.**
 - **Be careful not to splash brake fluid on painted areas.**

BRAKE HYDRAULIC LINE

Without Anti-lock Braking System (A.B.S.)

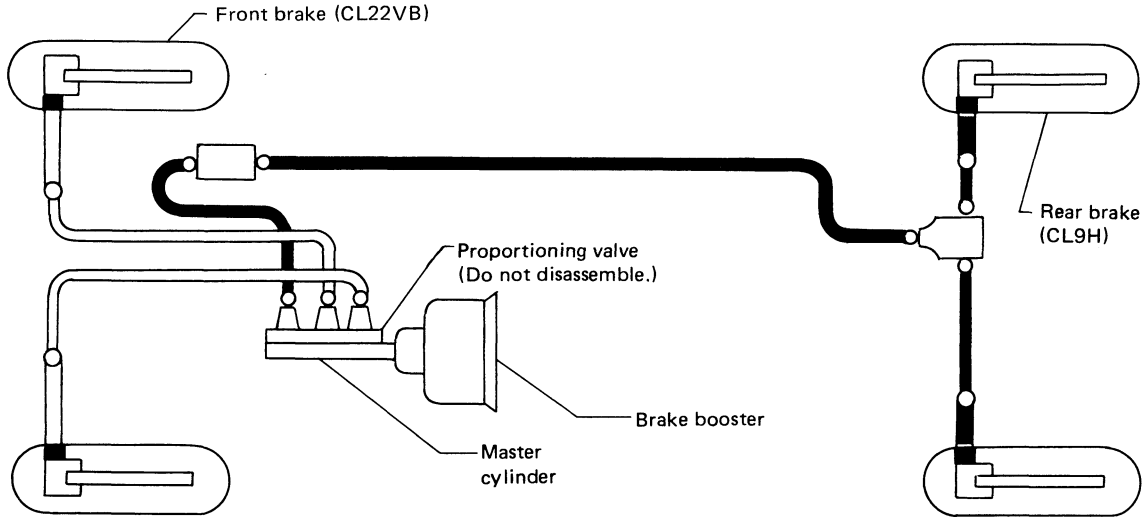

With Anti-lock Braking System (A.B.S.)

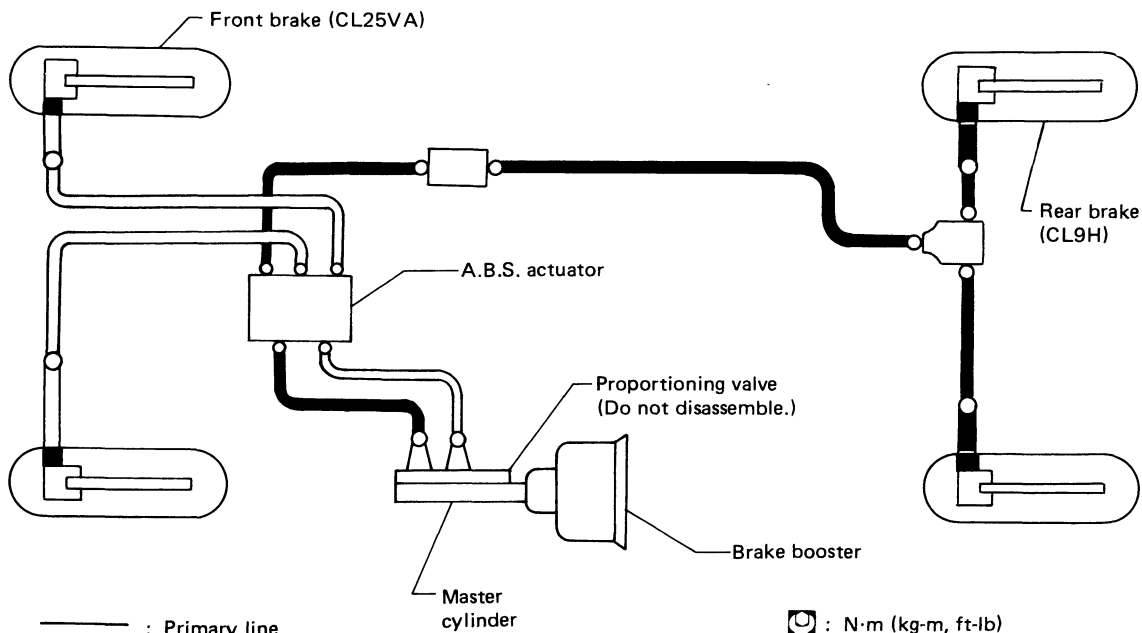

— : Primary line
 — : Secondary line

⊗ : N·m (kg·m, ft·lb)

○ : Flare nut
 15 - 18 (1.5 - 1.8, 11 - 13)
 ■ : Connecting bolt
 17 - 20 (1.7 - 2.0, 12 - 14)

SBR501A

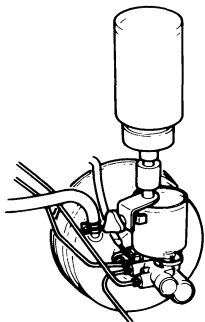

SBR995

Bleeding Procedure

CAUTION:

- Carefully monitor brake fluid level at master cylinder during bleeding operation.
- Fill reservoir with recommended brake fluid. Make sure it is full at all times while bleeding air out of system.
- Place a container beneath master cylinder to avoid spillage of brake fluid.

BRAKE HYDLAULIC LINE

Bleeding Procedure (Cont'd)

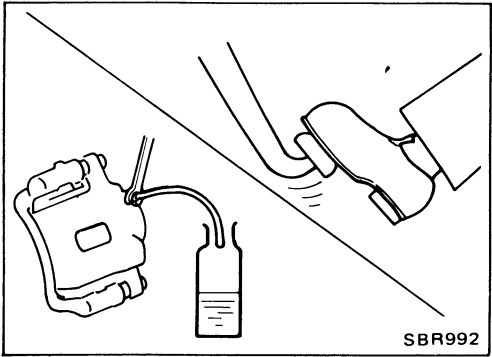

- Bleed air according to the following procedure.

Without Anti-lock Braking System:

Left rear caliper
↓
Right rear caliper
↓
Left front caliper
↓
Right front caliper

With Anti-lock Braking System:

Left rear caliper
↓
Right rear caliper
↓
Left front caliper
↓
Right front caliper
↓
Front side air bleeder on A.B.S. actuator
↓
Rear side air bleeder on A.B.S. actuator

- To bleed air out of lines, wheel cylinders and calipers, use the following procedure.

- 1) Connect a transparent vinyl tube to air bleeder valve.
- 2) Fully depress brake pedal several times.
- 3) With brake pedal depressed, open air bleeder valve to release air.
- 4) Close air bleeder valve.
- 5) Release brake pedal slowly.
- 6) Repeat steps 2) through 5) until clear brake fluid comes out of air bleeder valve.

Removal and Installation

1. To remove brake hose, first remove flare nut securing brake tube to hose, then withdraw lock spring.
2. Cover openings to prevent entrance of dirt whenever disconnecting hydraulic line.
3. All hoses must be free from excessive bending, twisting and pulling.
4. After installing brake lines, check for oil leakage by fully depressing brake pedal.

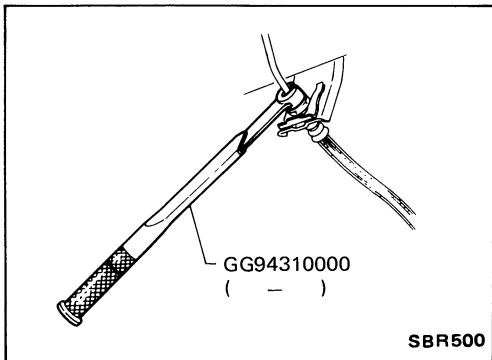

Inspection

Check brake lines (tubes and hoses) for cracks, deterioration or other damage. Replace any damaged parts.
If leakage occurs around joints, retighten or, if necessary, replace damaged parts.

BRAKE PEDAL AND BRACKET

Removal and Installation

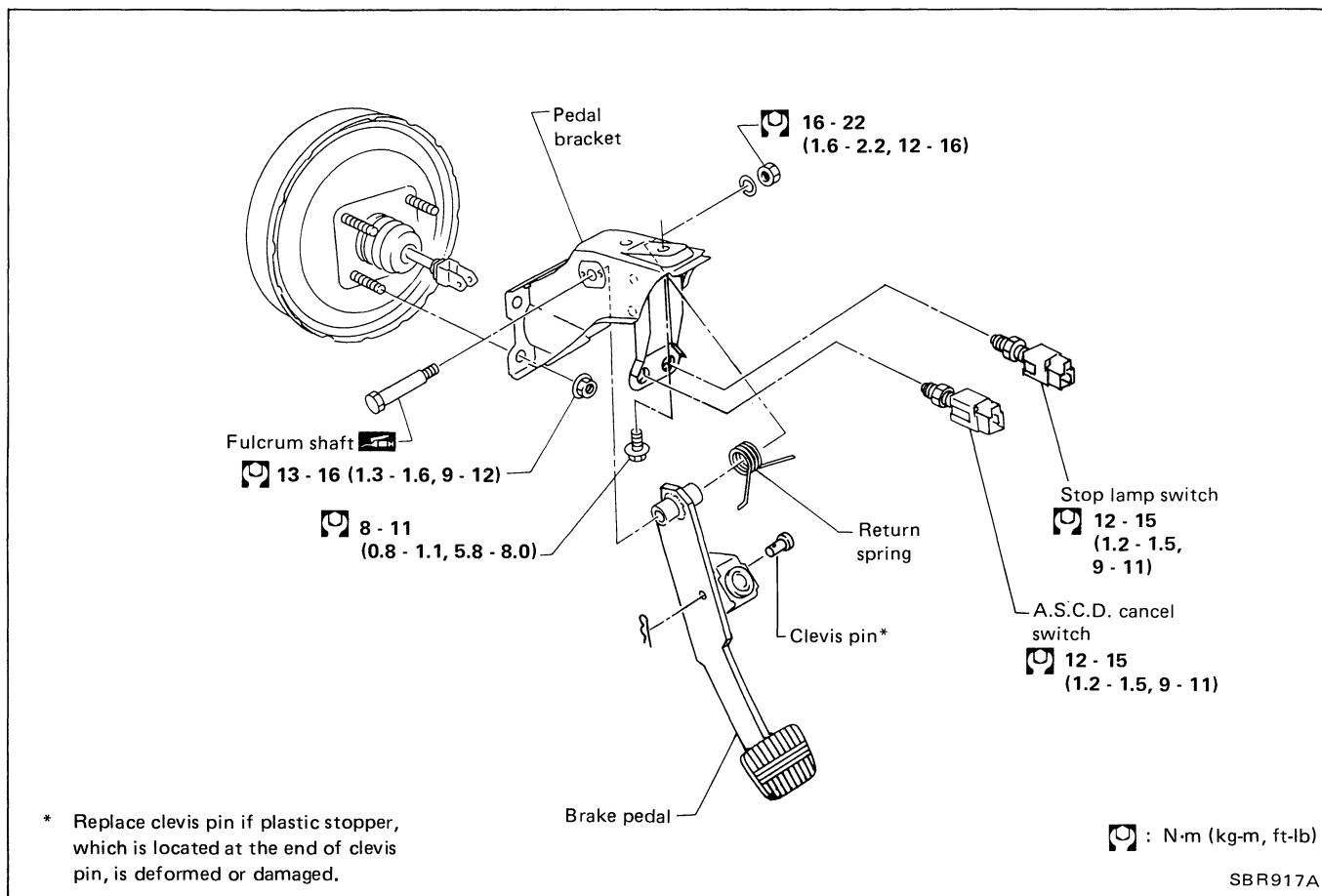

Inspection

Check brake pedal for following items.

- Brake pedal bend
- Clevis pin deformation
- Crack of any welded portion

BRAKE PEDAL AND BRACKET

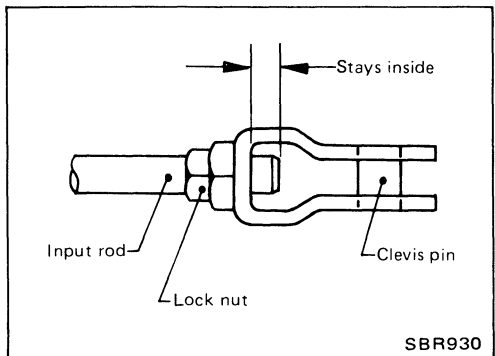
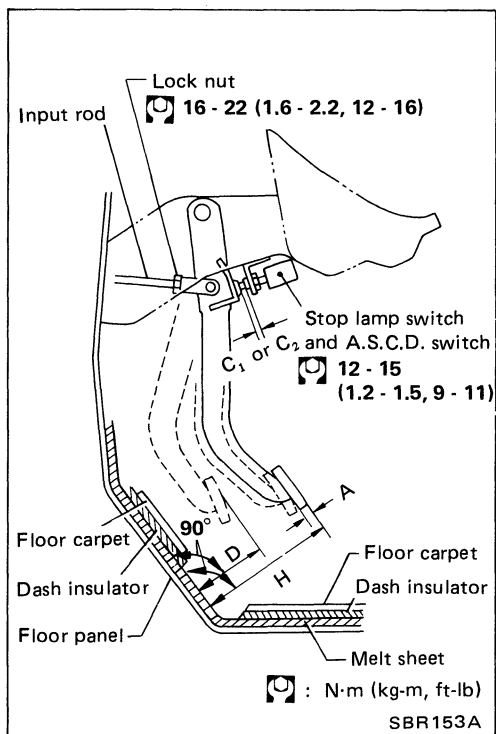

Adjustment

Check brake pedal free height from dash reinforcement panel. Adjust if necessary.

- H: Free height**
Refer to S.D.S.
- D: Depressed height**
Refer to S.D.S.
Under force of 490 N (50 kg, 110 lb) with engine running
- C₁: Clearance between pedal stopper and threaded end of stop lamp switch**
0.3 - 1.0 mm (0.012 - 0.039 in)
- C₂: Clearance between pedal stopper and threaded end of A.S.C.D. switch**
0.3 - 1.0 mm (0.012 - 0.039 in)
- A: Pedal free play**
1 - 3 mm (0.04 - 0.12 in)

1. Adjust pedal free height with brake booster input rod. Then tighten lock nut.

Make sure that tip of input rod stays inside.

2. Adjust clearance "C₁" and "C₂" with stop lamp switch and A.S.C.D. switch respectively. Then tighten lock nuts.
3. Check pedal free play.

Make sure that stop lamp is off when pedal is released.

4. Check brake pedal's depressed height while engine is running.

If depressed height is below specified value, check brake system for leaks, accumulation of air or any damage to components (master cylinder, wheel cylinder, etc.); then make necessary repairs.

BRAKE BOOSTER

Removal and Installation

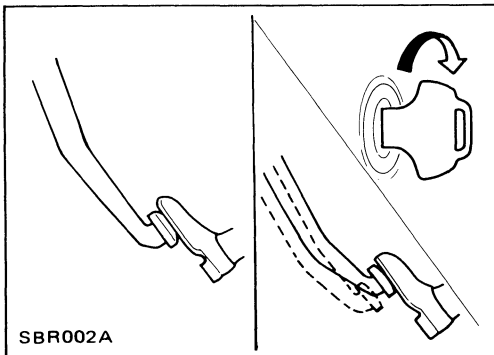
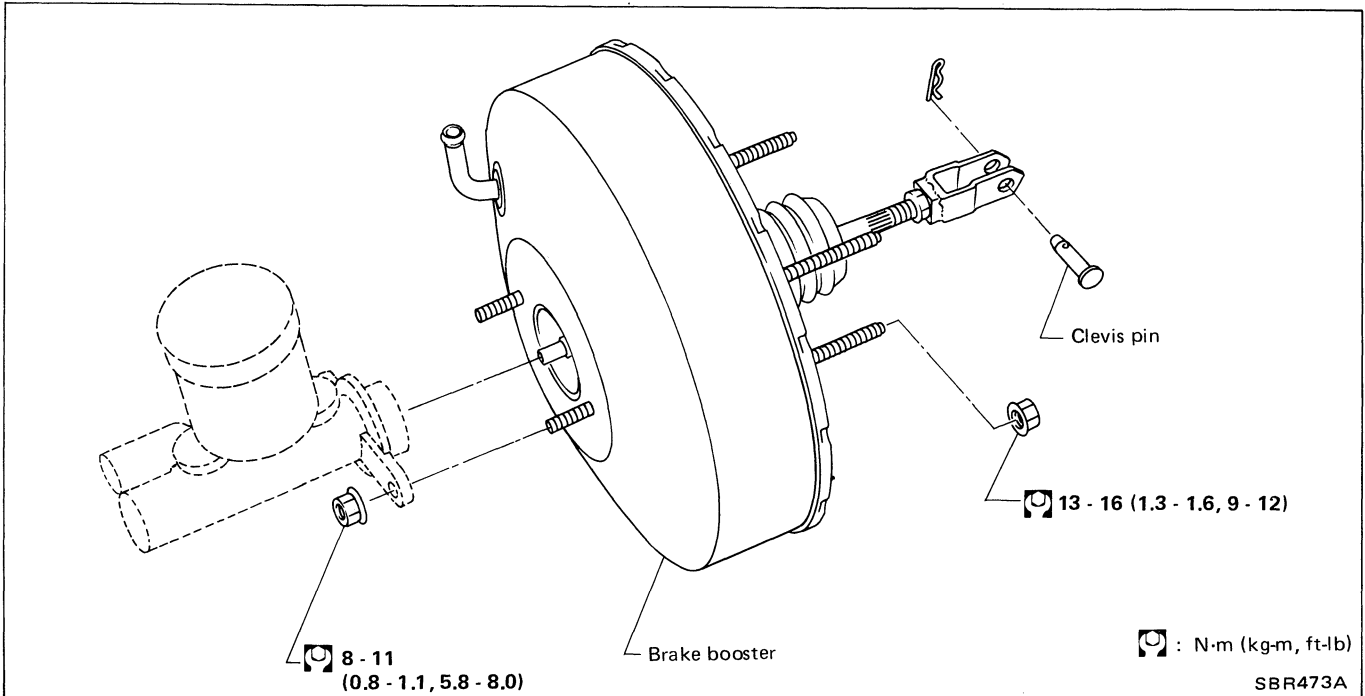

Inspection

OPERATING CHECK

- Depress brake pedal several times with engine off, and check that there is no change in pedal stroke.
- Depress brake pedal, then start engine. If pedal goes down slightly, operation is normal.

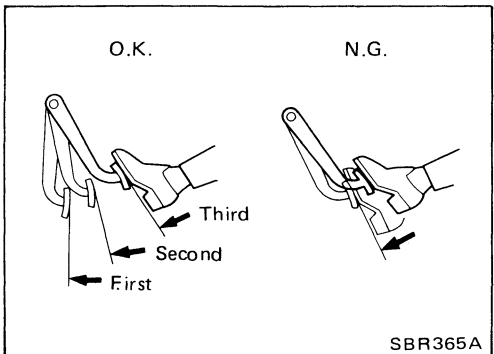

AIRTIGHT CHECK

- Start engine, and stop it after one or two minutes. Depress brake pedal several times slowly. If pedal goes further down the first time and gradually rises after second or third time, booster is airtight.
- Depress brake pedal while engine is running, and stop engine with pedal depressed. If there is no change in pedal stroke after holding pedal down **30 seconds**, brake booster is airtight.

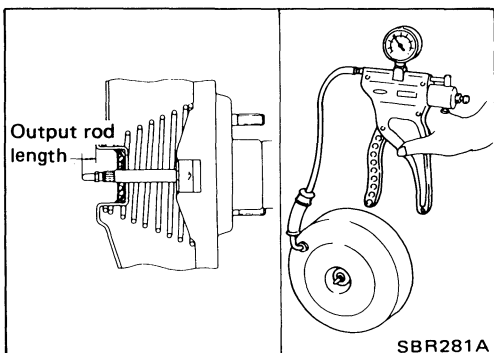

OUTPUT ROD LENGTH CHECK

1. Supply brake booster with vacuum of -66.7 kPa (-500 mmHg, -19.69 inHg) using a handy vacuum pump.
2. Check output rod length.

Specified length:

10.275 - 10.525 mm (0.4045 - 0.4144 in)

BRAKE BOOSTER

Inspection (Cont'd)

3. Adjust rod length if necessary.
4. If rod length is without specification, replace brake booster.

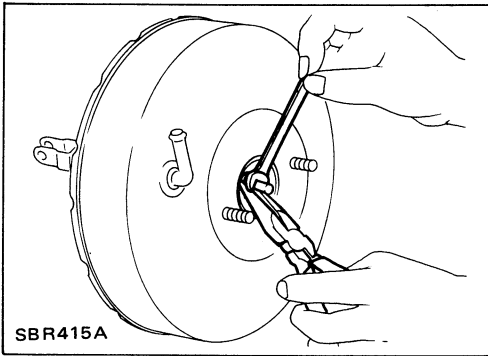

VACUUM PIPING

Removal and Installation

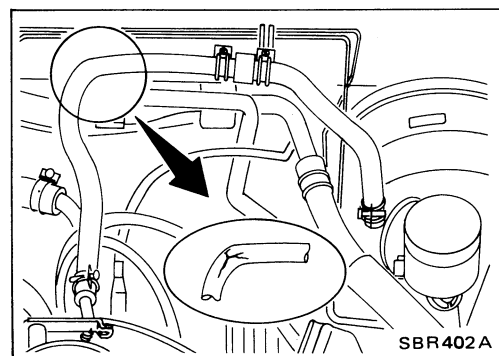
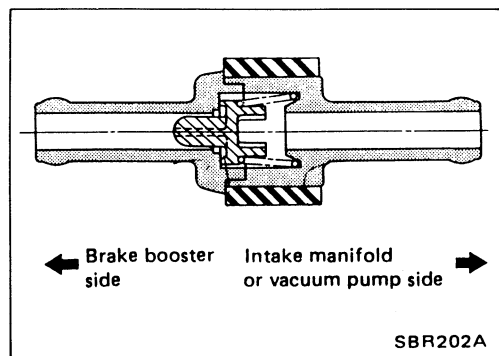
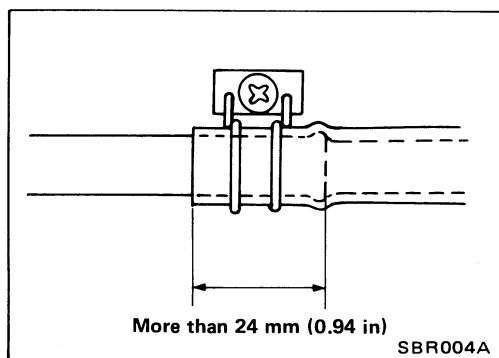
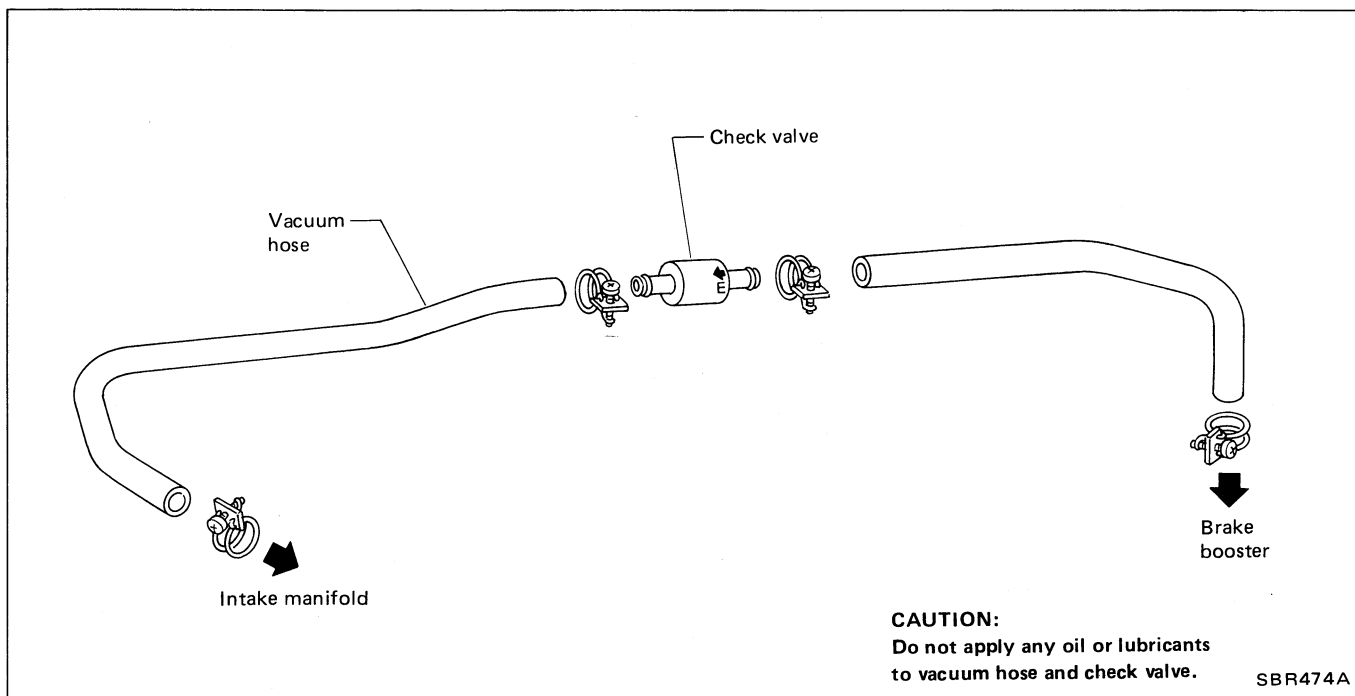

- Insert vacuum tube into vacuum hose more than 24 mm (0.94 in).

- Install check valve, paying attention to its direction.

Inspection

HOSES AND CONNECTORS

- Check vacuum lines, connections and check valve for airtightness, improper attachment chafing and deterioration.

VACUUM PIPING

Inspection (Cont'd)

CHECK VALVE

- When pressure is applied to brake booster side of check valve and valve does not open, replace check valve with a new one.

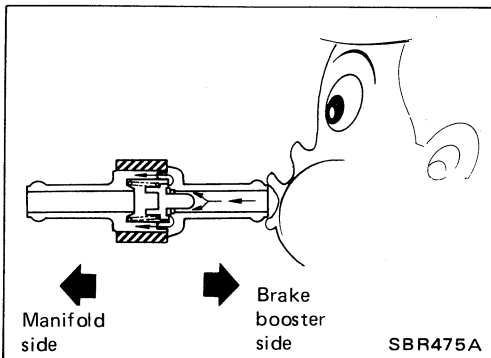

MASTER CYLINDER

Removal and Installation

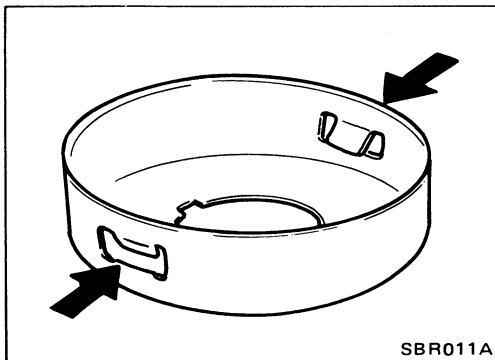
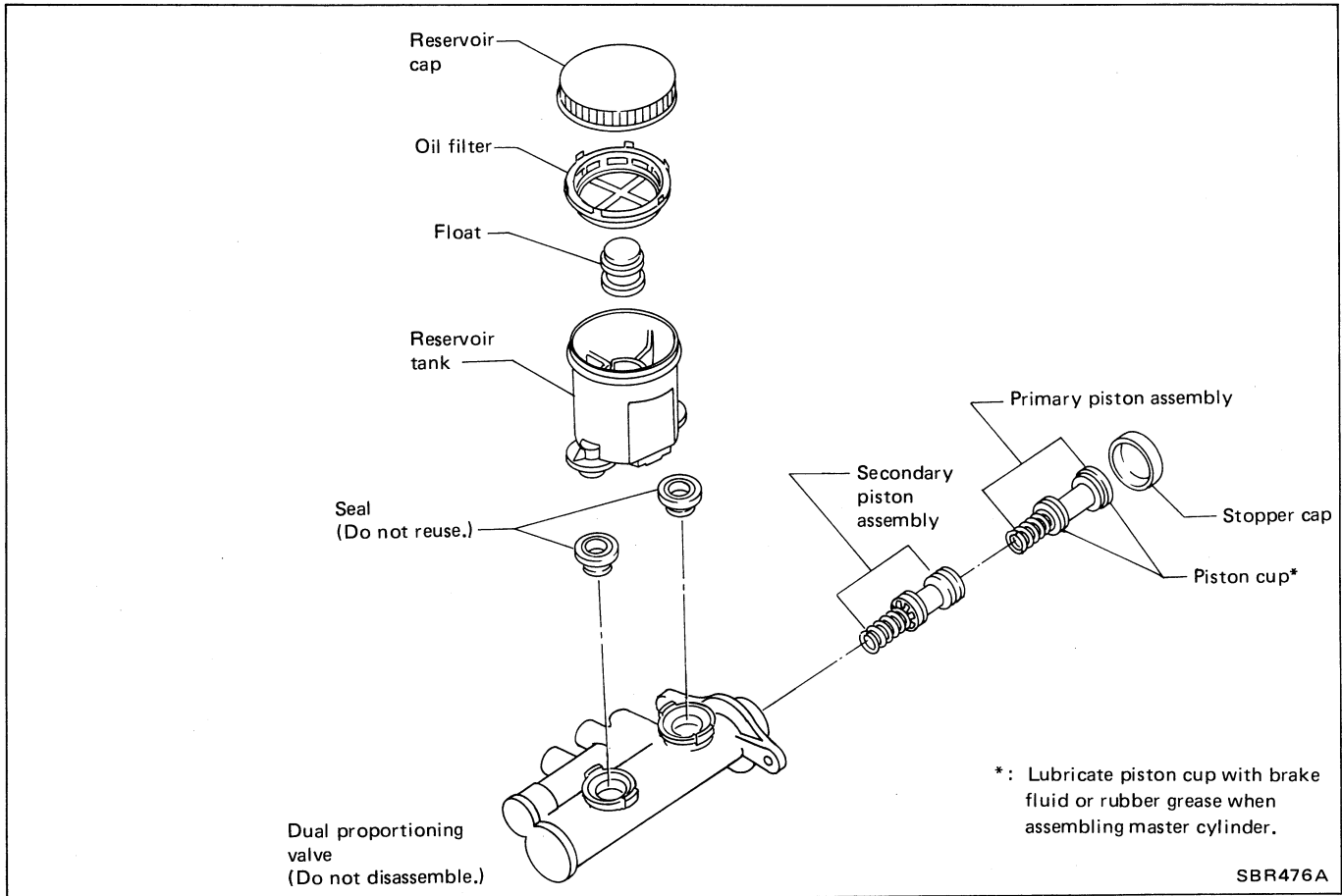

- Replace stopper cap if claw is damaged or deformed.
- Bend claws inward when installing stopper cap.

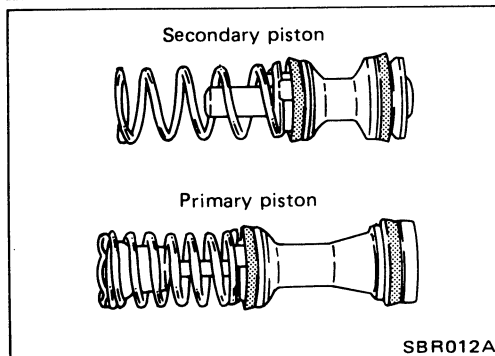

- Pay attention to direction of piston cups in figure at left.
- Check parts for wear or damage. Replace if necessary.

FRONT DISC BRAKE (CL22VB, CL25VA) — Caliper

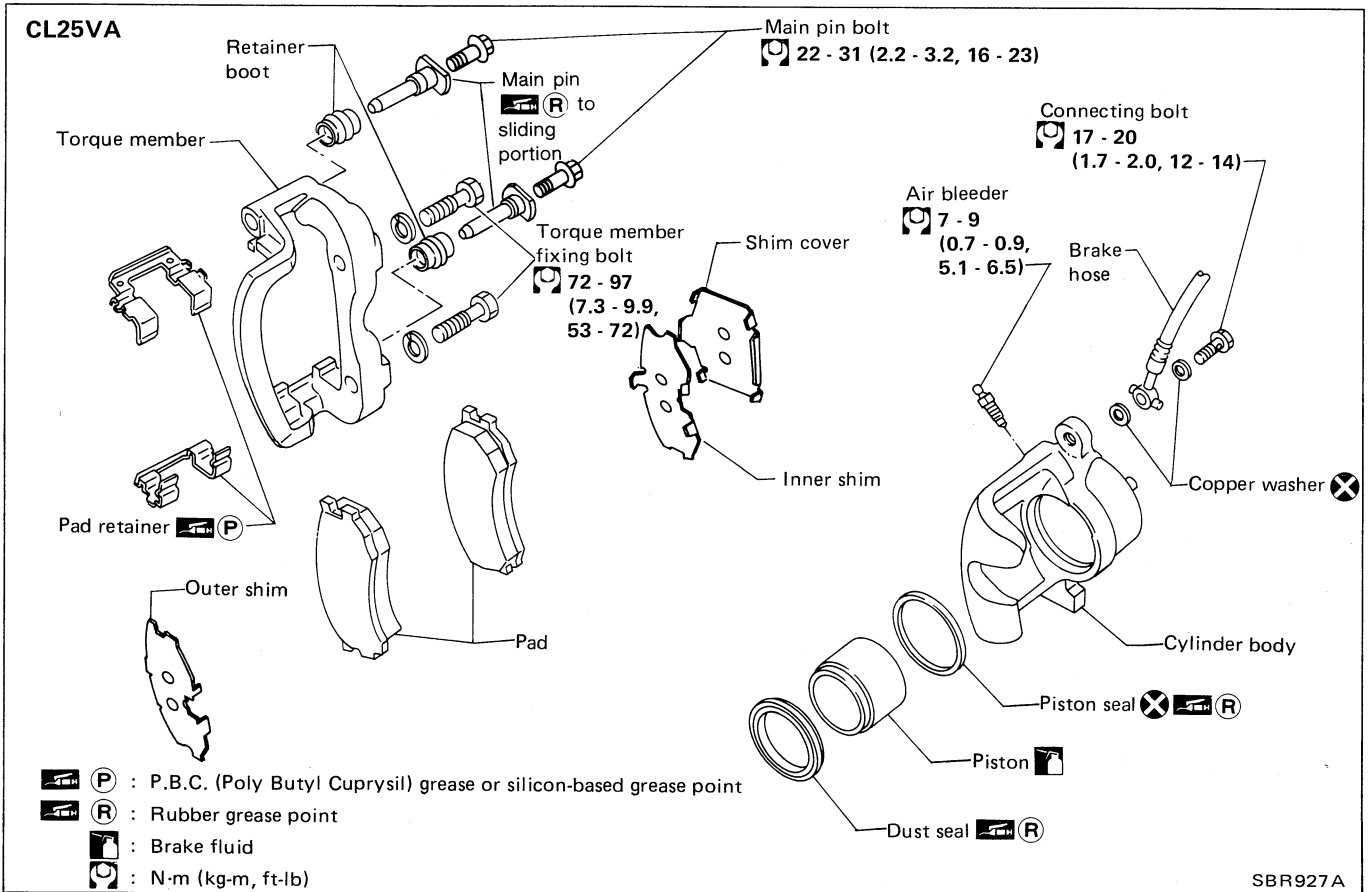
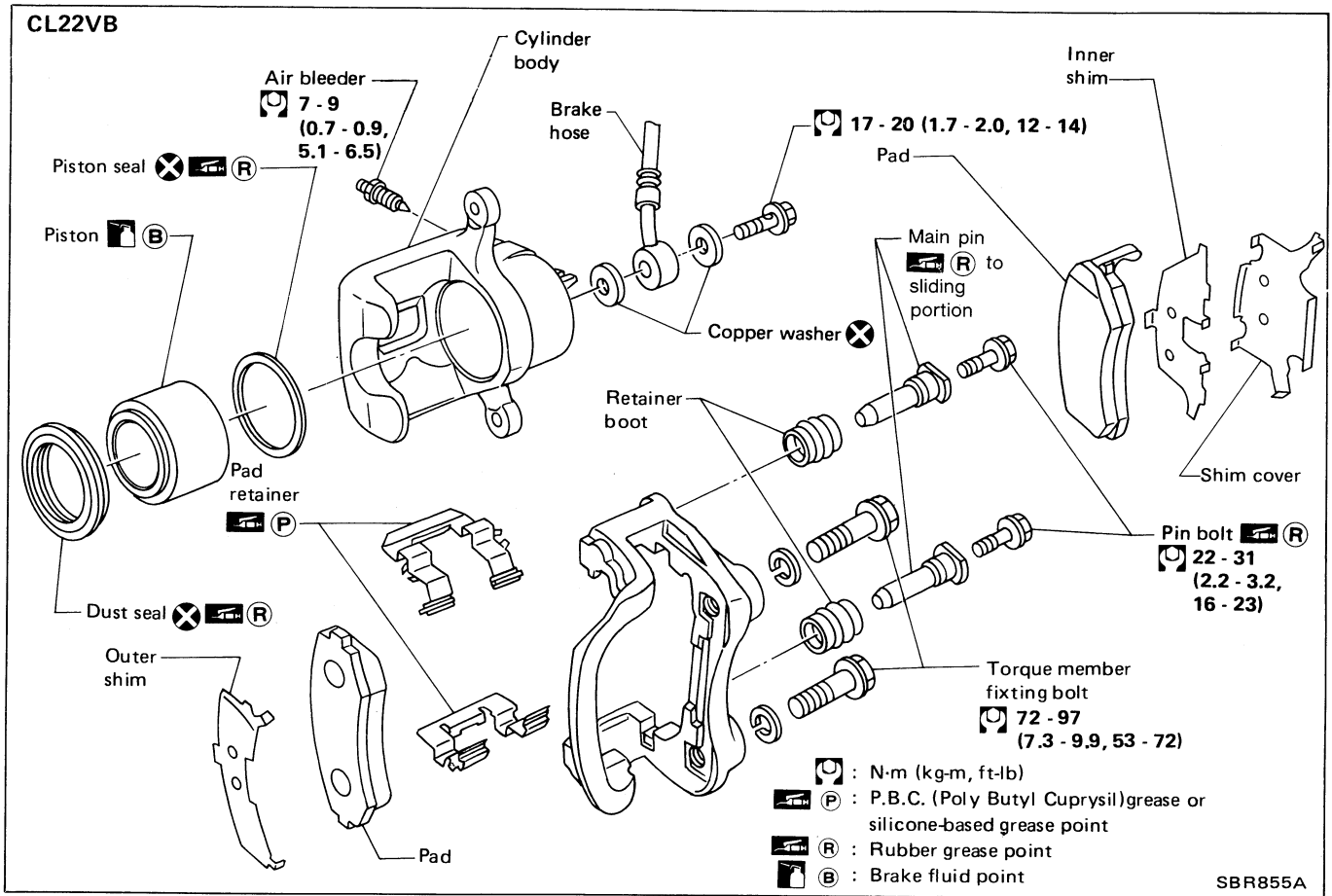

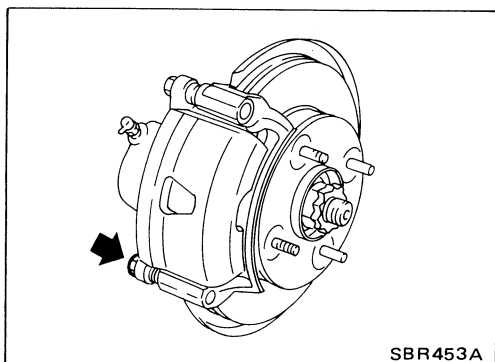

SBR453A

Pad Replacement

1. Remove pin bolt.

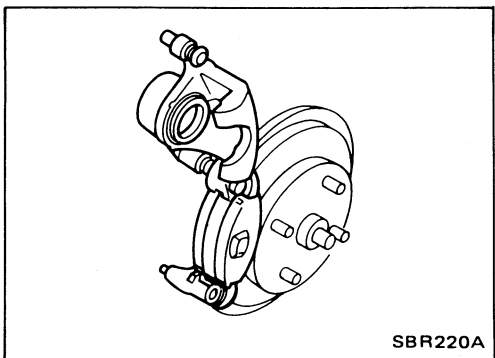

SBR220A

2. Swing cylinder body upward. Then remove pad retainer, and inner and outer shims.

CAUTION:

- When cylinder body is swung up, do not depress brake pedal because piston will pop out.
- Be careful not to damage dust seal or get oil on rotor. Always replace shims when replacing pads.

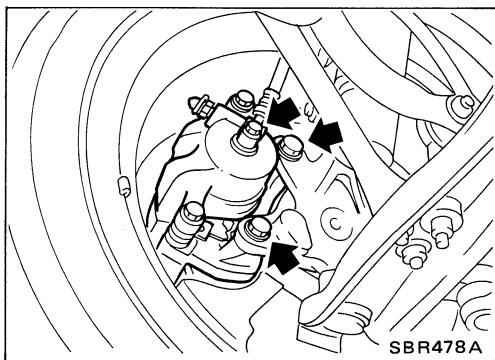

SBR478A

Removal and Installation

- Remove torque member fixing bolts and union bolt.

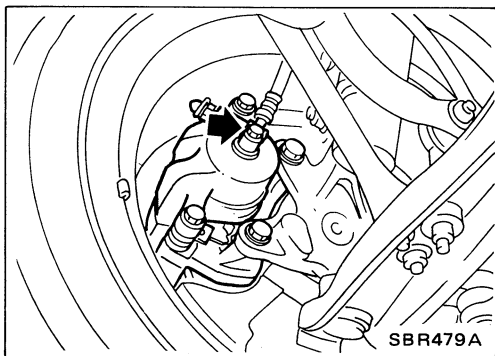

SBR479A

- Install brake hose to caliper at protrusions securely.

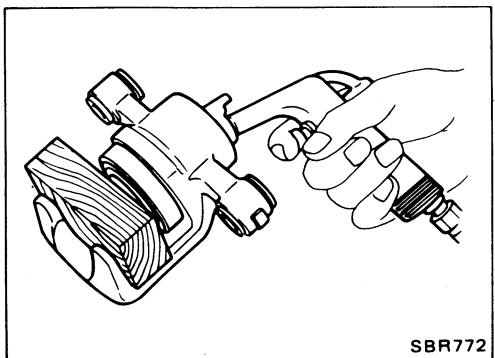

SBR772

Disassembly

Push out piston with dust seal using compressed air.

Inspection

CYLINDER BODY

- Check inside surface of cylinder for scoring, rust, wear, damage or foreign materials. Replace if any such condition exists.
- Eliminate minor damage from rust or foreign materials by polishing surface with fine emery paper.

CAUTION:

Use brake fluid to clean.

PISTON

Check piston for scoring, rust, wear, damage or foreign materials. Replace if any condition exists.

CAUTION:

Piston sliding surface is plated. Do not polish with emery paper even if rust or foreign materials are stuck to sliding surface.

PIN, PIN BOLT AND PIN BOOT

Check for wear, cracks or other damage. Replace if any condition exists.

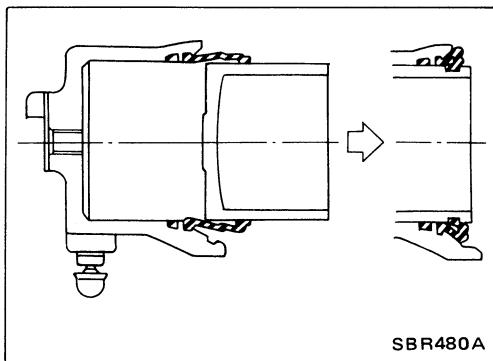

Assembly

- Place piston boot over rear of piston. Fit piston boot's lip properly in corresponding groove on cylinder body.
- Insert piston into cylinder body and fit boot's lip properly in corresponding groove on piston.

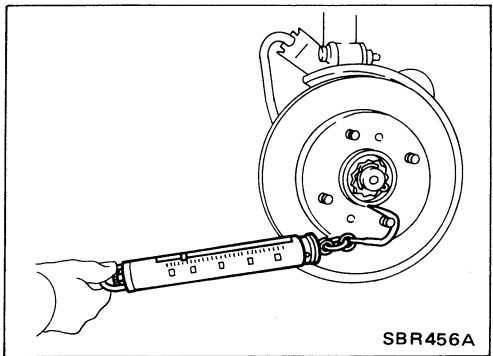

Inspection (On-vehicle)

INSPECTION OF BRAKE DRAG FORCE

1. Swing cylinder body upward.
2. Make sure that wheel bearing is adjusted properly. Refer to section FA.
3. Measure rotating force (F_1).

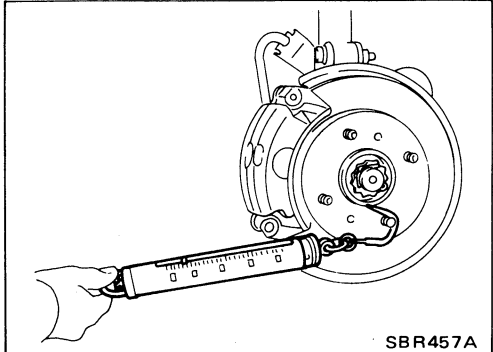

4. Install caliper with pads to original position.
5. Depress brake pedal for 5 seconds.
6. Release brake pedal and rotate disc rotor 10 revolutions.
7. Measure rotating force (F_2).
8. Calculate brake drag force by subtracting F_1 from F_2 .

Maximum brake drag force ($F_2 - F_1$):

59.8 N (6.1 kg, 13.5 lb)

If it is not within specification, check main pins and retainer boots in caliper.

Inspection (On-vehicle) (Cont'd)

DISC PAD

Check disc pad for wear or damage.

Pad standard thickness (A):

10.0 mm (0.394 in)

Pad wear limit (A):

2.0 mm (0.079 in)

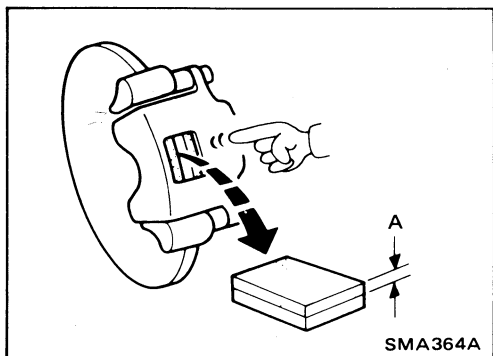

Inspection

RUBBING SURFACE

Check rotor for roughness, cracks or chips.

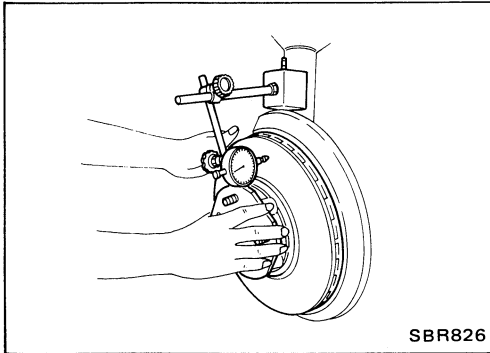

RUNOUT

Adjust wheel bearing preload. Check runout using a dial indicator.

Rotor repair limit:

Maximum runout

**(Total indicator reading at center of rotor pad
contact surface)**

0.07 mm (0.0028 in)

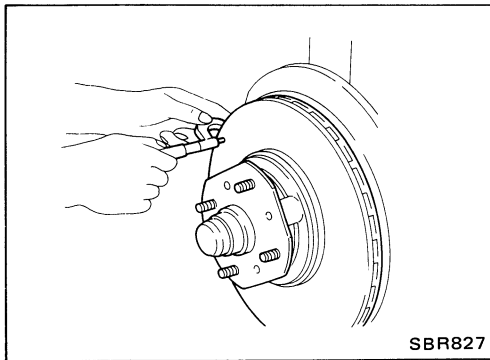

THICKNESS

Standard thickness:

20.0 mm (0.787 in)

Minimum thickness:

18.0 mm (0.709 in)

REAR DISC BRAKE (CL9H) — Caliper

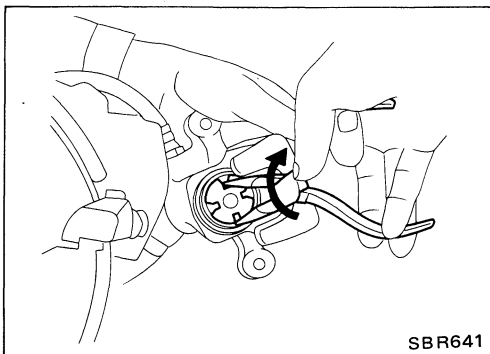
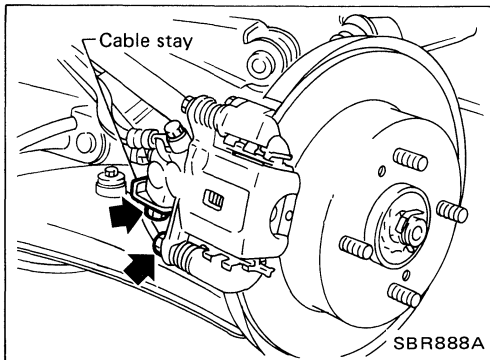
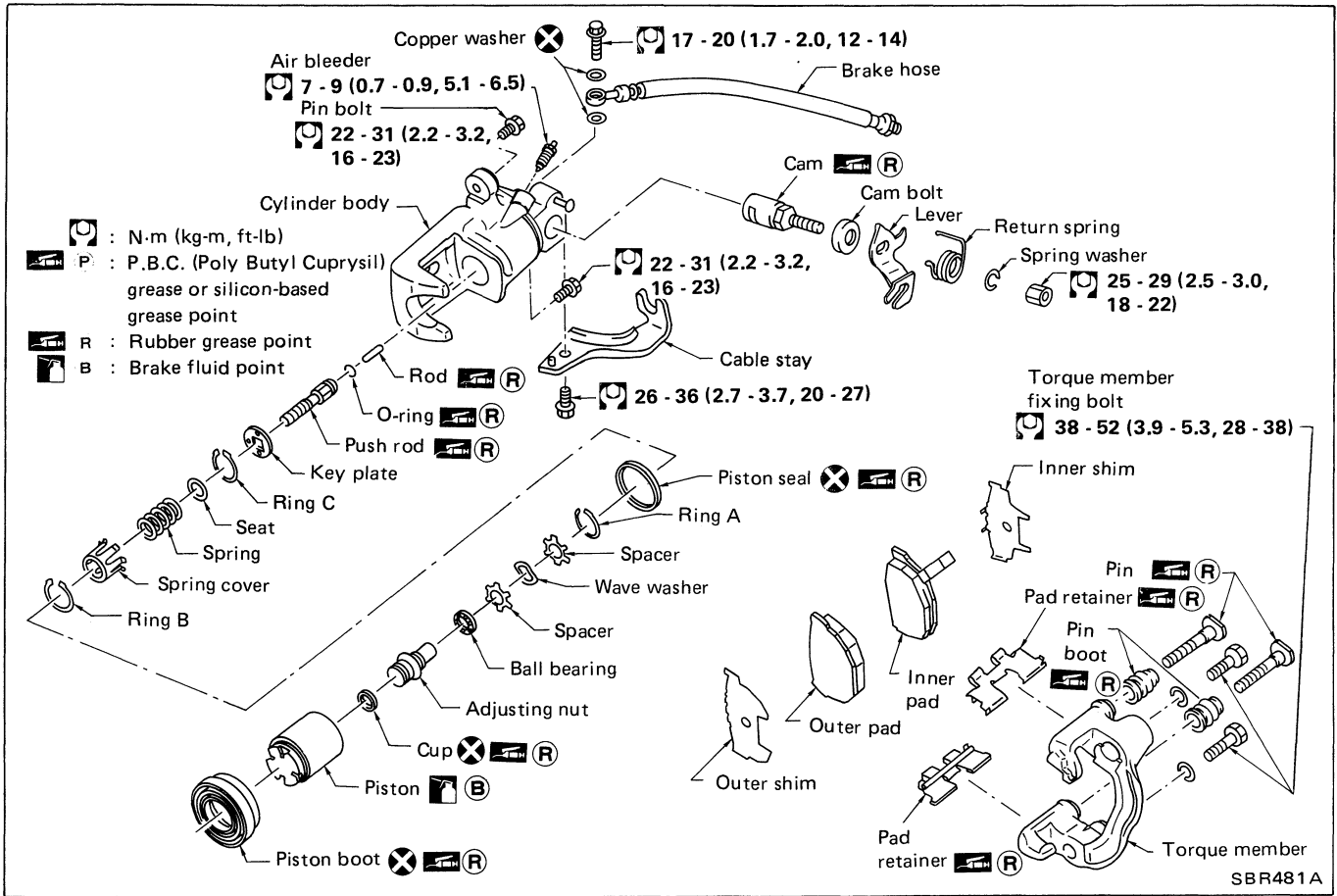

Pad Replacement

CAUTION:

When cylinder body is swung up, do not depress brake pedal because piston will pop out.

- Release parking brake.
- Remove parking cable stay fixing bolt, pin bolts and lock spring. Then remove pad retainers, pads and shims.

- When installing pads, retract piston into cylinder body by turning it clockwise.

Be careful not to damage piston boot or get oil on rotor. Always replace shims when replacing pads.

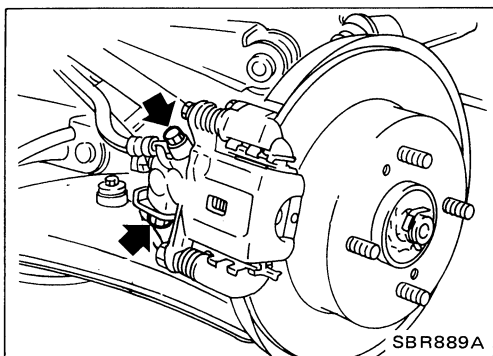

Removal and Installation

- Release parking brake.
- Disconnect parking brake cable and brake hose, then remove caliper assembly.

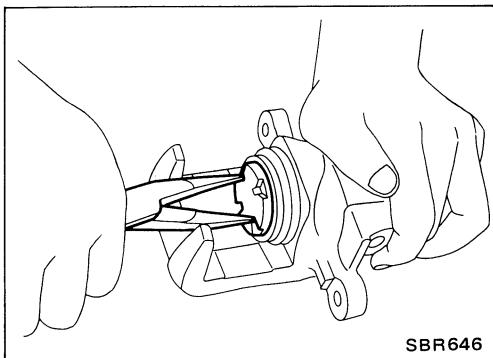

Disassembly

1. Remove piston by turning it counterclockwise with suitable longnose pliers.

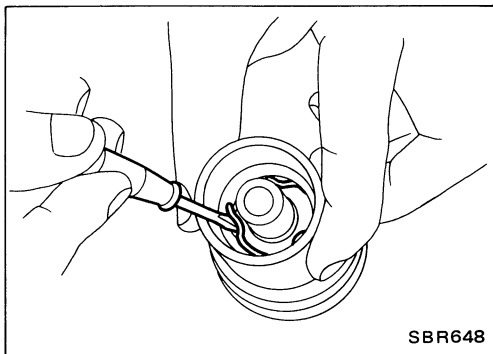

2. Pry off ring A from piston with suitable pliers and remove adjusting nut.

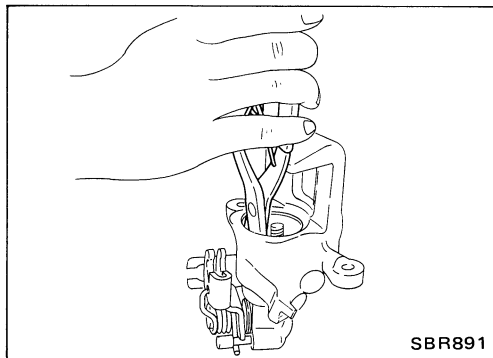

3. Disassemble cylinder body.
 - Pry off rings B and C with pliers, then remove spring cover, spring and seat.

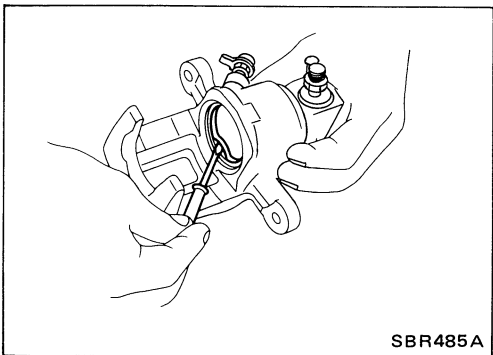

- Remove piston seal.
Be careful not to damage cylinder body.

REAR DISC BRAKE (CL9H) — Caliper

Disassembly (Cont'd)

4. Remove return spring and lever.

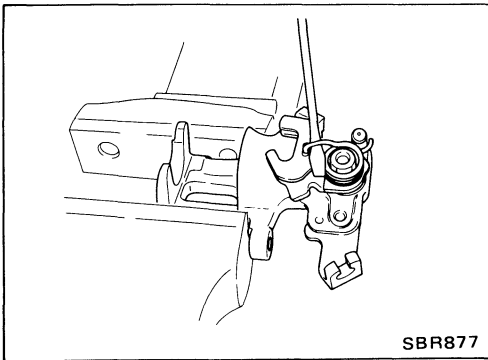

Inspection

CYLINDER BODY

- Check inside surface of cylinder for score, rust, wear or other damage.
- Minor damage from rust or foreign materials may be eliminated by polishing surface with a fine emery paper. Replace if necessary.

CAUTION:

Use brake fluid to clean.

TORQUE MEMBER

Check for wear, cracks or other damage. Replace if necessary.

PISTON

Check piston for score, rust, wear or other damage. Replace if necessary.

CAUTION:

Piston sliding surface is plated. Do not polish with emery paper even if rust or foreign matter is stuck to sliding surface.

PIN AND PIN BOOT

Check for wear, cracks or other damage. Replace if necessary.

Assembly

- Install cup securely in the specified direction.

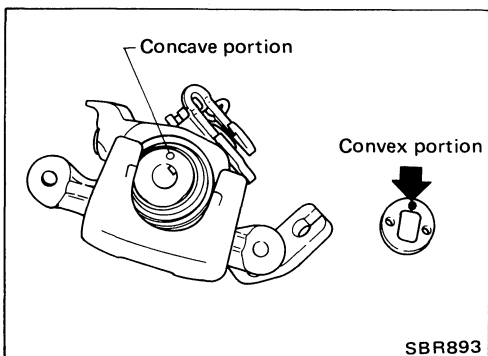
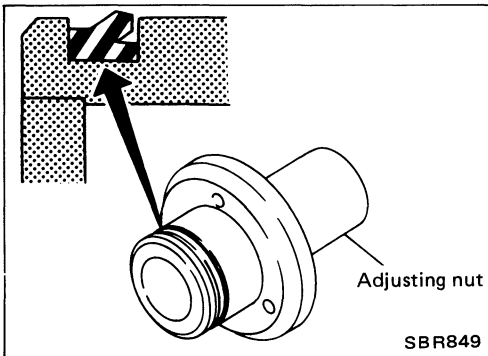

- Fit push rod into square hole in key plate. Also match convex portion of key plate with concave portion of cylinder.

REAR DISC BRAKE (CL9H) — Caliper

Assembly (Cont'd)

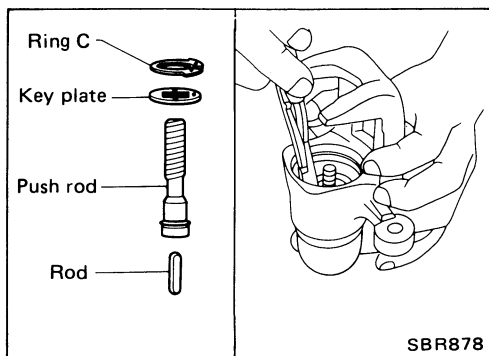

- Install ring C with suitable tool.

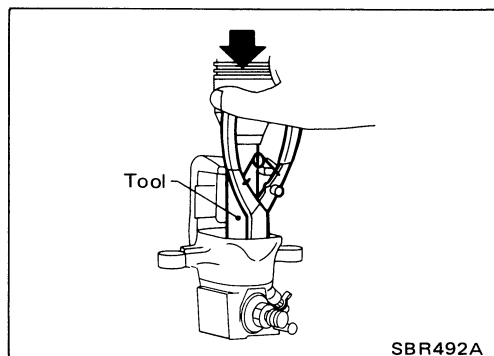

- Install seat, spring, spring cover and ring B with suitable press and drift.

Inspection (On-vehicle)

INSPECTION OF BRAKE DRAG FORCE

1. Swing cylinder body upward.
2. Make sure that wheel bearing is adjusted properly. Refer to section RA.
3. Measure rotating force (F_1).

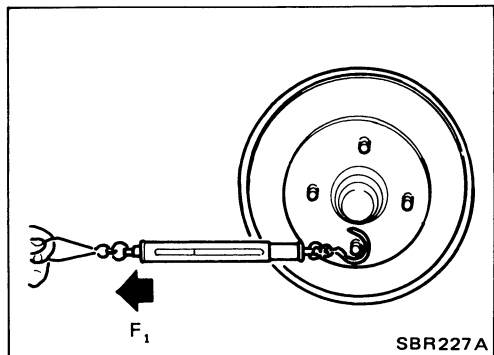

4. Install caliper with pads to original position.
5. Depress brake pedal for 5 seconds.
6. Release brake pedal, rotate disc rotor 10 revolutions.
7. Measure rotating force (F_2).
8. Calculate brake drag force by subtracting F_1 from F_2 .

Maximum brake drag force ($F_2 - F_1$):

86.3 N (8.8 kg, 19.4 lb)

If it is not within specification, check pins and pin boots in caliper.

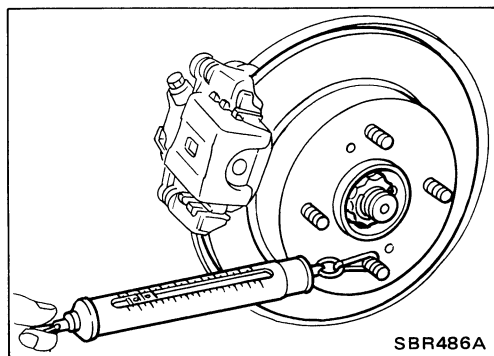

DISC PAD

Check disc pad for wear or damage.

Standard thickness (A):

9.5 mm (0.374 in)

Pad wear limit (A):

1.5 mm (0.059 in)

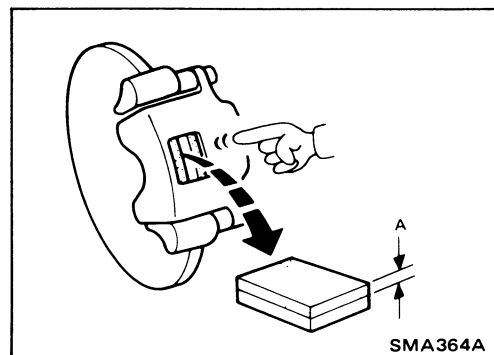

Inspection

RUBBING SURFACE

Check rotor for roughness, cracks or chips.

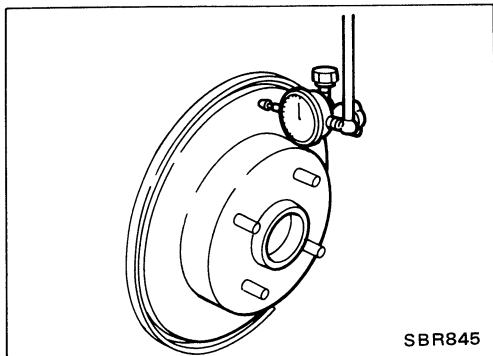

RUNOUT

- Check runout using a dial indicator.
- Make sure that axial end play is within the specifications before measuring. Refer to section RA.

Rotor repair limit:

Maximum runout
(Total indicator reading at center of rotor pad contact surface)
0.07 mm (0.0028 in)

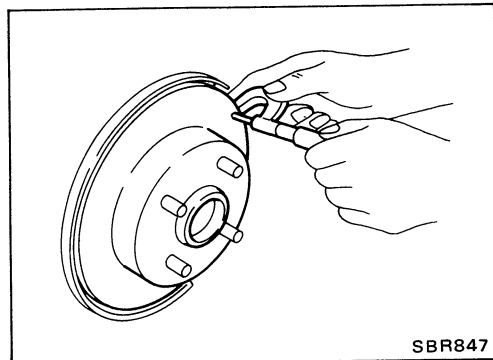

THICKNESS

Rotor repair limit:

Minimum thickness
8.0 mm (0.315 in)

PARKING BRAKE CONTROL

Removal and Installation

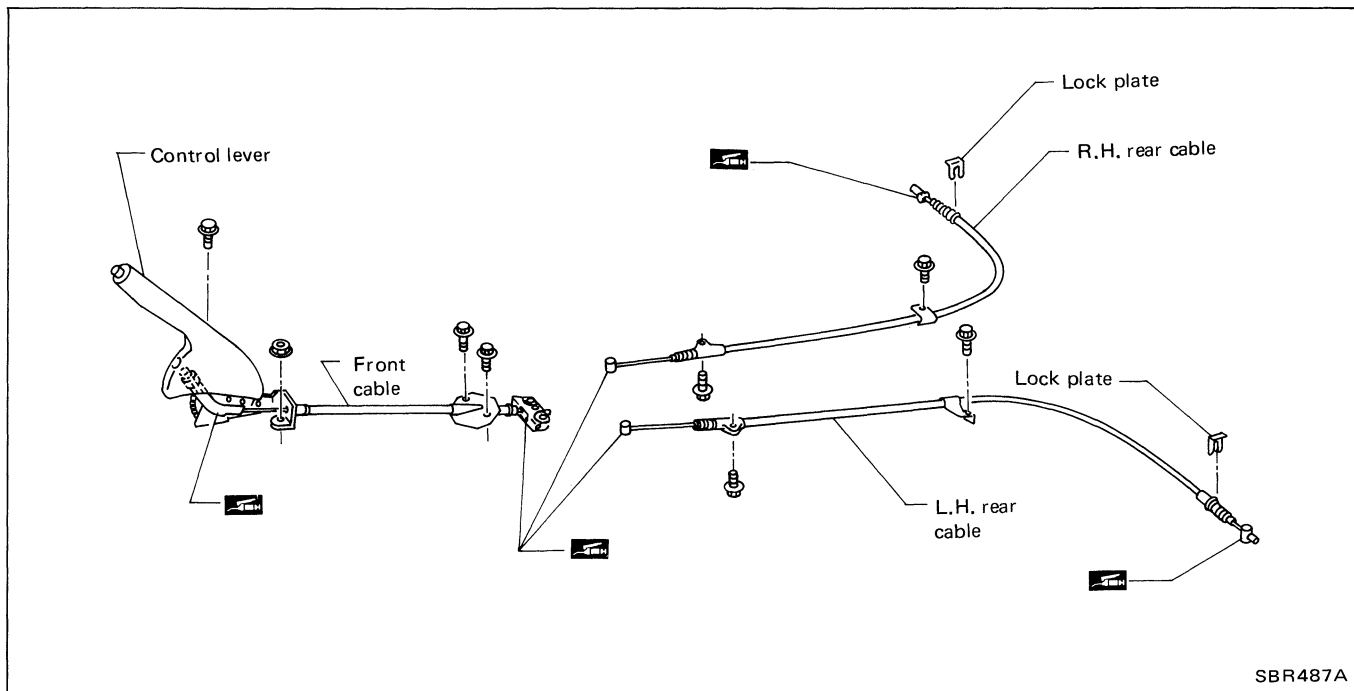

SBR487A

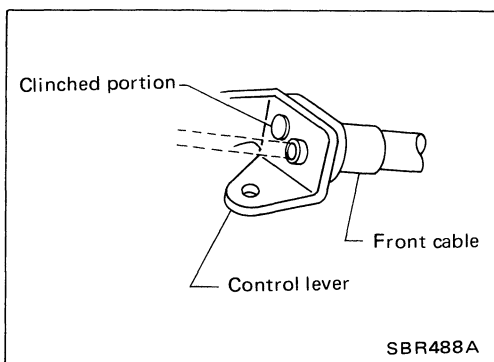

SBR488A

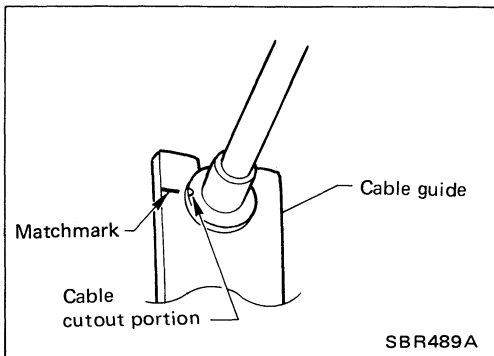

SBR489A

REMOVAL

- Before removing parking brake control, remove console box.
- Loosen cable using control lever adjuster, and separate front and rear cables.
- Break clinched portion of control lever using a hammer and chisel as shown in figure at left, and replace cables with new parts.

Apply multi-purpose grease to areas between control lever drum and cables.

INSTALLATION

Be careful not to damage boot and inner cable.

- When installing parking brake cable at rear caliper, make sure to align matchmark on parking cable stay and cable.

Inspection

1. Check control lever for wear or other damage. Replace if necessary.
2. Check parking brake cables, lamp and switch. Replace if necessary.
3. Check parts at each connecting portion for deformation or damage. If found, replace.

PARKING BRAKE CONTROL

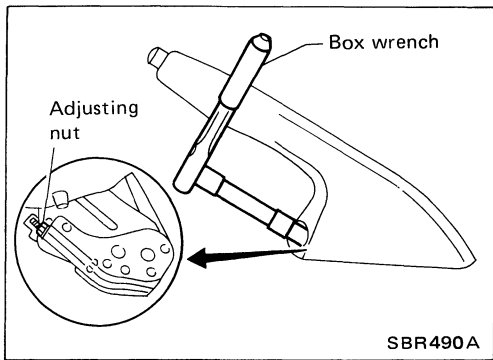

Adjustment

1. Ensure that parking brake releases when control lever is pulled down completely. If control lever does not release parking brake, proceed as follows:
 - Pull control lever up by 4 or 5 notches.
 - Insert a box wrench into opening in control lever and loosen self-lock adjusting nut to slacken cables. Completely push control lever down.
2. Forcefully depress brake pedal about five times (so that caliper is automatically set in position.).
3. Pull lever up by 4 or 5 notches.
4. Turn adjusting nut as shown in figure at left and adjust lever stroke to specified value.
5. Completely push control lever down and ensure that:
 - Parking brake is released completely.
 - Rear brakes are free from dragging.

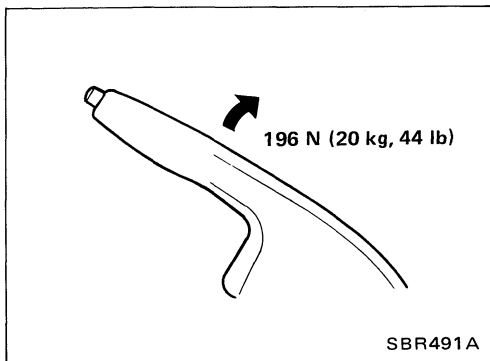

6. Pull control lever with specified amount of force. Check lever stroke and ensure smooth operation.

Number of notches:

Center lever type 6 - 8

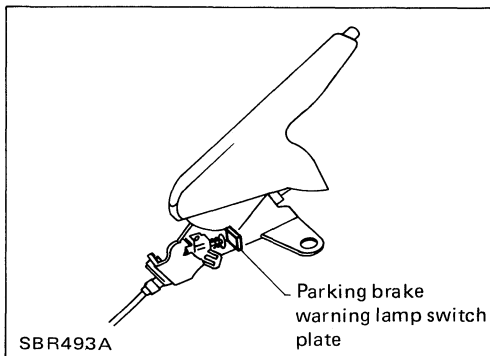

7. Bend parking brake warning lamp switch plate so that brake warning light comes on when ratchet at parking brake lever is pulled "A" notches and goes out when fully released.

Number of "A" notches: 1

ANTI-LOCK BRAKING SYSTEM

System Components

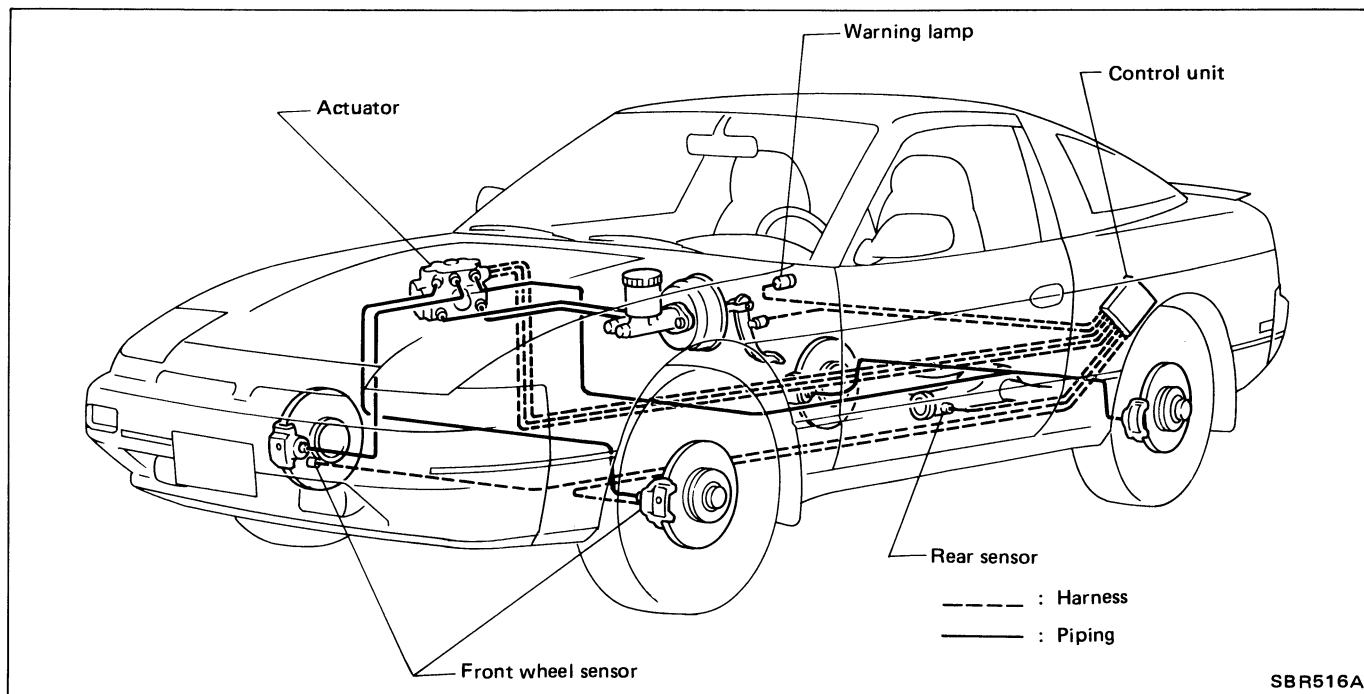

Hydraulic Circuit

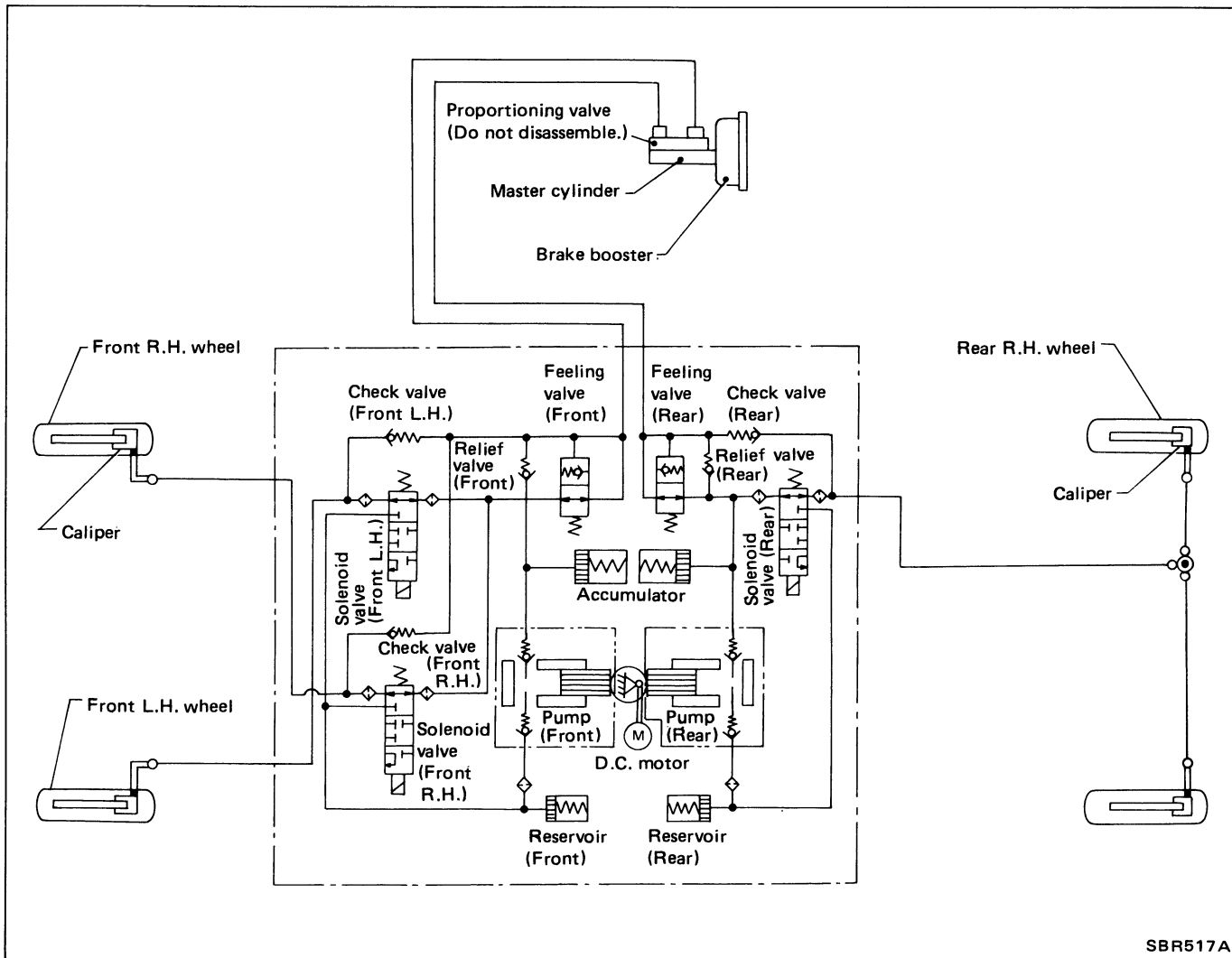

ANTI-LOCK BRAKING SYSTEM

Wiring Diagram

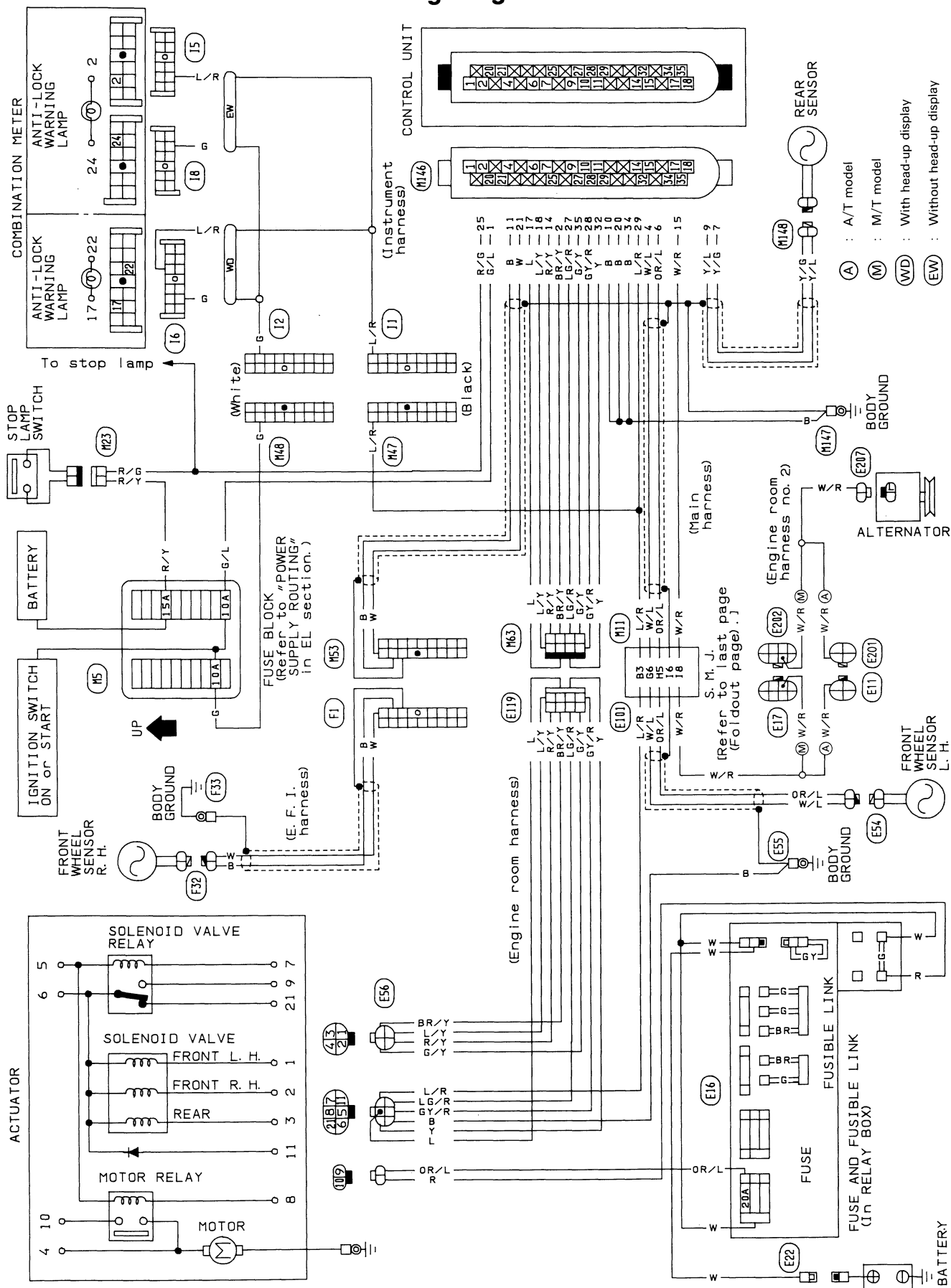

SBR552B

ANTI-LOCK BRAKING SYSTEM

Removal and Installation

CAUTION:

Be careful not to damage sensor edge and sensor rotor teeth.

FRONT WHEEL SENSOR

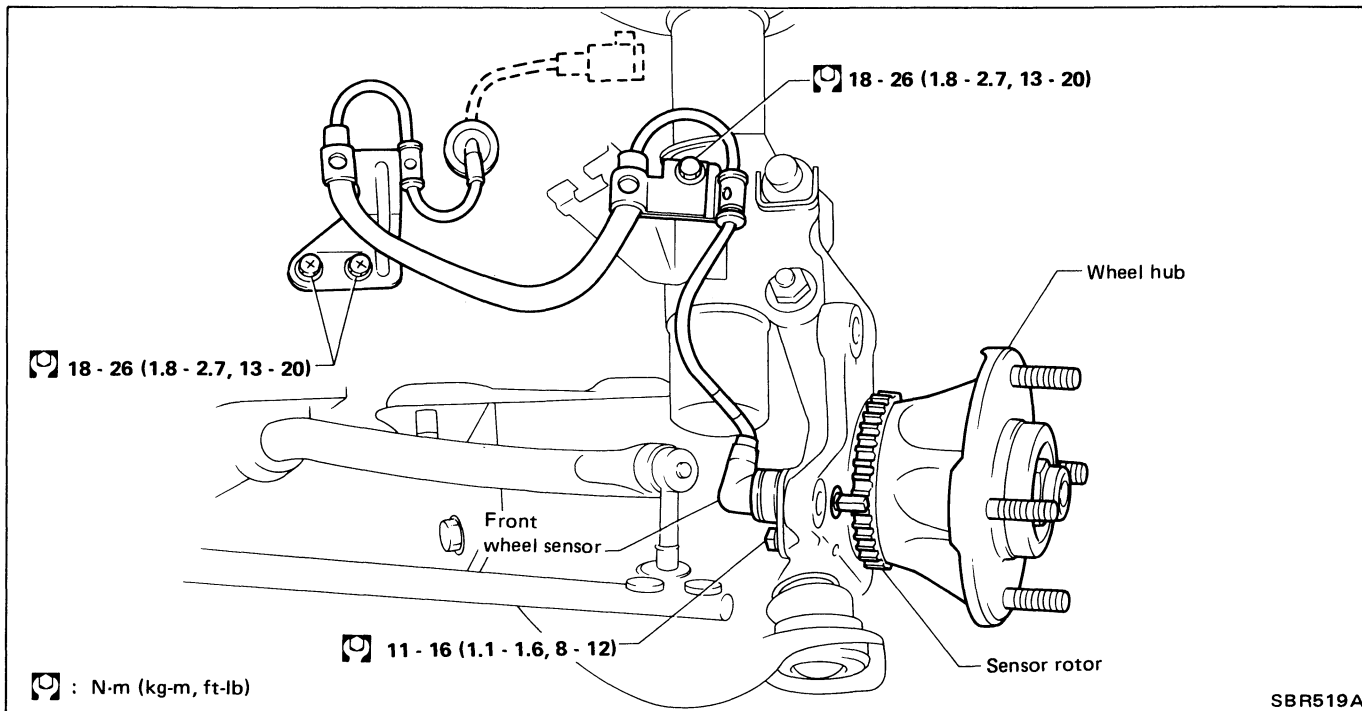

REAR SENSOR

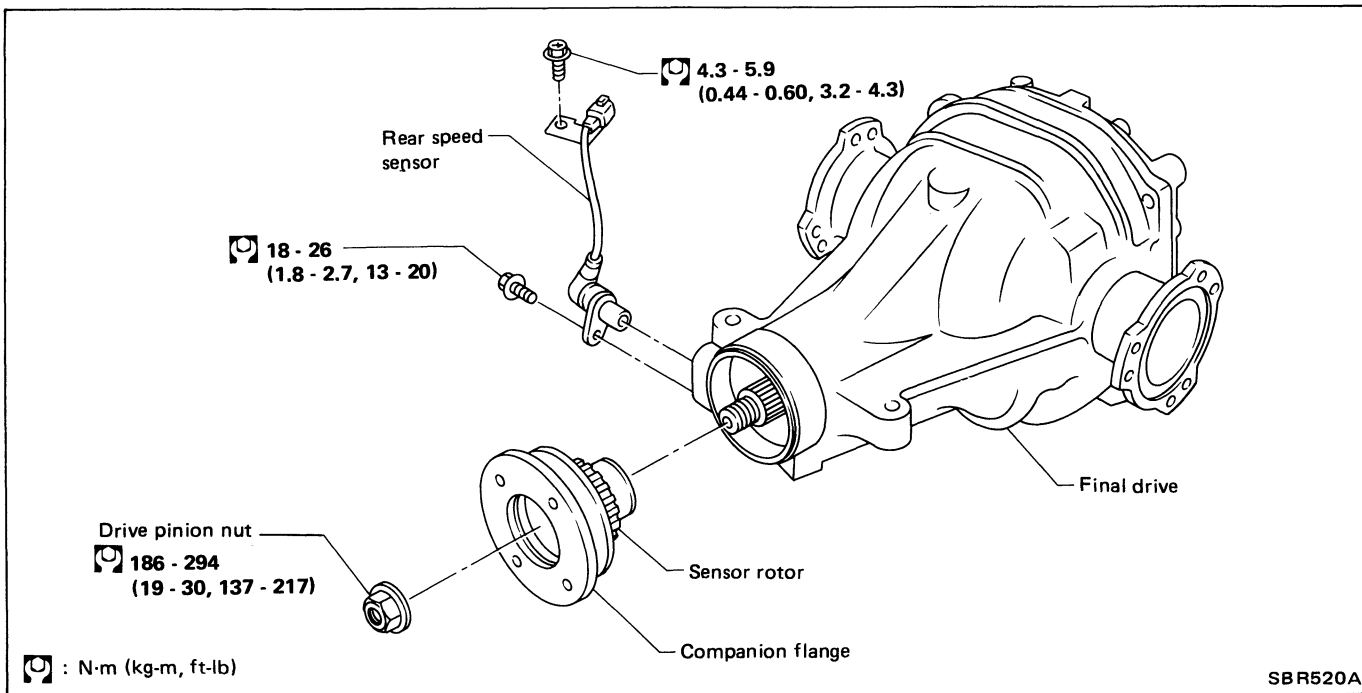

- Remove rear sensor rotor with companion flange after propeller shaft removal. Refer to PD section.

ANTI-LOCK BRAKING SYSTEM

Removal and Installation (Cont'd) ACTUATOR

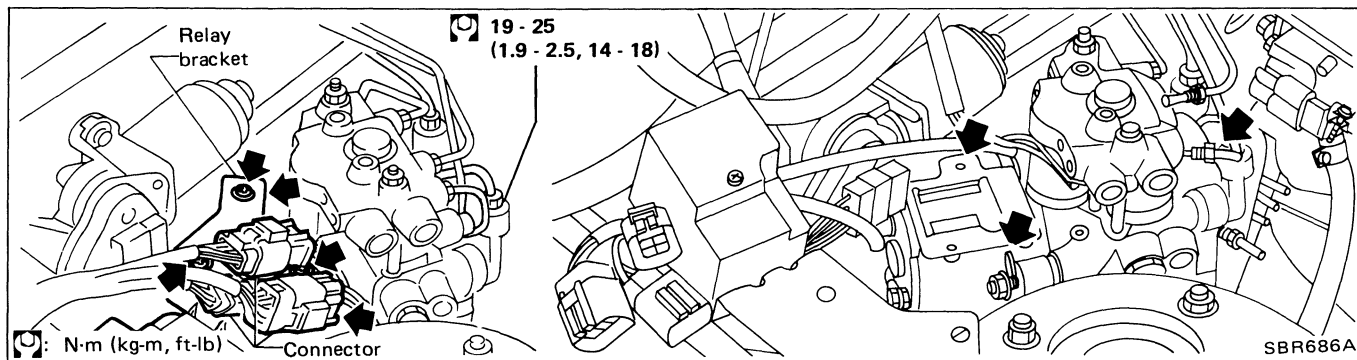

- Disconnect 3 connectors and brake tubes.
- Remove relay bracket.
- Remove actuator by removing 3 nuts fixing actuator to bracket.

TROUBLE DIAGNOSES

Contents

How to Perform Trouble Diagnoses for Quick and Accurate Repair	BR-30
Symptom Chart	BR-33
Preliminary Check 1	BR-34
Preliminary Check 2	BR-35
Preliminary Check 3, 4	BR-36
Self-diagnosis	BR-37
Component Parts Location	BR-38
Harness Connector Location	BR-39
Ground Circuit Check	BR-40
Circuit Diagram for Quick Pinpoint Check	BR-41
Diagnostic Procedure 1	BR-42
Diagnostic Procedure 2	BR-43
Diagnostic Procedure 3	BR-44
Diagnostic Procedure 4	BR-44
Diagnostic Procedure 5	BR-45
Diagnostic Procedure 6	BR-45
Diagnostic Procedure 7	BR-46
Diagnostic Procedure 8	BR-47
Diagnostic Procedure 9	BR-48
Diagnostic Procedure 10	BR-49
Diagnostic Procedure 11	BR-50
Diagnostic Procedure 12	BR-51
Electrical Components Inspection	BR-52

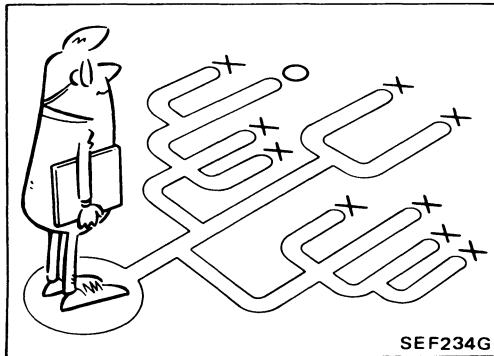
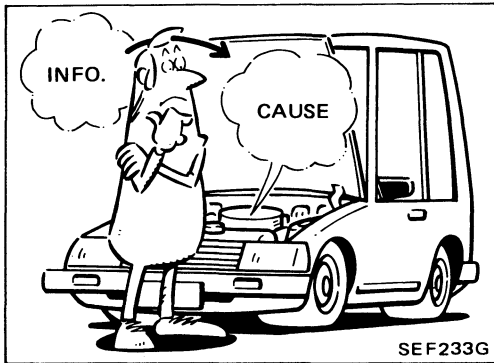

How to Perform Trouble Diagnoses for Quick and Accurate Repair

INTRODUCTION

The A.B.S. system has an electronic control unit to control major functions. The control unit accepts input signals from sensors and instantly drives actuators. It is essential that both kinds of signals are proper and stable. At the same time, it is important that there are no conventional problems such as air leaks in the booster or lines, lack of brake fluid, or other problems with brake system.

It is much more difficult to diagnose a problem that occurs intermittently rather than continuously. Most intermittent problems are caused by poor electric connections or faulty wiring. In this case, careful checking of suspicious circuits may help prevent the replacement of good parts.

A visual check only may not find the cause of the problems, so a road test should be performed.

Before undertaking actual checks, take just a few minutes to talk with a customer who approaches with a A.B.S. complaint. The customer is a very good source of information on such problems; especially intermittent ones. Through the talks with the customer, find out what symptoms are present and under what conditions they occur.

Start your diagnosis by looking for "conventional" problems first. This is one of the best ways to troubleshoot brake problems on an A.B.S. controlled vehicle.

TROUBLE DIAGNOSES

How to Perform Trouble Diagnoses for Quick and Accurate Repair (Cont'd)

WORK FLOW

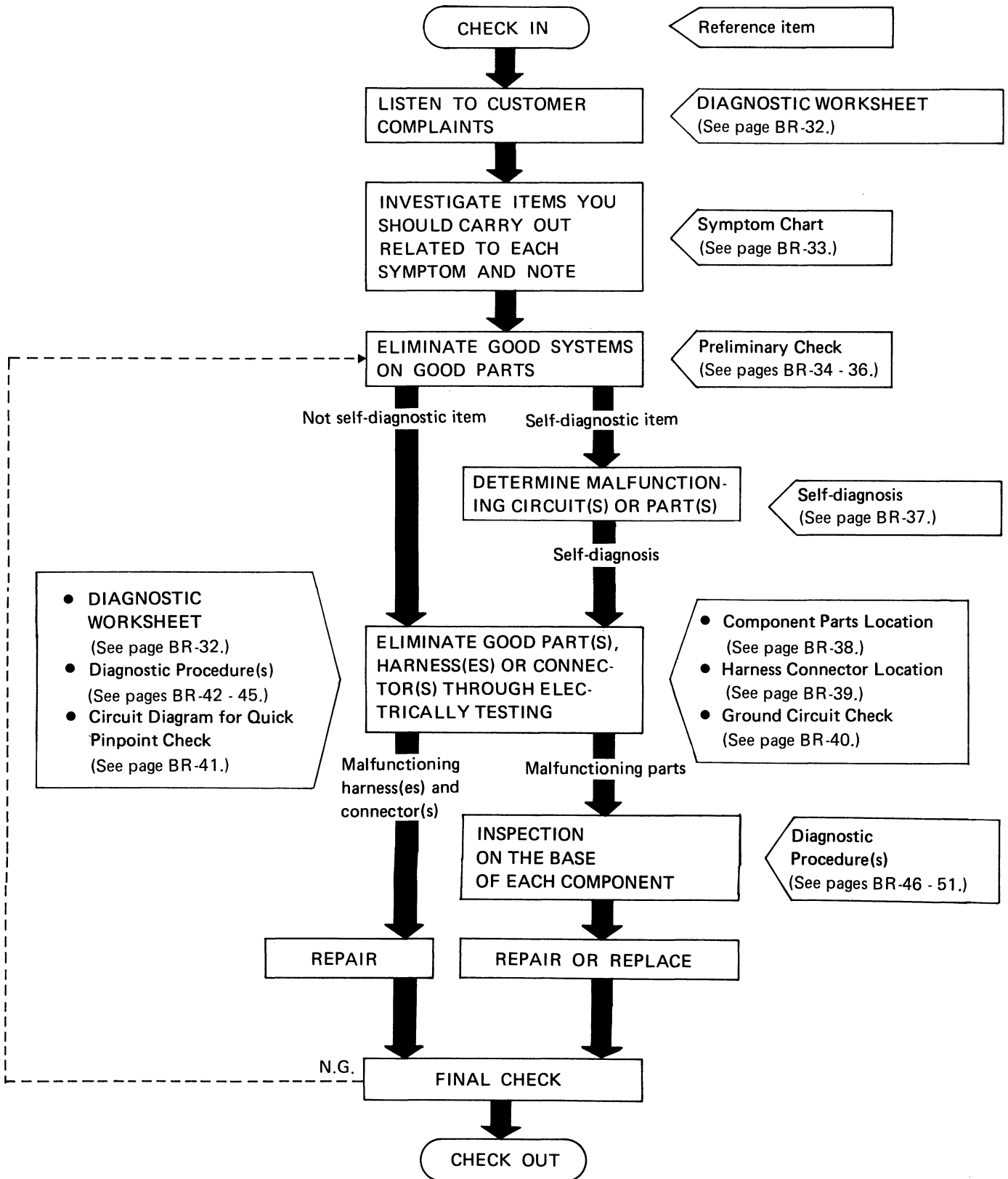

TROUBLE DIAGNOSES

KEY POINTS

WHAT Vehicle model
WHEN Date, Frequencies
WHERE Road conditions
HOW Operating conditions,
 Weather conditions,
 Symptoms

How to Perform Trouble Diagnoses for Quick and Accurate Repair (Cont'd)

DIAGNOSTIC WORKSHEET

There are many kinds of operating conditions that lead to customer complaints, even if the system is normal.

A good grasp of such conditions can make trouble-shooting faster and more accurate.

In general, feelings for a problem depend on each customer's information. It is therefore important to fully understand the symptoms or under what conditions a customer complains.

Make good use of a diagnostic worksheet such as the one shown below in order to utilize all the complaints for trouble-shooting.

Worksheet sample

Customer name MR/MS	Model & Year	VIN
Engine #	Trans.	Mileage
Incident Date	Manuf. Date	In Service Date
Symptoms	<input type="checkbox"/> Pedal vibration and noise <input type="checkbox"/> Warning activates <input type="checkbox"/> Long stopping distance <input type="checkbox"/> Abnormal pedal action	<input type="checkbox"/> A.B.S. doesn't work <input type="checkbox"/> A.B.S. works but warning activates <input type="checkbox"/> A.B.S. works frequently
Engine conditions	<input type="checkbox"/> When starting <input type="checkbox"/> After starting <input type="checkbox"/> Engine speed: 5,000 rpm or more	
Road conditions	<input type="checkbox"/> Low friction road (<input type="checkbox"/> Snow <input type="checkbox"/> Gravel <input type="checkbox"/> Other) <input type="checkbox"/> Protrusion	
Driving conditions	<input type="checkbox"/> High speed cornering <input type="checkbox"/> Vehicle speed: Greater than 10 km/h (6 MPH) <input type="checkbox"/> Vehicle speed: 10 km/h (6 MPH) or less <input type="checkbox"/> Vehicle is stopped	
Applying brake conditions	<input type="checkbox"/> Suddenly <input type="checkbox"/> Gradually	
Other conditions	<input type="checkbox"/> Operation of electrical equipment <input type="checkbox"/> Large pedal stroke <input type="checkbox"/> Operation of clutch	

TROUBLE DIAGNOSES

Symptom Chart

PROCEDURE	REFERENCE PAGE	SYMPTOM	Pedal vibration & noise	Warning activates	Long stopping distance	Abnormal pedal action	A.B.S. doesn't work	A.B.S. works but warning activates	A.B.S. works frequently
Electrical Components Inspection	BR-52	Actuator inspection					○		
	BR-40	Motor ground					○		
Ground Circuit Check	BR-40	Sensor shield	○						○
	BR-51	L.E.D. comes off	○	○	○	○	○	○	
Diagnostic Procedure (Select inspection with L.E.D. flashing No.)	BR-50	L.E.D. flashing 16	○	○	○	○	○	○	
	BR-49	L.E.D. flashing 10	○	○	○	○	○	○	
	BR-48	L.E.D. flashing 9	○	○	○	○	○	○	
	BR-47	L.E.D. flashing 5 - 8	○	○	○	○	○	○	
	BR-46	L.E.D. flashing 1 - 4	○	○	○	○	○	○	
	Diagnostic Procedure	BR-45	Diagnostic Procedure 6						
BR-45		Diagnostic Procedure 5					○		
BR-44		Diagnostic Procedure 4					○		
BR-44		Diagnostic Procedure 3				○			
BR-43		Diagnostic Procedure 2			○				
BR-42		Diagnostic Procedure 1	○						
Preliminary Check	BR-36	Preliminary Check 4	○	○	○	○	○	○	
	BR-36	Preliminary Check 3	○	○					
	BR-35	Preliminary Check 2		○			○		○
	BR-34	Preliminary Check 1			○	○			○

TROUBLE DIAGNOSES

Preliminary Check 1

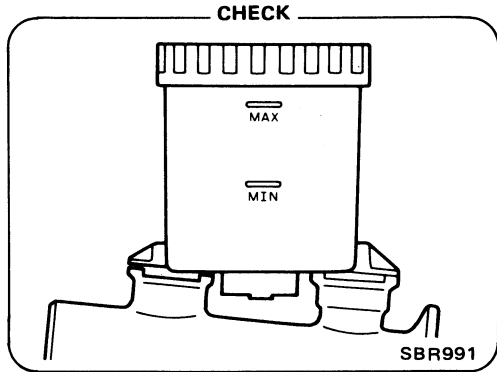

Check brake fluid level in reservoir tank.

N.G. → Fill up brake fluid.

O.K. →

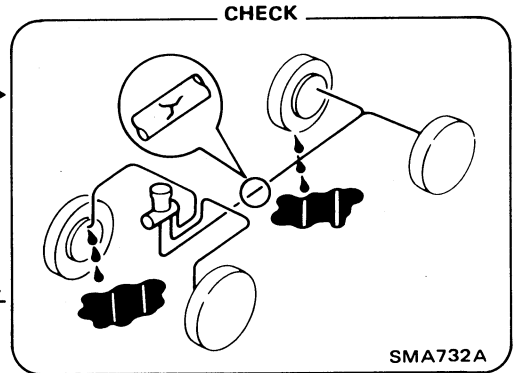

Check brake system.
Refer to CHECK AND ADJUSTMENT.

Repair brake system. ← N.G.

O.K. ↓

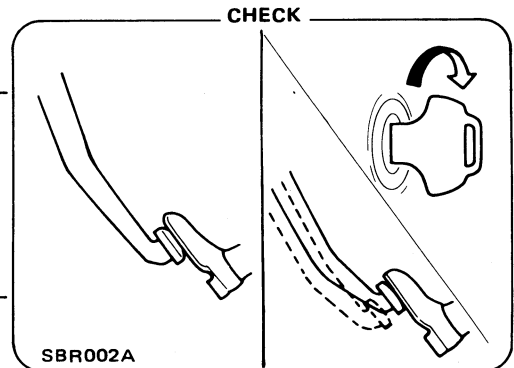

Check brake booster operation and airtightness.
Refer to "Inspection" of BRAKE BOOSTER.

Repair or replace booster system. ← N.G.

O.K. →

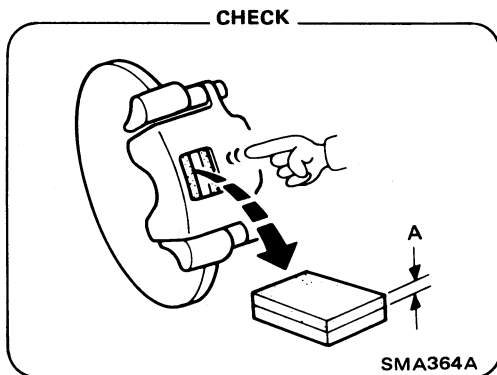

Check brake pads and rotor.
Refer to "Inspection" of FRONT and REAR DISC BRAKE.

N.G. → Replace malfunctioning parts.

TROUBLE DIAGNOSES

Preliminary Check 2

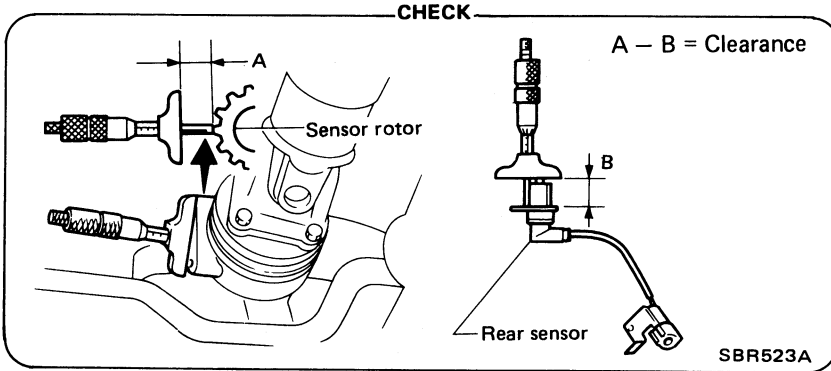
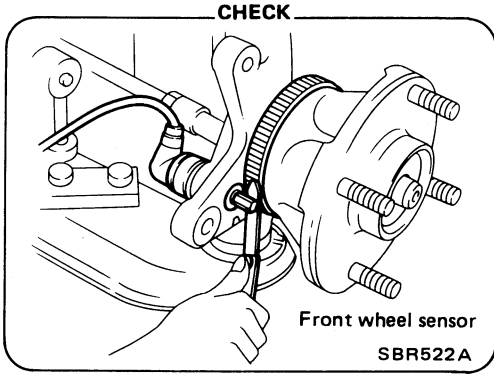

Check sensor clearance.

	Clearance mm (in)
Front wheel sensor	0.275 - 0.75 (0.0108 - 0.0295)
Rear sensor	0.35 - 0.625 (0.0138 - 0.0246)

N.G.

Check sensor for the following items:

- Dust, foreign materials, etc., at fastening portion
- Improper installation
- Breakage

O.K.

N.G.

Repair or replace malfunctioning sensor.

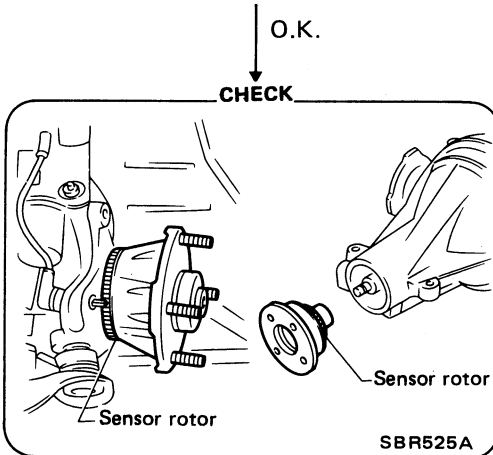

N.G.

Replace sensor rotor with wheel hub or companion flange as a set.

Check sensor rotor for teeth damage.

TROUBLE DIAGNOSES

Preliminary Check 3 CHECK

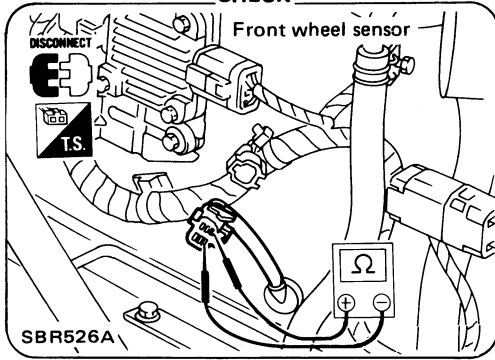

Measure each sensor resistance.

0.8 - 1.2 kΩ

N.G. → Replace.

O.K. →

Preliminary Check 3, 4

Preliminary Check 4 CHECK

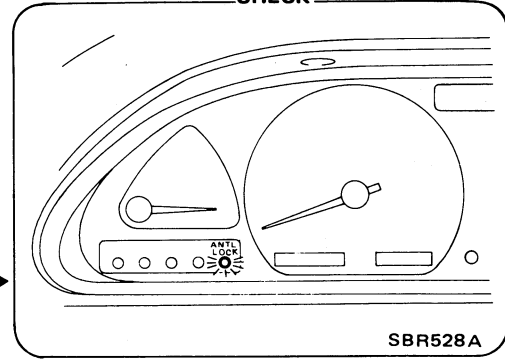

Check warning lamp activation.

When ignition switch is turned on, warning lamp turns on.

O.K. →

N.G. ↓

Check fuse.

Check bulb condition and remedy.

CHECK

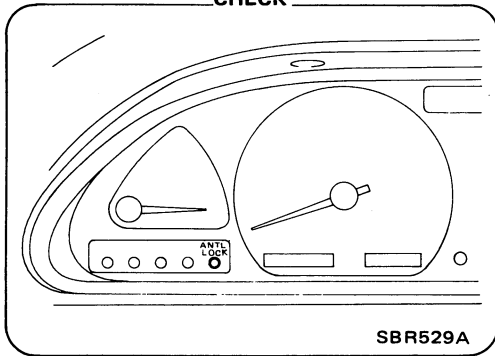

Check warning lamp for deactivation.

When engine starts, warning lamp deactivates.

O.K. ↓

DRIVE

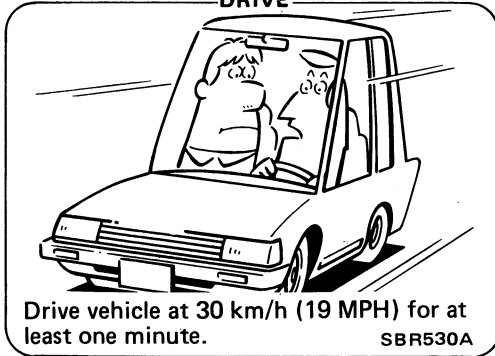

Drive vehicle at 30 km/h (19 MPH) for at least one minute.

CHECK

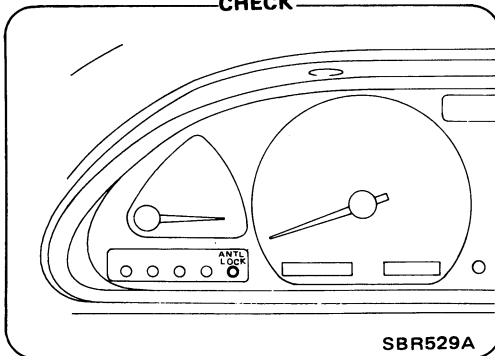

Ensure warning lamp remains off while driving.

N.G. →

O.K. →

If Preliminary Check 2 is not performed and there is abnormal A.B.S. operation, perform Preliminary Check 2.

CHECK

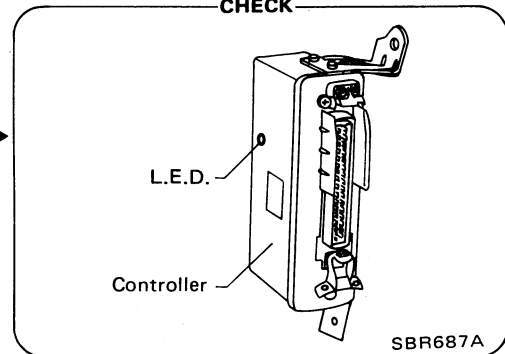

- Keep engine on and running.
- Remove rear side finisher.
- Count the number of L.E.D. flashes during 5 to 10 second "OFF" period.

Go to Self-diagnosis.
(See page BR-37.)

TROUBLE DIAGNOSES

Self-diagnosis

CHECKING THE NUMBER OF L.E.D. FLASHES

When a problem occurs in the A.B.S., the warning light on the instrument panel comes on. As shown in the Table, the control unit performs self-diagnosis.

To obtain satisfactory self-diagnosing results, the vehicle must be driven above 30 km/h (19 MPH) for at least one minute before the self-diagnosis is performed. After the vehicle is stopped, the number of L.E.D. flashes is counted while the engine is running.

The L.E.D. is located on the control unit, identifying a malfunctioning part or unit by the number of flashes. Both the warning light and the L.E.D. persistently activate, even after a malfunctioning part or unit has been repaired, unless the ignition switch is turned "OFF". After repairs, turn the ignition switch "OFF". Then start the engine and drive the vehicle over 30 km/h (19 MPH) for at least one minute to ensure that the malfunctioning part or unit has been repaired properly.

If more than two circuits malfunction at the same time, the L.E.D. will flash to indicate one of the malfunctioning circuits. After the circuit has been repaired, the L.E.D. will then flash to indicate that the other circuit is malfunctioning.

No. of L.E.D. flashes	Malfunctioning part or unit
1	Left front actuator solenoid circuit
2	Right front actuator solenoid circuit
3 or 4	Rear actuator solenoid circuit
5	Left front rotor sensor circuit
6	Right front rotor sensor circuit
7 or 8	Rear rotor sensor circuit
9	Actuator motor, motor relay circuit
10	Actuator solenoid valve relay
16	Control unit
Warning activates and L.E.D. "OFF"	Power supply or ground circuit for control unit

Example

Improper operation of left front rotor sensor circuit

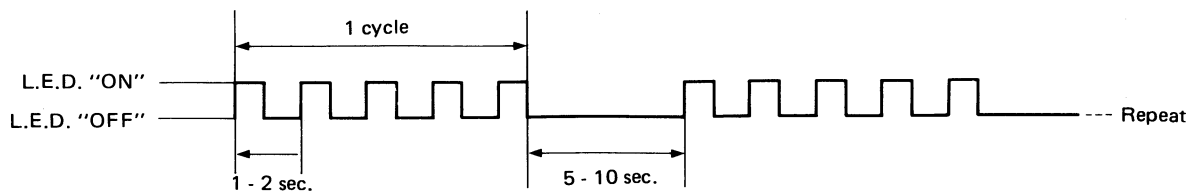

SBR531A

Go to Diagnostic Procedure from 7 to 10, where malfunction portion is concerned.

TROUBLE DIAGNOSES

Component Parts Location

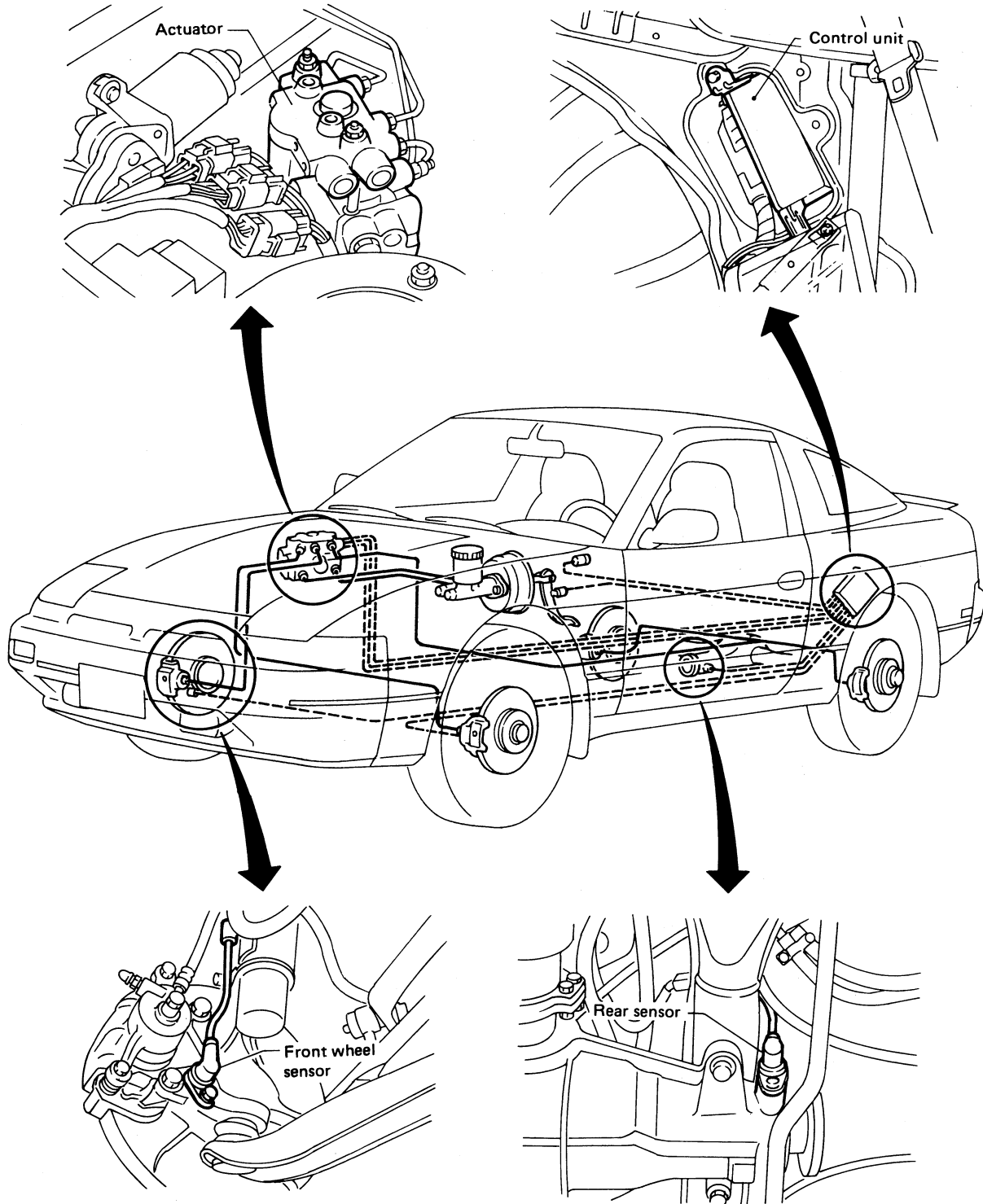

TROUBLE DIAGNOSES

Harness Connector Location

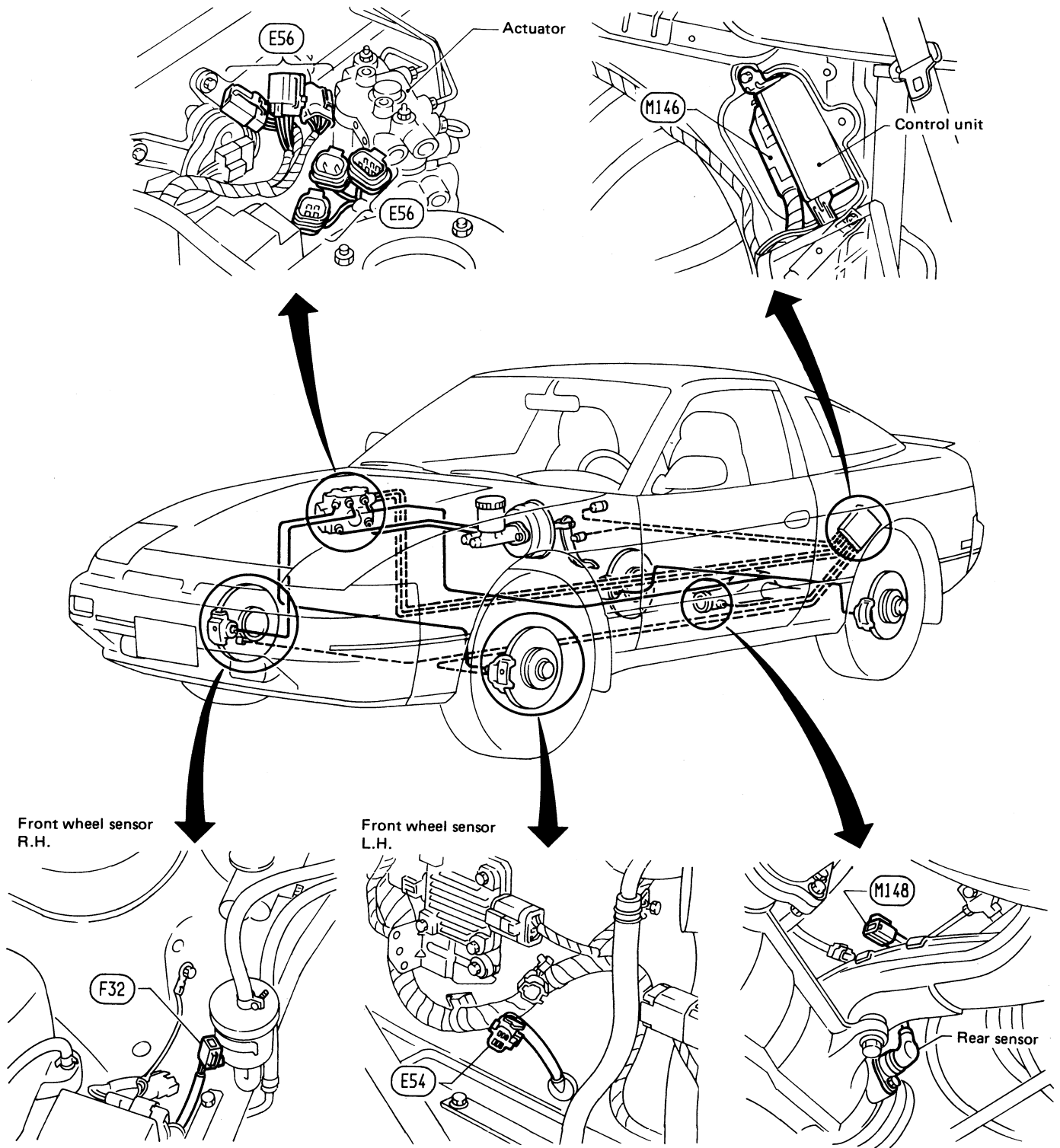

TROUBLE DIAGNOSES

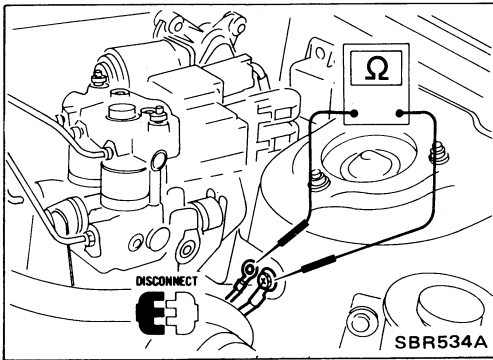

Ground Circuit Check

FRONT WHEEL SENSOR L.H. SHIELDED WIRE GROUND

- Check resistance between both terminals.
Resistance: 0Ω

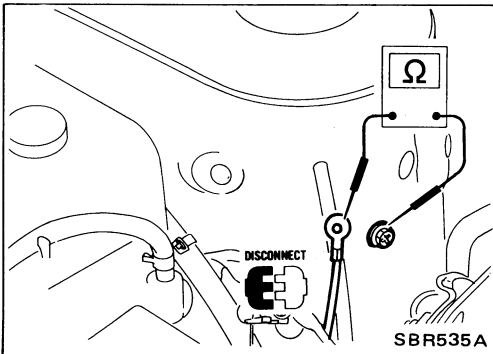

FRONT WHEEL SENSOR R.H. SHIELDED WIRE GROUND

- Check resistance between both terminals.
Resistance: 0Ω

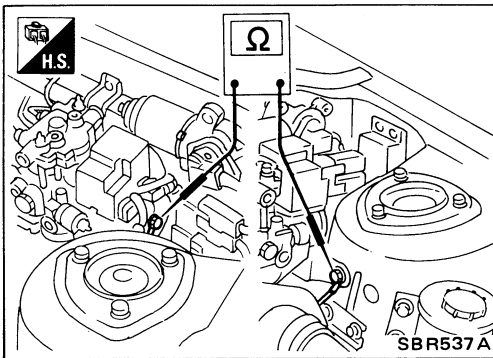

ACTUATOR MOTOR GROUND

- Check resistance between both terminals.
Resistance: 0Ω

TROUBLE DIAGNOSES

Circuit Diagram for Quick Pinpoint Check

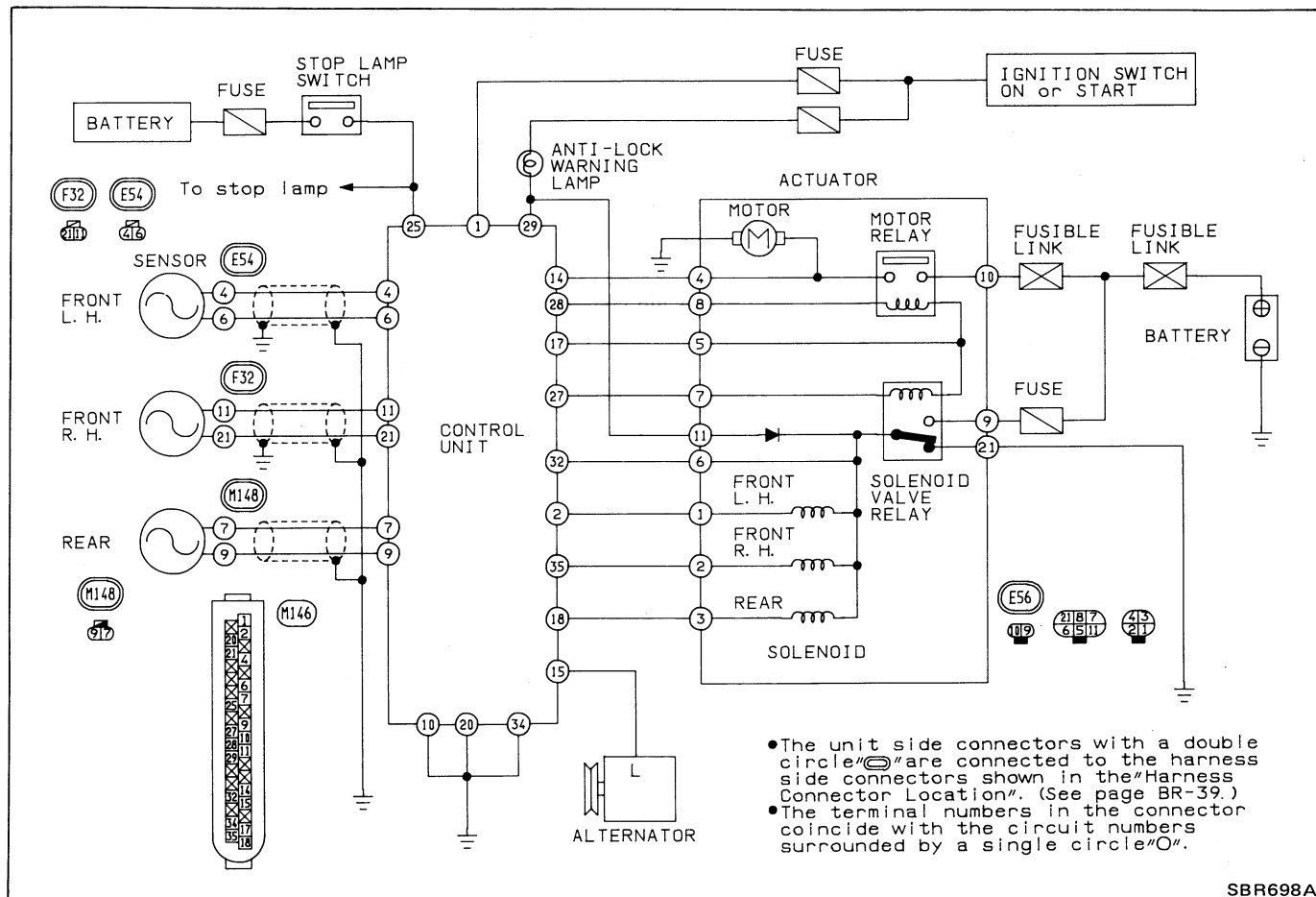

SBR698A

Diagnostic Procedure 1

SYMPTOM: Pedal vibration and noise

Refer to worksheet result.

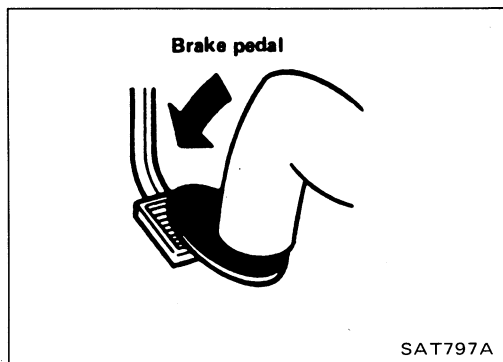

Check whether the symptom appears only when brake is applied suddenly.

Yes

When brake is normally applied, A.B.S. works and produces pedal vibration or noise.

No

Check whether the symptom appears only when engine is started.

Yes

Refer to Preliminary Check 4 result.

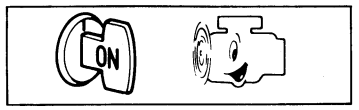

No

Check whether the symptom appears only when the vehicle speed is within 10 km/h (6 MPH) after starting engine.

Yes

Check whether the symptom disappears within 5 seconds.

No

(A)

Yes

A.B.S. may sometimes operate when load is high and voltage is low due to insufficient alternator output.

No

Check whether the symptom appears while the vehicle is being driven.

No

(A)

Yes

Check whether the symptom appears when brake is applied gradually.

No

(Appears when brake is not applied.)

Check if there are any conditions, among those listed below, when symptom appears.

- Shifting
- Operating clutch
- Passing protrusion

No

(B)

Yes

Under these conditions individual wheel speed can change suddenly. This may sometimes cause the A.B.S. to operate.

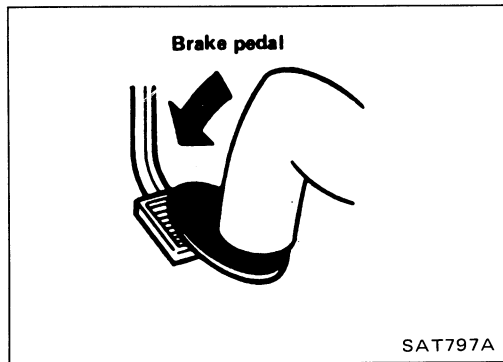
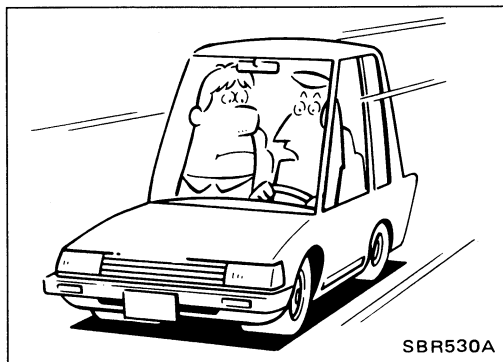

TROUBLE DIAGNOSES

Diagnostic Procedure 1 (Cont'd)

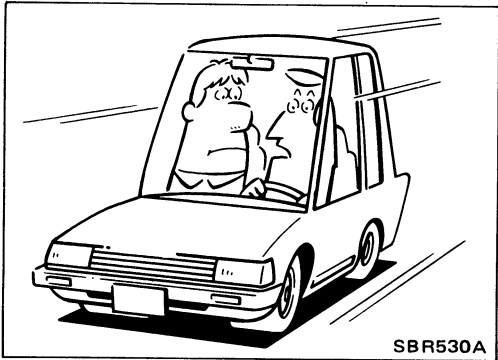
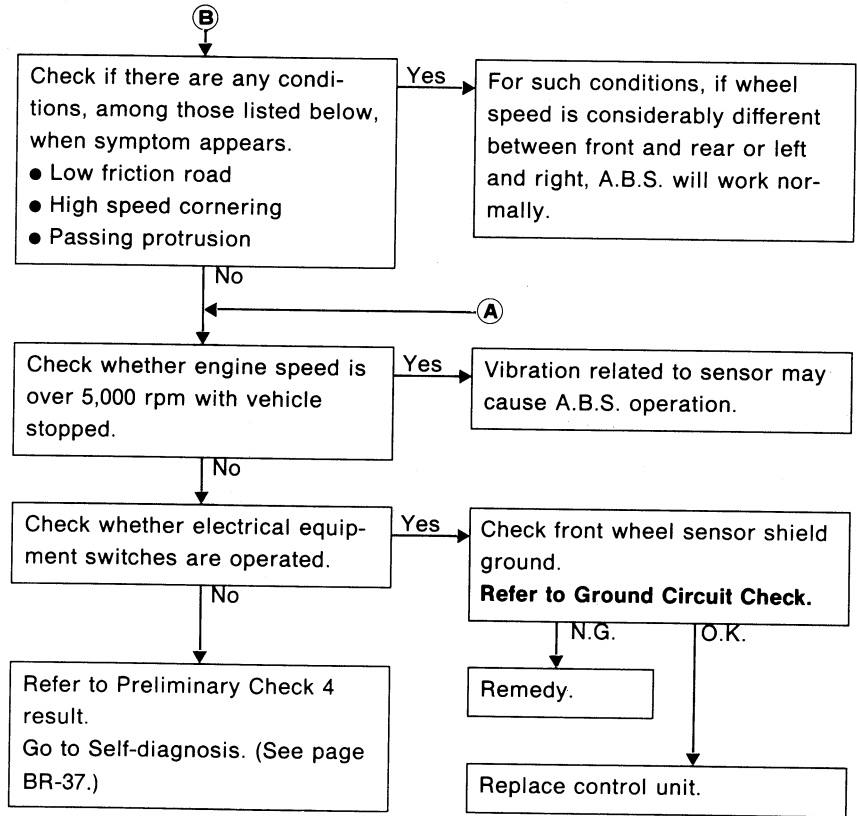

Diagnostic Procedure 2

SYMPTOM: Long stopping distance

Refer to worksheet results.

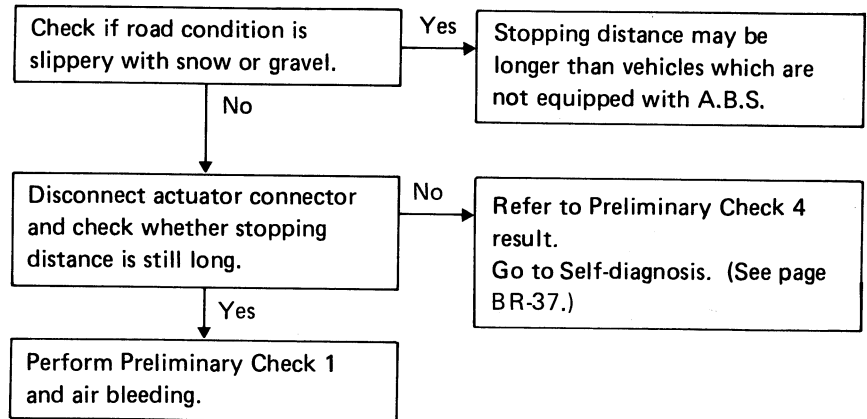

TROUBLE DIAGNOSES

Diagnostic Procedure 3

SYMPTOM: Abnormal pedal action

Refer to worksheet results.

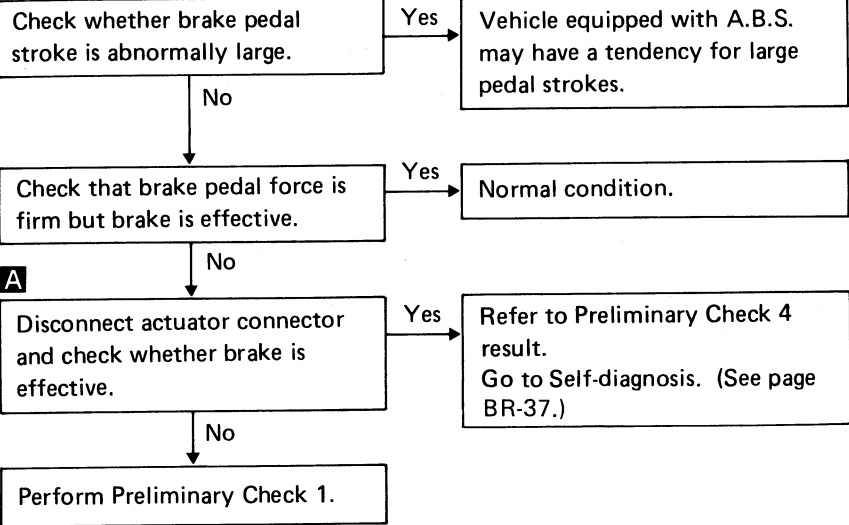
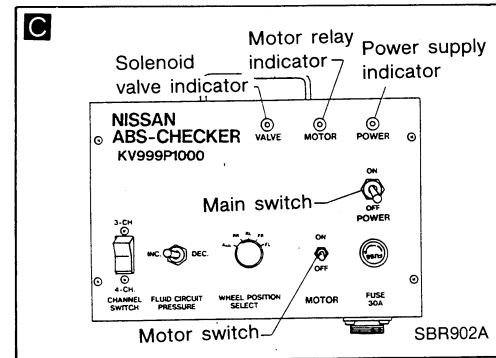
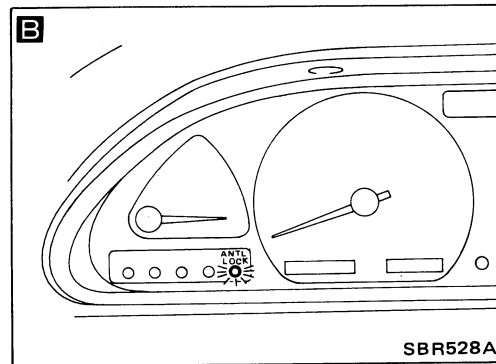
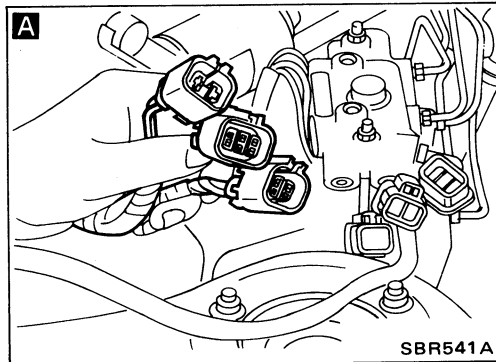
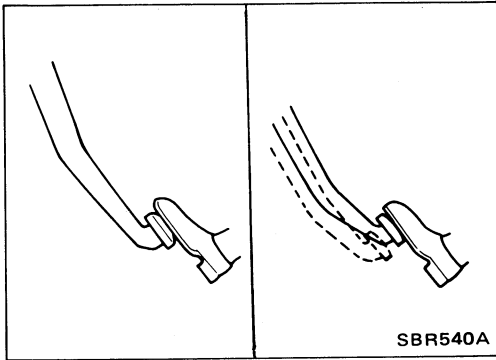

Diagnostic Procedure 4

SYMPTOM: A.B.S. doesn't work.

Refer to worksheet results.

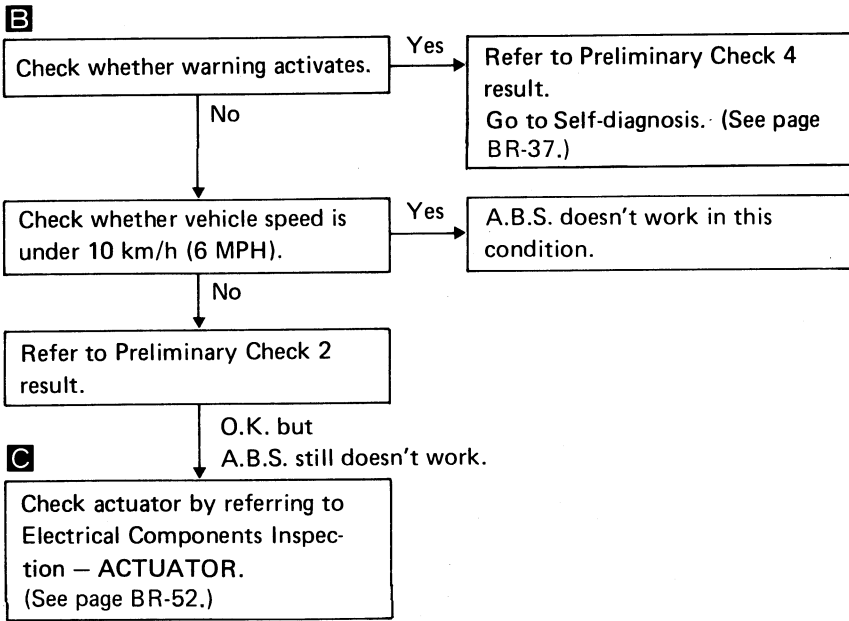

TROUBLE DIAGNOSES

Diagnostic Procedure 5

SYMPTOM: A.B.S. works but warning activates.

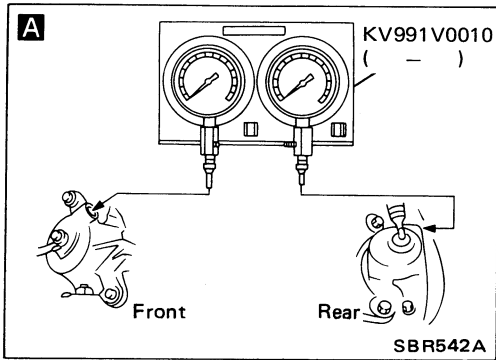
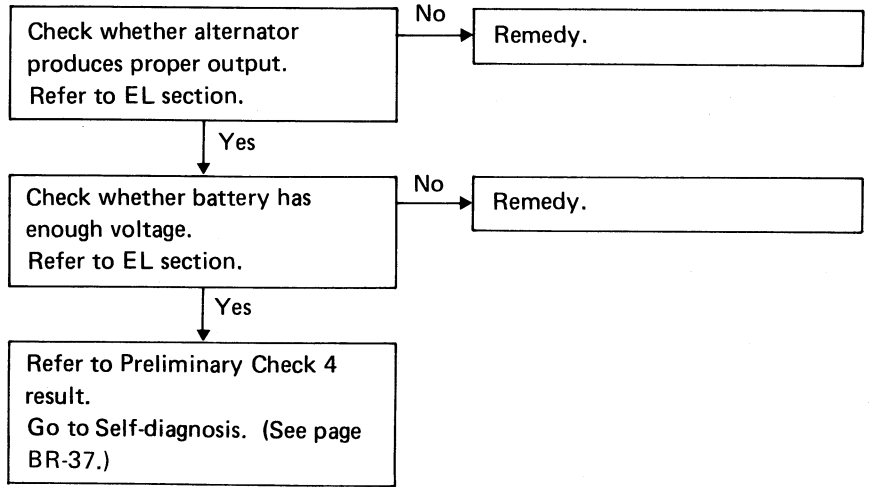

Diagnostic Procedure 6

SYMPTOM: A.B.S. works frequently.

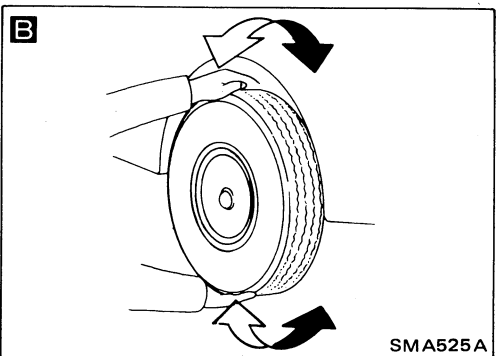
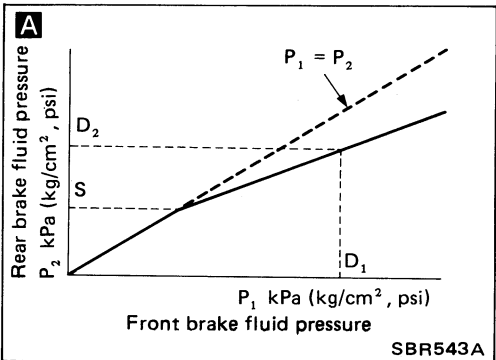
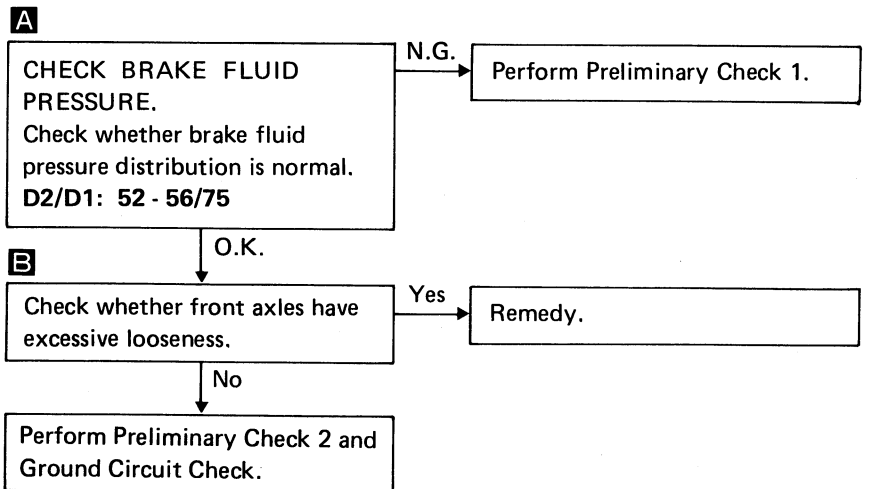

TROUBLE DIAGNOSES

Diagnostic Procedure 7

ACTUATOR SOLENOID (L.E.D. flashing number 1 - 4)

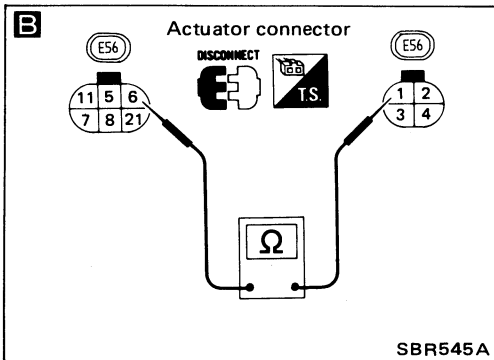
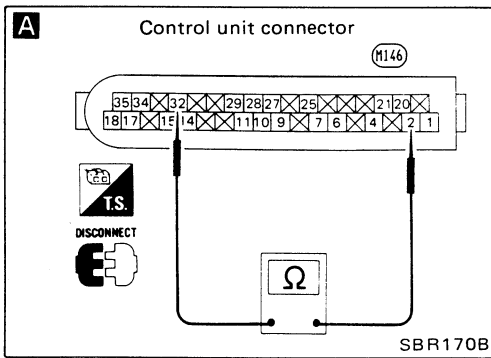

INSPECTION START
Remove battery negative terminal connector.

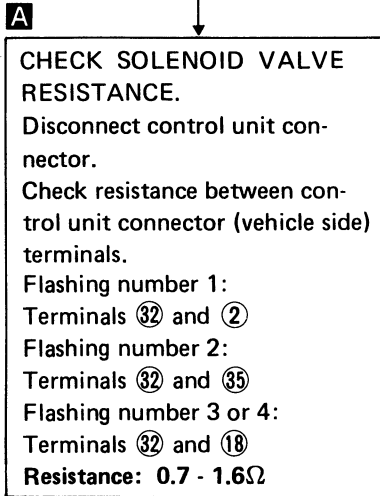

O.K. → Replace control unit.

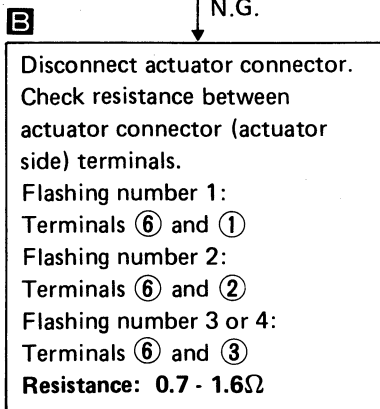

O.K. → Repair harness between actuator connector and control unit connector.

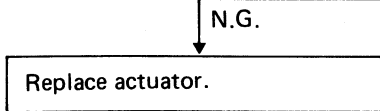

TROUBLE DIAGNOSES

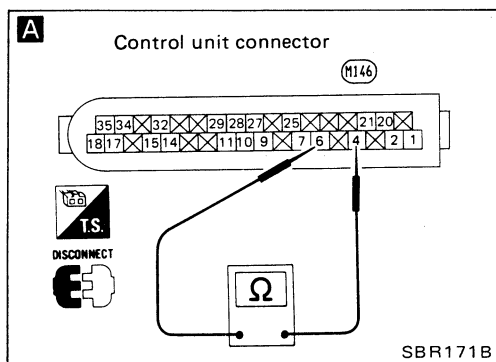

Diagnostic Procedure 8

WHEEL SPEED SENSOR (L.E.D. flashing number 5 - 8)

INSPECTION START
Remove battery negative terminal connector.

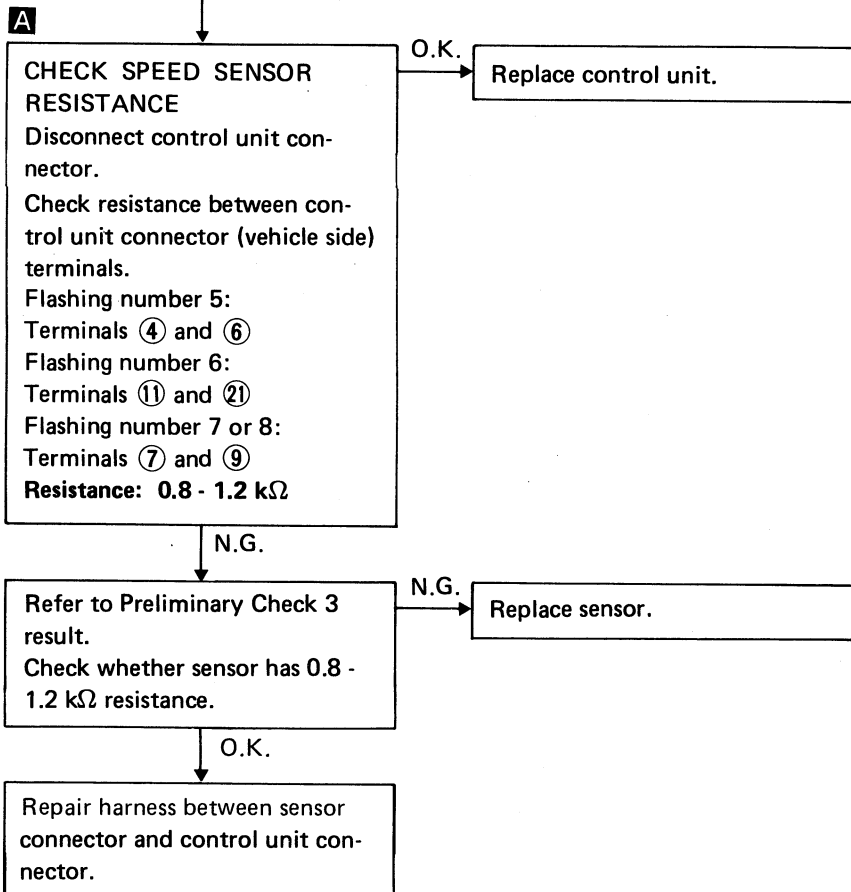

TROUBLE DIAGNOSES

Diagnostic Procedure 9

ACTUATOR MOTOR RELAY (L.E.D. flashing number 9)

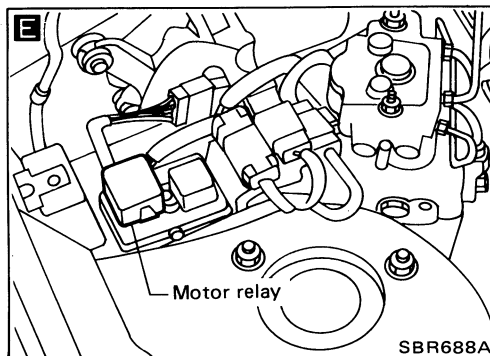
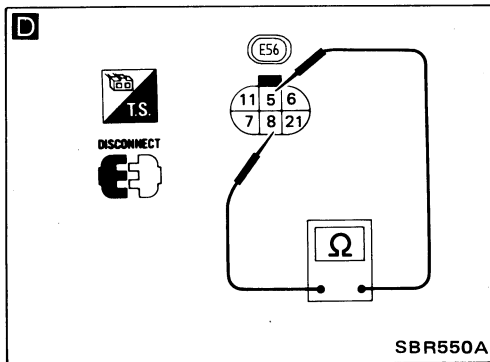
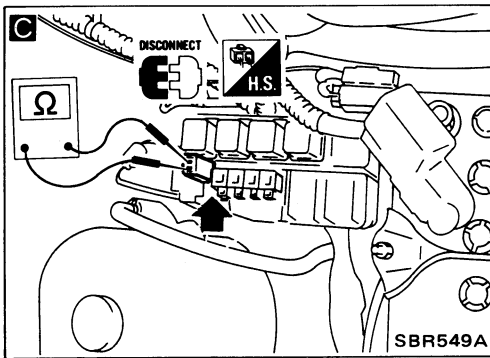
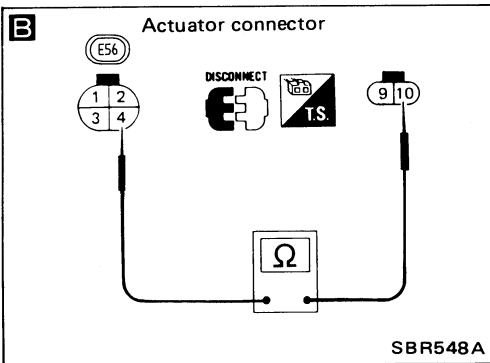
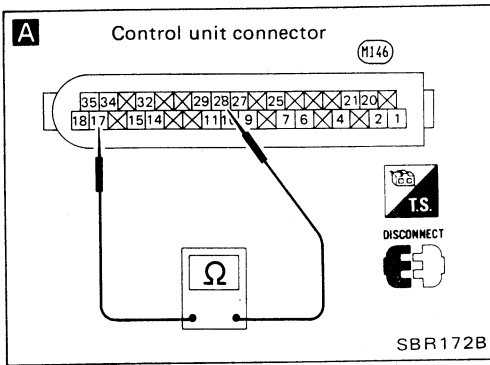

INSPECTION START
Remove battery negative terminal connector.

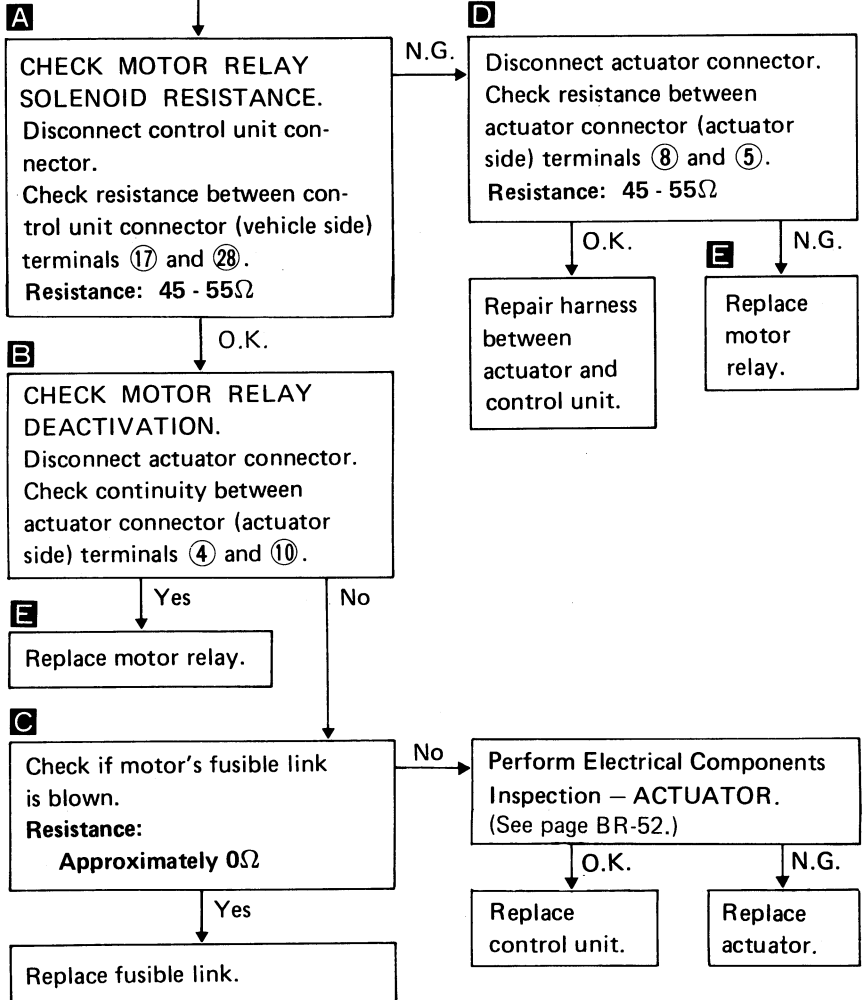

Diagnostic Procedure 10

ACTUATOR SOLENOID VALVE RELAY (L.E.D. flashing number 10)

INSPECTION START
Remove battery negative terminal connector.

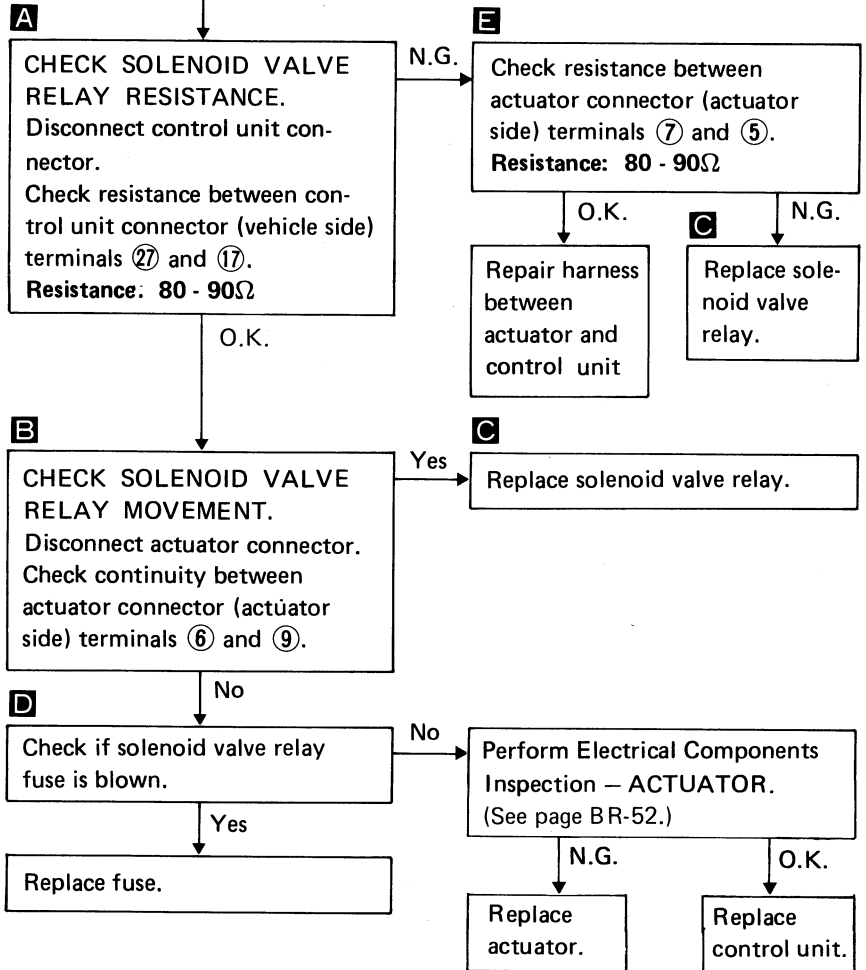
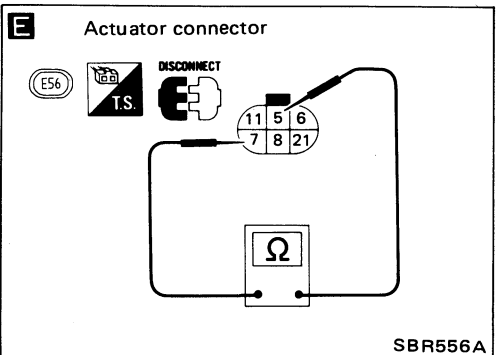
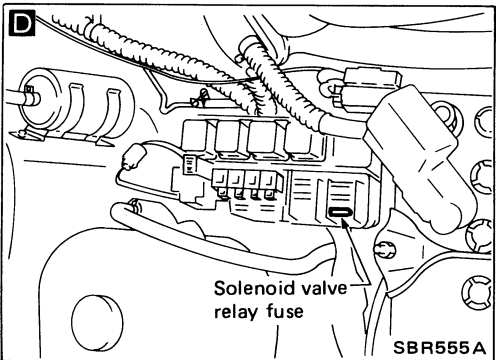
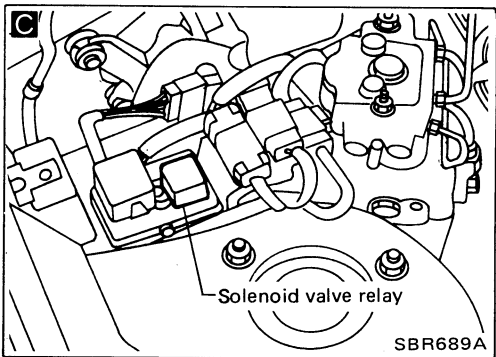
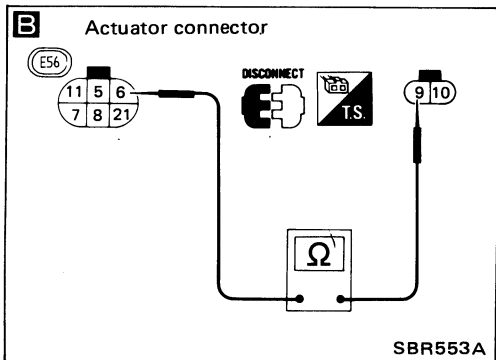
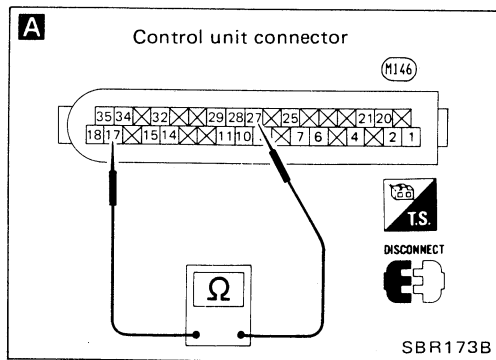

TROUBLE DIAGNOSES

Diagnostic Procedure 11

CONTROL UNIT (L.E.D. flashing number 16)

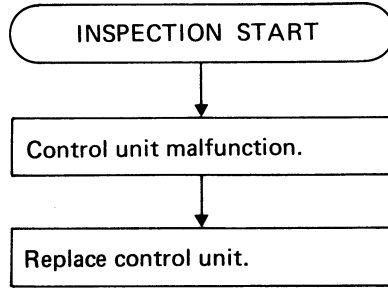

Diagnostic Procedure 12 CONTROL UNIT OR POWER SUPPLY AND GROUND CIRCUIT (Warning activates but L.E.D. comes off.)

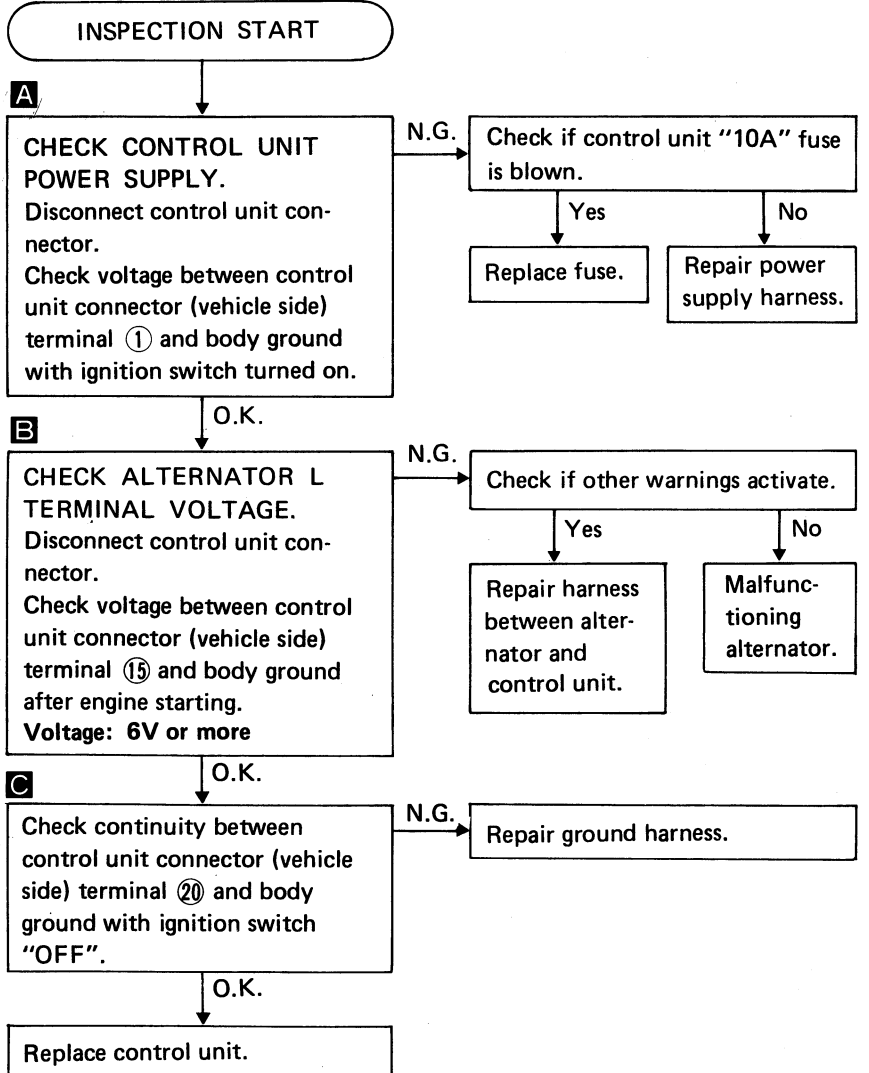
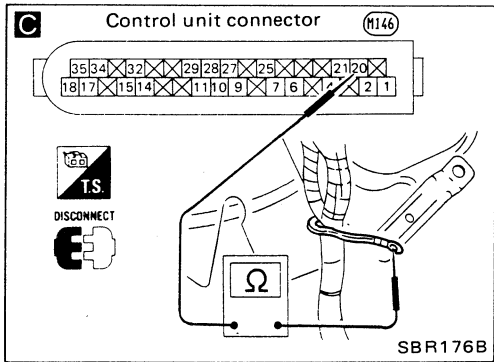
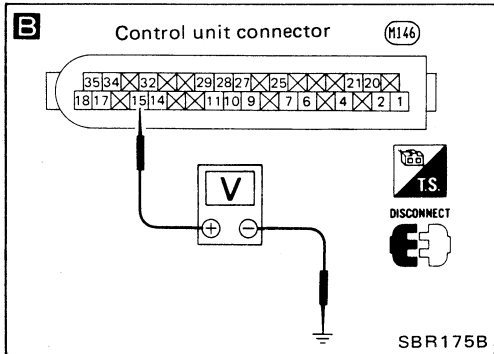
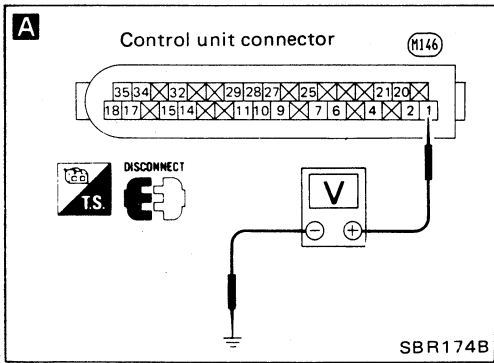

Electrical Components Inspection

ACTUATOR (Not self-diagnostic item)

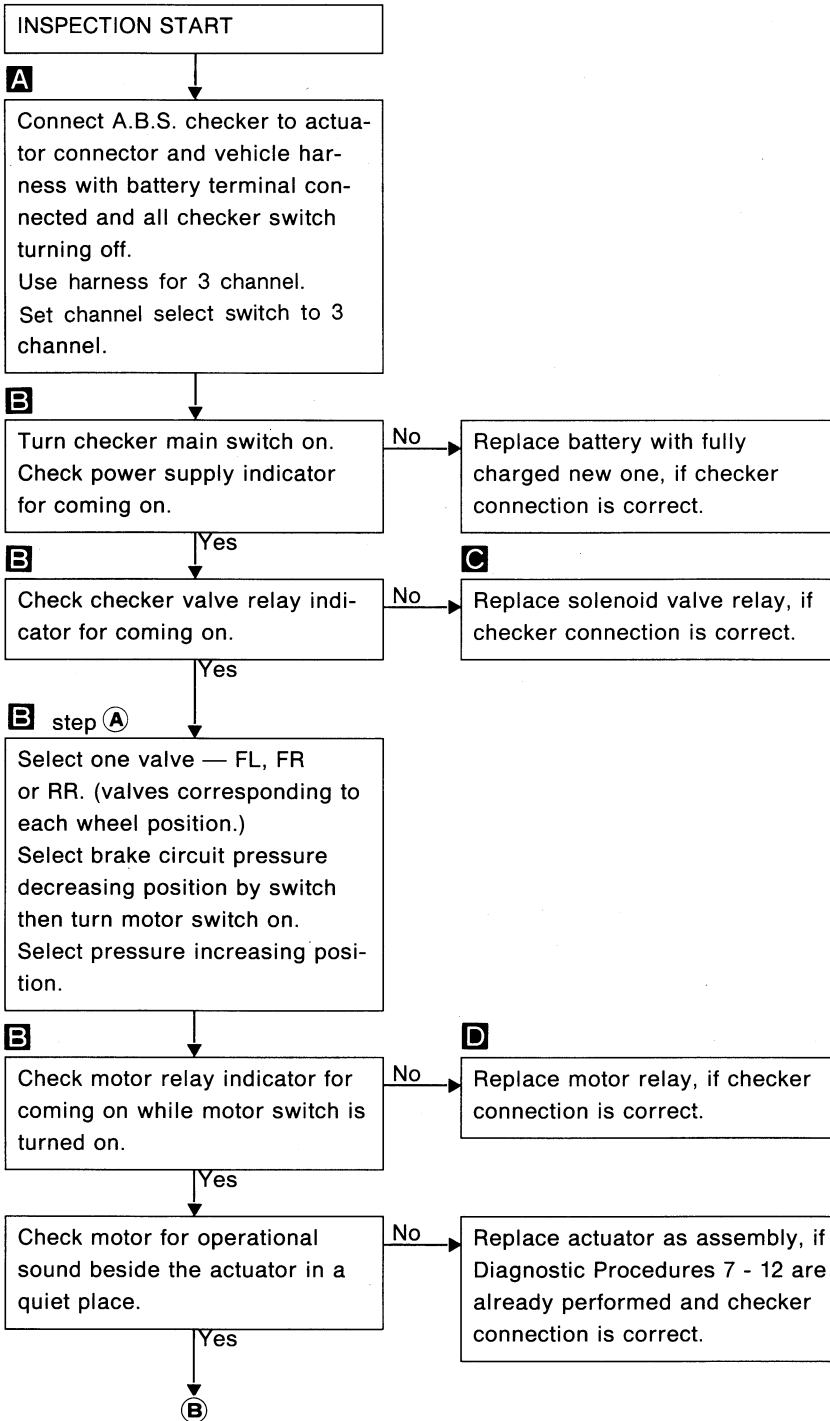
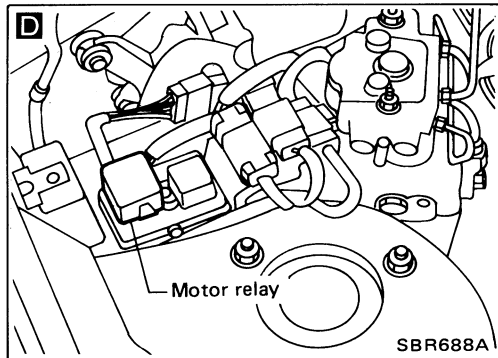
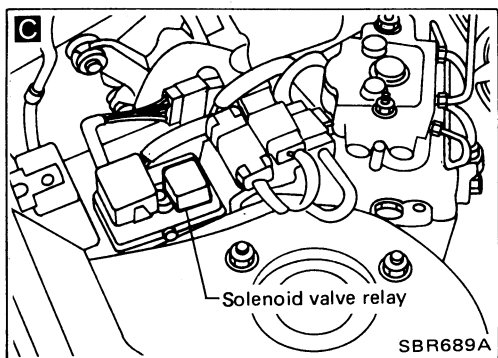
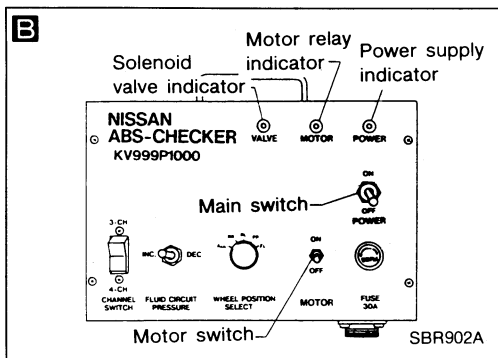
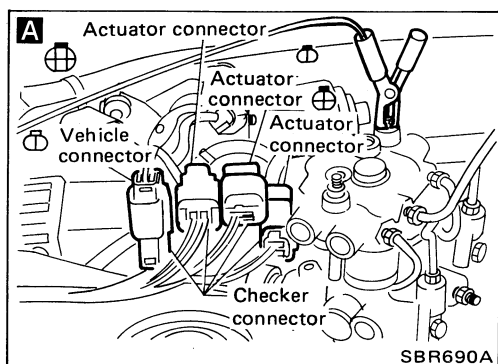

TROUBLE DIAGNOSES

Electrical Components Inspection (Cont'd)

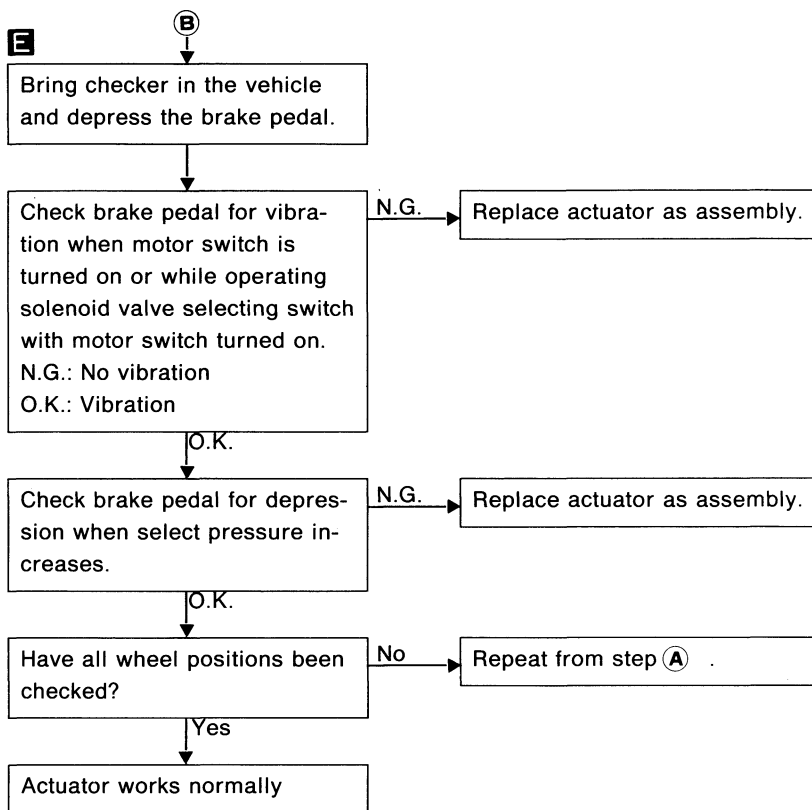
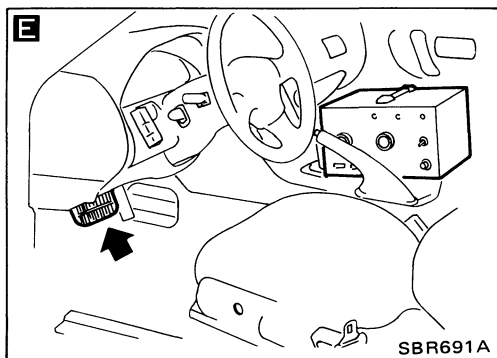

CAUTION:

Do not set checker at pressure decrease position for more than 5 seconds at a time. Actuator solenoid valve may be damaged.

SERVICE DATA AND SPECIFICATIONS (S.D.S.)

General Specifications

	Without A.B.S.	With A.B.S.
Front brake		
Brake model	CL22VB	CL25VA
Cylinder bore diameter mm (in)	54.0 (2.126)	57.2 (2.252)
Pad length x width x thickness mm (in)	112.8 x 44.8 x 10.0 (4.44 x 1.764 x 0.394)	125.6 x 45.3 x 11.0 (4.94 x 1.783 x 0.433)
Rotor outer diameter x thickness mm (in)	252 x 20 (9.92 x 0.79)	257 x 22 (10.12 x 0.87)
Rear brake		
Brake model	CL9H	
Cylinder bore diameter mm (in)	33.96 (1.3370)	
Pad length x width x thickness mm (in)	75.0 x 40.0 x 9.5 (2.953 x 1.575 x 0.374)	
Rotor outer diameter x thickness mm (in)	258 x 9 (10.16 x 0.35)	
Master cylinder		
Cylinder bore diameter mm (in)	22.22 (7/8)	23.81 (15/16)
Control valve		
Valve model	Proportioning valve (within master cylinder)	
Sprit point x reducing ratio kPa (kg/cm ² , psi)	3,923 (40, 569) x 0.4	
Brake booster		
Booster model	M23	M195T
Diaphragm diameter mm (in)	230 (9.06)	Primary 205 (8.07) Secondary 180 (7.09)
Brake fluid		
Recommended brake fluid	DOT 3	

SERVICE DATA AND SPECIFICATIONS (S.D.S.)

Inspection and Adjustment

FRONT DISC BRAKE

Item \ Brake model	CL22VB	CL25VA
Pad wear limit Minimum thickness mm (in)	2.0 (0.079)	
Rotor repair limit Minimum thickness mm (in)	18.0 (0.709)	20.0 (0.787)
Maximum runout mm (in)	0.07 (0.0028)	

REAR DISC BRAKE

Item \ Brake model	CL9H	
Pad wear limit Minimum thickness mm (in)	1.5 (0.059)	
Rotor repair limit Minimum thickness mm (in)	8.0 (0.315)	
Maximum runout mm (in)	0.07 (0.0028)	

BRAKE PEDAL

Free height M/T	mm (in) 177.0 - 187.0 (6.97 - 7.36)
A/T	186.0 - 196.0 (7.32 - 7.72)
Depressed height [under force of 490 N (50 kg, 110 lb) with engine running]	mm (in) 100 (3.94) or more
Clearance between pedal stopper and threaded end of stop lamp switch	mm (in) 0.3 - 1.0 (0.012 - 0.039)
Clearance between pedal stopper and threaded end of A.S.C.D. switch	mm (in) 0.3 - 1.0 (0.012 - 0.039)
Pedal free play at clevis	mm (in) 1 - 3 (0.04 - 0.12)

PARKING BRAKE

Item \ Control type	Center lever
Number of notches [under force of 196 N (20 kg, 44 lb)]	6 - 8
Number of notches (when warning switch comes on)	1

STEERING SYSTEM

SECTION **ST**

CONTENTS

PRECAUTIONS	ST- 2
PREPARATION	ST- 3
ON-VEHICLE INSPECTION	ST- 5
ON-VEHICLE INSPECTION (Power steering)	ST- 7
STEERING WHEEL AND STEERING COLUMN	ST-10
POWER STEERING GEAR AND LINKAGE (Model PR24SC)	ST-14
POWER STEERING OIL PUMP	ST-26
SUPER HICAS SYSTEM	ST-29
SUPER HICAS SYSTEM — On-vehicle Inspection	ST-30
SUPER HICAS SYSTEM — Repair of Component Parts	ST-34
SUPER HICAS SYSTEM — Trouble Diagnoses	ST-45
SERVICE DATA AND SPECIFICATIONS (S.D.S.)	ST-80

ST

PRECAUTIONS

- Before disassembly, thoroughly clean the outside of the unit.
 - Disassembly should be done in a clean work area. It is important to prevent the internal parts from becoming contaminated by dirt or other foreign matter.
 - When disassembling parts, be sure to place them in order in a parts rack so they can be reinstalled in their proper positions.
 - Use nylon cloths or paper towels to clean the parts; common shop rags can leave lint that might interfere with their operation.
 - Before inspection or reassembly, carefully clean all parts with a general purpose, non-flammable solvent.
 - Before assembly, apply a coat of recommended A.T.F.* to hydraulic parts. Vaseline may be applied to O-rings and seals. Do not use any grease.
 - Replace all gaskets, seals and O-rings. Avoid damaging O-rings, seals and gaskets during installation. Perform functional tests whenever designated.
- *: Automatic transmission fluid

PREPARATION

SPECIAL SERVICE TOOLS

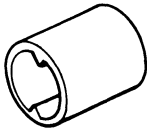
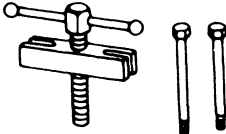
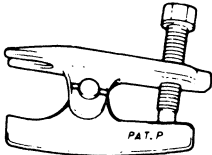
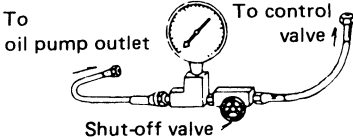
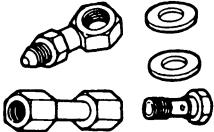
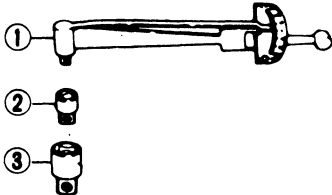
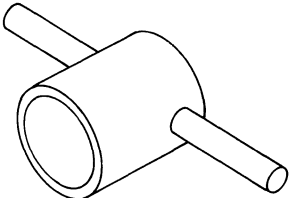
Tool number (Kent-Moore No.) Tool name	Description	
KV48100700 (J26364) Torque adapter		Measuring pinion rotating torque
ST27180001 (J25726-A) Steering wheel puller		Removing and installing steering wheel
HT72520000 (J25730-A) Ball joint remover		Removing ball joint
ST27091000 (J26357) Pressure gauge		Measuring oil pressure
KV48102500 (-) Pressure gauge adapter		Measuring oil pressure
ST3127S000 (See J25765-A) ① GG91030000 (J25765-A) Torque wrench ② HT62940000 (-) Socket adapter ③ HT62900000 (-) Socket adapter		Measuring turning torque
KV48104400 (-) Rack seal ring reformer		Reforming teflon ring

PREPARATION

SPECIAL SERVICE TOOLS (Cont'd)

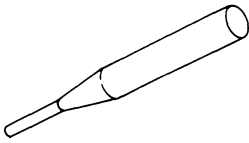
Tool number (Kent-Moore No.) Tool name	Description	
KV32101100 (—) Pin punch		Removing and installing tube seat

COMMERCIAL SERVICE TOOLS

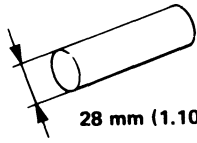
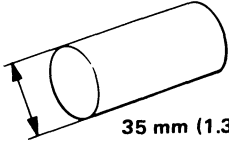
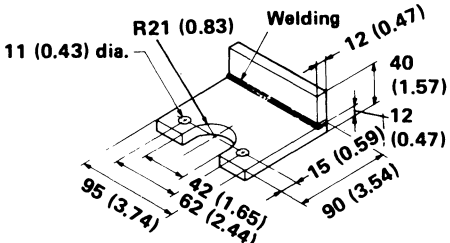
Tool name	Description	
Rear oil seal drift	 <p style="text-align: center;">28 mm (1.10 in) dia.</p>	Installing rear oil seal
Pinion oil seal drift	 <p style="text-align: center;">35 mm (1.38 in) dia.</p>	Installing pinion oil seal
Oil pump attachment	 <p style="text-align: center;">Unit: mm (in) SST481A</p>	Disassembling and assembling oil pump

ON-VEHICLE INSPECTION

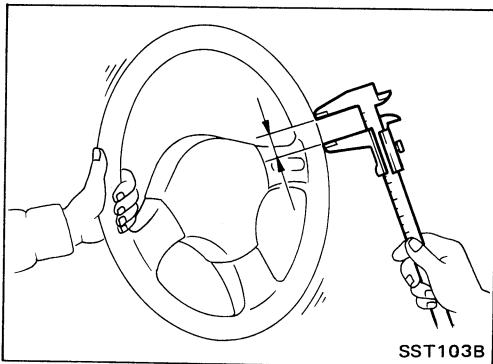

Checking Steering Wheel Play

1. With wheels in a straight-ahead position, check steering wheel play.

Steering wheel play:

35 mm (1.38 in) or less

2. If it is not within specification, check steering gear assembly when front suspension and axle, steering gear assembly and steering column are mounted correctly.

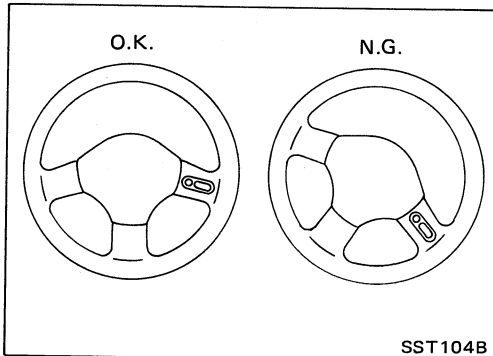

Checking Neutral Position on Steering Wheel

Pre-checking

- Make sure that wheel alignment is correct.

Wheel alignment:

Refer to section FA for S.D.S.

- Verify that the steering gear is centered before removing the steering wheel.

Checking

- Check that the steering wheel is in the neutral position when driving straight ahead.
- If it is not in the neutral position, remove the steering wheel and reinstall it correctly.
- If the neutral position is between two serrated teeth, loosen tie-rod lock nut and move tie-rod in the opposite direction by the same amount on both left and right sides to compensate for error in the neutral position.

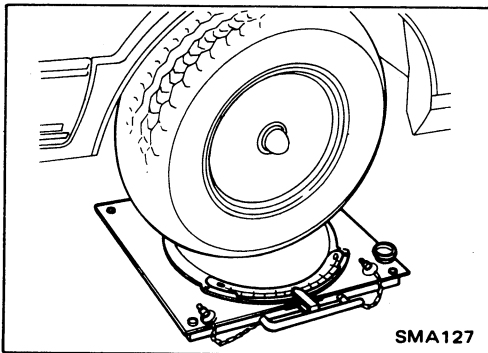

Front Wheel Turning Angle

- Rotate steering wheel all the way right and left; measure turning angle.

Turning angle of full turns:

Refer to section FA for S.D.S.

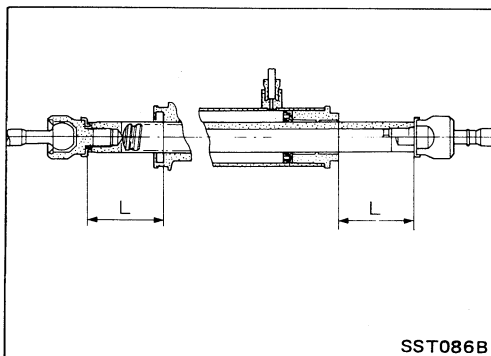

- If it is not within specification, check rack stroke.

Measured length "L":

Refer to S.D.S.

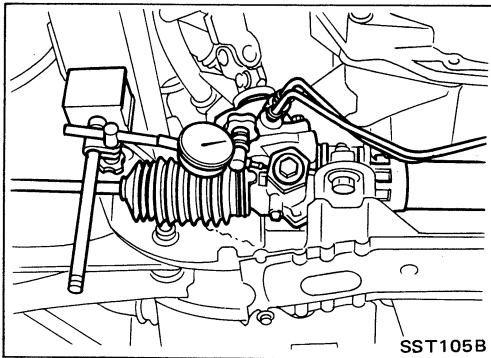

Checking Gear Housing Movement

1. Check the movement of steering gear housing during stationary steering on a dry paved surface.
 - Apply a force of 49 N (5 kg, 11 lb) to steering wheel to check the gear housing movement.Turn off ignition key while checking.

Movement of gear housing:

$\pm 2 \text{ mm } (\pm 0.08 \text{ in})$ or less

2. If movement exceeds the limit, replace mount insulator after confirming proper installation of gear housing clamps.

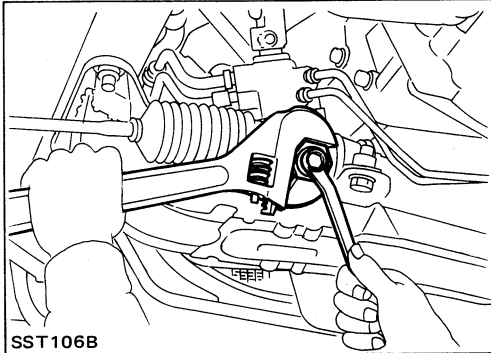

Adjusting Rack Retainer

- Perform this driving test on a flat road.
1. Check whether vehicle moves in a straight line when steering wheel is released.
 2. Check whether steering wheel returns to neutral position when steering wheel is released from a slightly turned (approx. 20°) position.
- If any abnormality is found, correct it by resetting adjusting screw.

Checking and Adjusting Drive Belts

Refer to section MA for Drive Belt Inspection.

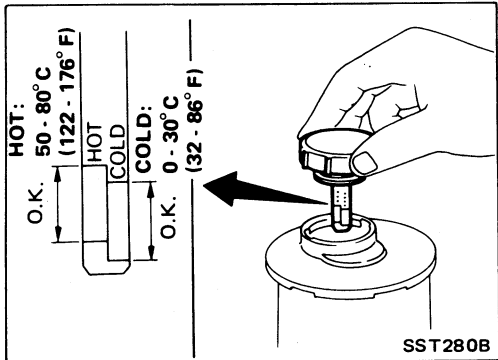

Checking Fluid Level

Check fluid level.

Fluid level should be checked using "HOT" range on dipstick at fluid temperatures of 50 to 80°C (122 to 176°F) or using "COLD" range on dipstick at fluid temperatures of 0 to 30°C (32 to 86°F).

CAUTION:

- Do not overfill.
- Recommended fluid is Automatic Transmission Fluid "DEX-RON™" type.

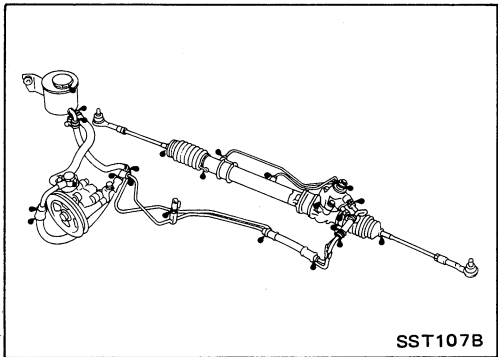

Checking Fluid Leakage

Check the lines for improper attachment and for leaks, cracks, damage, loose connections, chafing or deterioration.

1. Run engine at idle speed or 1,000 rpm.

Make sure temperature of fluid in oil tank rises to 60 to 80°C (140 to 176°F).

2. Turn steering wheel right-to-left several times.
3. Hold steering wheel at each "lock" position for five seconds and carefully check for fluid leakage.

CAUTION:

Do not hold the steering wheel in a locked position for more than 15 seconds.

4. If fluid leakage at connectors is noticed, loosen flare nut and then retighten.

Do not overtighten connector as this can damage O-ring, washer and connector.

Bleeding Hydraulic System

1. Raise front end of vehicle until wheels clear ground.
 2. Add fluid into oil tank to specified level. Meanwhile, quickly turn steering wheel fully to right and left and lightly touch steering stoppers.
Repeat steering wheel operation until fluid level no longer decreases.
 3. Start engine.
Repeat step 2 above.
- Incomplete air bleeding will cause the following to occur.
When this happens, bleed air again.

ON-VEHICLE INSPECTION (Power steering)

Bleeding Hydraulic System (Cont'd)

- Generation of air bubbles in reservoir tank
- Generation of clicking noise in oil pump
- Excessive buzzing in oil pump

While the vehicle is stationary or while turning the steering wheel slowly, fluid noise may occur in the valve or oil pump. This noise is inherent in this steering system, and it will not affect performance or durability of the system.

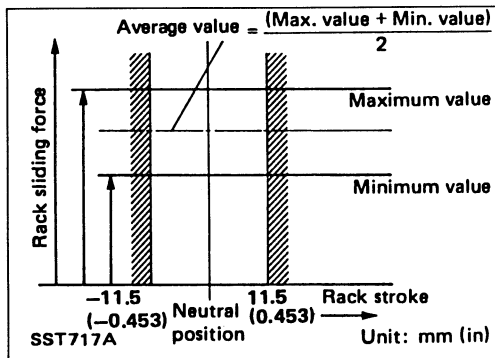
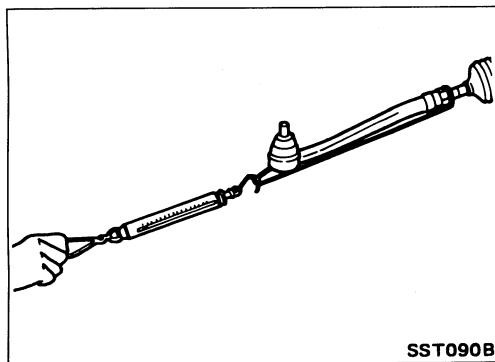
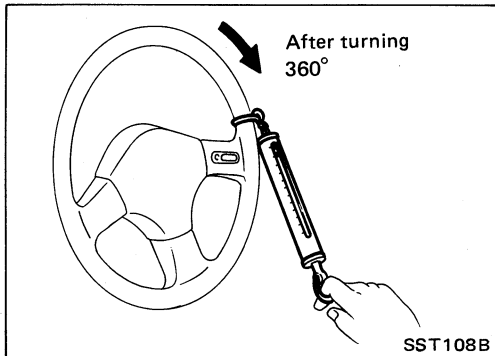

Checking Steering Wheel Turning Force

- Park vehicle on a level, dry surface and set parking brake.
- Start engine.
- Bring power steering fluid up to adequate operating temperature. [Make sure temperature of fluid is approximately 60 to 80°C (140 to 176°F).]

Tires need to be inflated to normal pressure.

- Check steering wheel turning force when steering wheel has been turned 360° from the neutral position.

Steering wheel turning force:

39 N (4 kg, 9 lb) or less

- If steering wheel turning force is out of specifications, check rack sliding force to detect condition of steering gear assembly.
 - Disconnect steering column lower joint and knuckle arms from the gear.
 - Start and run engine at idle to make sure steering fluid has reached normal operating temperature.
 - While pulling tie-rod slowly in the ± 11.5 mm (± 0.453 in) range from the neutral position, make sure rack sliding force is within specification.

Average rack sliding force:

167 - 226 N (17 - 23 kg, 37 - 51 lb)

- If rack sliding force is not within specification, overhaul steering gear assembly.

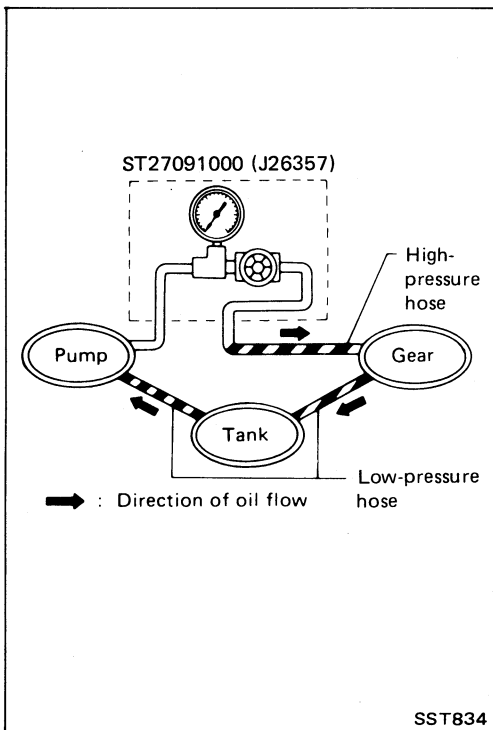

Checking Hydraulic System

Before starting, check belt tension, driving pulley and tire pressure.

1. Set Tool. Open shut-off valve. Then bleed air. (See "Bleeding Hydraulic System".)
2. Run engine.

Make sure temperature of fluid in tank rises to 60 to 80°C (140 to 176°F).

WARNING:

Warm up engine with shut-off valve fully opened. If engine is started with shut-off valve closed, oil pressure in oil pump will increase to relief pressure, resulting in an abnormal rise in oil temperature.

3. Check pressure with steering wheel fully turned to left and right positions with engine idling at 1,000 rpm.

CAUTION:

Do not hold the steering wheel in a locked position for more than 15 seconds.

Refer to S.D.S.

4. If oil pressure is below the standard pressure, slowly close shut-off valve and check pressure.
 - When pressure reaches standard pressure, gear is damaged.
 - When pressure remains below standard pressure, pump is damaged.

CAUTION:

Do not close shut-off valve for more than 15 seconds.

5. If oil pressure is higher than standard pressure, check oil pump flow control valve.
6. After checking hydraulic system, remove Tool and add fluid as necessary, then completely bleed air out of system.

STEERING WHEEL AND STEERING COLUMN

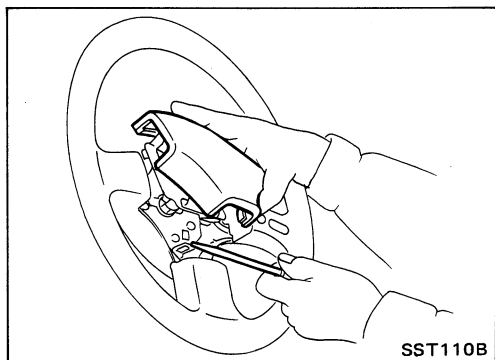
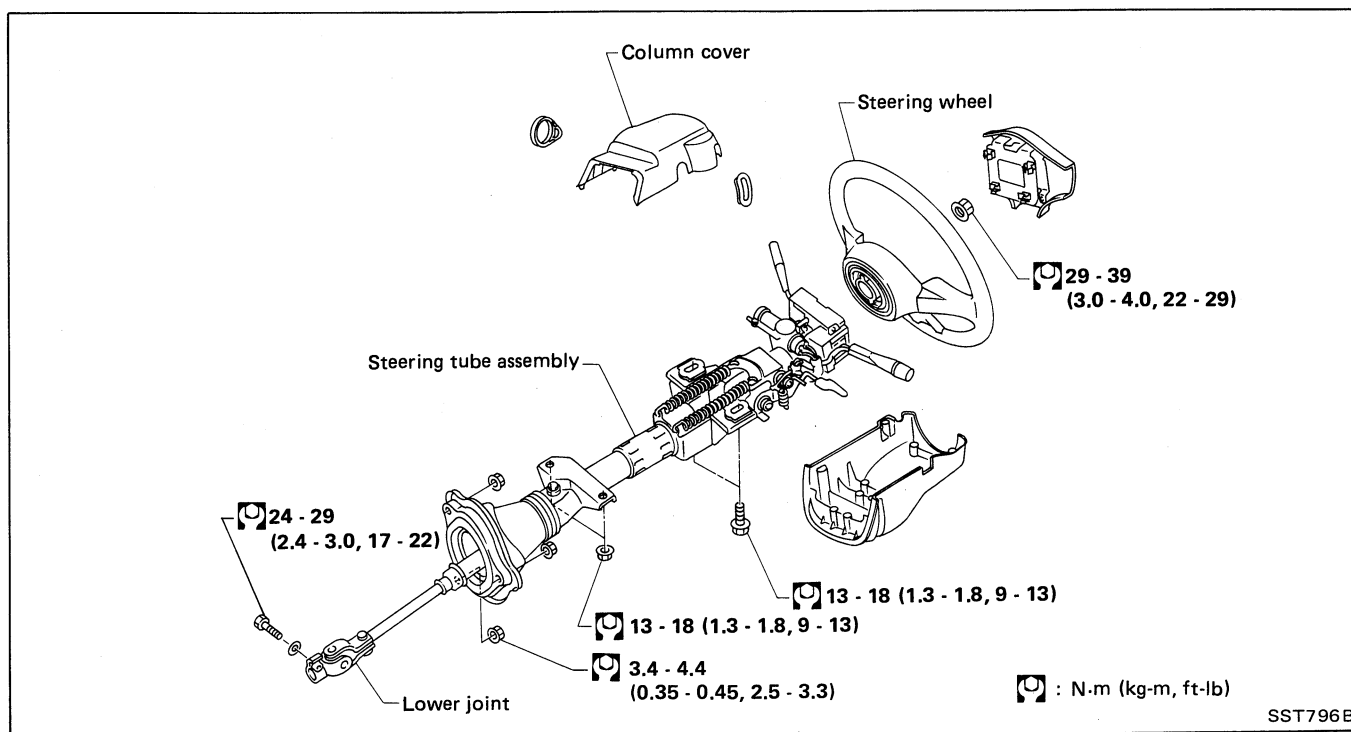

Removal STEERING WHEEL

- Pull out horn pad.

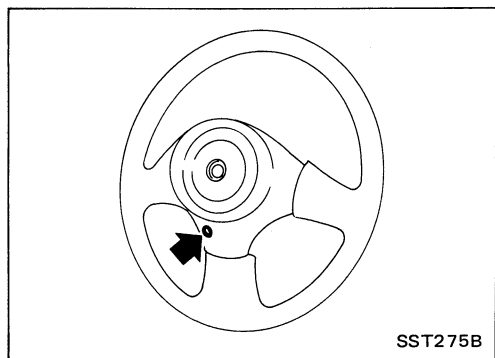

If it is hard to pull out horn pad, temporarily loosen fixing screw of horn pad retaining spring.

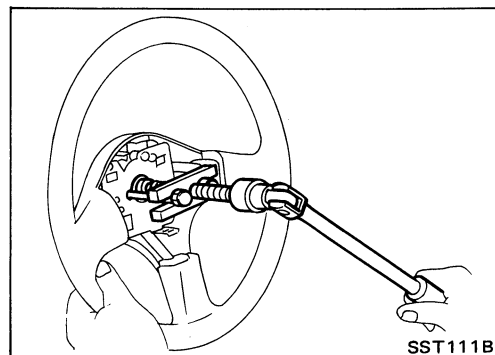

- Remove steering wheel with Tool.

STEERING WHEEL AND STEERING COLUMN

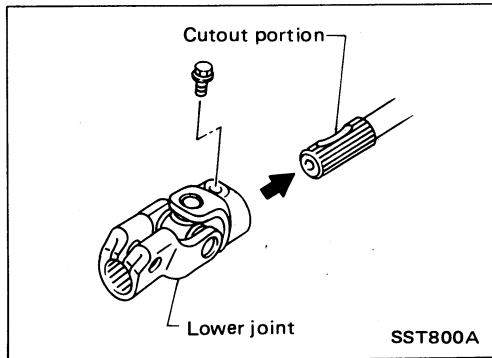
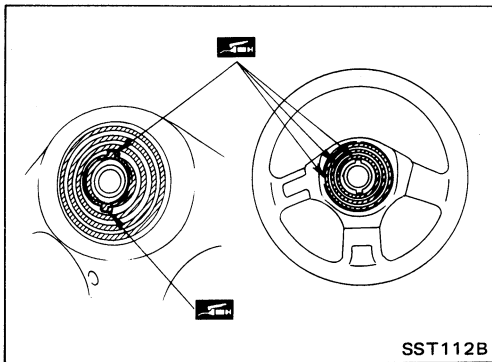

Installation

STEERING WHEEL

When installing steering wheel, apply multi-purpose grease to entire surface of turn signal cancel pin (both portions) and also to horn contact slip ring.

STEERING COLUMN

- When installing steering column, fingertighten all lower bracket and clamp retaining bolts; then tighten them securely. Do not apply undue stress to steering column.
- When attaching coupling joint, be sure tightening bolt faces cutout portion.

CAUTION:

After installing steering column, turn steering wheel to make sure it moves smoothly and that the number of turns from the straight forward position to left and right locks are equal.

Be sure that the steering wheel is in a neutral position when driving straight ahead.

STEERING WHEEL AND STEERING COLUMN

Disassembly and Assembly

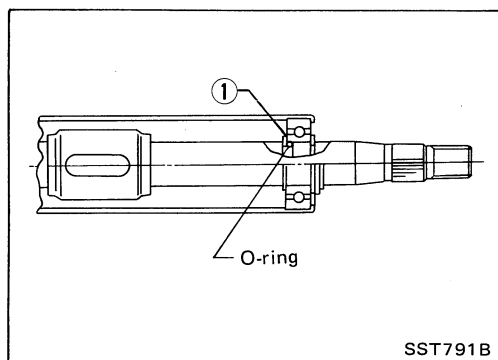
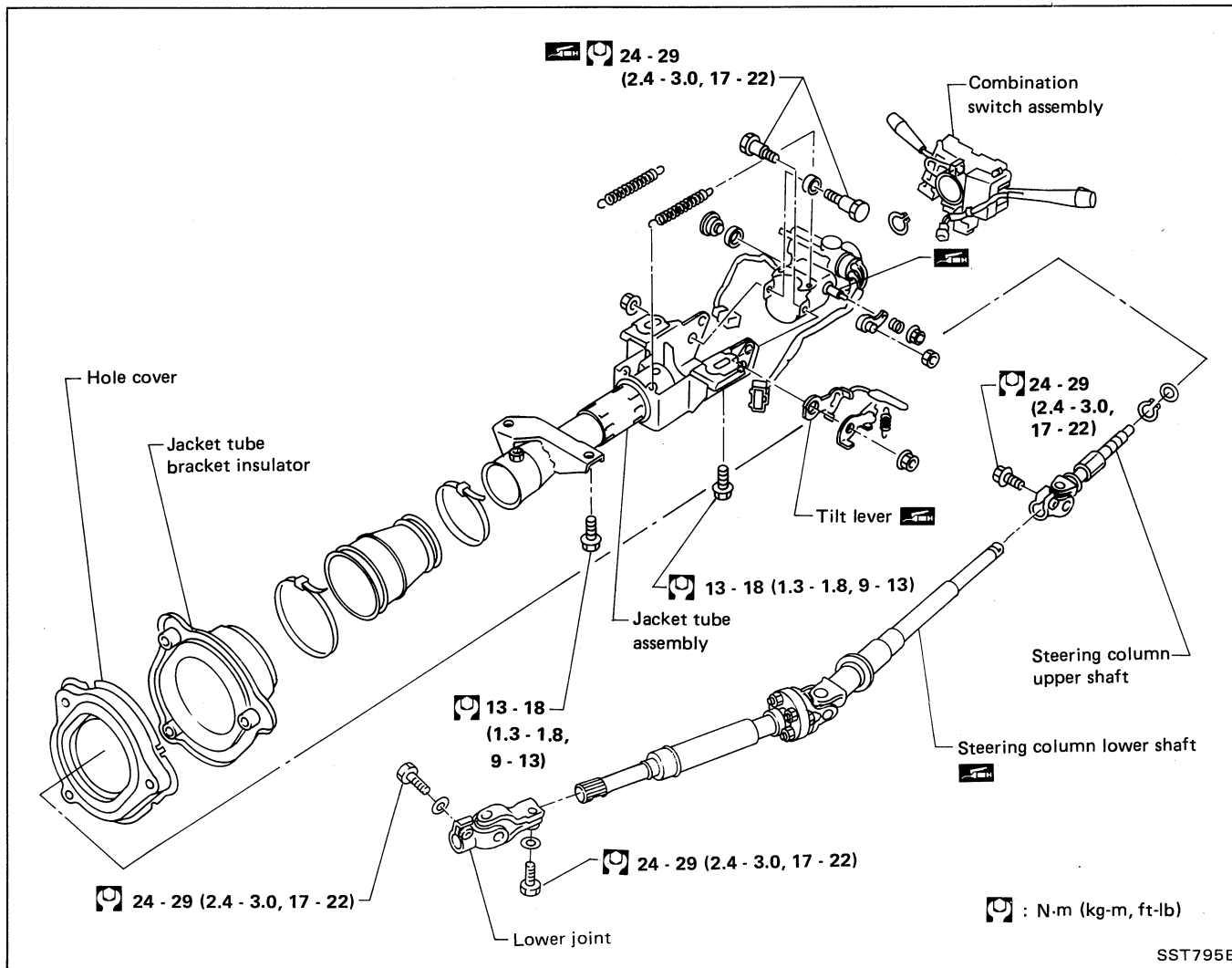

- When disassembling and assembling, unlock steering lock with key.
- Ensure that rounded surface of snap ring faces toward bearing when snap ring is installed.
- Install snap ring ①, then install o-ring into groove before inserting shaft into jacket tube.

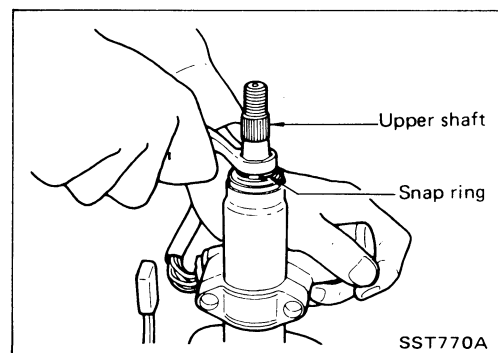

- Install snap ring on upper shaft with box wrench.

STEERING WHEEL AND STEERING COLUMN

Disassembly and Assembly (Cont'd)

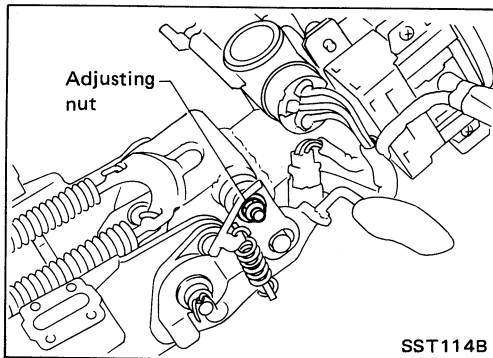

- Tilt mechanism
Tighten adjusting nut to specification.
⌚: 4 - 5 N·m
(0.4 - 0.5 kg-m, 2.9 - 3.6 ft-lb)

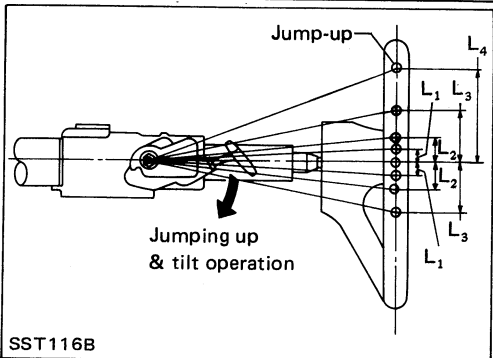

- After installing steering column, check tilt mechanism operation.
 - L₁: 9.8 mm (0.386 in)
 - L₂: 19.5 mm (0.768 in)
 - L₃: 29.3 mm (1.154 in)
 - L₄: 58.2 mm (2.291 in)

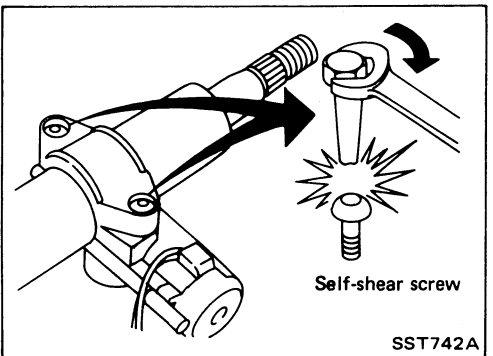

- Steering lock
 - a) Break self-shear type screws with a drill or other appropriate tool.
 - b) Install self-shear type screws and then cut off self-shear type screw heads.

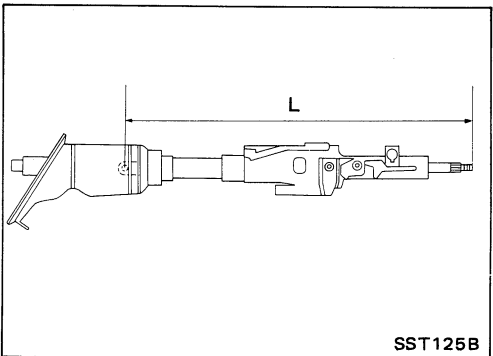

Inspection

- When steering wheel can not be rotated smoothly, check the steering column for the following matters and replace damaged parts.
 - a. Check column bearings for damage or unevenness. Lubricate with recommended multi-purpose grease or replace steering column as an assembly, if necessary.
 - b. Check steering column lower shaft for deformation or breakage. Replace if necessary.
- When the vehicle is involved in a light collision, check steering column length "L₁" and steering column lower shaft length "L₂". If it is not within specifications, replace steering column as an assembly.

Steering column length "L₁":
652.9 - 654.5 mm (25.70 - 25.77 in)

Steering column lower shaft length "L₂":
323.9 - 325.5 mm (12.75 - 12.81 in)

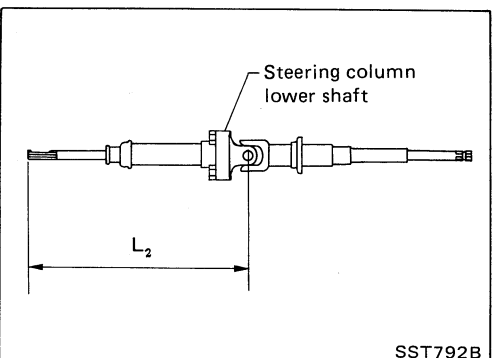

POWER STEERING GEAR AND LINKAGE (Model PR24SC)

Removal and Installation

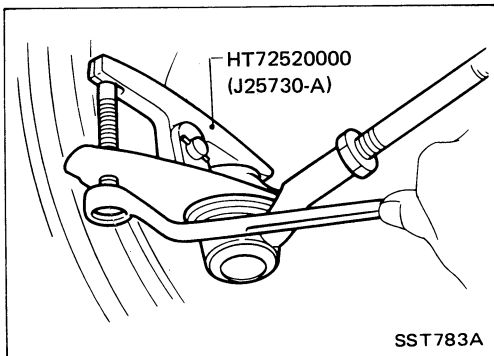
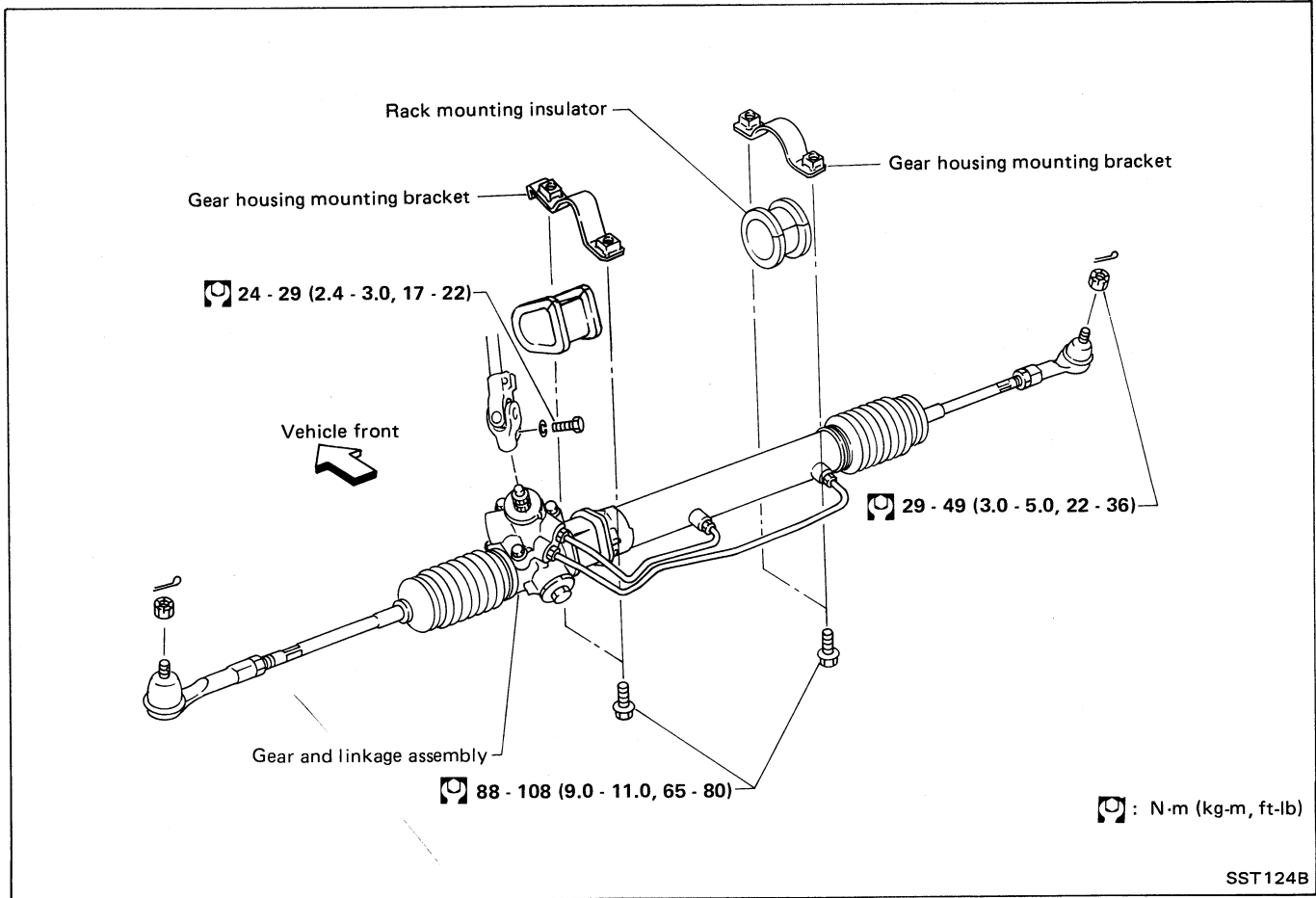

- Detach tie-rod outer sockets from knuckle arms with Tool.

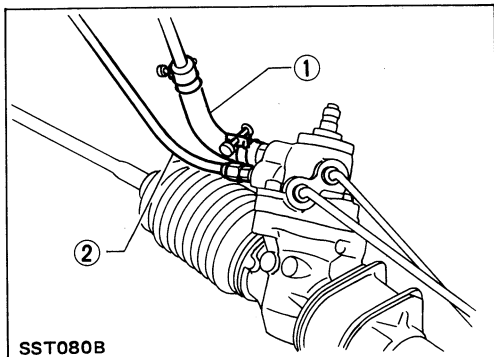

- Install pipe connector.
- Observe specified tightening torque when tightening high-pressure and low-pressure pipe connectors. Excessive tightening can damage threads or damaged connector O-ring.
- The O-ring in low-pressure pipe connector is larger than that in high-pressure connector. Take care to install the proper O-ring.

Connector tightening torque:

Low-pressure side "1"

27 - 39 N·m (2.8 - 4.0 kg-m, 20 - 29 ft-lb)

High-pressure side "2"

15 - 25 N·m (1.5 - 2.5 kg-m, 11 - 18 ft-lb)

POWER STEERING GEAR AND LINKAGE (Model PR24SC)

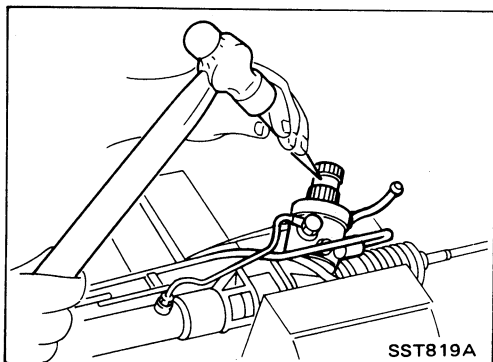
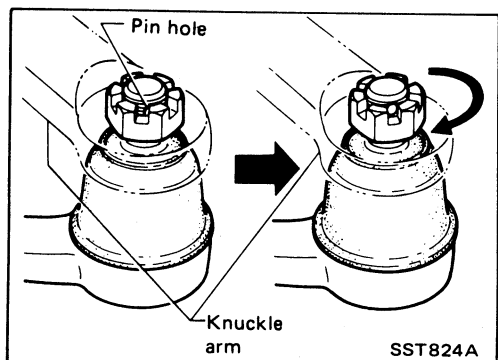

Removal and Installation (Cont'd)

- Initially, tighten nut on tie-rod outer socket and knuckle arm to 29 to 39 N·m (3 to 4 kg-m, 22 to 29 ft-lb). Then tighten further to align nut groove with first pin hole so that cotter pin can be installed.

CAUTION:

Tightening torque must not exceed 49 N·m (5 kg-m, 36 ft-lb).

- Before removing lower joint from gear, set gear in neutral (wheels in straight-ahead position). After removing lower joint, put matching mark on pinion shaft and pinion housing to record neutral position of gear.
- To install, set left and right dust boots to equal deflection, and attach lower joint by aligning matching marks of pinion shaft and pinion housing.

POWER STEERING GEAR AND LINKAGE (Model PR24SC)

Disassembly and Assembly

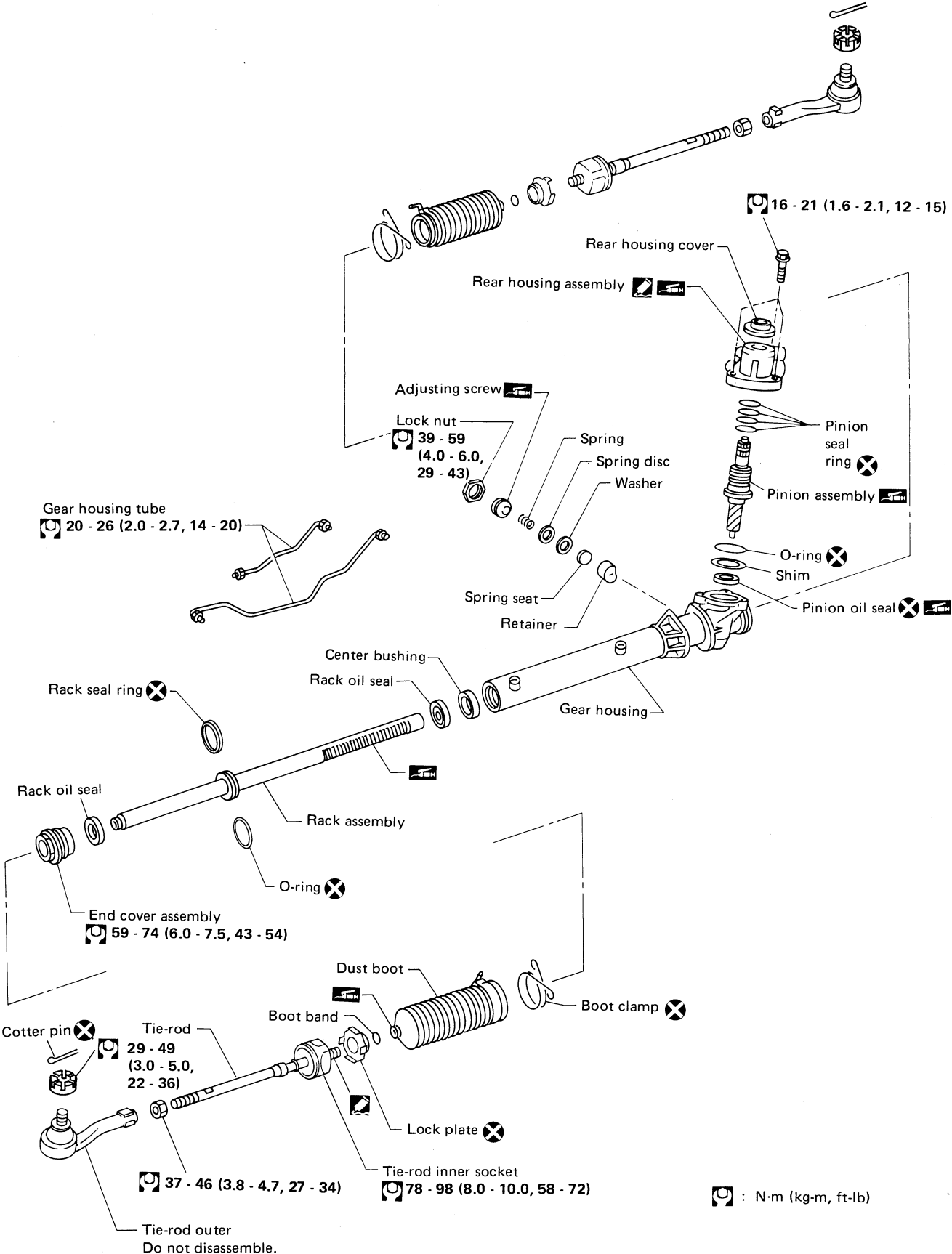

: N-m (kg-m, ft-lb)

POWER STEERING GEAR AND LINKAGE (Model PR24SC)

Disassembly

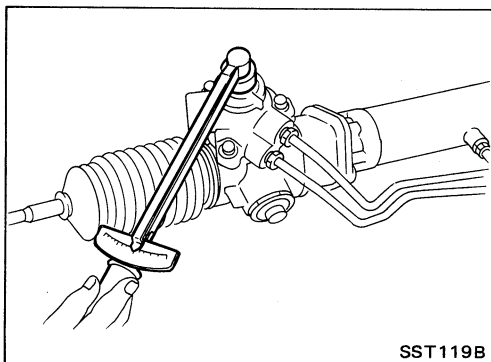

1. Prior to disassembling, measure pinion rotating torque. Record the pinion rotating torque as a reference.

- Before measuring, disconnect cylinder tube and drain fluid.
- Use soft jaws when holding steering gear housing. Handle gear housing carefully, as it is made of aluminum. Do not grip cylinder in a vise.

2. Remove pinion gear.

Be careful not to damage pinion gear when removing pinion seal ring.

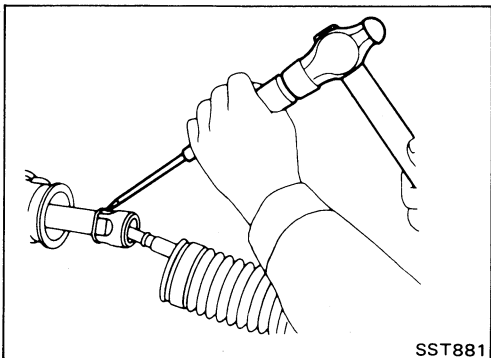

3. Remove tie-rod outer sockets and boots.

4. Loosen tie-rod inner socket by prying up staked portion, and remove socket.

5. Remove retainer.

6. Remove pinion assembly.

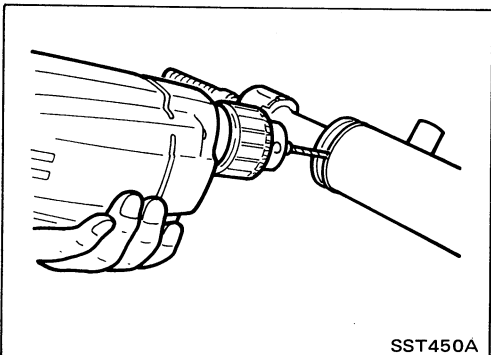

7. Drill staked portion of cylinder end cover with drill of 2 to 2.5 mm (0.079 to 0.098 in) diameter, until the staking is eliminated.

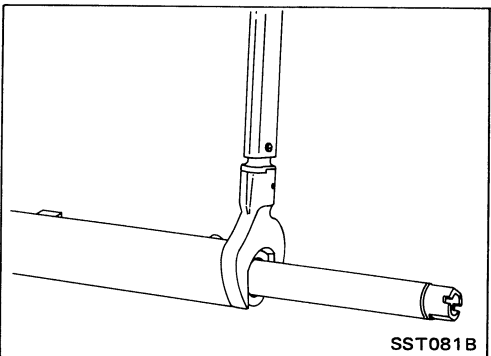

8. Remove gear housing end cover assembly with Tool.

9. Draw out rack assembly.

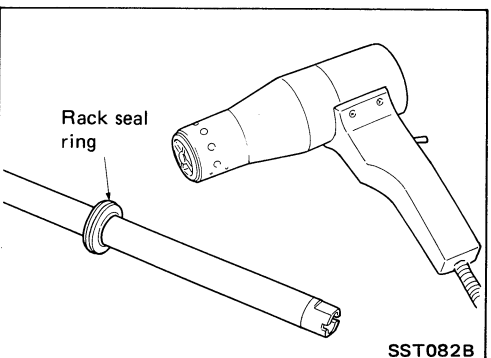

10. Remove rack seal ring.

- Using a heat gun, heat rack seal to approximately 40°C (104°F).
- Remove rack seal ring.

Be careful not to damage rack.

POWER STEERING GEAR AND LINKAGE (Model PR24SC)

Disassembly (Cont'd)

11. Remove center bushing and rack oil seal using tape wrapped socket and extension bar.

Do not scratch inner surfaces of pinion housing.

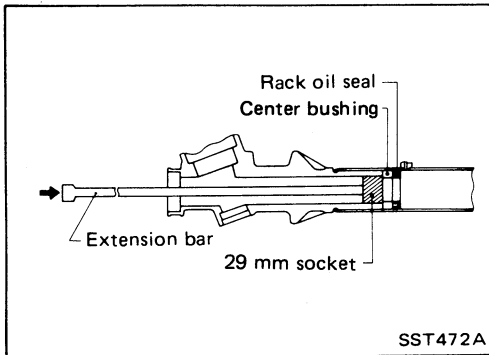

Inspection

Thoroughly clean all parts in cleaning solvent or automatic transmission fluid "Dexron™" type, and blow dry with compressed air, if available.

BOOT

Check condition of boot. If cracked excessively, replace it.

RACK

Thoroughly examine rack gear. If damaged, cracked or worn, replace it.

PINION ASSEMBLY

- Thoroughly examine pinion gear. If pinion gear is damaged, cracked or worn, replace it.
- Inspect bearings to see that they roll freely and are free from cracked, pitted, or worn balls, rollers and races. Replace if necessary.

GEAR HOUSING CYLINDER

Check gear housing cylinder bore for scratches or other damage. Replace if necessary.

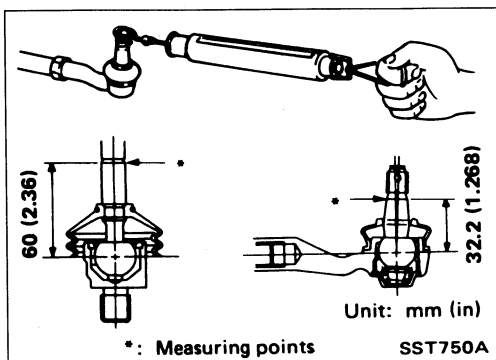

TIE-ROD OUTER AND INNER SOCKET

- Check ball joint for swinging force.

Tie-rod outer ball joint:

8.8 - 91.2 N
(0.9 - 9.3 kg, 2.0 - 20.5 lb)

Tie-rod inner ball joint:

7.8 - 122.6 N
(0.8 - 12.5 kg, 1.8 - 27.6 lb)

POWER STEERING GEAR AND LINKAGE (Model PR24SC)

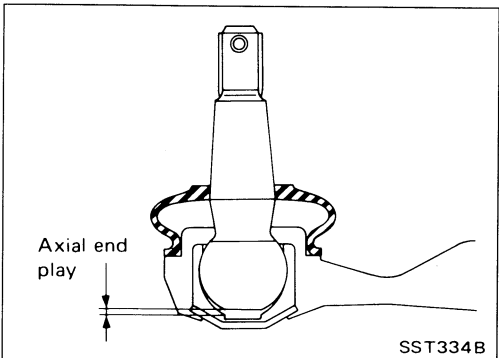
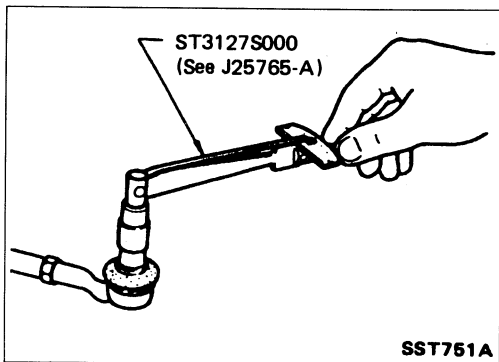

Inspection (Cont'd)

- Check ball joint for rotating torque.

Tie-rod outer ball joint:

0.3 - 2.9 N·m

(3 - 30 kg-cm, 2.6 - 26.0 in-lb)

Tie-rod inner ball joint:

7.4 N·m (75 kg-cm, 65 in-lb) or less

- Check ball joint for axial end play.

Tie-rod outer ball joint:

0.5 mm (0.020 in) or less

Tie-rod inner ball joint:

0 mm (0 in)

- Check condition of dust cover. If cracked excessively, replace it.

CYLINDER TUBES

Check cylinder tubes for scratches or other damage. Replace if necessary.

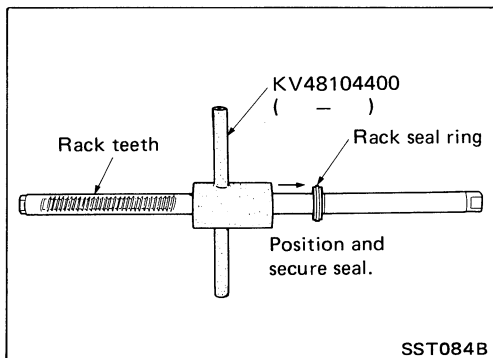
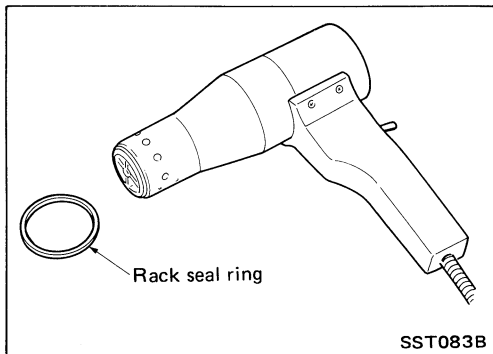

Assembly

1. Using a heat gun, heat rack seal ring (made of Teflon) to approximately 40°C (104°F) and install it onto rack with your hand.

2. Using Tool, compress periphery of rack seal ring (made of Teflon) to position and secure it on rack.

Always insert the tool from the rack gear side.

POWER STEERING GEAR AND LINKAGE (Model PR24SC)

Assembly (Cont'd)

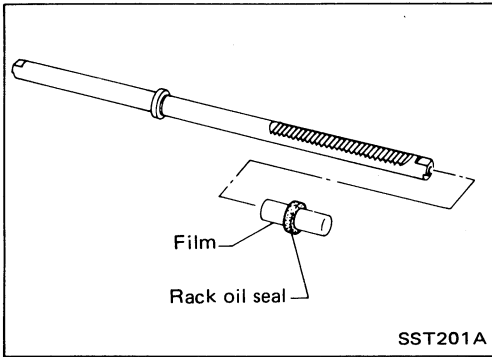

3. Insert rack oil seal.

- Place plastic film into rack oil seal to prevent damage by rack teeth.
- Always remove plastic film after rack oil seal is positioned properly.
- Make sure lips of rack oil seal face each other.

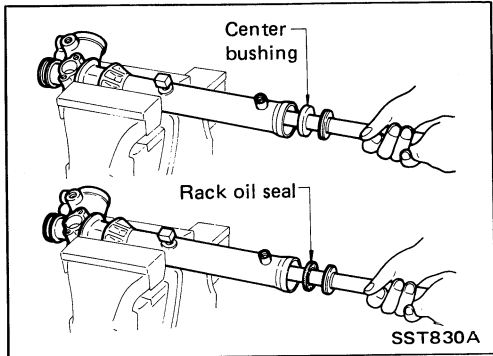

4. Install center bushing and rack oil seal with rack assembly.

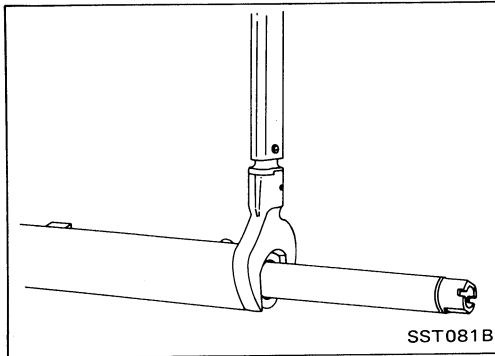

5. Tighten cylinder end cover assembly with Tool.

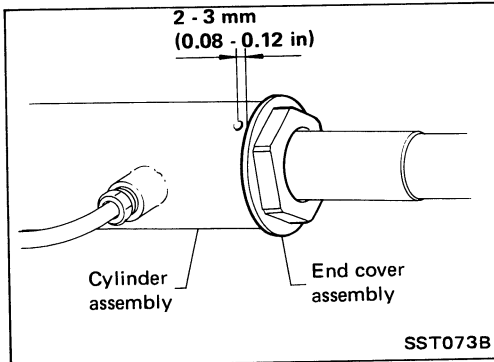

6. Fasten cylinder end cover assembly to gear housing by staking.

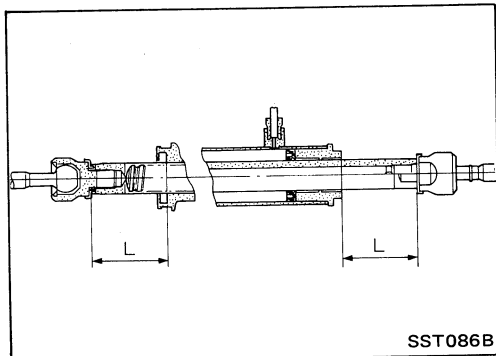

7. Set rack gear in the neutral position.

Measured length "L":
Refer to S.D.S.

POWER STEERING GEAR AND LINKAGE (Model PR24SC)

Assembly (Cont'd)

8. Coat seal lip of oil seal with multi-purpose grease and install new pinion oil seal to pinion housing with a suitable tool. **Make sure lip of oil seal faces up when installed.**

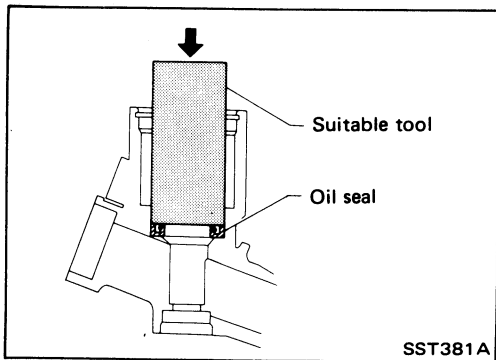

9. Install pinion bearing adjusting shim(s). **Whenever pinion assembly, gear housing and rear housing are disassembled, replace shim(s) with new ones. Always use the same number of shim(s) when replacing.**

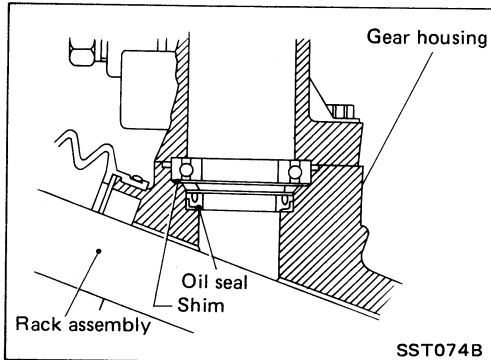

10. Install new pinion seal ring on pinion gear assembly.
- Using a heat gun, heat pinion seal ring to approximately 40°C (104°F) before installing it onto pinion gear assembly.
 - Make sure pinion seal ring is properly settled in valve groove.

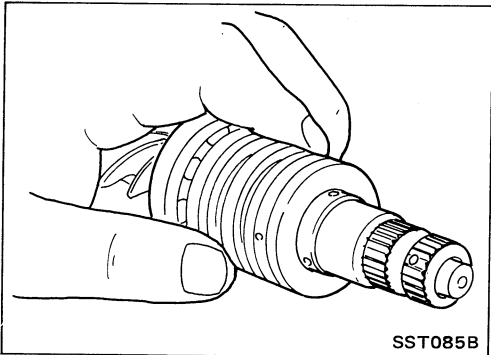

11. Apply a coat of multi-purpose grease to needle bearing roller and oil seal lip before installing pinion assembly in gear housing.

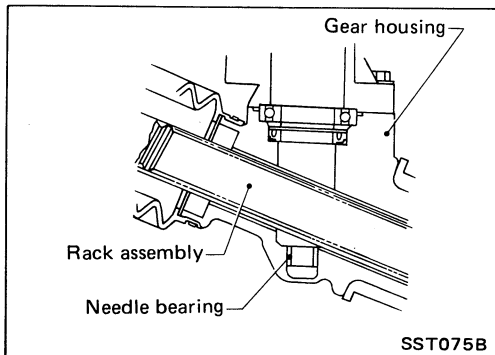

12. Install pinion assembly to pinion housing. **Be careful not to damage pinion oil seal.**

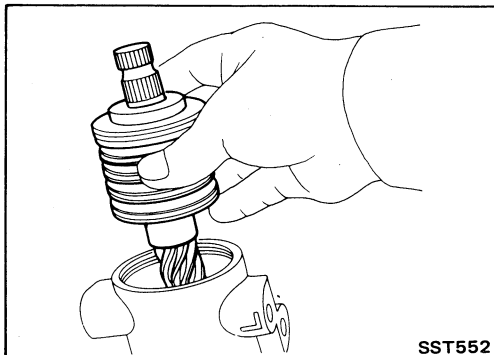

POWER STEERING GEAR AND LINKAGE (Model PR24SC)

Assembly (Cont'd)

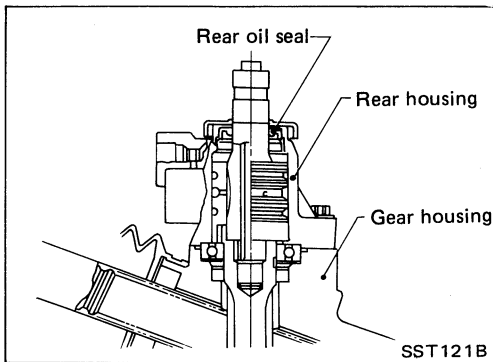

13. Apply a coat of multi-purpose grease to rear oil seal lip before installing rear housing.

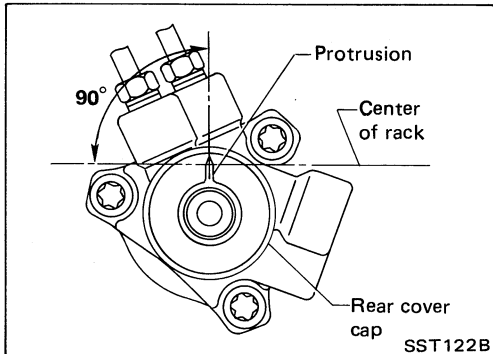

14. Install rear cover cap so that protrusion of rear housing cover is positioned as shown in figure at left when rack is centralized. **Be careful not to damage worm ring and oil seal.**

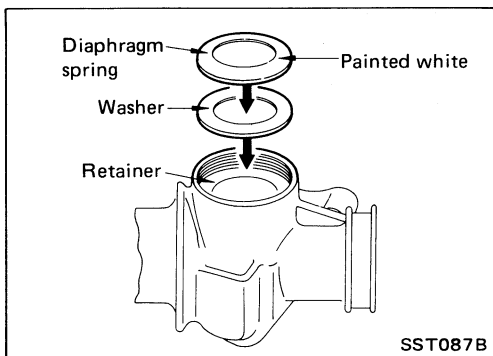

15. Install diaphragm spring at retainer.
- Always install retainer, spring washer and diaphragm spring in that order.
 - Make sure convex end (painted white) of diaphragm spring faces outward when installing.
16. Install retainer spring and adjusting screw temporarily.

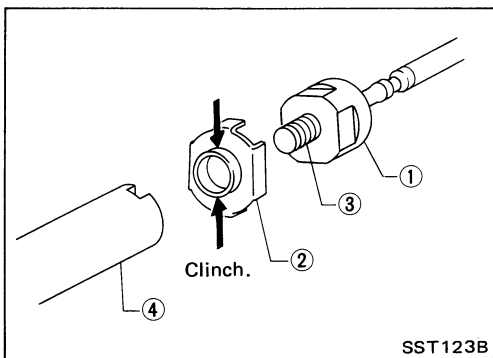

17. Install new lock plate.
- Attach lock plate ② to side rod inner socket ①.
 - Apply locking sealant to inner socket threads ③.
 - Screw inner socket into rack ④ and tighten to specified torque.
 - Clinch two places of lock plate at rack's groove.

CAUTION:
To prevent scratching the boot, remove burrs from lock plate.

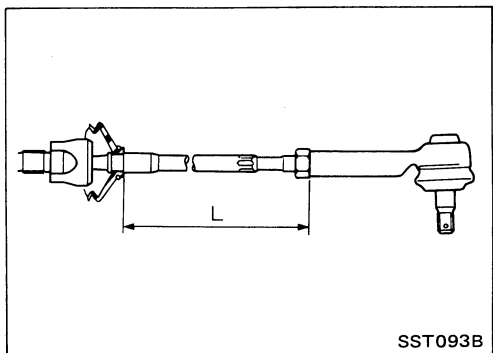

18. Tighten outer socket lock nut.
- Tie-rod length "L":**
Refer to S.D.S.

POWER STEERING GEAR AND LINKAGE (Model PR24SC)

Assembly (Cont'd)

19. Measure rack stroke.

Measured length "L":
Refer to S.D.S.

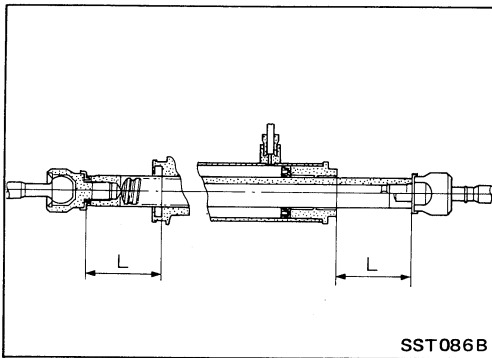

20. Before installing boot, coat the contact surfaces between boot and tie-rod with grease.

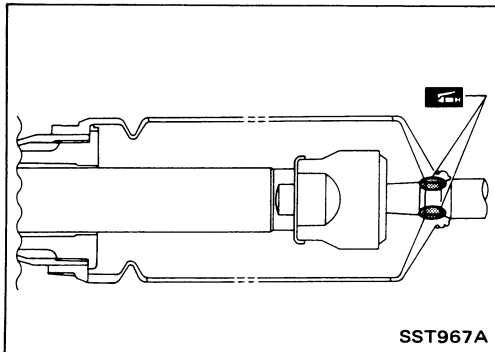

21. Install boot clamps.

- To install, wrap boot clamp around boot groove twice. Tighten clamp by twisting rings at both ends 4 to 4-1/2 turns with screwdriver while pulling with a force of approx. 98 N (10 kg, 22 lb).

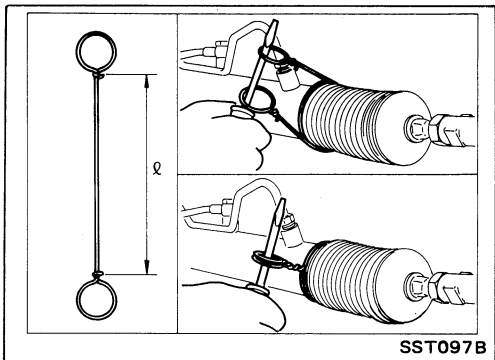

- Install boot clamps so they are behind the gear housing when gear assembly is attached to the body. (This will prevent interference with other parts.)

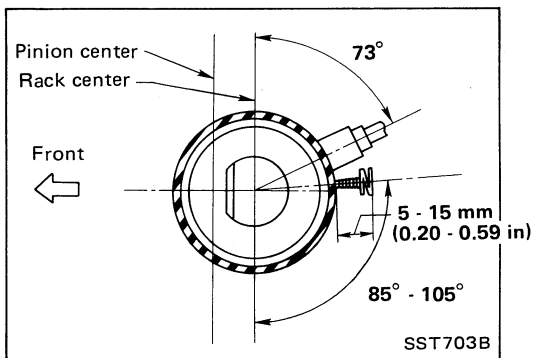

- Twist boot clamp in the direction shown in figure at left.

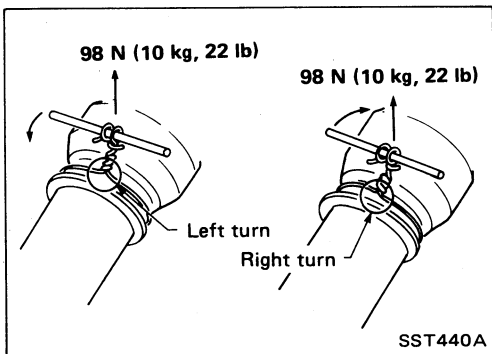

POWER STEERING GEAR AND LINKAGE (Model PR24SC)

Assembly (Cont'd)

- After twisting boot clamp, bend twisted and diagonally so it does not contact boot.

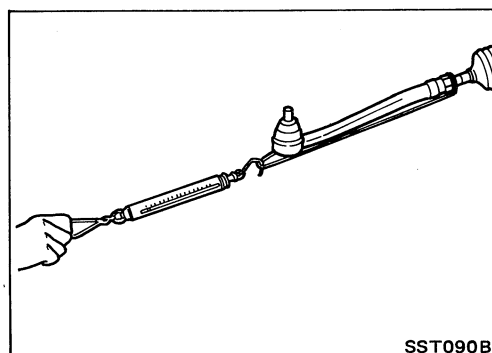
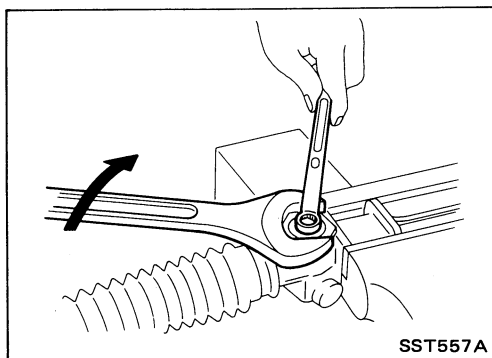
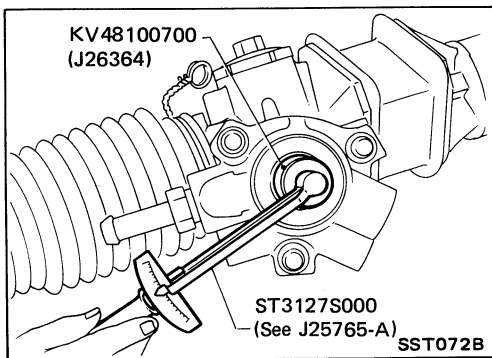
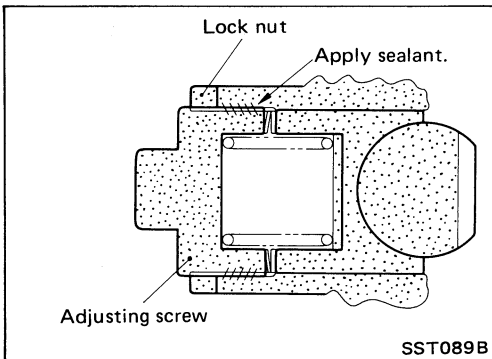
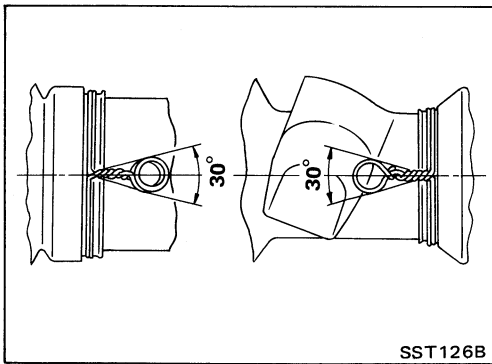

Adjustment

Adjust pinion rotating torque as follows:

1. Set gears to Neutral without fluid in the gear.
2. Coat the adjusting screw with locking sealant and screw it in.
3. Lightly tighten lock nut.
4. Tighten adjusting screw to a torque of 4.9 to 5.9 N•m (50 to 60 kg-cm, 43 to 52 in-lb).
5. Loosen adjusting screw, then retighten it to 0.05 to 0.20 N•m (0.5 to 2 kg-cm, 0.43 to 1.74 in-lb).
6. Move rack over its entire stroke several times.
7. Measure pinion rotating torque within the range of 180° from neutral position.
Stop the gear at the point of maximum torque.
8. Loosen adjusting screw, then retighten it to 4.9 N•m (50 kg-cm, 43 in-lb).
9. Loosen adjusting screw by 70° to 110°.
10. Prevent adjusting screw from turning, and tighten lock nut to specified torque.

11. Check steering gear for rack sliding frictional force.

Around neutral point of rack stroke

± 5.5 mm (± 0.217 in):

122.6 - 166.7 N (12.5 - 17 kg, 27.6 - 37.5 lb)

Except above range:

122.6 - 186.3 N (12.5 - 19 kg, 27.6 - 41.9 lb)

If sliding frictional force is out of specification, repeat the adjustment procedure, starting from No. 4.

After the readjustment, if sliding force is still out of specification, steering gear is damaged.

POWER STEERING GEAR AND LINKAGE (Model PR24SC)

Adjustment (Cont'd)

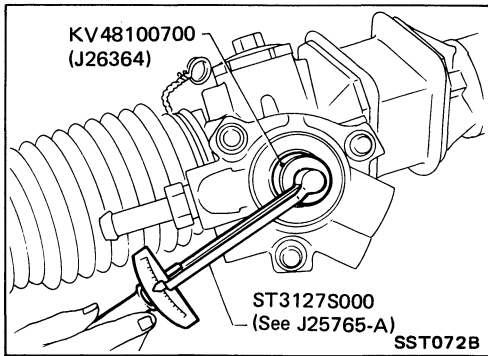

12. Measure pinion rotating torque within the range of $\pm 100^\circ$ from the neutral point.

Average rotating torque

[(Max. measured value + Min. measured value) x 0.5]:

0.8 - 1.3 N·m (8 - 13 kg-cm, 6.9 - 11.3 in-lb)

Maximum torque increment:

Less than 0.4 N·m (4 kg-cm, 3.5 in-lb)

Except for above mentioned measuring range:

Maximum rotating torque

1.9 N·m (19 kg-cm, 16 in-lb)

Maximum torque increment

Less than 0.6 N·m (6 kg-cm, 5.2 in-lb)

- If pinion rotating torque is not within specification, readjust it.
 - After the readjustment, if pinion rotating torque is still out of specification, steering gear is damaged.
13. As a final check, measure rack sliding force and steering wheel turning force under normal operating conditions. Refer to Checking Steering Wheel Turning Force in ON-VEHICLE INSPECTION (Power steering).

POWER STEERING OIL PUMP

Disassembly and Assembly

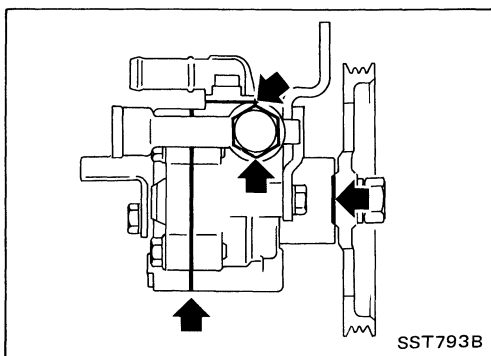
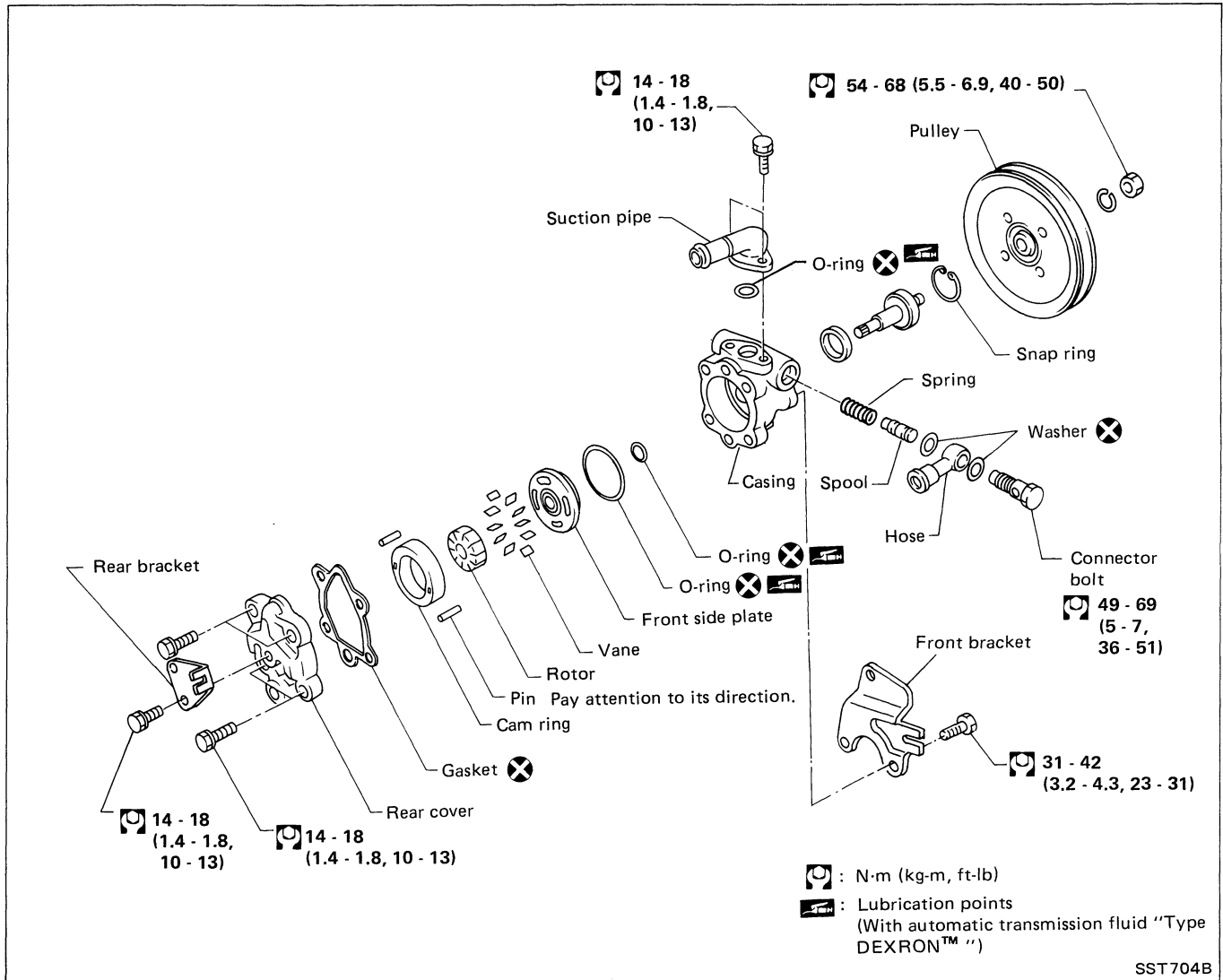

Pre-disassembly Inspection

Disassemble the power steering oil pump only if the following items are found.

- Oil leak from any point shown in the figure.
- Deformed or damaged pulley.
- Poor performance.

Disassembly

CAUTION:

- Parts which can be disassembled are strictly limited. Never disassemble parts other than those specified.
- Disassemble in as clean a place as possible.
- Clean your hands before disassembly.
- Do not use rags; use nylon cloths or paper towels.
- Follow the procedures and cautions in the Service Manual.
- When disassembling and reassembling, do not let foreign matter enter or contact the parts.

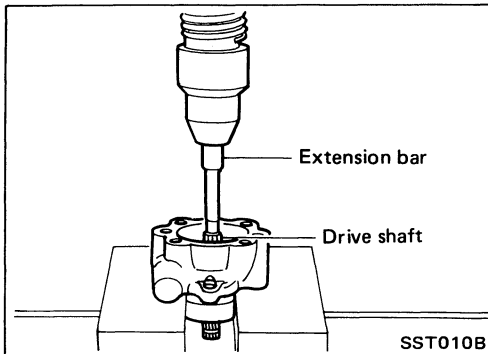

- Remove snap ring, then draw pulley shaft out.
Be careful not to drop pulley shaft.

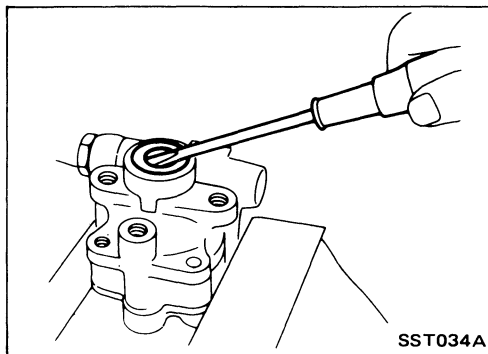

- Remove oil seal.
Be careful not to damage front housing.

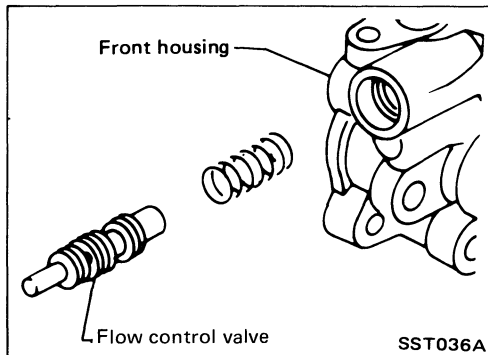

- Remove connector.
Be careful not to drop flow control valve.

Inspection

PULLEY AND PULLEY SHAFT

- If pulley is cracked or deformed, replace it.
- If an oil leak is found around pulley shaft oil seal, replace the seal.
- If serration of pulley or pulley shaft is deformed or worn, replace it.

POWER STEERING OIL PUMP

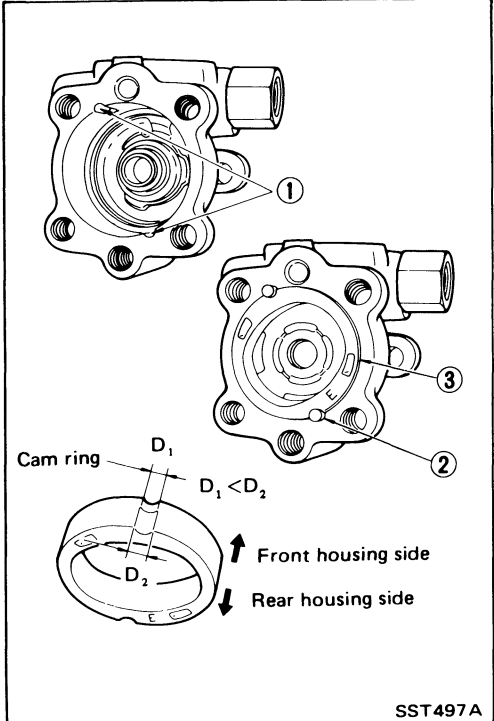
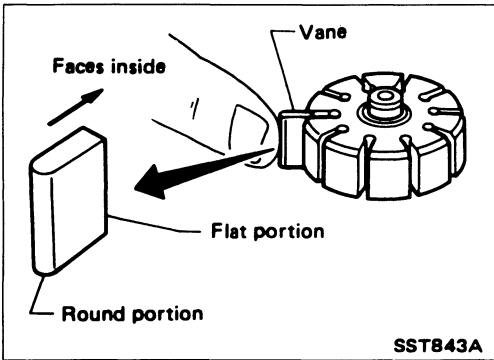
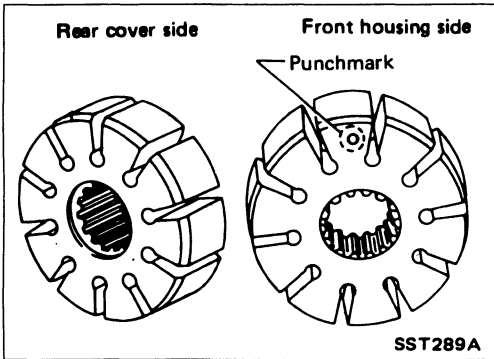
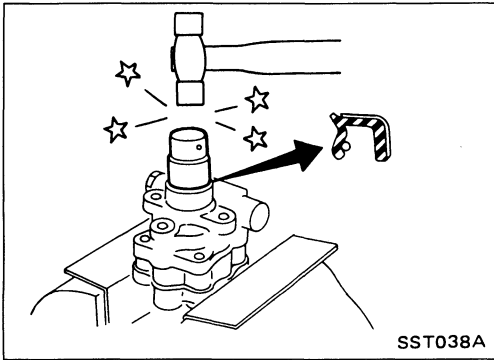

Assembly

Assemble oil pump, noting the following instructions.

- Make sure O-rings and oil seal are properly installed.
- Always install new O-rings and oil seal.

Be careful of oil seal direction.

- Cam ring, rotor and vanes must be replaced as a set if necessary.
- Coat each part with A.T.F. when assembling.

- Pay attention to the direction of rotor.

- When assembling vanes to rotor, rounded surfaces of vanes must face cam ring side.

- Insert pin ② into pin groove ① of front housing and front side plate. Then install cam ring ③ as shown at left.

SUPER HICAS SYSTEM

HICAS Component Parts Location

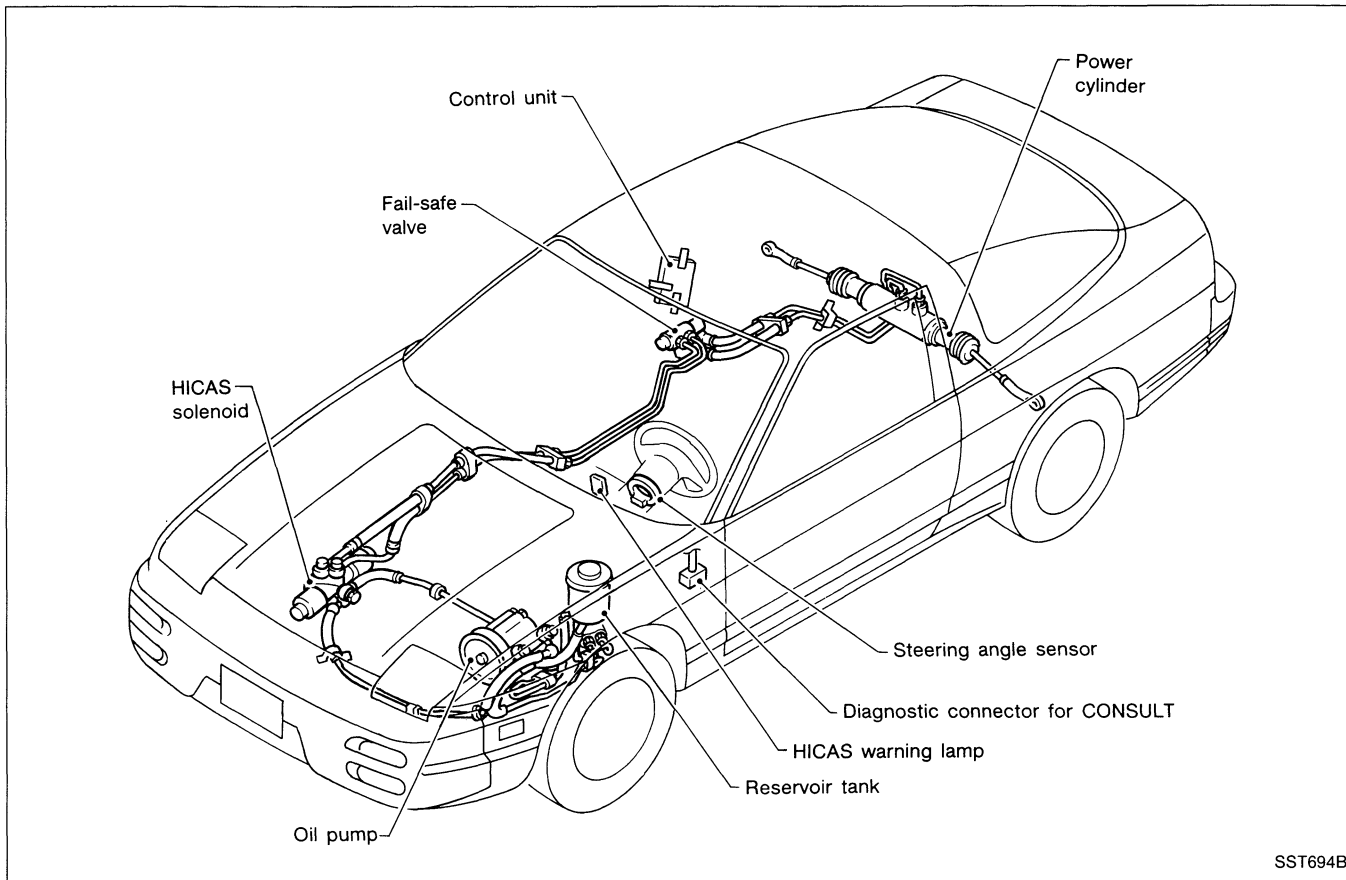

System Diagram

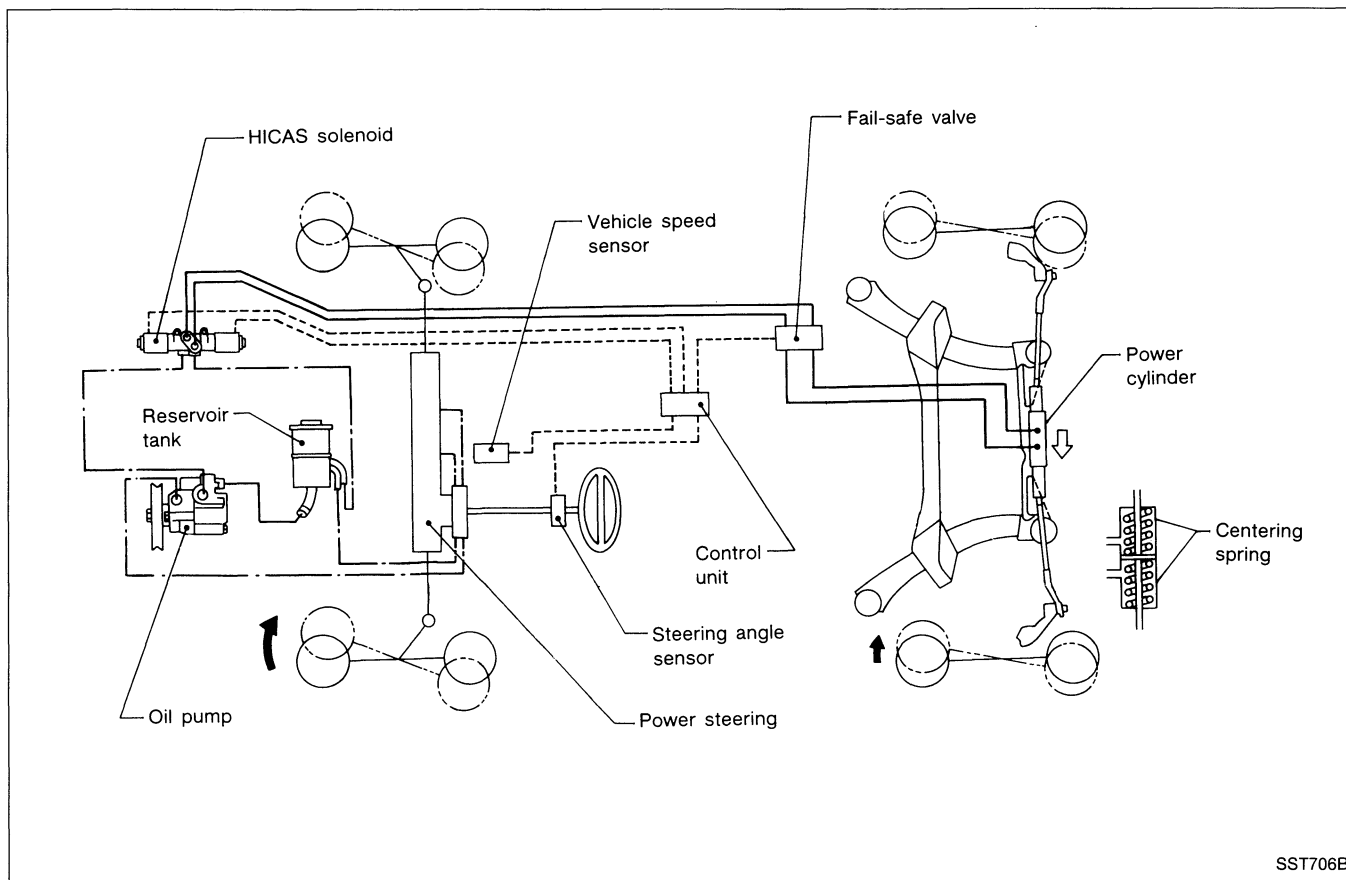

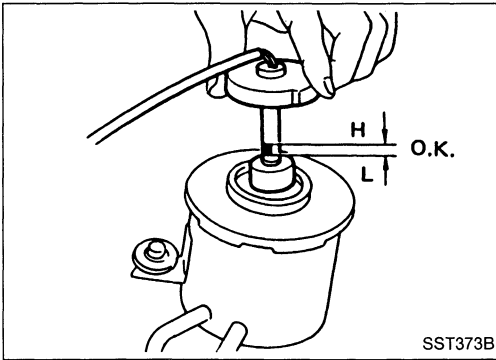

Checking Fluid Level

Maintain the fluid level so that the lower surface of the float is maintained between the "L" and "H" marks on the gauge rod. The fluid level should be checked when the engine is stopped and the fluid temperature is normal.

CAUTION:

- Do not overfill.
- Recommended fluid is Automatic Transmission Fluid "Dexron™" type.

Checking Fluid Leakage

Check lines for proper attachment, leaks, cracks, damage, loose connections, chafing and deterioration. Fluid leakage should be checked for when the oil temperature is normal with the engine idling.

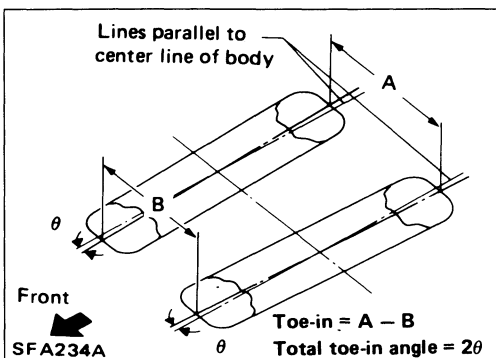
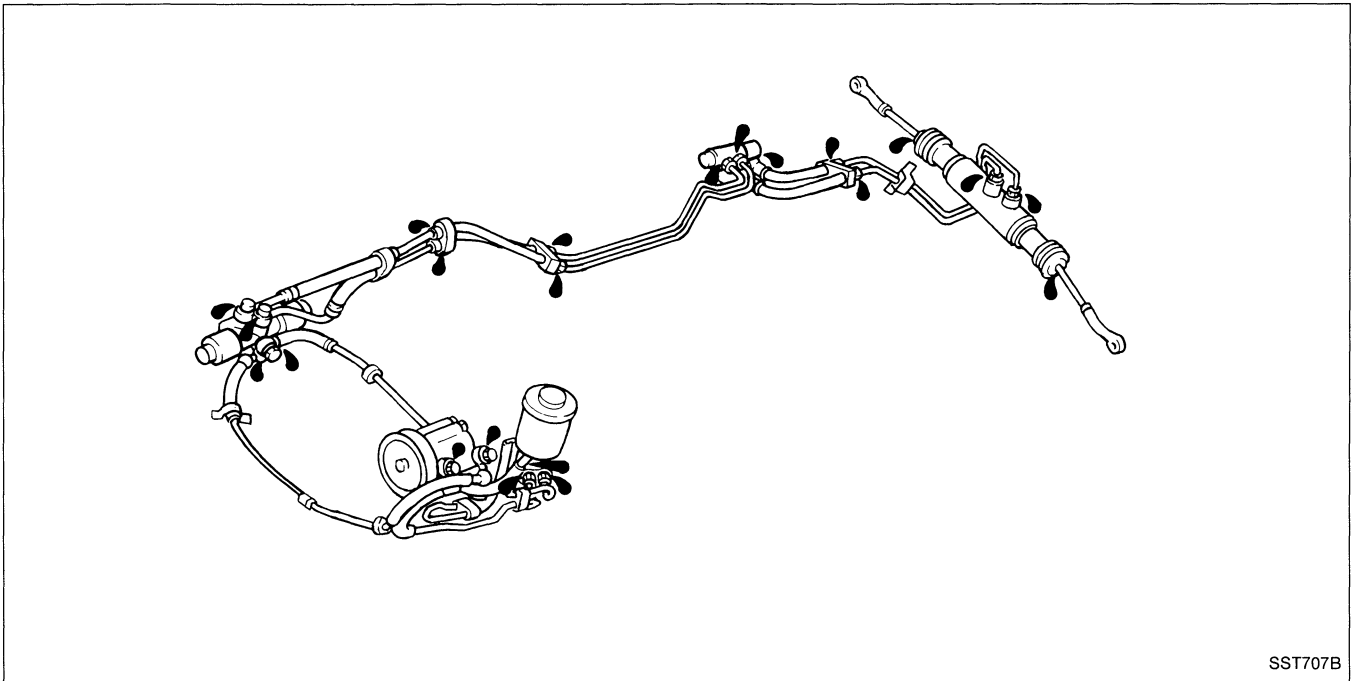

Measuring Rear Toe-in

Measure distance "A" and "B" at the same height as hub center.

Toe-in:

A - B
0 - 4 mm (0 - 0.16 in)

2θ (Total toe-in angle)
0° - 23°

Refer to "SUPER HICAS" in RA section.

Inspection of HICAS System Operation

CAUTION:

Ensure that shift lever is set to “P” (A/T model) or “Neutral” (M/T model) before checking HICAS system operation.

When CONSULT is used: 

1. Have a helper sit in the driver’s compartment and raise vehicle.
(Use a two-pole lift or a center pole lift so that the four wheels are free to rotate.)
2. Connect CONSULT unit to diagnostic connector and start engine.
3. Touch “START” on CONSULT display.
4. Touch “HICAS”, “ACTIVE TEST” and “SIMULATED DRIVE” in that order.

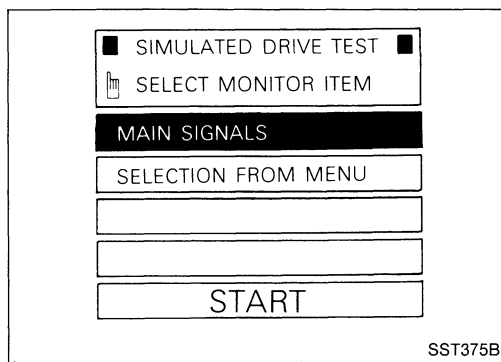

5. Touch “START” when MAIN SIGNALS display is reversed.

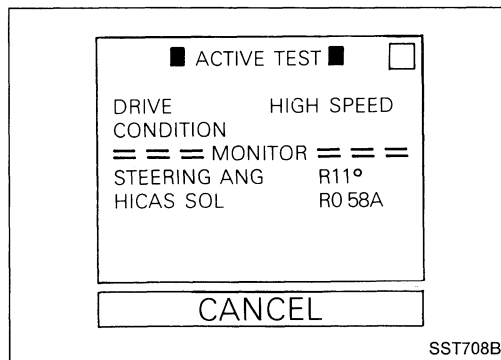

6. Touch “START”.

After simulated drive condition has continued for 5 minutes, it will automatically cancel and CONSULT unit will then show “TEST IS INTERRUPTED TO AVOID OIL TEMP. RISE” display. To cancel this mode during self-diagnosis, simply touch “CANCEL”.

Inspection of HICAS System Operation (Cont'd)

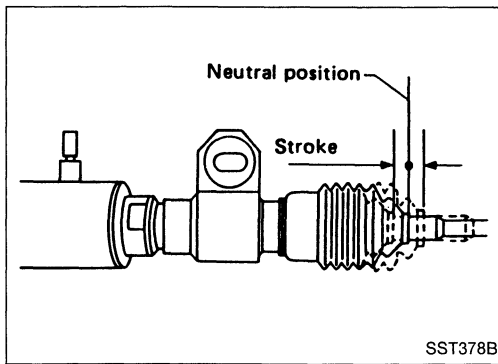

- Operate engine at speeds greater than 2,000 rpm, and turn steering wheel 180° in one direction from the neutral position. Measure extension value of one power cylinder rod and retraction value of the other. Then, turn steering wheel 180° in the other direction from the neutral position, and measure extension value of one cylinder rod and retraction value of the other. Determine strokes of respective power cylinders by adding (measured) extension and retraction values.

Measure rod strokes in as short a period of time as possible.

Specifications:

When turned to the right

3 mm (0.12 in)

When turned to the left

3 mm (0.12 in)

Total stroke

6 mm (0.24 in)

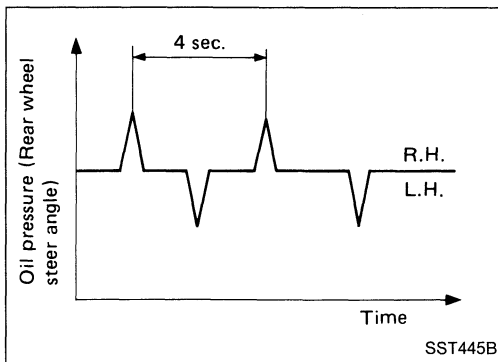

When CONSULT is not used:



- Have a helper sit in the driver's compartment and raise vehicle.
(Use a 2-pole lift or a center pole lift so that the four wheels are free to rotate.)
- Set HICAS system in self-diagnosis mode.
 - Turn ignition switch "OFF".
 - Set shift lever to "P" or "N" position (A/T model), or "Neutral" position (M/T model).
 - Turn ignition switch "ON".
 - Immediately start engine.
 - Turn steering wheel from left to right (at least 20° from the neutral position) 5 times or more, then depress foot brake pedal at least 5 times all within 10 seconds after ignition switch has been turned "ON".
- Set steering wheel to a point approximately 10° from the neutral position and check to ensure that rear wheels turn to the left and right alternately.

SUPER HICAS SYSTEM — On-vehicle Inspection

Inspection of HICAS System Operation (Cont'd)

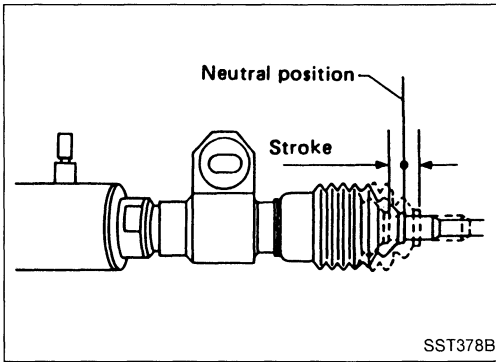

4. Operate engine at speeds greater than 2,000 rpm, and turn steering wheel 180° in one direction from the neutral position. Measure extension value of one power cylinder rod and retraction value of the other. Then, turn steering wheel 180° in the other direction from the neutral position, and measure extension value of one cylinder rod and retraction value of the other. Determine strokes of respective power cylinder rods by adding (measured) extension and retraction values.

Measure rod strokes in as short a period of time as possible.

Specifications:

When turned to the right

3 mm (0.12 in)

When turned to the left

3 mm (0.12 in)

Total stroke

6 mm (0.24 in)

Do not depress foot brake pedal during operation check, otherwise the operation will be stopped.

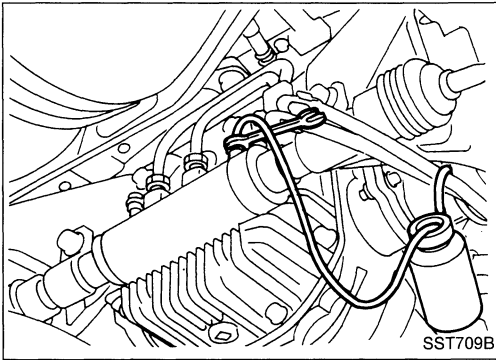

Bleeding Hydraulic System

Before bleeding air from the HICAS system, be sure to bleed air from the power steering system.

Refer to "SUPER HICAS SYSTEM — Repair of Component Parts".

Power Cylinder

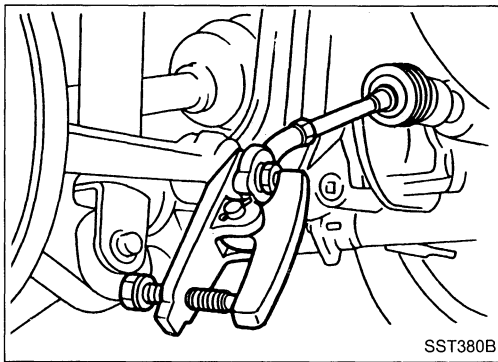
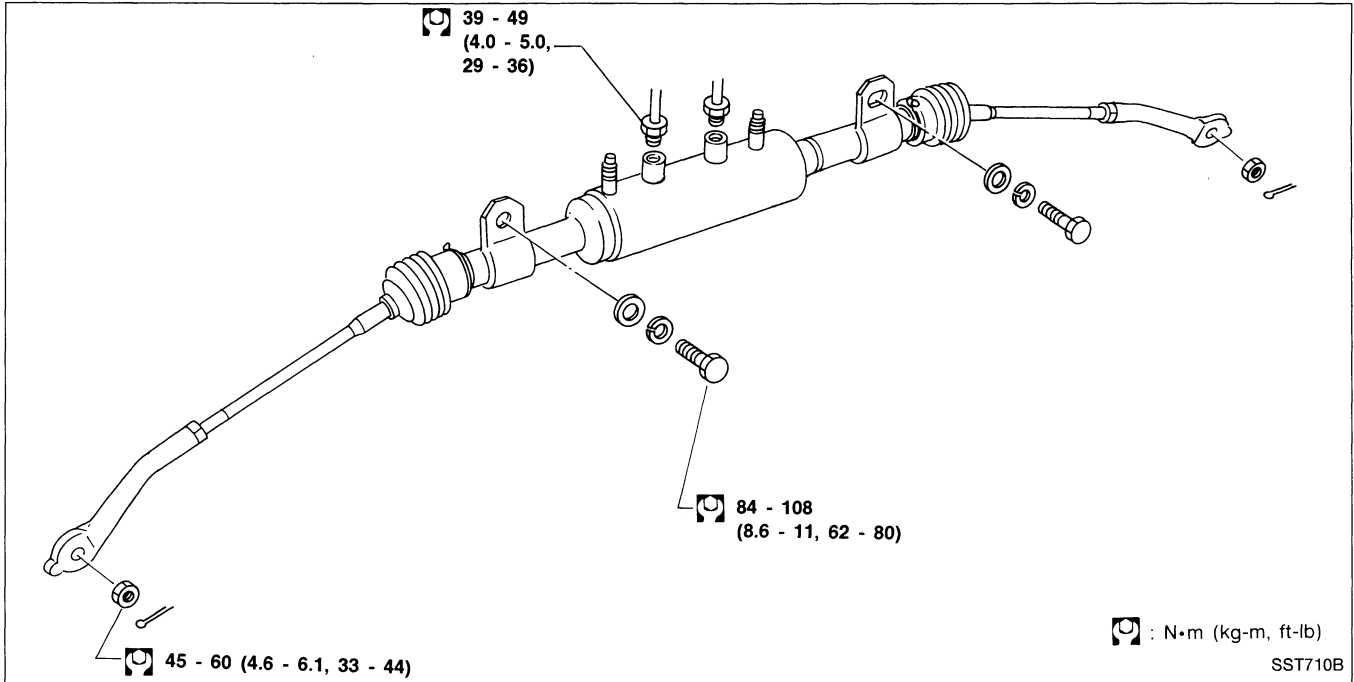

REMOVAL

- Detach power cylinder lower links from axle housing sockets with Tool.

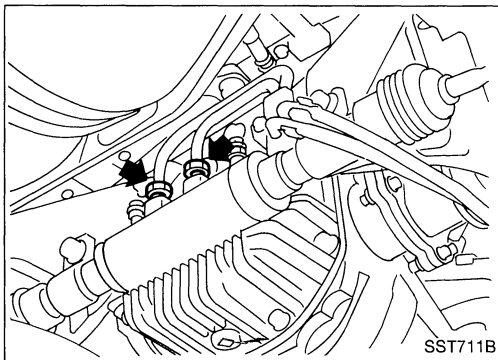

- Disconnect oil pipes from power cylinders and remove power cylinders.

CAUTION:

Plug openings of oil pipes and power cylinders to prevent entry of foreign particles after removal.

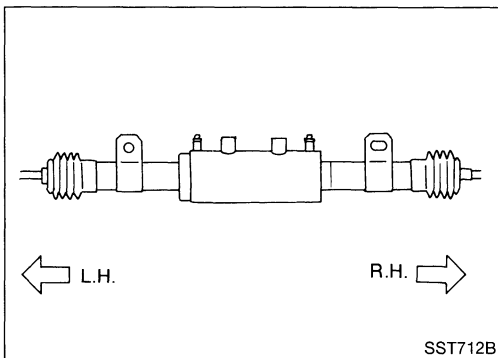

INSTALLATION

1. Before installing power cylinder on suspension member, wipe power cylinder bracket and mating surface of suspension member. Using the left side of the bracket as a reference point, locate the right side (oblong hole side) and install power cylinder.

CAUTION:

- a. To prevent entry of foreign particles, clean oil pipes and connectors using dry compressed air.
- b. Ensure that your hands are clean and free from foreign particles when connecting oil pipes.

Power Cylinder (Cont'd)

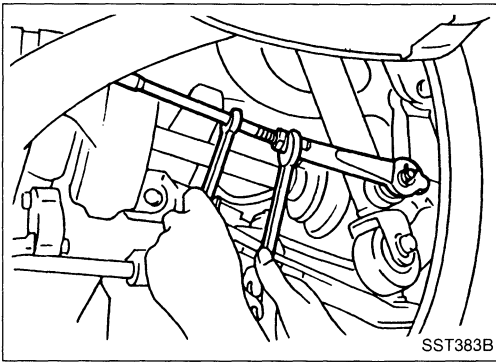

2. Install power cylinders and oil pipes.
3. After installing lower link assemblies, check toe-in to ensure that it is within specifications. If it is not within specifications, perform proper adjustments. Refer to "SUPER HICAS" in section RA.

BLEEDING HYDRAULIC SYSTEM

Before bleeding air from the HICAS system, be sure to bleed air from the power steering system.

CAUTION:

Ensure that shift lever is set to "P" (A/T model) or "Neutral" (M/T model).

When CONSULT is used: 

1. Connect CONSULT unit to diagnostic connector on body side.
2. Have a helper sit in the driver's compartment and raise vehicle.

Use a two-pole lift or a center pole lift so that the four wheels are free to rotate.

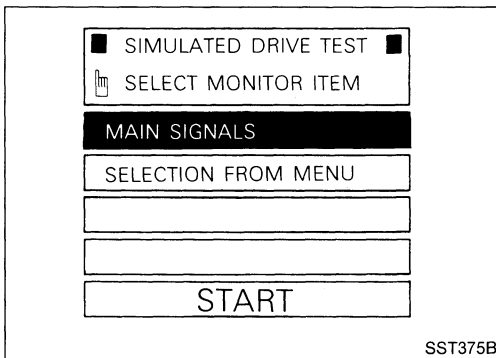

3. Start engine.
4. Touch "START" on CONSULT display. (Display will then change.)
5. Touch "HICAS", "ACTIVE TEST", "SIMULATED DRIVE" and "START" in that order.

Before touching "START", ensure that MAIN SIGNALS display is reversed.

6. Touch "START".

Power Cylinder (Cont'd)

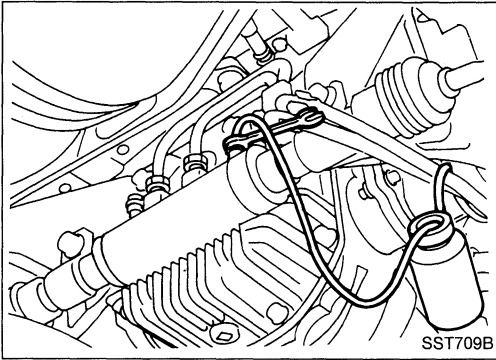

7. Operate engine at speeds greater than 2,000 rpm, and turn steering wheel 180° to the right from the neutral position. Loosen right power cylinder bleeder valve to bleed air, then retighten. Return steering wheel to the neutral position.
8. Operate engine at speeds greater than 2,000 rpm, and turn steering wheel 180° to the left from the neutral position. Loosen left power cylinder bleeder valve to bleed air, then retighten. Return steering wheel to the neutral position.
9. Repeat steps 7. and 8. until there are no air bubbles in fluid. While bleeding air from power cylinders, never allow fluid level to drop below inlet port of reservoir tank (by adding fluid as required).
10. Touch "CANCEL" on CONSULT display and turn ignition switch OFF.

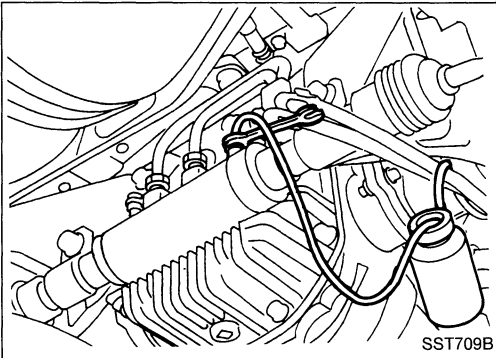
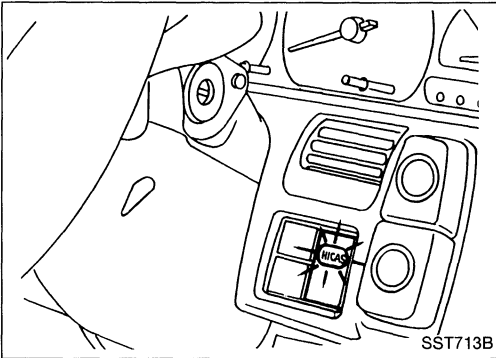

When CONSULT is not used:



1. Have a helper sit in the driver's compartment, and raise vehicle.

Use a two-pole lift or center pole lift so that the four wheels are free to rotate.

2. Set HICAS system in self-diagnosis mode.
 - (1) Turn ignition switch "OFF".
 - (2) Set shift lever to "P" or "N" position (A/T model), or "Neutral" position (M/T model).
 - (3) Turn ignition switch "ON".
 - (4) Immediately start engine.
 - (5) Turn steering wheel from left to right (at least 20° from the neutral position) 5 times or more, then depress foot brake pedal at least 5 times all within 10 seconds after ignition switch has been turned "ON".
3. Set steering wheel within 10° from the neutral position. Ensure that rear wheels turn to the left and right alternately.
4. Operate engine at idling speed, and turn steering wheel 180° to the right from the neutral position. Loosen right power cylinder bleeder valve to bleed air, then retighten. Return steering wheel to the neutral position.
5. Operate engine at idling speed, and turn steering wheel 180° to the left from the neutral position. Loosen left power cylinder bleeder valve to bleed air, then retighten. Return steering wheel to the neutral position.
6. Repeat steps 4. and 5. above until there are no air bubbles in fluid. While bleeding air from power cylinders, never allow fluid level to drop below inlet port of reservoir tank (by adding fluid as required).
7. Turn ignition switch OFF to complete self-diagnosis operation.

SUPER HICAS SYSTEM — Repair of Component Parts

Power Cylinder (Cont'd)

DISASSEMBLY AND ASSEMBLY

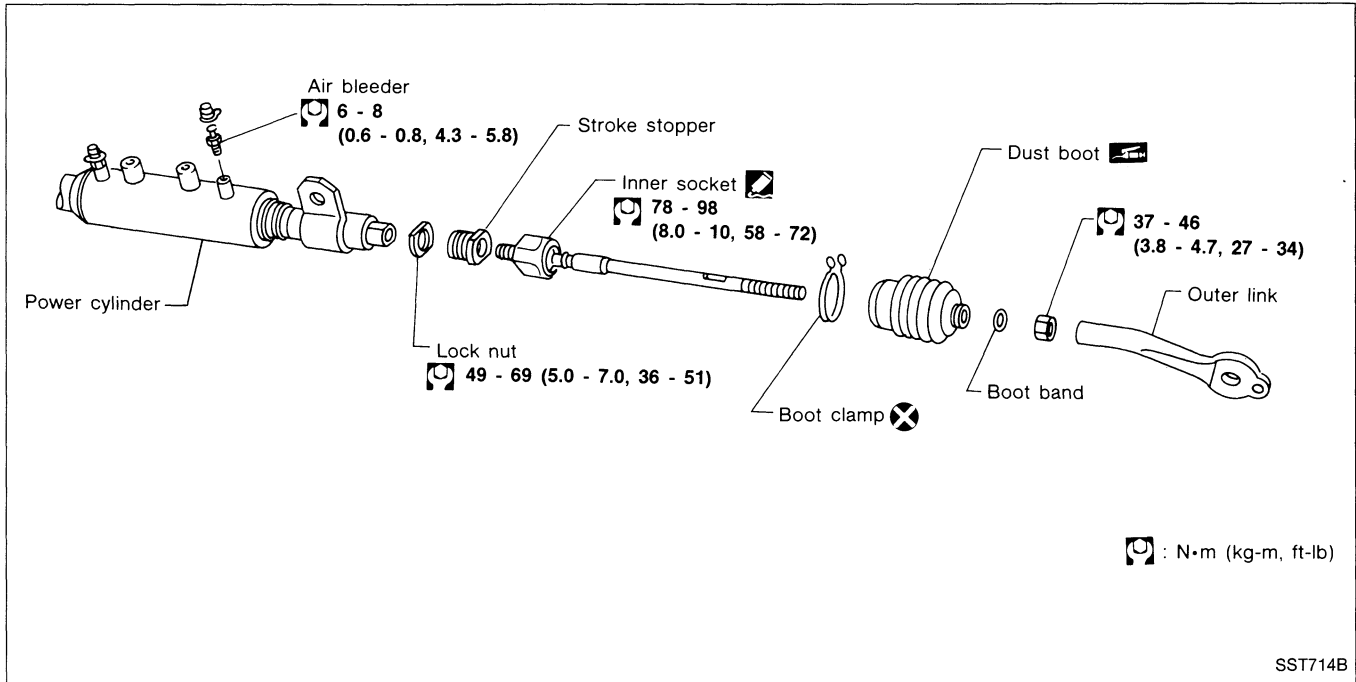

Power cylinder assembly cannot be disassembled. When it is malfunctioning, replace power cylinder as an assembly.

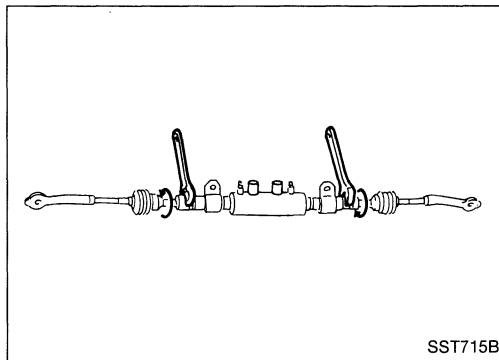

DISASSEMBLY

1. Remove clamps from left and right dust boots, and move dust boots toward outer links.
2. Attach wrenches to left and right ball joint sockets, and turn in directions that loosen lower links. Remove one of loosened lower link assemblies.

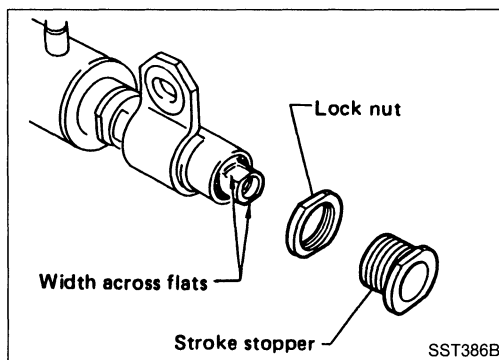

3. Loosen stroke stopper lock nut from which lower link assembly was removed, and remove stroke stopper.

SUPER HICAS SYSTEM — Repair of Component Parts

Power Cylinder (Cont'd)

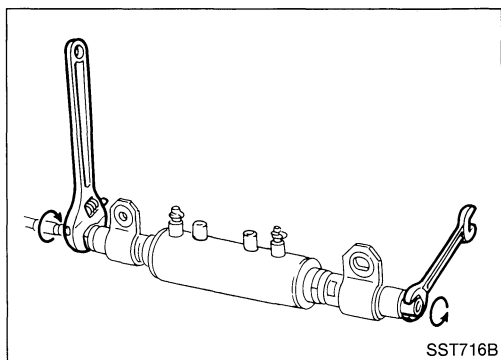

- While attaching a wrench to “width across flats” section of rod end from which stroke stopper was removed, remove the other lower link assembly.

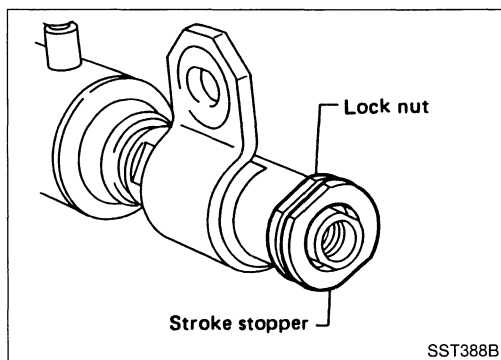

ASSEMBLY

1. Install stroke stopper and lock nut on the lower link assembly to be assembled.

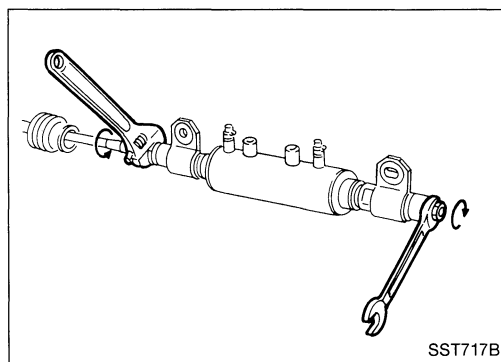

2. Apply Loctite to inner ball joint thread. Attach a wrench to “width across flats” section of piston rod (located on the other side) to prevent rod from turning. Install lower link assembly.

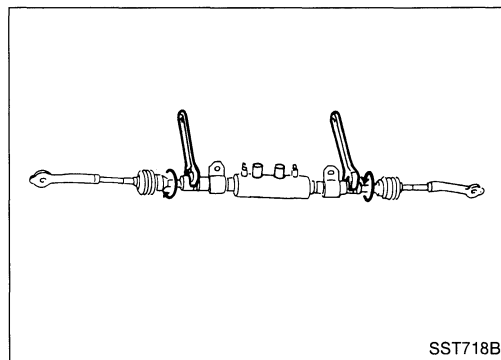

3. After installing stroke stopper and lock nut on the other lower link assembly, install lower link assembly. Attach a wrench to inner ball joint (to prevent it from turning), tighten inner socket to specified torque.

Inner socket:

: 78 - 98 N·m (8 - 10 kg-m, 58 - 72 ft-lb)

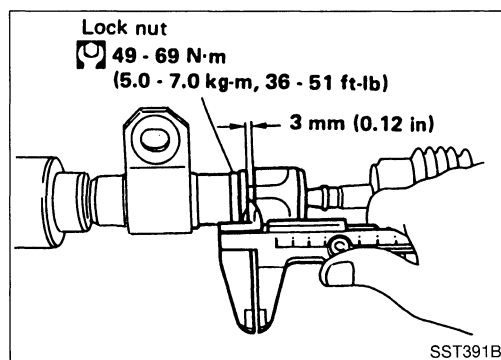

4. If stroke stopper was moved during removal of lower link, adjust it after installation, as described below:

- (1) Loosen lock nut which secures stroke stopper.
- (2) Turn stroke stopper until clearance between inner ball joint and stroke stopper is 3 mm (0.12 in) on each side.
- (3) Tighten lock nut securely.

Lock nut:

: 49 - 69 N·m (5.0 - 7.0 kg-m, 36 - 51 ft-lb)

- (4) Recheck clearance between inner ball joint and stroke stopper on each side.

SUPER HICAS SYSTEM — Repair of Component Parts

Power Cylinder (Cont'd)

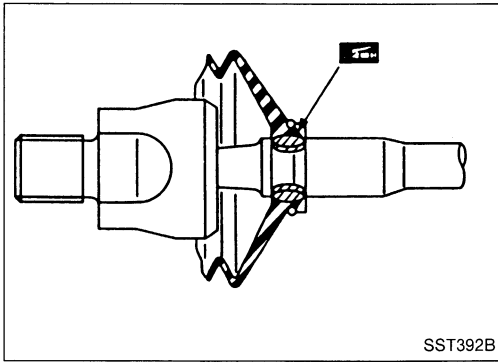

5. Install dust boot using new boot band and clamp.
 - Apply a coat of grease to grooves at boot location.

Oil Pump

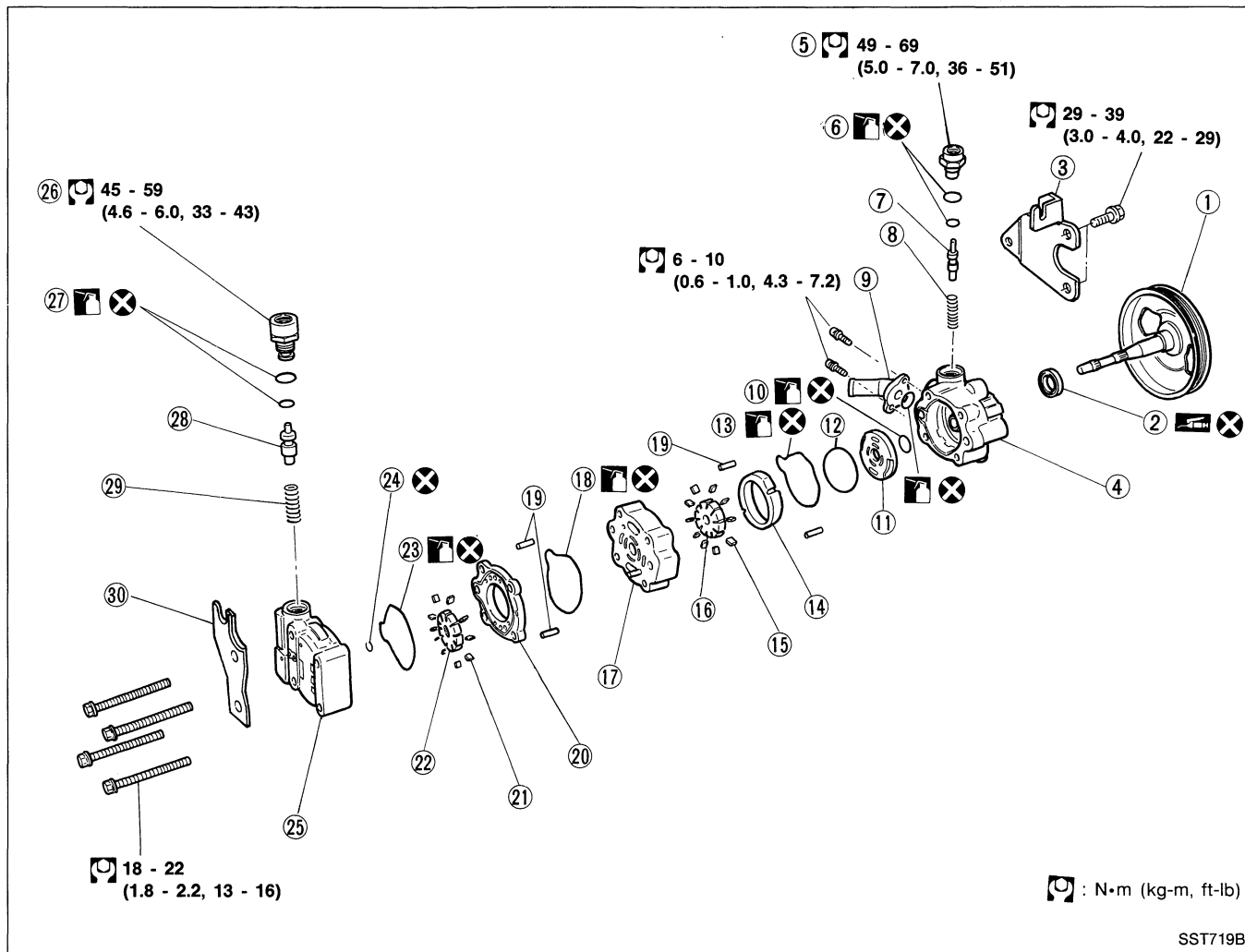

- | | | |
|----------------------|------------------|----------------------|
| ① Pulley | ⑪ Side plate | ⑳ Vane |
| ② Oil seal | ⑫ O-ring | ㉑ Rotor |
| ③ Bracket | ⑬ O-ring | ㉒ O-ring |
| ④ Front housing | ⑭ Cam | ㉓ O-ring |
| ⑤ Outlet connector | ⑮ Vane | ㉔ Snap ring |
| ⑥ O-ring | ⑯ Rotor | ㉕ Rear housing |
| ⑦ Flow control valve | ⑰ Center housing | ㉖ Outlet connector |
| ⑧ Spring | ⑱ O-ring | ㉗ O-ring |
| ⑨ Inlet connector | ㉑ Pin | ㉘ Flow control valve |
| ⑩ O-ring | ㉒ Cam | ㉙ Spring |
| | | ㉚ Bracket |

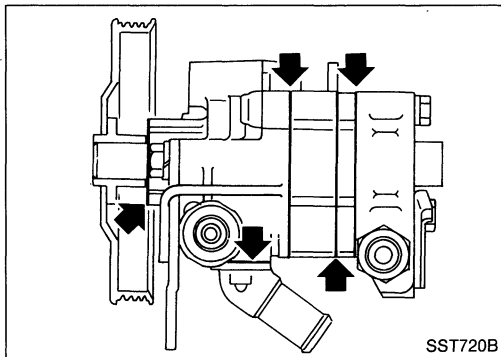

PRE-DISASSEMBLY INSPECTION

Disassemble the power steering oil pump only if the following items are found.

- Oil leak from any point shown in the figure.
- Deformed or damaged pulley.
- Poor performance

Disassembly

CAUTION:

- Parts which can be disassembled are strictly limited. Never disassemble parts other than those specified.
- Disassemble in as clean a place as possible.
- Clean your hands before disassembly.
- Do not use rags; use nylon cloths or paper towels.
- Follow the procedures and cautions in the Service Manual.
- When disassembling and reassembling, do not let foreign matter enter or contact the parts.

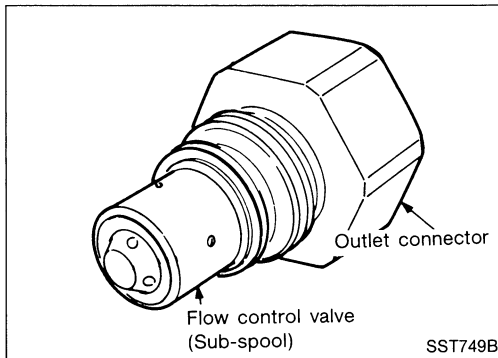

- Remove connector.
- The discharge connector incorporates a flow control valve (sub-spool). Pay attention so as not to drop connector, as this may cause deformation.
- Do not disassemble discharge connector and flow control valve.

Be careful not to confuse main side with sub side.

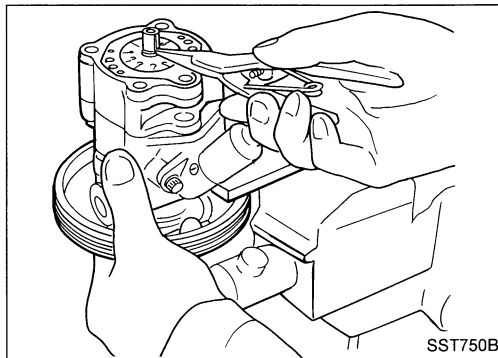

- Remove snap ring, then remove shaft with pulley.

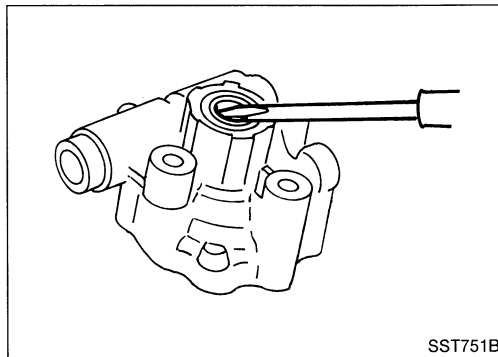

- Remove oil seal.

Be careful not to damage front housing.

Inspection

If any of the following parts are scratched or damaged, replace oil pump assembly.

- Mating surfaces of front housing and cam center housing
- Mating surfaces of rear housing and cam center housing
- Front housing oil seal
- Flow control valve
- Drive shaft
- Rotor

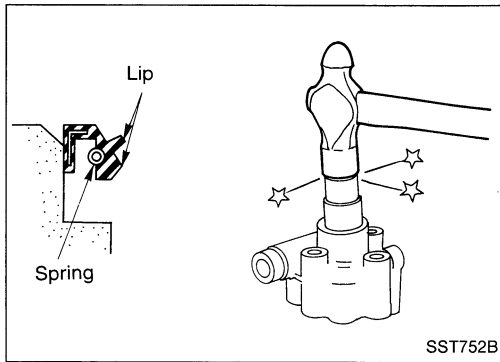

Assembly

Assemble oil pump, noting the following instructions.

- Make sure O-rings and oil seal are properly installed.
- Always install new O-rings and oil seal.

Be careful of oil seal direction.

- Cam ring, rotor and vanes must be replaced as a set if necessary.
- Coat each part with A.T.F. when assembling.

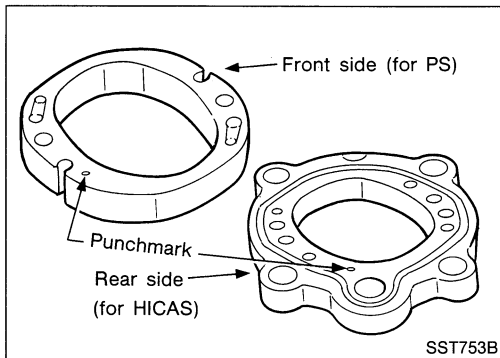

- The cam ring shape is different between front side cam (for PS) and rear side cam (for HICAS). Install front side cam ring with punchmark set on the pulley side, and install rear side cam ring with punchmark set on rear housing side.

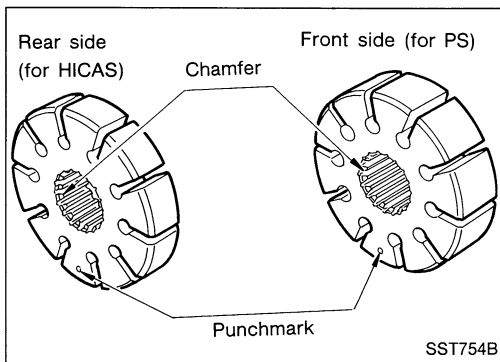

- Pay attention to rotor direction.

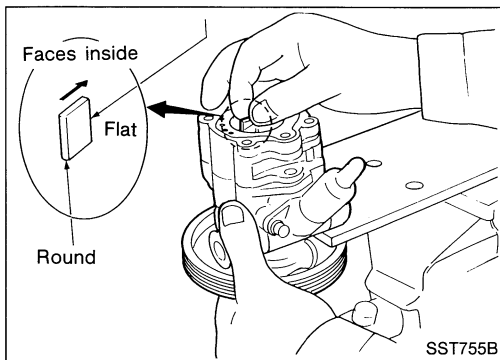

- When assembling vanes to rotor, rounded surfaces of vanes must face cam ring side.

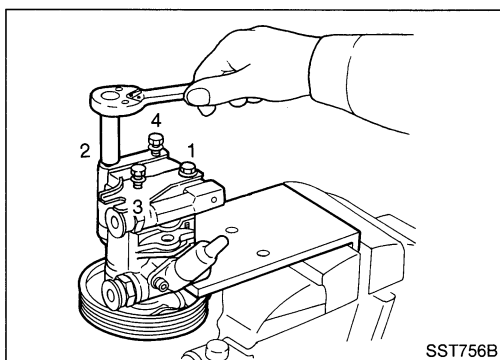

- Tighten rear housing bolts in diagonal sequence. First tighten bolts to about a half of the standard tightening torque, then tighten them again to the standard torque.

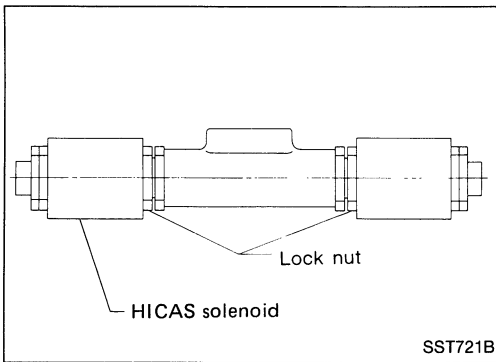

HICAS Solenoid and Fail-safe Valve

- Do not loosen lock nut which secures solenoid since HICAS solenoid and fail-safe valves are of types that should not be disassembled.
- If any part is found to be malfunctioning, always replace as a valve assembly.

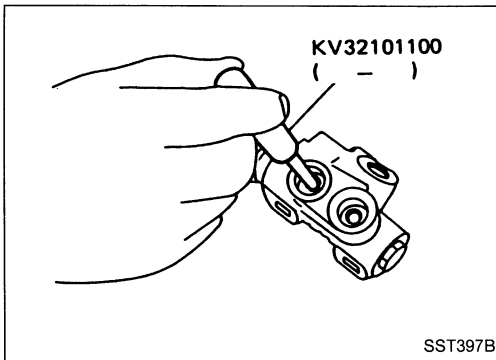
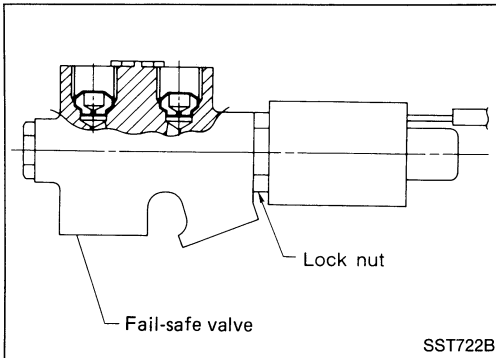

- Whenever tubes are disconnected from fail-safe valve check tube seat for scratches or damage. A scratched or cracked tube seat may cause oil leakage. Replace it using pin punch.

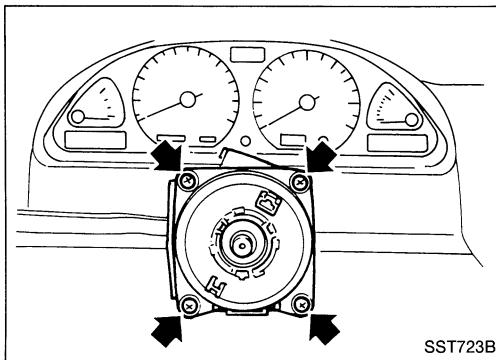

Steering Angle Sensor

- Ensure that steering angle sensor bolts are secure and tight.
- If any part of steering angle sensor is malfunctioning, replace steering angle sensor assembly.

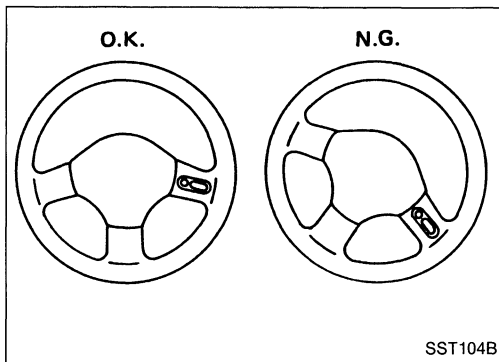

Steering Wheel

CHECKING NEUTRAL POSITION

- Check that the steering wheel is in the neutral position when driving straight ahead at a speed of at least 70 km/h (43 MPH).
- If it is not in the neutral position, remove the steering wheel and reinstall it correctly.
- If the neutral position is between two serrated teeth, loosen tie-rod lock nut and move tie-rod in the opposite direction by the same amount on both left and right sides to compensate for error in the neutral position.

Contents

How to Perform Trouble Diagnoses for Quick and Accurate Repair	ST-46
Symptom Chart	ST-47
Preliminary Check	ST-48
Component Parts and Harness Connector Locations	ST-51
Circuit Diagram for Quick Pinpoint Check	ST-52
Wiring Diagram	ST-53
Self-diagnosis	ST-54
Diagnostic Procedure 1	ST-60
Diagnostic Procedure 2	ST-61
Diagnostic Procedure 3	ST-63
Diagnostic Procedure 4	ST-64
Diagnostic Procedure 5	ST-70
Diagnostic Procedure 6	ST-72
Diagnostic Procedure 7	ST-73
Diagnostic Procedure 8	ST-74
Diagnostic Procedure 9	ST-75
Diagnostic Procedure 10	ST-77
Diagnostic Procedure 11	ST-78
Control Unit Inspection Table	ST-79

How to Perform Trouble Diagnoses for Quick and Accurate Repair

WORK FLOW

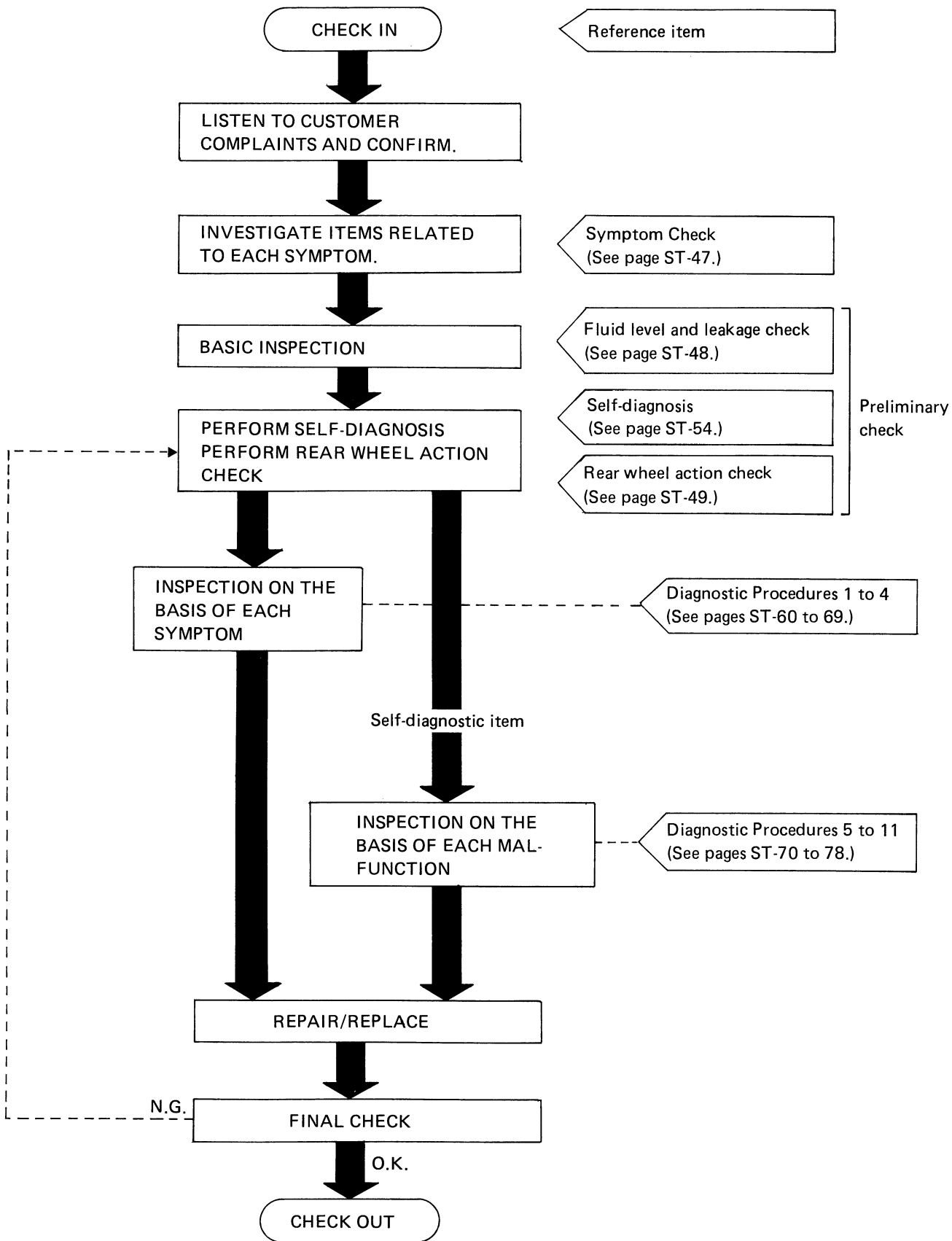

SUPER HICAS SYSTEM — Trouble Diagnoses

Symptom Chart

DIAGNOSTIC TABLE

PROCEDURE			Preliminary Check			Diagnostic Procedure										
REFERENCE PAGE (ST-)			48	48	49	60	61	63	64	70	72	73	74	75	77	78
SYMPTOM			Preliminary check 1	Preliminary check 2	Preliminary check 3	Diagnostic procedure 1	Diagnostic procedure 2	Diagnostic procedure 3	Diagnostic procedure 4	Diagnostic procedure 5	Diagnostic procedure 6	Diagnostic procedure 7	Diagnostic procedure 8	Diagnostic procedure 9	Diagnostic procedure 10	Diagnostic procedure 11
No warning lamp comes on when ignition switch is turned "ON"			<input type="checkbox"/>			<input type="checkbox"/>										
Warning lamp comes on when engine is running			<input type="checkbox"/>	<input type="checkbox"/>	<input type="checkbox"/>		<input type="checkbox"/>		<input type="checkbox"/>	<input type="checkbox"/>	<input type="checkbox"/>	<input type="checkbox"/>	<input type="checkbox"/>	<input type="checkbox"/>	<input type="checkbox"/>	<input type="checkbox"/>
Abnormal noise is emitted.			<input type="checkbox"/>	<input type="checkbox"/>	<input type="checkbox"/>			<input type="checkbox"/>								
Vehicle behavior is unusual (due to malfunctioning HICAS system.)			<input type="checkbox"/>	<input type="checkbox"/>	<input type="checkbox"/>				<input type="checkbox"/>	<input type="checkbox"/>	<input type="checkbox"/>	<input type="checkbox"/>	<input type="checkbox"/>	<input type="checkbox"/>	<input type="checkbox"/>	<input type="checkbox"/>
Self-diagnostic results	System is not set in self-diagnosis mode.									<input type="checkbox"/>						
	Self-diagnosis code No.	Diagnosed part	CONSULT indication													
	1	HICAS solenoid (RH) output is not present.	HICAS SOLENOID-R [ABNORMAL SIGNAL]								<input type="checkbox"/>					
	2	HICAS solenoid (LH) output is not present.	HICAS SOLENOID-L [ABNORMAL SIGNAL]								<input type="checkbox"/>					
	3	Fail-safe valve output is not present.	FAIL-SAFE VALVE [ABNORMAL SIGNAL]									<input type="checkbox"/>				
	4	(Constantly normal mode)	—													
	5	Vehicle speed signal is not present.	VEHICLE SPEED SENSOR [NO SIGNAL] (-a) CAR SPEED SENSOR [SIG-SUDDEN TURN] (-b)											<input type="checkbox"/>		
	6	Steering angle sensor input is not present.	STEERING ANGLE SEN [NO ANG SIGNAL] (-a) STEERING ANGLE SEN [NO NEUT SIGNAL] (-b)												<input type="checkbox"/>	
	7		STEERING ANGLE SEN [NEUT SIG-360° OFF] (-c) STEERING ANGLE SEN [NEUT SIG-30° ON] (-d)													
	8	Parking brake (AT) or clutch switch (MT) input is not present.	—													<input type="checkbox"/>
9	Inhibitor switch (AT) or neutral switch (MT) input is not present.	—														<input type="checkbox"/>

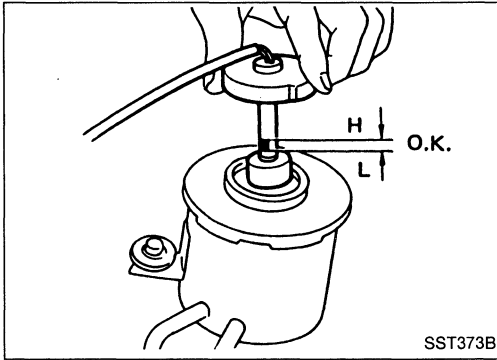

Preliminary Check

CHECK 1

Checking fluid level and fluid leakage

Refer to "SUPER HICAS SYSTEM — On-vehicle Inspection" on page ST-30.

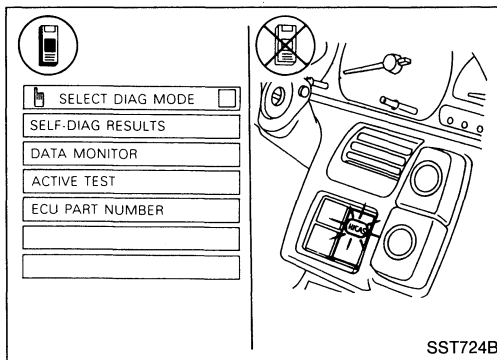
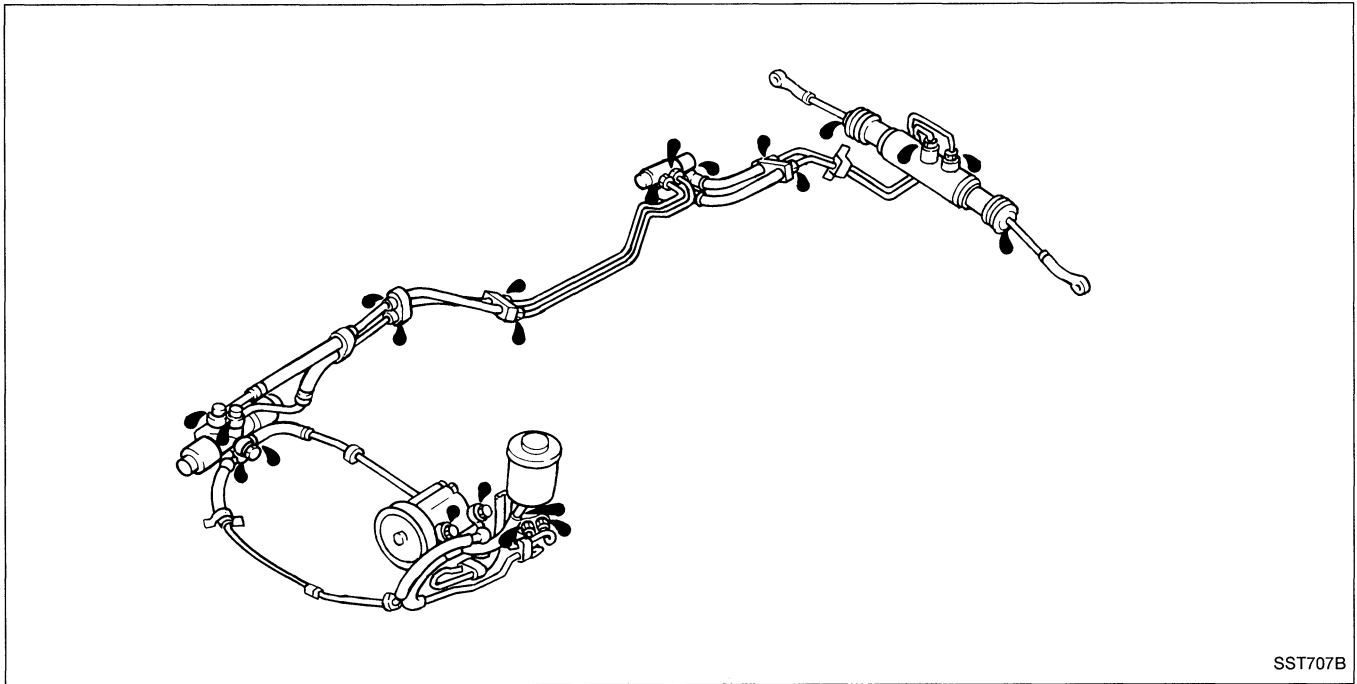

CHECK 2

Perform self-diagnosis.

Refer to "Self-diagnosis" on page ST-54.

Preliminary Check (Cont'd)

CHECK 3

Perform rear wheel action check.

When CONSULT is used:

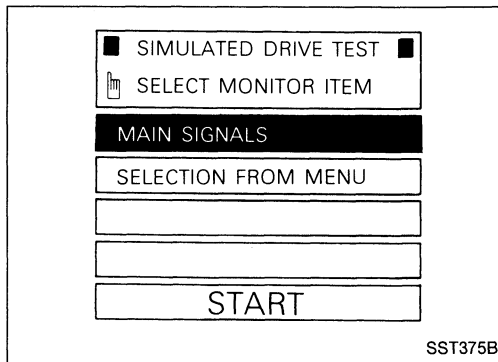

1. Have a helper sit in the driver's compartment, and raise vehicle.
(Use a two-pole lift or a center pole lift so that the four wheels are free to rotate.)
2. Connect CONSULT unit to diagnostic connector and start engine.
3. Touch "START" on CONSULT display.
4. Touch "HICAS", "ACTIVE TEST" and "SIMULATED DRIVE" in that order.
5. Touch "START" when "MAIN SIGNALS" display is reversed.

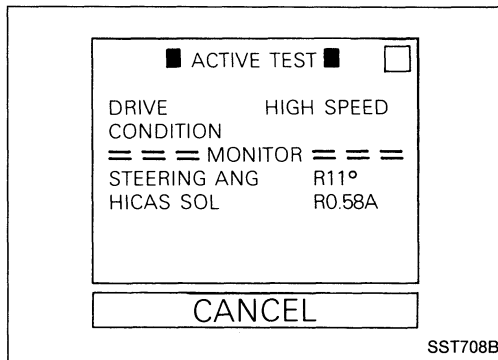

6. Touch "START."

After simulated drive condition has continued for 5 minutes, it will automatically cancel and CONSULT unit will then show "TEST IS INTERRUPTED TO AVOID OIL TEMP RISE" display. To cancel this mode during self-diagnosis, simply touch "CANCEL".

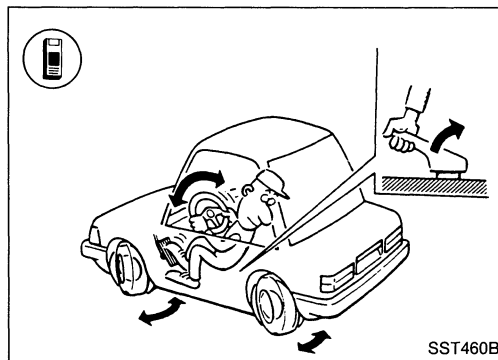

7. While running engine at speeds greater than 2,000 rpm, turn steering wheel 180° to the left and right from the neutral position. Ensure that rear wheels steer in response to rotation of steering wheel.

SUPER HICAS SYSTEM — Trouble Diagnoses

Preliminary Check (Cont'd)

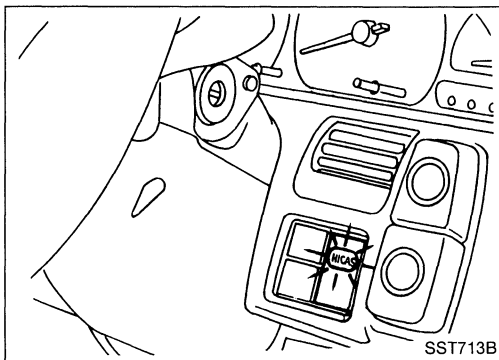

When CONSULT is not used:



1. Turn key switch "OFF".
2. Set HICAS system in self-diagnosis mode.
 - (1) Turn ignition switch "OFF".
 - (2) Set shift lever to "P" or "N" position (A/T model), or "Neutral" position (M/T model).
 - (3) Turn ignition switch "ON".
 - (4) Immediately start engine.
 - (5) Turn steering wheel from left to right (at least 20° from the neutral position) 5 times or more, then depress foot brake pedal at least 5 times all within 10 seconds after ignition switch has been turned "ON".
3. Set steering wheel to a point approximately 10° from the neutral position and check to ensure that rear wheels turn to the left and right alternately.

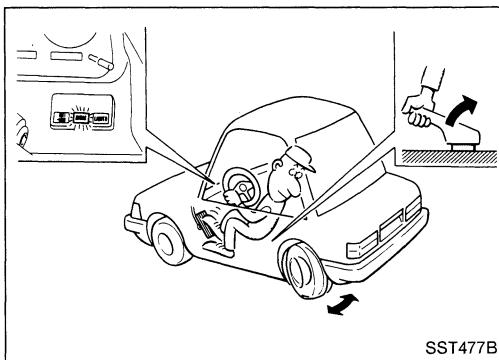

Component Parts and Harness Connector Location

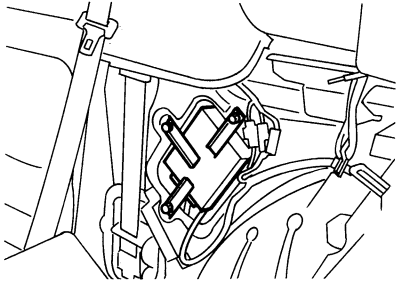

Control unit

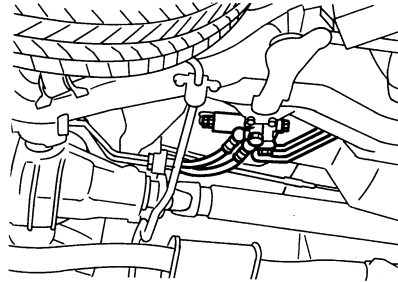

Fail-safe valve

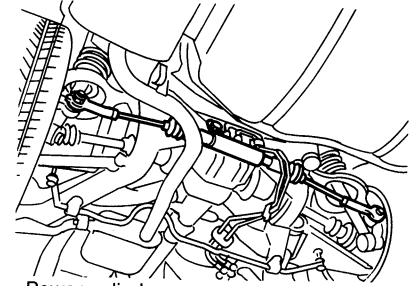

Power cylinder

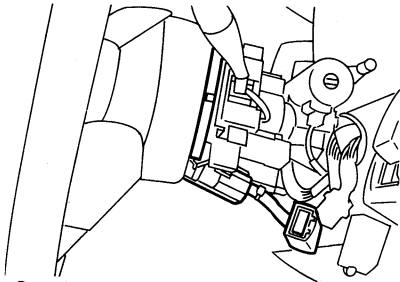

Steering angle sensor

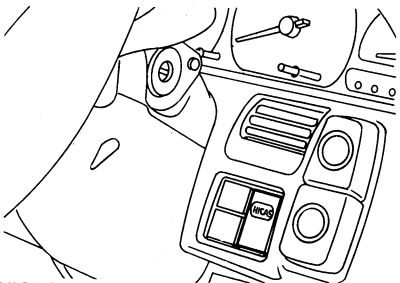

HICAS warning lamp

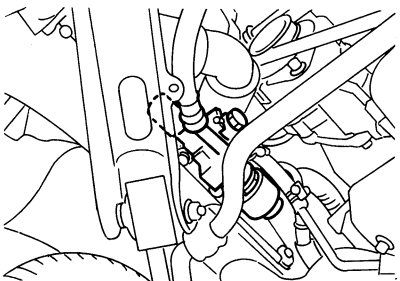

HICAS solenoid

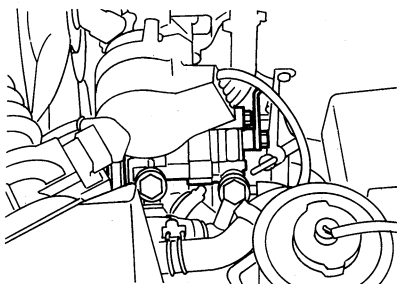

Oil pump

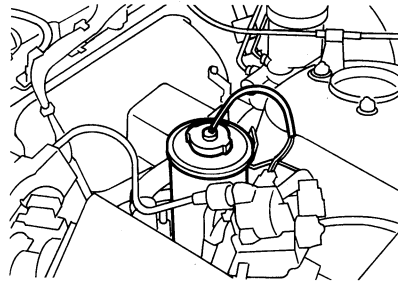

Reservoir tank

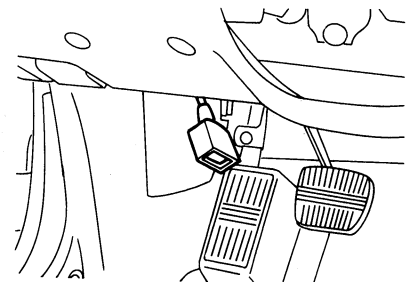

Diagnostic connector for CONSULT

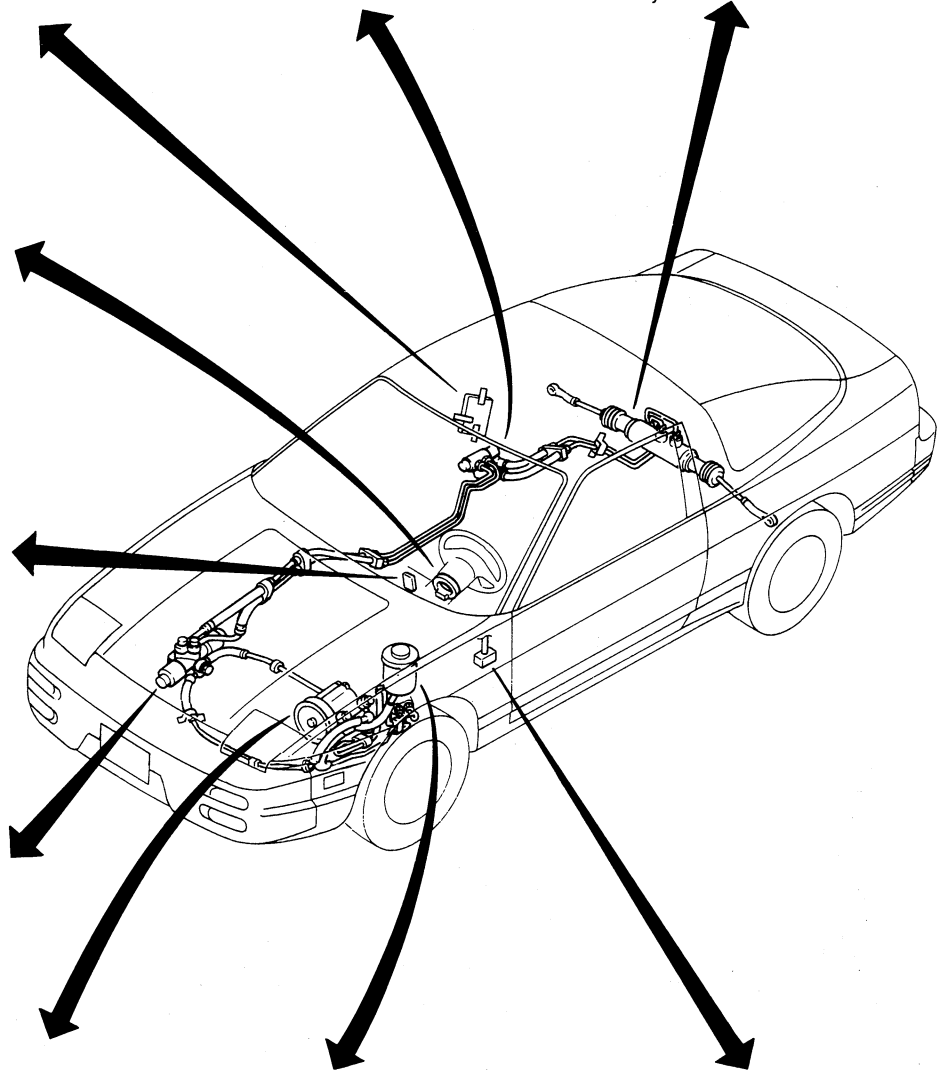

Circuit Diagram for Quick Pinpoint Check

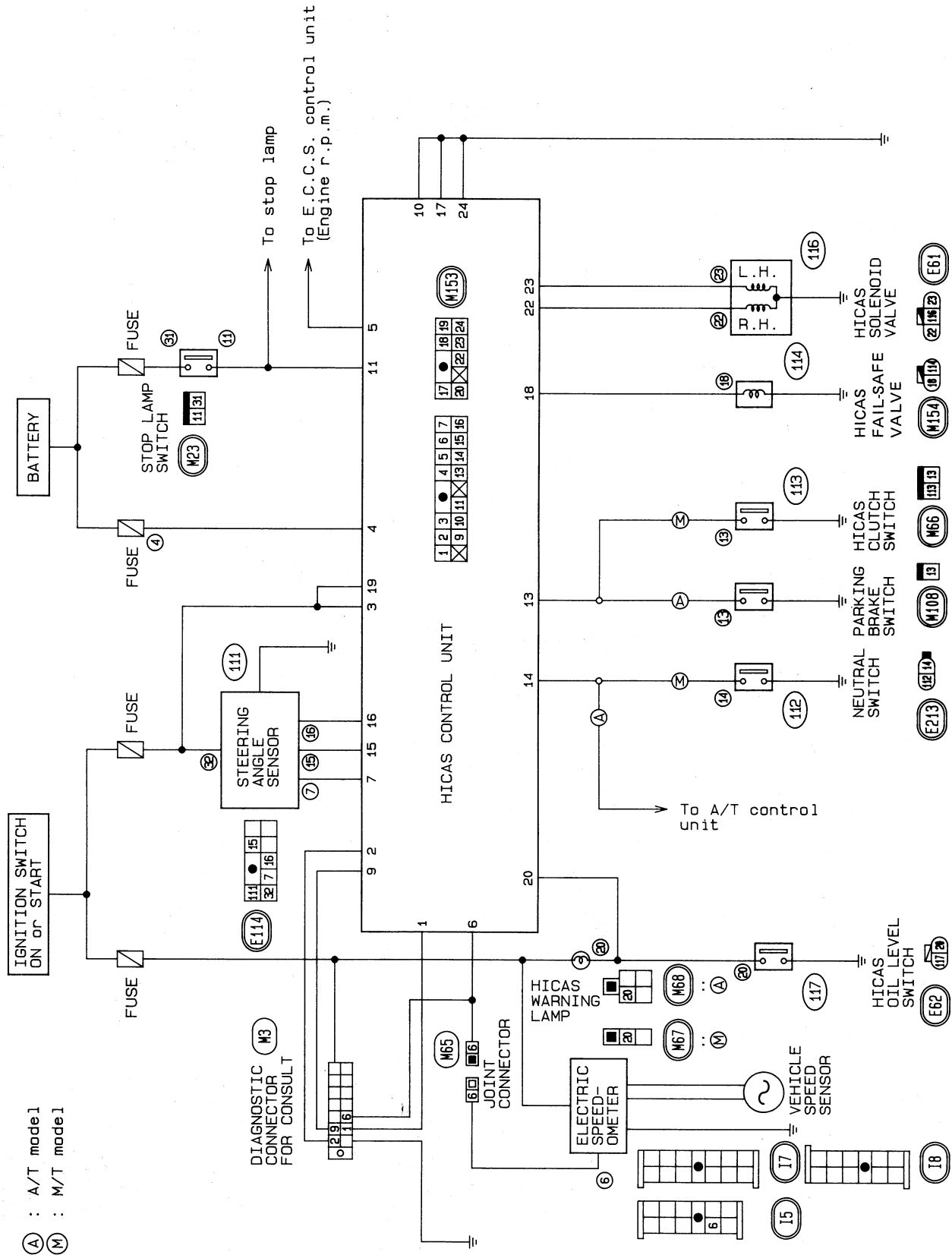

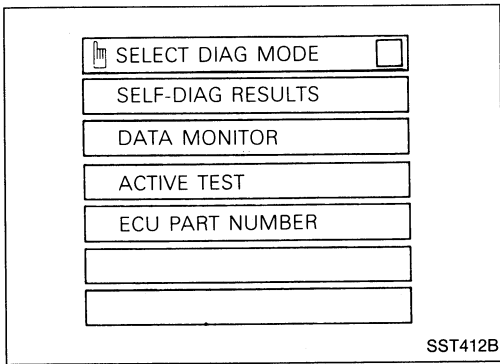

Self-diagnosis (When CONSULT is used)

- Start engine.
- Touch START (on CONSULT display).
- Touch HICAS.
- Touch SELF-DIAG RESULTS.

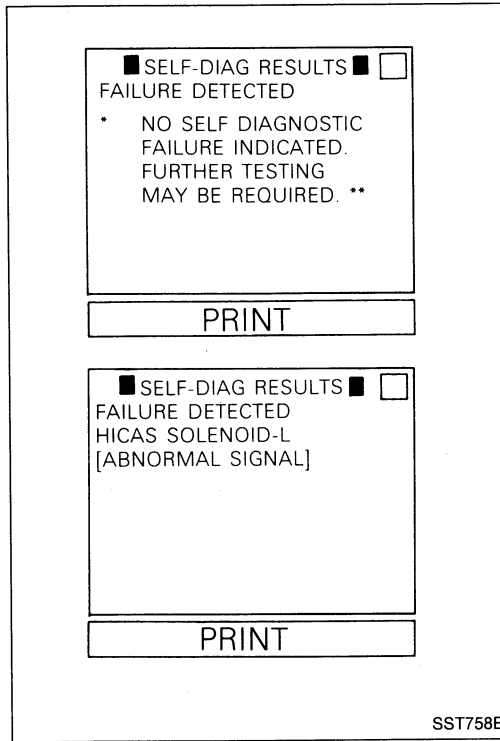

- Self-diagnostic results are shown on display. Refer to Table on page ST-55.

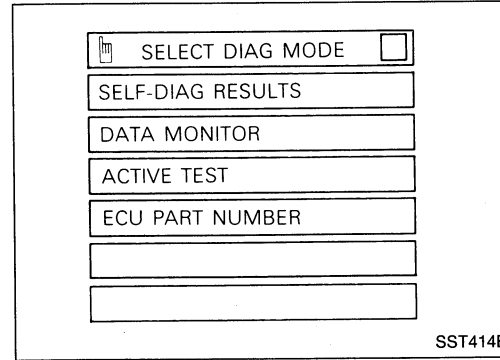

For reference:

Recording input/output signals using data monitor function

- Start engine.
- Touch START (on CONSULT display).
- Touch HICAS.
- Touch DATA MONITOR.

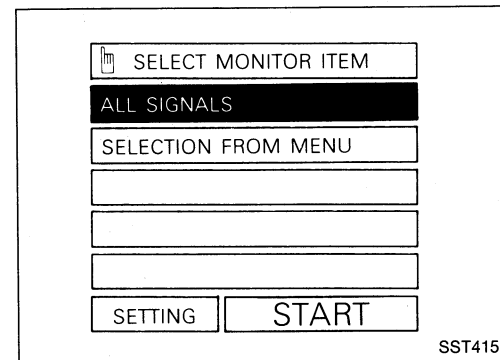

- Check to ensure that the ALL SIGNALS display is reversed. Touch START. Refer to Table on page ST-56.

SUPER HICAS SYSTEM — Trouble Diagnoses

Self-diagnosis (When CONSULT is used) (Cont'd)

☆ MONITOR
☆ NO FAIL
▼

CAR SPEED (REF)	0km/h
STEERING ANG	L8°
NEUTRAL SIG	ON
STOP LAMP SW	OFF
PKB/CLUTCH SW	ON
NEUTRAL SW	ON
ENG REV UNDER 1500	
HICAS SOL	R0.00A
FAILSAFE/V	OFF

RECORD

☆ MONITOR
☆ NO FAIL
▲

FAILSAFE	NON
WARNING LAMP	OFF

RECORD

SST728B

- Touch RECORD to record data.
- Ensure that ON-OFF signal is produced when signal is entered from each sensor while monitoring.

To cancel data recording during operation, touch CANCEL.

Self-diagnosis items

Diagnostic item	Description
* NO SELF DIAGNOSTIC FAILURE INDICATED. FURTHER TESTING MAY BE REQUIRED. **	● Even if no self diagnostic failure is indicated, further testing may be required as far as the customer complains.
VEHICLE SPEED SENSOR [NO SIGNAL] (-a)	● No vehicle speed signal is entered after vehicle has been operated.
VEHICLE SPEED SENSOR [SIG-SUDDEN TURN] (-b)	● Vehicle speed signal abruptly changes during operation.
STEERING ANGLE SEN [NO ANG SIGNAL] (-a)	● Steering angle has not been changed while driving at a speed of at least 60 km/h (37 MPH).
STEERING ANGLE SEN [NO NEUT SIGNAL] (-b)	● Neutral (ON) signal is not entered after vehicle has been driven.
STEERING ANGLE SEN [NEUT SIG-360° OFF] (-c)	● Neutral (ON) signal is not entered even after steering wheel has been turned at least 360°.
STEERING ANGLE SEN [NEUT SIG-30° ON] (-d)	● Neutral (ON) signal is continually shown at steering angle of at least 30°.
FAILSAFE VALVE [ABNORMAL SIGNAL]	● Output terminal voltage is abnormal due to broken or shorted HICAS fail-safe valve circuit.
HICAS SOLENOID-R [ABNORMAL SIGNAL]	● Output terminal voltage is abnormal due to broken or shorted HICAS solenoid (RH) circuit.
HICAS SOLENOID-L [ABNORMAL SIGNAL]	● Output terminal voltage is abnormal due to broken or shorted HICAS solenoid (LH) circuit.

SUPER HICAS SYSTEM — Trouble Diagnoses

Self-diagnosis (When CONSULT is used) (Cont'd)

Data monitoring items

○: Standard
△: Optional selection

Item	Monitor item selection		Remarks
	All items	Item menu	
Vehicle speed sensor (km/h)	○	△	—
Steering angle sensor (deg)	○	△	Abnormal value is shown before straight-ahead position ("0") is set and after battery is disconnected and reconnected.
Neutral signal (ON-OFF display)	○	△	—
Stop lamp switch signal (ON-OFF display)	○	△	—
Parking brake/Clutch switch (ON-OFF display)	○	△	Clutch switch signal for M/T model and parking brake switch signal for A/T model.
Neutral switch (ON-OFF display)	○	△	Neutral switch signal for M/T model and inhibitor relay (N or P) signal for A/T model.
Engine rpm ("OVER 1,500" or "UNDER 1,500" is shown.)	○	△	Engine speed greater than/less than 1,500 rpm is shown.
HICAS solenoid (R/L) (A)	○	△	Controlled current flow from control unit to HICAS solenoid and direction of current control are shown.
Fail-safe valve (ON-OFF display)	○	△	ON (when connected) or OFF (when disconnected) is shown.
Fail-safe system (CUT-NON display)	○	△	NON (fail-safe valve ON) referring to "normal" conditioner CUT (fail-safe valve OFF) when in "fail-safe" condition are shown.
Warning lamp (ON-OFF display)	○	△	Illumination control of control unit's HICAS warning lamp is shown.
■ Voltage (V)	—	△	Voltage measured with voltage probes is shown.
■ Pulse (ms, Hz or)	—	△	Value measured with pulse probes is shown. If pulse cannot be measured, "#" is down. "#" is also shown at left of final data until measurement results are determined.

Self-diagnosis (When CONSULT is not used)

SELF-DIAGNOSIS PROCEDURES

1. Input starting conditions for self-diagnosis.
 - (1) Turn ignition switch "OFF".
 - (2) Set shift lever to "P" or "N" position (A/T model), or "Neutral" position (M/T model).
 - (3) Turn ignition switch "ON".
 - (4) Immediately start engine.
 - (5) Turn steering wheel from left to right (at least 20° from the neutral position) 5 times or more, then depress foot brake pedal at least 5 times all within 10 seconds after ignition switch has been turned "ON".
2. Input self-diagnosis item.
 - (1) Depress and release foot brake pedal.
 - (2) Turn steering wheel from left to right (at least 20°) from the neutral position.
 - (3) (M/T model)
Depress clutch pedal and move gear shift lever to any position other than Neutral and return to Neutral. Release clutch pedal.
(A/T model)
Disengage and engage parking brake lever. Move shift lever to any position other than Neutral or Parking and return to Parking.
 - (4) Move car at least 3 meters (10 ft) forward and proceed at an indicated speed of at least 2 km/h (1 MPH) in self-diagnosis mode.

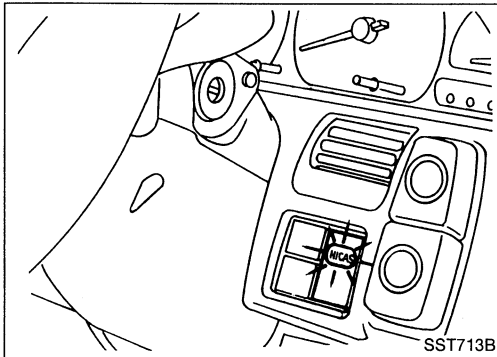

3. The self-diagnosis mode will then appear in the "HICAS" warning lamp.

When all systems are normal:

HICAS warning lamp flashes at 0.25-second intervals.

SUPER HICAS SYSTEM — Trouble Diagnoses

Self-diagnosis (When CONSULT is not used) (Cont'd)

When there is a system malfunction:

Example: When ② HICAS solenoid LH, and ⑤ vehicle speed sensor have experienced a malfunction.

The warning lamp displays abnormal mode (1 sec. ON).

A If fail-safe system was operated (fail-safe valve is operating) when ignition switch was turned OFF for the last time, fail-safe items will be displayed in numerical order in modes indicated. After all items are displayed, display is repeated again.

- To change the display mode to **A**, turn OFF ignition switch after mode **B** is displayed.
- When battery charge is insufficient, mode **B** is displayed.

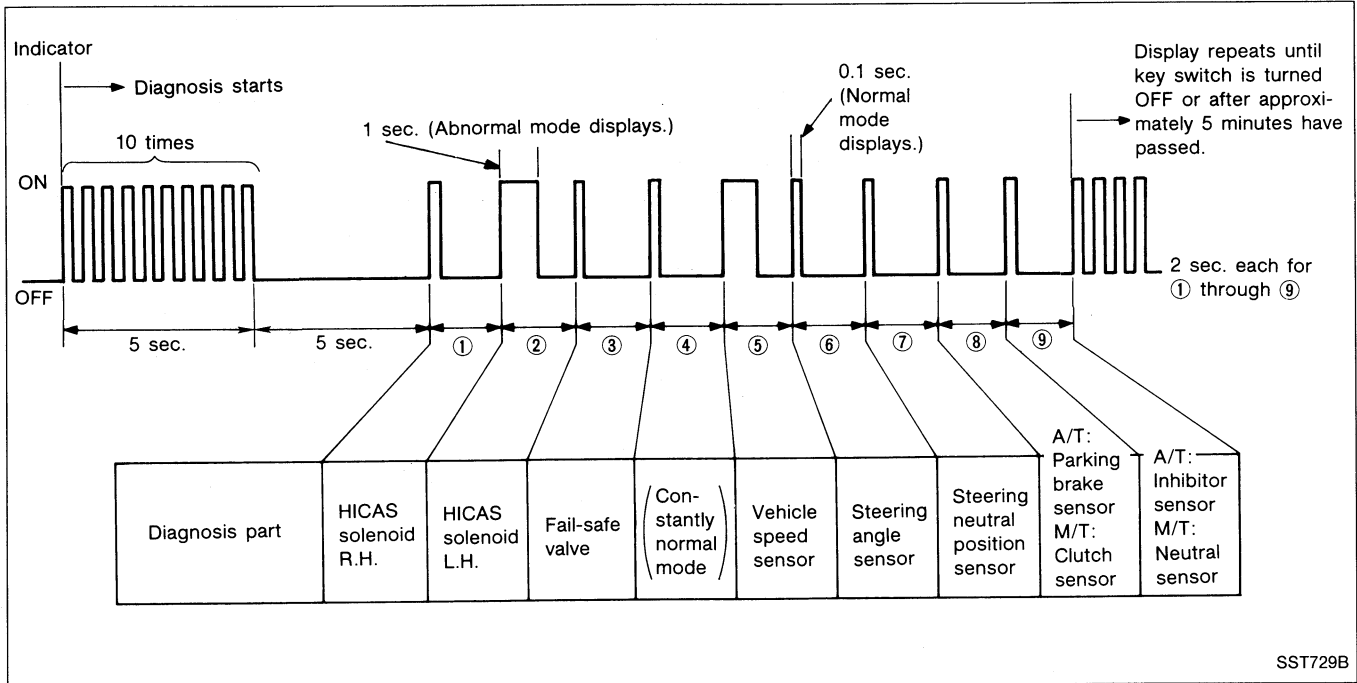

SUPER HICAS SYSTEM — Trouble Diagnoses

Self-diagnosis (When CONSULT is not used) (Cont'd)

■ If fail-safe system was not operated when ignition switch was turned OFF for the last time, display will show self-diagnosis results in numerical sequence in modes indicated below. After all self-diagnosis results are shown, display is repeated again.

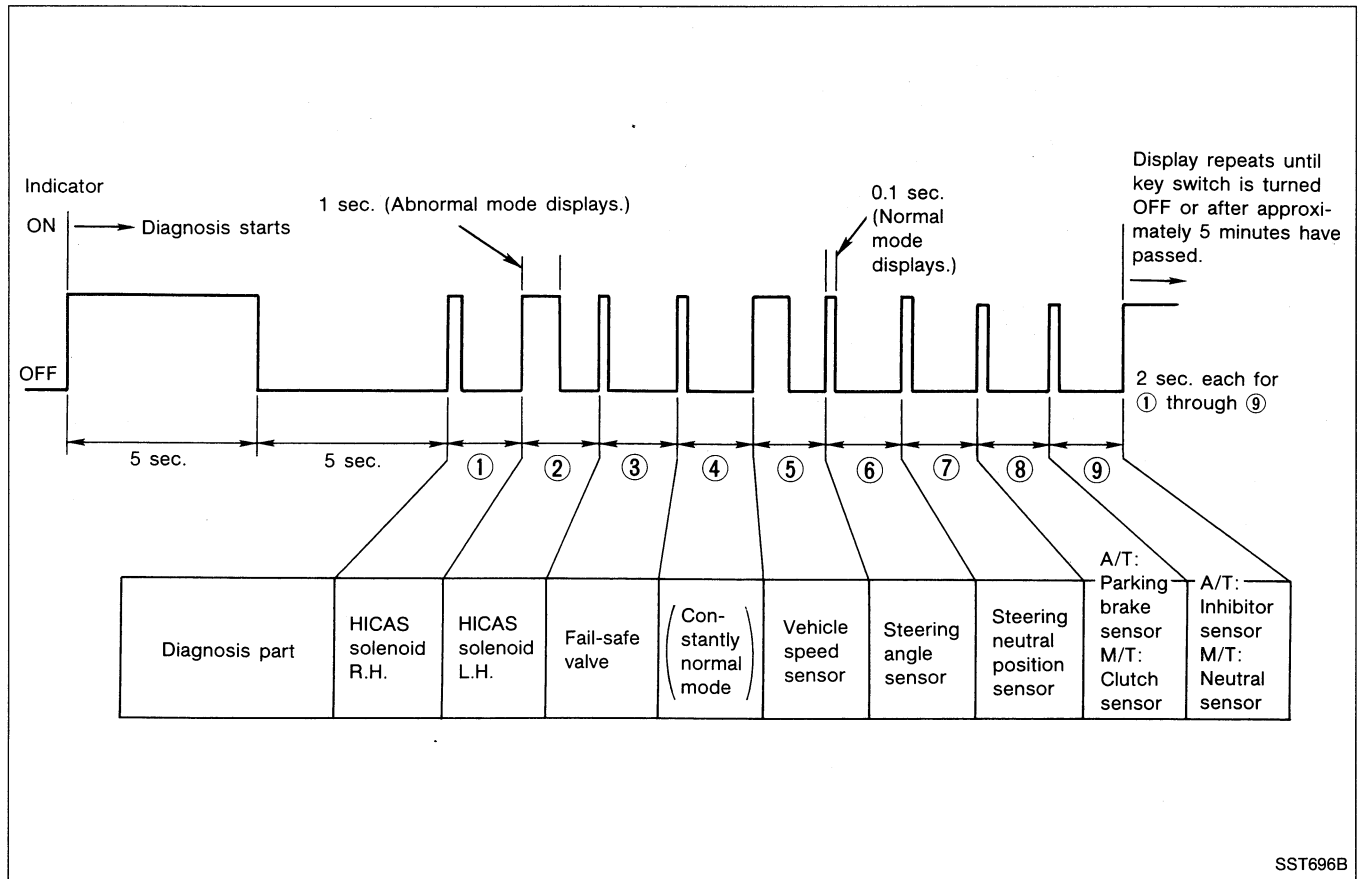

CANCELING THE SELF-DIAGNOSIS FUNCTION

There are three methods for canceling the self-diagnosis function, as described below:

- The self-diagnosis system is canceled by the turning ignition switch "OFF".
- After self-diagnosing has been operated for approximately 5 minutes, the self-diagnosis system will be automatically canceled.
- The self-diagnosis system is canceled by a vehicle speed of 30 km/h (19 MPH) or over.

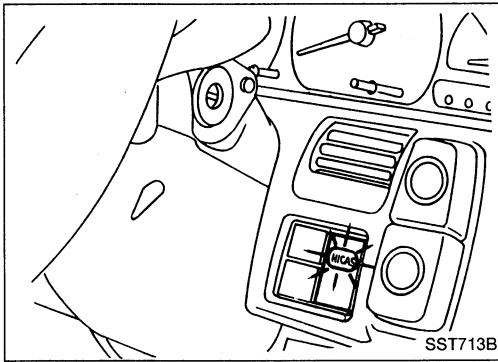

Diagnostic Procedure 1

SYMPTOM:

No warning lamp comes on when ignition switch is turned "ON".

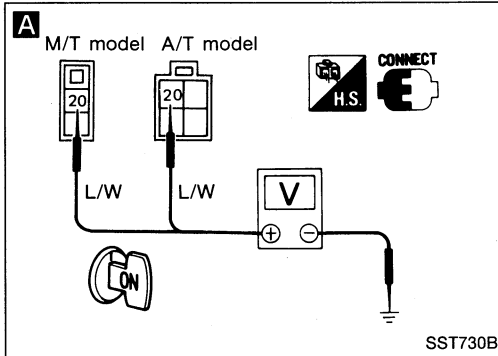
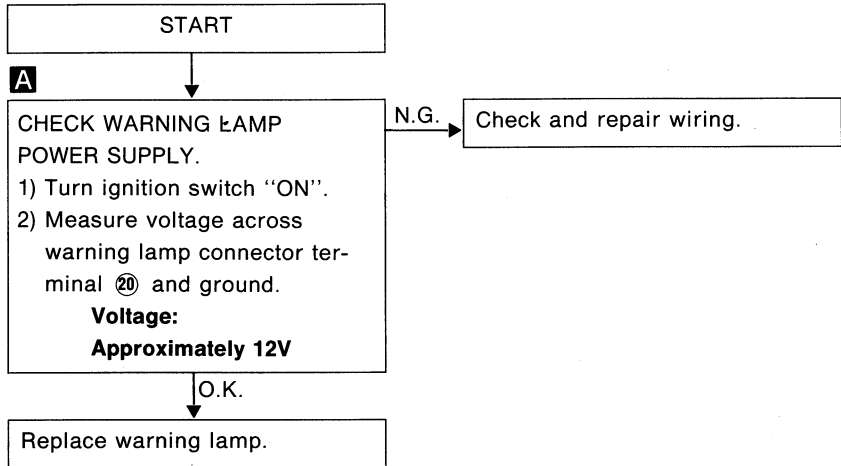

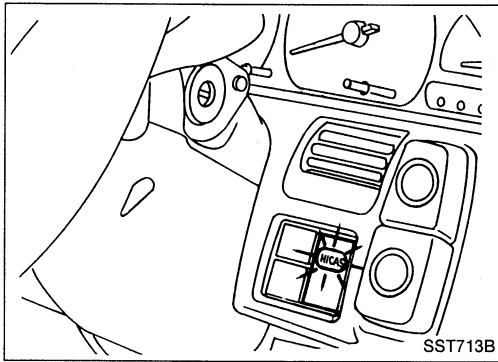

Diagnostic Procedure 2

SYMPTOM (A):

Warning lamp comes on during operation.

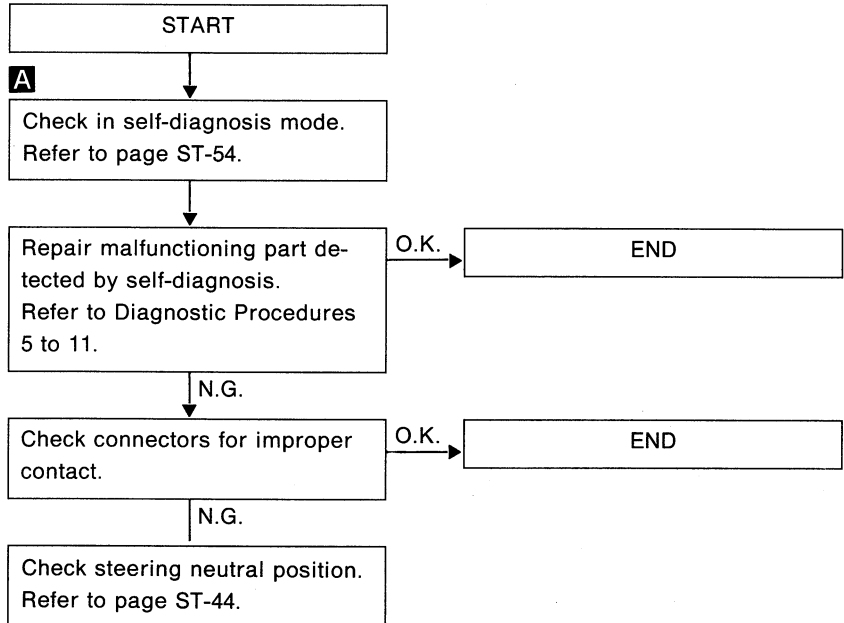
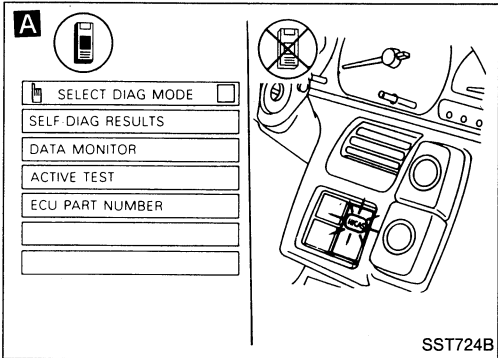

SUPER HICAS SYSTEM — Trouble Diagnoses

Diagnostic Procedure 2 (Cont'd)

SYMPTOM (B):

Warning lamp comes on when ignition switch is turned ON; however, it does not go out after engine start.

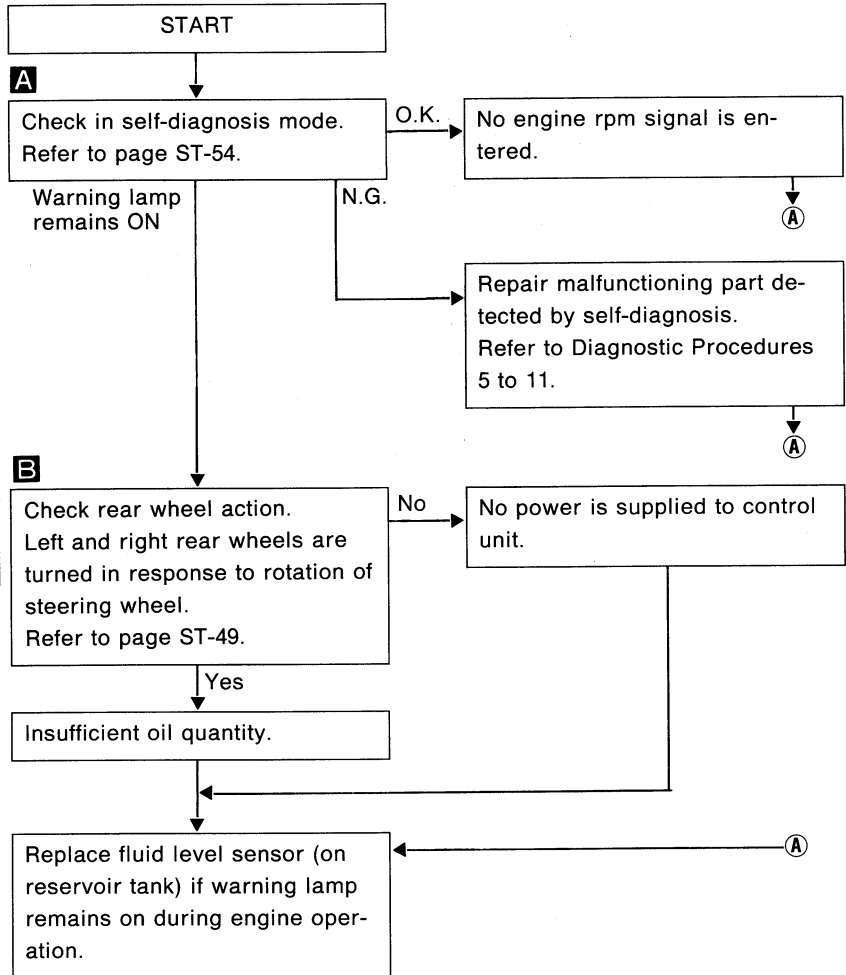
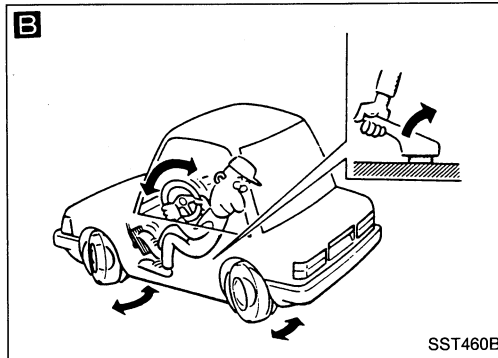
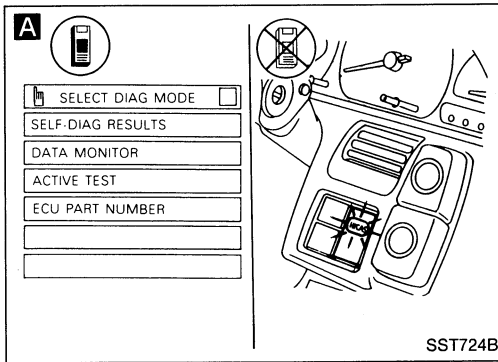

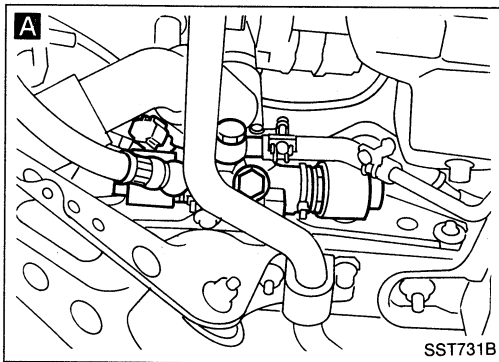

Diagnostic Procedure 3

SYMPTOM:
Abnormal noise occurs.

START

A Disconnect HICAS solenoid connector and check noise for changes.

Yes → Noise stops.

No
Noise occurs in any system other than HICAS.

Locate and repair.

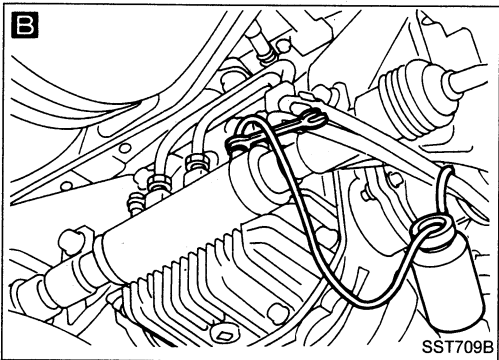

B Bleed air from hydraulic system. Refer to page ST-35.

N.G. ↓ O.K. → END

Replace control unit.

N.G. ↓ O.K. → END

Replace HICAS solenoid valve.

Diagnostic Procedure 4

SYMPTOM:
Vehicle behavior is abnormal. (Vehicle sways or jerks.)

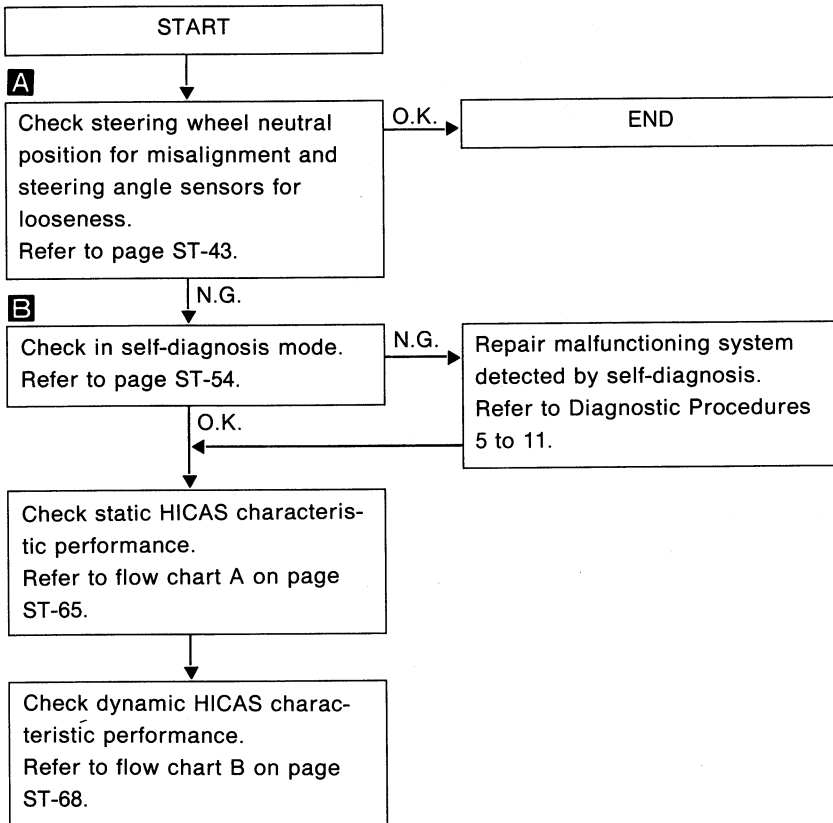
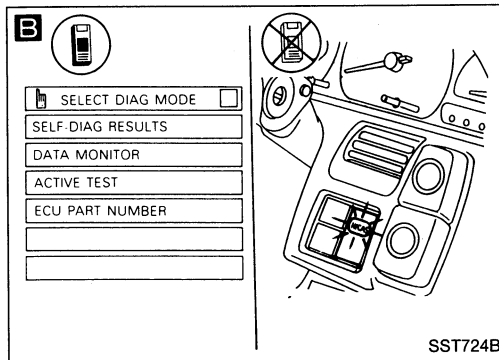
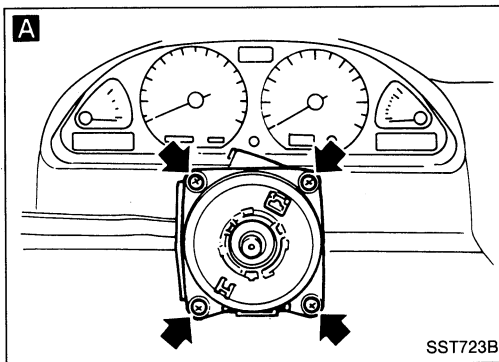

SUPER HICAS SYSTEM — Trouble Diagnoses

Diagnostic Procedure 4 (Cont'd)

A. Static HICAS characteristic performance check

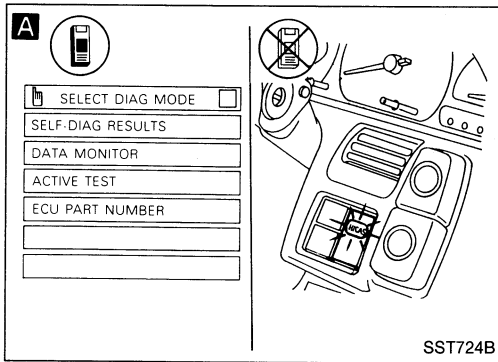

START

A

Set CONSULT in ACTIVE TEST mode.
OR
Set self-diagnosis mode.
Refer to page ST-54.

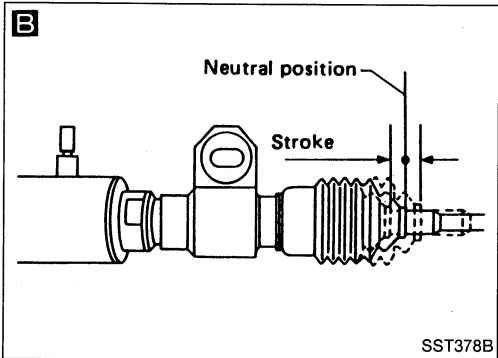

B

- Run engine at a speed or less than 2,000 rpm.
- Turn steering wheel approximately 180° to the left or right.

CHECK POWER CYLINDER STROKES.
Each stroke from neutral position:
2.9 - 3.1 mm
(0.114 - 0.122 in)
Refer to page 31.

O.K. → END

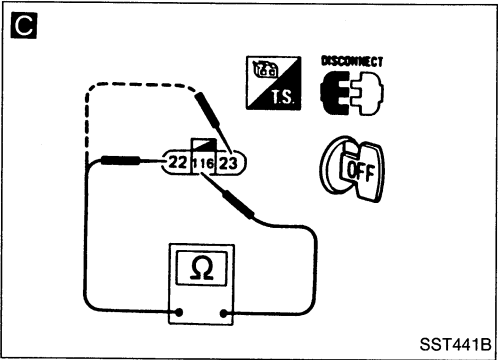

C

N.G.

CHECK RESISTANCE OF HICAS SOLENOID VALVE.
Stop engine and disconnect HICAS solenoid valve.
Measure resistance between HICAS solenoid connector terminals 22 and 23, and 116.
Resistance:
4 - 6Ω

N.G. → Replace HICAS solenoid valve.

O.K. → **A**

SUPER HICAS SYSTEM — Trouble Diagnoses

Diagnostic Procedure 4 (Cont'd)

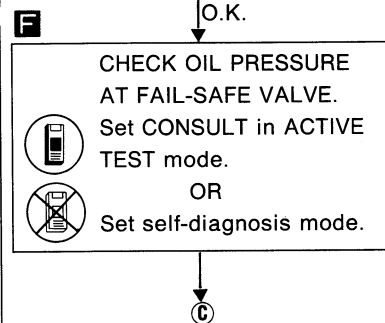
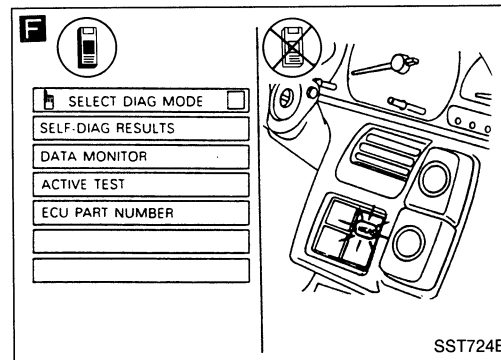
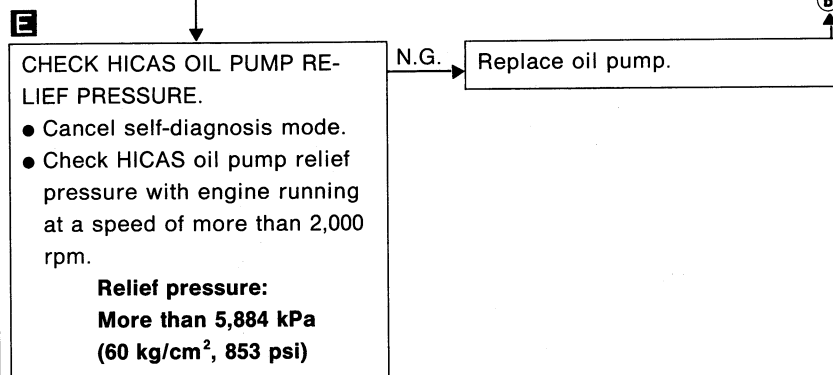
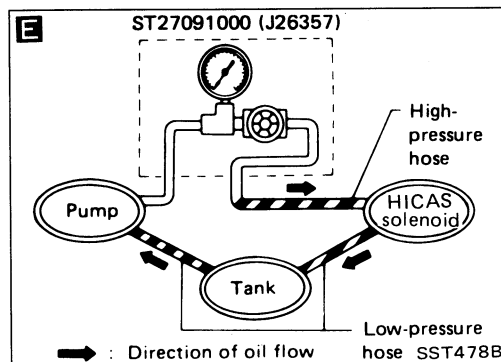
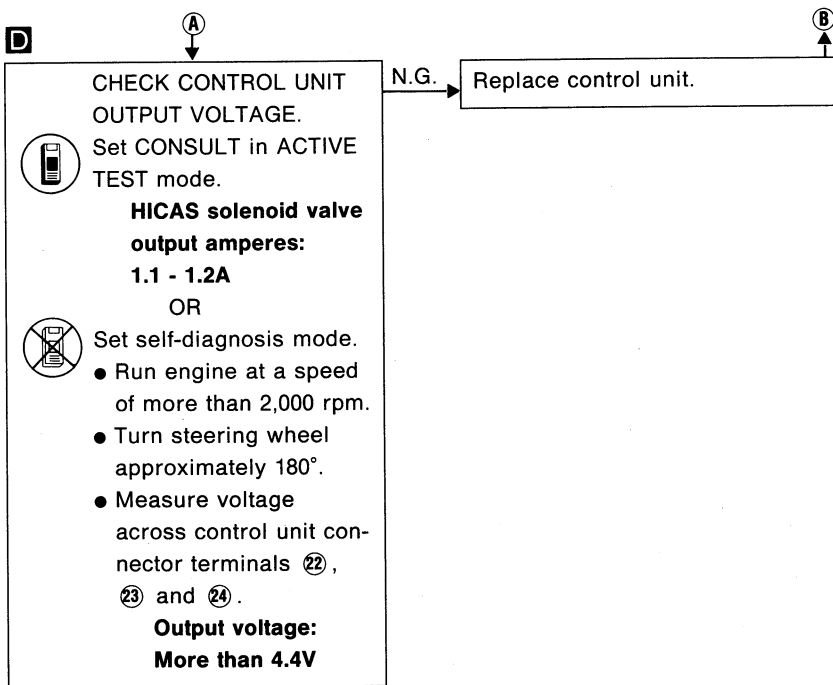
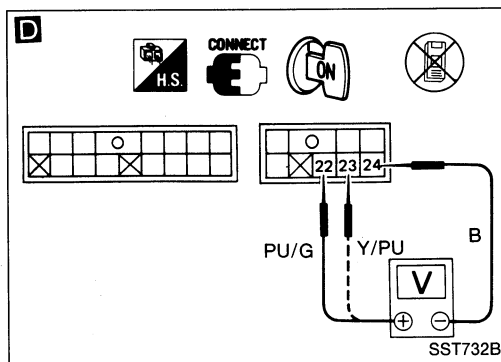
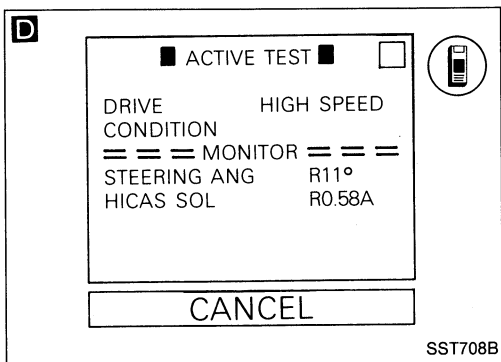

SUPER HICAS SYSTEM — Trouble Diagnoses

Diagnostic Procedure 4 (Cont'd)

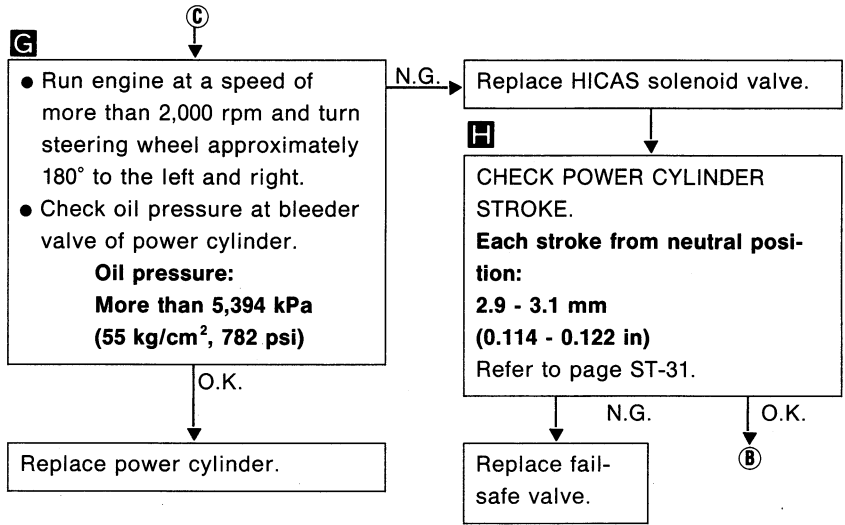
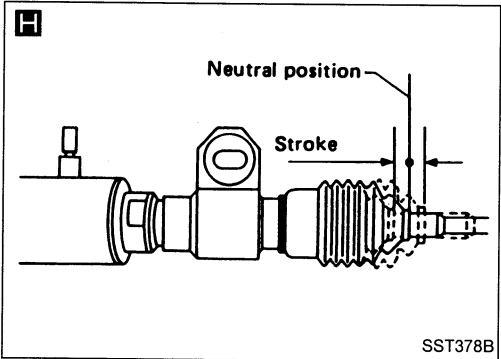
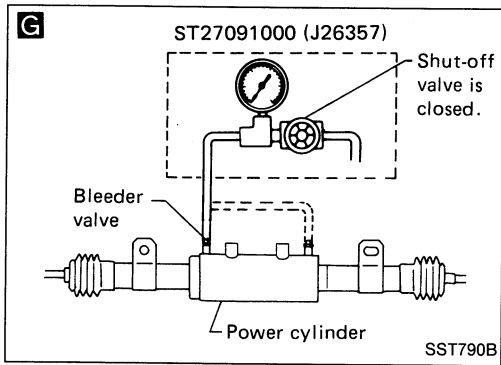

Diagnostic Procedure 4 (Cont'd)

B. Dynamic HICAS characteristic performance check

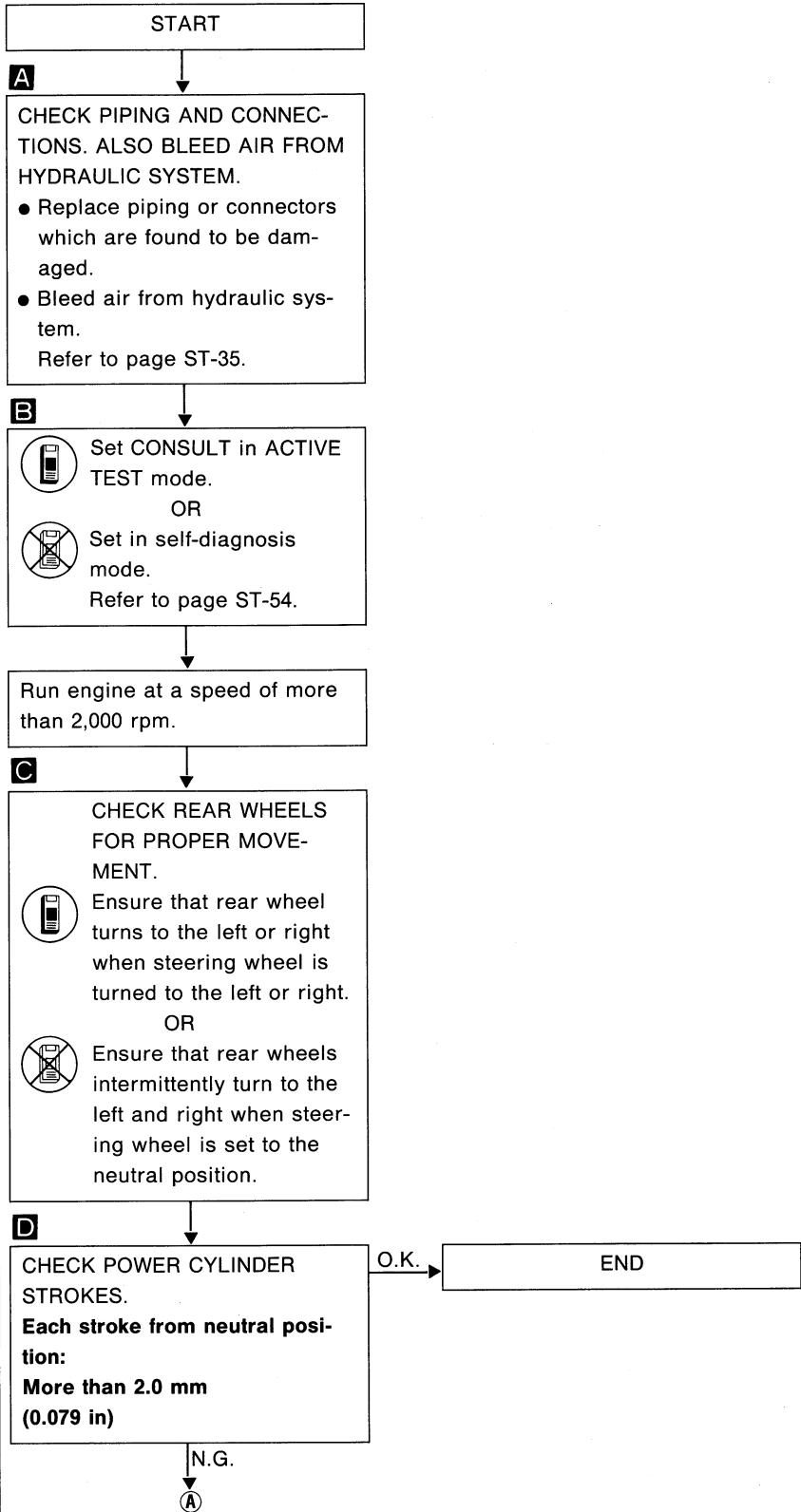
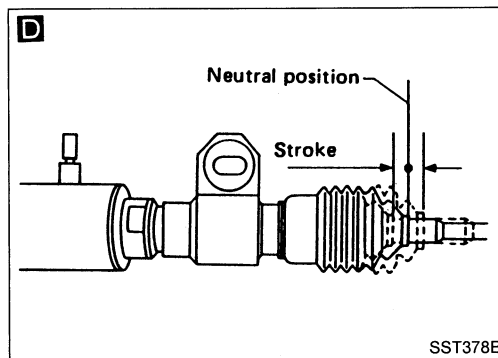
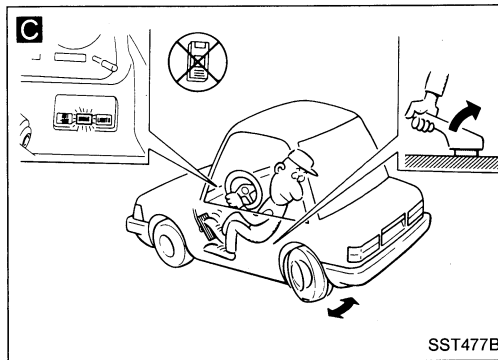
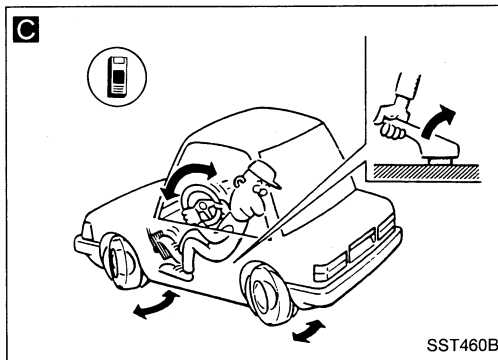
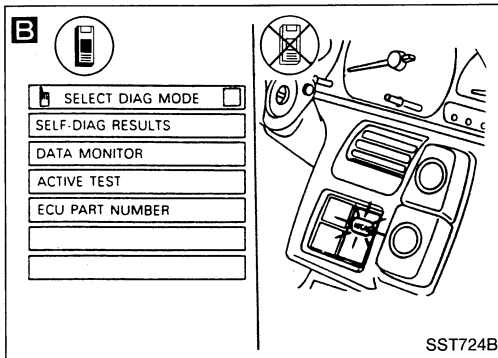
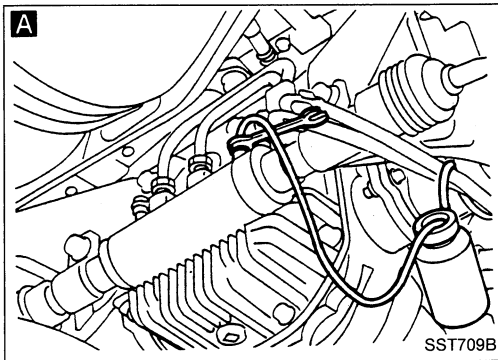

SUPER HICAS SYSTEM — Trouble Diagnoses

Diagnostic Procedure 4 (Cont'd)

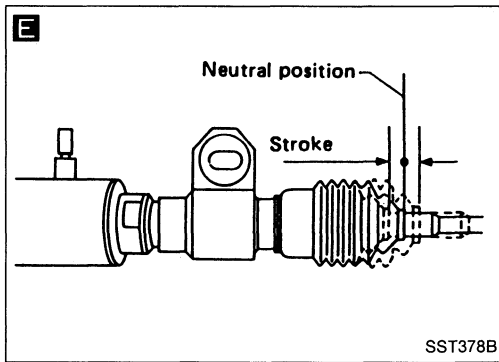

SST378B

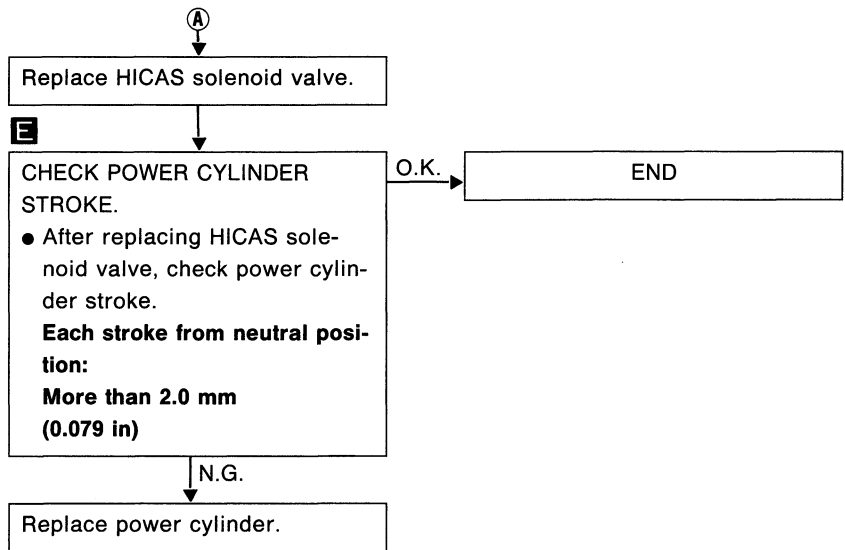

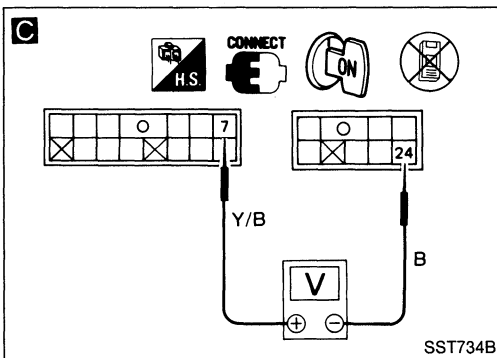
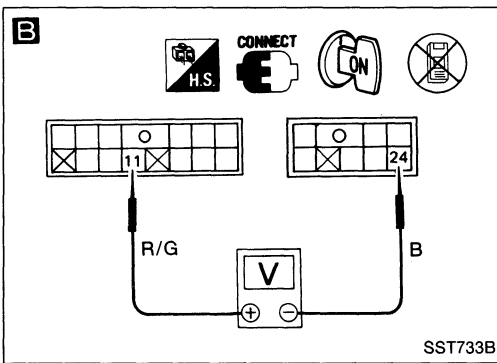
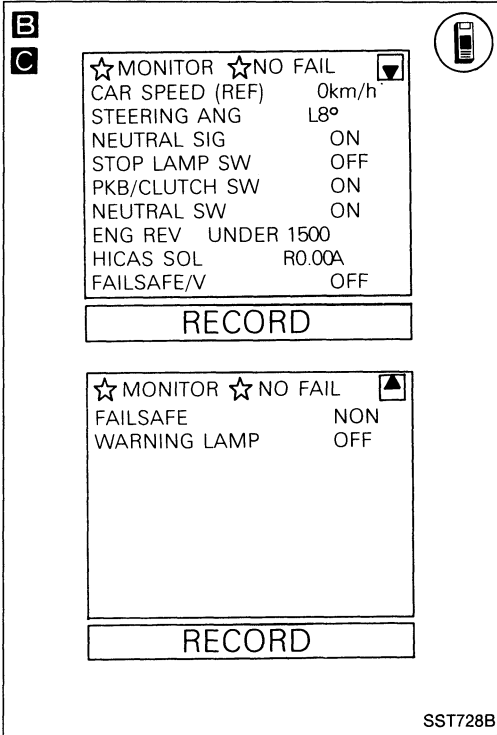
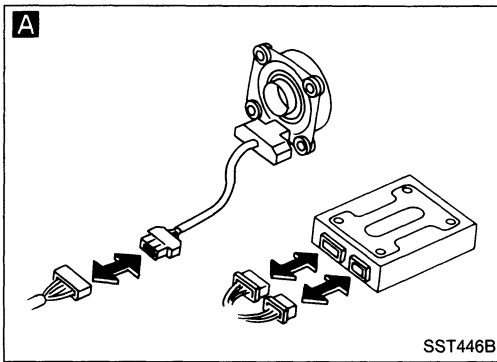

Diagnostic Procedure 5

SYMPTOM:
System is not set in self-diagnosis mode.

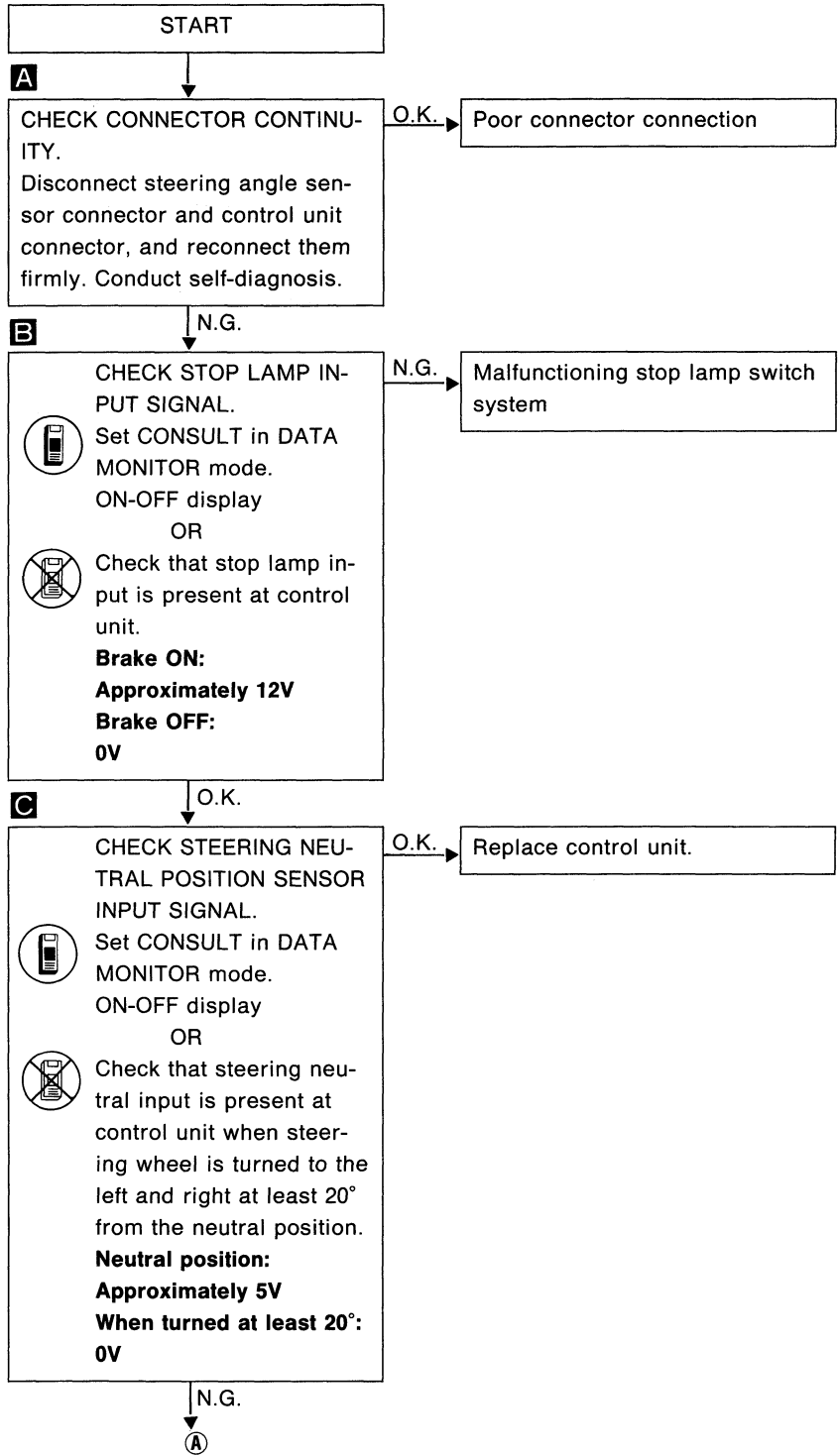

SUPER HICAS SYSTEM — Trouble Diagnoses

Diagnostic Procedure 5 (Cont'd)

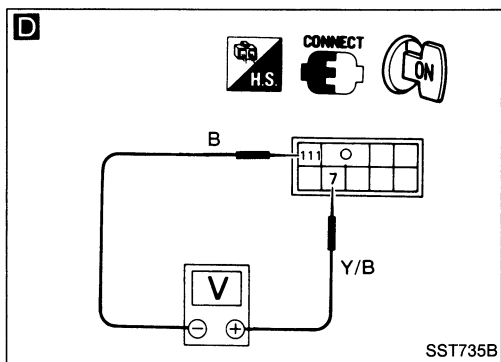

D

CHECK STEERING NEUTRAL POSITION SENSOR OUTPUT SIGNAL.

Check that steering neutral output is present when steering wheel is turned to the left and right at least 20° from the neutral position.

Neutral position:
Approximately 5V
When turned at least 20°:
0V

O.K.

Repair or replace harness between control unit and steering angle sensor.

N.G.

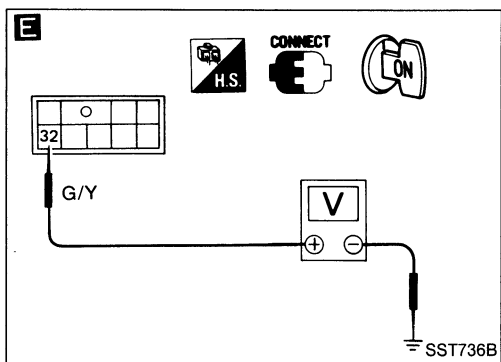

E

CHECK STEERING ANGLE SENSOR POWER SUPPLY.

- 1) Turn ignition switch "ON".
- 2) Measure voltage across steering angle sensor connector terminal IGN and ground.

Voltage:
Approximately 12V

O.K.

Replace steering angle sensor.

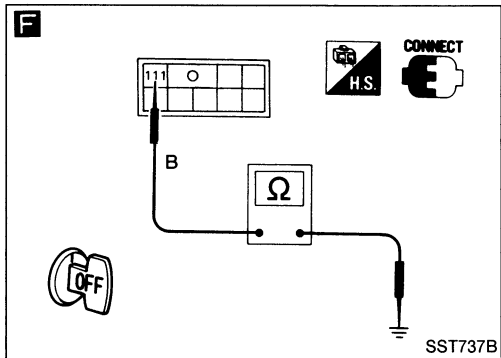

F

CHECK STEERING ANGLE SENSOR GROUND CIRCUIT.

Check continuity between steering angle sensor terminal GND and body metal (ground).

Continuity should exist.

N.G.

Check and repair power supply harness or ground harness.

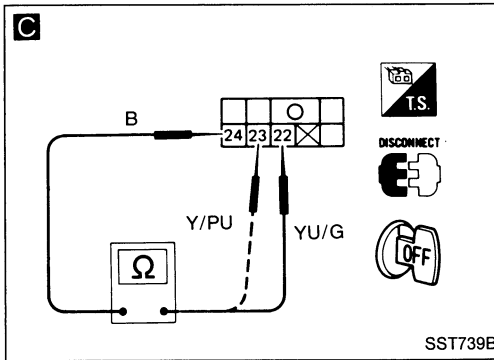
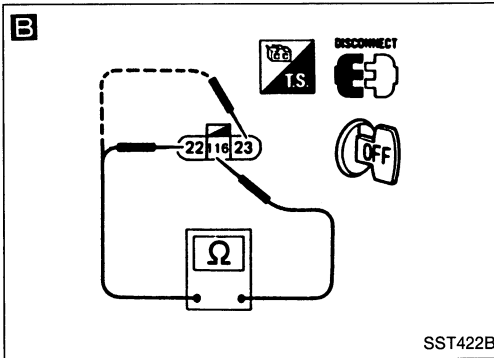
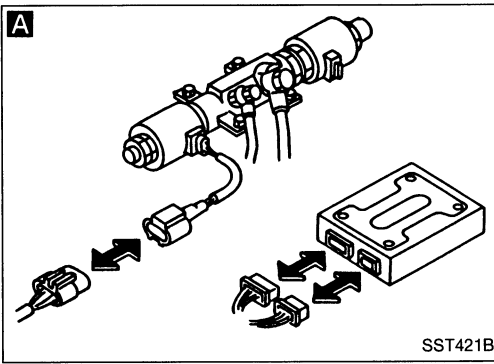

Diagnostic Procedure 6

SYMPTOM:
HICAS solenoid (left and right) output is not present.

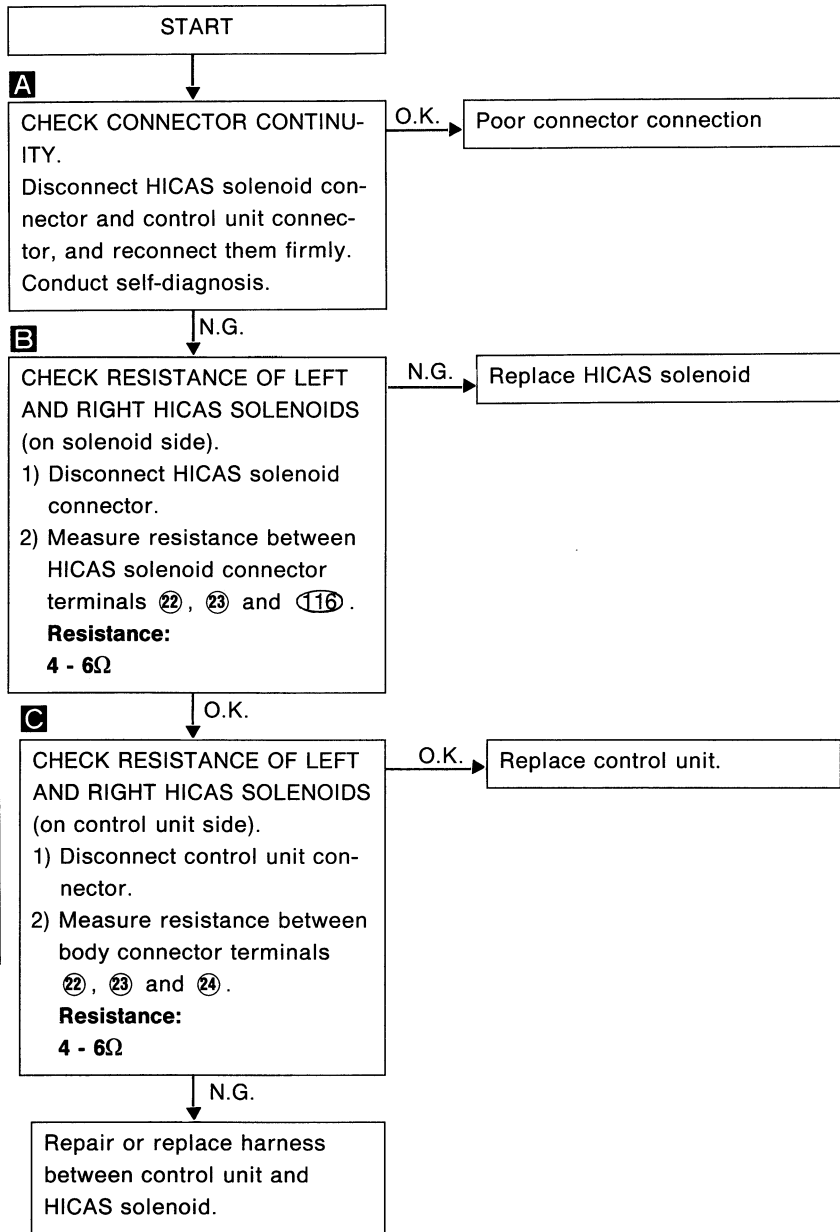

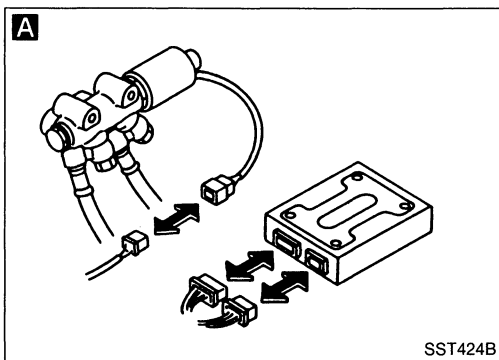

SST424B

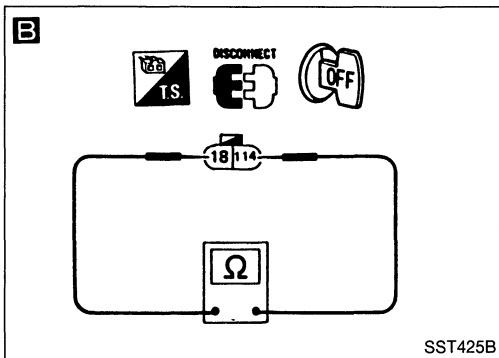

SST425B

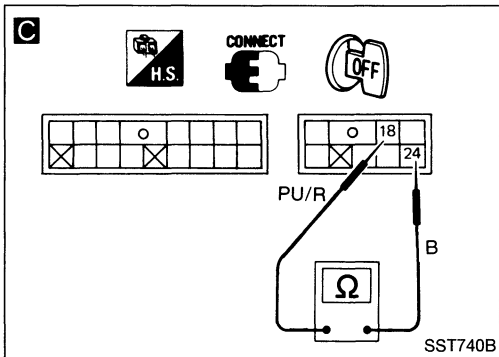

SST740B

Diagnostic Procedure 7

SYMPTOM:

Fail-safe valve output is not present.

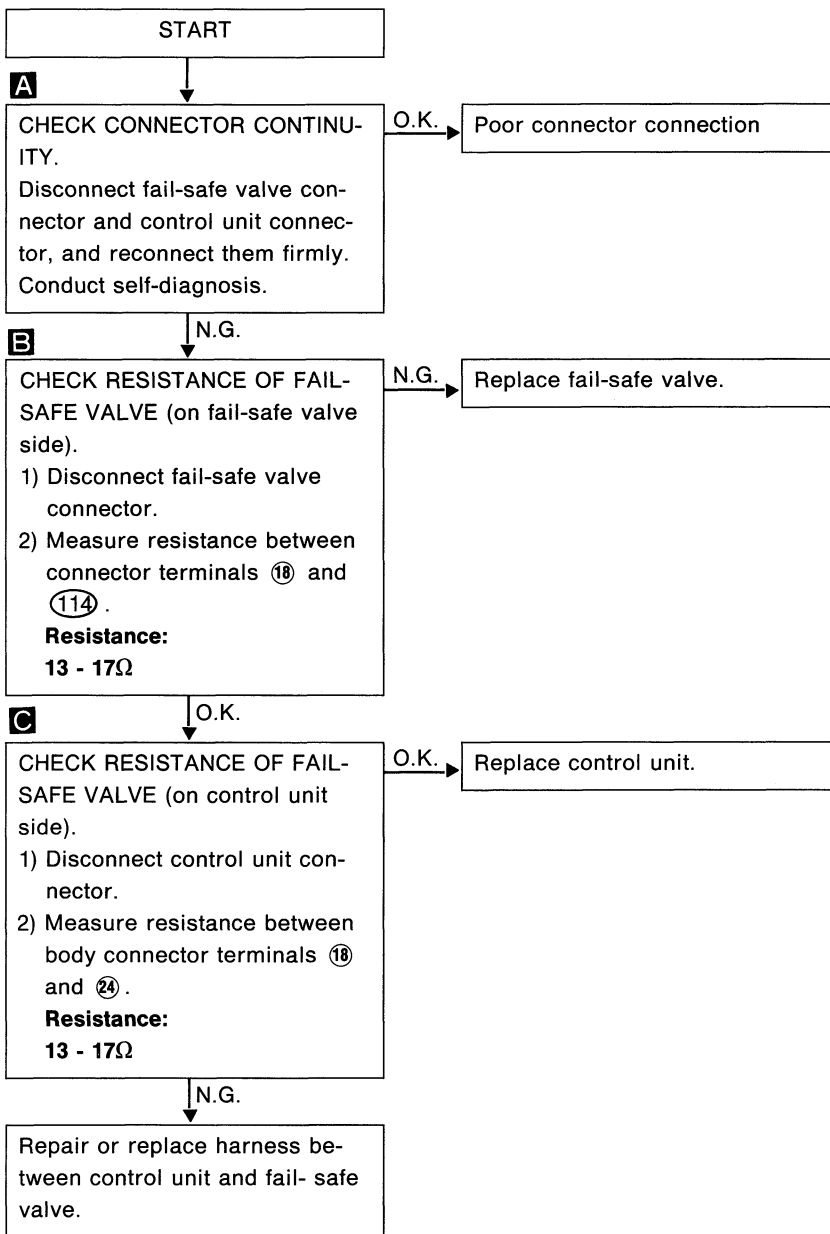

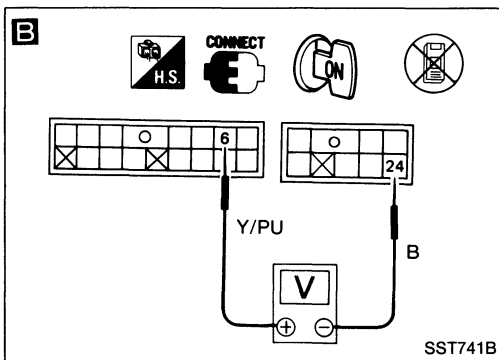
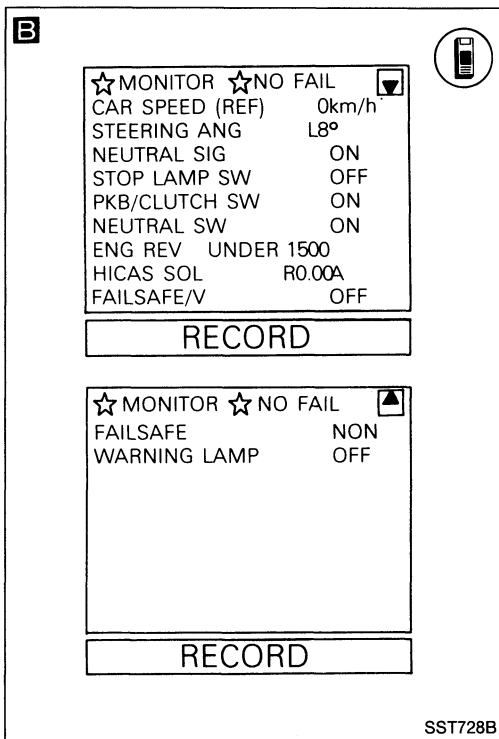
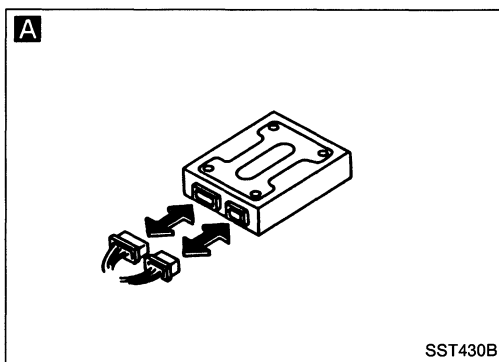

Diagnostic Procedure 8

SYMPTOM:

Vehicle speed signal is not present.

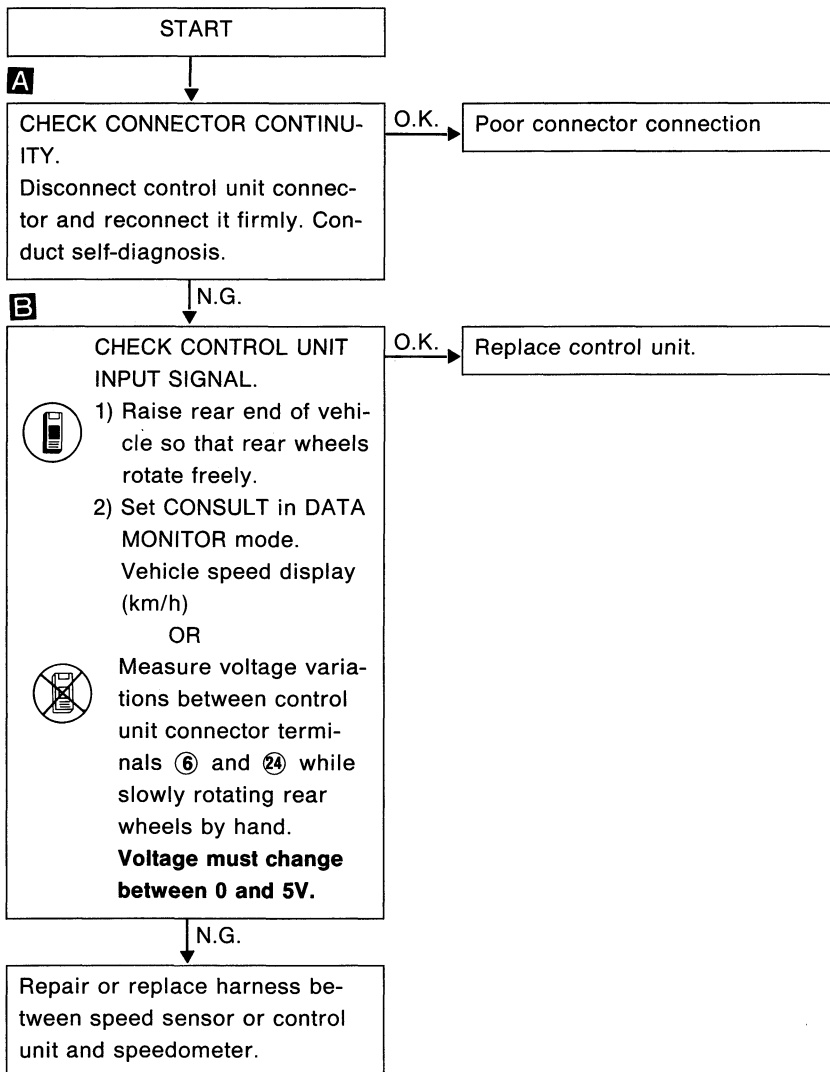

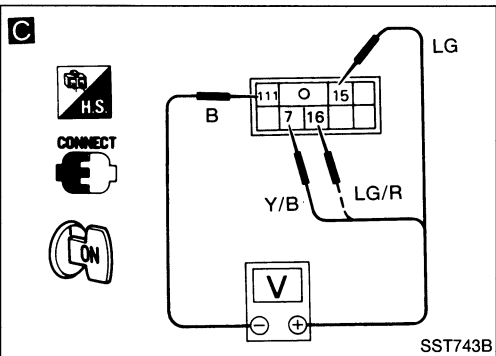
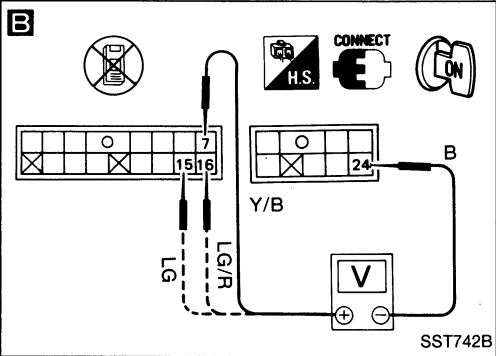
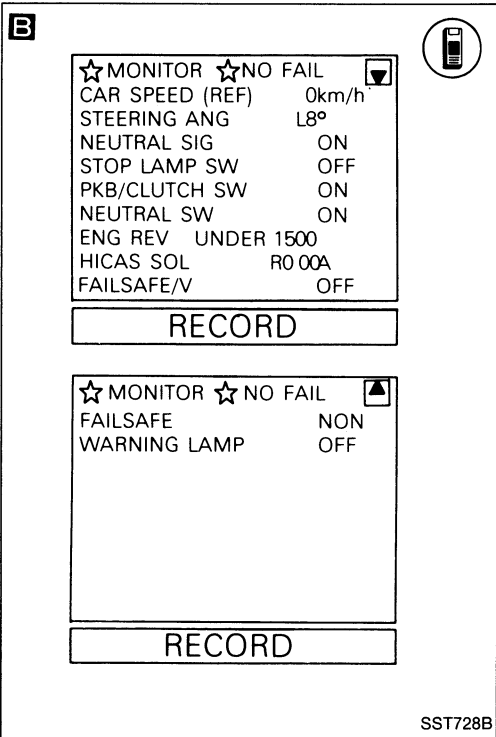
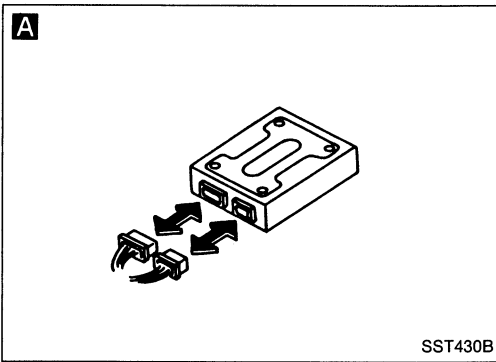

Diagnostic Procedure 9

SYMPTOM:

Steering angle sensor input is not present.

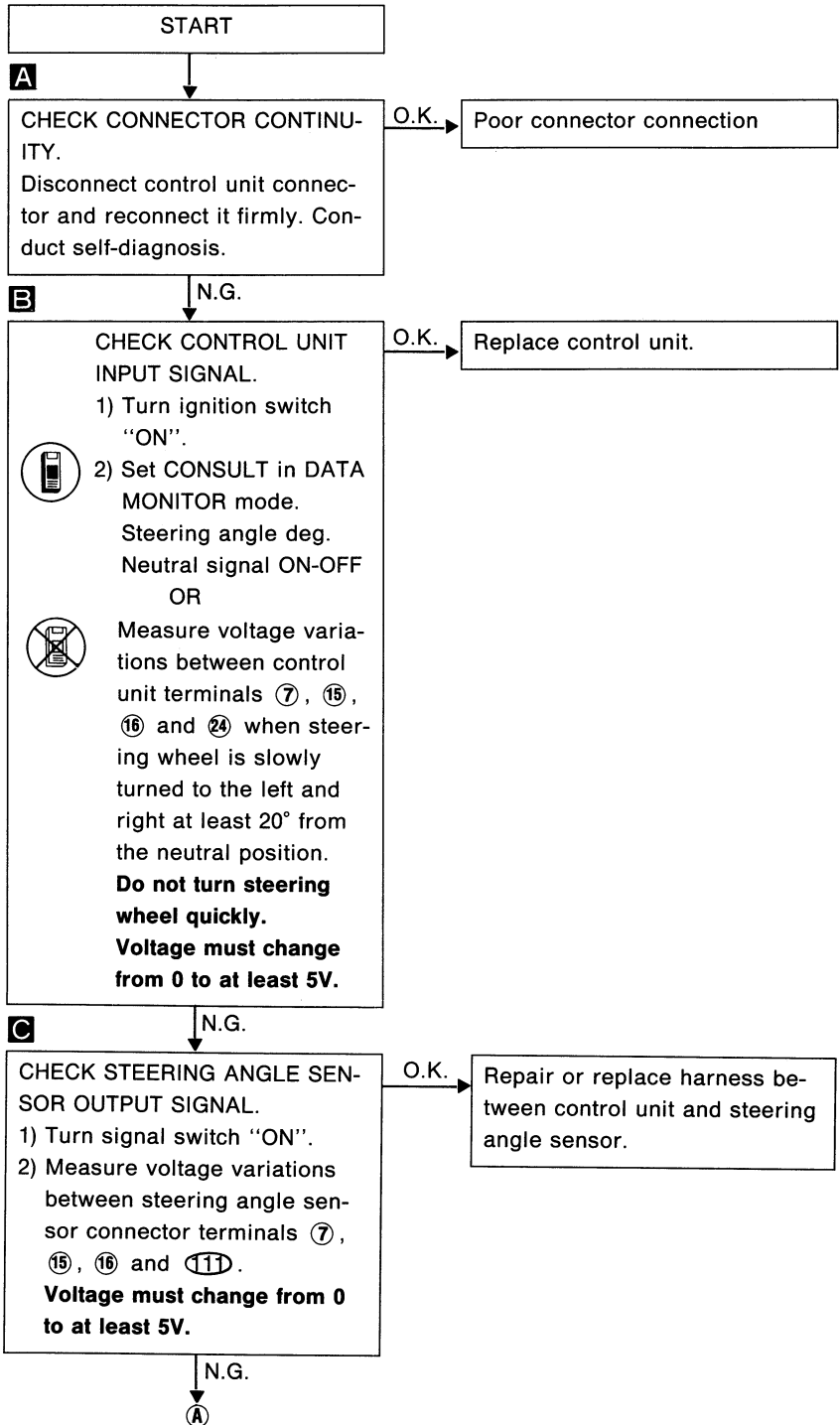

SUPER HICAS SYSTEM — Trouble Diagnoses

Diagnostic Procedure 9 (Cont'd)

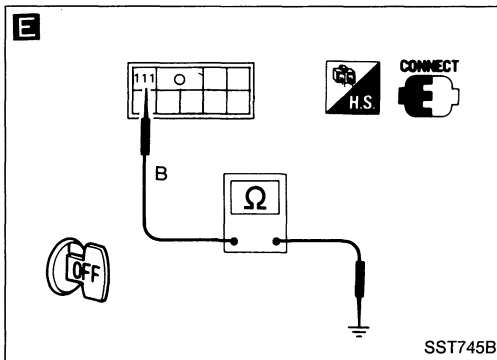
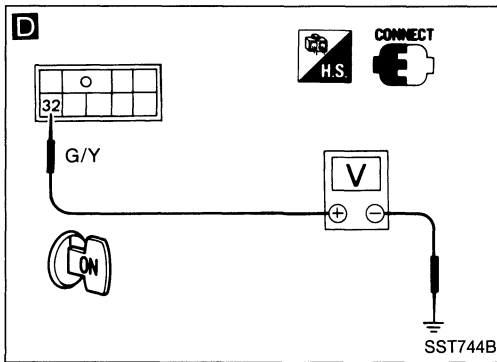

D CHECK STEERING ANGLE SENSOR POWER SUPPLY.

- 1) Turn ignition switch "ON".
- 2) Measure voltage across steering angle sensor connector terminal ③② and ground.

Voltage:

Approximately 12V

E CHECK STEERING ANGLE SENSOR GROUND CIRCUIT.

Check continuity between steering angle sensor terminal ①① and body metal (ground).

Continuity should exist.

O.K.

Replace steering angle sensor.

N.G.

Repair or replace power supply harness or ground harness.

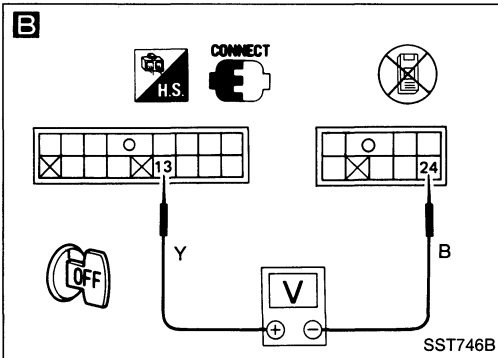
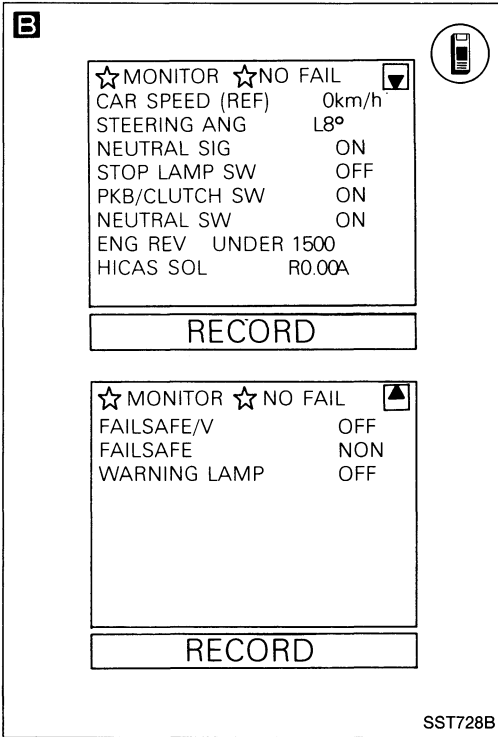
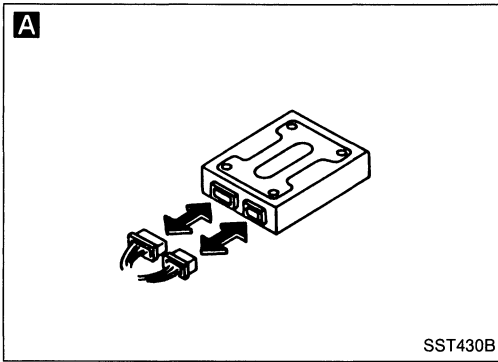

Diagnostic Procedure 10

SYMPTOM:

Parking brake (A/T) or clutch switch (M/T) input is not present.

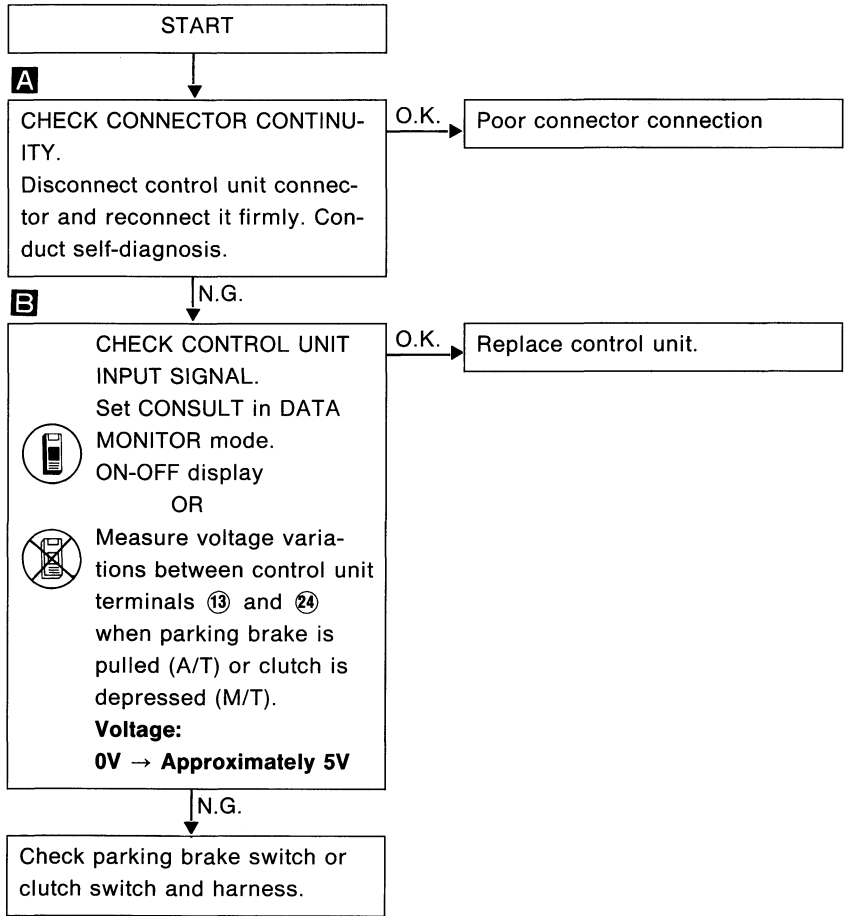

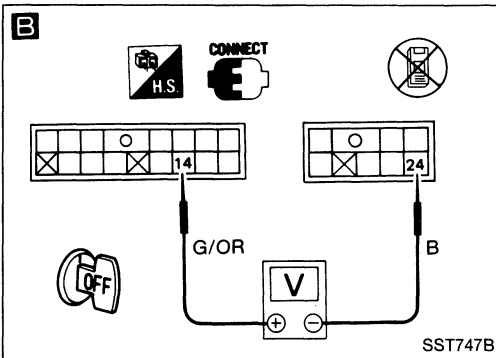
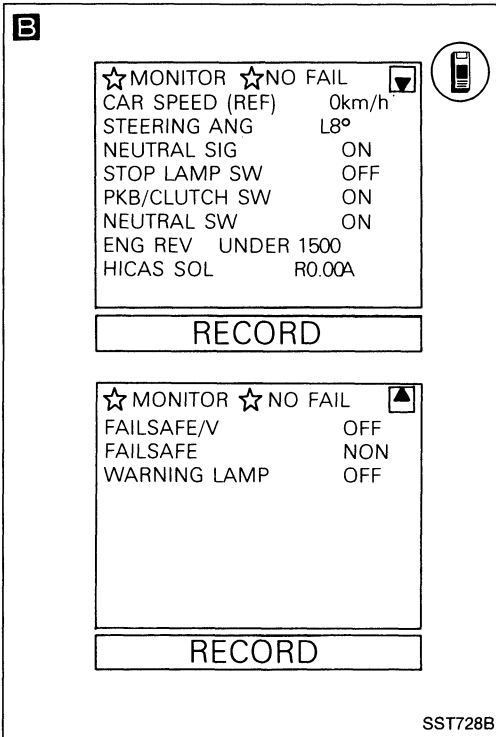
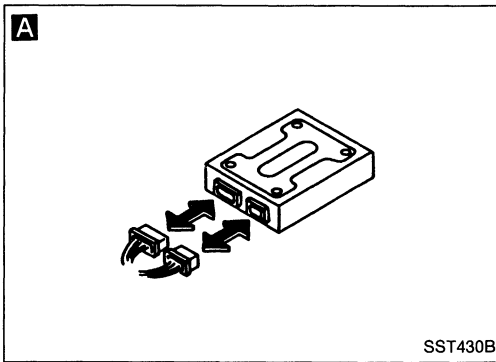

Diagnostic Procedure 11

SYMPTOM:

Inhibitor switch (A/T) or neutral switch (M/T) input is not present.

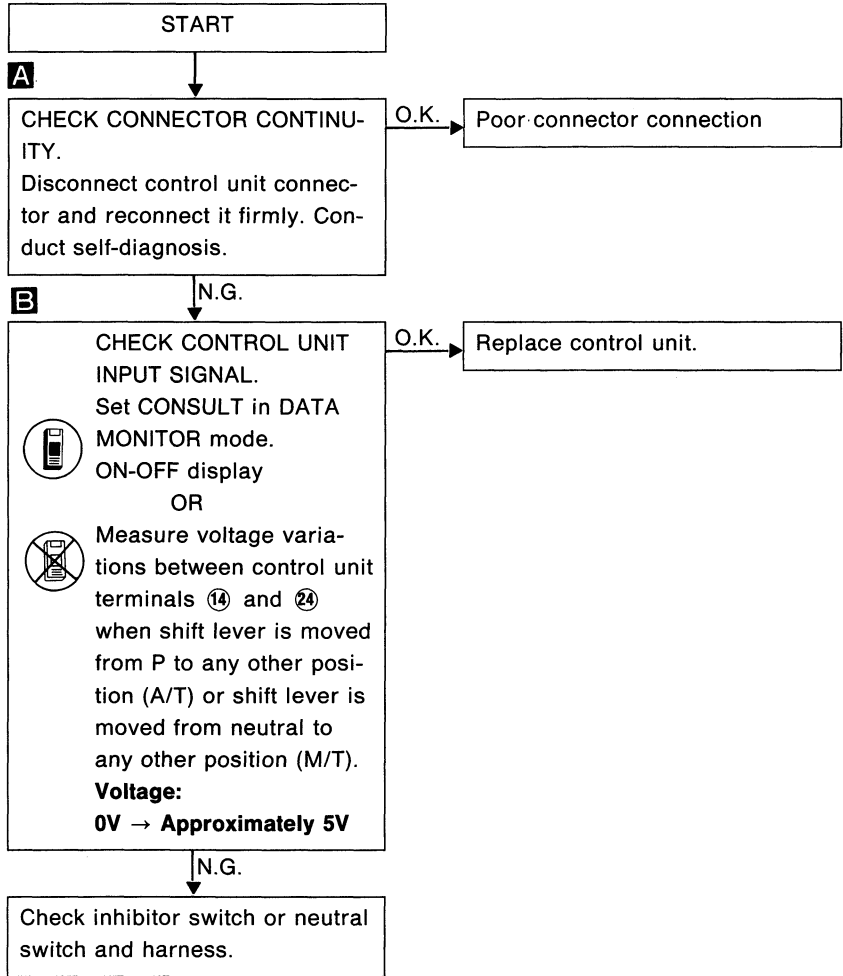

SUPER HICAS SYSTEM — Trouble Diagnoses

Control Unit Inspection Table

The standard values (voltage) measured with an analog tester, in contact with the control unit terminal, are shown below:

Terminal No.	Application	Standard value
1	Service support CLK input	—
2	Service support RX output	—
3	IGN power supply	Key switch ON: Approximately 12V Key switch in other position: 0V
4	Battery	Approximately 12V
5	E.C.C.S. revolution signal	—
6	Vehicle speed signal	Rear wheel rotating 0V ↔ greater than 5V (approx.), intermittent
7	Steering neutral position sensor	Approximately 5V (Neutral position)
9	Service support TX output	—
10	Ground	0V
11	Stop lamp switch signal	Brake ON: Approximately 12V Brake OFF: 0V
13	Parking brake signal (A/T), Clutch signal (M/T)	Parking brake engaged (A/T)/ clutch disengaged (M/T): Approximately 5V
14	Inhibitor signal (A/T), Neutral signal (M/T)	Shift lever in any position other than Parking (A/T) or neutral (M/T): Approximately 5V
15	Steering angle sensor-1 signal	Steering wheel turned 0 ↔ Approximately 5V, intermittent
16	Steering angle sensor-2 signal	Steering wheel turned 0 ↔ Approximately 5V, intermittent
17	Ground	0V
18	Resistance of fail-safe valve	13 - 17Ω
19	IGN power supply	Ignition switch ON: Approximately 12V Ignition switch in other position: 0V
20	HICAS warning lamp	Lamp OFF: Approximately 12V Lamp ON: 0V
22	Resistance of HICAS solenoid (R.H.)	4 - 6Ω
23	Resistance of HICAS solenoid (L.H.)	4 - 6Ω
24	Ground	0V

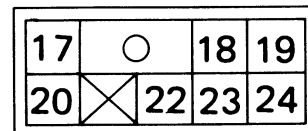
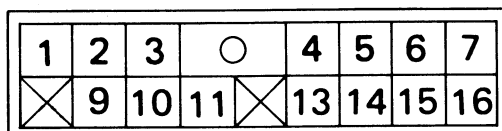

SST748B

SERVICE DATA AND SPECIFICATIONS (S.D.S.)

General Specifications

Steering model	Power steering
Steering gear type	PR24SC
Steering overall gear ratio	16.8
Turn of steering wheel (Lock to lock)	3.1
Steering column type	Collapsible, tilt

Inspection and Adjustment

GENERAL

Steering wheel axial play mm (in)	0 (0)
Steering wheel play mm (in)	0 - 35 (0 - 1.38)
Allowable movement of gear housing mm (in)	±2 (±0.08)

STEERING COLUMN

Steering column length "L ₁ " mm (in)	652.9 - 654.5 (25.70 - 25.77)
Steering column lower shaft length "L ₂ " mm (in)	323.9 - 325.5 (12.75 - 12.81)

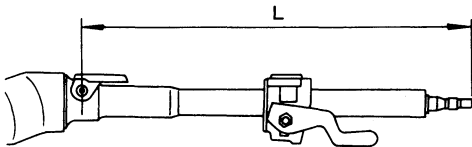

SST802A

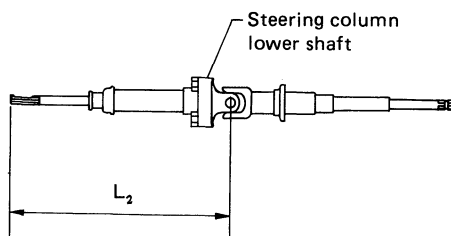

SST792B

STEERING GEAR AND LINKAGE

Item	Steering gear type	PR24SC
Tie-rod outer ball joint Swinging force at cotter pin hole	N (kg, lb)	6.9 - 64.7 (0.7 - 6.6, 1.5 - 14.6)
	Rotating torque N·m (kg-cm, in-lb)	0.29 - 2.94 (3.0 - 30.0, 2.6 - 26.0)
Axial end play	mm (in)	0(0)
Tie-rod inner ball joint Swinging force*	N (kg, lb)	7.8 - 110.8 (0.8 - 11.3, 1.8 - 24.9)
	Rotating torque N·m (kg-cm, in-lb)	7.4 (75, 65) or less
Axial end play	mm (in)	0 (0)
Tie-rod standard length "L"	mm (in)	174.8 (6.88)

*: Measuring point

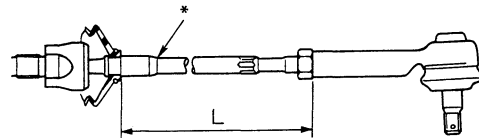

SST487B

Rack stroke "L"	mm (in)	68.5 (2.697)
-----------------	---------	--------------

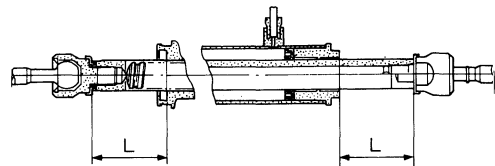

SST086B

SERVICE DATA AND SPECIFICATIONS (S.D.S.)

Inspection and Adjustment (Cont'd)

STEERING GEAR AND LINKAGE (Cont'd)

Pinion gear preload without gear oil N·m (kg-cm, in-lb)	
Within $\pm 100^\circ$ from the neutral position	
Average rotating torque	0.8 - 1.3 (8 - 13, 6.9 - 11.3)
Maximum torque deviation	0.4 (4, 3.5)
Except above range	
Maximum rotating torque	1.9 (19, 16)
Maximum torque deviation	0.6 (6, 5.2)
Rack sliding force without gear oil N (kg, lb)	
Within ± 5.5 mm (± 0.217 in) from the neutral position	122.6 - 166.7 (12.5 - 17, 27.6 - 37.5)
Except above range	122.6 - 186.3 (12.5 - 19, 27.6 - 41.9)

POWER STEERING

Rack sliding force Under normal operating oil pressure Range within ± 11.5 mm (± 0.453 in) from the neutral position	N (kg, lb)	167 - 226 (17 - 23, 37 - 51)
Retainer adjustment Adjusting screw Initial tightening torque	N·m (kg-cm, in-lb)	4.9 - 5.9 (50 - 60, 43 - 52)
Retightening torque after loosening		0.2 (2, 1.7)
Tightening torque after gear has settled		4.9 (50, 43)
Returning angle	degree	$70^\circ - 110^\circ$
Steering wheel turning force (Measured at one full turn from the neutral position)	N (kg, lb)	39 (4, 9) or less
Fluid capacity (Approximate)	ℓ (US qt, Imp qt)	0.9 (1, 3/4)
Oil pump maximum pressure	kPa (kg/cm ² , psi)	
Without HICAS		7,159 - 7,748 (73 - 79, 1,038 - 1,123)
With HICAS		
Main (For power steering)		7,159 - 7,748 (73 - 79, 1,038 - 1,123)
Sub (For HICAS)		6,375 - 6,865 (65 - 70, 924 - 995)

POWER CYLINDER LOWER LINK (SUPER HICAS)

Power cylinder lower link ball joint		
Swinging force*	N (kg, lb)	2.9 - 41.2 (0.3 - 4.2, 0.7 - 9.3)
Axial end play	mm (in)	0 (0)
Power cylinder lower link standard length "L"	mm (in)	309.5 (12.19)
Stroke	mm (in)	3.0 (0.118)

*: Measuring point

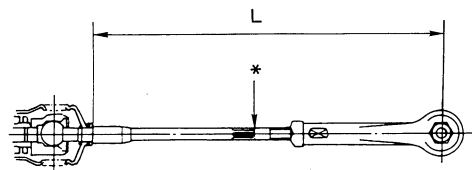

SST486B

SECTION BF**CONTENTS**

GENERAL SERVICING	
(Including all clips & fasteners)	BF- 2
BODY END	BF- 6
DOOR	
(Including "Power Window" & "Power Door Lock")	BF-12
INSTRUMENT PANEL	BF-18
INTERIOR AND EXTERIOR	
(In EXTERIOR, including "Weatherstrips")	BF-20
SEAT	BF-30
AUTOMATIC SEAT BELT SYSTEM	BF-32
TROUBLE DIAGNOSES	BF-41
SUN ROOF	BF-68
WINDSHIELD AND WINDOWS	BF-72
MIRROR – Door Mirror	BF-79
REAR COMBINATION LAMP	BF-80
FRONT AND REAR AIR SPOILER	BF-81
BODY ALIGNMENT	BF-83

When you read wiring diagrams:

- Read GI section, "HOW TO READ WIRING DIAGRAMS".
- See EL section, "POWER SUPPLY ROUTING" for power distribution circuit.

When you perform trouble diagnoses, read GI section, "HOW TO FOLLOW FLOW CHART IN TROUBLE DIAGNOSES".

BF

★ For conventional seat belt, refer to MA section.

GENERAL SERVICING

Precautions

- When removing or installing various parts, place a cloth or padding onto the vehicle body to prevent scratches.
- Handle trim, molding, instruments, grille, etc. carefully during removing or installation. Be careful not to soil or damage them.
- Apply sealing compound where necessary when installing parts.
- When applying sealing compound, be careful that the sealing compound does not protrude from parts.
- When replacing any metal parts (for example body outer panel, members, etc.), be sure to take rust prevention measures.

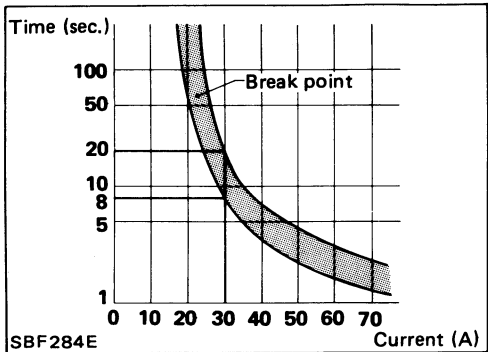

Circuit Breaker Inspection

For example, when current is 30A, the circuit is broken within 8 to 20 seconds.

Circuit breakers are used in the following systems.

- Power window & power door lock
- Automatic seat belt
- Power sun roof





Clip and Fastener

- Clips and fasteners in BF section correspond to the following numbers and symbols.
- Replace any clips and/or fasteners which are damaged during removal or installation.

No.	Symbol	Shape	Removal & Installation
C101	 SBF092B	 SBF109B	<p>Removal: Remove by bending up with a flat-bladed screwdriver.</p> <p>SBF094B</p>
C102	 SBF113B	 SBF114B SBF137B	<p>Removal: Pull up by rotating.</p> <p>SBF115B</p>

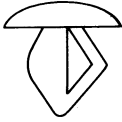
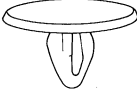
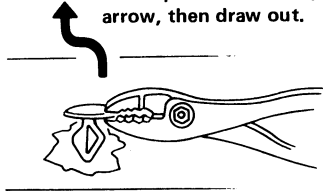
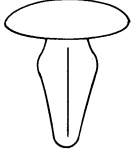
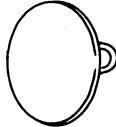
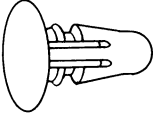

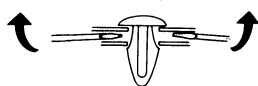
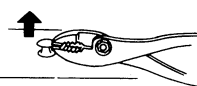
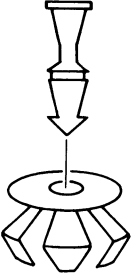
GENERAL SERVICING

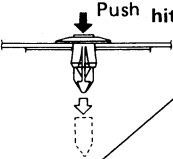
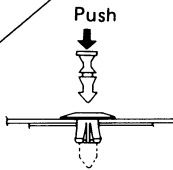
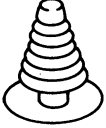
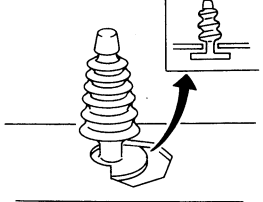
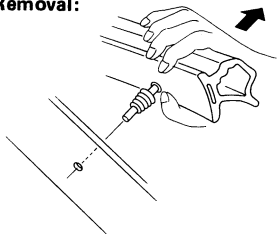
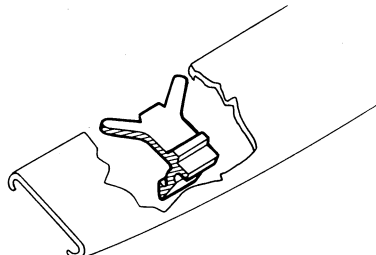
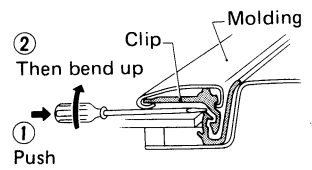
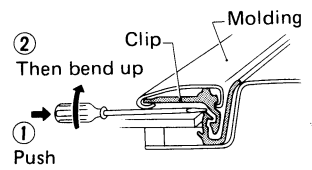
Clip and Fastener (Cont'd)

No.	Symbol	Shape	Removal & Installation
C105	 SBF141B	 SBF142B	<p>Removal: Tilt clip as indicated by arrow, then draw out.</p>  SBF143B
C106	 SBF089B	   SBF090B	<p>Removal: Remove with a flat-bladed screwdrivers or plier.</p>   SBF091B
C203	 SBF318C	 SBF319C	<p>Push center pin to catching position. (Do not remove center pin by hitting it.)</p>   <p>Installation: SBF320C</p>
CE103	 SBF103B	 SBF104B	<p>Removal:</p>  SBF147B
CE106	 SBF653B	 SBF654B	<p>Removal:</p>  SBF654B

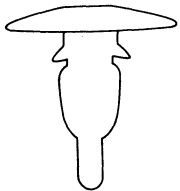
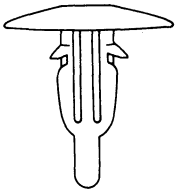
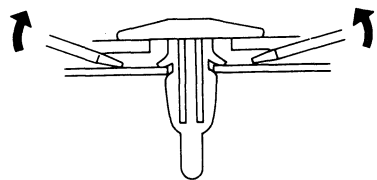
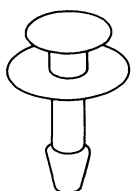
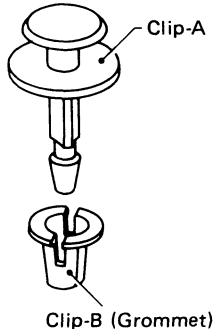
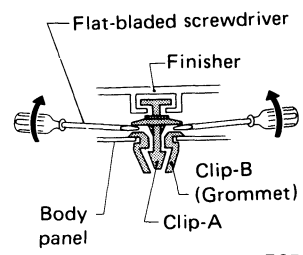
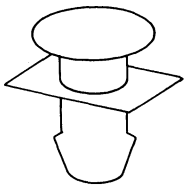
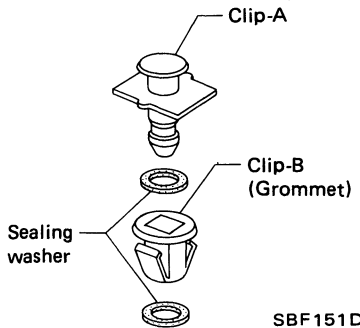
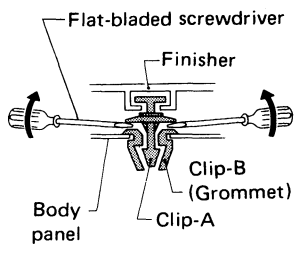
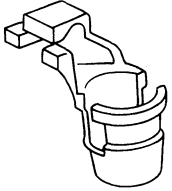
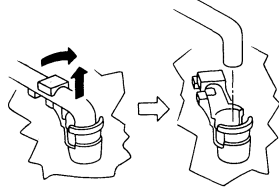

GENERAL SERVICING

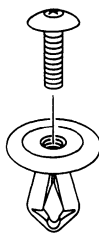
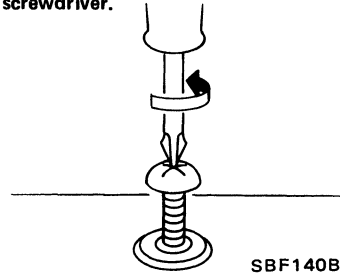
Clip and Fastener (Cont'd)

No.	Symbol	Shape	Removal & Installation
(CE117)	 SBF173D	 SBF174D	<p>Removal: Remove with a flat-bladed screwdriver or pliers.</p>  SBF175D
(CF113)	 SBF035C	 SBF036C Clip-B (Grommet)	<p>Removal:</p>  SBF652B
(CF118)	 SBF150D	 SBF151D	<p>Removal:</p>  SBF652B
(CR103)		 SBF768B	<p>Removal: Holder portion of clip must be spread out to remove rod.</p>  SBF770B
(CS102)	 SBF138B	 SBF139B	<p>Removal: Screw out with a Phillips screwdriver.</p>  SBF140B

GENERAL SERVICING

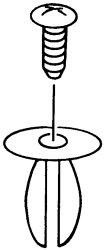
Clip and Fastener (Cont'd)

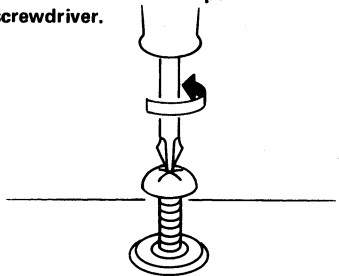
No.	Symbol	Shape	Removal & Installation
CS104	 <p>SBF361B</p>	 <p>SBF362B</p>	<p>Removal: Screw out with a Phillips screwdriver.</p>  <p>SBF140B</p>

BODY END

Body Front End

- Hood adjustment: Adjust at hinge portion.
- Hood lock adjustment: After adjusting, check hood lock control operation. Apply a coat of grease to hood locks engaging mechanism.
- Hood opener: Do not attempt to bend cable forcibly.

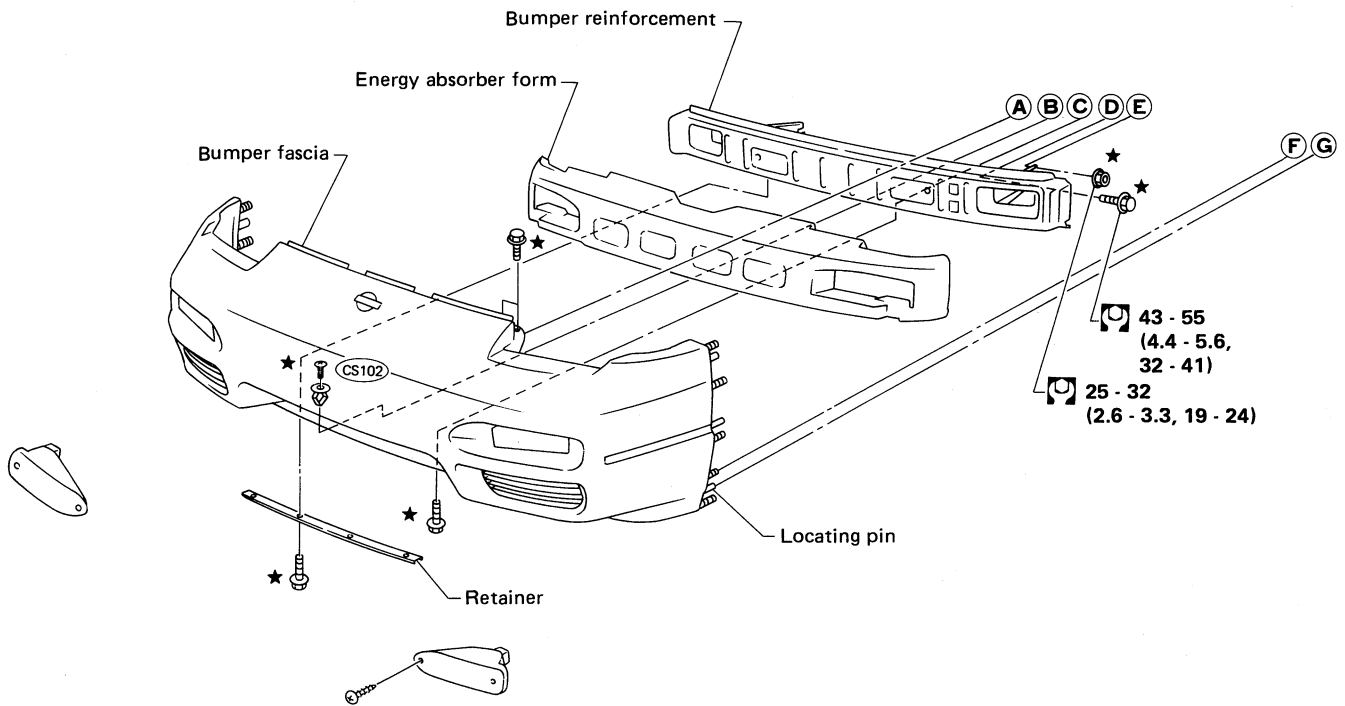

BODY END

Body Front End (Cont'd)

Hood lock adjustment

- Adjust lock so that hood primary lock meshes at a position where hood is 1 to 1.5 mm (0.039 to 0.059 in) lower than fender.
- After hood lock adjustment, adjust bumper rubber.
- When securing hood lock, ensure it does not tilt. Striker must be positioned at the center of hood primary lock.
- After adjustment, ensure that hood primary and secondary lock operate properly.

Hood lock secondary latch hooking length

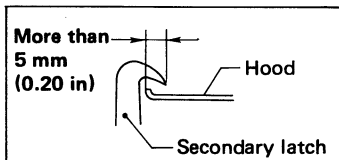

Bumper rubber adjustment

- Adjust so that hood is aligned with fender. [Bumper rubber free height is approx. 20 mm (0.79 in).]

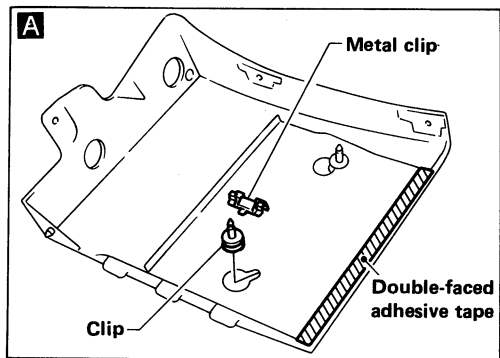
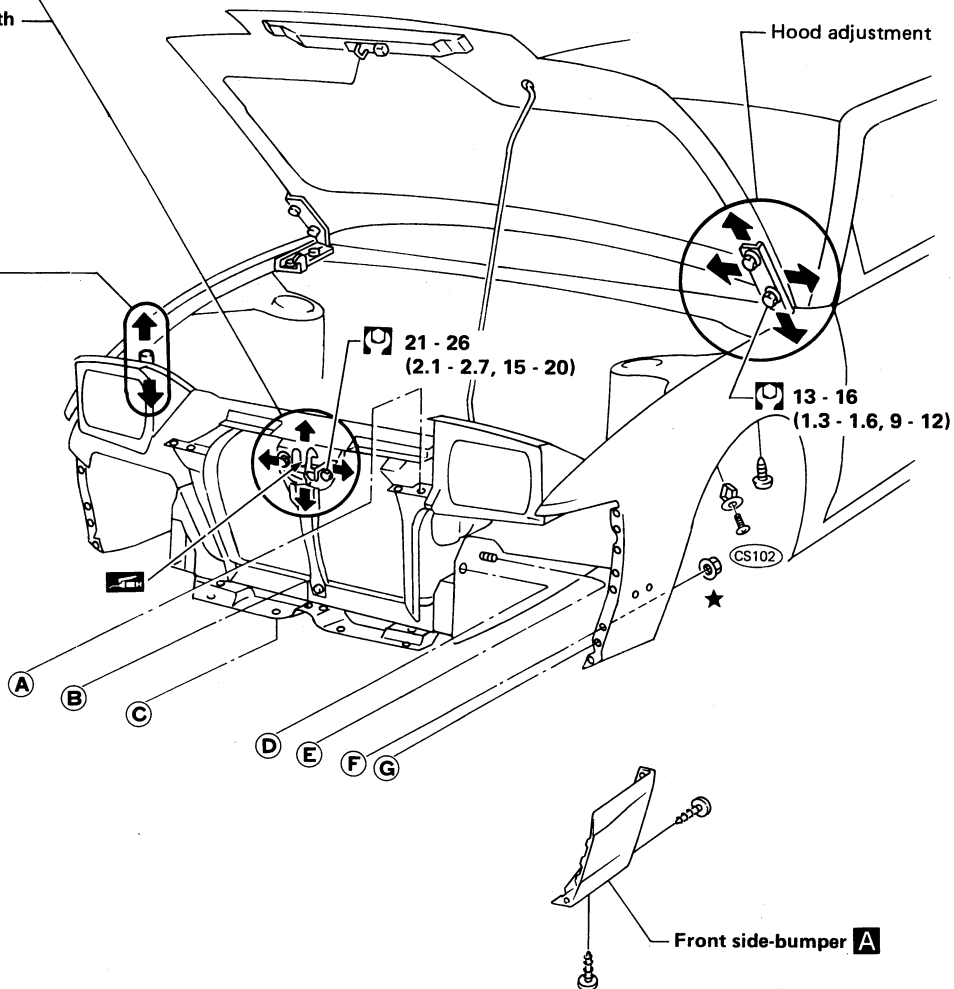

- ★ : Bumper assembly mounting bolts, nuts and clips
- ☐ : N·m (kg·m, ft·lb)

MBF217A

BODY END

Body Rear End and Opener

- Back door adjustment: Adjust at hinge-body portion for proper back door fit.
- Back door lock system adjustment: Adjust lock & striker so that they are in the center. After adjustment, check back door lock operation.
- Trunk lid adjustment: Adjust at hinge-trunk lid portion for proper trunk lid fit.
- Trunk lid lock system adjustment: Adjust striker so that it is in the center of the lock. After adjustment, check trunk lid lock operation.

WARNING:

- Be careful not to scratch back door stay when installing back door. A scratched stay may cause gas leakage.**
 - The contents of the back door stay are under pressure. Do not take apart, puncture, apply heat or allow fire near it.**
- Opener cable: do not attempt to bend cable using excessive force.
 - After installation, make sure that trunk lid/back door and fuel filler lid open smoothly.

FASTBACK

- Before removing rear bumper, remove right drafter which is secured with two upper nuts and butyl seal.

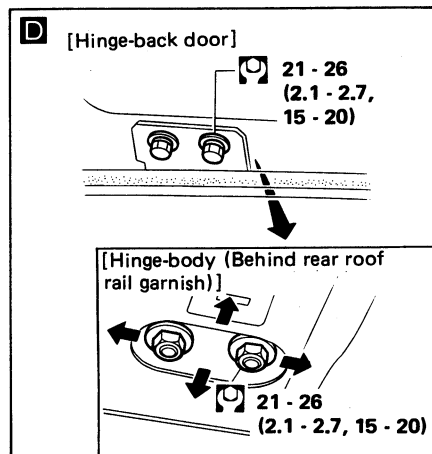
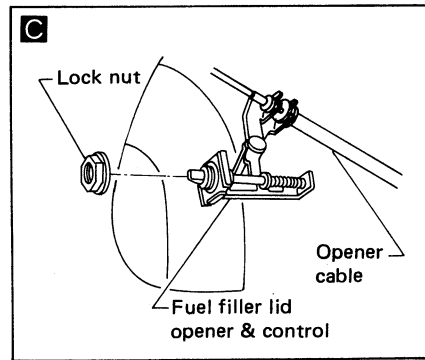
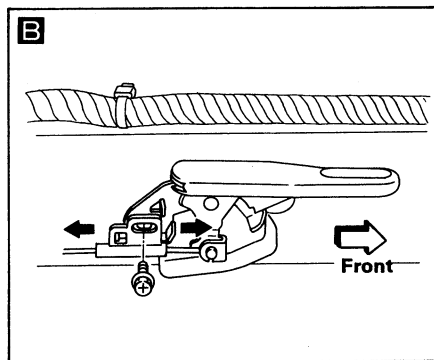
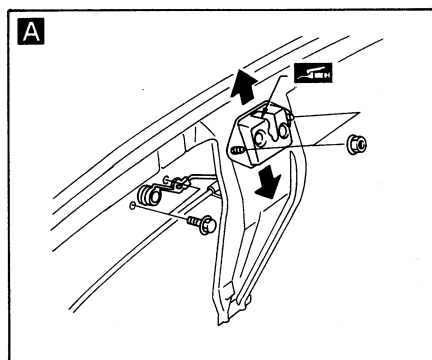

BODY END

Body Rear End and Opener (Cont'd)

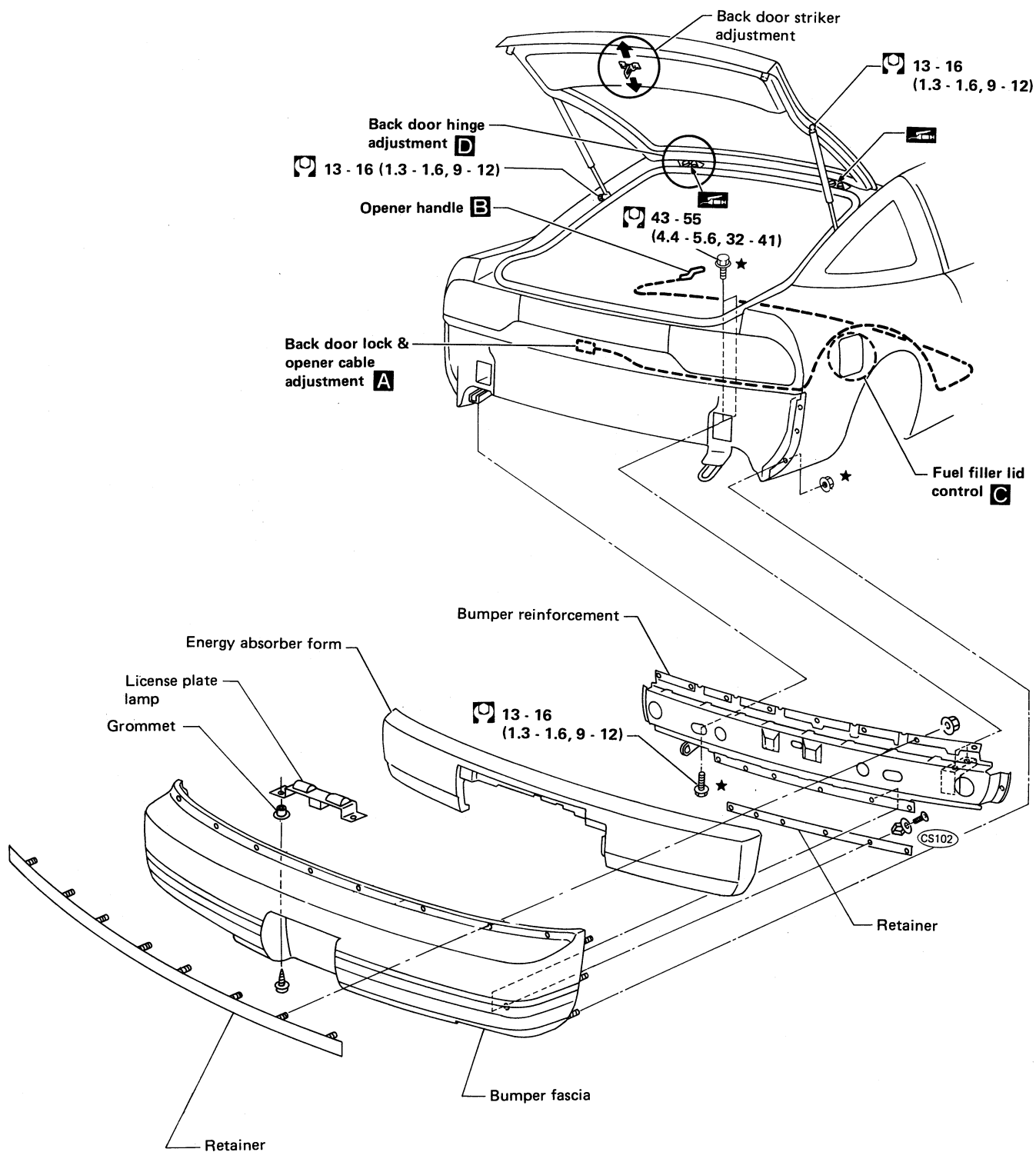

★ : Bumper assembly mounting bolts and nuts
⊙ : N·m (kg·m, ft·lb)

SBF998E

BODY END

Body Rear End and Opener (Cont'd)

COUPE

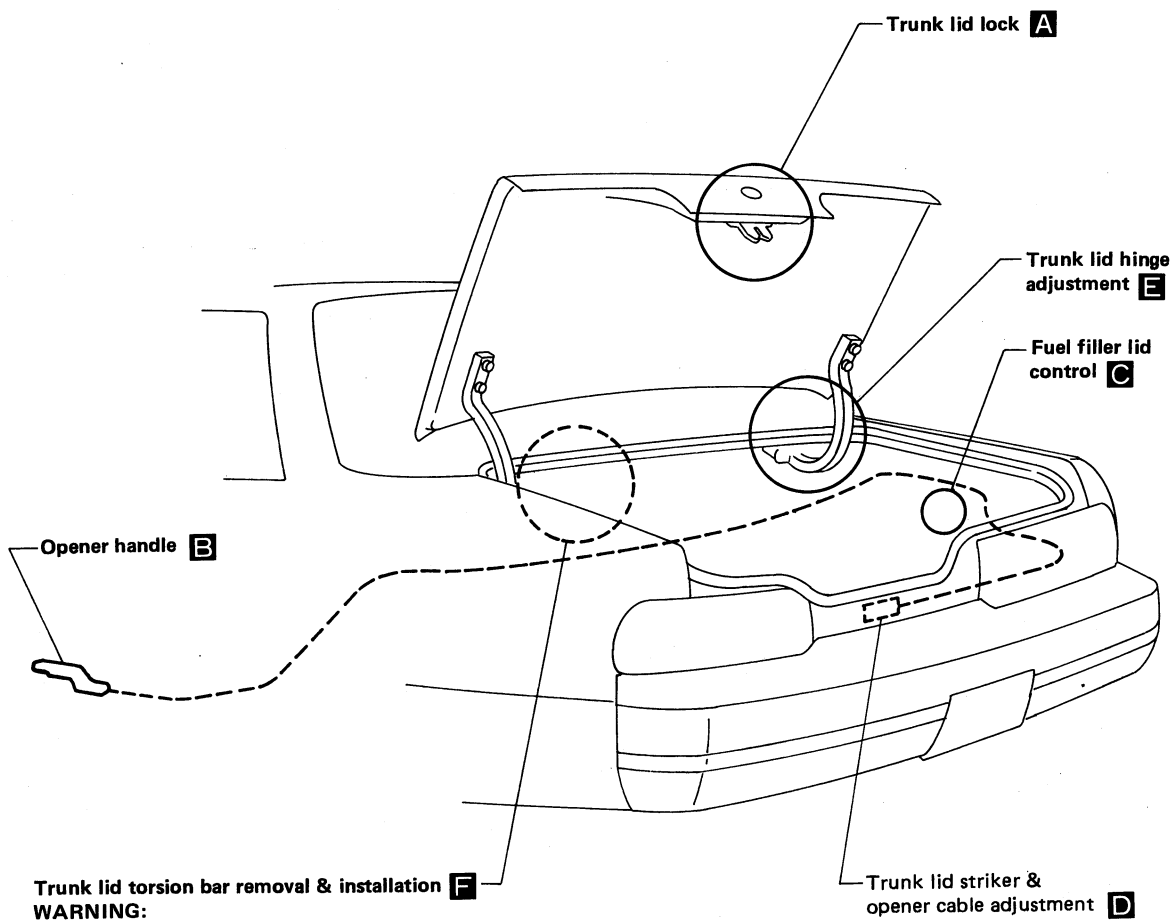

Trunk lid torsion bar removal & installation **F**

WARNING:
When removing and installing
torsion bar, be careful as it is
under tension.

Trunk lid striker &
opener cable adjustment **D**

BODY END

Body Rear End and Opener (Cont'd)

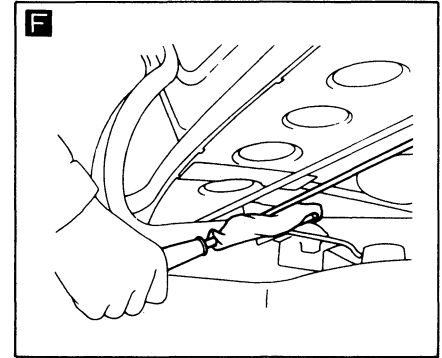
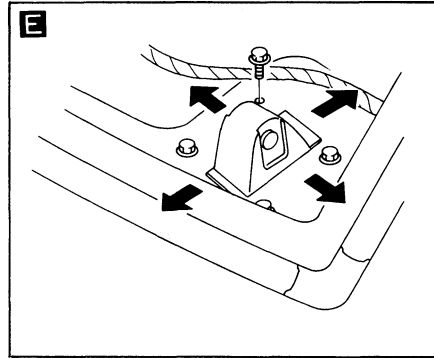
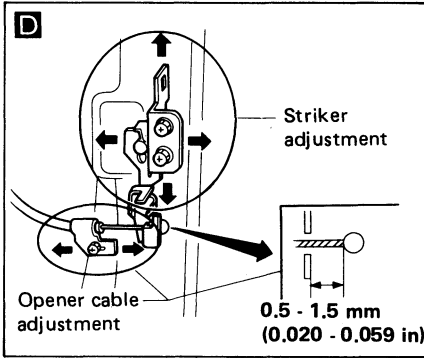
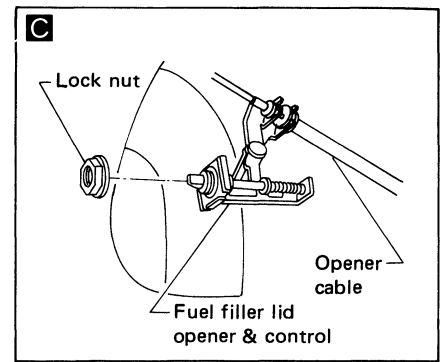
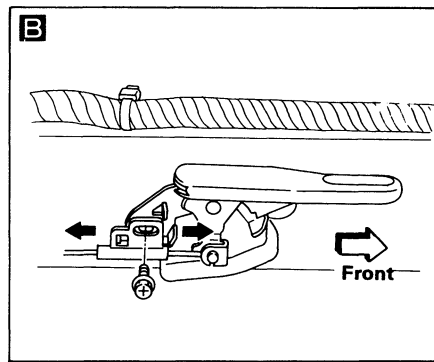
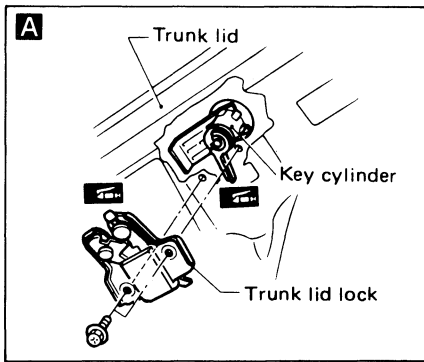

DOOR

- After adjusting door or door lock, check door lock operation.

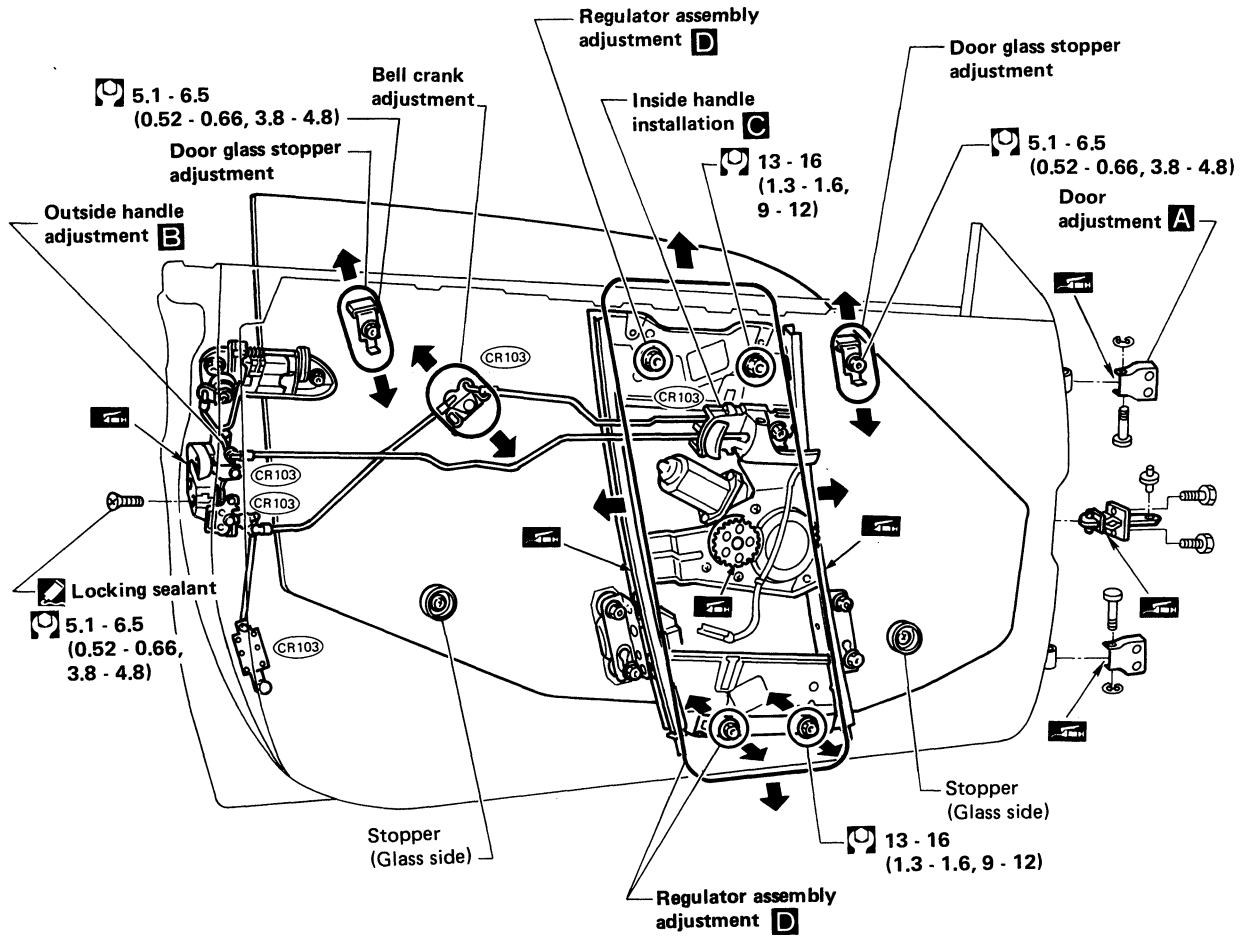

: N·m (kg·m, ft·lb)

DOOR

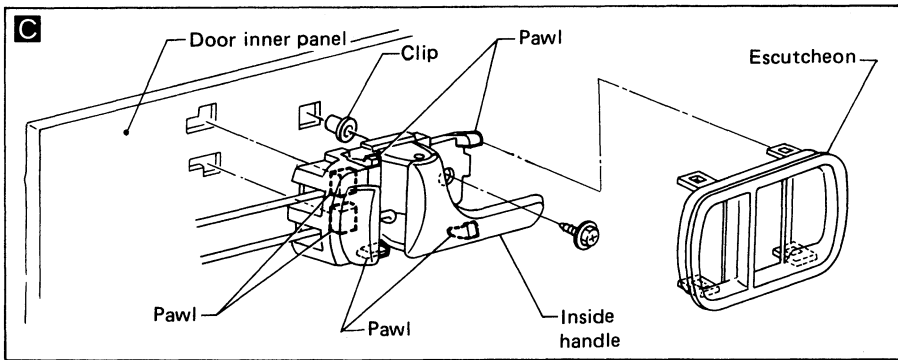
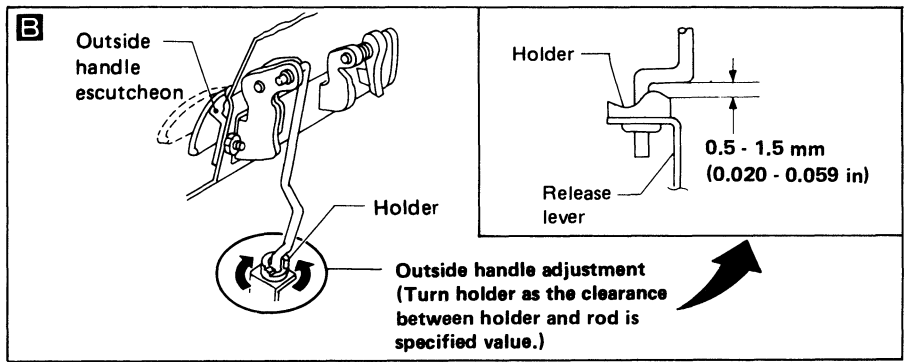
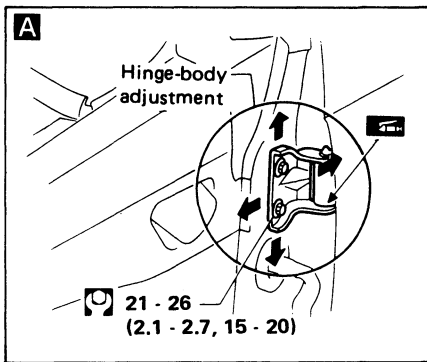

Striker adjustment

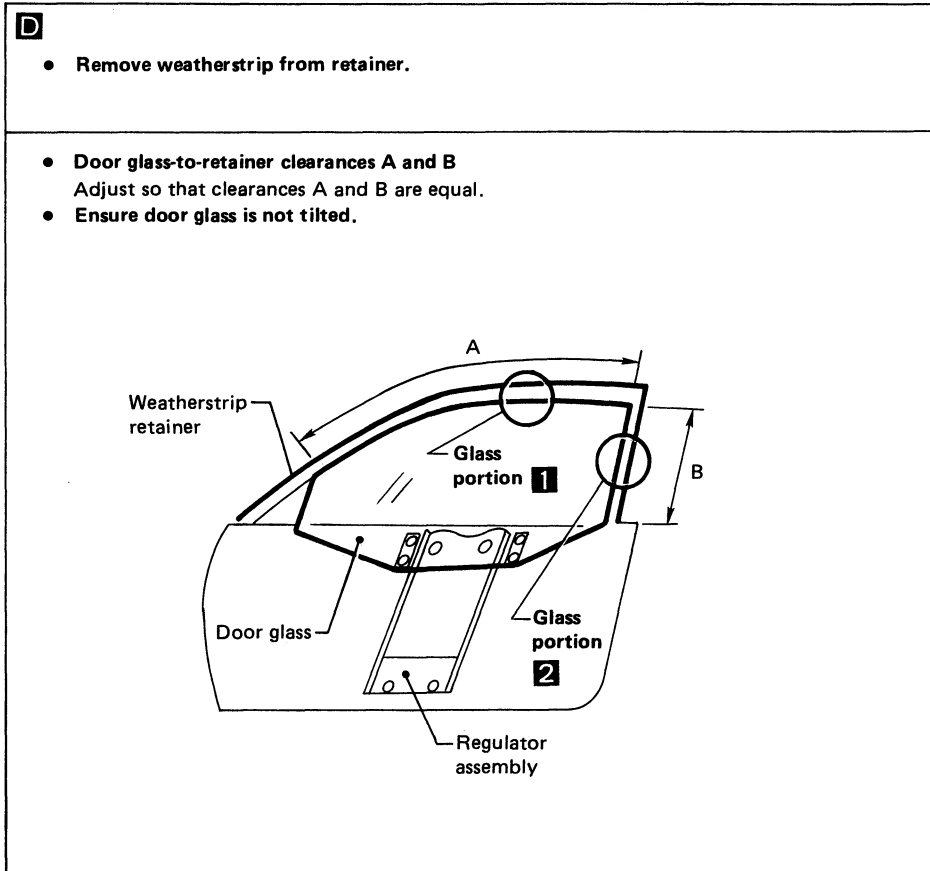
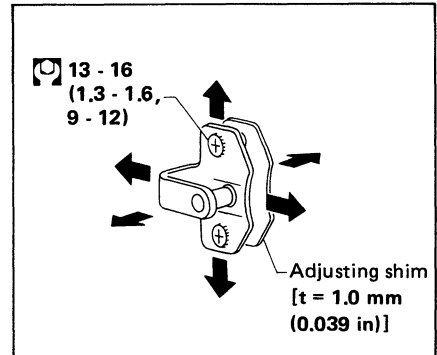

Glass portion 1

- Adjust to provide proper light surface contact of glass and retainer.

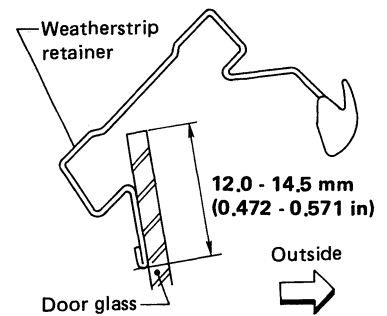

Glass portion 2

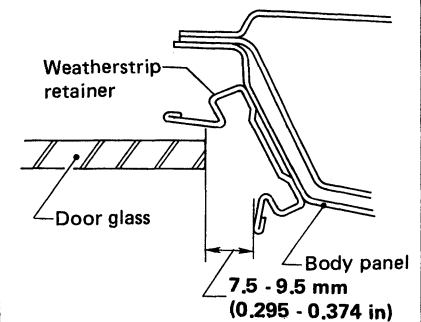

Power Window

WIRING DIAGRAM

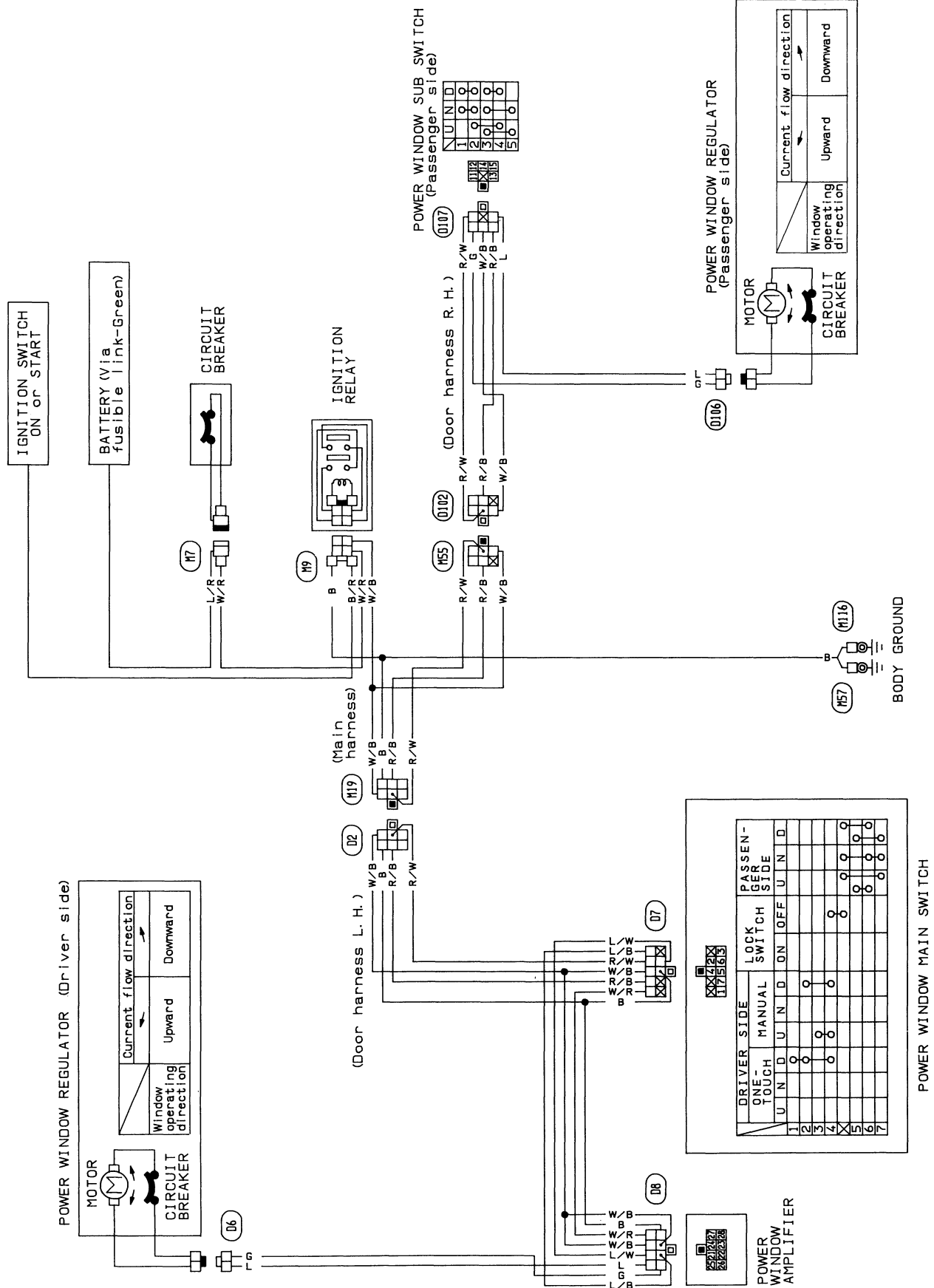

DOOR

Power Window (Cont'd)

POWER WINDOW AMP. INSPECTION

Carry out the inspections below.

- (1) Power source and ground: Battery voltage should exist between terminals ②④ and ②⑦.
- (2) Input signals: Battery voltage should exist between terminal ②③ and ground (IGN "ON" or "ST"). Continuity should exist between terminal ②⑧, ②①, ②② and ground in "ON" condition, and should not exist in "OFF" condition.
- (3) Output signals: Battery voltage shown in the chart should exist.

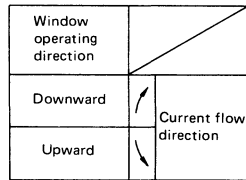
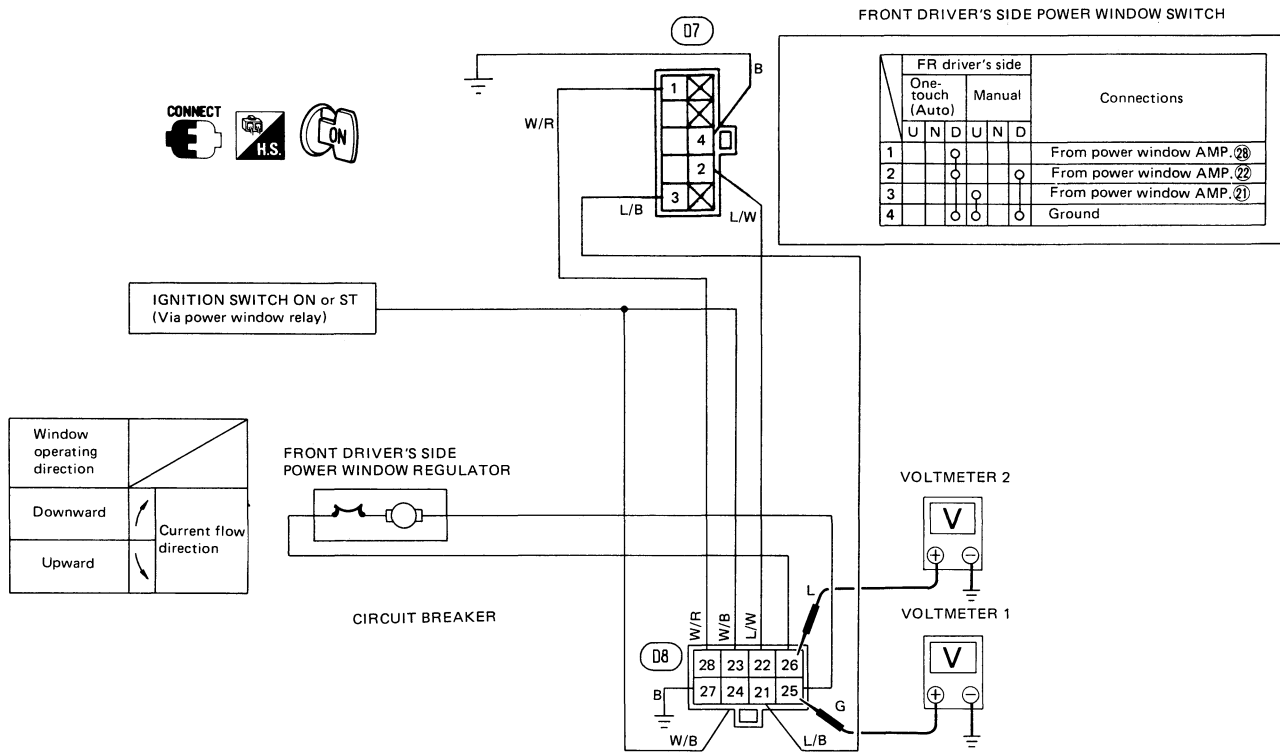

FRONT DRIVER'S SIDE POWER WINDOW REGULATOR

CIRCUIT BREAKER

VOLTMETER 2

VOLTMETER 1

Connections		AMP. OPERATION					
		Operations					
		Manual operation			One-touch (Auto) operation		
		N	UP	Down	N	Down → N	
24	Power source (IGN)	12V	12V	12V	12V	12V	12V
27	Ground	Ground	Ground	Ground	Ground	Ground	Ground
23	From ignition SW (ON or ST)	12V	12V	12V	12V	12V	12V
	To FR driver's side power window SW (AUTO) ①	OFF	OFF	OFF	OFF	ON	OFF
	To FR driver's side power window SW (UP) ③	OFF	ON	OFF	OFF	OFF	OFF
21	To FR driver's side power window SW (DOWN) ②	OFF	OFF	ON	OFF	ON	OFF
25	FR driver's side regulator (Upward power source) VOLTMETER 1	Approx. 0V	Approx. over 9V	Approx. 0V	Approx. 0V	Approx. 0V	Approx. 0V
	FR driver's side regulator (Downward power source) VOLTMETER 2	Approx. 0V	Approx. 0V	Approx. over 9V	Approx. 0V	Approx. over 9V	Approx. over 9V
Regulator Operating Condition		Stop	Upward operation	Downward operation	Stop	Starting	Keeping operation until fully open, then stops automatically.
						Downward operation	

Carry out the operation check in this chart from left to right continuously

POWER WINDOW AMP – Driver's side door

Power Door Lock

WIRING DIAGRAM

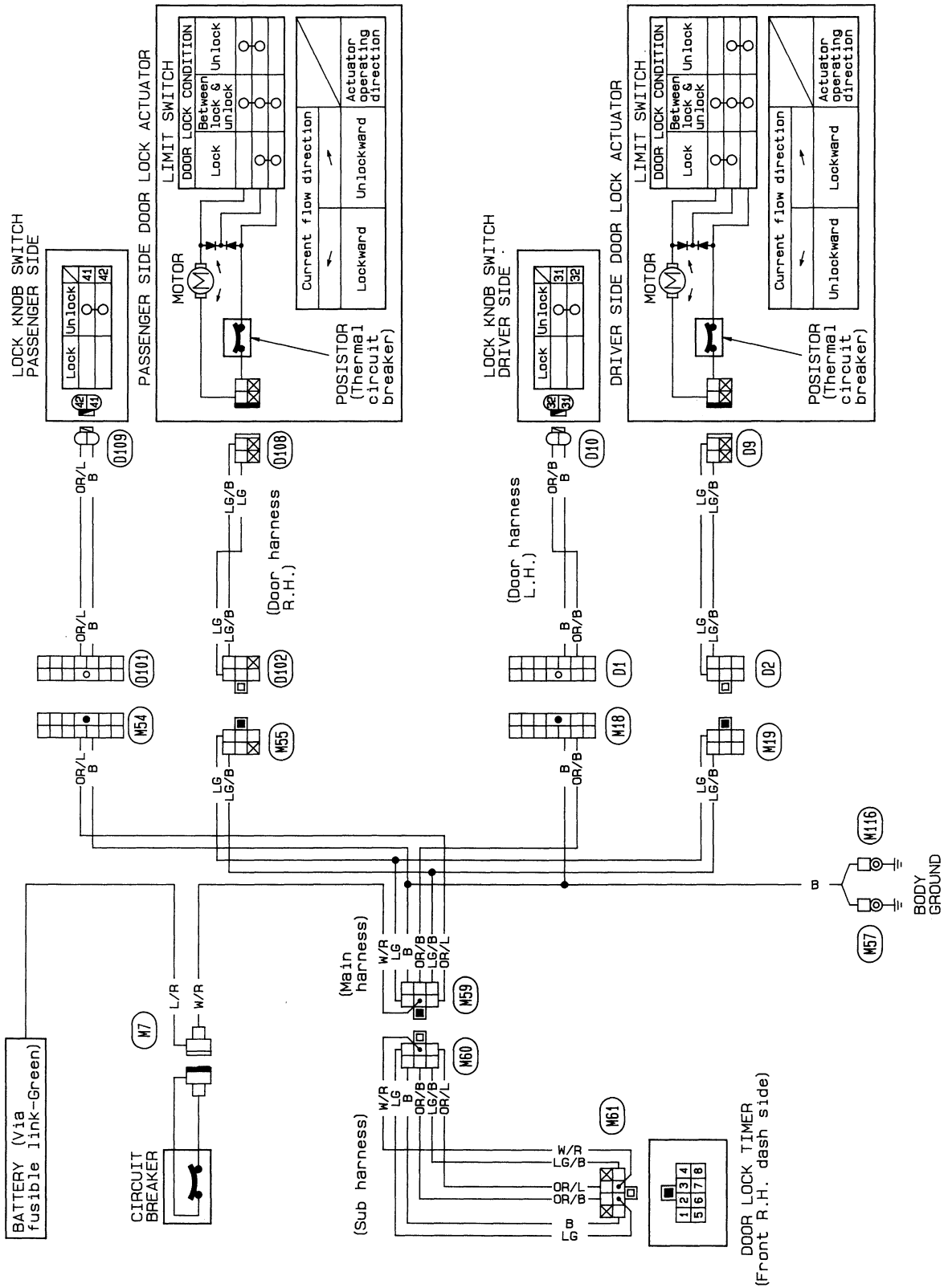

DOOR

Power Door Lock (Cont'd)

DOOR LOCK TIMER INSPECTION

Door lock timer

- Carry out the inspections below.
- (1) Power source and ground: Battery voltage should exist between terminals ③ and ①.
- (2) Input signals: Continuity should exist between terminals ⑥, ⑦ and ground in "ON" condition, and should not exist in "OFF" condition.
- (3) Output signals: Voltage shown in the chart should exist.

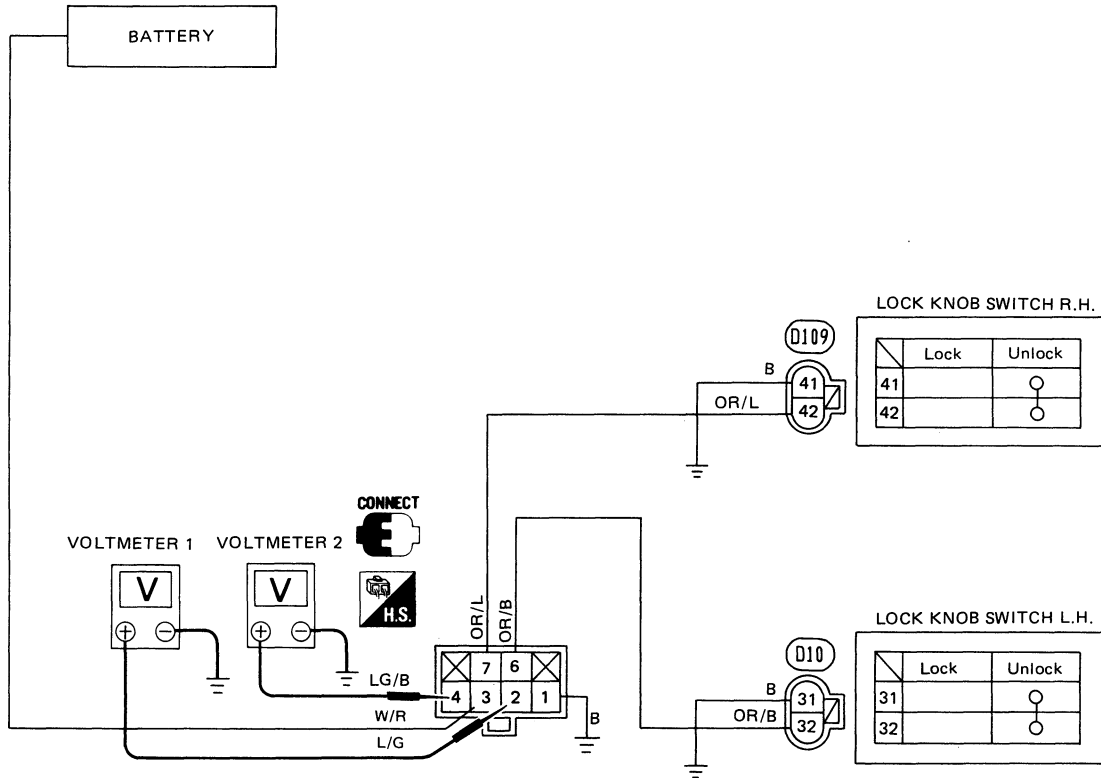

Connections		Operations				
		Lock knob switch L.H.			Lock knob switch R.H.	
		Lock →	Unlock →	Lock	Lock →	Unlock
3	Power source	12V	12V	12V	12V	12V
1	Ground	Ground	Ground	Ground	Ground	Ground
6	Input signal Lock knob switch ③② L.H.	OFF	ON	OFF	—	—
		—	—	—	OFF	ON
7	Input signal Lock knob switch ④② R.H.	—	—	—	OFF	ON
		—	—	—	OFF	ON
2	Output signal Door lock actuator (Lock power source) VOLTMETER 1	0V	0V	12V (Approx. 1.0 sec.) → 0V	0V	0V
		0V	12V (Approx. 1.0 sec.) → 0V	0V	0V	12V (Approx. 1.0 sec.) → 0V
4	Output signal Door lock actuator (Unlock power source) VOLTMETER 2	0V	12V (Approx. 1.0 sec.) → 0V	0V	0V	12V (Approx. 1.0 sec.) → 0V

INSTRUMENT PANEL

- When removing instrument panel assembly, remove defroster grille, combination meter, A/C or heater control, cluster lid C and S.M.J. first.

HEAD-UP DISPLAY (H.U.D.)

- When removing H.U.D. finisher, be extremely careful not to scratch H.U.D.'s reflective surface. To avoid scratching, cover H.U.D.'s reflective surface or finisher with a cloth or vinyl sheet. **L**

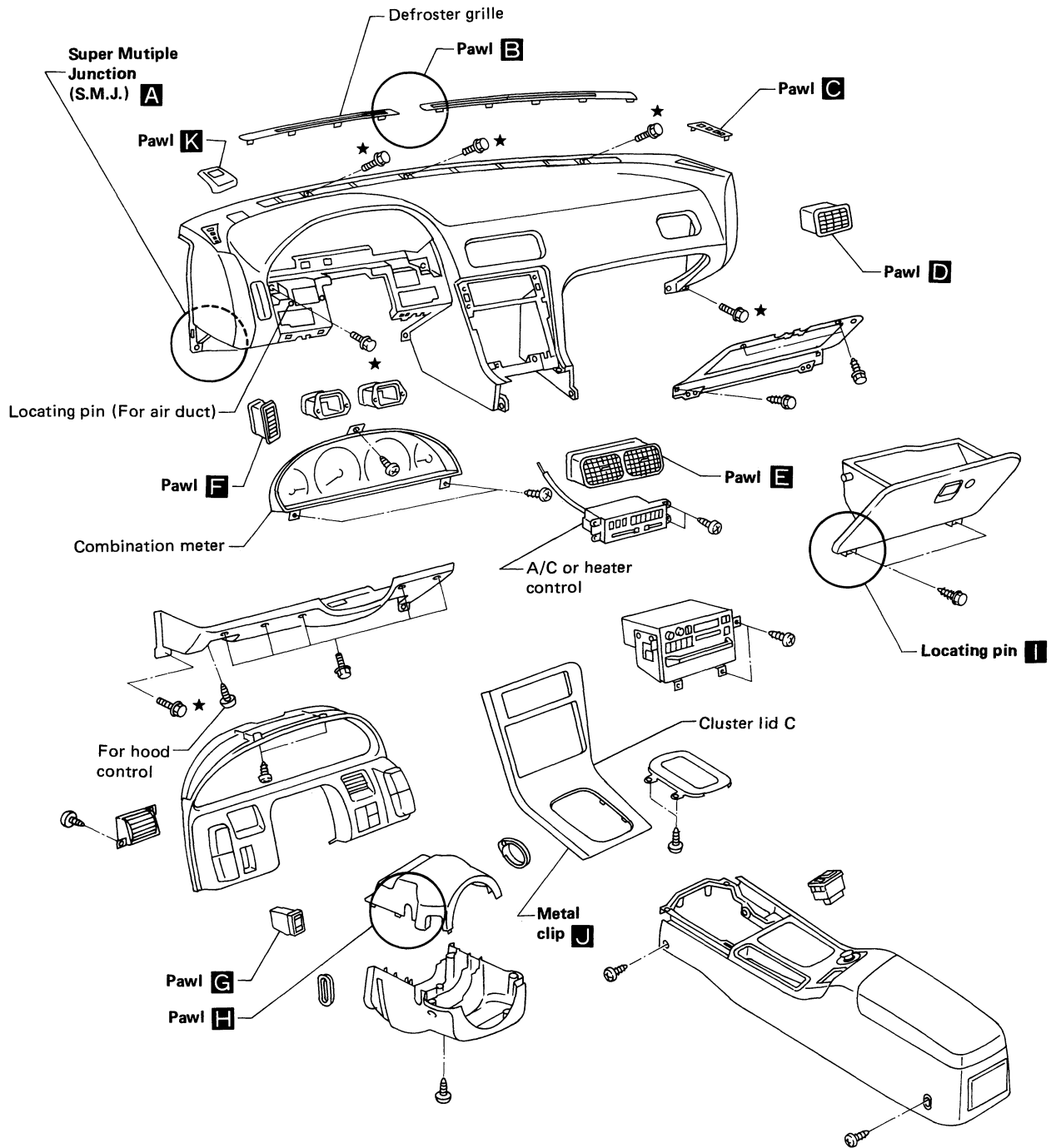

★ : Instrument panel assembly mounting bolts

INSTRUMENT PANEL

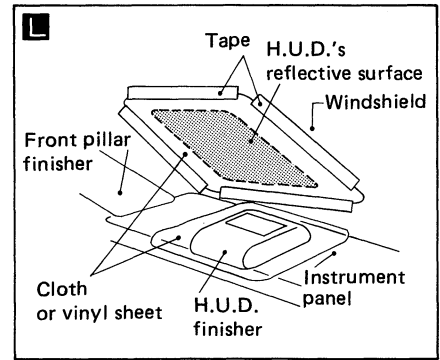
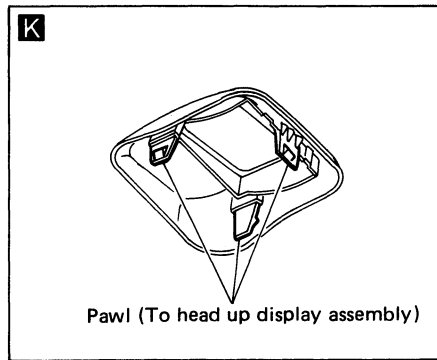
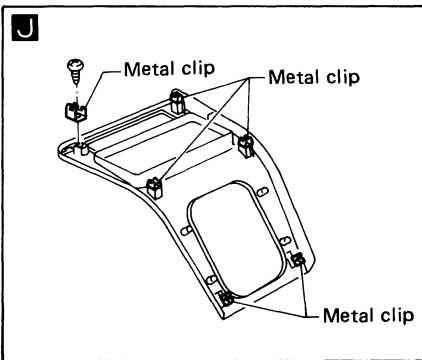
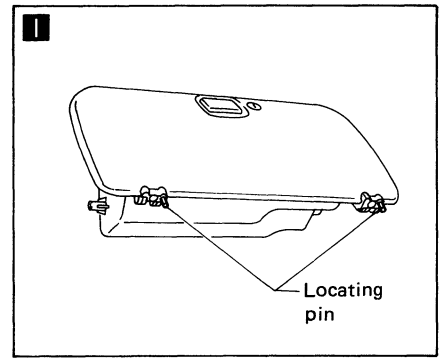
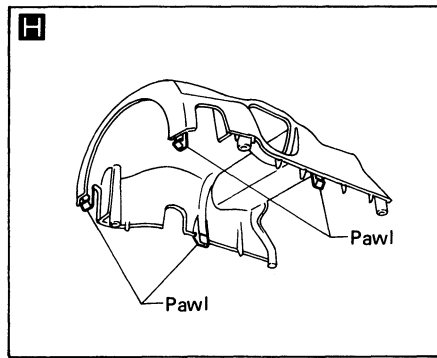
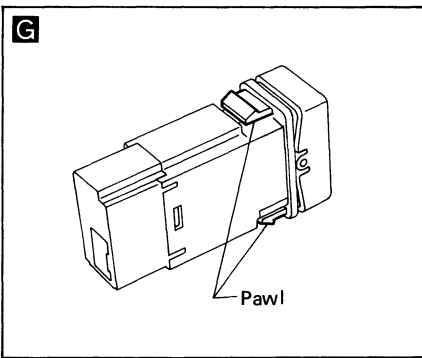
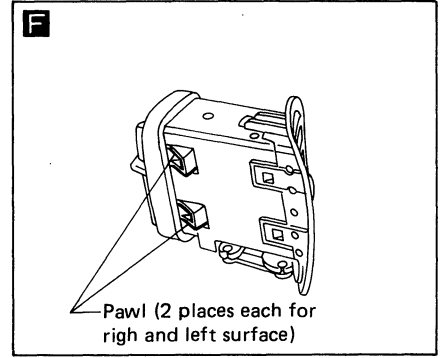
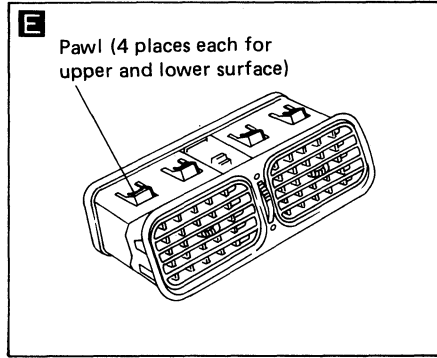
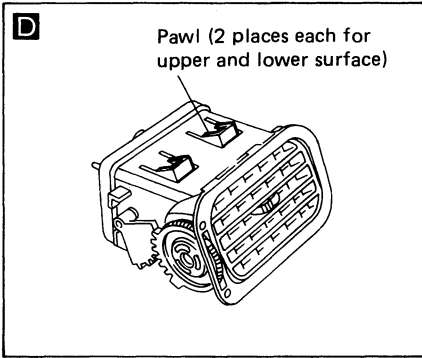
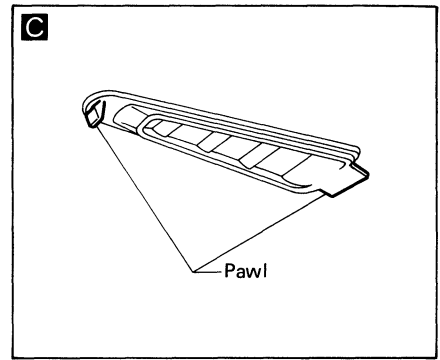
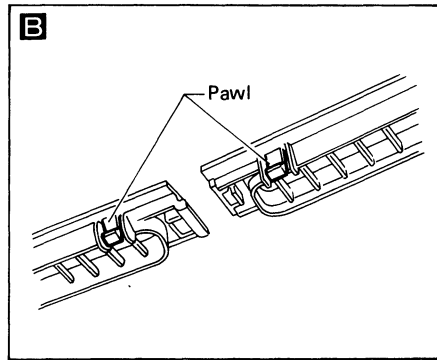
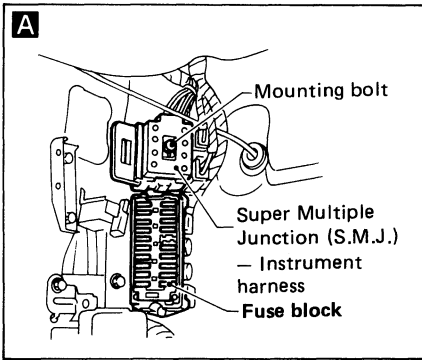

INTERIOR AND EXTERIOR

Interior

SIDE, LUGGAGE AND FLOOR TRIM – Fastback

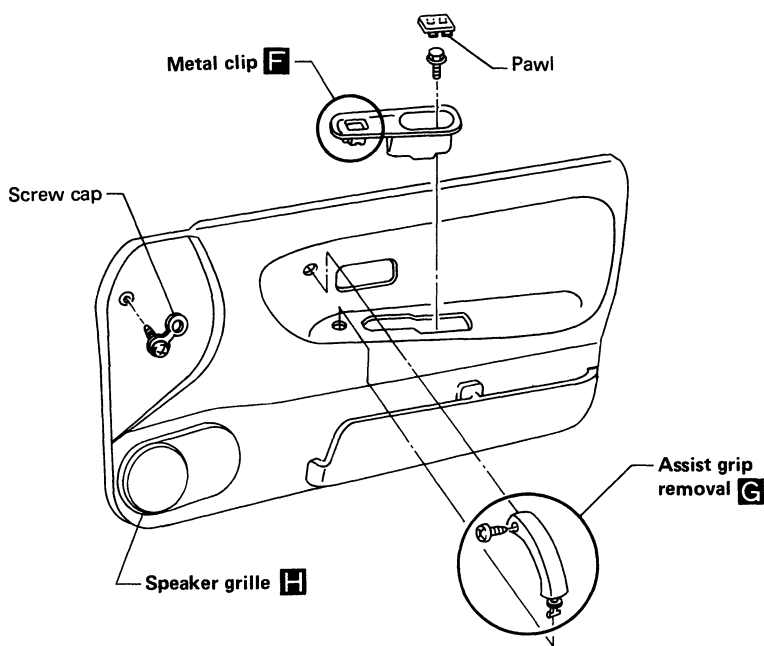
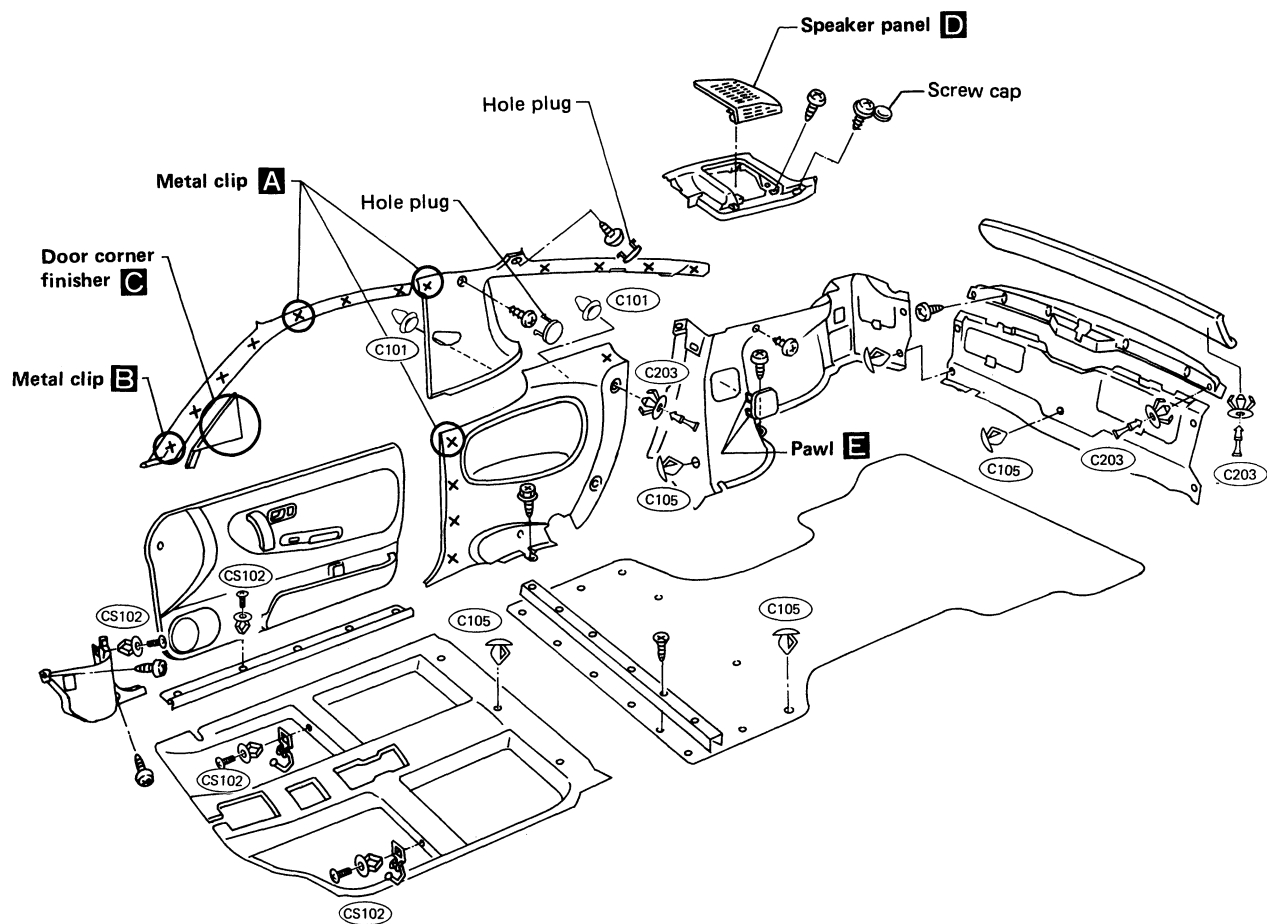

INTERIOR AND EXTERIOR

Interior (Cont'd)

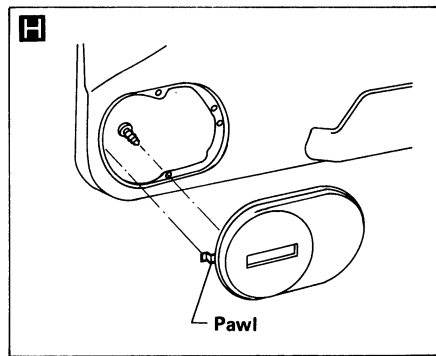
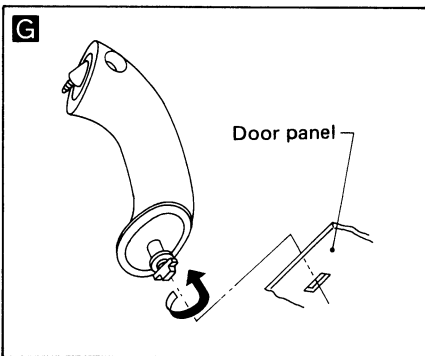
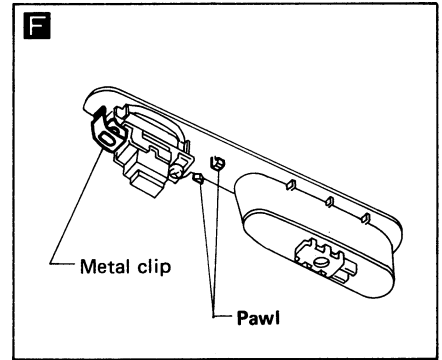
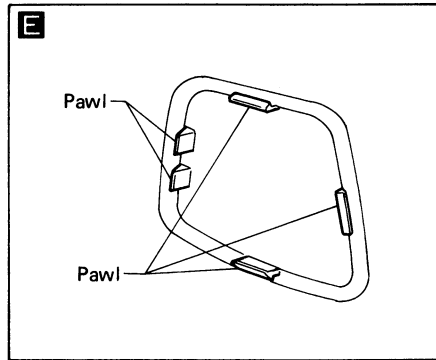
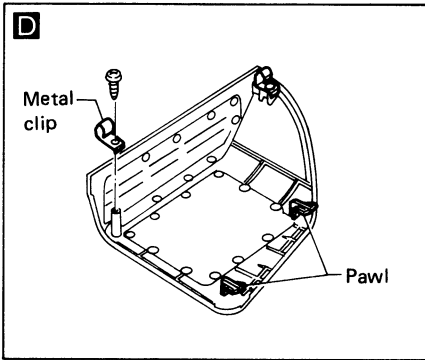
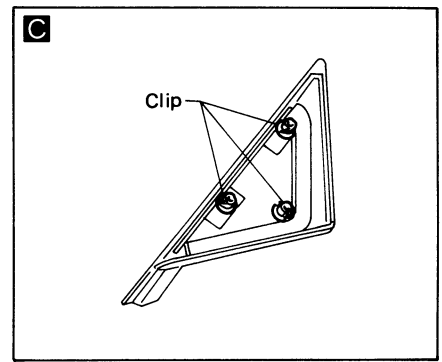
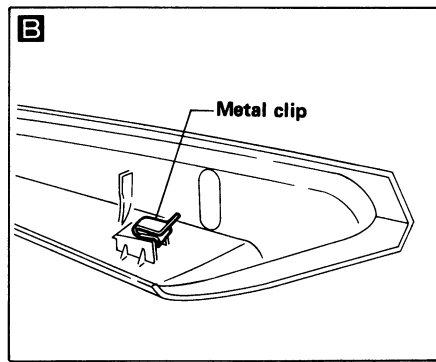
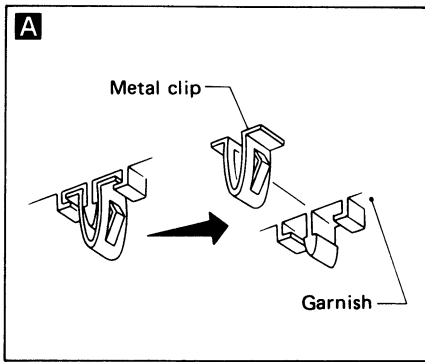

INTERIOR AND EXTERIOR

Interior (Cont'd)

SIDE TRIM – Coupe

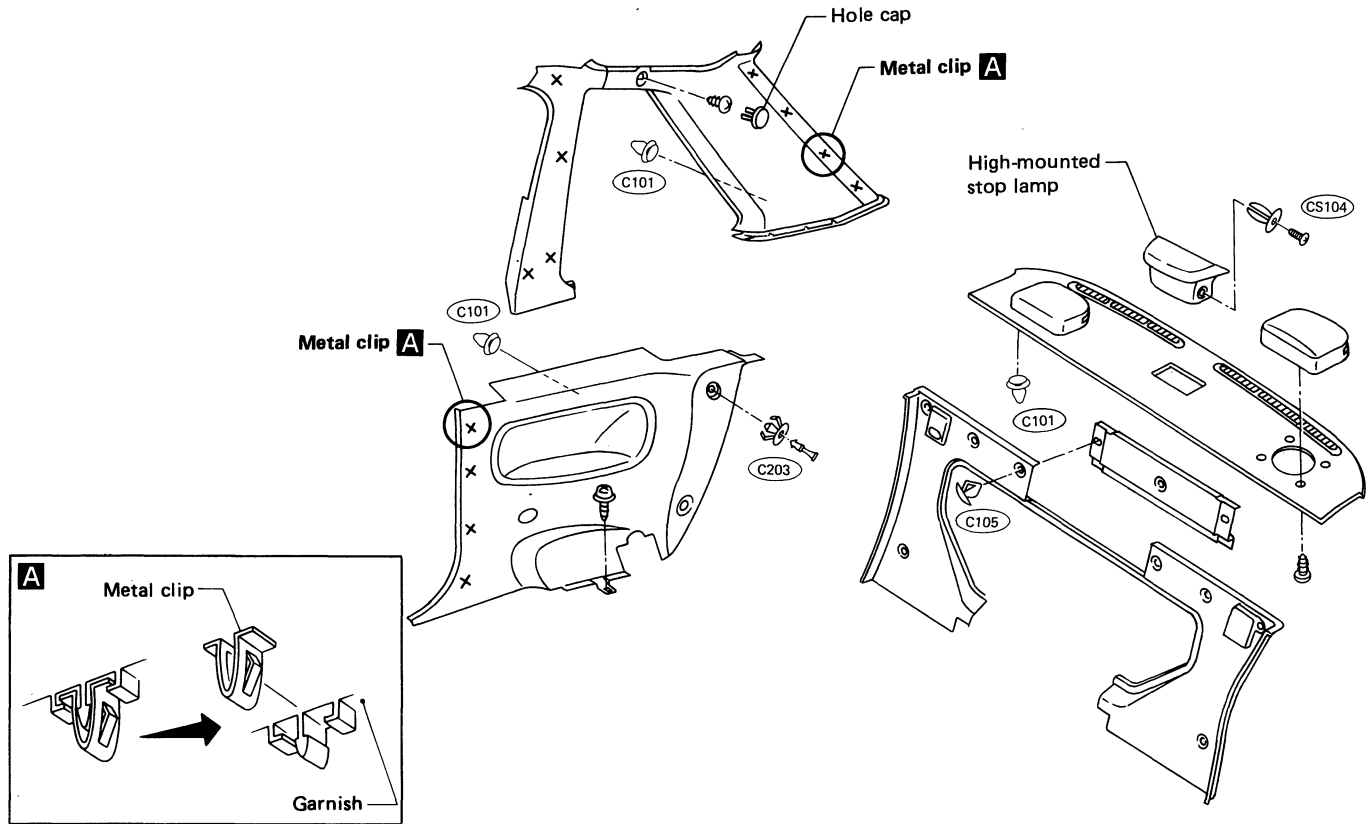

SBF180E

LUGGAGE ROOM TRIM – Coupe

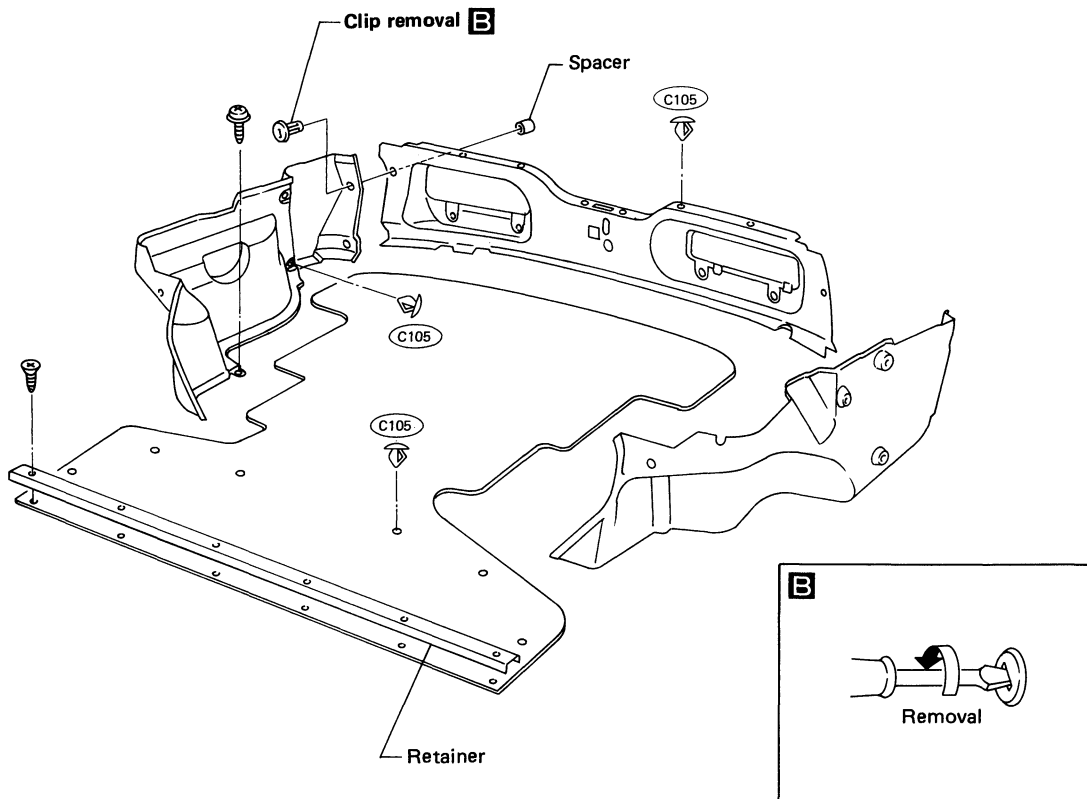

SBF181E

INTERIOR AND EXTERIOR

Interior (Cont'd)

ROOF TRIM

Fastback

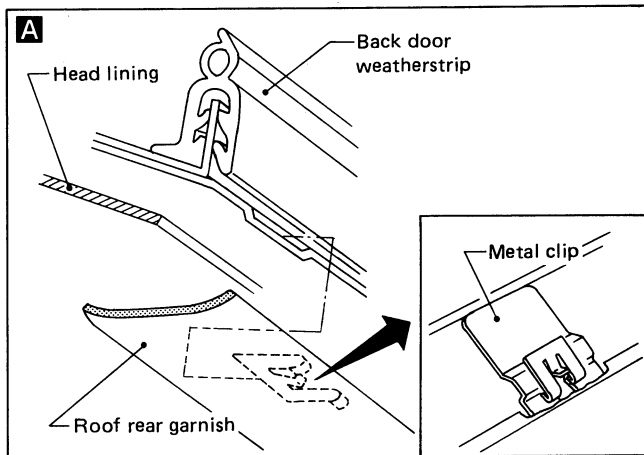
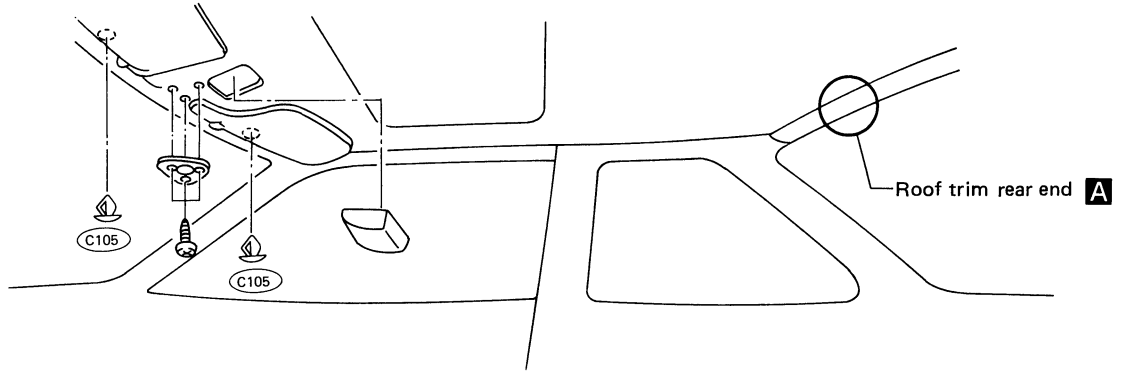

Coupe

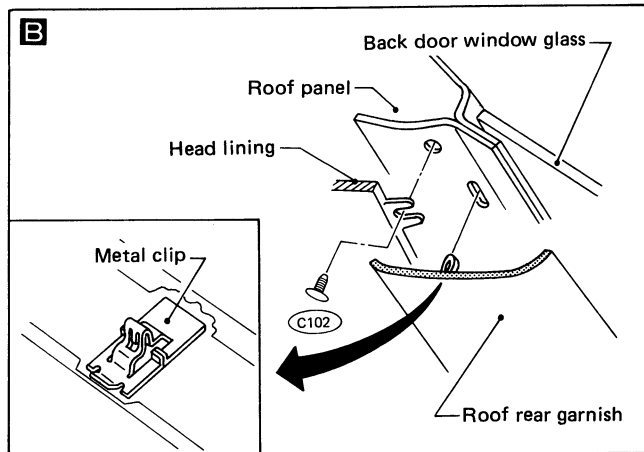
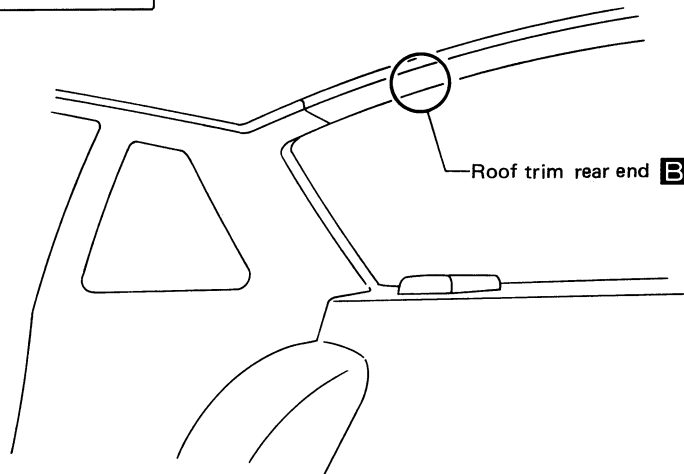

INTERIOR AND EXTERIOR

Exterior

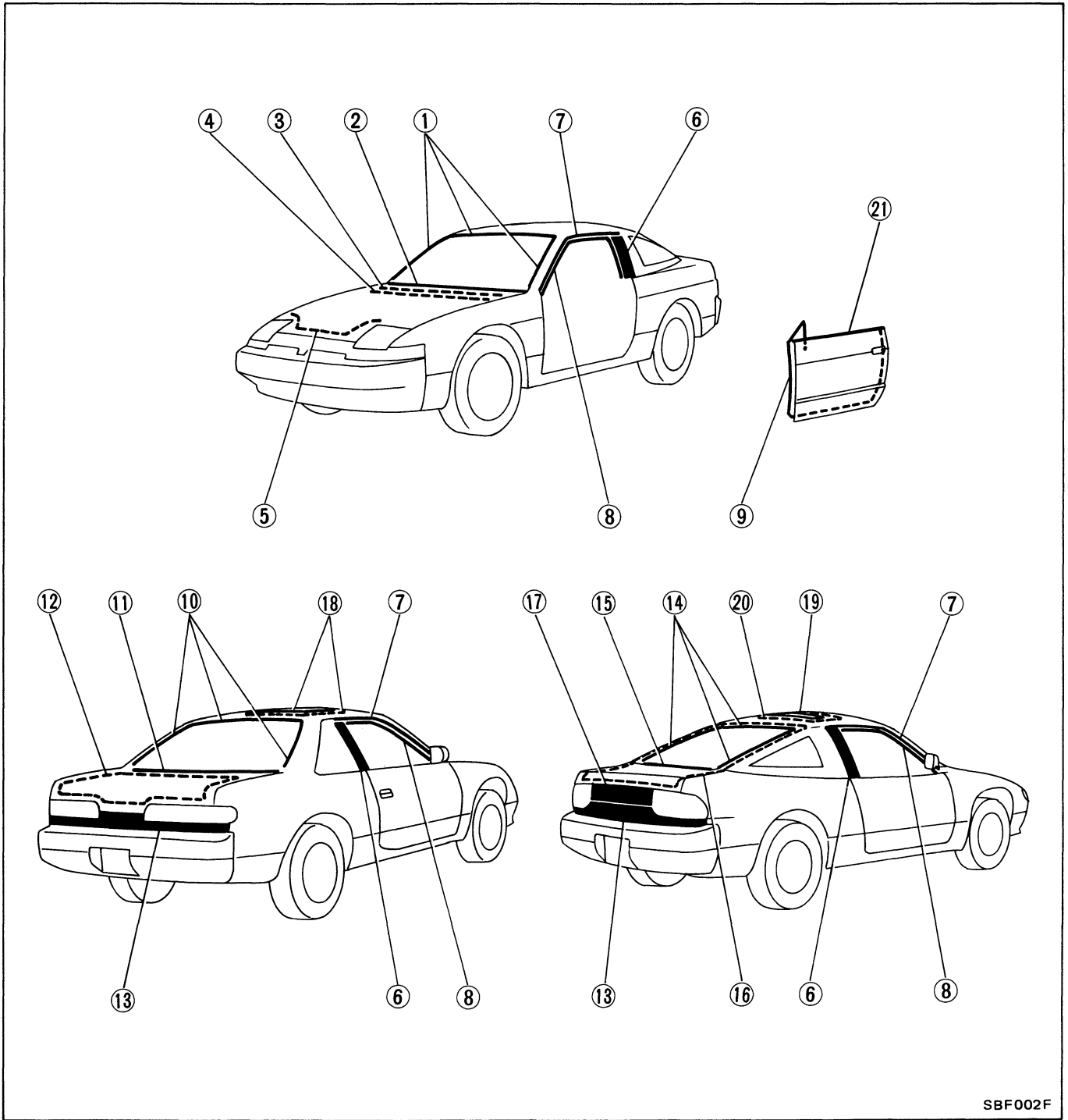

SBF002F

INTERIOR AND EXTERIOR

Exterior (Cont'd)

① Windshield upper and side molding

Method 1

Cut off top portion of molding and clean glass and panel surfaces.

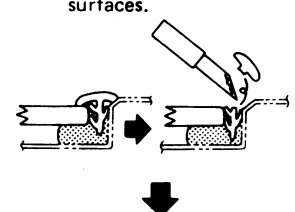

Apply sealant to top portion of molding.



Cut off lower portion of new molding.

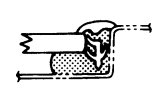

Finish well to give it a good appearance.

Method 2

1. Cut off sealant at glass end.
2. Clean the side on which panel was mounted.
3. Set molding fastener and apply sealant & primer to body panel, and apply primer to molding.

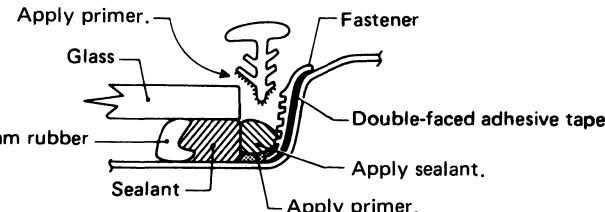

Apply primer. Fastener
Glass
Dam rubber
Sealant
Double-faced adhesive tape
Apply sealant.
Apply primer.

4. Install molding by aligning the molding mark located on center with vehicle center.
Be sure to install tightly so that there is no gap around the corner.

SBF519B

② Windshield lower molding It is mounted with screws.

③, ④ Cowl top grille and hood rear sealing rubber

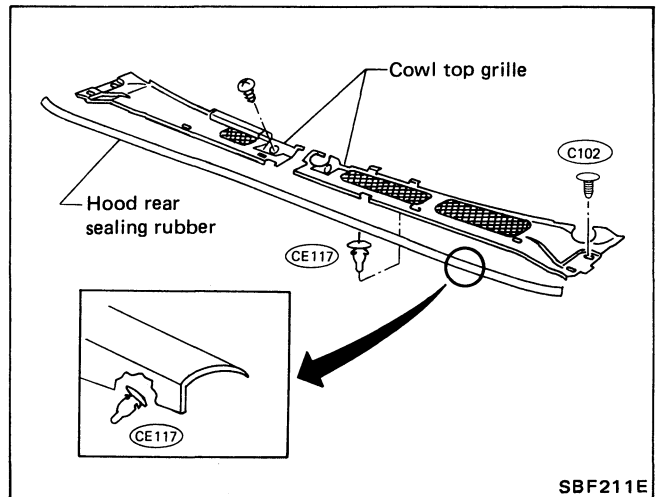

⑤ Hood front sealing rubber

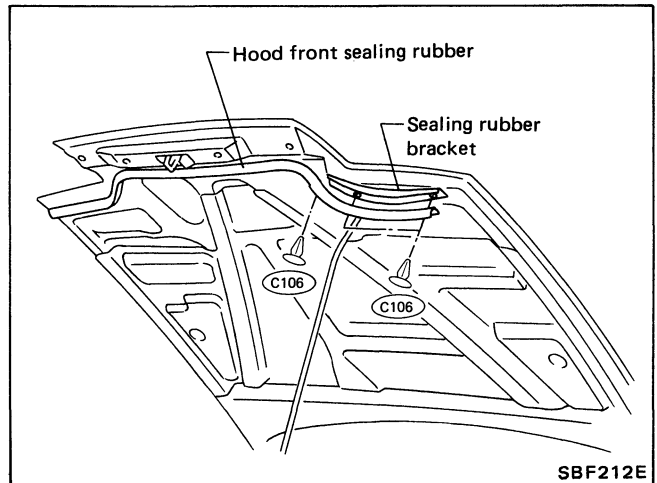

⑥ Center pillar finisher

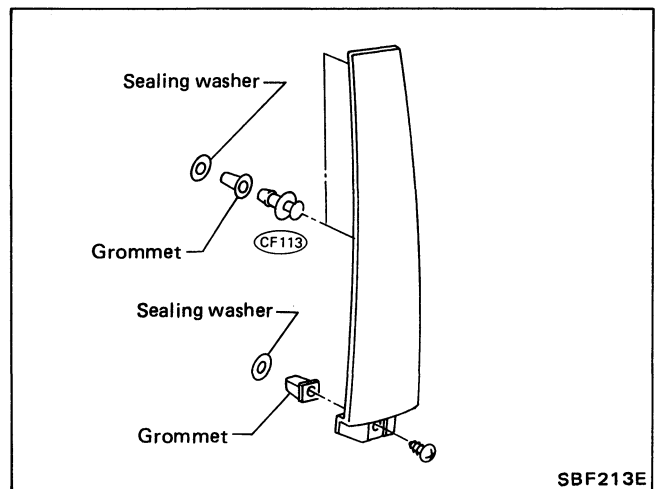

INTERIOR AND EXTERIOR

Exterior (Cont'd)

⑦, ⑧ Body side weatherstrip and weatherstrip retainer

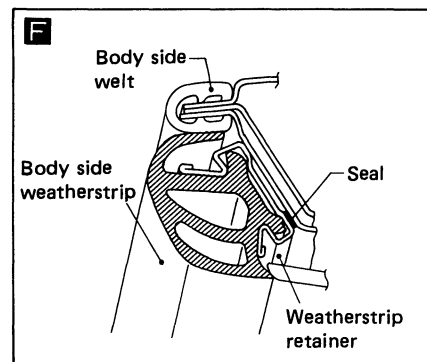
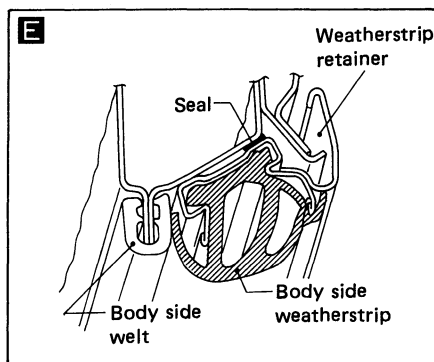
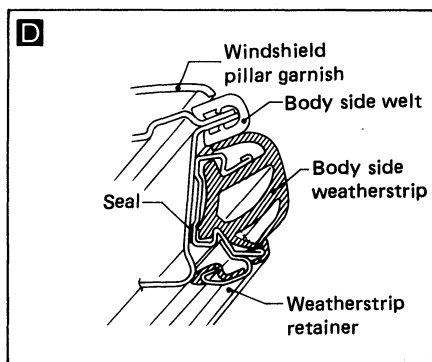
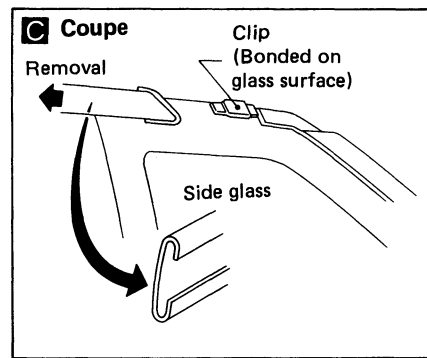
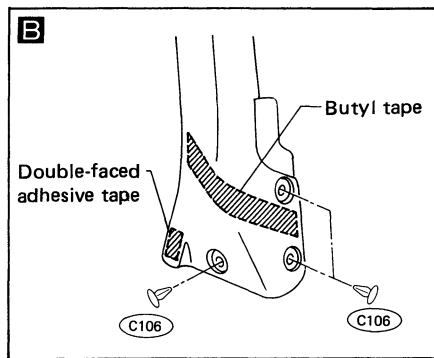
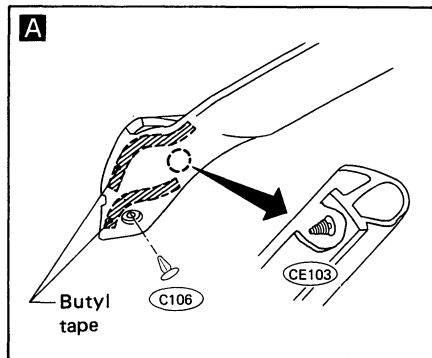
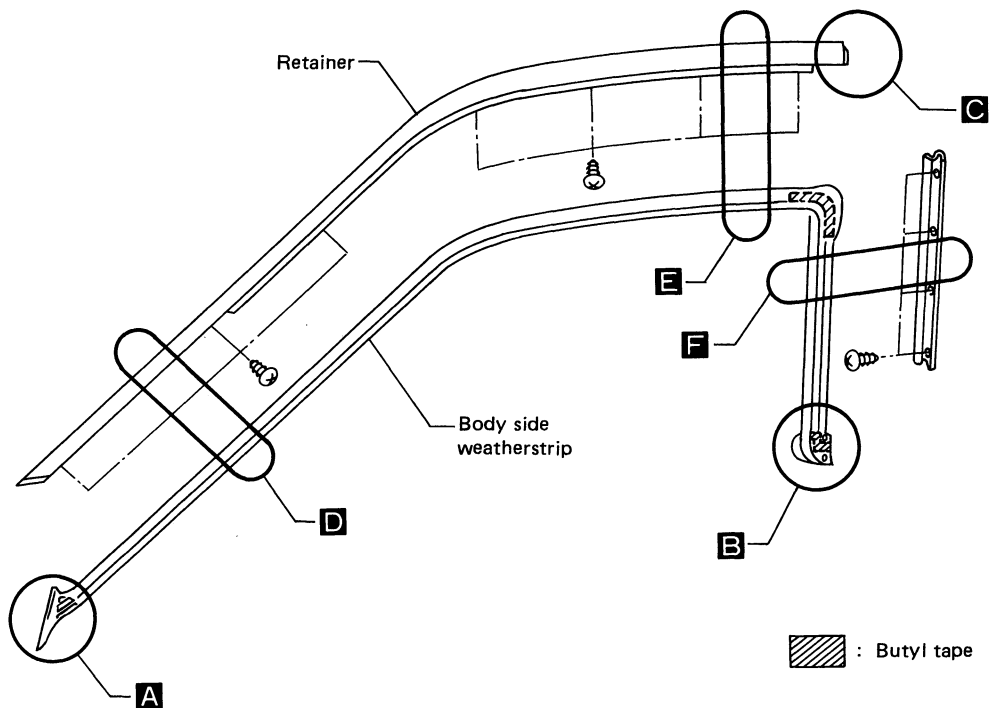

INTERIOR AND EXTERIOR

Exterior (Cont'd)

⑨ Door weatherstrip

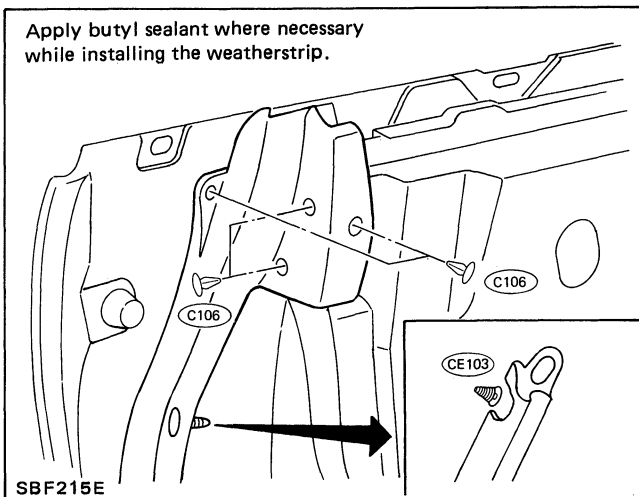

⑬ Rear sight shield

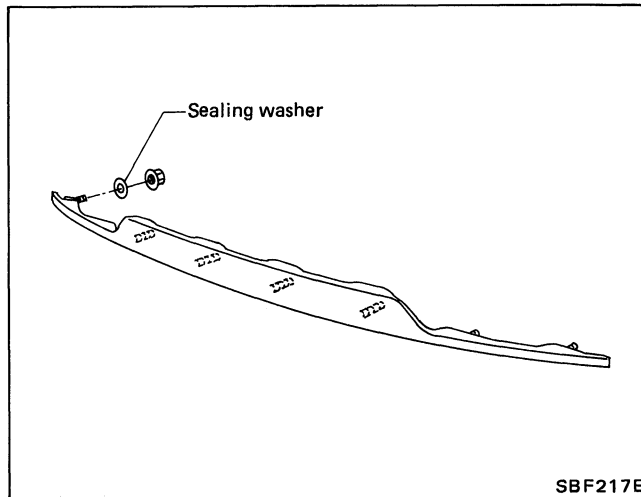

- ⑩ Back window upper and side molding (Coupe)
Basically the same as windshield upper and side molding.

- ⑪ Back window lower molding (Coupe)
It is mounted with screws.

⑫ Trunk lid weatherstrip

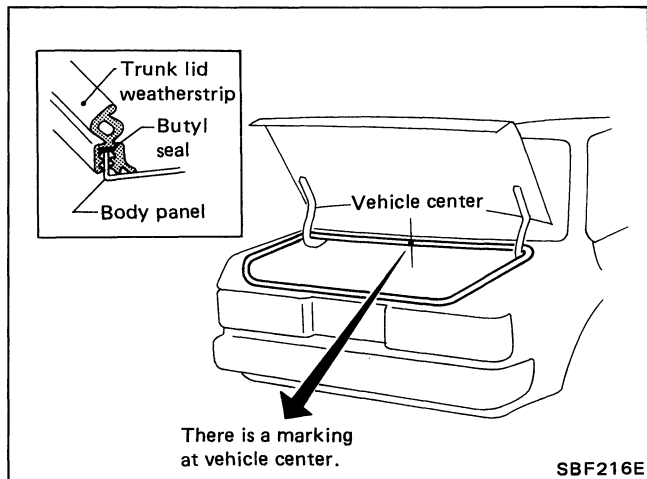

- ⑭ Back door window upper and side molding (Fastback)
Bonded on back door glass side.

- ⑮ Back door window lower molding (Fastback)

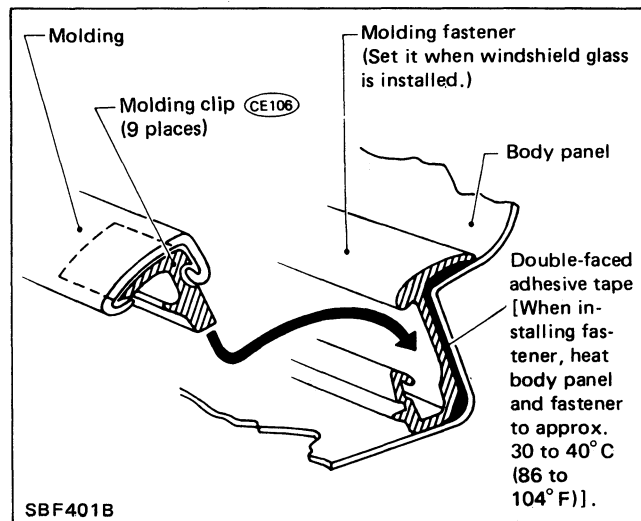

INTERIOR AND EXTERIOR

Exterior (Cont'd)

16 Back door weatherstrip

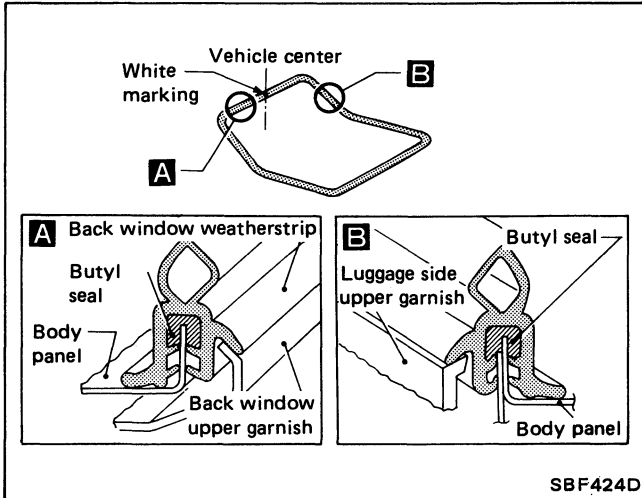

17 Rear panel finisher (Fastback)

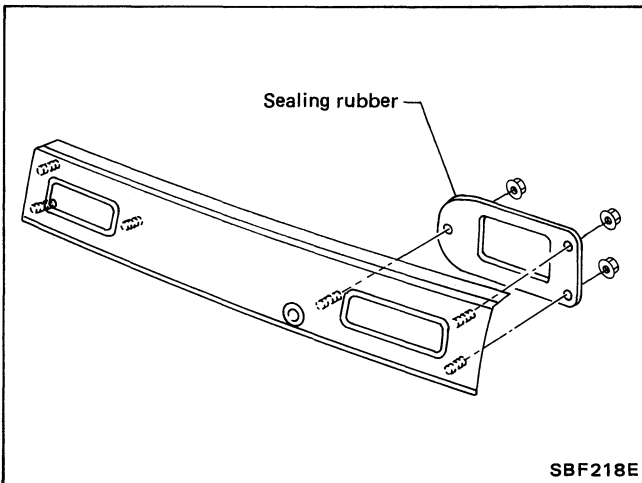

18 Sun roof lid weatherstrip and sun roof frame weatherstrip (Coupe)

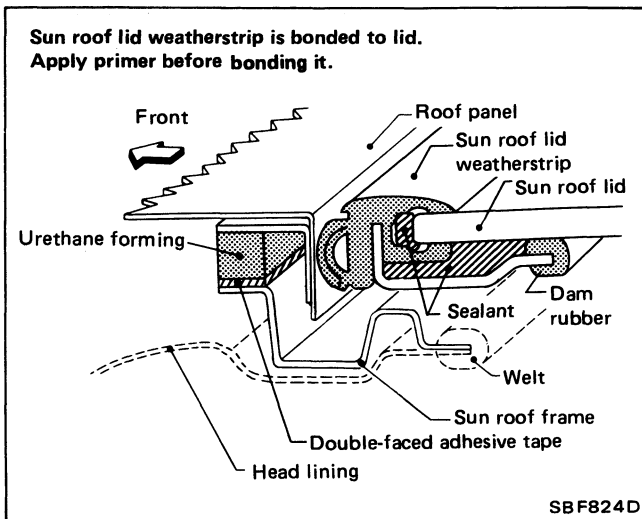

19 Sun roof lid weatherstrip

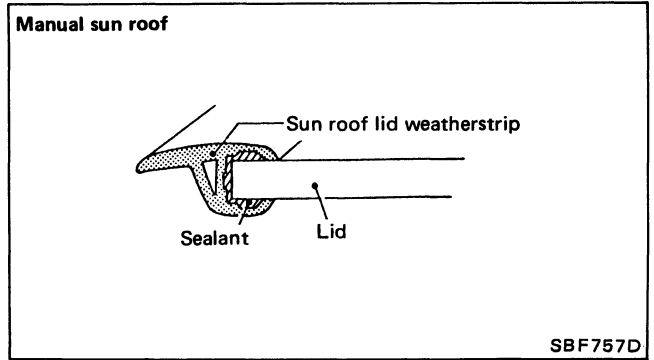

20 Sun roof weatherstrip

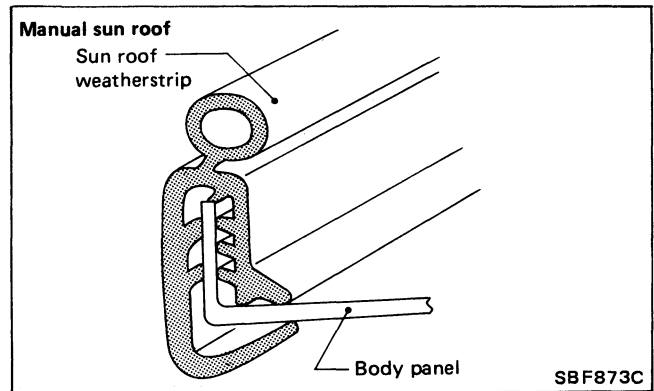

21 Door waist outside molding

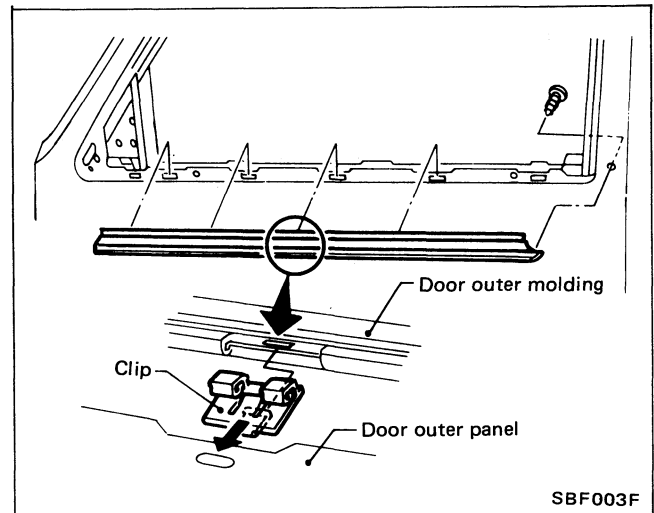



INTERIOR AND EXTERIOR

NOTE

SEAT

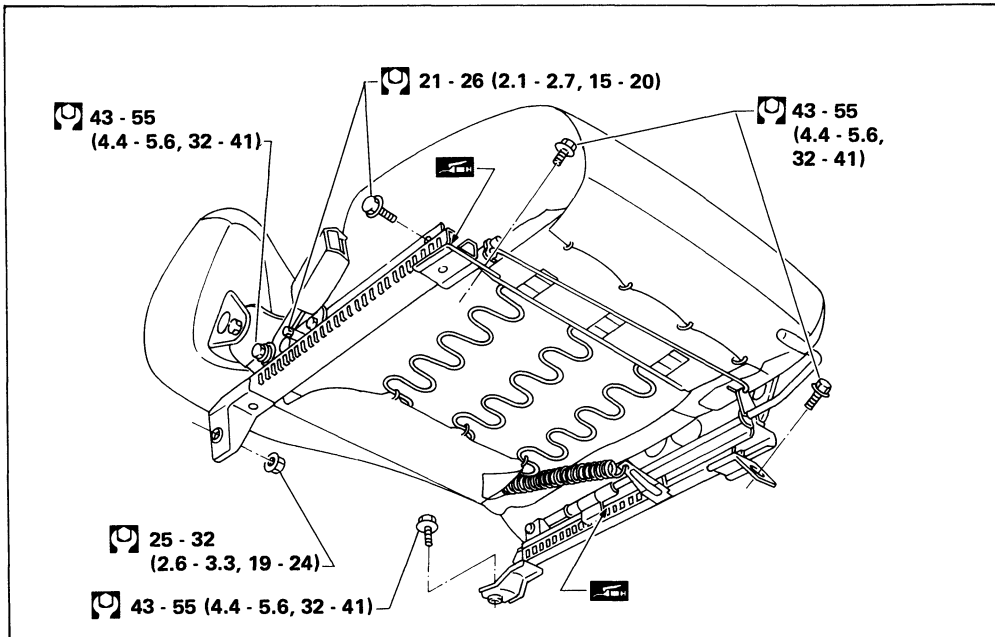
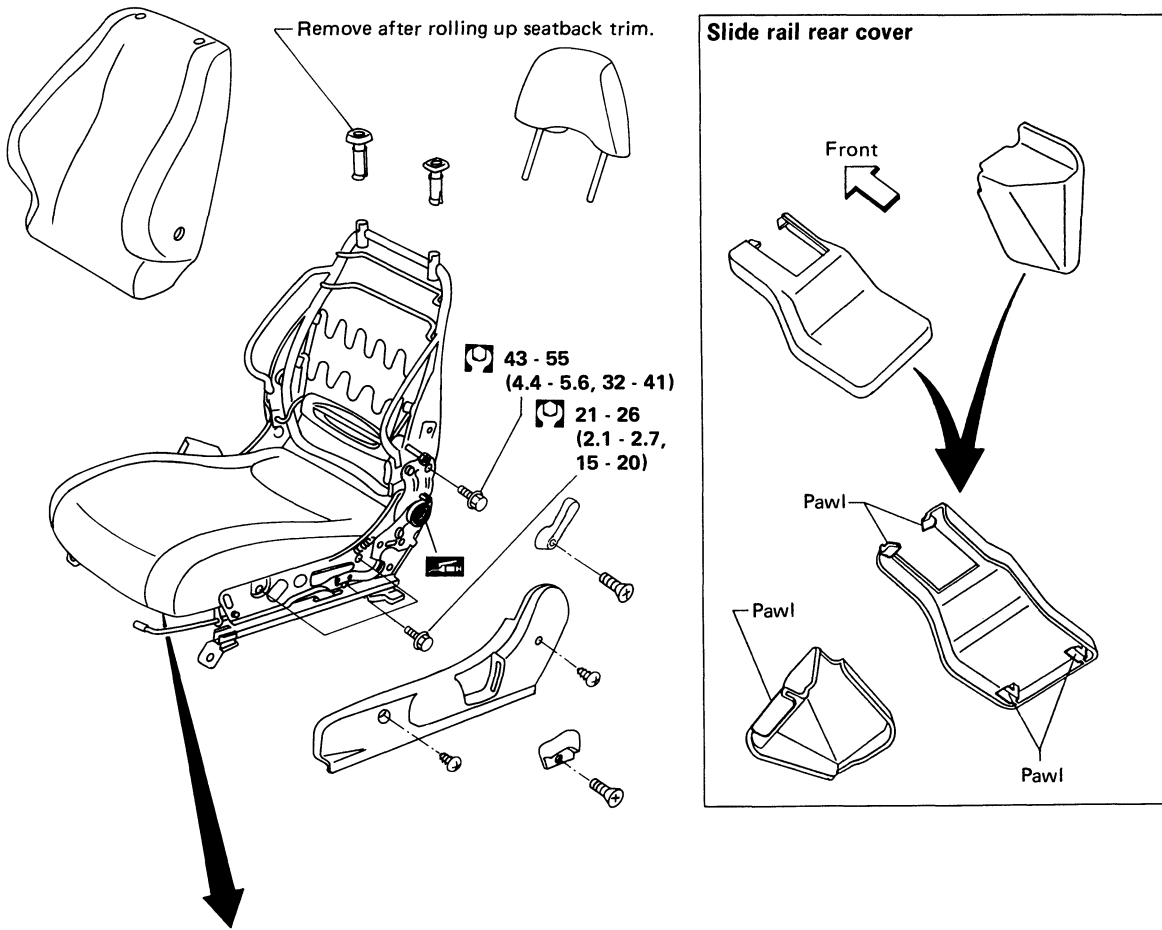
Front Seat



 : N-m (kg-m, ft-lb)

MBF218A

SEAT

Rear Seat

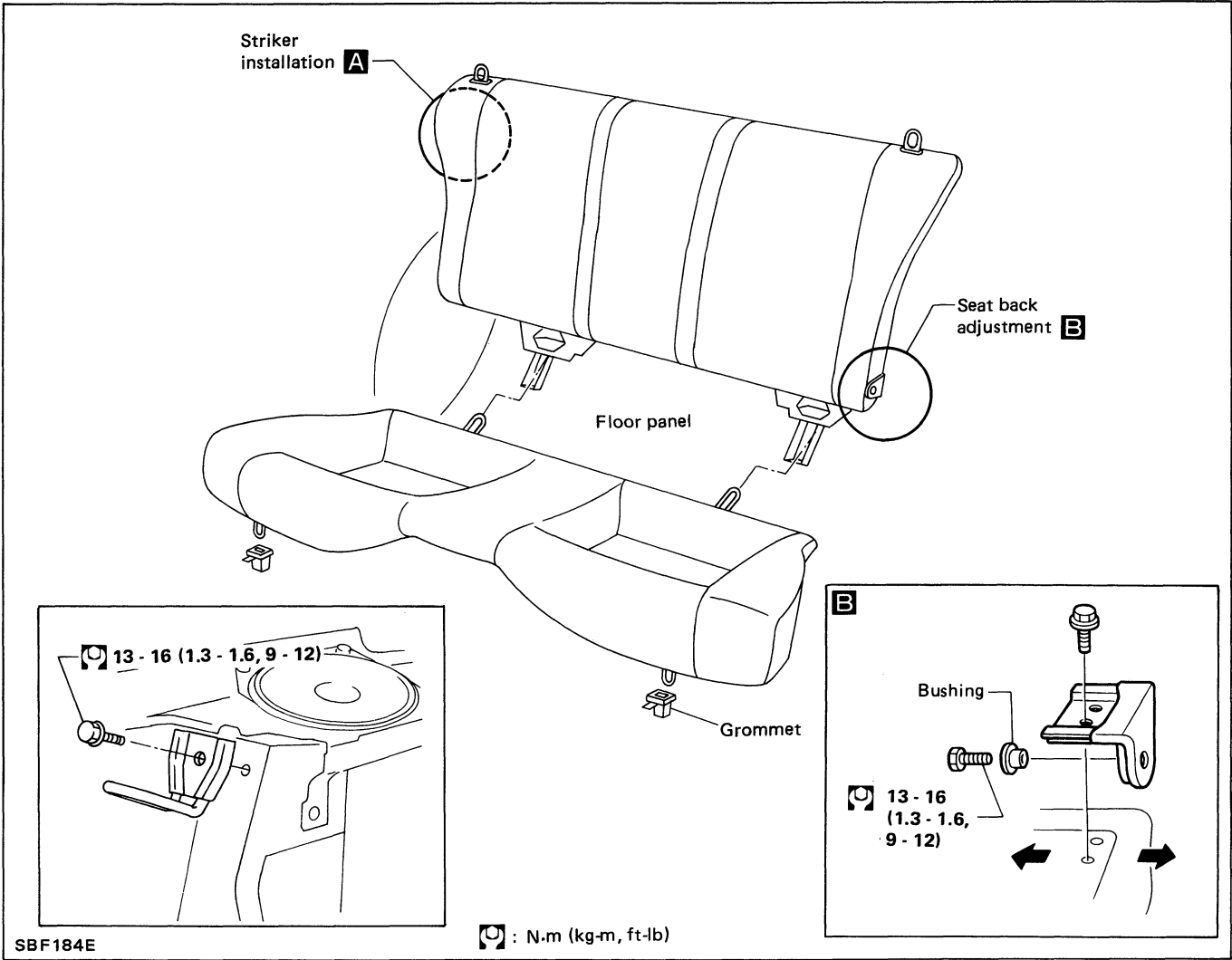

AUTOMATIC SEAT BELT SYSTEM

Unit Location

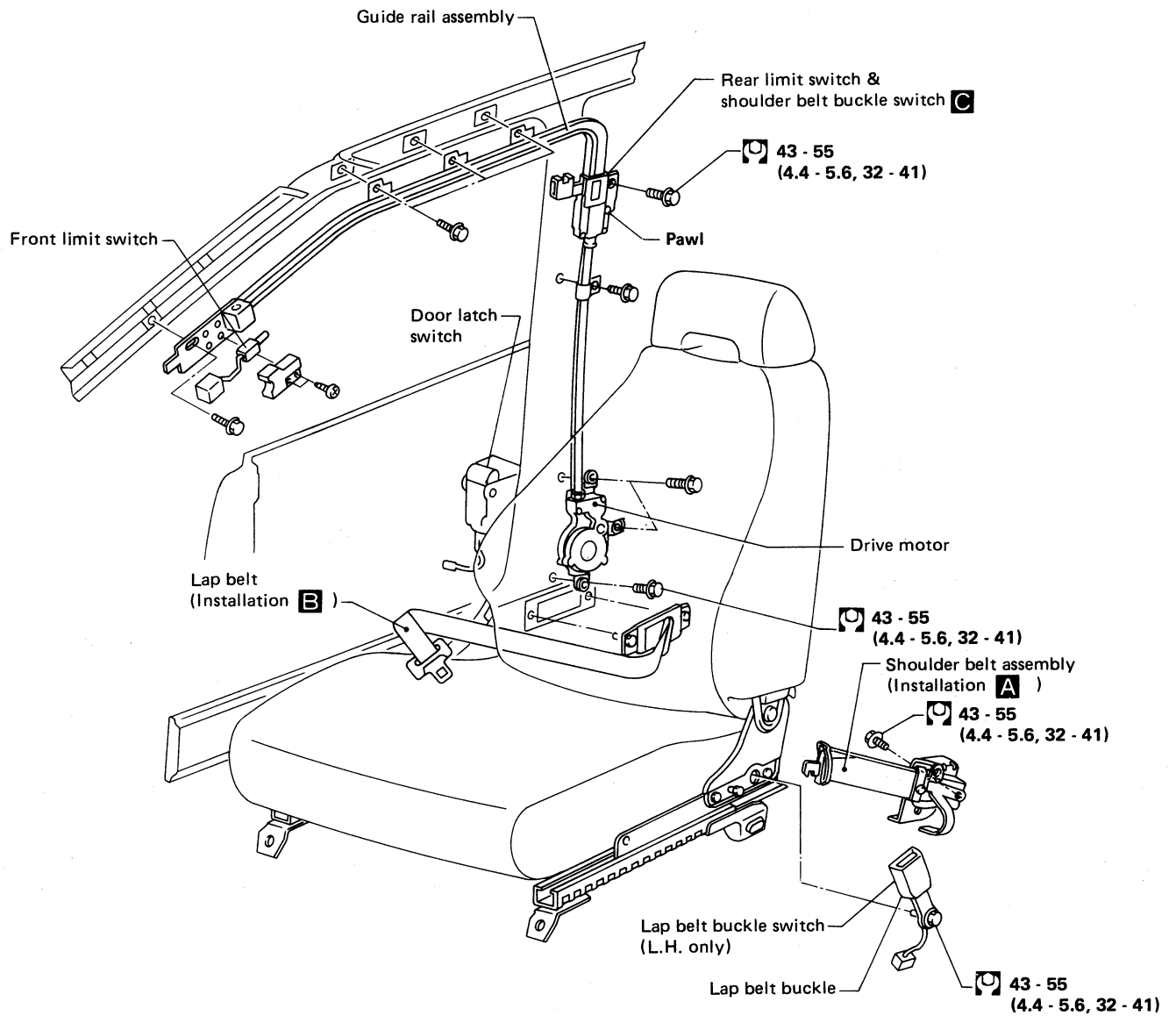

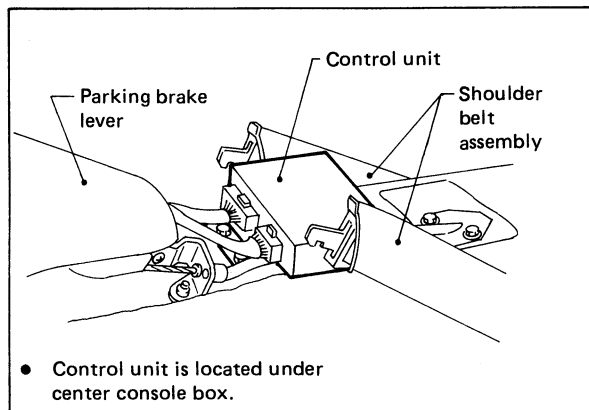

Control unit

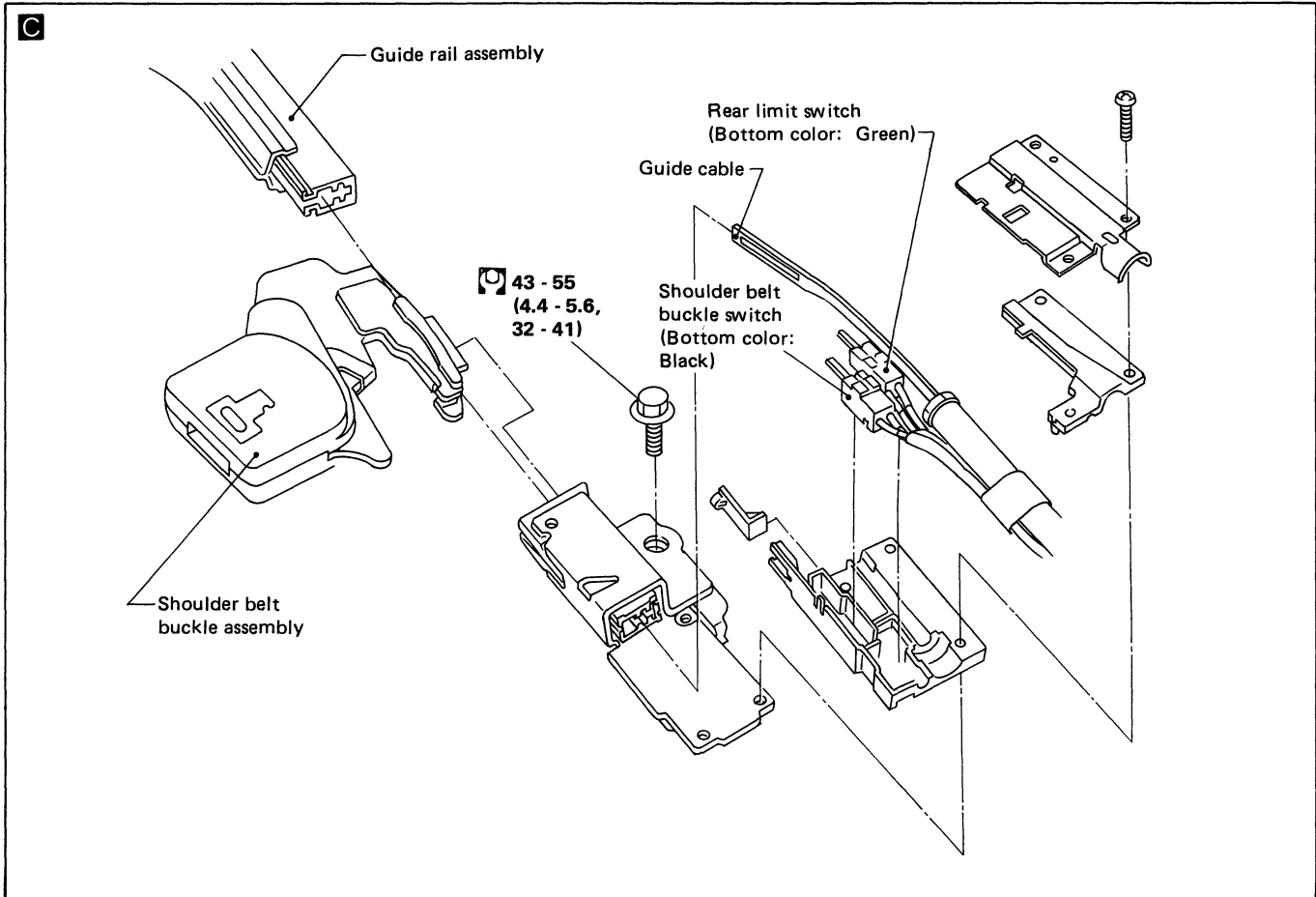
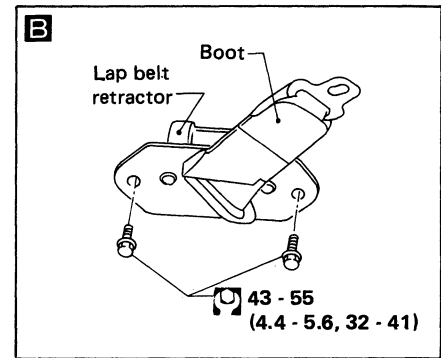
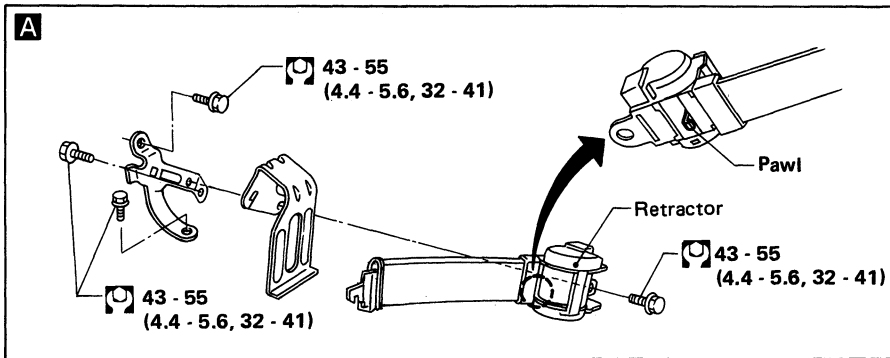

AUTOMATIC SEAT BELT SYSTEM

Unit Location (Cont'd)



 : N·m (kg·m, ft·lb)

AUTOMATIC SEAT BELT SYSTEM

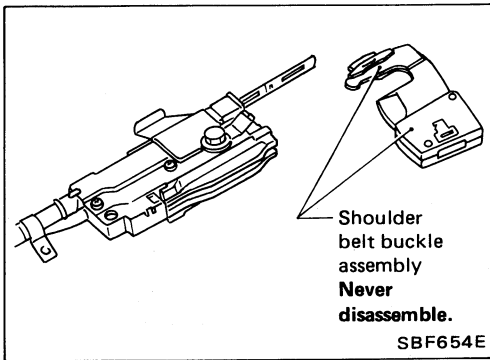

Replacement of Rear Switch Assembly

CAUTION:

- Never disassemble shoulder belt buckle assembly.
- Keep dirt out.

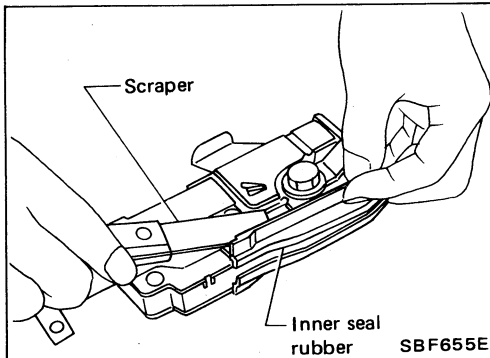

DISASSEMBLY

1. Remove inner seal rubber from locking device assembly with scraper.

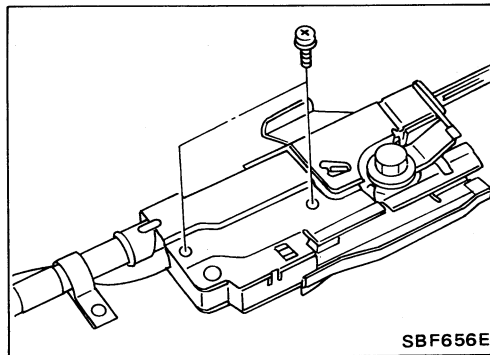

2. Remove screws from locking device assembly.

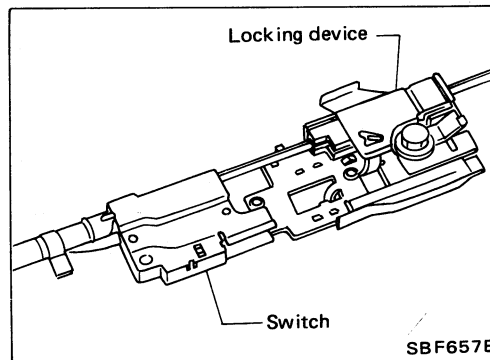

3. Slide locking device up and remove it from switch holders.

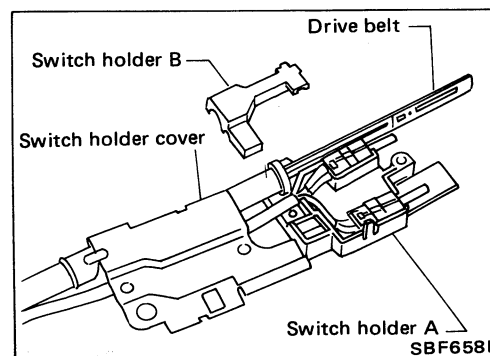

4. Slide switch holder cover down and remove it from switch holders A and B.

5. Remove switch holder B.

6. Remove rear switch assembly.

Never turn drive belt.

AUTOMATIC SEAT BELT SYSTEM

Replacement of Rear Switch Assembly (Cont'd)

ASSEMBLY

1. Set rear switch assembly to switch holder A.

Be sure to set rear limit switch and shoulder belt buckle switch to appropriate position.

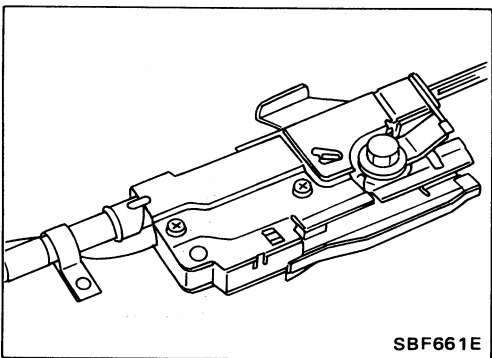
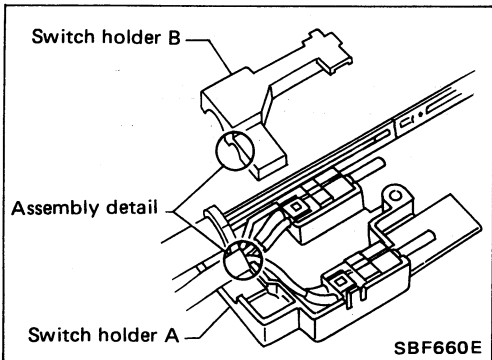
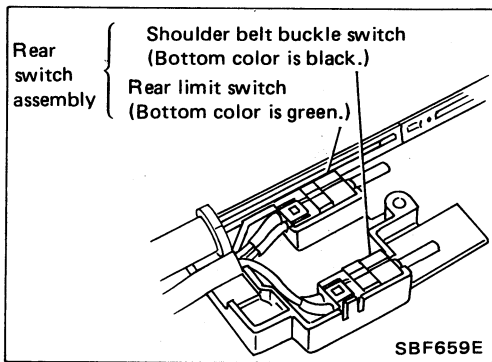

2. Cover switch holder A by switch holder B.

Take care not to catch harness between holders A and B.

3. Slide switch holder cover up until it is aligned with switch holders A and B.

4. Slide locking device down until it is aligned with switch holders.

5. Secure screws to locking device assembly.

 : 0.6 - 0.9 N·m (0.06 - 0.09 kg·m, 0.4 - 0.7 ft·lb)

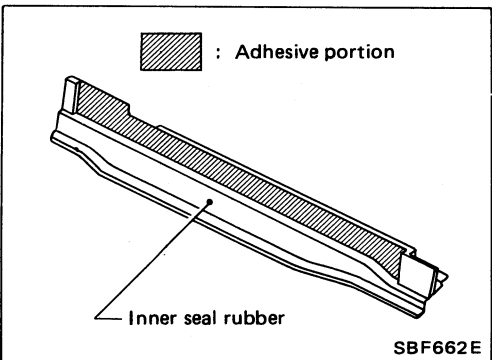

6. Apply adhesive on adhesive surface of inner seal rubber.
Do not apply too much adhesive.

7. Fix inner seal rubber to locking device assembly.

AUTOMATIC SEAT BELT SYSTEM

Wiring Diagram

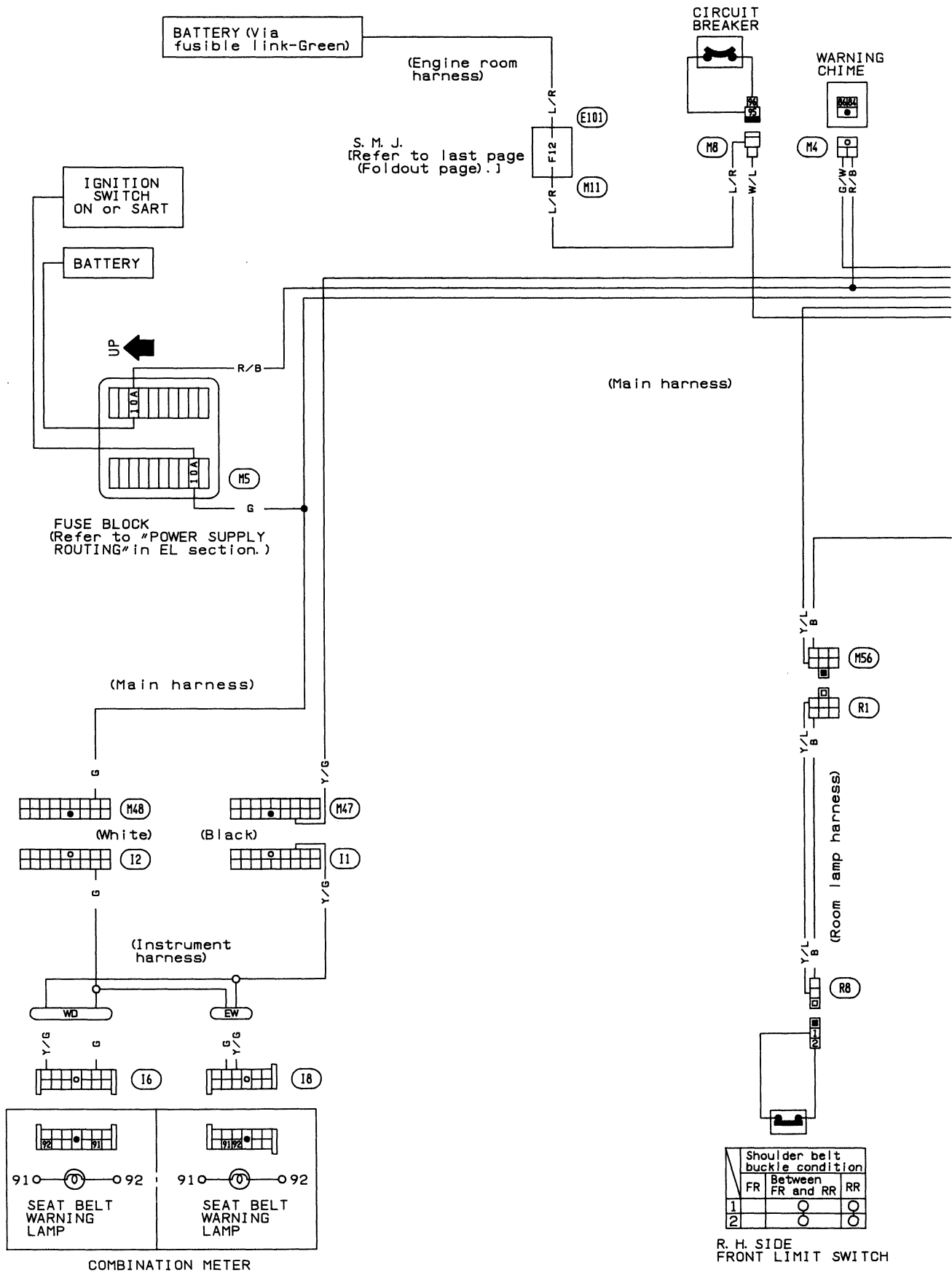

	Shoulder belt buckle condition		
	FR	Between FR and RR	RR
1	○	○	○
2	○	○	○

AUTOMATIC SEAT BELT SYSTEM

Wiring Diagram (Cont'd)

AUTOMATIC SEAT BELT CONTROL UNIT

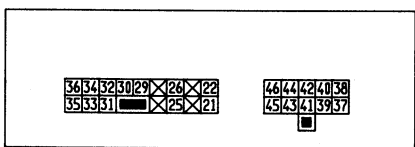

Ⓜ: With head-up display

Ⓦ: Without head-up display

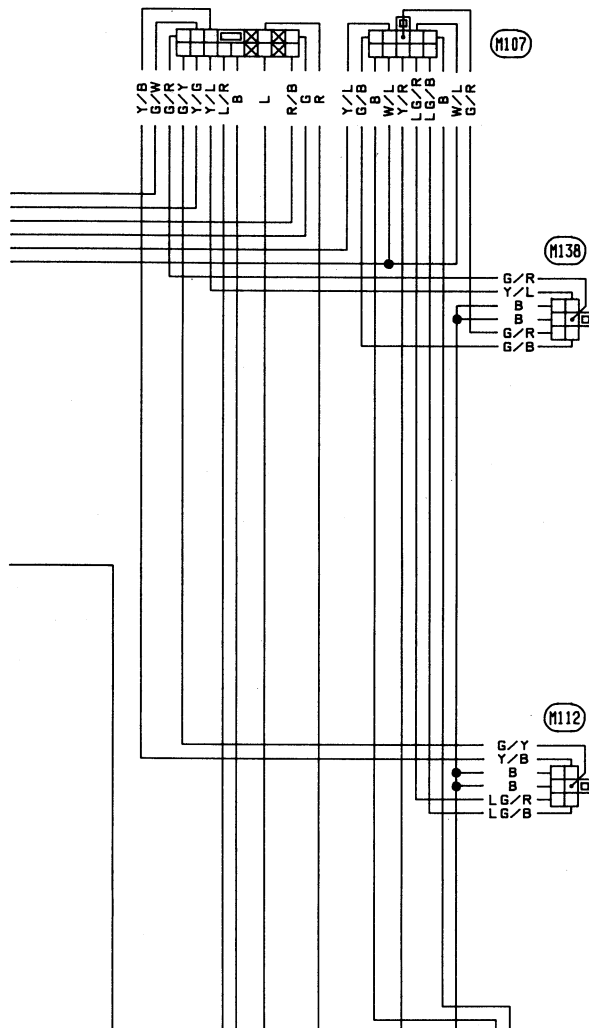

R. H. SIDE

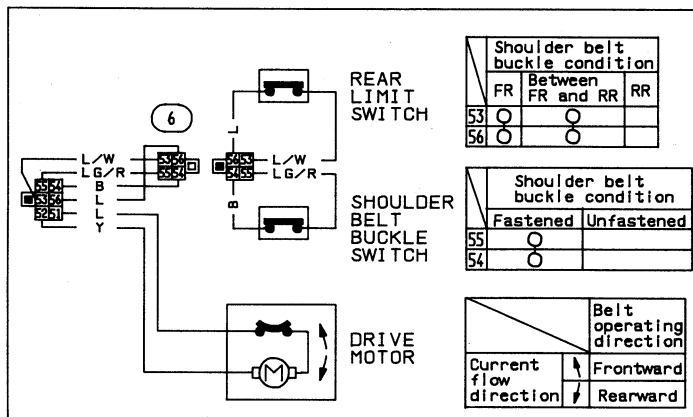

L. H. SIDE

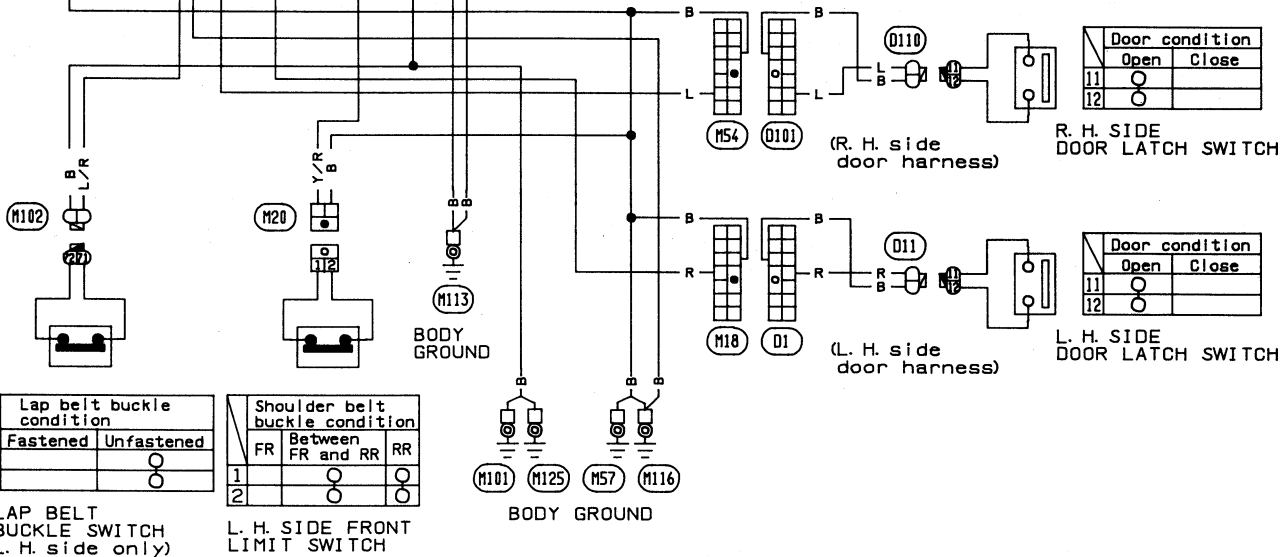
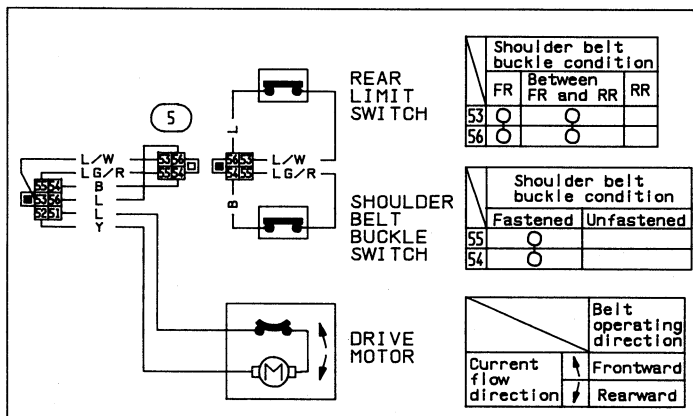

SBF784E

AUTOMATIC SEAT BELT SYSTEM

Description

FUNCTION

Shoulder belt buckle is mainly operated while ignition switch is "ON".

Condition (A): Ignition switch is "ON".

When door is opened, shoulder belt buckle is moved frontward and when door is closed, buckle is moved rearward.

Condition (B): Ignition switch is "OFF".

When door is opened, shoulder belt buckle is moved frontward. When the door is closed, buckle will remain in this position.

(Voltage of output signal is approximate value.)

Input signal	Ignition switch	OFF	OFF	ON	ON	ON	ON	ON	ON	OFF	OFF	OFF
	Door latch switch	OFF	ON	OFF	OFF	OFF	ON	ON	ON	OFF	ON	ON
	Front limit switch	OFF	OFF	OFF	ON	ON	ON	ON	OFF	ON	ON	ON
	Rear limit switch	ON	ON	ON	ON	OFF	OFF	ON	ON	OFF	OFF	ON
Output signal	Drive motor power source for frontward operation	0V	0V	0V	0V	0V	12V	12V	0V	0V	12V	12V
	Drive motor power source for rearward operation	0V	0V	12V	12V	0V	0V	0V	0V	0V	0V	0V
Shoulder belt buckle	Function	Stop	Stop	Start to move	Moving	Stop	Start to move	Moving	Stop	Stop	Start to move	Moving
	Position	Front	Front	Front	Between Front & Rear	Rear	Rear	Between Front & Rear	Front	Rear	Rear	Between Front & Rear

TIMER (Ignition switch either "ON" or "OFF")

If limit switch does not operate (when accomplishing frontward operation, front limit switch can not be turned "OFF" or when accomplishing rearward operation, rear limit switch can not be turned "OFF"), control unit will continue to supply power to drive motor for 15 seconds.

QUICK WARNING (Ignition switch "ON")

If front limit switch is not turned "OFF" after accomplishing frontward operation, control unit will stop supplying power 15 seconds later and warning lamp will flash and chime will operate rapidly for approximately 6 seconds.

REAR LOCK (Fail safe operation)

If quick warning functions twice successively while ignition switch is "ON", shoulder belt buckle will move to rear position when the door is closed as normal but will remain in rear position even if door is opened. This operation is canceled when ignition switch is "OFF".

AUTOMATIC SEAT BELT SYSTEM

NOTE

TROUBLE DIAGNOSES

Contents

Symptom Chart	BF-42
Preliminary Check	BF-43
Main Power Supply and Ground Circuit Check	BF-47
Harness Layout	BF-48
Circuit Diagram for Quick Pinpoint Check	BF-50
Diagnostic Procedure 1 (Check motor circuit and stop signals.)	BF-51
Diagnostic Procedure 2 (Check door switch circuit.)	BF-54
Diagnostic Procedure 3 (Check front limit switch circuit.)	BF-56
Diagnostic Procedure 4 (Check rear limit switch circuit.)	BF-58
Diagnostic Procedure 5 (Check shoulder belt switch circuit.)	BF-60
Diagnostic Procedure 6 (Check lap belt switch circuit.)	BF-62
Diagnostic Procedure 7 (Check warning chime circuit.)	BF-64
Diagnostic Procedure 8 (Check warning lamp circuit.)	BF-65
Electrical Components Inspection	BF-66

Since left and right component parts are basically the same, harness layout and methods for electronic components inspection are shown for one side only.

For those methods enclosed by double rectangles, component parts on both sides must be checked.

TROUBLE DIAGNOSES

Symptom Chart

Procedure	Reference page	SYMPTOM	○	○	○	○	○	○	○	
Electrical Components Inspection	R.H. side	BF-66	Motor	○	○					
		BF-66	Shoulder belt buckle switch	○				○		
		BF-66	Door latch switch	○		○	○			
		BF-66	Rear limit switch	○	○	○		○		
		BF-66	Front limit switch	○	○		○		○	
		BF-67	Lap belt switch	○					○	
	L.H. side	BF-66	Motor	○	○					
		BF-66	Shoulder belt buckle switch	○				○		
		BF-66	Door latch switch	○		○	○			
		BF-66	Rear limit switch	○	○	○		○		
		BF-66	Front limit switch	○	○		○		○	
		BF-67	Warning chime	○					○	
	-	Warning lamp	○					○		
	Diagnostic Procedure	BF-65	Procedure 8						○	
		BF-64	Procedure 7						○	
		BF-62	Procedure 6						○	
		BF-60	Procedure 5						○	
		BF-58	Procedure 4	○	○	○			○	
BF-56		Procedure 3	○	○			○		○	
BF-54		Procedure 2			○	○				
BF-51		Procedure 1	○	○						
Main Power Supply and Ground Circuit Check	BF-47	Procedure 2		○						
	BF-47	Procedure 1	○							
Preliminary Check	BF-45	Procedure 2						○		
	BF-43	Procedure 1		○	○	○				
		SYMPTOM								
		No operation has made. (No warning indicated and no buckles movement performed)								
		Shoulder belt buckle in L.H. or R.H. side does not move.								
		Shoulder belt buckle moves frontwards only. (not rearwards)								
		Shoulder belt buckle moves rearwards only. (not frontwards)								
		Warnings indicate incorrectly or do not function.								
		Quick warning operates.								

TROUBLE DIAGNOSES

Preliminary Check

PROCEDURE 1

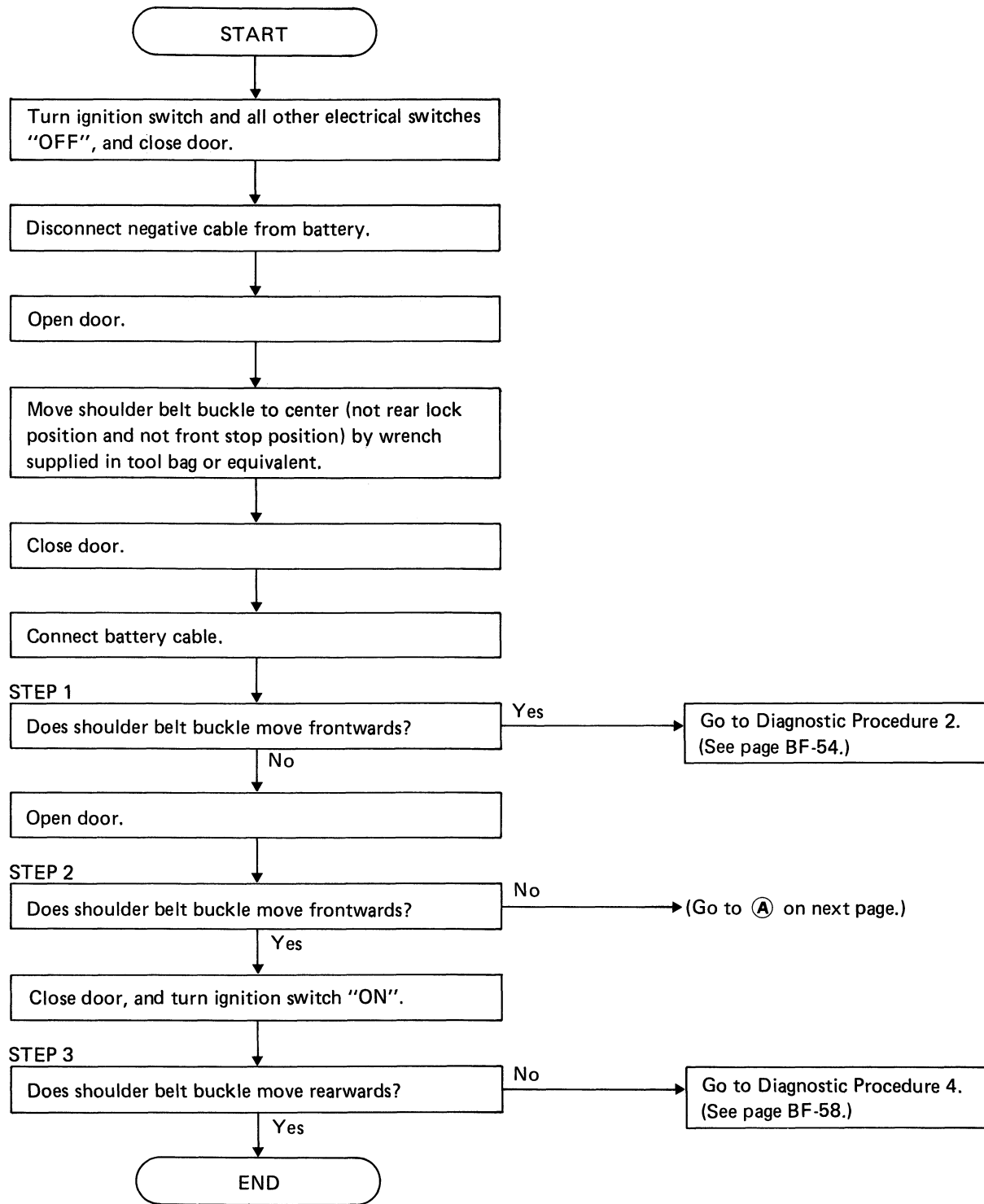

TROUBLE DIAGNOSES

Preliminary Check (Cont'd)

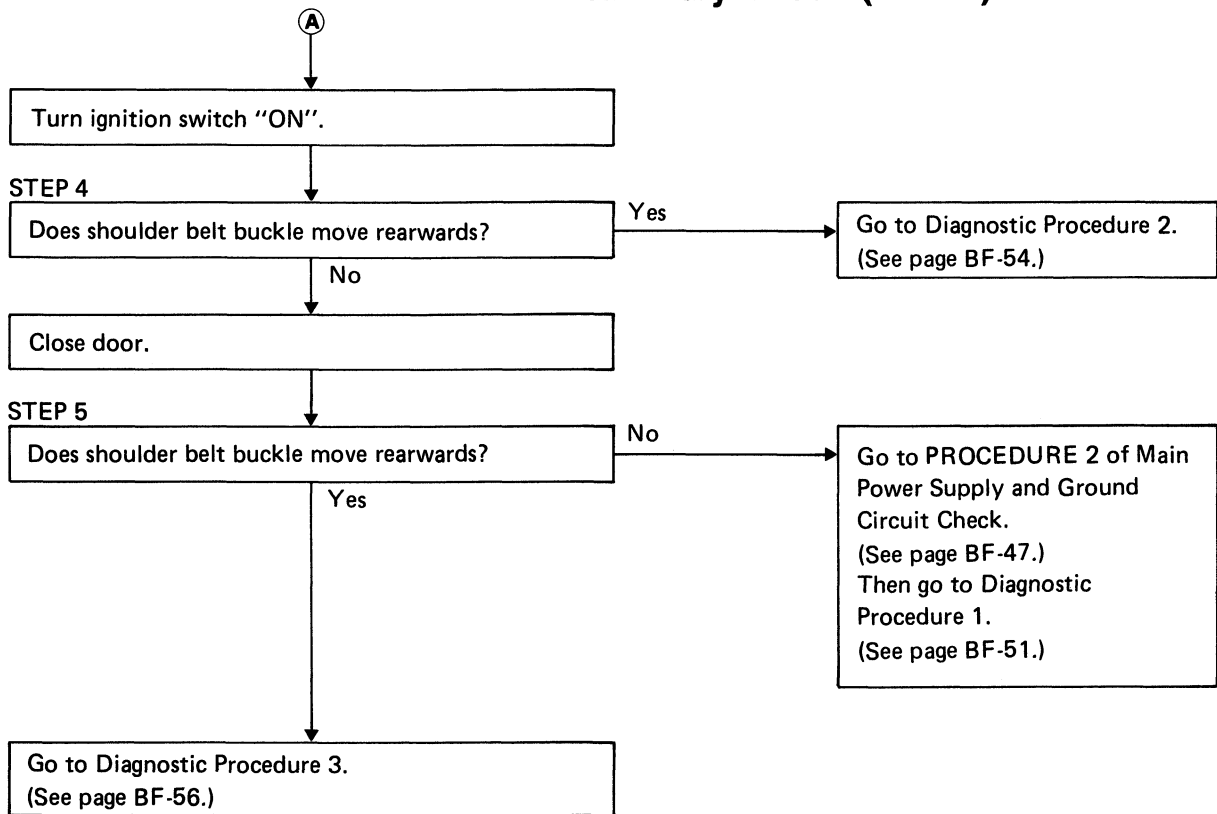

TROUBLE DIAGNOSES

Preliminary Check (Cont'd)

PROCEDURE 2

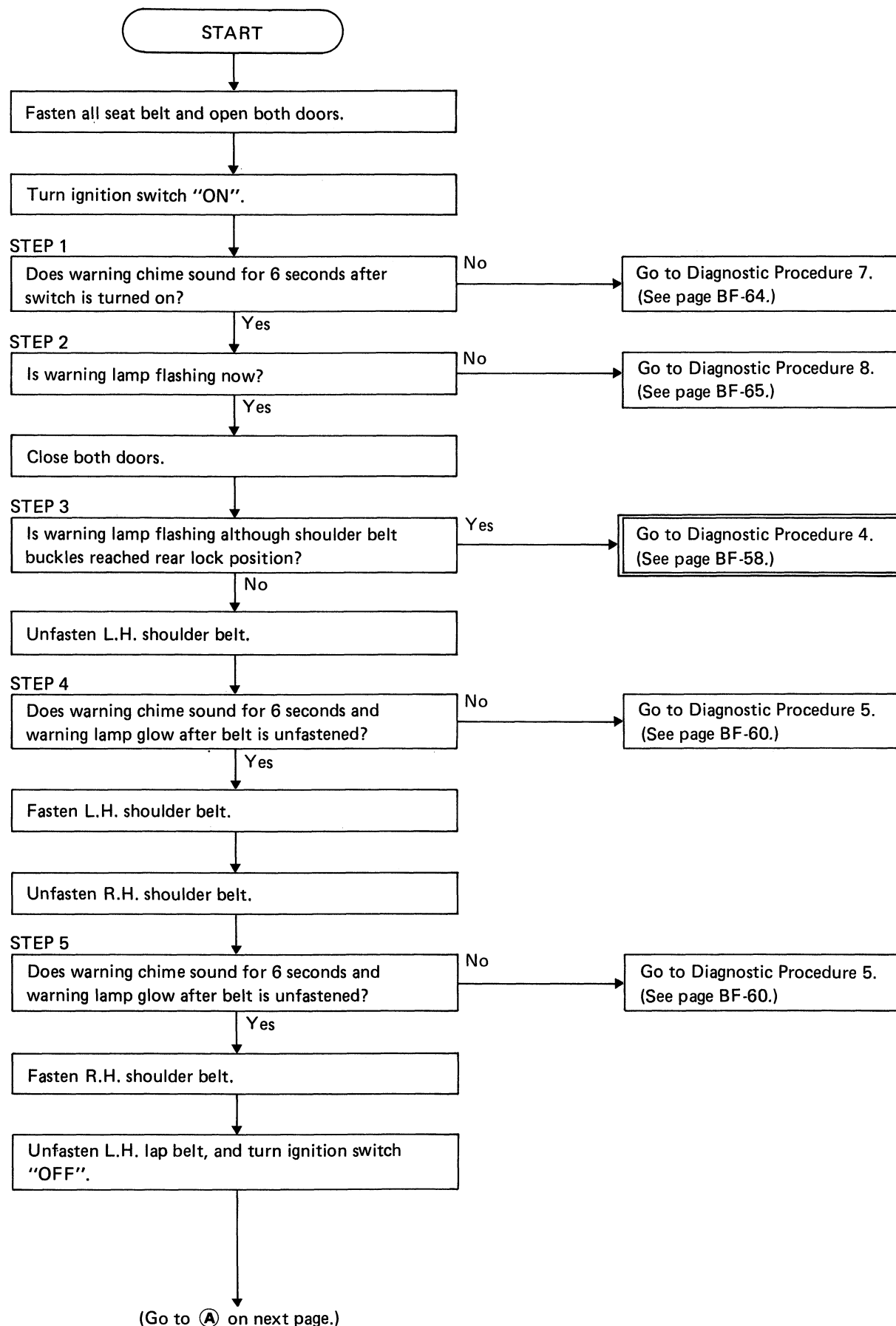

TROUBLE DIAGNOSES

Preliminary Check (Cont'd)

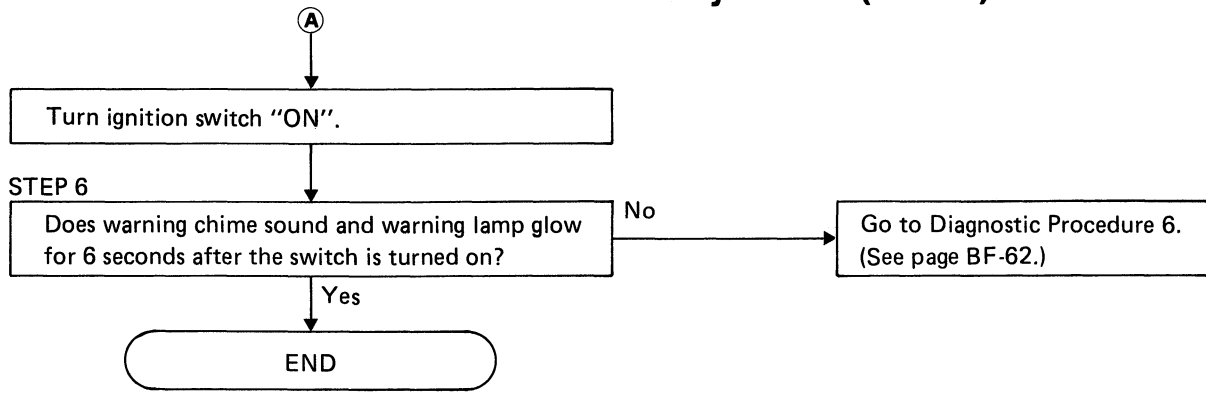

TROUBLE DIAGNOSES

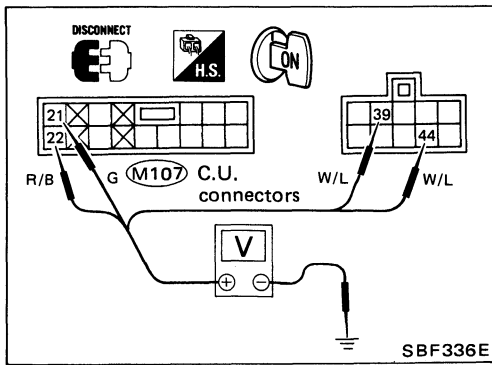

Main Power Supply and Ground Circuit Check

PROCEDURE 1

Main power supply

Terminals	Battery voltage existence condition	
	Ignition switch "ON"	Other than ignition switch "ON"
②1 - Ground	Yes	No
②2 - Ground	Yes	Yes
③9 - Ground	Yes	Yes
④4 - Ground	Yes	Yes

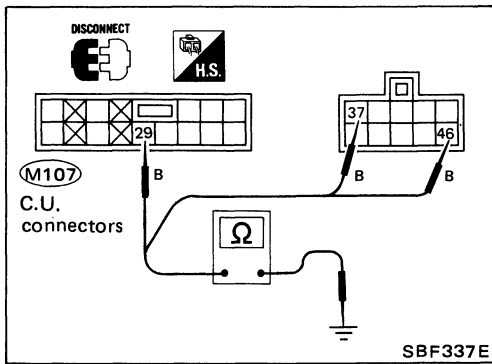

Ground circuit

Terminals	Continuity
②9 - Ground	Yes
③7 - Ground	Yes
④6 - Ground	Yes

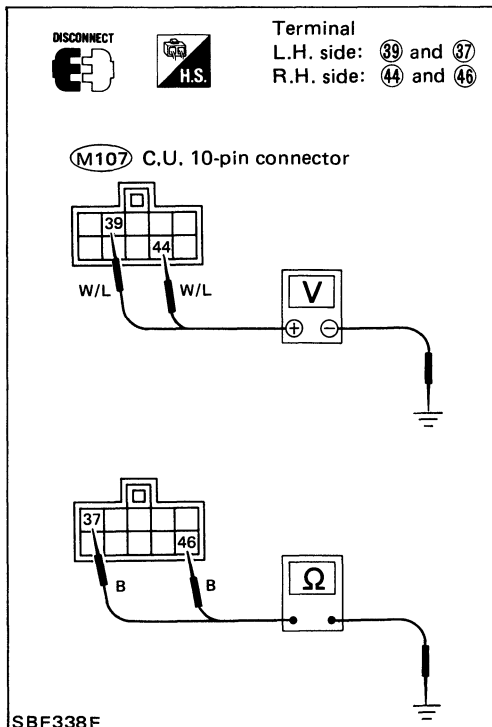

PROCEDURE 2

Power supply for motor drive

	Terminals	Battery voltage existence
L.H. side	③9 - Ground	Yes
R.H. side	④4 - Ground	Yes

Ground circuit for motor drive

	Terminals	Continuity
L.H. side	③7 - Ground	Yes
R.H. side	④6 - Ground	Yes

TROUBLE DIAGNOSES

Harness Layout

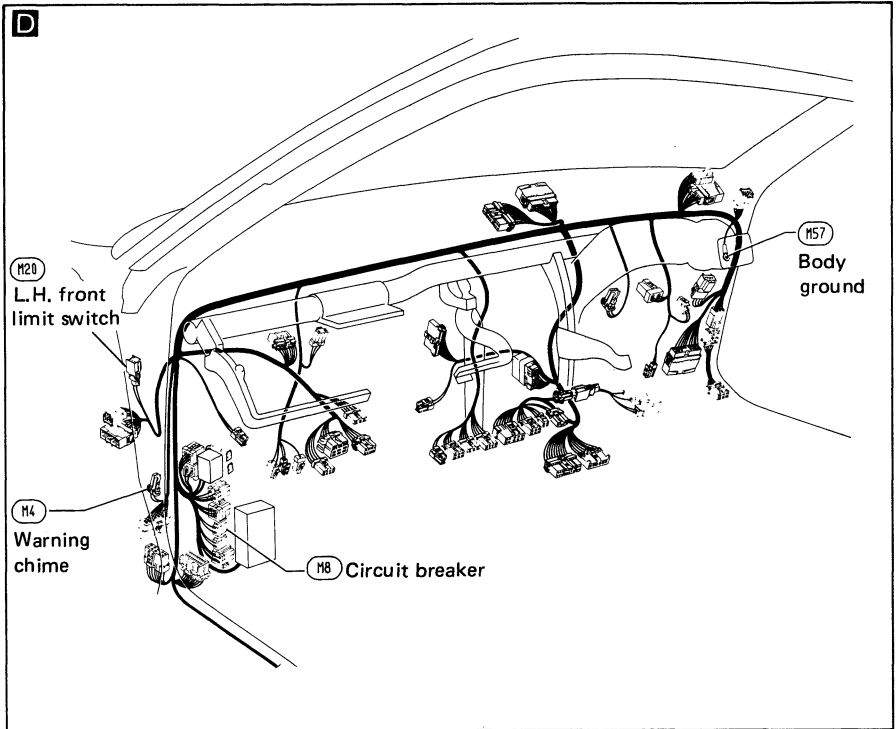
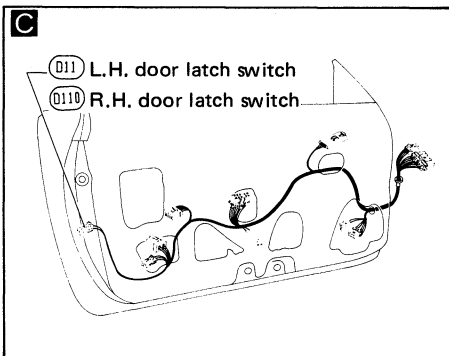
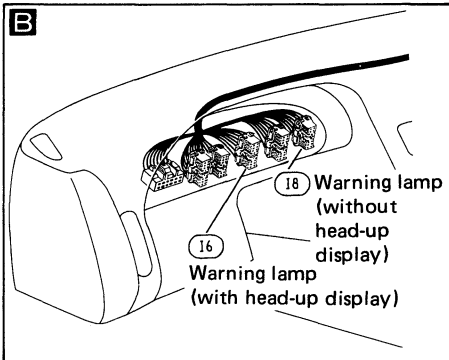
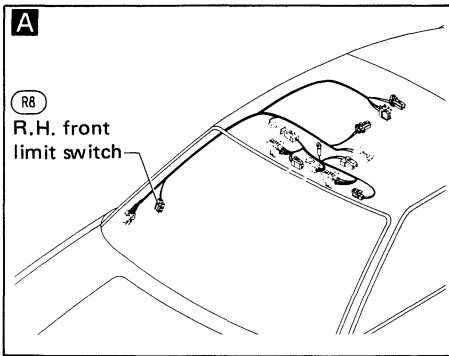
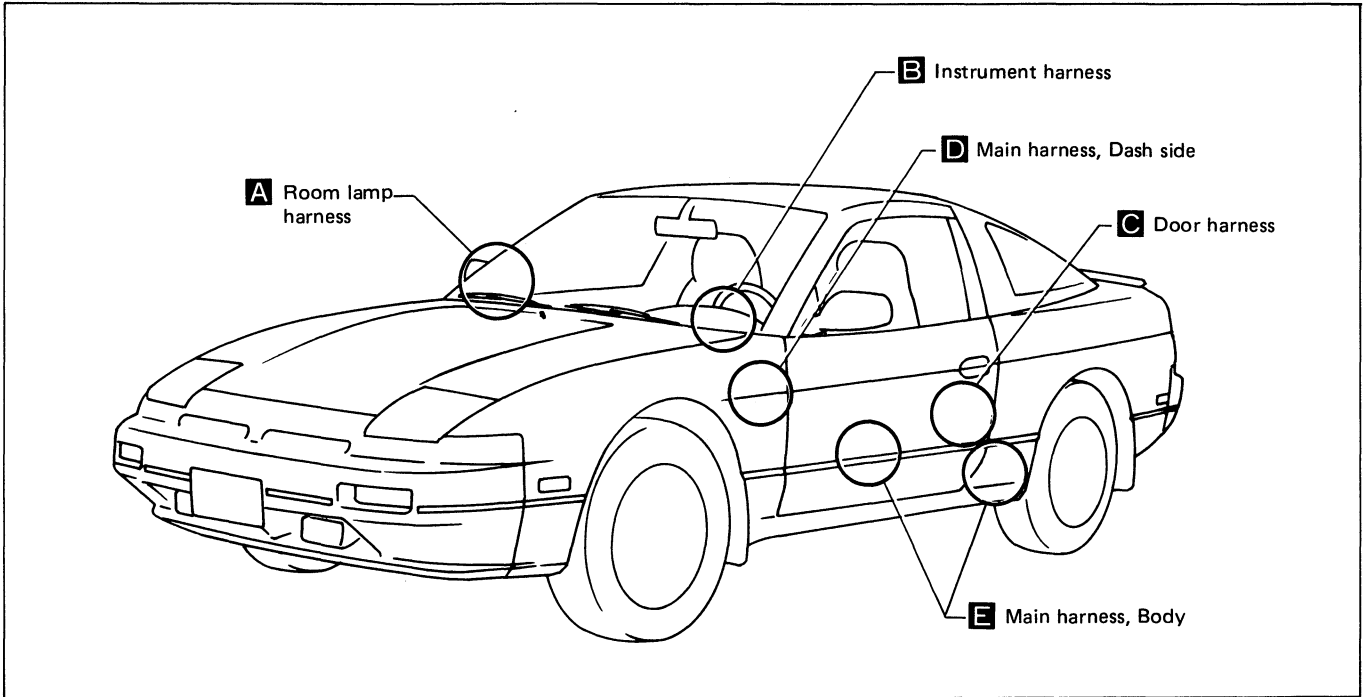

TROUBLE DIAGNOSES

Harness Layout (Cont'd)

E

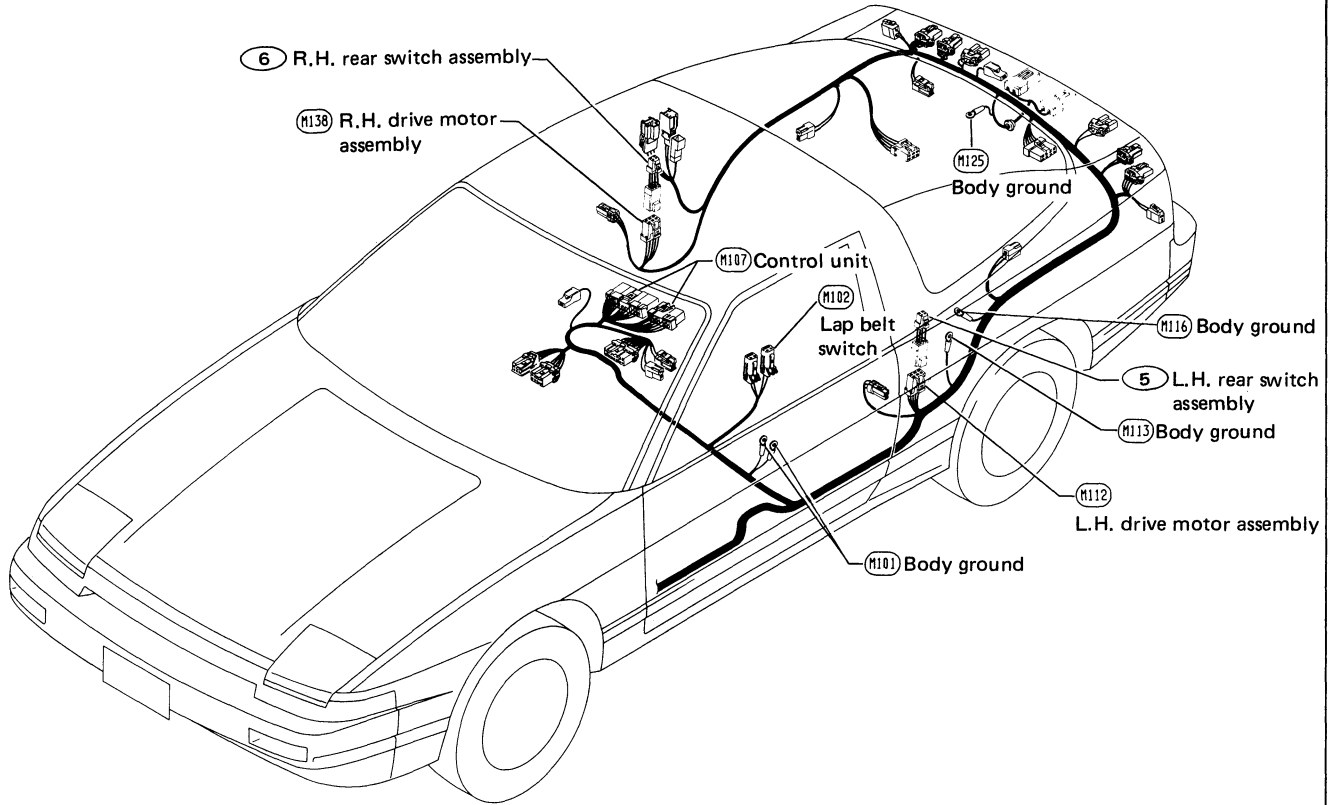

TROUBLE DIAGNOSES

Circuit Diagram for Quick Pinpoint Check

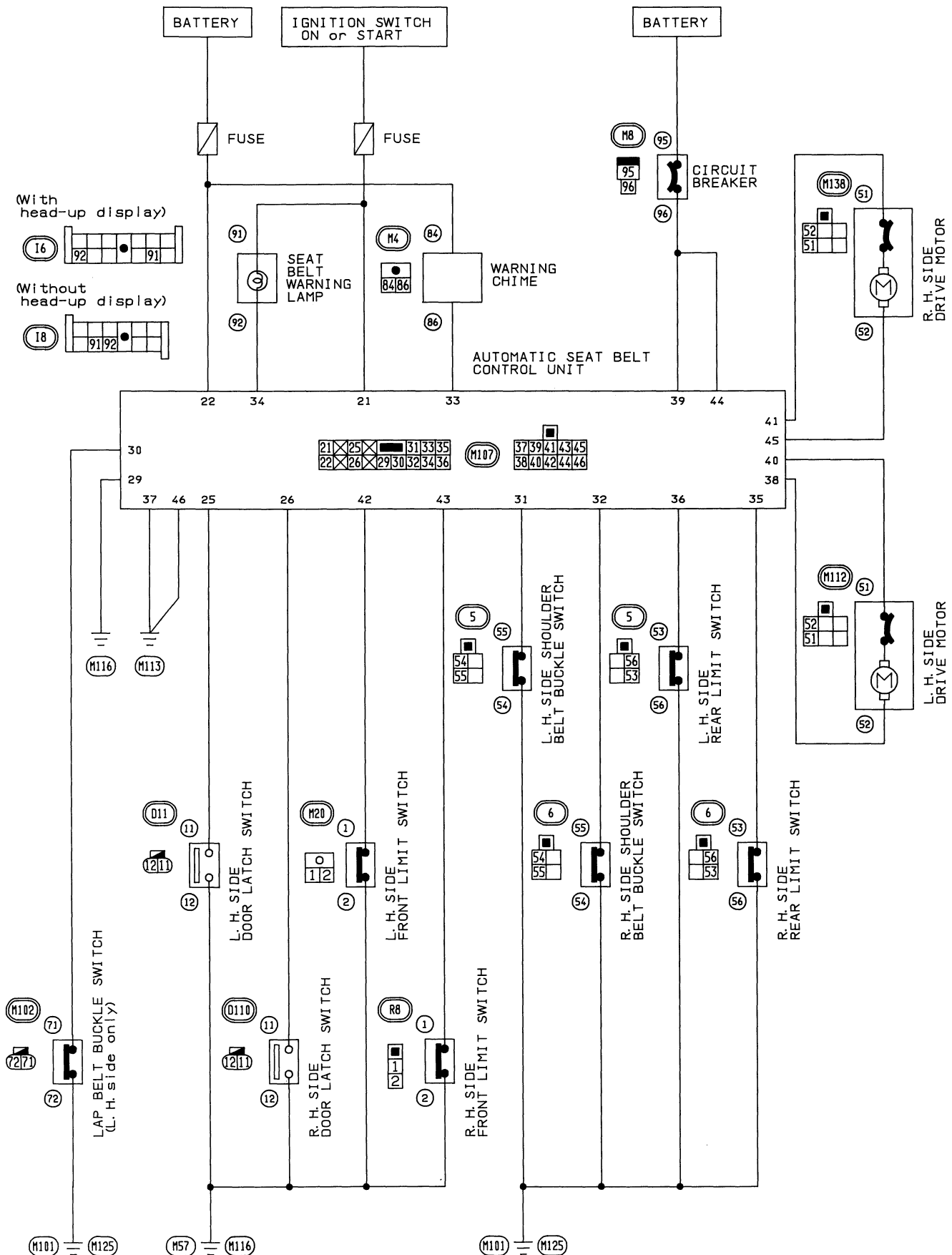

TROUBLE DIAGNOSES

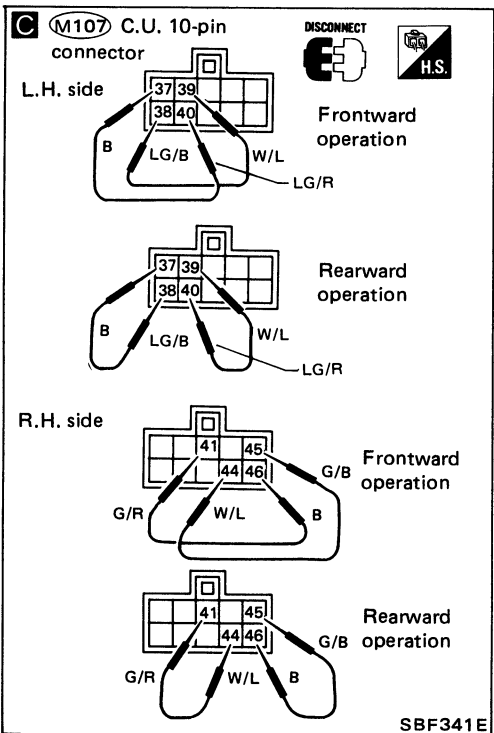
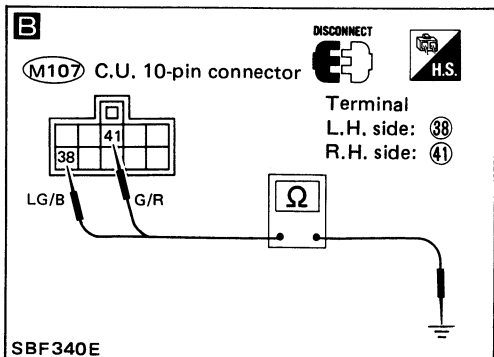
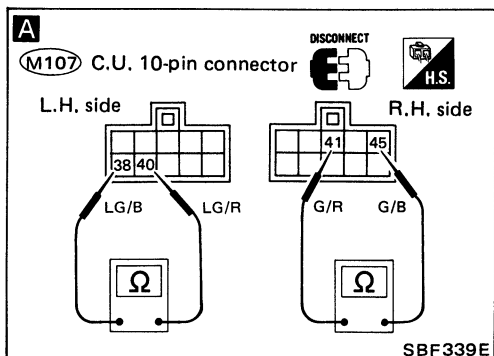

Diagnostic Procedure 1

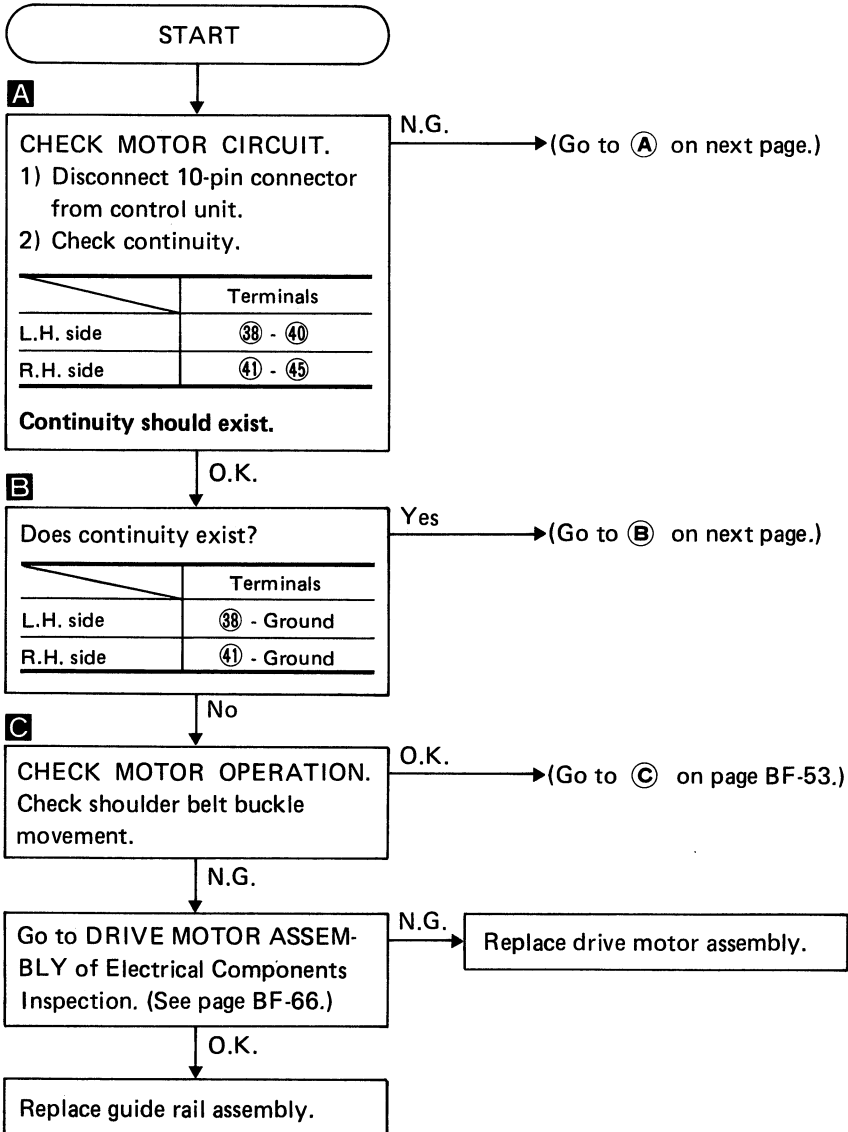

TROUBLE DIAGNOSES

Diagnostic Procedure 1 (Cont'd)

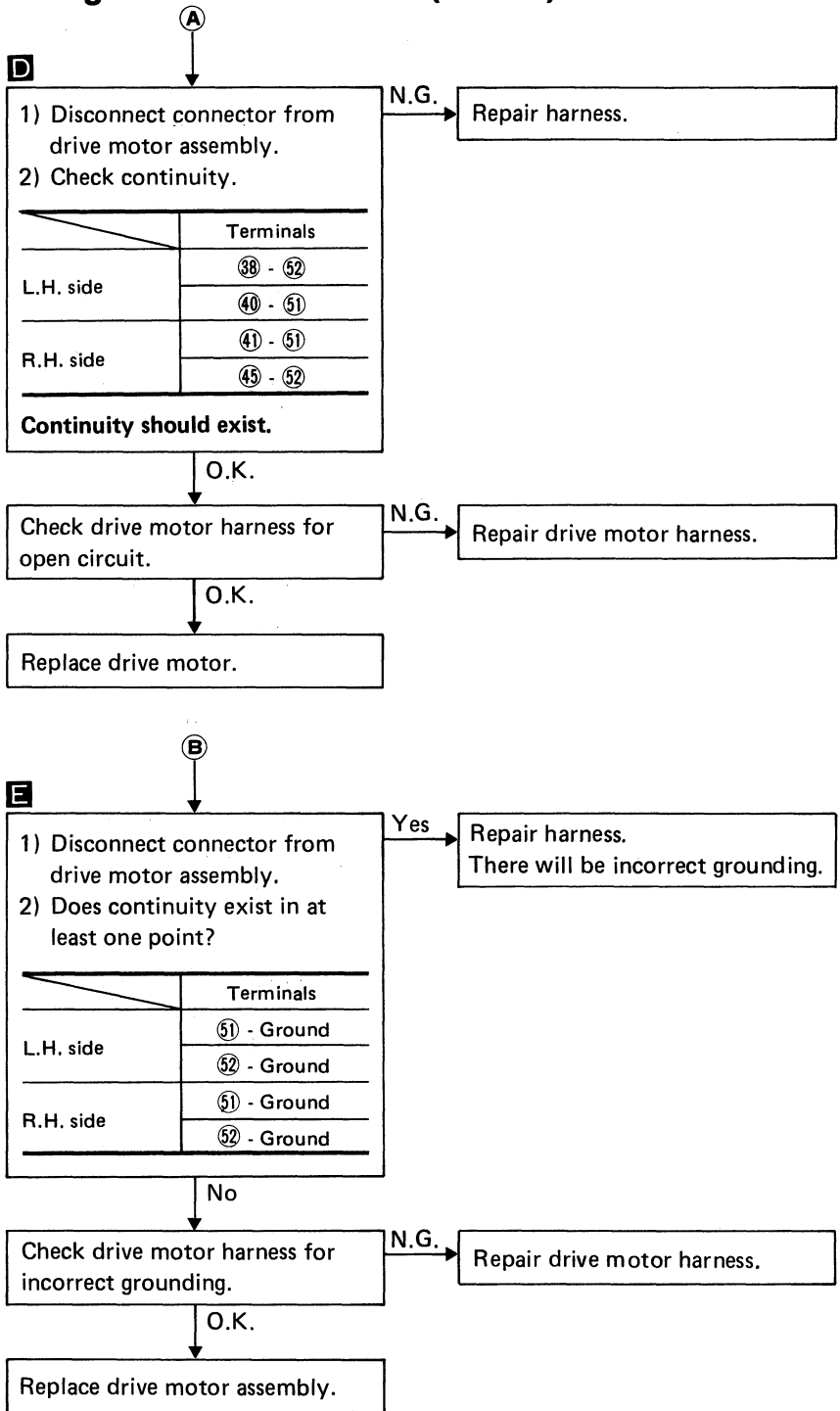
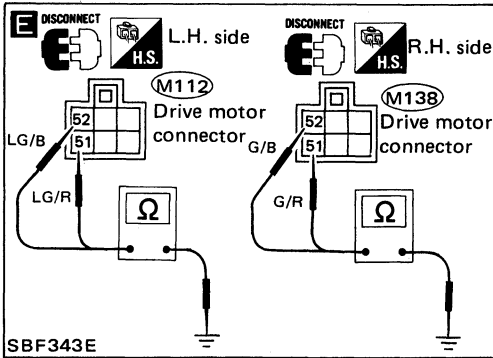
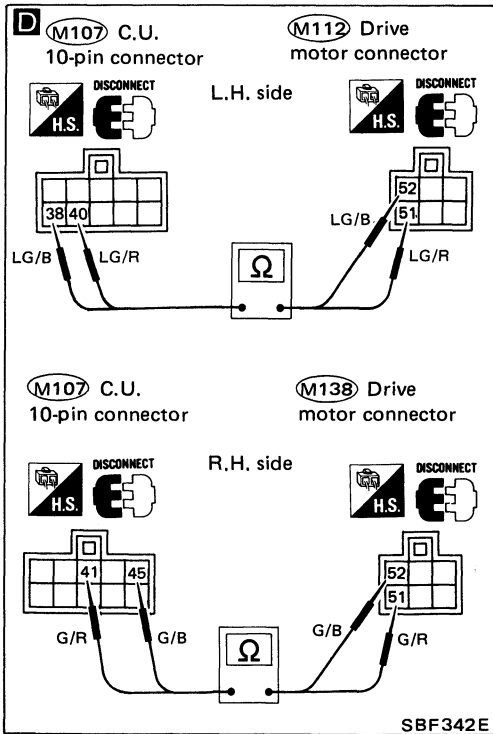

TROUBLE DIAGNOSES

Diagnostic Procedure 1 (Cont'd)

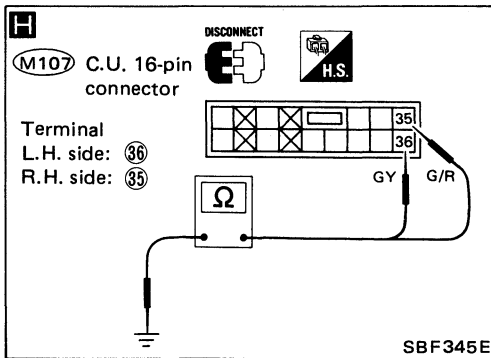
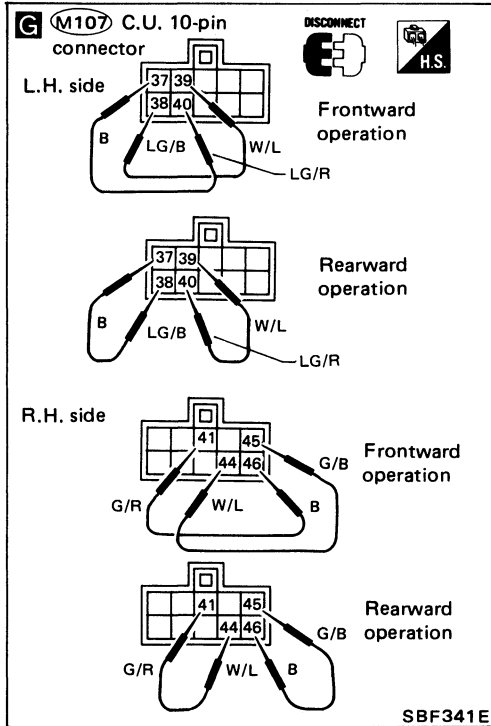
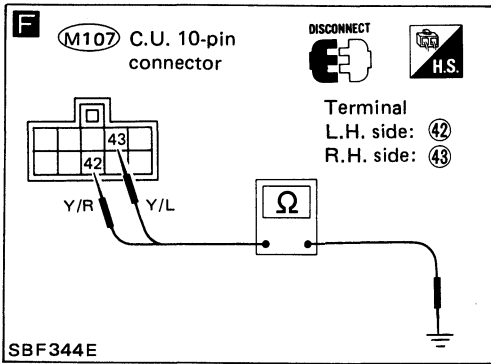

C

F

CHECK STOP SIGNAL.

- 1) Move shoulder belt buckle to center (not rear lock position and not front).
- 2) Check continuity.

	Terminals
L.H. side	④② - Ground
R.H. side	④③ - Ground

Continuity should exist.

G Refer to figure **G** to move shoulder belt buckle.

N.G. → Go to Diagnostic Procedure 3 (See page BF-56.) and return to next step.

O.K. →

H

- 1) Disconnect 16-pin connector from control unit.
- 2) Check continuity.

	Terminals
L.H. side	③⑥ - Ground
R.H. side	③⑤ - Ground

Continuity should exist.

N.G. → Go to Diagnostic Procedure 4 (See page BF-58.) and return to next step.

O.K. →

Is this the second time? Yes → Replace control unit.

No →

Reinstall any part removed.

Go to PROCEDURE 1 (START) of Preliminary Check. (See page BF-43.)

TROUBLE DIAGNOSES

Diagnostic Procedure 2

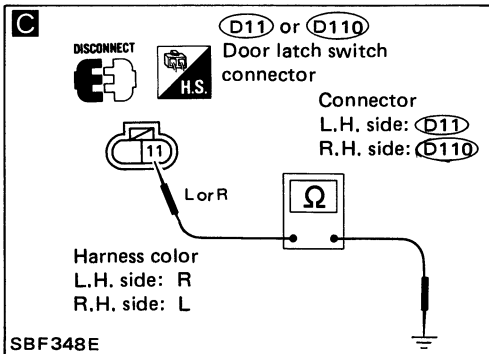
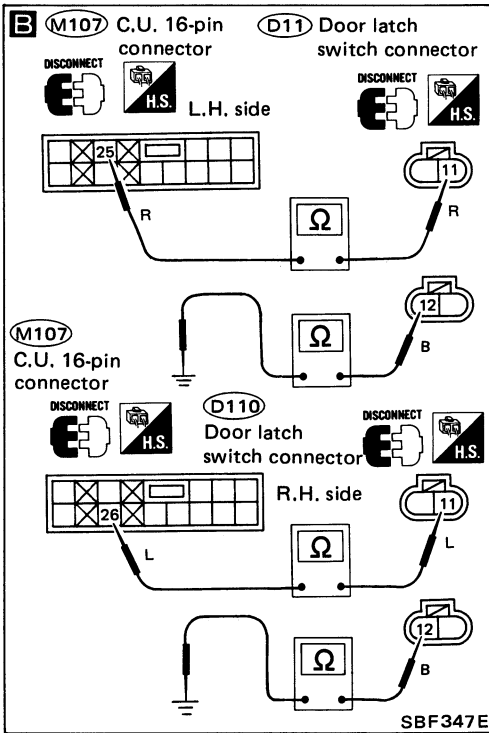
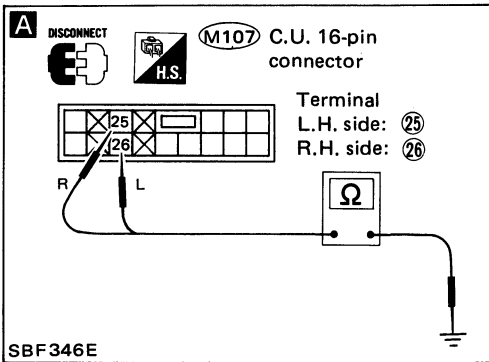

START

A CHECK DOOR SWITCH CIRCUIT. (Go to **A** on next page.)

- 1) Disconnect 16-pin connector from control unit.
- 2) Check continuity.

	Terminals	Door condition	Continuity
L.H. side	25 - Ground	Open	Yes
		Close	No
R.H. side	26 - Ground	Open	Yes
		Close	No

B N.G.

- 1) Disconnect door latch switch connector.
- 2) Check continuity.

	Terminals
L.H. side	25 - 11
	12 - Ground (M57, M116)
R.H. side	26 - 11
	12 - Ground (M57, M116)

Continuity should exist.

C O.K.

Does continuity exist?

	Connector	Terminals
L.H. side	D11	11 - Ground
R.H. side	D110	11 - Ground

No

Go to DOOR LATCH SWITCH of Electrical Components Inspection. (See page BF-66.)

N.G.

Check door latch switch harness for open and short circuit.

O.K.

Replace door lock assembly.

O.K. (Go to **A** on next page.)

N.G. Repair harness.

Yes Repair harness. There will be incorrect grounding between terminals 25 and 11 or 26 and 11.

O.K. Reinstall any part removed.

Go to PROCEDURE 1 (START) of Preliminary Check. (See page BF-43.)

N.G. Repair door latch switch harness.

TROUBLE DIAGNOSES

Diagnostic Procedure 2 (Cont'd)

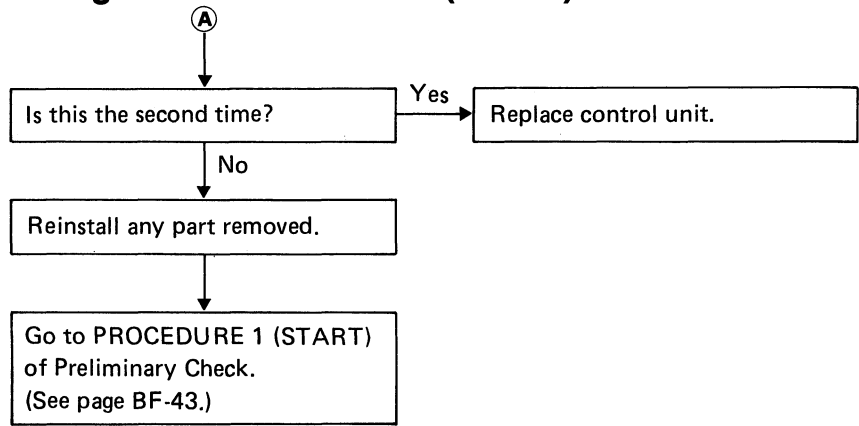

TROUBLE DIAGNOSES

Diagnostic Procedure 3

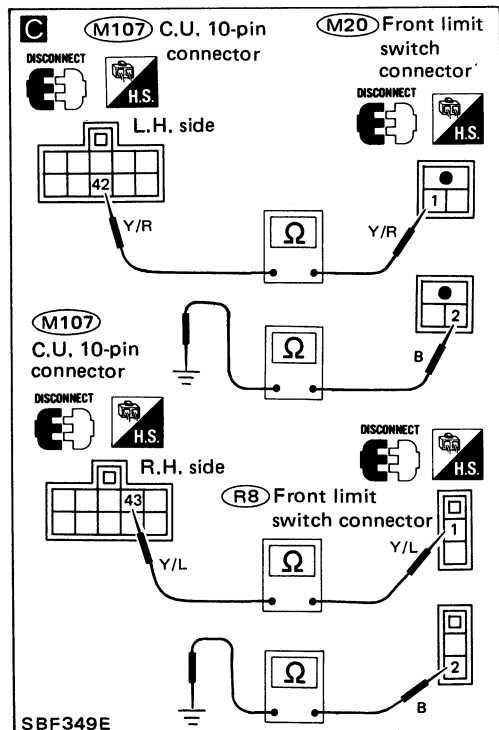
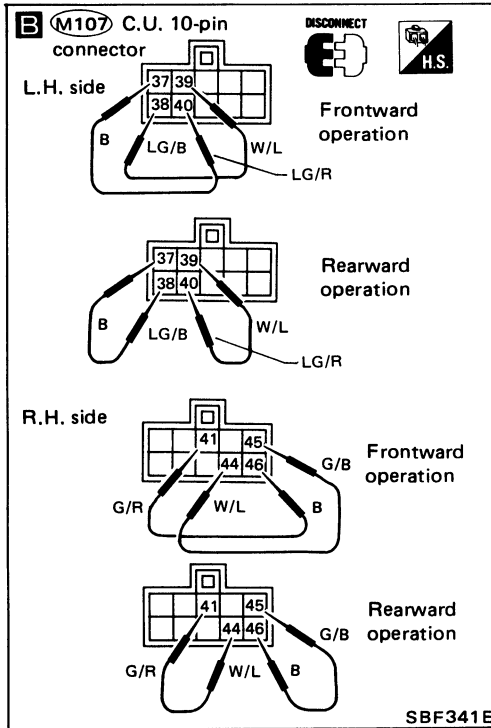
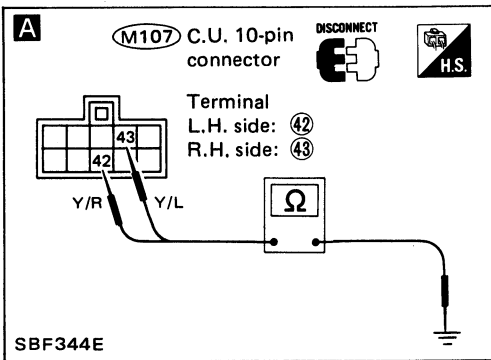

START

A

CHECK FRONT LIMIT SWITCH CIRCUIT.

O.K. → (Go to **B** on next page.)

- 1) Disconnect 10-pin connector from control unit.
- 2) Check continuity.

	Terminals	Shoulder belt buckle position	Continuity
L.H. side	④② - Ground	At front	No
		Not at front	Yes
R.H. side	④③ - Ground	At front	No
		Not at front	Yes

B Refer to figure **B** to move shoulder belt buckle.

N.G.

C

- 1) Disconnect connector from front limit switch.
- 2) Check continuity.

N.G. → Repair harness.

	Terminals
L.H. side	④② - ①
	② - Ground (M57, M116)
R.H. side	④③ - ①
	② - Ground (M57, M116)

Continuity should exist.

O.K.

(Go to **A** on next page.)

TROUBLE DIAGNOSES

Diagnostic Procedure 3 (Cont'd)

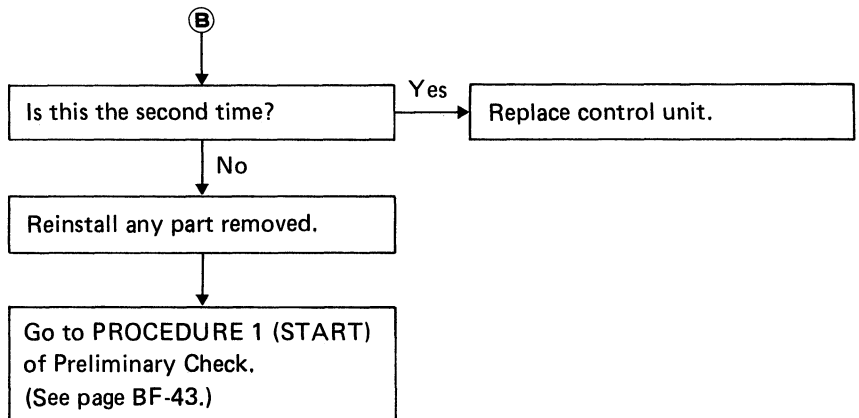
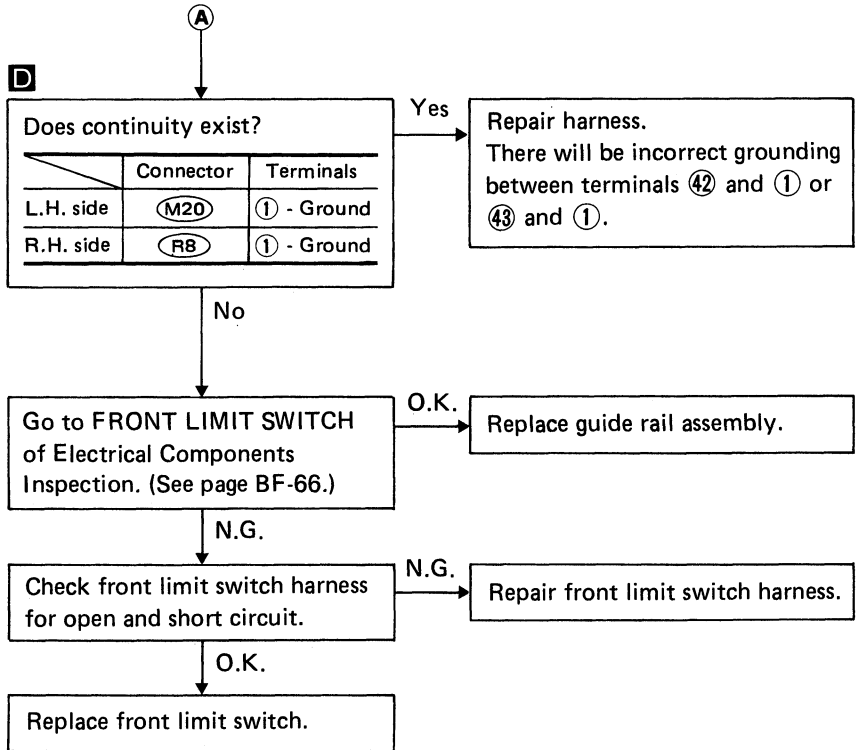
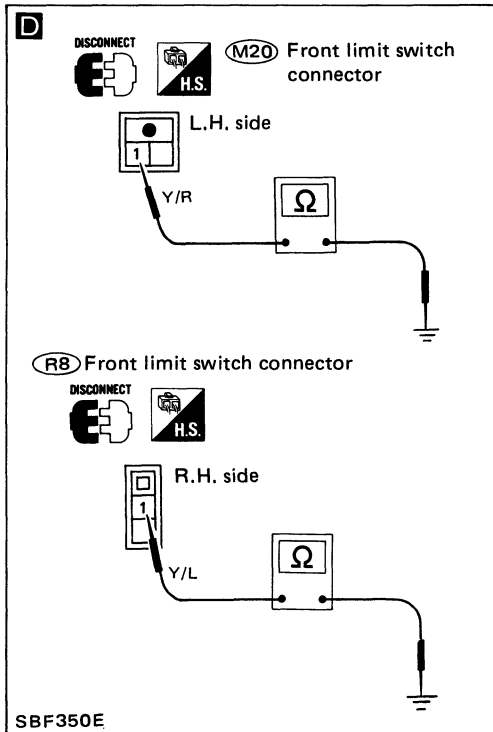

Diagnostic Procedure 4

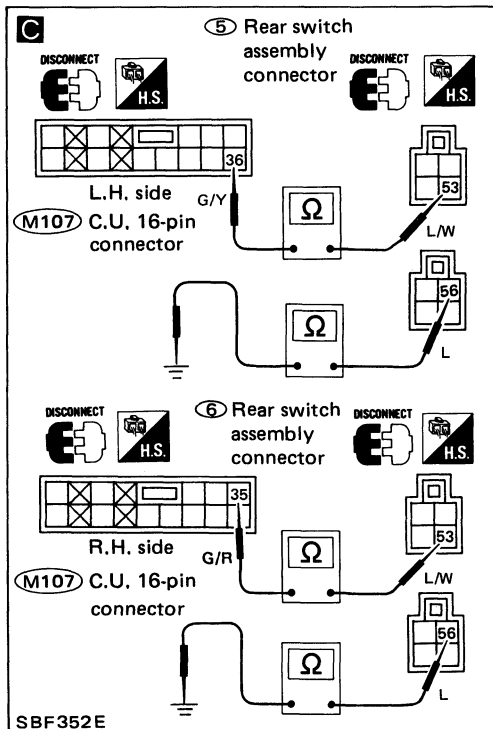
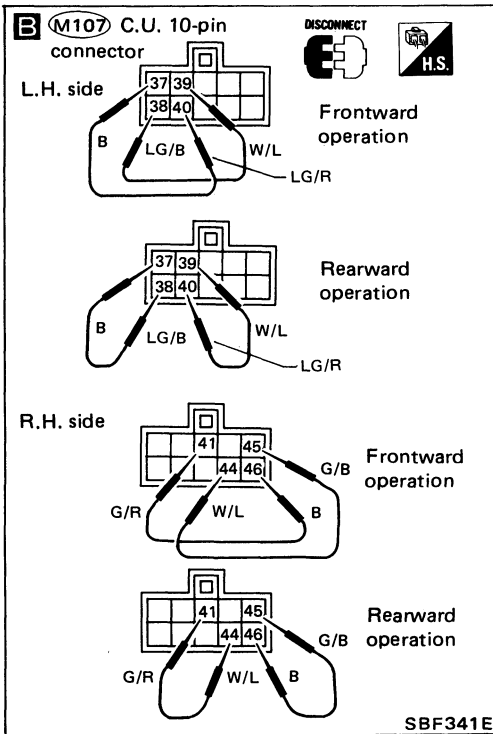
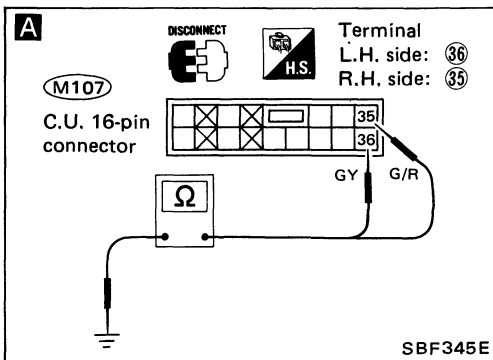

A

CHECK REAR LIMIT SWITCH CIRCUIT.

- 1) Disconnect 16-pin connector from control unit.
- 2) Check continuity.

	Terminals	Shoulder belt buckle position	Continuity
L.H. side	③⑥ - Ground	At rear	No
		Not at rear	Yes
R.H. side	③⑤ - Ground	At rear	No
		Not at rear	Yes

B Refer to figure **B** to move shoulder belt buckle.

O.K. (Go to **B** on next page.)

C

N.G.

- 1) Disconnect connector from rear switch assembly.
- 2) Check continuity.

	Terminals
L.H. side	③⑥ - ⑤③ ⑤⑥ - Ground (M107, M125)
R.H. side	③⑤ - ⑤③ ⑤⑥ - Ground (M107, M125)

Continuity should exist.

N.G. Repair harness.

O.K.

(Go to **A** on next page.)

TROUBLE DIAGNOSES

Diagnostic Procedure 4 (Cont'd)

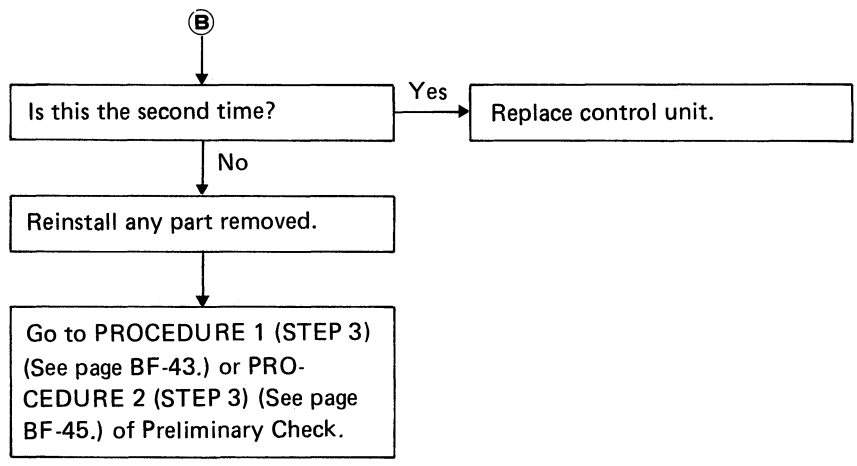
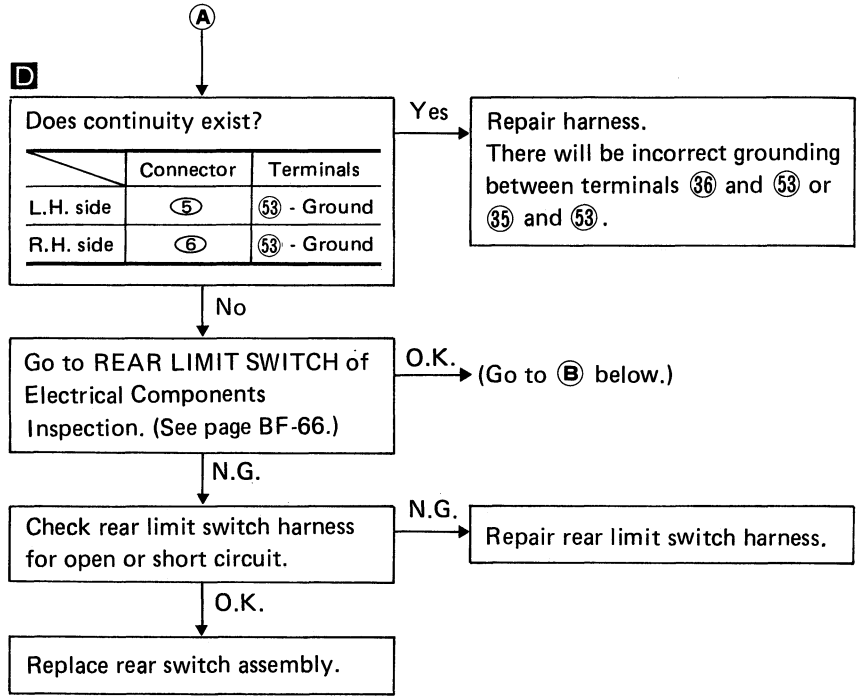
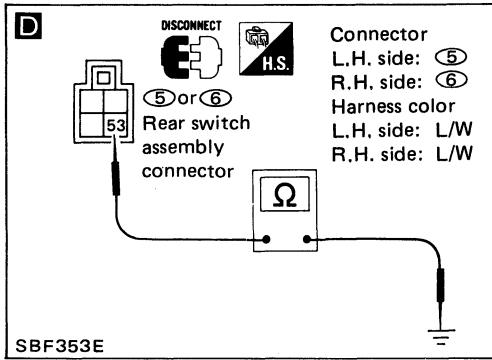

TROUBLE DIAGNOSES

Diagnostic Procedure 5

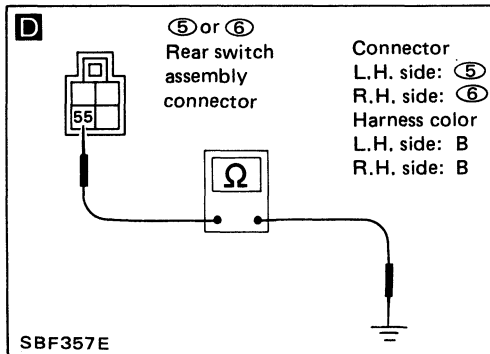
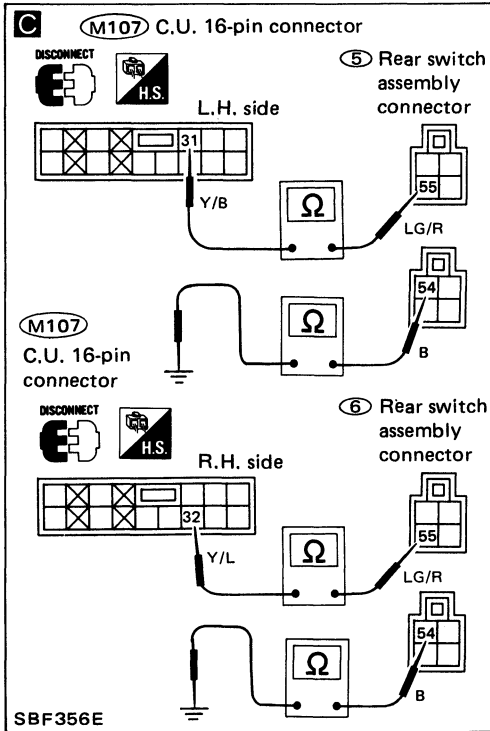
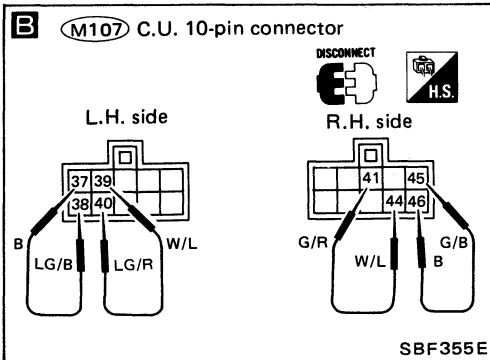
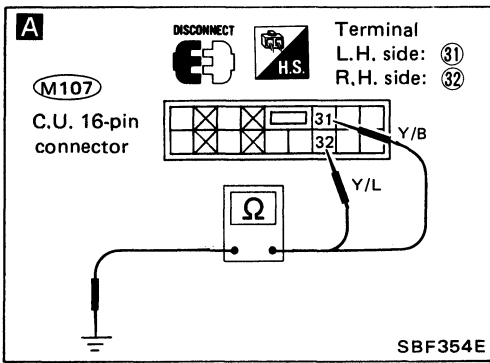

START

A

CHECK SHOULDER BELT BUCKLE SWITCH CIRCUIT.

O.K. (Go to **B** on next page.)

- 1) Disconnect 16-pin connector from control unit.
- 2) Check continuity when shoulder belt buckle is at rear lock position.

	Terminals	Shoulder belt	Continuity
L.H. side	① - Ground	Fasten	Yes
		Unfasten	No
R.H. side	② - Ground	Fasten	Yes
		Unfasten	No

B If shoulder belt buckle is not rear lock position, do as figure **B** to move it to rear.

N.G.

- C**
- 1) Disconnect connector from rear switch assembly.
 - 2) Check continuity.

N.G.

Repair harness.

	Terminals
L.H. side	① - ⑤
	④ - Ground (M101, M125)
R.H. side	② - ⑤
	④ - Ground (M101, M125)

Continuity should exist.

O.K.

D

Does continuity exist?

Yes

Repair harness.
There will be incorrect grounding between terminals ① and ⑤ or ② and ⑤.

	Connector	Terminals
L.H. side	⑤	⑤ - Ground
R.H. side	⑥	⑤ - Ground

No

Go to SHOULDER BELT BUCKLE SWITCH of Electrical Components Inspection.
(See page BF-66.)

O.K. (Go to **B** on next page.)

N.G.

(Go to **A** on next page.)

TROUBLE DIAGNOSES

Diagnostic Procedure 5 (Cont'd)

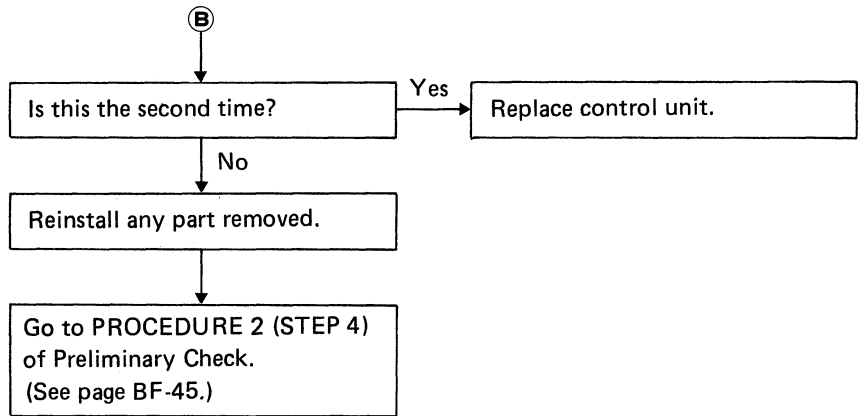
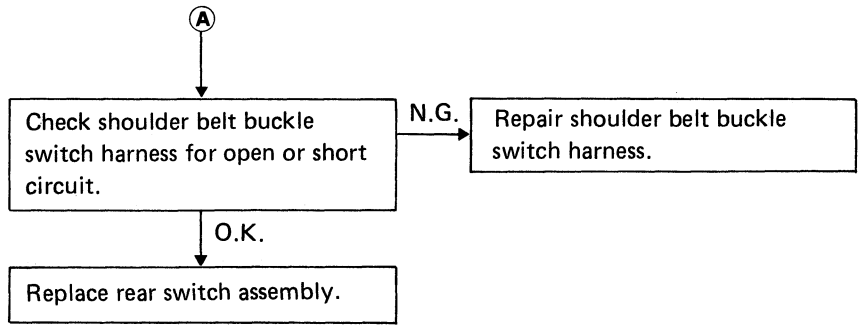

TROUBLE DIAGNOSES

Diagnostic Procedure 6

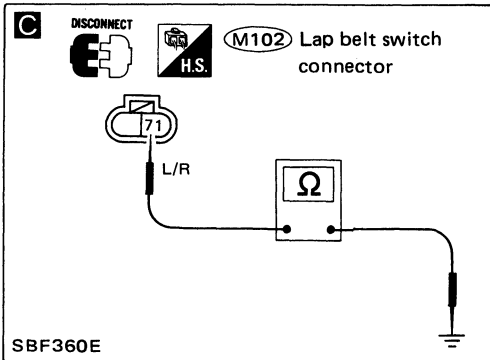
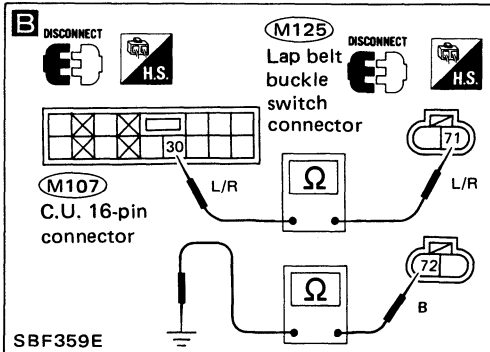
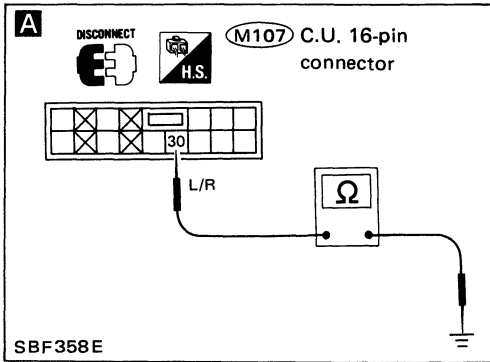

START

A CHECK LAP BELT BUCKLE SWITCH CIRCUIT (L.H. only).
 1) Disconnect 16-pin connector from control unit.
 2) Check continuity.

O.K. (Go to **A** on next page.)

Terminals	Lap belt	Continuity
③⑩ - Ground	Fasten	No
	Unfasten	Yes

N.G.

B 1) Disconnect lap belt switch connector.
 2) Check continuity.

N.G. Repair harness.

Terminals
③⑩ - ⑦①
⑦② - Ground (M101, M125)

Continuity should exist.

O.K.

C Does continuity exist?

Yes Repair harness. There will be incorrect grounding.

Terminals
⑦① - Ground

No

Go to LAP BELT BUCKLE SWITCH of Electrical Components Inspection. (See page BF-67.)

O.K. (Go to **A** on next page.)

N.G.

Check lap belt buckle switch harness for open and short circuit.

N.G. Repair lap belt buckle switch harness.

O.K.

Replace shoulder belt buckle assembly.

TROUBLE DIAGNOSES

Diagnostic Procedure 6 (Cont'd)

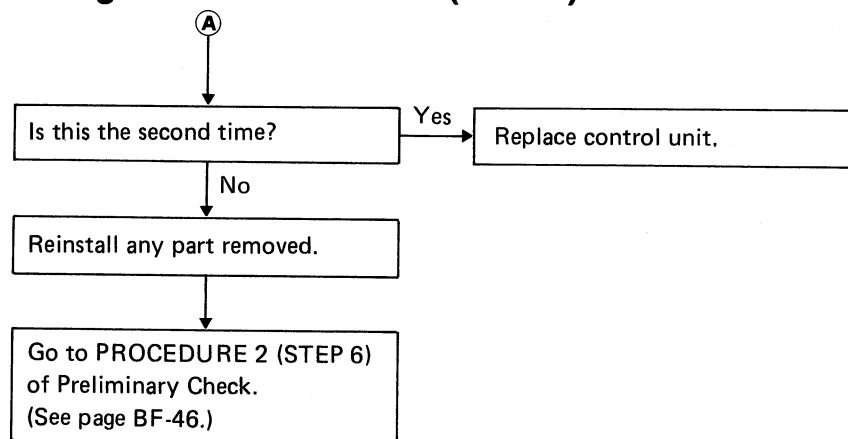

TROUBLE DIAGNOSES

Diagnostic Procedure 7

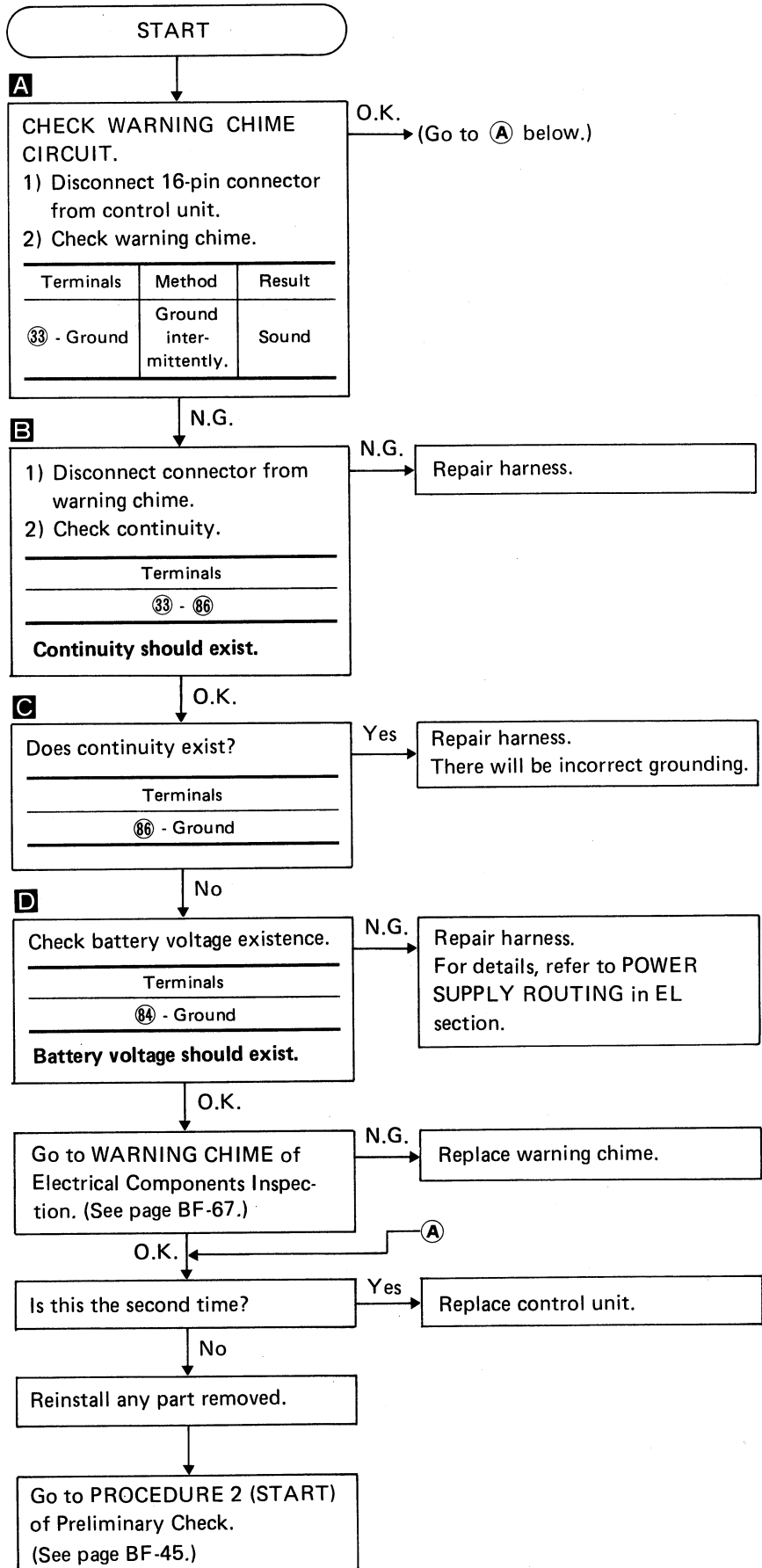
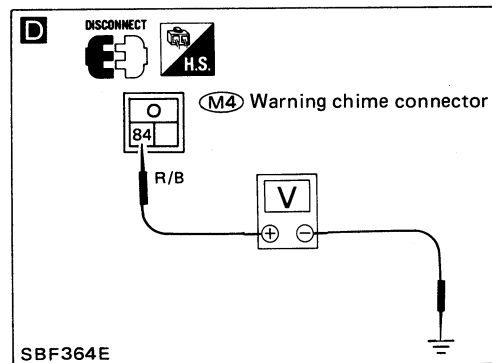
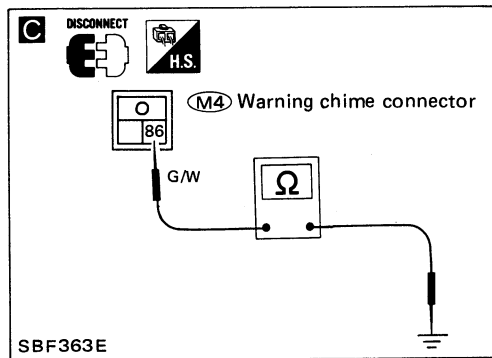
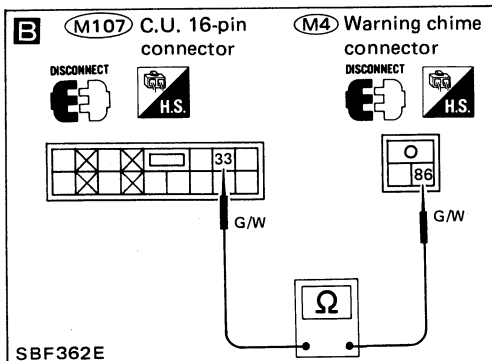
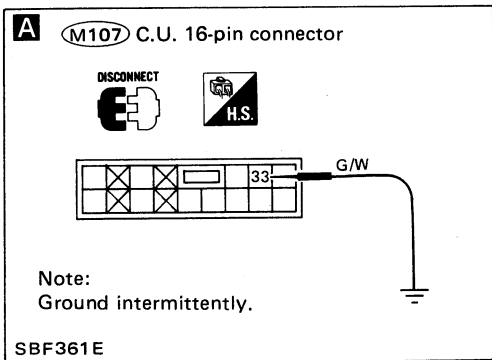

TROUBLE DIAGNOSES

Diagnostic Procedure 8

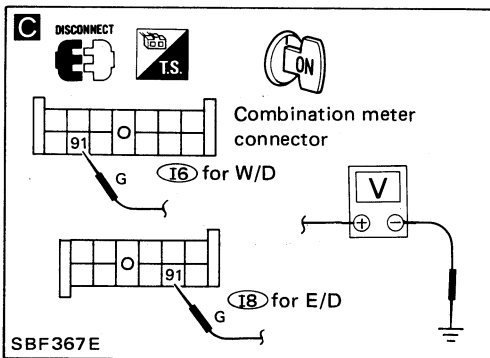
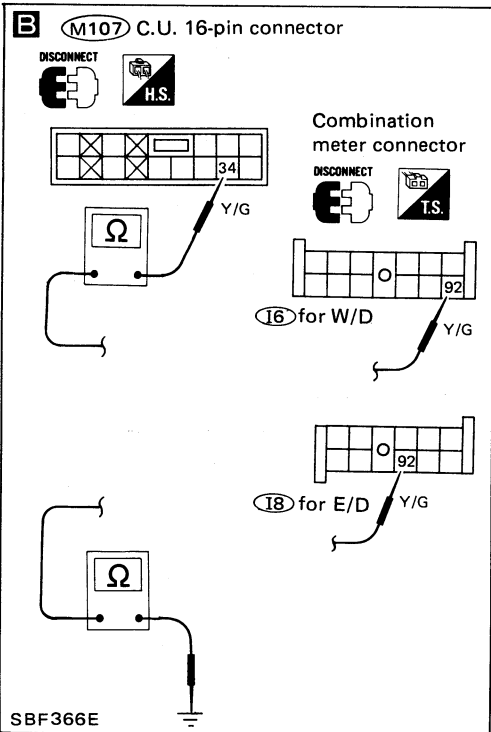
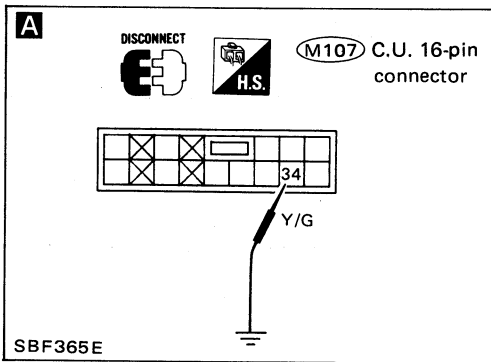

W/D: With Head-up Display
E/D: Without Head-up Display

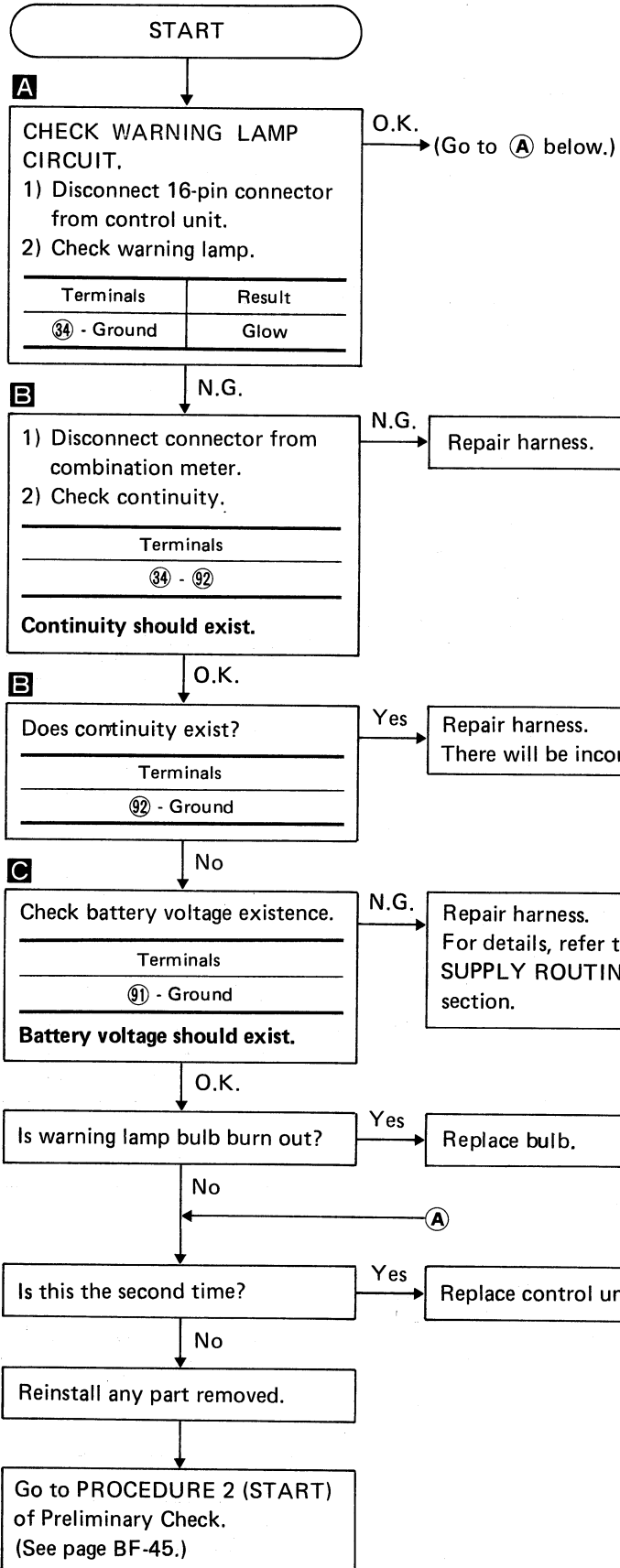

TROUBLE DIAGNOSES

Electrical Components Inspection

FRONT LIMIT SWITCH

Condition	Continuity
Pushed	No
Released	Yes

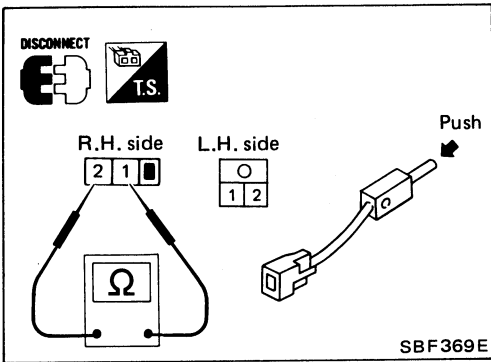

REAR LIMIT SWITCH

Condition	Continuity
Pushed	No
Released	Yes

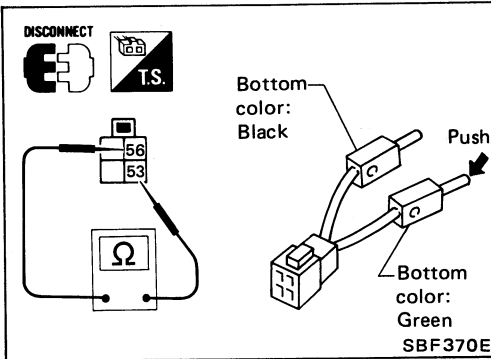

SHOULDER BELT BUCKLE SWITCH

Condition	Continuity
Pushed	Yes
Released	No

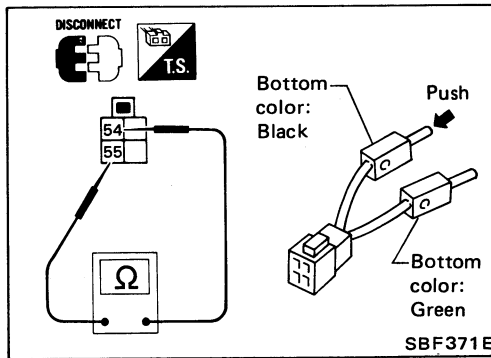

DOOR LATCH SWITCH (Built-in door lock assembly)

Door condition	Continuity
Open	Yes
Closed	No

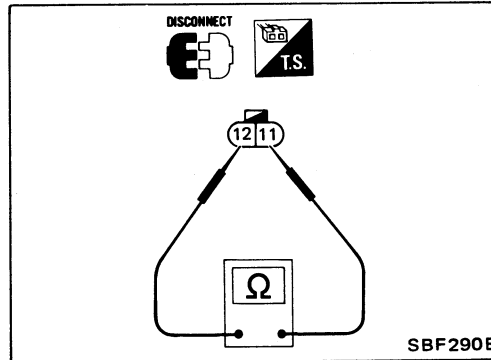

DRIVE MOTOR ASSEMBLY

Terminals		Drive belt operation
+	-	
52	51	Lengthen
51	52	Shorten

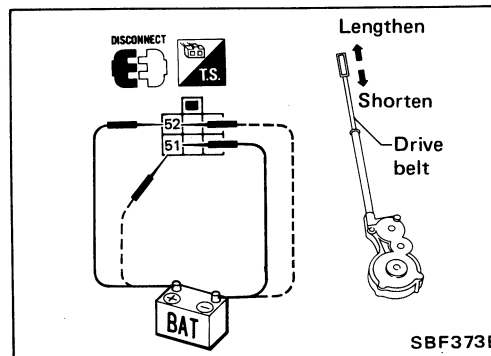

TROUBLE DIAGNOSES

Electrical Components Inspection (Cont'd) WARNING CHIME

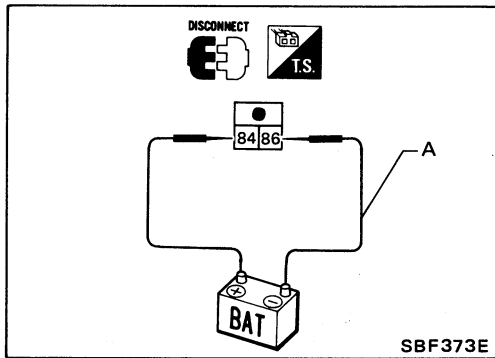

Condition	Operation
Connect and disconnect harness A as shown at left	Sounds

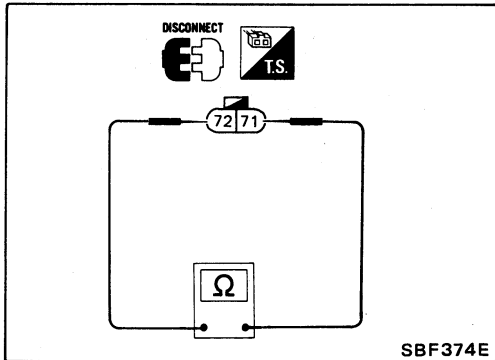

LAP BELT BUCKLE SWITCH (Built-in lap belt buckle for L.H. side)

Condition	Continuity
Fastened	No
Unfastened	Yes

SUN ROOF

Electrical Sun Roof

- Do not move or remove limit switch unless it is necessary.
- After any adjustment, check sun roof operation and lid alignment.

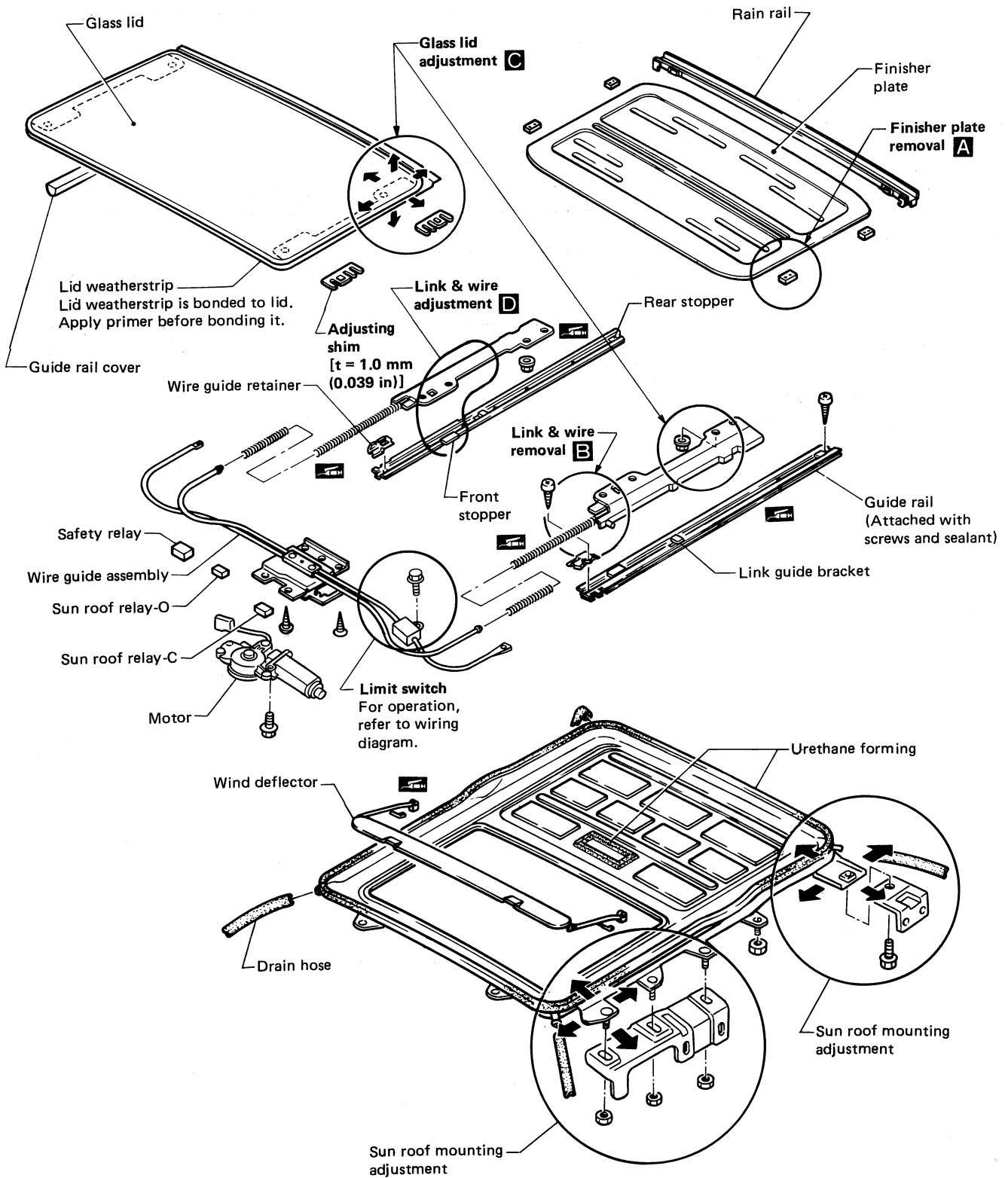

 : Grease-up points

SUN ROOF

Electrical Sun Roof (Cont'd)

Finisher plate removal & installation

A Remove guide rail cover and pull up pawl, then draw out finisher plate with sun roof lid open.

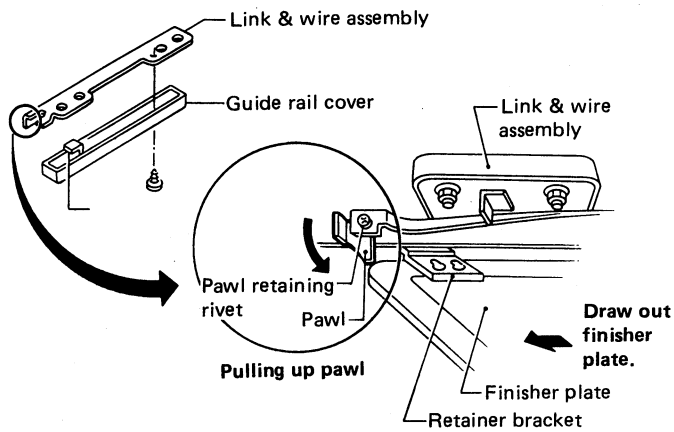

Removal:
Raise pawl of retainer bracket, shift finisher plate and remove locating pins from retainer bracket. Then remove finisher plate.

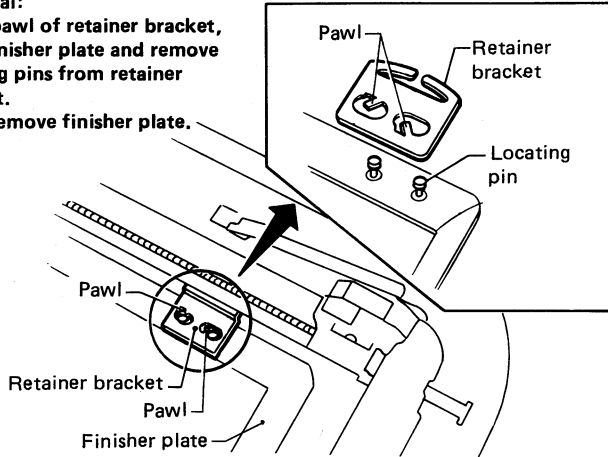

Link & wire removal & installation

- B**
- When replacing wire, remove rail first and then link & wire assembly.
 - Be sure to lubricate.

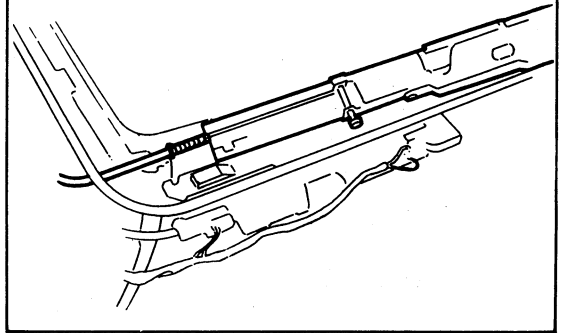

Glass lid adjustment

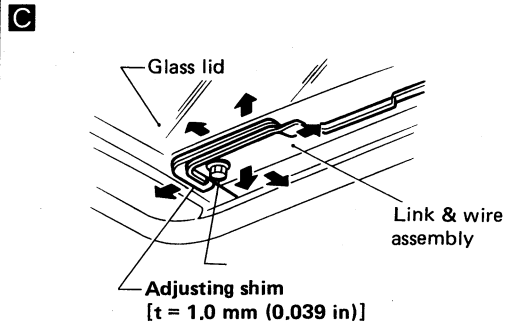

Link & wire adjustment

D Move link & wire assembly to closed lid position and after closing fully (as shown in figure below), install motor.

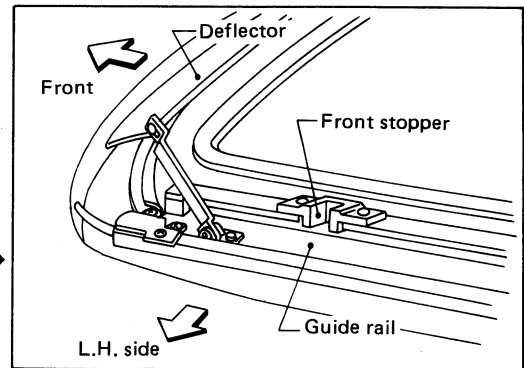
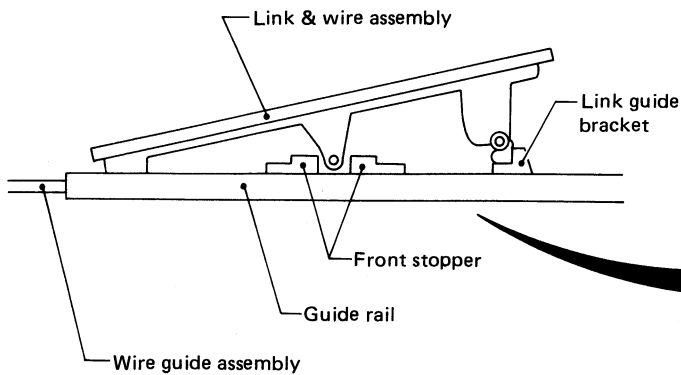

SUN ROOF

Wiring Diagram

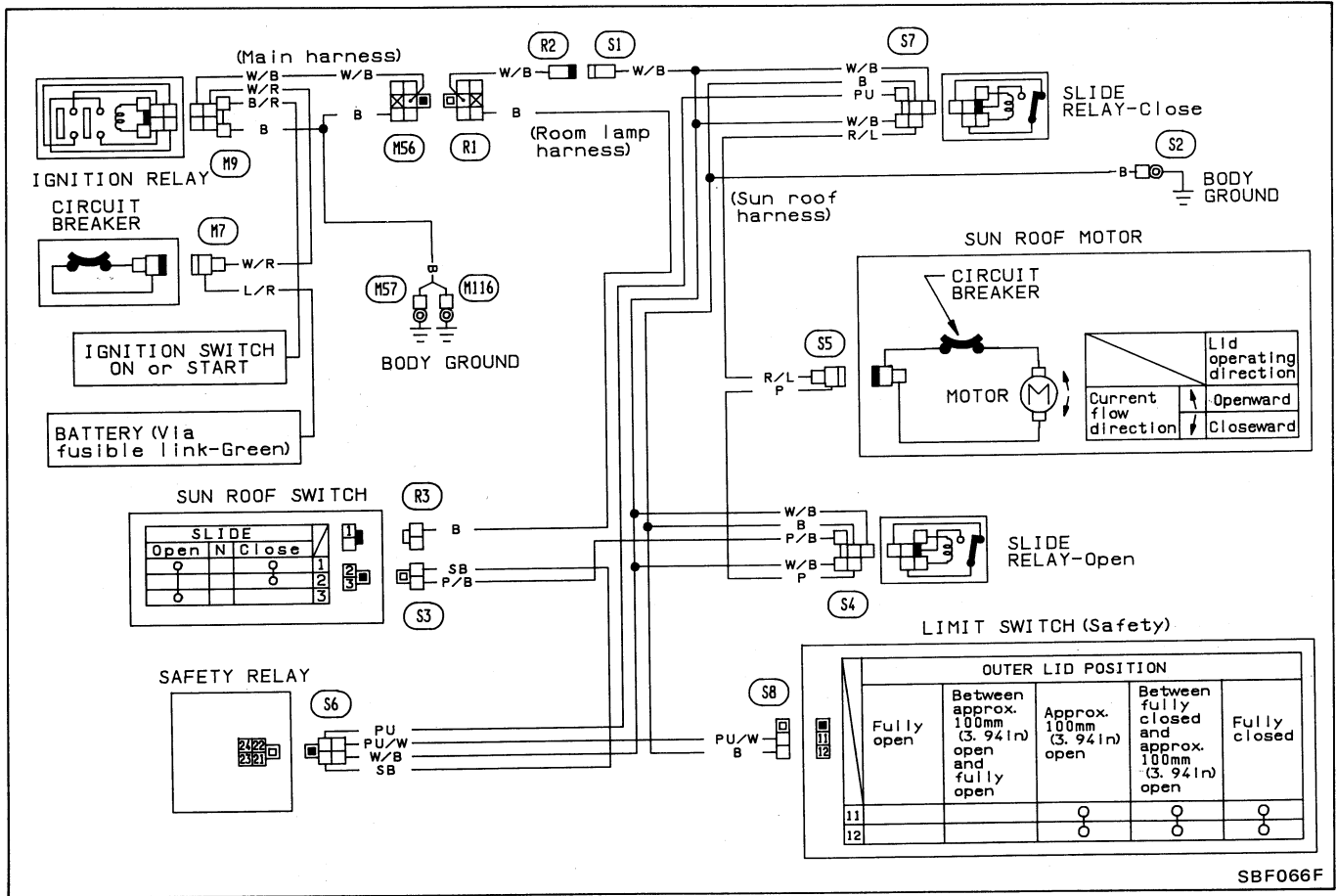

SBF066F

SUN ROOF

Manual Sun Roof

Handle adjustment

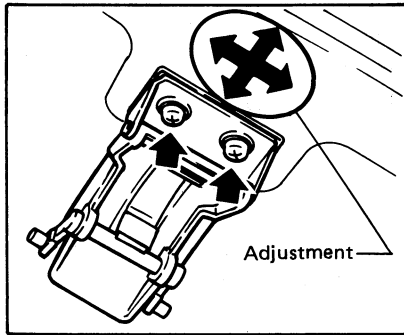

Female hinge

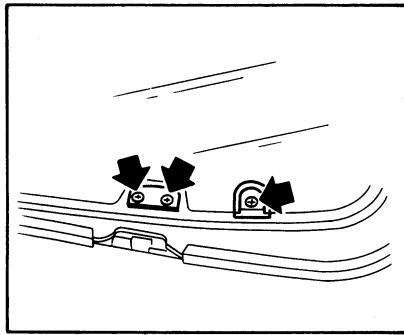

Hinge bracket

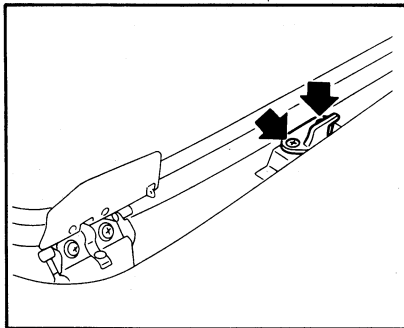

Air deflector adjustment

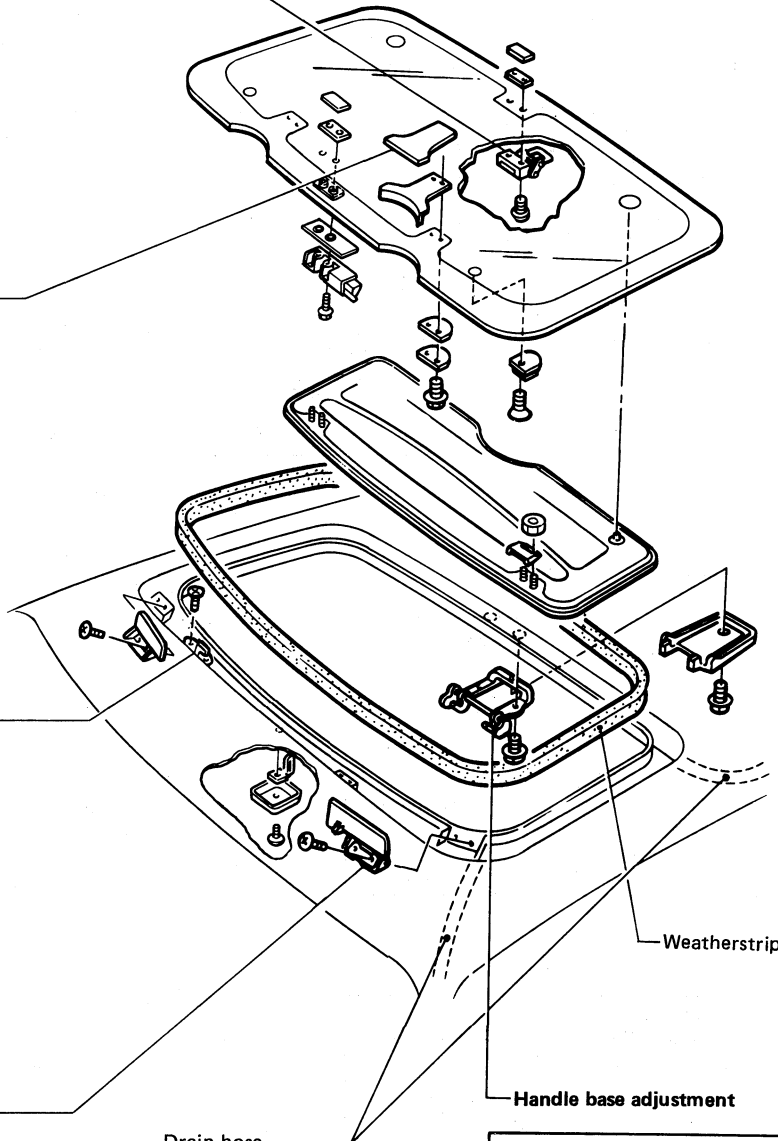
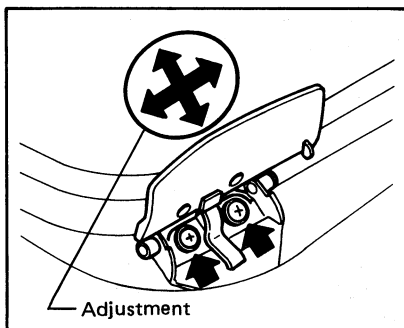

Handle base adjustment

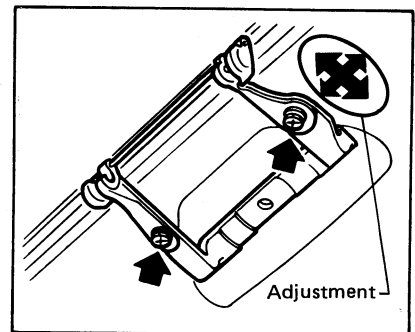

Drain hose

- After installation of drain hoses, make sure water drains smoothly.

WINDSHIELD AND WINDOWS

Windshield

REMOVAL

After removing moldings, remove glass.

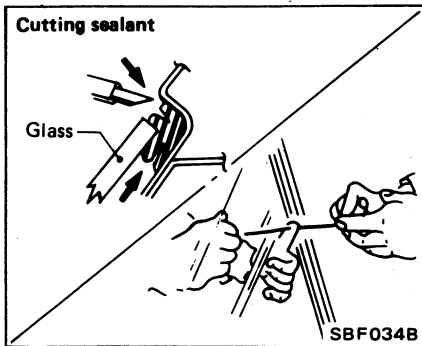

CAUTION:

Be careful not to scratch glass when removing.

INSTALLATION

- Use genuine Nissan Sealant kit or equivalent. Follow instructions furnished with it.
- After installation, the vehicle should remain stationary for about 24 hours.
- Do not use sealant which is more than 12 months past its production date.
- Do not leave cartridge unattended with its cap open.
- Keep primers and sealant in a cool, dry place. Nissan recommends that they are stored in a refrigerator.
- Be sure to install moldings.

WARNING:

Keep heat or open flames away as primers are flammable.

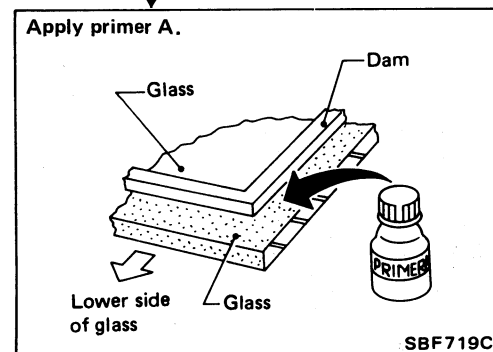
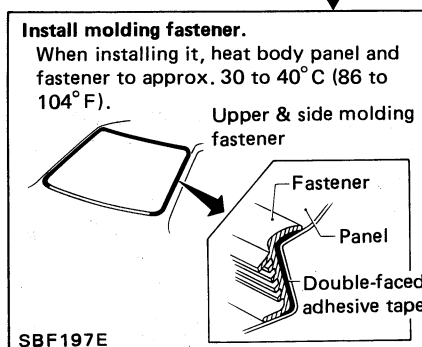
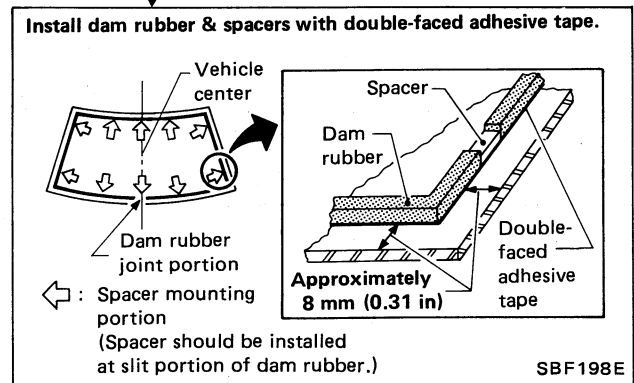
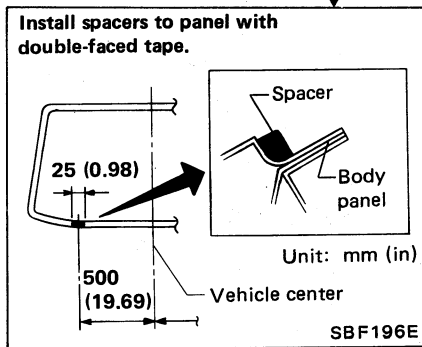
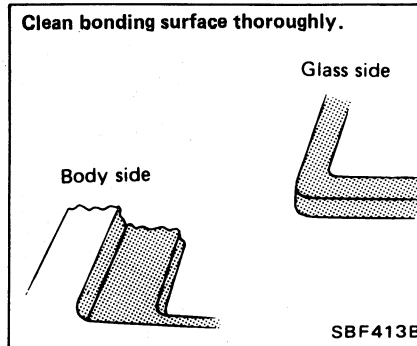

CAUTION:

Allow primers to dry for 10 to 15 minutes before proceeding to the next step.

A

B

WINDSHIELD AND WINDOWS

Windshield (Cont'd)

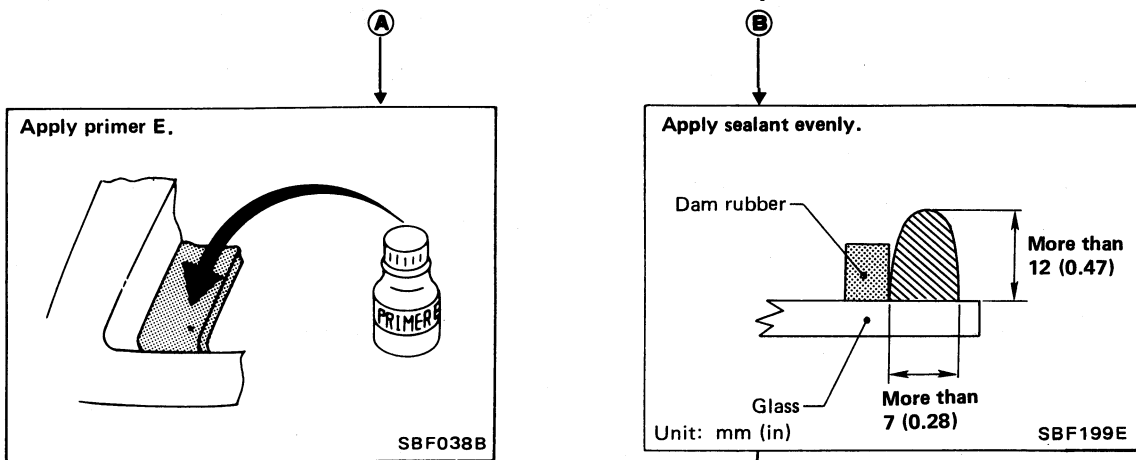

CAUTION:
Allow primers to dry for 10 to 15 minutes before proceeding to the next step.

CAUTION:
Windshield glass should be installed within 15 minutes of applying sealant: sealant starts to harden 15 minutes after it is applied.

Set glass in position and press glass lightly and evenly.

Apply sealant additionally to lower portion of glass and make it uniform as shown below:

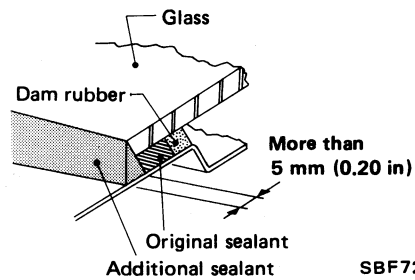

Check for water leakage.

CAUTION:
For sealant drying time, refer to "Drying Time for Sealant".

Apply sealant to upper & side molding fixing portion.

Install moldings.
(For details, refer to "Exterior".)

CAUTION:
Molding must be installed securely so that it is in position and leaves no gap.

WINDSHIELD AND WINDOWS

Back Window—Coupe

- Construction and removal/reinstallation methods of back window are basically the same as those of windshield.
For details of service procedures, refer to "Windshield".
- The difference between windshield and back window is as follows:
- For sealant drying period, refer to "Drying Time for Sealant".
- For details of moldings, refer to "Exterior".

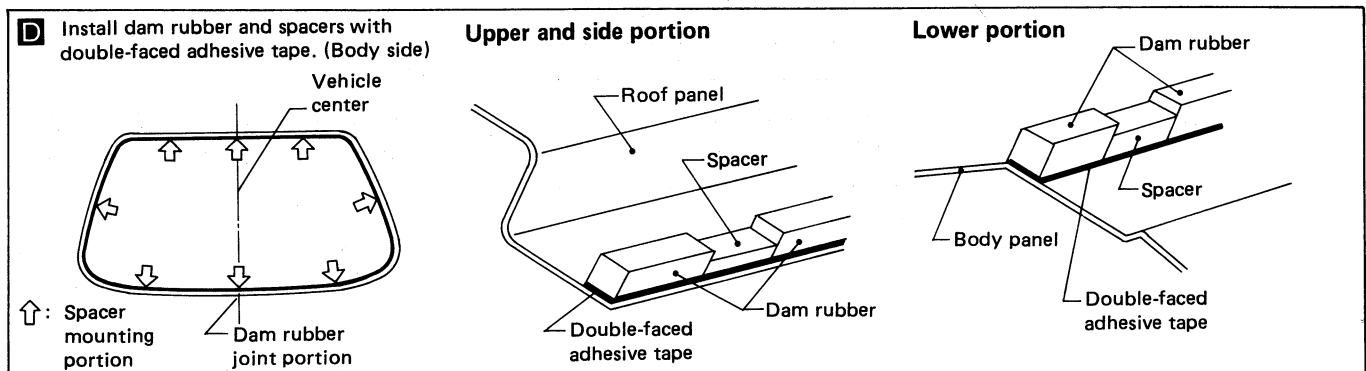
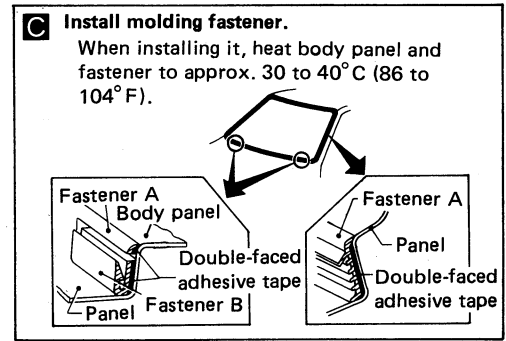
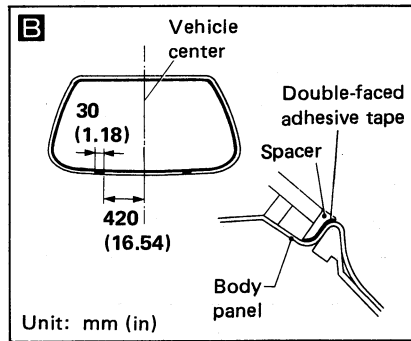
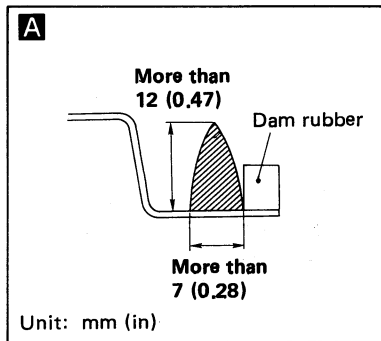
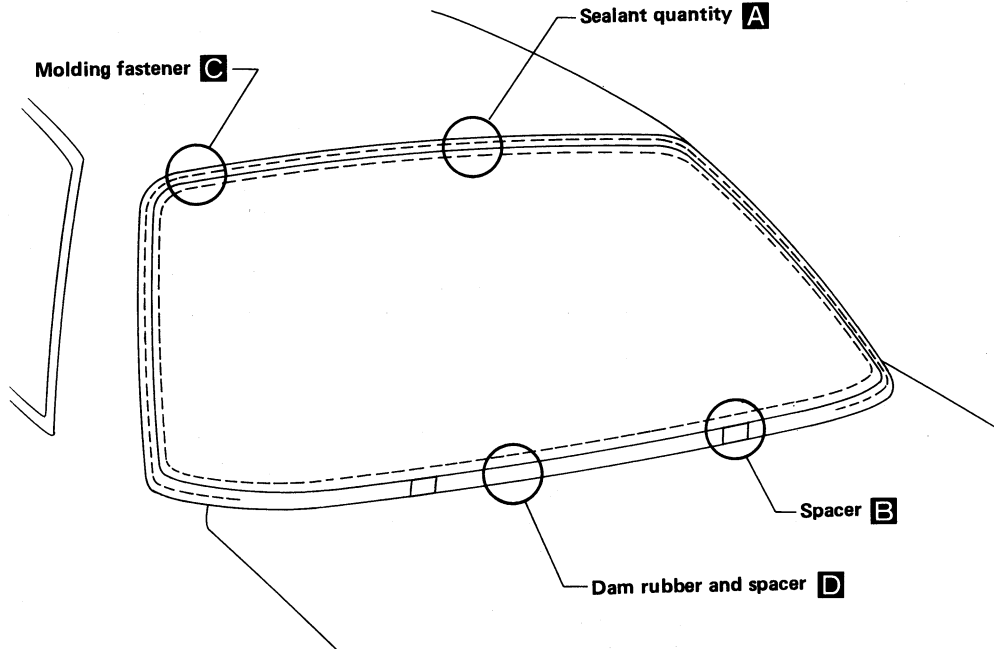

WINDSHIELD AND WINDOWS

Back Door Window—Fastback

- Construction and removal/reinstallation method of back door window are basically the same as those of windshield.
- Major differences are that sealant & dam rubber are installed to back door panel instead of glass surface. Spacer position is also changed. Moreover, there are locating pins in lower portion of glass. For details, refer to following figure.
- For sealant drying period, refer to "Drying Time for Sealant".
- For details of moldings, refer to "Exterior".

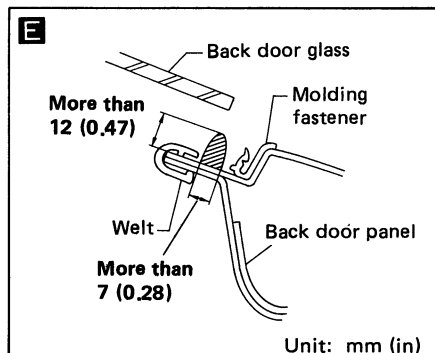
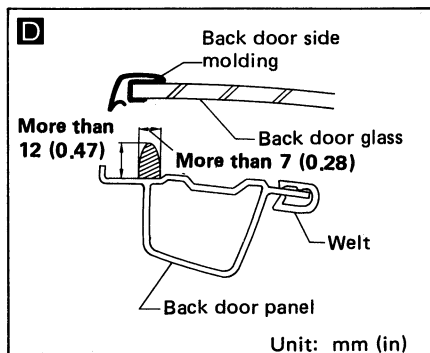
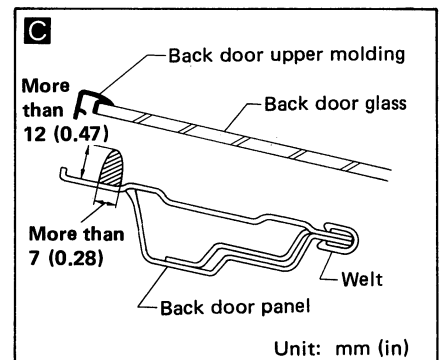
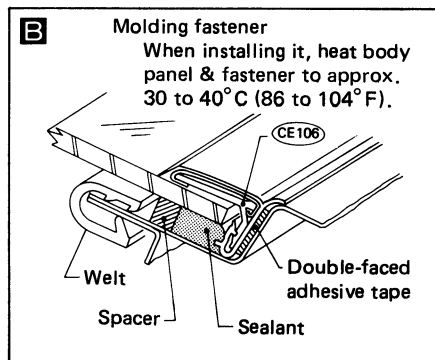
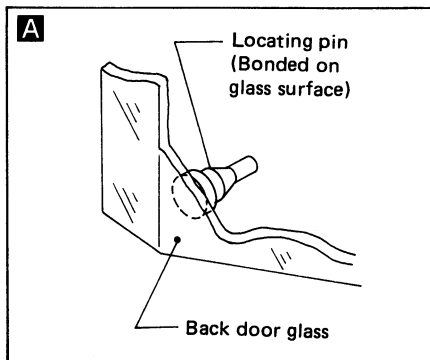
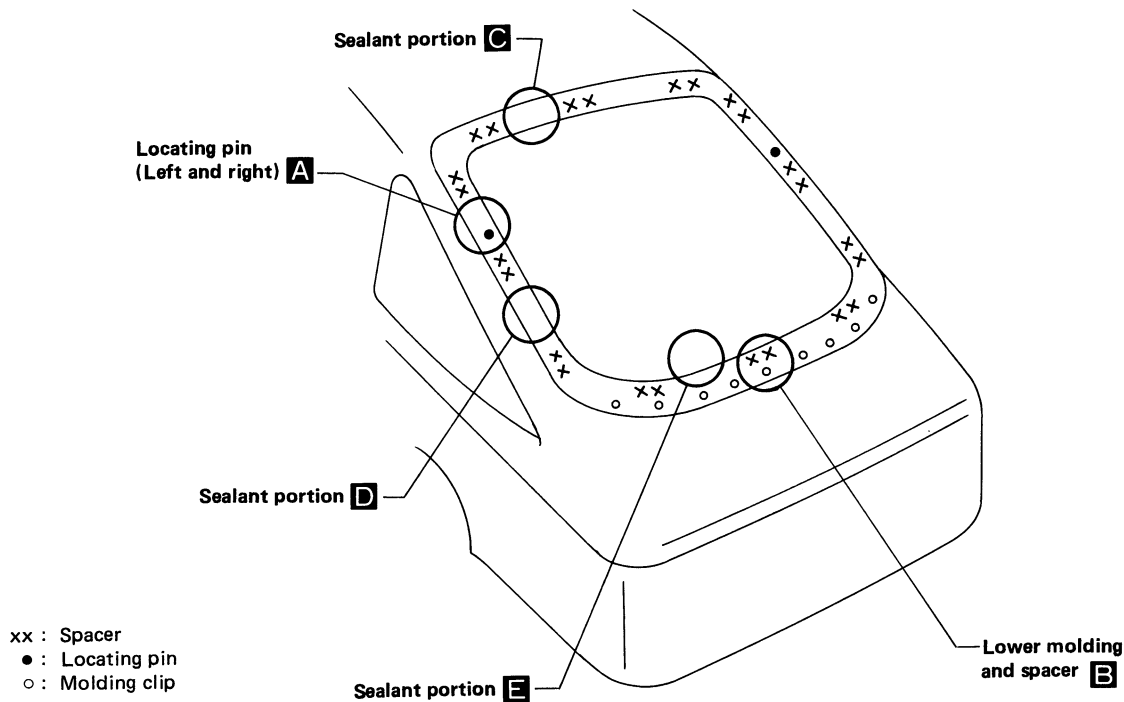

WINDSHIELD AND WINDOWS

Side Window

Side window is a molded type. During removal or installation, observe the following instructions.

1. Cut sealant in the same manner as that outlined under "Windshield."
2. Be careful not to scratch molding when cutting sealant. If molding is scratched, repair.
3. Remove clips and locating pins which have been exposed from vehicle body.

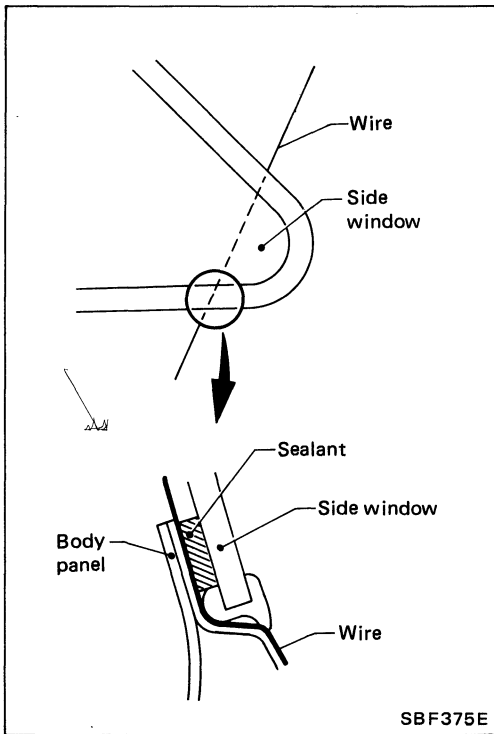

FASTBACK

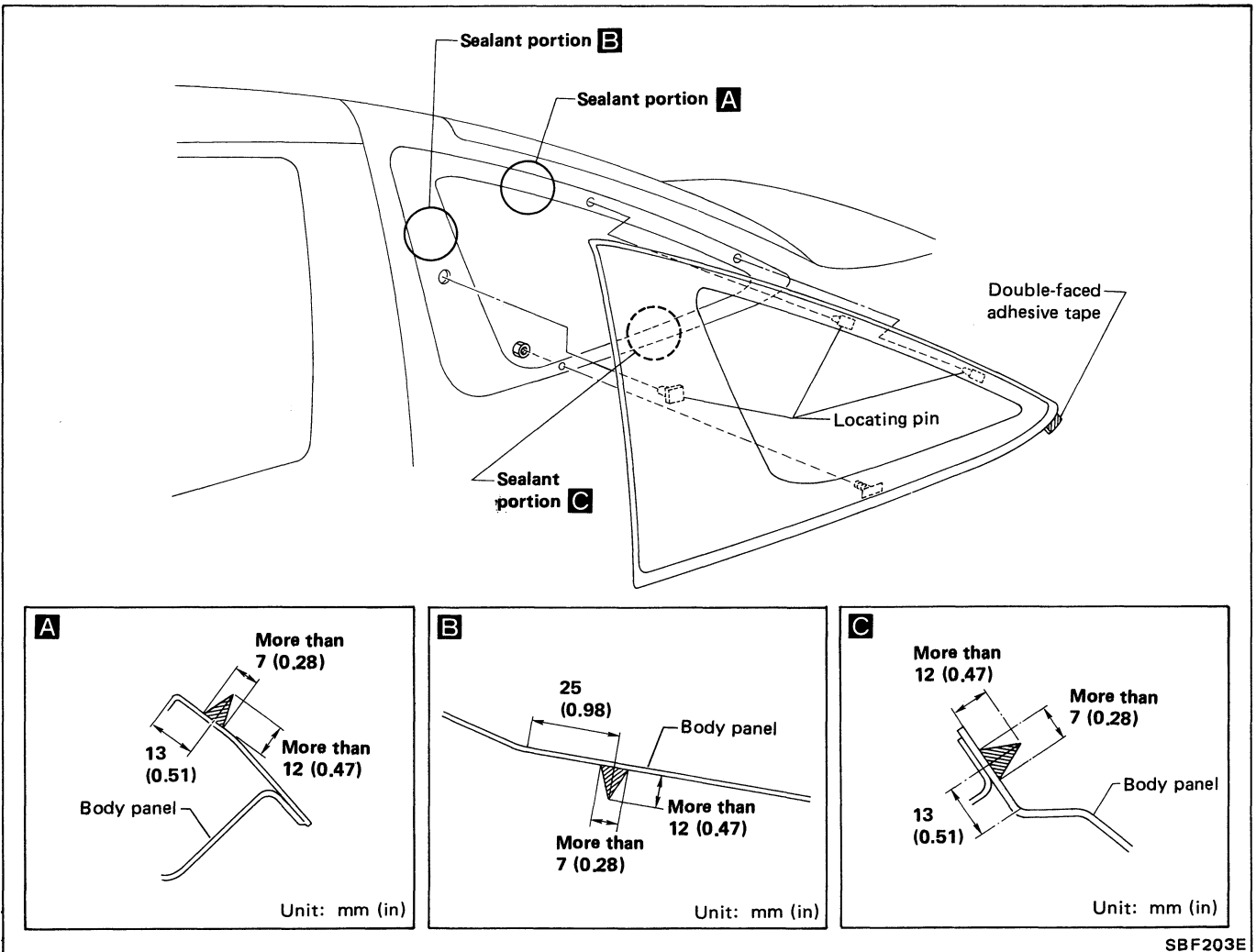

WINDSHIELD AND WINDOWS

Side Window (Cont'd)

COUPE

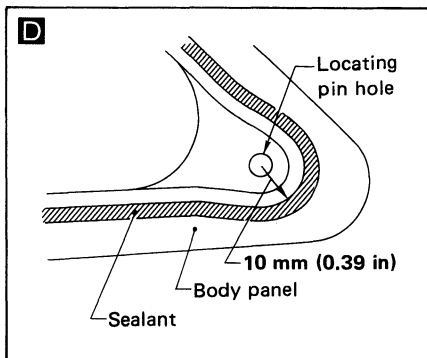
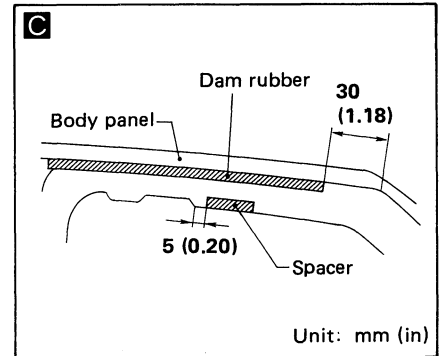
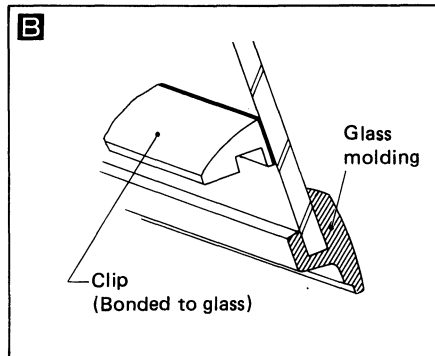
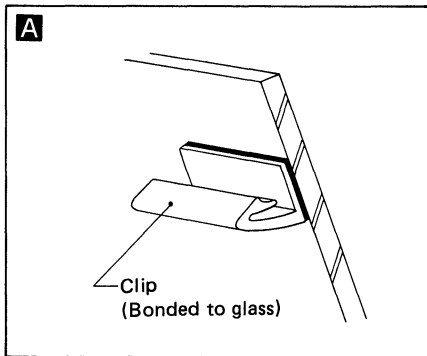
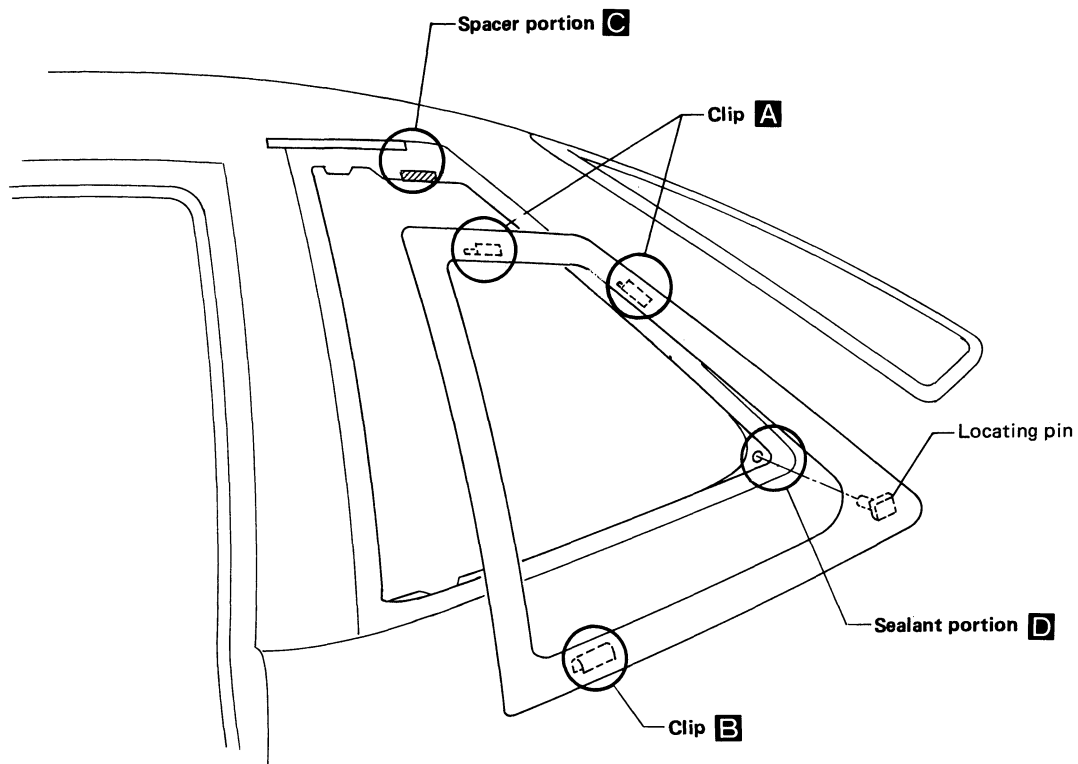

Sealant quantity

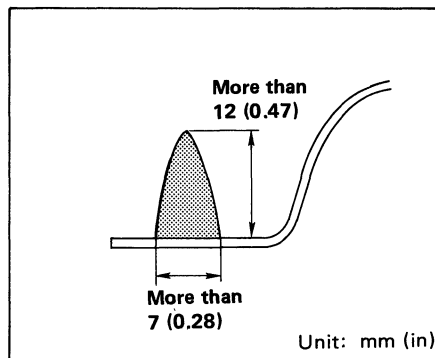

WINDSHIELD AND WINDOWS

Drying Time for Sealant

Reference: Time required for sealant to dry to desired hardness.

Unit: days

Relative humidity %	90	50	25
Temperature °C (°F)			
40 (104)	1.5	2.5	5.0
25 (77)	2.5	4.0	7.5
5 (41)	5.0	13.0	20.5

CAUTION:

Advise the user of the fact that vehicle should not be driven on rough roads or surfaces until sealant has properly vulcanized.

Repairing Water Leaks for Windshield and Back Window (Coupe)/Back Door Window (Fastback)

Leaks can be repaired without removing and reinstalling glass.

If water is leaking between caulking material and body or between glass and caulking material, determine the extent of the leak by applying water while pushing glass outward.

To stop the leak, apply primer and then sealant to the leak point.

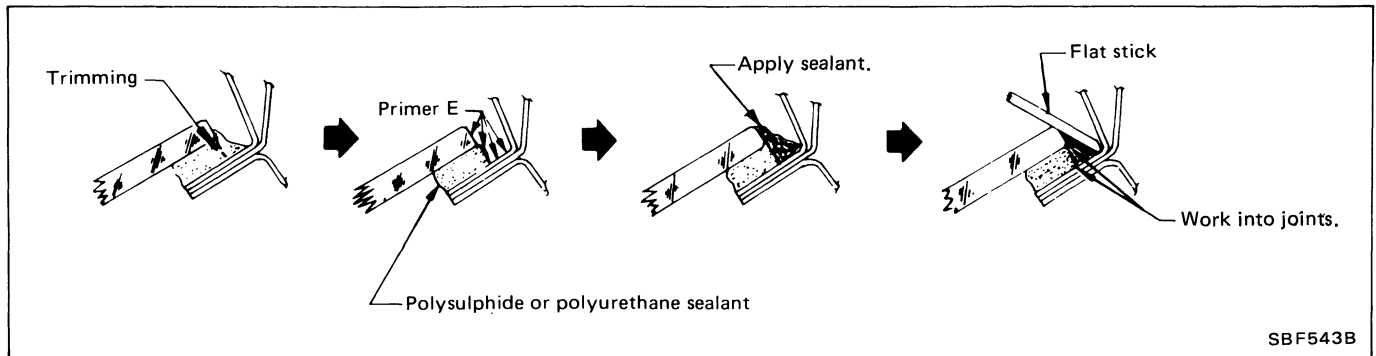

Afterwards, install molding securely.

MIRROR

Door Mirror

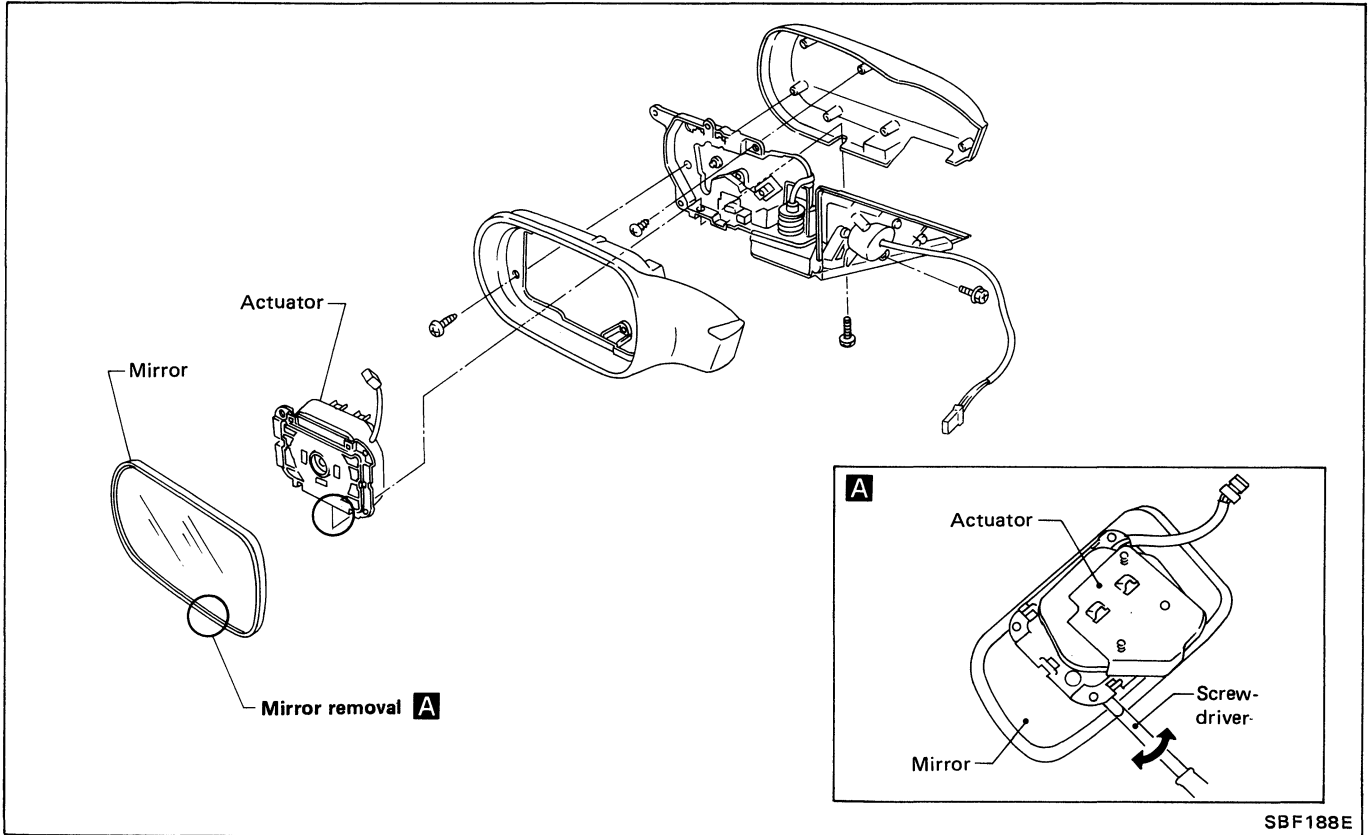

WIRING DIAGRAM

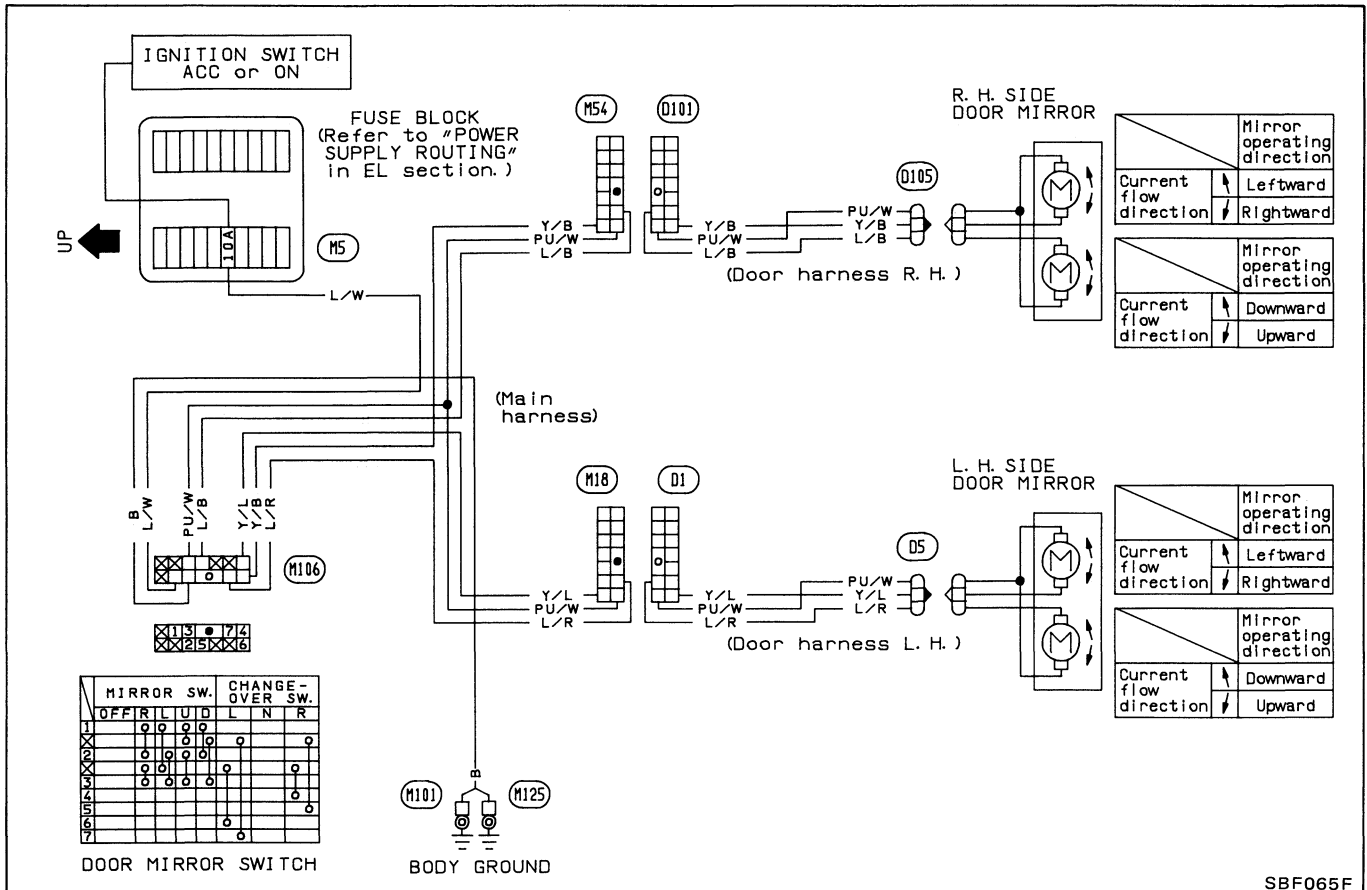

REAR COMBINATION LAMP

- Rear combination lamps are installed with nuts and butyl sealant.

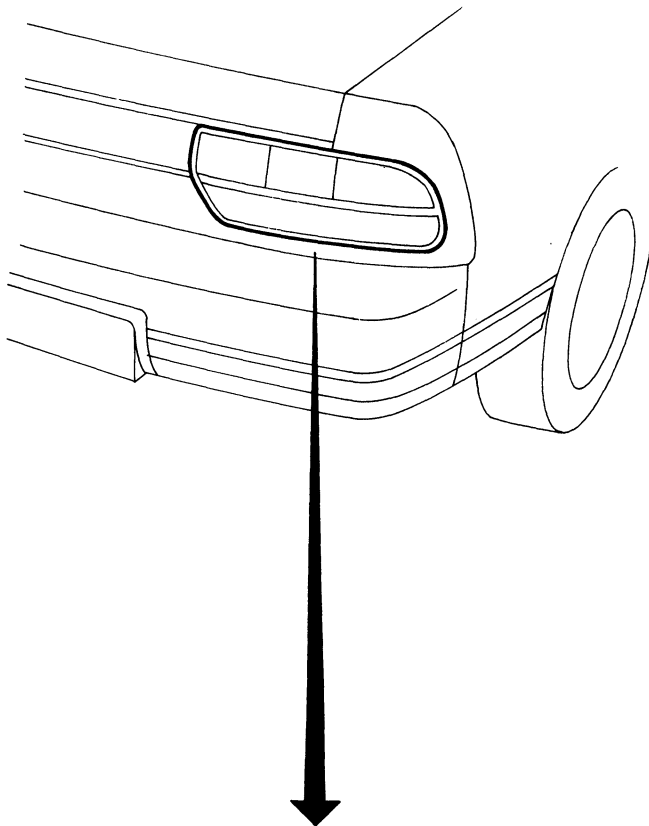

Removal

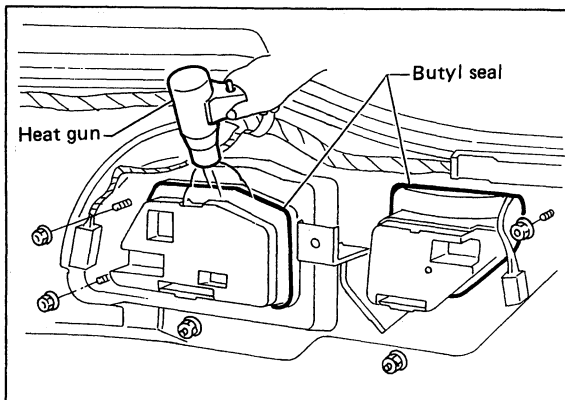

- Warm up lamp assembly area to a temperature of a little below 60°C (140°F).

Installation

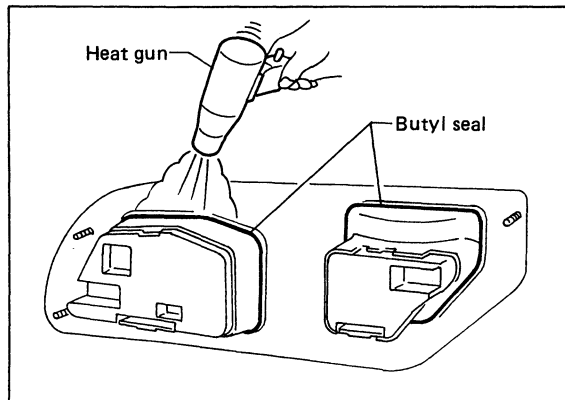

- Apply butyl seal evenly as it tends to become thin in the corners.
- Warm up lamp assembly area to a temperature of a little below 60°C (140°F).

SBF189E

FRONT AND REAR AIR SPOILER

- When installing, make sure that there are not gaps or waves at ends of air spoiler.
- Before installing spoiler, clean and remove oil from surface where spoiler will be mounted.

FRONT AIR SPOILER

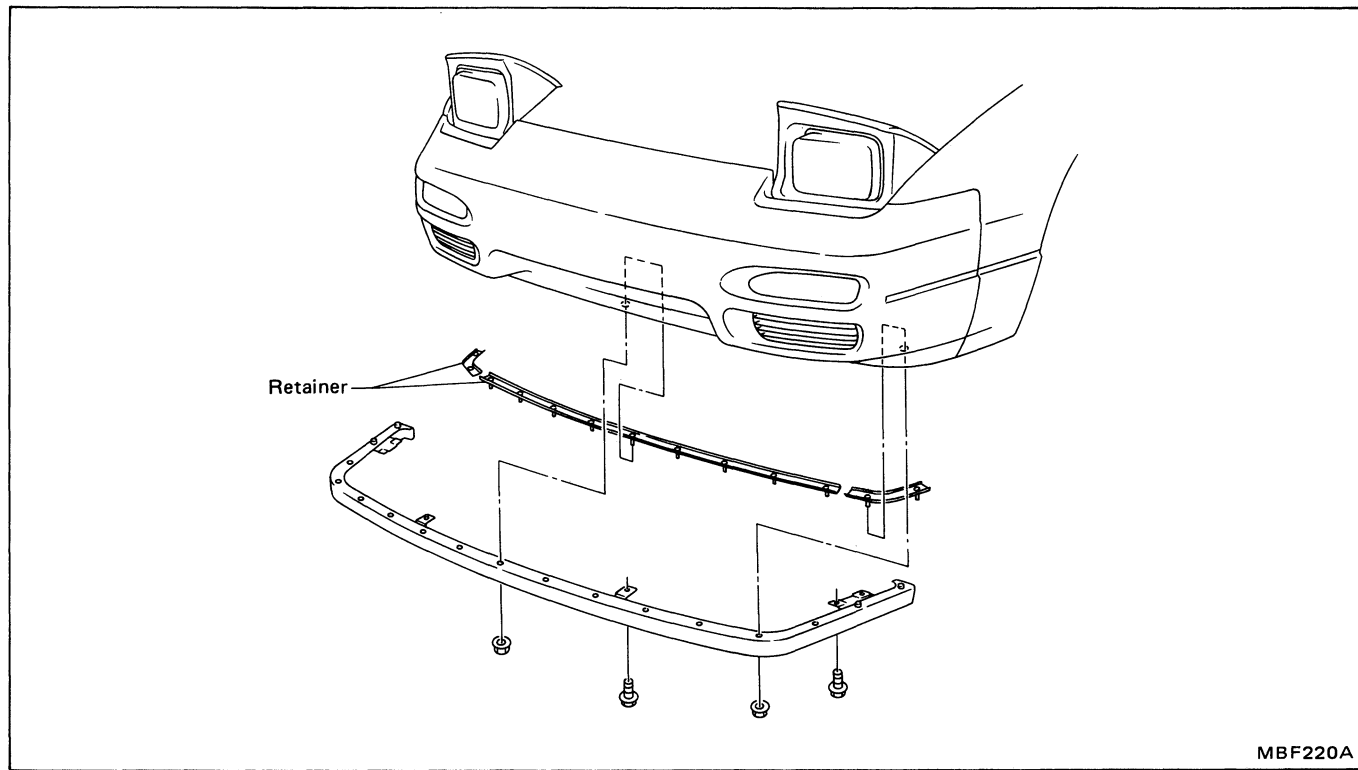

REAR AIR SPOILER – Fastback

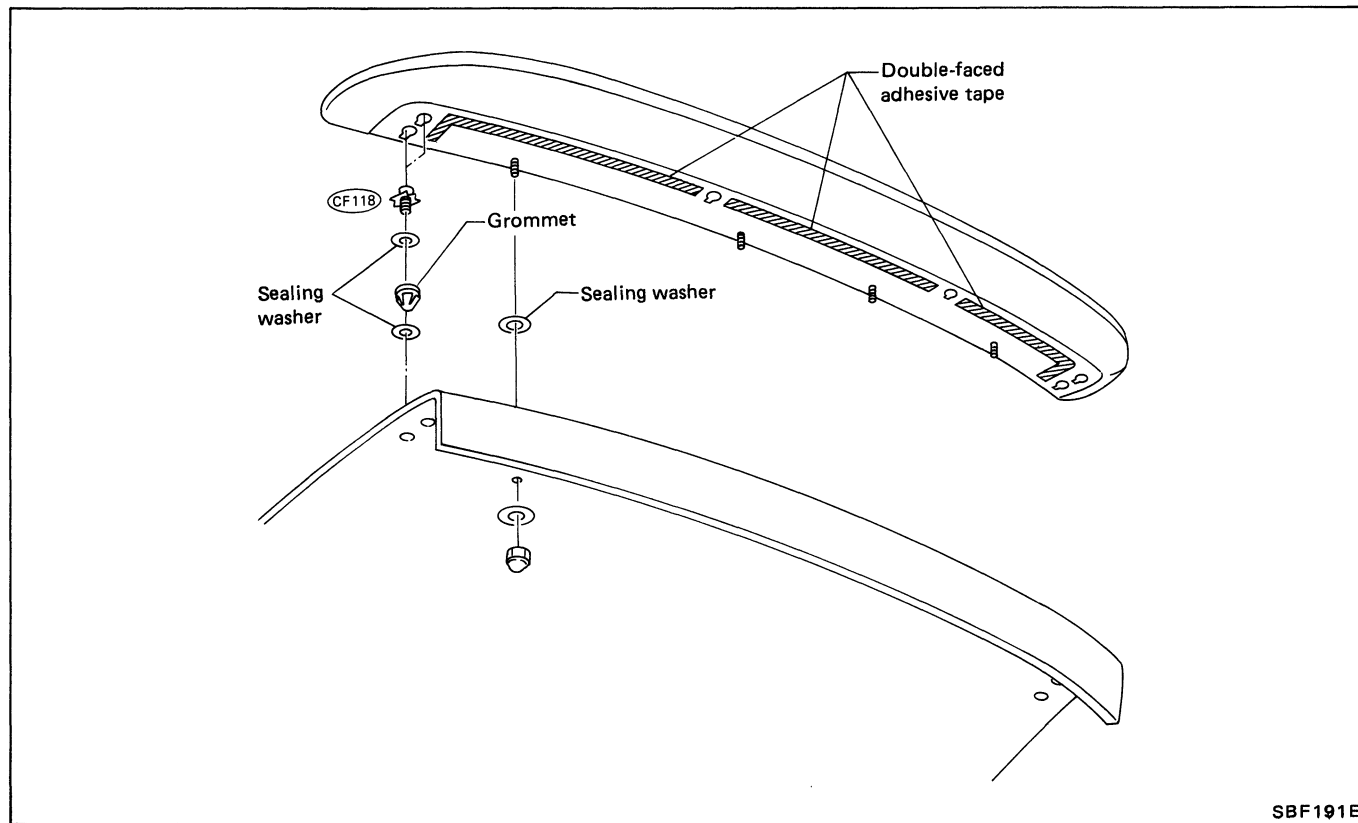

FRONT AND REAR AIR SPOILER

REAR AIR SPOILER – Coupe

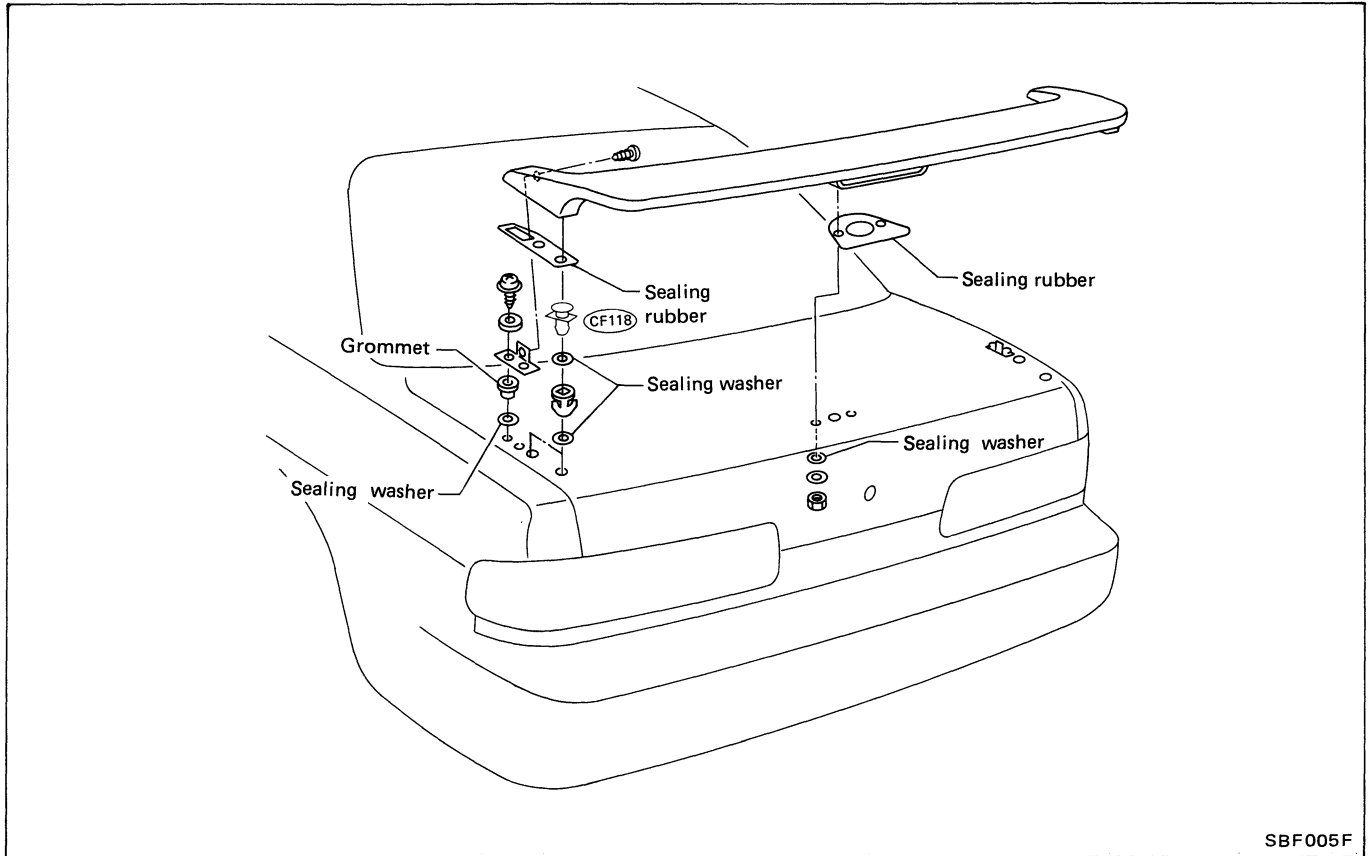

SBF005F

BODY ALIGNMENT

- All dimensions indicated in figures are actual ones.
- When a tram tracking gauge is used, adjust both pointers to equal length and check the pointers and gauge itself to make sure there is no free play.
- When a measuring tape is used, check to be sure there is no elongation, twisting or bending.
- Measurements should be taken at the center of the mounting holes.
- An asterisk (*) following the value at the measuring point indicates that the measuring point on the other side is symmetrically the same value.
- The coordinates of the measurement points are the distances measured from the standard line of "X", "Y" and "Z".

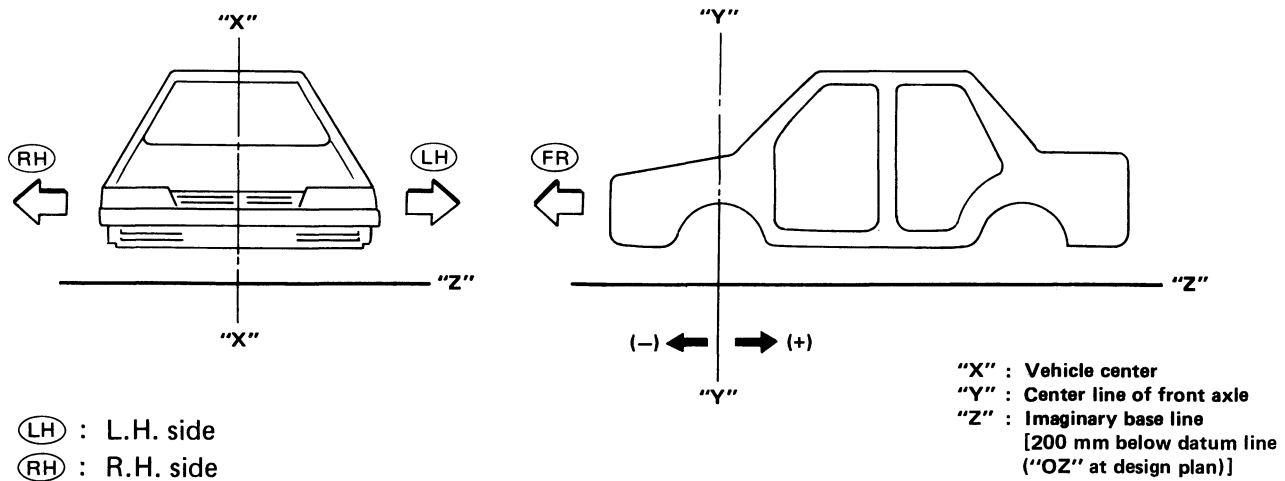

Engine Compartment

MEASUREMENT

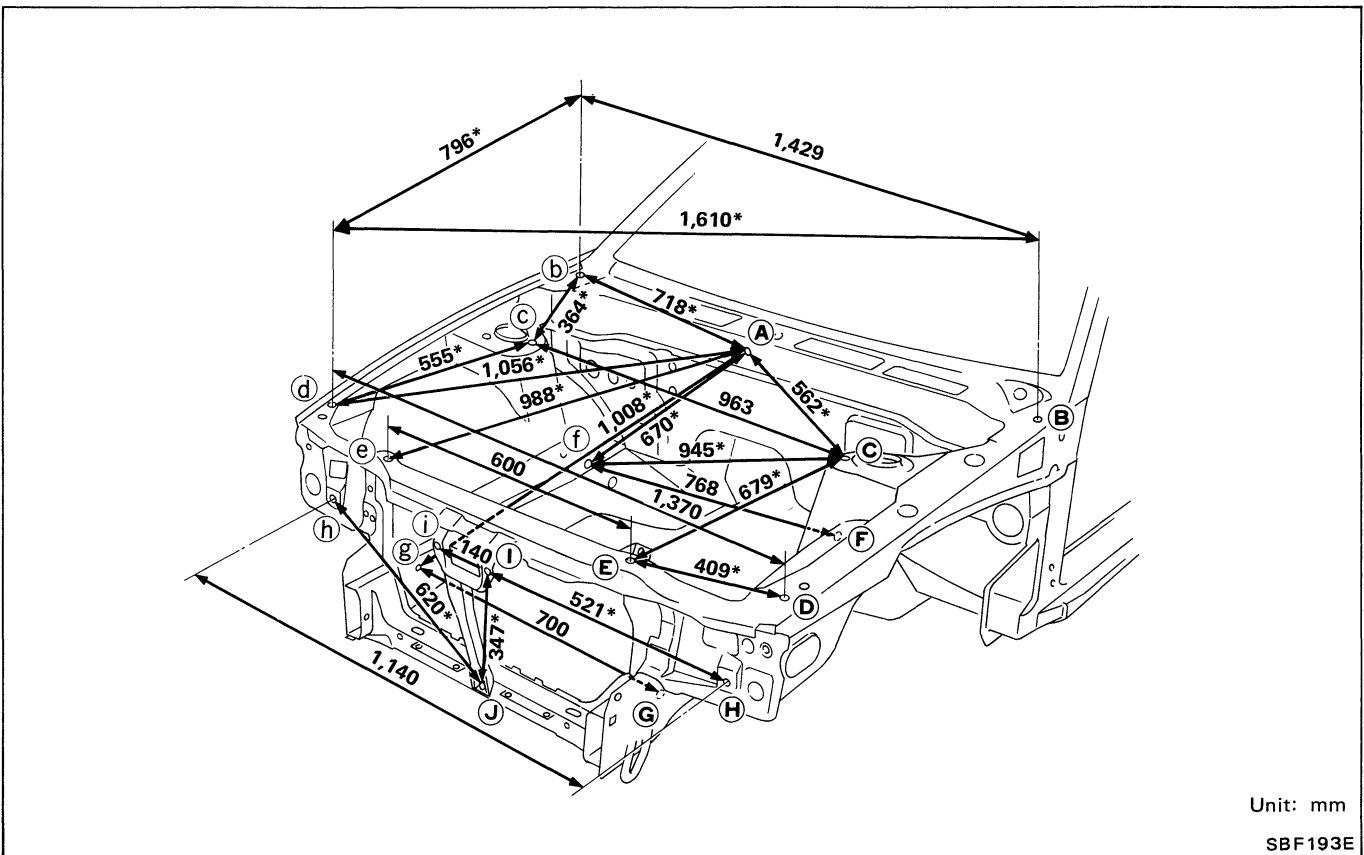

BODY ALIGNMENT

Engine Compartment (Cont'd)

MEASUREMENT POINTS

Unit: mm

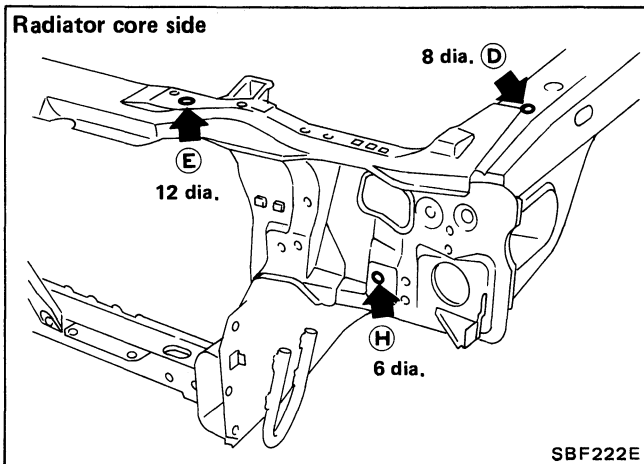
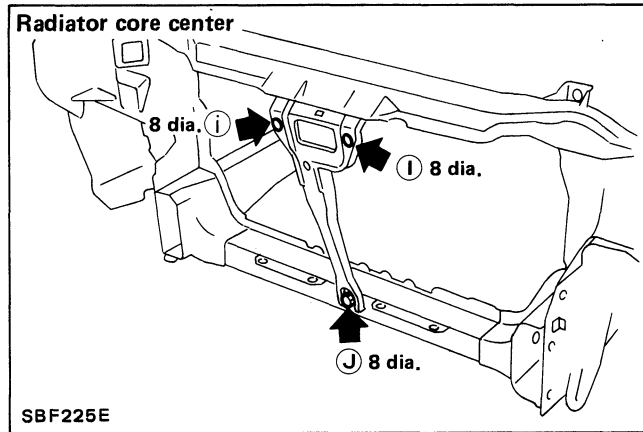
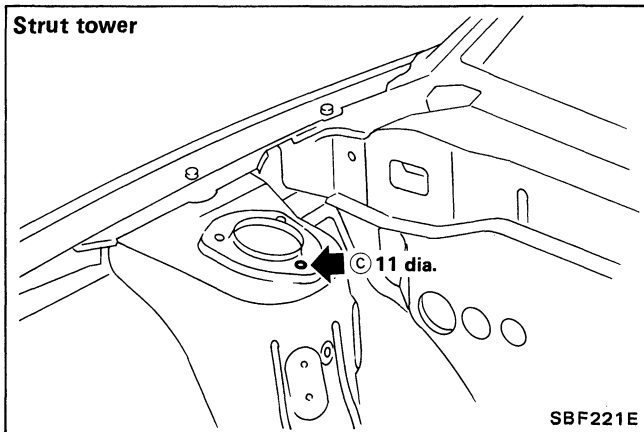
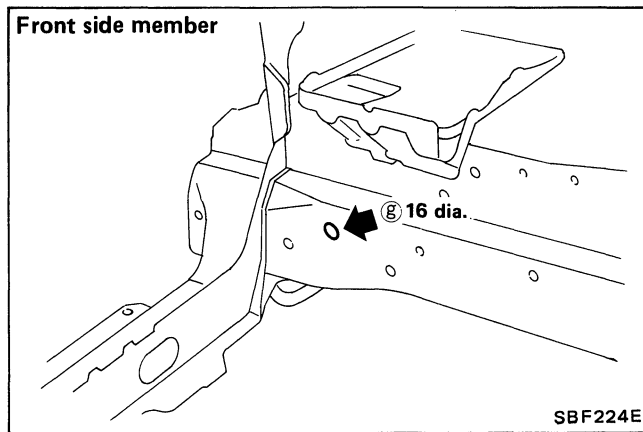
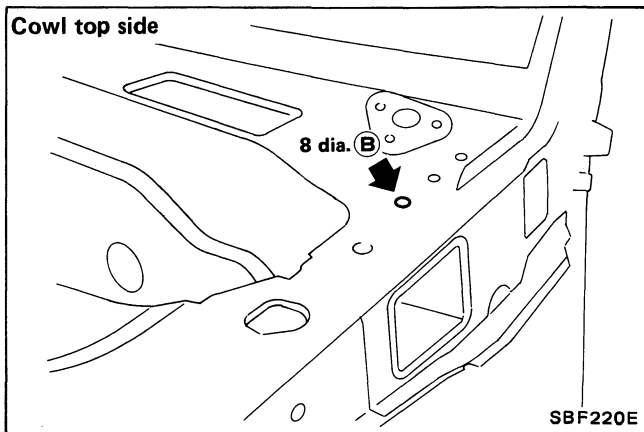
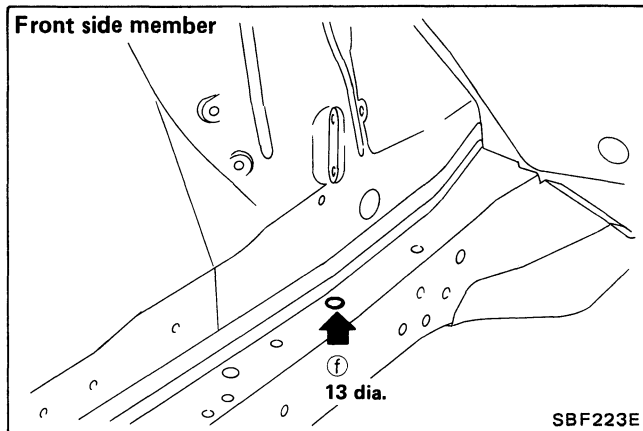
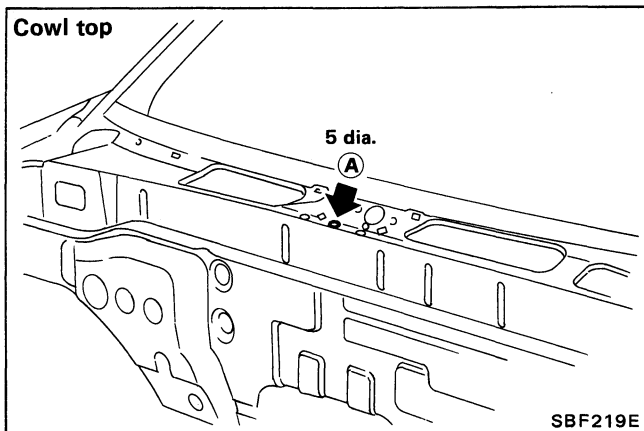

BODY ALIGNMENT

Underbody

MEASUREMENT

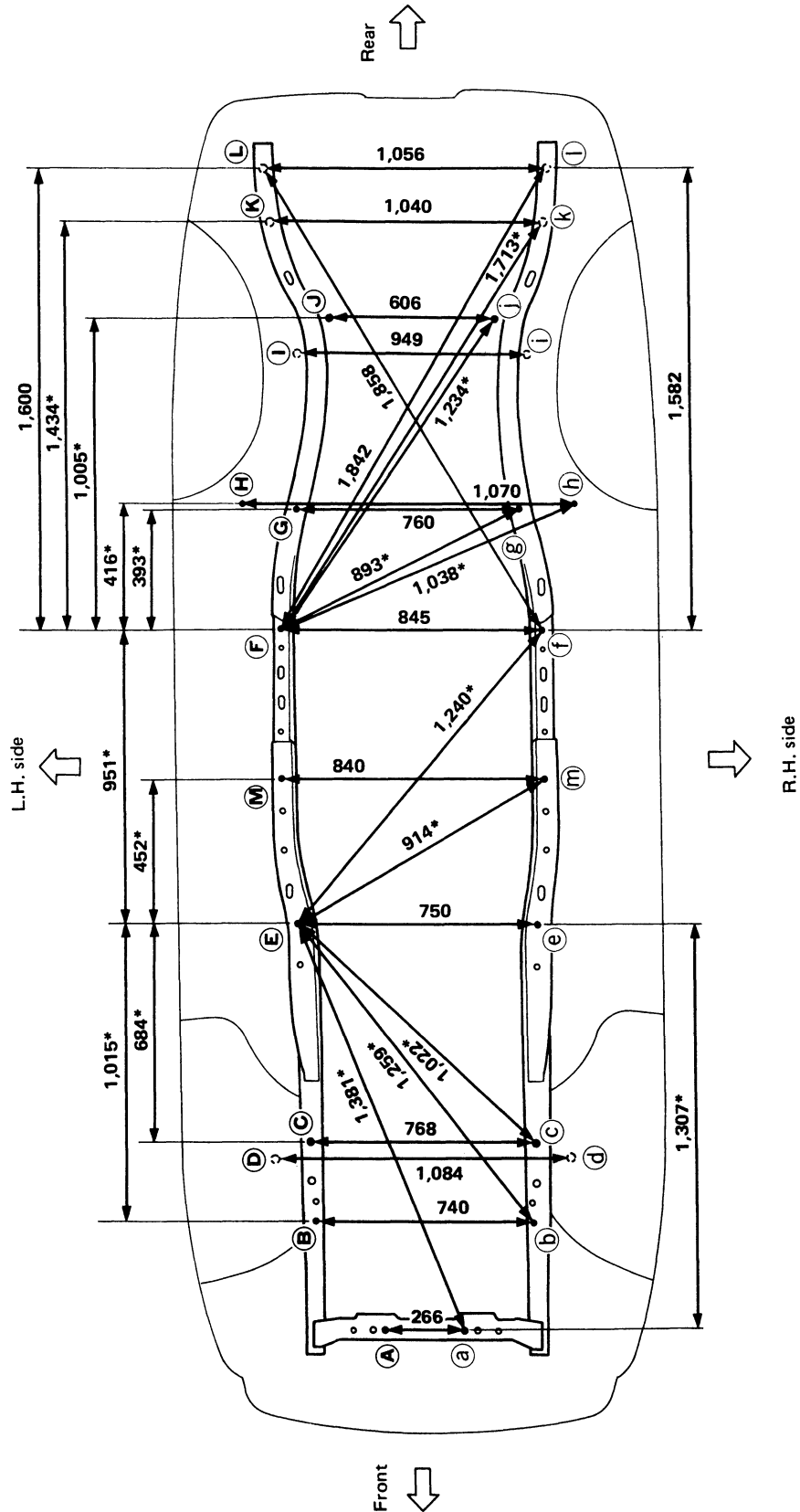

Unit: mm

All dimensions indicated in this figure are actual ones.
(There are no projected dimensions.)

BODY ALIGNMENT

Underbody (Cont'd)

MEASUREMENT POINTS

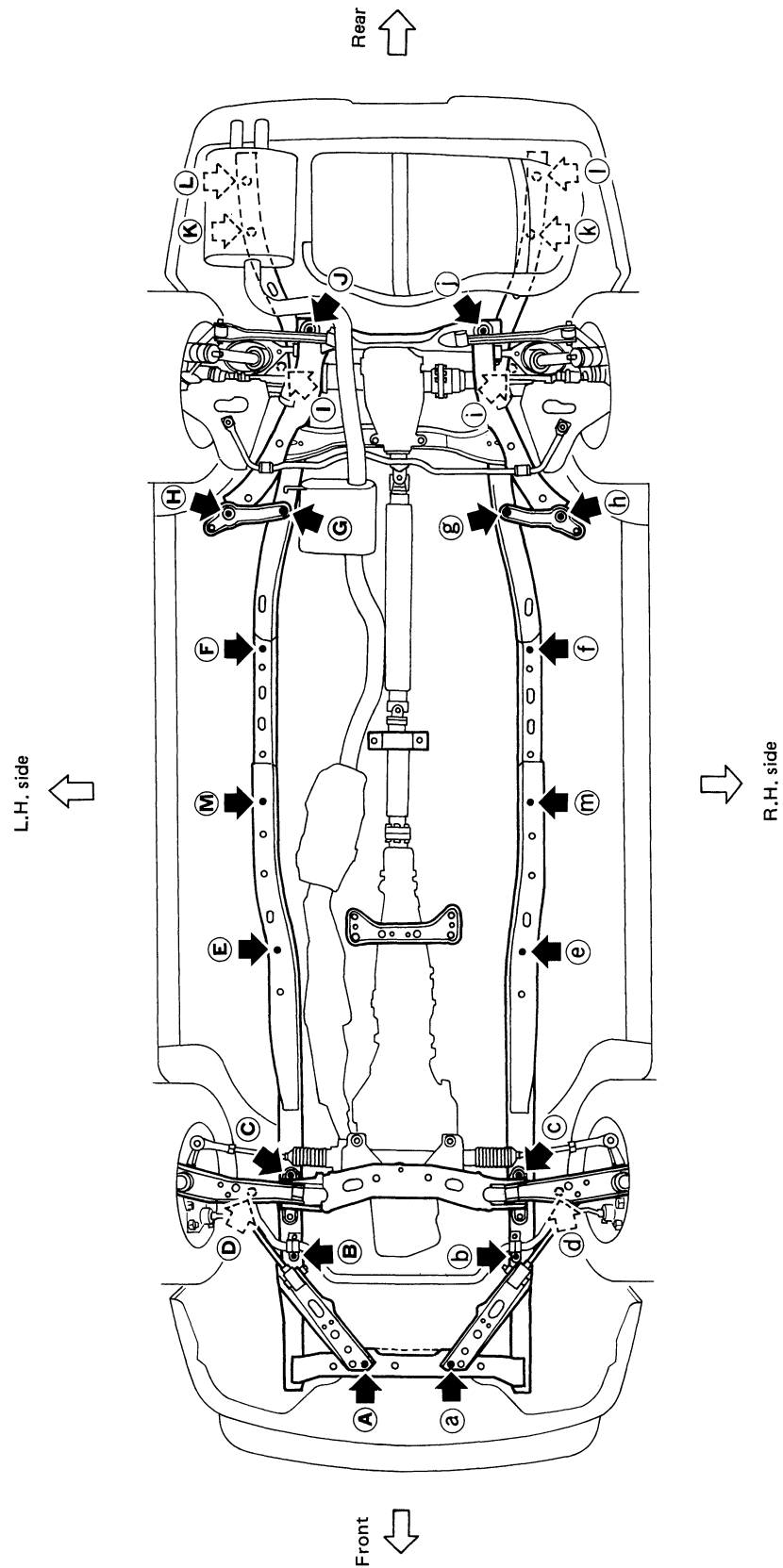

BODY ALIGNMENT

Underbody (Cont'd)

Unit: mm

Front and rear strut tower centers

Coordinates:

(D), (d)
X: 542.2
Y: 63.5
Z: 725.7
(I), (i)
X: 474.5
Y: 2,500
Z: 658.9

Front: **(D), (d)** 87 dia.
Rear: **(I), (i)** 48 dia.

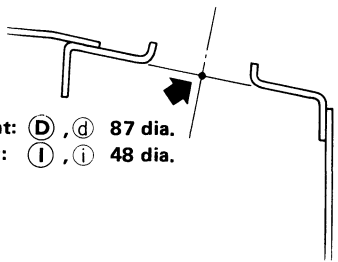

SBF119C

Rear suspension member front mounting bolt threaded end

Coordinates:

(H), (h)
X: 535
Y: 2,050
Z: 116.3

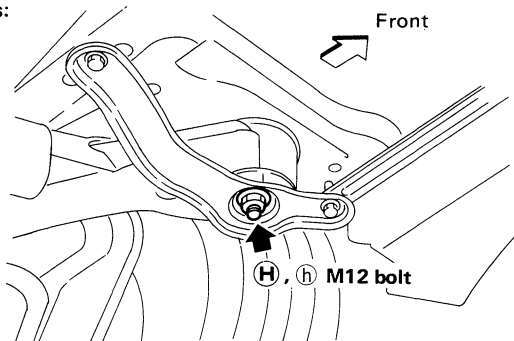

SBF226E

Rear suspension member rear mounting bolt threaded end

Coordinates:

(J), (j)
X: 303
Y: 2,635
Z: 265.8

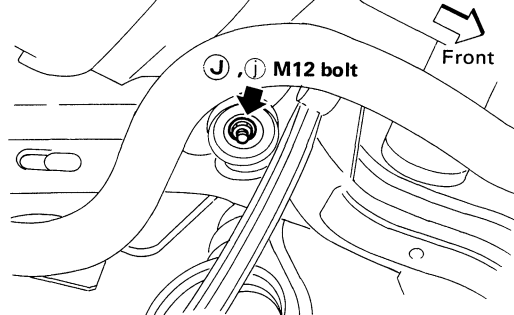

SBF227E

Front side member and front extension

Coordinates:

(A), (a)
X: 132.9
Y: -582
Z: 189
(B), (b)
X: 370
Y: -304
Z: 255
(C), (c)
X: 384.2
Y: 32
Z: 255
(E), (e)
X: 375
Y: 700
Z: 106.2
(M), (m)
X: 420
Y: 1,150
Z: 106.2

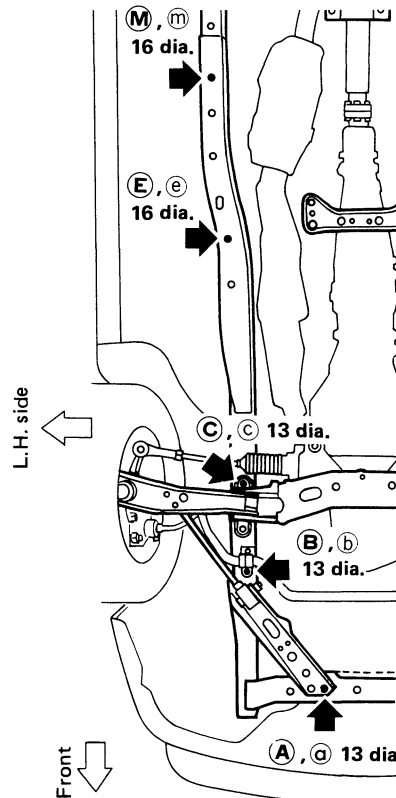

SBF271E

Center side member, rear side member and rear extension

Coordinates:

(F), (f)
X: 422.5
Y: 1,650
Z: 104
(G), (g)
X: 380
Y: 2,030
Z: 195.8
(K), (k)
X: 520
Y: 3,050
Z: 398.8
(L)
X: 528
Y: 3,221
Z: 386
(I)
X: 528
Y: 3,200
Z: 400

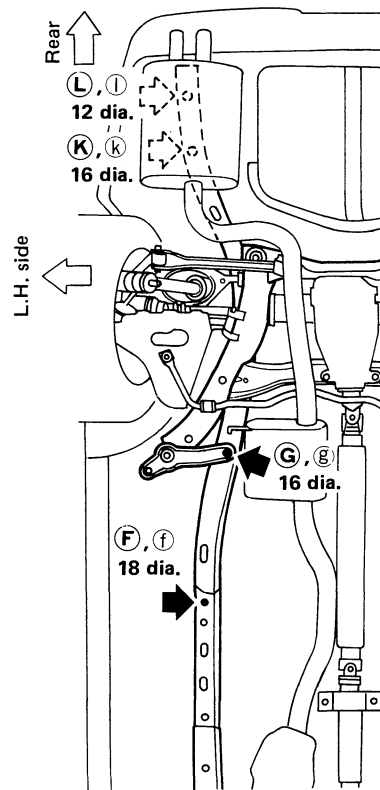

SBF272E

HEATER & AIR CONDITIONER

SECTION **HA**

CONTENTS

DESCRIPTION — Overall System	HA- 2
DESCRIPTION — Refrigeration System	HA- 5
PRECAUTIONS	HA- 15
PREPARATION	HA- 19
DISCHARGING, EVACUATING, CHARGING AND CHECKING	HA- 26
SERVICE PROCEDURES	HA- 38
COMPRESSOR OIL — Checking and Adjusting	HA- 43
COMPRESSOR — Model V-5 (CALSONIC make)	HA- 46
DIAGNOSES — Overall System	HA- 54
TROUBLE DIAGNOSES	HA- 65
SYSTEM DESCRIPTION — Push Control	HA-102
SERVICE DATA AND SPECIFICATIONS (S.D.S.)	HA-107

When you read wiring diagrams:

- Read G1 section, "HOW TO READ WIRING DIAGRAMS".
- See EL section, "POWER SUPPLY ROUTING" for power distribution circuit.

When you perform trouble diagnoses, read G1 section, "HOW TO FOLLOW FLOW CHART IN TROUBLE DIAGNOSES".

Control Operation

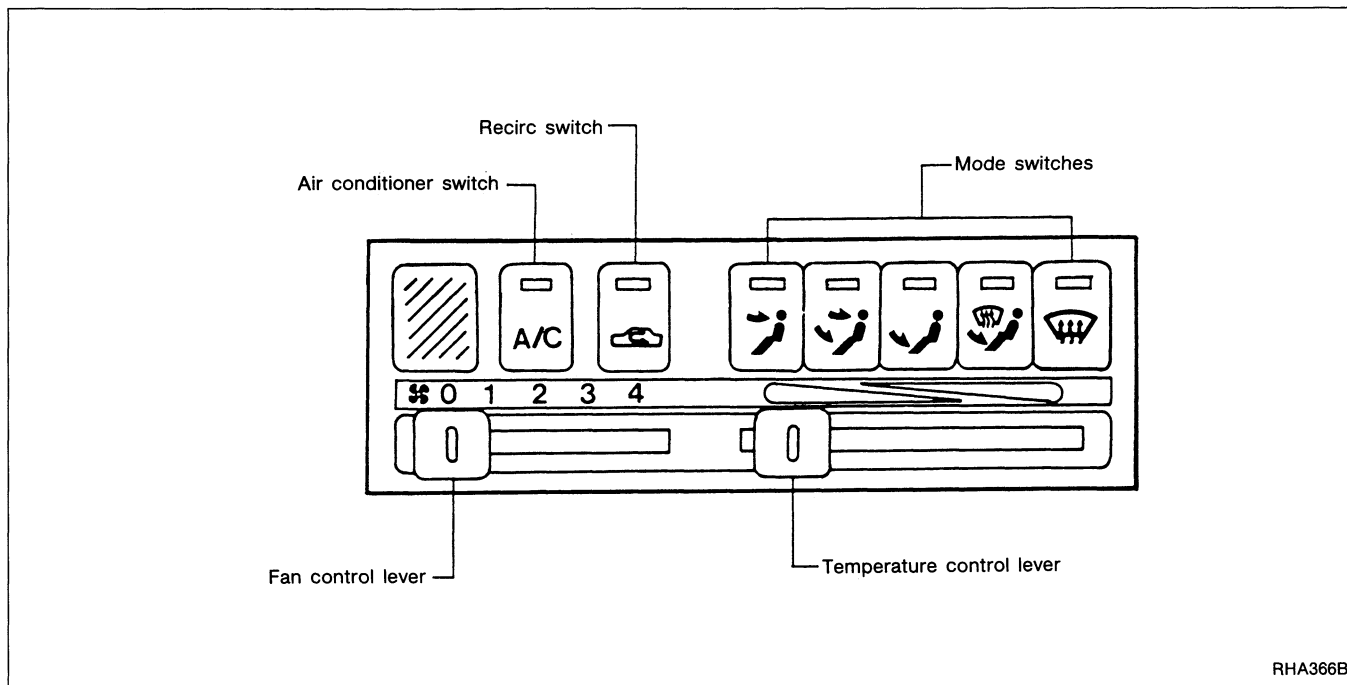

RHA366B

FAN CONTROL LEVER

This lever turns the fan ON and OFF, and controls fan speed.

MODE SWITCHES

These switches allow you to select the outlet air flow.

When the MODE is set to "DEF" or "F/D", the push control unit sets the intake door to "FRE". The compressor turns on when the MODE is set to "DEF".

TEMPERATURE CONTROL LEVER

This lever allows you to adjust the temperature of the outlet air.

RECIRC SWITCH

OFF position:

Outside air is drawn into the passenger compartment when this switch is OFF.

ON position:

Interior air is recirculated inside the vehicle.

Mode can not be set to "DEF" nor "F/D" when this switch is ON.

AIR CONDITIONER SWITCH

Start the engine, move the fan control lever to the desired (1 to 4) position and push the air conditioner switch to turn ON the air conditioner. The indicator light will come on when the air conditioner is ON. To stop the air conditioner, push the switch again to return it to the original position.

The air conditioner cooling function operates only when the engine is running.

DESCRIPTION — Overall System

Component Layout

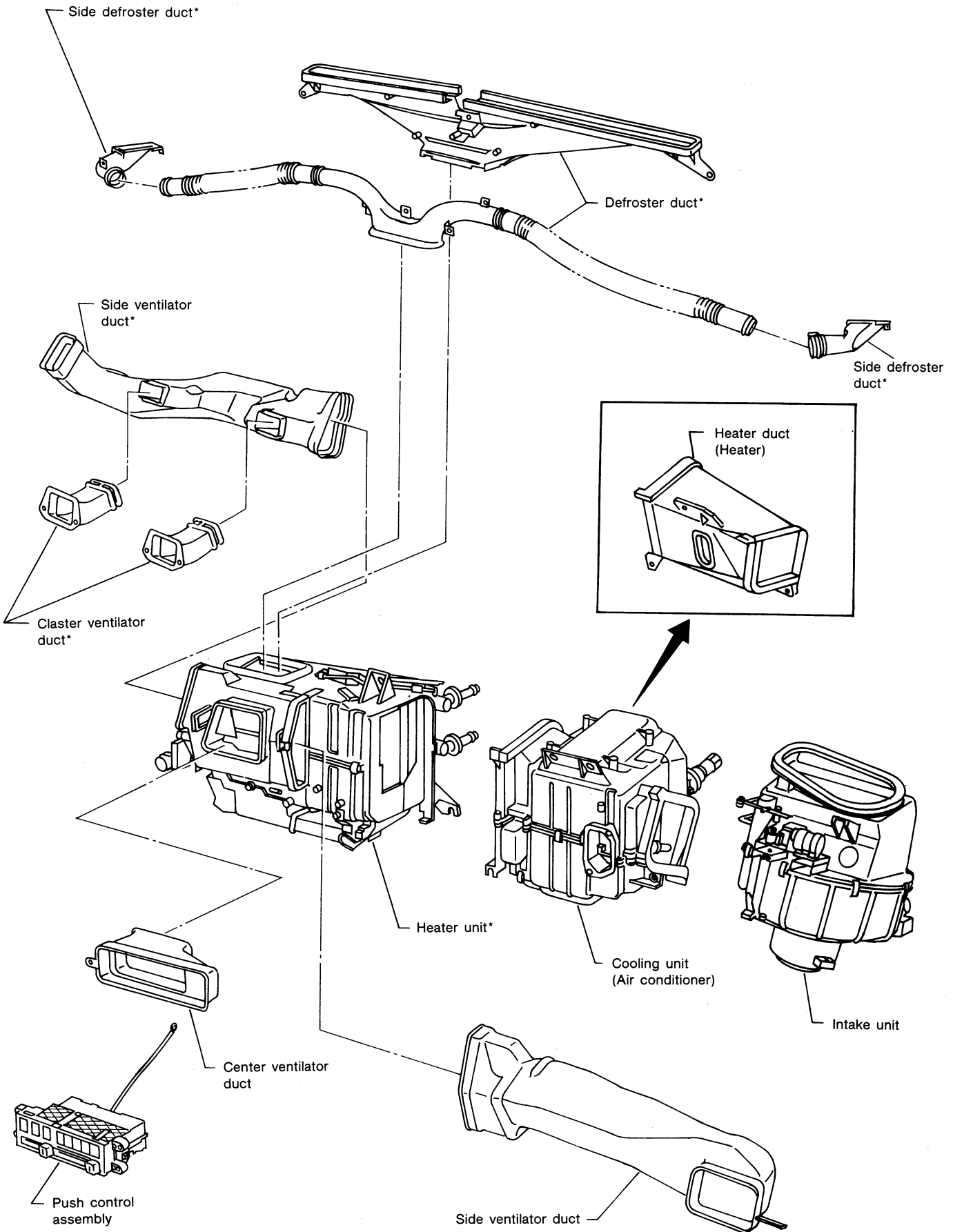

*: For removal, it is necessary to remove instrument assembly.

DESCRIPTION — Overall System

Air Flow

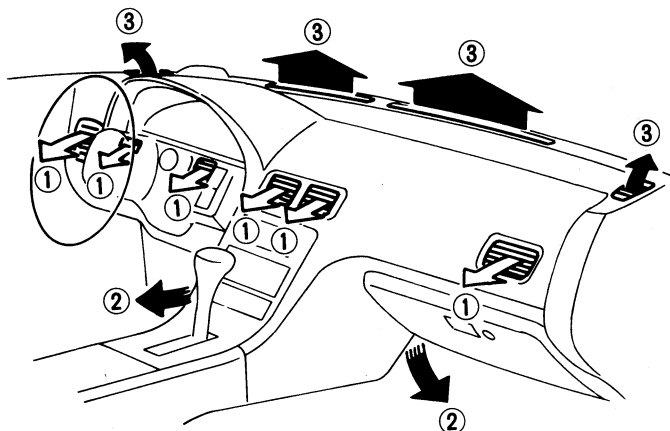

Ventilation (REC switch "ON")

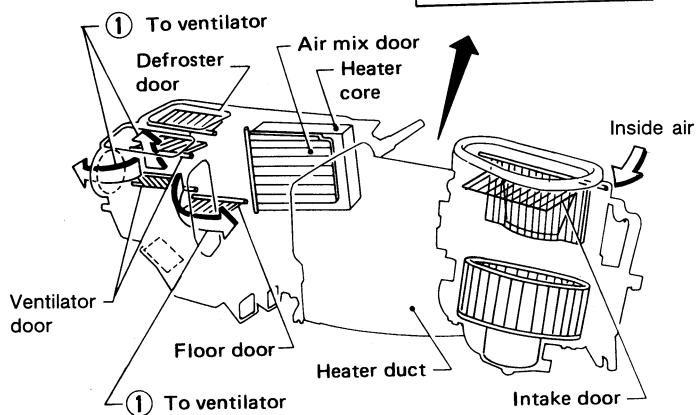
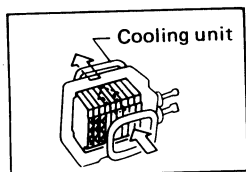
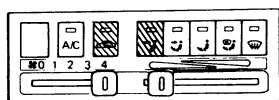

Bi-level

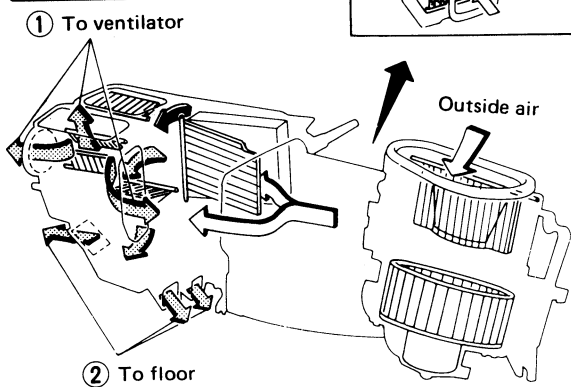
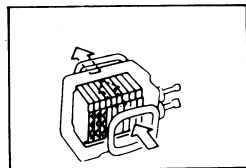
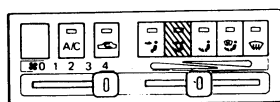

Floor

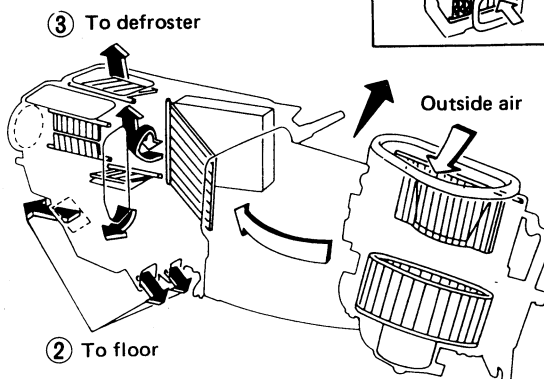
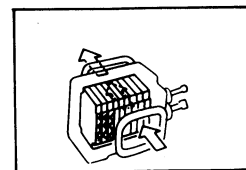
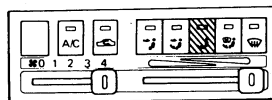

Floor and defroster

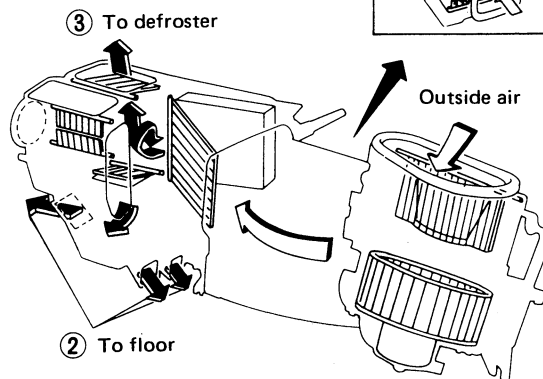
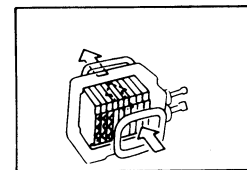
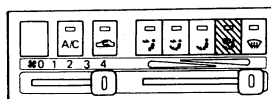

Defroster

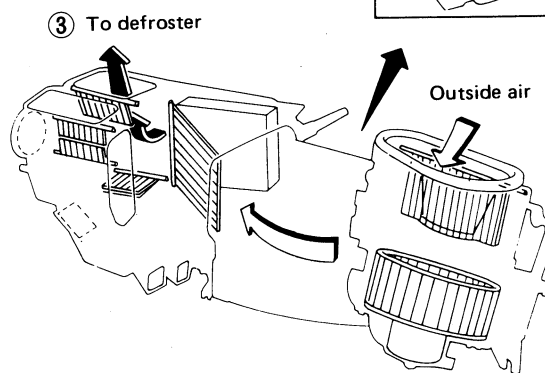
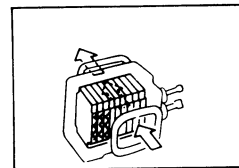
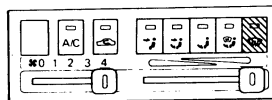

- ← : Air passed through heater core
- ← + ← : Mixed air (← + ←)
- ← : Air not passed through heater core

Refrigeration Cycle

REFRIGERANT FLOW

The refrigerant flows in the standard pattern, that is, through the compressor, the condenser, the receiver drier, through the evaporator, and the compressor.

The refrigerant evaporation through the evaporator coil is controlled by an externally equalized expansion valve, located inside evaporator case.

FREEZE PROTECTION

When the A/C is switched on, the compressor runs continuously, and the evaporator pressure is controlled by the V-5 variable displacement compressor.

The compressor cycles on and off to maintain the evaporator temperature within a specified range. When the evaporator coil temperature falls below a specified point, the thermo-control amplifier interrupts the compressor operation. When the evaporator coil temperature rises above the specification, the thermo-control amplifier allows compressor operation.

REFRIGERANT SYSTEM PROTECTION

Dual-pressure switch

The refrigerant system is protected against excessively high or low pressure by the dual-pressure switch, located on the receiver drier. If the system pressure rises above, or falls below the specifications, the dual-pressure switch opens to interrupt compressor operation.

Fusible plug

Open at temperatures above 105°C (221°F), thereby discharging refrigerant to the atmosphere. If this plug is melted and opened, check the refrigerant line and replace the receiver drier.

Pressure relief valve

The refrigerant system is also protected by a pressure relief valve, located on the end of compressor. When the pressure of the refrigerant in the system increases to an abnormal level [more than 3,727 kPa (38 kg/cm², 540 psi)], the release port on the pressure relief valve automatically opens and releases refrigerant into the atmosphere.

DESCRIPTION — Refrigeration System

Refrigeration Cycle (Cont'd)

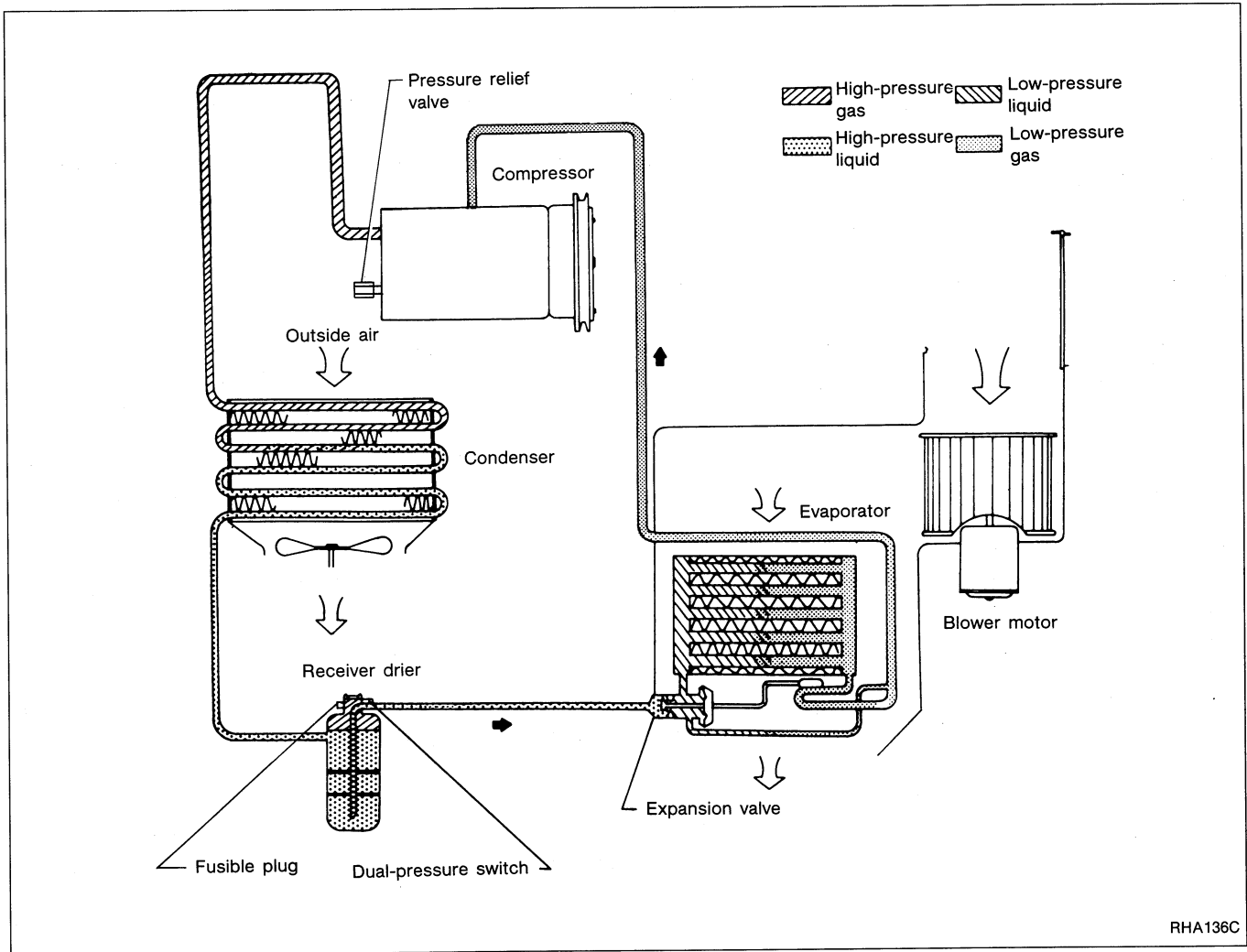

Refrigerant Lines

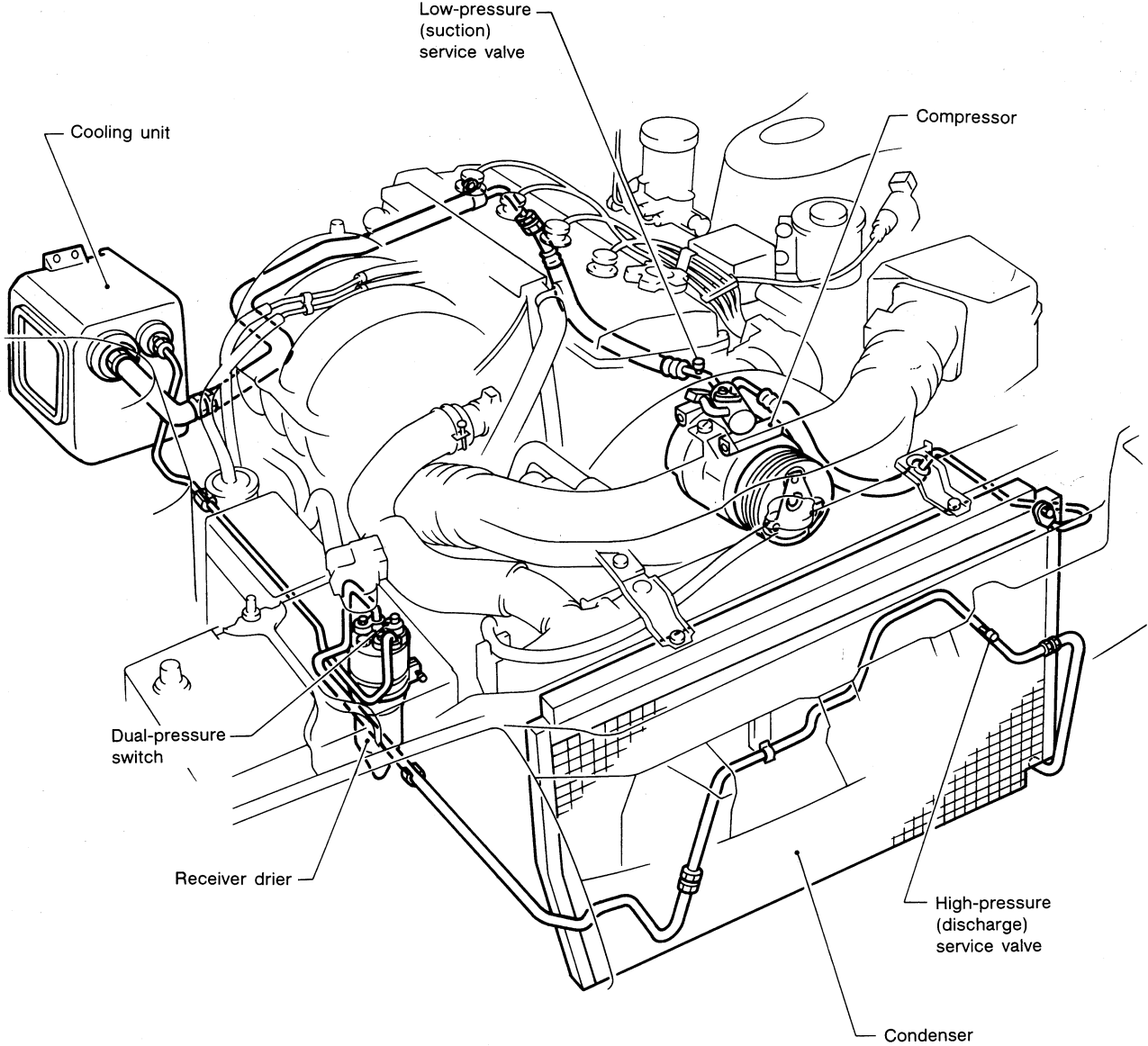

V-5 Variable Displacement Compressor

GENERAL INFORMATION

1. The V-5 variable compressor differs from previous units in that the vent temperatures do not drop too far below 5°C (41°F) at a suction temperature of less than 20°C (68°F) while the engine is running at speeds less than 1,500 rpm. This is because the V-5 compressor provides a means of "capacity" control.
2. The V-5 variable compressor provides refrigerant control under varying conditions. During the winter season when ambient temperatures are low, it sometimes does not produce high refrigerant pressure discharge (compared to previous units) when used with automobile air conditioning systems. Air bubbles in the sight glass also may not disappear. However, these symptoms are not a matter of concern. When charging the refrigerant, always use a service can. Extreme care should be taken not to charge the refrigerant excessively.
3. A "clanking" sound may occasionally be heard during refrigerant charge. The sound indicates that the tilt angle of the swash plate has changed and is not a problem.
4. In air conditioning systems which are equipped with the V-5 compressor, the clutch remains engaged unless the system main switch, fan switch or ignition switch is turned OFF. When the acceleration cut system is operating or when the amount of refrigerant is insufficient, the clutch is disengaged to protect the compressor.
5. A constant range of suction pressure is maintained when engine speed is greater than a certain value. It normally ranges from 147 to 177 kPa (1.5 to 1.8 kg/cm², 21 to 26 psi) under varying conditions. In previous compressors, however, suction pressure was reduced with increases in engine speed.
6. If the ambient temperature drops below approx. 22°C (72°F), the ambient temperature switch turns OFF and F.I.C.D. operation stops. The reason is that the variable displacement compressor is controlling the volume of air, and when the ambient temperature is low and refrigerating load becomes small, the compressor requires less torque, which eliminates the need for the F.I.C.D., idling r.p.m. increase.

DESCRIPTION — Refrigeration System

V-5 Variable Displacement Compressor (Cont'd)

DESCRIPTION

General

The variable compressor is basically a swash plate type that changes piston stroke in response to the required cooling capacity.

The tilt of the swash plate allows the piston's stroke to change so that refrigerant discharge can be continuously changed from 3 to 146 cm³ (0.18 to 8.91 cu in).

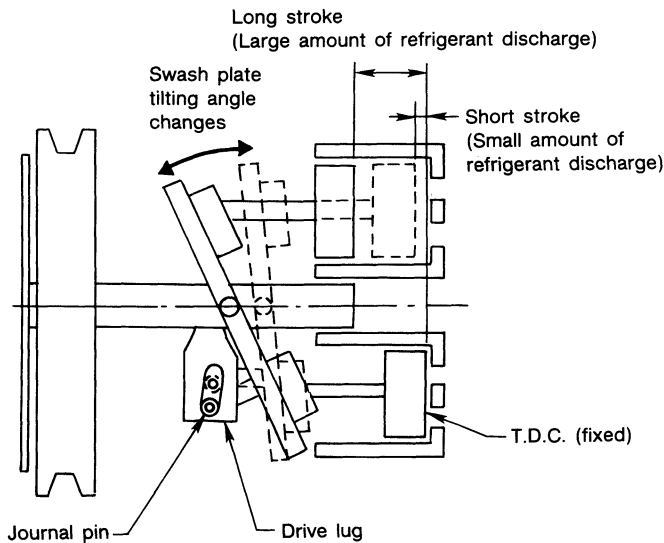
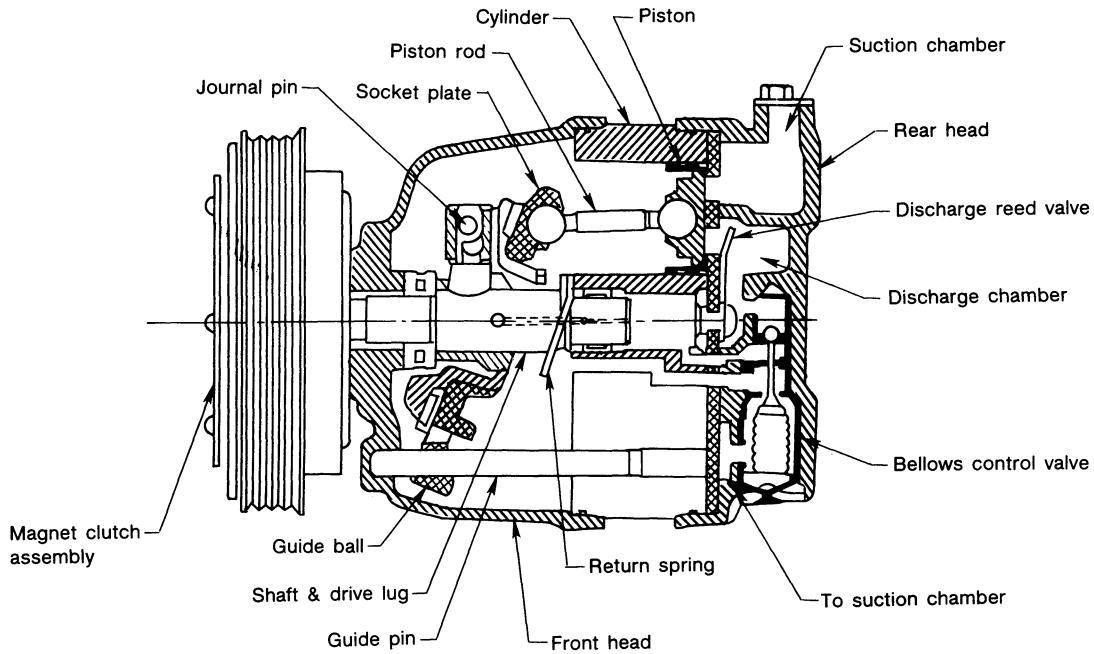

Discharge control	Discharge capacity cm ³ (cu in)/rev.	Piston stroke length mm (in)
Minimum	3 (0.18)	0.6 (0.024)
Maximum	146 (8.91)	28.6 (1.126)

RHA257B

DESCRIPTION — Refrigeration System

V-5 Variable Displacement Compressor (Cont'd)

Operation

1. Operation control valve

Operation control valve is located in the suction port (low-pressure) side, and opens or closes in response to changes in refrigerant suction pressure.

Operation of the valve controls the internal pressure of the crankcase.

The angle of the swash plate is controlled between the crankcase's internal pressure and the piston cylinder pressure.

2. Maximum cooling

Refrigerant pressure on the low-pressure side increases with an increase in heat loads.

When this occurs, the control valve's bellows compress to open the low-pressure side valve and close the high-pressure side valve.

This causes the crankcase's internal pressure to equal the pressure on the low-pressure side and the cylinder's internal pressure to be greater than the crankcase's internal pressure. Under this condition, the swash plate is set to the maximum stroke position.

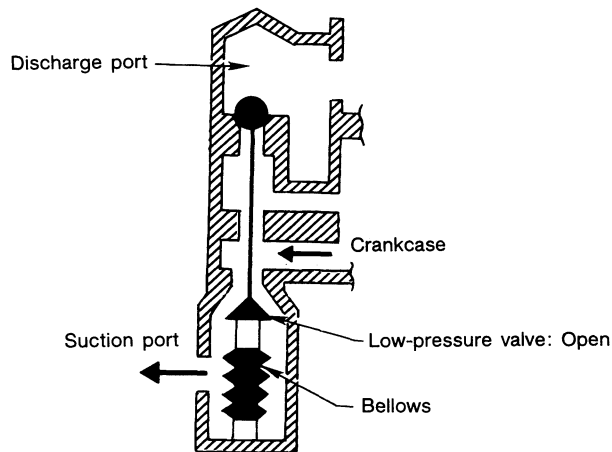

Valve position for lowering crankcase pressure

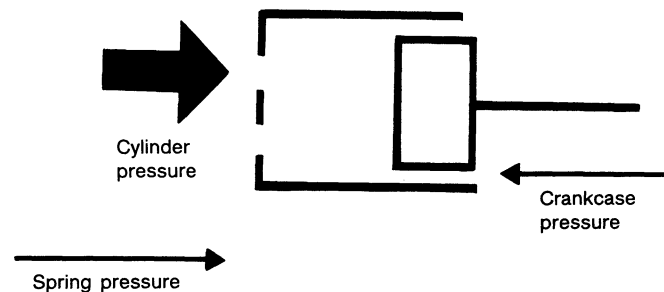

RHA258B

DESCRIPTION — Refrigeration System

V-5 Variable Displacement Compressor (Cont'd)

3. Capacity control

- Refrigerant pressure on suction side is low during high speed driving or when ambient or interior temperature is low.
- The bellows expands when refrigerant pressure on the suction pressure side drops below approximately 177 kPa (1.8 kg/cm², 26 psi).

Since suction pressure is low, it makes the suction port close and the discharge port open. Thus, crankcase pressure becomes high as high pressure enters the crankcase.

- The moment acts around the journal pin near the swash plate, and is generated by the pressure difference before and behind the piston.

The drive lug and journal pin are located where the piston generates the highest pressure. As the drive lug and journal pin take this high pressure no moment occurs. Piston pressure is between suction pressure P_s and discharge pressure P_d , which is near suction pressure P_s . If crankcase pressure P_c rises due to capacity control, the moment around the journal pin makes the swash plate angle decrease and also the piston stroke decrease. In other words, the pressure difference between the piston and the crankcase according to crankcase pressure increase changes the angle of the swash plate.

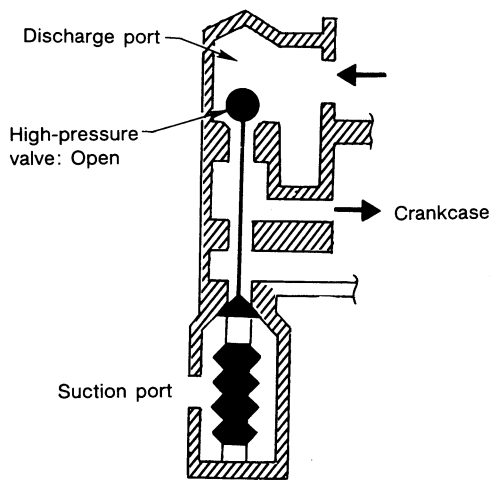

Valve position for raising crankcase pressure

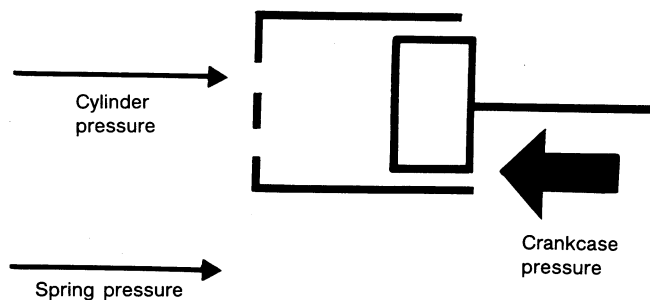

Forces needed to decrease stroke

RHA259B

DESCRIPTION — Refrigeration System

V-5 Variable Displacement Compressor (Cont'd)

F.I.C.D. CONTROL SYSTEM

General

With the variable displacement compressor, the compressor power requirements differ from when the ambient temperature is high and maximum cooling effect is required (i.e., when refrigerating load is large and the tilt angle of the compressor swash plate is large) to when the ambient temperature is low and less cooling effect is required (i.e., when refrigerating load is small and the tilt angle of the swash plate is small). To correspond correctly to this change in compressor power requirements, it is also necessary to control the operation of the F.I.C.D. according to the refrigerating load. Thus, an ambient air temperature switch is provided on the front face of the condenser so that the F.I.C.D. can be controlled depending on the ambient temperature.

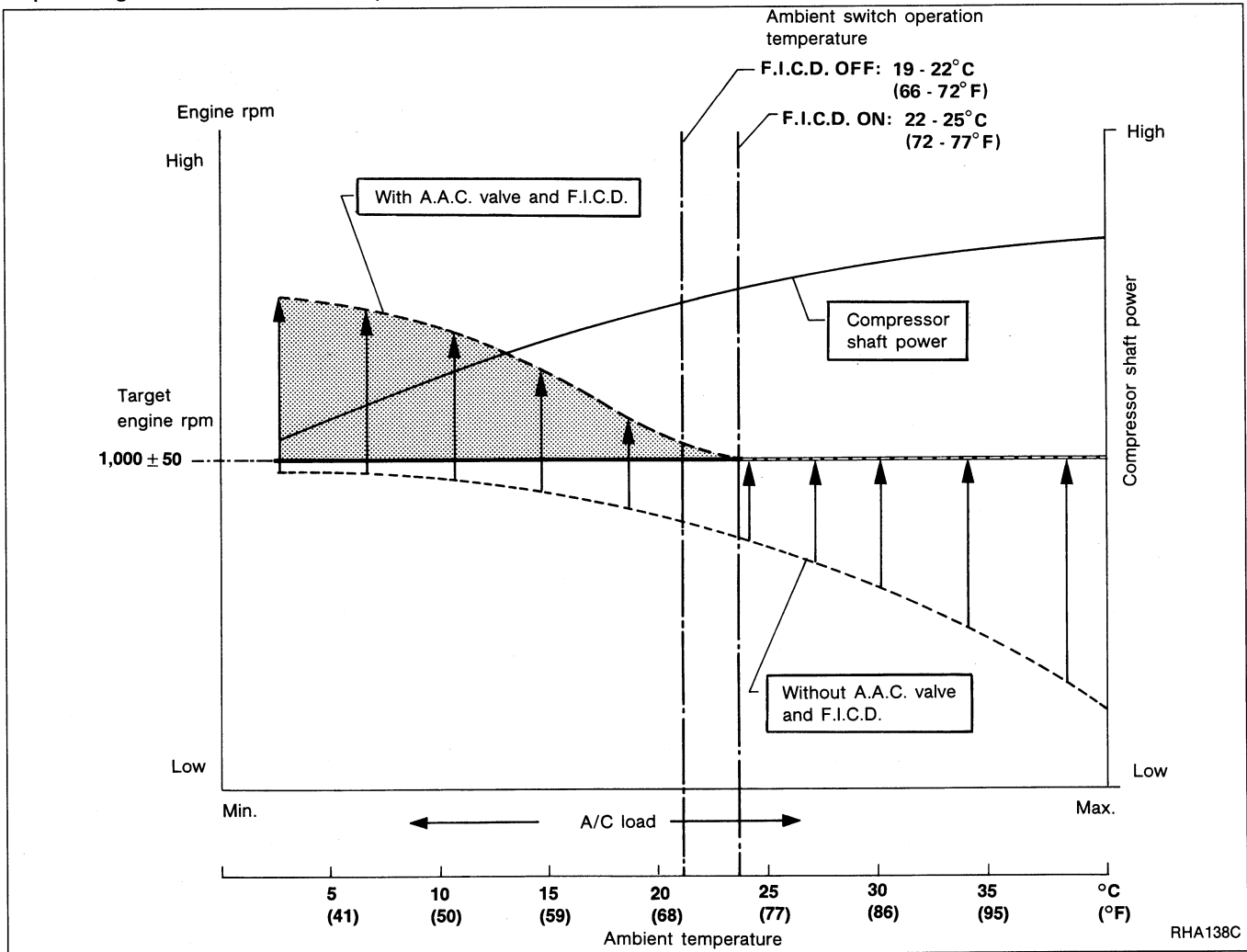

DESCRIPTION — Refrigeration System

V-5 Variable Displacement Compressor (Cont'd)

Operation

When the air conditioner is OFF, the E.C.C.S. detects the load applied to the engine, and controls the A.A.C. valve to adjust the engine idling speed to the appropriate rpm by supplying additional air from the A.A.C. valve.

When the air conditioner is ON (A/C relay is ON), and when the ambient temperature switch is ON (this switch turns ON automatically when the ambient temperature rises to approx. 25°C (77°F) or higher), the F.I.C.D. solenoid valve is energized and additional air is supplied to the engine.

If the appropriate engine speed is not reached, the A.A.C. valve supplies the additional air required to increase the engine rpm.

If the ambient temperature switch is OFF (this switch turns OFF when the ambient temperature is below 22°C (72°F) even when the air conditioner is ON (A/C relay is ON), the F.I.C.D. solenoid is deenergized, and the idling speed is controlled so that the appropriate rpm can be achieved by operation of the A.A.C. valve only.

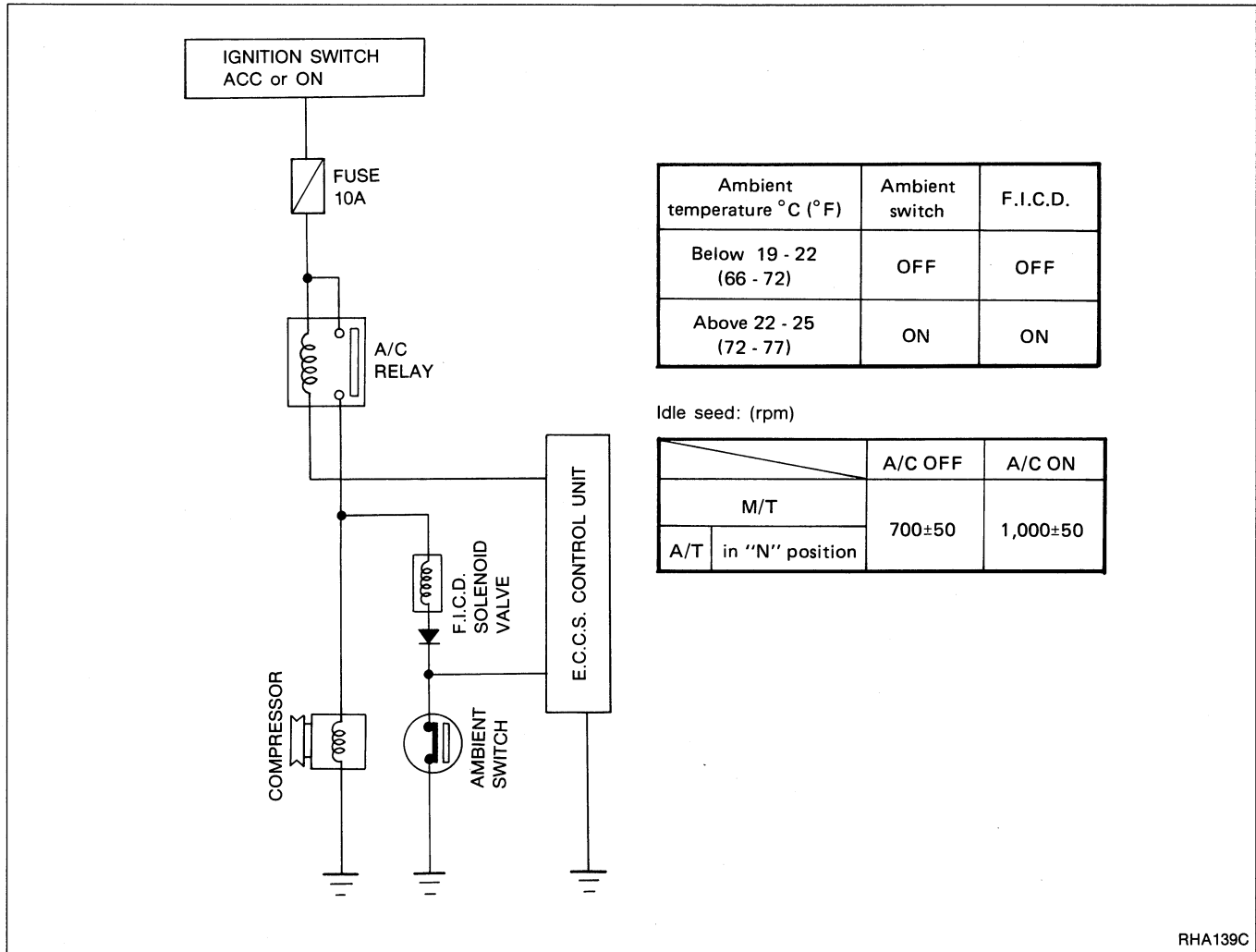

RHA139C

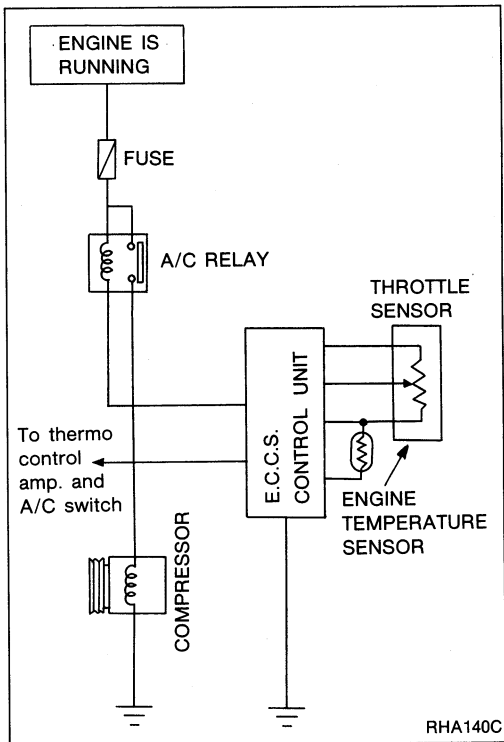

Acceleration Cut System

This system is controlled by the E.C.C.S. control unit. When the engine is heavily over loaded (throttle sensor judges that throttle valve is at full throttle position), the compressor is turned off for approx. 4 seconds to reduce overloading. Additionally when the temperature of engine coolant rises above approx. 113°C (235°F), the compressor is turned off.

PRECAUTIONS

Goggles

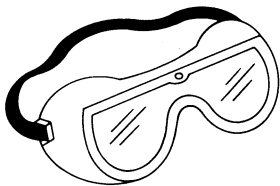

RHA260B

Gloves

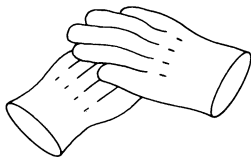

RHA261B

Avoid Open Flame

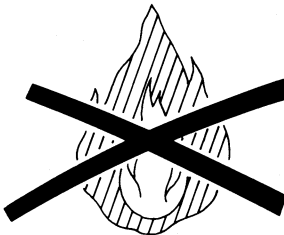

RHA262B

No Direct Heat on Container

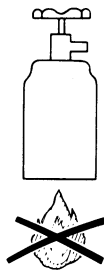

RHA263B

PRECAUTIONS FOR THE HANDLING OF REFRIGERANT

- Always wear eye protection when working around the system.
- Always be careful that refrigerant does not come in contact with your skin.
- Keep refrigerant containers stored below 40°C (104°F) and never drop from high places.
- Work in well-ventilated area because refrigerant gas evaporates quickly and breathing may become difficult due to the lack of oxygen.
- Keep refrigerant away from open flames because poisonous gas will be produced if it burns.
- Do not increase can temperature beyond 40°C (104°F) in charging.
- Do not heat refrigerant container with an open flame. There is a danger that container will explode.

CAUTION:

- Do not use stream to clean surface of condenser or evaporator. Be sure to use cold water or compressed air.
- Compressed air must never be used to clean a dirty line.

- Do not release refrigerant into the atmosphere.

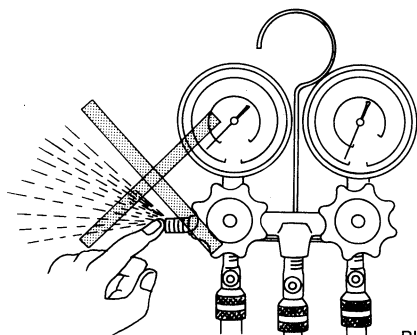

RHA676B

PRECAUTIONS

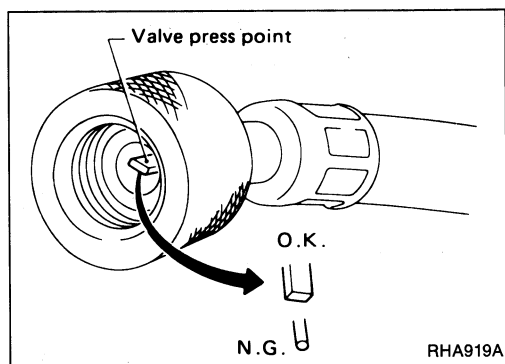

- Do not use manifold gauge whose press point shape is different from that shown. Otherwise, insufficient evacuating may occur.

- Do not over-tighten service valve cap.
- Do not allow refrigerant to rush out. Otherwise, compressor oil will be discharged along with refrigerant.

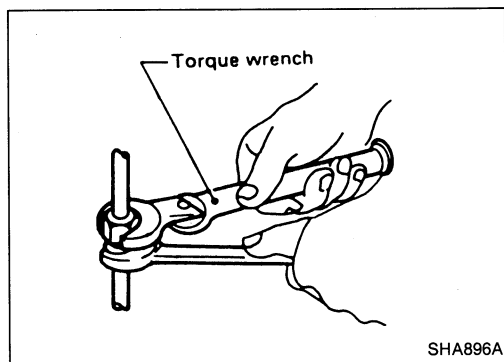

PRECAUTIONS FOR REFRIGERANT CONNECTION

WARNING:

Make sure all refrigerant is discharged into the recycling equipment and the pressure in the system is less than atmospheric. Then gradually loosen the discharge side hose fitting and remove it.

CAUTION:

When replacing or cleaning refrigerant cycle components, observe the following.

- Do not leave compressor on its side or upside down for more than 10 minutes, as compressor oil will enter low pressure chamber.
- When connecting tubes, always use a torque wrench and a back-up wrench.

PRECAUTIONS

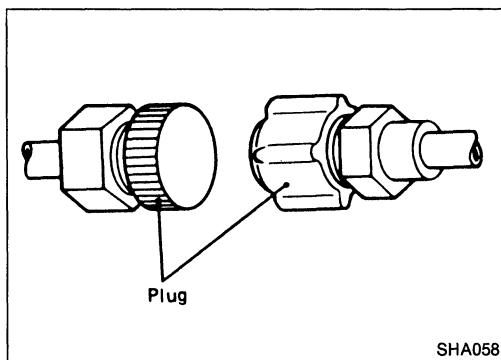

- After disconnecting tubes, plug all openings immediately to prevent entrance of dirt and moisture.

CAUTION:

- When installing an air conditioner in the vehicle, the pipes must be connected as the final stage of the operation. The seal caps of the pipes and other components must not be removed until their removal is required for connection.
- Before installing any air conditioner component that has been stored in a cool location to a vehicle that has been exposed to the hot sun, leave the component as it is for some time in a hot location with its seal cap unremoved. This step is necessary to prevent condensation of moisture inside the cold component.
- Thoroughly remove moisture from the refrigeration system before charging the refrigerant.

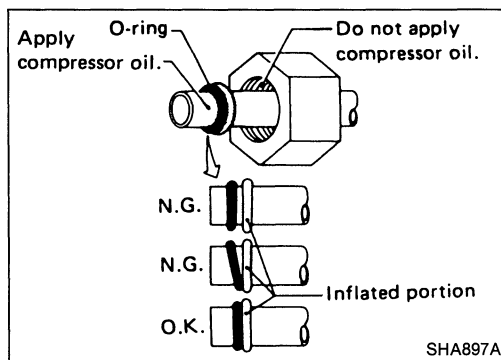

- Always replace used O-rings.
- When connecting tube, apply compressor oil to portions shown in illustration. Be careful not to apply oil to threaded portion.
- O-ring must be closely attached to inflated portion of tube.

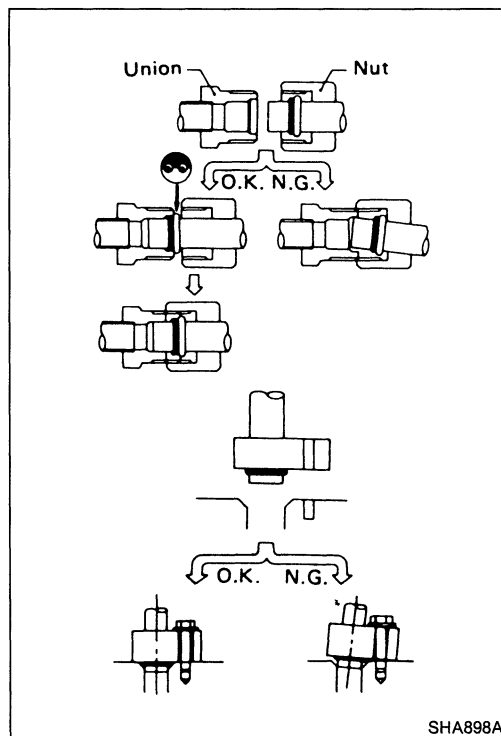

- After inserting tube into union until O-ring is no longer visible, tighten nut to specified torque.
- After connecting line, conduct leak test and make sure that there is no leakage from connections. When the gas leaking point is found, disconnect that line and replace the O-ring. Then tighten connections of seal seat to the specified torque.



PRECAUTIONS

Precautions for Servicing Compressor

- Attach a blind plug to the suction port (low pressure) and discharge port (high pressure) of the compressor to prevent oil from leaking out and dust from getting inside.
- Do not keep the compressor in the upside down position or laid on its side for more than 10 minutes.
- When replacing or repairing the compressor, be sure to remove oil from the compressor and check the oil quantity extracted.
- When replacing with a new compressor, be sure to remove oil from the new compressor so that the quantity of oil remaining in the new compressor is equal to the quantity collected from the removed compressor. See the section "COMPRESSOR OIL".
- Pay attention so as not to allow dirt and oil to attach on the friction surfaces between clutch and pulley. If the surface is contaminated with oil, wipe it off by using a clean waste cloth moistened with thinner.
- After completing the compressor service operation, be sure to rotate the compressor shaft more than five turns in both directions by hand to equalize oil distribution inside the compressor, then run the compressor for about one hour by idling the engine.
- When the compressor magnet clutch has been replaced, be sure to check the magnet clutch for normal operation by applying voltage to the clutch.

PREPARATION

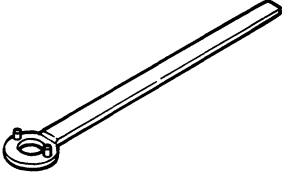
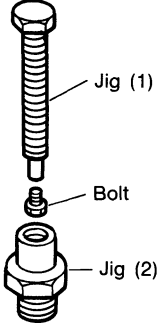
Special Service Tools

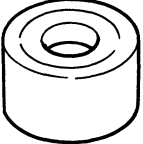
Tool number (Kent-Moore number) Tool name	Description
KV99845991 (—) Clutch disc wrench	 Removing center nut
Clutch disc puller set KV99845981 (—) Clutch jig (1) KV99849982 (—) Clutch jig (2) KV99845992 (—) Bolt (—)	 Removing/Installing clutch disc
KV99845993 (—) Bearing	 Installing pulley
KV99845972 (—) Pulley pressing jig	 Installing pulley
KV99845971 (—) Coil pressing jig	 Installing magnet clutch coil

PREPARATION

Service Tools

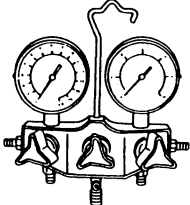
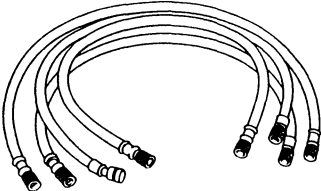
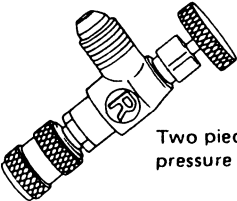
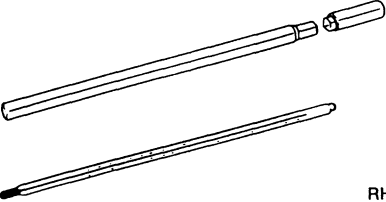
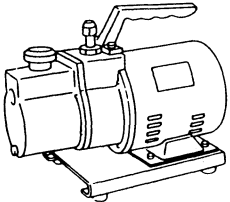
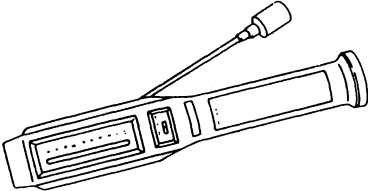
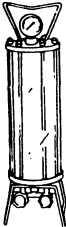
Tool name	Description
Manifold gauge (3-valve type)	<div style="display: flex; justify-content: space-between; align-items: center;">  <div style="text-align: right;"> <p>Discharging, evacuating and charging refrigerant</p> <p>RHA570B</p> </div> </div>
Charging hose (Four)	<div style="display: flex; justify-content: space-between; align-items: center;">  <div style="text-align: right;"> <p>Discharging, evacuating and charging refrigerant</p> <p>RHA571B</p> </div> </div>
Adapter valve	<div style="display: flex; justify-content: space-between; align-items: center;">  <div style="text-align: right;"> <p>Discharging, evacuating and charging refrigerant</p> <p>Two pieces on each high pressure and low pressure line</p> <p>RHA573B</p> </div> </div>
Thermometer	<div style="display: flex; justify-content: space-between; align-items: center;">  <div style="text-align: right;"> <p>Checking temperature</p> <p>RHA574B</p> </div> </div>
Vacuum pump	<div style="display: flex; justify-content: space-between; align-items: center;">  <div style="text-align: right;"> <p>Evacuating</p> <p>RHA575B</p> </div> </div>
Gas leak detector	<div style="display: flex; justify-content: space-between; align-items: center;">  <div style="text-align: right;"> <p>Checking refrigerant leaks</p> <p>RHA577B</p> </div> </div>
Charging cylinder	<div style="display: flex; justify-content: space-between; align-items: center;">  <div style="text-align: right;"> <p>Checking amount of refrigerant and charging refrigerant</p> <p>RHA578B</p> </div> </div>

PREPARATION
Service Tools (Cont'd)

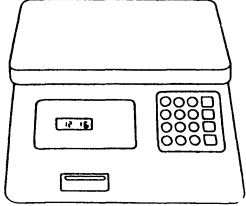
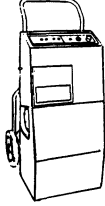
Tool name	Description
Weight scale	<div style="display: flex; justify-content: space-between; align-items: center;"><div data-bbox="618 201 862 405"></div><div data-bbox="1052 201 1398 231">Checking amount of refrigerant</div></div> <p style="text-align: right; margin-top: 10px;">RHA579B</p>
Refrigerant recycling equipment	<div style="display: flex; justify-content: space-between; align-items: center;"><div data-bbox="678 432 781 636"></div><div data-bbox="1052 426 1442 455">Capturing and recycling refrigerant</div></div> <p style="text-align: right; margin-top: 10px;">SHA732C</p>

For details of such handling methods, refer to the Instruction Manual attached to each of the service tools.

PREPARATION

Service Tools (Cont'd)

HANDLING METHOD AND STRUCTURE

Manifold gauge

The manifold gauge is used to measure the operating pressure accurately in the high pressure and low pressure lines of the refrigerating system.

The high pressure gauge measures from -101.3 kPa (-760 mmHg , -29.92 inHg) to $2,942 \text{ kPa}$ (30 kg/cm^2 , 427 psi), and the low pressure gauge measures generally from -101.3 kPa (-760 mmHg , -29.92 inHg) to $1,471 \text{ kPa}$ (15 kg/cm^2 , 213 psi).

CAUTION:

- When installing the gauge to the refrigerating system, use utmost care not to mistake high pressure and low pressure line connections. (Wrong connections will lead to a damaged gauge.)
- Before evacuating, confirm that the gauge has a negative pressure scale. (If not, the gauge will be damaged.)

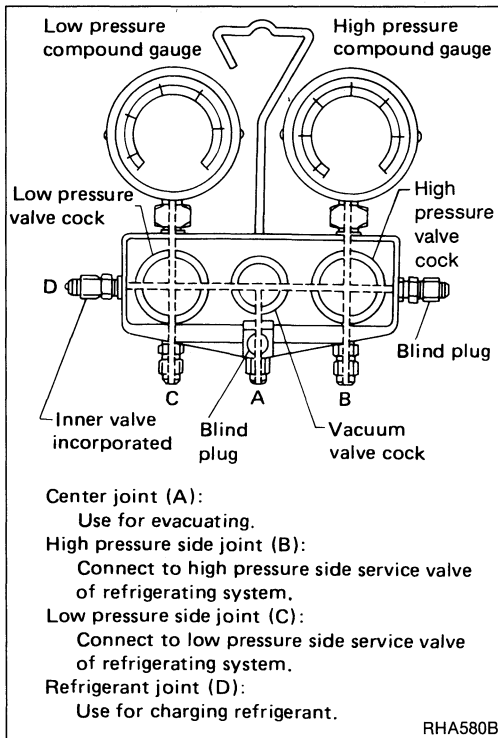

Charging hose

1. Completely tighten the high pressure valve, low pressure valve and vacuum pump valve cocks of the gauge manifold.
2. Connect the charging hoses to the high and low pressure lines.
3. Connect the charging hose fitted with a valve core to the refrigerant canister.
4. Connect the charging hose to the vacuum pump.

The high and low pressure hoses are color coded to prevent wrong connection.

High pressure line hose	Red
Low pressure line hose	Yellow
Refrigerant canister hose	Blue or green (with valve core)
Vacuum pump hose	Blue or green

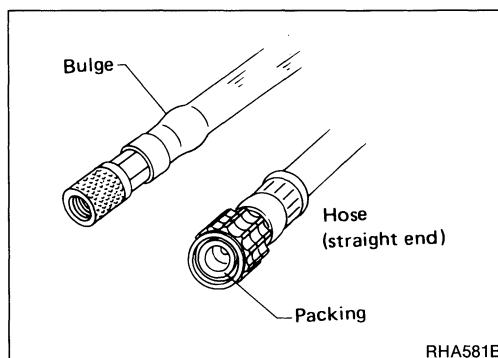

CAUTION:

- Check each hose for cracks. If found, discard the hose.
- Do not use any hose if bulges are found.
- Check the rubber packing. If any deterioration or cracks are found, replace it with a new one.

PREPARATION

Service Tools (Cont'd)

Installing the adapter valve

Install the adapter valve to each of the high pressure and low pressure service valves so that air purging from the charging hose can be omitted. This also ensures that refrigerant leakage upon disconnection of the hose can be prevented.

1. Before connecting the adapter valve to the on-vehicle service valve, turn the adapter valve handle fully counterclockwise to retract the pin.

CAUTION:

Check the packing for any sign of deterioration or cracks. If any abnormality is found, replace it with a new one.

2. Connect the charging hose to the adapter valve.

Turning the handle clockwise will cause the on-vehicle service valve pin to be pushed open by the adapter valve pin, thus opening the refrigerant passage.

Turning the handle counterclockwise will close the passage. Before removing the adapter valve from the on-vehicle service valve, be sure to fully turn the handle counterclockwise to shut off the refrigerant passage.

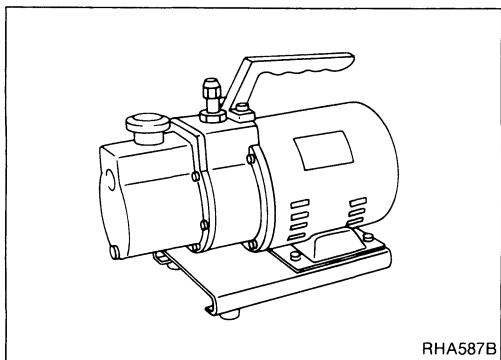
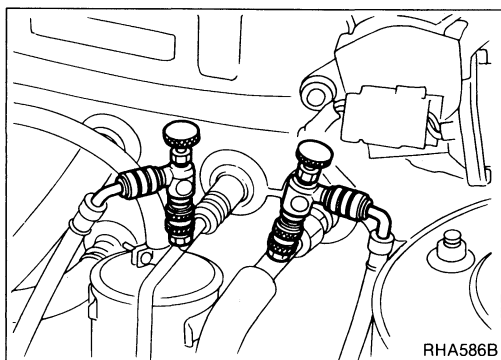
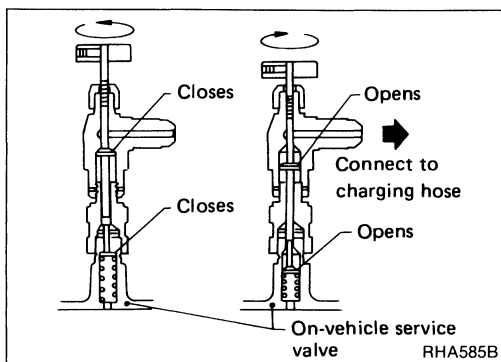

Vacuum pump

The vacuum pump is used to purge air and moisture from the inside of the refrigeration system by evacuation, thereby ensuring proper functioning of the air conditioner system.

Check the vacuum pump to see that the vacuum pump capacity is greater than -100.0 kPa (-750 mmHg, -29.53 inHg).

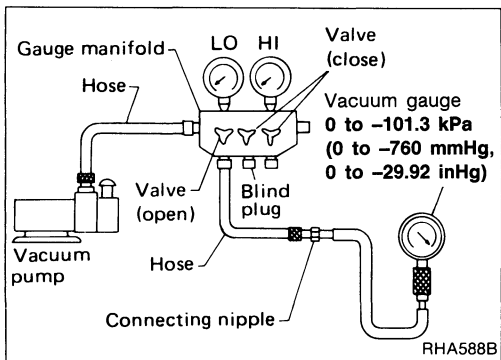

Vacuum pump performance check procedure

1. Connect the vacuum gauge to the system.
2. Run the vacuum pump, and check to see that the needle pointers of the gauge manifold and vacuum gauge move smoothly, indicating a similar value.
3. After running the vacuum pump for two or three minutes, read the vacuum gauge. The measured value indicates the capacity of the vacuum pump.

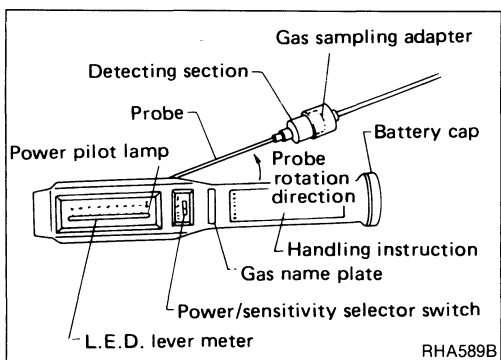

Gas leak detector

The gas leak detector is used to check whether the refrigeration system is leaking. The detector is available in two types; halide torch or electrical. The features of these gas leak detectors are listed on the next page.

PREPARATION

Service Tools (Cont'd)

Type	Detection ability	Features
Halide torch	200 g (7.05 oz)/year (thin green)	<ul style="list-style-type: none"> ● Low price ● Low sensitivity ● Less safe because of the use of flame for detection
Electrical	Discharge type (Suction type)	<ul style="list-style-type: none"> ● Easy handling ● Medium sensitivity ● Each point needs two or more seconds for detection.
	Positive ion emission type (Suction type)	<ul style="list-style-type: none"> ● High sensitivity ● High price ● Warm-up time is needed because a heater is incorporated.
Other simple checking method: Change in vacuum when evacuating	1 kg (2 lb)/month; if 13.3 kPa (100 mmHg, 3.94 inHg) change in vacuum is detected in 10 minutes.	<ul style="list-style-type: none"> ● Can be used easily in refrigerant charging operation. ● Detection ability is very low with vacuum gauge in gauge manifold.

- **Leakage inspection of a refrigeration system needs a sensitivity greater than 20 g (0.71 oz)/year.**
- **The actual amount of leak is estimated at 5 to 10 times the detected amount.**
- **Insufficient cooling may be felt if leakage exceeds 150 to 200 g (5.29 to 7.05 oz).**

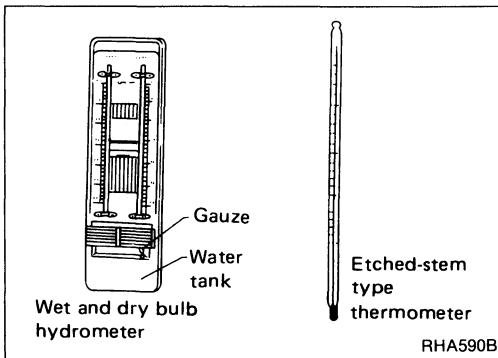

Temperature gauge

Use to check the air conditioner performance. An etched stem type thermometer may be used. A hygrometer must also be used because the air conditioner performance depends on the humidity.

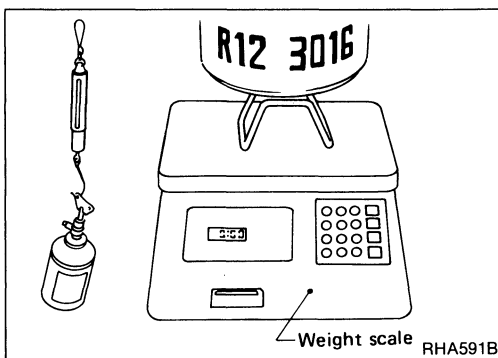

Scale

Measure the weight of the refrigerant to determine how much the refrigerant is charged.

PREPARATION

Service Tools (Cont'd)

Charging cylinder

The charging cylinder is used to correctly measure the amount of refrigerant to be charged.

Features

- With the charging cylinder, the operator can measure correctly the amount of refrigerant to be charged into the system.
- Change in the refrigerant volume due to a change in temperature and pressure can be supplemented, and this ensures correct charging of refrigerant.

CAUTION:

- **Never attempt to carry the charging cylinder containing refrigerant.**
- **Do not put the charging cylinder in a hot place. If the temperature and pressure of the refrigerant in the cylinder increase, the safety valve will be pushed open and the refrigerant will be released into the atmosphere.**
- **Do not expose the cylinder to the direct sunlight.**
- **Do not over-charge the refrigerant so that it exceeds the maximum limit of the cylinder.**
- **Do not charge the cylinder with more refrigerant than is needed.**

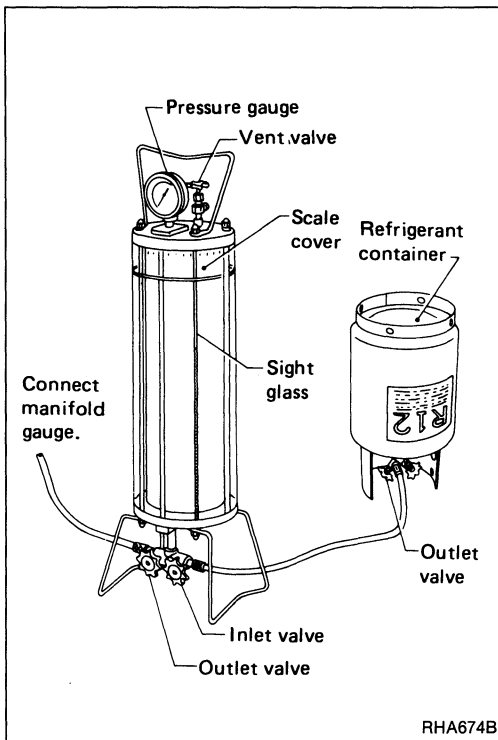

DISCHARGING, EVACUATING, CHARGING AND CHECKING

Work Procedure

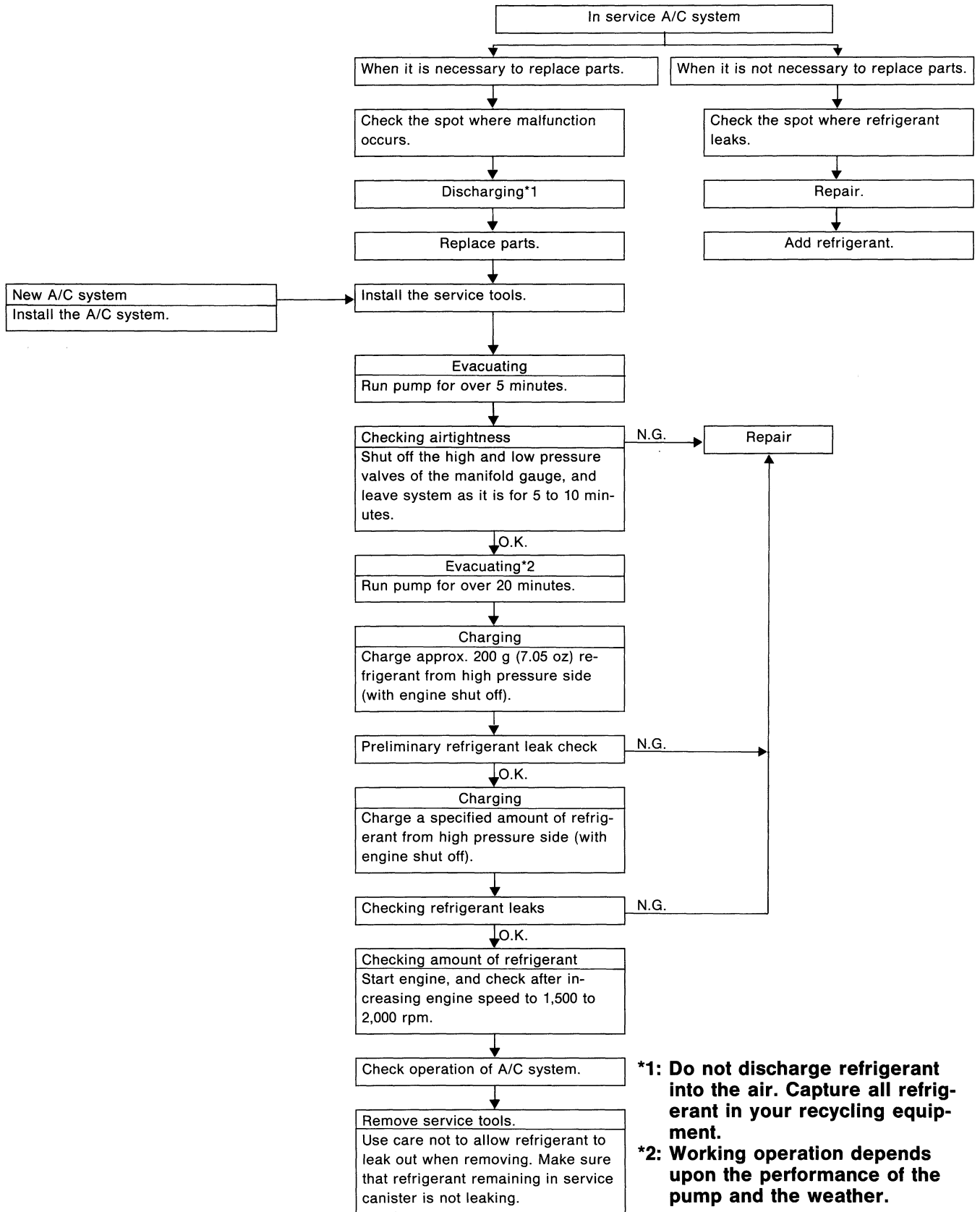

DISCHARGING, EVACUATING, CHARGING AND CHECKING

Setting of Service Tools

Make sure that the service tools are set as indicated below and that no refrigerant is leaking.

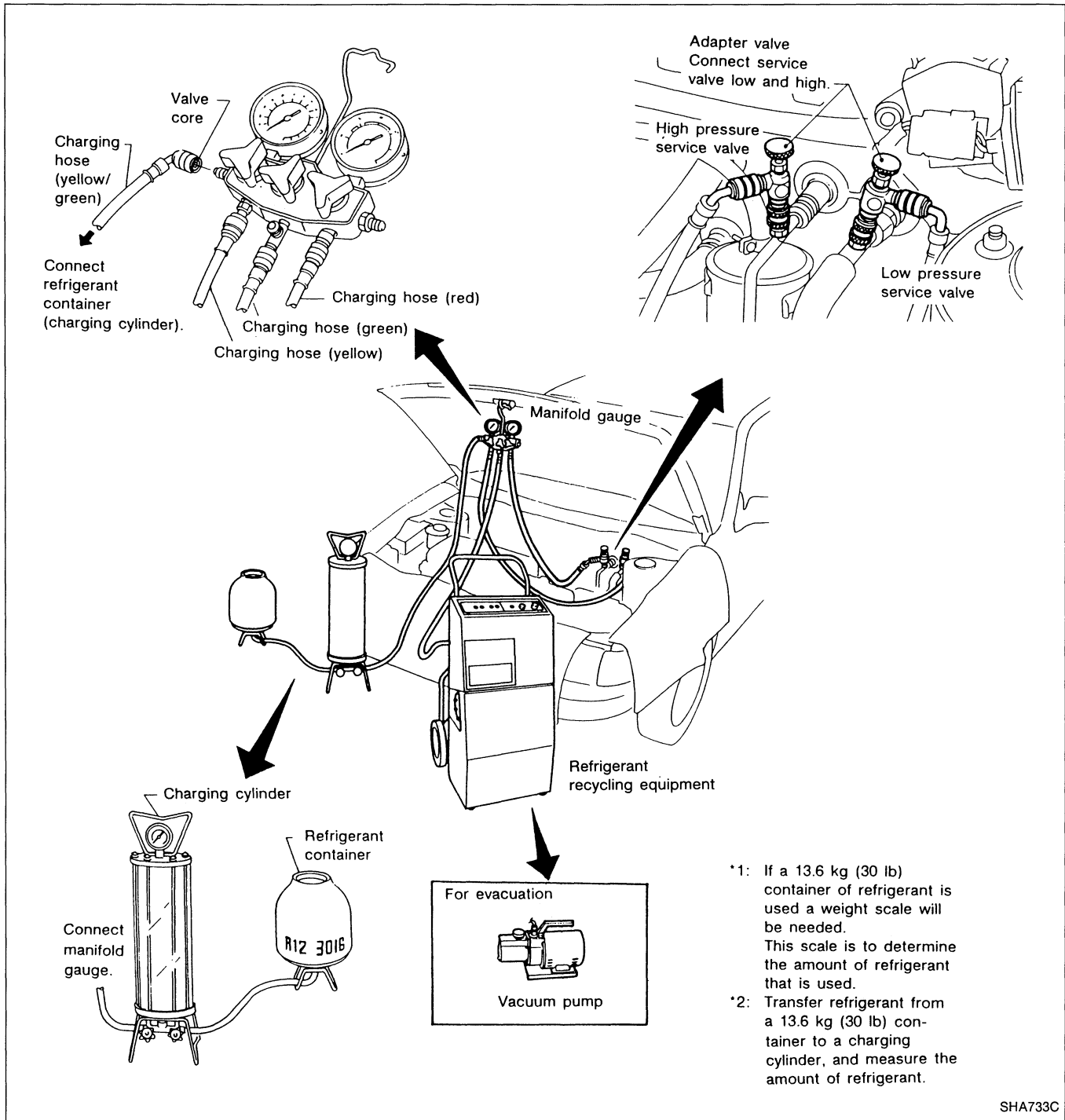

DISCHARGING, EVACUATING, CHARGING AND CHECKING

Setting of Service Tools (Cont'd)

When a 3-valve type manifold gauge is unavailable, use a 2-valve type manifold gauge with one additional valve at the end of the charging hose.

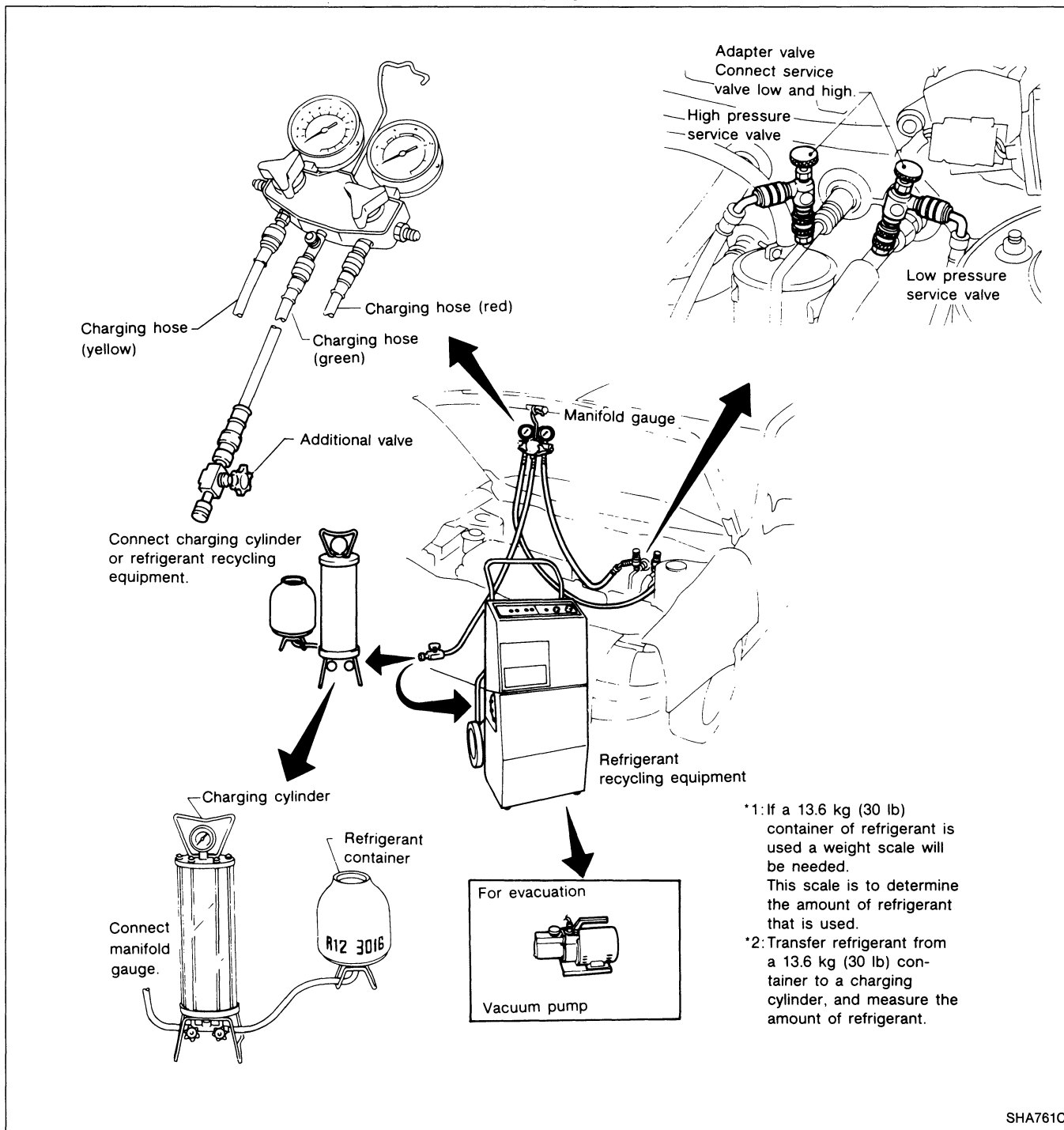

DISCHARGING, EVACUATING, CHARGING AND CHECKING

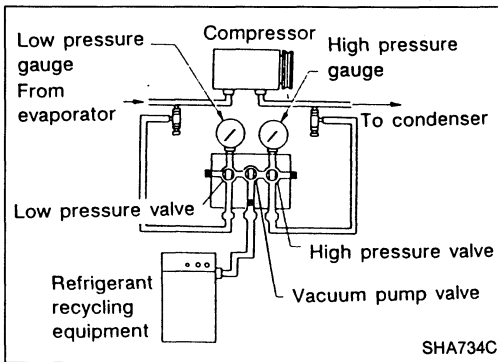

Discharging

WARNING:

**Discharge only into your recycling equipment.
Do not release refrigerant into the air.**

Slowly open the valves to discharge the refrigerant. If they are opened quickly, compressor oil will also be discharged.

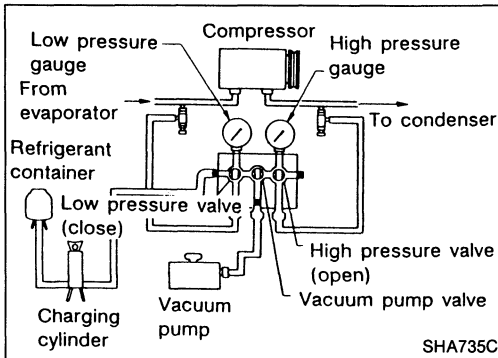

Evacuation

EVACUATION PROCEDURE

1. Completely tighten the low pressure and high pressure adapter valves.
Turn on the high and low pressure service valves.
2. Open the high and low pressure valves and vacuum pump valve of the manifold gauge set.
3. Run the vacuum pump.
4. Perform evacuation for more than five minutes to stabilize the vacuum inside the system. Check to ensure that the low pressure gauge indicates -98.6 to -101.3 kPa (-740 to -760 mmHg, -29.13 to -29.92 inHg).
5. Shut off the high and low pressure valves and vacuum pump valve of the manifold gauge set.

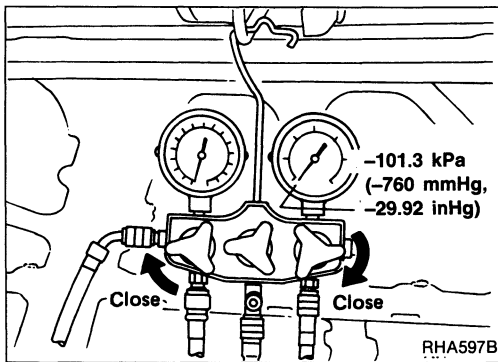

CHECKING AIRTIGHTNESS

1. Shut off the high and low pressure valves and vacuum pump valve of the manifold gauge set, and leave the system as it is for 5 to 10 minutes.
2. Make sure that the needle of the low pressure gauge will not move back toward the atmospheric pressure side (gauge pressure 0).

If any reverse movement is noted, it indicates poor system airtightness. Service the system until airtightness is complete. If pressure changes approx. 13.3 kPa (100 mmHg, 3.94 inHg) in 10 minutes, the refrigerant in the system will be exhausted in about one month.

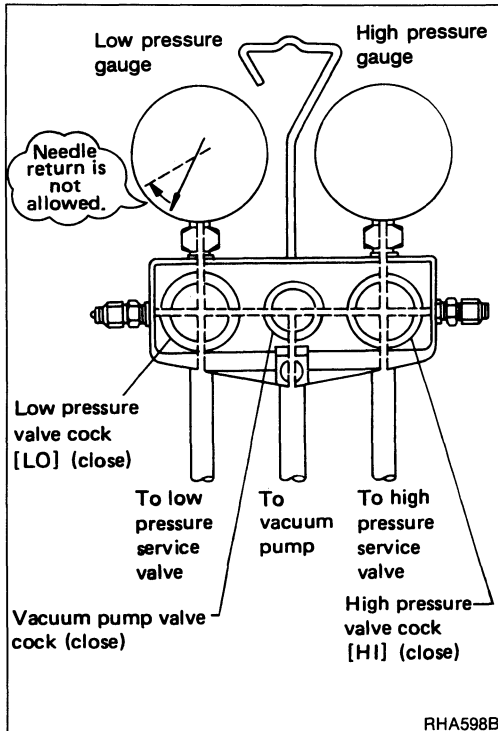

DISCHARGING, EVACUATING, CHARGING AND CHECKING

Evacuation (Cont'd)

MAINTENANCE

If inadequate airtightness is detected, check and service the following portions:

Leak from pipe joints	Leak from manifold gauge set
<ul style="list-style-type: none">● Contaminated, damaged, or deformed O-ring● No oil applied when connecting pipe● Excessive or insufficient tightening of pipe joint	<ul style="list-style-type: none">● Malfunctioning hose● Improper installation of manifold● Malfunctioning valve● Malfunctioning packing

EVACUATION

If no abnormality is found during the airtightness check, perform evacuation again for more than 20 minutes.

1. Run the vacuum pump.
2. Open the high and low pressure valve and vacuum pump valve of the manifold gauge set.
3. Evacuate for more than 20 minutes.
4. Close the high and low pressure valves and vacuum pump valve of the manifold gauge set.

Charging Refrigerant

Install the charging cylinder correctly to the vehicle. Refer to "Setting of Service Tools".

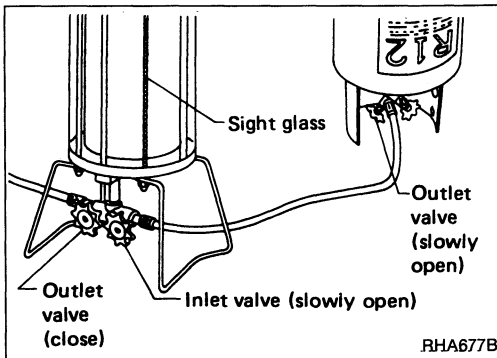

PRELIMINARY CHARGING OF REFRIGERANT-1

1. Make sure that the inlet and outlet valves of the charging cylinder are closed.
2. Slowly open the outlet valve of a refrigerant container [13.6 kg (30 lb)].
3. Slowly open the inlet valve of the charging cylinder.

The refrigerant will flow into the sight glass of the charging cylinder as the valve is opened.

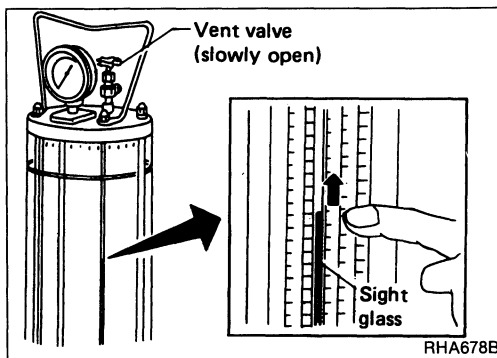

4. Slowly open the upper vent valve to release pressure from the charging cylinder. While doing so, continue charging until the required amount of refrigerant is reached.

The refrigerant volume changes with the temperature and pressure. It is necessary to charge refrigerant with a little more than the required amount (indicated on the sight glass).

5. Close the inlet valve and upper vent valve of the charging cylinder.

DISCHARGING, EVACUATING, CHARGING AND CHECKING

Charging Refrigerant (Cont'd)

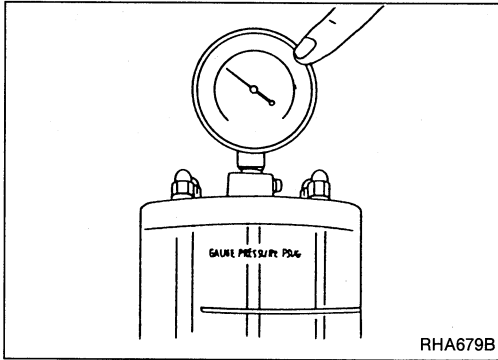

6. Turn on the heater switch (the charging cylinder is provided with a heater.)

The refrigerant charging time can be reduced by heating the refrigerant to increase its pressure. In this case, do not allow the pressure in the cylinder to rise higher than 1,030 kPa (10.5 kg/cm², 150 psi). (If pressure rises above this level, turn off the heater.)

The pressure in the charging cylinder can be measured by the upper pressure gauge.

EVACUATION AND AIRTIGHTNESS CHECK

Refer to "EVACUATION PROCEDURE" and "CHECKING AIRTIGHTNESS" in "Evacuation".

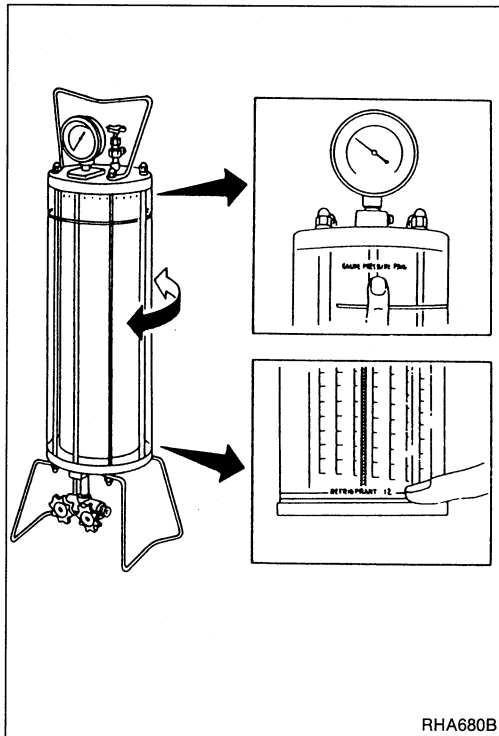

SETTING OF FLOW METER

1. Rotate the charging cylinder main body until the scale for R12 is at the correct position on the sight glass.
2. Read the charging cylinder pressure gauge.
3. Rotate the charging cylinder so that the scale of the charging cylinder agrees with the pressure value indicated on the pressure gauge.
4. Open the outlet valve of the charging cylinder.

DISCHARGING, EVACUATING, CHARGING AND CHECKING

Charging Refrigerant (Cont'd)

CALCULATING CHARGING AMOUNT OF REFRIGERANT

1. Record the amount of refrigerant in the sight glass before charging.
2. Subtract the required amount of refrigerant (charge quantity specified for the vehicle) from the amount of refrigerant recorded in step 1. Charge refrigerant into the system until the remaining value equals to the value indicated on the sight glass.

Example:

Level in sight glass: 3 lb 8 oz

Charge specification (from S.D.S.) 2.0 - 2.4 lb.

Calculate charge quantity into lb and oz as follows: 1 lb = 16 oz, and 0.1 lb = 1.6 oz, so that 2.0 lb = 32 oz, 2.4 lb = 32 + (4 x 1.6) = 32 + 6.4 = 38.4, round off to 38. Therefore our charge quantity will be between 32 and 38 oz, or 2 lb 0 oz to 2 lb 6 oz. Subtract 2 lb 6 oz from the level in the sight glass (3 lb 8 oz) = 1 lb 2 oz.

This will be our ending point.

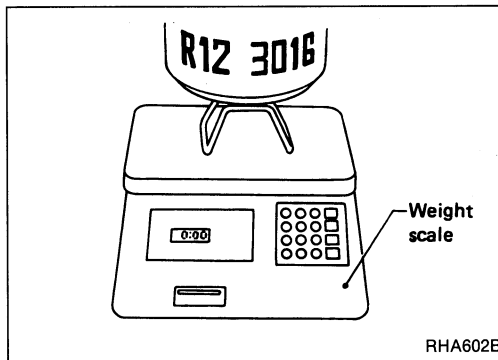
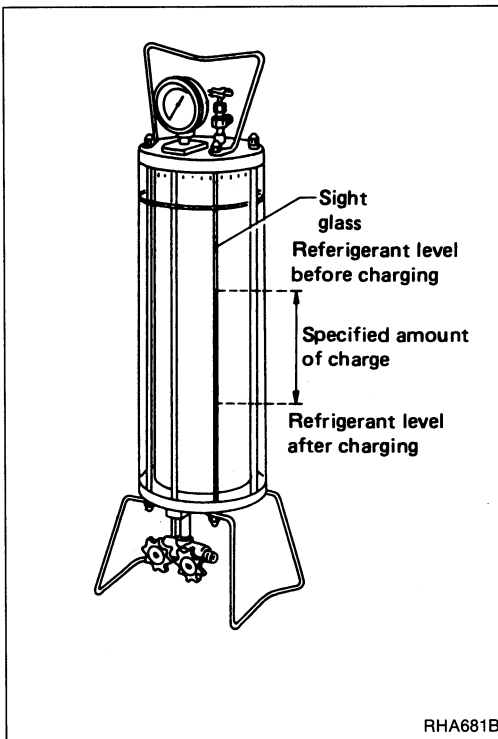

If a flow meter is not available, the amount of charged refrigerant also can be determined by subtracting the weight of the canister measured after charging from its weight measured before charging.

DISCHARGING, EVACUATING, CHARGING AND CHECKING

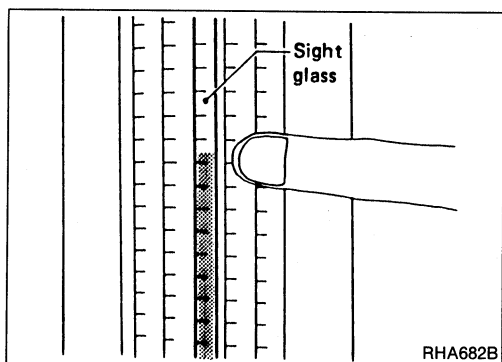

Charging Refrigerant (Cont'd)

PRELIMINARY CHARGING OF REFRIGERANT-2

1. Slowly open the high pressure side valve of the manifold gauge to charge refrigerant from the high pressure side.
2. Close the high pressure valve after charging approx. 200 g (7.05 oz) refrigerant.

CAUTION:

The refrigerant in the charging cylinder is kept in the liquid state, so the refrigerant should be charged from high pressure side. Do not start the engine with the high pressure valve kept open.

PRELIMINARY CHECK FOR REFRIGERANT LEAKS

Refer to "PRELIMINARY CHECK FOR REFRIGERANT LEAKS" in "Charging Refrigerant".

CHARGING REFRIGERANT

1. Slowly open the high pressure valve of the manifold gauge, and charge the calculated amount of refrigerant in "CALCULATING CHARGING AMOUNT OF REFRIGERANT".

CAUTION:

The refrigerant in the charging cylinder is kept in the liquid state, so the refrigerant should be charged from high pressure side. Do not start the engine with the high pressure valve kept open.

2. Close the high pressure valve of the manifold gauge.
3. Make sure that the calculated amount of refrigerant is in the sight glass.
4. Close the charging cylinder outlet valve.
5. Turn off the heater if it is on (when using heater equipped type).

Inspection for Refrigerant Leaks

WORK PROCEDURE

To facilitate inspection for refrigerant leaks, establish the following conditions:

- Start the engine.
- Run the air conditioner.
- Set the blower fan control to MAX.
- Set the temperature control to FULL COLD.
- Run the refrigerant system for more than 5 minutes after setting the above-mentioned conditions (to circulate the refrigerant through the system).

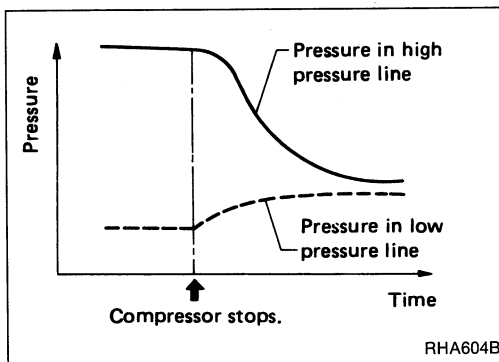

Refrigerant leaks should be checked immediately after stopping the engine, beginning with the high pressure line, using a gas leak detector. This is because the pressure in the high pressure line drops gradually after the refrigerant circulation stops while the pressure in the low pressure line rises gradually as shown in the graph. Leaks can be detected easily when pressure is high.

To prevent detecting errors, make sure that there is no refrigerant vapor or tobacco smoke in the vicinity of the vehicle. It is also necessary to shield the vehicle from the wind so that the leaking refrigerant is not blown away.

DISCHARGING, EVACUATING, CHARGING AND CHECKING

Inspection for Refrigerant Leaks (Cont'd)

INSPECTION POINTS

Check carefully each of the tube joints. To check, wipe the portion to be checked with waste cloth, and move the tester probe all around the joint.

Compressor

Check the shaft seals and bolt holes, and also around the magnet clutch.

Receiver drier

Check the pressure valve, safety valve and the fusible plug mounts.

Service valve

Check all around the service valves.

Ensure that the valve core is not loose.

The service valve cap must be attached to the valve (to prevent leak).

Also check that there are no foreign objects inside the cap.

Inside of cooling unit

To check, insert the leak tester probe into the drain hose immediately after stopping the engine. (Keep the probe inserted for more than 10 seconds.)

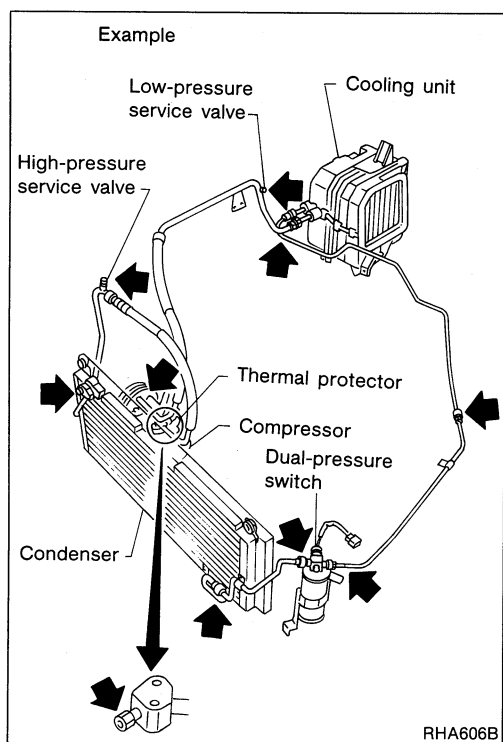

Confirmation of Amount of Charged Refrigerant

The amount of refrigerant charged into the system can be observed through the sight glass by watching the flow of the refrigerant and by reading the high pressure and low pressure manifold gauges under the following conditions:

CONDITIONS

- Doors:
Close completely.
- Window glasses:
Close completely.
- Intake door position:
RECIRC
- Mode door position:
VENT
- Blower fan:
HI
- TEMP control:
Optional [Set so that intake air temperature is 30 to 35°C (86 to 95°F).]
- AIR CON switch:
ON
- Engine speed:
Approx. 1,500 rpm

WORK PROCEDURE

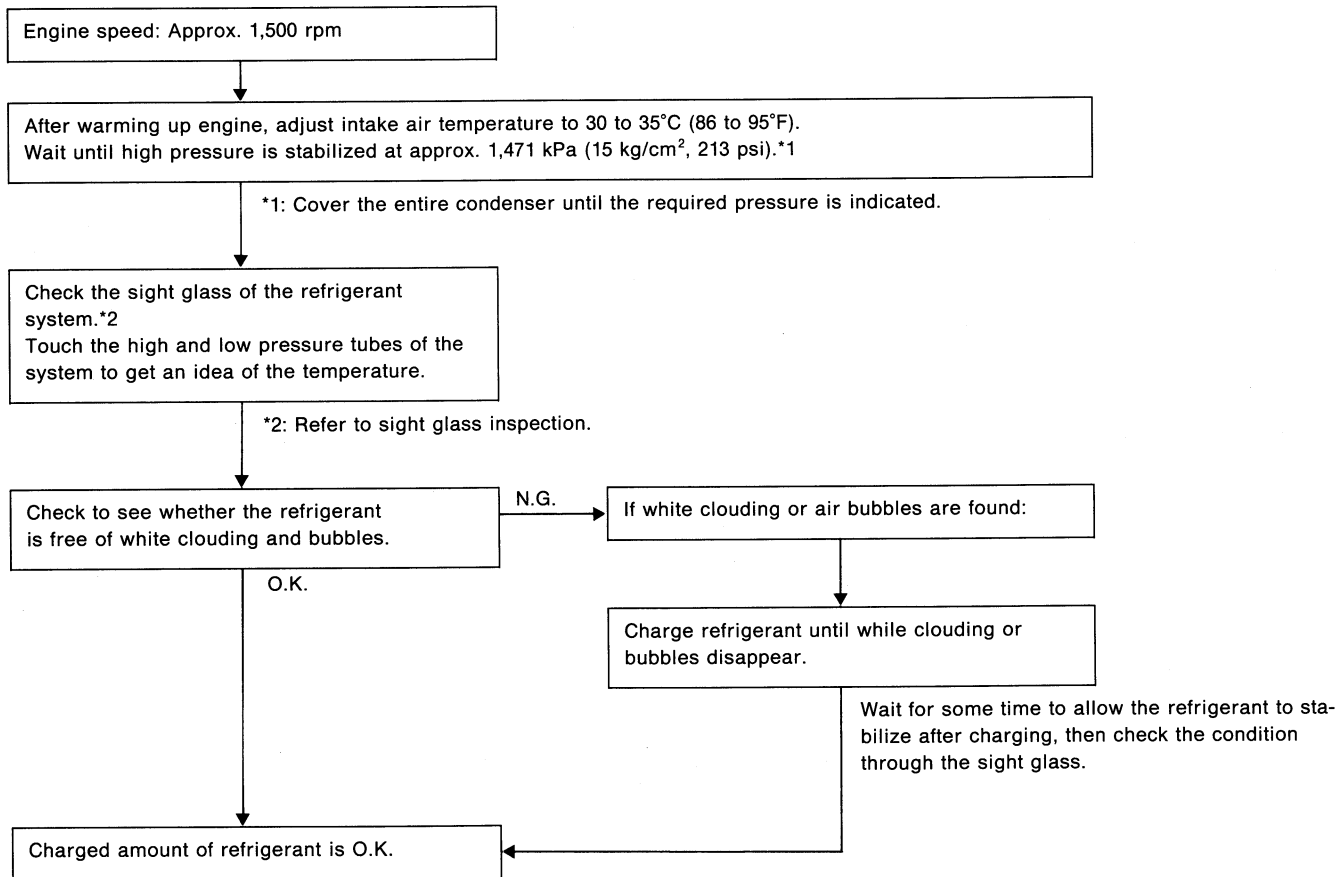

DISCHARGING, EVACUATING, CHARGING AND CHECKING

Confirmation of Amount of Charged Refrigerant (Cont'd)

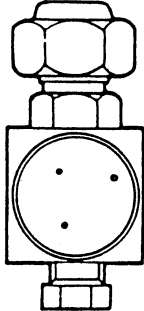
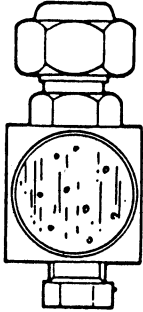
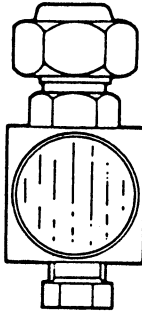
Amount of charge	Appropriate	Refrigerant is insufficient	Almost no refrigerant	Overcharged, or air in system
Check item				
Temperature of high and low pressure pipes	High pressure side is hot while low pressure side is cold.	High pressure side is warm and low pressure side is somewhat cold.	No difference is felt between high and low pressure sides.	High pressure side is very hot.
Flow of refrigerant viewed through sight glass	Mostly transparent. Occasionally some bubbles are seen when engine rpm is increased or decreased. 	Bubbles are always flowing. Refrigerant is cloudy. 	Nothing is visible. 	If overcharged, no bubbles are seen. If there is air in the system, large bubbles are seen.
Pressure	Normal high pressure: 1,373 - 1,765 kPa (14 - 18 kg/cm ² , 199 - 256 psi) Normal low pressure: 147 - 294 kPa (1.5 - 3 kg/cm ² , 21 - 43 psi)	Both high and low pressure values are insufficient.	High pressure value is very small.	Both high and low pressure values are excessive.
Action to take	Air bubbles may be generated when the receiver drier strainer is clogged, or when the expansion valve is opened excessively.	Add refrigerant after checking for leaks.	Check the refrigerant system.	Stop the compressor and extract excessive refrigerant. If air is found, perform evacuation, then charge the specified amount of refrigerant.

CAUTION:

The condition of bubbles seen through the sight glass as well as the intake and discharge pressures are influenced by the ambient temperature, wind velocity, weather, and by the air temperature in front of the condenser, etc.

SERVICE PROCEDURES

Refrigerant Lines

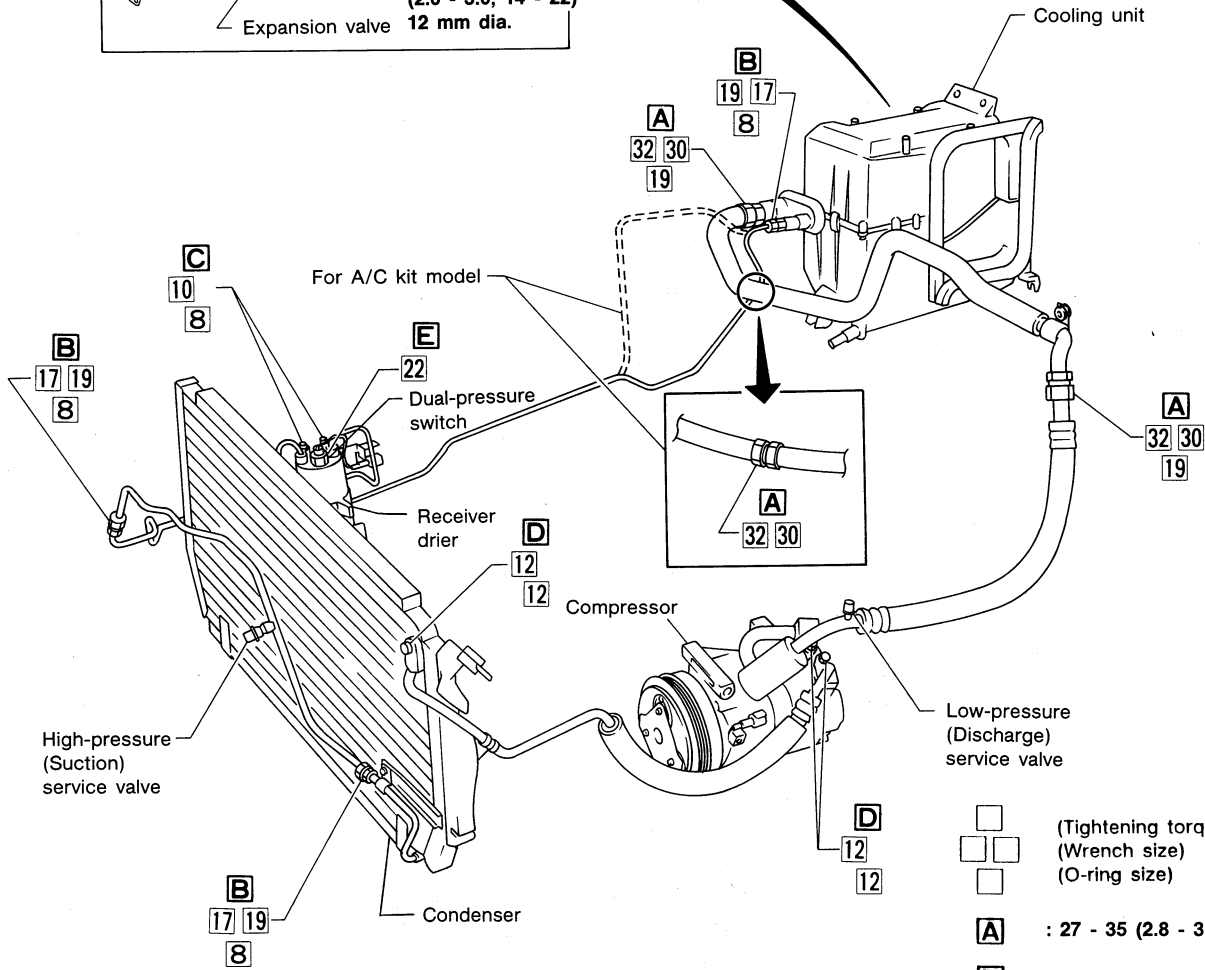
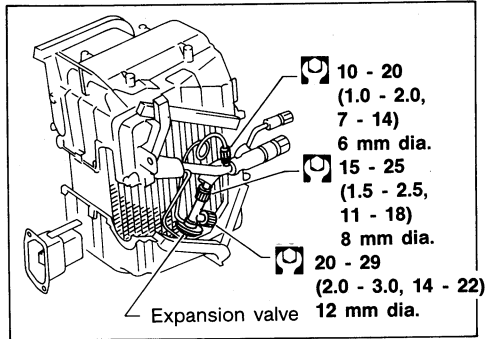

- | | |
|----------|---------------------------------|
| □ | (Tightening torque) |
| □ □ | (Wrench size) |
| □ | (O-ring size) |
| A | : 27 - 35 (2.8 - 3.6, 20 - 26) |
| B | : 16 - 19 (1.6 - 1.9, 12 - 14) |
| C | : 3 - 4 (0.3 - 0.4, 2.2 - 2.9) |
| D | : 8 - 11 (0.8 - 1.1, 5.8 - 8.0) |
| E | : 10 - 12 (1.0 - 1.2, 7 - 9) |
| ⊕ | : N·m (kg·m, ft·lb) |

SERVICE PROCEDURES

Compressor Mounting

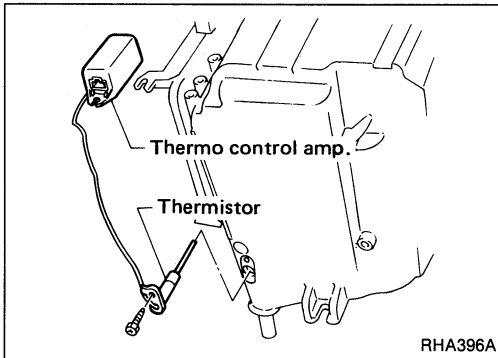
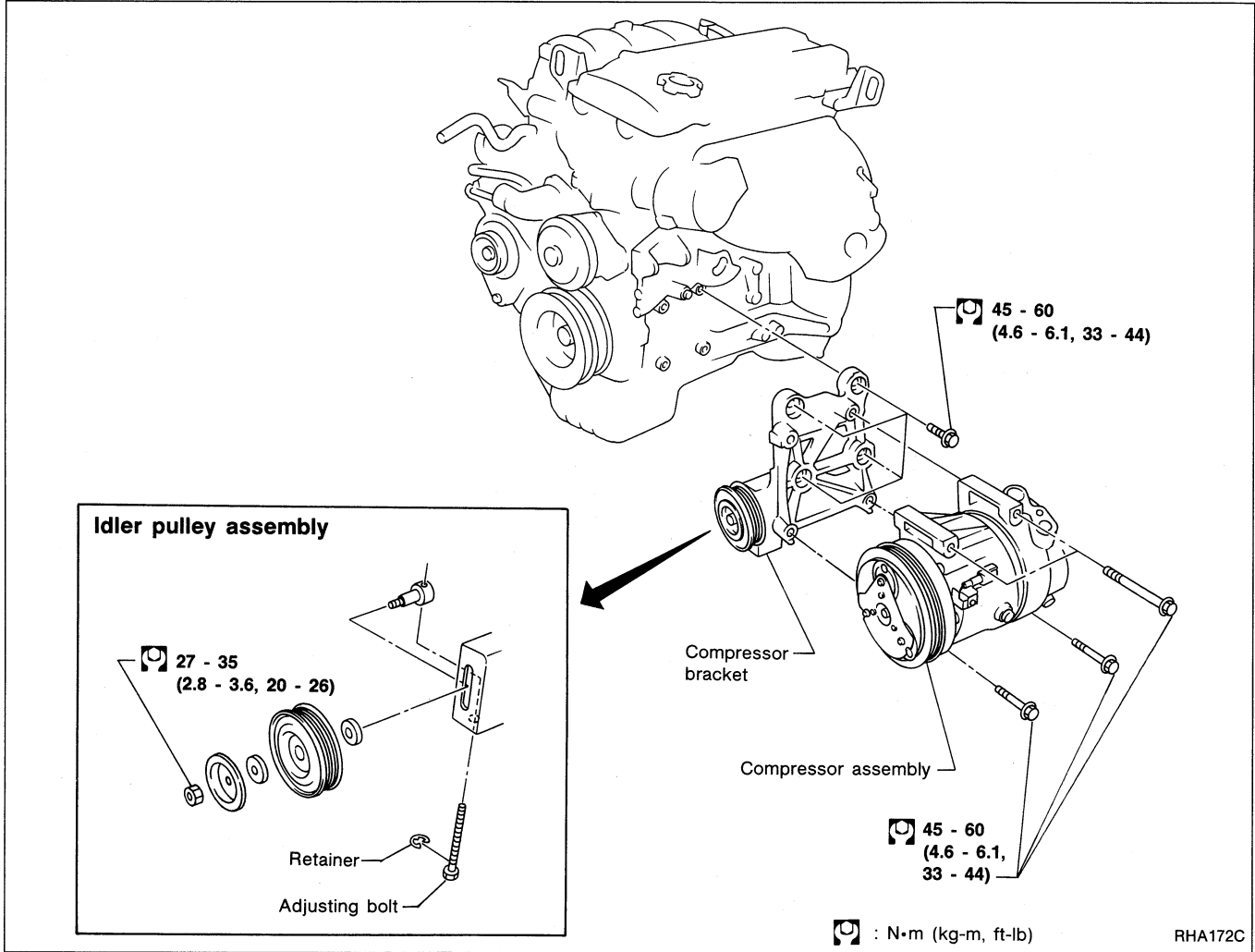

Thermo Control Amp.

REPLACEMENT

Remove screws, which secure thermistor locating stay, from front of cooling unit. Replace thermo control amp. assembly with a new one. (Without removing cooling unit, thermo control amp. can be replace.)

Belt Tension

- Refer to MA section.

Fast Idle Control Device (F.I.C.D.)

- Refer to EF & EC section.

SERVICE PROCEDURES

Condenser and Condenser Fan Motor

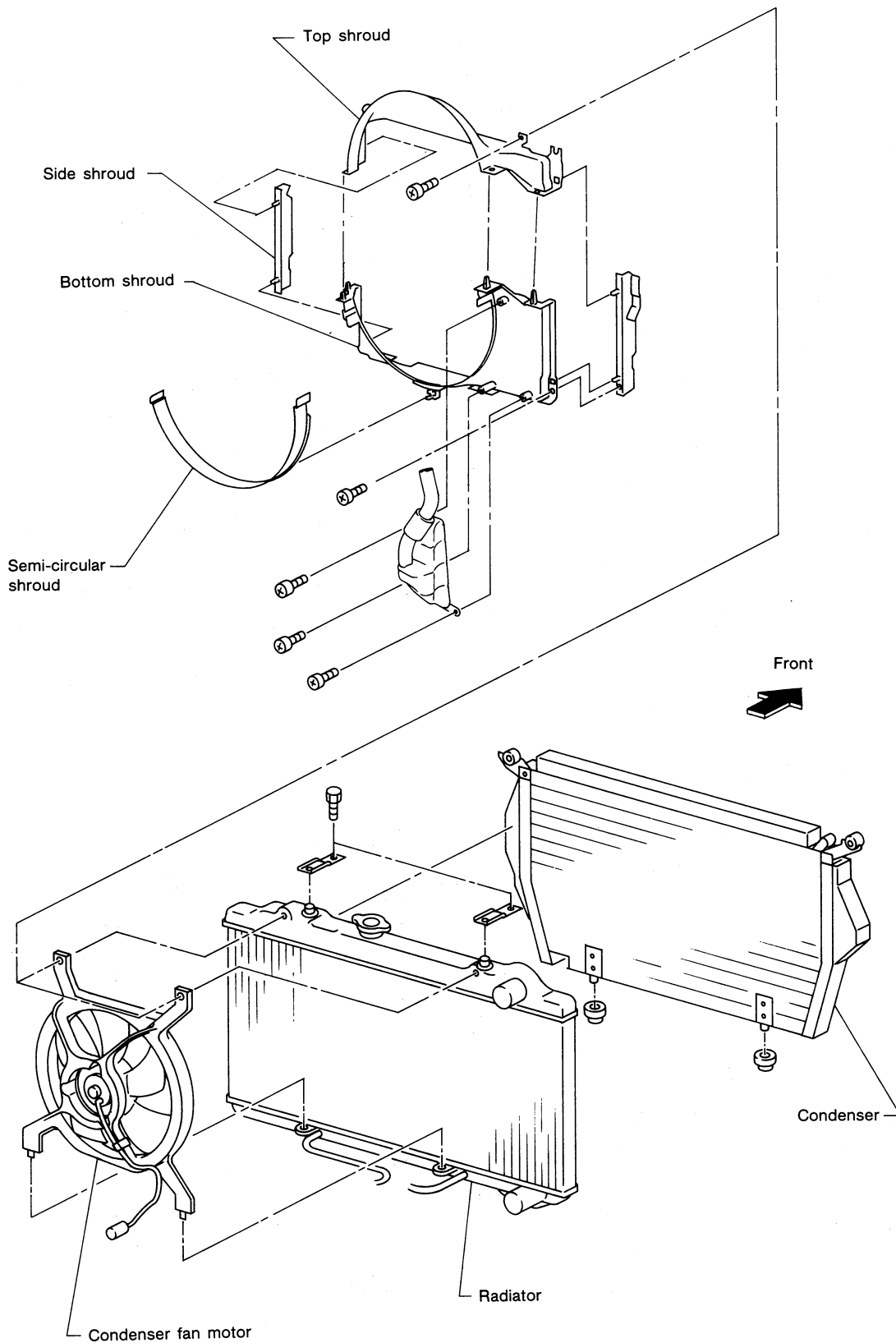

SERVICE PROCEDURES

Condenser and Condenser Fan Motor (Cont'd)

REMOVAL

1. Remove engine air inlet duct.
2. Remove air filter assembly.
3. Remove radiator top mounting bracket.
4. Remove harness clips from top shroud.
5. Move vacuum hoses and harness behind the back edge of shroud.
6. Remove radiator reservoir hose.
7. Remove undercover.

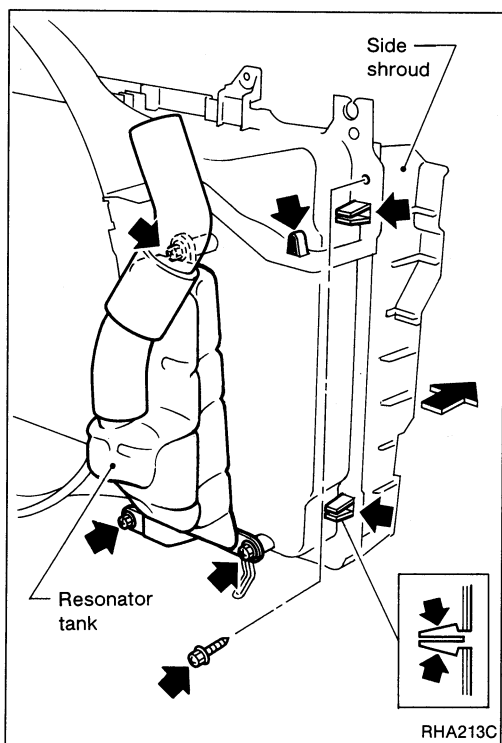

8. Remove the two bottom shroud mounting screws.
9. Remove the two top shroud mounting screws.
10. Disassemble top shroud from bottom shroud (two clips each side), and from side shroud pieces (one clip each side), then remove top shroud.
11. Remove resonator tank from bottom shroud.
12. Disassemble side shroud pieces from bottom shroud (one clip each side) and remove the two side shroud pieces.
13. Disconnect condenser fan motor harness connector.
14. Remove condenser fan motor from bottom of radiator.

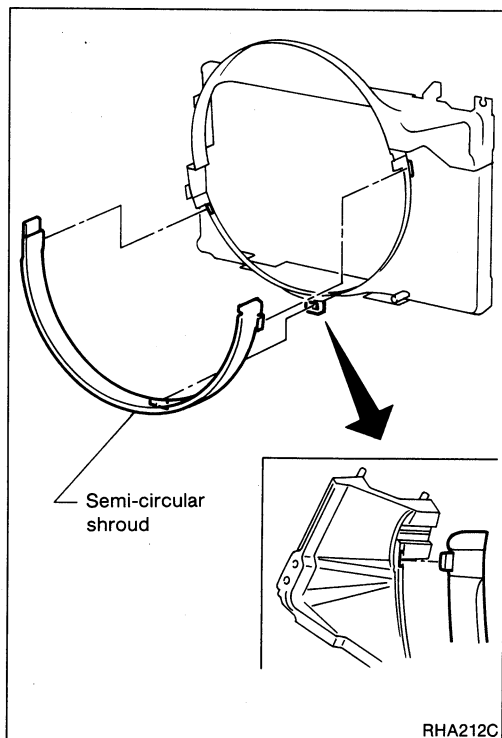

15. Unhook (by pressing on the tabs) and remove narrow semi-circle lower part of shroud.
16. Remove bottom shroud.

CAUTION:

Be careful not to damage radiator.

SERVICE PROCEDURES

Condenser and Condenser Fan Motor (Cont'd)

17. Disconnect high pressure tube from condenser outlet tube.
18. Disconnect high pressure hose from condenser.
19. Remove condenser mounting bolts.
20. Push top of radiator back toward engine.
21. Remove condenser assembly.

CAUTION:

Be careful not to damage condenser.

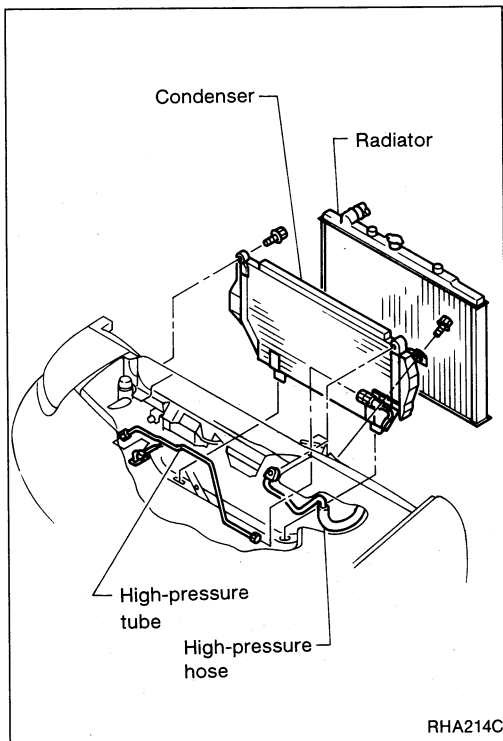

COMPRESSOR OIL — Checking and Adjusting

General

When replacing any refrigerant cycle component part of a compressor, condenser, liquid tank, cooling unit, etc., it is essential to drain the refrigerant in advance.

The refrigerant has a large affinity for the compressor oil, and a part of the oil is always circulating throughout the cycle together with the refrigerant. In other words, the oil is distributed throughout the cycle. Before draining the refrigerant, it is therefore necessary to collect as much compressor oil as possible by performing the oil return operation. If the compressor oil is not replenished, or added fully after replacing component parts of refrigerant cycle, the following trouble may occur:

- **Insufficient oil: Seized compressor**
- **Excessive oil: Poor cooling (Excess oil attached to parts obstructs normal heat exchange.)**

For this reason, whenever replacing any parts of the refrigerant cycle (except the compressor), it is necessary to replenish the compressor oil removed together with such parts. On the other hand, a new compressor contains a specified amount of compressor oil, and simple installation of the new compressor results in excessive oil quantity in the cycle. To prevent this, the oil must be extracted from the cycle so that the optimum oil quantity can be ensured inside the refrigerant cycle.

Checking and Adjusting

Adjust the oil quantity according to the flowchart shown below.

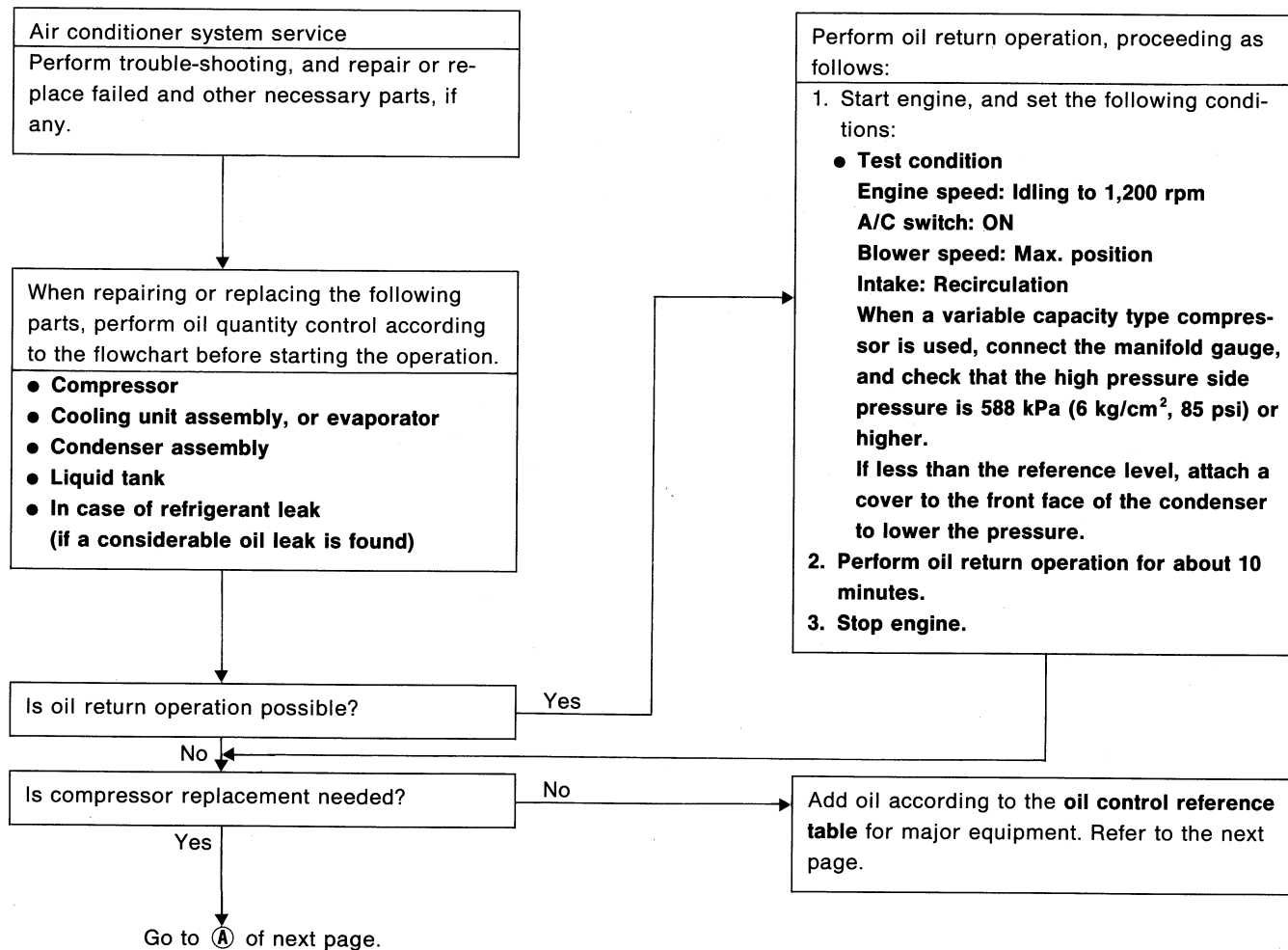

COMPRESSOR OIL — Checking and Adjusting

Checking and Adjusting (Cont'd)

A
↓

Remove compressor oil from the new compressor according to the following table so that the remaining amount of oil in the new compressor is equal to the amount of recollected oil in the removed compressor.

Unit: ml (US fl oz, Imp fl oz)

	Oil quantity contained in new compressor		Amount of collected oil	Amount of oil extracted from new compressor
Rotary type	DKV14C DKV14B	200 (6.8, 7.0)	70 (2.4, 2.5) or over	200 (6.8, 7.0) — [Amount collected + 20 (0.7, 0.7)]
			Below 70 (2.4, 2.5)	110 (3.7, 3.9)
	NVR140 NVR140S	200 (6.8, 7.0)	90 (3.0, 3.2) or over	200 (6.8, 7.0) — [Amount collected + 20 (0.7, 0.7)]
			Below 90 (3.0, 3.2)	90 (3.0, 3.2)
Swash plate type	DKS16H DKS16N	250 (8.5, 8.8)	190 (6.4, 6.7) or over	250 (8.5, 8.8) — [Amount collected + 20 (0.7, 0.7)]
			Below 190 (6.4, 6.7)	60 (2.0, 2.1)
	MKS170 MJS130	150 (5.1, 5.3)	—	80 (2.7, 2.8)
Variable displacement type	V-5	236 (8.0, 8.3)	95 (3.2, 3.3) or over	236 (8.0, 8.3) — [Amount collected + 20 (0.7, 0.7)]
			Below 95 (3.2, 3.3)	150 (5.1, 5.3)

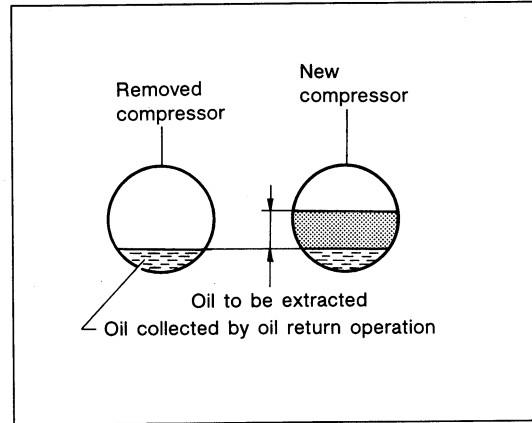

Is it necessary to replace any parts other than compressor?

Yes →

Add oil according to the oil management table for major equipment. Refer to oil management standard.

No ↓

Perform performance test. Refer to **performance test**.
If the result of performance test is N.G., carry out oil return operation again, and check the oil quantity.

←

COMPRESSOR OIL — Checking and Adjusting

Oil Management Standard for Major Equipment

When any major unit of the air conditioner has been replaced, add the following amount of oil.

Major unit	Amount of oil to be added		Remarks
	mℓ (US fl oz, Imp fl oz)	Percent (%) ^{*1}	
Cooling unit, evaporator	45 - 75 (1.5 - 2.5, 1.6 - 2.6)	30	Add compressor oil little by little from the low pressure side of the system cycle.
Condenser	30 - 50 (1.0 - 1.7, 1.1 - 1.8)	20	
Liquid tank	15 - 25 (0.5 - 0.8, 0.5 - 0.9)	10	
In case of refrigerant leak	30 - 50 (1.0 - 1.7, 1.1 - 1.8)	—	Add if large of oil leak is indicated.*2
	—	—	Addition of oil is not required if no oil leak is indicated.

*1: The percentage of the total amount of system oil

*2: Sudden leakage of refrigerant due to fusion of a fusible plug, opening of a relief valve, or damage of a component may accompany oil leak.

COMPRESSOR — Model V-5 (CALSONIC make)

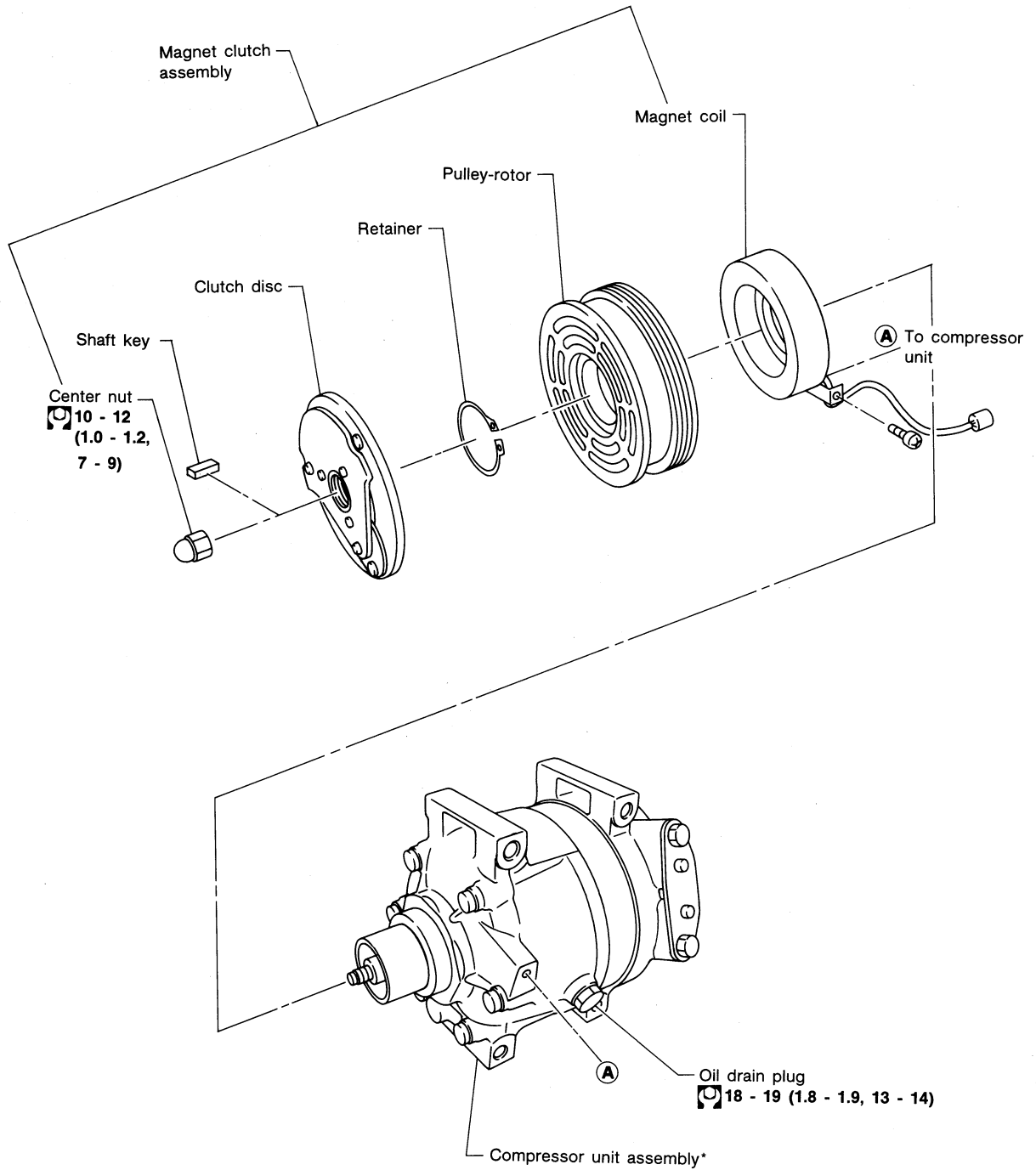

*: Do not disassemble compressor unit assembly.

: N·m (kg-m, ft-lb)

COMPRESSOR — Model V-5 (CALSONIC make)

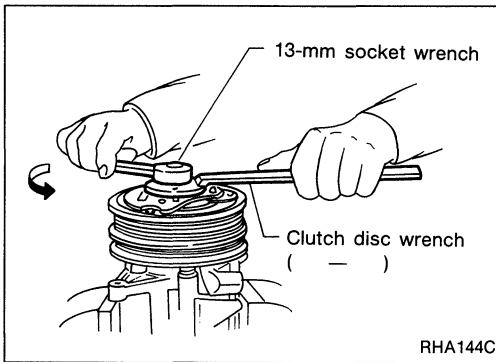

Removing Magnet Clutch Assembly

- Remove center nut while holding armature plate with clutch disc wrench.

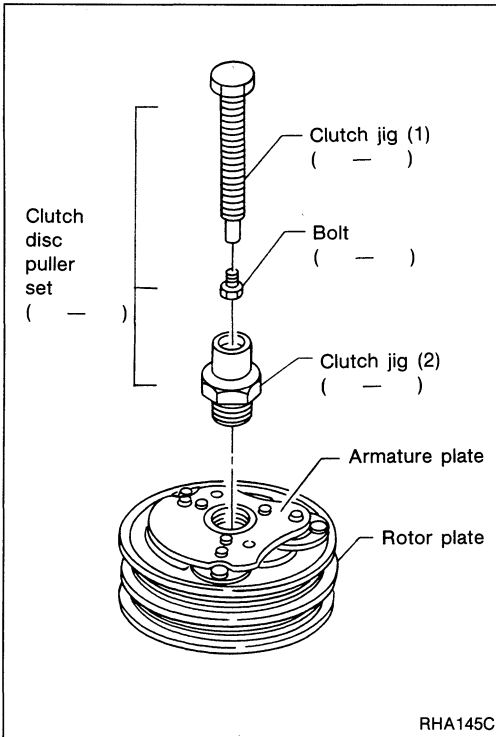

- Install jigs in the sequence shown, and tighten clutch jig (1) while holding clutch jig (2) with wrench. This will cause armature plate to be removed.

Fit a bolt to the tip of the clutch jig, and attach the jig to the clutch.

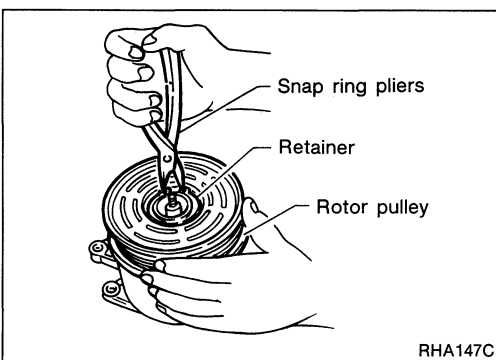
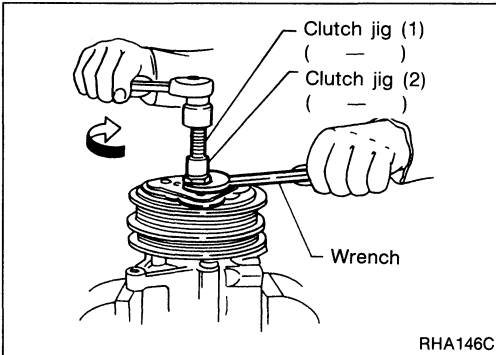

- Remove retainer using snap ring pliers.

COMPRESSOR — Model V-5 (CALSONIC make)

Removing Magnet Clutch Assembly (Cont'd)

- Remove pulley using gear puller.

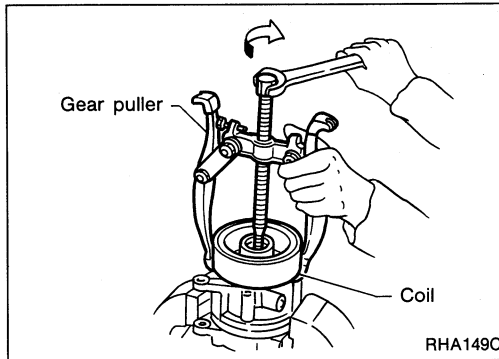
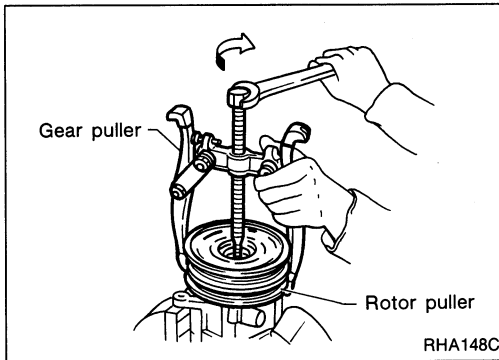

- Remove lead wire fixing screw, and remove coil.
When removing the coil, pay attention so as not to damage the lead and grounding wire with gear puller jaws.

Installation of Magnet Clutch Assembly

- Remove bolt from the tip of the clutch jig (1), and attach jigs in the sequence shown.

Tighten clutch jig (1) to shaft securely.

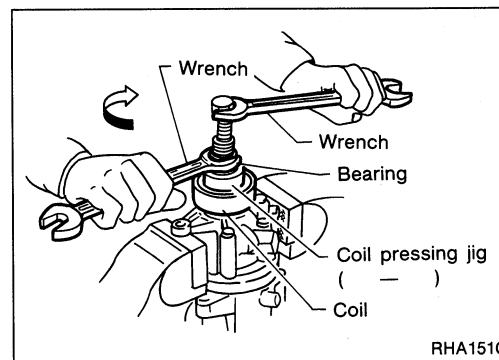
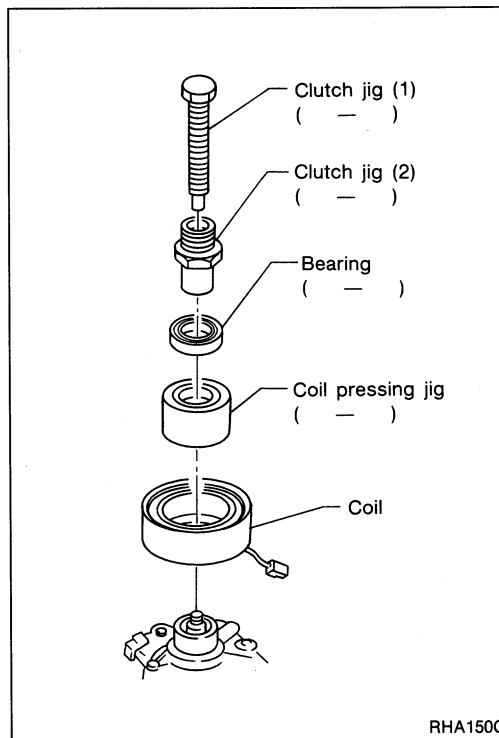

- Press fit the coil into compressor main body by tightening clutch jig (2) while holding clutch jig (1) with wrench.
Arrange coil lead and lead (connector) of compressor on the same side before press fitting the coil.

COMPRESSOR — Model V-5 (CALSONIC make)

Installation of Magnet Clutch Assembly (Cont'd)

- Install jigs in the sequence shown.

Tighten clutch jig (1) to shaft.

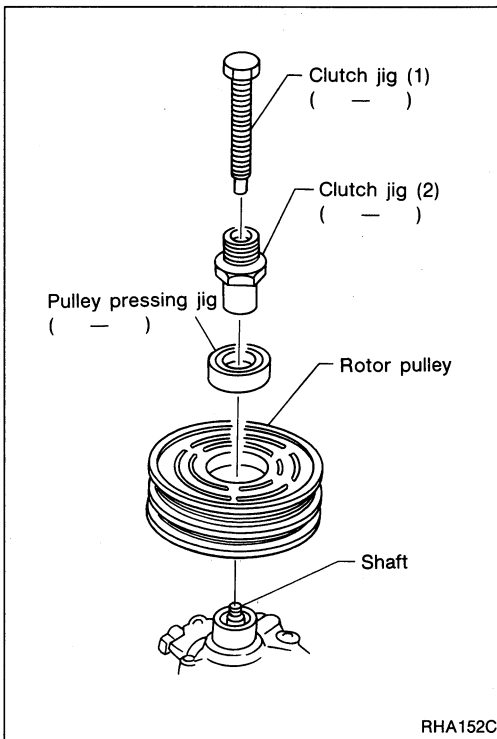

- Press fit the rotor pulley by tightening clutch jig (2) while holding clutch jig (1) with wrench.

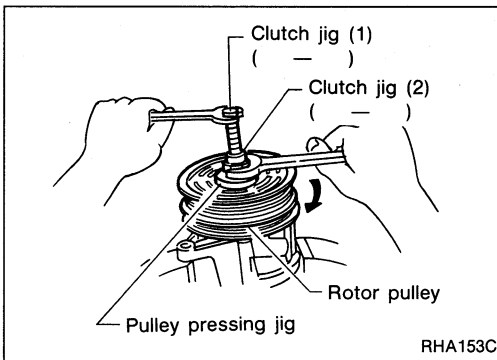

- Fit retainer using snap ring pliers.
- **Do not reuse retainer. Be sure to use a new one.**
- **Pay attention so as not to damage the bearing seal when fitting the retainer.**
- **Fit the retainer with its taper facing up.**

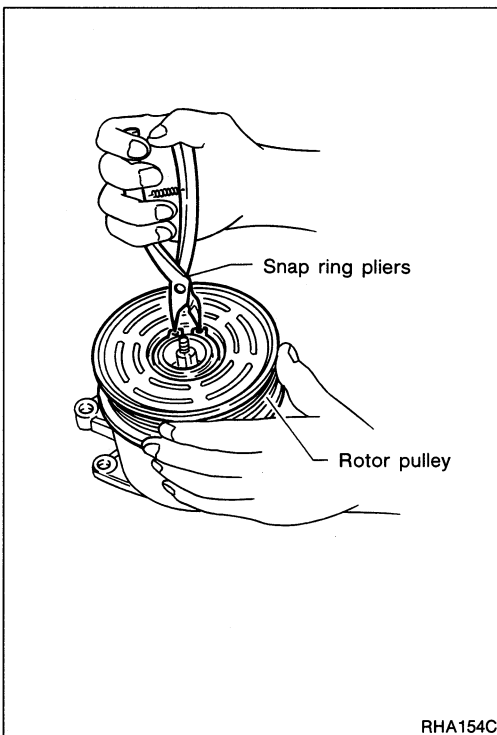

COMPRESSOR — Model V-5 (CALSONIC make)

Installation of Magnet Clutch Assembly (Cont'd)

- Insert shaft key by aligning shaft key groove with groove of armature plate.

Do not reuse a shaft key. Be sure to use a new one.

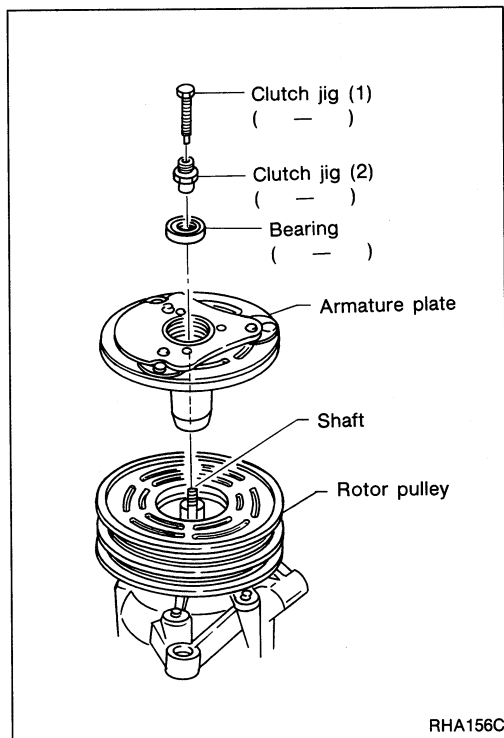
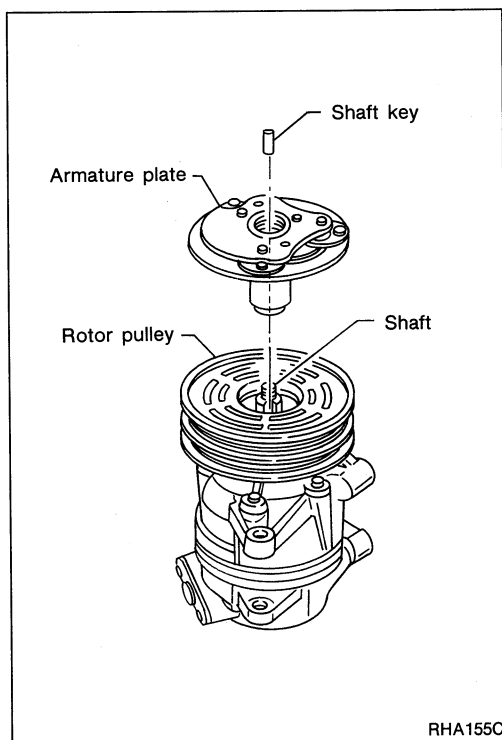

- Install jigs in the sequence shown. Press fit armature plate while observing the gap from rotor pulley. To press fit, tighten clutch jig (2) while holding clutch jig (1) with wrench.

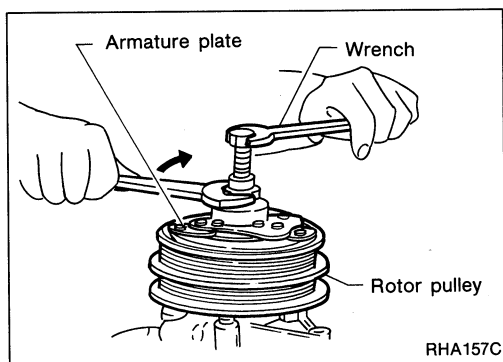

COMPRESSOR — Model V-5 (CALSONIC make)

Installation of Magnet Clutch Assembly (Cont'd)

Standard gap: 0.3 - 0.6 mm (0.012 - 0.024 in)

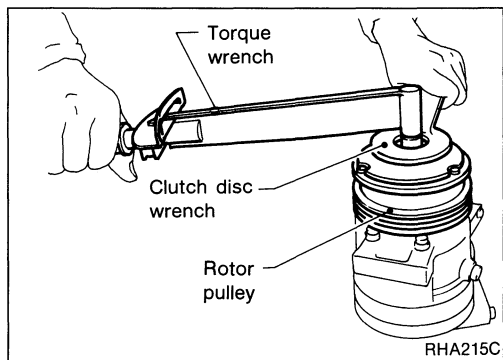
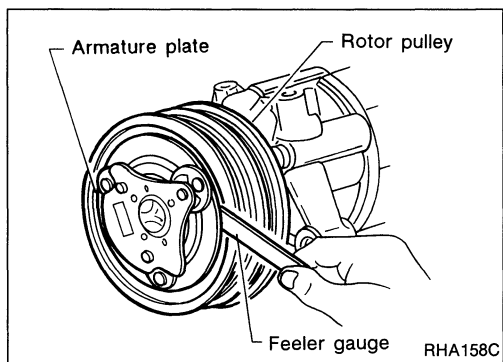

- Install center nut using clutch disc wrench.

Do not reuse the nut. Be sure to use a new one.

Nut tightening torque:

\square : 0.10 - 0.12 N·m

(1.0 - 1.2 kg·cm, 0.87 - 1.04 in·lb)

After assembling, rotate rotor pulley by hand, and check for smooth rotation without interference noise.

- Operation check procedure:
Apply battery voltage to magnet clutch coil, and check several times for normal clutch ON/OFF operation.
- Rotate compressor shaft more than five turns in both directions by hand to equalize oil distribution inside compressor, then run compressor for about one hour by idling engine.

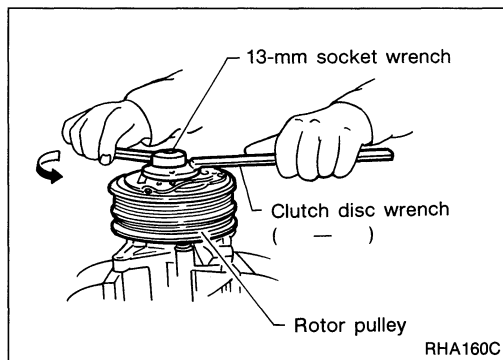

Gap Adjusting Procedure

WHEN GAP IS LARGE

- Remove center nut while holding armature plate.

COMPRESSOR — Model V-5 (CALSONIC make)

Gap Adjusting Procedure (Cont'd)

- Install clutch jigs in the sequence shown.

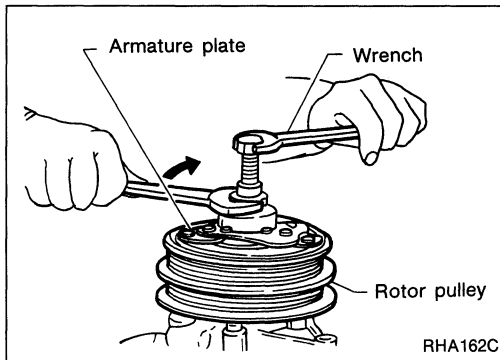
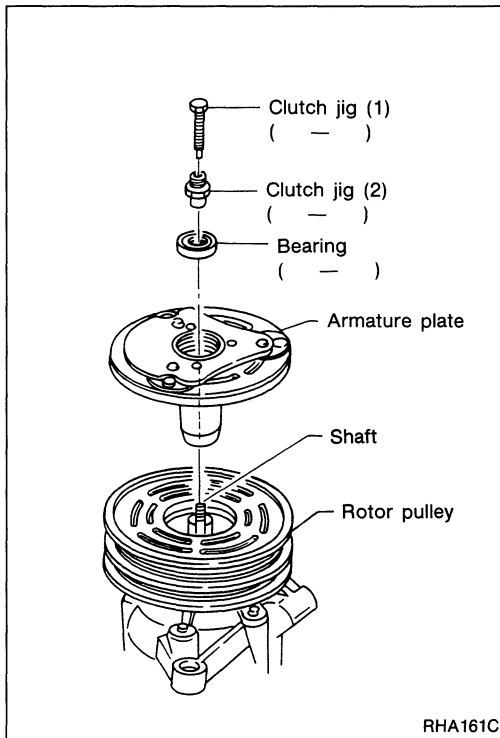

- Press fit the armature plate by tightening clutch jig (2) while holding clutch jig (1) with wrench.

Tighten clutch jig (1) into shaft.

- Measure the gap again.
After achieving the specified gap, install center nut using clutch disc wrench.

WHEN GAP IS SMALL

- Install jigs as shown.

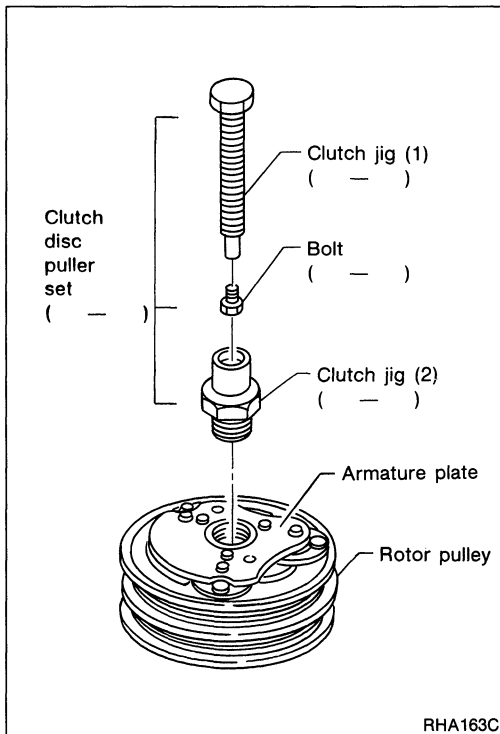

COMPRESSOR — Model V-5 (CALSONIC make)

Gap Adjusting Procedure (Cont'd)

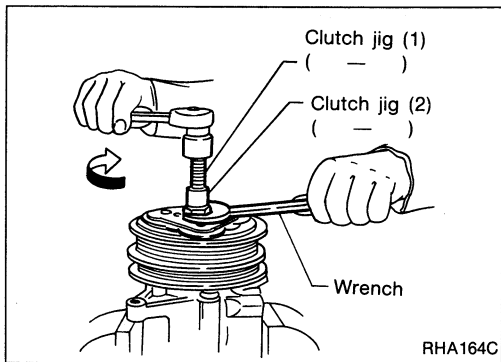

- Expand the gap by lifting up armature plate. To lift up armature plate, tighten clutch jig (1) while holding clutch jig (2) with wrench.

Center nut need not be removed when expanding the gap.

How to Perform Trouble Diagnoses for Quick and Accurate Repair

WORK FLOW

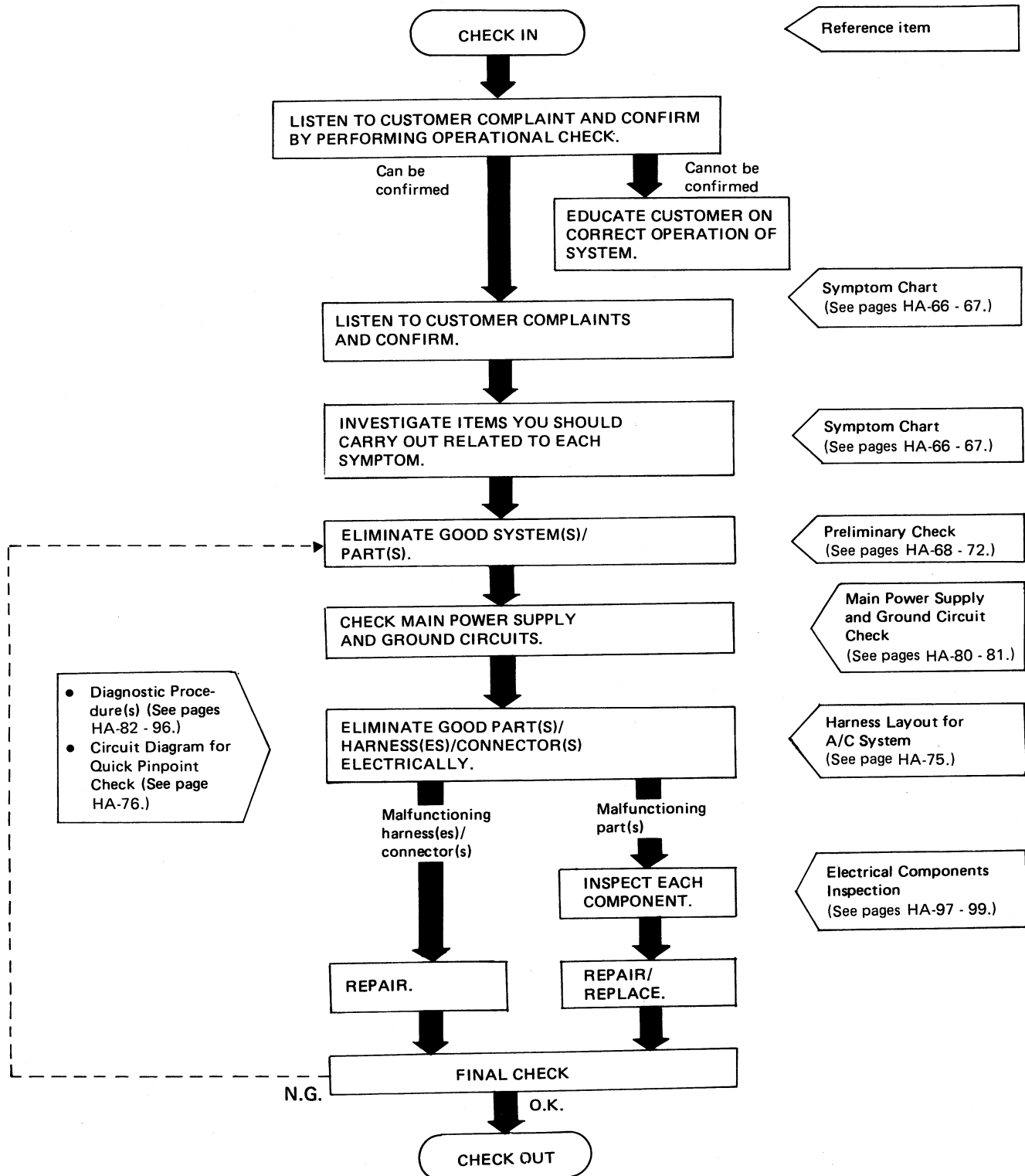

Operational Check

The purpose of the operational check is to confirm that the system operates as it should. The systems which are checked are the blower, mode (discharge air), intake air, temperature decrease, temperature increase.

CONDITIONS:

Engine running at normal operating temperature.

PROCEDURE:

1. Check blower

- 1) Slide Fan lever to 1-speed.
Blower should operate on 1-speed.
- 2) Then slide Fan Lever to 2-speed.
- 3) Continue checking blower speed until all four speeds are checked.
- 4) Leave blower on 4-speed.

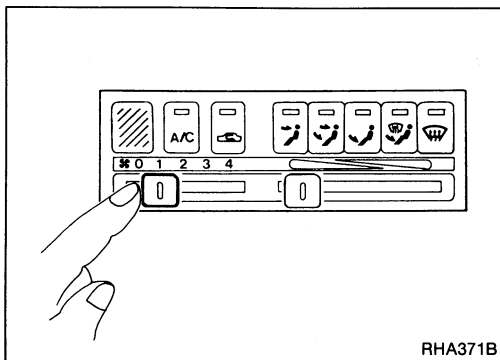

2. Check discharge air

- 1) Press the VENT button.
VENT indicator should light.
- 2) Confirm that all discharge air comes out of face vents.
- 3) Press the B/L button.
B/L indicator should light.
- 4) Confirm that discharge air comes out of face vents and foot vents.
- 5) Press the FOOT button.
FOOT indicator should light.
- 6) Confirm that discharge air comes out of foot vents, with some air from defroster vents.
- 7) Press the F/D button.
F/D indicator should light.
- 8) Confirm that discharge air comes out of foot vents, with some air from defroster vents, and that intake door position is at FRE.
- 9) Press the DEF button.
DEF indicator should light.
- 10) The discharge air should be coming only from defroster vents. At the same time compressor should turn ON and intake door position be at FRE.

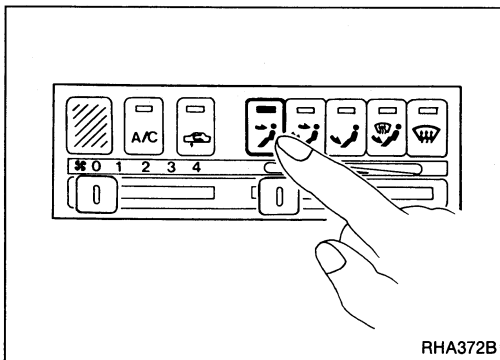

3. Check recirc

- 1) Press RECIRC button.
RECIRC indicator should light.
- 2) Listen for intake door position change (you should hear blower sound change slightly).

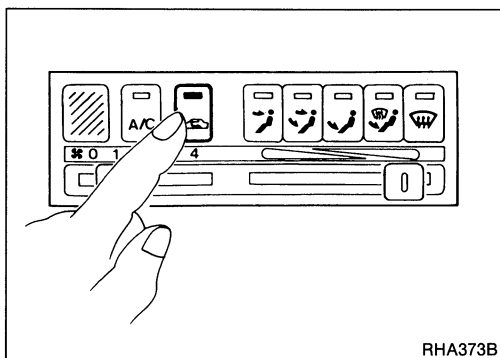

DIAGNOSES — Overall System

Operational Check (Cont'd)

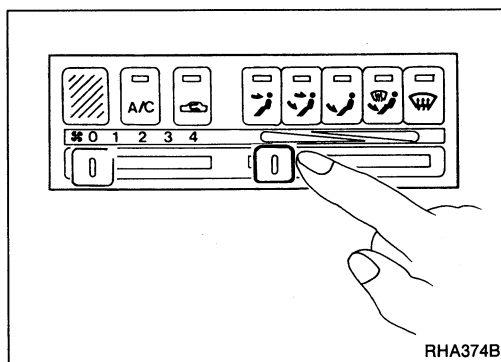

4. Check temperature decrease

- 1) Slide temperature control lever to full cold.
- 2) Check for cold air at discharge air outlets.

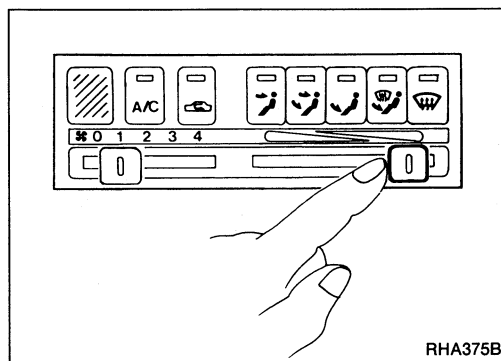

5. Check temperature increase

- 1) Slide temperature control lever to full hot.
- 2) Check for hot air at discharge air outlets.

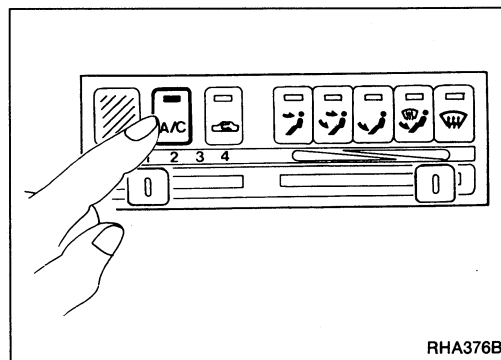

6. Check air conditioner switch

Move the fan control lever to the desired (1 to 4-speed) position and push the air conditioner button to turn ON the air conditioner.

The indicator light should come on when air conditioner is ON.

Performance Test Diagnoses

INSUFFICIENT COOLING

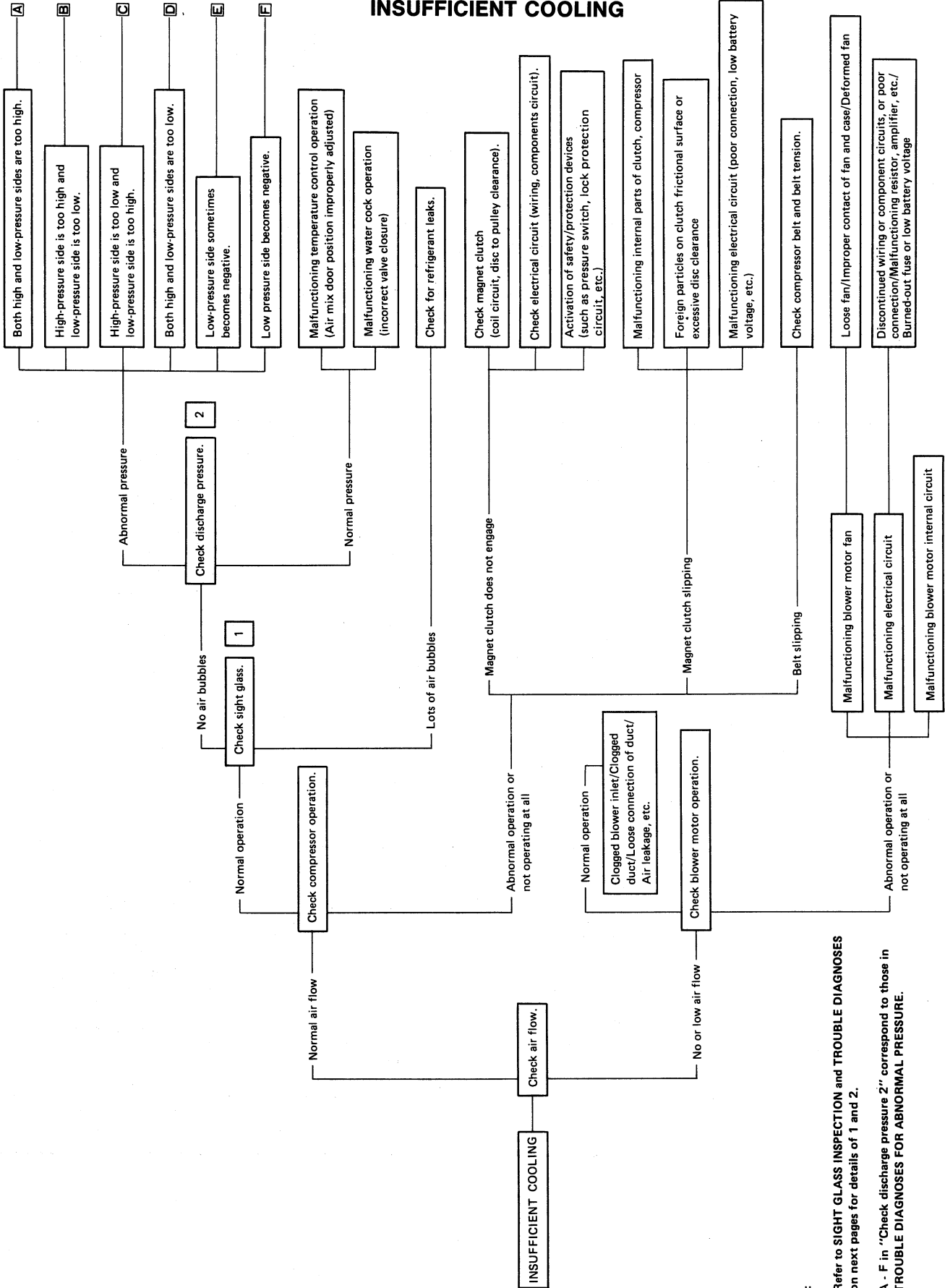

Note:

1) Refer to SIGHT GLASS INSPECTION and TROUBLE DIAGNOSES on next pages for details of 1 and 2.

2) A - F in "Check discharge pressure 2" correspond to those in TROUBLE DIAGNOSES FOR ABNORMAL PRESSURE.

DIAGNOSES — Overall System

Performance Chart

TEST CONDITION

Testing must be performed as follows:

Vehicle location: Indoors or in the shade (in a well ventilated place)

Doors: Closed

Door window: Open

Hood: Open

Temperature control lever: Max. COLD set

Mode switch:  (Ventilation) set

REC switch:  (Recirculation) set

Fan switch: Max. speed set

Engine speed: 1,500 rpm

Time required before starting testing after air conditioner starts operating: More than 10 minutes

TEST READING

Recirculating-to-discharge air temperature table

Inside air (Recirculating air) at blower assembly inlet		Discharge air temperature at center ventilator °C (°F)
Relative humidity %	Air temperature °C (°F)	
50 - 60	25 (77)	6.5 - 8.7 (44 - 48)
	30 (86)	10.0 - 12.4 (50 - 54)
	35 (95)	13.4 - 16.1 (56 - 61)
	40 (104)	17.7 - 20.7 (64 - 69)
60 - 70	25 (77)	8.7 - 11.0 (48 - 52)
	30 (86)	12.4 - 14.8 (54 - 59)
	35 (95)	16.1 - 18.7 (61 - 66)
	40 (104)	20.7 - 23.4 (69 - 74)

Ambient air temperature-to-compressor pressure table

Ambient air		High-pressure (Discharge side) kPa (kg/cm ² , psi)	Low-pressure (Suction side) kPa (kg/cm ² , psi)
Relative humidity %	Air temperature °C (°F)		
50 - 70	25 (77)	745 - 912 (7.6 - 9.3, 108 - 132)	177 - 216 (1.8 - 2.2, 26 - 31)
	30 (86)	883 - 1,089 (9.0 - 11.1, 128 - 158)	157 - 196 (1.6 - 2.0, 23 - 28)
	35 (95)	1,040 - 1,275 (10.6 - 13.0, 151 - 185)	167 - 216 (1.7 - 2.2, 24 - 31)
	40 (104)	1,196 - 1,451 (12.2 - 14.8, 173 - 210)	177 - 255 (1.8 - 2.6, 26 - 37)

Sight Glass Inspection for System

As previously stated, the inspection characteristics of the sight glass on a system equipped with the V-5 compressor are different from a system using a fixed displacement compressor. Refer to the information below:

Inspection conditions

1. Operate the engine at approximately 1,500 rpm.
2. Open the door windows.
3. Set the fan switch to the "MAX" position.
4. Turn the air conditioner switch "ON".
5. Ensure that compressor discharge pressure is at least 588 kPa (6 kg/cm², 85 psi).

When discharge pressure does not reach 588 kPa (6 kg/cm², 85 psi) in areas where outside air temperature is low, proceed as follows:

- Set the TEMP. LEVER to the "full-hot" position.
- Set the intake lever/switch to the recirculation position.
- Close the door windows completely.
- Increase the compartment temperature so that discharge pressure reaches at least 588 kPa (6 kg/cm², 85 psi).

Refrigerant charge amount checking

Check the refrigerant charge amount using the following table as a guide.

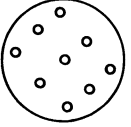
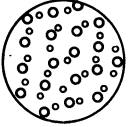
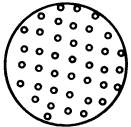
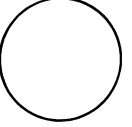
Item to check	Adequate	Insufficient	Almost no refrigerant	Too much refrigerant
State in sight glass	CLEAR Air bubbles sometimes appear when engine speed is increased or decreased. 	FOAMY or BUBBLY Air bubbles always appear. 	FROSTY Frost appears. 	NO FOAM No air bubbles appear. 
Temperature of high and low pressure lines	High-pressure side is hot while low-pressure side is cold. (A big temperature difference between high and low-pressure side.)	High-pressure side is warm and low-pressure side is slightly cold. (Not so large a temperature difference between high and low-pressure side.)	There is almost no temperature difference between high and low-pressure side.	High-pressure is hot and low-pressure side is slightly warm. (Slight temperature difference between high and low-pressure side.)
Pressure of system	Both pressures on high and low-pressure sides are normal.	Both pressures on high and low-pressure sides are slightly low.	High-pressure side is abnormally low.	Both pressure on high and low-pressure sides are abnormally high.

RHA264B

Performance Test Diagnoses

TROUBLE DIAGNOSES FOR ABNORMAL PRESSURE

Whenever abnormal pressure of high and/or low sides of the system is noted, diagnosis must be conducted by using a manifold gauge. The large-line zone on the gauge scale (see illustrations.) shown in the following table refers to the standard (normal) pressure range for the corresponding pressure side (high or low). Since the standard (normal) pressure, however, differs from vehicle to vehicle, refer to the "Ambient Temperature-Pressure Characteristics" chart.

Pressure measurements are effective only when ambient temperature is in the range indicated under the heading "INSPECTION DATA (2) Measurement of compressor's high and low pressures".

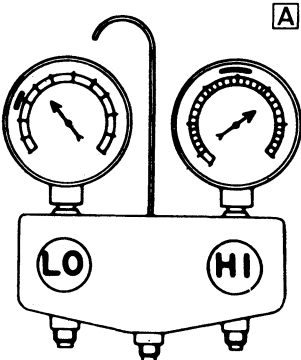
Gauge indication	Refrigerant cycle	Probable cause	Corrective action
<p>Both high and low-pressure sides are too high.</p>  <p style="text-align: right;">AC359A</p>	<ul style="list-style-type: none"> ● Pressure is reduced soon after water is splashed on condenser. ● No air bubbles appear in sight glass when pressure is reduced. 	Excessive refrigerant charge in refrigeration cycle	Reduce refrigerant until specified pressure is obtained.
	Air suction by radiator or condenser fan is insufficient.	Insufficient condenser cooling performance ↓ ① Condenser fins are clogged. ② Improper rotation of radiator fan or condenser fan	<ul style="list-style-type: none"> ● Clean condenser. ● Check and repair radiator or condenser fan as necessary.
	<ul style="list-style-type: none"> ● Low-pressure pipe is not cold. ● When compressor is stopped high-pressure value quickly drops by approximately 196 kPa (2 kg/cm², 28 psi). It then decreases gradually thereafter. 	Poor heat exchange in condenser (After compressor operation stops, high pressure decreases too slowly.) ↓ Air in refrigeration cycle	Evacuate repeatedly and recharge system.
	Engine tends to overheat.	Engine cooling systems malfunction.	Check and repair each engine cooling system.
	<ul style="list-style-type: none"> ● Areas near low-pressure pipe connection and service valves are considerably cold compared with areas near expansion valve outlet or evaporator. ● Plates are sometimes covered with frost. 	<ul style="list-style-type: none"> ● Excessive liquid refrigerant on low-pressure side ● Excessive refrigerant discharge flow ● Expansion valve is open a little compared with the specification. ↓ ① Improper thermal valve installation ② Improper expansion valve adjustment	Replace expansion valve.

DIAGNOSES — Overall System

Performance Test Diagnoses (Cont'd)

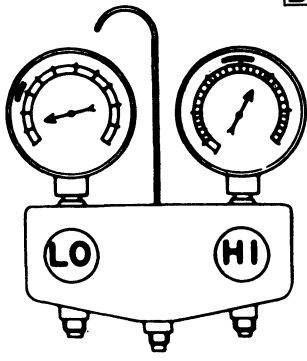
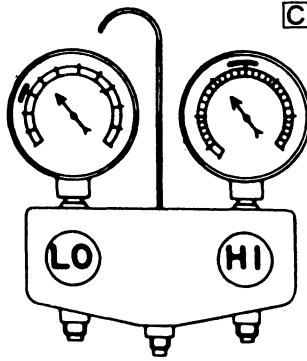
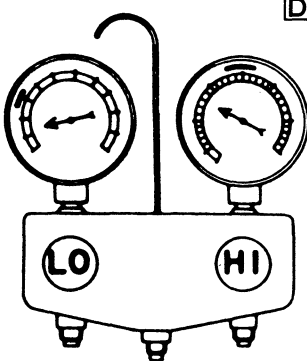
Gauge indication	Refrigerant cycle	Probable cause	Corrective action
<p>High-pressure side is too high and low-pressure side is too low.</p> <p style="text-align: right;">B</p>  <p style="text-align: right;">AC360A</p>	<p>Upper side of condenser and high-pressure side are hot, however, receiver drier is not so hot.</p>	<p>High-pressure tube or parts located between compressor and condenser are clogged or crushed.</p>	<ul style="list-style-type: none"> ● Check and repair or replace malfunctioning parts. ● Check compressor oil for contamination.
<p>High-pressure side is too low and low-pressure side is too high.</p> <p style="text-align: right;">C</p>  <p style="text-align: right;">AC356A</p>	<p>High and low-pressure sides become equal soon after compressor operation stops.</p>	<p>Compressor pressure operation is improper.</p> <p style="text-align: center;">↓</p> <p>Damaged inside compressor packings</p>	<p>Replace compressor.</p>
	<p>No temperature difference between high and low-pressure sides</p>	<p>Compressor discharge capacity does not change. (Compressor stroke is set at maximum.)</p>	<p>Replace compressor.</p>
<p>Both high-and low-pressure sides are too low.</p> <p style="text-align: right;">D</p>  <p style="text-align: right;">AC353A</p>	<ul style="list-style-type: none"> ● There is a big temperature difference between receiver drier outlet and inlet. Outlet temperature is extremely low. ● Receiver drier inlet and expansion valve are frosted. 	<p>Receiver drier inside is clogged a little.</p>	<ul style="list-style-type: none"> ● Replace receiver drier ● Check compressor oil for contamination.
	<ul style="list-style-type: none"> ● Temperature of expansion valve inlet is extremely low as compared with areas near receiver drier. ● Expansion valve inlet may be frosted. ● Temperature difference occurs somewhere in high-pressure side 	<p>High-pressure pipe located between receiver drier and expansion valve is clogged.</p>	<ul style="list-style-type: none"> ● Check and repair malfunctioning parts. ● Check compressor oil for contamination.

DIAGNOSES — Overall System

Performance Test Diagnoses (Cont'd)

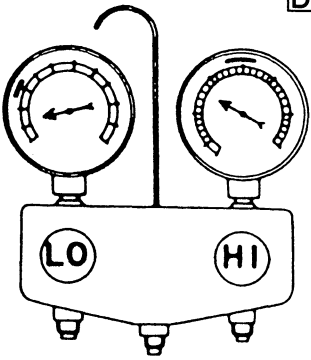
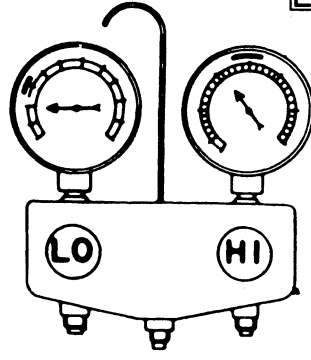
Gauge indication	Refrigerant cycle	Probable cause	Corrective action
<p>Both high and low-pressure sides are too low.</p> <div style="text-align: right;">D</div>  <p style="text-align: right;">AC353A</p>	<p>There is a big temperature difference between expansion valve inlet and outlet while the valve itself is frosted.</p>	<p>Expansion valve closes a little compared with the specification.</p> <p style="text-align: center;">↓</p> <p>① Improper expansion valve adjustment ② Malfunctioning thermal valve ③ Outlet and inlet may be clogged.</p>	<ul style="list-style-type: none"> ● Remove foreign particles by using compressed air. ● Check compressor oil for contamination.
	<p>Areas near low-pressure pipe connection and service valve are extremely cold as compared with areas near expansion valve outlet and evaporator.</p>	<p>Low-pressure pipe is clogged or crushed.</p>	<ul style="list-style-type: none"> ● Check and repair malfunctioning parts. ● Check compressor oil for contamination.
	<p>Air flow volume is not enough or is too low.</p>	<p>Evaporator is frozen.</p> <p style="text-align: center;">↓</p> <p>Compressor discharge capacity does not change. (Compressor stroke is set at maximum length.)</p>	<p>Replace compressor.</p>
<p>Low-pressure side sometimes becomes negative.</p> <div style="text-align: right;">E</div>  <p style="text-align: right;">AC354A</p>	<ul style="list-style-type: none"> ● Air conditioning system does not function and does not cyclically cool the compartment air. ● The system constantly functions for a certain period of time after compressor is stopped and restarted. 	<p>Refrigerant does not discharge cyclically.</p> <p style="text-align: center;">↓</p> <p>Moisture is frozen at expansion valve outlet and inlet.</p> <p style="text-align: center;">↓</p> <p>Water is mixed with refrigerant.</p>	<ul style="list-style-type: none"> ● Drain water from refrigerant or replace refrigerant. ● Replace receiver drier.

DIAGNOSES — Overall System

Performance Test Diagnoses (Cont'd)

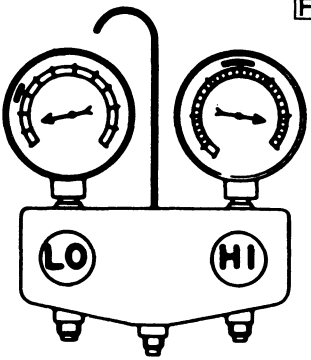
Gauge indication	Refrigerant cycle	Probable cause	Corrective action
<p>Low-pressure side becomes negative.</p>  <p>AC362A</p>	<p>Receiver drier or front/rear side of expansion valve's pipe is frosted or dewed.</p>	<p>High-pressure side is closed and refrigerant does not flow.</p> <p style="text-align: center;">↓</p> <p>Expansion valve or receiver drier is frosted.</p>	<p>After the system is left at rest, start it again in order to confirm whether or not problem is caused by water or foreign particles.</p> <ul style="list-style-type: none"> ● If the problem is due to water, drain water from refrigerant or replace refrigerant. ● If it is due to foreign particles, remove expansion valve and remove them with dry and compressed air. ● If either of the above methods cannot correct the problem, replace expansion valve. ● Replace receiver drier. ● Check compressor oil for contamination.

DIAGNOSES — Overall System

NOTE

TROUBLE DIAGNOSES

Contents

Symptom Chart	HA- 66
Preliminary Check	HA- 68
PRELIMINARY CHECK 1 (Intake door is not set at "FRESH" in DEF or FOOT mode.)	HA- 68
PRELIMINARY CHECK 2 (A/C does not blow cold air.)	HA- 69
PRELIMINARY CHECK 3 (Magnet clutch does not engage in DEF mode.)	HA- 70
PRELIMINARY CHECK 4 (Air outlet does not change.)	HA- 71
PRELIMINARY CHECK 5 (Noise)	HA- 72
A/C Compartment Layout	HA- 73
Harness Layout for A/C System	HA- 75
Circuit Diagram for Quick Pinpoint Check	HA- 76
Wiring Diagram	HA- 77
Main Power Supply and Ground Circuit Check	HA- 80
Diagnostic Procedure 1 (SYMPTOM: Blower motor does not rotate.)	HA- 82
Diagnostic Procedure 2 (SYMPTOM: Air outlet does not change.)	HA- 85
Diagnostic Procedure 3 (SYMPTOM: Intake door does not change in VENT, B/L or FOOT mode.)	HA- 87
Diagnostic Procedure 4 (SYMPTOM: Magnet clutch does not engage with A/C switch and fan switch are ON.)	HA- 88
Diagnostic Procedure 5 (SYMPTOM: Illumination or indicators of push control unit do not come on.)	HA- 93
Electrical Components Inspection	HA- 97
Control Cable Adjustment	HA-100

TROUBLE DIAGNOSES

Symptom Chart

DIAGNOSTIC TABLE

PROCEDURE	Preliminary Check					Diagnostic Procedure					Main Power Supply and Ground Circuit Check			
REFERENCE PAGE	HA-68	HA-69	HA-70	HA-71	HA-72	HA-82	HA-85	HA-87	HA-88	HA-93	HA-80	HA-80	HA-81	HA-80
SYMPTOM	Preliminary check 1	Preliminary check 2	Preliminary check 3	Preliminary check 4	Preliminary check 5	Diagnostic procedure 1	Diagnostic procedure 2	Diagnostic procedure 3	Diagnostic procedure 4	Diagnostic procedure 5	15A Fuses	10A Fuse	Push control unit	Thermo control amp.
A/C does not blow cold air.		①				○			○		○	○		○
Blower motor does not rotate.		①				②					○			
Air outlet does not change.				①			②					○	○	
Intake door does not change in VENT, B/L or FOOT mode.								①				○	○	
Intake door is not set at "FRESH" in DEF or FOOT mode.	①							○				○	○	
Magnet clutch does not engage when A/C switch and fan switch are ON.		①							②			○		○
Magnet clutch does not engage in DEF mode.		①	②						○			○		○
Illumination or indicators of push control unit do not come on.										①		○		
Noise					①									

①, ② : The number means checking order.

○ : As for checking order, refer to each flow chart. (It depends on malfunctioning portion.)

TROUBLE DIAGNOSES

Preliminary Check

PRELIMINARY CHECK 1

Intake door is not set at "FRESH" in DEF or FOOT mode.

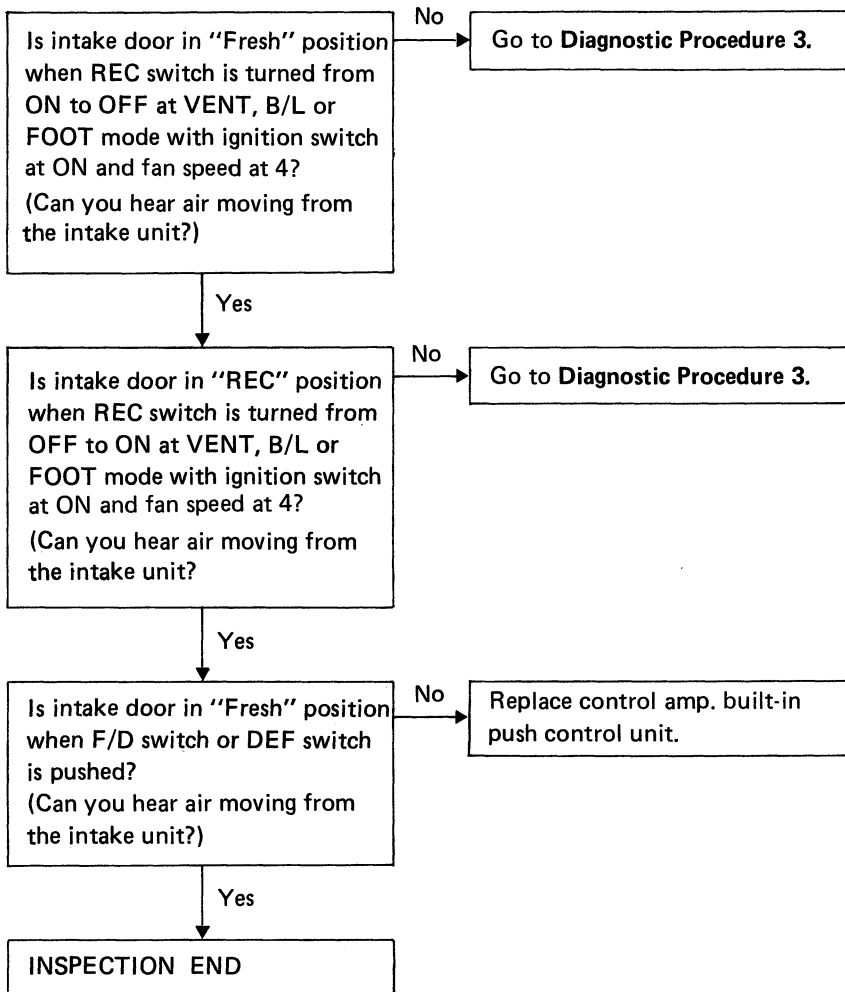

TROUBLE DIAGNOSES

Preliminary Check (Cont'd)

PRELIMINARY CHECK 2

A/C does not blow cold air.

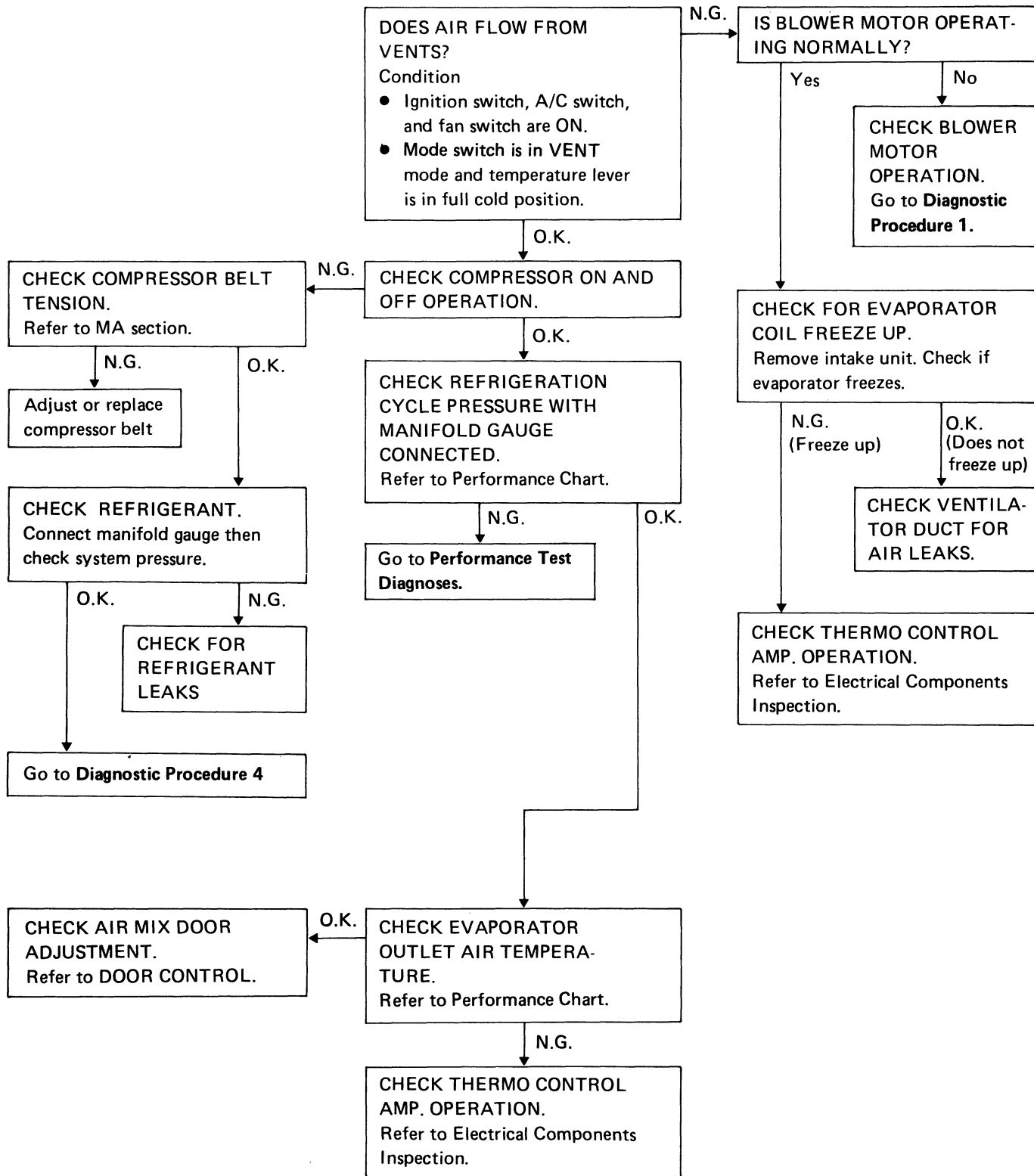

TROUBLE DIAGNOSES

Preliminary Check (Cont'd)

PRELIMINARY CHECK 3

Magnet clutch does not engage in DEF mode.

- Perform PRELIMINARY CHECK 2 before referring to the following flow chart.

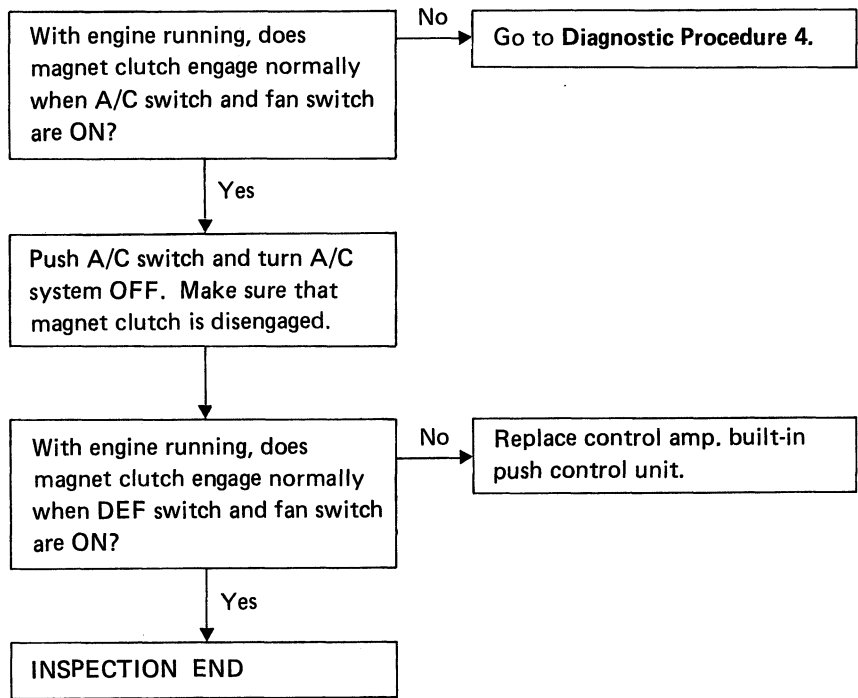

TROUBLE DIAGNOSES

Preliminary Check (Cont'd)











PRELIMINARY CHECK 4

Air outlet does not change.

DOES AIR COME OUT FROM EACH DUCT NORMALLY WHEN EACH MODE SWITCH IS PUSHED WITH IGNITION SWITCH AT ON?

No

Go to Diagnostic Procedure 2.

Switch		Indicator illuminates					Air outlet
							
Mode		○					VENT
			○				FOOT & VENT
				○			FOOT & DEF
					○		FOOT & DEF
						○	DEF

Air distribution ratios

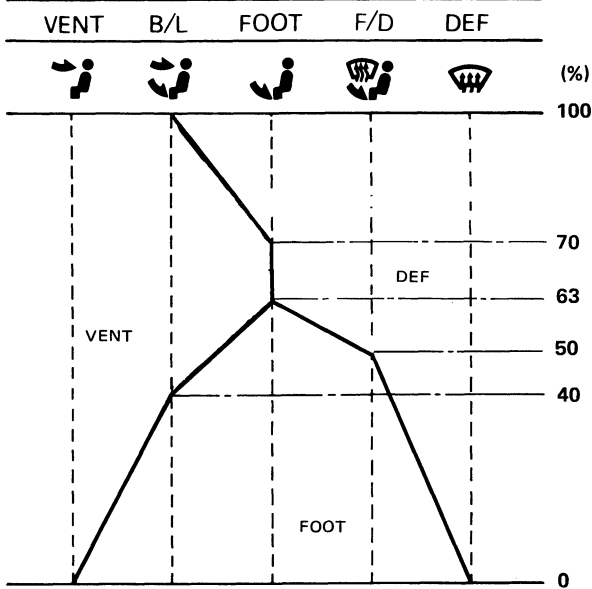

Yes

INSPECTION END

TROUBLE DIAGNOSES

Preliminary Check (Cont'd)

PRELIMINARY CHECK 5

Noise

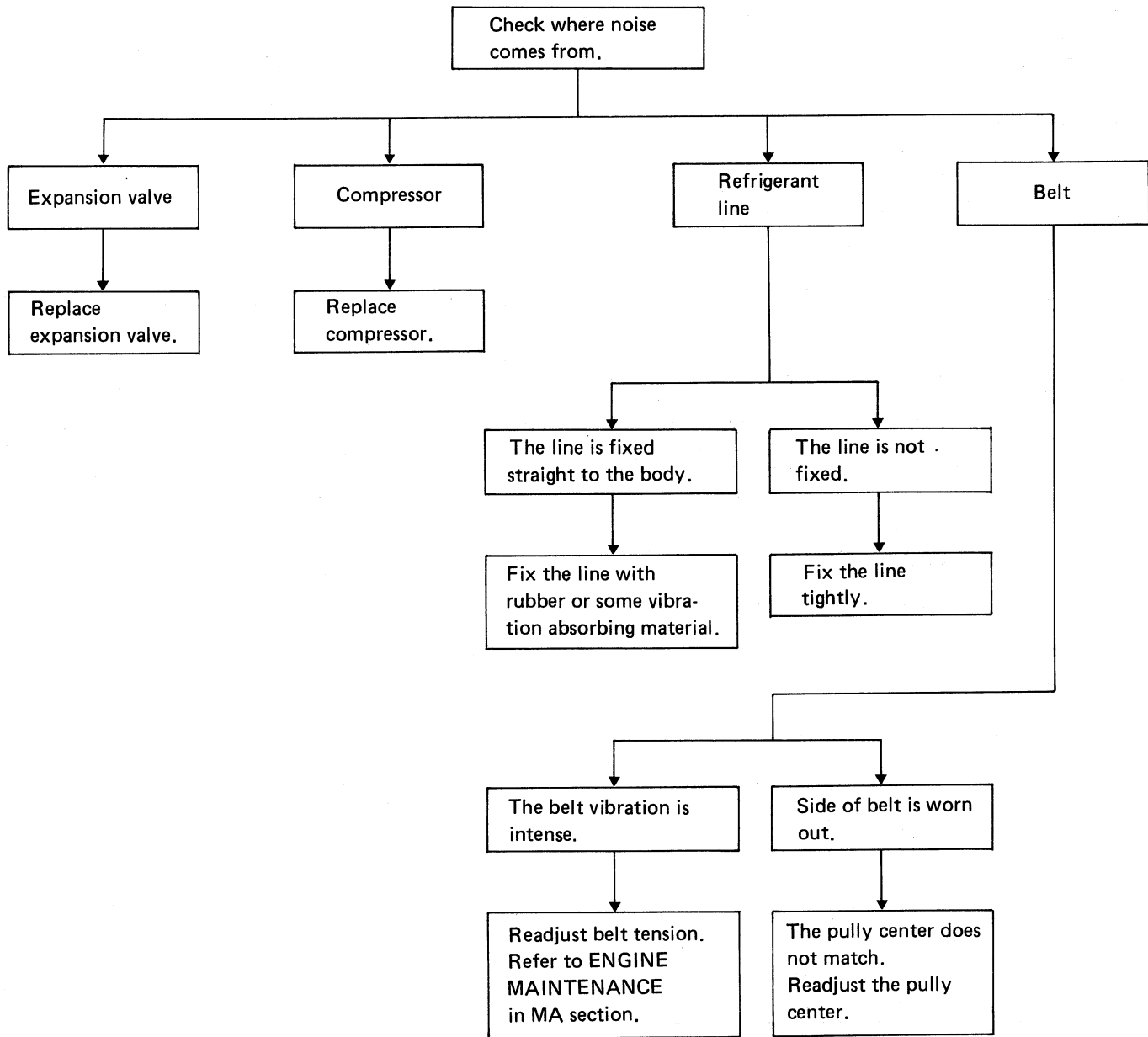

TROUBLE DIAGNOSES

A/C Component Layout

Passenger compartment

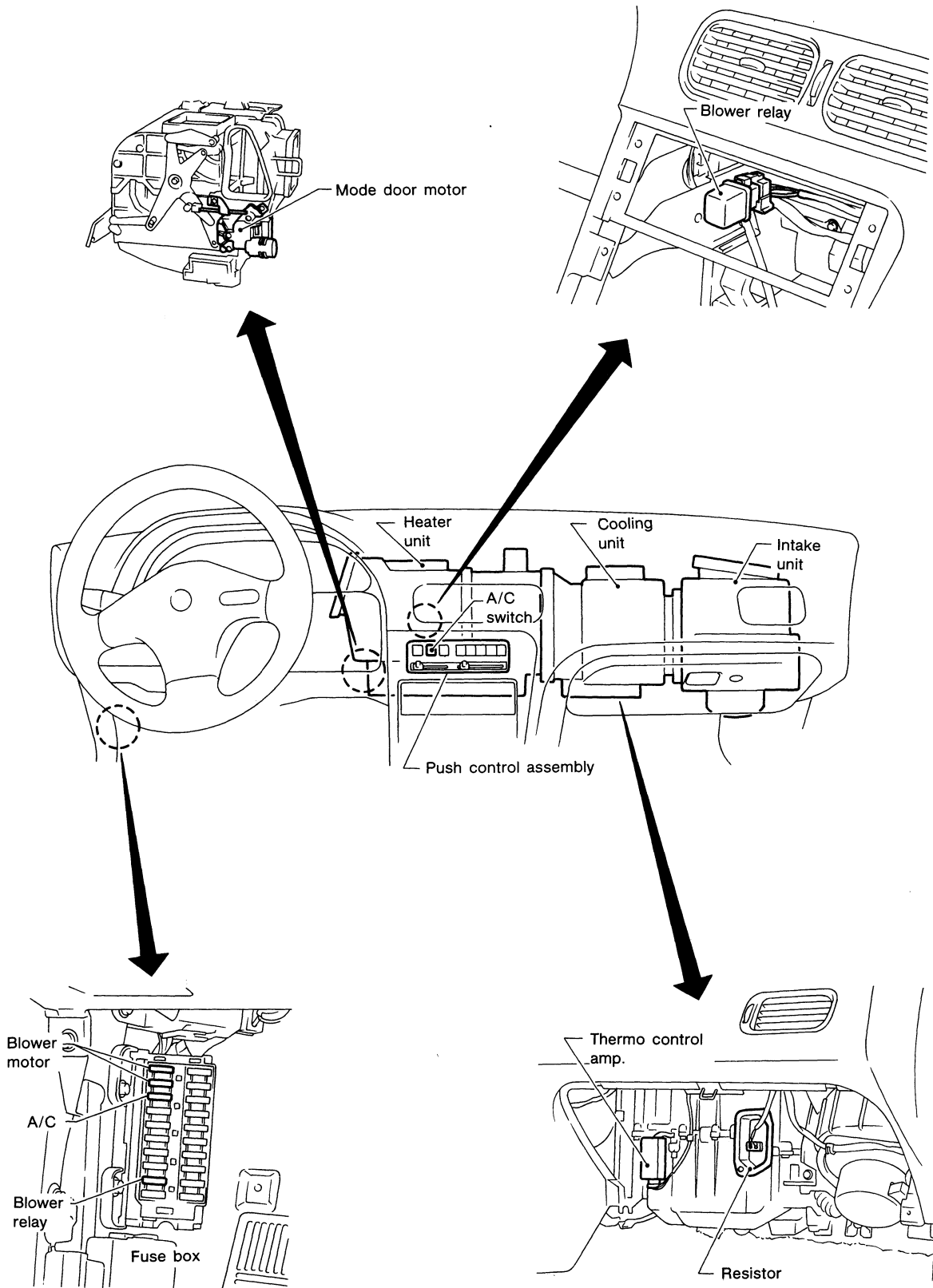

TROUBLE DIAGNOSES

A/C Component Layout (Cont'd)

Engine compartment

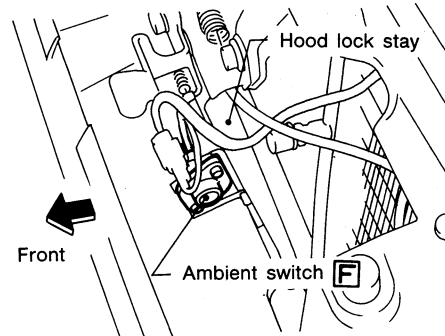
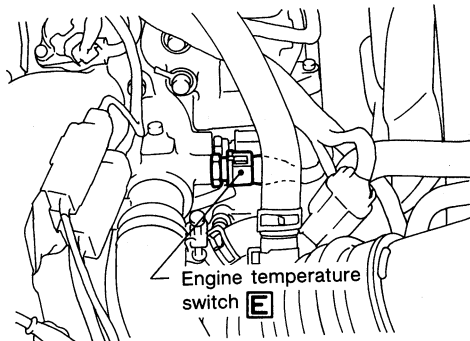
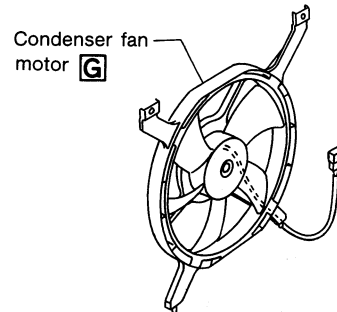
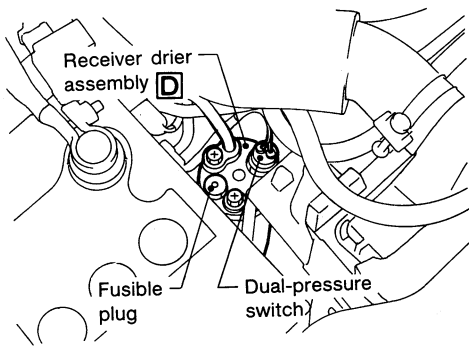
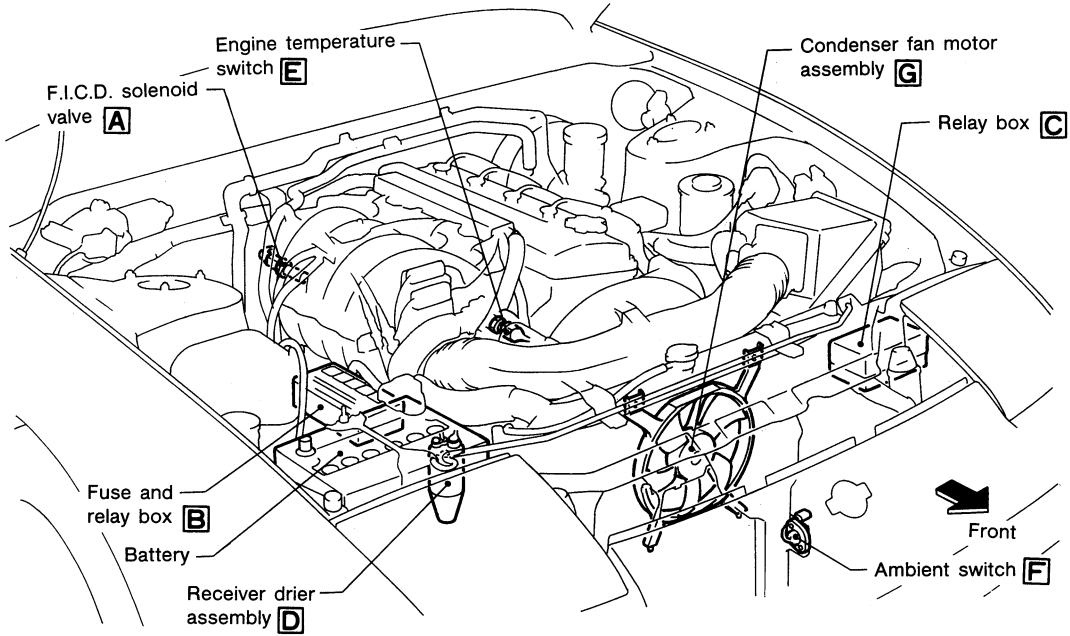
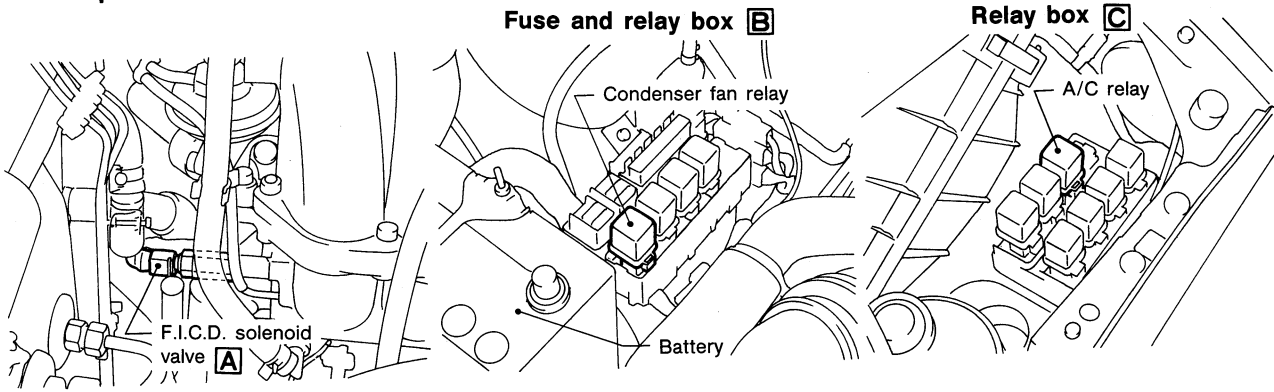

TROUBLE DIAGNOSES

Harness Layout for A/C System

Passenger compartment

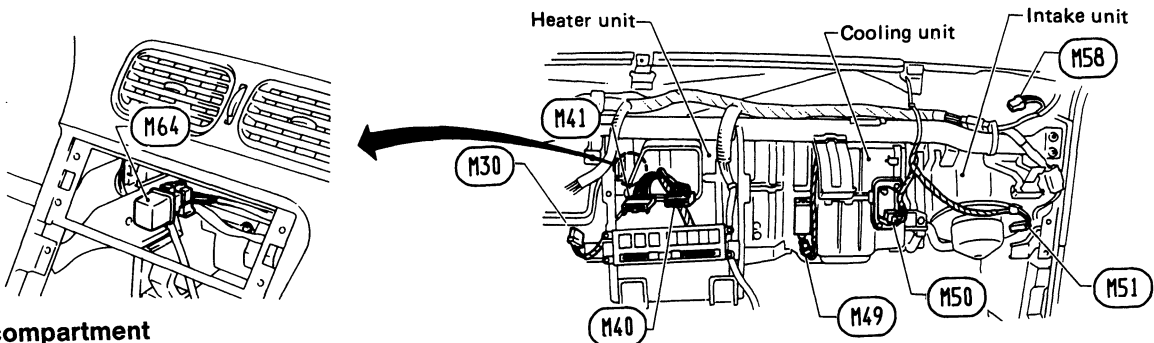

Engine compartment

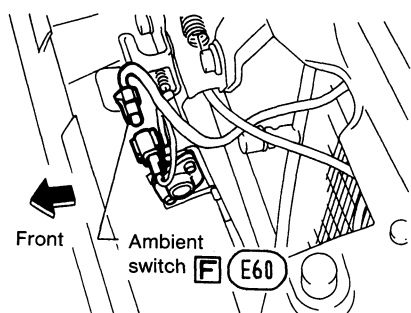
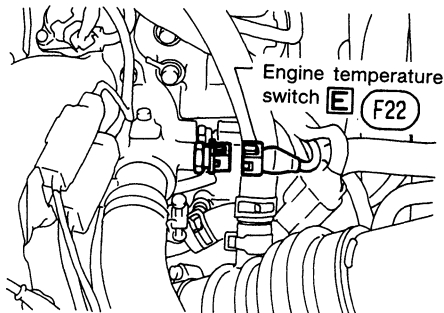
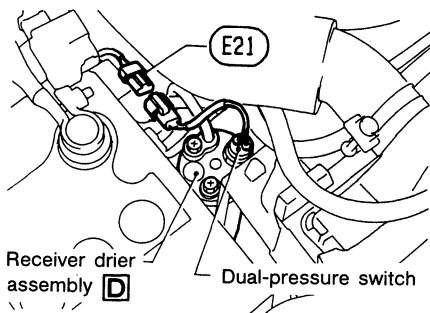
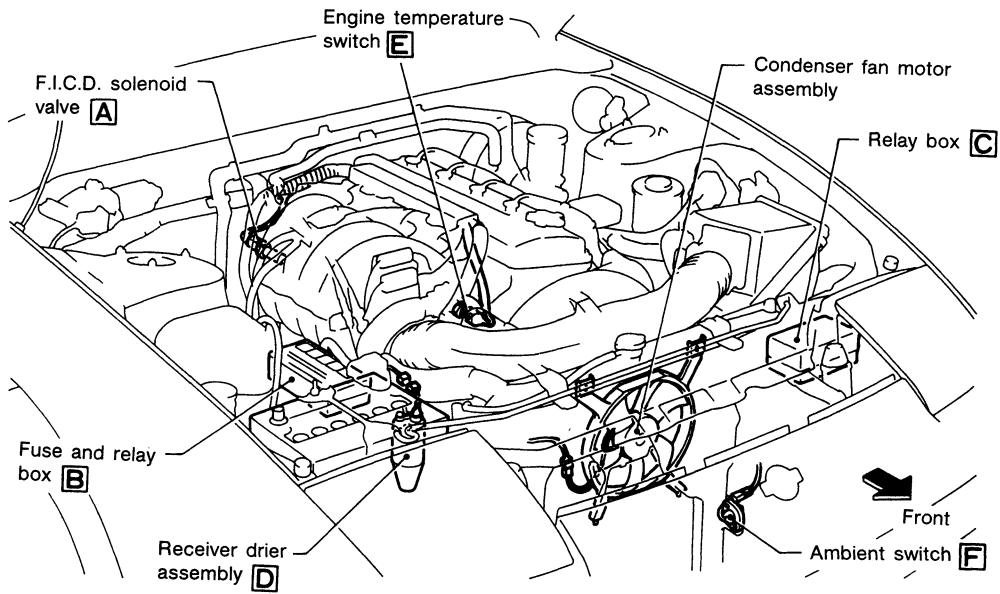
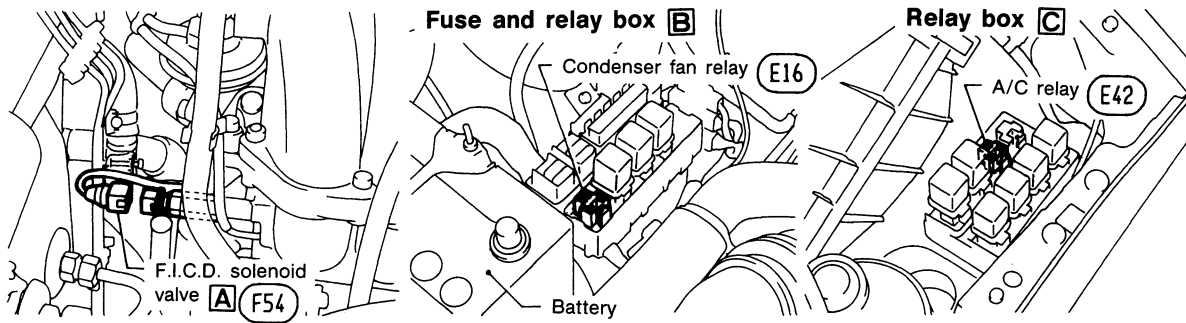

TROUBLE DIAGNOSES

Circuit Diagram for Quick Pinpoint Check

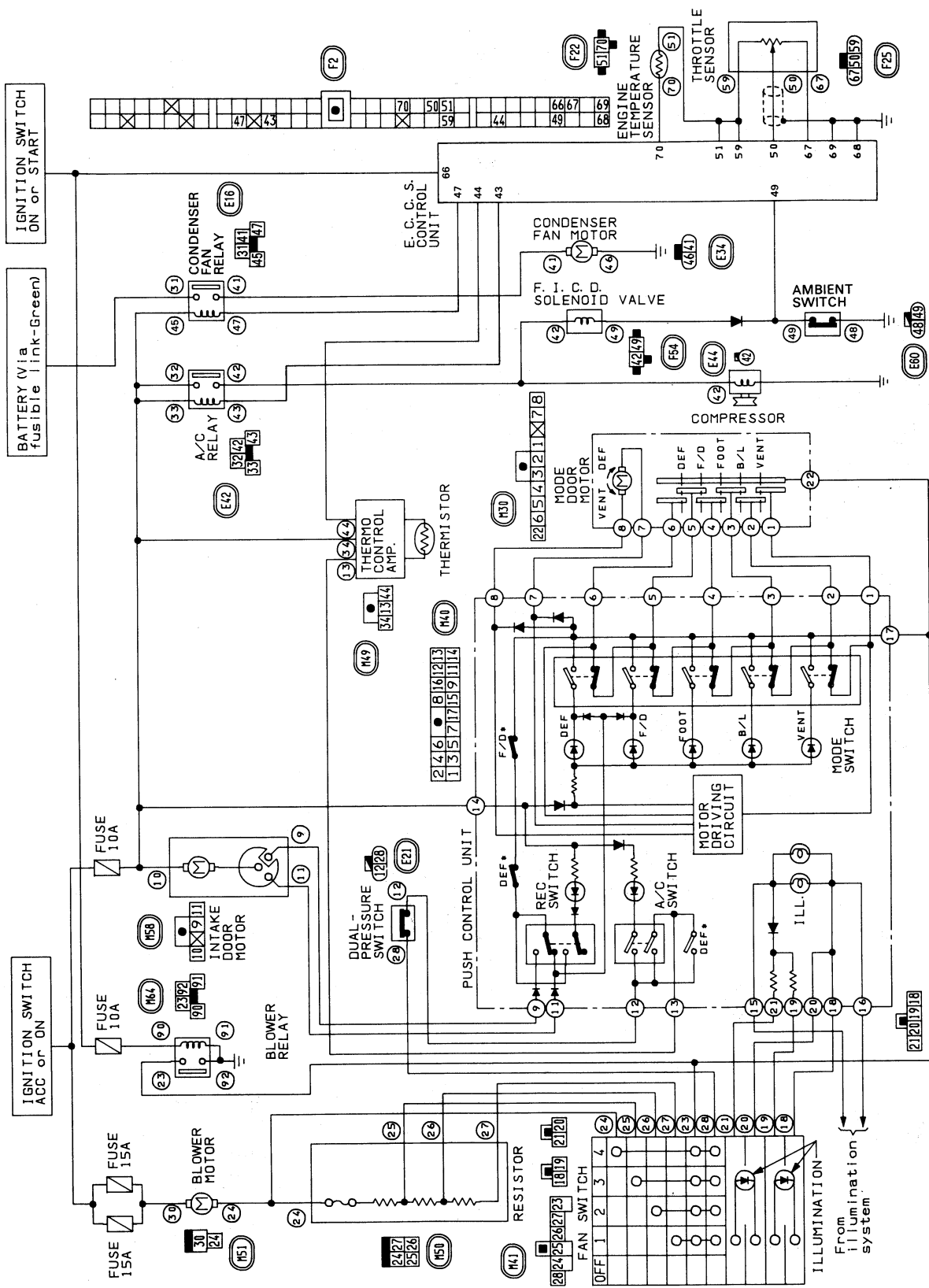

- All connectors shown in this illustration are unit side connectors.
- The unit side connectors with a double circle "⊙" are connected to the harness side connectors shown in the "Harness Layout for A/C System". (See page HA-75.)
- The terminal numbers in the connector coincide with the circuit numbers surrounded by a single circle "○".
- *: These switches are built into push control unit and mechanically linked to corresponding switches.

TROUBLE DIAGNOSES

Wiring Diagram

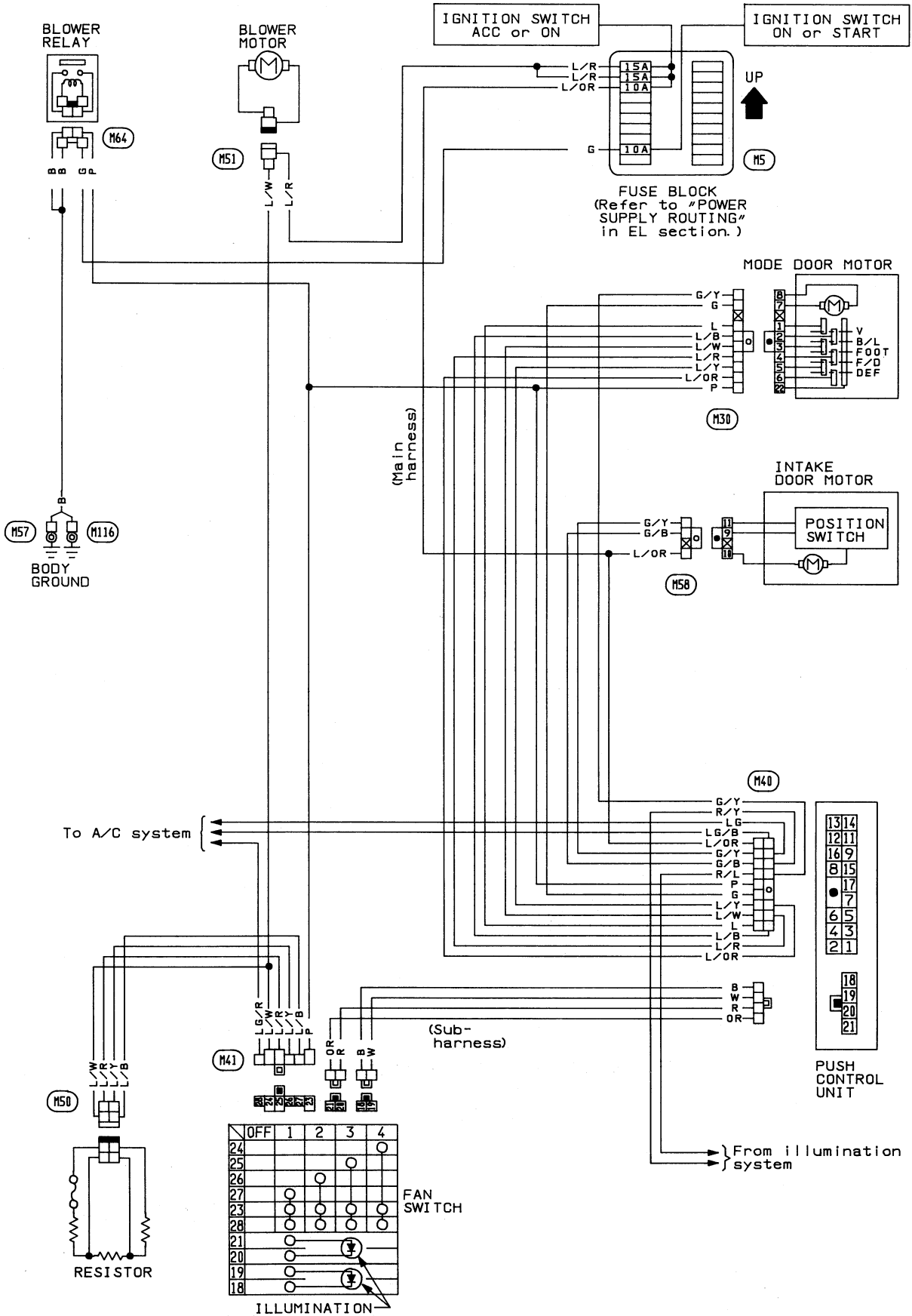

TROUBLE DIAGNOSES

Wiring Diagram (Cont'd)

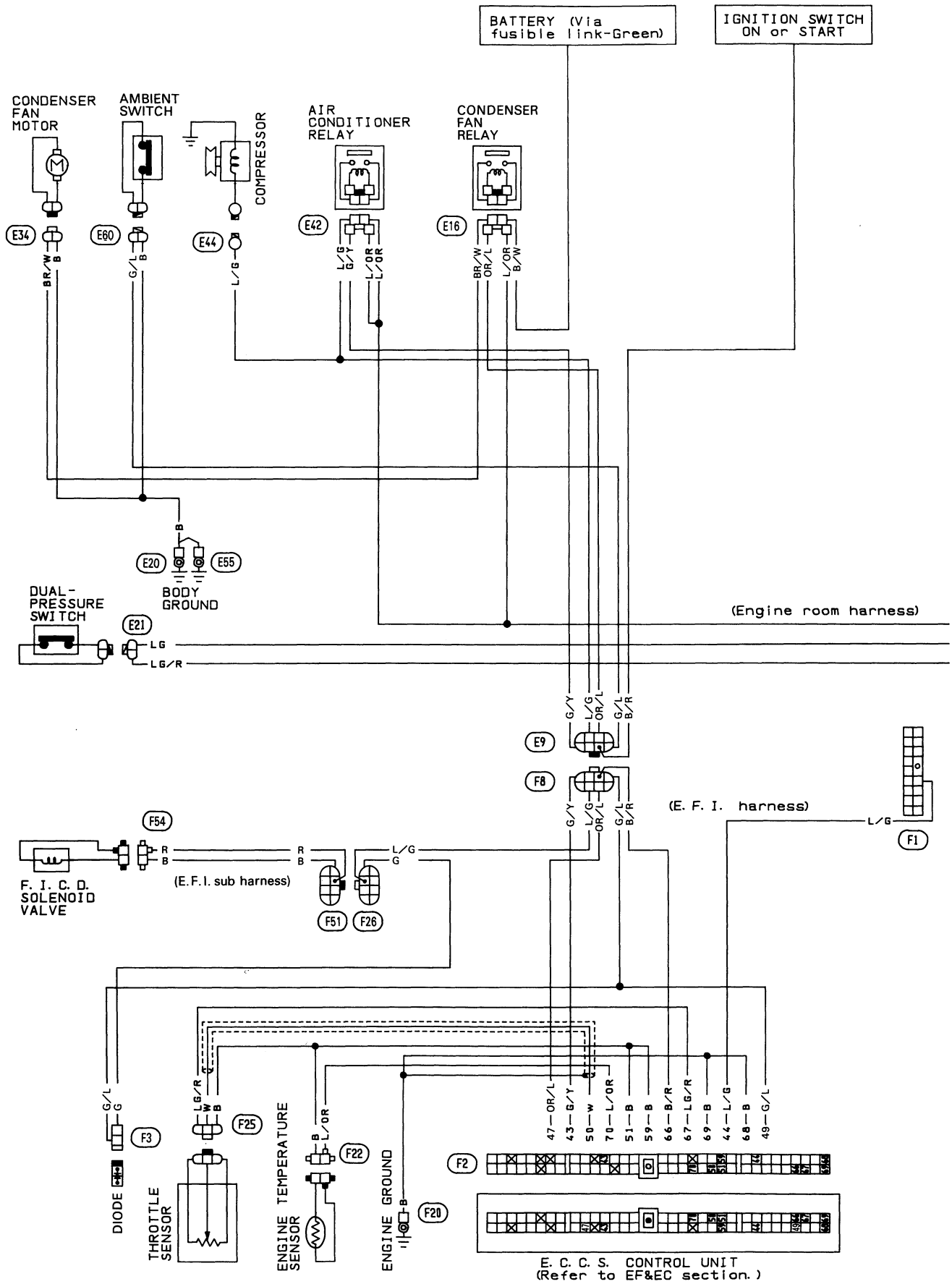

TROUBLE DIAGNOSES

Wiring Diagram (Cont'd)

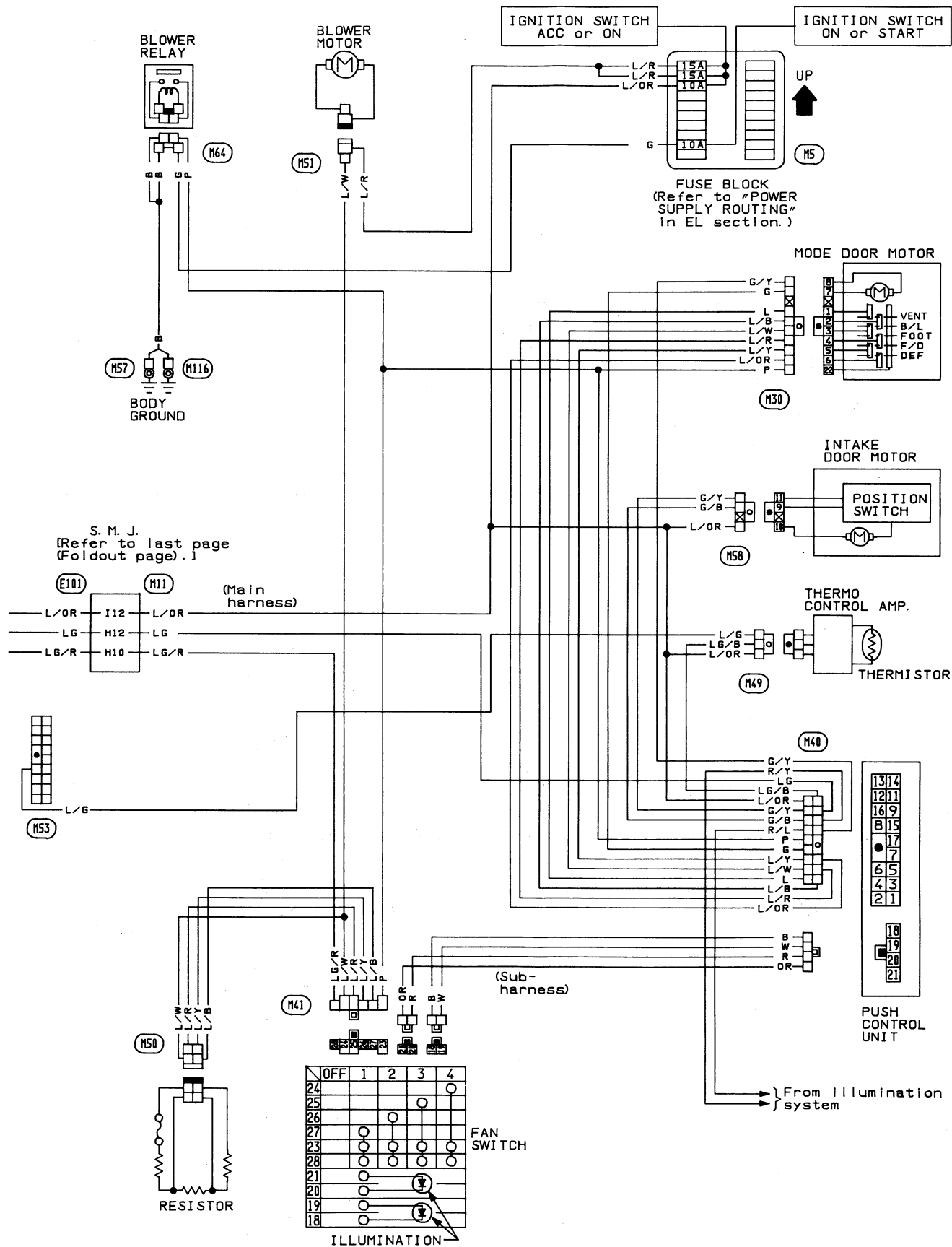

TROUBLE DIAGNOSES

Main Power Supply and Ground Circuit Check

POWER SUPPLY CIRCUIT CHECK FOR A/C SYSTEM

Check power supply circuit for air conditioning system.

Refer to "POWER SUPPLY ROUTING" in EL section and A/C ELECTRICAL CIRCUIT.

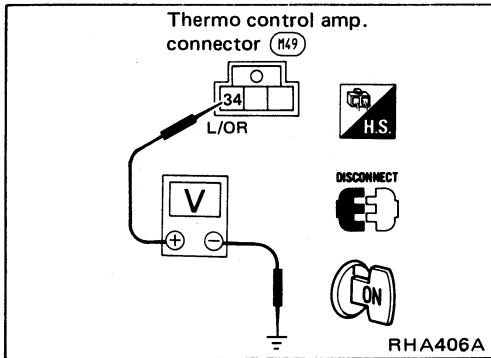

THERMO CONTROL AMP. CHECK

Check power supply circuit for thermo control amp. with ignition switch ON.

1. Disconnect thermo control amp. harness connector.
2. Connect voltmeter from harness side.
3. Measure voltage across terminal No. ③④ and body ground.

Voltmeter terminal		Voltage
⊕	⊖	
③④	Body ground	Approx. 12V

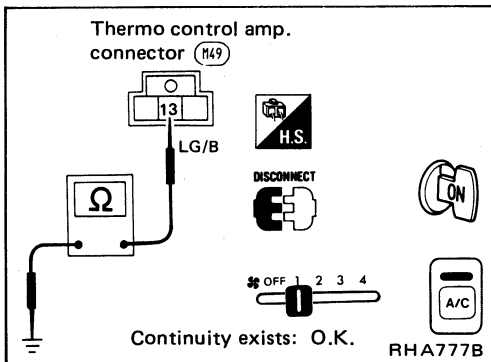

Check body ground circuit for thermo control amp. with ignition switch ON, A/C switch ON and fan switch ON.

1. Disconnect thermo control amp. harness connector.
2. Connect ohmmeter from harness side.
3. Check for continuity between terminal No. ⑬ and body ground.

Ohmmeter terminal		Continuity
⊕	⊖	
⑬	Body ground	Yes

TROUBLE DIAGNOSES

Main Power Supply and Ground Circuit Check (Cont'd)

PUSH CONTROL UNIT CHECK

Check power supply circuit for push control unit with ignition switch at ACC.

1. Disconnect push control unit harness connector.
2. Connect voltmeter from harness side.
3. Measure voltage across terminal No. ⑭ and body ground.

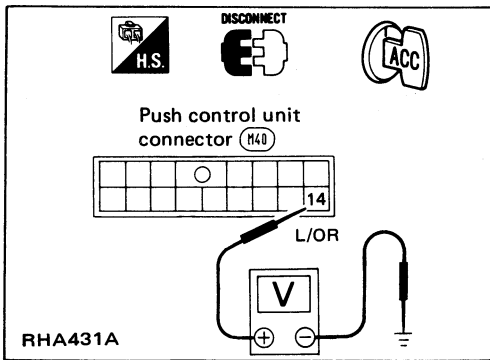

Voltmeter terminal		Voltage
⊕	⊖	
⑭	Body ground	Approx. 12V

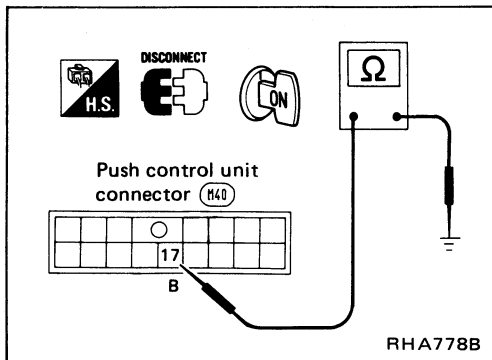

Check body ground circuit for push control unit with ignition switch ON.

1. Disconnect push control unit harness connector.
2. Connect ohmmeter from harness side.
3. Check for continuity between terminal No. ⑰ and body ground.

TROUBLE DIAGNOSES

INCIDENT	Flow chart No.
1 Fan fails to rotate.	1
2 Fan does not rotate at 1-speed.	2
3 Fan does not rotate at 2-speed.	3
4 Fan does not rotate at 3-speed.	4
5 Fan does not rotate at 4-speed.	5

Diagnostic Procedure 1

SYMPTOM: Blower motor does not rotate.

- Perform **PRELIMINARY CHECK 2** before referring to the following flow chart.

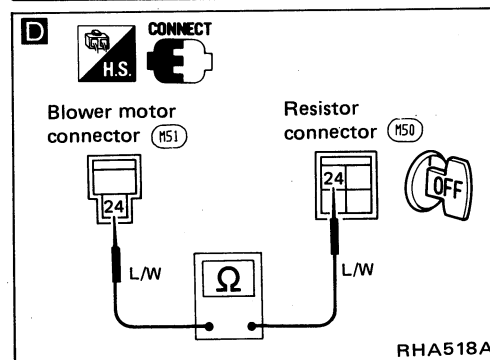
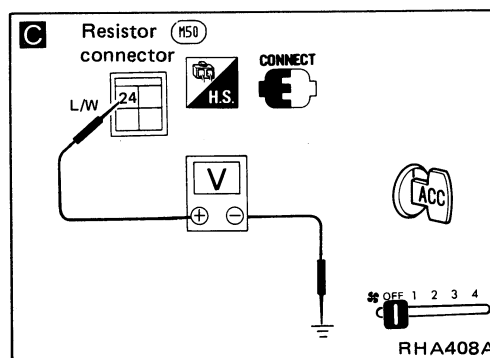
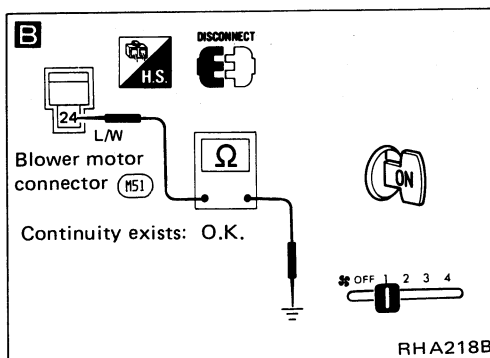
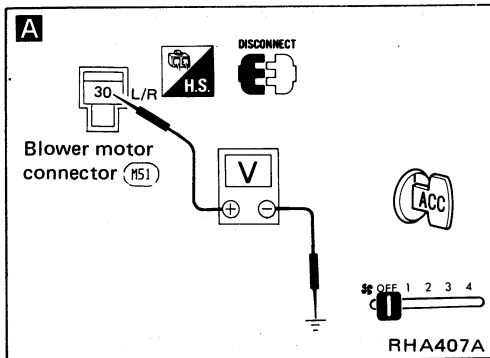

Check if blower motor rotates properly at each fan speed. Conduct check as per flow chart at left.

A

1

CHECK POWER SUPPLY FOR BLOWER MOTOR.
Disconnect blower motor harness connector. Do approx. 12 volts exist between blower motor harness terminal No. ③⑩ and body ground?

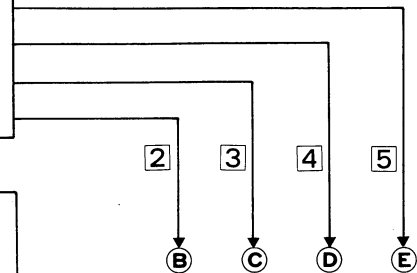

(Go to next page.)

B

Check 15A fuses at fuse block. (Refer to "POWER SUPPLY ROUTING" in EL section and A/C ELECTRICAL CIRCUIT.)

O.K.

B

Check circuit continuity between blower motor harness terminal No. ②④ and body ground.

N.G.

Reconnect blower motor harness connector.

O.K.

CHECK BLOWER MOTOR.
(Refer to Electrical Components Inspection.)

N.G.

Replace blower motor.

C

CHECK BLOWER MOTOR CIRCUIT BETWEEN BLOWER MOTOR AND RESISTOR.
Do approx. 12 volts exist between resistor harness terminal No. ②④ and body ground?

N.G.

Disconnect blower motor and resistor harness connectors.

D

Note

Check circuit continuity between blower motor harness terminal No. ②④ and resistor harness terminal No. ②④.

O.K.

A

(Go to next page.)

Note:
If the result is N.G. after checking circuit continuity, repair harness or connector.

TROUBLE DIAGNOSES

Diagnostic Procedure 1 (Cont'd)

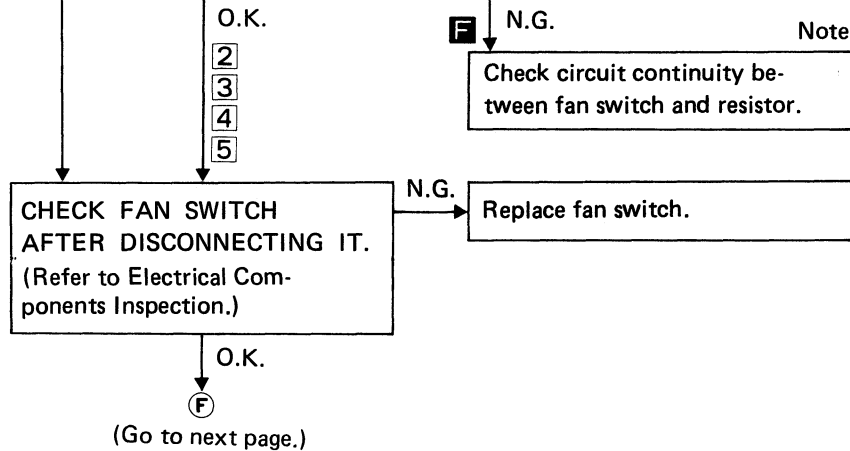
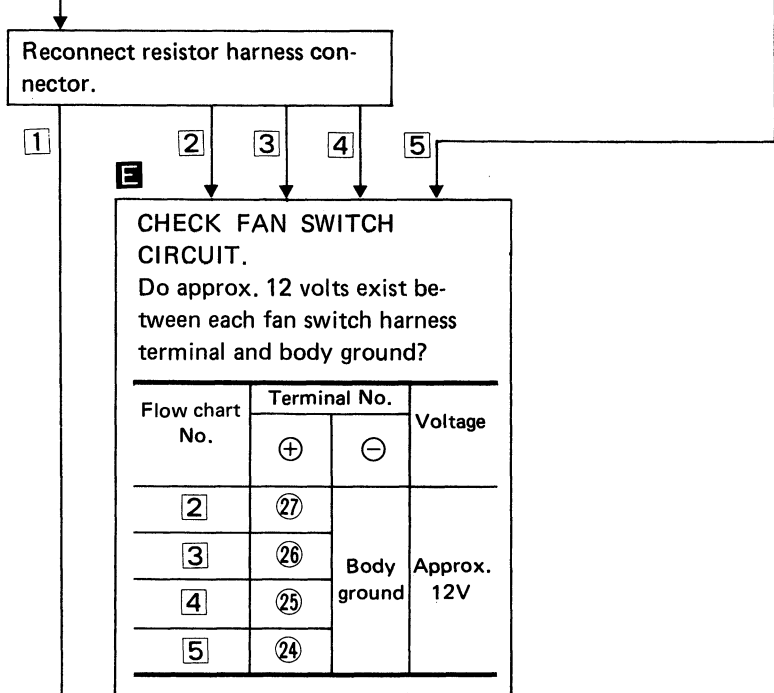
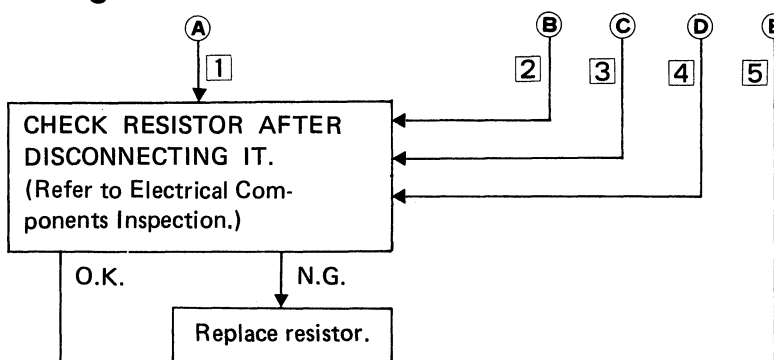
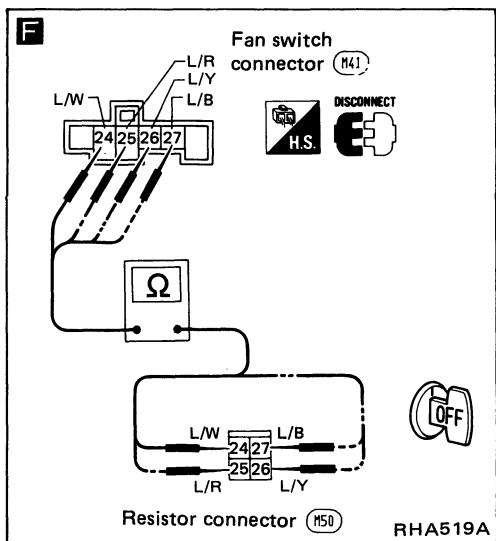
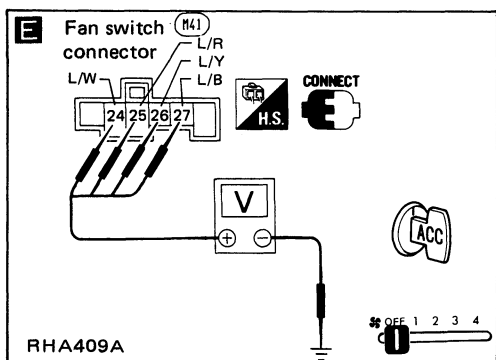

Note:

If the result is N.G. after checking circuit continuity, repair harness or connector.

TROUBLE DIAGNOSES

Diagnostic Procedure 1 (Cont'd)

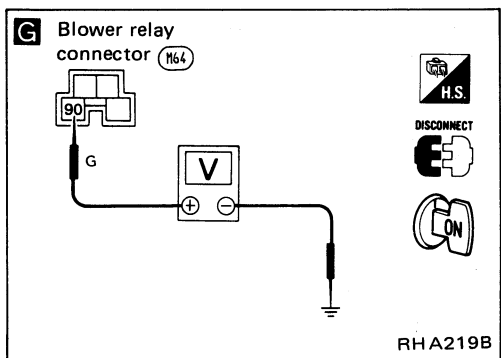

F

G CHECK POWER SUPPLY FOR BLOWER RELAY. Disconnect blower relay harness connector. Do approx. 12 volts exist between blower relay harness terminal No. ⑨⑩ and body ground?

N.G. Check 10A fuse at fuse block. (Refer to "POWER SUPPLY ROUTING" in EL section and A/C ELECTRICAL CIRCUIT.)

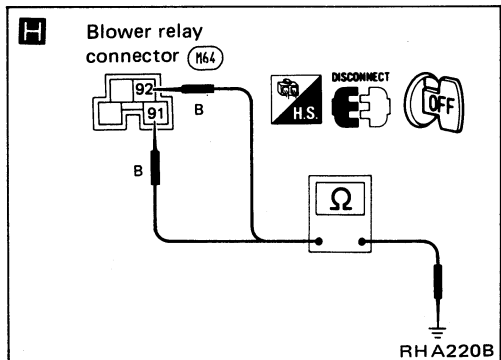

H O.K. Note Check circuit continuity between blower relay harness terminal No. ⑨①, ⑨② and body ground.

O.K. Reconnect fan switch harness connector.

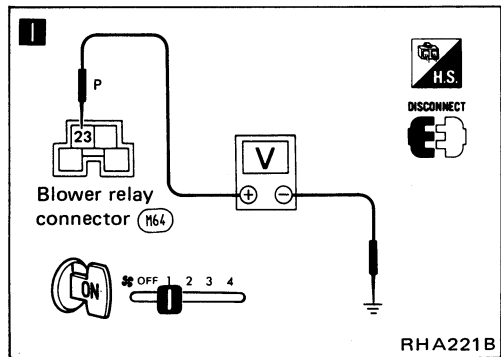

I CHECK FAN SWITCH CIRCUIT BETWEEN FAN SWITCH AND BLOWER RELAY. Do approx. 12 volts exist between blower relay harness terminal No. ②③ and body ground?

N.G. Disconnect fan switch harness connector.

J Note Check circuit continuity between fan switch harness terminal No. ②③ and blower relay harness terminal No. ②③.

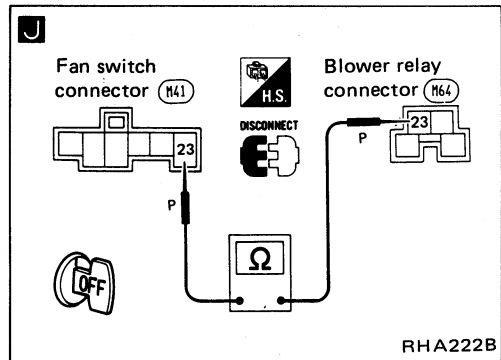

O.K. CHECK BLOWER RELAY AFTER DISCONNECTING IT. (Refer to Electrical Components Inspection.)

N.G. Replace blower relay.

Note:
If the result is N.G. after checking circuit continuity, repair harness or connector.

TROUBLE DIAGNOSES

Diagnostic Procedure 2

SYMPTOM: Air outlet does not change.

- Perform **PRELIMINARY CHECK 4** and **Main Power Supply and Ground Circuit Check** before referring to the following flow chart.

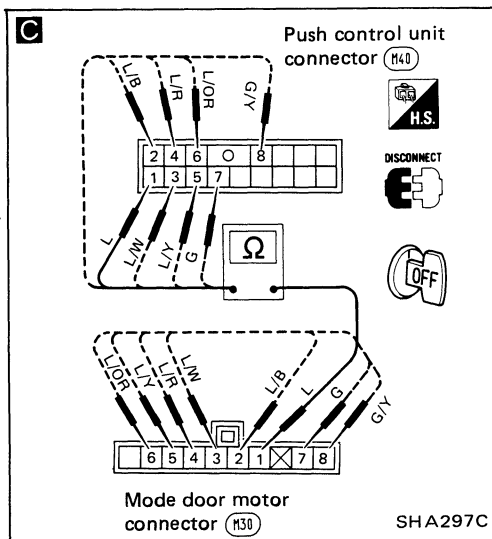
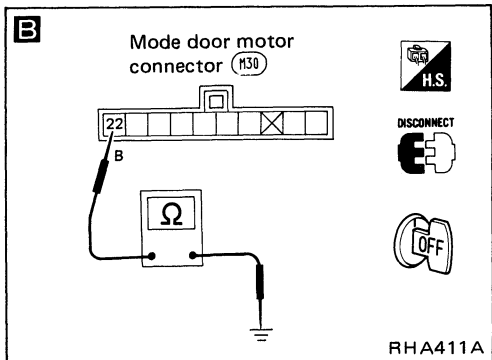
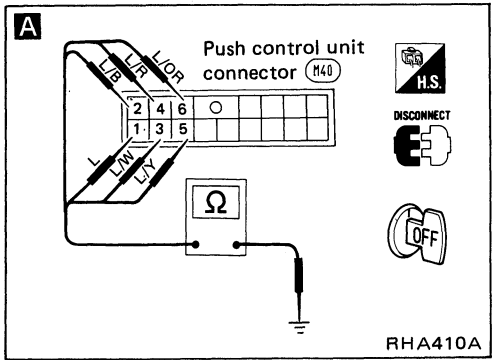

A

CHECK MODE DOOR MOTOR POSITION SWITCH.

1. Turn VENT switch ON with ignition switch at ACC position.
2. Turn ignition switch OFF. Disconnect push control unit connector.
3. Check if continuity exists between terminal No. ① or ② of push control unit harness connector and body ground.
4. Using above procedures, check for continuity in any other mode, as indicated in chart.

Mode switch	Terminal No.		Continuity
	⊕	⊖	
VENT	① or ②	Body ground	Yes
B/L	② or ③		
FOOT	③ or ④		
F/D	④ or ⑤		
DEF	⑤ or ⑥		

O.K.

CHECK SIDE LINK.
Refer to **DOOR CONTROL.**

N.G. Disconnect mode door motor harness connector.

Note

B

CHECK BODY GROUND CIRCUIT FOR MODE DOOR MOTOR.
Does continuity exist between mode door motor harness terminal No. ②② and body ground?

O.K. **Note**

C

Check circuit continuity between each terminal on push control unit and on mode door motor.

Terminal No.	Terminal No.		Continuity
	⊕	⊖	
Push control unit	Mode door motor	Yes	
①	①		
②	②		
③	③		
④	④		
⑤	⑤		
⑥	⑥		
⑦	⑦		
⑧	⑧		

(Go to next page.)

Note:
If the result is N.G. after checking circuit continuity, repair harness or connector.

TROUBLE DIAGNOSES

Diagnostic Procedure 2 (Cont'd)

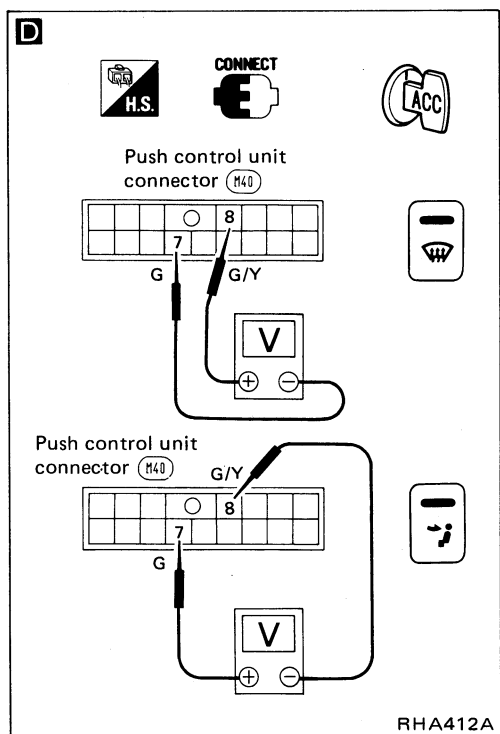

A

Reconnect push control unit and mode door motor harness connectors.

D

CHECK FOR OUTPUT OF PUSH CONTROL UNIT.
Do approx. 12 volts exist between push control unit harness terminal No. ⑦ and ⑧ when mode is switched from "VENT" to "DEF" or when mode is switched from "DEF" to "VENT"?

Terminal No.		Mode door motor	
⑦	⑧	Mode door operation	Direction of linkage rotation
⊖	⊖	Stop	Stop
⊖	⊕	VENT → DEF	Clockwise
⊕	⊖	DEF → VENT	Counter-clockwise

N.G. Replace control amp. built-in push control unit.

O.K.

Replace mode door motor.

TROUBLE DIAGNOSES

Diagnostic Procedure 3

SYMPTOM: Intake door does not change in VENT, B/L or FOOT mode.

- Perform **PRELIMINARY CHECK 1** and **Main Power Supply and Ground Circuit Check** before referring to the following flow chart.

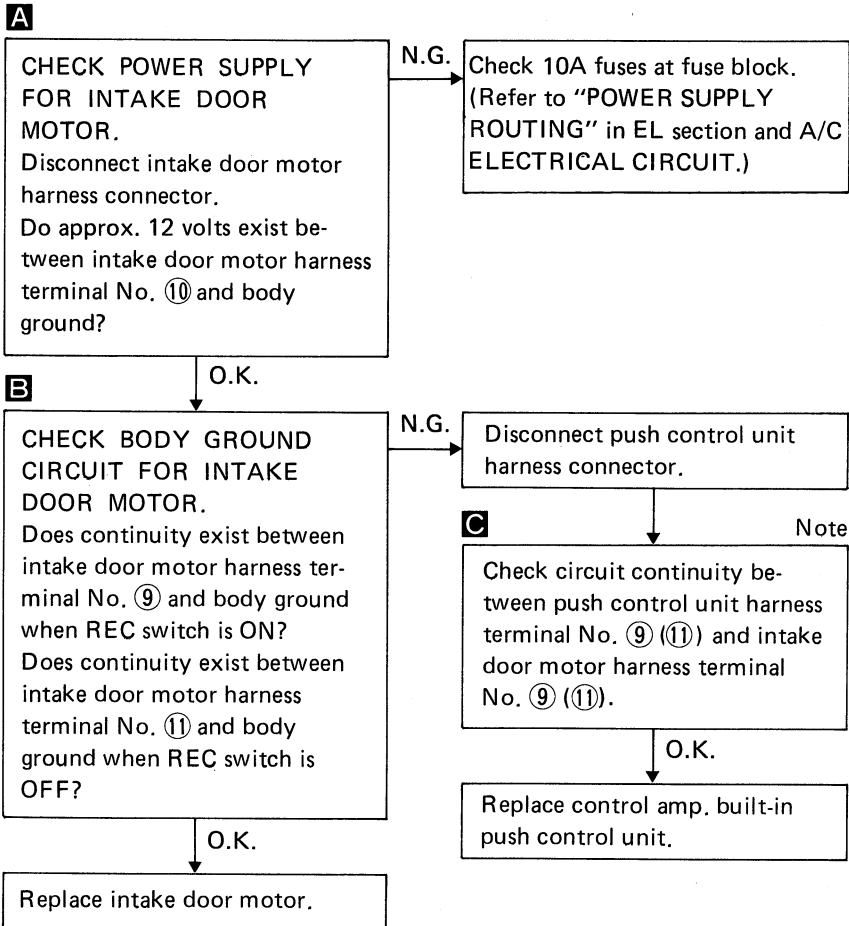
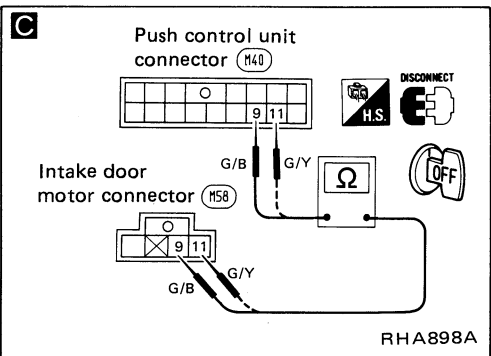
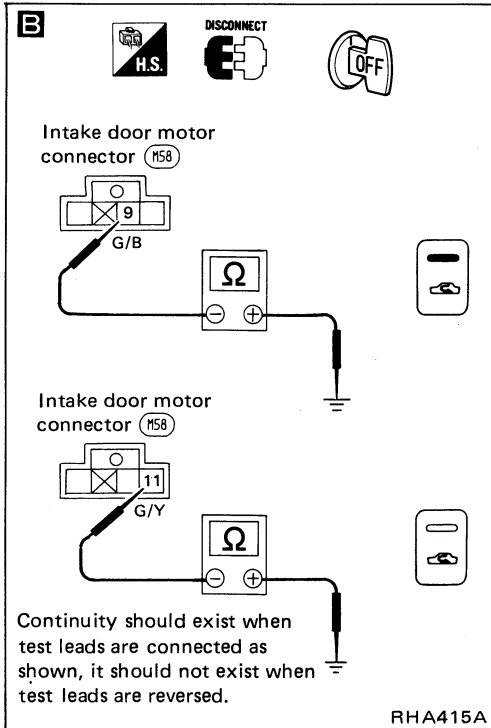
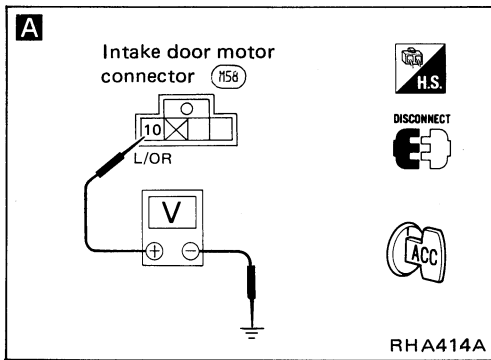

Note:

If the result is N.G. after checking circuit continuity, repair harness or connector.

TROUBLE DIAGNOSES

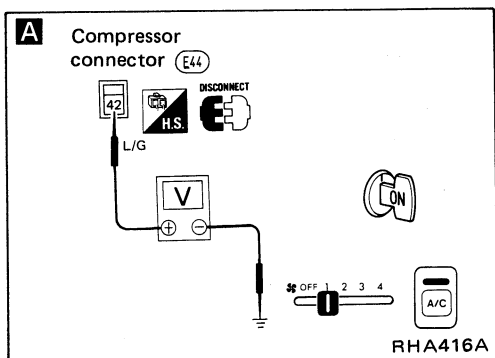

Diagnostic Procedure 4

SYMPTOM: Magnet clutch does not engage with A/C switch and fan switch are ON.

- Perform **PRELIMINARY CHECK 2** before referring to the following flow chart.

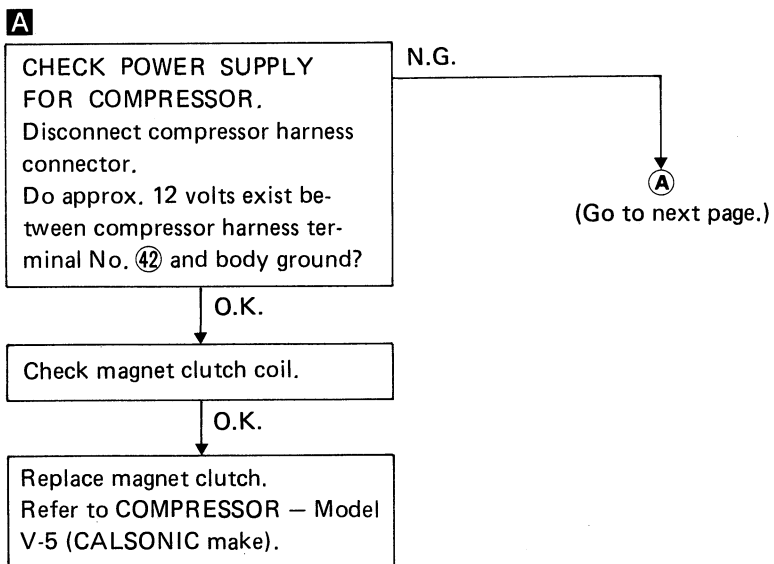

TROUBLE DIAGNOSES

Diagnostic Procedure 4 (Cont'd)

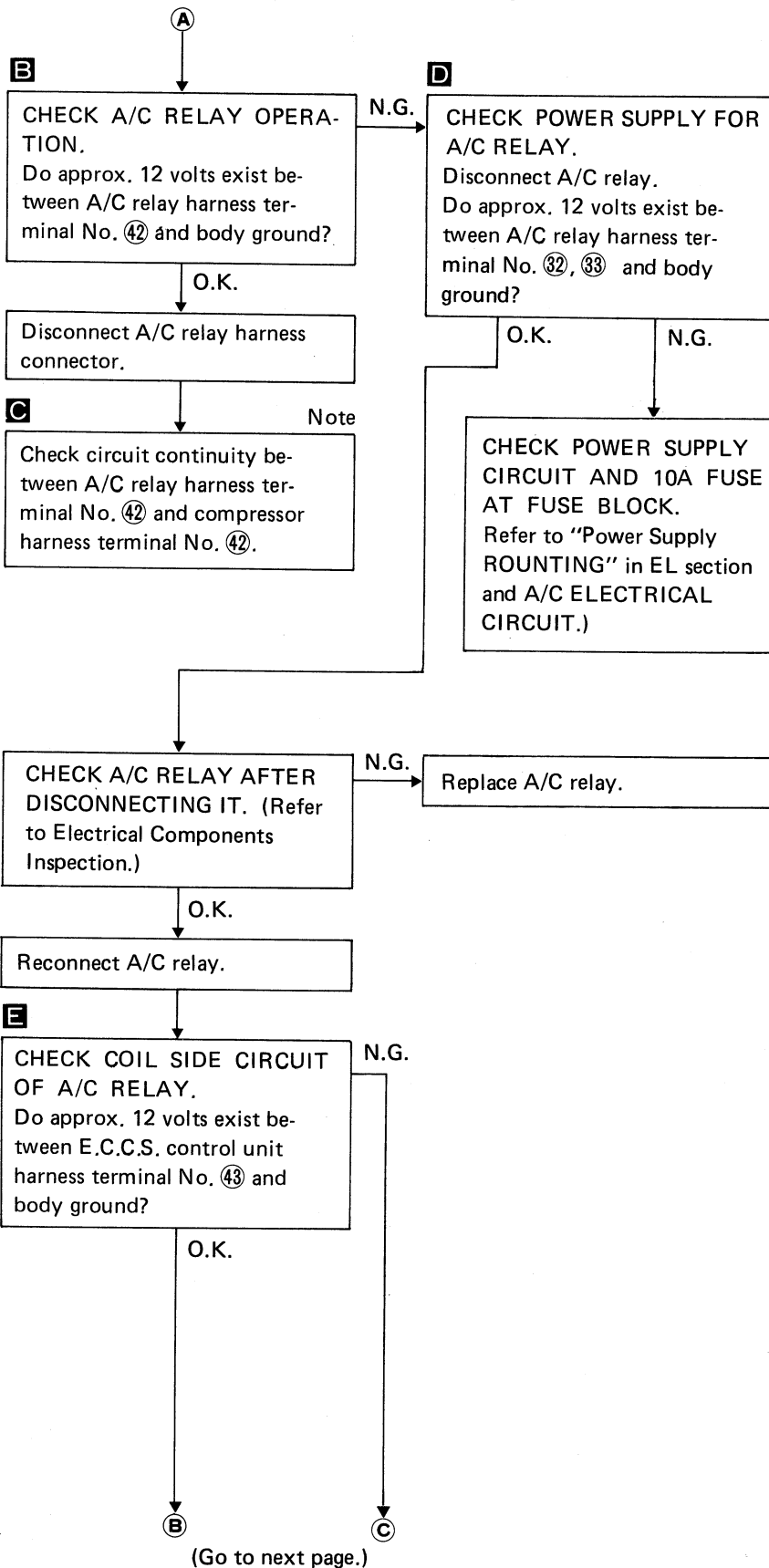
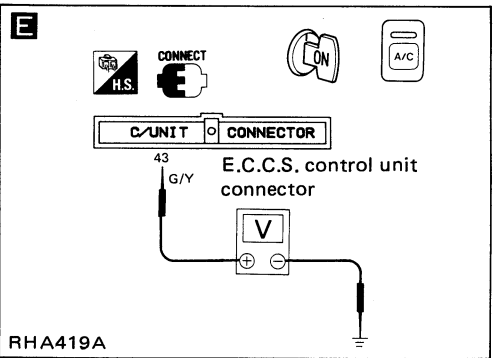
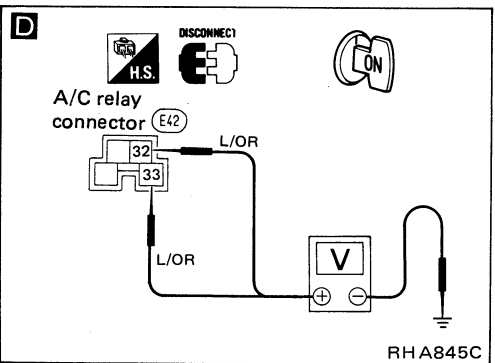
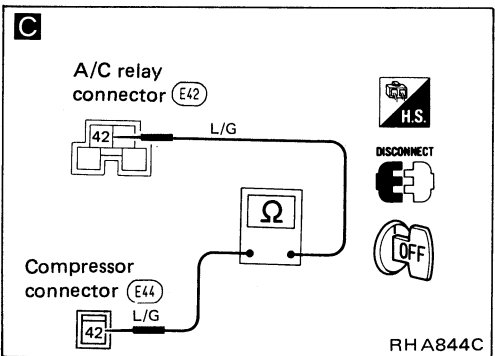
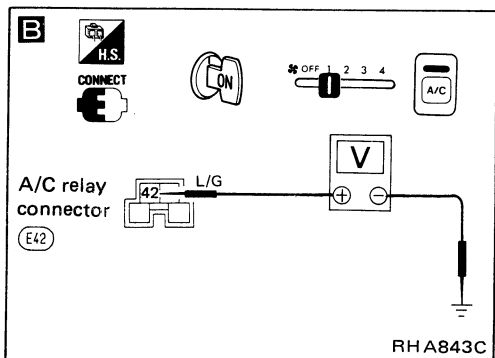

Note:

If the result is N.G. after checking circuit continuity, repair harness or connector.

TROUBLE DIAGNOSES

Diagnostic Procedure 4 (Cont'd)

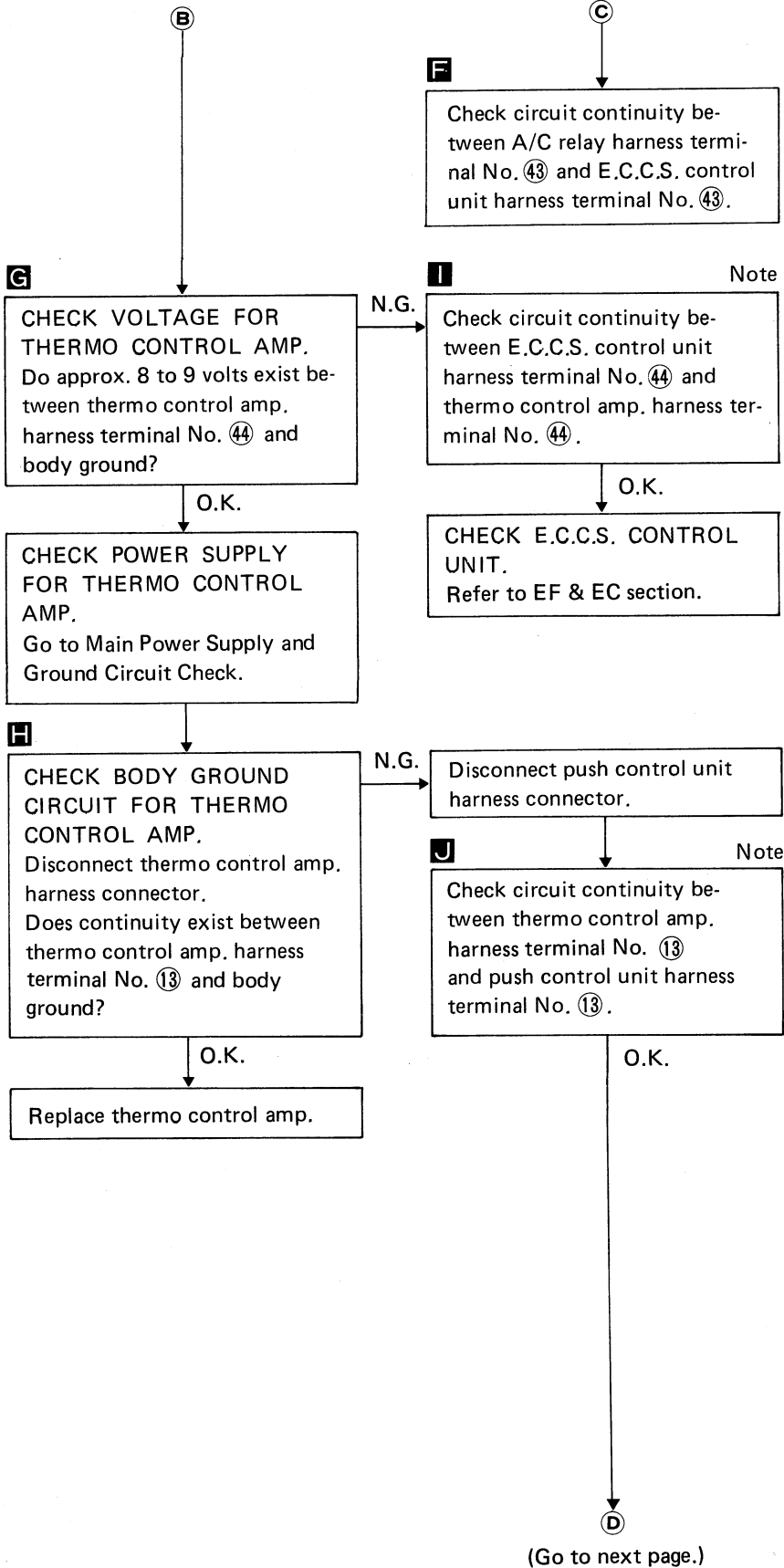
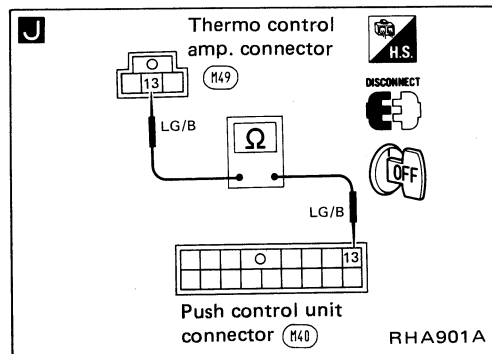
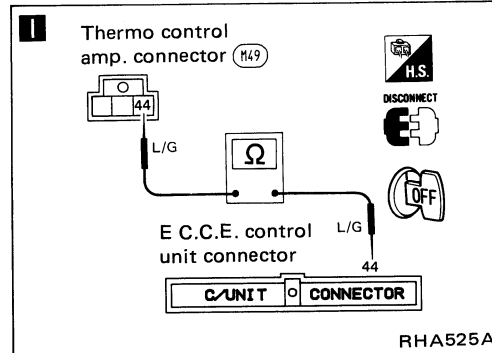
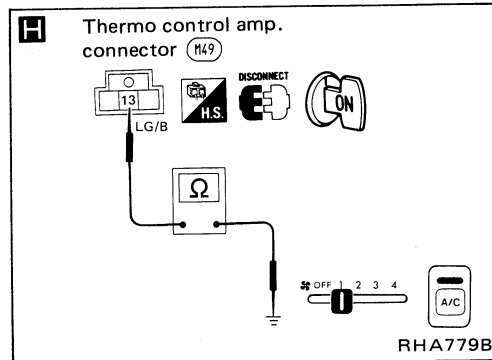
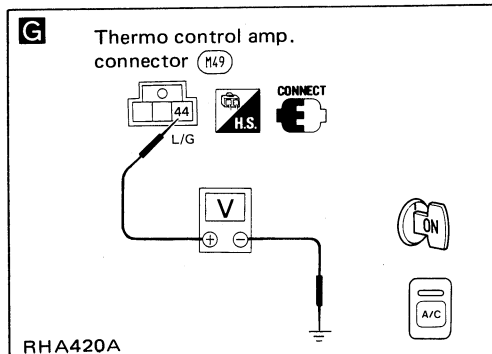
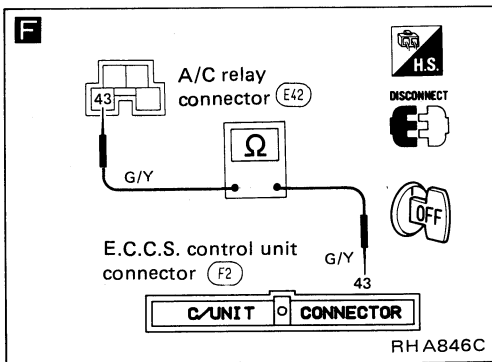

Note:
If the result is N.G. after checking circuit continuity, repair harness or connector.

TROUBLE DIAGNOSES

Diagnostic Procedure 4 (Cont'd)

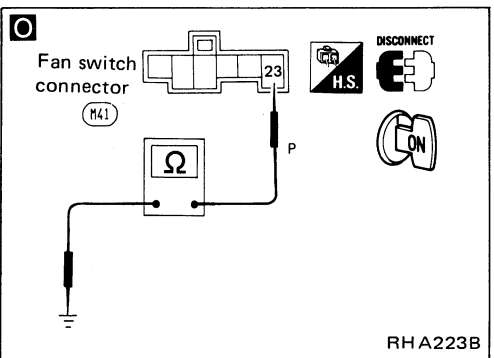
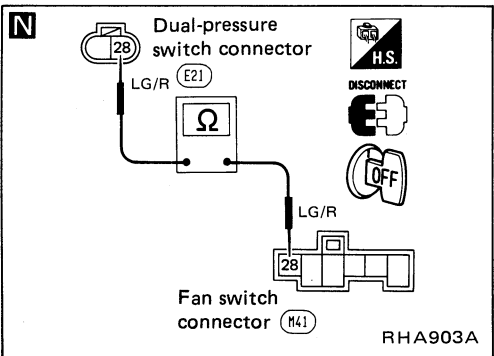
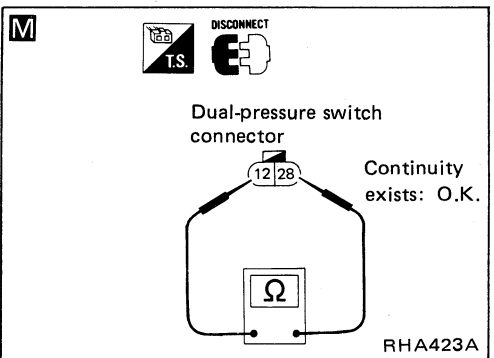
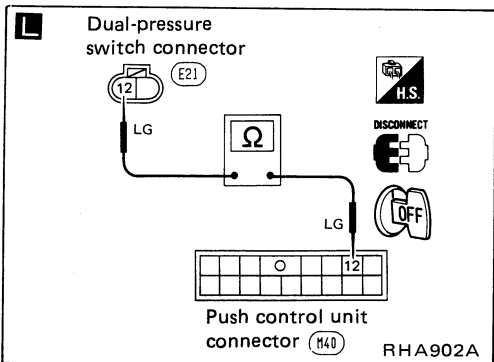
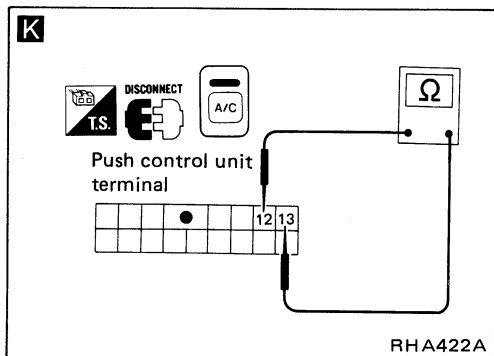

D

K

CHECK PUSH CONTROL UNIT.
Does continuity exist between push control unit terminals No. ⑫ and ⑬?

N.G. → Replace control amp. built-in push control unit

O.K. →

Disconnect dual-pressure switch.

L Note

Check circuit continuity between dual-pressure switch harness terminal No. ⑫ and push control unit harness terminal No. ⑫.

O.K. →

M

CHECK DUAL-PRESSURE SWITCH
Does continuity exist between dual-pressure switch terminals?

N.G. → Replace dual-pressure switch.

O.K. →

Disconnect fan switch harness connector.

N Note

Check circuit continuity between dual-pressure switch harness terminal No. ⑳ and fan switch harness terminal No. ⑳.

O.K. →

O Note

CHECK BODY GROUND CIRCUIT FOR FAN SWITCH.
Does continuity exist between fan switch harness terminal No. ㉓ and body ground?

N.G. → **E** (Go to next page.)

O.K. →

CHECK FAN SWITCH.
(Refer to Electrical Components Inspection.)

N.G. → Replace fan switch.

Note:
If the result is N.G. after checking circuit continuity, repair harness or connector.

TROUBLE DIAGNOSES

Diagnostic Procedure 4 (Cont'd)

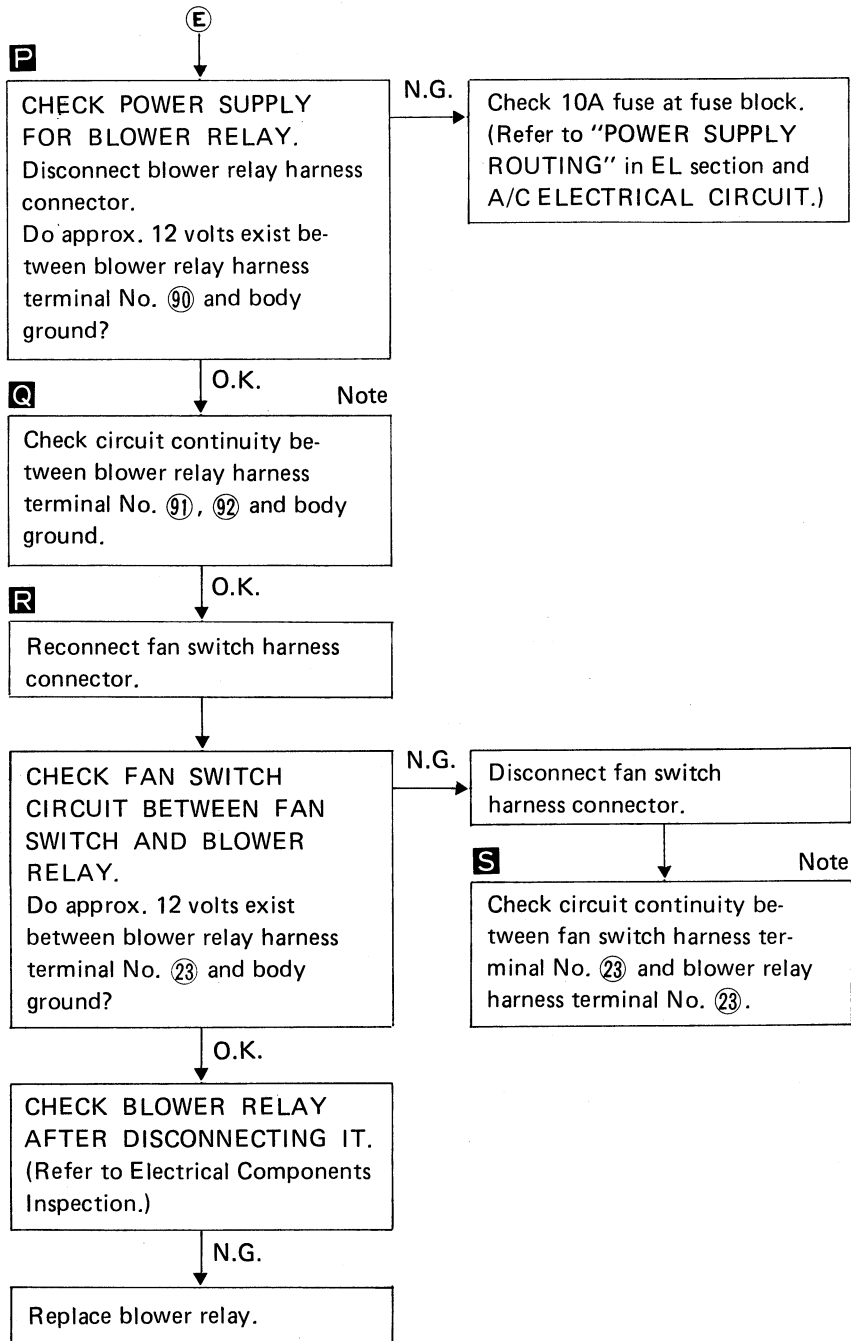
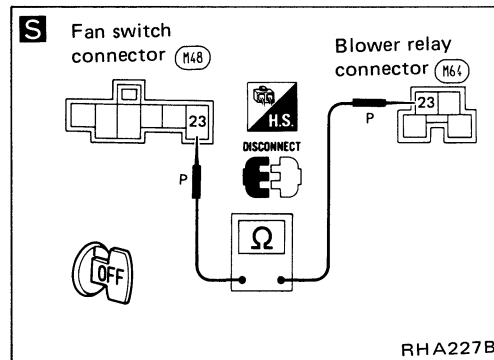
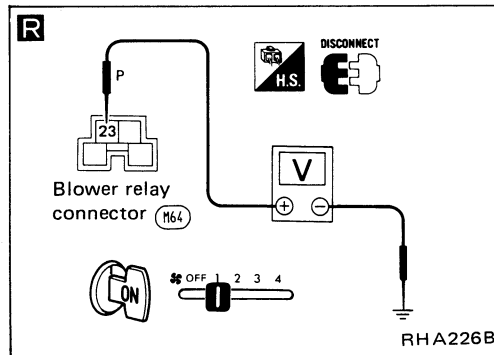
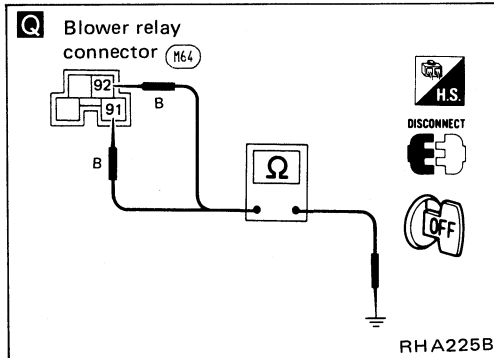
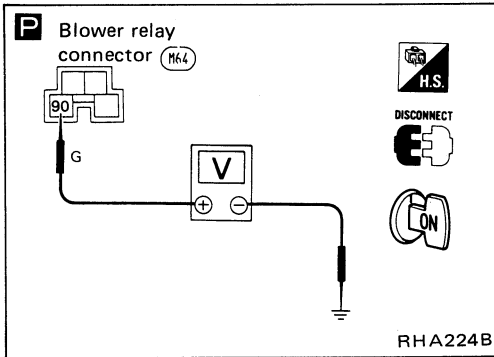

Note:

If the result is N.G. after checking circuit continuity, repair harness or connector.

TROUBLE DIAGNOSES

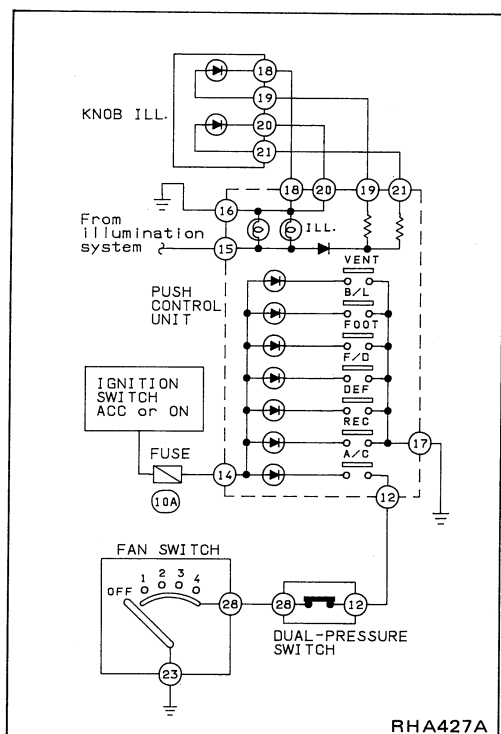

Diagnostic Procedure 5

SYMPTOM: Illumination or indicators of push control unit do not come on.

- Perform Main Power Supply and Ground Circuit Check before referring to the following flow chart.

Turn ignition switch and lighting switch ON.

CHECK ILLUMINATION AND INDICATORS.

- Turn A/C, REC and fan switches ON.
- Push VENT, B/L, FOOT, F/D and DEF switches in order.
- Check for incidents and follow the repairing methods as shown:

INCIDENTS								"How to repair"
ILL.	VENT	B/L	FOOT	F/D	DEF	REC	A/C	
X	○	○	○	○	○	○	△	Go to DIAGNOSTIC PROCEDURE 5-1.
△	○	○	○	○	○	○	X	Go to DIAGNOSTIC PROCEDURE 5-2.
○	X	X	X	X	X	X	△	Go to DIAGNOSTIC PROCEDURE 5-3.
△	△						△	Replace control amp. built-in push control unit.
○	X	X	X	X	X	X	○	Replace control amp. built-in push control nit.
△	X	X	X	X	X	X	○	Go to DIAGNOSTIC PROCEDURE 5-4.

○: Illumination or indicator comes on.
 X: Illumination or indicator does not come on.
 △: Some indicators for VENT, B/L, FOOT, F/D, DEF or REC come on.

DIAGNOSTIC PROCEDURE 5-1

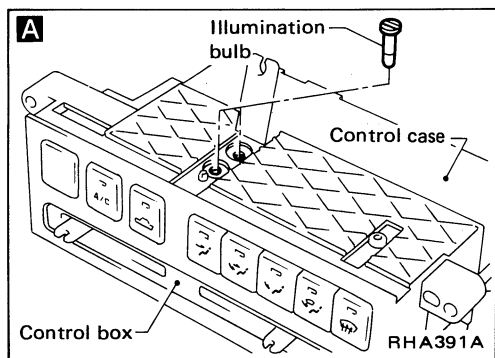
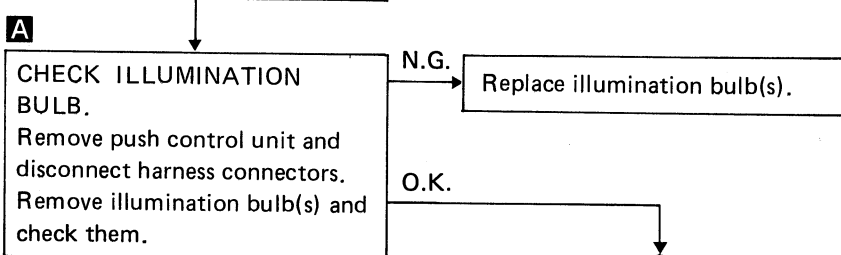
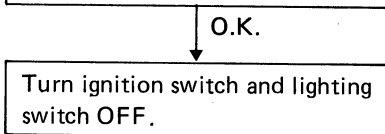
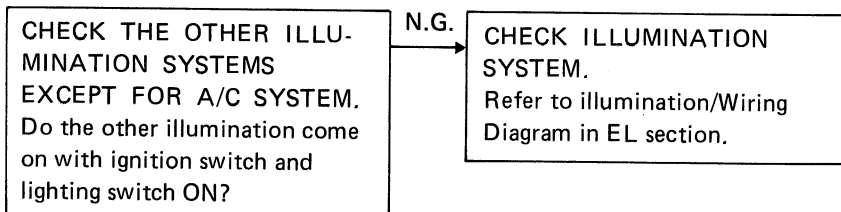

(Go to next page.)

TROUBLE DIAGNOSES

Diagnostic Procedure 5 (Cont'd)

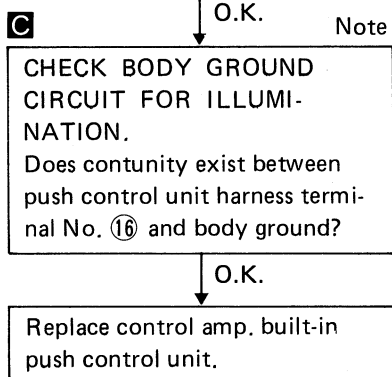
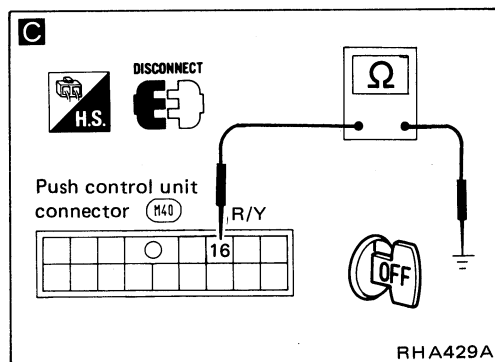
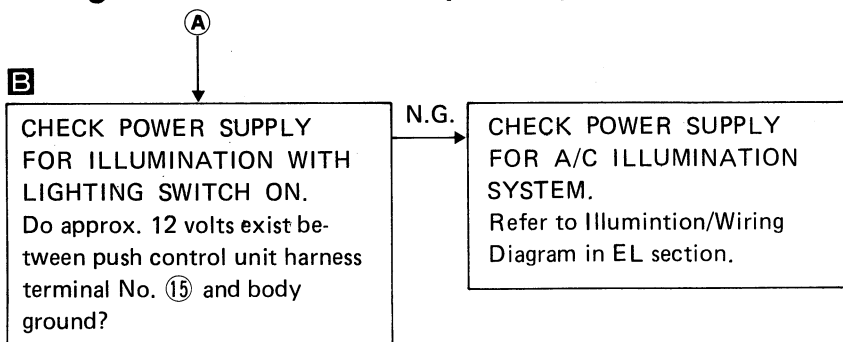
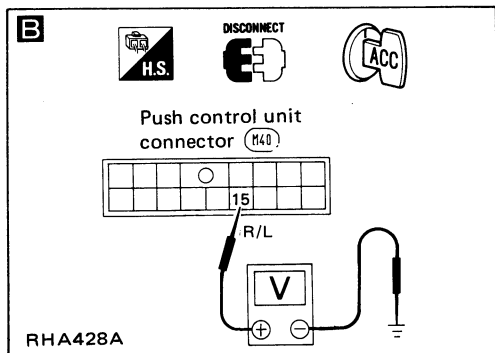

DIAGNOSTIC PROCEDURE 5-2

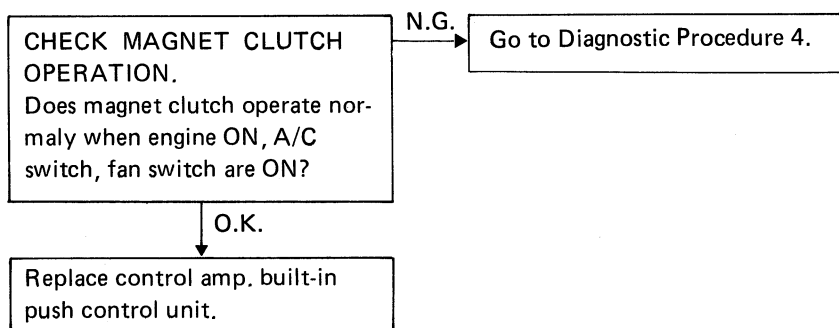

Note:

If the result is N.G. after checking circuit continuity, repair harness or connector.

TROUBLE DIAGNOSES

Diagnostic Procedure 5 (Cont'd)

DIAGNOSTIC PROCEDURE 5-3

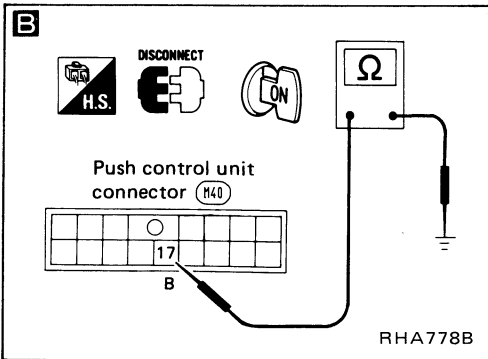
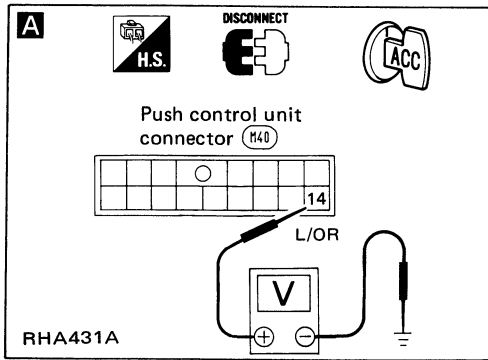

Turn ignition switch and lighting switch OFF.

Disconnect push control unit harness connector.

A

CHECK POWER SUPPLY FOR PUSH CONTROL UNIT. Do approx. 12 volts exist between push control unit harness terminal No. ⑭ and body ground?

N.G.

Check 10A fuse at fuse block. (Refer to "POWER SUPPLY ROUTING" in EL section and A/C ELECTRICAL CIRCUIT.)

O.K.

Note

B

CHECK BODY GROUND CIRCUIT FOR PUSH CONTROL UNIT. Does continuity exist between push control unit harness terminal No. ⑰ and body ground?

O.K.

Replace control amp. built-in push control unit.

Note:

If the result is N.G. after checking circuit continuity, repair harness or connector.

TROUBLE DIAGNOSES

Diagnostic Procedure 5 (Cont'd)

DIAGNOSTIC PROCEDURE 5-4

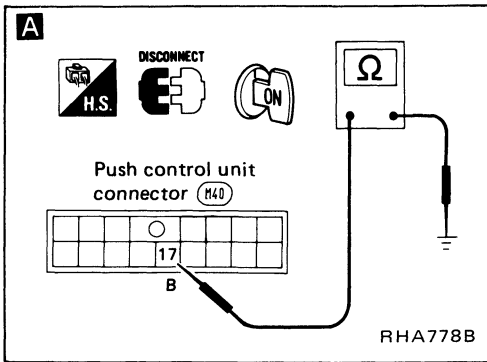

Turn ignition switch and lighting switch OFF.

Disconnect push control unit harness connector.

A Note

CHECK BODY GROUND CIRCUIT FOR PUSH CONTROL UNIT.
Does continuity exist between push control unit harness terminal No. ⑰ and body ground?

O.K.

Replace control amp. built-in push control unit.

Note:

If the result is N.G. after checking circuit continuity, repair harness or connector.

TROUBLE DIAGNOSES

Electrical Components Inspection

FAN SWITCH

Check continuity between terminals at each switch position.

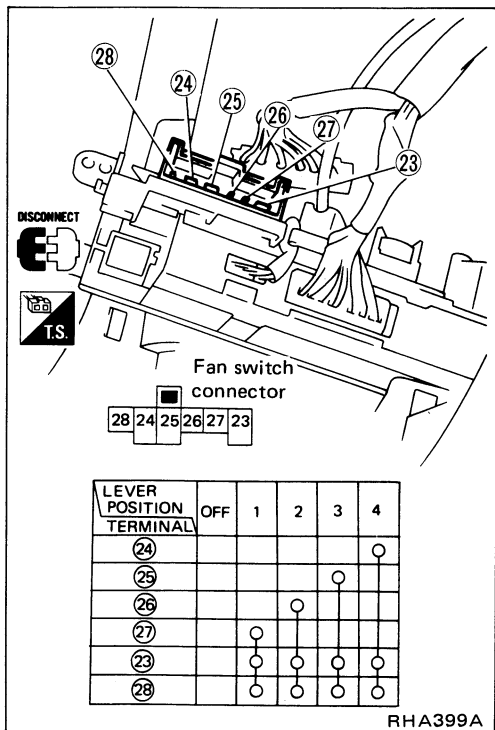

BLOWER MOTOR

Confirm smooth rotation of the blower motor.

- Ensure that there are no foreign particles inside the intake unit.

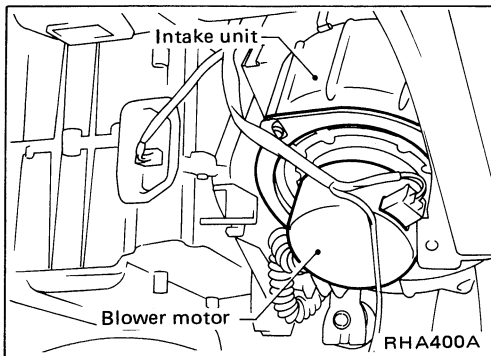

BLOWER RESISTOR

Check continuity between terminals.

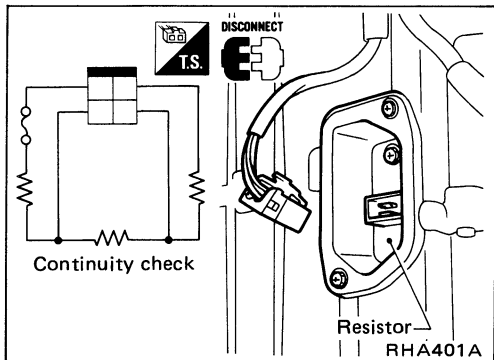

TROUBLE DIAGNOSES

Electrical Components Inspection (Cont'd)

A/C SWITCH

Check continuity between terminals at each switch position.

DISCONNECT

Push control unit

TS

Push control unit connector

Switch condition		Terminal No.		Continuity
A/C	DEF	⊕	⊖	
ON	ON			Yes
ON	OFF	⑬	⑫	
OFF	ON			

RHA469A

DUAL-PRESSURE SWITCH

Dual-pressure switch

DISCONNECT

TS

RHA470A

High-pressure side line pressure kPa (kg/cm ² , psi)	Operation	Continuity
Decreasing to 177 - 216 (1.8 - 2.2, 26 - 31) Increasing to 2,452 - 2,844 (25 - 29, 356 - 412)	Turn OFF	Does not exist
Increasing to 177 - 235 (1.8 - 2.4, 26 - 34) Decreasing to 1,863 - 2,256 (19 - 23, 270 - 327)	Turn ON	Exists

TROUBLE DIAGNOSES

Electrical Components Inspection (Cont'd)

THERMO CONTROL AMP.

1. Run engine, and operate A/C system.
2. Connect the voltmeter from harness side.
3. Check thermo control amp. operation shown in the table.

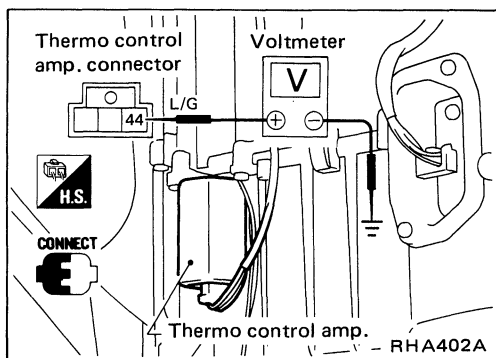

Evaporator outlet air temperature °C (°F)	Thermo amp. operation	Tester
Decreasing to 1.5 - 2.5 (35 - 37)	Turn OFF	Approx. 12V
Increasing to 3.0 - 4.0 (37 - 39)	Turn ON	Approx. 0V

A/C RELAY

Check circuit continuity between terminals by supplying 12 volts to coil side terminal of A/C relay.

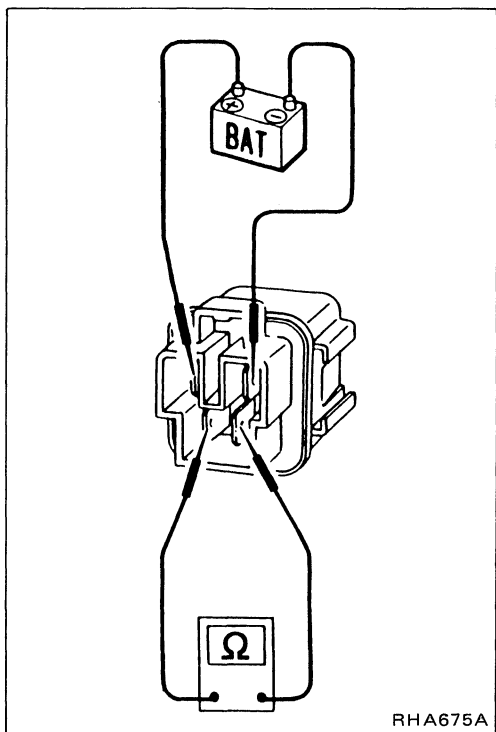

ENGINE TEMPERATURE SWITCH

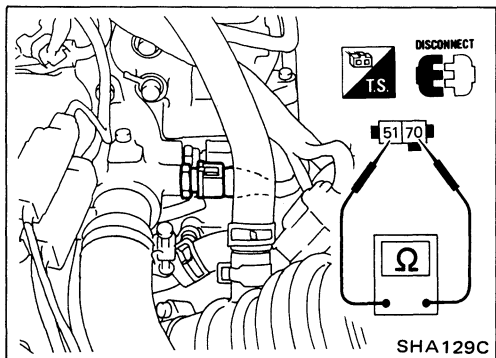

Water temperature °C (°F)	Operation	Continuity
Decreasing to 85 - 91 (185 - 196)	Turn OFF	Does not exist
Increasing to 92 - 98 (198 - 208)	Turn ON	Exists

Control Cable Adjustment

- When disconnecting control cable, remove E-ring and take off cable while pushing cable outer.

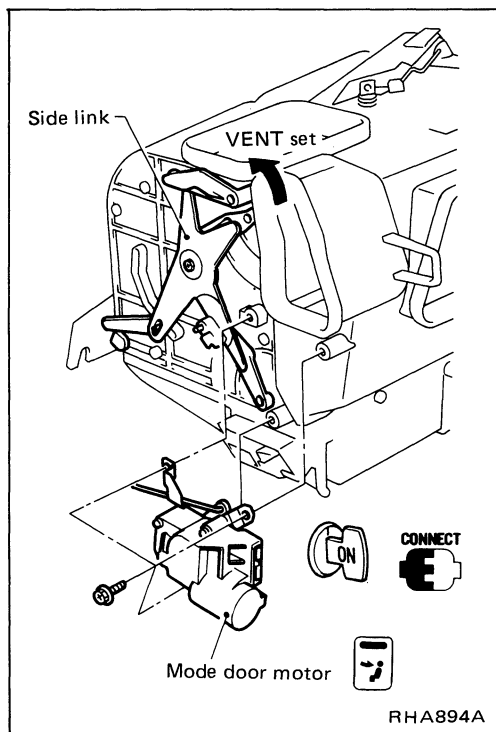

MODE DOOR

1. Move side link with hand and hold mode door in VENT mode.
2. Install mode door motor on heater unit and connect it to body harness.
3. Turn ignition switch to ON.
4. Turn VENT switch ON.
5. Attach mode door motor rod to side link rod holder.
6. Turn DEF switch ON. Check that side link operates at the fully-open position. Also turn VENT switch ON to check that side link operates at the fully-open position.

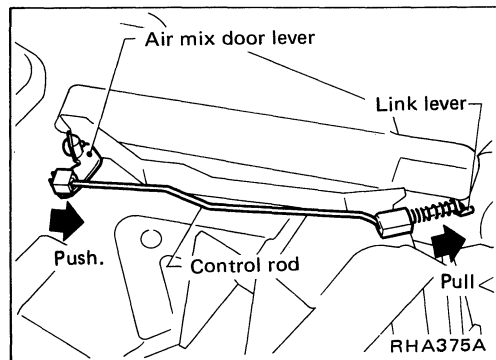

WATER COCK CONTROL ROD

- When adjusting water cock control rod, first disconnect temperature control cable from air mix door lever. Reconnect and readjust temperature control cable.

1. Push air mix door lever in direction of arrow.
2. Pull control rod of water cock in direction of arrow so as to give a clearance of about 2 mm (0.08 in) between ends of rod and link lever. Connect control rod to door lever.

After connecting control rod, check it operates properly.

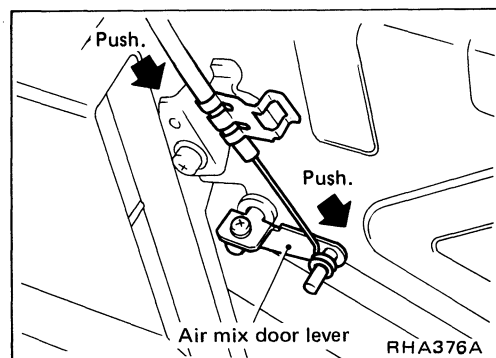

TEMPERATURE CONTROL CABLE

- Move temperature control lever to full hot position. Push air mix door lever in direction of arrow. Pull on outer cable in direction of arrow and then clamp it.

After positioning control cable, check it operates properly.

TROUBLE DIAGNOSES

Control Cable Adjustment (Cont'd)

INTAKE DOOR

1. Connect intake door motor harness connector before installing on intake door motor.
2. Turn ignition switch to ON.
3. Turn REC switch ON.
4. Install intake door lever and intake door motor.
5. Set intake door rod in REC and secure door rod to holder.
6. Check that intake door operates properly when REC switch is turned ON and OFF.

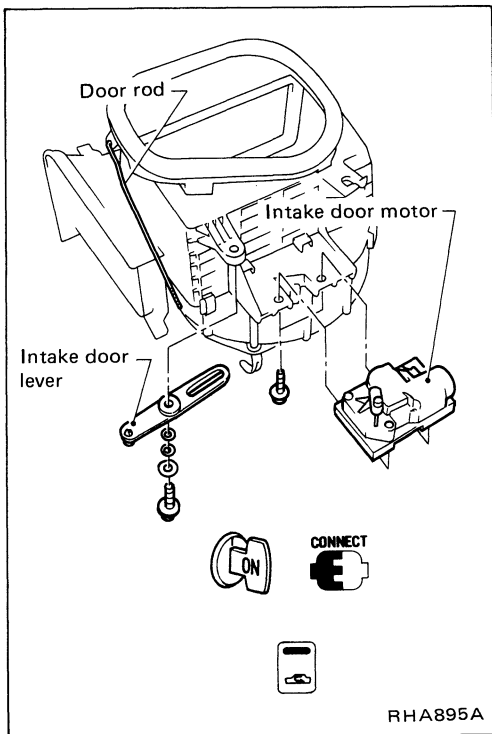

Push Control System

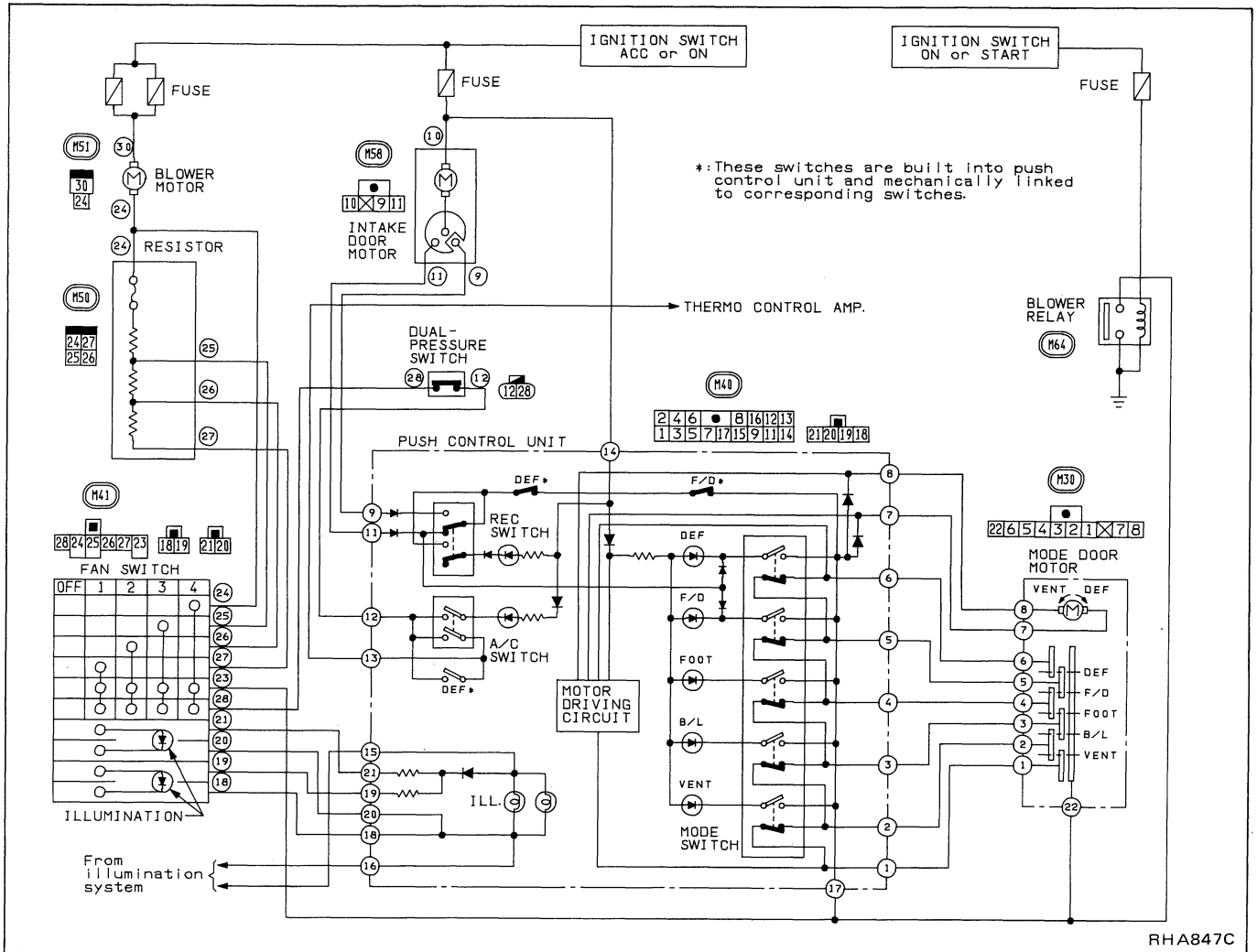

This push control system operates the intake and mode door motors to activate their corresponding doors.

SWITCHES AND THEIR CONTROL FUNCTIONS

Switch	Indicator illuminates							Air outlet	Intake air	Compressor
	A/C									
A/C	○									ON*1
Mode			○					VENT		
				○				B/L		
					○			FOOT		
						○		F/D	FRE	
							○	DEF	FRE	ON*1
									○*2	REC

*1: Compressor is operated by thermo control amp.

*2: It depends on mode switch position.

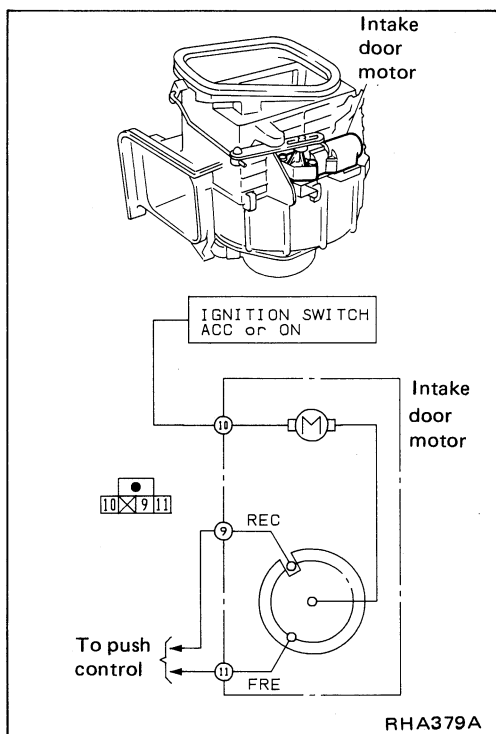

Intake Door Motor

The intake door motor is installed on the front portion of the intake unit. Using a rod and link it opens and closes the intake door.

When the REC switch is ON (OFF), the ground line of the intake door motor is switched from terminal ⑩ to ⑨ (⑨ to ⑩). This causes the motor to start because the position switch contacts built into it are set to the current flow position. The contacts turn along with the motor. When they reach the non-current flow position, the motor will stop. The motor always turns in the same direction.

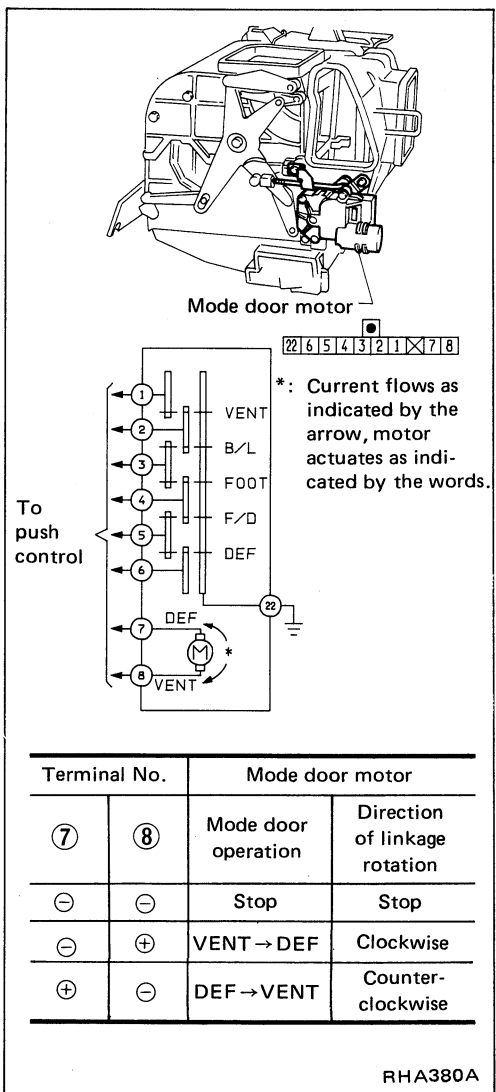

Mode Door Motor

The mode door motor is located on the left side of the heater unit. Through the side link it opens and closes the vent, foot and defroster door.

When one mode switch is pushed, the position switch built into it reads the corresponding mode to determine the direction of motor rotation. As soon as the desired mode is set, the position switch stops the motor.

Removal and Installation

1. Remove cluster lid C.

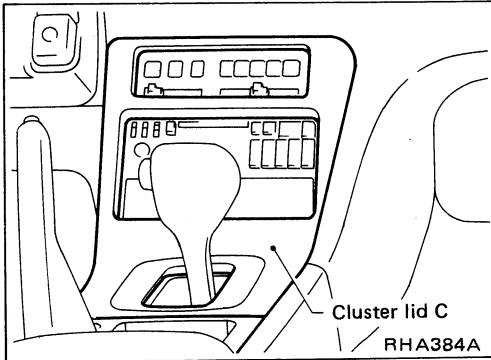

2. Remove audio (radio).
3. Remove four screws of push control unit.
4. Remove temperature control cable.
5. Disconnect push control unit harness connectors.
6. Remove push control unit.
7. Installation is in the reverse order of removal.

Refer to Control Cable Adjustment for temperature control cable.

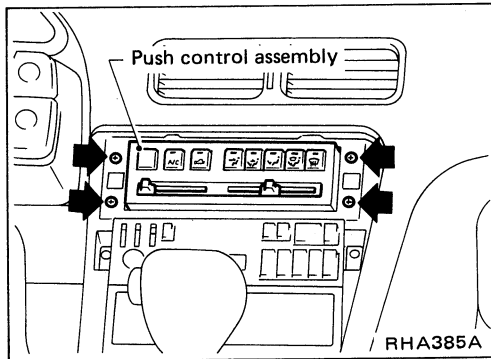

Overhaul — Push control unit assembly

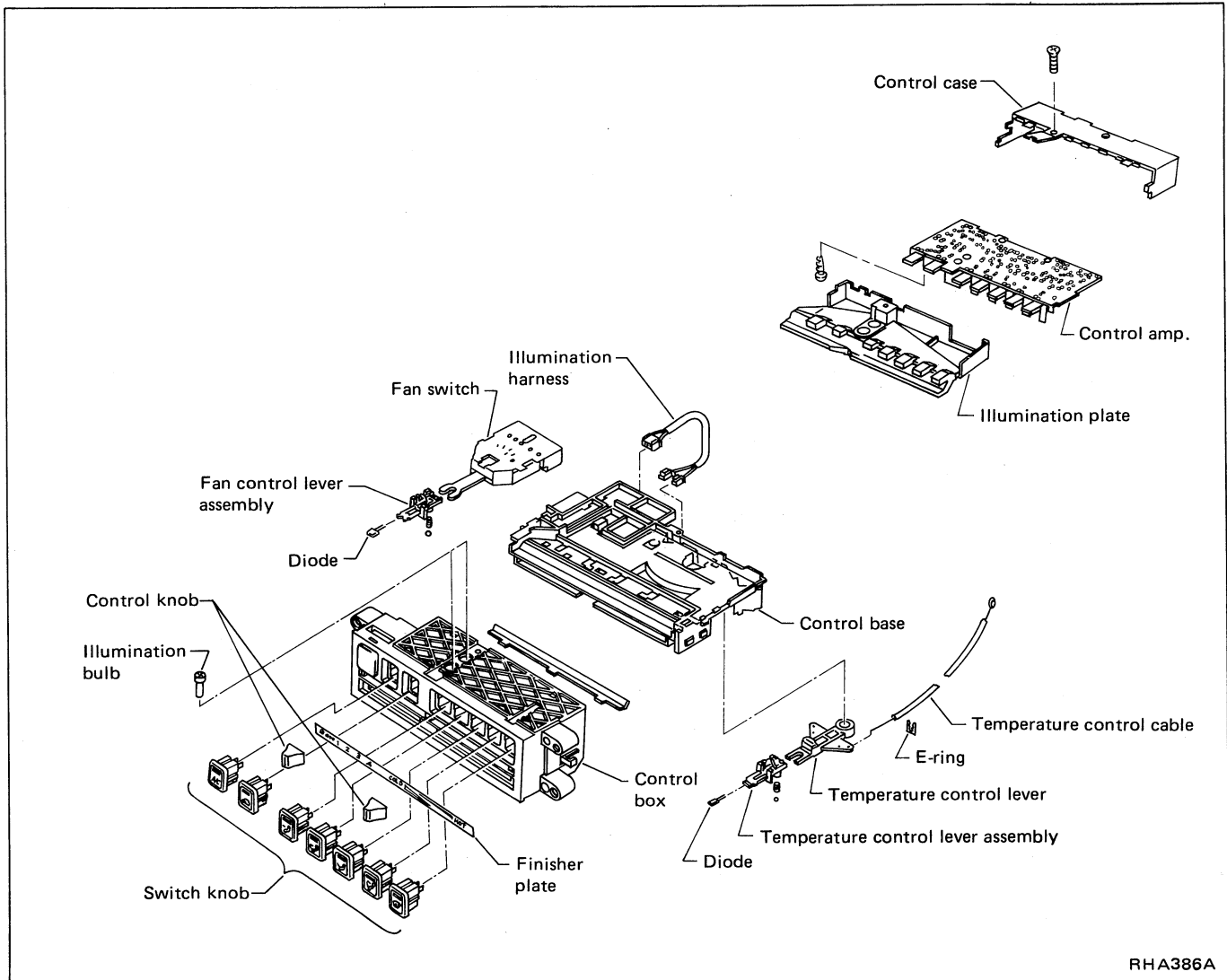

SYSTEM DESCRIPTION — Push Control

Overhaul — Push control unit assembly (Cont'd)

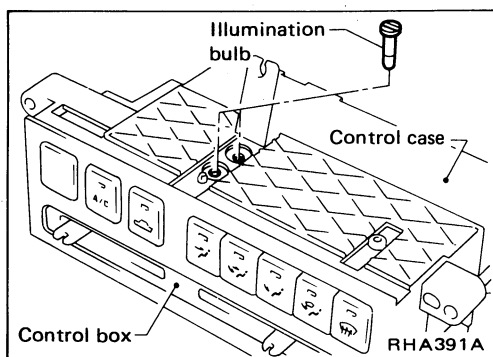
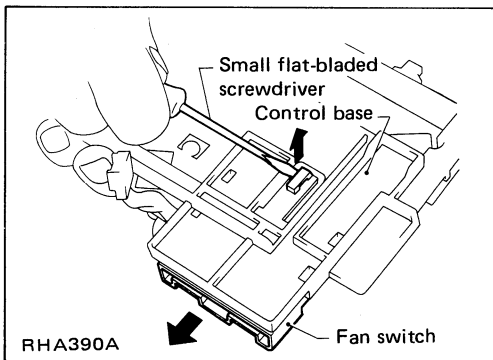
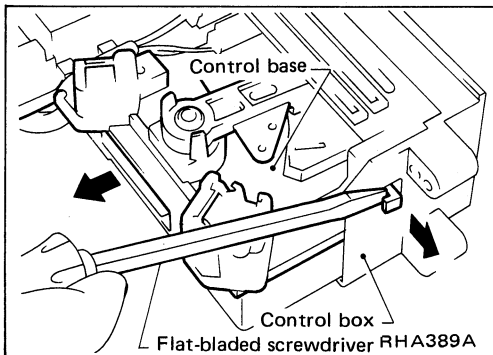
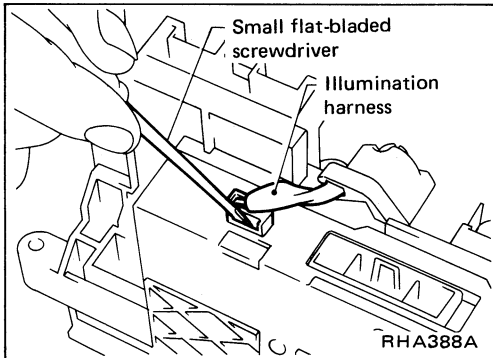
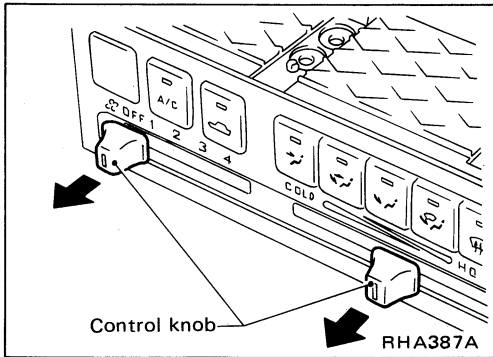

1. Remove control knobs.

Wrap knobs with a cloth and pull in direction indicated by arrow as shown in figure at left. Be careful not to scratch knobs during removal.

2. Disconnect illumination harness connectors.

3. Remove control base.

Undo hook at each end of control box and remove control base from control box by moving it in direction indicated by arrow.

4. Remove fan switch.

5. Remove illumination bulb.

SYSTEM DESCRIPTION — Push Control

Overhaul — Push control unit assembly (Cont'd)

6. Remove control knobs.

Wrap finisher with a cloth and remove knobs using pliers or similar tool. Be careful not to scratch finisher's surface.

7. Remove control case.

8. Remove illumination plate.

Be careful not to scratch control amp. when removing illumination plate.

9. Remove finisher plate.

10. Remove control amp.

Be careful not to damage substrate when removing.

11. Disconnect temperature control cable.

12. Installation is in reverse order of removal.

SERVICE DATA AND SPECIFICATIONS (S.D.S.)

General Specifications

COMPRESSOR

Model	CALSONIC make V-5
Type	V-5 variable displacement
Displacement cm ³ (cu in)/rev.	
Max.	146 (8.91)
Min.	3 (0.18)
Cylinder bore x stroke mm (in)	36.1 (1.421) x [0.6 - 28.6 (0.024 - 1.126)]
Direction of rotation	Clockwise (viewed from drive end)
Drive belt	Poly V

LUBRICATION OIL

Model	CALSONIC make V-5
Type	SUNISO 5GS or equivalent
Capacity ml (US fl oz, Imp fl oz)	
Total in system	236 (8.0, 8.3)
Amount of oil which can be drained	95 (3.2, 3.3)
Compressor (Service part) charging amount	236 (8.0, 8.3)

REFRIGERANT

Type	R-12
Capacity kg (lb)	0.8 - 0.9 (1.8 - 2.0)

Inspection and Adjustment

ENGINE IDLING SPEED (When A/C is ON)

- Refer to EF & EC section.

BELT TENSION

- Refer to Checking Drive Belts (MA section).

COMPRESSOR

Model	CALSONIC make V-5
Clutch disc-pulley clearance mm (in)	0.3 - 0.6 (0.012 - 0.024)

ELECTRICAL SYSTEM

SECTION **EL**

When you read wiring diagrams:

- Read G1 section, "HOW TO READ WIRING DIAGRAMS".

CONTENTS

HARNESS CONNECTOR	EL- 2
STANDARDIZED RELAY	EL- 3
POWER SUPPLY ROUTING	EL- 5
BATTERY	EL- 7
STARTING SYSTEM	EL- 15
STARTING SYSTEM — Starter —	EL- 17
CHARGING SYSTEM	EL- 22
CHARGING SYSTEM — Alternator —	EL- 24
COMBINATION SWITCH	EL- 28
HEADLAMP	EL- 31
EXTERIOR LAMP	EL- 42
INTERIOR LAMP	EL- 50
METER AND GAUGES	EL- 52
WARNING LAMPS AND CHIME	EL- 59
TIME CONTROL SYSTEM	EL- 63
WIPER AND WASHER	EL- 73
HORN, CIGARETTE LIGHTER AND CLOCK	EL- 78
REAR WINDOW DEFOGGER	EL- 79
AUDIO AND POWER ANTENNA	EL- 82
AUTOMATIC SPEED CONTROL DEVICE (A.S.C.D.)	EL- 87
LOCATION OF ELECTRICAL UNITS	EL- 97
HARNESS LAYOUT	EL-101
SPECIAL SERVICE TOOL	EL-118
SUPER MULTIPLE JUNCTION (S.M.J.)	EL-119

WIRING DIAGRAM REFERENCE CHART

E.C.C.S.	PULL-OUT FOLLOWING PAGE EL-124
A/T CONTROL, SHIFT LOCK CONTROL	AT SECTION
ANTI-LOCK BRAKING SYSTEM	BR SECTION
SUPER HICAS SYSTEM	ST SECTION
ELECTRIC DOOR MIRROR, SUN ROOF, DOOR LOCK, POWER WINDOW AND AUTOMATIC SEAT BELT	BF SECTION
HEATER AND AIR CONDITIONER	HA SECTION

EL

HARNESS CONNECTOR

Description

HARNESS CONNECTOR

- All harness connectors have been modified to prevent accidental looseness or disconnection.
- The connector can be disconnected by pushing or lifting the locking section.

CAUTION:

Do not pull the harness when disconnecting the connector.

[Example]

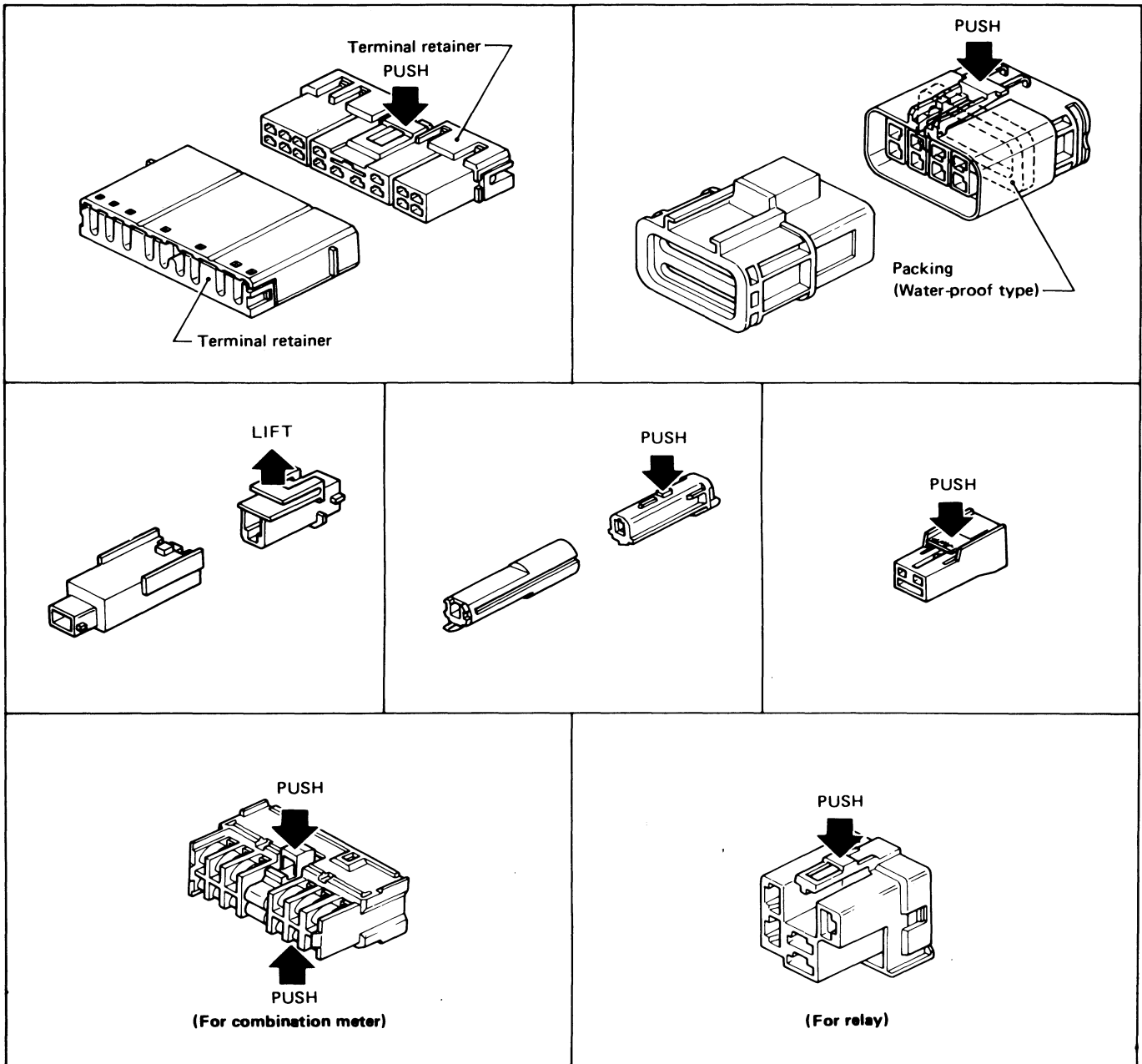

SEL769D

STANDARDIZED RELAY

Description

NORMAL OPEN, NORMAL CLOSED AND MIXED TYPE RELAYS

Relays can mainly be divided into three types: normal open, normal closed and mixed type relays.

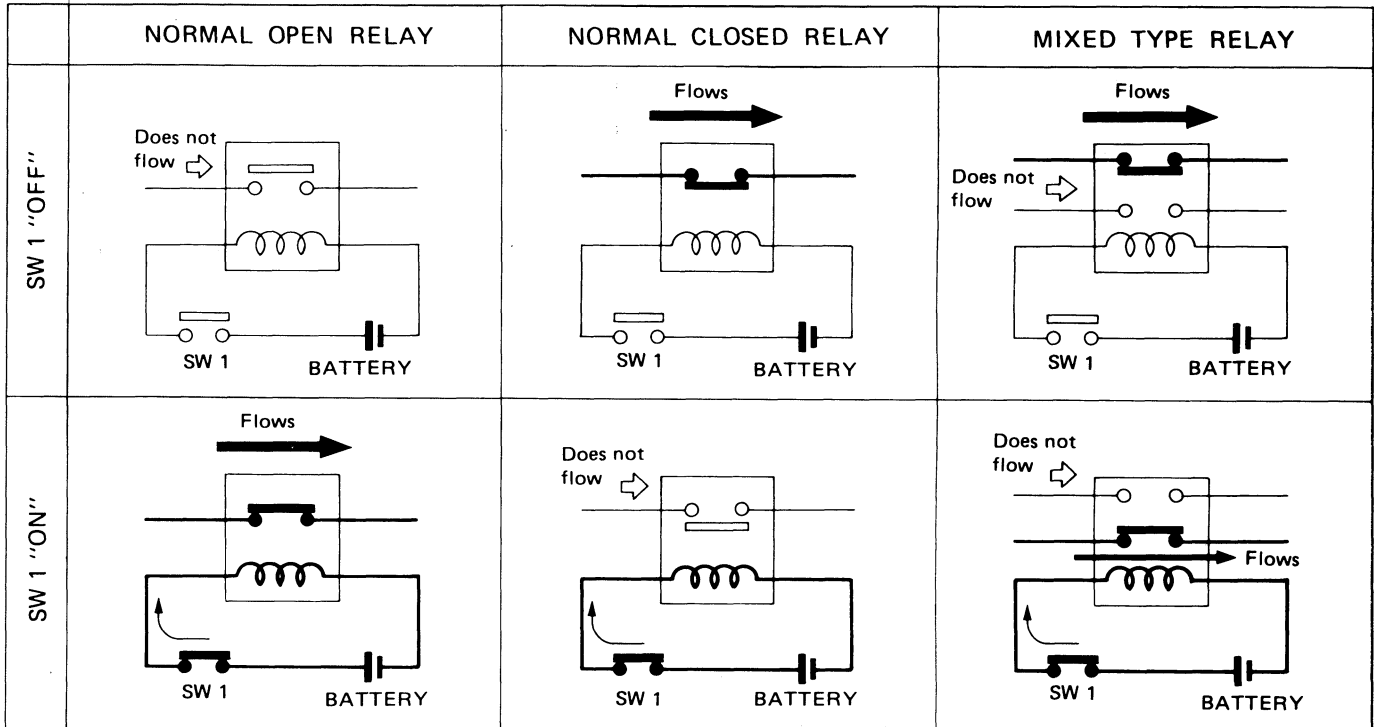

SEL881H

TYPE OF STANDARDIZED RELAYS

1M 1 Make

2M 2 Make

1T 1 Transfer

1M·1B 1 Make 1 Break

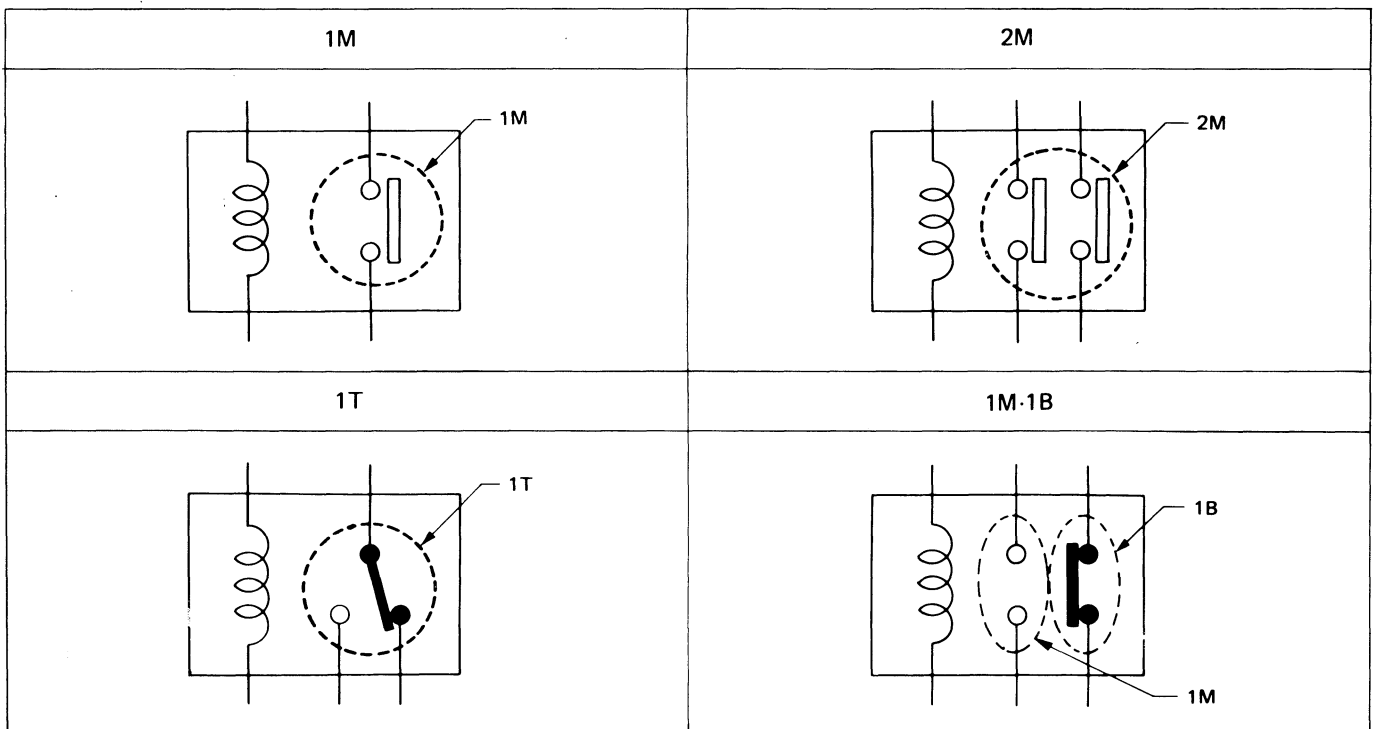

SEL882H

STANDARDIZED RELAY

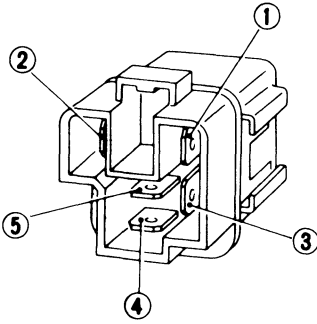
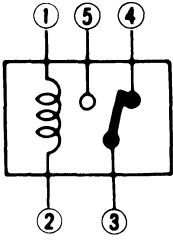
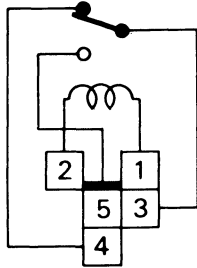
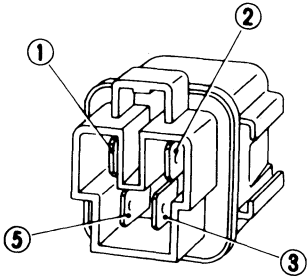
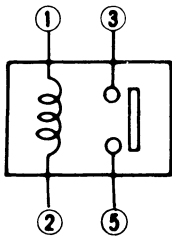
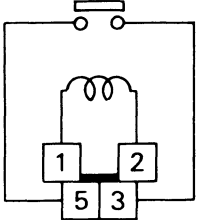
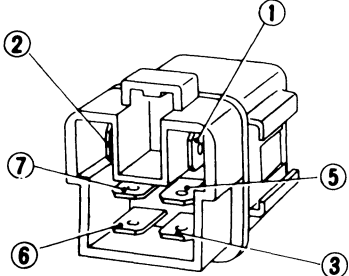
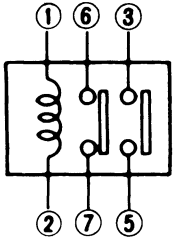
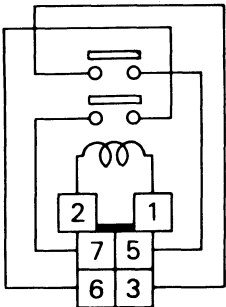
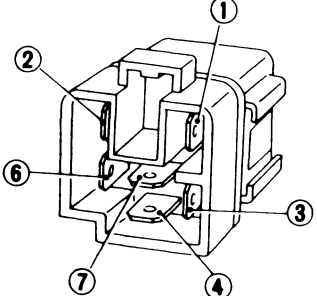
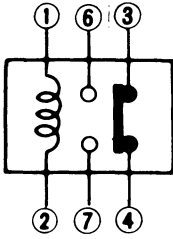
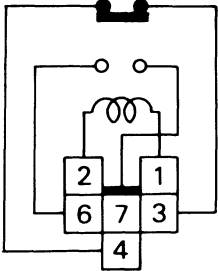
Type	Outer view	Circuit	Connector symbol and connection	Case color
1T				BLACK
1M				BLUE or GREEN
2M				BROWN
1M-1B				GRAY

SEL883H

POWER SUPPLY ROUTING

Wiring Diagram

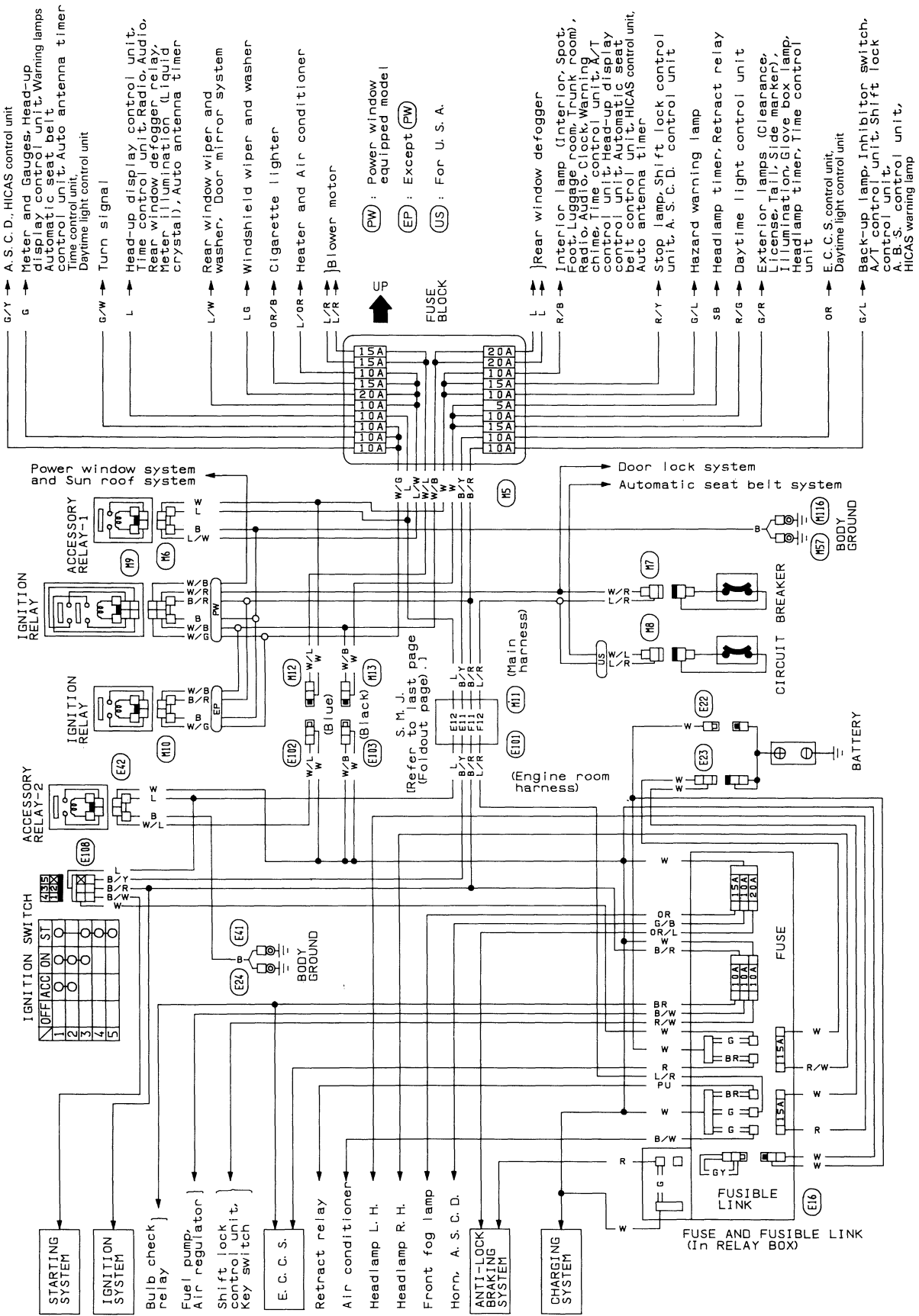

POWER SUPPLY ROUTING

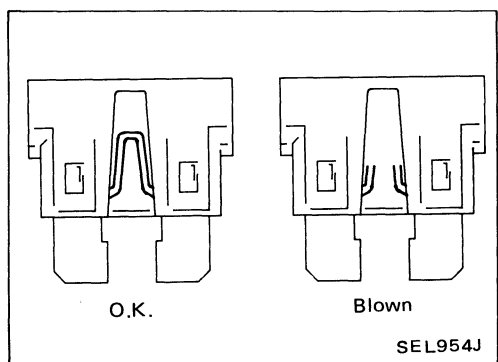

Fuse

- If fuse is blown, be sure to eliminate cause of problem before installing new fuse.
- Use fuse of specified rating. Never use fuse of more than specified rating.
- Do not install fuse in oblique direction; always insert it into fuse holder properly.
- Remove fuse for clock if vehicle is not used for a long period of time.

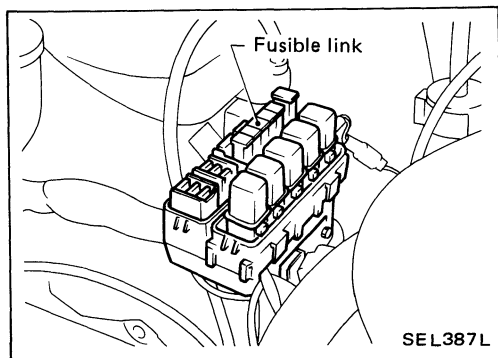

Fusible Link

A melted fusible link can be detected either by visual inspection or by feeling with finger tip. If its condition is questionable, use circuit tester or test lamp.

CAUTION:

- If fusible link should melt, it is possible that critical circuit (power supply or large current carrying circuit) is shorted. In such a case, carefully check and eliminate cause of problem.
- Never wrap periphery of fusible link with vinyl tape. Extreme care should be taken with this link to ensure that it does not come into contact with any other wiring harness or vinyl or rubber parts.

BATTERY

CAUTION:

- If it becomes necessary to start the engine with a booster battery and jumper cables, use a 12-volt booster battery.
- After connecting battery cables, ensure that they are tightly clamped to battery terminals for good contact.
- Never add distilled water through the hole used to check specific gravity.

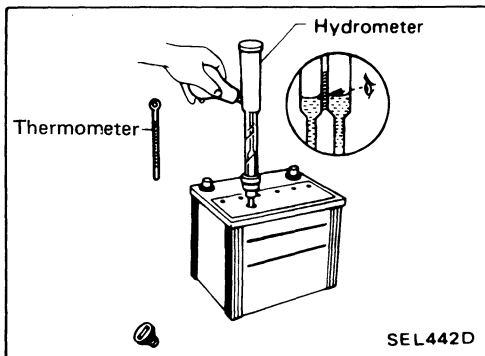
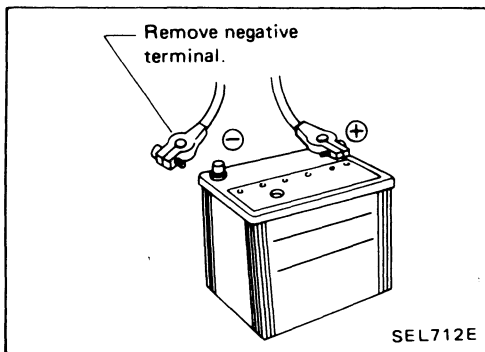
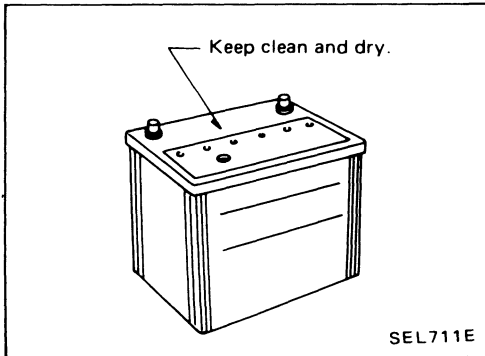

How to Handle Battery

METHODS OF PREVENTING OVER-DISCHARGE

The following precautions must be taken to prevent over-discharging a battery..

- The battery surface (particularly its top) should always be kept clean and dry.
If the top surface of a battery is wet with electrolyte or water, leakage current will cause the battery to discharge. Always keep the battery clean and dry.
- When the vehicle is not going to be used over a long period of time, disconnect the negative battery terminal. (If the vehicle has an extended storage switch, turn it off.)
- Check the charge condition of the battery.
Periodically check the specific gravity of the electrolyte. Keep a close check on charge condition to prevent over-discharge.

BATTERY

How to Handle Battery (Cont'd)

CHECKING ELECTROLYTE LEVEL

WARNING:

Do not allow battery fluid to come in contact with skin, eyes, fabrics, or painted surfaces. After touching a battery, do not touch or rub your eyes until you have thoroughly washed your hands. If the acid contacts the eyes, skin or clothing, immediately flush with water for 15 minutes and seek medical attention.

Normally the battery does not require additional water. However, when the battery is used under severe conditions, adding distilled water may be necessary during the battery life.

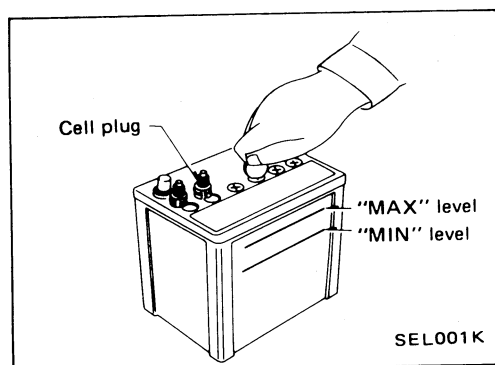

- Remove the cell plug using a suitable tool.
- Add distilled water up to the MAX level.

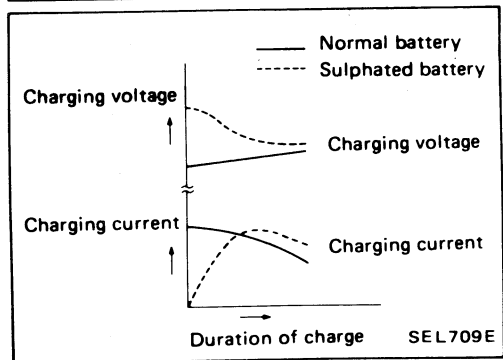

SULPHATION

When a battery has been left unattended for a long period of time and has a specific gravity of less than 1.100, it will be completely discharged, resulting in sulphation on the cell plates.

Compared with a battery discharged under normal conditions, the current flow in a "sulphated" battery is not as smooth although its voltage is high during the initial stage of charging, as shown in the figure at the left.

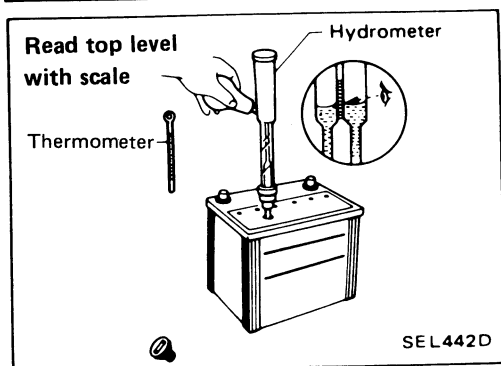

SPECIFIC GRAVITY CHECK

1. Read hydrometer and thermometer indications at eye level.

BATTERY

How to Handle Battery (Cont'd)

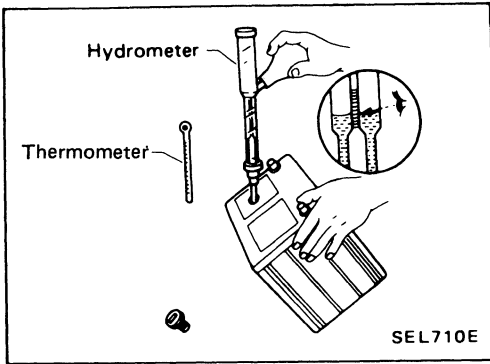

- When electrolyte level is too low, tilt battery case to raise it for easy measurement.

2. Convert into specific gravity at 20°C (68°F).

Example:

- When electrolyte temperature is 35°C (95°F) and specific gravity of electrolyte is 1.230, converted specific gravity at 20°C (68°F) is 1.240.
- When electrolyte temperature is 0°C (32°F) and specific gravity of electrolyte is 1.210, converted specific gravity at 20°C (68°F) is 1.196.

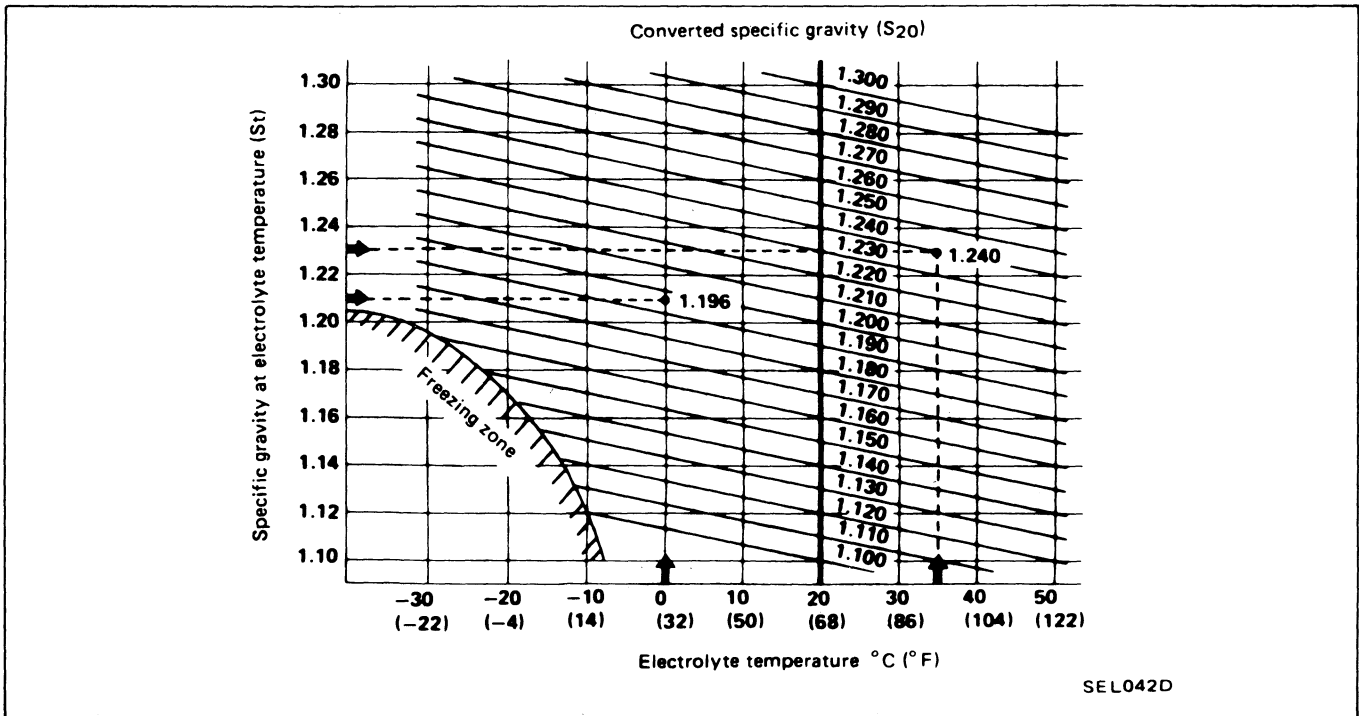

BATTERY

Battery Test and Charging Chart

Chart I

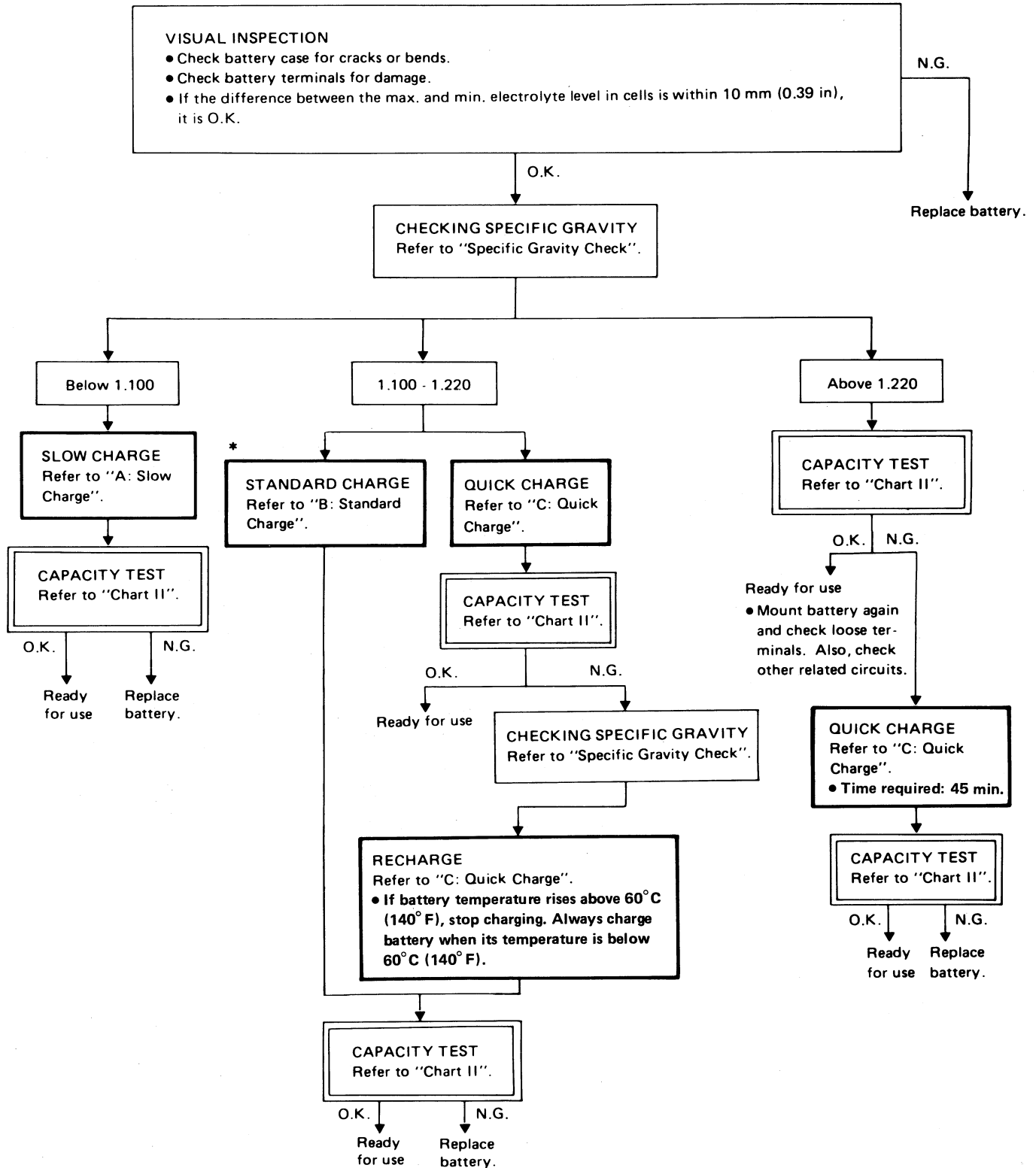

* "STANDARD CHARGE" is recommended in case shaft the vehicle is in storage after charging.

BATTERY

Battery Test and Charging Chart (Cont'd)

Chart II

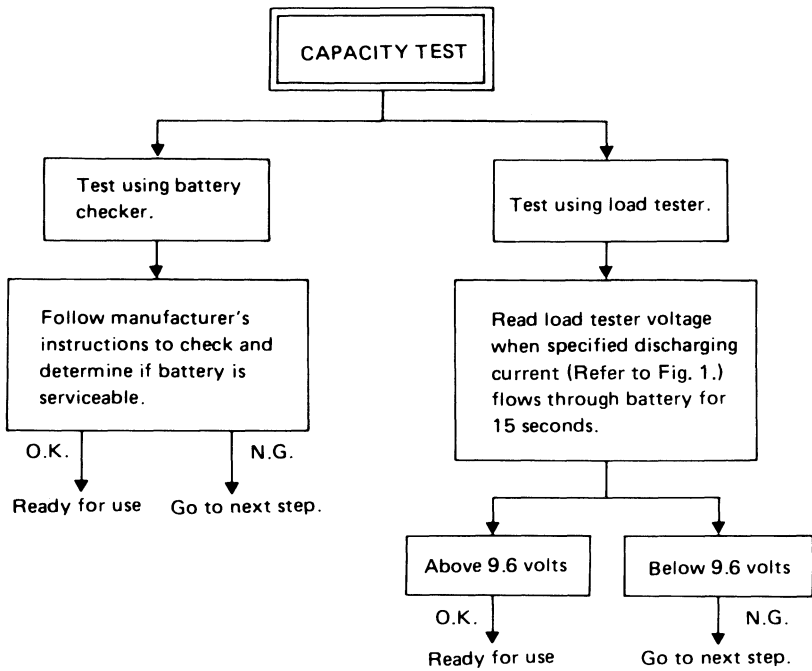

- Check battery type and determine the specified current using the following table.

Fig. 1 DISCHARGING CURRENT (Load tester)

Type	Current (A)
28B19R(L)	90
34B19R(L)	99
46B24R(L)	135
55B24R(L)	135
50D23R(L)	150
55D23R(L)	180
65D26R(L)	195
80D26R(L)	195
75D31R(L)	210
95D31R(L)	240
95E41R(L)	300
130E41R(L)	330

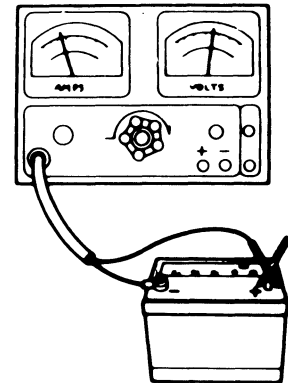

SEL697B

BATTERY

Battery Test and Charging Chart (Cont'd)

A: SLOW CHARGE

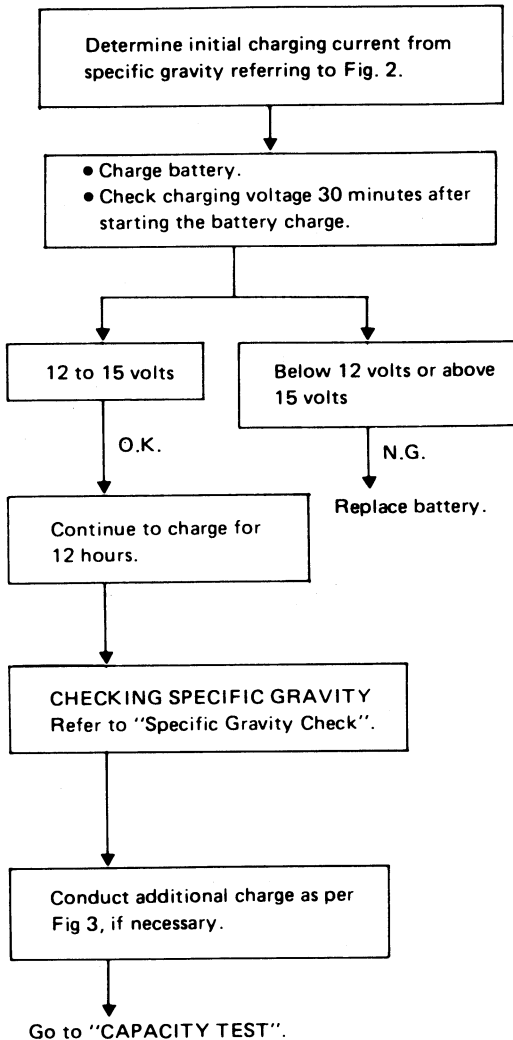
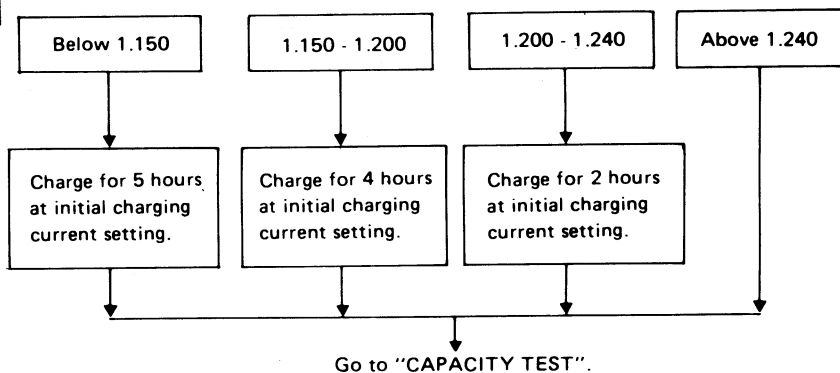

Fig. 2 INITIAL CHARGING CURRENT SETTING (Slow charge)

BATTERY TYPE CON- VERTED SPECIFIC GRAVITY	28B19R(L)	34B19R(L)	46B24R(L)	55B24R(L)	50D23R(L)	55D23R(L)	65D26R(L)	80D26R(L)	75D31R(L)	95D31R(L)	95E41R(L)	130E41R(L)
	Below 1.100	4.0 (A)	5.0 (A)	7.0 (A)	8.0 (A)	9.0 (A)	10.0 (A)	14.0 (A)				

- Check battery type and determine the specified current using the table shown above.
- After starting charging, adjustment of charging current is not necessary.

Fig. 3 ADDITIONAL CHARGE (Slow charge)



CAUTION:

- Set charging current to value specified in Fig. 2. If charger is not capable of producing specified current value, set its charging current as close to that value as possible.
- Keep battery away from open flame while it is being charged.
- When connecting charger, connect leads first, then turn on charger. Do not turn on charger first, as this may cause a spark.
- If battery temperature rises above 60°C (140°F), stop charging. Always charge battery when its temperature is below 60°C (140°F).

BATTERY

Battery Test and Charging Chart (Cont'd)

B: STANDARD CHARGE

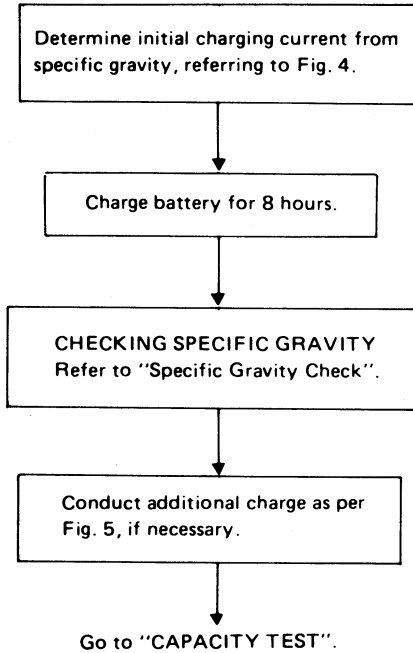
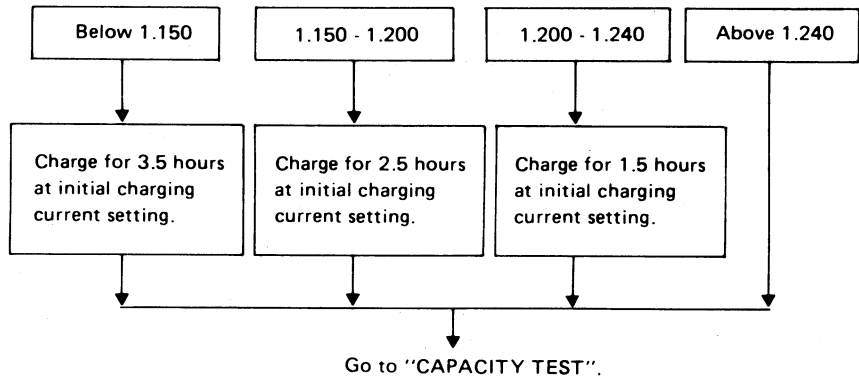

Fig. 4 INITIAL CHARGING CURRENT SETTING
(Standard charge)

BATTERY TYPE CON- VERTED SPECIFIC GRAVITY	28B19R(L) 34B19R(L)		46B24R(L) 55B24R(L)		50D23R(L) 55D23R(L)		65D26R(L) 80D26R(L)		75D31R(L)	95D31R(L) 95E41R(L)		130E41R(L)
	1.100 - 1.130	1.130 - 1.160	1.160 - 1.190	1.190 - 1.220	4.0 (A)	5.0 (A)	6.0 (A)	7.0 (A)	8.0 (A)	9.0 (A)	13.0 (A)	
1.100 - 1.130	4.0 (A)	5.0 (A)	6.0 (A)	7.0 (A)	8.0 (A)	9.0 (A)	13.0 (A)					
1.130 - 1.160	3.0 (A)	4.0 (A)	5.0 (A)	6.0 (A)	7.0 (A)	8.0 (A)	11.0 (A)					
1.160 - 1.190	2.0 (A)	3.0 (A)	4.0 (A)	5.0 (A)	6.0 (A)	7.0 (A)	9.0 (A)					
1.190 - 1.220	2.0 (A)	2.0 (A)	3.0 (A)	4.0 (A)	5.0 (A)	5.0 (A)	7.0 (A)					

- Check battery type and determine the specified current using the table shown above.
- After starting charging, adjustment of charging current is not necessary.

Fig. 5 ADDITIONAL CHARGE (Standard charge)



CAUTION:

- Do not use standard charge method on a battery whose specific gravity is less than 1.100.
- Set charging current to value specified in Fig. 4. If charger is not capable of producing specified current value, set its charging current as close to that value as possible.
- Keep battery away from open flame while it is being charged.
- When connecting charger, connect leads first, then turn on charger. Do not turn on charger first, as this may cause a spark.
- If battery temperature rises above 60°C (140°F), stop charging. Always charge battery when its temperature is below 60°C (140°F).

BATTERY

Battery Test and Charging Chart (Cont'd)

C: QUICK CHARGE

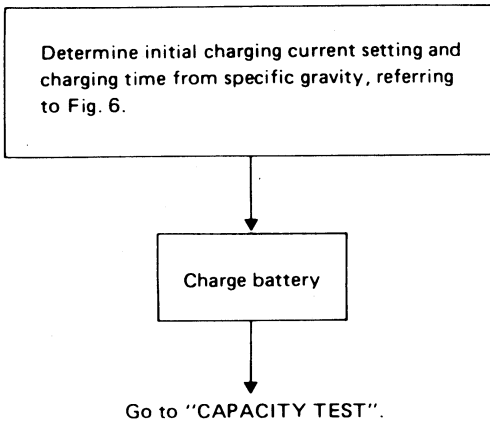

Fig. 6 INITIAL CHARGING CURRENT SETTING AND CHARGING TIME (Quick charge)

CON- VERTED SPECIFIC GRAVITY	BATTERY TYPE		CUR- RENT [A]		130E41R(L)
	28B19R(L) 34B19R(L)	46B24R(L) 55B24R(L) 50D23R(L)	55D23R(L) 65D26R(L) 80D26R(L)	75D31R(L) 95D31R(L) 95E41R(L)	
	10 (A)	15 (A)	20 (A)	30 (A)	40 (A)
1.100 - 1.130	2.5 hours				
1.130 - 1.160	2.0 hours				
1.160 - 1.190	1.5 hours				
1.190 - 1.220	1.0 hours				
Above 1.220	0.75 hours (45 min.)				

- Check battery type and determine the specified current using the table shown above.
- After starting charging, adjustment of charging current is not necessary.

CAUTION:

- Do not use quick charge method on a battery whose specific gravity is less than 1.100.
- Set initial charging current to value specified in Fig. 6. If charger is not capable of producing specified current value, set its charging current as close to that value as possible.
- Keep battery away from open flame while it is being charged.
- When connecting charger, connect leads first, then turn on charger. Do not turn on charger first, as this may cause a spark.
- Be careful of a rise in battery temperature because a large current flow is required during quick-charge operation.
If battery temperature rises above 60°C (140°F), stop charging. Always charge battery when its temperature is below 60°C (140°F).
- Do not exceed the charging time specified in Fig. 6, because charging battery over the charging time can cause deterioration of the battery.

Service Data and Specifications (S.D.S.)

Applied area	U.S.A.	Canada
Type	55D23R	65D26R
Capacity	V-AH 12-60	12-65

STARTING SYSTEM

Wiring Diagram

M/T MODEL

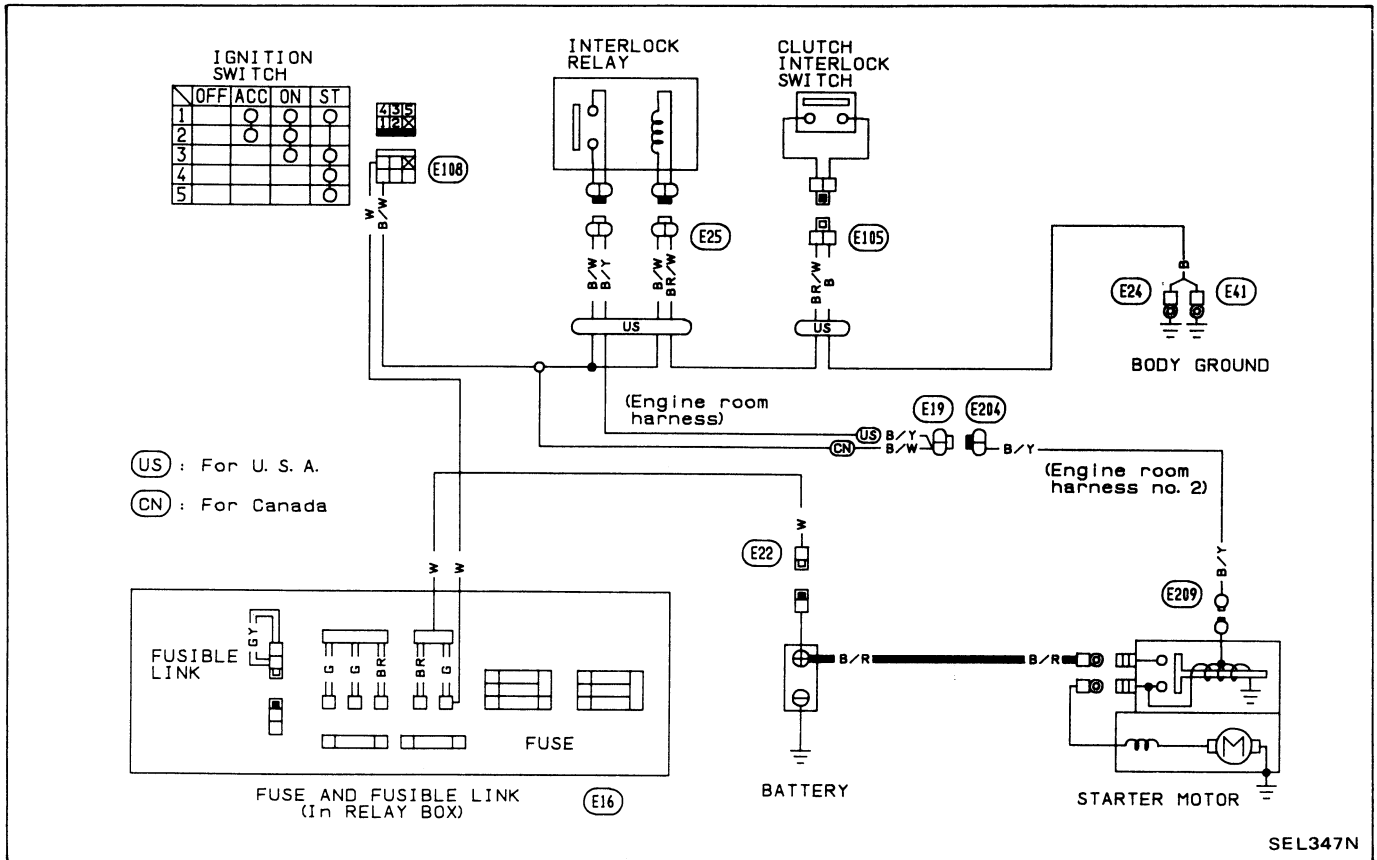

A/T MODEL

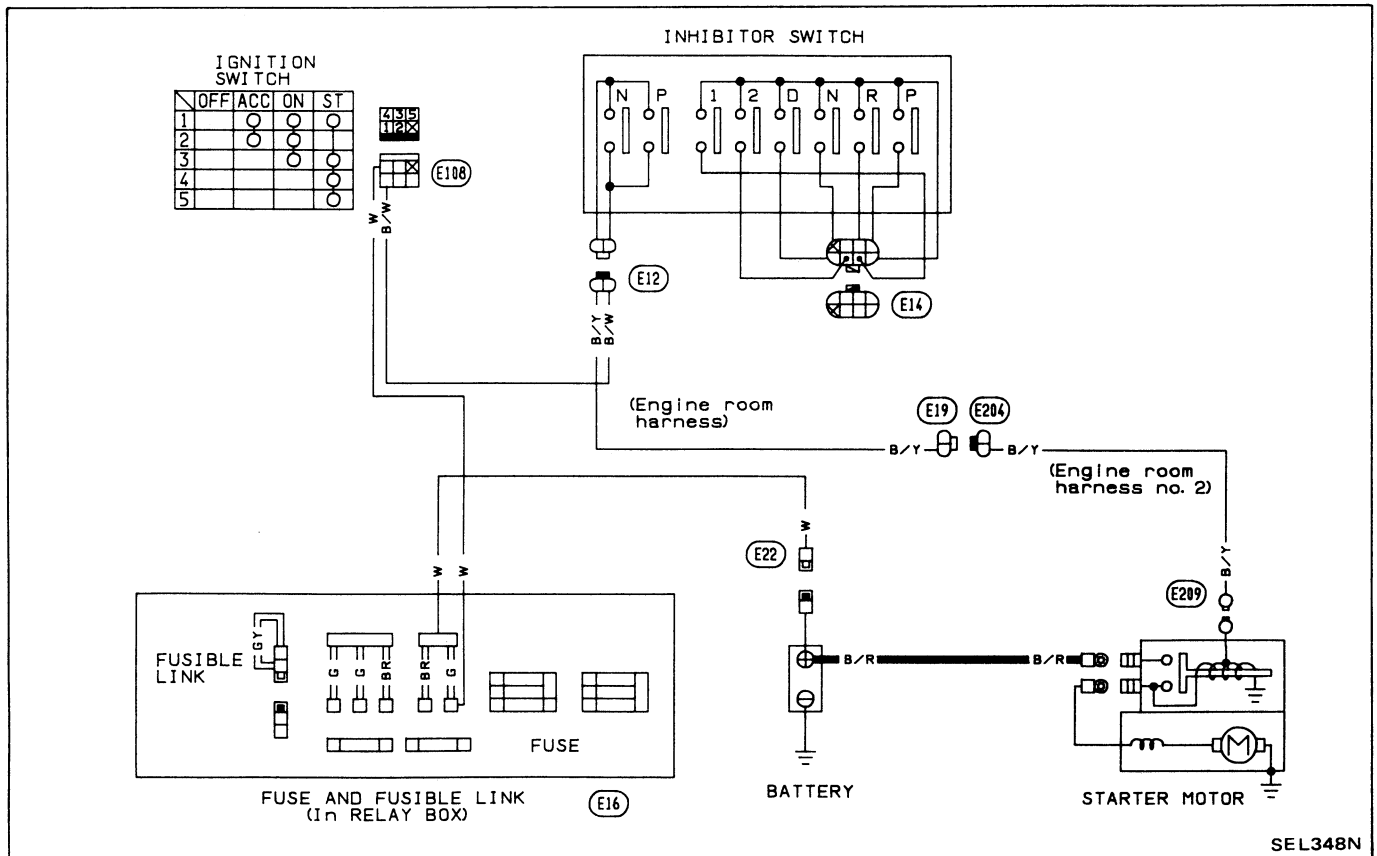

STARTING SYSTEM

TROUBLE-SHOOTING

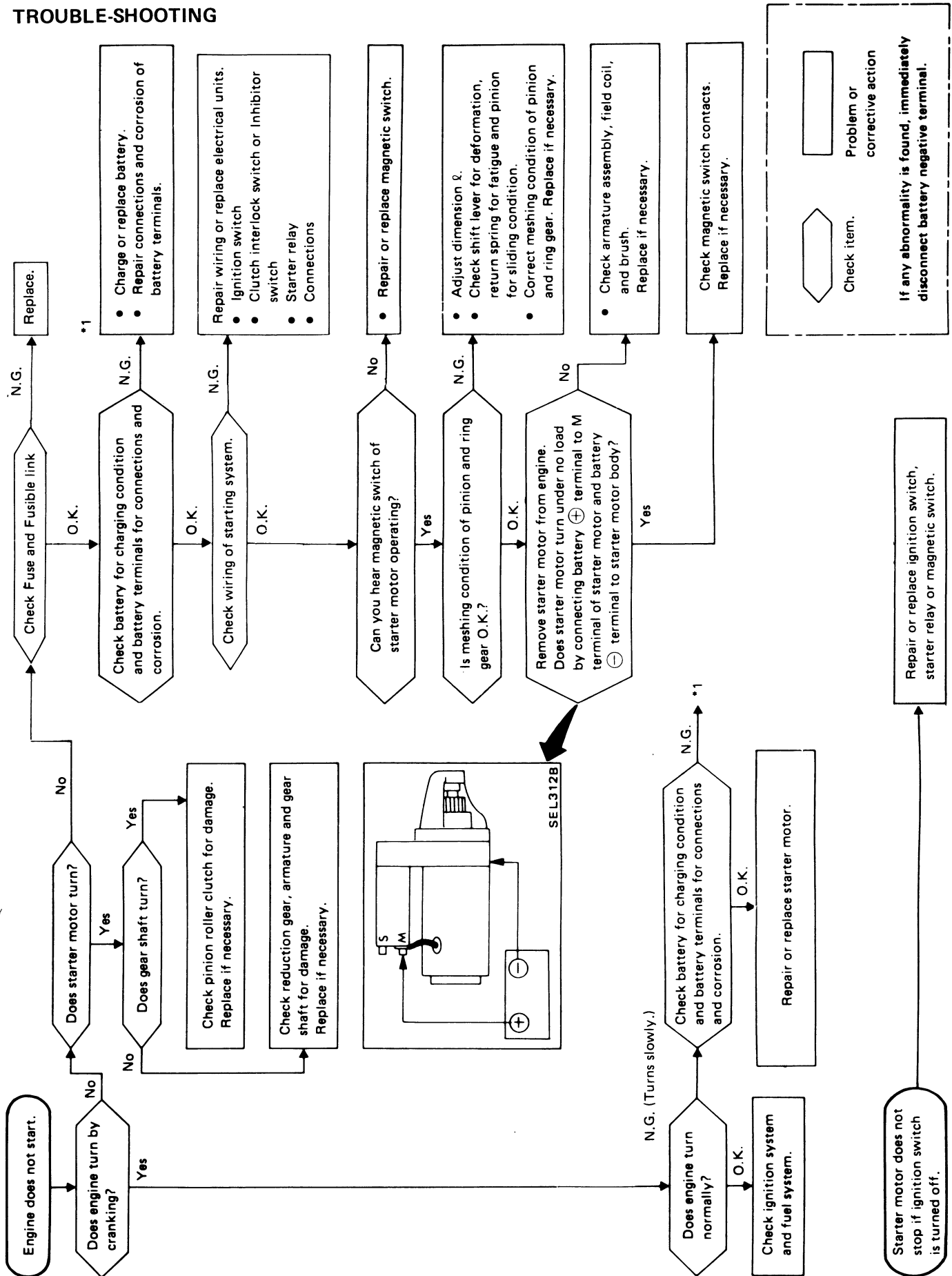

M1T72781

Construction

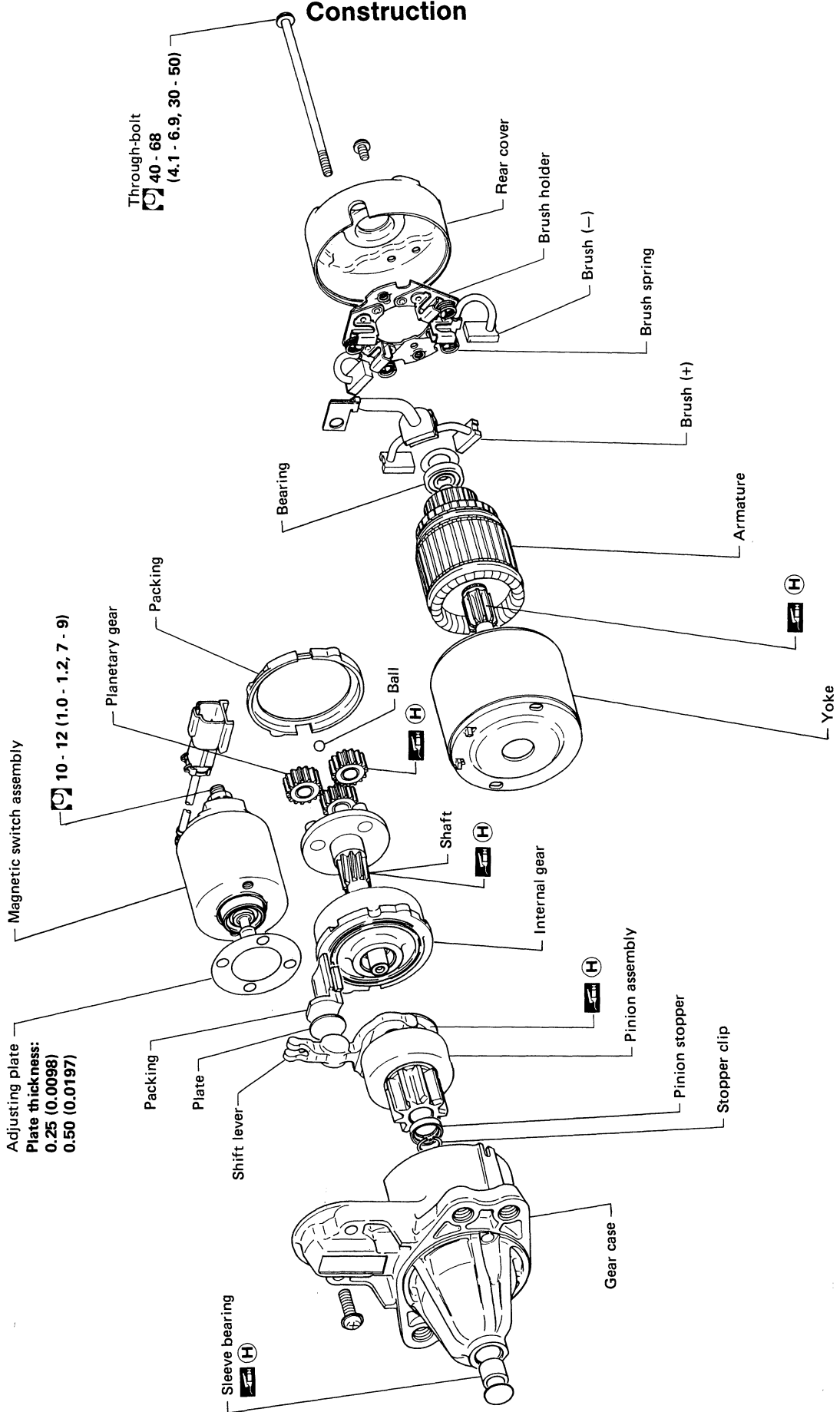

Unit: mm (in)
 □ : N·m (kg·m, ft·lb)
 Ⓜ : High-temperature grease point

SEL628L

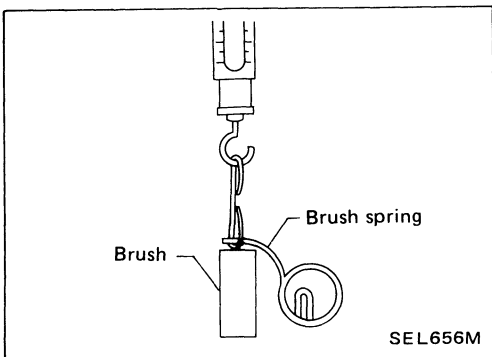
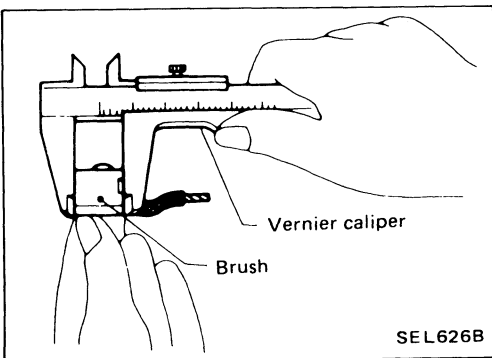
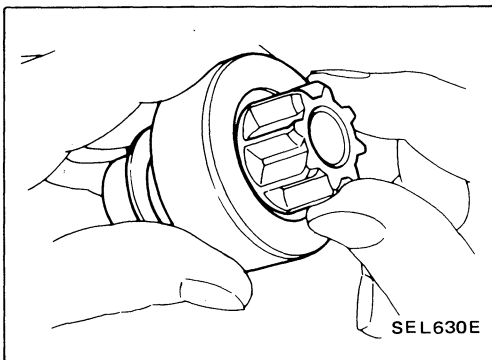
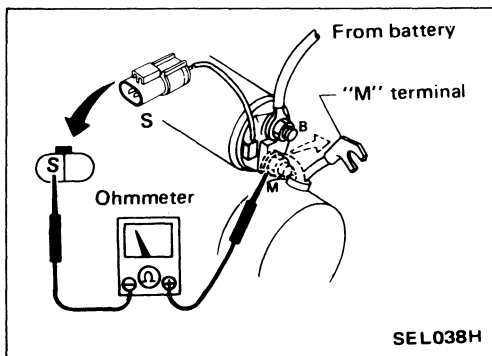
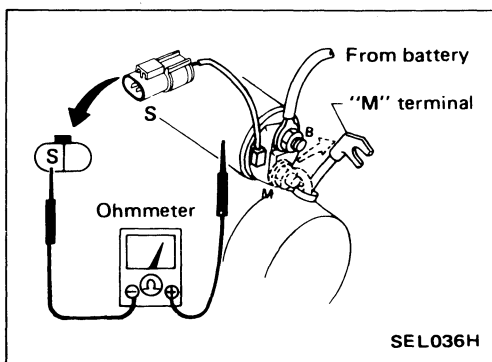

Magnetic Switch Check

- Before starting to check, disconnect battery ground cable.
 - Disconnect "M" terminal of starter motor.
1. Continuity test (between "S" terminal and switch body).
 - No continuity ... Replace.
 2. Continuity test (between "S" terminal and "M" terminal).
 - No continuity ... Replace.

Pinion/Clutch Check

1. Inspect pinion teeth.
 - Replace pinion if teeth are worn or damaged. (Also check condition of ring gear teeth.)
2. Check to see if pinion locks in one direction and rotates smoothly in the opposite direction.
 - If it does not lock (or locks) in either direction or unusual resistance is evident. ... Replace.
3. Inspect internal gear teeth.
 - Replace internal gear if teeth are worn or damaged. (Also check condition of armature shaft gear teeth.)

Brush Check

BRUSH

Check wear of brush.

Wear limit length:

Refer to S.D.S.

- Excessive wear ... Replace.

BRUSH SPRING PRESSURE

Check brush spring pressure with brush spring detached from brush.

Spring pressure (with new brush):

Refer to S.D.S.

- Not within the specified values ... Replace.

Brush Check (Cont'd)

BRUSH HOLDER

1. Perform insulation test between brush holder (positive side) and its base (negative side).
 - Continuity exists. ... Replace.
2. Check brush to see if it moves smoothly.
 - If brush holder is bent, replace it; if sliding surface is dirty, clean.

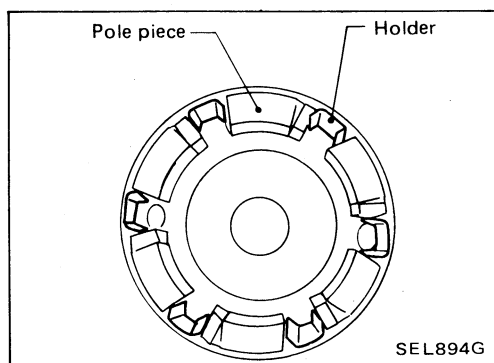
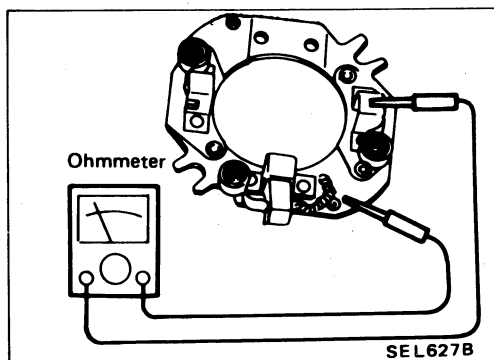

Pole Piece Check

Pole piece is secured to yoke by bonding agent. Check pole piece to see that it is secured to yoke and for any cracks. Replace malfunctioning parts as an assembly.

Holder may move slightly as it is only inserted and not bonded.

CAUTION:

Do not clamp yoke in a vice or strike it with a hammer.

Armature Check

1. Continuity test (between two segments side by side).
 - No continuity ... Replace.

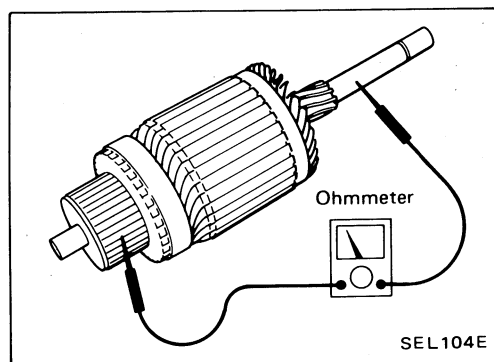
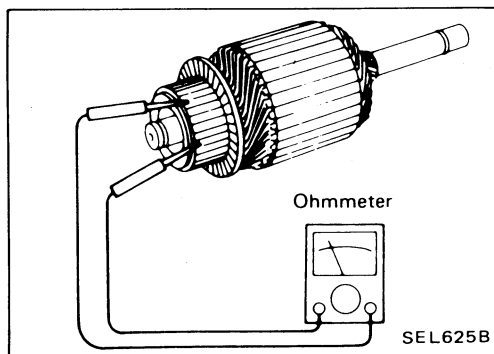

2. Insulation test (between each commutator bar and shaft).
 - Continuity exists. ... Replace.

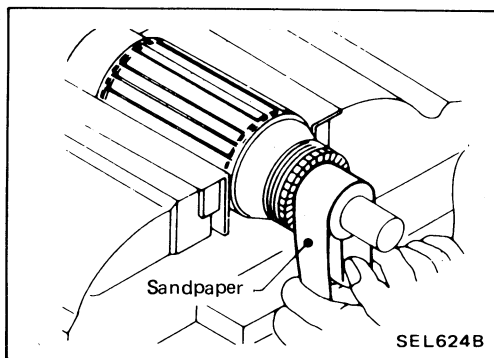

3. Check commutator surface.
 - Rough ... Sand lightly with No. 500 to 600 sandpaper.

Armature Check (Cont'd)

4. Check diameter of commutator.

Commutator minimum diameter:

Refer to S.D.S.

- Less than specified value ... Replace.

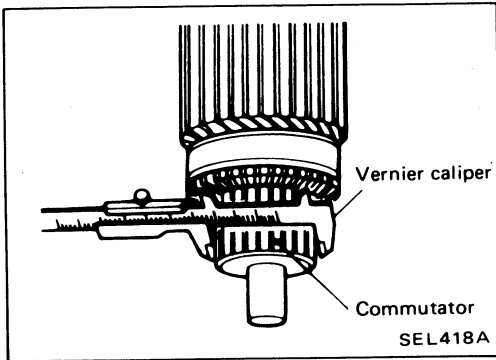

5. Check depth of insulating mold from commutator surface.

- Less than 0.2 mm (0.008 in) ... Undercut to 0.5 to 0.8 mm (0.020 to 0.031 in)

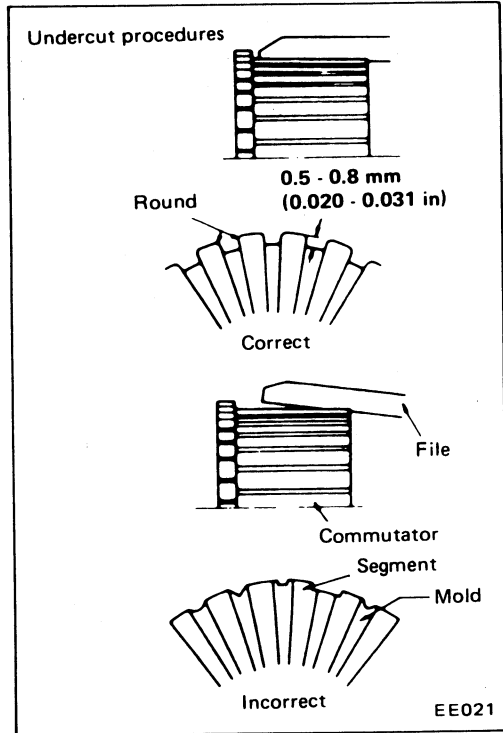

Assembly

Apply high-temperature grease to lubricate the bearing, gears and frictional surface when assembling the starter.

PINION PROTRUSION LENGTH ADJUSTMENT

With pinion driven out by magnetic switch, push pinion back to remove slack and measure clearance "ℓ" between the front edge of the pinion and the pinion stopper.

Clearance "ℓ":

Refer to S.D.S.

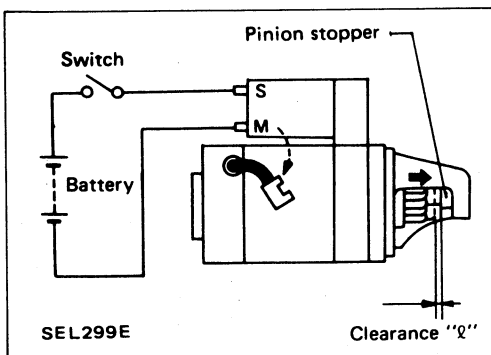

Assembly (Cont'd)

- Not in the specified value ... Adjust by adjusting plate.

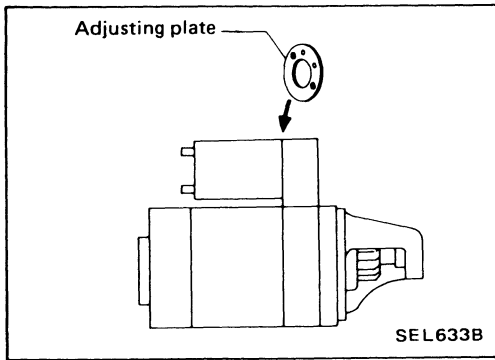

Service Data and Specifications (S.D.S.)

STARTER

		M1T72781
Type		MITSUBISHI make
		Reduction gear type
System voltage	V	12
No-load Terminal voltage	V	11.0
Current	A	50 - 75
Revolution	rpm	3,000 - 4,000
Minimum diameter of commutator	mm (in)	28.8 (1.134)
Minimum length of brush	mm (in)	12.0 (0.472)
Brush spring tension	N (kg, lb)	13.7 - 25.5 (1.4 - 2.6, 3.1 - 5.7)
Clearance "Q" between pinion front edge and pinion stopper	mm (in)	0.5 - 2.0 (0.020 - 0.079)

CHARGING SYSTEM

Wiring Diagram

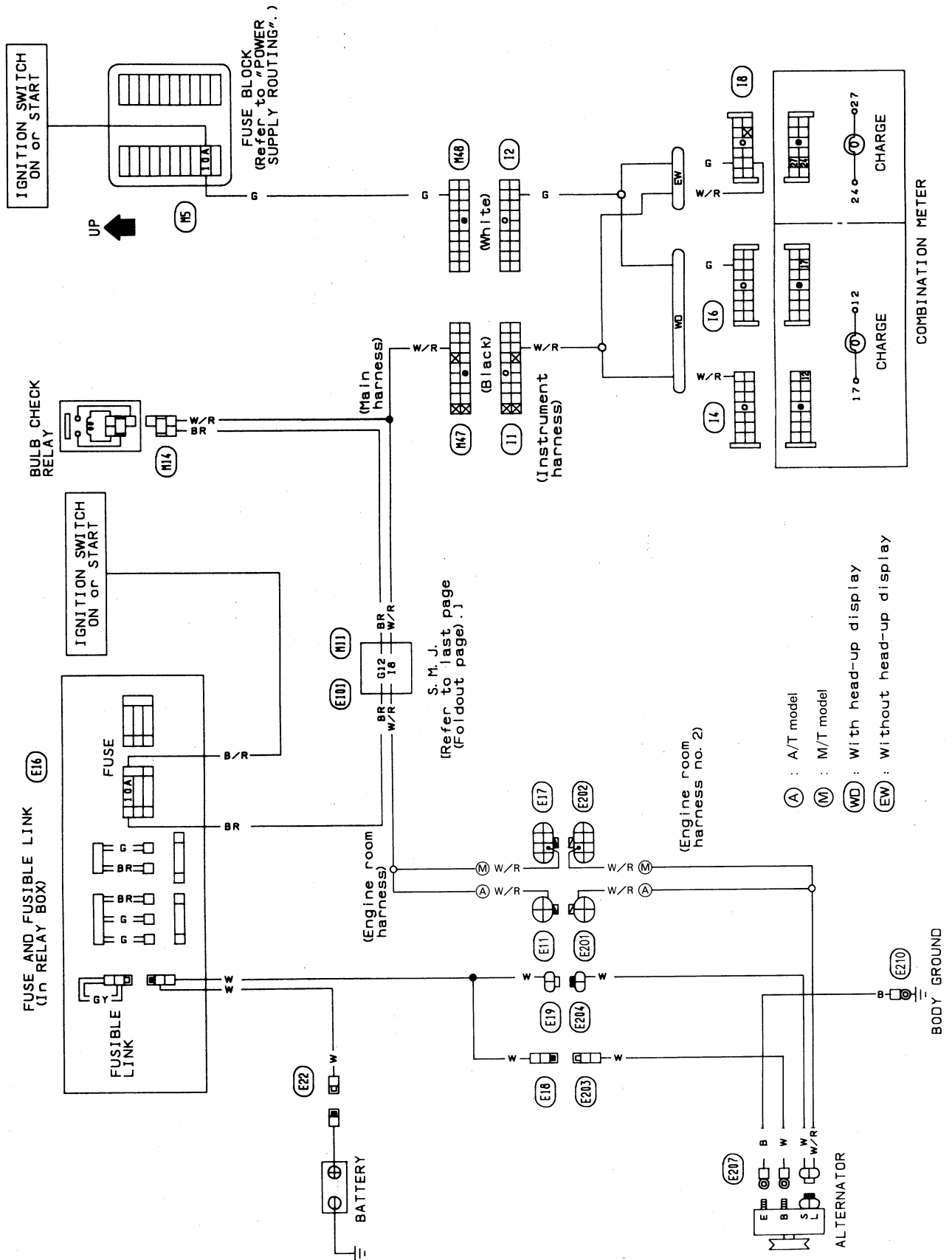

CHARGING SYSTEM

Trouble-shooting

Before conducting an alternator test, make sure that the battery is fully charged. A 30-volt voltmeter and suitable test probes are necessary for the test. The alternator can be checked easily by referring to the Inspection Table.

Before starting trouble-shooting, inspect the fusible link.

WITH IC REGULATOR

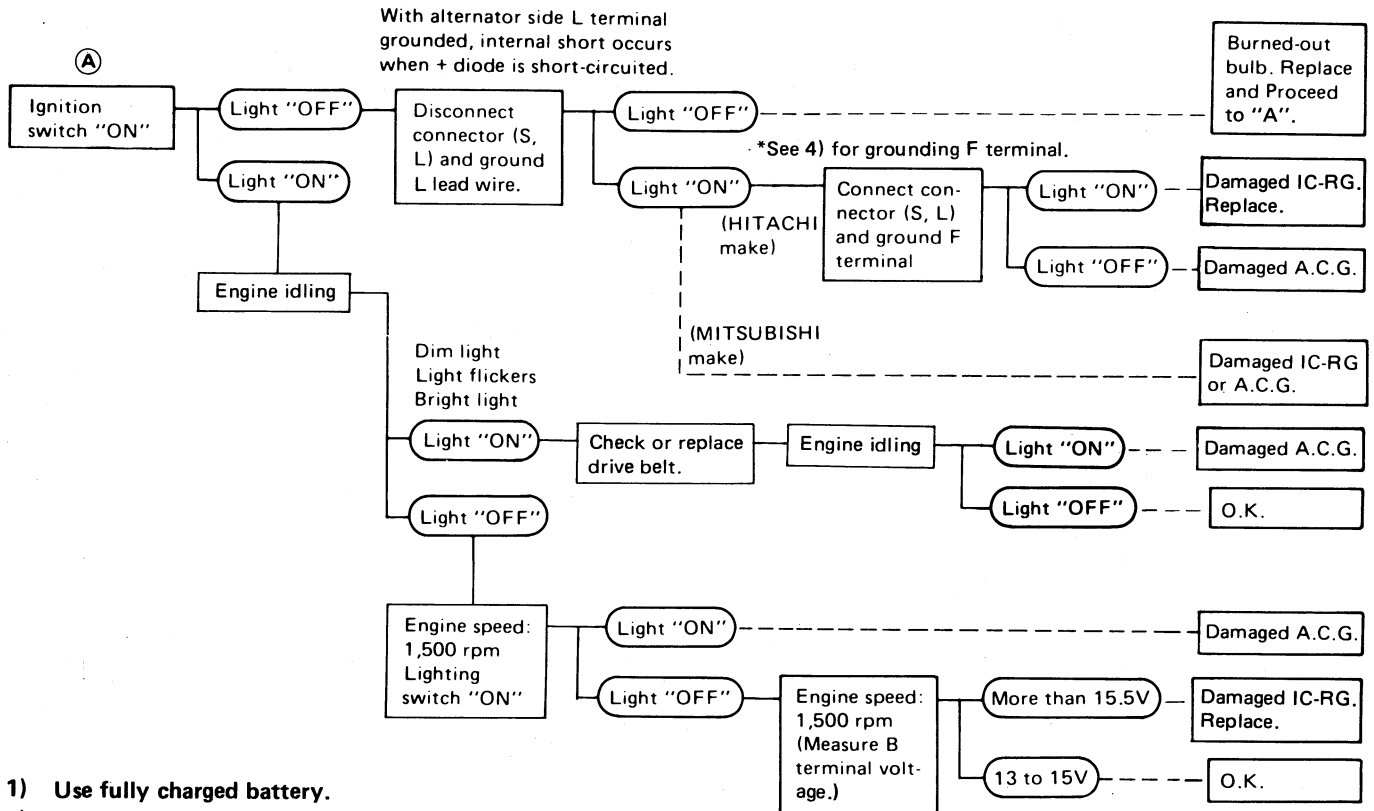

Make sure connector (S, L) is connected correctly.

- 1) Use fully charged battery.
- 2) Light : Charge warning light
A.C.G. : Alternator parts except IC regulator
IC-RG : IC regulator
O.K. : IC alternator is in good condition.
- 3) When reaching "Damaged A.C.G.", remove alternator from vehicle and disassemble, inspect and correct or replace faulty parts.
- 4) *Method of grounding F terminal (HITACHI make only)

Gasoline engine model

Contact tip of wire with brush and attach wire to alternator body.

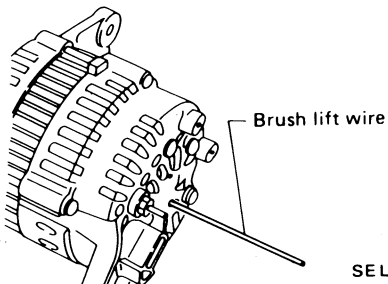

- 5) Terminals "S", "L", "B" and "E" are marked on rear cover of alternator.

Construction

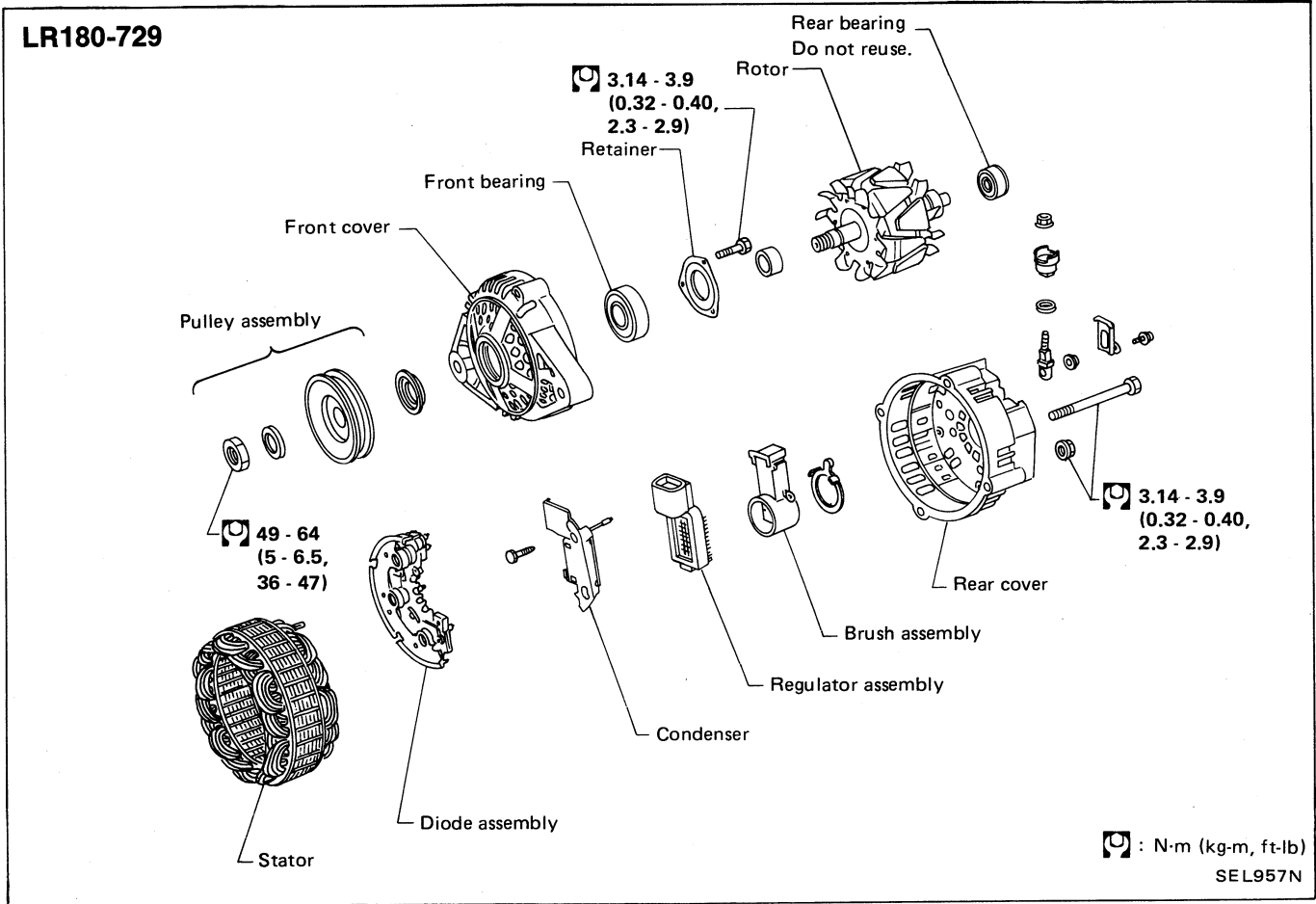

* Rear bearing

CAUTION:

Rear cover may be hard to remove because a ring is used to lock outer race of rear bearing. Be careful not to lose this ring during removal.

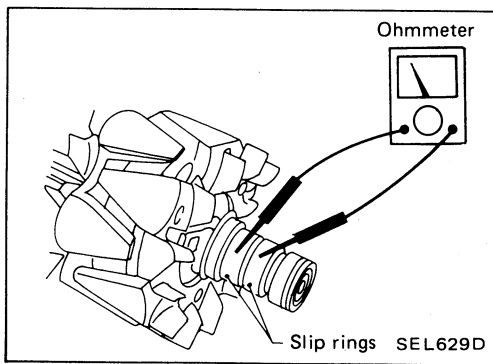

Rotor Slip Ring Check

1. Continuity test
 - No continuity ... Replace rotor.

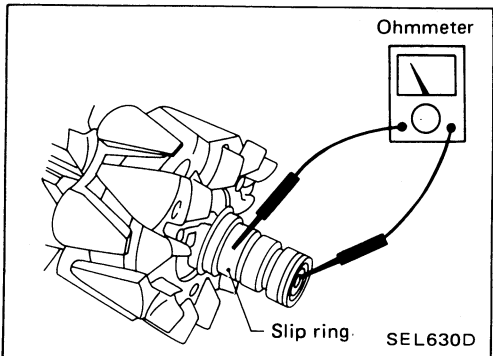

2. Insulator test
 - Continuity exists ... Replace rotor.
3. Check slip ring for wear.

Slip ring minimum outer diameter:
Refer to "Service Data and Specifications."

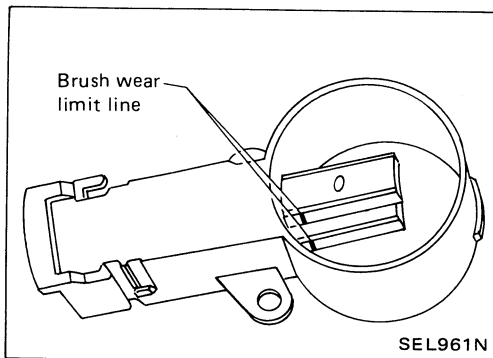

Brush Check

Check brush as follows:

1. Smooth movement
2. Wear

If either of the above conditions occur, replace brush assembly.

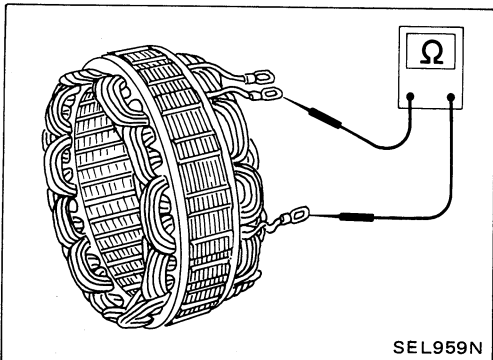

Stator Check

1. Continuity test
 - No continuity ... Replace stator.

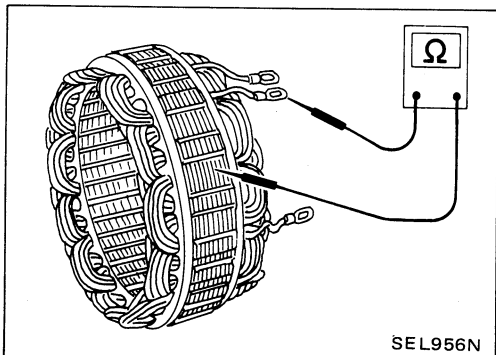

2. Ground test
 - Continuity exists ... Replace stator.

Diode Check

DIODES

- Use an ohmmeter to check condition of diodes as indicated in chart below.
- If any of the test results is not satisfactory, replace diode assembly.

	Ohmmeter probes		Continuity
	Positive ⊕	Negative ⊖	
Diodes check (Positive side)	Positive diode plate	Diode terminals	Yes
	Diode terminals	Positive diode plate	No
Diodes check (Negative side)	Negative diode plate	Diode terminals	No
	Diode terminals	Negative diode plate	Yes

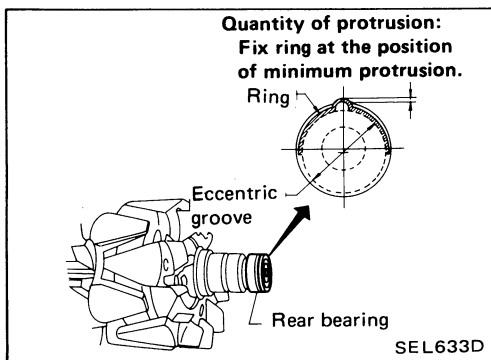
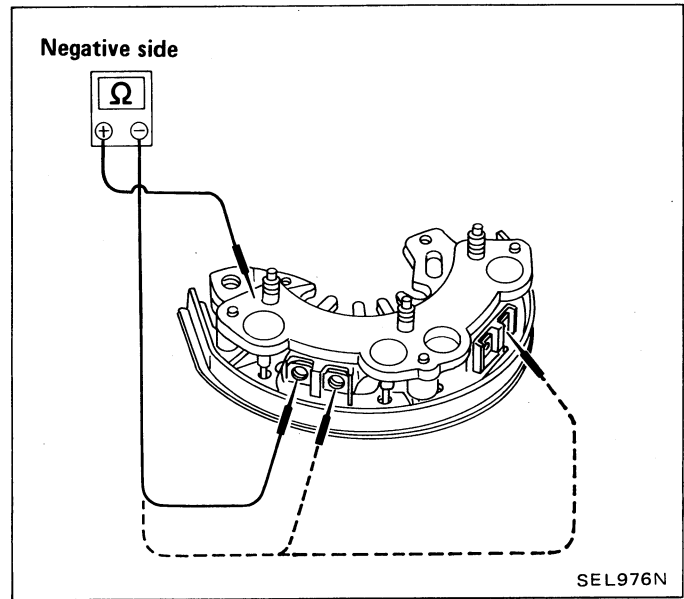
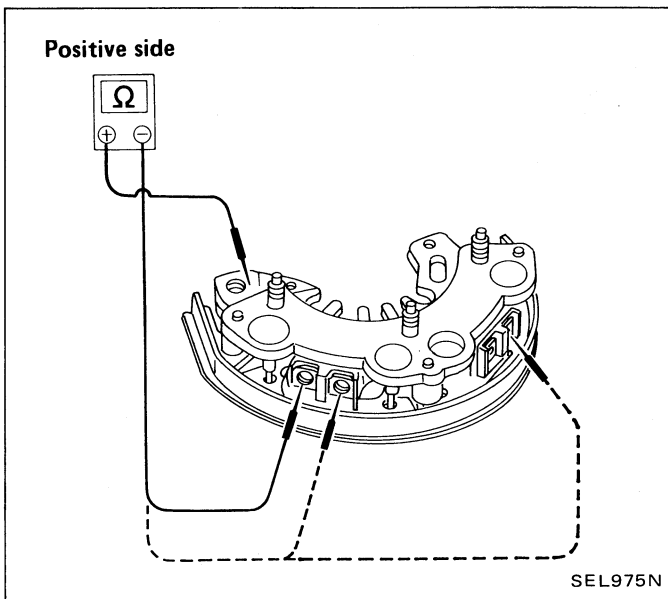

Assembly

RING FITTING IN REAR BEARING

- Fix ring into groove in rear bearing so that it is as close to the adjacent area as possible.

CHARGING SYSTEM — Alternator —

Assembly (Cont'd)

REAR COVER INSTALLATION

- (1) Fit brush assembly, diode assembly, regulator assembly and stator.
 - (2) Push brushes up with fingers and install them to rotor.
- Take care not to damage slip ring sliding surface.

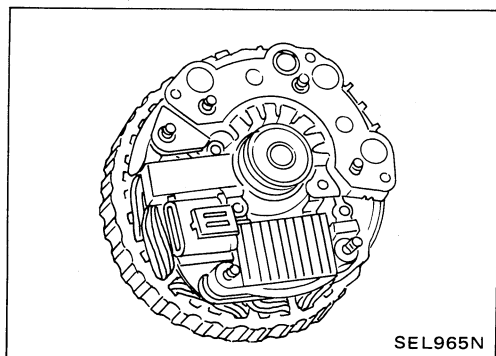
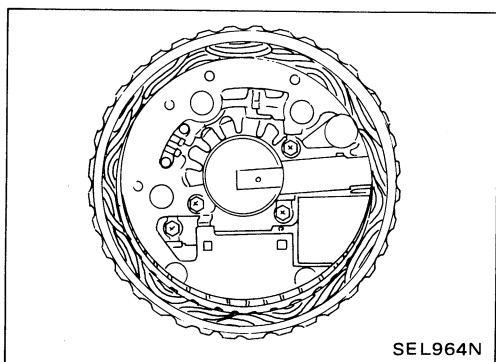

Service Data and Specifications (S.D.S.) ALTERNATOR

Type		LR180-729
Nominal rating	V-A	12-80
Ground polarity		Negative
Minimum revolution under no-load (When 13.5 volts is applied)	rpm	Less than 950
Hot output current	A/rpm	More than 23/1,300 More than 63/2,500 More than 77/5,000
Regulated output voltage	V	14.1 - 14.7
Minimum length of brush	mm (in)	6.0 (0.236)
Brush spring pressure	N (g, oz)	1.000 - 3.432 (102 - 350, 3.60 - 12.34)
Slip ring minimum outer diameter	mm (in)	26.0 (1.024)

COMBINATION SWITCH

Combination Switch/Check

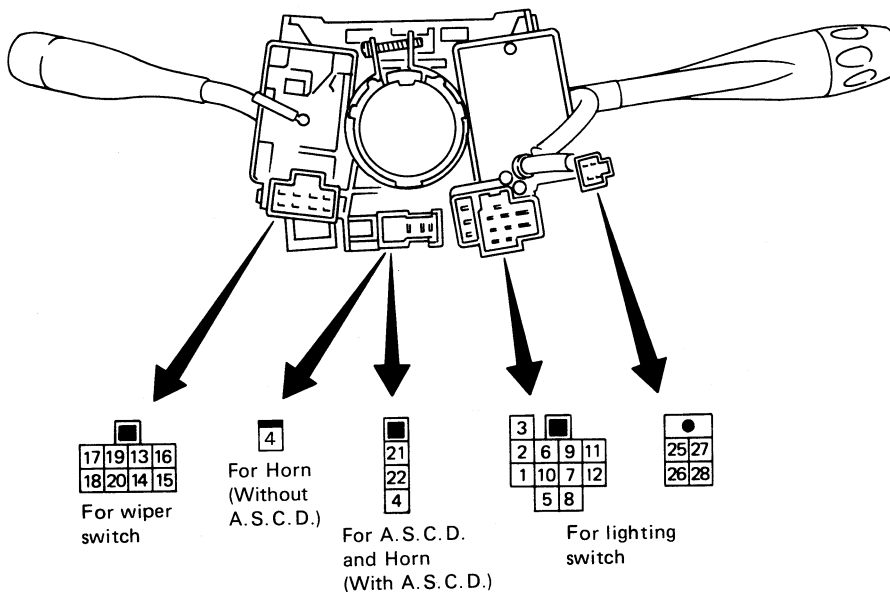
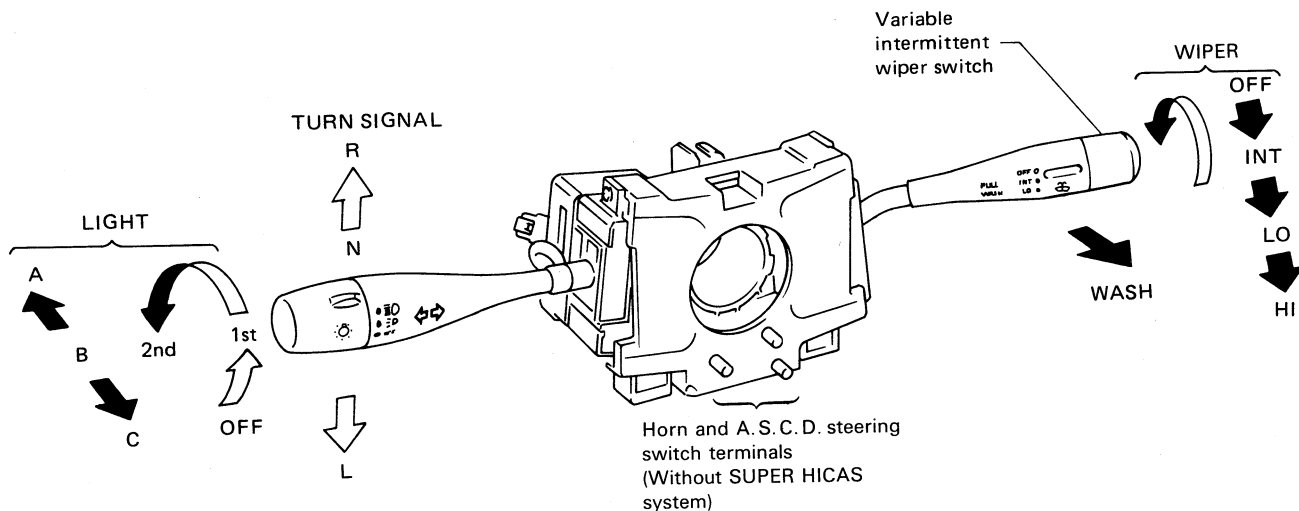

LIGHTING SWITCH

	OFF	1	2					
	A	B	C	A	B	C	A	B
5								
6								
7								
8								
9								
10								
11								
12								
25								
26								
27								
28								

WIPER SWITCH

	OFF	INT	LO	HI	WASH
13					
14					
15					
16					
17					
18					

INTERMITTENT WIPER VOLUME

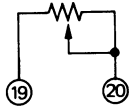

HORN SWITCH

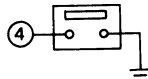

A. S. C. D. STEERING SWITCH

	RESUME ACCEL	N	SET COAST	OFF	CANCEL
4					
22					
21					

TURN SIGNAL SWITCH

	R	N	L
1			
2			
3			

SEL884P

COMBINATION SWITCH

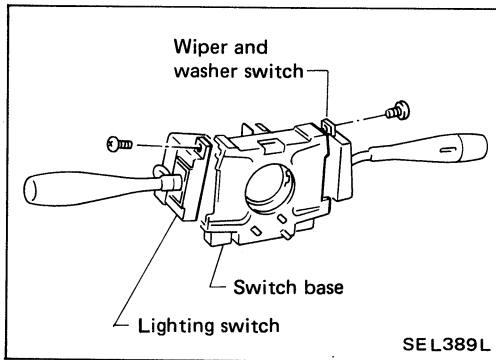

Replacement

- Each switch can be replaced without removing combination switch base.

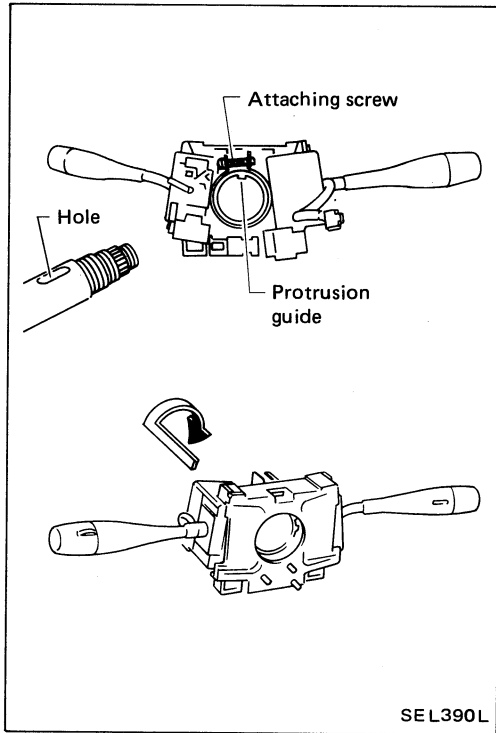

- To remove combination switch base, remove base attaching screw and turn after pushing on it.

COMBINATION SWITCH

Steering Switch/Check

WITH SUPER HICAS SYSTEM

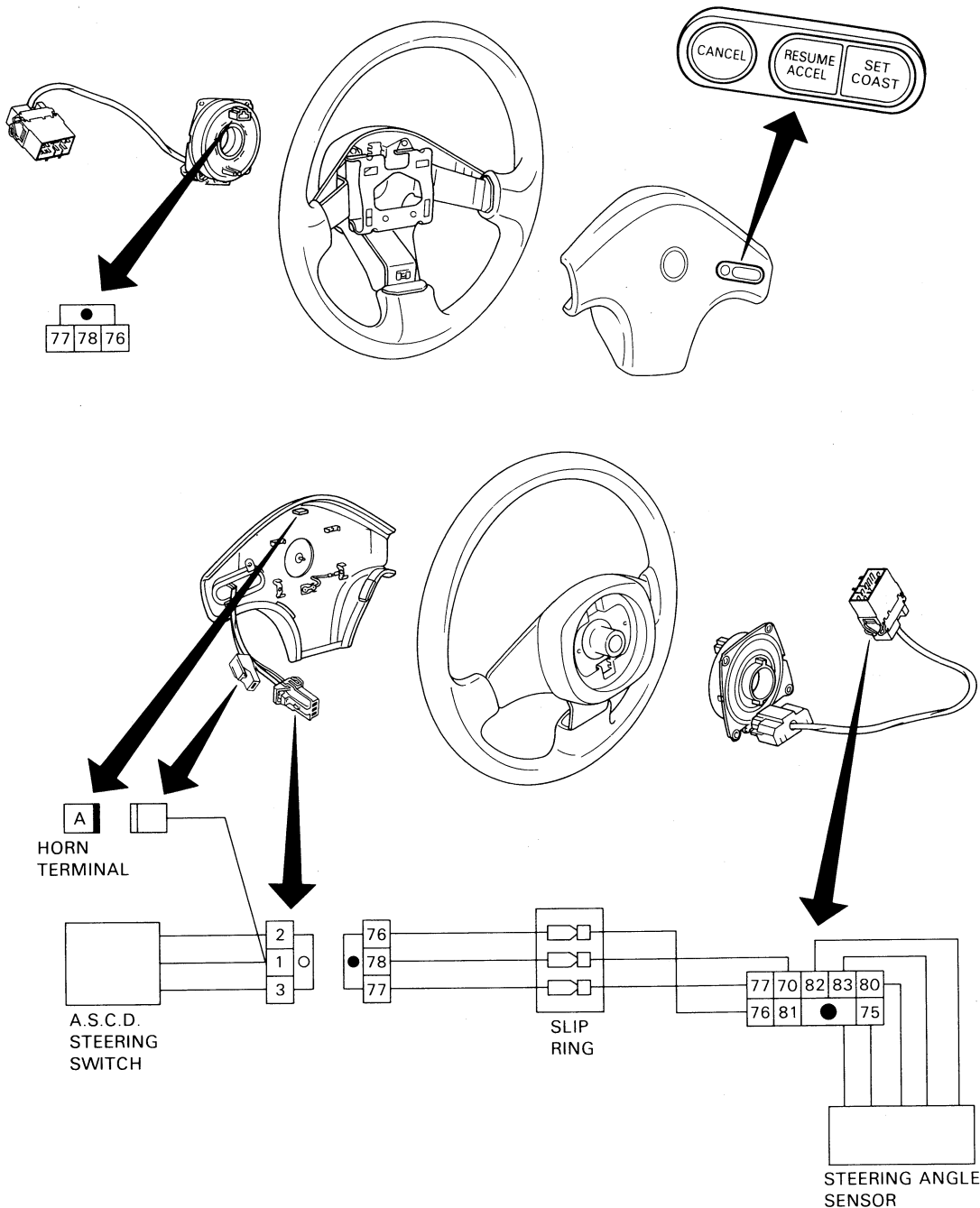

A
HORN
TERMINAL

A.S.C.D.
STEERING
SWITCH

SLIP
RING

STEERING ANGLE
SENSOR

A.S.C.D. STEERING SWITCH

	RESUME ACCEL	N	SET COAST	OFF	CANCEL
1	○		○		○
2	○		○	⚡	○
3	○				○

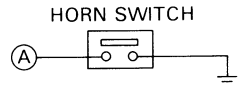

HEADLAMP

Schematic

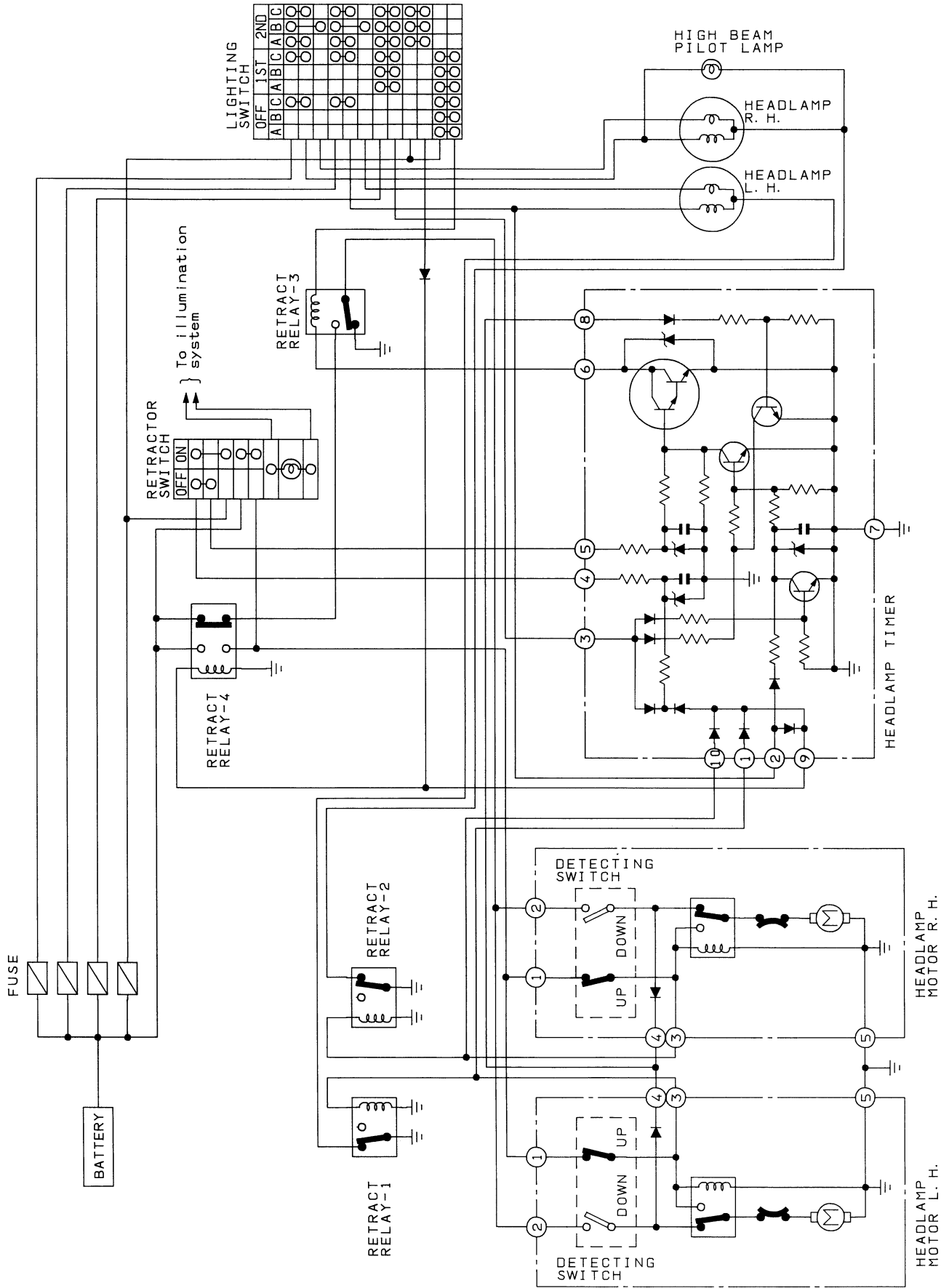

SEL469L

HEADLAMP

Wiring Diagram

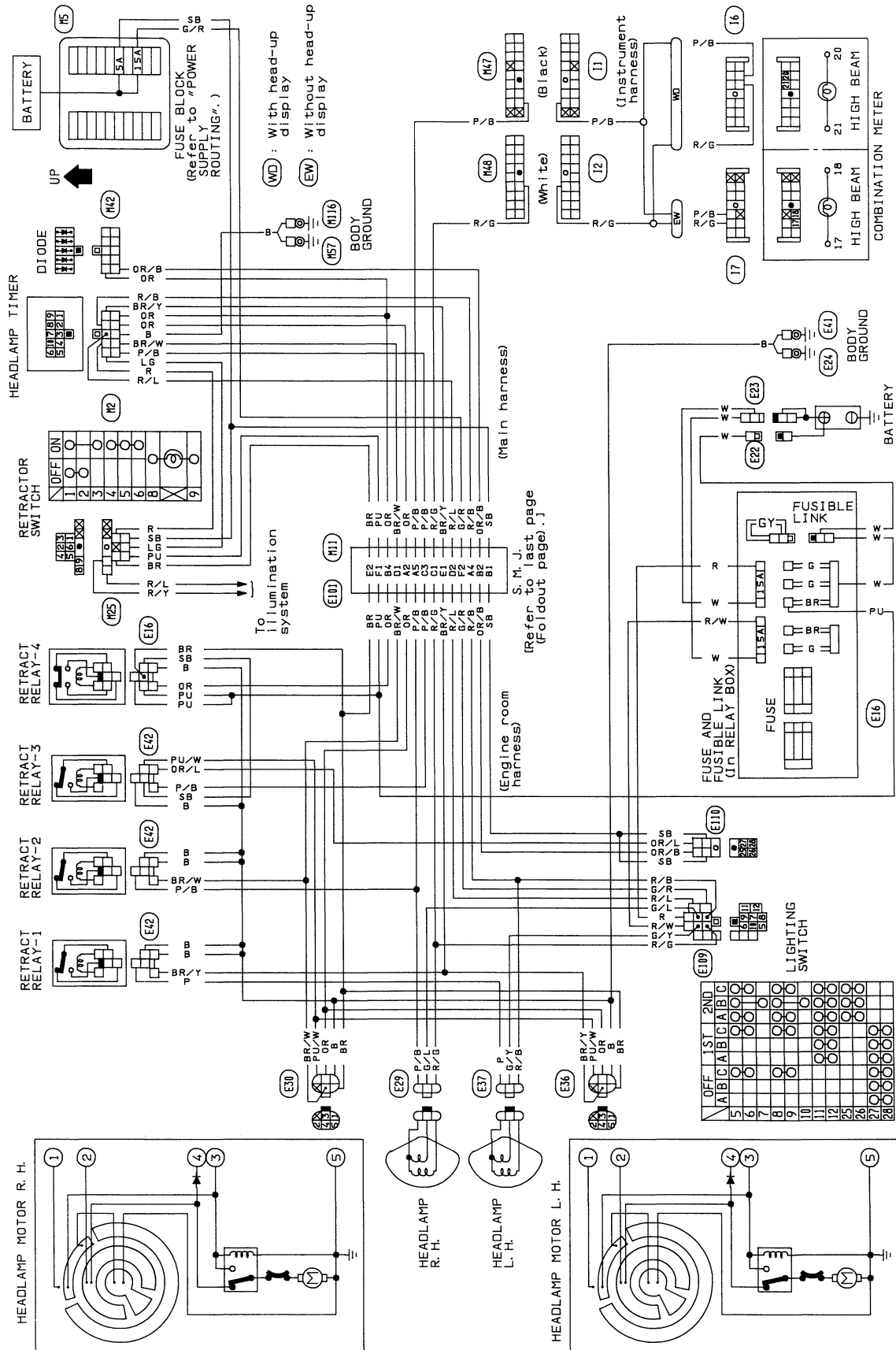

HEADLAMP

Description

BASIC OPERATION

Condition		Operation		
Lighting switch	Retractor switch	C/O*	Headlamp motor	Headlamps
OFF → 1ST	OFF		No operation	OFF
1ST → 2ND	OFF	[A]	Open	ON after headlamp motor reaches fully open position.
2ND → 1ST	OFF		Held to open position	OFF
1ST → OFF	OFF	[B]	Closed	OFF
Momentarily turned to PASSING	OFF	[C]	Opened and closed after headlamps go off.	Momentarily ON after headlamp motor reaches fully open position, and go off.
OFF	ON	[D]	Open	OFF

*: Refer to CIRCUIT OPERATION.

HEADLAMP

Description (Cont'd)

CIRCUIT OPERATION

[A] When lighting switch is switched from "1ST" → "2ND"

A-1: While operating the headlamp motor to open position

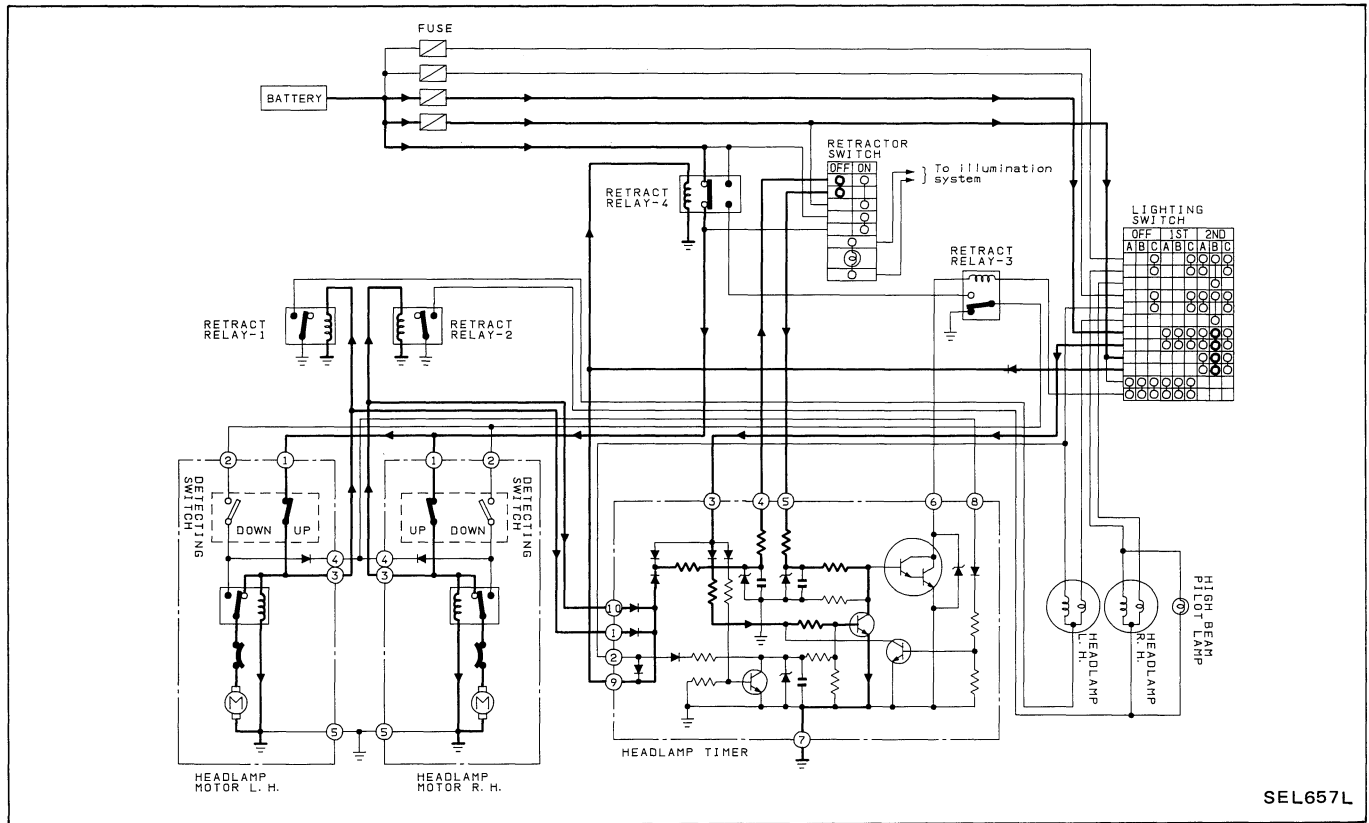

A-2: After the headlamp motor reaches fully open position

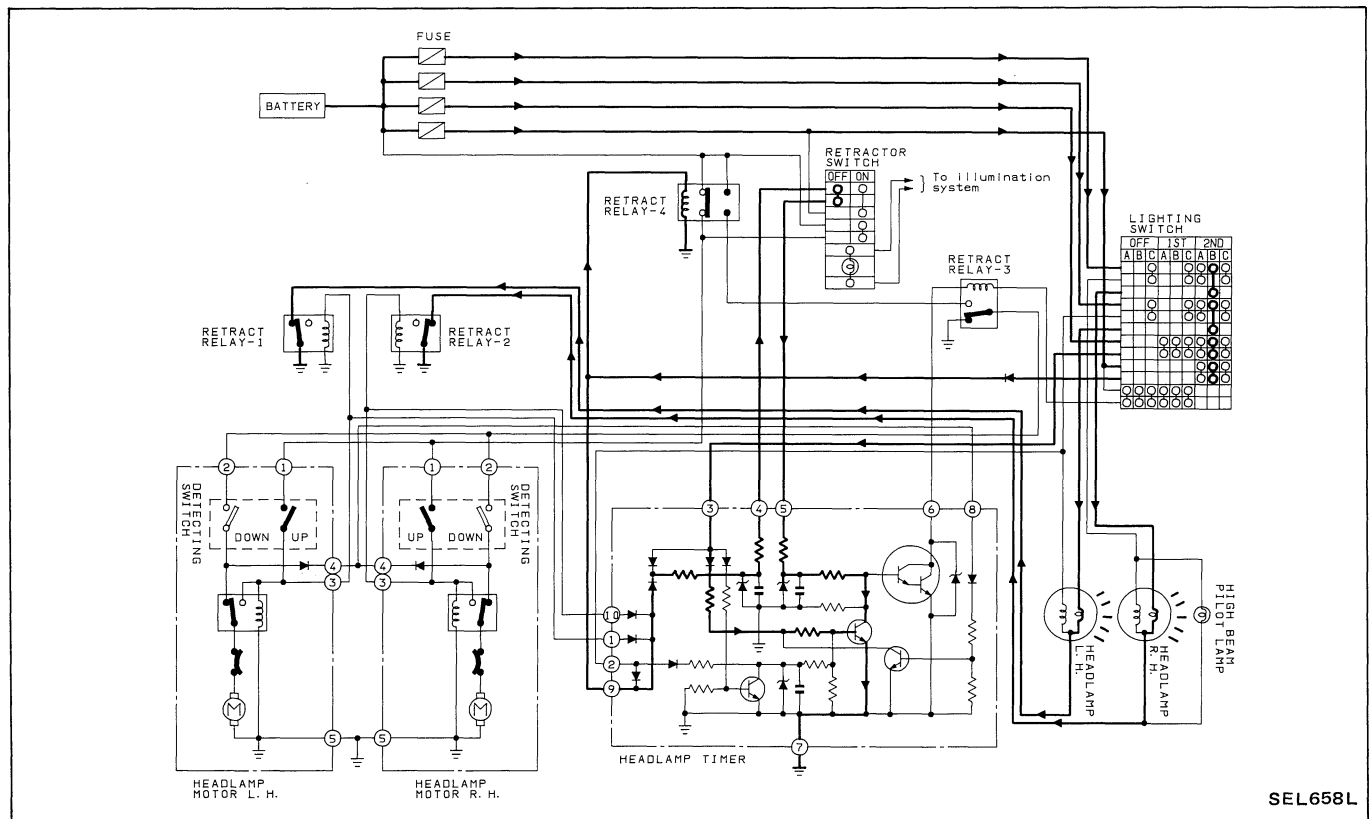

HEADLAMP

Description (Cont'd)

- [B] When lighting switch is switched from "1ST" → "OFF"
(While operating the headlamp motor to closed position)

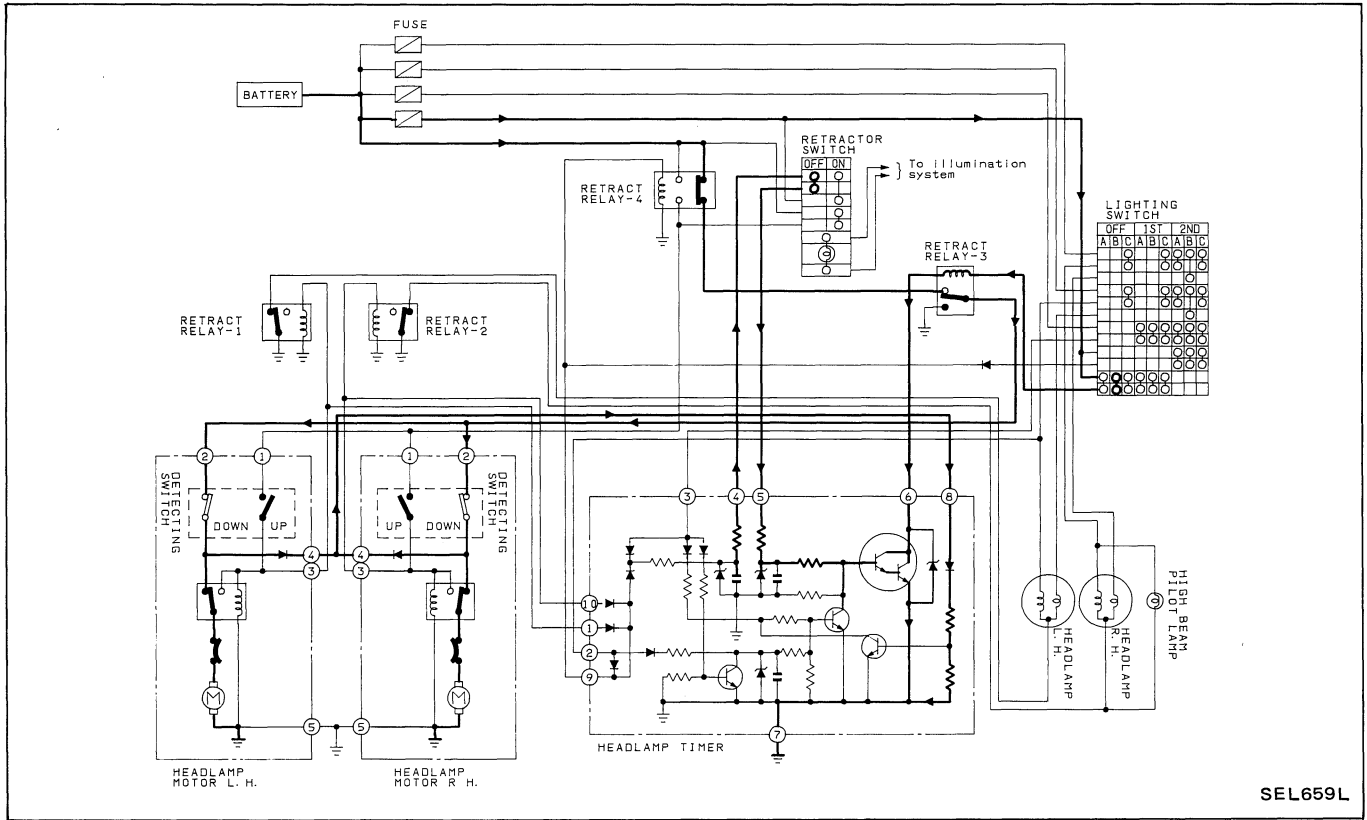

- [C] When lighting switch is switched to "PASSING"
C-1: While operating the headlamp motor to open position

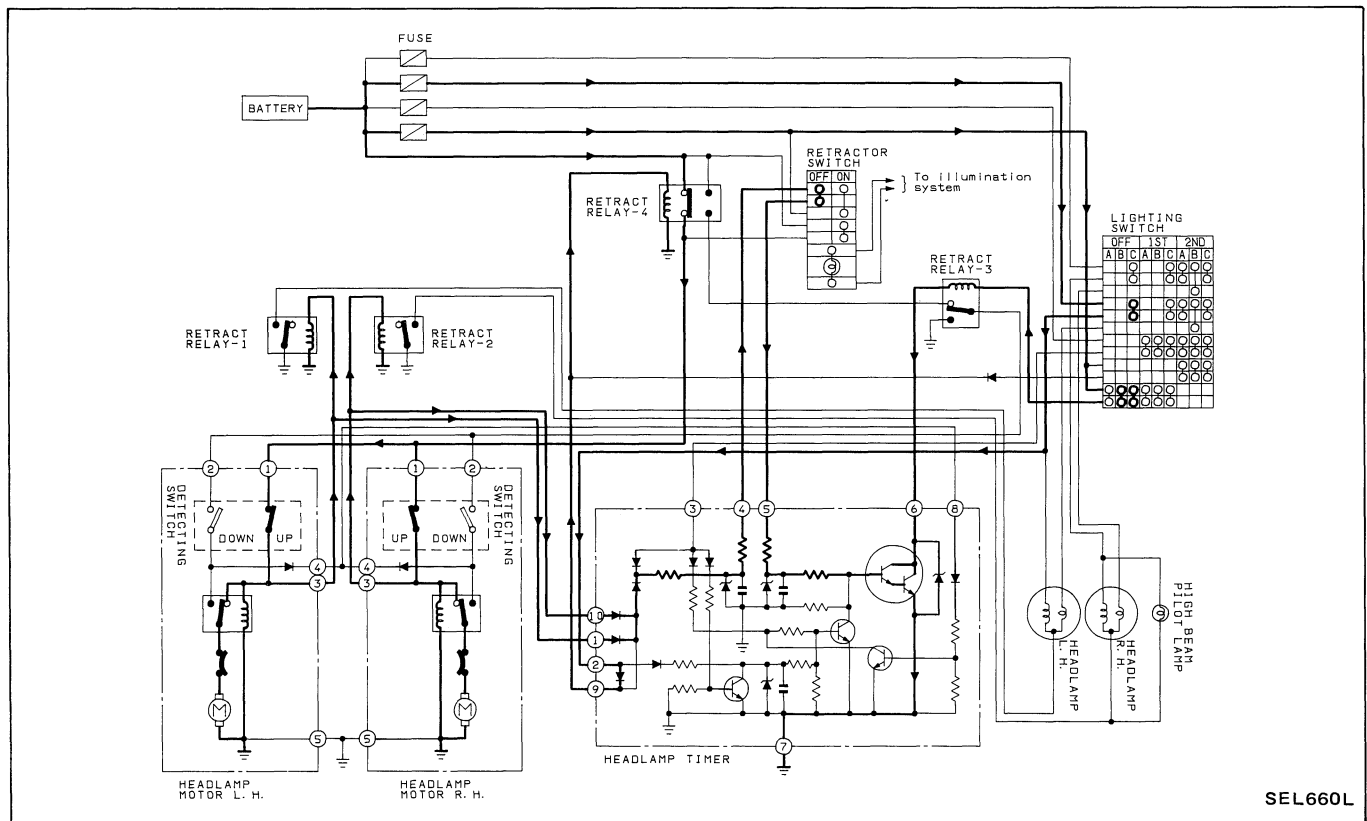

HEADLAMP

Description (Cont'd)

C-2: After the headlamp reaches fully open position

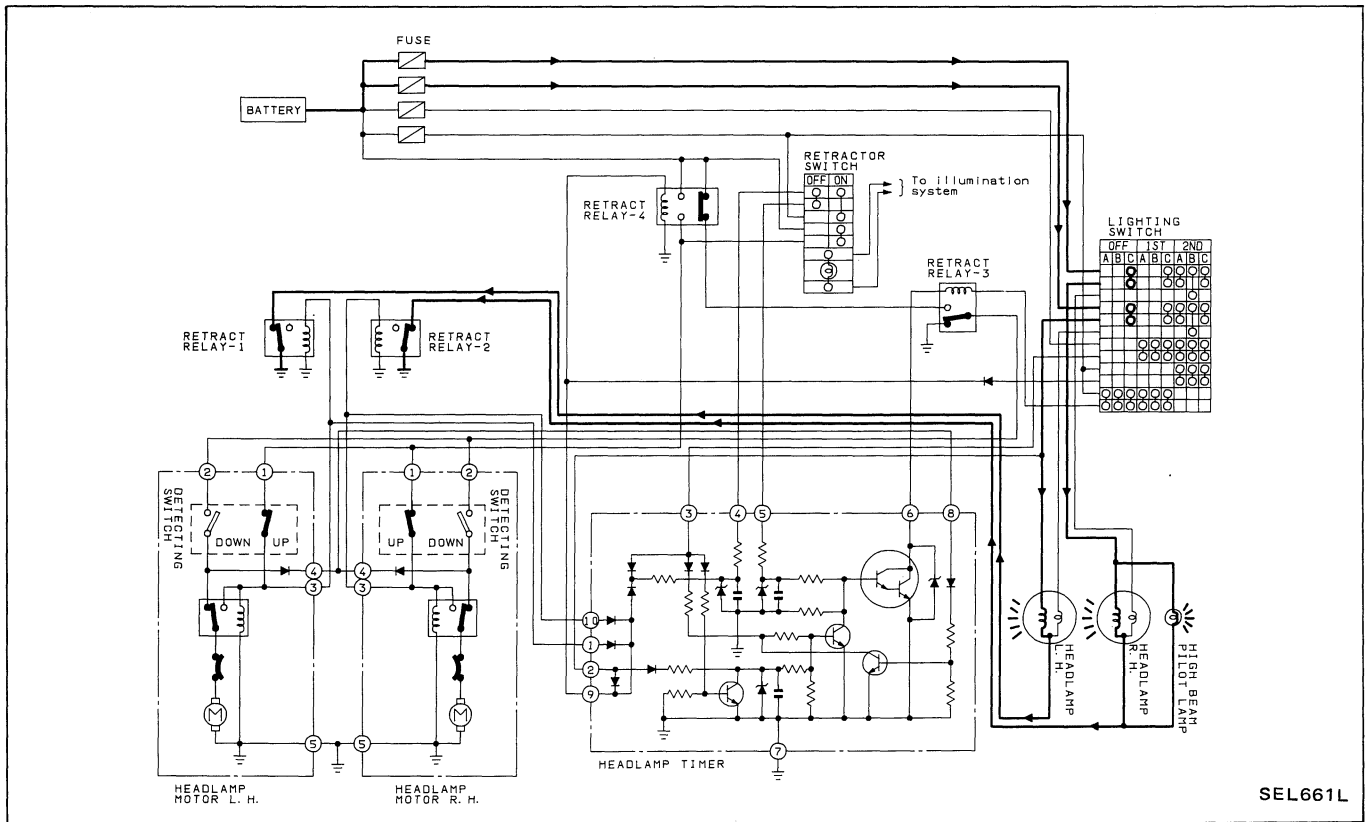

SEL661L

[D] When retractor switch is turned ON (While operating the headlamp motor to open position)

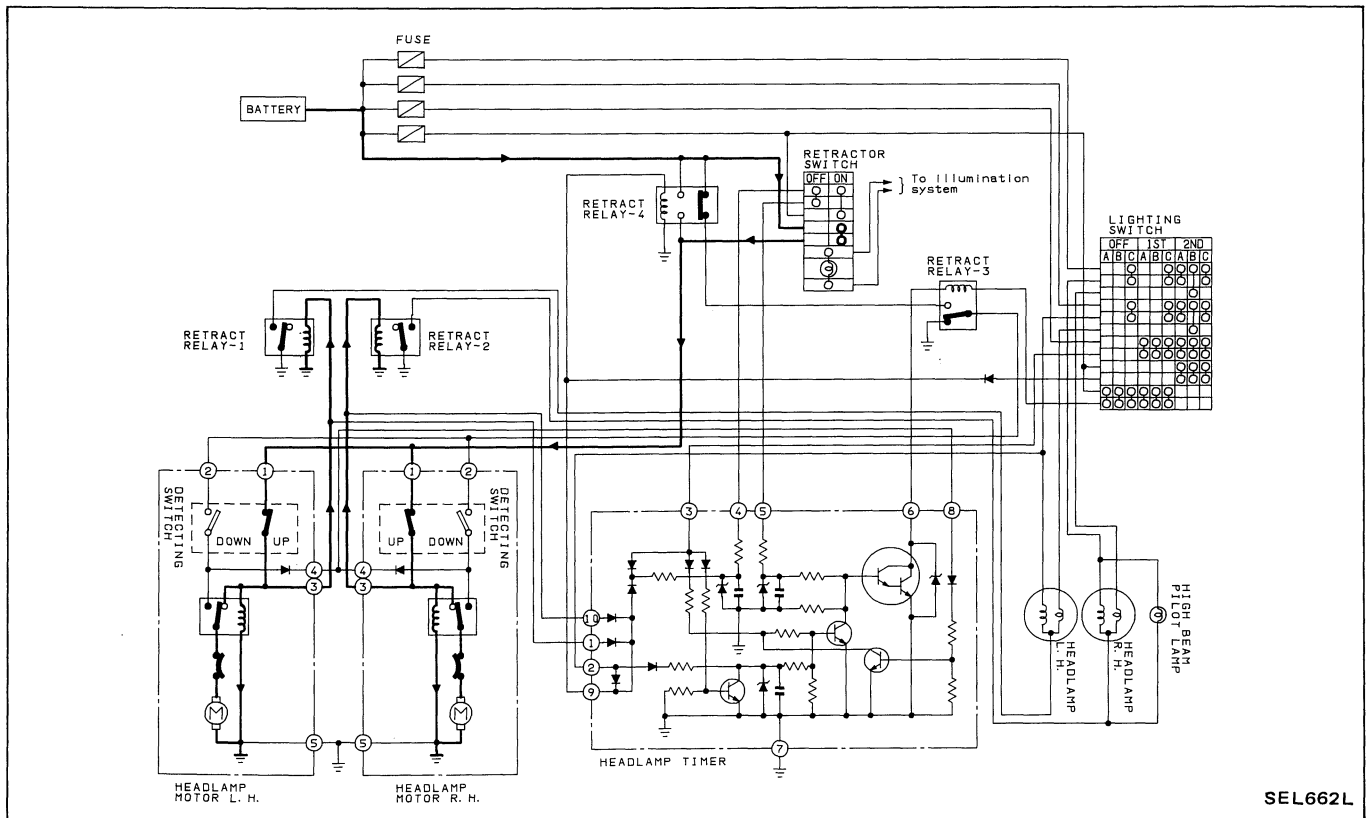

SEL662L

HEADLAMP

Constructions

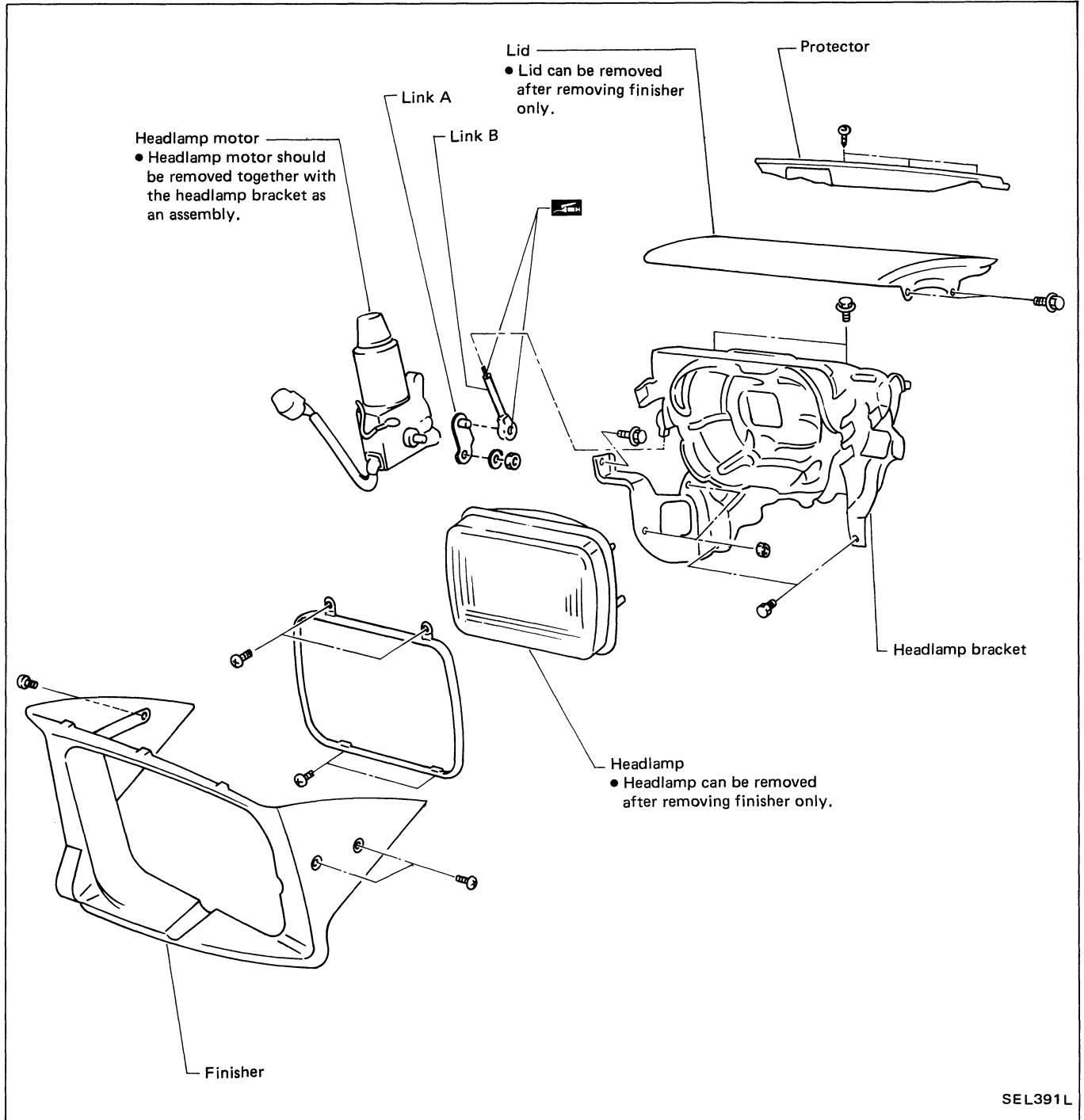

SEL391L

HEADLAMP

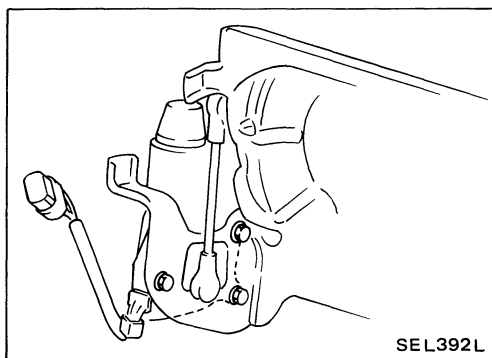

Assembly

1. Install headlamp motor, ball joint and link A (as one unit) on headlamp bracket.
2. While turning link B, install link A's ball joint on headlamp housing's ball joint.
3. Set distance between centers of upper and lower ball joints as shown in figure at left, and tighten lock nuts.
4. Assemble headlamp, finisher and lid.

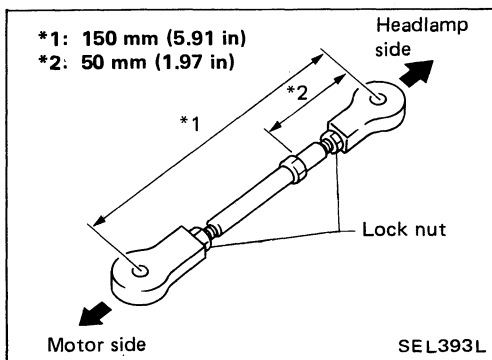

Installation and Adjustment

Before doing this, be sure to disconnect battery ground cable.

1. Install headlamp bracket to body temporarily.
 - 1) Determine headlamp bracket location on body so that alignment between lid, hood, and fender looks straight.
 - 2) After adjusting alignment, tighten headlamp bracket to body.

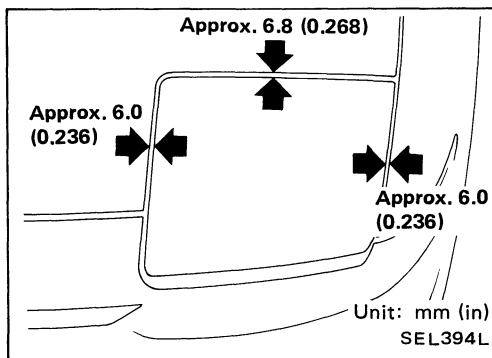

2. Adjust lid alignment.
 - Adjust lid, hood and fender for alignment while opening and closing headlamp with motor manual knob.
Use motor manual knob to open and close headlamp, and adjust alignment while checking that lid is not interfering with hood.

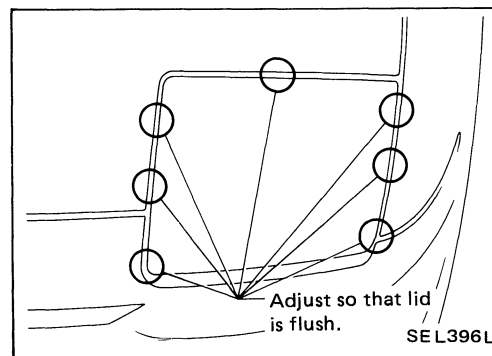
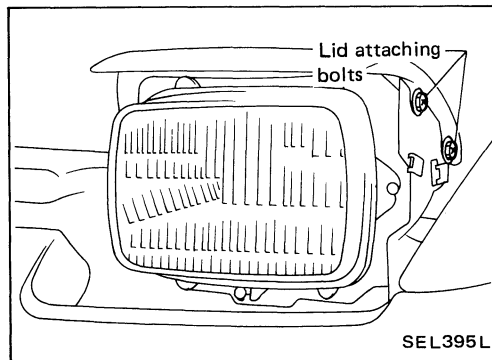

HEADLAMP

Installation and Adjustment (Cont'd)

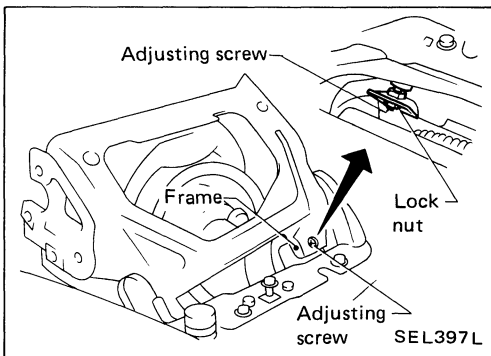

3. Adjust stopper.
- 1) Loosen lock nut on stopper.
- 2) Turn motor manual knob to open headlamp assembly completely.
- 3) Adjust stopper screw.

Headlamp Motor Check

1. Disconnect battery ground cable.
2. Disconnect the headlamp motor connector.
3. Use an ohmmeter to check for continuity in headlamp motor circuit while rotating motor with manual knob.

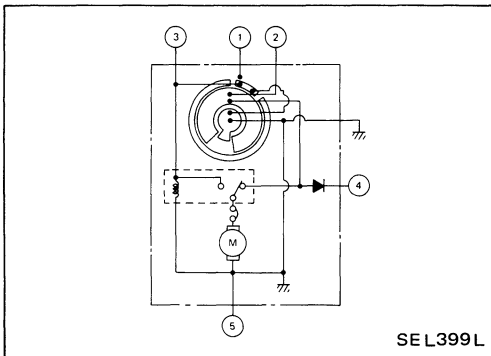
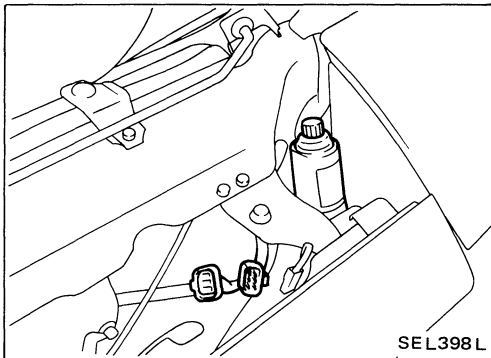

INSTALLING HEADLAMP RUBBER CAP

When installing the rubber cap, set the "TOP" or "▲" mark so that it is facing up.

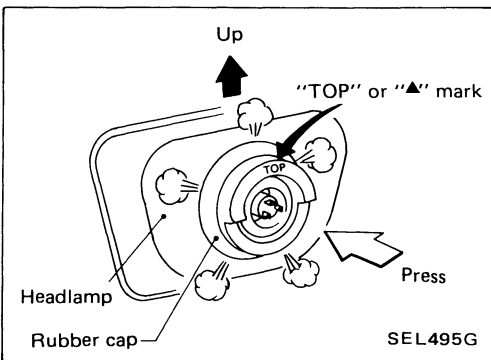

Press the rubber cap firmly so that the lip makes contact with the headlamp body.

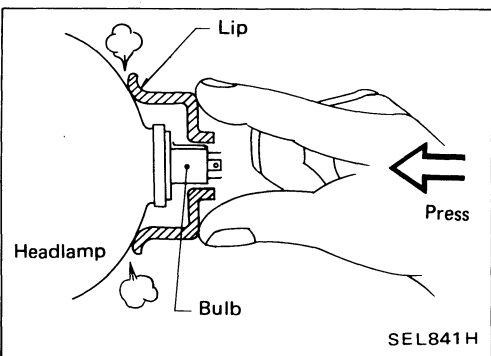

HEADLAMP

Aiming Adjustment

When performing headlamp aiming adjustment, use an aiming machine, aiming wall screen or headlamp tester. For operating instructions of any aimer, it should be in good repair, calibrated and used according to respective operation manuals supplied with the unit.

If any aimer is not available, aiming adjustment can be done as follows:

For details, refer to the regulations in your own country.

CAUTION:

- Keep all tires inflated to correct pressures.
- Place vehicle and tester on one and same flat surface.
- See that there is no-load in vehicle (coolant, engine oil filled up to correct level and full fuel tank) other than the driver (or equivalent weight placed in driver's position).

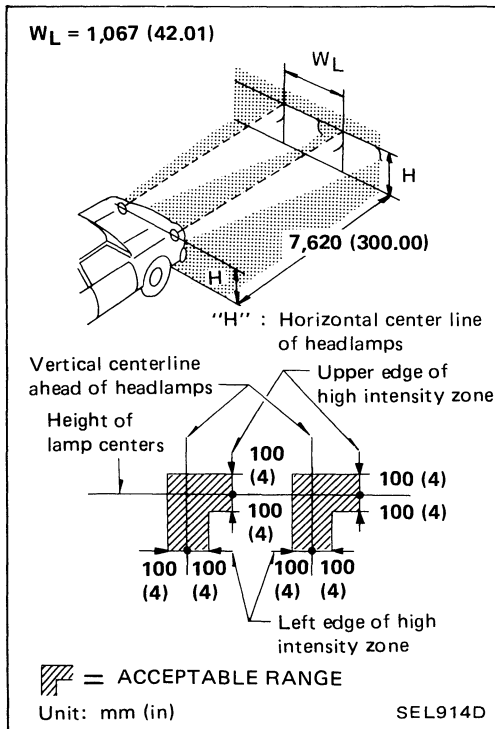

- Adjust headlamps so that upper edge and left edge of high intensity zone are within the acceptable range as shown.
- Dotted lines in illustration show center of headlamp.

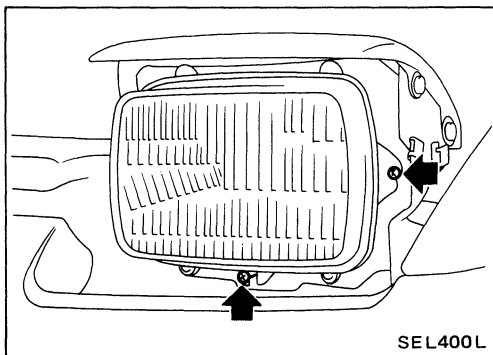

ADJUSTING SCREWS

HEADLAMP

Aiming Adjustment (Cont'd)

AIMER ADJUSTMENT MARK

When using a mechanical aimer, adjust adapter legs to the data marked on the headlamps.

Example:

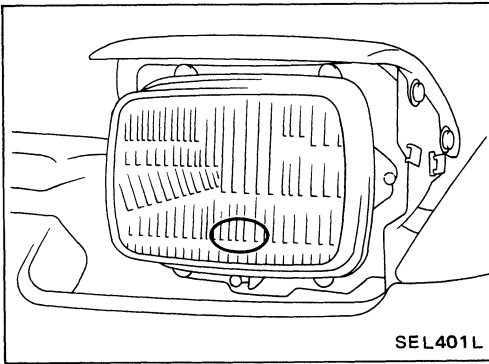
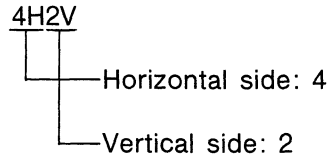

EXTERIOR LAMP

Daytime Light/Description

OPERATION

After starting the engine with the lighting switch in the "OFF" or "1ST" position, the daytime light automatically turns on. With the lighting switch in the "2ND" position, the daytime light turns on while the headlamp motor is operating the headlamps to the open position and turns off after the headlamps reach the fully open position. Lighting switch operations other than the above are the same as in conventional systems.

Engine		With engine stopped									With engine running								
		OFF			1ST			2ND			OFF			1ST			2ND		
Lighting switch		A	B	C	A	B	C	A	B	C	A	B	C	A	B	C	A	B	C
Headlamp	High beam	X	X	O	X	X	O	O	X	O	X	X	O	X	X	O	O	X	O
	Low beam	X	X	X	X	X	X	X	O	X	X	X	X	X	X	X	X	O	X
Clearance and tail lamp		X	X	X	O	O	O	O	O	O	X	X	X	O	O	O	O	O	O
License and instrument illumination lamp		X	X	X	O	O	O	O	O	O	X	X	X	O	O	O	O	O	O
Daytime light		X	X	X	X	X	X	X	X	X	O	O	O	O	O	O	X	X	X

O : Lamp "ON"
X : Lamp "OFF"

EXTERIOR LAMP

Daytime Light/Schematic

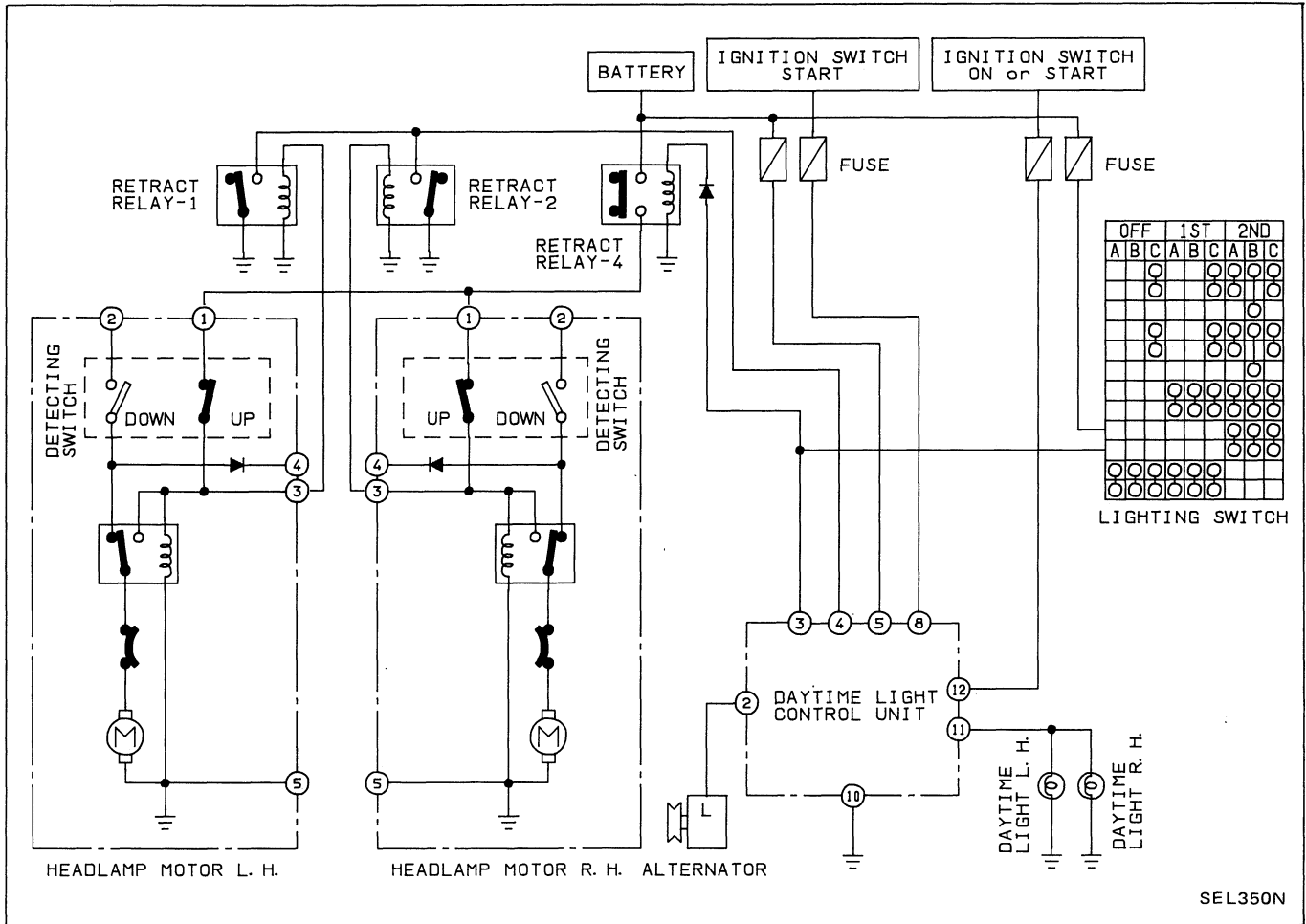

SEL350N

EXTERIOR LAMP

Daytime Light/Wiring Diagram

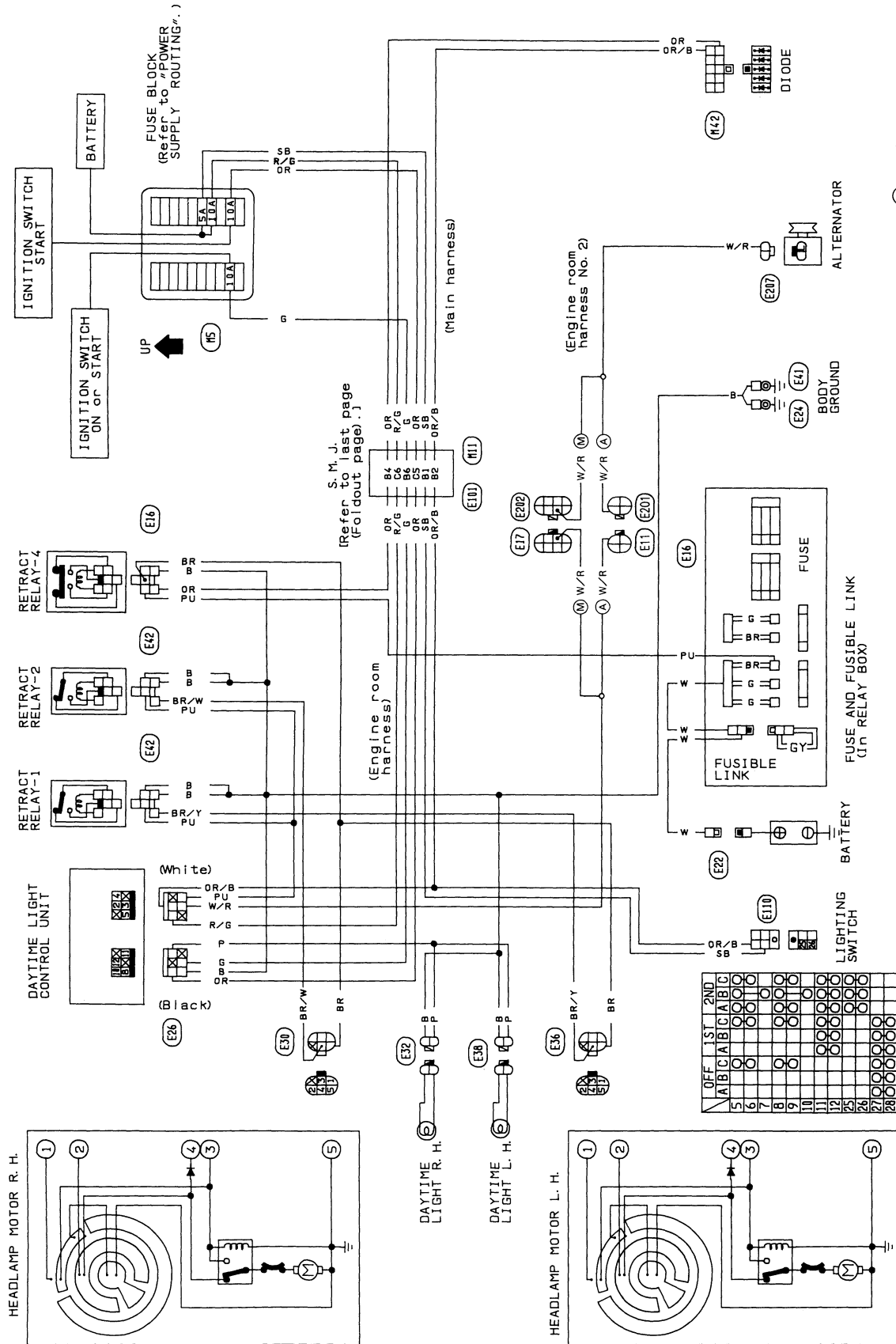

EXTERIOR LAMP

Clearance, License, Tail and Stop Lamps/Wiring Diagram

FASTBACK

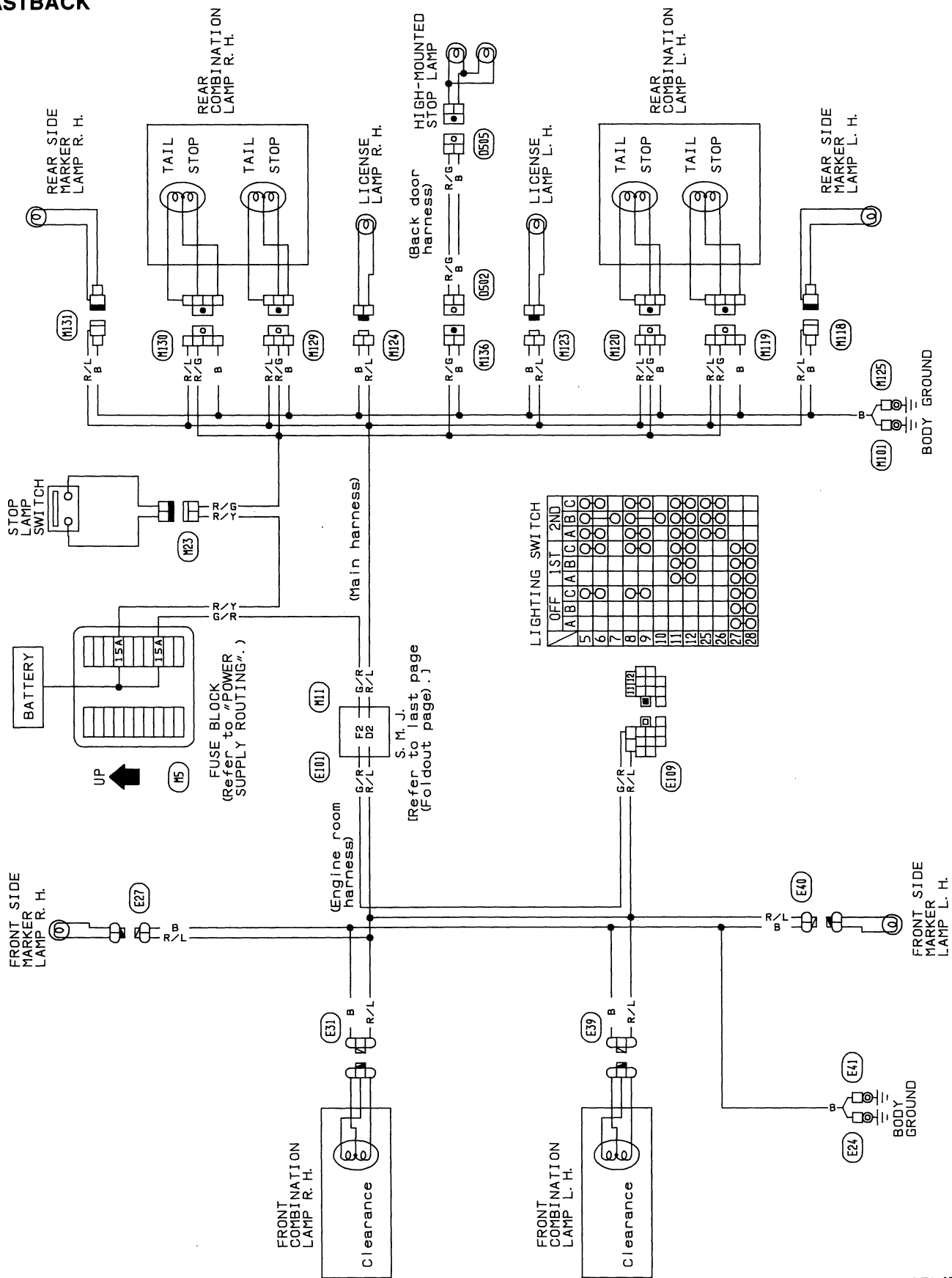

SEL471L

EXTERIOR LAMP

Clearance, License, Tail and Stop Lamps/Wiring Diagram (Cont'd)

COUPE

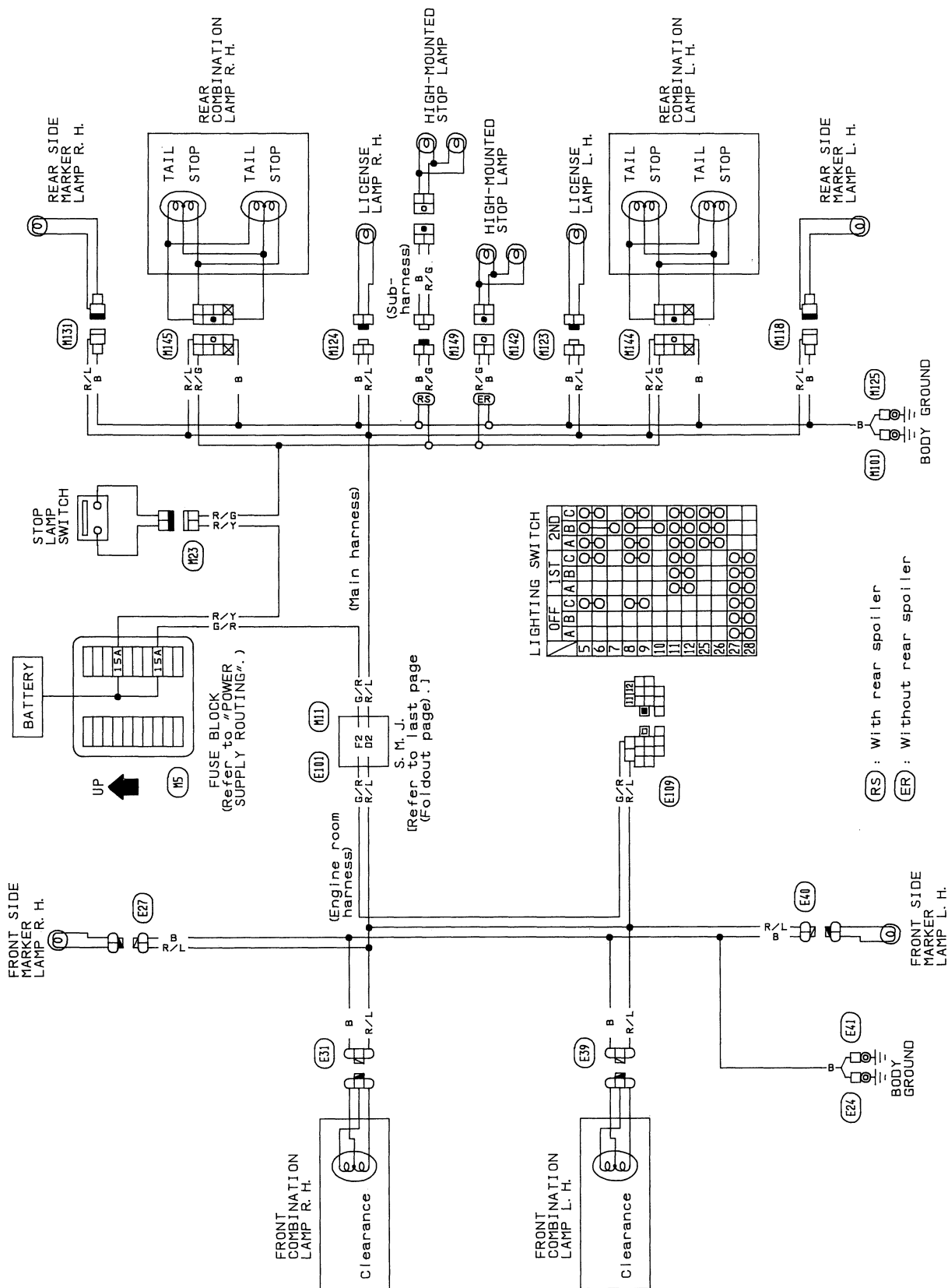

EXTERIOR LAMP

Back-up Lamp/Wiring Diagram

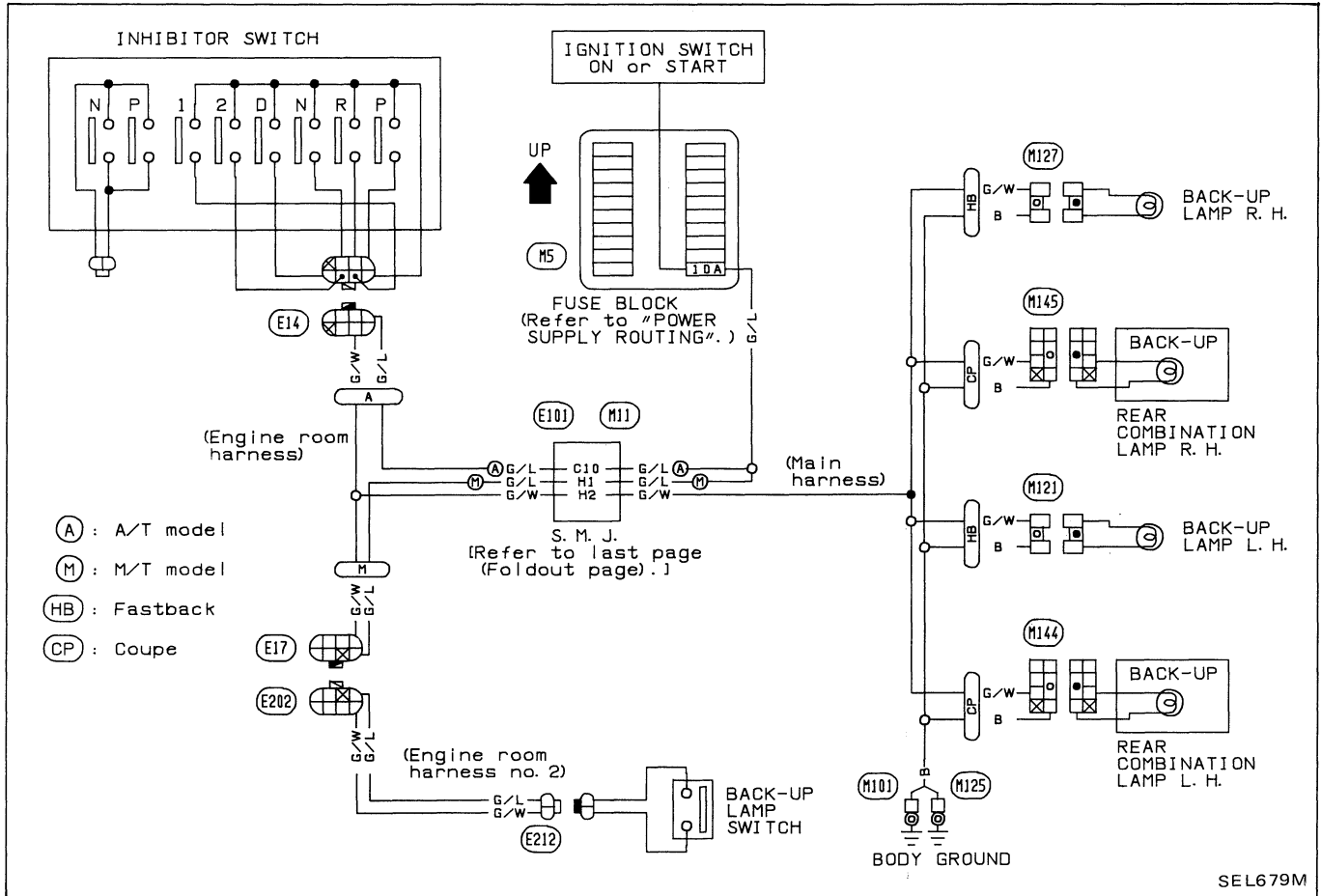

SEL679M

EXTERIOR LAMP

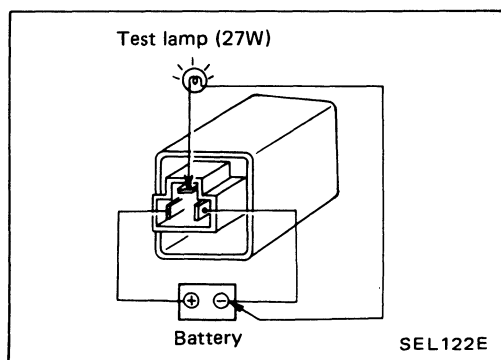

Combination Flasher Unit Check

- Before checking, ensure that bulbs meet specifications.
- Connect a battery and test lamp to the combination flasher unit, as shown. Combination flasher unit is properly functioning if it blinks when power is supplied to the circuit.

Bulb Specifications

Item	Wattage (W)
Headlamp (Sealed)	65/35
Daytime light	27
Front combination lamp	
Front turn signal/Clearance	27/8
Front side marker lamp	3.8
Rear side marker lamp	3.8
Rear combination lamp	
Turn signal lamp	27
Stop/Tail lamp	27/8
Back-up lamp (Coupe)	27
Back-up lamp (Fastback)	27
License plate lamp	7.5
Interior lamp	10
Spot lamp	8
Trunk room lamp (Coupe)	3.4
Foot well lamp	3
Luggage compartment lamp (Fastback)	5
High-mounted stop lamp	18

INTERIOR LAMP

Interior Lamp/Wiring Diagram

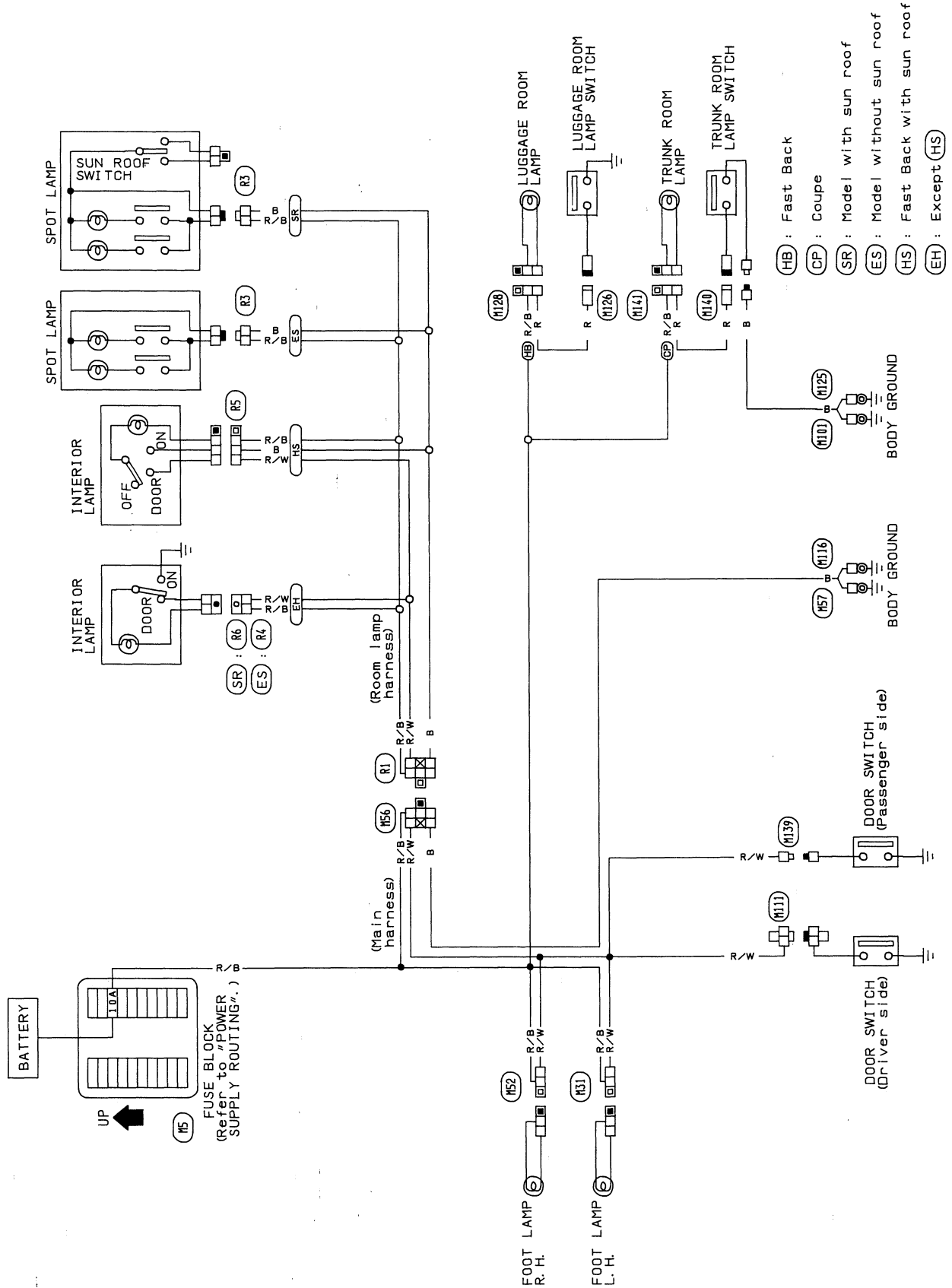

METER AND GAUGES

Combination Meter

NEEDLE TYPE

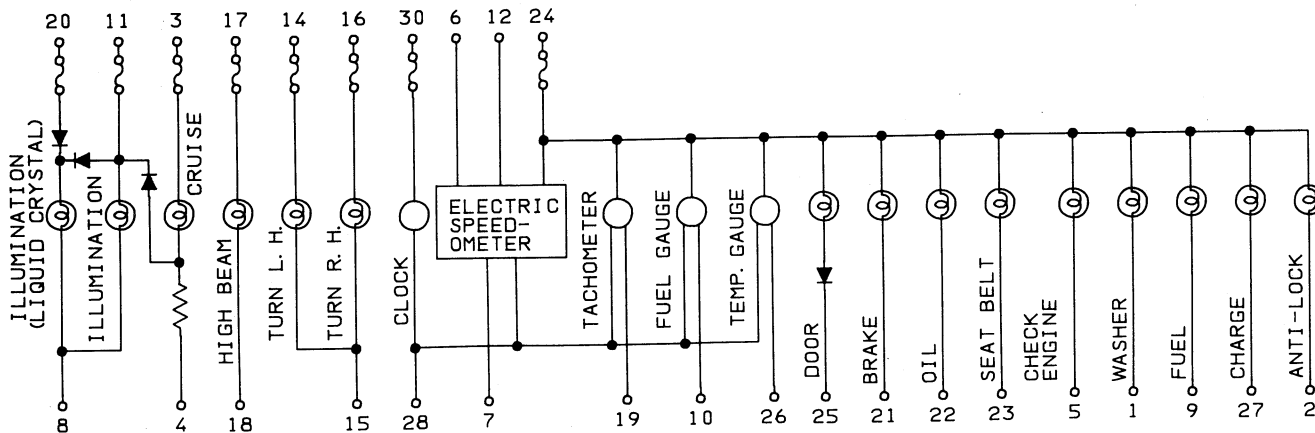
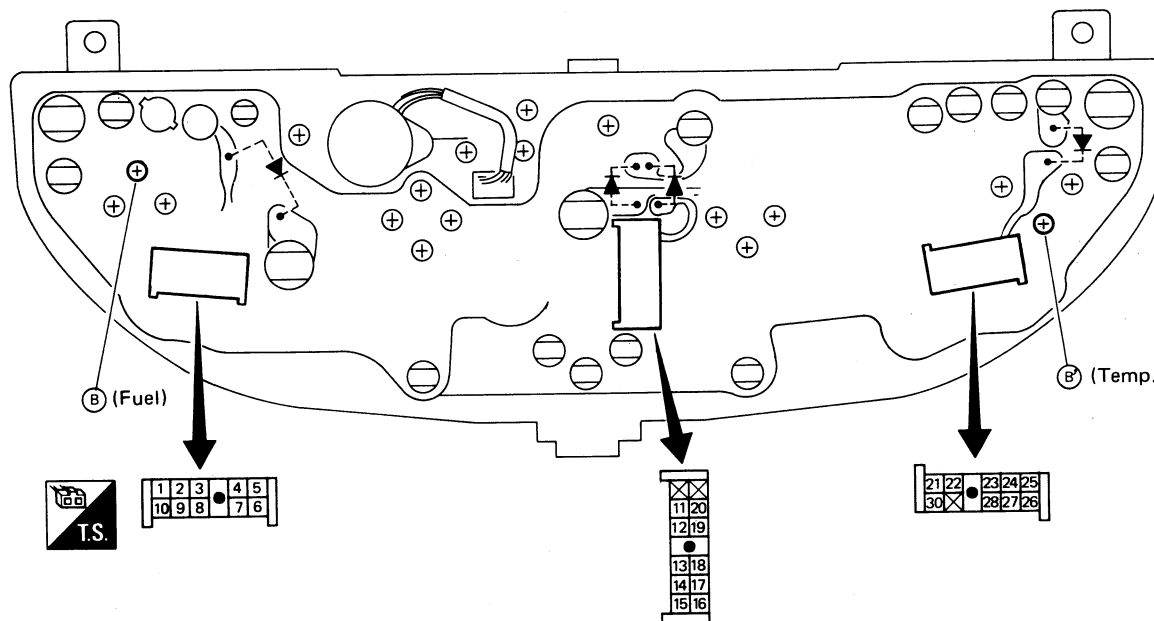
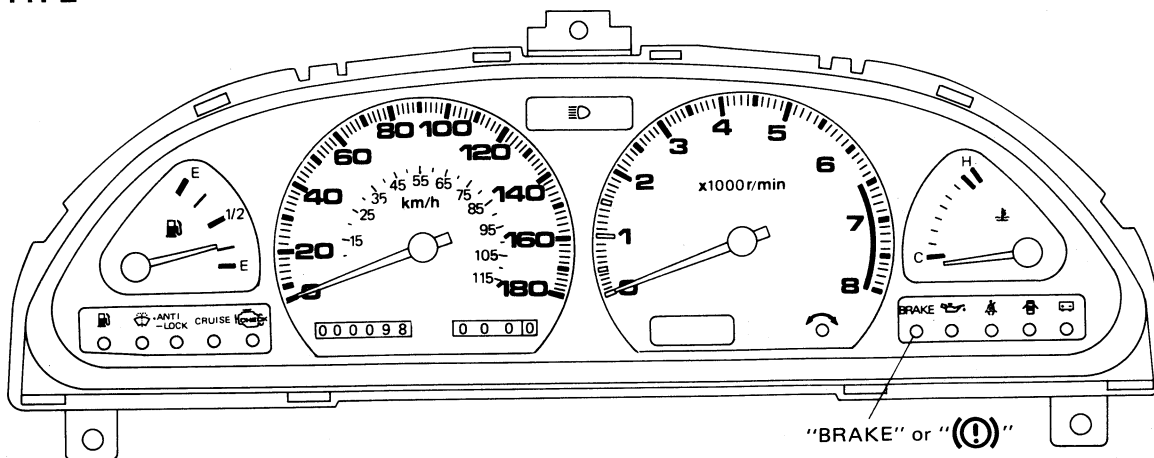

SEL810P

METER AND GAUGES

Combination Meter (Cont'd)

DIGITAL TYPE

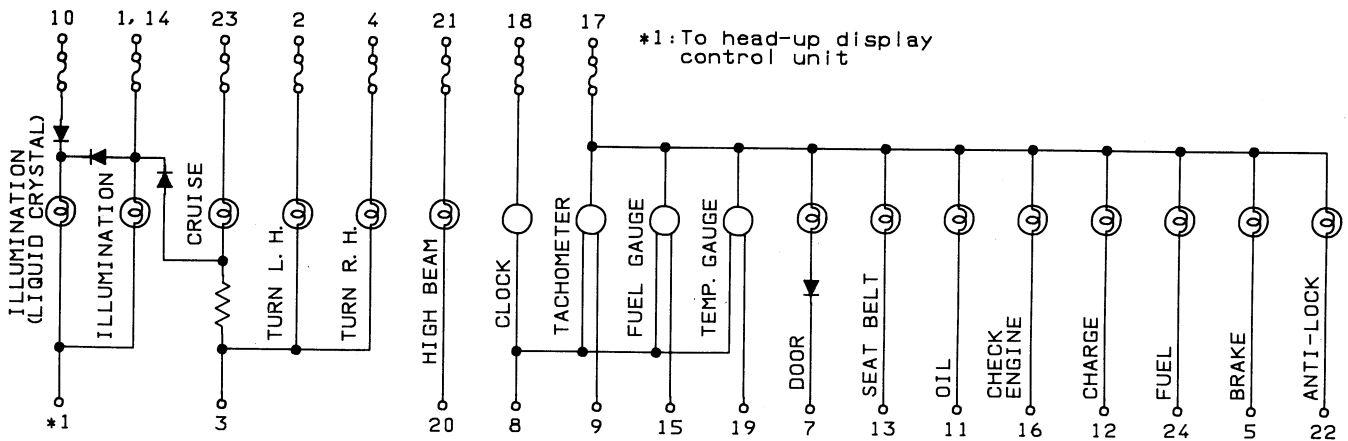
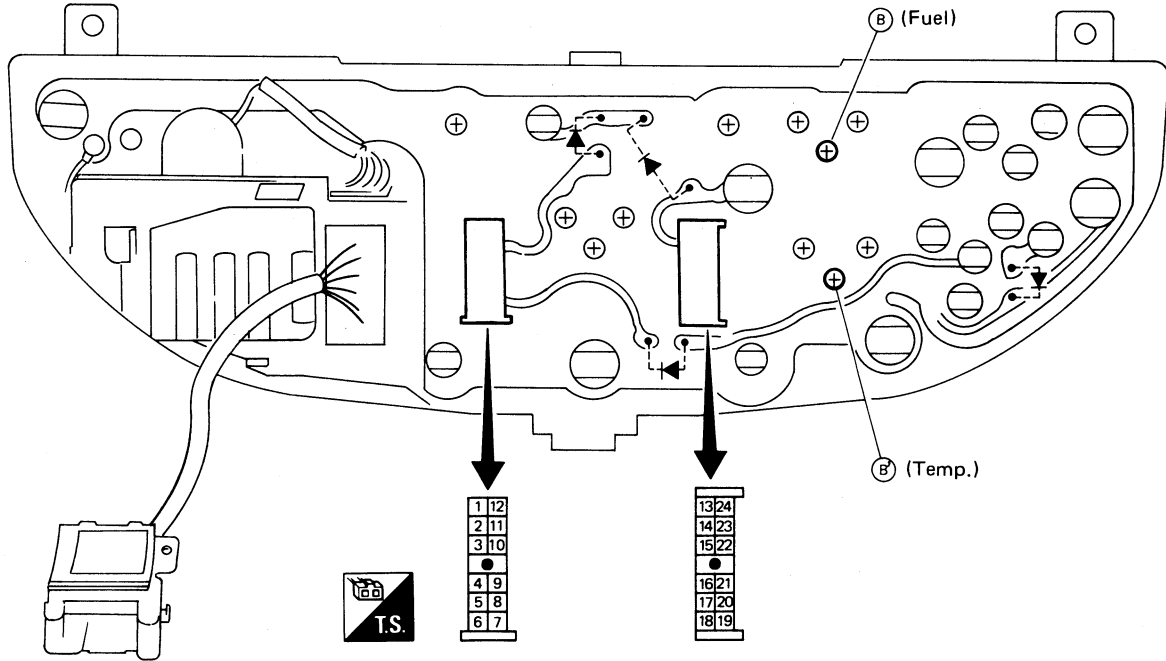
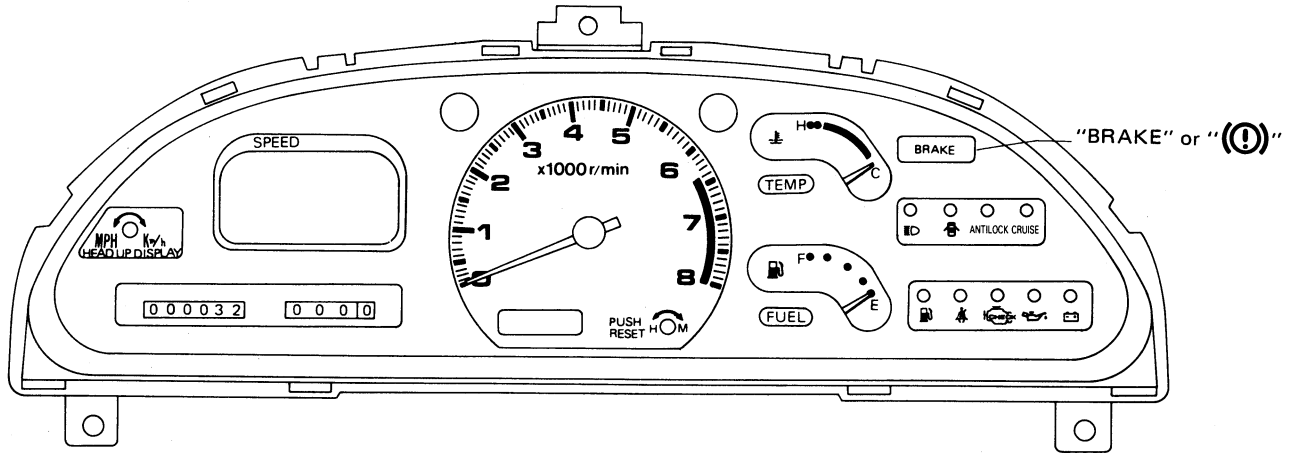

SEL811P

Combination Meter/Wiring Diagram

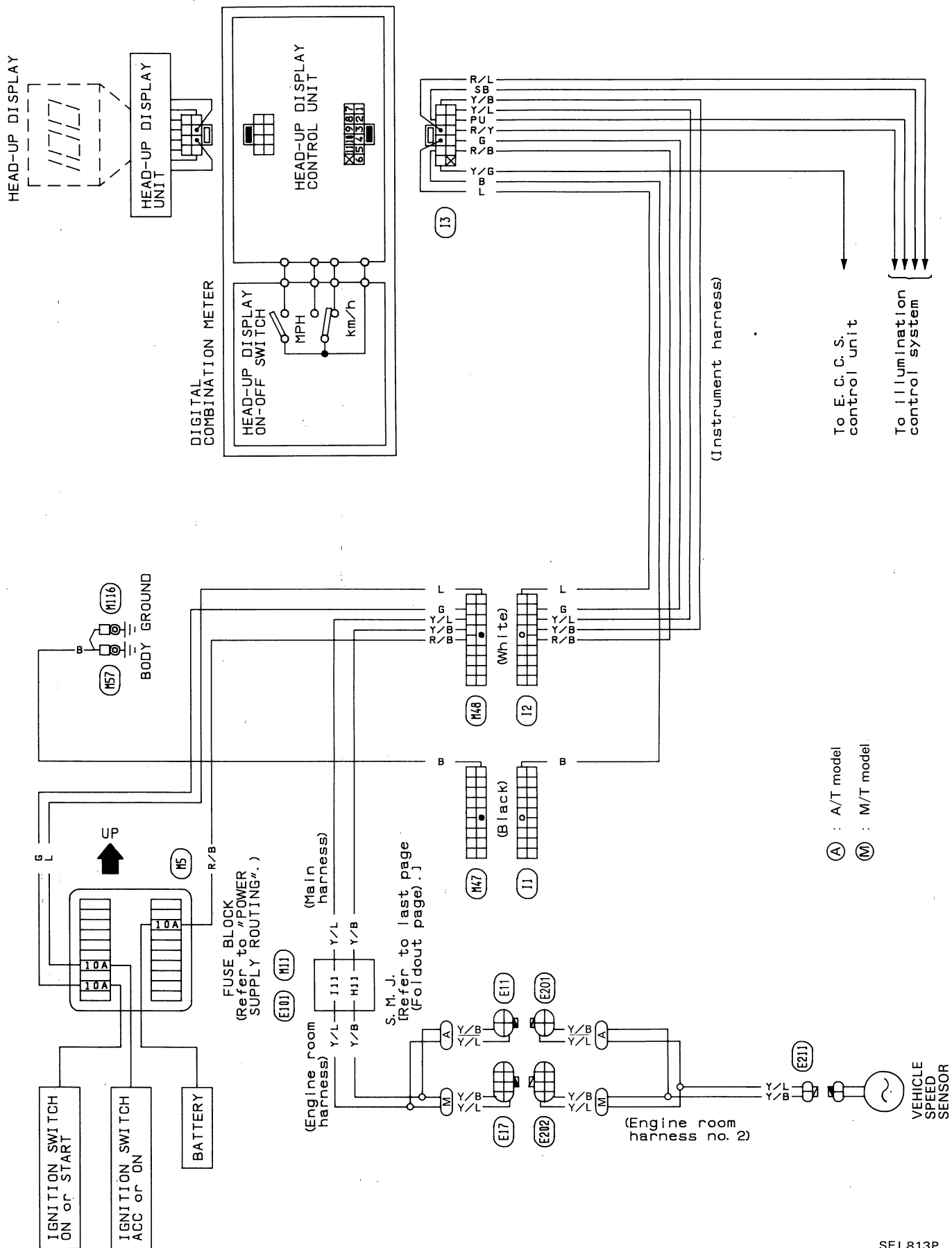

METER AND GAUGES

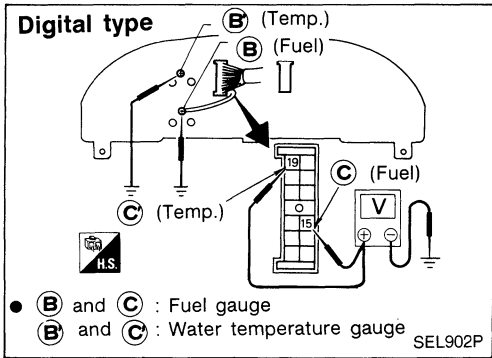
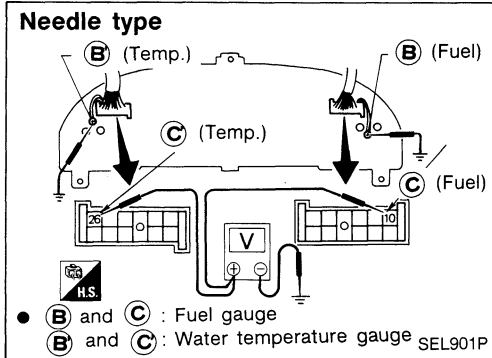
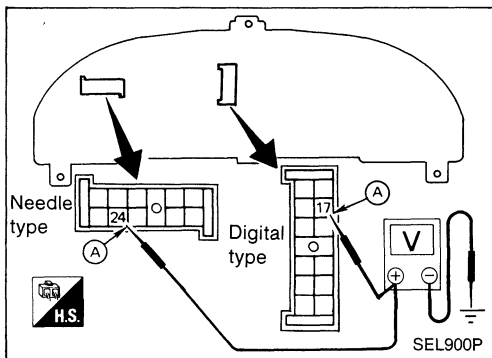

Inspection/Fuel Gauge and Water Temperature Gauge

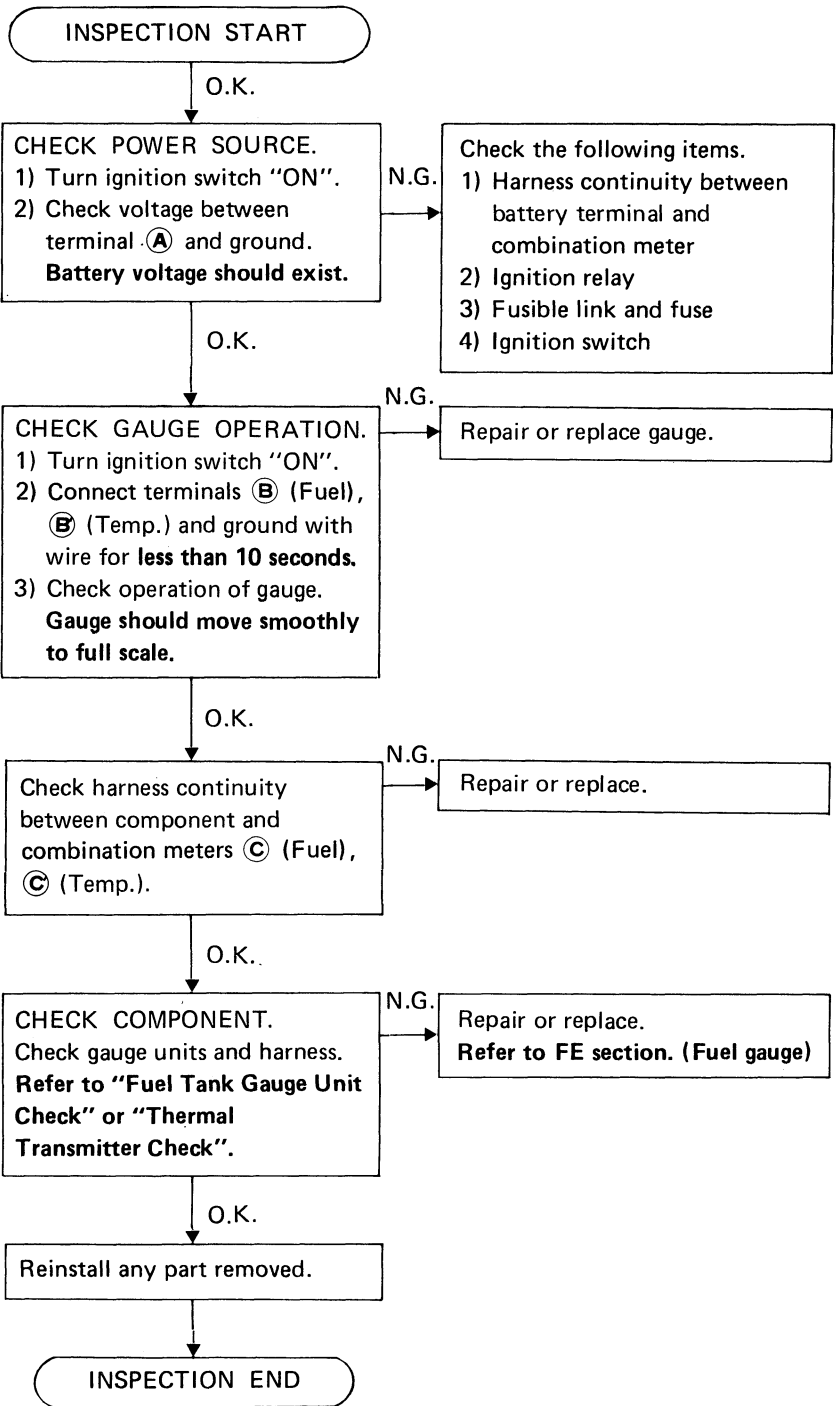

METER AND GAUGES

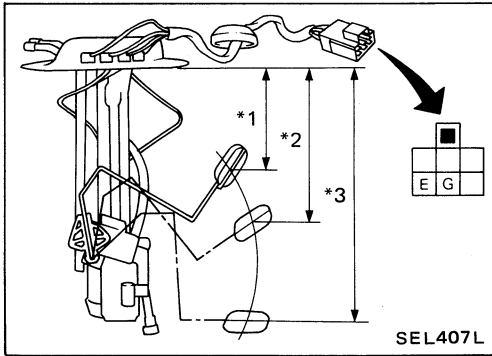

Fuel Tank Gauge Unit Check

- For removal, refer to FE section.
- Check the resistance between terminals **G** and **E**.

Ohmmeter		Float position		Resistance Ω	Fuel value ℓ (US gal, Imp gal)
(+)	(-)		mm (in)		
G	E	*1	Full	Approx. 92 (3.62)	4.3 - 5.8 57.6 (15-1/4, 12-5/8)
		*2	1/2	Approx. 154 (6.06)	27.7 - 34.3 32.9 (8-3/4, 7-1/4)
		*3	Empty	Approx. 226 (8.90)	78.3 - 84.8 6.6 (1-3/4, 1-1/2)

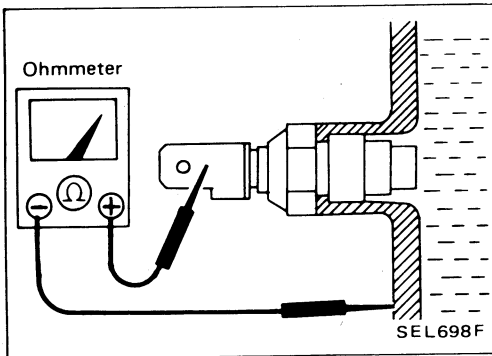

Thermal Transmitter Check

Check the resistance between the terminals of thermal transmitter and body ground.

Water temperature	Resistance
60°C (140°F)	Approx. 70 - 90 Ω
100°C (212°F)	Approx. 21 - 24 Ω

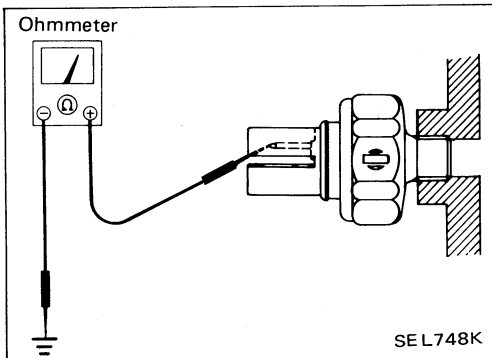

Oil Pressure Switch Check

Check the continuity between the terminals of oil pressure switch and body ground.

	Oil pressure kPa (kg/cm ² , psi)	Continuity
Engine start	More than 10 - 20 (0.1 - 0.2, 1.4 - 2.8)	NO
Engine stop	Less than 10 - 20 (0.1 - 0.2, 1.4 - 2.8)	YES

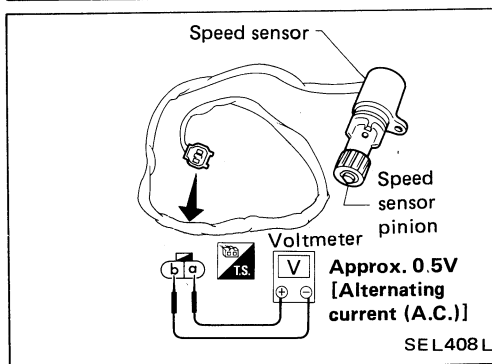

Speed Sensor Signal Check

1. Remove speed sensor from transmission.
Location: Refer to "Location of Electrical Units".
2. Turn speedometer pinion quickly and measure voltage across **a** and **b**.

WARNING LAMPS AND CHIME

Warning Lamps/Schematic

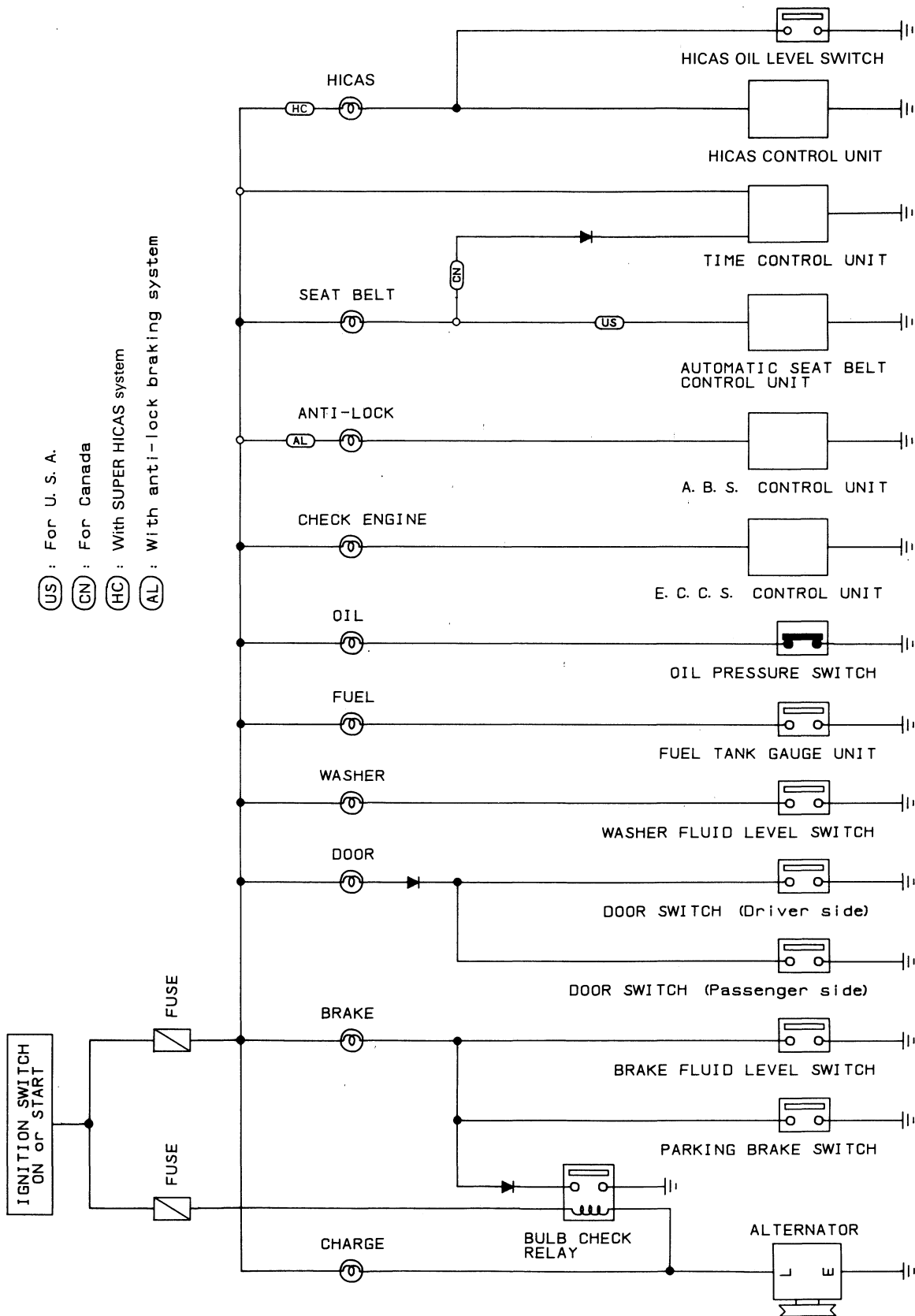

SEL815P

Warning Lamps/Wiring Diagram

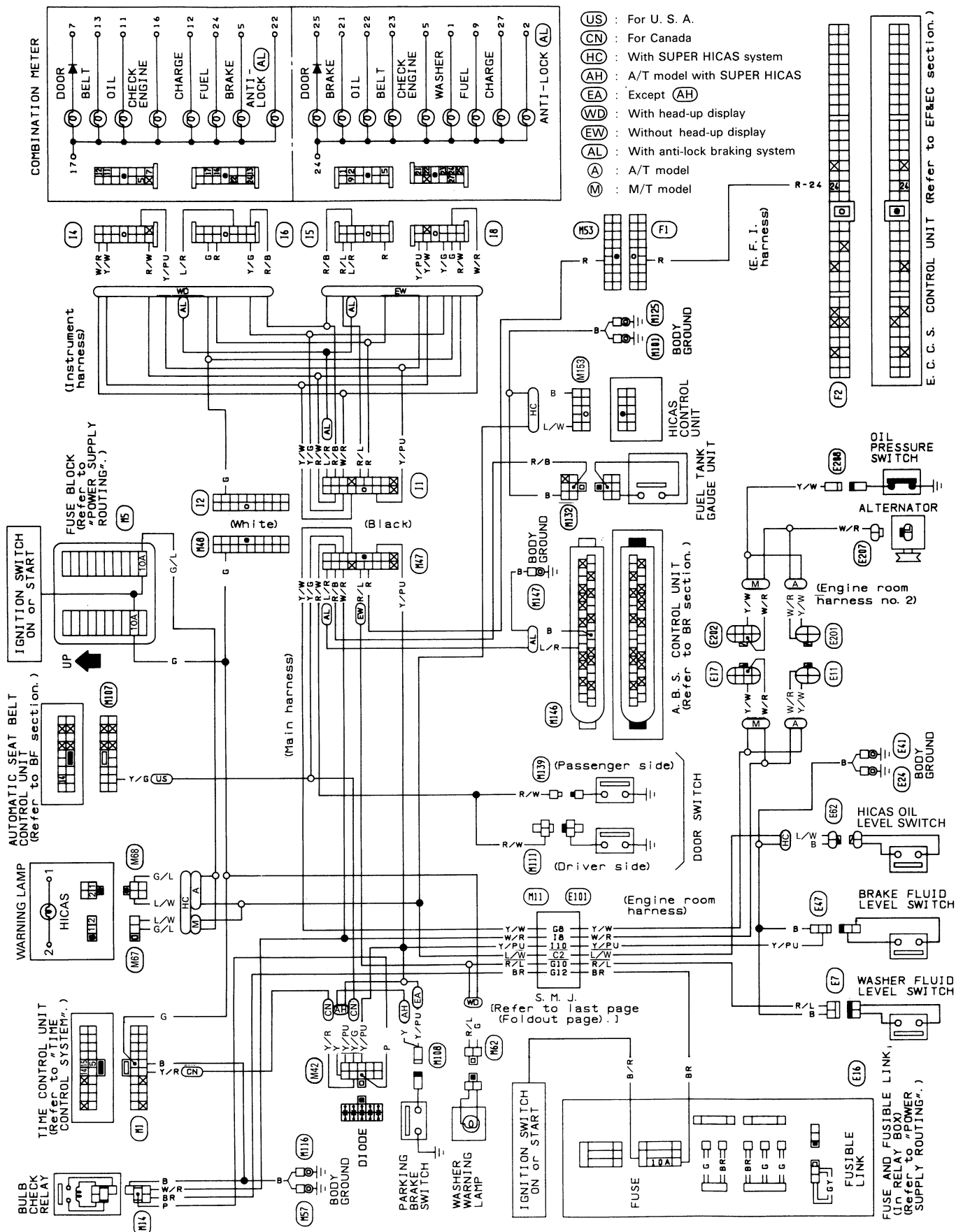

WARNING LAMPS AND CHIME

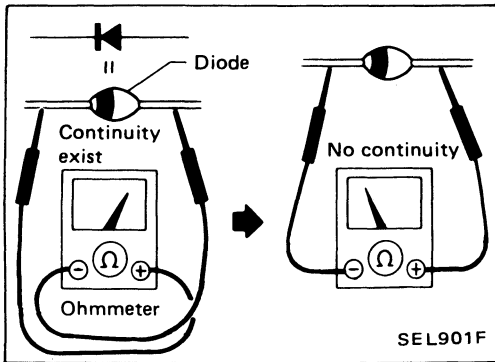

Diode Check

- Check continuity using an ohmmeter.
- Diode is functioning properly if test results are as shown in the figure at left.

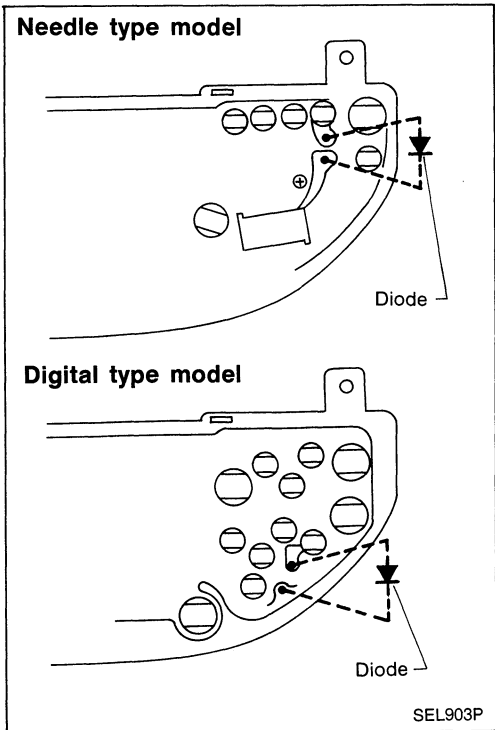

- Diodes for warning lamps are built into the combination meter printed circuit.

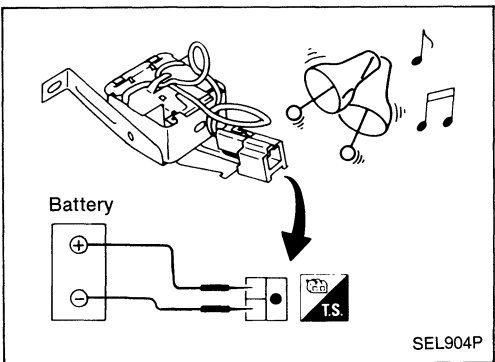

Warning Chime Check

TIME CONTROL SYSTEM

Wiring Diagram

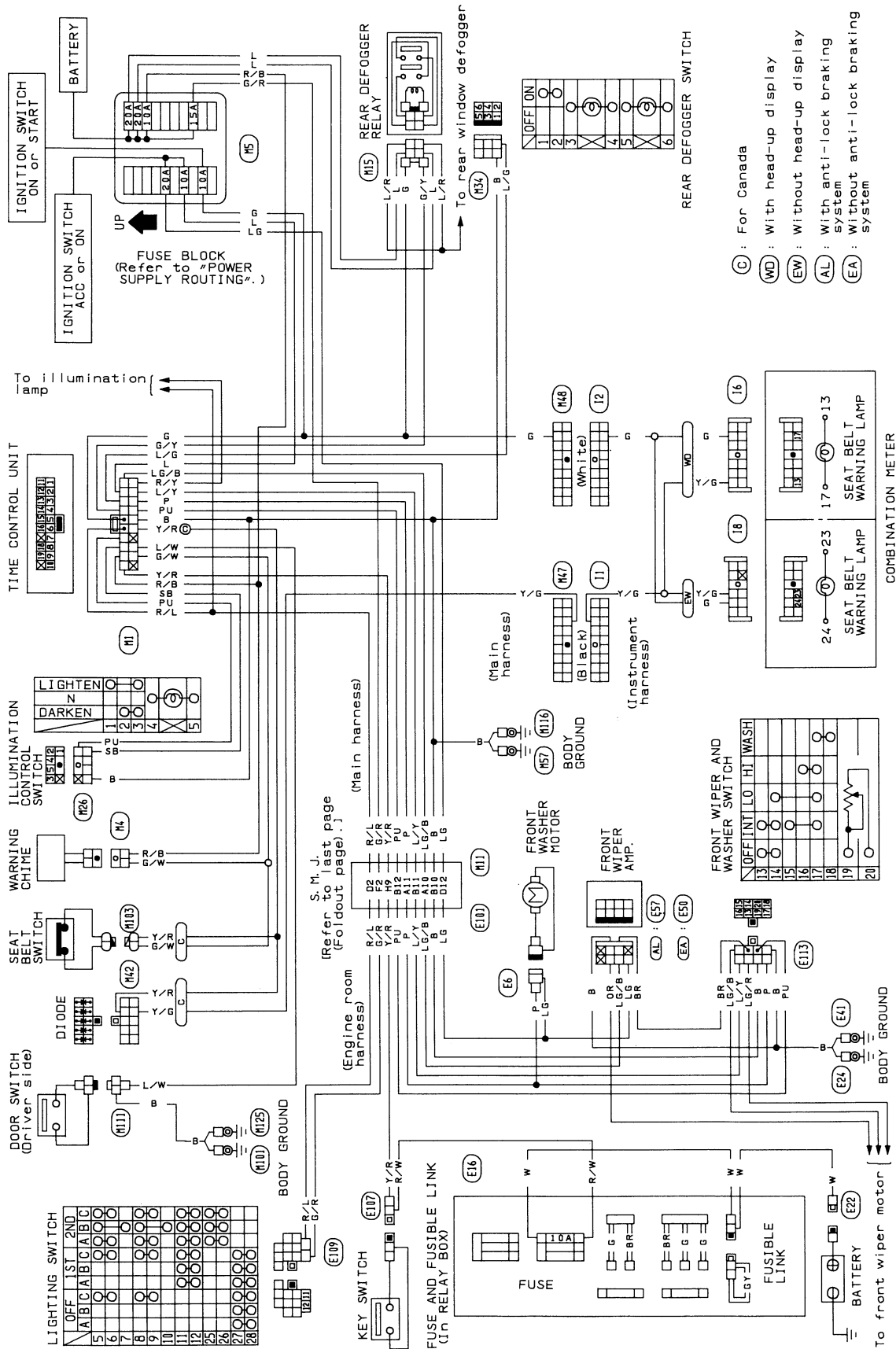

- (C) : For Canada
- (WD) : With head-up display
- (EW) : Without head-up display
- (AL) : With anti-lock braking system
- (EA) : Without anti-lock braking system

TIME CONTROL SYSTEM

Description

FUNCTION

- Time control unit has the following functions.

Item		Details of control
1	Intermittent wiper control	Regulates intermittent time from approximately 3 to 12 seconds depending on the intermittent wiper volume setting.
2	Washer and wiper combination control	Wiper is operated in conjunction with washer switch.
3	Illumination control	Regulates brightness of illumination in 16 stages depending on the illumination control switch setting.
4	Light warning chime timer	When driver's door is opened with light switch ON and ignition switch OFF, warning chime sounds.
5	Seat belt warning lamp timer	Seat-belt warning lamp blinks for about 7 seconds when ignition switch is turned to "ON"
6	Seat belt warning chime timer	Sounds warning chime for about 7 seconds if ignition switch is turned "ON" when seat belt switch is "ON" (seat belt is unfastened).

OPERATING CONDITIONS

Item	Input signal	Power source from battery	Ignition switch	Light switch	Wiper switch "INT"	Washer switch	Driver's side door switch *1	Seat belt switch *2	Illumination control switch
	Input terminal Output terminal								
		⑨	② or ⑤	⑥	⑫	⑬	⑱	⑰	⑦ or ⑧
Intermittent wiper control	①	ON	ACC or ON		ON				
Washer and wiper combination control	⑫	ON	ACC or ON			ON			
Illumination control	⑪	ON		ON					ON
Light warning chime timer	⑲	ON	OFF or ACC	ON			ON		
Seat belt warning lamp timer	⑰	ON	OFF or ACC → ON						
Seat belt warning chime timer	⑲	ON	OFF or ACC → ON					ON	

*1 Door switch is turned ON when door is opened.

*2 Seat belt switch is turned ON when driver's side seat belt is unfastened.

TIME CONTROL SYSTEM

Trouble-shooting

Symptom		DIAGNOSTIC PROCEDURE
Wiper & washer	Intermittent wiper does not operate.	1
	Intermittent time of wiper cannot be adjusted.	2
	Wiper and washer activate individually but not in combination	3
Illumination	Illumination control system does not actuate.	4
Warning	Light warning chime does not activate.	5
	Seat belt warning chime does not activate.	6
	Seat belt warning lamp does not go off nor come on.	7
	Ignition key warning chime does not activate.	8
Rear defogger	Rear defogger does not activate, or does not go off.	9

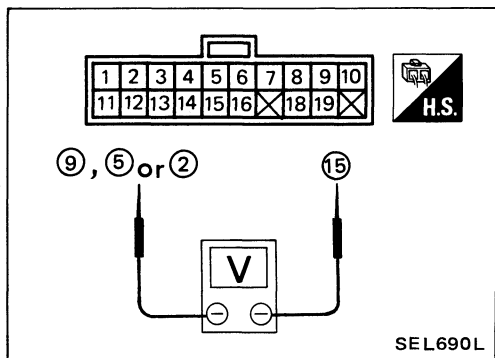
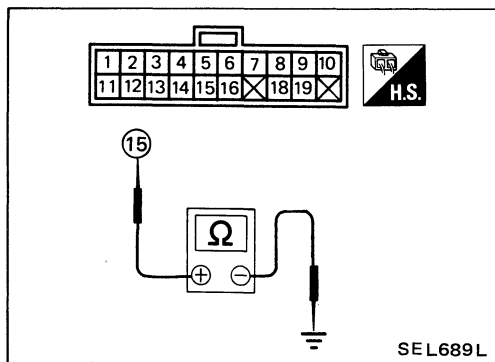

PREPARATION FOR TROUBLE-SHOOTING

1. Remove driver's side dash side cover.
2. Remove time control unit with harness connected.

POWER SUPPLY CIRCUIT CHECK

1. Connect ohmmeter from harness side.
2. Check continuity between terminal ⑮ and body ground.

Ohmmeter terminals		Continuity
(+)	(-)	
⑮	Body ground	Yes

3. Connect voltmeter from harness side.
4. Measure voltage across terminal ⑮ and terminals ②, ⑤ or ⑨.

Voltmeter terminals		Ignition switch position		
(+)	(-)	OFF	ACC	ON
⑨	⑮	Approx. 12V	Approx. 12V	Approx. 12V
⑤	⑮	0V	0V	Approx. 12V
②	⑮	0V	Approx. 12V	Approx. 12V

TIME CONTROL SYSTEM

A T.C.U. OUTPUT FOR WIPER RELAY CIRCUIT CHECK
 Measure voltage across ① and ⑮.

Wiper switch → "INT"
 Needle swings from 0 to 12V every 3 to 12 seconds.

SEL652L

B WIPER SWITCH CIRCUIT CHECK
 Check continuity between ⑫ and ⑮.

Wiper switch
 "INT": 0V
 "OFF": 12V

SEL653L

A INTERMITTENT WIPER VOLUME CIRCUIT CHECK
 Measure resistance between ⑭ and ⑮ while turning intermittent wiper volume.

Intermittent wiper knob
 0Ω at "S" position
 Approx. 1 kΩ at "L" position

SEL654L

Trouble-shooting (Cont'd)

DIAGNOSTIC PROCEDURE-1

Intermittent wiper does not operate.

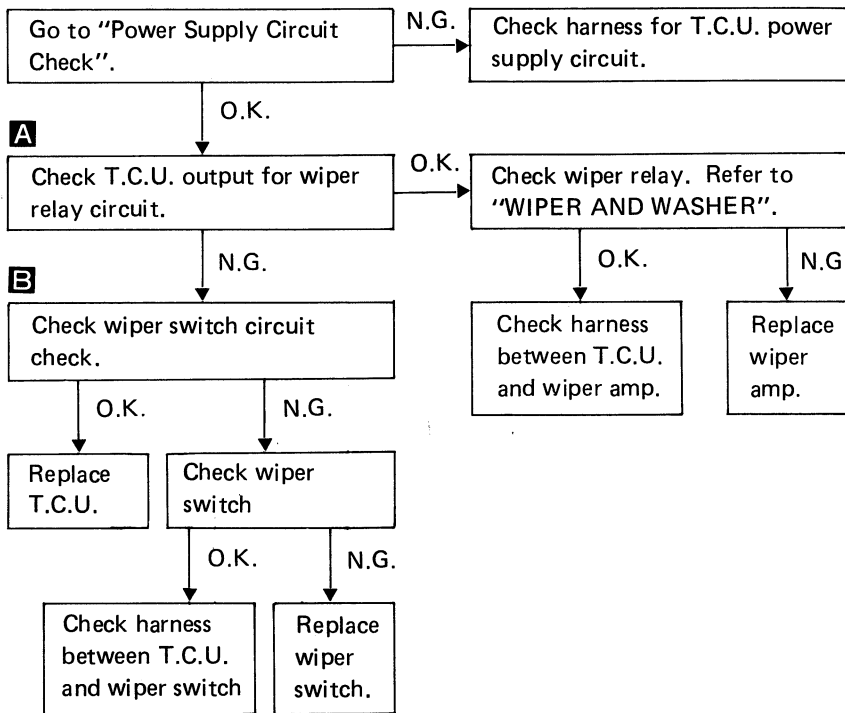

DIAGNOSTIC PROCEDURE-2

Intermittent time of wiper cannot be adjusted.

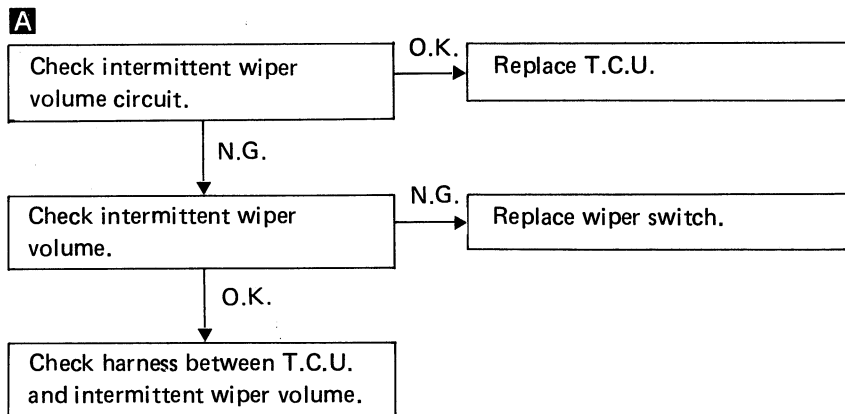

TIME CONTROL SYSTEM

Trouble-shooting (Cont'd)

DIAGNOSTIC PROCEDURE-3

Wiper and washer activate individually but not in combination.

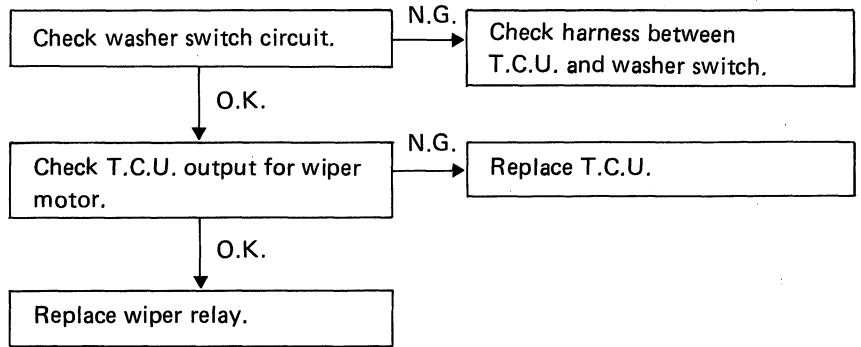

A T.C.U. OUTPUT FOR LIGHT SWITCH CIRCUIT CHECK

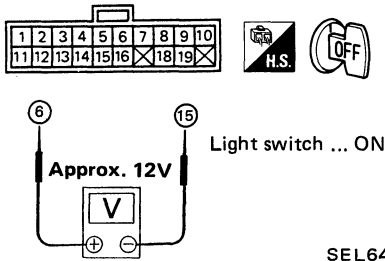

SEL648L

B ILLUMINATION CIRCUIT CHECK

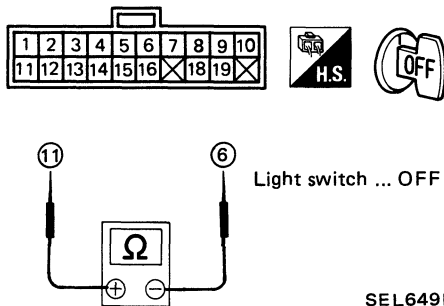

SEL649L

C ILLUMINATION CONTROL CIRCUIT CHECK

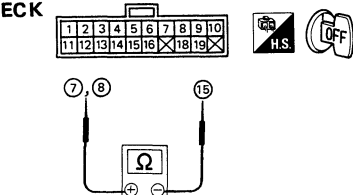

Ohmmeter		Illumination control switch	
(+)	(-)	DARK	BRIGHT
8	15	0Ω	Except 0Ω
7	15	Except 0Ω	0Ω

SEL650L

DIAGNOSTIC PROCEDURE-4

Illumination control system does not actuate.

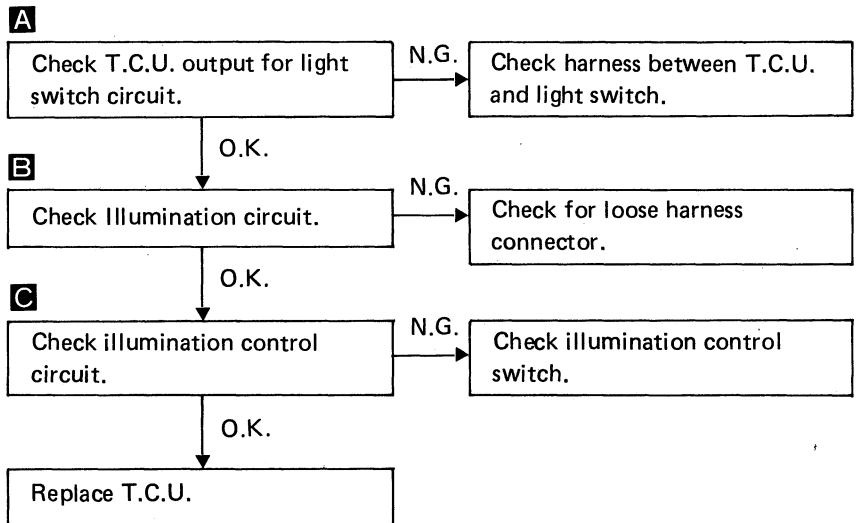

TIME CONTROL SYSTEM

Trouble-shooting (Cont'd)

DIAGNOSTIC PROCEDURE-5

Light warning chime does not activate.

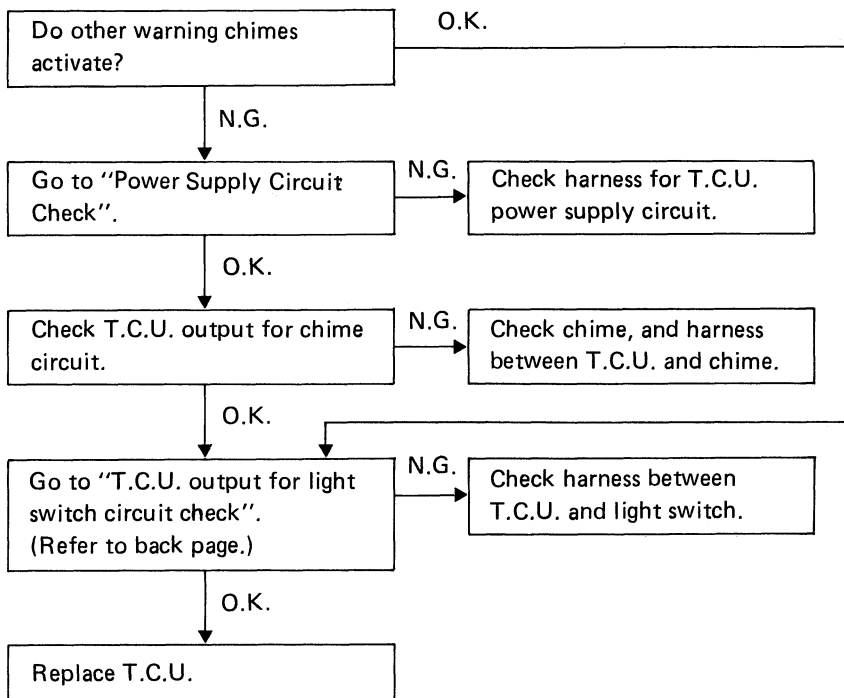

A T.C.U. OUTPUT FOR CHIME CIRCUIT CHECK

Measure voltage across ⑲ and ⑮ when driver's door is opened and closed.



- Approx. 12V when driver's side door is closed.
- Voltmeter needle swings (0 ↔ 12V) when driver's side door is opened.

SEL642L

B SEAT BELT SWITCH CIRCUIT CHECK

1. Unfasten driver's seat belt.
2. Check continuity between ⑲ and ⑯.
3. Fasten driver's seat belt.
4. Check to determine if continuity does not exist between ⑲ and ⑯.

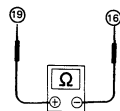
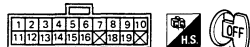

SEL643L

DIAGNOSTIC PROCEDURE-6

Seat belt warning chime does not activate.

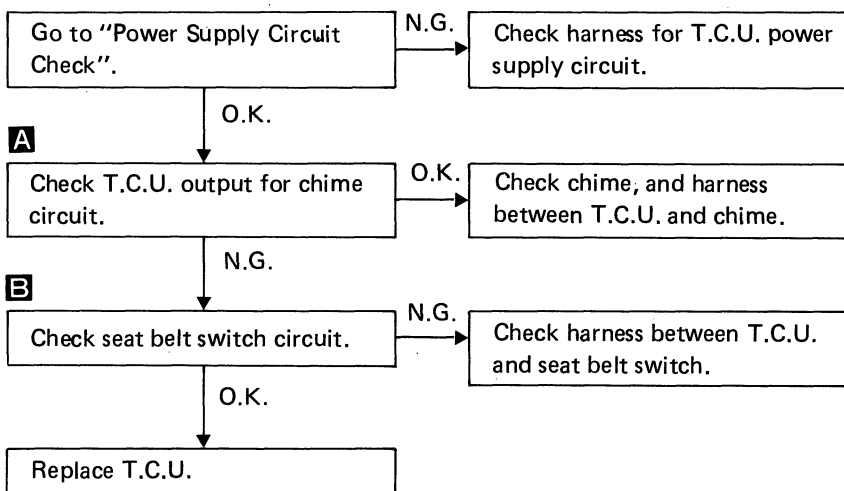

TIME CONTROL SYSTEM

Trouble-shooting (Cont'd)

DIAGNOSTIC PROCEDURE-7

Seat belt warning lamp does not go off nor comes on.

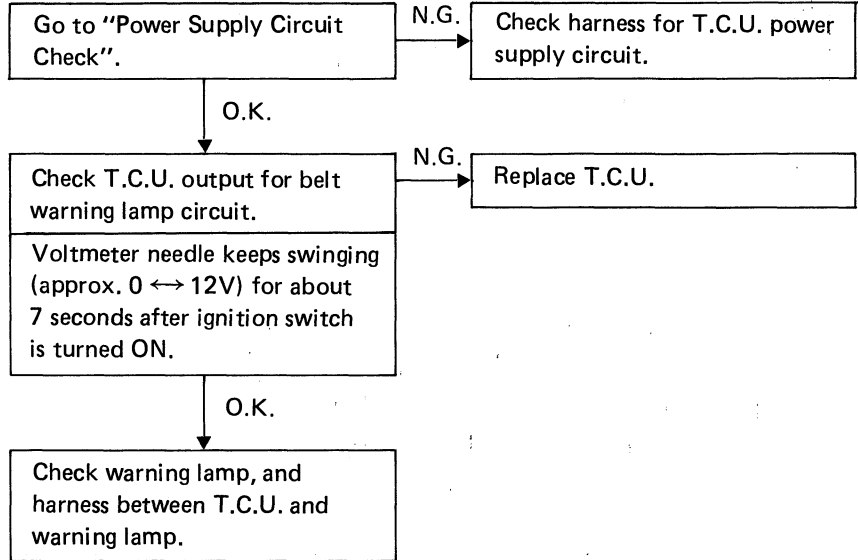
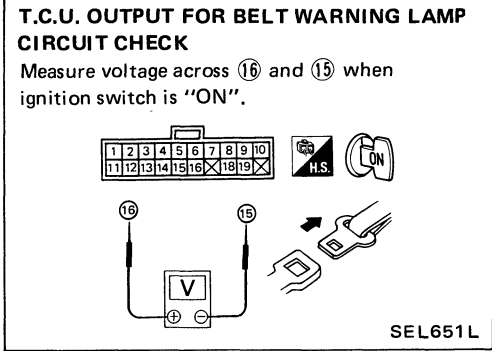

TIME CONTROL SYSTEM

Trouble-shooting (Cont'd)

DIAGNOSTIC PROCEDURE-8

Ignition key warning chime does not activate.

A KEY SWITCH CIRCUIT CHECK
Measure voltage across ⑩ and ⑮.

SEL641L

B T.C.U. OUTPUT FOR CHIME CIRCUIT CHECK
Measure voltage across ⑲ and ⑮ when driver's door is opened and closed.

- Approx. 12V when driver's side door is opened.

SEL639L

C DRIVER'S DOOR SWITCH CIRCUIT CHECK
Check continuity between ⑱ and ⑮.

Driver's side door ... Open

SEL640L

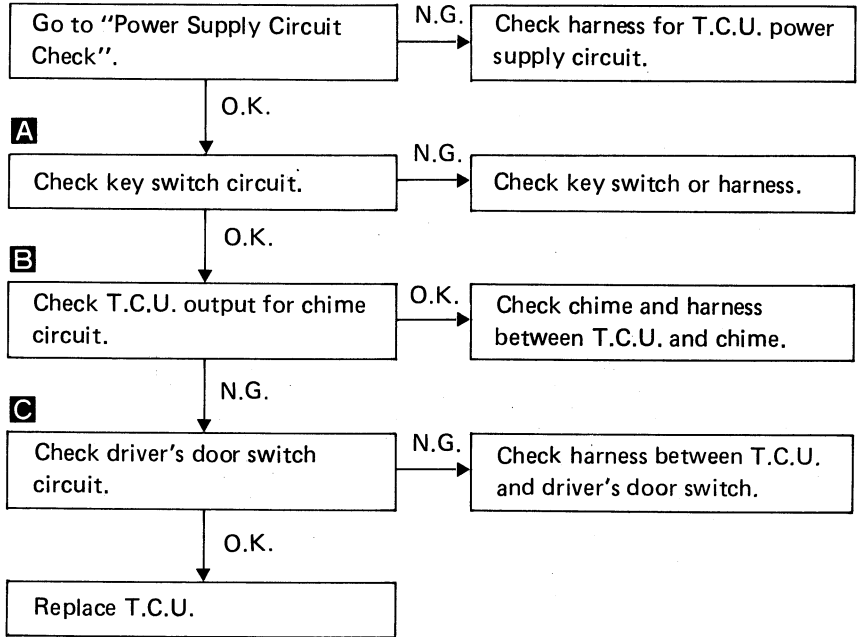

TIME CONTROL SYSTEM

Trouble-shooting (Cont'd)

DIAGNOSTIC PROCEDURE-9

Rear defogger does not activate, or does not go off.

A T.C.U. OUTPUT FOR REAR DEFOGGER CIRCUIT CHECK
 Measure voltage across ④ and ⑮ while operating rear defogger switch.

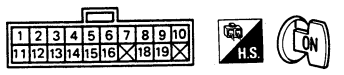

- Rear defogger switch "OFF": Approx. 12V
- Rear defogger switch "ON": Approx. 0V

SEL644L

B DEFOGGER SWITCH CIRCUIT CHECK

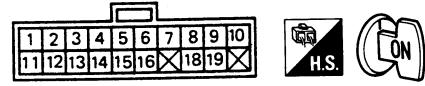

- Rear defogger switch "OFF": Except 0Ω
- Rear defogger switch "ON": 0Ω

SEL645L

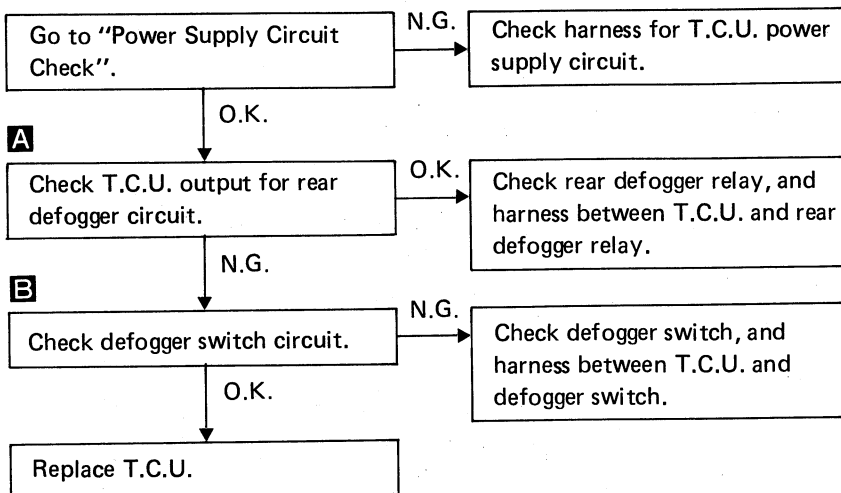

WIPER AND WASHER

Rear Wiper and Washer/Wiring Diagram

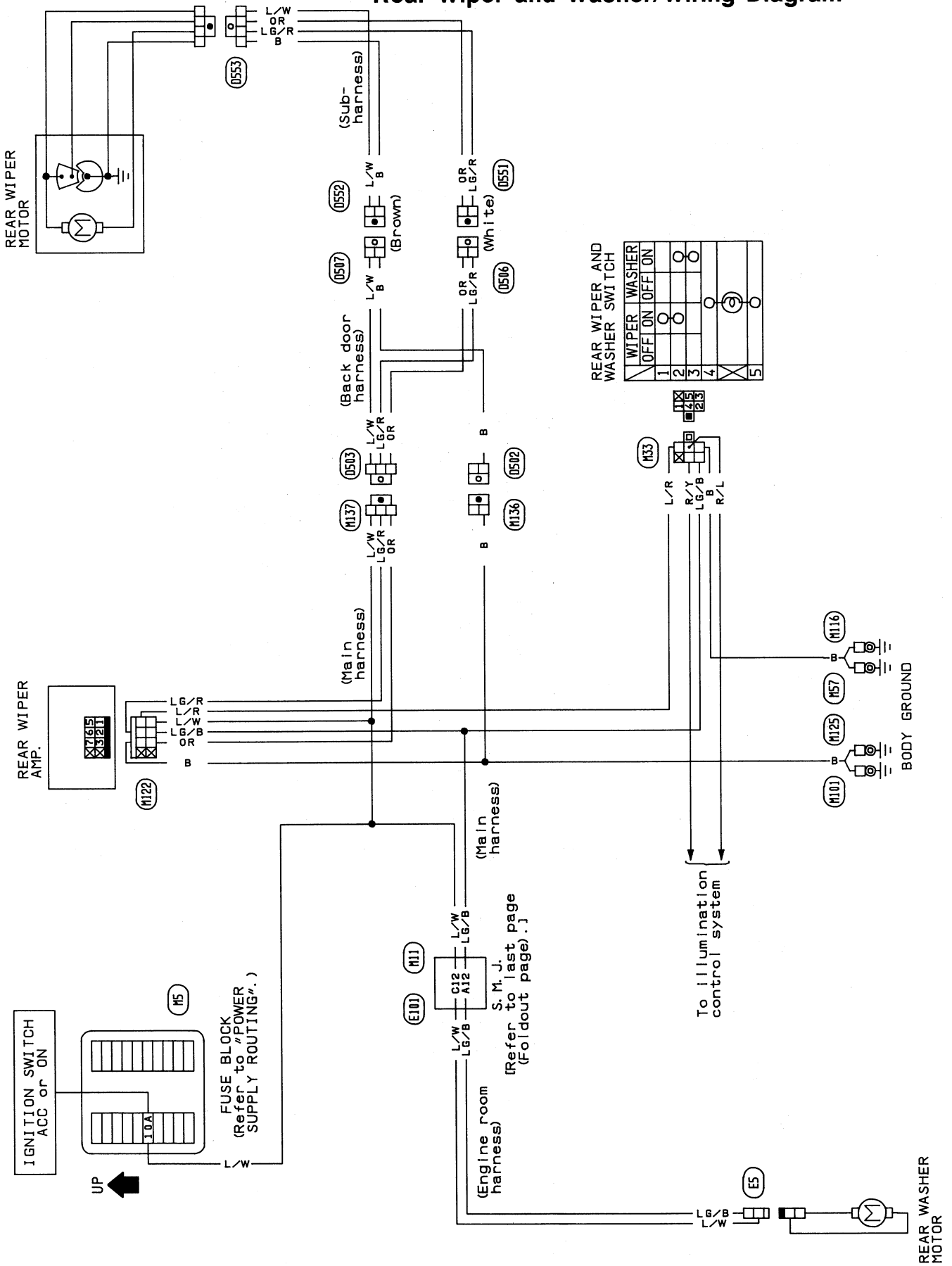

WIPER AND WASHER

Wiper and Washer Adjustment

INSTALLATION

1. Prior to wiper arm installation, turn on wiper switch to operate wiper motor and then turn it "OFF" (Auto Stop).
2. Lift the blade up and then set it down onto glass surface to set the blade center to clearance "L₁" & "L₂" immediately before tightening nut.
3. Eject washer fluid. Turn on wiper switch to operate wiper motor and then turn it "OFF".
4. Ensure that wiper blades stop within clearance "L₁" & "L₂".

Clearance "L₁": 17.5 - 32.5 mm (0.689 - 1.280 in)

Clearance "L₂": 25 - 35 mm (0.98 - 1.38 in)

- Tighten wiper arm nuts to specified torque.

Front wiper: 17 - 23 N·m (1.7 - 2.3 kg-m, 12 - 17 ft-lb)

Rear wiper: 13 - 18 N·m (1.3 - 1.8 kg-m, 9 - 13 ft-lb)

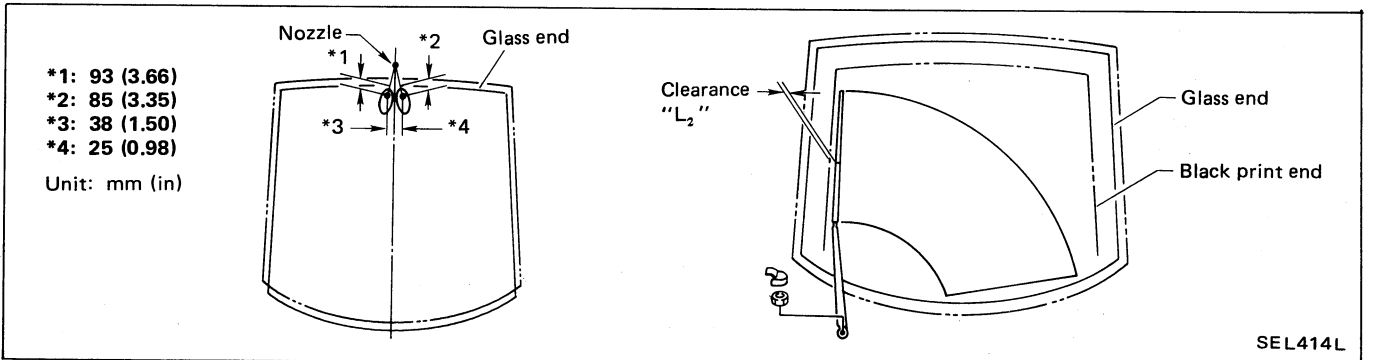
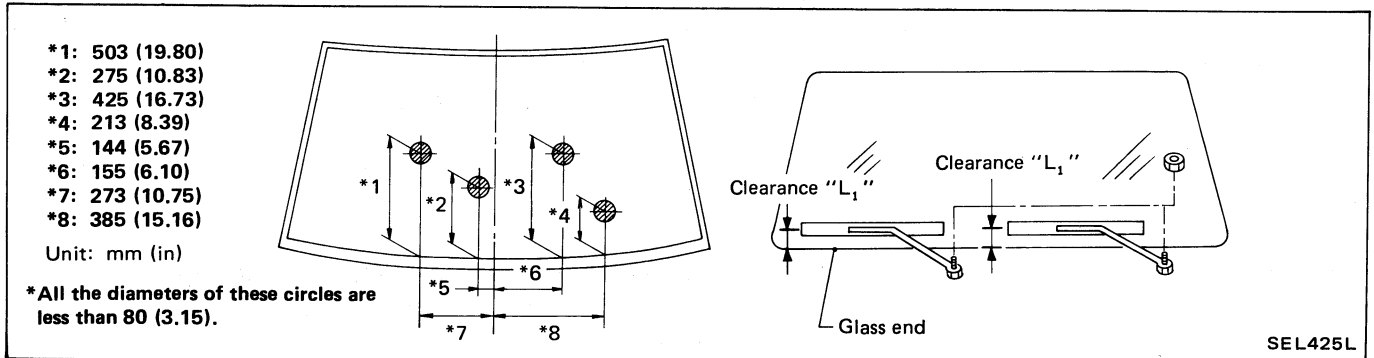

WIPER AND WASHER

Wiper and Washer Adjustment (Cont'd)

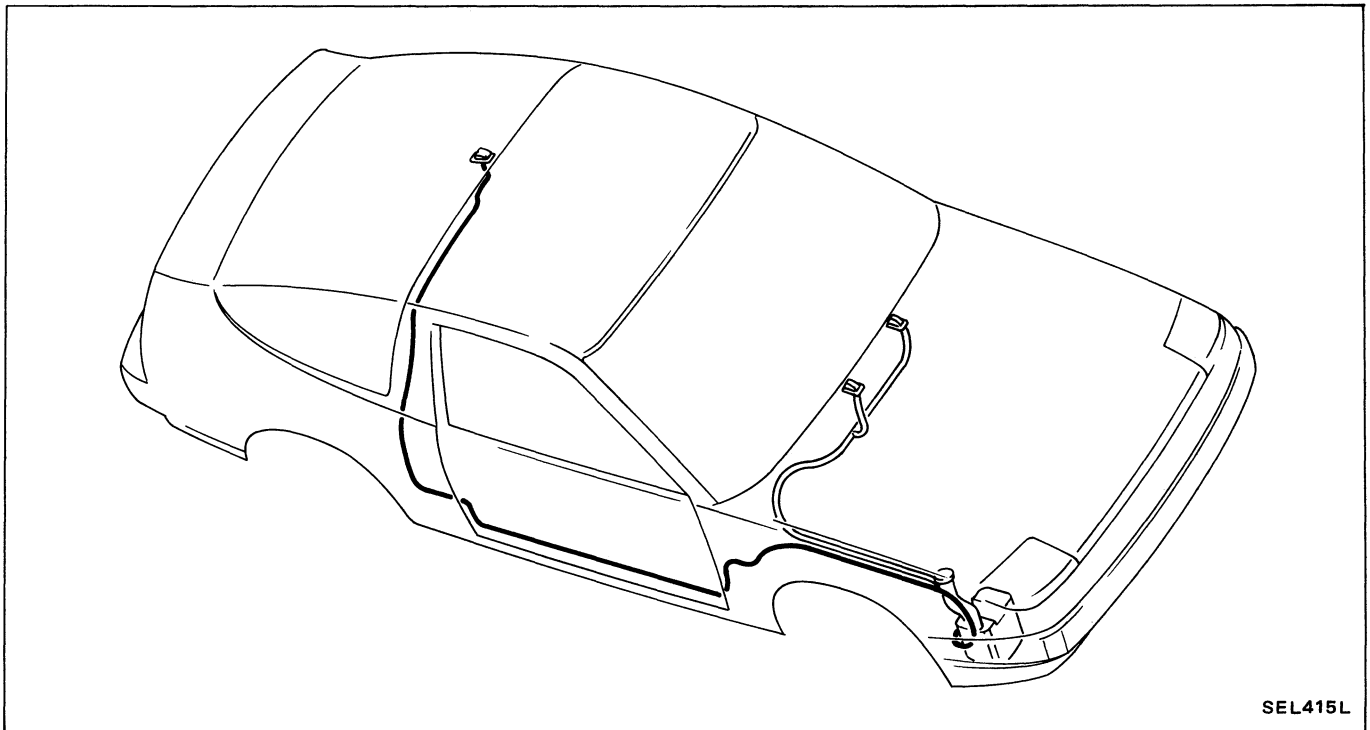

SEL415L

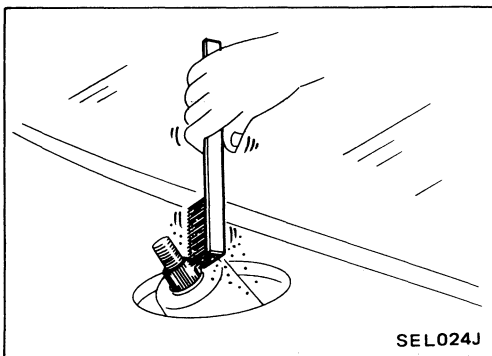

SEL024J

- Before reinstalling wiper arm, clean up the pivot area as illustrated. This will reduce possibility of wiper arm looseness.

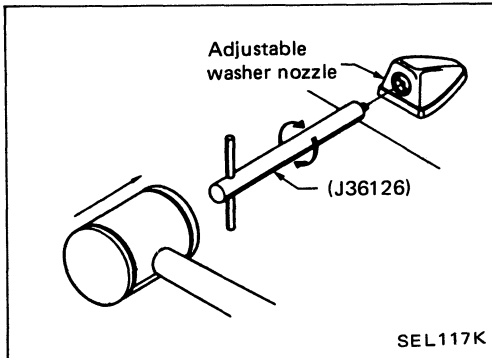

SEL117K

Washer Nozzle Adjustment

- Using Tool (J36126), adjust windshield washer nozzle to correct its spray pattern. Before attempting to turn the nozzle, gently tap the end of the tool to free the nozzle. This will prevent "rounding out" the small female square in the center of the nozzle.

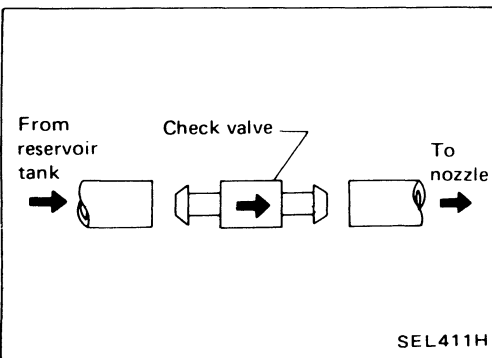

SEL411H

Check Valve

- A check valve is provided in the washer fluid line. Be careful not to connect check valve to washer tube in the wrong direction.

WIPER AND WASHER

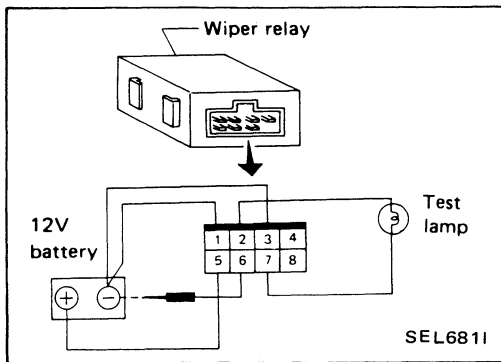

Wiper Amplifier Check

1. Connect as shown in the figure at left.
2. If test lamp comes on when connected to terminal ⑥ and battery ground, wiper relay is normal.

HORN, CIGARETTE LIGHTER AND CLOCK

Wiring Diagram

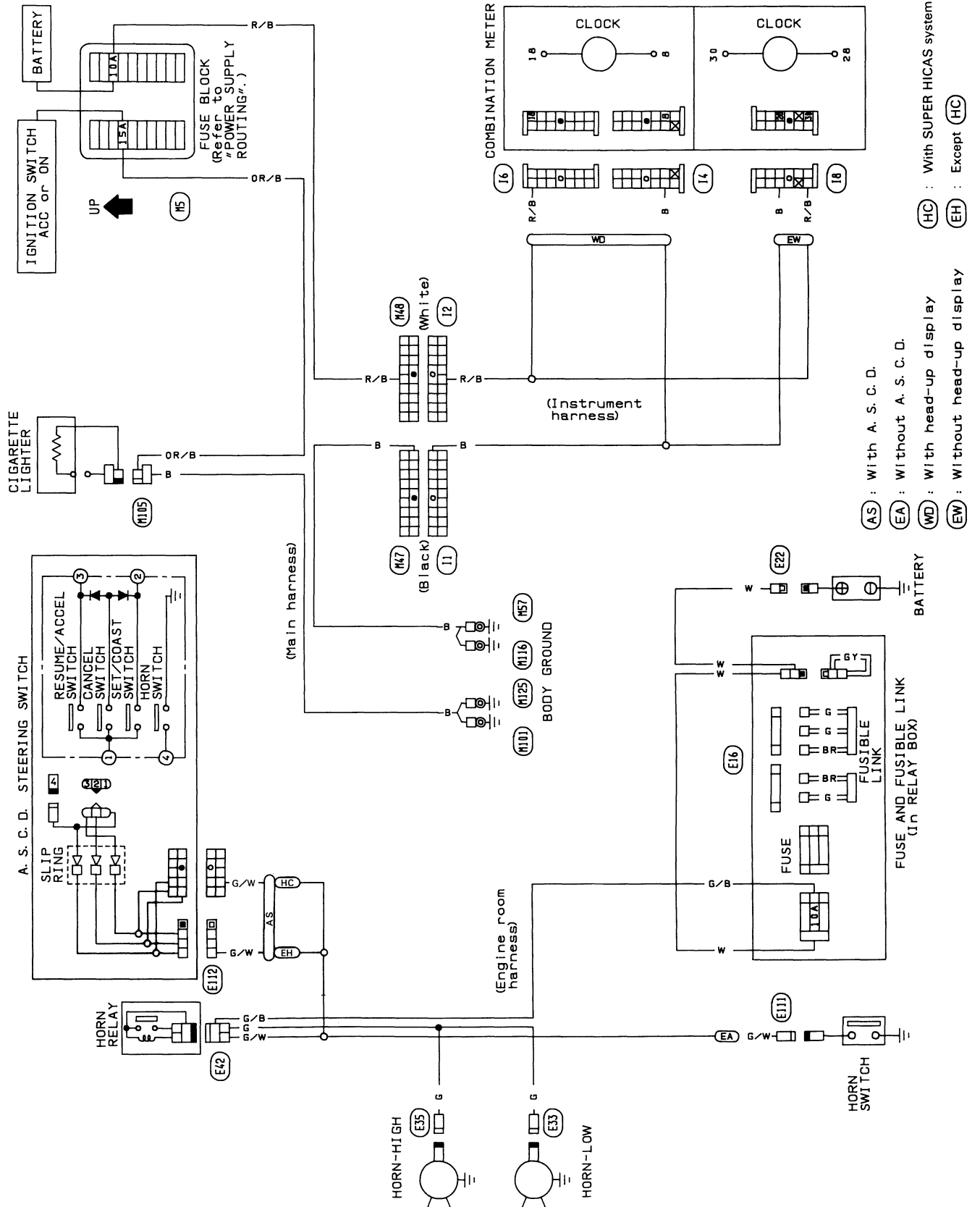

REAR WINDOW DEFOGGER

Wiring Diagram

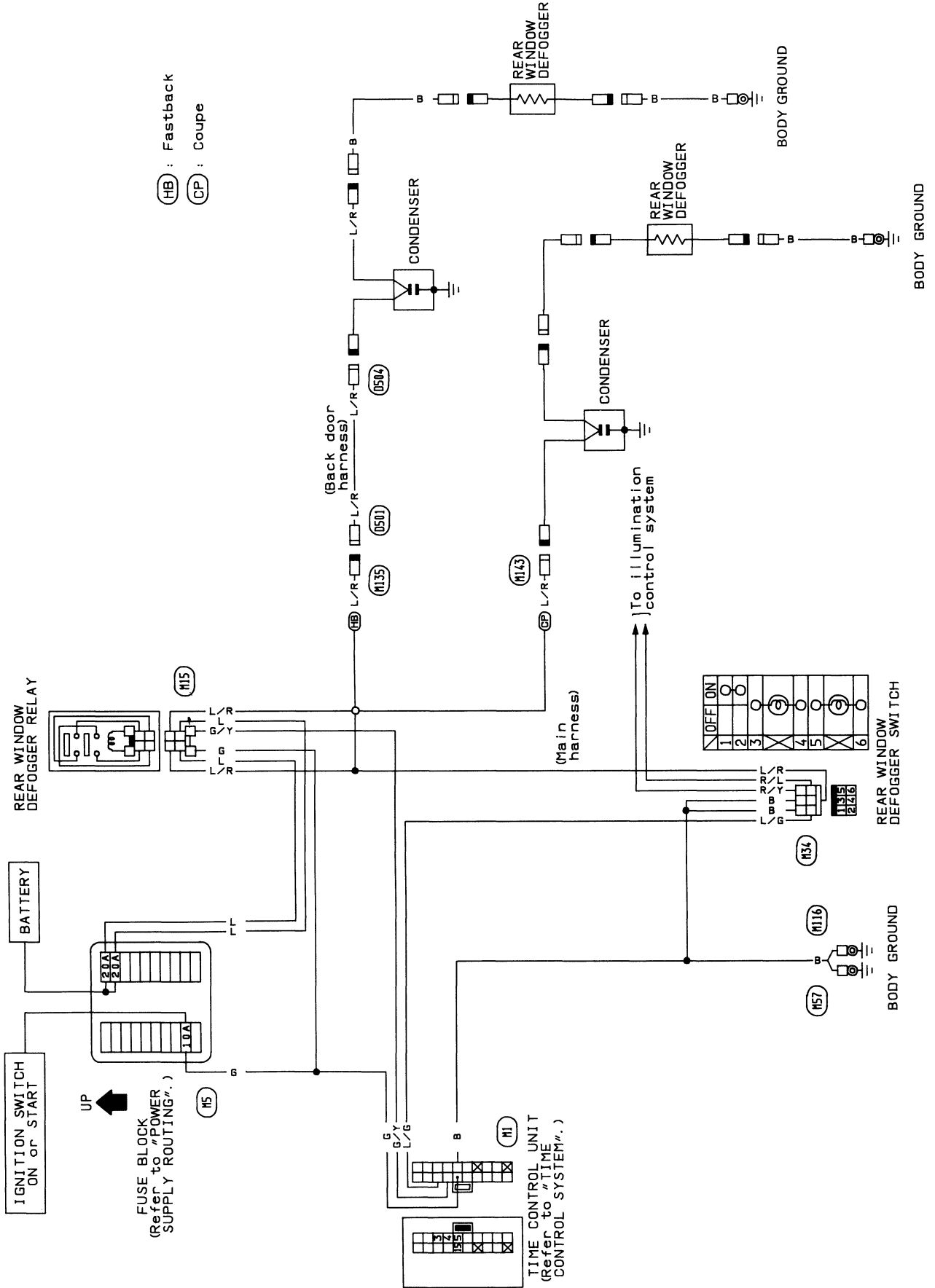

REAR WINDOW DEFOGGER

Filament Check

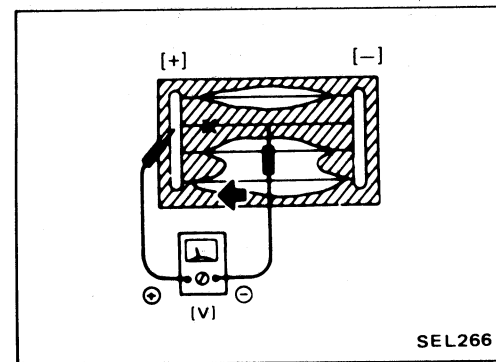
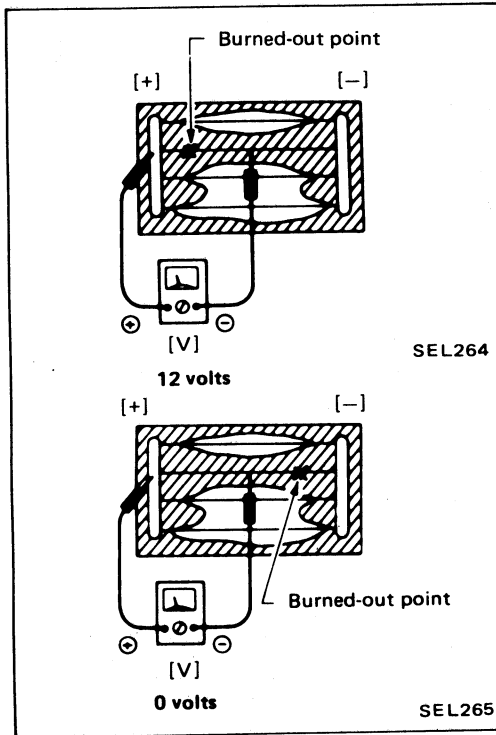
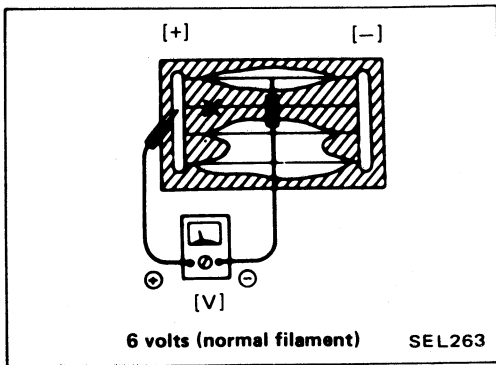

1. Attach probe circuit tester (in volt range) to middle portion of each filament.

2. If a filament is burned out, circuit tester registers 0 or 12 volts.

3. To locate burned out point, move probe to left and right along filament to determine point where tester needle swings abruptly.

REAR WINDOW DEFOGGER

Filament Repair

REPAIR EQUIPMENT

1. Conductive silver composition (Dupont No. 4817 or equivalent)
2. Ruler 30 cm (11.8 in) long
3. Drawing pen
4. Heat gun
5. Alcohol
6. Cloth

REPAIRING PROCEDURE

1. Wipe broken heat wire and its surrounding area clean with a cloth dampened in alcohol.
2. Apply a small amount of conductive silver composition to tip of drawing pen.

Shake silver composition container before use.

3. Place ruler on glass along broken line. Deposit conductive silver composition on break with drawing pen. Slightly overlap existing heat wire on both sides [preferably 5 mm (0.20 in)] of the break.

4. After repair has been completed, check repaired wire for continuity. This check should be conducted 10 minutes after silver composition is deposited.

Do not touch repaired area while test is being conducted.

5. Apply a constant stream of hot air directly to the repaired area for approximately 20 minutes with a heat gun. A minimum distance of 3 cm (1.2 in) should be kept between repaired area and hot air outlet. If a heat gun is not available, let the repaired area dry for 24 hours.

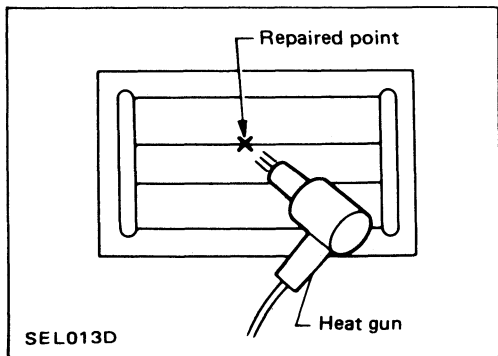
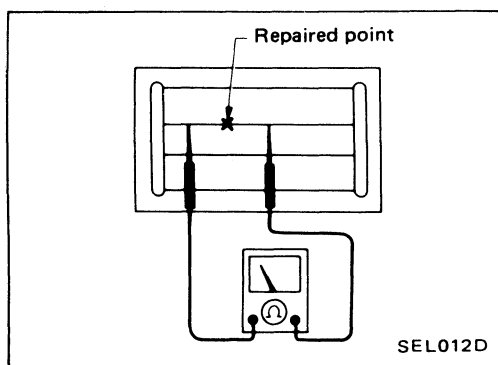
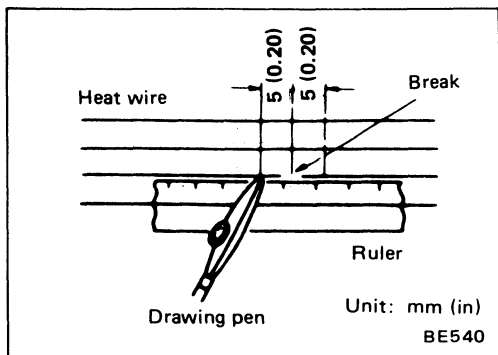

AUDIO AND POWER ANTENNA

Audio/Wiring Diagram

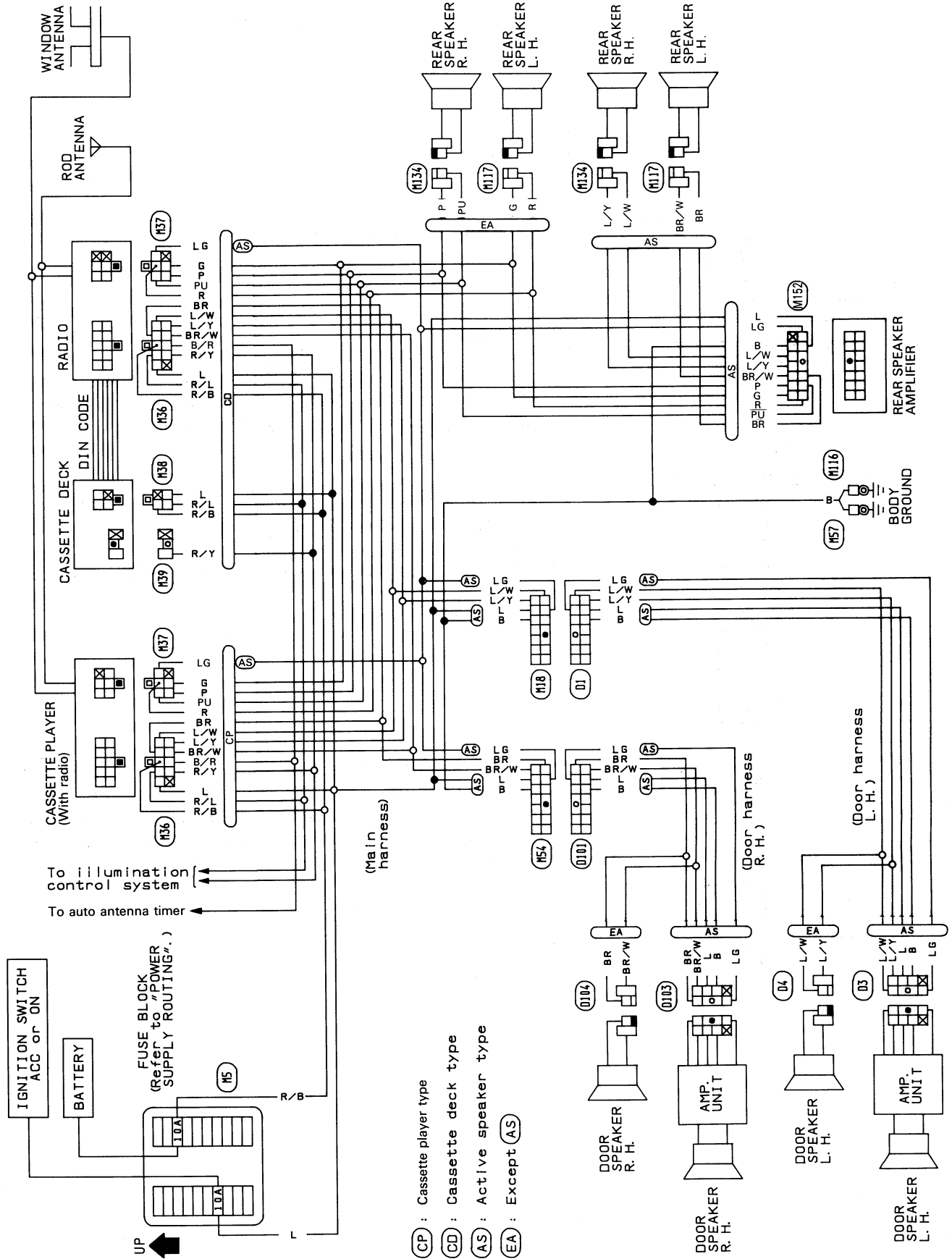

SEL819P

AUDIO AND POWER ANTENNA

Power Antenna/Wiring Diagram

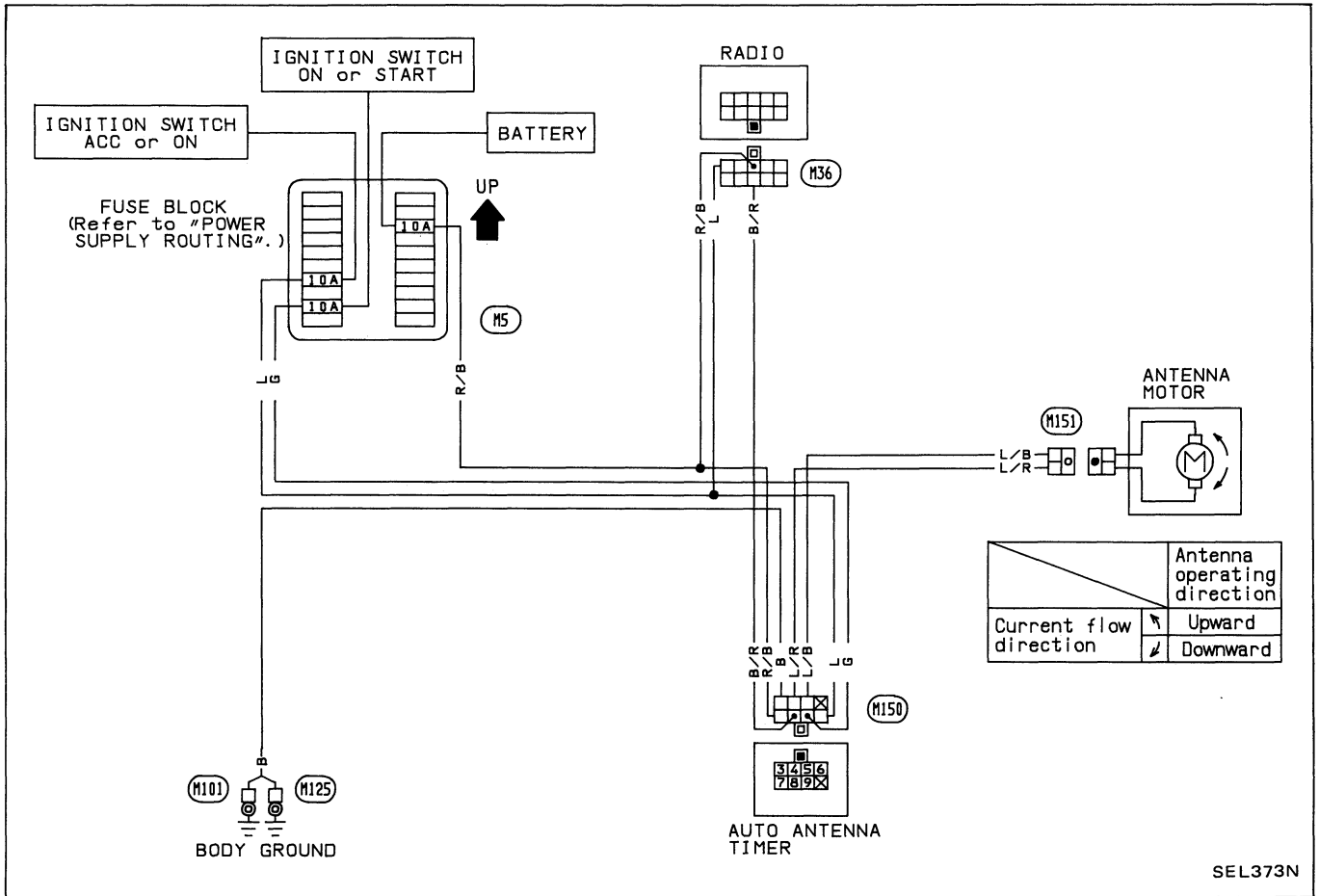

Location of Antenna

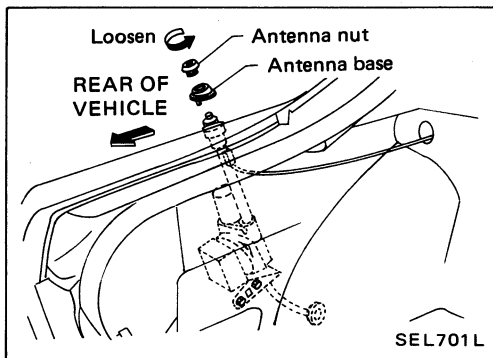
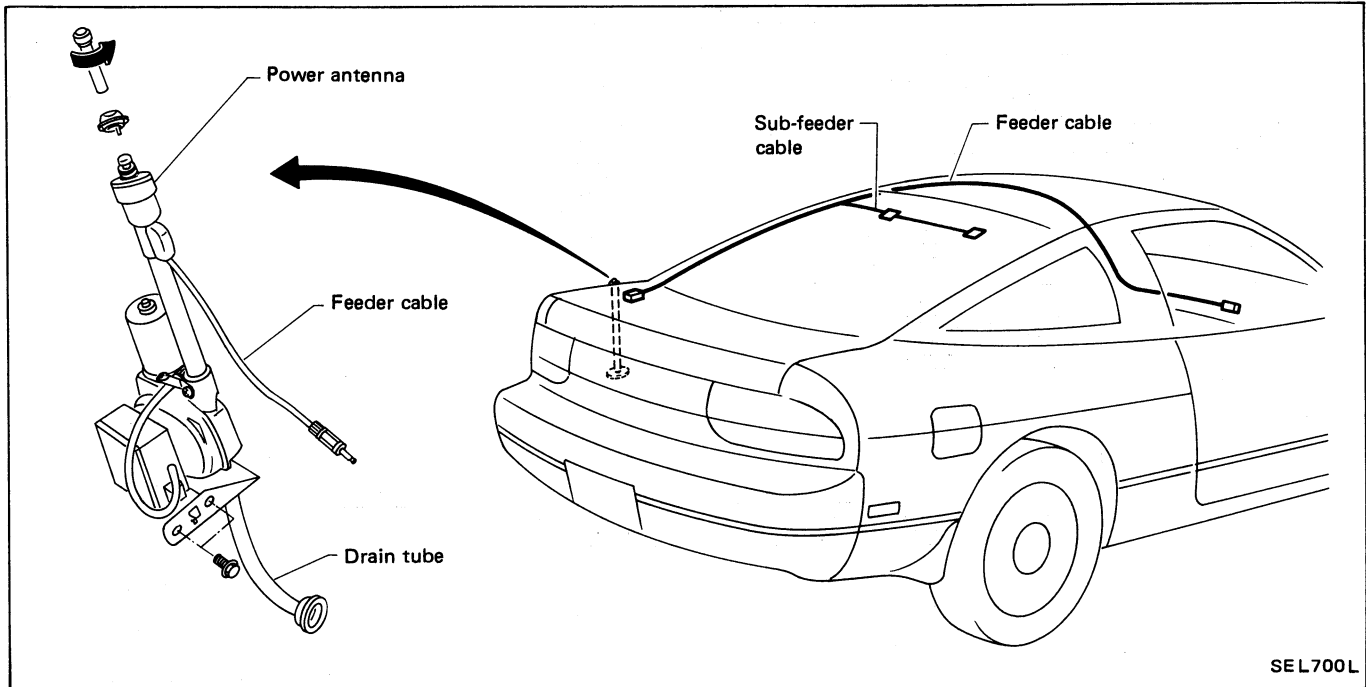

Antenna Rod Replacement

REMOVAL

1. Remove antenna nut and antenna base.

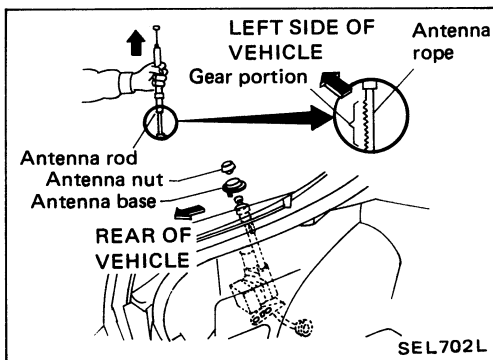

2. Withdraw antenna rod while raising it by operating antenna motor.
(Turn radio switch from "OFF" to "ON" to operate antenna motor.)

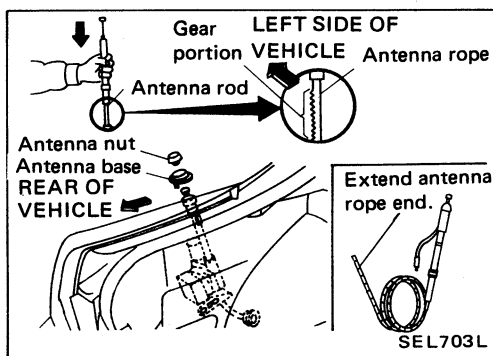

INSTALLATION

1. Lower antenna rod by operating antenna motor.
(Turn radio switch from "ON" to "OFF".)
2. Insert gear section of antenna rope into place with it facing toward antenna motor.
3. As soon as antenna rope is wound on antenna motor, stop antenna motor. Insert antenna rod lower end into antenna motor pipe.
4. Retract antenna rod completely by operating antenna motor.
(If the antenna motor stops before antenna has fully retracted, turn radio switch to "ON" and immediately turn to "OFF" again.)
5. Install antenna nut and base.

Radio Fuse Check

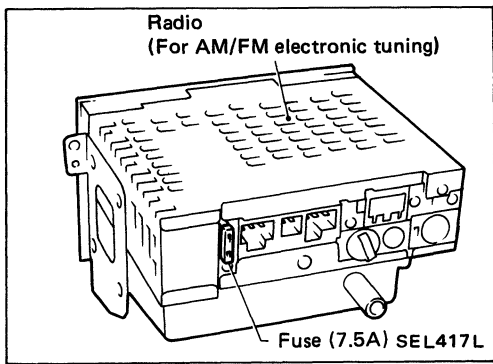

Window Antenna Repair

ELEMENT CHECK

1. Attach probe circuit tester (in ohm range) to antenna terminal on each side.

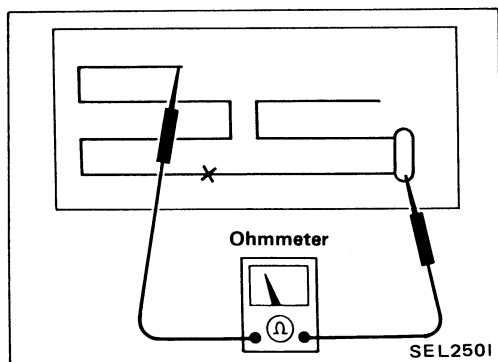

2. If an element is broken, no continuity will exist.

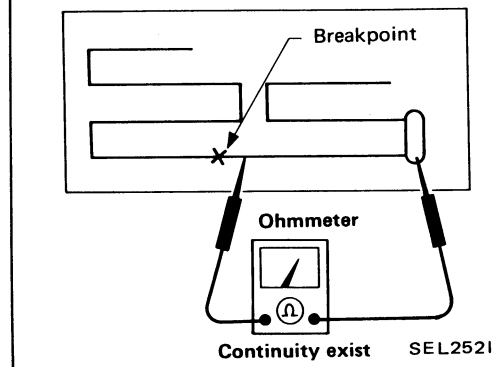
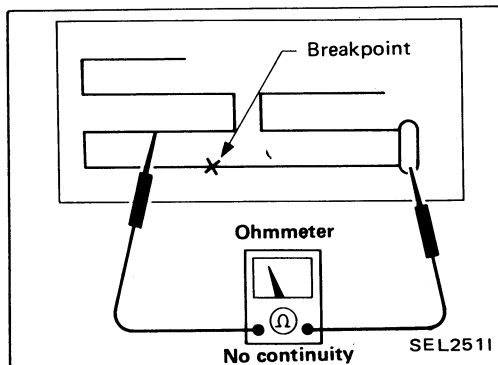

3. To locate broken point, move probe to left and right along element to determine point where tester needle swings abruptly.

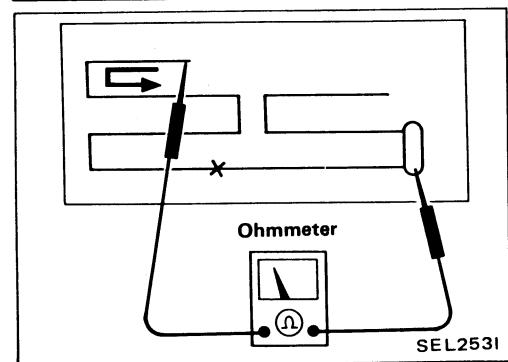

ELEMENT REPAIR

Refer to REAR WINDOW DEFOGGER "Filament Repair".

AUTOMATIC SPEED CONTROL DEVICE (A.S.C.D.)

Wiring Diagram

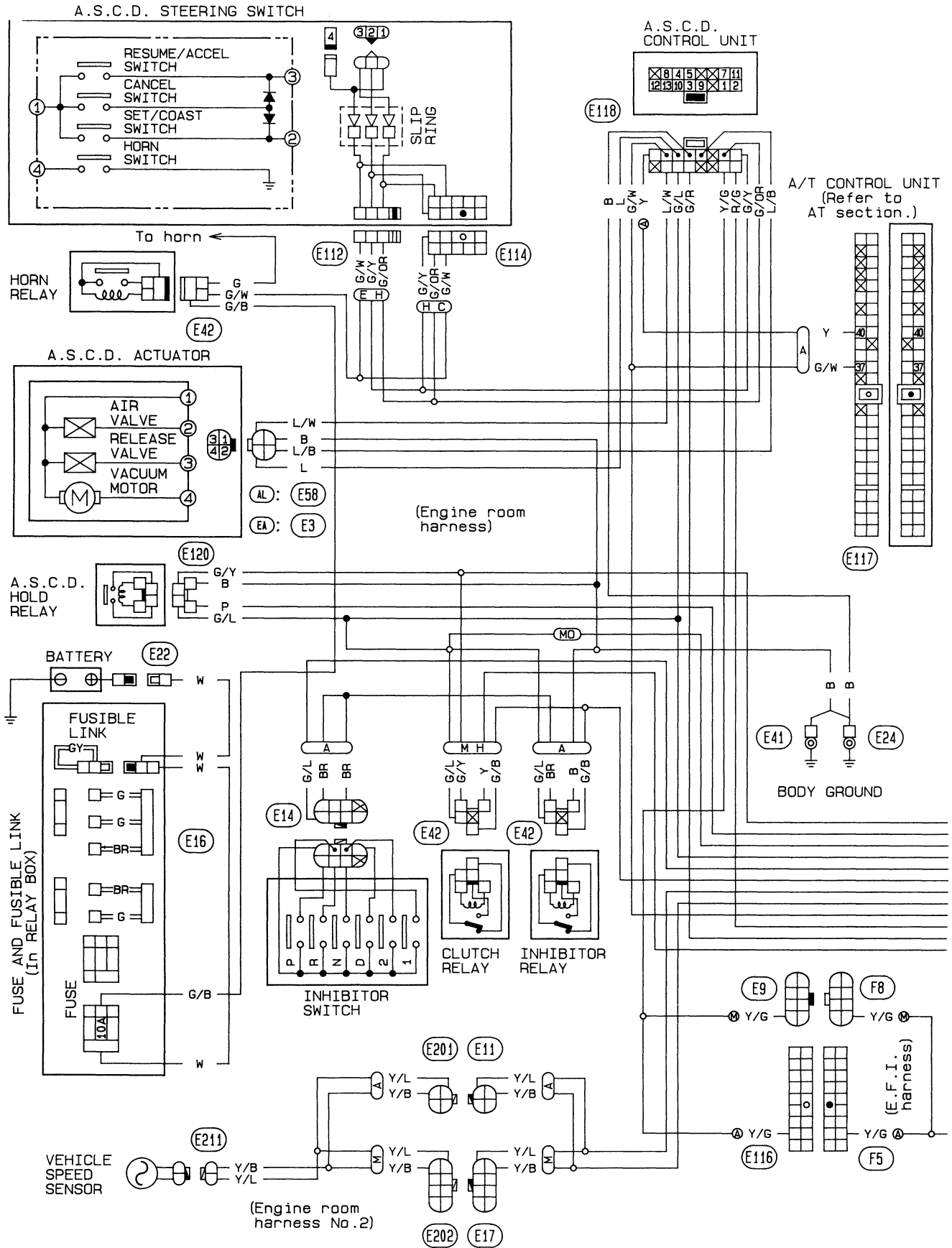

AUTOMATIC SPEED CONTROL DEVICE (A.S.C.D.)

Wiring Diagram (Cont'd)

*1 : Connected to head-up display control unit

HEAD-UP DISPLAY CONTROL UNIT

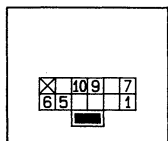

COMBINATION UNIT

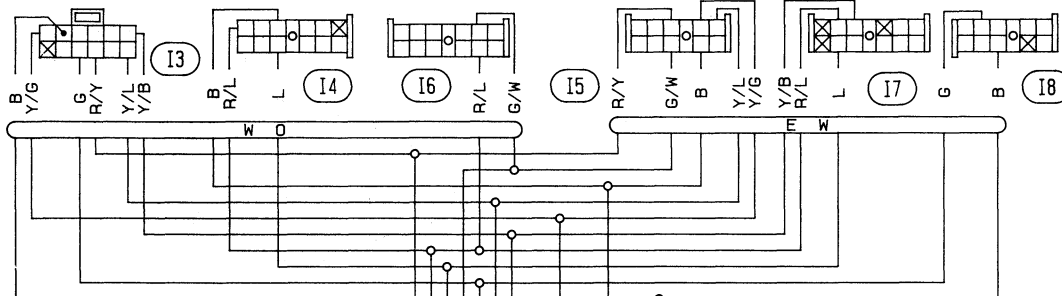
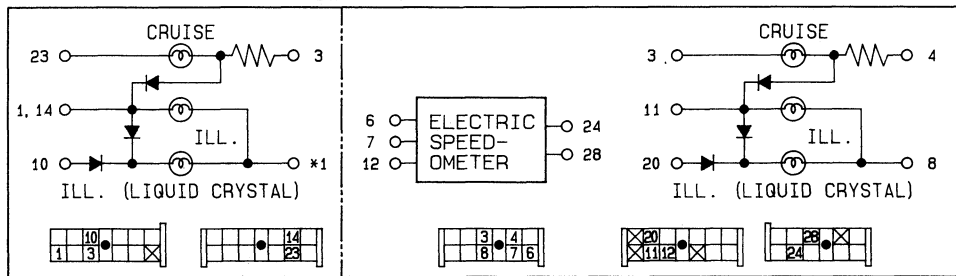

To illumination control system

A.S.C.D. MAIN SWITCH

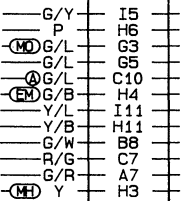
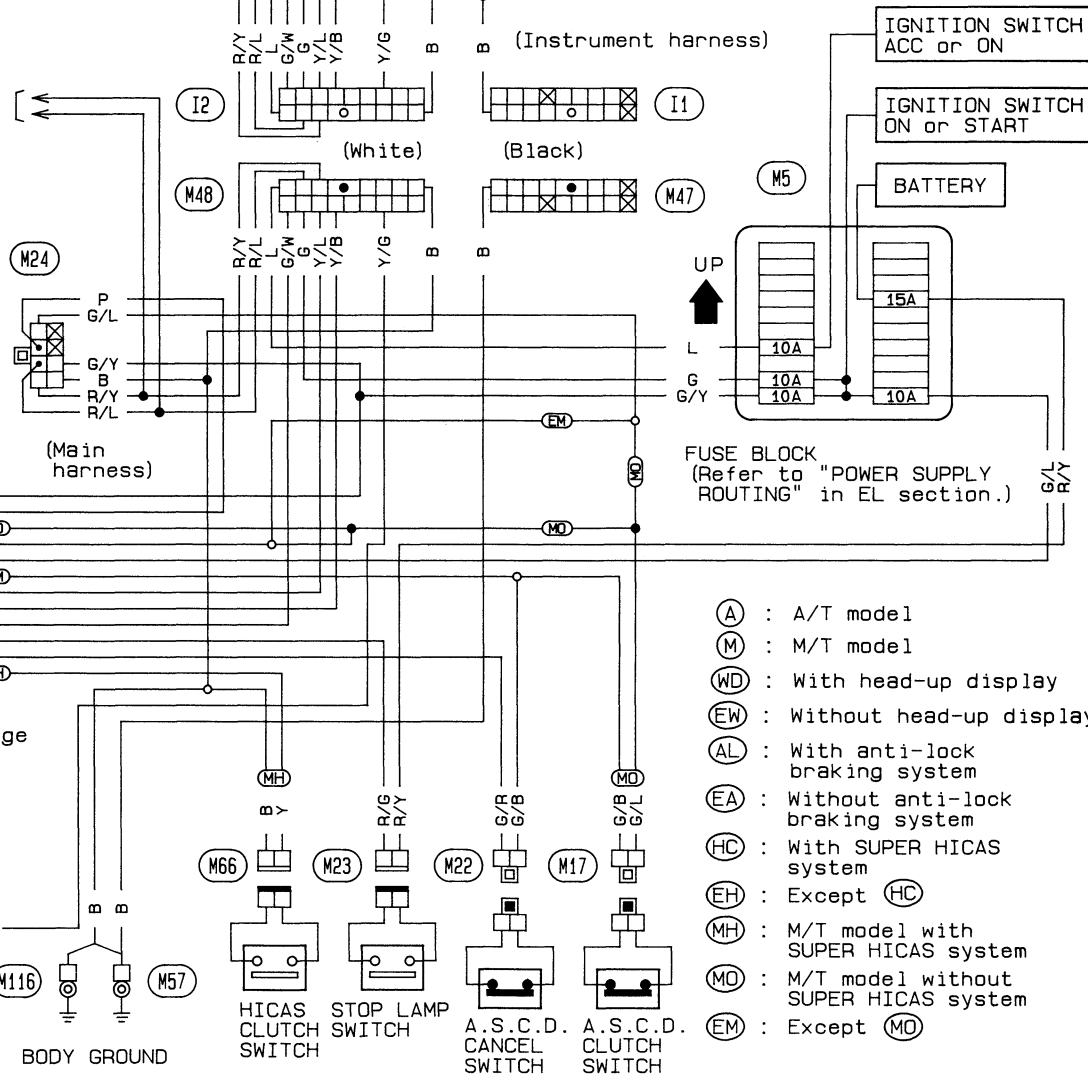
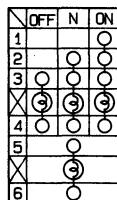

S.M.J. (Refer to last page <Foldout page>.)

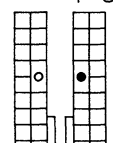

- (A) : A/T model
- (M) : M/T model
- (WD) : With head-up display
- (EW) : Without head-up display
- (AL) : With anti-lock braking system
- (EA) : Without anti-lock braking system
- (HC) : With SUPER HICAS system
- (EH) : Except (HC)
- (MH) : M/T model with SUPER HICAS system
- (MD) : M/T model without SUPER HICAS system
- (EM) : Except (MD)

AUTOMATIC SPEED CONTROL DEVICE (A.S.C.D.)

A.S.C.D. Wire Adjustment

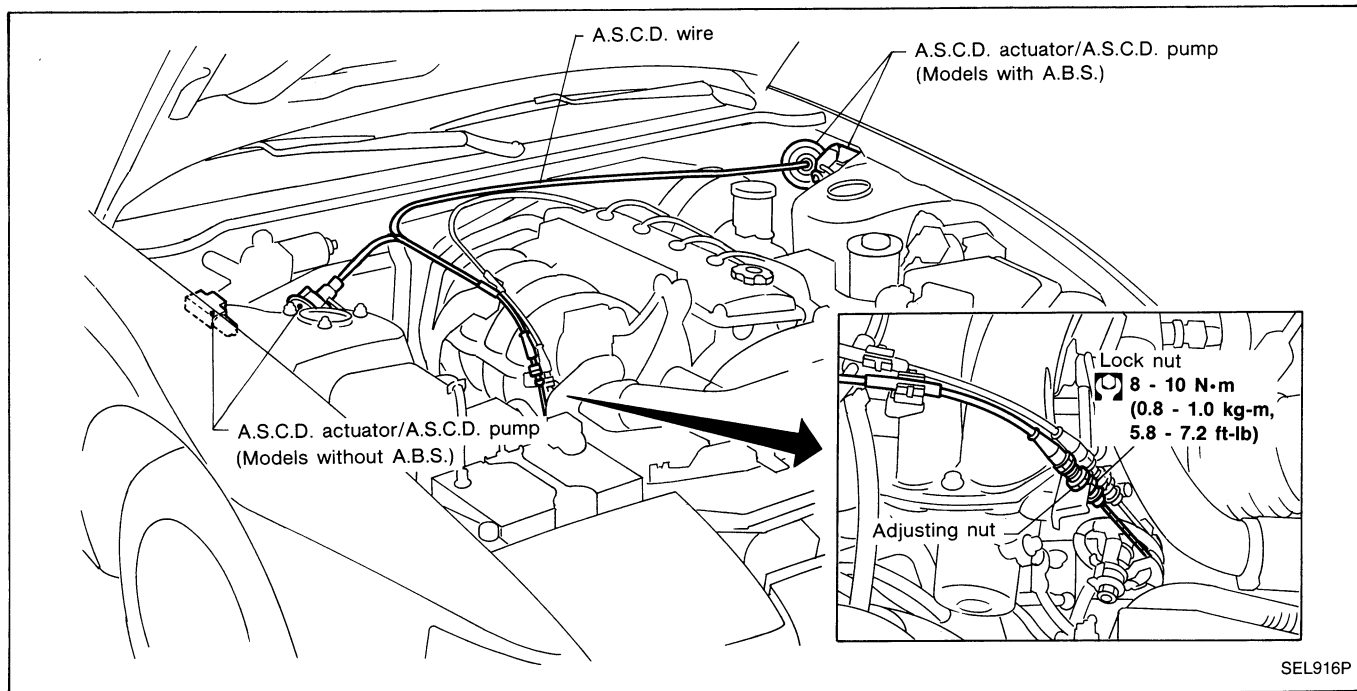

CAUTION:

- Be careful not to twist A.S.C.D. wire when removing it.
- Do not tense A.S.C.D. wire excessively during adjustment.

After confirming that accelerator wire is properly adjusted, adjust the tension of A.S.C.D. wire in the following manner.

- (1) After adjusting the length of the accelerator wire, turn a securing nut by 1/2 to 1 turn from throttle open starting position to the wire loosening direction to fix. (Must be securing carried out to prevent response delay of operation of the A.S.C.D.)
 - (2) Securely tighten lock nut to hold adjusting nut in place.
- For A.S.C.D. cancel switch and clutch switch adjustment, refer to BR and CL sections.

AUTOMATIC SPEED CONTROL DEVICE (A.S.C.D.)

Trouble Diagnoses

Symptom	DIAGNOSTIC PROCEDURE
A.S.C.D. control unit cannot be set properly.	1
Resume switch will not operate.	2
Cancel switch will not operate.	3
Engine hunts.	4
Large difference between set vehicle speed and actual speed.	5
Set speed cannot be cancelled.	6
A/T model only <ul style="list-style-type: none"> ● When A.S.C.D. is set while vehicle is operating in "O.D." range, O.D. will be cancelled and shifting to O.D. cannot be made thereafter. ● O.D. will not be cancelled even if actual vehicle speed is 6 km/h (4 MPH) lower than set speed. (Set speed cannot be maintained.) ● O.D. will not be cancelled even if accelerator switch is turned "ON". 	7

PREPARATION FOR TROUBLE-SHOOTING

1. Remove R.H. dash side cover.
2. Remove A.S.C.D. control unit with harness connected.
3. Perform check from harness side using circuit tester, with harness connector connected.

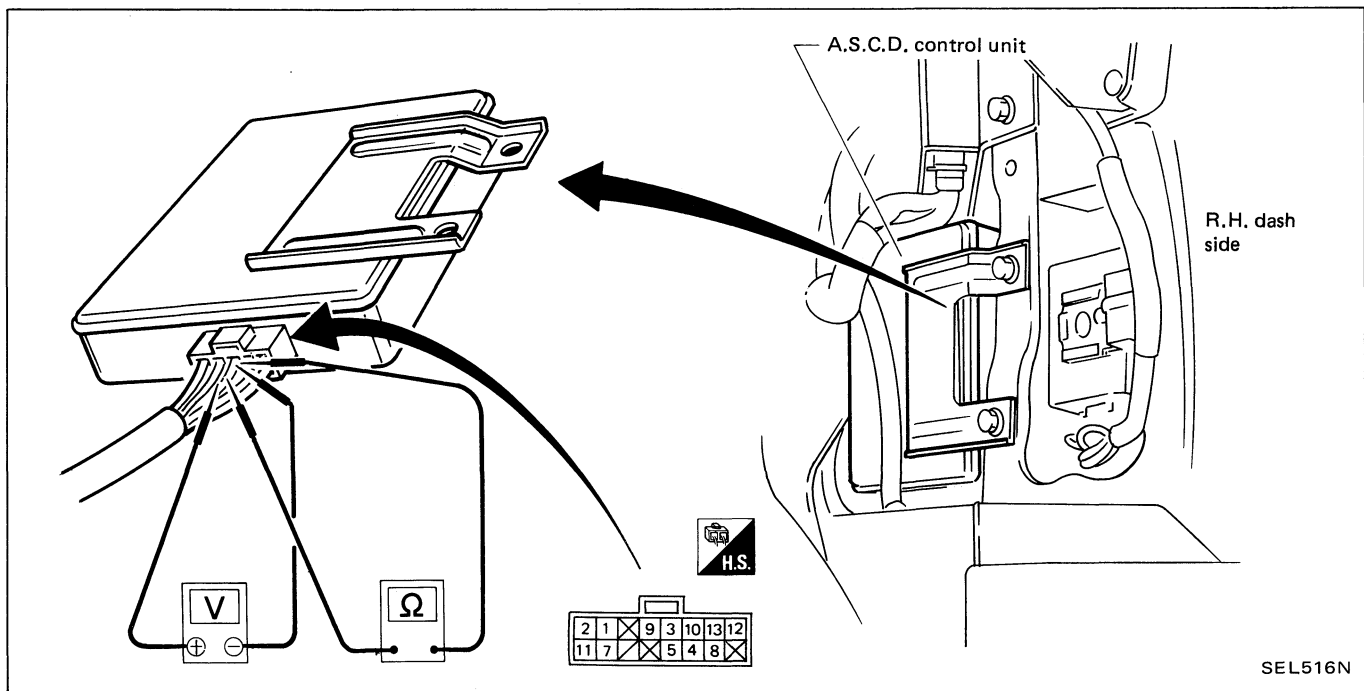

GROUND CIRCUIT CHECK

- Check continuity between ③ and body ground.

AUTOMATIC SPEED CONTROL DEVICE (A.S.C.D.)

Trouble Diagnoses (Cont'd)

DIAGNOSTIC PROCEDURE-1

A.S.C.D. control unit cannot be set properly.

POWER SUPPLY CIRCUIT CHECK

1. Turn A.S.C.D. main switch to "ON".
2. Check voltage between ④ and ③.

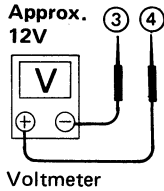
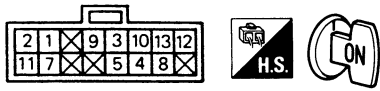

CUT-OFF CIRCUIT CHECK

1. Step on brake pedal.
2. Turn A.S.C.D. main switch to "ON".
3. Check voltage between ⑪ and ③.

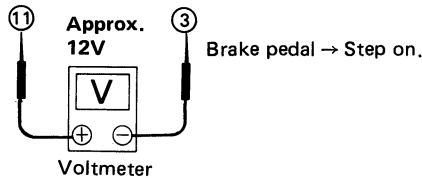
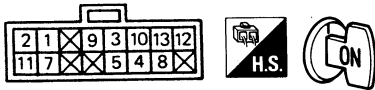

SEL629L

SET SWITCH CIRCUIT CHECK

1. Push A.S.C.D. set switch.
2. Check voltage between ② and ③.

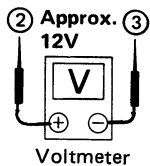
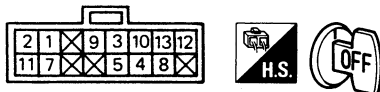

SPEED SENSOR CIRCUIT CHECK

1. Disconnect speed sensor from transmission.
 2. Connect a voltmeter between ⑦ and ③.
 3. Slowly turn speed sensor by hand to make sure voltmeter pointer deflects.
- Voltmeter pointer deflects twice per rotation of pinion.

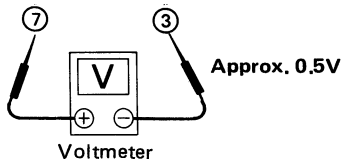
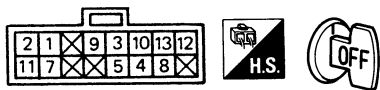

SEL630L

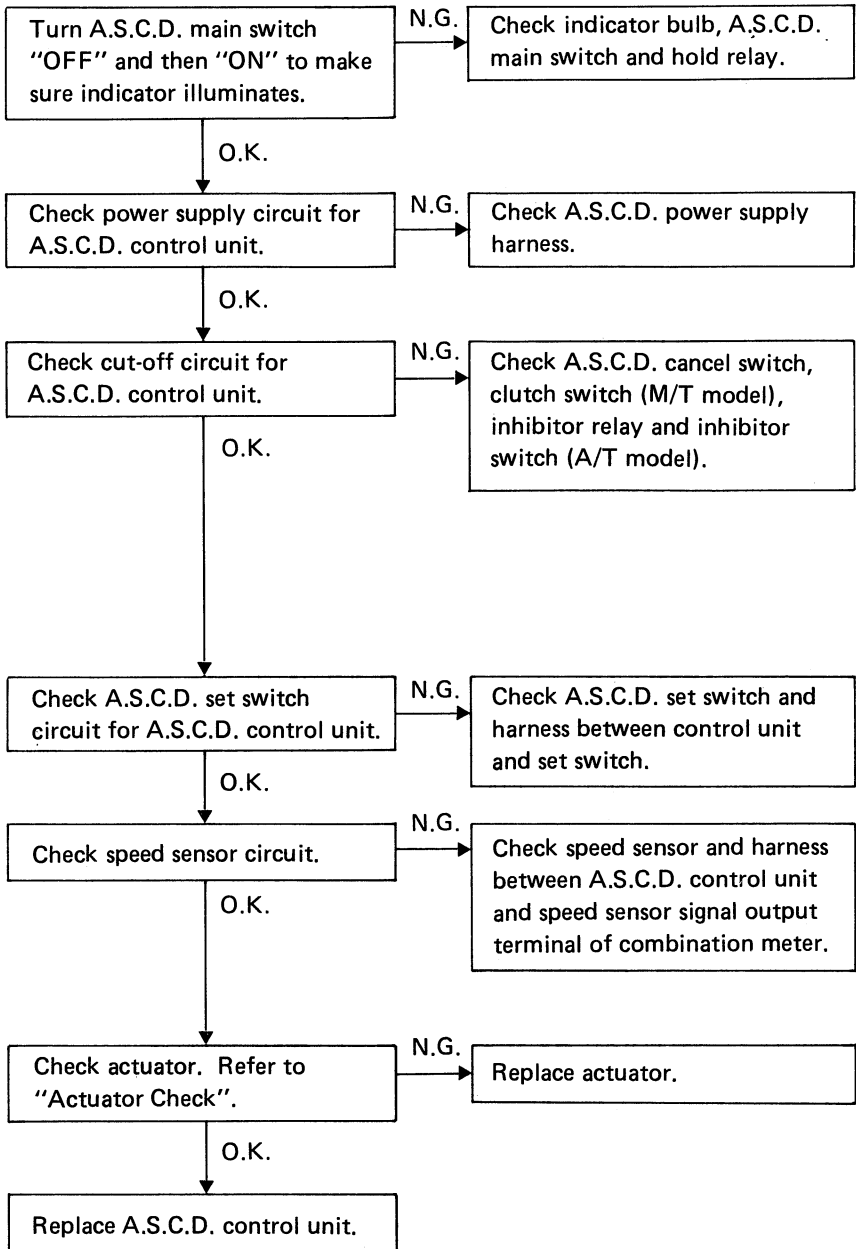

AUTOMATIC SPEED CONTROL DEVICE (A.S.C.D.)

Trouble Diagnoses (Cont'd)

DIAGNOSTIC PROCEDURE-2

Resume switch will not operate.

RESUME SWITCH CIRCUIT CHECK

1. Turn resume switch to "ON".
2. Check voltage between ① and ③.

Resume switch → ON

V
Voltmeter

Approx. 12V

SEL636L

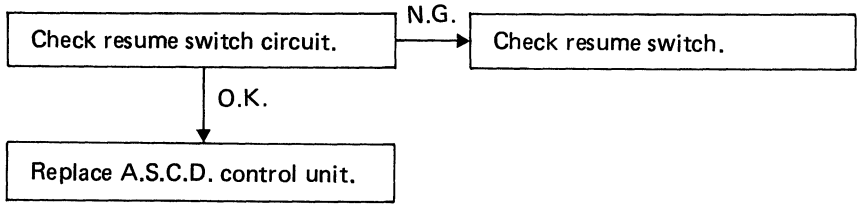

CANCEL SWITCH CIRCUIT CHECK

1. Turn cancel switch to "ON".
2. Check voltage between ② and ③ or ① and ③.

Cancel switch → ON

V
Voltmeter

Approx. 12V

SEL637L

DIAGNOSTIC PROCEDURE-3

Cancel switch will not operate.

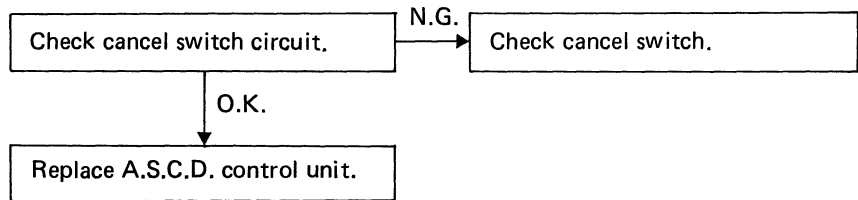

AUTOMATIC SPEED CONTROL DEVICE (A.S.C.D.)

Trouble Diagnoses (Cont'd)

DIAGNOSTIC PROCEDURE-4

Engine hunts.

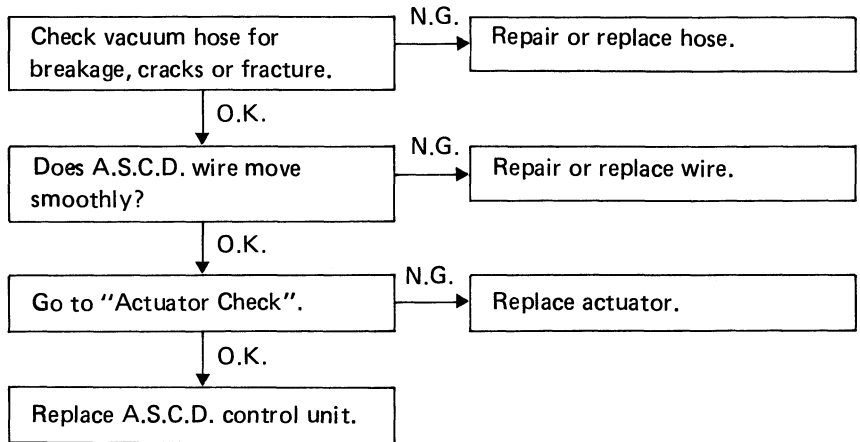

DIAGNOSTIC PROCEDURE-5

Large difference between set vehicle speed and actual speed.

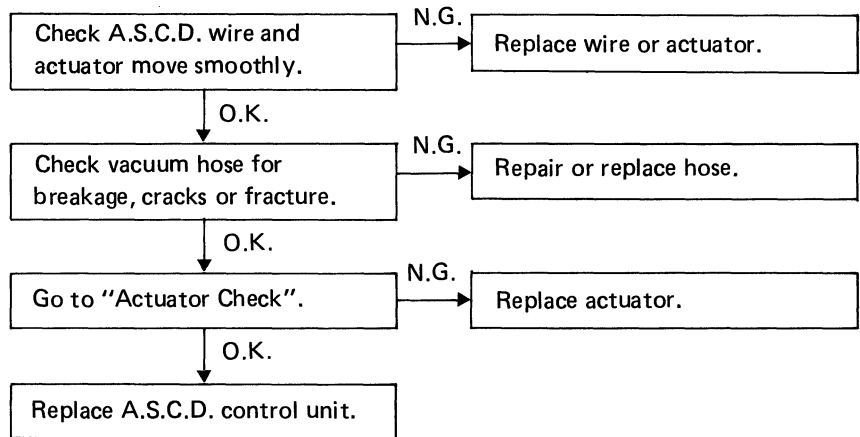

AUTOMATIC SPEED CONTROL DEVICE (A.S.C.D.)

CUT-OFF CIRCUIT CHECK

1. Turn A.S.C.D. main switch to "ON".
2. Turn A.S.C.D. main switch to "ON" again.
3. Step on brake pedal.
4. Step on clutch pedal (M/T) or shift in "N" range (A/T).
5. Check voltage between ⑤ and ③.

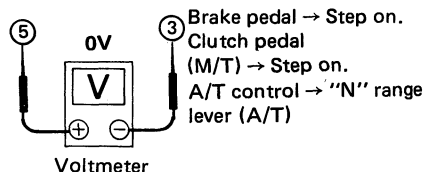
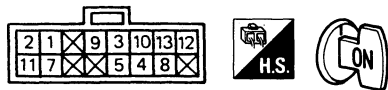

STOP LAMP CIRCUIT CHECK

1. Step on brake pedal.
2. Check voltage between ⑪ and ③.

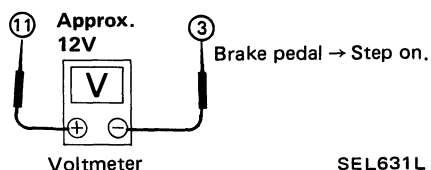
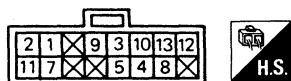

SEL631L

Trouble Diagnoses (Cont'd)

DIAGNOSTIC PROCEDURE-6

Set speed cannot be canceled.

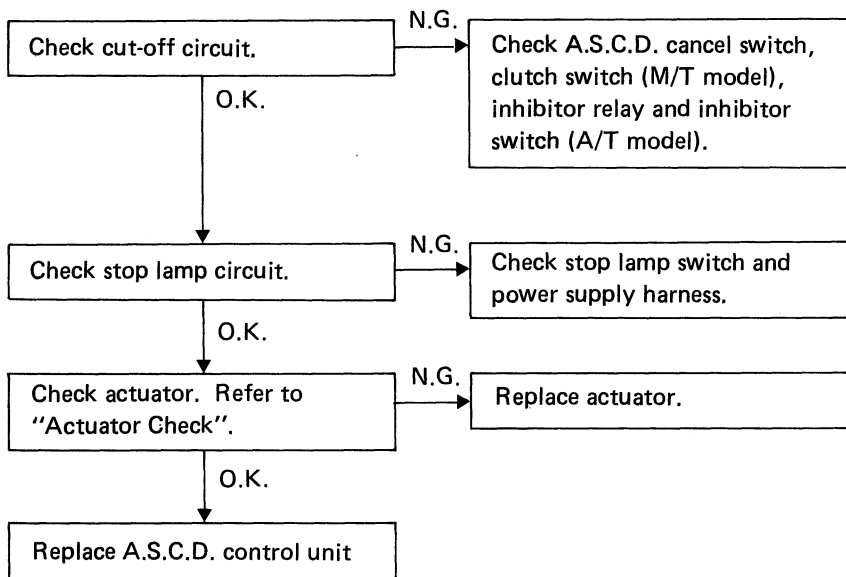

O.D. CANCEL CIRCUIT CHECK FOR A.S.C.D. CONTROL UNIT

1. Turn O.D. control switch to "ON"
2. Measure voltage across ⑫ and ③.

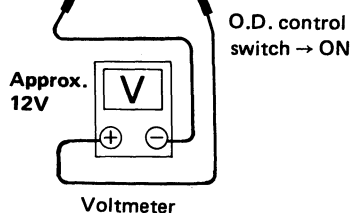

SEL640M

DIAGNOSTIC PROCEDURE-7

A/T model only:

- When A.S.C.D. is set while vehicle is operating in "O.D." range, O.D. will be cancelled and shifting to O.D. cannot be made thereafter.
- O.D. will not be cancelled even if actual vehicle speed is 6 km/h (4 MPH) lower than set speed. (Set speed cannot be maintained.)
- O.D. will not be cancelled even if accelerator switch is turned "ON".

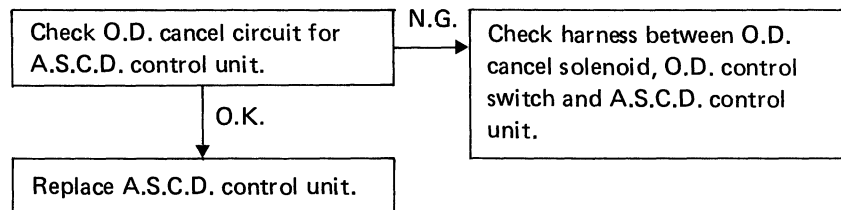

AUTOMATIC SPEED CONTROL DEVICE (A.S.C.D.)

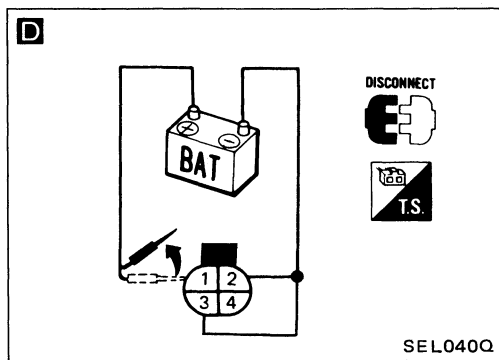
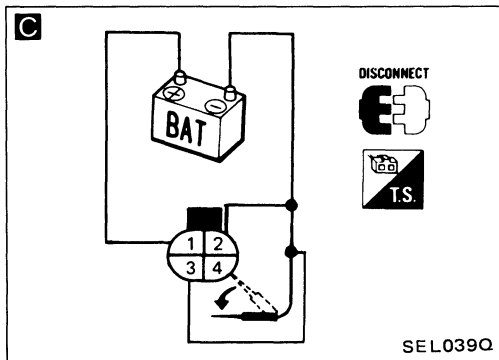
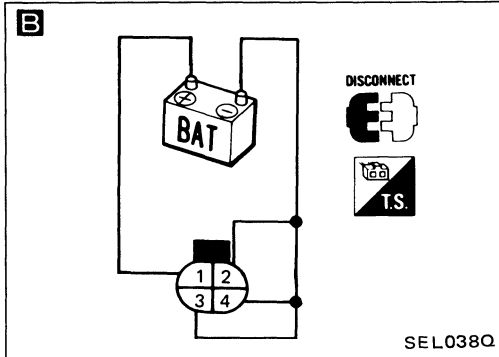
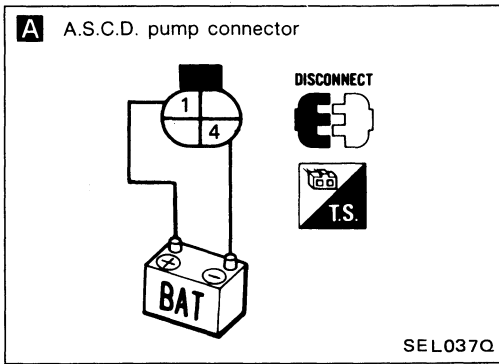

Actuator Check

1. Disconnect A.S.C.D. actuator/A.S.C.D. pump connector.
2. Check A.S.C.D. actuator/A.S.C.D. pump operations as shown.

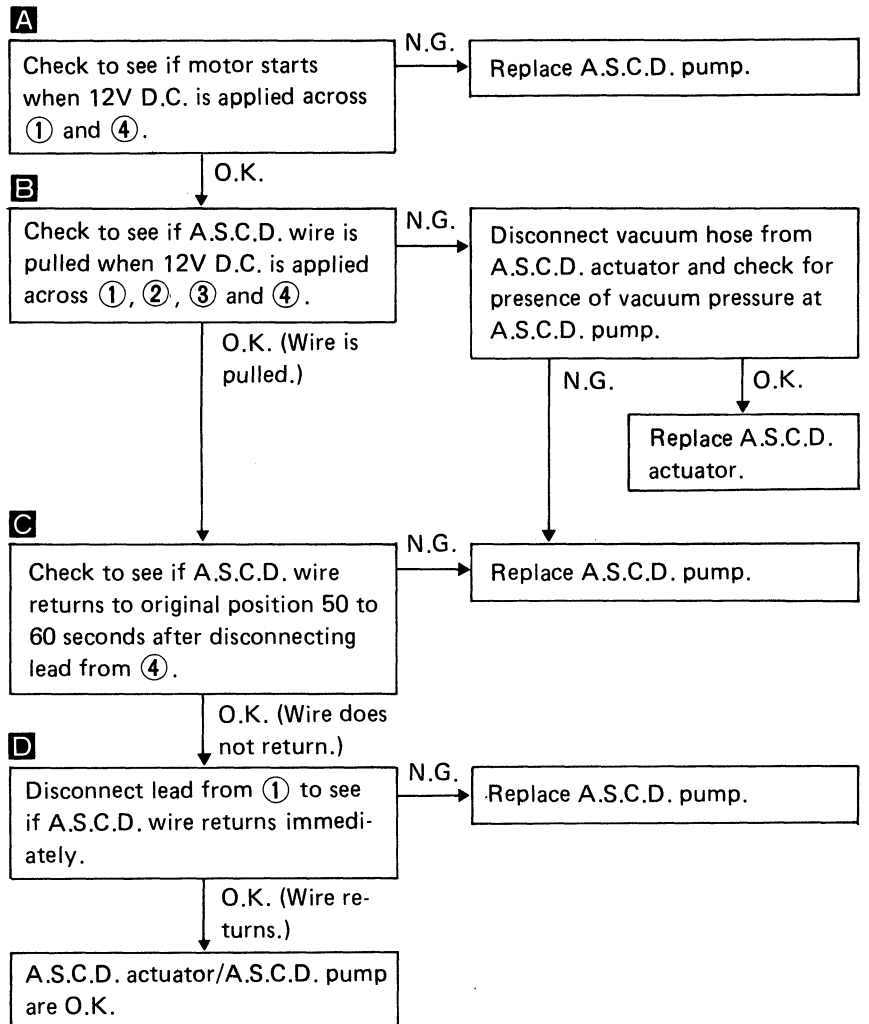

LOCATION OF ELECTRICAL UNITS

Engine Compartment

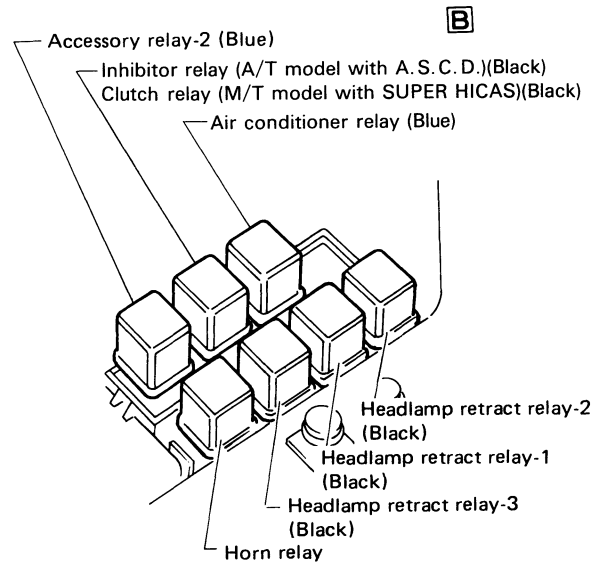
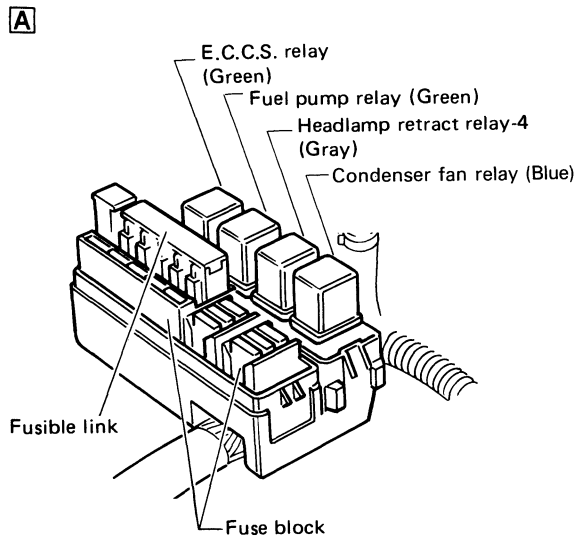
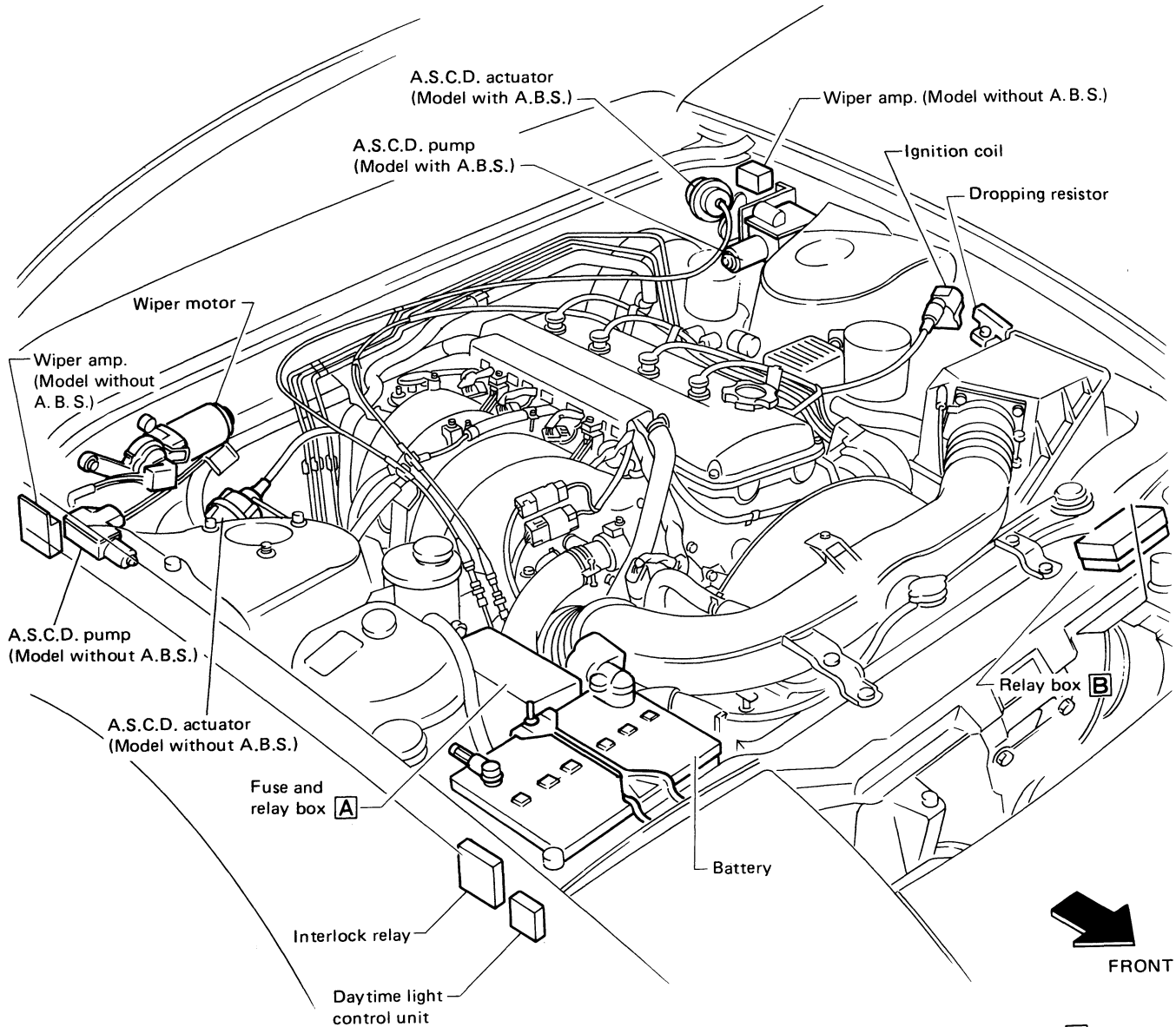

SEL886P

LOCATION OF ELECTRICAL UNITS

Passenger Compartment

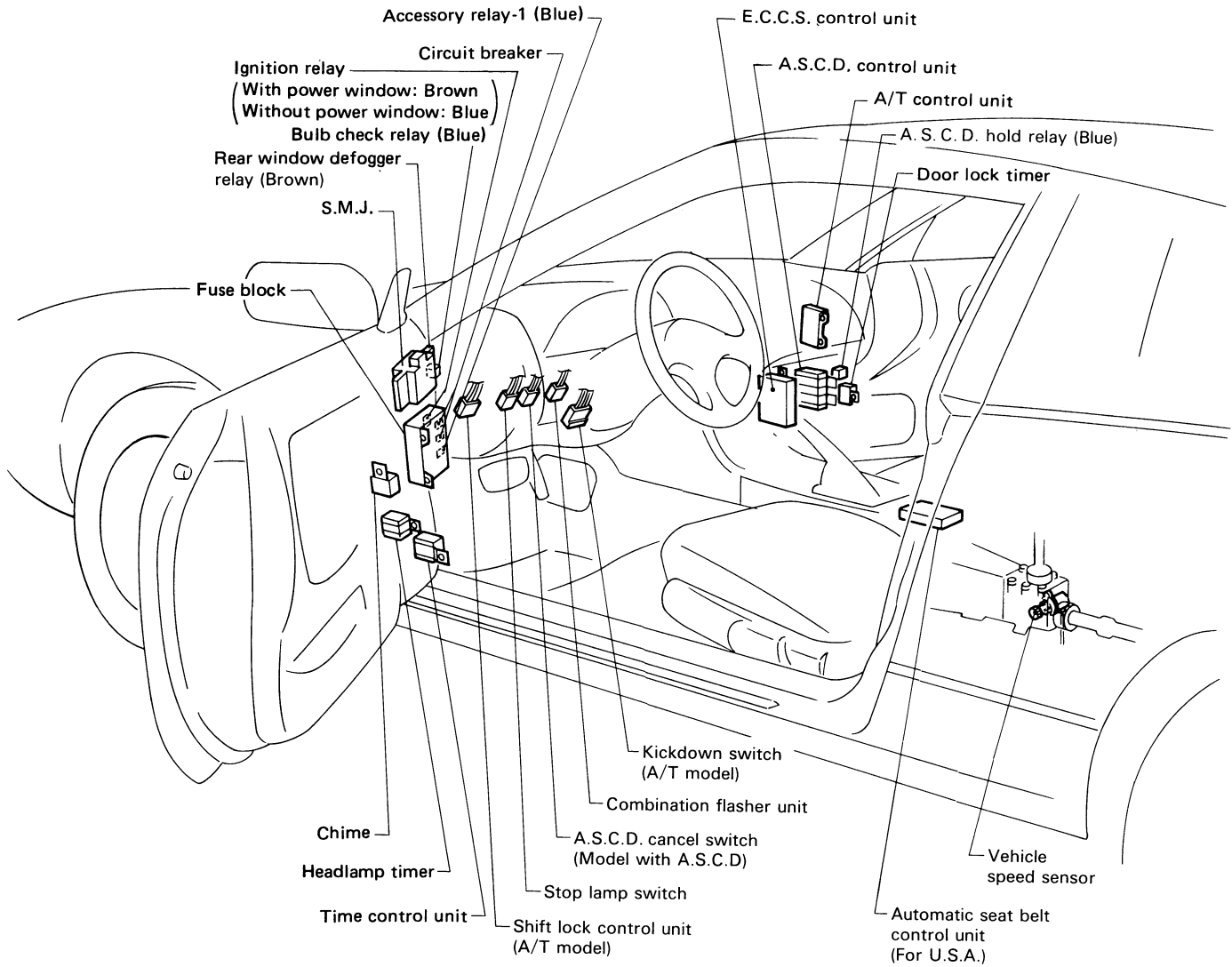

LOCATION OF ELECTRICAL UNITS

Passenger Compartment (Cont'd)

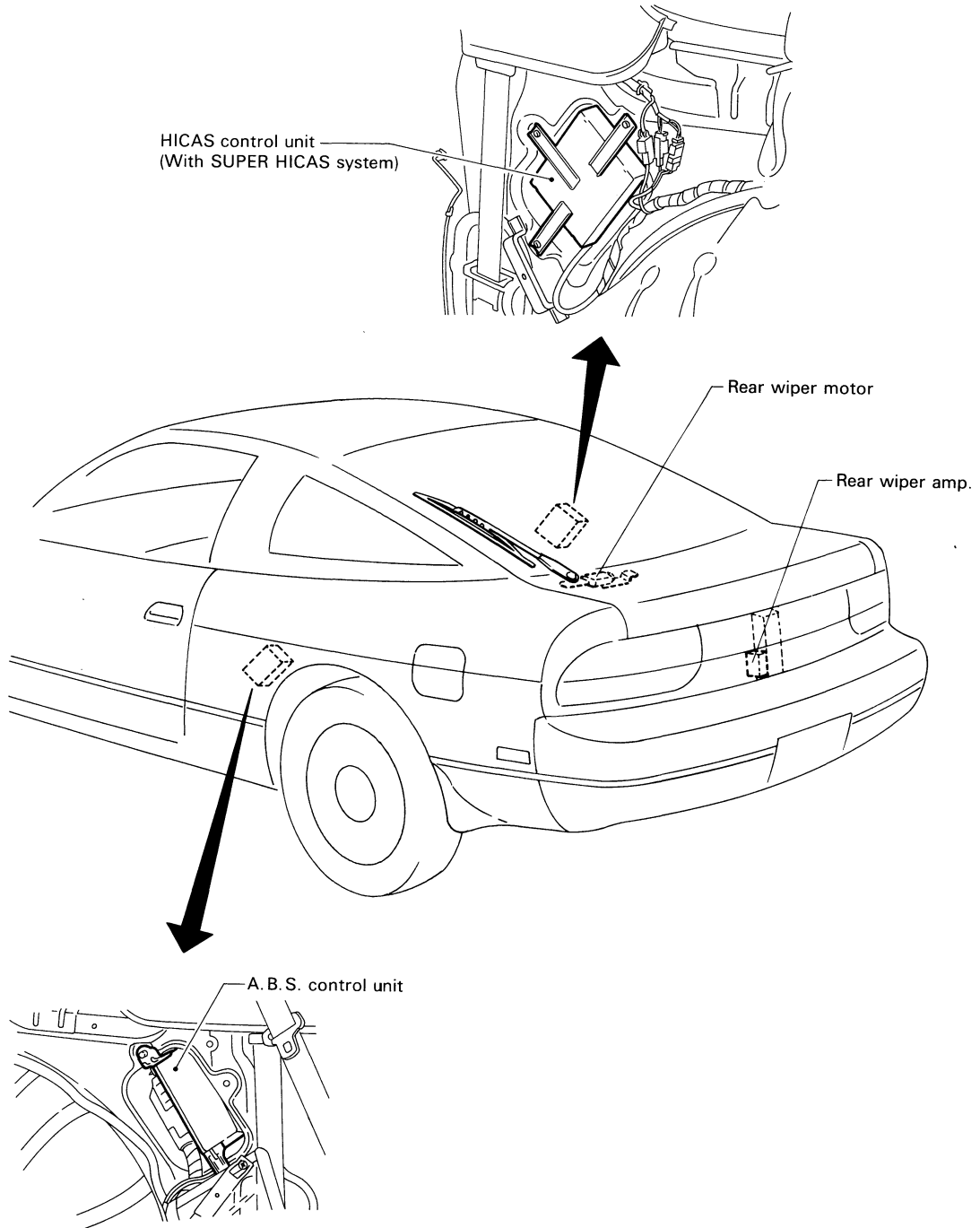

LOCATION OF ELECTRICAL UNITS

NOTE

HARNESS LAYOUT

Outline

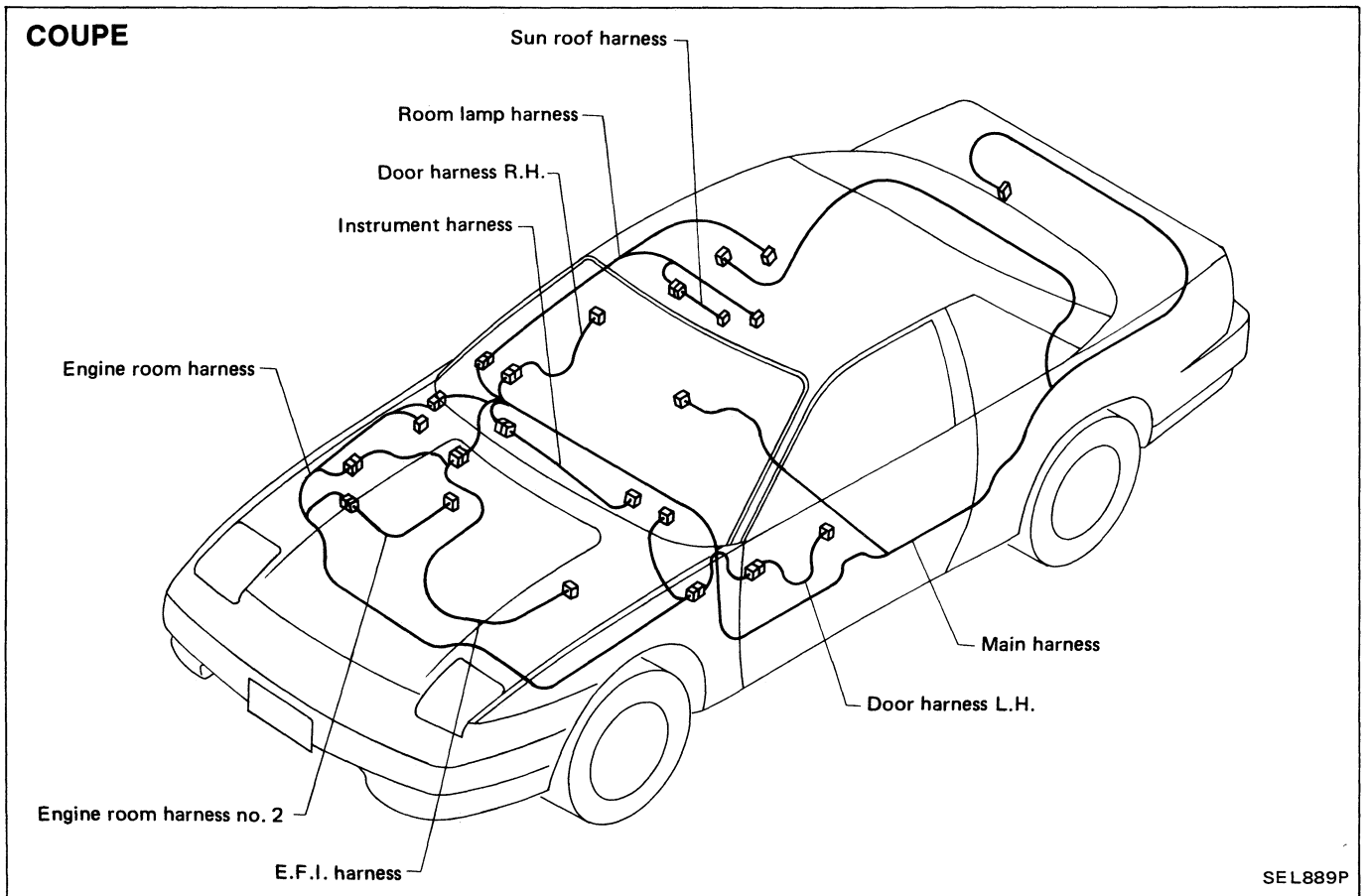
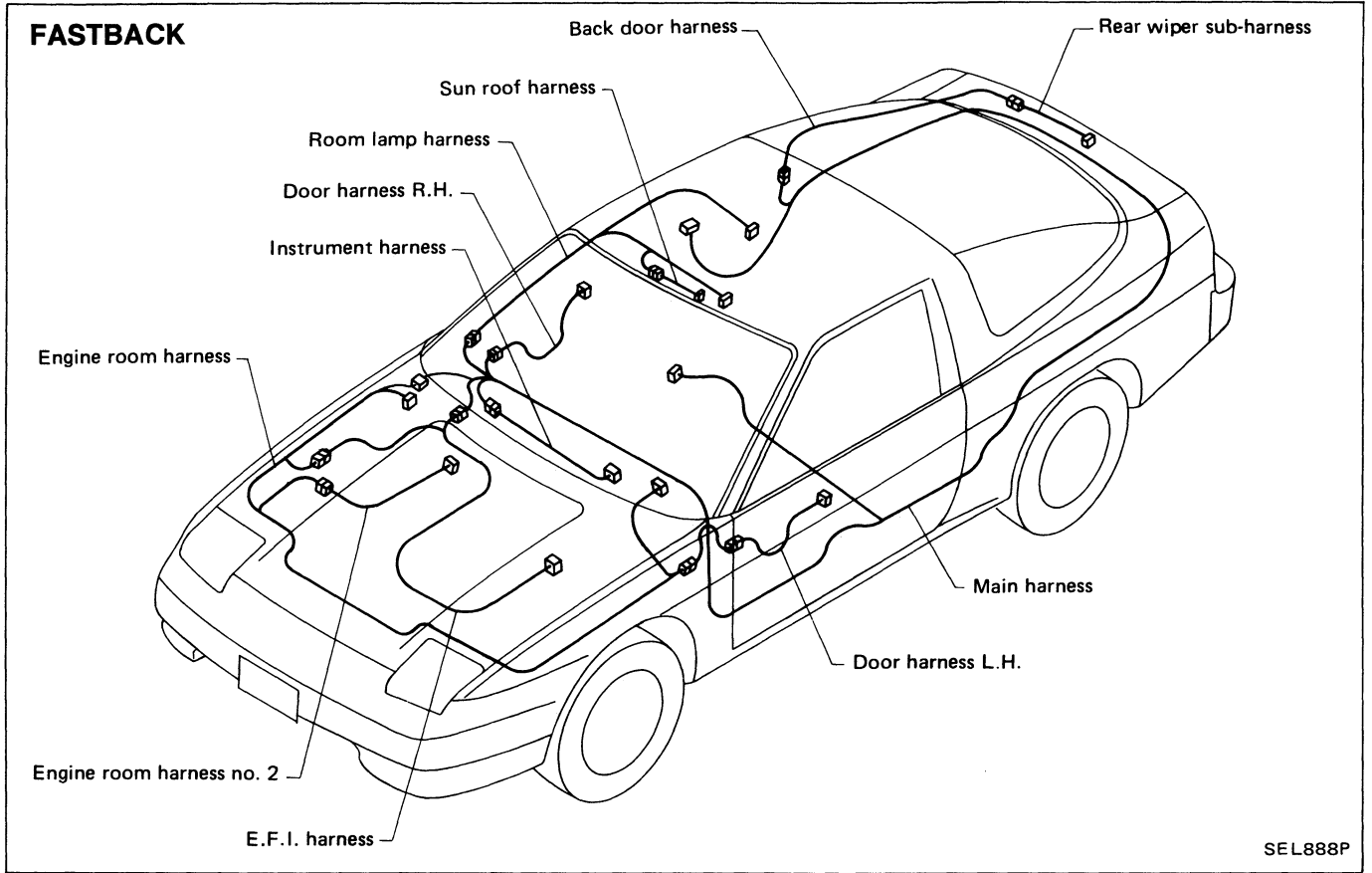

HARNESS LAYOUT

Main Harness

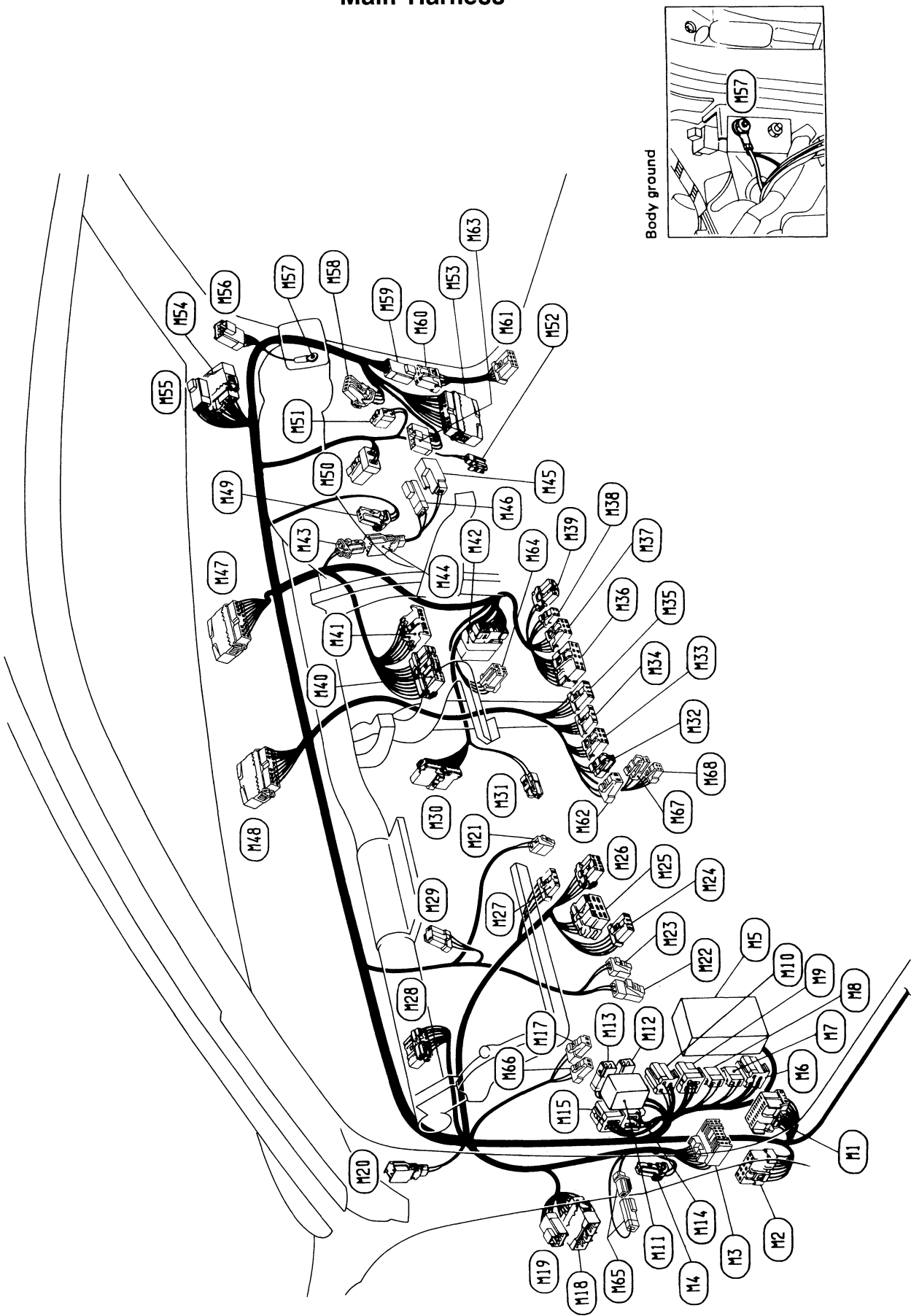

HARNESS LAYOUT

Main Harness (Cont'd)

- Ⓐ1 : Time control unit
- Ⓐ2 : Headlamp timer
- Ⓐ3 : Diagnostic connector for CONSULT
- Ⓐ4 : Warning chime
- Ⓐ5 : Fuse block
- Ⓐ6 : Accessory relay-1
- Ⓐ7 : Circuit breaker (Model with power window system)
- Ⓐ8 : Circuit breaker (For U.S.A.)
- Ⓐ9 : Ignition relay (Model with power window system)
- Ⓐ10 : Ignition relay (Model without power window system)
- Ⓐ11 : To engine room harness (E10) (S.M.J.)
- Ⓐ12 : To engine room harness (E102) (Blue)
- Ⓐ13 : To engine room harness (E103) (Black)
- Ⓐ14 : Bulb check relay
- Ⓐ15 : Rear window defogger relay
- Ⓐ17 : A.S.C.D. clutch switch (M/T model with A.S.C.D.)
- Ⓐ18 : To door harness L.H. (01)
- Ⓐ19 : To door harness L.H. (02)
- Ⓐ20 : Driver side front limit switch (For U.S.A.)
- Ⓐ21 : Kickdown switch (A/T model)
- Ⓐ22 : A.S.C.D. cancel switch (Model with A.S.C.D.)
- Ⓐ23 : Stop lamp switch
- Ⓐ24 : A.S.C.D. main switch (Model with A.S.C.D.)
- Ⓐ25 : Headlamp retractor switch
- Ⓐ26 : Illumination control switch
- Ⓐ27 : Not used
- Ⓐ28 : Shift lock control unit (A/T model)
- Ⓐ29 : Combination flasher unit
- Ⓐ30 : Mode door motor
- Ⓐ31 : Foot lamp L.H.
- Ⓐ32 : O.D. off indicator lamp (A/T model without SUPER HICAS system)
- Ⓐ33 : Rear wiper and washer switch
- Ⓐ34 : Rear window defogger switch
- Ⓐ35 : Hazard switch
- Ⓐ36 : Radio
- Ⓐ37 : Radio
- Ⓐ38 : Cassette deck
- Ⓐ39 : Cassette deck
- Ⓐ40 : Push control unit
- Ⓐ41 : Fan switch
- Ⓐ42 : Diode
- Ⓐ43 : To sub-harness (M44)
- Ⓐ44 : To main harness (M43)
- Ⓐ45 : Glove box lamp
- Ⓐ46 : Glove box lamp switch

- Ⓐ47 : To instrument harness (I1) (Black)
- Ⓐ48 : To instrument harness (I2) (White)
- Ⓐ49 : Thermo control amplifier
- Ⓐ50 : Heater resistor
- Ⓐ51 : Blower motor
- Ⓐ52 : Foot lamp R.H.
- Ⓐ53 : To E.F.I. harness (F1)
- Ⓐ54 : To door harness R.H. (010)
- Ⓐ55 : To door harness R.H. (0102)
- Ⓐ56 : To room lamp harness (R1)
- Ⓐ57 : Body ground
- Ⓐ58 : Intake door motor
- Ⓐ59 : To sub-harness (M60)
- Ⓐ60 : To main harness (M59)
- Ⓐ61 : Door lock timer
- Ⓐ62 : Washer warning lamp (Model with A.S.C.D.)
- Ⓐ63 : To engine room harness (E119)
- Ⓐ64 : Blower relay
- Ⓐ65 : Joint connector (Model with SUPER HICAS system)
- Ⓐ66 : HICAS clutch switch (M/T model with SUPER HICAS system)
- Ⓐ67 : HICAS warning lamp (M/T model with SUPER HICAS system)
- Ⓐ68 : O.D. off indicator and HICAS warning lamp (A/T model with SUPER HICAS system)

Diode (M42)

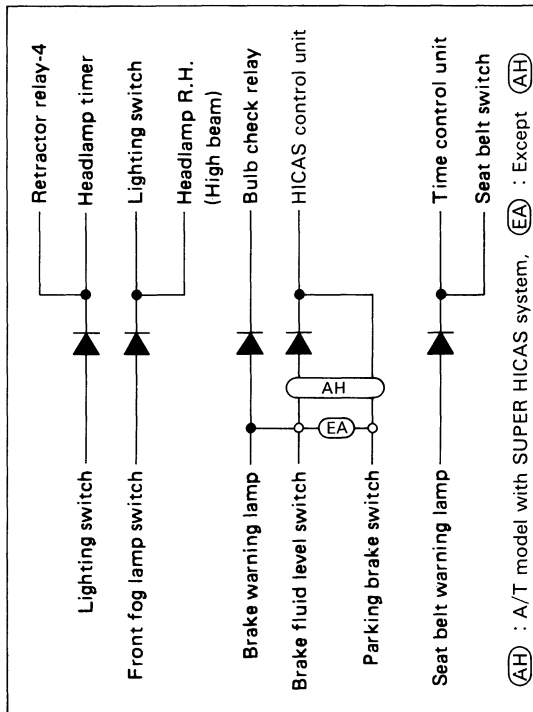

(AH) : A/T model with SUPER HICAS system, (EA) : Except (AH)

HARNESS LAYOUT

Main Harness (Cont'd)

FASTBACK

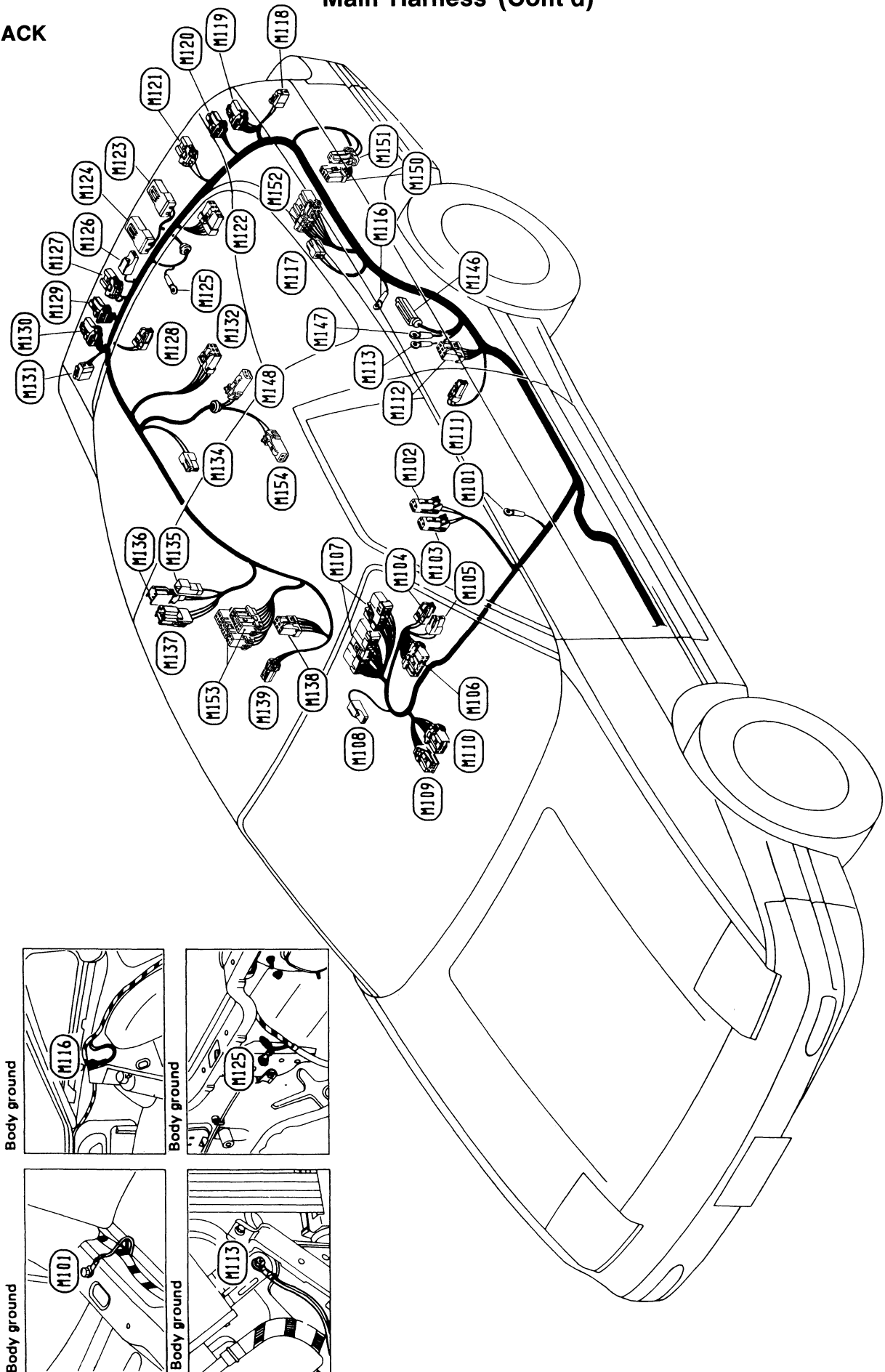

HARNES LAYOUT

Main Harness (Cont'd)

(M101) : Body ground
(M102) : Lap belt buckle switch (For U.S.A.)
(M103) : Seat belt switch (For Canada)
(M104) : Ash tray illumination
(M105) : Cigarette lighter
(M106) : Door mirror control switch
(M107) : Automatic seat belt control unit (For U.S.A.)
(M108) : Parking brake switch
(M109) : A/T device (A/T illumination and O.D. control switch) (A/T model)
(M110) : Shift lock solenoid (A/T model)
(M111) : Door switch L.H.
(M112) : Automatic seat belt motor assembly L.H. (For U.S.A.)
(M113) : Body ground (For U.S.A.)
(M114) : Body ground
(M115) : Rear speaker L.H.
(M116) : Rear side marker lamp L.H.
(M117) : Rear combination lamp L.H.
(M118) : Rear combination lamp L.H.
(M119) : Rear combination lamp L.H.

(M120) : Rear combination lamp L.H.
(M121) : Back-up lamp L.H.
(M122) : Rear wiper amplifier
(M123) : License lamp L.H.
(M124) : License lamp R.H.
(M125) : Body ground
(M126) : Luggage room lamp switch
(M127) : Back-up lamp R.H.
(M128) : Luggage room lamp
(M129) : Rear combination lamp R.H.
(M130) : Rear combination lamp R.H.
(M131) : Rear side marker lamp R.H.
(M132) : Fuel tank gauge unit
(M134) : Rear speaker R.H.
(M135) : To back door harness (0501)
(M136) : To back door harness (0502)
(M137) : To back door harness (0503)
(M138) : Automatic seat belt motor assembly R.H. (For U.S.A.)
(M139) : Door switch R.H.
(M146) : A.B.S. control unit (For Anti-lock Braking System)
(M147) : Body ground (For Anti-lock Braking System)
(M148) : Rear sensor (For Anti-lock Braking System)
(M150) : Auto antenna timer
(M151) : Auto antenna motor
(M152) : Rear speaker amplifier (Active speaker type)
(M153) : HICAS control unit (With SUPER HICAS system)
(M154) : HICAS fail safe solenoid valve (With SUPER HICAS system)

HARNESS LAYOUT

Main Harness (Cont'd)

COUPE

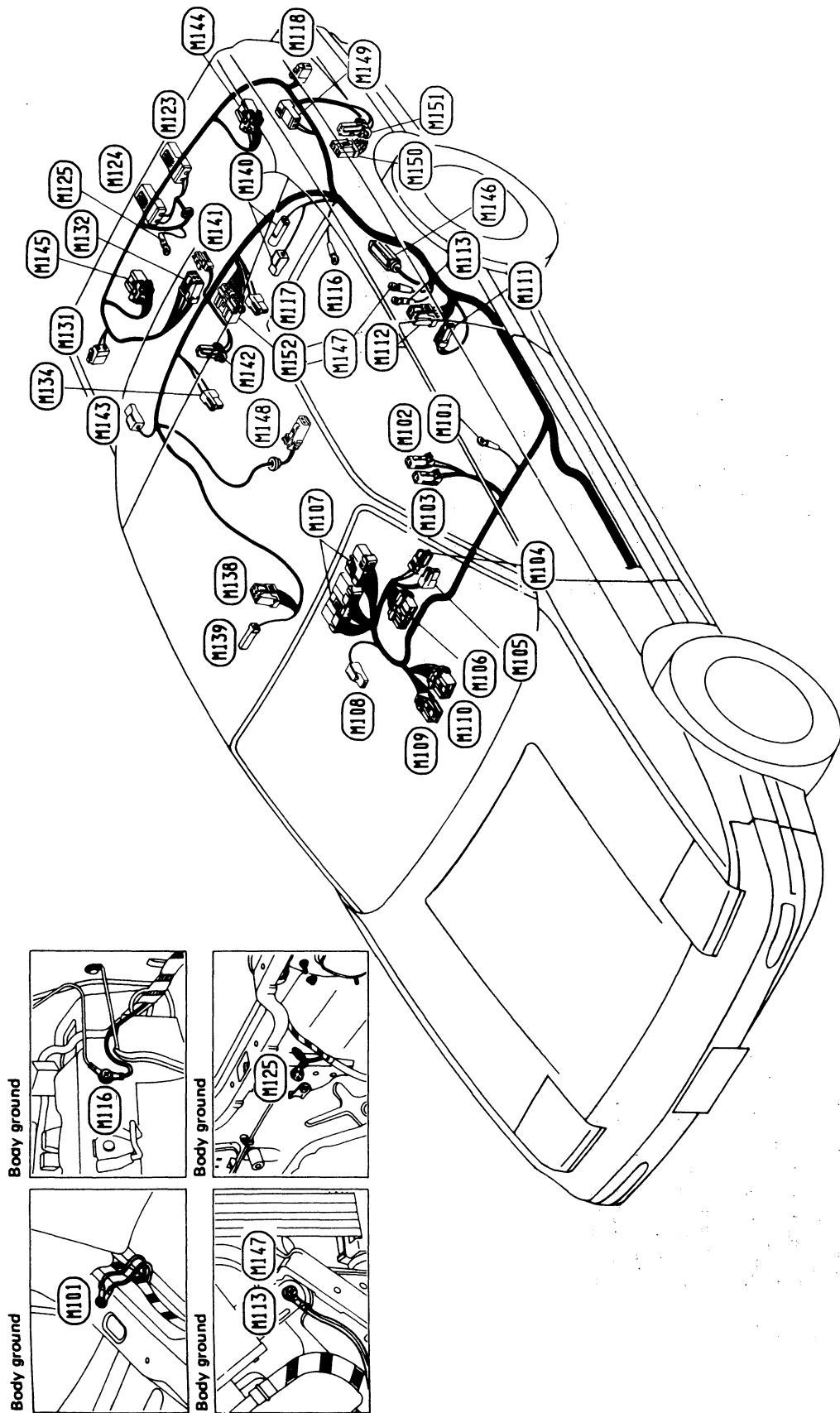

HARNES LAYOUT

Main Harness (Cont'd)

- (110) : Body ground
 - (112) : Lap belt buckle switch (For U.S.A.)
 - (113) : Seat belt switch (For Canada)
 - (114) : Ash tray illumination
 - (115) : Cigarette lighter
 - (116) : Door mirror control switch
 - (117) : Automatic seat belt control unit (For U.S.A.)
 - (118) : Parking brake switch
 - (119) : A/T device (A/T illumination and O.D. control switch) (A/T model)
 - (120) : Shift lock solenoid (A/T model)
 - (121) : Door switch L.H.
 - (122) : Automatic seat belt motor assembly L.H. (For U.S.A.)
 - (123) : Body ground (For U.S.A.)
 - (124) : Body ground
 - (125) : Rear speaker L.H.
 - (126) : Rear side marker lamp L.H.
 - (127) : Fuel tank gauge unit
 - (128) : Rear speaker R.H.
 - (129) : Automatic seat belt motor assembly R.H. (For U.S.A.)
 - (130) : Door switch R.H.
 - (131) : Trunk room lamp switch
 - (132) : Trunk room lamp
 - (133) : High-mounted stop lamp (Model without rear spoiler)
 - (134) : Rear window defogger
 - (135) : Rear combination lamp L.H.
 - (136) : Rear combination lamp R.H.
 - (137) : A.B.S. control unit (For Anti-lock Braking System)
 - (138) : Body ground (For Anti-lock Braking System)
 - (139) : Rear sensor (For Anti-lock Braking System)
 - (140) : To high-mounted stop lamp sub-harness (Model with rear spoiler)
 - (141) : Auto antenna timer
 - (142) : Auto antenna motor
 - (143) : Rear speaker amplifier (Active speaker type)
- (118) : Rear side marker lamp L.H.
 - (123) : License lamp L.H.
 - (124) : License lamp R.H.
 - (125) : Body ground
 - (131) : Rear side marker lamp R.H.
 - (132) : Fuel tank gauge unit
 - (133) : Rear speaker R.H.
 - (138) : Automatic seat belt motor assembly R.H. (For U.S.A.)
 - (139) : Door switch R.H.
 - (140) : Trunk room lamp switch
 - (141) : Trunk room lamp
 - (142) : High-mounted stop lamp (Model without rear spoiler)
 - (143) : Rear window defogger
 - (144) : Rear combination lamp L.H.
 - (145) : Rear combination lamp R.H.
 - (146) : A.B.S. control unit (For Anti-lock Braking System)
 - (147) : Body ground (For Anti-lock Braking System)
 - (148) : Rear sensor (For Anti-lock Braking System)
 - (149) : To high-mounted stop lamp sub-harness (Model with rear spoiler)
 - (150) : Auto antenna timer
 - (151) : Auto antenna motor
 - (152) : Rear speaker amplifier (Active speaker type)

HARNESS LAYOUT

Instrument Harness

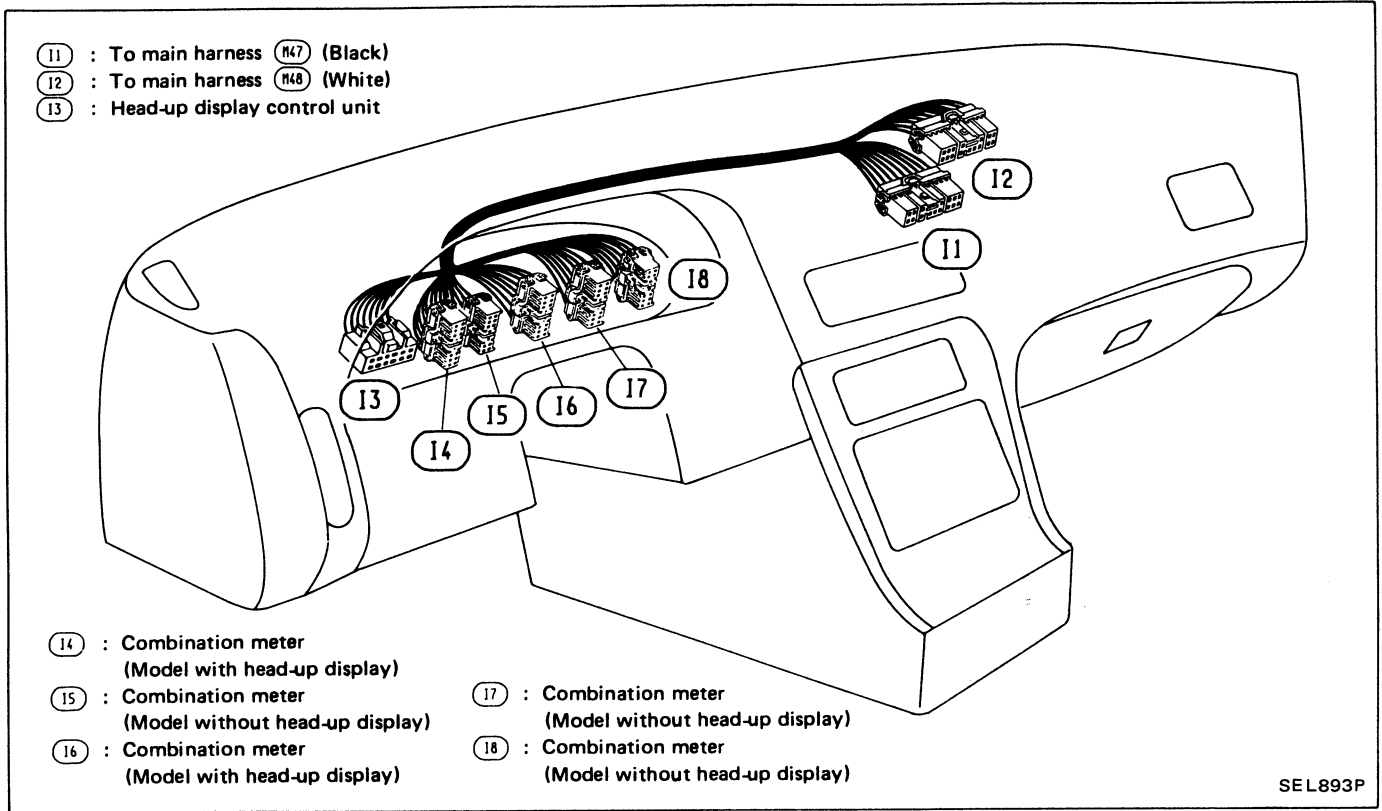

HARNESS LAYOUT

NOTE

REVISED 4/1/64



HARNES LAYOUT

Engine Room Harness

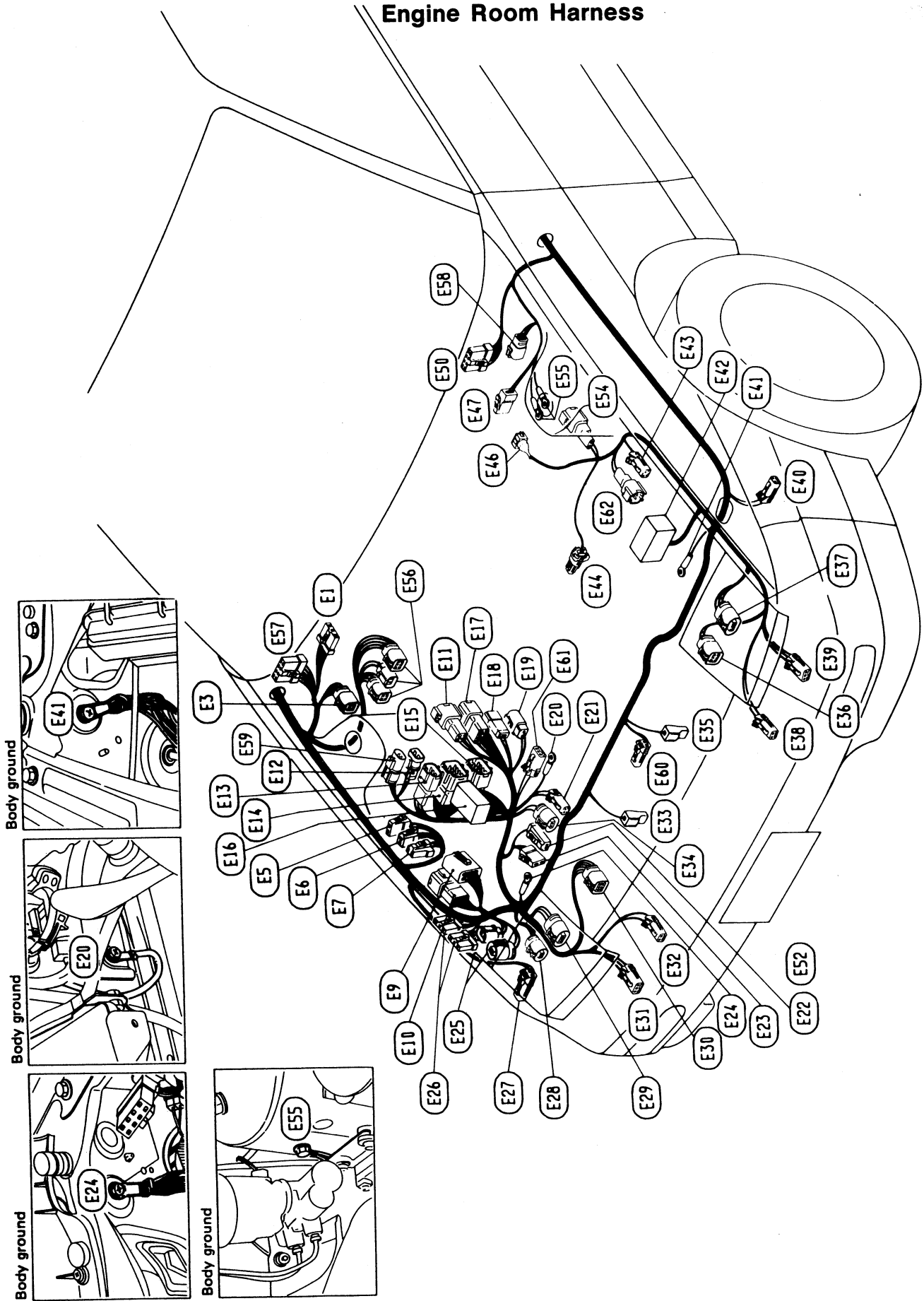

HARNES LAYOUT

Engine Room Harness (Cont'd)

E1	: Windshield wiper motor	
E2	: A.S.C.D. actuator (Model without Anti-lock Braking System)	
E3	: Rear washer motor	
E4	: Front washer motor	
E5	: Washer fluid level switch	
E6	: To E.F.I. harness (E8) (White)	
E7	: To E.F.I. harness (E9) (Brown)	
E8	: To engine room harness no. 2 (E201) (A/T model)	
E9	: Inhibitor switch (A/T model)	
E10	: Revolution sensor (A/T model)	
E11	: Inhibitor switch (A/T model) (Gray)	
E12	: To solenoid valve sub-harness (A/T model) (Brown)	
E13	: Relay box (Refer to page EL-97.)	
E14	: To engine room harness no. 2 (E202)	
E15	: To engine room harness no. 2 (E203)	
E16	: To engine room harness no. 2 (E204)	
E17	: Body ground	
E18	: Dual-pressure switch	
E19	: Battery	
E20	: Battery	
E21	: Body ground	
E22	: Interlock relay (M/T model for U.S.A.) U.S.A.)	
E23	: Daytime light control unit (For Canada)	
E24	: Front side marker lamp R.H.	
E25	: Not used	
E26	: Headlamp R.H.	
E27	: Headlamp motor R.H.	
E28	: Front combination lamp R.H.	
E29	: Daytime light R.H. (For Canada)	
E30	: Horn-low	
E31	: Condenser fan motor	
E32	: Horn-high	
E33	: Headlamp motor L.H.	
E34	: Headlamp L.H.	
E35	: Daytime light L.H. (For Canada)	
E36	: Front combination lamp L.H.	
E37	: Front side marker lamp L.H.	
E38	: Body ground	
E39	: Relay box (Refer to page EL-97.)	
E40	: Dropping resistor (A/T model.)	
E41	: Compressor	
E42	: A.I.V. control solenoid valve	
E43	: Brake fluid level switch	
E44	: Windshield wiper amplifier (Model without Anti-lock Braking System)	
E45	: Front wheel sensor L.H. (For Anti-lock Braking System)	
E46	: Body ground	
E47	: Actuator (For Anti-lock Braking System)	
E48	: Windshield wiper amplifier (Model with Anti-lock Braking System)	
E49	: A.S.C.D. actuator (Model with Anti-lock Braking System)	
E50	: To engine room harness no. 2 (E206) (M/T model)	
E51	: Ambient switch	
E52	: HICAS solenoid valve (With SUPER HICAS system)	
E53	: HICAS oil level switch (With SUPER HICAS system)	

HARNESS LAYOUT

Engine Room Harness (Cont'd)

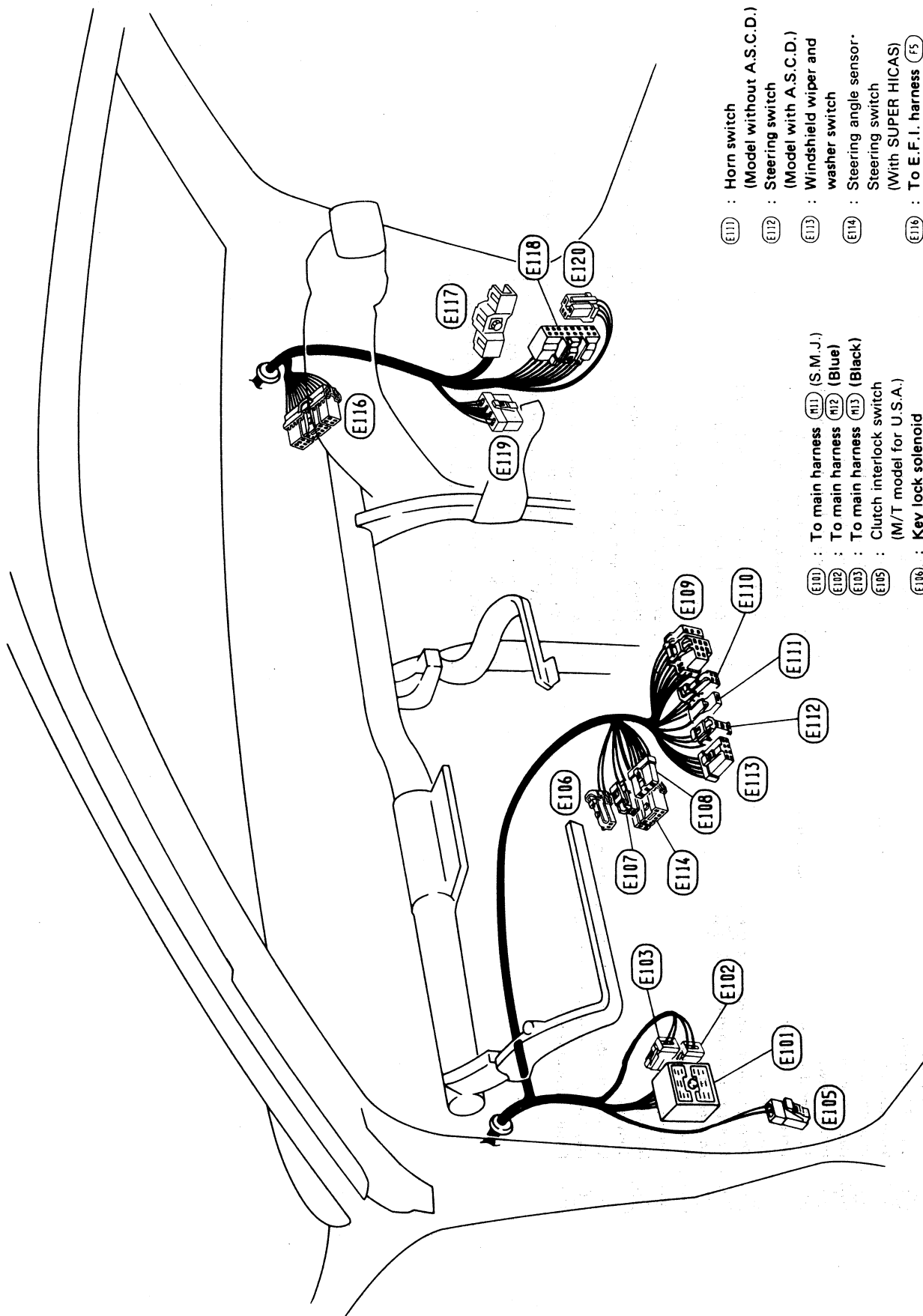

- (E111) : Horn switch
(Model without A.S.C.D.)
- (E112) : Steering switch
(Model with A.S.C.D.)
- (E113) : Windshield wiper and
washer switch
- (E114) : Steering angle sensor-
Steering switch
(With SUPER HICAS)
- (E116) : To E.F.I. harness (F5)
(A/T model)
- (E117) : A/T control unit
- (E118) : A.S.C.D. control unit
- (E119) : To main harness (R63)
- (E120) : A.S.C.D. hold relay

- (E101) : To main harness (R11) (S.M.J.)
- (E102) : To main harness (R12) (Blue)
- (E103) : To main harness (R13) (Black)
- (E105) : Clutch interlock switch
(M/T model for U.S.A.)
- (E106) : Key lock solenoid
(A/T model)
- (E107) : Key switch
- (E108) : Ignition switch
- (E109) : Combination switch
- (E110) : Combination switch

HARNES LAYOUT

E.F.I. Harness

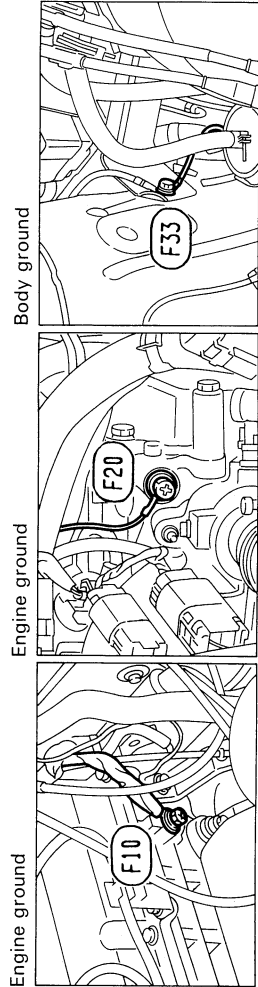

E.F.I. sub harness

- (F51) : To E.F.I. harness (F26)
- (F52) : Exhaust gas temperature sensor (For California)
- (F53) : Air regulator
- (F54) : F.I.C.D. solenoid valve
- (F55) : A.A.C. valve

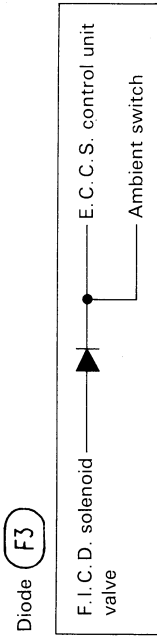

Diode (F3)

F.I.C.D. solenoid valve

E.C.C.S. control unit

Ambient switch

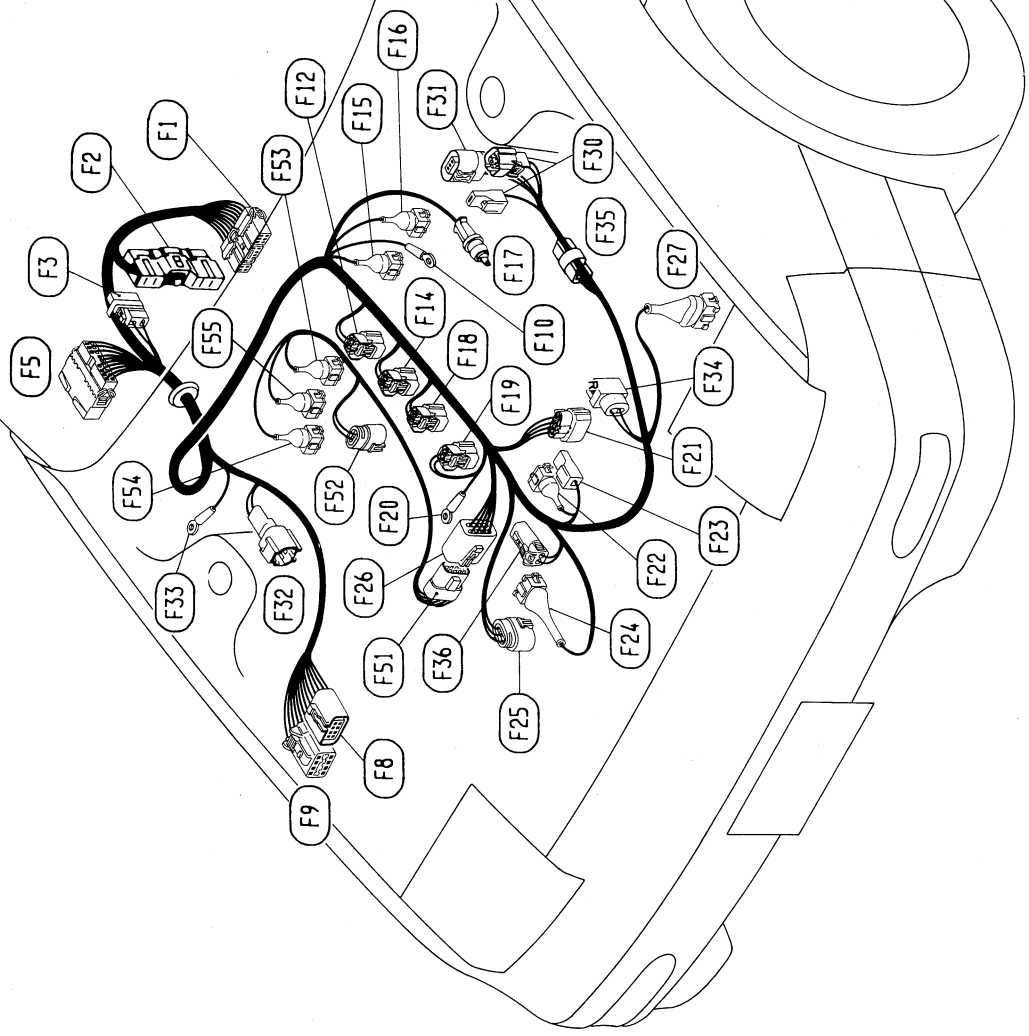

- (F1) : To main harness (F53)
- (F2) : E.C.C.S. control unit
- (F3) : Diode
- (F5) : To engine room harness (E116) (A/T model)
- (F8) : To engine room harness (E9) (White)
- (F9) : To engine room harness (E10) (Brown)
- (F10) : Engine ground
- (F12) : Injector no. 4
- (F14) : Injector no. 3
- (F15) : E.G.R. control solenoid valve
- (F16) : S.C.V. control solenoid valve
- (F17) : Exhaust gas sensor
- (F18) : Injector no. 2
- (F19) : Injector no. 1
- (F20) : Engine ground
- (F21) : Crank angle sensor
- (F22) : Engine temperature sensor
- (F23) : Thermal transmitter
- (F24) : Throttle valve switch
- (F25) : Throttle sensor
- (F26) : To E.F.I. sub harness (F51)
- (F27) : Air flow meter
- (F30) : Ignition coil
- (F31) : Power transistor
- (F32) : Front wheel sensor R.H. (For Anti-lock Braking System)
- (F33) : Body ground (For Anti-lock Braking System)
- (F34) : Power steering oil pressure switch
- (F35) : Resistor and condenser
- (F36) : To detonation sensor sub harness

HARNES LAYOUT

Engine Room Harness No. 2

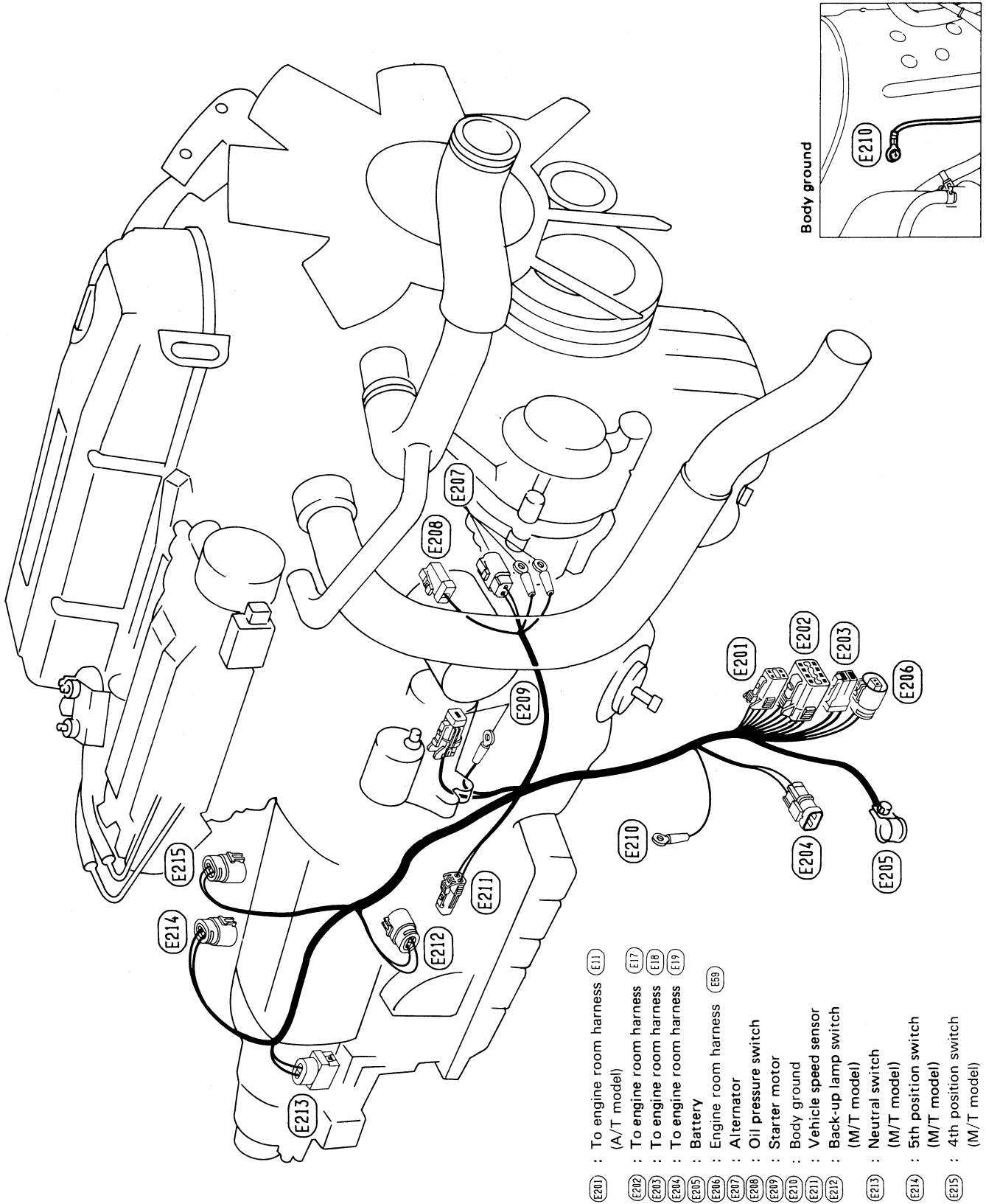

HARNESS LAYOUT

Back Door Harness

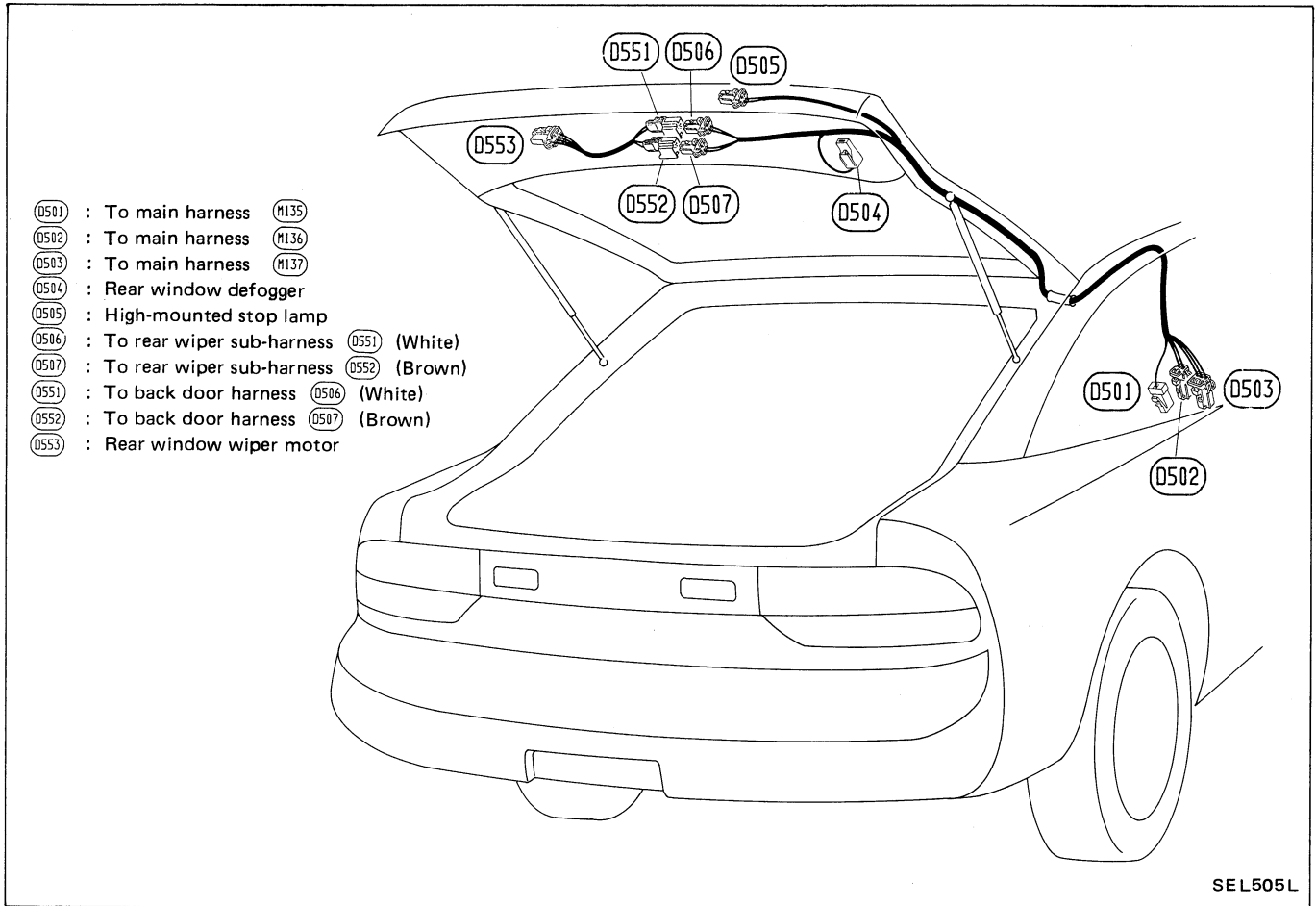

HARNESS LAYOUT

Room Lamp and Sun Roof Harness



Sun roof harness

- (R1) : To main harness (F156)
- (R2) : To sun roof harness (S1)
- (R3) : Spot lamp (Model with sun roof)
- (R4) : Interior lamp (Model without sun roof)
- (R5) : Interior lamp (Fastback with sun roof)
- (R6) : Interior lamp (Coupe with sun roof)
- (R8) : Automatic seat belt front limit switch (For U.S.A.)
- (S1) : To room lamp harness (R2)
- (S2) : Body ground
- (S3) : Sun roof switch
- (S4) : Slide relay — open
- (S5) : Sun roof motor
- (S6) : Safety relay
- (S7) : Slide relay — close
- (S8) : Safety limit switch

Room lamp harness

- (R1) : To main harness (F156)
- (R2) : To sun roof harness (S1)
- (R3) : Spot lamp (Model with sun roof)
- (R4) : Interior lamp (Model without sun roof)
- (R5) : Interior lamp (Fastback with sun roof)
- (R6) : Interior lamp (Coupe with sun roof)
- (R8) : Automatic seat belt front limit switch (For U.S.A.)

HARNESS LAYOUT

Door Harness L.H.

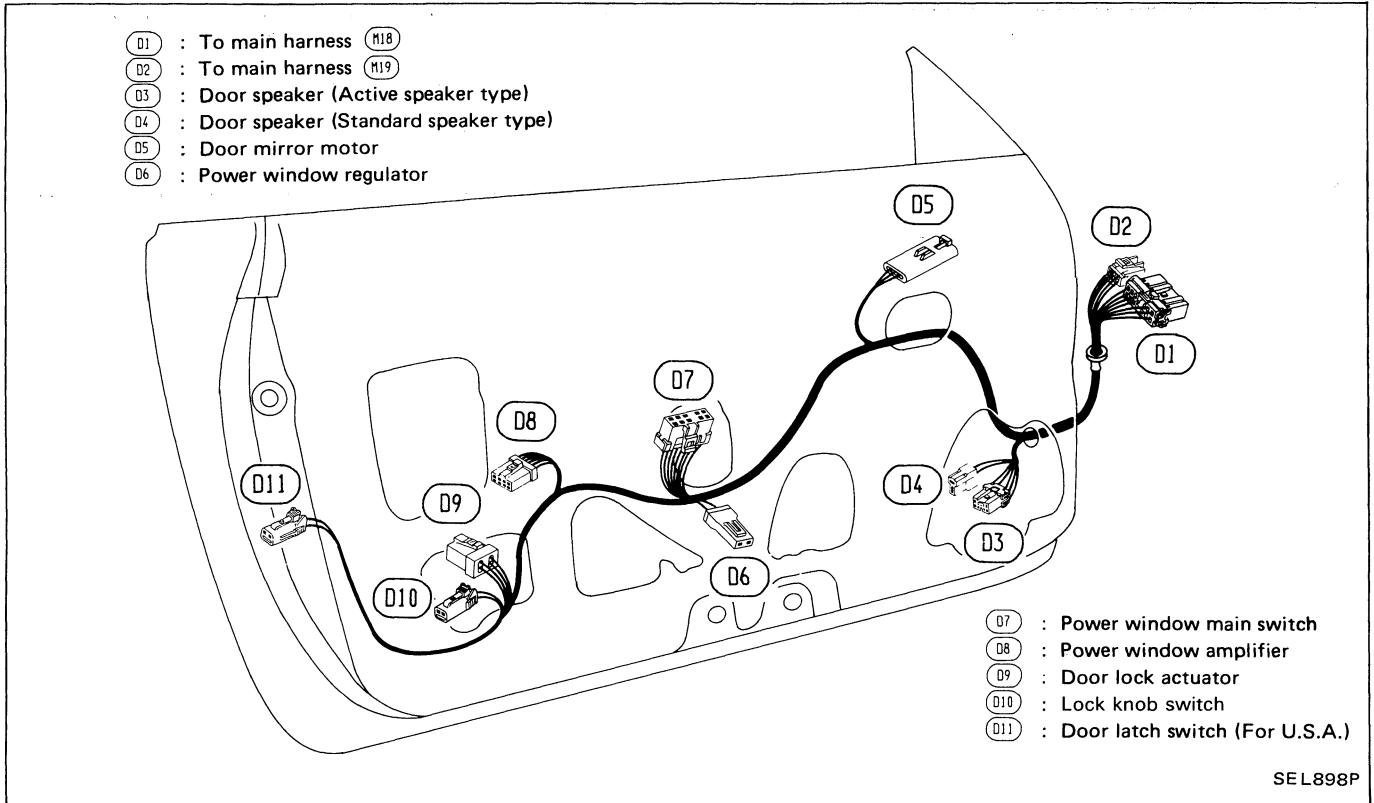

Door Harness R.H.

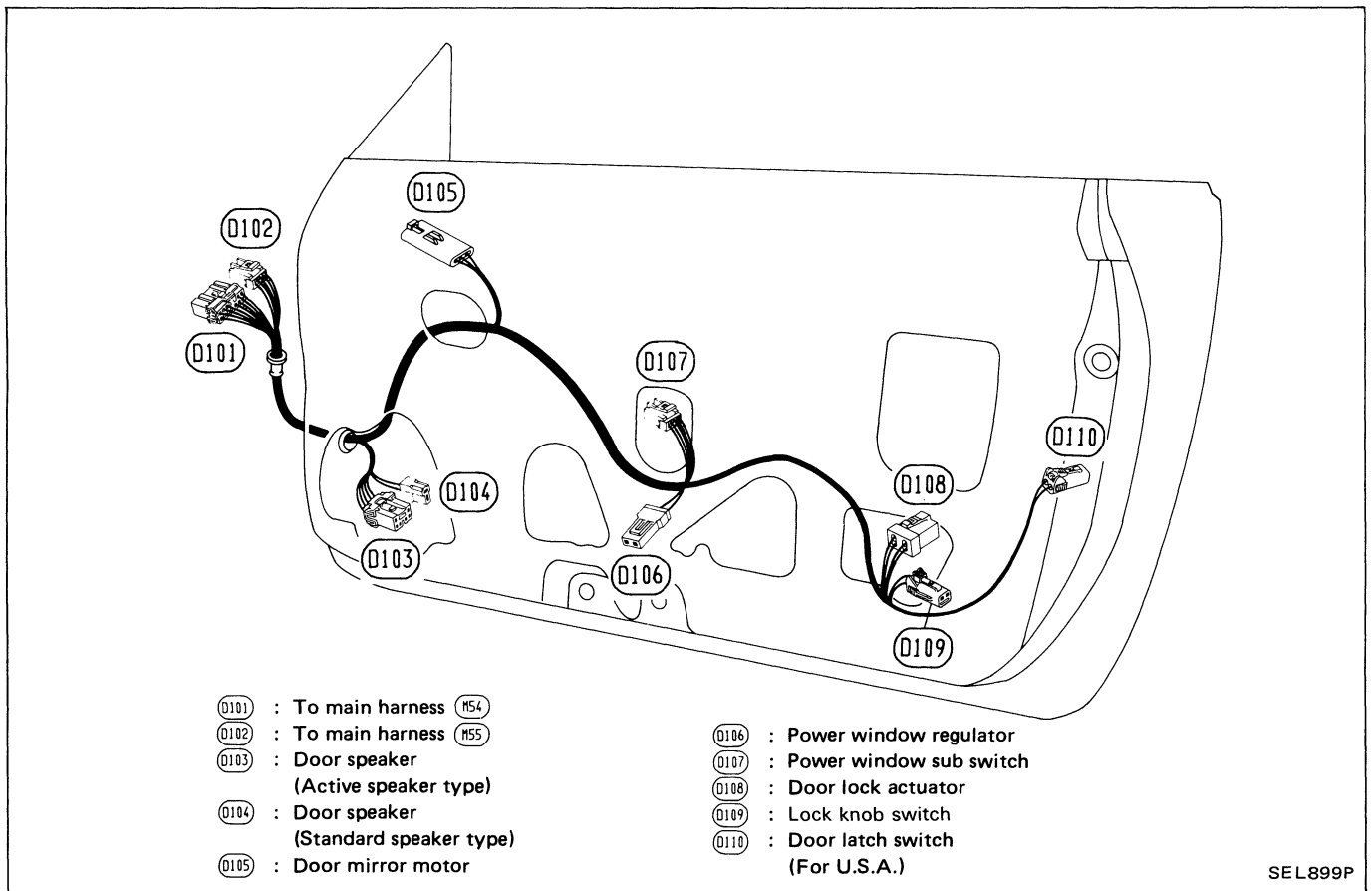

SPECIAL SERVICE TOOL

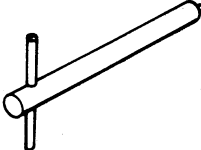
Tool number	Tool name
(J36126)	Washer nozzle adjusting tool 

SUPER MULTIPLE JUNCTION (S.M.J.)

Disconnecting and Connecting

- S.M.J. is located on left side of dash.
- To disconnect S.M.J., loosen fixing bolt.

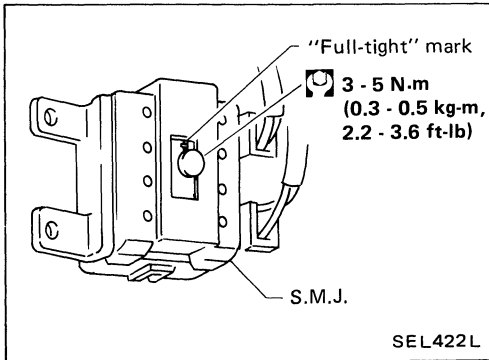

- To install S.M.J., tighten bolts until orange "full-tight" mark appears and then retighten to specified torque as required.

3 - 5 N·m
(0.3 - 0.5 kg-m, 2.2 - 3.6 ft-lb)

CAUTION:

Do not overtighten bolts, otherwise, they may be damaged.

SUPER MULTIPLE JUNCTION (S.M.J.)

Terminal Arrangement

MAIN HARNESS

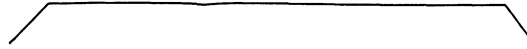

A1	A2	A3	A4	A5	A6	A7	A8	A9	A10	A11	A12
B1	B2	B3	B4	B5	B6	B7	B8	B9	B10	B11	B12
C1	C2	C3	C4	C5	C6	C7	C8	C9	C10	C11	C12
D1	D2								D11	D12	
E1	E2								E11	E12	
F1	F2								F11	F12	
G1	G2	G3	G4	G5	G6	G7	G8	G9	G10	G11	G12
H1	H2	H3	H4	H5	H6	H7	H8	H9	H10	H11	H12
I1	I2	I3	I4	I5	I6	I7	I8	I9	I10	I11	I12



I1	I2	I3	I4	I5	I6	I7	I8	I9	I10	I11	I12
H1	H2	H3	H4	H5	H6	H7	H8	H9	H10	H11	H12
G1	G2	G3	G4	G5	G6	G7	G8	G9	G10	G11	G12
F1	F2								F11	F12	
E1	E2								E11	E12	
D1	D2								D11	D12	
C1	C2	C3	C4	C5	C6	C7	C8	C9	C10	C11	C12
B1	B2	B3	B4	B5	B6	B7	B8	B9	B10	B11	B12
A1	A2	A3	A4	A5	A6	A7	A8	A9	A10	A11	A12

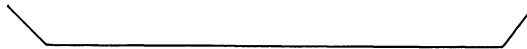

ENGINE ROOM HARNESS

E.C.C.S. CONTROL UNIT

101	102	103	104	105	106	107	108	1	2	3	4	5	6	7	15	16	17	18	19	20	21	22	31	32	33	34	35	36	37	38	39
109	110	111	112	113	114	115	116	8	9	10	11	12	13	14	23	24	25	26	27	28	29	30	40	41	42	43	44	45	46	47	48



View from harness side

A/T CONTROL UNIT

1	2	3	4	9	10	11	12	13	14	15	23	24	25	26	27	28	29	30	31	32	33	34	35
5	6	7	8	16	17	18	19	20	21	22	36	37	38	39	40	41	42	43	44	45	46	47	48



View from harness side

1991 NISSAN 240SX CIRCUIT DIAGRAM

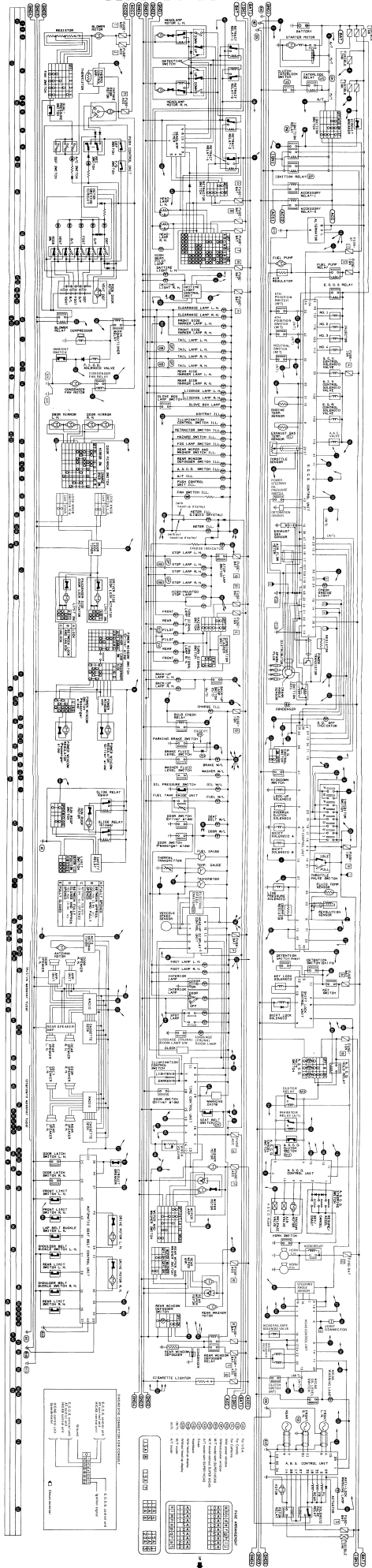

INCH TO METRIC CONVERSION TABLE

(Rounded-off for automotive use)

inches	mm	inches	mm
.100	2.54	.610	15.49
.110	2.79	.620	15.75
.120	3.05	.630	16.00
.130	3.30	.640	16.26
.140	3.56	.650	16.51
.150	3.81	.660	16.76
.160	4.06	.670	17.02
.170	4.32	.680	17.27
.180	4.57	.690	17.53
.190	4.83	.700	17.78
.200	5.08	.710	18.03
.210	5.33	.720	18.29
.220	5.59	.730	18.54
.230	5.84	.740	18.80
.240	6.10	.750	19.05
.250	6.35	.760	19.30
.260	6.60	.770	19.56
.270	6.86	.780	19.81
.280	7.11	.790	20.07
.290	7.37	.800	20.32
.300	7.62	.810	20.57
.310	7.87	.820	20.83
.320	8.13	.830	21.08
.330	8.38	.840	21.34
.340	8.64	.850	21.59
.350	8.89	.860	21.84
.360	9.14	.870	22.10
.370	9.40	.880	22.35
.380	9.65	.890	22.61
.390	9.91	.900	22.86
.400	10.16	.910	23.11
.410	10.41	.920	23.37
.420	10.67	.930	23.62
.430	10.92	.940	23.88
.440	11.18	.950	24.11
.450	11.43	.960	24.38
.460	11.68	.970	24.64
.470	11.94	.980	24.89
.480	12.19	.990	25.15
.490	12.45	1.000	25.40
.500	12.70	2.000	50.80
.510	12.95	3.000	76.20
.520	13.21	4.000	101.60
.530	13.46	5.000	127.00
.540	13.72	6.000	152.40
.550	13.97	7.000	177.80
.560	14.22	8.000	203.20
.570	14.48	9.000	228.60
.580	14.73	10.000	254.00
.590	14.99	20.000	508.00
.600	15.24		

METRIC TO INCH CONVERSION TABLE

(Rounded-off for automotive use)

mm	inches	mm	inches
1	.0394	51	2.008
2	.079	52	2.047
3	.118	53	2.087
4	.157	54	2.126
5	.197	55	2.165
6	.236	56	2.205
7	.276	57	2.244
8	.315	58	2.283
9	.354	59	2.323
10	.394	60	2.362
11	.433	61	2.402
12	.472	62	2.441
13	.512	63	2.480
14	.551	64	2.520
15	.591	65	2.559
16	.630	66	2.598
17	.669	67	2.638
18	.709	68	2.677
19	.748	69	2.717
20	.787	70	2.756
21	.827	71	2.795
22	.866	72	2.835
23	.906	73	2.874
24	.945	74	2.913
25	.984	75	2.953
26	1.024	76	2.992
27	1.063	77	3.031
28	1.102	78	3.071
29	1.142	79	3.110
30	1.181	80	3.150
31	1.220	81	3.189
32	1.260	82	3.228
33	1.299	83	3.268
34	1.339	84	3.307
35	1.378	85	3.346
36	1.417	86	3.386
37	1.457	87	3.425
38	1.496	88	3.465
39	1.535	89	3.504
40	1.575	90	3.543
41	1.614	91	3.583
42	1.654	92	3.622
43	1.693	93	3.661
44	1.732	94	3.701
45	1.772	95	3.740
46	1.811	96	3.780
47	1.850	97	3.819
48	1.890	98	3.858
49	1.929	99	3.898
50	1.969	100	3.937

ENGINE TUNE-UP DATA

Engine model	KA24DE		
Firing order	1-3-4-2		
Idle speed	rpm	700±50	
M/T		700±50	
A/T (in "N" position)		700±50	
Ignition timing (degree B.T.D.C. at idle speed)		20°±2°	
Idle "CO" (% at idle speed)	idle mixture screw is preset and sealed at factory.		
Valve clearance (Hot)	mm (in)	0.31 - 0.39 (0.012 - 0.015)	
Intake		0.33 - 0.41 (0.013 - 0.016)	
Exhaust		0.33 - 0.41 (0.013 - 0.016)	
High tension cable resistance	kΩ	Less than 30	
Spark plug		BKR5E-11	
Standard		BKR6E-11	
Type		BKR7E-11	
Cold		BKR7E-11	
Gap	mm (in)	1.0 - 1.1 (0.039 - 0.043)	
Drive belt deflection (Cold)	mm (in)	Used belt deflection	
		Limit	Deflection after adjustment
Alternator	11 (0.43)	7 - 8 (0.28 - 0.31)	6 - 7 (0.24 - 0.28)
		7.5 - 8.5 (0.295 - 0.335)	6.5 - 7.5 (0.256 - 0.295)
Air conditioner compressor	12 (0.47)	7.5 - 8.5 (0.295 - 0.335)	6.5 - 7.5 (0.256 - 0.295)
Power steering pump	9 (0.35)	6.5 - 7.5 (0.256 - 0.295)	5.5 - 6.5 (0.217 - 0.256)
with super HICAS		7.5 - 8.5 (0.295 - 0.335)	6.5 - 7.5 (0.256 - 0.295)
without super HICAS	13 (0.51)	7.5 - 8.5 (0.295 - 0.335)	6.5 - 7.5 (0.256 - 0.295)
Applied pressed force	N (kg, lb)	98 (10, 22)	
Tightening torque		N-m	kg-m
Spark plug		20 - 29	2.0 - 3.0
Oil pan drain plug		29 - 39	3.0 - 4.0
			ft-lb
			14 - 22
			22 - 29

CLUTCH PEDAL

Unit: mm (in)

Pedal height	186 - 196 (7.32 - 7.72)
Pedal free play	1 - 3 (0.04 - 0.12)

FRONT WHEEL ALIGNMENT (Unladen*)

Camber	degree	-1°30' to 0°
Caster	degree	6°00' - 7°30'
Toe-in	mm (in)	0.3 - 2.3 (0.012 - 0.091)
	degree	2' - 13' (Total toe-in angle)
Full turns		
Inner wheel		39° - 43°
Outer wheel		33°

* Fuel, radiator coolant and engine oil full.
Spare tire, jack, hand tools and mats in designated positions.

REAR WHEEL ALIGNMENT (Unladen*)

Camber	degree	-1°36' to -0°36'
Toe-in	mm (in)	0.5 - 4.5 (0.020 - 0.177)
	degree	3' - 25' (Total toe-in angle)

* Fuel, radiator coolant and engine oil full.
Spare tire, jack, hand tools and mats in designated positions.

BRAKE

Unit: mm (in)

Disc brake		
Pad repair limit		2.0 (0.079)
Rotor thickness	Front side	20.0 (0.787), 22 (0.87)*3
repair limit	Rear side	9.0 (0.354)
Pedal free height		
M/T model		177 - 187 (6.97 - 7.36)
A/T model		186 - 196 (7.32 - 7.72)
Pedal depressed height*1		100 (3.94) or more
Parking brake		
Number of notches*2		6 - 8

*1: Under force of 490 N (50 kg, 110 lb) with engine running
*2: At pulling force: 196 N (20 kg, 44 lb)
*3: Models with A.B.S.

REFILL CAPACITIES

Unit	Liter	US measure
Engine model	KA24DE	
Fuel tank	60	15-7/8 gal
Coolant	With reservoir tank	6.7
		7-1/8 qt
Engine	With oil filter	3.5
	Without oil filter	3.2
		3-3/8 qt
Transmission	M/T	2.4
	A/T	8.3
		5-1/8 pt
Differential carrier	R200	1.8
		3-7/8 pt
Power steering system		0.9
		1 qt
Air conditioning system	Compressor oil	0.236
	Refrigerant	0.8 - 0.9 kg
		8.0 fl oz
		1.8 - 2.0 lb



NISSAN MOTOR CO., LTD.

Overseas Service Department

Tokyo, Japan

Edition: August 1990
Printing: August 1990 (05)
Publication No. SM1E-0S13U0
Printed in Japan