

CLUTCH

SECTION **CL**

GI

MA

EM

LC

EF &
EC

FE

CL

MT

AT

PD

FA

RA

BR

ST

BF

HA

EL

CONTENTS

PRECAUTIONS AND PREPARATION	2	Clutch Master Cylinder	6
Precautions.....	2	Operating Cylinder.....	7
Special Service Tools	2	CLUTCH RELEASE MECHANISM	8
Commercial Service Tools	2	CLUTCH DISC AND CLUTCH COVER	10
CLUTCH SYSTEM	3	Clutch Cover and Flywheel	10
INSPECTION AND ADJUSTMENT	4	Clutch Disc	11
Adjusting Clutch Pedal	4	SERVICE DATA AND SPECIFICATIONS (S.D.S.)	12
Bleeding Procedure	5	General Specifications.....	12
HYDRAULIC CLUTCH CONTROL	6	Inspection and Adjustment.....	12

PRECAUTIONS AND PREPARATION

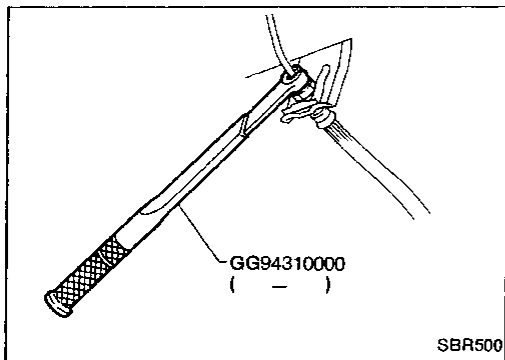

Precautions

- Recommended fluid is brake fluid "DOT 3".
- Never reuse drained brake fluid.
- Be careful not to splash brake fluid on painted areas.
- When removing and installing clutch piping, use Tool.
- Use new brake fluid to clean or wash all parts of master cylinder, operating cylinder and clutch damper.
- Never use mineral oils such as gasoline or kerosene. It will ruin the rubber parts of the hydraulic system.

WARNING:

After cleaning the clutch disc, wipe it with a dust collector. Do not use compressed air.

Special Service Tools

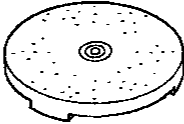
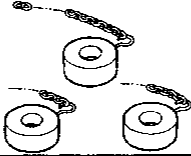
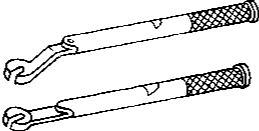
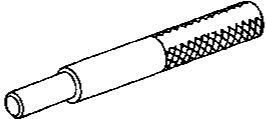
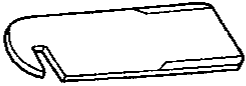
Tool number (Kent-Moore No.) Tool name	Description	
ST20050010 (—) Base plate		Inspecting diaphragm spring of clutch cover
ST20050100 (—) Distance piece		Inspecting diaphragm spring of clutch cover
GG94310000 (—) Flare nut torque wrench		Removing and installing each clutch piping
ST20600000 (J26366) Clutch aligning bar		Installing clutch cover and clutch disc
ST20050240 (—) Diaphragm spring adjusting wrench		Adjusting unevenness of diaphragm spring of clutch cover

Commercial Service Tools

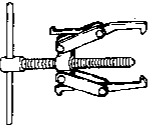
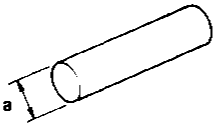
Tool name	Description	
Bearing puller		Removing release bearing
Bearing drift		Installing release bearing

a: 50 mm (1.97 in) dia.

CLUTCH SYSTEM

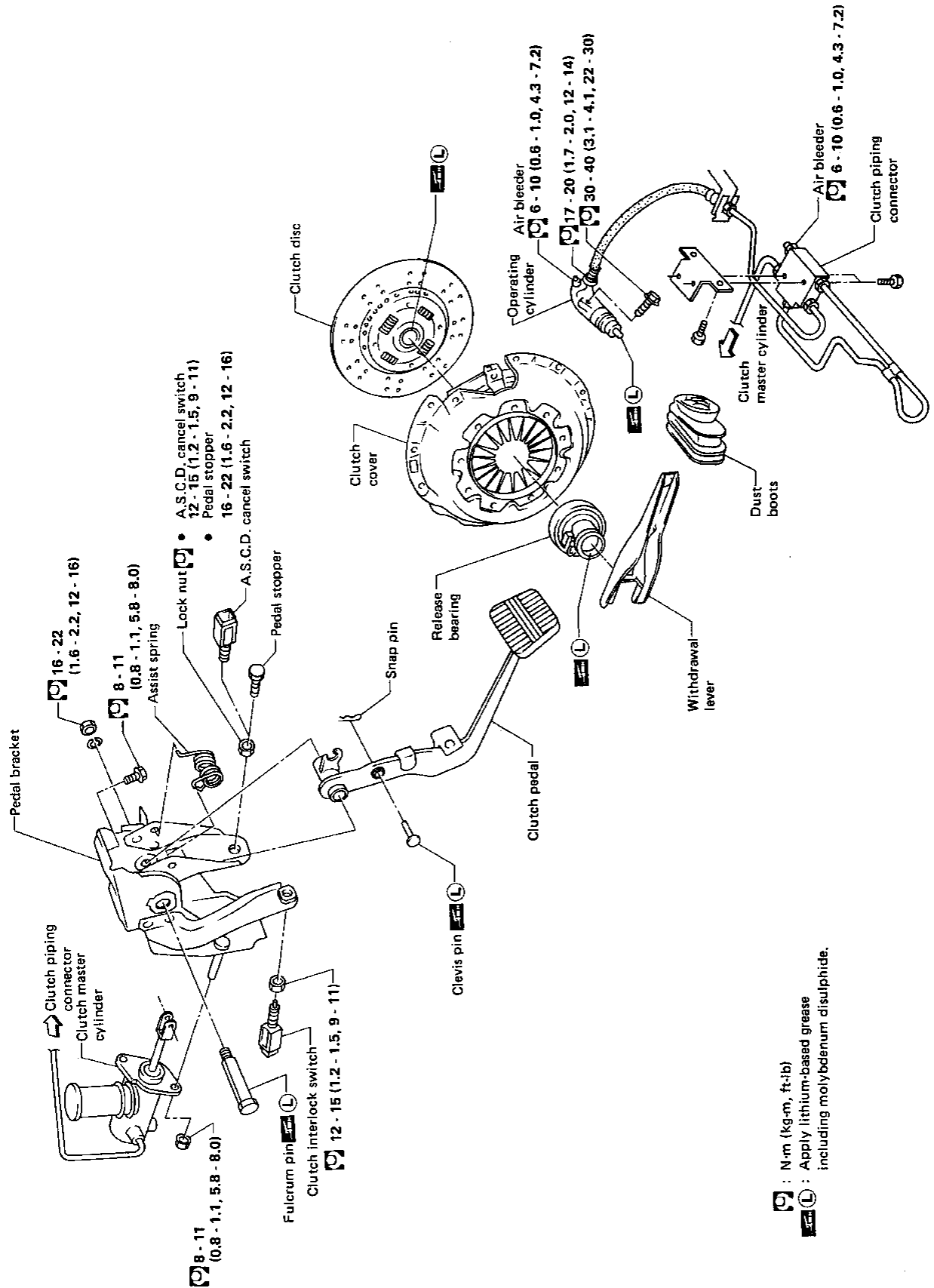

- GI
- MA
- EM
- LC
- EF & EC
- FE
- CL**
- MT
- AT
- PD
- FA
- RA
- BR
- ST
- BF
- HA
- EL

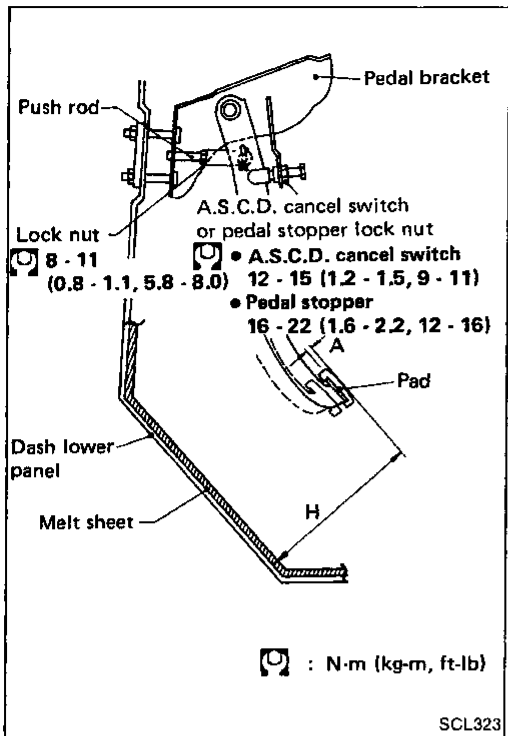

Adjusting Clutch Pedal

1. Adjust pedal height with pedal stopper or A.S.C.D. cancel switch.

Pedal height "H":
186 - 196 mm (7.32 - 7.72 in)

2. Adjust pedal free play with master cylinder push rod. Then tighten lock nut.

Pedal free play "A":
1.0 - 3.0 mm (0.039 - 0.118 in)

Pedal free play means the following total measured at position of pedal pad:

- **Play due to clevis pin and clevis pin hole in clutch pedal.**
3. Make sure that clevis pin can be rotated smoothly. If not, readjust pedal free play with master cylinder push rod.

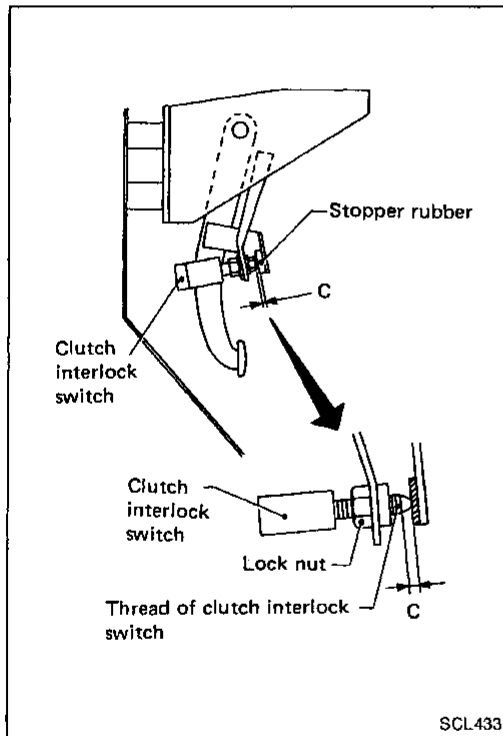

— U.S.A. model only —

3. Adjust clearance "C" between pedal stopper rubber and threaded end of clutch interlock switch while depressing clutch pedal fully.

Clearance C:
1.0 - 2.0 mm (0.039 - 0.079 in)

INSPECTION AND ADJUSTMENT

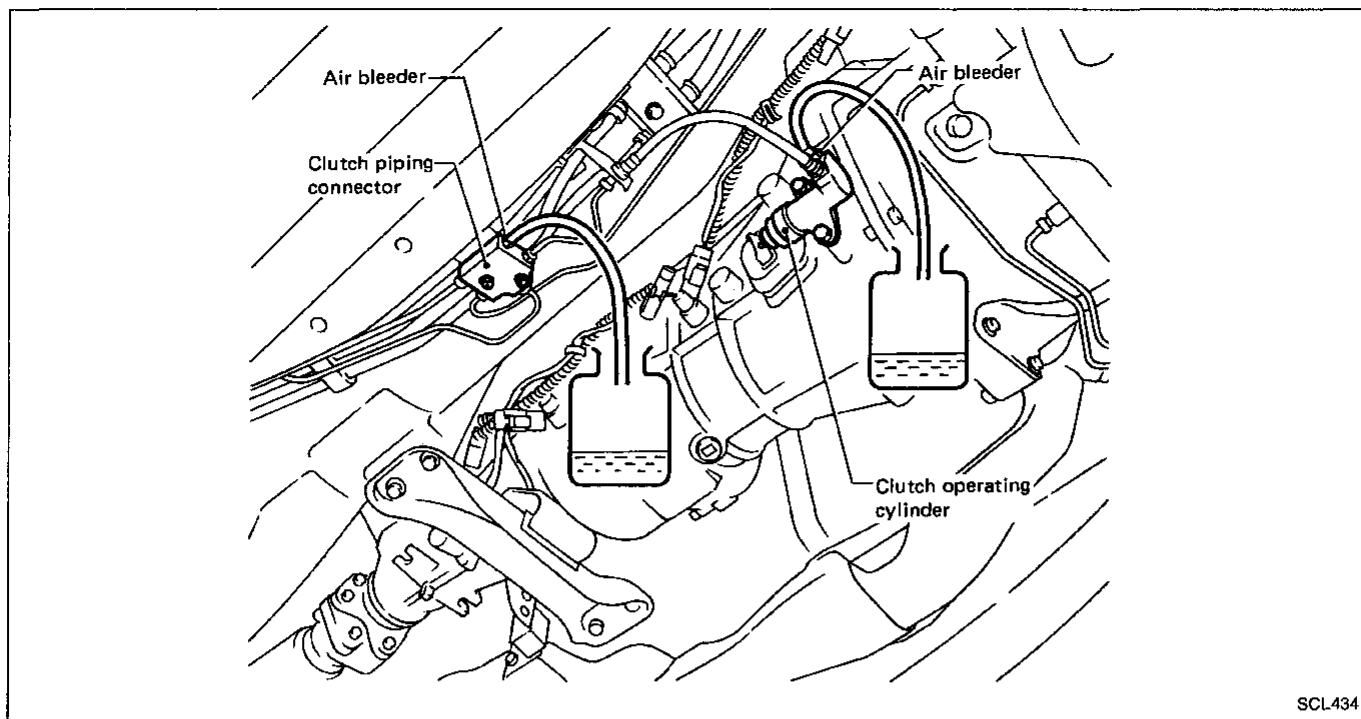

Bleeding Procedure

1. Bleed air from clutch operating cylinder according to the following procedure.

Carefully monitor fluid level at master cylinder during bleeding operation.

- a. Top up reservoir with recommended brake fluid.
 - b. Connect a transparent vinyl tube to air bleeder valve.
 - c. Fully depress clutch pedal several times.
 - d. With clutch pedal depressed, open bleeder valve to release air.
 - e. Close bleeder valve.
 - f. Repeat steps c through e above until brake fluid flows from air bleeder valve without air bubbles.
2. Bleed air from clutch piping connector according to the above same procedure.
 3. Repeat the above bleeding procedures 1 and 2 several times.

GI

MA

EM

LC

EF &
EC

FE

CL

MT

AT

PD

FA

RA

BR

ST

BF

HA

EL

Clutch Master Cylinder

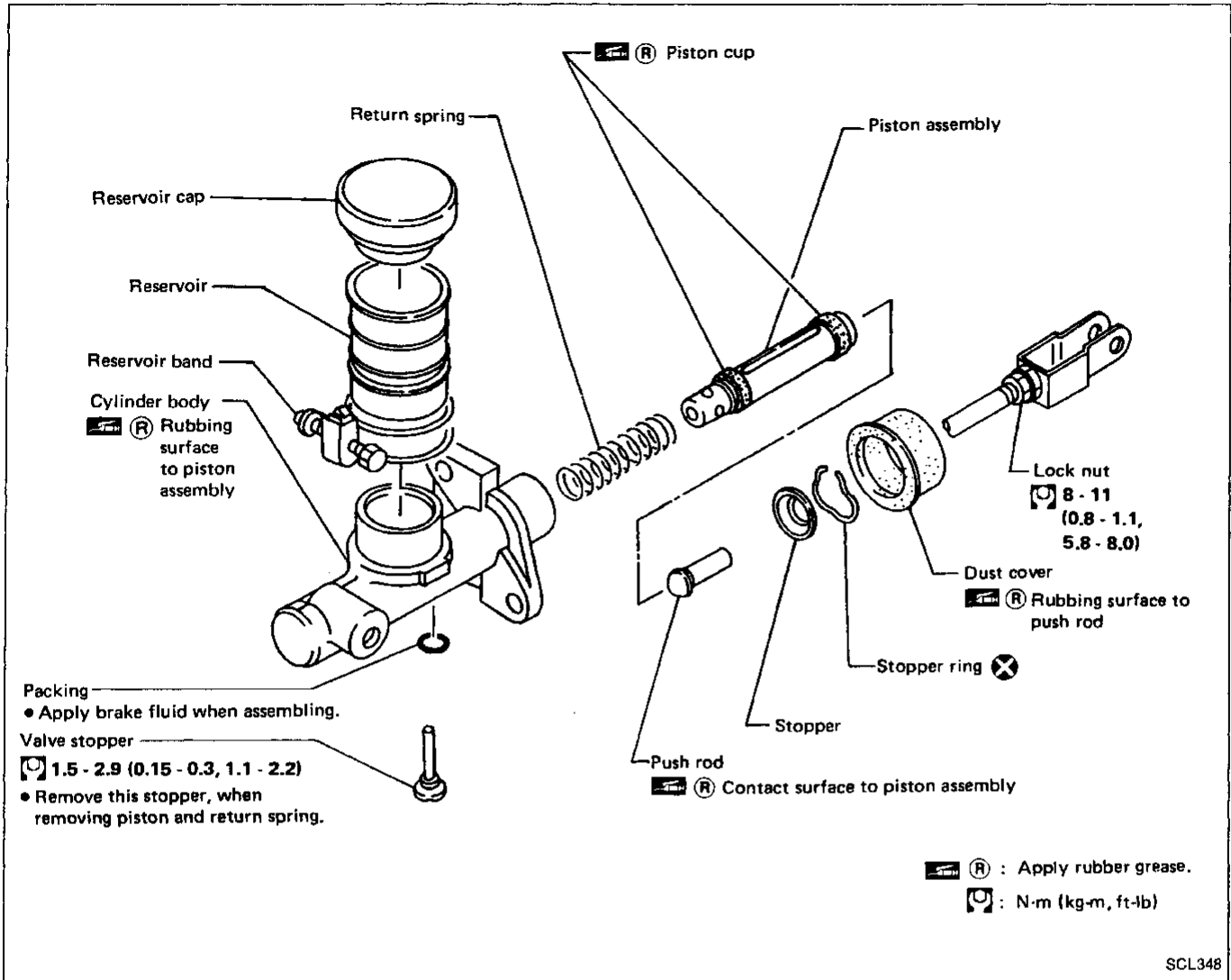

DISASSEMBLY AND ASSEMBLY

- Push piston into cylinder body with screwdriver when removing and installing valve stopper.

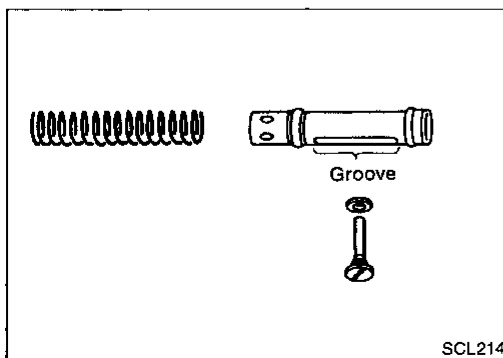

- Align groove of piston assembly and valve stopper when installing valve stopper.
- Check direction of piston cups.

HYDRAULIC CLUTCH CONTROL

Clutch Master Cylinder (Cont'd)

INSPECTION

- Check cylinder and piston rubbing surface for uneven wear, rust or damage. Replace if necessary.
- Check piston with piston cup for wear or damage. Replace if necessary.
- Check return spring for wear or damage. Replace if necessary.
- Check reservoir for deformation or damage. Replace if necessary.
- Check dust cover for cracks, deformation or damage. Replace if necessary.

Operating Cylinder

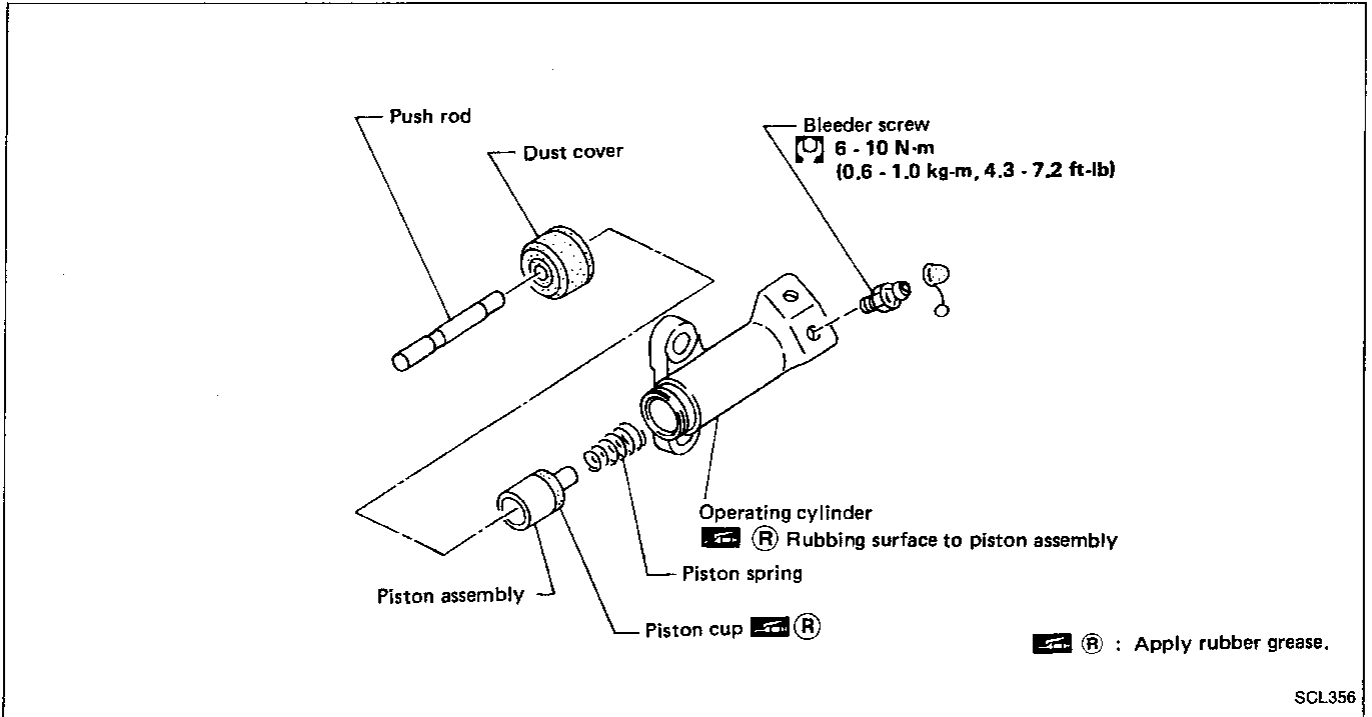

INSPECTION

- Check rubbing surface of cylinder for wear, rust or damage. Replace if necessary.
- Check piston with piston cup for wear or damage. Replace if necessary.
- Check piston spring for wear or damage. Replace if necessary.
- Check dust cover for cracks, deformation or damage. Replace if necessary.

CLUTCH RELEASE MECHANISM

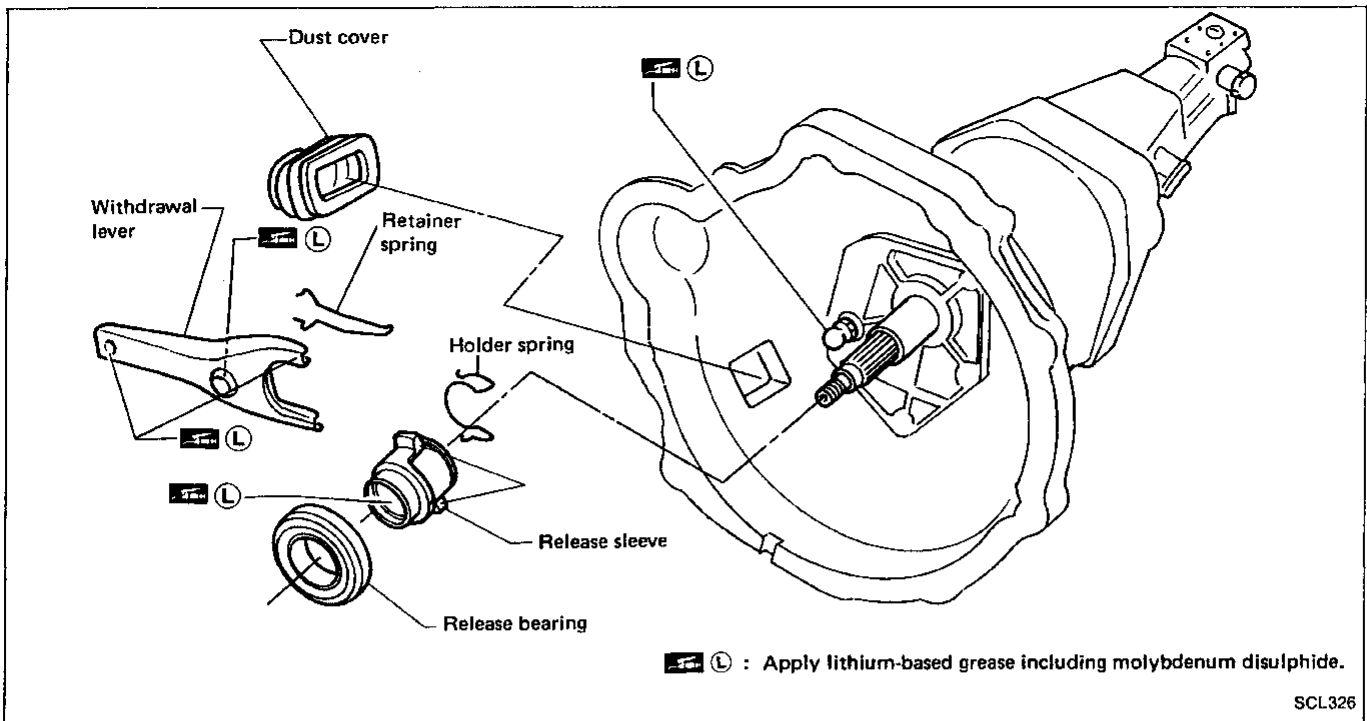

REMOVAL AND INSTALLATION

- Install retainer spring and holder spring.

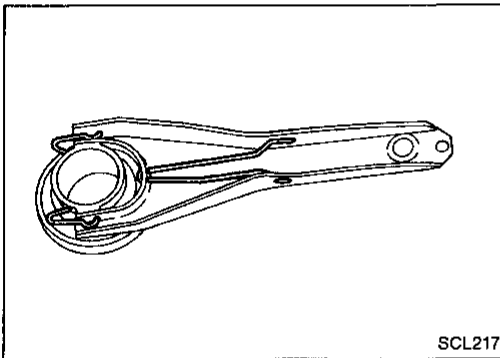

- Remove release bearing.

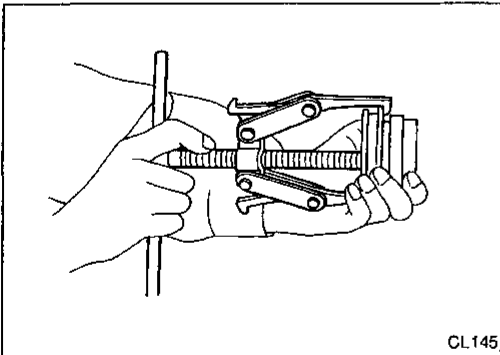

- Install release bearing with suitable drift.

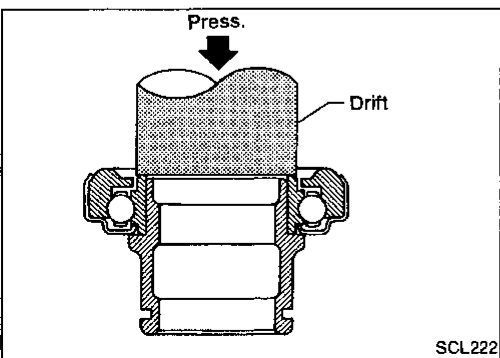

CLUTCH RELEASE MECHANISM

INSPECTION

- Check release bearing to see that it rolls freely and is free from noise, cracks, pitting or wear. Replace if necessary.
- Check release sleeve and withdrawal lever rubbing surface for wear, rust or damage. Replace if necessary.

GI

MA

EM

LC

EF &
EC

FE

CL

MT

AT

PD

FA

RA

BR

ST

BF

HA

EL

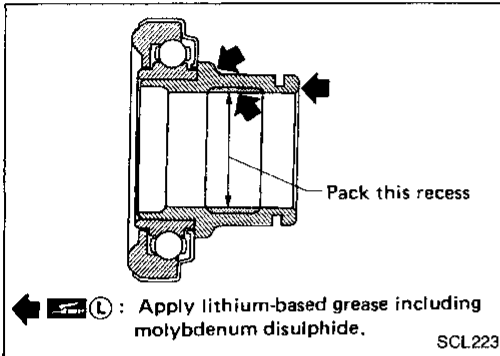

LUBRICATION

- Apply recommended grease to contact surface and rubbing surface.

Too much lubricant might damage clutch disc facing.

CLUTCH DISC AND CLUTCH COVER

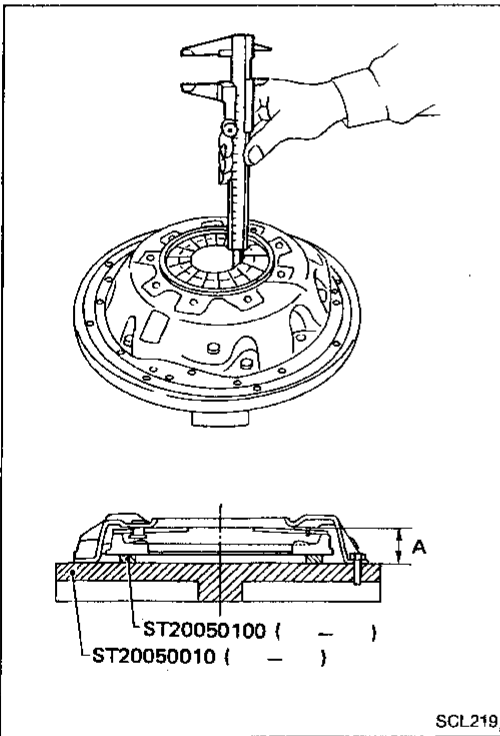
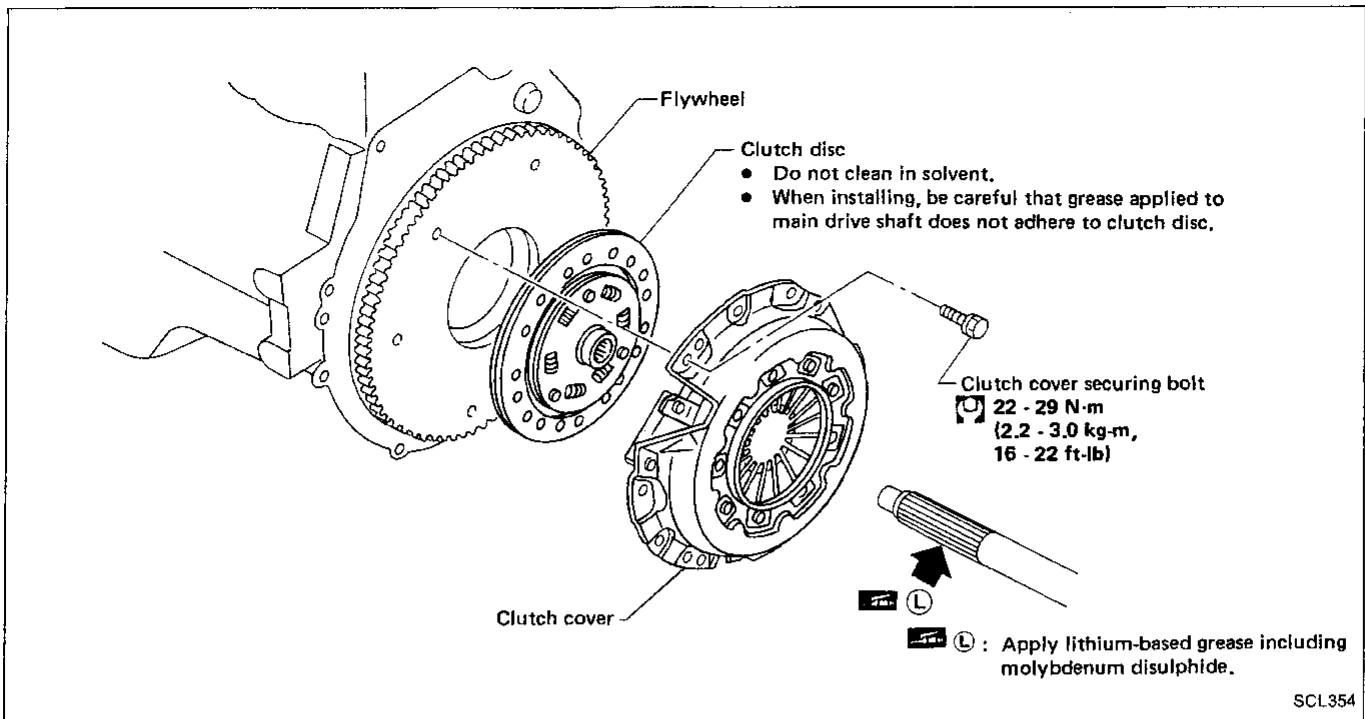

Clutch Cover and Flywheel

INSPECTION AND ADJUSTMENT

- Set Tool and check height and unevenness of diaphragm spring.

Diaphragm spring height "A":

33.0 - 35.0 mm (1.299 - 1.378 in)

- Check thrust rings for wear or damage by shaking cover assembly and listening for chattering noise, or lightly hammering on rivets for a slightly cracked noise. Replace clutch cover assembly if necessary.
- Check pressure plate and clutch disc contact surface for slight burns or discoloration. Repair pressure plate with emery paper.
- Check pressure plate and clutch disc contact surface for deformation or damage. Replace if necessary.

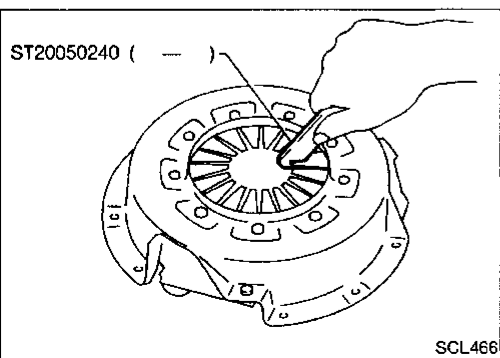

- Adjust unevenness of diaphragm spring with Tool.

Uneven limit:

0.7 mm (0.028 in)

CLUTCH DISC AND CLUTCH COVER

Clutch Cover and Flywheel (Cont'd)

FLYWHEEL INSPECTION

- Check contact surface of flywheel for slight burns or discoloration. Repair flywheel with emery paper.
- Check flywheel runout.

Runout (Total Indicator Reading):
Less than 0.15 mm (0.0059 in)

GI

MA

EM

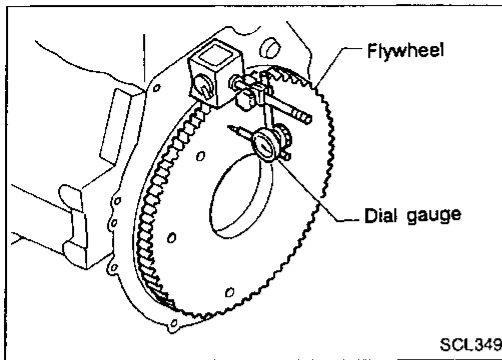

INSTALLATION

- Insert Tool into clutch disc hub when installing clutch cover and disc.

LC

EF &
EC

FE

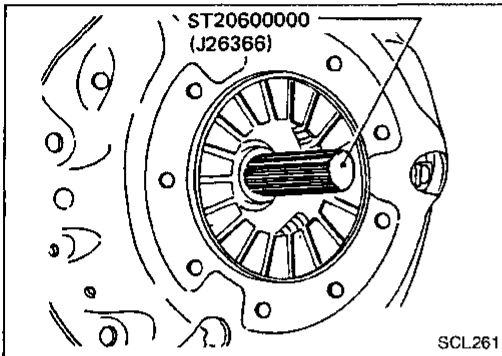

- Tighten clutch cover fixing bolts in numerical order by 2 steps.

Tightening torque:

First step 20 N·m (2.0 kg-m, 14 ft-lb)

Final step 22 - 29 N·m (2.2 - 3.0 kg-m, 16 - 22 ft-lb)

MT

AT

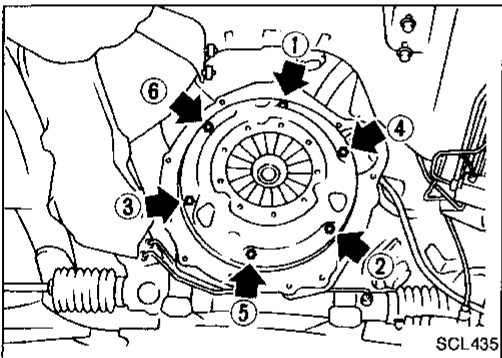

PD

FA

Clutch Disc

INSPECTION

- Check clutch disc for wear of facing.
 - Wear limit of facing surface to rivet head:**
0.3 mm (0.012 in)
- Check for backlash of spline and runout of facing.
 - Maximum backlash of spline (at outer edge of disc):**
0.9 mm (0.035 in)
 - Runout limit:**
1.0 mm (0.039 in)
 - Distance of runout check point (from hub center):**
107.5 mm (4.23 in)
- Check clutch disc for burns, discoloration or oil or grease leakage. Replace if necessary.

RA

BR

ST

BF

HA

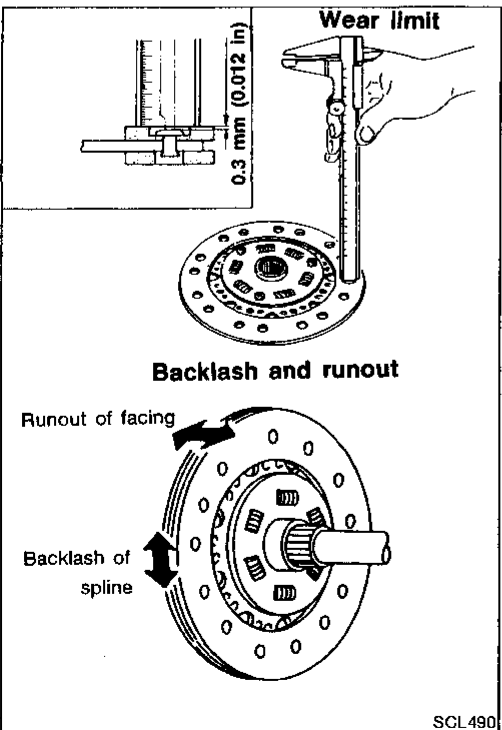

INSTALLATION

- Apply recommended grease to contact surface of spring portion.

EL

Too much lubricant might damage clutch disc facing.

SERVICE DATA AND SPECIFICATIONS (S.D.S.)

General Specifications

CLUTCH CONTROL SYSTEM

Type of clutch control	Hydraulic
------------------------	-----------

CLUTCH MASTER CYLINDER

Inner diameter	mm (in)	15.87 (5/8)
----------------	---------	-------------

CLUTCH OPERATING CYLINDER

Inner diameter	mm (in)	19.05 (3/4)
----------------	---------	-------------

CLUTCH DISC

Model	225LTD
Facing size (Outer dia. x inner dia. x thickness)	225 x 150 x 3.5 (8.86 x 5.91 x 0.138)
Thickness of disc assembly With load	7.6 - 8.0 (0.299 - 0.315) with 5,394 N (550 kg, 1,213 lb)

CLUTCH COVER

Model	C225S
Full load	N (kg, lb) 5,394 (550, 1,213)

Inspection and Adjustment

CLUTCH PEDAL

Unit: mm (in)

Pedal height "H"	186 - 196 (7.32 - 7.72)
Pedal free play (Backlash at clevis)	1.0 - 3.0 (0.039 - 0.118)
Clearance between pedal stopper rubber and threaded end of clutch interlock switch	1.0 - 2.0 (0.039 - 0.079)

*: Measured from surface of melt sheet to pedal pad

CLUTCH COVER

Unit: mm (in)

Model	C225S
Diaphragm spring height	33.0 - 35.0 (1.299 - 1.378)
Uneven limit of diaphragm spring toe height	0.7 (0.028)

CLUTCH DISC

Unit: mm (in)

Model	225LTD
Wear limit of facing surface to rivet head	0.3 (0.012)
Runout limit of facing	1.0 (0.039)
Distance of runout check point (from the hub center)	107.5 (4.23)
Maximum backlash of spline (at outer edge of disc)	0.9 (0.035)