

# MAINTENANCE

## SECTION MA

GI

MA

EM

LC

EF &amp;

EC

FE

CL

MT

AT

PD

FA

RA

BR

ST

BF

HA

EL

## CONTENTS

<b>GENERAL MAINTENANCE</b> .....	2	Changing M/T Oil .....	13
<b>PERIODIC MAINTENANCE</b> .....	4	Checking A/T Fluid .....	13
Schedule 1 .....	5	Changing A/T Fluid .....	14
Schedule 2 .....	6	Checking Differential Gear Oil .....	14
<b>RECOMMENDED LUBRICANTS AND FLUIDS</b> .....	7	Changing Differential Gear Oil .....	14
Lubricants and Fluids .....	7	Balancing Wheels .....	14
SAE Viscosity Number .....	7	Tire Rotation .....	14
<b>ENGINE MAINTENANCE</b> .....	8	Checking Brake Fluid Level and Leaks .....	15
Checking Drive Belts .....	8	Checking Brake Lines and Cables .....	15
Changing Engine Coolant .....	9	Checking Disc Brake .....	15
Checking Fuel Lines .....	10	Checking Steering Gear and Linkage .....	15
Changing Fuel Filter .....	10	Checking Power Steering Fluid and Lines .....	16
Changing Air Cleaner Filter .....	11	Checking SUPER HICAS Linkage (With SUPER	
Changing Engine Oil .....	11	HICAS system) .....	16
Changing Oil Filter .....	12	Lubricating Locks, Higes and Hood Latches .....	17
Changing Spark Plugs .....	12	Checking Ssat Belts, Buckles, Retractors,	
Checking Vapor Lines .....	12	Anchors and Adjusters .....	17
<b>CHASSIS AND BODY MAINTENANCE</b> .....	13	<b>SERVICE DATA AND SPECIFICATIONS (S.D.S.)</b> .....	18
Checking Exhaust System .....	13	Engine Maintenance .....	18
Checking Clutch Fluid Level and Leaks .....	13	Chassis and Body Maintenance .....	18
Checking M/T Oil .....	13		

## GENERAL MAINTENANCE

General maintenance includes those items which should be checked during the normal day-to-day operation of the vehicle. They are essential if the vehicle is to continue operating properly. The owners can perform the checks and inspections themselves or they can have their NISSAN dealers do them.

Item	Reference page
<b>OUTSIDE THE VEHICLE</b>	
The maintenance items listed here should be performed from time to time, unless otherwise specified.	
<b>Tires</b> Check the pressure with a gauge periodically when at a service station, including the spare, and adjust to the specified pressure if necessary. Check carefully for damage, cuts or excessive wear.	—
<b>Wheel nuts</b> When checking the tires, make sure no nuts are missing, and check for any loose nuts. Tighten if necessary.	—
<b>Tire rotation</b> Tires should be rotated every 12,000 km (7,500 miles).	MA-14
<b>Wheel alignment and balance</b> If the vehicle should pull to either side while driving on a straight and level road, or if you detect uneven or abnormal tire wear, there may be a need for wheel alignment. If the steering wheel or seat vibrates at normal highway speeds, wheel balancing may be needed.	MA-14 FA-5
<b>Windshield wiper blades</b> Check for cracks or wear if they do not wipe properly.	—
<b>Doors and engine hood</b> Check that all doors and the engine hood operate smoothly as well as the trunk lid and back hatch. Also ensure, that all latches lock securely. Lubricate hinges, latches, rollers and links if necessary. Make sure that the secondary latch keeps the hood from opening when the primary latch is released. When driving in areas using road salt or other corrosive materials, check lubrication frequently.	MA-17
<b>INSIDE THE VEHICLE</b>	
The maintenance items listed here should be checked on a regular basis, such as when performing periodic maintenance, cleaning the vehicle, etc.	
<b>Lights</b> Make sure that the headlights, stop lights, tail lights, turn signal lights, and other lights are all operating properly and installed securely. Also check headlight aim.	—
<b>Warning lights and buzzers/chimes</b> Make sure that all warning lights and buzzers/chimes are operating properly.	—
<b>Windshield wiper and washer</b> Check that the wipers and washer operate properly and that the wipers do not streak.	—
<b>Windshield defroster</b> Check that the air comes out of the defroster outlets properly and in sufficient quantity when operating the heater or air conditioner.	—
<b>Steering wheel</b> Check that it has the specified free play. Be sure to check for changes in the steering condition, such as excessive free play, hard steering or strange noises. <b>Free play: Less than 35 mm (1.38 in)</b>	—
<b>Seats</b> Check seat position controls such as seat adjusters, seatback recliner, etc. to ensure they operate smoothly and that all latches lock securely in every position. Check that the head restraints move up and down smoothly and that the locks (if so equipped) hold securely in all latched positions. Check that the latches lock securely for folding-down rear seatbacks.	—
<b>Seat belts</b> Check that all parts of the seat belt system (e.g. buckles, anchors, adjusters and retractors) operate properly and smoothly, and are installed securely. Check the belt webbing for cuts, fraying, wear or damage.	MA-17

## GENERAL MAINTENANCE

Item	Reference page	
<b>Clutch pedal</b> Make sure the pedal operates smoothly and check that it has the proper free travel.	CL-4	
<b>Brakes</b> Check that the brake does not pull the vehicle to one side when applied.	—	GI
<b>Brake pedal</b> Check the pedal for smooth operation and make sure it has the proper distance under it when depressed fully. Check the brake booster function. Be certain to keep floor mats away from the pedal.	BR-7, 8	MA
<b>Parking brake</b> Check that the lever has the proper travel and confirm that your vehicle is held securely on a fairly steep hill with only the parking brake applied.	BR-19	EM
<b>Automatic transmission "Park position" mechanism</b> Check that the lock release button on the selector lever operates properly and smoothly. On a fairly steep hill check that your vehicle is held securely with the selector lever in the "P" position without applying any brakes.	—	LC
<b>UNDER THE HOOD AND VEHICLE</b>		
The maintenance items listed here should be checked periodically (e.g. each time you check the engine oil or refuel).		
<b>Windshield washer fluid</b> Check that there is adequate fluid in the tank.	—	EF & EC
<b>Engine coolant level</b> Check the coolant level when the engine is cold.	MA-10	FE
<b>Radiator and hoses</b> Check the front of the radiator and clean off any dirt, insects, leaves, etc., that may have accumulated. Make sure the hoses have no cracks, deformation, rot or loose connections.	—	CL
<b>Brake and clutch fluid levels</b> Make sure that the brake and clutch fluid levels are between the "MAX" and "MIN" lines on the reservoir.	MA-13, 15	MT
<b>Battery</b> Check the fluid level in each cell. It should be between the "MAX" and "MIN" lines.	—	AT
<b>Engine drive belts</b> Make sure that no belt is frayed, worn, cracked or oily.	MA-8	
<b>Engine oil level</b> Check the level on the dipstick after parking the vehicle on a level spot and turning off the engine.	MA-11	PD
<b>Power steering fluid level and lines</b> Check the level when the fluid is cold and the engine is turned off. Check the lines for proper attachment, leaks, cracks, etc.	MA-16	FA
<b>Automatic transmission fluid level</b> Check the level on the dipstick after putting the selector lever in "P" with the engine idling.	MA-13	RA
<b>Exhaust system</b> Make sure there are no loose supports, cracks or holes. If the sound of the exhaust seems unusual or there is a smell of exhaust fumes, immediately locate the trouble and correct it.	MA-13	BR
<b>Underbody</b> The underbody is frequently exposed to corrosive substances such as those used on icy roads or to control dust. It is very important to remove these substances, otherwise rust will form on the floor pan, frame, fuel lines and around the exhaust system. At the end of winter, the underbody should be thoroughly flushed with plain water, being careful to clean those areas where mud and dirt can easily accumulate.	—	ST
<b>Fluid leaks</b> Check under the vehicle for fuel, oil, water or other fluid leaks after the vehicle has been parked for a while. Water dripping from the air conditioner after use is normal. If you should notice any leaks or gasoline fumes are evident, check for the cause and correct it immediately.	—	BF
		HA
		EL

## **PERIODIC MAINTENANCE**

---

Two different maintenance schedules are provided, and should be used, depending upon the conditions in which the vehicle is mainly operated. **After 60,000 miles (96,000 km) or 48 months, continue the periodic maintenance at the same mileage/time intervals.**

### **SCHEDULE 1**

Follow Periodic Maintenance Schedule 1 if your driving habits frequently includes one or more of the following driving conditions:

- Repeated short trips of less than 5 miles (8 km).
- Repeated short trips of less than 10 miles (16 km) with outside temperatures remaining below freezing.
- Operating in hot weather in stop-and-go “rush hour” traffic.
- Extensive idling and/or low speed driving for long distances, such as police, taxi or door-to-door delivery use.
- Driving in dusty conditions.
- Driving on rough, muddy, or salt spread roads.
- Towing a trailer, using a camper or a car-top carrier.

### **SCHEDULE 2**

Follow Periodic Maintenance Schedule 2 if none of the driving conditions shown in Schedule 1 apply to your driving habits.

# PERIODIC MAINTENANCE

## Schedule 1

Abbreviations: R = Replace I = Inspect. Correct or replace if necessary. [ ] : At the mileage intervals only

MAINTENANCE OPERATION	MAINTENANCE INTERVAL												Reference page				
Perform at number of miles, kilometers or months, whichever comes first.	3.75	7.5	11.25	15	18.75	22.5	26.25	30	33.75	37.5	41.25	45	48.75	52.5	56.25	60	
Miles x 1,000	(6)	(12)	(18)	(24)	(30)	(36)	(42)	(48)	(54)	(60)	(66)	(72)	(78)	(84)	(90)	(96)	
Months	3	6	9	12	15	18	21	24	27	30	33	36	39	42	45	48	
<b>Emission control system maintenance</b>																	
Drive belts	See NOTE (1)															I*	MA-8
Air cleaner filter	See NOTE (2)															[R]	MA-11
Vapor lines	I*															I*	MA-12
Fuel lines	I*															I*	MA-10
Fuel filter	See NOTE (3)*																MA-10
Engine coolant	See NOTE (4)															R*	MA-9
Engine oil	R	R	R	R	R	R	R	R	R	R	R	R	R	R	R	R	MA-11
Engine oil filter (Use Nissan PREMIUM type or equivalent.)	R	R	R	R	R	R	R	R	R	R	R	R	R	R	R	R	MA-12
Spark plugs	[R]															[R]	MA-13
Intake & exhaust valve clearances	See NOTE (5)*																EM-28
<b>Chassis and body maintenance</b>																	
Brake lines & cables	I	I	I	I	I	I	I	I	I	I	I	I	I	I	I	I	MA-15
Brake pads & discs	I	I	I	I	I	I	I	I	I	I	I	I	I	I	I	I	MA-15
Manual and automatic transmission oil, & differential gear oil	See NOTE (6)															I	MA-13, 14
Steering gear & linkage, axle & suspension parts	I	I	I	I	I	I	I	I	I	I	I	I	I	I	I	I	MA-15, FA-5, RA-4
Steering linkage ball joints & front suspension ball joints	I	I	I	I	I	I	I	I	I	I	I	I	I	I	I	I	MA-15, FA-5
SUPER HICAS linkage	I	I	I	I	I	I	I	I	I	I	I	I	I	I	I	I	MA-16
Exhaust system	I	I	I	I	I	I	I	I	I	I	I	I	I	I	I	I	MA-13

**NOTE: (1)** After 60,000 miles (96,000 km) or 48 months, inspect every 15,000 miles (24,000 km) or 12 months.  
**(2)** If operating mainly in dusty conditions, more frequent maintenance may be required.  
**(3)** If vehicle is operated under extremely adverse weather conditions or in areas where ambient temperatures are either extremely low or extremely high, the filters might become clogged. In such an event, replace them immediately.  
**(4)** After 60,000 miles (96,000 km) or 48 months, replace every 30,000 miles (48,000 km) or 24 months.  
**(5)** If valve noise increases, inspect valve clearances.  
**(6)** If towing a trailer, using a camper or a car-top carrier, or driving on rough or muddy roads, change (not just inspect) oil at every 30,000 miles (48,000 km) or 24 months.  
**(7)** Maintenance items and intervals with "\*" are recommended by NISSAN for reliable vehicle operation. The owner need not perform such maintenance in order to maintain the emission warranty or manufacturer recall liability. Other maintenance items and intervals are required.

# PERIODIC MAINTENANCE

## Schedule 2

Abbreviations: R = Replace I = Inspect. Correct or replace if necessary. [ ]: At the mileage intervals only

MAINTENANCE OPERATION	MAINTENANCE INTERVAL								Reference page	
	Miles x 1,000 (km x 1,000)	7.5 (12)	15 (24)	22.5 (36)	30 (48)	37.5 (60)	45 (72)	52.5 (84)		
Perform at number of miles, kilometers or months, whichever comes first.	Months	6	12	18	24	30	36	42	48	
<b>Emission control system maintenance</b>										
Drive belts	See NOTE (1)								I*	MA-8
Air cleaner filter					[R]				[R]	MA-11
Vapor lines					I*				I*	MA-12
Fuel lines					I*				I*	MA-10
Fuel filter	See NOTE (2)*									MA-10
Engine coolant	See NOTE (3)								R*	MA-9
Engine oil		R	R	R	R	R	R	R	R	MA-11
Engine oil filter (Use Nissan PREMIUM type or equivalent.)			R		R	R	R	R	R	MA-12
Spark plugs					[R]				[R]	MA-13
Intake & exhaust valve clearances	See NOTE (4)*									EM-28
<b>Chassis and body maintenance</b>										
Brake lines & cables		I	I	I	I	I	I	I	I	MA-15
Brake pads & discs			I		I		I		I	MA-15
Manual and automatic transmission oil, & differential gear oil			I		I		I		I	MA-13, 14
Steering gear linkage, axle & suspension parts					I				I	MA-15, FA-5, RA-4
SUPER HICAS linkage					I				I	MA-16
Exhaust system									I	MA-13

**NOTE:** (1) After 60,000 miles (96,000 km) or 48 months, inspect every 15,000 miles (24,000 km) or 12 months.  
 (2) If vehicle is operated under extremely adverse weather conditions or in areas where ambient temperatures are either extremely low or extremely high, the filters might become clogged. In such an event, replace them immediately.  
 (3) After 60,000 miles (96,000 km) or 48 months, replace every 30,000 miles (48,000 km) or 24 months.  
 (4) If valve noise increases, inspect valve clearances.  
 (5) Maintenance items and intervals with "\*" are recommended by NISSAN for reliable vehicle operation. The owner need not perform such maintenance in order to maintain the emission warranty or manufacturer recall liability. Other maintenance items and intervals are required.

# RECOMMENDED LUBRICANTS AND FLUIDS

## Lubricants and Fluids

	Capacity (Approximate)			Recommended lubricants and fluids
	US measure	Imp measure	Liter	
Engine oil (Refill)				
With oil filter	4 qt	3-3/8 qt	3.8	Energy Conserving Oils of API SG*2, *3
Without oil filter	3-3/4 qt	3-1/8 qt	3.5	
Cooling system (with reservoir tank)	7-1/8 qt	5-7/8 qt	6.7	Anti-freeze coolant (Ethylene glycol base)
Manual transmission oil	5-1/8 pt	4-1/4 pt	2.4	API GL-4*2
Differential gear oil				
R200	2-3/4 pt	2-1/4 pt	1.3	API GL-5*2
R200V	3-1/8 pt	2-5/8 pt	1.5	
Automatic transmission fluid	8-3/4 qt	7-1/4 qt	8.3	Genuine Nissan ATF*1 or equivalent Type DEXRON II™
Power steering fluid	—	—	—	Type DEXRON II™ or equivalent
Brake fluid	—	—	—	Genuine Nissan Brake Fluid*1 or equivalent DOT 3 (US FMVSS No. 116)
Multi-purpose grease	—	—	—	NLGI No. 2 (Lithium soap base)

\*1: Available in mainland U.S.A. through your Nissan dealer.

\*2: For further details, see "SAE Viscosity Number".

\*3: Energy Conserving Oils

These oils can be identified by such labels as EC-I, EC-II, energy conserving, energy saving, improved fuel economy, etc.

### SAE Viscosity Number

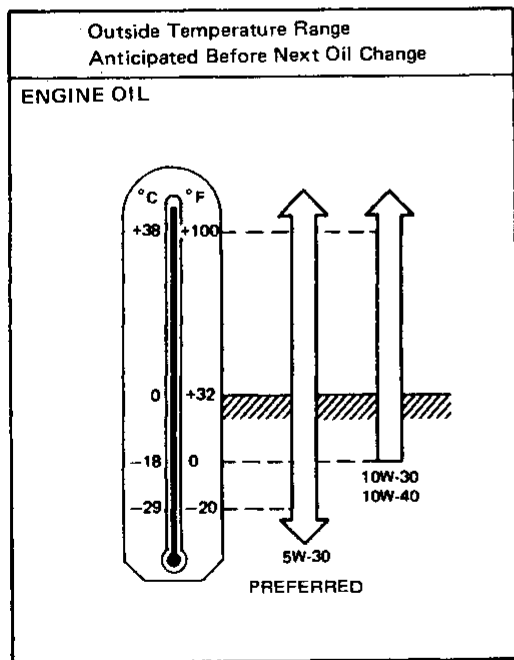

**5W-30 is preferable for all ambient temperatures. 20W-40 and 20W-50 are usable if the ambient temperature is above 10°C (50°F) for all seasons.**

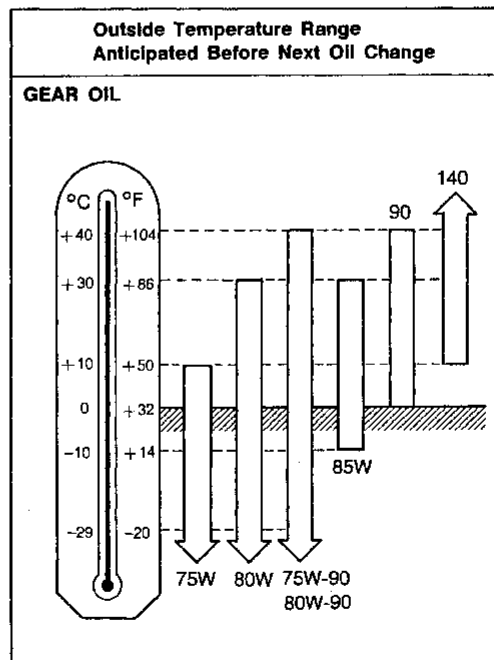

**75W-90 for the transmission and 80W-90 for the differential are preferable if the ambient temperature is below 40°C (104°F).**

## Checking Drive Belts

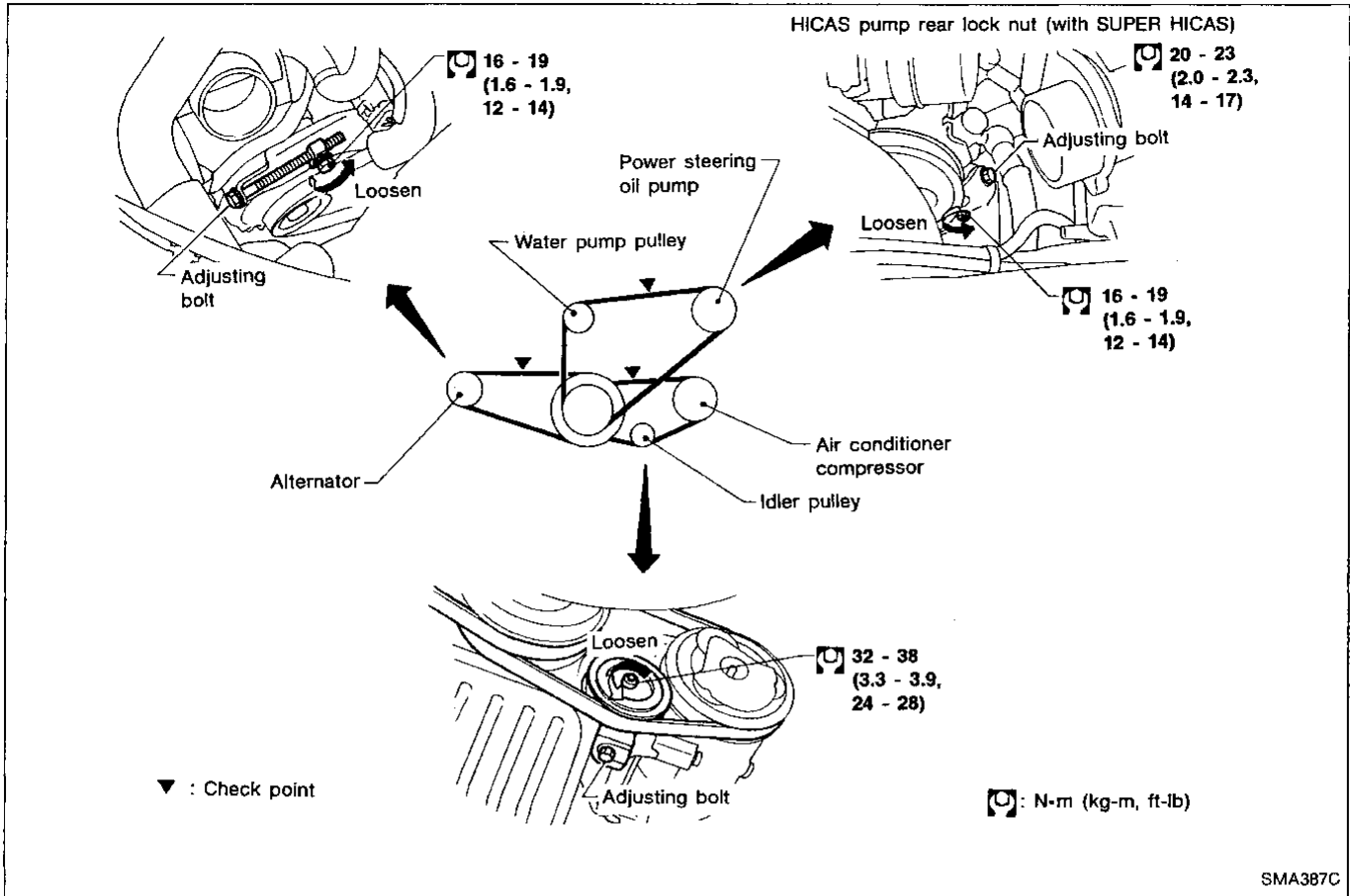

1. Inspect for cracks, fraying, wear or oil adhesion. If necessary, replace with a new one.
2. Inspect drive belt deflections by pushing on the belt midway between pulleys.

**Adjust if belt deflections exceed the limit.**

**Belt deflection:**

**Inspect drive belt deflections when engine is cold.**

Unit: mm (in)

	Used belt deflection		Deflection of new belt
	Limit	Deflection after adjustment	
Alternator	11 (0.43)	7 - 8 (0.28 - 0.31)	6 - 7 (0.24 - 0.28)
Air conditioner compressor	12 (0.47)	7.5 - 8.5 (0.295 - 0.335)	6.5 - 7.5 (0.256 - 0.295)
Power steering oil pump			
Without SUPER HICAS	13 (0.51)	7.5 - 8.5 (0.295 - 0.335)	6.5 - 7.5 (0.256 - 0.295)
With SUPER HICAS	9 (0.35)	6.5 - 7.5 (0.256 - 0.295)	5.5 - 6.5 (0.217 - 0.256)
Applied pushing force	98 N (10 kg, 22 lb)		



## Changing Engine Coolant

### WARNING:

To avoid being scalded, never change the coolant when the engine is hot.

1. Move heater "TEMP" control lever all the way to "HOT" position.
2. Remove undercover.

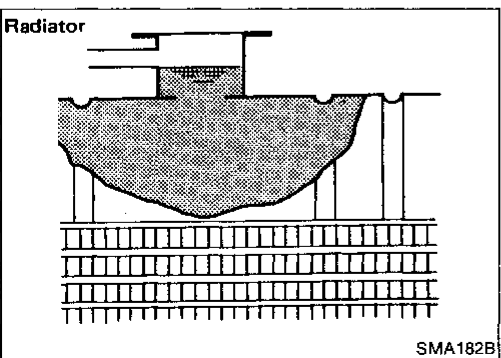
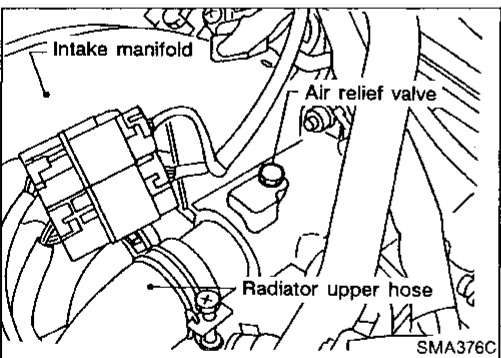
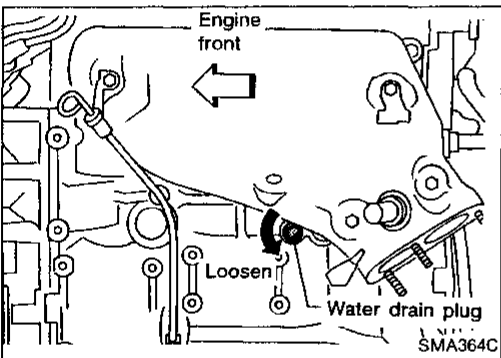
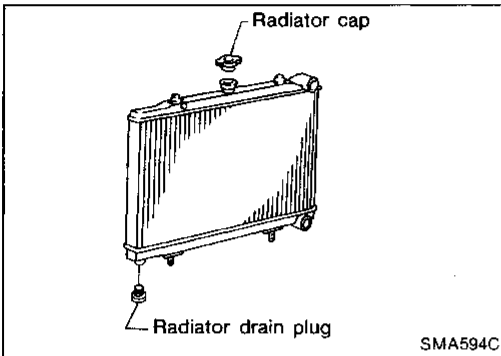
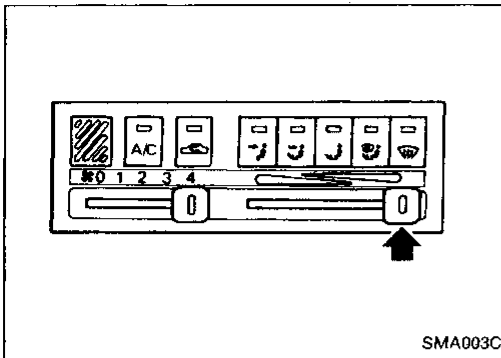

3. Open drain plug at the bottom of radiator, and remove radiator cap.

4. Remove drain plug on cylinder block.
5. Close drain plug and tighten drain plug securely.

- Apply sealant to the thread of drain plug.

Ⓜ: 34 - 44 N·m

(3.5 - 4.5 kg-m, 25 - 33 ft-lb)

6. Open air relief plug.
7. Fill radiator with water and close air relief plug and radiator cap.
8. Run engine and warm it up sufficiently.
9. Race engine 2 or 3 times under no-load.
10. Stop engine and wait until it cools down.
11. Repeat step 2 through step 9 until clear water begins to drain from radiator.
12. Drain water.

13. Open radiator cap and air relief plug.
14. Fill radiator with coolant up to specified level. Follow instructions attached to anti-freeze container for mixing ratio of anti-freeze to water.

**Coolant capacity (With reservoir tank):**

6.7 ℓ (7-1/8 US qt, 5-7/8 Imp qt)

**Pour coolant through coolant filler neck slowly to allow air in system to escape.**

GI

MA

EM

LC

EF &  
EC

FE

CL

MT

AT

PD

FA

RA

BR

ST

BF

HA

EL

## ENGINE MAINTENANCE

### Changing Engine Coolant (Cont'd)

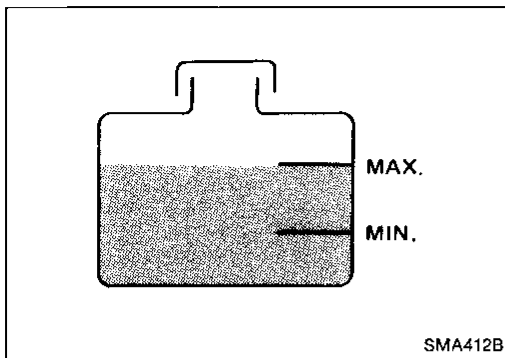

15. Close air relief plug.
16. Remove reservoir tank, drain coolant, then clean reservoir tank.
17. Install reservoir tank and fill it with coolant up to "MAX" level and then install radiator cap.
18. Run engine and warm it up sufficiently.
19. Race engine 2 or 3 times under no-load.
20. Stop engine and cool it down, then add coolant as necessary.

### Checking Fuel Lines

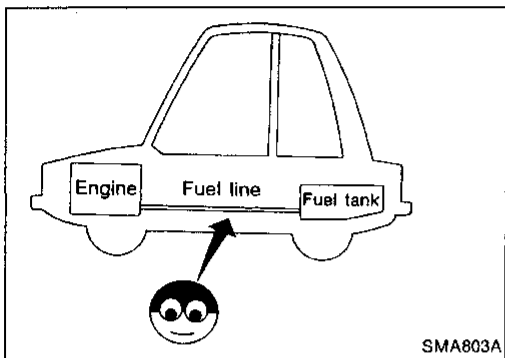

Inspect fuel lines and tank for improper attachment and for leaks, cracks, damage, loose connections, chafing and deterioration.

If necessary, repair or replace faulty parts.

### Changing Fuel Filter

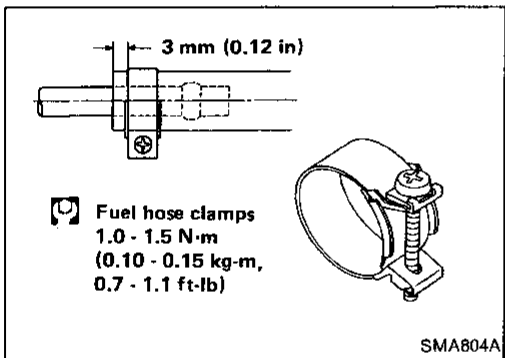

#### CAUTION:

Tighten high-pressure rubber hose clamp so that clamp end is 3 mm (0.12 in) from hose end.

Ensure that screw does not contact adjacent parts.

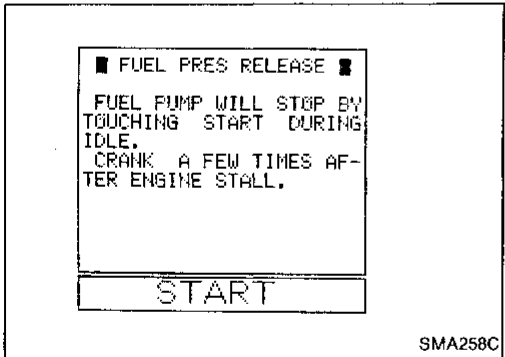

#### WARNING:

Before removing fuel filter, release fuel pressure from fuel line.

1. Start engine.
2. Perform "FUEL PRESSURE RELEASE" in "WORK SUPPORT" mode to release fuel pressure to zero.
3. After engine stalls, crank engine two or three times to make sure that fuel pressure is released.
4. Turn ignition switch off.

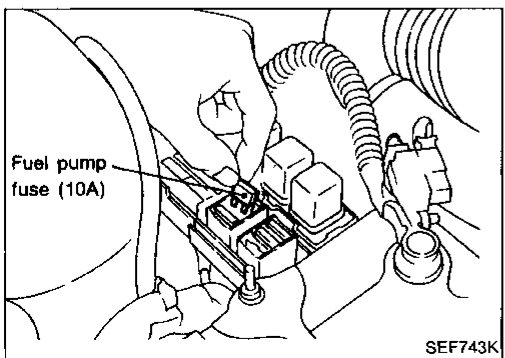

1. Remove fuse for fuel pump.
2. Start engine.
3. After engine stalls, crank engine two or three times to make sure that fuel pressure is released.
4. Turn ignition switch off and install fuse for fuel pump.

# ENGINE MAINTENANCE

## Changing Fuel Filter (Cont'd)

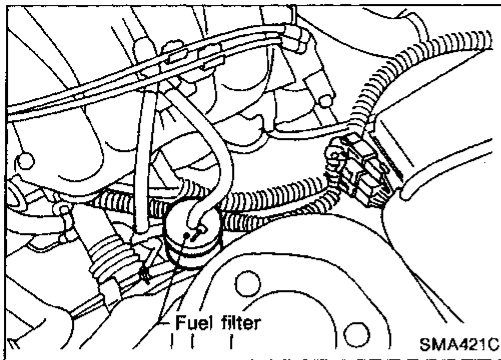

5. Loosen fuel hose clamps.
  6. Replace fuel filter.
- Be careful not to spill fuel over engine compartment. Place a shop towel to absorb fuel.
  - Use a high-pressure type fuel filter. Do not use a synthetic resinous fuel filter.
  - When tightening fuel hose clamps, refer to "Checking Fuel Lines".

GI

MA

EM

## Changing Air Cleaner Filter

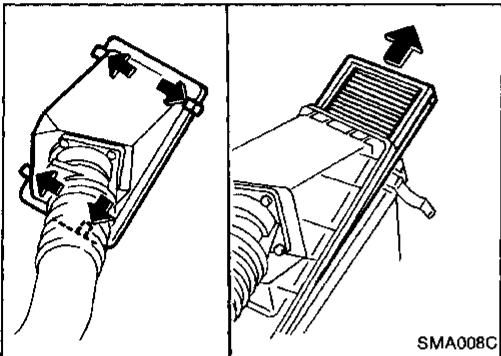

The viscous paper type filter does not need cleaning between renewals.

LC

EF &  
EC

FE

CL

## Changing Engine Oil

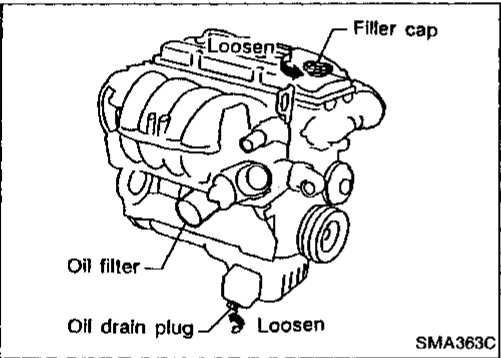

### WARNING:

Be careful not to burn yourself, as the engine oil is hot.

1. Warm up engine, and check for oil leakage from engine components.
2. Remove drain plug and oil filler cap.
3. Drain oil and refill with new engine oil.

Oil grade: API SG

Viscosity: See MA-7.

Refill oil capacity (Approximately):

With oil filter change

3.8 ℓ (4 US qt, 3-3/8 Imp qt)

Without oil filter change

3.5 ℓ (3-3/4 US qt, 3-1/8 Imp qt)

### CAUTION:

- Be sure to clean drain plug and install with new washer.  
Drain plug:  
[ ]: 29 - 39 N·m  
(3.0 - 4.0 kg-m, 22 - 29 ft-lb)
- The refill capacity changes depending on the oil temperature and drain time; use these values as a reference and be certain to check with the dipstick when changing the oil.

MT

AT

PD

FA

RA

BR

ST

BF

HA

EL

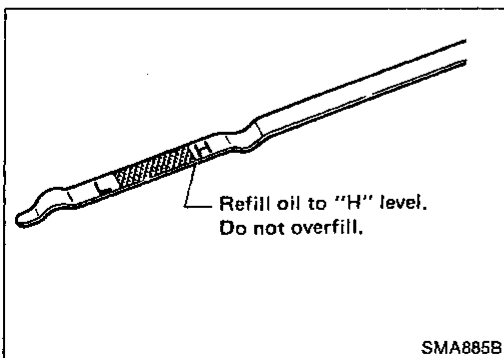

4. Check oil level.
5. Start engine and check area around drain plug and oil filter for oil leakage.
6. Run engine for a few minutes, then turn it off. After several minutes, check oil level.

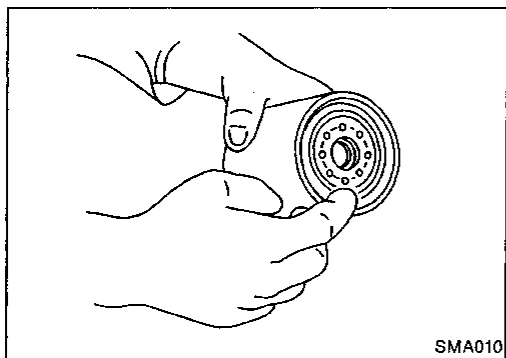

## Changing Oil Filter

1. Remove oil filter with a suitable tool.

### WARNING:

**Be careful not to burn yourself, as the engine and the engine oil are hot.**

2. Before installing new oil filter, clean the oil filter mounting surface on cylinder block, and coat the rubber seal of oil filter with a little engine oil.

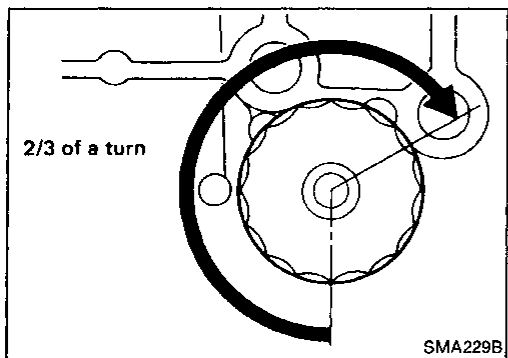

3. Screw in the oil filter until a slight resistance is felt, then tighten additionally more than 2/3 turn.
4. Add engine oil.

**Refer to Changing Engine Oil.**

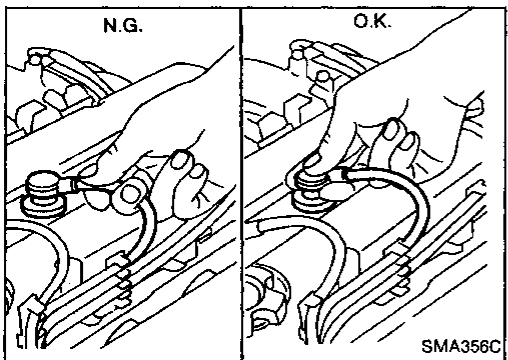

## Changing Spark Plugs

1. Disconnect ignition wires from spark plugs at boot. Do not pull on the wire.
2. Remove spark plugs with 16 mm (0.63 in) spark plug wrench.

### Spark plug:

**Standard type**

**BKR5E-11**

**Cold type**

**BKR6E-11**

**BKR7E-11**

3. Check plug gap of each new spark plug.  
**Gap: 1.0 - 1.1 mm (0.039 - 0.043 in)**
4. Install spark plugs. Reconnect ignition wires according to Nos. indicated on them.

### Spark plug:

**⊗: 20 - 29 N·m**

**(2.0 - 3.0 kg-m, 14 - 22 ft-lb)**

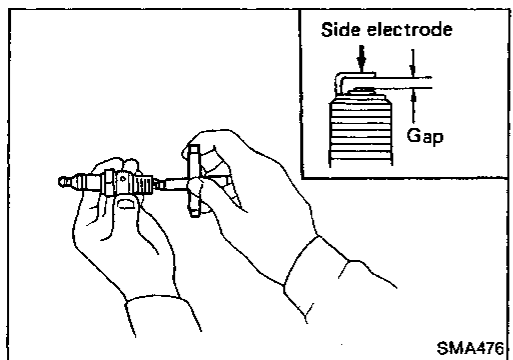

## Checking Vapor Lines

1. Visually inspect vapor lines for improper attachment and for cracks, damage, loose connections, chafing and deterioration.
2. Inspect vacuum relief valve of fuel tank filler cap for clogging, sticking, etc.

**Refer to EVAPORATIVE EMISSION SYSTEM in section "EF & EC".**

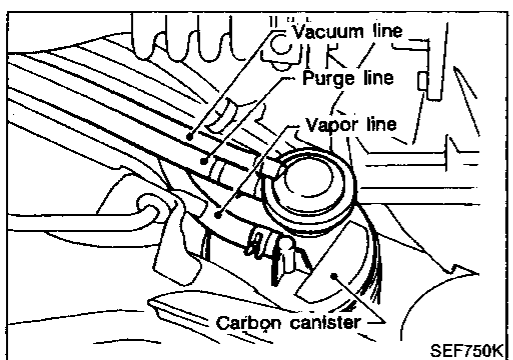

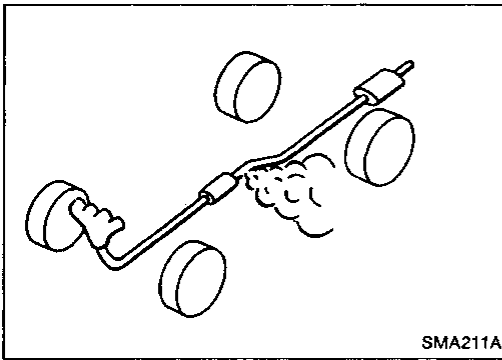

## Checking Exhaust System

- Check exhaust pipes, muffler and mounting for improper attachment, leaks, cracks, damage, loose connections, chafing and deterioration.

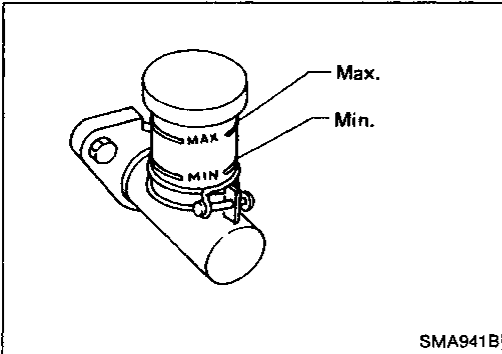

## Checking Clutch Fluid Level and Leaks

- If fluid level is extremely low, check clutch system for leaks.

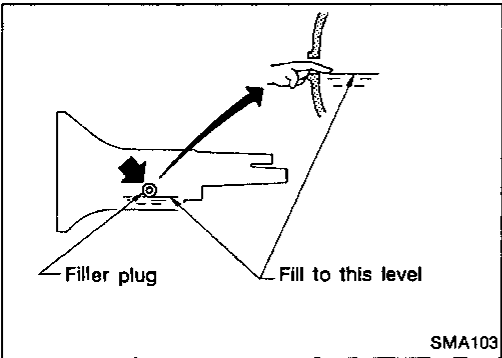

## Checking M/T Oil

- Check for oil leakage and oil level.  
Never start engine while checking oil level.

: Filler plug 25 - 34 N·m (2.5 - 3.5 kg·m, 18 - 25 ft·lb)

## Changing M/T Oil

1. Drain oil from drain plug and refill with new gear oil.
2. Check oil level.

**Oil capacity: 2.4 l (5-1/8 US pt, 4-1/4 Imp pt)**

: Drain plug 25 - 34 N·m (2.5 - 3.5 kg·m, 18 - 25 ft·lb)

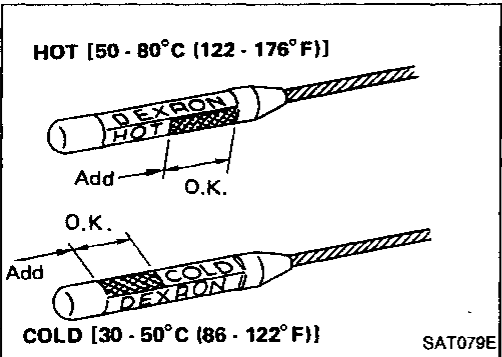

## Checking A/T Fluid

1. Check for fluid leakage and fluid level.  
Fluid level should be checked using "HOT" range on dipstick at fluid temperatures of 50 to 80°C (122 to 176°F) after vehicle has been driven approximately 5 minutes in urban areas after engine is warmed up. But it can be checked at fluid temperatures of 30 to 50°C (86 to 122°F) using "COLD" range on dipstick for reference after engine is warmed up and before driving. However, fluid level must be rechecked using "HOT" range.

- 1) Park vehicle on level surface and set parking brake.
- 2) Start engine and then move selector lever through each gear range, ending in "P".
- 3) Check fluid level with engine idling.
- 4) Remove dipstick and wipe it clean with lint-free paper.
- 5) Reinsert dipstick into charging pipe as far as it will go.
- 6) Remove dipstick and note reading. If level is at low side of either range, add fluid to the charging pipe.

**Do not overfill.**

GI

MA

EM

LC

EF &  
EC

FE

CL

MT

AT

PD

FA

RA

BR

ST

BF

HA

EL

## CHASSIS AND BODY MAINTENANCE

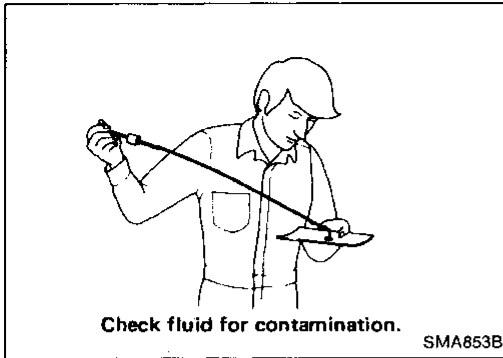

### Checking A/T Fluid (Cont'd)

2. Check fluid for contamination. If fluid is very dark or smells burned, or contains frictional material (clutches, band, etc.), check operation of A/T.  
Refer to section AT for checking operation of A/T.

### Changing A/T Fluid

1. Drain fluid by removing oil pan.
  2. Replace gasket with new one.
  3. Refill with fluid and then check fluid level.
- Oil capacity (With torque converter):**  
8.3 ℓ (8-3/4 US qt, 7-1/4 Imp qt)

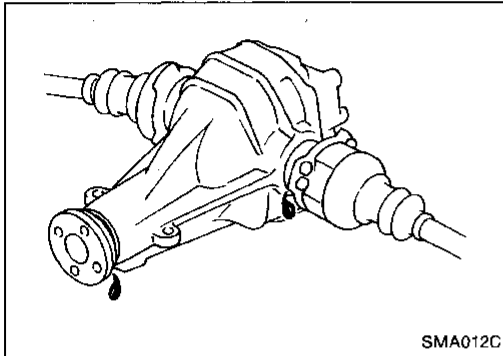

### Checking Differential Gear Oil

- Check for oil leakage and oil level.  
**Filler plug:**  
⌚: 39 - 59 N·m (4 - 6 kg-m, 29 - 43 ft-lb)

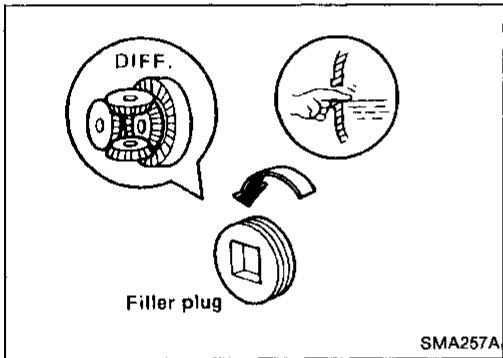

### Changing Differential Gear Oil

1. Drain oil from drain plug and refill with new gear oil.
  2. Check oil level.
- Oil capacity:**  
R200  
1.3 ℓ (2-3/4 US pt, 2-1/4 Imp pt)  
R200V  
1.5 ℓ (3-1/8 US pt, 2-5/8 Imp pt)
- Drain plug:**  
⌚: 39 - 59 N·m (4 - 6 kg-m, 29 - 43 ft-lb)

### Balancing Wheels

- Adjust wheel balance using road wheel center.  
**Wheel balance (Maximum allowable unbalance):**  
Refer to S.D.S.

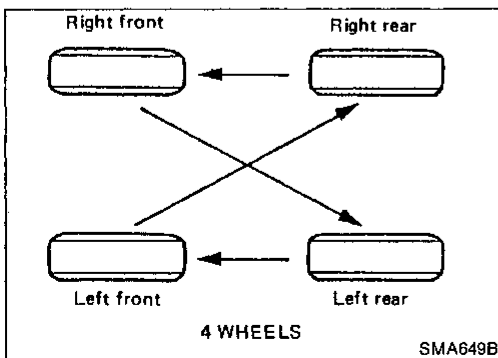

### Tire Rotation

- Do not include the T-type spare tire when rotating the tires.  
**Wheel nuts:**  
⌚: 98 - 118 N·m  
(10.0 - 12.0 kg-m, 72 - 87 ft-lb)

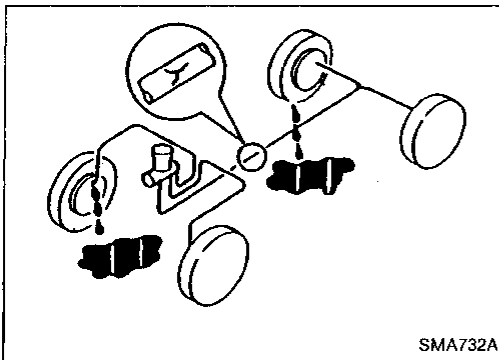

SMA732A

## Checking Brake Fluid Level and Leaks

- If fluid level is extremely low, check brake system for leaks.

## Checking Brake Lines and Cables

- Check brake fluid lines and parking brake cables for improper attachment and for leaks, chafing, abrasions, deterioration, etc.

GI

MA

EM

LC

EF &  
EC

FE

CL

MT

AT

PD

FA

RA

BR

ST

BF

HA

EL

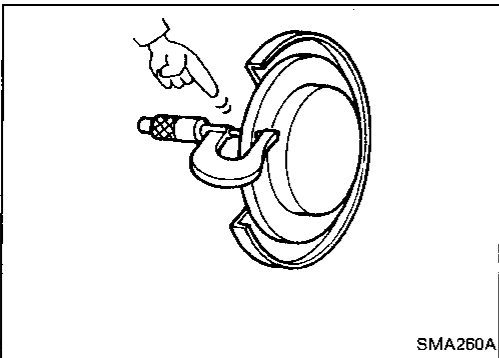

SMA260A

## Checking Disc Brake

### ROTOR

- Check condition and thickness.

Unit: mm (in)

	Front		Rear
	CL22VB	CL25VA*	CL9H
Disc brake type			
Standard thickness	20.0 (0.787)	22.0 (0.866)	9.0 (0.354)
Minimum thickness	18.0 (0.709)	20.0 (0.787)	8.0 (0.315)

\*: With ABS

### CALIPER

- Check operation and for leakage.

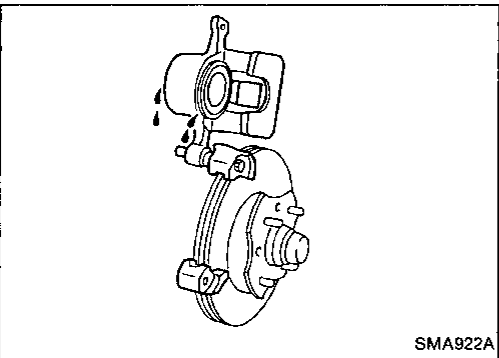

SMA922A

### PAD

- Check for wear or damage.

Unit: mm (in)

	Front		Rear
	CL22VB	CL25VA*	CL9H
Disc brake type			
Standard thickness	10.0 (0.394)	11.0 (0.433)	9.5 (0.374)
Minimum thickness	2.0 (0.079)		

\*: With ABS

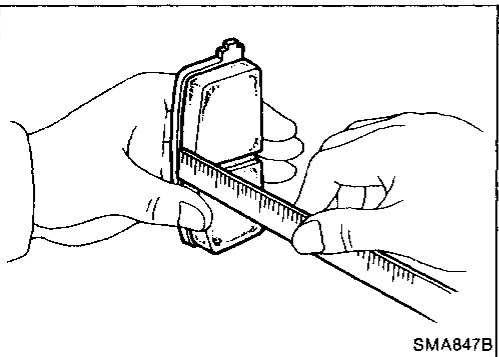

SMA847B

## Checking Steering Gear and Linkage

### STEERING GEAR

- Check gear housing and boots for looseness, damage or grease leakage.
- Check connection with steering column for looseness.

### STEERING LINKAGE

- Check ball joint, dust cover and other component parts for looseness, wear, damage or grease leakage.

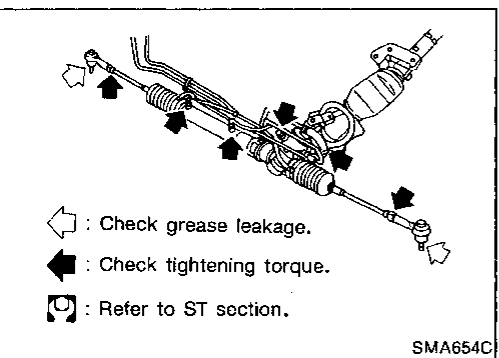

SMA654C

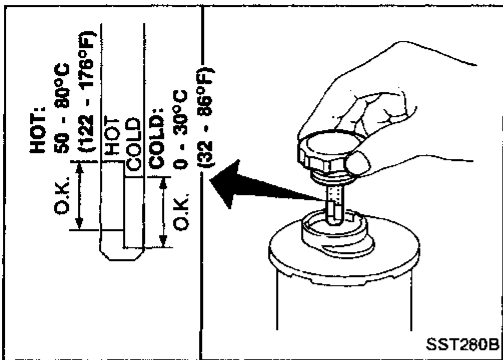

## Checking Power Steering Fluid and Lines

### CHECKING FLUID LEVEL (WITHOUT SUPER HICAS SYSTEM)

Fluid level should be checked using "HOT" range on dipstick at fluid temperatures of 50 to 80°C (122 to 176°F) or using "COLD" range on dipstick at fluid temperatures of 0 to 30°C (32 to 86°F).

**CAUTION:**  
Do not overfill.

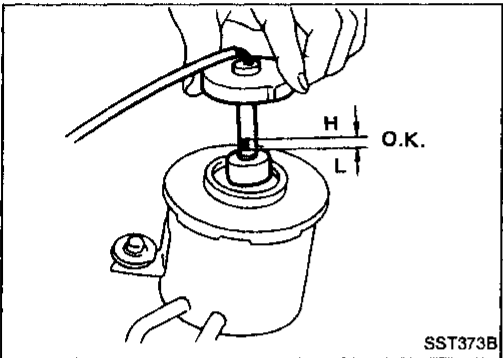

### CHECKING FLUID LEVEL (WITH SUPER HICAS SYSTEM)

Maintain the fluid level so that the lower surface of the float is maintained between the "L" and "H" marks on the gauge rod. The fluid level should be checked when the engine is stopped and the fluid temperature is normal.

**CAUTION:**  
Do not overfill.

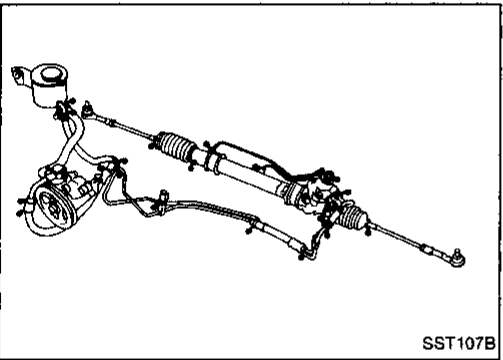

### CHECKING LINES

Check lines for improper attachment, leaks, cracks, damage, loose connections, chafing and deterioration.

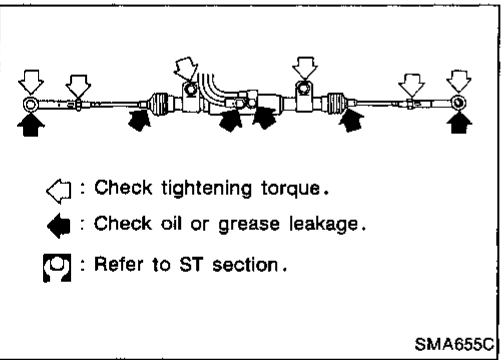

### Checking SUPER HICAS Linkage (With SUPER HICAS system)

- Check power cylinder and linkage for damage, looseness and leakage of oil or grease.



## Lubricating Locks, Higes and Hood Latches

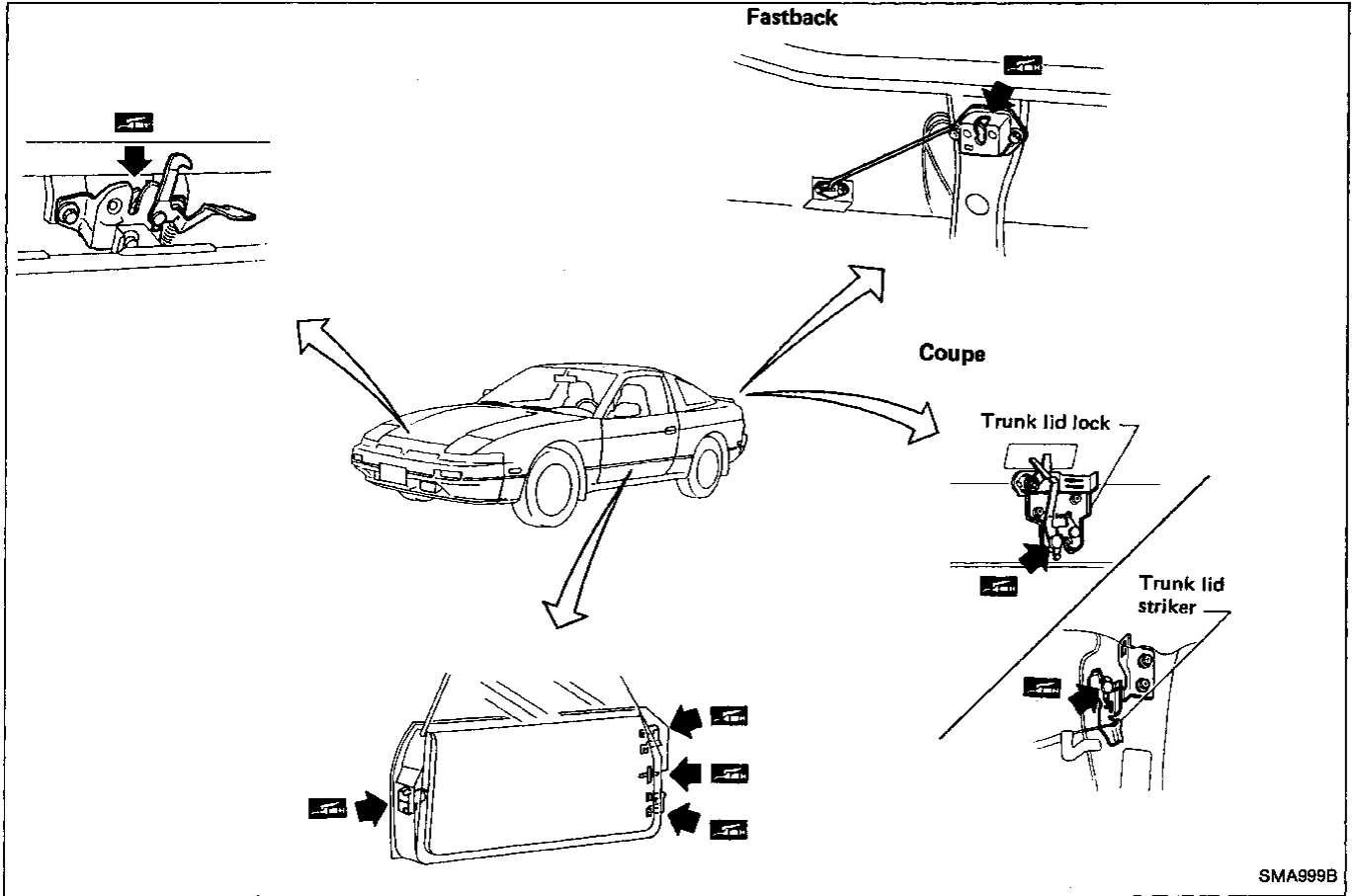

## Checking Seat Belts, Buckles, Retractors, Anchors and Adjusters

**CAUTION:**

1. All seat belt assemblies, including retractors and attaching hardware such as guide rail set, etc., should be inspected after any collision. Nissan recommends that all seat belt assemblies in use during a collision be replaced unless the collision was minor and the belts show no damage and continue to operate properly. Seat belt assemblies not in use during a collision should also be inspected and replaced if either damage or improper operation is noted.
2. If the condition of any component of a seat belt is questionable, do not have seat belt repaired, but replaced as a belt assembly.
3. If webbing is cut, frayed, or damaged, replace belt assembly.
4. Do not spill drinks, oil, etc. on inner lap belt buckle. Never oil tongue and buckle.
5. Use a NISSAN genuine seat belt assembly.

For automatic seat belt details, refer to BF section.

 **Anchor bolt**  
24 - 31 N.m  
(2.4 - 3.2 kg-m, 17 - 23 ft-lb)  
For automatic seat belt, refer to BF section.

- Check anchors for loose mounting.
- Check belts for damage.
- Check retractor for smooth operation.
- Check function of buckles and tongues when buckled and released.

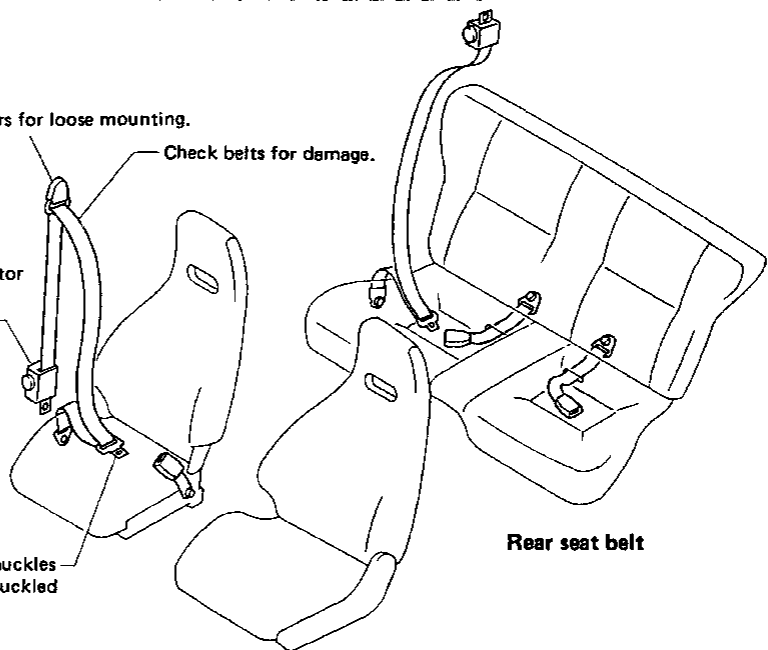

SMA430C

# SERVICE DATA AND SPECIFICATIONS (S.D.S.)

## Engine Maintenance

### INSPECTION AND ADJUSTMENT

#### Drive belt deflection

	Used belt deflection		Deflection of new belt
	Limit	Deflection after adjustment	
Alternator	11 (0.43)	7 - 8 (0.28 - 0.31)	6 - 7 (0.24 - 0.28)
Air conditioner compressor	12 (0.47)	7.5 - 8.5 (0.295 - 0.335)	6.5 - 7.5 (0.256 - 0.295)
Power steering oil pump			
Without SUPER HICAS	13 (0.51)	7.5 - 8.5 (0.295 - 0.335)	6.5 - 7.5 (0.256 - 0.295)
With SUPER HICAS	9 (0.35)	6.5 - 7.5 (0.256 - 0.295)	5.5 - 6.5 (0.217 - 0.256)
Applied pushing force	98 N (10 kg, 22 lb)		

Unit: mm (in)

#### Spark plug

Standard type	BKR5E-11
Cold type	BKR6E-11 BKR7E-11
Plug gap	1.0 - 1.1 mm (0.039 - 0.043 in)

#### Ignition wire

Resistance kΩ	Less than 30
---------------	--------------

## Chassis and Body Maintenance

### INSPECTION AND ADJUSTMENT

#### Wheel balance

Maximum allowable unbalance	Dynamic (at rim flange)	10 (0.35) (One side)
	g (oz)	
	Static	20 (0.71)
	g (oz)	

#### Brake

Unit: mm (in)

Disc brake		
Pad		
Standard thickness		
CL22VB		10.0 (0.394)
CL25VA		11.0 (0.433)
CL9H		9.5 (0.374)
Minimum thickness		
All		2.0 (0.079)
Rotor		
Standard thickness		
CL22VB		20.0 (0.787)
CL25VA		22.0 (0.866)
CL9H		9.0 (0.354)
Minimum thickness		
CL22VB		18.0 (0.709)
CL25VA		20.0 (0.787)
CL9H		8.0 (0.315)