

MANUAL TRANSMISSION

SECTION **MT**

GI
MA
EM
LC
EF &
EC
FE
CL
MT
AT
PD
FA
RA
BR
ST
BF
HA
EL

CONTENTS

PREPARATION	2	Case Components.....	10
Special Service Tools.....	2	Shift Control Components.....	11
Commercial Service Tool.....	3	Gear Components.....	12
ON-VEHICLE SERVICE	4	INSPECTION	15
Replacing Rear Oil Seal.....	4	Shift Control Components.....	15
Check of Position Switches.....	4	Gear Components.....	15
REMOVAL AND INSTALLATION	5	ASSEMBLY	17
Removal.....	5	Gear Components.....	17
Installation.....	6	Shift Control Components.....	23
MAJOR OVERHAUL	7	Case Components.....	25
Case Components.....	7	SERVICE DATA AND SPECIFICATIONS (S.D.S.)	27
Gear Components.....	8	General Specifications.....	27
Shift Control Components.....	9	Inspection and Adjustment.....	28
DISASSEMBLY	10		

PREPARATION

Special Service Tools

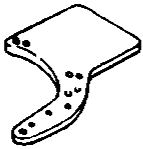
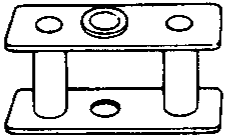
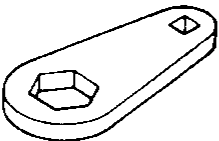
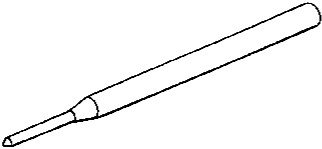
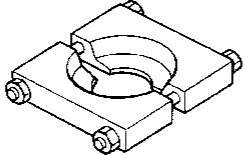
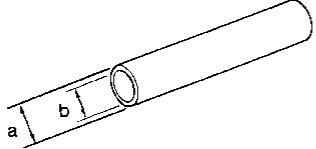
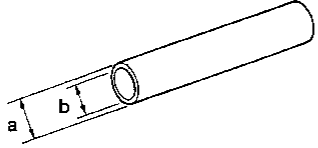
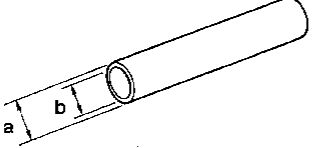
Tool number (Kent-Moore No.) Tool name	Description
ST23810001 (—) Adapter setting plate	 <p style="text-align: right;">Fixing adapter plate with gear assembly</p>
KV31100401 (—) Transmission press stand	 <p style="text-align: right;">Pressing counter gear and mainshaft</p>
ST22520000 (J26348) Wrench	 <p style="text-align: right;">Tightening mainshaft lock nut</p>
ST23540000 (J25689-A) Pin punch	 <p style="text-align: right;">Removing and installing fork rod retaining pin</p>
ST30031000 (J22912-01) Puller	 <p style="text-align: right;">Removing and installing 1st gear bushing Removing main drive gear bearing Measuring wear of baulk rings</p>
ST23860000 (—) Drift	 <p style="text-align: right;">Installing counter drive gear</p> <p style="text-align: right;">a: 38 mm (1.50 in) dia. b: 33 mm (1.30 in) dia.</p>
ST22360002 (J25679-01) Drift	 <p style="text-align: right;">Installing counter gear front and rear end bearings</p> <p style="text-align: right;">a: 29 mm (1.14 in) dia. b: 23 mm (0.91 in) dia.</p>
ST22350000 (J25678-01) Drift	 <p style="text-align: right;">Installing O.D. gear bushing</p> <p style="text-align: right;">a: 34 mm (1.34 in) dia. b: 28 mm (1.10 in) dia.</p>

PREPARATION

Special Service Tools (Cont'd)

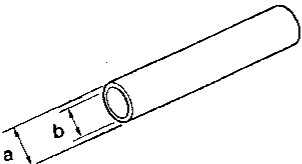
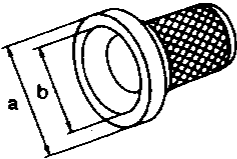
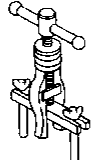
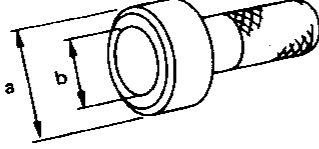
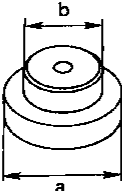
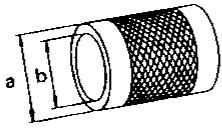
Tool number (Kent-Moore No.) Tool name	Description	
ST23800000 (J25691-01) Drift		Installing front cover oil seal
	a: 44 mm (1.73 in) dia. b: 31 mm (1.22 in) dia.	GI MA
ST33400001 (J26082) Drift		Installing rear oil seal
	a: 60 mm (2.36 in) dia. b: 47 mm (1.85 in) dia.	EM LC
ST33290001 (J25810-A) Puller		Removing rear oil seal
		EF & EC FE
ST30720000 (—) Drift		Installing mainshaft ball bearing
	a: 77 mm (3.03 in) dia. b: 55.5 mm (2.185 in) dia.	CL MT
ST30613000 (J25742-3) Drift		Installing main drive gear bearing
	a: 71.5 mm (2.815 in) dia. b: 47.5 mm (1.870 in) dia.	AT PD FA
ST33200000 (J26082) Drift		Installing counter rear bearing Installing 3rd & 4th synchronizer assembly
	a: 60 mm (2.36 in) dia. b: 44.5 mm (1.752 in) dia.	RA BR

Commercial Service Tool

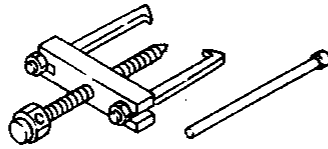
Tool name	Description	
Puller		Removing counter bearings, counter drive and O.D. gears
		BF HA EL

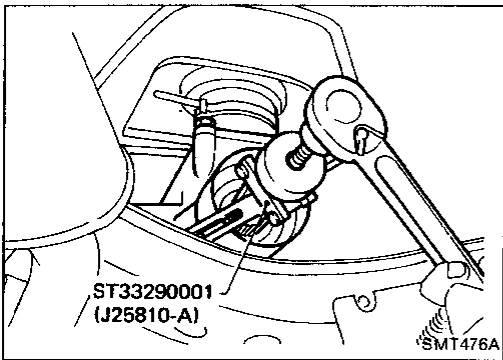

Replacing Rear Oil Seal

REMOVAL

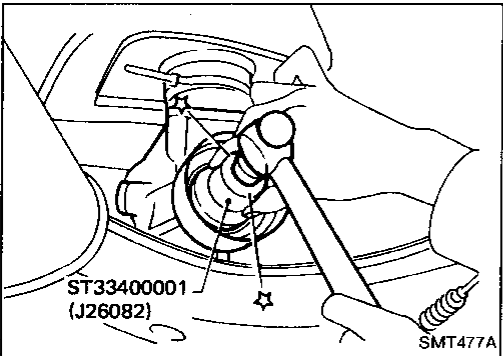

INSTALLATION

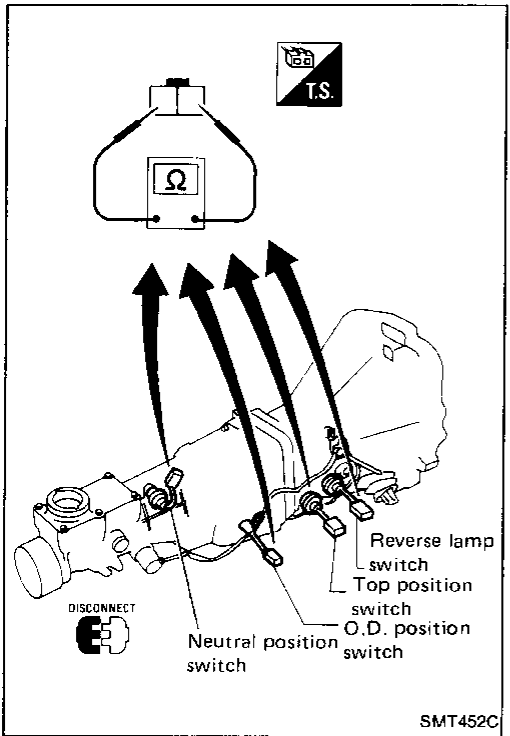

Check of Position Switches

Switch	Gear position	Continuity
Reverse lamp switch	Reverse	Yes
	Other than reverse	No
Neutral position switch	Neutral	Yes
	Other than neutral	No
Top (4th) position switch	4th	Yes
	Other than 4th	No
O.D. (5th) position switch	5th	Yes
	Other than 5th	No

REMOVAL AND INSTALLATION

Removal

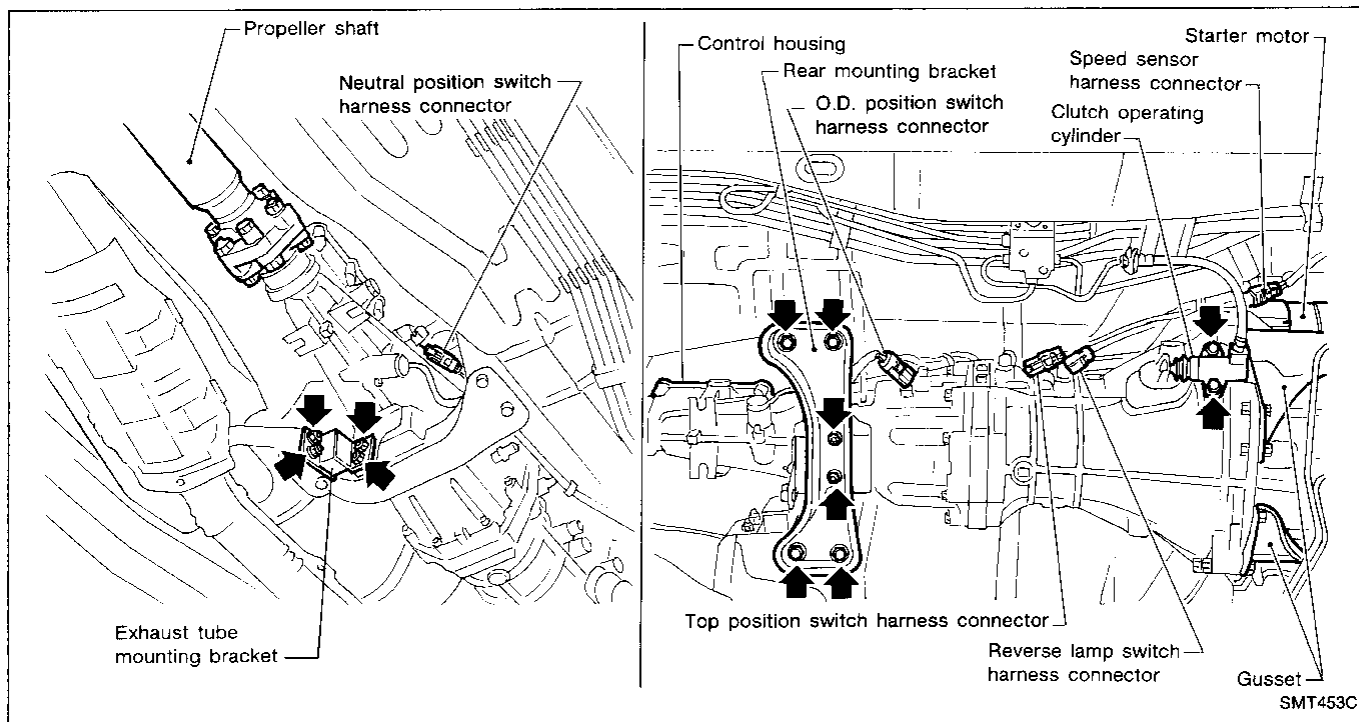

- Remove clutch operating cylinder from transmission.
- Disconnect speed sensor, O.D. position switch, top (4th) position switch, reverse lamp switch and neutral position switch harness connectors.
- Remove starter motor from transmission.
- Remove propeller shaft. — Refer to section PD.
- **Insert plug into rear oil seal after removing propeller shaft.**
- **Be careful not to damage spline, sleeve yoke and rear oil seal when removing propeller shaft.**
- Remove exhaust tube mounting bracket from transmission.
- Support manual transmission with a jack.
- Remove rear mounting bracket.
- Lower manual transmission as much as possible.
- Remove shift lever with control housing from transmission.

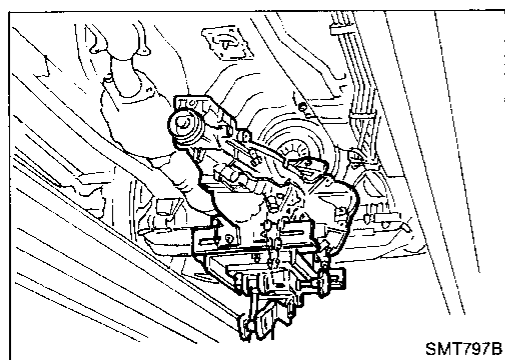

- Remove gussets and transmission fixing bolts.
- Remove transmission from engine.
- **Support manual transmission while removing it.**

GI
MA
EM
LC
EF &
EC
FE
CL

MT

AT

PD

FA

RA

BR

ST

BF

HA

EL

REMOVAL AND INSTALLATION

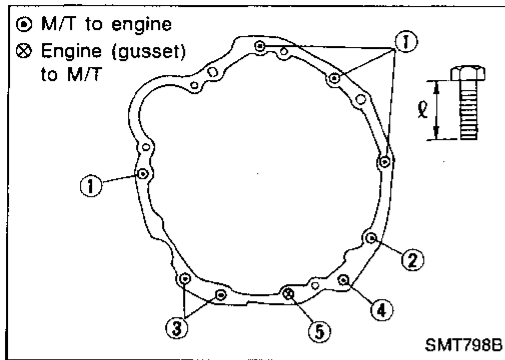

Installation

- Tighten transmission fixing bolts.

Bolt No.	Tightening torque N·m (kg-m, ft-lb)	"ℓ" mm (in)
①	39 - 49 (4.0 - 5.0, 29 - 36)	60 (2.36)
②	39 - 49 (4.0 - 5.0, 29 - 36)	70 (2.76)
③*	29 - 39 (3.0 - 4.0, 22 - 29)	35 (1.38)
④*	29 - 39 (3.0 - 4.0, 22 - 29)	65 (2.56)
⑤	29 - 39 (3.0 - 4.0, 22 - 29)	25 (0.98)
Gusset to engine	29 - 39 (3.0 - 4.0, 22 - 29)	20 (0.79)

*: With nut.

- Install any part removed.

MAJOR OVERHAUL

Case Components

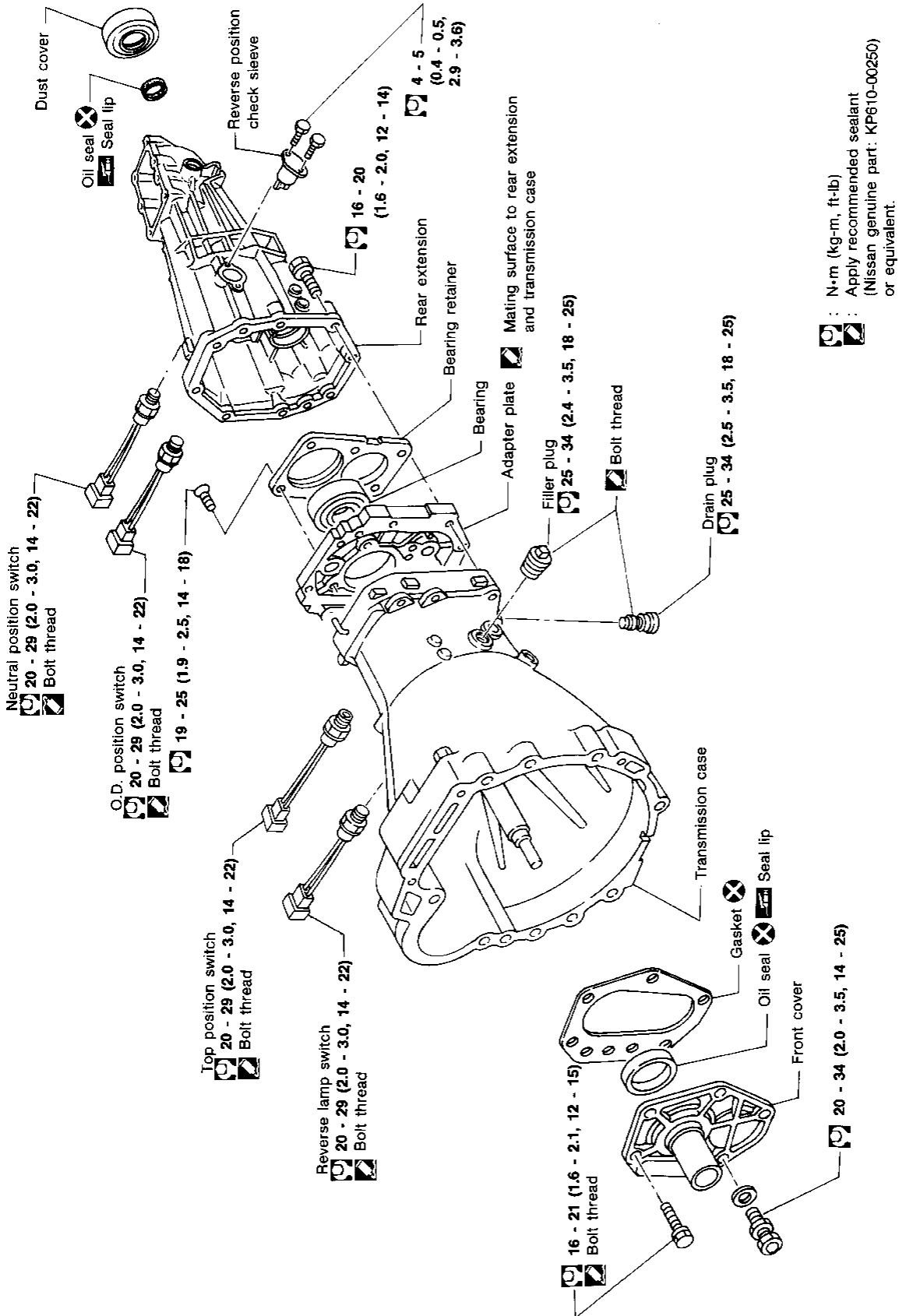

GI
 MA
 EM
 LC
 EF &
 EC
 FE
 CL
MT
 AT
 PD
 FA
 RA
 BR
 ST
 BF
 HA
 EL

MAJOR OVERHAUL

Gear Components

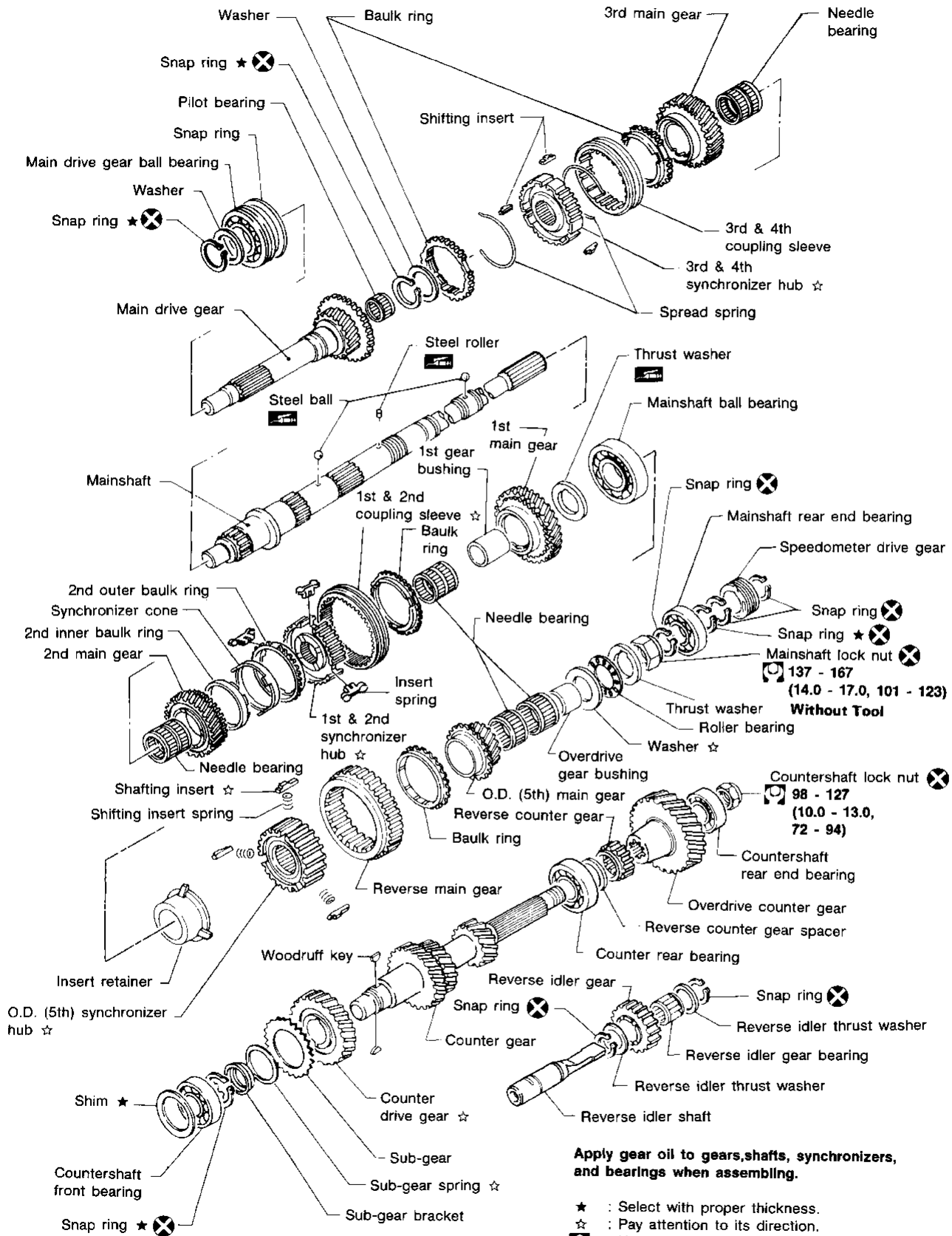

Shift Control Components

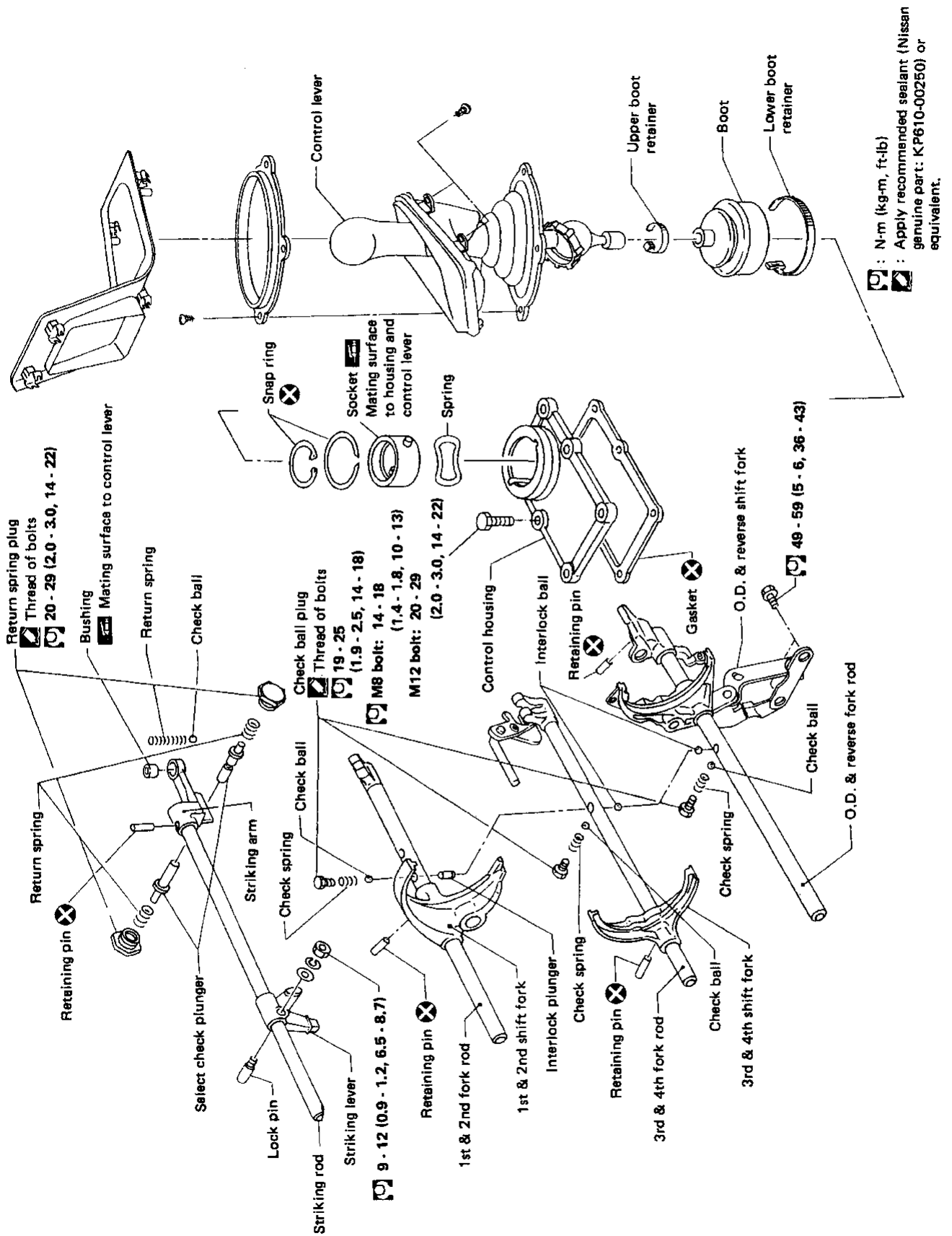

: N·m (kg-m, ft-lb)
 : Apply recommended sealant (Nissan genuine part: KP610-00250) or equivalent.

- GI
- MA
- EM
- LC
- EF & EC
- FE
- CL
- MT**
- AT
- PD
- FA
- RA
- BR
- ST
- BF
- HA
- EL

DISASSEMBLY

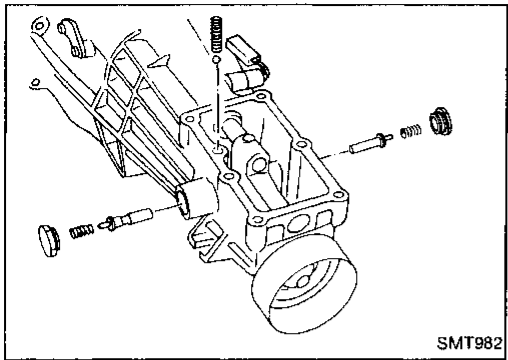

Case Components

1. Remove rear extension.
 - a. Remove control housing, check ball, return spring plug, select check plunger and return springs.

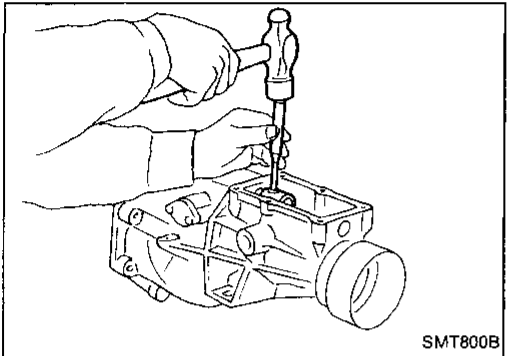

- b. Drive out striking arm retaining pin.
 - c. Remove striking arm from striking rod.

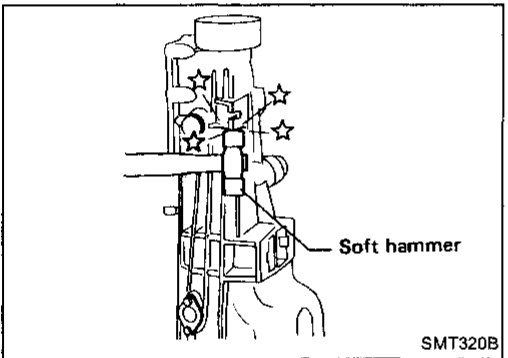

- d. Remove rear extension by lightly tapping it.

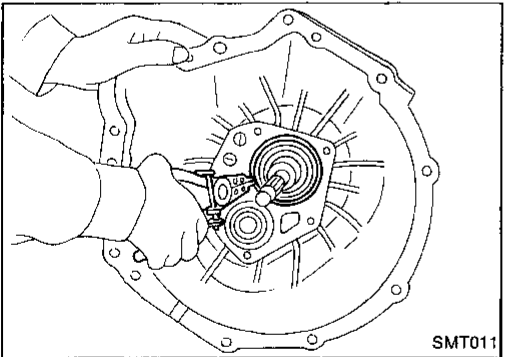

2. Remove front cover, gasket, shim of countershaft front bearing, and snap ring of main drive gear ball bearing.

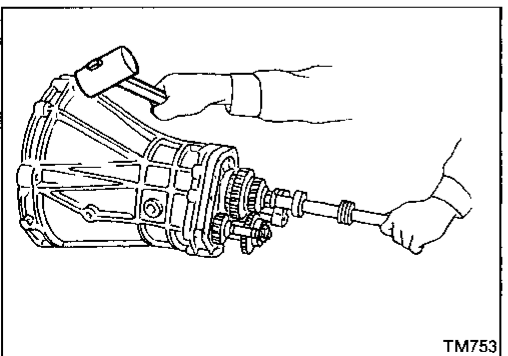

3. Remove transmission case by tapping lightly.

DISASSEMBLY

Case Components (Cont'd)

4. Remove front cover oil seal.

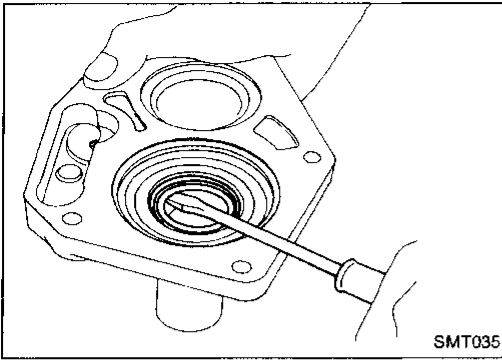

GI

MA

EM

Shift Control Components

1. Set up Tool on adapter plate.
2. Remove striking rod from adapter plate.
3. Remove check ball plugs, check springs, and check balls.

LC

EF &
EC

FE

CL

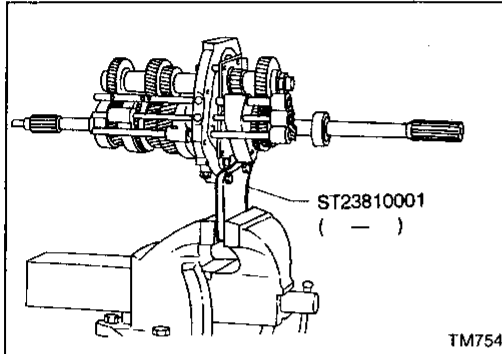

4. Drive out retaining pins. Then drive out fork rods and remove interlock balls.

MT

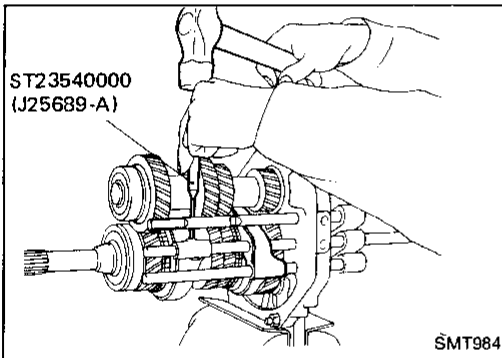

AT

PD

FA

5. Remove lever bracket securing bolt.

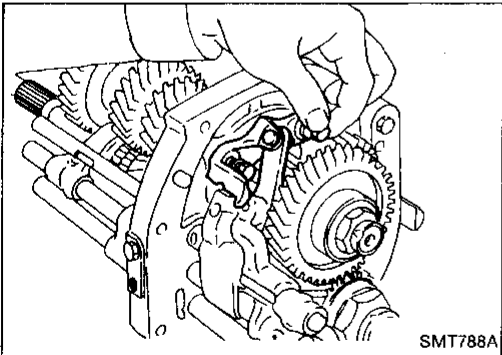

RA

BR

ST

BF

6. Draw out 3rd-4th fork rod.

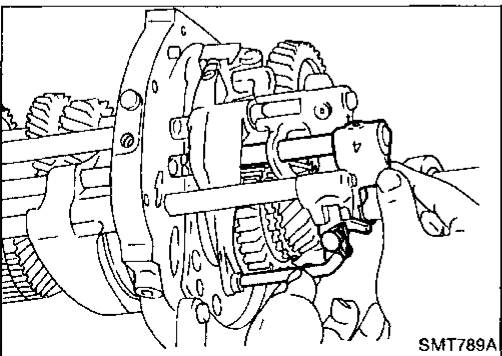

HA

EL

DISASSEMBLY

Shift Control Components (Cont'd)

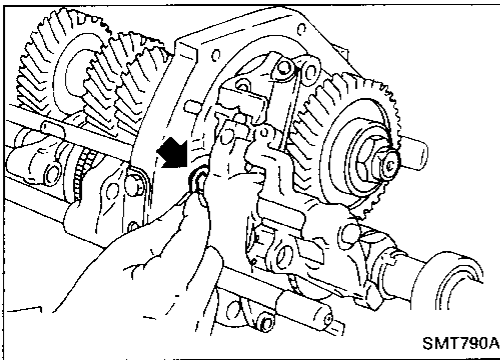

7. Remove E-ring from O.D. and reverse fork rod.

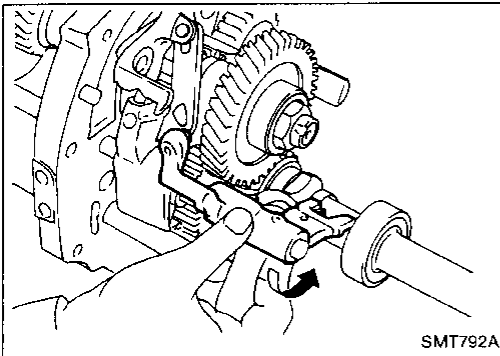

8. Draw out O.D. and reverse fork shaft by rotating O.D. and reverse bracket counterclockwise.

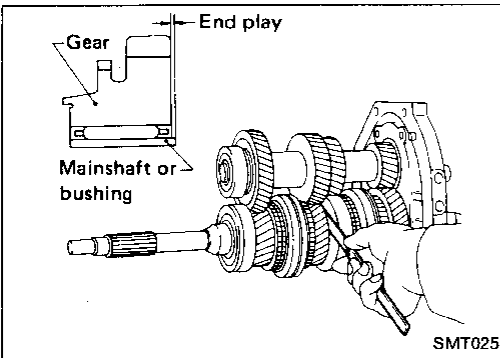

Gear Components

1. Before removing gears and shafts, measure each gear end play.

Gear end play: Refer to S.D.S.

If not within specification, disassemble and check contact surface of gear to hub, washer, bushing, needle bearing and shaft.

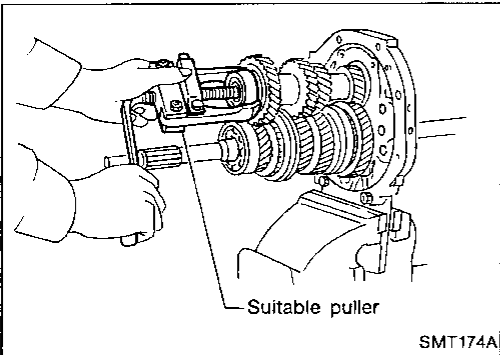

2. Mesh 2nd and reverse gear, then draw out counter front bearing with suitable puller.
3. Remove snap ring and then remove sub-gear bracket, sub-gear spring and sub-gear.

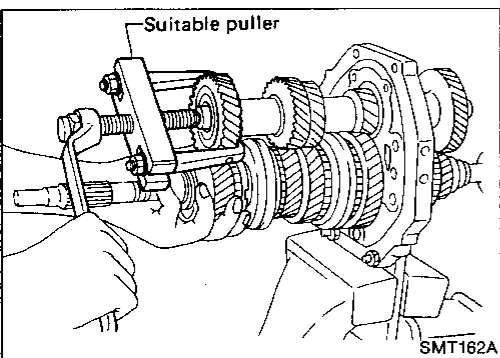

4. Draw out counter drive gear with main drive gear assembly with suitable puller.
- **When drawing out main drive gear assembly, be careful not to drop pilot bearing and baulk ring.**

DISASSEMBLY

Gear Components (Cont'd)

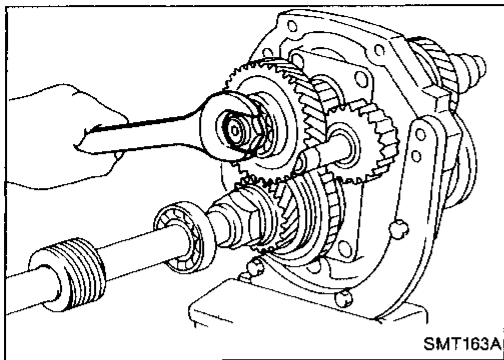

5. Remove rear side components on mainshaft and counter gear.
 - a. Release staking on countershaft nut and mainshaft nut and loosen these nuts.

Mainshaft nut: Left-hand thread

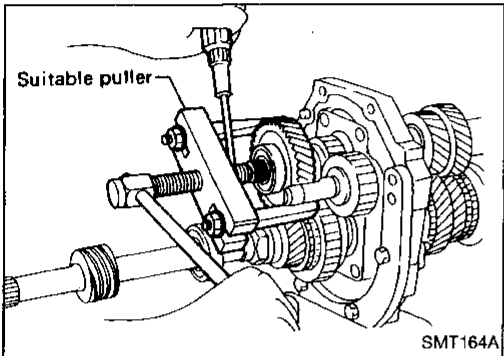

- b. Pull out O.D. counter gear with bearing with suitable puller.
 - c. Draw out reverse counter gear and spacer.
 - d. Remove snap rings from reverse idler shaft and draw out reverse idler gear, thrust washers and reverse idler gear bearing.
 - e. Remove speedometer drive gear and steel ball.

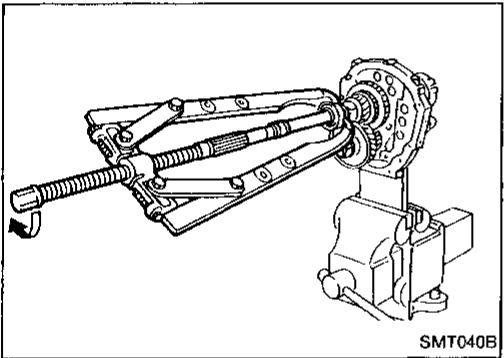

- f. Remove snap ring and pull out overdrive mainshaft bearing, then remove snap ring.
 - g. Remove mainshaft nut.
 - h. Remove steel roller and washer.
 - i. Remove roller bearing and washer.
 - j. Remove O.D. main gear, needle bearing and baulk ring (O.D.).
 - k. Remove O.D. coupling sleeve, shifting inserts and shifting insert springs.

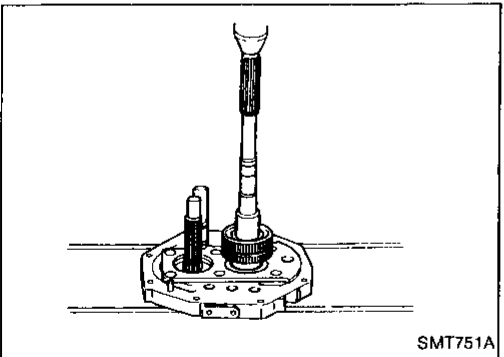

- l. Press out mainshaft and counter gear alternately.
- **Make sure to alternate pressing of mainshaft and counter gear so as not to allow the front surface of one to contact the rear surface of the other.**

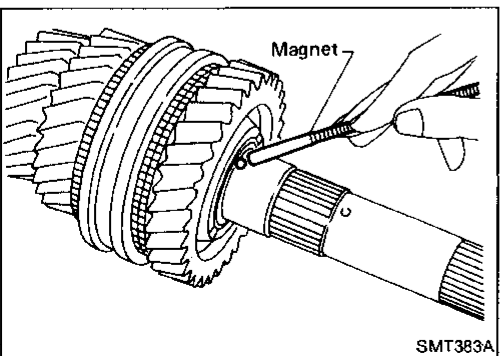

6. Remove front side components on mainshaft.
 - a. Remove 1st gear washer and steel ball.
 - b. Remove 1st main gear and 1st gear needle bearing.

GI

MA

EM

LC

EF &
EC

FE

CL

MT

AT

PD

FA

RA

BR

ST

BF

HA

EL

DISASSEMBLY

Gear Components (Cont'd)

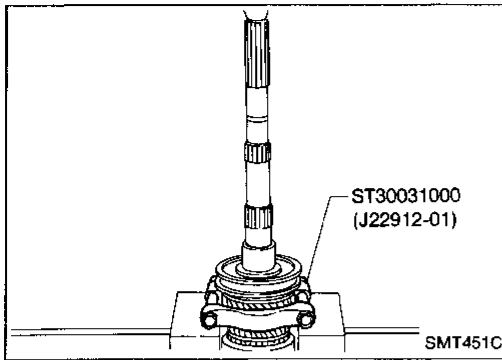

- c. Press out 2nd main gear together with 1st gear bushing and 1st & 2nd synchronizer assembly.
- d. Remove mainshaft front snap ring.

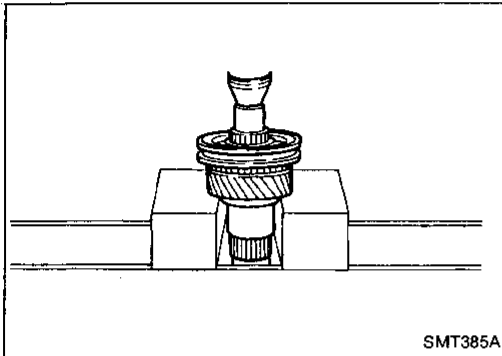

- e. Press out 3rd main gear together with 3rd & 4th synchronizer assembly and 3rd gear needle bearing.

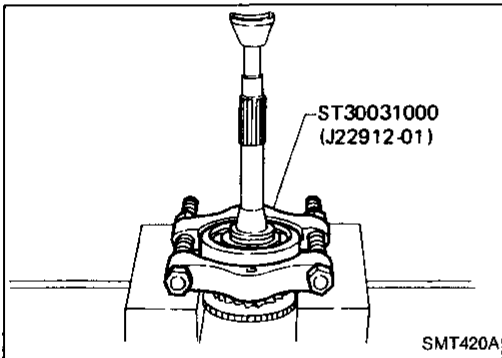

- 7. Remove main drive gear bearing.
 - a. Remove main drive gear snap ring and spacer.
 - b. Press out main drive gear bearing.

Shift Control Components

- Check contact surface and sliding surface for wear, scratches, projections or other damage.

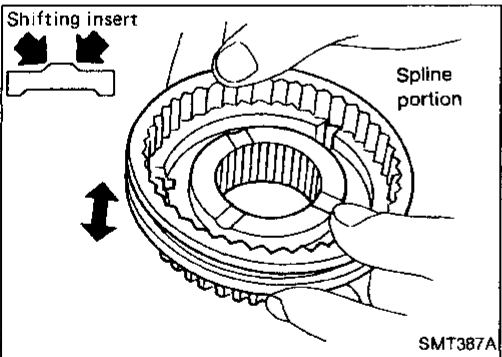
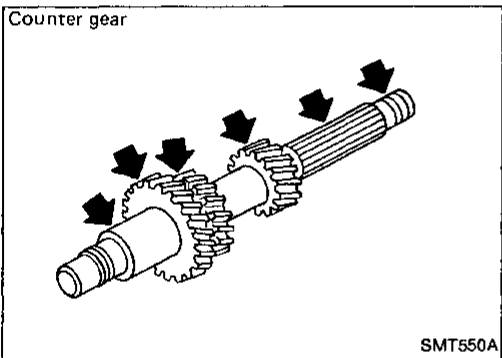
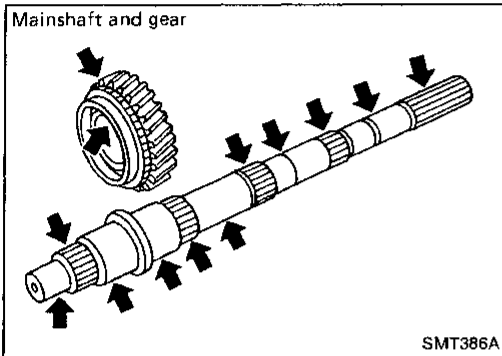
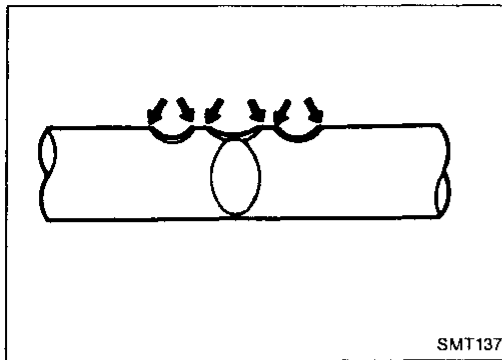

Gear Components

GEAR AND SHAFT

- Check shafts for cracks, wear or bending.
- Check gears for excessive wear, chips or cracks.

SYNCHRONIZERS

- Check spline portion of coupling sleeves, hubs and gears for wear or cracks.
- Check baulk rings for cracks or deformation.
- Check shifting inserts for wear or deformation.
- Check insert springs for deformation.

GI

MA

EM

LC

EF &
EC

FE

CL

MT

AT

PD

FA

RA

BR

ST

BF

HA

EL

INSPECTION

Gear Components (Cont'd)

- Measure clearance between baulk ring and gear.

Clearance between baulk ring and gear

(1st, 3rd, main drive and O.D. baulk ring):

Unit: mm (in)

Dimension	Standard	Wear limit
1st	1.2 - 1.6 (0.047 - 0.063)	0.8 (0.031)
3rd and main drive	1.2 - 1.6 (0.047 - 0.063)	
O.D.	1.2 - 1.4 (0.047 - 0.055)	

If the clearance is smaller than the wear limit, replace baulk ring.

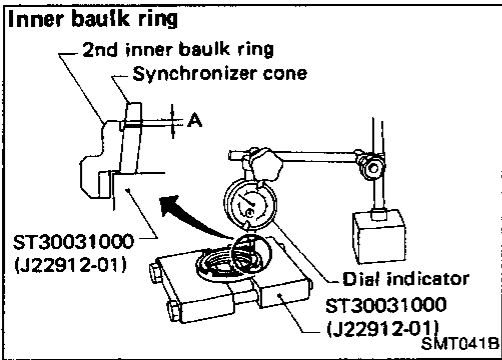
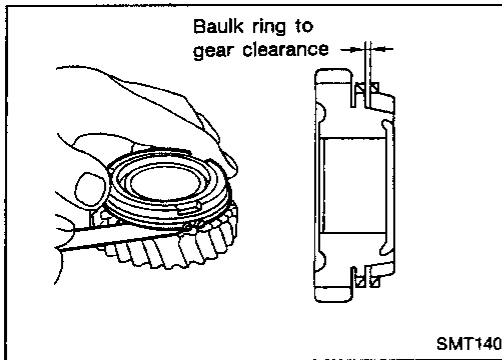

- Measure wear of 2nd baulk ring.

- Place baulk rings in position on synchronizer cone.
- While holding baulk rings against synchronizer cone as far as it will go, measure dimensions "A" and "B".

Unit: mm (in)

Dimension	Standard	Wear limit
A	0.6 - 1.1 (0.024 - 0.043)	0.2 (0.008)
B	0.7 - 0.9 (0.028 - 0.035)	

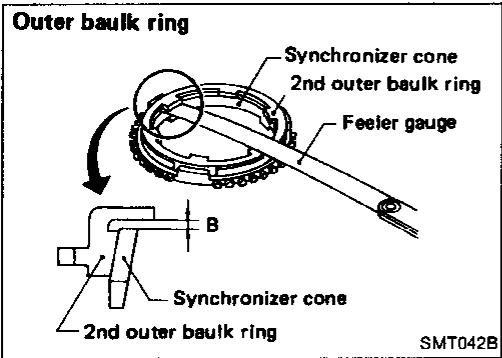

- If dimension "A" or "B" is smaller than the wear limit, replace baulk ring.

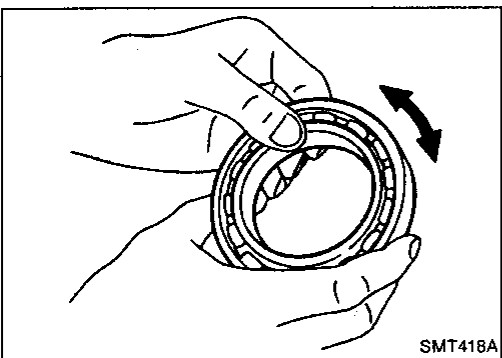

BEARINGS

- Make sure bearings roll freely and are free from noise, crack, pitting or wear.

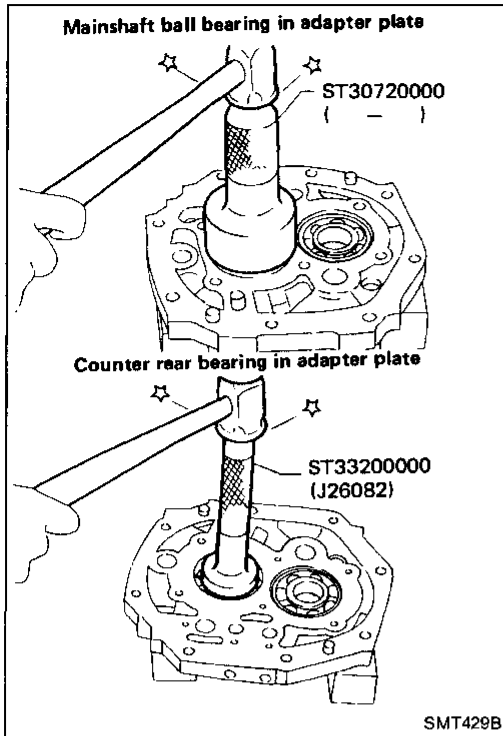

Gear Components

1. Install bearings into case components.

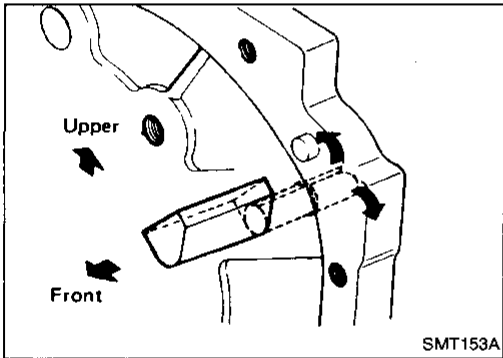

2. Assemble adapter plate parts.
 - Install oil gutter on adapter plate and expand on rear side.

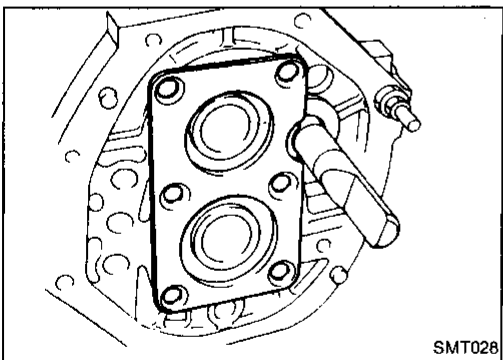

- Install bearing retainer.
 - a. Insert reverse shaft, then install bearing retainer.

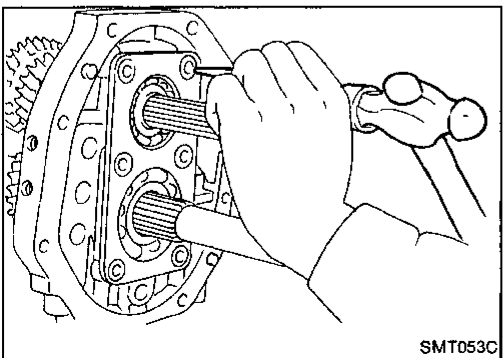

- b. Tighten each screw, then stake each at two points.

GI

MA

EM

LC

EF &
EC

FE

CL

MT

AT

PD

FA

RA

BR

ST

BF

HA

EL

ASSEMBLY

Gear Components (Cont'd)

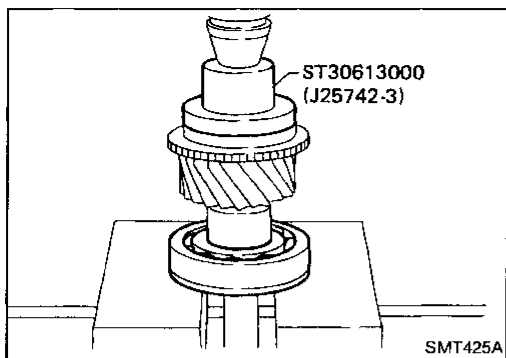

3. Install main drive gear bearing.
 - a. Press main drive gear bearing.
 - b. Install main drive gear spacer.

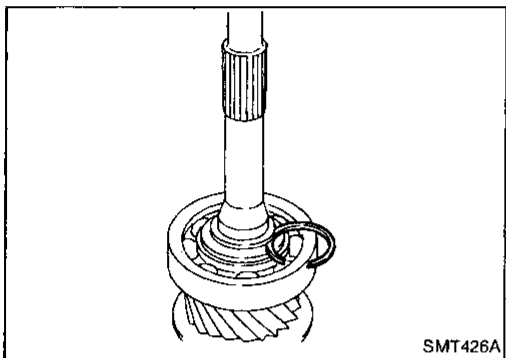

- c. Select proper main drive gear snap ring to minimize clearance of groove and install it.

Allowable clearance of groove:

0 - 0.13 mm (0 - 0.0051 in)

Main drive gear snap ring:

Refer to S.D.S.

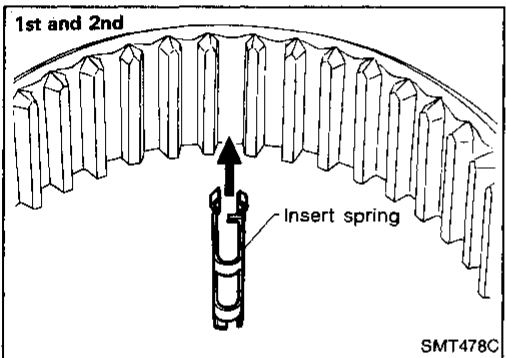

4. Assemble synchronizers.
 - 1st & 2nd synchronizer

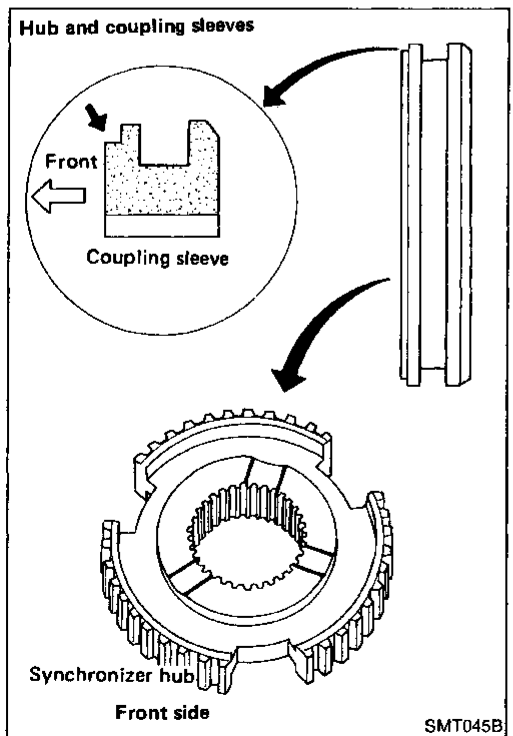

- Check coupling sleeve and synchronizer hub orientation.

ASSEMBLY

Gear Components (Cont'd)

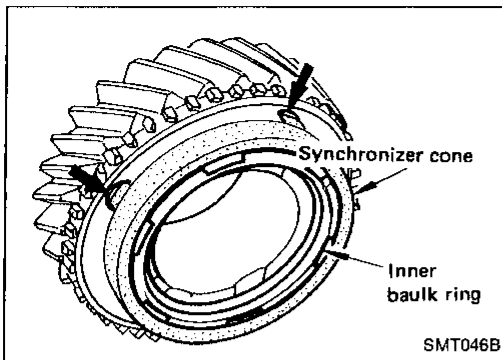

GI

MA

EM

LC

EF &
EC

FE

CL

MT

AT

PD

FA

RA

BR

ST

BF

HA

EL

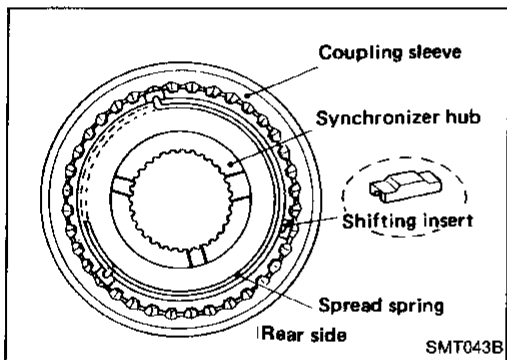
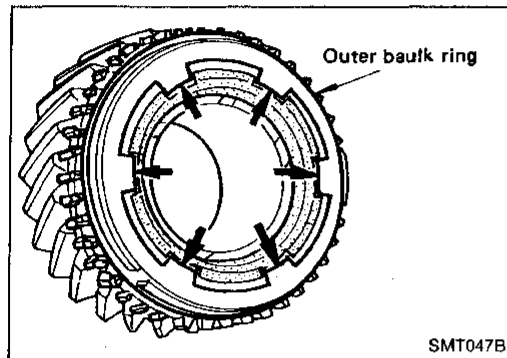

- 3rd & 4th synchronizer

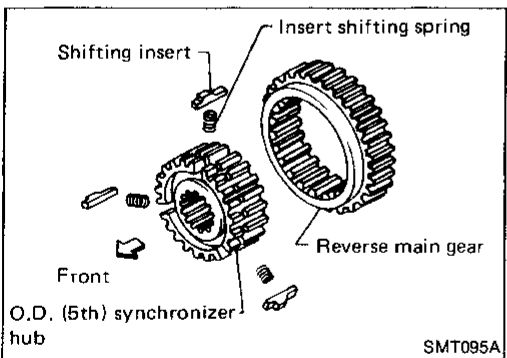

- O.D. synchronizer

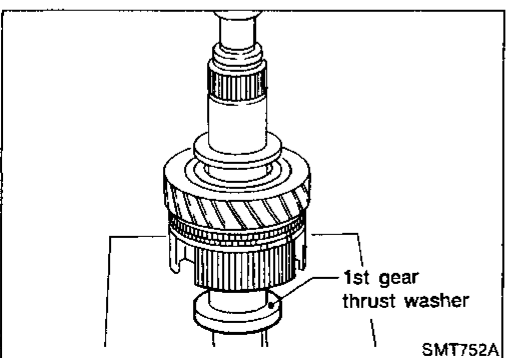

5. Install front side components on main shaft.
 - a. Assemble 2nd main gear, needle bearing and 1st & 2nd synchronizer assembly, then press 1st gear bushing on mainshaft.
 - b. Install 1st main gear.

ASSEMBLY

Gear Components (Cont'd)

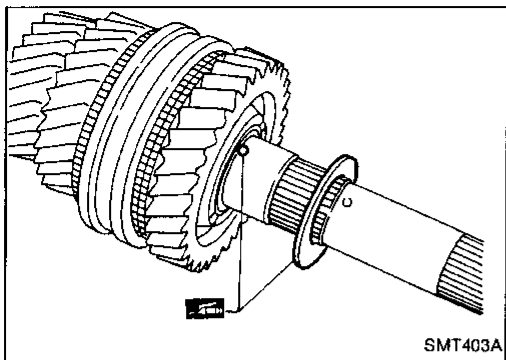

- c. Install steel ball and 1st gear washer.
- Apply multi-purpose grease to steel ball and 1st gear washer before installing.

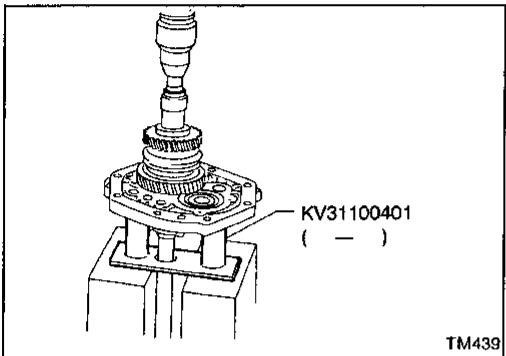

- 6. Install mainshaft and counter gear on adapter plate and main drive gear on mainshaft.
- a. Press mainshaft assembly to adapter plate with Tool.

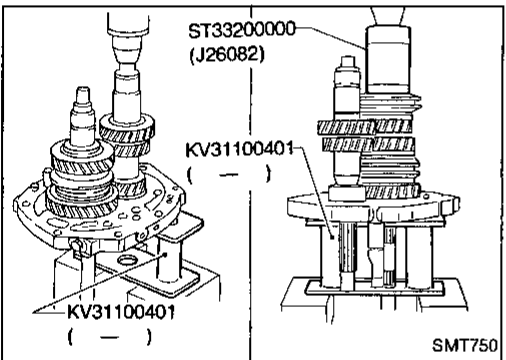

- b. Press counter gear into adapter plate with Tool.
- c. Install 3rd main gear and then press 3rd & 4th synchronizer assembly.

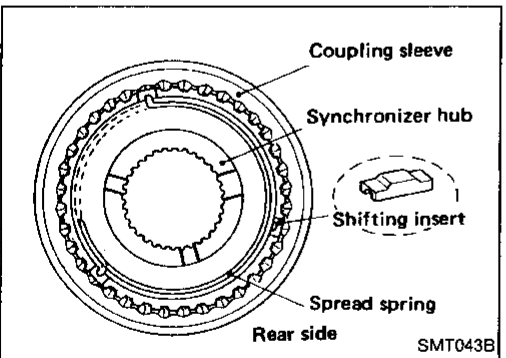

- Pay attention to direction of 3rd & 4th synchronizer.

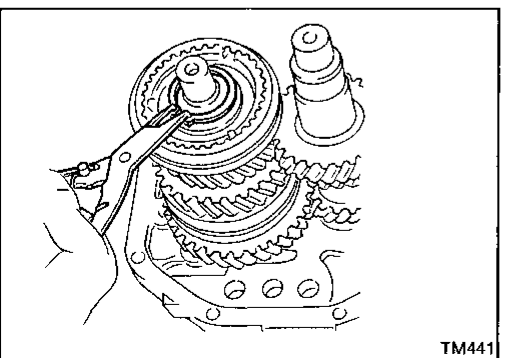

- d. Install thrust washer on mainshaft and secure it with mainshaft front snap ring.
Select proper snap ring to minimize clearance of groove in mainshaft.

Allowable clearance of groove:

0 - 0.18 mm (0 - 0.0071 in)

Mainshaft front snap ring:

Refer to S.D.S.

- e. Apply gear oil to mainshaft pilot bearing and install it on mainshaft.

ASSEMBLY

Gear Components (Cont'd)

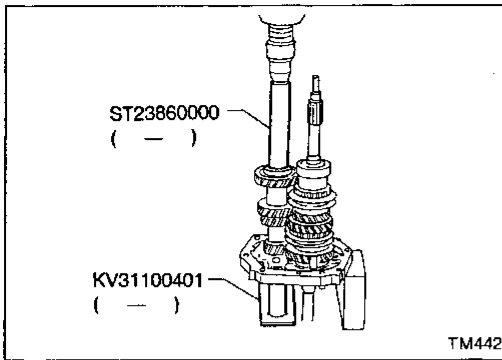

f. Press counter drive gear with main drive gear with Tool.

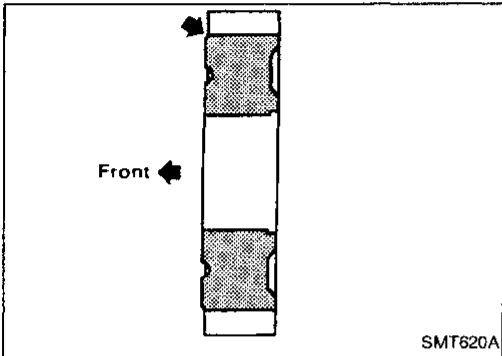

● Pay attention to direction of counter drive gear.

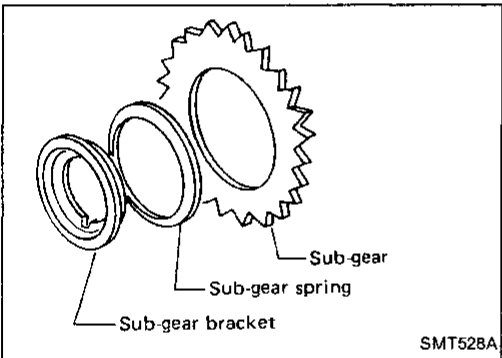

g. Install sub-gear components.

(1) Install sub-gear and sub-gear bracket on counter drive gear and then select proper snap ring to minimize clearance of groove in counter gear.

**Allowable clearance of groove:
0 - 0.18 mm (0 - 0.0071 in)**

Counter drive gear snap ring: Refer to S.D.S.

(2) Remove snap ring, sub-gear bracket and sub-gear from counter gear.

(3) Reinstall sub-gear, sub-gear spring and sub-gear bracket.

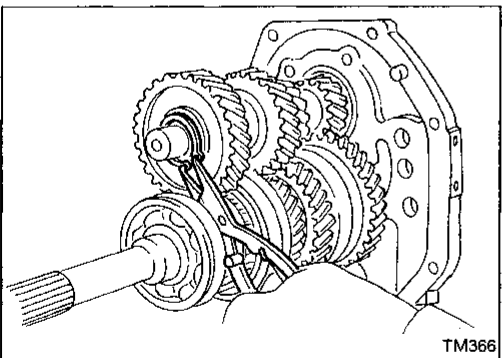

h. Install selected counter drive gear snap ring.

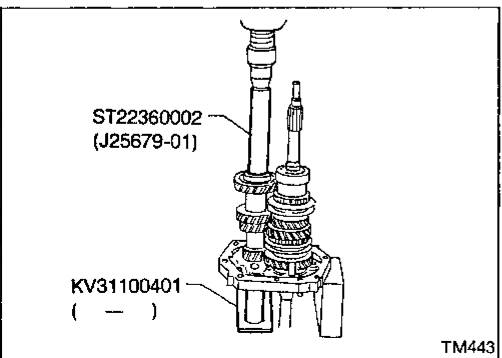

i. Press counter gear front bearing onto counter gear.

GI

MA

EM

LC

EF &
EC

FE

CL

MT

AT

PD

FA

RA

BR

ST

BF

HA

EL

ASSEMBLY

Gear Components (Cont'd)

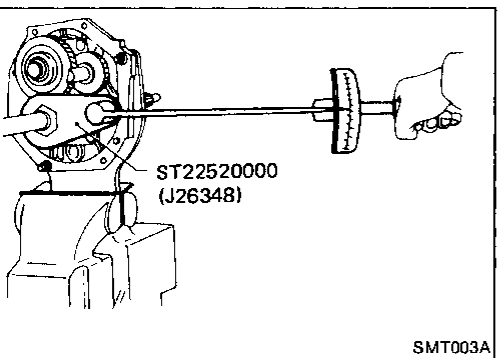
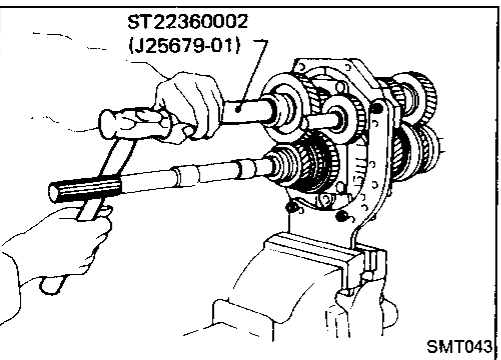
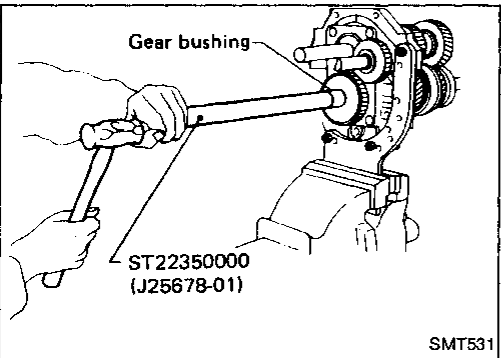
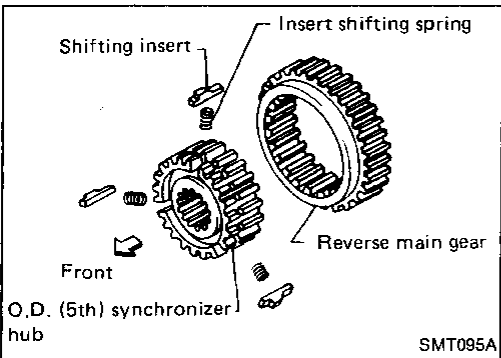
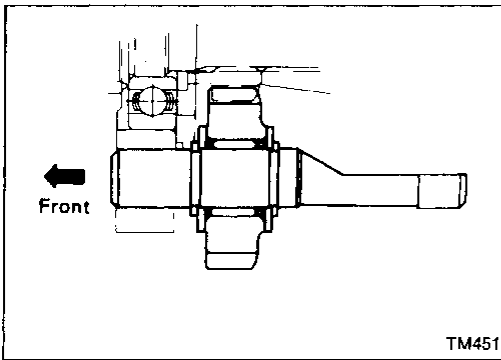

7. Install rear side components on mainshaft and counter gear.
 - a. Install reverse idler gear to reverse idler shaft with spacers, snap rings and needle bearing.

- b. Install insert retainer and O.D. synchronizer to mainshaft.
 - Pay attention to direction of hub.

- c. Install O.D. gear bushing with Tool.
 - d. Install O.D. main gear and needle bearing.
 - e. Install spacer, reverse counter gear and O.D. counter gear.
 - O.D. main gear and O.D. counter gear should be handled as a matched set.
 - f. Install washer, roller bearing, steel roller and thrust washer.
 - g. Tighten mainshaft lock nut temporarily.
 - Always use new lock nut.

- h. Install countershaft rear end bearing with Tool.

8. Mesh 2nd and reverse gears, then tighten mainshaft lock nut with Tool.

ASSEMBLY

Gear Components (Cont'd)

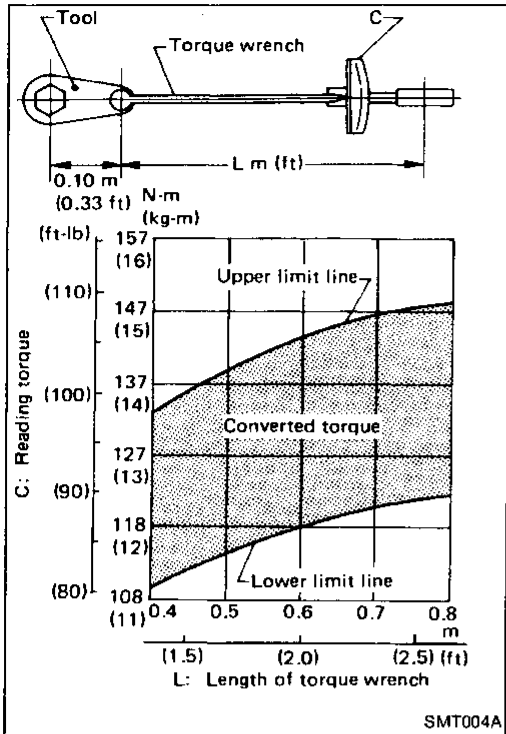

- Use the left chart when deciding the reading torque. (Length of torque wrench vs. setting or reading torque)
9. Tighten countershaft lock nut.
- Always use new lock nut.

GI

MA

EM

LC

EF &
EC

FE

CL

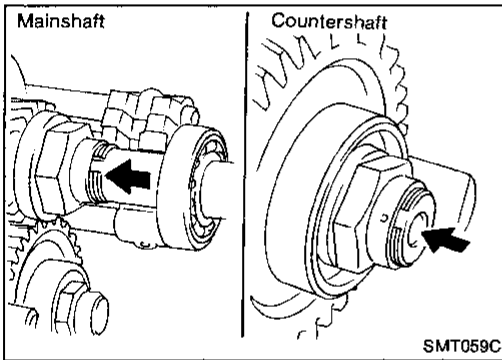

10. Stake mainshaft lock nut and countershaft lock nut with a punch.
11. Measure gear end play. For the description, refer to DIS-ASSEMBLY for Gear Components.

MT

AT

PD

FA

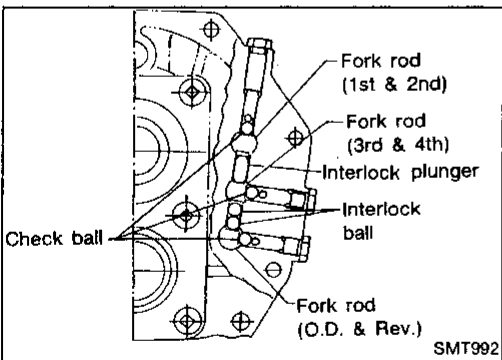

Shift Control Components

1. Install shift rods, interlock plunger, interlock balls and check balls.

RA

BR

ST

BF

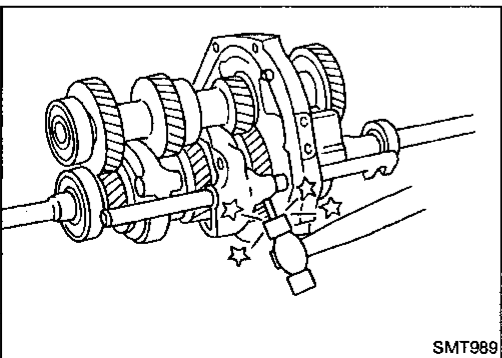

- a. 1st-2nd shift fork

HA

EL

ASSEMBLY

Shift Control Components (Cont'd)

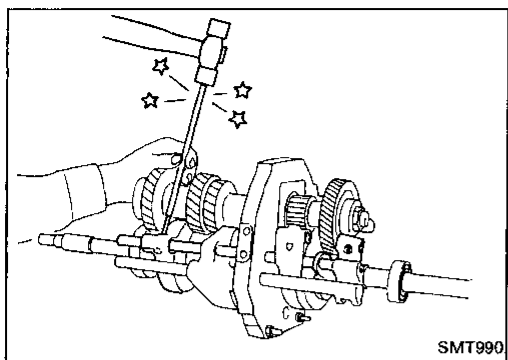

b. 3rd-4th shift fork

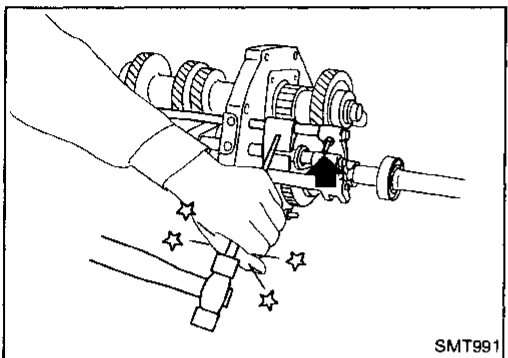

c. O.D.-reverse shift fork or reverse shift fork.

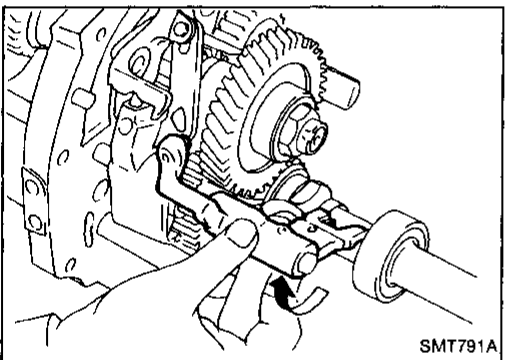

2. Install O.D. and reverse fork shaft by rotating O.D. and reverse bracket clockwise.

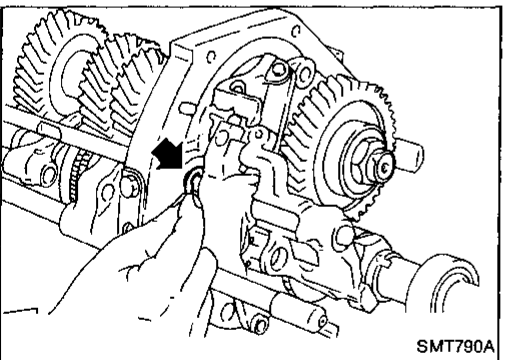

3. Install E-ring on O.D. and reverse fork rod.

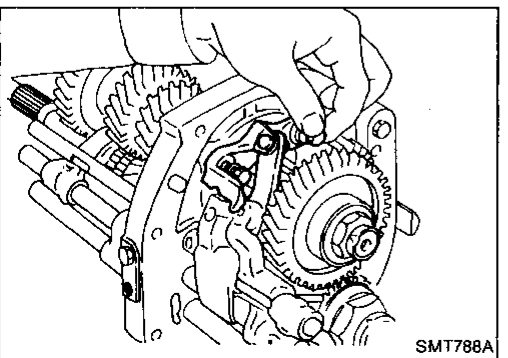

4. Install lever bracket securing bolt.

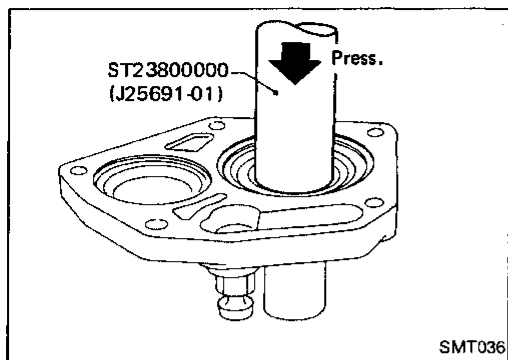

Case Components

1. Install front cover oil seal.
 - Apply multi-purpose grease to seal lip of oil seal before installing.

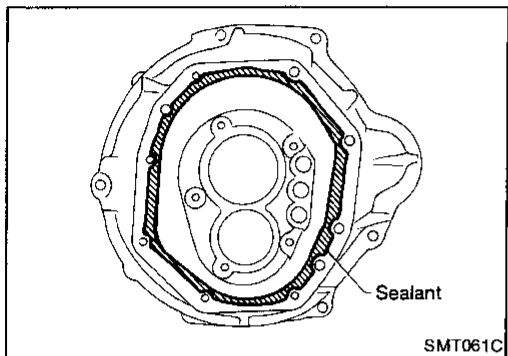

2. Apply sealant to mating surface of transmission case.

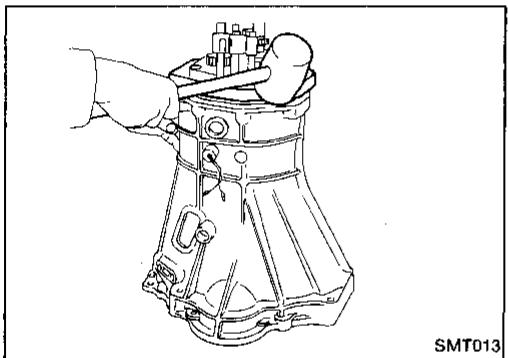

3. Install gear assembly onto transmission case.

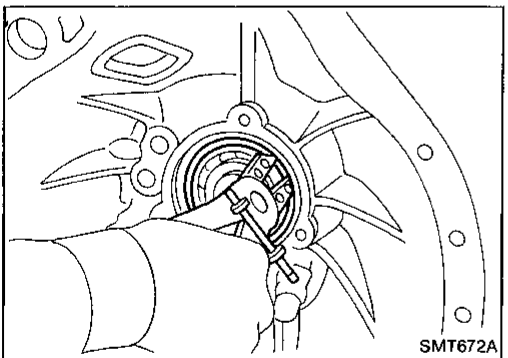

4. Install snap ring of main drive bearing.

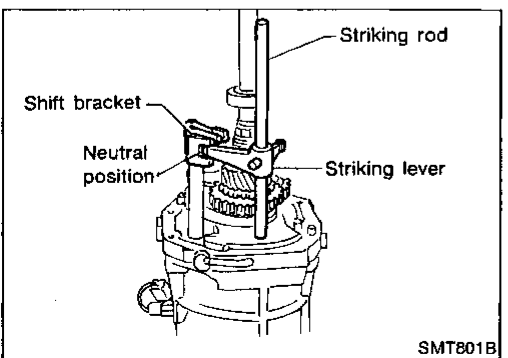

5. Set 1st & 2nd, 3rd & 4th and 5th & reverse shift forks in neutral position.
6. Install striking rod onto adapter plate while aligning striking lever with shift brackets.

GI

MA

EM

LC

EF &
EC

FE

CL

MT

AT

PD

FA

RA

BR

ST

BF

HA

EL

ASSEMBLY

Case Components (Cont'd)

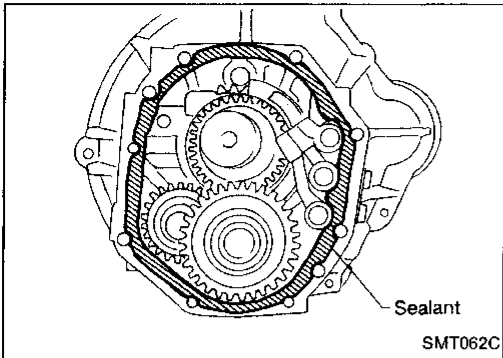

7. Apply sealant to mating surface of adapter plate.
8. Install rear extension while inserting striking arm into striking rod.

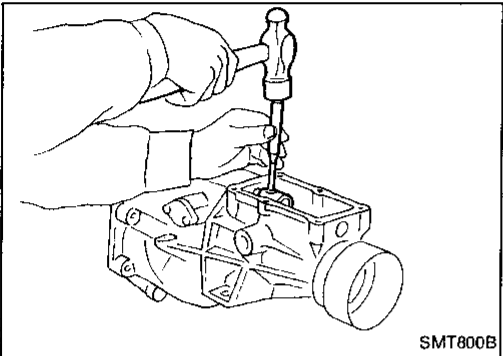

9. Install striking arm retaining pin.

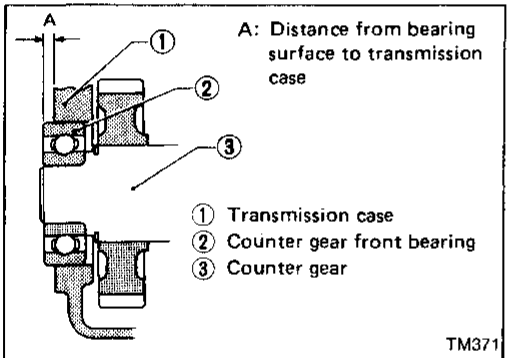

10. Select counter front bearing shim.
Counter front bearing shim: Refer to S.D.S.
11. Install gasket and front cover.

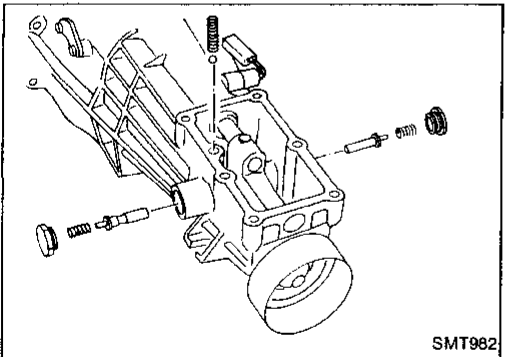

12. Install return spring plugs, check ball, return springs and select check plunger.
13. Install control housing and gasket.

SERVICE DATA AND SPECIFICATIONS (S.D.S.)

General Specifications

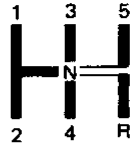
Transmission model		FS5W71C	GI
Number of speeds		5	MA
Shift pattern			EM
Synchromesh type		Warner	LC
Gear ratio	1st	3.321	EF & EC
	2nd	1.902	
	3rd	1.308	
	4th	1.000	
	O.D.	0.759	
	Reverse	3.382	
Number of teeth			FE
Mainshaft	Drive	22	
	1st	33	CL
	2nd	27	
	3rd	26	
	O.D.	21	MT
	Reverse	36	
Countershaft	Drive	31	AT
	1st	14	
	2nd	20	PD
	3rd	28	
	O.D.	39	FA
	Reverse	15	
Reverse idler gear		21	
Oil capacity [(US pt, Imp pt)		2.4 (5-1/8, 4-1/4)	RA
Remarks	Sub-gear	○	
	Mainshaft braking mechanism	○	BR
	Double baulk ring type synchronizer	2nd synchronizer	ST

SERVICE DATA AND SPECIFICATIONS (S.D.S.)

Inspection and Adjustment

GEAR END PLAY

Gear	End play mm (in)
1st gear	0.31 - 0.41 (0.0122 - 0.0161)
2nd gear	0.11 - 0.21 (0.0043 - 0.0083)
3rd gear	0.11 - 0.21 (0.0043 - 0.0083)
O.D. gear	0.24 - 0.41 (0.0094 - 0.0161)

CLEARANCE BETWEEN BAULK RING AND GEAR

1st, 3rd, main drive and O.D. baulk ring

Unit: mm (in)

	Standard	Wear limit
1st	1.2 - 1.6 (0.047 - 0.063)	0.8 (0.031)
3rd and main drive	1.2 - 1.6 (0.047 - 0.063)	
O.D.	1.2 - 1.4 (0.047 - 0.055)	

2nd baulk ring

Unit: mm (in)

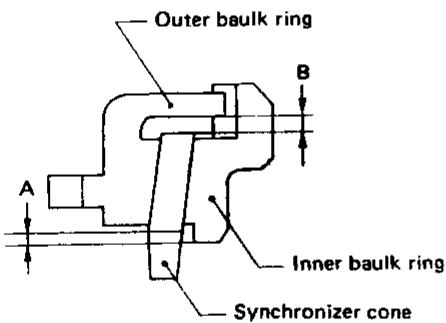

SMT044B

Dimension	Standard	Wear limit
A	0.6 - 1.1 (0.024 - 0.043)	0.2 (0.008)
B	0.7 - 0.9 (0.028 - 0.035)	

AVAILABLE SNAP RINGS

Main drive gear bearing

Allowable clearance	0 - 0.13 mm (0 - 0.0051 in)	
Thickness mm (in)	Part number	
1.73 (0.0681)	32204-78005	
1.80 (0.0709)	32204-78000	
1.87 (0.0736)	32204-78001	
1.94 (0.0764)	32204-78002	
2.01 (0.0791)	32204-78003	
2.08 (0.0819)	32204-78004	

Mainshaft front

Allowable clearance	0 - 0.18 mm (0 - 0.0071 in)	
Thickness mm (in)	Part number	
2.4 (0.094)	32263-V5200	
2.5 (0.098)	32263-V5201	
2.6 (0.102)	32263-V5202	

Mainshaft rear end bearing

Allowable clearance	0 - 0.14 mm (0 - 0.0055 in)	
Thickness mm (in)	Part number	
1.1 (0.043)	32228-20100	
1.2 (0.047)	32228-20101	
1.3 (0.051)	32228-20102	
1.4 (0.055)	32228-20103	

Counter drive gear

Allowable clearance	0 - 0.18 mm (0 - 0.0071 in)	
Thickness mm (in)	Part number	
1.4 (0.055)	32215-E9000	
1.5 (0.059)	32215-E9001	
1.6 (0.063)	32215-E9002	

AVAILABLE SHIMS

Counter front bearing

Unit: mm (in)

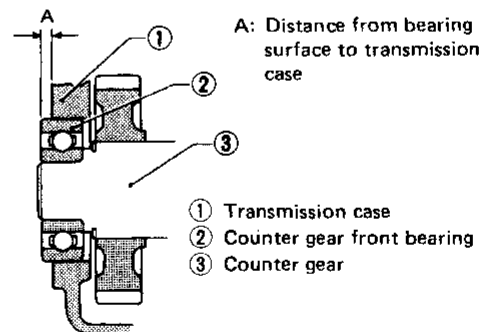

TM371

"A"	Thickness of shim	Part number
4.52 - 4.71 (0.1780 - 0.1854)	Not necessary	
4.42 - 4.51 (0.1740 - 0.1776)	0.1 (0.004)	32218-V5000
4.32 - 4.41 (0.1701 - 0.1736)	0.2 (0.008)	32218-V5001
4.22 - 4.31 (0.1661 - 0.1697)	0.3 (0.012)	32218-V5002
4.12 - 4.21 (0.1622 - 0.1657)	0.4 (0.016)	32218-V5003
4.02 - 4.11 (0.1583 - 0.1618)	0.5 (0.020)	32218-V5004
3.92 - 4.01 (0.1543 - 0.1579)	0.6 (0.024)	32218-V5005