

FRONT AXLE & FRONT SUSPENSION



SECTION FA

CONTENTS

FRONT AXLE	FA- 2	SUSPENSION CROSSMEMBER	FA-10
REMOVAL	FA- 2	SERVICE DATA AND SPECIFICATIONS (S.D.S.)	FA-10
INSPECTION	FA- 2	GENERAL SPECIFICATIONS	FA-10
INSTALLATION	FA- 3	INSPECTION AND ADJUSTMENT	FA-11
FRONT SUSPENSION	FA- 4	TIGHTENING TORQUE	FA-11
SPRING AND STRUT ASSEMBLY	FA- 4	TROUBLE DIAGNOSES AND CORRECTIONS	FA-12
CARTRIDGE TYPE SHOCK ABSORBER	FA- 7	SPECIAL SERVICE TOOLS	FA-15
TENSION ROD AND STABILIZER BAR	FA- 8		
TRANSVERSE LINK AND LOWER BALL JOINT	FA- 9		

Refer to Section MA (Front Axle and Front Suspension) for:

- ADJUSTING WHEEL BEARING PRELOAD
- CHECKING WHEEL ALIGNMENT



INSPECTION
WHEEL BEARING



ADJUSTING WHEEL BEARING PRELOAD



CHECKING WHEEL ALIGNMENT

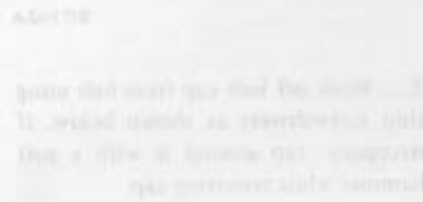
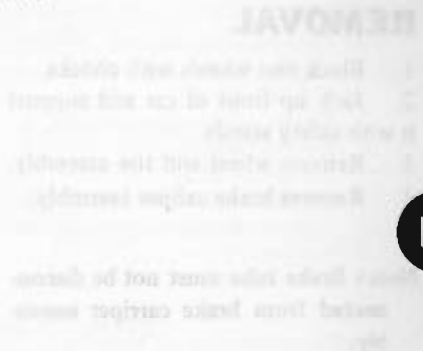

FA

FRONT AXLE

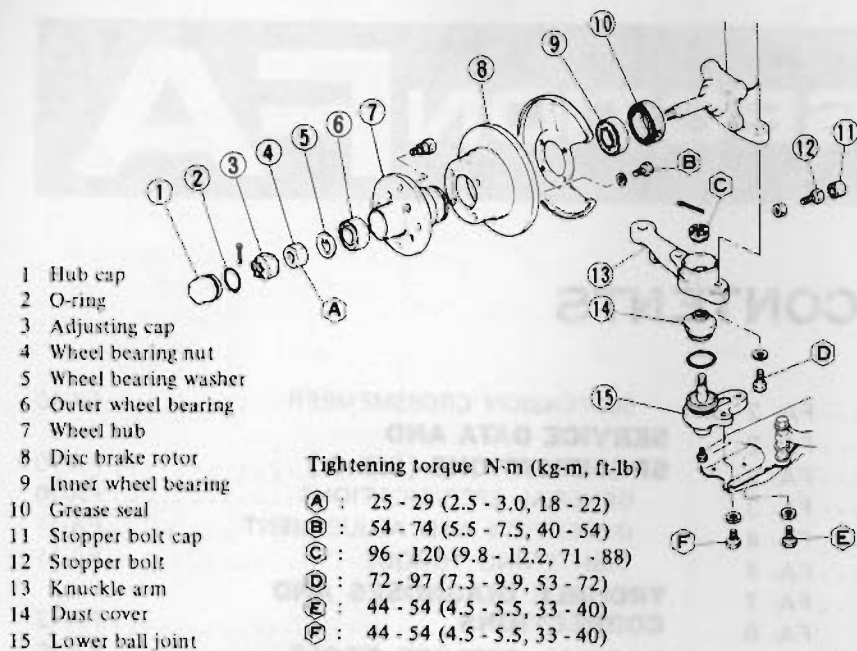

- 1 Hub cap
- 2 O-ring
- 3 Adjusting cap
- 4 Wheel bearing nut
- 5 Wheel bearing washer
- 6 Outer wheel bearing
- 7 Wheel hub
- 8 Disc brake rotor
- 9 Inner wheel bearing
- 10 Grease seal
- 11 Stopper bolt cap
- 12 Stopper bolt
- 13 Knuckle arm
- 14 Dust cover
- 15 Lower ball joint

Tightening torque N-m (kg-m, ft-lb)

- A** : 25 - 29 (2.5 - 3.0, 18 - 22)
- B** : 54 - 74 (5.5 - 7.5, 40 - 54)
- C** : 96 - 120 (9.8 - 12.2, 71 - 88)
- D** : 72 - 97 (7.3 - 9.9, 53 - 72)
- E** : 44 - 54 (4.5 - 5.5, 33 - 40)
- F** : 44 - 54 (4.5 - 5.5, 33 - 40)

Note: Be careful not to drop outer bearing cone out of hub when removing hub from knuckle spindle.

- 8. Remove outer bearing inner race and washer.
- 9. Loosen four bolts securing brake disc; remove disc brake rotor from wheel hub assembly.

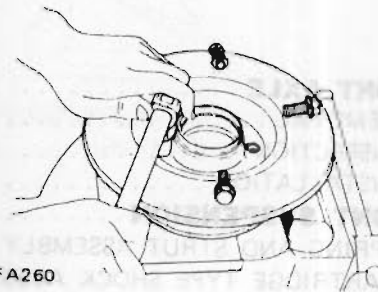

FA260

Loosen screws securing baffle plate; take out baffle plate.

FA700

REMOVAL

- 1. Block rear wheels with chocks.
- 2. Jack up front of car and support it with safety stands.
- 3. Remove wheel and tire assembly.
- 4. Remove brake caliper assembly.

Note: Brake tube must not be disconnected from brake carrier assembly.

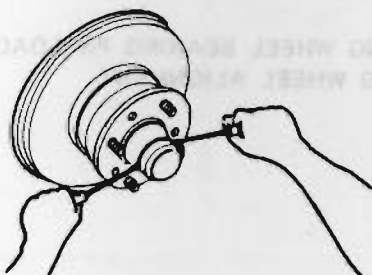

FA702

O-ring must not be reused.

- 6. Pry off cotter pin; take out adjusting cap and wheel bearing lock nut.

Cotter pin must not be reused.

- 7. Remove wheel hub with disc brake rotor from spindle with bearing installed.

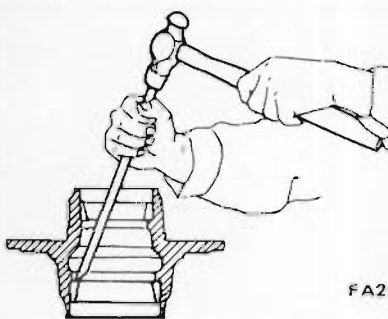

FA259

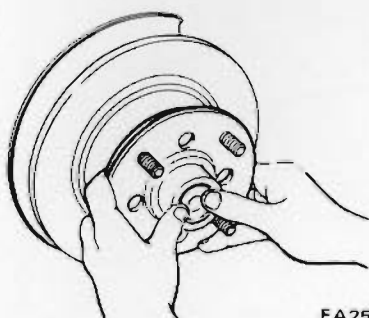

FA258

INSPECTION

WHEEL BEARING

Thoroughly clean grease and dirt from wheel bearing with cleaning solvent, and dry with compressed air free from moisture. Check wheel bearing to see that it rolls freely and is free from noise, crack, pitting, or wear.

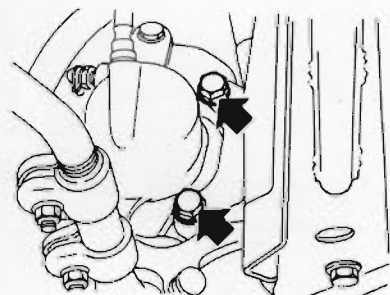

BR169A

- 5. Work off hub cap from hub using thin screwdrivers as shown below. If necessary, tap around it with a soft hammer while removing cap.

WHEEL HUB

Check wheel hub for crack by means of a magnetic exploration or dyeing test, and replace if cracked.

INSTALLATION

Install front axle in the reverse order of removal, noting the following:

1. Install bearing outer race with Front Wheel Bearing Drift ST35300000 until they seat in hub.
2. Pack hub and hub cap with recommended multi-purpose grease up to shaded portions.

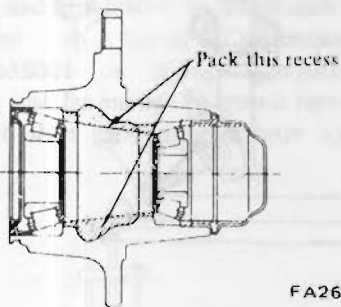

3. Coat each bearing cone with recommended multi-purpose grease.

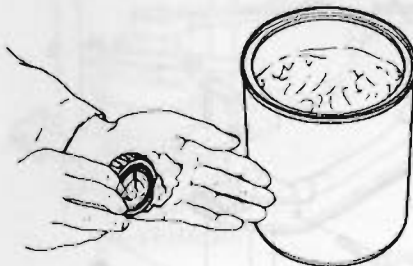

4. Place inner bearing cone in hub and install a new grease seal, coating sealing lips with recommended multi-purpose grease.
5. Concerning installation of brake parts, refer to Section BR.

T : Rotor to hub
54 - 74 N·m
(5.5 - 7.5 kg·m,
40 - 54 ft·lb)

6. Install hub with rotor and outer bearing cone.

7. Sparingly apply recommended multi-purpose grease to threaded portion of spindle and bearing washer to bearing contacting face. Then install washer and wheel bearing nut.

8. Adjust wheel bearing preload. Refer to Section MA for adjustment.

- a. In order to assure correct bearing starting torque and to extend service life of wheel bearings, be sure to avoid dirt and foreign particles getting in bearings, grease seal, washer, bearing nut, etc.
- b. Grease should be changed at each disassembly and in accordance with Periodic Maintenance Schedule.

8. Install O-ring on hub cap and install hub cap on hub.

9. Install brake caliper assembly, referring to Section BR.

10. Install wheel and tire.

FRONT SUSPENSION

When removing each suspension part, check wheel alignment and adjust if necessary. Refer to section MA for front axle and front suspension.

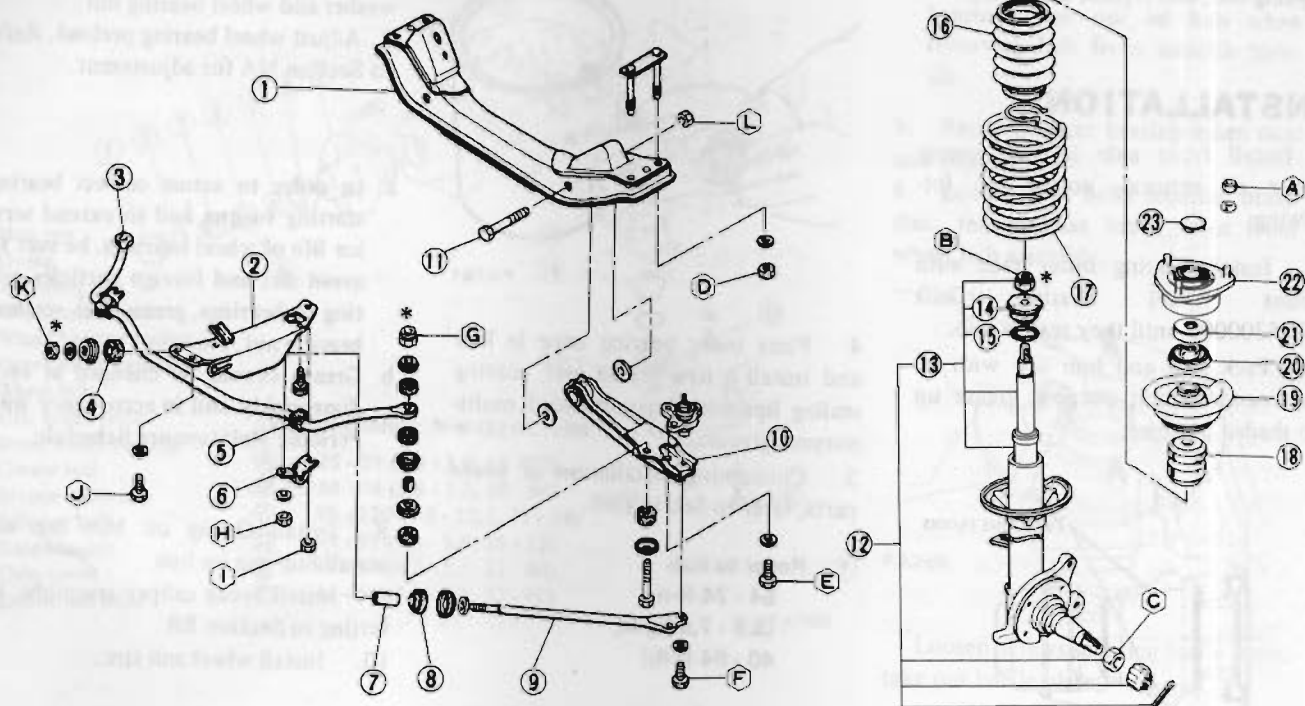

- 1 Suspension crossmember
- 2 Tension rod bracket
- 3 Stabilizer bar
- 4 Tension rod mounting bushing
- 5 Stabilizer bushing
- 6 Stabilizer bracket
- 7 Tension rod collar
- 8 Tension rod mounting bushing
- 9 Tension rod
- 10 Transverse link

- 11 Transverse link mounting bolt
- 12 Strut assembly
- 13 Shock absorber
- 14 Gland packing
- 15 O-ring
- 16 Dust cover
- 17 Front spring
- 18 Bound bumper
- 19 Front spring upper seat
- 20 Dust seal
- 21 Strut mounting bearing
- 22 Strut mounting insulator
- 23 Cap

Tightening torque N-m (kg-m, ft-lb)

- A : 29 - 39 (3.0 - 4.0, 22 - 29)
- B : 59 - 74 (6.0 - 7.5, 43 - 54)
- C : 25 - 29 (2.5 - 3.0, 18 - 22)
- D : 69 - 88 (7.0 - 9.0, 51 - 65)
- E : 44 - 54 (4.5 - 5.5, 33 - 40)
- F : 44 - 54 (4.5 - 5.5, 33 - 40)
- G : 16 - 22 (1.6 - 2.2, 12 - 16)
- H : 26 - 36 (2.7 - 3.7, 20 - 27)
- I : 26 - 36 (2.7 - 3.7, 20 - 27)
- J : 31 - 42 (3.2 - 4.3, 23 - 31)
- K : 44 - 54 (4.5 - 5.5, 33 - 40)
- L : 78 - 98 (8.0 - 10.0, 58 - 72)

*: Replace self-locking nut whenever strut, tension rod and stabilizer are disassembled.

FA790

SPRING AND STRUT ASSEMBLY

REMOVAL

1. Disconnect brake tube from brake assembly.
2. Remove brake caliper assembly.
3. Remove wheel hub and wheel bearing, if necessary.
4. Remove bolt connecting strut to knuckle arm.

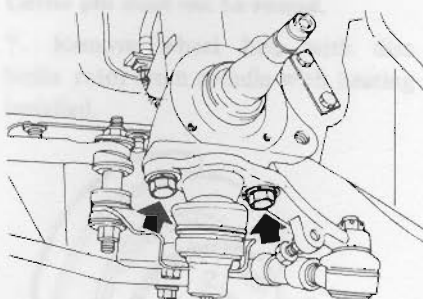

FA704

lower arm down with a suitable bar.

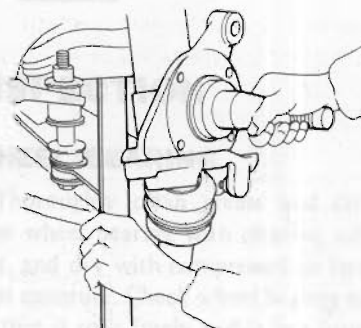

FA791

5. Detach knuckle arm from bottom of strut. This can be done by forcing

6. Support strut assembly with a jack or suitable stand and remove three nuts securing strut to hoodledge. Strut assembly and spring can then be removed as a unit.

DISASSEMBLY

When disassembling a strut, extra caution should be exercised to avoid dirt and dust getting inside strut. This dirt and dust is loaded with abrasive which, if enters strut, causes internal leak and premature wear of moving parts.

1. Secure Strut & Steering Gear Housing Attachment KV48100300 in a vise and install strut on attachment.
2. Set up Spring Compressor ST3565S001 on spring. Compress spring just far enough to permit turning of strut mounting insulator by hand.

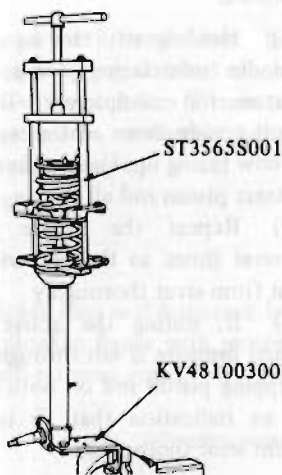

FA658

3. Remove lock nut on top of piston rod; remove mounting insulator, strut mounting bearing, dust seal, strut seat, spring and bumper rubber.

CAUTION:

Be sure to hook special tool (ST35651001) evenly on a minimum of three coils, paying attention not to damage piston rod.

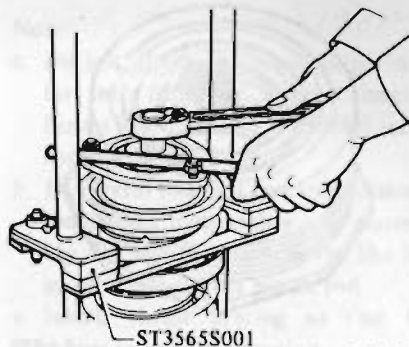

FA706

4. Retract piston rod by pushing it down until it bottoms. Remove gland packing with Gland Packing Wrench ST35500001.

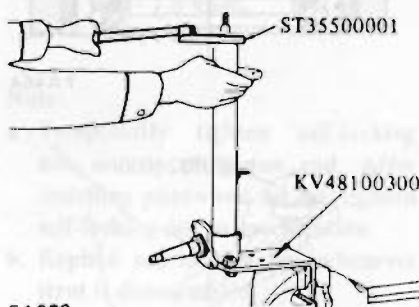

FA209

Note: Clean gland packing of mud and other foreign particles accumulated.

5. Remove O-ring from top of piston rod guide bushing.
6. Lift out piston rod together with cylinder.

Note: Do not remove piston rod quickly as this will cause oil to spurt out.

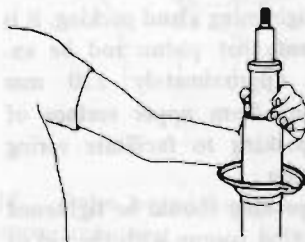

FA275

Note: Piston rod, piston rod guide and cylinder are adjusted to provide precision mating surfaces and should be handled as a matched set.

7. Drain fluid thoroughly from inner cylinder and discard.
8. Wash all parts in suitable solvent.
9. Drain fluid thoroughly from outer casing.

Note: This operation is very important since performance of strut varies with amount of fluid filled within strut.

INSPECTION

1. Replace gland packing, O-ring and fluid whenever strut is disassembled.
2. Wash all parts, except for non-metallic parts, with suitable solvent and dry with compressed air.
3. Blow dirt and dust off of non-metallic parts using compressed air.

Note:

- a. Oil oozing out at and around gland packing does not call for strut maintenance. If oil leaks past spring seat, check piston rod and gland packing to correct the cause of problem. If oil leakage occurs on welded portion of outer strut casing, replace strut outer casing assembly.
- b. If shock absorber itself is malfunctioning, replace as an assembly (including piston rod, cylinder, bottom valve and guide bushing).

Outer casing

Check outer casing for evidences of deformation, cracking or other damage. If necessary, discard.

Strut mounting insulator

Replace if cemented rubber-to-metal joints are melted or cracked. Rubber parts should also be replaced, if deteriorated.

Strut mounting bearing

Replace if inspection reveals abnormal noise or excessive rattle in axial direction.

Note: Check dust seal for scratches or cracks on lips and replace if necessary.

ASSEMBLY

When assembling strut, be careful not to drop or scratch parts since they are precisely machined to very close tolerances. Before assembly, clean away all dirt to prevent any possible entry of dirt into strut.

Note: If replacement of any strut component parts is found to be necessary, make sure that parts are the same brand as those used in the strut assembly.

1. Install strut outer casing on Strut & Steering Gear Housing Attachment KV48100300.
2. Install cylinder and piston rod assembly (shock absorber kit) in outer casing.
3. Remove piston rod guide from cylinder and pour correct amount of new fluid into cylinder and strut outer casing.

Amount of oil:
 275 ml (9.3 US fl oz,
 9.7 Imp fl oz)

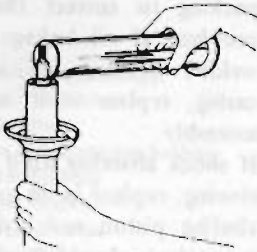

FA065

Note:

- a. It is important that correct amount of fluid be poured into strut to assure correct damping force of shock absorber.
 - b. Use **GENUINE NISSAN STRUT OIL** or equivalent every after over-haul.
4. Securely install piston rod guide in cylinder.

Note: Be careful not to damage guide with thread portion of piston rod.

5. Install new O-ring over rod guide.
6. Lubricate sealing lips of gland packing with lithium base grease (containing molybdenum disulphide) and install gland packing with Gland Packing Guide ST35520000.

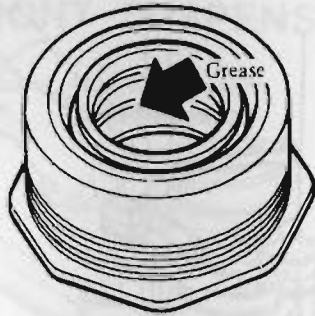

FA659

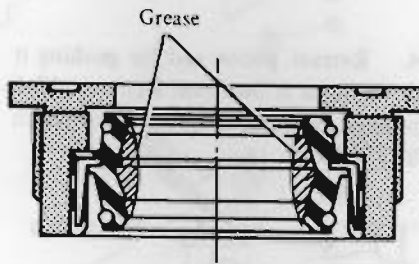

FA464



FA276

7. Tighten gland packing.

Ⓣ : Gland packing
 98 - 127 N·m
 (10.0 - 13.0 kg·m,
 72 - 94 ft·lb)

Note:

- a. When tightening gland packing, it is important that piston rod be extended approximately 120 mm (4.72 in) from upper surface of gland packing to facilitate spring installation.
- b. Gland packing should be tightened to specified torque with the aid of Gland Packing Wrench ST35500001. When doing so, the amount of torque to be read beneath wrench needle should be modified according to the following formula:

$$C \text{ N}\cdot\text{m} = 98 \times \left(\frac{L}{L + 0.10} \right) \text{ or}$$

$$C \text{ kg}\cdot\text{m} = 10 \times \left(\frac{L}{L + 0.10} \right) \text{ or}$$

$$C \text{ ft}\cdot\text{lb} = 72 \times \left(\frac{L}{L + 0.33} \right)$$

where,

C Value to be read on the torque wrench [N·m (kg·m, ft·lb)]

L Effective length of torque wrench [m (ft)]

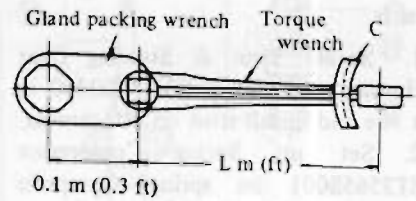

FA278

8. Bleed air out of shock absorber as follows:

- (1) Holding strut by hand with its spindle side facing down, pull out piston rod completely. Then, turn strut upside down so that spindle side is now facing up. Under this condition, retract piston rod all the way in.
- (2) Repeat the above procedure several times so that air will be bled out from strut thoroughly.
- (3) If, during the above step, an equal pressure is felt through the hand gripping piston rod on both strokes, it is an indication that air is expelled from strut thoroughly.

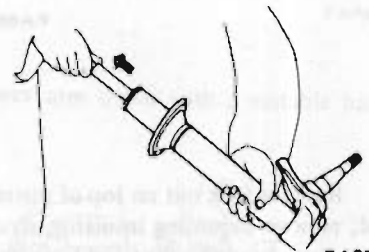

FA070

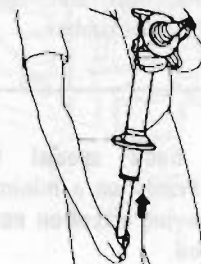

FA071

9. Place Strut & Steering Gear Housing Attachment KV48100300 in jaws of a vise.

10. Before proceeding with further steps, pull piston rod all the way out to the limit of its stroke; install bound bumper rubber in place to prevent piston rod from falling by its own weight.

11. Compress spring with Spring Compressor ST35651001.

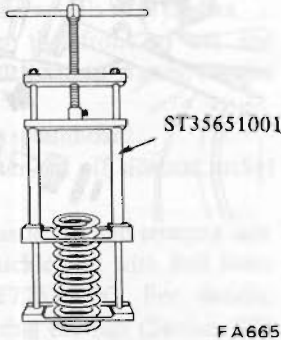

Note: To prevent interference between upper spring seat and special tool, leave upper 2.5 to 3 turns of spring coils free, compress spring and assemble to strut.

12. Lubricate dust seal indicated by arrow in following figure with recommended multi-purpose grease.

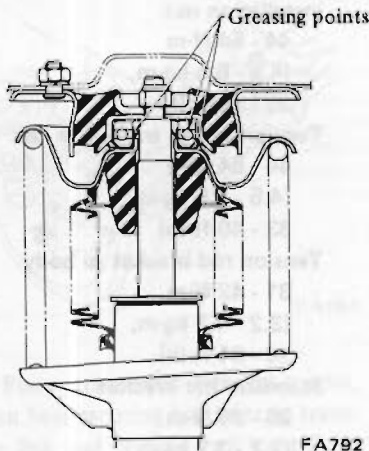

13. Install dust cover, upper spring seat, dust seal, mounting bearing and insulator in this written order.

Note:

- Do not allow piston rod to go too far into strut. If it does, screw Piston Rod Puller ST35600000 into rod end and pull out.
- Be careful to avoid damaging piston rod during disassembly and assembly. Do not use pliers or the like in an effort to extract piston rod.
- Install thrust bearing so that it points in correct direction.

14. Tighten new piston rod self-locking nut.

⊕ : Piston rod self-locking nut
 59 - 74 N·m
 (6.0 - 7.5 kg·m,
 43 - 54 ft·lb)

Note:

- Temporarily tighten self-locking nut on tip of piston rod. After installing piston rod on car, tighten self-locking nut to specification.
- Replace self-locking nut whenever strut is disassembled.

15. To prevent entry of water and dust, apply a thick coat of recommended multi-purpose grease

16. After placing spring in position between upper and lower spring seats, release compressor gradually.

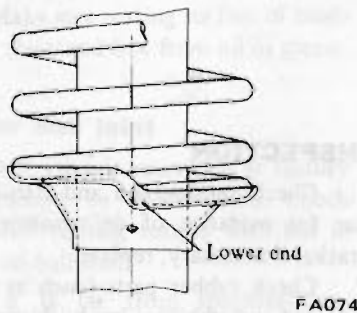

17. Raise bound bumper rubber to upper spring seat.

INSTALLATION

Install strut and spring assembly in reverse order of removal.

⊕ : Strut to hoodledge

29 - 39 N·m
 (3.0 - 4.0 kg·m,
 22 - 29 ft·lb)

Steering knuckle arm to strut

72 - 97 N·m
 (7.3 - 9.9 kg·m,
 53 - 72 ft·lb)

Note: Make sure brake hose is secure and not twisted.

CARTRIDGE TYPE SHOCK ABSORBER

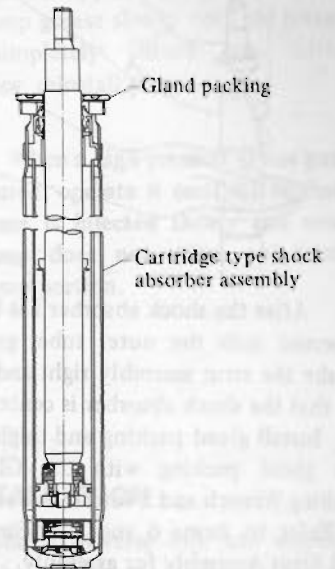

REMOVAL, INSTALLATION AND DISASSEMBLY

Refer to Spring and Strut Assembly for removal, disassembly and installation.

ASSEMBLY

1. Visually check the exterior of the shock absorber for any abnormality.

Note: Also check the part number of the shock absorber to see that the shock absorber is the correct type specified for the car.

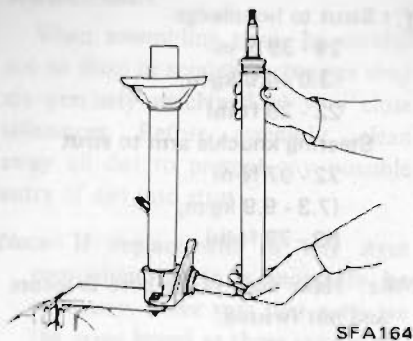

SFA164

2. Carefully insert the shock absorber into the outer strut tube.

CAUTION:

Do not drop the shock absorber or otherwise mishandle it.

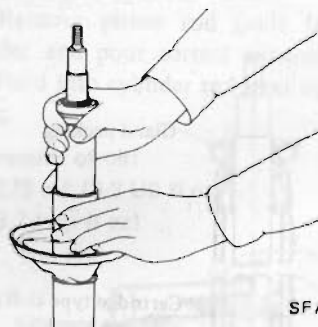

SFA165

3. After the shock absorber has been inserted into the outer tube, gently shake the strut assembly right and left so that the shock absorber is centered.

4. Install gland packing and tighten the gland packing with the Gland Packing Wrench and a torque wrench.

Refer to items 6 and 7 of Spring and Strut Assembly for assembly.

Note: Be careful not to damage the piston rod during tightening.

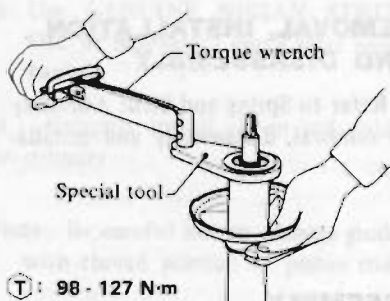

SFA167

Ⓣ: 98 - 127 N·m
(10 - 13 kg·m,
72 - 94 ft·lb)

5. Further steps are the same procedure as the standard type spring and strut assembly. Refer to item 8 through 17 of Spring and Strut Assembly for assembly.

TENSION ROD AND STABILIZER BAR

REMOVAL

1. Jack up the front of car and support it with safety stands; remove wheels.
2. Remove splashboard.
3. Back off nut ③ securing tension rod to bracket and remove bolts ④ which secure tension rod to lower arm. Tension rod can then be taken out.

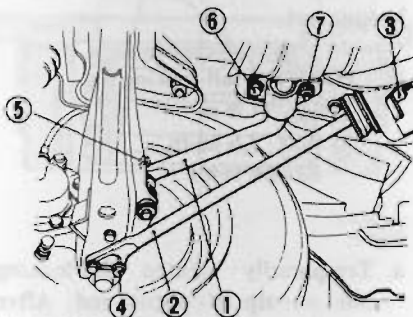

FA835

- 1 Stabilizer bar
- 2 Tension rod

4. Remove nuts ⑤ securing stabilizer bar to connecting rod.

Note: Two wrenches are necessary in this operation.

5. Remove bolts ⑥ and nuts ⑦ securing stabilizer bar bracket in position. Stabilizer bar can then be taken out.

INSPECTION

1. Check tension rod and stabilizer bar for evidence of deformation or cracks; if necessary, replace.
2. Check rubber parts (such as tension rod and stabilizer bar bushings) to be sure they are not deteriorated or cracked; if necessary, replace.

INSTALLATION

Install tension rod and stabilizer bar in the reverse order of removal.

Note:

- a. To install stabilizer bar, first temporarily tighten stabilizer bar bracket securing nuts and bolts. Final tightening should be carried out at curb weight with tires on ground.
- b. Noting direction of tension rod bushing, properly center bushing in tension rod bushing washer.

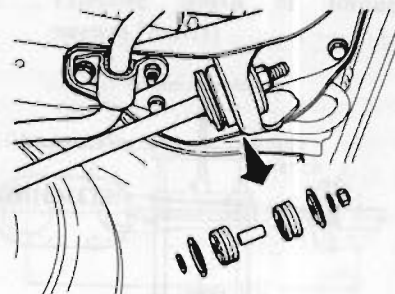

FA793

- c. After installation, make sure minimum clearances between tension rods and stabilizer bar are equal on both sides.
- d. Closely observe torque specification when tightening tension rod bracket retaining bolts.
- e. First tighten tension rod on bracket side to specified torque setting; then tighten the other end on lower arm.

Ⓣ: Tension rod bushing installation nut

44 - 54 N·m
(4.5 - 5.5 kg·m,
33 - 40 ft·lb)

Tension rod to transverse link

44 - 54 N·m
(4.5 - 5.5 kg·m,
33 - 40 ft·lb)

Tension rod bracket to body

31 - 42 N·m
(3.2 - 4.3 kg·m,
23 - 31 ft·lb)

Stabilizer bar bracket

26 - 36 N·m
(2.7 - 3.7 kg·m,
20 - 27 ft·lb)

Stabilizer bar connecting rod

16 - 22 N·m
(1.6 - 2.2 kg·m,
12 - 16 ft·lb)

TRANSVERSE LINK AND LOWER BALL JOINT

The transverse link is connected to the suspension member through a rubber bushing and to the strut through a ball joint.

The lower ball joint is assembled at factory and cannot be disassembled.

REMOVAL

1. Block rear wheels with chocks.
2. Jack up the front of car and support it with safety stands; remove wheel.
3. Remove splashboard.
4. Pry cotter pin off side rod socket ball joint.

Remove castle nut and separate side rod from knuckle arm with Ball Joint Remover HT72520000. For details, refer to Steering Linkage (Section ST) for removal.

5. Loosen bolts securing knuckle arm to lower end of strut, and separate knuckle arm from strut. For details, refer to Spring and Strut Assembly for removal.

6. Remove tension rod and stabilizer bar. For details, refer to Tension Rod and Stabilizer Bar for removal.

7. Loosen transverse link mounting bolt and separate transverse link from suspension member. Remove transverse link with lower ball joint and knuckle arm.

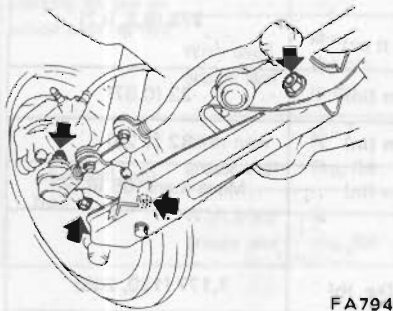

FA794

8. Place transverse link in a vise, loosen bolt securing ball joint to transverse link and remove ball joint from transverse link.

9. Withdraw transverse link bushing from transverse link using Front Transverse Link Bushing Replacer Set KV40101200.

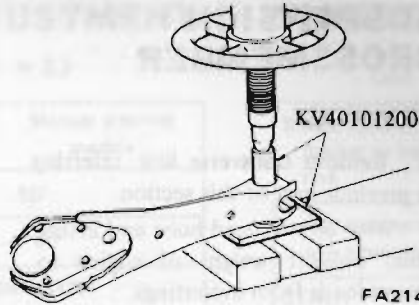

FA214

10. Remove suspension ball joint from knuckle arm using a press.

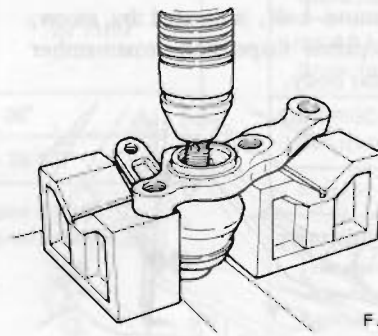

FA712

INSPECTION

Transverse link

1. Repair or replace transverse link if deformed, cracked or damaged.
2. If rubber bushing shows evidence of cracking, replace with a new one.
3. Make sure mating surface of bushing is clean and free from oil or grease.

Lower ball joint

1. Ball joint is assembled at factory and cannot be disassembled. Check ball stud turning torque with nut in place on ball stud.

If it is far from specifications, replace.

Turning torque:

New parts
 2.5 - 7.8 N·m
 (25 - 80 kg-cm,
 22 - 69 in-lb)

Used parts
 More than 1.5 N·m
 (15 kg-cm, 13 in-lb)

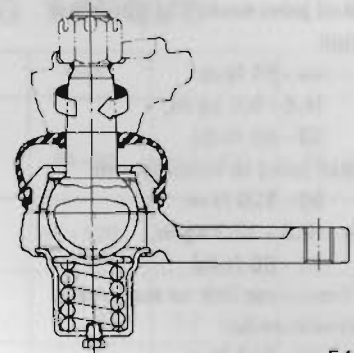

FA333

2. Check condition of dust cover. If it is cracked excessively, replace ball joint.

3. Lubricate ball joint with recommended multi-purpose grease.

To lubricate, remove plug and install grease nipple.

Pump grease slowly until old grease is completely forced out. After greasing, reinstall plug.

Note: When a high-pressure grease gun is used, operate it carefully so that grease is injected slowly and new grease does not come out from clamp portion.

INSTALLATION

Install transverse link and suspension ball joint in reverse order of removal.

Note:

- a. When installing transverse link spindle, install it together with rear side lower arm bushing.
- b. To install transverse link, first temporarily tighten nuts securing transverse link spindle which connects transverse link to suspension crossmember. Final tightening should be carried out at curb weight with tires on ground. And also, at this time, front side nut should be tightened before rear side nuts.
- c. Make sure mating surface of bushing is clean and free from oil and grease.

Ⓣ : Ball joint socket to transverse link

44 - 54 N·m
(4.5 - 5.5 kg-m,
33 - 40 ft-lb)

Ball joint to knuckle arm

96 - 120 N·m
(9.8 - 12.2 kg-m,
71 - 88 ft-lb)

Transverse link to suspension crossmember

78 - 108 N·m
(8.0 - 11.0 kg-m,
58 - 80 ft-lb)

Side rod ball joint to knuckle arm

54 - 98 N·m
(5.5 - 10.0 kg-m,
40 - 72 ft-lb)

Knuckle arm to strut

72 - 97 N·m
(7.3 - 9.9 kg-m,
53 - 72 ft-lb)

SUSPENSION CROSSMEMBER

REMOVAL

1. Remove transverse link, referring to previous part of this section.
2. With an overhead hoist and lifting cable, support weight of engine to remove loads from mountings.
3. Remove engine mounting nuts. Separate suspension crossmember from engine.
4. Separate steering gear from suspension crossmember. Refer to section ST.
5. Remove bolt, indicated by arrow, and separate suspension crossmember from car body.

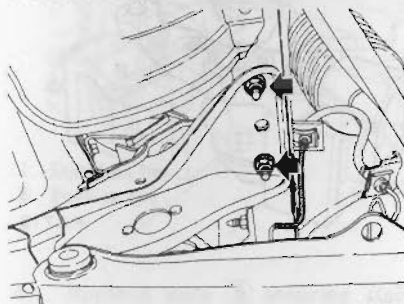

FA713

INSPECTION

Check suspension crossmember for evidence of deformation or cracking; if necessary, replace.

INSTALLATION

Install suspension crossmember in reverse order of removal.

Ⓣ : Suspension member to body frame

69 - 88 N·m
(7.0 - 9.0 kg-m,
51 - 65 ft-lb)

Engine mounting insulator to suspension member

31 - 42 N·m
(3.2 - 4.3 kg-m,
23 - 31 ft-lb)

SERVICE DATA AND SPECIFICATIONS (S.D.S.)

GENERAL SPECIFICATIONS

COIL SPRING

Model	Side	Dimension A x C x L *1	Color identi- fication	Spring constant N/mm (kg/mm, lb/in)
2 seater (Except GL)	R.H.	13.0 x 150 x 306.5 (0.512 x 5.91 x 12.07)	White & Yellow	22.16 (2.26 126.6)
	L.H.			
2 seater GL 2 + 2 seater (Except GL)	R.H.	13.0 x 150 x 315.5 (0.512 x 5.91 x 12.42)	White & White	22.16 (2.26, 126.6)
	L.H.			
2 + 2 seater GL	R.H.	13.0 x 150 x 324.5 (0.512 x 5.91 x 12.78)	Red & Blue	22.16 (2.26, 126.6)
	L.H.			

*1: A x C x L

Wire diameter [mm (in)] x Coil diameter [mm (in)]
x Free length [mm (in)]

STRUT ASSEMBLY

Shock absorber type	Double acting hydraulic	
Shock absorber fluid mℓ (US fl oz, Imp fl oz)	275 (9.3, 9.7)	
Piston rod diameter	mm (in)	22 (0.87)
Piston diameter	mm (in)	32 (1.26)
Stroke	mm (in)	More than 165 (6.50)
Damping force [at 0.3 m (1.0 ft)/sec.]		
Expansion	N (kg, lb)	1,177 (120, 265)
Compression	N (kg, lb)	392 (40, 88)

STABILIZER BAR

Bar diameter	mm (in)	23 (0.91)
--------------	---------	-----------

INSPECTION AND ADJUSTMENT TIGHTENING TORQUE

WHEEL ALIGNMENT (Unladen * 1)

		Power steering models	Manual steering models
Camber	degree	-35' - 55'	
Caster	degree	4° 10' - 5° 40'	
Toe-in	mm (in)	1 - 3 (0.04 - 0.12)	
	degree *2	6' - 16'	
Kingpin inclination	degree	8° 35' - 10° 5'	
Front wheel turning angle	Toe-out-turns (Inside/Outside) degree	20°/18.1°	20°/18.7°
	Inside degree	32° - 36°	
	Outside degree	24-1/2° - 28-1/2°	

- *1: Tankful of fuel, radiator coolant and engine oil full. Spare tire, jack, hand tools, mats in designed position.
- *2: On both sides

WHEEL BEARING

Wheel bearing axial play	mm (in)	0 (0)	
Wheel bearing nut tightening torque	N·m (kg·m, ft·lb)	25 - 29 (2.5 - 3.0, 18 - 22)	
Return angle	degree	60°	
Wheel bearing starting torque at wheel bearing nut	With new grease seal	N·m (kg·cm, in·lb)	0.39 - 0.83 (4.0 - 8.5, 3.5 - 7.4)
	With used grease seal	N·m (kg·cm, in·lb)	0.10 - 0.44 (1.0 - 4.5, 0.9 - 3.9)
At wheel hub bolt	With new grease seal	N (kg, lb)	Less than 17.7 (1.8, 4.0)
	With used grease seal	N (kg, lb)	Less than 6.9 (0.7, 1.5)

LOWER BALL JOINT

Turning torque	New parts	N·m (kg·cm, in·lb)	2.5 - 7.8 (25 - 80, 22 - 69)
	Used parts	N·m (kg·cm, in·lb)	More than 1.5 (15, 13)

Unit	N·m	kg·m	ft·lb
BALL JOINT			
Socket to transverse link	44 - 54	4.5 - 5.5	33 - 40
Ball joint to knuckle arm (stud nut)	96 - 120	9.8 - 12.2	71 - 88
STRUT			
Knuckle arm to strut	72 - 97	7.3 - 9.9	53 - 72
Strut to hoodledge	29 - 39	3.0 - 4.0	22 - 29
Piston rod self-locking nut	59 - 74	6.0 - 7.5	43 - 54
Gland packing	98 - 127	10.0 - 13.0	72 - 94
DISC BRAKE			
Rotor to hub	54 - 74	5.5 - 7.5	40 - 54
SIDE ROD			
Ball joint nut	54 - 98	5.5 - 10.0	40 - 72
Side rod lock nut	78 - 98	8.0 - 10.0	58 - 72
TRANSVERSE LINK			
Transverse link to suspension cross-member	78 - 108	8.0 - 11.0	58 - 80
TENSION ROD			
Bushing nut	44 - 54	4.5 - 5.5	33 - 40
Tension rod to transverse link	44 - 54	4.5 - 5.5	33 - 40
Tension rod bracket	31 - 42	3.2 - 4.3	23 - 31
STABILIZER BAR			
Stabilizer bar bracket	26 - 36	2.7 - 3.7	20 - 27
Stabilizer mounting nut	16 - 22	1.6 - 2.2	12 - 16
SUSPENSION CROSSMEMBER			
Suspension member to body frame	69 - 88	7.0 - 9.0	51 - 65
Engine mounting insulator to suspension member	31 - 42	3.2 - 4.3	23 - 31

TROUBLE DIAGNOSES AND CORRECTIONS

Condition	Probable cause	Corrective action
<p>Vibration, shock and shimmy of steering wheel.</p> <p>Vibration: Loose connection of the serration parts and wear of each part of linkage cause vibration of front wheels and, steering wheel vibration. This is very noticeable when travelling on rough road.</p> <p>Shock: When the front wheels are travelling on bumpy roads, the play of the steering linkage is transmitted to the steering wheel. This is especially noticeable when travelling on rough road.</p> <p>Shimmy: Abnormal vibration of the front suspension system and the whole steering linkage, which occurs at specific speeds.</p>	<p>Improper tire pressure.</p> <p>Imbalance and deformation of road wheel.</p> <p>Unevenly worn tire or insufficient tightening of wheel nuts.</p> <p>Improperly adjusted or worn front wheel bearing.</p> <p>Faulty wheel alignment.</p> <p>Worn lower arm bushings.</p> <p>Insufficiently tightened steering gear housing.</p> <p>Wear of steering linkage.</p> <p>Worn suspension ball joint.</p> <p>Excessive backlash due to improper adjustment of the steering gear box.</p> <p>Damaged idler arm.</p> <p>Worn column bearing, weakened column bearing spring, or loose clamp.</p> <p>Malfunction of shock absorber (inside the strut) or loose installation bolts.</p> <p>Imbalance of car level.</p>	<p>Adjust.</p> <p>Correct the imbalance or replace.</p> <p>Replace or tighten.</p> <p>Adjust or tighten.</p> <p>Adjust.</p> <p>Replace.</p> <p>Tighten.</p> <p>Replace faulty parts.</p> <p>Replace.</p> <p>Adjust correctly.</p> <p>Replace.</p> <p>Replace or retighten.</p> <p>Replace or retighten.</p> <p>Correct the imbalance.</p>
<p>Car pulls to right or left.</p> <p>When driving with hands off the steering wheel on a flat road, the car gently swerves to right or left.</p> <p>Note: A faulty rear suspension may also be the cause of this problem and, therefore, see also Section RA.</p>	<p>Improper tire pressure or insufficient tightening of wheel nuts.</p> <p>Difference in wear and tear of right and left tire treads.</p> <p>Incorrect adjustment or abrasion of front wheel bearing.</p> <p>Collapsed or twisted front spring.</p> <p>Incorrect wheel alignment.</p> <p>Incorrect brake adjustment (binding).</p> <p>Worn rubber bushings for lower arm and tension rod.</p> <p>Deformed steering linkage and lower arm and tension rod.</p> <p>Imbalance of car level.</p>	<p>Adjust or tighten.</p> <p>Replace tires.</p> <p>Adjust or replace.</p> <p>Replace.</p> <p>Adjust.</p> <p>Adjust.</p> <p>Replace.</p> <p>Replace.</p> <p>Correct the imbalance.</p>





Front Axle & Front Suspension

Condition	Probable cause	Corrective action
<p>Instability of car.</p>	<p>Improper tire pressure. Worn rubber bushings for lower arm and tension rod. Incorrect wheel alignment. Worn or deformed steering linkage and suspension link. Incorrect adjustment of steering gear. Deformed or unbalanced wheel.</p>	<p>Adjust. Replace. Adjust. Replace. Adjust. Correct or replace.</p>
<p>Stiff steering wheel. (Checking up procedure)</p> <p>Jack up front wheels, detach the steering gear arm and operate the steering wheel, and;</p> <p>If it is light, check steering linkage, and suspension parts. If it is heavy, check steering gear and steering column parts.</p>	<p>Improper tire pressure. Insufficient lubricants or mixing impurities in steering gear box or excessively worn steering linkage. Stiff or damaged suspension ball joint, or lack of grease. Worn or incorrectly adjusted wheel bearing. Worn or damaged steering gear and bearing. Incorrectly adjusted steering gear. Deformed steering linkage. Incorrect wheel alignment. Damaged strut mounting bearing. Damaged or stiff piston or shock absorber piston rod (in the strut). Interference of steering column with turn signal switch.</p>	<p>Adjust. Replenish grease or replace the part. Replace. Replace or adjust. Replace. Adjust. Replace. Adjust. Replace. Replace. Replace.</p>
<p>Excessive steering wheel play.</p>	<p>Incorrectly adjusted steering gear housing. Worn steering linkage. Improperly fitted gear housing. Incorrectly adjusted wheel bearing. Worn lower arm and tension rod bushings.</p>	<p>Adjust. Replace. Retighten. Adjust. Replace.</p>
<p>Noises.</p>	<p>Improper tire pressure. Insufficient lubricating oil and grease for suspension ball joint and steering linkage, or their breakage. Loose steering gear bolts, linkage and suspension parts. Faulty shock absorber (inside the strut). Faulty wheel bearing. Worn steering linkage and steering gear. Worn lower arm and tension rod bushings. Broken or collapsed coil spring.</p>	<p>Adjust. Replenish lubricating oil and grease, or replace. Retighten. Replace. Replace. Replace. Replace. Replace.</p>

Front Axle & Front Suspension

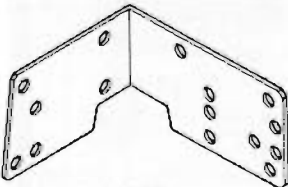
Condition	Probable cause	Corrective action
	Loose stabilizer bar installation bolts and nuts.	Retighten.
	Loose strut to hoodledge installation nuts.	Retighten.
Grating tire noise.	Improper tire pressure. Incorrect wheel alignment. Deformed knuckle spindle and suspension linkage.	Adjust. Adjust. Replace.
Jumping of disc wheel.	Improper tire pressure. Imbalanced wheels. Faulty shock absorber. Faulty tire. Deformed wheel rim.	Adjust. Adjust. Replace. Replace. Replace.
Excessively or partially worn tire.	Improper tire pressure. Incorrect wheel alignment. Faulty wheel bearing. Incorrect brake adjustment. Tires not rotated. Rough and improper driving manner.	Adjust. Adjust. Replace. Adjust. Rotate tires at recommended intervals. Drive more gently.

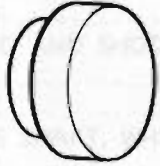
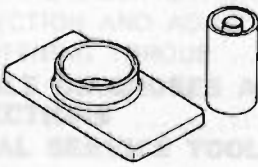
SPECIAL SERVICE TOOLS

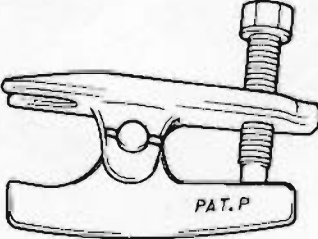
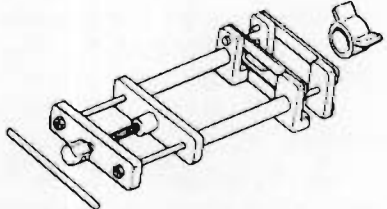
Tool number & tool name	Kent-Moore No.	Tool number & tool name	Kent-Moore No.
	Reference page		Reference page
KV48100300 Strut and steering gear housing attachment 	J 25729	ST35520000 Gland packing guide 	J25826
	Page FA-5		Page FA-6
ST35300000 Front wheel bearing drift 	—	KV40101200 Transverse link bushing replacer 	See J26363-A
	Page FA-3		Page FA-9
ST35500001 Gland packing wrench 	J 25825	HT72520000 Ball joint remover 	J25730-A
	Page FA-5		Page FA-9
ST3565S001 Coil spring compressor set 	J 25833		
	Page FA-5		