

DATSUN 280Z
MODEL S30 SERIES



NISSAN MOTOR CO., LTD.
TOKYO, JAPAN

SECTION EE

ENGINE ELECTRICAL SYSTEM

EE

BATTERY	EE- 2
STARTING MOTOR	EE- 5
CHARGING CIRCUIT	EE-13
ALTERNATOR	EE-15
REGULATOR	EE-20
IGNITION CIRCUIT	EE-26
DISTRIBUTOR	EE-27
TRANSISTOR IGNITION UNIT	EE-32
IGNITION COIL	EE-45
SPARK PLUG	EE-46

BATTERY

CONTENTS

REMOVAL	EE-2	BATTERY FREEZING	EE-3
CHECKING ELECTROLYTE LEVEL	EE-2	CHARGING	EE-3
CHECKING SPECIFIC GRAVITY	EE-2	INSTALLATION.....	EE-3

REMOVAL

1. Disconnect negative and positive cables.
2. Remove nuts from battery clamps; take off clamps.
3. Remove battery.

CHECKING ELECTROLYTE LEVEL

Remove six vent plugs and check for electrolyte level in each cell. If necessary, pour distilled water.

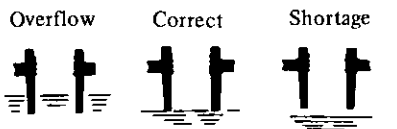

EE358

Fig. EE-1 Inspecting electrolyte level

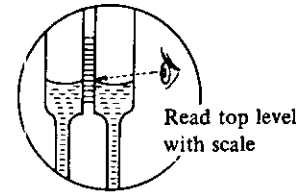
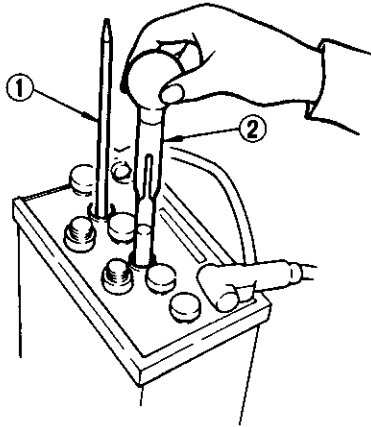

- 1 Thermal gauge
 - 2 Hydrometer
- EE001

Fig. EE-2 Checking specific gravity

$$S_{20} = St + 0.0007 (t - 20)$$

Where

- St: Specific gravity of electrolyte at t°C
 S₂₀: Specific gravity of electrolyte corrected at 20°C (68°F)
 t: Electrolyte temperature

For example: A hydrometer reading of 1.260 at 30°C (86°F) would be 1.267 corrected to 20°C (68°F), indicating fully charged battery. On the other hand, a hydrometer reading of 1.220 at -10°C (14°F) would be 1.199 corrected to 20°C (68°F), indicating a partially charged battery.

The state of charge of battery can be determined by the following table if the specific gravity of electrolyte is known. Before checking, be sure that cells are filled to correct level.

CHECKING SPECIFIC GRAVITY

Specific gravity of battery electrolyte is tested by a hydrometer. If the state of charge of battery is 60% or specific gravity reading is below 1.20 [as corrected at 20°C (68°F)], battery must be recharged or battery-electrolyte concentration adjusted.

Add or subtract gravity points according to whether the electrolyte temperature is above or below 20°C (68°F) standard.

The gravity of electrolyte changes 0.0007 for every 1°C (1.8°F) temperature. A correction can then be made by using the following formula:

Converted specific gravity (S₂₀)

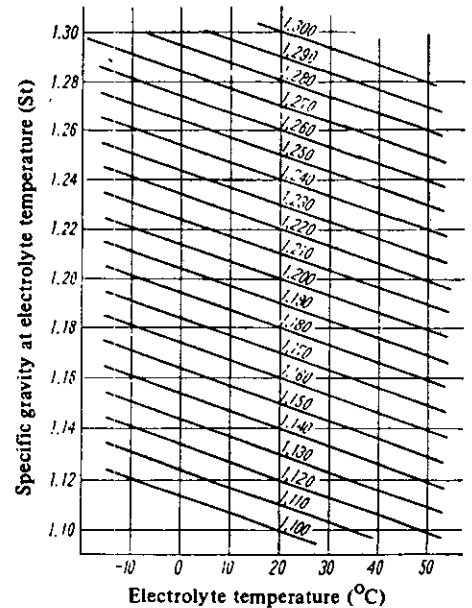

EE003

Fig. EE-4 Specific gravity at electrolyte temperature

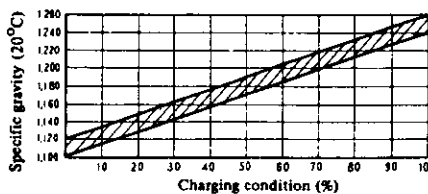

EE002

Fig. EE-3 Charging condition

BATTERY FREEZING

Battery electrolyte freezing point varies with acid concentration or its specific gravity. A battery with an insufficient charge will freeze at lower temperatures. If specific gravity of a battery falls below 1.1, this is an

indication that battery is completely discharged and will freeze readily when temperatures fall below freezing.

Note: Use extreme caution to avoid freezing battery since freezing will generally ruin the battery.

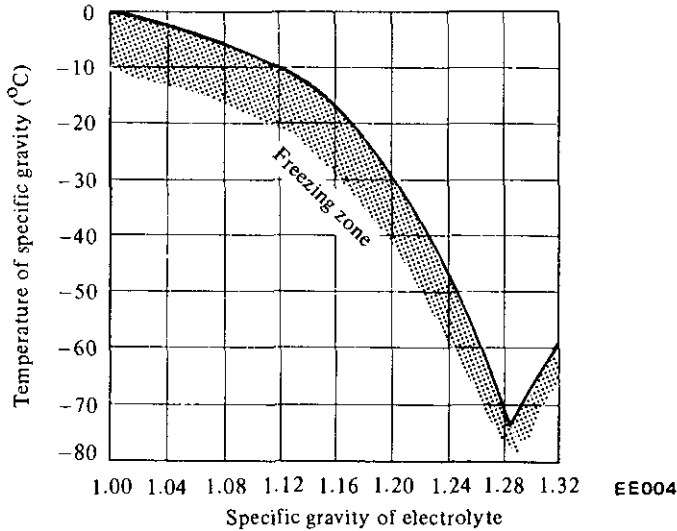

Fig. EE-5 Freezing point of electrolyte

CHARGING

If electrolyte level is satisfactory, battery must be recharged when electrolyte-gravity reading falls below 1.20. If battery on car is quick-charged

to bring it up to full charge, the operation should be carried out with negative cable removed.

Prior to charging, corroded ter-

minals should be cleaned with a brush and common baking-soda solution. In addition, the following items should be observed while battery is being charged.

1. Be sure that electrolyte level is above top of each plate.
2. Keep removed plugs in a safe place.
3. Do not allow electrolyte temperature to go over 45°C (113°F).
4. After recharging, check to be certain that specific gravity does not exceed 1.260 [at 20°C (68°F)]. Correction can be made by adding distilled water into cells as necessary.
5. Keep battery away from open flame while it is being recharged.
6. After all vent plugs have been tightened, clean all sprayed electrolyte off upper face of battery.

INSTALLATION

1. Install and tighten clamps securely.
2. After clamps have been tightened, clean battery cable terminals and apply grease to retard formation of corrosion.

TROUBLE DIAGNOSES AND CORRECTIONS

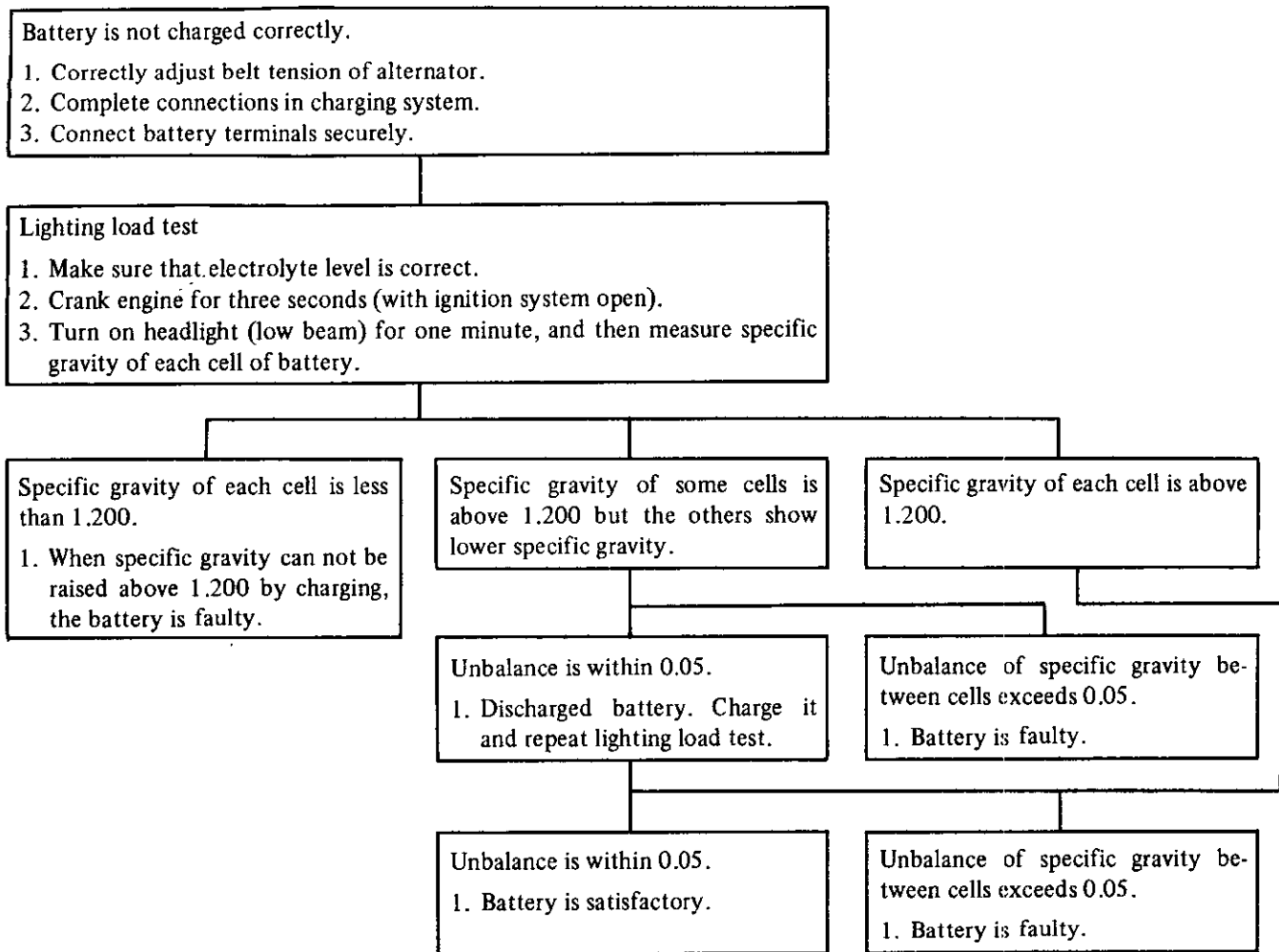

STARTING MOTOR

CONTENTS

DESCRIPTION	EE- 5	OVERRUNNING CLUTCH ASSEMBLY	EE-10
OPERATION	EE- 5	BRUSH HOLDER TEST FOR	
CONSTRUCTION	EE- 7	GROUND	EE-10
REMOVAL	EE- 8	BEARING METAL	EE-10
DISASSEMBLY	EE- 8	MAGNETIC SWITCH ASSEMBLY	EE-10
TYPE S114-122N	EE- 8	ASSEMBLY	EE-10
TYPE S114-182	EE- 8	TEST	EE-11
CLEANING AND INSPECTION	EE- 9	PERFORMANCE TEST	EE-11
TERMINAL	EE- 9	MAGNETIC SWITCH ASSEMBLY	
FIELD COIL	EE- 9	TEST	EE-11
BRUSHES AND BRUSH LEAD WIRE	EE- 9	SERVICE DATA AND SPECIFICATIONS	EE-12
BRUSH SPRING TENSION	EE- 9	TROUBLE DIAGNOSES AND	
ARMATURE ASSEMBLY	EE-10	CORRECTIONS	EE-12

DESCRIPTION

Type	Transmission
S114-122N	Manual
S114-182	Automatic

The function of the starting system which consists of the battery, ignition switch, starting motor and solenoid, is to crank the engine. The electrical energy is supplied from the battery,

the solenoid completes the circuit to operate the starting motor, and then the motor carries out the actual cranking of the engine.

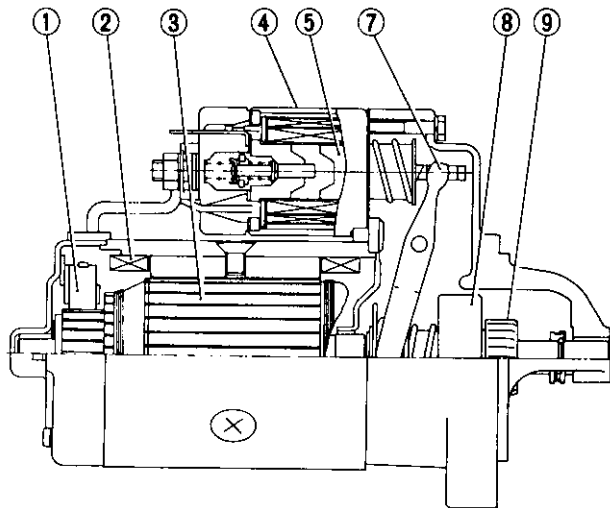

Type S114-122N

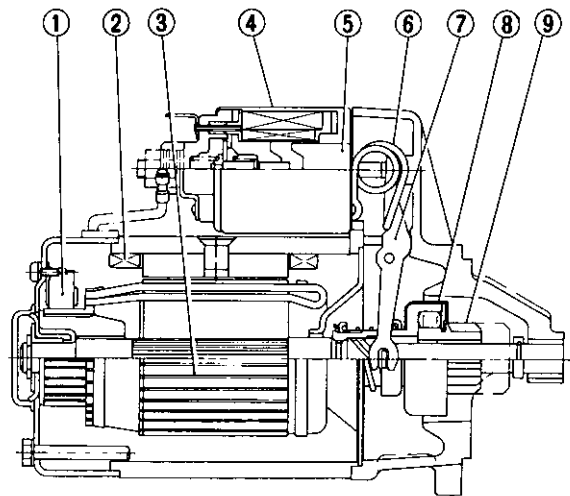

Type S114-182

EE359

- | | | |
|--------------|-------------------|----------------------|
| 1 Brush | 4 Magnetic switch | 7 Shift lever |
| 2 Field coil | 5 Plunger | 8 Overrunning clutch |
| 3 Armature | 6 Torsion spring | 9 Pinion |

Fig. EE-6 Sectional view of starting motor

OPERATION

When the ignition switch is turned fully clockwise to the START position, battery current flows through "series" and "shunt" coils of the solenoid, magnetizing the solenoid.

The plunger is pulled into the solenoid so that it operates the shift lever to move the drive pinion into the flywheel ring gear. Then the solenoid switch contacts close after the drive

pinion is partially engaged with the ring gear.

Closing of the solenoid switch contacts causes the motor to crank the engine and also cut out the "series"

Engine Electrical System

coil of the solenoid, the magnetic pull of the "shunt" coil being sufficient to hold the pinion in mesh after the shifting has been performed.

After the engine starts running, the driver releases the ignition key and it automatically returns to the ON position.

The return (torsion) spring then

actuates the shift lever to pull the pinion, which allows the solenoid switch contacts to open. Consequently, the starting motor stops.

More positive meshing and demeshing of the pinion and the ring gear teeth are secured by means of the overrunning clutch. The overrunning

clutch employs a shift lever to slide the pinion along the armature shaft, into or out of mesh with the ring gear teeth. The overrunning clutch is designed to transmit driving torque from the motor armature to the ring gear, but prevent the armature from overrunning after the engine has started.

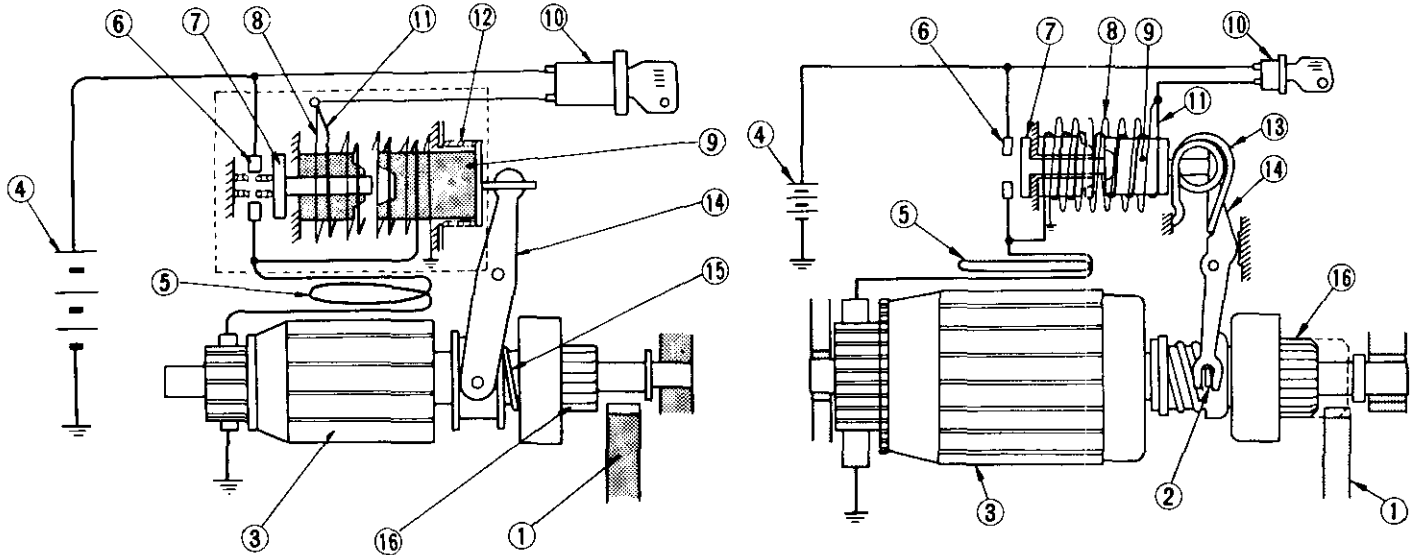

Type S114-122N

Type S114-182

- | | |
|----------------------|-------------------------|
| 1 Ring gear | 9 Plunger |
| 2 Shift lever guide | 10 Ignition switch |
| 3 Armature | 11 Series coil |
| 4 Battery | 12 Return spring |
| 5 Field coil | 13 Torsion spring |
| 6 Stationary contact | 14 Shift lever |
| 7 Movable contactor | 15 Pinion sleeve spring |
| 8 Shunt coil | 16 Pinion |

EE360

Fig. EE-7 Starting motor circuit

CONSTRUCTION

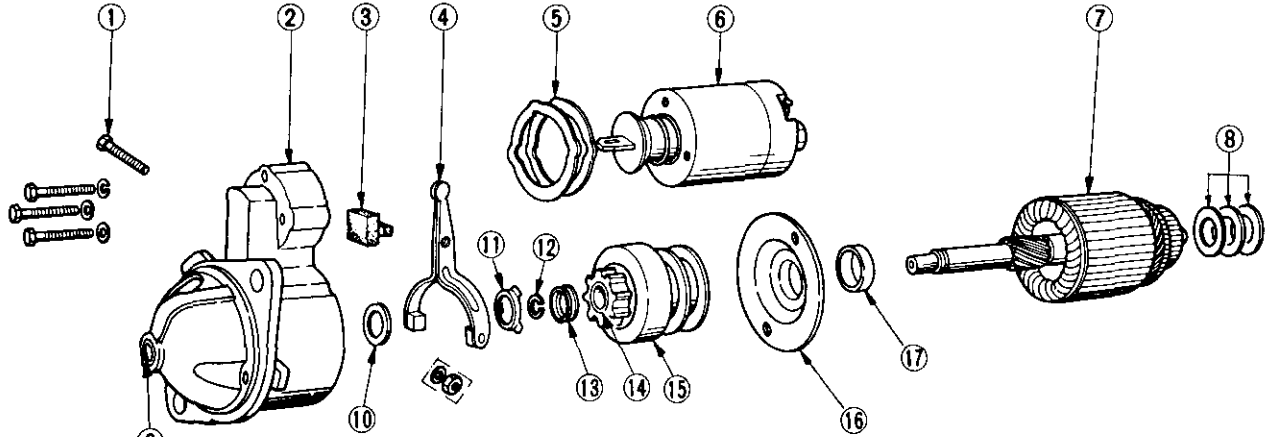

- | | |
|----------------------------|--------------------------|
| 1 Shift lever pin | 13 Pinion stopper |
| 2 Gear case | 14 Pinion |
| 3 Dust cover | 15 Overrunning clutch |
| 4 Shift lever | 16 Center bracket |
| 5 Dust cover | 17 Center bearing |
| 6 Magnetic switch assembly | 18 Field coil |
| 7 Armature | 19 Yoke |
| 8 Thrust washer | 20 Brush (+) |
| 9 Metal | 21 Brush (-) |
| 10 Thrust washer | 22 Brush spring |
| 11 Stopper washer | 23 Brush holder assembly |
| 12 Stopper clip | 24 Metal |
| | 25 Rear cover |
| | 26 Through bolt |

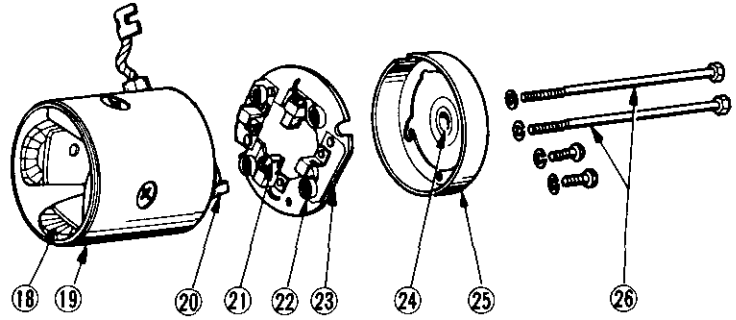

Type S114-122N

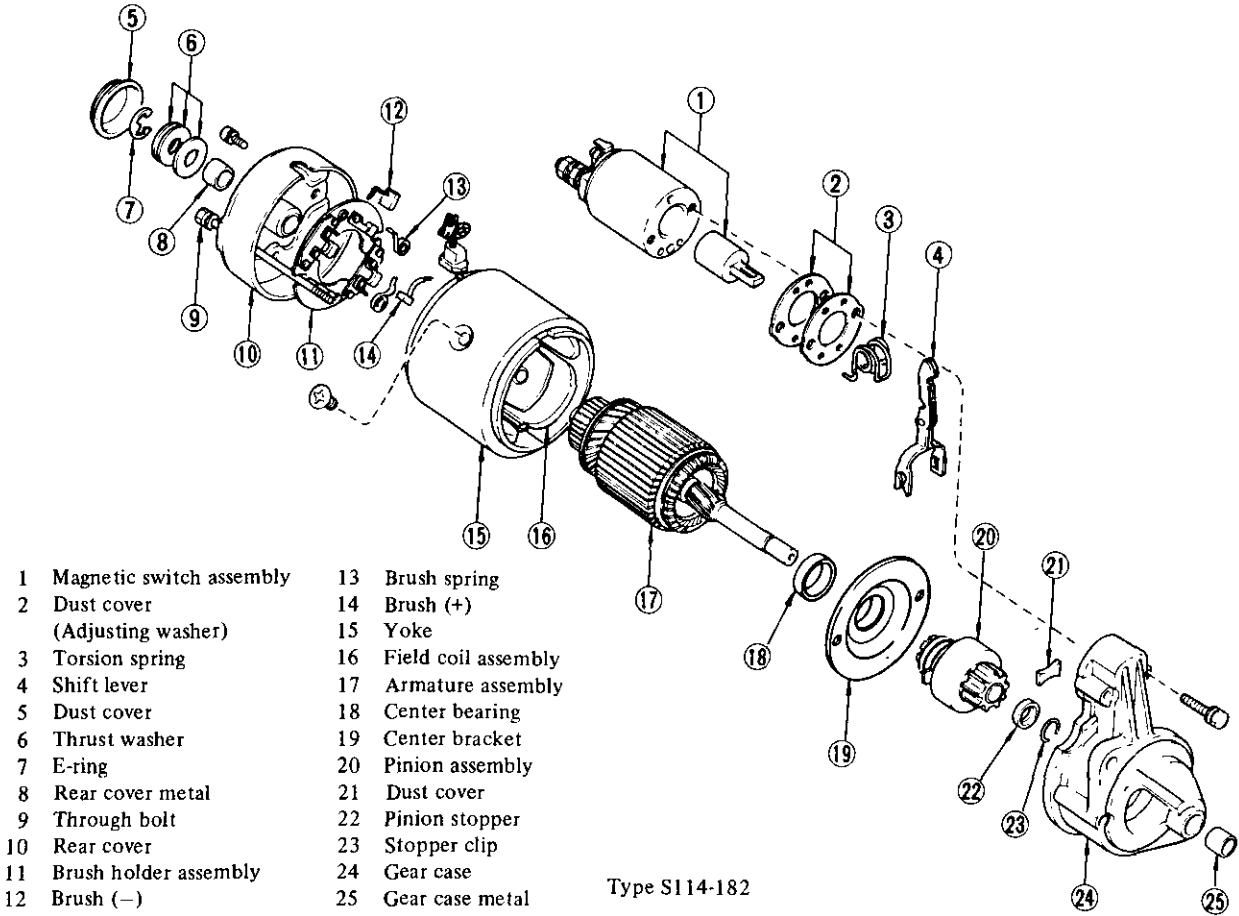

- | | |
|---------------------------------|------------------------|
| 1 Magnetic switch assembly | 13 Brush spring |
| 2 Dust cover (Adjusting washer) | 14 Brush (+) |
| 3 Torsion spring | 15 Yoke |
| 4 Shift lever | 16 Field coil assembly |
| 5 Dust cover | 17 Armature assembly |
| 6 Thrust washer | 18 Center bearing |
| 7 E-ring | 19 Center bracket |
| 8 Rear cover metal | 20 Pinion assembly |
| 9 Through bolt | 21 Dust cover |
| 10 Rear cover | 22 Pinion stopper |
| 11 Brush holder assembly | 23 Stopper clip |
| 12 Brush (-) | 24 Gear case |
| | 25 Gear case metal |

Type S114-182

Fig. EE-8 Exploded view of starting motor

REMOVAL

1. Disconnect battery ground cable.
Disconnect black wire with yellow stripe from magnetic switch terminal, and black battery cable from battery terminal of magnetic switch.
2. Remove two bolts securing starting motor to transmission case. Pull starter assembly forward and remove starting motor.

DISASSEMBLY

TYPE S114-122N

1. Loosen nut securing connecting plate to magnetic switch "M" terminal. Remove three screws securing magnetic switch and remove magnetic switch assembly.

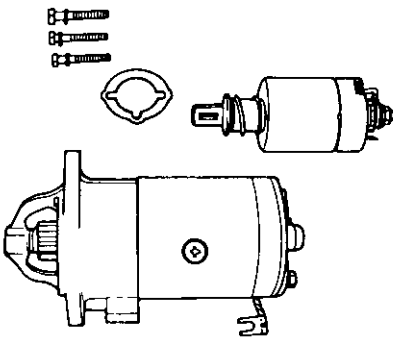

EE008

Fig. EE-9 Removing magnetic switch assembly

2. Remove two through bolts and rear cover.

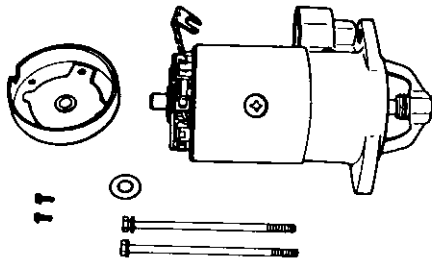

EE009

Fig. EE-10 Removing brush cover

3. Set brushes free from commutator by lifting up brush springs.

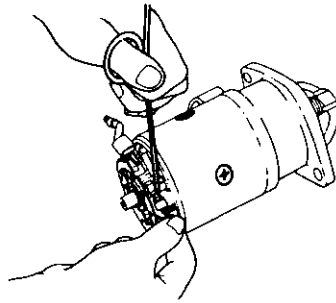

EE013

Fig. EE-11 Setting free brushes

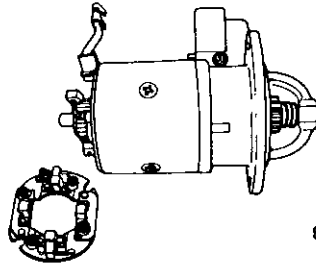

EE014

Fig. EE-12 Removing brush holder

4. Remove yoke assembly by hitting lightly with a wooden hammer.

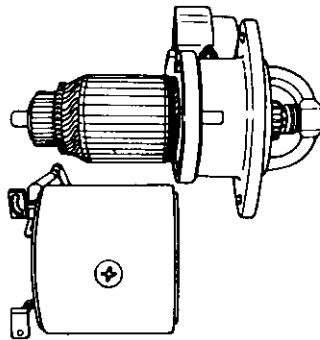

EE010

Fig. EE-13 Removing yoke assembly

5. Withdraw armature assembly and shift lever.

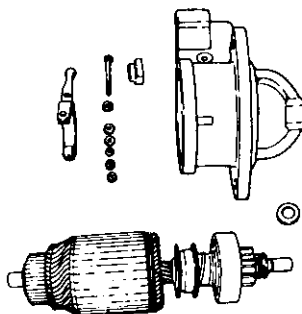

EE011

Fig. EE-14 Removing armature assembly and shift lever

6. Remove pinion stopper located at the end of armature shaft. To remove stopper, first remove stopper washer and push stopper to clutch side and then, after removing stopper clip, remove stopper with over-running clutch. Withdraw over-running clutch assembly from armature shaft.

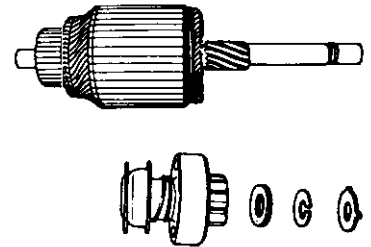

EE012

Fig. EE-15 Removing over-running clutch assembly

TYPE S114-182

1. Disconnect connecting plate from "M" terminal of magnetic switch. Remove two screws securing magnetic switch and remove magnetic switch assembly.
2. Remove dust cover, E-ring and thrust washer(s).

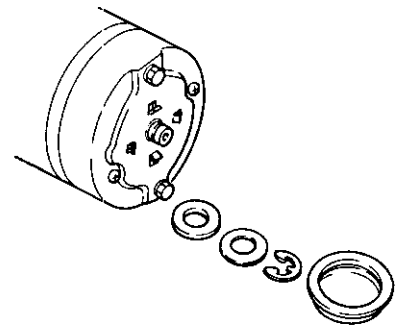

EE317

Fig. EE-16 Removing dust cover, E-ring and thrust washer(s)

3. Remove two screws securing brush holder assembly.

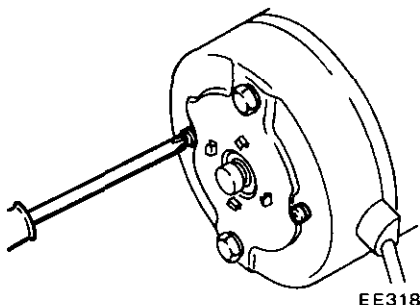

Fig. EE-17 Removing brush holder setscrews

4. Remove two through bolts and rear cover.

5. Remove brushes from their holder by moving each brush spring away from brush with a hook.

Remove brush holder.

6. Remove yoke assembly and withdraw armature assembly and shift lever.

7. Remove pinion stopper located at the end of armature shaft. To remove stopper, first move stopper toward pinion and after removing stopper clip, remove stopper with overrunning clutch assembly from armature shaft.

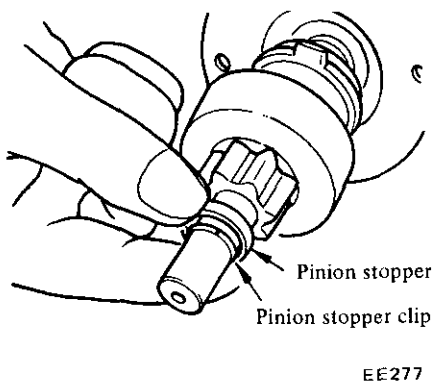

Fig. EE-18 Removing pinion stopper

CLEANING AND INSPECTION

Clean all disassembled parts, but do not use grease dissolving solvents for cleaning overrunning clutch, armature assembly, magnetic switch assembly and field coils since such a solvent would dissolve grease packed in clutch mechanism and would damage coils or other insulators.

Check them for excessive damage or wear, and replace if necessary.

TERMINAL

Check terminal for damage and wear, and replace magnetic switch assembly if necessary.

FIELD COIL

Check field coil for insulation. If the insulation of coil is damaged or worn it should be replaced.

Testing field coil for continuity:

Connect the probe of a circuit tester or an ohmmeter to field coil positive terminal and positive brush holder.

If tester shows no conduction field circuit or coil is open.

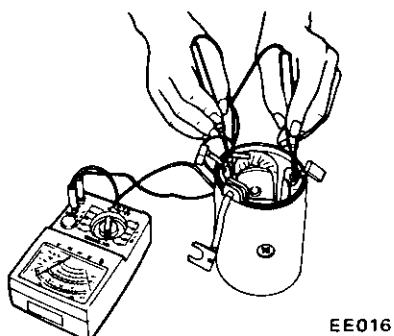

Fig. EE-19 Testing field coil for continuity

Testing field coil for ground:

Place one probe of circuit tester onto yoke and the other onto field coil lead (positive terminal).

If very little resistance is read, field coil is grounded.

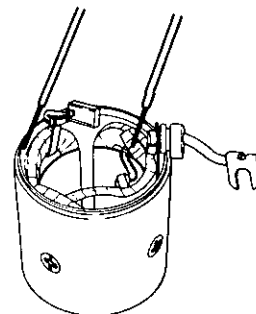

Fig. EE-20 Testing field coil for ground

BRUSHES AND BRUSH LEAD WIRE

Check the surface condition of brush contact and wear of brush. If a loose contact is found it should be replaced.

If brush is worn so that its length is less than 12.5 mm (0.492 in) for S114-122N and 12 mm (0.472 in) for S114-182, replace.

Check the connection of lead clip and lead wire.

Check brush holders and spring clip to see if they are not deformed or bent, and will properly hold brushes against the commutator.

If brushes or brush holders are dirty, they should be cleaned.

BRUSH SPRING TENSION

Check brush spring tension by a spring scale as shown in Figure EE-21. The reading should be 1.6 kg (3.5 lb). Replace spring if tension is lower than 1.4 kg (3.1 lb).

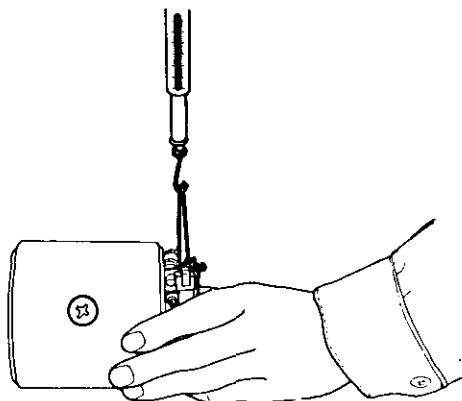

Fig. EE-21 Inspecting brush spring tension

ARMATURE ASSEMBLY

Check external appearance of armature and commutator.

1. Inspect commutator. If the surface of commutator is rough, it must be sanded lightly with a No. 500 emery cloth. If the depth of insulating mica is less than 0.2 mm (0.0079 in) from commutator surface, insulating mica should also be undercut so that

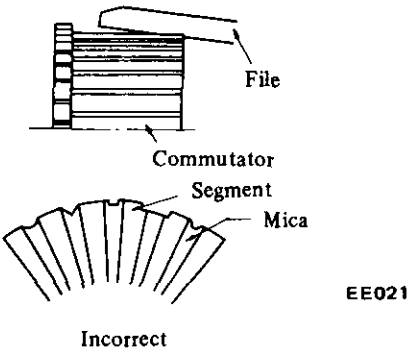
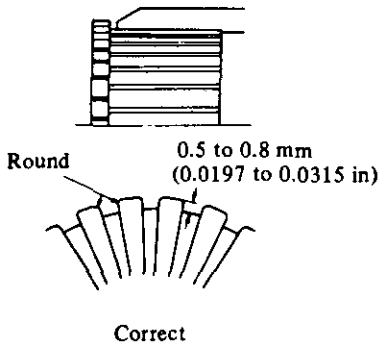

Fig. EE-22 Undercutting insulating mica

2. Inspect soldered connection of armature lead and commutator. If loose connection is found, solder it using resin flux.

3. Armature test for ground

Using a circuit tester, place one test probe onto armature shaft and other onto each commutator bar.

If tester shows continuity, armature is grounded and must be replaced.

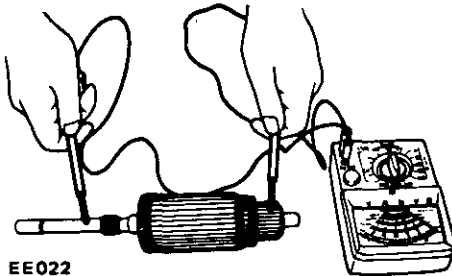

Fig. EE-23 Testing armature for ground

4. Check armature for short by placing it on armature tester (growler) with a piece of iron over armature core, rotating armature. If the plate vibrates, armature is shorted.

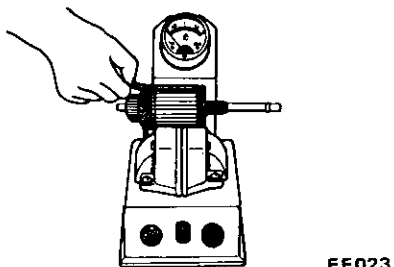

Fig. EE-24 Testing armature for short

its depth is 0.5 to 0.8 mm (0.0197 to 0.0315 in).

The wear limit of commutator diameter is 1 mm (0.0394 in). If the diameter of commutator is less than 34 mm (1.339 in) for S114-122N and 39 mm (1.535 in) for S114-182, replace armature assembly.

BRUSH HOLDER TEST FOR GROUND

Using a circuit tester, place one test probe onto negative side of brush holder and another onto positive side. If tester shows conduction, brush holder is shorted to ground. Replace brush holder.

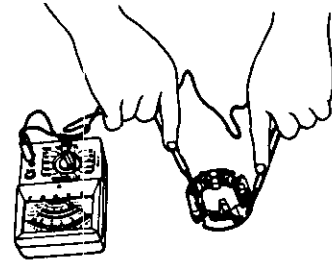
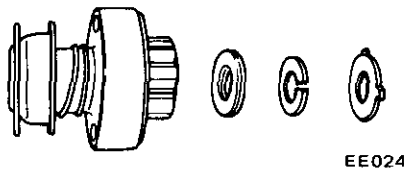

Fig. EE-26 Testing brush for ground

5. Check armature for continuity by placing probes of tester on two segments side by side. If tester shows no continuity, the circuit is open.

OVERRUNNING CLUTCH ASSEMBLY

Inspect pinion assembly and screw sleeve. Screw sleeve must slide freely along armature shaft splines. If damage is found or resistance is felt when sliding, it must be repaired. Inspect pinion teeth. If excessive rubbing is found on teeth, replace. Flywheel ring gear also must be inspected.



Type S114-122N

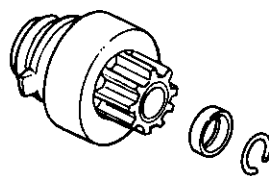

Type S114-182

Fig. EE-25 Overrunning clutch assembly

BEARING METAL

Inspect bearing metal for wear or side play. If the clearance between bearing metal and armature shaft is more than 0.2 mm (0.0079 in), replace metal.

MAGNETIC SWITCH ASSEMBLY

1. Using a circuit tester, check continuity between "S" terminal of magnetic switch and switch body metal. If continuity does not exist, shunt coil is opened.

Replace switch assembly.

2. In the same manner as above, check continuity between terminals "S" and "M". If continuity does not exist, series coil is opened.

Replace switch assembly.

ASSEMBLY

Reassemble starting motor in reverse sequence of disassembly.

When assembling, be sure to apply grease to gear case and rear cover bearing metal, and apply oil lightly to pinion.

TEST

PERFORMANCE TEST

Starter motor should be subjected to a "no-load" test whenever it has been overhauled to ensure that its performance will be satisfactory when installed to engine. Starter motor should also be subjected to the test when the cause of abnormal operation is to be determined. A brief outline of the test is given below.

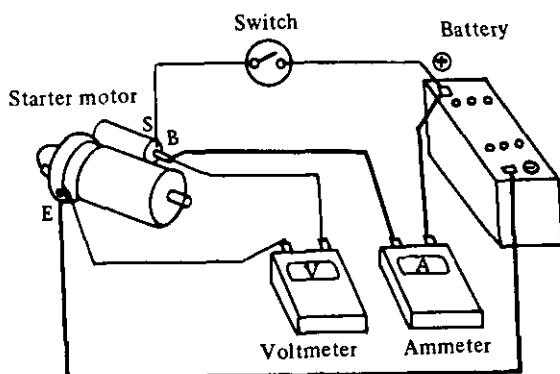

Fig. EE-27 No-load testing

Diagnoses of test

1. Low speed with no-load and high current draw may result from the following :

- (1) Tight, dirty or worn bearings.
- (2) Bent armature shaft or loosened field probe.
- (3) Shorted armature;
Check armature further.
- (4) A grounded armature or field;
 - a. Remove input terminal.
 - b. Raise two negative side brushes from commutator.
 - c. Using a circuit tester, place one probe onto input terminal and the other onto yoke.
 - d. If tester indicates continuity, raise the other two brushes and check field and armature separately to determine whether field or armature is grounded.

2. Failure to operate with high current draw may be caused by the

No-load test

Connect starting motor in series with specified (12 volts) battery and an ammeter capable of indicating 1,000 amperes.

Specified current draw and revolution in these test are shown in "Specifications".

following:

- (1) A grounded or open field coil:
Inspect the connection and trace circuit by a circuit tester.
 - (2) Armature coil does not operate:
Inspect commutator for excessive burning. In this case, arc may occur on damaged commutator when motor is operated with no-load.
 - (3) Burned out commutator bar:
Weak brush spring tension, broken brush spring, rubber bush, thrust out of mica in commutator or a loose contact between brush and commutator would cause commutator bar to burn.
3. Low current draw and low no-load speed would cause high internal resistance due to loose connections, damaged leads, dirty commutator and causes listed on item 2-(3).

MAGNETIC SWITCH ASSEMBLY TEST

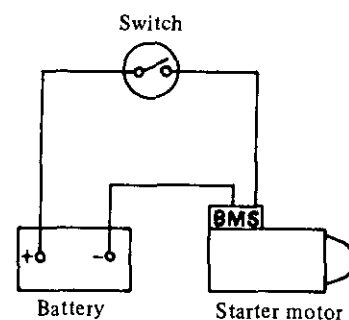

EE351

Fig. EE-28 Circuit of magnetic switch assembly test

If the starting motor check is "OK", check magnetic switch assembly. Connect cables between "negative" battery terminal and starting motor "M" terminal, "positive" battery terminal and starting motor "S" terminal connecting a switch in series as shown in Figure EE-20.

With the switch on, push pinion back to remove all slack and measure the clearance " \mathcal{L} " between pinion front edge and pinion stopper. The clearance should be held within 0.3 to 1.5 mm (0.012 to 0.059 in). If necessary, adjust it by changing or adding adjusting washer(s). Adjusting washers are available into two different sizes, 0.5 mm (0.020 in) and 0.8 mm (0.032 in).

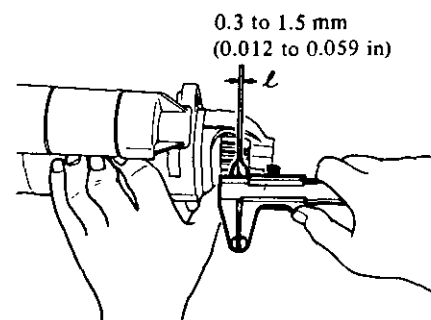

EE028

Fig. EE-29 Measuring gap " \mathcal{L} "

SERVICE DATA AND SPECIFICATIONS

		Manual transmission	Automatic transmission
Type		S114-122N	S114-182
System voltage	V	12	
No load			
Terminal voltage	V	12	
Current	A	Less than 60	
Revolution	rpm	More than 5,000	More than 6,000
Outer diameter of commutator	mm (in)	More than 34 (1.34)	More than 39 (1.54)
Brush length	mm (in)	More than 12.5 (0.49)	More than 12 (0.47)
Brush spring tension	kg (lb)	1.4 to 1.8 (3.1 to 4.0)	
Clearance between bearing metal and armature shaft	mm (in)	Less than 0.2 (0.008)	
Clearance "L" between pinion front edge and pinion stopper	mm (in)	0.3 to 1.5 (0.012 to 0.059)	

TROUBLE DIAGNOSES AND CORRECTIONS

Condition	Probable cause	Corrective action
Starting motor will not operate.	Discharged battery. Damaged solenoid switch. Loose connections of terminal. Damaged brushes. Starting motor inoperative.	Charge or replace battery. Repair or replace solenoid switch. Clean and tighten terminal. Replace brushes. Remove starting motor and make test.
Noisy starting motor.	Loose securing bolt. Worn pinion gear. Poor lubrication. Worn commutator. Worn brushes.	Tighten. Replace. Add oil. Replace. Replace.
Starting motor cranks slowly.	Discharged battery. Loose connection of terminal. Worn brushes. Locked brushes.	Charge. Clean and tighten. Replace. Inspect brush spring tension or repair brush holder.

Engine Electrical System

Condition	Probable cause	Corrective action
Starting motor cranks slowly.	Dirty or worn commutator. Armature rubs field coil. Damaged solenoid switch.	Clean and repair. Replace assembly. Repair or replace.
Starting motor operates but does not crank engine.	Worn pinion. Locked pinion guide. Worn ring gear.	Replace. Repair. Replace.
Starting motor will not disengage even if ignition switch is turned off.	Damaged solenoid switch. Damaged gear teeth.	Repair or replace. Replace damaged gear.

CHARGING CIRCUIT

The charging circuit consists of the battery, alternator, regulator and necessary wiring to connect these parts. The purpose of this system is to convert mechanical energy from the engine into electrical energy which is used to operate all electrically operated units and to keep the battery fully charged.

When the ignition switch is set to "ON", current flows from the battery to ground through the ignition switch, voltage regulator IG terminal, primary side contact point "P1," movable contact point "P2", voltage regulator "F" terminal, alternator "F" terminal, rotor (field) coil and alternator "E" terminal, as shown in Figure EE-30 by full line arrow marks. Then the rotor in the alternator is excited.

When the alternator begins to operate, three-phase alternating current is induced in the stator (armature) coil. This alternating current is rectified by the positive and negative silicon diodes. The rectified direct current output reaches the alternator "A" and "E" terminals.

When the alternator speed is increased or the voltage starts to rise excessively, the movable contact point "P2" is separated from the primary side contact "P1" by the magnetic force of coil "VC2". Therefore, resistor "R1" is applied into the rotor circuit and output voltage is decreased. As the output voltage is decreased, the movable contact point "P2", and primary side contact "P1" comes into contact once again, and the alternator

voltage increases. Thus, the rapid vibration of the movable contact point "P2", maintains an alternator output voltage constant.

When the alternator speed is further increased or the voltage starts to rise excessively, the movable contact point "P2" comes into contact with secondary side contact point "P3". Then, the rotor current is shut off and alternator output voltage is decreased immediately. This action causes movable contact "P2" to separate from secondary contact "P3". Thus, the rapid vibration of the movable contact point "P2", or breaking and completing the rotor circuit, maintains an alternator output voltage constant.

Engine Electrical System

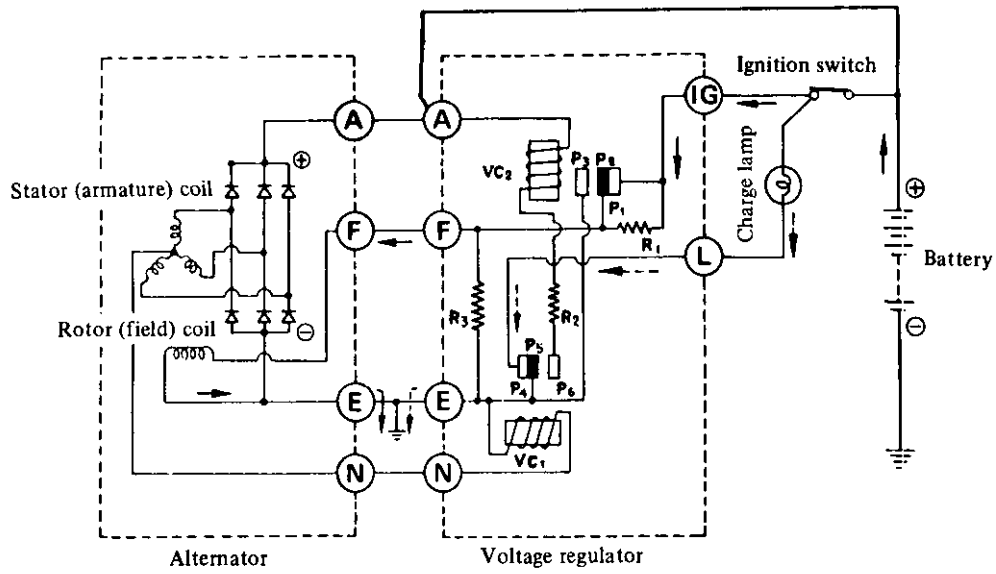

EE 423

Fig. EE-30 Charging circuit (I)

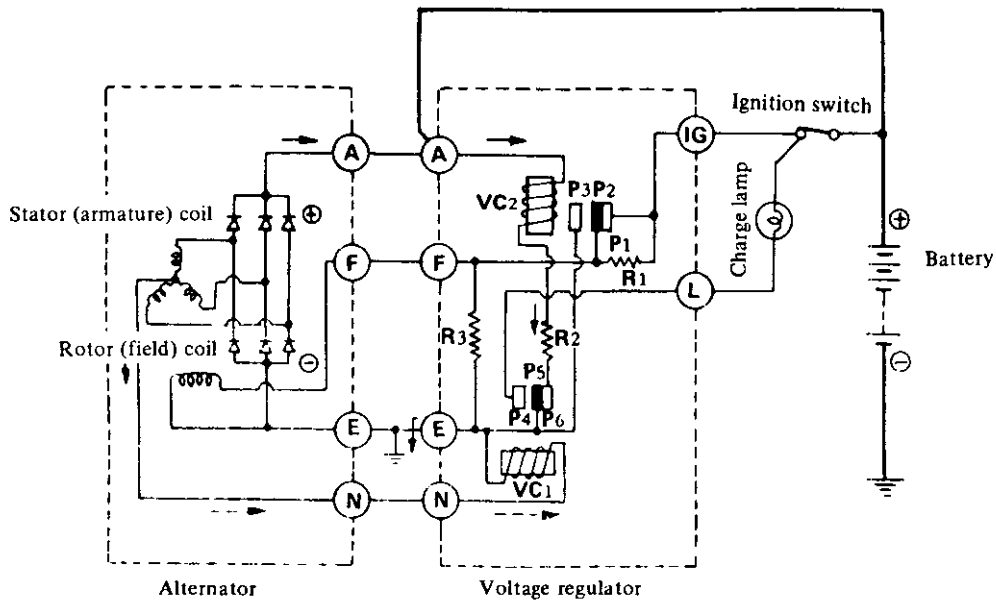

EE424

Fig. EE-31 Charging circuit (II)

ALTERNATOR

CONTENTS

DESCRIPTION	EE-15	INSPECTION OF DIODE	EE-17
REMOVAL	EE-16	INSPECTION OF BRUSH	EE-18
DISASSEMBLY	EE-16	SPRING PRESSURE TEST	EE-18
INSPECTION AND REPAIR	EE-16	ASSEMBLY	EE-18
ROTOR INSPECTION	EE-17	ALTERNATOR TEST	EE-19
INSPECTION OF STATOR	EE-17	SERVICE DATA AND SPECIFICATIONS	EE-19

DESCRIPTION

In the alternator, a magnetic field is produced by the rotor which consists of alternator shaft, field coil, pole pieces, and slip rings. The slip rings pressed in the shaft conduct only a small field current. Output current is generated in the armature coils located in the stator. The stator has three windings and generates three-phase

alternating current. Silicon diodes act like a one-way valve for electricity so that charging current passes easily but reverse current is shut out.

In this alternator, pack type silicon diodes are used.

Six diodes (three negative and three positive), are installed in positive and negative plates as an assembly.

These diodes are direct-soldered at their tips, and constructed with positive and negative conjunction.

They are mounted on the two plates which combine the function of heat-dissipating plate and positive/negative terminals and are light in weight and easy to service.

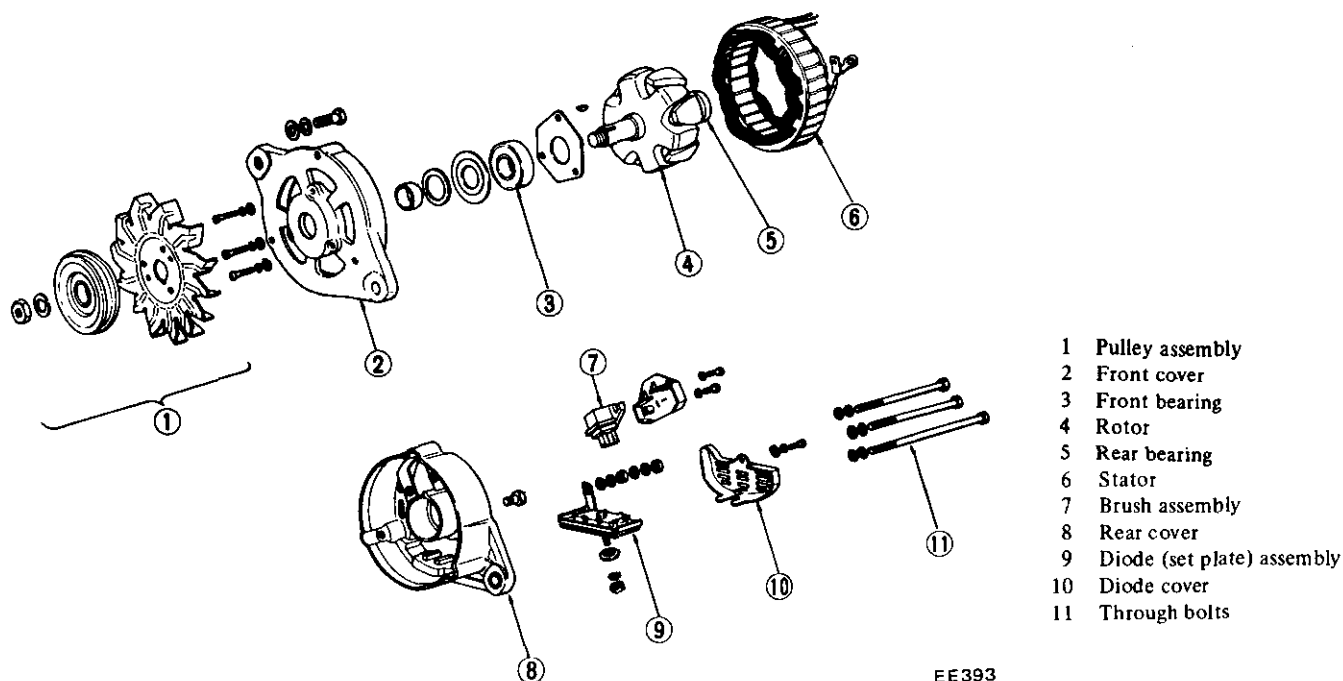

EE393

Fig. EE-32 Exploded view of alternator

REMOVAL

1. Disconnect battery negative cable.
2. Disconnect two lead wires and connector from alternator.
3. Loosen adjusting bolt.
4. Remove alternator drive belt.
5. Remove parts associated with alternator from engine.
6. Remove alternator from car.

DISASSEMBLY

1. Remove pulley nut and pulley assembly.

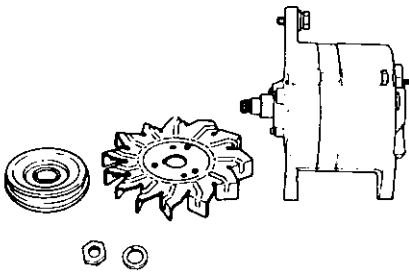

EE362

Fig. EE-33 Removing pulley and fan

2. Remove brush holder fixing screws, and remove brush holder cover. Pull brush holder forward, and remove brushes together with brush holder.

Note: Do not disconnect N terminal from stator coil lead wire.

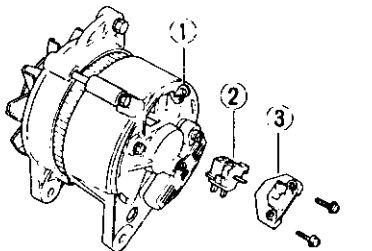

EE209

- 1 "N" terminal
- 2 Brush holder
- 3 Brush holder cover

Fig. EE-34 Removing brush

3. Remove through bolts. Separate front cover with rotor from rear cover with stator by lightly tapping front bracket with a wooden mallet.

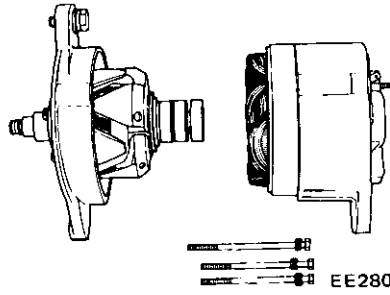

EE280

Fig. EE-35 Separating front cover with rotor from rear cover

4. Remove three set screws from bearing retainer, and separate rotor from front cover.

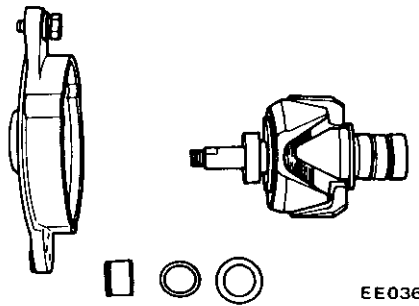

EE036

Fig. EE-36 Removing rotor

5. Pull rear bearing out from rotor assembly with a press or bearing puller.

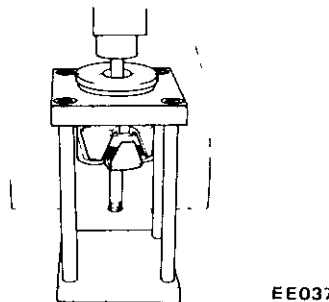

EE037

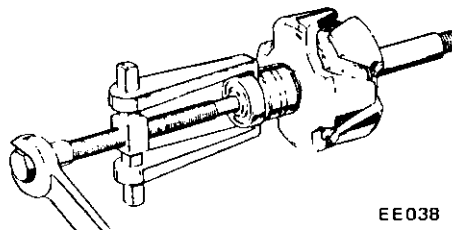

EE038

Fig. EE-37 Pulling out of rear bearing

6. Remove diode cover fixing screw, and remove diode cover. Disconnect three stator coil lead wires from diode terminal with a soldering iron.
7. Remove A terminal nut and diode installation nut, and remove diode assembly.

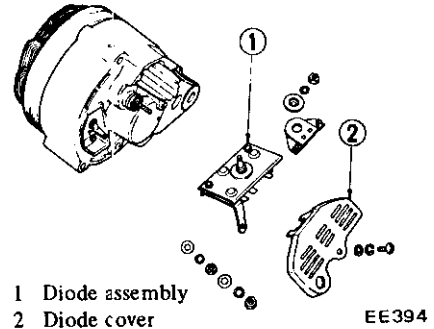

- 1 Diode assembly
- 2 Diode cover

EE394

Fig. EE-38 Removing diode assembly

Note: Use care in handling diode assembly to prevent an undue stress on it.

INSPECTION AND REPAIR

Remove alternator from car and connect a circuit tester between F terminal and E terminal.

When the resistance is approximately 5Ω , the condition of brush and field coil is satisfactory. When no continuity exists in brush or field coil, or when resistance differs significantly between those parts, disassemble and inspect.

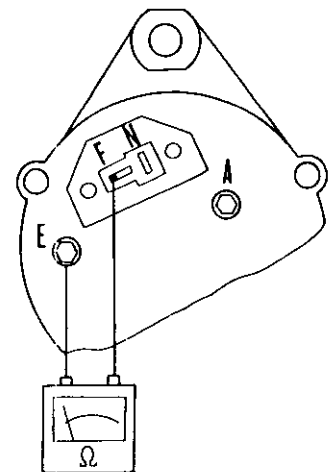

EE282

Fig. EE-39 Inspecting alternator

ROTOR INSPECTION

1. Continuity test of rotor coil

Apply tester between slip rings of rotor as shown in Figure EE-32. If there is no continuity field coil is open.

Replace rotor assembly.

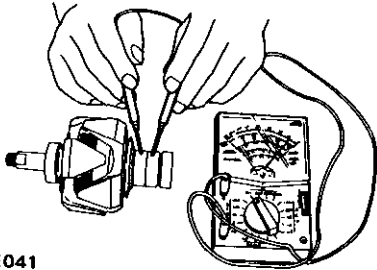

EE041

Fig. EE-40 Continuity test of rotor coil

2. Ground test of rotor coil

Check continuity between slip ring and rotor core. If continuity exists, replace rotor assembly, because rotor coil or slip ring may be grounded.

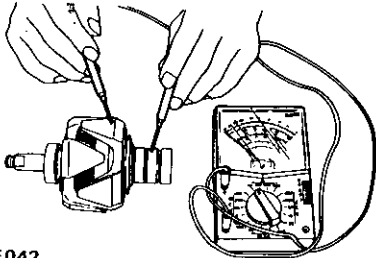

EE042

Fig. EE-41 Testing rotor coil for ground

INSPECTION OF STATOR

1. Continuity test

Stator is normal when there is continuity between individual stator coil terminals. When there is no continuity between individual terminals, cable is broken.

Replace stator assembly.

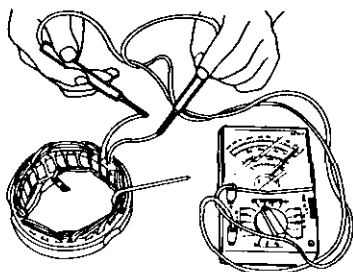

EE043

Fig. EE-42 Testing stator for continuity

2. Ground test

If each lead wire of stator coil (including neutral wire) is not conductive with stator core, condition is satisfactory. If there is continuity, stator coil is grounded.

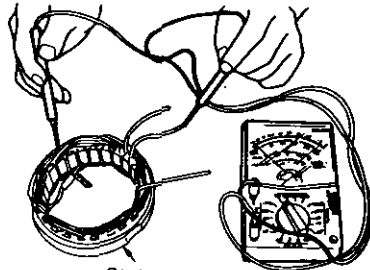

Stator core

EE044

Fig. EE-43 Testing stator for ground

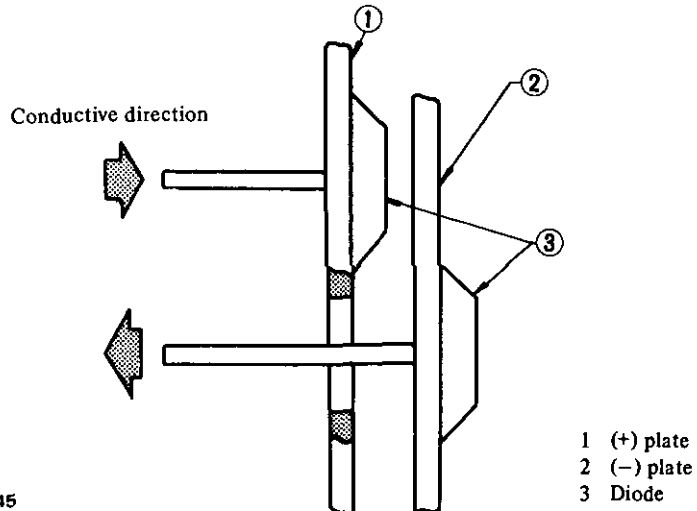

EE045

Fig. EE-44 Conductive direction of diode

Diode installed on \oplus plate is a positive diode which allows current flowing from terminal to \oplus plate only. In other words, current does not flow from \oplus plate to terminal.

Diode installed on \ominus plate is a negative diode which allows current flowing from \ominus plate to terminal only. In other words, current does not flow from terminal to \ominus plate.

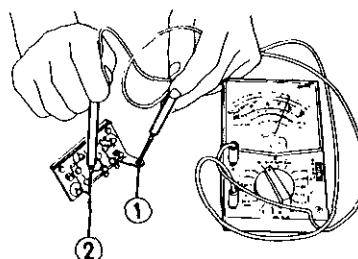

1 (+) plate
2 Terminal

EE046

Fig. EE-45 Inspecting positive diode

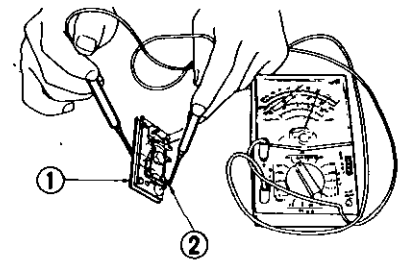

1 (-) plate
2 Terminal

EE047

Fig. EE-46 Inspecting negative diode

Engine Electrical System

If current flows in both positive and negative directions, diode is short-circuited. If current flows in one direction only, diode is in good condition.

If there is a faulty diode, replace all diodes (six diodes) as an assembly. (See table below.) These diodes are unserviceable.

Test probe of a circuit tester		Conduction
⊖	⊕	
terminal	⊕ plate	0
⊕ plate	terminal	—
terminal	⊖ plate	—
⊖ plate	terminal	0
⊖ plate	⊕ plate	0
⊕ plate	⊖ plate	—

INSPECTION OF BRUSH

Check movement of brush and if movement is not smooth, check brush holder and clean if necessary.

Check brush for wear. If it is worn down to less than the specified limit, replace brush assembly.

Check brush pig tail and, if damaged, replace.

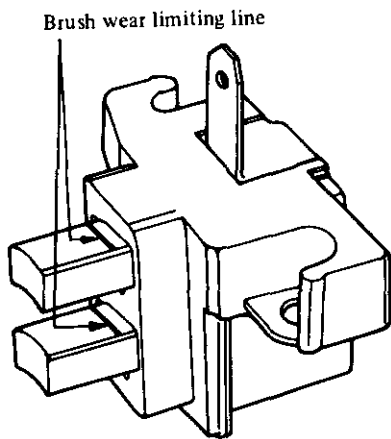

EE127

Fig. EE-47 Brush wear limit

SPRING PRESSURE TEST

With brush projected approximately 2 mm (0.079 in) from brush holder, measure brush spring pressure by the use of a spring balance. Normally, the rated pressure of a new brush spring is 255 to 345 gr (9.0 to 12.2 oz).

Moreover, when brush is worn, pressure decreases approximately 20 g (0.7 oz) per 1 mm (0.0394 in) wear.

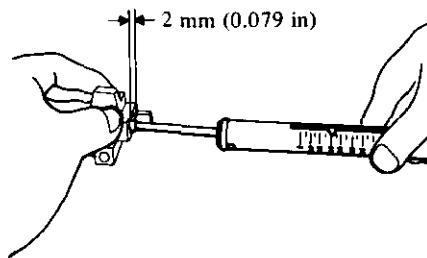

EE049

Fig. EE-48 Measuring spring pressure

ASSEMBLY

Assemble alternator in the reverse sequence of disassembly noting the following:

1. When soldering each stator coil lead wire to diode assembly terminal, carry out the operation as fast as possible.
2. When installing diode A terminal, install insulating bush correctly.

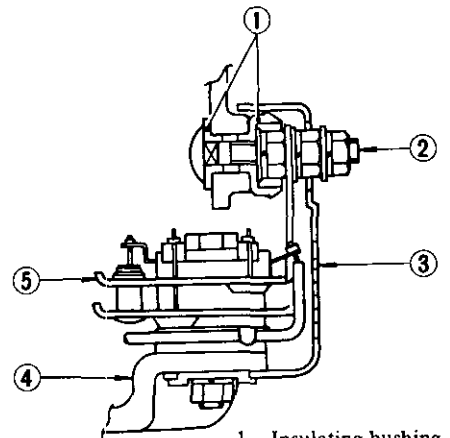

EE363

- 1 Insulating bushing
- 2 "A" terminal bolt
- 3 Diode cover
- 4 Rear cover
- 5 Diode assembly

Fig. EE-49 Sectional view of diode and A terminal

3. Tighten pulley nut with tightening torque of 3.5 to 4.0 kg-m (25.3 to 29.0 ft-lb). When pulley is tightened, make sure that deflection of V-groove is less than 0.3 mm (0.0118 in).

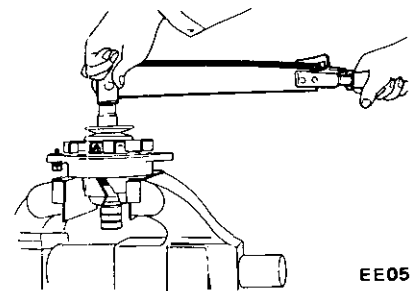

EE051

Fig. EE-50 Tightening pulley nut

ALTERNATOR TEST

Before conducting an alternator test, make sure that the battery is fully charged.

A 30-Volt voltmeter and suitable test probes are necessary for the test. Set up a test circuit as shown in

Figure EE-51 and test alternator in the manner indicated in the flow chart below:

1. Disconnect connectors at alternator.
2. Connect "A" terminal to "F" terminal.
3. Connect one test probe from voltmeter positive terminal to "A" terminal. Connect the other test probe to ground. Make sure that voltmeter registers battery voltage.
4. Turn on headlights and switch to High Beam.
5. Start engine.
6. Increase engine speed gradually until it is approximately 1,100 rpm, and take the voltmeter reading.

Measured value: Below 12.5 Volts
Alternator is in trouble. remove and check it for condition.

Measured value: Over 12.5 Volts
Alternator is in good condition.

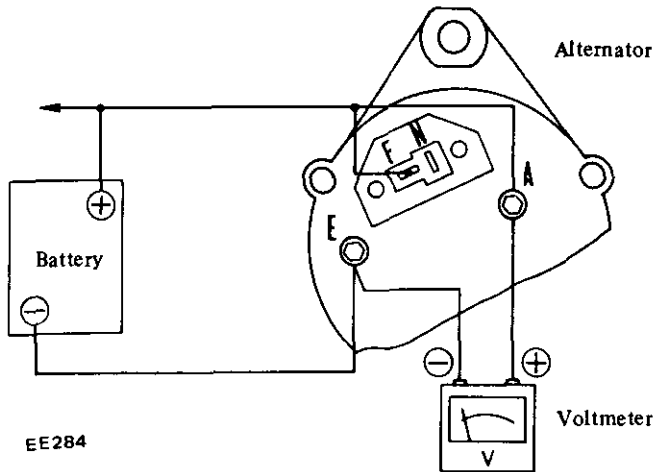

Notes:

- a. Do not run engine at the speed of more than 1,100 rpm while test is being conducted on alternator.
- b. Do not race engine.

SERVICE DATA AND SPECIFICATIONS

Type	LT160-23	
Nominal rating	V-A	12-60
Ground polarity	Negative	
Minimum revolution under no load (When 14 volt is applied)	rpm	Less than 1,050
Hot output current	A/rpm	45/2,500 60/5,000
Pulley ratio	2.09	
Brush		
Length	mm (in)	More than 7.5 (0.31)
Spring pressure	gr (oz)	255 to 345 (9.0 to 12.2)
Slip ring outer diameter	mm (in)	More than 30 (1.18)

REGULATOR

CONTENTS

DESCRIPTION EE-20
 MEASUREMENT OF REGULATOR
 VOLTAGE EE-21
 ADJUSTMENT EE-23
 VOLTAGE REGULATOR EE-23

CHARGING RELAY EE-23
 SERVICE DATA AND SPECIFICATIONS EE-24
 TROUBLE DIAGNOSES AND
 CORRECTIONS (Including alternator) EE-25

DESCRIPTION

The regulator consists basically of a voltage regulator and a charge relay. The voltage regulator has two sets of contact points, a lower set and an upper set, to control alternator voltage. An armature plate placed between the two sets of contacts moves upward or downward or vibrates. The lower contacts, when closed, complete the

field circuit direct to ground; and the upper contacts, when closed, complete the field circuit to ground through a resistance (field coil), and produce alternator output.

The charge relay is similar in construction to the voltage regulator.

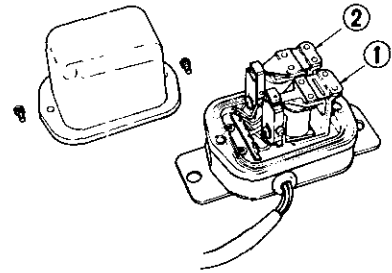

1 Charge relay
 2 Voltage regulator

EE285

Fig. EE-52 View of removing cover

As regards the construction, the voltage regulator is very similar to the charge relay as shown in Figure EE-53.

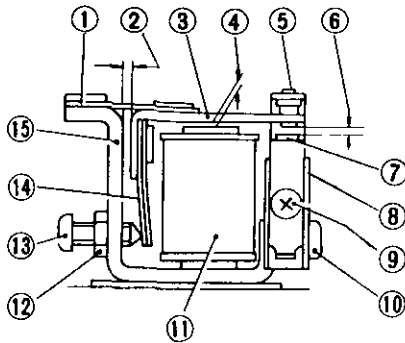

- | | |
|----------------------|------------------------------|
| 1 Connecting spring | 9 3mm (0.118 in) dia. screw |
| 2 Yoke gap | 10 4mm (0.157 in) dia. screw |
| 3 Armature | 11 Coil |
| 4 Core gap | 12 Lock nut |
| 5 Low speed contact | 13 Adjusting screw |
| 6 Point gap | 14 Adjusting spring |
| 7 High speed contact | 15 Yoke |
| 8 Contact set | |

(a) Construction of voltage regulator

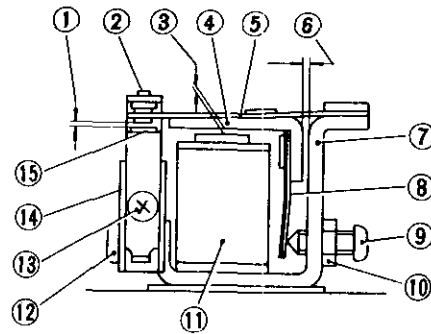

- | | |
|------------------------|------------------------------|
| 1 Point gap | 9 Adjusting screw |
| 2 Charge relay contact | 10 Lock nut |
| 3 Core gap | 11 Coil |
| 4 Armature | 12 4mm (0.157 in) dia. screw |
| 5 Connecting spring | 13 3mm (0.118 in) dia. screw |
| 6 Yoke gap | 14 Contact set |
| 7 Yoke | 15 Voltage regulator contact |
| 8 Adjusting spring | |

EE397

(b) Construction of charge relay

Fig. EE-53 Structural view

MEASUREMENT OF REGULATOR VOLTAGE

Regulator voltage is measured with regulator assembled with alternator. When measuring voltage with regulator mounted on car, it is necessary to rotate engine at high speed.

Connect DC voltmeter (15-30V), DC ammeter (15-30A), battery and a 0.25Ω resistor (rated at 25W) with cables as shown.

1. Check to be sure that all electrical loads such as lamps, air conditioner, radio etc. are turned off.
2. Before starting engine, be sure to make short circuit with a cable between fuse side terminal of resistor (0.25Ω) and negative side terminal of ammeter. Failure to follow this precaution will cause needle of ammeter to swing violently, resulting in a damaged ammeter.

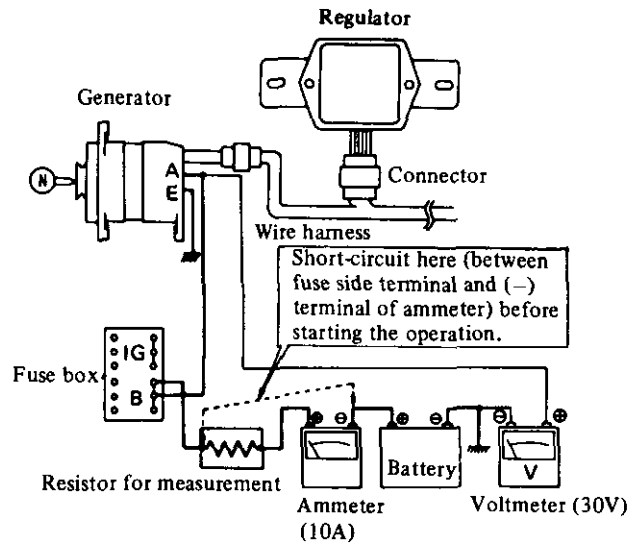

EE055

Fig. EE-54 Measuring regulator voltage with regulator on vehicle

3. Refer to the following chart to determine if regulator and relative parts are in good condition:

Engine Electrical System

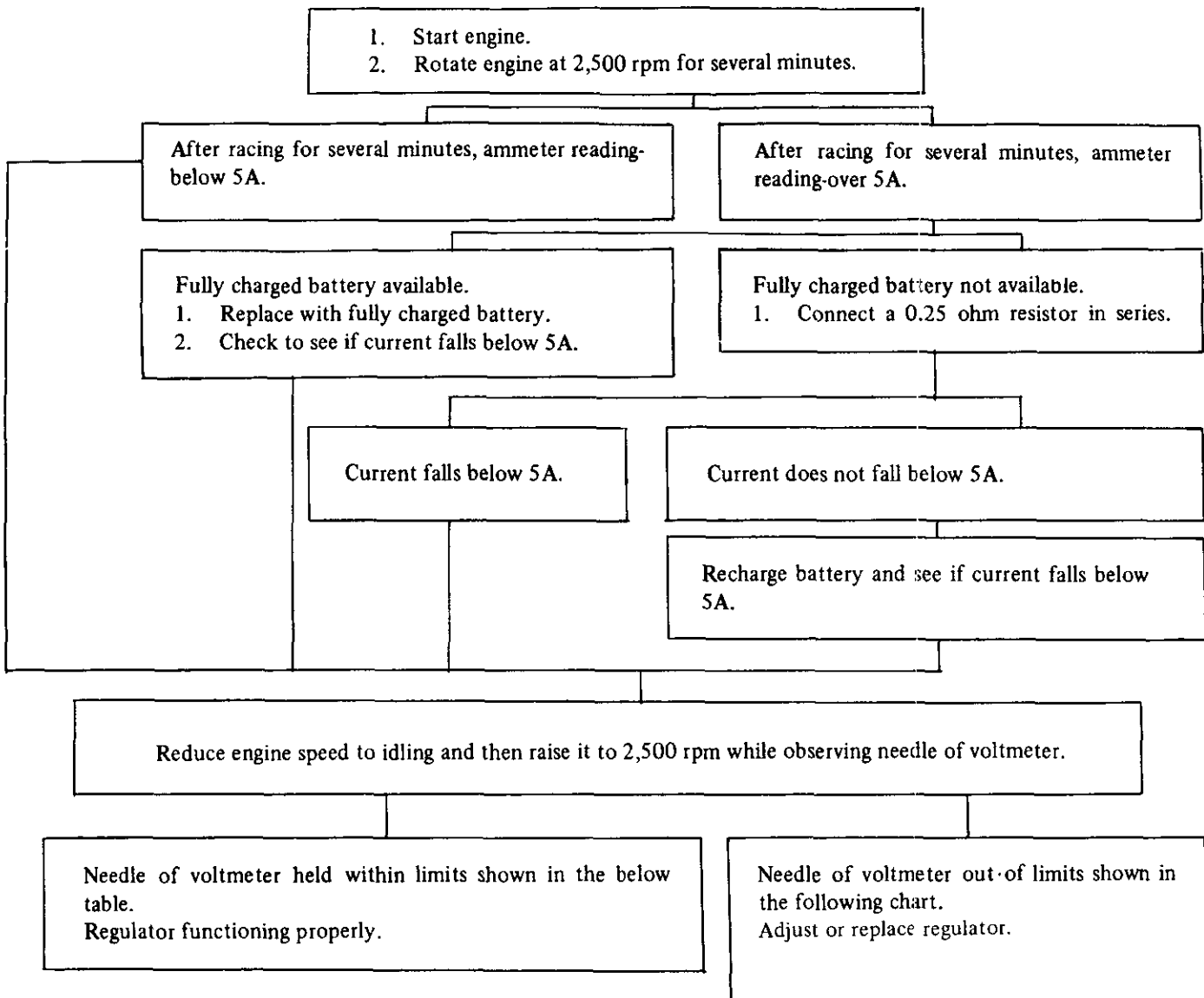

Regulator type TL1Z-85

Temperature °C (°F)	Voltage V
-10 (14)	14.75 to 15.75
0 (32)	14.60 to 15.60
10 (50)	14.45 to 15.45
20 (68)	14.30 to 15.30
30 (86)	14.15 to 15.15
40 (104)	14.00 to 15.00

Notes:

a. Do not measure voltage immediately after driving. Do this while

regulator is cold.

b. To measure voltage, raise engine speed gradually from idling to rated

speed.

c. Voltage may be approximately 0.3 V higher than rated for two to three minutes after engine is started, or more specifically, when regulator becomes self-heated. Measurements should then be made within one minute after starting engine, or when regulator is cold.

d. The regulator is of a temperature-compensating type. Before measuring voltage, be sure to measure surrounding temperature and correct measurements according to the table at left.

ADJUSTMENT

VOLTAGE REGULATOR

When regulating voltage, as measured above, deviates from rated value, adjust regulator in accordance with the following instructions.

1. Inspect contact surface, and if rough, lightly polish with fine emery paper (#500 or 600).
2. Measure each gap, and adjust if necessary. Adjust core gap and point gap in that order. No adjustment is required for yoke gap.
3. Adjusting core gap.

Loosen screw [4 mm (0.157 in) diameter] which is used to secure contact set on yoke, and move contact upward or downward properly. (See Figure EE-55.)

Core gap:
0.6 to 1.0 mm
(0.024 to 0.039 in)

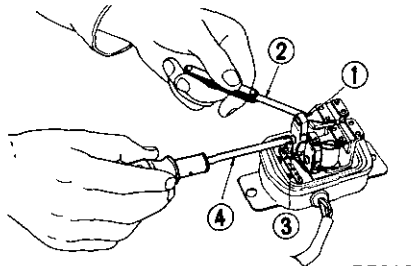

- 1 Contact set
- 2 Thickness gauge
- 3 4 mm (0.157 in) dia. screw
- 4 Crosshead screwdriver

Fig. EE-55 Adjusting core gap

4. Adjusting point gap

Loosen screw [3 mm (0.118 in) diameter] used to secure upper contact, and move upper contact upward or downward as necessary. (See Figure EE-56.)

Point gap:
0.35 to 0.45 mm
(0.014 to 0.018 in)

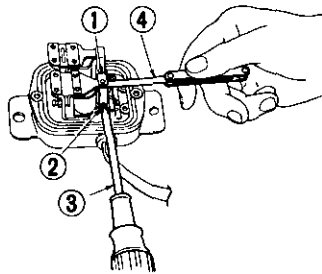

- 1 Thickness gauge
- 2 3 mm (0.118 in) dia. screw
- 3 Crosshead screwdriver
- 4 Upper contact

Fig. EE-56 Adjusting point gap

5. Adjusting voltage

Adjust regulating voltage as follows:

Loosen lock nut securing adjusting screw. Turn this screw clockwise to increase, or counterclockwise to decrease, regulating voltage. (See Figure EE-57.)

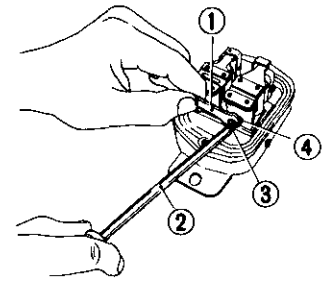

- 1 Wrench
- 2 Crosshead screwdriver
- 3 Adjusting screw
- 4 Lock nut

Fig. EE-57 Adjusting regulating voltage

CHARGING RELAY

Charging relay is used as an engine revolution sensor in starter interlock system.

Normal relay operating voltage is 8 to 10V as measured at alternator "A" terminal. Relay itself, however, operates at 4 to 5 V.

Use a DC voltmeter, and set up a circuit as shown in Figure EE-58.

Adjust charge relay in the same manner as that for voltage regulator.

1. Connect positive terminal of voltmeter to regulator lead connector "N" terminal with negative terminal grounded.
2. Start engine and keep it idle.
3. Take voltmeter reading.

0 Volt

1. Check for continuity between "N" terminals of regulator and alternator.
2. Alternator circuit inoperative if continuity exists.

Below 5.2 Volts

1. Check fan belt tension.
2. If correct, remove regulator and adjust as necessary.

Over 5.2 Volts

Charge relay coil or contact points out of order. Replace regulator.

Over 5.2 Volts

Charge relay assembly is in good condition.

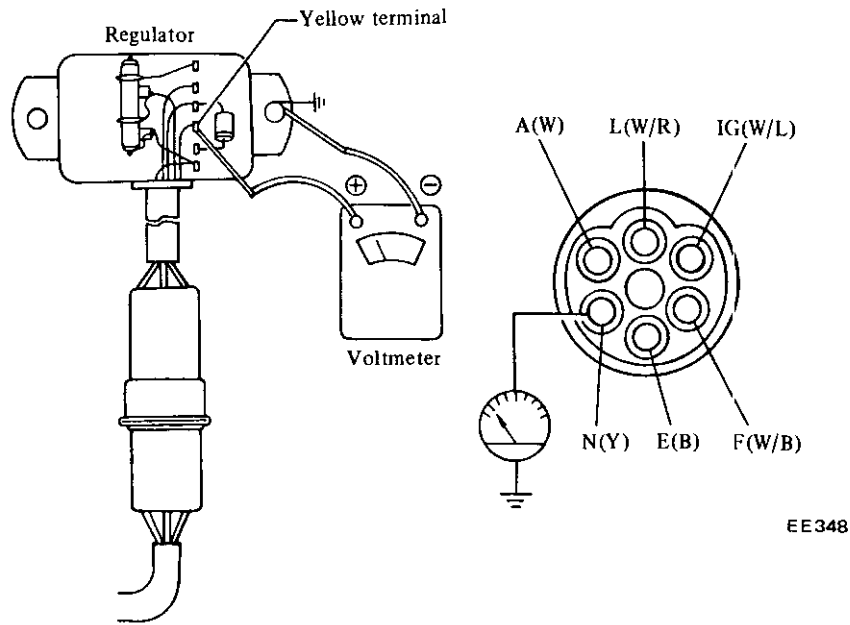

Fig. EE-58 Testing charging relay

SERVICE DATA AND SPECIFICATIONS

Voltage regulator

Type	TL1Z-85B
Regulating voltage (with fully charged battery) V	*14.3 to 15.3 [at 20°C (68°F)]
Voltage coil resistance Ω	10.5 [at 20°C (68°F)]
Rotor coil inserting resistance Ω	10
Voltage coil series resistance Ω	31
Smoothing resistance Ω	40
Core gap mm (in)	0.6 to 1.0 (0.024 to 0.039)
Point gap mm (in)	0.35 to 0.45 (0.014 to 0.018)

Charge relay

Release voltage V	4.2 to 5.2 at "N" terminal
Voltage coil resistance Ω	37.8 [at 20°C (68°F)]
Core gap mm (in)	0.8 to 1.0 (0.031 to 0.039)
Point gap mm (in)	0.4 to 0.6 (0.016 to 0.024)

*Standard temperature gradient: -0.015V/°C

TROUBLE DIAGNOSES AND CORRECTIONS (Including alternator)

Condition	Probable cause	Corrective action
No output	Sticking brushes. Dirty brushes and slip rings. Loose connections or broken leads. Open stator winding. Open rotor winding. Open diodes. Shorted rotor. Shorted stator. Grounded "A" terminal. Broken fan belt.	Correct or replace brushes and brush springs. Clean. Retighten or solder connections. Replace leads if necessary. Repair or replace stator. Replace rotor. Replace. Replace rotor. Repair or replace. Replace insulator. Replace.
Excessive output	Broken neutral wire (color of wire is yellow.) Voltage regulator breakdown. Poor grounding of alternator and voltage regulator "E" terminal. Broken ground wire (color of wire is black.)	Replace. Check regulator operation and repair or replace as required. Retighten terminal connection. Replace.
Low output	Loose or worn fan belt. Sticking brushes. Low brush spring tension. Voltage regulator breakdown. Dirty slip rings. Partial short, ground, or open in stator winding. Partially shorted or grounded rotor winding. Open or damaged diode.	Retighten or replace. Correct or replace brushes and springs if necessary. Replace brush springs. Check regulator operation and repair or replace as required. Clean. Replace stator. Replace rotor. Replace diode.
Noisy alternator	Loose mounting. Loose drive pulley. Broken ball bearing. Improperly seated brushes.	Retighten bolts. Retighten. Replace. Seat correctly.

IGNITION CIRCUIT

The ignition circuit consists of ignition switch, transistor ignition unit, distributor, wiring, spark plugs and battery.

The distributor is of the contactless type and is equipped with a pick-up coil which electrically detects the ignition timing signal in place of the circuit breaker of the conventional distributor. The transistor ignition unit is a new addition, which generates the signal required for the make and break of the primary electric current for the ignition coil.

The circuit is equipped with a resistor. During cranking, electrical current bypasses the secondary resistor, thereby connecting the ignition coil through the primary resistor. This makes battery voltage available at efficiently and keeps ignition voltage as high as possible.

The primary resistor serves to protect transistor ignition circuit.

The low voltage current is supplied by the battery or alternator and flows through the primary circuit.

It consists of the ignition switch, resistor, primary winding of the ignition coil, transistor ignition unit and all connecting low tension wiring.

The high voltage current is produced by the ignition coil and flows through the secondary circuit, result-

ing in high voltage spark between the electrodes of the spark plugs in engine cylinders.

This circuit contains the secondary winding of the ignition coil, distributor high tension wires to coil and spark plugs, distributor rotor and cap.

When the ignition switch is turned on and the distributor reluctor rotates, the primary current flows through the primary winding of the coil and through transistor ignition unit to ground.

When the primary circuit is opened by circuit of transistor ignition unit, the magnetic field built up in the primary winding of the coil moves through the secondary winding of the coil, inducing high voltage. This high voltage is produced every time the primary circuit opens.

The high voltage current flows through the high tension wire to the distributor cap, then the rotor distributor cap, then the rotor distributes the current to one of the spark plug terminals in the distributor cap.

Then the spark occurs while the high voltage current jumps the gap between the insulated electrode and the ground side electrode of the spark plug. This process is repeated for each power stroke of the engine.

The spark plug should be inspected, cleaned and regapped, at tune up. Spark plugs should also be replaced periodically as specified in the "Maintenance Schedule".

The remainder of the ignition component parts should be inspected for only their operation, air gap of distributor, tightness of electrical terminals, and wiring condition.

Apply grease (NLGI consistency No. 1 containing MoS₂ or equivalent) to distributor rotor shaft as required.

On the Non-California model, the advance control relay and water temperature switch are provided. The temperature switch is a bimetal type. When the engine coolant is at low temperatures, the contact points are close and current flows through the relay, so that the transistor ignition unit transmits advanced ignition signals.

When the coolant reaches a fixed temperature and the bimetal temperature switch contacts are so opened as not to let an electric current flow the relay, relay contacts are closed and another voltage is applied to the ignition unit, which transmits retarded ignition signals. In this way, advanced signal is changed over by the temperature of engine coolant.

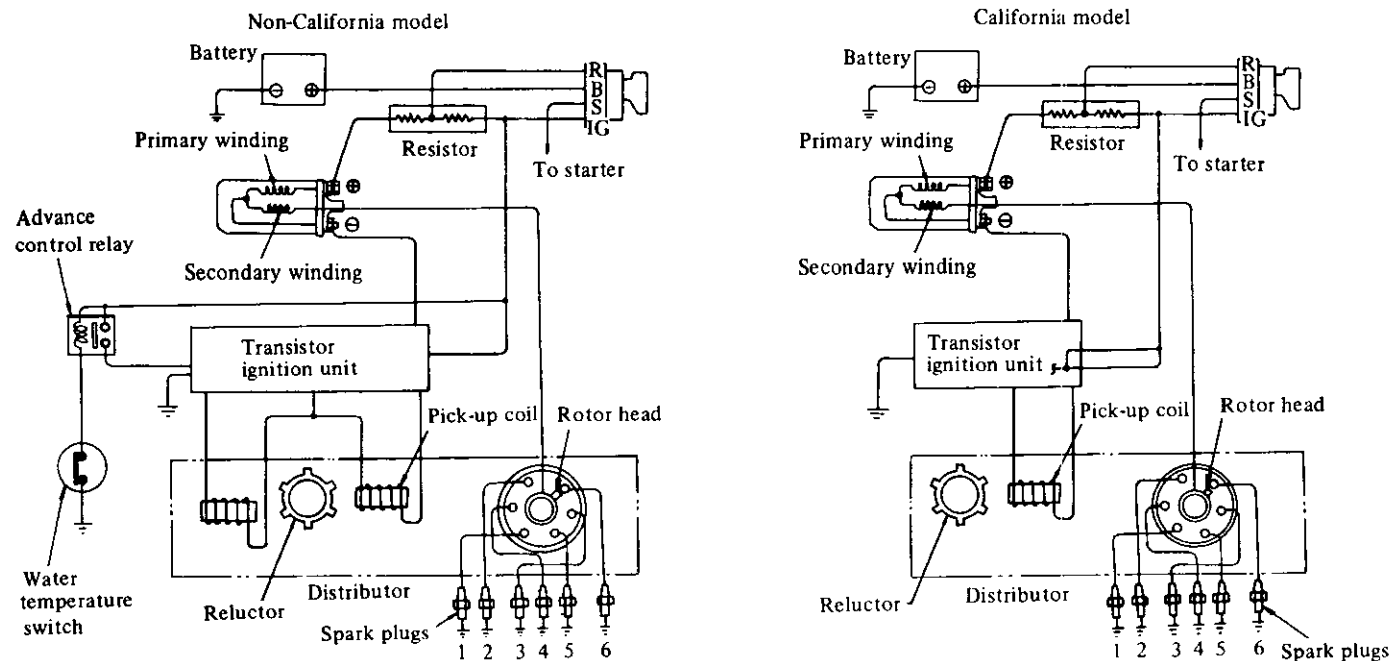

EE364

Fig. EE-59 Ignition system circuit diagram

DISTRIBUTOR

CONTENTS

CONSTRUCTION	EE-27	PHASE DIFFERENCE	EE-29
CHECKING AND ADJUSTMENT	EE-28	ADVANCE MECHANISMS	EE-29
CAP AND ROTOR HEAD	EE-28	DISASSEMBLY	EE-30
AIR GAP	EE-28	ASSEMBLY	EE-30
		SERVICE DATA AND	
		SPECIFICATIONS	EE-31

CONSTRUCTION

Distributor type	Applied model	Transmission	Remarks
D6F4-01	Non-California	Manual	2 pick-up type
D6F4-02		Automatic	
D6F4-03	California	Manual and Automatic	1 pick-up type

In the conventional distributor the ignition point is detected by the cam and breaker arm, while in this transistor ignition unit it is detected by the reluctor on the shaft and the pick-up coil provided in place of the breaker. The pick-up coil consists of a magnet, coil, etc. The amount of magnetic flux passing through the pole piece in the coil is changed at the moment the pole piece faces the protrusion of the reluctor, and then the electrical signal is generated in the pick-up coil.

This electric signal is conducted into the transistor ignition unit, which in turn breaks the primary coil current running through the ignition coil and

generates high voltage in the secondary winding. Also, this transistor ignition unit utilizes this electric signal to restore the primary coil to the original state after cutting off the primary current for a fixed time.

The D6F4-03 type has a single pick-up coil. The D6F4-01 and D6F4-02 types have dual pick-up coils that always generate both advanced and retarded signals and send to the control unit. The advance circuit of ignition unit is on, while the retard circuit is off when the relay is on and the contacts are opened. Refer to Figure EE-59.

A phase difference of 6° crank angle is adopted. Two pick-up coils, which consist of advanced and retarded coil, are placed in parallel with each other in the primary ignition circuit.

The difference in phase can be adjusted by turning the adjusting screw.

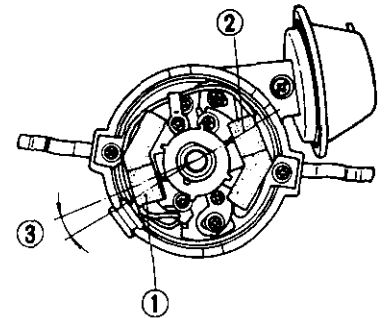

EE365

- 1 Advanced pick-up coil
- 2 Retarded pick-up coil
- 3 Phase difference

Fig. EE-60 Dual pick-up coils

The centrifugal and vacuum advance mechanisms employ the conventional mechanical type. The contactor is used to eliminate vacuum and centrifugal advance hysteresis.

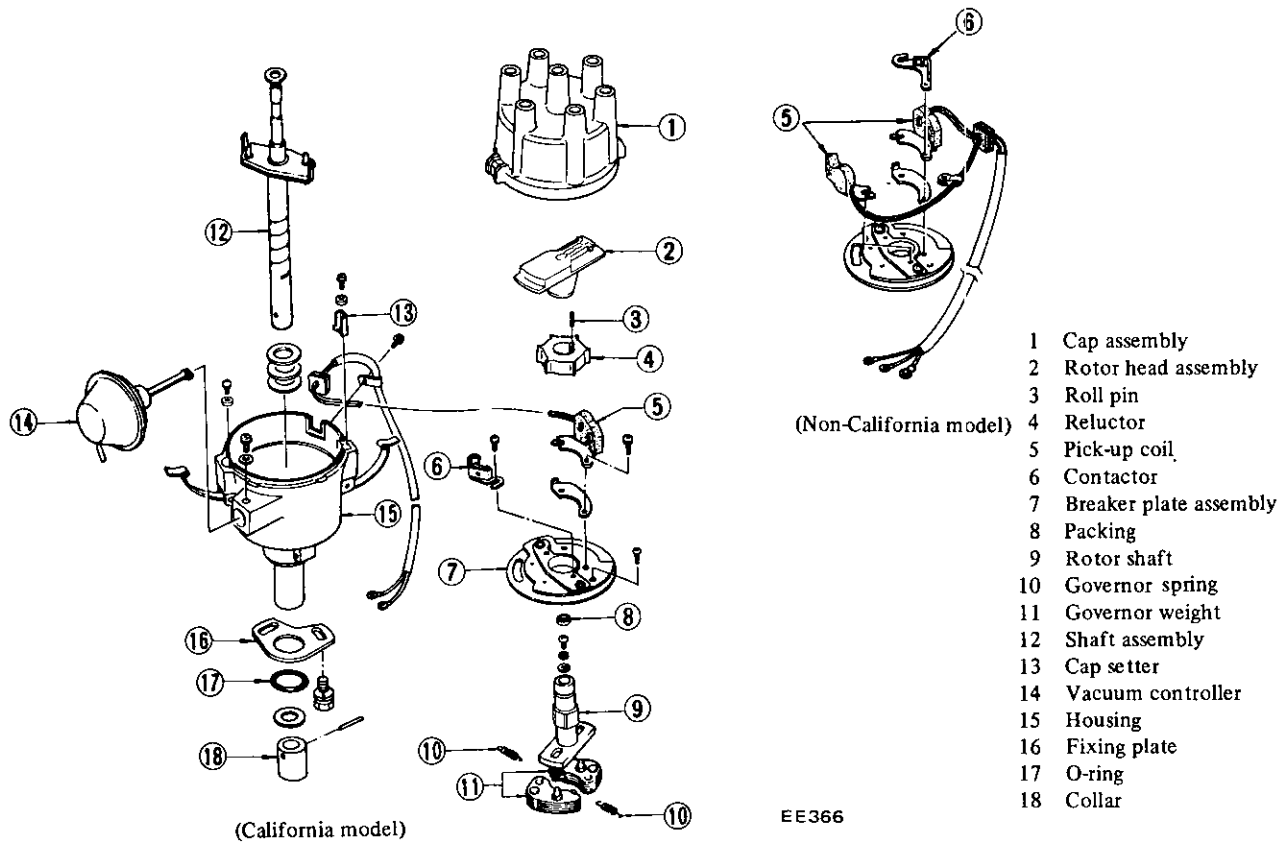

Fig. EE-61 Exploded view of distributor

CHECKING AND ADJUSTMENT

CAP AND ROTOR HEAD

Cap and rotor head must be inspected periodically as specified in the "Maintenance Schedule". Remove cap and clean all dust and carbon deposits from cap and rotor from time to time. If cap is cracked or is leaking, replace with a new one.

AIR GAP

Standard air gap is 0.2 to 0.4 mm (0.008 to 0.016 in).

If the gap is off the standard, adjustment should be made by loosening pick-up coil screws.

Gap gauge is required for adjustment.

Air gap: 0.2 to 0.4 mm
(0.008 to 0.016 in)

- | | |
|--|-------------------------------------|
| 1 Pick-up coil set screws (air gap) | 4 Air gap |
| 2 Adjuster plate set screws (phase difference) | 5 Pole piece |
| 3 Pick-up coil (retarded side) | 6 Pick-up coil (advanced side) |
| | 7 Adjuster plate (phase difference) |
| | 8 Reluctor |

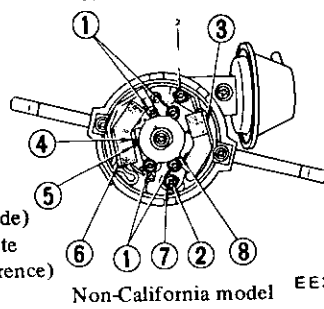
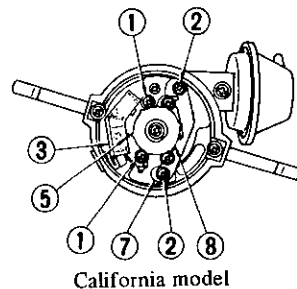
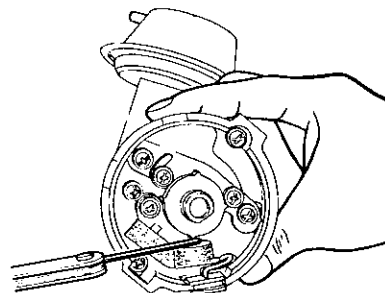
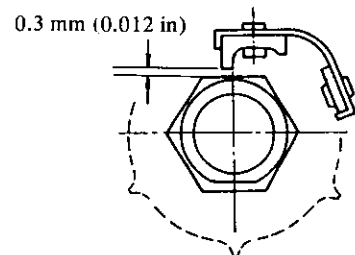

Fig. EE-62 Checking air gap

Adjusting dual pick-up type distributor for air gap can disturb cam-to-contact clearance adjustment. After air gap has been adjusted properly, check the clearance to ensure that it is approximately 0.3 mm (0.0118 in) and that contactor touches the highest point of cam. See Figure EE-63.



EE368

Fig. EE-63 Cam-to-contact clearance

To replace pick-up coil, disconnect primary lead wires at terminal block and remove two pick-up coil setscrews.

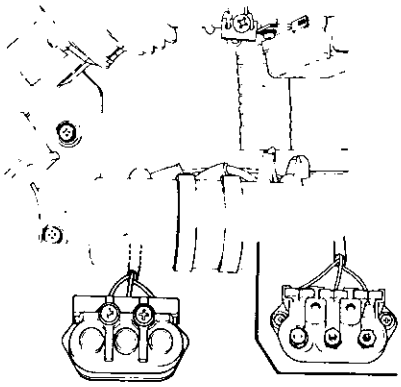

Fig. EE-64 Terminal block

PHASE DIFFERENCE (Non-California models only)

To check phase difference, install distributor on engine and proceed as follows:

1. Disconnect engine harness red wire connector from water temperature switch.
2. Ground engine harness red wire to engine body with a suitable lead wire. See Figure EE-65.

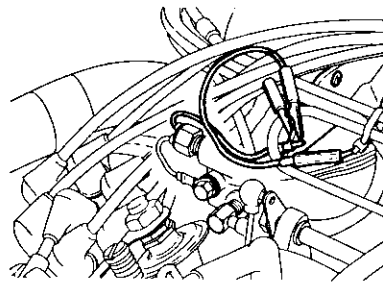

Fig. EE-65 Short-circuit of advance control relay

3. With engine idling, adjust ignition timing by rotating distributor to specifications.
4. With engine harness red wire connector disconnected, idle engine and check that phase delay is 6 degrees in terms of crankshaft angular displacement.

To correct as follows:

- (1) Referring to Figure EE-66, turn out adjuster plate screws 1/2 to 2 turns. The screws are located at pick-up coil assembly on retarded side.
- (2) Turn adjuster plate until correct phase difference is obtained. Ignition timing is retarded when plate is turned counterclockwise.

Note: Refer to graduations on breaker plate to make adjustment easier. One graduation corresponds to a crankshaft angular displacement of 4 degrees.

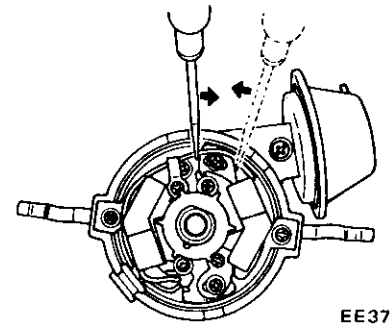

Fig. EE-66 Adjusting phase difference

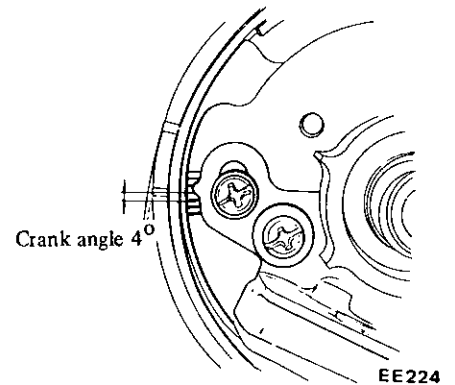

Fig. EE-67 Phase difference adjusting scale

- (3) Make sure that the ignition timing of advanced side meets specifications.
- (4) After adjustment, connect engine harness red wire to water temperature switch.

ADVANCE MECHANISMS

« Specifications »

Item \ Type	D6F4-01	D6F4-02	D6F4-03
Applied model	Non-California		California
Transmission	Manual	Automatic	Manual and Automatic
Vacuum advance [Distributor degrees/distributor mmHg (inHg)]	0°/200 (7.9) 7.5°/350 (13.8)	0°/250 (9.8) 5.5°/350 (13.8)	0°/200 (7.9) 7.5°/350 (13.8)
Centrifugal advance [Distributor degrees/distributor rpm]	0°/600 10°/1,360		0°/600 8.5°/1,250

◀ Vacuum advance mechanism mechanical parts ▶

If vacuum advance mechanism fails to operate properly, check for the following items and correct the problem as required.

1. Check vacuum inlet for signs of leakage at its connection. If necessary, retighten or replace with a new one.
2. Check vacuum diaphragm for air leak.

If leak is found, replace vacuum controller assembly.

3. Inspect breaker plate for smooth moving.

If plate does not move smoothly, this condition could be due to sticky steel balls or pivot. Apply grease to steel balls or, if necessary, replace distributor assembly.

◀ Centrifugal advance mechanical parts ▶

When cause of engine malfunction is traced to centrifugal advance mechanical parts, use distributor tester to check its characteristics. See to the specifications above.

If nothing is wrong with its characteristics, conceivable causes are faulty or abnormal wear of driving part or others. So do not disassemble it.

In the event of improper characteristics, check closely rotor shaft assembly, governor weight and shaft.

If any of above parts are malfunctioning, replace distributor assembly.

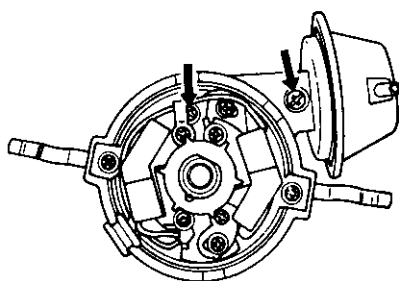

EE372

Fig. EE-68 Removing vacuum controller

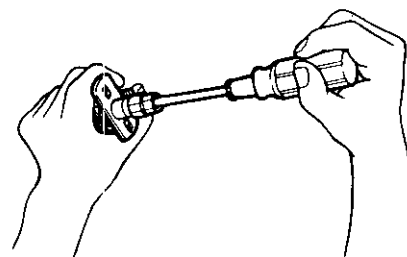

EE075

Fig. EE-71 Removing rotor shaft

3. Remove pick-up coil assembly.
4. Using two pry bars, pry reluctor from shaft. Be careful not to distort or damage the teeth of reluctor.

Remove roll pin.

5. Remove breaker plate setscrews and remove breaker plate assembly.

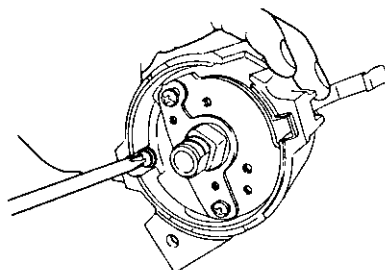

Fig. EE-69 Removing breaker plate setscrews

6. Pull roll pin out and remove collar.
7. Remove rotor shaft and drive shaft assembly.

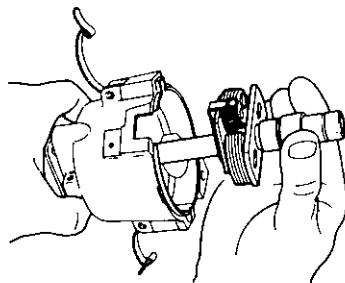

Fig. EE-70 Removing rotor shaft and drive shaft assembly

8. Mark rotor shaft and drive shaft. Remove packing from the top of rotor shaft and unscrew rotor shaft setscrew.

9. Mark one of the governor springs and its bracket. Also mark one of the governor weights and its pivot pins.

10. Carefully unhook and remove governor springs.

11. Remove governor weights.

Apply grease to governor weights after disassembling.

ASSEMBLY

To assemble, reverse the order of disassembly. Carefully observe the following instructions.

1. Align match marks so that parts are assembled to their original positions.

2. If, for any reason, contactor is removed from breaker plate, adjust cam-to-contactor clearance to 0.3 mm (0.012 in) as shown in Figure EE-63 after installation.

3. Ensure that reluctor is properly oriented when installing on shaft.

Always drive in roll pin with its slit toward the outer end of shaft. See Figure EE-72. Be sure to use a new roll pin.

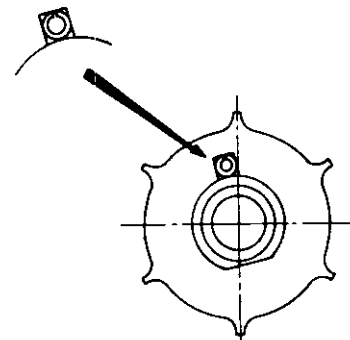

EE373

Fig. EE-72 Driving in roll pin

DISASSEMBLY

To disassemble, follow the procedure below.

1. Take off cap and remove rotor head.
2. Remove two screws shown in Figure EE-68 and detach vacuum controller.

Engine Electrical System

- | | | |
|---|--|--|
| <p>4. Apply grease to the top of rotor shaft as required.</p> <p>5. Check the operation of governor</p> | <p>before installing distributor on engine.</p> <p>6. Adjust ignition timing after distributor is installed on engine.</p> | |
|---|--|--|

SERVICE DATA AND SPECIFICATIONS

Type	D6F4-01	D6F4-02	D6F4-03
Firing order	1-5-3-6-2-4		
Rotating direction	Counterclockwise		
Duty	70% (20 to 40% at idling)		
Air gap mm (in)	0.2 to 0.4 (0.008 to 0.016)		
Cap insulation resistance MΩ	More than 50		
Rotor head insulation resistance MΩ	More than 50		
Cap carbon point length mm (in)	10 (0.39)		
Ignition timing (B.T.D.C.) at idle speed degree/rpm			
Manual transmission	7°/800 (Retarded) 13°/800 (Advanced)	-	10°/800
Automatic transmission in "D" range	-	7°/700 (Retarded) 13°/700	10°/700
Phase difference degree	6°		-

TRANSISTOR IGNITION UNIT

CONTENTS

DESCRIPTION	EE-32	3. RETARDED SIDE PICK-UP COIL	
TRANSISTOR IGNITION UNIT	EE-32	CONTINUITY CHECK	EE-34
SPARK TIMING CONTROL SYSTEM	EE-32	4. ADVANCED SIDE PICK-UP COIL	
REMOVAL AND INSTALLATION	EE-33	CONTINUITY CHECK	EE-34
INSPECTION	EE-33	5. PICK-UP COIL POWER	
1. POWER SUPPLY WIRING		SINGLE PULSE CHECK	EE-34
AND BATTERY CHECK	EE-33	6. TRANSISTOR IGNITION UNIT	
2. CONTINUITY CHECK OF		CHECK	EE-37
PRIMARY CIRCUIT	EE-34		

DESCRIPTION

TRANSISTOR IGNITION UNIT

The transistor ignition unit provides the following functions:

1. It makes and breaks the electric current in the primary circuit of the ignition coil.
2. The duty control circuit sets the rate of make and break within one cycle, i.e., this maintains good ignition characteristics of engine from low speed to high speed and is equal to the dwell angle in the conventional breaker type distributor.
3. A preventive circuit against locking is provided. This cuts off the primary electric current in the ignition

coil even when the ignition switch is turned on with the engine not running.

4. On Non-California models, a dual pick-up coil distributor is used. Two signals with phase difference are generated and transmitted to the transistor ignition unit from the distributor. The transistor ignition unit receives two signals, advanced or retarded, and has the circuit to select either of them with the advance control relay. The transistor ignition unit used together with the single pick-up coil distributor is basically the same as the transistor ignition unit used with the dual pick-up coil distributor, except the advance circuit.

Each component part of this unit is highly reliable, however, should any

part be found faulty, the entire assembly must be replaced.

SPARK TIMING CONTROL SYSTEM

When the engine coolant is at low temperatures, electric current flows through the advance control relay and its contact points are opened.

Thus the advance circuit of the transistor ignition unit operates. When the engine coolant temperature rises, current will not flow through the relay and its contact points are closed.

Thus the retarded circuit of transistor ignition unit operates.

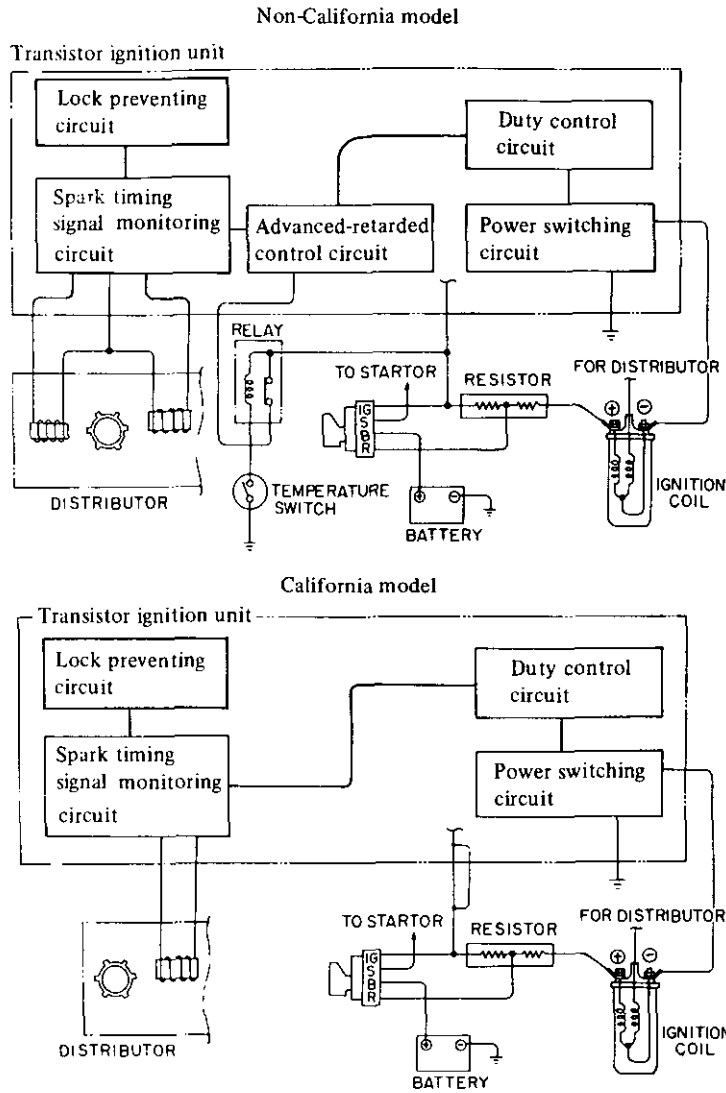

Fig. EE-73 Transistor ignition unit circuit diagram

INSPECTION

If the engine does not run due to faulty ignition system, check the ignition system as follows:

Check for a cracked distributor rotor or cap and corroded terminals. Visually inspect high tension wires for condition and, if necessary, use an ignition oscilloscope or a circuit tester to make performance checks. Check spark plugs and adjust gaps as necessary.

Replace a spark plug which is not suitable for further use. If the above checks cannot correct the problem, check the entire ignition system with an oscilloscope or a circuit tester.

CHECKING WITH AN OSCILLOSCOPE

An oscilloscope can be used for checking almost all the items in a transistor ignition system.

CHECKING WITH A CIRCUIT TESTER

A circuit tester can not be used for the duty control circuit and power transistor performance tests. Both methods (use of an oscilloscope and a circuit tester) are described in this section.

The items are classified by numerals in accordance with the objective of checks to be performed. Several wiring diagrams are found on pages EE-87 to EE-93. The thick lines indicate the objective of each individual item check.

When checking a circuit with an oscilloscope or a circuit tester, be careful not to confuse the polarity of the lead wires if a potential difference exists between the check points at which the lead wires are to be contacted. Also, do not attempt to connect the lead wires to any points in the circuit other than those designated. Careless handling of the lead wires will result in damage to the transistor ignition unit as well as to the oscilloscope or circuit tester.

The connection of a tachometer or a timing light in parallel with an oscilloscope or a circuit tester is allowable, provided that such a connection is made with due consideration to wiring connections.

REMOVAL AND INSTALLATION

Transistor ignition unit is located on the right-hand dash side panel in passenger compartment.

1. Disconnect battery negative cable.
2. Disconnect wiring harness from unit.
3. Remove two setscrews and remove unit.
4. To install, reverse the order of removal.

Note: Be sure to connect wiring harnesses to their proper positions. Failure to do so will damage the unit.

Refer to Figure EE-74.

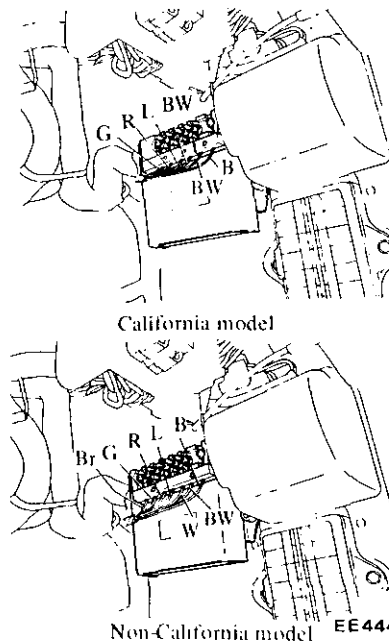

Fig. EE-74 External view of ignition unit

Engine Electrical System

1. POWER SUPPLY WIRING AND BATTERY CHECK (See wiring diagram in Figure EE-87)

Procedure:

1. Turn on ignition switch.
2. Connect a circuit tester or an oscilloscope as shown in the figure below.

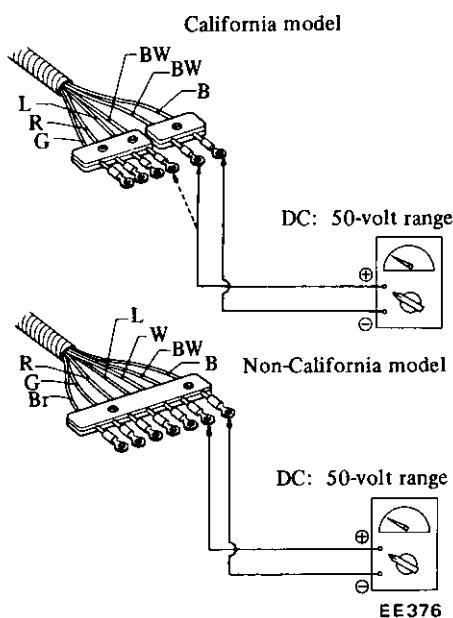

Fig. EE-75 Checking power supply wiring and battery

Criterion:

When power source (battery) voltage is indicated OK
Lower or no indication N.G.

If the result is "N.G." – Take the following measures:

1. Check "BW" and "B" color wire harness respectively, for proper conductance.
2. Check battery cables for proper connection.
3. Check charge condition of battery if an excessively low voltage is indicated.

2. CONTINUITY CHECK OF PRIMARY CIRCUIT

2-1. Checking primary circuit (See wiring diagram in Fig. EE-88)

Procedure:

1. Disconnect "L" color wire from ignition unit.
2. Turn on ignition switch.

3. Connect a circuit tester or an oscilloscope as shown in Figure EE-76.

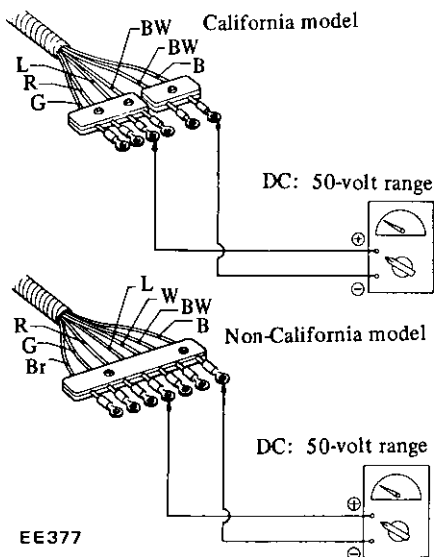

Fig. EE-76 Checking primary circuit

Criterion:

When normal power source (battery) voltage is indicated OK
Lower or no indication N.G.

If the result is "N.G." – Take the following measures:

1. Check "BW" and "L" color wire harness respectively for proper conductance.
2. Check resistor and ignition coil terminals for loose contact.
3. Check resistor and ignition coil for discontinuity.
4. Check "WB" color wire harness of ignition coil assembly for proper continuity.

2-2. Checking ignition coil assembly (See wiring diagram in Fig. EE-89)

Procedure:

1. Disconnect engine room harness from ignition coil external resistor terminals.
2. Connect a circuit tester as shown in the figure below.

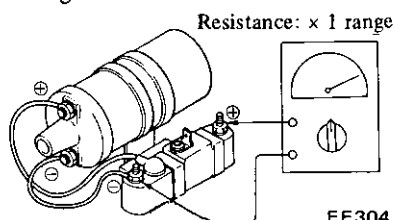

Fig. EE-77 Checking ignition coil assembly

Criterion:

When approximately 1.6 to 2.0 ohm is indicated OK
More than 2.0 ohm N.G.

If the result is "N.G." – Replace ignition coil assembly.

3. RETARDED SIDE PICK-UP COIL CONTINUITY CHECK (See wiring diagram in Figure EE-90)

Procedure:

1. Disconnect "R" and "G" color wires from ignition unit.
2. Connect a circuit tester as shown in the figure below:

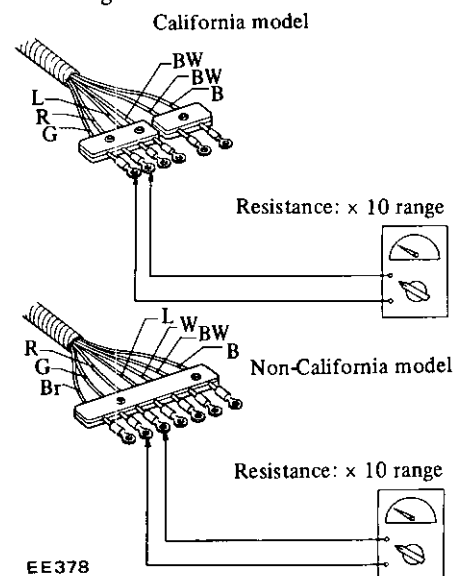

Fig. EE-78 Checking retarded side pick-up coil

Criterion:

When approximately 720 ohm is indicated OK

Far less than or more than 720 ohm N.G.

If the result is "N.G." – Replace pick-up coil assembly. (Retarded side)

4. ADVANCED SIDE PICK-UP COIL CONTINUITY CHECK Non-California models only (See wiring diagram Figure EE-91)

Procedure:

1. Disconnect "Br" color wire from ignition unit.
2. Connect a circuit tester as shown in Figure EE-79.

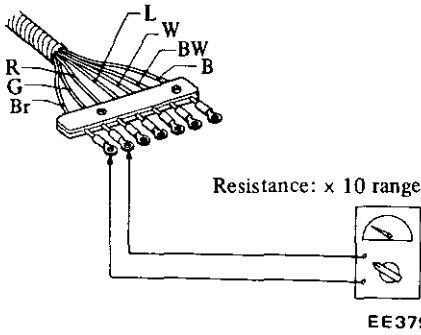

EE379
Fig. EE-79 Checking advanced side pick-up coil

Criterion:

When approximately 720 ohm is indicated OK
For less than or more than 720 ohm N.G.

If the result is "N.G." – Replace pick-up coil assembly. (Advanced side)

5. PICK-UP COIL POWER SIGNAL PULSE CHECK

1. Turn ignition switch off and disconnect electronic fuel injection harness connector from cold start valve. (California models only)
2. Disconnect pick-up coil lead wires from engine room harness at terminal block.
3. Connect positive lead of an oscilloscope to pick-up coil lead wire connected to "R" color wire of engine room harness, and negative lead to pick-up coil lead wire connected to "G" color wire of engine room harness.
4. Set "SLOPE" select switch of oscilloscope to the positive side. (If so equipped.)
5. Rotate starter motor and check the wave form as shown in the figure below.

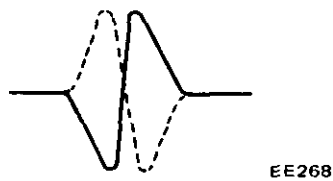

EE268
Fig. EE-80 Wave form of pick-up coil signal pulse

Criterion:

When the wave form takes

the shape of a full line OK
When the wave form takes the shape of a dashed line or when there is no wave form N.G.

If the result is "N.G." – Replace pick-up coil assembly. (On non-California models, also check the advanced side.)

– If an oscilloscope is not available –

Use a circuit tester for the check. For accurate testing of pulse signals, however, an oscilloscope is necessary.

Procedure:

1. Turn ignition switch off and disconnect electronic fuel injection harness connector from cold start valve. (California models only)
2. Connect a circuit tester as shown in the figure below.
3. Rotate starter motor.
4. Read the tester indication.

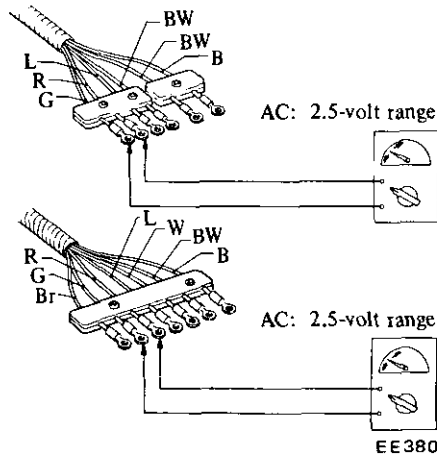

EE380
Fig. EE-81 Checking pick-up coil power signal pulse

Criterion:

When pointer deflects slightly OK
When pointer does not deflect at all N.G.

If the result is "N.G." – Replace pick-up coil assembly. (On Non-California models also check the advanced side, following the same steps as above.)

6. TRANSISTOR IGNITION UNIT CHECK (See wiring diagram in Figure EE-92)

Check items 6-1 and 6-2 with an oscilloscope.

Where an oscilloscope is not available, check to make sure that all previous tests are satisfactory and that no spark is issuing from the secondary high-tension wire.

If everything else is satisfactory, then the transistor ignition unit is faulty or there is discontinuity in the secondary high-tension wire. Replace the faulty part. After replacement check the sparks from the secondary wire.

6-1. Checking operation of transistor ignition unit

Procedure:

1. Connect engine room harness to ignition coil external resistor terminals.
2. Connect wiring harness to the ignition unit.

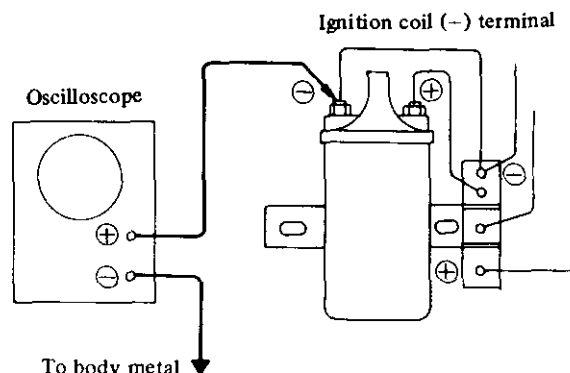

EE307
Fig. EE-82 Checking operation of transistor ignition unit

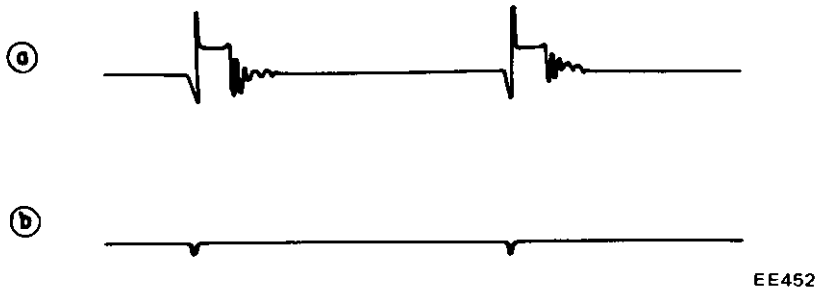

Fig. EE-83 Wave form of pulse

3. Connect pick-up coil lead wires to engine room harness at terminal block.
4. Turn ignition switch off and disconnect electronic fuel injection harness connectors from injectors and cold start valve. (California models only)
5. Connect oscilloscope as shown in Figure EE-82, rotate the starter motor and observe the wave form on the oscilloscope.

Criterion:

See Figure EE-83.
 When a wave form similar to (a) is observed OK
 When a wave form similar to (b) is observed or when no wave form is observed N.G.

If the result is "N.G.", the fault lies either in the transistor unit or in the secondary high-tension wire.

Replace these parts.

— If an oscilloscope is not available —

Procedure:

1. Connect engine room harness to ignition coil external resistor terminals.
2. Connect wiring harness to ignition unit.
3. Turn ignition switch off and disconnect electronic fuel injection harness connectors from injectors and cold start valve. (California models only)
4. Keep the secondary high tension wire end 4 to 5 mm (0.16 to 0.20 in) away from engine blocks or body metal, rotate the starter motor, and

check whether sparks jump across the clearance.

Caution: Do not attempt to make this test near electronic fuel injection harness. If this harness is close to high tension wire end, sparks can jump across the air gap and damage control unit.

Criterion:

Where sparks issue OK
 Where no spark issues N.G.

If the result is "N.G.", the fault lies either in the transistor unit or in the secondary high-tension wire.

Replace these parts.

6-2. Checking operation of duty

Procedure:

1. Turn ignition switch off and connect electronic fuel injection harness connectors to injectors and cold start valve. (California models only)
2. While the engine is idling, observe the wave form on the oscilloscope in the same way as stated in item 5-1, Figure EE-82. Determine the ratio t/T as shown in Figure EE-84.

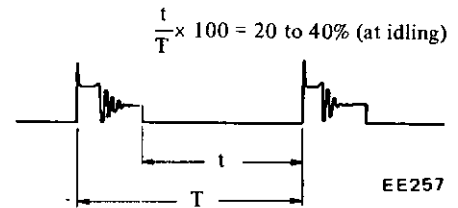

Fig. EE-84 Wave form of duty pulse

Criterion:

When a standard ratio of about 20 to 40% is obtained OK
 When the ratio obtained is less than 20%, or more than 40% N.G.

If the result is "N.G." – Replace transistor ignition unit.

6-3. Checking two Pick-up switching mechanism (See wiring diagram Fig. EE-93) (Non-California models only)

Procedure:

1. Disconnect the connections of oscilloscope to the negative terminal on ignition coil and to the ground.
2. Disconnect "W" color wire from ignition unit. (This state corresponds to that in which water temperature switch is on and the advance control relay contacts are opened.)
3. Start engine and read ignition timing.
4. Connect "BW" color wire terminal of ignition unit to "W" color wire terminal of ignition unit. (This state corresponds to that in which water temperature switch is off and the advance control relay contacts are closed.)
5. Check ignition timing to see whether the timing is delayed or not.

Transmission	Ignition timing (Non-California models)	
	Retarded	Advanced
Manual	7° B.T.D.C./800 rpm	13° B.T.D.C./800 rpm
Automatic	7° B.T.D.C./700 rpm in "D" range	13° B.T.D.C./700 rpm in "D" range

Criterion:

When rated timing delay appears OK
 When smaller timing delay or no delay appears N.G.
 If the result is "N.G." – Take the following measures:

1. When a small delay appears, adjust an advance-side pick-up coil in the distributor.
2. When no delay appears, adjust an advance-side pick-up coil in the distributor (to advance further). If delay is still too small, replace the transistor ignition unit.

6-4. Checking lock preventive circuit

– If a circuit tester is used –

Procedure:

1. Connect a circuit tester as shown in Figure EE-82 or EE-85; positive terminal of tester is connected to "L" color wire and negative terminal of tester is grounded.
2. Turn on ignition switch. Check to see whether the tester indicates the voltage of power source (battery) as soon as ignition switch is turned on.

Criterion:

When power source voltage is indicated OK
 When approximately zero-voltage is indicated N.G.

If the result is "N.G." – Take the following measures:

Replace transistor ignition unit.

– If an oscilloscope is used –

Procedure:

1. When using an oscilloscope instead of a tester, arrange the connection in the same way as shown in Figure EE-82 or Figure EE-85. Turn on ignition switch.
- Check to see whether the wave form on the oscilloscope rises up to the power source voltage as soon as ignition switch is turned on.

Criterion:

The same as described before for use of a tester.

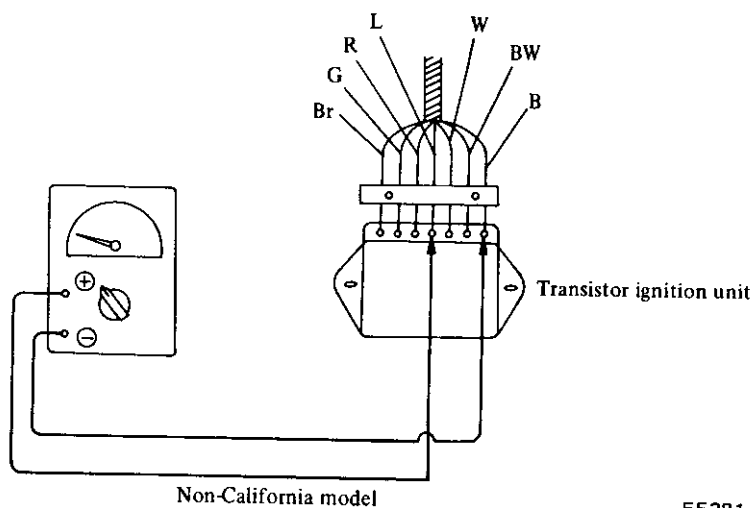
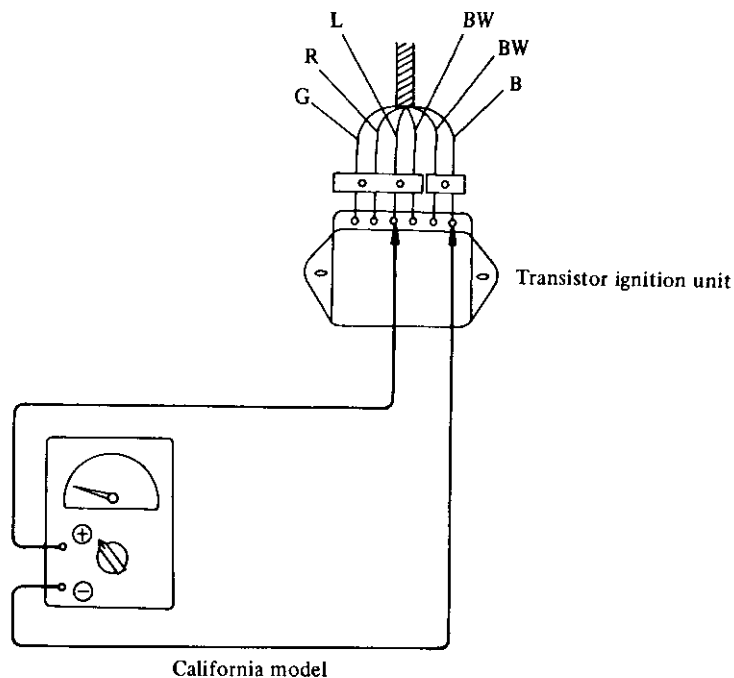

EE381
 Fig. EE-85 Checking lock preventive circuit

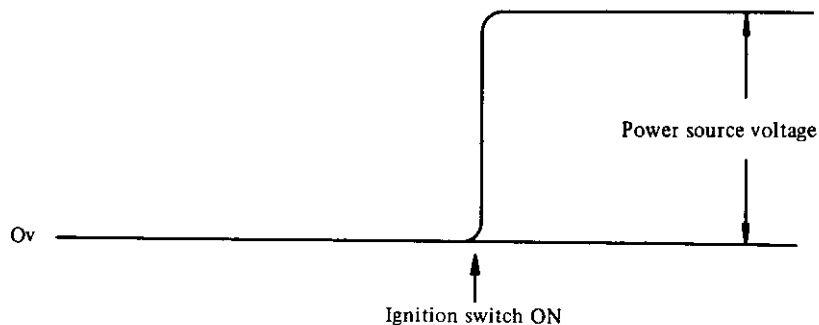

EE430
 Fig. EE-86 Wave form of lock preventive circuit

Engine Electrical System

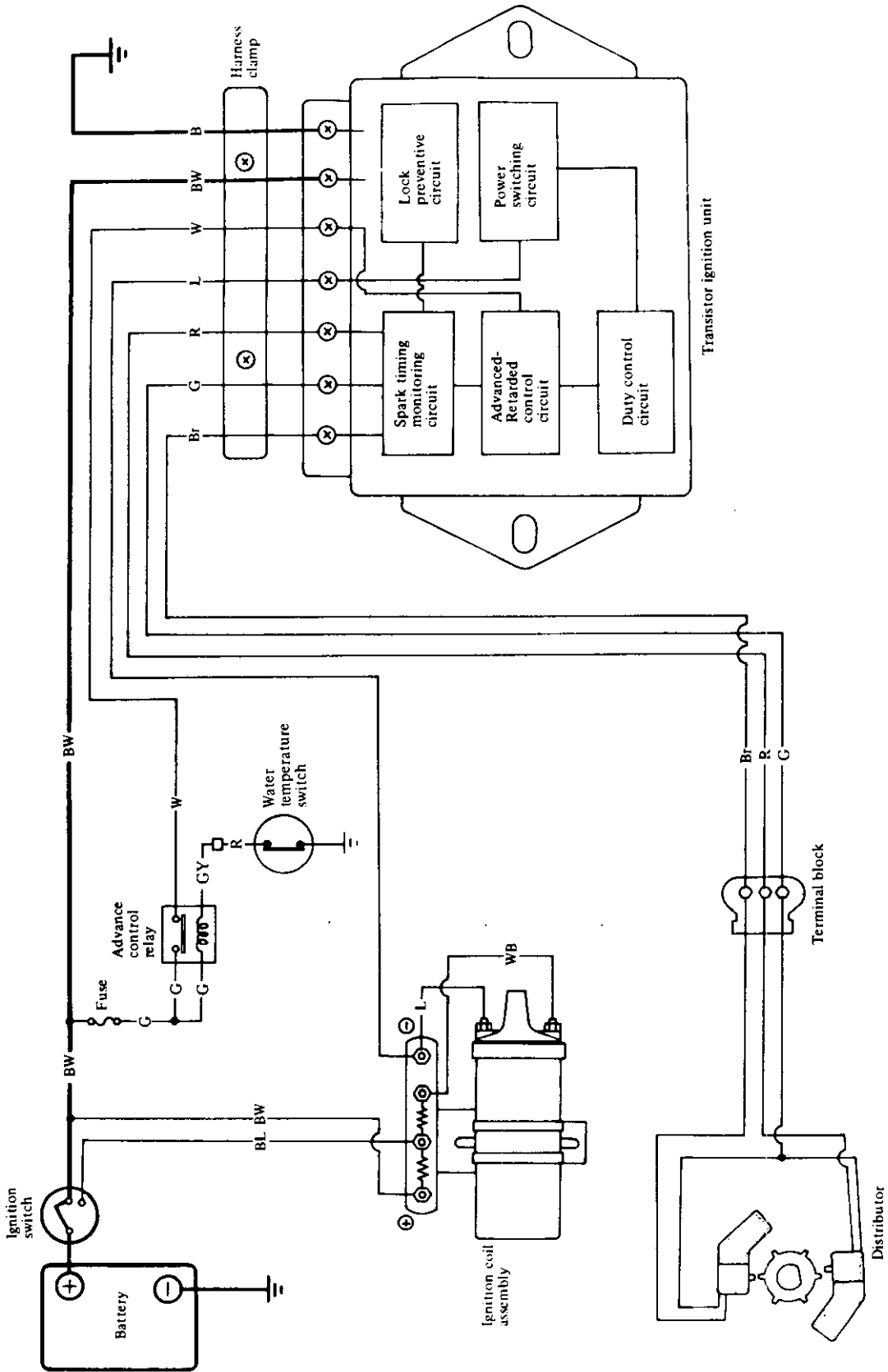

EE445

Fig. EE-87 Wiring diagram for item (1) (Power supply wiring and battery check)

Engine Electrical System

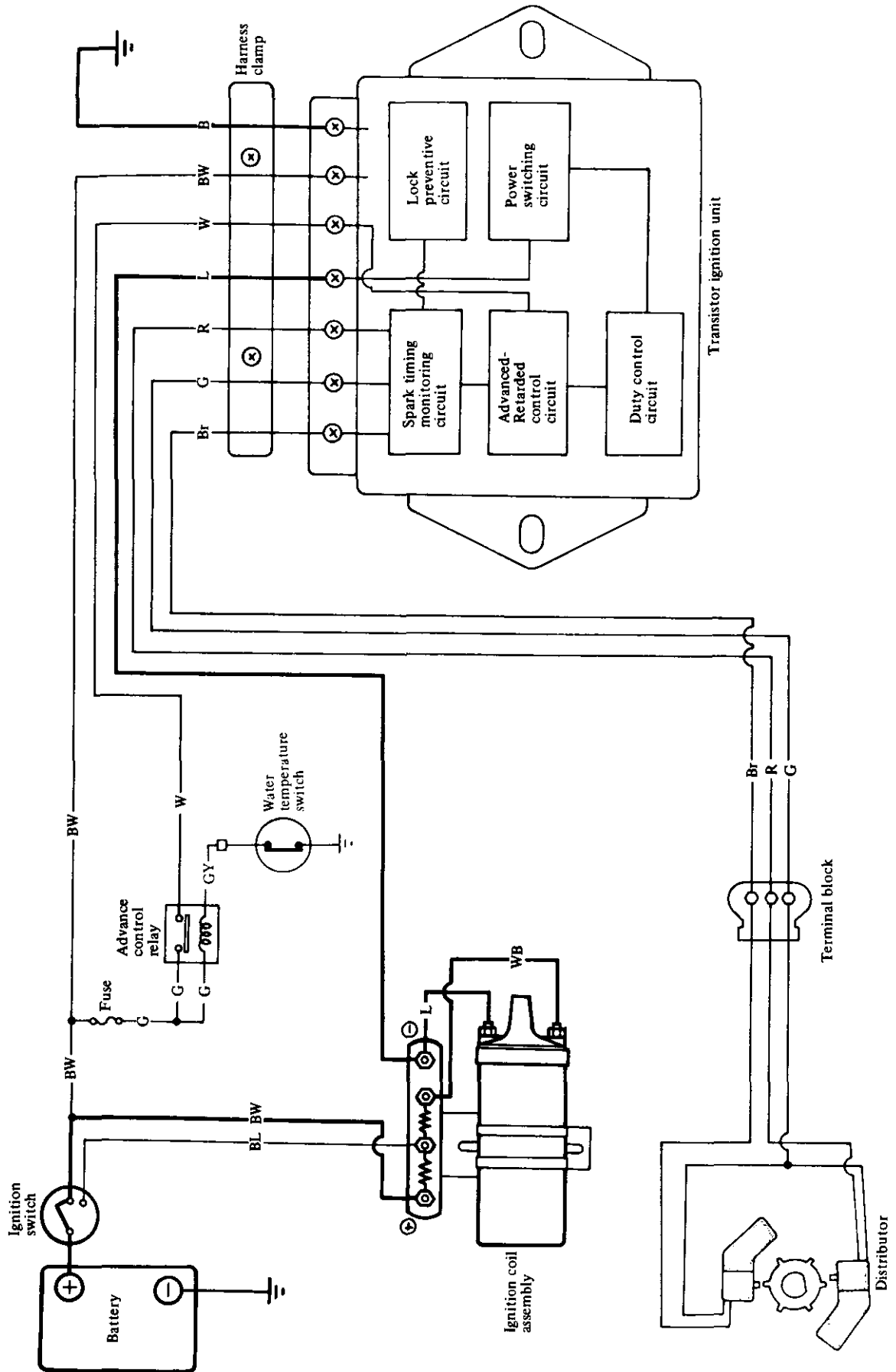
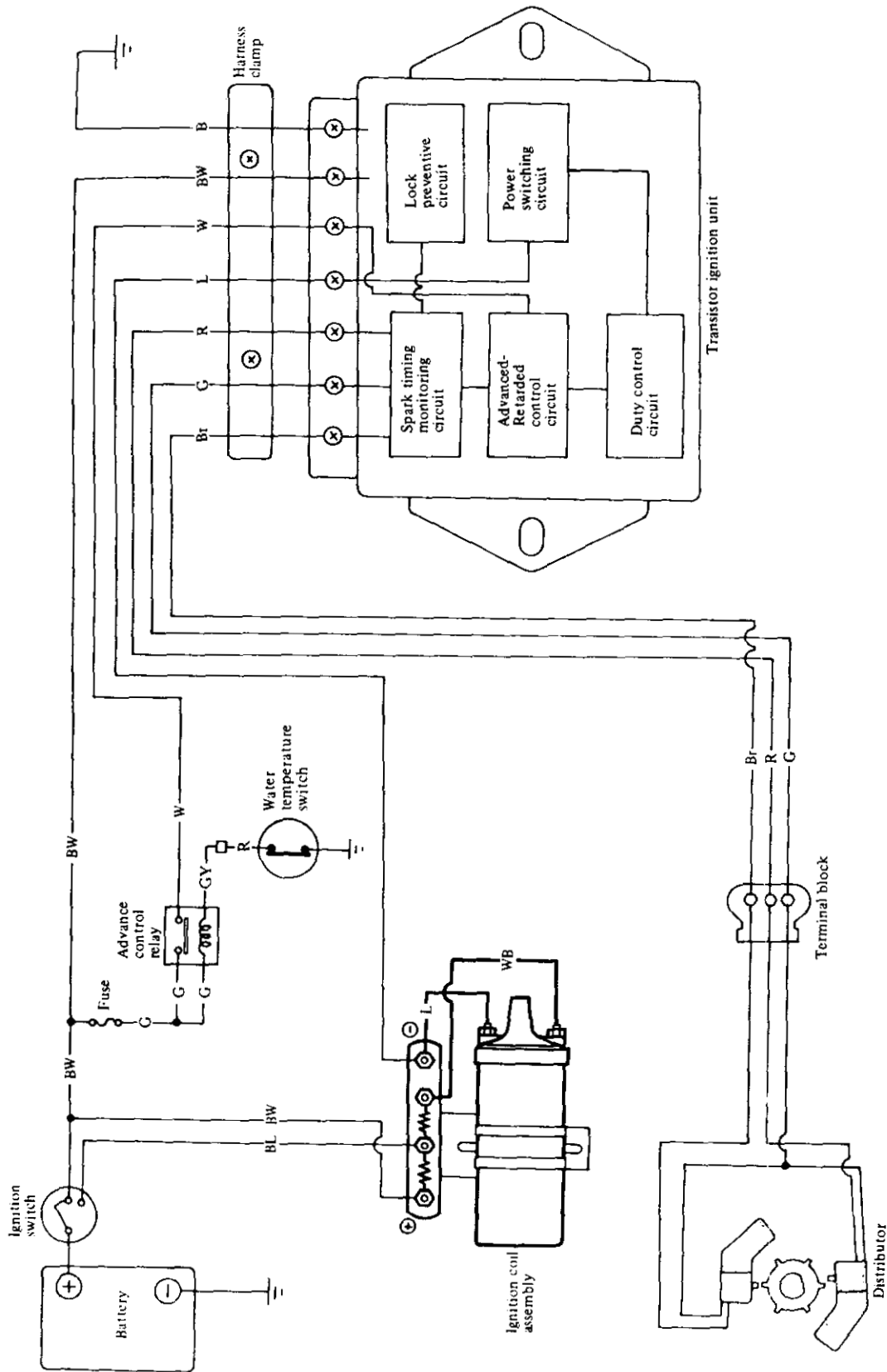

Fig. EE-88 Wiring diagram for item (2)-1 (Checking primary circuit)

Engine Electrical System



EE447

Fig. EE-89 Wiring diagram for item (2)-2 (Checking ignition coil assembly)

Engine Electrical System

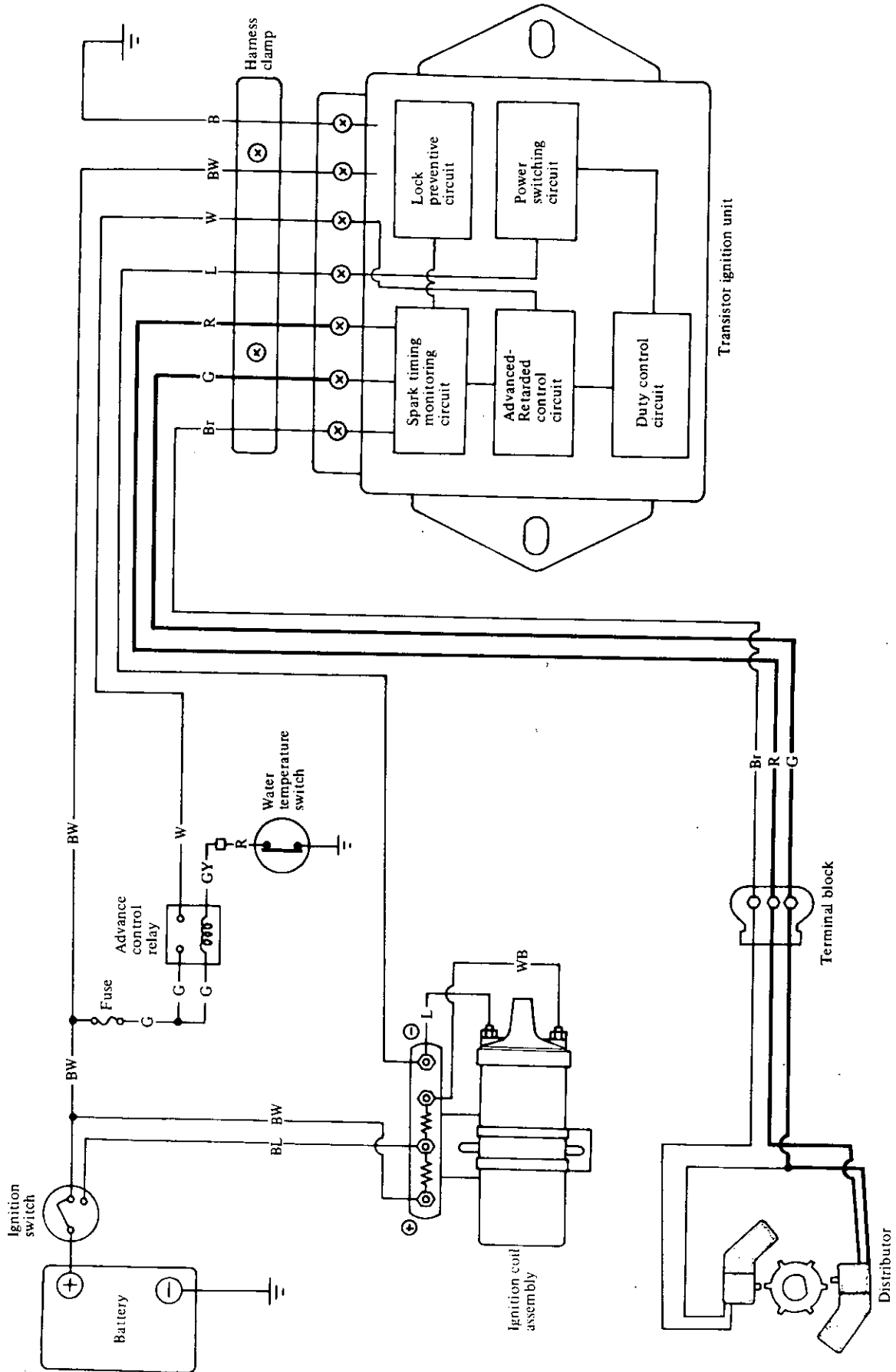

Fig. EE-90 Wiring diagram for item (3) (Retarded side pick-up coil continuity check)

Engine Electrical System

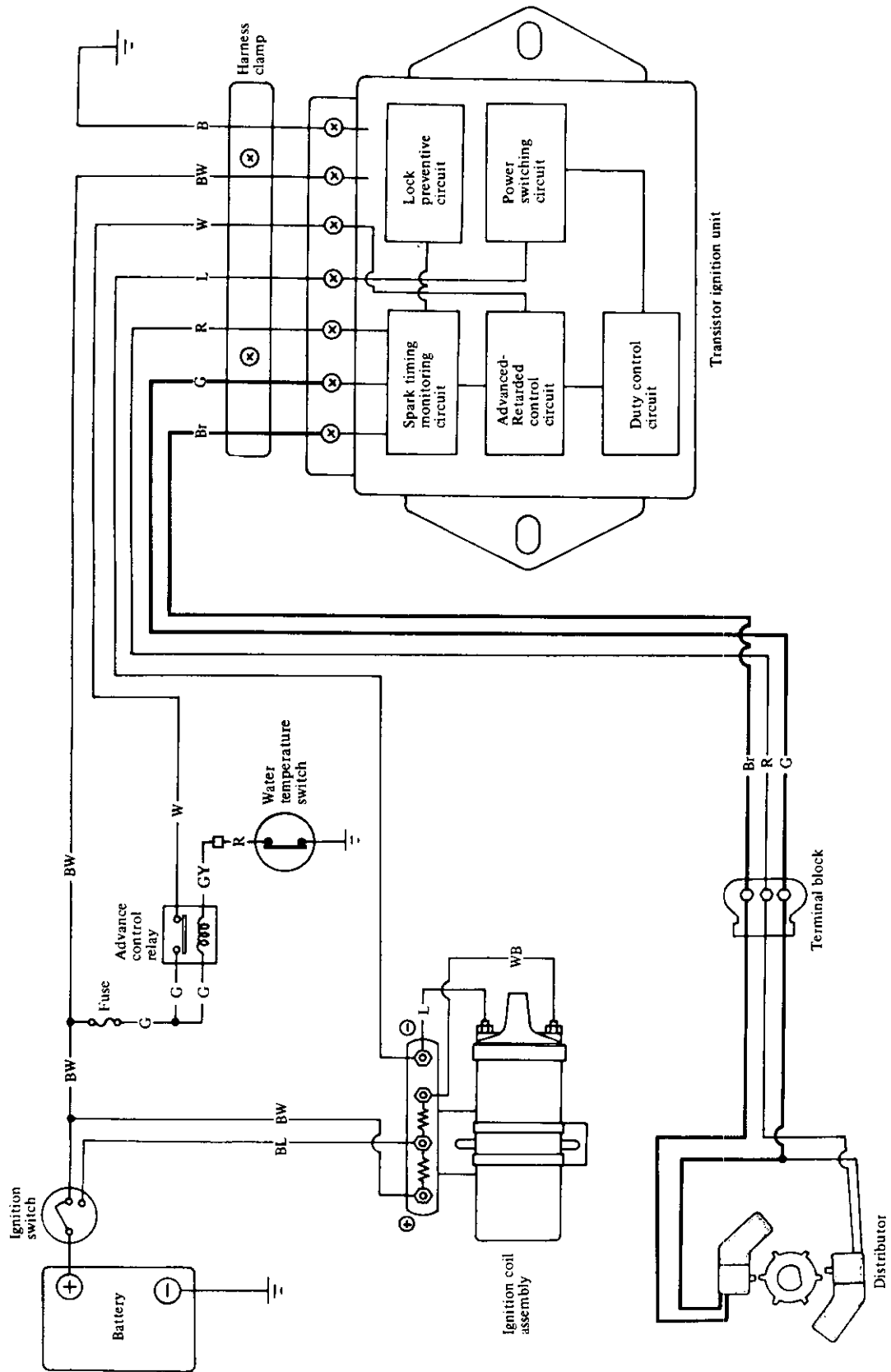

Fig. EE-91 Wiring diagram for item (4) (Advanced side pick-up coil continuity check)

EE449

Engine Electrical System

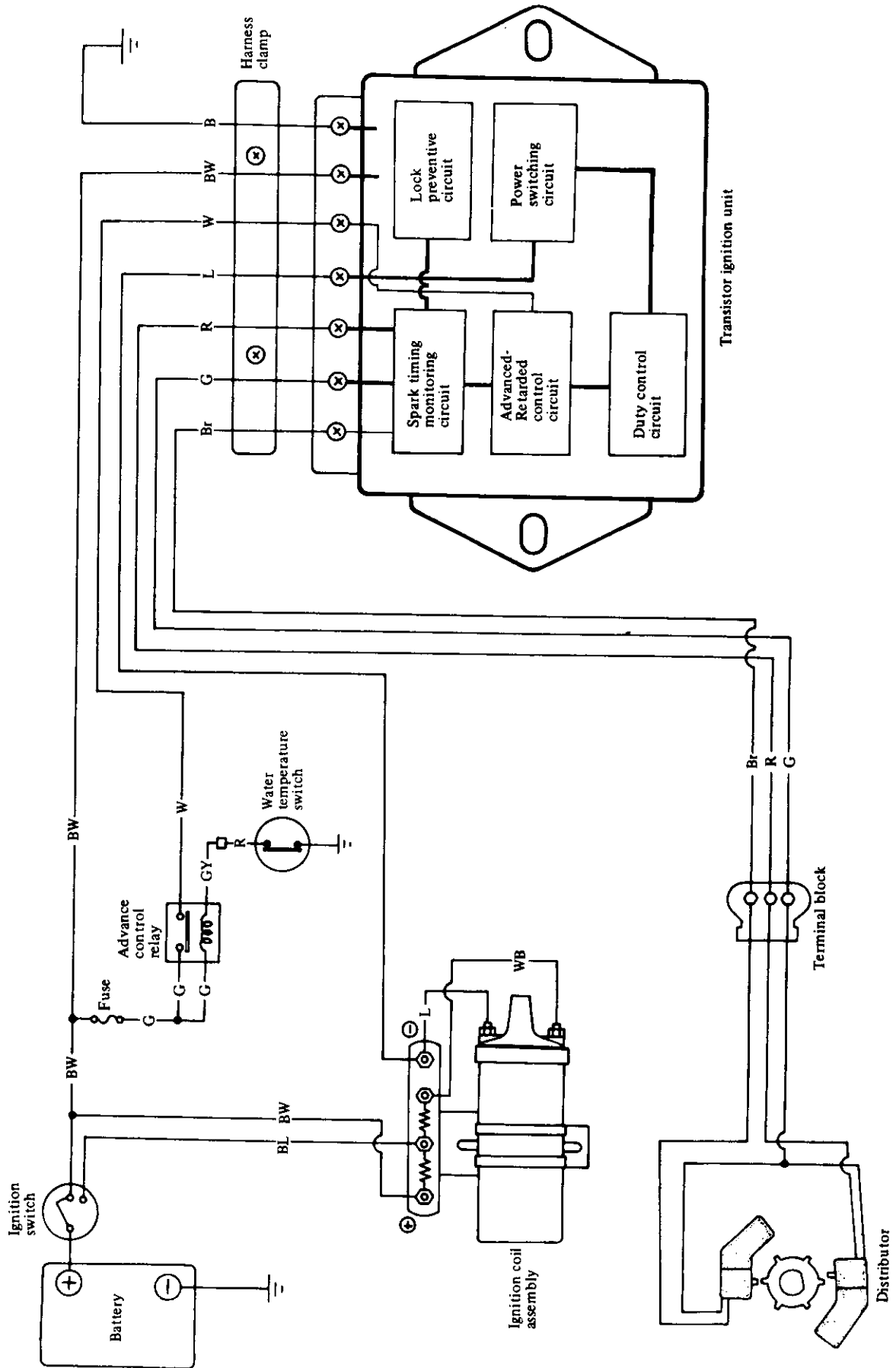

Fig. EE-92 Wiring diagram for item (6) (Transistor ignition unit check)

Engine Electrical System

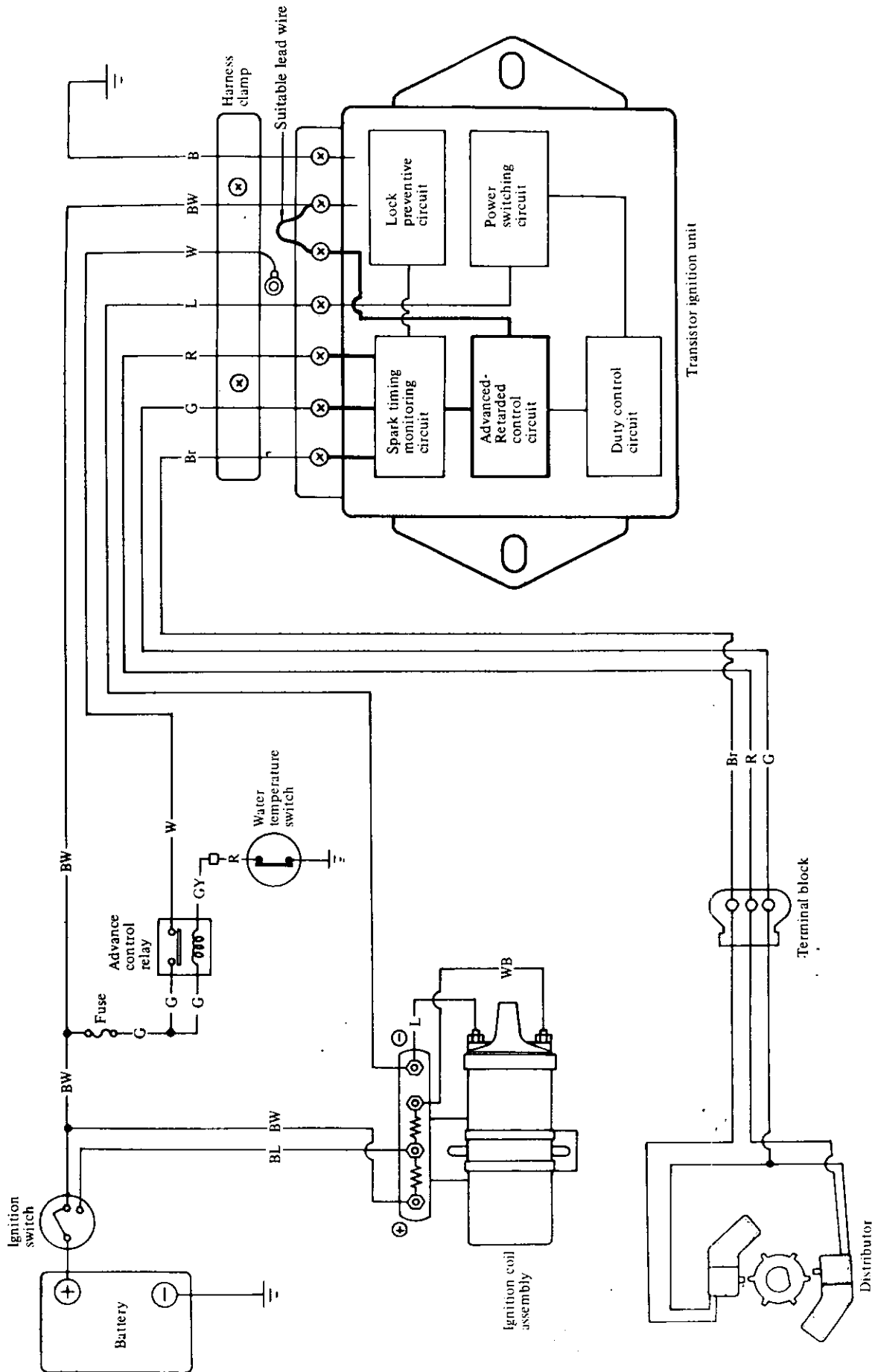

Fig. EE-93 Wiring diagram for item (6)-3 (Checking two pick-up switching mechanisms)

EE 451

IGNITION COIL

The ignition coil is of an oil-filled type. The ignition coil case is filled with oil which has good insulating and heat-radiating characteristics.

The ignition coil has a greater ratio between the primary and secondary windings to step up the battery voltage to the high voltage to cause stronger sparks to jump the spark plug gap.

The cap is made of alkyd resin which offers high resistance to electric arc and increased insulation.

The ignition coil and external resistor should be handled as a matched set.

When high tension wire is installed to ignition coil, there should be no clearance between their caps. Always secure a sufficient clearance between high tension wire and electronic fuel injection harness as shown in Figure EE-95.

Note: Do not disconnect high tension wires from spark plugs during engine running. (California models only)

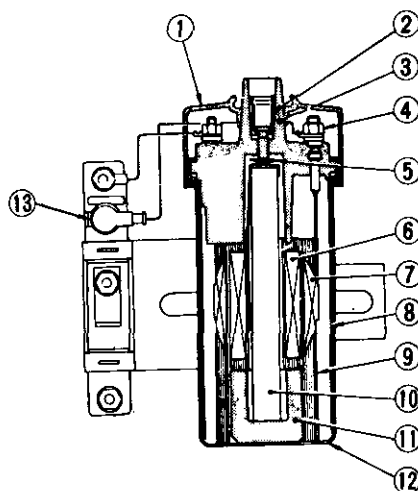

- 1 Rubber cap for ignition coil
- 2 Secondary terminal
- 3 Cap
- 4 Primary terminal
- 5 Spring
- 6 Secondary winding
- 7 Primary winding
- 8 Side core
- 9 Insulator coil
- 10 Center core
- 11 Segment
- 12 Case
- 13 Rubber cap for terminal

EE389

Fig. EE-94 Construction

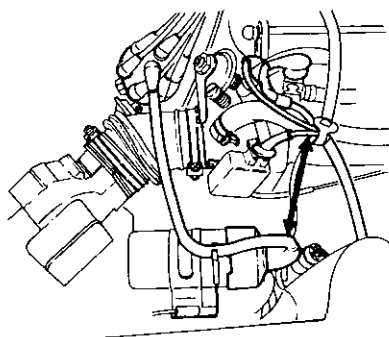

EE429

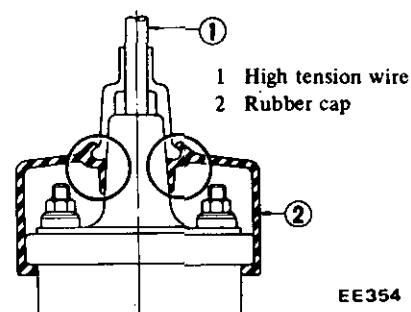

EE354

Fig. EE-95 Correct installation of high tension wire

SPECIFICATIONS

Type	C1T18, STC-12
Primary voltage	V 12
Spark gap	mm (in) More than 7 (0.28)
Primary resistance at 20°C (68°F)	Ω 0.45 to 0.55
Secondary resistance at 20°C (68°F)	kΩ 8.5 to 12.7
External resistor at 20°C (68°F)	Ω 1.15 to 1.45 (Standard resistor 0.4 + 0.9)

SPARK PLUG

CONTENTS

DESCRIPTION	EE-46	SERVICE DATA AND SPECIFICATIONS	EE-47
INSPECTION	EE-46	TROUBLE DIAGNOSES AND	
CLEANING AND REGAP	EE-46	CORRECTIONS	EE-47

DESCRIPTION

The spark plugs are of the conventional type, having 14 mm (0.551 in) threads and a gap of 0.7 to 0.8 mm (0.028 to 0.031 in). The inspection and cleaning should be made every suitable maintenance period. If necessary, replace.

Note: All spark plugs installed on an engine must be of the same brand and the same number of heat range.

INSPECTION

1. Remove spark plug wire by pulling on boot, not on wire itself.
2. Remove spark plugs.
3. Check electrodes and inner and outer porcelains of plugs, noting the type of deposits and the degree of electrode erosion. Refer to Figure EE-81.

Normal: Brown to grayish-tan deposits and slight electrode wear indicate correct spark plug heat range.

Carbon fouled: Dry fluffy carbon deposits on the insulator and electrode are usually caused by slow speed driving in city, weak ignition, too rich fuel mixture, dirty air cleaner, etc.

It is advisable to replace with plugs having hotter heat range.

Oil fouled: Wet black deposits indicate excessive oil entrance into combustion chamber through worn rings and pistons or excessive clearance between valve guides and stems. If the same condition remains after repair, use a hotter plug.

Overheating: White or light gray insulator with black or gray brown spots and bluish burnt electrodes indicate engine overheating. Moreover, the appearance results from incorrect ignition timing, loose

spark plugs, low fuel pump pressure, wrong selection of fuel, a hotter plug, etc. It is advisable to replace with plugs having colder heat range.

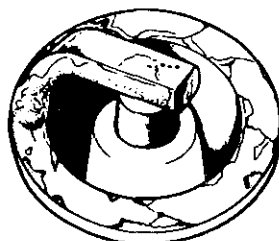

Normal



Carbon fouled

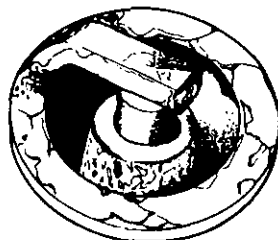

Overheating

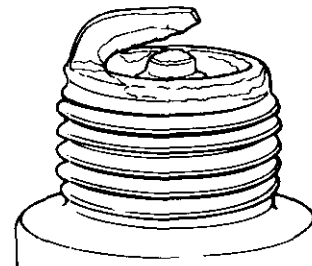

Worn

Fig. EE-96 Spark plug

EE079

4. After cleaning, dress electrodes with a small fine file to flatten the surfaces of both center and side electrodes in parallel. Set spark plug gap to specification.
5. Install spark plugs and torque each plug to 1.5 to 2.0 kg-m (11 to 14 ft-lb).
6. Connect spark plug wires.

CLEANING AND REGAP

Clean spark plugs in a sand blast type cleaner. Avoid excessive blasting. Clean and remove carbon or oxide deposits, but do not wear away porcelain. If deposits are too stubborn, discard plugs.

After cleaning spark plugs, renew firing surface of electrodes with file mentioned above. Then gap spark plugs to 0.7 to 0.8 mm (0.028 to 0.031 in) using a round wire feeler gauge. All spark plugs new or used should have the gap checked and reset by bending ground electrode.

SERVICE DATA AND SPECIFICATIONS

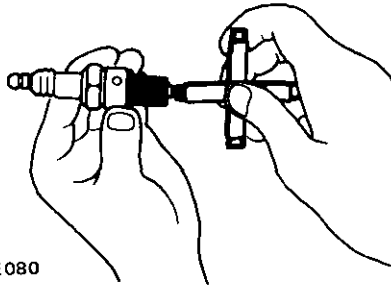

EE080

Fig. EE-97 Setting spark plug gap

Item	B6ES, L45W
Applied engine	L28
Size (screw dia. x reach) mm (in)	14 x 19 (0.55 x 0.75)
Plug gap mm (in)	0.7 to 0.8 (0.028 to 0.031)
Tightening torque kg-m (ft-lb)	1.5 to 2.0 (11 to 14)

TROUBLE DIAGNOSES AND CORRECTIONS

1. When engine does not start

If there is no problem in fuel system, ignition system should be checked. This can be easily done by detaching a high tension wire from spark plug, starting engine and observing condition of spark that occurs between high tension wire and spark

plug terminal. After checking this, repair as necessary.

Notes:

a. On California models, disconnect electronic fuel injection harness connectors from injectors and cold start valve to cut off supply of fuel to engine and then observe the

condition of sparks while starter motor is in operation.

b. Do not attempt to make this test near electronic fuel injection harness. If this harness is close to high tension wire end, sparks can jump across the air gap and damage control unit.

Condition	Location	Probable cause	Corrective action
No sparks at all	Distributor	Breakage of lead-wire on low tension side. Poor insulation of cap and rotor head. Open pickup coil. Air gap wider than specification.	Repair. Replace. Replace. Adjust
	Ignition coil	Wire breakage or short circuit of coil.	Replace with new one.
	High tension wire	Wire coming off. Faulty insulation.	Repair. Replace.
	Transistor ignition unit	Faulty transistor ignition unit.	Replace.
Spark length more than 6 mm (0.236 in)	Spark plugs	Spark plug gap too wide. Too much carbon. Broken neck of insulator. Expiration of plug life.	Correct or replace. Clean or replace. Replace. Replace.
	Distributor Transistor ignition unit	Air gap too wide. Faulty transistor ignition unit.	Correct. Replace.

Engine Electrical System

2. Engine rotates but does not run smoothly.

This may be caused by the ignition

system or other engine conditions not related to ignition. Therefore, first a

complete inspection of ignition system should be carried out.

Condition	Location	Probable cause	Corrective action
Engine misses	Distributor	Foreign matter on pick up coil.	Clean.
		Improper air gap.	Correct.
		Leak of electricity at cap and rotor head.	Repair or replace.
		Breakage of pick up coil lead wire.	Replace.
		Worn or shaky breaker plate.	Replace assembly.
Engine misses	Ignition coil	Layer short circuit or inferior quality coil.	Replace assembly.
	High tension wire	Deterioration of insulation with consequent leak of electricity.	Replace with good one.
			Replace.
	Spark plugs	Fouled.	Clean.
	Spark plugs	Leak of electricity at upper porcelain insulator.	Repair or replace.
Replace.			
Engine causes knocking very often	Distributor	Improper ignition timing. (too advanced)	Correct the fitting.
		Coming off or breakage of governor spring.	Correct or replace.
		Worn pin or hole of governor.	Replace.
Engine causes knocking very often	Spark plugs	Burnt too much.	Replace.
	Engine does not deliver enough power	Distributor	Improper ignition timing. (too retarded)
Improper functioning governor.			Replace assembly.
Foreign particles stuck in air gap.			Clean.
Engine does not deliver enough power	Spark plugs	Fouled.	Clean.



509 Debby Lane
Adamsville, AL 35005
<http://www.zcarcreations.com>
cborden@zcarcreations.com

NISSAN FACTORY SERVICE MANUAL CDROM END-USER LICENSE AGREEMENT

NOTICE TO USER: THIS IS A CONTRACT. BY PURCHASING AND USING THE SERVICE MANUAL ON CDROM, YOU ACCEPT ALL THE TERMS AND CONDITIONS OF THIS AGREEMENT.

This End User License Agreement accompanies the Service Manual on CDROM product and related explanatory materials. Please read this Agreement carefully. By purchasing and using the Service Manual on CDROM, you are implying that you have carefully read, agree with, and will adhere to the conditions set forth in this agreement. If you do not wish to accept the terms of this End User Agreement please do not use the Service Manual on CDROM. You will not be permitted to use the Service Manual on CDROM without consenting to this end user agreement.

Upon your acceptance of this Agreement, Z Car Creations, LLC grants to you a nonexclusive license to use the Service Manual on CDROM, provided that you agree to the following:

USE OF SOFTWARE

You may install the contents of the CD on a hard disk or other storage device for personal use only. Each Service Manual on CDROM comes with a single user license. Under no circumstances should the contents of the Service Manual CDROM be placed on a server for purposes of distributing or allowing access to the material over a network.

COPYRIGHT AND TRADEMARK RIGHTS

The Service Manual CDROM is owned by Z Car Creations, LLC and its structure and organization, all graphics and coding are considered intellectual property of Z Car Creations, LLC. The manual content itself is property of Nissan Motors. The Service Manual on CDROM is also protected by United States Copyright Law and International Treaty provisions. This Agreement does not grant you any intellectual property or resale rights to the Service Manual CDROM.

RESTRICTIONS

You agree not to modify, adapt, translate, reverse engineer, decompile or disassemble the PDF file on the Service Manual CDROM. The Service Manual on CDROM is licensed and distributed by Z Car Creations, LLC for single user utilization of its contents only. Licensed users will be permitted to use the contents of the Service Manual CDROM for multimedia presentation to an audience from a single machine using a large display or projection device but the Service Manual CDROM may not otherwise be distributed, sold to or made accessible to multiple users.

NO WARRANTY

The software is being delivered to you AS IS and Z Car Creations, LLC makes no warranty as to its use or performance. Z CAR CREATIONS, LLC DOES NOT AND CANNOT WARRANT THE PERFORMANCE OR RESULTS YOU MAY OBTAIN BY USING THE SERVICE MANUAL CDROM OR DOCUMENTATION, NOR MAKES ANY WARRANTIES, EXPRESS OR IMPLIED, AS TO NONINFRINGEMENT OF THIRD-PARTY RIGHTS, MERCHANTABILITY, OR FITNESS FOR ANY PARTICULAR PURPOSE. IN NO EVENT WILL Z CAR CREATIONS, LLC BE LIABLE TO YOU FOR ANY CONSEQUENTIAL, INCIDENTAL, OR SPECIAL DAMAGES FOR ANY REASON.



509 Debby Lane
Adamsville, AL 35005
<http://www.zcarcreations.com>
cborden@zcarcreations.com

GOVERNING LAW AND GENERAL PROVISIONS

This Agreement will be governed by the laws of the State of Alabama, USA, excluding the application of its conflicts of law rules. This Agreement will not be governed by the United Nations Convention on Contracts for the International Sale of Goods, the application of which is expressly excluded. If any part of this Agreement is found void and unenforceable, it will not affect the validity of the balance of the Agreement, which shall remain valid and enforceable according to its terms. You agree that the Service Manual on CDROM will not be shipped, transferred or exported into any country or used in any manner prohibited by the United States Export Administration act or any other export laws, restrictions or regulations. This Agreement shall automatically terminate upon failure by you to comply with its terms. This Agreement may only be modified in writing signed by and authorized officer for Z Car Creations, LLC.

Craig Borden
Z Car Creations, LLC
509 Debby Lane
Adamsville, AL 35005
USA

YOUR ACCEPTANCE OF THE FOREGOING AGREEMENT IS IMPLIED UPON PURCHASING AND USING THE SERVICE MANUAL CDROM.