

# HEATER & AIR CONDITIONER

## SECTION HA

### CONTENTS

#### HEATER

<b>DESCRIPTION (Heater)</b> .....	HA- 2
HEATER SYSTEM .....	HA- 2
HEATER COMPONENTS .....	HA- 2
AIR FLOW .....	HA- 3
<b>SERVICE PROCEDURES (Heater)</b> .....	HA- 4
REMOVAL AND INSTALLATION .....	HA- 4
HEATER CONTROL ADJUSTMENT .....	HA- 5
DISASSEMBLY AND ASSEMBLY OF HEATER UNIT .....	HA- 5
INSPECTION .....	HA- 5
<b>ELECTRICAL CIRCUIT (Heater)</b> .....	HA- 6
WIRING DIAGRAM .....	HA- 6
<b>TROUBLE DIAGNOSES AND CORRECTIONS (Heater)</b> .....	HA- 7

#### AIR CONDITIONER

<b>GENERAL SERVICE (Air conditioner)</b> .....	HA- 8
REFRIGERANT R-12 .....	HA- 8
COMPRESSOR OIL .....	HA- 8
GENERAL SERVICE INSTRUCTIONS .....	HA- 8
SAFETY PRECAUTIONS .....	HA- 8
EVACUATING AND CHARGING SYSTEM .....	HA- 8
COMPRESSOR OIL LEVEL CHECK .....	HA-14
PERFORMANCE TEST .....	HA-16
REFRIGERANT LEAKS .....	HA-16

#### (MANUAL TYPE)

<b>DESCRIPTION (Manual air conditioner)</b> .....	HA-17
REFRIGERATION SYSTEM .....	HA-17
OUTLINE OF AIR CONDITIONER .....	HA-18
AIR FLOW AND VACUUM SYSTEM .....	HA-19
ELECTRICAL CIRCUIT .....	HA-20
<b>SERVICE PROCEDURES (Manual air conditioner)</b> .....	HA-21
PRECAUTIONS FOR REMOVAL AND INSTALLATION .....	HA-21
REFRIGERANT LINES .....	HA-22
IDLER PULLEY AND COMPRESSOR DRIVE BELT .....	HA-22
COMPRESSOR .....	HA-23
CONDENSER .....	HA-24
CONDENSER FAN (Turbo-charged model only) .....	HA-24
CONDENSER FAN RELAY (Turbo-charged model only) .....	HA-24
RECEIVER DRIER .....	HA-25
ACCUMULATOR .....	HA-25
FAST IDLE ACTUATOR .....	HA-26
VACUUM TANK .....	HA-26
AIR CONDITIONER RELAY .....	HA-27
COOLING UNIT .....	HA-27
EXPANSION VALVE .....	HA-28
SUCTION THROTTLE VALVE .....	HA-29

HEATER UNIT .....	HA-29
HEATER CONTROL .....	HA-30
BLOWER UNIT .....	HA-32
BLOWER MOTOR .....	HA-32
BLOWER RELAY .....	HA-32
VACUUM CONTROL SWITCH .....	HA-32
VACUUM HOSE DIAGRAM .....	HA-32
ELECTRICAL DIAGRAM .....	HA-33

#### COMPRESSOR—Model MJ-167 (HITACHI make)

DESCRIPTION .....	HA-34
PRELIMINARY CLEANING .....	HA-35
COMPRESSOR CLUTCH .....	HA-35
SHAFT SEAL .....	HA-36
DISCHARGE VALVE .....	HA-38
SUCTION VALVE .....	HA-38
REAR COVER AND REAR CYLINDER HEAD .....	HA-39
FRONT COVER, FRONT CYLINDER HEAD AND CYLINDER .....	HA-40

#### TROUBLE DIAGNOSES AND CORRECTIONS

<b>(Manual air conditioner)</b> .....	HA-42
AIR CONDITIONER DIAGNOSES .....	HA-42
PERFORMANCE TEST DIAGNOSES .....	HA-44
BLOWER MOTOR DIAGNOSES .....	HA-48
COMPRESSOR CLUTCH DIAGNOSES .....	HA-50
COMPRESSOR DIAGNOSES .....	HA-52
FAST IDLE CONTROL DEVICE DIAGNOSES .....	HA-54
PERFORMANCE CHART .....	HA-55

#### (AUTO TEMPERATURE TYPE)

<b>DESCRIPTION (Auto air conditioner)</b> ..	HA-56
SYSTEM OPERATION .....	HA-56
FUNCTION AND OPERATION OF EACH UNIT ..	HA-57
UNITS LOCATION .....	HA-59
AIR FLOW .....	HA-61

#### SERVICE PROCEDURES

<b>(Auto air conditioner)</b> .....	HA-64
INSPECTION OF "CHECK" TERMINAL .....	HA-64
UNIT INSPECTION .....	HA-66
ELECTRICAL DIAGRAM .....	HA-70
VACUUM DIAGRAM .....	HA-71
TROUBLE DIAGNOSES .....	HA-72

#### SERVICE DATA AND SPECIFICATIONS (S.D.S.)

GENERAL SPECIFICATIONS .....	HA-77
INSPECTION AND ADJUSTMENT .....	HA-77
TIGHTENING TORQUE .....	HA-77

#### SPECIAL SERVICE TOOLS

HA-78
-------

Refer to Section MA (Heater and Air Conditioner) for:

- CHECKING REFRIGERANT LEVEL
- CHECKING REFRIGERANT LEAKS

Refer to Section MA (Basic Mechanical System) for:

- CHECKING AND ADJUSTING DRIVE BELTS

## DESCRIPTION (Heater)

### HEATER SYSTEM

Outside air drawn in through the cowl top grille is directed through the air intake box to the heater unit by the fan. The heater unit includes an air mix door which controls the air temperature, and a ventilation door and floor door which change the distribution of air flow. The intake door inside the intake box shuts out the outside air when the heater is off.

The heater controls, consisting of two levers and one knob, are located in the middle portion of the instrument panel. They are the MODE lever which selects the air outlet, the TEMP lever which controls the temperature and the FAN switch knob which regulates air flow with the fan.

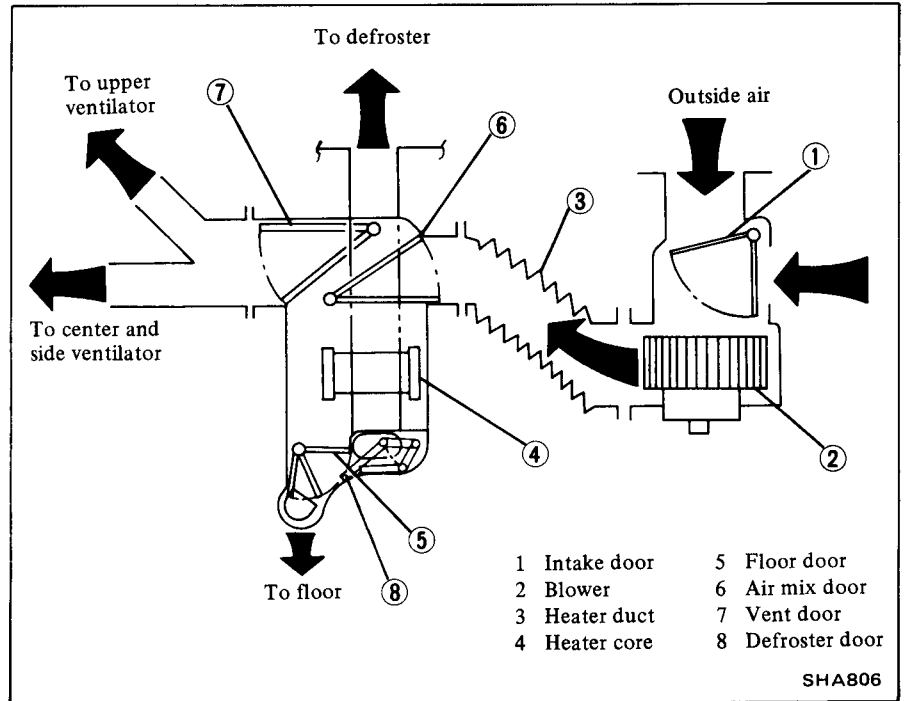

### HEATER COMPONENTS

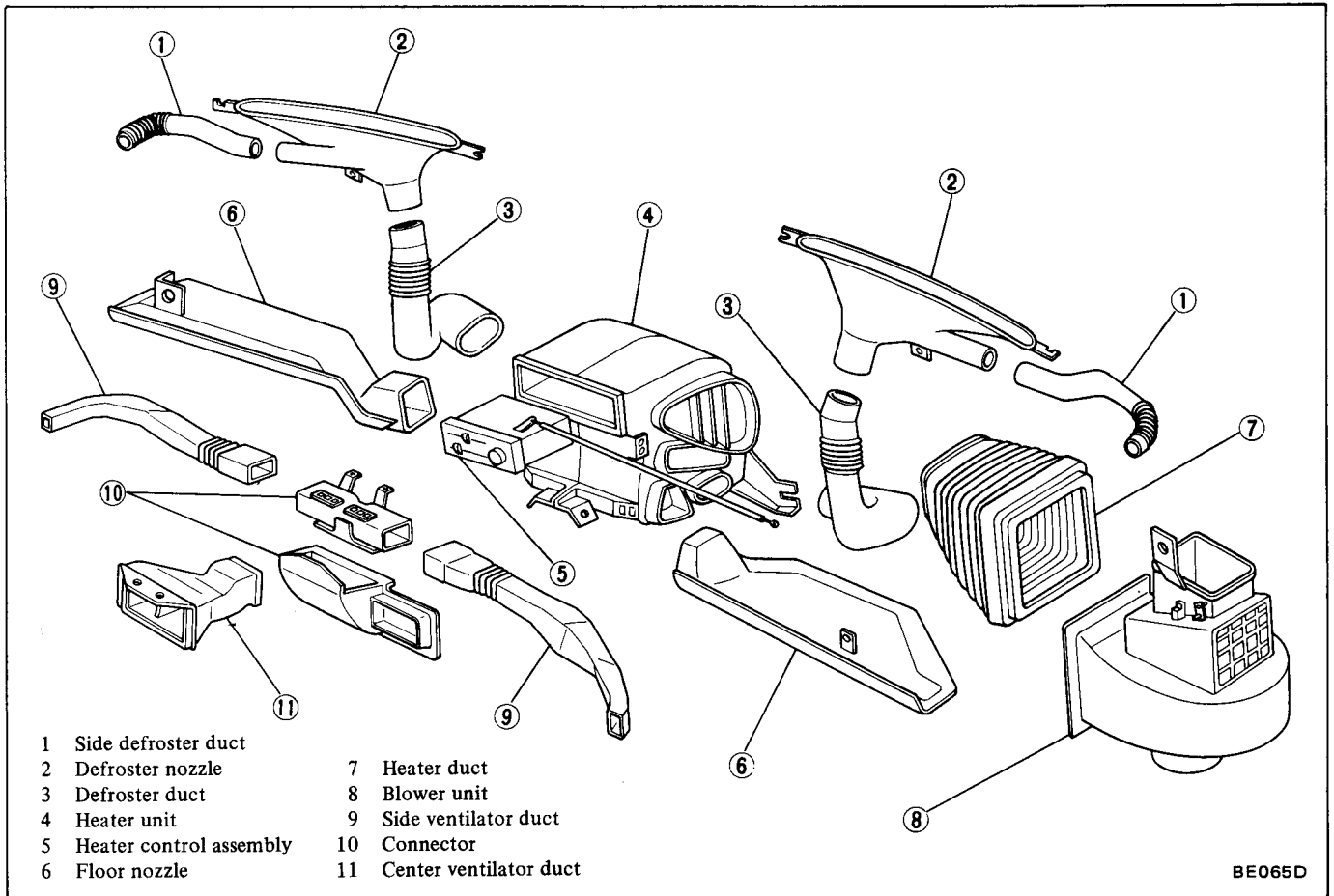

## AIR FLOW

### VENTILATING

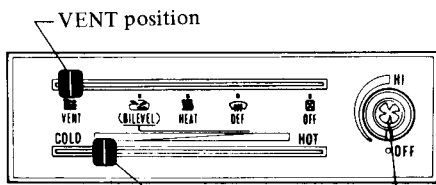

Move the lever to the desired temperature.

Turn the knob to the desired air flow.

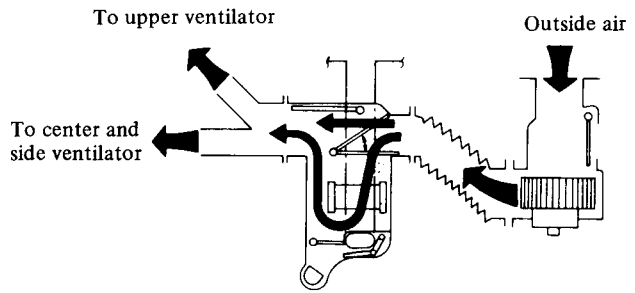

### BI-LEVEL

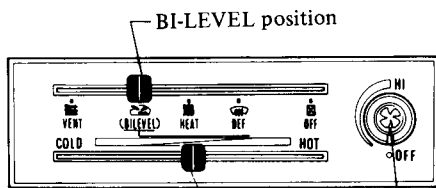

Move the lever to the desired temperature.

Turn the knob to the desired air flow.

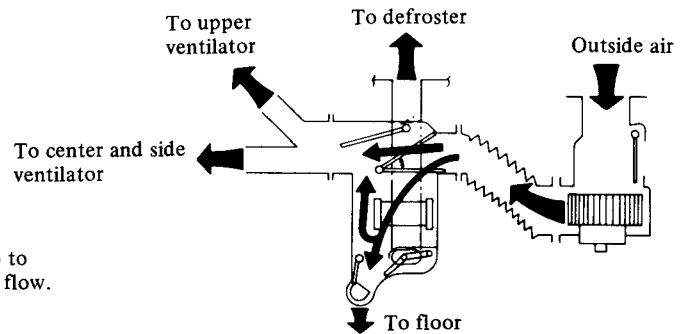

### DEFROSTING

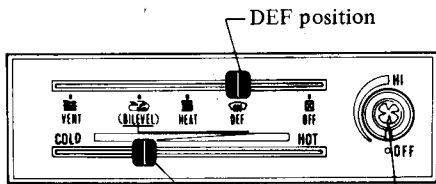

Move the lever to the desired temperature.

Turn the knob to the desired air flow.

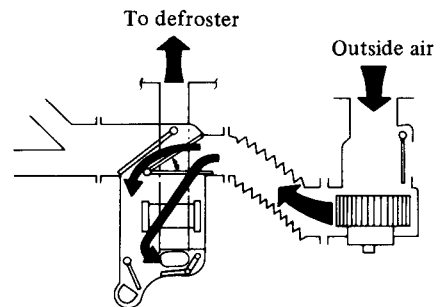

### HEATING

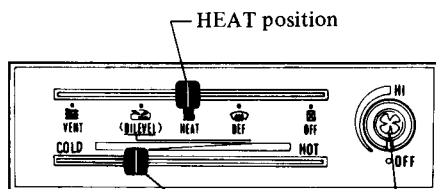

Move the lever to the desired temperature.

Turn the knob to the desired air flow.

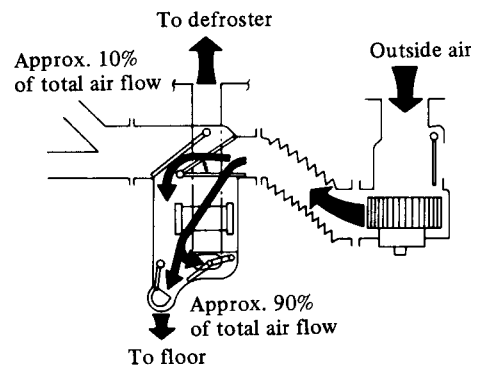

### RECIRCULATING

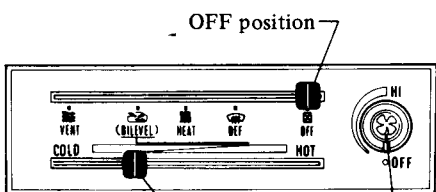

Move the lever to the desired temperature.

Turn the knob to the desired air flow.

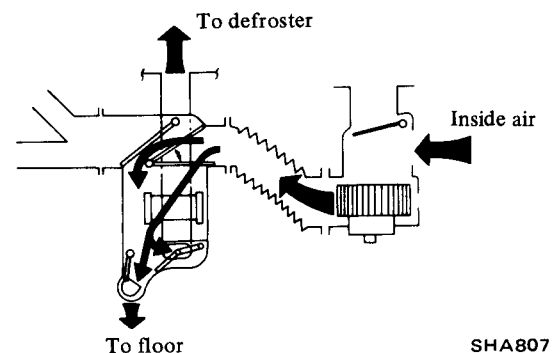

## SERVICE PROCEDURES (Heater)

### REMOVAL AND INSTALLATION

#### HEATER CONTROL ASSEMBLY

1. Disconnect battery ground cable.
2. Remove instrument lower covers, floor nozzles and defroster ducts.
3. Remove instrument console. Refer to Section BF.
4. Remove instrument center ventilator.
5. Disconnect door control cables and rod at each door.
6. Remove heater control assembly by loosening attaching screws.
7. Install heater control assembly in the reverse order of removal. After installing heater control assembly, control cables and rod must be adjusted by referring to Adjusting Heater Control.

#### HEATER UNIT

1. Disconnect battery ground cable.
2. Set TEMP lever to max. HOT position and drain engine coolant.
3. Remove instrument lower covers, floor nozzles, defroster ducts instrument console and instrument center ventilator.

Refer to Section BF.

4. Remove glove box. Refer to Section BF.
5. Remove heater duct.
6. Disconnect control cables and rod from heater unit.
7. Remove heater control assembly by loosening attaching screws.
8. Disconnect inlet and outlet heater hoses from passenger compartment.
9. Remove blower assembly. Refer to Blower Assembly.
10. Remove bolts attaching heater unit and then remove heater unit.

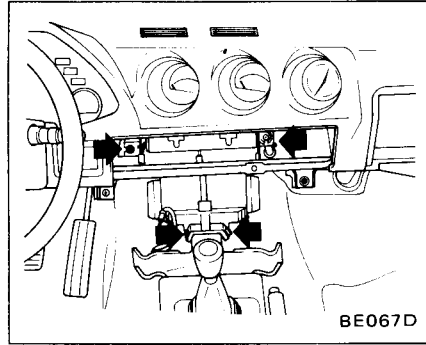

11. Install heater unit in the reverse order of removal. After installing heater unit, adjust control cable by referring to Heater Control Adjustment.

#### WATER COCK

1. Disconnect battery ground cable.
2. Remove instrument lower cover, floor nozzle and defroster duct on the right side.
3. Drain engine coolant.
4. Remove heater duct.
5. Disconnect outlet and inlet hoses, and loosen clamp of hose connecting water cock to heater unit.
6. Disconnect temperature control cable and air-mix door rod from water cock lever.
7. Remove water-cock by loosening retaining screws.

8. Install in the reverse order of removal. After installing water cock, adjust control cable and rod by referring to Heater Control Adjustment.

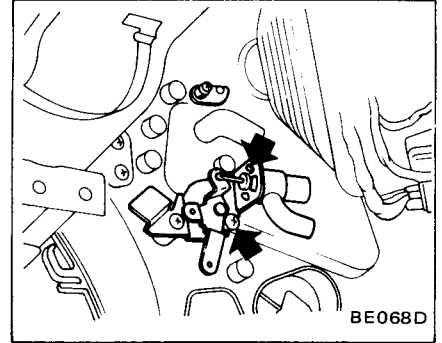

#### BLOWER ASSEMBLY

1. Disconnect battery ground cable.
2. Remove instrument lower cover and glove box.
3. Remove floor nozzle, defroster duct and side defroster duct on the right side.
4. Remove heater duct.
5. Disconnect wire harness at blower motor harness connector.
6. Disconnect control cable at blower assembly by removing clip.
7. Remove bolts securing assembly and then remove blower assembly.

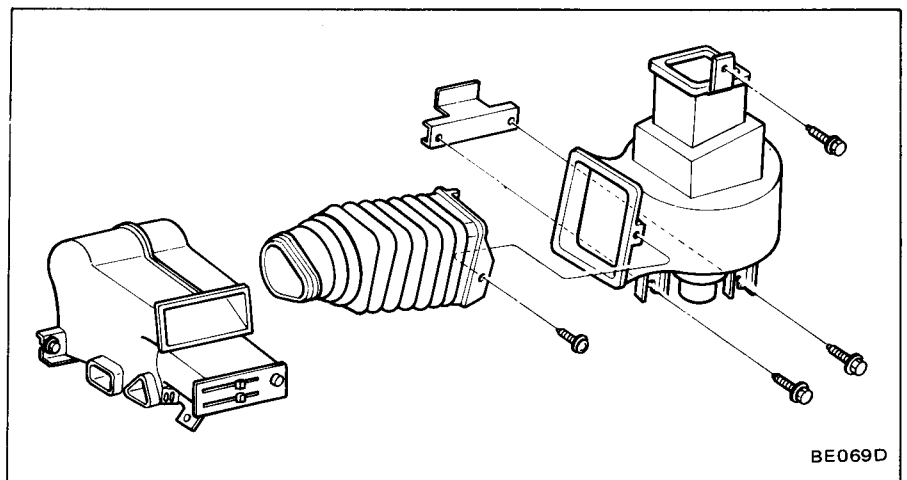

8. Installation is in the reverse order of removal.

**BLOWER MOTOR**

1. Disconnect battery ground cable.
2. Remove instrument lower cover and floor nozzle on the right side.
3. Disconnect wire harness at blower motor harness connector.
4. Remove blower motor attaching screws, and then remove blower motor with fan.

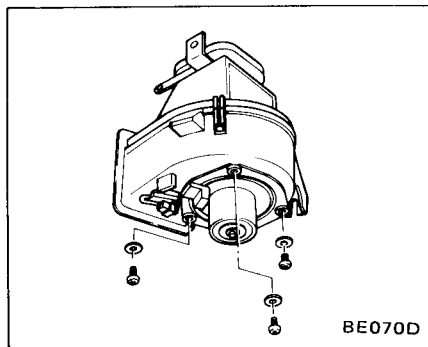

5. Installation is in the reverse order of removal.

**HEATER CONTROL ADJUSTMENT**

**TEMPERATURE CONTROL CABLE**

1. Set temperature lever in maximum cold position.
2. Temporarily tighten control rod mounting screw.
3. Push water cock lever in the direction of arrow (to closing side), and press temperature control cable outer case in the direction of arrow (to temperature lever side). While doing so, secure outer case with clip.

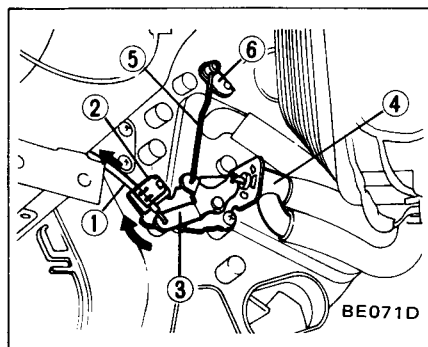

- |   |                      |
|---|----------------------|
| 1 Temperature control cable outer cable | 4 Water cock         |
| 2 Clip                                  | 5 Rod                |
| 3 Water cock lever                      | 6 Air-mix door lever |

4. Set temperature lever in maximum HOT position, and tighten securely control rod to air-mix door lever while pushing the lever in the direction of arrow.

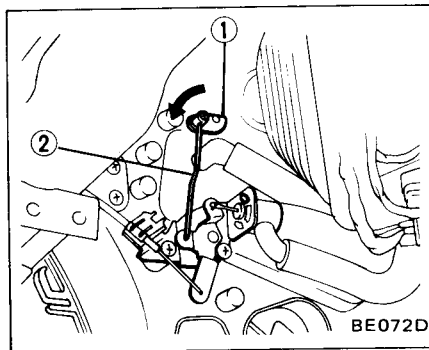

- |                      |
|----------------------|
| 1 Air-mix door lever |
| 2 Rod                |

**AIR INTAKE DOOR**

1. Set MODE lever at OFF position.
2. Push air intake door lever in direction of arrow (to shut out outside air flow), and press air intake door control cable outer case in direction of arrow. While doing so, secure outer case with clip.

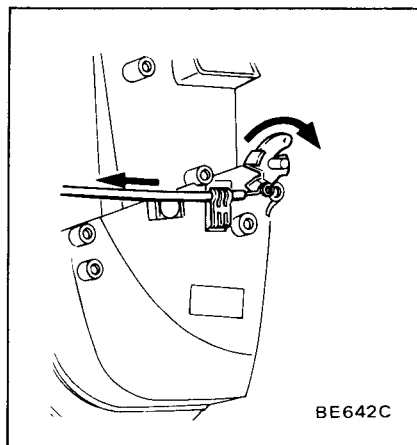

**AIR CONTROL ROD, VENTILATION DOOR ROD, FLOOR DOOR ROD AND DEFROSTER DOOR ROD**

1. Set MODE lever at VENT position.
2. Bring link into contact with stoppers A and B and secure air control rod.

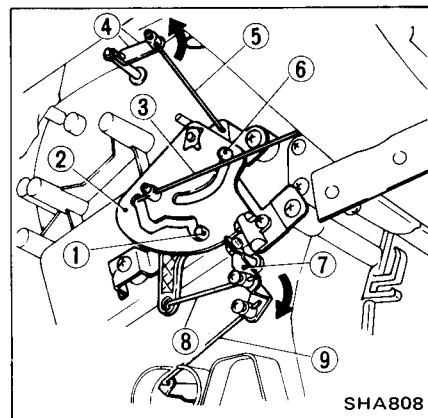

- |                          |
|--------------------------|
| 1 Stopper A              |
| 2 Link                   |
| 3 Air control rod        |
| 4 Ventilation door lever |
| 5 Ventilation door rod   |
| 6 Stopper B              |
| 7 Floor door lever       |
| 8 Floor door rod         |
| 9 Defroster door rod     |

3. Under this condition, push up on ventilation door lever in direction of arrow and secure ventilation door rod. Then push floor door lever in direction of arrow and secure floor door rod.
4. Set MODE lever at DEF position.
5. Open defroster door fully and secure defroster door rod.

**DISASSEMBLY AND ASSEMBLY OF HEATER UNIT**

1. Remove heater unit.
2. Remove water cock.
3. Remove clips securing right and left heater case, then separate heater case.
4. Take out heater core.
5. Assemble heater unit in the reverse order of disassembly.

**INSPECTION**

Inspect all parts of heater for damage. Refer to Trouble Diagnoses and Corrections. For electrical system, check wiring, fan switch and fan motor for continuity.

If fan motor fails to rotate, check following items.

1. Fuse and fusible link.
2. To check for burned out fuse, follow same procedure as for ordinary fuses using a circuit tester or test lamp.
3. Loose wire connection.

**BLOWER MOTOR POWER SUPPLY**

1. Disconnect blower motor harness to connect main harness.
2. Connect one test lamp lead wire to "LB" wire terminal in connector of main harness for blower motor and the other to ground.
3. Turn ignition switch to "ACC" position. Test lamp should go on.

**FAN SWITCH**

Test continuity through fan switch with a test lamp or ohmmeter.

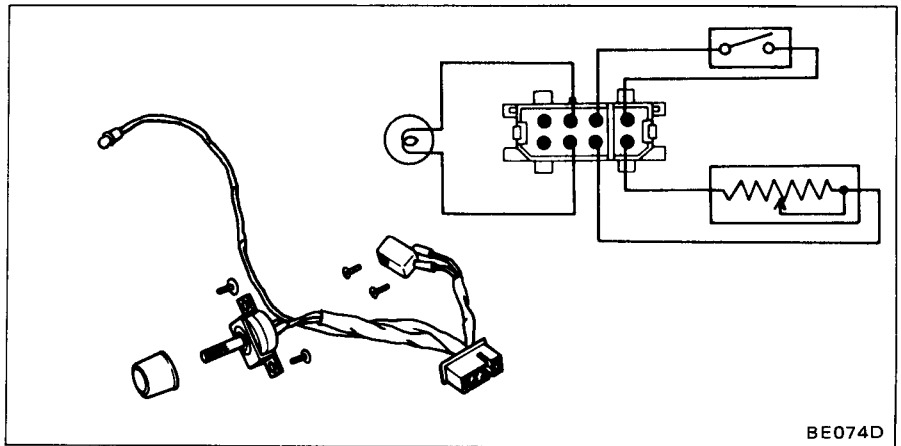

BE074D

**ELECTRICAL CIRCUIT (Heater)**

**WIRING DIAGRAM**

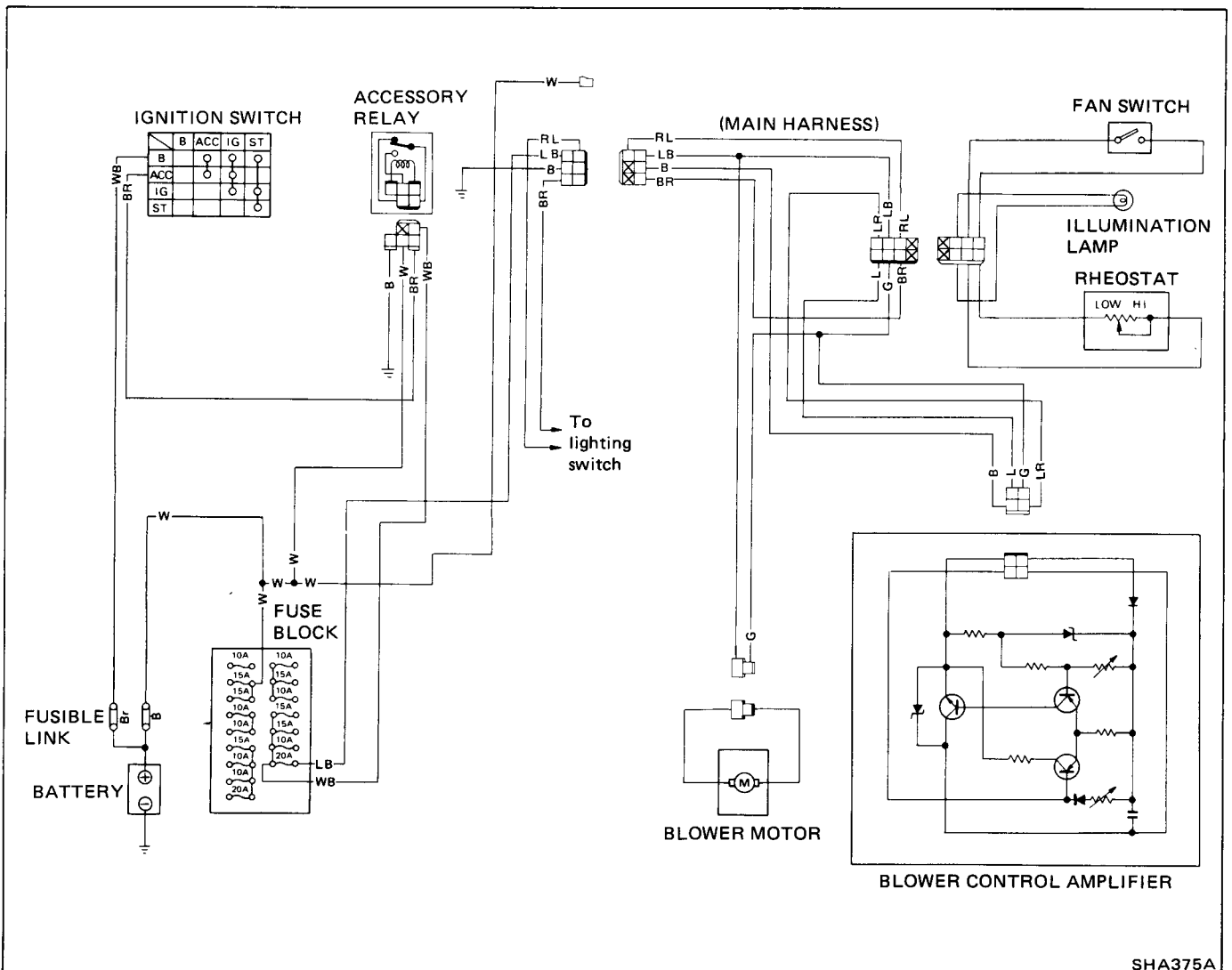

SHA375A

**TROUBLE DIAGNOSES AND CORRECTIONS (Heater)**

Condition	Probable cause	Corrective action
Insufficient heating performance. No heated air discharged.	Cooling water temperature too low. Heater core plugged. Insufficient cooling water level. Malfunctioning air mix door. Malfunctioning water cock.	Check thermostat. Replace as necessary. Clean. Refill. Adjust control cable. Adjust control cable.
Insufficient air flow to floor.	Blower motor speed too low. Malfunctioning floor door.	Check motor terminal voltage. Repair poor connection and discontinuity. Replace motor if necessary. Replace blower control amplifier if necessary. Adjust control cable.
Insufficient defrosting performance. Cold air discharged.	Refer to "No heated air discharged".	
Insufficient air flow to defroster.	Malfunctioning floor door (or faulty seal). Defroster nozzle plugged. Leak at defroster duct-to-nozzle connection.	Adjust control cable. Clean. Correct.
Heated air discharged with lever in VENT.	Water cock not operating properly. Mode door not operating properly (or seal damaged).	Adjust control cable. Adjust control cable.
Blower motor does not run.	Fuse melted. Motor wire connector disconnected. Faulty switch. Faulty motor. Faulty blower control amplifier.	Correct cause and replace. Correct. Replace. Check and correct. Replace.
Control lever drags.	Inner wire rubbing against outer case end. Control cable bent excessively. Malfunctioning doors, door levers, etc.	Adjust control cable. Correct. Check and correct.
Outside air comes in with fan in OFF.	Air intake door not operating properly. Control cable out of adjustment.	Repair or replace. Adjust control cable.
Noise from blower motor.	Loose bolt in blower motor.	Check and tighten loose bolts.

## GENERAL SERVICE (Air conditioner)

### REFRIGERANT R-12

The refrigerant used in the air conditioner is generally called "Refrigerant-12 (R-12)". No other refrigerant than the above refrigerant should be used.

**Note:** Exercise care when handling refrigerant as it is stored under high pressure.

### COMPRESSOR OIL

The "SUNISO 5GS" refrigeration lubricant should be used to assure the successful compressor operation. Use of oils other than recommended or mixing of the oil with other oils would cause chemical reaction or lead to lowered viscosity or deficient lubrication.

### GENERAL SERVICE INSTRUCTIONS

If dirt, water or air enters the air conditioner system, it will be seriously affected. Be sure to observe the following:

1. Always keep the working place clean and dry and free from dirt and dust. Wipe water off from the line fittings with a clean cloth before disconnecting.
2. Have all necessary tools in preparation beforehand and have tools clean and dry.
3. Handling plug when the system line is disconnected.
4. Handling compressor oil

For details, refer to each description in this manual.

### SAFETY PRECAUTIONS

#### WARNING:

1. Since direct contact of the liquid refrigerant with your skin will cause frostbite, always be careful when handling the refrigerant. Always wear goggles to protect your eyes when working around the system.
2. The refrigerant service container has a safe strength. However, if handled incorrectly, it will explode. Therefore, always follow the instructions on the label. In particular, never store it in a hot location [above 52°C (126°F)] or drop it from a high height.
3. The refrigerant gas is odorless and colorless and breathing may become difficult due to the lack of oxygen. Since the refrigerant gas is heavier than air and will lay close to the floor, be especially careful when handling it in small, confined spaces.
4. The refrigerant itself is nonflammable. However, a toxic gas (phosgene gas) is produced when it contacts fire and special care is therefore required when checking for leaks in the system with a halide torch.
5. Do not steam clean on the system, especially condenser since excessively high pressure will build up in the system, resulting in explosion of the system. The above precautions are essential in handling of Refrigerant-12, and their strict observation requires sufficient training. Therefore, it is of first importance that any other personnel than a well-trained serviceman should not be allowed to handle the refrigerant.

### EVACUATING AND CHARGING SYSTEM

During servicing, use caution to keep air from getting into refrigerant. When air enters the system, all refrigerant must be evacuated from system prior to charging new refrigerant. Air in refrigerant has the following deleterious effects:

1. Since the condensation temperature of the air is extremely low, the air will not be condensed when refrigerant gas is condensed in the condenser, and the air will thus remain in gaseous form. Consequently, the effective thermal transmission area of condenser for refrigerant gas will be reduced and refrigerant gas to be condensed will be reduced. The pressure rise will become proportional to the volume of the air in system.
2. When air and refrigerant are mixed in system, a chemical reaction will be produced and hydrochloric acid which will adversely affect the aluminum, copper, iron, and other materials in system may be generated.

### HANDLING MANIFOLD GAUGE

The pressure at the high- and low-sides of system should be measured when evacuating and charging refrigerant and when diagnosing trouble in the system. The manifold gauge is used for these purposes. A manifold gauge has two pressure gauges; a low pressure gauge and a high pressure gauge. These gauges are connected to the high- and low-side service valves of system through flexible charging hoses. The construction of manifold gauge is shown in the figure.

When valve stem is fully screwed, the valve is front-seated and valve path and the center path are blocked. When valve stem is backed off, the paths are opened.



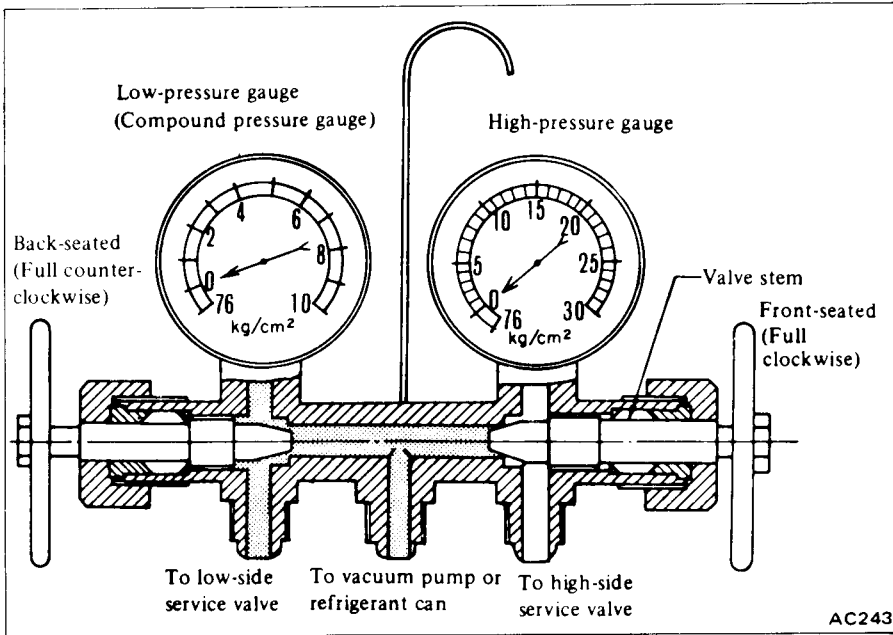

**Connection to service valve**

1. Fully close both valves of manifold gauge. Connect high- and low-pressure charging hoses to manifold gauge.
2. Remove caps from service valves. Connect high- and low-pressure charging hoses to service valves in system. The refrigerant gas will be discharged since check valve is open when pressing charging hose onto service valve.
3. Next, loosen the connection fitting of charging hose at manifold gauge side for 2 to 3 seconds to purge any air inside charging hose by the pressurized gas in system.

**Disconnection from service valve**

1. Fully close both valves of manifold gauge.
2. Disconnect two charging hoses from service valves. At this time, the gas will be discharged until check valve is closed. Therefore, disconnect hose quickly.

**WARNING:**  
Work with fingers protected with cloth against frostbite by refrigerant.

**HANDLING SERVICE VALVE**

An automatic check valve is built into service valve. When this valve presses against the connection fitting, that is, when charging hose is connected to service valve, the valve is open. When charging hose is disconnected, the valve is closed automatically. Always observe the following usage precautions:

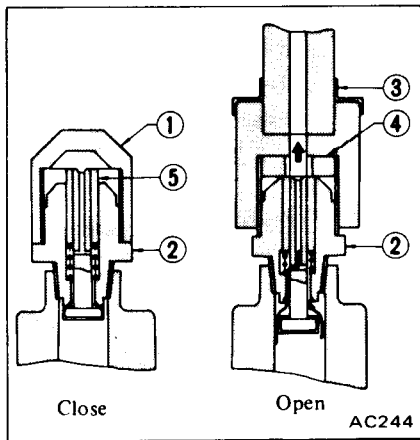

- |                 |               |
|-----------------|---------------|
| 1 Cap           | 4 Packing     |
| 2 Service valve | 5 Check valve |
| 3 Charging hose |               |

1. Always install valve cap after using service valve.

When high speed operation is performed without valve cap, a negative

pressure will gradually build up at the low pressure side of system and air may be sucked in. In addition, dirt and dust will easily enter the valve resulting in foreign matter entering the system.

**CAUTION:**  
Do not over-tighten valve cap.

2. Check valve will be half opened during connection and disconnection of charging hoses and refrigerant will be forcefully discharged. Therefore, connect and disconnect charging hoses quickly while pressing flare nut of charging hose against service valve.

**WARNING:**  
Work with fingers protected with cloth against frostbite by refrigerant.

3. Since close contact between the thread of valve cap and the thread of service valve will prevent gas leakage, keep these areas clean and free of scratches and damage.
4. Since packing of charging hose will be lost during long use, always check packing prior to installing charging hose.

**HANDLING CAN TAP**

A wide variety of can taps are available. The following procedures apply to conventional can taps.

For the correct usage, refer to the manufacturer's instructions.

1. Connect charging hose to the center fitting of manifold gauge. At this time, confirm that both stems are fully turned in (front-seated).
2. Turn can tap handle fully counter-clockwise so that the needle is pulled up.
3. Attach can tap to refrigerant can firmly.
4. Turn can tap handle fully clockwise to make a hole in refrigerant can.
5. Turn the handle fully counter-clockwise to raise the needle. Refrigerant gas will flow up to the center

fitting of manifold gauge.

6. Loosen the connection at the

center fitting of manifold gauge for a few seconds to purge air inside charging hose.

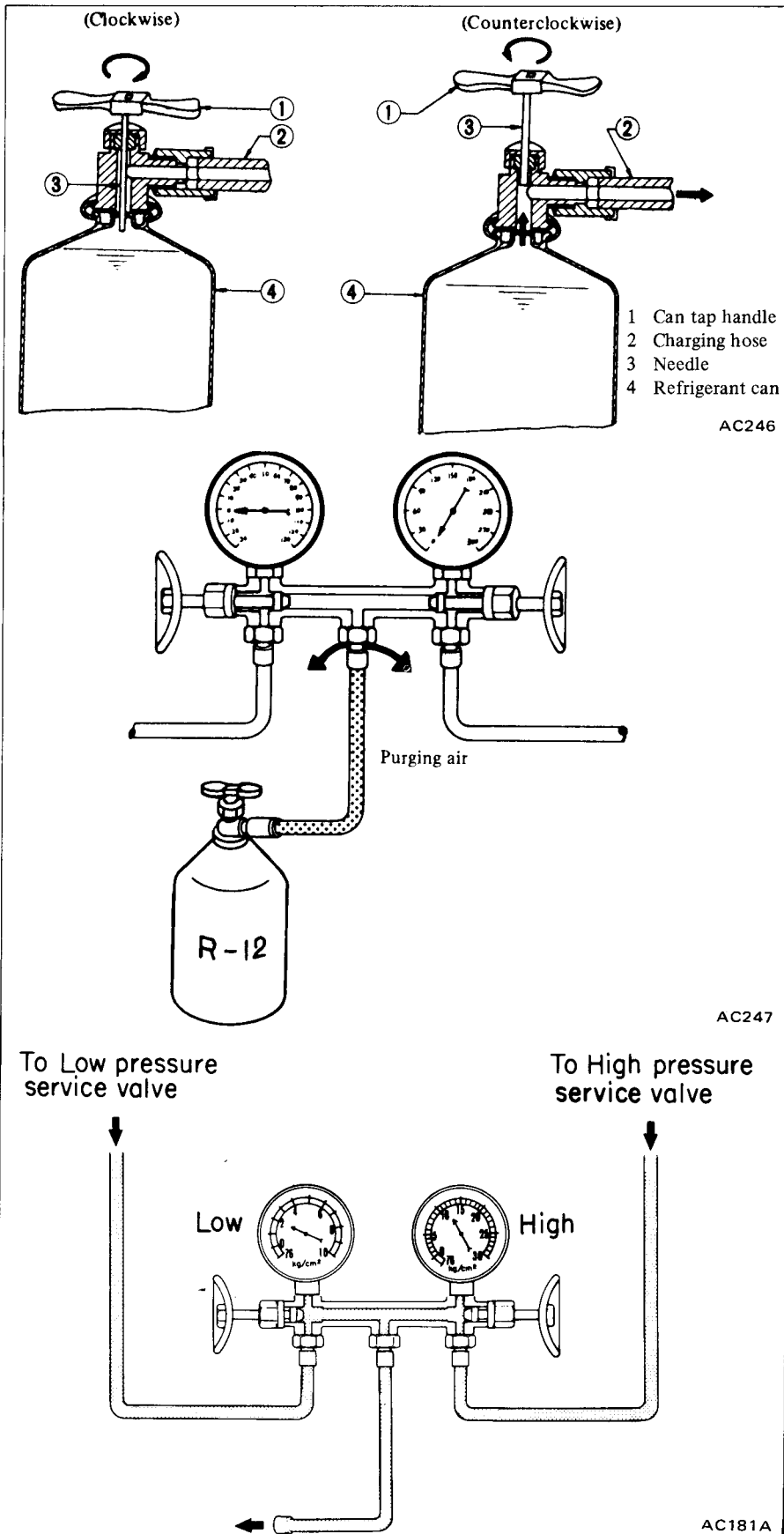

## DISCHARGING SYSTEM

The pressurized refrigerant gas inside system must be discharged to a pressure approaching atmospheric pressure prior to evacuating refrigerant inside system. This operation should be also made to permit safe removal when replacing system components.

1. Close high- and low-pressure valves of manifold gauge fully.
2. Connect two charging hoses of manifold gauge to their respective service valves.

### WARNING:

Securely connect high pressure (discharge) service valve to that of manifold gauge with a hose; also connect low pressure (suction) service valve to that of manifold gauge.

3. Open both manifold gauge valves slightly and slowly discharge refrigerant from system.

### WARNING:

Protect fingers with cloth against frostbite by refrigerant when connecting the charging hose to the service valve or disconnecting it therefrom.

Do not allow refrigerant to rush out. Otherwise, compressor oil will be discharged along with refrigerant.

## EVACUATING SYSTEM

1. Connect high- and low-pressure charging hoses of manifold gauge to their respective service valves of system and discharge refrigerant from system. Refer to Discharge System.
2. When refrigerant has been discharged to a pressure approaching atmospheric pressure, connect center charging hose to a vacuum pump.
3. Close both valves of manifold gauge fully. Then start vacuum pump.
4. Open low-pressure valve and suck

old refrigerant from system.

5. When low-pressure gauge reading has reached to approximately 66.7 kPa

(500 mmHg, 19.69 inHg), slowly open high pressure valve.

Elevation m (ft)	Vacuum of system* kPa (mmHg, inHg)
0 (0)	94.6 (710, 28)
300 (1,000)	91.3 (685, 27)
600 (2,000)	88.0 (660, 26)
900 (3,000)	84.6 (635, 25)

\*: Values show reading of the low-pressure gauge.

b. The rate of ascension of the low-pressure gauge should be less than 3.3 kPa (25 mmHg, 0.98 inHg) in five minutes.

If the pressure rises or the specified negative pressure can not be obtained, there is a leak in the system. In this case, immediately charge system with refrigerant and repair the leak described in the following.

(1) Charge system with a can of refrigerant [about 0.4 kg (0.9 lb)]. Refer to Charging Refrigerant.

(2) Check for refrigerant leakage with a leak detector. Repair any leakages found. Refer to Heater and Air Conditioner (Section MA) for inspection.

(3) Discharge refrigerant again, and then evacuate system.

**CHARGING REFRIGERANT**

1. Install manifold gauge to system. Refer to Handling Manifold Gauge.

**WARNING:**  
Securely connect high pressure (discharge) service valve to that of manifold gauge with a hose; also connect low pressure (suction) service valve to that of manifold gauge.

**CAUTION:**

- a. Be sure to purge air from the high- and low-pressure charging hoses.
- b. If air is mixed with refrigerant gas in system, evacuation of system should be performed. Refer to Evacuating System.

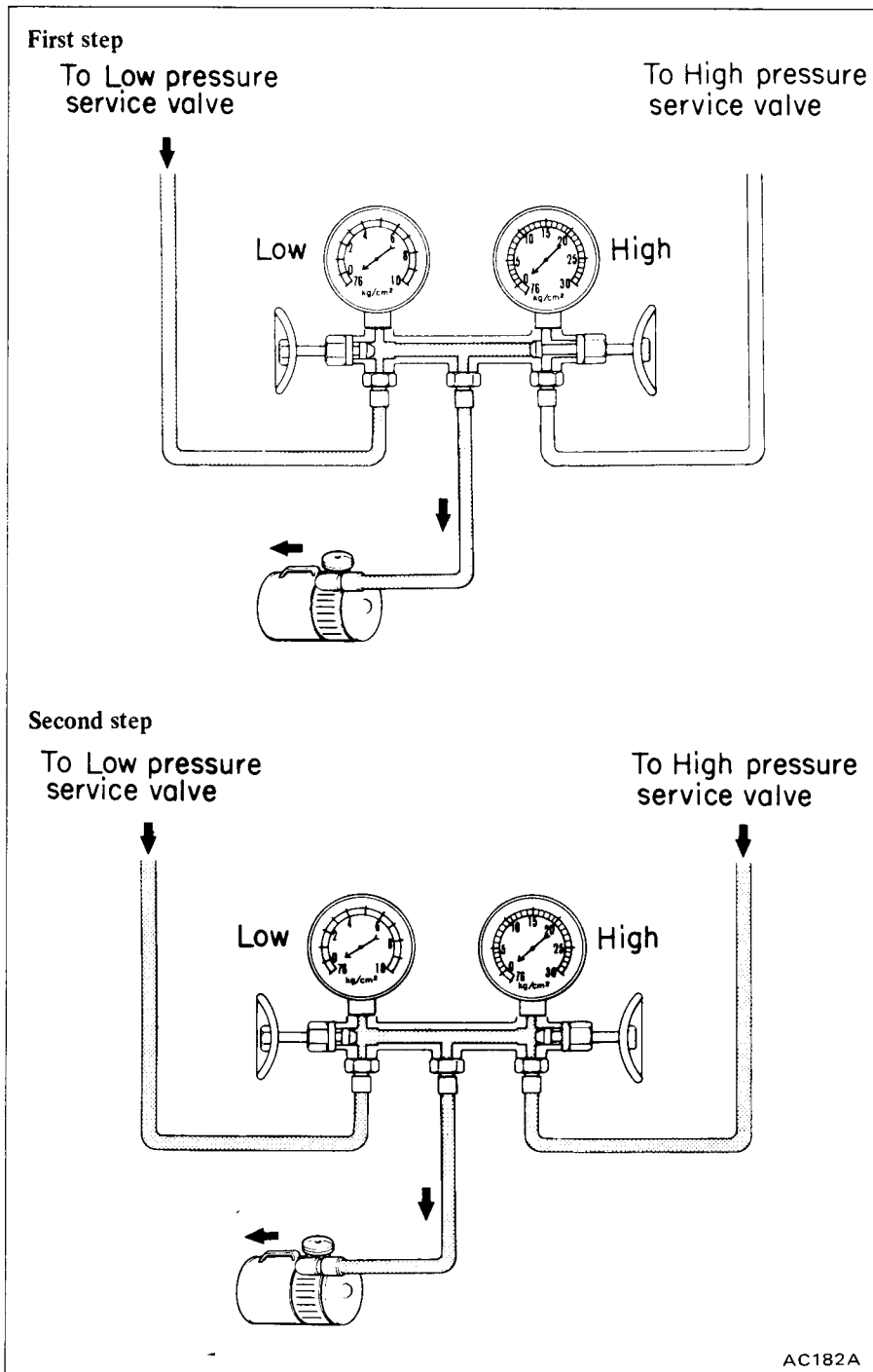

AC182A

6. When pressure inside system has dropped to 94.6 kPa (710 mmHg, 27.95 inHg), fully close both of valves of manifold gauge and stop vacuum pump. Let stand it for 5 to 10 minutes in this state and confirm that the reading does not rise.

a. The low-pressure gauge reads lower by 3.3 kPa (25 mmHg, 0.98 inHg) per a 300 m (1,000 ft) elevation. Perform evacuation according to the following table.

- Attach center charging hose of manifold gauge to refrigerant can through can tap. Break seal of refrigerant can to allow refrigerant to enter manifold gauge. Loosen charging hose at the center fitting of manifold gauge and purge air from inside charging hose. Refer to Handling Can Tap.
- Open high- and low-pressure

valves of manifold gauge and charge refrigerant into system.

When refrigerant charging speed is slow, immerse refrigerant can in water heated to a temperature of about 40°C (104°F) for a short time.

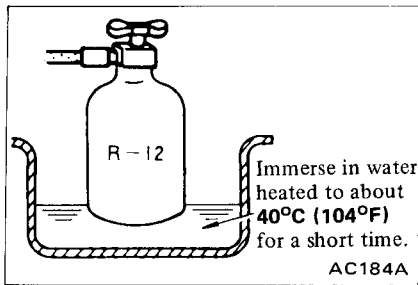

**WARNING:**

- Under any circumstances the refrigerant can must not be warmed in water heated to a temperature of over 52°C (126°F).
- A blow torch or stove must never be used to warm up the can.

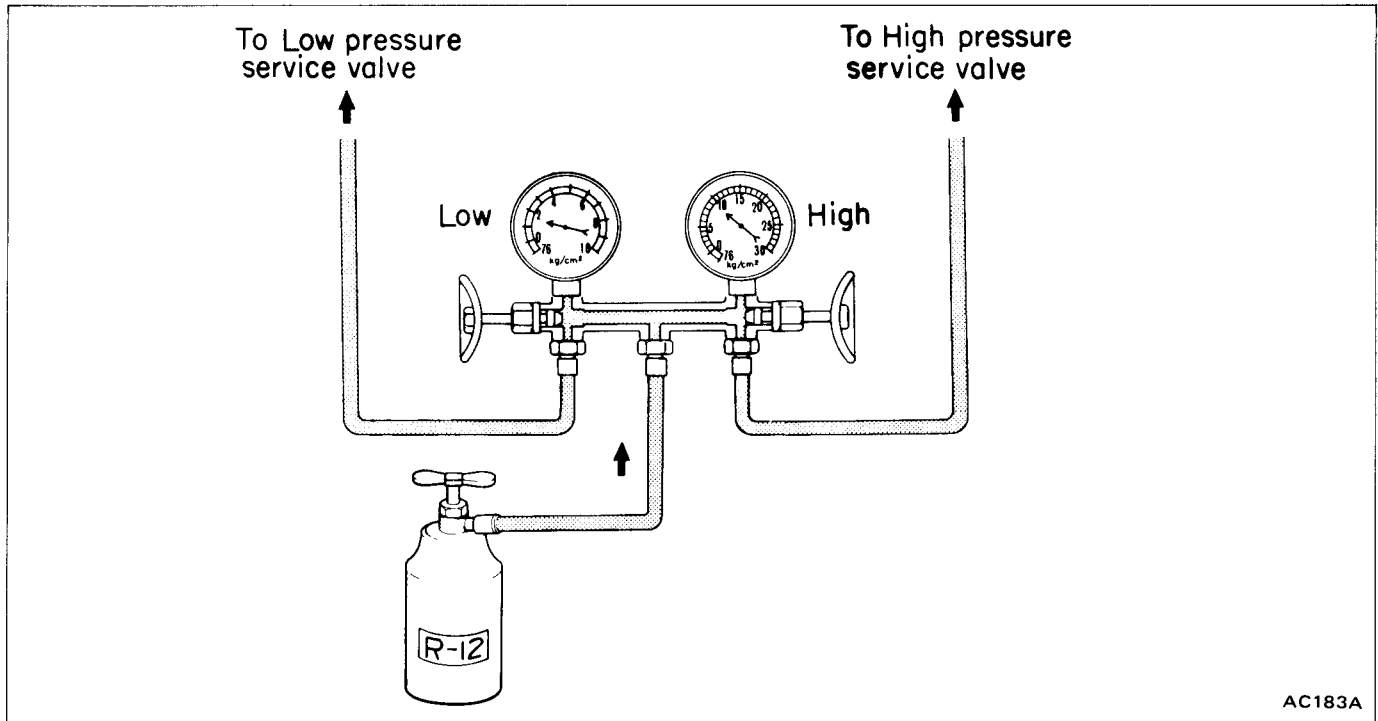

**CAUTION:**

When charging liquefied refrigerant into the system with the can turned upside down to reduce charging time, charge it only through high pressure (discharge) service valve, but not through low pressure (suction) service valve. After completion of charging, the compressor should always be turned several times manually.

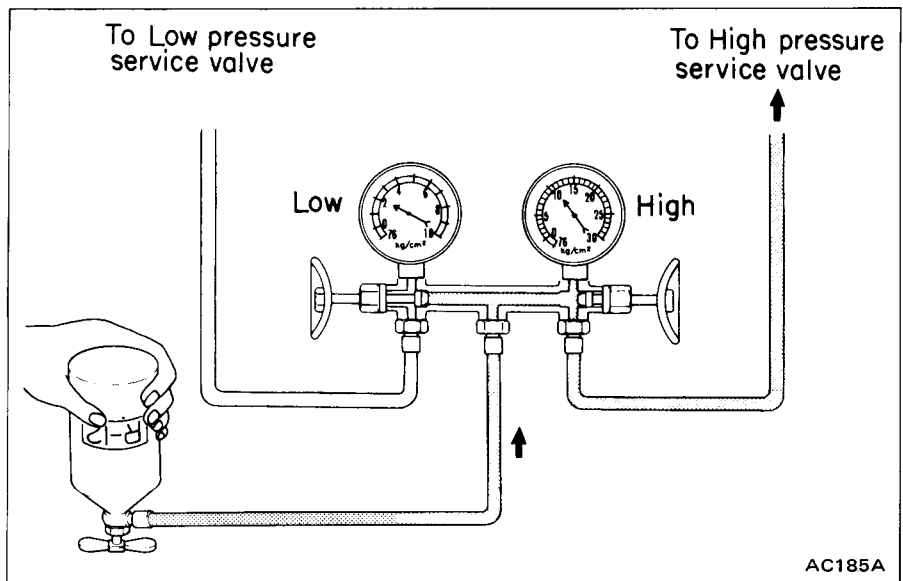

4. If refrigerant charging speed slows down, charge it while running the compressor for ease of charging. After having taken the steps up to 3 above, proceed with charging in the following order.

- (1) Shut off high pressure valve of manifold gauge.
- (2) Run the engine at idling speeds below 1,500 rpm.
- (3) Set the Temperature lever and Fan switch at maximum cool and maximum speed respectively.

(4) Charge refrigerant while controlling low-pressure gauge reading at 275 kPa (2.8 kg/cm<sup>2</sup>, 40 psi) or less by turning in or out low-pressure valve of manifold gauge.

**WARNING:**  
 Never charge refrigerant through high pressure side (discharge side) of system since this will force refrigerant back into refrigerant can and can may explode.

**Refrigerant capacity:**

0.8 - 1.0 kg  
 (1.8 - 2.2 lb)

The presence of bubbles in sight glass of receiver drier is an unsuitable method of checking the amount of refrigerant charged in system. The state of the bubbles in sight glass should only be used for checking whether the amount of charged refrigerant is small or not. The amount of charged refrigerant can be correctly judged by means of discharge pressure. Refer to Heater and Air Conditioner (Section MA) for inspection.

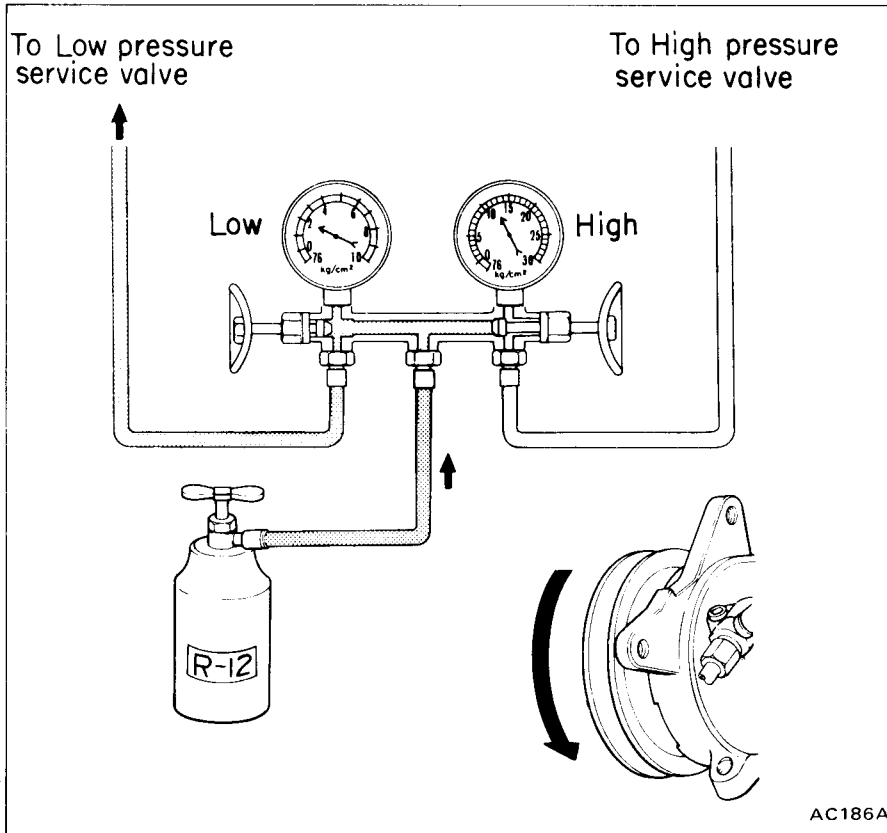

AC186A

5. When refrigerant can is empty, fully close both valves of manifold gauge and replace refrigerant can with a new one.

Before opening manifold gauge valve to charge refrigerant from new can, be sure to purge air from inside charging hose.

6. Charge the specified amount of refrigerant into system by weighing charged refrigerant with scale. Overcharging will cause discharge pressure to rise.

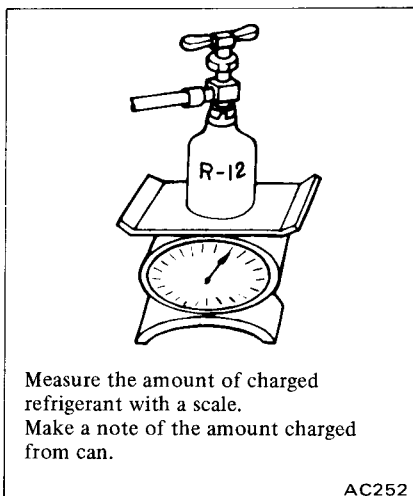

Measure the amount of charged refrigerant with a scale. Make a note of the amount charged from can.

AC252

7. After the specified amount of refrigerant has been charged into system, close manifold gauge valves. Then detach charging hoses from service valves of system. Be sure to install valve cap to service valve.

8. Confirm that there are no leaks in system by checking with a leak detector.

Refer to Heater and Air Conditioner (Section MA) for inspection.

Conducting a performance test prior to removing manifold gauge is a good service operation. Refer to Performance Test.

## COMPRESSOR OIL LEVEL CHECK

A completely sealed system will be free from compressor oil leakage. As long as the system operates satisfactorily, a compressor oil level check is unnecessary. Because of its structure, almost all compressor oil is circulating in the system together with refrigerant. If an excessive quantity of oil is charged into the system, most of the oil goes around the system and stays in the condenser or in the evaporator, thus causing considerable reduction in the cooling capacity of the system. Insufficient compressor oil leads to poor lubrication of the compressor. Whenever replacing any component of the refrigeration system, the original total oil charge must always be maintained.

**Amount of oil in the system:**  
**150 ml**  
**(5.1 US fl oz, 5.3 Imp fl oz)**

Check and adjust the quantity of oil according to the following procedures.

### CAUTION:

- a. The oil should not be transfused from a container into another, as the failure will possibly cause moisture to mix with the oil.
- b. The used oil should not be returned into a container.
- c. The oil should not be used if its state of preservation is not clear enough.

### Checking and adjusting (Using oil separator)

The Oil Separator Kit KV992A9690 is used to efficiently withdraw the oil in the refrigeration system (that is, to separate oil and refrigerant). If an excessive quantity of oil is charged in the system, or if the quantity of oil in the system is unknown, adjust the quantity of oil in the system to specification, proceeding as follows:

1. Discharge air conditioning system. Refer to Discharging System.
2. Using two special flexible hoses and double union in Oil Separator Kit KV992A9690, connect oil separator between compressor discharge side and condenser.

3. Evacuate and charge system. Refer to General Service for evacuating and charging system.
4. Fully open all windows or all doors of car.
5. Operate compressor at engine idling with air conditioner set for maximum cooling and high fan speed.

**Never allow engine speed to exceed idling speed.**

6. Observe oil separator oil level gauge. If rise of oil level has stopped, immediately stop compressor operation. (This indicates that oil has been withdrawn.)

### CAUTION:

**Do not continue oil withdrawal operation more than 10 minutes.**

**In some cases, fluid refrigerant may be mixed with oil, causing unusual rise of oil level. In such a case, stop compressor operation after ten minutes of withdrawal operation.**

7. Discharge system. Refer to General Service for discharging system.
8. Disconnect oil separator, two flexible hoses and double union from system.
9. Connect refrigerant lines to original positions.
10. Disconnect low flexible hose from compressor suction valve.
11. Add oil from compressor suction valve.

**Amount of oil to be added:**

**120 ml**  
**(4.1 US fl oz, 4.2 Imp fl oz)**

- a. Oil remains unremoved in the system about 30 ml (1.0 US fl oz, 1.1 Imp fl oz).
- b. To facilitate replenishment, it is a good practice to disconnect the low-pressure (flexible) hose to the evaporator and add oil to the compressor through the hose.

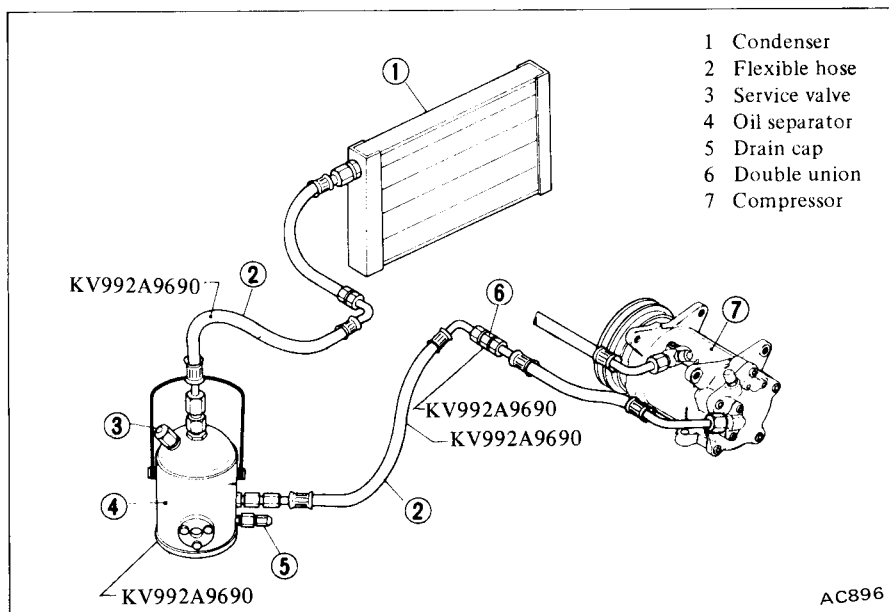

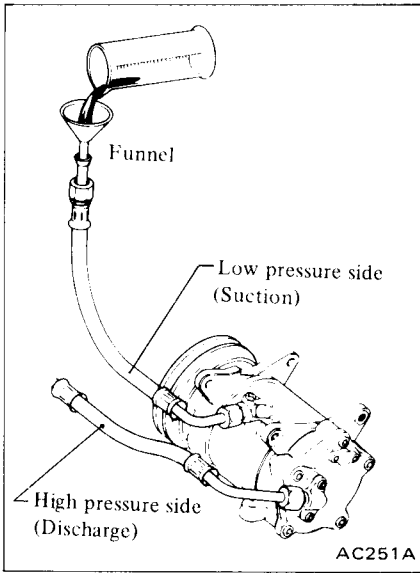

12. After charging, rotate compressor clutch with hand 5 to 10 turns.
13. Connect low flexible hose to compressor suction valve. Evacuate and charge system. Refer to General Service for evacuating system and charging refrigerant.
14. Conduct leak test and performance test.
15. Gradually loosen drain cap of oil separator to release residual pressure. Remove cap and drain oil.
16. To prevent formation of rust and intrusion of moisture or dust, perform the following before placing oil separator kit into storage.

- hoses and double union securely.
- (2) Cap oil separator, evacuate it from service valve, and charge refrigerant.

- (1) Cap each opening of two flexible

**Checking and adjusting (Alternate method)**

If the Oil Separator is not available, control the quantity of oil in accordance with the table below when charging compressor oil into the system.

OIL CHARGE TABLE

Condition		Proper charging method	Amount of oil to be added ml (US fl oz, Imp fl oz)
Replacement of compressor		1. Remove all oil from new and old compressors.* 2. Charge new compressor with the same amount of oil as was in the old compressor.	
Replacement of evaporator		Add amount of oil shown in right column.	70 (2.4, 2.5)
Replacement of receiver dryer (liquid tank)		Oil need not be added.	—
Replacement of accumulator		Add amount of oil shown in right column.	30 (1.0, 1.1)
Replacement of condenser	There is no sign of oil leakage from condenser.	Oil need not be added.	—
	There are evidences of a large amount of oil leakage from condenser.	Add amount of oil shown in right column.	50 (1.7, 1.8)
Replacement of flexible hose or copper tube	There is no sign of oil leakage.	Oil need not be added.	—
	There are evidences of a large amount of oil leakage.	Add amount of oil shown in right column.	50 (1.7, 1.8)
Gas leakage	There is no sign of oil leakage.	Oil need not be added.	—
	There are evidences of a large amount of oil leakage.	Add amount of oil shown in right column.	50 (1.7, 1.8)

\* Remove compressor oil as follows

1. With the compressor upside down, completely drain the oil through the suction port (from the embossed letter “S” mark side).

Be sure to use a clean container to receive the oil.

2. When the oil stops flowing out, rotate the clutch hub (compressor shaft) two or three times to completely drain the oil.

**When replacing two or more of the parts indicated in the above chart, follow each instruction under the proper charging method column for the proper amount of oil to be added.**

– Example –

When replacing the evaporator and compressor, drain all oil out of the new compressor and then charge the compressor with the total amount of oil [70 ml (2.4 US fl oz, 2.5 Imp fl oz) for the evaporator and the same amount of oil as was in the old compressor.]

If total amount of oil to be added exceeds 150 ml (5.1 US fl oz, 5.3 Imp fl oz), add 150 ml (5.1 US fl oz, 5.3 Imp fl oz).

The method of adding oil is the same as in the case of using the oil separator. Oil is added into the compressor. Refer to the figure on page HA-15.

## PERFORMANCE TEST

The cooling performance of the air conditioner changes considerably with changes in surrounding conditions. Testing must be performed using the correct method. This test is used to judge whether system is operating correctly and can also be used as a guide in checking for problems.

1. Park the car indoors or in the shade.

2. Open all the windows of the car fully. However, close the doors.

3. Open the hood.

4. Connect manifold gauge to high- and low-side service valves of the system. Refer to Handling Manifold Gauge.

5. Set air lever to AIR-CON RECIRC position.

6. Set temperature lever to maximum cold position.

7. Set blower to its highest speed.

8. Start the engine and hold engine speed at 1,500 rpm.

9. After the air conditioner has been operated for about 10 minutes, measure system pressures at high-pressure (discharge) side and low-pressure (suction) side.

10. Measure the temperature of discharge air at the center outlet grille.

11. Measure the temperature and humidity of the evaporator intake air at the recirculating air inlet of the evaporator.

12. Measure the temperature and humidity of the ambient air at a point 1 m (3.3 ft) front of condenser. However, a dry bulb and wet bulb must not be placed in direct sunlight.

13. Check for any abnormalities by comparing the test results with standard pressure. Refer to Performance Chart.

**a. The pressure will change in the following manner with changes in conditions:**

- When blower speed is low, discharge pressure will drop.
- When the relative humidity of intake air is low, discharge pressure will drop.

**b. The temperature will change in the following manner with changes in conditions:**

**When the ambient air temperature is low, the outlet air temperature will become low.**

If the test reveals that there is any abnormality in system pressure, isolate the cause and repair. Refer to Trouble Diagnoses and Corrections.

## REFRIGERANT LEAKS

If leaks are noticeable, leaky parts should be repaired. Then system should be filled with refrigerant.

### CAUTION:

**Do not operate compressor with refrigerant level excessively low. If this caution is neglected, a burnt compressor will result since heavy loss of refrigerant usually indicates heavy loss of compressor oil.**

If system has been exposed to atmosphere for an extended period of time, receiver drier must be replaced. If leaks are slight and no air is present in system, add refrigerant as necessary.

To detect leaks, refer to Heater and Air Conditioner (Section MA). Here is how leaks are stopped.

1. Check torque on the connection fitting and, if too loose, tighten to the proper torque. Check for gas leakage with a leak detector.

2. If leakage continues even after the fitting has been retightened, discharge refrigerant from system, disconnect the fittings, and check its seating face for damage. Always replace even if damage is slight.

3. Check compressor oil and add oil if required.

4. Charge refrigerant and recheck for gas leaks. If no leaks are found, evacuate and charge system.



## DESCRIPTION (Manual air conditioner)

### REFRIGERATION SYSTEM

If you were to paint your finger with alcohol, your finger would feel cold. This is because the liquid alcohol takes heat away from your finger while it evaporates. If a quickly evaporating liquid such as alcohol is placed

in a container inside a box, the temperature inside the box will drop. This is because the alcohol is evaporated absorbing the heat from the air inside the box. If the gaseous alcohol is collected and cooled with cold water, it will be changed back into a liquid by absorption of its heat by the cold water.

The cooler operates on this principle. The liquid used is the refrigerant R-12. The heat inside the passenger compartment is absorbed by changing the refrigerant from a liquid to a gas and then dissipated to the outside by changing the refrigerant from a gas back to a liquid.

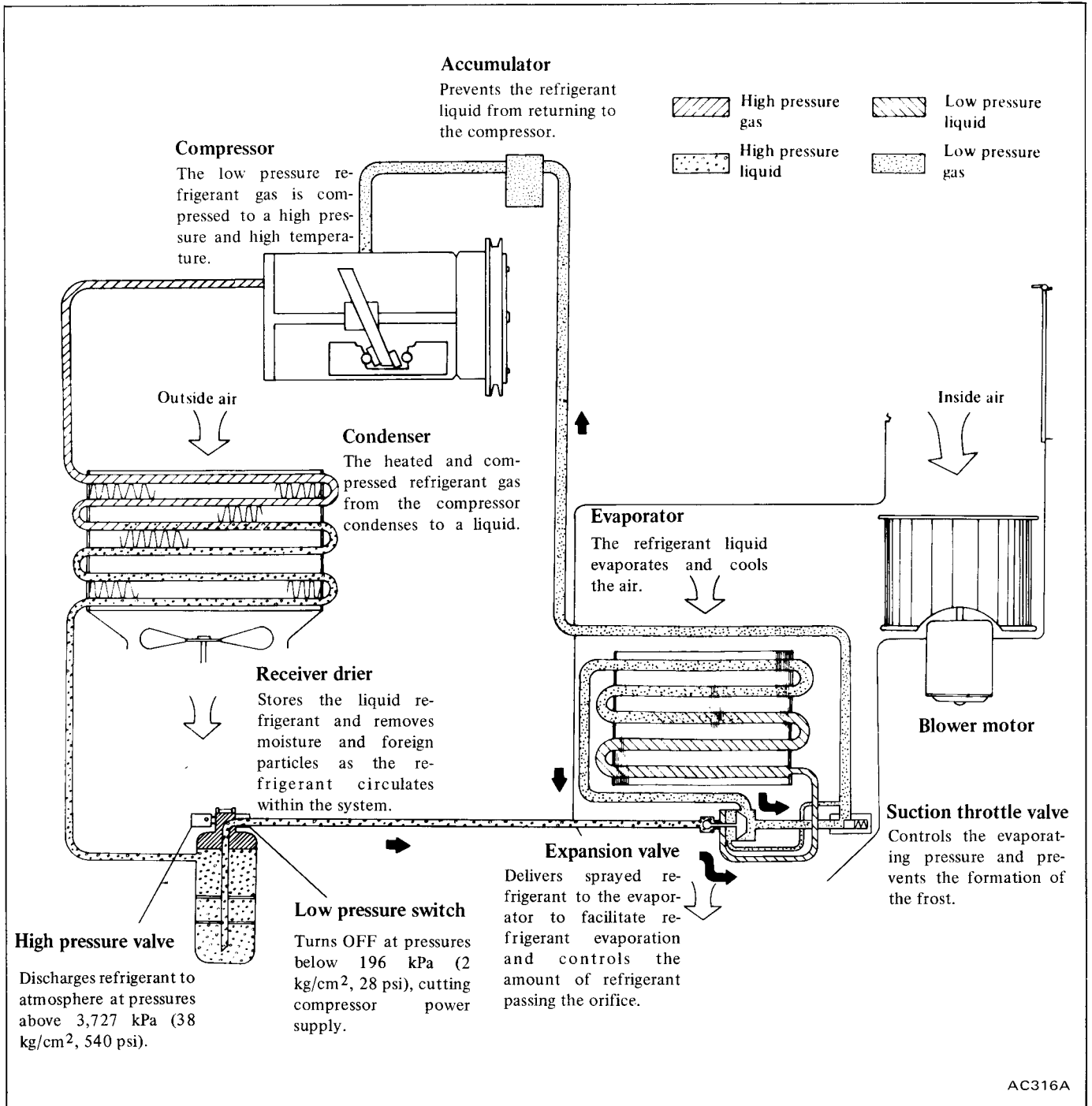

## OUTLINE OF AIR CONDITIONER

The air conditioner is a combined unit of an evaporator, heater and

blower and provides heating and cooling functions. In addition, it has bi-level and ventilation functions. Its control system consists of a mechani-

cal system using cables and engine vacuum.

The air conditioning unit is installed in the passenger compartments.

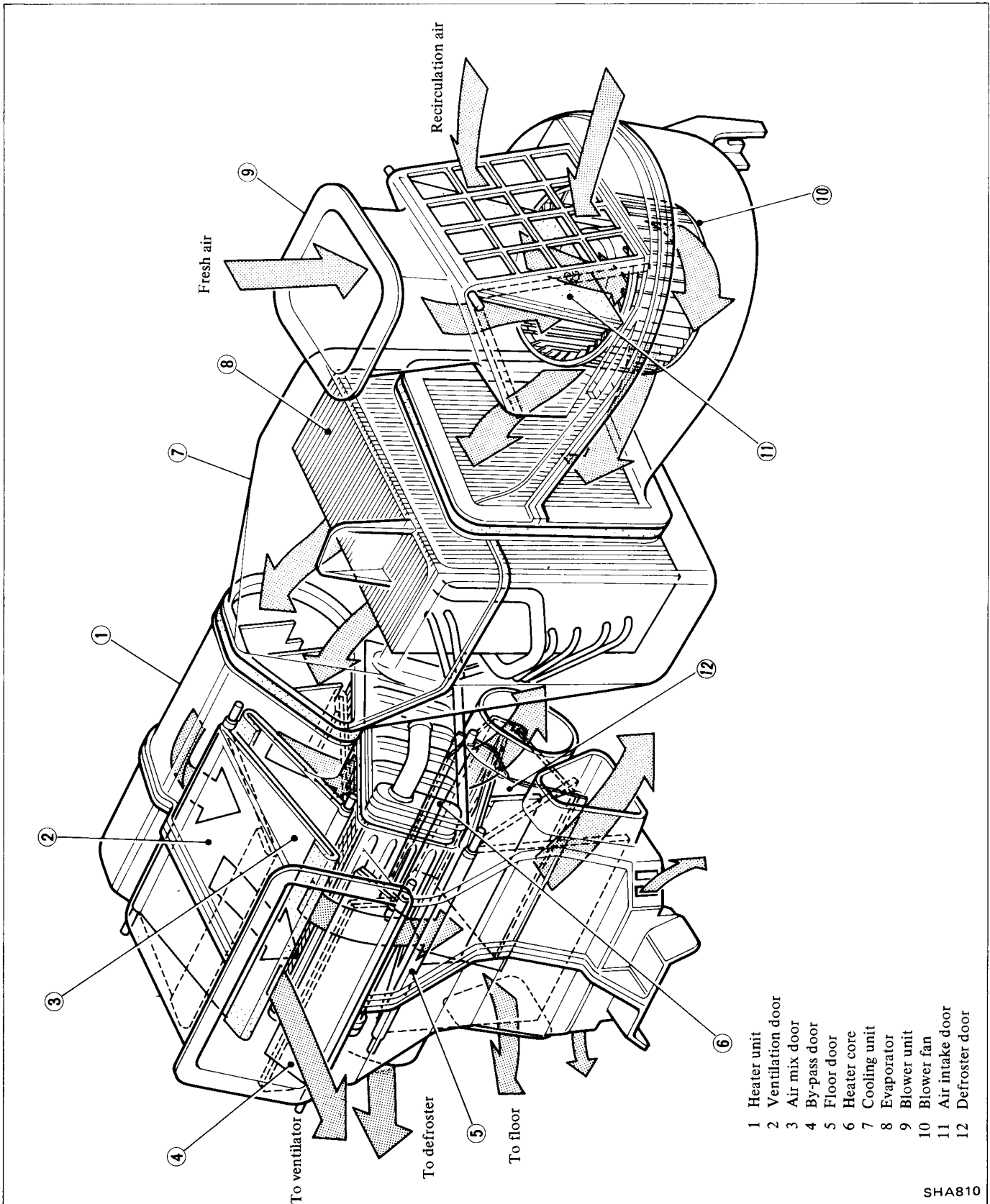

SHA810

# AIR FLOW AND VACUUM SYSTEM

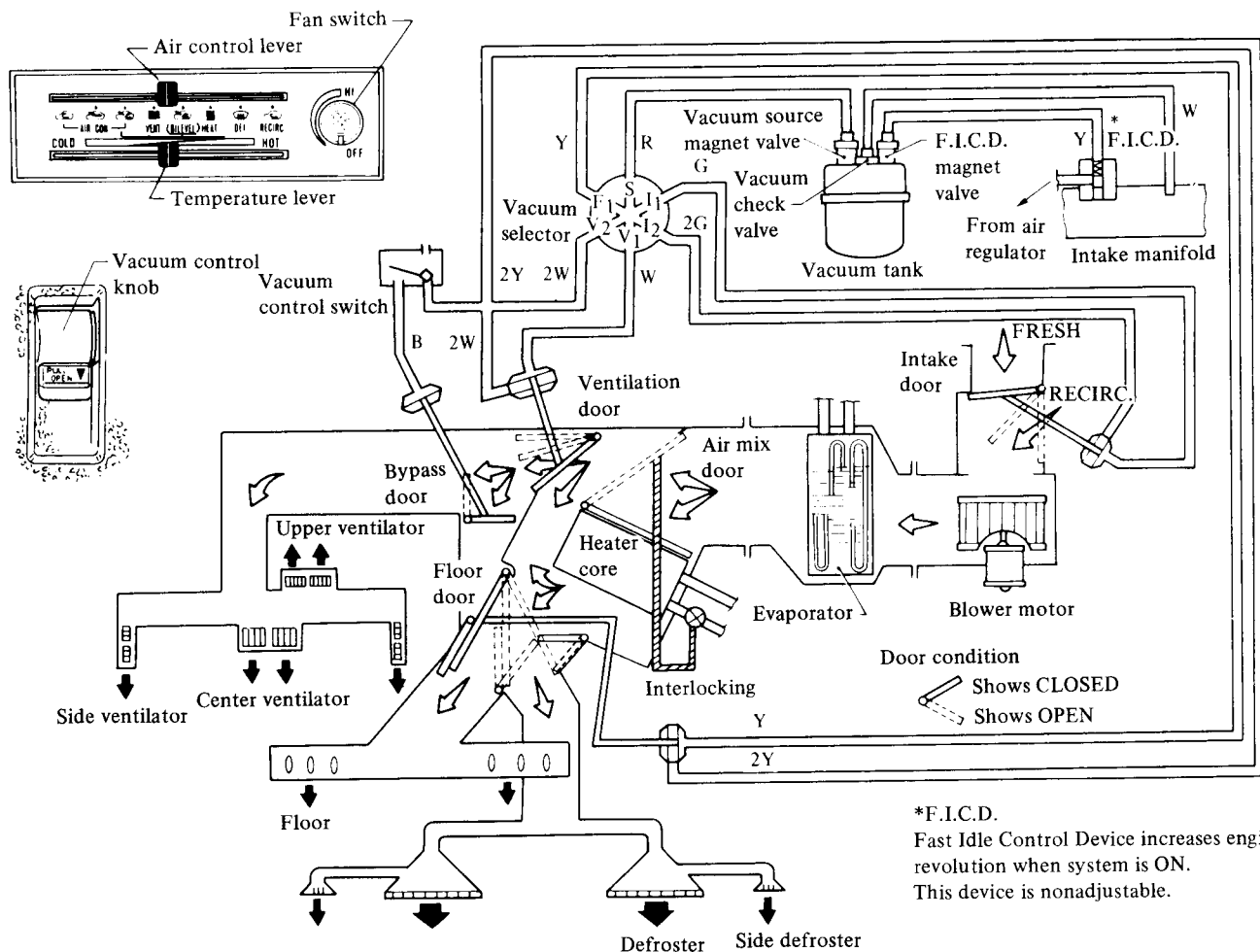

Air control lever position		Vacuum connection					Door position					Compressor and F.I.C.D.	Air flow distribution		
		S	I <sub>1</sub>	I <sub>2</sub>	V <sub>1</sub>	V <sub>2</sub>	F <sub>1</sub>	Intake Door	Air Mix Door	Ventilation Door	Bypass Door		Floor Door	Defroster	Ventilator
AIR-CON.	RECIRC	○	○	○	○	○	CLOSED	OPEN (Temperature lever on HOT); CLOSED (Temperature lever on COLD)	OPEN	*1 OPEN	OPEN	ON	0%	85%	15%
										*2 CLOSED		ON	0%	100%	0%
	FRESH	○	○	○	○	○	½ OPEN		OPEN	*1 OPEN	OPEN	ON	0%	85%	15%
									*2 CLOSED		ON	0%	100%	0%	
	B/L	○	○	○	○		OPEN		½ OPEN	CLOSED	CLOSED	ON	0% *4	50% *3	50% *3
VENT		○	○	○	○	○	OPEN		OPEN	*1 OPEN	OPEN	OFF	0%	85%	15%
										*2 CLOSED		OFF	0%	100%	0%
B/L		○	○	○	○		OPEN		½ OPEN	CLOSED	CLOSED	OFF	0% *4	50% *3	50% *3
HEAT		○	○	○			OPEN	CLOSED	CLOSED	CLOSED	OFF	20%	0%	80%	
DEF		○	○	○	○		OPEN	CLOSED	CLOSED	½ OPEN	OFF	100%	0%	0%	
RECIRC		○					CLOSED	CLOSED	CLOSED	CLOSED	OFF	20%	0%	80%	

\*1 Vacuum control knob is pulled out.  
\*2 Vacuum control knob is not pulled out.

\*3 Temperature lever: Center position  
\*4 When fan switch is in low position

# ELECTRICAL CIRCUIT

## OFF position

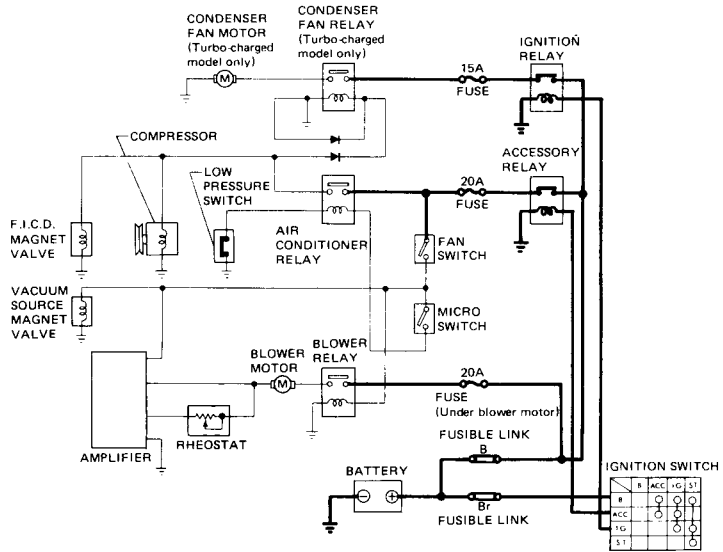
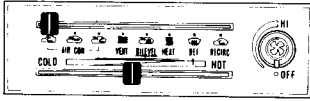

## VENT, B/L, HEAT, DEF and RECIRC position

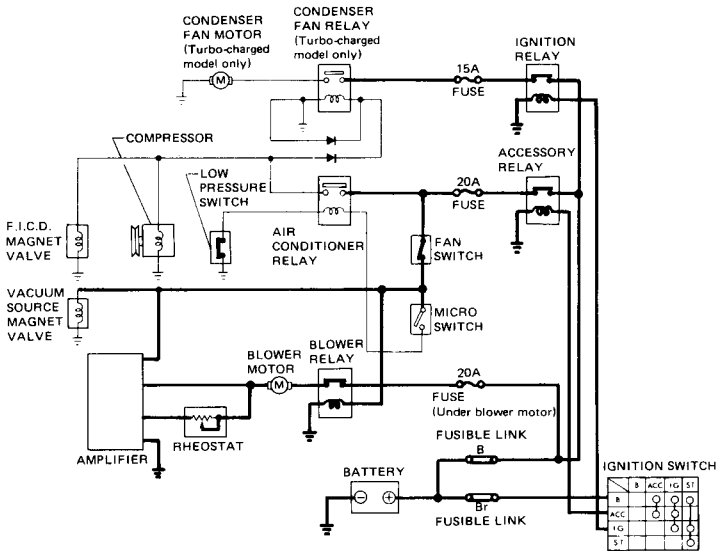
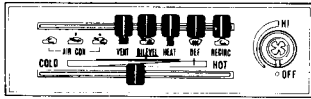

## AIR-CON position

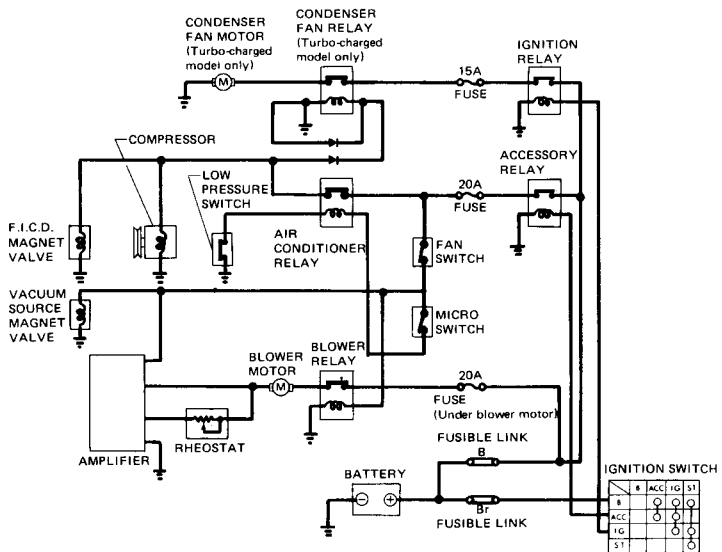
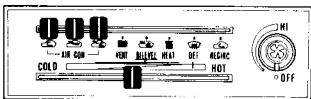

## SERVICE PROCEDURES (Manual air conditioner)

### PRECAUTIONS FOR REMOVAL AND INSTALLATION

When replacing refrigerant cycle components, observe the following:

#### CAUTION:

- When disconnecting or connecting tubes, be sure to use two wrenches on both tubes.

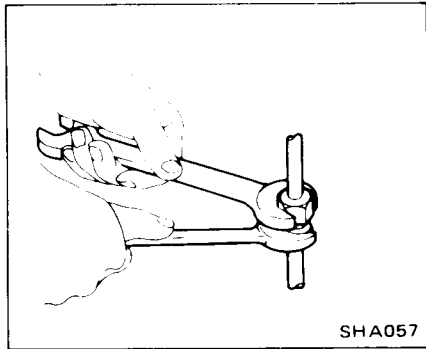

- After disconnecting tubes, plug all openings immediately to prevent entrance of dirt and moisture.

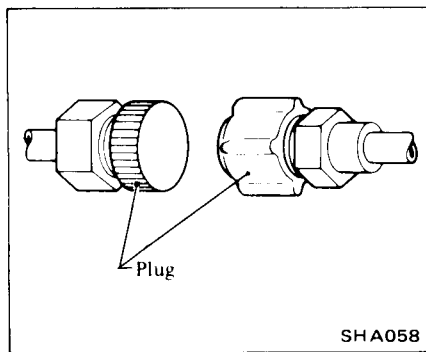

- Compressed air must never be used to clean dirty line. Clean with refrigerant gas.
- Do not reuse used O-ring.

1. Disconnect battery ground cable.
2. Before starting work, be sure to discharge system.

#### WARNING:

Gradually loosen discharge side hose fitting, and remove it after remaining pressure has been released.

- When connecting tube, apply compressor oil to portions shown in illustration. Be careful not to apply oil to threaded portion.
- O-ring must be closely attached to inflated portion of tube.

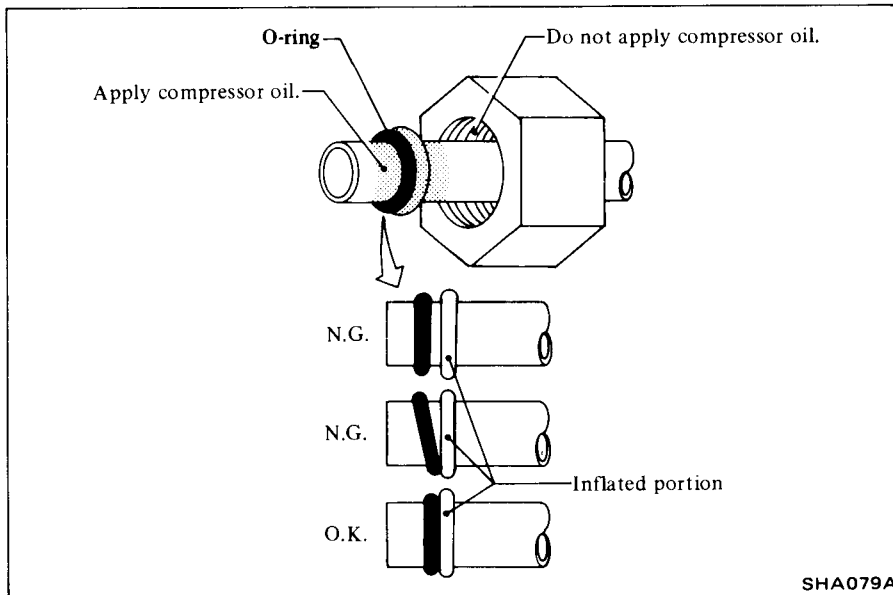

- After inserting tube into union until O-ring is no more visible, tighten nut to specified torque.

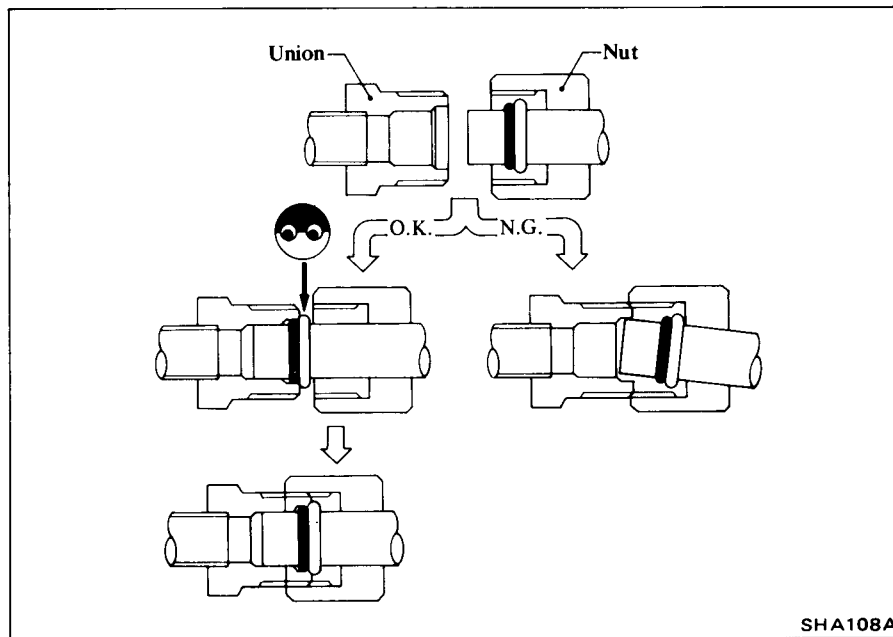

- After connecting line, conduct leak test and make sure that there is no leak from connections.

## REFRIGERANT LINES

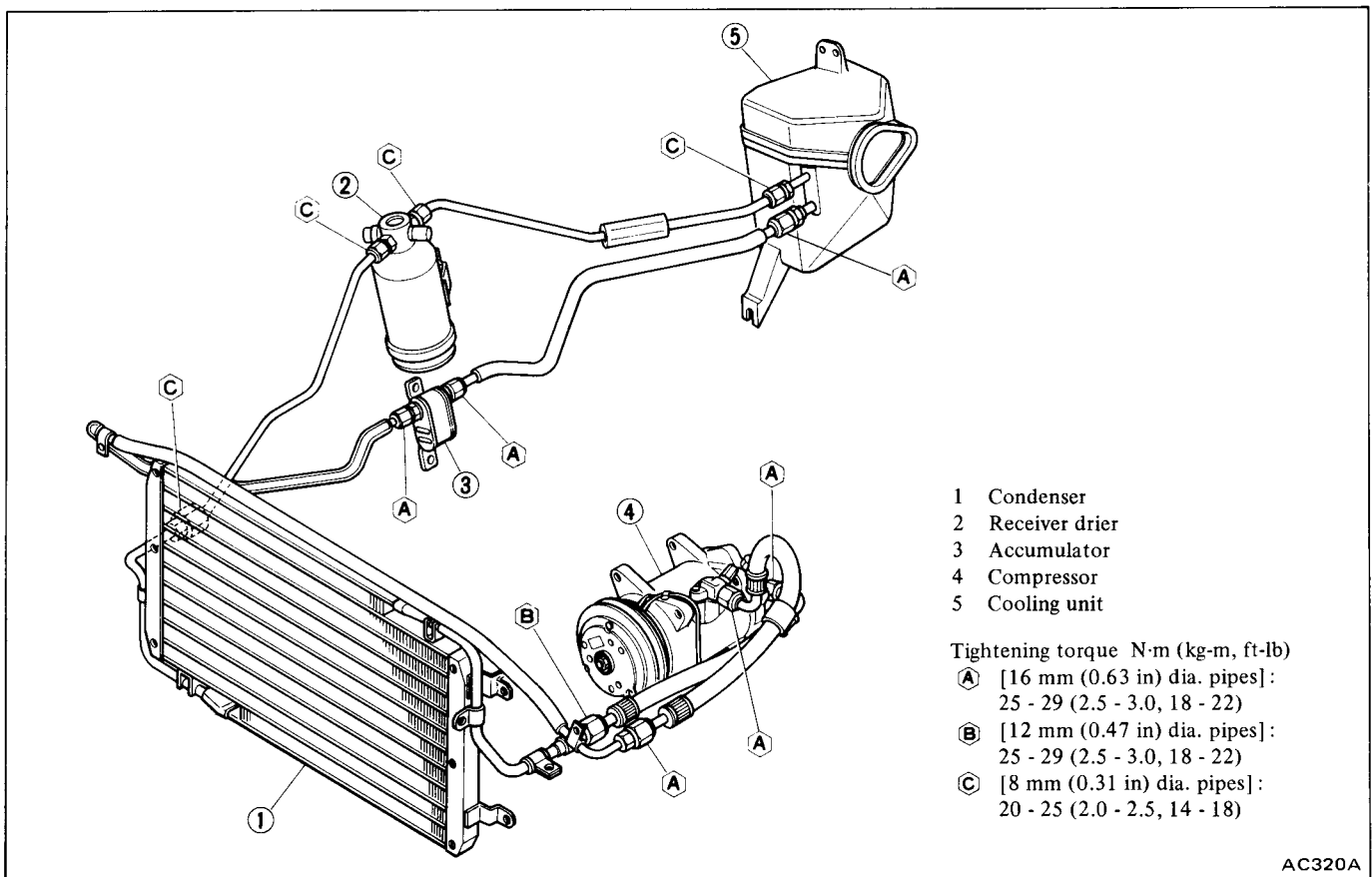

## IDLER PULLEY AND COMPRESSOR DRIVE BELT

### ADJUSTMENT OF BELT TENSION

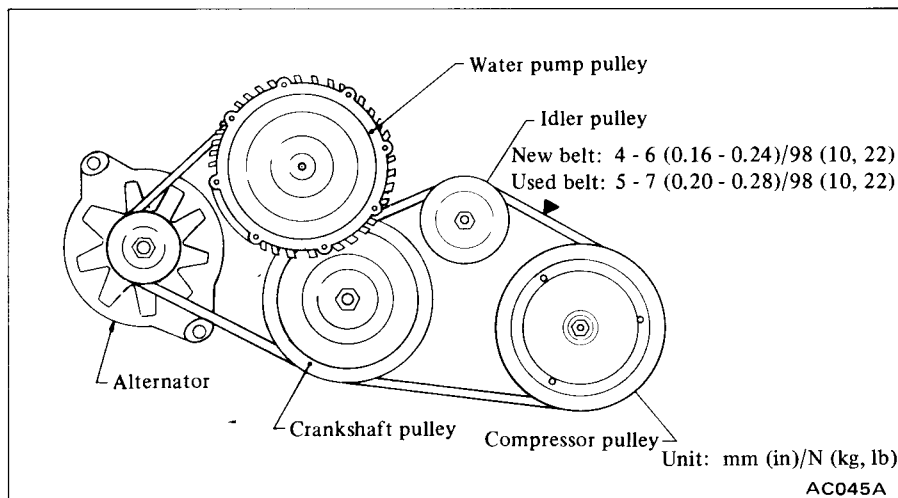

Specified compressor belt tension is 4 to 6 mm (0.16 to 0.24 in) (new belt) and 5 to 7 mm (0.20 to 0.28 in) (used belt) when thumb pressure of 98 N (10 kg, 22 lb) is applied midway between idler pulley and compressor pulley.

HA-22

1. Loosen idler pulley lock nut and then adjust pulley by turning adjusting bolt.
2. After adjustment, tighten idler pulley lock nut.

### REMOVAL AND INSTALLATION

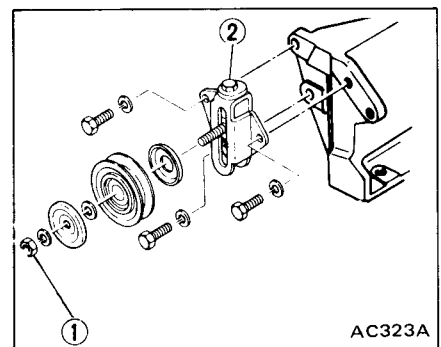

- 1 Lock nut
- 2 Adjusting bolt

1. Loosen idler pulley lock nut.
2. Loosen pulley adjusting bolt fully and remove lock nut and pulley.
3. Remove bracket mounting bolts. Remove bracket.
4. Install bracket and pulley in the reverse order of removal.
5. Adjust compressor belt tension.

## COMPRESSOR

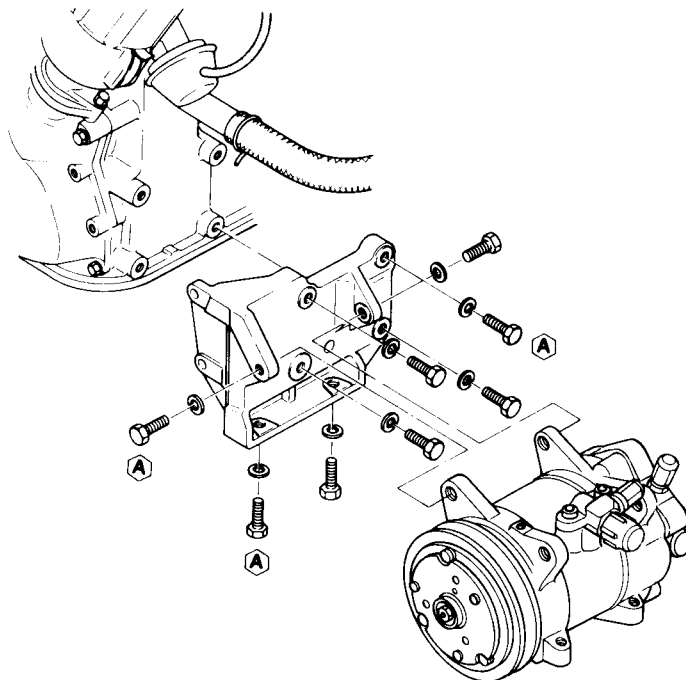

Tightening torque

**A**: 44 - 54 N·m (4.5 - 5.5 kg·m, 33 - 40 ft·lb)

AC324A

### REMOVAL

1. Operate compressor, if possible, at engine idling speed with air conditioner controls set for maximum cooling and high blower speed for 10 to 15 minutes with all windows open to return oil into compressor.
2. Discharge system. Refer to Discharging System.
3. Disconnect battery ground cable.
4. Loosen idler pulley lock nut and loosen tension adjusting bolt fully. Remove compressor drive belt.
5. Disconnect compressor clutch wire at connector.
6. Remove high and low flexible hoses from compressor.

#### WARNING:

Gradually loosen discharge side hose fitting, and remove it after remaining pressure has been released.

#### CAUTION:

Be sure to immediately put plug in flexible hose and compressor openings.

7. Remove two bolts mounting compressor's top side.
8. Jack up front of car and remove under cover.
9. Holding compressor, remove bolts mounting compressor's lower side.
10. Remove compressor with compressor clutch facing up.

#### CAUTION:

Do not attempt to leave the compressor on its side or upside down for more than 10 minutes, as the compressor oil will enter the low pressure chambers. If, under that condition, compressor should be operated suddenly, internal damage would result. To expel oil from chambers, hand-crank compressor several times in its installed condition.

### INSTALLATION

Install in the reverse order of removal, observing the following:

1. Determine quantity of oil to be charged into compressor by referring to Compressor Oil Level Check in General Service.
2. Check tightening torque of bolt securing compressor bracket. Retighten bolts if necessary. Refer to above figure.
3. Compressor plugs and flexible hose plugs should be kept in place until preparation of connection is completed.
4. Upon installation of compressor, turn compressor clutch by hand a few turns.
5. For tightening torque on refrigerant line fittings, refer to Refrigerant Line.

When connecting high and low flexible hoses to compressor, install new O-ring into connection.

6. Provide a clearance of more than 10 mm (0.39 in) between low pressure hose and high-pressure hose at compressor side.
7. For compressor drive belt tension, refer to Idler Pulley and Compressor Drive Belt.

8. Evacuate and recharge system. Refer to Evacuating System and Charging Refrigerant in General Service.
9. Conduct leak test and make sure that there is no leak from connections.

## CONDENSER

### REMOVAL

1. Disconnect battery ground cable.
2. Discharge system. Refer to General Service for discharging system.
3. Remove air flow meter duct.
4. Remove canister.
5. Disconnect refrigerant lines from condenser.

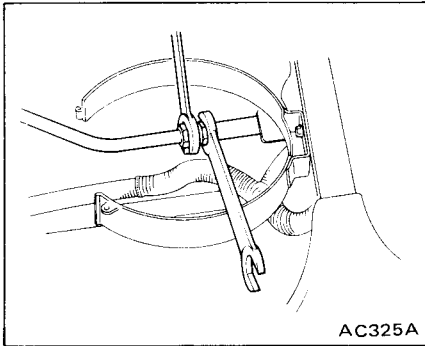

### CAUTION:

- a. Use wrench to fix union on condenser, and then loosen flare nut of refrigerant line with another wrench.
- b. Plug up all openings in condenser and system.

6. Remove condenser tube clamp
7. Remove air cleaner and duct.
8. Remove four mounting bolts, then remove condenser from car.

### INSPECTION

Inspect joints of inlet and outlet pipes for cracks and scratches. Upon finding any problem which may cause gas to leak, repair or replace condenser.

Condenser fins or air passages clogged with dirt, insects or leaves will reduce cooling efficiency of condenser. In such a case, clean fins or air passages with compressed air.

### CAUTION:

**Do not clean condenser with steam. Be sure to use cold water or compressed air.**

### INSTALLATION

Install condenser in the reverse order of removal, observing the following:

1. Keep plugs in place until immediately before connecting work is started.
2. For tightening torque on line connections, refer to Refrigerant Line.

**When connecting line, install new O-ring into connection.**

3. Determine quantity of oil to be charged into compressor by referring to Compressor Oil Level Check in General Service.
4. For evacuating and charging system, refer to General Service.
5. Conduct leak test and make sure that there is no leak from connections.

## CONDENSER FAN (Turbo-charged model only)

### REMOVAL AND INSTALLATION

1. Disconnect battery ground cable.
2. Remove air cleaner duct R.H.

3. Disconnect condenser fan fixing nuts.

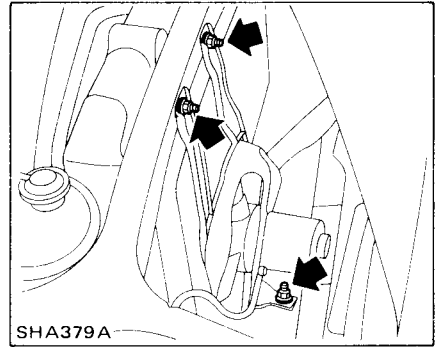

4. Disconnect harness connector, and remove condenser fan.
5. Installation is in the reverse order of removal.

## CONDENSER FAN RELAY (Turbo-charged model only)

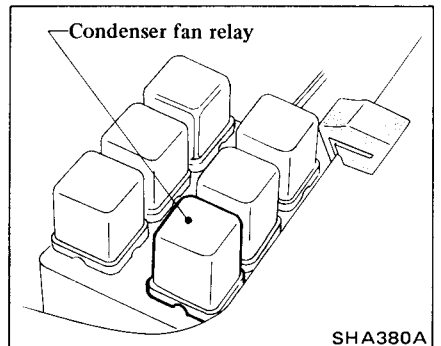

### INSPECTION

Test continuity of relay with ohmmeter or test lamp.

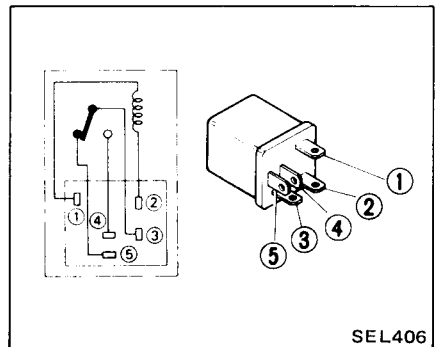



## RECEIVER DRIER

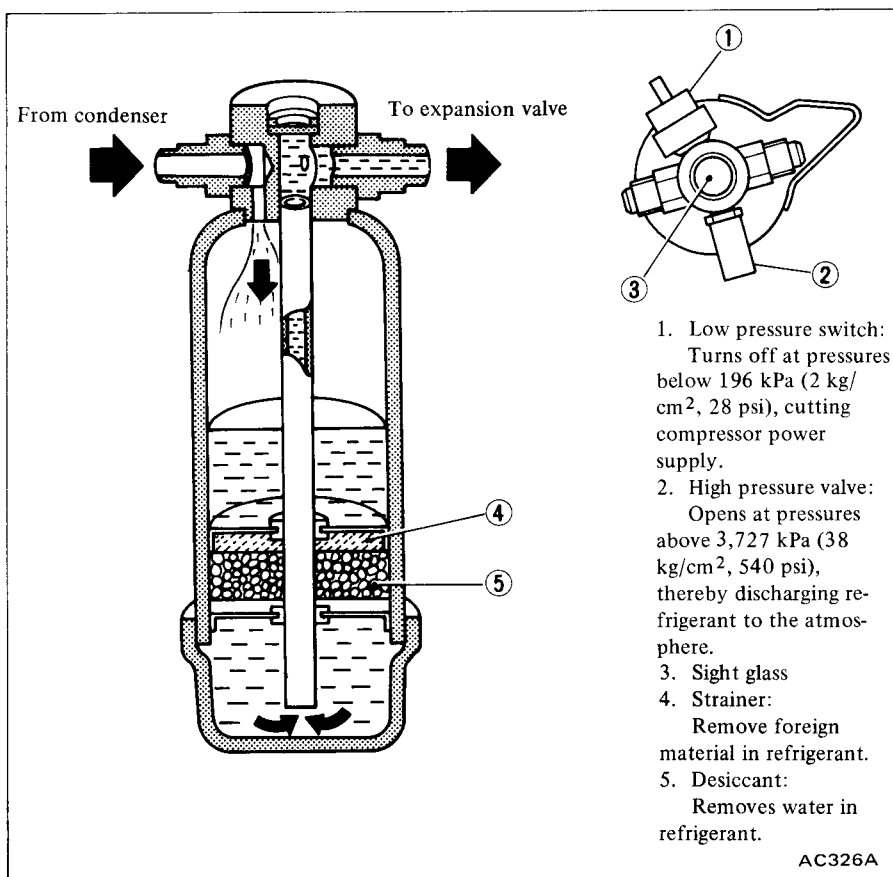

### REMOVAL AND INSTALLATION

1. Disconnect battery ground cable.
2. Discharge system. Refer to Discharging System in General Service.
3. Remove low pressure switch leads.
4. Remove fuel filter and bracket.

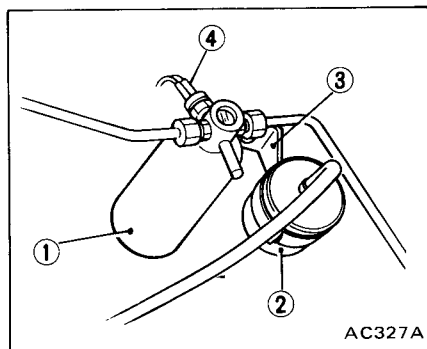

- 1 Receiver drier
- 2 Fuel filter
- 3 Fuel filter bracket
- 4 Low pressure switch leads

5. Disconnect refrigerant lines from receiver driver.

### CAUTION:

Plug all openings to prevent entrance of dirt and moisture.

6. Remove receiver drier mounting screws. Remove receiver drier.
7. Install receiver drier in the reverse order of removal. With plugs taken off immediately before connecting work is started, connect line and receiver drier. For tightening torque, refer to Refrigerant Line.

When connecting line, install new O-ring into connection.

8. For evacuating and charging system, refer to General Service.
9. Conduct leak test and make sure that there is no leak from connections.

### INSPECTION

Check receiver drier for leaks or damage. If necessary, replace.

## ACCUMULATOR

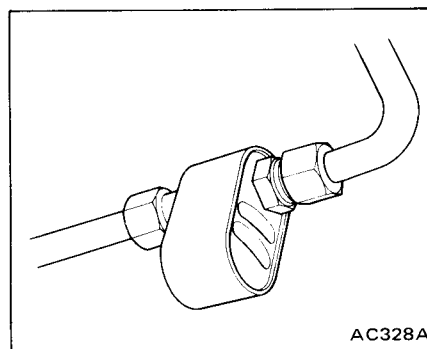

### REMOVAL

1. Disconnect battery ground cable.
2. Discharge system Refer to General Service for discharging system.
3. Disconnect refrigerant lines from accumulator.

### CAUTION:

- a. Use wrench to fix union on condenser, and then loosen flare nut of refrigerant line with another wrench.
- b. Plug up all openings in accumulator and system.

### INSPECTION

Inspect joints of inlet and outlet pipes for cracks and scratches. Upon finding any problem which may cause gas to leak, repair or replace condenser.

### INSTALLATION

Install accumulator in the reverse order of removal, observing the following:

1. Keep plugs in place until immediately before connecting work is started.
2. For tightening torque on line connections, refer to Refrigerant Line.

When connecting line, install new O-ring into connection.

3. Determine quantity of oil to be charged into compressor by referring to Compressor Oil Level Check in General Service.

4. For evacuating and charging system, refer to General Service.

5. Conduct leak test and make sure that there is no leak from connections.

## VACUUM TANK

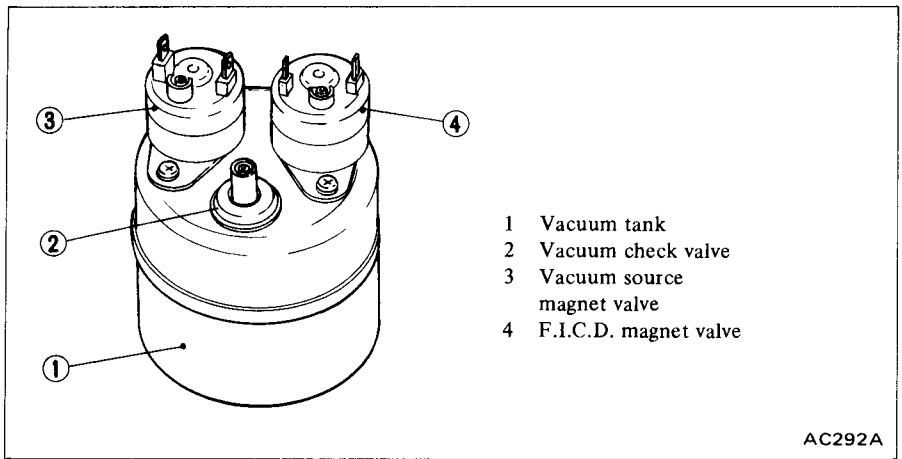

## FAST IDLE ACTUATOR

Being a non-adjustable type, this fast idle actuator requires no adjustment.

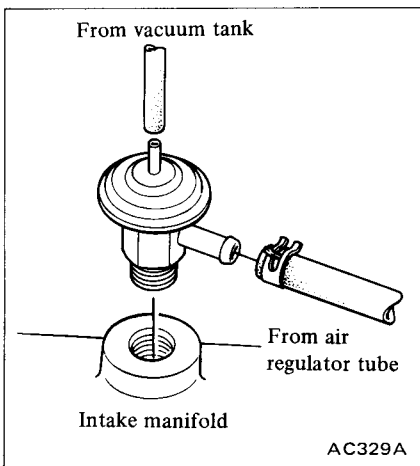

## REMOVAL AND INSTALLATION

1. Remove vacuum hoses from actuator.
2. Remove actuator.
3. Install actuator in the reverse order of removal.

## INSPECTION

1. Remove actuator. Refer to Removal and Installation.
2. Install vacuum hose from vacuum tank.
3. Plug hole in intake manifold and hose to air regulator tube.
4. With air conditioner on, set engine to idling speed.
5. Make sure that air regulator side of actuator is open to intake manifold side.
6. Remove vacuum hose and make sure that air regulator side is closed to intake manifold side.

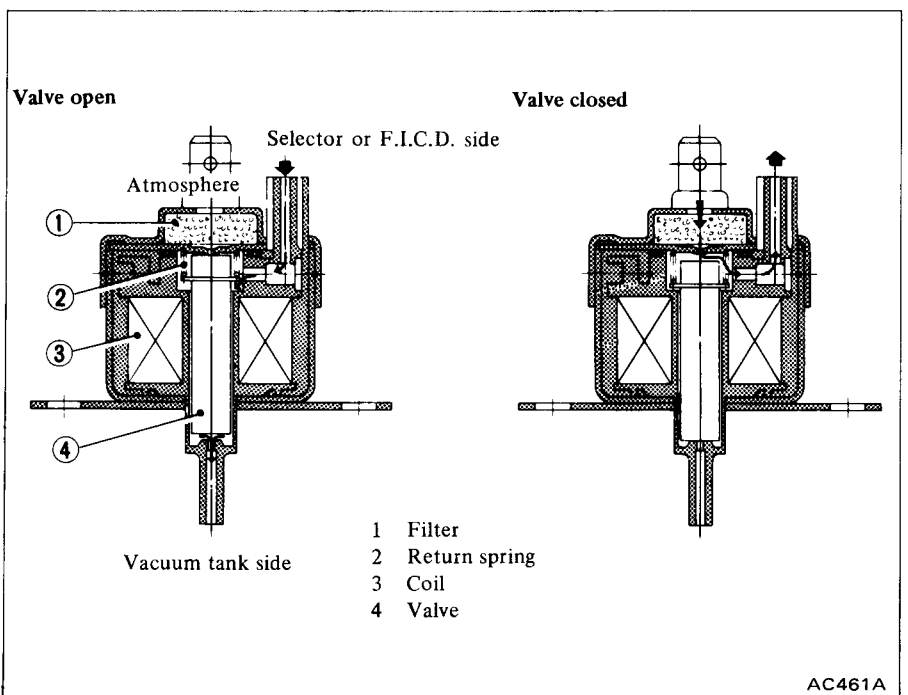
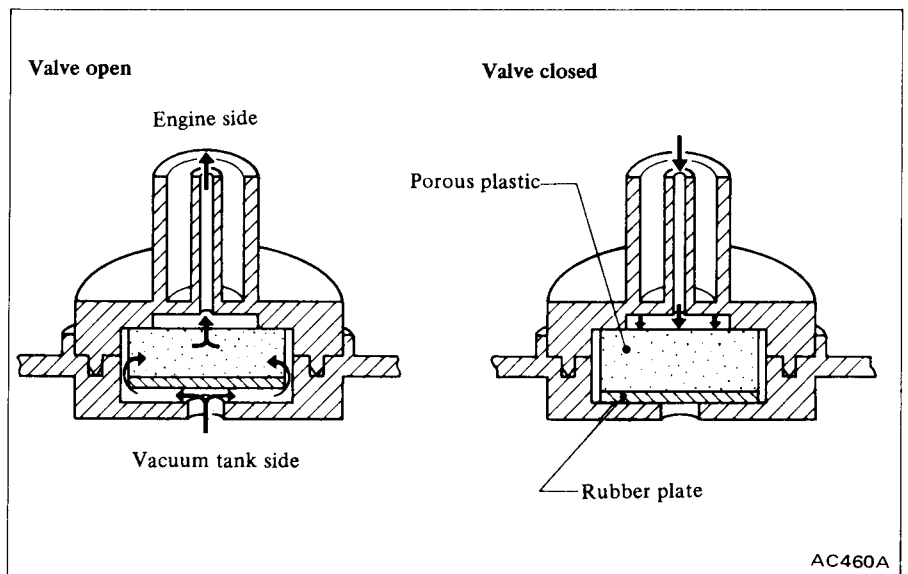

## REMOVAL AND INSTALLATION

1. Disconnect battery ground cable.
2. Remove vacuum hose and wire at connector.
3. Remove vacuum tank with bracket.
4. Remove vacuum tank from bracket.
5. Install vacuum tank in the reverse order of removal.

## INSPECTION

1. Check vacuum tank for leak.
2. Check vacuum check valve and magnet valves.

## AIR CONDITIONER RELAY

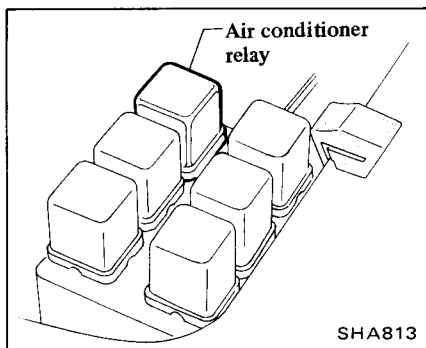

## INSPECTION

Test continuity of relay with ohmmeter or test lamp. In testing compressor relay, there must be continuity between ① and ②.

When 12V direct current is applied to ① - ②, ③ - ④ normally close (with air control lever moved to AIR-CON position, fan switch in ON and ignition switch in ON or ACC position).

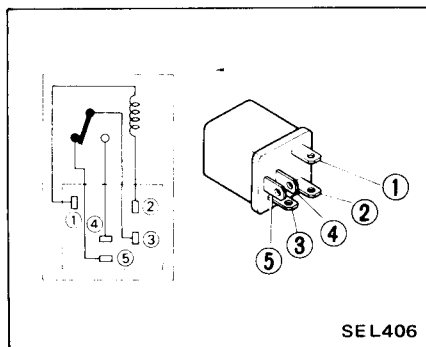

## COOLING UNIT

### REMOVAL

1. Disconnect battery ground cable.
2. Discharge refrigerant from system. Refer to General Service.
3. Loosen flare nuts at each connection of inlet and outlet pipes of evaporator.

**CAUTION:**  
Immediately plug up all openings to prevent entrance of dirt and moisture.

4. Remove heater unit.
5. Remove defroster duct on pas-

senger's side.

6. Remove mounting bolt and then remove cooling unit from dash panel.

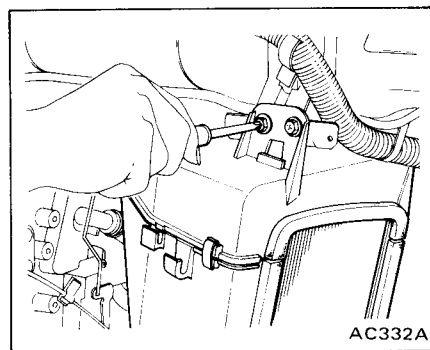

### DISASSEMBLY AND ASSEMBLY

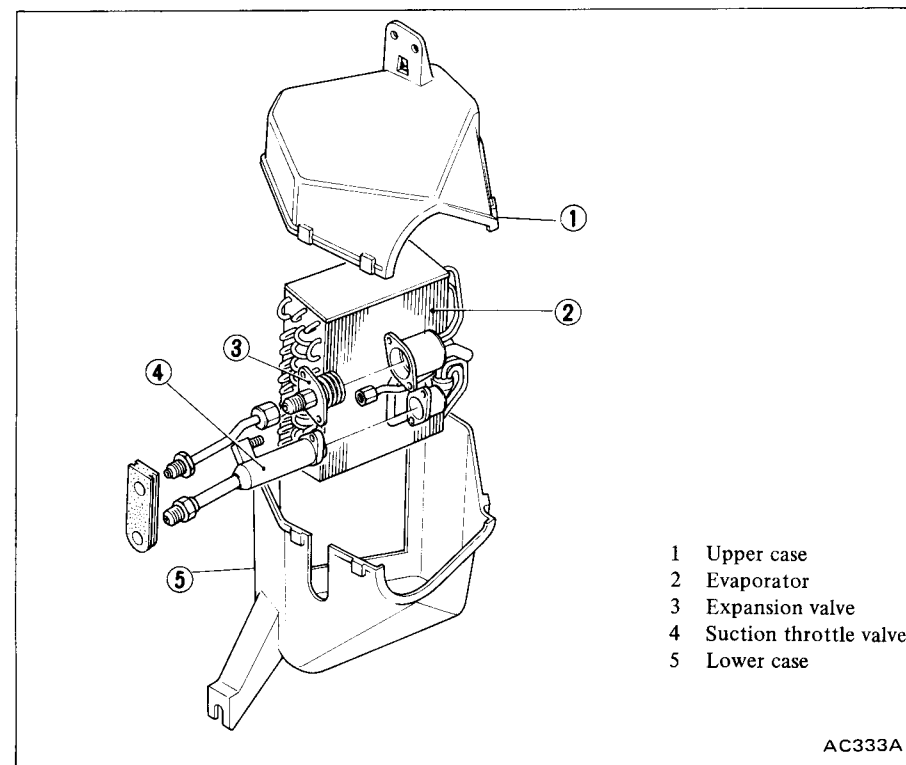

## INSPECTION

In case evaporator core, suction throttle valve or expansion valve shows gas leaking, repair or replace it with a new one as necessary.

Dirt and nicotine accumulation on evaporator case will go bad and smell. This means that you have to remove them from time to time to assure healthful fresh air inside car.

1. Remove clips fixing upper case to lower case.
2. Using a knife, cut packings at upper and lower case fit-in portion.
3. Withdraw evaporator assembly out of lower case.
4. To assemble, reverse the order of disassembly. Be sure to join mating surface of packings at upper and lower case fit-in portion.

## INSTALLATION

Install evaporator in the reverse order of removal, observing the following:

1. When replacing evaporator with new one, determine quantity of oil to be charged into compressor by refer-

ring to Compressor Oil Level Check in General Service.

2. Evaporator case should be installed as close as possible to heater unit and blower assembly.
3. Connect line and evaporator. For tightening torque, refer to Refrigerant Line.

When connecting line, install new O-ring into connection.

4. As to evacuating and charging system, refer to section concerned in General Service.
5. Conduct leak test and ensure that there is no gas leak from connection.

## EXPANSION VALVE

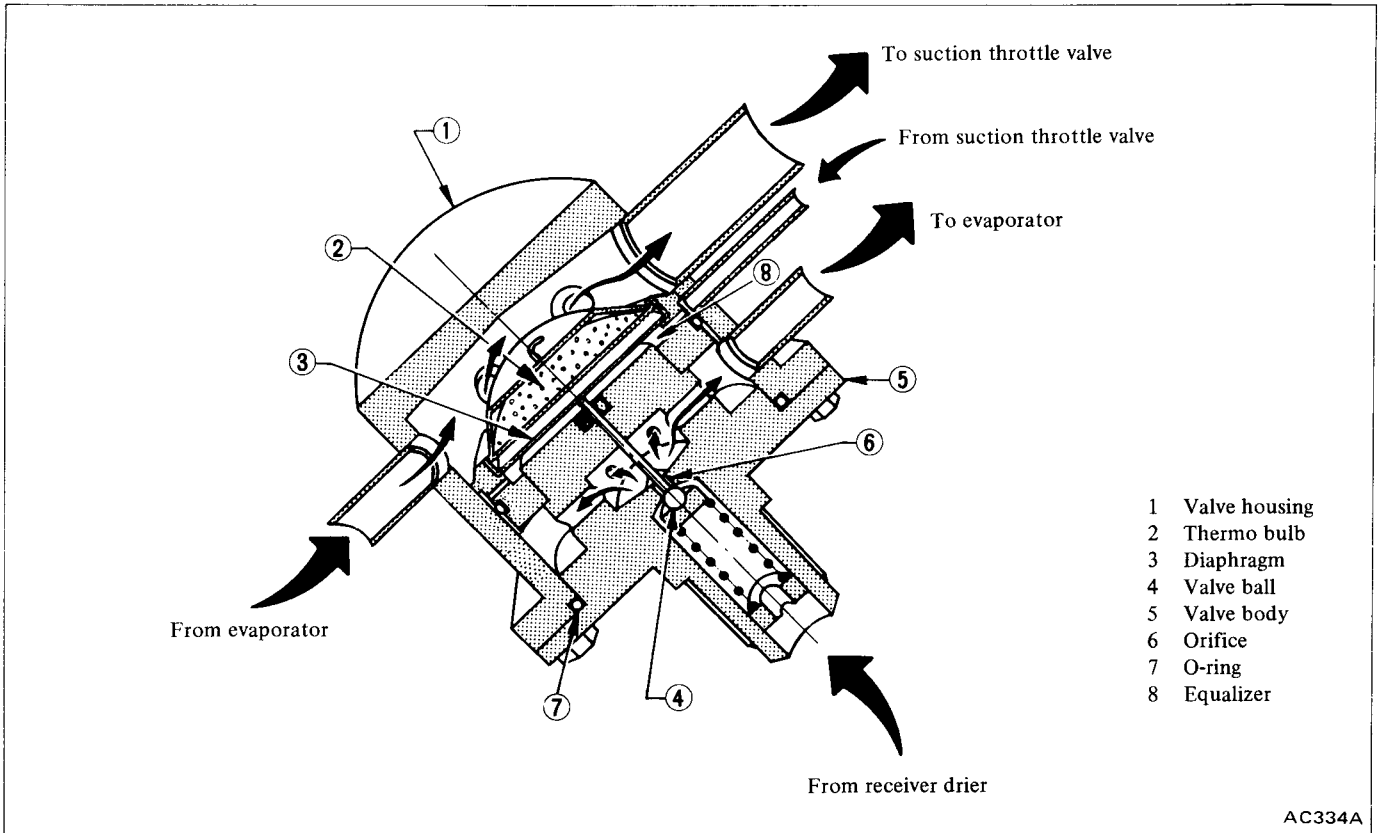

The expansion valve restricts the flow of liquid refrigerant as it passes through it and delivers sprayed refrigerant to the evaporator to facilitate refrigerant evaporation.

The refrigerant within the thermo bulb changes in pressure through the super heat condition of vaporized refrigerant gas which comes out of the evaporator, causing the deflection of the diaphragm. The lift of the ball valve attached to the diaphragm is changed by the deflection of the diaphragm, thus controlling the amount of refrigerant passing the orifice.

Expansion valve is equipped with

an adjusting screw. However, since the screw is set properly at the factory, adjustment is unnecessary. If expansion valve is damaged, replace with new one.

## REMOVAL AND INSTALLATION

1. Disconnect battery ground cable.
2. Remove evaporator. Refer to Cooling Unit.
3. Loosen flare nuts, and remove expansion valve from evaporator and inlet pipe.

### CAUTION:

Plug all openings to prevent entrance of dirt and moisture.

4. Loosen fixing nut.
5. Installation is in the reverse order of removal.

## SUCTION THROTTLE VALVE

This device makes it possible to use air conditioning in locations having a wide range of temperatures throughout the year. When operating the cooler in cold weather, frost will form on the fins of the evaporator. The suction throttle valve is used to prevent the formation of this frost.

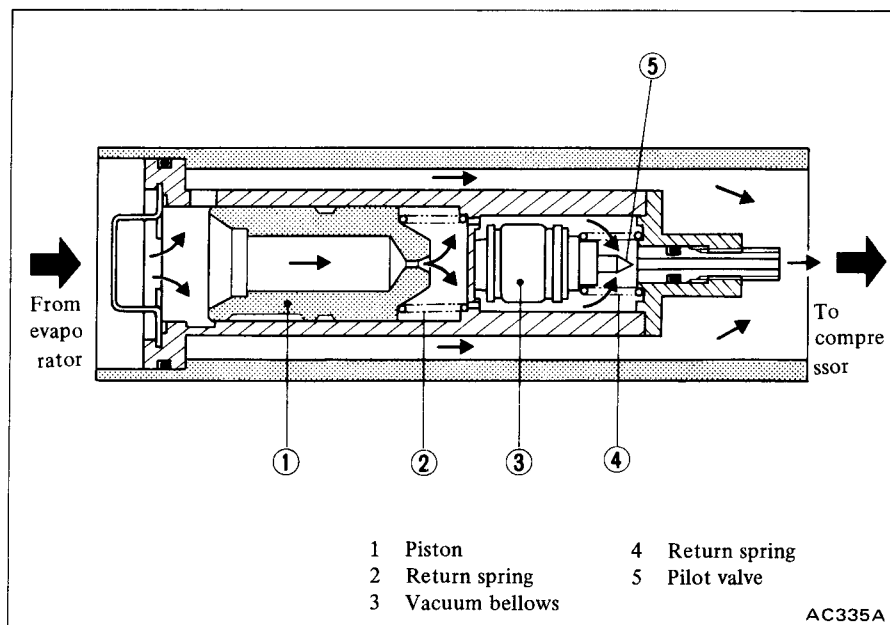

## HEATER UNIT

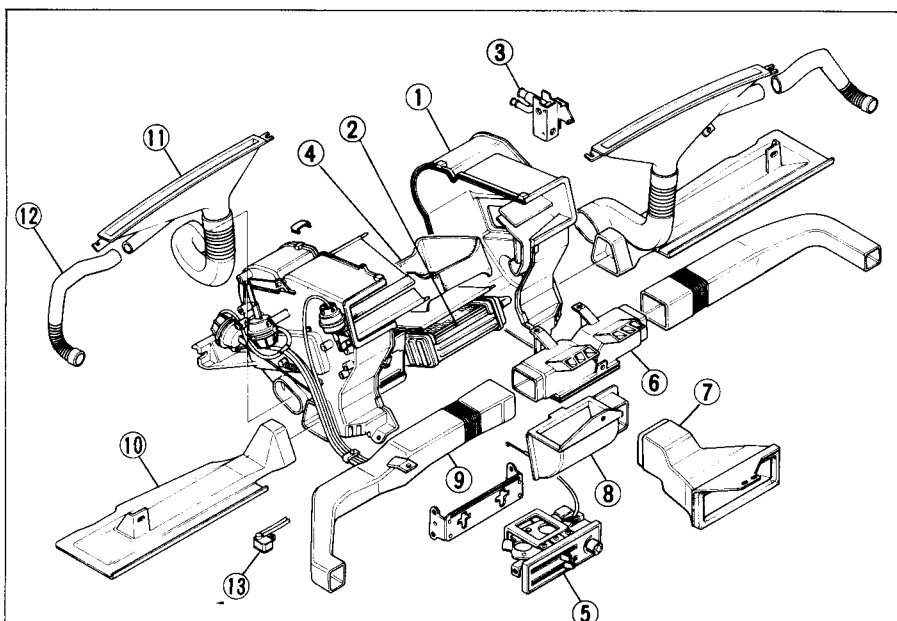

- |                  |                           |                          |
|------------------|---------------------------|--------------------------|
| 1 Heater case    | 6 4-way connector         | 10 Floor nozzle          |
| 2 Heater core    | 7 Center ventilation duct | 11 Defroster nozzle      |
| 3 Water cock     | 8 2-way connector         | 12 Side defroster duct   |
| 4 Felt           | 9 Side ventilation duct   | 13 Vacuum control switch |
| 5 Heater control |                           |                          |

AC336A

## REMOVAL AND INSTALLATION

1. Disconnect battery ground cable.
2. Set TEMP lever to max. HOT position and drain engine coolant.
3. Remove blower unit, cooling unit and heater control.
4. Remove instrument lower cover and floor nozzle on driver's side.
5. Disconnect inlet and outlet heater hoses.
6. Remove attaching bolts and then remove heater unit.

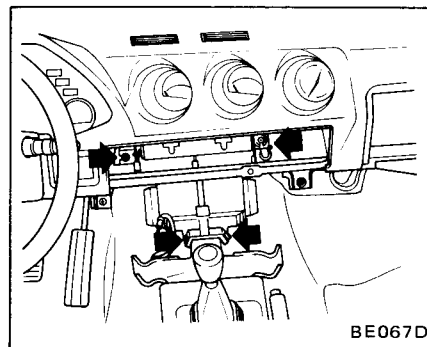

7. Install heater unit in the reverse order of removal.

## DISASSEMBLY AND ASSEMBLY

1. Remove heater unit. Refer to Heater Unit Removal and Installation.
2. Remove water cock.
3. Remove clips securing right and left heater cases, then separate heater cases.
4. Take out heater core.
5. Assemble heater unit in the reverse order of removal.

## DISASSEMBLY AND ASSEMBLY

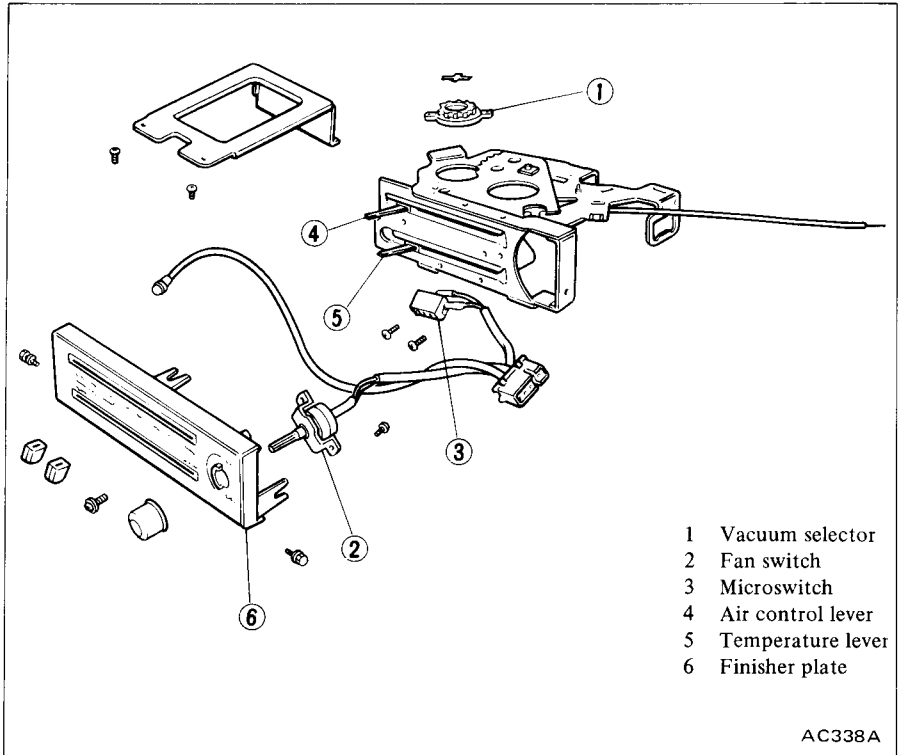

- 1 Vacuum selector
- 2 Fan switch
- 3 Microswitch
- 4 Air control lever
- 5 Temperature lever
- 6 Finisher plate

AC338A

## HEATER CONTROL

### REMOVAL AND INSTALLATION

1. Disconnect battery ground cable.
2. Remove instrument lower covers.
3. Remove instrument console. Refer to Section BF.
4. Remove instrument center ventilator and duct.
5. Disconnect water cock control cable.
6. Disconnect wiring connector and vacuum hoses, or remove vacuum selector with hoses.

**When removing vacuum hose, put a mark on each hose or mark color to prevent erroneous installation.**

7. Remove heater control assembly by loosening attaching screws.
8. Install heater control assembly in the reverse order of removal. After installing heater control assembly, control cables and rod must be adjusted by referring to Adjusting Temperature Control Cable.

**When installing vacuum selector, align upper and lower slits of vacuum selector with hole in air control lever.**

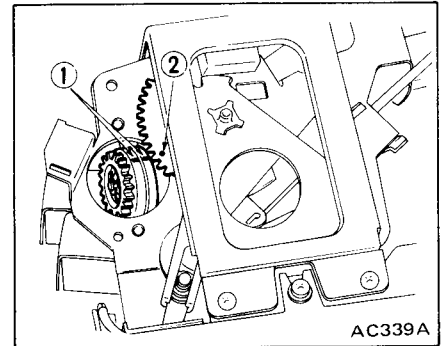

AC339A

- 1 Slit
- 2 Hole

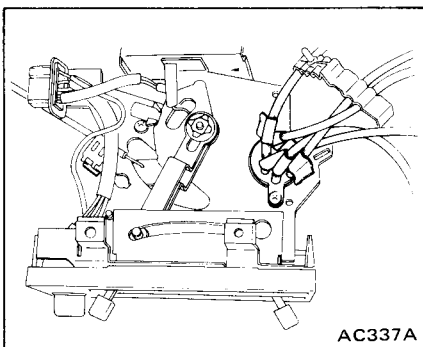

AC337A

**INSPECTION**

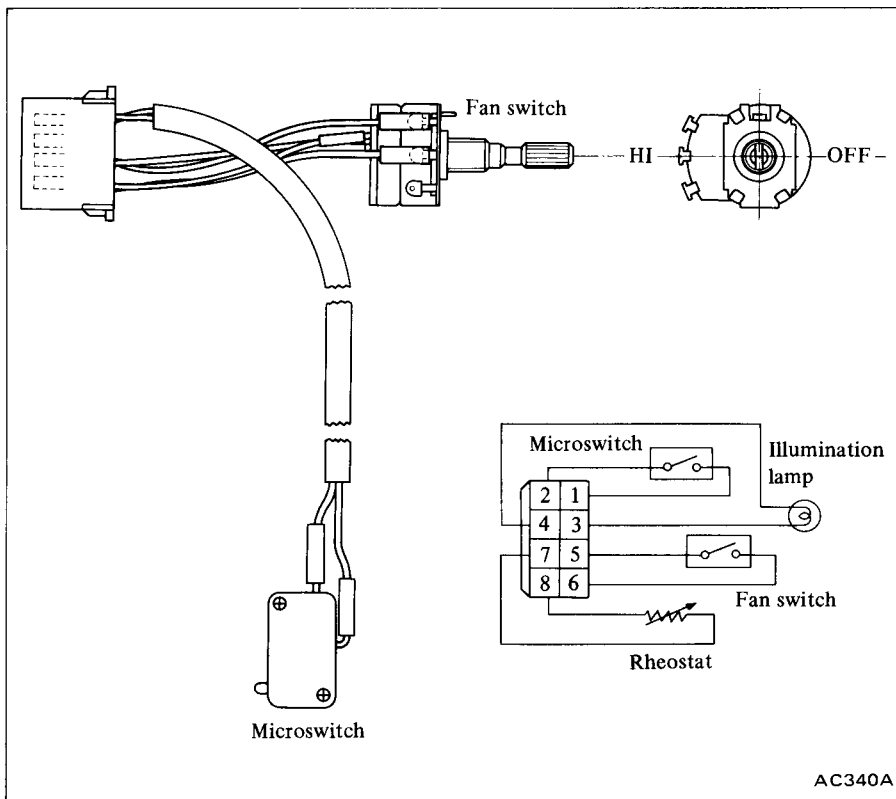

**Adjusting temperature control cable**

1. Set temperature lever in maximum cold position.
2. Temporarily tighten control rod mounting screw.
3. Push water cock lever in the direction of arrow (to closing side), and press temperature control cable outer case in the direction of arrow (to temperature lever side). While doing so, secure outer case with clip.

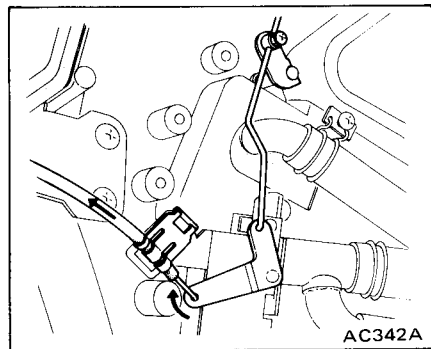

**Fan switch**

Check fan switch for continuity and measure resistance as follows.

With fan switch in OFF position:

Connector pins 5 and 6 are OFF.

With fan switch in ON position:

Connector pins 5 and 6 are ON.

With fan switch in OFF position:

Resistance across pins 7 and 8 is 0 kΩ.

With fan switch in Max. HI position:

Resistance across pins 7 and 8 is about 1.1 kΩ.

**Vacuum selector**

Make sure that continuity exists with vacuum selector connected as shown on page HA-10.

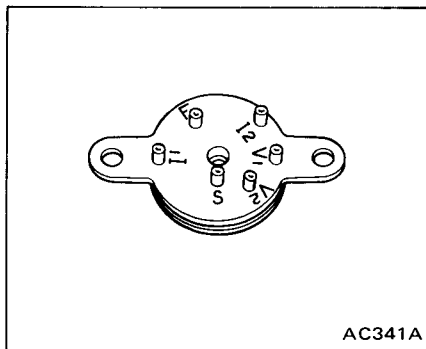

4. Set temperature lever in maximum HOT position, and tighten securely control rod to air-mix door lever while pushing lever in direction of the arrow.

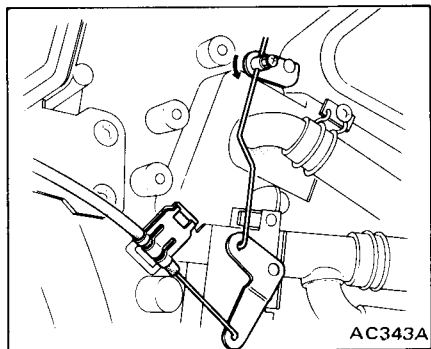

**Microswitch**

Check microswitch for continuity as follows.

With air control lever in AIR-CON position:

Connector pins 1 and 2 are ON.

With air control lever in a position other than AIR CON:

Connector pins 1 and 2 are OFF.

## BLOWER UNIT

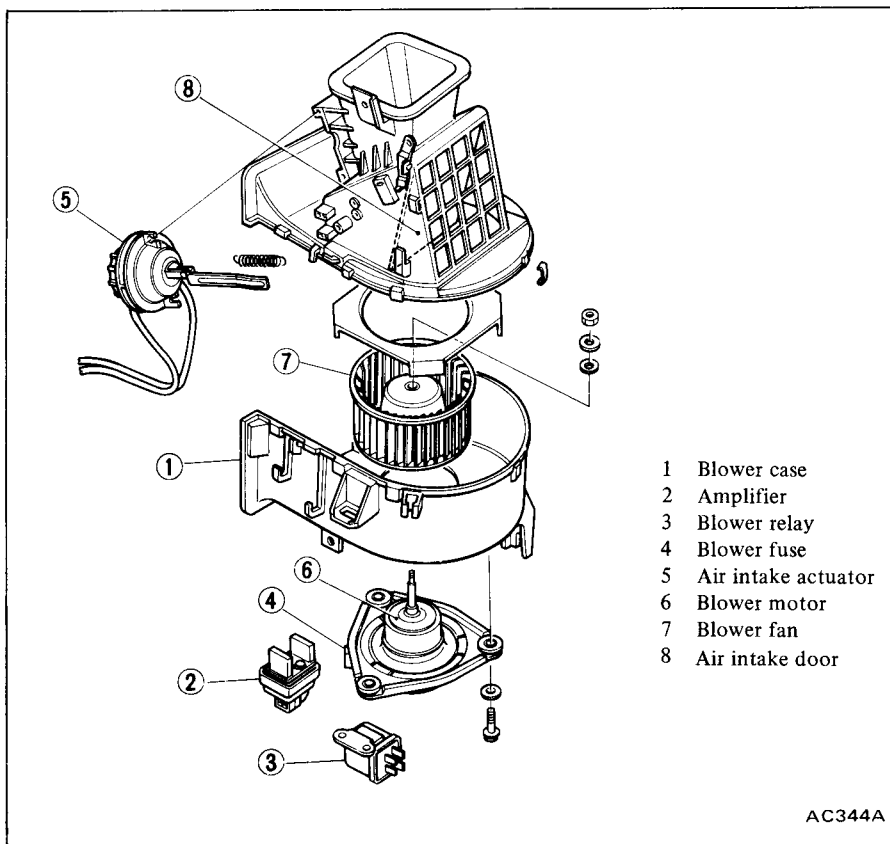

### REMOVAL AND INSTALLATION

1. Disconnect battery ground cable.
2. Remove instrument lower cover on passenger's side and glove box.
3. Remove floor nozzle, defroster duct and side defroster duct on passenger's side.
4. Disconnect wire harness at blower motor harness connector.
5. Disconnect two vacuum hoses.
6. Remove bolts securing blower assembly and then remove blower assembly.

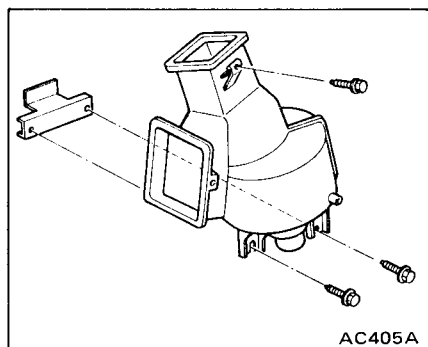

7. Installation is in the reverse order of removal.

## BLOWER MOTOR

### REMOVAL AND INSTALLATION

1. Disconnect battery ground cable.
2. Remove instrument lower cover and floor nozzle on passenger's side.
3. Disconnect wire harness at blower motor harness connector.
4. Remove blower motor attaching screws, and then remove blower motor with fan.

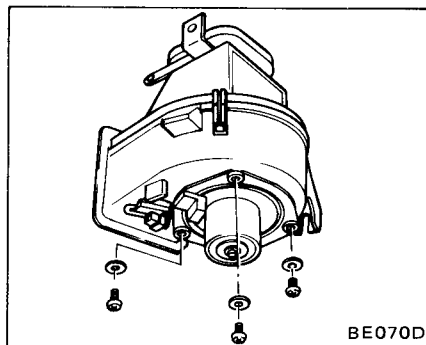

5. Installation is in the reverse order of removal.

## BLOWER RELAY

### INSPECTION

Test continuity of relay with ohmmeter or test lamp.

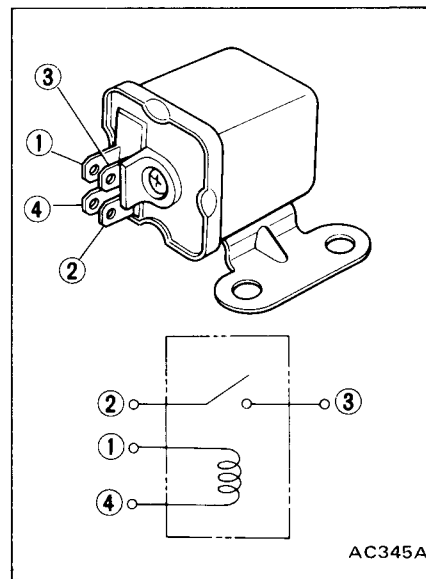

## VACUUM CONTROL SWITCH

### INSPECTION

Make sure that air flows when the switch is pulled and that no air flows when the switch is pushed.

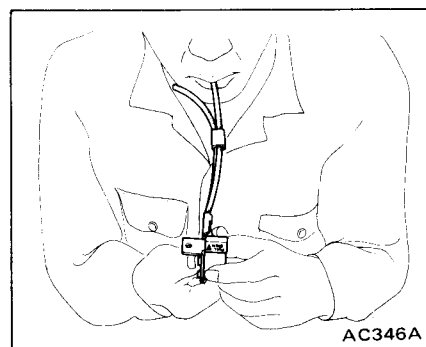

## VACUUM HOSE DIAGRAM

Refer to Air Flow and Vacuum System of Description (Manual air conditioner).





# COMPRESSOR—Model MJ-167 (HITACHI make)

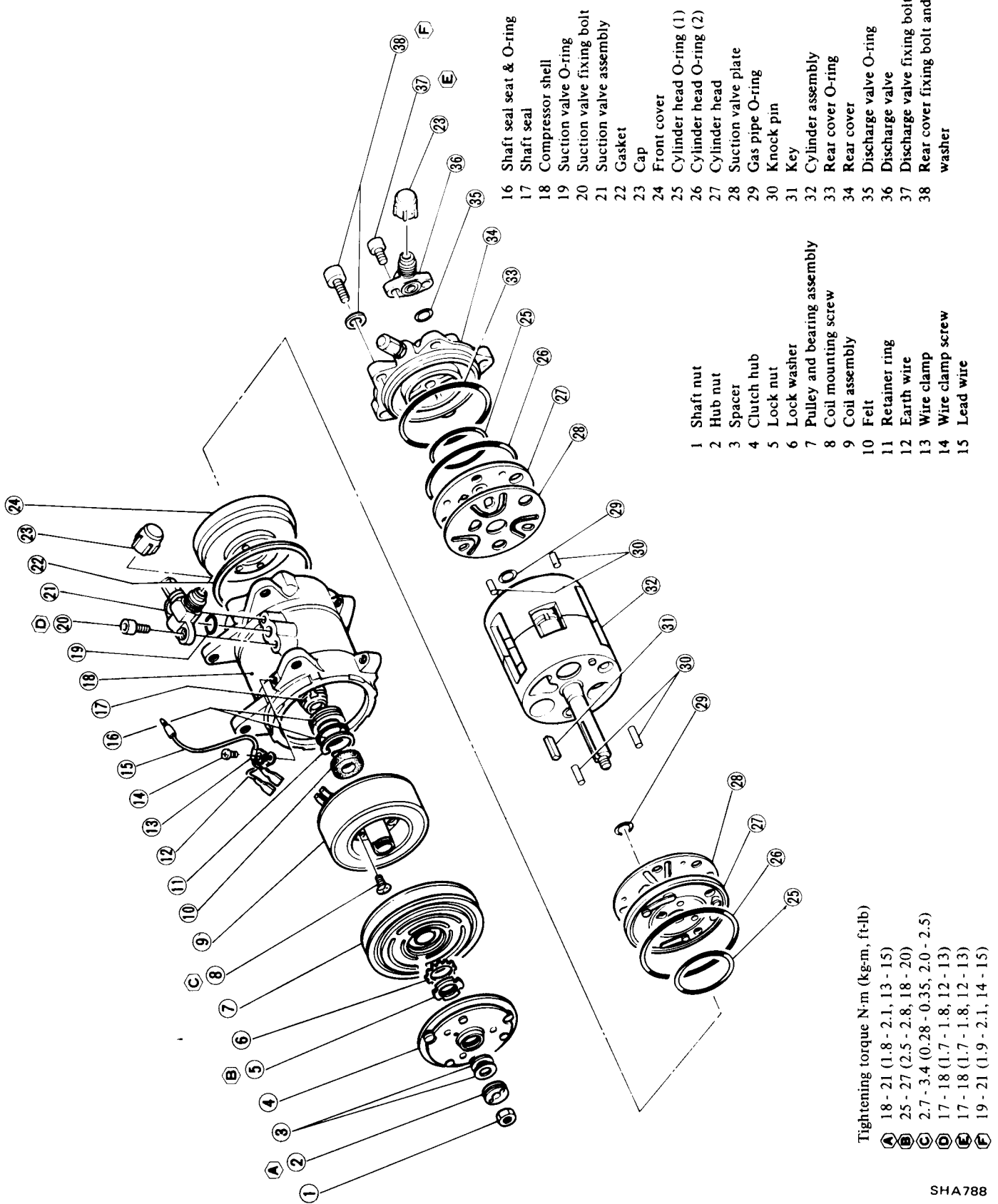

- 1 Shaft nut
- 2 Hub nut
- 3 Spacer
- 4 Clutch hub
- 5 Lock nut
- 6 Pulley and bearing assembly
- 7 Pulley and bearing assembly
- 8 Coil mounting screw
- 9 Coil assembly
- 10 Felt
- 11 Retainer ring
- 12 Earth wire
- 13 Wire clamp
- 14 Wire clamp screw
- 15 Lead wire
- 16 Shaft seal seat & O-ring
- 17 Shaft seal
- 18 Compressor shell
- 19 Suction valve O-ring
- 20 Suction valve fixing bolt
- 21 Suction valve assembly
- 22 Gasket
- 23 Cap
- 24 Front cover
- 25 Cylinder head O-ring (1)
- 26 Cylinder head O-ring (2)
- 27 Cylinder head
- 28 Suction valve plate
- 29 Gas pipe O-ring
- 30 Knock pin
- 31 Key
- 32 Cylinder assembly
- 33 Rear cover O-ring
- 34 Rear cover
- 35 Discharge valve O-ring
- 36 Discharge valve
- 37 Discharge valve fixing bolt
- 38 Rear cover fixing bolt and washer

- Tightening torque N·m (kg-m, ft-lb)
- A 18 - 21 (1.8 - 2.1, 13 - 15)
  - B 25 - 27 (2.5 - 2.8, 18 - 20)
  - C 2.7 - 3.4 (0.28 - 0.35, 2.0 - 2.5)
  - D 17 - 18 (1.7 - 1.8, 12 - 13)
  - E 17 - 18 (1.7 - 1.8, 12 - 13)
  - F 19 - 21 (1.9 - 2.1, 14 - 15)

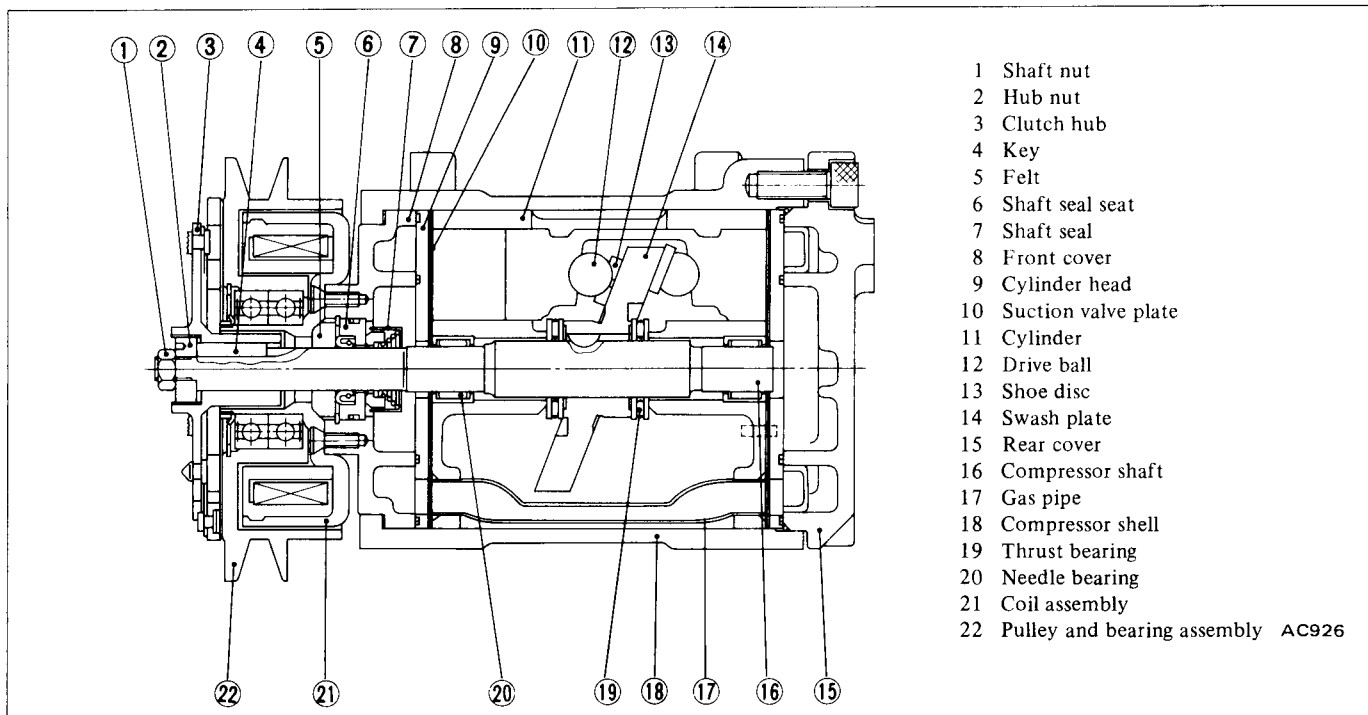

- 1 Shaft nut
- 2 Hub nut
- 3 Clutch hub
- 4 Key
- 5 Felt
- 6 Shaft seal seat
- 7 Shaft seal
- 8 Front cover
- 9 Cylinder head
- 10 Suction valve plate
- 11 Cylinder
- 12 Drive ball
- 13 Shoe disc
- 14 Swash plate
- 15 Rear cover
- 16 Compressor shaft
- 17 Gas pipe
- 18 Compressor shell
- 19 Thrust bearing
- 20 Needle bearing
- 21 Coil assembly
- 22 Pulley and bearing assembly AC926

## DESCRIPTION

The MJ167 compressor employs an oil-mist jet system in which some lubricant is mixed in the refrigerant and the mixture is sprayed directly to the sliding portions from the compressor suction side.

## PRELIMINARY CLEANING

Before starting work, remove dirt from outside the detached compressor. Clean the workbench, tool, and your hands.

## COMPRESSOR CLUTCH

The most likely source of problem is clutch slippage. Factors are listed here. Exercise ample care.

1. Clearance between clutch hub and pulley should be 0.5 to 0.8 mm (0.020 to 0.031 in) at all peripheral points.
2. Make sure that there is no oil or dirt on friction surfaces of clutch disc (clutch hub) and pulley. Remove any oil or dirt with a dry rag.
3. Make sure that terminal voltage at magnetic coil is above 10.5V.

## REMOVAL

### CAUTION:

**Do not leave compressor on its side or upside down for more than 10 minutes, as compressor oil will enter low pressure chamber.**

1. Using Clutch Hub Wrench KV99412302, hold clutch hub. With suitable socket wrench, remove shaft nut from shaft.
2. Then, using Hub Nut Socket KV99412305, remove clutch hub nut. Remove spacers.

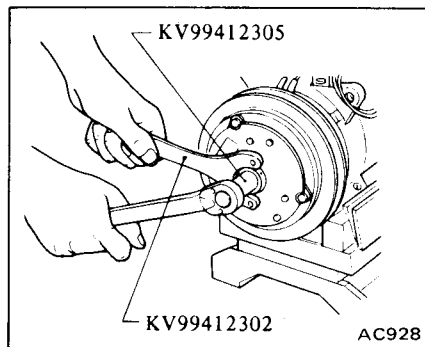

3. Using Clutch Hub Puller KV99412306, remove clutch hub. Thread tool into the bore of clutch

hub, hold tool with wrench, and then thread in center bolt.

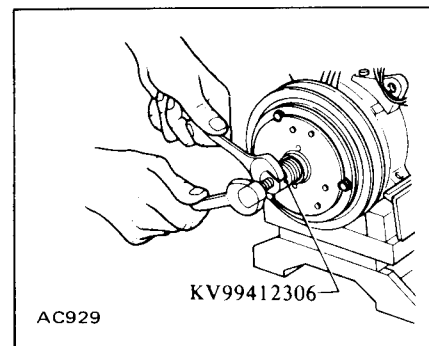

4. With an ordinary screwdriver, flatten lock washer tab.

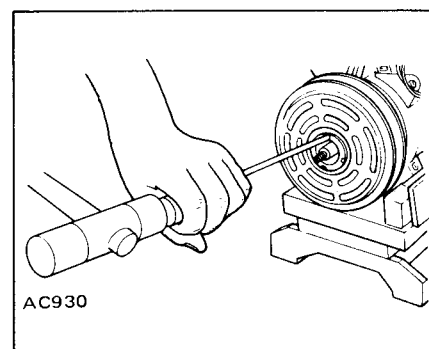

5. Using Lock Nut Socket KV99412310, loosen lock nut. Remove lock nut and lock washer.

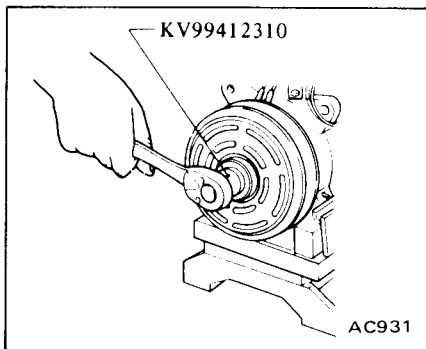

6. Remove pulley and bearing assembly. When the assembly can not be removed by hand, use a puller and Puller Pilot KV99412312.

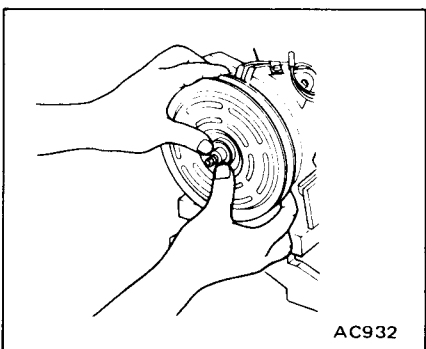

7. Using an impact tool, loosen six coil mounting screws. Use of the impact tool is advisable as screws have been calked.

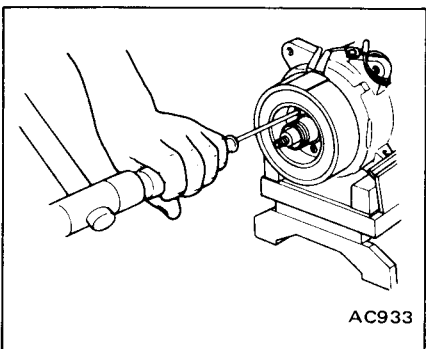

8. Remove coil mounting screws and separate coil assembly.

### INSPECTION

1. Check the friction surfaces of the clutch for damage due to excessive heat, or excessive grooving due to slippage. If necessary, replace coil, pulley and bearing assembly, and clutch hub as a set.
2. Oil or dirt on the friction surfaces should be cleaned with a suitable

solvent and a dry rag.

3. Check coil for shorted or opened binding leads.

### INSTALLATION

1. Using a Phillips screwdriver, tighten coil assembly mounting screws in an alternating pattern. After screws have been firmly tightened, punch-lock each at one location to prevent loosening.

Ⓣ : Coil mounting screw  
**2.7 - 3.4 N·m**  
**(0.28 - 0.35 kg·m,**  
**2.0 - 2.5 ft·lb)**

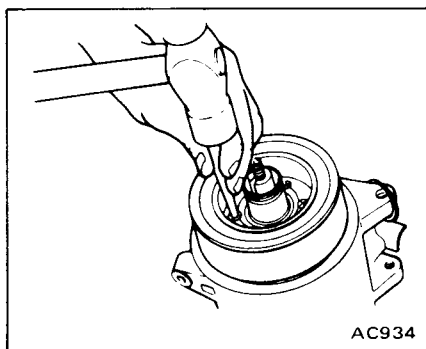

2. Using a plastic mallet, drive pulley and bearing assembly onto the neck of the installed coil assembly. Turn the pulley, making sure that there is no noise and that rotation is free. Also make sure that there is no pulley play.

3. Position lock washer and lock nut in place. Using Lock Nut Socket KV99412310, tighten lock nut firmly. With lock washer tab and lock nut cutouts matched, bend the tab with the screwdriver. Proceed carefully to avoid bearing cage damage.

Ⓣ : Lock nut  
**25 - 27 N·m**  
**(2.5 - 2.8 kg·m,**  
**18 - 20 ft·lb)**

4. Fit key and clutch hub to the shaft. Select adjusting spacer which gives the correct clearance between the pulley and clutch hub. Coat hub nut with Locktite (equivalent to HI-LOCK FT-15B).

Ⓣ : Hub nut  
**18 - 21 N·m**  
**(1.8 - 2.1 kg·m,**  
**13 - 15 ft·lb)**

5. Coat shaft nut with Locktite (equivalent to HI-LOCK FT-15B).

Ⓣ : Shaft nut  
**19 - 21 N·m**  
**(1.9 - 2.1 kg·m,**  
**14 - 15 ft·lb)**

6. Using a thickness gauge, measure the clutch hub-to-pulley clearance.

**Hub-to-pulley clearance:**  
**0.5 - 0.8 mm**  
**(0.020 - 0.031 in)**

If the specified clearance is not obtained, replace adjusting spacer and readjust.

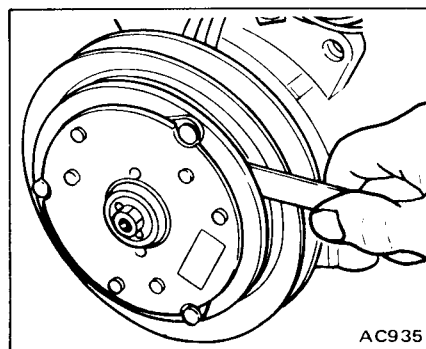

**When replacing compressor clutch assembly, do not forget break-in operation, accomplished by engaging and disengaging the clutch some thirty times. Break-in operation raises the level of transmitted torque.**

### SHAFT SEAL

#### REMOVAL

1. Turn compressor upside down, and drain oil from suction valve.

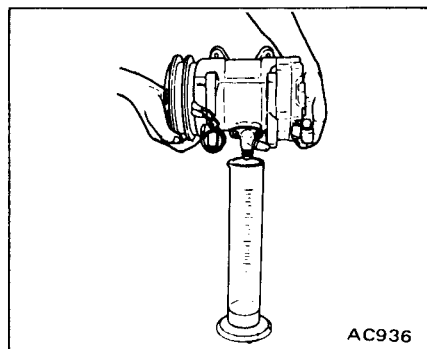

2. Remove clutch hub, pulley and bearing assembly, and coil assembly. Refer to Compressor Clutch for removal.
3. Remove felt.
4. Using snap ring pliers, compress and remove retainer ring.

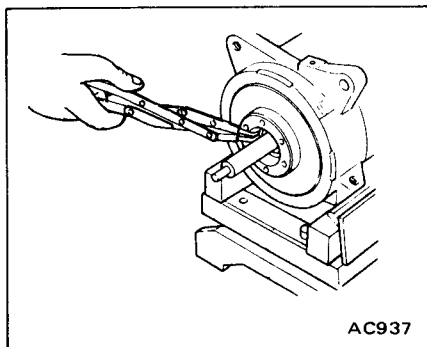

5. Plug low and high pressure (suction and discharge) valve openings of compressor. Wrap rag around shaft. Apply pressure [196 to 490 kPa (2 to 5 kg/cm<sup>2</sup>, 28 to 71 psi)] from low pressure (suction) service valve of compressor, and receive shaft seal seat in rag.

**CAUTION:**

Use refrigerant for pressurizing. Do not use compressed air as it involves moisture in the system.

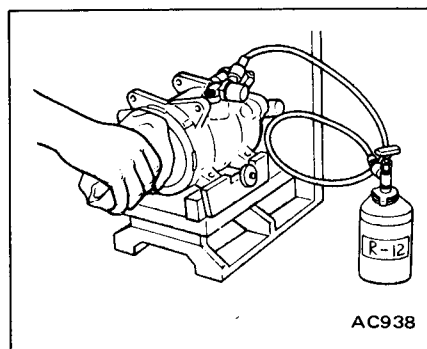

If shaft seal seat cannot be pulled out, reset it to its original position, and again try to pressurize.

6. Insert Shaft Seal Remover & Installer KV99412321 through the open end of front cover. Depress the carbon seal and hook the tool at the case projection of shaft seal. Slowly pull out the tool, thereby removing shaft seal.

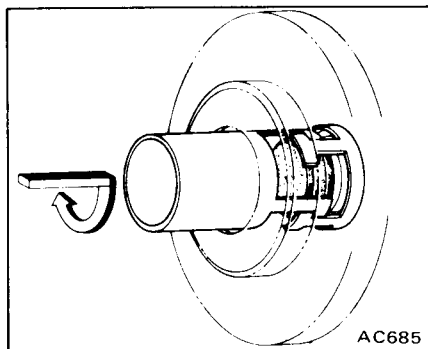
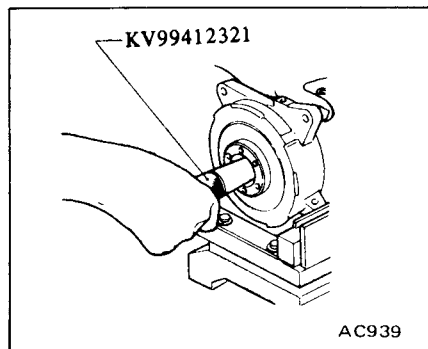

**INSPECTION**

1. Check the carbon seal surface of shaft seal for damage.

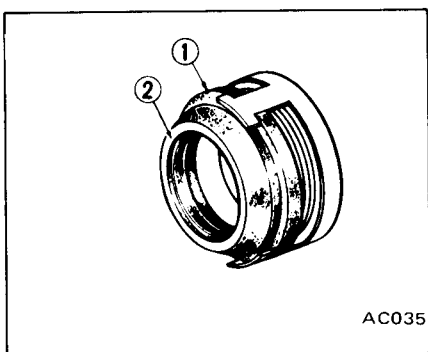

- 1 Carbon seal
- 2 Contact surface

2. Check O-ring and the carbon seal contact surface of shaft seal seat for damage. Make sure that O-ring contact surface at front cover is not damaged. Make sure that grease is applied to oil seal in shaft seal seat.

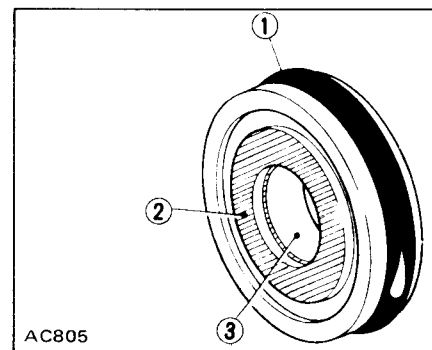

- 1 O-ring
- 2 Contact surface
- 3 Oil seal

**INSTALLATION**

Do not reuse shaft seal and shaft seal seat.

**CAUTION:**

In placing a new seal kit on the workbench, make sure that the contact surface faces upward. Take necessary steps to avoid damage.

1. Make sure that the shaft seal contact surface is free of dirt and amply lubricated with compressor oil.
2. Cap Shaft Seal Pilot KV99412322 to the top end of compressor shaft.
3. Using Shaft Seal Remover & Installer KV99412321, insert shaft seal with shaft seal case and shaft cutout aligned.

Apply force to turn the seal somewhat to the left and right. Insure that shaft seal seats properly in the shaft cutout.

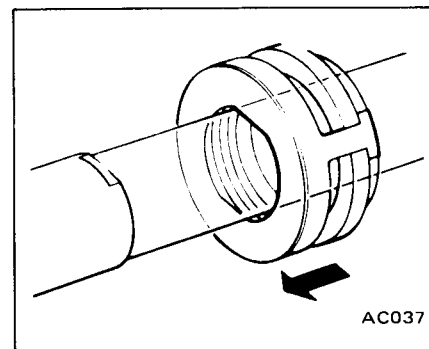

4. Fit O-ring to the outside groove of shaft seal seat, making sure that it seats properly.
5. Apply quite a bit of compressor oil on contact surface and around shaft seal seat so that it can slide easily

in front cover. Lightly coat surface of shaft with recommended multi-purpose grease (or compressor oil). Following this, push in shaft seal seat so that it seats properly at the land of front cover.

6. Using snap ring pliers, compress retainer ring and fit it into front cover. Seat retainer ring firmly in the groove. Thoroughly wipe grease or oil from shaft surface.

7. Install felt.

8. Install clutch hub and key to the shaft of compressor, and turn the shaft 5 to 6 turns in the clockwise direction.

9. Then, check for gas leakage as follows.

(1) Plug high and low pressure (discharge and suction) valve openings on

compressor with blind caps.

**To plug low pressure (suction) valve, use cap to which seal rubber is fitted.**

(2) Connect charging hoses in the lines between manifold gauge and high and low pressure (discharge and suction) service valves.

Connect refrigerant can to the middle hose of manifold gauge.

(3) Open valve of can tap, charge refrigerant through low pressure (suction) service valve and purge air from high pressure (discharge) service valve.

(4) Conduct a leak test. If there is a leak, remove and then install parts again.

1. Using Allen Socket KV99412324, remove hex. socket head bolts.

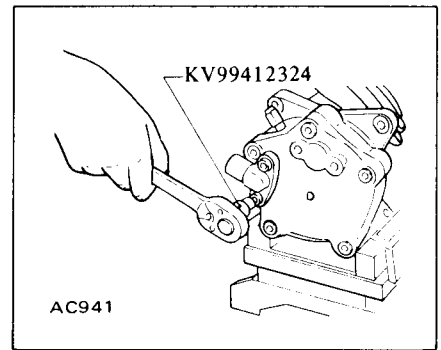

2. Remove discharge valve.

3. Discard the old O-ring.

### INSPECTION

1. Check for scratched seating surface of discharge valve and of rear cover.

2. Replace discharge valve which is scratched.

3. If a scratch is found on the groove of rear cover O-ring, replace rear cover.

### INSTALLATION

**Note:** Do not reuse old O-ring.

1. Apply a coating of compressor oil to the groove of discharge valve and O-ring, and install these parts in their proper positions on rear cover.

2. Using Allen Socket KV99412324, secure discharge valve to rear cover with hex. socket head bolts.

Ⓣ : Discharge valve fixing bolt  
 17 - 18 N·m  
 (1.7 - 1.8 kg·m,  
 12 - 13 ft·lb)

3. Conduct a gas leak test. Refer to Shaft Seal for gas leak test.

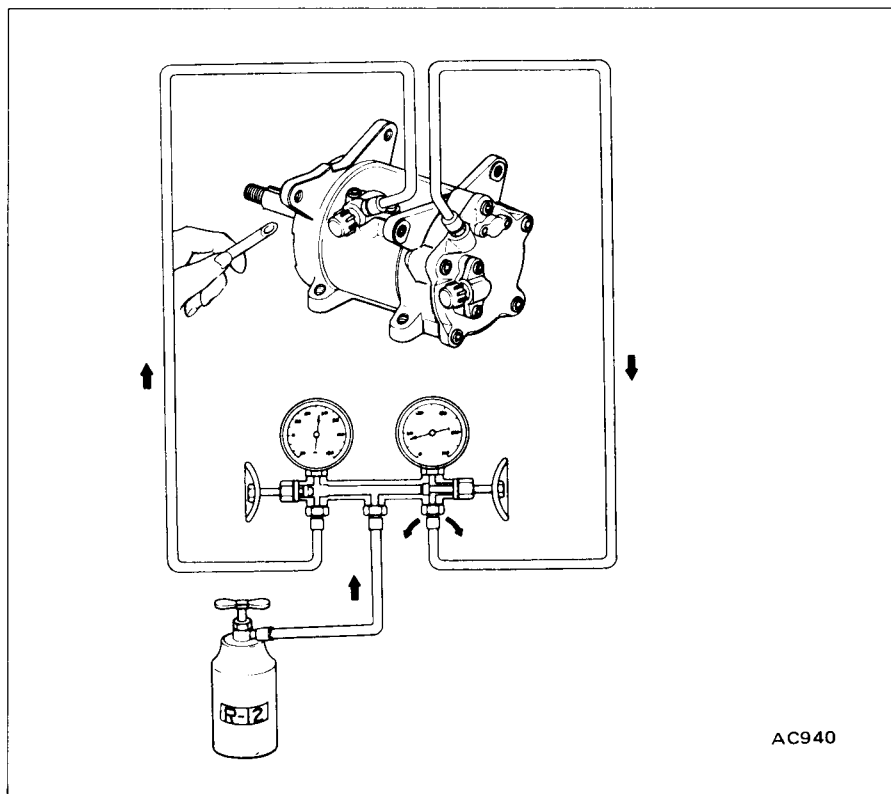

10. Install compressor clutch assembly. Refer to Compressor Clutch for installation.

11. From suction valve, charge compressor with same amount of new oil as was drained before. Refer to Oil Level Check for required amount of oil.

## DISCHARGE VALVE

### REMOVAL

#### CAUTION:

**Do not leave compressor on its side or upside down for more than 10 minutes as compressor oil will enter low pressure chamber.**

## SUCTION VALVE

### REMOVAL

#### CAUTION:

**Do not leave compressor on its side or upside down for more than 10 minutes as compressor oil will enter low pressure chamber.**

1. Using Allen Socket KV99412324, remove hex. socket head bolts.
2. Remove suction valve.
3. Discard old O-ring.

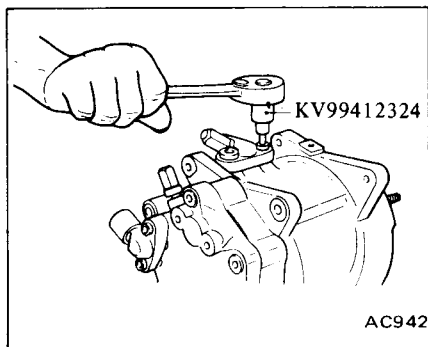

Starting at the top, loosen all bolts one turn in an alternating pattern. Then remove bolts in turn.

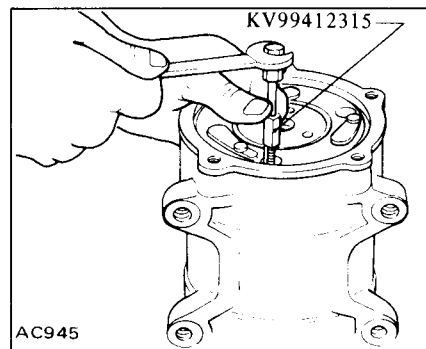
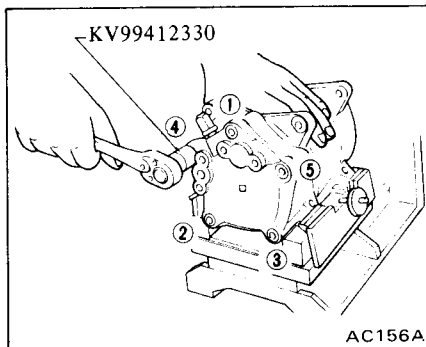

### INSPECTION

1. Check for scratched seating surface of suction valve and shell.
2. Replace suction valve which is scratched.
3. If a scratch is found on groove of shell O-ring, replace shell.

4. Grasp rear cover and carefully separate it from compressor. Tap the flange lightly and alternately as required with a plastic mallet.

### INSPECTION

1. If replacement of low pressure (suction) service valve is necessary, replace rear cover with a new one.
2. Check suction valve plate and cylinder head for broken valves.

### INSTALLATION

**Do not reuse old O-ring.**

1. Apply a coating of compressor oil to groove of suction valve and O-ring, and install these parts in their proper positions on shell.
2. Using Allen Socket KV99412324, secure suction valve to shell with hex. socket head bolts.

**T** : Suction valve fixing bolt  
 17 - 18 N·m  
 (1.7 - 1.8 kg·m,  
 12 - 13 ft·lb)

3. Conduct a gas leak test. Refer to Shaft Seal for gas leak test.

### CAUTION:

**Do not tap on the compressor shaft.**

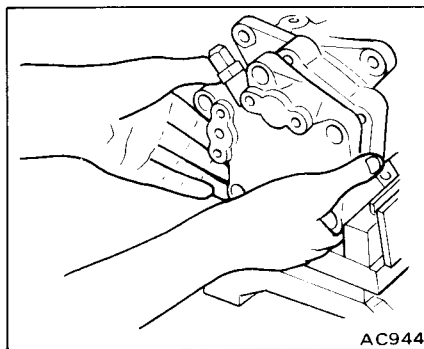

## REAR COVER AND REAR CYLINDER HEAD

### REMOVAL

1. Turn compressor upside down, and drain oil from suction valve.
2. Remove discharge valve.
3. Using Allen Socket KV99412330, remove rear cover mounting bolts.

5. Remove three O-rings. Discard used O-rings.
6. Remove rear cylinder head, suction valve plate, two pins and O-ring. Carefully remove suction valve plate, avoiding deformation.
7. When removal proves difficult, use Cylinder Head Remover KV99412315. Insert this tool into hole in cylinder head. With the nut in firm contact with the back side of cylinder head, tighten the bolt slowly to break loose the head.

### INSTALLATION

**Do not reuse old O-ring.**

Using clean compressor oil, remove dirt and other matter from rear cover, cylinder head and suction valve plate. Clean the workbench.

1. Using suitable blocks, position compressor with the front face downward and the rear upward.
2. Install two pins and gas pipe O-ring in the rear of cylinder. Coat O-ring beforehand with an ample amount of oil.
3. Install suction valve plate, making sure that the three valves properly align with cylinder cutouts.

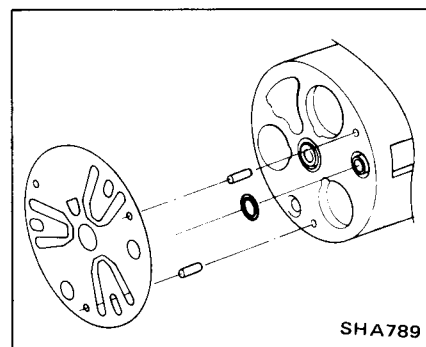

5. Assemble cylinder head and install three O-rings in their respective positions. Coat O-rings with ample amount of oil before installation.
5. Carefully fit rear cover to the rear of compressor.

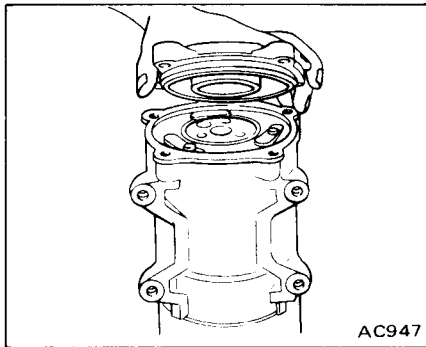

6. Using Allen Socket KV99412330, tighten up five bolts in an alternating pattern, starting at the top. Do not forget lock washers.

ⓧ : Rear cover fixing bolt  
 19 - 21 N·m  
 (1.9 - 2.1 kg·m,  
 14 - 15 ft·lb)

7. Install discharge valve. Refer to Discharge Valve for installation.
8. Upon completion of the above operation, conduct a leak test. Refer to Shaft Seal for gas leak test.
9. From suction valve, charge compressor with same amount of new oil as was drained before. Refer to Oil Level Check for required amount of oil.

## FRONT COVER, FRONT CYLINDER HEAD AND CYLINDER

### REMOVAL

1. Turn compressor upside down, and drain oil from suction valve.
2. Remove compressor clutch assembly. Refer to Compressor Clutch.
3. Using snap ring pliers, remove shaft seal retainer ring. Then remove shaft seal seat. Refer to Shaft Seal. Removal of shaft seal is not absolutely necessary. It may be removed when

- cylinder assembly is removed from front cover. In fact, this approach facilitates work.
4. Remove discharge valve. Refer to Discharge Valve for removal.
5. Remove rear cover, three O-rings, cylinder head, suction valve plate, two pins and O-ring in that order. Refer to Rear Cover and Rear Cylinder Head. This exposes the rear part of cylinder.
6. Remove cylinder assembly from compressor shell.

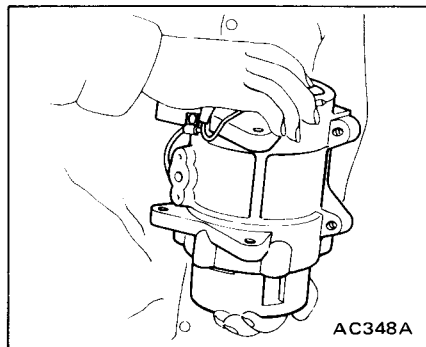

**Do not drop cylinder assembly and scratch.**

**When cylinder does not drop from shell, top shell lightly with plastic mallet. Do not top compressor shaft.**

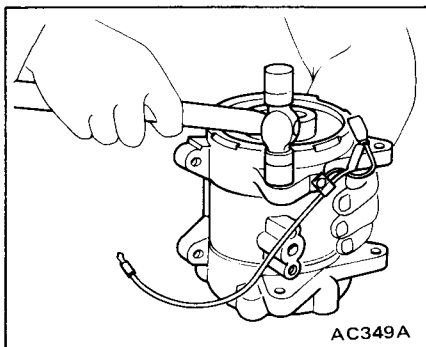

7. Detach front cover from shell.

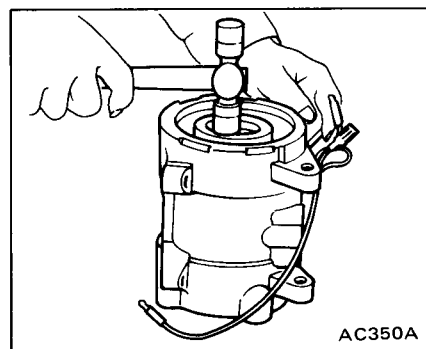

8. Remove shaft seal from the shaft.
9. Remove two O-rings, cylinder head, suction valve plate, two pins and O-ring. In removing two pins, proceed carefully to avoid cylinder head damage. Discard old O-rings.

### CAUTION:

**Do not deform suction valve plate when removing it.**

### INSTALLATION

Suction valve plates and cylinder heads are the same as those of front and rear.

**Do not reuse old gasket and O-ring.**

1. Using suitable blocks, face cylinder assembly upward. Install two pins and O-ring. Lubricate O-ring before assembly.
2. Position suction valve plate in the order listed while making sure that three valves of suction valve plate are aligned with the cylinder cutouts. Install cylinder head.

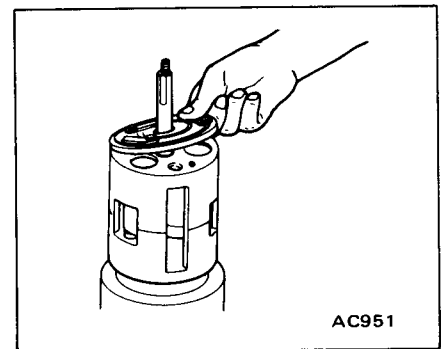
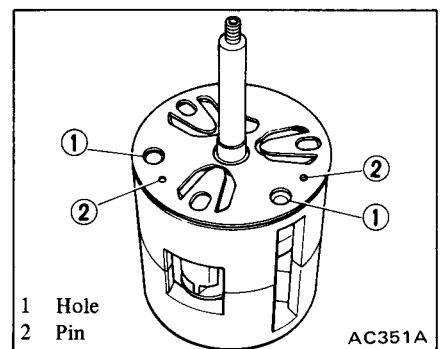



3. Align shaft seal with the shaft cutaway. Firmly seat shaft seal at the shaft land. Attempt to turn shaft seal to clockwise and counterclockwise, confirming that it is seated properly.
4. Install two O-rings on cylinder head. Coat O-rings with ample amount of oil before installation.
5. Install front cover as follows:

Front cover must be installed in such a manner that clutch terminal can be positioned in cut portion of shell when these three parts are assembled. See the illustration at step 12. For this purpose, install front cover on cylinder head so that angle between 5 mm (0.20 in) threaded hole in front cover and low pressure side refrigerant passage in cylinder head is about 45°.

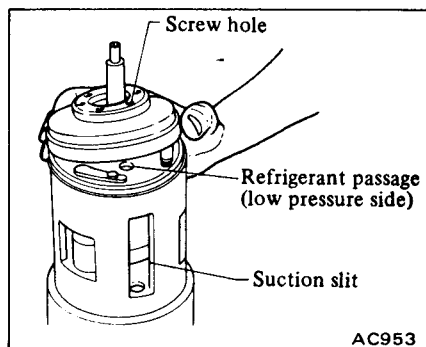
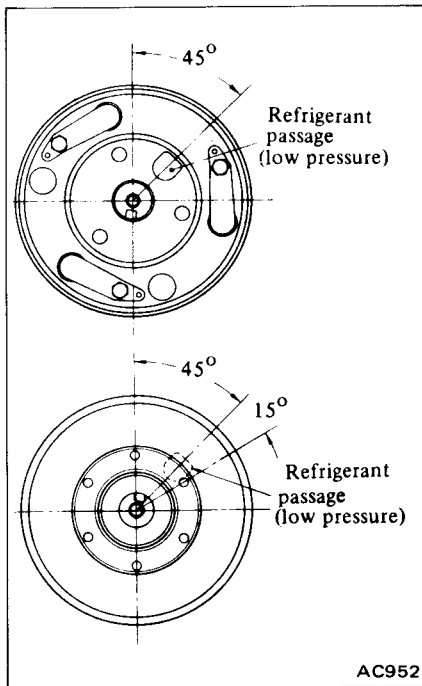

6. Install gasket on front cover. Install shell on cylinder head. In this case, adjust position of shell so that suction inlet of shell opens in the same direction as suction slot of cylinder assembly. Then, make sure swash plate is visible in suction inlet by removing suction valve.

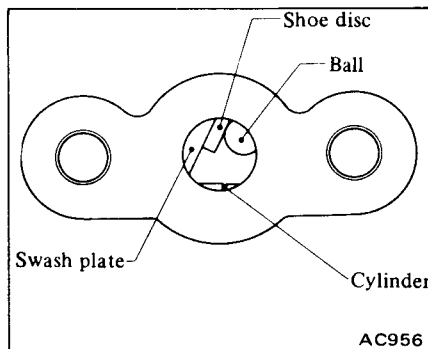
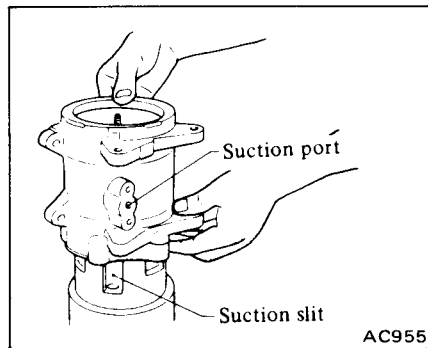
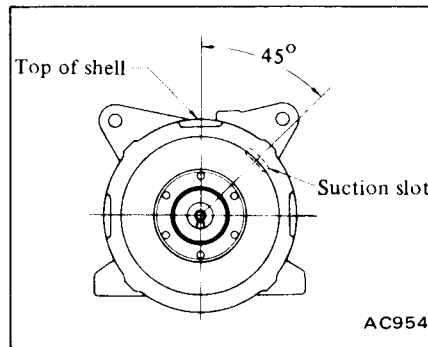

7. Turn over the assembled shell and cylinder, that is, with the front downward.

**CAUTION:**

**Hold securely with hand shell and cylinder assembly to prevent possible mismatching. Otherwise, O-ring will be deflected or moved.**

8. Continue with work up to installation of rear cover. Refer to Rear Cover and Rear Cylinder Head for installation.
9. Continue with work up to installation of discharge valve. Refer to Discharge Valve for installation.
10. Install shaft seal seat. Refer to Shaft Seal for installation.
11. Install and adjust compressor clutch. Refer to Compressor Clutch for installation.
12. Make sure that clutch terminal is in cut portion provided on top of shell. If no coincidence is observed, repeat installation procedure starting from step 3.

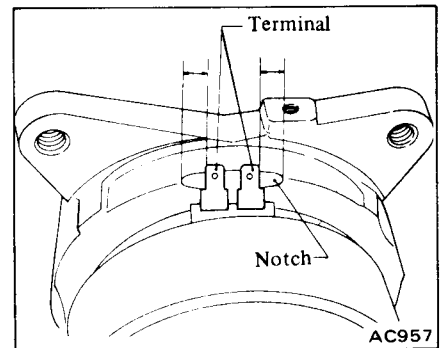

13. Conduct a leak test. Refer to Shaft Seal for gas leak test.
14. From suction valve, charge compressor with same amount of new oil as was drained before. Refer to Oil Level Check for required amount of oil.

# TROUBLE DIAGNOSES AND CORRECTIONS (Manual air conditioner)

## AIR CONDITIONER DIAGNOSES

When insufficient cooling is noticed, check refrigerant line for gas leakage. If the amount of refrigerant is less than normal or there is no refrigerant in the system, check for the point of leakage as follows:

1. Charge refrigerant.
2. Start engine and operate air conditioning system.  
Check connections and unit for gas leakage using a leak tester.

**Extreme care should be taken at connections or unit locations where oil seepage or dust adhesion is noticed. Thoroughly clean the affected part and place soapy water over it to determine whether leakage is present.**

3. Stop engine and leave it unattended for approximately 20 minutes. Repeat step 2 above.

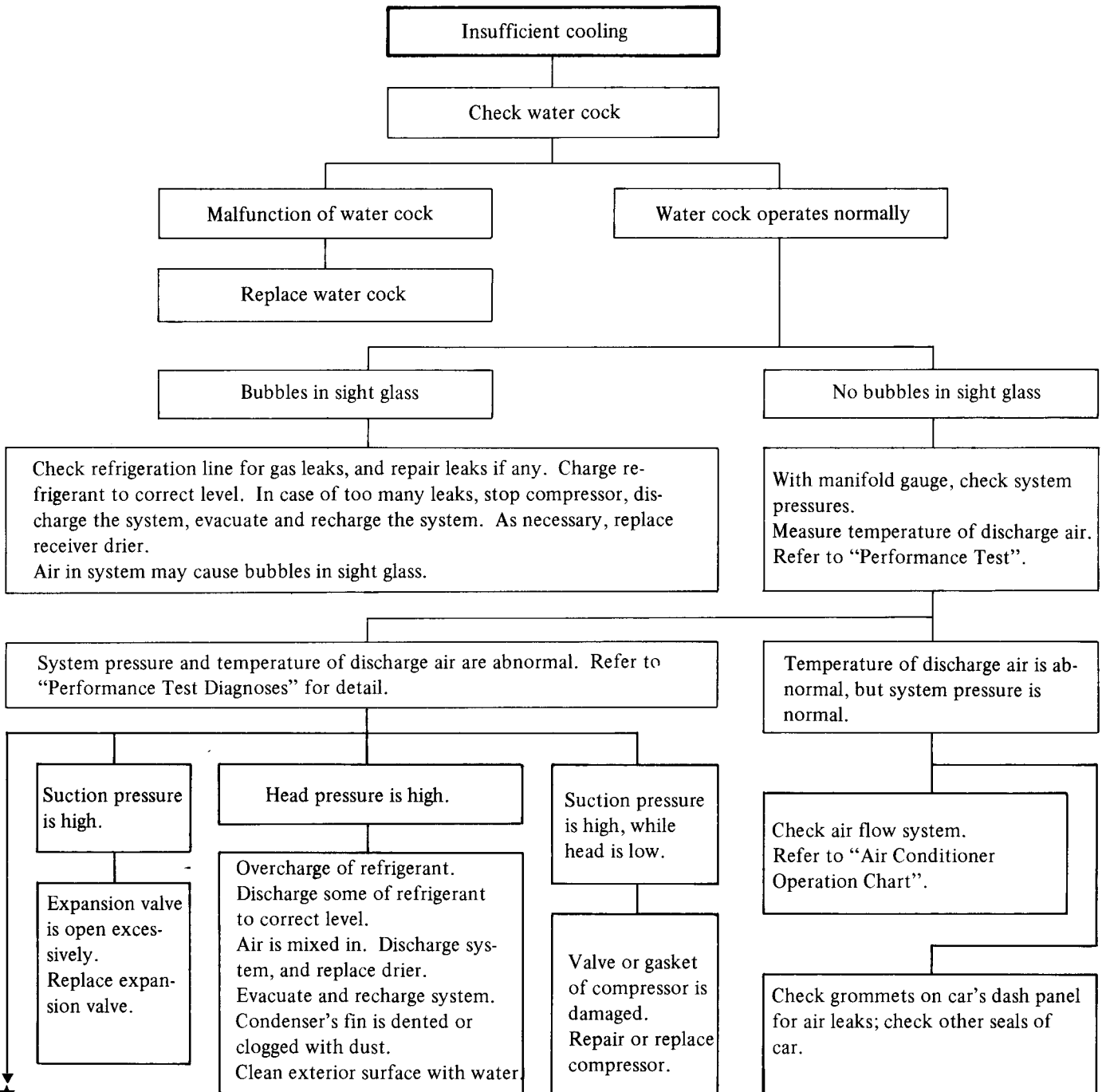

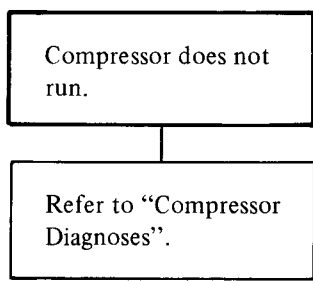
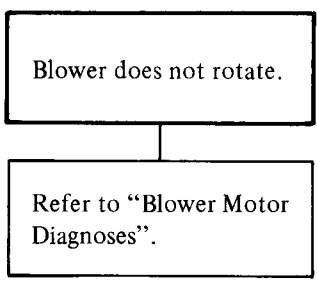
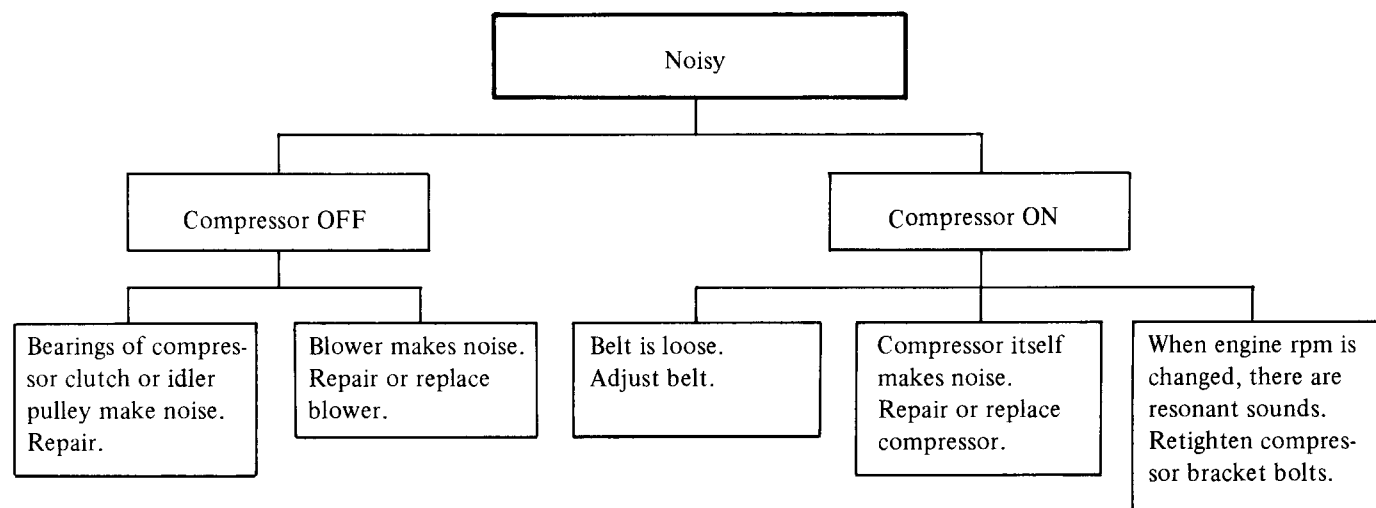
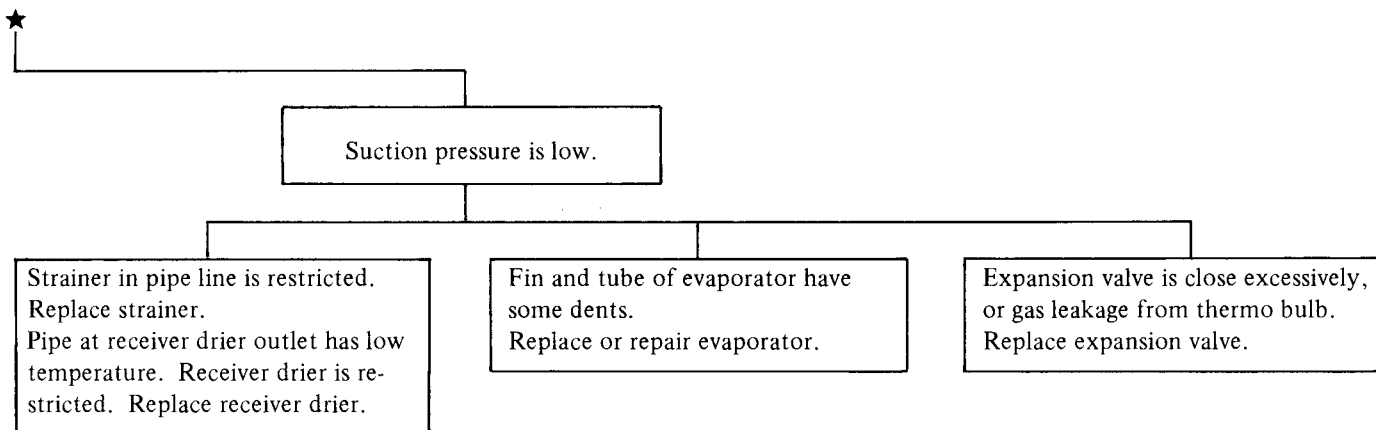

# PERFORMANCE TEST DIAGNOSES

Of various conditions caused to the air conditioning system, the characteristics revealed on manifold gauge reading are shown in the following.

As to the method of a performance test, refer to the item of "Performance Test".

indicates a range based on the assumption that the air conditioning system is in good order. This range is described in PERFORMANCE CHART.

In the following table, the portion smeared with ink on each gauge scale

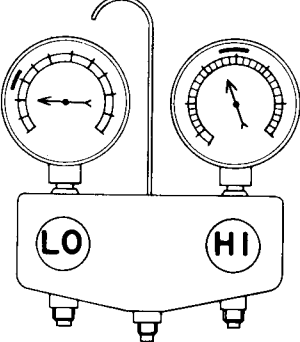
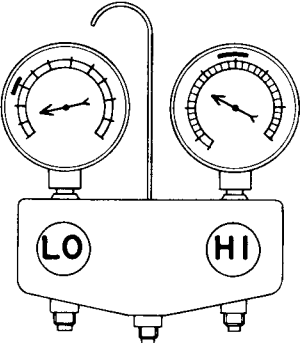
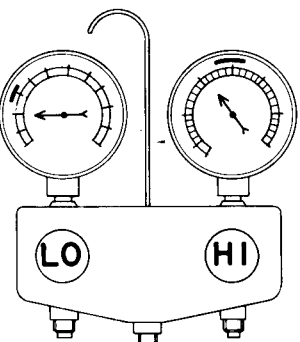
Condition	Probable cause	Corrective action
<p><b>INSUFFICIENT REFRIGERANT CHARGE</b></p>  <p>AC352A</p> <p>Insufficient cooling. Bubbles appear in sight glass.</p>	<p>Refrigerant is small, or leaking a little.</p>	<ol style="list-style-type: none"> <li>1. Leak test.</li> <li>2. Repair leak.</li> <li>3. Charge system.</li> </ol> <p><b>Evacuate, as necessary, and recharge system.</b></p>
<p><b>ALMOST NO REFRIGERANT</b></p>  <p>AC353A</p> <p>No cooling action. In sight glass appear a lot of bubbles or something like mist.</p>	<p>Serious refrigerant leak.</p>	<p><b>Stop compressor immediately.</b></p> <ol style="list-style-type: none"> <li>1. Leak test.</li> <li>2. Discharge system.</li> <li>3. Repair leak(s).</li> <li>4. Replace receiver drier if necessary.</li> <li>5. Check oil level.</li> <li>6. Evacuate and recharge system.</li> </ol>
<p><b>FAULTY EXPANSION VALVE</b></p>  <p>AC354A</p> <p>Slight cooling. Sweating or frosted expansion valve inlet.</p>	<p>Expansion valve restricts refrigerant flow.</p> <ul style="list-style-type: none"> <li>● Expansion valve is clogged.</li> <li>● Expansion valve is inoperative.</li> </ul> <p>Valve stuck closed. Thermal bulb has lost charge.</p>	<p>If valve inlet reveals sweat or frost:</p> <ol style="list-style-type: none"> <li>1. Discharge system.</li> <li>2. Remove valve and clean it. Replace it if necessary.</li> <li>3. Evacuate system.</li> <li>4. Charge system.</li> </ol> <p>If valve does not operate:</p> <ol style="list-style-type: none"> <li>1. Discharge system.</li> <li>2. Replace valve.</li> <li>3. Evacuate and charge system.</li> </ol>

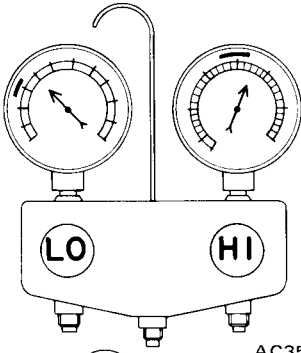
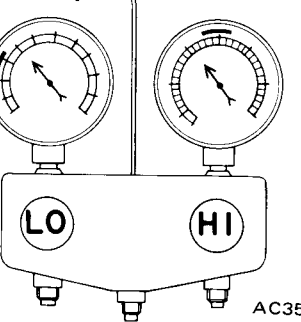
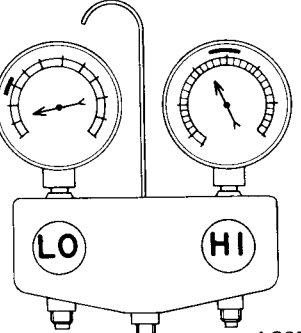
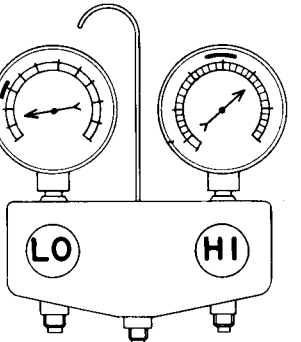
Condition	Probable cause	Corrective action
 <p>AC355A</p>  <p>AC356A</p>	<p>Insufficient cooling. Sweated suction line.</p> <p>No cooling. Sweating or frosted suction line.</p>	<p>Expansion valve allows too much refrigerant through evaporator.</p> <p>Faulty expansion valve.</p> <p>1. Check valve for operation. If suction side does not show a pressure decrease, replace valve.</p> <p>1. Discharge system. 2. Replace valve. 3. Evacuate and replace system.</p>
<p><b>FAULTY SUCTION THROTTLE VALVE</b></p>  <p>AC357A</p>	<p>Insufficient cooling. Frosted evaporator.</p>	<p>Suction throttle valve is inoperative.</p> <p>1. Discharge system. 2. Replace valve. 3. Evacuate and charge system.</p>
 <p>AC358A</p>	<p>Insufficient cooling.</p>	<p>Suction throttle valve restricts refrigerant flow.</p> <p>1. Discharge system. 2. Replace valve. 3. Evacuate and charge system.</p>

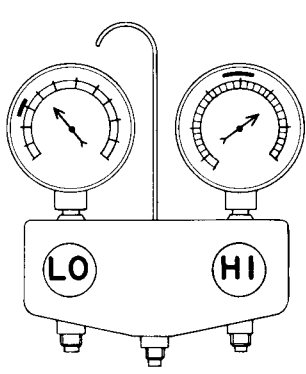
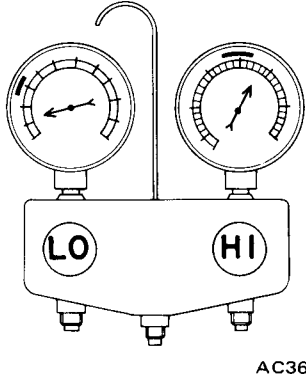
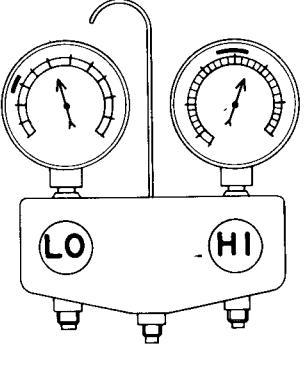
Condition	Probable cause	Corrective action
<p><b>AIR IN SYSTEM</b></p>  <p>AC359A</p> <p>Insufficient cooling. Sight glass shows occasional bubbles.</p>	<p>Air mixed with refrigerant in system.</p>	<ol style="list-style-type: none"> <li>1. Discharge system.</li> <li>2. Replace receiver drier.</li> <li>3. Evacuate and charge system.</li> </ol>
<p><b>MOISTURE IN SYSTEM</b></p>  <p>AC360A</p> <p>After operation for a while, pressure on suction side may show vacuum pressure reading. During this condition, discharge air will be warm. As warning of this, reading shows 39 kPa (0.4 kg/cm<sup>2</sup>, 6 psi) vibration.</p>	<p>Drier is saturated with moisture. Moisture has frozen at expansion valve. Refrigerant flow is restricted.</p>	<ol style="list-style-type: none"> <li>1. Discharge system.</li> <li>2. Replace receiver drier (twice if necessary).</li> <li>3. Evacuate system completely. (Repeat 30-minute evacuating three times.)</li> <li>4. Recharge system.</li> </ol>
<p><b>FAULTY CONDENSER</b></p>  <p>AC361A</p> <p>No cooling action: engine may overheat. Bubbles appear in sight glass of drier. Suction line is very hot.</p>	<p>Condenser is often found not functioning well.</p>	<ul style="list-style-type: none"> <li>● Check fan belt and fluid coupling.</li> <li>● Check condenser for dirt accumulation.</li> <li>● Check engine cooling system for overheat.</li> <li>● Check for refrigerant overcharge.</li> </ul> <p><b>If pressure remains high in spite of all above actions taken, remove and inspect the condenser for possible oil clogging.</b></p>

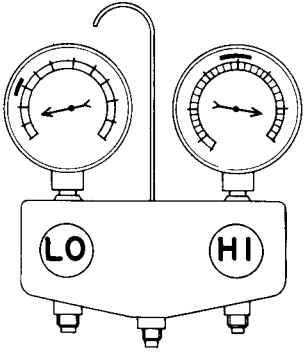
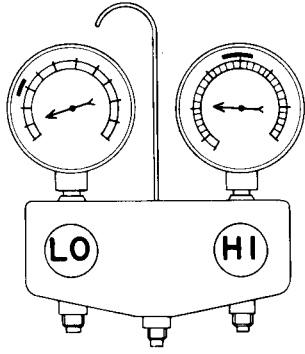
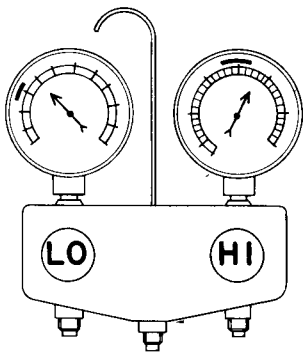
Condition	Probable cause	Corrective action
<p><b>HIGH PRESSURE LINE BLOCKED</b></p>  <p>AC362A</p> <p>Insufficient cooling. Frosted high pressure liquid line.</p>	<p>Drier clogged, or restriction in high pressure line</p>	<ol style="list-style-type: none"> <li>1. Discharge system.</li> <li>2. Remove receiver drier or strainer and replace it.</li> <li>3. Evacuate and charge system.</li> </ol>
<p><b>FAULTY COMPRESSOR</b></p>  <p>AC363A</p> <p>Insufficient cooling.</p>	<p>Internal problem in compressor, or damaged gasket and valve.</p>	<ol style="list-style-type: none"> <li>1. Discharge system.</li> <li>2. Remove and check compressor.</li> <li>3. Repair or replace compressor.</li> <li>4. Check oil level.</li> <li>5. Replace receiver drier.</li> <li>6. Evacuate and charge system.</li> </ol>
<p><b>TOO MUCH OIL IN SYSTEM (Excessive)</b></p>  <p>AC364A</p> <p>Insufficient cooling.</p>	<p>Too much oil circulates with refrigerant, causing the cooling capacity of the system to be reduced.</p>	<p>Refer to Oil Level Check for correcting oil level.</p>

# BLOWER MOTOR DIAGNOSES

- : Condition
- : Check
- : Probable cause

## Test conditions

- Battery : O.K.
- Fusible link (Black) : O.K.
- Fusible link (Brown) : O.K.
- Ignition switch : O.K.
- Accessory relay : O.K.
- Fuse 20A (in fuse block) : O.K.
- Fuse 20A (under blower motor) : O.K.
- Position of ignition switch : ACC
- Position of fan switch : ON

Quick check : Check that wiper, radio, stereo and power window operate.

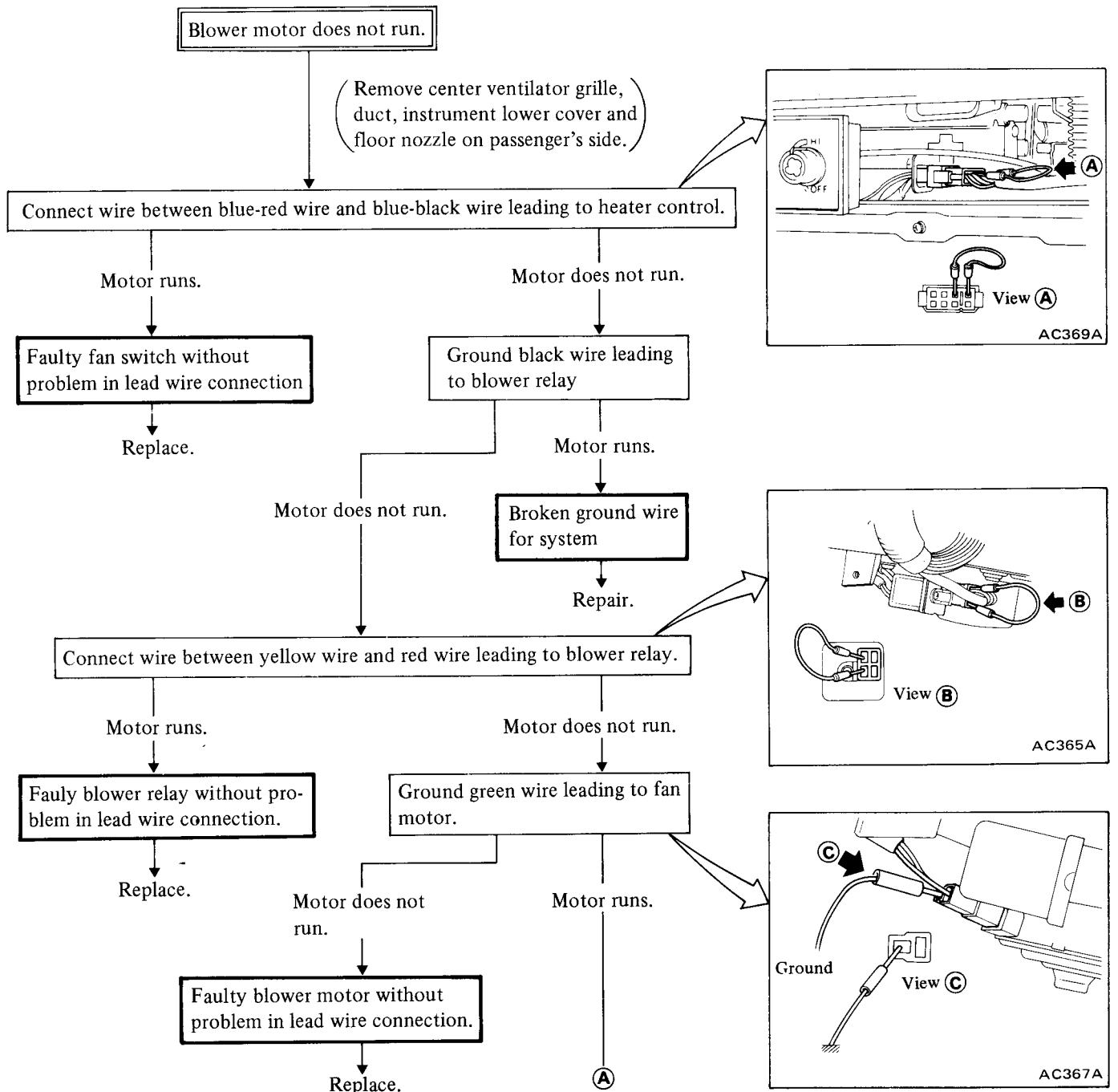



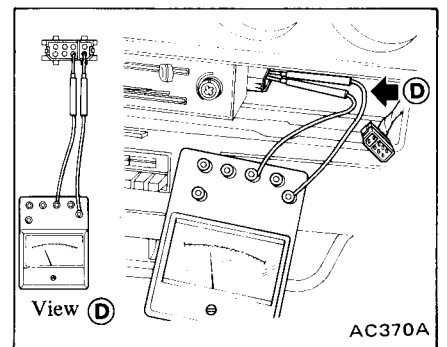
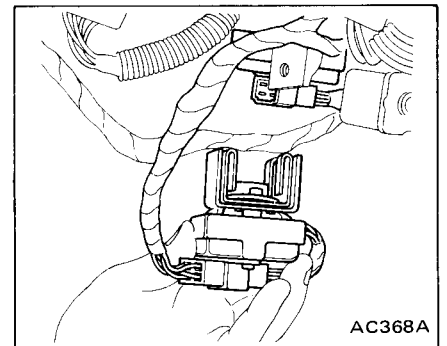
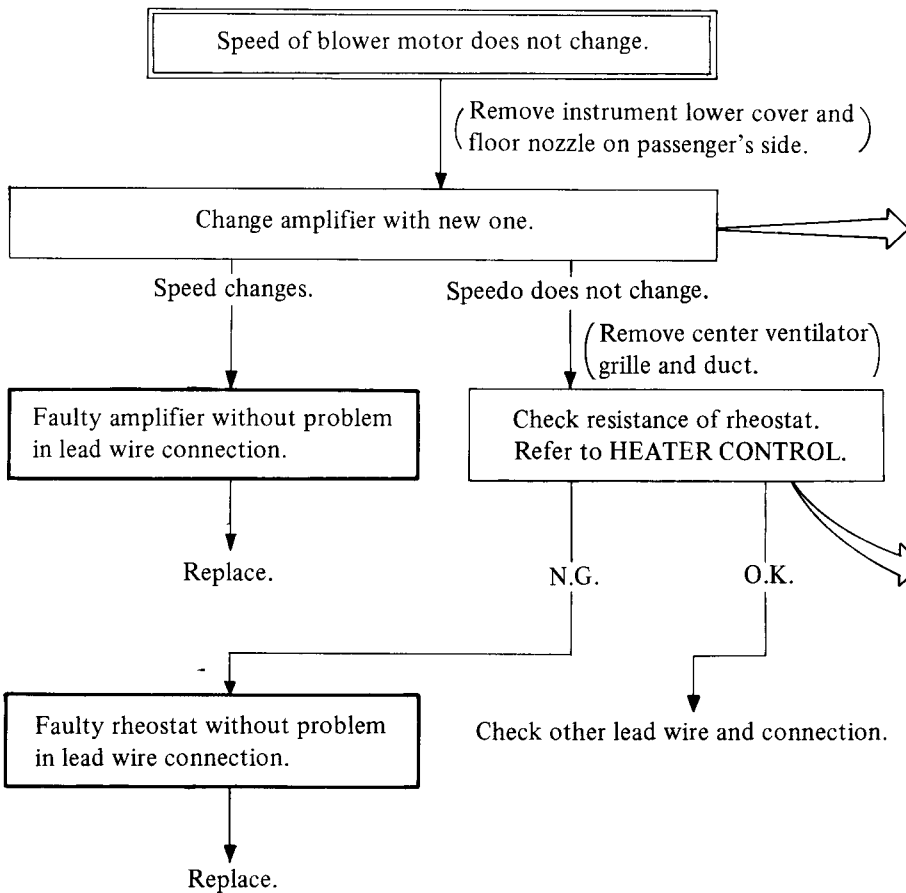
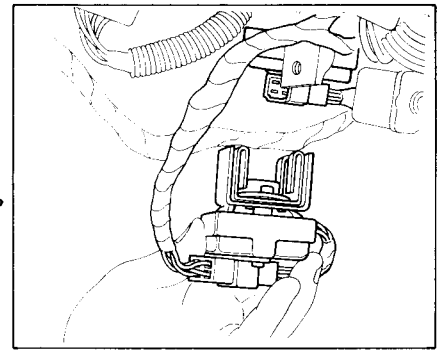
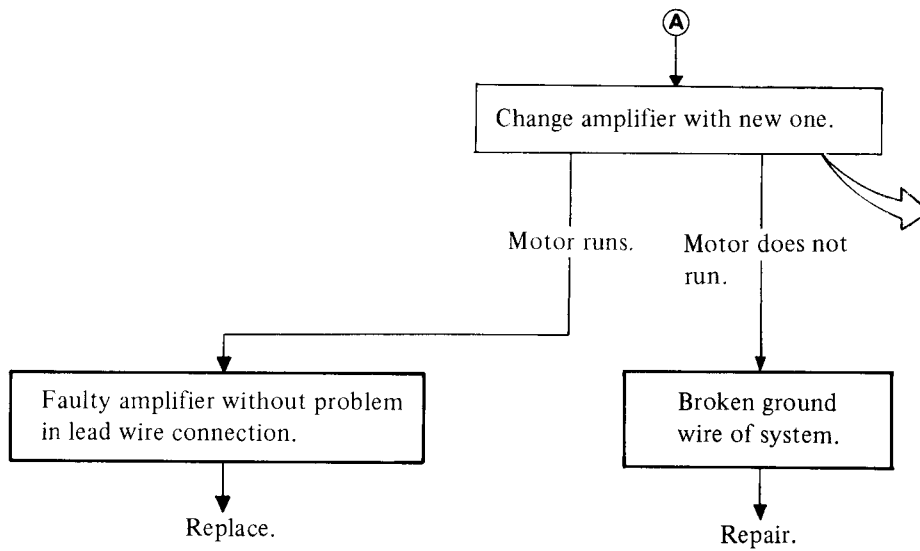

# COMPRESSOR CLUTCH DIAGNOSES

- : Condition
- : Check
- : Probable cause

## Test conditions

- Battery : O.K.
- Fusible link (Black) : O.K.
- Fusible link (Brown) : O.K.
- Ignition switch : O.K.
- Accessory relay : O.K.
- Fuse 20A (in fuse block) : O.K.

Quick check : Check that wiper, radio, stereo and power window operate.

- Position of ignition switch : ACC
- Position of fan switch : ON
- Position of air control lever : AIR-CON

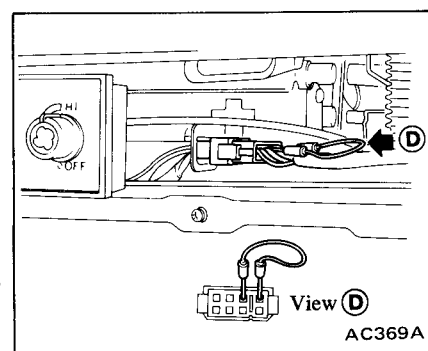
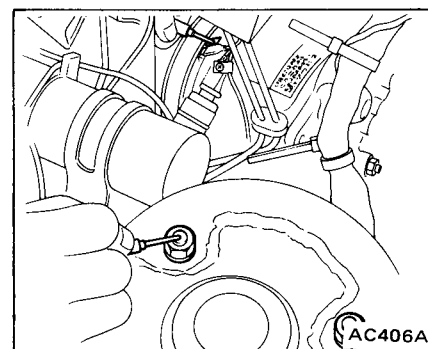
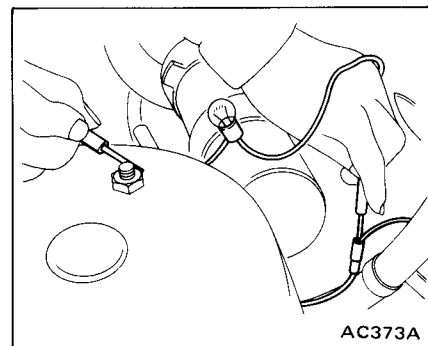
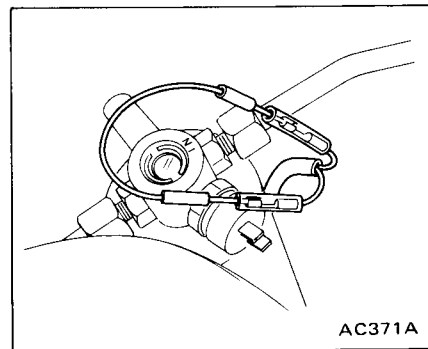
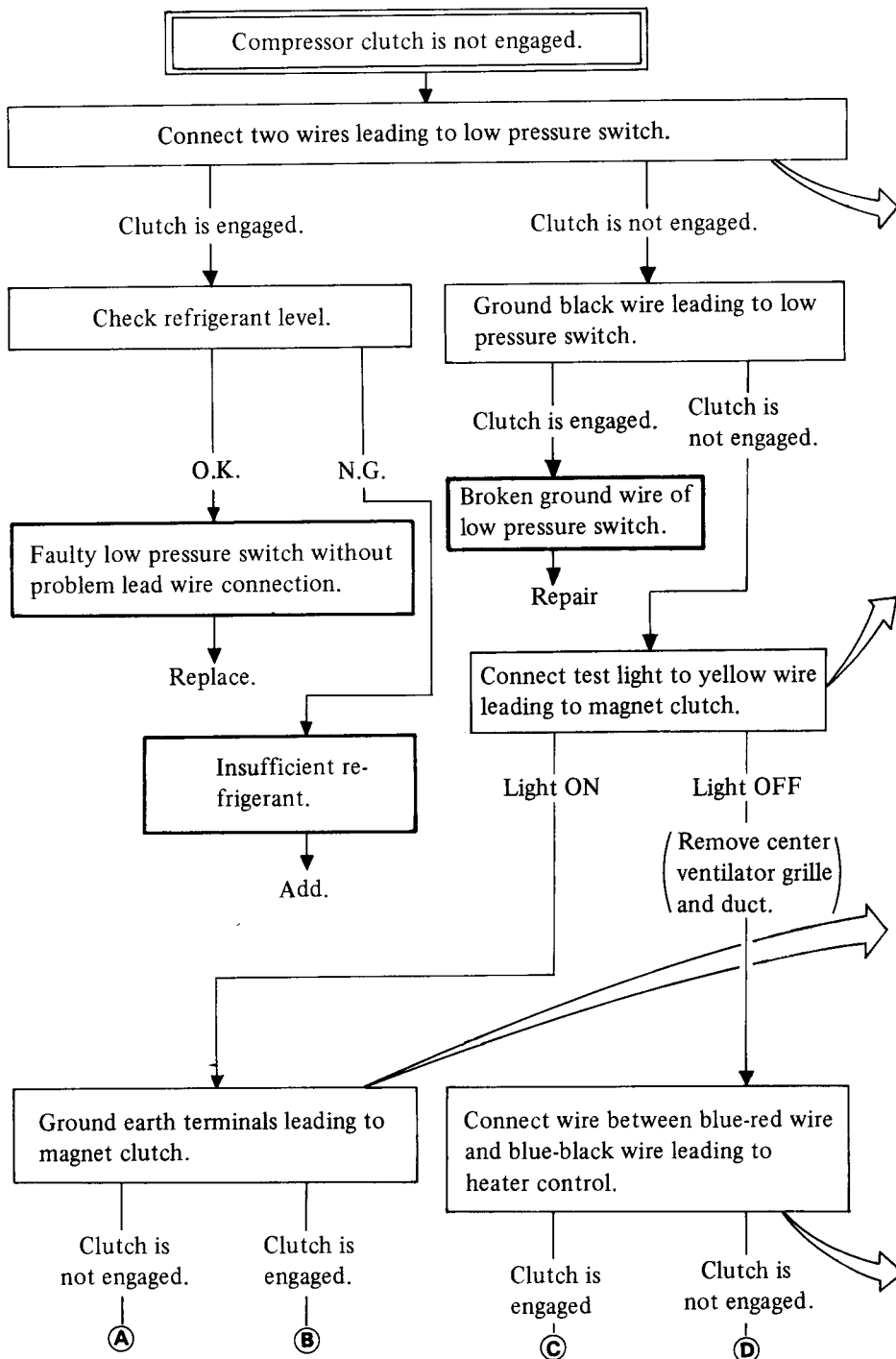

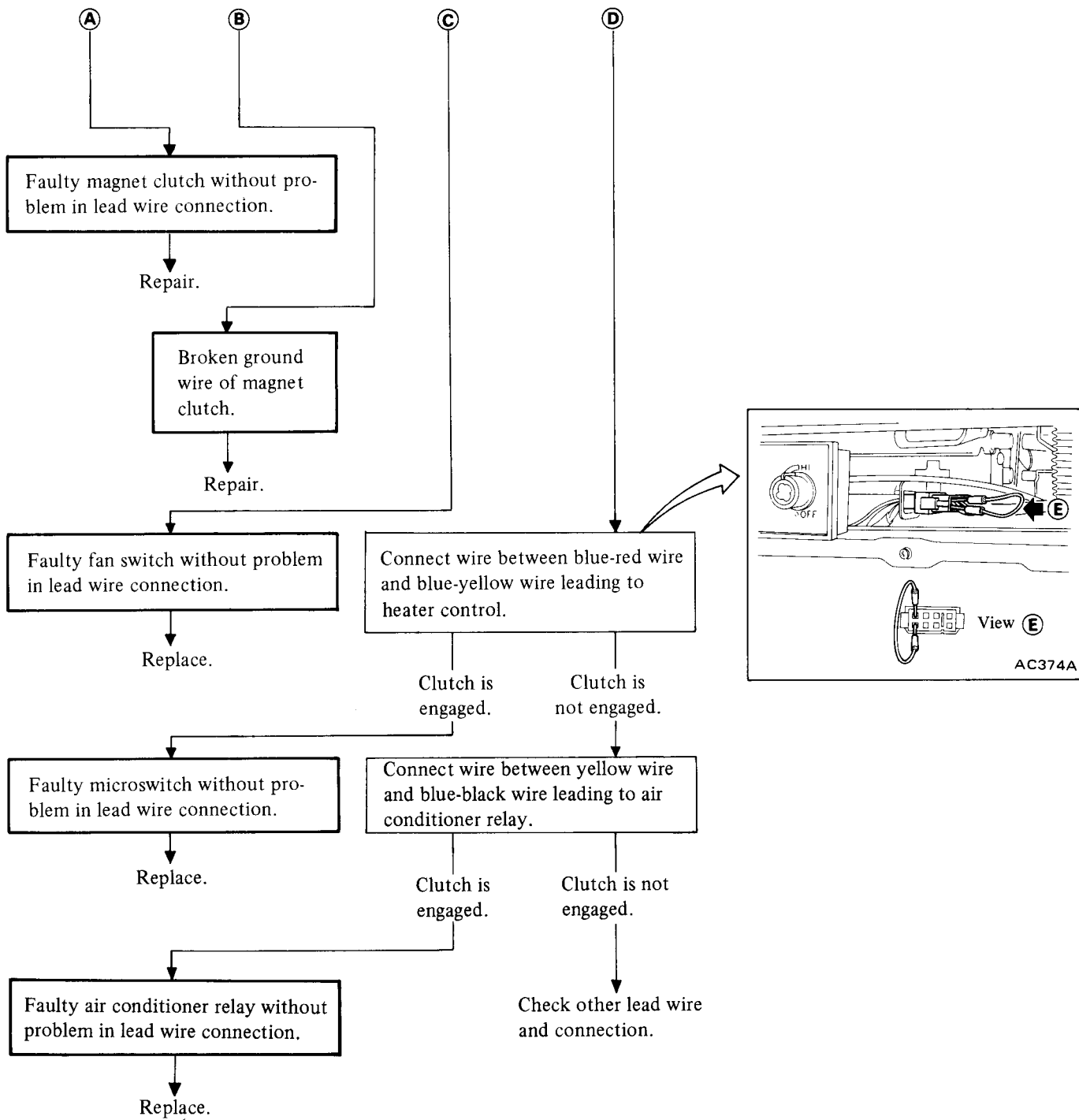

## COMPRESSOR DIAGNOSES

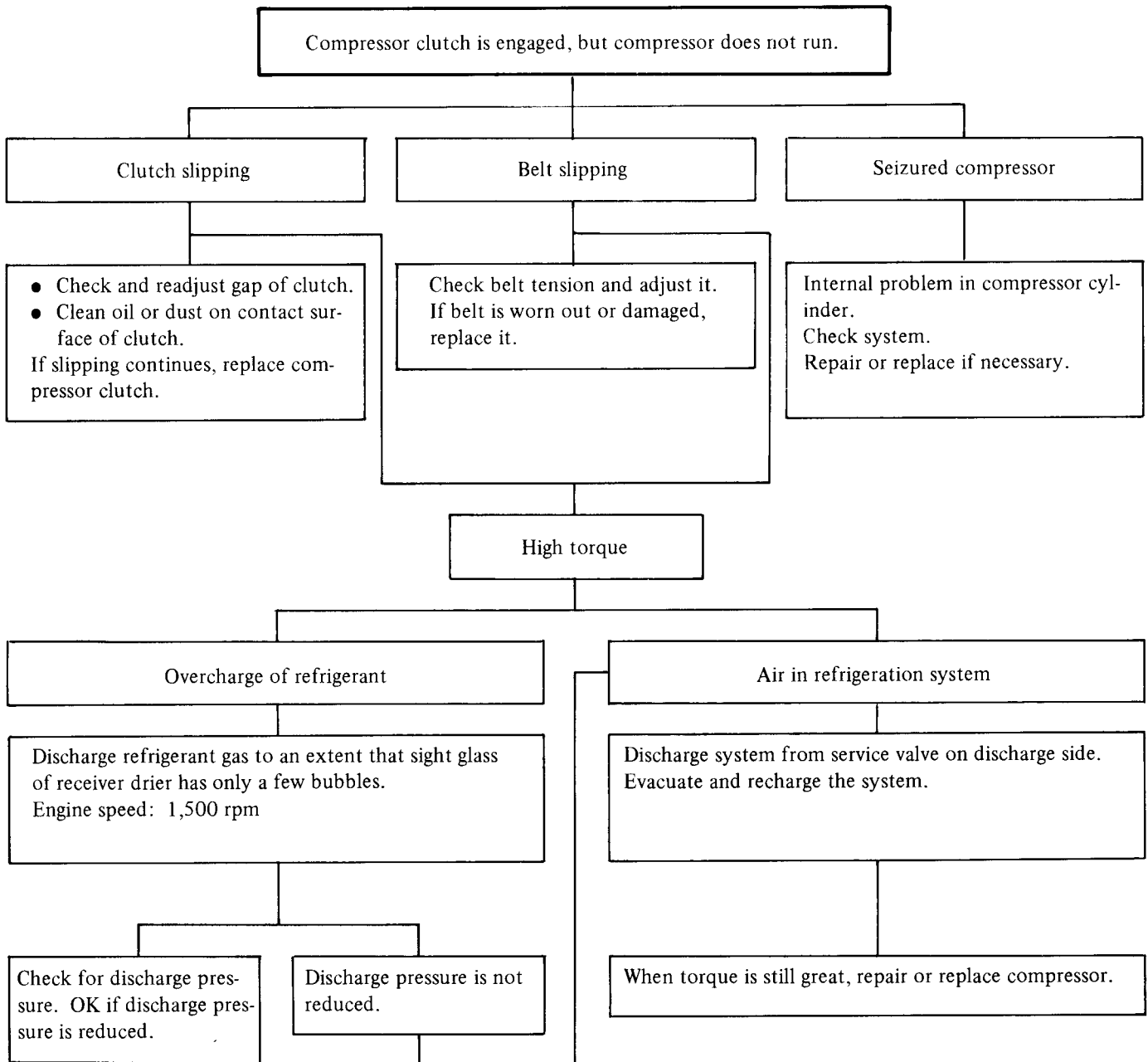

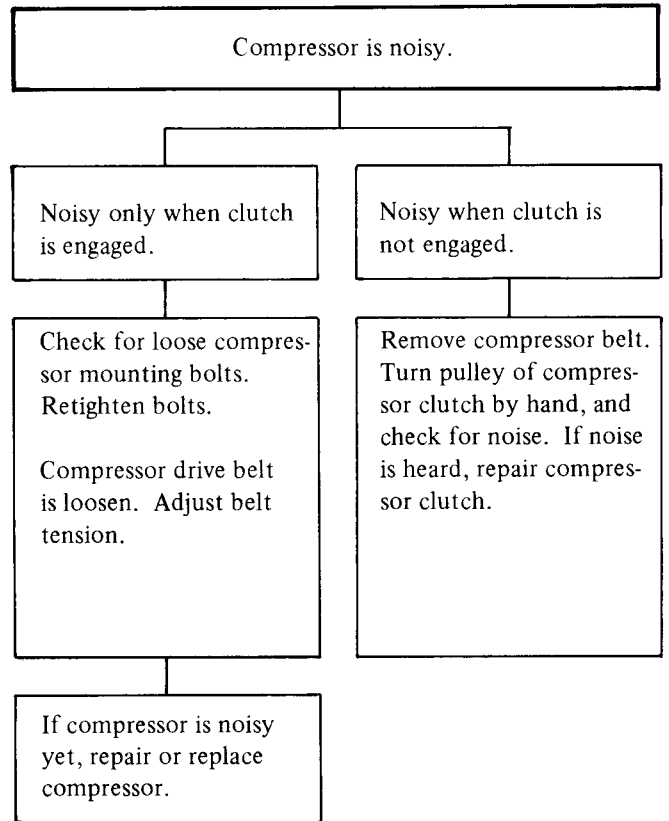
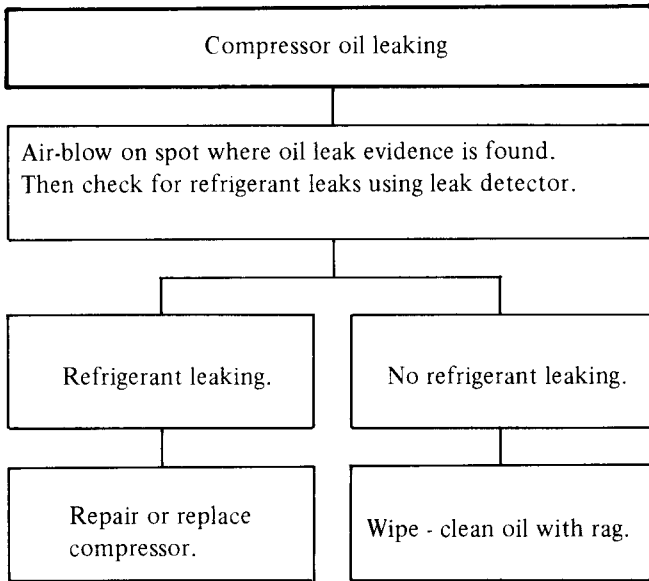

# FAST IDLE CONTROL DEVICE DIAGNOSES

## Test conditions

- Battery : O.K.
- Fusible link (Black) : O.K.
- Fusible link (Brown) : O.K.
- Ignition switch : O.K.
- Accessory relay : O.K.
- Fuse 20A (in fuse block) : O.K.

Quick check : Check that wiper, radio, stereo and power window operate.

- Position of ignition switch : ON (Engine running)
- Position of fan switch : ON
- Position of air control lever : AIR-CON

- : Condition
- : Check
- : Probable cause

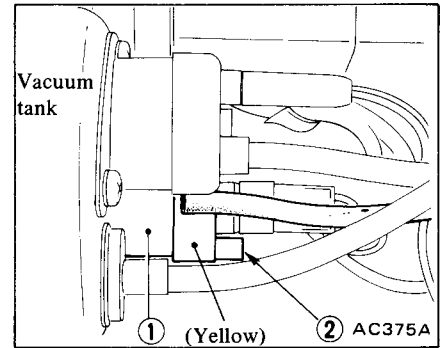
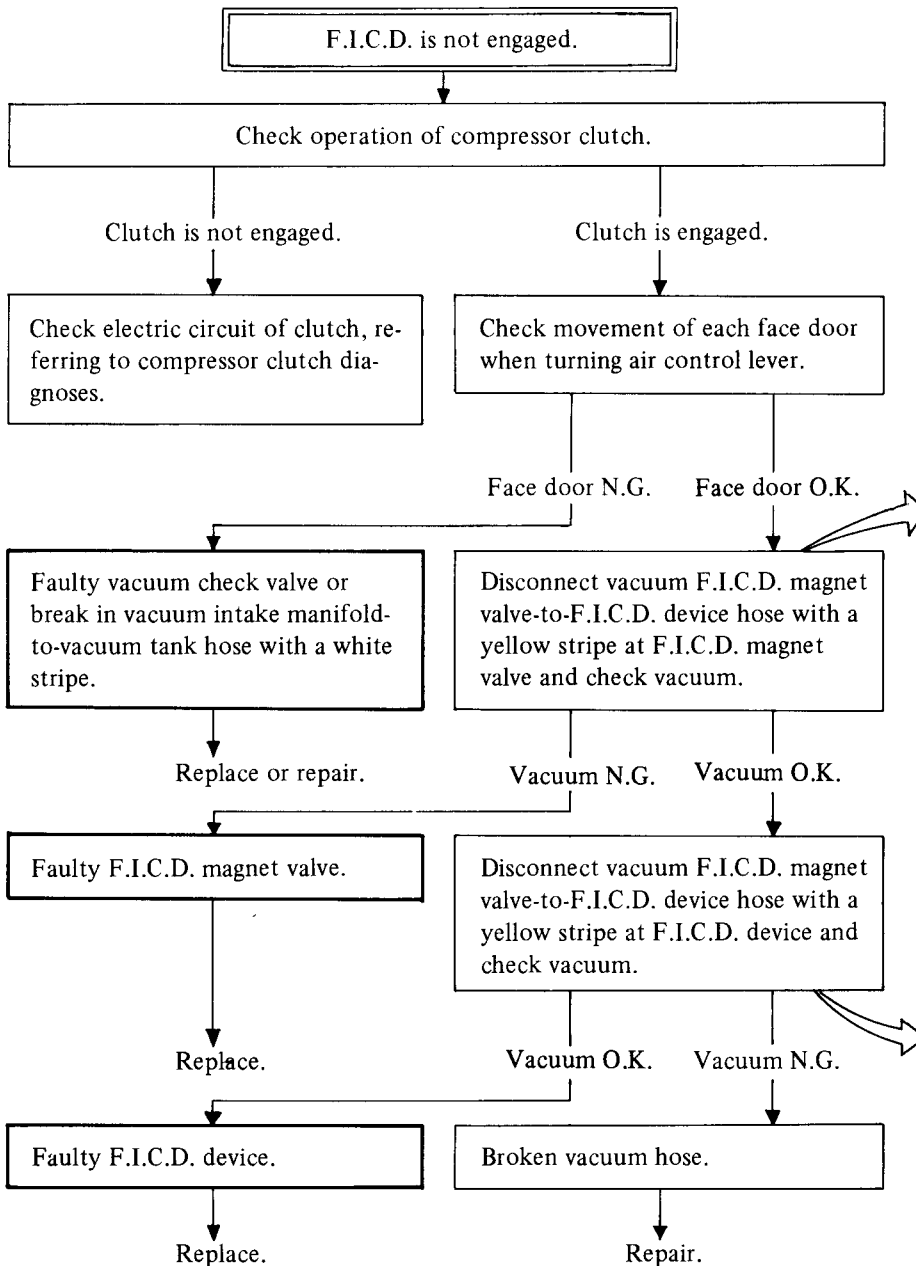

- 1 F.I.C.D. magnet valve
- 2 Check vacuum

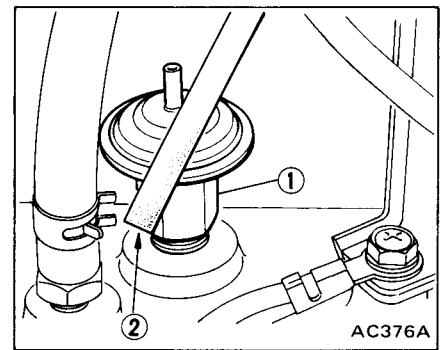

- 1 F.I.C.D. device
- 2 Check vacuum

## PERFORMANCE CHART

### Test conditions

Test car location	: Indoors or in the shade (Outside wind velocity: Less than 2 m/sec)
Doors	: Closed
Door window	: Open
Hood	: Open
Air control lever	: AIR-CON RECIRC
Temperature lever	: Max. COLD
Fan switch	: Max. HI
Engine speed	: 1,500 rpm

### Test reading

Inside air (Recirculating air) at blower assembly inlet		Discharge air temperature at center ventilator °C (°F)
Relative humidity %	Air temperature °C (°F)	
50 to 90	12 (54)	1.2 - 4.9 (34.2 - 40.8)
	15 (59)	1.6 - 5.4 (34.9 - 41.7)
	20 (68)	2.8 - 7.4 (37.0 - 45.3)
	25 (77)	5.2 - 11.0 (41.4 - 51.8)
	30 (86)	9.8 - 17.0 (49.6 - 62.6)
	35 (95)	16.4 - 24.0 (61.5 - 75.2)

Ambient air		Pressure high (Discharge side) kPa (kg/cm <sup>2</sup> , psi)	Pressure low (Suction side) kPa (kg/cm <sup>2</sup> , psi)
Relative humidity %	Temperature °C (°F)		
50 - 90	18 (64)	696 - 804 (7.1 - 8.2, 101 - 117)	73.6 - 117.7 (0.75 - 1.20, 10.7 - 17.1)
	20 (68)	716 - 843 (7.3 - 8.6, 104 - 122)	73.6 - 122.6 (0.75 - 1.25, 10.7 - 17.8)
	25 (77)	834 - 1,020 (8.5 - 10.4, 121 - 148)	88.3 - 152.0 (0.90 - 1.55, 12.8 - 22.0)
	30 (86)	1,030 - 1,226 (10.5 - 12.5, 149 - 178)	112.8 - 201.0 (1.15 - 2.05, 16.4 - 29.2)
	35 (95)	1,245 - 1,451 (12.7 - 14.8, 181 - 210)	147.1 - 255.0 (1.50 - 2.60, 21.3 - 37.0)
	40 (104)	1,461 - 1,687 (14.9 - 17.2, 212 - 245)	196.1 - 308.9 (2.00 - 3.15, 28.4 - 44.8)

## DESCRIPTION (Auto air conditioner)

Parts described here are only those specially designed for use in the auto temperature type air conditioner. For the other component parts, refer to the section under the heading "Manual Type Air Conditioner".

### SYSTEM OPERATION

The auto temperature control air conditioner consists of the following six systems:

- (1) System starting control
- (2) Compressor switching control
- (3) Automatic outlet air temperature control
- (4) Automatic blower speed control
- (5) Automatic air distribution control
- (6) Recirculation control

Each system is activated by an electrical circuit and/or a vacuum mechanism in order to set the positions of the control levers control switch and air mix door.

← : Vacuum connection

← : Electrical connection

← - - - : Link connection

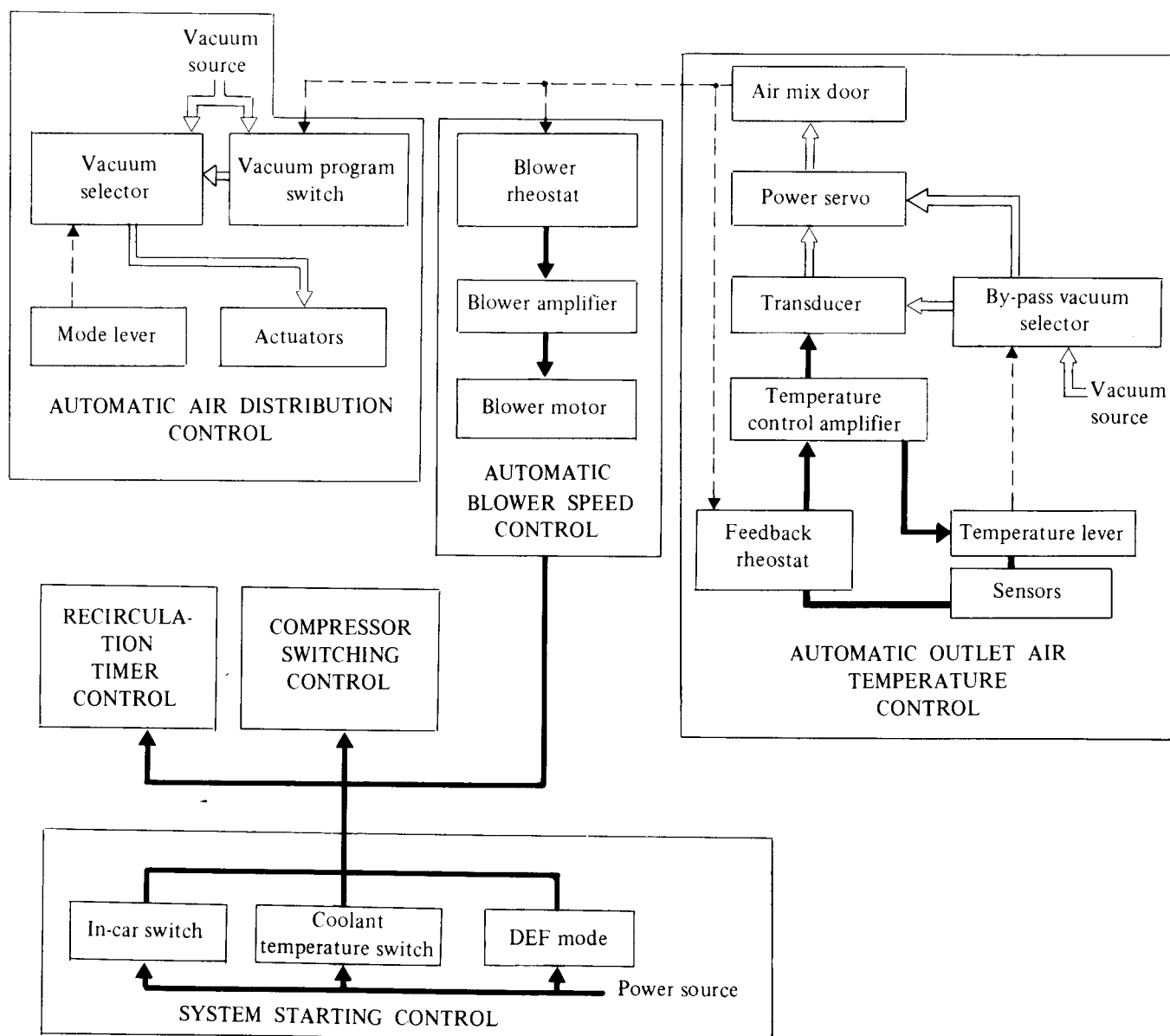



## FUNCTION AND OPERATION OF EACH UNIT

### SYSTEM STARTING CONTROL

#### Coolant temperature switch

This switch keeps the blower OFF until coolant temperature rise over 50°C (122°F) so that interior air can be warmed up quickly, e.g., during the winter season.

#### In-car switch

This switch quickly activates the starting control system when the car's interior temperature is extremely high, e.g., during the summer season even if the coolant temperature switch is not activated.

### COMPRESSOR SWITCHING CONTROL

#### Ambient switch

This switch is used to turn OFF the compressor when the ambient air temperature is low.

### AUTOMATIC OUTLET AIR TEMPERATURE CONTROL

#### In-car sensor (Thermistor)

This switch is located in the instrument panel and registers a resistance value which varies with the car's interior temperature and the quantity of heat resulting from sunlight.

#### Ambient sensor (Thermistor)

This sensor is located behind the front bumper and registers a resistance value which varies with the surrounding temperature.

#### Temperature control rheostat (Variable resistor)

This rheostat registers a resistance value which varies with the temperature control lever position.

#### Feedback rheostat (Variable resistor)

This rheostat automatically changes its resistance value depending on the air mix door's position, in order to stabilize the power servo's operation.

#### Temperature control amplifier

This amplifier registers the total resistance value of the in-car sensor, ambient sensor, trimmer, temperature control rheostat and feedback rheostat, which are all connected in series, and then transmits a signal that corresponds to the total resistance value to the transducer.

#### Transducer

The transducer sends vacuum that is proportional to the current received from the temperature control amplifier to the power servo.

#### Power servo (Actuator)

The power servo activates in order to move the air mix door's position in proportion to the vacuum received from the transducer.

#### By-pass vacuum selector

By setting temperature lever at the hottest position, the vacuum does not pass through the transducer but is sent directly to the power servo. When it is set at the coldest position, the vacuum line will be blocked.

#### Vacuum lock valve

This valve serves to block the vacuum line when the source vacuum momentarily drops.

### AUTOMATIC BLOWER SPEED

#### Blower control rheostat (Variable resistor)

This rheostat is activated in conjunction with the air mix door and registers a resistance value which varies with the air mix door's position.

#### Blower amplifier

This amplifier sends a voltage to the blower motor which is proportional to the blower control rheostat's resistance value.

### AUTOMATIC AIR DISTRIBUTION CONTROL

#### Vacuum selector

This selector selects the vacuum lines needed to open or close outlets in accordance with mode lever position.

#### Vacuum program switch

This selector also selects the vacuum lines needed to open or close outlets in accordance with air mix door position.

#### Air valve and vacuum switch

The  $V_1'$  point of vacuum program switch and the  $V_1'$  point of vacuum selector are connected via air valve and vacuum switch for obtaining positive operation of the floor door.

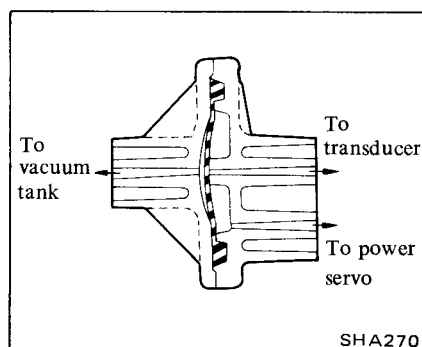

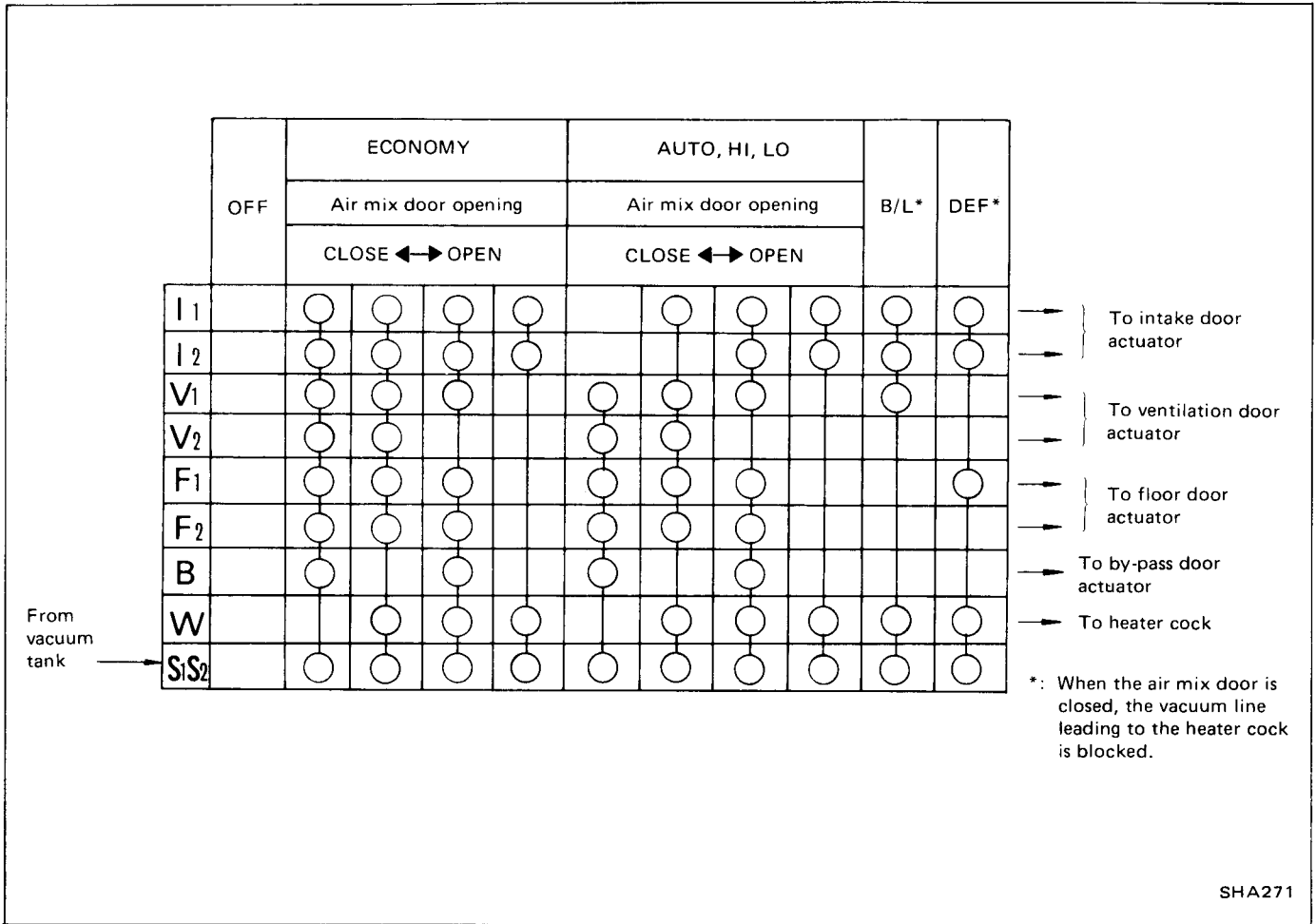

SHA271

## RECIRCULATION CONTROL

### Recirculation timer

This timer is used to recirculate interior air. When its switch is depressed, the interior air will be recirculated for approximately 10 minutes. Depressing the switch again will stop the process.

### Air valve (Intake door)

This air valve is controlled by the recirculation timer switch. When the switch is depressed, current stops flowing through the air valve and it closes. This causes the intake door actuator's vacuum line to be blocked and sets the intake door in the recirculation position.

## UNITS LOCATION

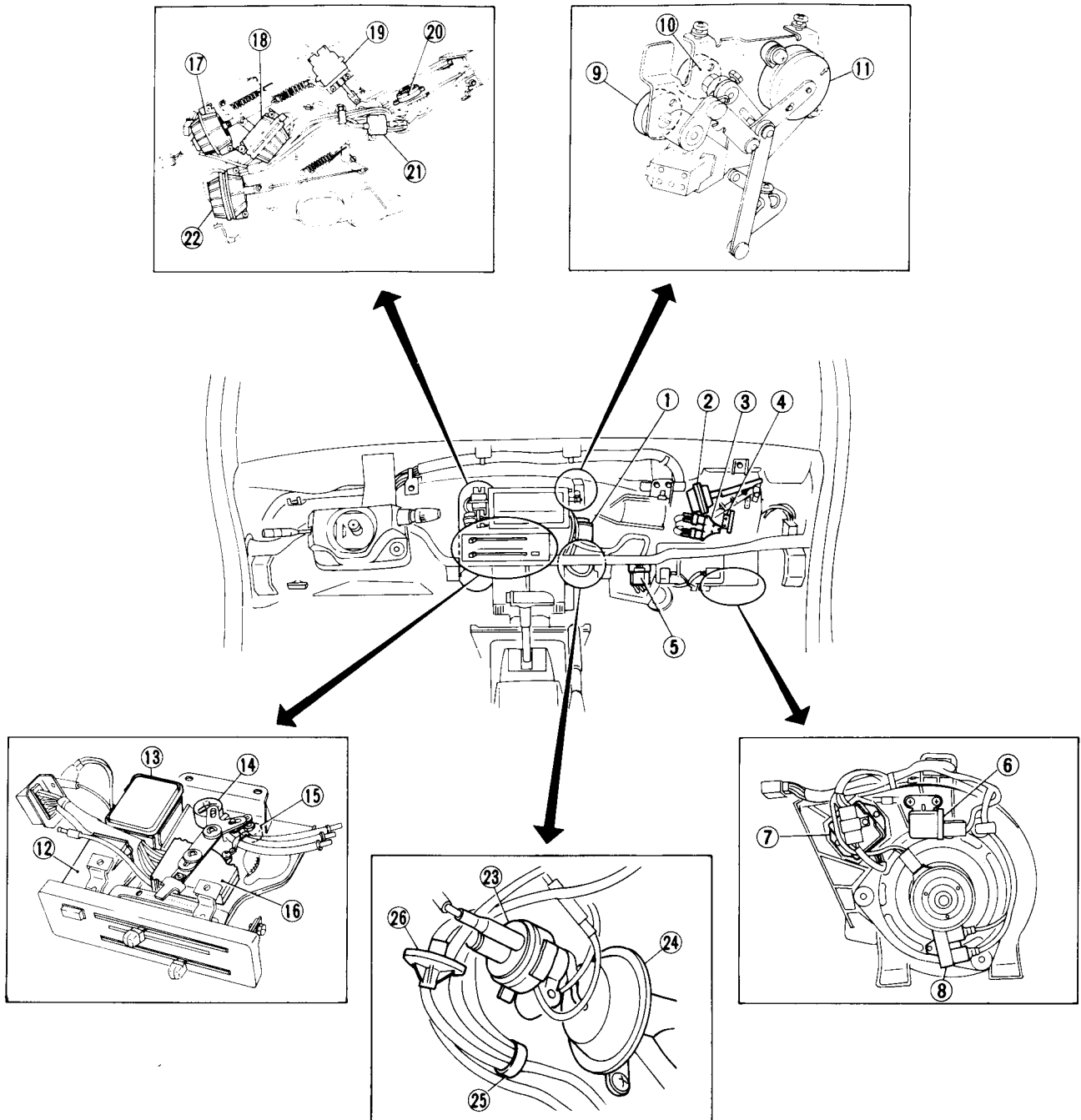

- |                           |                                  |                              |
|---------------------------|----------------------------------|------------------------------|
| 1 Transducer              | 11 Vacuum program switch         | 21 Air valve (DEF clamp)     |
| 2 Intake door actuator    | 12 Recirculation timer           | 22 Floor door actuator       |
| 3 Air valve (Intake door) | 13 Temperature control amplifier | 23 Vacuum switch (DEF clamp) |
| 4 In-car switch           | 14 By-pass vacuum selector       | 24 Heater cock               |
| 5 Check terminal          | 15 Temperature control rheostat  | 25 Vacuum divider            |
| 6 Blower relay            | 16 Program switch                | 26 Vacuum lock valve         |
| 7 Blower amplifier        | 17 Power servo                   |                              |
| 8 Fuse (Blower motor)     | 18 Ventilation door actuator     |                              |
| 9 Blower control rheostat | 19 By-pass door actuator         |                              |
| 10 Feedback rheostat      | 20 Vacuum selector               |                              |

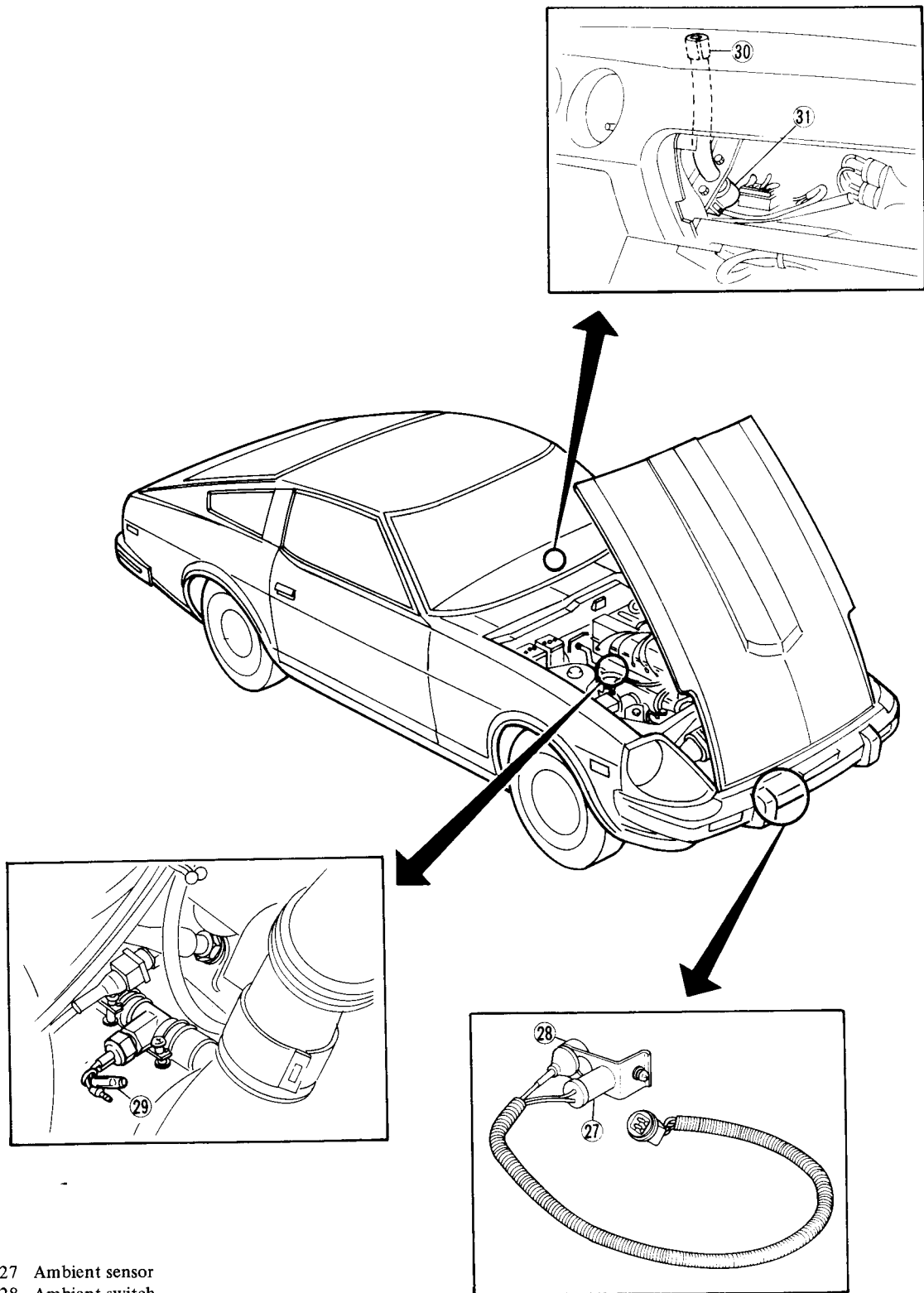

- 27 Ambient sensor
- 28 Ambient switch
- 29 Coolant temperature switch
- 30 In-car sensor
- 31 Aspirator fan

**AIR FLOW**

**OFF MODE**

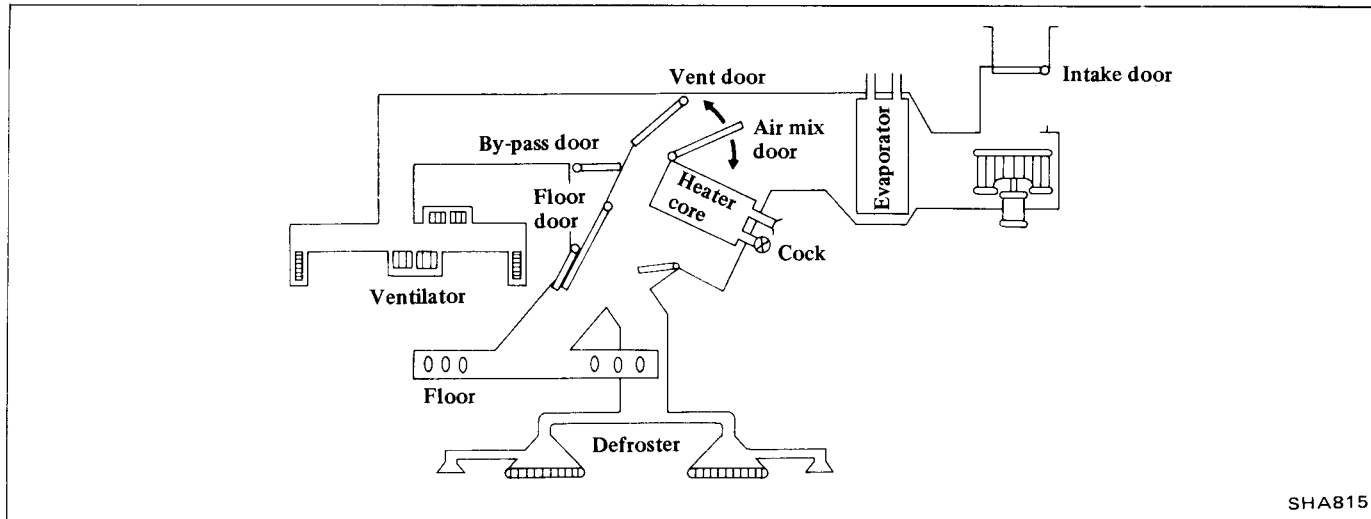

SHAB15

Air mix* door	Blower	Door position				Heater cock	Compressor and F.I.C.D.
		Intake	Vent	By-pass	Floor		
CLOSE ↕ OPEN	OFF	CLOSE	CLOSE	CLOSE	CLOSE	CLOSE	OFF

\*: The air mix door operates in order to prevent any delay in the automatic temperature control system's operation.

**BI-LEVEL MODE**

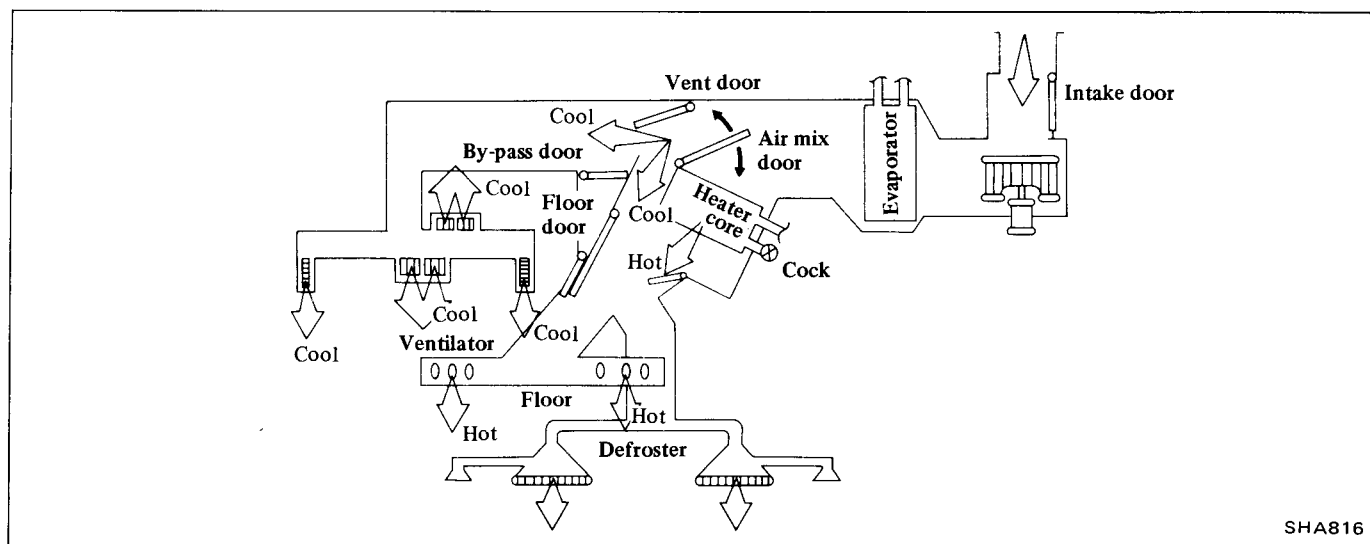

SHA816

Air mix door	Blower	Door position				Heater cock	Compressor and F.I.C.D.
		Intake	Vent	By-pass	Floor		
CLOSE ↕ OPEN	HI ↑ LO ↓ HI	OPEN	1/2 OPEN	CLOSE	CLOSE	OPEN	ON



**ECONOMY, LO, AUTO, HI MODE**

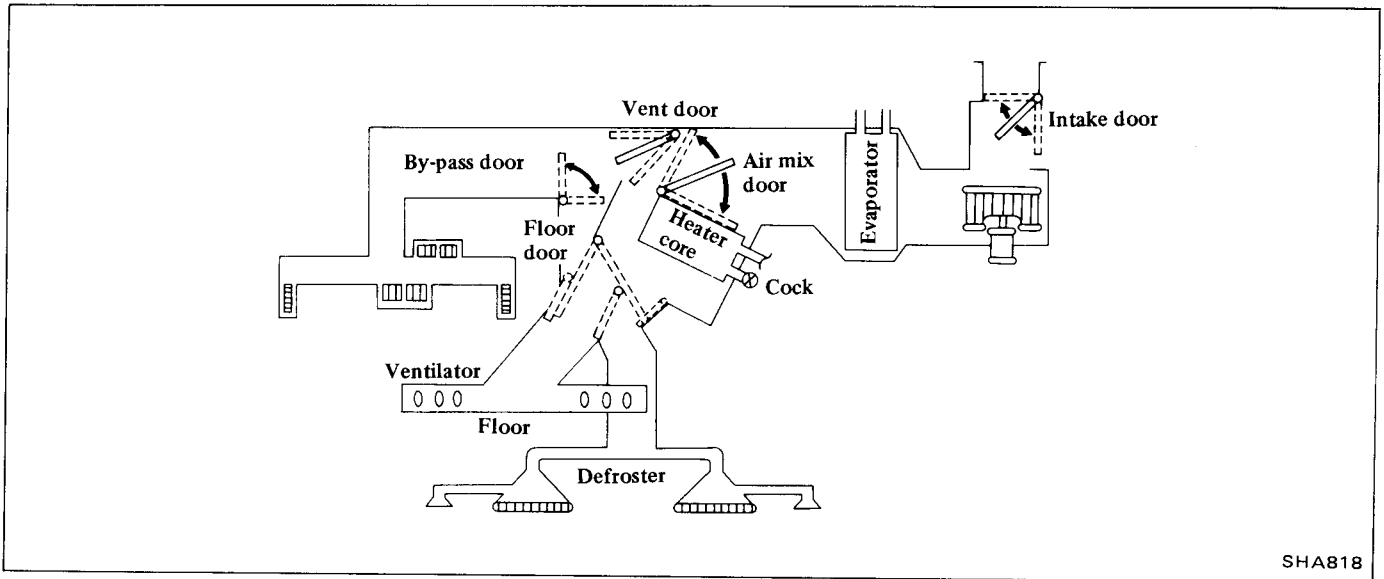

SHA818

**Economy mode**

Air mix door	Blower	Door position				Heater cock	Compressor and F.I.C.D.
		Intake	Vent	By-pass	Floor		
CLOSE ↑ ↓ OPEN	HI ↑ LO ↓ HI	OPEN	OPEN	OPEN	CLOSE	CLOSE	OFF
				CLOSE			
			1/2 OPEN	OPEN			
			CLOSE	CLOSE			

**Auto, Hi, Lo mode**

Air mix door	Blower*	Door position				Heater cock	Compressor and F.I.C.D.
		Intake	Vent	By-pass	Floor		
CLOSE ↑ ↓ OPEN	HI ↑ LO ↓ HI	CLOSE	OPEN	OPEN	CLOSE	CLOSE	ON
		1/2 OPEN		CLOSE			
		OPEN	1/2 OPEN	OPEN	OPEN		
			CLOSE	CLOSE			

\*: Blower speed is set at HI or LO when the system is operating in the HI or LO mode.

## SERVICE PROCEDURES (Auto air conditioner)

### INSPECTION OF "CHECK" TERMINAL

#### SCHEMATIC/CHECK TERMINAL

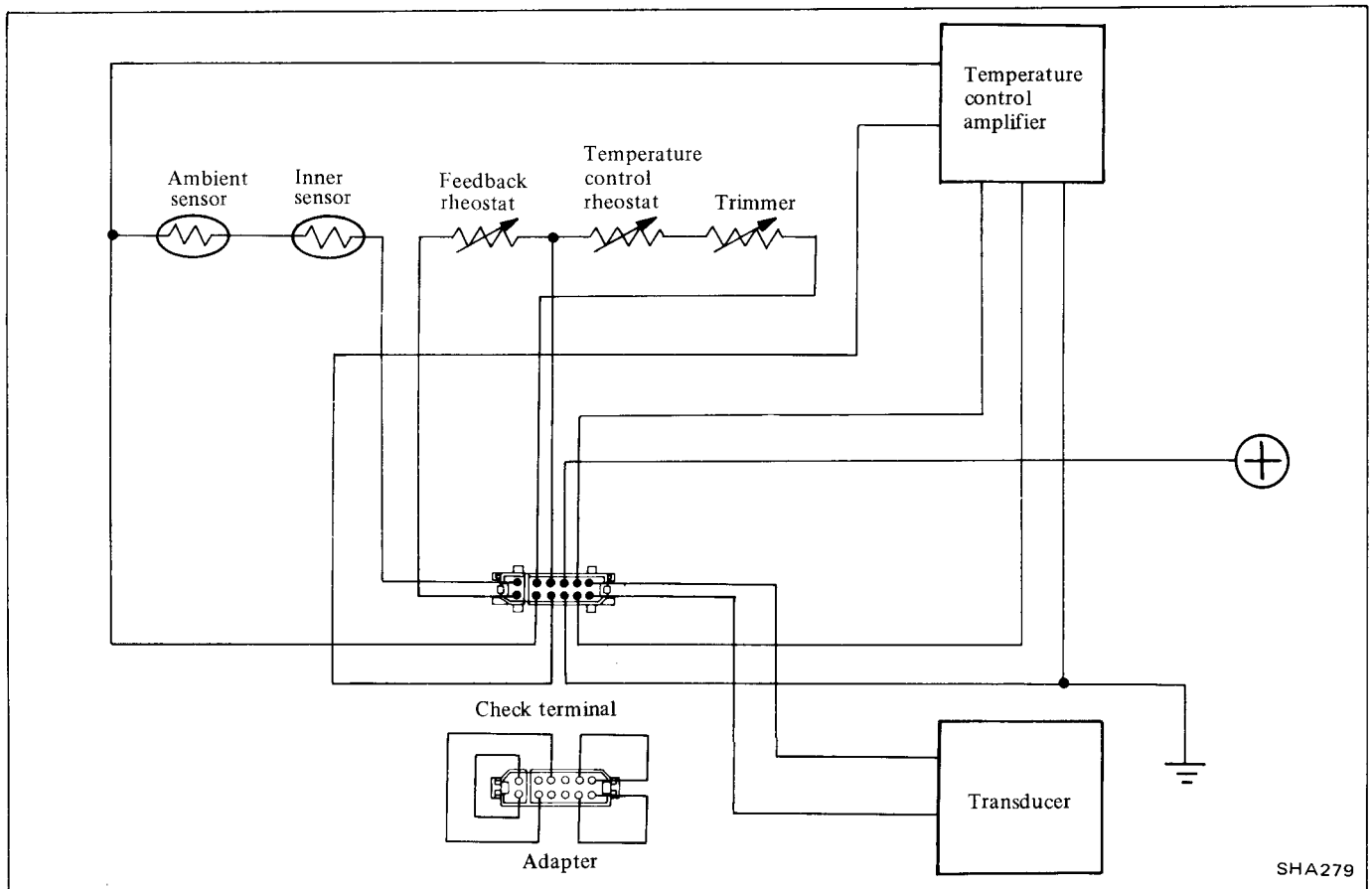

The "check" terminal is designed to allow the temperature control amplifier, transducer, ambient sensor, in-car sensor, feedback rheostat, and trimmer to be inspected without the instrument panel being removed.

Electrical system inspection can be performed by using the AUTOMATIC TEMPERATURE CONTROL AIR CONDITIONER TESTER (J28810).

If the tester is not available, use the following procedures.

#### Location

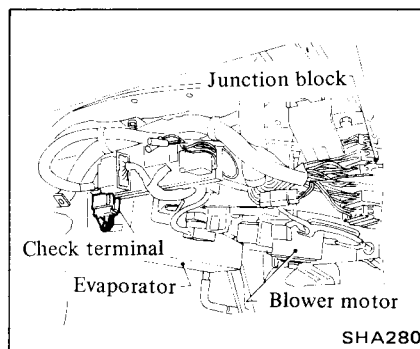

The "check" terminal will be accessible after the right-hand instrument lower cover and right-hand floor nozzle are removed.

#### (1) CHECKING AMBIENT SENSOR AND IN-CAR SENSOR

1. Open car door(s) to equalize in-

terior and exterior air temperatures.

2. Remove adapter.
3. Turn ignition switch to "ACC", and set mode lever at "OFF".
4. Set a circuit tester in "ohm" range, and contact test probes to terminals (+) and (-) as shown, and measure resistance values.

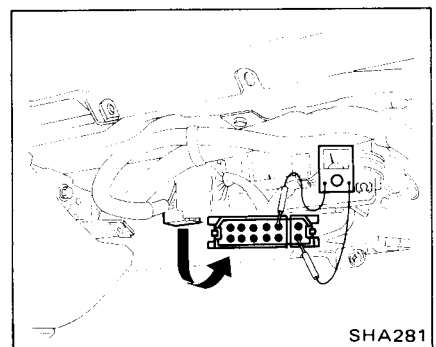



Temperature		Resistance
°C	°F	
4	40	Approx. 230 Ω
10	50	Approx. 190 Ω
16	60	Approx. 160 Ω
21	70	Approx. 130 Ω
27	80	Approx. 110 Ω
32	90	Approx. 90 Ω

If measured values do not agree with values set forth in the above chart, check for an open circuit in harness, ambient sensor and/or in-car sensor.

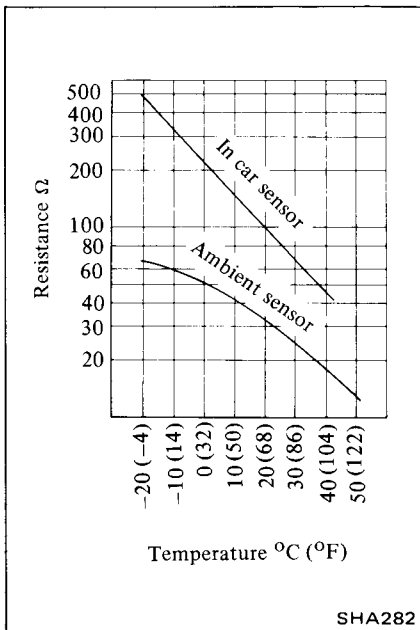

## (2) CHECKING TEMPERATURE CONTROL RHEOSTAT AND TRIMMER

1. Remove adapter.
2. Set both ignition switch and mode lever in OFF.
3. Set a circuit tester in “ohm” range, and contact test probes to terminals, as shown below.

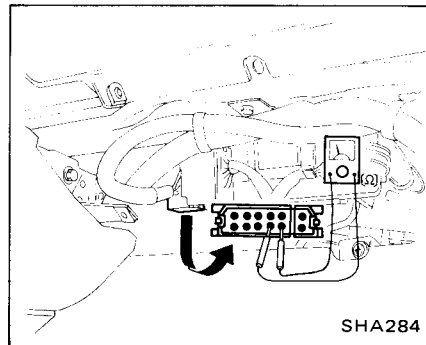
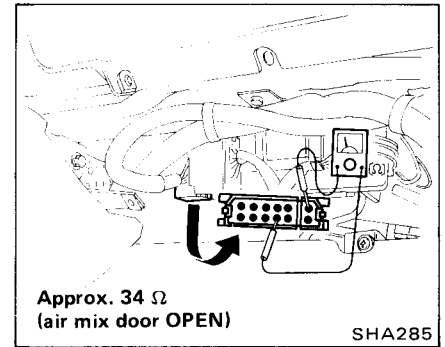

3. Start engine, and set mode lever in AUTO and temperature control lever below 20°C (65°F) (coldest).

Circuit tester indication:  
Approx. 75 Ω  
(air mix door CLOSE)

Temperature lever		Resistance
°C	°F	
20	65	Approx. 60 Ω
25	75	Approx. 92 Ω
30	85	Approx. 124 Ω

Observe tester indicator to ensure its reading smoothly varies with temperature control lever’s movement.

**CAUTION:**  
Do not attempt to adjust trimmer control during this procedure.

## (4) CHECKING TEMPERATURE CONTROL AMPLIFIER

1. With adapter in place, set mode lever in OFF.
2. Set a circuit tester in “VOLT” range, and connect test probes, (+) and (–) to correct terminals, reaching behind adapter, as shown.

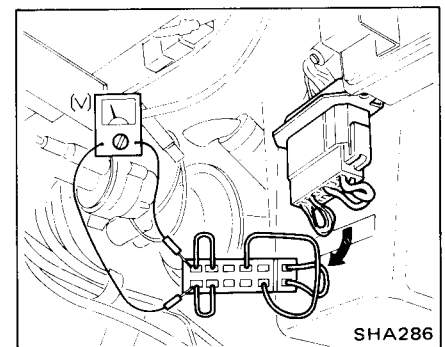

The circuit tester indicator should register a total resistance value for ambient sensor and in-car sensor. If ambient temperature is greater or lower than the values indicated in the chart, use the graph to determine the correct temperature.

## (3) CHECKING FEEDBACK RHEOSTAT

1. Remove adapter.
2. Turn ignition switch OFF. Set a circuit tester in “ohm” range and contact test probes to terminals, as shown.

3. Set ignition switch in ACC, and mode lever in AUTO and move temperature control lever left and right.  
Read tester **immediately** after setting mode lever in AUTO.

Circuit tester indication:  
 20°C (65°F) setting  
 Approx. 2.5 V  
 30°C (85°F) setting  
 Approx. 7.0 V

2. Remove connector attaching bolts.

3. Remove connector and check connector's terminals using a circuit tester and the following chart.

## UNIT INSPECTION

### PROGRAM SWITCH

#### Inspection

1. Remove instrument center ventilator and duct.

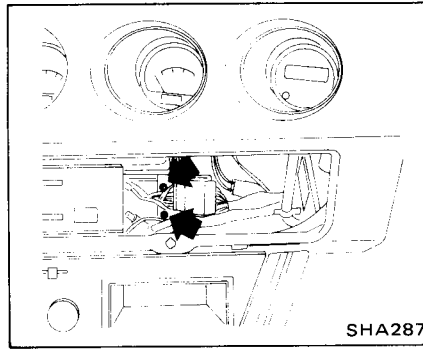

	OFF	ECON	LO	AUTO	HI	B/L	DEF
②		○	○	○	○	○	○
⑬		○	○	○	○	○	
⑩		○	○	○	○	○	
⑯							○
①			○	○	○	○	○
⑥							○
⑭		○		○		○	
⑮		○		○	○	○	○
⑨		○	○	○	○	○	○
⑳			○				

③, ④ are for illumination lamp

SHA809

## COOLANT TEMPERATURE SWITCH

#### Inspection

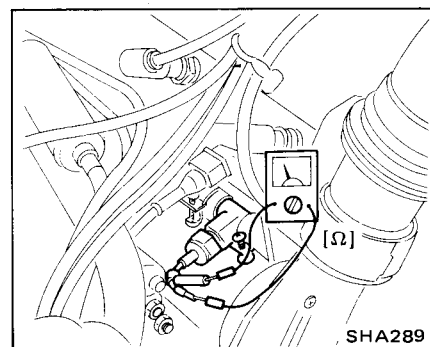

Water temperature below approx.  
 50°C (122°F):  
 Infinity ( $\infty \Omega$ )

After sufficient warm up of engine:  
 0  $\Omega$

## IN-CAR SWITCH

#### Location

The in-car switch is situated behind the glove box, and is accessible after the glove box is removed.

#### Inspection

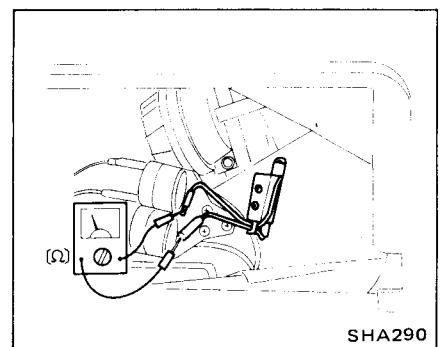

Interior temperature above 25°C (77°F):  
0 Ω

Interior temperature below 25°C (77°F):  
Infinity (∞ Ω)

Ambient switch:  
Above 6°C (43°F)  
0 Ω

–4°C - 6°C (25°F - 43°F)  
0 Ω or ∞ Ω

Below –4°C (25°F)  
∞ Ω

### TEMPERATURE CONTROL AMPLIFIER

#### Inspection

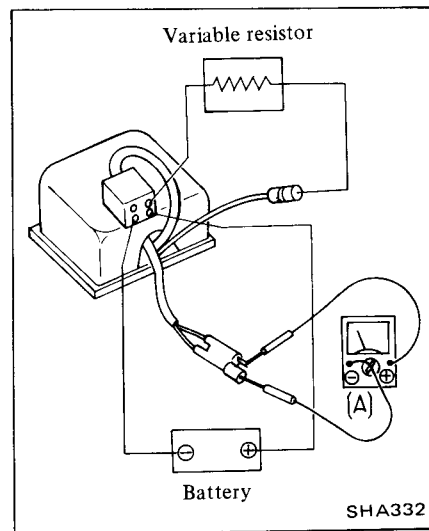

Variable resistor (Ω)	Tester indication (A)
250	0.3
270	0.1

### AMBIENT SWITCH AND AMBIENT SENSOR

#### Location

Both the ambient switch and ambient sensor are attached to the front bumper's back.

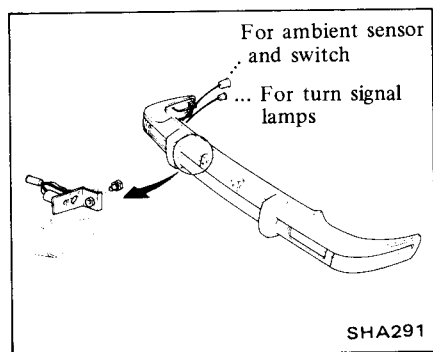

Ambient sensor:

Temperature		Resistance
°C	°F	
4	40	Approx. 47 Ω
10	50	Approx. 42 Ω
16	60	Approx. 37 Ω
21	70	Approx. 33 Ω
27	80	Approx. 29 Ω
32	90	Approx. 26 Ω

### IN-CAR SENSOR

#### Inspection

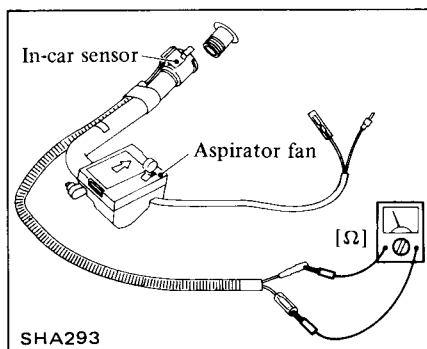

#### Inspection

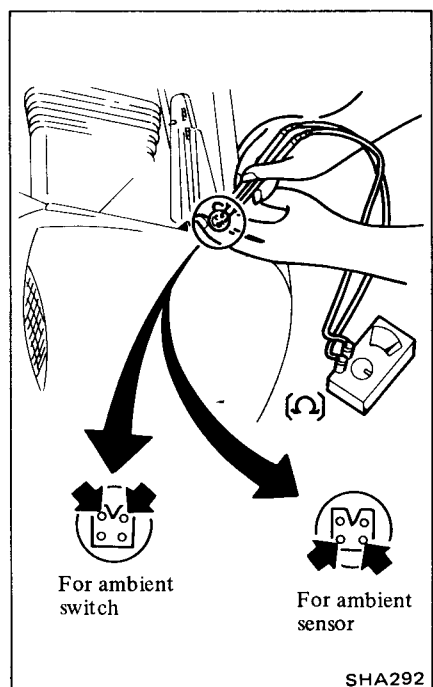

Temperature		Resistance
°C	°F	
4	40	Approx. 183 Ω
10	50	Approx. 148 Ω
16	60	Approx. 123 Ω
21	70	Approx. 97 Ω
27	80	Approx. 81 Ω
32	90	Approx. 64 Ω

### VACUUM LOCK VALVE

#### Inspection

1. Check to be sure that the valve opens by blowing air through port of transducer side.

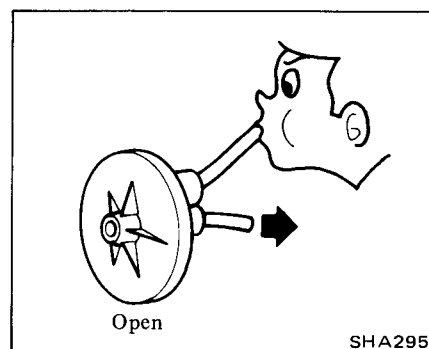

2. Check to be sure that the valve closes by inhaling air through port of transducer side.

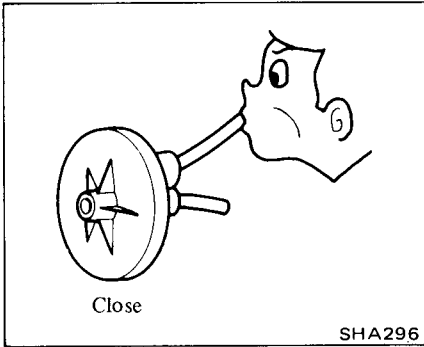

### TRANSDUCER

#### Inspection

1. Measure the resistance between terminals.

**Circuit tester indication:**  
Approx. 25 Ω

2. Check to be sure that output vacuum of transducer is proper.

- (1) Disconnect vacuum hose and connect vacuum gauge.
- (2) Using about 15 Ω (5 W) resistor, apply 0.3 A direct current between terminals.

This check should be performed with the transducer installed on car.

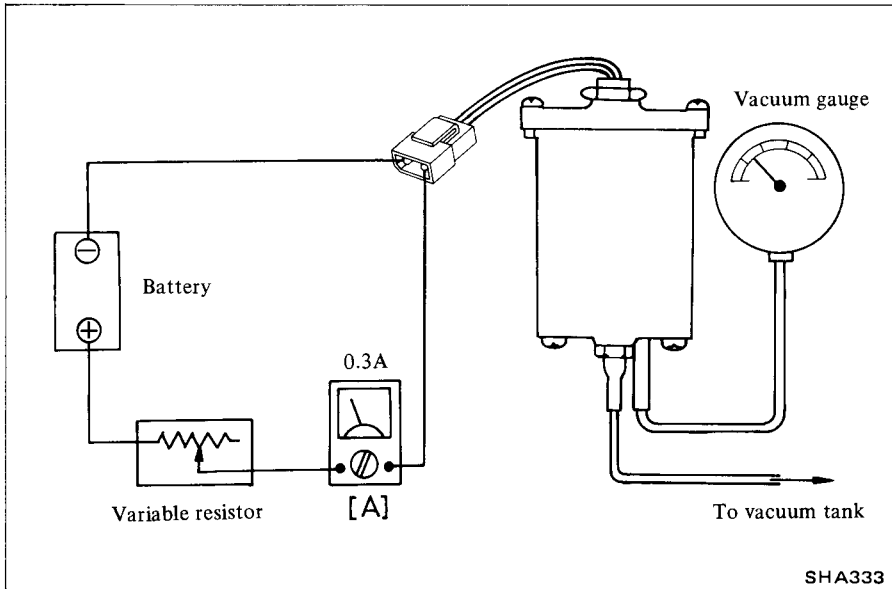

**Vacuum gauge indication:**  
-26.7 kPa  
(-200 mmHg, -7.87 inHg)

### AIR VALVE

#### Inspection

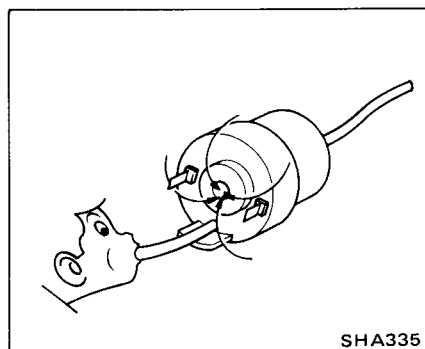
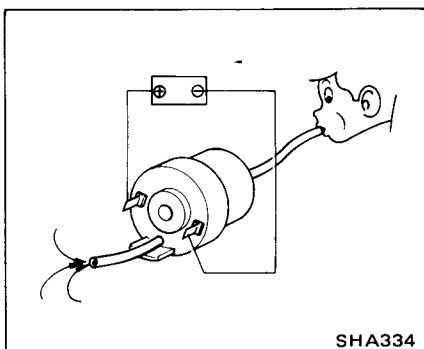

### VACUUM SWITCH

#### Inspection

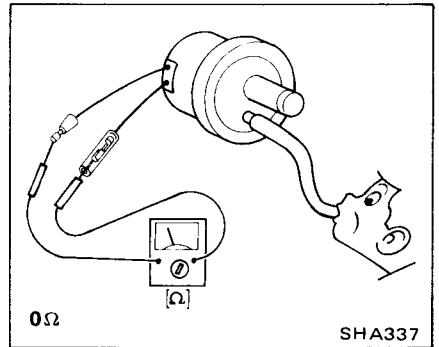
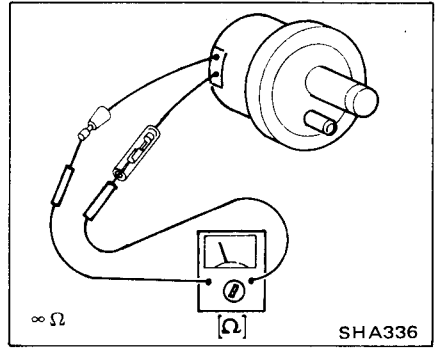

### BLOWER CONTROL RHEOSTAT

#### Location

The blower control rheostat is situated at the right side of heater unit, and is accessible after instrument panel is removed.

#### Inspection

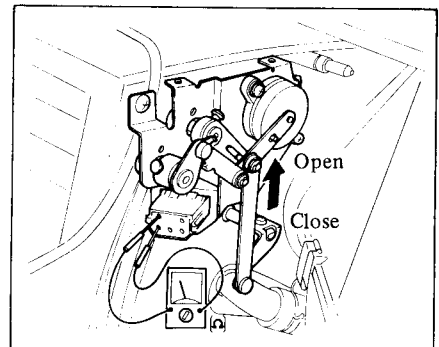

**Circuit tester indication:**  
Air mix door OPEN or CLOSE  
Approx. 1,000Ω  
Air mix door 1/2 OPEN  
Approx. 100 Ω

**RECIRC TIMER**

**Inspection**

1. Remove instrument center ventilator.
2. Disconnect connector from recirculation timer.
3. Reaching behind connector receptacle, connect test probes, (+) and (-), and attach connector in its recirculation timer position.
4. Turn ignition switch ON, and set mode lever at any position other than DEF.

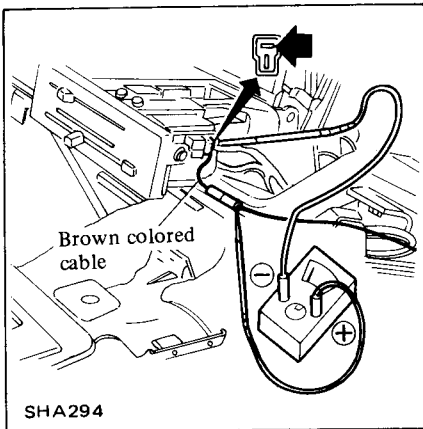

**Circuit tester indication:**  
 Recirculation switch "OFF"  
 0 V  
 Recirculation switch "ON"  
 About 12 V

**TRIMMER**

**Adjustment**

1. Measure the deviation between setting temperature and interior actual temperature.

2. Turn trimmer clockwise or counterclockwise with a thin blade screw driver.

- In case actual temperature is higher than setting temperature:

Turning direction	Deviation				
		1°C (1.8°F)	2°C (3.6°F)	3°C (5.4°F)	4°C (7.2°F)
$\theta = 30^\circ$		$\theta = 60^\circ$	$\theta = 90^\circ$	$\theta = 120^\circ$	$\theta = 150^\circ$

- In case actual temperature is lower than setting temperature:

Turning direction	Deviation				
		1°C (1.8°F)	2°C (3.6°F)	3°C (5.4°F)	4°C (7.2°F)
$\theta = 30^\circ$		$\theta = 60^\circ$	$\theta = 90^\circ$	$\theta = 120^\circ$	$\theta = 150^\circ$

**CAUTION:**  
 Do not turn trimmer more than 150 degrees.

# ELECTRICAL DIAGRAM

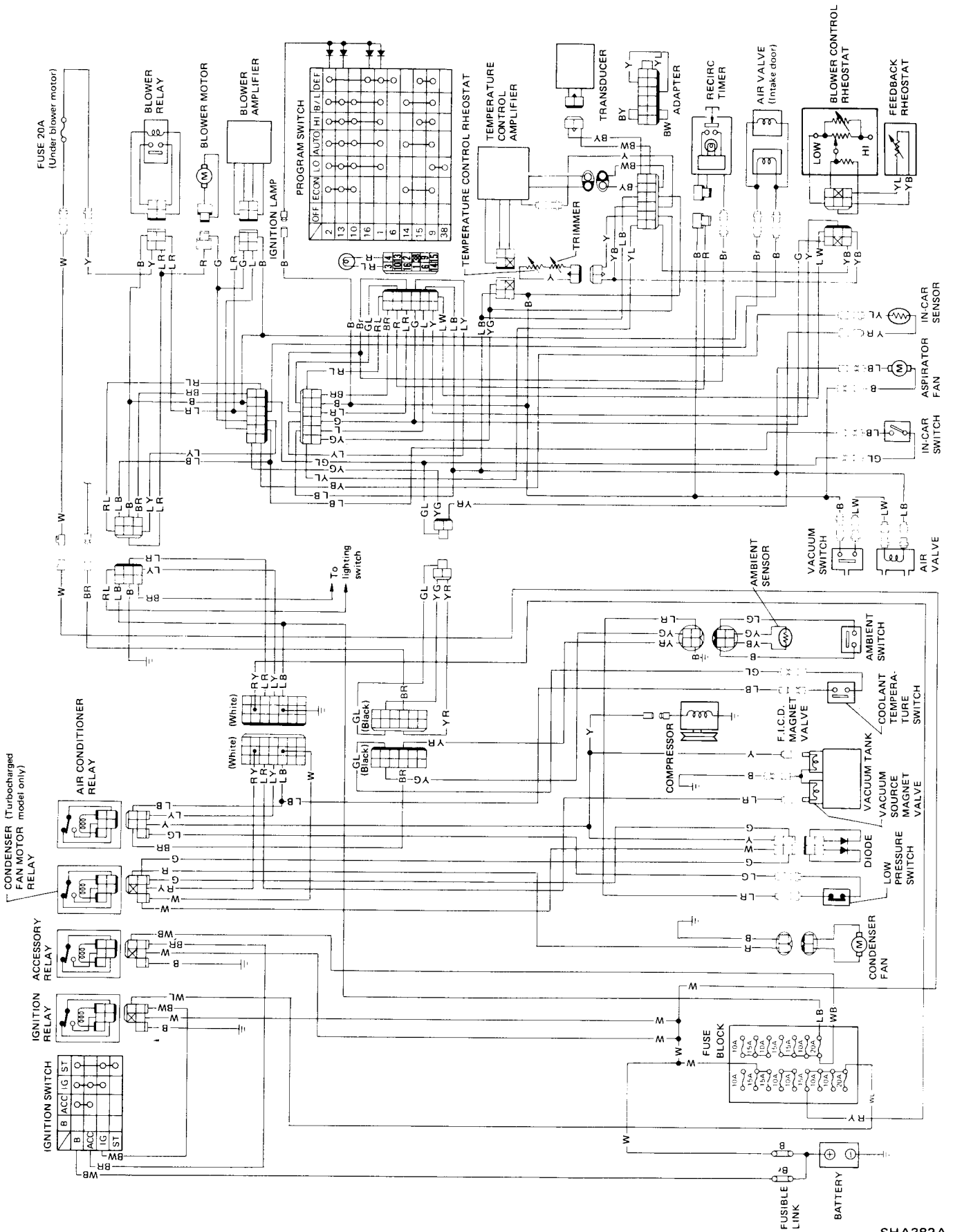

SHA382A

**VACUUM DIAGRAM**

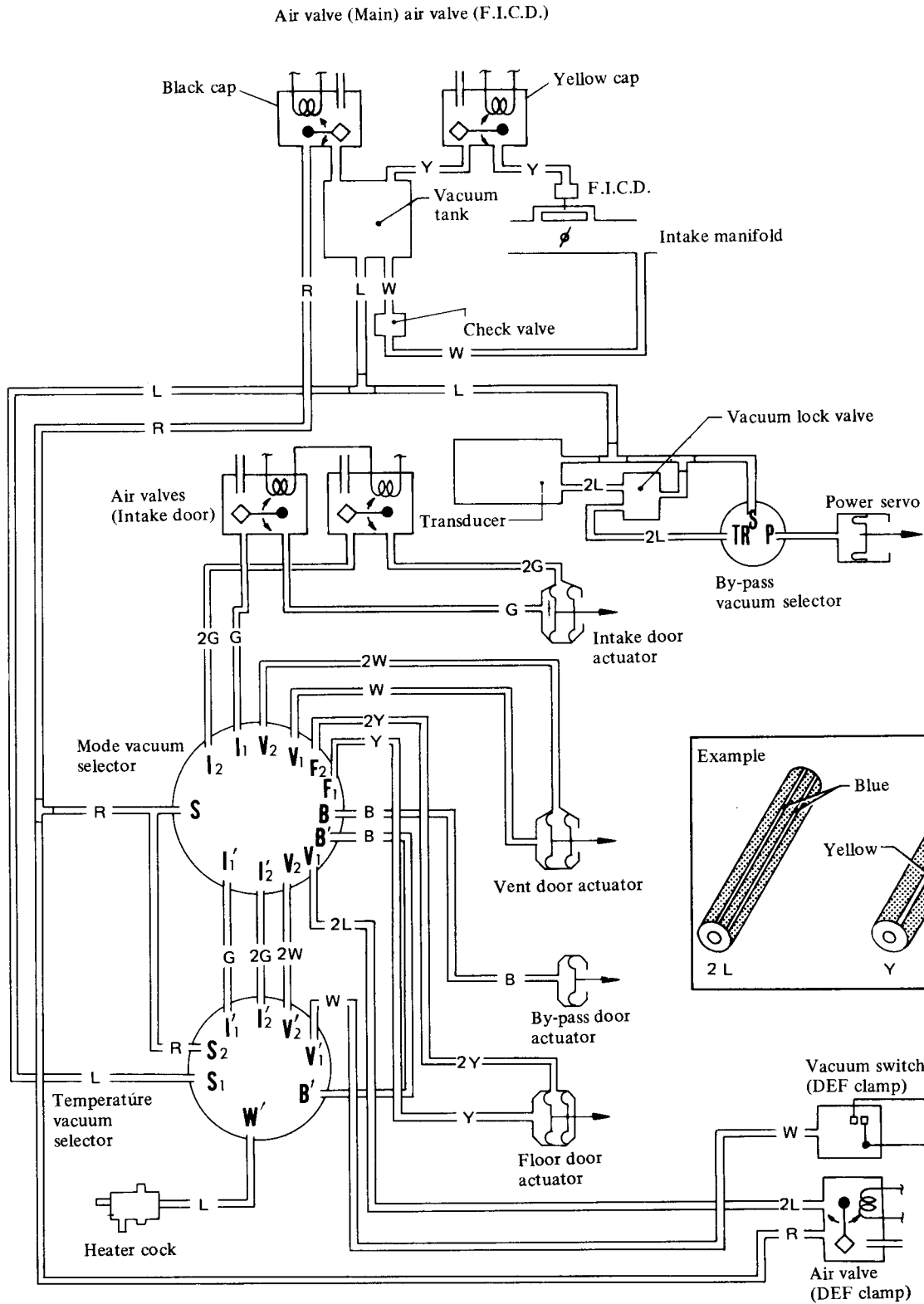

## TROUBLE DIAGNOSES

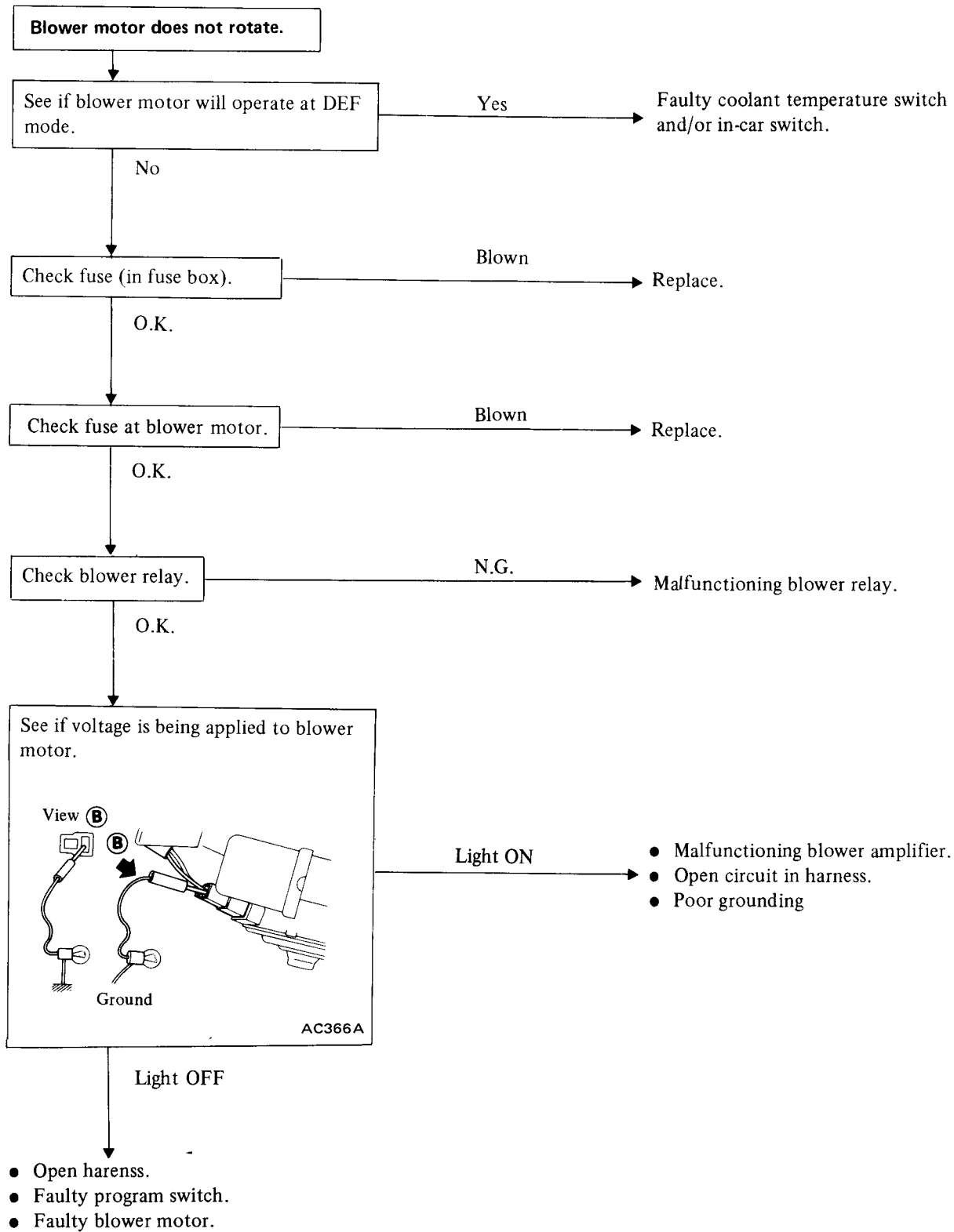



Air is discharged from incorrect outlets.

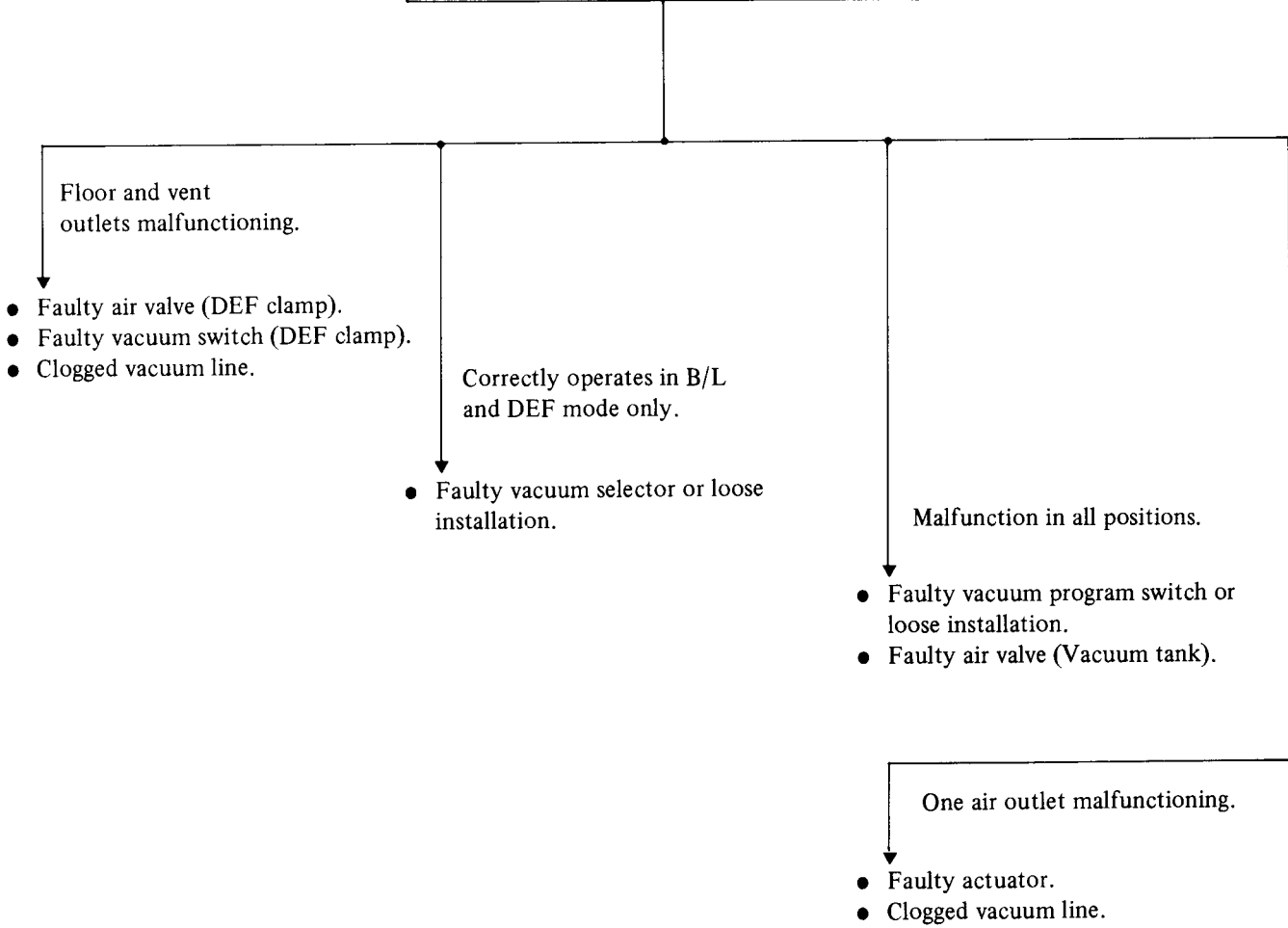

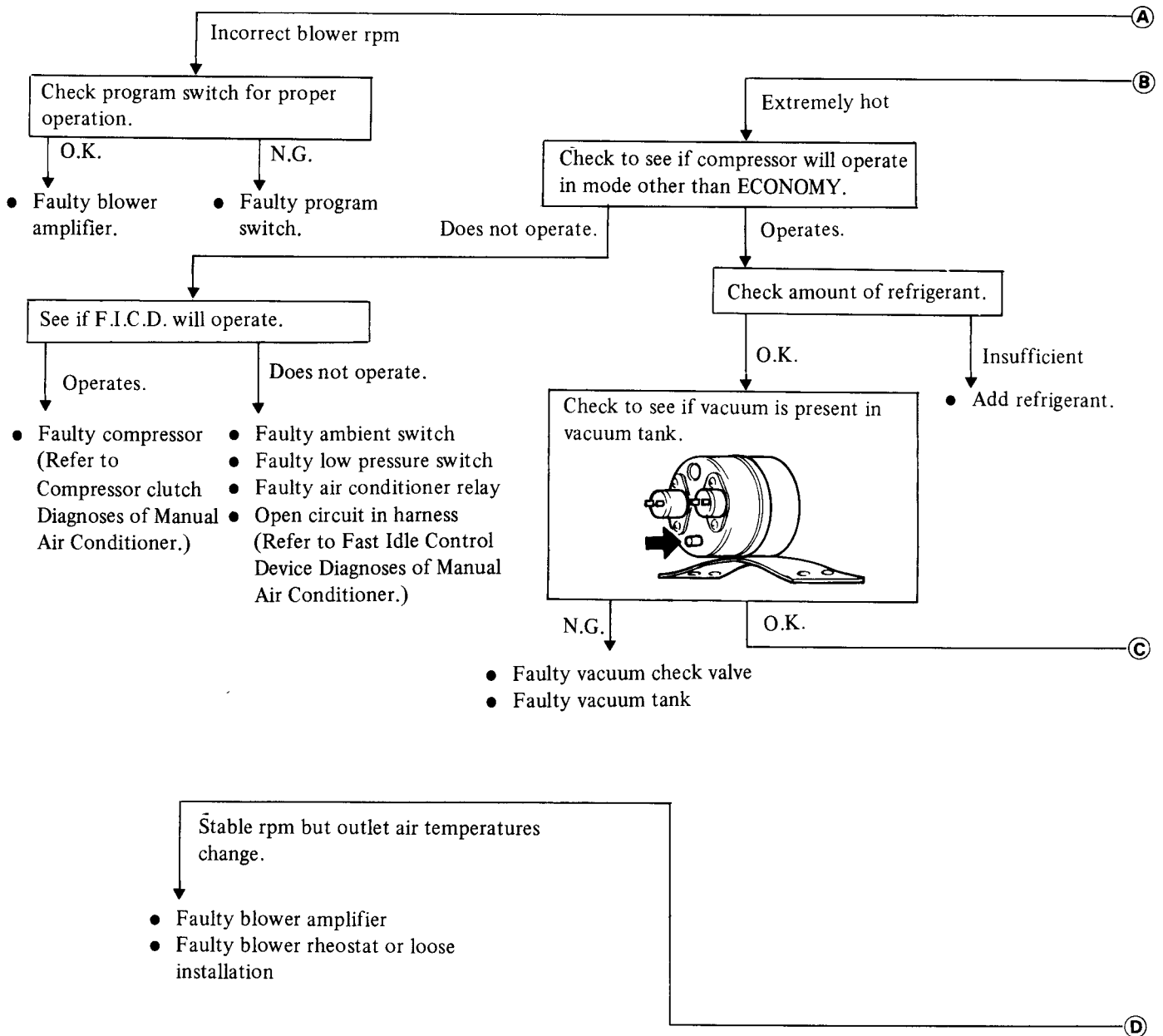

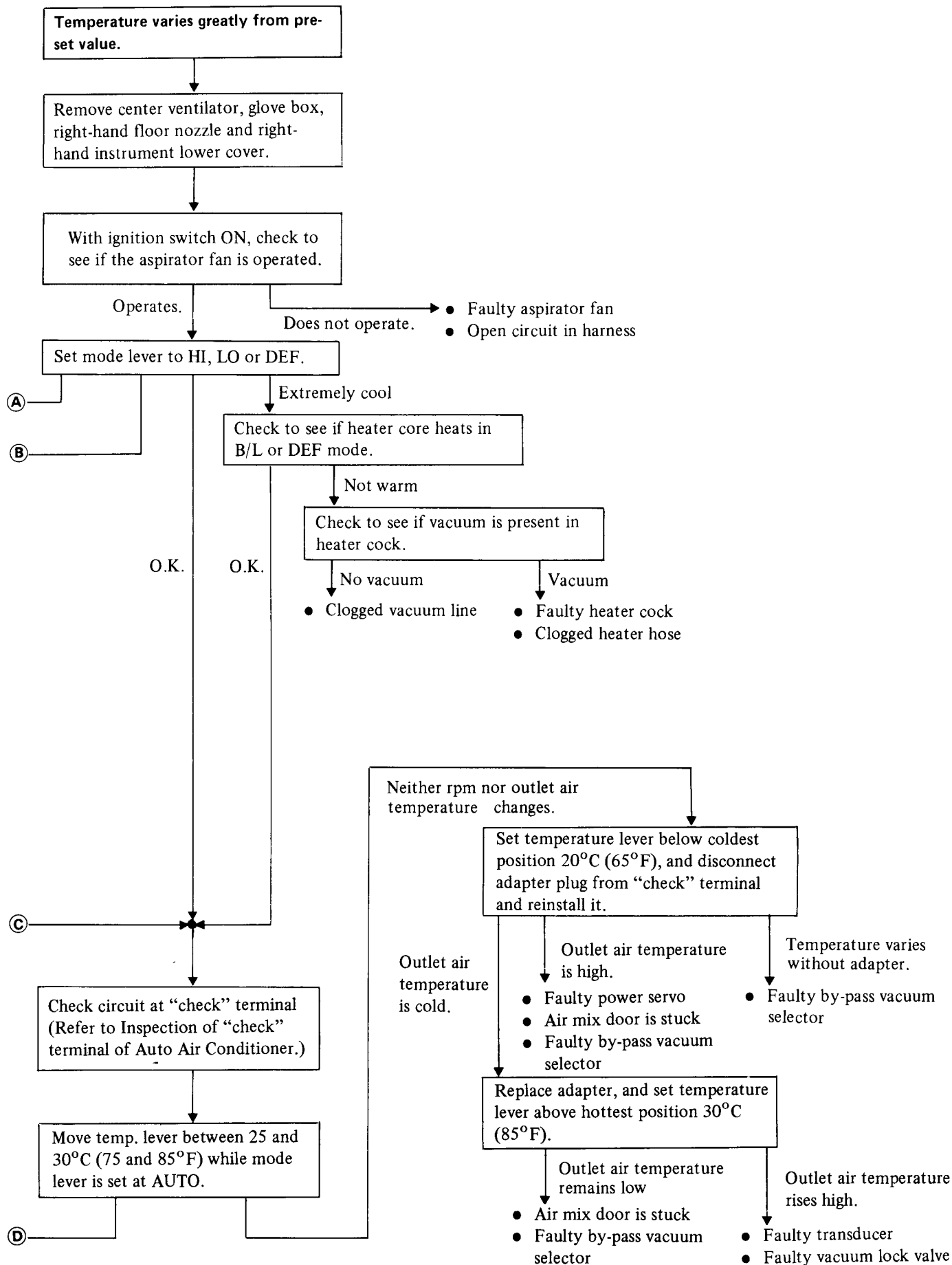

System cannot be shifted from outside to inside air (recirculation) mode or vice versa.

Measure terminal voltage across air valve (intake door) when recirculation switch is ON and OFF.

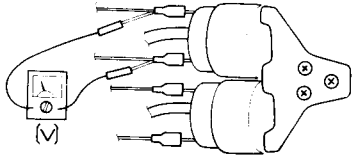

ON ... 0 Volt  
OFF ... 12 Volts

0 or 12 volts (regardless of recirculation switch position)

Remove vacuum tube and check to see if a vacuum is present in air valve.

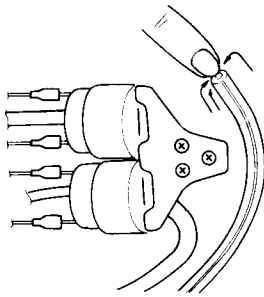

Vacuum

No vacuum

- Intake door is stuck.
- Intake door actuator malfunctioning.

Check recirculation timer.

N.G.

Replace.

O.K.

- Faulty program switch

Look for pinched or deformed vacuum tube.

N.G.

Repalce.

- Vacuum selector or vacuum program switch malfunctioning

## SERVICE DATA AND SPECIFICATIONS (S.D.S.)

### GENERAL SPECIFICATIONS

#### COMPRESSOR

Model	MJ167
Type	Swash plate
Displacement cm <sup>3</sup> (cu in)/rev.	167 (10.19)
Cylinder bore x stroke mm (in)	37.2 x 25.7 (1.465 x 1.012)
Direction of rotation	Clockwise (Viewed from drive end)
Type of driving belt	A type

#### LUBRICATING OIL

Type	SUNISO 5GS
Capacity ml (US fl oz, Imp fl oz)	150 (5.1, 5.3)

#### REFRIGERANT

Type	R-12
Capacity kg (lb)	0.8 - 1.0 (1.8 - 2.2)

#### ENGINE IDLING SPEED

Transmission	When A/C is OFF	When A/C is ON	
		Except turbo-charged model	Turbo-charged model
Manual rpm	700±100	Approximately 820	Approximately 750
Automatic rpm	700±100 at "D" range	Approximately 820 in "N" range	Approximately 750 in "N" range

### INSPECTION AND ADJUSTMENT

#### BELT TENSION

	New	Used
Fan belt/Applied pressure mm (in)/N (kg, lb)	4 - 6 (0.16 - 0.24)/ 98 (10, 22)	5 - 7 (0.20 - 0.28)/ 98 (10, 22)



#### COMPRESSOR

Clutch hub to pulley clearance mm (in)	0.5 - 0.8 (0.020 - 0.031)
--	---------------------------

#### TIGHTENING TORQUE

Unit	N-m	kg-m	ft-lb	
Compressor bracket to cylinder block	44 - 54	4.5 - 5.5	33 - 40	
Compressor to compressor bracket	44 - 54	4.5 - 5.5	33 - 40	
Refrigerant line connection				
Outside diameter of pipe	8 mm (0.31 in)	20 - 25	2.0 - 2.5	14 - 18
	12 mm (0.47 in)	25 - 29	2.5 - 3.0	18 - 22
	16 mm (0.63 in)	25 - 29	2.5 - 3.0	18 - 22
Compressor				
Shaft nut	19 - 21	1.9 - 2.1	14 - 15	
Lock nut	25 - 27	2.5 - 2.8	18 - 20	
Clutch hub nut	18 - 21	1.8 - 2.1	13 - 15	
Clutch coil screw	2.7 - 3.4	0.28 - 0.35	2.0 - 2.5	
Rear cover bolt	19 - 21	1.9 - 2.1	14 - 15	
Discharge valve bolt/Discharge connector bolt	17 - 18	1.7 - 1.8	12 - 13	
Suction valve bolt/Suction connector bolt	17 - 18	1.7 - 1.8	12 - 13	

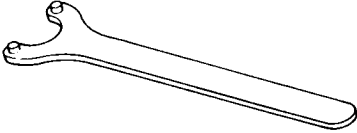
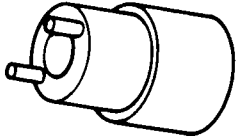
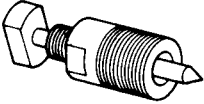
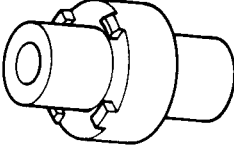
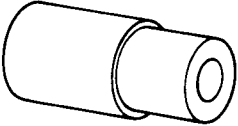
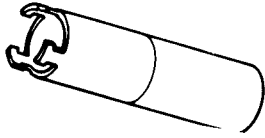
## SPECIAL SERVICE TOOLS

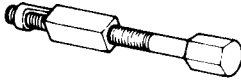
Tool number (Kent-Moore No.)	Tool name	
KV99412302 (J 24878-1)	Clutch hub wrench	
KV99412305 (J 24878-2)	Hub nut socket	
KV99412306 (J 24878-3)	Clutch hub puller	
KV99412310 (J 24878-4)	Lock nut socket	
KV99412312 (J 25472)	Puller pilot	
KV99412321 (J 26067)	Shaft seal remover and installer	
KV99412322 (J 25473)	Shaft seal pilot	
KV99412330 ( - )	Allen socket	
KV99412315 ( - )	Cylinder head remover	
KV992A9690 ( - )	Oil separator kit	