

# ENGINE MECHANICAL

## SECTION EM

EM

### CONTENTS

<b>ENGINE COMPONENTS (Outer parts)</b> . . .	EM- 2	CRANKSHAFT . . . . .	EM-13
<b>ENGINE COMPONENTS (Internal parts)</b> . . .	EM- 5	MAIN BEARING AND	
<b>ENGINE DISASSEMBLY</b> . . . . .	EM- 6	CONNECTING ROD BEARING . . . . .	EM-14
PRECAUTIONS . . . . .	EM- 6	MISCELLANEOUS COMPONENTS . . . . .	EM-14
DISASSEMBLY . . . . .	EM- 6	<b>ENGINE ASSEMBLY</b> . . . . .	EM-15
DISASSEMBLING PISTON		PRECAUTIONS . . . . .	EM-15
AND CONNECTING ROD . . . . .	EM- 8	ASSEMBLING CYLINDER HEAD . . . . .	EM-16
DISASSEMBLING CYLINDER HEAD . . . . .	EM- 8	ASSEMBLING PISTON AND	
<b>INSPECTION AND REPAIR</b> . . . . .	EM- 9	CONNECTING ROD . . . . .	EM-16
CYLINDER HEAD . . . . .	EM- 9	ASSEMBLING ENGINE OVERALL . . . . .	EM-17
CAMSHAFT AND CAMSHAFT		<b>SERVICE DATA AND</b>	
BEARING . . . . .	EM-11	<b>SPECIFICATIONS (S.D.S.)</b> . . . . .	EM-21
CYLINDER BLOCK . . . . .	EM-11	INSPECTION AND ADJUSTMENT . . . . .	EM-21
PISTON PISTON PIN AND		TIGHTENING TORQUE . . . . .	EM-25
PISTON RING . . . . .	EM-12	<b>SPECIAL SERVICE TOOLS</b> . . . . .	EM-26
CONNECTING ROD . . . . .	EM-13		

# ENGINE COMPONENTS (Outer parts)

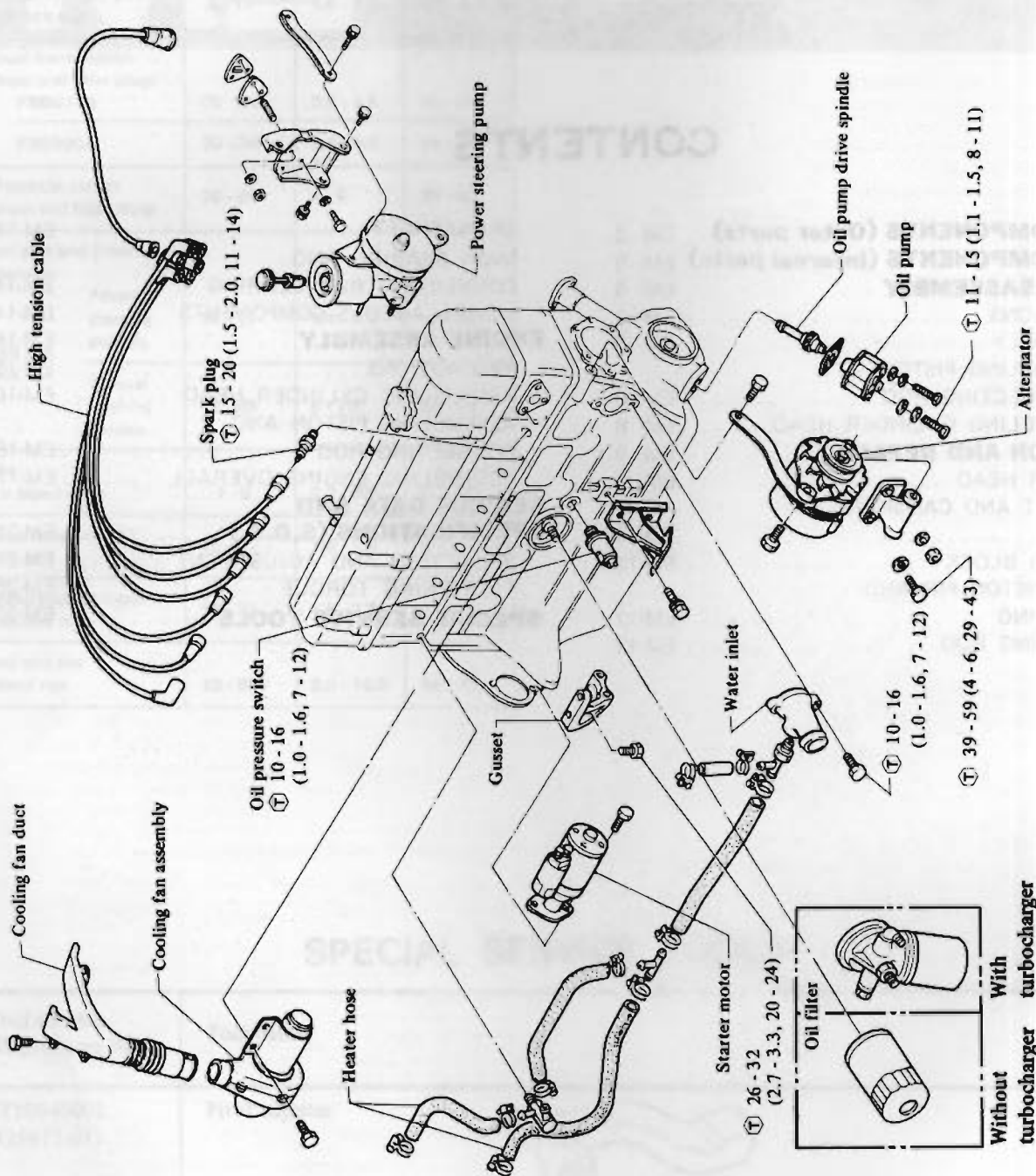

Ⓣ : N·m (kg·m, ft·lb)

# ENGINE COMPONENTS (Outer parts)

Without turbocharger

- ★  $\text{T}$  M10:
  - 34 - 44
  - (3.5 - 4.5, 25 - 33)
- M8 bolt:
  - 15 - 25
  - (1.5 - 2.5, 11 - 18)
- M8 nut:
  - 12 - 16
  - (1.2 - 1.6, 9 - 12)

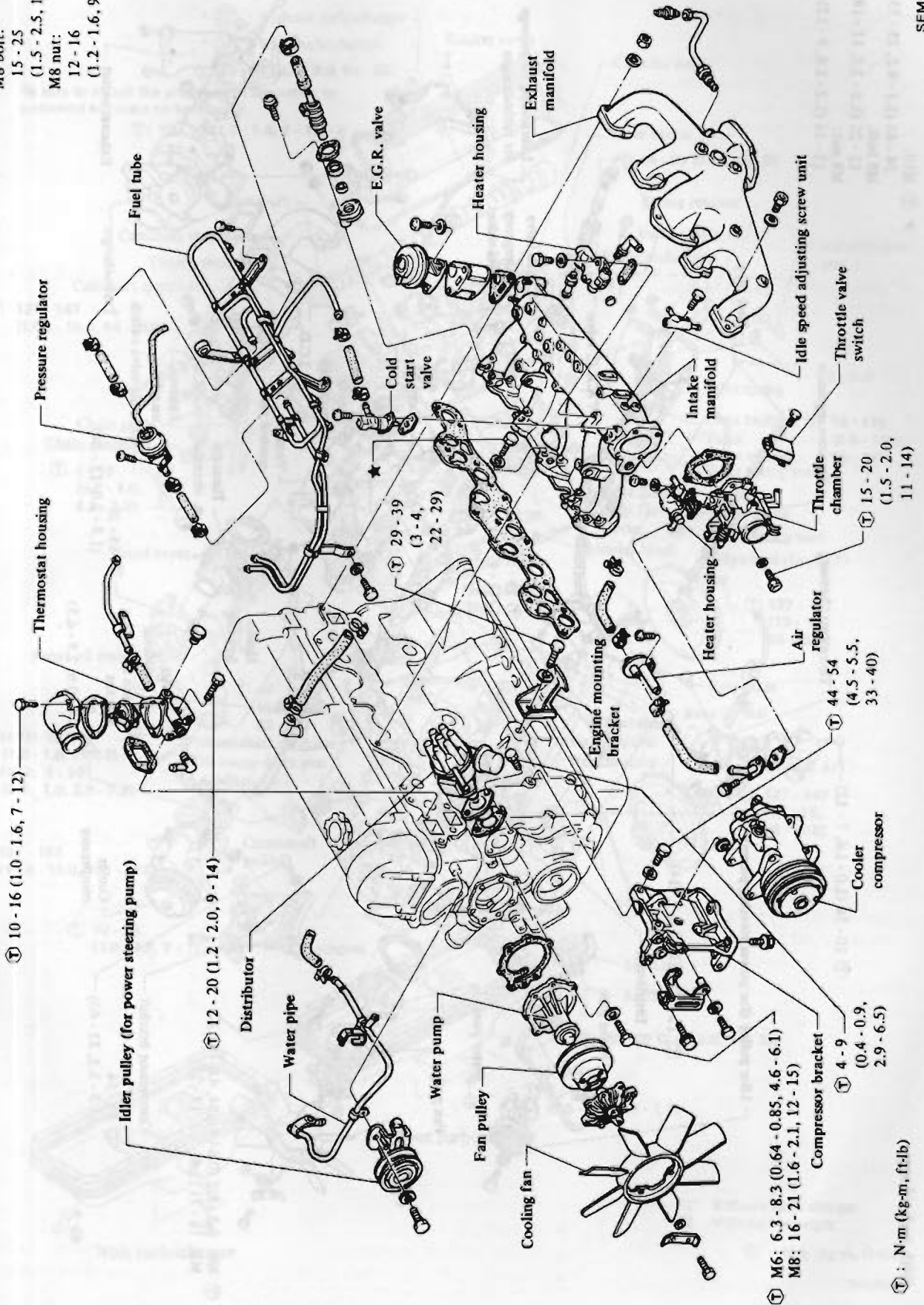

# ENGINE COMPONENTS (Outer parts)

With turbocharger

★ ① M10:

- 34 - 44 (3.5 - 4.5, 25 - 33)
- M8 bolt:
- 15 - 25 (1.5 - 2.5, 11 - 18)
- M8 nut:
- 12 - 16 (1.2 - 1.6, 9 - 12)

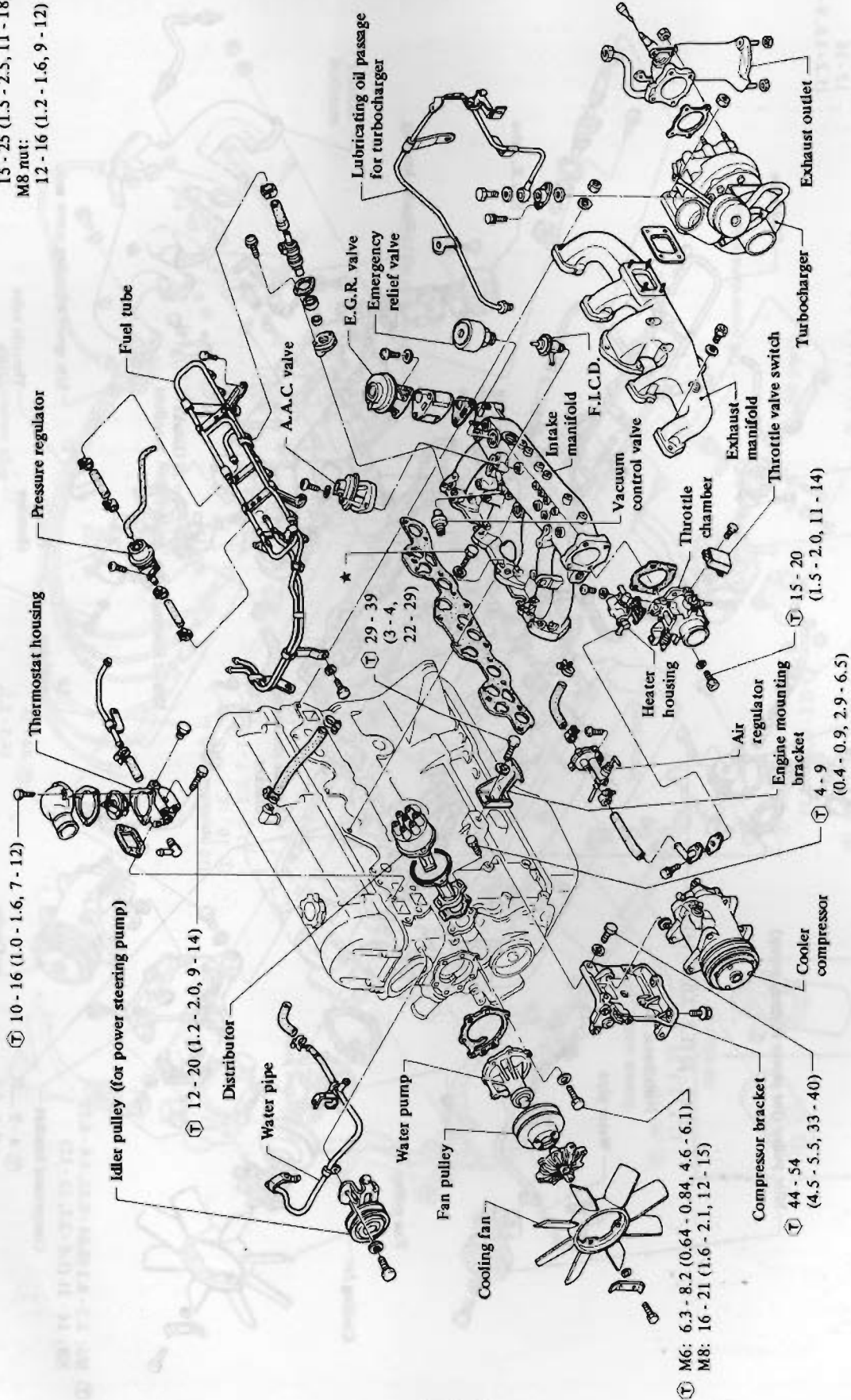

① : N·m (kg·m, ft·lb)

# ENGINE COMPONENTS (Internal parts)

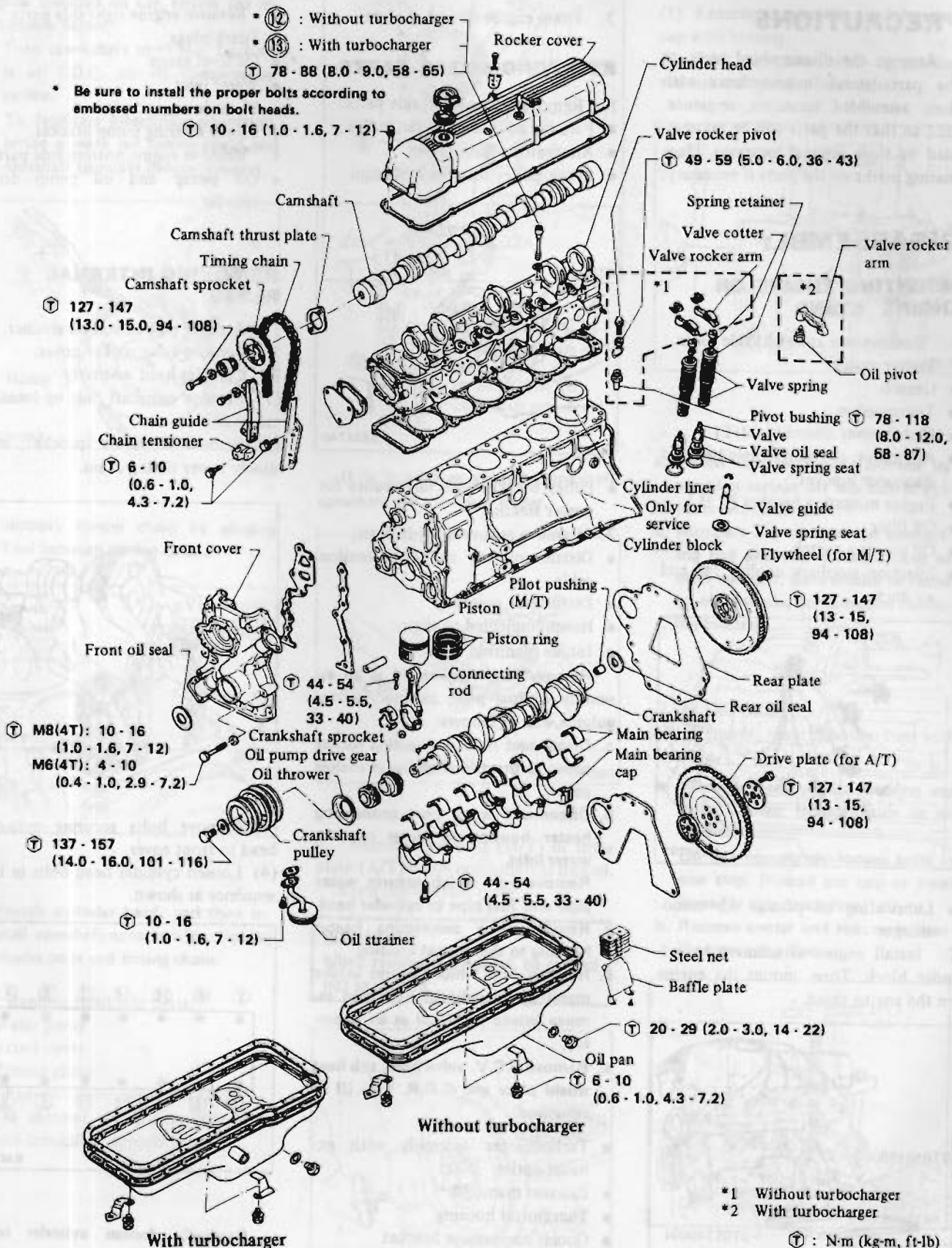

# ENGINE DISASSEMBLY

## PRECAUTIONS

Arrange the disassembled parts on the parts stand in accordance with their assembled locations, sequence, etc., so that the parts will be reassembled in their original locations. Place mating marks on the parts if necessary.

## DISASSEMBLY

### MOUNTING ENGINE ON ENGINE STAND

1. Remove rear and right side parts.
  - Starter motor
  - Gussets
  - Transmission
  - Clutch cover assembly (M/T)
  - Alternator, alternator drive belt and alternator bracket
  - Engine mounting bracket (R.H.)
  - Oil filter
  - Oil pressure switch
  - Injection auxiliary cooling fan and air duct.

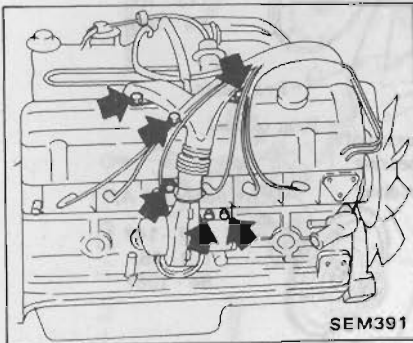

- Lubricating oil passage for turbo-charger
2. Install engine attachment to cylinder block. Then, mount the engine on the engine stand.

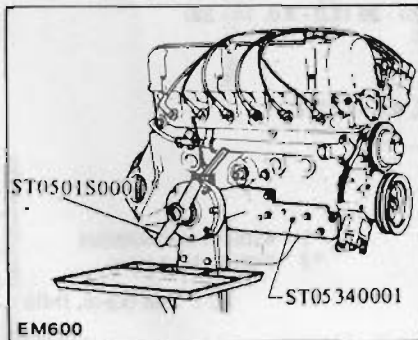

3. Drain engine oil and coolant.

### REMOVING OUTER PARTS

1. Remove engine front side parts:
  - Fan, fan coupling and fan pulley
  - Alternator adjusting bar
  - Crank pulley using suitable tool

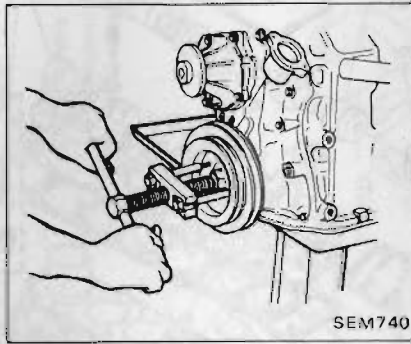

- Pulley bracket with idler pulley for power steering
2. Remove engine left side parts:
    - Distributor cap and high tension cable
    - Distributor assembly
    - Hoses connected to engine
    - Intake manifold

Remove intake manifold as an assembly of fuel pipe, injector, air regulator, etc. as follows:

- a. Disconnect hose connecting rocker cover to throttle chamber at rocker cover.
- b. Disconnect water pipe connecting heater housing to water inlet at water inlet. Remove bolt which secures water pipe and fuel pipe to cylinder head.
- c. Remove tube connecting heater housing to thermostat housing.
- d. Remove bolt which secures intake manifold to cylinder head and remove intake manifold as an assembly.
- e. Remove P.C.V. valve hose, sub heat shield plate and E.G.R. tube (if so equipped).

- Turbocharger assembly with exhaust outlet
- Exhaust manifold
- Thermostat housing
- Cooler compressor bracket
- Engine mounting bracket (L.H.)

3. Remove engine right side parts:

- Spark plugs
  - Oil level gauge
  - Water inlet
  - Water hoses and pipes
  - Power steering pump bracket
4. Remove engine bottom side parts:
    - Oil pump and oil pump drive spindle

### REMOVING INTERNAL PARTS

1. Remove oil pan and oil strainer.
2. Remove valve rocker cover.
3. Cylinder head assembly.
  - (1) Remove camshaft bolt by locking camshaft.
  - (2) Remove camshaft sprocket, and slowly lower timing chain.

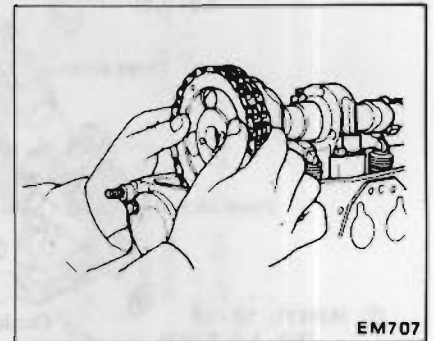

- (3) Remove bolts securing cylinder head to front cover.
- (4) Loosen cylinder head bolts in the sequence as shown.

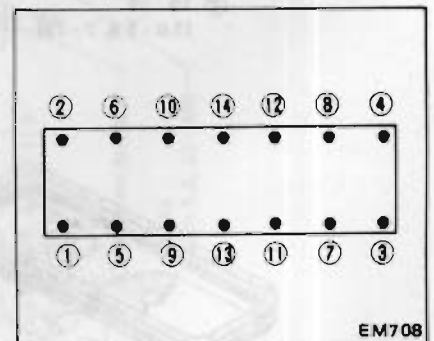

Gradually loosen cylinder head bolts in two or three stages.

## ENGINE DISASSEMBLY

### (5) Remove cylinder head.

When removing cylinder head from engine installed on car, follow the instructions below.

- a. Turn crankshaft until No. 1-piston is at T.D.C. on its compression stroke.
- b. To facilitate assembling operation, scribe a mark on timing chain and camshaft sprocket before removal.

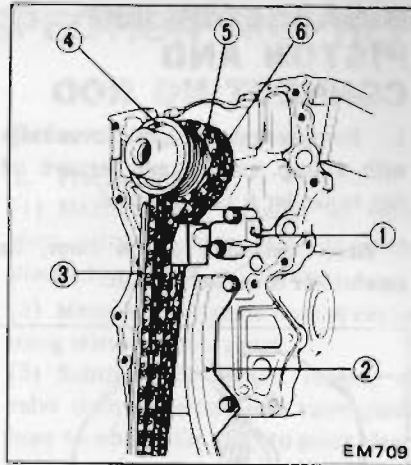
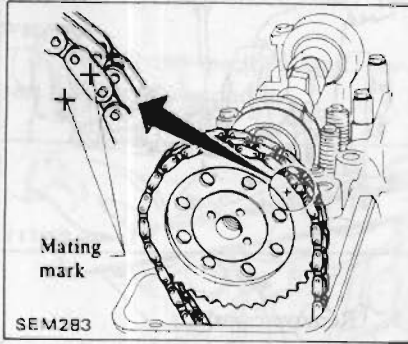

- 1 Chain tensioner
- 2 Slack side chain guide
- 3 Tension side chain guide
- 4 Oil thrower
- 5 Oil pump drive gear
- 6 Crankshaft sprocket

If it is hard to extract crankshaft sprocket, use a suitable puller.

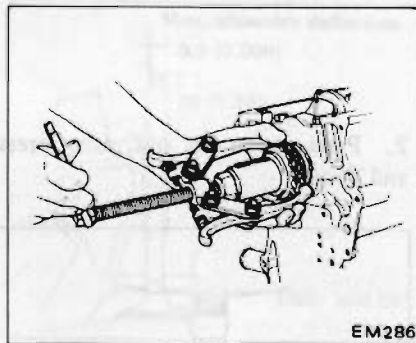

5. Remove flywheel (M/T) or drive plate (A/T) while crankshaft is locked. Then remove rear plate.

**WARNING:**  
When removing flywheel, be careful not to drop it.

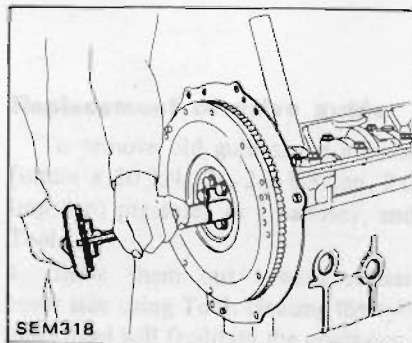

### 6. Piston and connecting rod assembly.

- (1) Remove connecting rod bearing cap with bearing.
- (2) Push out piston with connecting rod toward cylinder head side.

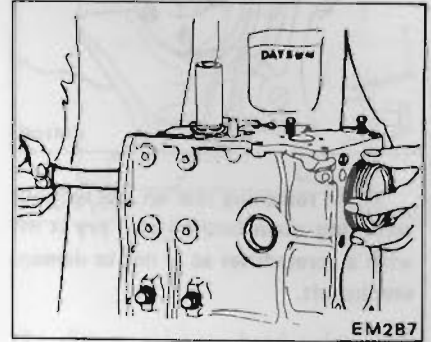

- a. Piston can be easily removed by scraping carbon off top face of cylinder with a scraper.

- b. Numbers are stamped on connecting rod and cap corresponding to each cylinder. Care should be taken to avoid wrong combination including bearing.

### 7. Crankshaft.

- (1) Remove main bearing cap with bearing.

- a. When loosening main bearing cap bolts, loosen from outside in sequence.

Do not completely loosen bolts in one step. Instead use two or three steps for this procedure.

- b. Remove center and rear main bearing caps using Tool.

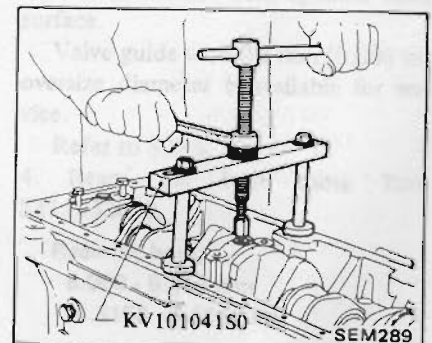

- c. Keep them in order.

- c. Support timing chain by placing Tool between timing chains.

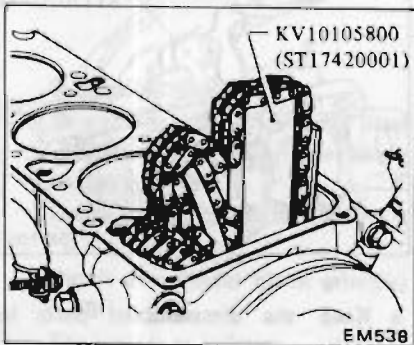

- d. Install cylinder head, and then install camshaft sprocket by aligning marks on it and timing chain.

### 4. Remove front side parts.

- Water pump
- Front cover
- Timing chain
- Chain tensioner and chain guides
- Oil thrower, oil pump drive gear and crankshaft sprocket.

(2) Remove rear oil seal.

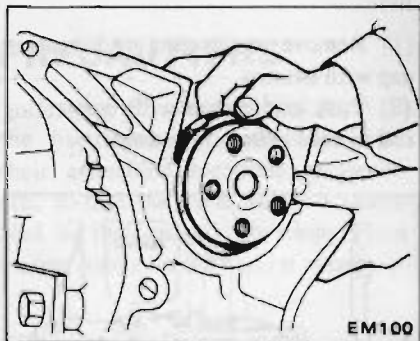

When removing rear oil seal without removing main bearing cap, pry it off with a screwdriver so as not to damage crankshaft.

(3) Remove crankshaft.

(4) Remove main bearing on the side of the block.

8. Remove baffle plate and steel net from cylinder block.

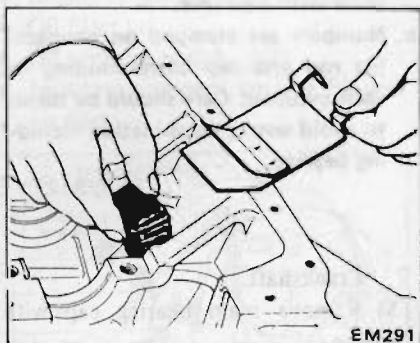

### DISASSEMBLING PISTON AND CONNECTING ROD

1. Remove top & second piston rings with a ring remover and remove oil ring expander & rails by hand.

When removing piston rings, be careful not to scratch piston.

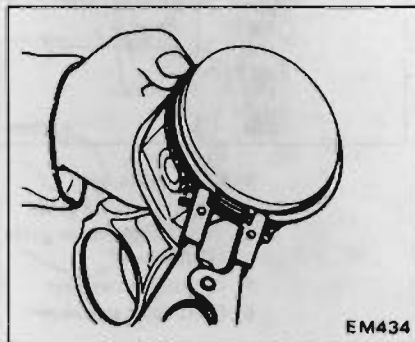

2. Press piston pin out, using press and Tool.

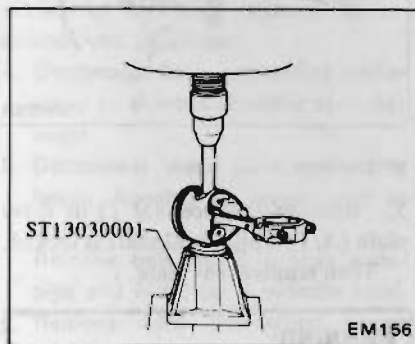

### DISASSEMBLING CYLINDER HEAD

1. Remove valve rocker spring.  
2. Loosen valve rocker pivot lock nut and set cam nose to upper position, then remove rocker arm by pressing down on valve spring.

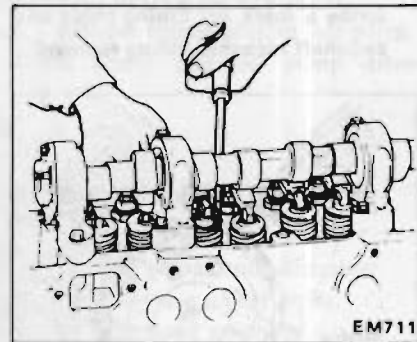

3. Remove camshaft.  
4. Remove valves, valve springs and relating parts using Tool.

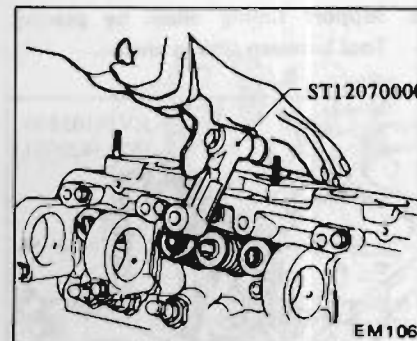

- Keep the disassembled parts in order.
- Do not remove rocker pivot bushing from cylinder head.
- Do not remove camshaft bearing from cylinder head.



## INSPECTION AND REPAIR

## CYLINDER HEAD

## CHECKING CYLINDER HEAD MATING FACE

1. Make a visual check for cracks and flaws.
2. Measure the surface of cylinder head (on cylinder block side) for warpage.

If beyond the specified limit, correct with a surface grinder.

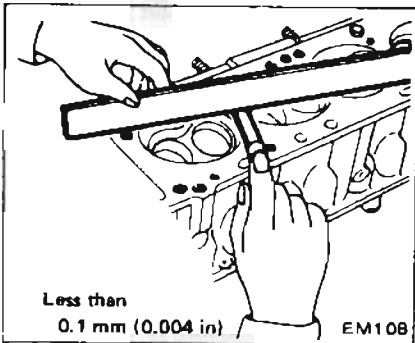
**Surface grinding limit:**

The grinding limit of cylinder head is determined by the cylinder block grinding in an engine.

Depth of cylinder head grinding is "A"

Depth of cylinder block grinding is "B"

The limit is as follows:

$$A + B = 0.2 \text{ mm (0.008 in)}$$

**Determining clearance**

1. Precise method:
  - (1) Measure the diameter of valve stem with a micrometer in three places; top, center and bottom.
  - (2) Measure valve guide bore at center using telescope hole gauge.
  - (3) Subtract the highest reading of valve stem diameter from valve guide bore to obtain the stem to guide clearance.

**Stem to guide clearance:**  
**Maximum Limit**  
 0.10 mm (0.0039 in)

2. Expedient method  
 Pry the valve in a lateral direction, and measure the deflection at stem tip with dial gauge.

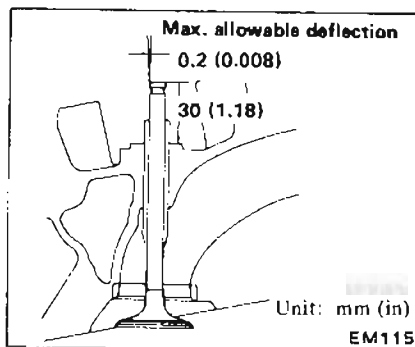

Valve should be moved in parallel with rocker arm. (Generally, a large amount of wear occurs in this direction.)

**Replacement of valve guide**

To remove old guides, use a press [under a 20 kN (2t, 2.2 US ton, 2.0 Imp ton) pressure] or a hammer, and Tool.

1. Drive them out toward rocker cover side using Tool. Heating the cylinder head will facilitate the operation.

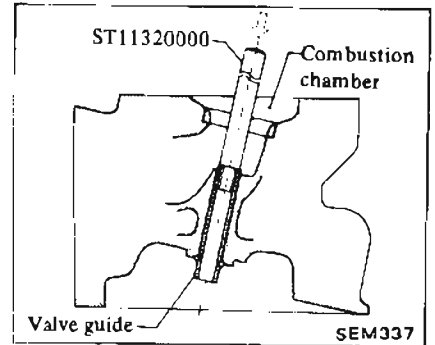

2. Ream cylinder head valve guide hole using Tool at room temperature.

**Reaming bore:**  
 12.223 - 12.234 mm  
 (0.4812 - 0.4817 in)

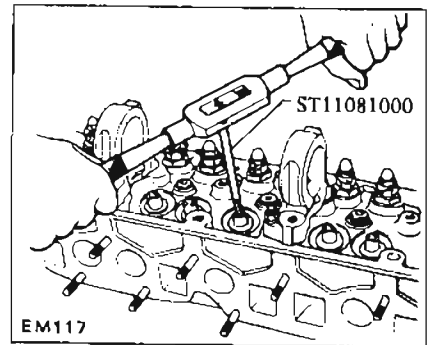

3. Fit snap ring on new valve guide. Heat cylinder head to 150 to 160°C (302 to 320°F), and press the guide onto cylinder head until the snap ring comes in contact with cylinder head surface.

Valve guide with 0.2 mm (0.008 in) oversize diameter is available for service.

Refer to S.D.S.

4. Ream the bore using Tool ST11032000.

**Reaming bore:**  
 8.000 - 8.018 mm  
 (0.3150 - 0.3157 in)

5. Correct valve seat surface with new valve guide as the axis.

## VALVE GUIDE

Measure the clearance between valve guide and valve stem. If the clearance exceeds the specified limit, replace the worn parts or both valve and valve guide. In this case, it is essential to determine if such a clearance has been caused by a worn or bend valve stem or by a worn valve guide.

**VALVE SEAT INSERTS**

Check valve seat inserts for any evidence of pitting at valve contact surface, and reseal or replace if worn out excessively.

Correct valve seat surface with Tool and grind with a grinding compound.

Valve seat insert of 0.5 mm (0.020 in) oversize is available for service.

Refer to S.D.S.

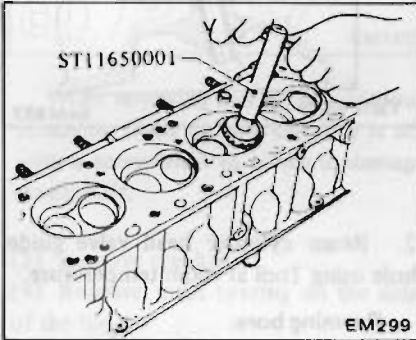

a. When repairing valve seat, check valve and valve guide for wear beforehand. If worn, replace them. Then correct valve seat.

b. The cutting should be done with both hands for uniform cutting.

**Replacement**

1. Old insert can be removed by boring out until it collapses. The machine stop depth should be set so that boring cannot continue beyond the bottom face of the insert recess in cylinder head.

2. Select a suitable valve seat insert and check its outside diameter.

3. Machine the cylinder head recess in the concentric circles which center on the valve guide.

4. Ream the cylinder head recess at room temperature.

Refer to S.D.S.

5. Heat cylinder head to a temperature of 150 to 160°C (302 to 320°F).

6. Fit insert ensuring that it bends on the bottom face of its recess, and caulk more than 4 points.

7. Newly-fitted valve seats should be cut or ground using Tool ST11650001 at the specified dimensions as shown in S.D.S.

8. Apply small amount of fine grinding compound to valve contacting face and put valve into guide. Lap valve

against its seat until proper valve seating is obtained. Remove valve and then clean valve and valve seat.

**VALVE**

1. Check each of the intake and exhaust valves for worn, damaged or deformed valve head or stem. Correct or replace the valve that is faulty.

2. Valve face or valve stem end surface should be refaced by using a valve grinder.

When valve head has been worn down to 0.5 mm (0.020 in) in-margin-thickness, replace the valve.

Grinding allowance for valve stem end surface is 0.5 mm (0.020 in) or less.

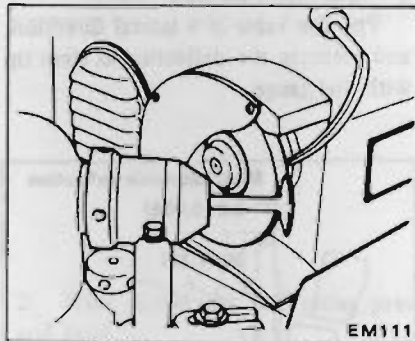

**VALVE SPRING**

1. Check valve spring for squareness using a steel square and surface plate. If spring is out of square "S" more than specified limit, replace with new ones.

- Out of square:**  
 Outer spring 2.2 mm (0.087 in)  
 Inner spring 1.2 mm (0.047 in)

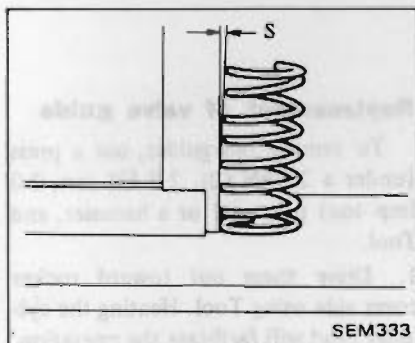

2. Measure the free length and the tension of each spring. If the measured value exceeds the specified limit, replace spring.

Refer to S.D.S.

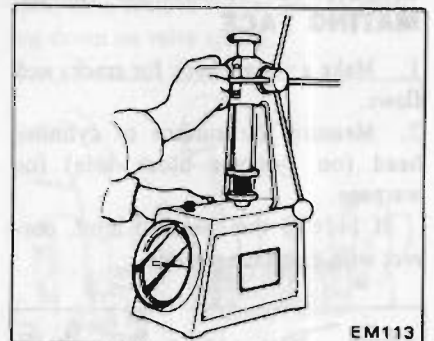

**ROCKER ARM AND VALVE ROCKER PIVOT (Without turbocharger)**

Check pivot head and cam contact and pivot contact surfaces of rocker arm for damage or wear. If faults are found, replace them. A faulty pivot necessitates its replacement together with the corresponding rocker arm.

**VALVE ROCKER OIL PIVOT (With turbocharger)**

1. Remove rocker cover.  
 2. Remove rocker arm. If oil pivot plunger does not pop up, replace pivot.

**Do not lift up plunger forcibly.**

3. Depress pivot plunger forcibly with your finger.

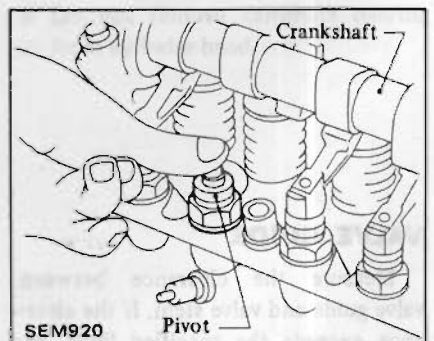

If it moves about 1 mm (0.04 in), it indicates air is inside pivot. Bleed air.

4. Re-install rocker arm and rocker cover.

- Bleed air by running engine at 1,000 rpm under no-load for about 10 minutes.
- Next, remove rocker cover and rocker arm and check to ensure all air is bled. (Refer to step 3 above.)
- If there is still air, replace pivot.

**CAUTION:**

- Care should be taken to install parts in order.
- When installing pivot, clean screw threads of cylinder head using engine oil or light oil.

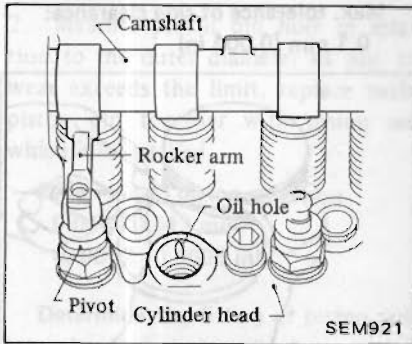

**CAMSHAFT AND CAMSHAFT BEARING**

**CAMSHAFT BEARING CLEARANCE**

Measure the inside diameter of camshaft bearing with an inside dial gauge and the outside diameter of camshaft journal with a micrometer. If any malfunction is found, replace camshaft or cylinder head assembly.

**Max. tolerance of camshaft bearing clearance:**  
0.1 mm (0.004 in)

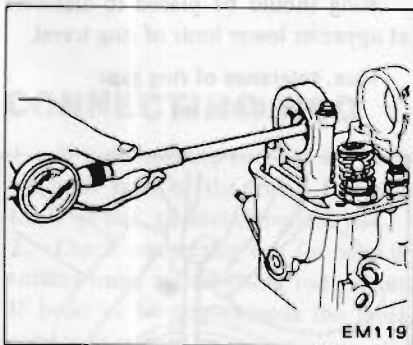

Do not remove camshaft brackets. If camshaft bracket were removed, install them by checking for a smooth rotation with the camshaft.

**CAMSHAFT ALIGNMENT**

- Check camshaft, camshaft journal and cam surface for bend, wear or damage. If beyond specified limits, replace them.
- Camshaft can be checked for bend by placing it on V-blocks and using a dial gauge with its indicating finger resting on center journal.

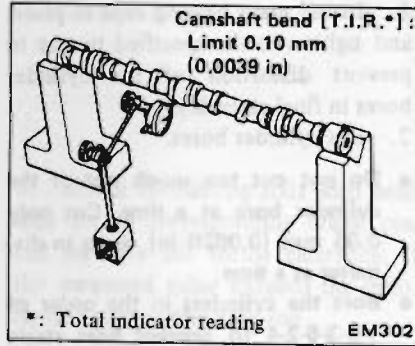

- Measure camshaft cam height. If beyond the specified limit, replace camshaft.

**Wear limit of cam height:**  
0.15 mm (0.0059 in)

- Measure camshaft end play. If beyond the specified limit, replace thrust plate.

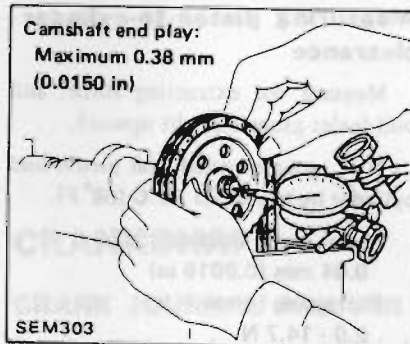

**CYLINDER BLOCK**

- Visually check cylinder block for cracks or flaws.
- Measure the top of cylinder block (cylinder head mating face) for warp-age. If warp-age exceeds the specified limit, correct with a grinder.

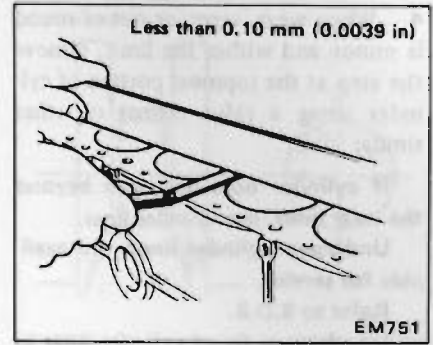

Surface grinding limit; The grinding limit of cylinder block is determined by the cylinder head grinding in an engine.

Depth of cylinder head grinding is "A"

Depth of cylinder block grinding is "B"

The limit is as follows:

$$A + B = 0.2 \text{ mm (0.008 in)}$$

- Using a bore gauge, measure cylinder bore for wear, out-of-round or taper. If they are excessive, rebore the cylinder walls with a boring machine. Measurement should be taken along bores for taper and around bores for out-of-round.

Refer to S.D.S.

Out-of-round ..... X-Y  
Taper ..... A-B

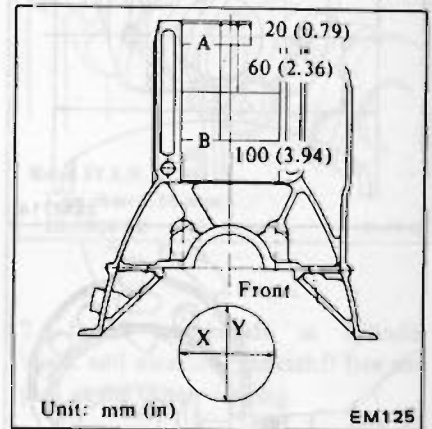

Unit: mm (in)

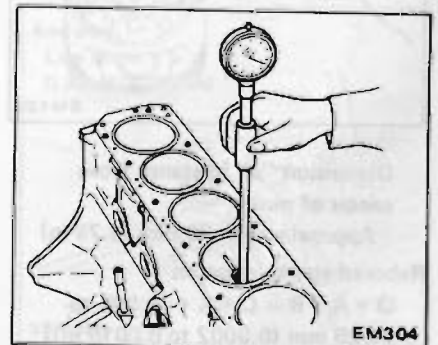

4. When wear, taper or out-of-round is minor and within the limit, remove the step at the topmost portion of cylinder using a ridge reamer or other similar tool.

If cylinder bore has worn beyond the wear limit, use cylinder liner.

Undersize cylinder liners are available for service.

Refer to S.D.S.

Interference fit of cylinder liner in cylinder block should be 0.075 to 0.085 mm (0.0030 to 0.0033 in).

### CYLINDER BORING

When any cylinder needs boring, all other cylinders must also be bored at the same time.

#### Determining bore size

1. Determine piston oversize according to amount of cylinder wear.

Refer to S.D.S.

2. The size to which cylinders must be honed is determined by adding piston-to-cylinder clearance to the piston skirt diameter "A".

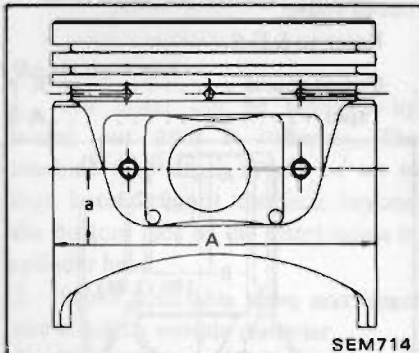

SEM714

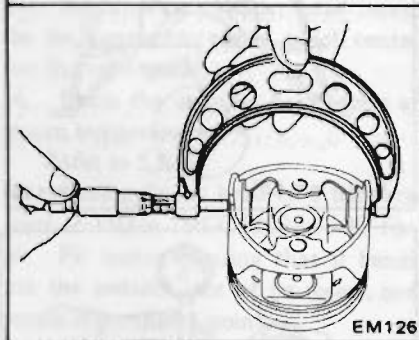

EM126

Dimension "a" (distance from center of pin):

Approximately 20 mm (0.79 in)

Rebored size calculation

$D = A + B - C = A + [0.005 \text{ to } 0.025 \text{ mm (0.0002 to 0.0010 in)}]$

where,

- D : Honed diameter
- A : Skirt diameter as measured
- B : Piston-to-wall clearance
- C : Machining allowance  
0.02 mm (0.0008 in)

#### Boring

1. Install main bearing caps in place, and tighten to the specified torque to prevent distortion of the cylinder bores in final assembly.

2. Cut cylinder bores.

- Do not cut too much out of the cylinder bore at a time. Cut only 0.05 mm (0.0020 in) or so in diameter at a time.

- Bore the cylinders in the order of 1-5-3-6-2-4 to prevent heat strain due to cutting.

3.hone the cylinders to the required size referring to S.D.S.

- Use clean sharp stones of proper grade.

- Cross-hatch pattern should be approximately 45°.

4. Measure the finished cylinder bore for out-of-round and taper.

#### Measuring piston-to-cylinder clearance

Measure the extracting force, and pull feeler gauge straight upward.

It is recommended that piston and cylinder be heated to 20°C (68°F).

Feeler gauge thickness:

0.04 mm (0.0016 in)

Extracting force:

2.0 - 14.7 N

(0.2 - 1.5 kg, 0.4 - 3.3 lb)

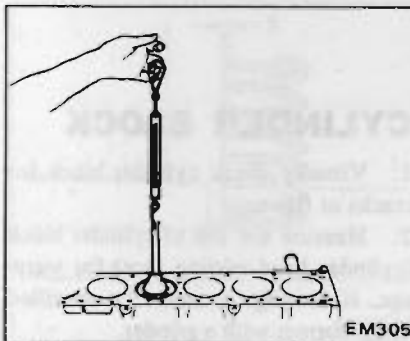

EM305

## PISTON, PISTON PIN AND PISTON RING

### PISTON

1. Scrape carbon off piston and ring grooves with a carbon scraper and a curved steel wire. Clean out oil slots in bottom land of oil ring groove.

2. Check for damage, scratches and wear. Replace if such a fault is detected.

3. Measure the side clearance of rings in ring grooves as each ring is installed.

Max. tolerance of side clearance:  
0.1 mm (0.004 in)

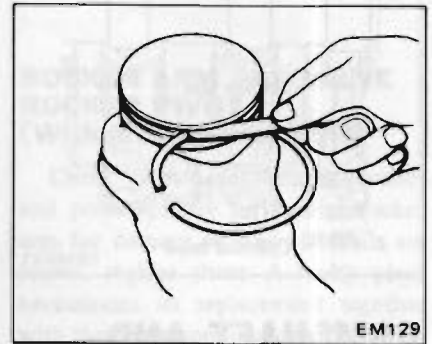

EM129

If side clearance exceeds the specified limit, replace piston together with piston ring.

### PISTON RING

Measure ring gap with a feeler gauge, placing ring squarely in cylinder using piston.

Ring should be placed to diameter at upper or lower limit of ring travel.

Max. tolerance of ring gap:

1.0 mm (0.039 in)

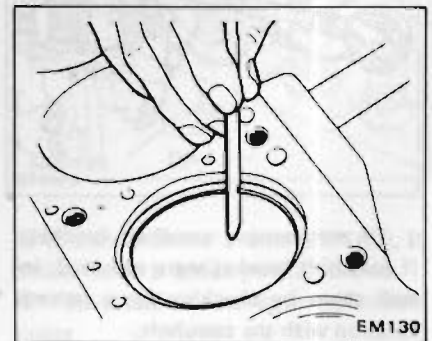

EM130

- a. When piston ring only is to be replaced, without cylinder bore being corrected, measure the gap at the bottom of cylinder where the wear is minor.
- b. Oversize piston rings are available for service.  
0.5 mm (0.020 in), 1.0 mm (0.039 in) oversize.

**PISTON PIN**

1. Check piston pin and piston pin hole for signs of sticking and other abnormalities.
2. Measure piston pin hole in relation to the outer diameter of pin. If wear exceeds the limit, replace such piston pin together with piston on which it is installed.

**Piston pin to piston clearance:**  
0.006 - 0.013 mm  
(0.0002 - 0.0005 in)

Determine the fitting of piston pin into piston pin hole to such an extent that it can be pressed smoothly by finger at room temperature.

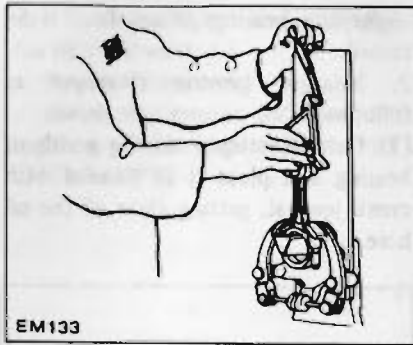
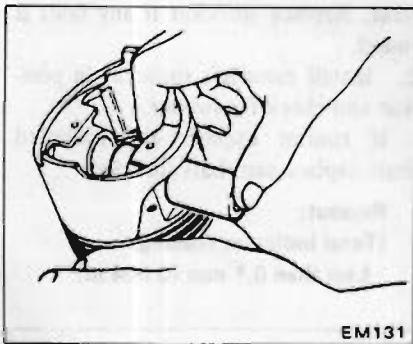

3. Install connecting rods with bearings on to corresponding crank pins and measure the thrust clearance. If the measured value exceeds the limit, replace such connecting rod.

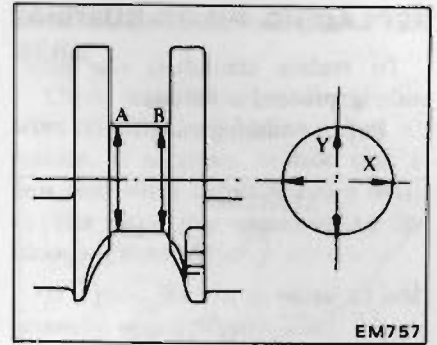
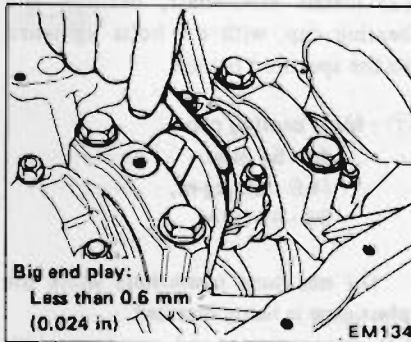

3. After regrinding crankshaft, finish it to the necessary size indicated in the chart under S.D.S. by using an adequate undersize bearing according to the extent of required repair.

**BEND AND END PLAY**

1. Crankshaft can be checked for bend by placing it on V-blocks and using a dial gauge with its indicating finger resting on the center journal.

If bend exceeds the specified limit, replace or repair.

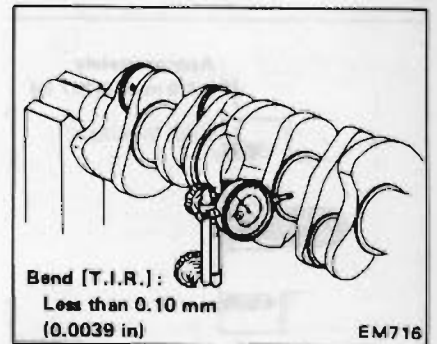

**CONNECTING ROD**

1. If a connecting rod has any flaw on both sides of the thrust face and the large end, correct or replace it.
2. Check connecting rod for bend or torsion using a connecting rod aligner. If bend or torsion exceeds the limit, correct or replace.

**Bend and torsion**  
[per 100 mm (3.94 in) length]:  
Less than  
0.05 mm (0.0020 in)

**CRANKSHAFT**

**CRANK JOURNAL AND PIN**

1. Repair or replace as required. If faults are minor, correct with fine crocus cloth.
2. Check journals and crank pins with a micrometer for taper and out-of-round. Measurement should be taken along journals for taper and around journals for out-of-round.

If out-of-round or taper exceeds the specified limit, replace or repair.

**Out-of-round (X-Y) and  
Taper (A-B):**  
Less than 0.03 mm (0.0012 in)

2. Install crankshaft in cylinder block and measure crankshaft free end play at the center bearing.

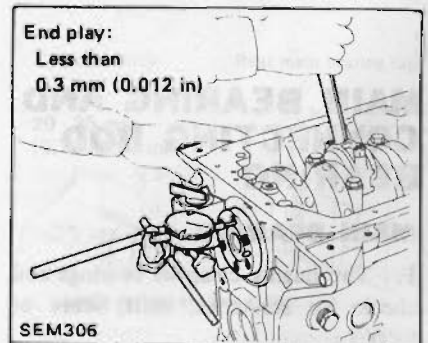

## REPLACING PILOT BUSHING

To replace crankshaft rear pilot bushing, proceed as follows:

1. Pull out bushing using Tool.

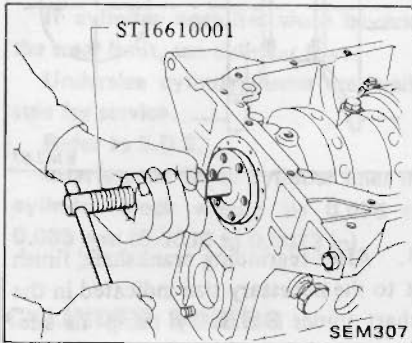

2. Before installing a new bushing, thoroughly clean bushing hole.
3. Insert pilot bushing until distance between flange end and pilot bushing is the specified distance.

When installing pilot bushing, be careful not to damage edge of pilot bushing and do not insert excessively.

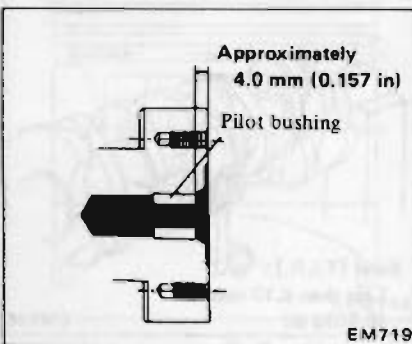

## MAIN BEARING AND CONNECTING ROD BEARING

### MAIN BEARING

1. Thoroughly clean all bearings and check for scratches, melt, score or wear.

Replace bearings, if any fault is detected.

2. Measure bearing clearance as follows:

(1) Cut a plastigage to the width of bearing and place it in parallel with crank journal, getting clear of the oil hole.

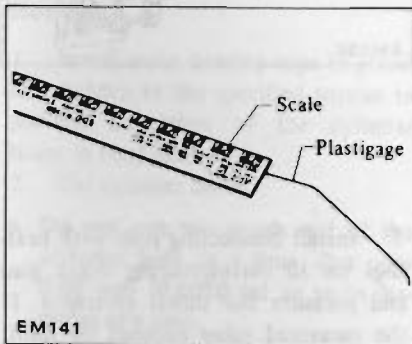

- (2) Install crankshaft, bearings and bearing cap, with the bolts tightened to the specified torque.

⊕ : Main bearing cap:  
 44 - 54 N·m  
 (4.5 - 5.5 kg·m,  
 33 - 40 ft·lb)

Do not turn crankshaft while the plastigage is being inserted.

- (3) Remove cap, and compare width of the plastigage at its widest part with the scale printed in the plastigage envelope.

Max. tolerance of main bearing clearance:  
 0.12 mm (0.0047 in)

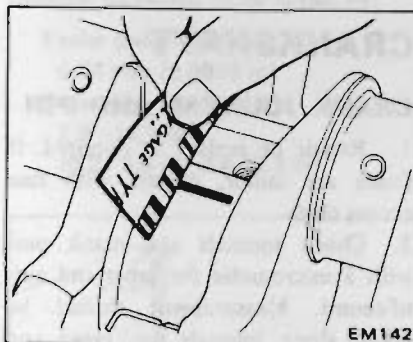

3. If clearance exceeds the specified value, replace bearing with an under-size bearing and grind crankshaft journal adequately.

Refer to S.D.S.

## CONNECTING ROD BEARING

1. Measure connecting rod bearing clearance in the same manner as above.

⊕ : Connecting rod bearing cap  
 44 - 54 N·m  
 (4.5 - 5.5 kg·m,  
 33 - 40 ft·lb)

Max. tolerance of connecting rod bearing clearance:  
 0.12 mm (0.0047 in)

2. If clearance exceeds the specified value, replace bearing with an under-size bearing and grind the crankshaft journal adequately.  
 Refer to S.D.S.

## MISCELLANEOUS COMPONENTS

### CAMSHAFT SPROCKET

1. Check tooth surface for flaws or wear. Replace sprocket if any fault is found.
2. Install camshaft sprocket in position and check for runout.

If runout exceeds the specified limit, replace camshaft sprocket.

Runout:  
 (Total indicator reading)  
 Less than 0.1 mm (0.004 in)

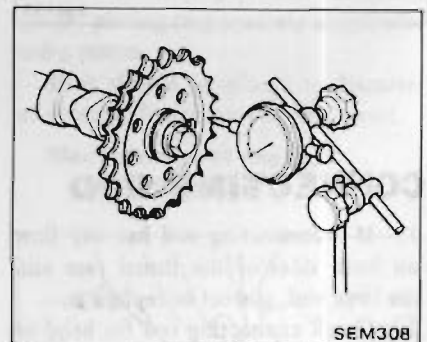

### CHAIN

- Check chain for damage and excessive wear at roller links. Replace if faulty.

## CHAIN TENSIONER AND CHAIN GUIDE

Check for wear and breakage. Replace if necessary.

## FLYWHEEL (M/T models)

1. Check the clutch disc contact surface on flywheel for damage or wear. Repair or replace if necessary.
2. Measure runout of the clutch disc contact surface with a dial gauge. If it exceeds the specified limit, replace it.

### Runout:

(Total indicator reading)

Less than 0.15 mm (0.0059 in)

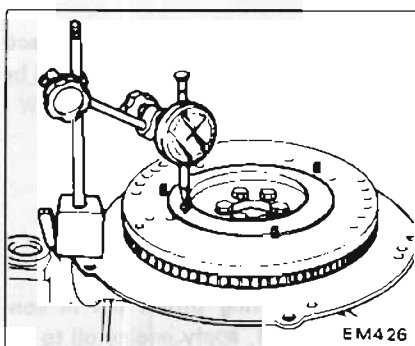

3. Check tooth surfaces of ring gear for flaws or wear.

Replace if necessary.

Install ring gear on fly wheel, heat- ing ring gear to about 180 to 220°C (356 to 428°F)

## DRIVE PLATE (A/T models)

1. Check drive plate for cracks or distortion.
2. Check tooth surfaces of ring gear for flaws or wear.

Replace drive plate assembly if necessary.

## FRONT AND REAR OIL SEAL

Check front, and rear oil seals for worn or folded over sealing lip and oil leakage. If necessary, replace with a new seal. When installing a new front or rear seal, pay attention to its mounting direction.

It is good practice to renew oil seal whenever engine is overhauled.

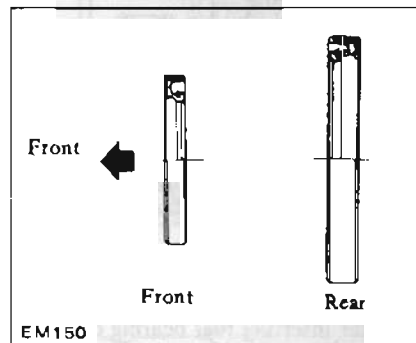

# ENGINE ASSEMBLY

## PRECAUTIONS

1. When installing sliding parts such as bearings, be sure to apply engine oil on the sliding surfaces.
2. Use new packings and oil seals.
3. Be sure to follow the specified order and tightening torque.
4. Applying sealant

Use sealant to eliminate water and oil leaks. **Do not apply too much sealant.** Parts requiring sealant are:

- (1) Front cover.

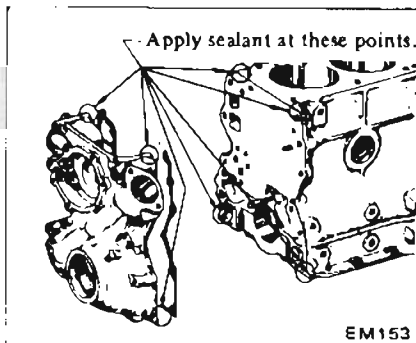

- (2) Main bearing cap and cylinder block:

Each side of rear main bearing cap and each corner of cylinder block.

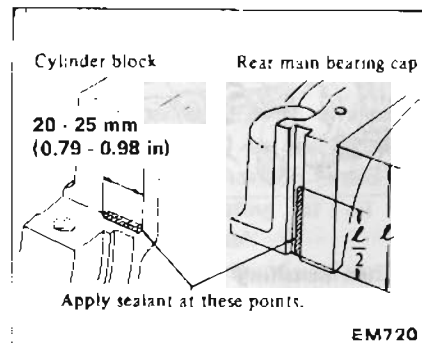

(3) Cylinder block:

Step portions on the bottom and at the four mating surfaces (cylinder block to front cover and cylinder block to rear main bearing cap).

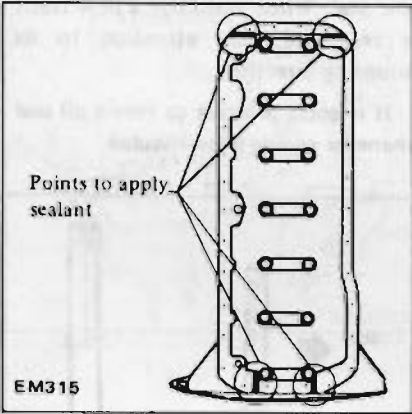

After inserting rear bearing cap side seals, apply sealant to rear main bearing cap.

- b. Check whether the valve face is free from foreign matter.
- c. Outer valve spring is of an uneven pitch type. Install valve spring with its narrow pitch side (painted) at cylinder head side.

2. Install valve rocker pivot assembly.

Screw valve rocker pivots joined with lock nuts into pivot bushing. Install valve spring retainer.

Fully screw in valve rocker pivot.

3. Install camshaft assembly in cylinder head carefully.

Do not damage the bearing inside.

4. Set thrust plate.

- Ⓣ : Camshaft thrust plate
- 6 - 10 N·m
- (0.6 - 1.0 kg·m,
- 4.3 - 7.2 ft·lb)

The oblong groove must be directed toward the front side of engine.

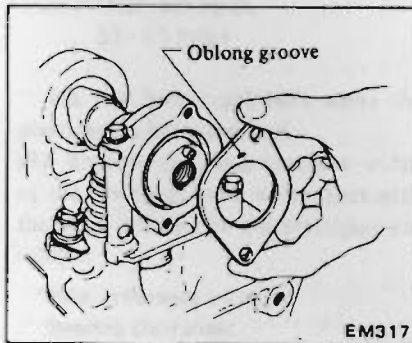

**ASSEMBLING CYLINDER HEAD**

1. Install valve and valve spring.

(1) Set valve spring inner and outer seat and install valve oil seal to valve guide.

(2) Install valve, inner and outer valve spring, valve spring retainer and valve spring collet by using Tool.

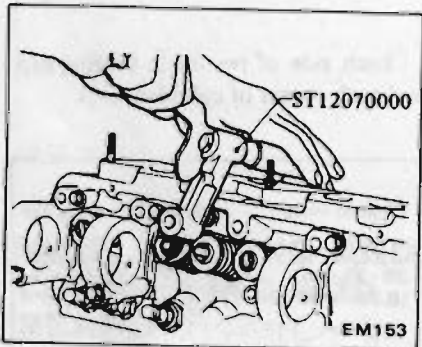

a. When installing valve, apply engine oil on the valve stem and lip of valve oil seal.

- 5. Install valve rocker guides.
- 6. Install rocker arms by pressing valve springs down with a screwdriver, etc.

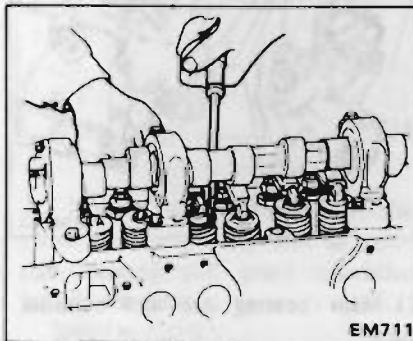

- 7. Install valve rocker springs.
- 8. After assembling cylinder head, turn camshaft until No. 1 piston is at T.D.C. on its compression stroke.

**ASSEMBLING PISTON AND CONNECTING ROD**

1. Assemble pistons, piston pins and connecting rods of the designated cylinders.

a. Piston pin is pressed into connecting rod, and fitting force should be within the specified limit.

Piston pin fitting force:

- 4.9 - 14.7 kN
- (0.5 - 1.5 t, 0.6 - 1.7 US ton,
- 0.5 - 1.5 Imp ton)

When pressing piston pin in connecting rod, apply engine oil to pin and small end of connecting rod.

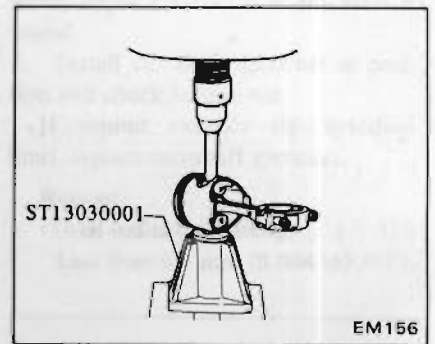

b. Arrange so that oil hole on big end of connecting rod points toward the right side of cylinder block.

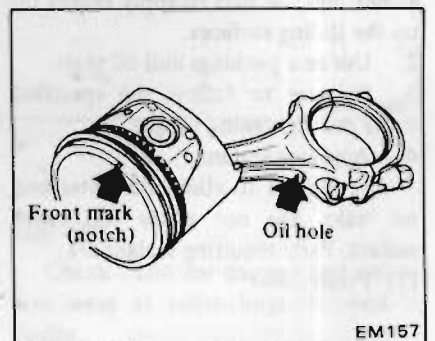



c. Connecting rods are marked at side of big end for indentifying the designated cylinders.

2. Install piston rings.

Install so that stamped mark on ring faces upward.

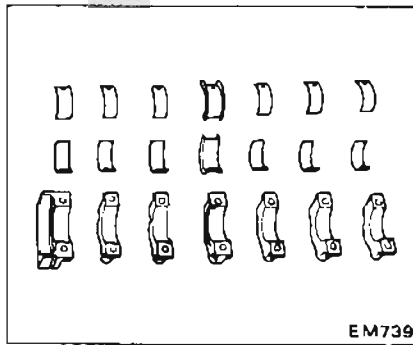
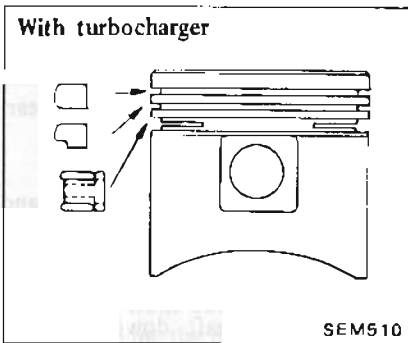
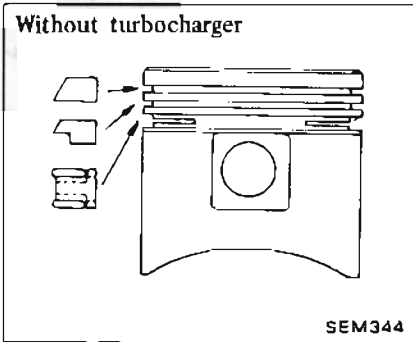

(5) Make sure that there exists proper end play at crankshaft.

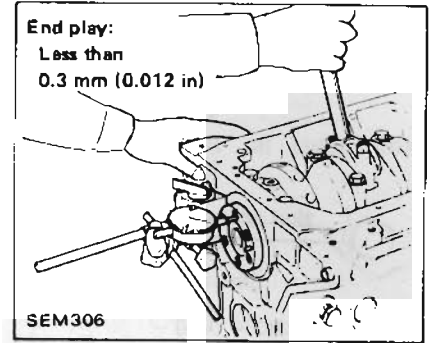

(2) Apply engine oil to main bearing surfaces on both sides of cylinder block and cap.

(3) Install crankshaft.

(4) Install main bearing cap and tighten bolts to specified torque.

Ⓣ : Main bearing cap bolts:  
44 - 54 N·m  
(4.5 - 5.5 kg·m,  
33 - 40 ft·lb)

- a. Apply sealant to each side of rear main bearing cap and each corner of cylinder block. Refer to Precautions.
- b. Arrange the parts so that the arrow mark on bearing cap faces toward the front of engine.
- c. Prior to tightening bearing cap bolts, place bearing cap in proper position by shifting crankshaft in the axial direction.
- d. Tighten bearing cap bolts gradually in separating two to three stages and in sequence outwardly from center bearing.

3. Side oil seals. Apply sealant to these seals. Then install them into main bearing cap.

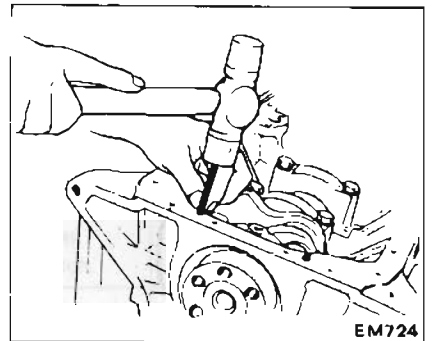

## ASSEMBLING ENGINE OVERALL

### INSTALLING INTERNAL PARTS

First, mount cylinder block on engine stand (refer to Engine Disassembly).

1. Baffle plate and steel net.

Install them into crankcase and tighten the screws applying Locktite.

2. Crankshaft.

(1) Set upper main bearings at the proper portion of cylinder block.

a. Upper bearings have oil hole and oil groove, however lower bearings do not.

b. Only center bearing (No. 4) is a flange type.

c. Front bearing (No. 1) is also the same type as rear bearing (No. 7).

d. Other inter bearings, except center bearing, are the same type.

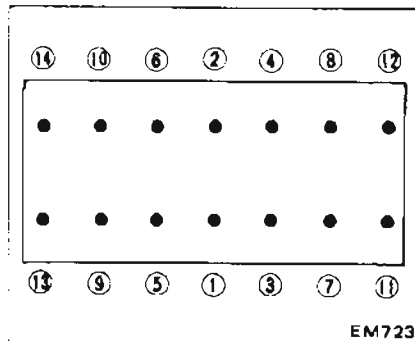

e. After securing bearing cap bolts, ascertain that crankshaft turns smoothly by hand.

4. Rear oil seal. Install rear oil seal by using Tool.

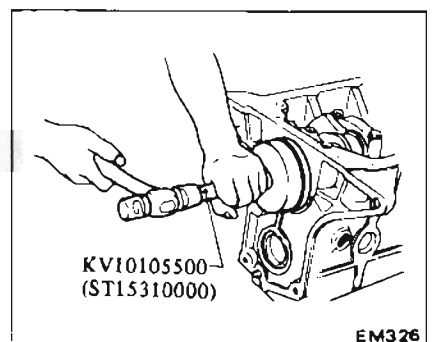

a. When installing oil seal, give coating of engine oil to mating shaft to prevent scratches and folded lip. Also apply coating of oil to periphery of oil seal.

b. Install oil seal in the direction that dust seal lip faces to the outside of crankcase.

5. Piston with connecting rod.  
 (1) Install them into corresponding cylinders using Tool.

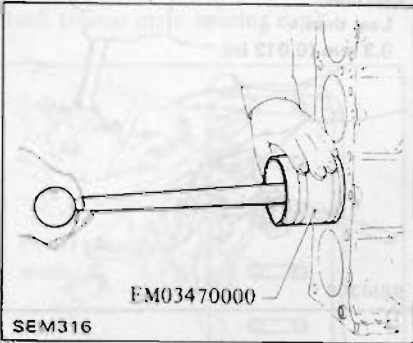

- a. Apply engine oil to sliding parts.
- b. Arrange so that the front mark on piston head faces to the front of engine.
- c. Set piston rings as shown below.

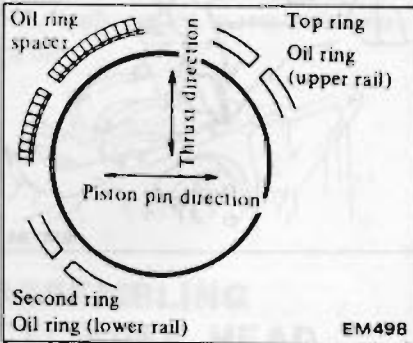

- (2) Install connecting rod caps.

- ⊕ : Connecting rod cap nuts  
 44 · 54 N·m  
 (4.5 · 5.5 kg·m,  
 33 · 40 ft·lb)

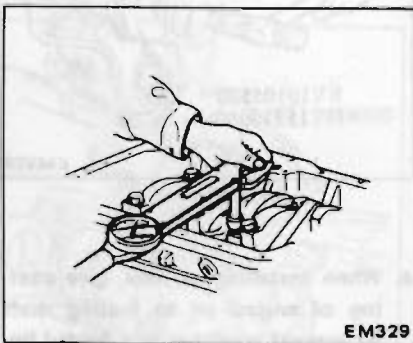

Arrange connecting rods and connecting rod caps so that the cylinder numbers face in the same direction.

- (3) Make sure that there exists proper end play at connecting rod big end. Refer to Inspection and Repair.

6. Rear plate and flywheel or drive plate.

- ⊕ : Flywheel or drive plate fixing bolts  
 127 · 147 N·m  
 (13.0 · 15.0 kg·m,  
 94 · 108 ft·lb)

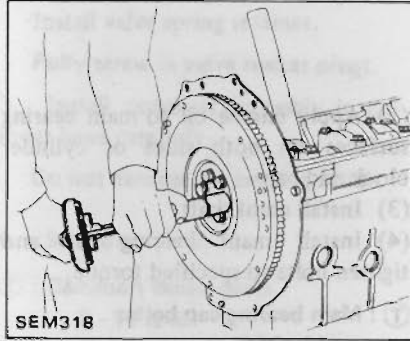

**Do not lock at ring gear.**

7. Cylinder head assembly. Install it through gasket by accommodating knock pin of cylinder block as follows:

- (1) Thoroughly clean cylinder block and head surface.

Do not apply sealant to any other part of cylinder block and head surface.

- (2) Turn crankshaft until No. 1 piston is at T.D.C. on its compression stroke.

- (3) When installing cylinder head, set intake and exhaust valve for No. 1 piston on its compression stroke by turning camshaft.

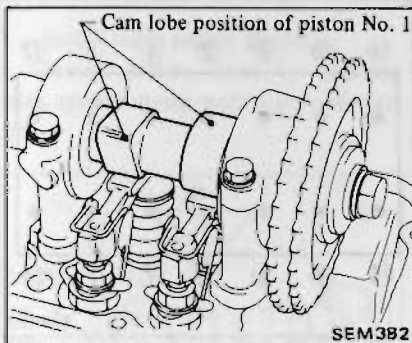

- (4) Temporarily tighten two center bolts.

- ⊕ : Cylinder head bolt  
 20 N·m (2 kg·m, 14 ft·lb)

- a. Final tightening should be carried out after installing chain and front cover.
- b. Do not rotate crankshaft and camshaft separately, because valves will hit piston heads.
- c. Always use new cylinder head gasket.
- d. There are two kinds of of cylinder head bolts with different lengths.

## INSTALLING TIMING CHAIN

1. Install crankshaft sprocket, oil pump drive gear and oil thrower.

- (1) Make sure that the mating marks of crankshaft sprocket face front.

- (2) Install oil pump drive gear so that large chamfered inner side faces rearward.

2. Install timing chain.

- (1) Align timing marks on chain and crankshaft sprocket properly.

- (2) Align No. 1 mark on camshaft sprocket with timing mark on chain.

- (3) Insert camshaft dowel pin into No. 1 hole in camshaft sprocket, and install camshaft sprocket bolt.

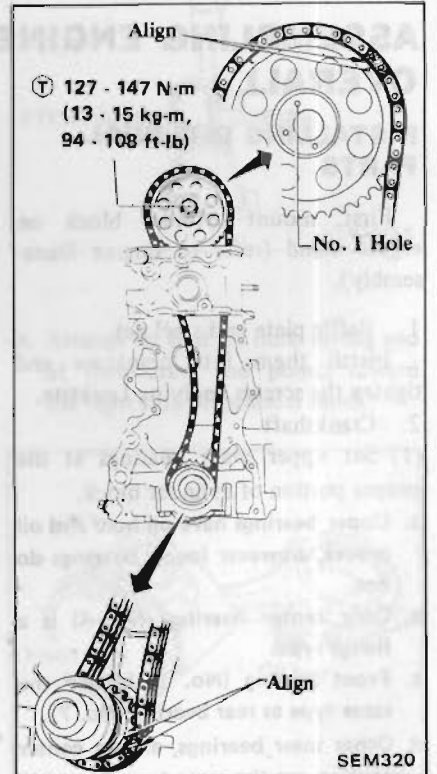

(4) Install chain guide and chain tensioner. Then tighten slack side chain guide mounting bolt so that protrusion of chain tensioner spindle is 0 mm (0 in).

- ⊕ : Chain guide and chain tensioner mounting bolt  
6 - 10 N·m  
(0.6 - 1.0 kg·m,  
4.3 - 7.2 ft·lb)

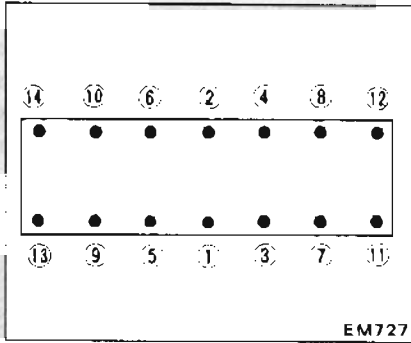
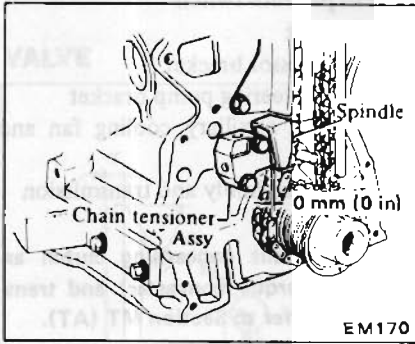

4. Finally tighten front cover to cylinder block bolts and cylinder head to front cover bolts.

Install water pump assembly with new gasket.

- ⊕ : Front cover bolts and water pump fixing bolts

	N·m	kg·m	ft·lb
MB	10 - 16	1.0 - 1.6	7 - 12
M6	4 - 10	0.4 - 1.0	2.9 - 7.2

- ⊕ : Cylinder head to front cover bolts  
8 - 14 N·m  
(0.8 - 1.4 kg·m,  
5.8 - 10.1 ft·lb)

5. Install crankshaft pulley and washer and tighten pulley bolt by locking crankshaft.

- ⊕ : Crankshaft pulley bolt  
137 - 157 N·m  
(14 - 16 kg·m,  
101 - 116 ft·lb)

6. Install fan pulley, fan coupling and fan.  
7. Install idler pulley for power steering (if so equipped).

### INSTALLING SIDE PARTS AND OIL PAN

1. Install engine right side parts.
  - Spark plugs
  - Lubricating oil passage for turbocharger

- Engine mounting brackets

- ⊕ : Bracket bolt  
29 - 39 N·m  
(3.0 - 4.0 kg·m,  
22 - 29 ft·lb)

- Oil level dipstick
- Oil pump and oil pump drive spindle

- ⊕ : Oil pump attaching bolt  
11 - 15 N·m  
(1.1 - 1.5 kg·m,  
8 - 11 ft·lb)

2. Install left side engine parts.

- Intake and exhaust manifold.

When installing exhaust manifold, be sure that manifold installing hole on cylinder head and exhaust manifold installing hole are aligned.

Always install a new gasket.

	N·m	kg·m	ft·lb
M10 Bolt	34 - 44	3.5 - 4.5	25 - 33
M8 Bolt	15 - 25	1.5 - 2.5	11 - 18
M8 Nut	12 - 16	1.2 - 1.6	9 - 12

- Turbocharger assembly with exhaust outlet
- Thermostat housing

Always install a new gasket.

- ⊕ : 12 - 20 N·m  
(1.2 - 2.0 kg·m,  
9 - 14 ft·lb)

3. Install oil strainer and oil pan with new gasket.

- ⊕ : Oil strainer bolts  
10 - 16 N·m  
(1.0 - 1.6 kg·m,  
7 - 12 ft·lb)
- Oil pan bolts  
6 - 10 N·m  
(0.6 - 1.0 kg·m,  
4.3 - 7.2 ft·lb)

- a. Apply sealant to the designated portions. Refer to Precautions.
- b. Oil pan should be tightened in a criss-cross pattern. Do not over-tighten.
- c. Always use new oil pan gasket.

### INSTALLING FRONT SIDE PARTS

1. Install front cover with gasket in place observing the following:

- a. Before installing front cover, press new oil seal in front cover in the direction that dust seal lip faces to the outside of front cover.
- b. Apply sealant to gaskets and sealing portions designated. Refer to Precautions.
- c. Apply coating of engine oil to periphery of oil seal.

2. Tighten temporarily front cover to cylinder block bolts and cylinder head to front cover bolts.

Check the height difference between cylinder block upper face and front cover upper face. Its difference must be less than 0.15 mm (0.0059 in).

3. Tighten cylinder head bolts to the specified torque in several steps in the sequence as follows.

- ⊕ : Cylinder head bolt  
78 - 88 N·m  
(8.0 - 9.0 kg·m,  
58 - 65 ft·lb)

## 4. Install distributor assembly.

- a. Make sure that No. 1 Piston is at T.D.C. on its compression stroke.
- b. Align oil pump drive spindle with distributor assembly shaft.

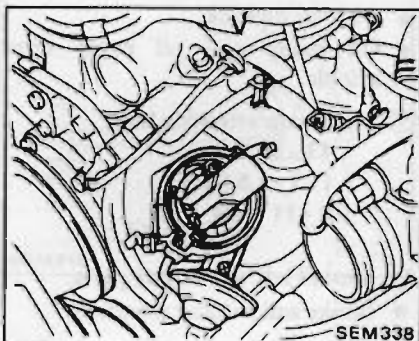

SEM338

- Install distributor gasket.
- Insert distributor into front cover so that crank angle sensor harness connector is on engine front side, then temporarily tighten installing bolts.

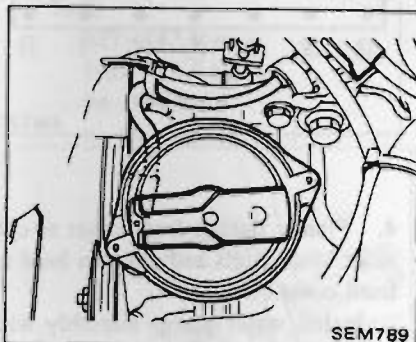

SEM789

As described above, install distributor by matching installing angle of drive shaft and distributor body angle. By adjusting rotor shaft slightly, distributor installing flange will fit front cover.

5. Install distributor cap and connect high tension cable.
6. Dismount engine from work stand and remove engine attachment.
7. Install the following parts.
  - Alternator bracket
  - Alternator assembly

## Ⓣ : Alternator bracket

39 - 59 N·m

(4 - 6 kg-m,

29 - 43 ft-lb)

## Alternator to adjusting bar bolt

20 - 29 N·m

(2.0 - 3.0 kg-m,

14 - 22 ft-lb)

- Water inlet and water hose
- Oil filter
- Oil pressure switch
- Fan belt
- Compressor bracket
- Power steering pump bracket
- Injector auxiliary cooling fan and duct
- Clutch assembly and transmission

For details concerning clutch assembly (torque converter) and transmission, refer to Section MT (AT).

## Turbocharger model

Install drive shaft after adjusting it on oil pump side.

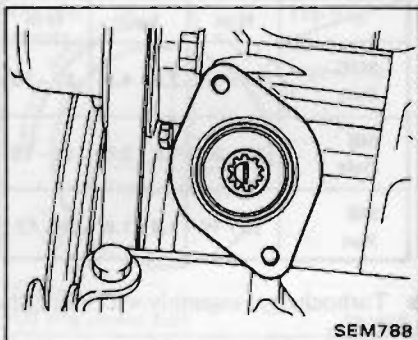

SEM788

## ENGINE TUNE-UP

After installing engine in car, tune-up engine. Refer to Section MA.

- Fill engine oil and coolant to the specified level.
- Adjust fan belt deflection.
- Adjust ignition timing.
- Adjust valve clearance.

# SERVICE DATA AND SPECIFICATIONS (S.D.S.)

## INSPECTION AND ADJUSTMENT

### CYLINDER HEAD

Unit: mm (in)

	Standard	Limit
Head surface flatness	Less than 0.05 (0.0020)	0.1 (0.004)

### VALVE

Unit: mm (in)

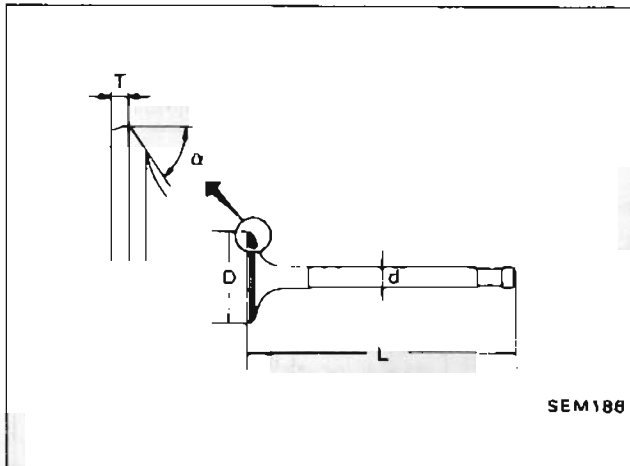

Valve head diameter "D"	Intake	44.0 - 44.2 (1.732 - 1.740)
	Exhaust	35.0 - 35.2 (1.378 - 1.386)
Valve length "L"	Intake	112.8 - 113.1 (4.4409 - 4.4527)
	Exhaust	113.6 - 113.9 (4.4724 - 4.4842)
Valve stem diameter "d"	Intake	7.965 - 7.980 (0.3136 - 0.3142)
	Exhaust	7.945 - 7.960 (0.3128 - 0.3134)
Valve face angle "α"	45°30'	
Valve margin "T" Limit	0.5 (0.020)	
Valve stem end surface grinding limit	0.5 (0.020)	

### Valve spring

Free height mm (in)	Outer	49.98 (1.9677)
	Inner	44.85 (1.7657)
Assembled height mm/N (mm/kg, in/lb)	Outer	40.0/208.9 (40.0/21.3, 1.575/47.0)
	Inner	35.0/120.6 (35.0/12.3, 1.378/27.1)
Out of square "S" mm (in)	Outer	2.2 (0.087)
	Inner	1.2 (0.047)

### Valve guide

Unit: mm (in)

	Standard	Service
Valve guide Outer diameter	12.023 - 12.034 (0.4733 - 0.4738)	12.223 - 12.234 (0.4812 - 0.4817)
Valve guide Inner diameter [Finished size]	8.000 - 8.018 (0.3150 - 0.3157)	
Cylinder head valve guide hole diameter	11.985 - 11.996 (0.4718 - 0.4723)	12.185 - 12.196 (0.4797 - 0.4802)
Interference fit of valve guide	0.027 - 0.049 (0.0011 - 0.0019)	
	Standard	Max. tolerance
Stem to guide clearance	Intake	0.1 (0.004)
	Exhaust	
Valve deflection limit	0.2 (0.008)	

**Valve seat**

Unit: mm (in)

**INTAKE**

Standard

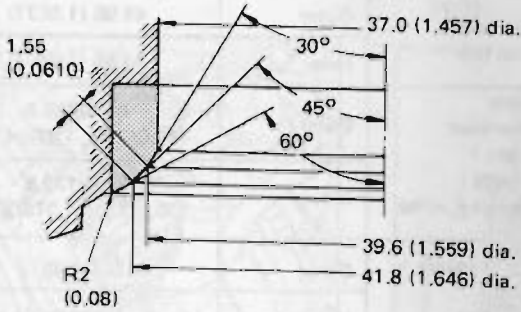

Oversize  
[0.5 (0.020)]

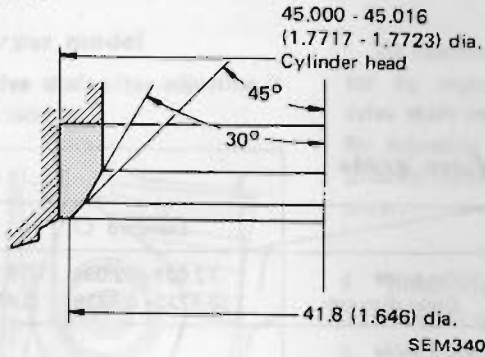

**EXHAUST**

Standard

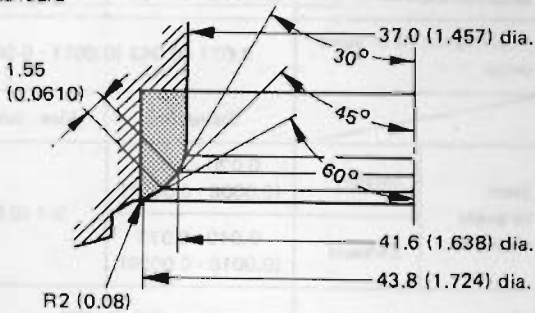

Oversize  
[0.5 (0.020)]

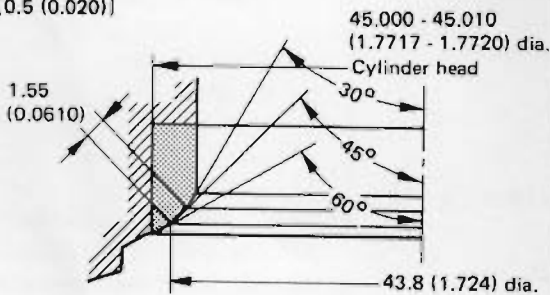

**CAMSHAFT AND CAMSHAFT BEARING**

Unit: mm (in)

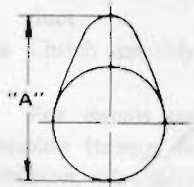
	Standard	Max. tolerance
Camshaft journal to bearing clearance	0.038 - 0.067 (0.0015 - 0.0026)	0.1 (0.004)
Inner diameter of camshaft bearing	48.000 - 48.016 (1.8898 - 1.8904)	-
Outer diameter of camshaft journal	47.949 - 47.962 (1.8878 - 1.8883)	-
Camshaft bend [T.I.R.*]	Less than 0.02 (0.0008)	0.05 (0.0020)
Camshaft end play	0.08 - 0.38 (0.0031 - 0.0150)	
 <p>EM671</p>		
Cam height "A"	For U.S.A.	Intake 39.95 - 40.00 (1.5728 - 1.5748)
		Exhaust 40.30 - 40.35 (1.5866 - 1.5886)
	For Canada	Intake & Exhaust 40.30 - 40.35 (1.5866 - 1.5886)
Wear limit of cam height	0.15 (0.0059)	

\*: Total indicator reading

# SERVICE DATA AND SPECIFICATIONS (S.D.S.)

## CYLINDER BLOCK

Unit: mm (in)

		Standard	Wear limit
Surface flatness		Less than 0.05 (0.0020)	0.10 (0.0039)
Cylinder bore	Inner diameter	86.000 - 86.050 (3.3858 - 3.3878)	—
	Out-of-round (X-Y)	Less than 0.02 (0.0008)	—
	Taper (A-B)	Less than 0.02 (0.0008)	—
Difference in inner diameter between cylinders		Less than 0.05 (0.0020)	—
Piston to cylinder clearance		0.025 - 0.045 (0.0010 - 0.0018)	—
		Outer diameter	Remarks
Outer diameter of cylinder liner for service	4.0 (0.157) Undersize	90.000 - 90.050 (3.5433 - 3.5453)	Interference fit cylinder liner to cylinder block 0.075 - 0.085 (0.0030 - 0.0033)
	4.5 (0.177) Undersize	90.50 - 90.55 (3.5630 - 3.5650)	
	5.0 (0.197) Undersize	91.00 - 91.05 (3.5827 - 3.5846)	

## PISTON, PISTON RING AND PISTON PIN

### Piston

Unit: mm (in)

Piston skirt diameter "A"	Standard		85.965 - 86.015 (3.3844 - 3.3864)
	Oversize for service	0.5 (0.020)	86.465 - 86.515 (3.4041 - 3.4061)
		1.0 (0.039)	86.965 - 87.015 (3.4238 - 3.4258)
"a" dimension			About 20 (0.79)
Piston pin hole diameter			21.001 - 21.008 (0.8268 - 0.8271)

## Piston ring

Unit: mm (in)

		Standard	Limit
Side clearance	Top	0.040 - 0.073 (0.0016 - 0.0029)	0.1 (0.004)
	2nd	0.030 - 0.063 (0.0012 - 0.0025)	
	Oil	0.023 - 0.070 (0.0009 - 0.0028)	—
Ring gap	Top	0.25 - 0.40 (0.0098 - 0.0157)	1.0 (0.039)
		0.19 - 0.33* (0.0075 - 0.0130)	
	2nd	0.15 - 0.30 (0.0059 - 0.0118)	
	Oil (rail ring)	0.3 - 0.9 (0.012 - 0.035)	

\* With turbocharger

## Piston pin

Unit: mm (in)

Piston pin outer diameter	20.993 - 20.998 (0.8265 - 0.8267)
Piston pin to piston clearance	0.006 - 0.013 (0.0002 - 0.0005)
Interference fit of piston pin to connecting rod	0.015 - 0.033 (0.0006 - 0.0013)

## CONNECTING ROD

Unit: mm (in)

Bend, torsion (per 100 mm (3.94 in))	Standard	Less than 0.025 (0.0010)
	Limit	0.05 (0.0020)
Piston pin bore dia.		20.965 - 20.978 (0.8254 - 0.8259)
Big end play	Standard	0.2 - 0.3 (0.008 - 0.012)
	Limit	0.6 (0.024)

# SERVICE DATA AND SPECIFICATIONS (S.D.S.)

## CRANKSHAFT

Unit: mm (in)

Crank journal dia.		54.942 - 54.955 (2.1631 - 2.1636)
Crank pin dia.		49.961 - 49.974 (1.9670 - 1.9675)
Out-of-round (X-Y) and taper(A-B)	Standard	Less than 0.01 (0.0004)
	Limit	0.03 (0.0012)
Bend [T.I.R.]	Standard	Less than 0.05 (0.0020)
	Limit	0.10 (0.0039)
Free end play	Standard	0.05 - 0.18 (0.0020 - 0.0071)
	Limit	0.30 (0.0118)
Pilot bushing insert distance		Approximately 4.0 (0.157)

## BEARING

### Bearing clearance

Unit: mm (in)

	Standard	Limit
Main bearing clearance	0.020 - 0.066 (0.0008 - 0.0026)	0.12 (0.0047)
Connecting rod bearing clearance	0.024 - 0.066 (0.0009 - 0.0026)	0.12 (0.0047)

## Main bearing undersize

Unit: mm (in)

	Crank journal diameter
Standard	54.942 - 54.955 (2.1631 - 2.1636)
0.25 (0.0098) Undersize	54.692 - 54.705 (2.1532 - 2.1537)
0.50 (0.0197) Undersize	54.442 - 54.455 (2.1434 - 2.1439)
0.75 (0.0295) Undersize	54.192 - 54.205 (2.1335 - 2.1341)
1.00 (0.0394) Undersize	53.942 - 53.955 (2.1237 - 2.1242)

## Connecting rod bearing undersize

Unit: mm (in)

	Crank journal diameter
Standard	49.961 - 49.974 (1.9670 - 1.9675)
0.06 (0.0024) Undersize	49.901 - 49.914 (1.9646 - 1.9651)
0.12 (0.0047) Undersize	49.841 - 49.854 (1.9622 - 1.9628)
0.25 (0.0098) Undersize	49.711 - 49.724 (1.9571 - 1.9576)
0.50 (0.0197) Undersize	49.461 - 49.474 (1.9473 - 1.9478)
0.75 (0.0295) Undersize	49.211 - 49.224 (1.9374 - 1.9379)
1.00 (0.0394) Undersize	48.961 - 48.974 (1.9276 - 1.9281)

## MISCELLANEOUS COMPONENTS

Unit: mm (in)

Camshaft sprocket Runout [T.I.R.]	Less than 0.1 (0.004)
Flywheel Runout [T.I.R.]	Less than 0.15 (0.0059)



# TIGHTENING TORQUE

## Engine outer parts



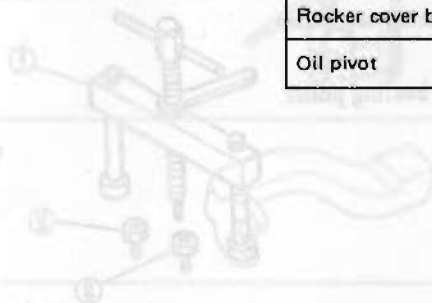

Unit	N·m	kg·m	ft·lb	
Alternator bracket bolt	39 - 59	4.0 - 6.0	29 - 43	
Alternator to adjusting bar bolt	20 - 29	2.0 - 3.0	14 - 22	
Compressor bracket bolt	44 - 54	4.5 - 5.5	33 - 40	
Distributor support bolt	4 - 8	0.4 - 0.8	2.9 - 5.8	
Engine mounting bracket	29 - 39	3.0 - 4.0	22 - 29	
Gusset attaching bolt	26 - 32	2.7 - 3.3	20 - 24	
Manifold bolt and nut	M10	34 - 44	3.5 - 4.5	25 - 33
	M8 bolt	15 - 25	1.5 - 2.5	11 - 18
	M8 nut	12 - 16	1.2 - 1.6	9 - 12
Oil pressure sending unit	10 - 16	1.0 - 1.6	7 - 12	
Oil pump bolt	11 - 15	1.1 - 1.5	8 - 11	
Spark plug	15 - 20	1.5 - 2.0	11 - 14	
Thermostat housing	12 - 20	1.2 - 2.0	9 - 14	
Water inlet bolt	10 - 16	1.0 - 1.6	7 - 12	
Water outlet bolt	10 - 16	1.0 - 1.6	7 - 12	
Water pump bolt	M6	6.3 - 8.2	0.64 - 0.84	4.6 - 6.1
	M8	16 - 21	1.6 - 2.1	12 - 15
Water pump pulley stud	6 - 10	0.6 - 1.0	4.3 - 7.2	

## Engine body parts



Unit	N·m	kg·m	ft·lb	
Camshaft locating plate bolt	6 - 10	0.6 - 1.0	4.3 - 7.2	
Camshaft sprocket bolt	127 - 147	13.0 - 15.0	94 - 108	
Chain guide bolt	6 - 10	0.6 - 1.0	4.3 - 7.2	
Chain tensioner bolt	6 - 10	0.6 - 1.0	4.3 - 7.2	
Clutch cover bolt	20 - 29	2.0 - 3.0	14 - 22	
Connecting rod big end nut	44 - 54	4.5 - 5.5	33 - 40	
Crank pulley bolt	137 - 157	14.0 - 16.0	101 - 116	
Cylinder head bolt	78 - 88	8.0 - 9.0	58 - 65	
Cylinder head to front cover bolt	8 - 14	0.8 - 1.4	5.8 - 10.1	
Drive plate bolt (A/T)	127 - 147	13.0 - 15.0	94 - 108	
Flywheel bolt (M/T)	127 - 147	13.0 - 15.0	94 - 108	
Front cover bolt	M6	4 - 10	0.4 - 1.0	2.9 - 7.2
	M8	10 - 16	1.0 - 1.6	7 - 12
Main bearing cap bolt	44 - 54	4.5 - 5.5	33 - 40	
Oil pan bolt	6 - 10	0.6 - 1.0	4.3 - 7.2	
Oil pan drain plug	20 - 29	2.0 - 3.0	14 - 22	
Oil strainer bolt	10 - 16	1.0 - 1.6	7 - 12	
Pivot bushing bolt	78 - 118	8.0 - 12.0	58 - 87	
Pivot lock nut	49 - 59	5.0 - 6.0	36 - 43	
Rocker cover bolt	10 - 16	1.0 - 1.6	7 - 12	
Oil pivot	44 - 54	4.5 - 5.5	33 - 40	

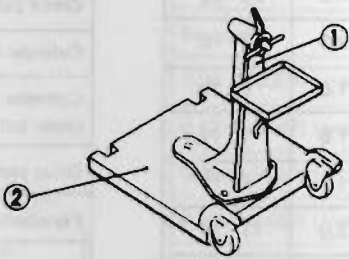
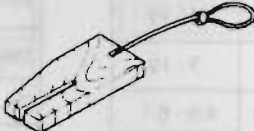

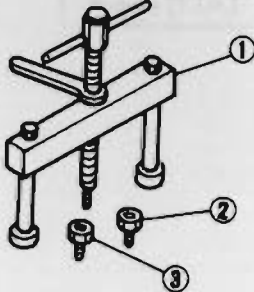
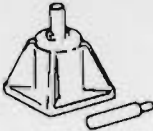
SPECIAL SERVICE TOOLS

Tool number (Kent-Moore No.)	Tool name	
ST19320000 (J25664)	Oil filter wrench	
ST05340001 (J26032)	Engine attachment	
ST0501S000 (J26023) ① ST05011000 (J26023-2) ② ST05012000 (J26023-1)	Engine stand assembly  Engine stand  Base	
KV10105800 (J25660-B)	Chain stopper	
ST10120000 (J25613)	Cylinder head bolt wrench	
KV101041S0 (J25647) ① KV10104110 ( - ) ② ST16512001 ( - ) ③ ST16701001 ( - )	Crankshaft main bearing cap puller  Crankshaft main bearing puller  Adapter  Adapter	
ST13030001 (J26365)	Piston pin press stand	

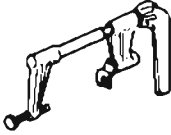
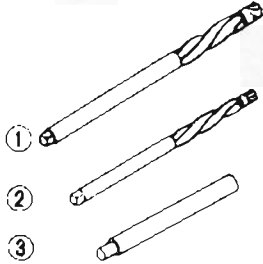
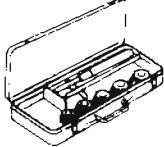
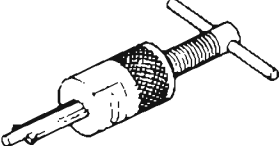
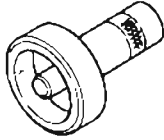
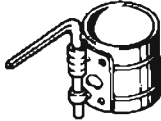
## SPECIAL SERVICE TOOLS

Tool number (Kent-Moore No.)	Tool name
ST12070000 (J25631)	Valve lifter 
KV101039S0 (J25618) ① ST11081000 (J25618-3) ② ST11032000 (J25618-2) ③ ST11320000 (J25618-1)	Valve guide reamer set Reamer [12.2 mm (0.480 in) dia.] Reamer [8.0 mm (0.315 in) dia.] Drift 
ST11650001 ( - )	Valve seat cutter set 
ST16610001 (J23907)	Pilot bushing puller 
KV10105500 (J25640-01)	Crankshaft rear oil seal drift 
EM03470000 ( - )	Piston ring compressor 
ST10640001 (J25615-01)	Pivot adjuster 
KV30100100 ( - )	Clutch aligning bar 