

AUTOMATIC TRANSMISSION



The Model E4N71B automatic transmission is the latest addition to the line-up of transmissions. This transmission is available on the model L4N71B (mounted on the front of the vehicle). By use of a shift lever with electronic control, side lockup control, and a clutch pedal lockup.

SECTION AT

CONTENTS

DESCRIPTION OF E4N71B	AT- 2
GENERAL SERVICE NOTICE	AT- 4
ON-VEHICLE SERVICE	AT- 9
REMOVAL AND INSTALLATION	AT-16
MAJOR OVERHAUL	AT-18
DISASSEMBLY	AT-20
REPAIR FOR COMPONENT PARTS	AT-26
ASSEMBLY	AT-49
TROUBLE-SHOOTING AND DIAGNOSES	AT-64
A/T INTERLOCK SYSTEM	AT-89
SERVICE DATA AND SPECIFICATIONS (S.D.S.)	AT-95
SPECIAL SERVICE TOOLS	AT-99

AT

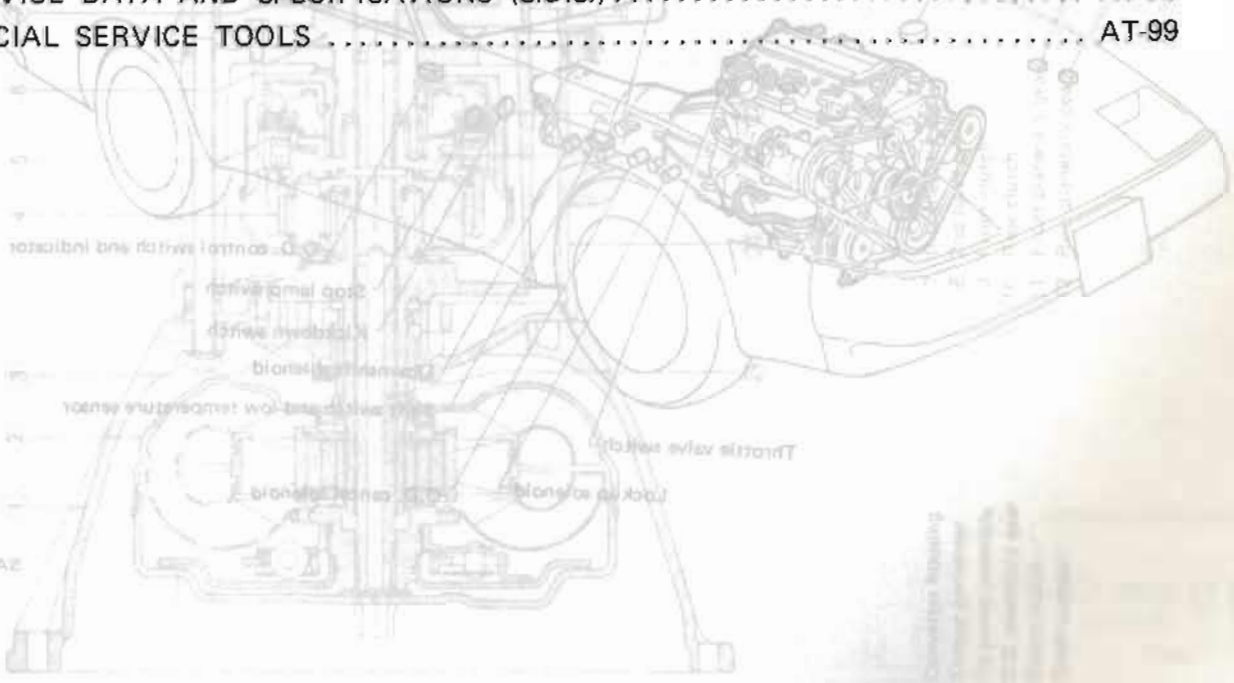

DESCRIPTION OF E4N71B

The Model E4N71B automatic transmission is the latest addition to Nissan's line-up of transmissions. This transmission is based on the model L4N71B (mounted on the 1983 model 810), and can provide lockup of 3rd and O.D. by electronic control. By use of a microcomputer, the electronic-controlled lockup system permits lockup.

Filler plug	25-34	2.5-3.5	18-25
Drain plug	25-34	2.5-3.5	18-25
Speedometer pinion installer	4-5	0.4-0.5	2.5-3.6
Interlock stopper fixing bolt	31-42	3.2-4.2	23-31
Check ball	24-25	1.9-2.2	14-19
Select claw	20-28	2.0-3.0	14-22
Reverse check spring fixing bolt	8-2	0.8-0.85	4.8-5.1
O.D. & reverse shift fork	25-34	2.5-3.0	18-22
O.D. and reverse shift fork	20-34	2.0-3.6	23-27

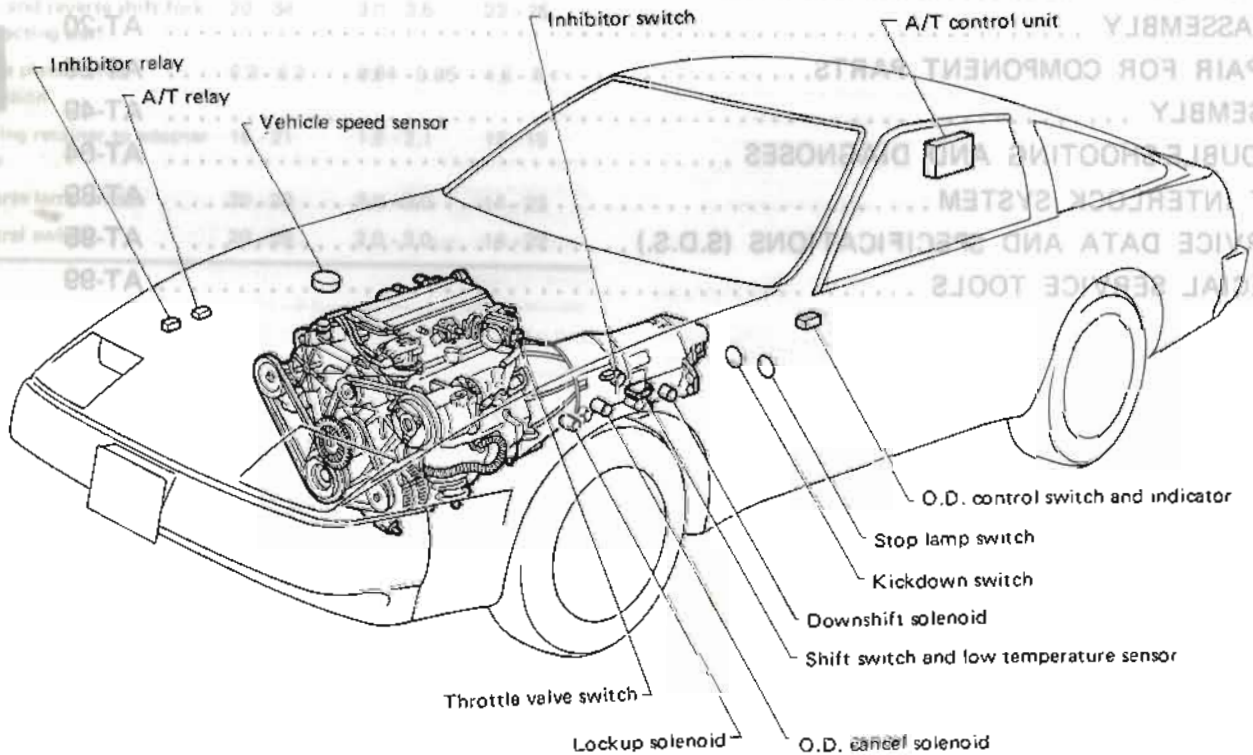

SAT588A

DESCRIPTION OF E4N71B

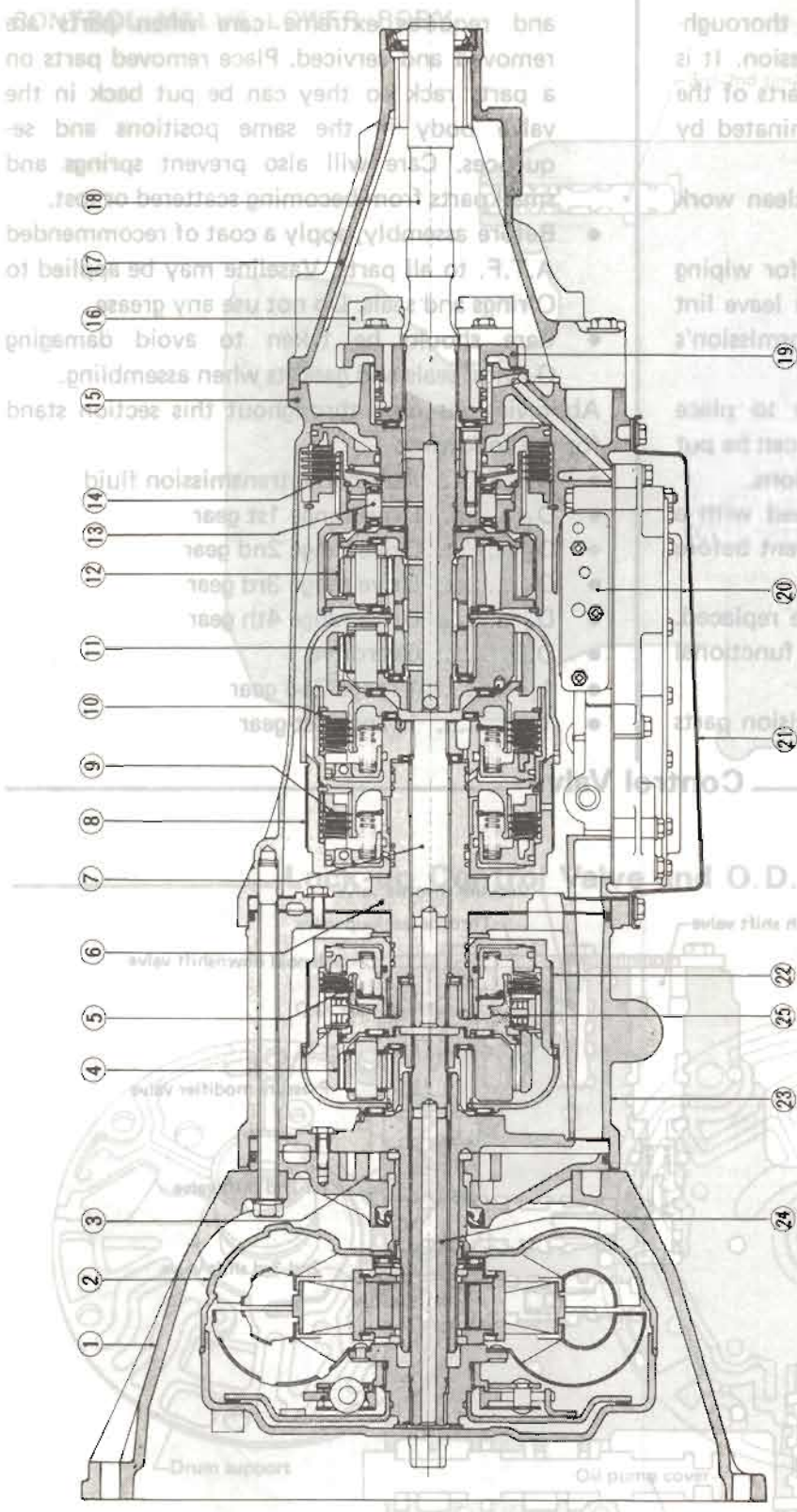

- 1 Converter housing
- 2 Torque converter
- 3 Oil pump assembly
- 4 O.D. planetary gear
- 5 Direct clutch
- 6 Drum support
- 7 Intermediate shaft
- 8 2nd band brake
- 9 Front clutch
- 10 Rear clutch
- 11 Front planetary gear
- 12 Rear planetary gear
- 13 One-way clutch
- 14 Low & reverse clutch
- 15 Transmission case
- 16 Governor valve assembly
- 17 Rear extension
- 18 Output shaft
- 19 Oil distributor
- 20 Control valve assembly
- 21 Oil pan
- 22 O.D. band brake
- 23 O.D. case
- 24 Input shaft
- 25 O.D. one-way clutch

247742

SAT226A

GENERAL SERVICE NOTICE

Repair Notes

- Before proceeding with disassembly, thoroughly clean the outside of the transmission. It is important to prevent the internal parts of the transmission from becoming contaminated by dirt or other foreign matter.
- Disassembly should be done in a clean work area.
- Use a nylon cloth or paper towel for wiping parts clean. Common shop rags can leave lint that might interfere with the transmission's operation.
- When disassembling parts, be sure to place them in order in parts rack so they can be put back in the unit in their proper positions.
- All parts should be carefully cleaned with a general purpose, non-flammable solvent before inspection or reassembly.
- Gaskets, seals, and O-rings should be replaced. It is also very important to perform functional tests whenever it is designated.
- The valve body contains many precision parts

and requires extreme care when parts are removed and serviced. Place removed parts on a parts rack so they can be put back in the valve body in the same positions and sequences. Care will also prevent springs and small parts from becoming scattered or lost.

- Before assembly, apply a coat of recommended A.T.F. to all parts. Vaseline may be applied to O-rings and seals. Do not use any grease.
- Care should be taken to avoid damaging O-rings, seals and gaskets when assembling.

Abbreviations used throughout this section stand for the following:

- A.T.F. Automatic transmission fluid
- D₁ Drive range 1st gear
- D₂ Drive range 2nd gear
- D₃ Drive range 3rd gear
- D₄ Drive range 4th gear
- O.D. Overdrive
- 1₂ 1 range 2nd gear
- 1₁ 1 range 1st gear

Control Valve

CONTROL VALVE UPPER BODY

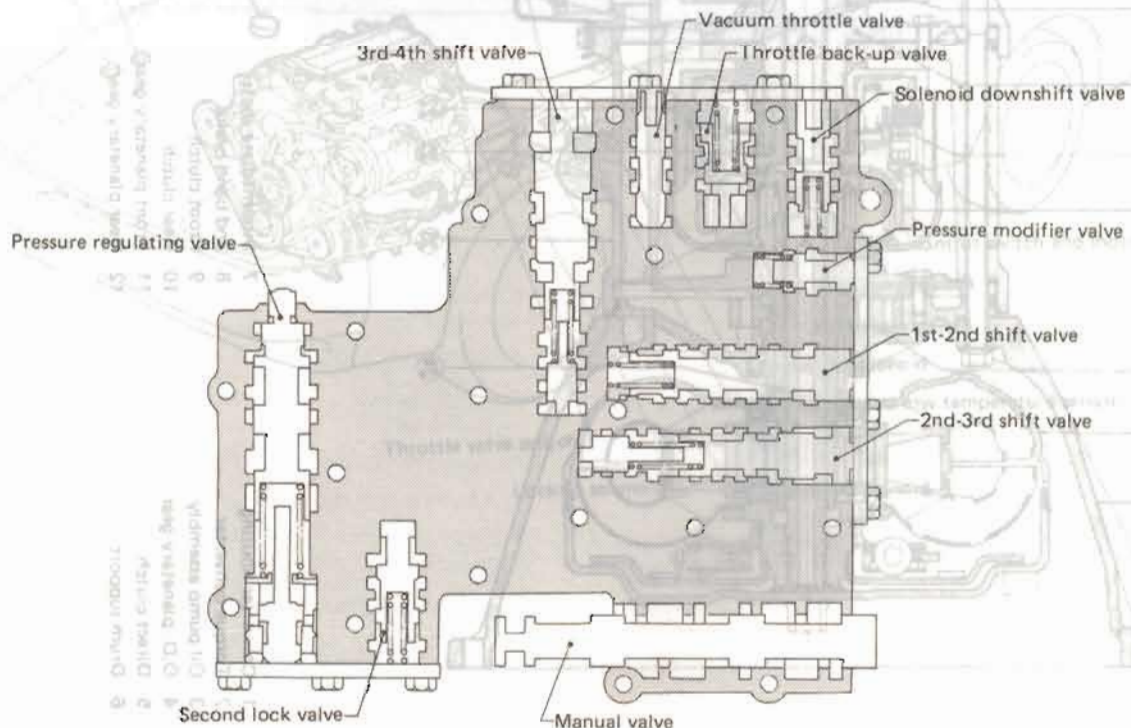

GENERAL SERVICE NOTICE

Control Valve (Cont'd)

CONTROL VALVE LOWER BODY

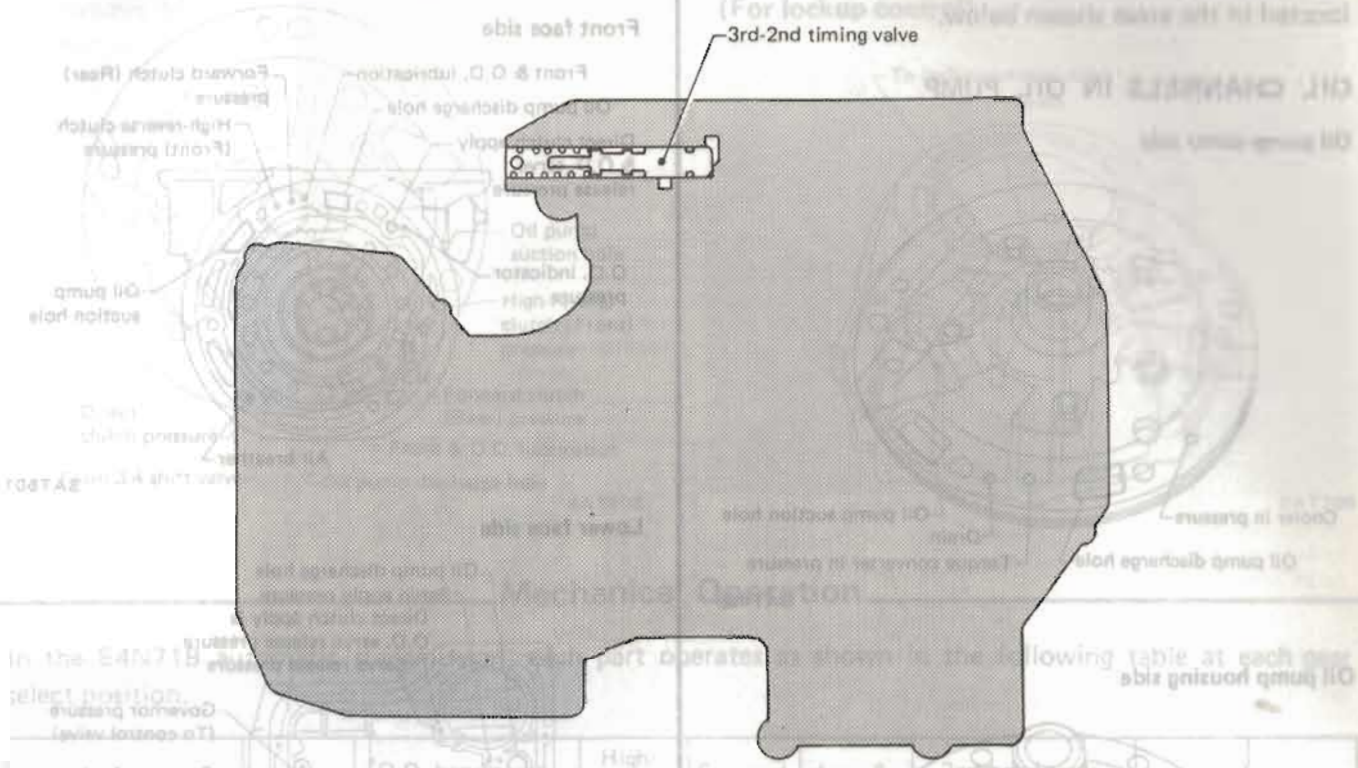

Lock-up Control Valve and O.D. Cancel Valve

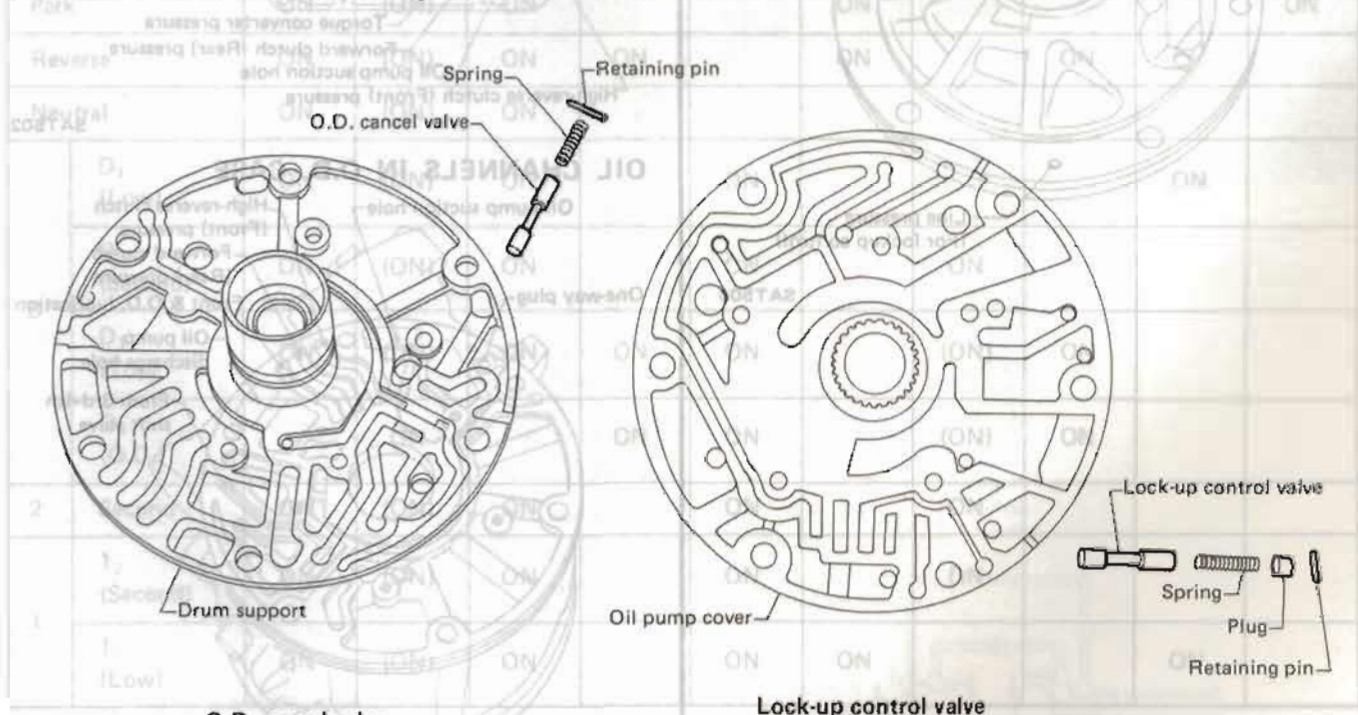

O.D. cancel valve

Lock-up control valve

The low & reverse pressure valve is designed to prevent free wheeling when coasting and allows engine braking. (For lock-up control valve) Located in the area shown in the following table at each gear.

SAT498

GENERAL SERVICE NOTICE

Oil Channel

Oil channels which connect components are located in the areas shown below.

OIL CHANNELS IN OIL PUMP

Oil pump cover side

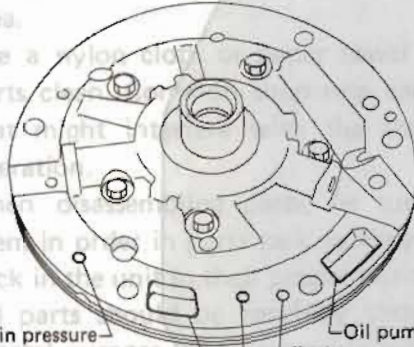

Cooler in pressure
Oil pump discharge hole
Drain
Torque converter in pressure
Oil pump suction hole

SAT499

Oil pump housing side



Line pressure
(For lockup control)

SAT500

OIL CHANNELS IN TRANSMISSION CASE

Front face side

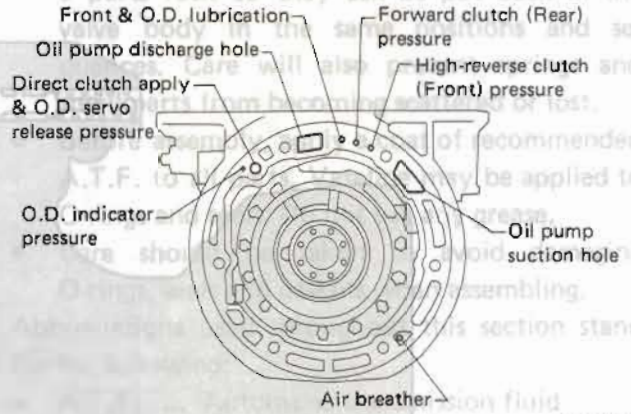

Front & O.D. lubrication
Oil pump discharge hole
Direct clutch apply & O.D. servo release pressure
O.D. indicator pressure
Forward clutch (Rear) pressure
High-reverse clutch (Front) pressure
Oil pump suction hole
Air breather

SAT501

Lower face side

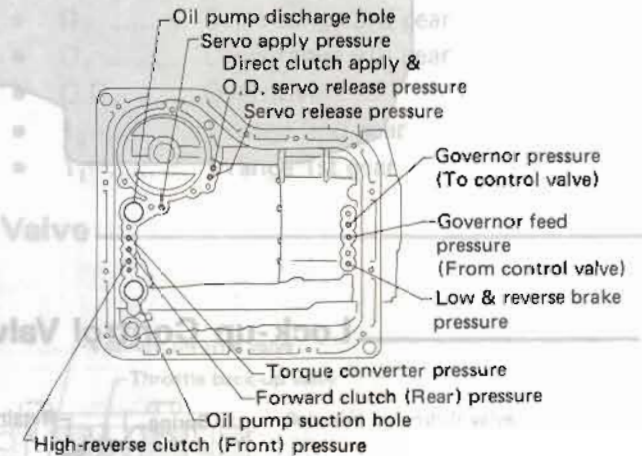

Oil pump discharge hole
Servo apply pressure
Direct clutch apply & O.D. servo release pressure
Servo release pressure
Governor pressure (To control valve)
Governor feed pressure (From control valve)
Low & reverse brake pressure
Torque converter pressure
Forward clutch (Rear) pressure
Oil pump suction hole
High-reverse clutch (Front) pressure

SAT502

OIL CHANNELS IN O.D. CASE

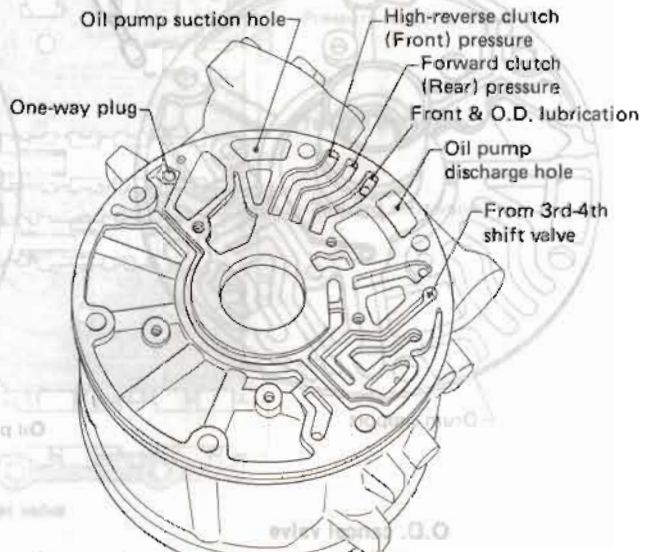

Oil pump suction hole
One-way plug
High-reverse clutch (Front) pressure
Forward clutch (Rear) pressure
Front & O.D. lubrication
Oil pump discharge hole
From 3rd-4th shift valve

In regards to one-way plug, refer to page AT-30.

SAT645

GENERAL SERVICE NOTICE

Oil Channel (Cont'd)

OIL CHANNELS IN DRUM SUPPORT

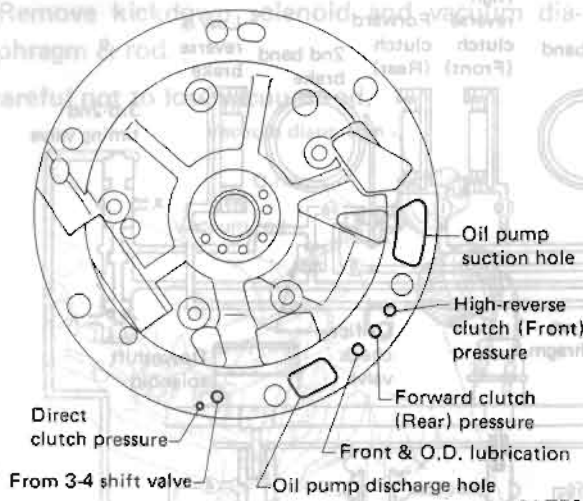

SAT503

OIL CHANNELS IN CONVERTER HOUSING (For lockup control)

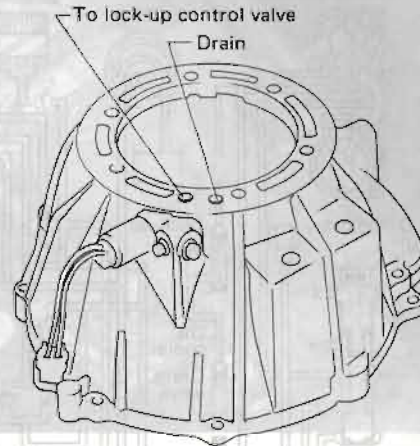

SAT706

Mechanical Operation

In the E4N71B automatic transmission, each part operates as shown in the following table at each gear select position.

Range	Direct clutch	O.D. band servo		High-reverse clutch (Front)	Forward clutch (Rear)	Low & reverse brake	2nd band servo		One-way clutch	Parking pawl
		Apply	Release				Apply	Release		
Park	ON	(ON)	ON			ON				ON
Reverse	ON	(ON)	ON	ON		ON		ON		
Neutral	ON	(ON)	ON							
D	D ₁ (Low)	ON	(ON)	ON	ON				ON	
	D ₂ (Second)	ON	(ON)	ON	ON		ON			
	D ₃ (Top)	ON	(ON)	ON	ON	ON	(ON)	ON		
	D ₄ (O.D.)		ON		ON	ON	(ON)	ON		
2	Second	ON	(ON)	ON	ON		ON			
1	1 ₂ (Second)	ON	(ON)	ON	ON		ON			
	1 ₁ (Low)	ON	(ON)	ON	ON	ON			ON	

The low & reverse brake is applied in "1₁" range to prevent free wheeling when coasting and allows engine braking.

GENERAL SERVICE NOTICE

Hydraulic Control Circuits

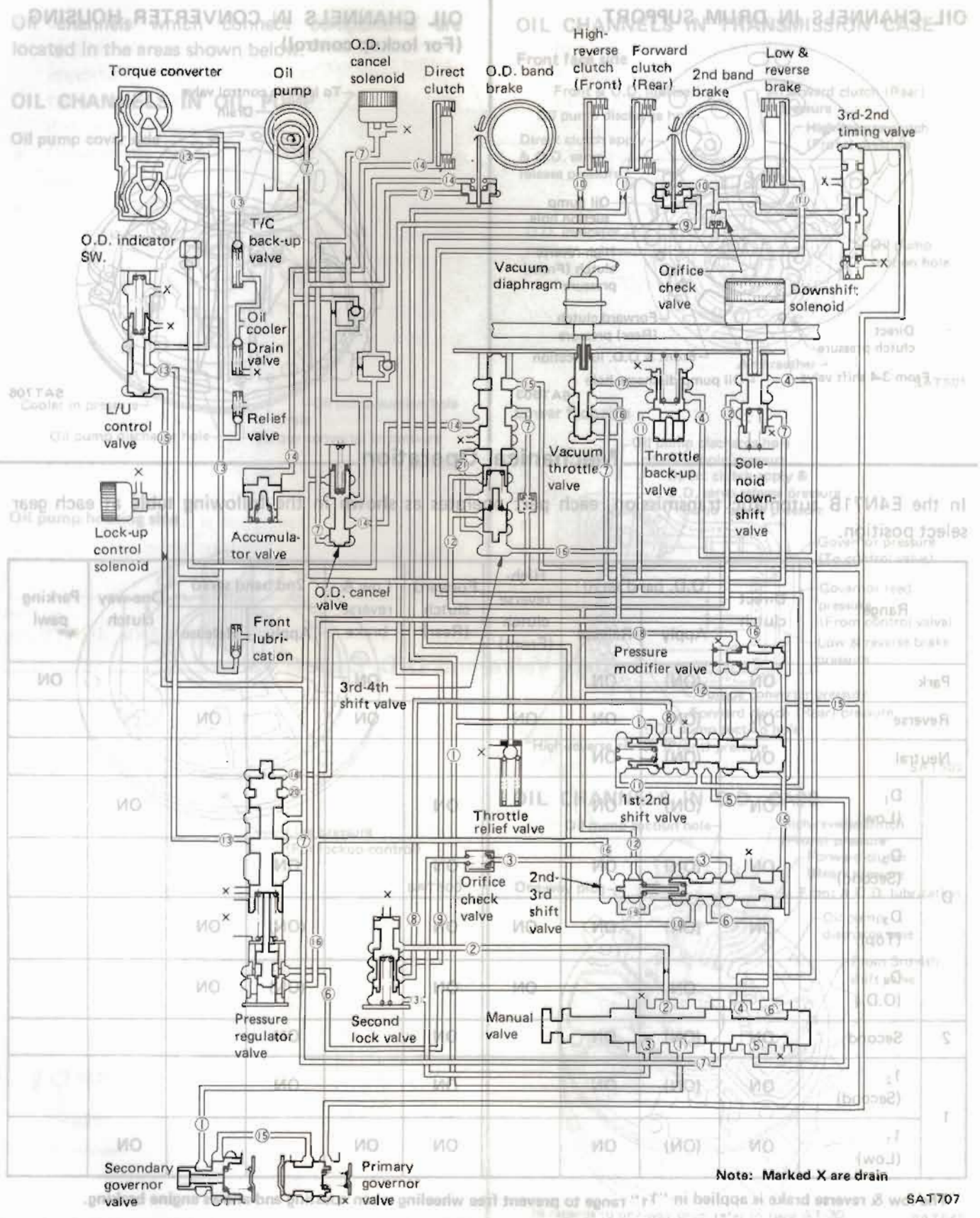

ON-VEHICLE SERVICE

Control Valve

1. Drain fluid by removing oil pan.
2. Remove kickdown solenoid and vacuum diaphragm & rod.

Be careful not to lose vacuum rod.

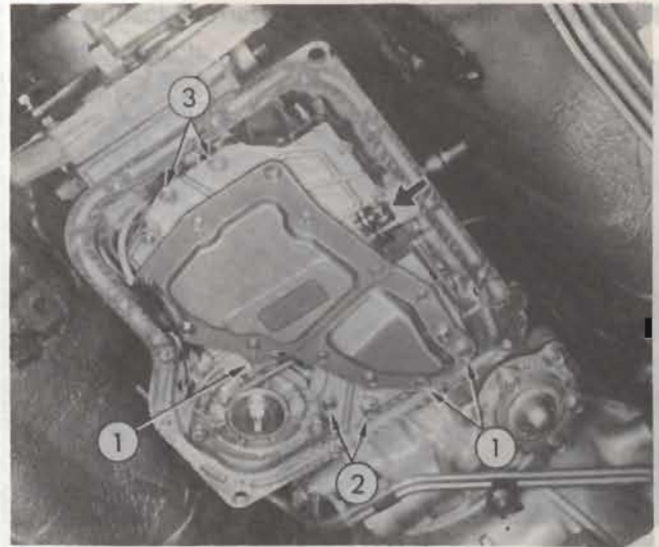
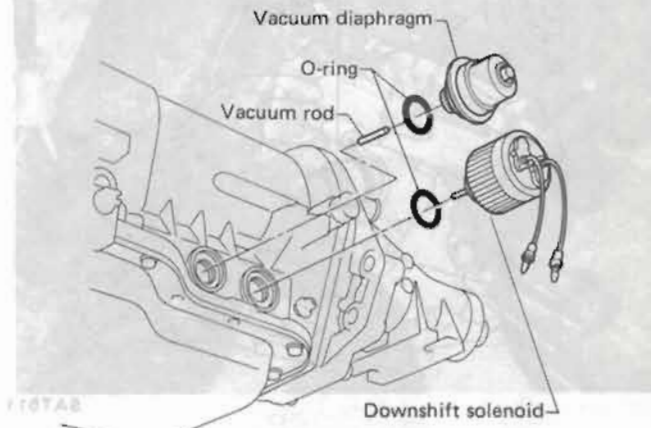

- | | |
|---|-----------------|
| 1 | 40 mm (1.57 in) |
| 2 | 35 mm (1.38 in) |
| 3 | 25 mm (0.98 in) |

3. Remove control valve assembly.



Be careful not to drop manual valve out of valve body.

4. Disassemble, inspect and assemble control valve assembly. Refer to Control Valve Body.
 5. Install control valve assembly.
- Set manual shaft at Neutral, then align manual plate with groove in manual valve of control valve assembly.
 - Securing bolts come in 3 different lengths.

- After installing control valve to transmission case, make sure that control lever can be moved to all positions.

6. Install kickdown solenoid and vacuum diaphragm & rod.

Make sure that vacuum diaphragm rod does not interfere with side plate of control valve.

ON-VEHICLE SERVICE

Extension Oil Seal Replacement

1. Remove oil seal.

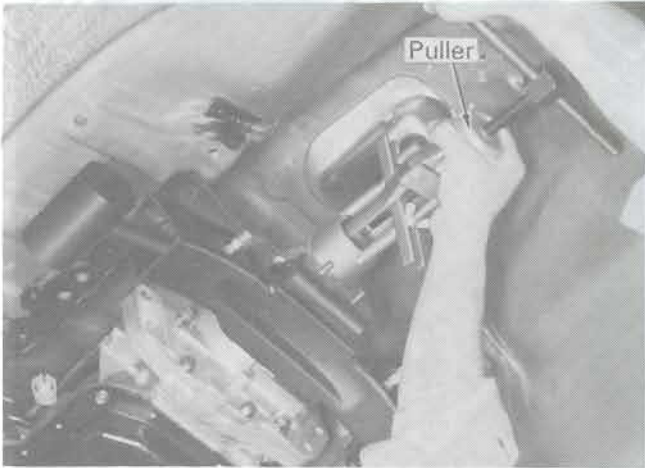

2. Apply coat of A.T.F. to oil seal surface, then drive new oil seal into place.



3. Coat sealing lips with vaseline, then install propeller shaft.

Parking Component

1. Remove oil pan.
2. Remove propeller shaft.
3. Remove speedometer pinion.

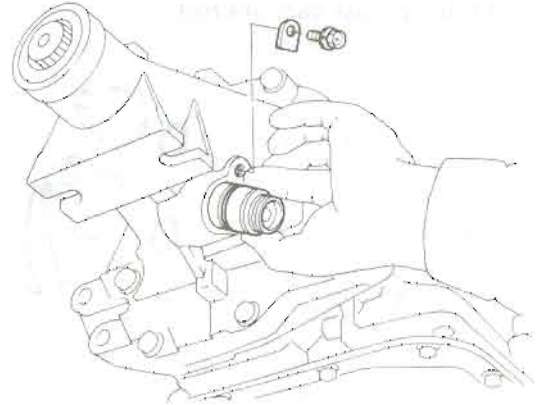

SAT511

4. Support transmission with a jack, then remove rear mounting bolts.

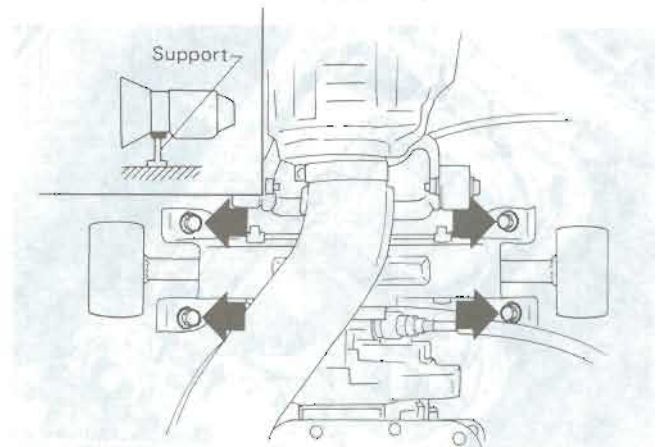

SAT709

ON-VEHICLE SERVICE

Parking Component (Cont'd)

- Remove rear extension bolts, then draw out rear extension with rear mounting.



- Remove control valve assembly.
- Inspect and repair parking components. Check component parts for wear or damage.

Governor Valve Assembly

- Drain oil by removing oil pan.
- Remove rear extension with rear mounting.
- Remove governor valve assembly.

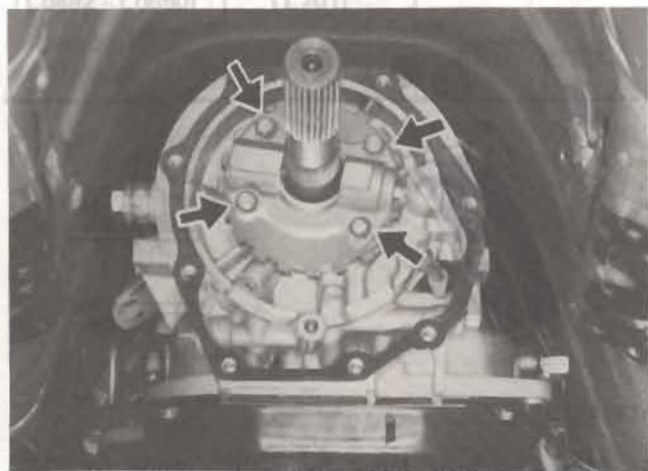

- Inspect and repair governor valve assembly. Refer to Governor for inspection.

Inhibitor Switch Adjustment

(Cont'd)

Disconnect harness at connector, then remove inhibitor switch.

- Check continuity at "N", "P" and "R" ranges.

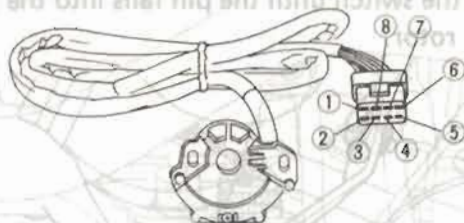

	P	R	N	D	2	1
1	○	○	○	○	○	○
2	○					
3		○				
4			○			
5	○					
6				○		
7					○	
8						○

- Check to see if inhibitor switch is operating properly. If faulty, replace it with a new one.

SAT060A

- With control lever held in "Neutral", turn manual lever an equal amount in both directions to see if current flow ranges are nearly the same. (Current normally begins to flow before manual lever reaches a angle of 1.5° in either direction.)

If current flows outside normal range, or if normal flow range is out of specifications, properly adjust inhibitor switch.

Adjust inhibitor switch as follows:

- Place the manual valve in Neutral (vertical position).
- Remove the screw.

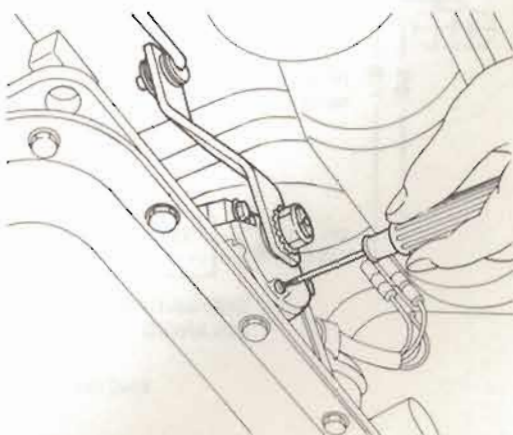

SAT097

ON-VEHICLE SERVICE

Inhibitor Switch Adjustment (Cont'd)

- Loosen the attaching bolts.
- Using an aligning pin, [2.0 mm (0.079 in) dia.] move the switch until the pin falls into the hole in the rotor.

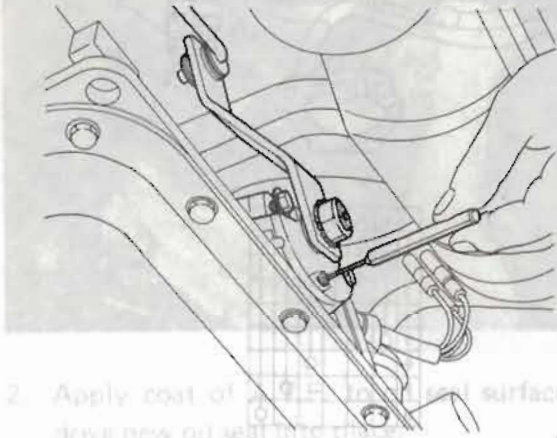

- Tighten the attaching bolts equally.
- Recheck for continuity. If faulty, replace the switch.

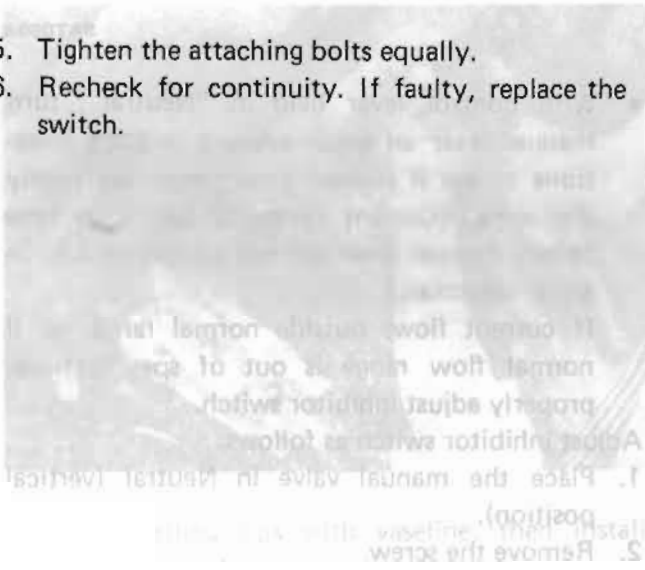

Manual Linkage Adjustment

Move the shift lever from the "P" range to "1" range. You should be able to feel the detents in each range.

If the detents cannot be felt or the pointer indicating the range is improperly aligned, the linkage needs adjustment.

- Place selector lever in "P" range.
- Loosen lock nuts.



- Tighten lock nut (X) until it touches trunnion pulling selector lever toward "R" range side without pushing button.
- Back off lock nut (X) 1/4 - 1/2 turns and tighten lock nut (Y) to the specified torque.

: Lock nut
8 - 11 N·m
(0.8 - 1.1 kg·m, 5.8 - 8.0 ft·lb)

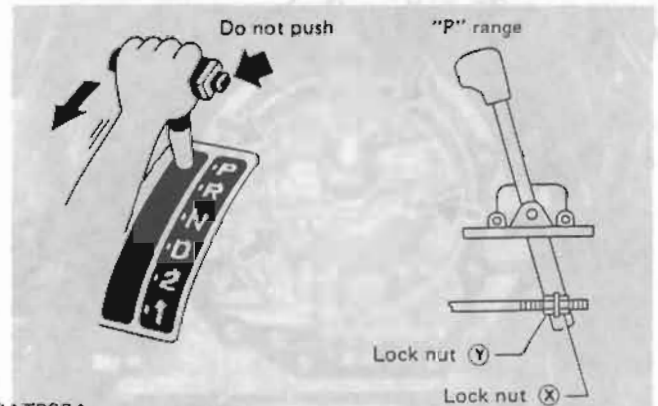

- Move selector lever from "P" range to "1" range. Make sure that selector lever can move smoothly.

ON-VEHICLE SERVICE

Vacuum Diaphragm Rod Adjustment Downshift Solenoid

1. Remove diaphragm from transmission case.
2. Using a depth gauge, measure depth "L". Be sure vacuum throttle valve is pushed into valve body as far as possible.
3. Check "L" depth with chart below and select proper length rod.

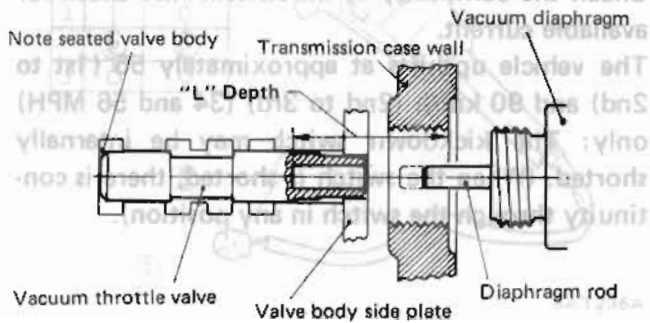

SAT078

Vacuum diaphragm rod selection

Measured depth "L" mm (in)	Rod length mm (in)	Part number
Under 25.55 (1.0059)	29.0 (1.142)	31932 - X0103
25.65 - 26.05 (1.0098 - 1.0256)	29.5 (1.161)	31932 - X0104
26.15 - 26.55 (1.0295 - 1.0453)	30.0 (1.181)	31932 - X0100
26.65 - 27.05 (1.0492 - 1.0650)	30.5 (1.201)	31932 - X0102
Over 27.15 (1.0689)	31.0 (1.220)	31932 - X0101

1. Remove downshift solenoid and O-ring. Catch oil dropping out of the hole.

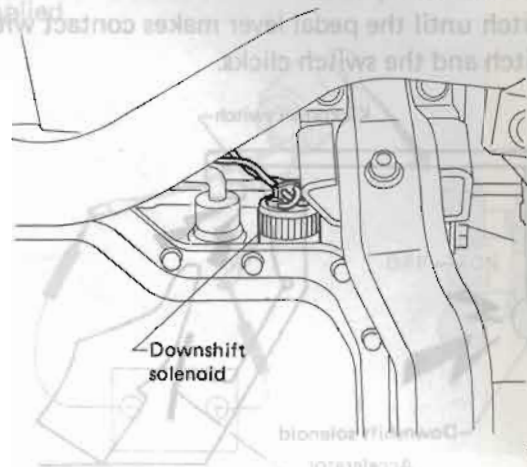

SAT516

2. Check to verify that downshift solenoid is operating properly. If faulty, replace it with a new one.

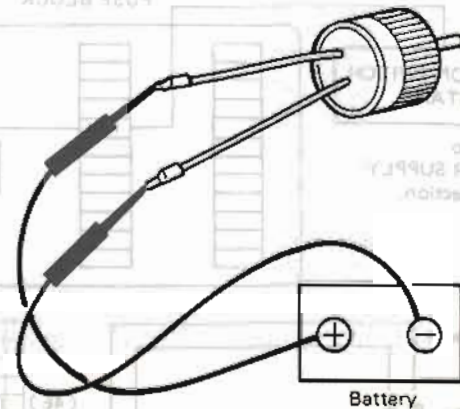

SAT517

ON-VEHICLE SERVICE

Kickdown Switch Adjustment

(Cont'd)

When the pedal is fully depressed, a click can be heard just before the pedal bottoms out. If the click is not heard, loosen the locknut and extend the switch until the pedal lever makes contact with the switch and the switch clicks.

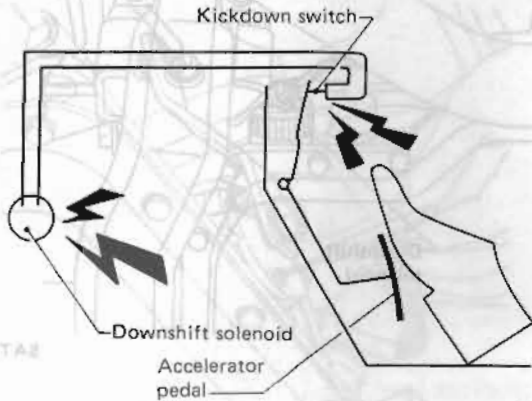

SAT719

Do not allow the switch to make contact too soon. This would cause the transmission to downshift on part throttle.

DIAGNOSIS:

Switch can be heard clicking, and the transmission still does not kickdown:

Check the continuity of the switch. Also check for available current.

The vehicle upshifts at approximately 55 (1st to 2nd) and 90 km/h (2nd to 3rd) (34 and 56 MPH) only: The kickdown switch may be internally shorted. (When the switch is shorted, there is continuity through the switch in any position).

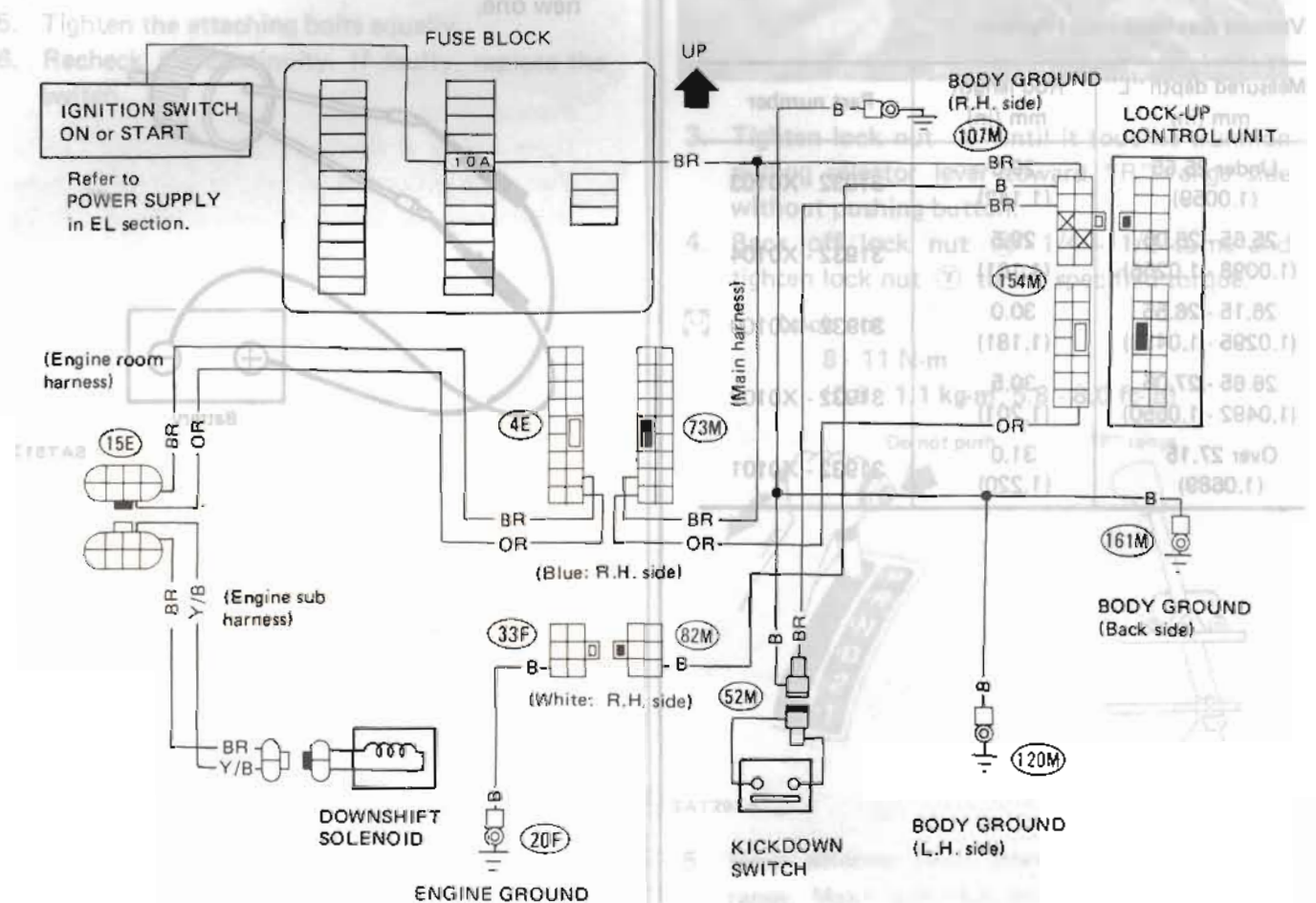

SAT567B

Overdrive and Lockup Control

O.D. CONTROL SWITCH & O.D. INDICATOR LAMP

Inspection

	ON	OFF
1		
2		
3		

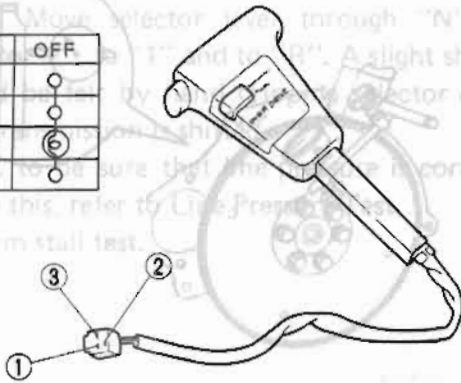

SAT236A

O.D. CANCEL SOLENOID AND LOCKUP SOLENOID

Location

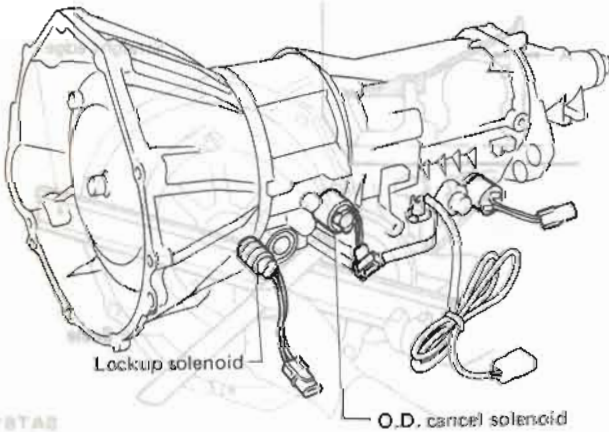

Lockup solenoid

O.D. cancel solenoid

- Install converter to drive plate. Align matching marks painted across both parts during disassembly.
- After converter is installed, rotate crankshaft several turns and check to be sure that transmission rotates freely without binding.

SAT063A

Inspection

Confirm that clicking sound is heard when power is applied.

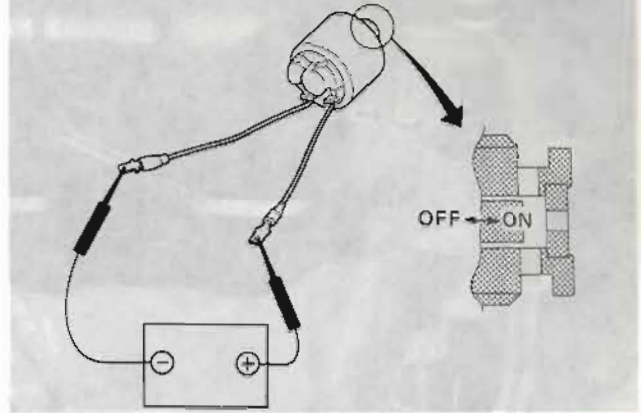

SAT620

- Plug up openings such as oil charging pipe, etc.
- CAUTION:** Take care when dismounting transmission not to strike any adjacent parts.

REMOVAL AND INSTALLATION

Removal Installation

- Remove bolts securing torque converter to drive plate.

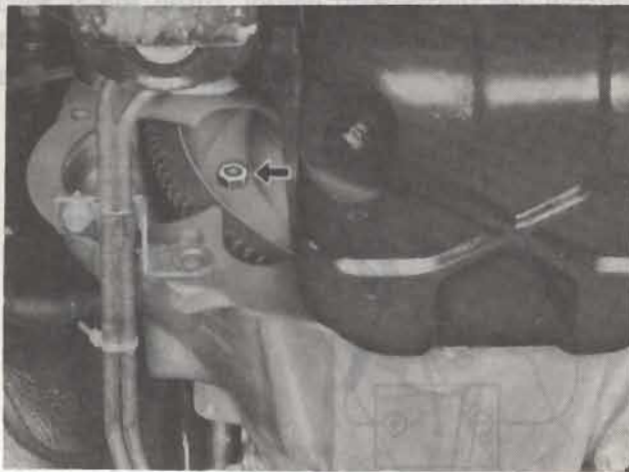

- Remove those bolts turning crank shaft.
 - Before removing torque converter, inscribe matching marks on two parts so that they may be replaced in their original positions during assembly.
- Plug up openings such as oil charging pipe, etc.

CAUTION:

Take care when dismantling transmission not to strike any adjacent parts.

- Drive plate runout
Maximum allowable runout:
0.5 mm (0.020 in)

DIAGNOSIS:

Switch can be heard clicking, and the transmission still does not kickdown:
Check the kickdown switch for proper operation. The valve is approximately 1.5 in (38 mm) to 2nd gear (2nd gear is 34 and 56 MPH) only: When the switch is shorted there is continuity through the switch in any position.

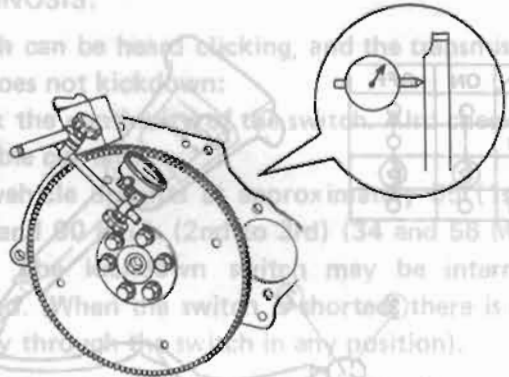

SAT718

SAT615

If this runout is out of allowance, replace drive plate and ring gear.

- When connecting torque converter to transmission, measure distance "A" to be certain that they are correctly assembled.

Distance "A":

More than 35 mm (1.38 in)

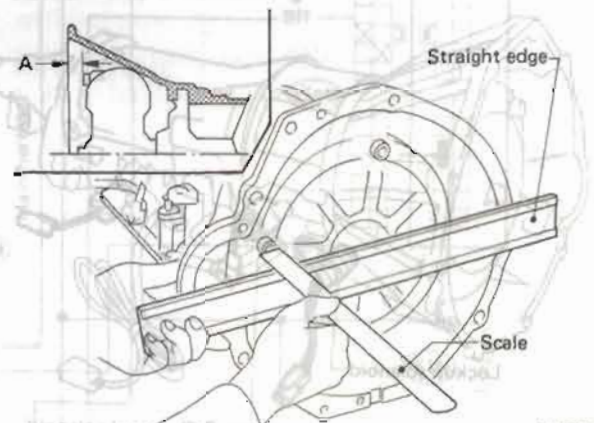

SAT615

- Install converter to drive plate.
Align matching marks painted across both parts during disassembly.
- After converter is installed, rotate crankshaft several turns and check to be sure that transmission rotates freely without binding.

REMOVAL AND INSTALLATION

Installation (Cont'd)

- Check inhibitor switch for operation.
- Check fluid level in transmission.
- Move selector lever through all positions to be sure that transmission operates correctly. With parking brake applied, rotate engine at idling. Move selector lever through "N" to "D", to "2", to "1" and to "R". A slight shock should be felt by hand gripping selector each time transmission is shifted.
- Check to be sure that line pressure is correct. To do this, refer to Line Pressure Test.
- Perform stall test.

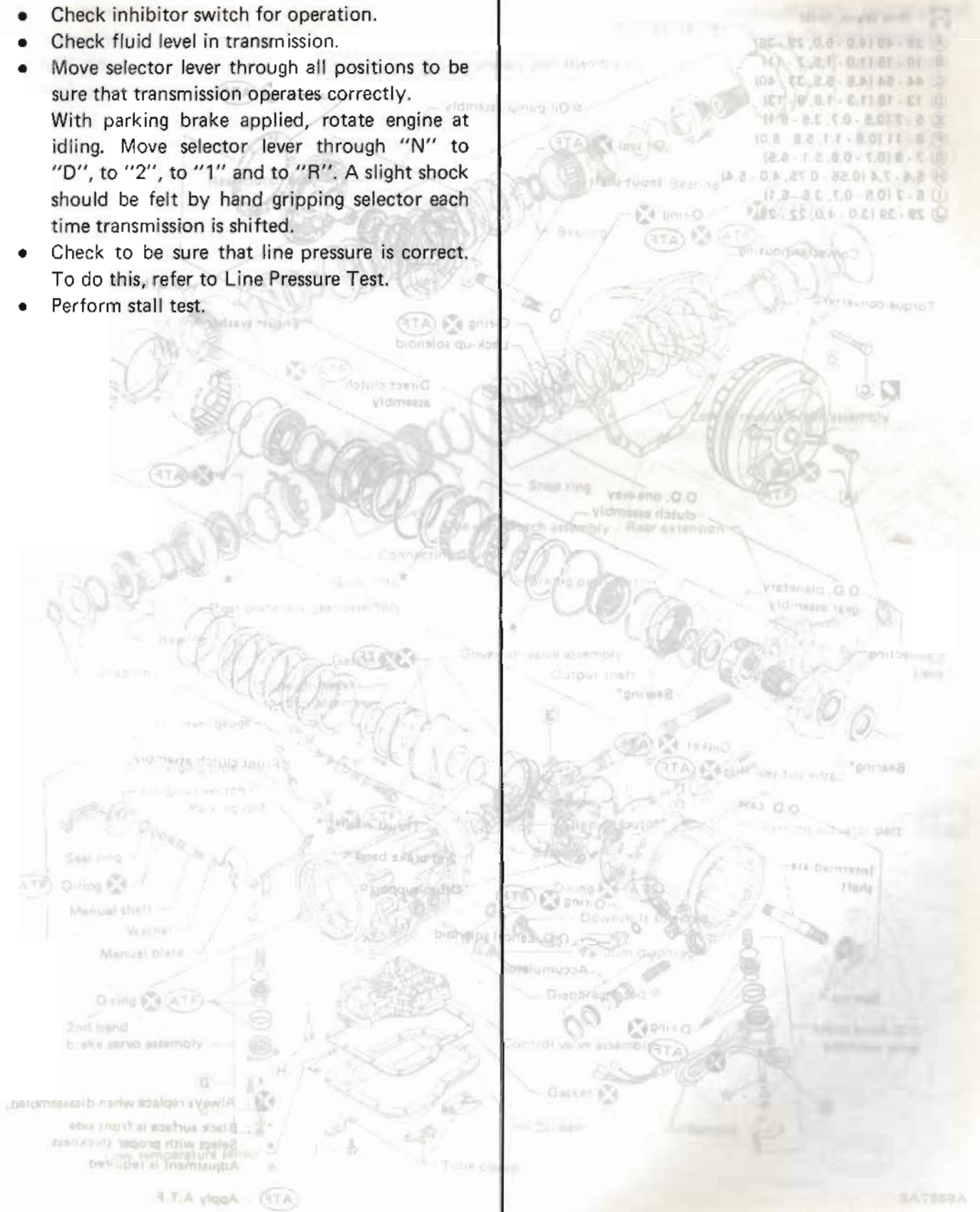

REAR MAJOR OVERHAUL

Removal

Ⓜ : N·m (kg·m, ft·lb)

- Ⓐ 39 · 49 (4.0 · 5.0, 29 · 36)
- Ⓑ 10 · 15 (1.0 · 1.5, 7 · 11)
- Ⓒ 44 · 54 (4.5 · 5.5, 33 · 40)
- Ⓓ 13 · 18 (1.3 · 1.8, 9 · 13)
- Ⓔ 5 · 7 (0.5 · 0.7, 3.6 · 5.1)
- Ⓕ 8 · 11 (0.8 · 1.1, 5.8 · 8.0)
- Ⓖ 7 · 9 (0.7 · 0.9, 5.1 · 6.5)
- Ⓗ 5.4 · 7.4 (0.55 · 0.75, 4.0 · 5.4)
- Ⓘ 5 · 7 (0.5 · 0.7, 3.6 · 5.1)
- Ⓝ 29 · 39 (3.0 · 4.0, 22 · 29)

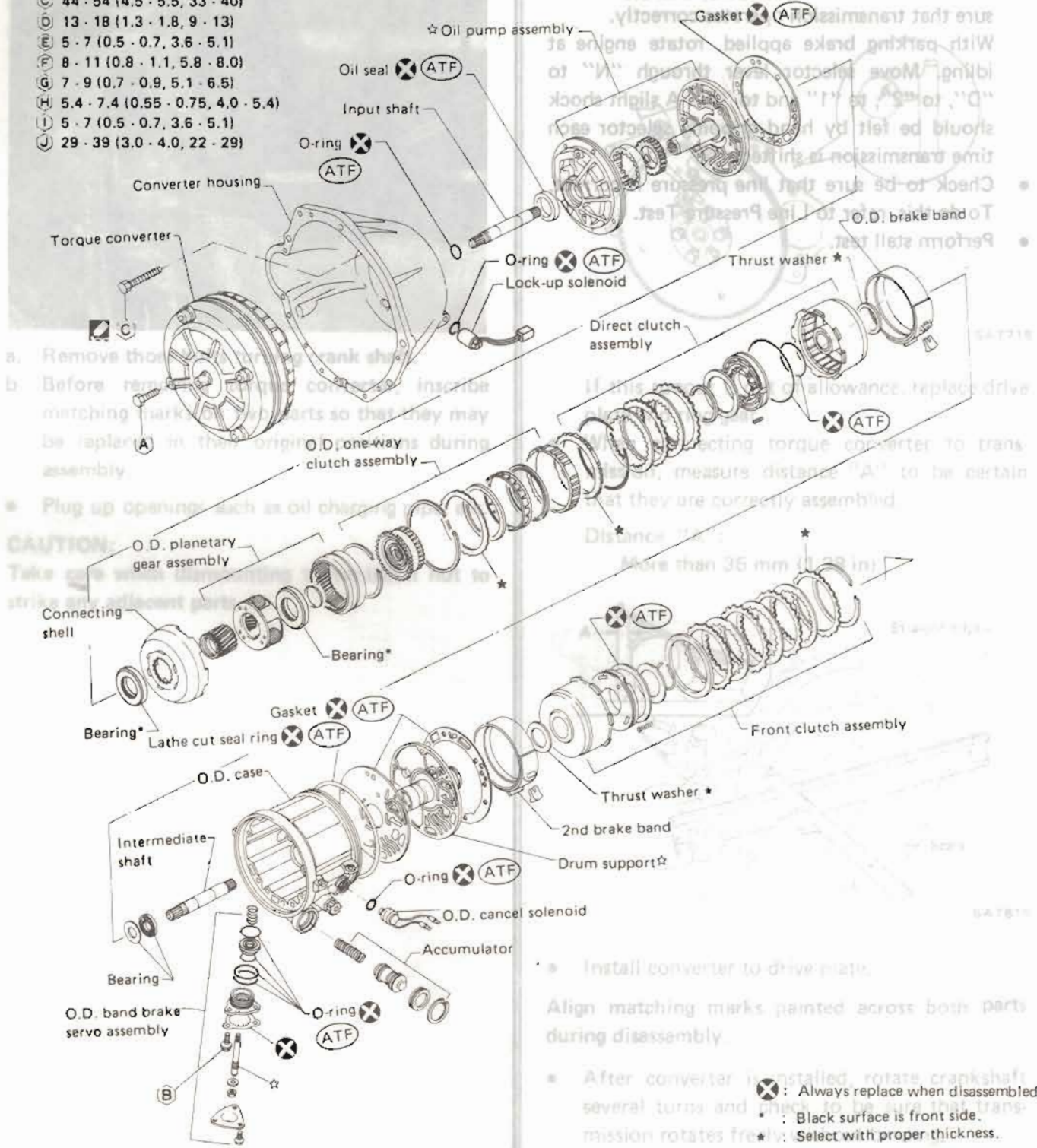

a. Remove those marking crank shaft
 b. Before reassembly, inscribe matching mark on both parts so that they may be replaced in their original position during assembly

Plug up openings such as oil charging

CAUTION:

Take up the oil pump assembly to strike the oil pump housing to

- Check inhibitor switch for operation
- Check fluid level in transmission
- Move selector lever through all positions to be sure that transmission is in correct
- With parking brake applied rotate engine at idling. Move selector lever through "N" to "D", to "2", to "1" and to "R" and check that should be felt by hand selector lever
- Check to be sure that the pressure
- To band adjust to the Pressure Test
- Perform stall test

If this gear has allowance, replace drive
 When selecting torque converter to trans-
 mission, measure distance "A" to be certain
 that they are correctly assembled

Distance "A":
 More than 36 mm (1.42 in)

- Install converter to drive plate.
- Align matching marks painted across both parts during disassembly.
- After converter is installed, rotate crankshaft several turns and check to be sure that transmission rotates freely.

- ⓧ : Always replace when disassembled.
- ★ : Black surface is front side.
- ☆ : Select with proper thickness.
- ☆ : Adjustment is required.

Ⓜ : Apply A.T.F.

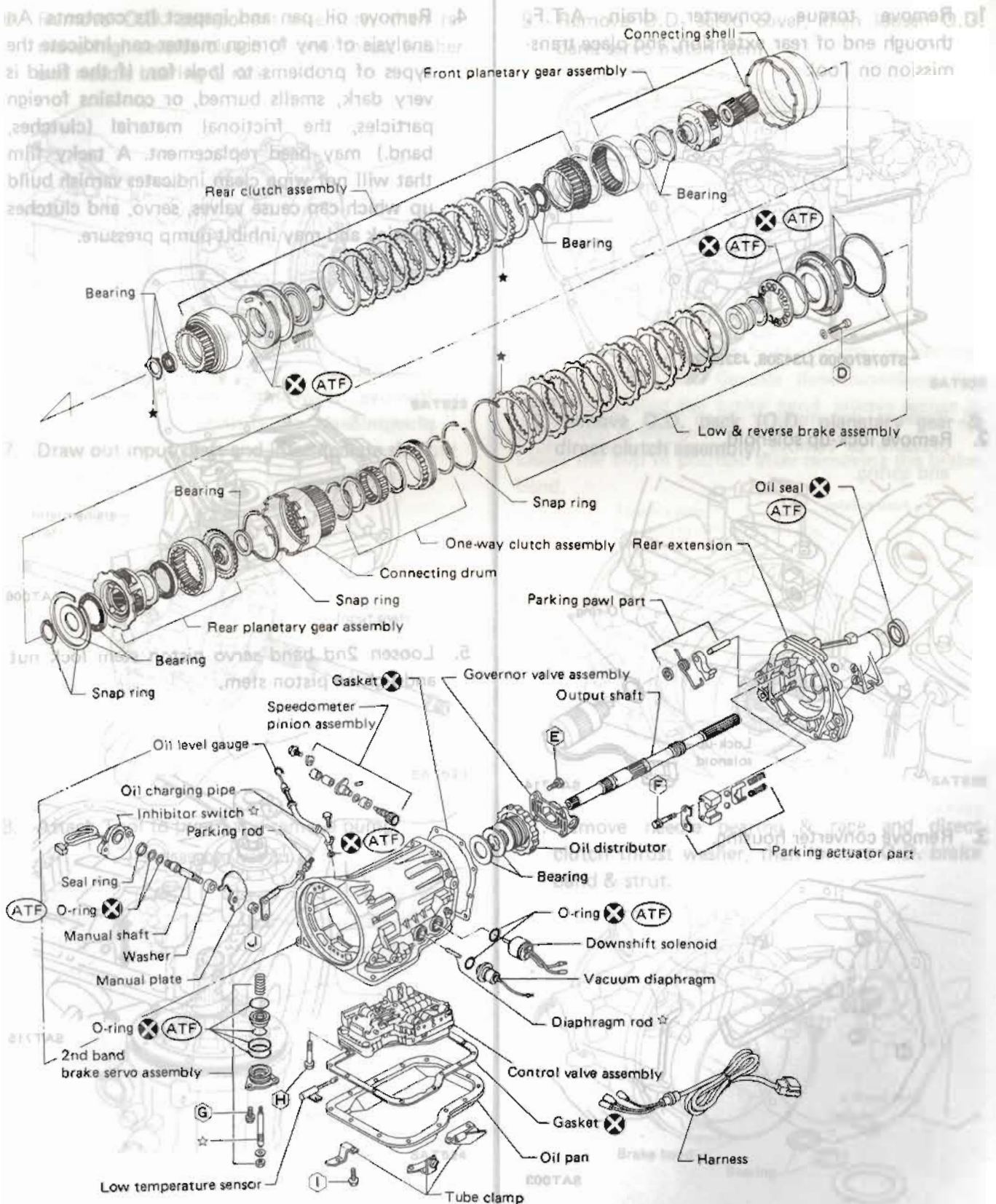

SAT559A

DISASSEMBLY

1. Remove torque converter, drain A.T.F. through end of rear extension, and place transmission on Tool.

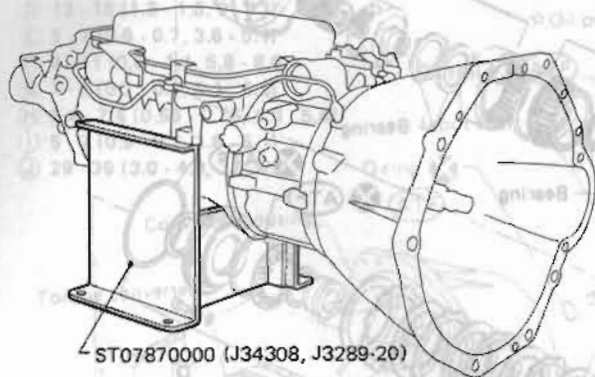

SAT520

2. Remove lock-up solenoid.

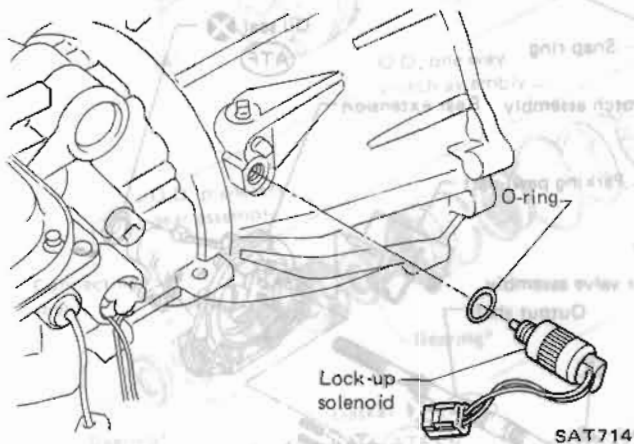

3. Remove converter housing.

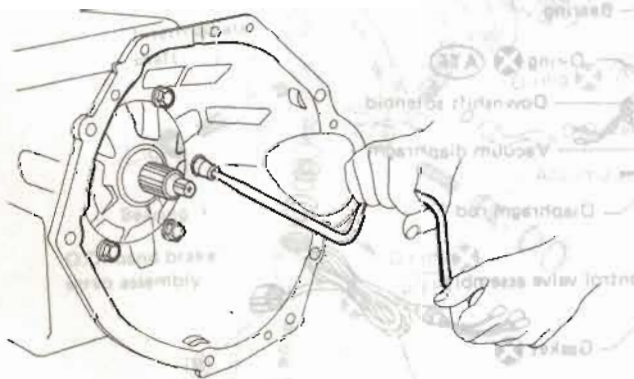

4. Remove oil pan and inspect its contents. An analysis of any foreign matter can indicate the types of problems to look for. If the fluid is very dark, smells burned, or contains foreign particles, the frictional material (clutches, band.) may need replacement. A tacky film that will not wipe clean indicates varnish build up which can cause valves, servo, and clutches to stick and may inhibit pump pressure.



5. Loosen 2nd band servo piston stem lock nut and tighten piston stem.

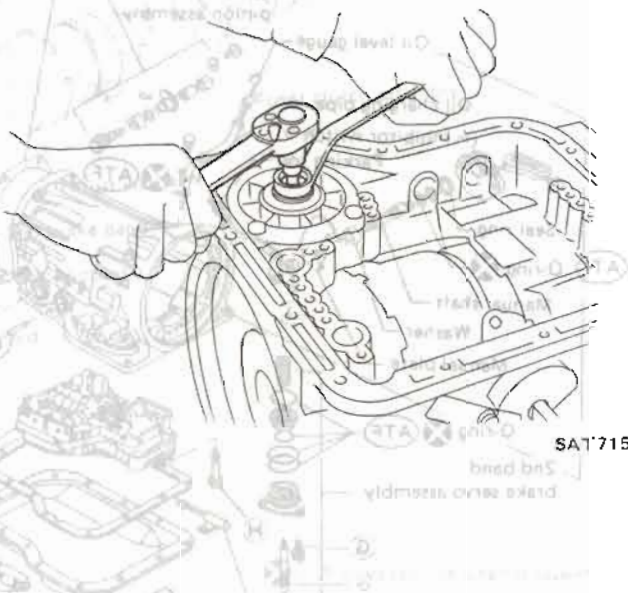

DISASSEMBLY

6. Remove O.D. component assembly, then remove high-reverse clutch (Front) thrust washer and needle bearing & race.

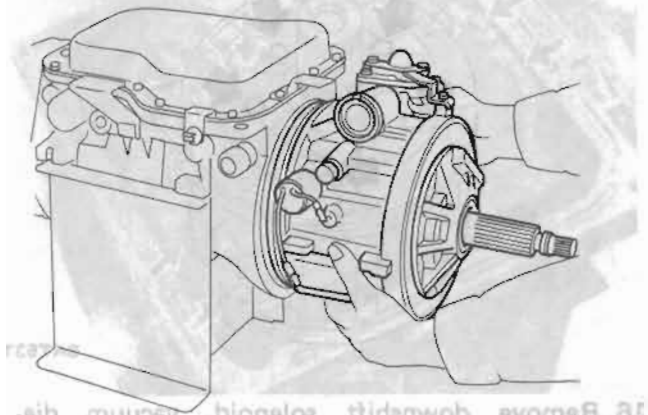

7. Draw out input shaft and intermediate shaft, accidentally.

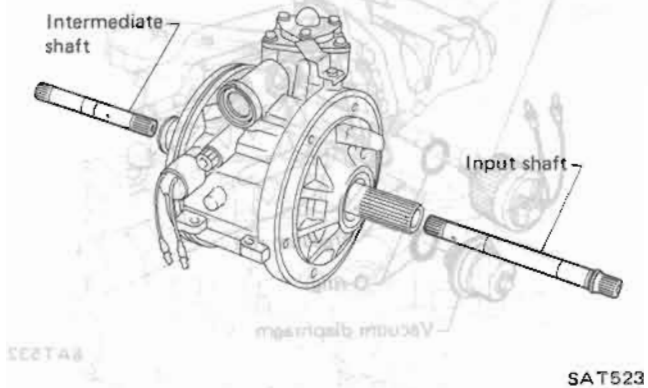

8. Attach Tool to pump and remove pump.

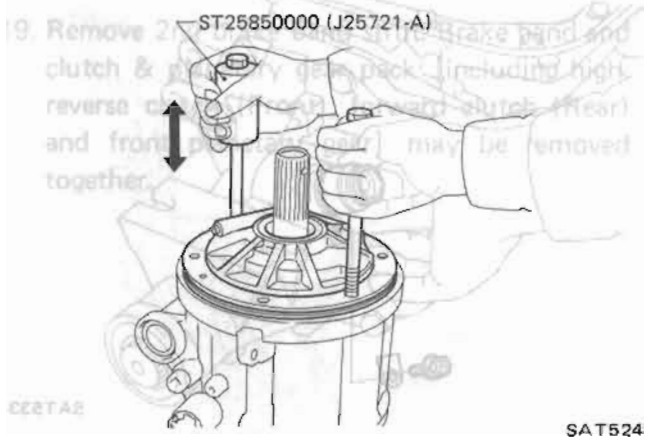

9. Remove O.D. servo cover, then loosen O.D. band servo piston stem.

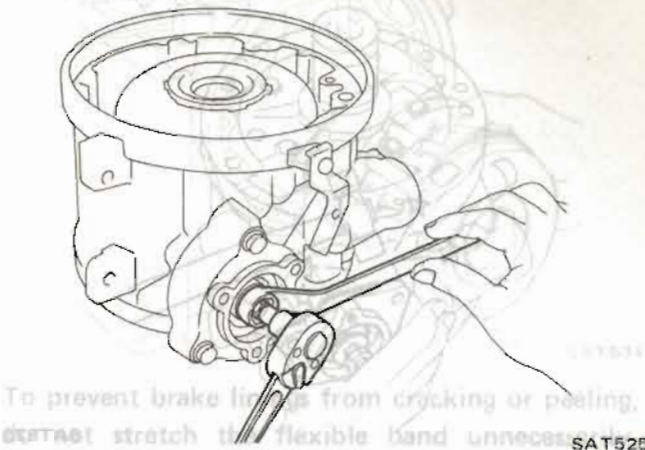

To prevent brake lining from cracking or peeling, stretch the flexible band unnecessarily.

10. Remove O.D. pack (O.D. planetary gear & direct clutch assembly).

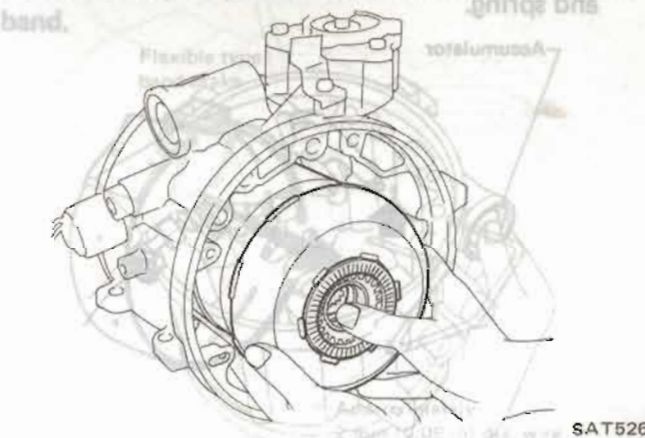

11. Remove needle bearing & race and direct clutch thrust washer, then remove O.D. brake band & strut.

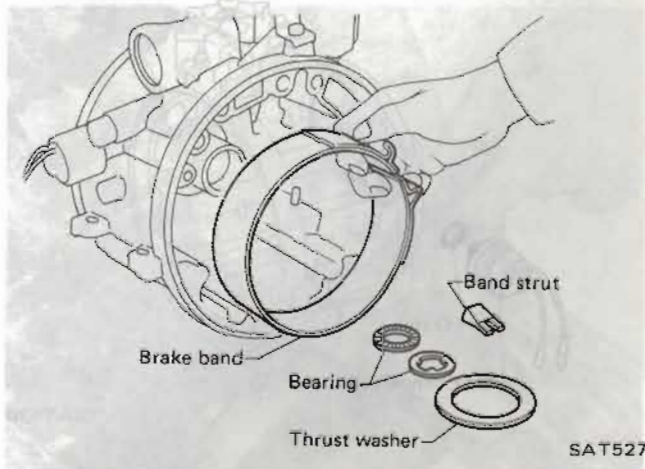

DISASSEMBLY

12. Remove O.D. servo assembly by lightly tapping retainer.

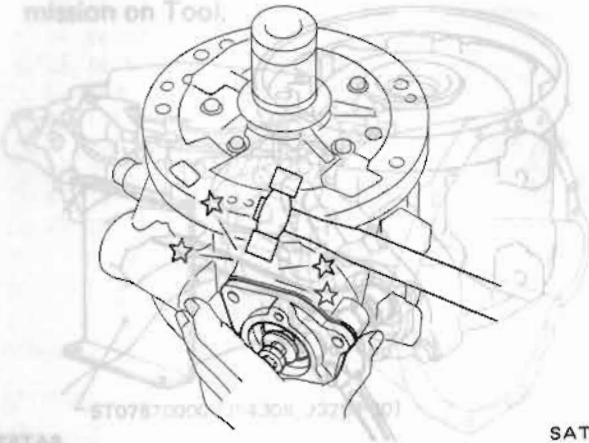

SAT528

13. Remove accumulator snap ring, then apply pressure to remove accumulator plug, piston and spring.

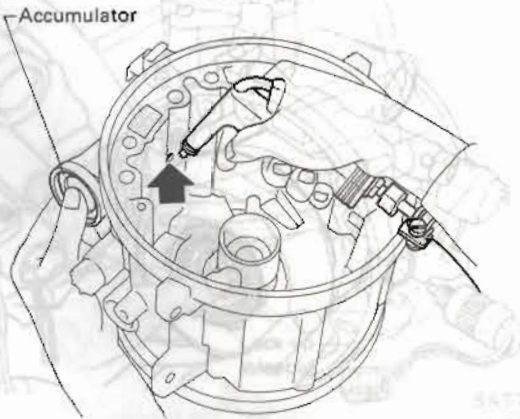

SAT529

14. Remove O.D. cancel solenoid and O-ring.

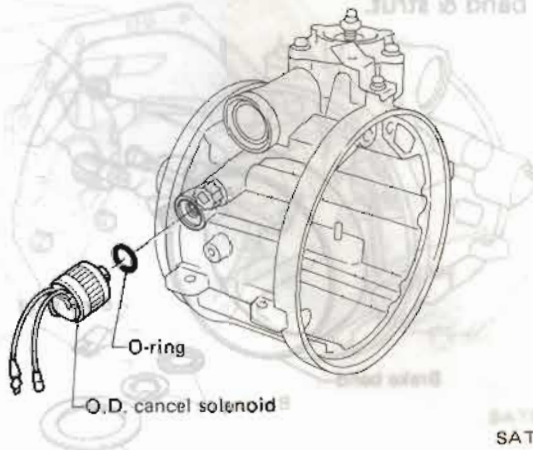

SAT530

15. Remove drum support.

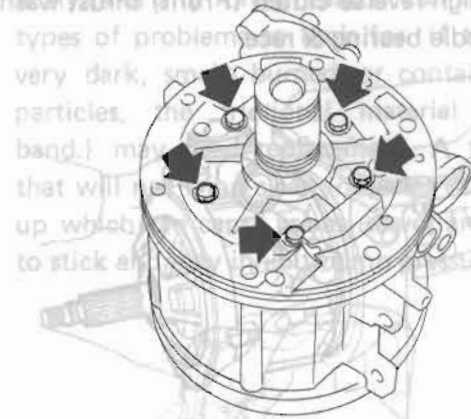

SAT531

16. Remove downshift solenoid, vacuum diaphragm & rod and O-rings.

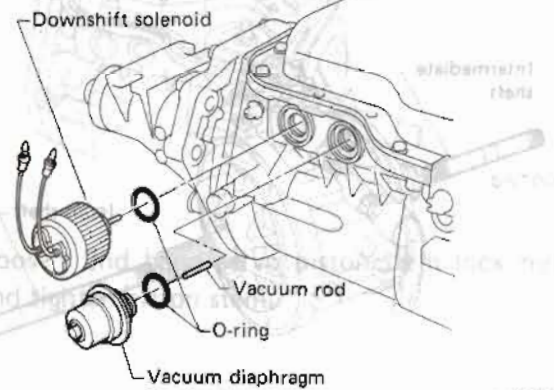

SAT532

17. Remove speedometer pinion.

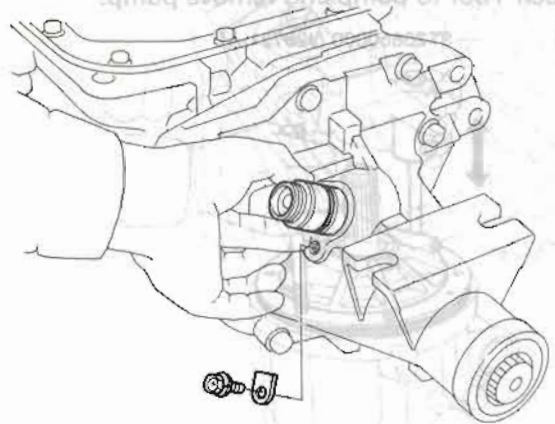

SAT533

DISASSEMBLY

18. Remove control valve body.

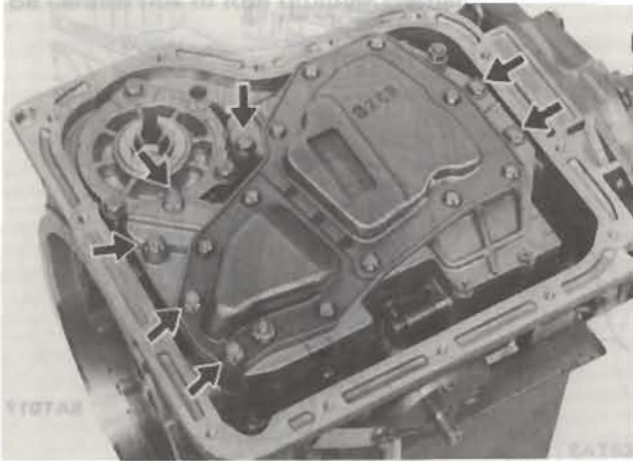

25. Pry off one end of snap ring with a screwdriver.
 26. Remove manual valve from valve body as a precaution, to prevent valve from dropping out accidentally.

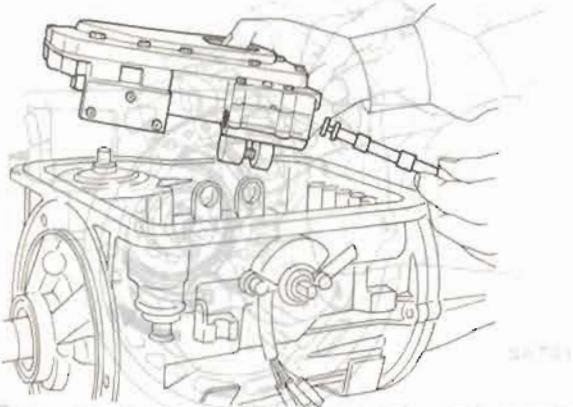

28. Remove governor shaft washer and needle bearing.

19. Remove 2nd brake band strut. Brake band and clutch & planetary gear pack [including high-reverse clutch (Front), forward clutch (Rear) and front planetary gear] may be removed together.

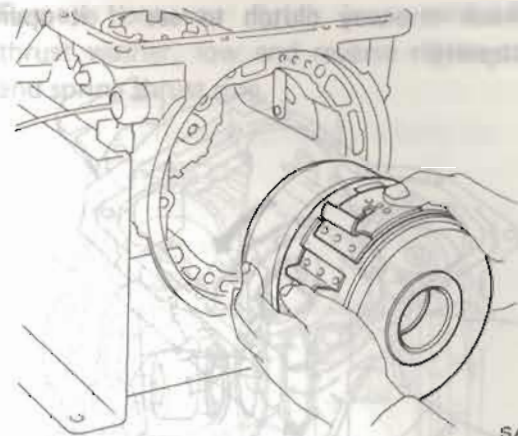

To prevent brake linings from cracking or peeling, do not stretch the flexible band unnecessarily. Before removing the brake band, always secure it with a clip as shown in the figure below. Leave the clip in position after removing the brake band.

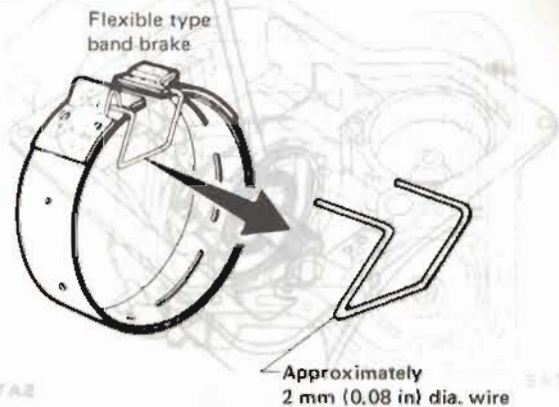

32. Remove snap ring.
 20. Remove 2nd band servo retaining bolts. Apply pressure to remove 2nd band servo.



DISASSEMBLY

21. Check one-way clutch to see if it operates properly.

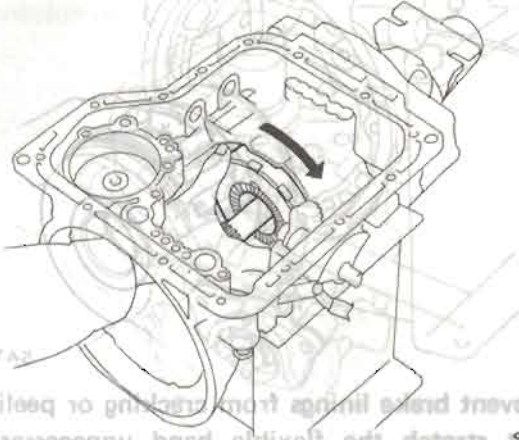

22. Remove rear planetary carrier snap ring and rear planetary carrier.

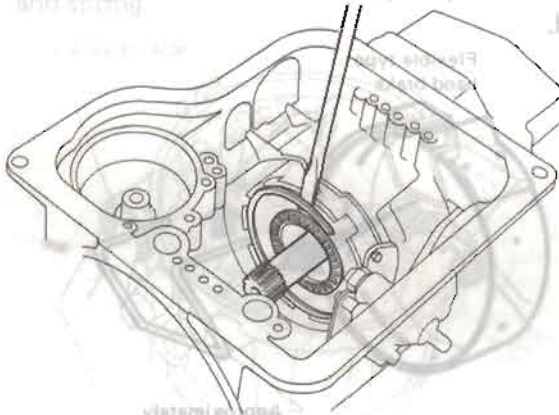

23. Remove output shaft snap ring.

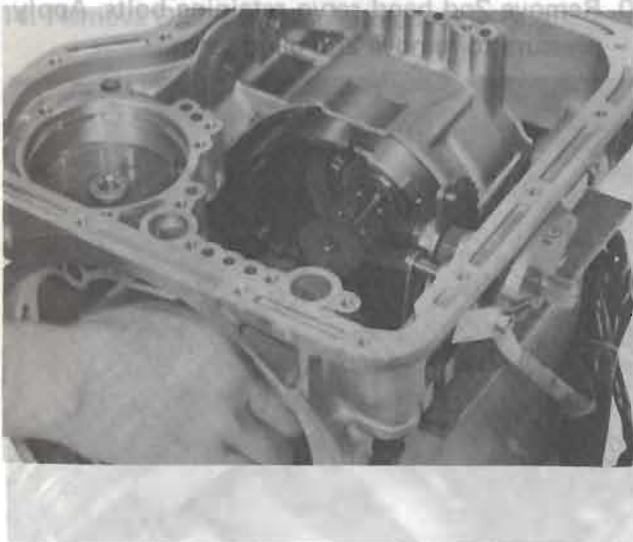

24. Remove connecting drum with internal gear.

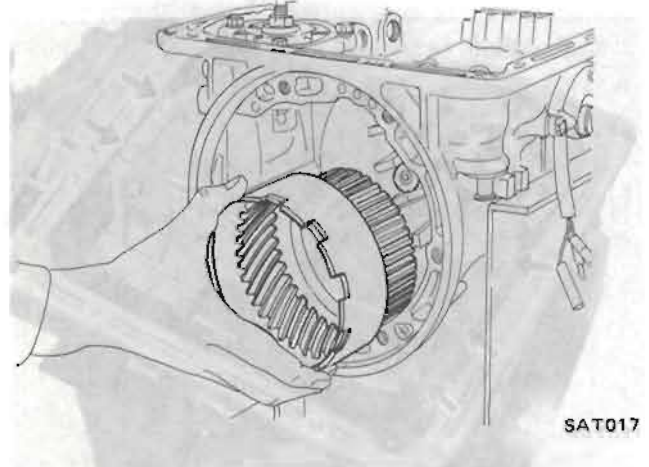

25. Pry off one end of snap ring with a screwdriver.
Remove snap ring from low and reverse brake assembly while applying plier force in direction of arrow.

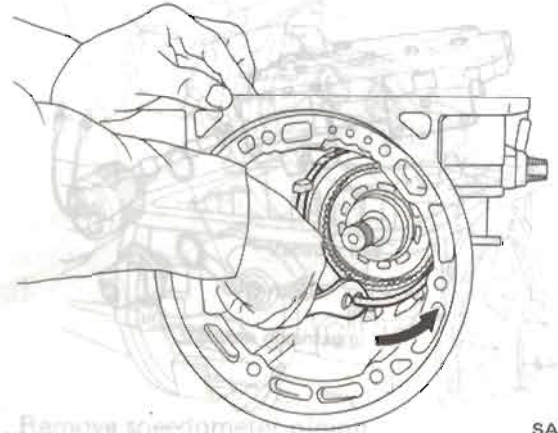

26. Remove low and reverse brake clutch assembly.

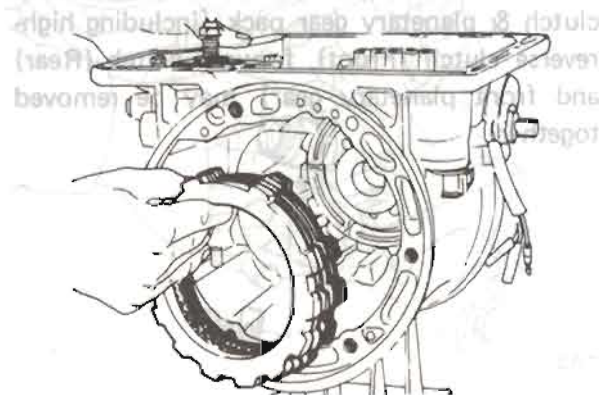

27. Remove rear extension.

Be careful not to lose retainer washer.

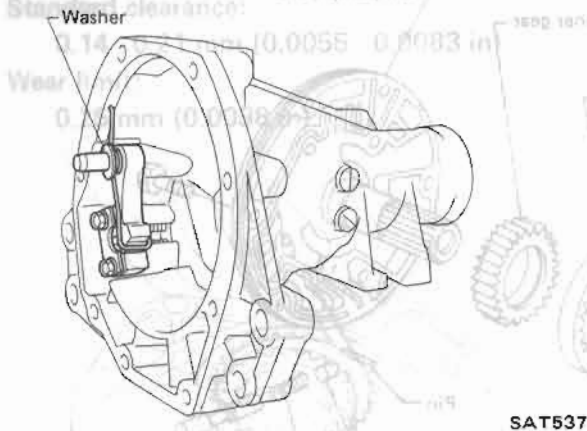

SAT537

28. Remove output shaft with governor.

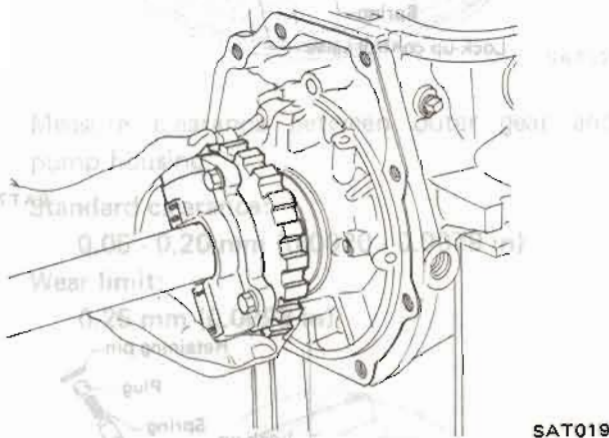

SAT019

29. Remove governor thrust washer and needle bearing.

Remove one-way clutch inner race attaching hex-head slotted bolts using Tool.

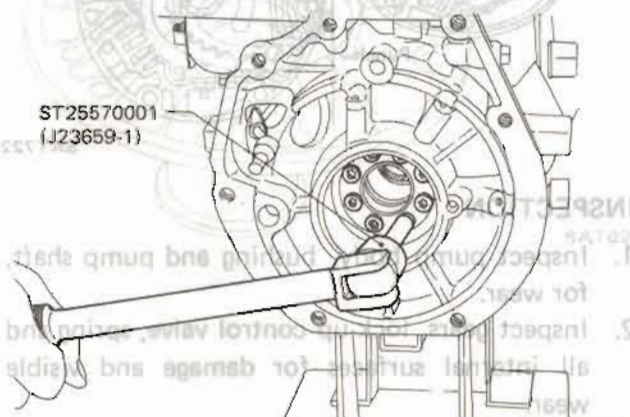

SAT020

30. Remove one-way clutch inner race, return thrust washer, low and reverse return spring, and spring thrust ring.

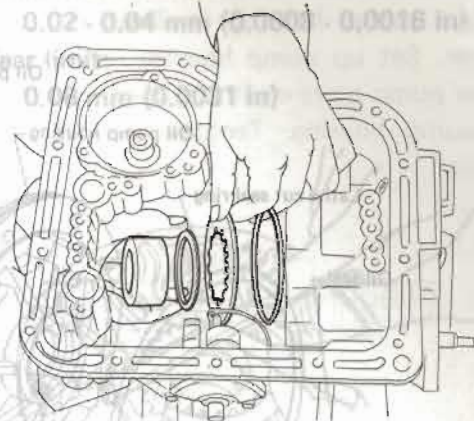

SAT021

31. Apply air pressure to remove low and reverse brake piston.

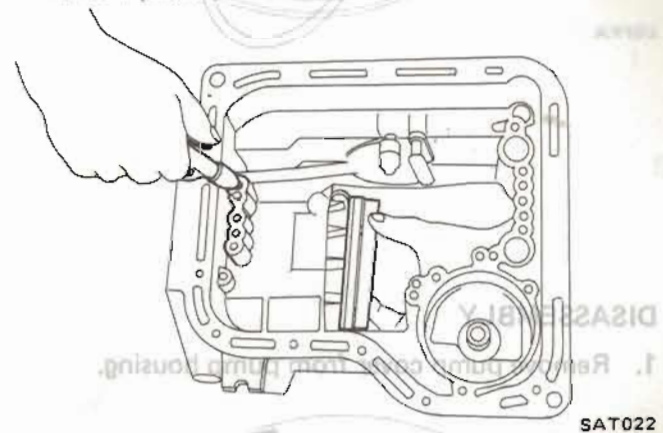

SAT022

32. Remove snap ring, then remove lock nut, manual plate and parking rod.

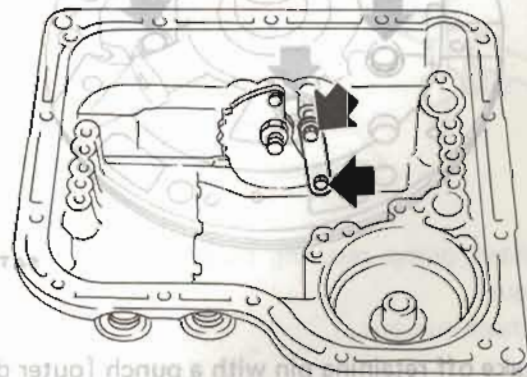

SAT720

33. Remove inhibitor switch and manual shaft.

34. Remove O.D. indicator switch and O-ring.

REPAIR FOR COMPONENT PARTS

Oil Pump

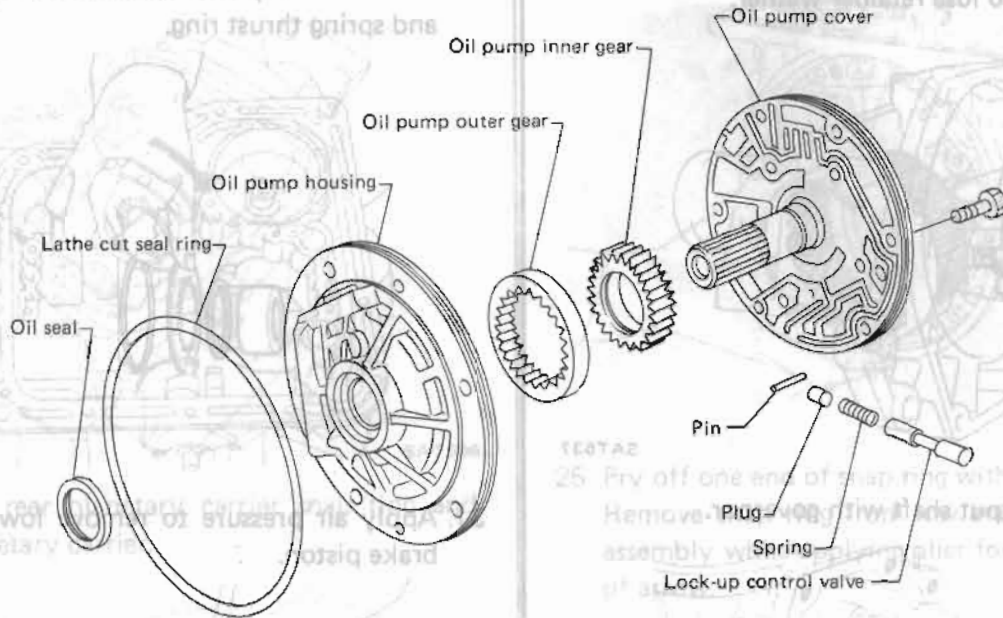

DISASSEMBLY

1. Remove pump cover from pump housing.

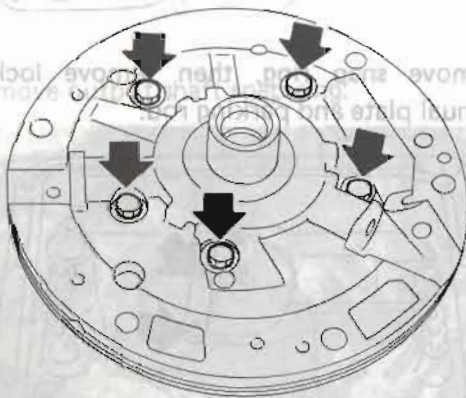

SAT538

2. Stake off retaining pin with a punch [outer dia. 1.5 to 1.8 mm (0.059 to 0.071 in)], then remove lock-up control valve and spring.

24. Remove retaining pin from pump cover.
25. Pry off one end of the pin with a screwdriver.
26. Remove output shaft with 404-000-0000.

SAT721

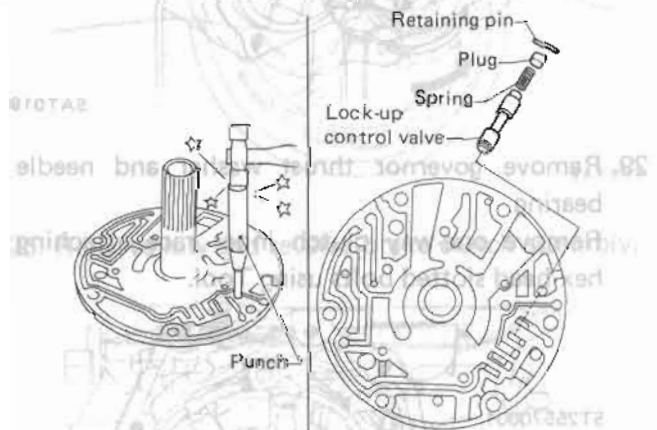

SAT722

INSPECTION

1. Inspect pump body, bushing and pump shaft, for wear.
2. Inspect gears, lock-up control valve, spring and all internal surfaces for damage and visible wear.

REPAIR FOR COMPONENT PARTS

Oil Pump (Cont'd)

3. Measure clearance between outer gear and crescent.

Standard clearance:

0.14 - 0.21 mm (0.0055 - 0.0083 in)

Wear limit:

0.25 mm (0.0098 in)

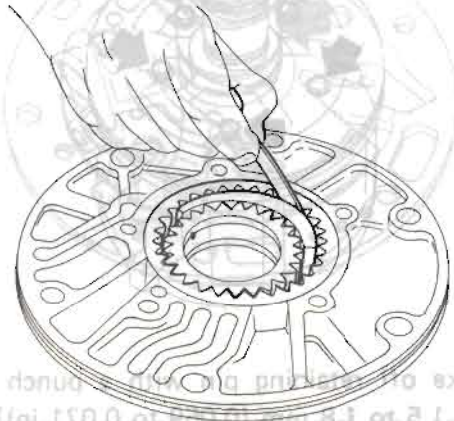

4. Measure clearance between outer gear and pump housing.

Standard clearance:

0.05 - 0.20 mm (0.0020 - 0.0079 in)

Wear limit:

0.25 mm (0.0098 in)

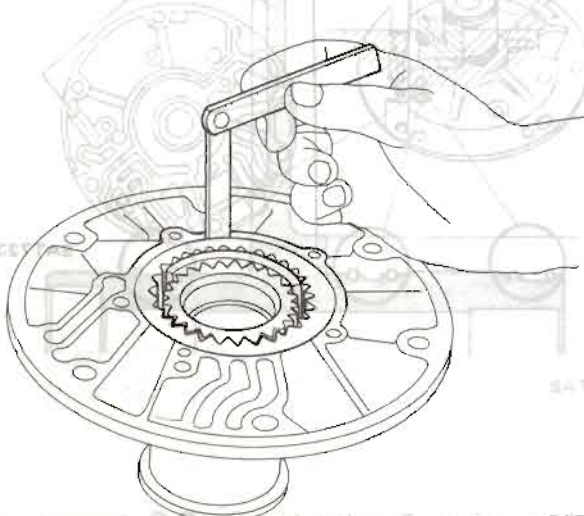

5. Measure clearance between gears and pump cover with a feeler gauge and straight edge.

Standard clearance:

0.02 - 0.04 mm (0.0008 - 0.0016 in)

Wear limit:

0.08 mm (0.0031 in)

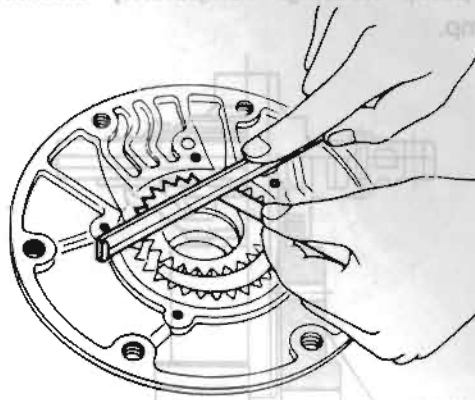

3. Set the cover to within the run-out of the specified total indicator reading. Total indicator reading: Less than 0.07 mm (0.0028 in)

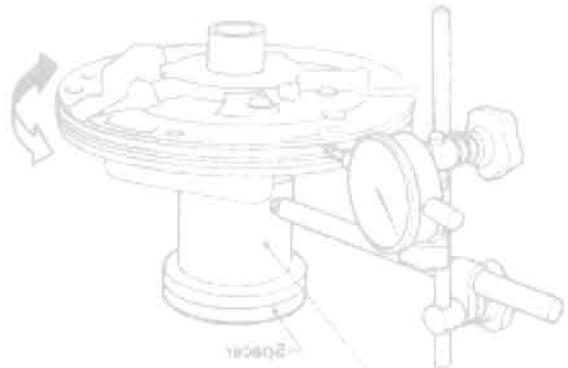

4. Tighten pump securing bolts to the specified torque. Recheck run out.

REPAIR FOR COMPONENT PARTS

Oil Pump (Cont'd)

Drum Support

ASSEMBLY

1. Install lock-up control valve and spring into oil pump cover, then tap new retaining pin.
2. Mount pump housing in Tool and suitable spacer. Set up pump housing with inner and outer pump gears on it and install pump cover to pump housing. Temporarily assemble oil pump.

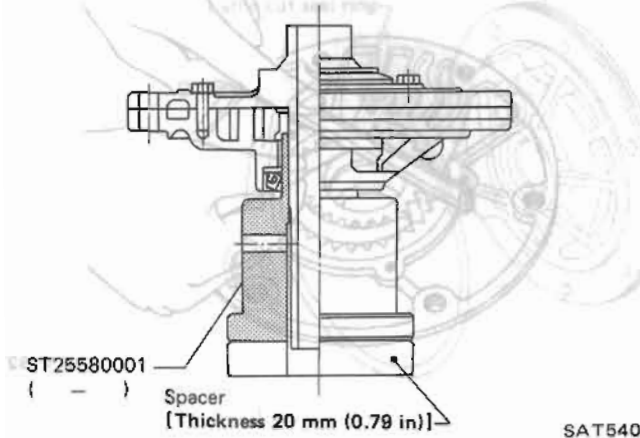

SAT540

3. Set the cover to within the run-out of the specified total indicator reading.

Total indicator reading:

Less than 0.07 mm (0.0028 in)

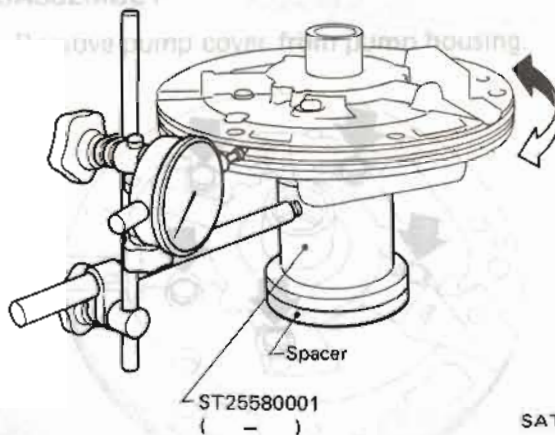

SAT541

4. Tighten pump securing bolts to the specified torque.
Recheck run-out.

2. Stake off retaining pin with a punch [outer dia. 1.5 to 1.8 mm (0.059 to 0.071 in)], then remove O.D. cancel valve and spring.

DISASSEMBLY

1. Remove drum support and gasket from O.D. case.

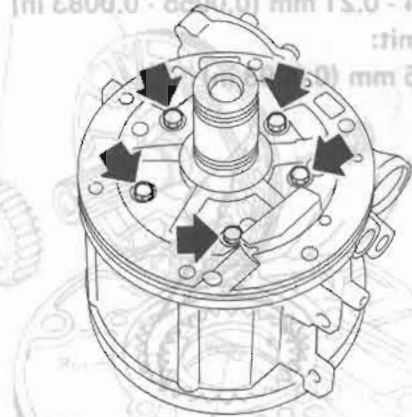

SAT531

2. Stake off retaining pin with a punch [outer dia. 1.5 to 1.8 mm (0.059 to 0.071 in)], then remove O.D. cancel valve and spring.

Don't stake it off from contacting face side.

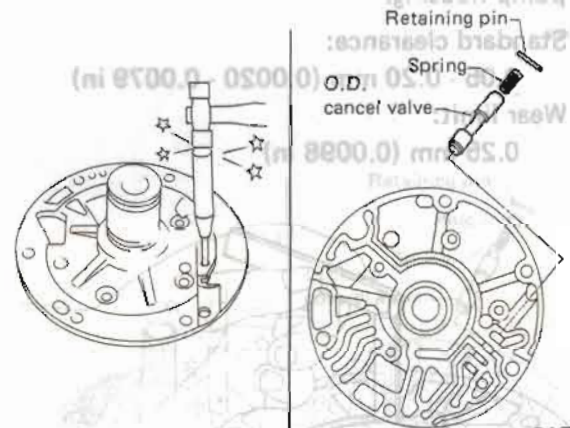

SAT723

INSPECTION

3C0TA2

1. Inspect pump body for wear.
2. Inspect gear for wear.

REPAIR FOR COMPONENT PARTS

Drum Support (Cont'd)

INSPECTION

- Inspect drum support bushing and ring groove areas for wear.

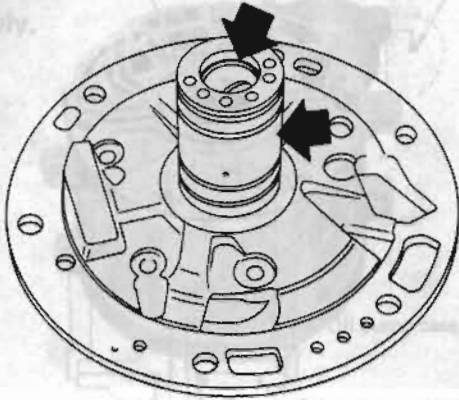

SAT542

- Measure clearance between seal ring and ring groove.

Standard clearance:

0.05 - 0.20 mm (0.0020 - 0.0079 in)

Wear limit:

0.20 mm (0.0079 in)

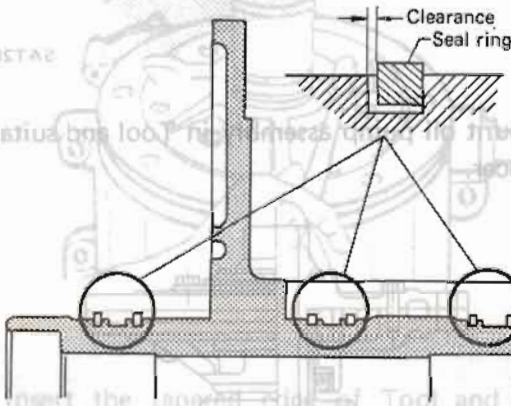

SAT545

- Inspect O.D. cancel valve & spring and all internal surfaces for damage visible wear.

1. Inspect O.D. cancel valve and spring into drum support. (See Fig. 10)
2. Inspect internal surfaces of drum support.



10. Remove Tool (J33909)
11. Check to drum support is within the range of the specified tooling prior reading.

Total indicator reading:

Less than 0.20 mm (0.0020 in)



SAT546

REPAIR FOR COMPONENT PARTS

Drum Support (Cont'd)

ASSEMBLY

1. Install O.D. cancel valve and spring into drum support, then tap new retaining pins.
2. Install lubrication plug in drum support.

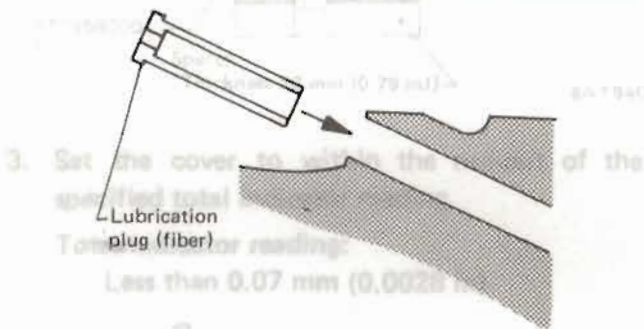
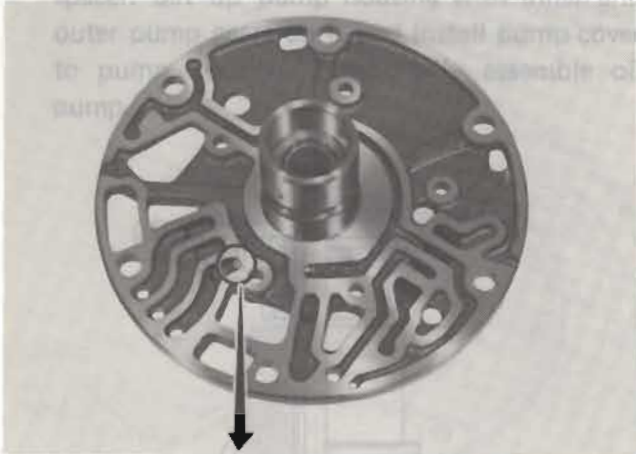

3. Install one-way orifice in O.D. case.

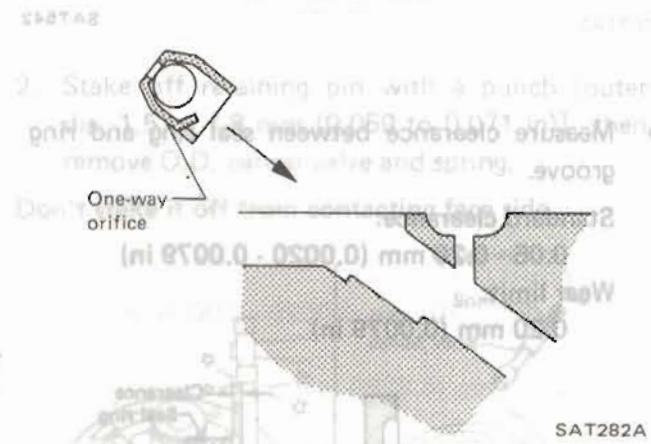
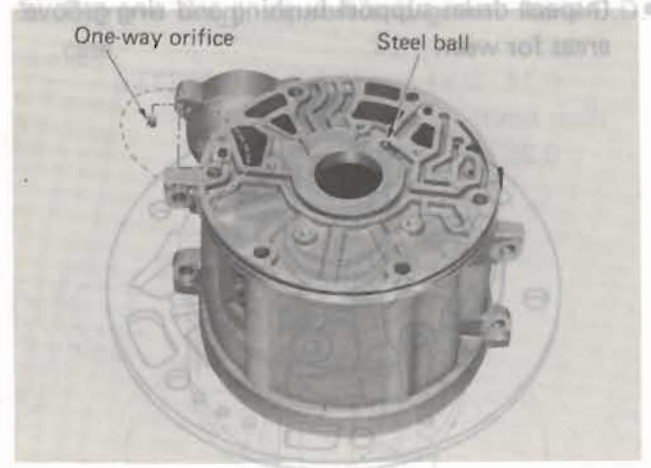

4. Mount oil pump assembly in Tool and suitable spacer.

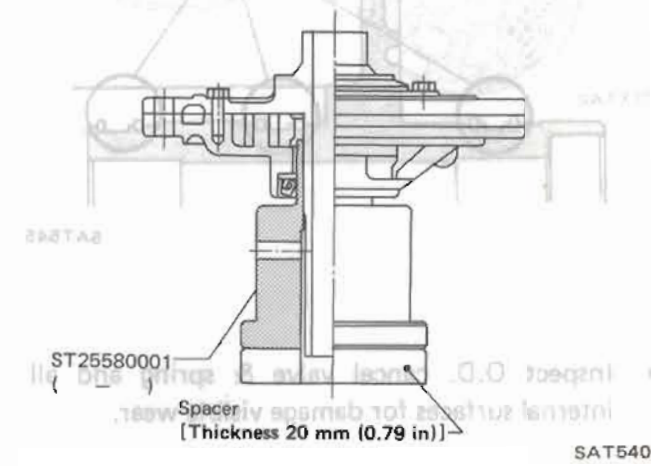

Tighten torque.
Recheck...

REPAIR FOR COMPONENT PARTS

Drum Support (Cont'd)

5. Mount O.D. case, drum support and gasket in oil pump assembly.

Ensure O.D. case is inserted properly into oil pump assembly.

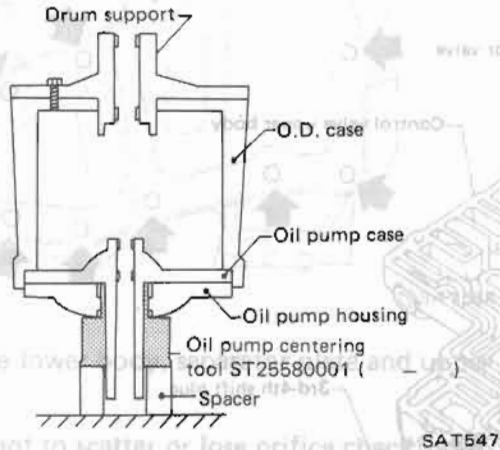

SAT547

6. Loosen drum support bolts before inserting Tool (J33909).

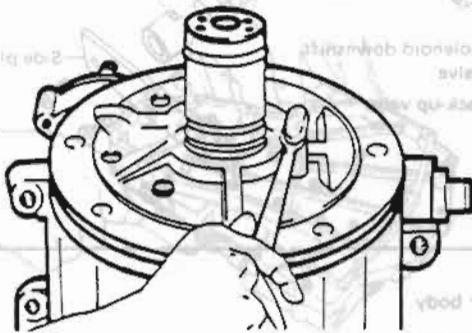

SAT935

7. Insert the tapered edge of Tool and install Tool until it completely passes through O.D. case.

INSPECTION
 Check for excessive wear on the valve body bores. If inspection reveals excessive clearances (0.0012 in) or more between the valve body bores, replace the entire valve body rather than attempt rework. If one or more valves are sticking from varnish deposits or burns resulting from deteriorated oil or sludge, you may be able to clean the valves

and valve bodies. Always use a clean, lint-free cloth, as it is too fine to use on the valves. The valve bodies can be dip cleaned in a solvent.

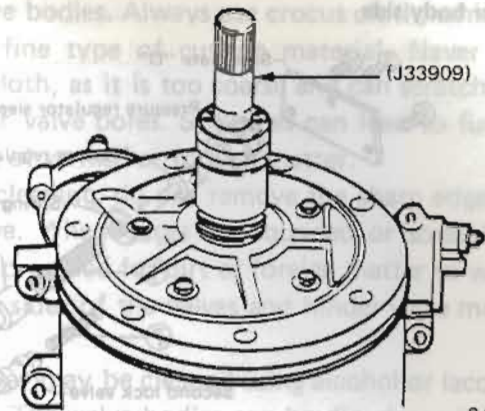

SAT936

8. Rotate Tool to ensure proper alignment.
9. Tighten drum support bolts while Tool is inside O.D. case.

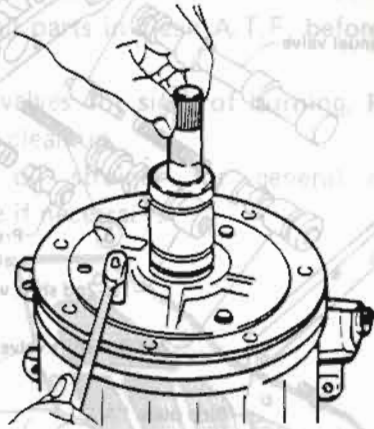

SAT937

10. Remove Tool (J33909)
11. Check to drum support is within the run-out of the specified total indicator reading.

Total indicator reading:

Less than 0.05 mm (0.0020 in)

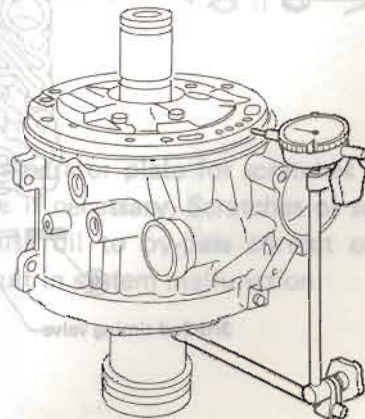

SAT600

REPAIR FOR COMPONENT PARTS

Control Valve Body

Upper body side

1. Install Side plate "D" and pressure regulator sleeve into drum support.
2. Install pressure regulator plug into drum support.

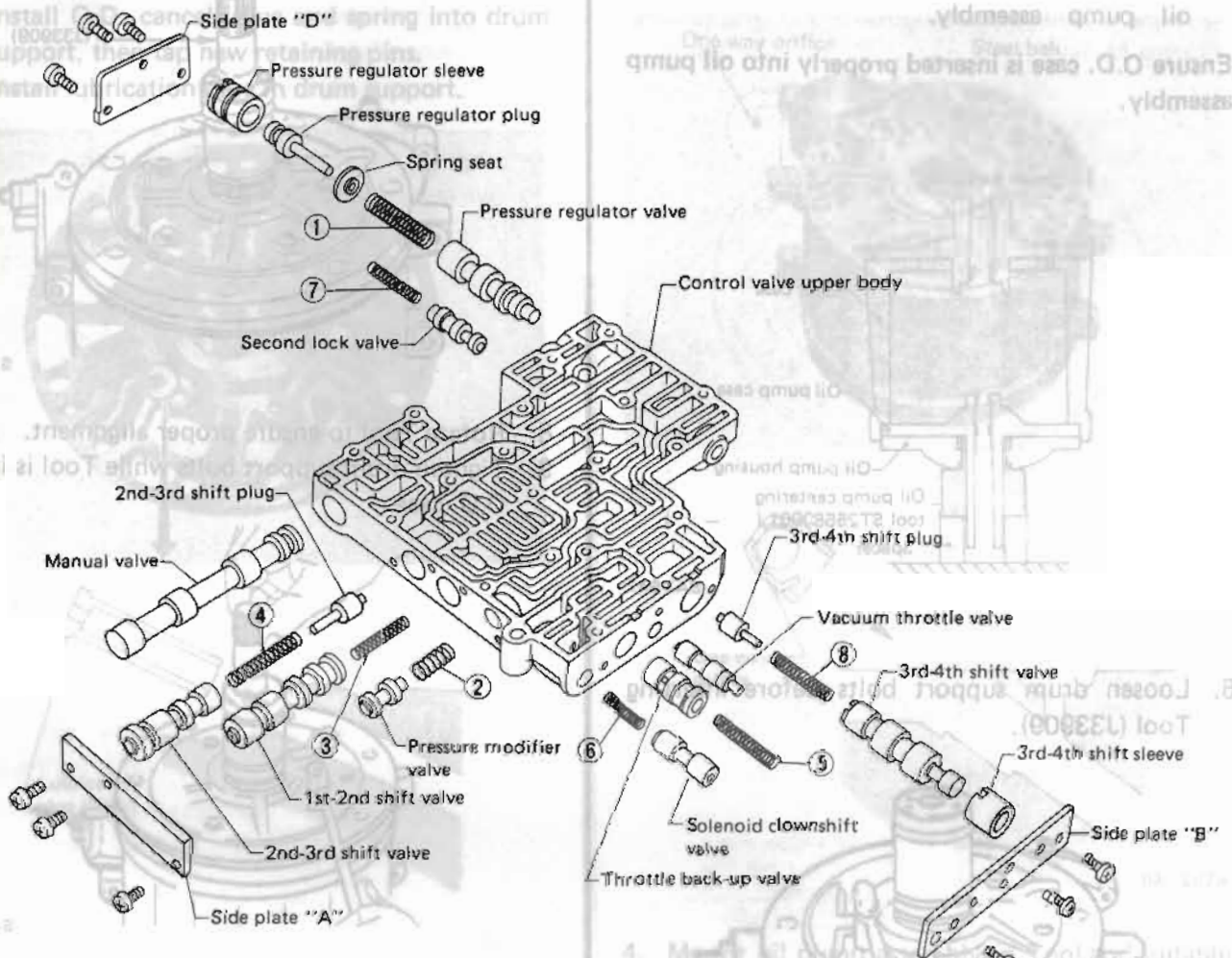

Lower body side

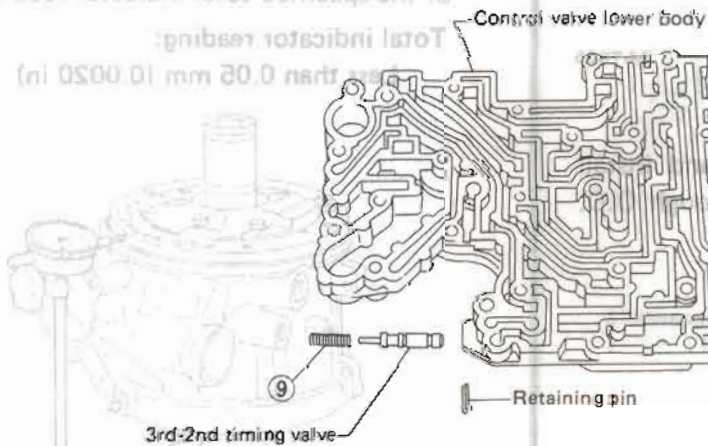

REPAIR FOR COMPONENT PARTS

Control Valve Body (Cont'd)

DISASSEMBLY

1. Remove oil strainer.

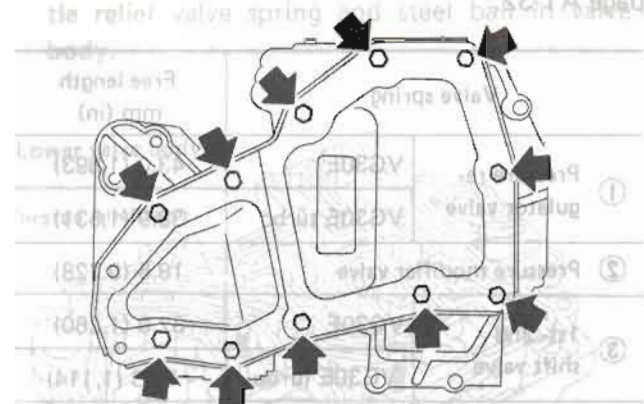

SAT564

2. Separate lower body, separator plate and upper body.

Be careful not to scatter or lose orifice check valve, servo orifice check valve, or throttle relief check valve (ball) and related springs.

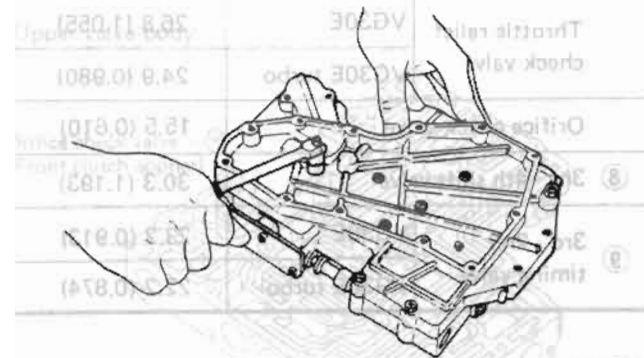

SAT067A

INSPECTION

A newly manufactured valve body represents precision manufactured valves assembled with close tolerances into precision bores of the valve body. If inspection reveals excessive clearances, 0.03 mm (0.0012 in) or more, between the valves and the valve body bores, replace the entire valve body rather than attempt rework.

If one or more valves are sticking from varnish deposits or burns resulting from deteriorated oil or overheating, you may be able to clean the valves

and valve bodies. Always use crocus cloth, which is a very fine type of cutting material. Never use emery cloth, as it is too coarse and can scratch the valves or valve bores. Scratches can lead to future deposits of varnish or foreign matter.

During cleaning, do not remove the sharp edges of the valve. When edges are rounded or scratched, entry is provided for dirt or foreign matter to work into the sides of the valves and hinder valve movement.

The valves may be cleaned using alcohol or lacquer thinner. The valve bodies can be dip cleaned with a good carburetor cleaner or lacquer thinner. Do not leave valve bodies submerged in carburetor cleaner longer than five minutes. Rinse parts thoroughly and dry.

Lubricate all parts in clean A.T.F. before reassembly.

1. Check valves for signs of burning. Replace if beyond clean-up.
2. Check oil strainer for general condition. Replace if necessary.

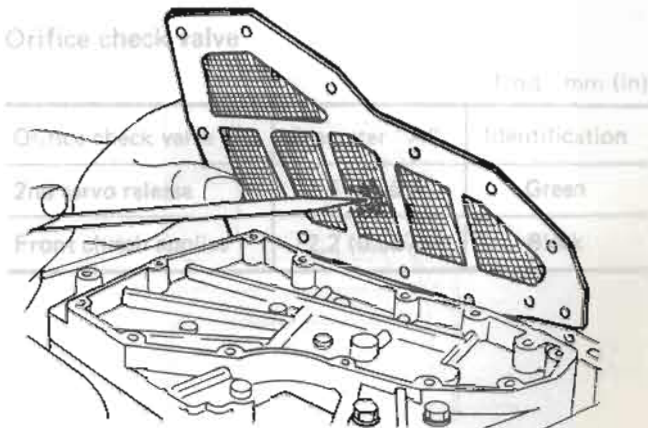

SAT045

3. Check separator plate for scratches or damage. Replace if necessary. Scratches or score marks can cause oil to by-pass correct oil passages and result in system malfunction.

REPAIR FOR COMPONENT PARTS

Control Valve Body (Cont'd)

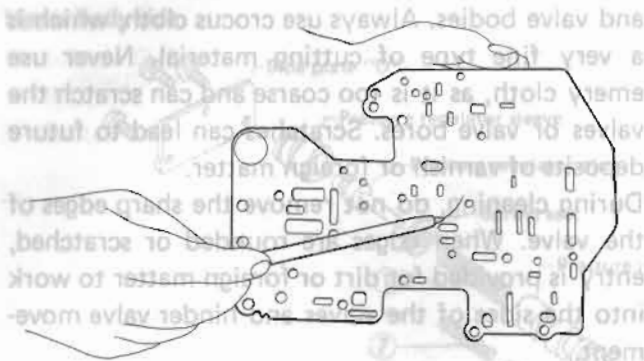

SAT046

4. Check oil passages in upper and lower valve bodies for varnish deposits, scratches or other damage that would impair valve movement. Check threaded holes and related bolts and screws for stripped threads; replace as needed.
5. Check valve springs for damage. Measure free length of valve springs. If the free length is out of specification, replace it.

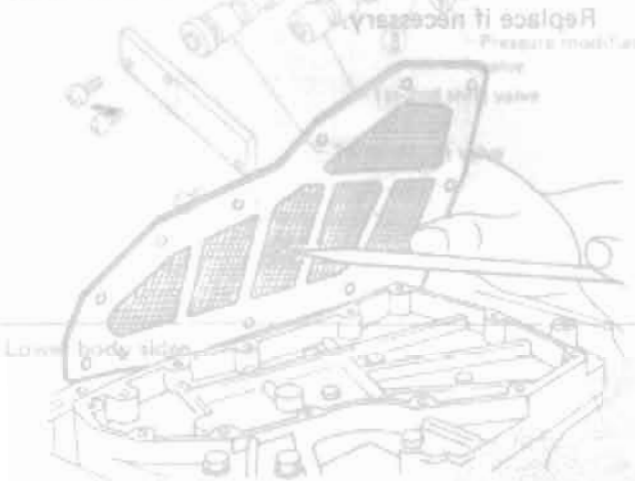

SAT045

3. Check separator plate for scratches or damage. Replace if necessary. Scratches or score marks can cause oil to bypass correct oil passages and result in system malfunction.

Numbers stamped on valve springs listed in table below are the same as those in the figure on page AT-32.

Valve spring		Free length mm (in)
① Pressure regulator valve	VG30E	43.0 (1.693)
	VG30E turbo	38.9 (1.531)
② Pressure modifier valve		18.5 (0.728)
③ 1st - 2nd shift valve	VG30E	32.0 (1.260)
	VG30E turbo	28.3 (1.114)
④ 2nd - 3rd shift valve	VG30E	42.0 (1.654)
	VG30E turbo	39.2 (1.543)
⑤ Throttle back-up valve	VG30E	31.8 (1.252)
	VG30E turbo	36.0 (1.417)
⑥ Solenoid downshift valve		22.0 (0.866)
⑦ Second lock valve		33.5 (1.319)
Throttle relief check valve	VG30E	26.8 (1.055)
	VG30E turbo	24.9 (0.980)
Orifice check valve		15.5 (0.610)
⑧ 3rd - 4th shift valve		30.3 (1.193)
⑨ 3rd - 2nd timing valve	VG30E	23.2 (0.913)
	VG30E turbo	22.2 (0.874)

REPAIR FOR COMPONENT PARTS

Control Valve Body (Cont'd)

ASSEMBLY

1. Install orifice check valves, valve springs, throttle relief valve spring and steel ball in valve body.

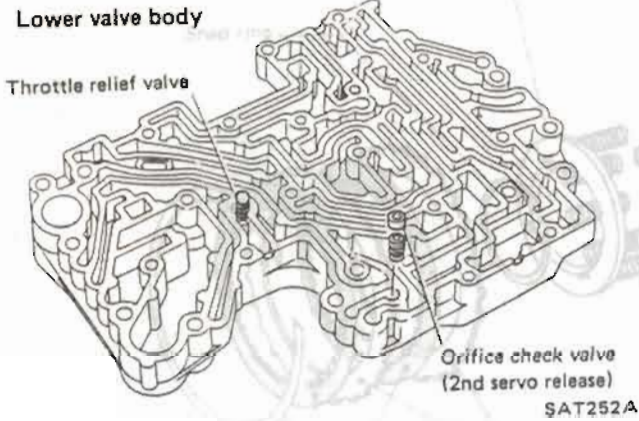

Upper valve body

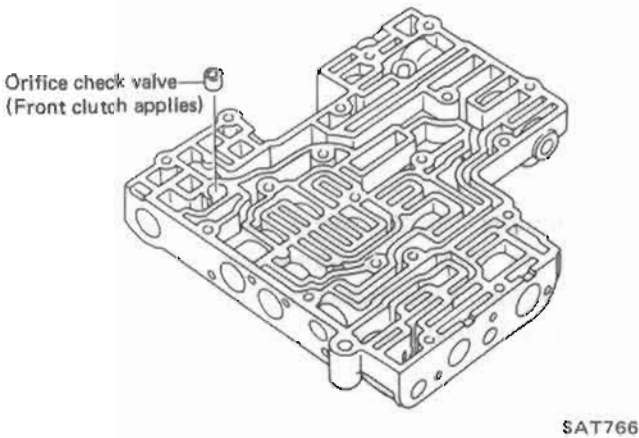

2. Assemble separator plate and upper valve body on lower valve body, then tighten bolts.

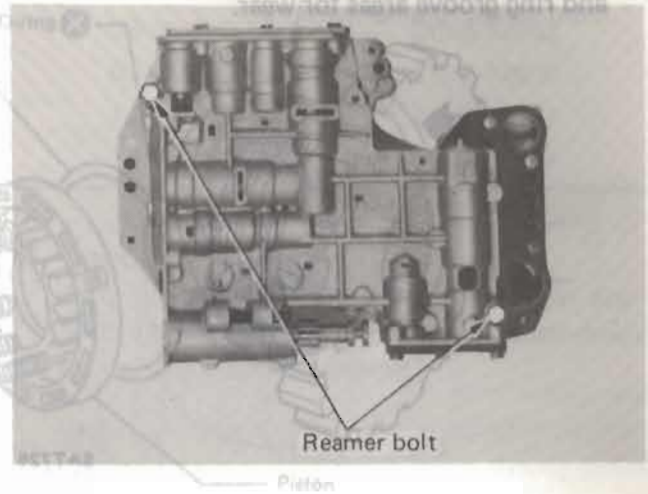

When installing these bolts, first be sure to install the two reamer bolts to their original positions.

3. Install oil strainer.

Orifice check valve

Unit: mm (in)

Orifice check valve	Diameter "A"	Identification
2nd servo release	1.5 (0.059)	Green
Front clutch applies	2.2 (0.087)	Black

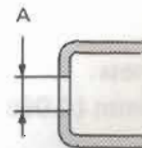

SAT924

REPAIR FOR COMPONENT PARTS

Oil Distributor

INSPECTION

- Inspect contacting surface of oil distributor and ring groove areas for wear.

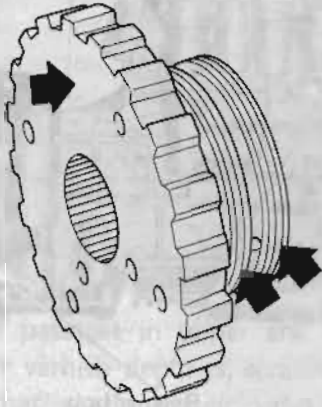

SAT725

- Measure clearance between seal ring and ring groove.

Standard clearance:

0.04 - 0.16 mm (0.0016 - 0.0063 in)

Wear limit:

0.16 mm (0.0063 in)

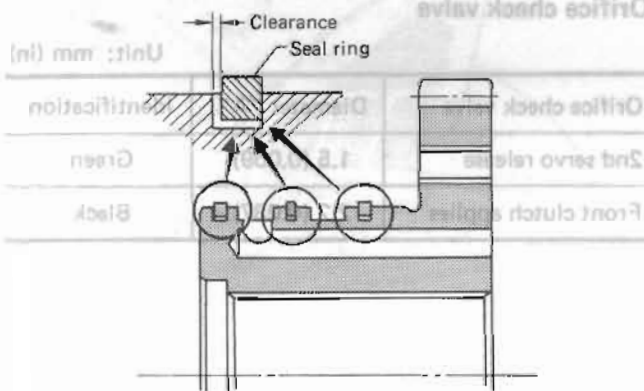

SAT726

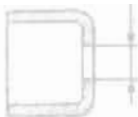

SAT727

Numbers stamped on valve springs list assembly. Install valve springs in the order shown below. See the notes at the end of this page.

Valve spring	Free length (mm (in))
1 Pressure regulator	169 (6.65)
2 Pressure control	169 (6.65)
3 1st - 2nd valve	169 (6.65)
4 2nd - 3rd valve	169 (6.65)
5 3rd - 4th valve	169 (6.65)
6 4th - 5th valve	169 (6.65)
7 5th - 6th valve	169 (6.65)
Throttle relief check valve	169 (6.65)
8 3rd - 2nd valve	169 (6.65)
9 2nd - 1st valve	169 (6.65)

REPAIR FOR COMPONENT PARTS

Direct Clutch

b. Reinstall snap ring. Be sure snap ring is properly seated.

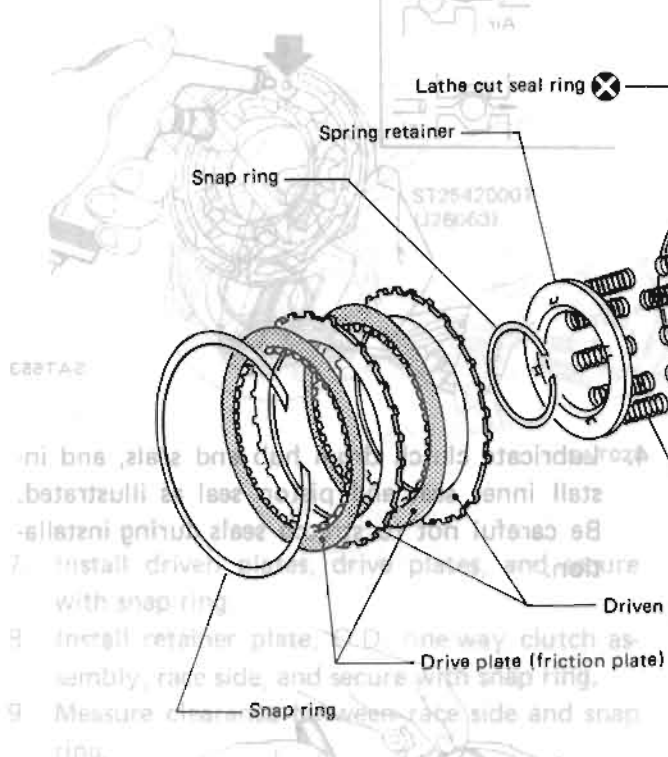

Specified clearance:
 0 - 0.2 mm (0 - 0.008 in)

If necessary, try other race side having different thicknesses until correct clearance is obtained.

5. Assemble piston, being careful not to allow seal to kink or become damaged during installation. After installing, turn piston by hand to ensure that there is no binding.

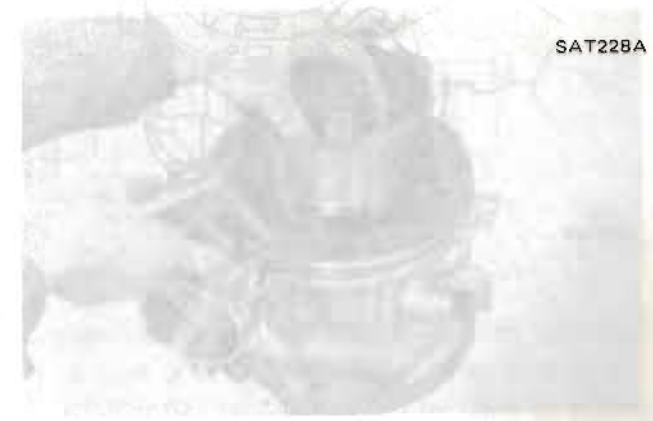
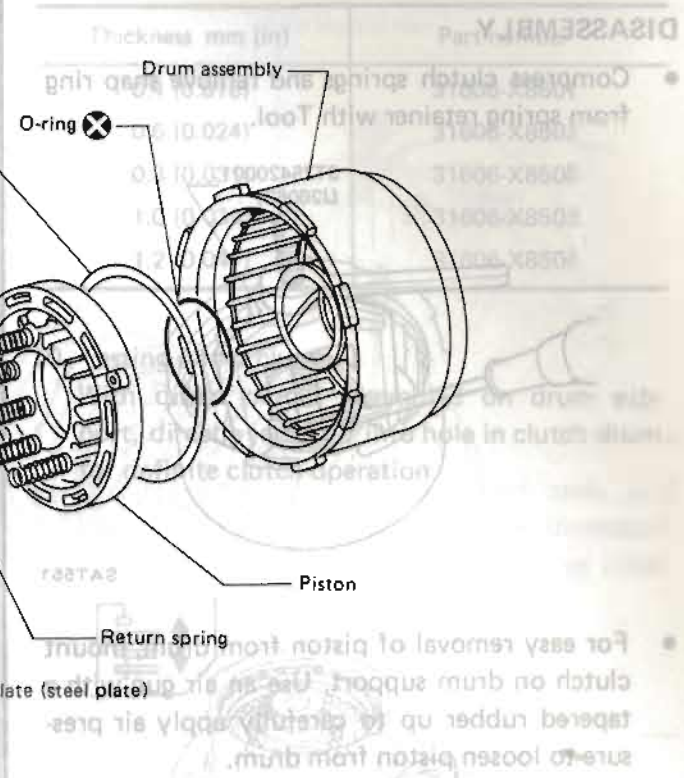

- INSPECTION AND ASSEMBLY
1. Check clutch drive plate facing for wear or damage.
 Standard thickness:
 1.50 - 1.65 mm (0.0591 - 0.0650 in)
 Wear limit:
 1.4 mm (0.055 in)
 2. Check for wear on snap ring, weak or broken coil springs, and warped spring retainer.
 3. Check the operation of check ball in piston using compressed air.

REPAIR FOR COMPONENT PARTS

Direct Clutch (Cont'd)

DISASSEMBLY

- Compress clutch springs and remove snap ring from spring retainer with Tool.

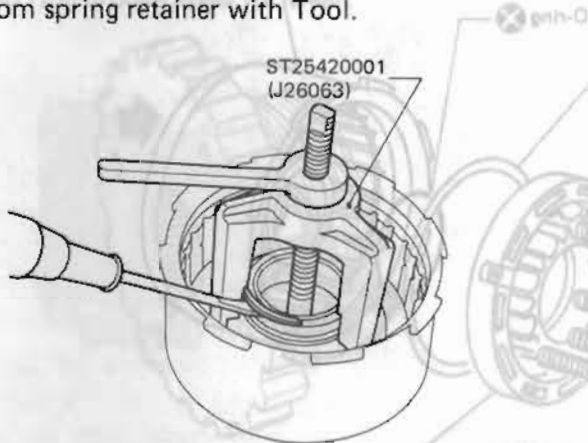

- For easy removal of piston from drum, mount clutch on drum support. Use an air gun with a tapered rubber up to carefully apply air pressure to loosen piston from drum.



INSPECTION AND ASSEMBLY

- Check clutch drive plate facing for wear or damage.

Standard thickness:

1.50 - 1.65 mm (0.0591 - 0.0650 in)

Wear limit:

1.4 mm (0.055 in)

- Check for wear on snap ring, weak or broken coil springs, and warped spring retainer.
- Check the operation of check ball in piston using compressed air.

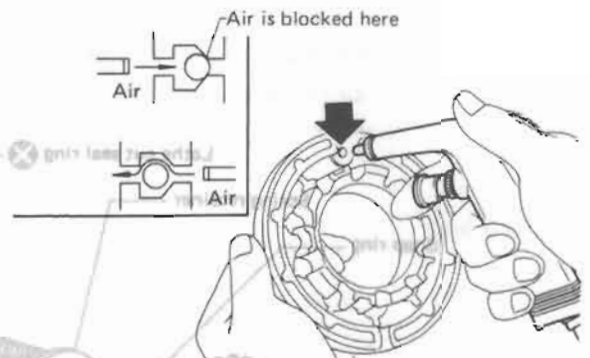

- Lubricate clutch drum hub and seals, and install inner seal and piston seal as illustrated. Be careful not to stretch seals during installation.



- Assemble piston, being careful not to allow seal to kink or become damaged during installation. After installing, turn piston by hand to ensure that there is no binding.

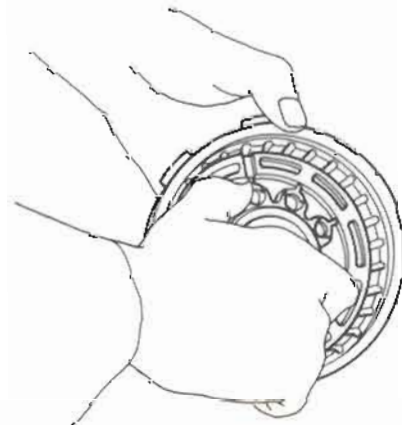

REPAIR FOR COMPONENT PARTS

Direct Clutch (Cont'd)

6. Reassemble spring and retainer. Reinstall snap ring. Be sure snap ring is properly seated.

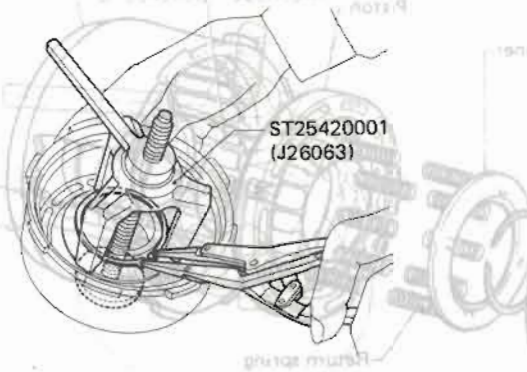

SAT028

7. Install driven plates, drive plates, and secure with snap ring.
 8. Install retainer plate, O.D. one-way clutch assembly, race side, and secure with snap ring.
 9. Measure clearance between race side and snap ring.

Specified clearance:

0 - 0.2 mm (0 - 0.008 in)

If necessary, try other race side having different thicknesses until correct clearance is obtained.

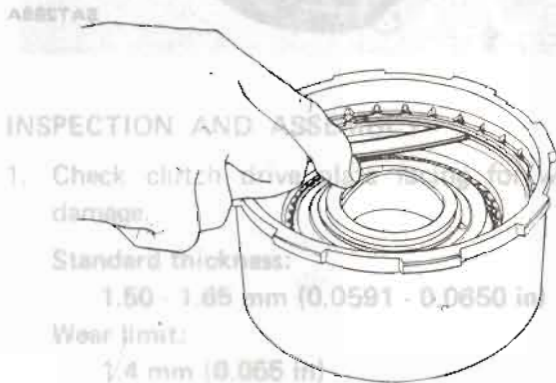

SAT034

1. Check clutch drum for wear or damage.

Standard thickness:

1.50 - 1.65 mm (0.0591 - 0.0650 in)

Wear limit:

1.4 mm (0.055 in)

Check for wear on snapping, weak or broken coil springs, and warped spring retainer. Check the operation of check bell in piston using compressed air.

Thickness mm (in)	Part number
0.4 (0.016)	31606-X8501
0.6 (0.024)	31606-X8502
0.8 (0.031)	31606-X8500
1.0 (0.039)	31606-X8503
1.2 (0.047)	31606-X8504

10. Testing direct clutch.

With direct clutch assembled on drum support, direct a jet of air into hole in clutch drum for definite clutch operation.

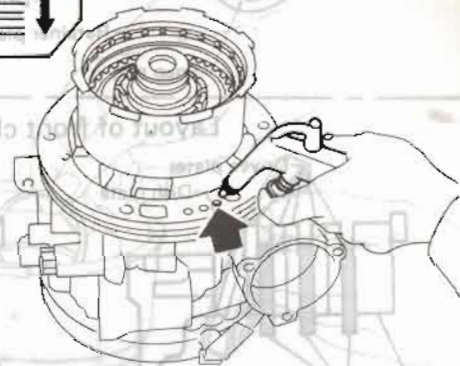

SAT621

5. Assemble piston, being careful not to allow seal to kink or become damaged during installation. After installing, turn piston by hand to ensure that there is no binding.

REPAIR FOR COMPONENT PARTS

Front Clutch

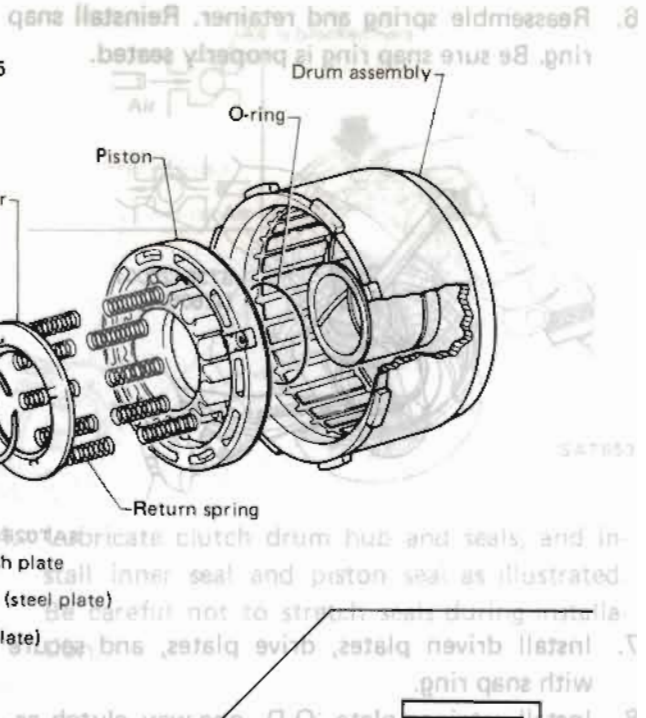
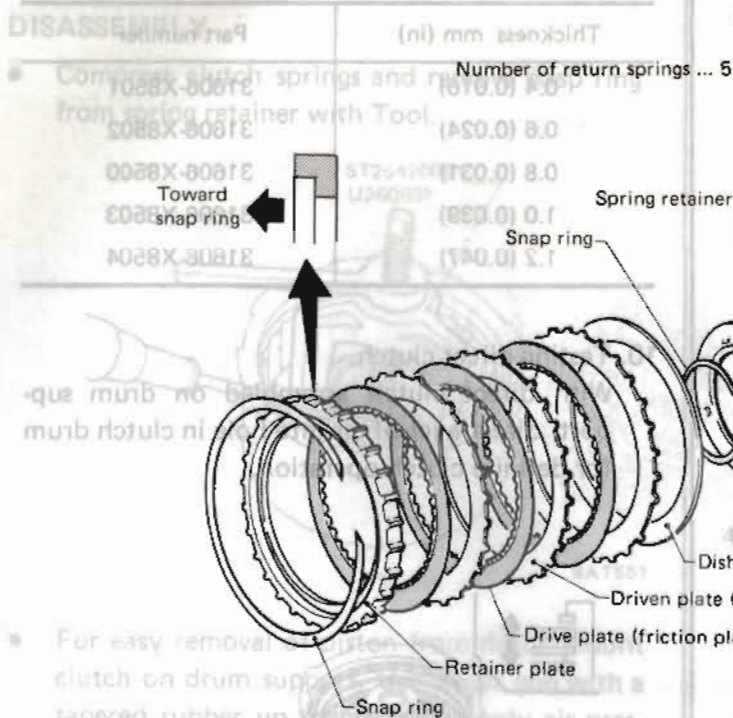

Layout of front clutch plates

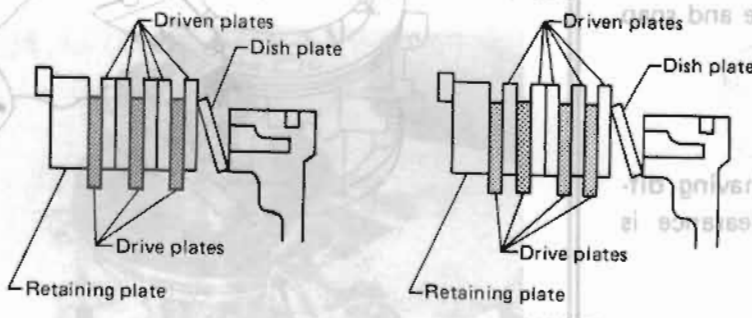

VG30E

VG30E turbo

INSPECTION AND ASSEMBLY

1. Check clutch drive plate facing for wear or damage.
Standard thickness:
1.50 - 1.65 mm (0.0591 - 0.0650 in)
Wear limit:
1.4 mm (0.055 in)
2. Check for wear on snap ring, weak or broken coil springs, and warped spring retainer.
3. Check the operation of check ball or piston using compressed air.

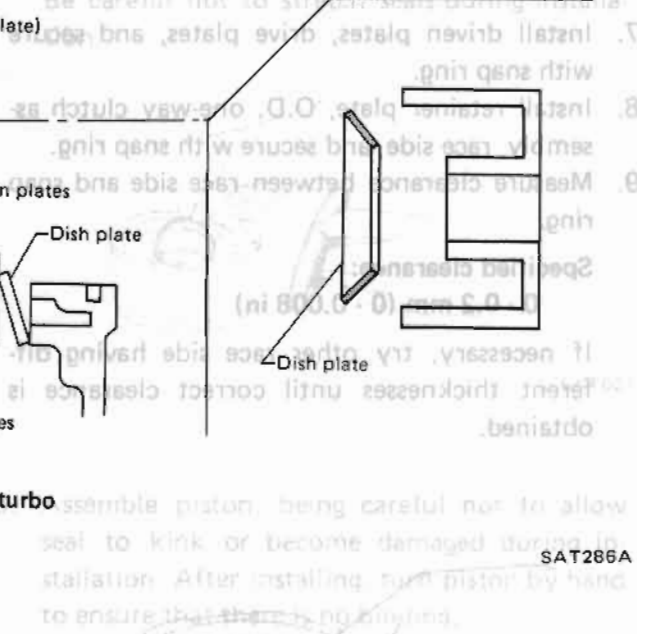

SAT286A

REPAIR FOR COMPONENT PARTS

Front Clutch (Cont'd)

DISASSEMBLY

- Compress clutch springs and remove snap ring from spring retainer with Tool.

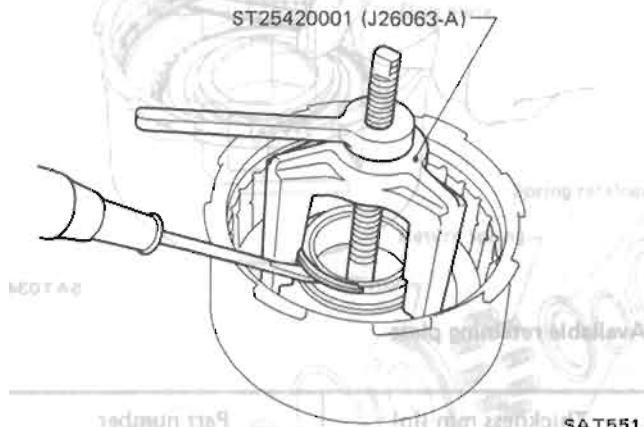

- For easy removal of piston from drum, mount clutch on drum support. Use an air gun with a tapered rubber up to carefully apply air pressure to loosen piston from drum.

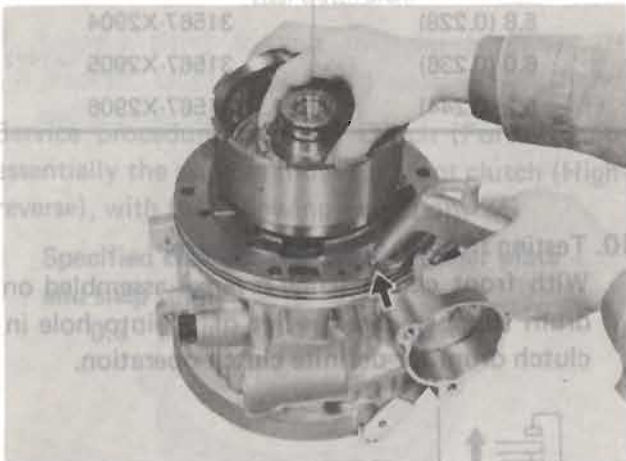

INSPECTION AND ASSEMBLY

- Check clutch drive plate facing for wear or damage.

Standard thickness:

1.50 - 1.65 mm (0.0591 - 0.0650 in)

Wear limit:

1.4 mm (0.055 in)

- Check for wear on snapping, weak or broken coil springs, and warped spring retainer.
- Check the operation of check ball in piston using compressed air.

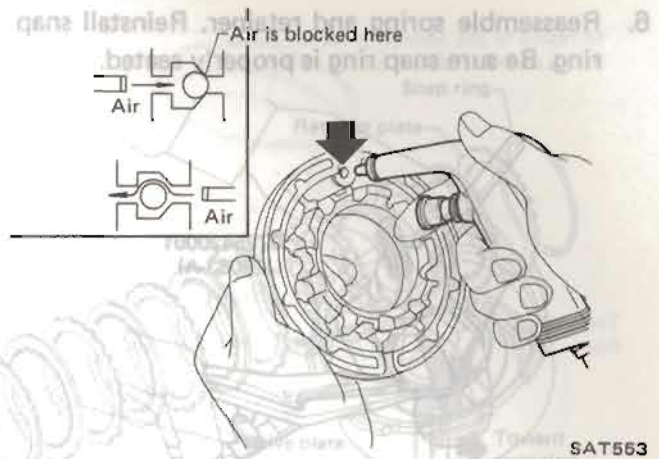

- Lubricate clutch drum hub and seals, and install inner seal and piston seal as illustrated. Be careful not to stretch seals during installation.

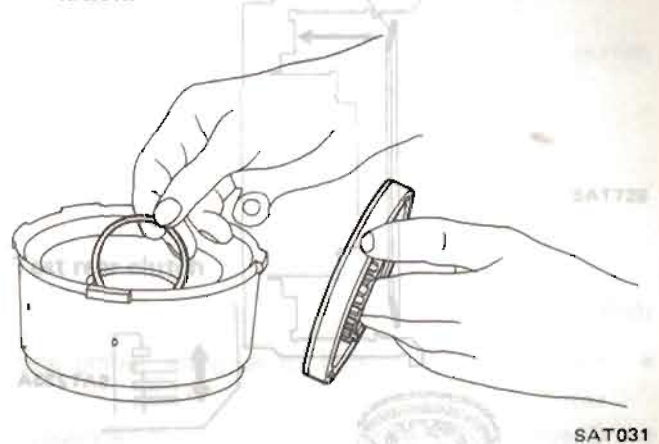

- Assemble piston, being careful not to allow seal to kink or become damaged during installation. After installing, turn piston by hand to ensure that there is no binding.

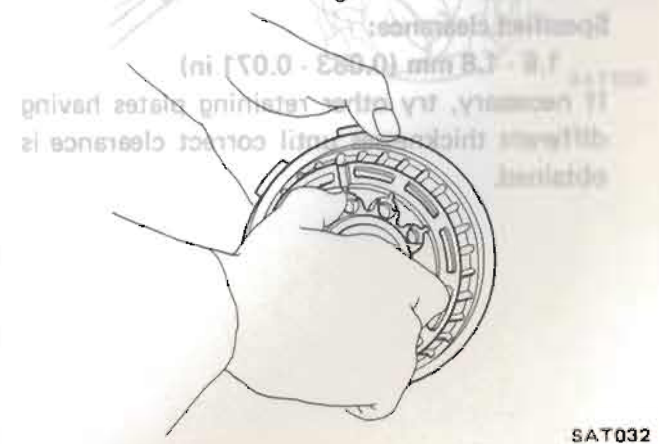

REPAIR FOR COMPONENT PARTS

Front Clutch (Cont'd)

6. Reassemble spring and retainer. Reinstall snap ring. Be sure snap ring is properly seated.

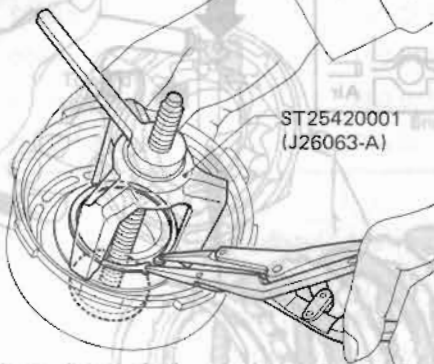

ST25420001
(J26063-A)

SAT028

7. Install dish plate.

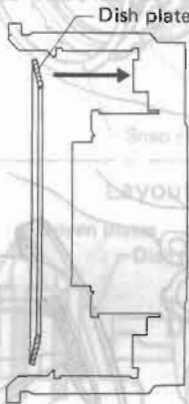

Dish plate

SAT233A

8. Install driven plates, drive plates, and secure with snap ring.

9. Measure clearance between retainer plate and snap ring.

Specified clearance:

1.6 - 1.8 mm (0.063 - 0.071 in)

If necessary, try other retaining plates having different thicknesses until correct clearance is obtained.

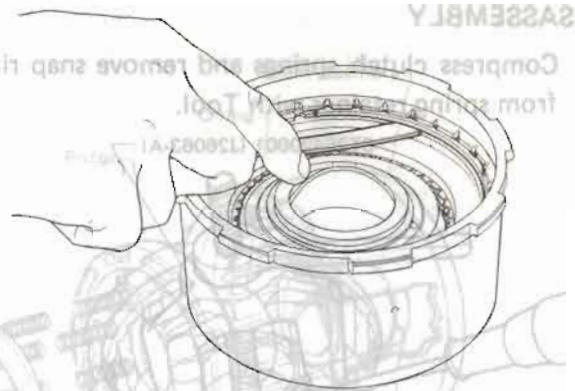

Available retaining plate

SAT034

Thickness mm (in)	Part number
5.0 (0.197)	31567-X2900
5.2 (0.205)	31567-X2901
5.4 (0.213)	31567-X2902
5.6 (0.220)	31567-X2903
5.8 (0.228)	31567-X2904
6.0 (0.236)	31567-X2905
6.2 (0.244)	31567-X2906

10. Testing front clutch (High-reverse)

With front clutch (High-reverse) assembled on drum support, direct a jet of air into hole in clutch drum for definite clutch operation.

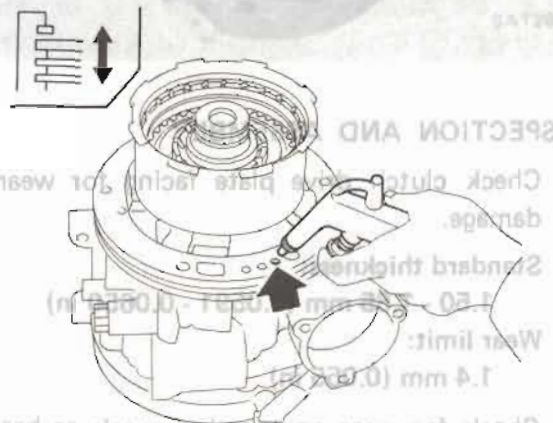

SAT621

REPAIR FOR COMPONENT PARTS

Rear Clutch (Forward)

In regard to the number of clutch sheets (drive plate and driven plate), refer to S.D.S.

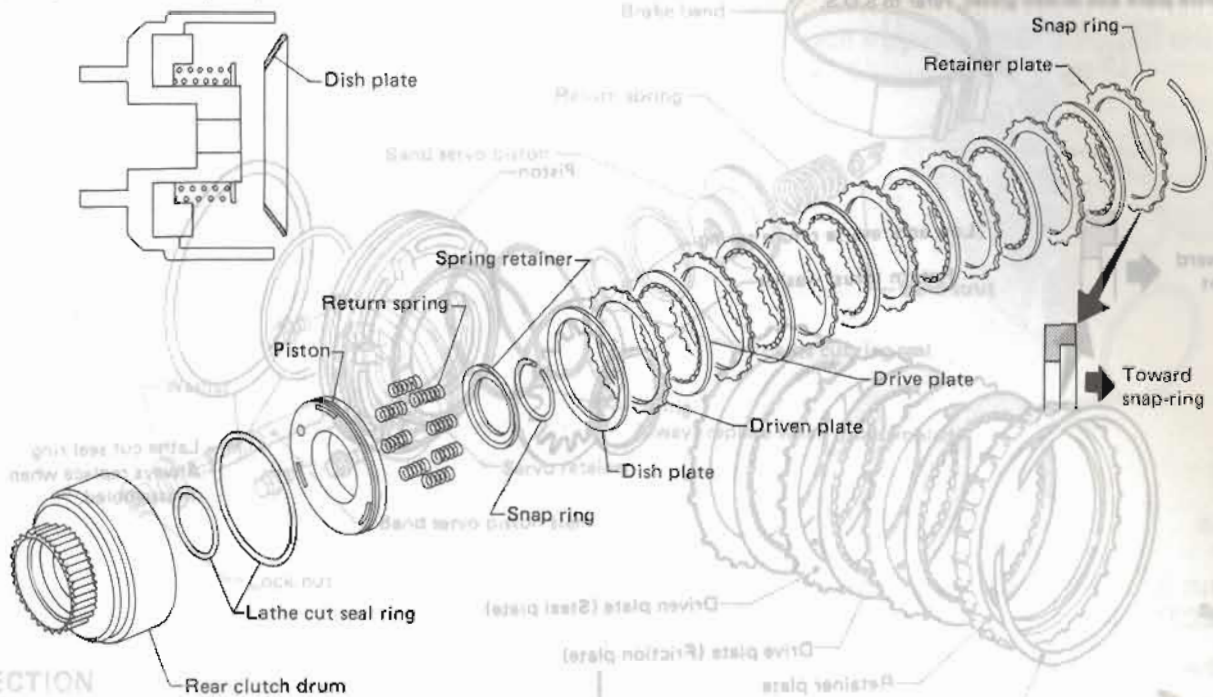

INSPECTION

Inspect band friction material for wear. If cracked, chipped or burnt spots are apparent, replace the band.

Service procedures for rear clutch (Forward) are essentially the same as those for front clutch (High-reverse), with the following exception:

Specified clearance between retainer plate and snap ring:

0.8 - 1.0 mm (0.031 - 0.039 in)

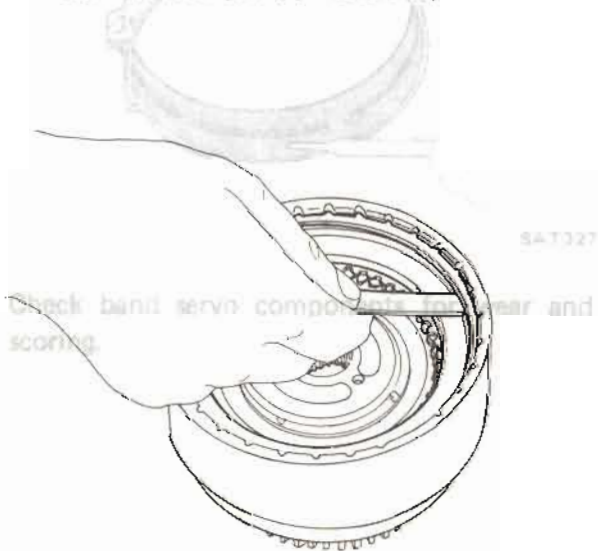

SAT035

Test rear clutch

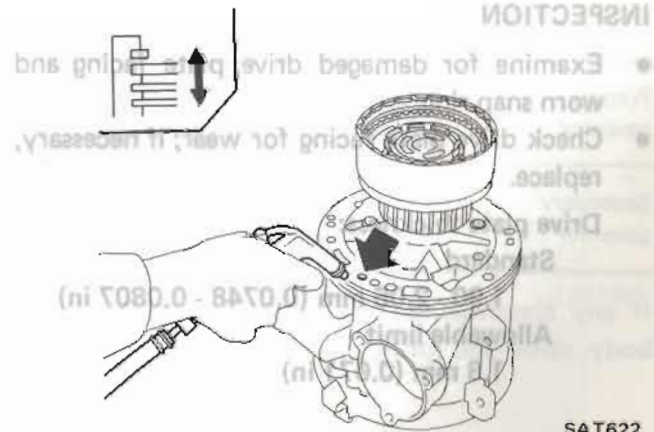

SAT728

SAT622

REPAIR FOR COMPONENT PARTS

Low & Reverse Brake

6. Reassemble spring and retainer. Reinstall snap ring. In regard to the number of clutch sheets (drive plate and driven plate), refer to S.D.S. seated.

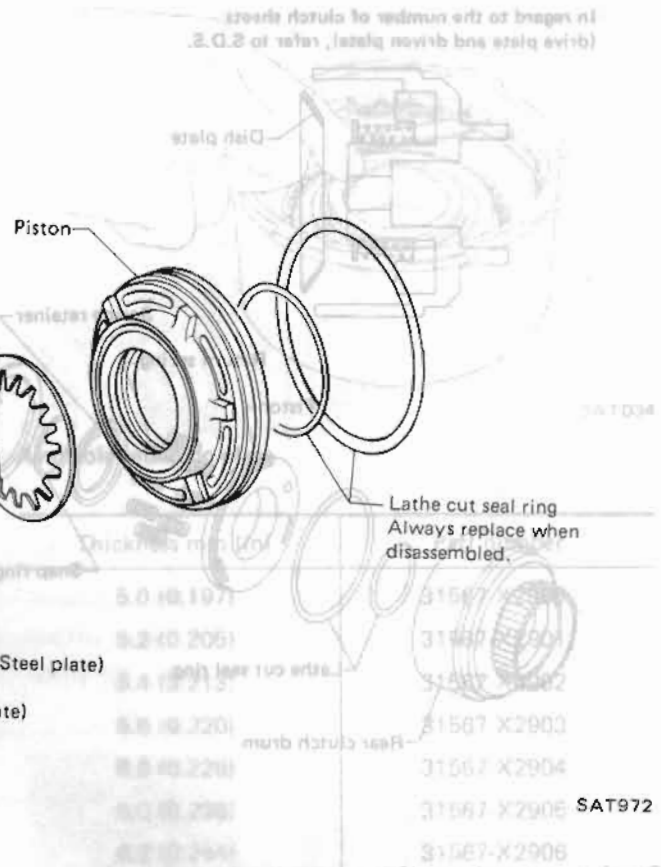
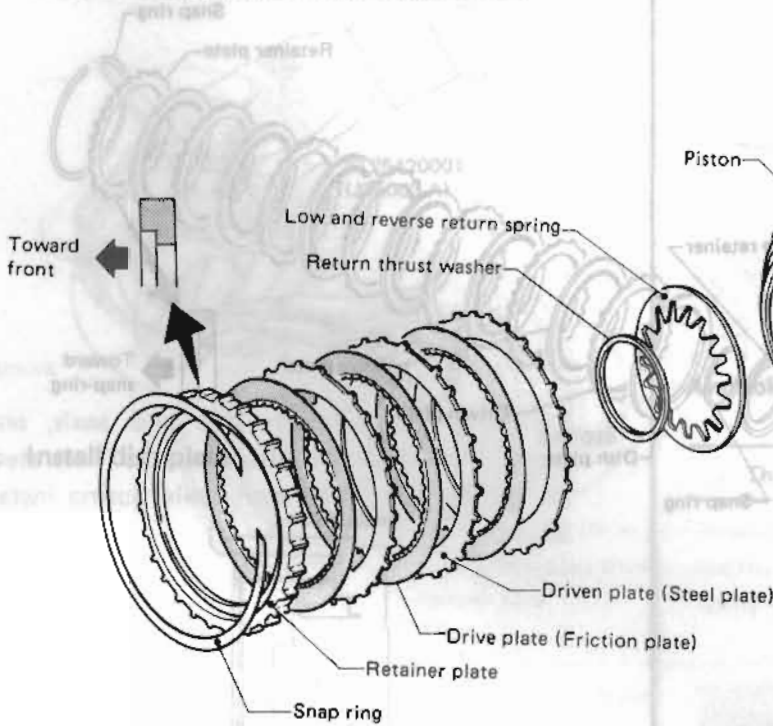

INSPECTION

- Examine for damaged drive plate facing and worn snap ring.
- Check drive plate facing for wear; if necessary, replace.

8. **Drive plate thickness:**
Standard 1.90 - 2.05 mm (0.0748 - 0.0807 in)
Allowable limit 1.8 mm (0.071 in)
Specified 1.8 mm (0.071 in)
 If necessary, try other retaining plates having different thicknesses until correct clearance is obtained.

10. Testing low and reverse clutch operation. Specified clearance between retaining plate and snap ring (High reverse) is 0.081 - 0.088 mm (0.0031 - 0.0035 in). With front clutch (High reverse) is 0.081 - 0.088 mm (0.0031 - 0.0035 in).
 Service procedures for rear clutch (Forward) are essentially the same as those for front clutch (High reverse), with the following exception:



REPAIR FOR COMPONENT PARTS

Brake Band and Band Servo

INSPECTION

Check clearance between pinion gear and planetary carrier with a feeler gauge.

Standard clearance:

0.70 mm (0.0278 in)

Wear limit:

0.80 mm (0.0315 in)

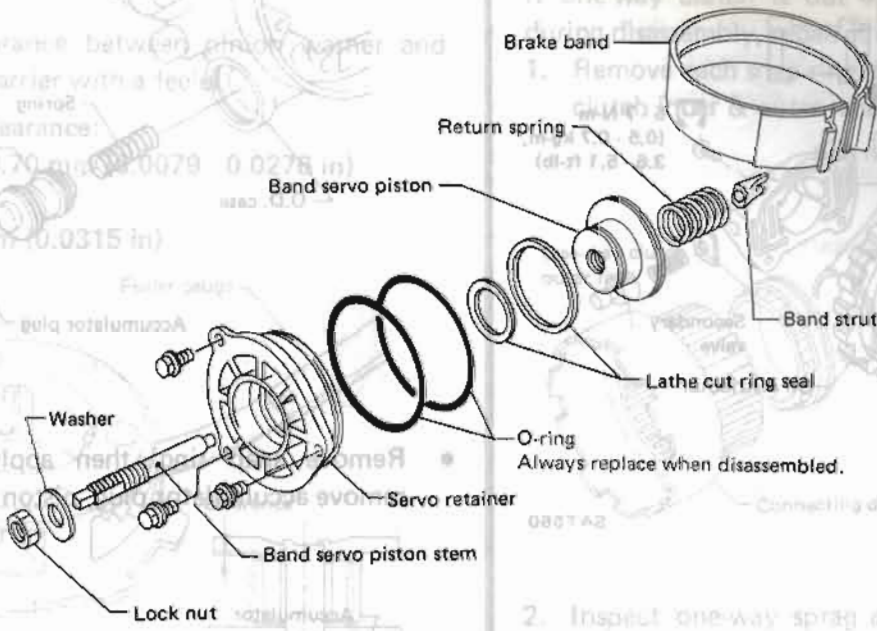

INSPECTION

- Inspect band friction material for wear. If cracked, chipped or burnt spots are apparent, replace the band.

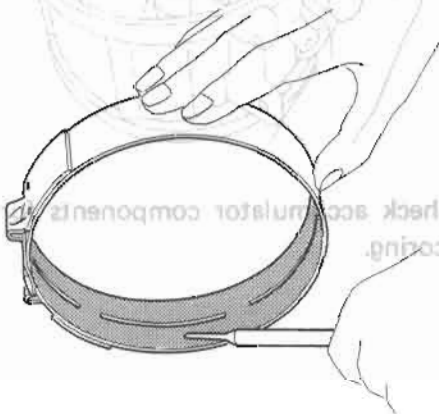

SAT327

- Check band servo components for wear and scoring.

If one-way clutch is out of adjustment...

1. Remove...

2. Inspect one-way sprag contacting surface for wear or burns.

3. Assemble those parts...

Check governor valves and valve body for indication of burning or scuffing.

Part No.	Part Name	Free length (mm)	Free length (in)
VG30E	Primary governor	108 (0.413)	4.25 (0.167)
VG30E	Secondary governor	218 (0.858)	8.58 (0.338)
VG30E	...	217 (0.854)	8.54 (0.336)
VG30E	...	198 (0.780)	7.80 (0.307)

If any abnormalities are found, replace governor body, valves and springs as an assembly.

REPAIR FOR COMPONENT PARTS

Governor

Accumulator

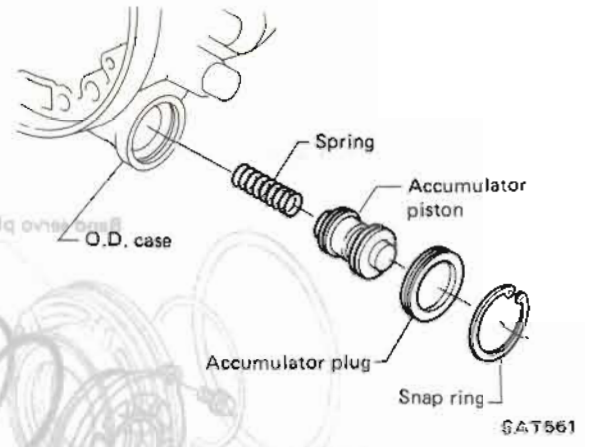
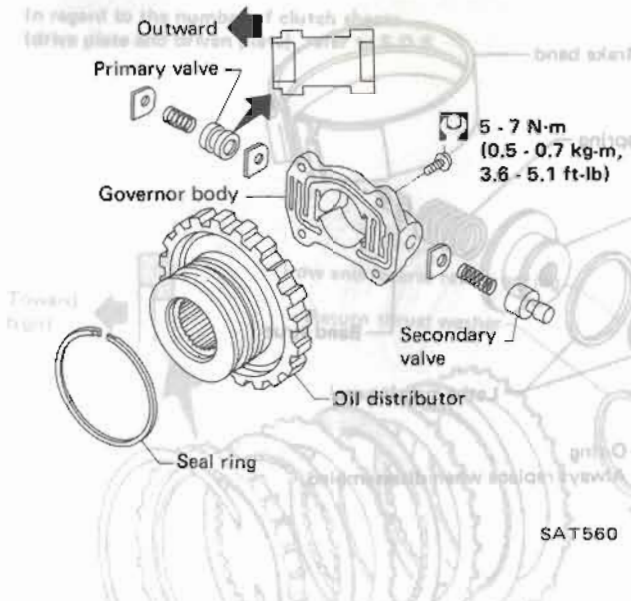

INSPECTION

- Check governor valves and valve body for indication of burning or scratches.
- Check valve springs for damage. Measure free length of valve springs.

Valve spring		Free length mm (in)
Primary governor	VG30E	10.5 (0.413)
	VG30E turbo	21.8 (0.858)
Secondary governor	VG30E	21.7 (0.854)
	VG30E turbo	19.8 (0.780)

If any abnormalities are found, replace governor body, valves and springs as an assembly.

- Remove snap ring, then apply pressure to remove accumulator plug, piston and spring.

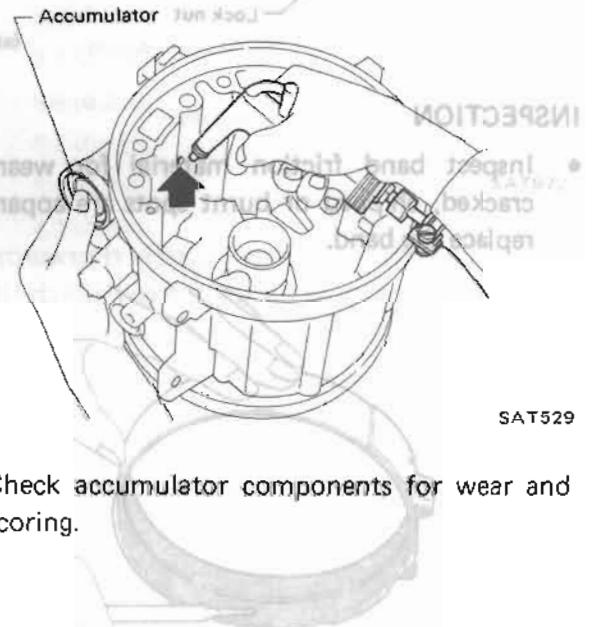

- Check accumulator components for wear and scoring.

REPAIR FOR COMPONENT PARTS

Planetary Carrier

INSPECTION

- Check clearance between pinion washer and planetary carrier with a feeler.

Standard clearance:

0.20 - 0.70 mm (0.0079 - 0.0276 in)

Wear limit:

0.80 mm (0.0315 in)

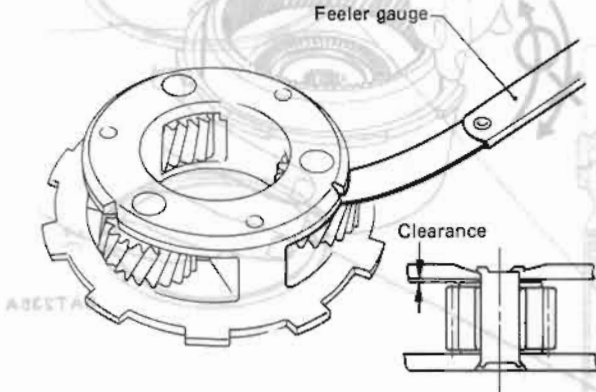

SAT730

- Check planetary gear sets and bearings for damaged or worn gears.

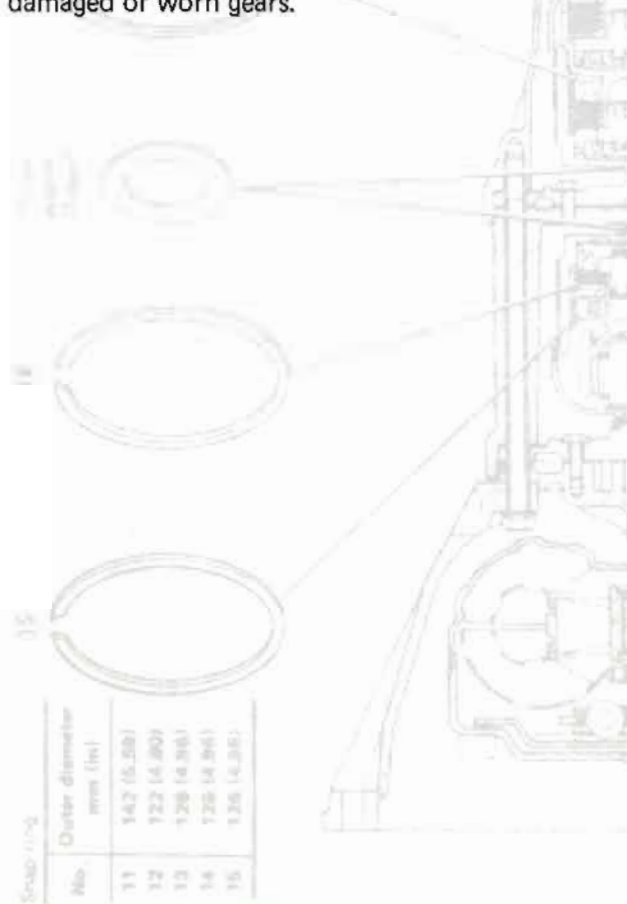

Snag ring	No.	Outer diameter mm (in)
	11	142 (5.59)
	12	122 (4.80)
	13	128 (4.96)
	14	126 (4.96)
	15	126 (4.96)

Connecting Drum Assembly

If one-way clutch is out of order as determined during disassembly, repair it as follows:

1. Remove each snap ring, then draw out one-way clutch inner & outer race.

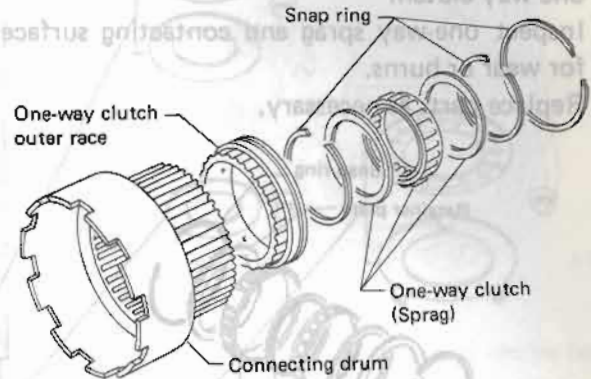

SAT562

2. Inspect one-way sprag and contacting surface for wear or burns. Replace parts as necessary.
3. Assemble those parts.

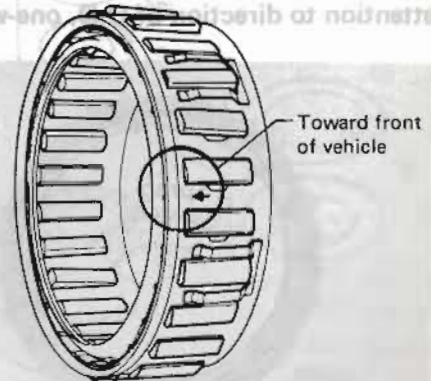

SAT563

REPAIR FOR COMPONENT PARTS

O.D. One-way Clutch

If one-way clutch is out of order as determined during disassembly, repair it as follows:

1. Remove each snap ring, then draw out O.D. one-way clutch.
2. Inspect one-way sprag and contacting surface for wear or burns.

Replace parts as necessary.

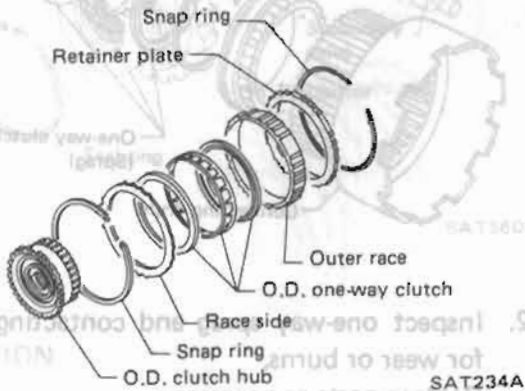

3. Assemble those parts.

Pay attention to direction of O.D. one-way clutch.

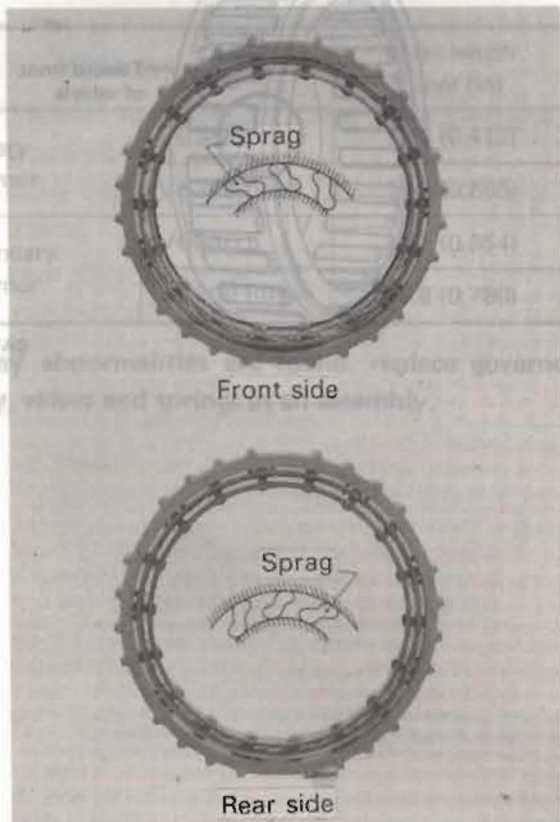

4. After assembly, check O.D. one-way clutch to see if it operates properly.

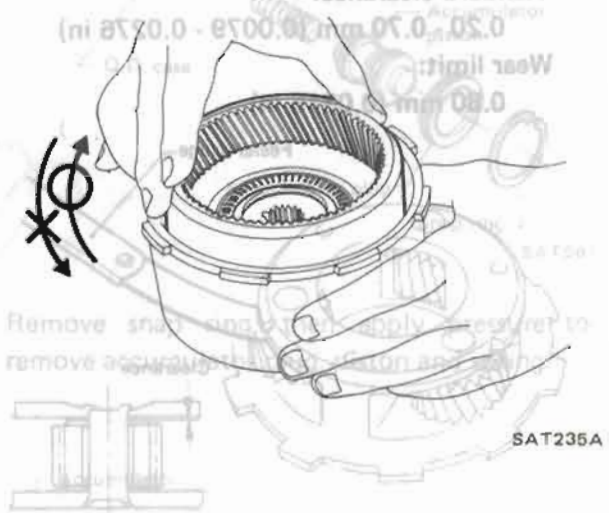

ASSEMBLY

When installing/assembling needle bearing, bearing race, snap ring and thrust washer, use the following illustration as a guide to installation procedures and locations.

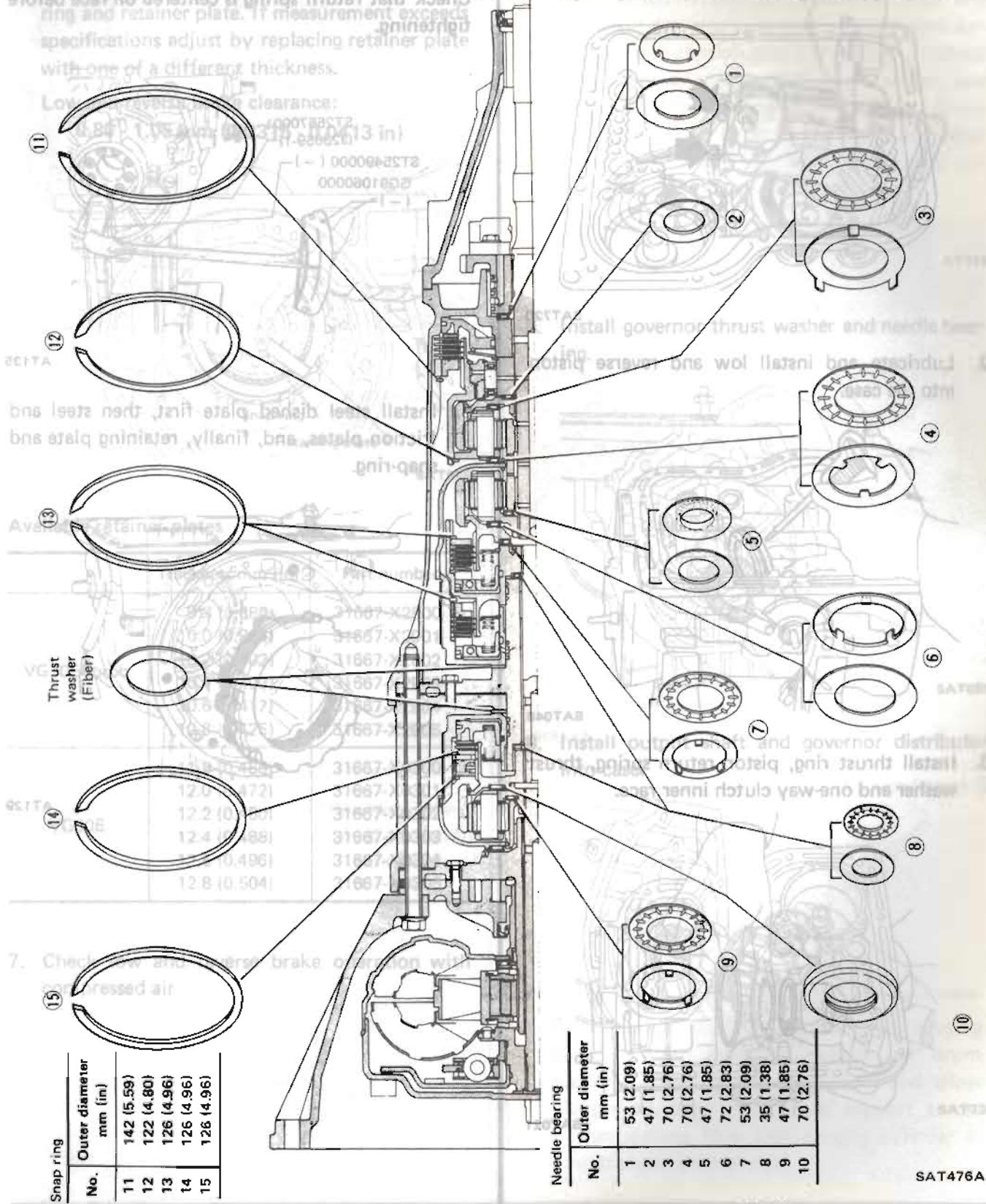

Snap ring	Outer diameter
No.	mm (in)
11	142 (5.59)
12	122 (4.80)
13	126 (4.96)
14	126 (4.96)
15	126 (4.96)

Needle bearing	Outer diameter
No.	mm (in)
1	53 (2.09)
2	47 (1.85)
3	70 (2.76)
4	70 (2.76)
5	47 (1.85)
6	72 (2.83)
7	53 (2.09)
8	35 (1.38)
9	47 (1.85)
10	70 (2.76)

SAT476A

REPAIR FOR ASSEMBLY PARTS

1. Install parking rod, manual plate, manual plate lock nut, parking brake lever and snap rings.

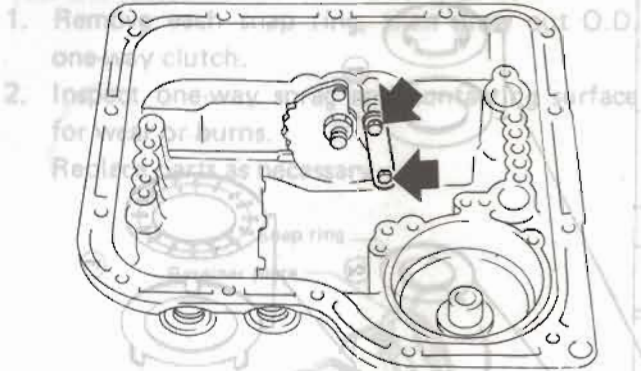

SAT720

2. Lubricate and install low and reverse piston into the case.

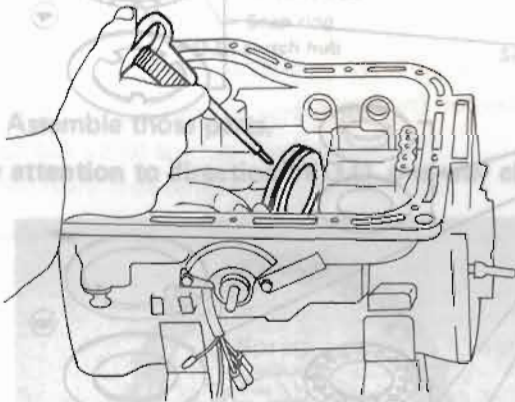

SAT048

3. Install thrust ring, piston return spring, thrust washer and one-way clutch inner race.

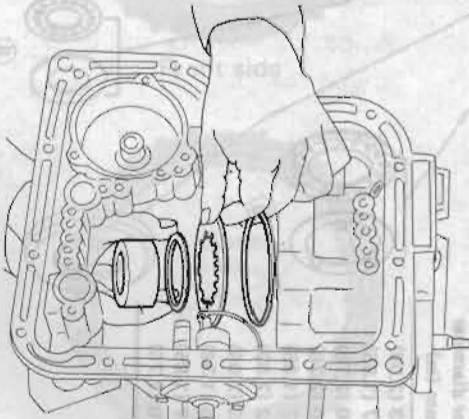

SAT021

4. Install hex-head slotted bolts. Check that return spring is centered on race before tightening.

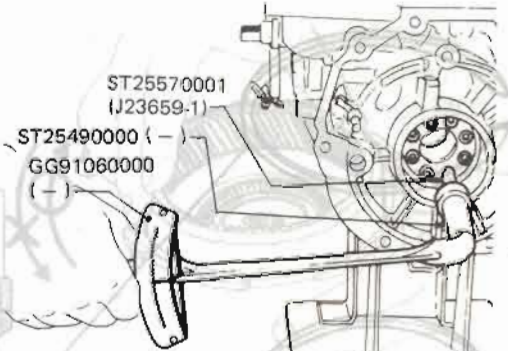

AT135

5. Install steel dished plate first, then steel and friction plates, and, finally, retaining plate and snap-ring.

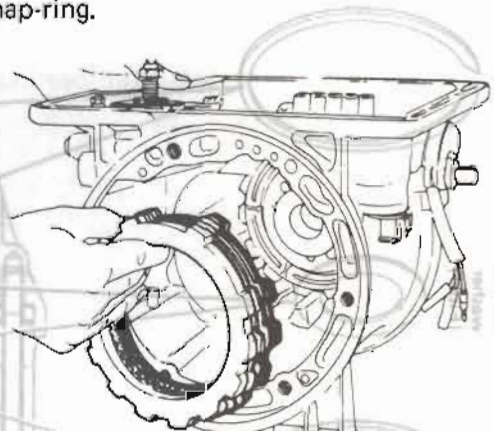

AT129

Part No.	Q'ty	Notes
12	1	Oil seal
13	1	Oil seal
14	1	Oil seal
15	1	Oil seal
16	1	Oil seal
17	1	Oil seal
18	1	Oil seal
19	1	Oil seal
20	1	Oil seal
21	1	Oil seal
22	1	Oil seal
23	1	Oil seal
24	1	Oil seal
25	1	Oil seal
26	1	Oil seal
27	1	Oil seal
28	1	Oil seal
29	1	Oil seal
30	1	Oil seal
31	1	Oil seal
32	1	Oil seal
33	1	Oil seal
34	1	Oil seal
35	1	Oil seal
36	1	Oil seal
37	1	Oil seal
38	1	Oil seal
39	1	Oil seal
40	1	Oil seal
41	1	Oil seal
42	1	Oil seal
43	1	Oil seal
44	1	Oil seal
45	1	Oil seal
46	1	Oil seal
47	1	Oil seal
48	1	Oil seal
49	1	Oil seal
50	1	Oil seal
51	1	Oil seal
52	1	Oil seal
53	1	Oil seal
54	1	Oil seal
55	1	Oil seal
56	1	Oil seal
57	1	Oil seal
58	1	Oil seal
59	1	Oil seal
60	1	Oil seal
61	1	Oil seal
62	1	Oil seal
63	1	Oil seal
64	1	Oil seal
65	1	Oil seal
66	1	Oil seal
67	1	Oil seal
68	1	Oil seal
69	1	Oil seal
70	1	Oil seal
71	1	Oil seal
72	1	Oil seal
73	1	Oil seal
74	1	Oil seal
75	1	Oil seal
76	1	Oil seal
77	1	Oil seal
78	1	Oil seal
79	1	Oil seal
80	1	Oil seal
81	1	Oil seal
82	1	Oil seal
83	1	Oil seal
84	1	Oil seal
85	1	Oil seal
86	1	Oil seal
87	1	Oil seal
88	1	Oil seal
89	1	Oil seal
90	1	Oil seal
91	1	Oil seal
92	1	Oil seal
93	1	Oil seal
94	1	Oil seal
95	1	Oil seal
96	1	Oil seal
97	1	Oil seal
98	1	Oil seal
99	1	Oil seal
100	1	Oil seal

ASSEMBLY

10. Install connecting drum with sprag by rotating drum clockwise.

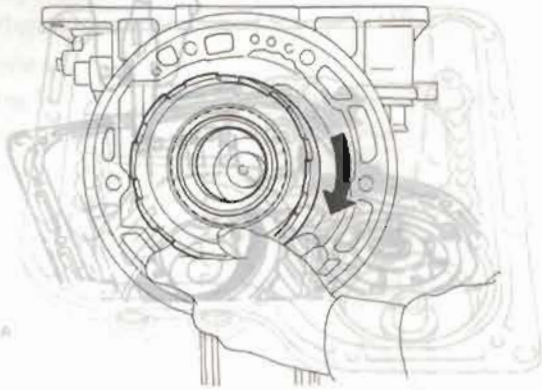

821TA

SAT732

11. Check one-way clutch to see if it operates properly.

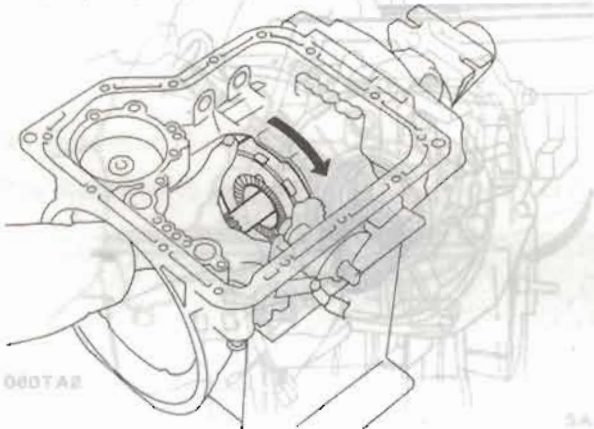

040TA2

SAT048

SAT536

12. Install rear internal gear.

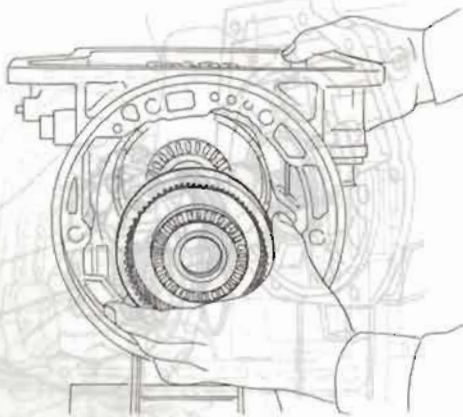

817TA2

SAT054

13. Install snap-ring on shaft.

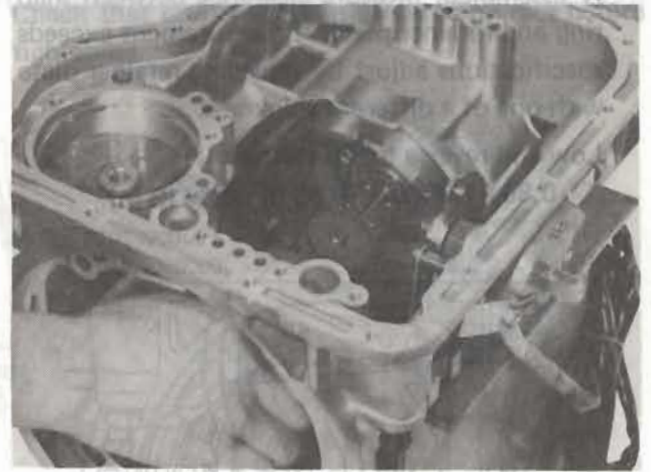

14. Secure thrust bearing and thrust washer with vaseline and install rear planetary carrier.

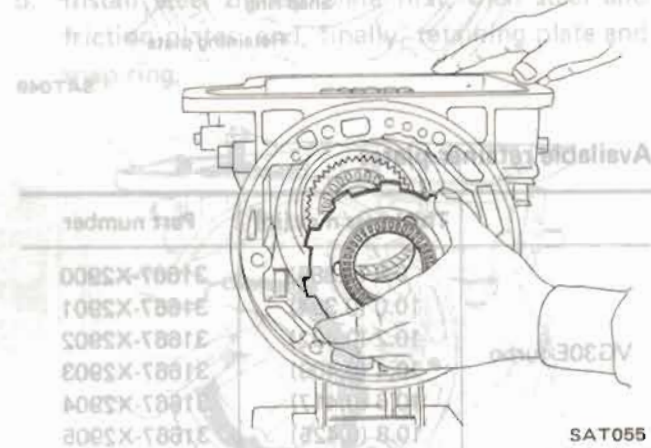

SAT055

15. Install rear planetary carrier snap ring.

If you have insufficient space to install snap ring into drum groove, pull connecting drum forward as far as possible.

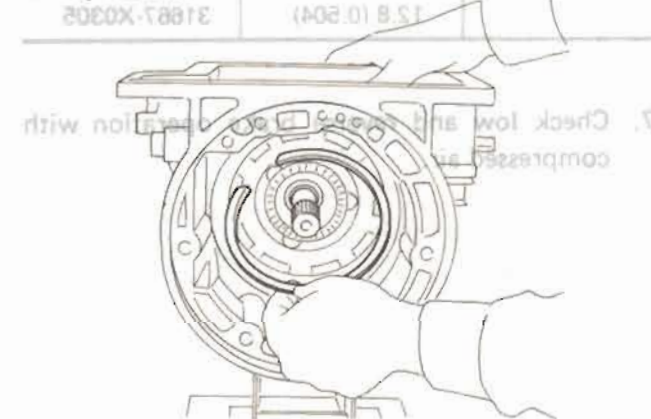

SAT056

ASSEMBLY

16. Adjust end play as follows:

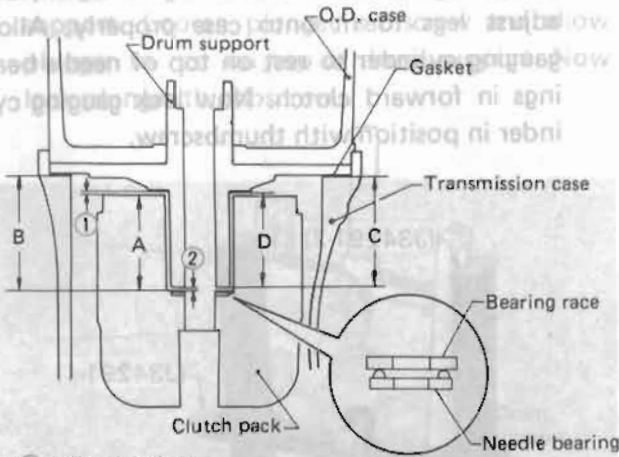

- ① : Front end play
- ② : Total end play

SAT733

1) Assemble front internal gear, front planetary carrier and connecting shell. Secure thrust bearing with vaseline.

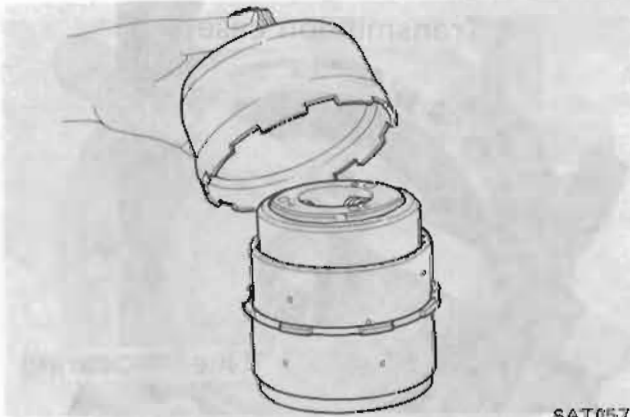

SAT657

2) Install assembly into transmission case. Check that parts are properly seated before proceeding with measurements.

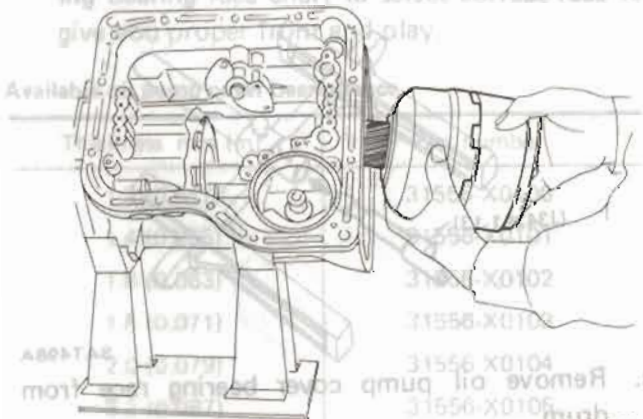

SAT058

3) Adjust front end play.

a. Place J34291-1 (bridge), J34291-2 (legs) and J34291-5 (gauging cylinder) on machined surface of transmission case (no gasket). Position bridge legs so short end of legs is down, and adjust legs to fit onto case properly. Allow gauging cylinder to rest on top of thrust washer surface of clutch pack. Now lock gauging cylinder in position with thumbscrew.



b. Remove thrust washer from drum support.
c. Now insert J34290-12 (gauging plunger) into gauging cylinder. Lock gauging plunger by tightening thumbscrew.

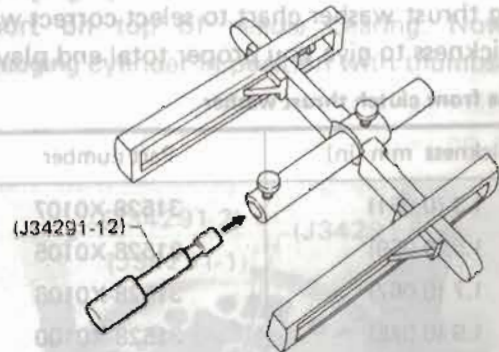

SAT496A

d. Place bridge, gauging cylinder and gauging plunger onto machined surface of drum support. Loosen plunger set screw and allow plunger to drop onto drum support thrust washer surface. Now lock gauging cylinder in position with thumbscrew.

ASSEMBLY

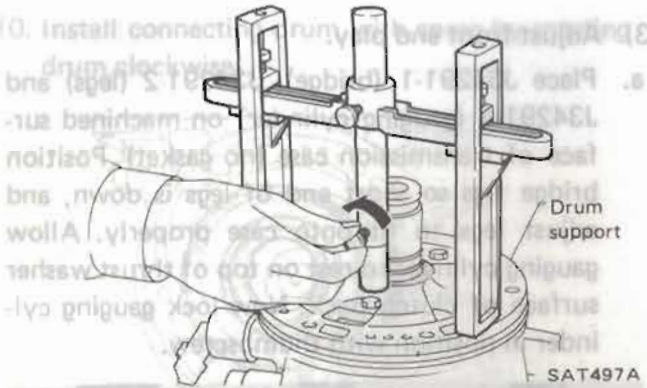

e. Use feeler gauge to measure gap between gauging cylinder and shoulder of gauging plunger.

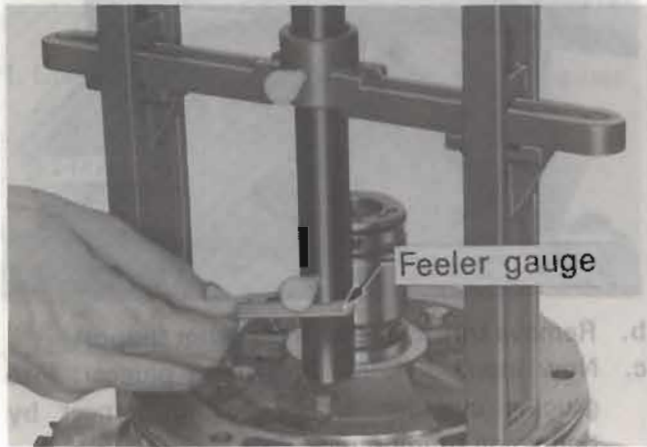

f. Use your feeler gauge measurement and following thrust washer chart to select correct washer thickness to give you proper total end play.

Available front clutch thrust washer

Thickness mm (in)	Part number
1.3 (0.051)	31528-X0107
1.5 (0.059)	31528-X0105
1.7 (0.067)	31528-X0106
1.9 (0.075)	31528-X0100
2.1 (0.083)	31528-X0101
2.3 (0.091)	31528-X0102
2.5 (0.098)	31528-X0103
2.7 (0.106)	31528-X0104

4) Adjust total end play.

a. Place J34291-1 (bridge), J34291-2 (legs) and J34291-5 (gauging cylinder) on machined sur-

13. face of transmission case (no gasket). Position bridge legs so short end of legs is down, and adjust legs to fit onto case properly. Allow gauging cylinder to rest on top of needle bearings in forward clutch. Now lock gauging cylinder in position with thumbscrew.

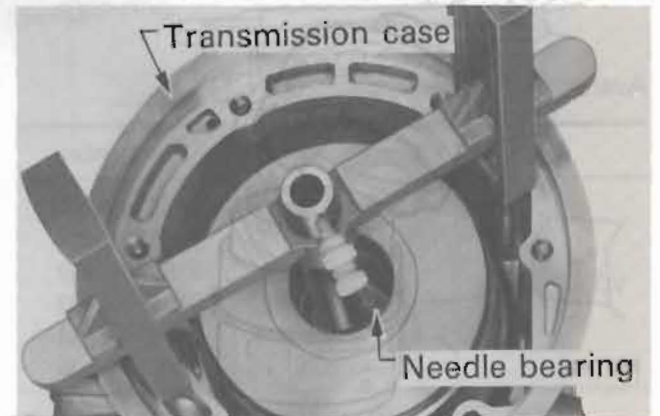
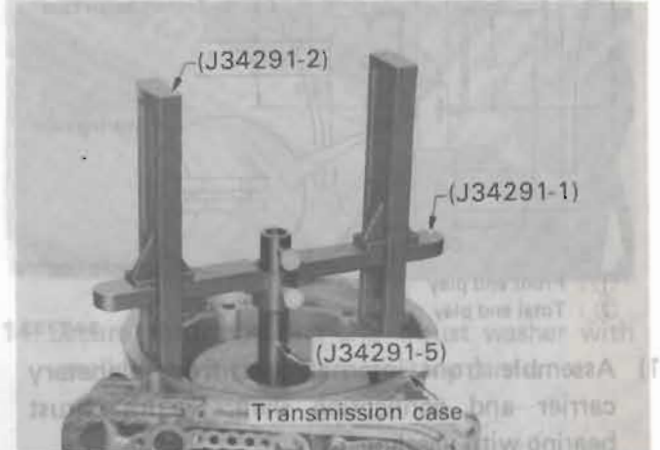

b. Now insert J34291-13 (gauging plunger) into gauging cylinder. Lock gauging plunger by tightening thumbscrew.

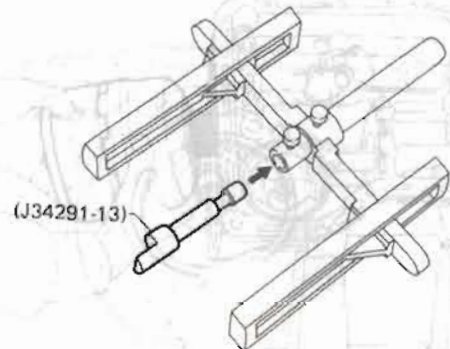

SAT498A

c. Remove oil pump cover bearing race from drum.

ASSEMBLY

d. Place bridge, gauging cylinder, and gauging plunger onto machined surface of drum support. Loosen plunger set screw and allow plunger to rest on top of drum support. Now lock plunger thumbscrew.

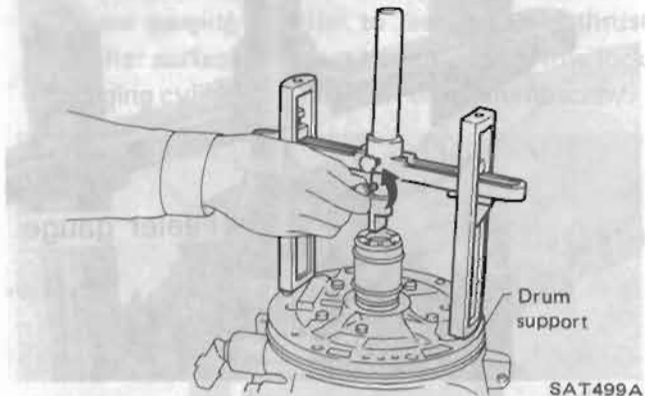

e. Use feeler gauge to measure gap between gauging cylinder and shoulder of gauging plunger.



f. Use your feeler gauge measurement and following bearing race chart to select correct race to give you proper front end play.

Available oil pump cover bearing race

Thickness mm (in)	Part number
1.2 (0.047)	31556-X0100
1.4 (0.055)	31556-X0101
1.6 (0.063)	31556-X0102
1.8 (0.071)	31556-X0103
2.0 (0.079)	31556-X0104
2.2 (0.087)	31556-X0105

17. Adjust O.D. end play as follows:

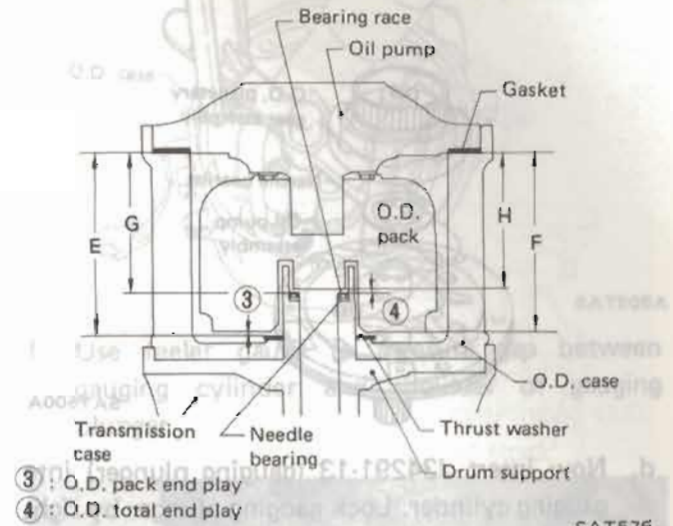

- 1) Adjust O.D. total end play.
 - a. Remove O.D. bearing race from direct clutch drum support. Leave needle thrust washer in place.
 - b. Place J34291-1 (bridge), J34291-2 (legs) and J34291-5 (gauging cylinder) on machined surface of O.D. case. Position bridge legs so short end of legs is down (toward drum support), and adjust legs to fit on case properly. Allow gauging cylinder to rest inside direct drum support on top of needle bearing. Now lock gauging cylinder in position with thumbscrew.

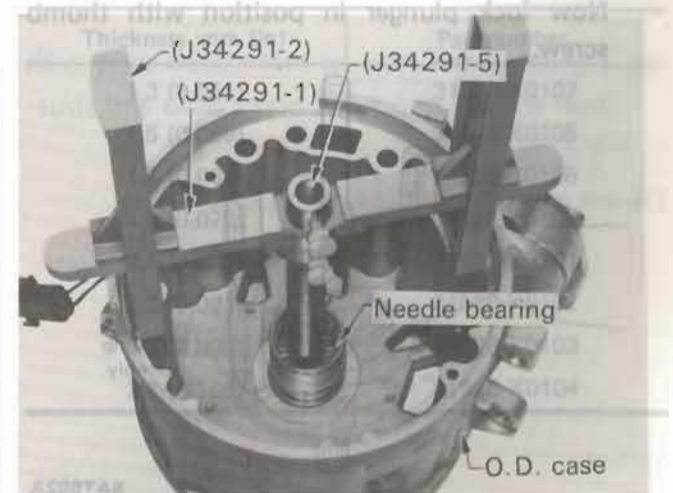

ASSEMBLY

c. Put oil pump bearing and O.D. planetary gear assembly on pump.

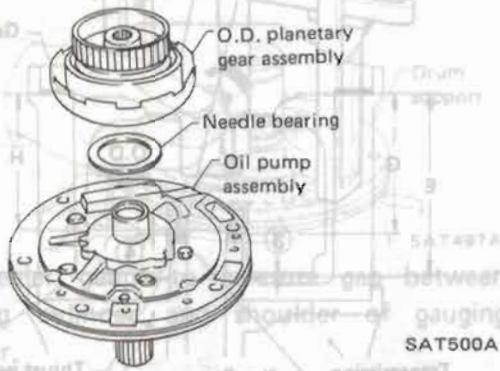

d. Now insert J34291-13 (gauging plunger) into gauging cylinder. Lock gauging plunger by tightening thumbscrew.

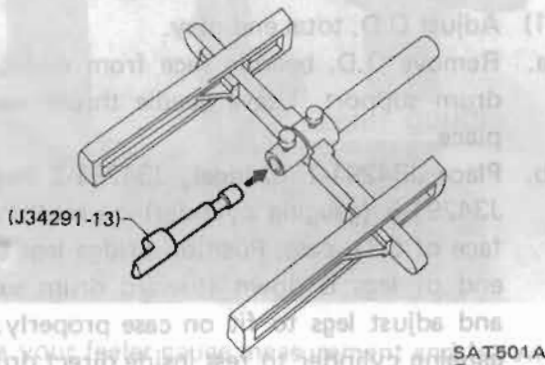

e. Place bridge, gauging cylinder, and gauging plunger on machined surface of oil pump. Loosen plunger set screw and allow plunger to rest on bearing surface of O.D. internal gear. Now lock plunger in position with thumb-screw.

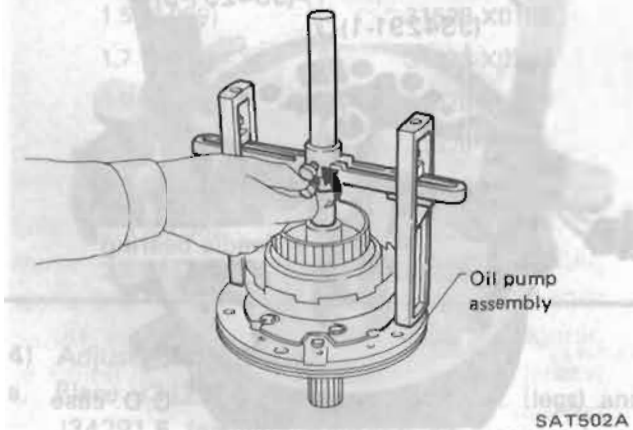

f. Use feeler gauge to measure gap between gauging cylinder and shoulder of gauging plunger.



g. Use your feeler gauge measurement and following O.D. bearing race chart to select correct race thickness to give you proper O.D. total end play.

Available O.D. bearing races

Thickness mm (in)	Part number
1.2 (0.047)	31603-X8600
1.4 (0.055)	31603-X8601
1.6 (0.063)	31603-X8602
1.8 (0.071)	31603-X8603
2.0 (0.079)	31603-X8604
2.2 (0.087)	31603-X8605

2) Adjust O.D. pack end play. Put thrust needle bearings and O.D. pack on oil pump.

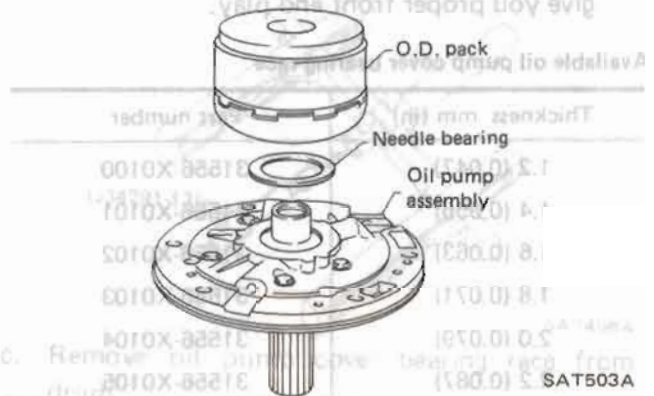

ASSEMBLY

- b. Place J34291-1 (bridge), J34291-2 (legs) and J34291-5 (gauging cylinder) on machined surface of oil pump (no gasket). Position bridge legs so that long end of legs is down (to pump) and adjust legs to fit onto oil pump properly. Allow gauging cylinder to rest on top of thrust washer surface of direct clutch drum. Now lock gauging cylinder in position with thumbscrew.



- c. Remove O.D. thrust washer from O.D. drum support.
 d. Insert J34291-12 (gauging plunger) into gauging cylinder. Lock gauging plunger by tightening thumbscrew.

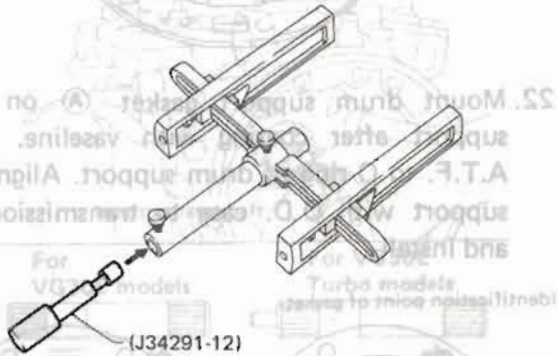

- e. Place bridge, gauging cylinder, and gauging plunger onto machined surface of O.D. case. Loosen plunger set screw and allow plunger to rest on machined thrust washer surface in O.D. case. Now lock plunger thumbscrew.

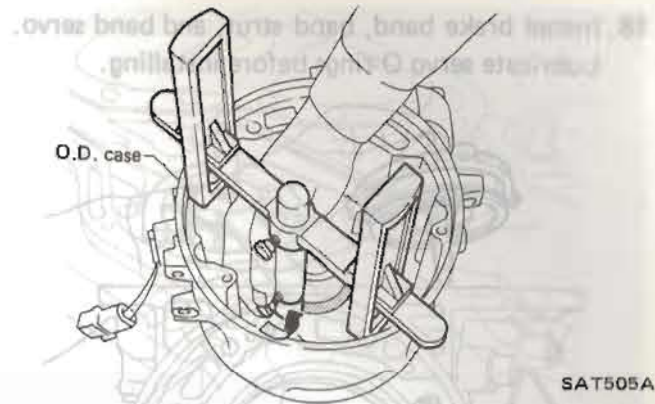

- f. Use feeler gauge to measure gap between gauging cylinder and shoulder of gauging plunger.



- g. Use your feeler gauge measurement and following thrust washer chart to select correct washer thickness for proper total O.D. pack end play.

Available O.D. thrust washer

Thickness mm (in)	Part number
1.3 (0.051)	31528-X0107
1.5 (0.059)	31528-X0105
1.7 (0.067)	31528-X0106
1.9 (0.075)	31528-X0100
2.1 (0.083)	31528-X0101
2.3 (0.091)	31528-X0102
2.5 (0.098)	31528-X0103
2.7 (0.106)	31528-X0104

ASSEMBLY

18. Install brake band, band strut, and band servo.
Lubricate servo O-rings before installing.

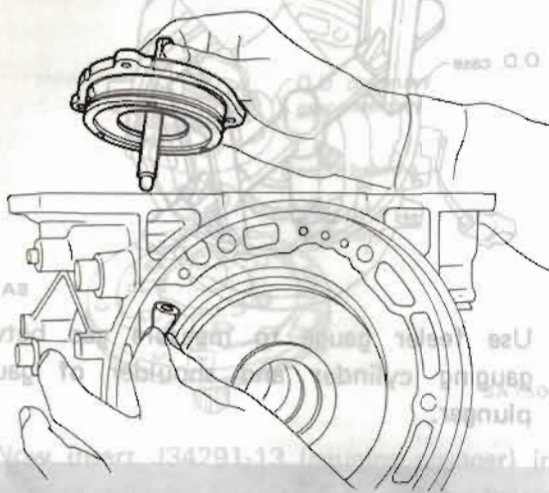

SAT066

19. Install and tighten the retainer bolts.
Loosen piston stem.

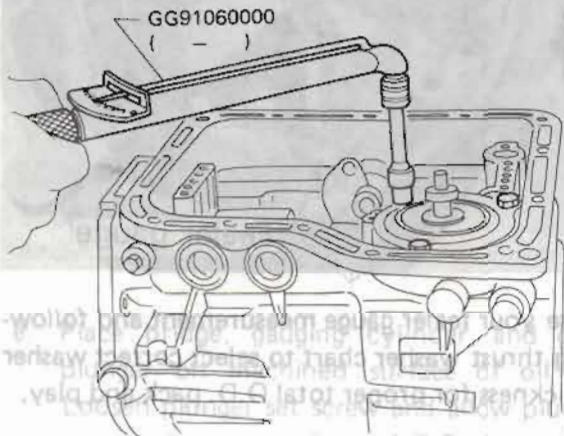

SAT067

20. Tighten piston stem of brake band servo with finger enough to prevent brake band and strut from falling out.

Do not adjust brake band at this time.

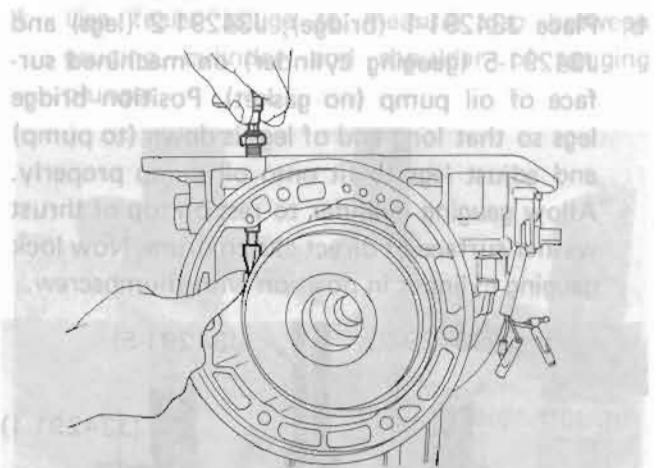

SAT068

21. Apply vaseline to bearing race and thrust washer, then mount them on drum support.

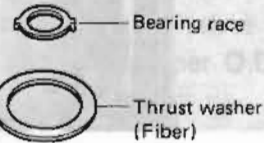

SAT573

22. Mount drum support gasket (A) on drum support after coating with vaseline. Apply A.T.F. to O-ring of drum support. Align drum support with O.D. case to transmission case and install.

Identification point of gasket

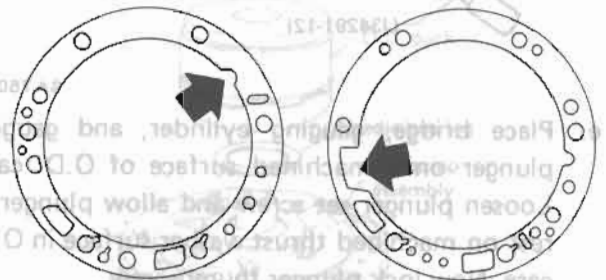

Between oil pump and O.D. case (B)

Between drum support to transmission case (A)

SAT624

ASSEMBLY

23. Apply A.T.F. to O-ring of drum support, then install drum support and O.D. case.

Before installing drum support and O.D. case on transmission case, ensure that they have been centered properly. Refer to Component Parts for Drum Support.

24. Temporarily tighten O.D. case with two converter housing securing bolts.

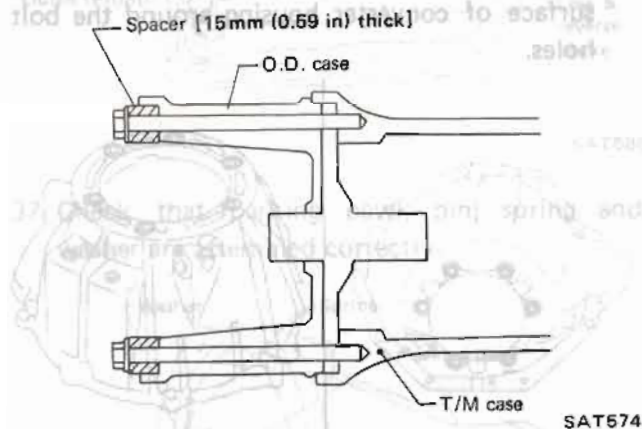

25. Insert intermediate shaft.

Be careful of shaft direction.

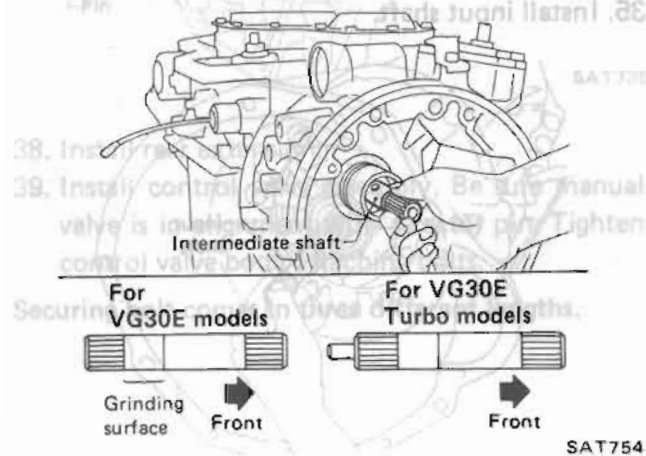

26. Adjust 2nd brake band. Tighten piston stem to the specified value. Back off three full turns and secure with lock nut.

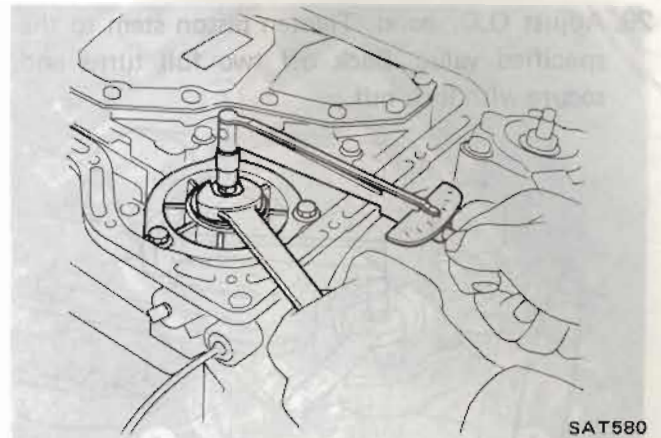

27. Lubricate O.D. servo O-rings, then install O.D. band servo, brake band and band strut.

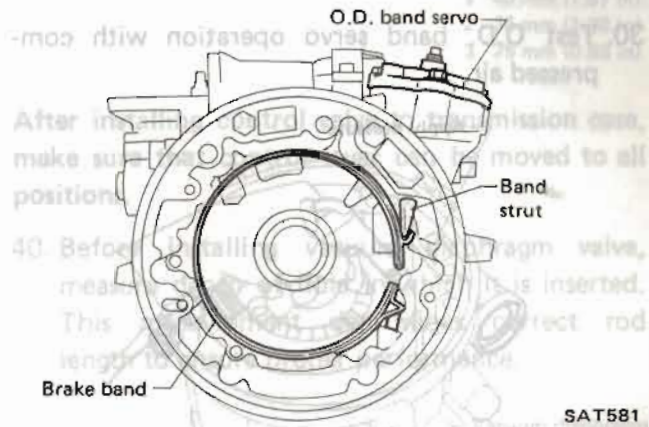

28. Lubricate seal ring of drum support, then install O.D. bearing & race, O.D. thrust washer and O.D. pack on drum support. Make sure that brake band strut is correctly installed.

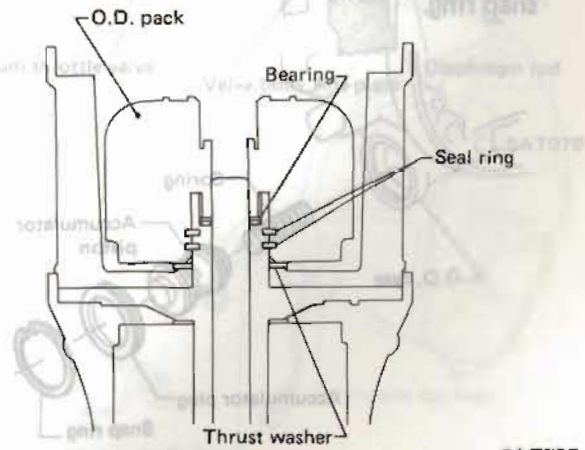

ASSEMBLY

29. Adjust O.D. band. Tighten piston stem to the specified value. Back off two full turns and secure with lock nut.

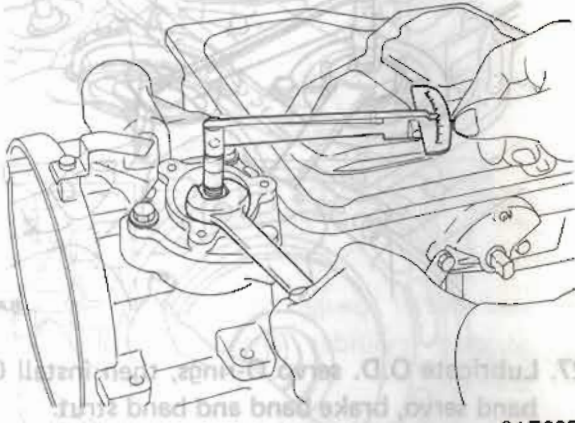

30. Test O.D. band servo operation with compressed air.

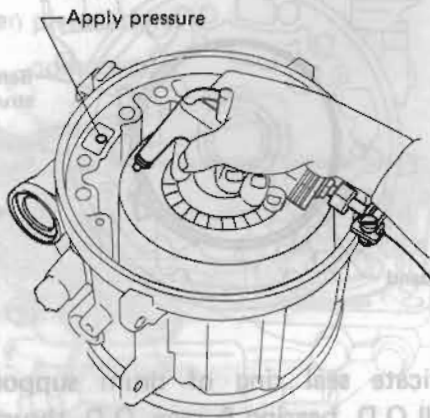

31. Install accumulator parts, then secure with snap ring.

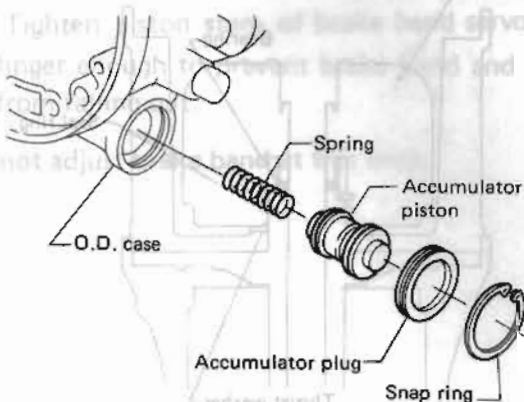

32. Lubricate O-ring of oil pump, then install needle bearing & race and oil pump.

Before installing oil pump housing and oil pump on O.D. case, ensure that they have been centered properly.

Refer to Oil Pump in Repair for Component parts.

33. Remove the two bolts used to temporarily tighten O.D. case. Apply sealant to seating surface of converter housing around the bolt holes.

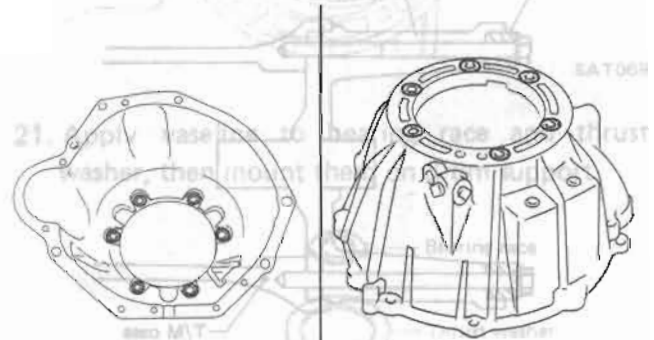

■ : Apply sealant

34. Install converter housing on O.D. case and tighten to the specified torque.

35. Install input shaft.

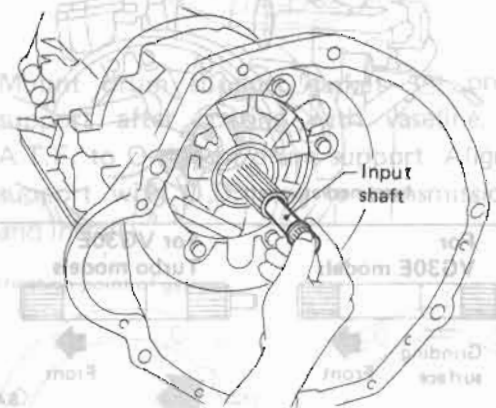

36. Before installing valve body assembly, perform a final operation check of all assembled components, with compressed air.

ASSEMBLY

Air check point

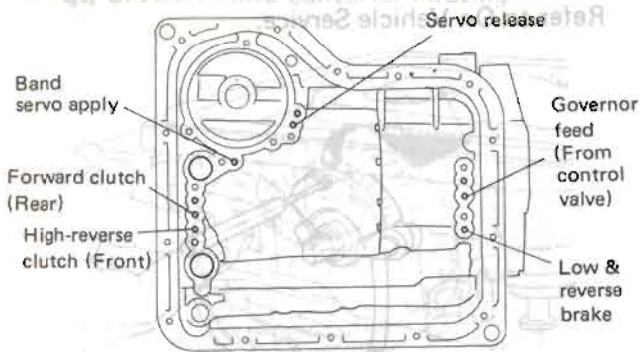

SAT586

37. Check that parking pawl, pin, spring and washer are assembled correctly.

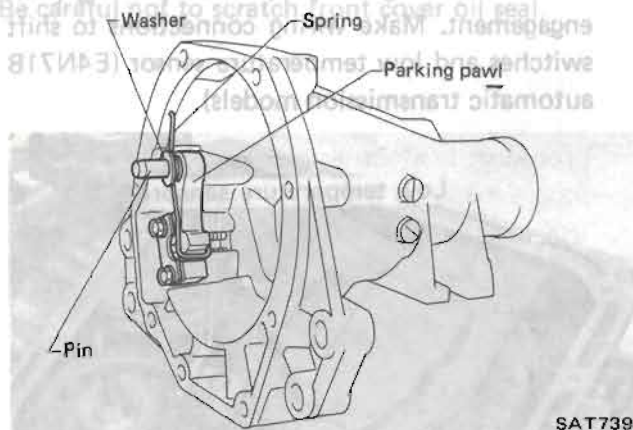

SAT739

38. Install rear extension.

39. Install control valve assembly. Be sure manual valve is in alignment with selector pin. Tighten control valve body attaching bolts.

Securing bolt comes in three different lengths.

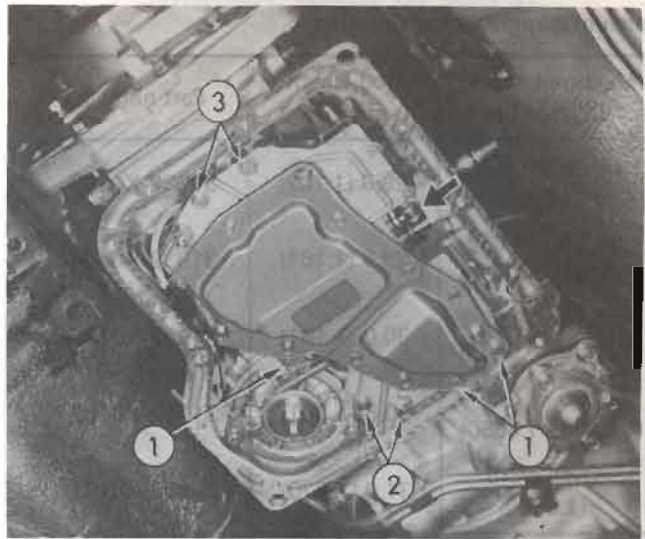

- 1 40 mm (1.57 in)
- 2 35 mm (1.38 in)
- 3 25 mm (0.98 in)

After installing control valve to transmission case, make sure that control lever can be moved to all positions.

40. Before installing vacuum diaphragm valve, measure depth of hole in which it is inserted. This measurement determines correct rod length to ensure proper performance.

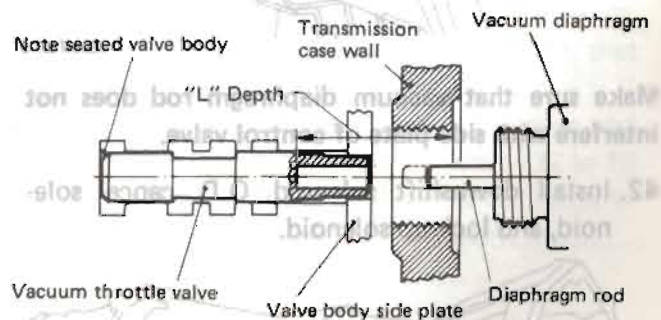

SAT078

ASSEMBLY

Vacuum diaphragm rod selection

Measured depth "L" mm (in)	Rod length mm (in)	Part number
Under 25.55 (1.0059)	29.0 (1.142)	31932-X0103
25.65 - 26.05 (1.0098 - 1.0256)	29.5 (1.161)	31932-X0104
26.15 - 26.55 (1.0295 - 1.0453)	30.0 (1.181)	31932-X0100
26.65 - 27.05 (1.0492 - 1.0650)	30.5 (1.201)	31932-X0102
Over 27.15 (1.0689)	31.0 (1.220)	31932-X0101

41. Install vacuum diaphragm.

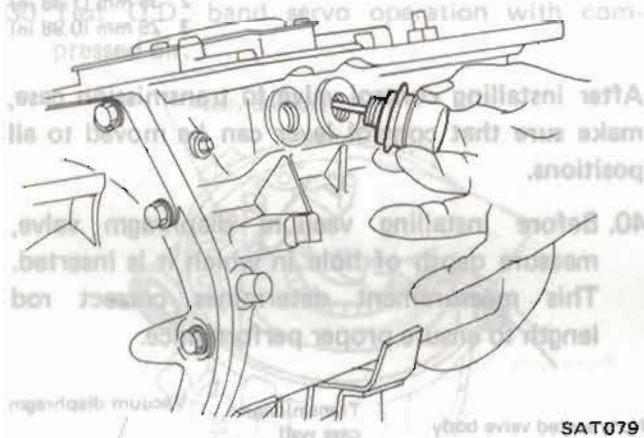

Make sure that vacuum diaphragm rod does not interfere with side plate of control valve.

42. Install downshift solenoid, O.D. cancel solenoid, and lock-up solenoid.

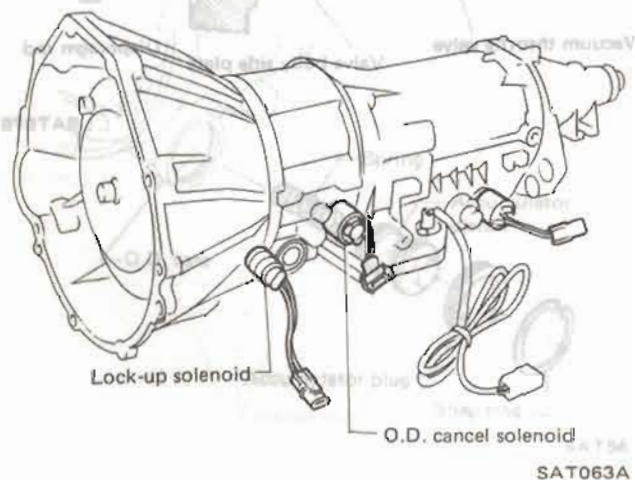

43. Install inhibitor switch. Check for proper operation in each range with a circuit tester. Refer to On Vehicle Service.

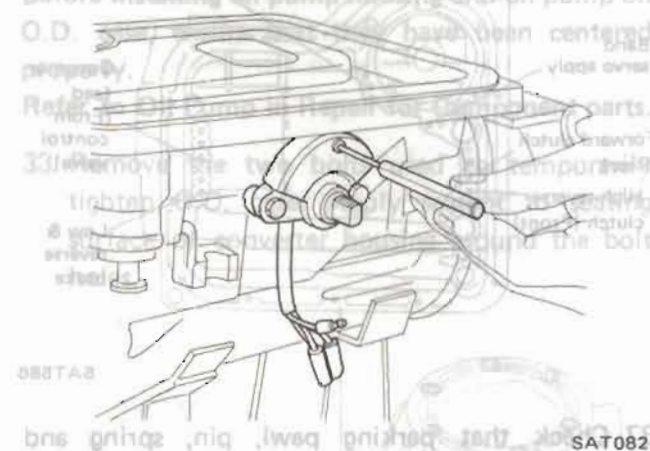

44. Before installing oil pan, check parking pawl engagement. Make wiring connections to shift switches and low temperature sensor (E4N71B automatic transmission models).

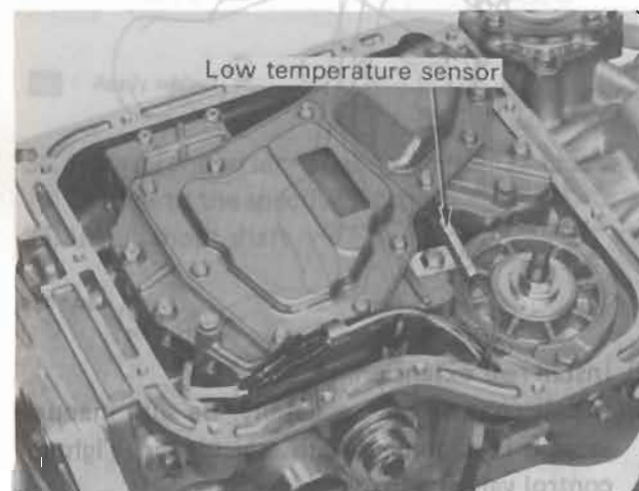

45. Install oil pan with new gasket.

ASSEMBLY

46. Pour approx. 2-liters (2-1/8 US qt, 1-3/4 Imp qt) of A.T.F. into converter housing.



60ATA2

SAT518

47. Install torque converter to converter housing.
Be careful not to scratch front cover oil seal.

1. Place the control lever in "P" range and start the engine. Stop the engine and repeat the procedure in all other ranges and neutral.

2. Stop vehicle on a slight upgrade and place control lever in "P" range. Release parking brake.

3. Check to ensure vehicle remains locked.

4. "R" RANGE
Manually shift the control lever from "P" to "R" and note shift quality.

5. Drive the vehicle in reverse long enough to detect slippage or other abnormalities.

"N" RANGE
1. Manually shift the control lever from "R" to "D" or "N" and note quality.

2. Release parking brake with control lever in "N" range. Lightly depress accelerator pedal to make sure vehicle does not move. (When vehicle is new or soon after clutches have been replaced, vehicle may move slightly. This is not a problem.)

"D" RANGE

1. Manually shift the gear selector from "N" to "D" range, and note shift quality.

(Prior to Road Testing)
5. When vehicle is in 1st gear, depress accelerator pedal to 55 km/h (34 mph) and note engine speed. (If engine speed is low, check for air leaks in the intake system.)
6. Check for leaks in the transmission and torque converter housing.
7. Check for leaks in the engine oil pan.
8. Check for leaks in the coolant system.
9. Check for leaks in the brake system.
10. Check for leaks in the power steering system.
11. Check for leaks in the fuel system.
12. Check for leaks in the exhaust system.
13. Check for leaks in the air conditioning system.
14. Check for leaks in the windshield washer system.
15. Check for leaks in the battery electrolyte.

FLUID CONDITION

1. Examine the A.T.F. and note its color, texture and odor. (If the fluid is dark brown or black, it may be contaminated.)

2. With a burned odor, check for slippage or other abnormalities.

3. Varnished fluid, light to dark brown and tacky: Oxidation.

4. Overdriving: Overheating.

5. While vehicle is being driven in "1" range, release accelerator pedal to make sure that engine compression acts as a brake.

6. Shift control lever to "D" or "2" range and allow vehicle to run at 20 to 30 km/h (12 to 19 MPH). Then, shift control lever to "1" range to make sure the downshift to 1st gear is smooth.

TROUBLE-SHOOTING AND DIAGNOSES

Preliminary Checks (Prior to Road Testing)

FLUID LEAKAGE

To detect a fluid leak:

- 1) Raise vehicle.
- 2) Clean area suspected of leaking.
- 3) Start engine, apply foot brake, place control lever in drive, and wait a few minutes.
- 4) Stop engine.
- 5) Check for fresh leakage.

FLUID CONDITION

Examine the A.T.F. and note its color, texture, and odor.

- 1) Dark of Black Fluid:
 - With a burned odor.
 - Worn friction material.
- 2) Milky Pink Fluid: Water Contamination
 - Road water entering through filler tube or breather.
- 3) Varnished Fluid, light to dark brown and tacky: Oxidation
 - Over or Underfilling.
 - Overheating.

Make sure that vacuum diaphragm rod does not interfere with side plate of control valve.

42. Install downshift solenoid, O.D. cancel solenoid, and lock-up solenoid.



Road Testing

- Before starting road tests, install vacuum gauge.

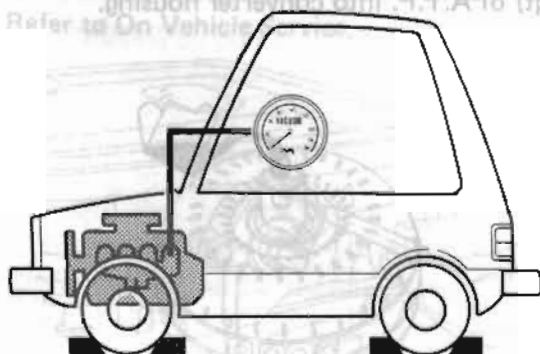

SAT596

- Perform road tests, using "Symptom" chart, as follows:

"P" RANGE

1. Place the control lever in "P" range and start the engine. Stop the engine and repeat the procedure in all other ranges and neutral.
2. Stop vehicle on a slight upgrade and place control lever in "P" range. Release parking brake to make sure vehicle remains locked.

"R" RANGE

1. Manually shift the control lever from "P" to "R", and note shift quality.
2. Drive the vehicle in reverse long enough to detect slippage or other abnormalities.

"N" RANGE

1. Manually shift the control lever from "R" and "D" to "N" and note quality.
2. Release parking brake with control lever in "N" range. Lightly depress accelerator pedal to make sure vehicle does not move. (When vehicle is new or soon after clutches have been replaced, vehicle may move slightly. This is not a problem.)

"D" RANGE

1. Manually shift the gear selector from "N" to "D" range, and note shift quality.

TROUBLE-SHOOTING AND DIAGNOSES

Road Testing (Cont'd)

- Using the shift schedule as a reference, drive vehicle in "D" range. Record, on symptom chart, respective vehicle speeds at which upshifting and downshifting occur. Check that there is not a considerable jolt when shifting gears. Also determine the timing at which shocks are encountered during shifting and which clutches are engaged.

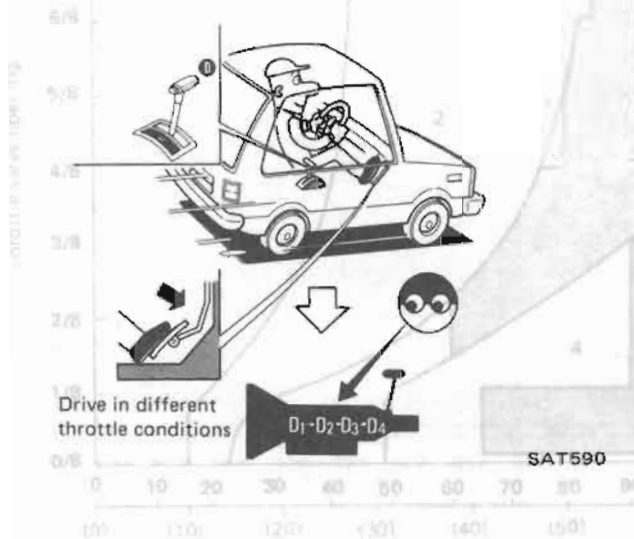

- Check to determine if shifting speed changes when accelerator pedal is depressed slowly and when it is depressed quickly.
- Check to determine if shifting to overdrive gear cannot be made while O.D. control switch is "OFF".

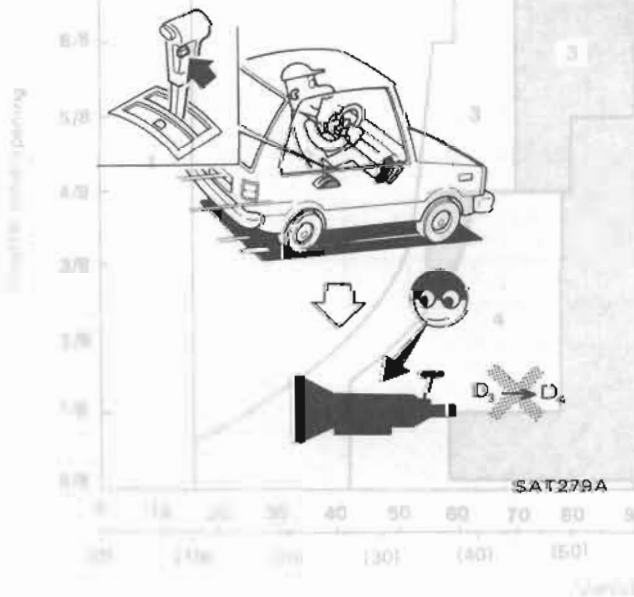

- When vehicle is being driven in the 65 to 85 km/h (40 to 53 MPH) range in "D₃" range at half to light throttle position, fully depress accelerator pedal to make sure it downshifts from 3rd to 2nd gear.
- When vehicle is being driven in the 25 to 35 km/h (16 to 22 MPH) ("D₂" range) at half to light throttle position, fully depress accelerator pedal to make sure it downshifts from 2nd to 1st gear.

"2" RANGE

- While vehicle is being driven in "2" range, make sure that it does not shift into 1st or 3rd gear, despite speed changes.
- Shift control lever to "D" range and allow vehicle to operate at 40 to 50 km/h (25 to 31 MPH). Then, shift to "2" range to make sure it downshifts to 2nd gear.

"1" RANGE

- Shift control lever to "1" range and allow vehicle to run. Ensure that it does not upshift from 1st to 2nd gear although vehicle speed increases.
- While vehicle is being driven in "1" range, release accelerator pedal to make sure that engine compression acts as a brake.
- Shift control lever to "D" or "2" range and allow vehicle to run at 20 to 30 km/h (12 to 19 MPH). Then, shift control lever to "1" range to make sure the downshift to 1st gear is made.

TRUBLE-SHOOTING AND DIAGNOSES

Road Testing (Cont'd)

VEHICLE SPEED WHEN SHIFTING GEARS

1. Disconnect harness from A/T control unit. Road test the vehicle to determine if all items listed in the following chart are within their specified values.
2. Reconnect harness to A/T control unit. Road test the vehicle to see if shifting corresponds to the specified shift schedule pattern.

FLUID CONDITION

VG30E engine

Throttle position	Gearshift	Vehicle speed km/h (MPH)
Full throttle	D ₁ → D ₂	65 - 73 (40 - 45)
	D ₂ → D ₃	110 - 118 (68 - 73)
	D ₃ → D ₄	—
	D ₄ → D ₃	—
	D ₃ → D ₂	98 - 106 (61 - 66)
	D ₂ → D ₁	44 - 52 (27 - 32)

VG30E turbo engine

Throttle position	Gearshift	Vehicle speed km/h (MPH)
Full throttle	D ₁ → D ₂	62 - 70 (39 - 43)
	D ₂ → D ₃	108 - 116 (67 - 72)
	D ₃ → D ₄	—
	D ₄ → D ₃	—
	D ₃ → D ₂	82 - 90 (51 - 56)
	D ₂ → D ₁	42 - 50 (26 - 31)

Using the shift schedule as a reference, drive vehicle in "D" range. Record on symptom chart, respective vehicle speeds at which up-shifting and downshifting occur. Check that there is not a considerable jolt when shifting gears. Also determine the timing at which shocks are encountered during shifting and which clutches are engaged.



- Perform "symptom" chart, as follows:

"P" RANGE

1. Place the control lever in "P" range, start the engine.
2. Perform the procedure in all other ranges and neutral.

"R" RANGE

1. Check to determine if shifting occurs when accelerator pedal is depressed slowly and when it is depressed quickly.
2. Check to determine if shifting to overdrive gear cannot be made with O.D. control switch in "OFF" position.
3. Drive the vehicle in reverse long enough to ensure no reverse or slipping occurs.

"N" RANGE

1. Manually shift the gear selector to "D" range and note shift quality.
2. Release the accelerator pedal. If the vehicle is in "N" range, lightly depress accelerator pedal. If the vehicle is in "D" range, lightly depress accelerator pedal. If the vehicle is in "N" range, lightly depress accelerator pedal. If the vehicle is in "D" range, lightly depress accelerator pedal.

"D" RANGE

1. Manually shift the gear selector to "D" range, and note shift quality.

TROUBLE-SHOOTING AND DIAGNOSES

Road Testing (Cont'd)

SHIFT SCHEDULE

VG30E engine

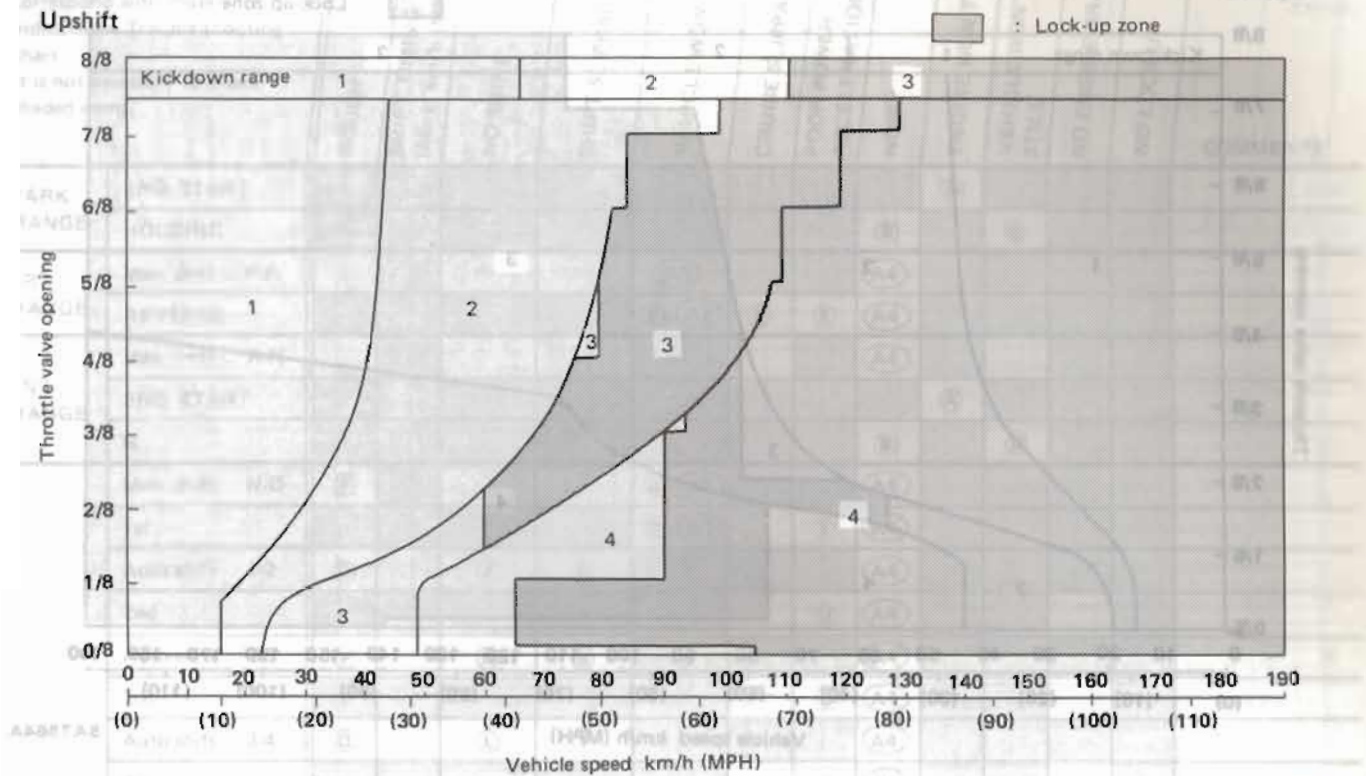

Downshift

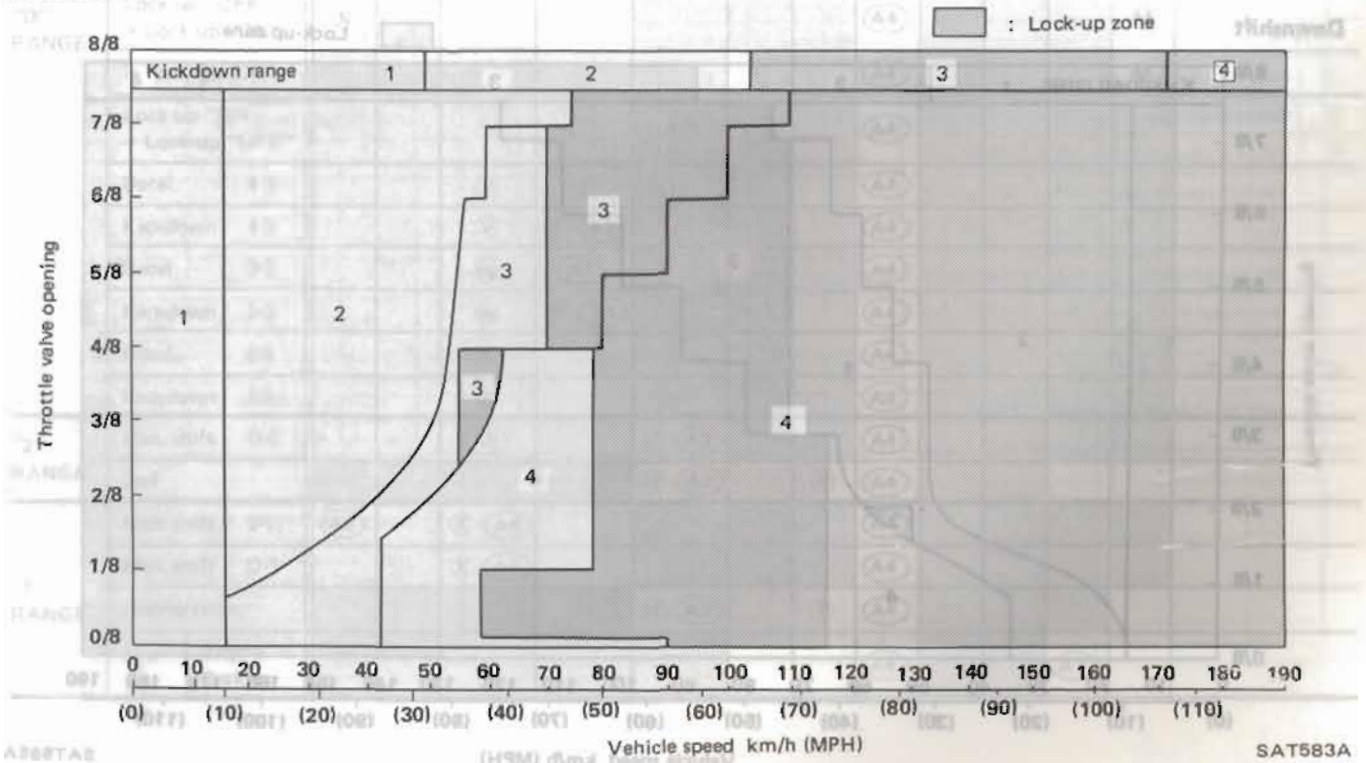

TROUBLE-SHOOTING AND DIAGNOSES

Road Testing (Cont'd)

VG30E Turbo engine WHEN SHIFTING GEARS

1. Disconnect harness from A/T control unit.
2. Road test the vehicle to determine if all items

SHIFT SCHEDULE
VG30E engine

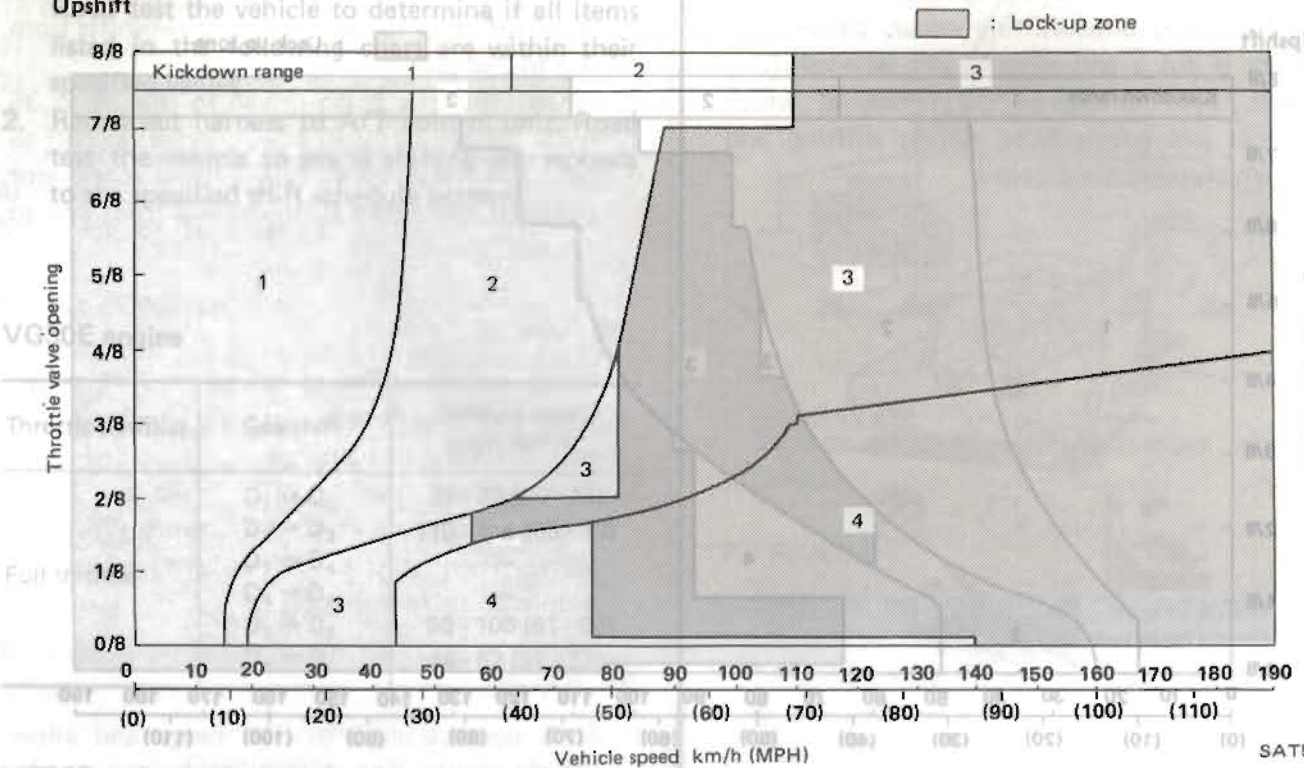

Downshift

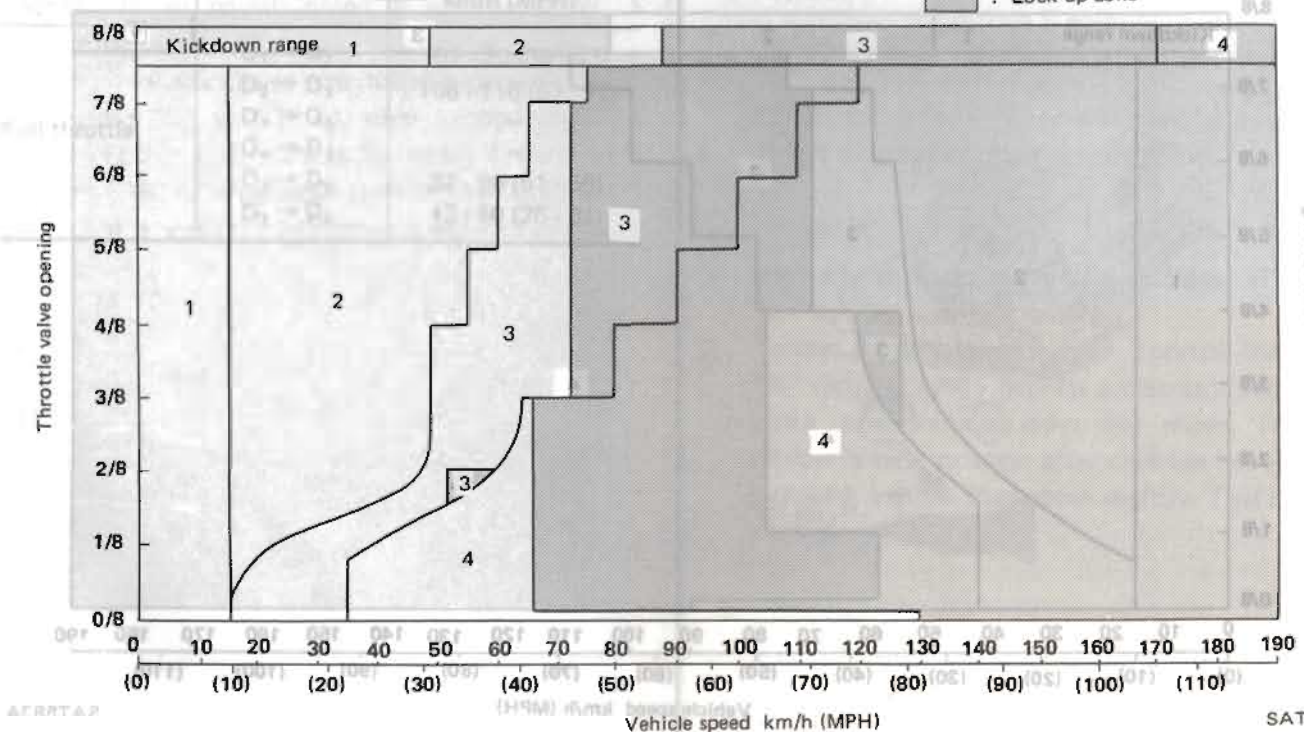

TROUBLE-SHOOTING AND DIAGNOSES

Road Test Symptom Chart

Numbers in chart below correspond with those indicated in Trouble-shooting chart.
It is not necessary to check shaded items.

		SHIFT QUALITY				VEHICLE WON'T MOVE	CRUISE SLIPPAGE	POOR POWER/ACCELERATION	NOISY	ENGINE WON'T START	VEHICLE WON'T STAND STILL	NO ENGINE BRAKING	NO LOCK-UP	COMMENTS
		ROUGH	SHIFT TIMING [Mark km/h (MPH)]	NO SHIFT	SHIFT SLIPPAGE									
PARK RANGE	ENG. START									(A)				
	HOLDING									(B)	(C)			
"R" RANGE	Man. shift P-R					(A3)				(A4)				
	REVERSE					(E) (A3)	(E)	(E)		(A4)				
"N" RANGE	Man. shift R-N									(A4)				
	ENG. START									(A)				
	N									(B)	(D)			
"D" RANGE	Man. shift N-D	(F)				(G) (A3)				(A4)				
	1st					(G) (A3)		(I)		(A4)				
	Auto shift 1-2	(O)		(J)	(R)					(A4)				
	2nd							(U)		(A4)				
	Auto shift 2-3	(P)		(K)	(S)					(A4)				
	3rd							(U)		(A4)				
	Auto shift 3-4	(Q)		(L)	(T)					(A4)				
	4th							(U)		(A4)				
	Lock-up "OFF" → Lock-up "ON"	(N)								(A4)			(M)	
	In lock-up "ON"									(A4)			(M)	
	Lock-up "ON" → Lock-up "OFF"									(A4)				
	Decel. 4-3			(V)	(Z)					(A4)				
	Kickdown 4-3			(V)	(Z) (A2)					(A4)				
	Decel. 3-2			(W)	(A1)					(A4)				
Kickdown 3-2			(W)	(Y) (A1)					(A4)					
Decel. 2-1			(X)						(A4)					
Kickdown 2-1			(X)						(A4)					
"2" RANGE	Man. shift D-2			(A5)		(H) (A3)				(A4)				
	2nd					(H) (A3)		(I)		(A4)				
"1" RANGE	Man. shift 2-1	(A9)		(X) (A8)						(A4)				
	Man. shift D-1			(X) (A6)						(A4)				
	Acceleration					(H) (A3)		(I)		(A4)				
	"1" Engine Braking									(A4)		(A7)		

TROUBLE-SHOOTING AND DIAGNOSES

Trouble-shooting Chart

Numbers are arranged in order of probability. Perform inspections starting with number one and working up. Circled numbers indicate that the transmission must be removed from the vehicle.

Reference	Description	ON vehicle										OFF vehicle																										
		Oil level	Range select linkage	Inhibitor switch and wiring	Vacuum diaphragm and piping	Kickdown solenoid, switch and wiring	Engine idling rpm	Line pressure	Control valve	Governor	2nd band servo	Transmission air check	Oil quality	Ignition switch and starter motor	Engine adjustment, brake inspection	O.D. band servo	O.D. control SW	O.D. cancel solenoid	Lock-up solenoid	Lock-up control unit and sensors	Direct clutch	Forward clutch (Rear)	High-reverse clutch (Front)	O.D. band brake	2nd band brake	Low and reverse brake	Oil pump	Oil passage leak	Torque converter	Transmission one-way clutch	Park linkage	Planetary gear	O.D. cancel valve	Lock-up control valve	Accumulator			
A	Engine does not start in "N", "P" ranges.	2	3									1						4	5																			
	Engine starts in range other than "N" and "P".	1	2																																			
B	Transmission noise in "P" and "N" ranges.	1						2																		3												
C	Vehicle moves when changing into "P" range or parking gear does not disengage when shifted out of "P" range.	1																																2				
D	Vehicle runs in "N" range.	1							3																													4
E	Vehicle will not run in "R" range (but runs in "D", "2" and "1" ranges). Clutch slips. Very poor acceleration.	1	2						3	5					6	4																						8
	Vehicle braked when shifting into "R" range.										3	2	1																									4
F	Sharp shock in shifting from "N" to "D" range.				2		1	3	4																													5
G	Vehicle will not run in "D" range (but runs in "2", "1" and "R" ranges).	1							2	3																												4
H	Vehicle will not run in "D", "1", "2" ranges (but runs in "R" range). Clutch slips. Very poor acceleration.	1	2						4	5					6	3																						8
	Clutches or brakes slip somewhat in starting.	1	2		6			3	5																													8
I	Excessive creep.						1																															8
	No creep at all.	1	2					3		5																												8
J	Failure to change gear from "1st" to "2nd".	1		2	3				5	6	8	7	4																									9
K	Failure to change gear from "2nd" to "3rd".	1		2	3				5	6	8	7	4																									9
L	Failure to change gear from "3rd" to "4th".	1		2	3				5	6	8	7	4																									9
	Too high a gear change point from "1st" to "2nd", from "2nd" to "3rd", from "3rd" to "4th".				1	2		3	5	6																												7
	Gear change directly from "1st" to "3rd" occurs.								2	4		3	1																									5
	Gear change directly from "2nd" to "4th" occurs.								2	4		3	1																									5
M	Lock-up does not occur in any range (E4N71B).																		1	2																	3	
N	Large jolt changing from lock-up "OFF" to "ON".							2	3			1								4																		5

TROUBLE-SHOOTING AND DIAGNOSES

Trouble-shooting Chart (Cont'd)

Numbers are arranged in order of probability. Perform inspections starting with number one and working up. Circled numbers indicate that the transmission must be removed from the vehicle.

Reference	Description	ON vehicle											OFF vehicle																						
		Oil level	Range select linkage	Inhibitor switch and wiring	Vacuum diaphragm and piping	Kickdown solenoid, switch and wiring	Engine idling rpm	Line pressure	Control valve Governor	2nd band servo	Transmission air check	Oil quality	Ignition switch and starter motor	Engine adjustment, brake inspection	O.D. band servo	O.D. control SW	O.D. cancel solenoid	Lock-up solenoid	Lock-up control unit and sensors	Direct clutch	Forward clutch (Rear)	High-reverse clutch (Front)	O.D. band brake	2nd band brake	Low and reverse brake	Oil pump	Oil passage leak	Torque converter	Transmission one-way clutch	Park linkage	Planetary gear	O.D. cancel valve	Lock-up control valve	Accumulator	
ⓐ	Too sharp a shock in change from "1st" to "2nd".				1	2		4		5	3							6	7					8			10							9	
ⓑ	Too sharp a shock in change from "2nd" to "3rd".				1		2	3		5	4							6	7			8					10							9	
ⓒ	Too sharp a shock in change from "3rd" to "4th".				1		2	3			7							5	6					8				10						9	
ⓓ	Almost no shock or clutches slipping in change from "1st" to "2nd".	1	2		3		4	6		8	7	5														9		10							
ⓔ	Almost no shock or slipping in change from "2nd" to "3rd". Engine races extremely fast.	1	2		3		4	6		8	7	5														9		10							
ⓕ	Almost no shock or slipping in change from "3rd" to "4th".	1	2		3		4	6		8	7	5														9		10							
	Vehicle braked by gear change from "1st" to "2nd".							2			1																								
	Vehicle braked by gear change from "2nd" to "3rd".							3		2	1																								
	Vehicle braked by gear change from "3rd" to "4th".							2			1																								
ⓖ	Maximum speed not attained. Acceleration poor.	1	2				5	4	7		6	3		8													11	12		9	10	13	14		
ⓗ	Failure to change gear from "4th" to "3rd".				1			3	4		5	2																9	10	11		12			13
ⓘ	Failure to change gear from "3rd" to "2nd" and from "4th" to "2nd".				1			3	4		6	5	2																7	10	8		9		
ⓙ	Failure to change gear from "2nd" to "1st" or from "3rd" to "1st".				1			3	4		6	5	2																	7			8		
	Gear change shock felt during deceleration by releasing accelerator pedal.		1		2	3		4	5	6																									8
	Too high a change point from "4th" to "3rd", from "3rd" to "2nd", from "2nd" to "1st".		1		2	3		4	5	6									7																
ⓚ	Kickdown does not operate when depressing pedal in "3rd" within kickdown vehicle speed.				2	1			4	5		3																							
	Kickdown operates or engine overruns when depressing pedal in "3rd" beyond kickdown vehicle speed limit.		1		2			3	5	6		7	4																						
ⓛ	Races extremely fast or slips in changing from "4th" to "3rd" when depressing pedal.				1			2	4		6	5	3																						
Ⓜ	Races extremely fast or slips in changing from "3rd" to "2nd" when depressing pedal.				1			2	4		6	5	3																						
Ⓨ	Kickdown does not operate when depressing pedal in "4th" within kickdown vehicle speed.				2	1			4	5		3																							
	Kickdown operates or engine overruns when depressing pedal in "4th" beyond kickdown vehicle speed limit.		1		2			3	5	6		7	4																						
	Shift pattern does not change.				1	3			7				5		2	4		6																	8

TROUBLE-SHOOTING AND DIAGNOSES

Trouble-shooting Chart (Cont'd)

Numbers are arranged in order of probability. Perform inspections starting with number one and working up. Circled numbers indicate that the transmission must be removed from the vehicle.

Reference	Symptom	ON vehicle										OFF vehicle																										
		Oil level	Range select linkage	Inhibitor switch and wiring	Vacuum diaphragm and piping	Kickdown solenoid, switch and wiring	Engine idling rpm	Line pressure	Control valve	Governor	2nd band servo	Transmission air check	Oil quality	Ignition switch and starter motor	Engine adjustment, brake inspection	O.D. band servo	O.D. control SW.	O.D. cancel solenoid	Lock-up solenoid	Lock-up control unit and sensors	Direct clutch	Forward clutch (Rear)	High-reverse clutch (Front)	O.D. band brake	2nd band brake	Low and reverse brake	Oil pump	Oil passage leak	Torque converter	Transmission one-way clutch	Park linkage	Planetary gear	O.D. cancel valve	Lock-up control valve	Accumulator	Rear lubrication		
A3	Vehicle will not run in any range.	1	2				3	5		6	4							8	7							9	10		11				12					
A4	Transmission noise in "D", "2", "1" and "R" ranges.	1					2																			3	5		4	5								
A5	Failure to change from "3rd" to "2nd" when changing lever into "2" range.		1				2	4		5	3														6		7											
	Gear change from "2" to "1st" or from "2nd" to "3rd" in "2" range.		1				2	3																														
	No shock at change from "1" to "2" range or engine races extremely.	1	2	3	4		7			8	6		5												9	10												
A6	Failure to change from "3rd" to "2nd" when shifting lever into "1" range.		1				2	4	5	7	6	3														8	9		10									
A7	Engine brake does not operate in "1" range.		1				2	4		5	3															6	7											
	Gear change from "1st" to "2nd" or from "2nd" to "3rd" in "1" range.		1				2																					3										
A8	Does not change from "2nd" to "1st" in "1" range.	1	2				4	5	6	7	3															8	9											
A9	Large shock changing from "2nd" to "1st" in "1" range.			1			4			3	2															5												
	Transmission overheats.	1					2	5		7	6	4		3	8										10	9	11	13	12	14	15	16	17				18	19
	Oil shoots out during operation, White smoke emitted from exhaust pipe during operation.	1		2			4	6		7	3		5												9	8	10	12	11	13	14	15	16				17	18
	Offensive smell at oil charging pipe.	1								2															3	4	5	6	7	8	9	10	11				12	
	Transmission shifts to overdrive even if O.D. control switch is turned to "ON"															1	2		3																	4		
	Lamp inside O.D. control switch does not glow even if ignition switch is turned to "ON" (engine not started).															1			2																			
	Lamp inside O.D. cancel switch does not glow even if transmission is shifted to O.D.															1			2																			

TROUBLE-SHOOTING AND DIAGNOSES

E4N71B Electrical System/Schematic

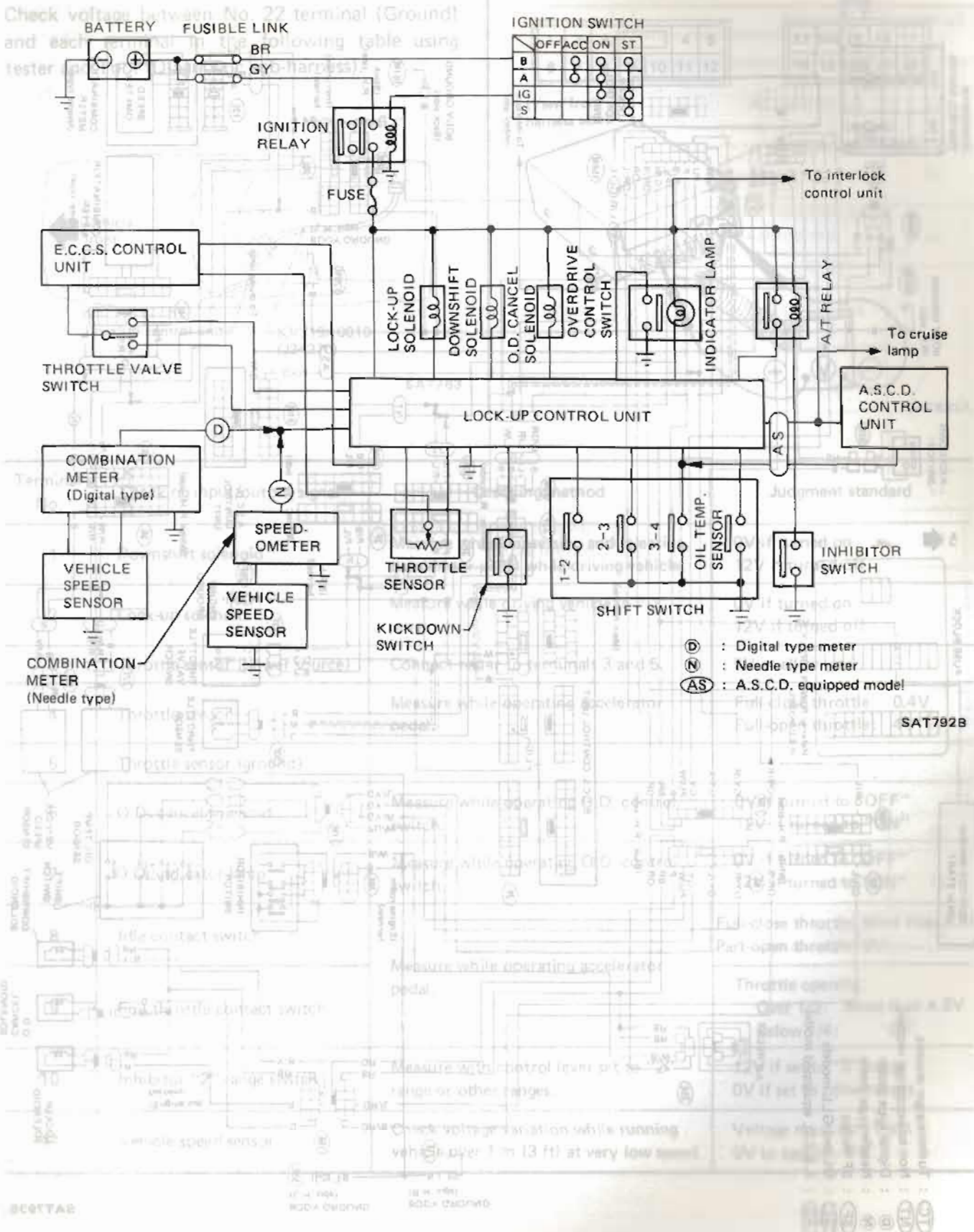

TROUBLE-SHOOTING AND DIAGNOSES

Inspection of A/T Control Unit

Check voltage between No. 22 terminal (Ground) and each terminal in the following table using tester and Tool (Diagnostic sub-harness).

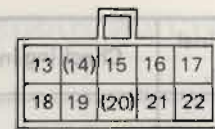
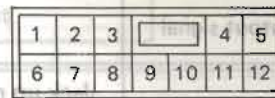

(View from harness side)

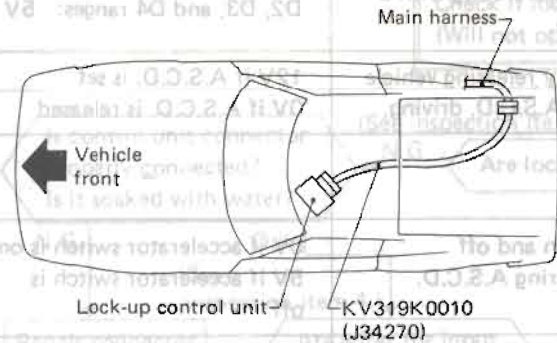

SAT763

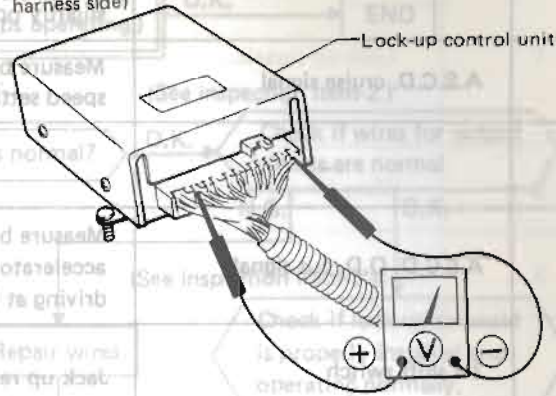

Terminal No.	Checking input/output signal	Checking method	Judgment standard
1	Downshift solenoid	Measure when depressing and releasing accelerator pedal while driving vehicle.	0V if turned on 12V if turned off
2	Lock-up solenoid	Measure while driving vehicle in "D" range.	0V if turned on 12V if turned off
3	Throttle sensor (power source)	Connect tester to terminals 3 and 5.	5V at all times
4	Throttle sensor	Measure while operating accelerator pedal.	Full-close throttle: 0.4V Full-open throttle: 4V
5	Throttle sensor (ground)	—	—
6	O.D. cancel solenoid	Measure while operating O.D. control switch.	0V if turned to "OFF" 12V if turned to "ON"
7	O.D. indicator lamp	Measure while operating O.D. control switch.	0V if turned to "OFF" 12V if turned to "ON"
8	Idle contact switch	—	Full-close throttle: More than 4.8V Part-open throttle: 0V
9	Full throttle contact switch	Measure while operating accelerator pedal.	Throttle opening Over 1/2: More than 4.8V Below 1/4: 0V
10	Inhibitor "2" range switch	Measure with control lever set to "2" range or other ranges.	12V if set to "2" range 0V if set to other ranges
11	Vehicle speed sensor	Check voltage variation while running vehicle over 1 m (3 ft) at very low speed.	Voltage must vary from 0V to approx. 5V.

TROUBLE-SHOOTING AND DIAGNOSES

Inspection of A/T Control Unit (Cont'd)

Terminal No.	Checking input/output signal	Checking method	Judgment standard
12	1-2 shift switch	Jack up rear wheels, set lever to D range, and measure while accelerating with a slightly open throttle.	D1 range: 0V D2, D3, and D4 ranges: 5V
13	A.S.C.D. cruise signal	Measure by repeatedly releasing vehicle speed setting during A.S.C.D. driving.	12V if A.S.C.D. is set 0V if A.S.C.D. is released
14	-	-	-
15	A.S.C.D. O.D. cut signal	Measure by turning on and off accelerator switch during A.S.C.D. driving at D4 speed.	0V if accelerator switch is on 5V if accelerator switch is off
	3-4 shift switch	Jack up rear wheels, set lever to D range range, and measure while accelerating with a slightly open throttle.	D1, D2, and D3 ranges: 0V D4 range: 5V
16	2-3 shift switch		D1 and D2 ranges: 0V D3 and D4 ranges: 5V
17	Power source	Make ground connection.	12V at all times
18	O.D. control switch	Measure while operating O.D. control switch.	0V if turned to "OFF" 5V if turned to "ON"
19	Low-temperature sensor	When checking in installed state, refer to the items on the right. Remove sensor from transmission and make continuity test.	Continuity test Zero continuity at 20°C (68°F) or higher Continuity at 10°C (50°F) or lower (Reference) 5V if oil temp. is over 20°C (68°F) 0V if oil temp. is below 10°C (50°F)
20			
21	Kickdown switch	Measure while operating accelerator pedal.	Full-open accelerator: 0V Less than full open: 5V
22	Ground		

TROUBLE-SHOOTING AND DIAGNOSES

Inspection of Lock-up Control

Details on each step will be described later.

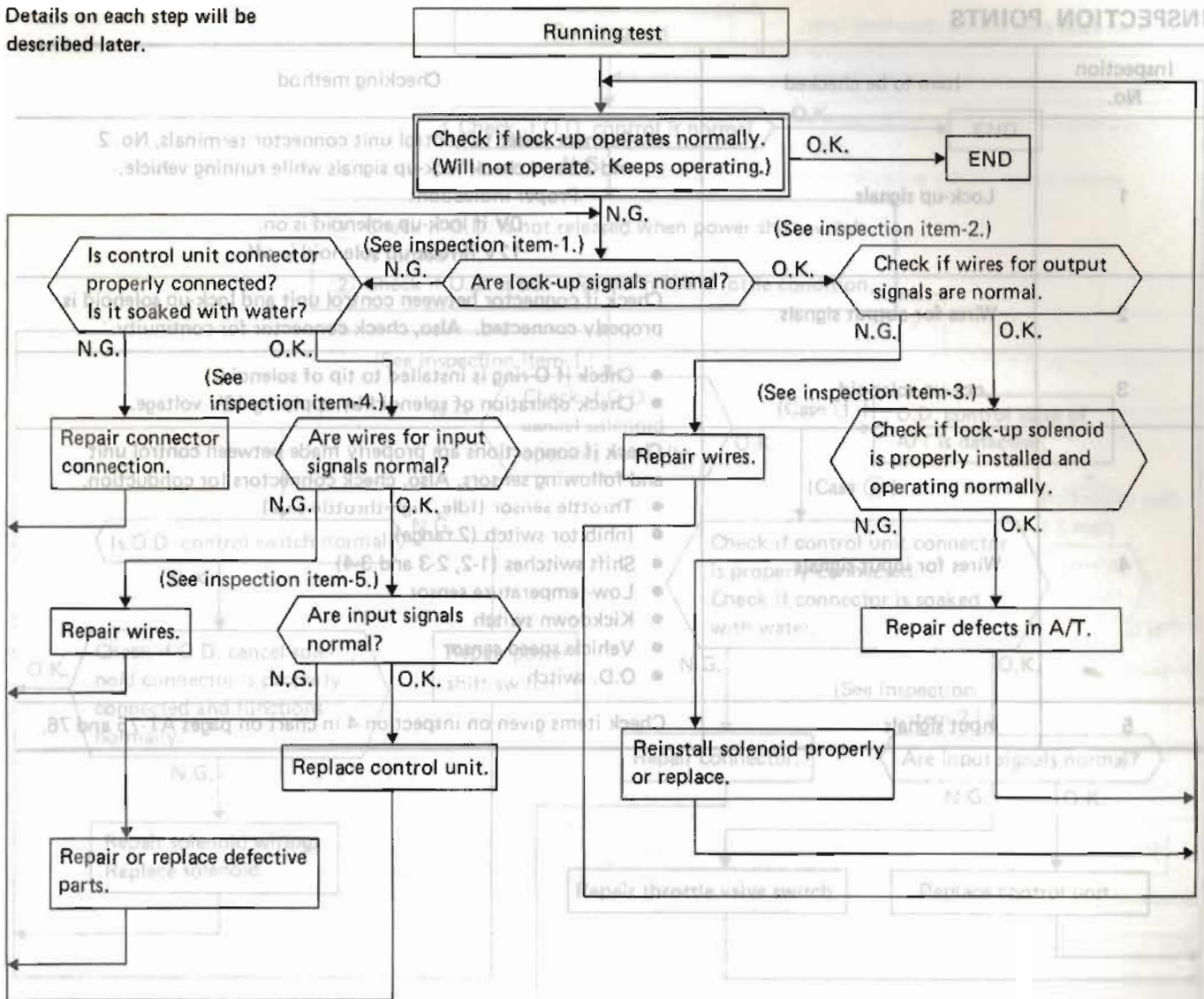

INSPECTION POINTS

Inspection No.	Inspection Item	Checking Method
1	Control unit connector	Check if connector terminals are properly connected. Also, check if it is soaked with water.
2	Input signals	Check items given on inspection 4 in chart on pages 78 and 79. <ul style="list-style-type: none"> Shift switches (1-2, 2-3 and 3-4) Vehicle speed sensor Full throttle contact switch Throttle sensor Low-temperature sensor

TROUBLE-SHOOTING AND DIAGNOSES

Inspection of Lock-up Control (Cont'd)

INSPECTION POINTS

Inspection No.	Item to be checked	Checking method
1	Lock-up signals	<ul style="list-style-type: none"> Connect tester to control unit connector terminals, No. 2 and 22 and check lock-up signals while running vehicle. Proper indication: 0V if lock-up solenoid is on. 12V if lock-up solenoid is off.
2	Wires for output signals	Check if connector between control unit and lock-up solenoid is properly connected. Also, check connector for continuity.
3	Lock-up solenoid	<ul style="list-style-type: none"> Check if O-ring is installed to tip of solenoid. Check operation of solenoid by applying 12V voltage.
4	Wires for input signals	Check if connections are properly made between control unit and following sensors. Also, check connectors for conduction. <ul style="list-style-type: none"> Throttle sensor (Idle, high-throttle side) Inhibitor switch (2 range) Shift switches (1-2, 2-3 and 3-4) Low-temperature sensor Kickdown switch Vehicle speed sensor O.D. switch
5	Input signals	Check items given on inspection-4 in chart on pages AT-75 and 76.
20		
21	Kick-down switch	
22	Ground	

TROUBLE-SHOOTING AND DIAGNOSES

Inspection of O.D. Control

INSPECTION POINTS

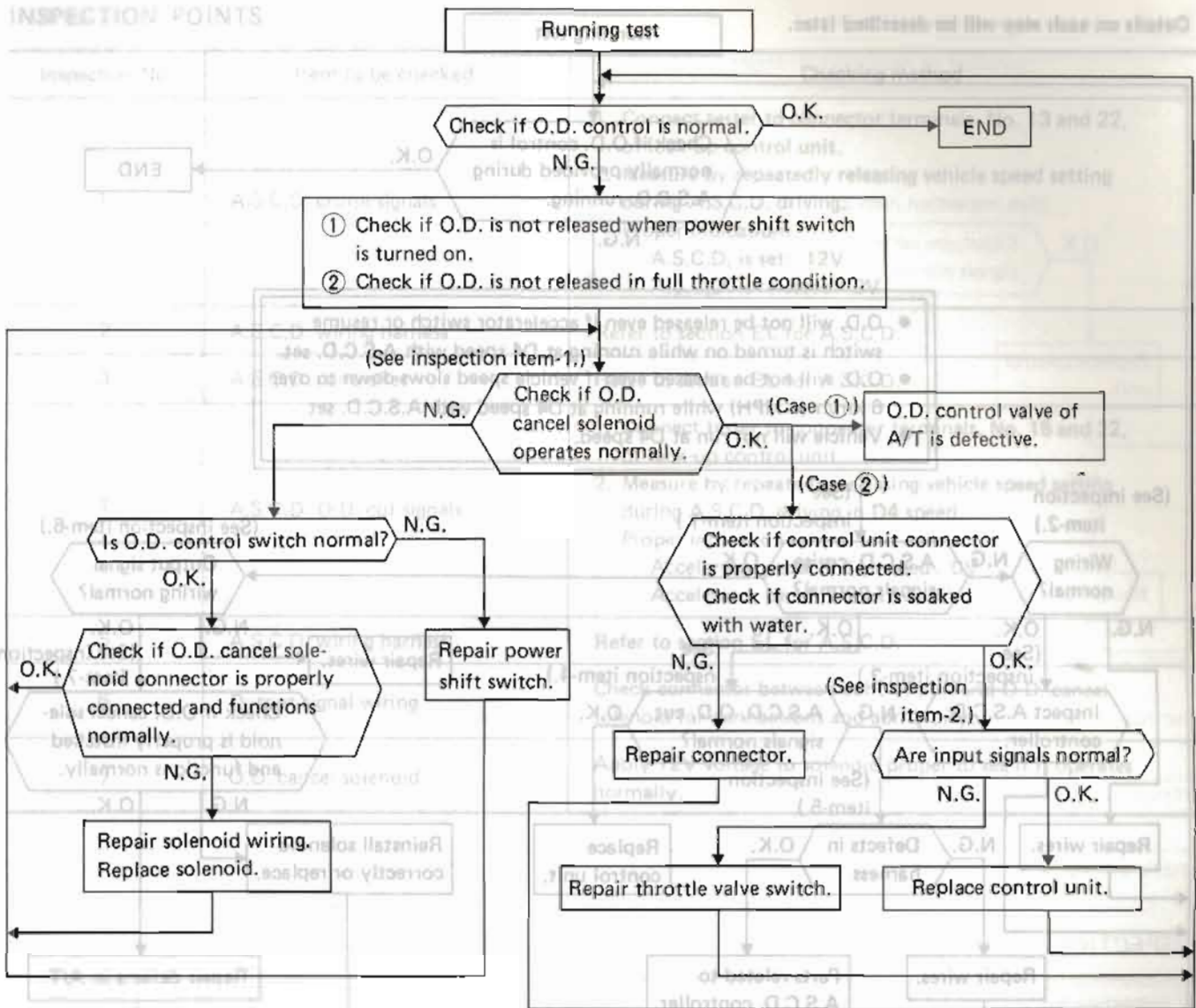

INSPECTION POINTS

Inspection No.	Item to be checked	Checking method
1	O.D. solenoid	Turn on key and set O.D. switch to "O.D. release" position to see if O.D. solenoid clicks.
2	Input signals	Inspect following items given in flow chart on pages AT-75 and 76. <ul style="list-style-type: none"> ● Shift switches (1-2, 2-3 and 3-4) ● Vehicle speed sensor ● Full throttle contact switch ● Throttle sensor ● Low-temperature sensor

TROUBLE-SHOOTING AND DIAGNOSES

Inspection of Parts Related to A.S.C.D.

Details on each step will be described later.

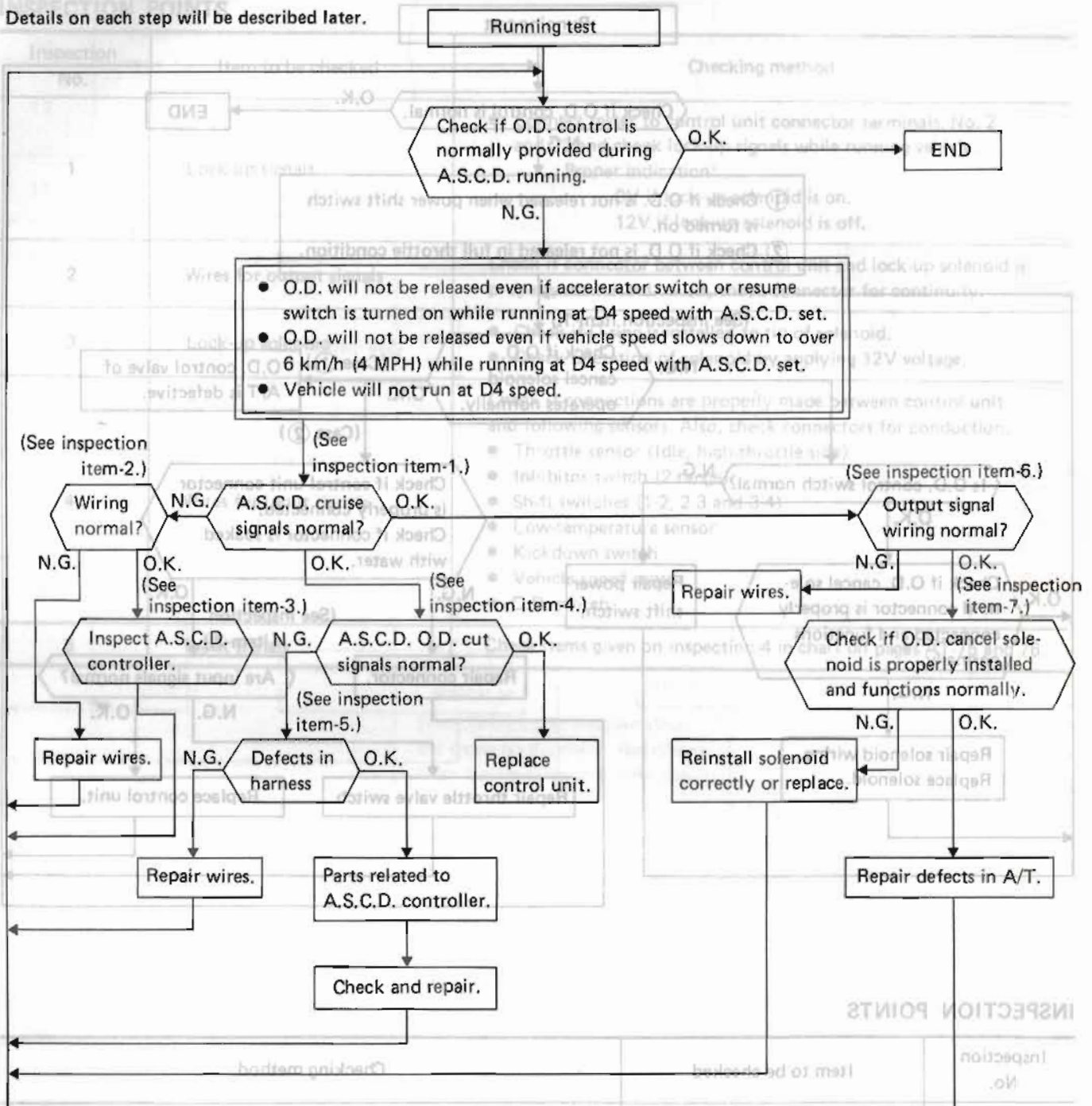

Inspection No.	Inspection Item to be checked	Checking method
1	O.D. solenoid	Turn on key and set O.D. switch to "O.D. release" position to see if O.D. solenoid clicks.
2	Input signals	Inspect following items given in flow chart on pages AT-78 and 79. • Low-temperature sensor • Throttle sensor • Full throttle contact switch • Vehicle speed sensor • Shift switches (1-2, 3-4 and 3-4)

TROUBLE-SHOOTING AND DIAGNOSES

Inspection of Parts Related to A.S.C.D. (Cont'd)

INSPECTION POINTS

Inspection No.	Item to be checked	Checking method
1	A.S.C.D. cruise signals	1. Connect tester to connector terminals, No. 13 and 22, of lock-up control unit. 2. Measure by repeatedly releasing vehicle speed setting during A.S.C.D. driving. Proper indication: A.S.C.D. is set: 12V A.S.C.D. is released: 0V
2	A.S.C.D. wiring harness	Refer to section EL for A.S.C.D.
3	A.S.C.D. controller	Refer to section EL for A.S.C.D.
4	A.S.C.D. O.D. cut signals	1. Connect tester to connector terminals, No. 15 and 22, of lock-up control unit. 2. Measure by repeatedly releasing vehicle speed setting during A.S.C.D. driving in D4 speed. Proper indication: Accelerator pedal is depressed: 0V Accelerator pedal is released: 5V
5	A.S.C.D. wiring harness	Refer to section EL for A.S.C.D.
6	Output signal wiring	Check connector between control unit and O.D. cancel solenoid for connections and continuity.
7	O.D. cancel solenoid	Apply 12V voltage to solenoid proper to see if it operates normally.

INSPECTION POINTS

Inspection No.	Item to be checked	Checking method
1	Downshift solenoid signals	1. Throttle release switch signals. 2. Kickdown switch signals. 3. Throttle position sensor signals.
2	Downshift solenoid	Apply 12V voltage to solenoid proper to see if it functions normally.
3	Input signal wiring	Check connector between kickdown switch and control unit for proper connection and continuity.
4	Downshift solenoid	Check connector between downshift solenoid and control unit for proper connection and continuity.
5	Downshift solenoid	Check connector between kickdown switch and control unit for proper connection and continuity.
6	Downshift solenoid	Check connector between kickdown switch and control unit for proper connection and continuity.

TROUBLE-SHOOTING AND DIAGNOSES

Inspection of Kickdown Control

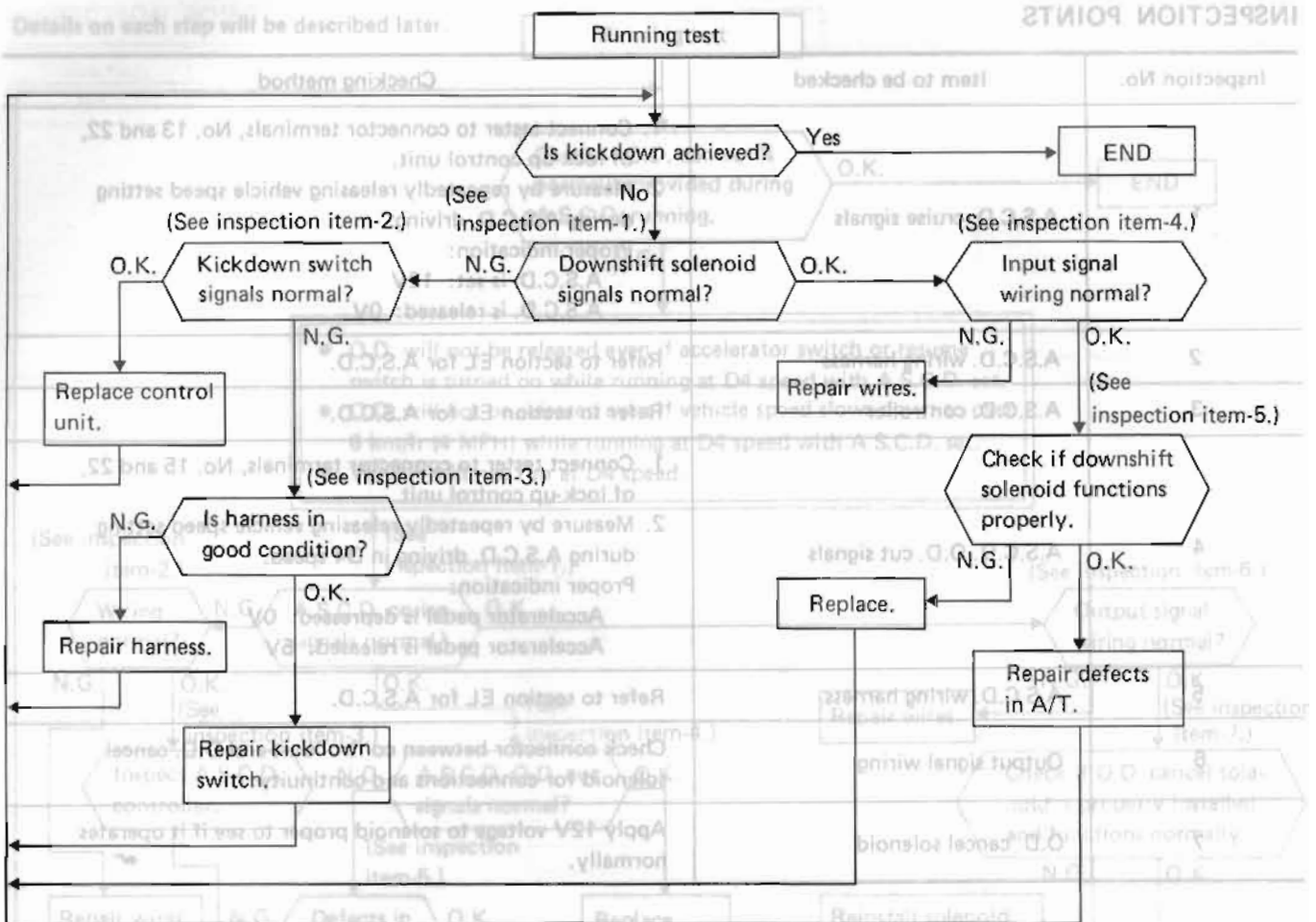

INSPECTION POINTS

Inspection No.	Item to be checked	Checking method
1	Downshift solenoid signals	Listen for a "click" to be emitted by downshift solenoid when accelerator pedal is fully depressed and ignition switch is "ON".
2	Kickdown switch signals	Connect tester to connector terminals, No. 21 and 22, of lock-up control unit. Measure while operating accelerator pedal. Full-open accelerator: 0V Less than full open: 5V
3	Wires for kickdown switch	Check connector between kickdown switch and control unit for proper connection and continuity.
4	Input signal wiring	Check connector between downshift solenoid and control unit for proper connection and continuity.
5	Downshift solenoid	Apply 12V voltage to solenoid proper to see if it functions normally.

TROUBLE-SHOOTING AND DIAGNOSES

Troubles Detected by Self-diagnosing and Their Indication

Trouble-shooting procedure

Before trouble-shooting the lock-up control unit, operate the self-diagnosis function as follows:

1. Turn O.D. control switch to "ON".
2. Turn the ignition switch to "ON".
Do not start the engine.
3. Press the kickdown switch to "ON" for at least one second.

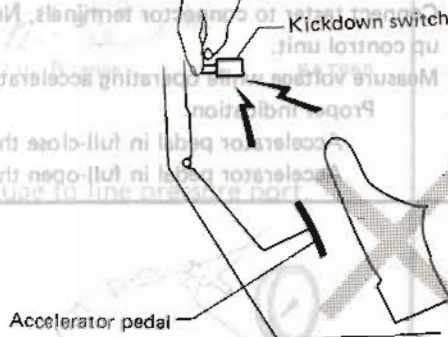

4. Start the engine and run the vehicle about 20 km/h (12 MPH), and check to see whether or not an abnormal condition exists.

Turning the ignition switch to "OFF" or "ACC" cancels the self-diagnosis function. If cancelled, repeat steps over again.

5. If an abnormal condition is indicated, track down the cause of the problem in accordance with the chart as shown below.

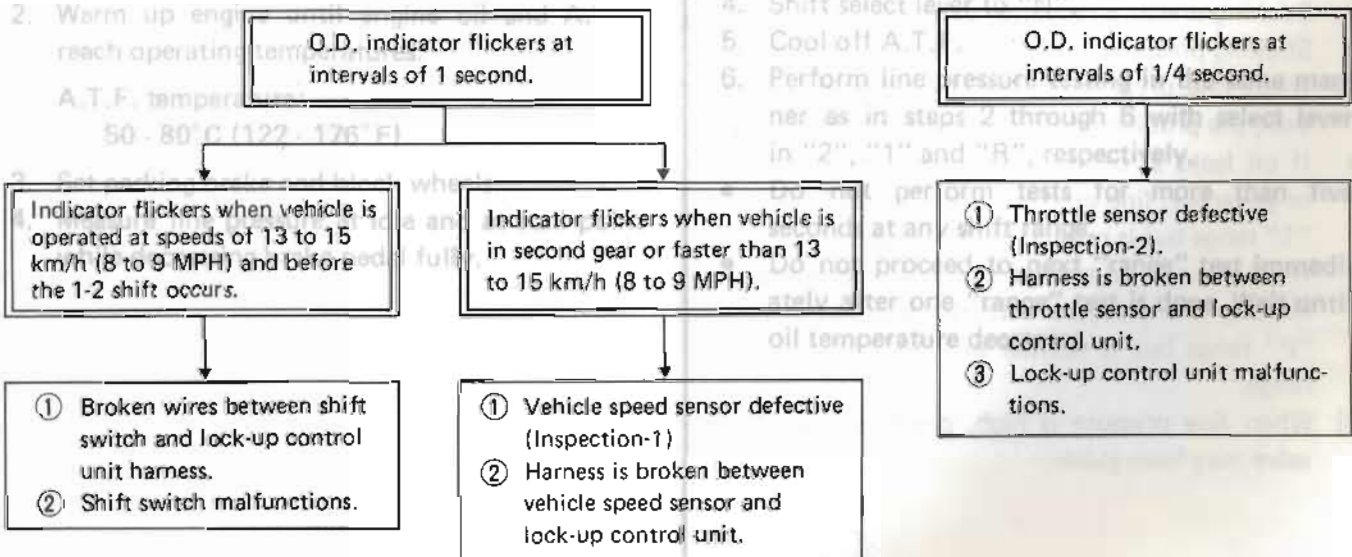

TROUBLE-SHOOTING AND DIAGNOSES

Troubles Detected by Self-diagnosing and Their Indication (Cont'd)

INSPECTION POINTS

No. of inspection	Checking item	Checking method
1	(See inspection item 2.) Vehicle speed sensor Kickdown switch signals normal?	1. Connect tester to connector terminals, No. 11 and 22, of lock-up control unit. 2. Check voltage variation by running vehicle over 1 m (3 ft) at very slow speed. Proper indication: Voltage must vary from 0V to over 5V.
2	Throttle sensor (See inspection item 3)	1. Connect tester to connector terminals, No. 4 and 22, of lock-up control unit. 2. Measure voltage while operating accelerator pedal. Proper indication: Accelerator pedal in full-close throttle position: 0.4 V Accelerator pedal in full-open throttle position: 4V

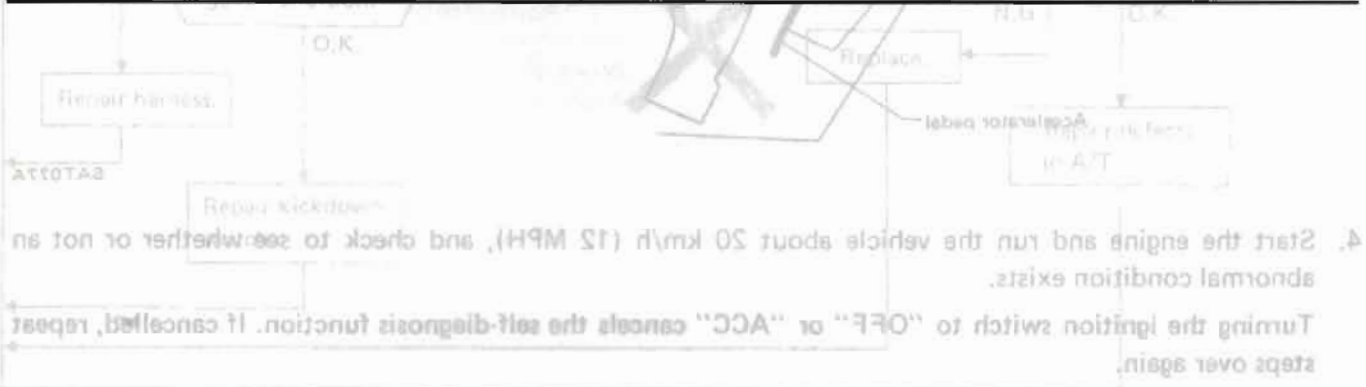

2. If an abnormal condition is indicated, track down the cause of the problem in accordance with the chart as shown below.

INSPECTION POINTS

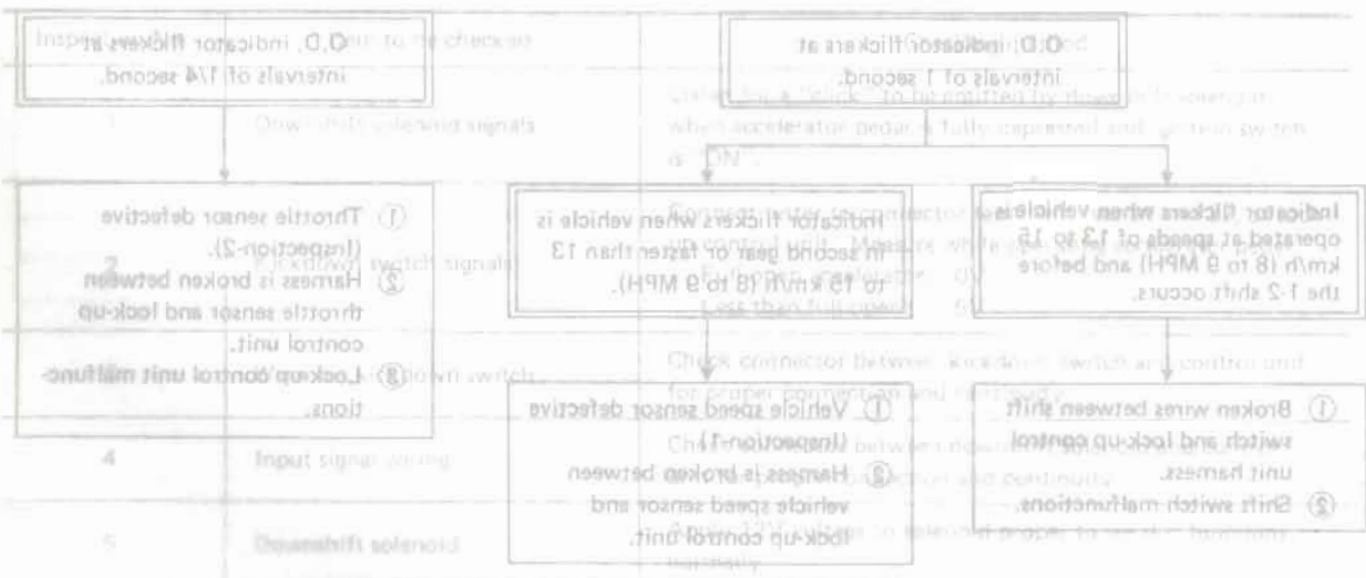

TROUBLE-SHOOTING AND DIAGNOSES

Pressure Testing

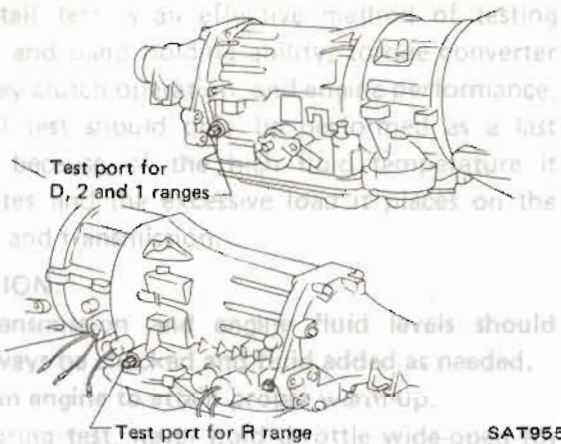

LINE PRESSURE

1. Install pressure gauge to line pressure port.

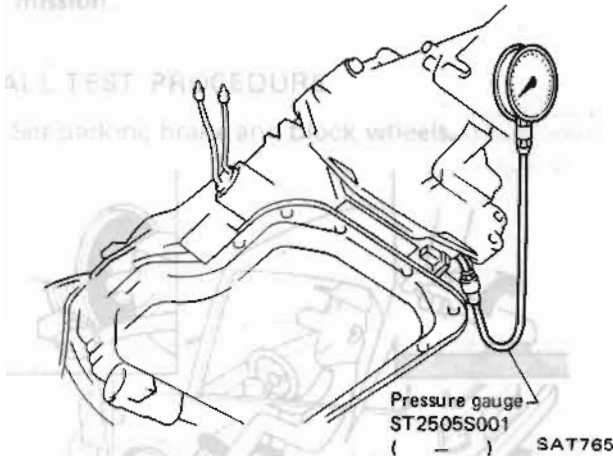

2. Warm up engine until engine oil and A.T.F. reach operating temperatures.

A.T.F. temperature:

50 - 80°C (122 - 176°F)

3. Set parking brake and block wheels.
4. Measure line pressure at idle and at stall point while depressing brake pedal fully.

Apply foot brake and accelerate to wide-open throttle.

Quickly note the engine stall speed and immediately depress the throttle.

Stall revolution:

VG30E engine without turbo

2,150 - 2,450 rpm

VG30E turbo engine

2,500 - 2,800 rpm

At idling

VG30E engine without turbo

Range	Line pressure kPa (kg/cm ² , psi)
R	569 - 755 (5.8 - 7.7, 82 - 109)
D	304 - 402 (3.1 - 4.1, 44 - 58)
2	549 - 1,128 (5.6 - 11.5, 80 - 164)
1	324 - 382 (3.3 - 3.9, 47 - 55)

VG30E turbo engine

Range	Line pressure kPa (kg/cm ² , psi)
R	392 - 490 (4.0 - 5.0, 57 - 71)
D	255 - 353 (2.6 - 3.6, 37 - 51)
2	588 - 1,177 (6.0 - 12.0, 85 - 171)
1	255 - 355 (2.6 - 3.6, 37 - 51)

At stall test

1. Start engine and place select lever in "D" range.
 2. Apply foot brake and accelerate to wide-open throttle.
 3. Quickly note the line pressure and immediately release throttle.
 4. Shift select lever to "N".
 5. Cool off A.T.F.
 6. Perform line pressure testing in the same manner as in steps 2 through 6 with select lever in "2", "1" and "R", respectively.
- Do not perform tests for more than five seconds at any shift range.
 - Do not proceed to next "range" test immediately after one "range" test is done. Wait until oil temperature decreases.

TROUBLE-SHOOTING AND DIAGNOSES

Pressure Testing (Cont'd)

VG30E engine without turbo

Range	Line pressure kPa (kg/cm ² , psi)
R	2,089 - 2,393 (21.3 - 24.4, 303 - 347)
D	1,128 - 1,275 (11.5 - 13.0, 164 - 185)
2	1,138 - 1,285 (11.6 - 13.1, 165 - 186)
1	1,128 - 1,275 (11.5 - 13.0, 164 - 185)

VG30E turbo engine

Range	Line pressure kPa (kg/cm ² , psi)
R	2,530 - 2,824 (25.8 - 28.8, 367 - 410)
D	1,824 - 1,981 (18.6 - 20.2, 264 - 287)
2	1,824 - 1,981 (18.6 - 20.2, 264 - 287)
1	1,824 - 1,981 (18.6 - 20.2, 264 - 287)

Judgment by measuring line pressure

If line pressure does not rise, first check to make sure that vacuum hose is connected properly.

- When line pressure is low at all positions, the problem may be due to:
 - Wear on interior of oil pump
 - Oil leakage at or around oil pump, control valve body, transmission case or governor
 - Sticking pressure regulator valve
 - Sticking pressure modifier valve
- When line pressure is low at a particular position, the problem may be due to the following:
 - If oil leaks at or around forward clutch (rear) or governor, line pressure is low in "D", "2" or "1" range but is normal in "R" range.
 - If oil leaks at or around low and reverse brake circuit, line pressure becomes low in "R" or "P" range but is normal in "D", "2" or "1" range.
- When line pressure is high, pressure regulator valve may have stuck.



Proper indication

Voltage must vary

Proper indication

Accelerator pedal

Accelerator pedal



Pressure gauge

Warm up engine until engine oil and A.T.F. reach operating temperatures.

A.T.F. temperature: 50 - 80°C (122 - 176°F)

Set parking brake and block wheels.

Measure line pressure at idle and at stall point while depressing brake pedal fully.

TROUBLE-SHOOTING AND DIAGNOSES

Stall Testing

The stall test is an effective method of testing clutch and band holding ability, torque converter one-way clutch operation, and engine performance. A stall test should only be performed as a last resort because of the high fluid temperature it generates and the excessive load it places on the engine and transmission.

CAUTION:

- Transmission and engine fluid levels should always be checked and fluid added as needed.
- Run engine to attain proper warm-up.
- During test, never hold throttle wide-open for more than 5 seconds.
- Do not test more than two gear ranges without driving vehicle to cool off engine and transmission.

STALL TEST PROCEDURE

- Set parking brake and block wheels.



SAT57

- Install a tachometer where it can be seen by driver during test.
- Start engine and place select lever in "D" range.
- Apply foot brake and accelerate to wide-open throttle.
- Quickly note the engine stall speed and immediately release throttle.

Stall revolution:

VG30E engine without turbo

2,150 - 2,450 rpm

VG30E turbo engine

2,500 - 2,800 rpm



SAT598

- Shift select lever to "N".
- Cool off A.T.F.
- Perform stall tests in the same manner as in steps 3 through 7 with select lever in "1" and "R", respectively.



TRUBLE-SHOOTING AND DIAGNOSES

STALL TEST ANALYSIS

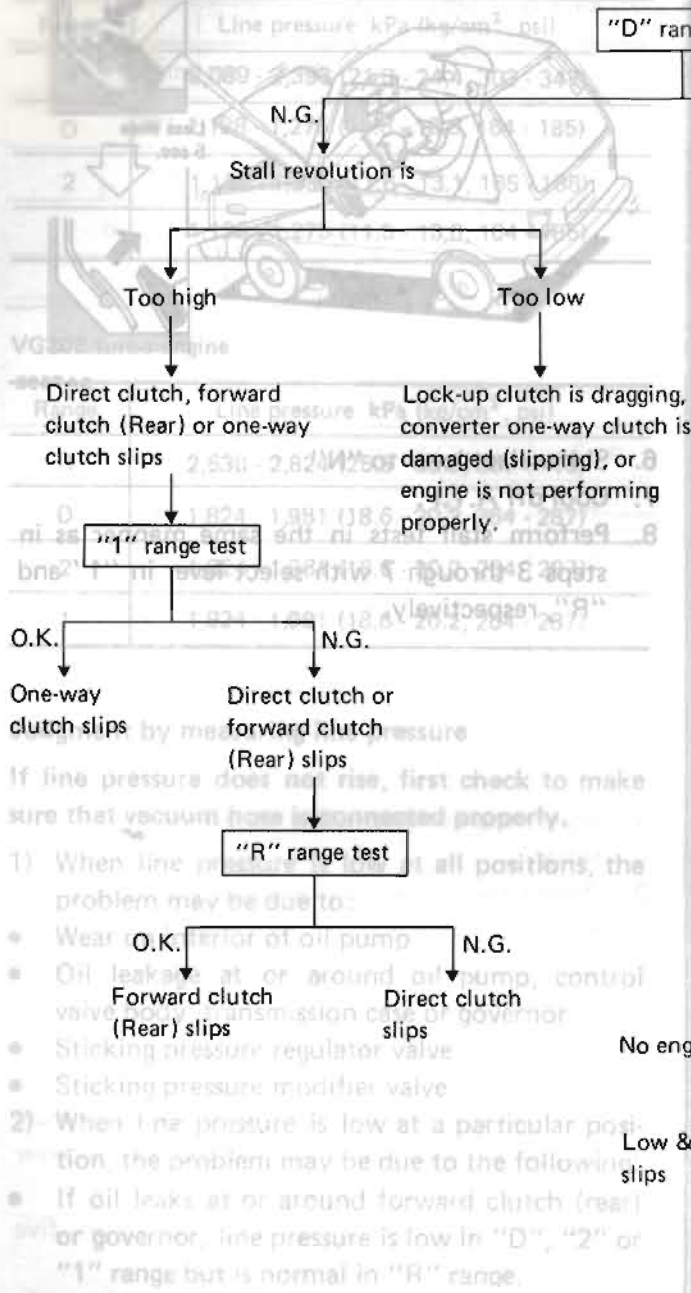

If converter one-way clutch is stuck, vehicle will have poor high speed performance and low engine rpm when it is raced in "N" range. If converter one-way clutch is slipping, vehicle will be sluggish up to 50 or 60 km/h (30 or 40 MPH).

3) When line pressure is low at a particular position, the problem may be due to the following:

- If oil leaks at or around forward clutch (rear) or governor, line pressure is low in "D", "2" or "1" range but is normal in "R" range.
- Sticking pressure regulator valve
- Sticking pressure modifier valve

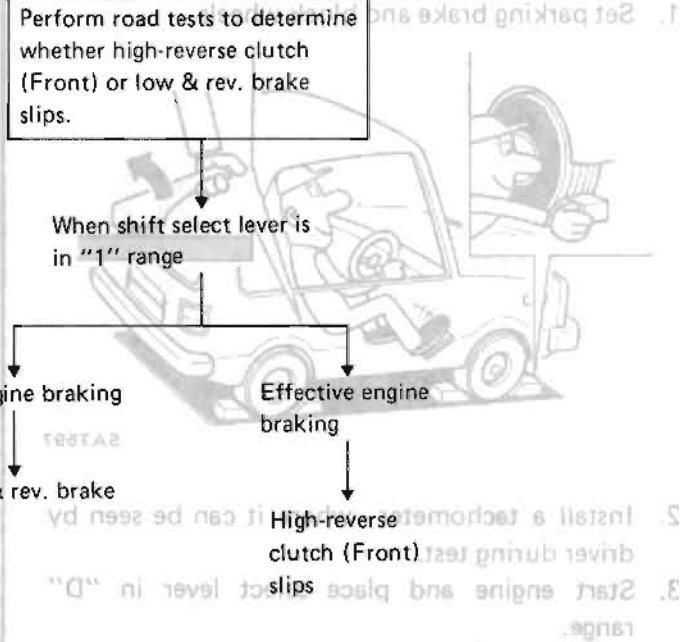
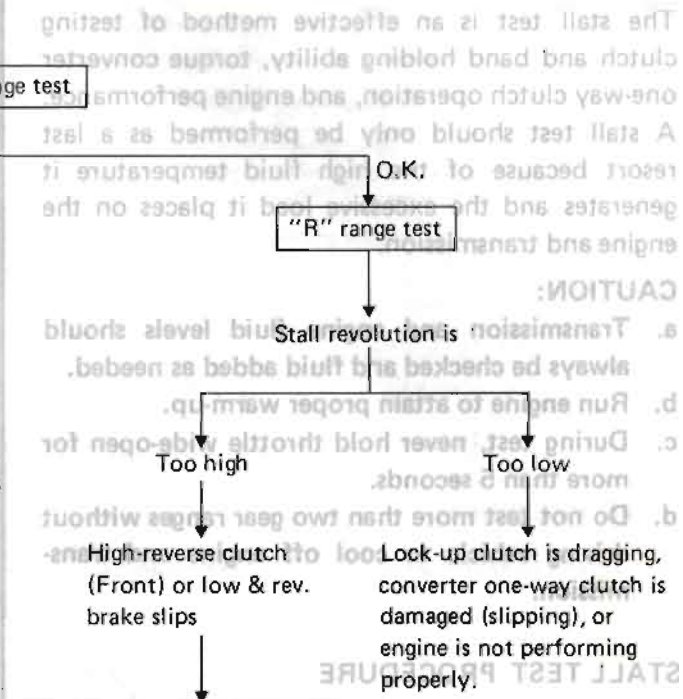

2) Quickly note the engine stall speed and immediately release throttle.

Stall revolution:

VG30E engine without turbo
2,150 - 2,450 rpm

VG30E turbo engine
2,500 - 2,800 rpm

A/T INTERLOCK SYSTEM

Location of Component Parts

SYMBOL

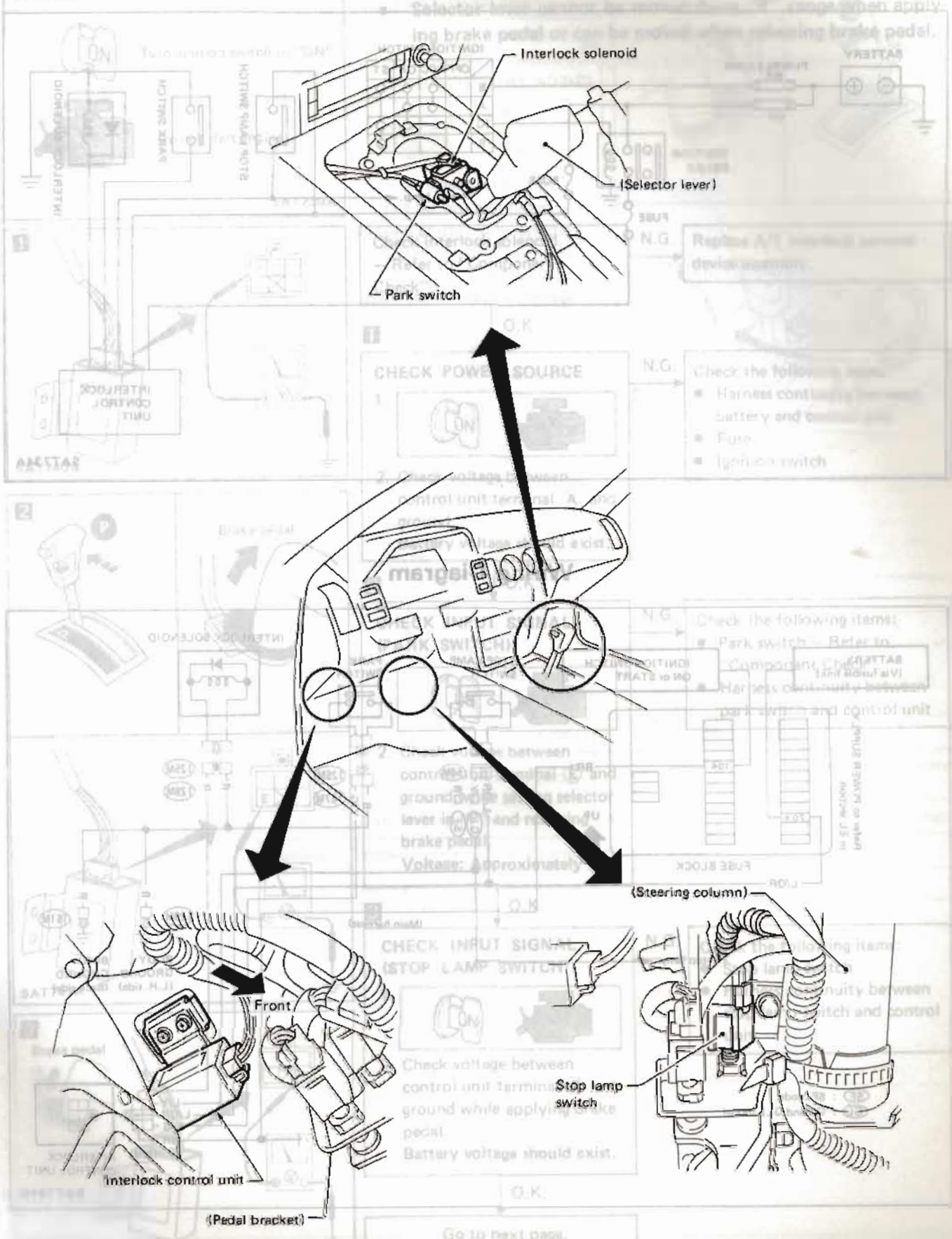

A/T INTERLOCK SYSTEM

Schematic

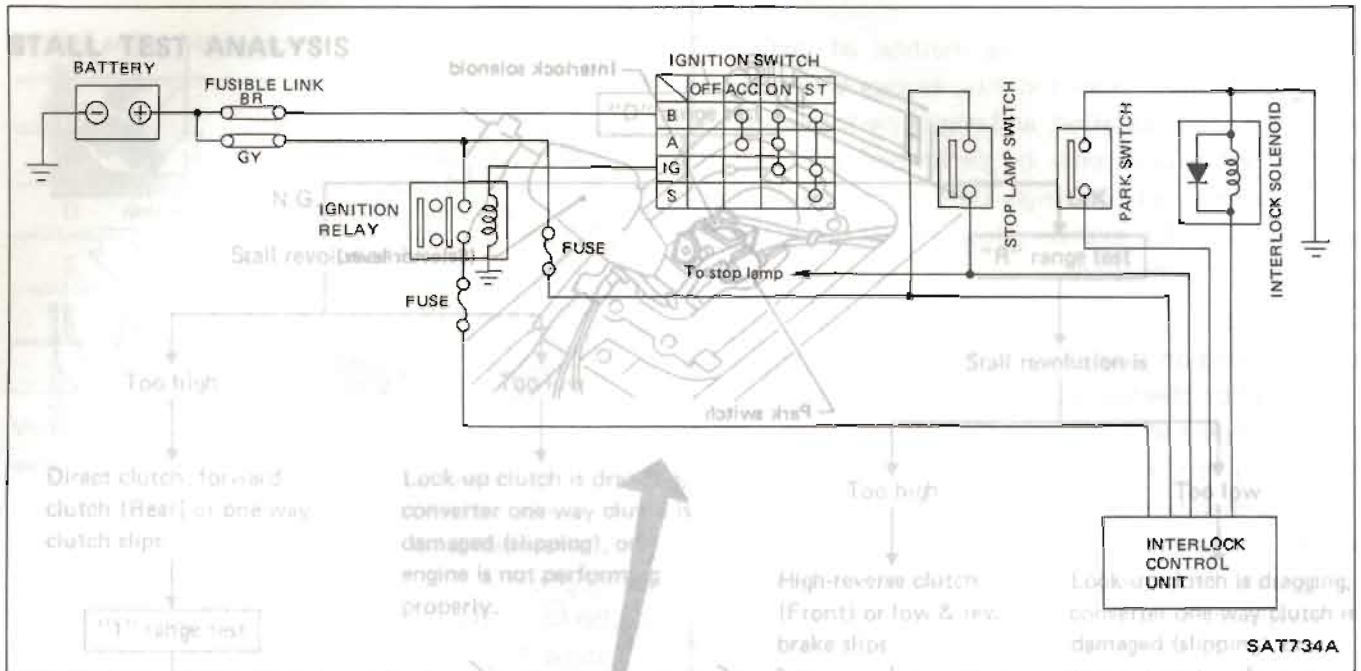

Wiring Diagram

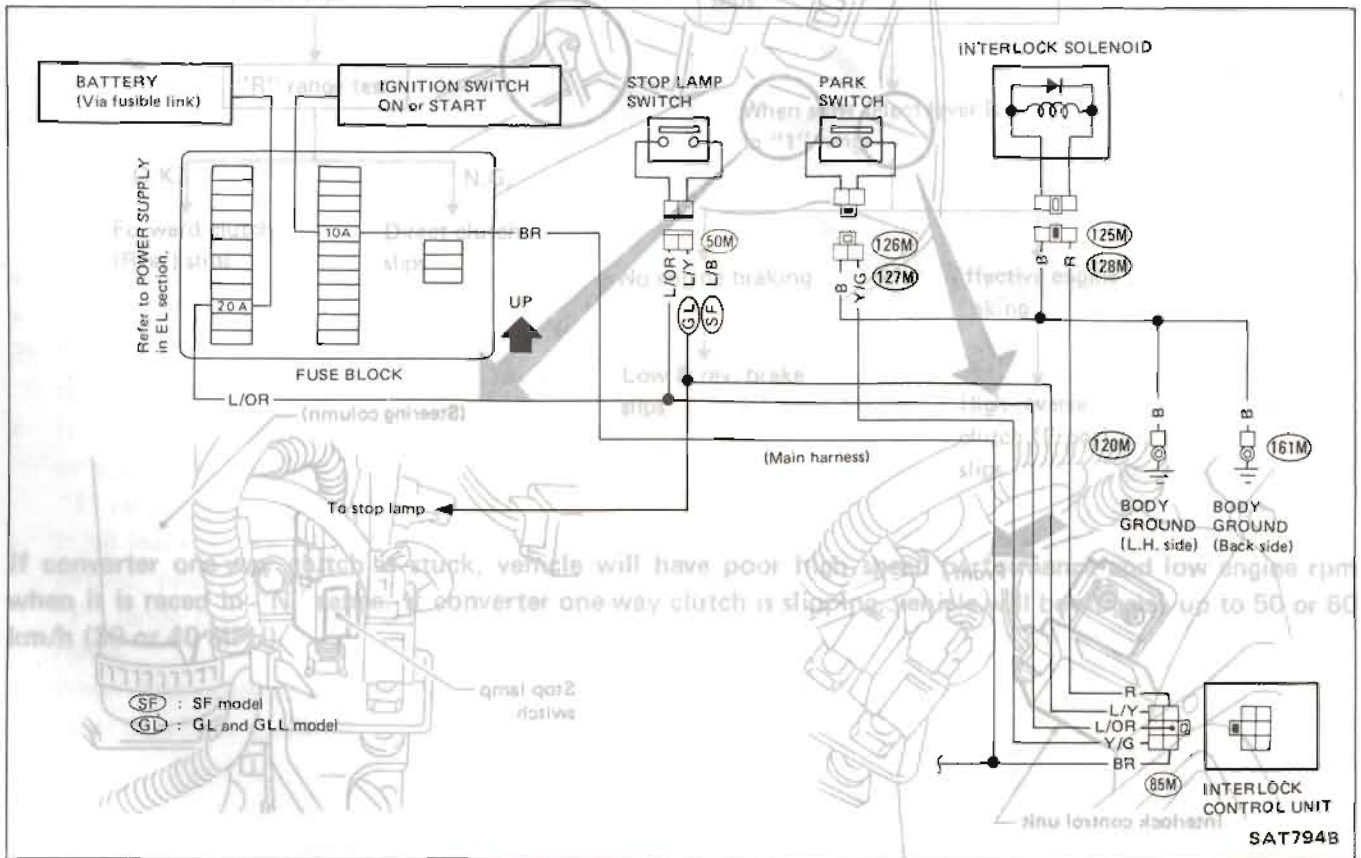

A/T INTERLOCK SYSTEM

SYMBOL



: Turn ignition switch to "ON".



: Do not start engine.

SAT739A

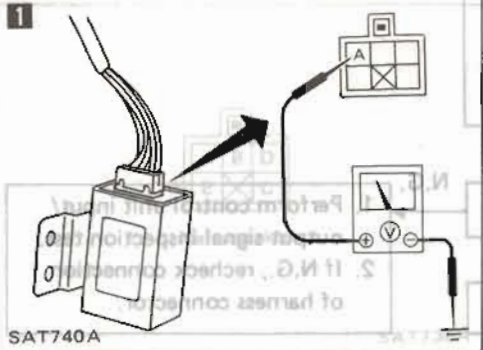

1. Check interlock solenoid. — Refer to "Component Check".

N.G. Replace A/T interlock control device assembly.

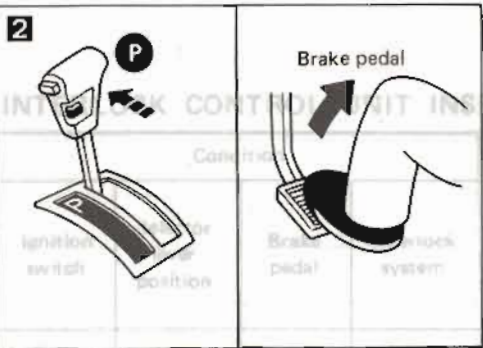

O.K.

CHECK POWER SOURCE

1. : Turn ignition switch to "ON".
2. Check voltage between control unit terminal (A) and ground. **Battery voltage should exist.**

N.G. Check the following items:

- Harness continuity between battery and control unit
- Fuse
- Ignition switch

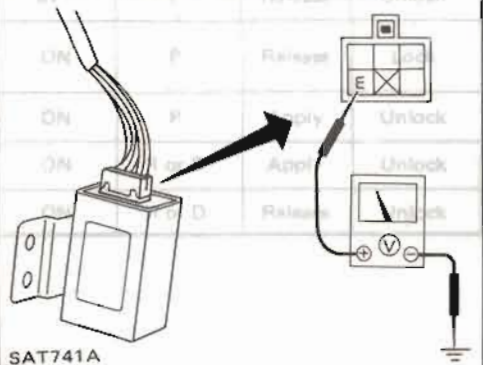

O.K.

CHECK INPUT SIGNAL (PARK SWITCH)

1. : Turn ignition switch to "ON".
2. Check voltage between control unit terminal (E) and ground while setting selector lever in "P" and releasing brake pedal. **Voltage: Approximately 10V**

N.G. Check the following items:

- Park switch — Refer to "Component Check".
- Harness continuity between park switch and control unit

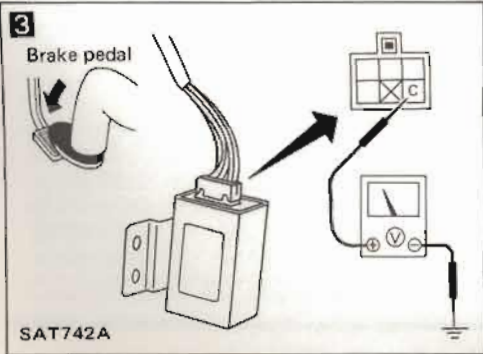

O.K.

CHECK INPUT SIGNAL (STOP LAMP SWITCH)

1. : Turn ignition switch to "ON".
2. Check voltage between control unit terminal (C) and ground while applying brake pedal. **Battery voltage should exist.**

N.G. Check the following items:

- Stop lamp switch
- Harness continuity between stop lamp switch and control unit

O.K.

Go to next page.

A/T INTERLOCK SYSTEM

Trouble-shooting and Diagnosis (Cont'd)

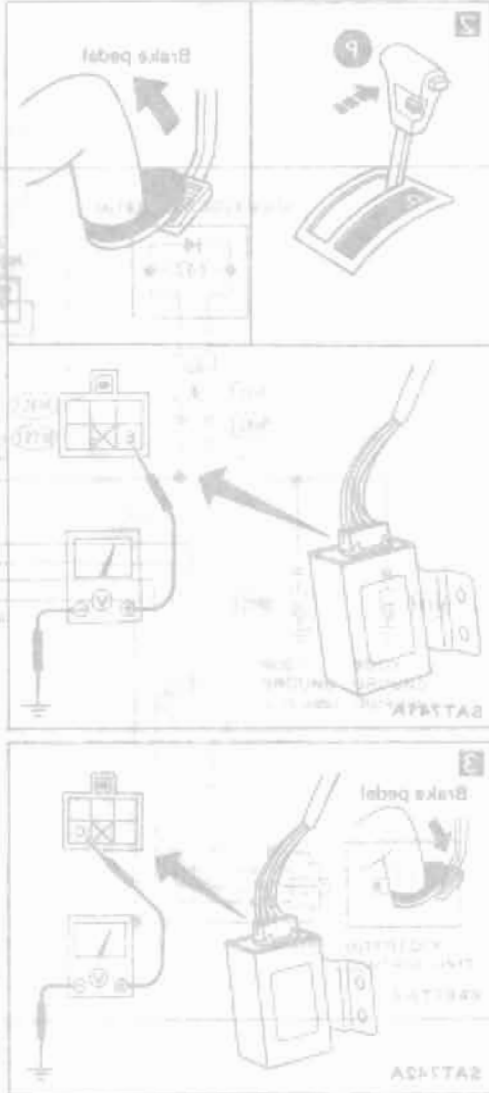
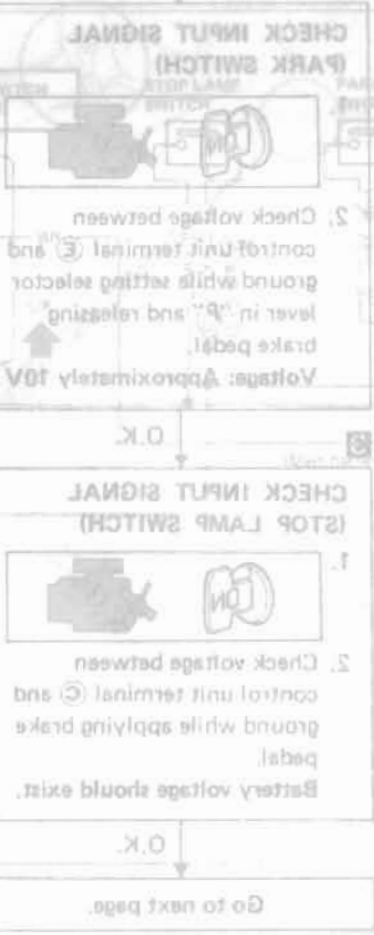
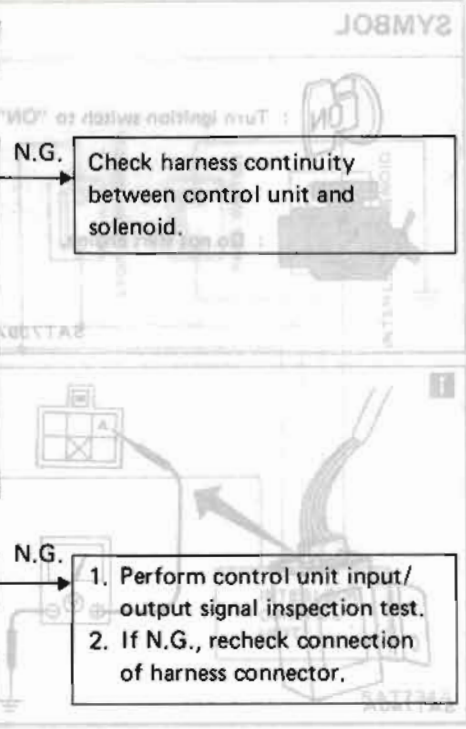
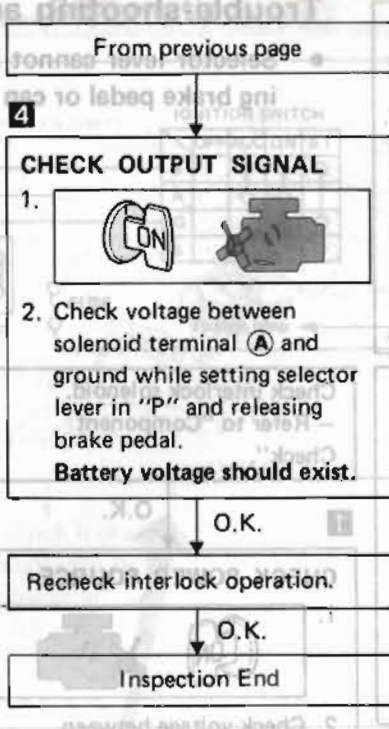
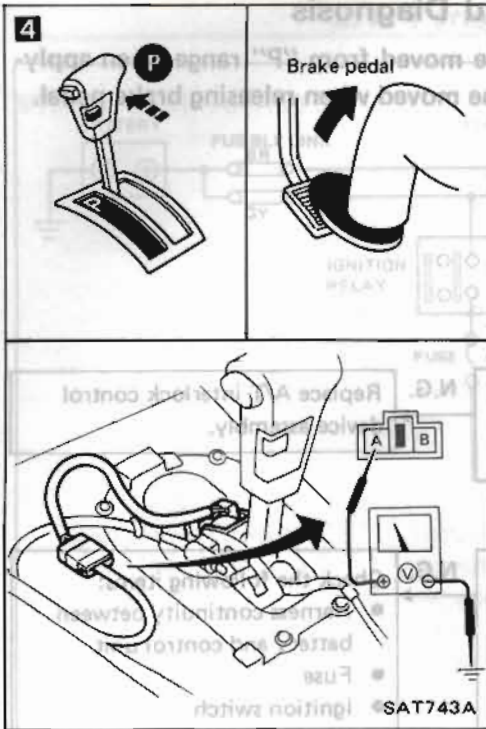

A/T INTERLOCK SYSTEM

Component Check

INTERLOCK CONTROL UNIT

- Measure voltage between each terminal and body ground by following "Interlock control unit inspection chart".

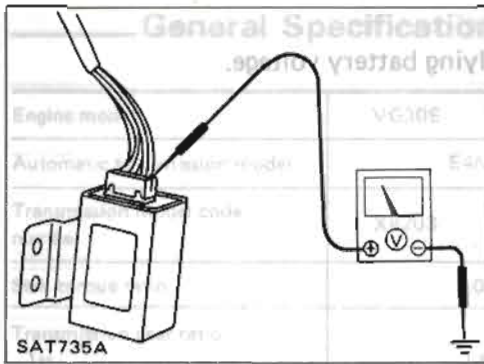

- Connector terminal layout.

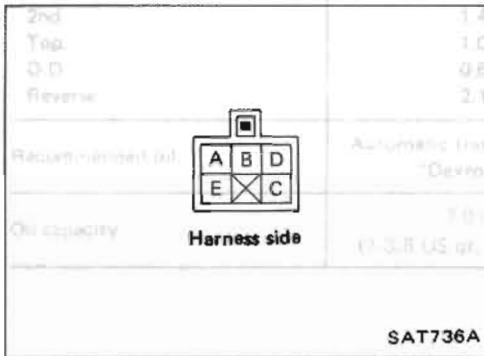

INTERLOCK CONTROL UNIT INSPECTION CHART

Condition				Terminal voltage (V)				
Ignition switch	Selector lever position	Brake pedal	Interlock system	A	B	C	D	E
				Power supply for interlock control unit	Power supply for stop lamp	Stop lamp switch	Interlock solenoid	Park switch
OFF	P	Release	Unlock	0	Battery voltage	0	0	0
ON	P	Release	Lock	Battery voltage	Battery voltage	0	Battery voltage	Approximately 10V
ON	P	Apply	Unlock	Battery voltage	Battery voltage	Battery voltage	0	Battery voltage
ON	R or D	Apply	Unlock	Battery voltage	Battery voltage	Battery voltage	0	0
ON	R or D	Release	Unlock	Battery voltage	Battery voltage	0	0	0

A/T INTERLOCK SYSTEM

Component Check (Cont'd)

INTERLOCK SOLENOID

- Check operation by applying battery voltage.

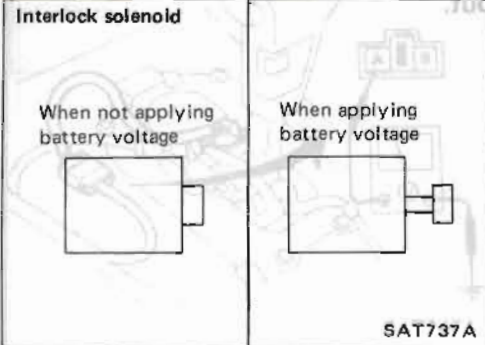
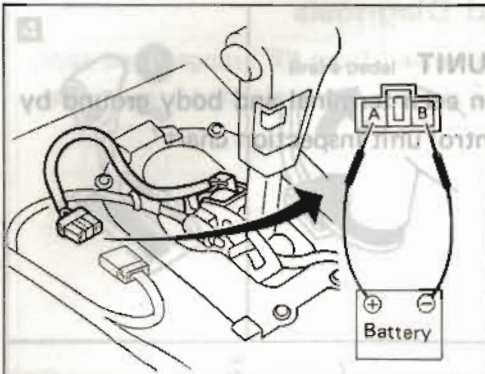

SAT737A

CHECK OUTPUT SIGNAL

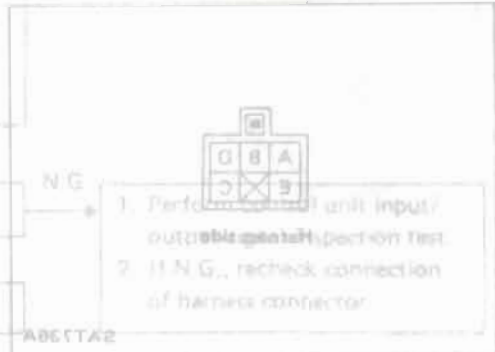
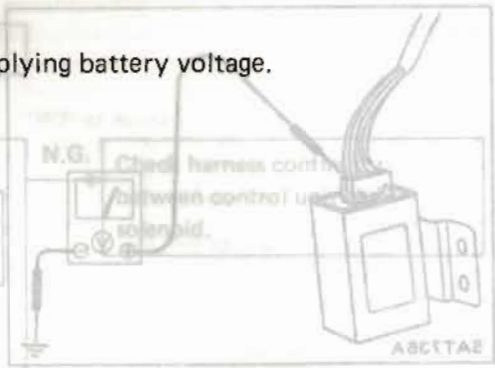
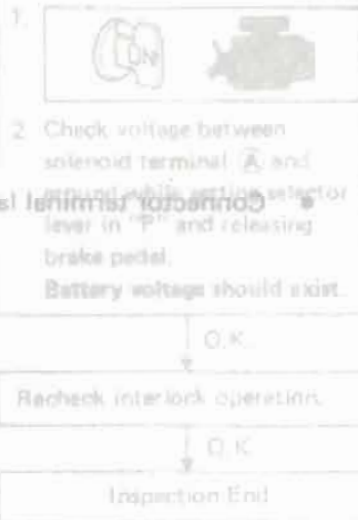

PARK SWITCH

- Check continuity while pushing or not pushing switch.

Resistance

Park switch position		Continuity
When pushing switch	No	
When not pushing switch	Yes	

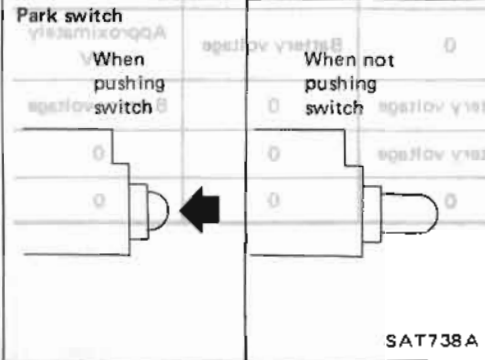
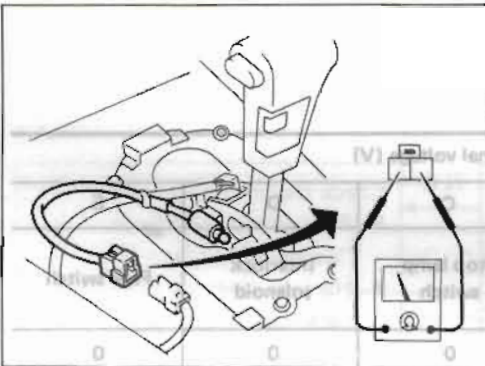

SAT738A

SERVICE DATA AND SPECIFICATIONS (S.D.S.)

General Specifications

Specifications and Adjustment

Engine model	VG30E	VG30E turbo	
Automatic transmission model	E4N71B		
Transmission model code number	X8203	X8206	
Stall torque ratio	2.0 : 1		
Transmission gear ratio			
1st	2.458		
2nd	1.458		
Top	1.000		
O.D.	0.686		
Reverse	2.182		
Recommended oil	Automatic transmission fluid "Dexron" type		
Oil capacity	7.0 liters (7-3/8 US qt, 6-1/8 Imp qt)		
Thickness of retaining plate			
Part number	Thickness (mm (in))	Part number	Thickness (mm (in))
318E7-X2800	11.8 (0.465)	318E7-X2801	12.0 (0.472)
318E7-X2802	12.3 (0.480)	318E7-X2803	12.4 (0.488)
318E7-X2804	12.8 (0.498)	318E7-X2805	12.8 (0.504)
Thickness of retaining plate			
Part number	Thickness (mm (in))	Part number	Thickness (mm (in))
318E7-X2800	8.8 (0.348)	318E7-X2801	10.0 (0.394)
318E7-X2802	10.2 (0.402)	318E7-X2803	10.4 (0.409)
318E7-X2804	10.8 (0.421)	318E7-X2805	10.8 (0.425)
O.D. of drive band			
Part number	Piston size (mm (in))	Part number	Piston size (mm (in))
80 (3.15)	44 (1.73)	80 (3.15)	44 (1.73)
Front end play (mm (in))			
0.5 - 0.8 (0.020 - 0.031)			
Thickness of high-reverse clutch (front) thrust washer			
Part number	Thickness (mm (in))	Part number	Thickness (mm (in))
318E7-X0107	1.3 (0.051)	318E7-X0108	1.5 (0.059)
318E7-X0109	1.7 (0.067)	318E7-X0110	1.8 (0.071)
318E7-X0111	2.1 (0.083)	318E7-X0112	2.2 (0.087)
318E7-X0113	2.8 (0.109)	318E7-X0114	2.7 (0.106)

Transmission model code number	X8203	X8206	
Torque converter assembly	Stamped mark on the torque converter		
	GXA	G	
Direct clutch			
Number of drive plates	2	2	
Number of driven plates	2	2	
Clearance (mm (in))	Standard: 0 - 0.2 (0 - 0.008) Allowable limit: 0.2 (0.008)		
Drive plate thickness (mm (in))	Standard: 1.50 - 1.65 (0.0591 - 0.0650) Allowable limit: 1.4 (0.055)		
Thickness of race side	Thickness (mm (in))	Part number	
	0.4 (0.016)	31606-X8501	
	0.6 (0.024)	31606-X8502	
	0.8 (0.031)	31606-X8503	
	1.0 (0.039)	31606-X8504	
	1.2 (0.047)	31606-X8505	
Allowable limits			
Standard	1.50 - 1.65 (0.0591 - 0.0650)		
Allowable limit	1.4 (0.055)		
Thickness of retaining plate			
Part number	Thickness (mm (in))	Part number	Thickness (mm (in))
318E7-X2800	8.2 (0.323)	318E7-X2801	8.4 (0.331)
318E7-X2802	8.8 (0.348)	318E7-X2803	8.8 (0.348)
318E7-X2804	9.0 (0.354)	318E7-X2805	9.0 (0.354)
Allowable limits			
Standard	1.50 - 1.65 (0.0591 - 0.0650)		
Allowable limit	1.4 (0.055)		

SERVICE DATA AND SPECIFICATIONS (S.D.S.)

Specifications and Adjustment (Cont'd)

Transmission model code number	X8203	X8206
Front clutch (High-reverse)		
Number of drive plates	3	4
Number of driven plates	5	5
Clearance mm (in)	1.6 - 1.8 (0.063 - 0.071)	
Standard	1.6 - 1.8 (0.063 - 0.071)	
Allowable limit	2.2 (0.087)	2.4 (0.094)
Drive plate thickness mm (in)	1.50 - 1.65 (0.0591 - 0.0650)	
Standard	1.50 - 1.65 (0.0591 - 0.0650)	
Allowable limit	1.4 (0.055)	
Thickness of retaining plate	Thickness mm (in)	Part number
	5.0 (0.197)	31567-X2900
	5.2 (0.205)	31567-X2901
	5.4 (0.213)	31567-X2902
	5.6 (0.220)	31567-X2903
	5.8 (0.228)	31567-X2904
	6.0 (0.236)	31567-X2905
6.2 (0.244)	31567-X2906	
Rear clutch (Forward)		
Number of drive plates	6	6
Number of driven plates	6	6
Clearance mm (in)	0.8 - 1.0 (0.031 - 0.039)	
Standard	0.8 - 1.0 (0.031 - 0.039)	
Allowable limit	1.5 (0.059)	1.5 (0.059)
Drive plate thickness mm (in)	1.50 - 1.65 (0.0591 - 0.0650)	
Standard	1.50 - 1.65 (0.0591 - 0.0650)	
Allowable limit	1.4 (0.055)	
Thickness of retaining plate	Thickness mm (in)	Part number
	6.2 (0.244)	31567-X2906
	6.4 (0.252)	31507-X8600
	6.6 (0.260)	31507-X8601
	6.8 (0.268)	31537-X2800
	7.0 (0.276)	31537-X2801
	7.2 (0.283)	31537-X0900
	7.4 (0.291)	31537-X0901
7.6 (0.295)	31537-X0902	

Transmission model code number	X8203	X8206
Low & reverse brake		
Number of drive plates	6	8
Number of driven plates	6	8
Clearance mm (in)	0.80 - 1.05 (0.0315 - 0.0413)	
Standard	0.80 - 1.05 (0.0315 - 0.0413)	
Allowable limit	2.0 (0.079)	2.4 (0.094)
Drive plate thickness mm (in)	1.90 - 2.05 (0.0748 - 0.0807)	
Standard	1.90 - 2.05 (0.0748 - 0.0807)	
Allowable limit	1.8 (0.071)	
Thickness of retaining plate	Thickness mm (in)	Part number
	11.8 (0.465)	31667-X0300
	12.0 (0.472)	31667-X0301
	12.2 (0.480)	31667-X0302
	12.4 (0.488)	31667-X0303
	12.6 (0.496)	31667-X0304
	12.8 (0.504)	31667-X0305
Thickness of retaining plate	Thickness mm (in)	Part number
	9.8 (0.386)	31667-X2900
	10.0 (0.394)	31667-X2901
	10.2 (0.402)	31667-X2902
	10.4 (0.409)	31667-X2903
	10.6 (0.417)	31667-X2904
10.8 (0.425)	31667-X2905	
2nd brake band Piston size mm (in)		
Big dia.	72 (2.83)	80 (3.15)
Small dia.	44 (1.73)	50 (1.97)
O.D. brake band Piston size mm (in)		
Big dia.	60 (2.36)	60 (2.36)
Small dia.	40 (1.57)	40 (1.57)
Front end play mm (in)	0.5 - 0.8 (0.020 - 0.031)	
Thickness of high-reverse clutch (Front) thrust washer	Thickness mm (in)	Part number
	1.3 (0.051)	31528-X0107
	1.5 (0.059)	31528-X0105
	1.7 (0.067)	31528-X0106
	1.9 (0.075)	31528-X0100
	2.1 (0.083)	31528-X0101
	2.3 (0.091)	31528-X0102
	2.5 (0.098)	31528-X0103
2.7 (0.106)	31528-X0104	

SERVICE DATA AND SPECIFICATIONS (S.D.S.)

Specifications and Adjustment (Cont'd)

Total end play mm (in)	0.25 - 0.50 (0.0098 - 0.0197)		
Thickness of oil pump cover bearing race	Thickness mm (in)	Part number	
	1.2 (0.047)	31556-X0100	
	1.4 (0.055)	31556-X0101	
	1.6 (0.063)	31556-X0102	
	1.8 (0.071)	31556-X0103	
	2.0 (0.079)	31556-X0104	
O.D. pack end play mm (in)	0.5 - 0.8 (0.020 - 0.031)		
	Thickness mm (in)	Part number	
	1.3 (0.051)	31528-X0107	
	1.5 (0.059)	31528-X0105	
	1.7 (0.067)	31528-X0106	
	1.9 (0.075)	31528-X0100	
Thickness of O.D. thrust washer	2.1 (0.083)	31528-X0101	
	2.3 (0.091)	31528-X0102	
	2.5 (0.098)	31528-X0103	
	2.7 (0.106)	31528-X0104	
	O.D. total end play mm (in)	0.25 - 0.50 (0.0098 - 0.0197)	
	Thickness of O.D. bearing race	Thickness mm (in)	Part number
1.2 (0.047)		31603-X8600	
1.4 (0.055)		31603-X8601	
1.6 (0.063)		31603-X8602	
1.8 (0.071)		31603-X8603	
2.0 (0.079)		31603-X8604	
O.D. case	2.2 (0.087)	31603-X8605	



Oil pump clearance mm (in)	
Outer gear-pump housing	
Standard	0.05 - 0.20 (0.0020 - 0.0079)
Allowable limit	0.25 (0.0098)
Outer gear-crescent	
Standard	0.14 - 0.21 (0.0055 - 0.0083)
Allowable limit	0.25 (0.0098)
Gears-pump cover	
Standard	0.02 - 0.04 (0.0008 - 0.0016)
Allowable limit	0.08 (0.0031)
Drum support mm (in)	
Seal ring-ring groove	
Standard	0.05 - 0.20 (0.0020 - 0.0079)
Allowable limit	0.20 (0.0079)
Oil distributor mm (in)	
Seal ring-ring groove	
Standard	0.04 - 0.16 (0.0016 - 0.0063)
Allowable limit	0.16 (0.0063)
Planetary carrier mm (in)	
Clearance between pinion washer and planetary carrier	
Standard	0.20 - 0.70 (0.0079 - 0.0276)
Allowable limit	0.80 (0.0315)
Run-out of oil pump cover to housing mm (in)	Less than 0.07 (0.0028)
Run-out of drum support to O.D. case mm (in)	Less than 0.05 (0.0020)

STALL REVOLUTION

VG30E engine without turbo	2,150 - 2,450 rpm
VG30E turbo engine	2,500 - 2,800 rpm

SERVICE DATA AND SPECIFICATIONS (S.D.S.)

Tightening Torque

Unit	N-m	kg-m	ft-lb
Transmission installation			
Drive plate to Crankshaft	137 - 157	14.0 - 16.0	101 - 116
Drive plate to torque converter	39 - 49	4.0 - 5.0	29 - 36
Converter housing to engine	39 - 49	4.0 - 5.0	29 - 36
Rear mounting bracket to transmission	31 - 42	3.2 - 4.3	23 - 31
Rear mounting bracket to rear insulator	31 - 42	3.2 - 4.3	23 - 31
Rear mounting member to body	59 - 78	6.0 - 8.0	43 - 58
Component part			
Transmission case to converter housing	44 - 54	4.5 - 5.5	33 - 40
Transmission case to rear extension	20 - 25	2.0 - 2.5	14 - 18
Oil pan to transmission case	5 - 7	0.5 - 0.7	3.6 - 5.1
2nd servo piston retainer to transmission case	7 - 9	0.7 - 0.9	5.1 - 6.5
2nd piston stem (when adjusting band brake)	12 - 15*1	1.2 - 1.5*1	9 - 11*1
2nd piston stem lock nut	15 - 39	1.5 - 4.0	11 - 29
One-way clutch inner race to transmission case	13 - 18	1.3 - 1.8	9 - 13
Control valve body to transmission case	5.4 - 7.4	0.55 - 0.75	4.0 - 5.4
Lower valve body to upper valve body	2.5 - 3.4	0.25 - 0.35	1.8 - 2.5
O.D. servo piston retainer to O.D. case	10 - 15	1.0 - 1.5	7 - 11
O.D. piston stem (when adjusting band brake)	7 - 10*2	0.7 - 1.0*2	5.1 - 7.2*2
O.D. piston stem lock nut	15 - 39	1.5 - 4.0	11 - 29
Side plate to control valve body	2.5 - 3.4	0.25 - 0.35	1.8 - 2.5
Nut for control valve reamer bolt	5 - 7	0.5 - 0.7	3.6 - 5.1
Oil strainer to lower valve body	3 - 4	0.3 - 0.4	2.2 - 2.9
Governor valve body to oil distributor	5 - 7	0.5 - 0.7	3.6 - 5.1
Oil pump housing to oil pump cover	6 - 8	0.6 - 0.8	4.3 - 5.8
Inhibitor switch to transmission case	5 - 7	0.5 - 0.7	3.6 - 5.1

Unit	N-m	kg-m	ft-lb
Manual shaft lock nut	29 - 39	3.0 - 4.0	22 - 29
Oil cooler pipe to transmission case	29 - 49	3.0 - 5.0	22 - 36
Test plug (oil pressure inspection hole)	14 - 21	1.4 - 2.1	10 - 15
Support actuator (parking rod inserting position) to rear extension	8 - 11	0.8 - 1.1	5.8 - 8.0
Drum support to O.D. case	7 - 9	0.7 - 0.9	5.1 - 6.5

*1 Turn back three turns after tightening.









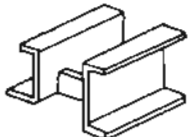

*2 Turn back two turns after tightening.

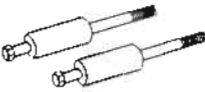
Part number	Thickness (mm)	Part number	Thickness (mm)
31803-X800	1.2 (0.047)	31803-X801	1.4 (0.055)
31803-X801	1.4 (0.055)	31803-X802	1.8 (0.083)
31803-X802	1.8 (0.083)	31803-X803	1.8 (0.071)
31803-X803	1.8 (0.071)	31803-X804	2.0 (0.079)
31803-X804	2.0 (0.079)	31803-X805	2.2 (0.087)

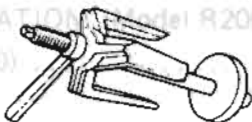
Part number	Thickness (mm)	Part number	Thickness (mm)
31803-X806	2.2 (0.087)	31803-X807	2.2 (0.087)
31803-X807	2.2 (0.087)	31803-X808	2.2 (0.087)
31803-X808	2.2 (0.087)	31803-X809	2.2 (0.087)
31803-X809	2.2 (0.087)	31803-X810	2.2 (0.087)
31803-X810	2.2 (0.087)	31803-X811	2.2 (0.087)
31803-X811	2.2 (0.087)	31803-X812	2.2 (0.087)
31803-X812	2.2 (0.087)	31803-X813	2.2 (0.087)
31803-X813	2.2 (0.087)	31803-X814	2.2 (0.087)
31803-X814	2.2 (0.087)	31803-X815	2.2 (0.087)
31803-X815	2.2 (0.087)	31803-X816	2.2 (0.087)
31803-X816	2.2 (0.087)	31803-X817	2.2 (0.087)
31803-X817	2.2 (0.087)	31803-X818	2.2 (0.087)
31803-X818	2.2 (0.087)	31803-X819	2.2 (0.087)
31803-X819	2.2 (0.087)	31803-X820	2.2 (0.087)
31803-X820	2.2 (0.087)	31803-X821	2.2 (0.087)
31803-X821	2.2 (0.087)	31803-X822	2.2 (0.087)
31803-X822	2.2 (0.087)	31803-X823	2.2 (0.087)
31803-X823	2.2 (0.087)	31803-X824	2.2 (0.087)
31803-X824	2.2 (0.087)	31803-X825	2.2 (0.087)
31803-X825	2.2 (0.087)	31803-X826	2.2 (0.087)
31803-X826	2.2 (0.087)	31803-X827	2.2 (0.087)
31803-X827	2.2 (0.087)	31803-X828	2.2 (0.087)
31803-X828	2.2 (0.087)	31803-X829	2.2 (0.087)
31803-X829	2.2 (0.087)	31803-X830	2.2 (0.087)
31803-X830	2.2 (0.087)	31803-X831	2.2 (0.087)
31803-X831	2.2 (0.087)	31803-X832	2.2 (0.087)
31803-X832	2.2 (0.087)	31803-X833	2.2 (0.087)
31803-X833	2.2 (0.087)	31803-X834	2.2 (0.087)
31803-X834	2.2 (0.087)	31803-X835	2.2 (0.087)
31803-X835	2.2 (0.087)	31803-X836	2.2 (0.087)
31803-X836	2.2 (0.087)	31803-X837	2.2 (0.087)
31803-X837	2.2 (0.087)	31803-X838	2.2 (0.087)
31803-X838	2.2 (0.087)	31803-X839	2.2 (0.087)
31803-X839	2.2 (0.087)	31803-X840	2.2 (0.087)
31803-X840	2.2 (0.087)	31803-X841	2.2 (0.087)
31803-X841	2.2 (0.087)	31803-X842	2.2 (0.087)
31803-X842	2.2 (0.087)	31803-X843	2.2 (0.087)
31803-X843	2.2 (0.087)	31803-X844	2.2 (0.087)
31803-X844	2.2 (0.087)	31803-X845	2.2 (0.087)
31803-X845	2.2 (0.087)	31803-X846	2.2 (0.087)
31803-X846	2.2 (0.087)	31803-X847	2.2 (0.087)
31803-X847	2.2 (0.087)	31803-X848	2.2 (0.087)
31803-X848	2.2 (0.087)	31803-X849	2.2 (0.087)
31803-X849	2.2 (0.087)	31803-X850	2.2 (0.087)

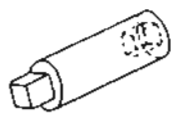
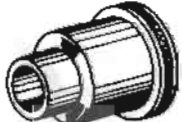
SPECIAL SERVICE TOOLS

PROPELLER SHAFT &
DIFFERENTIAL CARRIER

Tool number (Kent-Moore No.) Tool name	Tool	Tool number (Kent-Moore No.) Tool name	Tool
ST07870000 (J34308, J3289-20) Transmission case stand		(J34291) Shim setting gauge set	
ST25850000 (J25721-A) Sliding hammer			
GG91060000 (-) (GG93010000) (J25703) Torque wrench			
ST25420001 (J26063) (ST25420000) (J26063-A) Clutch spring compressor			
ST25570001 (J23659-A) (ST25570000) (J23659-1) Hex-head extension			
ST25490000 (-) (ST25512001) (-) Socket extension			
ST25580001 (-) Oil pump assembling gauge			
ST2505S001 (-) Oil pressure gauge set			
KV319K0010 (J34270) Diagnostic sub-harness			
(J33909) Transmission alignment arbor			

CONTENTS

PROPELLER SHAFT
DIFFERENTIAL CARRIER
SERVICE TOOLS
AND INSTALLATION (Model R200)
SLIP DIFFERENTIAL (Model R200)
AND SPECIFICATIONS (S.D.S.)

PD- 3
PD- 4
PD- 5
PD- 7
PD- 8
PD-12
PD-14
PD-24
PD-30
PD-36
PD-41

PD