

PROPELLER SHAFT & DIFFERENTIAL CARRIER

SECTION PD

Put match marks on flanges and separate propeller shaft from differential carrier.

Inspect propeller shaft for damage. If the propeller shaft assembly exceeds specific limits, replace the propeller shaft assembly.

CONTENTS

| | |
|--|-------|
| PROPELLER SHAFT | PD- 2 |
| FINAL DRIVE (Model R200) | PD- 4 |
| ON-VEHICLE SERVICE (Model R200) | PD- 5 |
| REMOVAL AND INSTALLATION (Model R200) | PD- 7 |
| DISASSEMBLY (Model R200) | PD- 8 |
| INSPECTION (Model R200) | PD-13 |
| ADJUSTMENT (Model R200) | PD-14 |
| ASSEMBLY (Model R200) | PD-24 |
| LIMITED SLIP DIFFERENTIAL (Model R200) | PD-30 |
| SERVICE DATA AND SPECIFICATIONS (S.D.S.) | PD-38 |
| SPECIAL SERVICE TOOLS | PD-41 |

PD

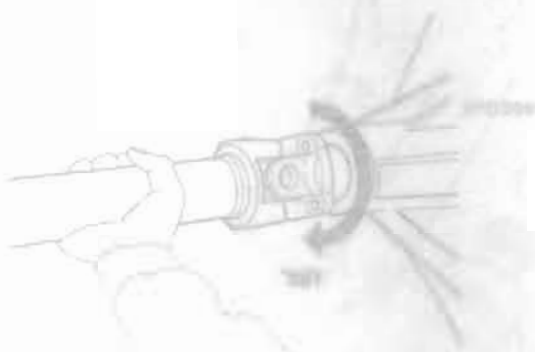

- Inspect propeller shaft tube surface for dents or cracks.
- If damaged, replace propeller shaft assembly.
- If center bearing is noisy or damaged, replace center bearing.

PROPELLER SHAFT VIBRATION

To check and correct an unbalanced propeller shaft, proceed as follows:

1. Remove undercoating and other foreign material which could upset shaft balance, and check shaft vibration by road test.
2. If shaft vibration is noted during road test, disconnect propeller shaft at differential carrier companion flange, rotate companion flange 180 degrees and reconnect propeller shaft.

Again check shaft vibration. If vibration still persists, replace propeller shaft assembly.

PROPELLER SHAFT

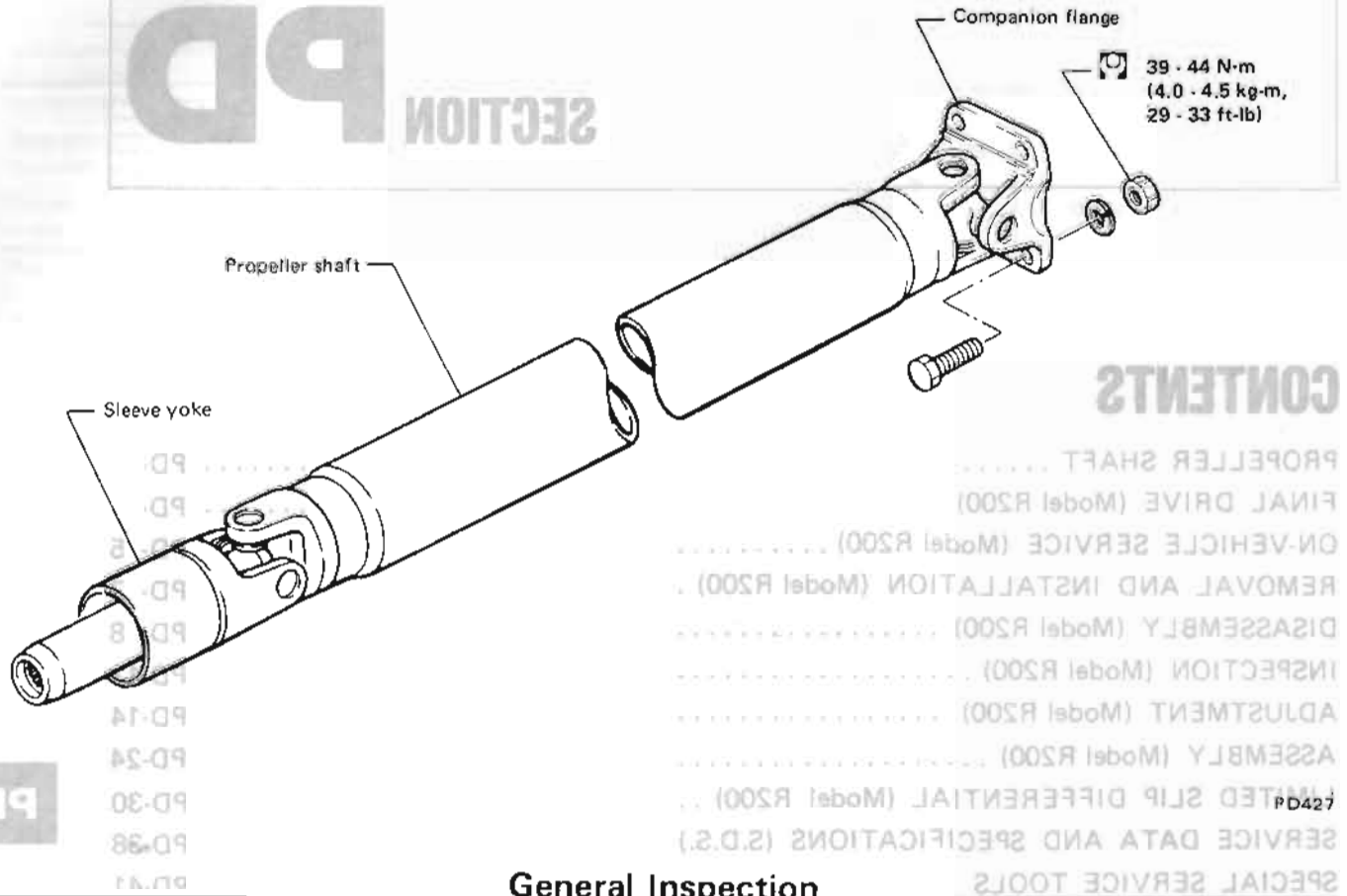

CONTENTS

| | |
|--|-------|
| PROPELLER SHAFT | PD-2 |
| FINAL DRIVE (Model R200) | PD-3 |
| ON-VEHICLE SERVICE (Model R200) | PD-4 |
| REMOVAL AND INSTALLATION (Model R200) | PD-5 |
| DISASSEMBLY (Model R200) | PD-6 |
| INSPECTION (Model R200) | PD-7 |
| ADJUSTMENT (Model R200) | PD-8 |
| ASSEMBLY (Model R200) | PD-9 |
| LIMITED SLIP DIFFERENTIAL (Model R200) | PD-10 |
| SERVICE DATA AND SPECIFICATIONS (S.D.S.) | PD-11 |
| SPECIAL SERVICE TOOLS | PD-12 |

General Inspection

- Inspect propeller shaft tube surface for dents or cracks.
If damaged, replace propeller shaft assembly.
- If center bearing is noisy or damaged, replace center bearing.

PROPELLER SHAFT VIBRATION

To check and correct an unbalanced propeller shaft, proceed as follows:

1. Remove undercoating and other foreign material which could upset shaft balance, and check shaft vibration by road test.
2. If shaft vibration is noted during road test, disconnect propeller shaft at differential carrier companion flange, rotate companion flange 180 degrees and reconnect propeller shaft.

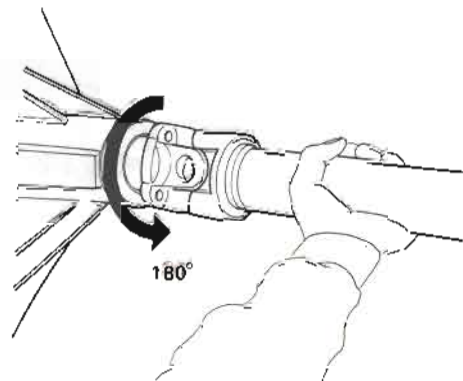

SPD102

3. Again check shaft vibration. If vibration still persists, replace propeller shaft assembly.

ON-V00 PROPELLER SHAFT

Removal and Installation Inspection

- Put match marks on flanges and separate propeller shaft from differential carrier.

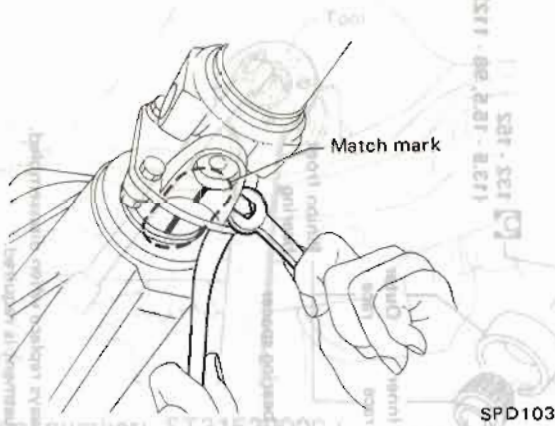

- Draw out propeller shaft from transmission and plug up rear end of transmission rear extension housing.

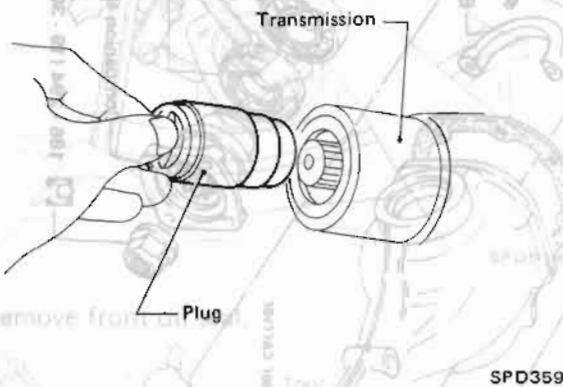

- Inspect propeller shaft runout. If runout exceeds specifications, replace propeller shaft assembly.

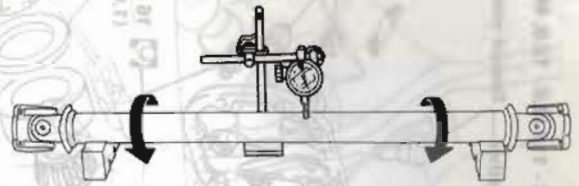

Runout limit: 0.6 mm (0.024 in)

- Inspect journal axial play. If the play exceeds specifications, replace propeller shaft assembly.

Journal axial play:
0 mm (0 in)

FINAL DRIVE (Model R200)

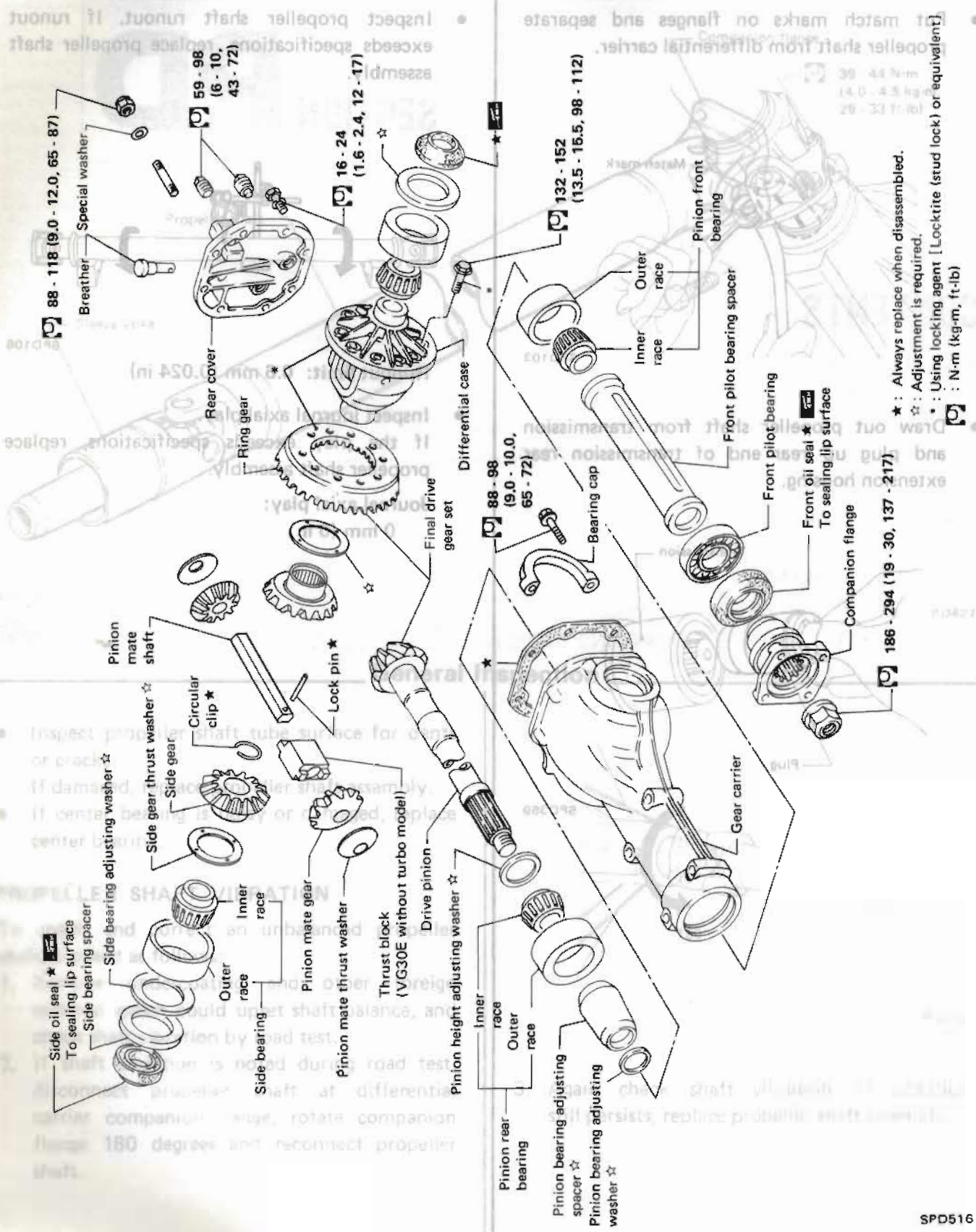

- ★ : Always replace when disassembled.
- ☆ : Adjustment is required.
- : Using locking agent [Locktite (stud lock) or equivalent].
- Ⓜ : N·m (kg·m, ft·lb)

REAR ON-VEHICLE SERVICE (Model R200) (200)

Front Oil Seal Replacement

1. Remove propeller shaft.
2. Loosen drive pinion nut.

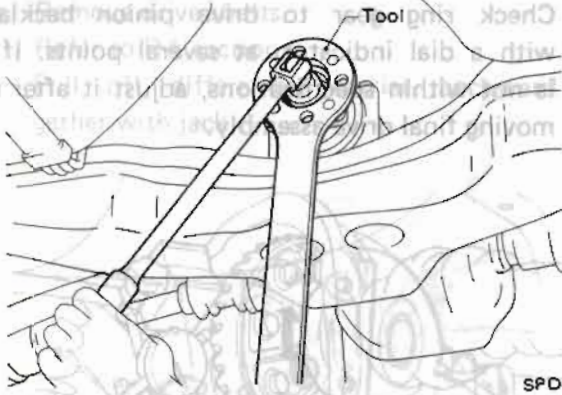

SPD517

Tool number: ST31520000 (-)

3. Remove companion flange.

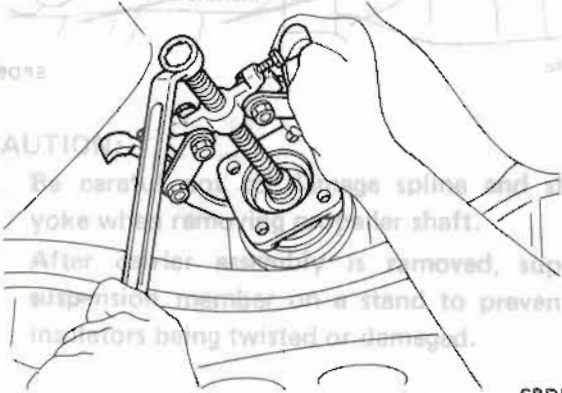

SPD518

4. Remove front oil seal.

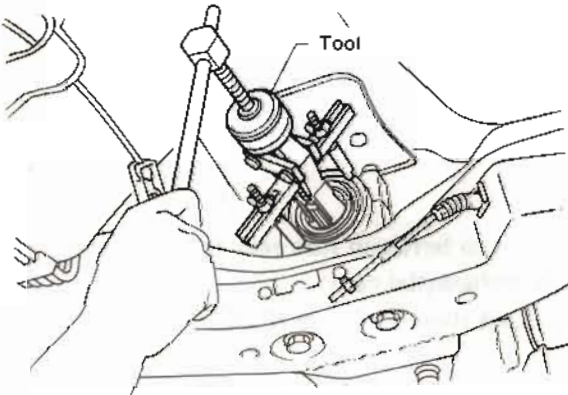

SPD519

Tool number: ST33290001 (J25810-A)

5. Apply multi-purpose grease to cavity at sealing lips of oil seal.
Press front oil seal into carrier.

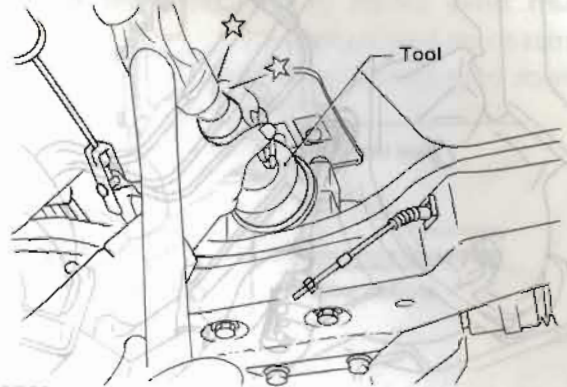

SPD520

Tool number: KV38100500 (-)

6. Install companion flange and drive pinion nut.
7. Install propeller shaft.



SPD521

Tool number: KV38100500 (-)

Install drive shafts.

ON-VEHICLE SERVICE (Model R200)

Side Oil Seal Replacement Ring Gear to Drive Pinion Backlash

1. Remove drive shafts.
Refer to section RA.
2. Remove oil seal.

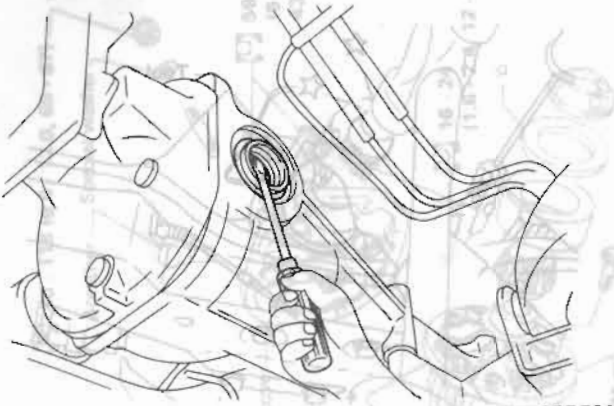

SPD521

3. Apply multi-purpose grease to cavity at sealing lips of oil seal.
Press-fit oil seal into carrier.

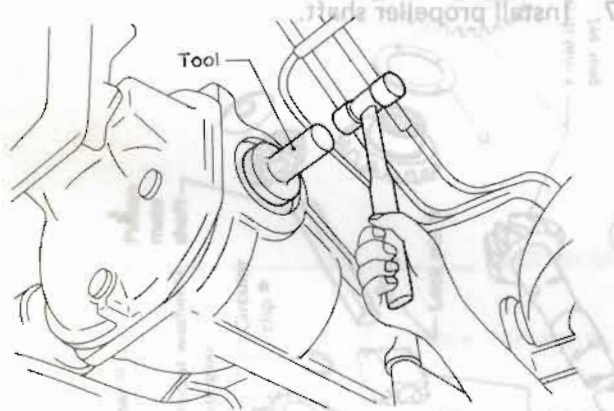

SPD522

Tool number: KV38100200 (-)

4. Install drive shafts.

1. Support carrier with a jack.
2. Remove rear cover.
3. Check ring gear to drive pinion backlash with a dial indicator, at several points. If it is not within specifications, adjust it after removing final drive assembly.

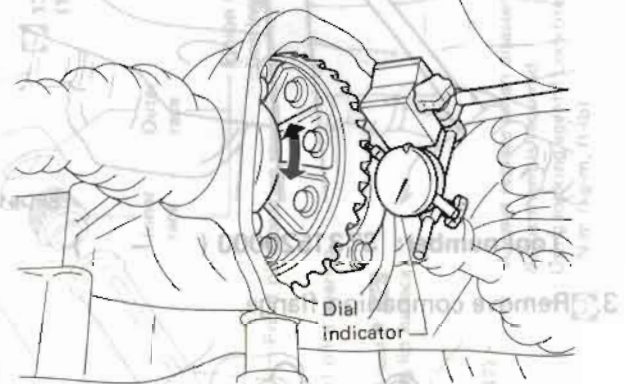

SPD523

REMOVAL AND INSTALLATION (Model R200)

Removal

- Remove propeller shaft.
Refer to Propeller Shaft.
- Remove drive shafts.
Refer to RA section.
- Pull off differential carrier backward together with jack.

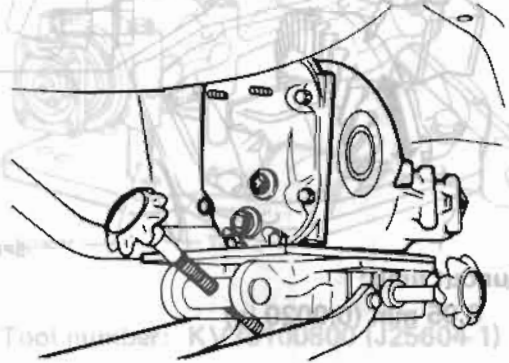

CAUTION:

- Be careful not to damage spline and sleeve yoke when removing propeller shaft.
- After carrier assembly is removed, support suspension member on a stand to prevent its insulators being twisted or damaged.

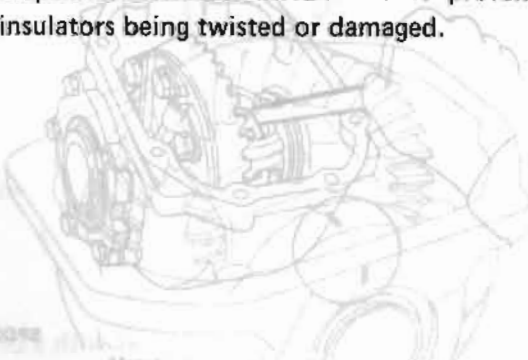

Clearance between side gear thrust washer and differential case:
Less than 0.15 mm (0.008 in)

Installation

- Full final drive with recommended gear oil.
Refer to section GI.

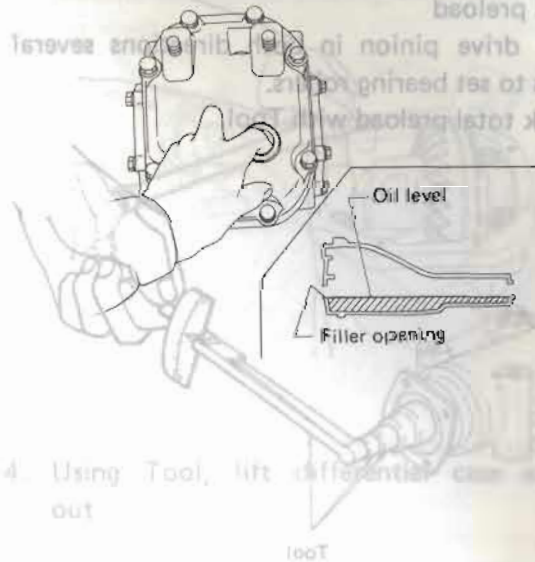

4. Using Tool, lift differential carrier out.

Tool number: ST125000 (See 125785-A.)

Total preload:
1.33 - 2.30 N·m
(12.5 - 23.2 kg·cm, 10.9 - 20.4 in·lb)

- Ring gear to drive pinion backlash.
Check backlash of ring gear with a dial indicator at several points.

Tool number: HT720000 ()

Be careful to keep the bearing outer races together with inner races when mixing them up.



Ring gear-to-drive pinion backlash:
0.13 - 0.18 mm
(0.0051 - 0.0071 in)

DISASSEMBLY (Model R200)

Pre-inspection

Before disassembling final drive, perform the following inspection.

- Total preload
 - 1) Turn drive pinion in both directions several times to set bearing rollers.
 - 2) Check total preload with Tool.

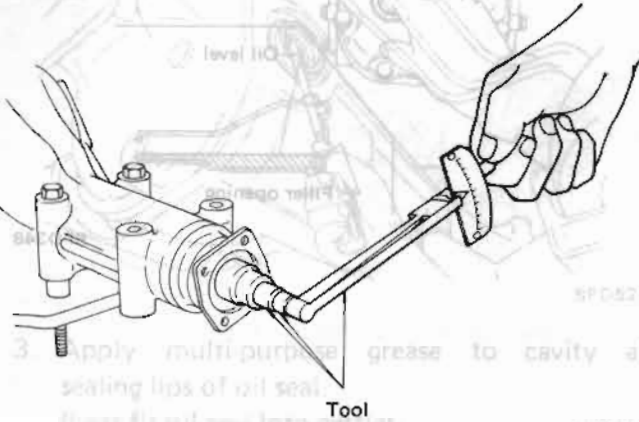

PD245

Tool number: ST3127S000 (See J25765-A.)

Total preload:

1.23 - 2.30 N·m

(12.5 - 23.5 kg-cm, 10.9 - 20.4 in-lb)

- Ring gear to drive pinion backlash.
Check backlash of ring gear with a dial indicator at several points.

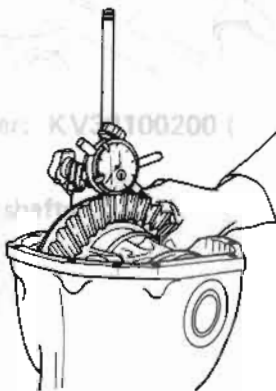

SPD513

Ring gear-to-drive pinion backlash:

0.13 - 0.18 mm

(0.0051 - 0.0071 in)

- Ring gear runout
 - 2) Check runout of ring gear with a dial indicator.

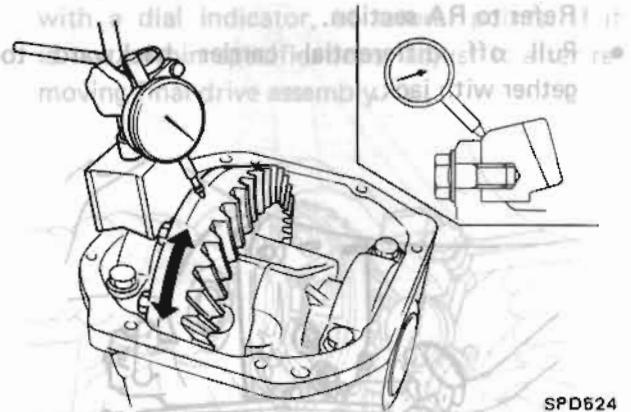

SPD524

Runout limit:

0.05 mm (0.0020 in)

- Tooth contact
Check tooth contact, referring to Adjustment.
- Side gear to pinion mate gear backlash
Measure clearance between side gear thrust washer and differential case with thickness gauge.

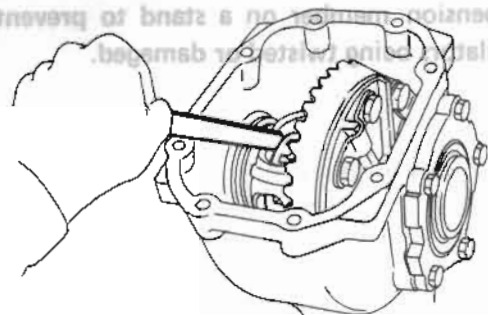

SPD370

Clearance between side gear thrust washer and differential case:

Less than 0.15 mm (0.0059 in)

DISASSEMBLY (Model R200)

Differential Carrier

1. Using three spacers [45 mm (1.77 in)], mount carrier on Tool.

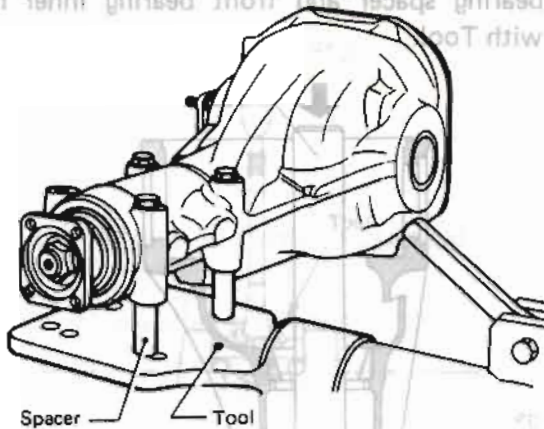

SPD525

Tool number: KV38100800 (J25604-1)

2. Put match marks on one side of side bearing cap and gear carrier with paint or punch to ensure that it is replaced in proper position during reassembly.

Bearing caps are line-board during manufacture and should be put back in their original places.

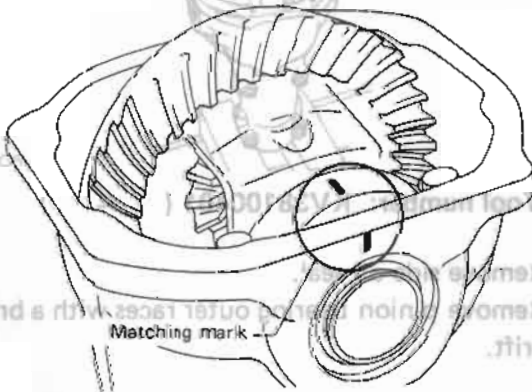

SPD526

3. Remove side bearing caps.

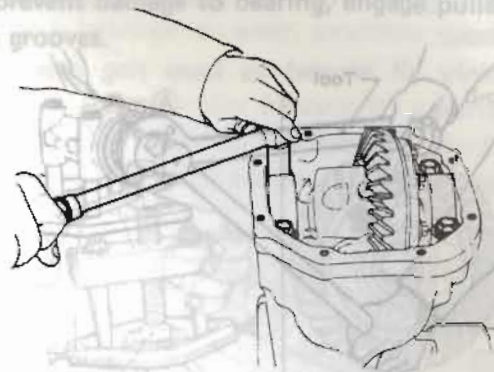

PD343

4. Using Tool, lift differential case assembly out.

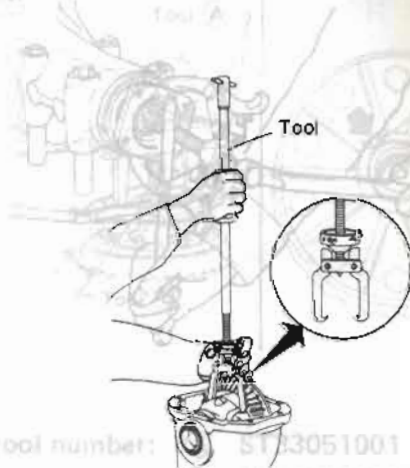

PD344

Tool number: HT72400000 (-)

Be careful to keep the side bearing outer races together with inner race — do not mix them up.

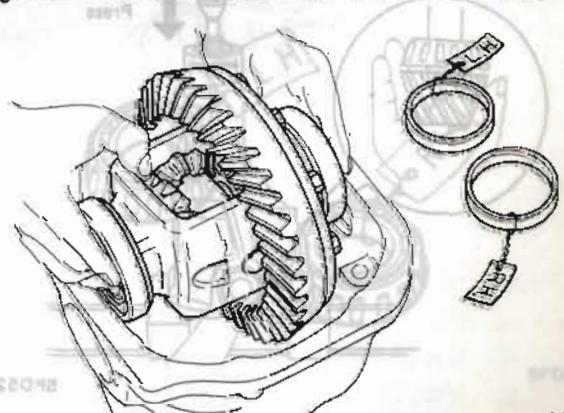

SPD527

DISASSEMBLY (Model R200)

Differential Carrier (Cont'd)

5. Loosen drive pinion nut and pull off companion flange.

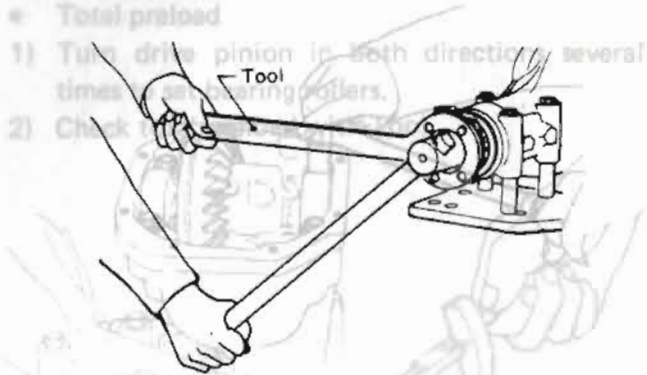

PD345

Tool number: ST31520000 (-)

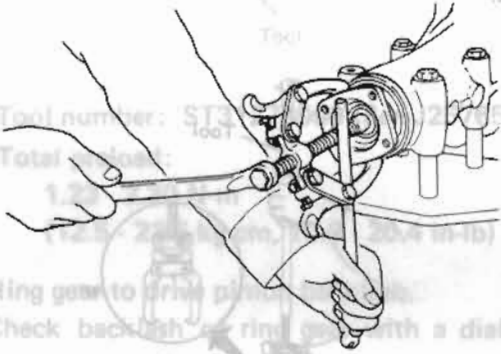

PD346

6. Take out drive pinion together with rear bearing inner race, bearing spacer and adjusting washer.

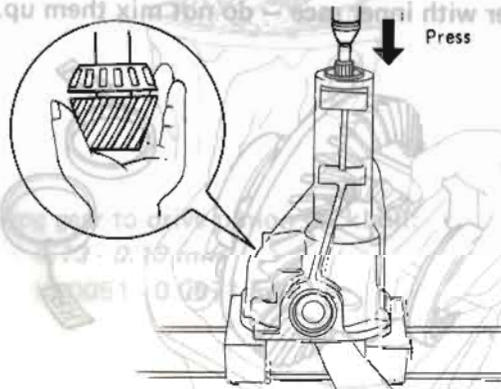

SPD528

7. Remove oil seal.
8. Remove pilot bearing together with pilot bearing spacer and front bearing inner race with Tool.

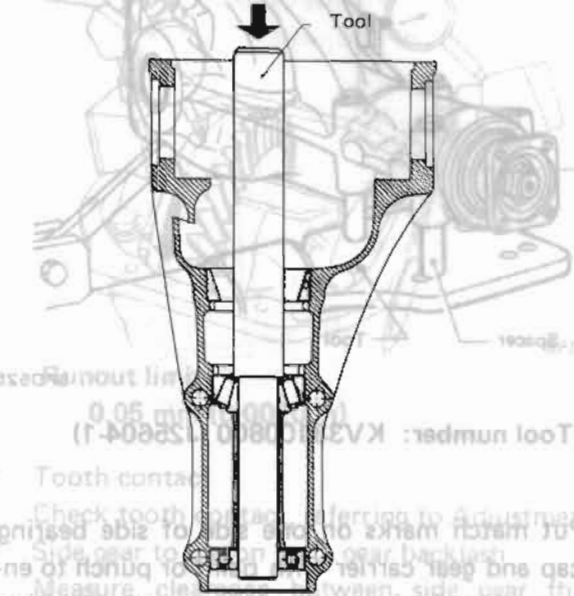

PD348

Tool number: KV38100401 (-)

9. Remove side oil seal.
10. Remove pinion bearing outer races with a brass drift.

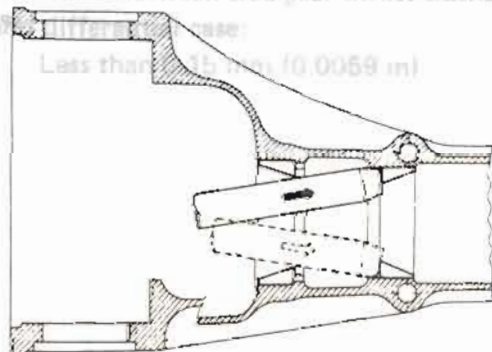

PD349

DISASSEMBLY (Model R200)

Differential Carrier (Cont'd)

11. Remove pinion rear bearing inner race and pinion height adjusting washer.



Differential Case Assembly

Check mating surfaces of differential case, side gears, pinion mate, pinion mate shaft, thrust block and thrust washers.

PD179

Tool number: ST30031000 (J22912-01)

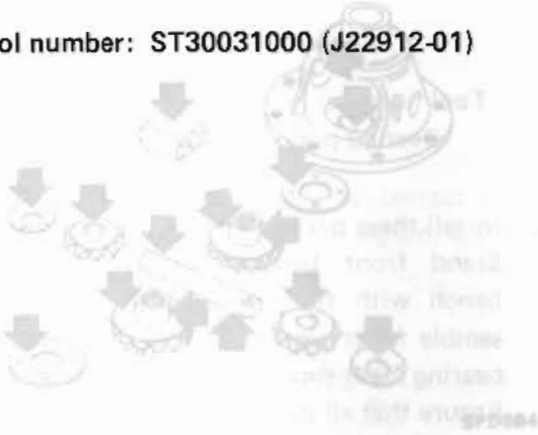

Differential Case

1. Remove side bearing inner races.

To prevent damage to bearing, engage puller paws with grooves.

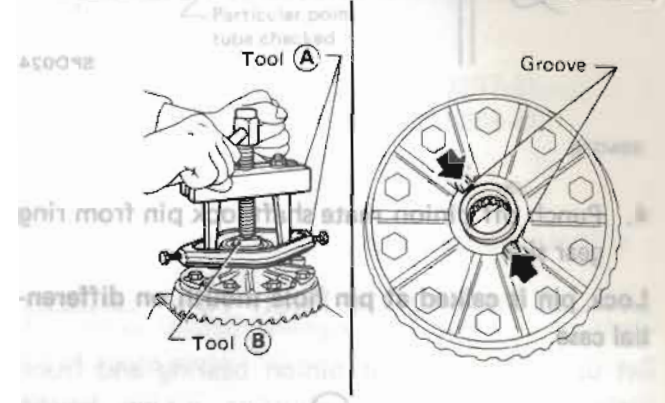
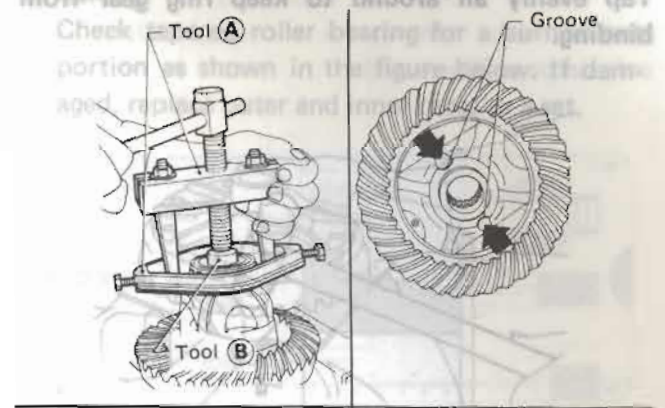

SPD529

Tool number: (A) ST33051001 (-)
(B) ST33061000 (J8107-2)

Be careful not to confuse the right and left hand parts.

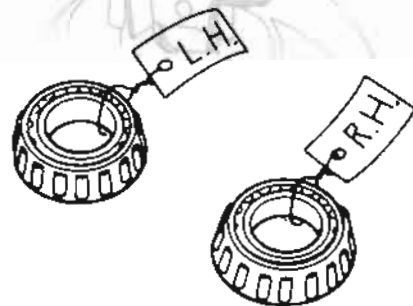

SPD022

DISASSEMBLY (Model R200)

Differential Case (Cont'd)

2. Loosen ring gear bolts in a criss-cross fashion.
 3. Tap ring gear off the gear case with a soft hammer.
- Tap evenly all around to keep ring gear from binding.

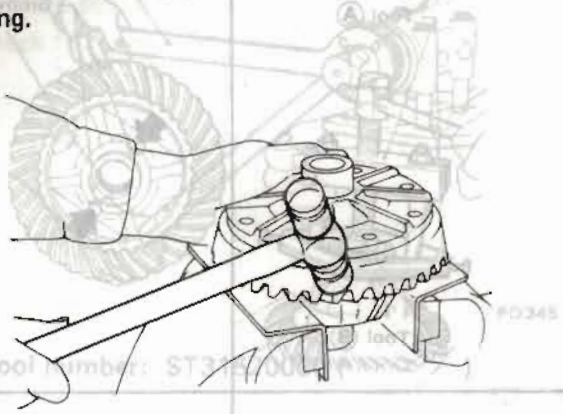

SPD024

4. Punch off pinion mate shaft lock pin from ring gear side.
- Lock pin is calked at pin hole mouth on differential case.

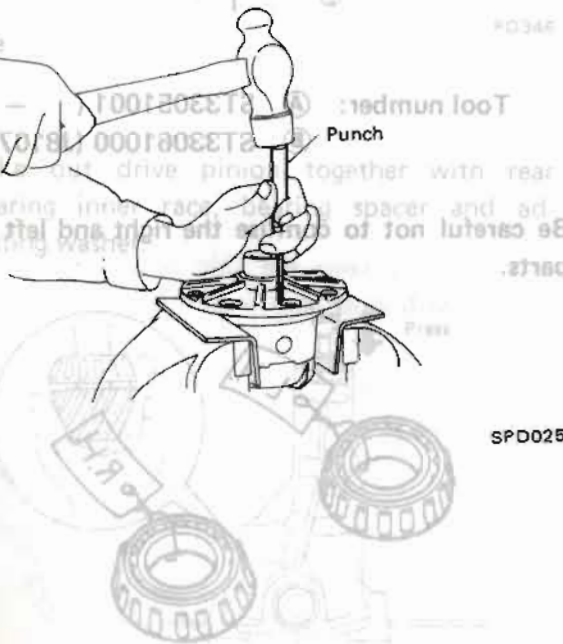

SPD025

7. Remove pinion test bearing inner race and pilot bearing together with the pilot pinion bearing.
8. Remove pilot bearing spacer and front bearing inner race with Tool.



Tool number: ST30081000 (022912-01)



Tool number: KV38100401

9. Remove side oil seal.
10. Remove pilot bearing spacer and front bearing inner race with Tool.

INSPECTION (Model R200)

Ring Gear and Drive Pinion

Check gear teeth for scoring, cracking or chipping. If any damaged part is evident, replace ring gear and drive pinion as a set (hypoid gear set).

Ensure that all parts turn freely and are properly aligned.

Differential Case Assembly

Check mating surfaces of differential case, side gears, pinion mate gears, pinion mate shaft, thrust block and thrust washers.

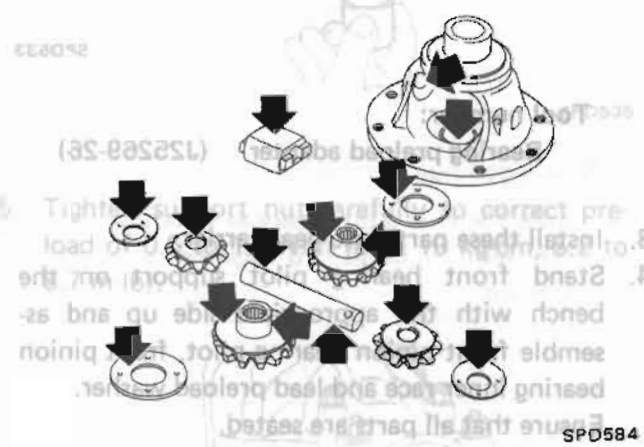

SPD584

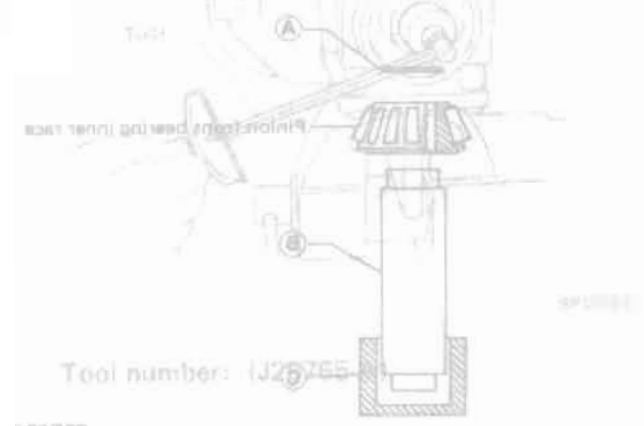

- Tool number: (J25265-2)
- ① Lead preload washer (J25265-2)
 - ② Front pinion bearing pilot (J25265-3)
 - ③ Front bearing pilot support (J25265-2)

Bearing

1. Thoroughly clean bearing and dry with compressed air.
2. Check bearings for wear, scratches, pitching or flaking.
3. Check tapered roller bearing for a burned out portion as shown in the figure below. If damaged, replace outer and inner races as a set.

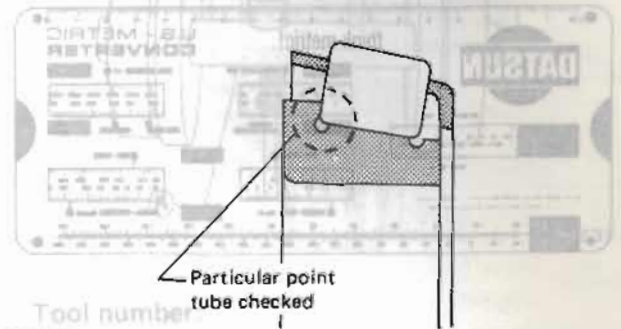

- Tool number: (J23597-1)
- A Arbor assembly (J23597-1)
 - B Side bearing disc (J25269-4)

SPD458

2. Place side bearing discs with arbor assembly into differential carrier.
- Setting Up Each Tool**
- Set up each tool, rear pinion bearing and front pinion bearing before adjusting pinion height and drive pinion bearing preload.
1. Install rear pinion bearing pilot into gauge plate and slide over hex head pilot.

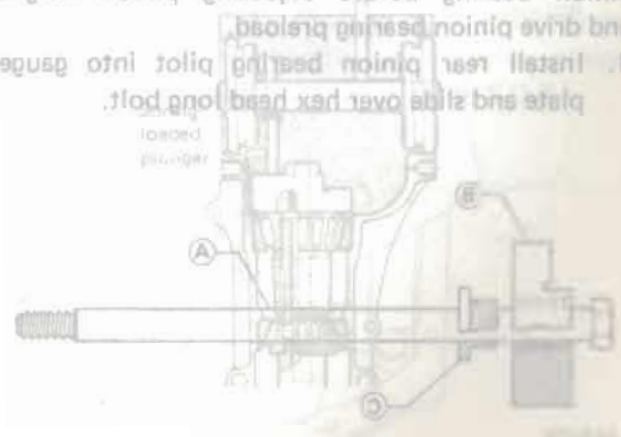

- Tool number: (J25269-4)
- ① Hex head long bolt (J25269-3)
 - ② Gauge plate (J25269-1)
 - ③ Rear pinion bearing pilot (J25269-2)

ADJUSTMENT (Model R200)

To avoid any confusion while calculating bearing shims, it is absolutely necessary to stay with the metric system. If you measure anything in inches, the results **MUST** be converted to the metric system. You can use a conversion chart or a calculator as illustrated.

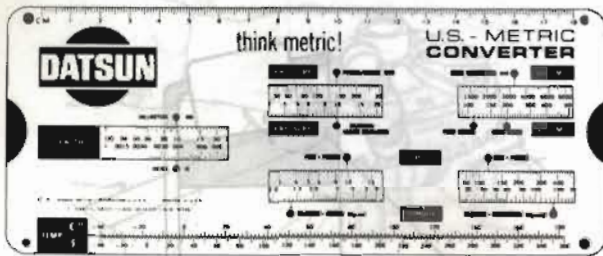

SPD531

82625

1. Punch off pinion mate shaft lock pin from ring gear side.

Setting Up Each Tool

Set up each tool, rear pinion bearing and front pinion bearing before adjusting pinion height and drive pinion bearing preload.

1. Install rear pinion bearing pilot into gauge plate and slide over hex head long bolt.

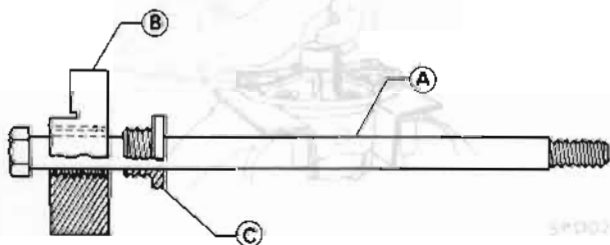

SPD532

Tool number:

- Ⓐ Hex head long bolt (J25269-23)
- Ⓑ Gauge plate (J25269-1)
- Ⓒ Rear pinion bearing pilot (J25269-2)

2. Slide pinion rear bearing inner race, bearing preload adapter and pinion bearing adjusting spacer over hex head long bolt.

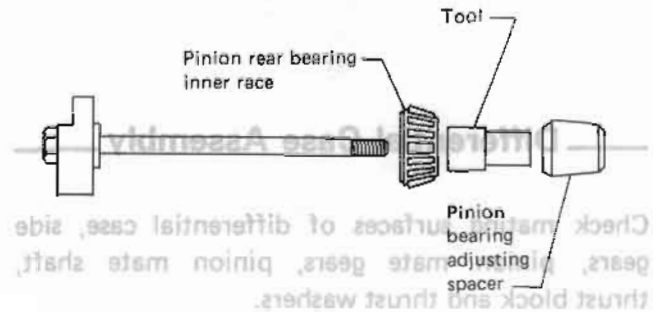

SPD533

Tool number:

Bearing preload adapter (J25269-26)

3. Install these parts into gear carrier.
 4. Stand front bearing pilot support on the bench with the appropriate side up and assemble front pinion bearing pilot, front pinion bearing inner race and lead preload washer.
- Ensure that all parts are seated.

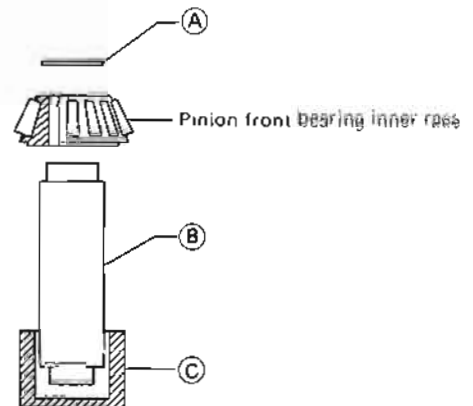

SPD534

Tool number:

- Ⓐ Lead preload washer (J25269-25)
- Ⓑ Front pinion bearing pilot (J25269-3)
- Ⓒ Front bearing pilot support (J25269-29)

ADJUSTMENT (Model R200)

Setting Up Each Tool (Cont'd)

5. Holding these parts together, slide the assembly over hex head long bolt into gear carrier. Install support nut. Finger-tighten the nut and ensure that all parts turn freely and are properly aligned.

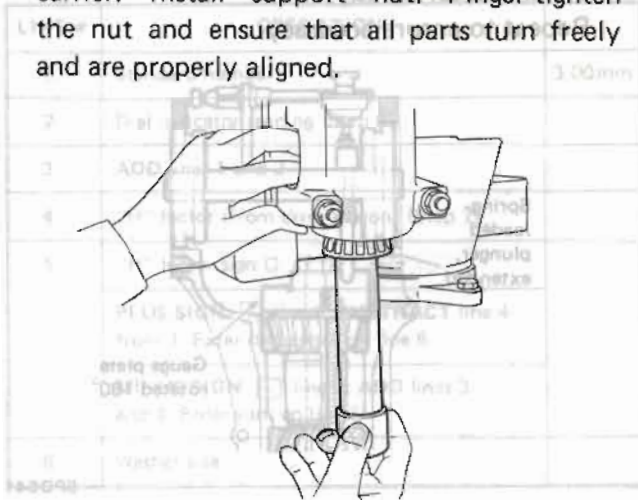

SPD535

6. Tighten support nut carefully to correct pre-load of 0.6 to 1.0 N·m (6 to 10 kg·cm, 5.2 to 8.7 in·lb).

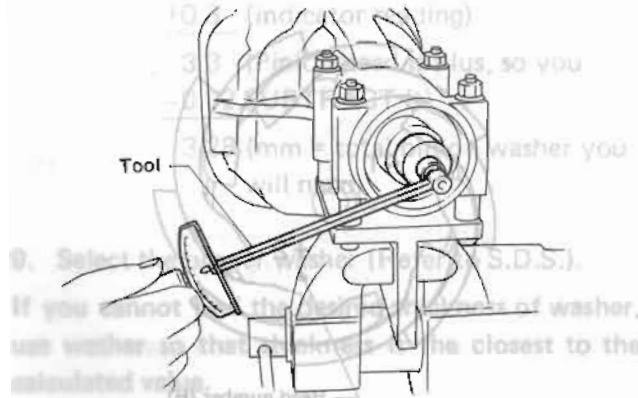

SPD536

Tool number: (J25765-A)

The correct washer is 3.27 mm
(Part number 38154 P0023).

Drive Pinion Height

1. Install two side bearing discs with arbor assembly. Ensure that arbor turns freely.

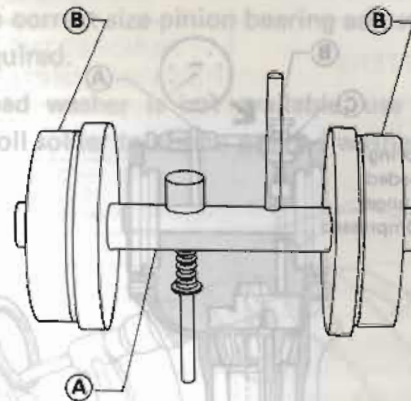

SPD537

Tool number:

(A) Arbor assembly (J23597-1)

(B) Side bearing disc (J25269-4)

2. Place side bearing discs with arbor assembly into differential carrier.

Lift spring loaded plunger and place it on the face of gauge plate.

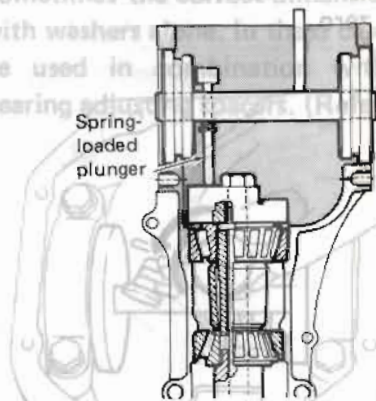

SPD538

ADJUSTMENT (Model R200)

Drive Pinion Height (Cont'd)

3. Install bearing caps.
4. Install dial indicator and tighten hold down clamp.

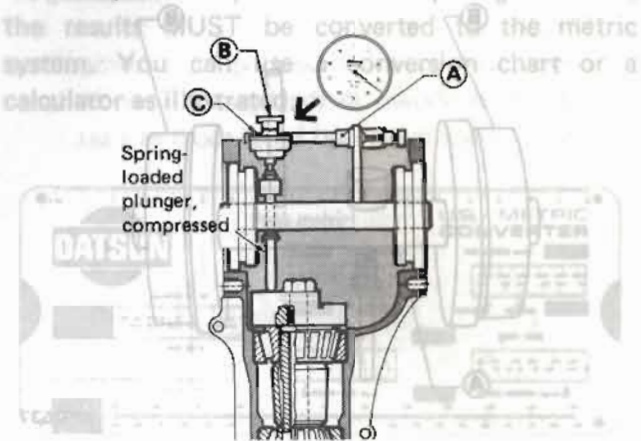

SPD539

Tool number:

- (A) Hold down clamp (J8001-1)
- (B) Dial indicator clamp (J8001-2)
- (C) Dial indicator (J8001-6)

5. To zero dial indicator, rotate arbor and plunger back and forth and note highest deflection (the point where needle changes direction). Set dial indicator at zero.

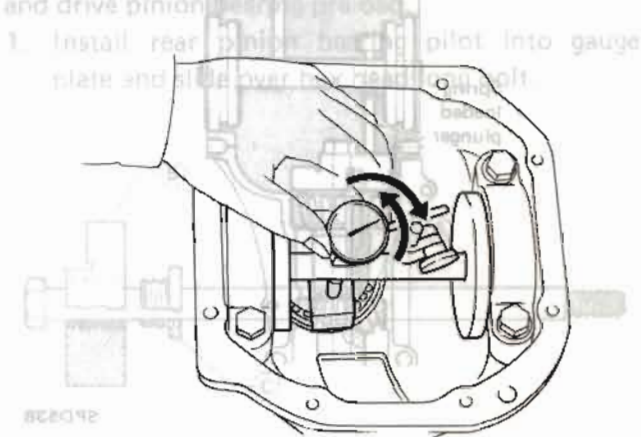

SPD540

Tool number

- (A) Hex head long bolt (J25269-23)
- (B) Gauge plate (J25269-1)
- (C) Rear pinion bearing pilot (J25269-2)

6. Rotate gauge plate until the plunger falls off gauge plate and read dial indicator (Read the dial indicator directly). Repeat to ensure accuracy.

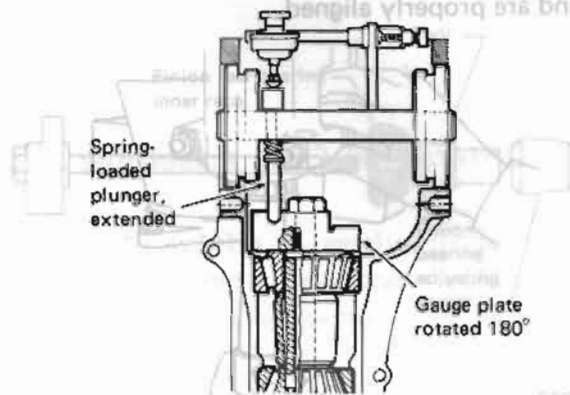

SPD541

7. Read head number (H) on drive pinion head.

The figure for H is a dimensional variation in units of 0.01 mm (0.0004 in) against a standard measurement.

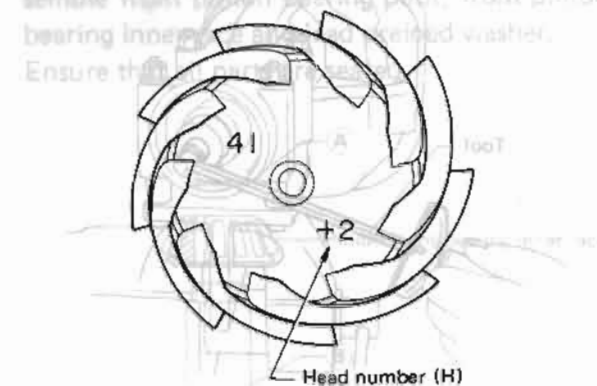

SPD542

SPD542

Tool number:

- (A) Lead preload washer (J25269-25)
- (B) Front pinion bearing pilot (J25289-3)
- (C) Front bearing pilot support (J25269-29)

ADJUSTMENT (Model R200)

Drive Pinion Height (Cont'd)

Drive Pinion Preload

8. Calculate washer thickness following the chart below.

| LINE # | OPERATION | |
|--------|--|--------|
| 1. | Standard number | 3.00mm |
| 2. | Dial indicator reading (Step 6) | |
| 3. | ADD lines 1 and 2 | |
| 4. | "H" factor (from drive pinion) (Step 7) | |
| 5. | "H" factor sign <input type="checkbox"/> | |
| | PLUS SIGN <input checked="" type="checkbox"/> line 5; SUBTRACT line 4 from 3. Enter difference on line 6 | |
| | MINUS SIGN <input type="checkbox"/> line 5; ADD lines 3 and 4. Enter sum on line 6 | |
| 6. | Washer size | |

Example: Dial Indicator Reading: 0.3 mm

Number on Pinion Head: +2

3.00 (standard measure)
+0.3 (indicator reading)

3.3 (Pinion head is plus, so you
-0.02 SUBTRACT it)

3.28 (mm = total pinion washer you
will need)

9. Select the proper washer (Refer to S.D.S.).

If you cannot find the desired thickness of washer, use washer so that thickness is the closest to the calculated value.

Example:

3.28 mm. (Calculated total pinion washer
in step 8)

The correct washer is 3.27 mm
(Part number 38154 P6023).

1. To determine pinion bearing preload, disassemble pinion height/bearing preload tools and measure thickness of lead washer. This is the correct size pinion bearing adjusting washer required.

If a lead washer is not available, use a piece of thick roll solder to obtain preload washer size.

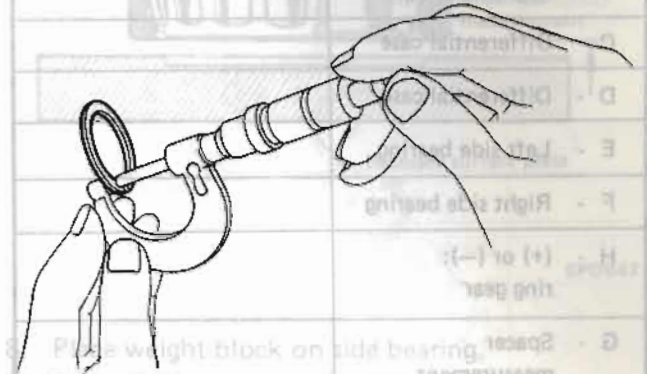

SPD543

2. Select the proper washer (Refer to S.D.S.).

- If you cannot find shims with the desired thickness, use shims so that the total thickness is the closest to the calculated value.
- Sometimes the correct dimension cannot be set with washers alone. In these cases, washers may be used in combination with drive pinion bearing adjusting spacers. (Refer to S.D.S.)

ADJUSTMENT (Model R200)

Side Bearing Preload

1. To simplify the job, make a chart, like the one below, to organize your calculations.

| LETTERS | HUNDREDTHS OF A MILLIMETER |
|------------------------------|----------------------------|
| A - Left housing | |
| B - Right housing | |
| C - Differential case | |
| D - Differential case | |
| E - Left side bearing | |
| F - Right side bearing | |
| H - (+) or (-): ring gear | |
| G - Spacer: measurement | |

2. Write the following numbers down in the chart.

A & B: Figures marked on gear carrier

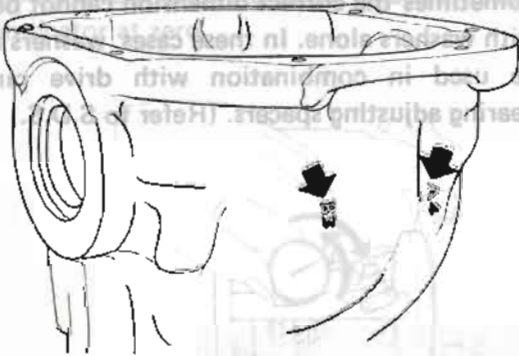

PD358

C & D: Figures marked on differential case



H: Figures marked on ring gear

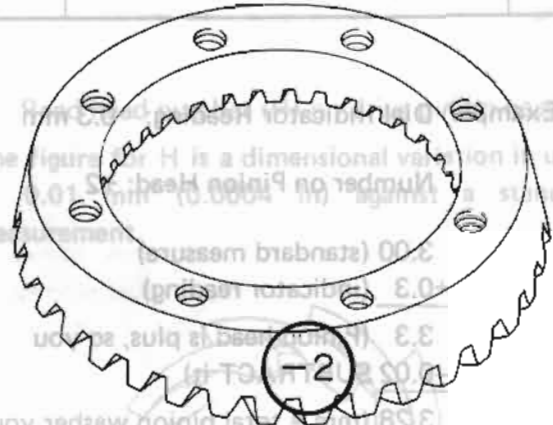

SPD576

G: This is the difference in thickness of side spacer against standard width

[8.10 mm (0.3189 in)]

(G = Standard spacer - Measured spacer)

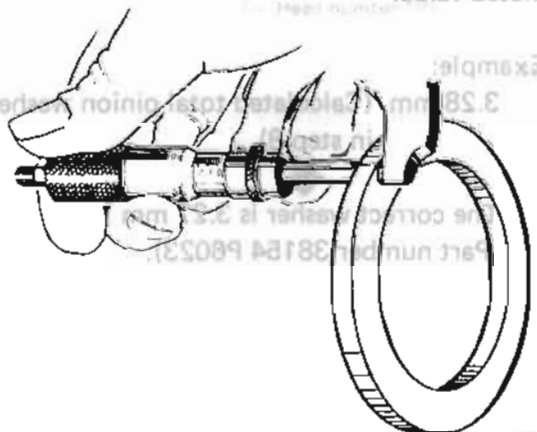

SPD544

ADJUSTMENT (Model R200)

Side Bearing Preload (Cont'd)

3. Measure how far under the standard thickness [21 mm (0.83 in)] the side bearings are. It will require the tools shown below.

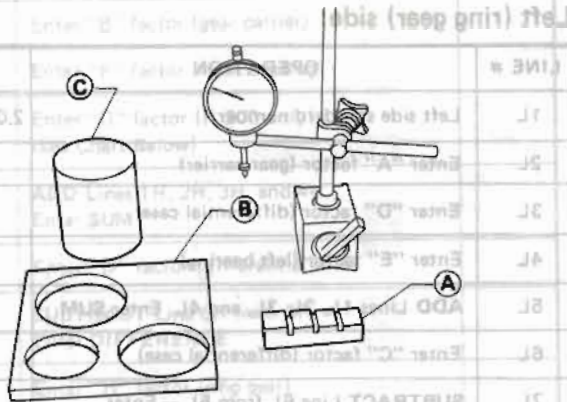

Tool number:

- (A) 4-step gauge block (J25407-1)
- (B) Base plate (J25407-2)
- (C) Weight block (J25407-3)

4. Set weight block, 4-step gauge block [21 mm (0.83 in)] and dial indicator on base plate.
5. Adjust dial indicator scale to zero.

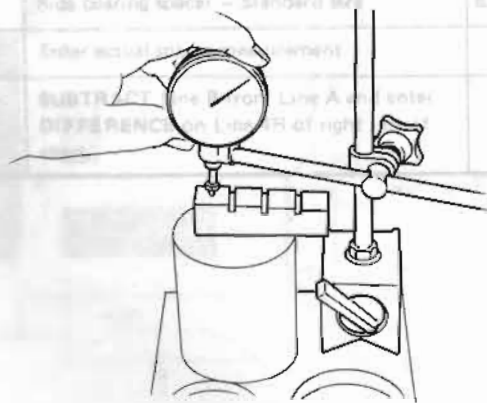

SPD546

6. Carefully slide 4-step gauge block and weight block out from under dial indicator.
7. Lubricate side bearing and place side bearing on base plate.

Make sure that base plate has a recess in it and that bearing will turn freely when positioned over the recess as shown.

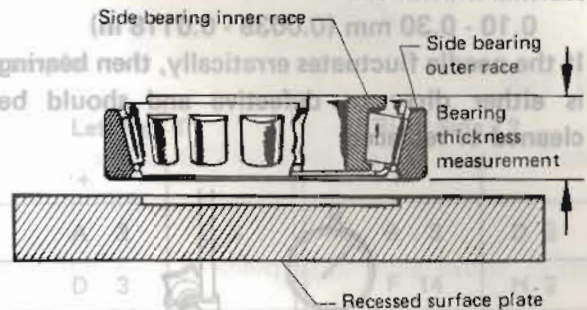

SPD547

8. Place weight block on side bearing.
9. Slide dial indicator on weight block.

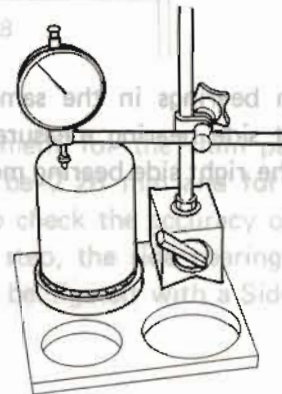

SPD548

ADJUSTMENT (Model R200)

Side Bearing Preload (Cont'd)

10. Turn weight block a few times to ensure that bearing is properly seated.
11. Read dial indicator.

- Normal indication: 0.10 - 0.30 mm (0.0039 - 0.0118 in)
- If the needle fluctuates erratically, then bearing is either dirty or defective and should be cleaned or replaced.

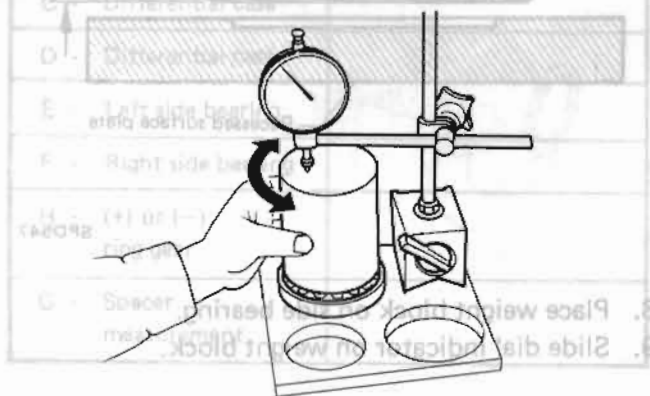

SPD549

12. Measure both bearings in the same way and write the left side bearing measurement next to "E" and the right side bearing measurement next to "F".



SPD548

0754

13. Calculate washer thickness following the charts below.

Left (ring gear) side:

| LINE # | OPERATION | |
|--------|---|---------|
| 1L | Left side standard number | 2.05 mm |
| 2L | Enter "A" factor (gear carrier) | |
| 3L | Enter "D" factor (differential case) | |
| 4L | Enter "E" factor (left bearing) | |
| 5L | ADD Lines 1L, 2L, 3L, and 4L. Enter SUM | |
| 6L | Enter "C" factor (differential case) | |
| 7L | SUBTRACT Line 6L from 5L - Enter DIFFERENCE | |
| 8L | Enter "H" factor (ring gear) | |
| 9L | Enter "H" factor's sign <input type="checkbox"/> PLUS SIGN + Line 9L; SUBTRACT Line 8L from 7L. Enter difference on Line 10L. | |
| | MINUS SIGN - Line 9L; ADD Lines 7L and 8L. Enter sum on Line 10L | |
| 10L | Left side shim size "T," | |

- G. This is the difference in thickness of side spacer minus standard width (8.16 mm to 8.18 mm) (G = Standard spacer - Measured spacer)



- H. Carefully slide 4-step gauge and weight block out from under dial indicator.
- I. Lubricate side bearing and place bearing on case plate.

SPD547

ADJUSTMENT (Model R200)

Side Bearing Preload (Cont'd)

Right side:

| LINE # | OPERATION | |
|--------|---|---------|
| 1R | Right side standard number | 1.95 mm |
| 2R | Enter "B" factor (gear carrier) | |
| 3R | Enter "F" factor (right bearing) | |
| 4R | Enter "G" factor (R 200 only) (See Chart Below) | |
| 5R | ADD Lines 1R, 2R, 3R, and 4R. Enter SUM | |
| 6R | Enter "D" factor (differential case) | |
| 7R | SUBTRACT Line 6R from 5R. - Enter DIFFERENCE | |
| 8R | Enter "H" factor (ring gear) | |
| 9R | Enter "H" factor's sign <input type="checkbox"/> | |
| | PLUS SIGN + Line 9R; ADD Lines 7R and 8R. Enter sum on Line 10R. | |
| | MINUS SIGN - Line 9R; SUBTRACT Line 8R from 7R. Enter difference on line 10R. | |
| 10R | Right side shim size "T ₂ " | |

The formulas are as follows:

$$T_1 = A - C + D + E - H + 2.05 \text{ (mm)}$$

$$T_2 = B - D + F + G + H + 1.95 \text{ (mm)}$$

Example:

| Left Side T1 | | Right Side T2 | |
|-------------------|-----|-------------------|-----|
| + | - | + | - |
| A 3 | C 3 | B 3 | D 3 |
| D 3 | | F 14 | H 2 |
| E 18 | | G 7 | |
| H 2 | | std. shim 1.95 | |
| std. shim 2.05 | | 2.19 | 5 |
| 2.31 | 3 | -5 | |
| -3 | | | |
| 2.28 | | 2.14 | |

The measurement for the shim pack on the left (T1) should be 2.28 mm and for the right (T2) 2.14 mm. To check the accuracy of your work in the previous step, the side bearing shim measurement should be figured with a Side Bearing Shim Calculator.

| G FACTOR CALCULATION R200 ONLY | | |
|--------------------------------|---|---------|
| A. | Side bearing spacer - Standard size | 8.10 mm |
| B. | Enter actual spacer measurement | |
| C. | SUBTRACT Line B from Line A and enter DIFFERENCE on Line 4R of right side of chart. | |



Step 3. Move slide 3 to place F (4 in line with H.5 (red-scale-for-right-side)).

Step 4. Read answer at right side arrow 2.14mm or closer to .088 in.

14. Compare these answers with the answers on the previous page. If both answers agree, proceed to the next step.

15. Select the proper washer (Refer to S.D.S.).

If you cannot find the desired thickness of washer, use washer so that thickness is the closest to the calculated value.

ADJUSTMENT (Model R200)

Side Bearing Preload (Cont'd)

Follow the instructions for the sample given below:

EXAMPLE CALCULATOR

Left Side

- Step 1. Move slide 1 to place C 3 in line with an arrow.
- Step 2. Move slide 2 to place D 3 in line with C 3.
- Step 3. Move slide 3 to place E 18 in line with H -2.
- Step 4. Read answer at left side arrow, 2.28mm or close to .087 in.

Right Side

- Step 1. Move slide 1 to place B 3 in line with an arrow.
- Step 2. Move slide 2 to place G 7 in line with D 3.
- Step 3. Move slide 3 to place F 14 in line with H 2 (red scale for right side).
- Step 4. Read answer at right side arrow 2.14mm or closer to .086 in.

14. Compare these answers with the answers on the previous page. If both answers agree, proceed to the next step.

15. Select the proper washer (Refer to S.D.S.).

If you cannot find the desired thickness of washer, use washer so that thickness is the closest to the calculated value.

13. Calculate washer thickness following the instructions below:

Diagram illustrating the Left Side adjustment process on a slide rule calculator. The calculator shows the following settings:

- Slide 1: C 3
- Slide 2: D 3
- Slide 3: E 18
- Left side arrow: 2.28

The result is 2.28 mm or close to .087 in.

Diagram illustrating the Right Side adjustment process on a slide rule calculator. The calculator shows the following settings:

- Slide 1: B 3
- Slide 2: G 7
- Slide 3: F 14
- Right side arrow: 2.14

The result is 2.14 mm or closer to .086 in.

ADJUSTMENT (Model R200)

Tooth Contact

Gear tooth contact pattern check is necessary to verify correct relationship between ring gear and drive pinion.

Hypoid gear set which are not positioned properly may be noisy, or have short life or both. With a pattern check, the most desirable contact for low noise level and long life can be assured.

1. Thoroughly clean ring gear and drive pinion teeth.
2. Sparingly apply a mixture of powdered ferric oxide and oil or equivalent to 3 or 4 teeth of ring gear drive side.

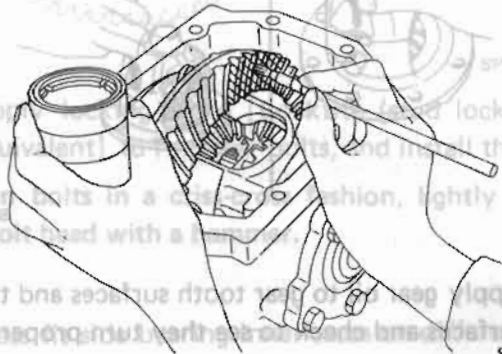

3. Hold companion flange steady by hand and rotate the ring gear in both directions.

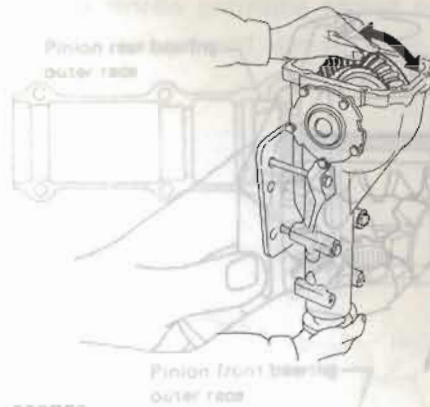

Usually the pattern will be correct if you have calculated the shims correctly and the backlash is correct.

However, in extremely rare cases you will have to use trial-and-error processes until you get a good tooth contact pattern.

The tooth pattern is the best indication of how well a differential has been set up.

Heel contact

Face contact



To correct, increase thickness of pinion height adjusting washer in order to bring drive pinion close to ring gear.



Toe contact

Flank contact



To correct, reduce thickness of pinion height adjusting washer in order to make drive pinion go away from ring gear.



Correct tooth contact

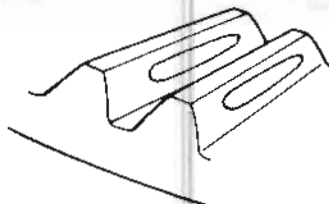

- Tool number:
- Ⓐ KV38100300 (J25523)
 - Ⓑ ST33081000 (J8107-2)

(ASSEMBLY (Model R200))

Side Differential Case

1. Install side gears, pinion mate gears, thrust washers and thrust block into differential case.

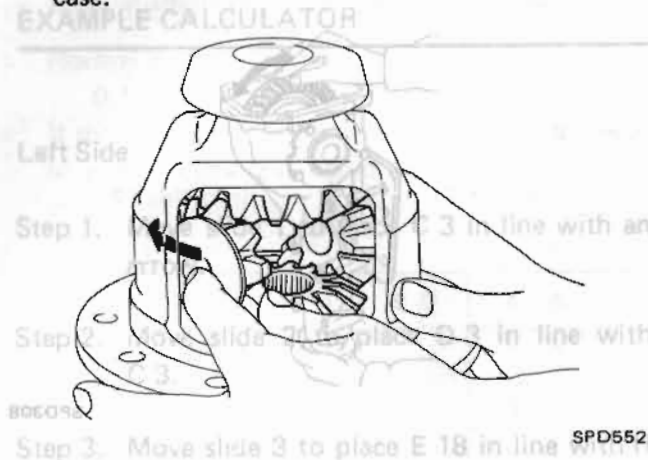

2. Fit pinion mate shaft to differential case so that it meets lock pin holes.

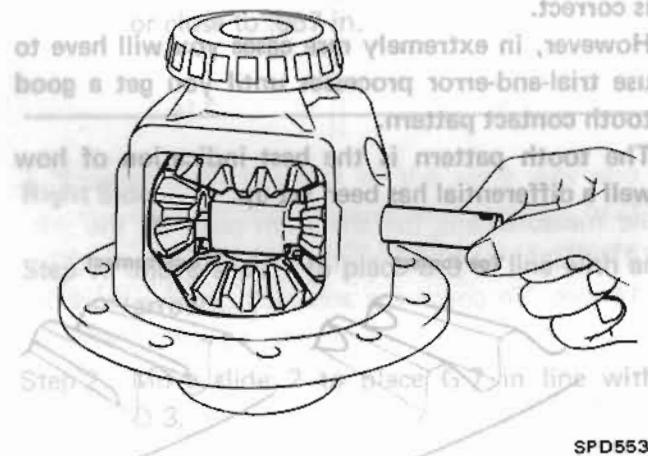

3. Adjust clearance between rear face of side gear and thrust washer by selecting side gear thrust washer (Refer to S.D.S.).

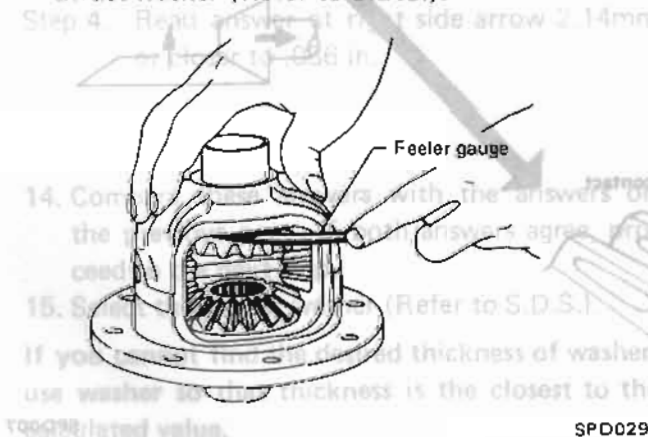

4. Install pinion mate shaft lock pin with a punch. Make sure lock pin is flush with case.

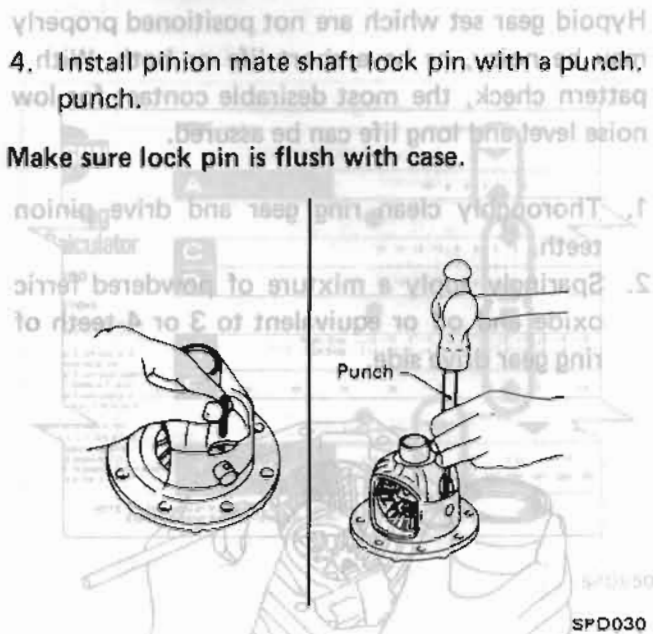

5. Apply gear oil to gear tooth surfaces and thrust surfaces and check to see they turn properly.

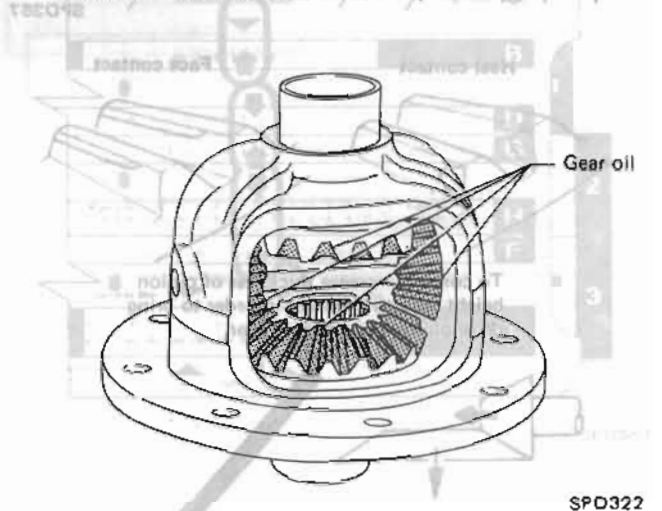

ASSEMBLY (Model R200)

Differential Case (Cont'd)

6. Apply locking agent [Locktite (stud lock) or equivalent] to contacting surfaces of ring gear and differential case, then place differential case on ring gear.

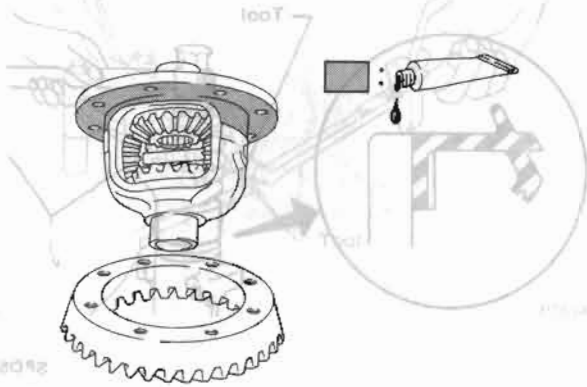

7. Apply locking agent [Locktite (stud lock) or equivalent] to ring gear bolts, and install them.

Tighten bolts in a criss-cross fashion, lightly tapping bolt head with a hammer.

8. Press fit side bearing inner races on differential case with Tool.



Tool number:

- (A) KV38100300 (J25523)
- (B) ST33061000 (J8107-2)

Differential Carrier

1. Press-fit front and rear bearing outer races with Tools.

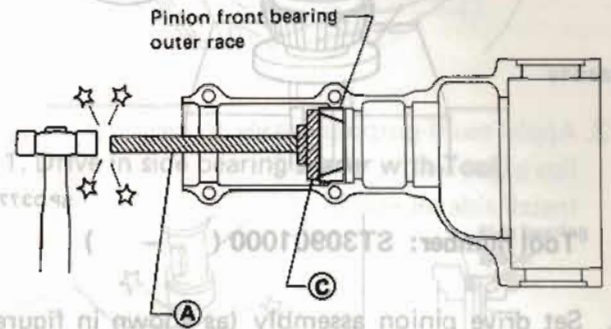
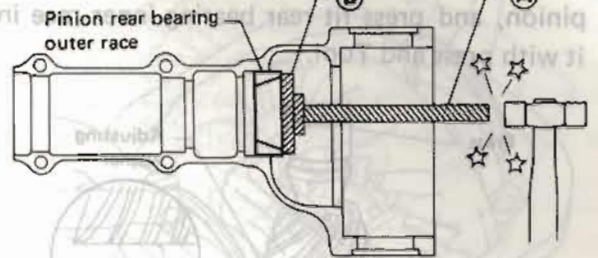

Tool number:

- (A) ST30611000 (J25742-1)
- (B) ST30621000 (-)
- (C) ST30613000 (J25742-3)

ASSEMBLY (Model R200)

Differential Carrier (Cont'd)

2. Select pinion height adjusting washer and pinion bearing adjusting washer spacer, referring to Adjustment.
3. Install pinion height adjusting washer in drive pinion, and press fit rear bearing inner race in it with press and Tool.

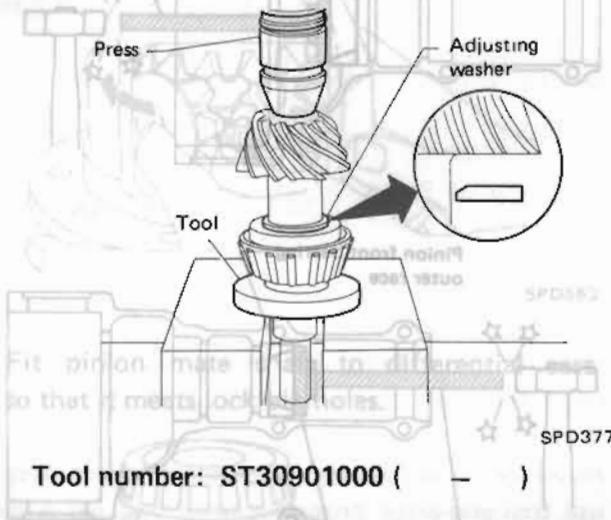

4. Set drive pinion assembly (as shown in figure below) in differential carrier and install drive pinion with press and suitable tool.

Stop when drive pinion touches bearing.

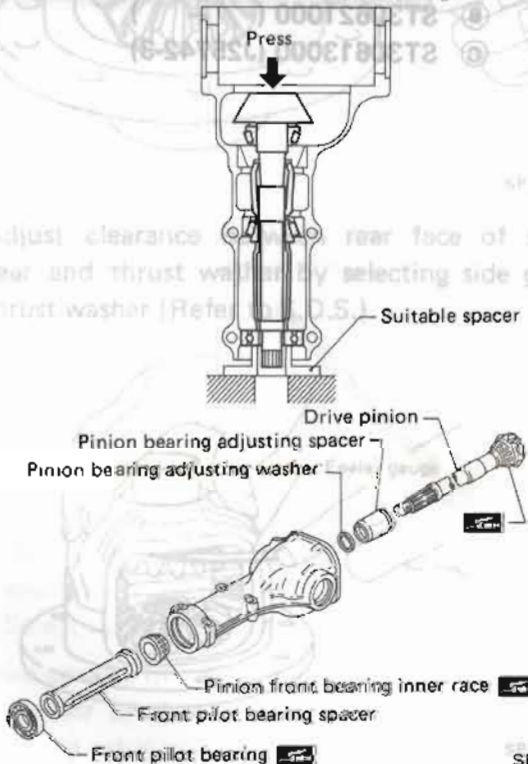

5. Apply multi-purpose grease to cavity at sealing lips of oil seal. Install front oil seal.

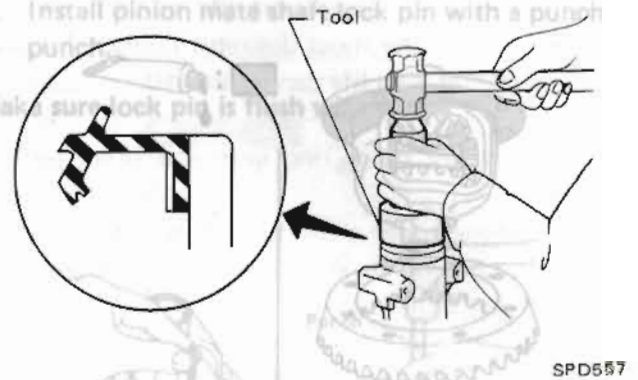

6. Install companion flange, and tighten pinion nut to specified torque.

Ascertain that threaded portion of drive pinion and pinion nut are free from oil or grease.

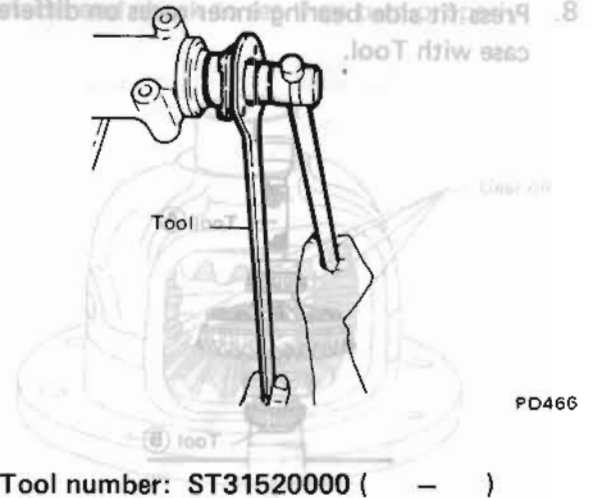

ASSEMBLY (Model R200)

Differential Carrier (Cont'd)

7. Turn drive pinion in both directions several times, and measure drive pinion preload.

If preload is too small, remove the same amount of shim to each side.

Never add or remove a different number of shims for each side as it will change the drive pinion backset.

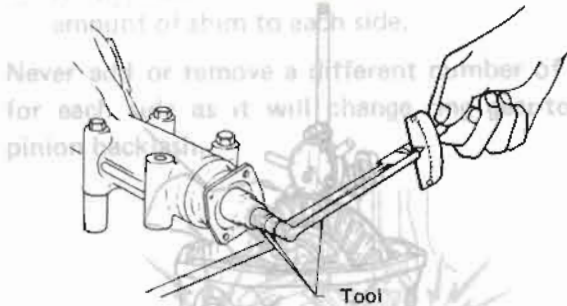

PD340

Tool number:

ST3127S000 (See J25765-A.)

Drive pinion preload (With front oil seal):

1.1 - 1.4 N·m

(11 - 14 kg·cm, 9.5 - 12.2 in·lb)

When drive pinion preload is outside the specifications, replace pinion bearing adjusting washer and spacer with a different thickness.

8. Select side bearing adjusting washer.
Refer to Adjustment.
9. Install differential case assembly with side bearing outer races into gear carrier.

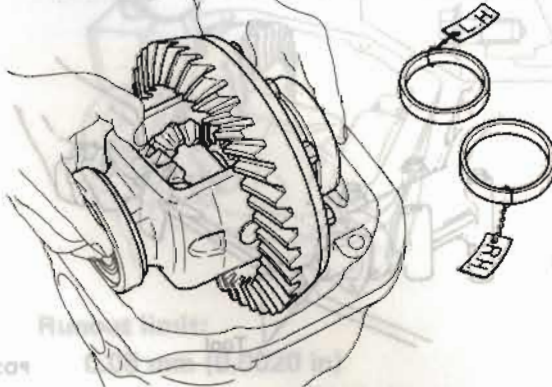

SPD527

10. Insert left and right side bearing adjusting washers in place between side bearings and carrier.

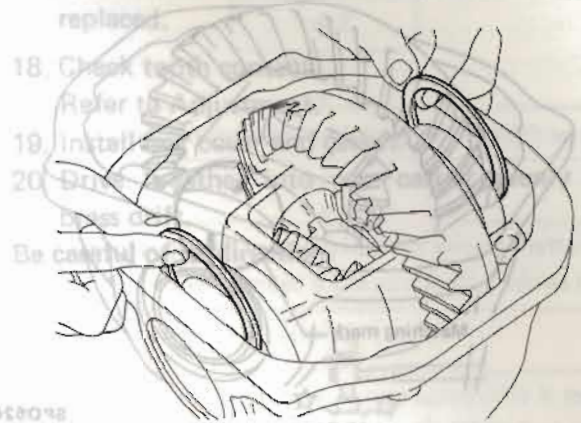

SPD558

11. Drive in side bearing spacer with Tool.

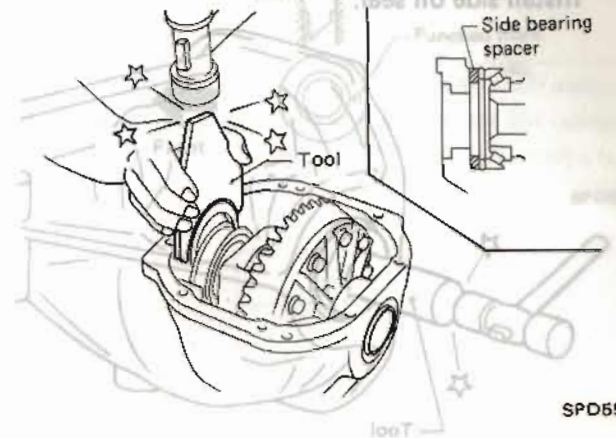

SPD659

Tool number: KV38100600 (J25267)

Tool number: KV38100500 (J25267)

ASSEMBLY (Model R200)

Differential Carrier (Cont'd)

12. Align mark on bearing cap with that on gear carrier and install bearing cap on gear carrier.

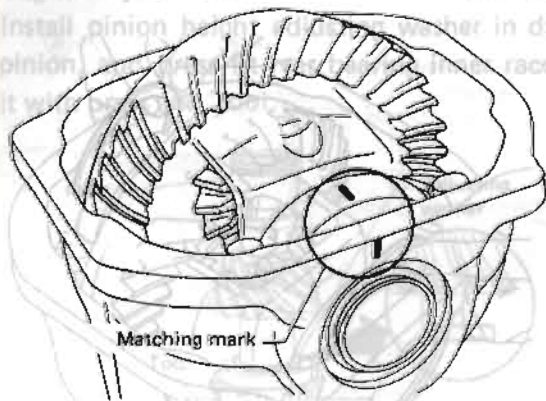

SPD526

13. Apply multi-purpose grease to cavity at sealing lips of oil seal. Install side oil seal.

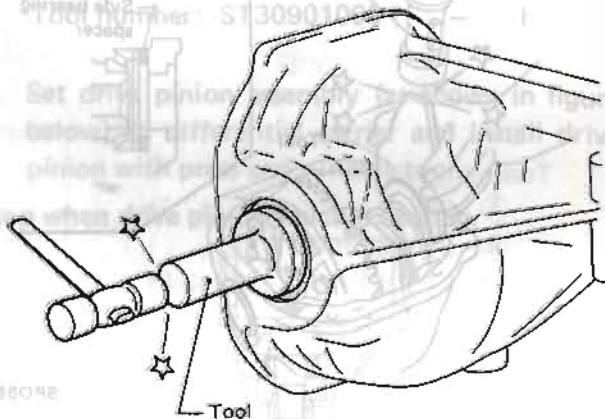

SPD560

Tool number: KV38100200 (-)

14. Measure ring gear-to-drive pinion backlash with a dial indicator.



SPD513

Ring gear-to-drive pinion backlash:

0.13 - 0.18 mm

(0.0051 - 0.0071 in)

- If backlash is too small, decrease thickness of right shim and increase thickness of left shim by the same amount.

If backlash is too great, reverse the above procedure.

Never change the total amount of shims as it will change the bearing preload.

15. Check total preload with Tool.

When checking preload, turn drive pinion in both directions several times to set bearing rollers.

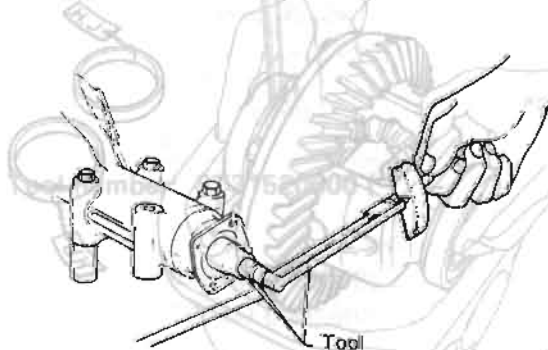

PD340

Tool number: ST3127S000 (See J25765-A.)

Total preload:

Measured drive pinion preload

+ 0.3 N·m (3 kg-cm, 2.6 in-lb)

ASSEMBLY (Model R200)

Differential Carrier (Cont'd)

- If preload is too great, add the same amount of shim to each side.
- If preload is too small, remove the same amount of shim to each side.

Never add or remove a different number of shims for each side as it will change ring gear-to-drive pinion backlash.

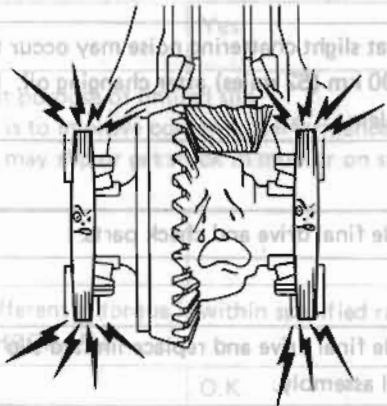

16. Recheck ring gear-to-drive pinion backlash because increase or decrease in thickness of shims will cause change of ring gear-to-pinion backlash.
17. Check runout of ring gear with a dial indicator.

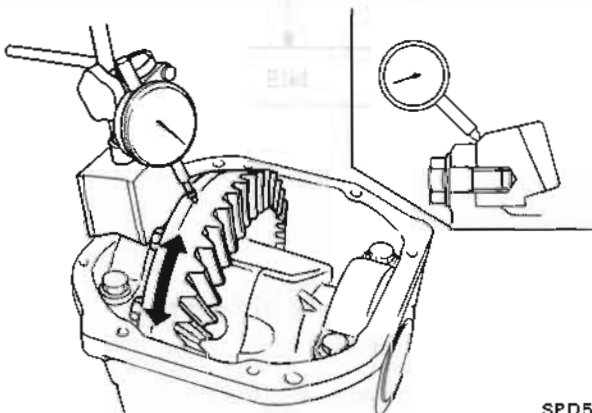

Runout limit:
0.05 mm (0.0020 in)

- If backlash varies excessively in different places, the variance may have resulted from foreign matter caught between the ring gear and the differential case.

- If the backlash varies greatly when the runout of the ring gear is within a specified range, the hypoid gear set or differential case should be replaced.

18. Check tooth contact.

Refer to Adjustment.

19. Install rear cover and gasket.

20. Drive breather into gear carrier evenly with brass drift.

Be careful of its direction.

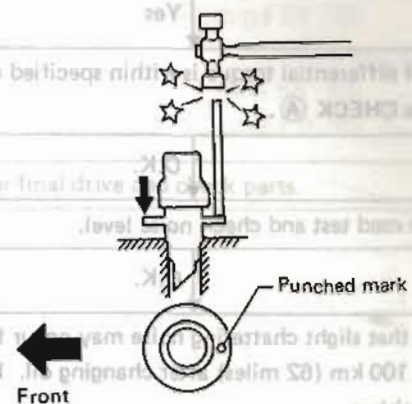

End

LIMITED SLIP DIFFERENTIAL (Model R200)

Trouble-shooting and diagnoses

Customer complaint: Final drive has high-pitched chattering noise during turning maneuvers.

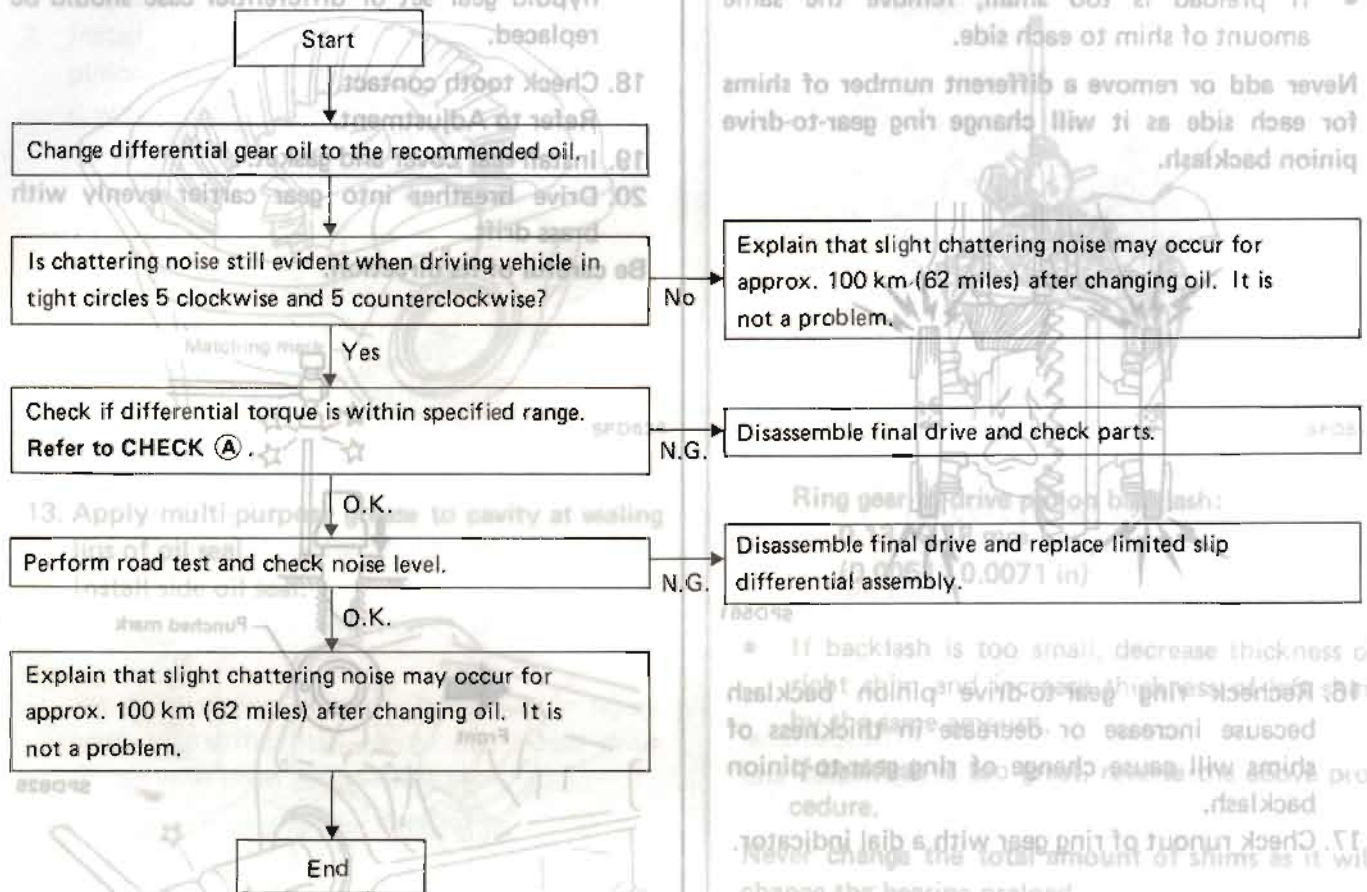

Never add or remove a different number of shims for each side as it will change ring gear-to-drive pinion backlash.

Explain that slight chattering noise may occur for approx. 100 km (62 miles) after changing oil. It is not a problem.

Disassemble final drive and check parts.

Disassemble final drive and replace limited slip differential assembly.

17. Check runout of ring gear with a dial indicator. It will be as small as the amount of shim to be added. Change the bearing preload.

15. Check total preload with Tool. When checking preload, turn drive pinion in both directions several times to set bearing rollers.

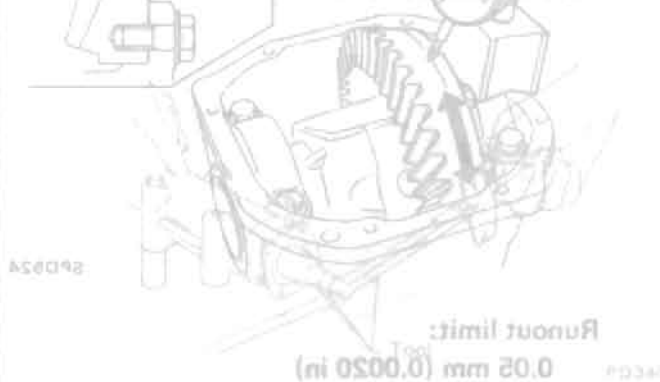

If backlash varies excessively in different places, the variance may have resulted from uneven wear between the ring gear and the differential case.

LIMITED SLIP DIFFERENTIAL (Model R200)

Trouble-shooting and diagnoses (Cont'd)

Customer complaint: Rear wheels slip and remain stuck in mud or on snowy roads.

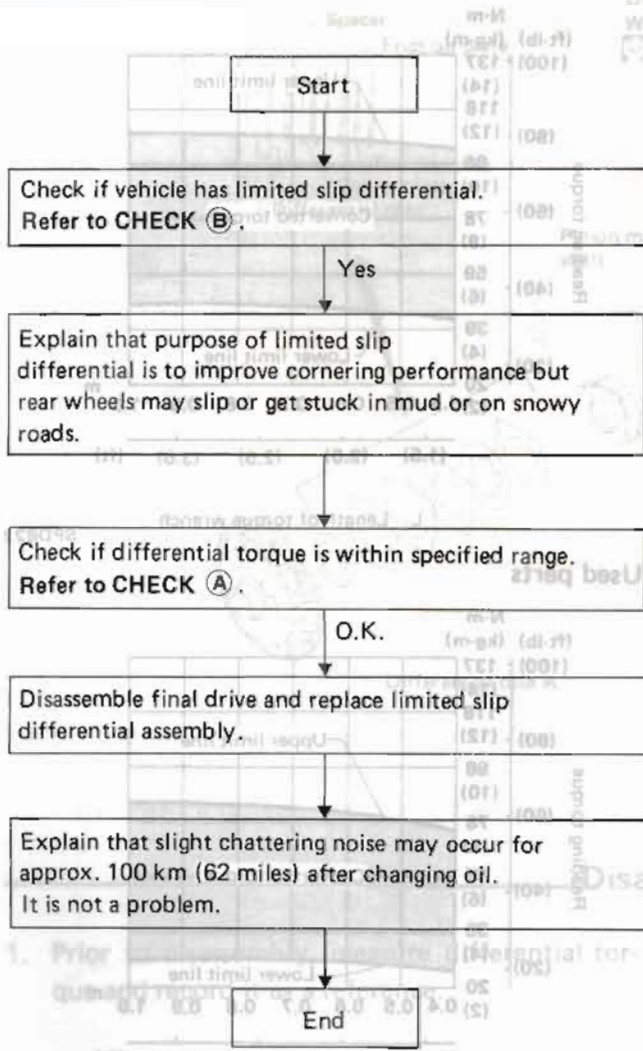

Explain that vehicle does not have limited slip differential.

Check if differential torque is within specified range. Refer to CHECK (A).

Disassemble final drive and check parts.

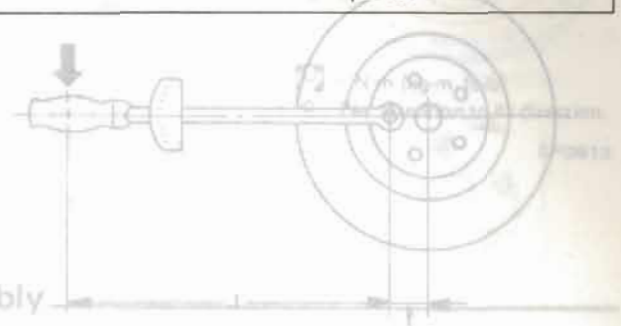

Remove screws on differential cases A and B and use a press.



3. Separate differential case A and B. Draw out component parts (discs and plates, etc.). Put marks on gears and pressure rings so that they can be reinstalled in their original positions.

CHECK (B) : Limited slip differential identification

1. Lift both rear wheels off ground.
2. Turn one rear wheel by hand.
3. If both rear wheels turn in the same direction simultaneously, vehicle is equipped with limited slip differential.

Differential torque:
 New parts
 25 - 49 N·m
 (2.5 - 5 kg·m, 18 - 36 ft·lb)

LIMITED SLIP DIFFERENTIAL (Model R200)

Trouble-shooting and diagnoses (Cont'd)

CHECK (A) : Check differential torque.

1. Drive vehicle enough to warm up differential oil.
2. Lift both rear wheels off ground.
3. Shift transmission gear into 1st (M/T model) or P range (A/T model).
4. Release parking brake.
5. Check differential torque at wheel stud bolt.

Differential torque (on vehicle):

New parts:

49 - 118 N·m
(5 - 12 kg·m, 36 - 87 ft·lb)

Used parts:

29 - 88 N·m
(3 - 9 kg·m, 22 - 65 ft·lb)

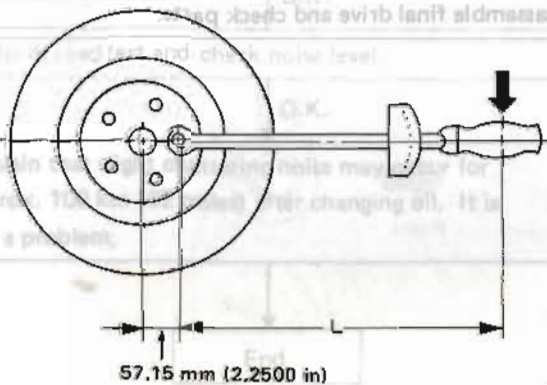

SPD820

New parts

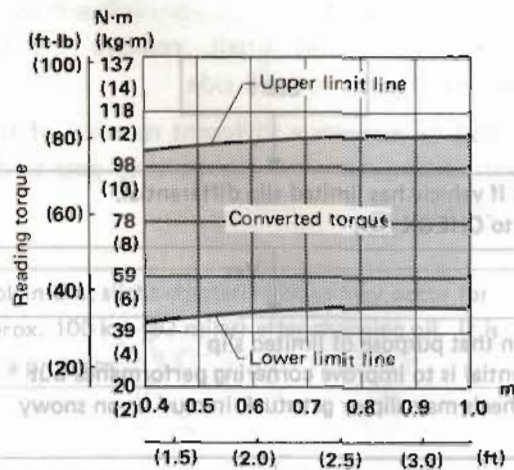

L: Length of torque wrench

SPD822

Used parts

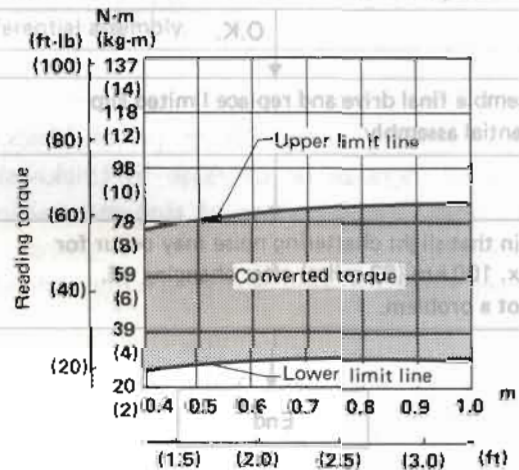

L: Length of torque wrench

SPD823

CHECK (B) : Limited slip differential identification.

1. Lift both rear wheels off ground.
2. Turn one rear wheel by hand.
3. If both rear wheels turn in the same direction simultaneously, vehicle is equipped with limited slip differential.

LIMITED SLIP DIFFERENTIAL (Model R200)

Pay attention to direction of parts and assembly procedures.

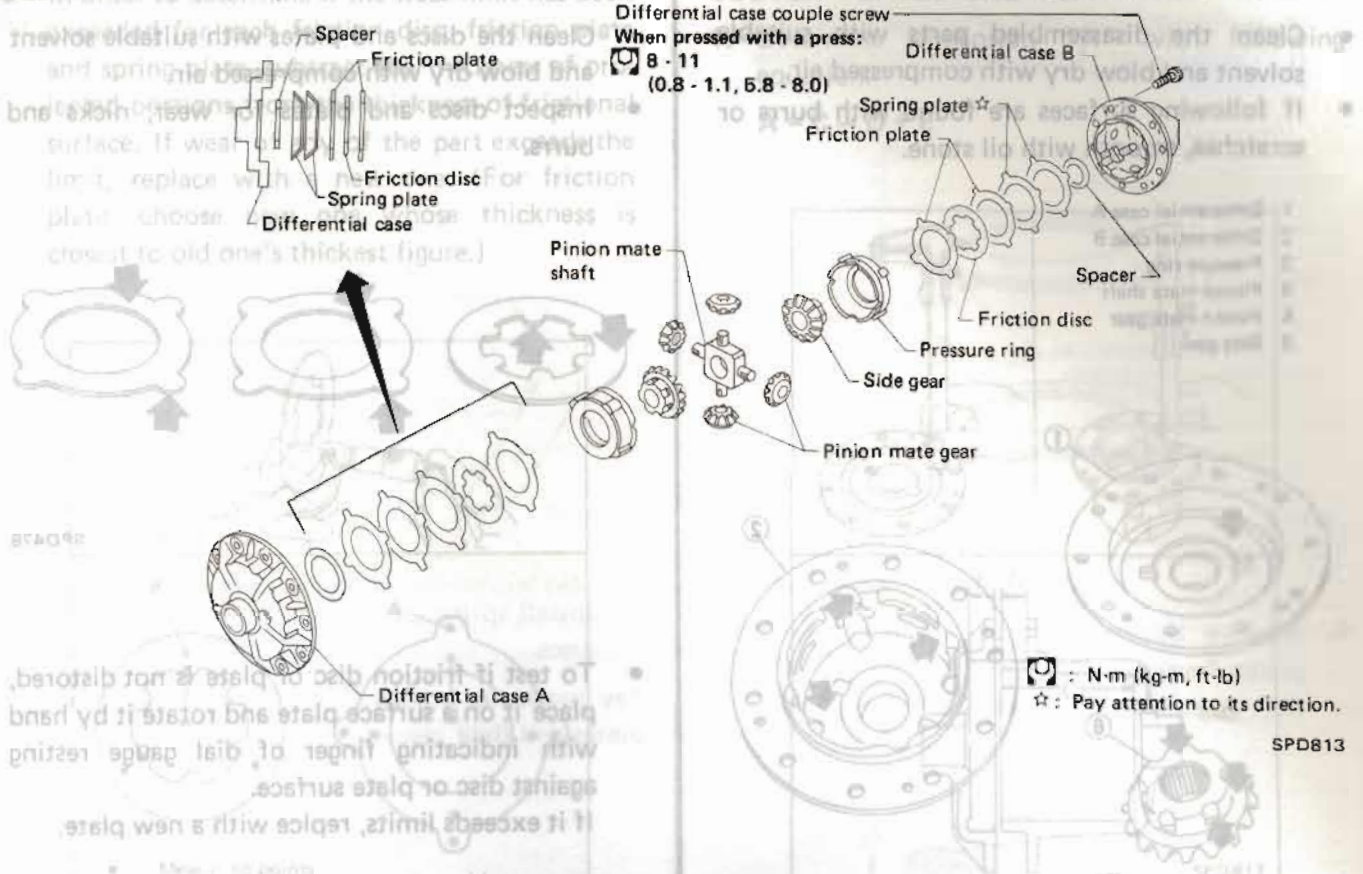

Disassembly

1. Prior to disassembly, measure differential torque and record it as a reference.

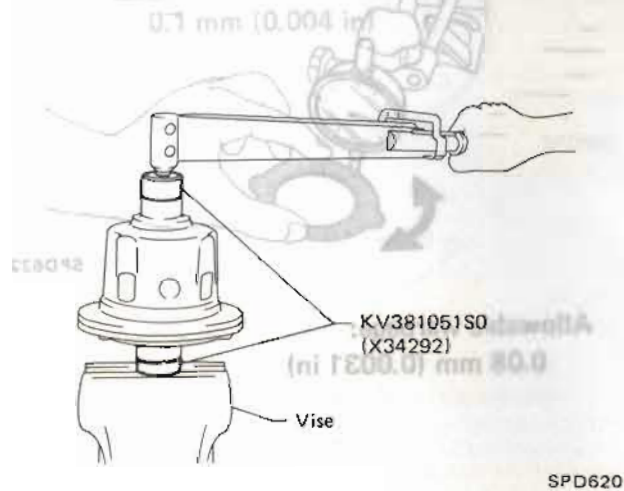

Differential torque:

New parts

25 - 49 N·m

(2.5 - 5 kg-m, 18 - 36 ft-lb)

2. Loosen screws on differential cases A and B using a press.

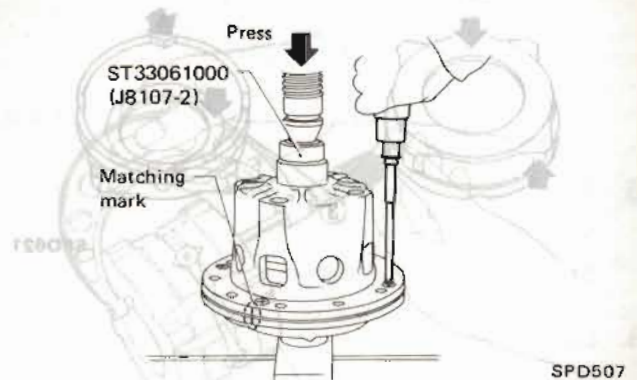

3. Separate differential case A and B. Draw out component parts (discs and plates, etc.).

Put marks on gears and pressure rings so that they can be reinstalled in their original positions.

LIMITED SLIP DIFFERENTIAL (Model R200)

Troubleshooting Inspection and Adjustment

CONTACT SURFACES

- Clean the disassembled parts with suitable solvent and blow dry with compressed air.
- If following surfaces are found with burrs or scratches, smooth with oil stone.

- 1 Differential case A
- 2 Differential case B
- 3 Pressure ring
- 4 Pinion mate shaft
- 5 Pinion mate gear
- 6 Side gear

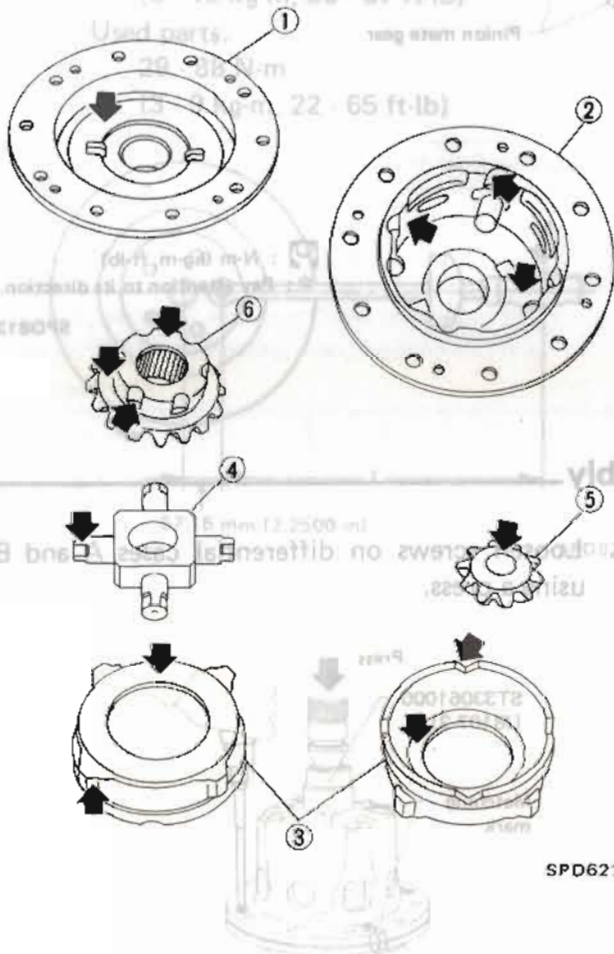

SPD621

DISC AND PLATE

- Clean the discs and plates with suitable solvent and blow dry with compressed air.
- Inspect discs and plates for wear, nicks and burrs.

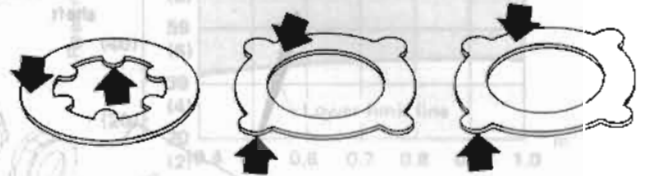

SPD478

- To test if friction disc or plate is not distorted, place it on a surface plate and rotate it by hand with indicating finger of dial gauge resting against disc or plate surface.

If it exceeds limits, replace with a new plate.



SPD622

Allowable warpage:
0.08 mm (0.0031 in)

LIMITED SLIP DIFFERENTIAL (Model R200)

Inspection and Adjustment (Cont'd)

- In order to determine if the wear limit has been exceeded for each friction disc, friction plate and spring plate, subtract the thickness of projected portions from the thickness of frictional surface. If wear of any of the part exceeds the limit, replace with a new one. (For friction plate, choose new one whose thickness is closest to old one's thickest figure.)

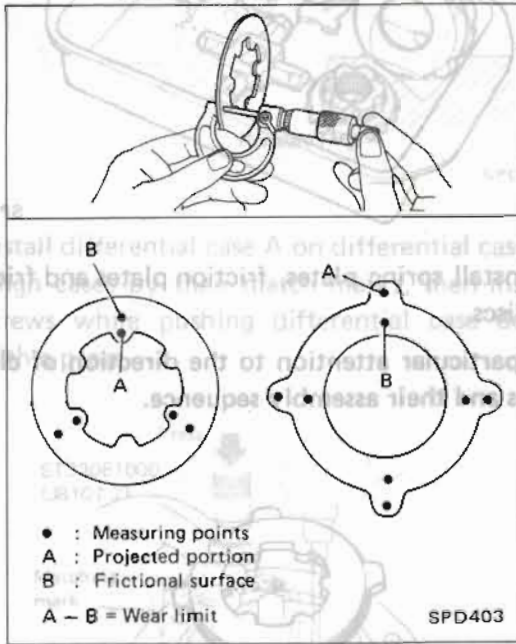

Wear limit:
0.1 mm (0.004 in)

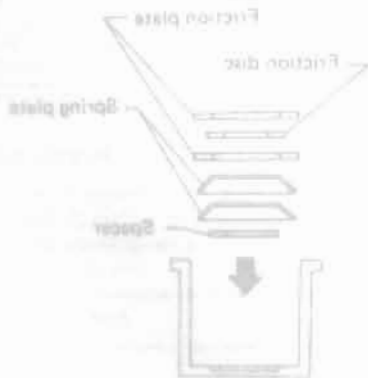

CLUTCH PLATES END PLAY

- Determine dimension "A" with following equation.

$$A = C - D + E$$

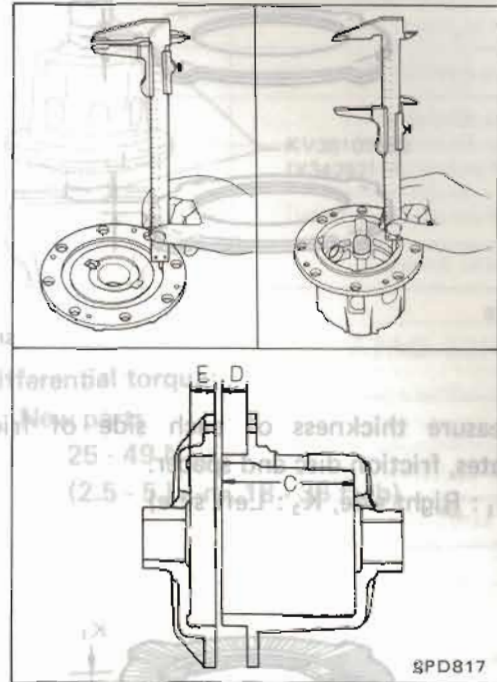

- Measure distance "F".

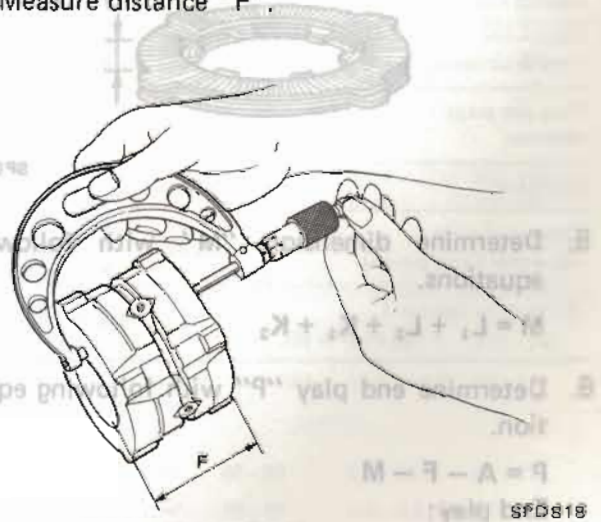

0.05 - 0.20 mm (0.0020 - 0.0079 in)
 7. If not within specification, select disc and plate to adjust correctly.

LIMITED SLIP DIFFERENTIAL (Model R200)

Inspection and Adjustment (Cont'd)

- Measure thickness of each side of spring plates.
(L_1 : Right side, L_2 : Left side)

If following surfaces are found with pits or scratches, smooth with oil stone.

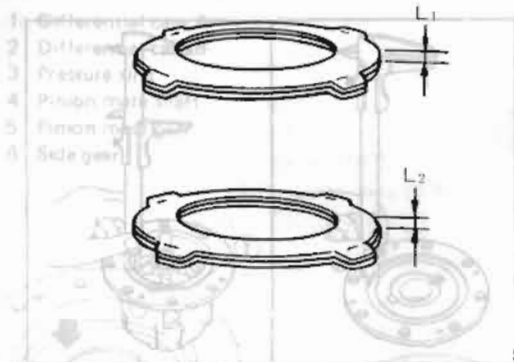

SPD814

- Measure thickness of each side of friction plates, friction disc and spacer.
(K_1 : Right side, K_2 : Left side)

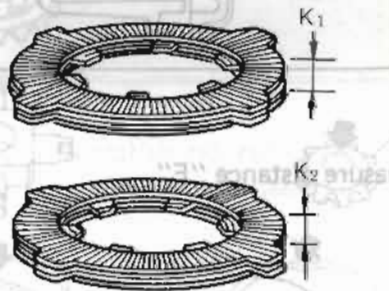

SPD815

- Determine dimension "M" with following equations.

$$M = L_1 + L_2 + K_1 + K_2$$

- Determine end play "P" with following equation.

$$P = A - F - M$$

End play:

$$0.05 - 0.20 \text{ mm (0.0020 - 0.0079 in)}$$

- If not within specification, select discs and plates to adjust correctly.

Assembly

- As an aid to installation, apply sufficient amounts of recommended L.S.D. gear oil (Refer to MA section) to the faces of pressure rings, discs and plates to be assembled together.

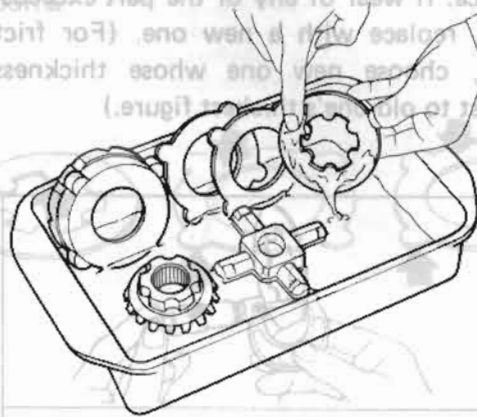

SPD479

- Install spring plates, friction plates and friction discs.

Pay particular attention to the direction of clutch plates and their assembly sequence.

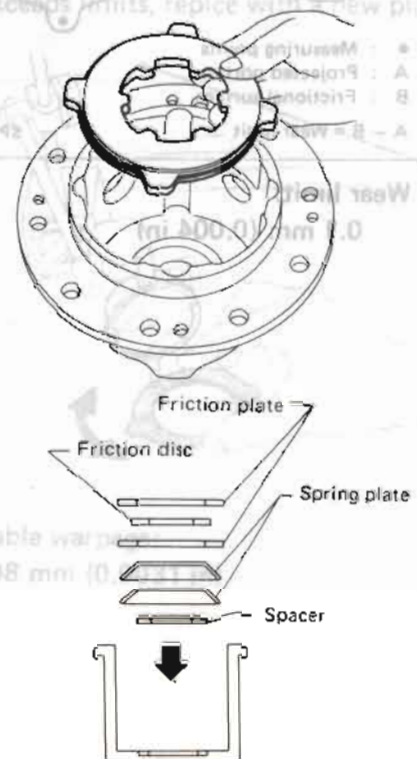

SPD623

- Always attach pinion mate shaft to "V" groove in pressure ring with flat surfaces facing up and down.

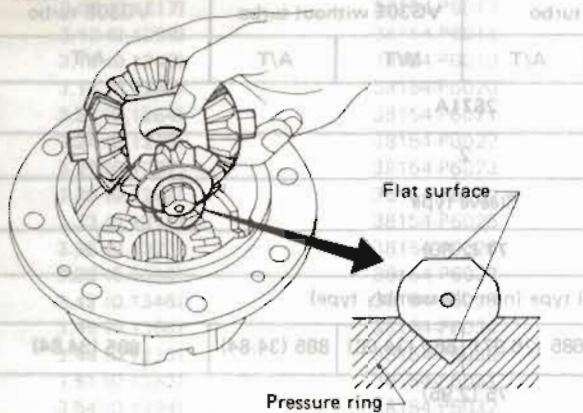

SPD483

- Install differential case A on differential case B. Align cases by their match marks, then install screws while pushing differential case down with a press.

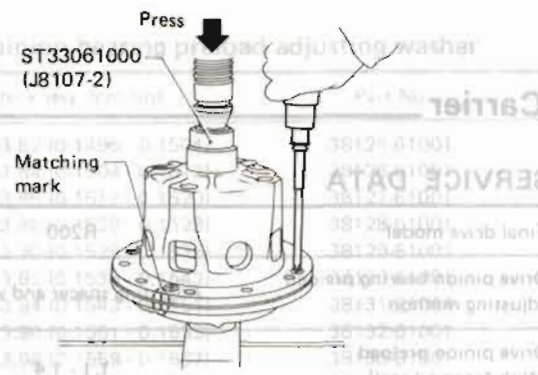

SPD507

- After assembly, measure differential torque. If it is not within the specification, adjust it by selecting friction disc (Refer to S.D.S.).

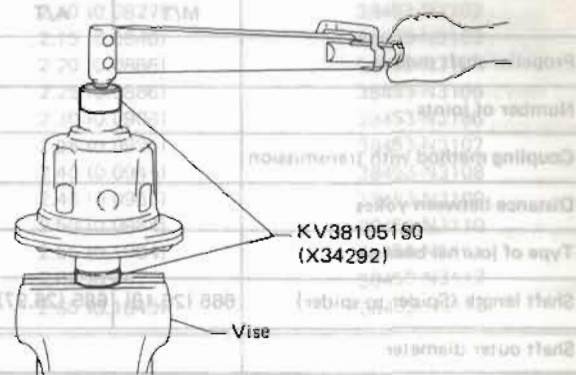

SPD620

Differential torque:

New parts

25 - 49 N·m
(2.5 - 5 kg-m, 18 - 36 ft-lb)

TIGHTENING TORQUE

GENERAL SPECIFICATIONS

| Part Name | Specification |
|--|---------------|
| Ring gear (mm) | 132 - 133 |
| Lock bolt (mm) | 13.5 - 14.5 |
| Side bearing cap bolt (mm) | 18 - 20 |
| Rear cover fixing bolt (mm) | 18 - 24 |
| Companion flange to propeller shaft fixing bolt (mm) | 18 - 24 |
| Filler and drain plug (mm) | 18 - 24 |

SERVICE DATA AND SPECIFICATIONS (S.D.S.)

Propeller Shaft

GENERAL SPECIFICATIONS

Unit: mm (in)

| Applied model | 2 seater | | | | 2+2 seater | | | |
|-----------------------------------|-----------------------------------|-------------|-------------|-------------|---------------------|-------------|-------------|--|
| | VG30E without turbo | | VG30E turbo | | VG30E without turbo | | VG30E turbo | |
| | M/T | A/T | M/T | A/T | M/T | A/T | A/T | |
| Propeller shaft model | 2S71A | | | | | | | |
| Number of joints | 2 | | | | | | | |
| Coupling method with transmission | Sleeve type | | | | | | | |
| Distance between yokes | 71 (2.80) | | | | | | | |
| Type of journal bearing | Shell type (non-disassembly type) | | | | | | | |
| Shaft length (Spider to spider) | 665 (26.18) | 685 (26.97) | 665 (26.18) | 685 (26.97) | 865 (34.06) | 885 (34.84) | 885 (34.84) | |
| Shaft outer diameter | 75 (2.95) | | | | | | | |

SERVICE DATA

Unit: mm (in)

| | |
|------------------------------|-------------|
| Model | 2S71A |
| Propeller shaft runout limit | 0.6 (0.024) |
| Journal axial play | 0 (0) |

TIGHTENING TORQUE

| Unit | N·m | kg·m | ft·lb |
|---------------------------------|---------|-----------|---------|
| Shaft to companion flange bolts | 39 - 44 | 4.0 - 4.5 | 29 - 33 |

Differential Carrier

GENERAL SPECIFICATIONS

| Applied model | VG30E | VG30E turbo |
|---|--------------------|-------------|
| | without turbo | |
| Final drive model | R200 | |
| Ring gear pitch diameter | 200 (7.87) | |
| Gear ratio | 3.900 | 3.700 |
| Number of teeth (Ring gear/Drive pinion) | 39/10 | 37/10 |
| Oil capacity (approx.) ℓ (US pt, Imp pt) | 1.3 (2-3/4, 2-1/4) | |

SERVICE DATA

| | |
|--|---|
| Final drive model | R200 |
| Drive pinion bearing preload adjusting method | Adjusting spacer and washer |
| Drive pinion preload (With front oil seal) | 1.1 - 1.4 (11 - 14, 9.5 - 12.2) |
| Total preload | Measured drive pinion preload +0.3 (3, 2.6) |
| Side bearing adjusting method | Shim |
| Backlash | |
| Drive pinion to ring gear | 0.13 - 0.18 (0.0051 - 0.0071) |
| Side gear to pinion mate gear (Clearance between side gear to differential case) | 0.10 - 0.20 (0.0039 - 0.0079) |
| Ring gear runout limit | 0.05 (0.0020) |

SERVICE DATA AND SPECIFICATIONS (S.D.S.)

Differential Carrier (Cont'd)

Pinion height adjusting washer

| Thickness mm (in) | Part No. |
|-------------------|-------------|
| 3.09 (0.1217) | 38154-P6017 |
| 3.12 (0.1228) | 38154-P6018 |
| 3.15 (0.1240) | 38154-P6019 |
| 3.18 (0.1252) | 38154-P6020 |
| 3.21 (0.1264) | 38154-P6021 |
| 3.24 (0.1276) | 38154-P6022 |
| 3.27 (0.1287) | 38154-P6023 |
| 3.30 (0.1299) | 38154-P6024 |
| 3.33 (0.1311) | 38154-P6025 |
| 3.36 (0.1323) | 38154-P6026 |
| 3.39 (0.1335) | 38154-P6027 |
| 3.42 (0.1346) | 38154-P6028 |
| 3.45 (0.1358) | 38154-P6029 |
| 3.48 (0.1370) | 38154-P6030 |
| 3.51 (0.1382) | 38154-P6031 |
| 3.54 (0.1394) | 38154-P6032 |
| 3.57 (0.1406) | 38154-P6033 |
| 3.60 (0.1417) | 38154-P6034 |
| 3.63 (0.1429) | 38154-P6035 |
| 3.66 (0.1441) | 38154-P6036 |

Drive pinion bearing preload adjusting washer

| Thickness mm (in) | Part No. |
|-------------------------------|-------------|
| 3.80 - 3.82 (0.1496 - 0.1504) | 38125-61001 |
| 3.82 - 3.84 (0.1504 - 0.1512) | 38126-61001 |
| 3.84 - 3.86 (0.1512 - 0.1520) | 38127-61001 |
| 3.86 - 3.88 (0.1520 - 0.1528) | 38128-61001 |
| 3.88 - 3.90 (0.1528 - 0.1535) | 38129-61001 |
| 3.90 - 3.92 (0.1535 - 0.1543) | 38130-61001 |
| 3.92 - 3.94 (0.1543 - 0.1551) | 38131-61001 |
| 3.94 - 3.96 (0.1551 - 0.1559) | 38132-61001 |
| 3.96 - 3.98 (0.1559 - 0.1567) | 38133-61001 |
| 3.98 - 4.00 (0.1567 - 0.1575) | 38134-61001 |
| 4.00 - 4.02 (0.1575 - 0.1583) | 38135-61001 |
| 4.02 - 4.04 (0.1583 - 0.1591) | 38136-61001 |
| 4.04 - 4.06 (0.1591 - 0.1598) | 38137-61001 |
| 4.06 - 4.08 (0.1598 - 0.1606) | 38138-61001 |
| 4.08 - 4.10 (0.1606 - 0.1614) | 38139-61001 |

Drive pinion bearing preload adjusting spacer

| Length mm (in) | Part No. |
|----------------|-------------|
| 55.10 (2.1693) | 38165-B4002 |
| 55.40 (2.1811) | 38165-B4003 |
| 55.70 (2.1929) | 38165-B4004 |
| 56.00 (2.2047) | 38165-61001 |
| 56.25 (2.2146) | 38166-61001 |

Side bearing adjusting washer

| Thickness mm (in) | Part No. |
|-------------------|-------------|
| 2.00 (0.0787) | 38453-N3100 |
| 2.05 (0.0807) | 38453-N3101 |
| 2.10 (0.0827) | 38453-N3102 |
| 2.15 (0.0846) | 38453-N3103 |
| 2.20 (0.0866) | 38453-N3104 |
| 2.25 (0.0886) | 38453-N3105 |
| 2.30 (0.0906) | 38453-N3106 |
| 2.35 (0.0925) | 38453-N3107 |
| 2.40 (0.0945) | 38453-N3108 |
| 2.45 (0.0965) | 38453-N3109 |
| 2.50 (0.0984) | 38453-N3110 |
| 2.55 (0.1004) | 38453-N3111 |
| 2.60 (0.1024) | 38453-N3112 |
| 2.65 (0.1043) | 38453-N3113 |

Side gear thrust washer

| Thickness mm (in) | Part No. |
|-------------------------------|-------------|
| 0.75 - 0.80 (0.0295 - 0.0315) | 38424-N3100 |
| 0.80 - 0.85 (0.0315 - 0.0335) | 38424-N3101 |
| 0.85 - 0.90 (0.0335 - 0.0354) | 38424-N3102 |
| 0.90 - 0.95 (0.0354 - 0.0374) | 38424-N3103 |

TIGHTENING TORQUE

| Type | R200 | | |
|--|-----------|-------------|-----------|
| Unit | N-m | kg-m | ft-lb |
| Final drive installation | | | |
| Drive shaft to rear axle | | | |
| Side puller | | | |
| VG30E without turbo | 39 - 49 | 4 - 5 | 29 - 36 |
| VG30E turbo | 59 - 69 | 6 - 7 | 43 - 51 |
| Rear cover to mounting insulator | 88 - 118 | 9.0 - 12.0 | 65 - 87 |
| Mounting insulator to body | | | |
| Bolt | 29 - 39 | 3 - 4 | 22 - 29 |
| Nut | 59 - 78 | 6 - 8 | 43 - 58 |
| Differential carrier to suspension member | 59 - 78 | 6 - 8 | 43 - 58 |
| Final drive assembly | | | |
| Drive pinion nut | 186 - 294 | 19 - 30 | 137 - 217 |
| Ring gear bolt [using Loctite (stud lock) or equivalent] | 132 - 152 | 13.5 - 15.5 | 98 - 112 |
| Side bearing cap bolt | 88 - 98 | 9.0 - 10.0 | 65 - 72 |
| Rear cover fixing bolt | 16 - 24 | 1.6 - 2.4 | 12 - 17 |
| Companion flange to propeller shaft fixing bolt | 39 - 44 | 4.0 - 4.5 | 29 - 33 |
| Filler and drain plug | 59 - 98 | 6 - 10 | 43 - 72 |

SERVICE DATA AND SPECIFICATIONS (S.D.S.)

Final Drive

SERVICE DATA

| | |
|--|----------------------------------|
| Differential torque (on-vehicle) | |
| N-m (kg-m, ft-lb) | |
| New parts | 49 - 118 (5 - 12, 36 - 87) |
| Used parts | 29 - 88 (3 - 9, 22 - 65) |
| Differential torque | |
| N-m (kg-m, ft-lb) | |
| New parts | 25 - 49 (2.5 - 5, 18 - 36) |
| Wear limit of friction disc, friction plate and spring plate | mm (in) |
| | 0.1 (0.004) |
| Allowable warp of friction disc and friction plate | mm (in) |
| | 0.08 (0.0031) |
| End play | mm (in) |
| | 0.05 - 0.20 (0.0020 - 0.0079) |

Friction plate

| Thickness mm (in) | Part number |
|-------------------|-------------|
| 1.75 (0.0689) | 38432-N9000 |
| 1.85 (0.0728) | 38432-N9001 |

Friction disc

| Thickness mm (in) | Part number |
|-------------------|-------------|
| 1.75 (0.0689) | 38433-N9000 |

TIGHTENING TORQUE











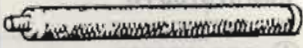

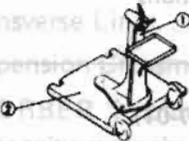

| Unit | N-m | kg-m | ft-lb |
|--------------------------------|--------|-----------|-----------|
| Differential case couple screw | 8 - 11 | 0.8 - 1.1 | 5.8 - 8.0 |

| Part name | Part No. | Length mm (in) |
|--|------------|-----------------------|
| Filler and drain plug | 38188-8101 | 58 - 58 (2.31 - 2.31) |
| Pinion bearing preloaded adjusting spacer | 38188-8101 | 58 - 58 (2.31 - 2.31) |
| Companion flange to propeller shaft fixing bolt | 38188-8101 | 58 - 58 (2.31 - 2.31) |
| Pinion cover fixing bolt | 38188-8101 | 58 - 58 (2.31 - 2.31) |
| Side bearing cap bolt | 38188-8101 | 58 - 58 (2.31 - 2.31) |
| Ring gear bolt (using Lockite (stud lock) or equivalent) | 38188-8101 | 58 - 58 (2.31 - 2.31) |
| Drive pinion nut | 38188-8101 | 58 - 58 (2.31 - 2.31) |

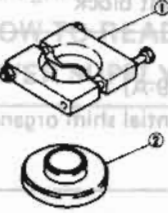







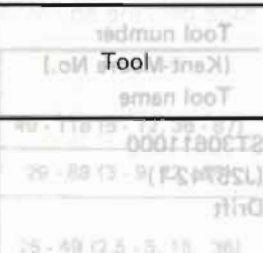

Pinion bearing preloaded adjusting washer

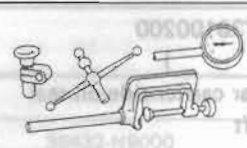
| Part No. | Thickness mm (in) |
|------------|-------------------------|
| 38188-8101 | 3.80 (0.1496) - 0.1504 |
| 38188-8101 | 3.85 (0.1516) - 0.1524 |
| 38188-8101 | 3.90 (0.1535) - 0.1543 |
| 38188-8101 | 3.95 (0.1555) - 0.1563 |
| 38188-8101 | 4.00 (0.1575) - 0.1583 |
| 38188-8101 | 4.05 (0.1594) - 0.1602 |
| 38188-8101 | 4.10 (0.1614) - 0.1622 |
| 38188-8101 | 4.15 (0.1634) - 0.1642 |
| 38188-8101 | 4.20 (0.1654) - 0.1662 |
| 38188-8101 | 4.25 (0.1674) - 0.1682 |
| 38188-8101 | 4.30 (0.1694) - 0.1702 |
| 38188-8101 | 4.35 (0.1714) - 0.1722 |
| 38188-8101 | 4.40 (0.1734) - 0.1742 |
| 38188-8101 | 4.45 (0.1754) - 0.1762 |
| 38188-8101 | 4.50 (0.1774) - 0.1782 |
| 38188-8101 | 4.55 (0.1794) - 0.1792 |
| 38188-8101 | 4.60 (0.1814) - 0.1822 |
| 38188-8101 | 4.65 (0.1834) - 0.1842 |
| 38188-8101 | 4.70 (0.1854) - 0.1862 |
| 38188-8101 | 4.75 (0.1874) - 0.1882 |
| 38188-8101 | 4.80 (0.1894) - 0.1892 |
| 38188-8101 | 4.85 (0.1914) - 0.1922 |
| 38188-8101 | 4.90 (0.1934) - 0.1942 |
| 38188-8101 | 4.95 (0.1954) - 0.1962 |
| 38188-8101 | 5.00 (0.1974) - 0.1982 |
| 38188-8101 | 5.05 (0.1994) - 0.1992 |
| 38188-8101 | 5.10 (0.2014) - 0.2022 |
| 38188-8101 | 5.15 (0.2034) - 0.2042 |
| 38188-8101 | 5.20 (0.2054) - 0.2062 |
| 38188-8101 | 5.25 (0.2074) - 0.2082 |
| 38188-8101 | 5.30 (0.2094) - 0.2102 |
| 38188-8101 | 5.35 (0.2114) - 0.2122 |
| 38188-8101 | 5.40 (0.2134) - 0.2142 |
| 38188-8101 | 5.45 (0.2154) - 0.2162 |
| 38188-8101 | 5.50 (0.2174) - 0.2182 |
| 38188-8101 | 5.55 (0.2194) - 0.2202 |
| 38188-8101 | 5.60 (0.2214) - 0.2222 |
| 38188-8101 | 5.65 (0.2234) - 0.2242 |
| 38188-8101 | 5.70 (0.2254) - 0.2262 |
| 38188-8101 | 5.75 (0.2274) - 0.2282 |
| 38188-8101 | 5.80 (0.2294) - 0.2302 |
| 38188-8101 | 5.85 (0.2314) - 0.2322 |
| 38188-8101 | 5.90 (0.2334) - 0.2342 |
| 38188-8101 | 5.95 (0.2354) - 0.2362 |
| 38188-8101 | 6.00 (0.2374) - 0.2382 |
| 38188-8101 | 6.05 (0.2394) - 0.2402 |
| 38188-8101 | 6.10 (0.2414) - 0.2422 |
| 38188-8101 | 6.15 (0.2434) - 0.2442 |
| 38188-8101 | 6.20 (0.2454) - 0.2462 |
| 38188-8101 | 6.25 (0.2474) - 0.2482 |
| 38188-8101 | 6.30 (0.2494) - 0.2502 |
| 38188-8101 | 6.35 (0.2514) - 0.2522 |
| 38188-8101 | 6.40 (0.2534) - 0.2542 |
| 38188-8101 | 6.45 (0.2554) - 0.2562 |
| 38188-8101 | 6.50 (0.2574) - 0.2582 |
| 38188-8101 | 6.55 (0.2594) - 0.2602 |
| 38188-8101 | 6.60 (0.2614) - 0.2622 |
| 38188-8101 | 6.65 (0.2634) - 0.2642 |
| 38188-8101 | 6.70 (0.2654) - 0.2662 |
| 38188-8101 | 6.75 (0.2674) - 0.2682 |
| 38188-8101 | 6.80 (0.2694) - 0.2702 |
| 38188-8101 | 6.85 (0.2714) - 0.2722 |
| 38188-8101 | 6.90 (0.2734) - 0.2742 |
| 38188-8101 | 6.95 (0.2754) - 0.2762 |
| 38188-8101 | 7.00 (0.2774) - 0.2782 |
| 38188-8101 | 7.05 (0.2794) - 0.2802 |
| 38188-8101 | 7.10 (0.2814) - 0.2822 |
| 38188-8101 | 7.15 (0.2834) - 0.2842 |
| 38188-8101 | 7.20 (0.2854) - 0.2862 |
| 38188-8101 | 7.25 (0.2874) - 0.2882 |
| 38188-8101 | 7.30 (0.2894) - 0.2902 |
| 38188-8101 | 7.35 (0.2914) - 0.2922 |
| 38188-8101 | 7.40 (0.2934) - 0.2942 |
| 38188-8101 | 7.45 (0.2954) - 0.2962 |
| 38188-8101 | 7.50 (0.2974) - 0.2982 |
| 38188-8101 | 7.55 (0.2994) - 0.2992 |
| 38188-8101 | 7.60 (0.3014) - 0.3022 |
| 38188-8101 | 7.65 (0.3034) - 0.3042 |
| 38188-8101 | 7.70 (0.3054) - 0.3062 |
| 38188-8101 | 7.75 (0.3074) - 0.3082 |
| 38188-8101 | 7.80 (0.3094) - 0.3102 |
| 38188-8101 | 7.85 (0.3114) - 0.3122 |
| 38188-8101 | 7.90 (0.3134) - 0.3142 |
| 38188-8101 | 7.95 (0.3154) - 0.3162 |
| 38188-8101 | 8.00 (0.3174) - 0.3182 |
| 38188-8101 | 8.05 (0.3194) - 0.3202 |
| 38188-8101 | 8.10 (0.3214) - 0.3222 |
| 38188-8101 | 8.15 (0.3234) - 0.3242 |
| 38188-8101 | 8.20 (0.3254) - 0.3262 |
| 38188-8101 | 8.25 (0.3274) - 0.3282 |
| 38188-8101 | 8.30 (0.3294) - 0.3302 |
| 38188-8101 | 8.35 (0.3314) - 0.3322 |
| 38188-8101 | 8.40 (0.3334) - 0.3342 |
| 38188-8101 | 8.45 (0.3354) - 0.3362 |
| 38188-8101 | 8.50 (0.3374) - 0.3382 |
| 38188-8101 | 8.55 (0.3394) - 0.3402 |
| 38188-8101 | 8.60 (0.3414) - 0.3422 |
| 38188-8101 | 8.65 (0.3434) - 0.3442 |
| 38188-8101 | 8.70 (0.3454) - 0.3462 |
| 38188-8101 | 8.75 (0.3474) - 0.3482 |
| 38188-8101 | 8.80 (0.3494) - 0.3502 |
| 38188-8101 | 8.85 (0.3514) - 0.3522 |
| 38188-8101 | 8.90 (0.3534) - 0.3542 |
| 38188-8101 | 8.95 (0.3554) - 0.3562 |
| 38188-8101 | 9.00 (0.3574) - 0.3582 |
| 38188-8101 | 9.05 (0.3594) - 0.3602 |
| 38188-8101 | 9.10 (0.3614) - 0.3622 |
| 38188-8101 | 9.15 (0.3634) - 0.3642 |
| 38188-8101 | 9.20 (0.3654) - 0.3662 |
| 38188-8101 | 9.25 (0.3674) - 0.3682 |
| 38188-8101 | 9.30 (0.3694) - 0.3702 |
| 38188-8101 | 9.35 (0.3714) - 0.3722 |
| 38188-8101 | 9.40 (0.3734) - 0.3742 |
| 38188-8101 | 9.45 (0.3754) - 0.3762 |
| 38188-8101 | 9.50 (0.3774) - 0.3782 |
| 38188-8101 | 9.55 (0.3794) - 0.3802 |
| 38188-8101 | 9.60 (0.3814) - 0.3822 |
| 38188-8101 | 9.65 (0.3834) - 0.3842 |
| 38188-8101 | 9.70 (0.3854) - 0.3862 |
| 38188-8101 | 9.75 (0.3874) - 0.3882 |
| 38188-8101 | 9.80 (0.3894) - 0.3902 |
| 38188-8101 | 9.85 (0.3914) - 0.3922 |
| 38188-8101 | 9.90 (0.3934) - 0.3942 |
| 38188-8101 | 9.95 (0.3954) - 0.3962 |
| 38188-8101 | 10.00 (0.3974) - 0.3982 |
| 38188-8101 | 10.05 (0.3994) - 0.4002 |
| 38188-8101 | 10.10 (0.4014) - 0.4022 |
| 38188-8101 | 10.15 (0.4034) - 0.4042 |
| 38188-8101 | 10.20 (0.4054) - 0.4062 |
| 38188-8101 | 10.25 (0.4074) - 0.4082 |
| 38188-8101 | 10.30 (0.4094) - 0.4102 |
| 38188-8101 | 10.35 (0.4114) - 0.4122 |
| 38188-8101 | 10.40 (0.4134) - 0.4142 |
| 38188-8101 | 10.45 (0.4154) - 0.4162 |
| 38188-8101 | 10.50 (0.4174) - 0.4182 |
| 38188-8101 | 10.55 (0.4194) - 0.4202 |
| 38188-8101 | 10.60 (0.4214) - 0.4222 |
| 38188-8101 | 10.65 (0.4234) - 0.4242 |
| 38188-8101 | 10.70 (0.4254) - 0.4262 |
| 38188-8101 | 10.75 (0.4274) - 0.4282 |
| 38188-8101 | 10.80 (0.4294) - 0.4302 |
| 38188-8101 | 10.85 (0.4314) - 0.4322 |
| 38188-8101 | 10.90 (0.4334) - 0.4342 |
| 38188-8101 | 10.95 (0.4354) - 0.4362 |
| 38188-8101 | 11.00 (0.4374) - 0.4382 |
| 38188-8101 | 11.05 (0.4394) - 0.4402 |
| 38188-8101 | 11.10 (0.4414) - 0.4422 |
| 38188-8101 | 11.15 (0.4434) - 0.4442 |
| 38188-8101 | 11.20 (0.4454) - 0.4462 |
| 38188-8101 | 11.25 (0.4474) - 0.4482 |
| 38188-8101 | 11.30 (0.4494) - 0.4502 |
| 38188-8101 | 11.35 (0.4514) - 0.4522 |
| 38188-8101 | 11.40 (0.4534) - 0.4542 |
| 38188-8101 | 11.45 (0.4554) - 0.4562 |
| 38188-8101 | 11.50 (0.4574) - 0.4582 |
| 38188-8101 | 11.55 (0.4594) - 0.4602 |
| 38188-8101 | 11.60 (0.4614) - 0.4622 |
| 38188-8101 | 11.65 (0.4634) - 0.4642 |
| 38188-8101 | 11.70 (0.4654) - 0.4662 |
| 38188-8101 | 11.75 (0.4674) - 0.4682 |
| 38188-8101 | 11.80 (0.4694) - 0.4702 |
| 38188-8101 | 11.85 (0.4714) - 0.4722 |
| 38188-8101 | 11.90 (0.4734) - 0.4742 |
| 38188-8101 | 11.95 (0.4754) - 0.4762 |
| 38188-8101 | 12.00 (0.4774) - 0.4782 |
| 38188-8101 | 12.05 (0.4794) - 0.4802 |
| 38188-8101 | 12.10 (0.4814) - 0.4822 |
| 38188-8101 | 12.15 (0.4834) - 0.4842 |
| 38188-8101 | 12.20 (0.4854) - 0.4862 |
| 38188-8101 | 12.25 (0.4874) - 0.4882 |
| 38188-8101 | 12.30 (0.4894) - 0.4902 |
| 38188-8101 | 12.35 (0.4914) - 0.4922 |
| 38188-8101 | 12.40 (0.4934) - 0.4942 |
| 38188-8101 | 12.45 (0.4954) - 0.4962 |
| 38188-8101 | 12.50 (0.4974) - 0.4982 |
| 38188-8101 | 12.55 (0.4994) - 0.5002 |
| 38188-8101 | 12.60 (0.5014) - 0.5022 |
| 38188-8101 | 12.65 (0.5034) - 0.5042 |
| 38188-8101 | 12.70 (0.5054) - 0.5062 |
| 38188-8101 | 12.75 (0.5074) - 0.5082 |
| 38188-8101 | 12.80 (0.5094) - 0.5102 |
| 38188-8101 | 12.85 (0.5114) - 0.5122 |
| 38188-8101 | 12.90 (0.5134) - 0.5142 |
| 38188-8101 | 12.95 (0.5154) - 0.5162 |
| 38188-8101 | 13.00 (0.5174) - 0.5182 |
| 38188-8101 | 13.05 (0.5194) - 0.5202 |
| 38188-8101 | 13.10 (0.5214) - 0.5222 |
| 38188-8101 | 13.15 (0.5234) - 0.5242 |
| 38188-8101 | 13.20 (0.5254) - 0.5262 |
| 38188-8101 | 13.25 (0.5274) - 0.5282 |
| 38188-8101 | 13.30 (0.5294) - 0.5302 |
| 38188-8101 | 13.35 (0.5314) - 0.5322 |
| 38188-8101 | 13.40 (0.5334) - 0.5342 |
| 38188-8101 | 13.45 (0.5354) - 0.5362 |
| 38188-8101 | 13.50 (0.5374) - 0.5382 |
| 38188-8101 | 13.55 (0.5394) - 0.5402 |
| 38188-8101 | 13.60 (0.5414) - 0.5422 |
| 38188-8101 | 13.65 (0.5434) - 0.5442 |
| 38188-8101 | 13.70 (0.5454) - 0.5462 |
| 38188-8101 | 13.75 (0.5474) - 0.5482 |
| 38188-8101 | 13.80 (0.5494) - 0.5502 |
| 38188-8101 | 13.85 (0.5514) - 0.5522 |
| 38188-8101 | 13.90 (0.5534) - 0.5542 |
| 38188-8101 | 13.95 (0.5554) - 0.5562 |
| 38188-8101 | 14.00 (0.5574) - 0.5582 |
| 38188-8101 | 14.05 (0.5594) - 0.5602 |
| 38188-8101 | 14.10 (0.5614) - 0.5622 |
| 38188-8101 | 14.15 (0.5634) - 0.5642 |
| 38188-8101 | 14.20 (0.5654) - 0.5662 |
| 38188-8101 | 14.25 (0.5674) - 0.5682 |
| 38188-8101 | 14.30 (0.5694) - 0.5702 |
| 38188-8101 | 14.35 (0.5714) - 0.5722 |
| 38188-8101 | 14.40 (0.5734) - 0.5742 |
| 38188-8101 | 14.45 (0.5754) - 0.5762 |
| 38188-8101 | 14.50 (0.5774) - 0.5782 |
| | |

SPECIAL SERVICE TOOLS

| Tool number (Kent-Moore No.) Tool name | Tool number (Kent-Moore No.) Tool name | Tool number (Kent-Moore No.) Tool name | Tool number (Kent-Moore No.) Tool name |
|--|---|--|---|
| ST31520000 (-) Drive pinion flange wrench |  | ST30611000 (J25742-1) Drift |  |
| KV38100800 (-) Differential attachment |  | ST30613000 (J25742-3) Drift |  |
| Equivalent tool (J25604-01) | | ST30621000 (-) Drift |  |
| ST0501S000 (J26023) Engine stand |  | KV38100200 (-) Gear carrier side oil seal drift |  |
| ① ST05011000 (-) Engine stand | | KV38100500 (-) Gear carrier front oil seal drift |  |
| ② ST05012000 (-) Base | | ST33290001 (J25810-A) Side bearing outer race puller |  |
| ST3090S000 (-) Drive pinion rear inner race puller set |  | KV38100300 (J25523) Diff. side bearing drift |  |
| ① ST30031000 (J22912-01) Puller | | KV38100401 (-) Pilot bearing drift |  |
| ② ST30901000 (-) Base | | KV38100600 (J25267) Side bearing spacer drift |  |
| ST3306S001 Diff. side bearing puller set |  | HT72400000 (-) Slide hammer |  |
| ① ST33051001 (-) Body | | | |
| ② ST33061000 (J8107-2) Adapter | | | |

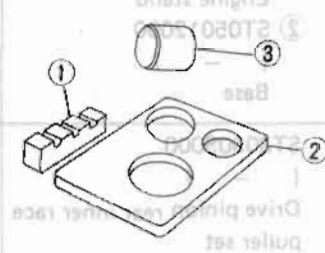
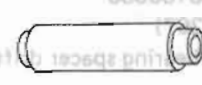
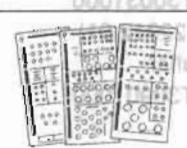
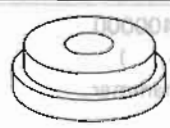
SERVICE SPECIAL SERVICE TOOLS (S.D.S.)

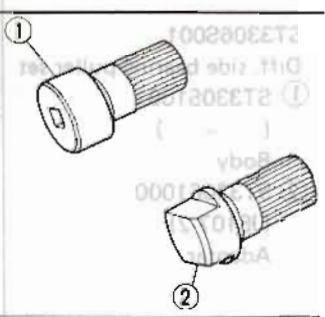
| Tool number (Kent-Moore No.) Tool name | Tool number (Kent-Moore No.) Tool name | Tool number (Kent-Moore No.) Tool name | Tool number (Kent-Moore No.) Tool name |
|--|---|---|---|
| ST3127S000 (See J25765-A) Preload gauge ① GG91030000 (J25765-A) Torque wrench ② HT62940000 (-) Socket adapter ③ HT62900000 (-) Socket adapter |  | (J25269-25) Lead preload washers (Pkg. of 5) |  |
| (J8001-M) Metric dial indicator set (J8001-6 dial indicator only) |  | (J25269-26) Bearing preload adapter |  |
| (J25269-B) Pinion height & preload gauge set ① J25269-23 Bolt & nut ② J23597-1 Arbor (Long plunger) Use with J23597-1 |  | (J25269-29) Front bearing pilot support |  |
| (J25269-1) Gauge plate |  | (J25269-32) Instructions |  |
| (J25269-2) Rear pinion bearing pilot |  | (J25407-01) Side bearing measuring set consists of: ① J25407-1 4-step gauge block ② J25407-2 Base plate ③ J25407-3 Weight block |  |
| (J25269-3) Front pinion bearing pilot |  | (J26099-A) Differential shim organizer |  |
| (J25269-4) Side bearing discs (2 Req'd) |  | (J26335) Differential filler plug wrench |  |
| | | KV381051S0 (X34292) Rear axle shaft dummy ① KV38105110 (-) Torque wrench side ② KV38105120 (-) Vise side |  |