

SECTION BF**CONTENTS**

GENERAL SERVICING (Including all clip & fastener for Z31)	BF- 2
BODY END AND DOOR (Including "Opener" and "Power window". And also including wiring diagram)	BF- 6
SEAT (Including "Power seat" and wiring diagram)	BF-13
SEAT BELT	BF-24
INSTRUMENT (Including "Center console")	BF-25
INTERIOR AND EXTERIOR	BF-26
WINDSHIELD AND WINDOWS	BF-32
T-BAR ROOF	BF-37
MIRROR (Including wiring diagram)	BF-38
REAR AIR SPOILER AND HIGH-MOUNTED STOP LAMP	BF-39
REAR COMBINATION LAMP	BF-40
BODY ALIGNMENT – Engine compartment & Underbody (Including the actual dimensions between the points and the coordinates of the points) ..	BF-41

- ★ For theft warning system and digital touch entry system, refer to EL section.
- ★ For seat belts, refer to MA section.
- ★ Method of reading electrical diagram in BF section is basically the same as in the EL section.
So refer to "HOW TO READ DIAGRAM" in EL section.
- ★ For power supply routing, refer to "POWER SUPPLY" in EL section.
- ★ Black box internal circuits in BF section are a summary of actual circuit.
Use only for studying the operation.
- ★ "Remarks" and "Connections" in electrical diagram show the terminal meaning and actual electrical flow.
- ★ For connector Nos. in wiring diagrams in this section, refer to Harness Layout in EL section.







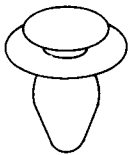

GENERAL SERVICING

Precautions

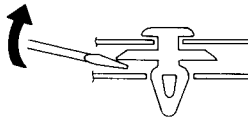
- When removing or installing various parts, place a cloth or padding onto the vehicle body to prevent scratches.
- Handle trim, molding, instruments, grille, etc. carefully during removing or installation. Be careful not to soil or damage them.
- Apply sealing compound where necessary while installing parts.
- When applying sealing compound, be careful that the sealing compound does not protrude from parts.
- When replacing any metal parts (for example body outer panel, members, etc.), be sure to take rust prevention measures.

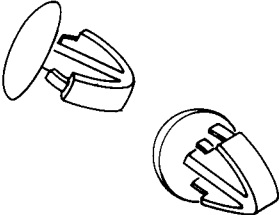

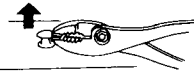
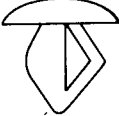
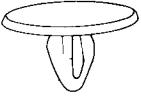
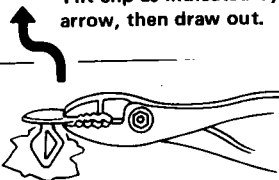
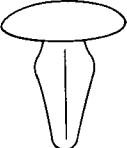
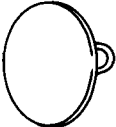

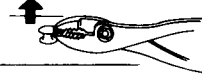
Clip and Fastener

- Clips and fasteners in BF section correspond to the following numbers and symbols.

No.	Symbol	Shape	Removal & Installation	Location
C101			<p>Removal: Remove by bending up with a flat-bladed screwdriver.</p> 	<ul style="list-style-type: none"> • Front door trim • Back door trim • L.H. rear side trim • Side window corner molding (2 seater)
C103			<p>Removal: Remove with flat-bladed screwdrivers or pliers.</p>  	<ul style="list-style-type: none"> • Front bumper • Rear bumper • Front pillar outer garnish • Front floor carpet • Front seat
C105			<p>Removal: Tilt clip as indicated by arrow, then draw out.</p> 	<ul style="list-style-type: none"> • Luggage floor mat
C106			<p>Removal: Remove with flat-bladed screwdrivers or pliers.</p>  	<ul style="list-style-type: none"> • Door weatherstrip • Body side weatherstrip • Hood front sealing rubber

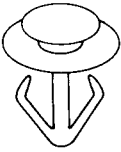
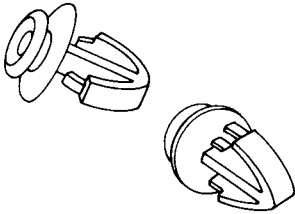
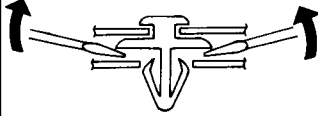

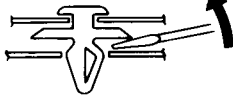
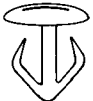
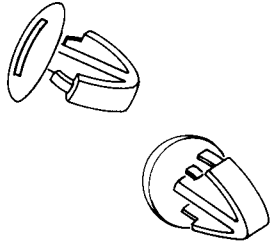
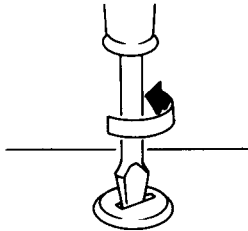
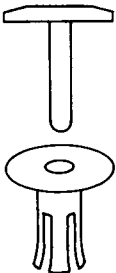
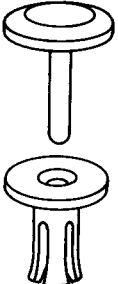
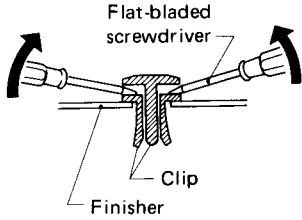
GENERAL SERVICING

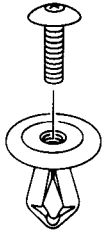
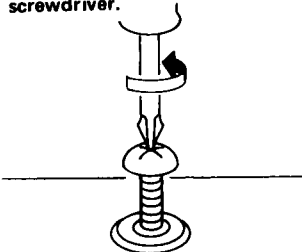
Clip and Fastener (Cont'd)

No.	Symbol	Shape	Removal & Installation	Location
C107	 <p style="text-align: center;">SBF365B</p>	 <p style="text-align: center;">SBF366B</p>	<p>Removal: Remove by bending up with flat-bladed screwdrivers.</p>  <p style="text-align: center;">SBF367B</p>	<ul style="list-style-type: none"> • Rear upper side trim • Rear lower side trim (2+2 seater)
C108	 <p style="text-align: center;">SBF564B</p>	 <p style="text-align: center;">SBF565B</p>	<p>Removal: Remove by bending up with a flat-bladed screwdriver.</p>  <p style="text-align: center;">SBF566B</p>	<ul style="list-style-type: none"> • Rear upper side trim • Rear wheelhouse trim (2 seater)
C111	 <p style="text-align: center;">SBF605C</p>	 <p style="text-align: center;">SBF606C</p>	 <p style="text-align: center;">SBF625C</p>	<ul style="list-style-type: none"> • Dash side finisher
C205	 <p style="text-align: center;">SBF636C</p>	 <p style="text-align: center;">SBF637C</p>	<p>Removal:</p>  <p style="text-align: center;">SBF638C</p>	<ul style="list-style-type: none"> • Front seat
CS102	 <p style="text-align: center;">SBF138B</p>	 <p style="text-align: center;">SBF139B</p>	<p>Removal: Screw out with a Phillips screwdriver.</p>  <p style="text-align: center;">SBF140B</p>	<ul style="list-style-type: none"> • Fender Protector

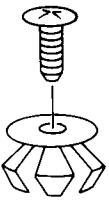
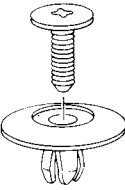
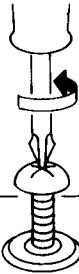
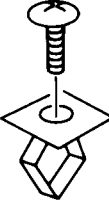
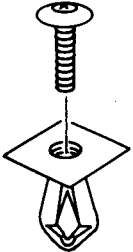

GENERAL SERVICING

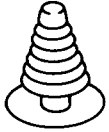
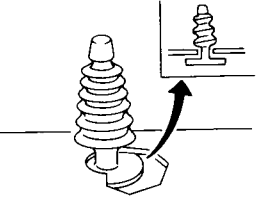
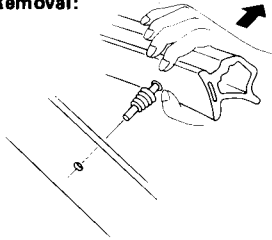
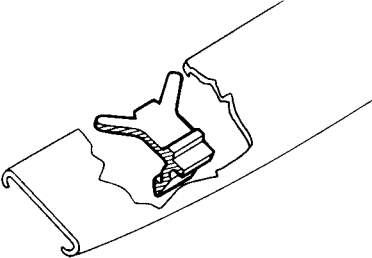
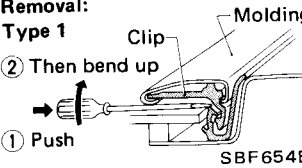
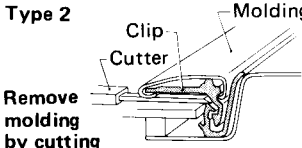
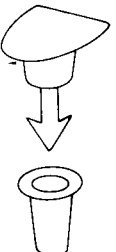
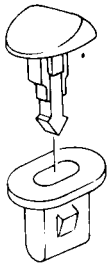
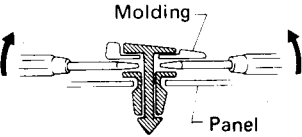
Clip and Fastener (Cont'd)

No.	Symbol	Shape	Removal & Installation	Location
CS103	 SBF363B	 SBF364B	 Removal: Screw out with a Phillips screwdriver.	<ul style="list-style-type: none"> Center pillar garnish
CS105	 SBF374B	 SBF375B	 SBF140B	<ul style="list-style-type: none"> Air inlet grille (Dash upper)
CE103	 SBF103B	 SBF104B	Removal:  SBF147B	<ul style="list-style-type: none"> Door weatherstrip Body side weatherstrip
CE106	 SBF653B		Removal: Type 1 ② Then bend up ① Push  SBF654B Type 2 Remove molding by cutting off the clip.  SBF914B	<ul style="list-style-type: none"> Windshield upper & side molding
CE108	 SBF922B	 SBF923B	Removal: Remove by bending up with flat-bladed screwdrivers.  SBF924B	<ul style="list-style-type: none"> Sill molding

GENERAL SERVICING

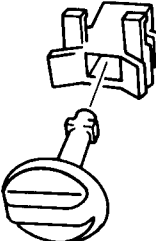
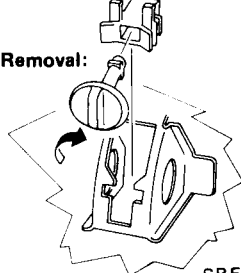
Clip and Fastener (Cont'd)

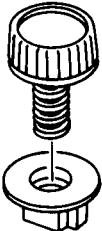
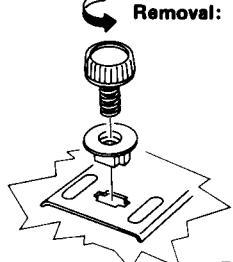
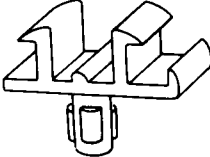
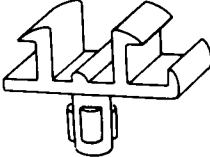
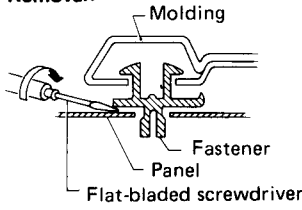
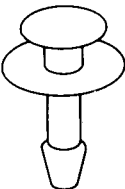
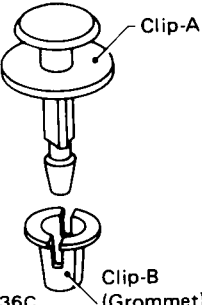
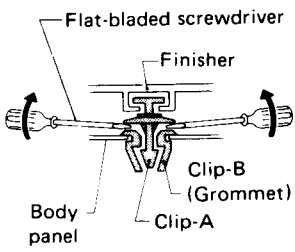
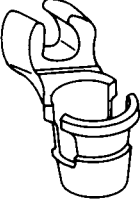
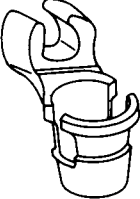
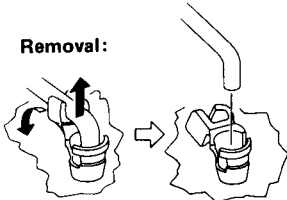
No.	Symbol	Shape	Removal & Installation	Location
<p>CF104</p>	 <p>SBF368B</p>	 <p>SBF369B</p>	<p>Removal:</p>  <p>SBF370B</p>	<ul style="list-style-type: none"> ● Rear trim
<p>CF105</p>	 <p>SBF371B</p>	 <p>SBF372B</p>	<p>Removal:</p>  <p>SBF373B</p>	<ul style="list-style-type: none"> ● Spare tire cover
<p>CF106</p>	 <p>SBF411B</p>	 <p>SBF412B</p>	<p>Removal:</p>  <p>SBF412B</p>	<ul style="list-style-type: none"> ● Back door upper molding
<p>CF113</p>	 <p>SBF035C</p>	 <p>SBF036C</p>	<p>Removal:</p>  <p>SBF652B</p>	<ul style="list-style-type: none"> ● Front door trim
<p>CR101</p>	 <p>SBF106B</p>	 <p>SBF106B</p>	<p>Removal:</p>  <p>SEF146B</p>	<ul style="list-style-type: none"> ● Front door lock system ● Back door lock system

BODY END AND DOOR

- When removing and installing hood or back door, place a cloth or other padding on hood or back door corners to avoid scratching vehicle body.
- When removing clip or fastener, refer to CLIP & FASTENER.
- Apply sealing compound where necessary when installing parts.

Front End

- Hood adjustment: Adjust at hinge portion.
- Hood lock adjustment: After adjusting, check hood lock control operation. Apply a coat of grease to hood locks engaging mechanism.
- Hood opener: Do not attempt to bend cable forcibly. Doing so increases effort required to unlock hood.
- Bumper fascia: It is made of plastic, so do not use excessive force and take care to keep oil away from it.
- When adjusting or removing/installing hood or removing/installing hood switch, check theft warning system operation.

WARNING:

- a. Be careful not to scratch hood stay when installing hood. A scratched stay may cause gas leakage.
- b. The contents of the hood stay and bumper shock absorber are under pressure. Do not take apart, puncture, apply heat or allow fire near it.

Bumper shock absorber inspection

1. Check shock absorber for oil leakage, cracks or deformation.
2. Function of shock absorber;
 - (1) Place vehicle in front of a wall.
Apply parking brake and place tire stoppers securely.
 - (2) Place a jack between bumper and wall; jack is positioned squarely with bumper directly in line with shock absorber to be checked.
 - (3) Apply pressure to compress shock absorber at least 10.0 mm (0.394 in).

Use a jack with capacity of more than 600 kg (1,323 lb).

- (4) Make sure bumper returns to its original position when jack is retracted. Replace if necessary.

CAUTION:

It is not recommended to confirm proper installation by driving into walls or other barriers as this could cause personal injury or damage to the vehicle.

When replacing shock absorbers, make sure they are of the same type and rating, and manufactured by the same maker.

BODY END AND DOOR

Front End (Cont'd)

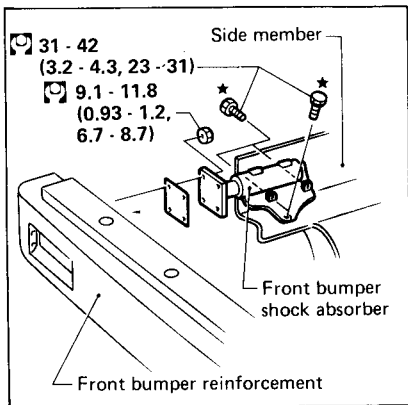
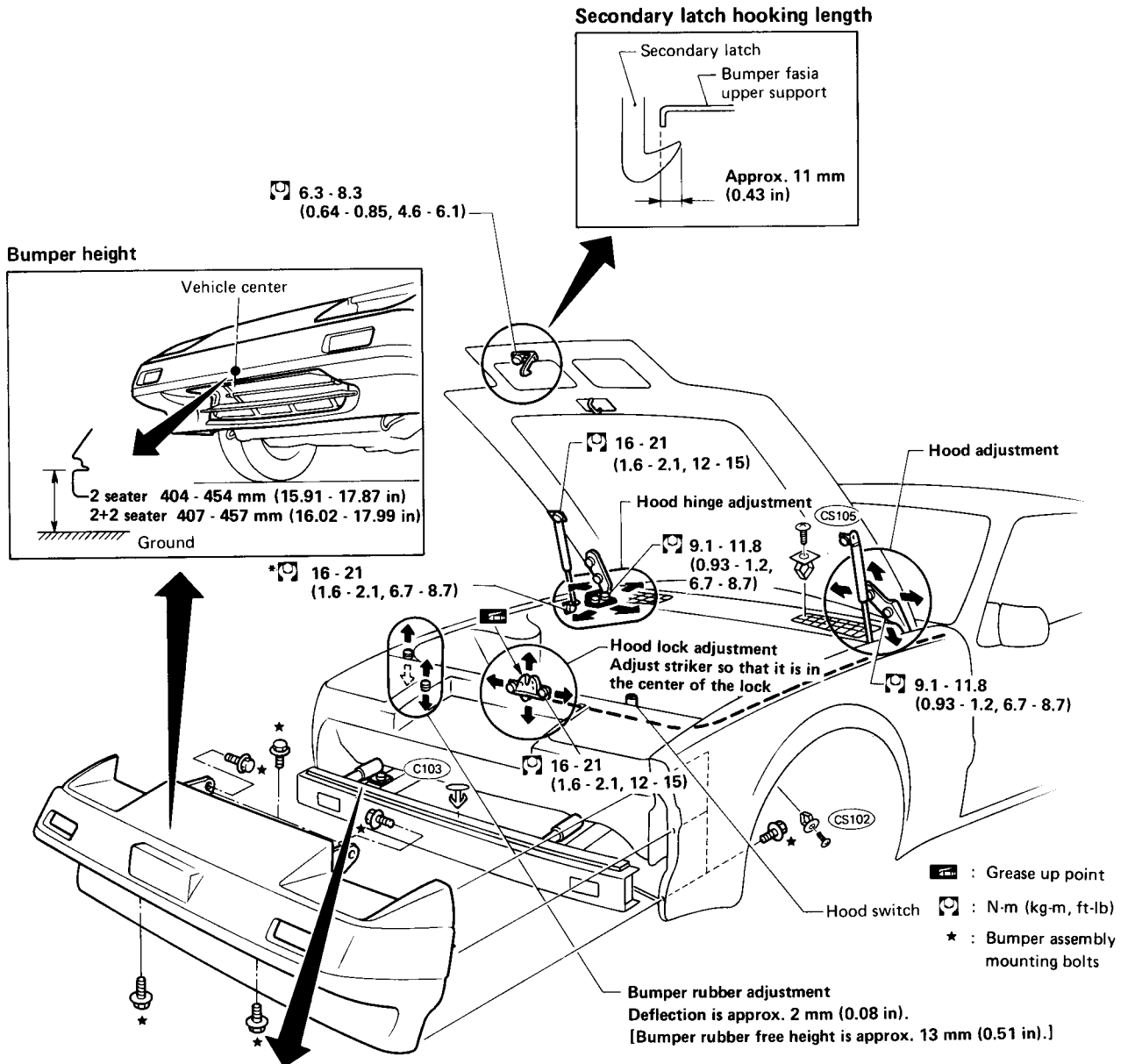

***Hood stay**
When removing/installing hood stay lower mounting (at stay-body portion), be careful not to drop collar.

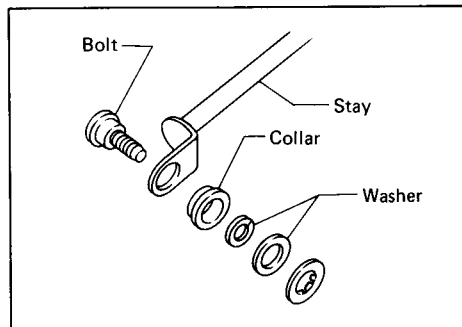

SBF582C

BODY END AND DOOR

Rear End

- Back door adjustment: Adjust at hinge for proper back door fit.
- Lock: Adjust lock so that it is in the center of the striker. After adjusting, check back door lock operation.
- Bumper fascia: It is made of plastic, so do not use excessive force and take care to keep oil away from it.
- When adjusting or removing/installing back door or removing/installing back door lock system, check theft warning system operation.
- Bumper shock absorber inspection: It's the same as front bumper. Refer to "Front End".

WARNING:

- Be careful not to scratch back door stay when installing back door. A scratched stay may cause gas leakage.
- The contents of the back door stay and bumper shock absorber are under pressure. Do not take apart, puncture, apply heat or allow fire near it.

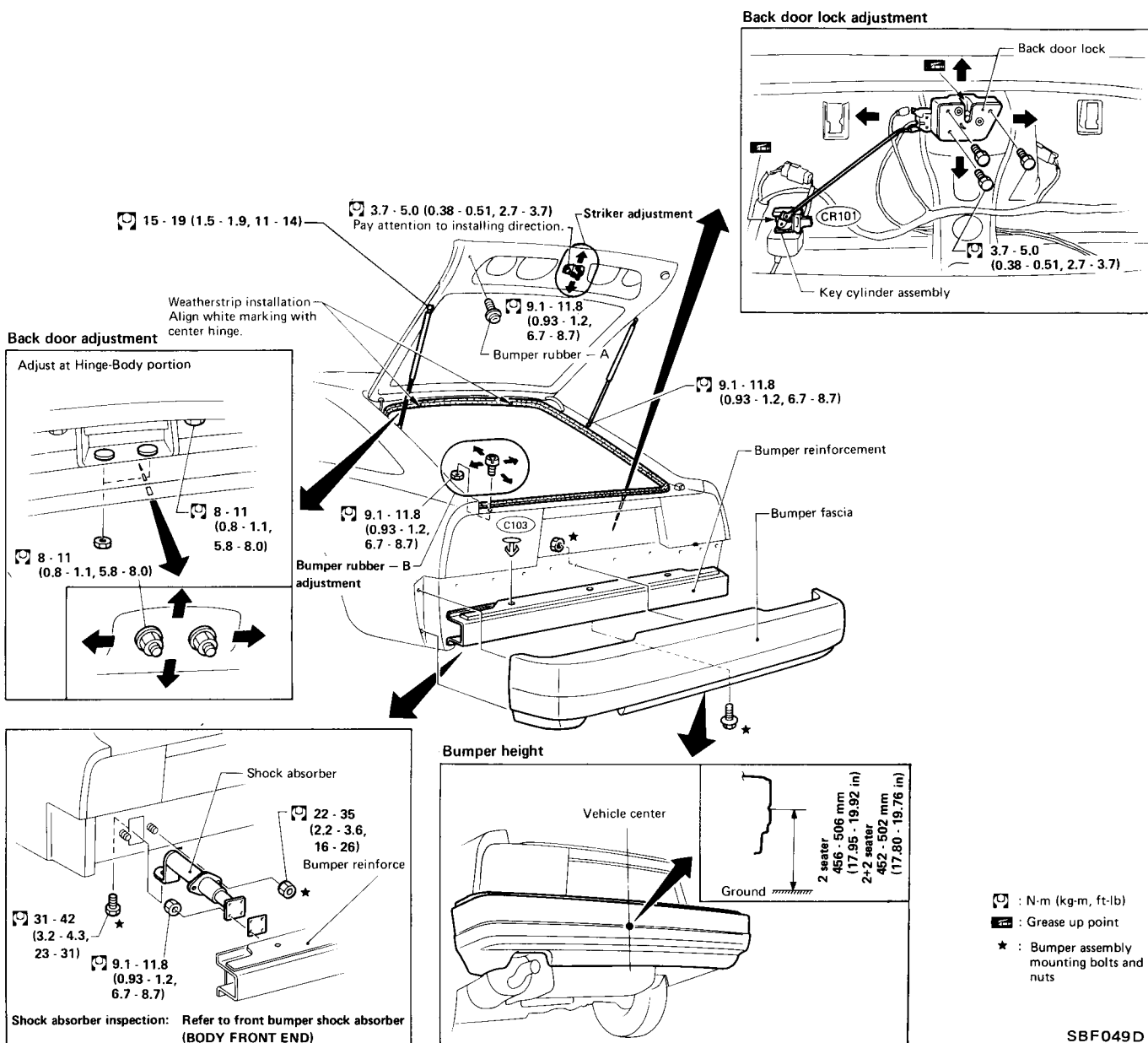

SBF049D

BODY END AND DOOR

Back Door and Fuel Filler Lid Opener

- Opener cable: Do not attempt to bend cable using excessive force.
- After installation, make sure that back door and fuel filler lid open smoothly.

Fuel filter lid opener

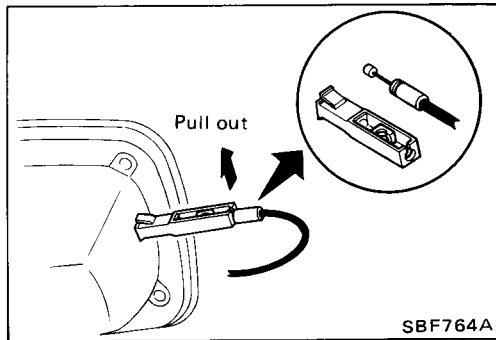

Back door lock

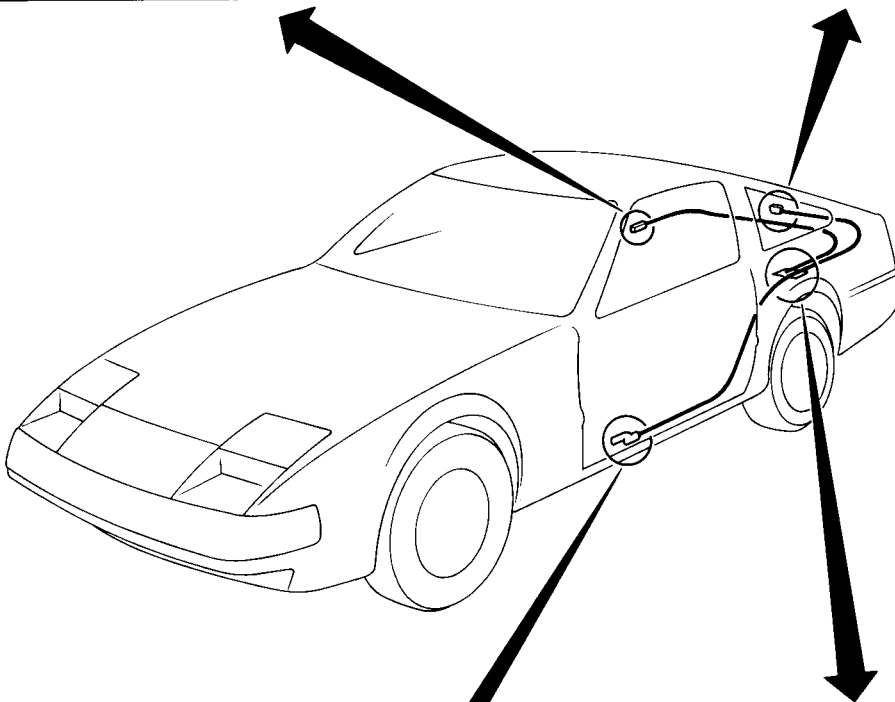
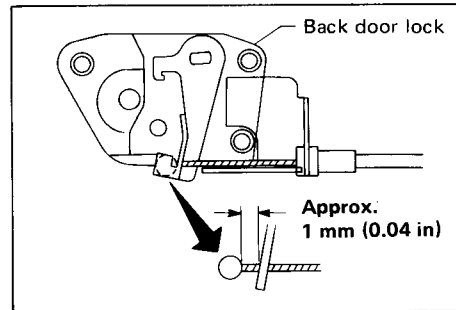

Opener handle

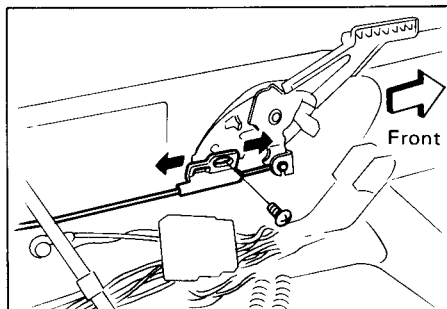

Fuel filler lid control

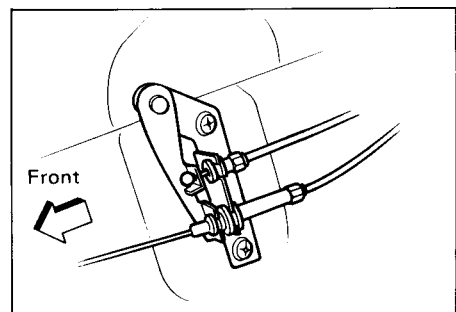

SBF389B

BODY END AND DOOR

Front Door

- After adjusting door or door lock, check door lock operation.
- When adjusting or removing/installing door or removing/installing door lock system or door switch, check theft warning system operation.

Outside handle adjustment

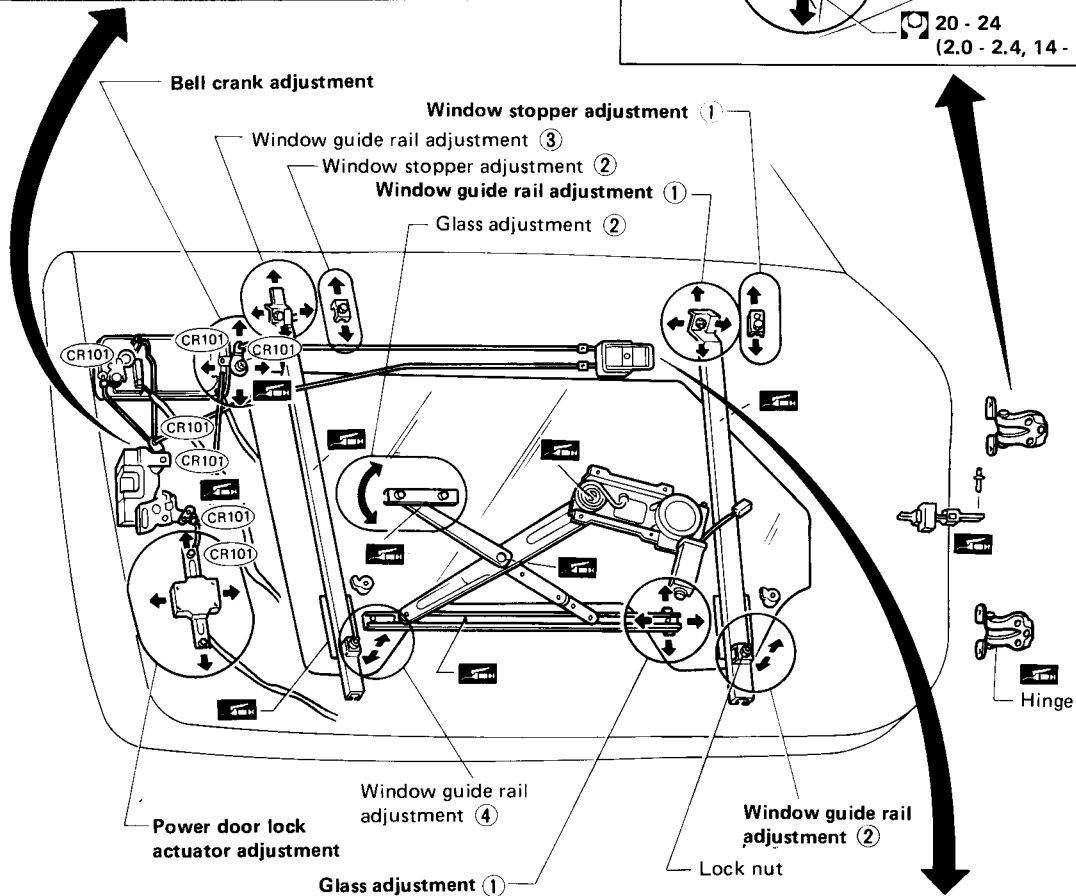
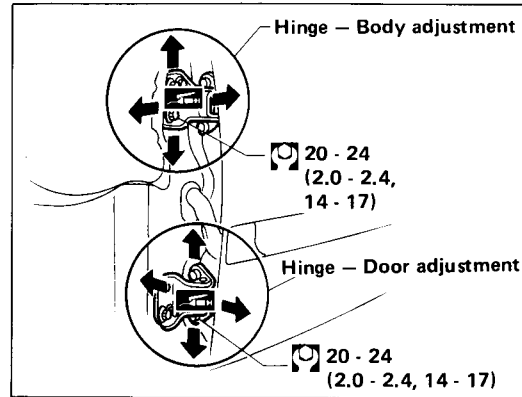
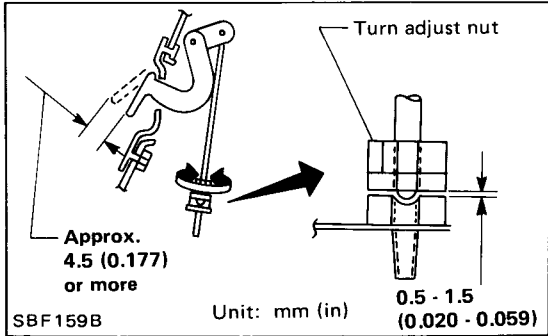

Striker adjustment

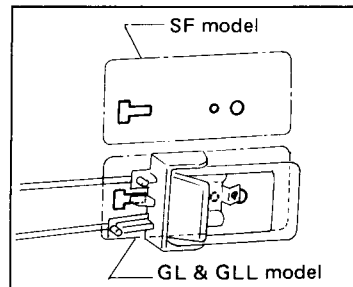
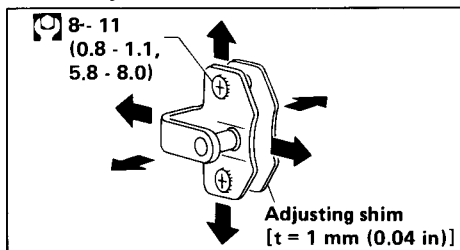

: N·m (kg·m, ft·lb)

: Grease-up portion

SBF584C

BODY END AND DOOR

Front Door (Cont'd)

POWER WINDOW/WIRING DIAGRAM

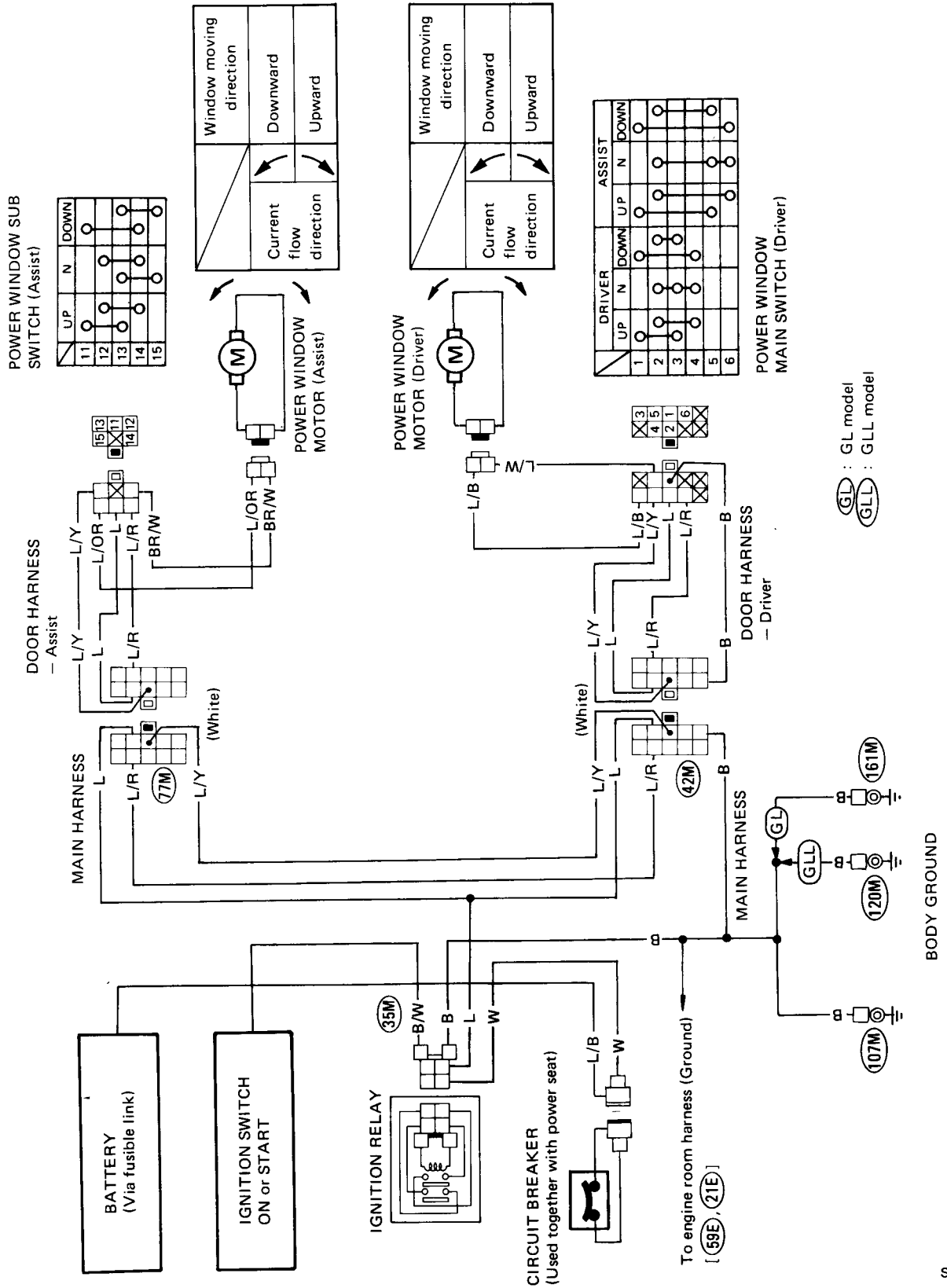

GL : GL model
 GLL : GLL model

BODY END AND DOOR

Front Door (Cont'd)

POWER DOOR LOCK/WIRING DIAGRAM

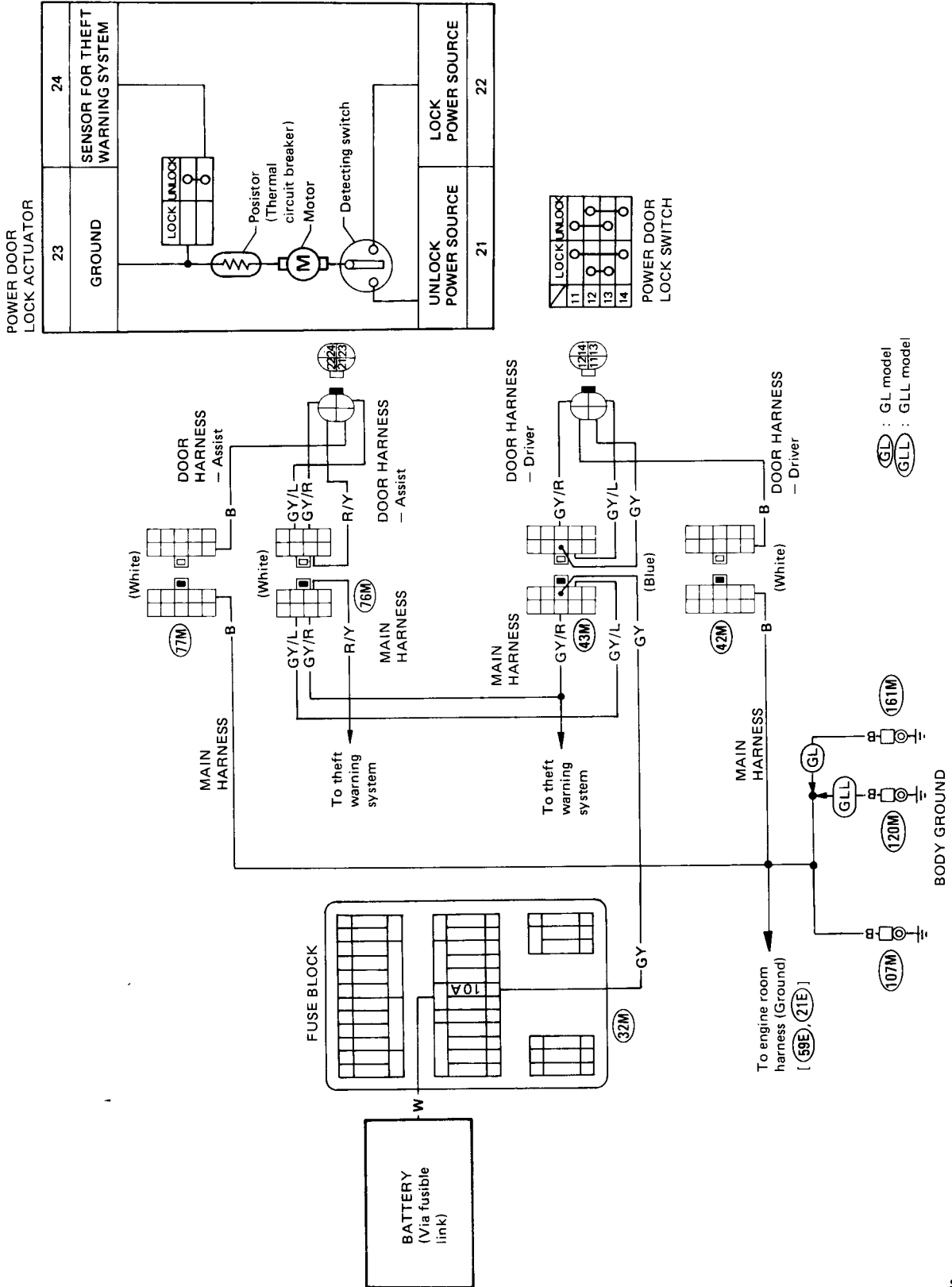

SEAT

- When removing or installing the seat trim, carefully handle it to keep dirt out and avoid damage.

Front Manual Driver Seat

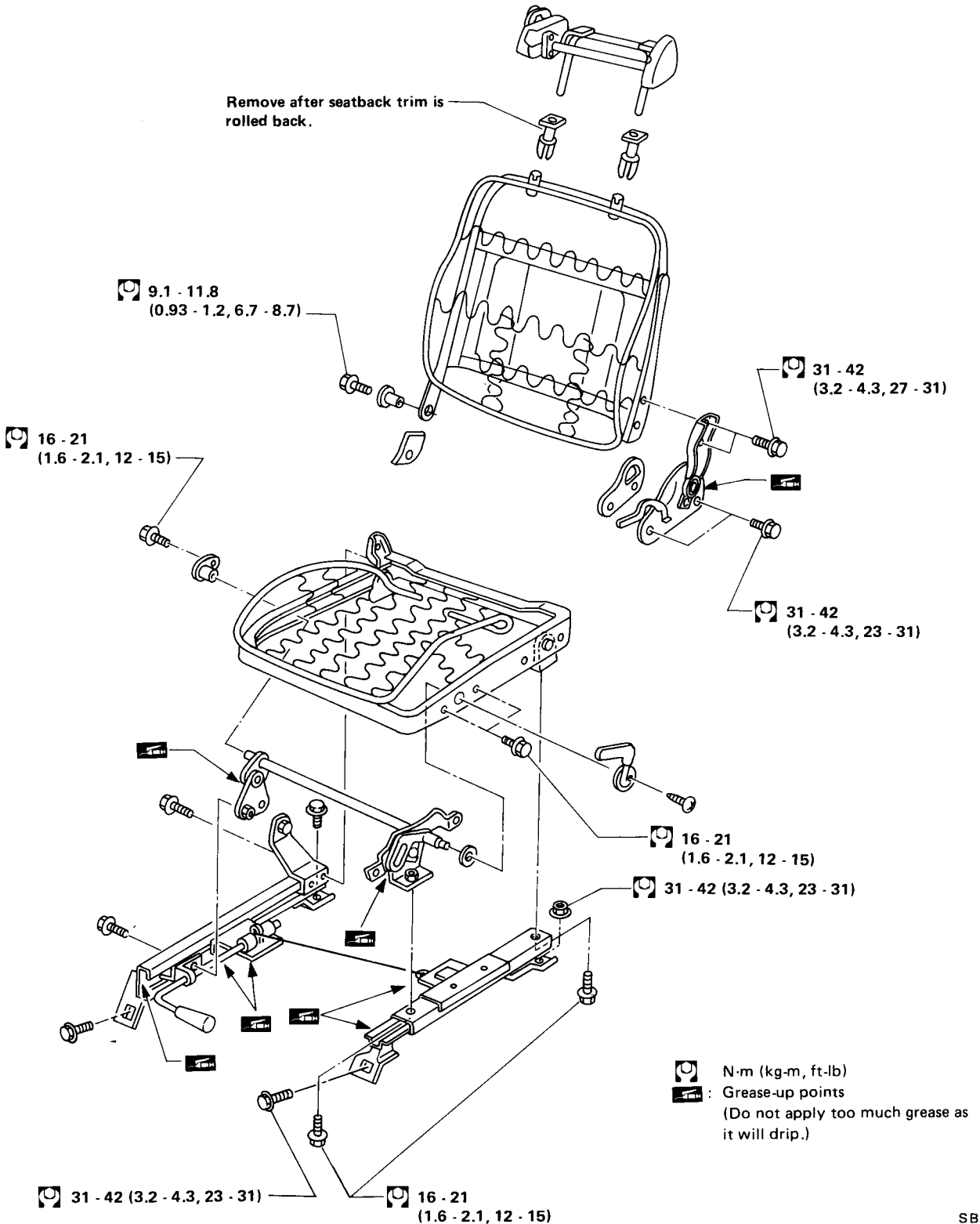

SBF527C

SEAT

Front Semi Power Driver Seat

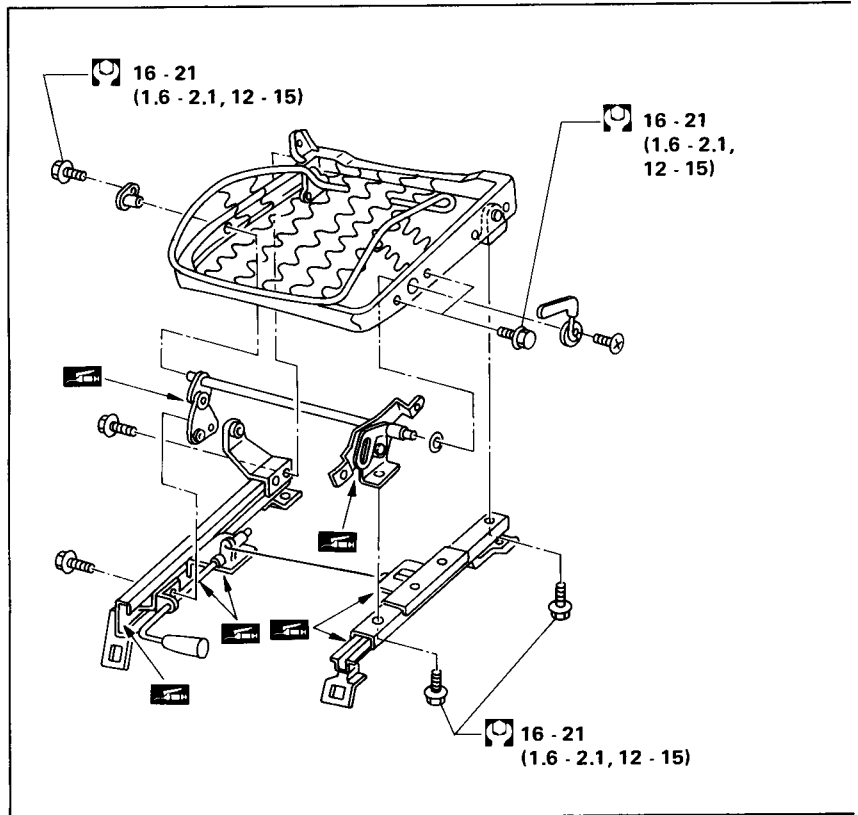
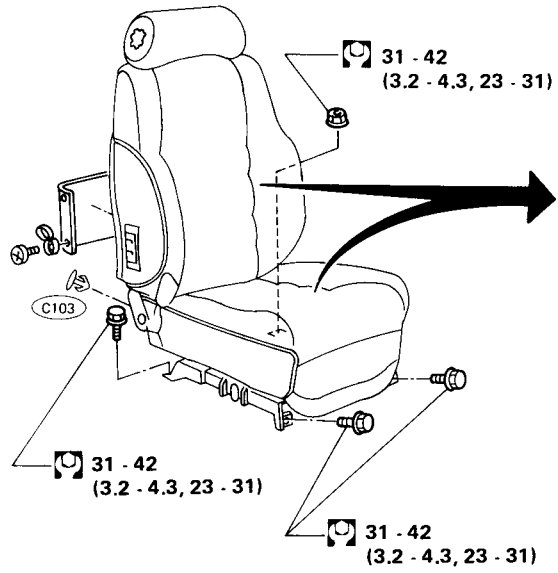

SEAT

Front Semi Power Driver Seat (Cont'd)

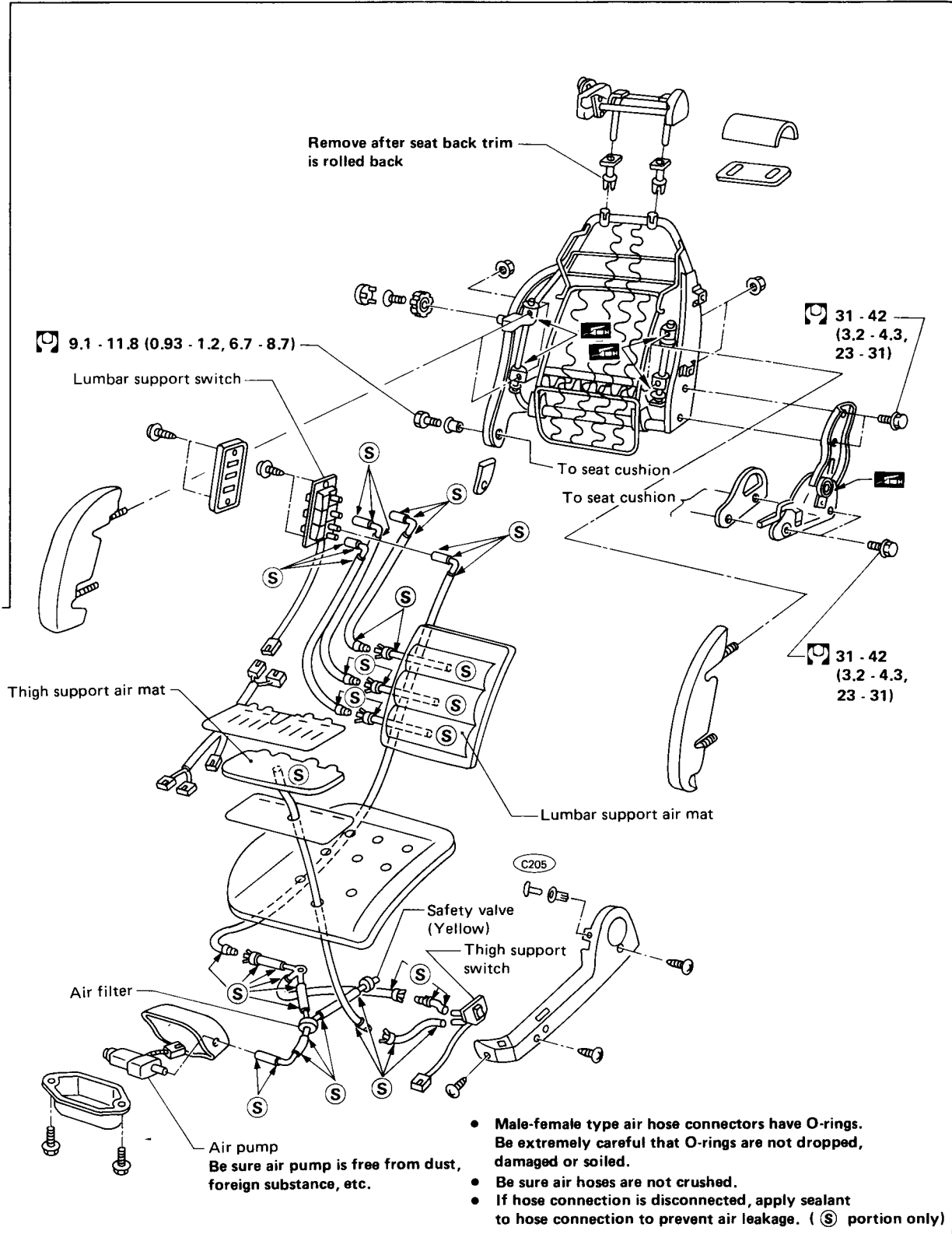

: N·m (kg·m, ft·lb)

: Grease-up points
(Do not apply too much grease as it will drip.)

: Sealant points

SBF526C

SEAT

Front Semi Power Driver Seat (Cont'd)

AIR DIAGRAM

- Be sure air hoses are not crushed.
- If hose connection is disconnected, apply sealant to hose connection to prevent air leakage. (S portion only)
- Be sure air pump is free from dust, foreign substance, etc.
- Install safety valve in its proper direction.
- Air pump operates only when each switch is turned ON.
- Male-female type air hose connectors have O-rings. Be extremely careful that O-rings are not dropped, damaged or soiled.

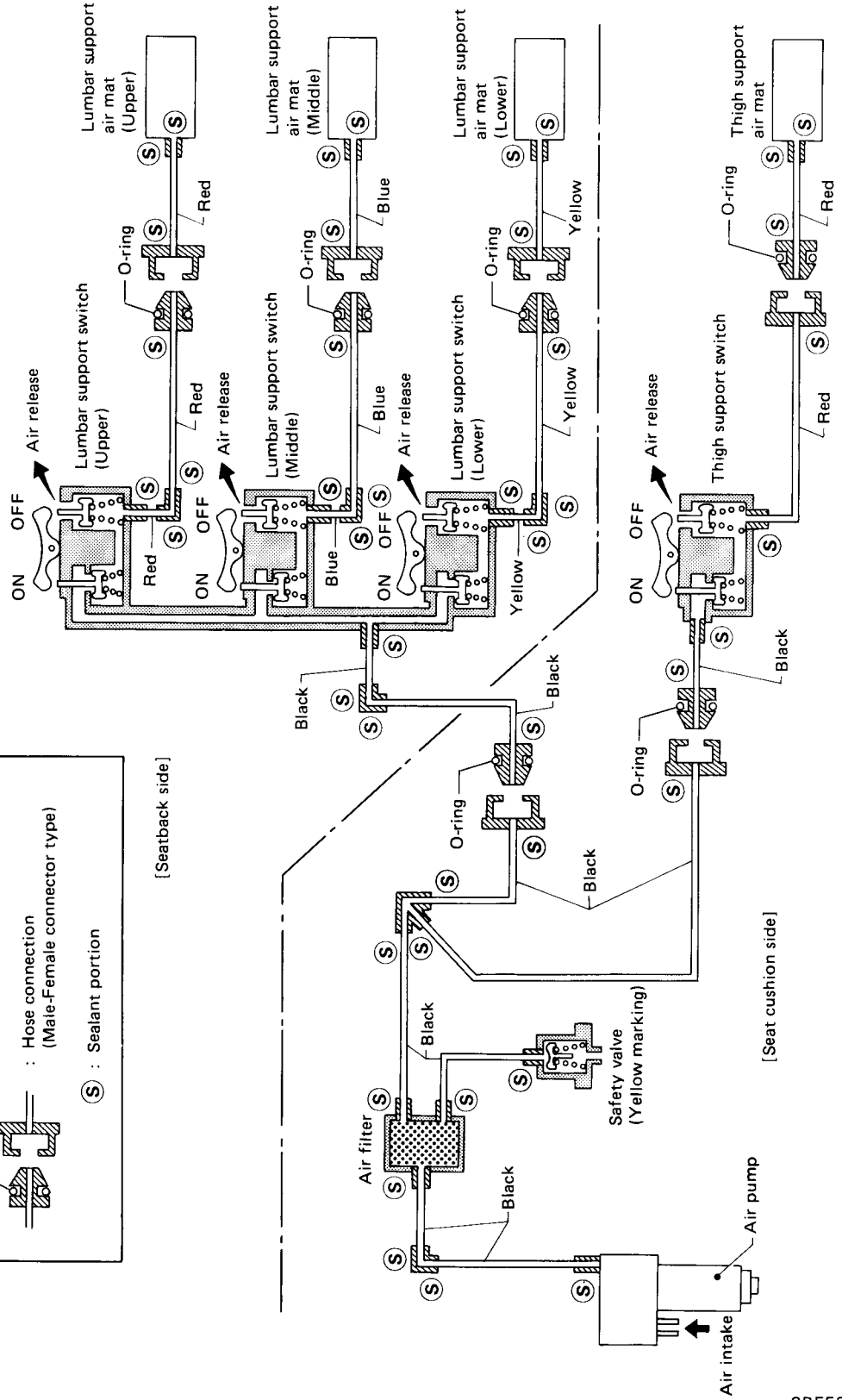
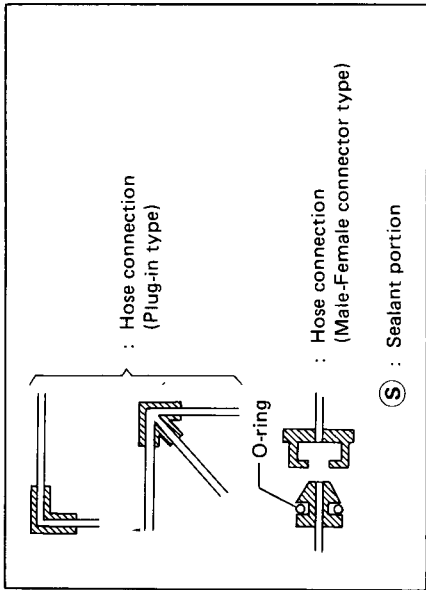

SBF532C

SEAT

Front Semi Power Driver Seat (Cont'd)

WIRING DIAGRAM

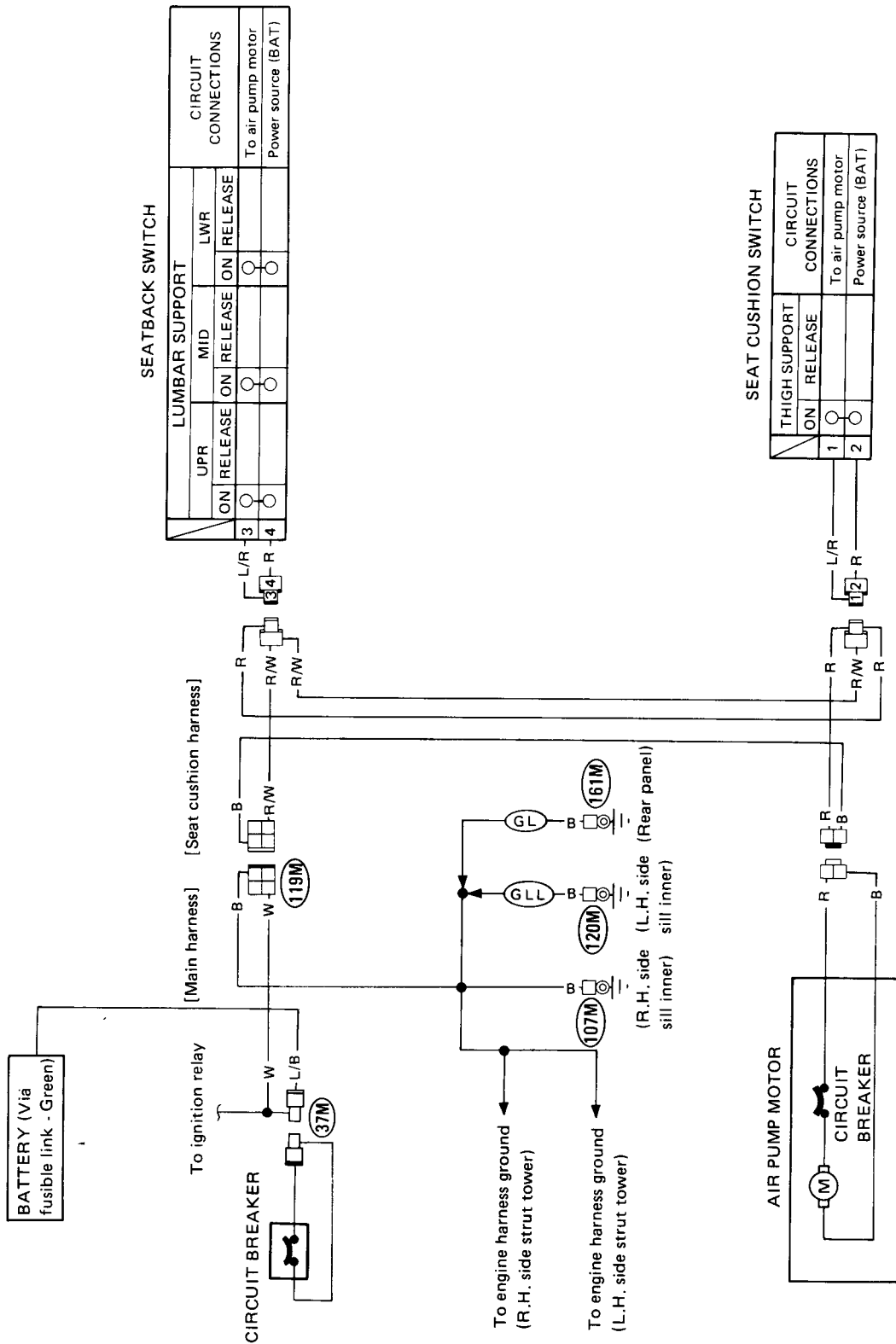

GL : GL model
 GLL : GLL model

SEAT

Front Full Power Driver Seat

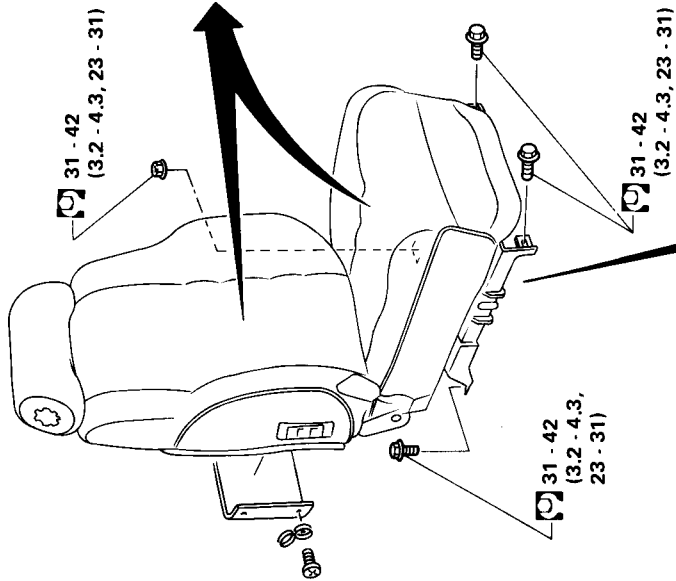
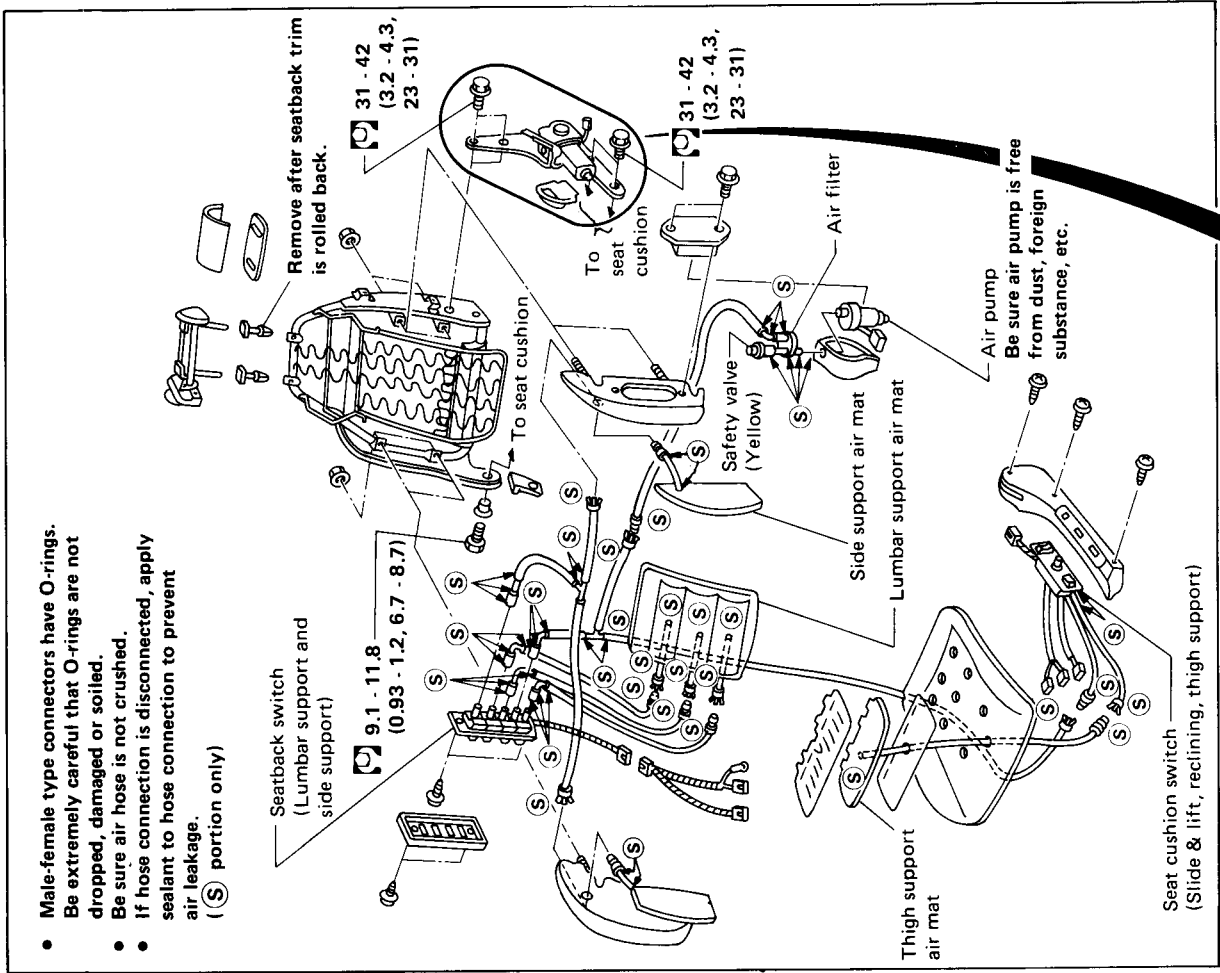

SEAT

Front Full Power Driver Seat (Cont'd)

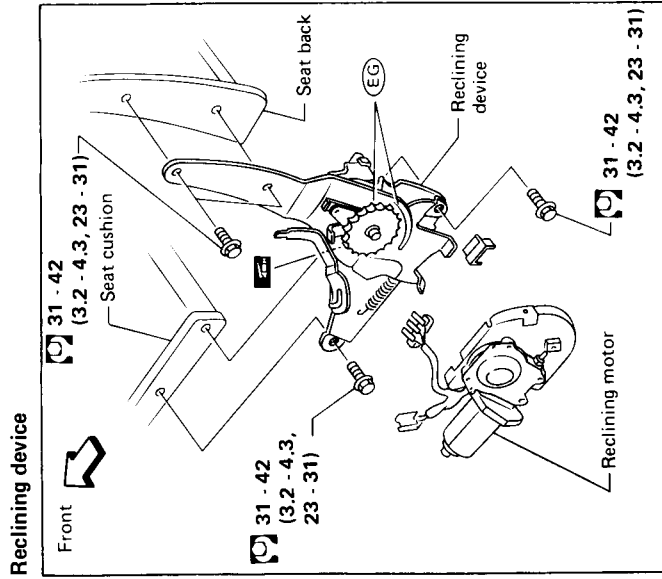

- : N·m (kg·m, ft·lb)
- : Grease up points (Do not apply too much grease as it will drip.)
- : Grease up points (Conductible type)
- : Sealant points

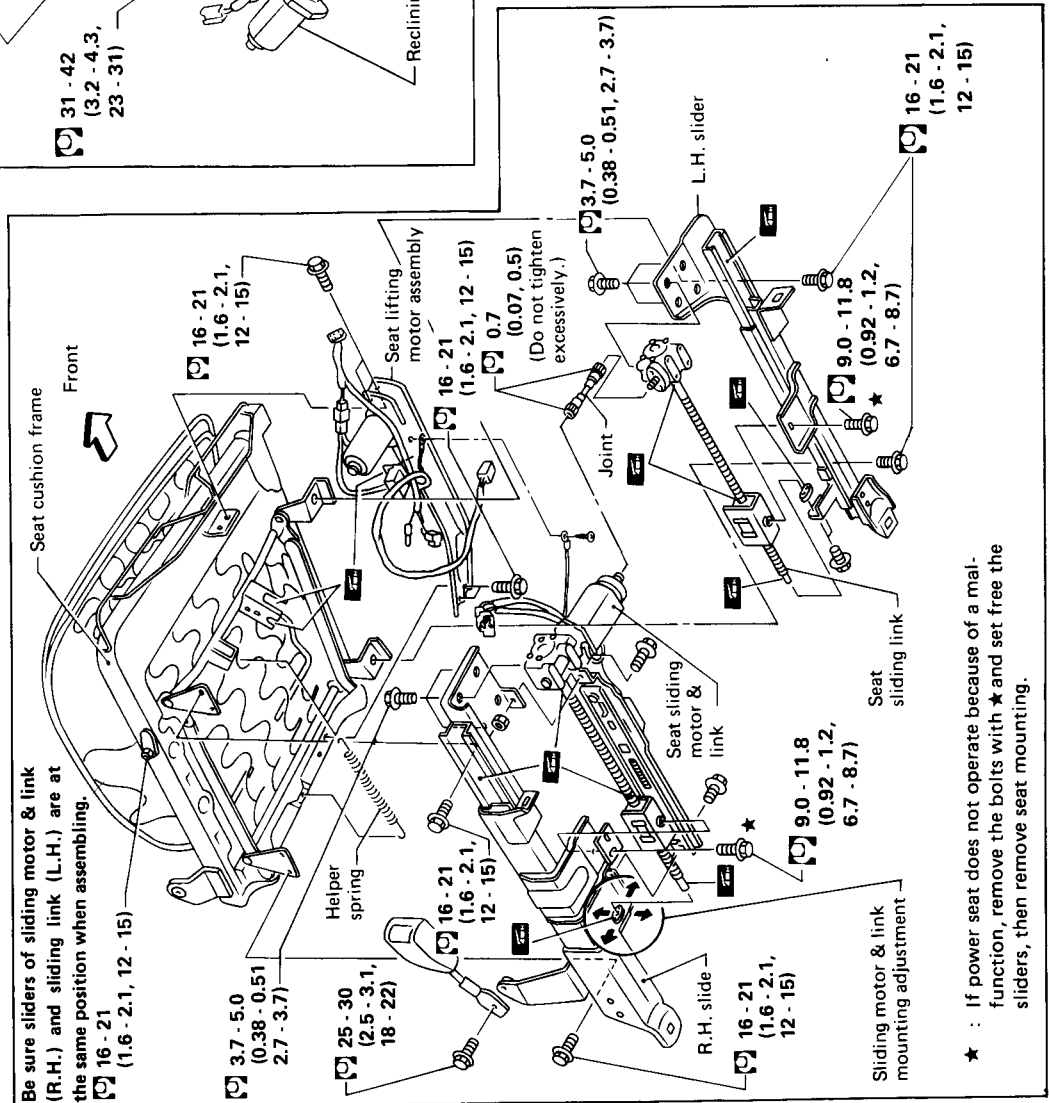

SEAT

Front Full Power Driver Seat (Cont'd)

AIR DIAGRAM

- Be sure air hoses are not crushed.
- If hose connection is disconnected, apply sealant to hose connection to prevent air leakage. (S portion only)
- Be sure air pump is free from dust, foreign substance, etc.
- Install safety valve in its proper direction.
- Air pump operates only when each switch is turned ON.
- Male-female type connectors have O-rings.
- Be extremely careful that O-rings are not dropped, damaged or soiled.

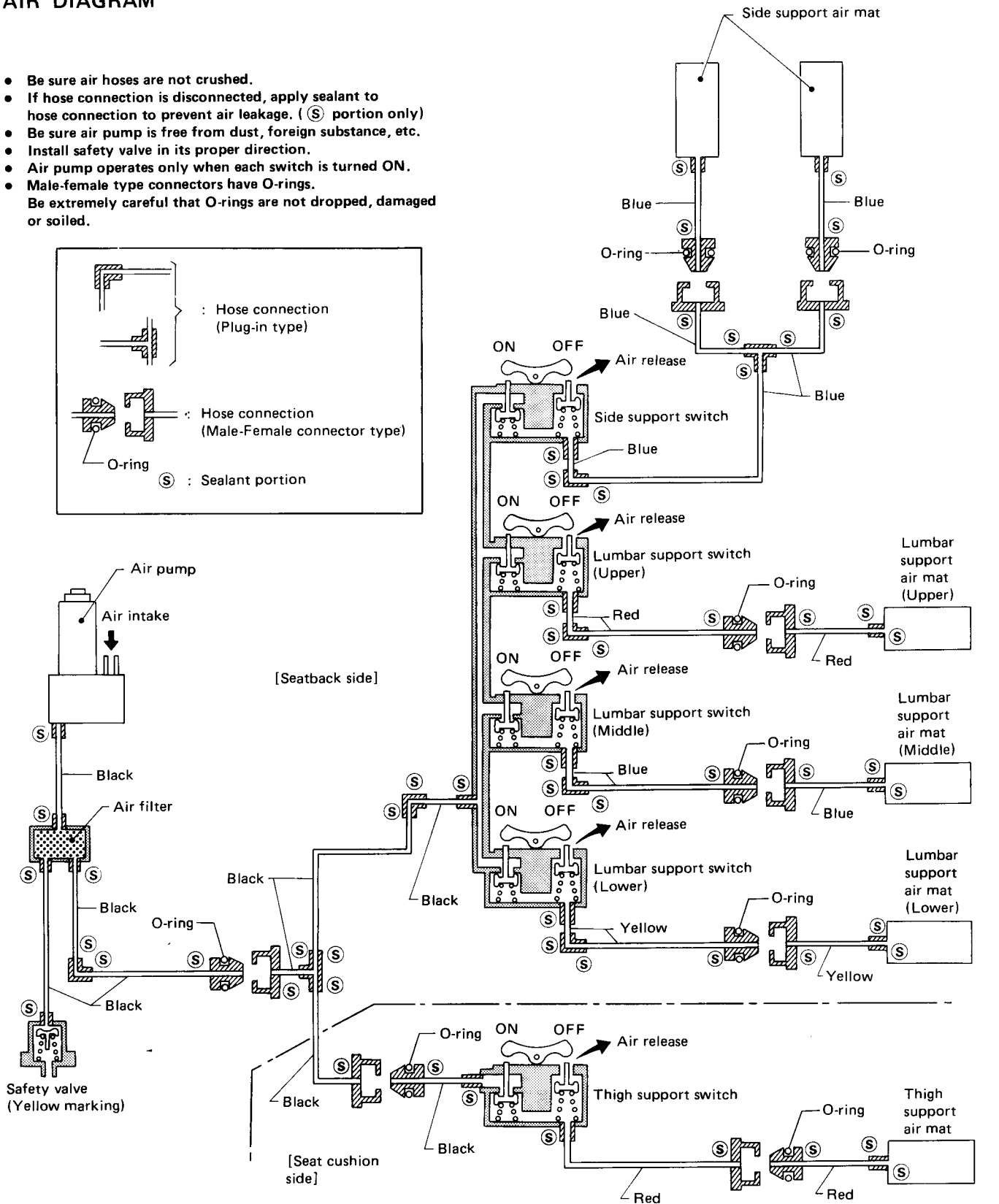
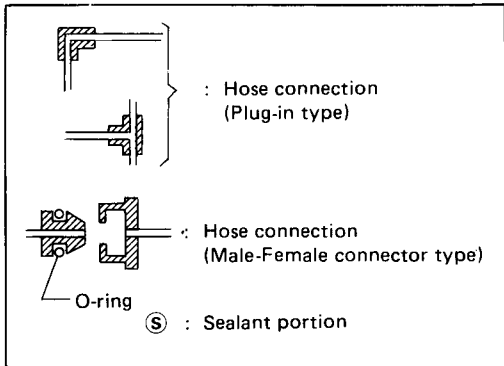

SBF531C

SEAT

Front Full Power Driver Seat (Cont'd)

WIRING DIAGRAM

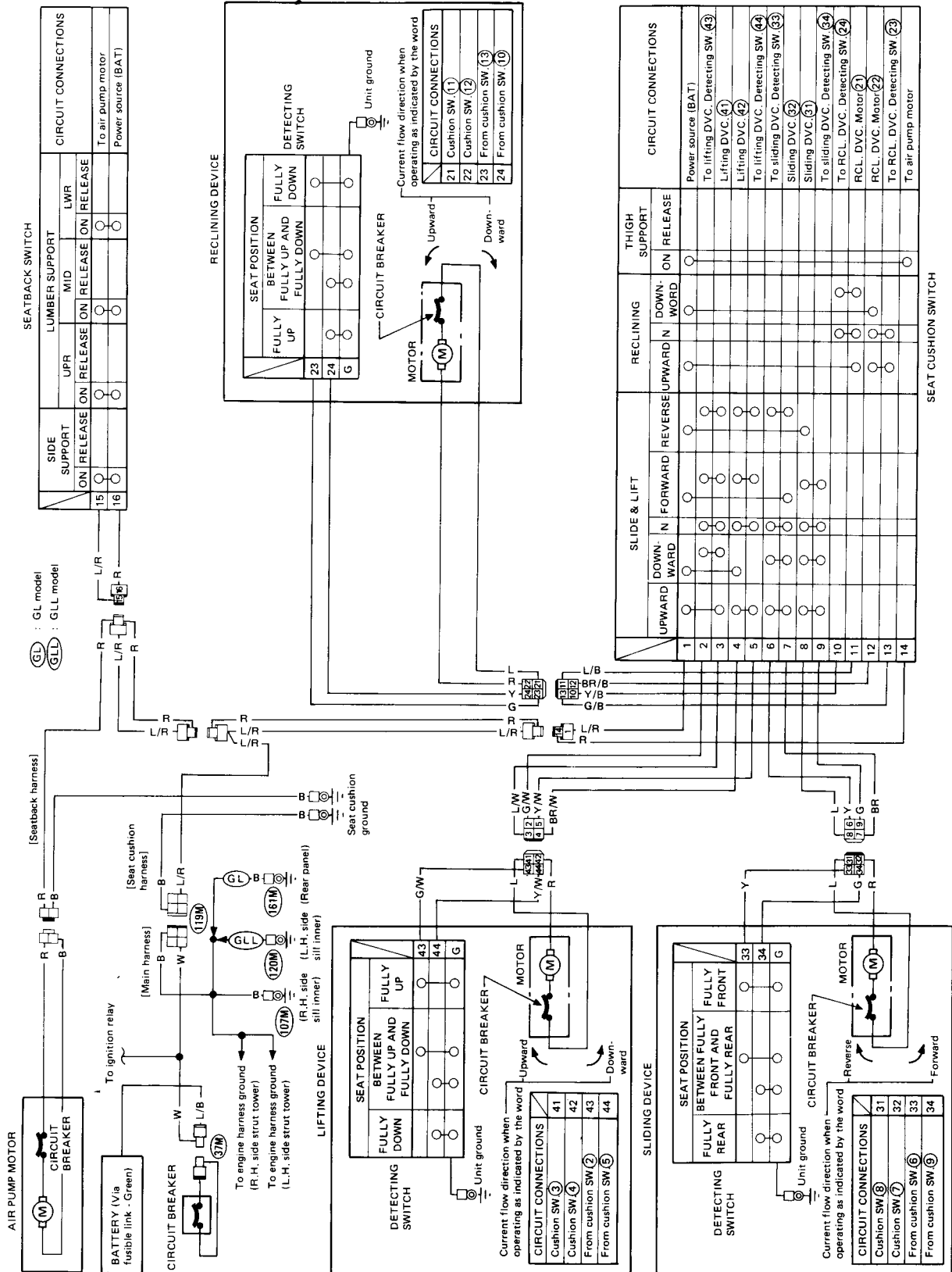

SBF529C

SEAT

Front Assist Seat

- Basically, this seat is the same as manual type front driver seat. 2 + 2 seater model differs from manual type front seat in the walk-in mechanism has been added to it. Refer to the description on manual type driver seat except for walk-in mechanism.

WALK-IN MECHANISM

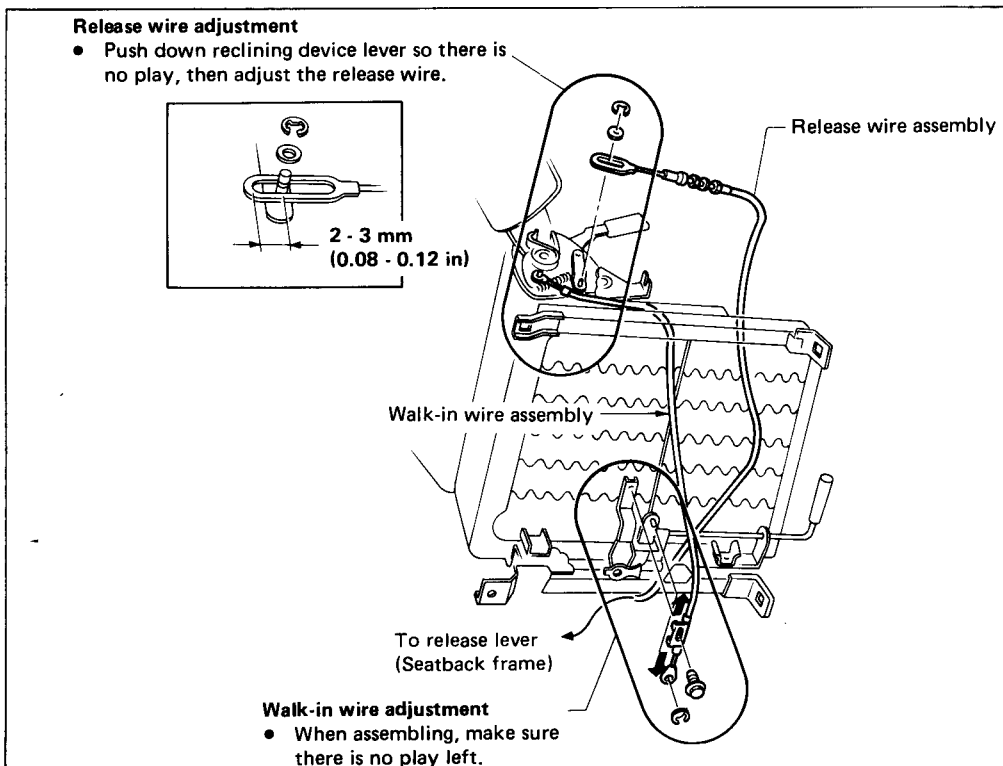
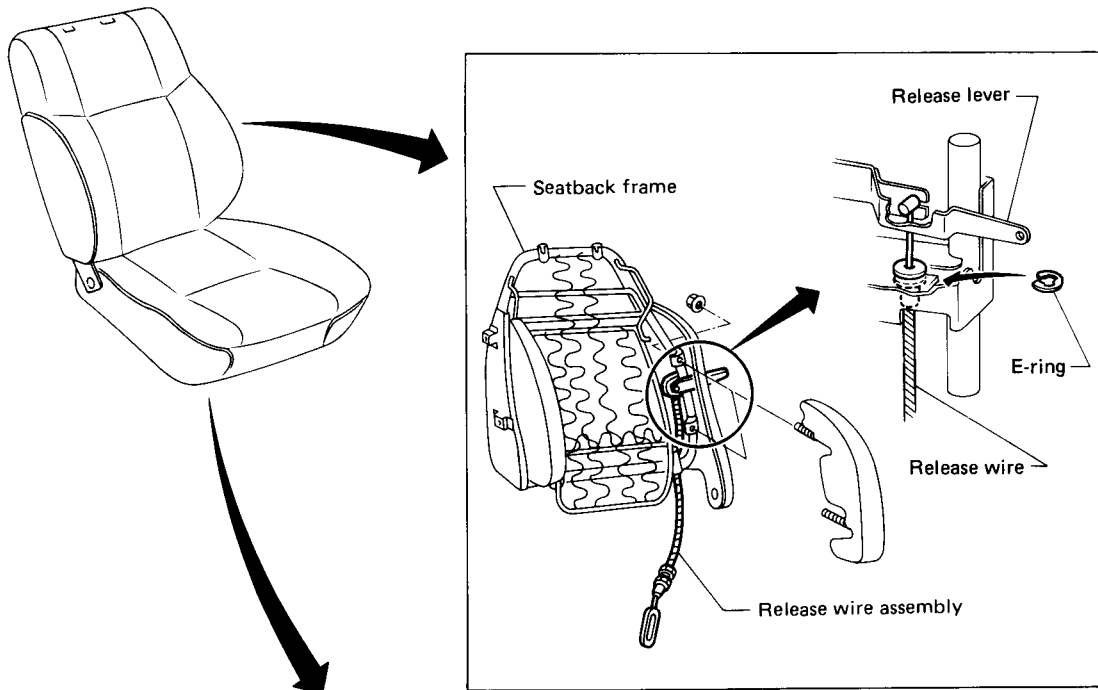

SBF528C

SEAT

Rear Seat

Striker

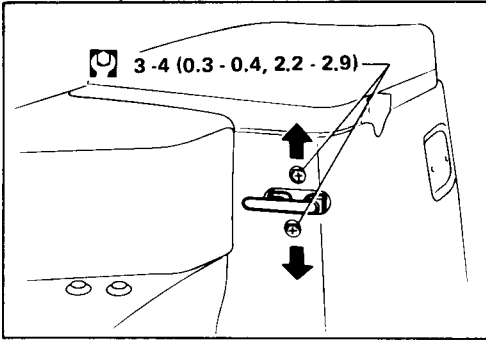

Seat back hinge

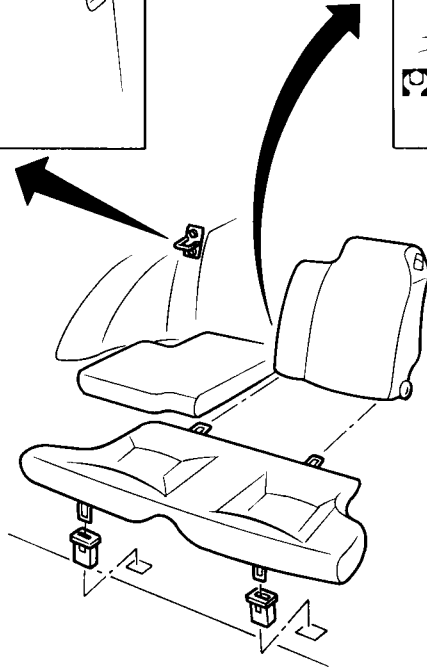
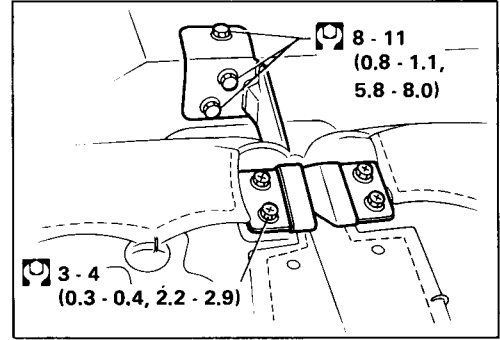

 : N·m (kg-m, ft-lb)

SBF587C

SEAT BELT

- Refer to MA section for installation of seat belts.
- GLL model has been equipped with seat belts with tension reducer. This unit reduces the force required to pull out seat belt while in use, and lessens pressure on the shoulder and hips for greater comfort.

TENSION REDUCER WIRING DIAGRAM

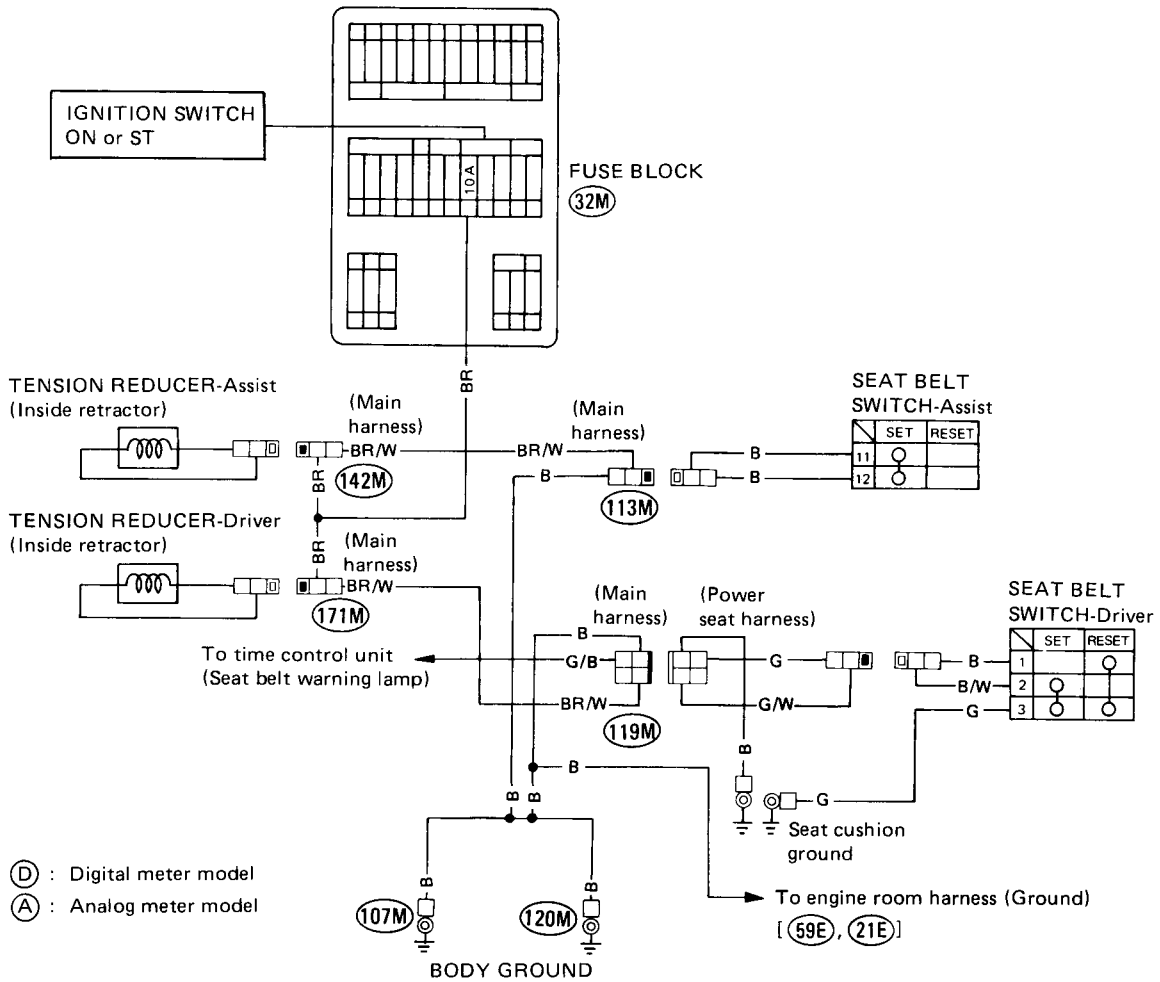

SBF588C

TENSION REDUCE OPERATION

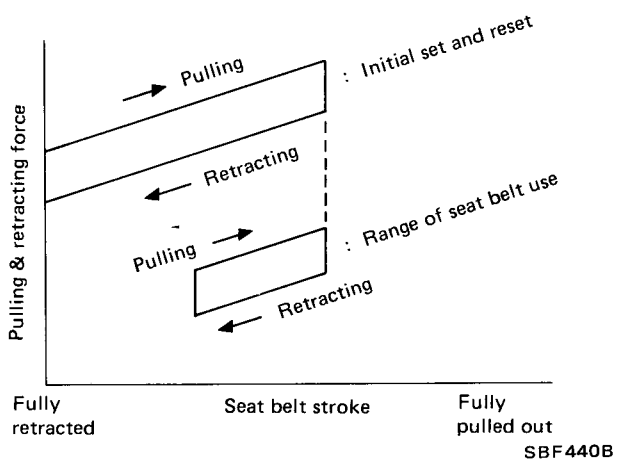

INSTRUMENT

- These parts are made of plastic, so do not use excessive force and be careful not to damage them.
- When you remove instrument assembly, you should remove radio, meter and defroster grille.

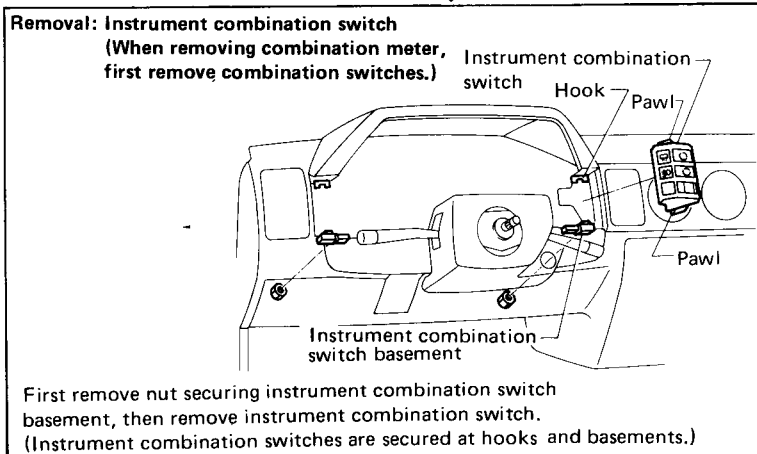
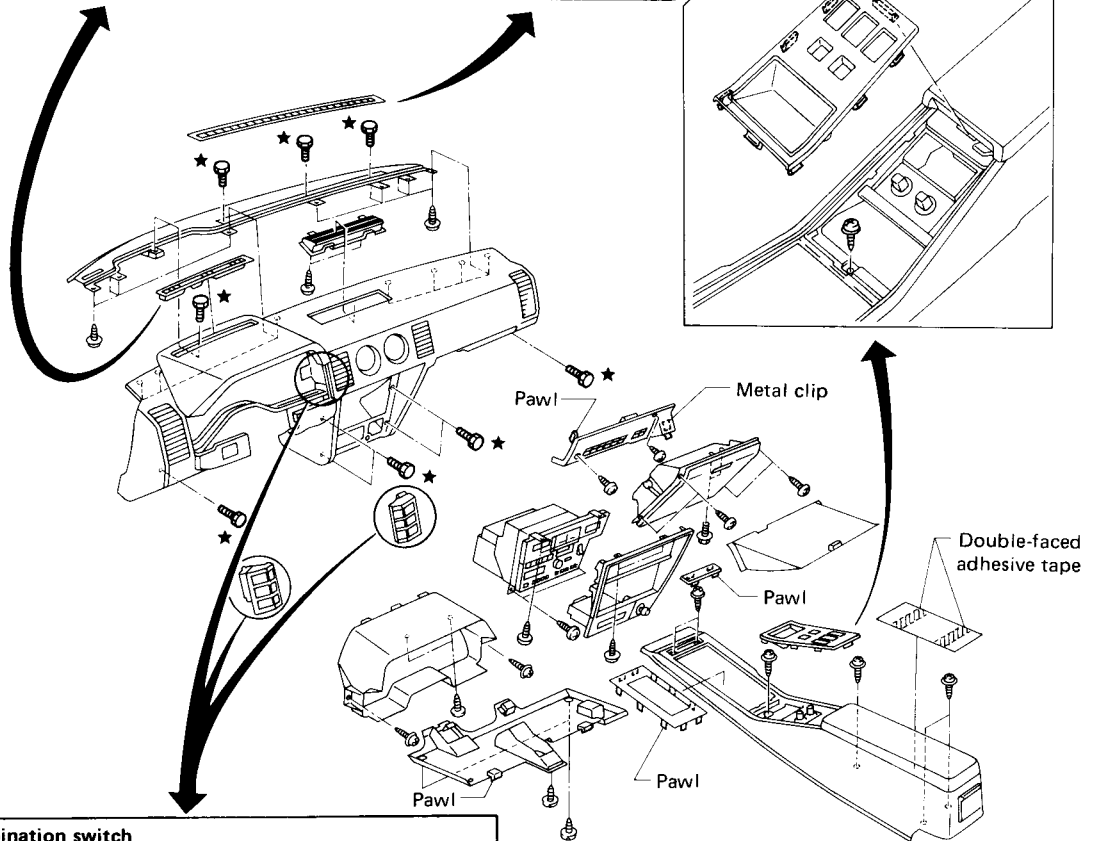
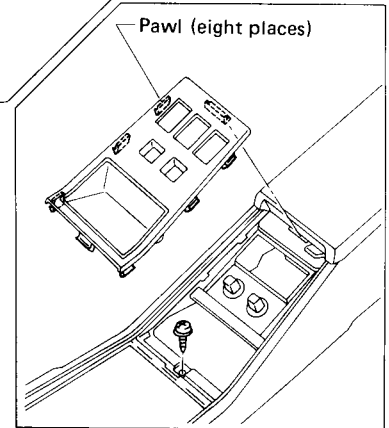
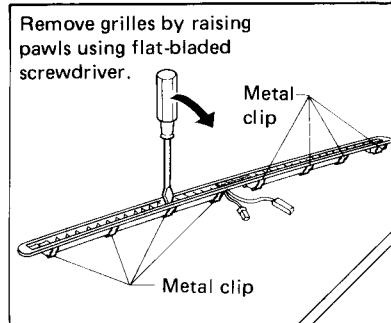
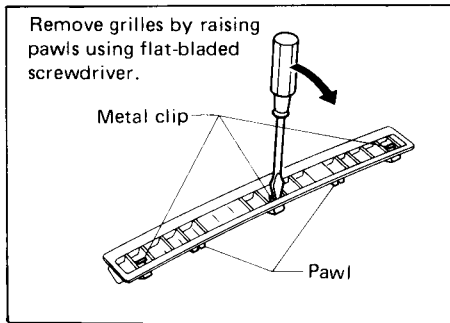

★ : Instrument assembly mounting screw

SBF589C

INTERIOR AND EXTERIOR

- When removing clip or fastener, refer to CLIP & FASTENER.
- When handling trim or molding, do not use excessive force and take care not to damage them.

Inside Trim

SIDE, LUGGAGE AND FLOOR TRIM

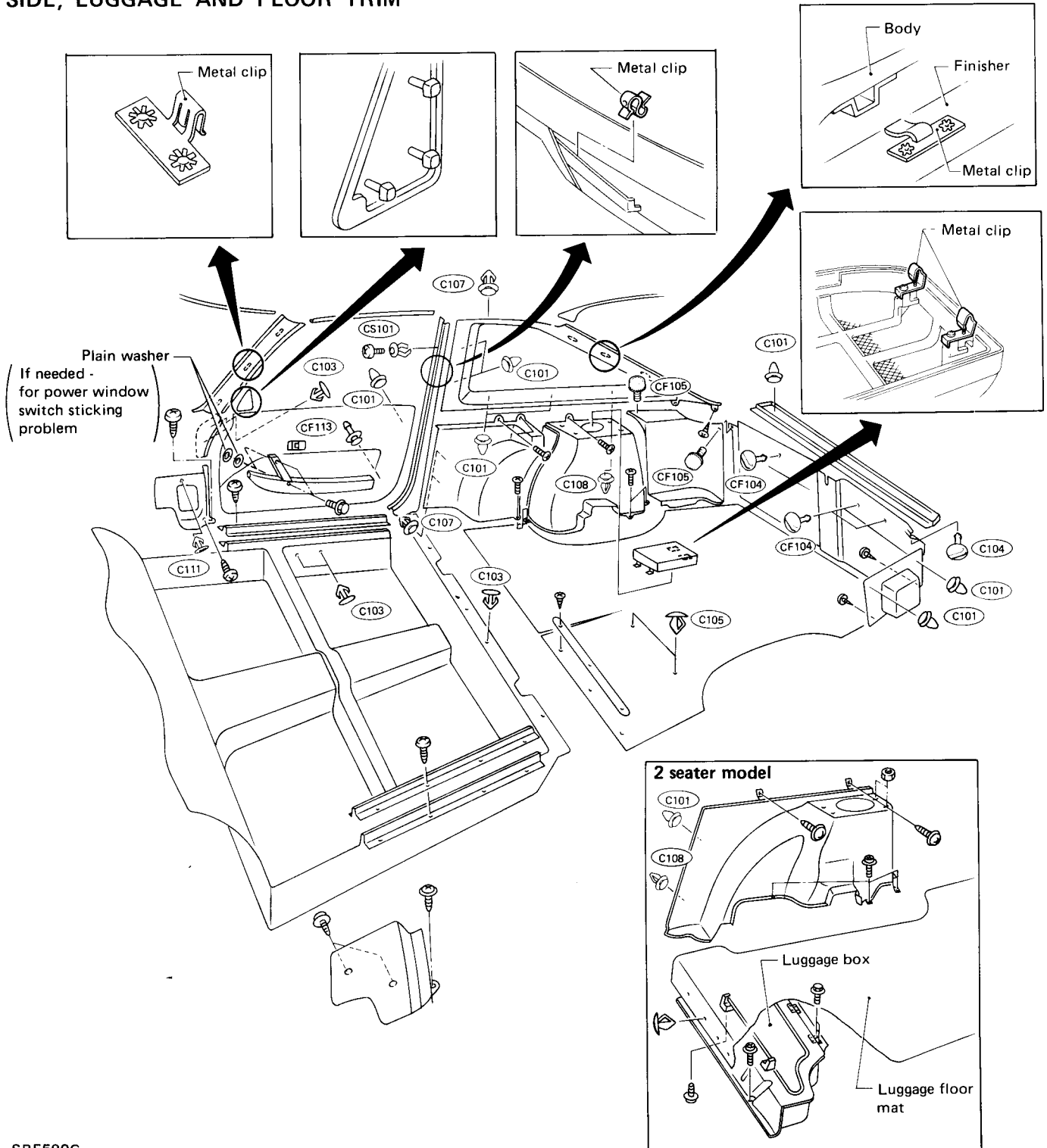

SBF590C

INTERIOR AND EXTERIOR

Inside Trim (Cont'd)

ROOF TRIM

Front portion

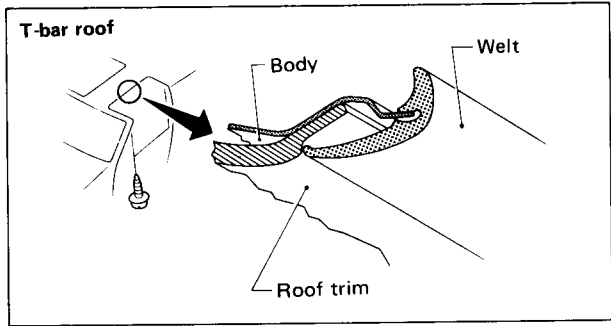
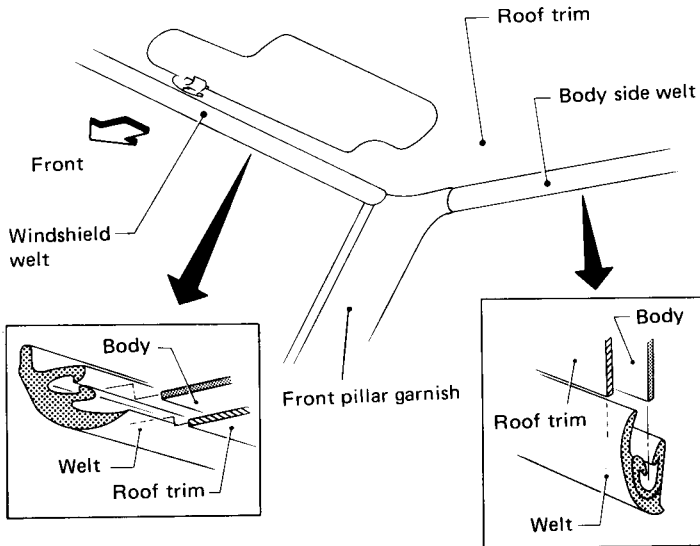

Rear portion

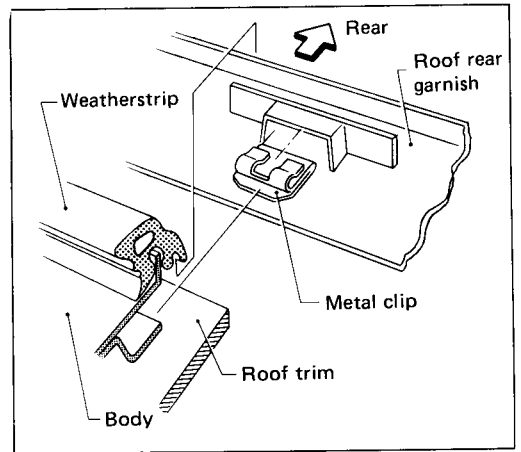
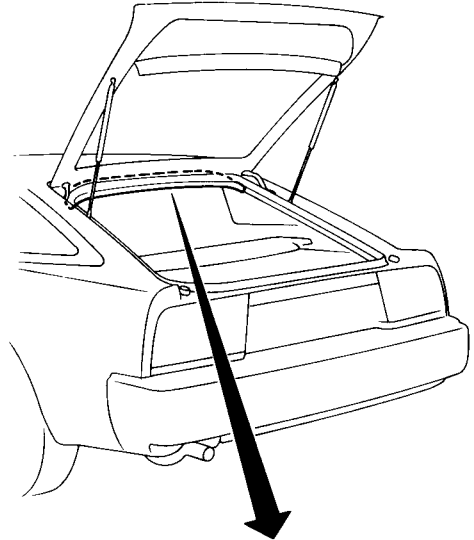

SBF591C

INTERIOR AND EXTERIOR

Exterior

- Apply sealing compound where necessary while installing parts.
- When applying sealing compound, be careful that the sealing compound does not protrude from parts.

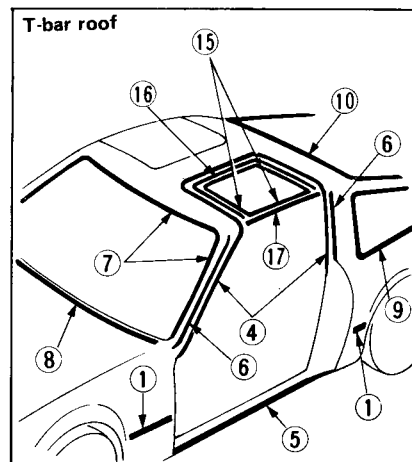
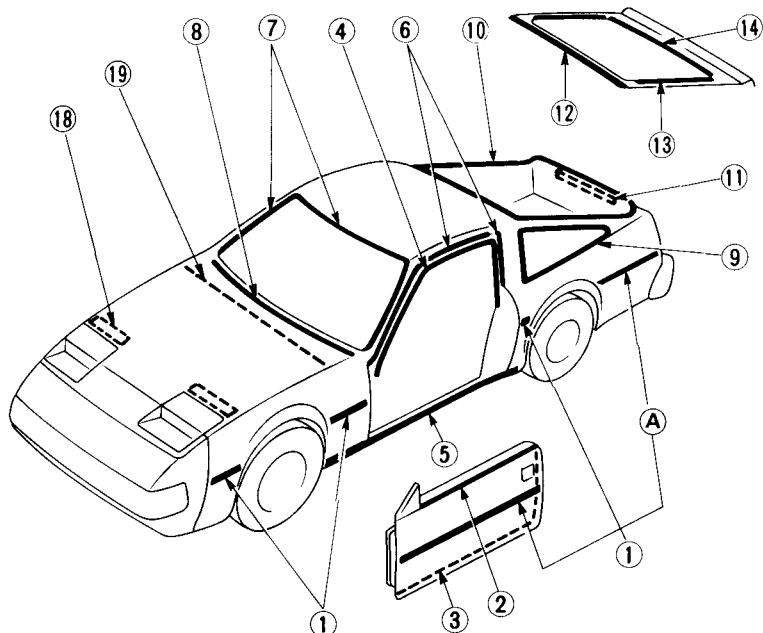

SBF592C

① Side guard molding

- Side guard molding is affixed to body panel with double-faced adhesive tape.
 - Remove it only if it is necessary to do so.
 - Removal:
1. Heat molding portion to 30 to 40°C (86 to 104°F) with a heat gun.

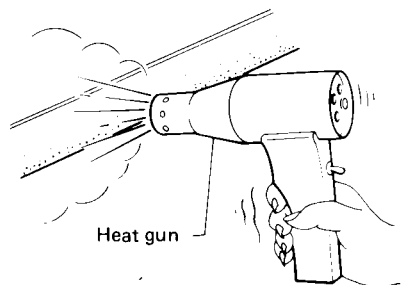

SBF455A

2. Raise end of molding and, while cutting off bonding agent, detach molding.

• Installation

1. Remove all traces of bonding agent from body panel. Then clean contact face of body.
2. Heat body panel and molding to 30 to 40°C (86 to 104°F) with a heat gun. Then install molding.

① - A Side guard molding

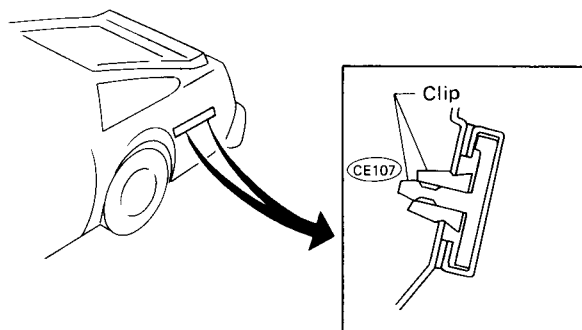

SBF604C

② Door molding

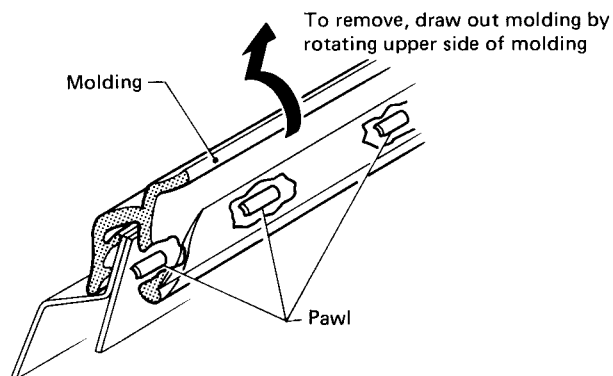

SBF593C

INTERIOR AND EXTERIOR

Exterior (Cont'd)

③, ④ Door weatherstrip and body side weatherstrip

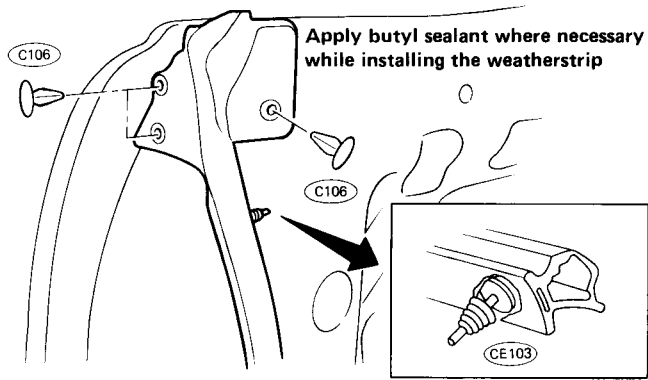

SBF398B

⑥ Drip molding

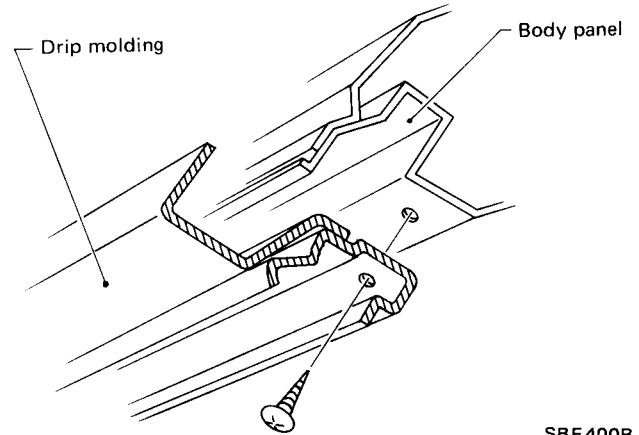

SBF400B

⑤ Sill flare and sill molding

Sill flare

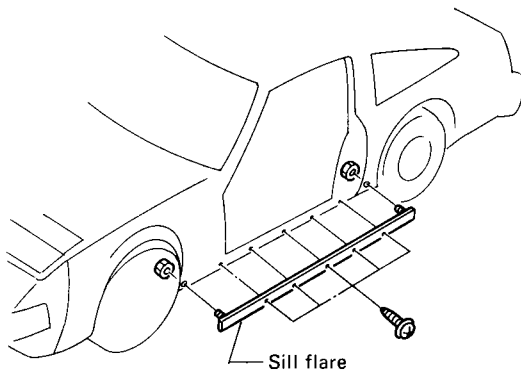

SBF594C

Sill molding

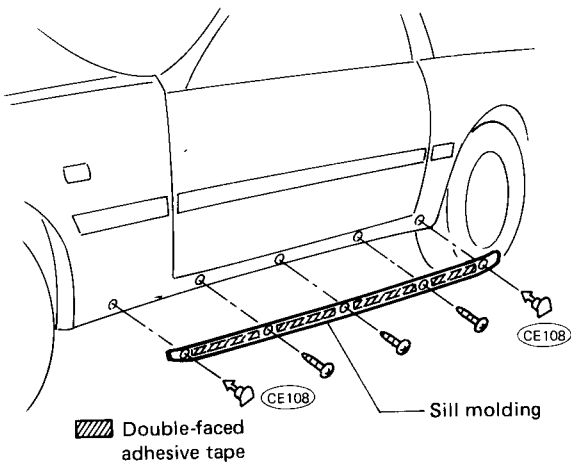

SBF639C

⑦ Windshield upper & side molding

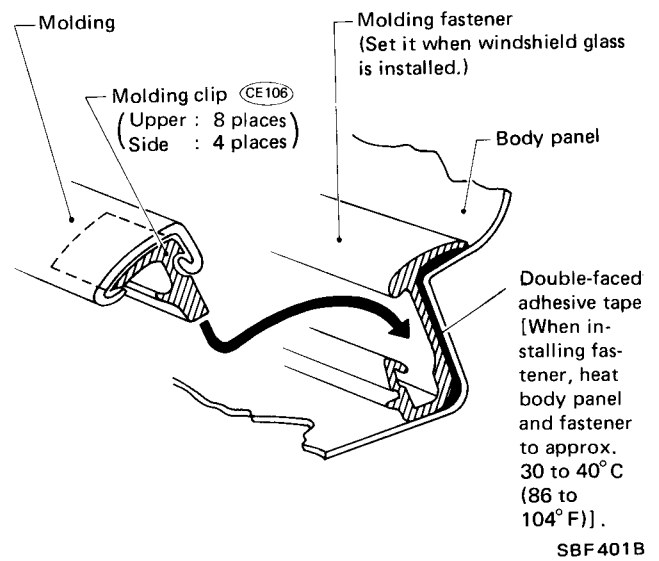

⑧ Windshield lower molding

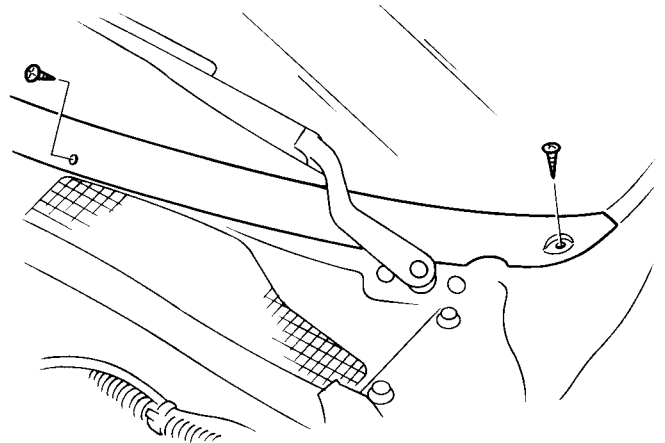

SBF402B

INTERIOR AND EXTERIOR

Exterior (Cont'd)

⑨ Side window molding

Refer to Side Window.

⑩ Back door weatherstrip

- Attach the weatherstrip by aligning each white marking with the center of each back door hinge.

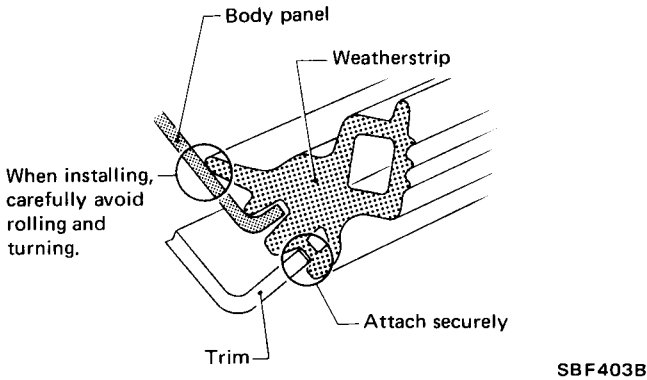

⑬ Back door side molding

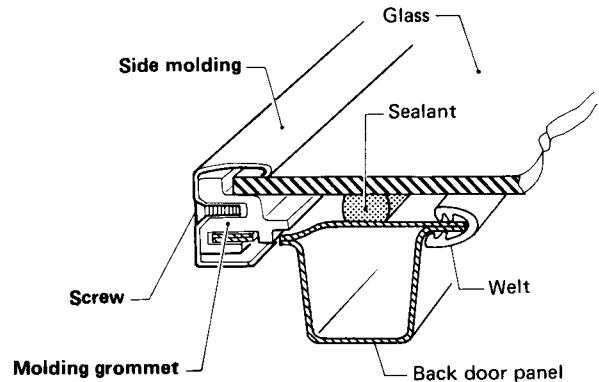

⑪ Rear panel outer finisher

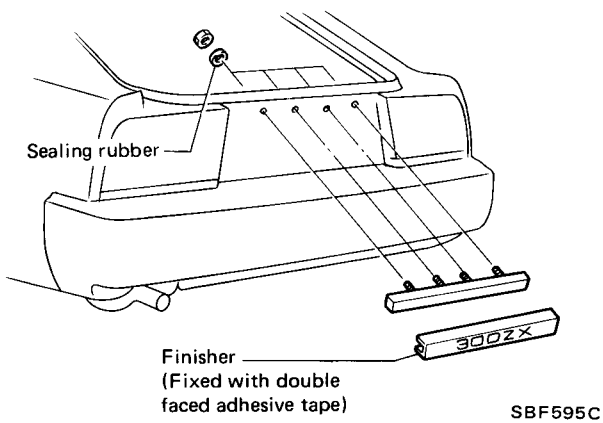

⑭ Back door lower molding

- Attach the molding to the glass before installing the glass.

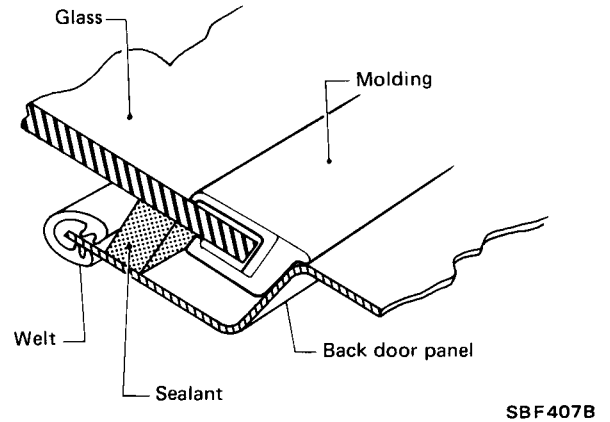

⑫ Back door upper molding

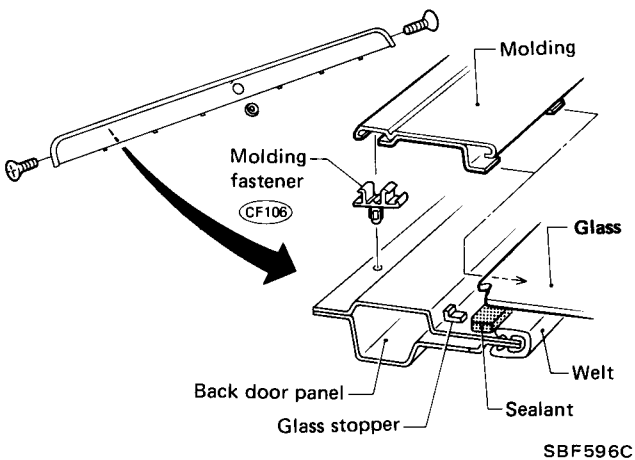

INTERIOR AND EXTERIOR

Exterior (Cont'd)

⑮ T-bar roof sash and T-bar roof side molding

They are part of the T-bar roof glass and cannot be removed. (Refer to T-bar Roof).

If they are damaged, you should replace entire T-bar roof glass assembly.

⑯ T-bar roof weatherstrip

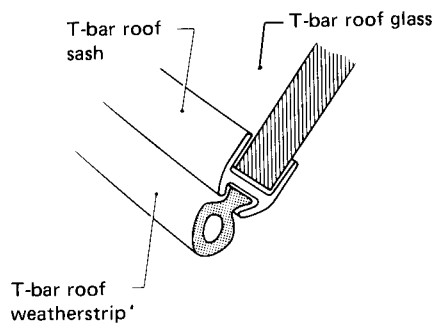

SBF435B

⑰ T-bar roof side weatherstrip

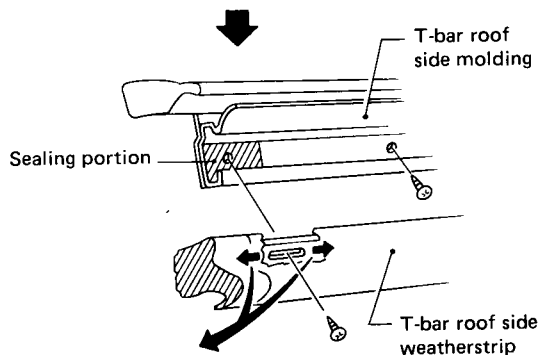
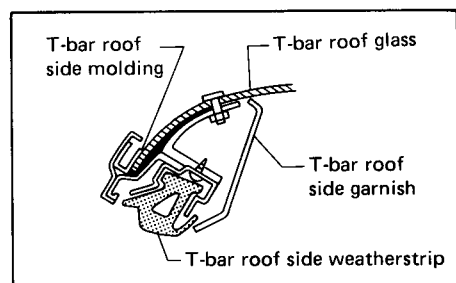

Always adjust if it is not sufficiently watertight.

SBF436B

⑱ Hood front sealing rubber

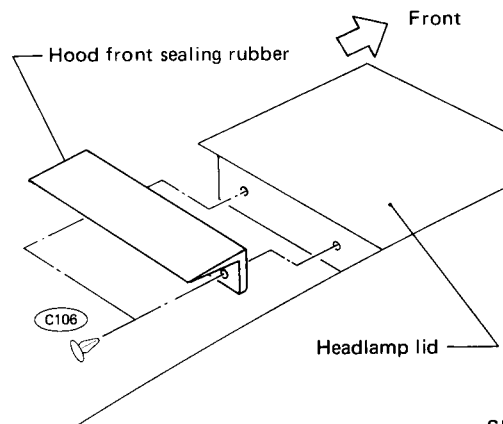

SBF597C

⑲ Hood rear sealing rubber

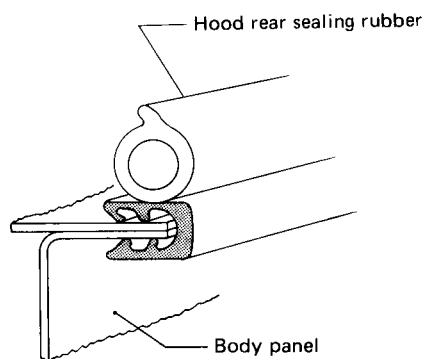

SBF598C

WINDSHIELD AND WINDOWS

Windshield

REMOVAL

After removing moldings, remove glass.

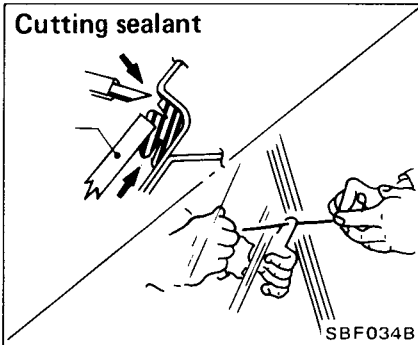

CAUTION:

Be careful not to scratch glass when removing.

INSTALLATION

- Use genuine Nissan Sealant kit or equivalent. Follow instructions furnished with it.
- After installation, the vehicle should remain stationary for about 24 hours.
- Do not use sealant which is more than 12 months past its production date.
- Do not leave cartridge unattended with its cap open.
- Keep Primers and sealant in a cool, dry place. Ideally, sealant should be stored in a refrigerator.

WARNING:

Keep heat or open flames away as Primers are flammable.

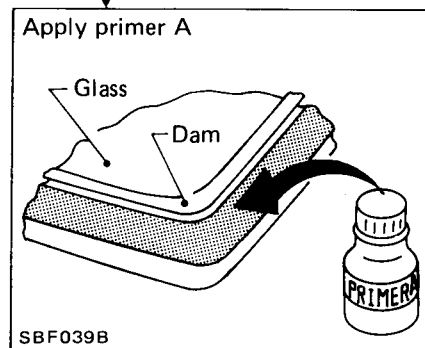
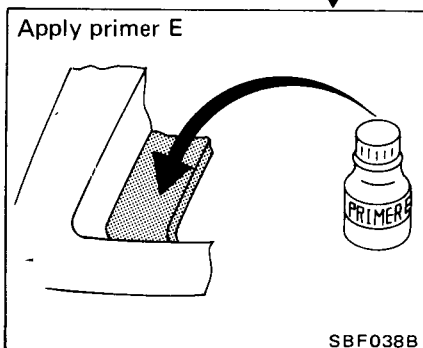
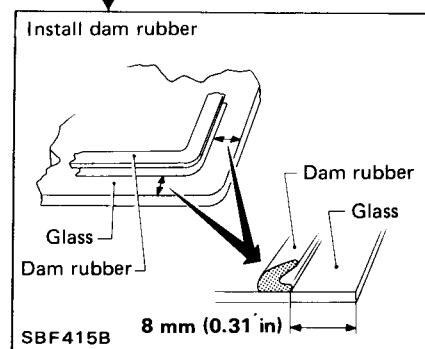
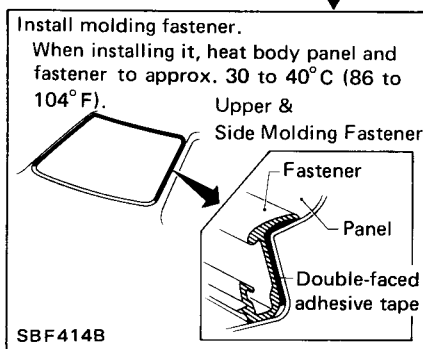
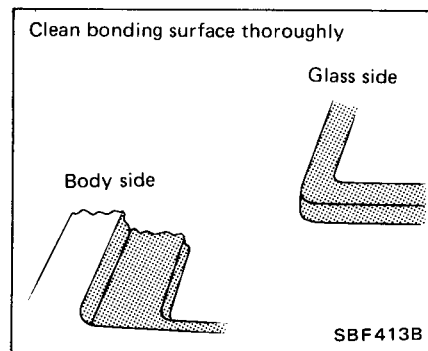

CAUTION:

Allow Primers to dry for 10 to 15 minutes before proceeding to the next step.

CAUTION:

Do not apply Primer A to windshield opening flanges.

WINDSHIELD AND WINDOWS

Windshield (Cont'd)

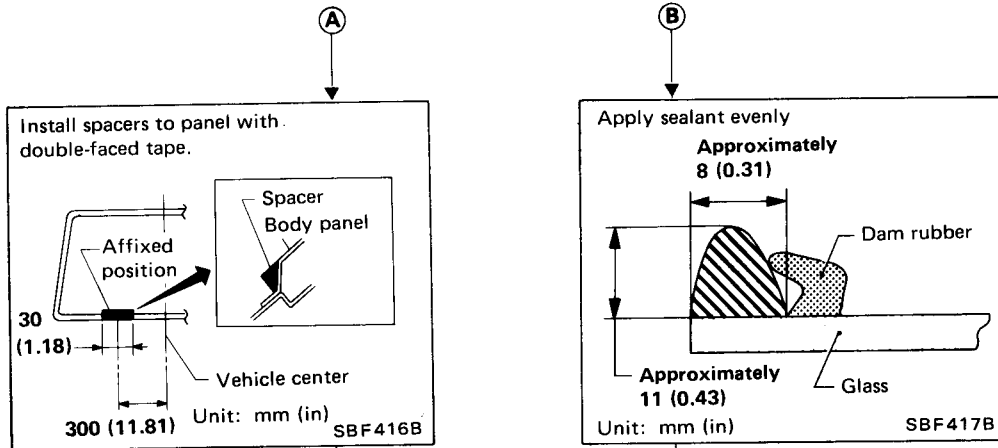

CAUTION:

Windshield glass should be installed within 15 minutes of applying sealant: sealant starts to harden 15 minutes after it is applied.

Set glass in position and press glass lightly and evenly.

Set moldings.

Check for water leakage.

Install molding.

Reference: Period required for sealant to dry to desired hardness.

Unit: days

Relative humidity %	90	50	25
Temperature °C (°F)			
25 (77)	1.6	2.9	6.1
5 (41)	3.5	9.1	15.0

CAUTION:

Advise the user of the fact that vehicle should not be driven on rough roads or surfaces until sealant has properly vulcanized.

WINDSHIELD AND WINDOWS

Back Door Window

- Attach the lower molding to the glass before installing the glass.
- Attach the glass stopper (glass upper portion) and the side molding grommet to the panel before installing the glass.
- The remaining procedure for removal and installation is the same as that for the windshield.

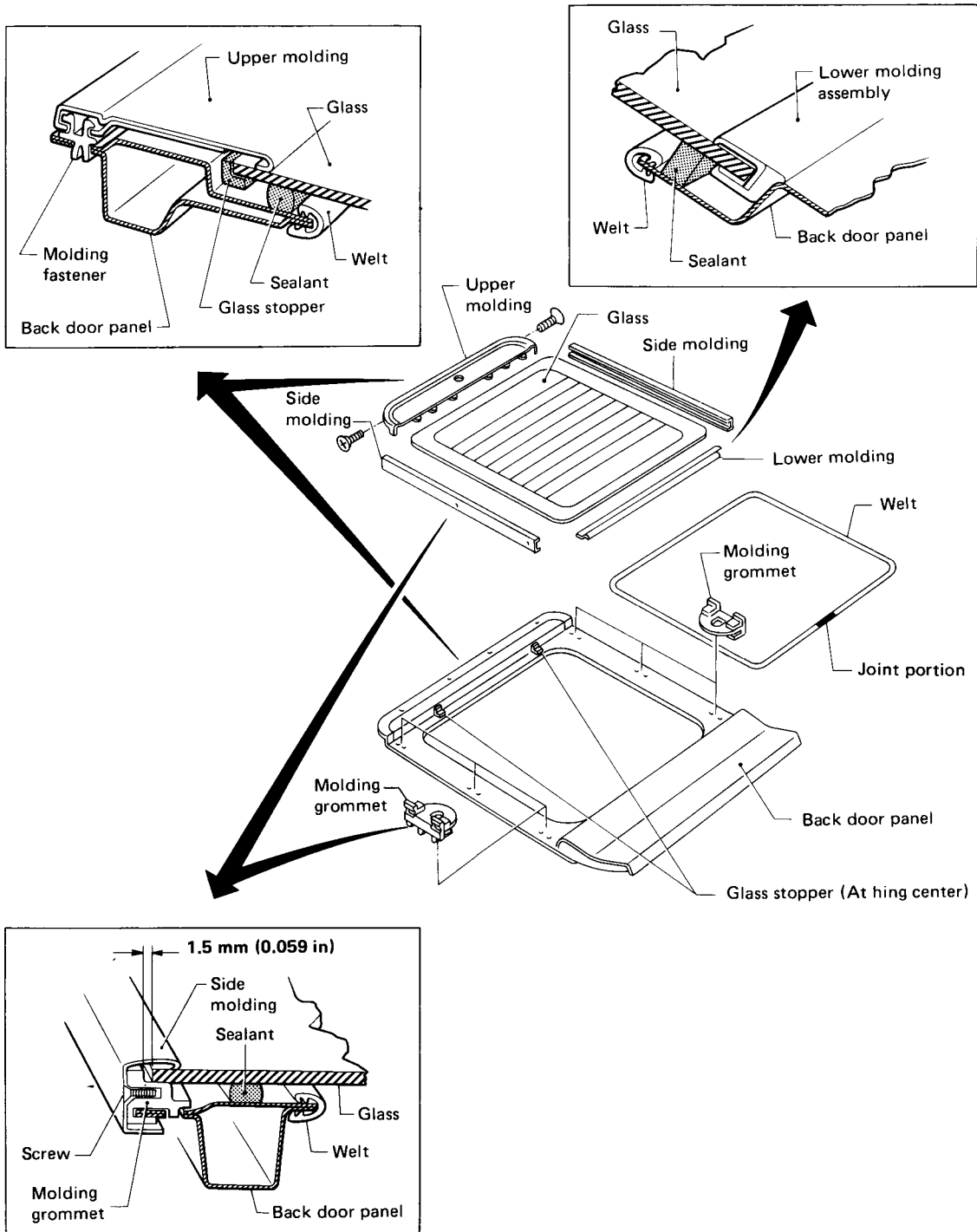

SBF599C

WINDSHIELD AND WINDOWS

Side Window

- When installing glass, assemble molding to glass, then install glass with butyl seal and nuts.

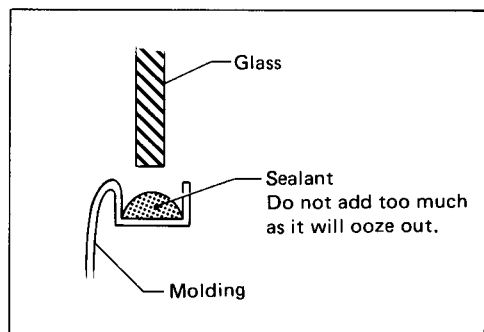
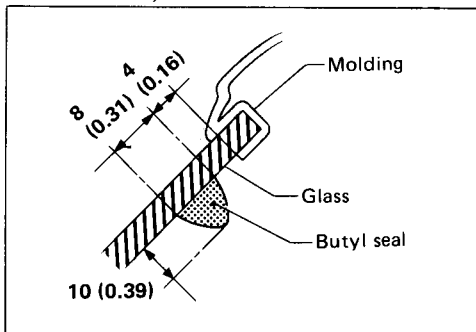
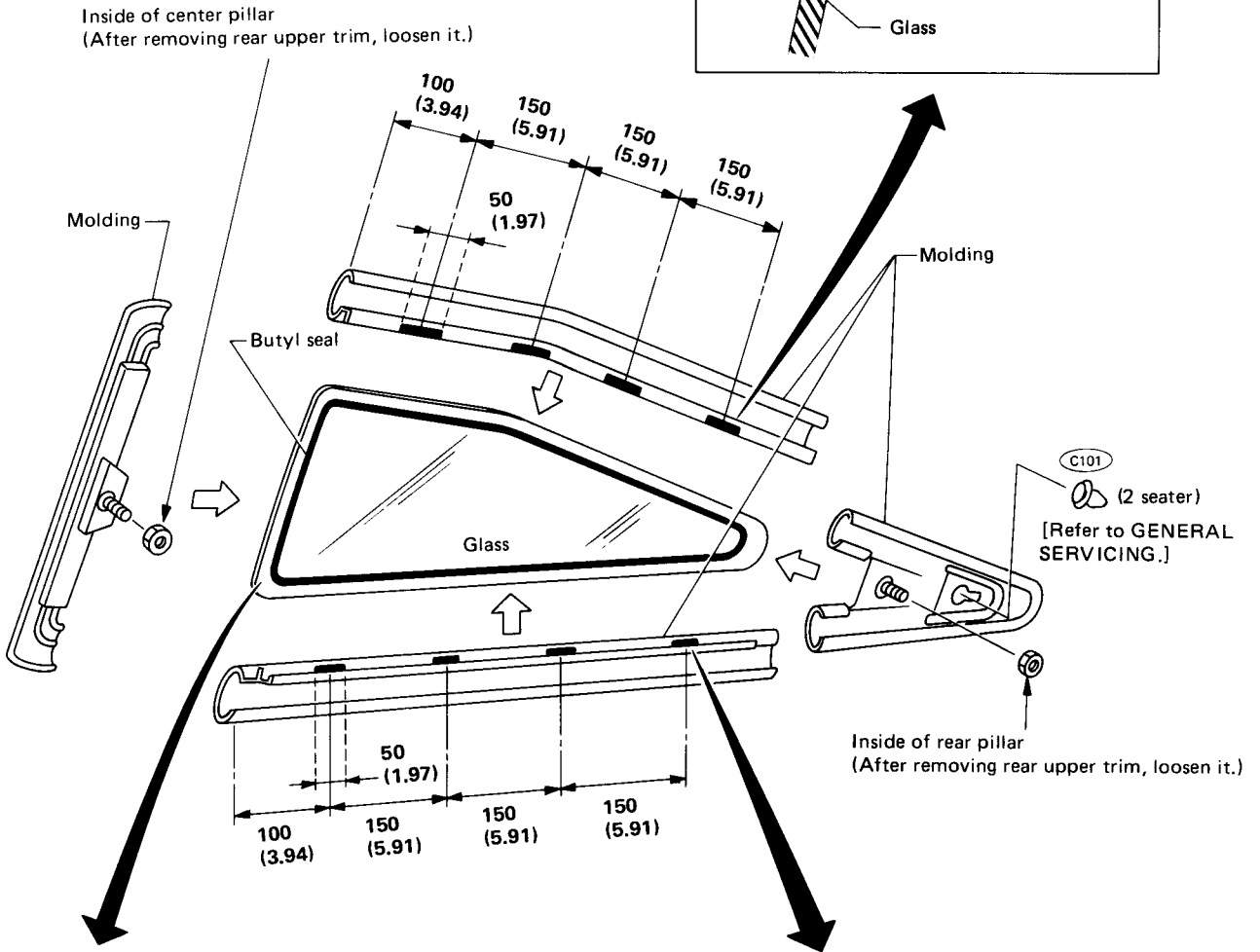
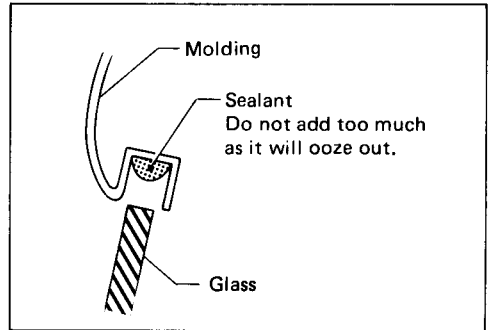

Unit: mm (in)

SBF600C

WINDSHIELD AND WINDOWS

Repairing Leaks

Leaks can be repaired without removing and re-installing glass.

If water is leaking between caulking material and body or between glass and caulking material, determine extent of leak by applying water while pushing glass outward.

To stop the leak apply Primer and then sealant to the leak point.

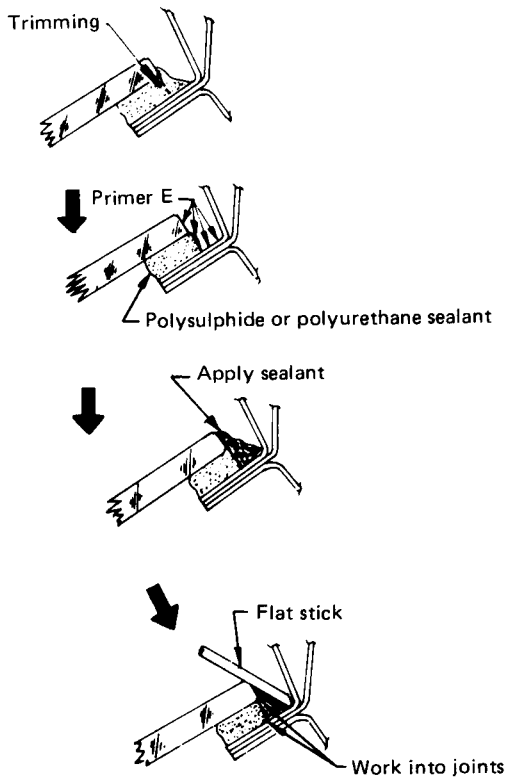

SBF182B

T-BAR ROOF

- Handle T-bar roof glass with care so not to damage it.
- Apply sealant to portions susceptible to water leakage if necessary.
- Side molding, sash, lock basement and glass of T-bar roof constitute one unit and cannot be disassembled.

T-bar roof female lock adjustment

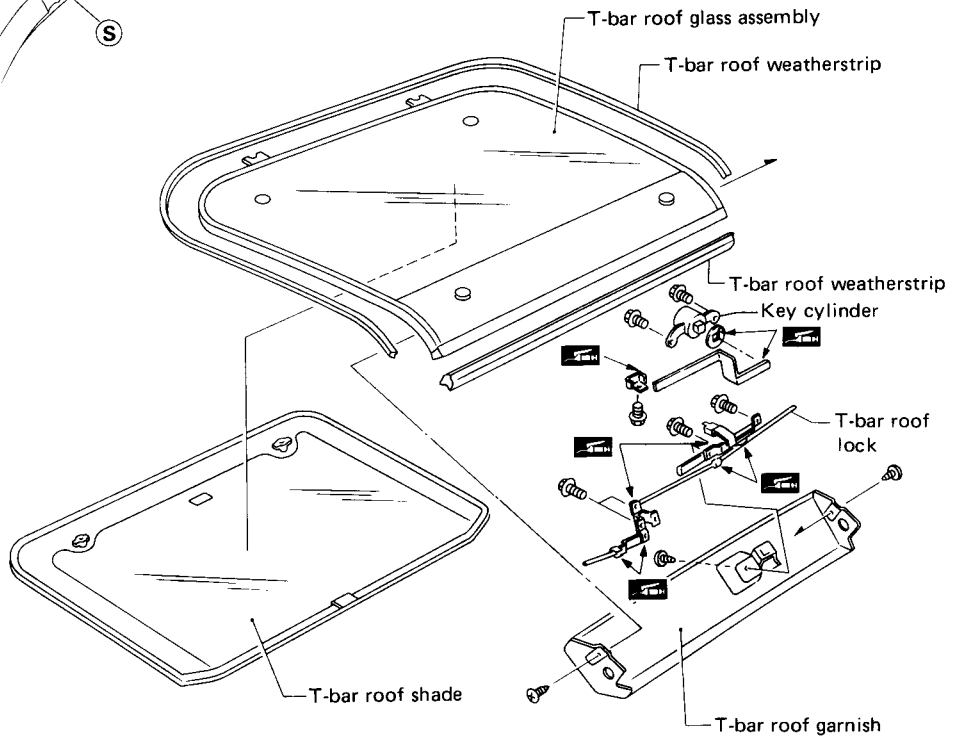
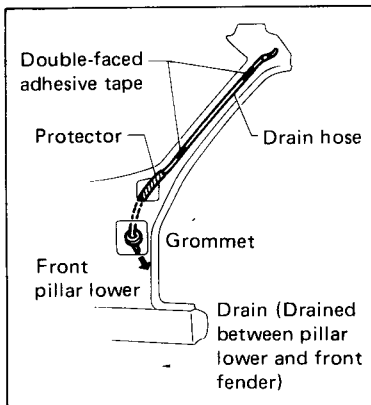
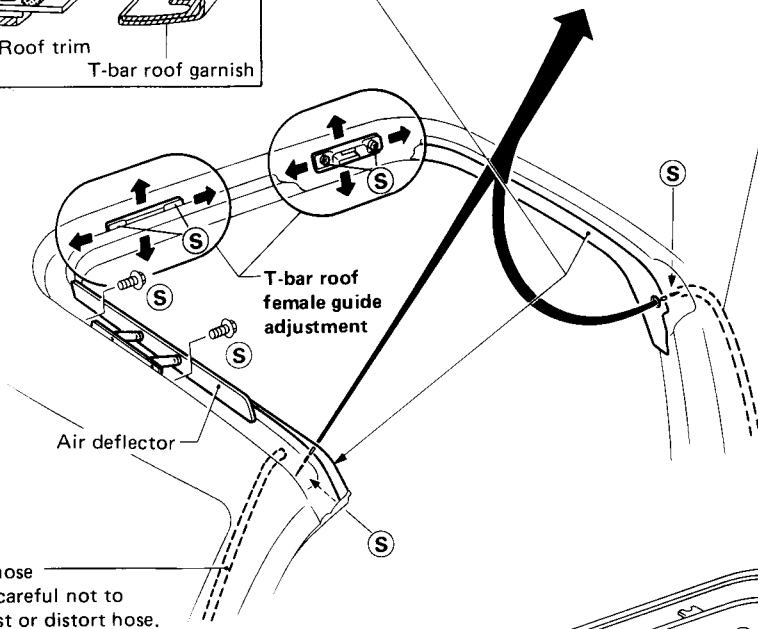
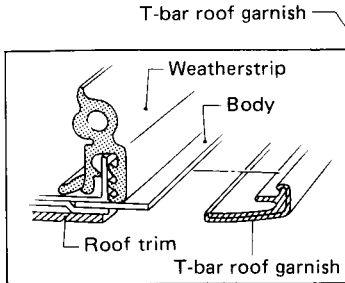
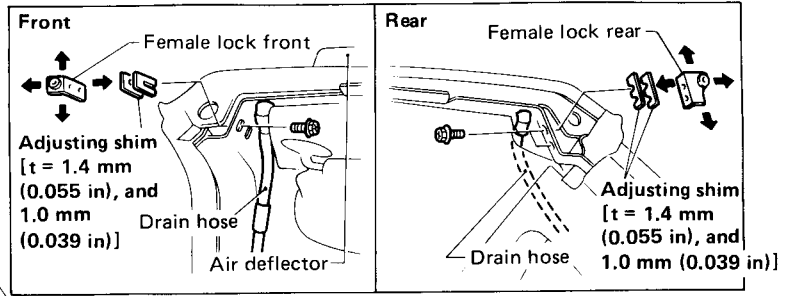

: Grease up point

: Sealant point

SBF601C

MIRROR

Door Mirror

 2.3 - 3.0 N·m
(0.23 - 0.31 kg·m, 1.7 - 2.2 ft·lb)

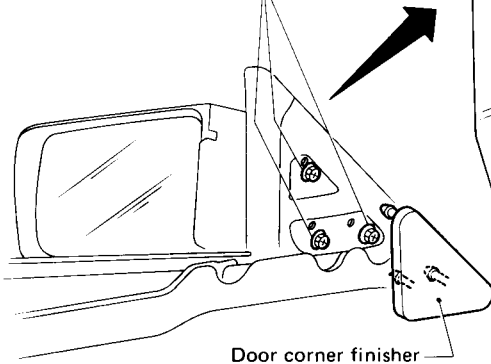

Initial setting

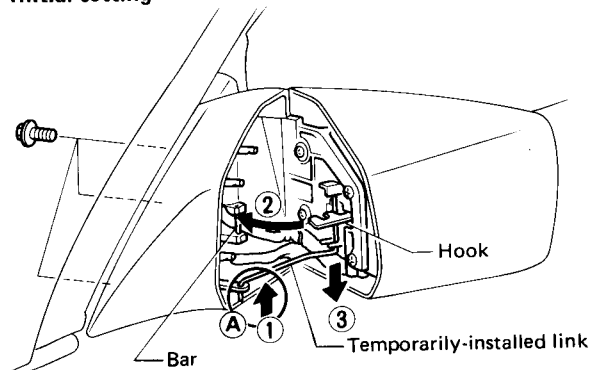

Procedure

- ① After installing mirror base to door, remove portion (A) of temporarily-installed link.
- ② Hook the bar with the hook and make sure it is hooked securely.
- ③ Tilt mirror body backward and while holding mirror, remove temporarily-installed link.

CAUTION:

Never remove temporarily-installed link from mirror body, before hooking the bar with the hook.

SBF434B

ELECTRICAL REMOTE CONTROL DOOR MIRROR/WIRING DIAGRAM

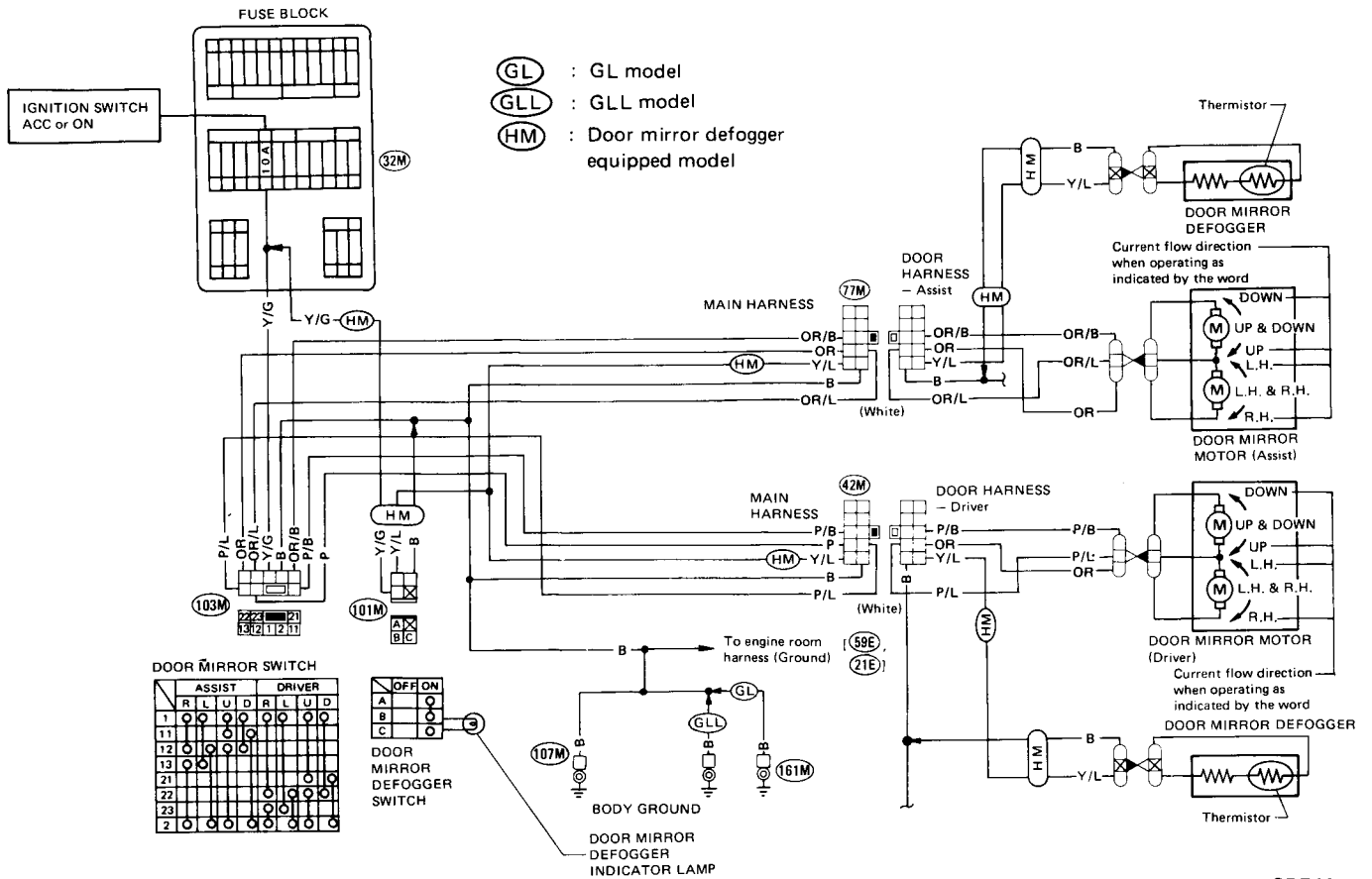

SBF602C

REAR AIR SPOILER AND HIGH-MOUNTED STOP LAMP

- When installing, make sure that there are no gaps or waves at ends of air spoiler.

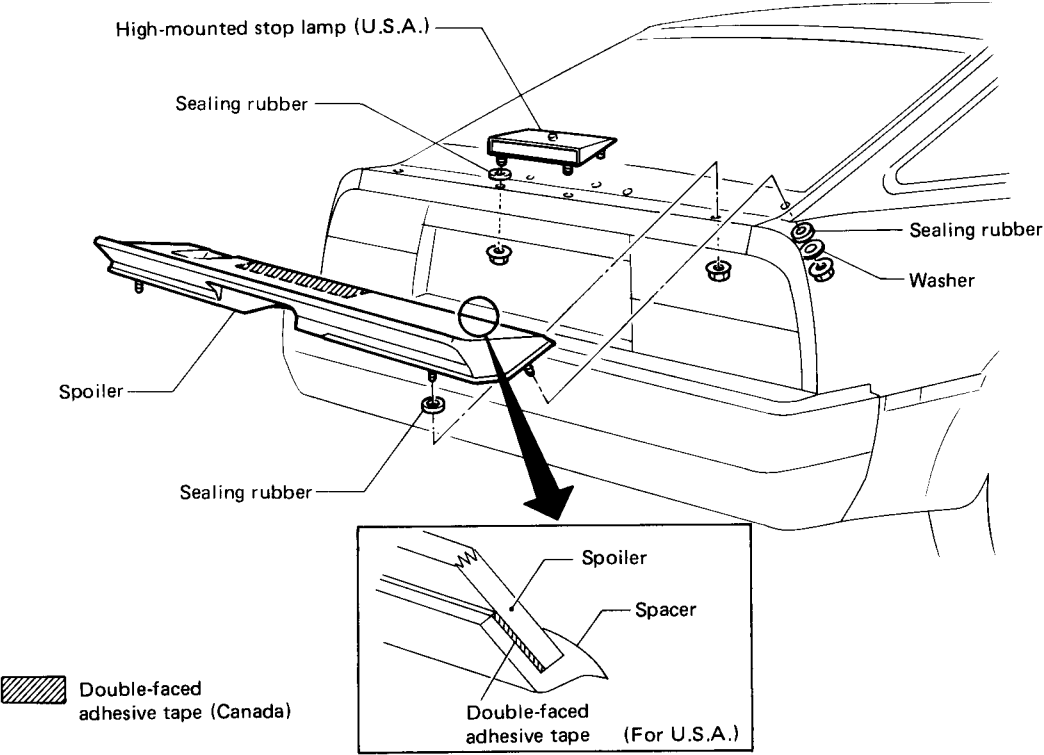

SBF603C

REAR COMBINATION LAMP

Removal and Installation

- Rear combination lamps are installed with nuts and butyl sealant.

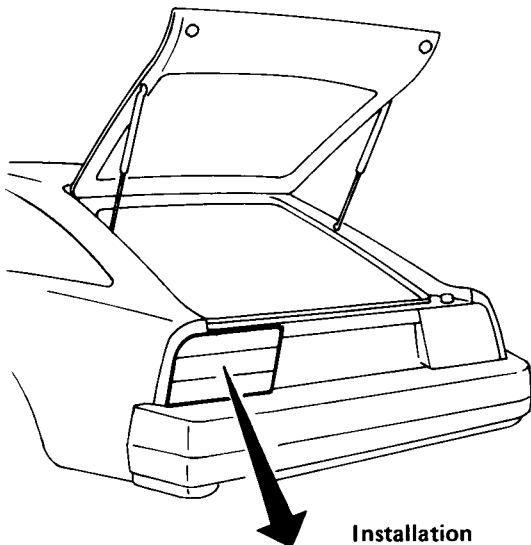

Removal

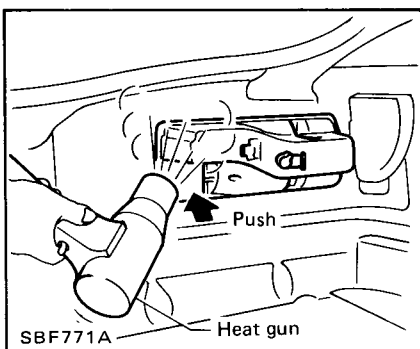

- Warm up lamp assembly area to a temperature of a little below 60°C (140°F).

Installation

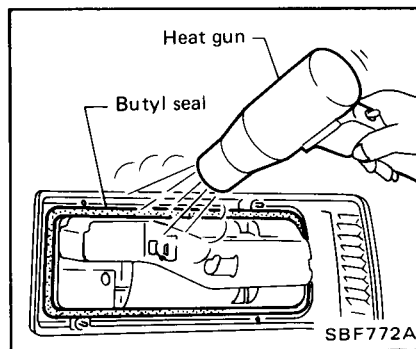

- Warm up lamp assembly area to a temperature of a little below 60°C (140°F).
- Apply butyl seal evenly as it tends to become thin in the corners.

SBF472B

BODY ALIGNMENT

- All dimensions indicated in figures are actual ones.
- When a tram tracking gauge is used, adjust both pointers to equal length and check the pointers and gauge itself to make sure there is no free play.
- When a measuring tape is used, check to be sure there is no elongation, twisting or bending.
- Measurements should be taken at the center of the mounting holes.
- An asterisk (*) following the value at the measuring point indicates that the measuring point on the other side is symmetrically the same value.
- Measurement points

The coordinates of the measurement points are the distances measured from the respective dimension lines in the directions of "x", "y" and "z".

Dimension lines: "x" line – Center line of vehicle

"y" line – Center line of front axle (Any measurement point in front of the dimension line refers to a minus "-" value.)

"z" line – Datum line (Any measurement point under the dimension line refers to a minus "-" value.)

Engine Compartment

MEASUREMENT

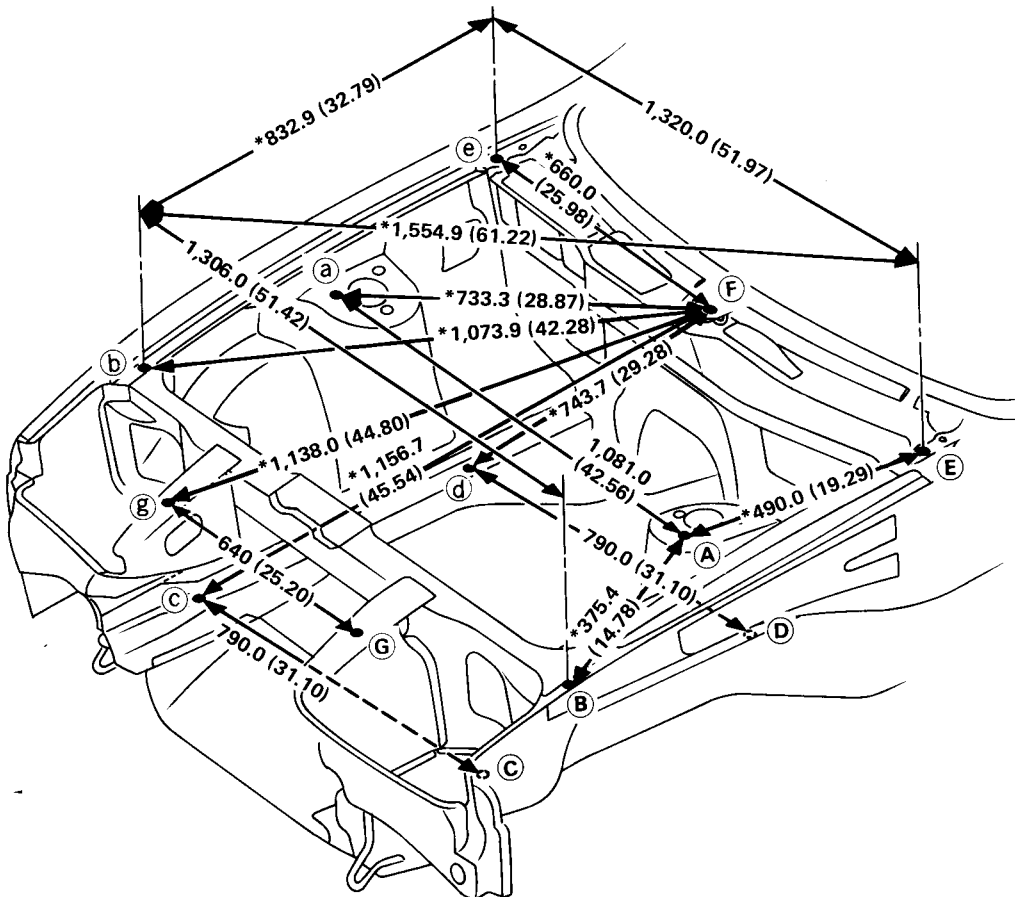

Unit: mm (in)

SBF420B

BODY ALIGNMENT

Engine Compartment (Cont'd)

MEASUREMENT POINTS

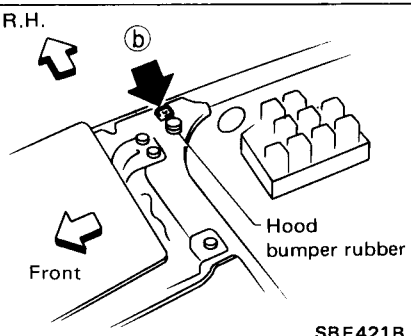
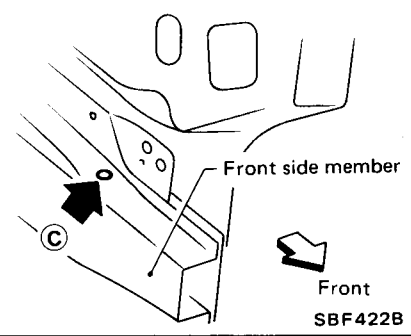
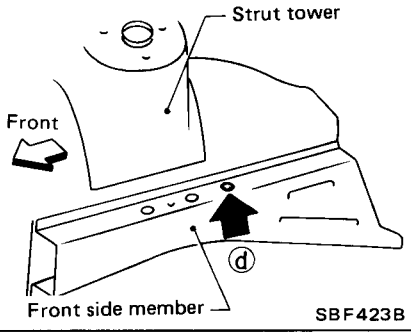
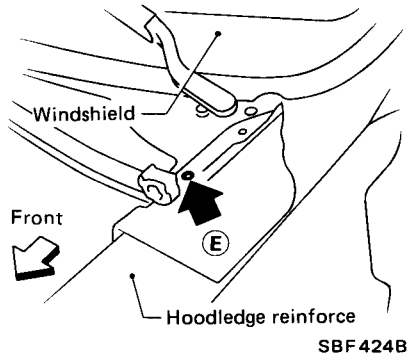
Points	Hole dia. mm (in)	Detailed points	Coordinates mm (in)		
			"x"	"y"	"z"
(A) (a)	12 (0.47)	Hole for front suspension upper mounting (Outside front hole)	540.5 (21.28)	26.8 (1.055)	919.0 (36.18)
(B) (b)	9 (0.35)	 <p>Hole for fixing front fender</p> <p>SBF421B</p>	653.0 (25.71)	-325.0 (-12.80)	852.0 (33.54)
(C) (c)	5.4 (0.213)	 <p>Hole for fixing harness clip at upperside of front side member</p> <p>SBF422B</p>	395.0 (15.55)	-460.0 (-18.11)	490.0 (19.29)
(D) (d)	8 (0.31)	 <p>Hole for fixing harness clip at upperside of front side member</p> <p>SBF423B</p>	395.0 (15.55)	100.0 (3.94)	490.0 (19.29)
(E) (e)	11 (0.43)	 <p>Hole for mounting hood hinge</p> <p>SBF424B</p>	660.0 (25.98)	500.0 (19.69)	966.0 (38.03)

BODY ALIGNMENT

Engine Compartment (Cont'd)

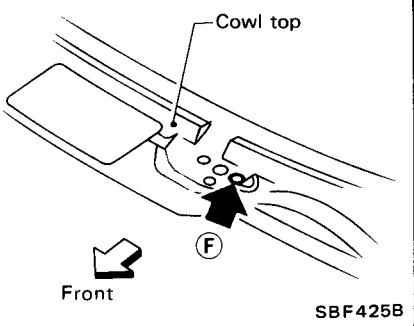
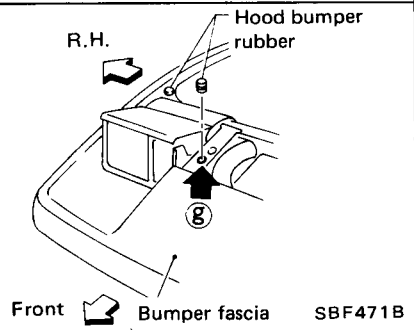
Points	Hole dia. mm (in)	Detailed points	Coordinates mm (in)		
			"x"	"y"	"z"
(F)	7 (0.28)	 <p>Cowl top</p> <p>Hole for mounting wiper pivot</p> <p>Front</p> <p>SBF425B</p>	0.0 (0)	520.8 (20.50)	959.0 (37.76)
(G) (G)	16 (0.63)	 <p>R.H.</p> <p>Hood bumper rubber</p> <p>Hole for mounting hood bumper rubber on headlamp side housing</p> <p>Front</p> <p>Bumper fascia</p> <p>SBF471B</p>	320.0 (12.60)	-556.5 (-21.91)	779.0 (30.67)

BODY ALIGNMENT

Underbody

MEASUREMENT

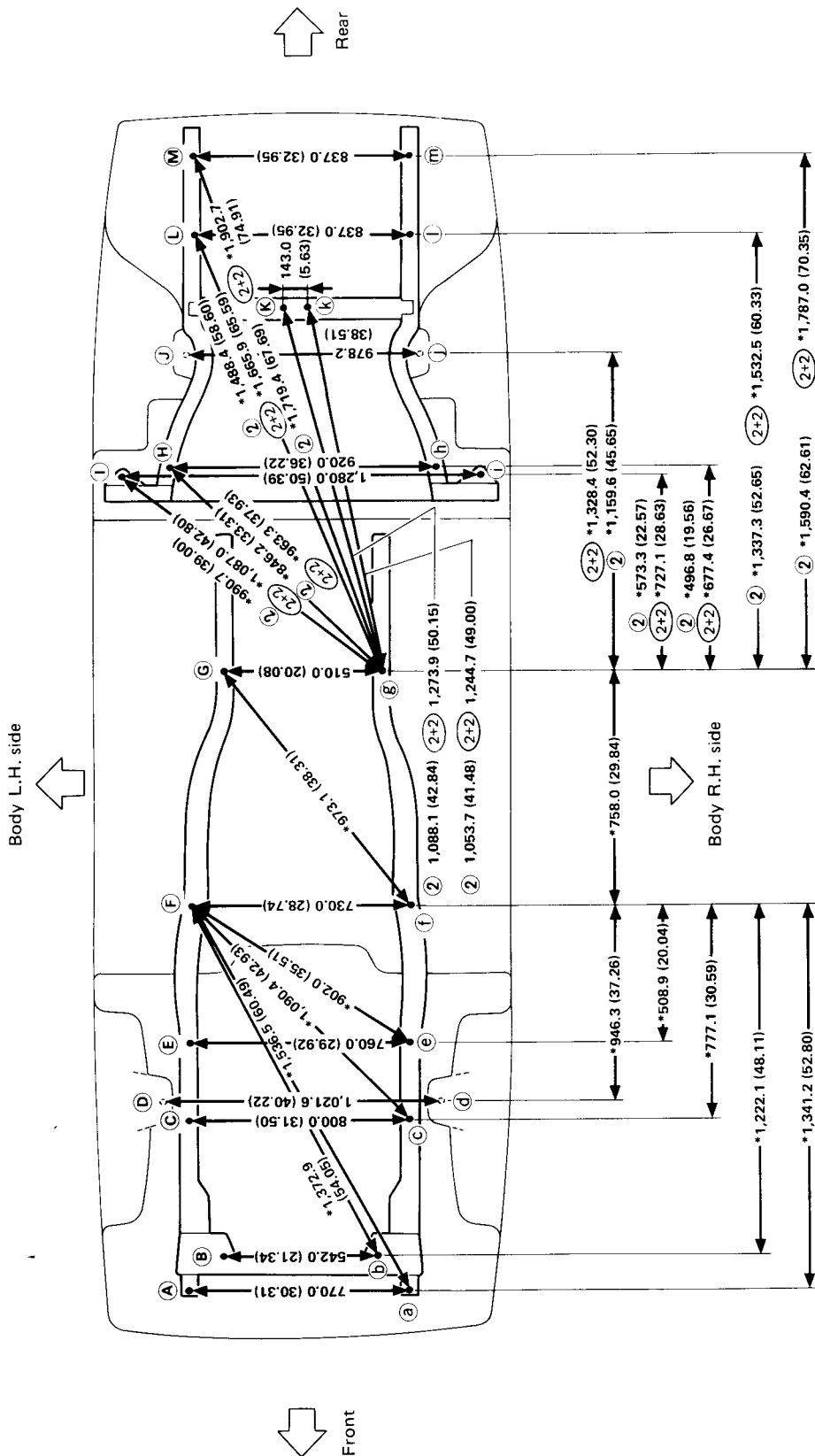

BODY ALIGNMENT

Underbody (Cont'd)

MEASUREMENT POINTS

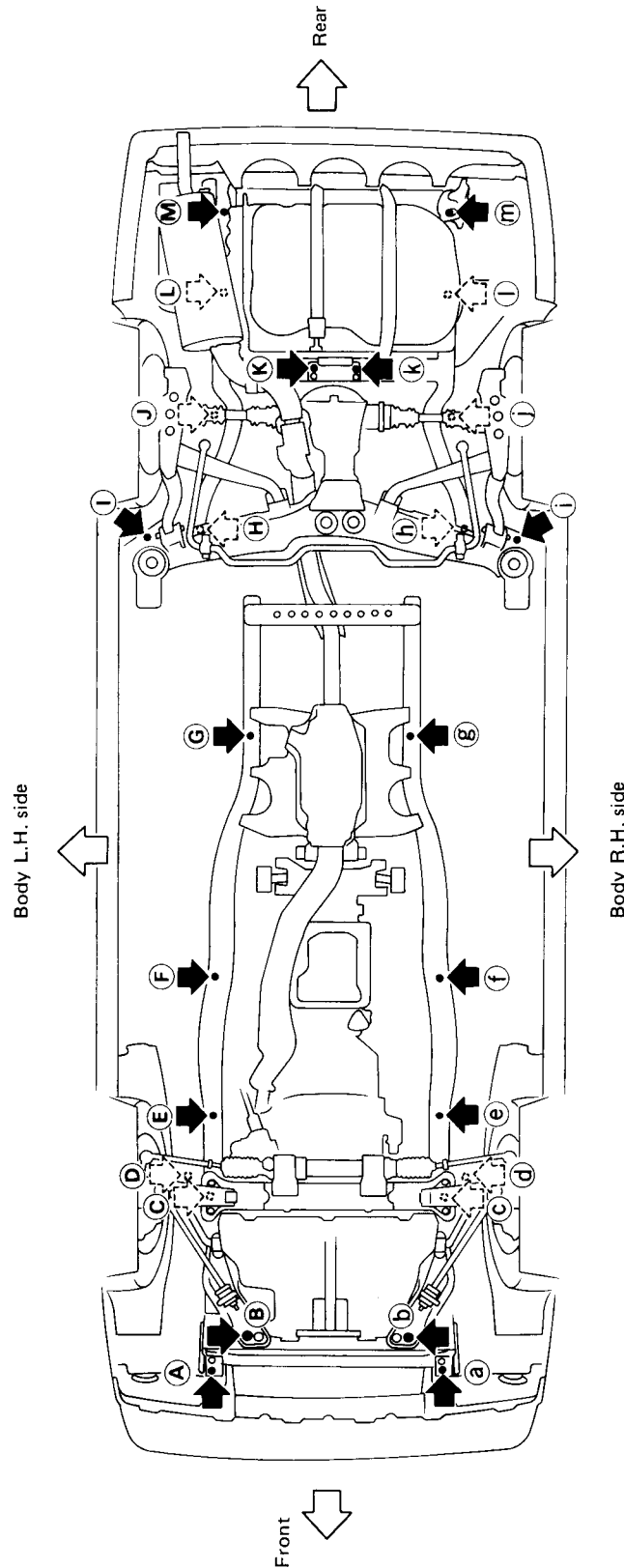

SBF433B

BODY ALIGNMENT

Underbody (Cont'd)

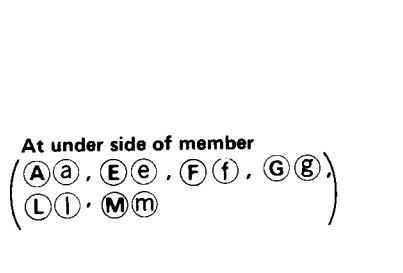
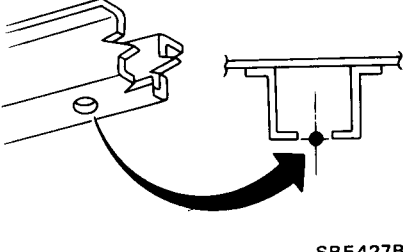
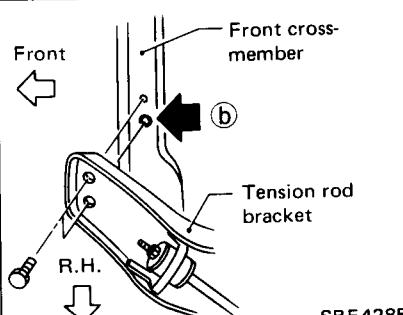
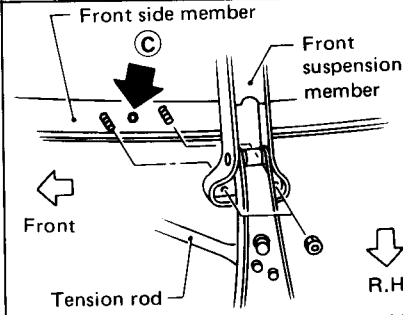
Points	Hole dia. mm (in)	Detailed points	Coordinates mm (in)		
			"x"	"y"	"z"
(A) (a)	13 (0.51)		385.0 (15.16)	-585.0 (-23.03)	388.0 (15.28)
(E) (e)	15 (0.59)		380.0 (14.96)	251.5 (9.90)	361.6 (14.24)
(F) (f)	18 (0.71)		365.0 (14.37)	750.0 (29.53)	260.5 (10.26)
(G) (g)	13 (0.51)		255.0 (10.04)	1,500.0 (59.06)	261.0 (10.28)
(L) (l)	13 (0.51)	<p>At under side of member (A a, E e, F f, G g), (L l, M m)</p> 	418.5 (16.48)	2+2 seater model 2,800.0 (110.24) 2+2 seater model 3,000.0 (118.11)	528.8 (20.82)
(M) (m)	15 (0.59)	 <p>SBF427B</p>	418.5 (16.48)	2 seater model 3,060.0 (120.47) 2+2 seater model 3,260.0 (128.35)	523.8 (20.62)
(B) (b)	13 (0.51)	 <p>Front R.H. Front cross-member Tension rod bracket</p> <p>SBF428B</p>	271.0 (10.67)	-465.0 (-18.31)	325.5 (12.81)
(C) (c)	16 (0.63)	 <p>Front R.H. Front side member Front suspension member Tension rod</p> <p>SBF429B</p>	400.0 (15.75)	-10.0 (-0.394)	422.0 (16.61)

BODY ALIGNMENT

Underbody (Cont'd)

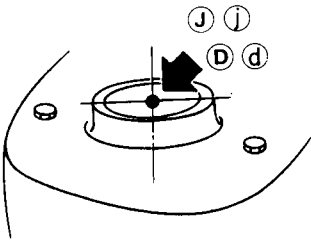
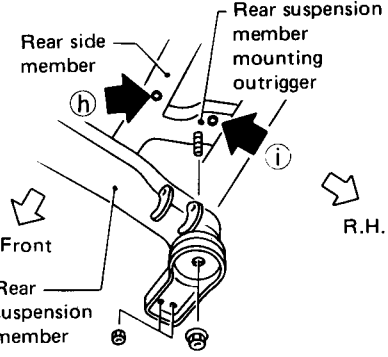
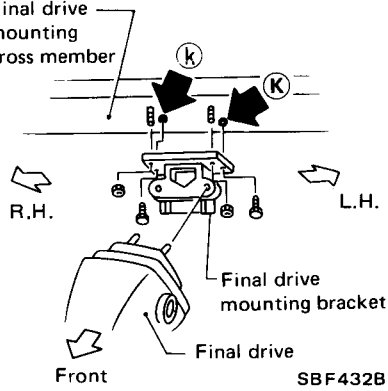
Points	Hole dia. mm (in)	Detailed points	Coordinates mm (in)			
			"x"	"y"	"z"	
Ⓓ Ⓓ	82.3 (3.240)	 <p style="text-align: center;">SBF430B</p>	Front suspension upper mounting	510.8 (20.11)	80.0 (3.150)	912.6 (35.93)
Ⓙ Ⓛ	54 (2.13)		Rear suspension shock absorber upper mounting	489.1 (19.26)	2 seater model 2,450.2 (96.46) 2+2 seater model 2,650.2 (104.34)	883.0 (34.76)
Ⓕ Ⓕ	15 (0.59)	 <p style="text-align: center;">SBF431B</p>	Hole for locating on underside of member	460.0 (18.11)	2 seater model 1,930.0 (75.98) 2+2 seater model 2,130.0 (83.86)	402.0 (15.83)
Ⓜ Ⓜ	13 (0.51)			640.0 (25.20)	2 seater model 1,900.0 (74.80) 2+2 seater model 2,100.0 (82.68)	404.0 (15.91)
Ⓚ	15 (0.59)	 <p style="text-align: center;">SBF432B</p>	Hole for mounting final drive on underside of final drive mounting crossmember	74.0 (2.913)	2 seater model 2,497.5 (98.33) 2+2 seater model 2,697.5 (106.20)	545.0 (21.46)
Ⓚ				69.0 (2.717)	2 seater model 2,497.5 (98.33) 2+2 seater model 2,697.5 (106.20)	545.0 (21.46)