

ENGINE CONTROL, FUEL & EXHAUST SYSTEMS

SECTION **FE**

CONTENTS

ENGINE CONTROL SYSTEM	FE-2
FUEL SYSTEM	FE-3
EXHAUST SYSTEM	FE-5

FE

ENGINE CONTROL SYSTEM

Accelerator Control System

- Check to see if throttle valve fully opens when accelerator pedal is fully depressed and returns to idle when released.
- Adjust accelerator pedal free play by turning adjusting nut.
- On automatic transmission models, make sure kickdown switch rod is fully pushed in when accelerator pedal is depressed completely.
- ON A.S.C.D. equipped models, first adjust accelerator wire and then A.S.C.D. cable. For details, refer to "Automatic Speed Control Device" in EL section.
- Check accelerator control parts for improper contact with any adjacent parts.
- When connecting accelerator wire, be careful not to twist or scratch its inner wire.
- Apply a light coat of recommended multi-purpose grease to all sliding or friction surfaces. Do not apply grease to wire.

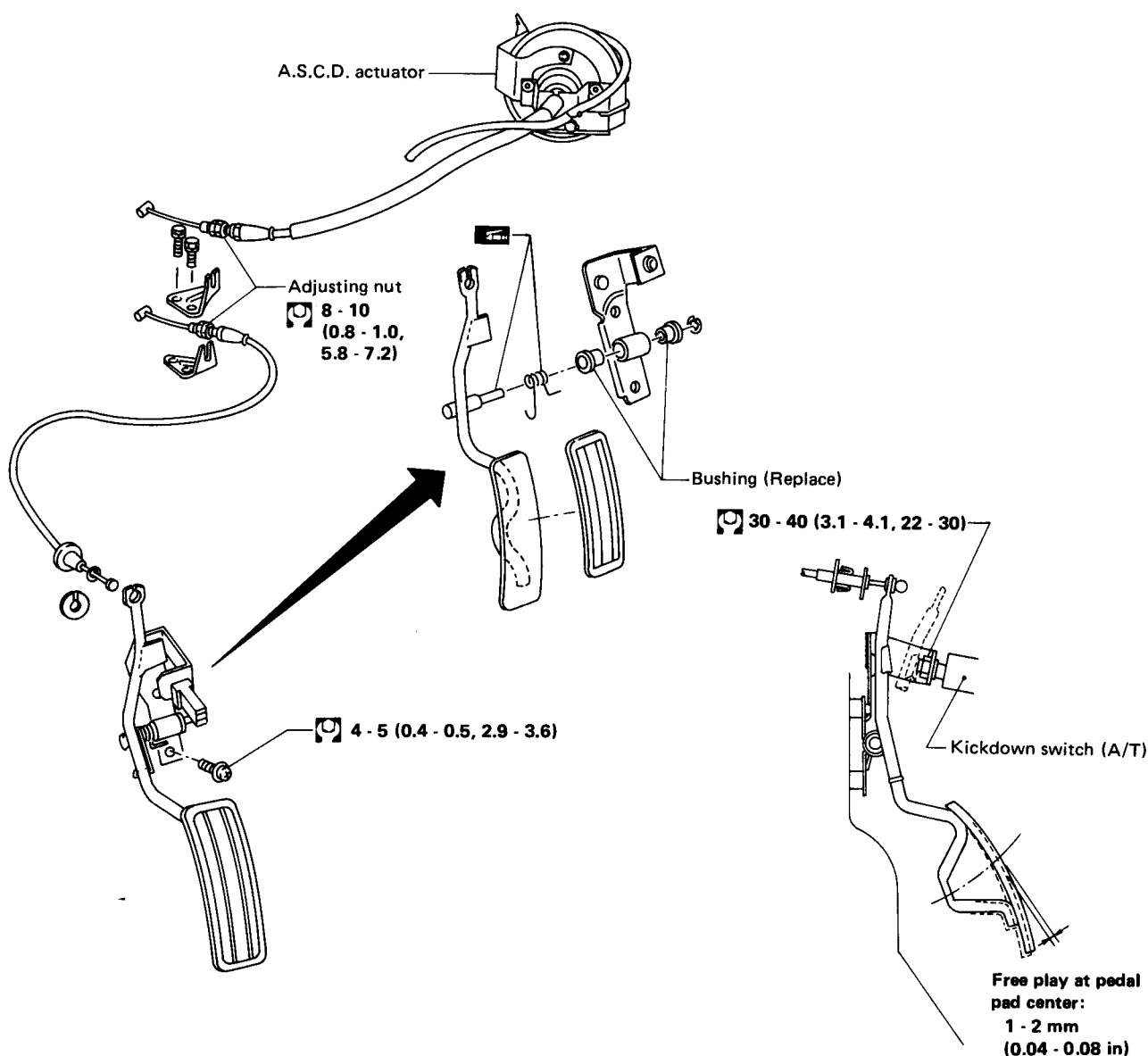

: N·m (kg·m, ft·lb)

SFE753

FUEL SYSTEM

WARNING:

When replacing fuel line parts, be sure to observe the following:

- Put a "CAUTION: INFLAMMABLE" sign in workshop.
- Be sure to furnish the workshop with a CO₂ fire extinguisher.
- Be sure to disconnect battery ground cable before conducting operations.
- Put drained fuel in an explosion-proof container and attach lid securely.

CAUTION:

Before disconnecting fuel hose, release fuel pressure from fuel line. Refer to the "Releasing Fuel Pressure" in EF & EC section.

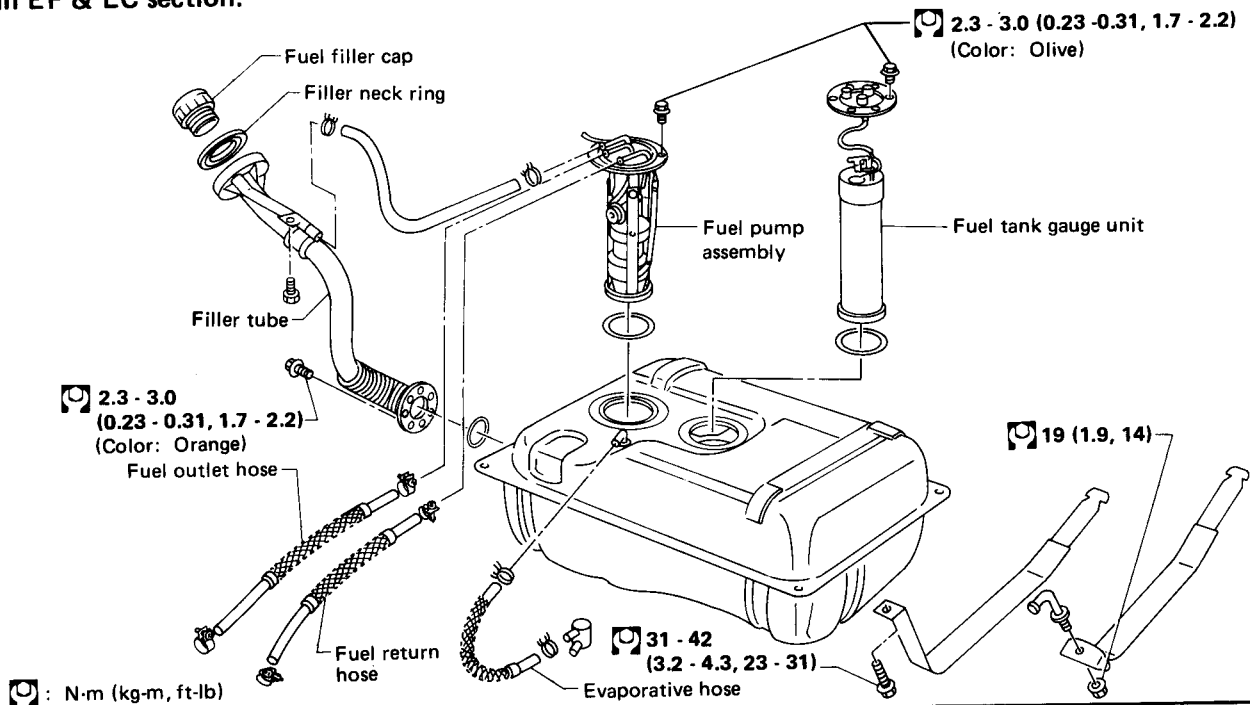

Fuel tank side

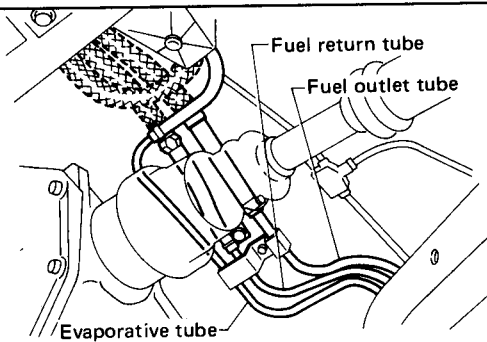

Engine room side

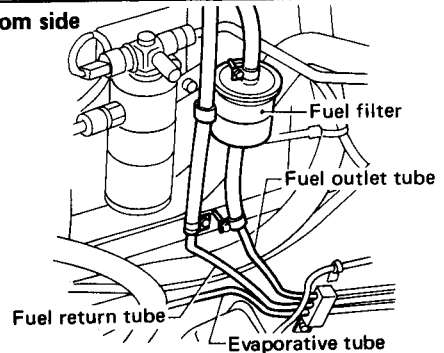

SFE754

- Do not disconnect any fuel line unless absolutely necessary.
- Plug hose and pipe openings to prevent entry of dust or dirt.
- Always replace O-ring and clamps with new ones.
- Do not kink or twist hose and tube when they are installed.
- Do not tighten hose clamps excessively to avoid damaging hoses.
- When installing fuel check valve, be careful of its designated direction (Refer to section EF & EC).
- Run the engine and check for leaks at connections.

FUEL SYSTEM

Removal of Fuel Tank

Do not separate fuel tank and fuel filler tube except when replacement is necessary.

1. Disconnect harness connectors of fuel tank gauge unit and electric fuel pump in luggage compartment.
2. Siphon or pump fuel from filler opening of fuel tank into a suitable container. Then blow away fuel from filler opening with compressed clean air.
3. Remove fuel filler neck ring.

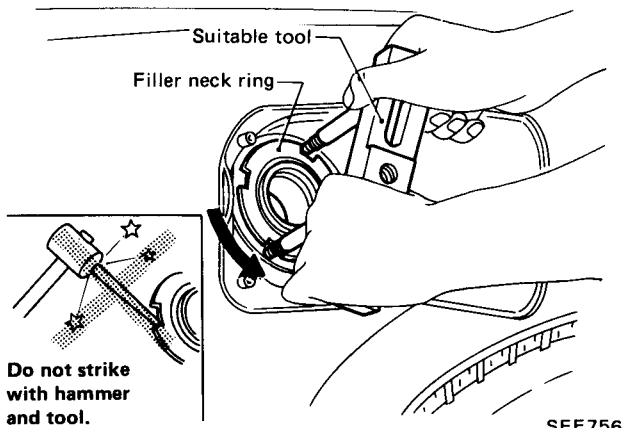

4. Remove rear right side wheel.
5. Remove fuel filler tube protectors and disconnect ventilation hose.

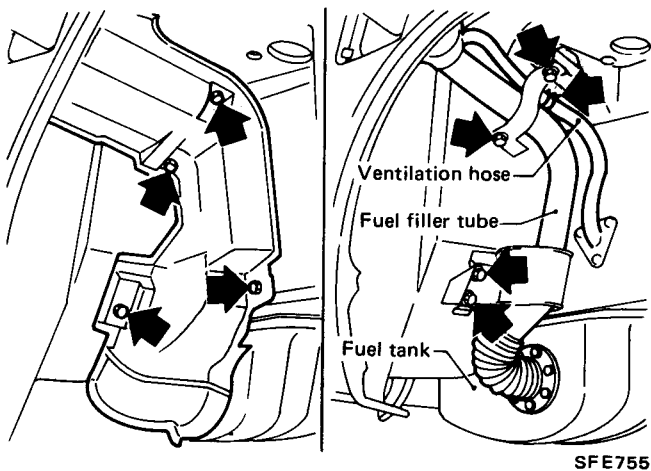

6. Disconnect fuel hoses and evaporative hose on fuel tube side.
7. Loosen bolt and nut securing mounting bands and then remove fuel tank with filler tube.

8. When installing fuel filler neck ring tighten as follows:

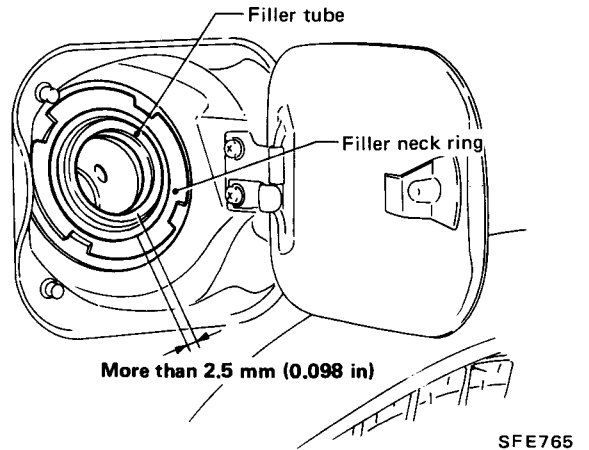

Removal of Fuel Gauge Unit

Lift fuel gauge unit straight up off the fuel tank.

Resistor gauge is made of ceramic material. Be careful not to bend it.

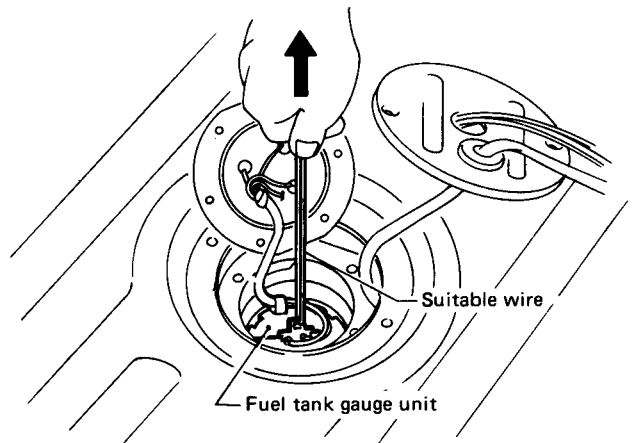

Removal of Electric Fuel Pump

Remove fuel tank, then detach fuel pump.

EXHAUST SYSTEM

CAUTION:

- a. Be careful not to drop or damage catalytic converter.
 - b. Never wet catalytic converter with water, oil, etc.
- When removing muffler assembly, always separate it from center tube.
 - On non-turbocharger models, when removing heat shield plates from front tube, remove the entire front tube assembly.
 - After installation, make sure that mounting brackets and mounting insulator are free from undue stress. If any of above parts is not installed properly, excessive noises or vibrations may be transmitted to vehicle body.
 - When connecting center tube and muffler assembly, use the Genuine Nissan Sealant "Exhaust Sealant Kit 20720-N2225" or an equivalent to eliminate gas leakage at the joint.
 - Check all tube connections for exhaust gas leaks, and entire system for unusual noises, with engine running.

EXHAUST SYSTEM

Turbo models

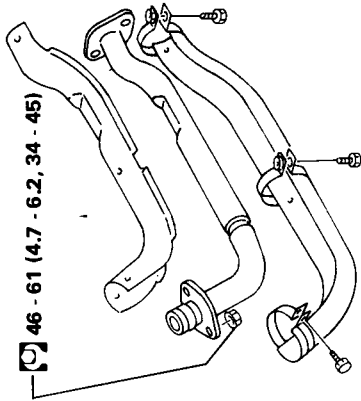

Non-turbo models

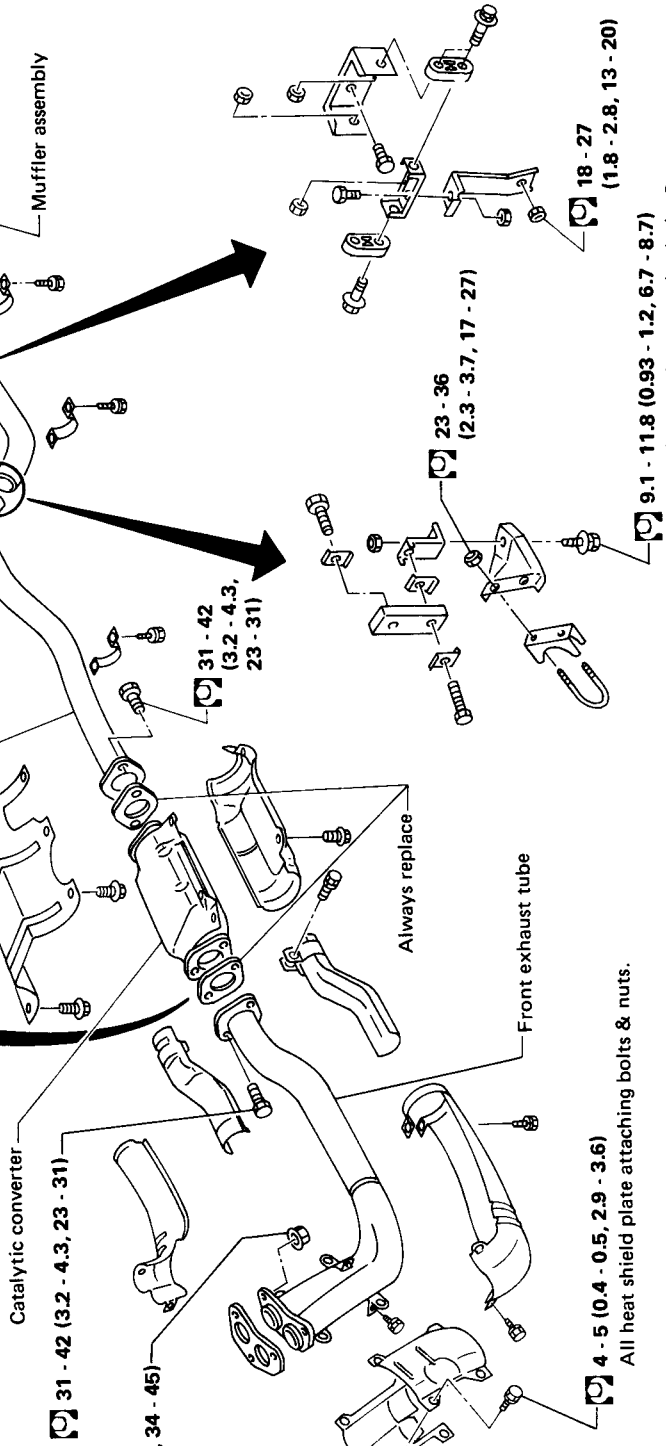

4 - 5 (0.4 - 0.5, 2.9 - 3.6)
All heat shield plate attaching bolts & nuts.

: N·m (kg-m, ft-lb)