

NISSAN 300ZX



1991



SERVICE MANUAL

INCH TO METRIC CONVERSION TABLE

(Rounded-off for automotive use)

inches	mm	inches	mm
.100	2.54	.610	15.49
.110	2.79	.620	15.75
.120	3.05	.630	16.00
.130	3.30	.640	16.26
.140	3.56	.650	16.51
.150	3.81	.660	16.76
.160	4.06	.670	17.02
.170	4.32	.680	17.27
.180	4.57	.690	17.53
.190	4.83	.700	17.78
.200	5.08	.710	18.03
.210	5.33	.720	18.29
.220	5.59	.730	18.54
.230	5.84	.740	18.80
.240	6.10	.750	19.05
.250	6.35	.760	19.30
.260	6.60	.770	19.56
.270	6.86	.780	19.81
.280	7.11	.790	20.07
.290	7.37	.800	20.32
.300	7.62	.810	20.57
.310	7.87	.820	20.83
.320	8.13	.830	21.08
.330	8.38	.840	21.34
.340	8.64	.850	21.59
.350	8.89	.860	21.84
.360	9.14	.870	22.10
.370	9.40	.880	22.35
.380	9.65	.890	22.61
.390	9.91	.900	22.86
.400	10.16	.910	23.11
.410	10.41	.920	23.37
.420	10.67	.930	23.62
.430	10.92	.940	23.88
.440	11.18	.950	24.11
.450	11.43	.960	24.38
.460	11.68	.970	24.64
.470	11.94	.980	24.89
.480	12.19	.990	25.15
.490	12.45	1.000	25.40
.500	12.70	2.000	50.80
.510	12.95	3.000	76.20
.520	13.21	4.000	101.60
.530	13.46	5.000	127.00
.540	13.72	6.000	152.40
.550	13.97	7.000	177.80
.560	14.22	8.000	203.20
.570	14.48	9.000	228.60
.580	14.73	10.000	254.00
.590	14.99	20.000	508.00
.600	15.24		

METRIC TO INCH CONVERSION TABLE

(Rounded-off for automotive use)

mm	inches	mm	inches
1	.0394	51	2.008
2	.079	52	2.047
3	.118	53	2.087
4	.157	54	2.126
5	.197	55	2.165
6	.236	56	2.205
7	.276	57	2.244
8	.315	58	2.283
9	.354	59	2.323
10	.394	60	2.362
11	.433	61	2.402
12	.472	62	2.441
13	.512	63	2.480
14	.551	64	2.520
15	.591	65	2.559
16	.630	66	2.598
17	.669	67	2.638
18	.709	68	2.677
19	.748	69	2.717
20	.787	70	2.756
21	.827	71	2.795
22	.866	72	2.835
23	.906	73	2.874
24	.945	74	2.913
25	.984	75	2.953
26	1.024	76	2.992
27	1.063	77	3.031
28	1.102	78	3.071
29	1.142	79	3.110
30	1.181	80	3.150
31	1.220	81	3.189
32	1.260	82	3.228
33	1.299	83	3.268
34	1.339	84	3.307
35	1.378	85	3.346
36	1.417	86	3.386
37	1.457	87	3.425
38	1.496	88	3.465
39	1.535	89	3.504
40	1.575	90	3.543
41	1.614	91	3.583
42	1.654	92	3.622
43	1.693	93	3.661
44	1.732	94	3.701
45	1.772	95	3.740
46	1.811	96	3.780
47	1.850	97	3.819
48	1.890	98	3.858
49	1.929	99	3.898
50	1.969	100	3.937

NISSAN 300ZX

MODEL Z32 SERIES

QUICK REFERENCE INDEX

GENERAL INFORMATION _____	GI
MAINTENANCE _____	MA
ENGINE MECHANICAL _____	EM
ENGINE LUBRICATION & COOLING SYSTEMS _____	LC
ENGINE FUEL & EMISSION CONTROL SYSTEM _____	EF & EC
ACCELERATOR CONTROL, FUEL & EXHAUST SYSTEMS _____	FE
CLUTCH _____	CL
MANUAL TRANSMISSION _____	MT
AUTOMATIC TRANSMISSION _____	AT
PROPELLER SHAFT & DIFFERENTIAL CARRIER _____	PD
FRONT AXLE & FRONT SUSPENSION _____	FA
REAR AXLE & REAR SUSPENSION _____	RA
BRAKE SYSTEM _____	BR
STEERING SYSTEM _____	ST
BODY _____	BF
HEATER & AIR CONDITIONER _____	HA
ELECTRICAL SYSTEM _____	EL

FOREWORD

This manual contains maintenance and repair procedures for the 1991 Nissan 300ZX.

In order to assure your safety and the efficient functioning of the vehicle, this manual should be read thoroughly. It is especially important that the PRECAUTIONS in the GI section be completely understood before starting any repair task.

All information in this manual is based on the latest product information at the time of publication. The right is reserved to make changes in specifications and methods at any time without notice.

IMPORTANT SAFETY NOTICE

The proper performance of service is essential for both the safety of the technician and the efficient functioning of the vehicle.

The service methods in this Service Manual are described in such a manner that the service may be performed safely and accurately.

Service varies with the procedures used, the skills of the technician and the tools and parts available. Accordingly, anyone using service procedures, tools or parts which are not specifically recommended by NISSAN must first completely satisfy himself that neither his safety nor the vehicle's safety will be jeopardized by the service method selected.



NISSAN MOTOR CO., LTD.

Overseas Service Department

Tokyo, Japan

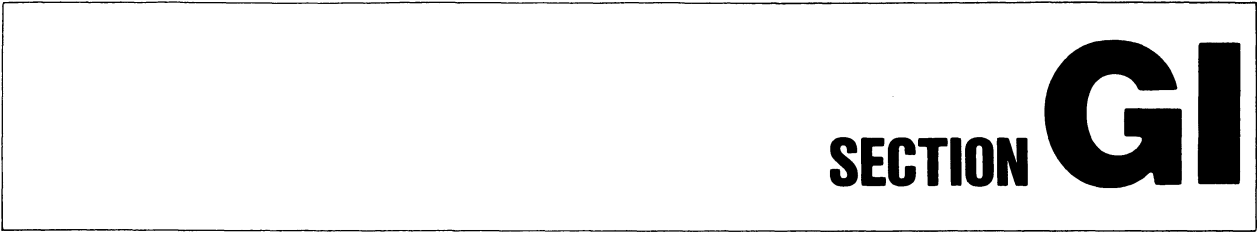

CONTENTS

PRECAUTIONS	GI- 2
HOW TO USE THIS MANUAL	GI- 6
HOW TO READ WIRING DIAGRAMS	GI- 8
HOW TO FOLLOW FLOW CHART IN TROUBLE DIAGNOSES	GI-11
CONSULT CHECKING SYSTEM	GI-14
IDENTIFICATION INFORMATION	GI-16
LIFTING POINTS AND TOW TRUCK TOWING	GI-21
TIGHTENING TORQUE OF STANDARD BOLTS	GI-24

PRECAUTIONS

Observe the following precautions to ensure safe and proper servicing. These precautions are not described in each individual section.

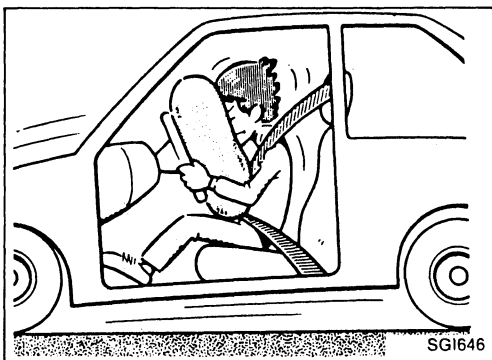

Precautions for Supplemental Restraint System "AIR BAG"

This model has a Supplemental Restraint System "Air Bag" to help reduce the risk or severity of injury to the driver in a frontal collision. The Supplemental Restraint System consists of an air bag (located in the center of the steering wheel), five sensors, a control unit, warning lamp, wiring harness and spiral cable. Information necessary to service the system safely is included in the BF section of this Service Manual.

WARNING:

- To avoid rendering the SRS inoperative, which could lead to personal injury or death in the event of a severe frontal collision, all maintenance must be performed by an authorized INFINITI dealer.
- Improper maintenance, including incorrect removal and installation of the SRS, can lead to personal injury caused by unintentional activation of the system.
- All SRS electrical wiring harnesses and connectors are covered with yellow outer insulation. Do not use electrical test equipment on these circuits.

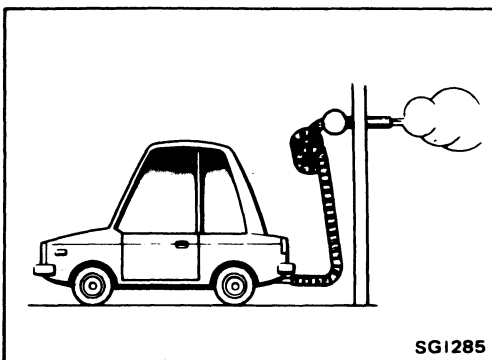

General Precautions

1. Do not operate the engine for an extended period of time without proper exhaust ventilation. Keep the work area well ventilated and free of any inflammable materials. Special care should be taken when handling any inflammable or poisonous materials, such as gasoline, refrigerant gas, etc. When working in a pit or other enclosed area, be sure to properly ventilate the area before working with hazardous materials. Do not smoke while working on the vehicle.
2. Before jacking up the vehicle, apply wheel chocks or other tire blocks to the wheels to prevent the vehicle from moving. After jacking up the vehicle, support the vehicle weight with safety stands at the points designated for proper lifting and towing before working on the vehicle. These operations should be done on a level surface.
3. When removing a heavy component such as the engine or transaxle/transmission, be careful not to lose your balance and drop them. Also, do not allow them to strike adjacent parts, especially the brake tubes and master cylinder.

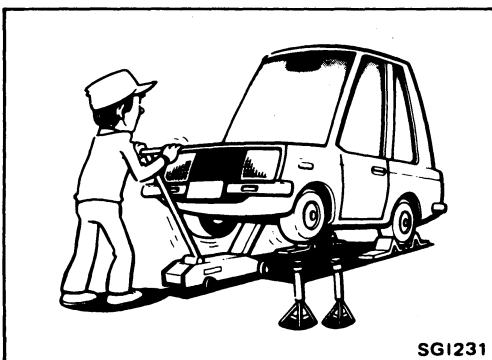

PRECAUTIONS

General Precautions (Cont'd)

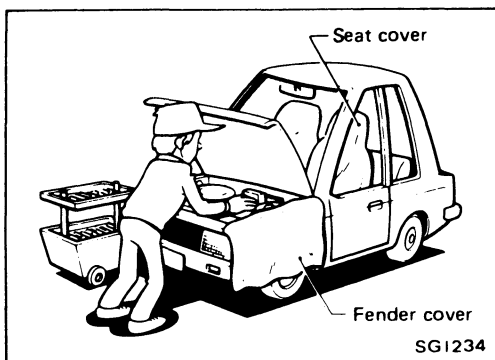
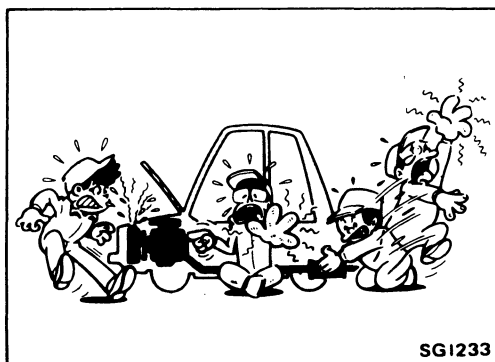
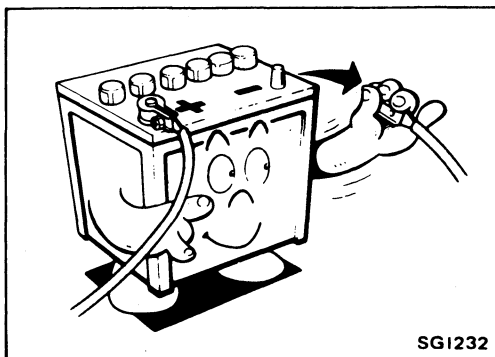

4. Before starting repairs which do not require battery power, always turn off the ignition switch, then disconnect the ground cable from the battery to prevent accidental short circuit.
5. To prevent serious burns, avoid contact with hot metal parts such as the radiator, exhaust manifold, tail pipe and muffler. Do not remove the radiator cap when the engine is hot.
6. Before servicing the vehicle, protect fenders, upholstery and carpeting with appropriate covers. Take caution that keys, buckles or buttons on your person do not scratch the paint.
7. Clean all disassembled parts in the designated liquid or solvent prior to inspection or assembly.
8. Replace oil seals, gaskets, packings, O-rings, locking washers, cotter pins, self-locking nuts, etc. with new ones.
9. Replace inner and outer races of tapered roller bearings and needle bearings as a set.
10. Arrange the disassembled parts in accordance with their assembled locations and sequence.
11. Do not touch the terminals of electrical components which use microcomputers (such as electronic control units). Static electricity may damage internal electronic components.
12. After disconnecting vacuum or air hoses, attach a tag to indicate the proper connection.
13. Use only the lubricants specified in MA section.
14. Use approved bonding agent, sealants or their equivalents when required.
15. Use tools and recommended special tools where specified for safe and efficient service repairs.
16. When repairing the fuel, oil, water, vacuum or exhaust systems, check all affected lines for leaks.
17. Dispose of drained oil or the solvent used for cleaning parts in an appropriate manner.

PRECAUTIONS

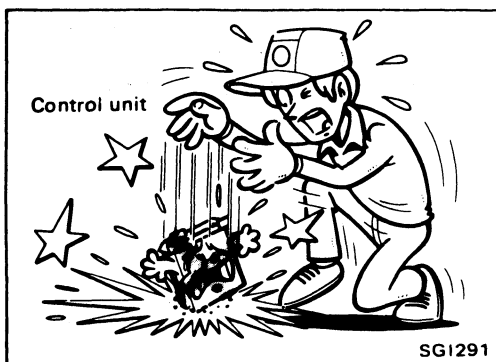

Precautions for E.F.I. or E.C.C.S. Engine

1. Before connecting or disconnecting E.F.I. or E.C.C.S. harness connector to or from any E.F.I. or E.C.C.S. control unit, be sure to turn the ignition switch to the "OFF" position and disconnect the negative battery terminal. Otherwise, there may be damage to control unit.
2. Before disconnecting pressurized fuel line from fuel pump to injectors, be sure to release fuel pressure to eliminate danger.
3. Be careful not to jar components such as control unit and air flow meter.

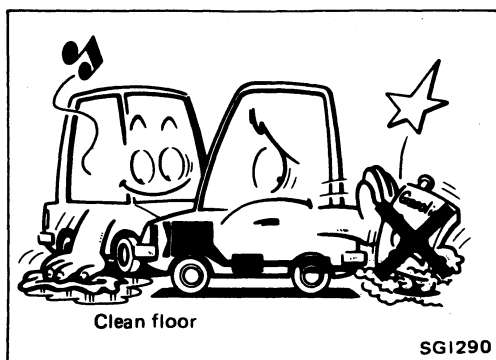

Precautions for Catalyst

If a large amount of unburned fuel flows into the converter, the converter temperature will be excessively high. To prevent this, follow the procedure below:

1. Use unleaded gasoline only. Leaded gasoline will seriously damage the catalytic converter.
2. When checking for ignition spark or measuring engine compression, make tests quickly and only when necessary.
3. Do not run engine when the fuel tank level is low, otherwise the engine may misfire causing damage to the converter.
4. Do not place the vehicle on inflammable material. Keep inflammable material off the exhaust pipe.

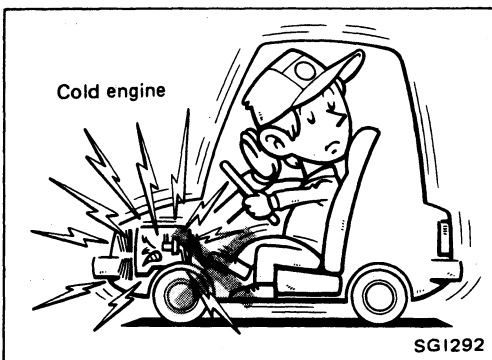

Precautions for Turbocharger

The turbocharger turbine revolves at extremely high speeds and becomes very hot. Therefore, it is essential to maintain a clean supply of oil flowing through the turbocharger and to follow all required maintenance instructions and operating procedures.

For proper operation of the system, follow the procedure below.

1. Always use the recommended oil. Follow the instructions for proper time to change the oil and proper oil level.
2. Avoid accelerating engine to a high rpm immediately after starting.
3. If engine had been operating at high rpm for an extended period of time, let it idle for a few minutes prior to shutting it off.

PRECAUTIONS

Precautions for Fuel

To maintain engine and exhaust system durability and performance, UNLEADED PREMIUM gasoline with an octane rating of at least 91 AKI (Research octane number 96) must be used.

If premium unleaded gasoline is not available, REGULAR UNLEADED gasoline with an octane rating of 87 AKI (Research octane number 91) may be used temporarily, but only under the following conditions:

- The fuel tank should be filled only partially with unleaded regular gasoline, and filled up with premium unleaded gasoline as soon as possible.
- Full throttle driving and abrupt acceleration should be avoided.

Use UNLEADED fuel only. Under no circumstances should leaded gasoline be used. Lead gasoline will damage the catalytic converter and increase dangerous emissions from the vehicle exhaust.

HOW TO USE THIS MANUAL

1. **A QUICK REFERENCE INDEX**, a black tab (e.g. **BR**) is provided on the first page. You can quickly find the first page of each section by mating it to the section's black tab.
2. **THE CONTENTS** are listed on the first page of each section.
3. **THE TITLE** is indicated on the upper portion of each page and shows the part or system.
4. **THE PAGE NUMBER** of each section consists of two letters which designate the particular section and a number (e.g. "BR-5").
5. **THE LARGE ILLUSTRATIONS** are exploded views (See below.) and contain tightening torques, lubrication points and other information necessary to perform repairs. The illustrations should be used in reference to service matters only. When ordering parts, refer to the appropriate **PARTS CATALOG**.

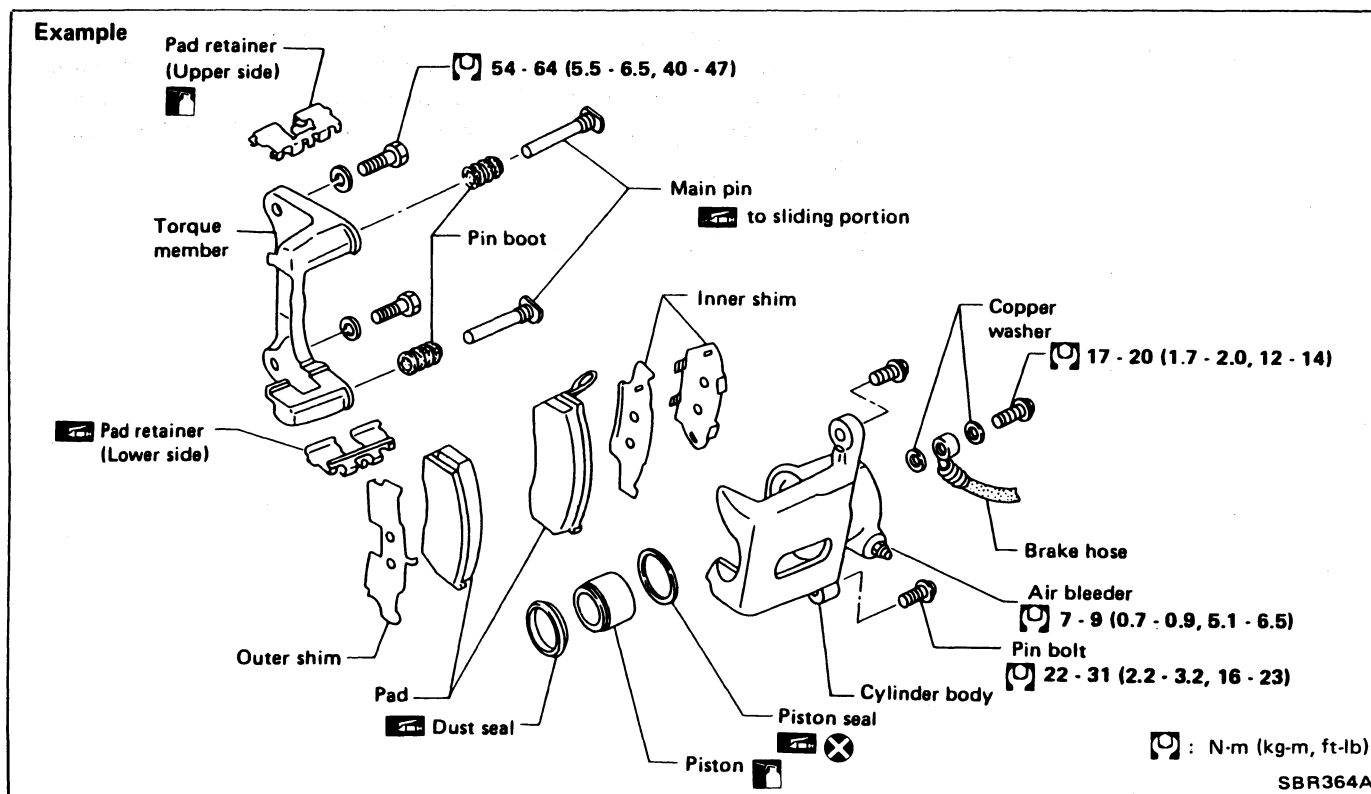

6. **THE SMALL ILLUSTRATIONS** show the important steps such as inspection, use of special tools, knacks of work and hidden or tricky steps which are not shown in the previous large illustrations. Assembly, inspection and adjustment procedures for complicated units such as the automatic transaxle or transmission, etc. are presented in a step-by-step format where necessary.

7. The following **SYMBOLS AND ABBREVIATIONS** are used:

	: Tightening torque	S.D.S.	: Service Data and Specifications
	: Should be lubricated with grease. Unless otherwise indicated, use recommended multi-purpose grease.	L.H., R.H.	: Left-Hand, Right-Hand
	: Should be lubricated with oil.	M/T	: Manual Transaxle/Transmission
	: Sealing point	A/T	: Automatic Transaxle/Transmission
	: Checking point	Tool	: Special Service Tools
	: Always replace after every disassembly.	A.T.F.	: Automatic Transmission Fluid
	: Apply petroleum jelly.	D ₁	: Drive range 1st gear
	: Apply A.T.F.	D ₂	: Drive range 2nd gear
★	: Select with proper thickness.	D ₃	: Drive range 3rd gear
☆	: Adjustment is required.	D ₄	: Drive range 4th gear
		O.D.	: Overdrive
		2 ₂	: 2nd range 2nd gear
		2 ₁	: 2nd range 1st gear
		1 ₂	: 1st range 2nd gear
		1 ₁	: 1st range 1st gear

HOW TO USE THIS MANUAL

8. The **UNITS** given in this manual are primarily expressed as SI UNITS (International System of Unit), and alternately expressed in the metric system and in the yard/pound system.

“**Example**”

Tightening torque:

59 - 78 N·m (6.0 - 8.0 kg-m, 43 - 58 ft-lb)

9. **TROUBLE DIAGNOSES** are included in sections dealing with complicated components.
10. **SERVICE DATA AND SPECIFICATIONS** are contained at the end of each section for quick reference of data.
11. The captions **WARNING** and **CAUTION** warn you of steps that must be followed to prevent personal injury and/or damage to some part of the vehicle.
- **WARNING** indicates the possibility of personal injury if instructions are not followed.
 - **CAUTION** indicates the possibility of component damage if instructions are not followed.
 - **BOLD TYPED STATEMENTS** except **WARNING** and **CAUTION** give you helpful information.

HOW TO READ WIRING DIAGRAMS

WIRING DIAGRAM

Symbols used in WIRING DIAGRAM are shown below:

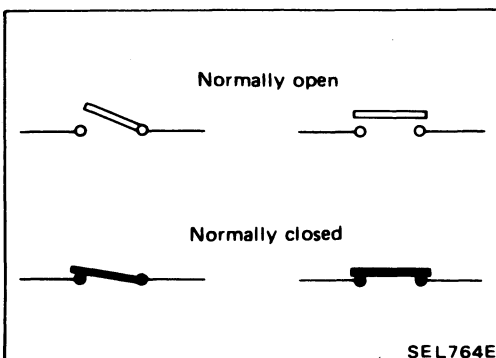
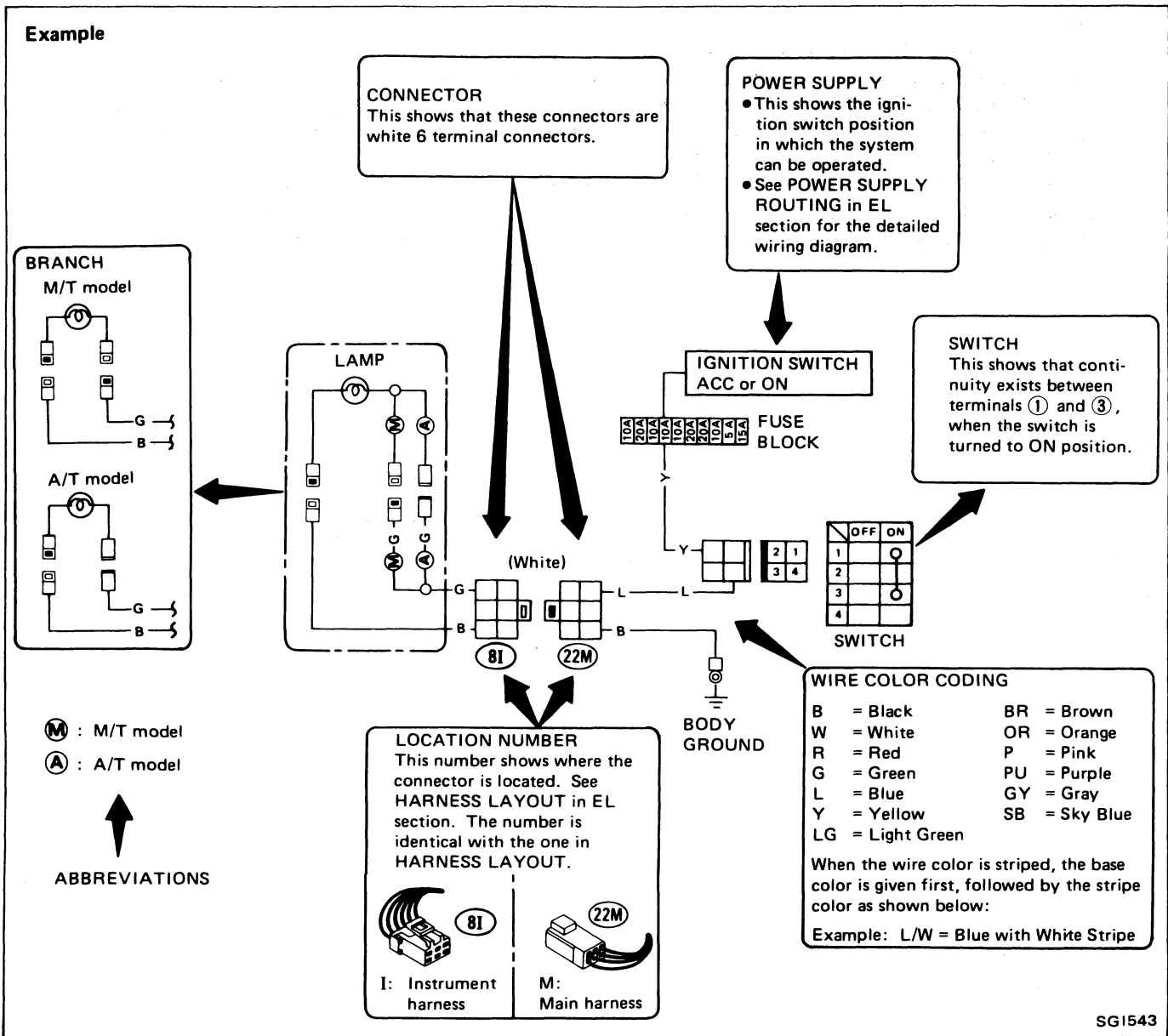

SWITCH POSITIONS

Wiring diagram switches are shown with the vehicle in the following condition.

- Ignition switch "OFF".
- Doors, hood and trunk lid/back door closed.
- Pedals are not depressed and parking brake is released.

HOW TO READ WIRING DIAGRAMS

Example

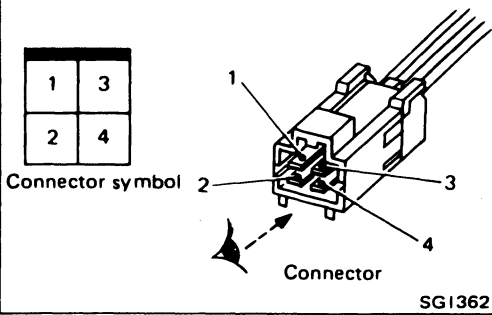

CONNECTOR SYMBOLS

- All connector symbols in wiring diagrams are shown from the terminal side.

Example

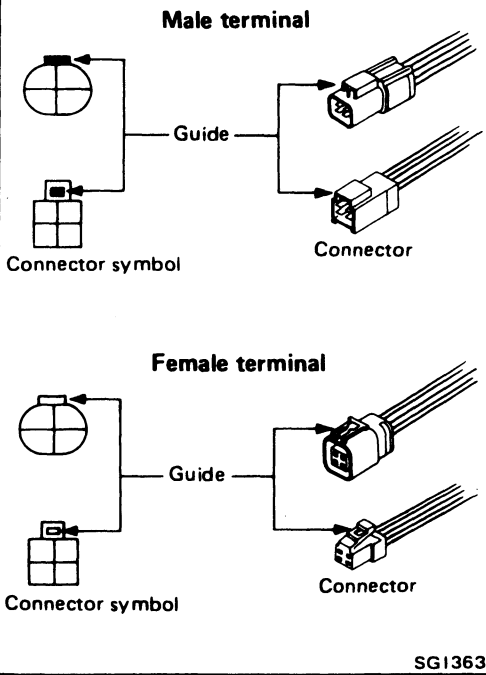

- Male and female terminals
Connector guides for male terminals are shown in black and female terminals in white in wiring diagrams.

MULTIPLE SWITCH

The continuity of the multiple switch is identified in the switch chart in wiring diagrams.

Example

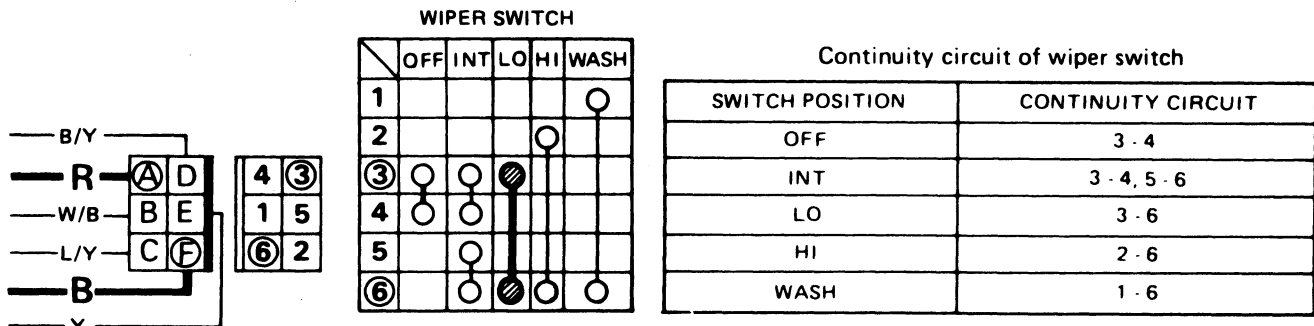

Example: Wiper switch in LO position

Continuity circuit: Red wire - (A) terminal - (3) terminal - Wiper switch (● - ● : LO) - (6) terminal - (F) terminal - Black wire

SG1365

HOW TO READ WIRING DIAGRAMS

SUPER MULTIPLE JUNCTION (S.M.J.)

- The "S.M.J." indicated in wiring diagrams is shown in a simplified form. The terminal arrangement should therefore be referred to in the foldout at the end of the Service Manual.
- The foldout should be spread to read the entire wiring diagram.

Example

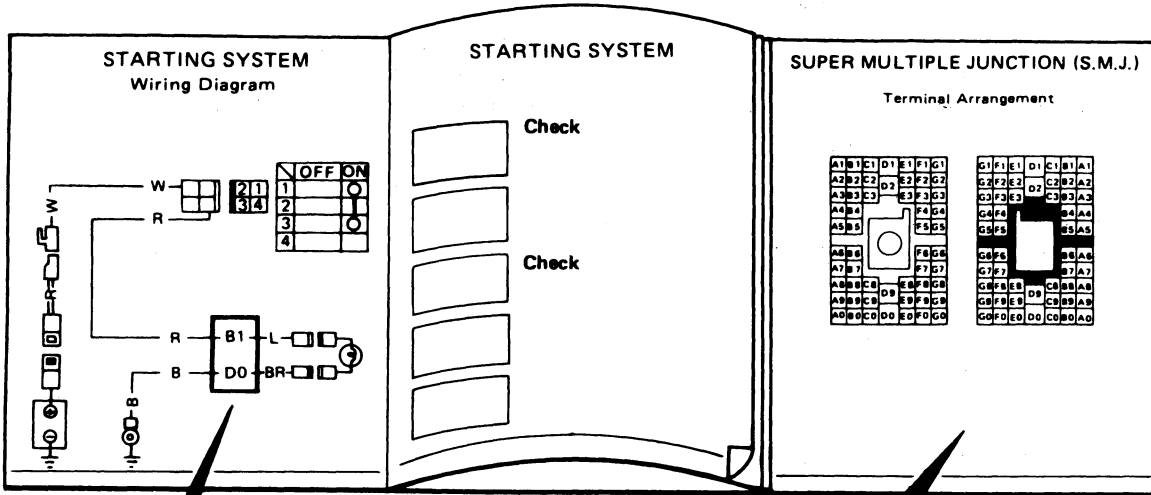

Super Multiple Junction (S.M.J.)

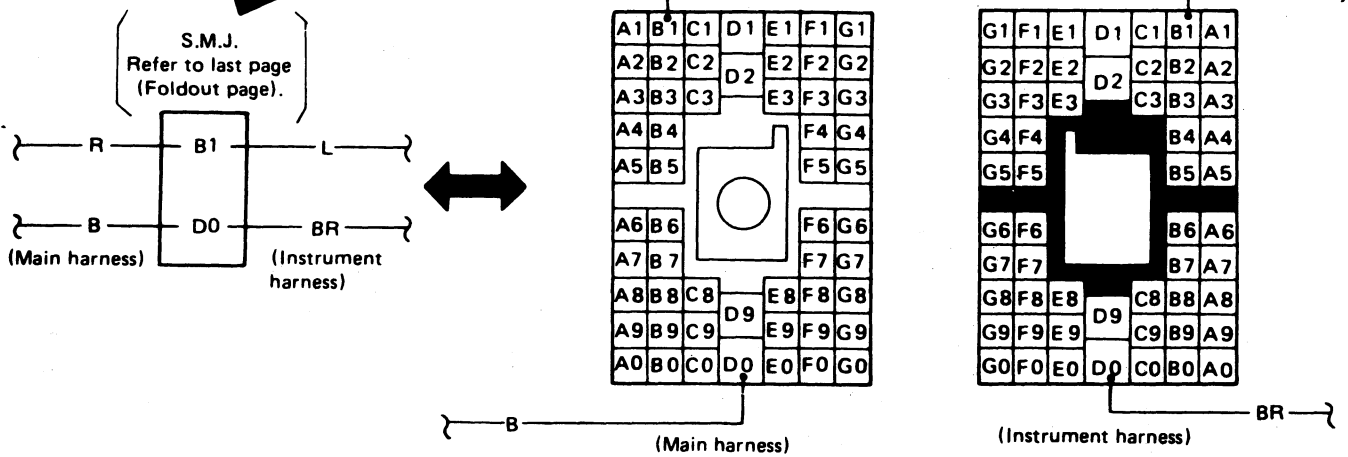

SEL653F

HOW TO FOLLOW FLOW CHART IN TROUBLE DIAGNOSES

Example

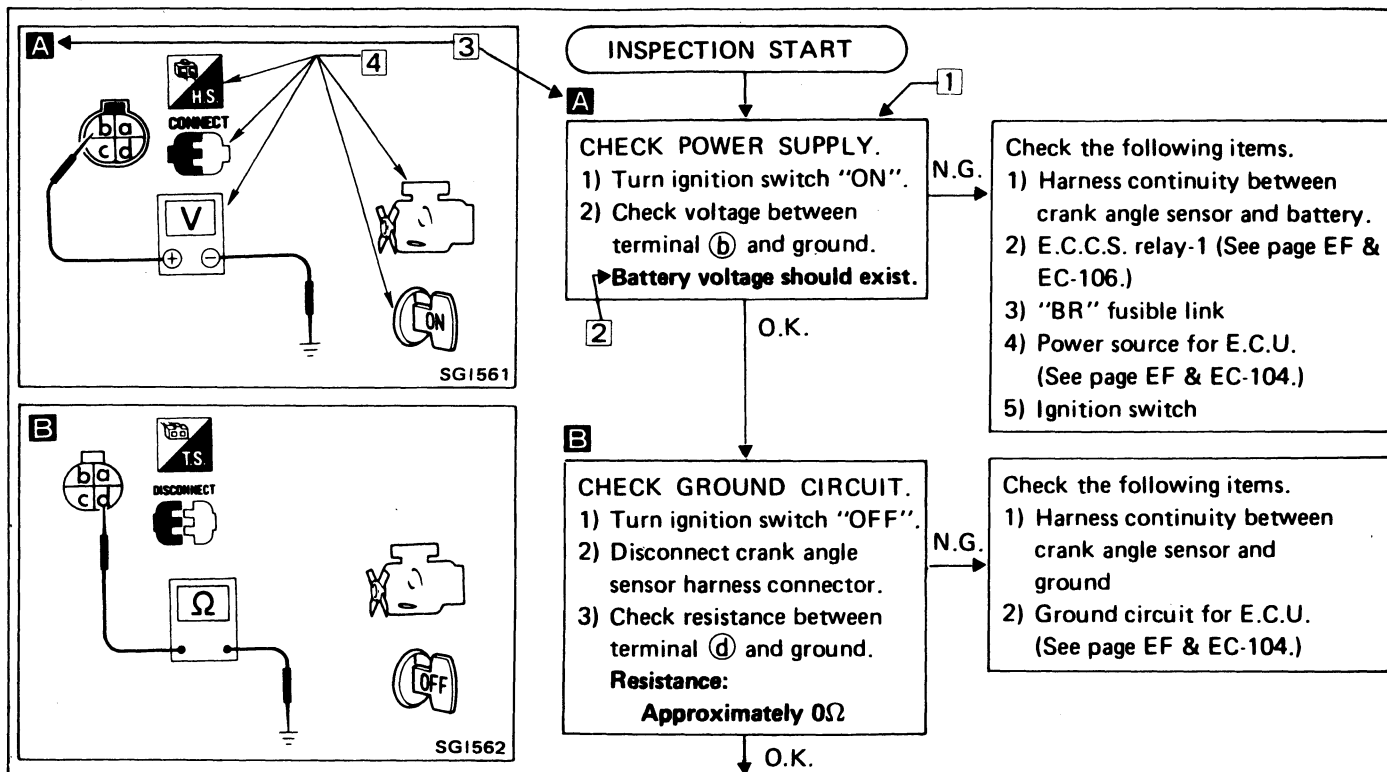

NOTICE

The flow chart indicates work procedures required to diagnose problems effectively. Observe the following instructions before diagnosing.

- 1) Use the flow chart after locating probable causes of a problem following the "Preliminary Check" or the "Symptom Chart".
- 2) After repairs, re-check that the problem has been completely eliminated.
- 3) Refer to Component Parts Location and Harness Layout for the Systems described in each section for identification/location of components and harness connectors.
- 4) Refer to the Circuit Diagram for Quick Pinpoint Check. If you must perform circuit continuity between harness connectors more detail, such as in case of sub-harness is used, refer to Wiring Diagram and Harness Layout in EL section for identification of harness connectors.
- 5) When checking circuit continuity, ignition switch should be "OFF".
- 6) Before checking voltage at connectors, check battery voltage.
- 7) After accomplishing the Diagnostic Procedures and Electrical Components Inspection, make sure that all harness connectors are reconnected as they were.

HOW TO FOLLOW FLOW CHART IN TROUBLE DIAGNOSES

HOW TO FOLLOW THIS FLOW CHART

1 Work and diagnostic procedure

Start to diagnose a problem using procedures indicated in enclosed blocks, as shown in the following example.

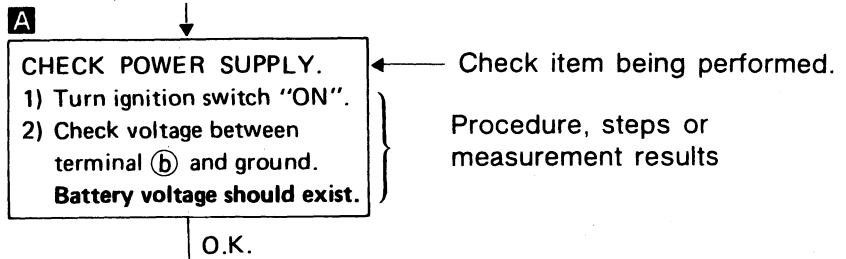

2 Measurement results

Required results are indicated in bold type in the corresponding block, as shown below:
These have the following meanings:

Battery voltage → 11 - 14V or approximately 12V
Voltage: Approximately 0V → Less than 1V

3 Cross reference of work symbols in the text and illustrations

Illustrations are provided as visual aids for work procedures. For example, symbol **A** indicated in the left upper portion of each illustration corresponds with the symbol in the flowchart for easy identification. More precisely, the procedure under the "CHECK POWER SUPPLY" outlined previously is indicated by an illustration **A**.

4 Symbols used in illustrations

Symbols included in illustrations refer to measurements or procedures. Before diagnosing a problem, familiarize yourself with each symbol.

Direction mark

A direction mark is shown to clarify the side of connector (terminal side or harness side).

Direction marks are mainly used in the illustrations indicating terminal inspection.



: View from terminal side ... T.S.

- All connector symbols shown from the terminal side are enclosed by a single line.



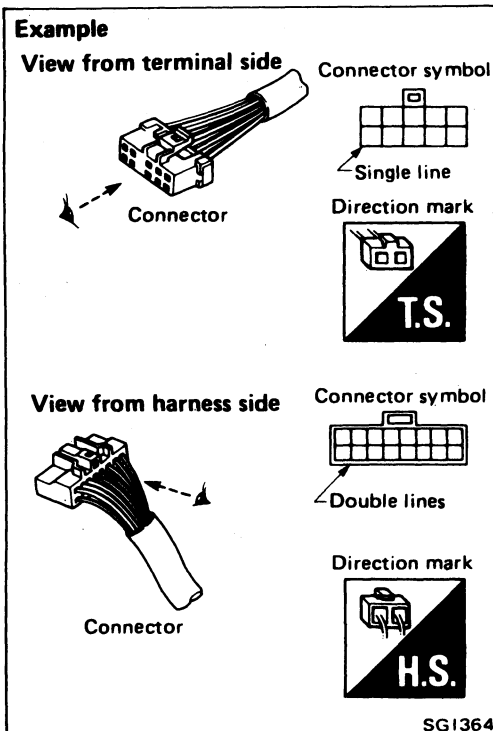

: View from harness side ... H.S.

- All connector symbols shown from the harness side are enclosed by a double line.



HOW TO FOLLOW FLOW CHART IN TROUBLE DIAGNOSES

Key to symbols signifying measurements or procedures

Symbol	Symbol explanation	Symbol	Symbol explanation
	Check after disconnecting the connector to be measured.		Current should be measured with an ammeter.
	Check after connecting the connector to be measured.		Procedure with CONSULT
	Insert key into ignition switch.		Procedure without CONSULT
	Turn ignition switch to "OFF" position.		A/C switch is "OFF".
	Turn ignition switch to "ON" position.		A/C switch is "ON".
	Turn ignition switch to "START" position.		Fan switch is "ON". (At any position except for "OFF" position)
	Turn ignition switch from "OFF" to "ACC" position.		Fan switch is "OFF".
	Turn ignition switch from "ACC" to "OFF" position.		Apply battery voltage directly to components.
	Turn ignition switch from "OFF" to "ON" position.		Drive vehicle.
	Turn ignition switch from "ON" to "OFF" position.		Disconnect battery negative cable.
	Do not start engine, or check with engine stopped.		Depress brake pedal.
	Start engine, or check with engine running.		Release brake pedal.
	Apply parking brake.		Depress accelerator pedal.
	Release parking brake.		Release accelerator pedal.
	Check after engine is warmed up sufficiently.	<p>Pin terminal check for S.M.J. type E.C.U. and A/T control unit connectors. For details regarding the terminal arrangement, refer to the foldout page.</p>  	
	Voltage should be measured with a voltmeter.		
	Circuit resistance should be measured with an ohmmeter.		

CONSULT CHECKING SYSTEM

Outside View

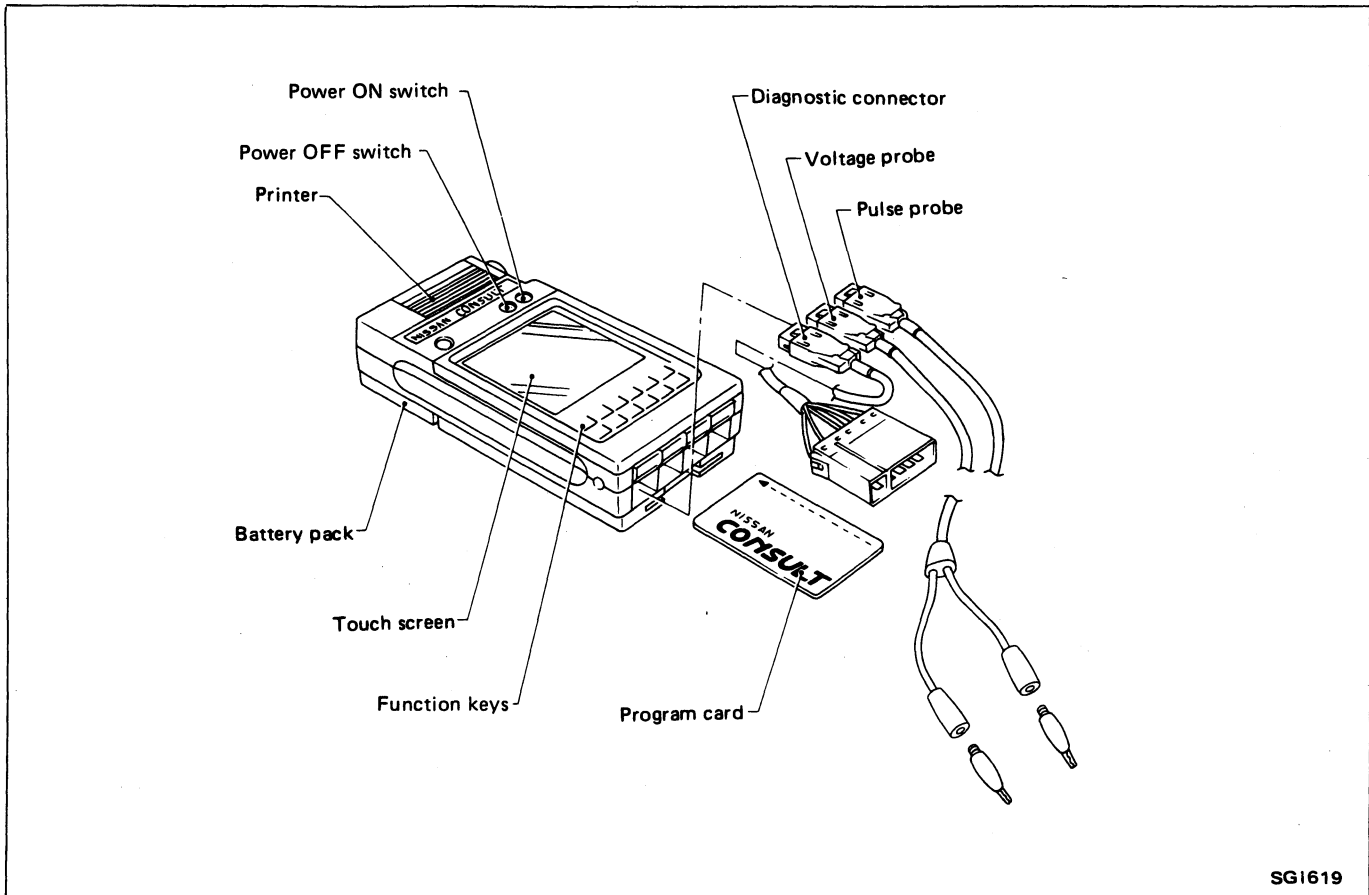

SG1619

System Application

System	System				
	E.C.C.S.	Auto A/C	A/T	HICAS	Air bag
Diagnostic mode					
Work support	X	X	-	-	-
Self-diagnostic results	X	X	X	X	X
Data monitor	X	X	X	X	-
Active test	X	X	-	X	-
E.C.U. part number	X	-	X	X	-
Function test	X	-	-	-	-

X: Applicable

CONSULT CHECKING SYSTEM

Function

Diagnostic mode	Function
Work support	This mode enables a technician to adjust some devices faster and more accurately by following the indications on CONSULT.
Self-diagnostic results	Self-diagnostic results can be read and erased quickly.
Data monitor	Input/Output data in the control unit can be read.
Active test	Mode in which CONSULT drives some actuators apart from the control units and also shifts some parameters in a specified range.
E.C.U. part number	E.C.U. part number can be read.

Checking Equipment

Tool name	Description
<p>NISSAN CONSULT kit</p> <ul style="list-style-type: none"> ① CONSULT unit and accessories ② Program card (UE900) ③ Operation manuals ④ Binder ⑤ Carrying case ⑥ Thermal paper (Rolls) 	

When ordering the above equipment, contact your NISSAN distributor.

IDENTIFICATION INFORMATION

Model Variation

Body	Destination		Model		Engine	Transmission	Differential carrier	Road wheel size ... offset mm (in)	Tire size
Standard roof	U.S.A.	Non-California	2 seater	RL-JU	VG30DE	RS5R30A	R200V	7-1/2JJx16 ... 45 (1.77)	P225/50R16 91V
T-bar roof				RL-JAU		RE4R01A			
				KRL-XU		RS5R30A			
				KRL-XAU		RE4R01A			
			KRL-XSU	VG30DETT	RS5R30A	R230V	FR: 7.5JJ-16 ... 45 (1.77) RR: 8.5JJ-16 ... 35 (1.38)	FR: P225/50ZR16 RR: P245/45ZR16	
					KRL-XASU				RE4R03A
		2+2	KRLG-XU	VG30DE	RS5R30A	R200V	7-1/2JJx16 ... 45 (1.77)	P225/50R16 91V	
Standard roof		California	2 seater	RL-JV	VG30DE	RS5R30A	R200V	7-1/2JJx16 ... 45 (1.77)	P225/50R16 91V
T-bar roof				RL-JAV		RE4R01A			
				KRL-XV		RS5R30A			
	KRL-XAV			RE4R01A					
	KRL-XSV		VG30DETT	RS5R30A	R230V	FR: 7.5JJ-16 ... 45 (1.77) RR: 8.5JJ-16 ... 35 (1.38)	FR: P225/50ZR16 RR: P245/45ZR16		
				KRL-XASV				RE4R03A	
	2+2	KRLG-XV	VG30DE	RS5R30A	R200V	7-1/2JJx16 ... 45 (1.77)	R225/50R16 91V		
Standard roof	Canada	2 seater	RL-JN	VG30DE	RS5R30A	R200V	7-1/2JJx16 ... 45 (1.77)	P225/50R16 91V	
T-bar roof			RL-JAN		RE4R01A				
			KRL-XN		RS5R30A				
			KRL-XAN		RE4R01A				
		KRL-XSN	VG30DETT	RS5R30A	R230V	FR: 7.5JJ-16 ... 45 (1.77) RR: 8.5JJ-16 ... 35 (1.38)	FR: P225/50ZR16 RR: P245/45ZR16		
KRL-XASN				RE4R03A					
2+2		KRLG-XN KRLG-XAN	VG30DE	RS5R30A	R200V	7-1/2JJx16 ... 45 (1.77)	R225/50R16 91V		
				RE4R01A					

IDENTIFICATION INFORMATION

Model Variation (Cont'd)

Prefix and suffix designations:

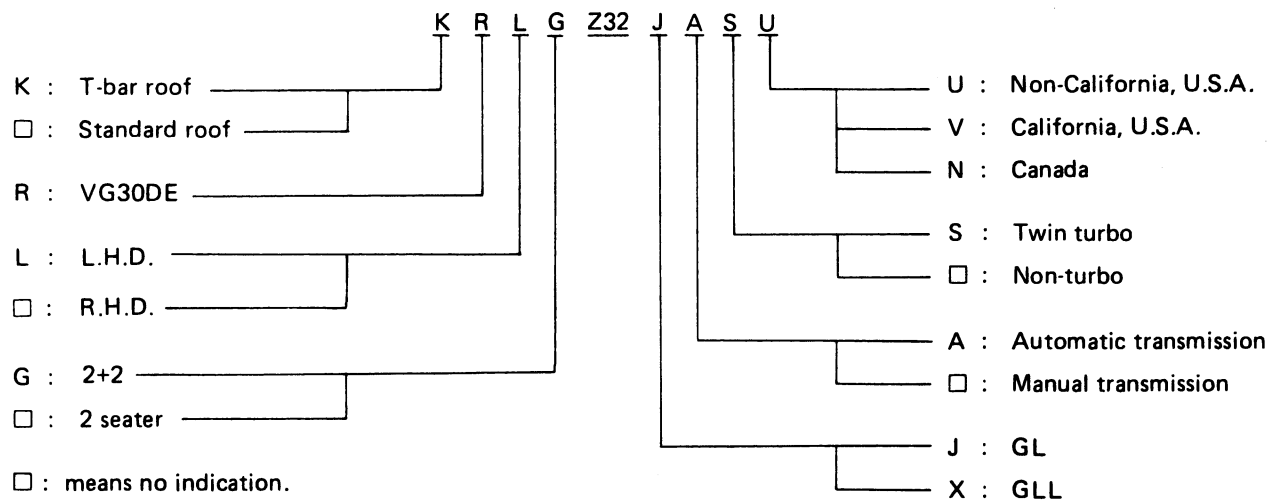

IDENTIFICATION INFORMATION

Identification Number

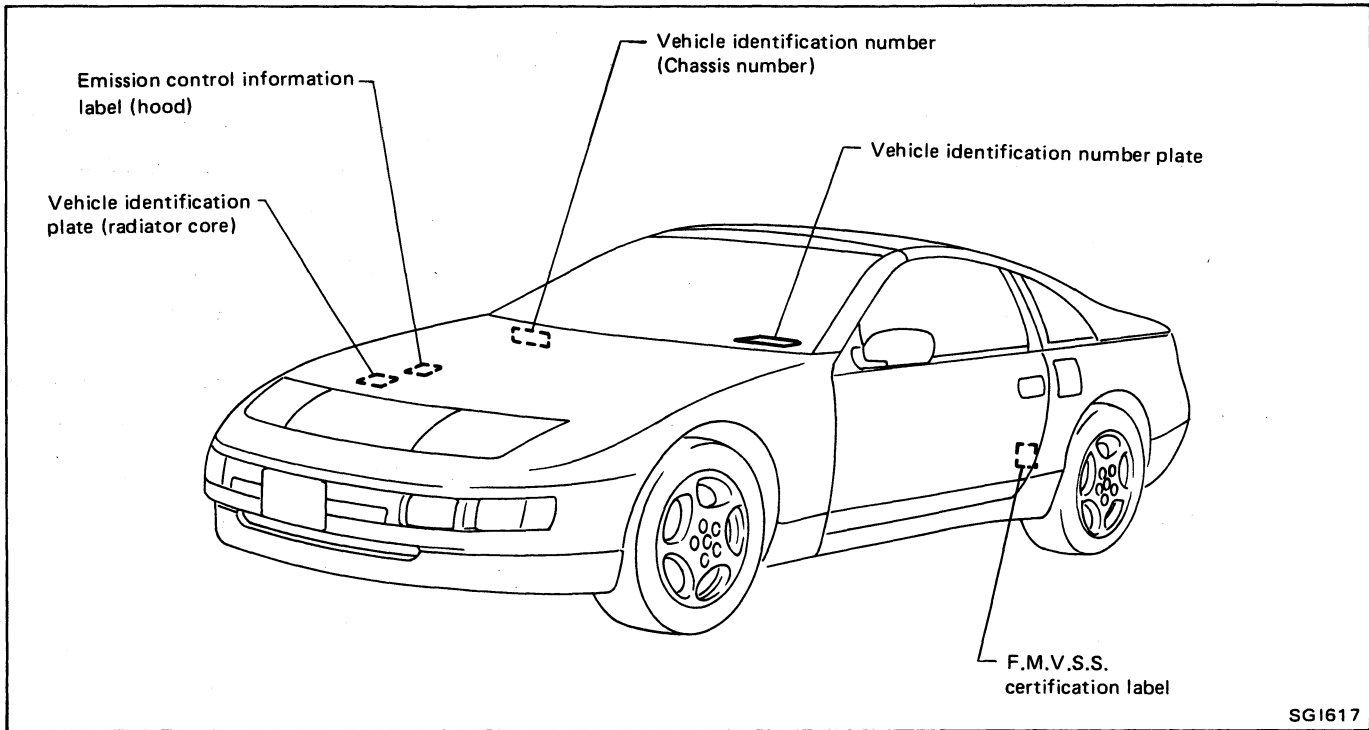

VEHICLE IDENTIFICATION NUMBER ARRANGEMENT

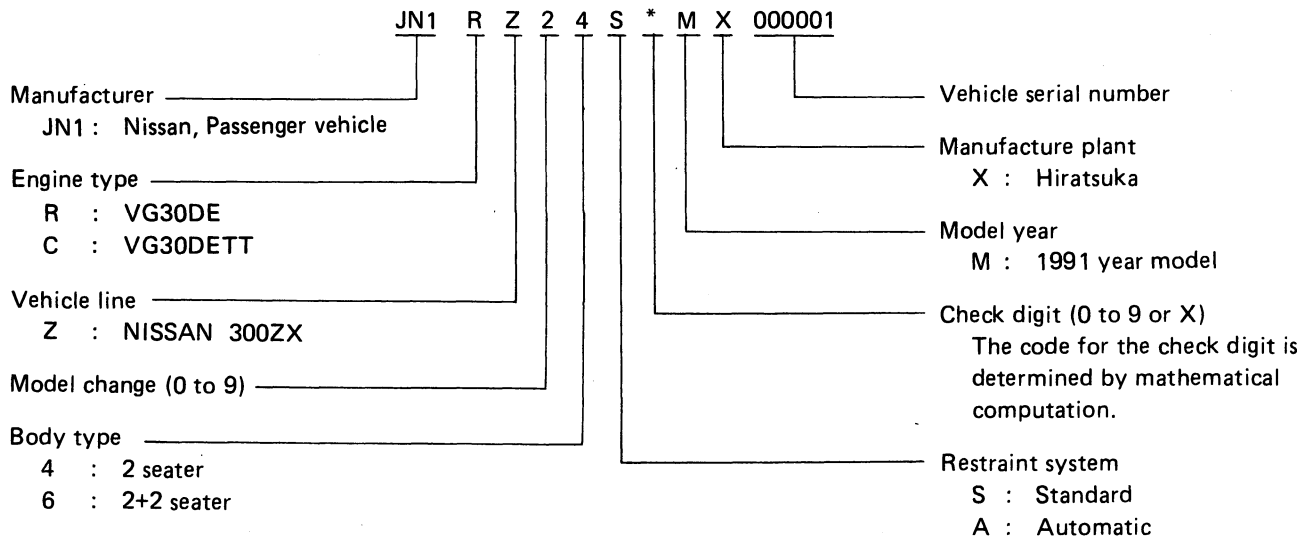

IDENTIFICATION INFORMATION

Identification Number (Cont'd) IDENTIFICATION PLATE

NISSAN MOTOR CO., LTD. JAPAN		
型式	TYPE TIPO	△
CHASSIS NO NO DE CHASIS		△
MODEL MODELO		△
○ カラー COLOR TRIM トリム COLOR GUARNICION	△ △	○
エンジン ENGINE ジン MOTOR	△ △	CC
ミッション TRANS. AXLE アクスル TRANS. EJE	△ △	
	工場	PLANT PLANTA
日産自動車株式会社		MADE IN JAPAN

SGI315

- 1 Type
- 2 Vehicle identification number (Chassis number)
- 3 Model
- 4 Body color code
- 5 Trim color code
- 6 Engine model
- 7 Engine displacement
- 8 Transmission model
- 9 Axle model

ENGINE SERIAL NUMBER

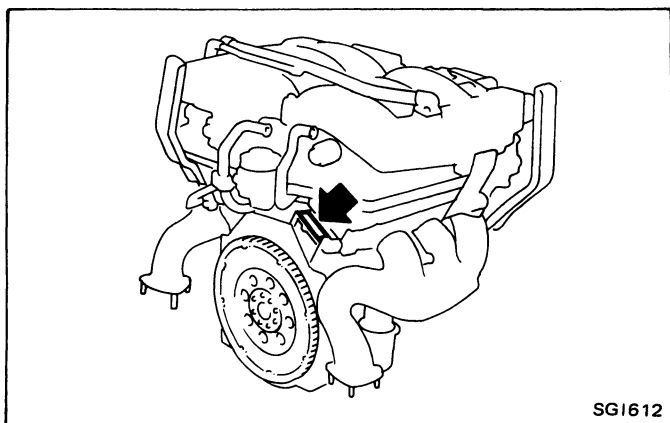

MANUAL TRANSMISSION NUMBER

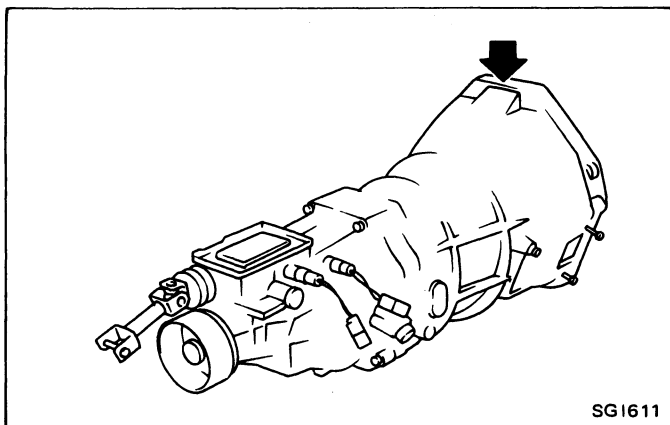

AUTOMATIC TRANSMISSION NUMBER

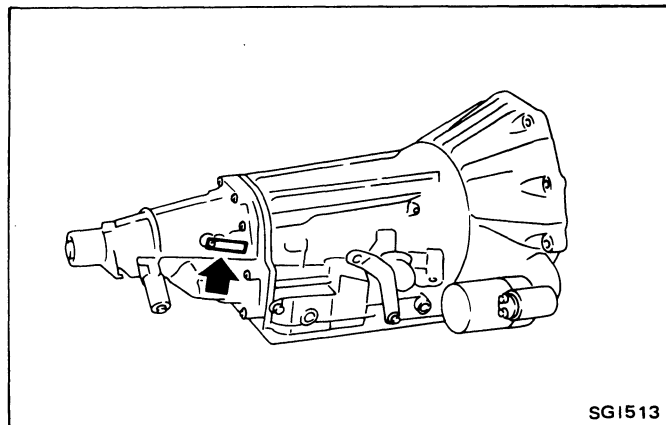

IDENTIFICATION INFORMATION

Dimensions

Unit: mm (in)

Item		Model	2 seater	2+2
Overall length			4,305 (169.5)	4,520 (178.0)
Overall width			1,790 (70.5)	1,800 (70.9)
Overall height	T-bar roof		1,250 (49.2)	1,255 (49.4)
	Standard		1,245 (49.0)	—
Wheelbase			2,450 (96.5)	2,570 (101.2)
Tread	Front		1,495 (58.9)	1,495 (58.9)
	Rear		1,535 (60.4)	1,535 (60.4)

Wheels and Tires

Road wheel	Aluminum	Steel	Offset mm (in)
Conventional	16 x 7.5JJ	—	45 (1.77)
	16 x 8.5JJ*1		35 (1.38)*1
T-type	—	16 x 4T	30 (1.18)
Space-saver tire	—	15 x 5J	30 (1.18)
Tire size			
Conventional		P225/50R16 91V P225/50ZR16*2 P245/45ZR16*3	
Spare			
T-type		T125/90D16	
Space-saver tire		165/80D15FS	

- *1: Rear wheel for turbo model
- *2: Front tire for turbo model
- *3: Rear tire for turbo model

Garage Jack and Safety Stand

WARNING:

- Never get under the vehicle while it is supported only by the jack. Always use safety stands to support the frame when you have to get under the vehicle.
- Place wheel chocks at the front wheels when the rear wheels are raised and place wheel chocks at the rear wheels when the front wheels are raised.

CAUTION:

Place a wooden or rubber block between safety stand and vehicle body when the supporting body is flat.

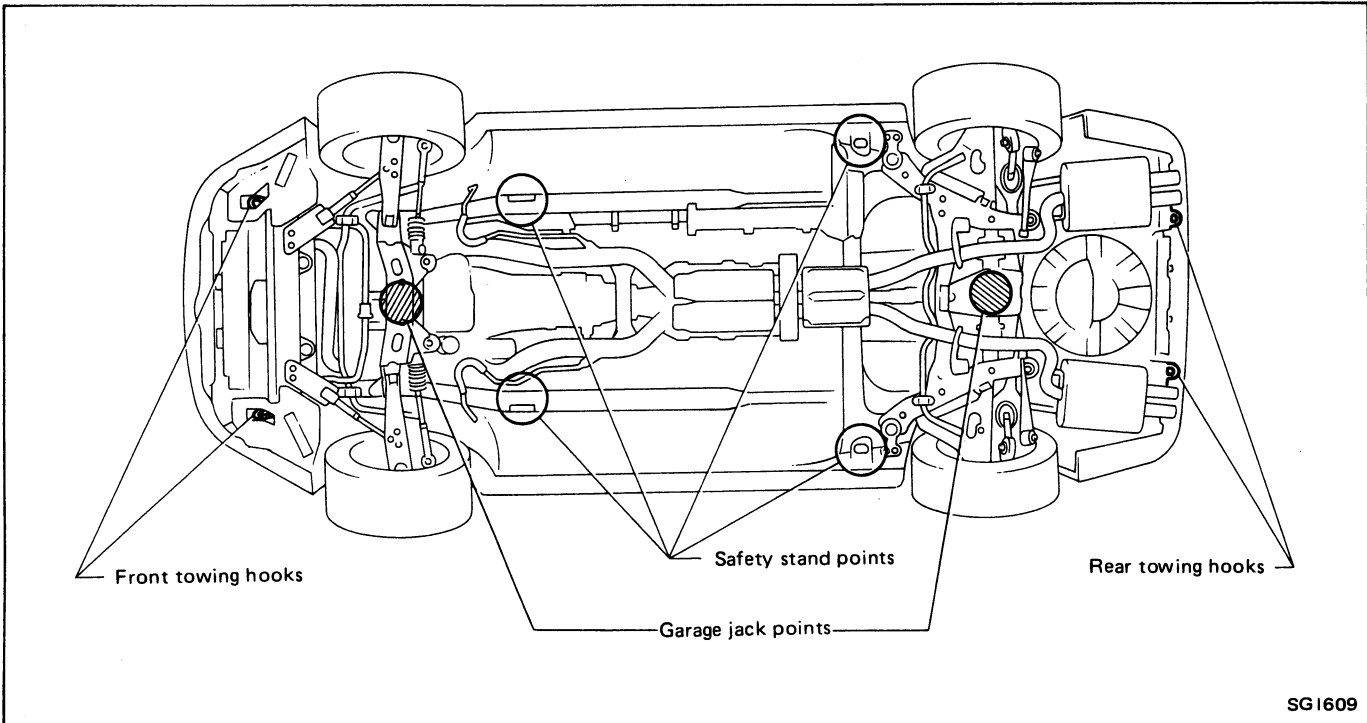

LIFTING POINTS AND TOW TRUCK TOWING

2-pole Lift

WARNING:

When lifting the vehicle, open the lift arms as wide as possible and ensure that the front and rear of the vehicle are well balanced.

When setting the lift arm, do not allow the arm to contact the brake tubes and fuel lines.

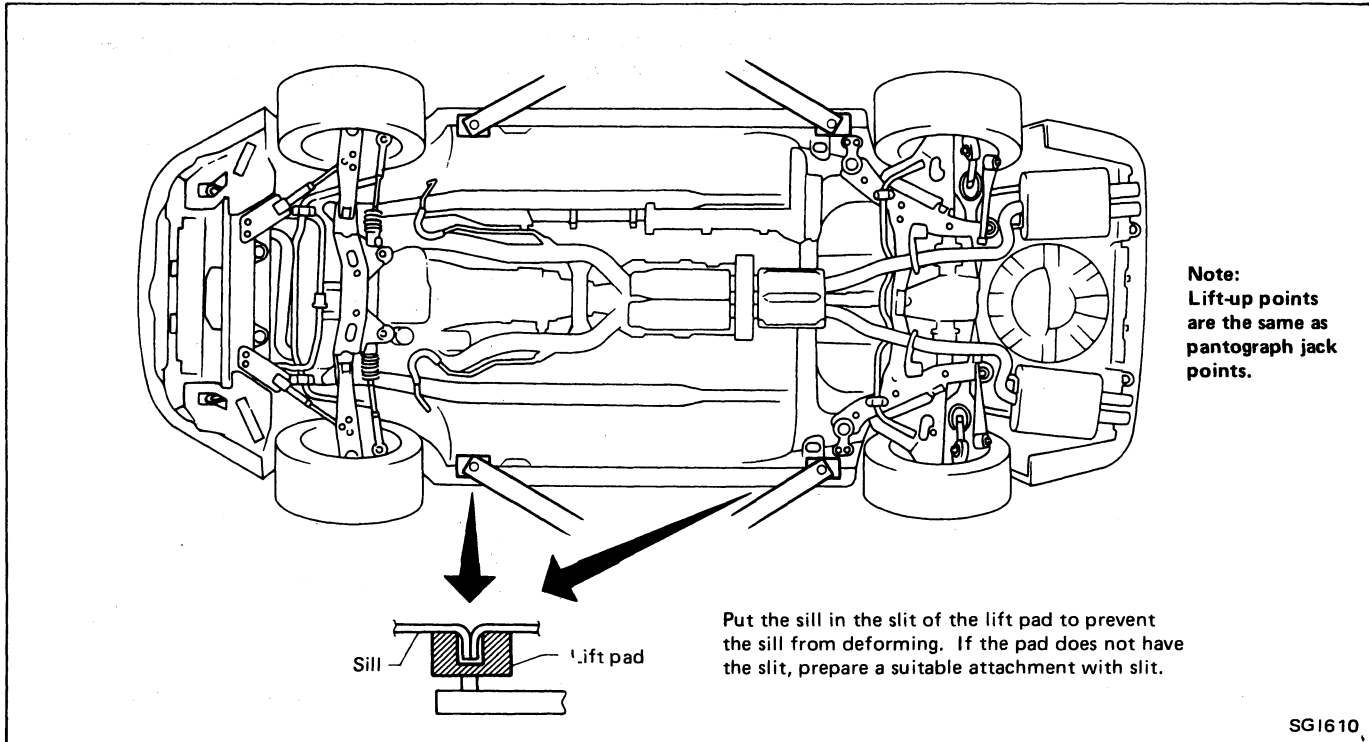

Tow Truck Towing

CAUTION:

- All applicable state or Provincial (in Canada) laws and local laws regarding the towing operation must be obeyed.
- It is necessary to use proper towing equipment to avoid possible damage to the vehicle during towing operation. Towing is in accordance with Towing Procedure Manual at dealer.
- When towing with the rear wheels on the ground, release the parking brake and move the gearshift lever to neutral ("N" position).

NISSAN recommends that vehicle be towed with the driving (rear) wheels off the ground as illustrated.

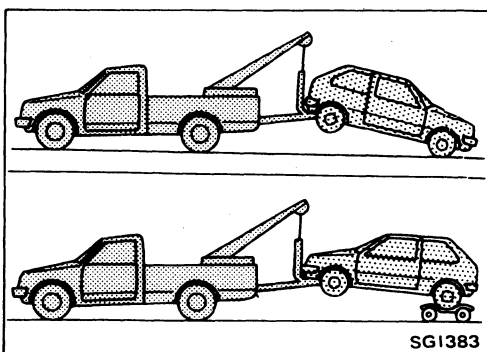

LIFTING POINTS AND TOW TRUCK TOWING

Tow Truck Towing (Cont'd)

TOWING AN AUTOMATIC TRANSMISSION MODEL WITH FOUR WHEELS ON GROUND OR TOWING WITH FRONT WHEELS RAISED (With rear wheels on ground)

Observe the following restricted towing speeds and distances.

Speed:

Below 50 km/h (30 MPH)

Distance:

Less than 65 km (40 miles)

If the speed or distance must necessarily be greater, remove the propeller shaft beforehand to prevent damage to the transmission.

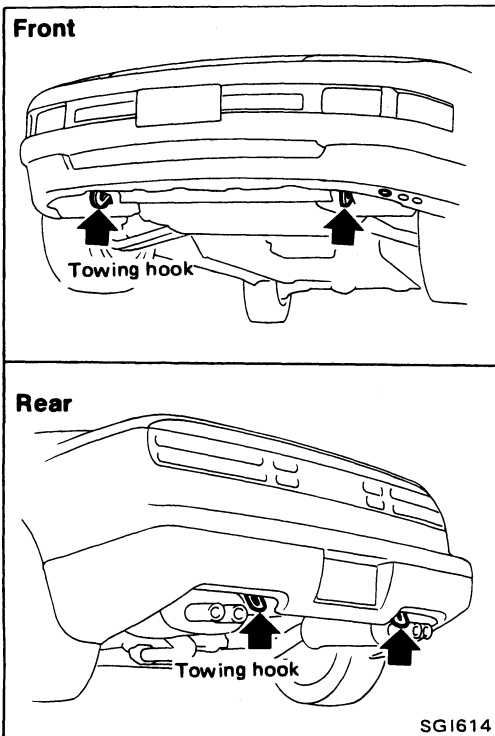

TOWING POINT

- Always pull the cable straight out from the vehicle. Never pull on the hook at a sideways angle.
- Remove the first bolt under the front fender protector when using the front towing hooks.

TIGHTENING TORQUE OF STANDARD BOLTS

Grade	Bolt size	Bolt diameter* mm	Pitch mm	Tightening torque (Without lubricant)					
				Hexagon head bolt			Hexagon flange bolt		
				N·m	kg·m	ft·lb	N·m	kg·m	ft·lb
4T	M6	6.0	1.0	5.1	0.52	3.8	6.1	0.62	4.5
	M8	8.0	1.25	13	1.3	9	15	1.5	11
			1.0	13	1.3	9	16	1.6	12
	M10	10.0	1.5	25	2.5	18	29	3.0	22
			1.25	25	2.6	19	30	3.1	22
	M12	12.0	1.75	42	4.3	31	51	5.2	38
1.25			46	4.7	34	56	5.7	41	
M14	14.0	1.5	74	7.5	54	88	9.0	65	
7T	M6	6.0	1.0	8.4	0.86	6.2	10	1.0	7
	M8	8.0	1.25	21	2.1	15	25	2.5	18
			1.0	22	2.2	16	26	2.7	20
	M10	10.0	1.5	41	4.2	30	48	4.9	35
			1.25	43	4.4	32	51	5.2	38
	M12	12.0	1.75	71	7.2	52	84	8.6	62
1.25			77	7.9	57	92	9.4	68	
M14	14.0	1.5	127	13.0	94	147	15.0	108	
9T	M6	6.0	1.0	12	1.2	9	15	1.5	11
	M8	8.0	1.25	29	3.0	22	35	3.6	26
			1.0	31	3.2	23	37	3.8	27
	M10	10.0	1.5	59	6.0	43	70	7.1	51
			1.25	62	6.3	46	74	7.5	54
	M12	12.0	1.75	98	10.0	72	118	12.0	87
1.25			108	11.0	80	137	14.0	101	
M14	14.0	1.5	177	18.0	130	206	21.0	152	

1. Special parts are excluded.
2. This standard is applicable to bolts having the following marks embossed on the bolt head.

*: Nominal diameter

Grade	Mark
4T	4
7T	7
9T	9

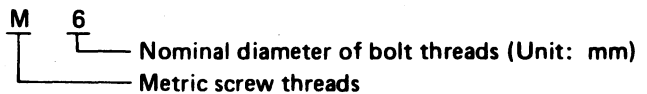

SECTION MA



CONTENTS

PRECAUTIONS MA- 2
GENERAL MAINTENANCE MA- 3
PERIODIC MAINTENANCE MA- 5
RECOMMENDED FLUIDS AND LUBRICANTS MA- 8
ENGINE MAINTENANCE MA-10
CHASSIS AND BODY MAINTENANCE MA-17
SERVICE DATA AND SPECIFICATIONS (S.D.S.) MA-24

PRECAUTIONS

Supplemental Restraint System "AIR BAG"

The Supplemental Restraint System "Air Bag" helps to reduce the risk or severity of injury to the driver in a frontal collision. The Supplemental Restraint System consists of an air bag (located in the center of the steering wheel), sensors, a control unit, warning lamp, wiring harness and spiral cable. Information necessary to service the system safely is included in the **BF section** of this Service Manual.

WARNING:

- a. To avoid rendering the SRS inoperative, which could lead to personal injury or death in the event of a severe frontal collision, all maintenance must be performed by an authorized NISSAN dealer.
- b. Improper maintenance, including incorrect removal and installation of the SRS, can lead to personal injury caused by unintentional activation of the system.
- c. All SRS electrical wiring harnesses and connectors are covered with yellow outer insulation. Do not use electrical test equipment on any circuit related to the SRS "Air Bag".

GENERAL MAINTENANCE

General maintenance includes those items which should be checked during the normal day-to-day operation of the vehicle. They are essential if the vehicle is to continue operating properly. The owners can perform the checks and inspections themselves or they can have their NISSAN dealers do them for a nominal charge.

Item	Reference page
OUTSIDE THE VEHICLE	
The maintenance items listed here should be performed from time to time, unless otherwise specified.	
Tires Check the pressure with a gauge periodically when at a service station, including the spare, and adjust to the specified pressure if necessary. Check carefully for damage, cuts or excessive wear.	—
Wheel nuts When checking the tires, make sure no nuts are missing, and check for any loose nuts. Tighten if necessary.	—
Tire rotation Tires should be rotated every 12,000 km (7,500 miles) for non-turbo models.	MA-21
Wheel alignment and balance If the vehicle should pull to either side while driving on a straight and level road, or if you detect uneven or abnormal tire wear, there may be a need for wheel alignment. If the steering wheel or seat vibrates at normal highway speeds, wheel balancing may be needed.	MA-20 FA-6
Windshield wiper blades Check for cracks or wear if they do not wipe properly.	—
Doors and engine hood Check that all doors and the engine hood operate smoothly as well as the trunk lid and back hatch. Also, ensure that all latches lock securely. Lubricate hinges and latches if necessary. Make sure that the secondary latch keeps the hood from opening when the primary latch is released. When driving in areas using road salt or other corrosive materials, check lubrication frequently.	MA-23
INSIDE THE VEHICLE	
The maintenance items listed here should be checked on a regular basis, such as when performing periodic maintenance, cleaning the vehicle, etc.	
Lights Make sure that the headlights, stop lights, tail lights, turn signal lights, and other lights are all operating properly and installed securely. Also check headlight aim.	—
Warning lights and buzzers/chimes Make sure that all warning lights and buzzers/chimes are operating properly.	—
Windshield wiper and washer Check that the wipers and washer operate properly and that the wipers do not streak.	—
Windshield defroster Check that the air comes out of the defroster outlets properly and in sufficient quantity when operating the heater or air conditioner.	—
Steering wheel Check that it has the specified free play. Be sure to check for changes in the steering condition, such as excessive free play, hard steering or strange noises. Free play: Less than 35 mm (1.38 in)	—
Seats Check seat position controls such as seat adjusters, seatback recliner, etc. to ensure they operate smoothly and that all latches lock securely in every position. Check that the head restraints move up and down smoothly and that the locks (if so equipped) hold securely in all latched positions. Check that the latches lock securely for folding-down rear seatbacks.	—
Seat belts Check that all parts of the seat belt system (e.g. buckles, anchors, adjusters and retractors) operate properly and smoothly, and are installed securely. Check the belt webbing for cuts, fraying, wear or damage.	MA-23

GENERAL MAINTENANCE

Item	Reference page
Clutch pedal Make sure the pedal operates smoothly and check that it has the proper free travel.	CL-6
Brakes Check that the brake does not pull the vehicle to one side when applied.	—
Brake pedal Check the pedal for smooth operation and make sure it has the proper distance under it when depressed fully. Check the brake booster function. Be certain to keep the floor mats away from the pedal.	BR-7
Parking brake Check that the lever has the proper travel and confirm that your vehicle is held securely on a fairly steep hill with only the parking brake applied.	BR-21
Automatic transmission "Park" mechanism Check that the lock release button on the selector lever operates properly and smoothly. On a fairly steep hill check that your vehicle is held securely with the selector lever in the "P" position without applying any brakes.	—
UNDER THE HOOD AND VEHICLE	
The maintenance items listed here should be checked periodically (e.g. each time you check the engine oil or refuel).	
Windshield washer fluid Check that there is adequate fluid in the tank.	—
Engine coolant level Check the coolant level when the engine is cold.	MA-12
Radiator and hoses Check the front of the radiator and clean off any dirt, insects, leaves, etc., that may have accumulated. Make sure the hoses have no cracks, deformation, rot or loose connections.	—
Brake and clutch fluid levels Make sure that the brake and clutch fluid levels are between the "MAX" and "MIN" lines on the reservoir.	MA-17, 18
Battery Check the fluid level in each cell. It should be between the "MAX" and "MIN" lines.	—
Engine drive belts Make sure that no belt is frayed, worn, cracked or oily.	MA-10
Engine oil level Check the level on the dipstick after parking the vehicle on a level spot and turning off the engine.	MA-14
Power steering fluid level and lines Check the level when the fluid is cold and the engine is turned off. Check the lines for proper attachment, leaks, cracks, etc.	MA-21
Automatic transmission fluid level Check the level on the dipstick after putting the selector lever in "P" with the engine idling.	MA-18
Exhaust system Make sure there are no loose supports, cracks or holes. If the sound of the exhaust seems unusual or there is a smell of exhaust fumes, immediately locate the trouble and correct it.	MA-22
Underbody The underbody is frequently exposed to corrosive substances such as those used on icy roads or to control dust. It is very important to remove these substances, otherwise rust will form on the floor pan, frame, fuel lines and around the exhaust system. At the end of winter, the underbody should be thoroughly flushed with plain water, being careful to clean those areas where mud and dirt can easily accumulate.	—
Fluid leaks Check under the vehicle for fuel, oil, water or other fluid leaks after the vehicle has been parked for a while. Water dripping from the air conditioner after use is normal. If you should notice any leaks or gasoline fumes are evident, check for the cause and correct it immediately.	—

PERIODIC MAINTENANCE

Two different maintenance schedules are provided, and should be used, depending upon the conditions in which the vehicle is mainly operated. **After 60,000 miles (96,000 km) or 48 months, continue the periodic maintenance at the same mileage/time intervals.**

SCHEDULE 1

Follow Periodic Maintenance Schedule 1 if your driving habits frequently includes one or more of the following driving conditions:

- Repeated short trips of less than 5 miles (8 km).
- Repeated short trips of less than 10 miles (16 km) with outside temperatures remaining below freezing.
- Operating in hot weather in stop-and-go "rush hour" traffic.
- Extensive idling and/or low speed driving for long distances, such as police, taxi or door-to-door delivery use.
- Driving in dusty conditions.
- Driving on rough, muddy, or salt spread roads.
- Towing a trailer, using a camper or a car-top carrier.

SCHEDULE 2

Follow Periodic Maintenance Schedule 2 if none of the driving conditions shown in Schedule 1 apply to your driving habits.

PERIODIC MAINTENANCE

Schedule 1

[] : At the mileage intervals only

MAINTENANCE INTERVAL

Perform at number of miles, kilometers or months, whichever comes first.	3	6	9	12	15	18	21	24	27	30	33	36	39	42	45	48	52.5	56.25	60	Reference page
Miles x 1,000	3,000	3,750	4,500	5,250	6,000	6,750	7,500	8,250	9,000	9,750	10,500	11,250	12,000	12,750	13,500	14,250	15,000	15,750	16,500	(96)
(km x 1,000)	(5)	(6)	(9)	(12)	(15)	(18)	(21)	(24)	(27)	(30)	(33)	(36)	(39)	(42)	(45)	(48)	(52.5)	(56.25)	(60)	(96)
Months	3	6	9	12	15	18	21	24	27	30	33	36	39	42	45	48	52.5	56.25	60	(96)

EMISSION CONTROL SYSTEM MAINTENANCE

Drive belts	See NOTE (1).																			I*	MA-10		
Air cleaner filter	See NOTE (2).																				[R]	MA-13	
Vapor lines																					I*	MA-16	
Fuel lines																					I*	MA-12	
Fuel filter	See NOTE (3).*																					MA-13	
Engine coolant	See NOTE (4).																					R*	MA-11
Engine oil																						R	MA-13
Engine oil filter (Use part No. 15208-60U00 or equivalent.)	Turbo model R	R	R	R	R	R	R	R	R	R	R	R	R	R	R	R	R	R	R	R	R	R	MA-13
		Then replace every 3,000 miles (5,000 km) or 3 months.																					
Spark plugs (PLATINUM-TIPPED type)	Turbo model R	R	R	R	R	R	R	R	R	R	R	R	R	R	R	R	R	R	R	R	R	MA-14	
		Then replace every oil change.																					
Timing belt																					[R]	MA-15	
																					[R]	EM-13	

CHASSIS AND BODY MAINTENANCE

Brake lines & cables																							I	MA-19
Brake pads & discs																							I	MA-20
Manual & automatic transmission oil, & differential gear oil	See NOTE (5).																						I	MA-17, 18, 19
Steering gear & linkage, axle & suspension parts																							I	MA-21, FA-5
Steering linkage ball joints & front suspension ball joints																							I	MA-21, FA-5
SUPER HICAS linkage (Turbo model)																							I	MA-22
Exhaust system																							I	MA-22
Air bag system	See NOTE (6).																						I	BF-59

NOTE: (1) After 60,000 miles (96,000 km) or 48 months, inspect every 15,000 miles (24,000 km) or 12 months.

(2) If operating mainly in dusty conditions, more frequent maintenance may be required.

(3) If vehicle is operated under extremely adverse weather conditions or in areas where ambient temperatures are either extremely low or extremely high, the filters might become clogged. In such an event, replace them immediately.

(4) After 60,000 miles (96,000 km) or 48 months, replace every 30,000 miles (48,000 km) or 24 months.

(5) If towing a trailer, using a camper or a car-top carrier, or driving on rough or muddy roads, change (not just inspect) oil at every 30,000 miles (48,000 km) or 24 months.

(6) Inspect the air bag system 10 years after the date of manufacture as noted on the F.M.V.S.S. certification label.

(7) Maintenance items and intervals with "*" are recommended by NISSAN for reliable vehicle operation. The owner need not perform such maintenance in order to maintain the emission warranty or manufacturer recall liability. Other maintenance items and intervals are required.

PERIODIC MAINTENANCE

Schedule 2

Abbreviations: R = Replace I = Inspect. Correct or replace if necessary. [] : At the mileage intervals only

MAINTENANCE OPERATION		MAINTENANCE INTERVAL								Reference page
Perform at number of miles, kilometers or months, whichever comes first.		5.0	7.5	15	22.5	30	37.5	45	52.5	60
		(8)	(12)	(24)	(36)	(48)	(60)	(72)	(84)	(96)
Months		6	6	12	18	24	30	36	42	48

EMISSION CONTROL SYSTEM MAINTENANCE

Drive belts	See NOTE (1).									I*	MA-10
Air cleaner filter					[R]					[R]	MA-13
Vapor lines					I*					I*	MA-16
Fuel lines					I*					I*	MA-12
Fuel filter	See NOTE (2)*.										MA-13
Engine coolant	See NOTE (3).									R*	MA-11
Engine oil		R	R	R	R	R	R	R	R	R	MA-13
	Turbo model										MA-13
Engine oil filter (Use Part No. 15208-60J00 or equivalent.)	Turbo model	R	R								MA-14
Spark plugs (PLATINUM-TIPPED type)										[R]	MA-15
Timing belt										[R]	EM-13

CHASSIS AND BODY MAINTENANCE

Brake lines & cables												MA-19
Brake pads & discs												MA-20
Manual & automatic transmission oil, & differential gear oil												MA-17, 18, 19
Steering gear linkage, axle & suspension parts												MA-21, FA-5
SUPER HICAS linkage (Turbo model)												MA-22
Exhaust system												MA-22
Air bag system	See NOTE (4).											BF-59

- NOTE:** (1) After 60,000 miles (96,000 km) or 48 months, inspect every 15,000 miles (24,000 km) or 12 months.
 (2) If vehicle is operated under extremely adverse weather conditions or in areas where ambient temperatures are either extremely low or extremely high, the filters might become clogged. In such an event, replace them immediately.
 (3) After 60,000 miles (96,000 km) or 48 months, replace every 30,000 miles (48,000 km) or 24 months.
 (4) Inspect the air bag system 10 years after the date of manufacture as noted on the F.M.V.S.S. certification label.
 (5) Maintenance items and intervals with "*" are recommended by NISSAN for reliable vehicle operation. The owner need not perform such maintenance in order to maintain the emission warranty or manufacturer recall liability. Other maintenance items and intervals are required.

RECOMMENDED FLUIDS AND LUBRICANTS

Fluids and Lubricants

	Capacity (Approximate)			Recommended fluids and lubricants
	US measure	Imp measure	Liter	
Engine oil (Refill)				
With oil filter	3-5/8 qt	3 qt	3.4	Energy Conserving Oils of API SG*2, *3
Without oil filter	3-1/8 qt	2-5/8 qt	3.0	
Cooling system (With reservoir)	10-5/8 qt	8-3/4 qt	10.0	Anti-freeze coolant (Ethylene glycol base)
Manual transmission gear oil	5-7/8 pt	4-7/8 pt	2.8	API GL-4*2
Differential gear oil	3-1/8 pt	2-5/8 pt	1.5	API GL-5*2
Turbo model	3-7/8 pt	3-1/8 pt	1.8	
Automatic transmission fluid	8-3/4 qt	7-1/4 qt	8.3	Genuine Nissan ATF*1 or equivalent Type DEXRON™
Turbo model	8-5/8 qt	7-1/4 qt	8.2	
Power steering fluid	—	—	—	Type DEXRON™
Brake and clutch fluid	—	—	—	Genuine Nissan Brake Fluid*1 or equivalent DOT 3 (US FMVSS No. 116)
Multi-purpose grease	—	—	—	NLGI No. 2 (Lithium soap base)

*1: Available in mainland U.S.A. through your Nissan dealer.

*2: For further details, see "Recommended SAE viscosity number".

*3: Energy conserving oils

These oils can be identified by such labels as EC-I, EC-II, energy conserving, energy saving, improved fuel economy, etc.

RECOMMENDED FLUIDS AND LUBRICANTS

SAE Viscosity Number

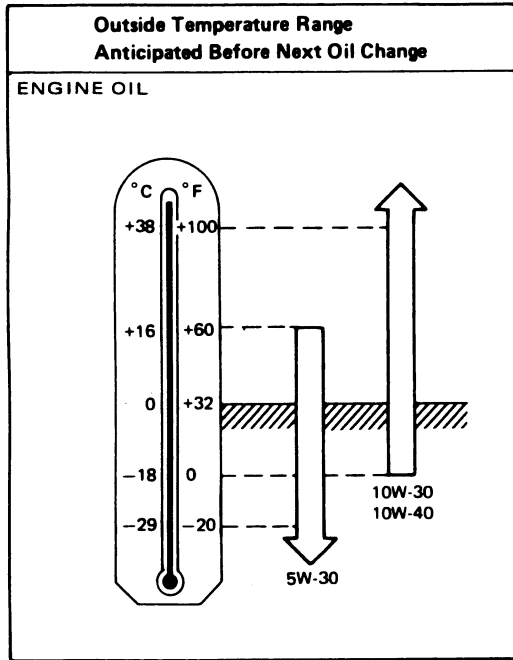

T10002

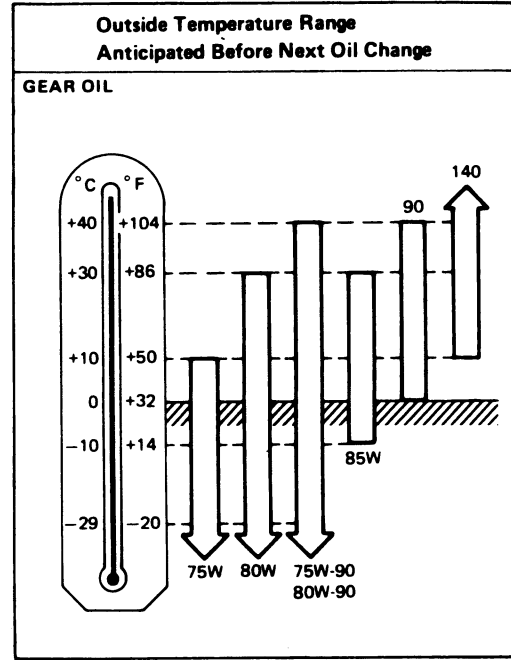

T10003

10W-30 is preferable for ambient temperatures above -18°C (0°F). 20W-40 and 20W-50 are usable for ambient temperatures above 10°C (50°F) for all seasons.

For turbo engines, 5W-30 should be used only under extremely cold conditions.

75W-90 for transmission and 80W-90 for differential gear are preferable for ambient temperatures below 40°C (104°F).

ENGINE MAINTENANCE

Checking Drive Belts

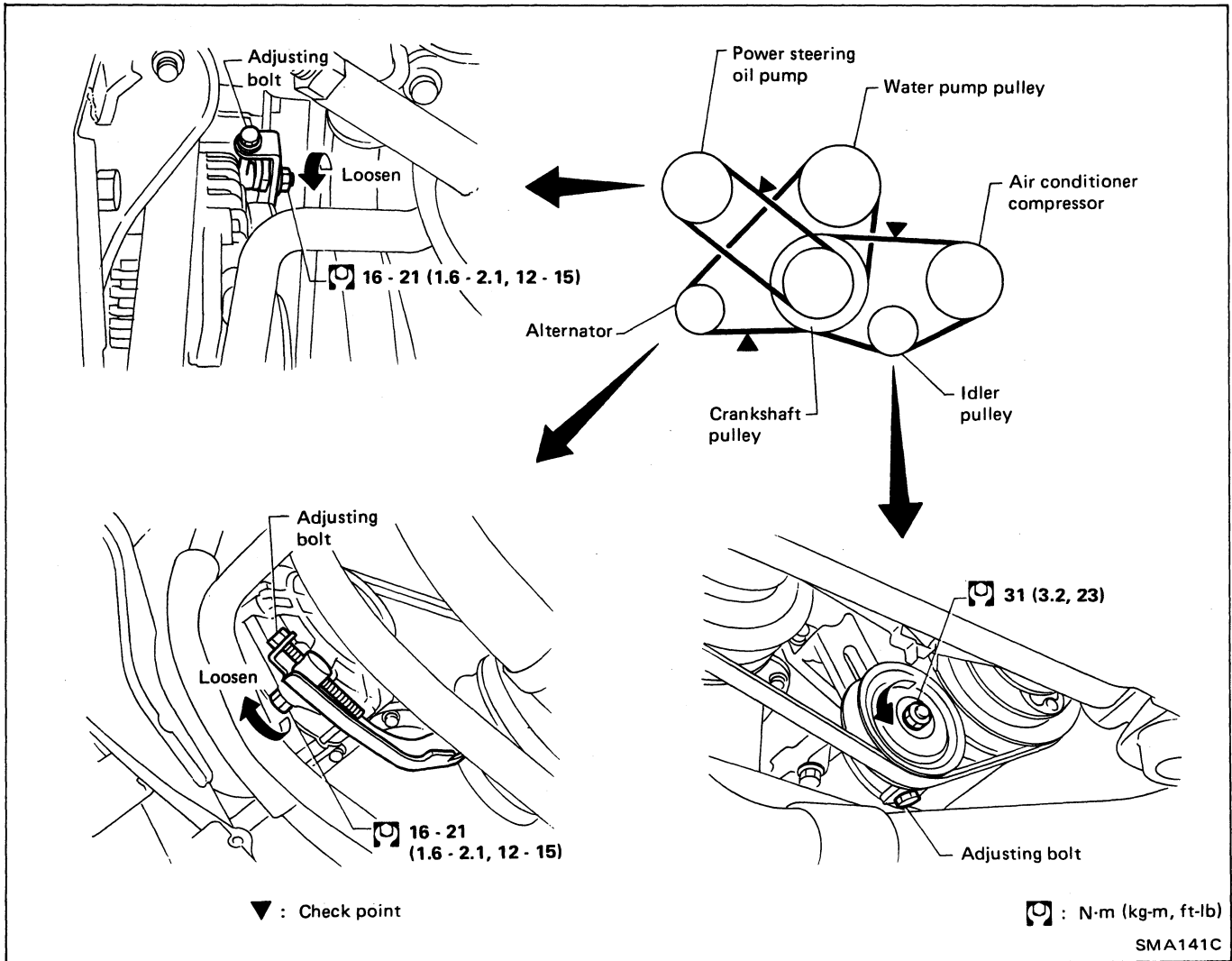

1. Inspect for cracks, fraying, wear or oil adhesion. If necessary, replace with a new one.
2. Inspect drive belt deflection by pushing on the belt midway between pulleys.

Adjust if belt deflection exceed the limit.

Belt deflection:

Unit: mm (in)

		Used belt deflection		Deflection of new belt
		Limit	Deflection after adjustment	
Alternator		11.5 (0.453)	7 - 8 (0.28 - 0.31)	6.5 - 7.5 (0.256 - 0.295)
Air conditioner compressor		12.5 (0.492)	8 - 9 (0.31 - 0.35)	7 - 8 (0.28 - 0.31)
Power steering oil pump	Non-Turbo	19 (0.75)	12 - 13.5 (0.472 - 0.531)	10.5 - 11.5 (0.413 - 0.453)
	Turbo	16 (0.63)	10 - 11 (0.39 - 0.43)	9 - 10 (0.35 - 0.39)
Applied pushing force		98 N (10 kg, 22 lb)		

Inspect drive belt deflection when engine is cold.

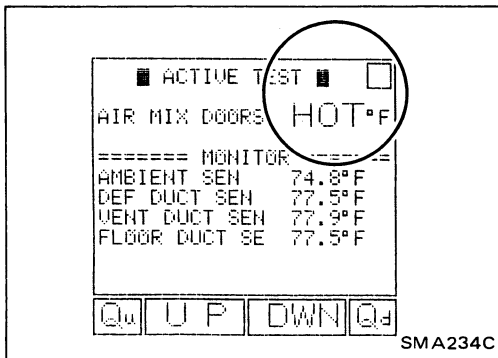

Changing Engine Coolant

WARNING:

To avoid the danger of being scalded, never change the coolant when the engine is hot.

MANUAL CONTROL

1. Turn ignition switch "ON" and set temperature control lever of manual air conditioner to maximum hot position.

AUTOMATIC CONTROL



1. Perform "AIR MIX DOORS" test in "ACTIVE TEST" mode of "AUTO A/C" (Automatic Air Conditioner) system.

Set "AIR MIX DOORS" at (full) HOT and wait 10 seconds before turning ignition switch off.



1. Perform self-diagnosis step 2 of Automatic Air Conditioner system, referring to the following notes:

- 1) Turn ignition switch from "OFF" to "ON".
- 2) Press both "AUTO" and "OFF" switches for at least 5 seconds.
- 3) Press "AUTO" switch 2 times.
- 4) Confirm indication of the A/C display shown at left.
- 5) Wait 10 seconds before turning ignition switch off.

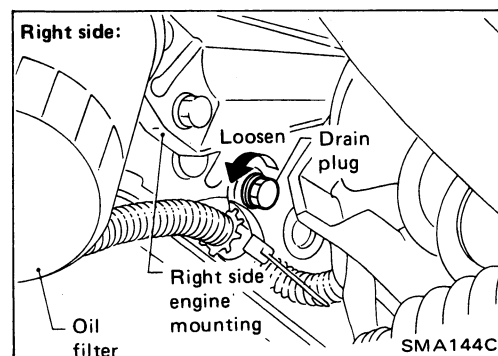
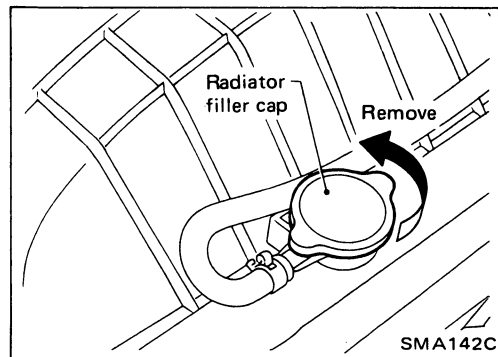
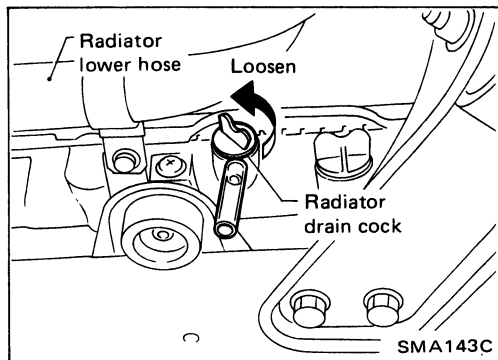
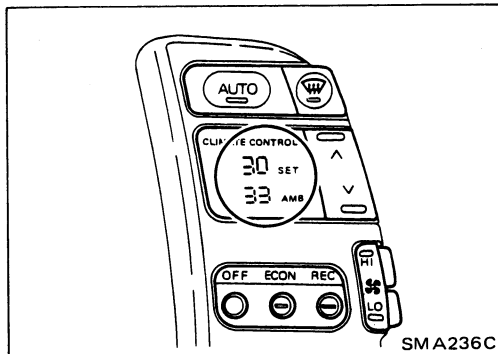

2. Open drain cock at the bottom of radiator, and remove radiator cap.

3. Open drain plugs on both sides of cylinder block.
 - Left side drain plug is located beside the left side engine mounting.

ENGINE MAINTENANCE

Changing Engine Coolant (Cont'd)

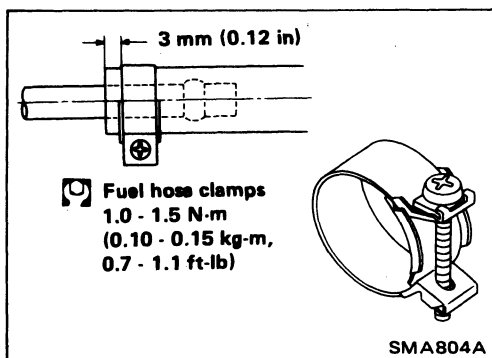
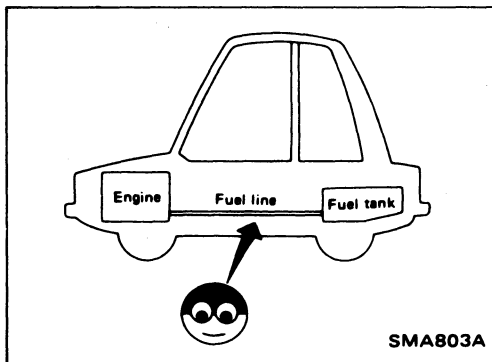
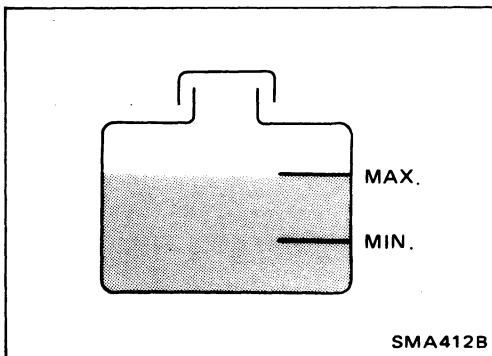
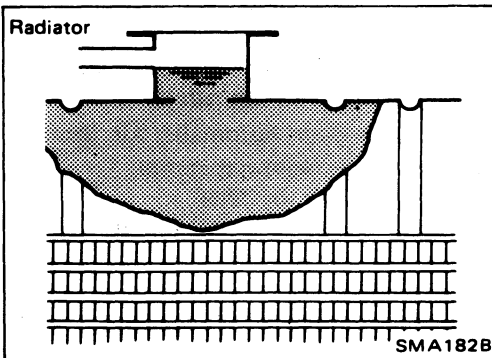
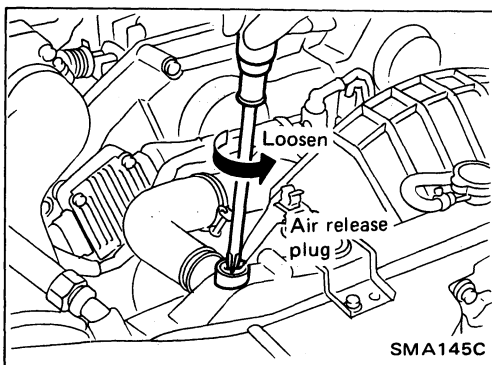

4. Open air release plug to drain coolant.
5. Flush cooling system by running fresh water through radiator.
6. Close drain cock and tighten drain plugs securely.

- Apply sealant to the drain plug thread.

⊗: 34 - 44 N·m

(3.5 - 4.5 kg·m, 25 - 33 ft·lb)

7. Fill radiator slowly with proper mixture of coolant and water. Fill reservoir tank up to the "H" level. Then install radiator cap and close air release plug.

Coolant capacity (With reservoir tank):

10.0 ℓ (10-5/8 US qt, 8-3/4 Imp qt)

Reservoir tank:

0.6 ℓ (5/8 US qt, 1/2 Imp qt)

Pour coolant through coolant filler neck slowly to allow air in system to escape.

8. Start engine and warm it up until it reaches normal operating temperature. Then race engine 2 or 3 times under no-load. Watch coolant temperature gauge for signs of overheating.
9. Stop engine. After it completely cools down, refill radiator up to filler opening. Fill reservoir tank up to the "H" level.
10. Check drain cock and drain plug for any sign of leakage.

Checking Fuel Lines

Inspect fuel lines and tank for improper attachment and for leaks, cracks, damage, loose connections, chafing and deterioration. If necessary, repair or replace faulty parts.

CAUTION:

Tighten high-pressure rubber hose clamp so that clamp end is 3 mm (0.12 in) from hose end.

Tightening torque specifications are the same for all rubber hose clamps.

Ensure that screw does not contact adjacent parts.

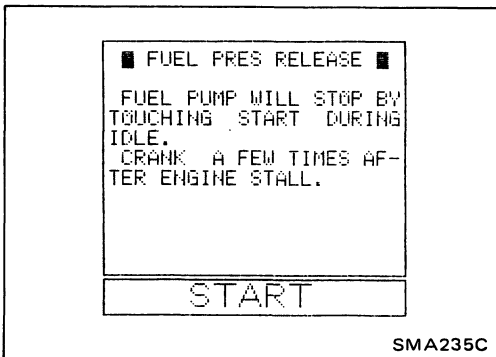

SMA235C

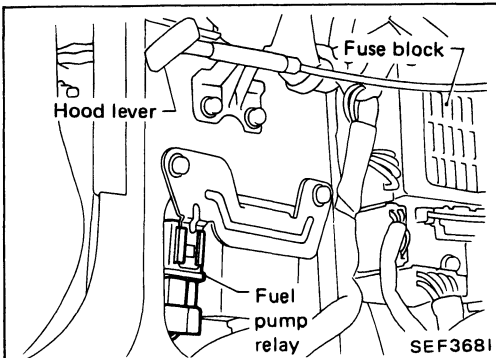

SEF368I

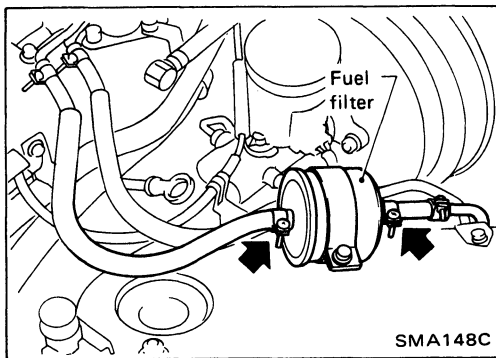

SMA148C

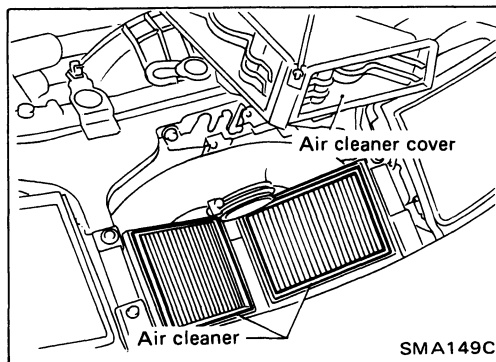

SMA149C

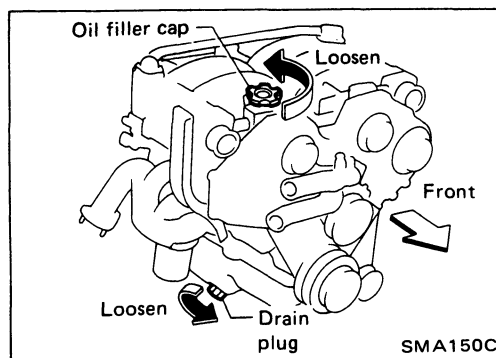

SMA150C

Changing Fuel Filter

WARNING:

Before removing fuel filter, release fuel pressure from fuel line to eliminate danger.



1. Perform "FUEL PRESSURE RELEASE" in "WORK SUPPORT" mode and release fuel pressure to zero.
2. Turn ignition switch off.



1. Disconnect fuel pump relay and start engine.
2. After engine stalls, crank engine two or three times to make sure that fuel pressure is released. Then turn ignition switch off and reconnect fuel pump relay.

3. Loosen fuel hose clamps.

4. Replace fuel filter.

- Be careful not to spill fuel over engine compartment. Place a shop towel to absorb fuel.
- Use a high-pressure type fuel filter. Do not use a synthetic resinous fuel filter.
- When tightening fuel hose clamps, refer to "Checking Fuel Lines".

Changing Air Cleaner Filter

The viscous paper type filter does not need cleaning between renewals.

Changing Engine Oil

WARNING:

Be careful not to burn yourself, as the engine oil is hot.

1. Warm up engine, and check for oil leakage from engine components.
2. Remove drain plug and oil filler cap.

ENGINE MAINTENANCE

Changing Engine Oil (Cont'd)

3. Drain oil and refill with new engine oil.

Oil capacity (Refill): 2 (US qt, Imp qt)

With oil filter

3.4 (3-5/8, 3)

Without oil filter

3.0 (3-1/8, 2-5/8)

CAUTION:

- Be sure to clean drain plug and install with new washer.

Oil pan drain plug:

☐: 29 - 39 N·m

(3.0 - 4.0 kg-m, 22 - 29 ft-lb)

- Use recommended engine oil.
- Since the refill capacity changes depending on the oil temperature and drain time, use these values as a reference and be certain to check with the dipstick when changing the oil.

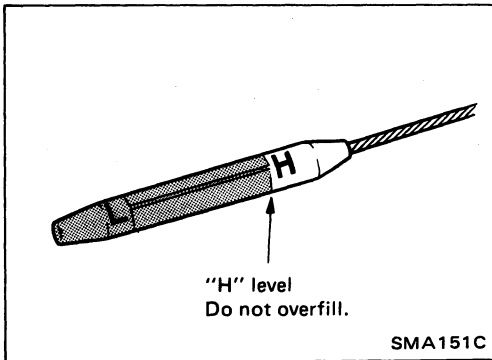

4. Check oil level.
5. Start engine and check area around drain plug and oil filter for oil leakage.
6. Run engine for a few minutes, then turn it off. After several minutes, check oil level.

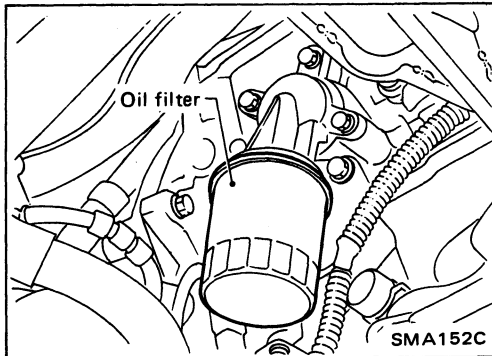

Changing Oil Filter

1. Remove oil filter with a suitable tool.

WARNING:

Be careful not to burn yourself, as the engine and engine oil are hot.

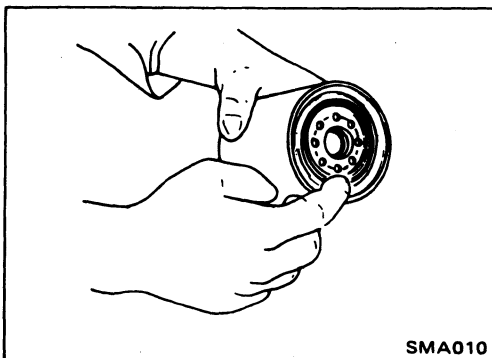

2. Before installing a new oil filter, clean the oil filter mounting surface on cylinder block, and coat the oil filter rubber seal with a little engine oil.

ENGINE MAINTENANCE

Changing Oil Filter (Cont'd)

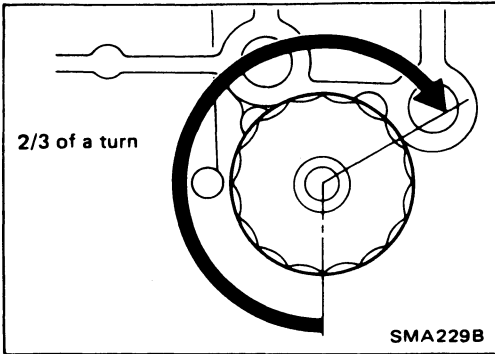

3. Screw in the oil filter until a slight resistance is felt, then tighten additionally more than 2/3 turn.
 4. Add engine oil.
- Refer to Changing Engine Oil.**

Changing Spark Plugs

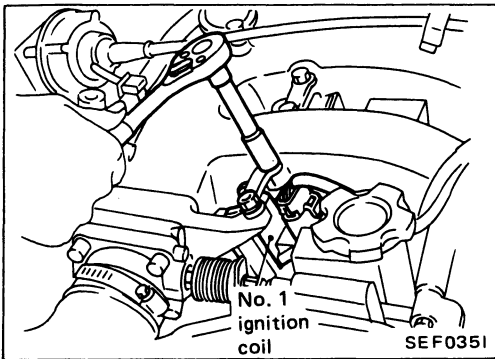

1. Disconnect ignition coil harness connector.
2. Loosen ignition coil fixing bolts and pull out coil from intake manifold collector.

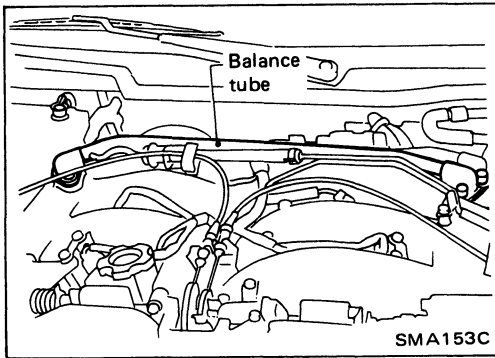

- When changing No. 5 and No. 6 cylinder spark plugs, remove balance tube first. (O-rings of balance tube may be reused, if they are not worn.)

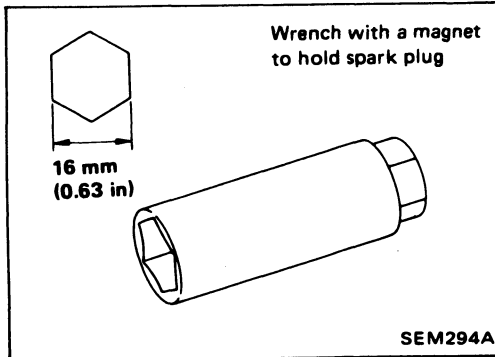

3. Remove spark plugs with suitable spark plug wrench.

Spark plug (Platinum-tipped type):

	Non-turbo	Turbo
Standard type	PFR6B-11	PFR5B-11B
Hot type	PFR5B-11	Ditto
Cold type	PFR7B-11	PFR6B-11B
		PFR6B-11

Ⓜ: 20 - 29 N·m (2 - 3 kg-m, 14 - 22 ft-lb)

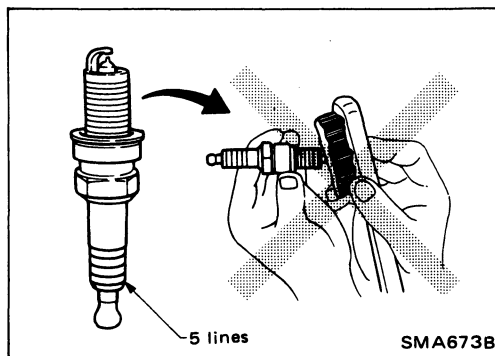

- Checking and adjusting plug gap are not required between renewals.
- Do not use a wire brush for cleaning.
- If plug tip is covered with carbon, spark plug cleaner may be used.

Cleaner air pressure:

Less than 588 kPa (6 kg/cm², 85 psi)

Cleaning time:

Less than 20 seconds

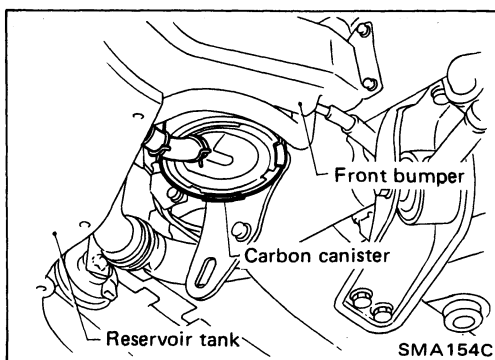

Checking Vapor Lines

1. Visually inspect vapor lines for improper attachment and for cracks, damage, loose connections, chafing and deterioration.
2. Inspect vacuum relief valve of fuel tank filler cap for clogging, sticking, etc.

Refer to "EVAPORATIVE EMISSION CONTROL SYSTEM" in EF & EC section.

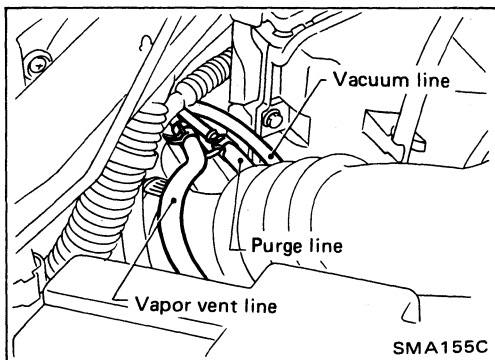

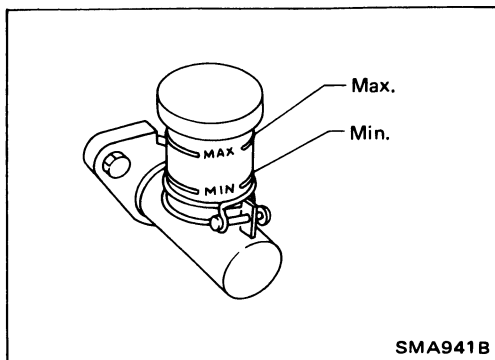

Checking Clutch Fluid Level and Leaks

- If fluid level is extremely low, check clutch system for leaks.

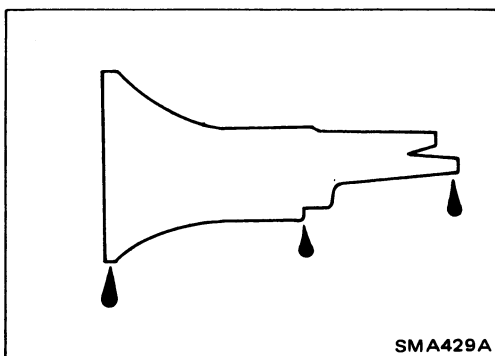

Checking M/T Oil

1. Check for oil leakage.

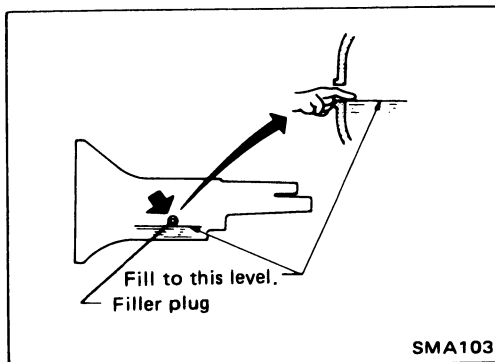

2. If leakage is found, check oil level.

Never start engine while checking oil level.

Filler plug:

⌘: 25 - 34 N·m (2.5 - 3.5 kg-m, 18 - 25 ft-lb)

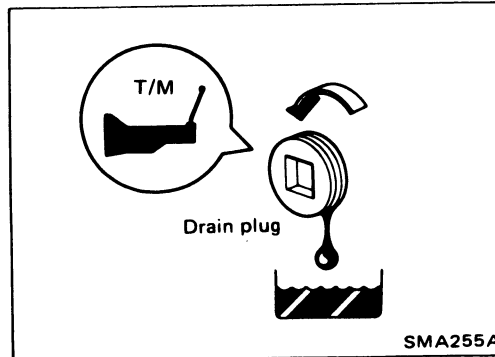

Changing M/T Oil

1. Drain oil and refill with new gear oil.
2. Check oil level.

Oil capacity:

2.8 ℓ (5-7/8 US pt, 4-7/8 Imp pt)

Drain plug:

⌘: 25 - 34 N·m (2.5 - 3.5 kg-m, 18 - 25 ft-lb)

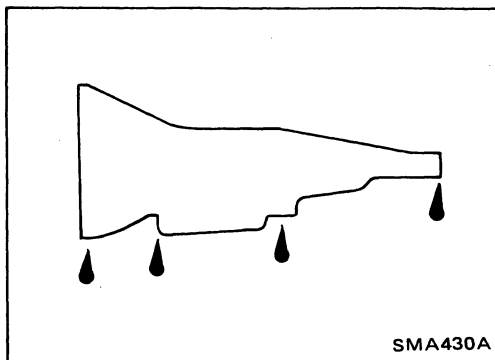

Checking A/T Fluid

1. Check for fluid leakage.

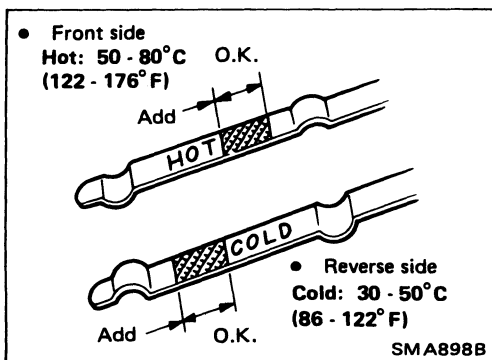

2. If leakage is found, check fluid level.

Fluid level should be checked using "HOT" range on dipstick at fluid temperatures of 50 to 80°C (122 to 176°F) after vehicle has been driven approximately 5 minutes in urban areas after engine is warmed up. But it can be checked at fluid temperatures of 30 to 50°C (86 to 122°F) using "COLD" range on dipstick for reference after engine is warmed up and before driving. However, fluid level must be rechecked using "HOT" range.

- 1) Park vehicle on level surface and set parking brake.
- 2) Start engine and then move selector lever through each gear range, ending in "P".
- 3) Check fluid level with engine idling.
- 4) Remove dipstick and wipe it clean with lint-free paper.
- 5) Reinsert dipstick into charging pipe as far as it will go.
- 6) Remove dipstick and note reading. If level is at low side of either range, add fluid to the charging pipe.

Do not overfill.

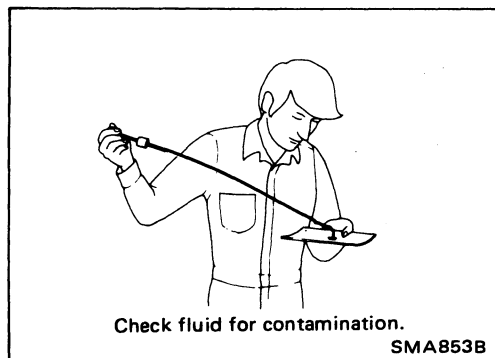

3. Check fluid condition.

Check fluid for contamination. If fluid is very dark or smells burned, or contains frictional material (clutches, band, etc.), check operation of A/T.

Refer to section AT for checking operation of A/T.

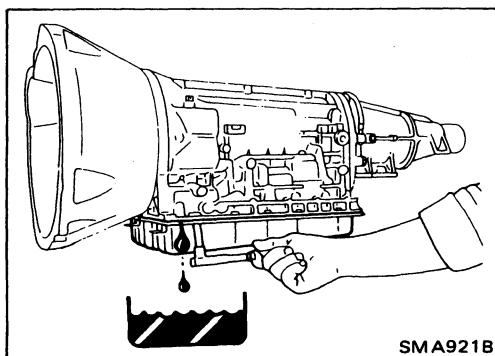

Changing A/T Fluid

1. Drain fluid by removing oil pan.
2. Replace gasket with new one.
3. Refill with fluid and then check fluid level.

Oil capacity (With torque converter):

Non-turbo

8.3 ℓ (8-3/4 US qt, 7-1/4 Imp qt)

Turbo

8.2 ℓ (8-5/8 US qt, 7-1/4 Imp qt)

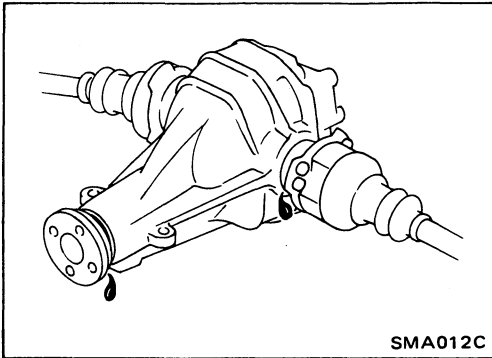

Checking Differential Gear Oil

1. Check differential carrier for oil leakage.

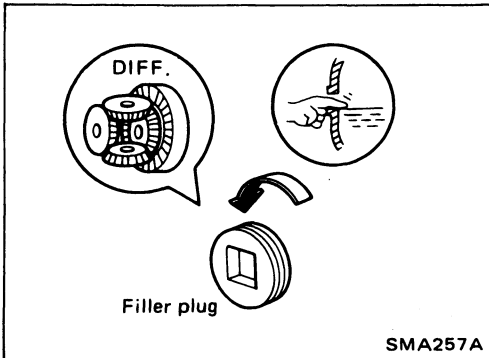

2. If leakage is found, check oil level.

Filler plug:

: 39 - 59 N·m (4 - 6 kg-m, 29 - 43 ft-lb)

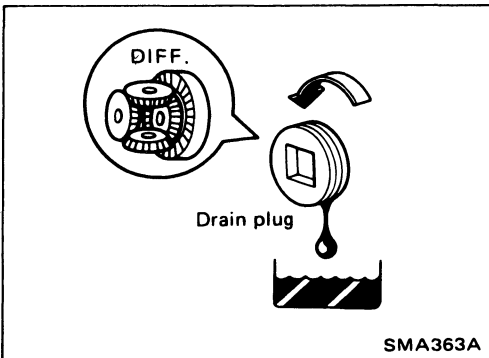

Changing Differential Gear Oil

1. Drain oil and refill with new gear oil.
2. Check oil level.

Oil capacity:

For non-turbo

1.5 ℓ (3-1/8 US pt, 2-5/8 Imp pt)

For turbo

1.8 ℓ (3-7/8 US pt, 3-1/8 Imp pt)

Drain plug:

: 39 - 59 N·m (4 - 6 kg-m, 29 - 43 ft-lb)

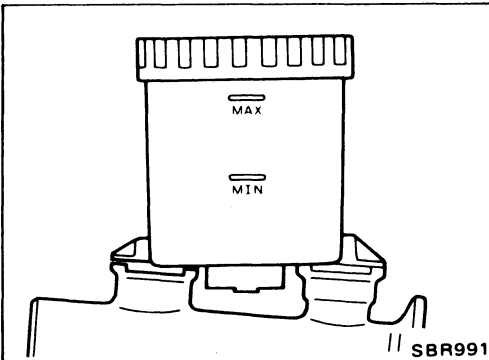

Checking Brake Fluid Level and Leaks

- If fluid level is extremely low, check brake system for leaks.

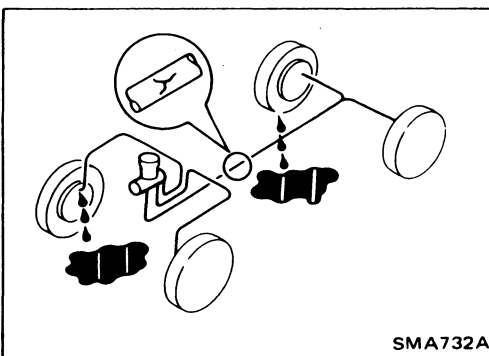

Checking Brake Lines and Cables

- Check brake fluid lines and parking brake cables for improper attachment and for leaks, chafing, abrasions, deterioration, etc.

CHASSIS AND BODY MAINTENANCE

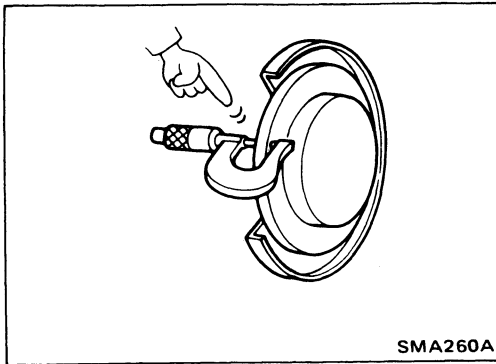

Checking Disc Brake

- Check condition of disc brake components.

ROTOR

- Check condition and thickness.

Unit: mm (in)

	Front	Rear
Disc brake type	OPZ25VA	OPZ11VB
Standard thickness	30.0 (1.181)	18 (0.71)
Minimum thickness	28.0 (1.102)	16.0 (0.630)

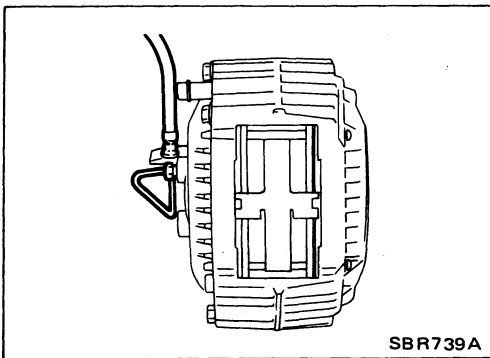

CALIPER

- Check operation and for leakage.

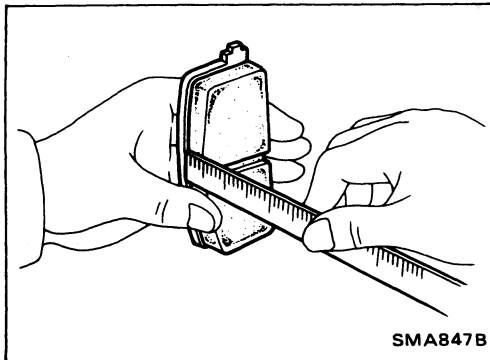

PAD

- Check for wear or damage.

Unit: mm (in)

	Front	Rear
Disc brake type	OPZ25VA	OPZ11VB
Standard thickness	10.0 (0.394)	11.5 (0.453)
Minimum thickness	2.0 (0.079)	

Balancing Wheels

- Adjust wheel balance using road wheel center.
Wheel balance (Maximum allowable unbalance at rim flange):
Refer to S.D.S.

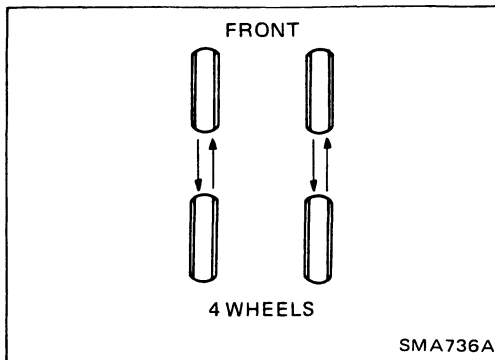

Tire Rotation (Non-turbo model only)

- Do not include the T-type or space saver spare tire when rotating the tires.

Wheel nuts:

☐: 98 - 118 N·m

(10.0 - 12.0 kg-m, 72 - 87 ft-lb)

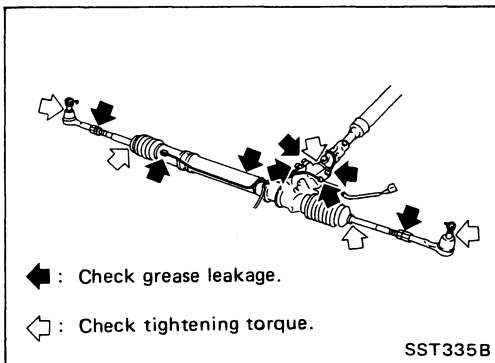

Checking Steering Gear and Linkage

STEERING GEAR

- Check gear housing and boots for looseness, damage or grease leakage.
- Check connection with steering column for looseness.

STEERING LINKAGE

- Check ball joint, dust cover and other component parts for looseness, wear, damage or grease leakage.

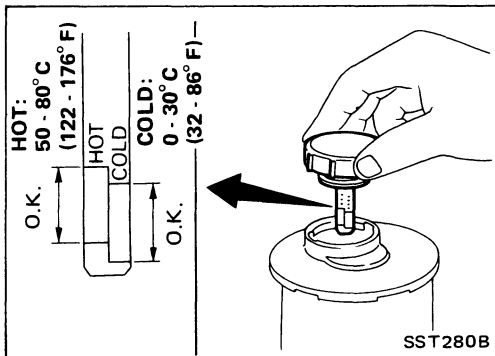

Checking Power Steering Fluid and Lines

CHECKING FLUID LEVEL (WITHOUT SUPER HICAS SYSTEM)

Fluid level should be checked using "HOT" range on dipstick at fluid temperatures of 50 to 80°C (122 to 176°F) or using "COLD" range on dipstick at fluid temperatures of 0 to 30°C (32 to 86°F).

CAUTION:

Do not overfill.

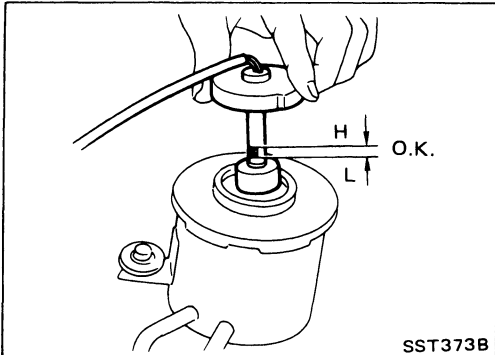

CHECKING FLUID LEVEL (WITH SUPER HICAS SYSTEM)

Maintain the fluid level so that the lower surface of the float is maintained between the "L" and "H" marks on the gauge rod. The fluid level should be checked when the engine is stopped and the fluid temperature is about 30°C (86°F).

CAUTION:

- Do not overfill.
- Recommended fluid is Automatic Transmission Fluid "Dexron™" type.
- Note that fluid level will vary with fluid temperature by approx. 1 mm/5°C (0.04 in/9°F) due to changes in fluid volume.

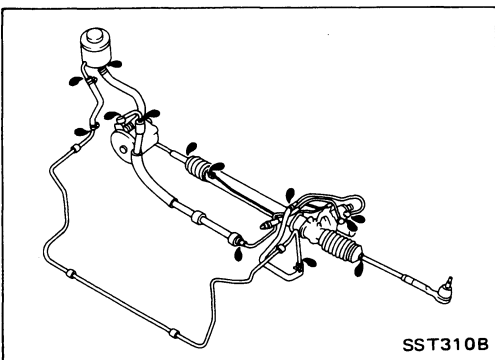

CHECKING LINES

Check lines for improper attachment, leaks, cracks, damage, loose connections, chafing and deterioration.

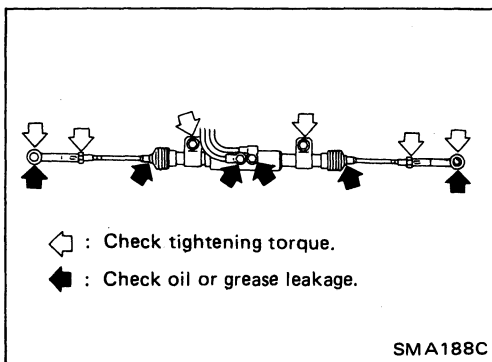

Checking SUPER HICAS Linkage (With SUPER HICAS system)

- Check power cylinder and linkage for damage, looseness and leakage of oil or grease.

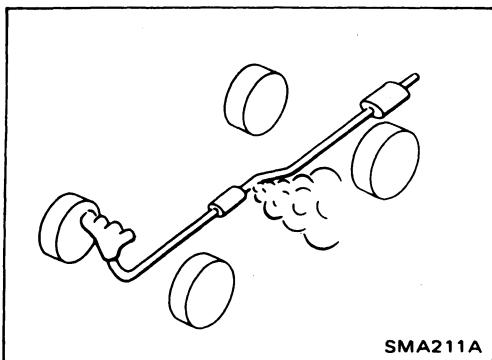

Checking Exhaust System

- Check exhaust pipes, muffler and mounting for proper attachment, leaks, cracks, damage, loose connections, chafing and deterioration.

Lubricating Locks, Hinges and Hood Latches

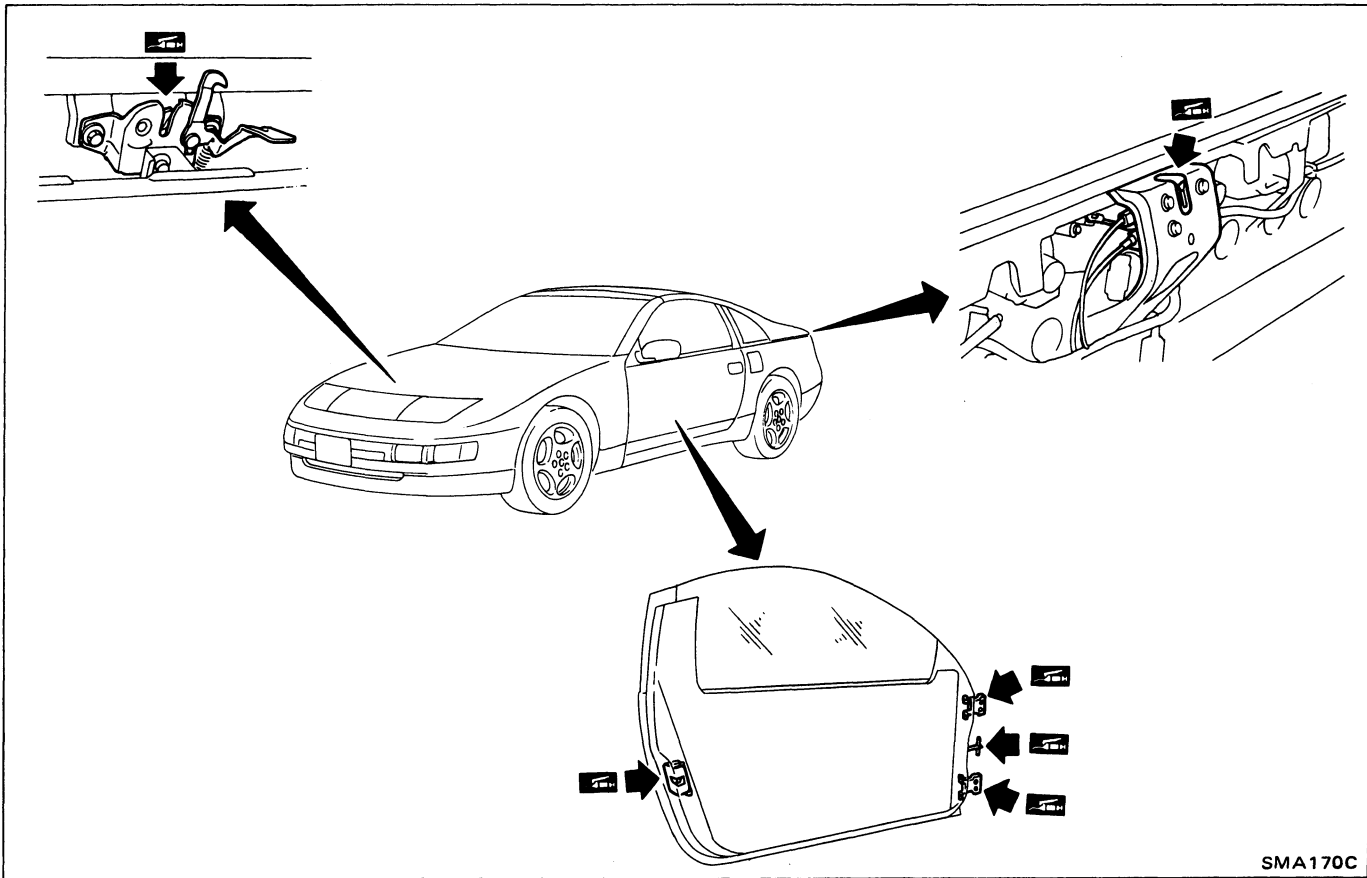

SMA170C

Checking Seat Belts, Buckles, Retractors, Anchors and Adjusters

CAUTION:

1. All seat belt assemblies, including retractors and attaching hardware such as guide rail set, etc., should be inspected after any collision. Nissan recommends that all seat belt assemblies in use during a collision be replaced unless the collision was minor and the belts show no damage and continue to operate properly. Seat belt assemblies not in use during a collision should also be inspected and replaced if either damage or improper operation is noted.
2. If the condition of any component of seat belt assembly is questionable, do not have it repaired, but replaced as seat belt assembly.
3. If webbing is cut, frayed, or damaged, replace belt assembly.
4. Do not spill drinks, oil, etc. on inner lap belt buckle. Never oil tongue and buckle.
5. Use a NISSAN genuine seat belt assembly.

 Anchor bolt
43 - 55 N·m
(4.4 - 5.6 kg-m, 32 - 41 ft-lb)

For automatic seat belt details, refer to BF section.

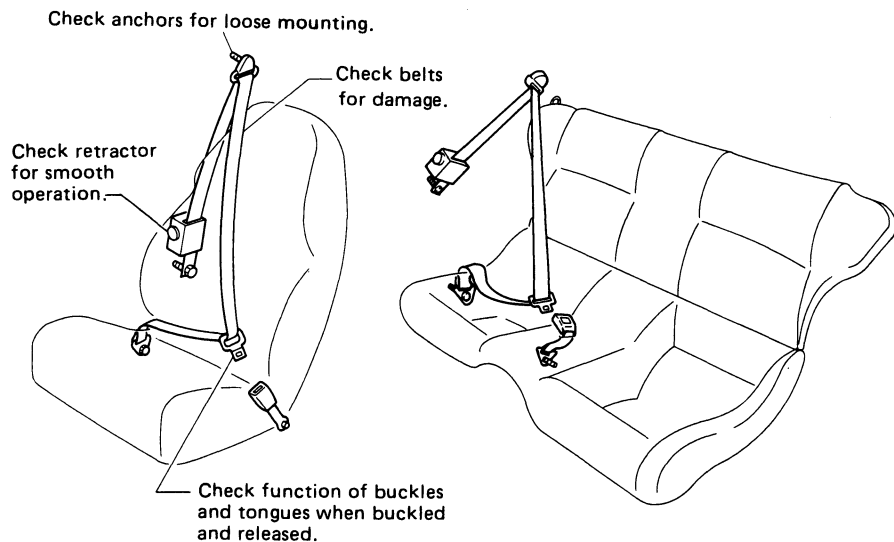

SMA431C

SERVICE DATA AND SPECIFICATIONS (S.D.S.)

Engine Maintenance

INSPECTION AND ADJUSTMENT

Drive belt deflection

Unit: mm (in)

	Used belt deflection		Deflection of new belt
	Limit	Deflection after adjustment	
Alternator	11.5 (0.453)	7 - 8 (0.28 - 0.31)	6.5 - 7.5 (0.256 - 0.295)
Air conditioner compressor	12.5 (0.492)	8 - 9 (0.31 - 0.35)	7 - 8 (0.28 - 0.31)
Power steering oil pump			
Non-Turbo	19 (0.75)	12 - 13.5 (0.472 - 0.531)	10.5 - 11.5 (0.413 - 0.453)
Turbo	16 (0.63)	10 - 11 (0.39 - 0.43)	9 - 10 (0.35 - 0.39)
Applied pushing force	98 N (10 kg, 22 lb)		

Spark plug

Non-Turbo

Standard type	PFR6B-11
Hot type	PFR5B-11
Cold type	PFR7B-11

Turbo

Standard & hot type	PFR5B-11B
Cold type	PFR686B-11B, PFR6B-11

Oil capacity (Refill)

Unit: ℓ (US qt, Imp qt)

With oil filter	3.4 (3-5/8, 3)
Without oil filter	3.0 (3-1/8, 2-5/8)

Coolant capacity

Unit: ℓ (US qt, Imp qt)

With reservoir tank	10.0 (10-5/8, 8-3/4)
Reservoir tank	0.6 (5/8, 1/2)

SERVICE DATA AND SPECIFICATIONS (S.D.S.)

Chassis and Body Maintenance

INSPECTION AND ADJUSTMENT

Clutch

Unit: mm (in)		
Engine	VG30DE	VG30DETT
Pedal free height	197 - 207 (7.76 - 8.15)	183 - 193 (7.20 - 7.60)
Pedal free play	1 - 3 (0.04 - 0.12)	

Front axle and front suspension (Unladen)*

Camber	degree	-1°35' to -0°05'
Caster	degree	9°00' - 10°30'
Toe-in	mm (in)	0 - 2 (0 - 0.08)
(Total toe-in angle)	degree	0' - 11'
Kingpin inclination	degree	12°10' - 13°40'
Front wheel turning angle		
Full turn		
Inside/outside	degree	32°20' - 36°20'/26°30' - 30°30'

*: Fuel, radiator coolant and engine oil full. Spare tire, jack, hand tools and mats in designated positions.

Rear axle and rear suspension (Unladen)*

Camber	degree	-1°36' to -0°36'
Toe-in	mm (in)	0 - 4 (0 - 0.16)
(Total toe-in angle)	degree	0' - 23'

*: Fuel, radiator coolant and engine oil full. Spare tire, jack, hand tools and mats in designated positions.

Wheel bearing

	Front	Rear
Wheel bearing axle end play mm (in)	0.05 (0.0020) or less	
Wheel bearing lock nut		
Tightening torque	206 - 284	206 - 275
N·m (kg·m, ft·lb)	(21 - 29, 152 - 210)	(21 - 28, 152 - 203)

Brake

Unit: mm (in)

Disc brake		
Pad		
Standard thickness		
OPZ25VA		10.0 (0.394)
OPZ11VB		11.5 (0.453)
Minimum thickness		
OPZ25VA		2.0 (0.079)
OPZ11VB		2.0 (0.079)
Rotor		
Standard thickness		
OPZ25VA		30.0 (1.181)
OPZ11VB		18 (0.71)
Minimum thickness		
OPZ25VA		28.0 (1.102)
OPZ11VB		16.0 (0.630)
Pedal		
Free height		
M/T		186 - 196 (7.32 - 7.72)
A/T		195 - 205 (7.68 - 8.07)
Free play at clevis		1 - 3 (0.04 - 0.12)
Depressed height		
[under force of 490 N (50 kg, 110 lb) with engine running]		
M/T		
Without A.B.S.		95 (3.74) or more
With A.B.S.		105 (4.13) or more
A/T		
Without A.B.S.		105 (4.13) or more
With A.B.S.		110 (4.33) or more
Parking brake		
Number of notches		6 - 7
[at pulling force 196 N (20 kg, 44 lb)]		

Wheel balance

Maximum allowable unbalance	Dynamic (at rim flange) g (oz)	10 (0.35) (One side)
	Static g (oz)	20 (0.71)

SERVICE DATA AND SPECIFICATIONS (S.D.S.)

Chassis and Body Maintenance (Cont'd)

TIGHTENING TORQUE

Unit	N·m	kg-m	ft-lb
Clutch			
A.S.C.D. cancel switch, HICAS clutch switch and power steering clutch switch lock nut	12 - 15	1.2 - 1.5	9 - 11
Manual transmission			
Drain and filler plugs	25 - 34	2.5 - 3.5	18 - 25
Final drive			
Drain plug	39 - 59	4 - 6	29 - 43
Filler plug	39 - 59	4 - 6	29 - 43
Front axle and front suspension			
Tie-rod lock nut	78 - 98	8.0 - 10.0	58 - 72
Rear axle and rear suspension			
Toe adjusting pin	69 - 88	7.0 - 9.0	51 - 65
Camber adjusting pin (Models without super HICAS)	69 - 88	7.0 - 9.0	51 - 65
Lower link lock nut (Models with super HICAS)	37 - 46	3.8 - 4.7	27 - 34
Brake system			
Air bleed valve	7 - 9	0.7 - 0.9	5.1 - 6.5
Brake lamp switch lock nut	12 - 15	1.2 - 1.5	9 - 11
Brake booster input rod lock nut	16 - 22	1.6 - 2.2	12 - 16
Wheel and tire			
Wheel nut	98 - 118	10.0 - 12.0	72 - 87

CONTENTS

PRECAUTIONS	EM- 2
PREPARATION	EM- 3
OUTER COMPONENT PARTS	EM- 6
COMPRESSION PRESSURE	EM- 9
OIL PAN	EM-10
TIMING BELT	EM-13
OIL SEAL REPLACEMENT	EM-21
THROTTLE CHAMBERS	EM-23
CYLINDER HEAD	EM-26
TURBOCHARGERS	EM-38
INTERCOOLERS	EM-43
ENGINE REMOVAL	EM-44
CYLINDER BLOCK	EM-48
SERVICE DATA AND SPECIFICATIONS (S.D.S.)	EM-60

PRECAUTIONS

Supplemental Restraint System "AIR BAG"

The Supplemental Restraint System "Air Bag" helps to reduce the risk or severity of injury to the driver in a frontal collision. The Supplemental Restraint System consists of an air bag (located in the center of the steering wheel), sensors, a control unit, warning lamp, wiring harness and spiral cable. Information necessary to service the system safely is included in the **BF** section of this Service Manual.

WARNING:

- a. To avoid rendering the SRS inoperative, which could lead to personal injury or death in the event of a severe frontal collision, all maintenance must be performed by an authorized NISSAN dealer.
- b. Improper maintenance, including incorrect removal and installation of the SRS, can lead to personal injury caused by unintentional activation of the system.
- c. All SRS electrical wiring harnesses and connectors are covered with yellow outer insulation. Do not use electrical test equipment on any circuit related to the SRS "Air Bag".

Parts Requiring Angular Tightening

- Some important engine parts are tightened using an angular-tightening method rather than a torque setting method.
- If these parts are tightened using a torque setting method, dispersal of the tightening force (axial bolt force) will be two or three times that of the dispersal produced by using the correct angular-tightening method.
- Although the torque setting values (described in this manual) are equivalent to those used when bolts and nuts are tightened with an angular-tightening method, they should be used for reference only.
- To assure the satisfactory maintenance of the engine, bolts and nuts must be tightened using an angular-tightening method.
- Before tightening the bolts and nuts, ensure that the thread and seating surfaces are clean and then coated with engine oil.
- The bolts and nuts which require the angular-tightening method are as follows:
 - (1) Cylinder head bolts
 - (2) Connecting rod cap nuts

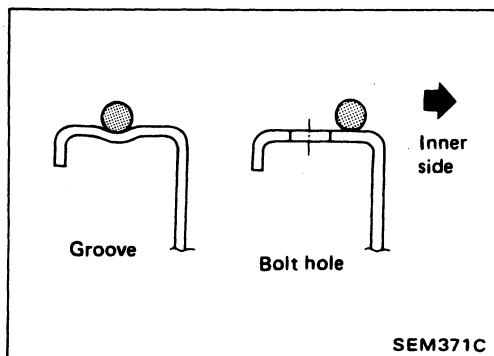

Liquid Gasket Application Procedure



- a. Before applying liquid gasket, use a scraper to remove all traces of old liquid gasket from mating surface.
- b. Apply a continuous bead of liquid gasket to mating surfaces. (Use Genuine Liquid Gasket or equivalent.)
 - Be sure liquid gasket is 3.5 to 4.5 mm (0.138 to 0.177 in) wide (for oil pan).
 - Be sure liquid gasket is 2.0 to 3.0 mm (0.079 to 0.118 in) wide (in areas except oil pan).
- c. Apply liquid gasket to inner sealing surface around entire perimeter area. (Assembly should be done within 5 minutes after coating.)
- d. Wait at least 30 minutes before refilling engine oil and engine coolant.

PREPARATION

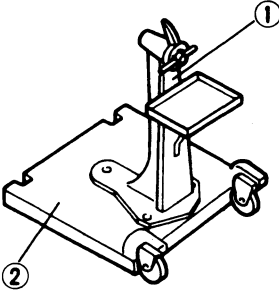
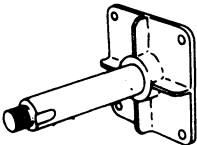
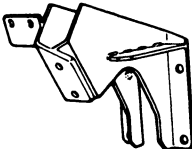
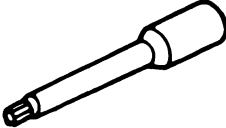
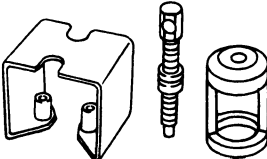
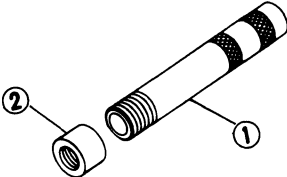
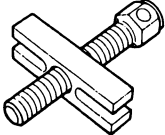
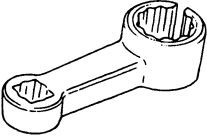
SPECIAL SERVICE TOOLS

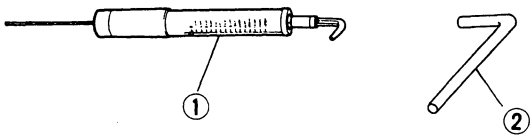
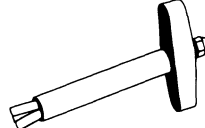
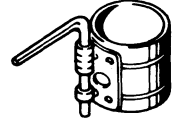

Tool number (Kent-Moore No.) Tool name	Description	
ST0501S000 (-) Engine stand assembly ① ST05011000 (-) Engine stand ② ST05012000 (-) Base	Disassembling and assembling	
KV10106500 (-) Engine stand shaft		
KV10110001 (-) Engine sub-attachment		
ST10120000 (J24239-01) Cylinder head bolt wrench	Loosening and tightening cylinder head bolt	
KV10111300 (-) Valve spring compressor	Disassembling and assembling valve components	
① KV10107501 (-) Valve oil seal drift ② KV10111400 (-) Attachment	Installing valve oil seal	
ST27180001 (J25726-A) Steering wheel puller	Removing crankshaft pulley	
KV10114400 (J-38365) Exhaust gas sensor wrench	Loosening or tightening exhaust gas sensor	

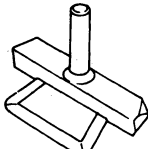
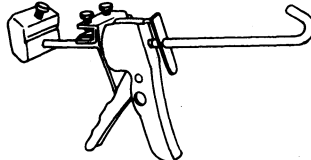
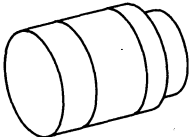
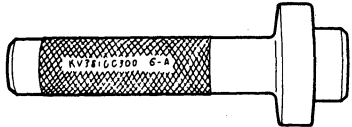
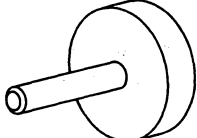
PREPARATION

Tool number (Kent-Moore No.) Tool name	Description
① EG14860000 (J-38387) Push-pull gauge ② KV10112000 (-) Hook	Adjusting timing belt tension 
(J36467) Valve oil seal remover	Removing valve oil seals 
EM03470000 (J8037) Piston ring compressor	Installing piston assembly into cylinder bore 
ST16610001 (J23907) Pilot bushing puller	Removing crankshaft pilot bushing 
KV10111100 (-) Seal cutter	Removing oil pan 
WS39930000 (-) Tube presser	Pressing the tube of liquid gasket 
ST33200000 (J26082) Drift	Installing camshaft oil seal 
KV38100300 (J22888) Drift	Installing front oil seal 
ST15310000 (J25640-B) Drift	Installing rear oil seal 

PREPARATION

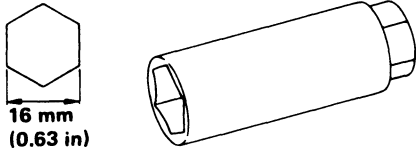
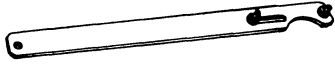
COMMERICAL SERVICE TOOLS

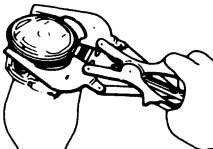
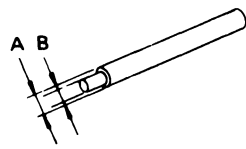
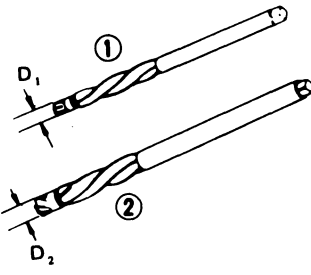
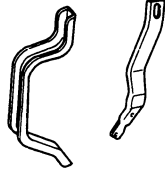
Tool name	Description										
Spark plug wrench	Removing and installing spark plug										
Pulley holder	Holding camshaft pulley while tightening or loosening camshaft bolt										
Valve seat cutter set	Finishing valve seat dimensions										
Piston ring expander	Removing and installing piston ring										
Valve guide drift	Removing and installing valve guide	<p style="text-align: center;">Intake & Exhaust: A = 9.5 mm (0.374 in) dia. B = 5.5 mm (0.217 in) dia.</p> 									
Valve guide reamer	Reaming valve guide ① or hole for oversize valve guide ②	<p style="text-align: center;">$D_1 = 6.0 \text{ mm (0.236 in) dia.}$ $D_2 = 10.2 \text{ mm (0.402 in) dia.}$</p> 									
Engine slinger	<table border="1" style="width: 100%; border-collapse: collapse; text-align: center;"> <tr> <td style="width: 20%;">Engine</td> <td style="width: 20%;">VG30DE</td> <td style="width: 20%;">VG30DETT</td> </tr> <tr> <td>Front</td> <td>10005-30P10</td> <td>10005-40P10</td> </tr> <tr> <td>Rear</td> <td colspan="2">10006-30P10</td> </tr> </table>	Engine	VG30DE	VG30DETT	Front	10005-30P10	10005-40P10	Rear	10006-30P10		
Engine	VG30DE	VG30DETT									
Front	10005-30P10	10005-40P10									
Rear	10006-30P10										

OUTER COMPONENT PARTS

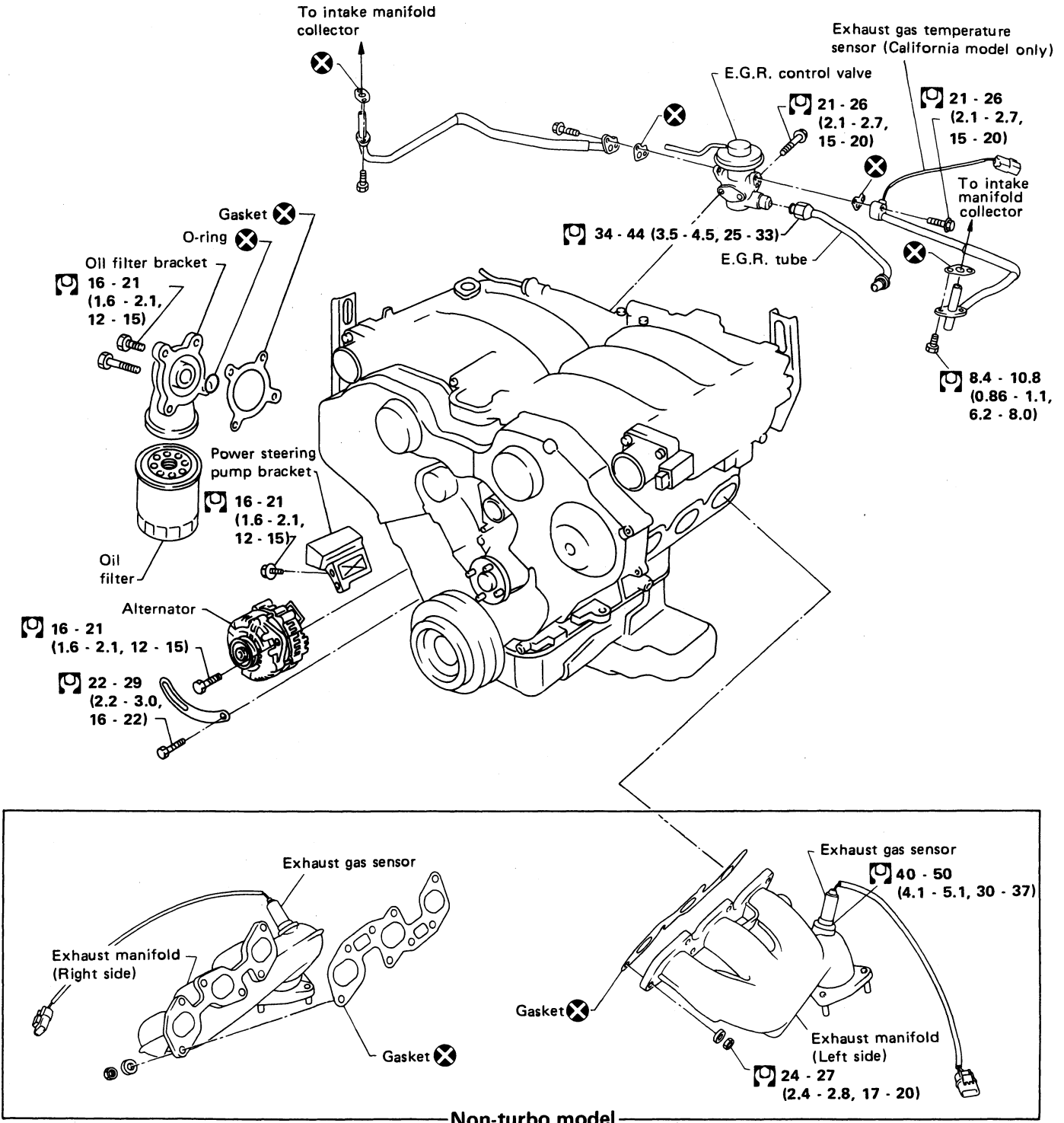

: N·m (kg·m, ft·lb)

SEM807C

OUTER COMPONENT PARTS

Turbo model

Right side

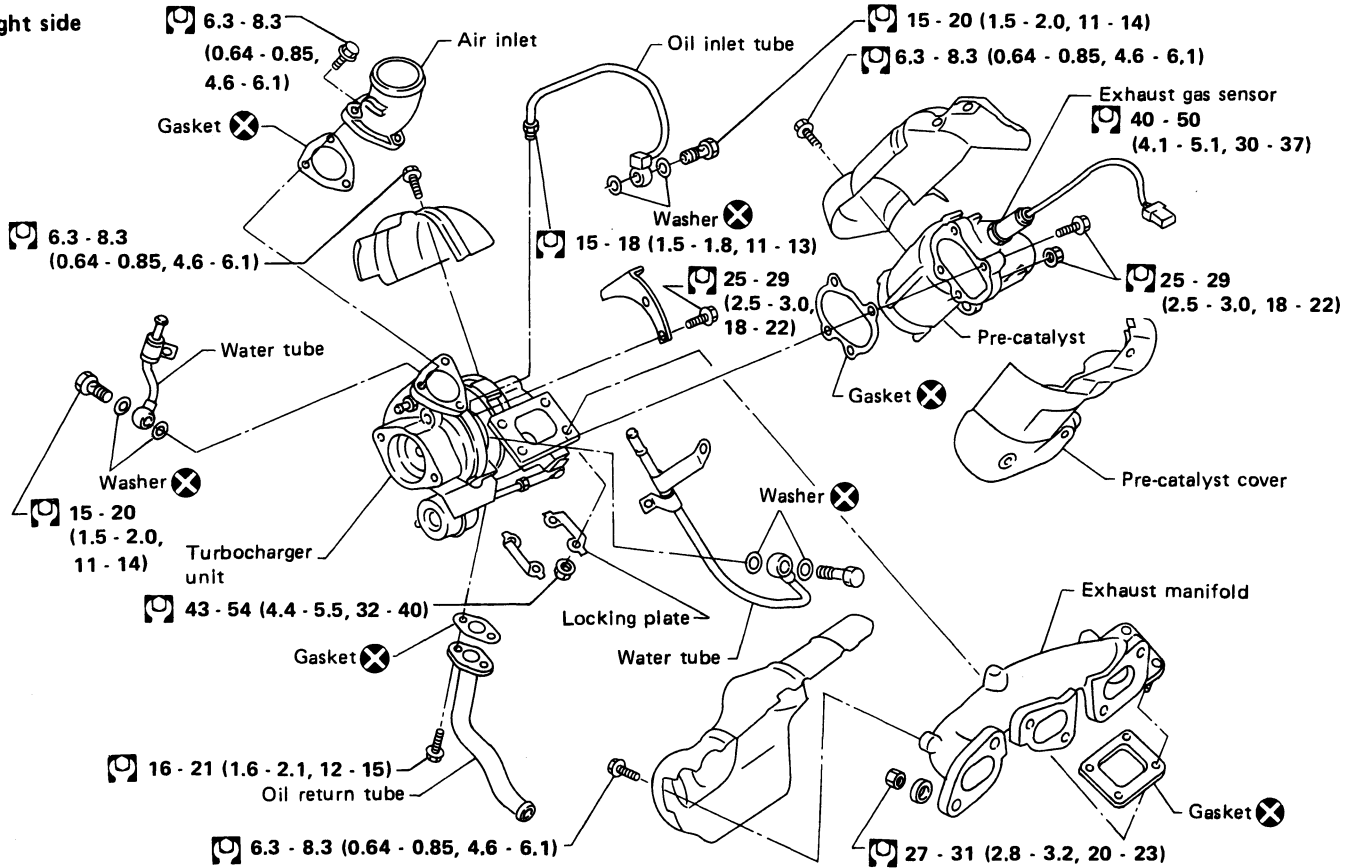

Left side

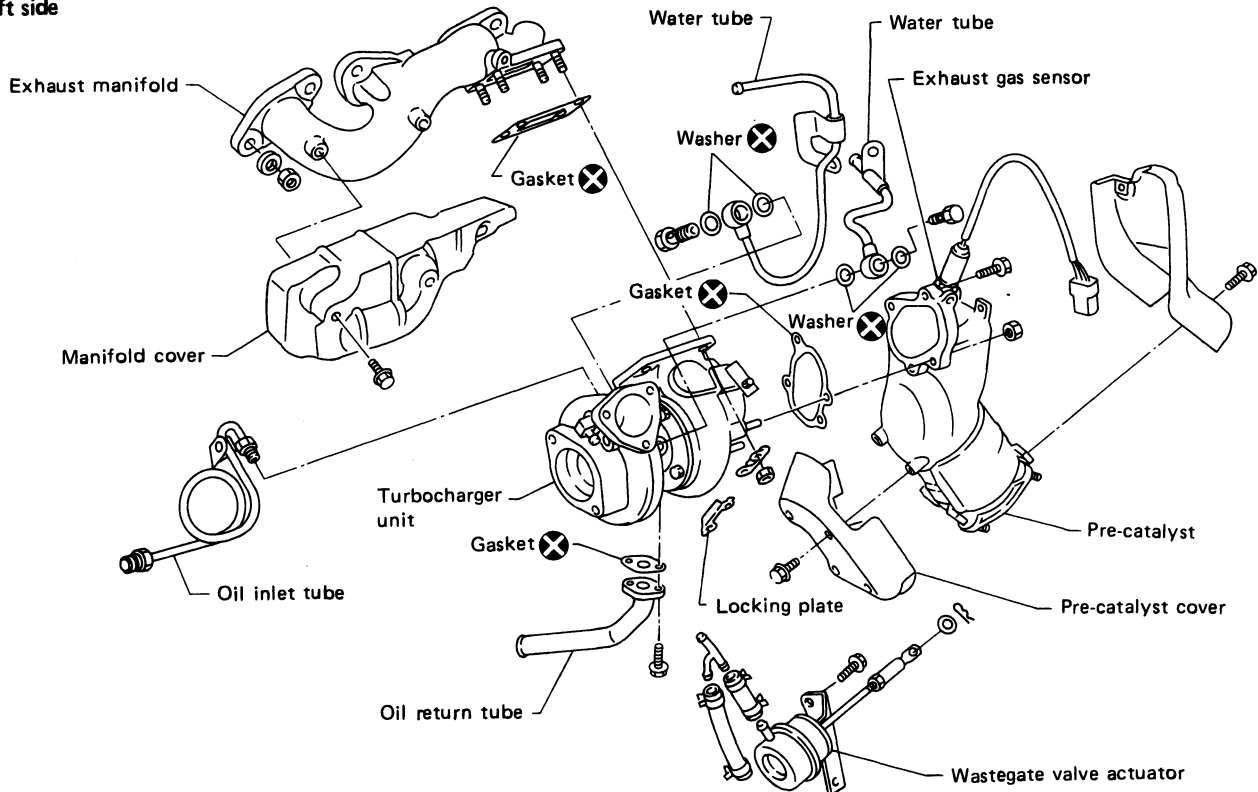

: N-m (kg-m, ft-lb)

SEM773C

OUTER COMPONENT PARTS

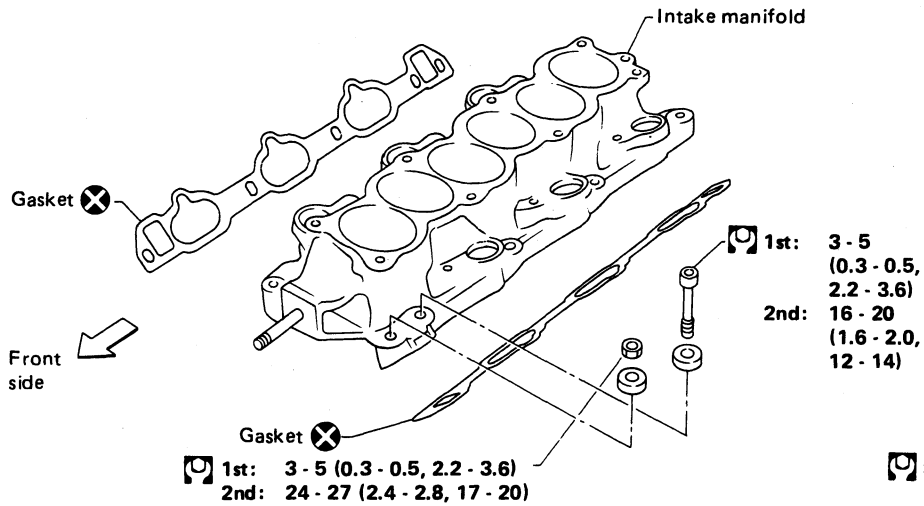
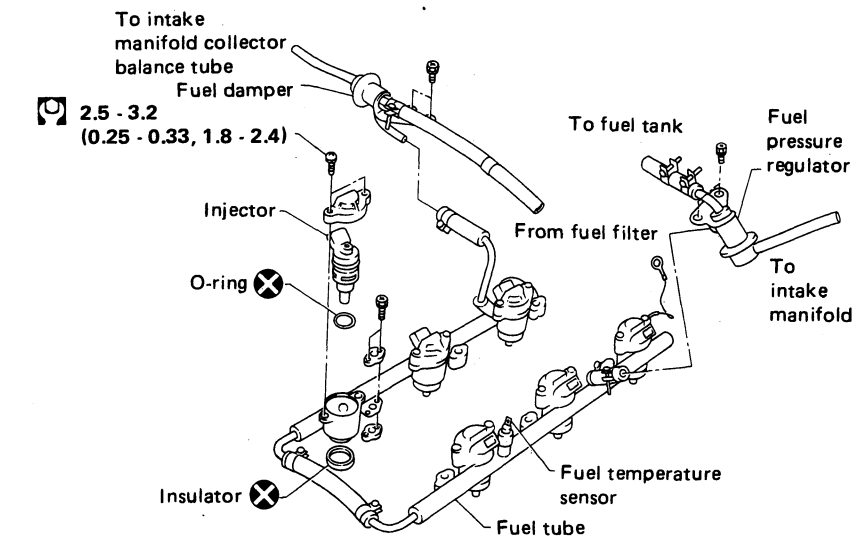
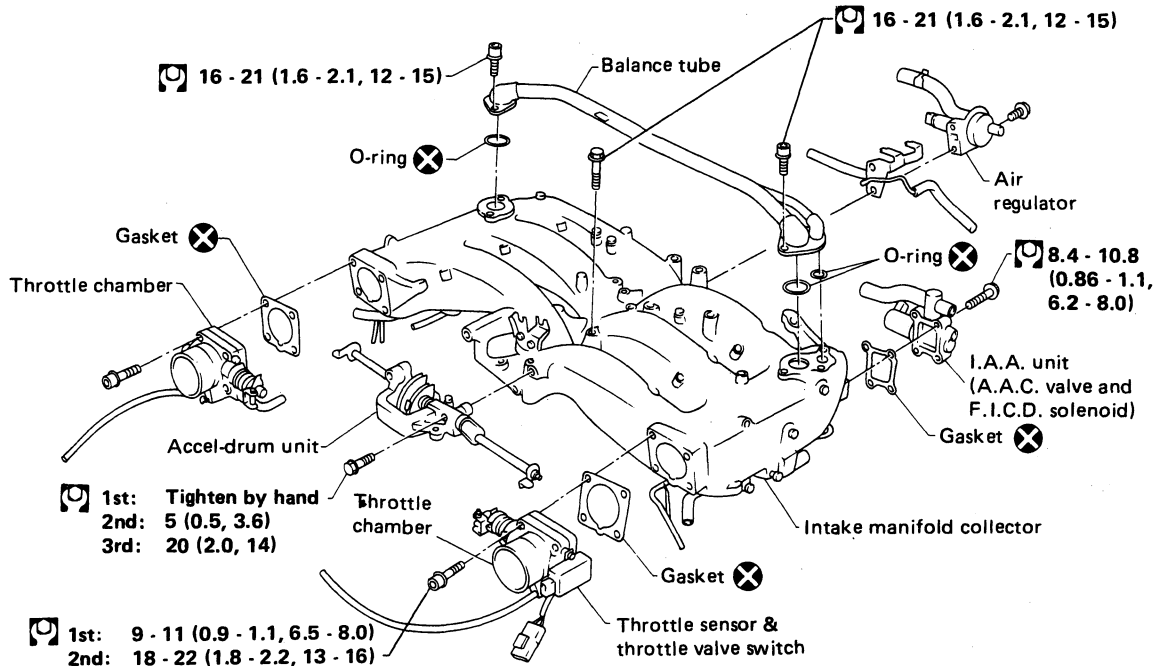

: N·m (kg-m, ft-lb)

COMPRESSION PRESSURE

Measurement of Compression Pressure

1. Warm up engine.
2. Turn ignition switch off.
3. Release fuel pressure.
Refer to "Releasing Fuel Pressure" in section EF & EC.
4. Remove all spark plugs.
5. Disconnect crank angle sensor harness connector.

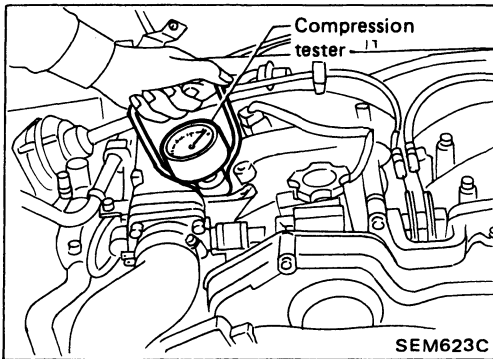

6. Attach a compression tester to No. 1 cylinder.
7. Depress accelerator pedal fully to keep throttle valve wide open.
8. Crank engine and record highest gauge indication.
9. Repeat the measurement on each cylinder as shown.

Always use a fully-charged battery to obtain specified engine revolution.

Compression pressure:

Unit: kPa (kg/cm², psi)/300 rpm

	VG30DE	VG30DETT
Standard	1,285 (13.1, 186)	1,177 (12.0, 171)
Minimum	981 (10.0, 142)	883 (9.0, 128)
Difference limit between cylinders	98 (1.0, 14)	

10. If cylinder compression in one or more cylinders is low, pour a small amount of engine oil into cylinders through the spark plug holes and retest compression.

- **If adding oil helps compression, piston rings may be worn or damaged. If so, replace piston rings after checking piston.**
- **If pressure stays low, a valve may be sticking or seating improperly. Inspect and repair valves and valve seats. (Refer to S.D.S.) If valves or valve seats are damaged excessively, replace them.**
- **If compression in any two adjacent cylinders is low and if adding oil does not help compression, there may be leakage past gasket surface. If so, replace cylinder head gasket.**

OIL PAN

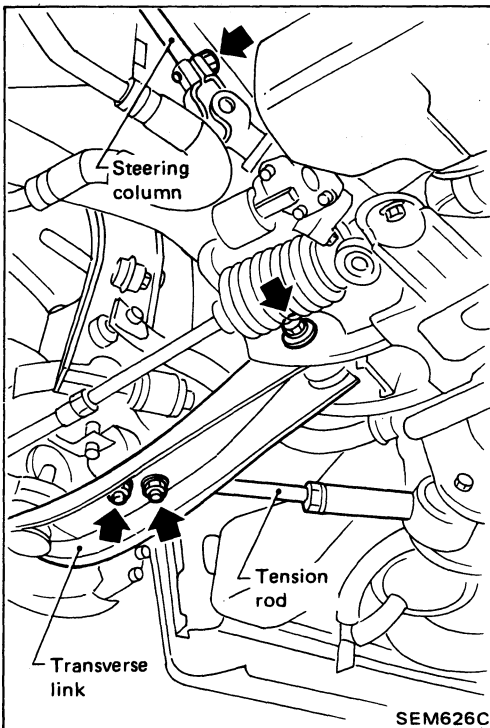
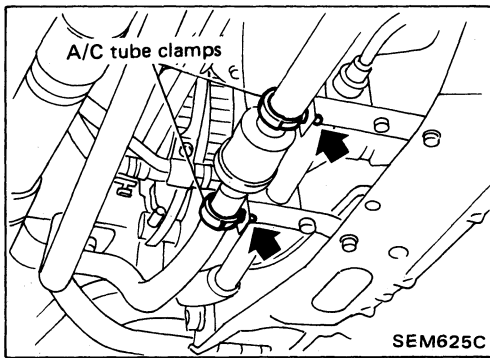
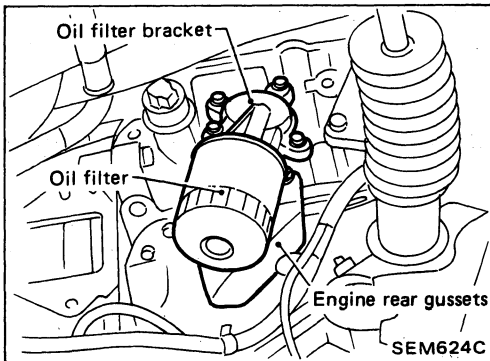
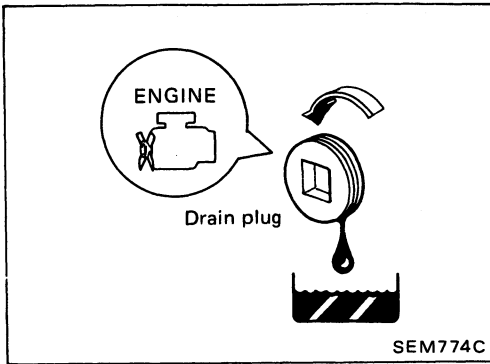

Removal

1. Drain engine oil.
2. Remove engine under cover.
3. Remove oil filter and bracket.
4. Remove engine rear gussets from both sides.
5. Disconnect A/C tube clamps as shown.
6. Disconnect steering column lower joint.
7. Remove tension rod fixing bolts from both sides.
8. Loosen transverse link bolts on both sides.

OIL PAN

Removal (Cont'd)

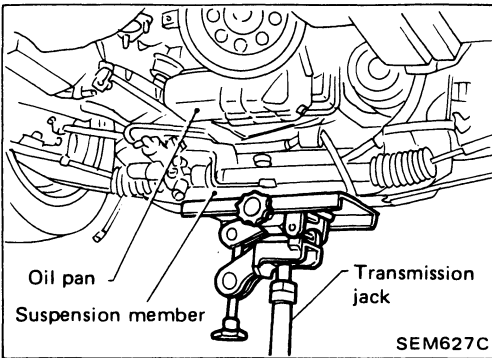

9. Set a suitable transmission jack under the suspension member.
 - At this time, hoist engine with engine slingers.
10. Remove suspension member fixing bolts.
11. Remove engine mounting bolts from both sides and then slowly lower transmission jack.
12. Remove oil pan bolts.

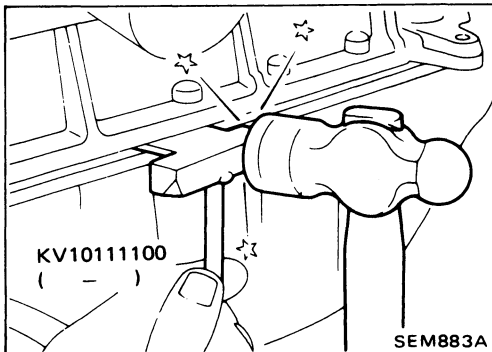

13. Remove oil pan.
 - (1) Insert Tool between cylinder block and oil pan.
 - **Do not drive seal cutter into oil pump or rear oil seal retainer, as aluminum mating surfaces may be damaged.**
 - **Do not insert screwdriver, or oil pan flange may be deformed.**

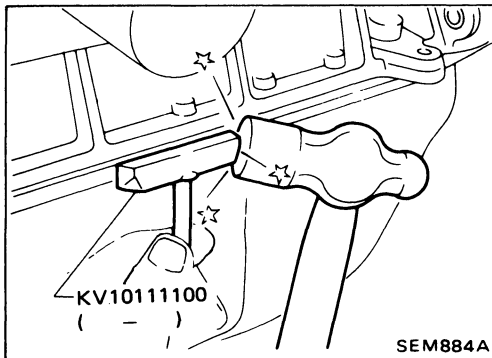

- (2) Slide Tool by tapping its side with a hammer, and remove oil pan.

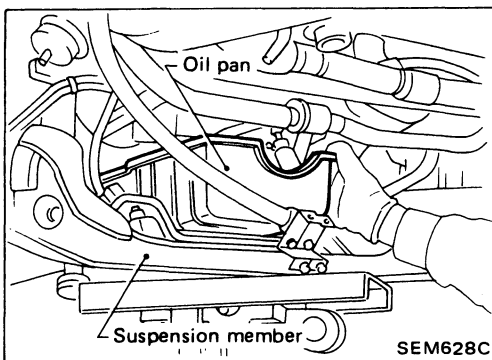

- (3) Remove oil pan.

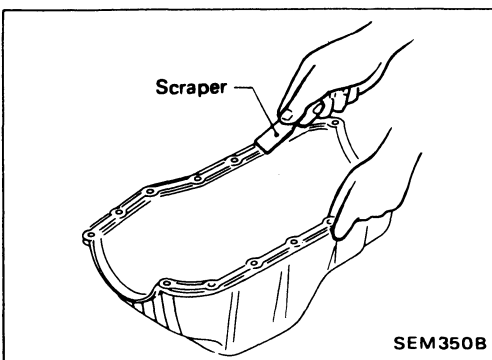

Installation

1. Before installing oil pan, remove all traces of liquid gasket from mating surface using a scraper.
 - Also remove traces of liquid gasket from cylinder block mating surface.

OIL PAN

Installation (Cont'd)

2. Apply sealant to oil pump gasket and rear oil seal retainer gasket.

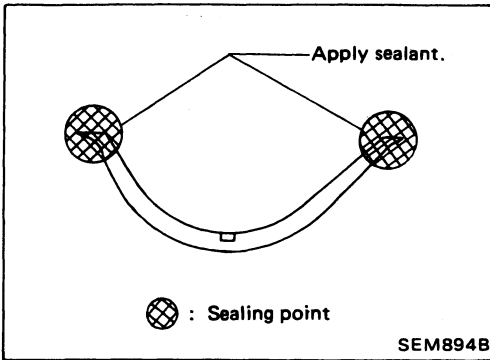

3. Apply a continuous bead of liquid gasket to oil pan mating surface.

Use Genuine Liquid Gasket or equivalent.

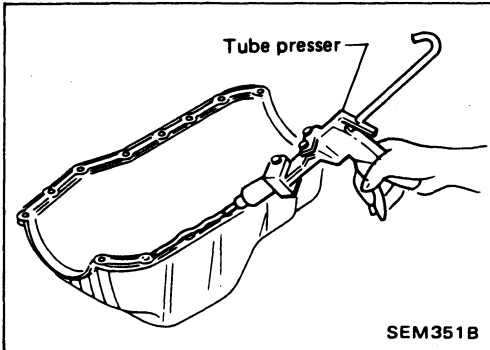

- Be sure liquid gasket is 3.5 to 4.5 mm (0.138 to 0.177 in) wide.

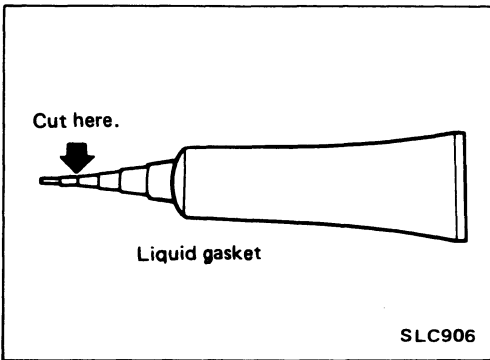

4. Apply liquid gasket to inner sealing surface as shown in figure.

- Attaching should be done within 5 minutes after coating.

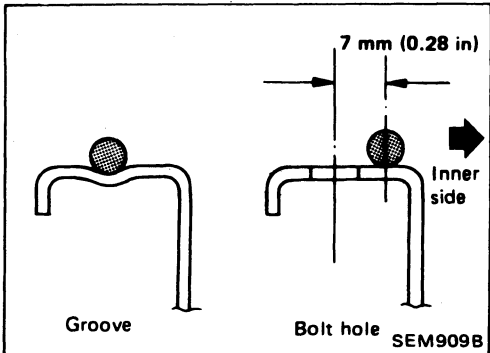

5. Install oil pan.

- Install bolts/nuts in their reverse order of removal.
- Wait at least 30 minutes before refilling engine oil.

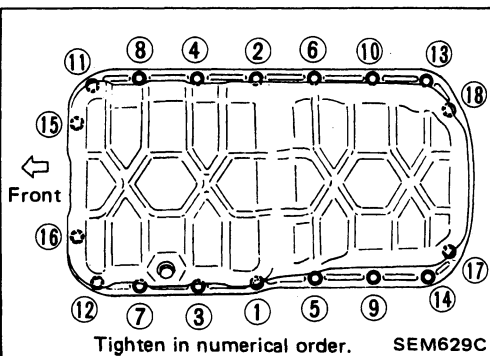

TIMING BELT

CAUTION:

- Do not bend or twist timing belt.
- After removing timing belt, do not turn crankshaft and camshaft separately because valves will strike piston heads.
- Make sure that timing belt, camshaft sprocket, crankshaft sprocket, idler pulley and auto-tensioner are clean and free of oil and water.
- Timing belt installation should be carried out when engine is cold.

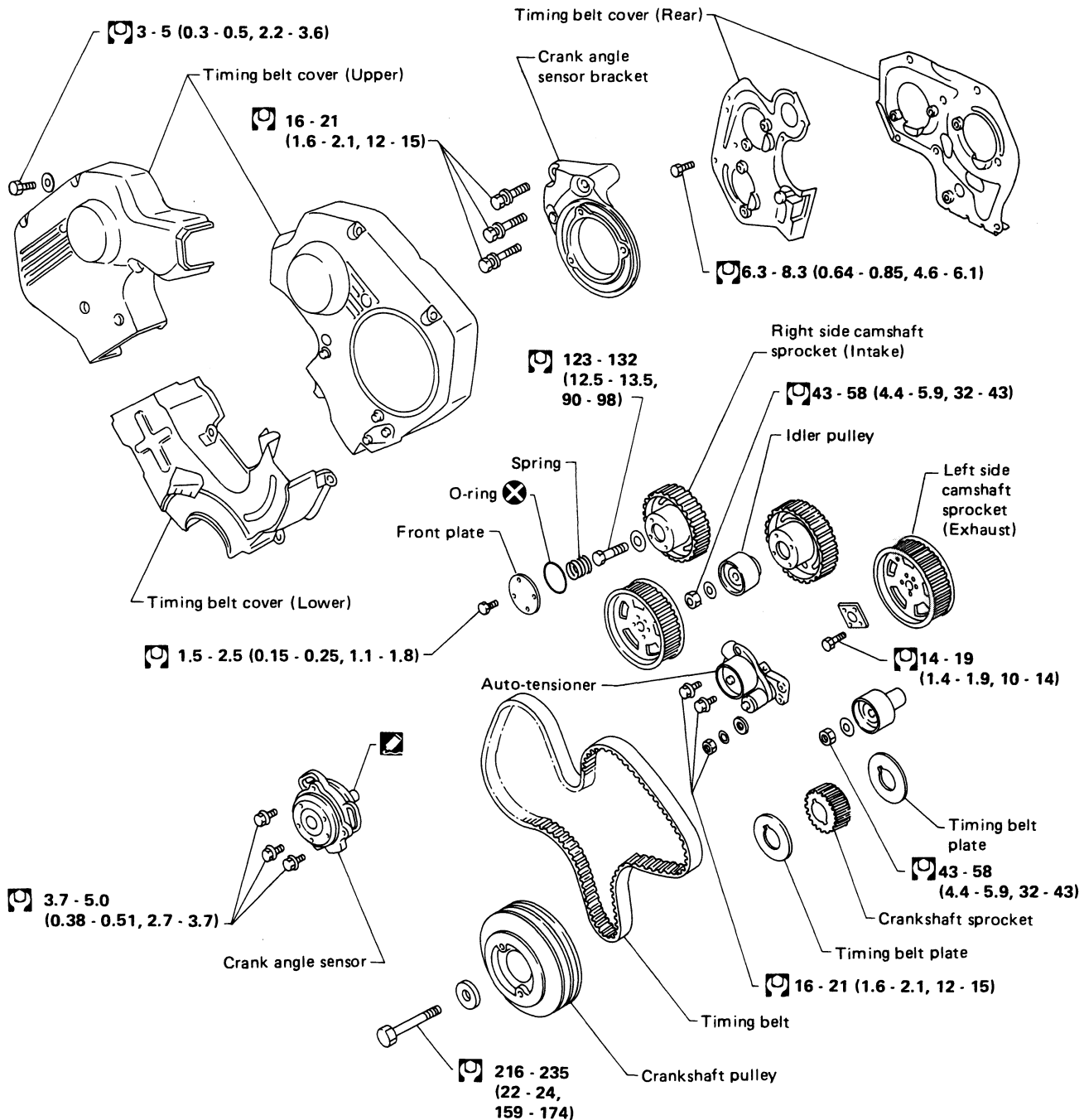

: N·m (kg·m, ft·lb)

TIMING BELT

Removal

1. Remove engine under cover.
2. Drain coolant from both cylinder block drain plugs, and radiator drain cock.

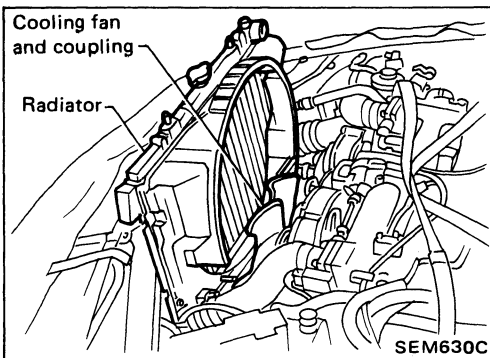

3. Remove radiator.
4. Remove drive belts, cooling fan and coupling.

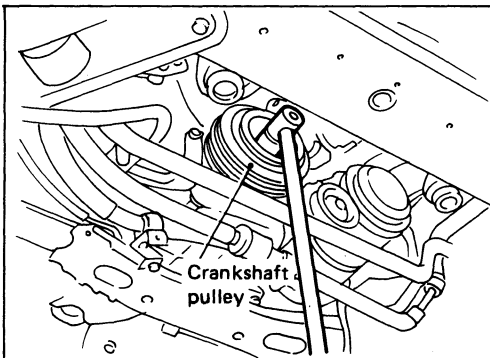

5. Remove crankshaft pulley bolt.
(At this time, remove starter motor and set a suitable tool to ring gear so that crankshaft cannot rotate.)

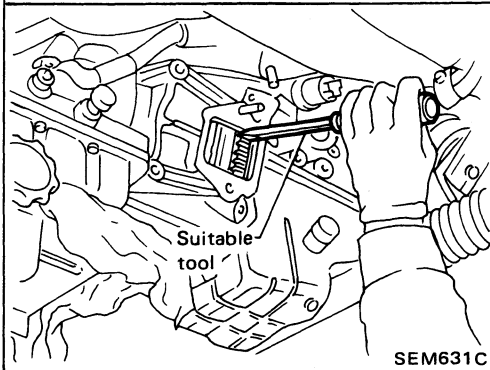

6. Remove crankshaft pulley using Tool.

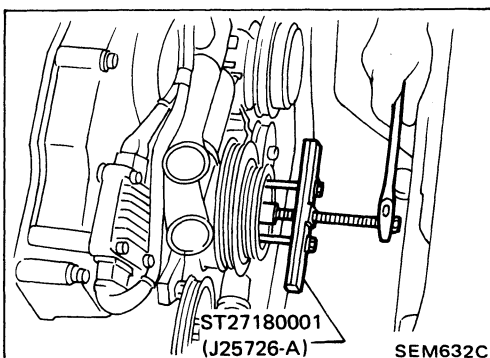

TIMING BELT

Removal (Cont'd)

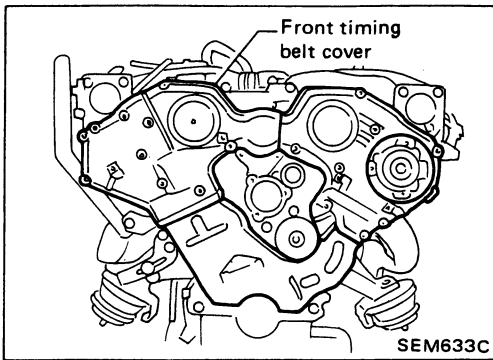

7. Remove water inlet and outlet.
8. Remove front timing belt covers.

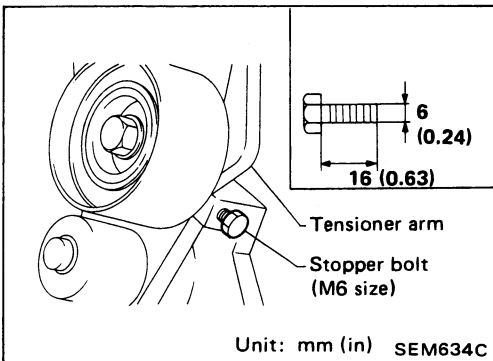

9. Install a suitable stopper bolt (M6) into tensioner arm of auto-tensioner so that auto-tensioner pusher does not spread out.

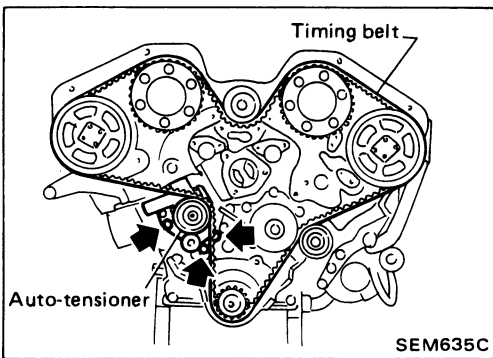

10. Set No. 1 cylinder at T.D.C. on its compression stroke.
11. Remove auto-tensioner and timing belt.

TIMING BELT

Inspection

Visually check the condition of timing belt.
Replace if any abnormality is found.

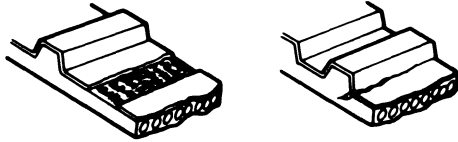
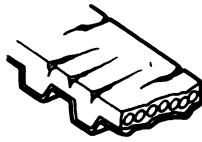
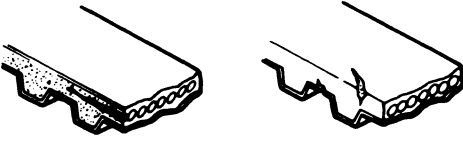
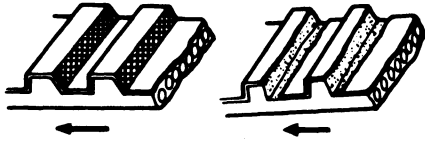
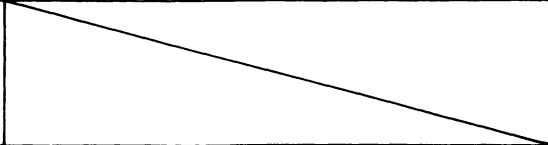
Item to check	Problem	Cause
Tooth is broken/ tooth root is cracked.	 <p style="text-align: right;">SEM394A</p>	<ul style="list-style-type: none"> ● Camshaft jamming ● Distributor jamming ● Damaged camshaft/crankshaft oil seal
Back surface is cracked/worn.	 <p style="text-align: right;">SEM395A</p>	<ul style="list-style-type: none"> ● Tensioner jamming ● Overheated engine ● Interference with belt cover
Side surface is worn.	 <ul style="list-style-type: none"> ● Belt corners are worn and round. ● Wicks are frayed and coming out. <p style="text-align: right;">SEM396A</p>	<ul style="list-style-type: none"> ● Improper installation of belt ● Malfunctioning crankshaft pulley plate/ timing belt plate
Teeth are worn.	 <p style="text-align: center;">Rotating direction</p> <ul style="list-style-type: none"> ● Canvas on tooth face is worn down. ● Canvas on tooth is fluffy, rubber layer is worn down and faded white, or weft is worn down and invisible. <p style="text-align: right;">SEM397A</p>	<ul style="list-style-type: none"> ● Poor belt cover sealing ● Coolant leakage at water pump ● Camshaft not functioning properly ● Distributor not functioning properly ● Excessive belt tension
Oil/Coolant or water is stuck to belt.		<ul style="list-style-type: none"> ● Poor oil sealing ● Coolant leakage at water pump ● Poor belt cover sealing

TIMING BELT

Inspection (Cont'd) AUTO-TENSIONER

Check for oil leaks from pusher rod and diaphragm.

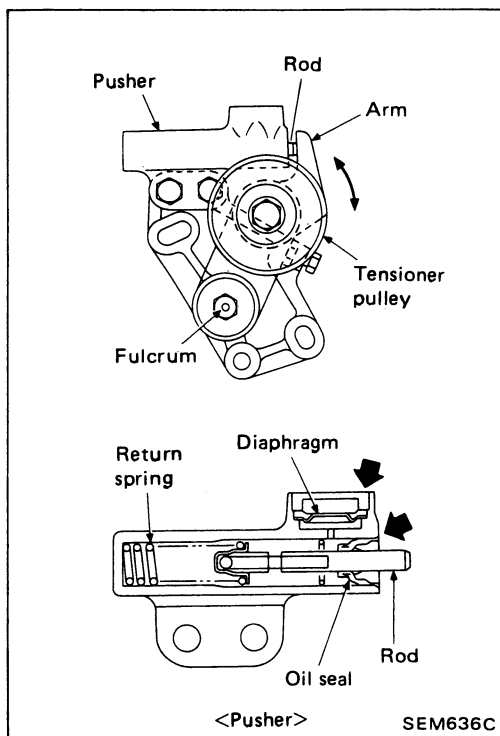

Installation

1. Confirm that No. 1 cylinder is set at T.D.C. on its compression stroke.
2. Align matching marks on camshaft and crankshaft sprockets with aligning marks on rear belt cover and oil pump housing.
3. Remove all spark plugs.

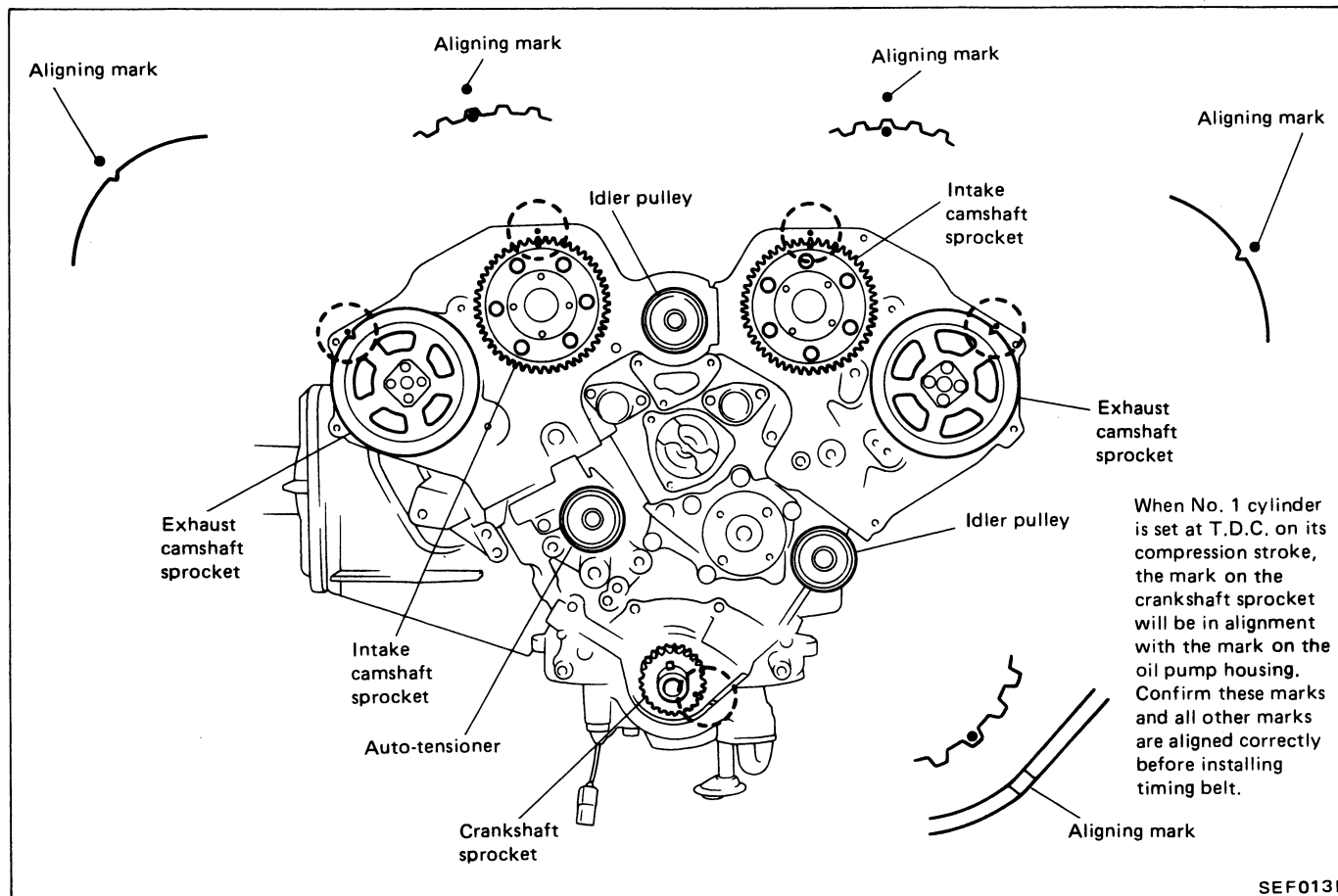

TIMING BELT

Installation (Cont'd)

4. Set timing belt.

- a. Ensure timing belt and sprockets are clean and free from oil or water. Do not bend or twist timing belt.
- b. Align white lines on timing belt with matching mark on camshaft sprocket and crankshaft sprocket.
- c. Point arrow on timing belt towards the front.

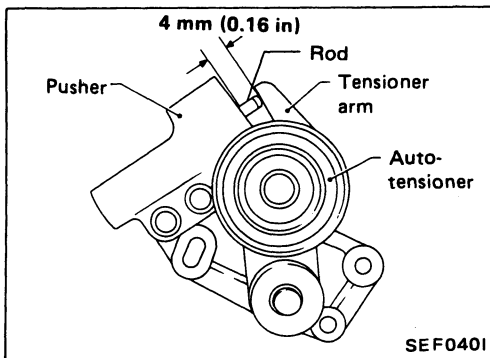
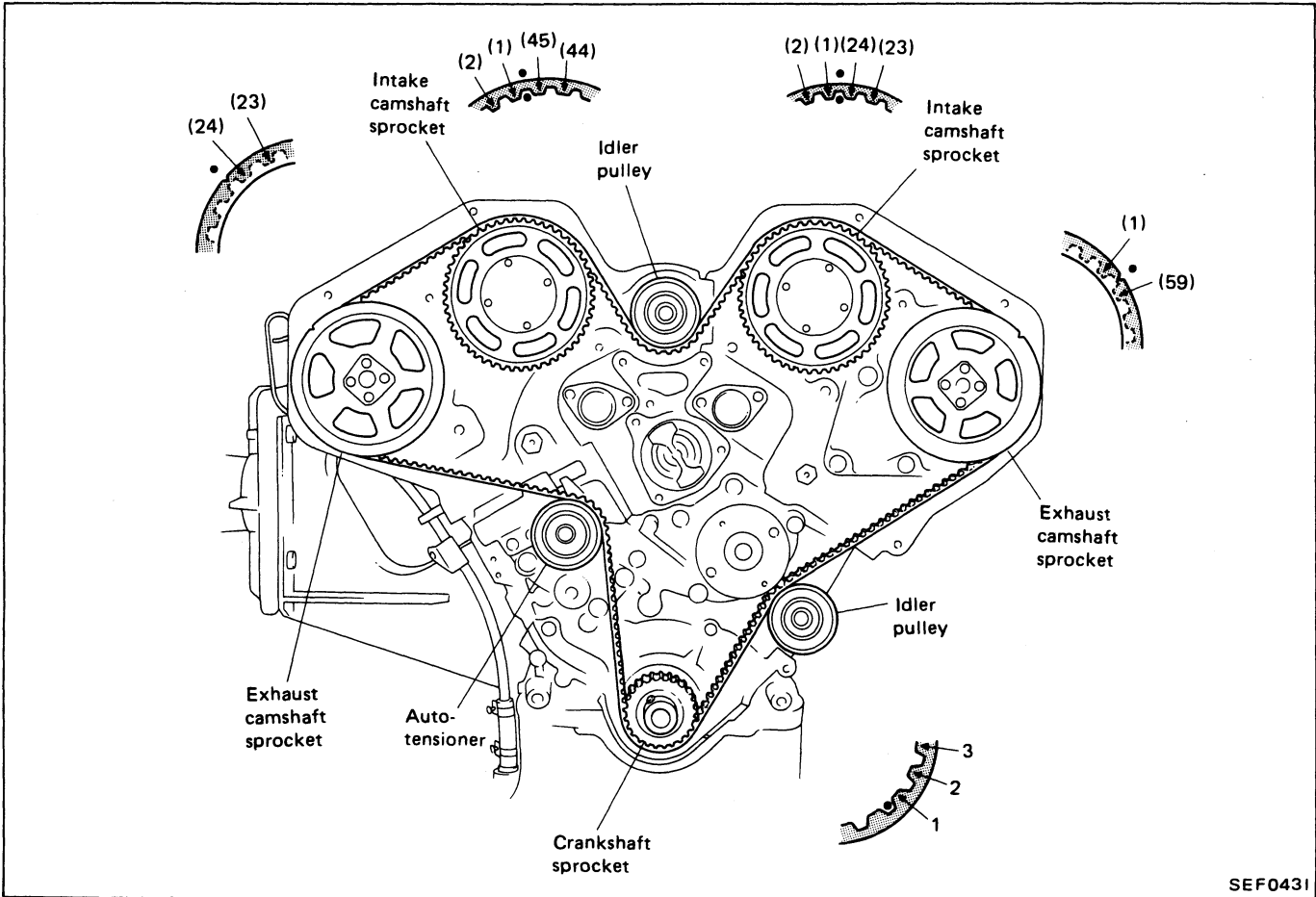

5. Adjust tensioner arm to give 4 mm (0.16 in) clearance with pusher of auto-tensioner using a suitable vise, and then insert stopper bolt into tensioner arm in order that clearance does not change.

When adjusting clearance, do not push tensioner arm with stopper bolt fitted because it will damage thread portion of stopper bolt.

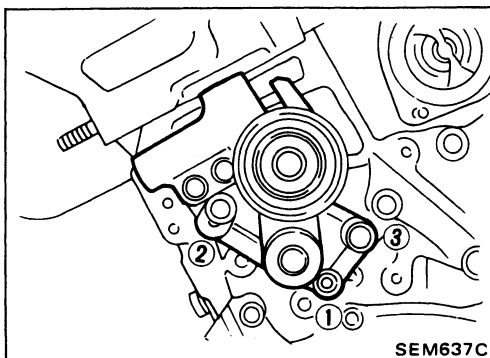

6. Install auto-tensioner and tighten nut (1) and bolts (2, 3) slightly by hand.

TIMING BELT

Installation (Cont'd)

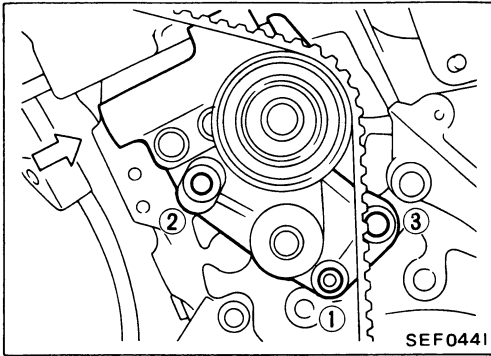

7. Push auto-tensioner slightly towards timing belt to prevent belt from slipping.

Set tensioner slightly by pushing timing belt. Then, turn crankshaft 10 degrees clockwise and tighten nut (①) and bolts (②, ③) to 16 to 21 N·m (1.6 to 2.1 kg-m, 12 to 15 ft-lb).

At this time, do not push auto-tensioner hard or belt will be adjusted too tightly.

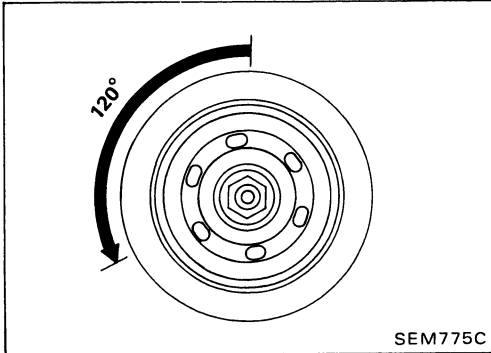

8. Turn crankshaft 120 degrees counterclockwise.

9. Loosen nut (①) and bolts (②, ③) 1/2 turn to set tensioner body as far back as it will go.

10. Turn crankshaft clockwise and set No. 1 cylinder at T.D.C. on its compression stroke.

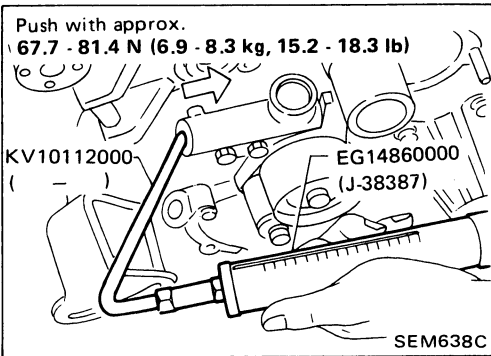

11. Push the end of pusher with approx. 58.8 N (6.0 kg, 13.2 lb) force using Tool (push-pull gauge) and tighten nut (①) and bolts (②, ③) to 16 to 21 N·m (1.6 to 2.1 kg-m, 12 to 15 ft-lb).

If deflection of timing belt exceeds specification in procedure 15., change applied pushing force.

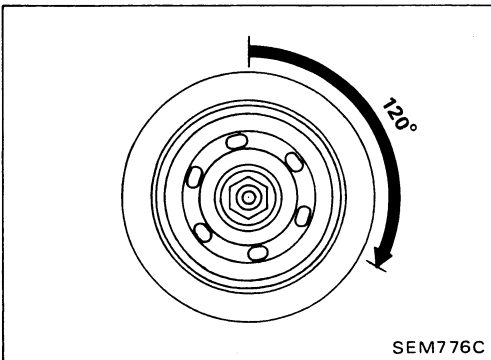

12. Turn crankshaft 120 degrees clockwise.

13. Turn crankshaft 120 degrees counterclockwise and set No. 1 cylinder at T.D.C. on its compression stroke.

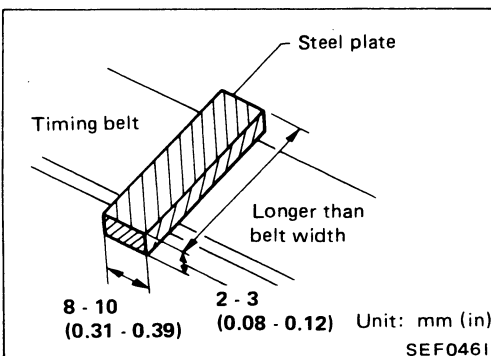

14. Prepare a suitable steel plate to measure belt deflection as shown.

TIMING BELT

Installation (Cont'd)

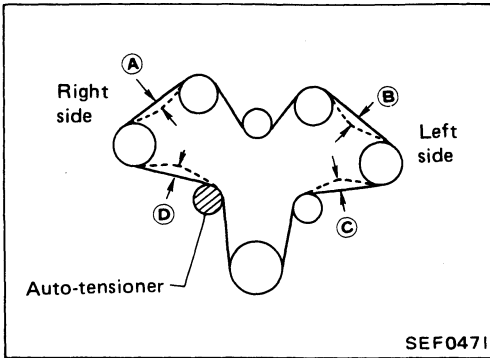

15.

- (1) Set plate and push it with 49 N (5 kg, 11 lb) force using Tool (push-pull gauge) at each position of timing belt mid-way between pulleys as shown.
- (2) Measure each deflection.

Deflection:

6 - 7 mm (0.24 - 0.28 in) or the average of each portion

$$\frac{A + B + C + D}{4}$$

is 6 - 7 mm (0.24 - 0.28 in)

If not within specification, repeat procedure from step 7 through step 15.

16. Confirm auto tensioner fixing nuts and bolts are tightened to 16 to 21 N·m (1.6 to 2.1 kg-m, 12 to 15 ft-lb).

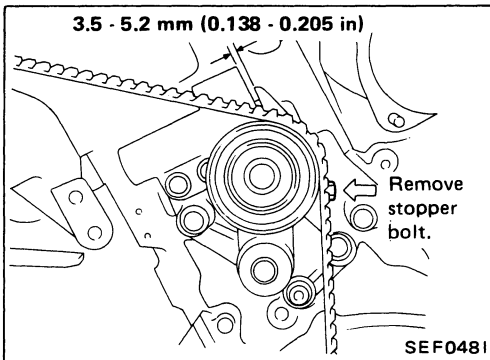

17.

- Remove the auto-tensioner stopper bolt.
- After 5 minutes check the projection of the rod (clearance between tensioner arm and pusher) stays at 3.5 - 5.2 mm (0.138 - 0.205 in).

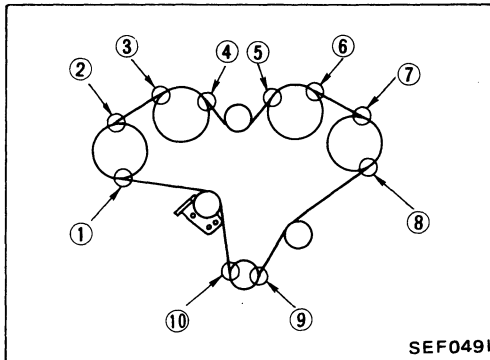

18. Check the proper installation (no slip or misplacement) of timing belt at each position as shown.

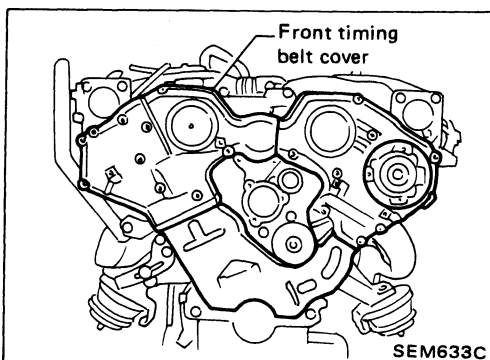

19. Install timing belt covers.

OIL SEAL REPLACEMENT

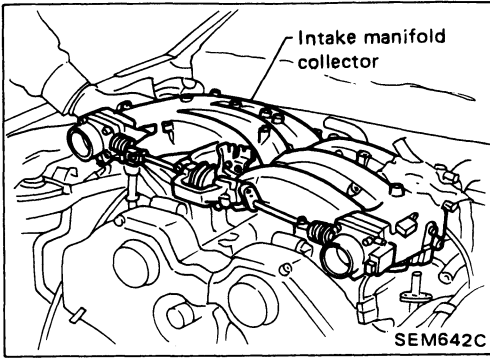

VALVE OIL SEAL

1. Remove intake manifold collector and valve cover.
2. Remove timing belt, camshaft sprocket and rear belt cover.
3. Remove camshaft brackets, camshaft and valve lifter.

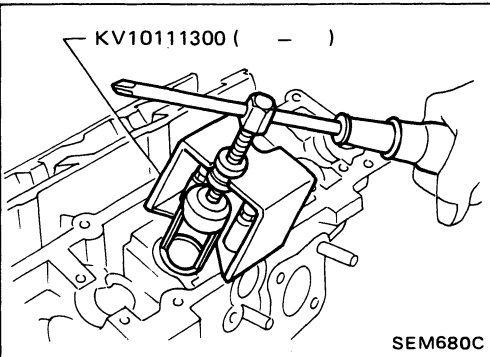

4. Remove valve spring using Tool or a suitable tool.
 - Piston concerned should be set at T.D.C. to prevent valve from falling.
5. Pry out valve oil seal.

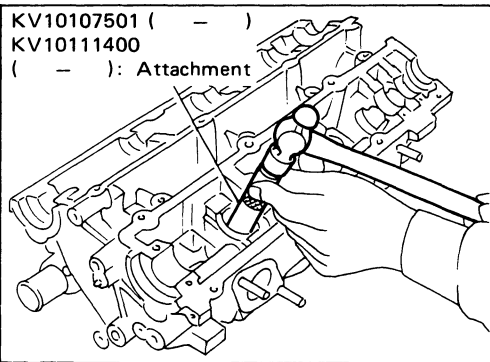

6. Apply engine oil to new valve oil seal and install it.
 - Before installing valve oil seal, install inner valve spring seat.

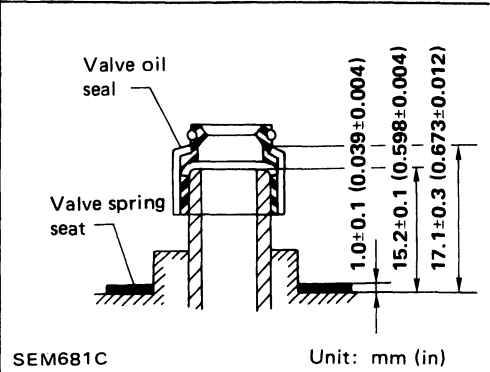

OIL SEAL INSTALLATION DIRECTION

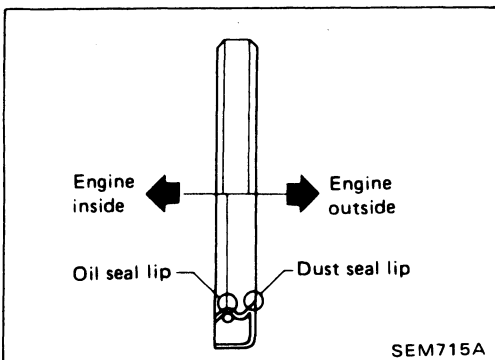

OIL SEAL REPLACEMENT

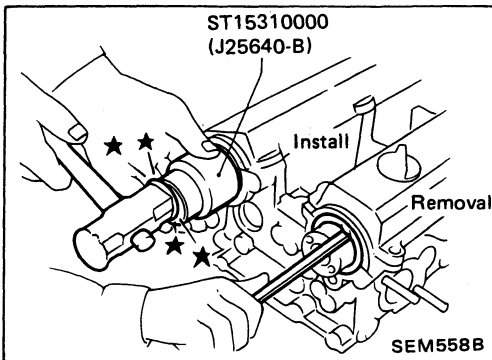

CAMSHAFT OIL SEAL

1. Remove timing belt and camshaft sprocket.
 2. Remove rear belt cover and camshaft oil seal.
- Be careful not to scratch camshaft.**
3. Apply engine oil to new camshaft oil seal and install it using Tool or a suitable tool.

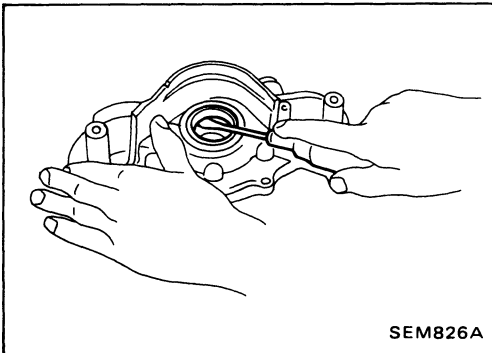

FRONT OIL SEAL

1. Remove timing belt and crankshaft sprocket.
2. Remove oil pan and oil pump assembly.
3. Remove front oil seal from oil pump body.

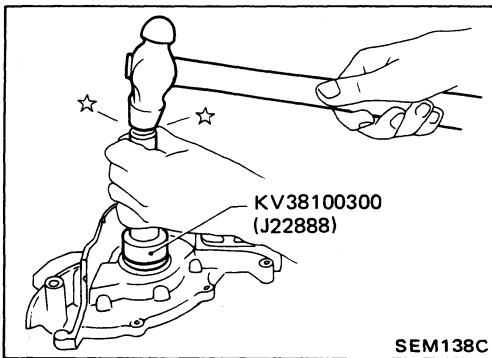

4. Apply engine oil to new oil seal and install it using Tool or a suitable tool.

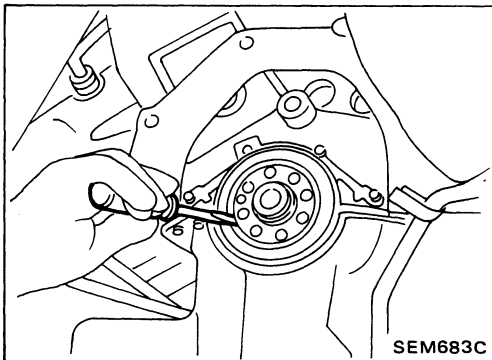

REAR OIL SEAL

1. Remove flywheel or drive plate.
 2. Remove rear oil seal from retainer.
- Be careful not to scratch crankshaft.**

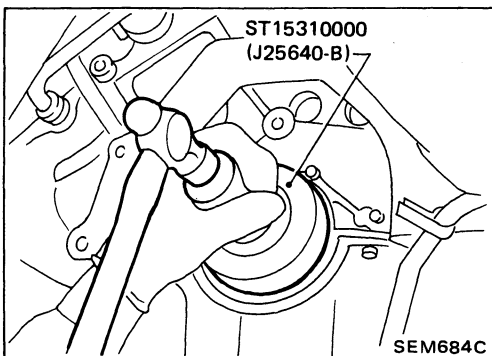

3. Apply engine oil to new oil seal and install it using Tool or a suitable tool.

THROTTLE CHAMBERS

Precaution

A letter, "U" or "L", is stamped on the throttle chambers. When changing a throttle chamber, replace it with a new one that has the same mark.

Installation

The intention of this installation and adjustment procedure is to assure accurate synchronization of the throttle chamber opening points.

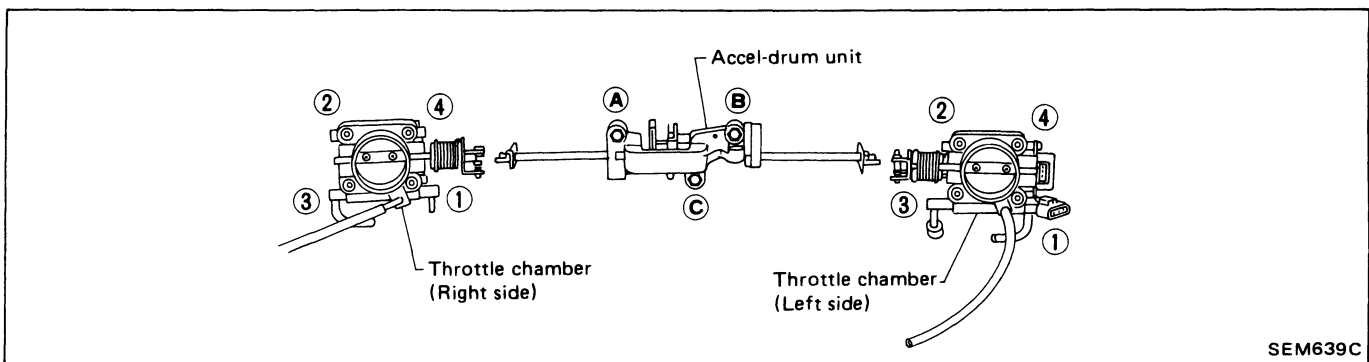

1. Install accel-drum unit and throttle chambers (right side and left side).

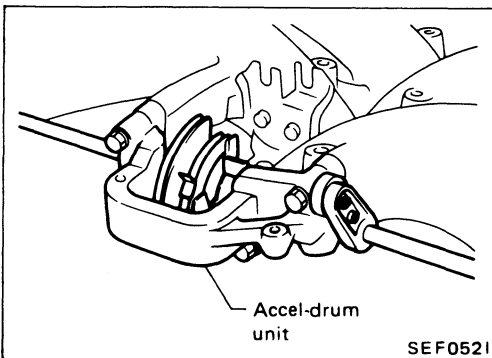

- When tightening bolts, free accel-drum unit so that drum unit is left under its own weight. Do not apply external force to accel-drum unit.
- When replacing throttle chambers only, you need not perform procedures (3), (4) and (5).

Tightening order:

- (1) ① → ② → ③ → ④:
9 - 11 N·m (0.9 - 1.1 kg-m, 6.5 - 8.0 ft-lb)
- (2) ① → ② → ③ → ④:
18 - 22 N·m (1.8 - 2.2 kg-m, 13 - 16 ft-lb)
- (3) A → B → C: Tighten by hand
- (4) A → B → C:
5 N·m (0.5 kg-m, 3.6 ft-lb)
- (5) A → B → C:
20 N·m (2.0 kg-m, 14 ft-lb)

THROTTLE CHAMBERS

Installation (Cont'd)

- Before installing each throttle chamber, confirm that stopper wire is installed in hole of rod pin. If not, install suitable wire.

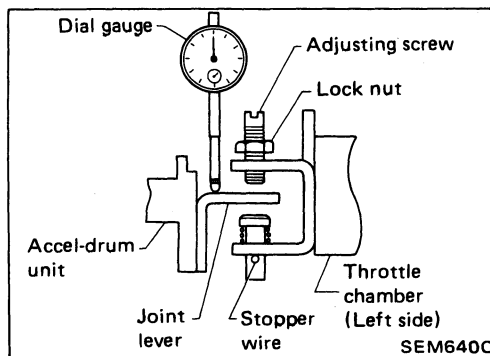
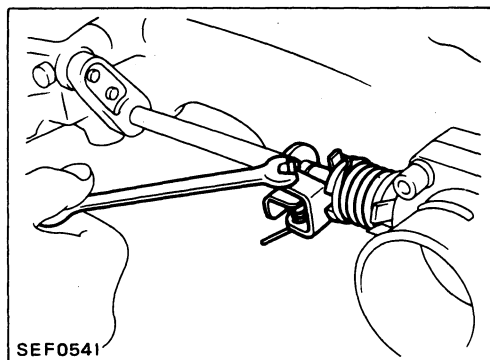
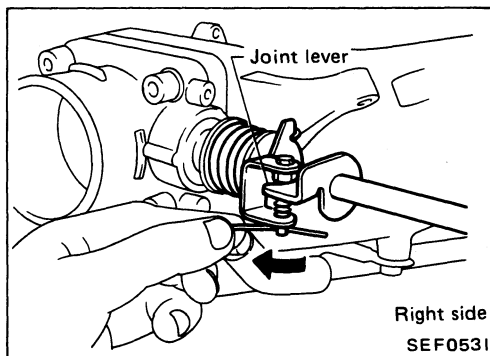
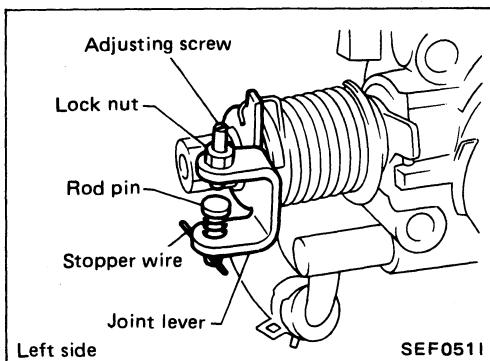
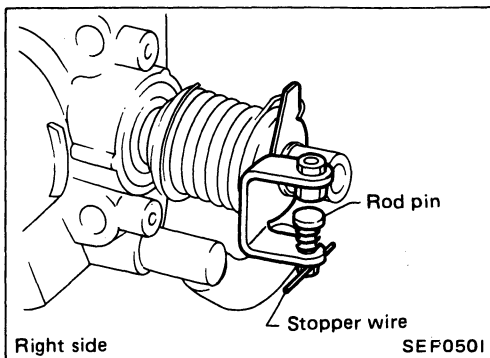

2. Pull out stopper wire of right side throttle chamber in order to secure right side joint lever.
3. Loosen left side throttle chamber lock nut and back-out adjusting screw until there is clearance between the screw and joint lever.
4. Set dial gauge on joint lever and set indicator to zero. Confirm that bottom end of adjusting screw is not in contact with joint lever of accelerator drum unit.

THROTTLE CHAMBERS

Installation (Cont'd)

5. Pull out left side throttle chamber stopper wire from rod pin.

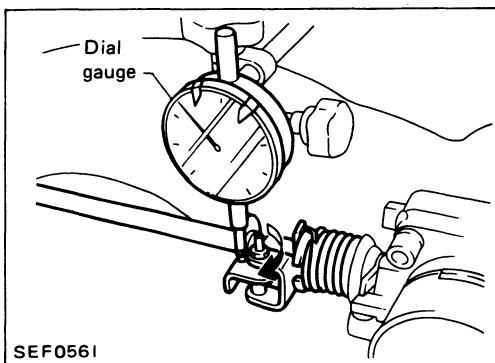
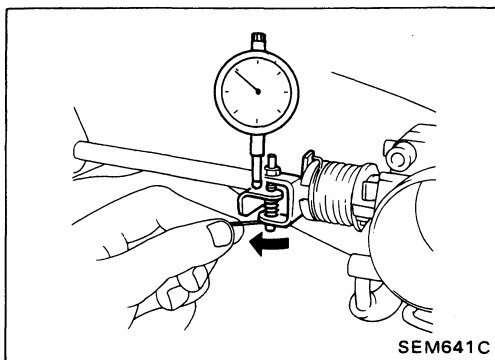

6. Turn adjusting screw until dial gauge indicator is within the following range.

Range: 0.07 - 0.13 mm (0.0028 - 0.0051 in)

Then tighten lock nut.

7. Confirm that the dial gauge indicator is still within the above range.

CYLINDER HEAD

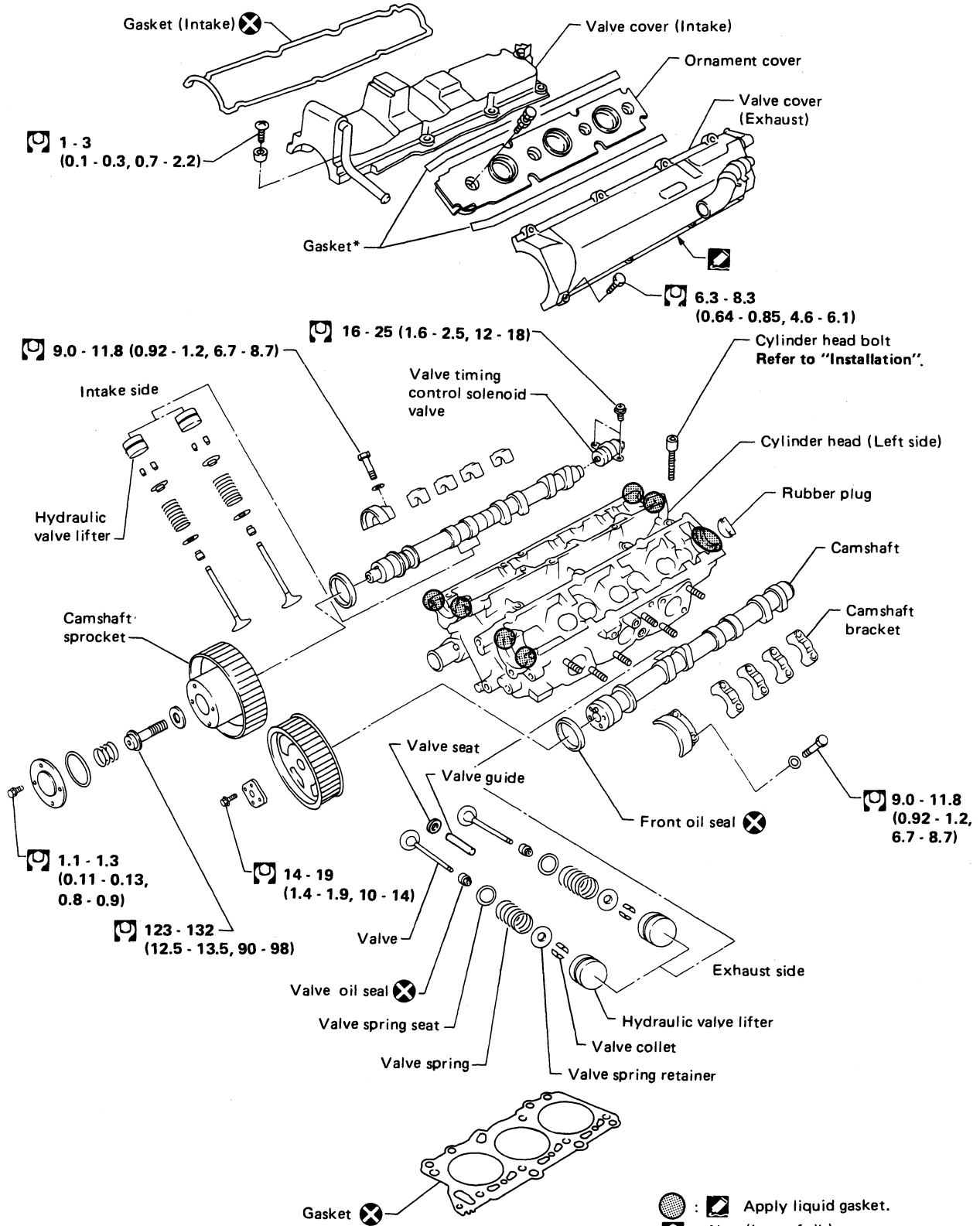

: Apply liquid gasket.
 : N·m (kg·m, ft·lb)
 * : After installing gasket, cut off any loose ends.

CYLINDER HEAD

CAUTION:

- When installing sliding parts such as camshaft, camshaft bracket and oil seal, be sure to apply new engine oil on their sliding surfaces.
- When tightening cylinder head bolts, intake camshaft sprocket bolts and camshaft bracket bolts, apply new engine oil to thread portions and seat surfaces of bolts.

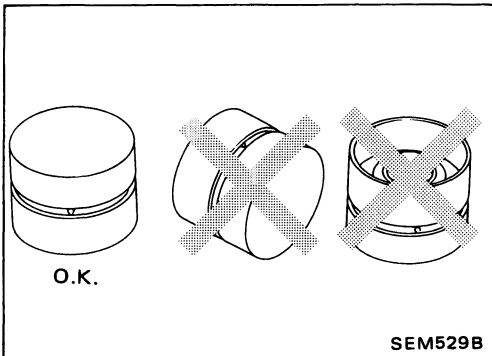

- Do not put hydraulic valve lifters upside down, otherwise air will enter valve lifter, causing it to make a noise.
- Do not disassemble hydraulic valve lifter.
- Attach tags to valve lifters so as not to mix them up.
- Valve lifters should be immersed in engine oil.

Removal

1. Remove intake manifold collector.

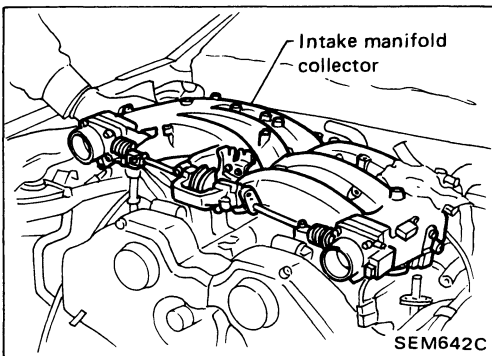

2. Remove injector pipe assembly.

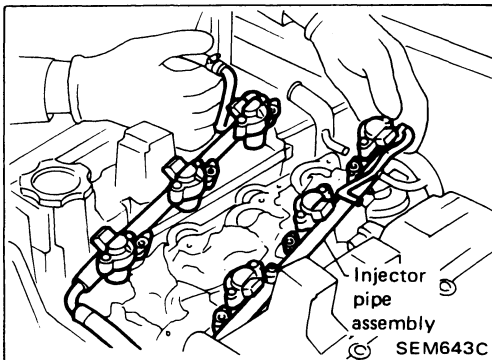

3. Remove valve covers.

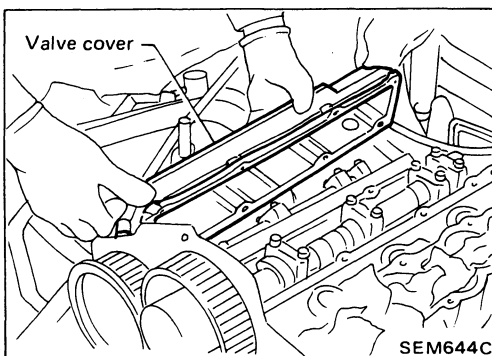

CYLINDER HEAD

Removal (Cont'd)

4. Remove timing belt.
Refer to "Removal" of TIMING BELT.
5. Remove idler pulley and its stud bolt.

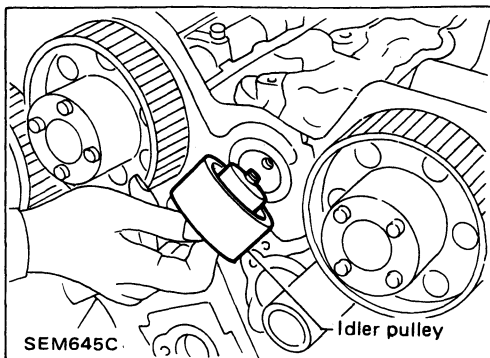

6. Remove intake manifold.

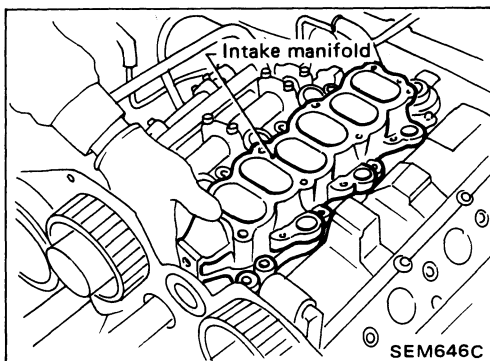

7. Disconnect front exhaust tube from exhaust manifold.
8. Remove cylinder head with exhaust manifold.
Cylinder head bolts should be loosened in two or three steps.

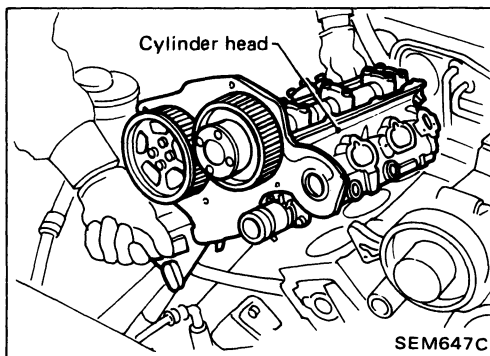

Disassembly

1. Remove exhaust manifold from cylinder head.
2. Remove camshaft sprockets.
3. Remove timing belt rear cover.

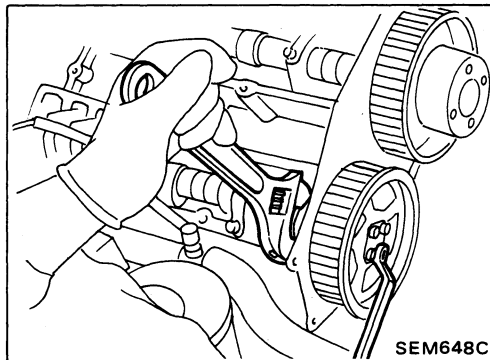

4. Remove camshaft brackets.
Bolts should be loosened in two or three steps.
Before removing camshaft, measure camshaft end play.
5. Remove oil seals, camshafts and hydraulic valve lifters.

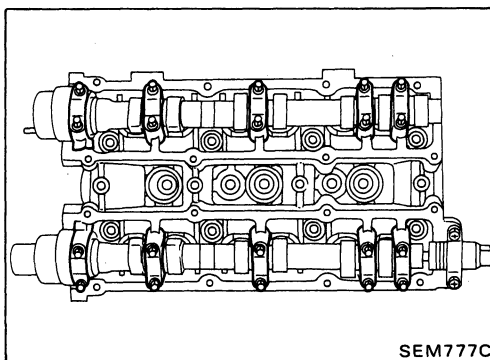

CYLINDER HEAD

Disassembly (Cont'd)

6. Remove valve springs with Tool or a suitable tool.

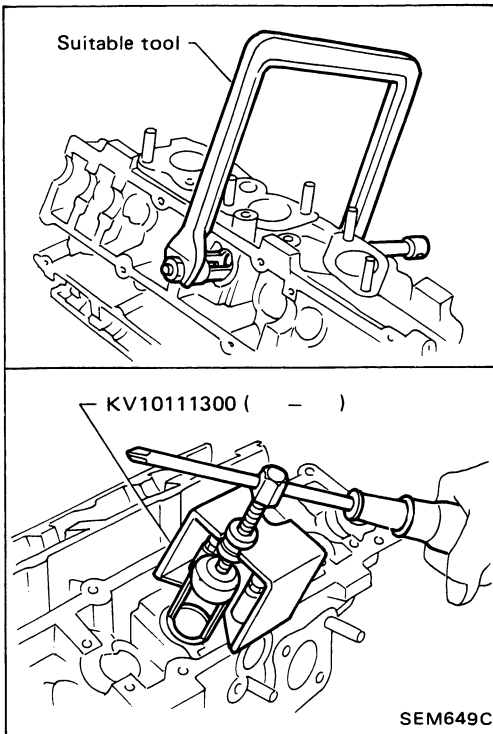

7. Pull out valve oil seals.

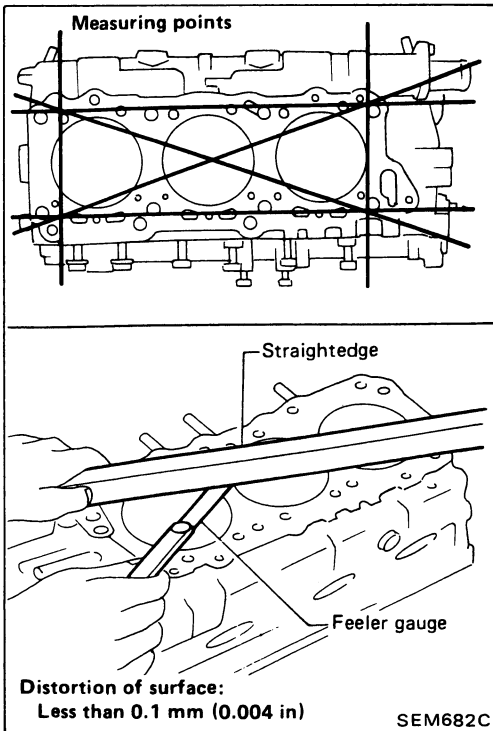

Inspection

CYLINDER HEAD DISTORTION

Head surface flatness:

Less than 0.1 mm (0.004 in)

If beyond the specified limit, replace it or resurface it.

Resurfacing limit:

The resurfacing limit of cylinder head is determined by the cylinder block resurfacing in an engine.

Amount of cylinder head resurfacing is "A".

Amount of cylinder block resurfacing is "B".

The maximum limit is as follows:

$A + B = 0.2 \text{ mm (0.008 in)}$

After resurfacing cylinder head, check to make sure that camshaft rotates freely by hand. If resistance is felt, cylinder head must be replaced.

Nominal cylinder head height from camshaft center:

Refer to S.D.S.

CYLINDER HEAD

Inspection (Cont'd)

CAMSHAFT VISUAL CHECK

Check camshaft for scratches, seizure and wear.

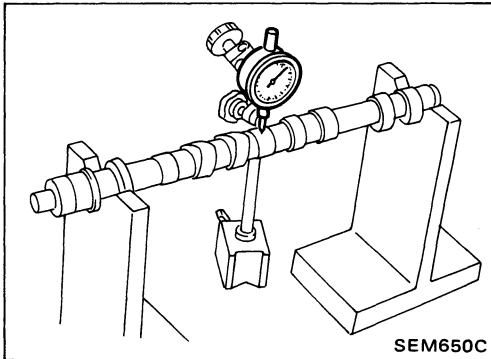

CAMSHAFT RUNOUT

1. Measure camshaft runout at the center journal.

Runout (Total indicator reading):

Limit 0.1 mm (0.004 in)

2. If it exceeds the limit, replace camshaft.

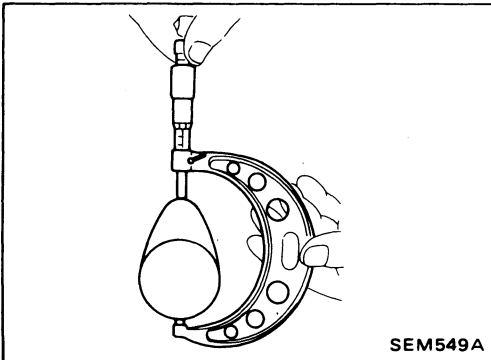

CAMSHAFT CAM HEIGHT

1. Measure camshaft cam height.

Standard cam height:

40.405 - 40.595 mm (1.5907 - 1.5982 in)

Cam wear limit:

0.15 mm (0.0059 in)

2. If wear is beyond the limit, replace camshaft.

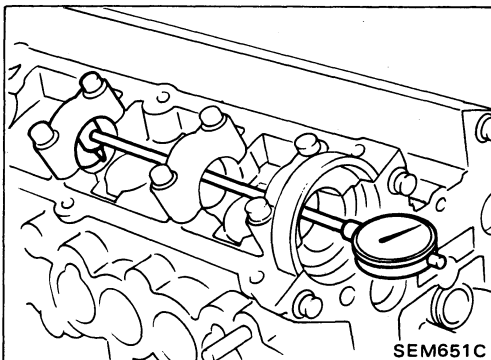

CAMSHAFT JOURNAL CLEARANCE

1. Install camshaft bracket and tighten bolts to the specified torque.

2. Measure inner diameter of camshaft bearing.

Standard inner diameter:

28.000 - 28.021 mm (1.1024 - 1.1032 in)

3. Measure outer diameter of camshaft journal.

Standard outer diameter:

27.935 - 27.955 mm (1.0998 - 1.1006 in)

4. If clearance exceeds the limit, replace camshaft and/or cylinder head.

Camshaft journal clearance limit:

0.15 mm (0.0059 in)

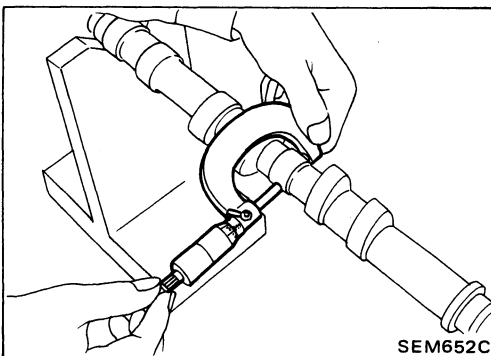

CYLINDER HEAD

Inspection (Cont'd)

CAMSHAFT END PLAY

1. Install camshaft in cylinder head.
2. Measure camshaft end play.

Camshaft end play:

Standard

0.03 - 0.08 mm (0.0012 - 0.0031 in)

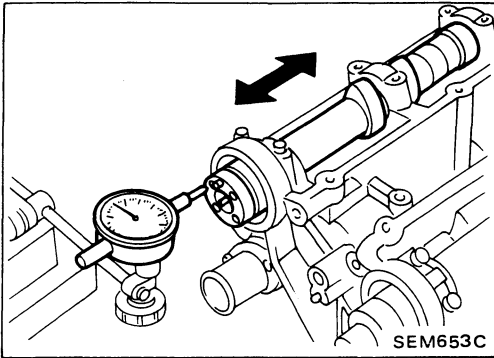

VALVE GUIDE CLEARANCE

1. Push valve stem out so that its end is even with valve guide height. Measure valve runout by moving valve.

Valve deflection limit (Dial gauge reading):

0.2 mm (0.008 in)

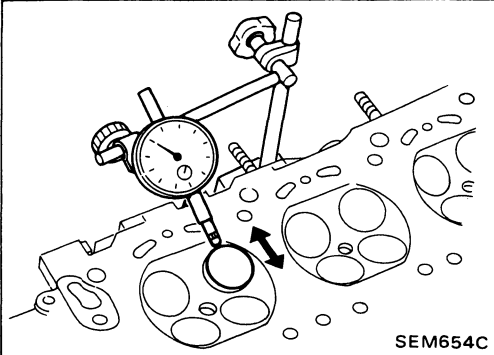

2. If it exceeds the limit, check valve to valve guide clearance.
 - a. Measure valve stem diameter and valve guide inner diameter.
 - b. Check that clearance is within specification.

Valve to valve guide clearance limit:

0.10 mm (0.0039 in)

- c. If it exceeds the limit, replace valve or valve guide.

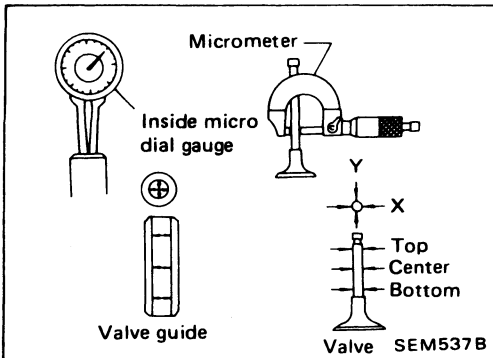

VALVE GUIDE REPLACEMENT

1. To remove valve guide, heat cylinder head to 150 to 160°C (302 to 320°F).

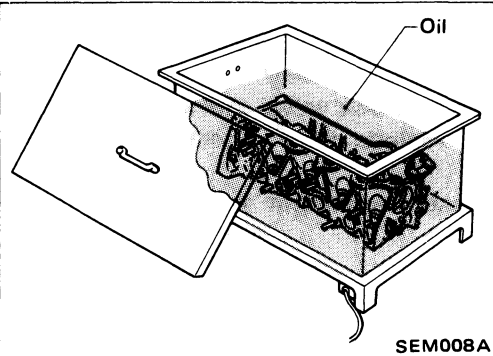

2. Drive out valve guide with a press [under a 20 kN (2 t, 2.2 US ton, 2.0 Imp ton) pressure] or hammer and suitable tool.

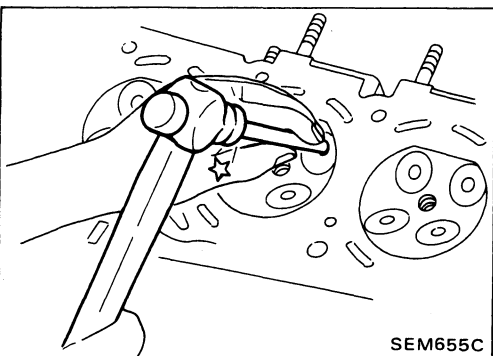

CYLINDER HEAD

Inspection (Cont'd)

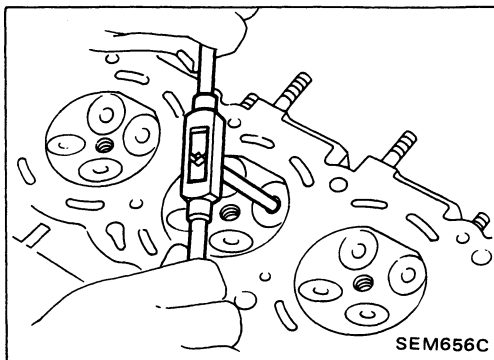

3. Ream cylinder head valve guide hole.

**Valve guide hole diameter
(for service parts):**

Intake and Exhaust

10.175 - 10.196 mm (0.4006 - 0.4014 in)

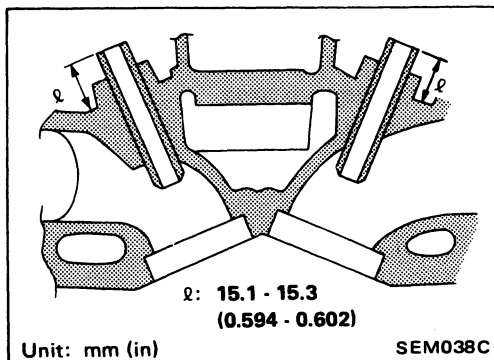

4. Heat cylinder head to 150 to 160°C (302 to 320°F) and press service valve guide onto cylinder head.

Projection "ℓ":

15.1 - 15.3 mm (0.594 - 0.602 in)

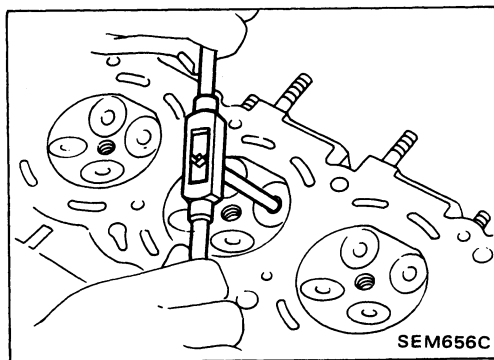

5. Ream valve guide.

Finished size:

Intake and Exhaust

6.000 - 6.018 mm (0.2362 - 0.2369 in)

VALVE SEATS

Check valve seats for evidence of pitting at valve contact surface, and reseat or replace if it is worn excessively.

- **Before repairing valve seats, check valve and valve guide for wear. If they have worn, replace them. Then correct valve seat.**
- **Cut with both hands to assure a uniform surface.**

CYLINDER HEAD

Inspection (Cont'd)

REPLACING VALVE SEAT FOR SERVICE PARTS

1. Bore out old seat until it collapses. The machine depth stop should be set so that boring cannot continue beyond the bottom face of the seat recess in cylinder head.
2. Ream cylinder head recess.

Reaming bore for service valve seat

Oversize [0.5 mm (0.020 in)]:

Intake

36.500 - 36.516 mm (1.4370 - 1.4376 in)

Exhaust

32.000 - 32.016 mm (1.2598 - 1.2605 in)

Reaming should be done to the concentric circles to valve guide center so that valve seat will have the correct fit.

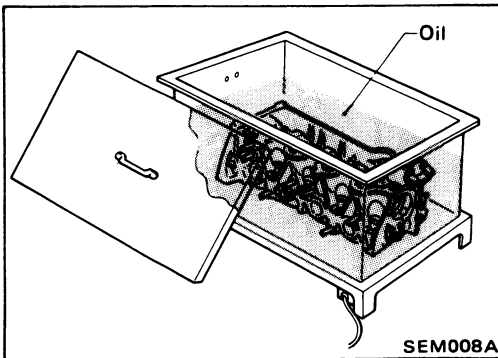
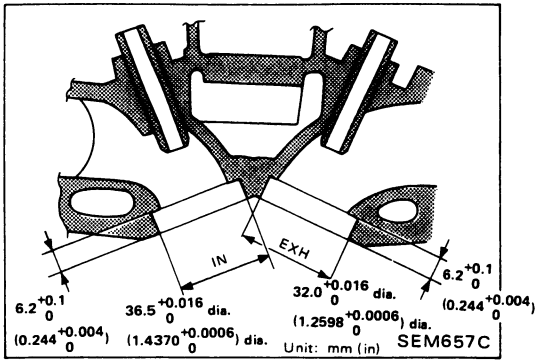

3. Heat cylinder head to 150 to 160°C (302 to 320°F).
4. Press fit valve seat until it seats on the bottom.

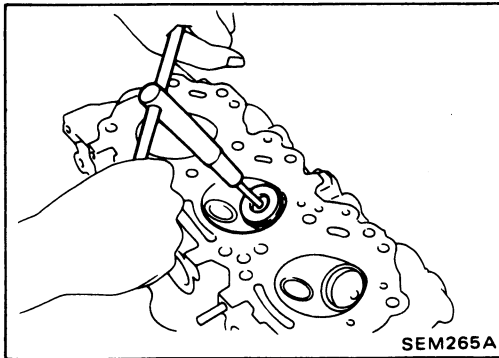

5. Cut or grind valve seat using suitable tool at the specified dimensions as shown in S.D.S.
6. After cutting, lap valve seat with abrasive compound.
7. Check valve seat contact condition.

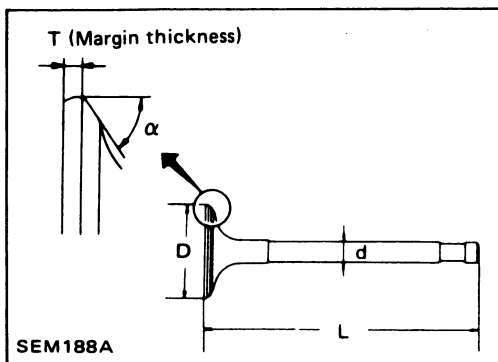

VALVE DIMENSIONS

Check dimensions in each valve. For dimensions, refer to S.D.S. When valve head has been worn down to 0.5 mm (0.020 in) in margin thickness, replace valve.

Grinding allowance for valve stem tip is 0.2 mm (0.008 in) or less.

CYLINDER HEAD

Inspection (Cont'd)

VALVE SPRING

Squareness

1. Measure "S" dimension.

Out-of-square:

Less than 1.8 mm (0.071 in)

2. If it exceeds the limit, replace spring.

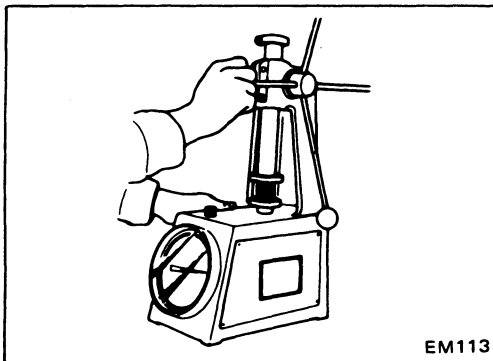
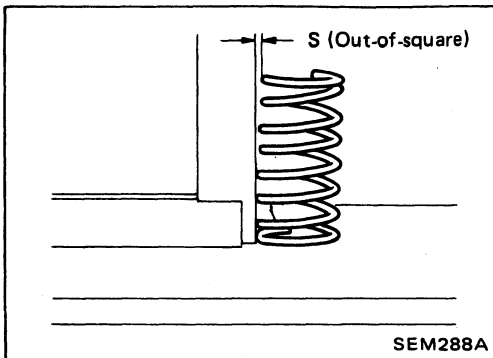

Pressure

Check valve spring pressure.

Pressure: N (kg, lb) at height mm (in)

Standard

536.4 (54.7, 120.6) at 26.5 (1.043)

Limit

More than 452.79 (46.17, 101.80) at 26.5 (1.043)

If it exceeds the limit, replace spring.

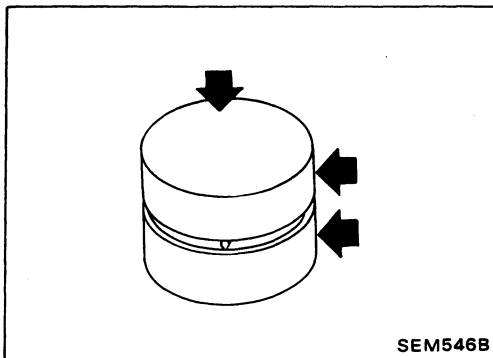

HYDRAULIC VALVE LIFTER

1. Check contact and sliding surfaces for wear or scratches.

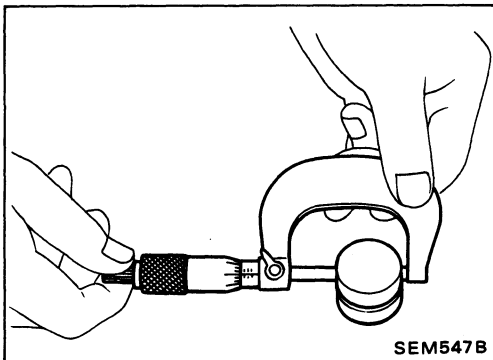

2. Check diameter of valve lifter.

Outer diameter:

30.955 - 30.965 mm (1.2187 - 1.2191 in)

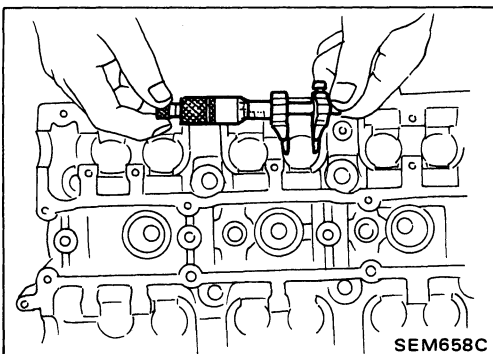

3. Check valve lifter guide inner diameter.

Inner diameter:

31.000 - 31.020 mm (1.2205 - 1.2213 in)

Standard clearance between valve lifter and lifter guide:

0.035 - 0.065 mm (0.0014 - 0.0026 in)

CYLINDER HEAD

Assembly

1. Install valve component parts.

- Always use new valve oil seal. (Refer to OIL SEAL REPLACEMENT.)
- Install valve spring (uneven pitch type) with its narrow pitch side (painted side) toward cylinder head side.

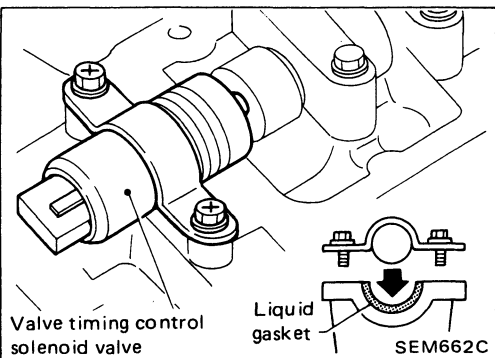
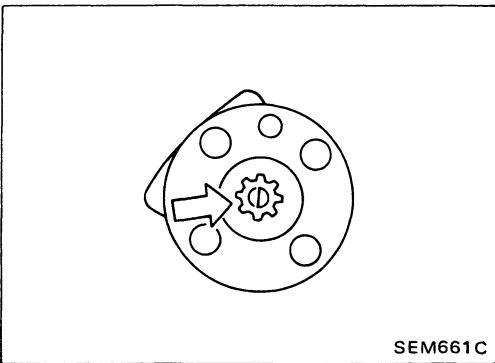
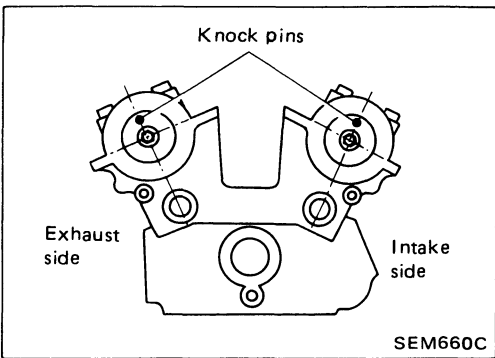
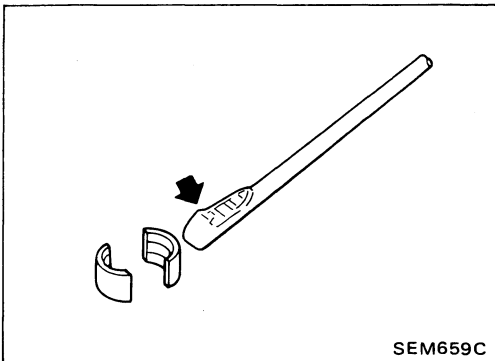
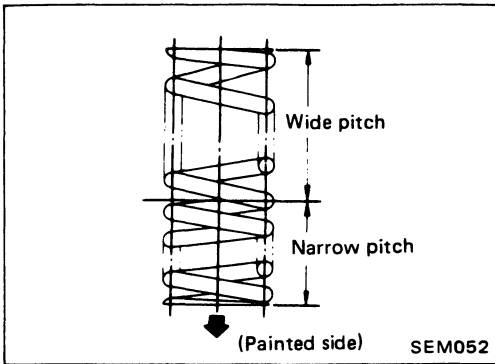

- To facilitate installation of collet, apply a small amount of grease to a piece of wire or a pencil and attach collet to wire or pencil, as shown.

2. Install camshafts as shown.

- Exhaust camshaft (left side) has spline for crank angle sensor.

- When installing valve timing control solenoid valves, apply liquid gasket to solenoid valve surfaces.

CYLINDER HEAD

Assembly (Cont'd)

3. Install camshaft brackets.

Tighten camshaft bracket bolts gradually in two or three stages.

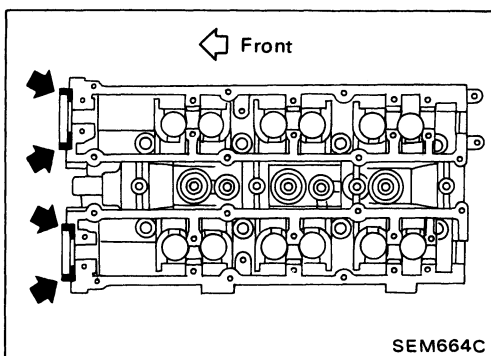
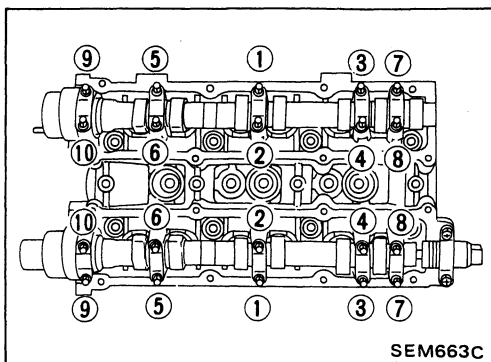

When installing front side camshaft brackets, apply liquid gasket as shown.

4. Apply engine oil to camshaft oil seal lip and install it in place.

Always use new camshaft oil seal.

5. Install rear timing belt cover.

6. Install camshaft sprockets.

When tightening bolts, fix camshaft to prevent it from rotating.

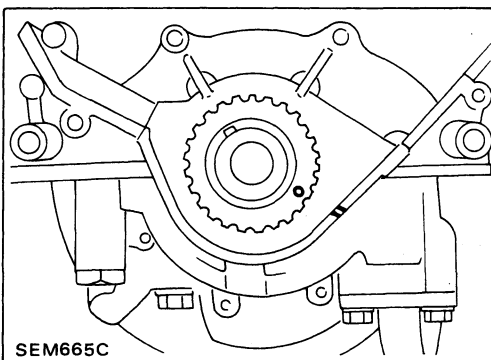

Installation

1. Set No. 1 piston at T.D.C. on its compression stroke as follows:

(1) Align crankshaft sprocket aligning mark with mark on oil pump body.

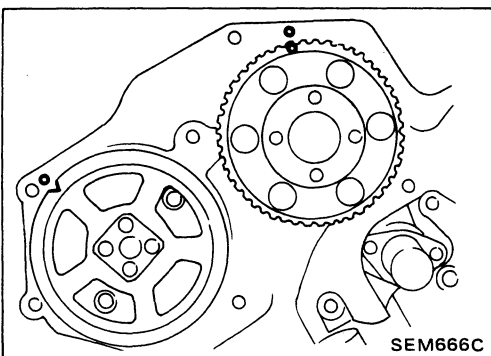

(2) Align camshaft sprocket aligning mark with mark on timing belt rear cover.

CYLINDER HEAD

Installation (Cont'd)

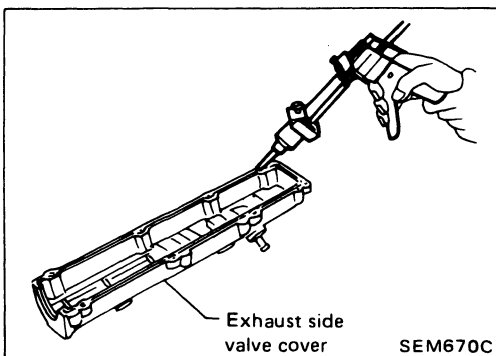
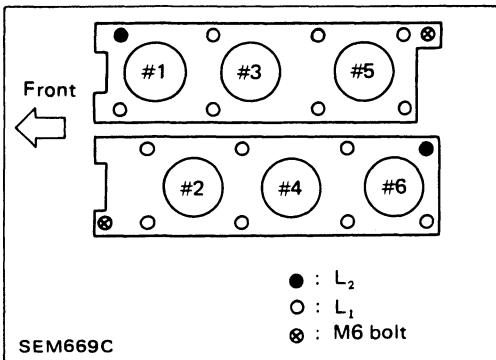
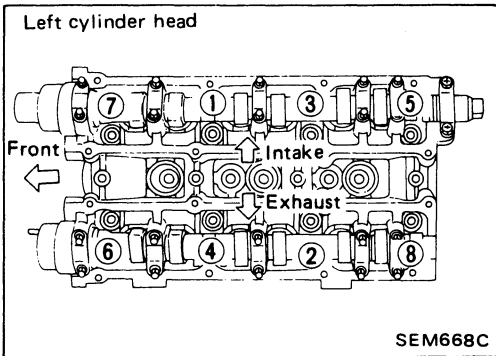
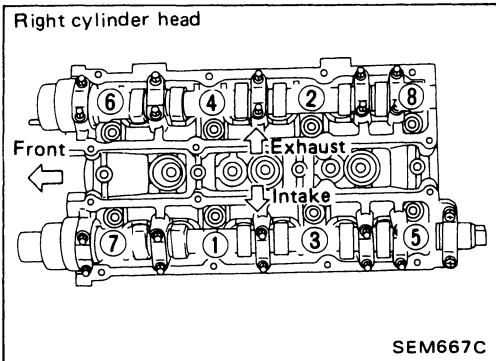
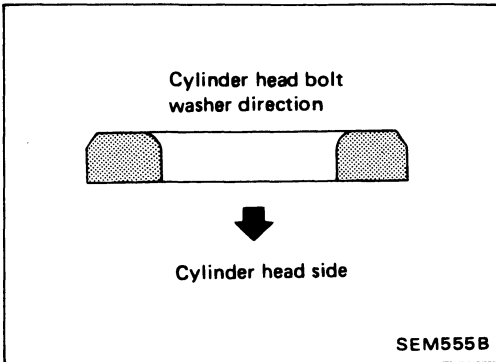

2. Install cylinder head with new gasket.
 - Be sure to install washers between bolts and cylinder head.
 - Do not rotate crankshaft and camshaft separately, or valves will hit piston heads.
3. Install cylinder head bolts.
 - Install short bolts (L₂) into the correct holes of cylinders #1 and #6 as shown in figure of step (6).

4. Tighten cylinder head bolts in numerical order.
 - Tightening procedure
 - (1) Tighten all bolts to 39 N·m (4.0 kg-m, 29 ft-lb).
 - (2) Tighten all bolts to 123 N·m (12.5 kg-m, 90 ft-lb).
 - (3) Loosen all bolts completely.
 - (4) Tighten all bolts to 34 to 44 N·m (3.5 to 4.5 kg-m, 25 to 33 ft-lb).
 - (5) Tighten all bolts to 123 N·m (12.5 kg-m, 90 ft-lb) or if an angle wrench is available, tighten bolts 70 to 75 degrees (L₁), 65 to 70 degrees (L₂) clockwise.

- (6) Tighten bolts (⊗) as shown to 10 to 12 N·m (1.0 to 1.2 kg-m, 7 to 9 ft-lb).

5. Install valve covers.
 - When installing exhaust side valve covers, apply liquid gasket as shown.
6. Install remaining parts.

TURBOCHARGERS

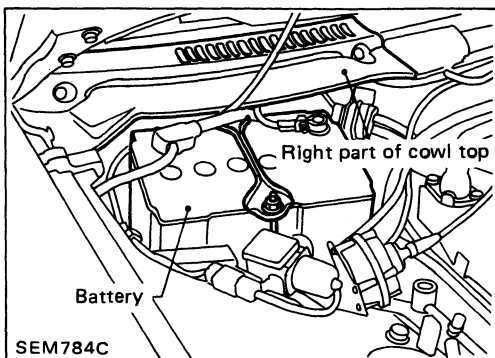

Removal

RIGHT SIDE UNIT

1. Remove right part of cowl top.
2. Remove battery.

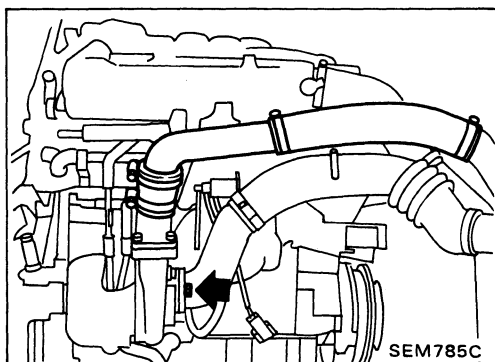

3. Remove air inlet hose and pipe.
4. Disconnect lower pipe from turbocharger unit.

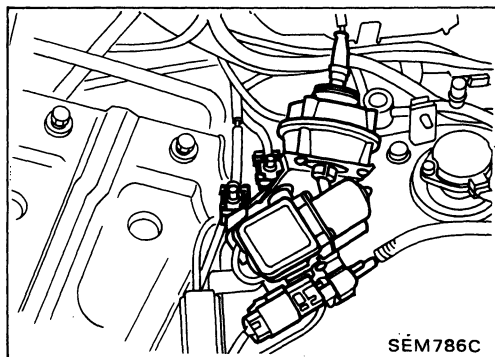

5. Remove A.S.C.D. bracket with wiper motor and solenoid valves.
6. Disconnect exhaust gas sensor harness connector.

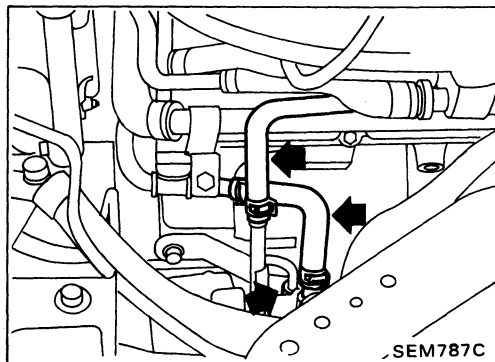

7. Remove turbocharger water hoses, and disconnect turbocharger oil inlet tube.
8. Remove two bolts fastening pre-catalyst to turbocharger unit.

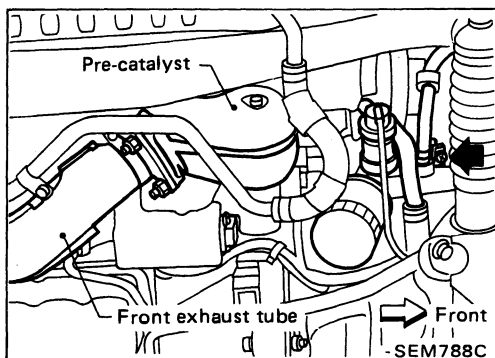

9. Remove the following parts;
 - oil pressure switch,
 - oil filter,
 - turbocharger oil return tube,
 - front exhaust tube,
 - pre-catalyst
10. Disconnect oil hose from oil filter bracket, and turbocharger water tubes from turbocharger unit.

TURBOCHARGERS

Removal (Cont'd)

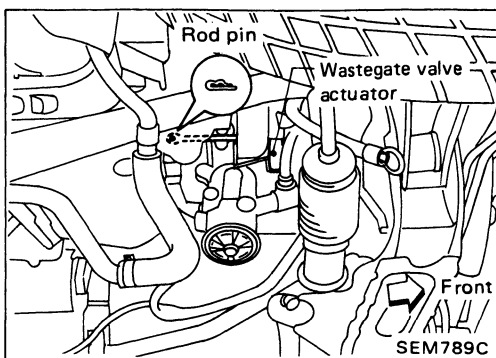

11. Remove rod pin of wastegate valve actuator.
12. Remove oil filter bracket.

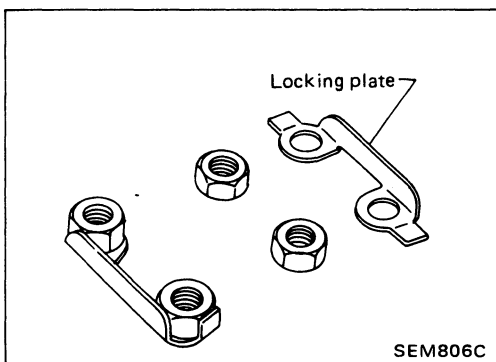

13. Unbend locking plates for fastening nuts of turbocharger unit.
14. Remove turbocharger unit.

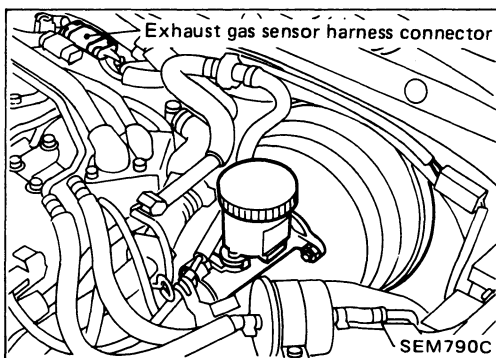

LEFT SIDE UNIT

1. Remove brake master cylinder and brake booster.
2. Disconnect exhaust gas sensor harness connector.

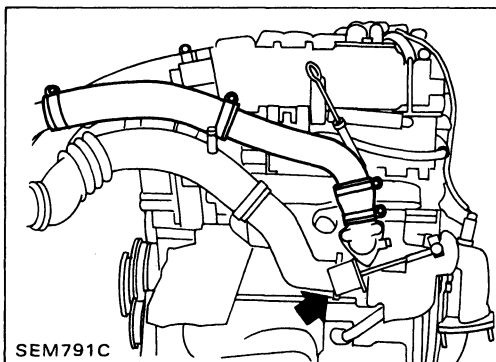

3. Remove air inlet hose and pipe.
4. Disconnect lower pipe from turbocharger unit.

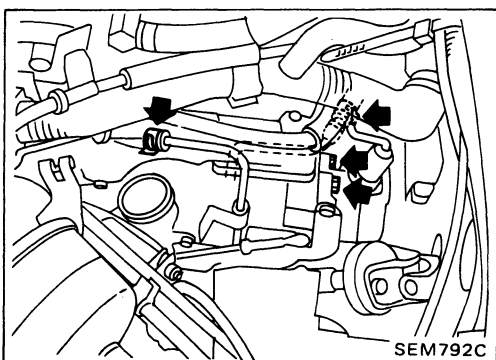

5. Disconnect water tubes.
6. Remove two bolts fastening pre-catalyst to turbocharger unit.

TURBOCHARGERS

Removal (Cont'd)

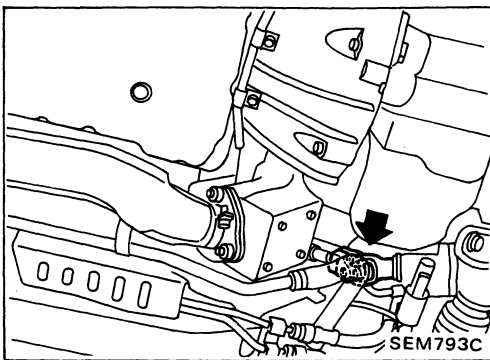

7. Remove front exhaust tube and pre-catalyst.
8. Disconnect steering lower joint.

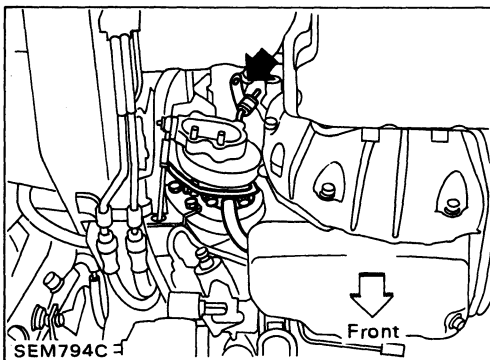

9. Remove turbocharger oil return tube and water tubes.
10. Disconnect E.G.R. tube and actuator bracket of turbocharger wastegate valve.

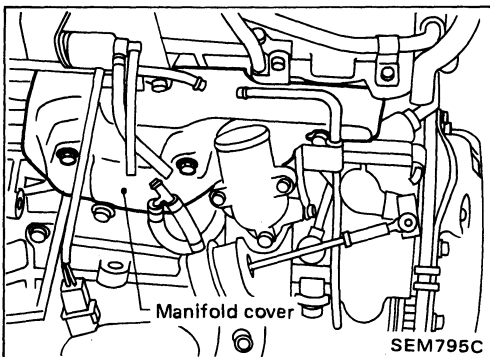

11. Remove manifold cover and fastening nuts.
12. Remove turbocharger unit with exhaust manifold.

Inspection

Proceed the following checks. If N.G., replace turbocharger unit.

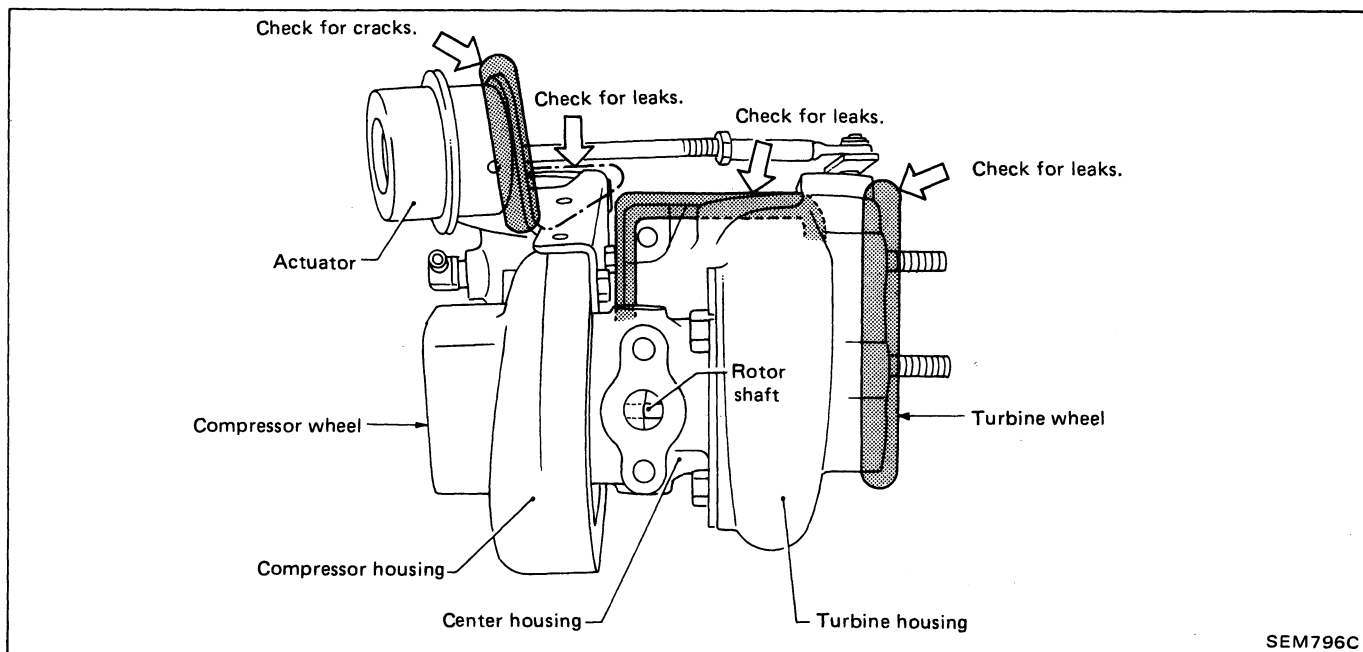

TURBOCHARGERS

Inspection (Cont'd) OIL AND WATER TUBES

Check tubes for clogging.

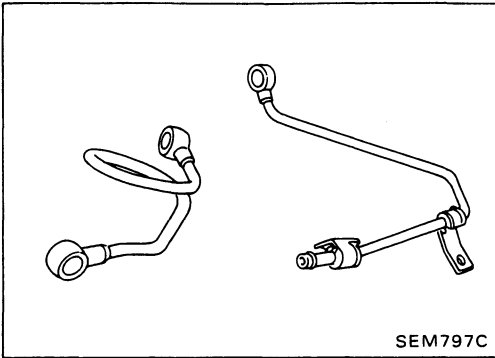

SEM797C

ROTOR SHAFT

1. Check rotor shaft for smooth rotating.

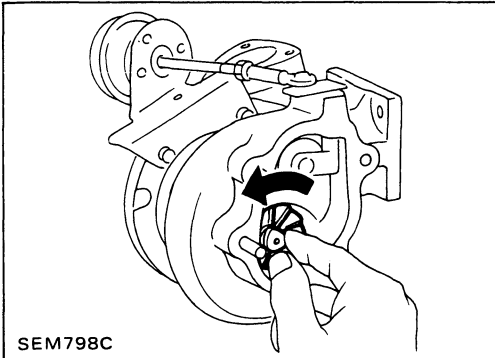

SEM798C

2. Check rotor shaft for carbon deposits.

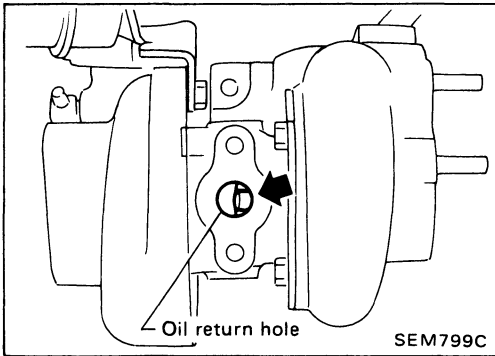

SEM799C

3. Measure runout of rotor shaft.

Runout (Total indicator reading):
0.056 - 0.127 mm (0.0022 - 0.0050 in)

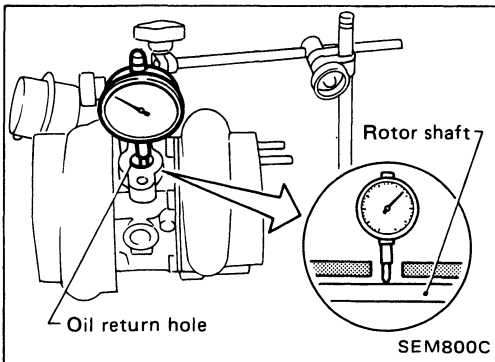

SEM800C

4. Measure end play of rotor shaft.

End play:
0.013 - 0.096 mm (0.0005 - 0.0038 in)

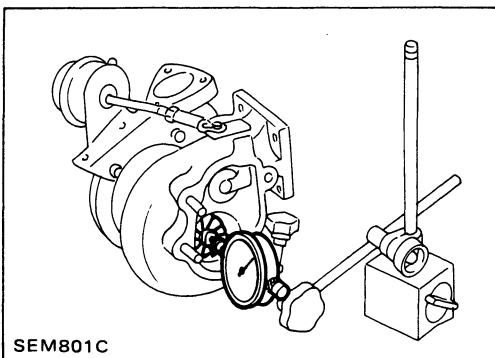

SEM801C

TURBOCHARGERS

Inspection (Cont'd) TURBINE WHEEL

Check turbine wheel for the following:

- Oil
- Carbon deposits
- Deformed fins
- Contact with turbine housing

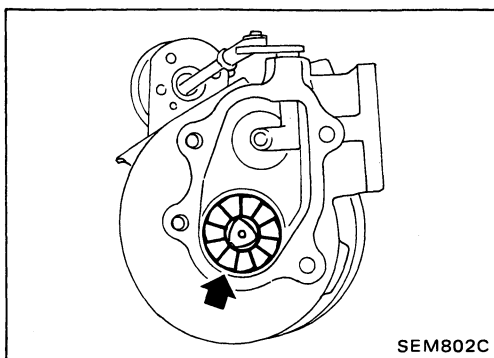

COMPRESSOR WHEEL

Check compressor wheel for the following:

- Oil
- Deformed fins
- Contact with compressor housing

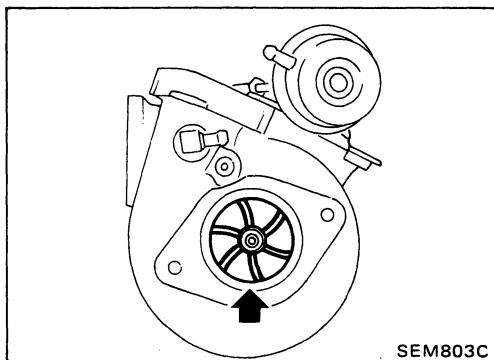

WASTEGATE VALVE

Remove rod pin and check wastegate valve for cracks, deformation and smooth movement.

Check valve seat surface for smoothness.

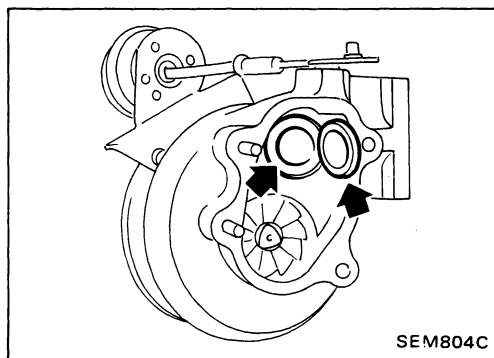

WASTEGATE VALVE ACTUATOR

Apply air pressure to wastegate valve actuator and check it for smooth movement.

- Do not keep applying air pressure to the actuator.
- The air pressure should be in the range of 78 to 88 kPa (0.8 to 0.9 kg/cm², 11 to 13 psi).

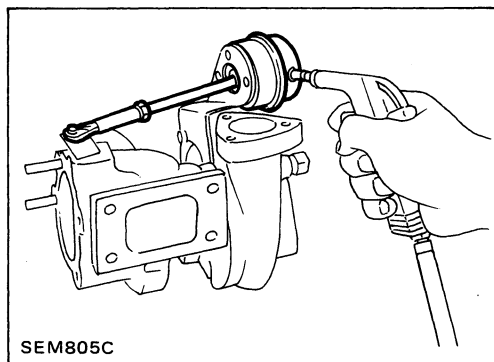

INTERCOOLERS

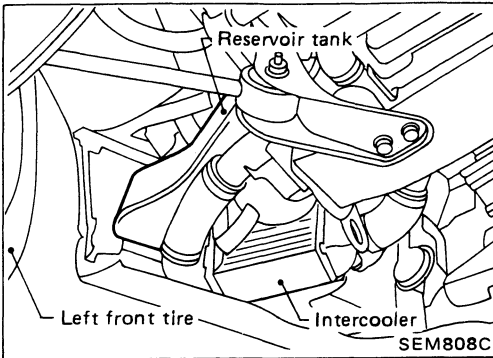

Removal

1. Remove front part of front fender protector.
2. Remove reservoir tank (left intercooler service only).

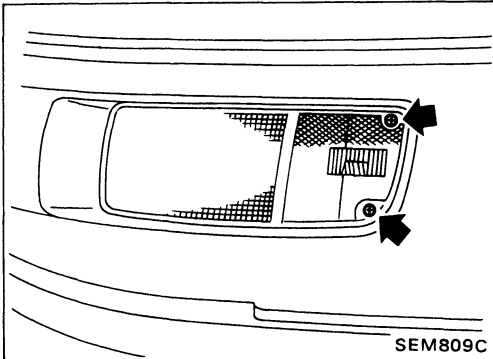

3. Remove front combination lamp.

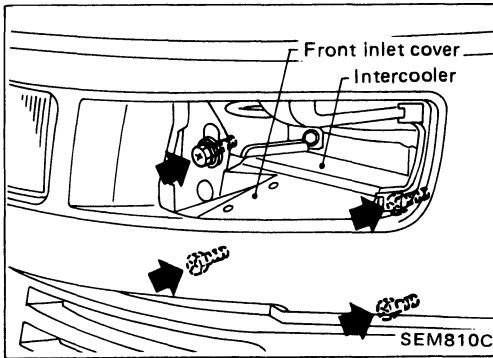

4. Remove bolts fastening intercooler and front inlet cover.

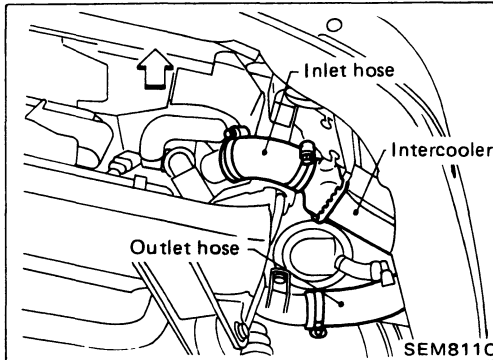

5. Remove inlet and outlet hoses.
6. Remove intercooler unit.

ENGINE REMOVAL

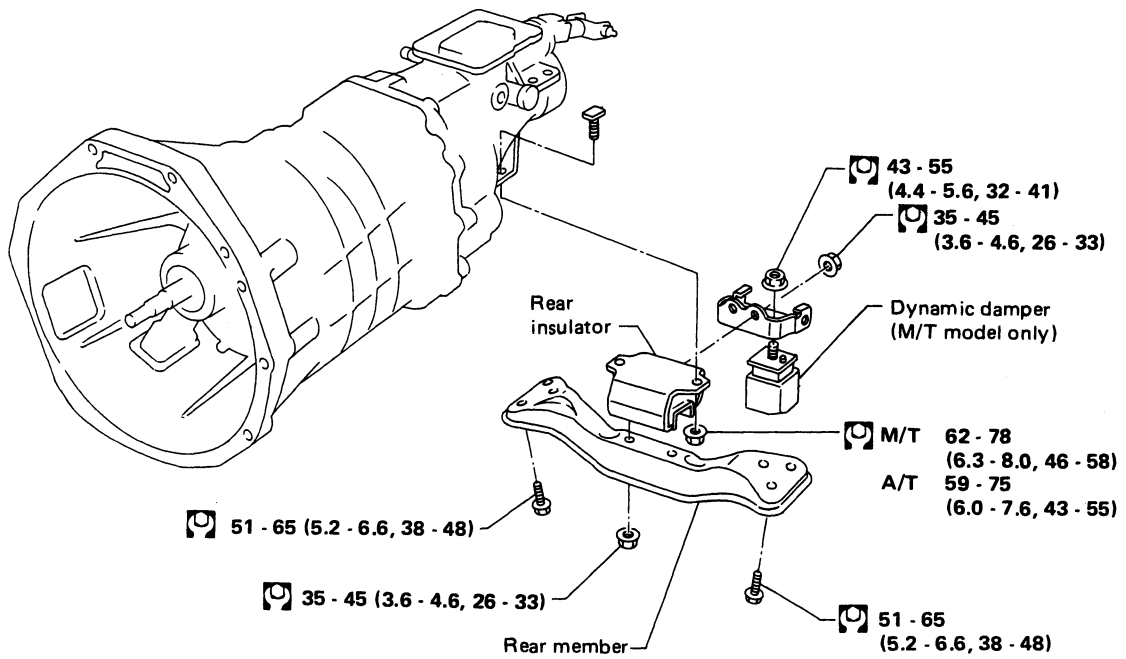
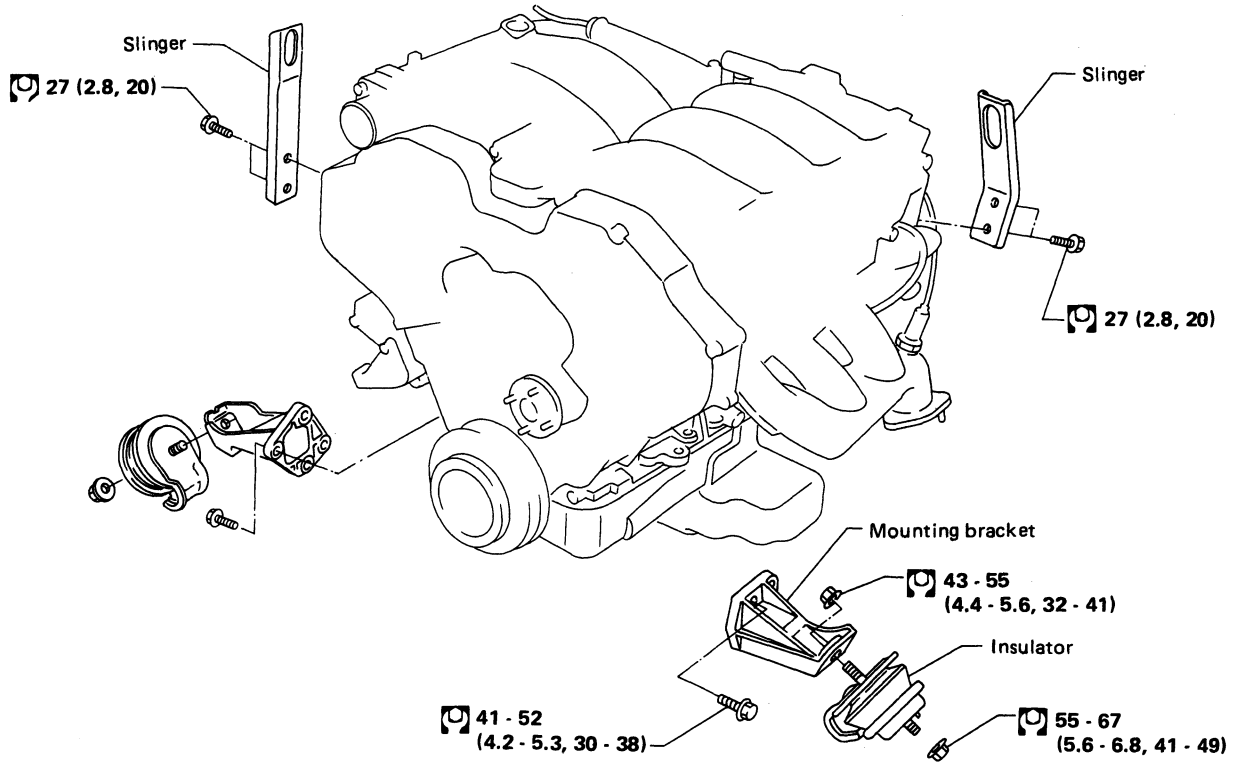

: N·m (kg-m, ft-lb)

SEM621C

ENGINE REMOVAL

WARNING:

- a. Situate vehicle on a flat and solid surface.
- b. Place chocks at front and back of rear wheels.
- c. Do not remove engine until exhaust system has completely cooled off. Otherwise, you may burn yourself and/or fire may break out in fuel line.
- d. For safety during subsequent steps, the tension of wires should be slackened against the engine.
- e. Before disconnecting fuel hose, release fuel pressure from fuel line.
Refer to "Releasing Fuel Pressure" in section EF & EC.
- f. Be sure to hoist engine and transmission in a safe manner.
- g. For engines not equipped with engine slingers, attach proper slingers and bolts described in PARTS CATALOG.

CAUTION:

- When lifting engine, be careful not to strike adjacent parts, especially accelerator wire casing, brake lines, and brake master cylinder.
- In hoisting the engine, always use engine slingers in a safe manner.

M/T model

1. Remove engine under cover and hood.
2. Drain coolant from both cylinder block drain plugs, and radiator drain cock.
3. Drain engine oil from drain plug of oil pan.
4. Remove vacuum hoses, fuel tubes, wires, harnesses and connectors and so on.
5. Remove front exhaust tubes and propeller shaft.
6. Remove radiator.
7. Remove drive belts, cooling fan and coupling.
8. Remove P/S oil pump, alternator, A/C pump from engine, and starter motor, and clutch operating cylinder.

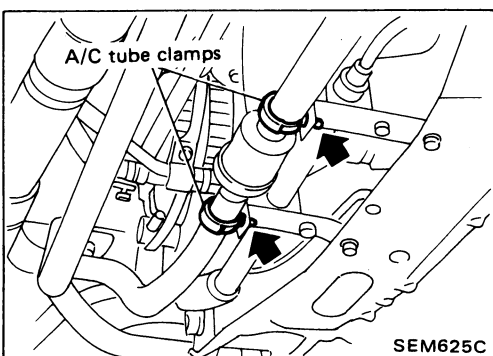
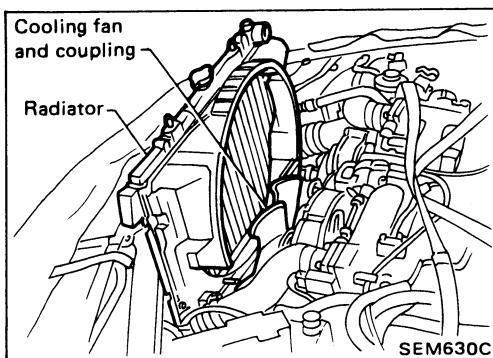

9. Disconnect A/C tube clamps as shown.

ENGINE REMOVAL

M/T model (Cont'd)

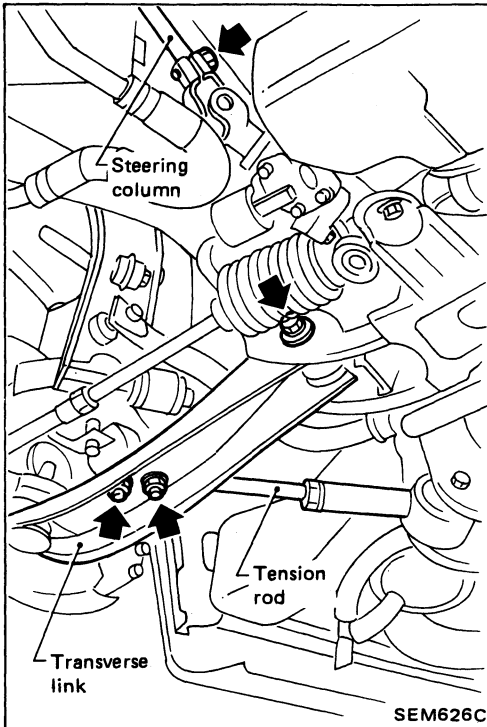

10. Disconnect steering column lower joint.
11. Remove tension rod fixing bolts from both sides.
12. Loosen transverse link bolts on both sides.

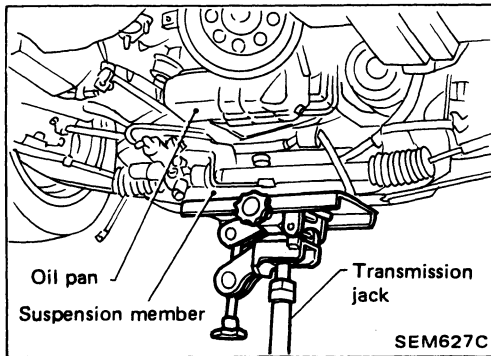

13. Set a suitable transmission jack under suspension member.
 - At this time, hoist engine with engine slinger.
14. Remove suspension member fixing bolts.
15. Remove engine mounting bolts from both sides and then slowly lower transmission jack.

ENGINE REMOVAL

M/T model (Cont'd)

16. Remove engine with transmission as shown.

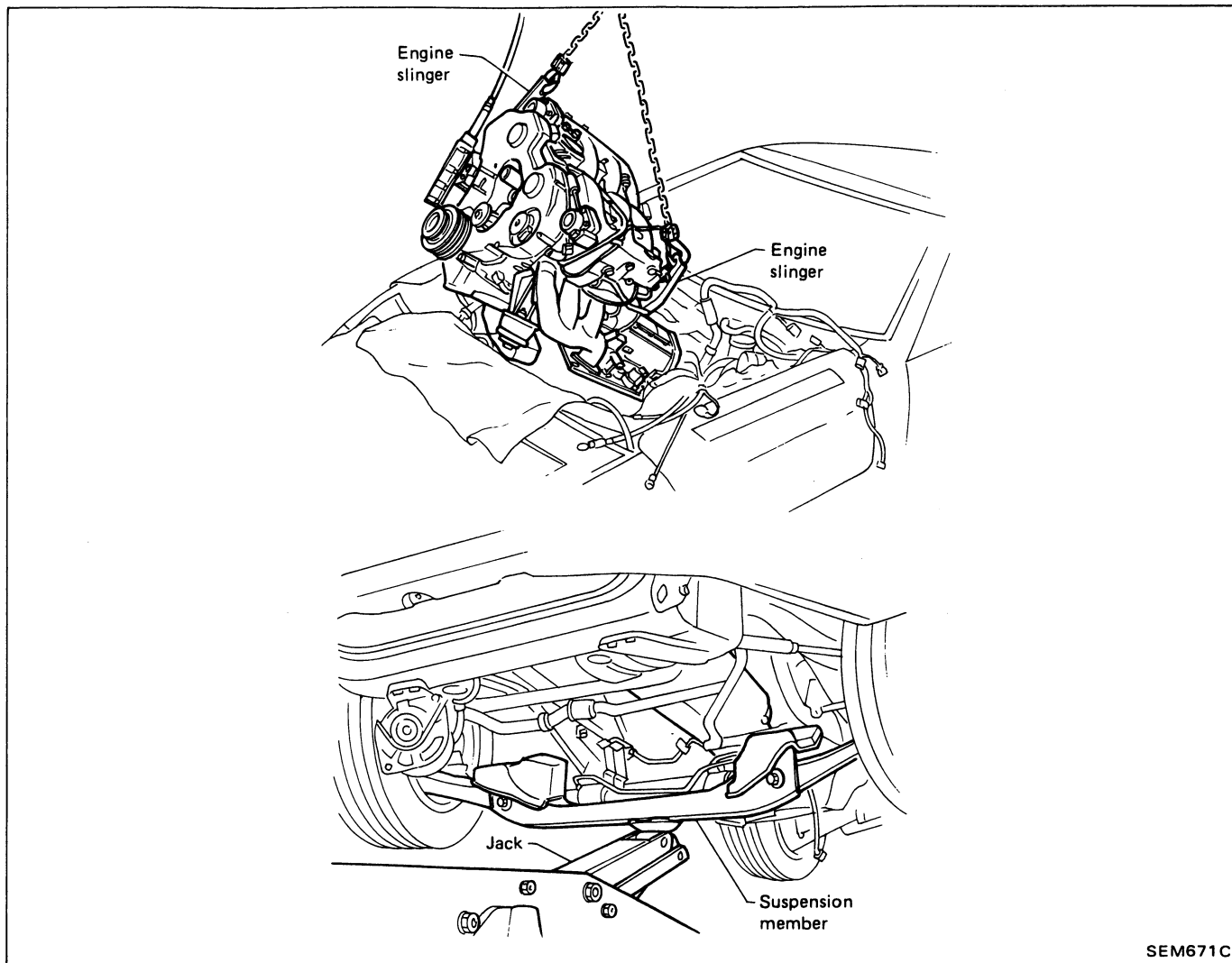

SEM671C

A/T model

1. Perform the same procedures (1 to 8) as for M/T model.
2. Remove transmission from vehicle.

Refer to AT section.

3. Hoist engine with engine slingers and remove engine mounting bolts from both sides.

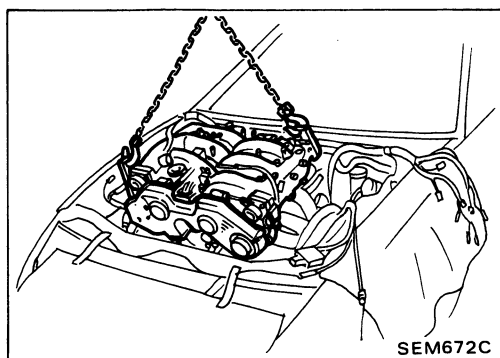

SEM672C

4. Remove engine from vehicle as shown.

CYLINDER BLOCK

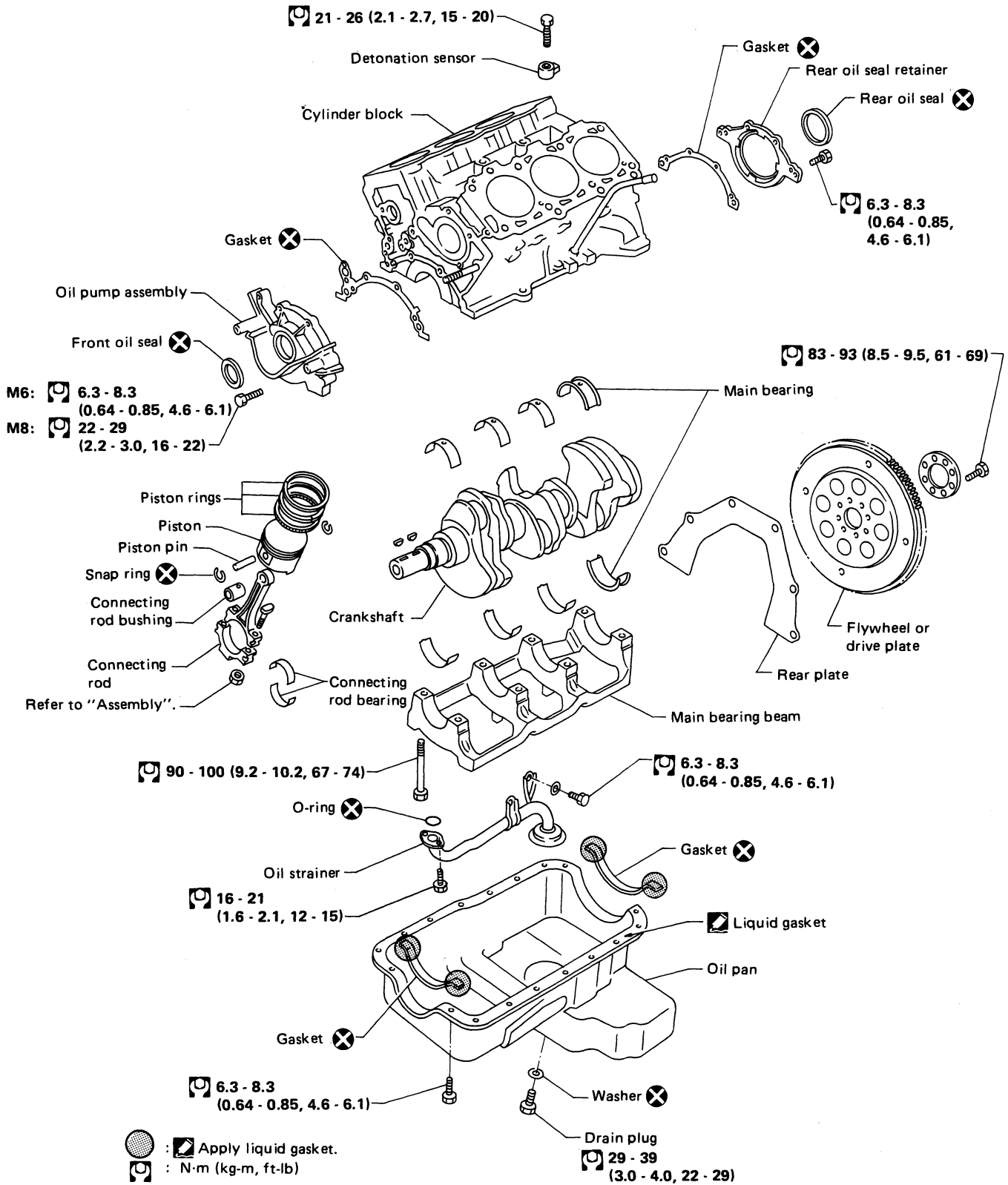

CYLINDER BLOCK

CAUTION:

- When installing sliding parts such as bearings and pistons, be sure to apply engine oil on the sliding surfaces.
- Place removed parts such as bearings and bearing caps in their proper order and direction.
- When tightening connecting rod bolts and main bearing cap bolts, apply engine oil to thread portion of bolts and seating surface of nuts.

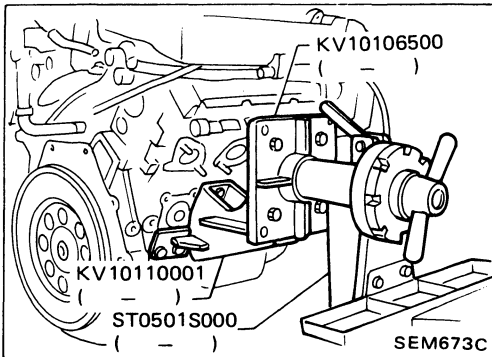

Disassembly

PISTON AND CRANKSHAFT

1. Place engine on a work stand.
2. Remove timing belt.
3. Drain coolant and remove water pump.
4. Drain oil.
5. Remove oil pan, oil pump and rear oil seal retainer.
6. Remove intake manifold collector, intake manifold and cylinder head.
7. Remove pistons.
 - When disassembling piston and connecting rod, remove snap ring first, then heat piston to 60 to 70°C (140 to 158°F) or use piston pin press stand at room temperature.

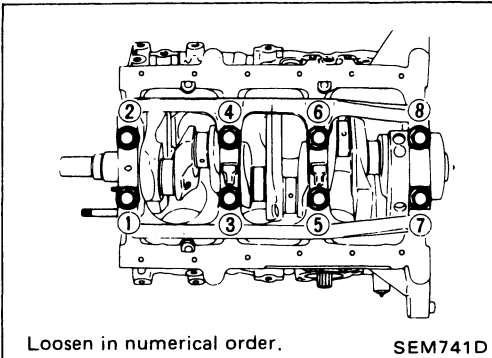
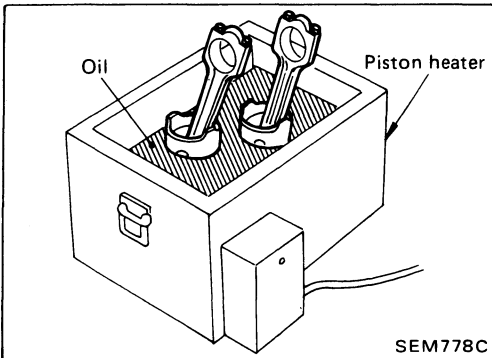

8. Remove bearing cap and crankshaft.
 - **Before removing bearing cap, measure crankshaft end play.**
 - **Bolts should be loosened in two or three steps.**

Inspection

PISTON AND PISTON PIN CLEARANCE

- Confirm the fitting of piston pin into piston pin hole by checking if it can be pressed in smoothly by finger pressure at room temperature.
1. Measure inner diameter of piston pin hole "dp".

Standard diameter "dp":

21.987 - 21.999 mm (0.8656 - 0.8661 in)

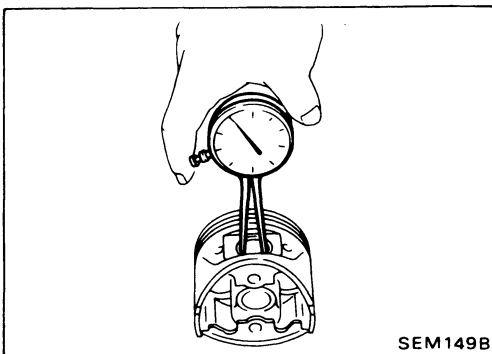

CYLINDER BLOCK

Inspection (Cont'd)

2. Measure outer diameter of piston pin "Dp".

Standard diameter "Dp":

21.989 - 22.001 mm (0.8657 - 0.8662 in)

3. Calculate piston pin clearance.

$dp - Dp = -0.004$ to 0 mm (-0.0002 to 0 in)

If it exceeds the above value, replace piston assembly with pin.

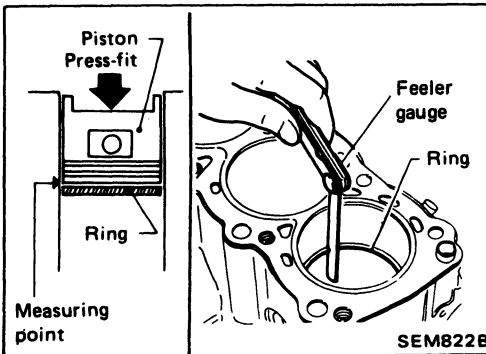
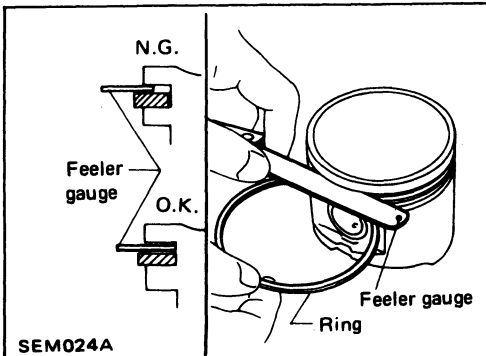
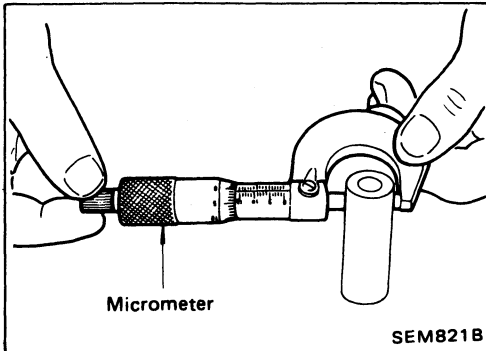

PISTON RING SIDE CLEARANCE

Side clearance:

Top ring

0.040 - 0.073 mm (0.0016 - 0.0029 in)

2nd ring

0.030 - 0.063 mm (0.0012 - 0.0025 in)

Max. limit of side clearance:

0.1 mm (0.004 in)

O-ring:

0.015 - 0.185 mm (0.0006 - 0.0073 in)

If out of specification, replace piston and/or piston ring assembly.

PISTON RING END GAP

End gap:

Top ring

0.21 - 0.40 mm (0.0083 - 0.0157 in)

2nd ring

0.50 - 0.76 mm (0.0197 - 0.0299 in)

Oil ring

0.20 - 0.76 mm (0.0079 - 0.0299 in)

Max. limit of end gap:

1.0 mm (0.039 in)

If out of specification, replace piston ring. If gap still exceeds the limit even with a new ring, rebore cylinder and use oversized piston and piston rings.

Refer to S.D.S.

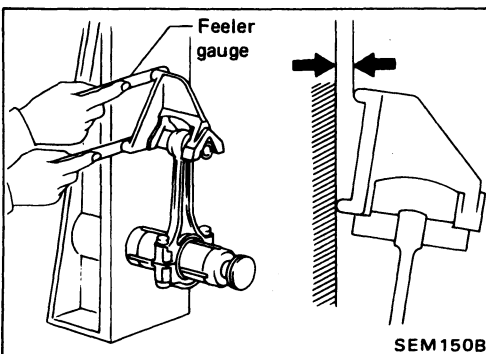

CONNECTING ROD BEND AND TORSION

Bend:

Limit 0.15 mm (0.0059 in) per 100 mm (3.94 in) length

Torsion:

Limit 0.3 mm (0.012 in) per 100 mm (3.94 in) length

If it exceeds the limit, replace connecting rod assembly.

CYLINDER BLOCK

Inspection (Cont'd)

CYLINDER BLOCK DISTORTION AND WEAR

1. Clean upper face of cylinder block and measure the distortion.

Limit:

0.10 mm (0.0039 in)

2. If out of specification, resurface it.

The resurfacing limit is determined by cylinder head resurfacing in engine.

Amount of cylinder head resurfacing is "A".

Amount of cylinder block resurfacing is "B".

The maximum limit is as follows:

$A + B = 0.2 \text{ mm (0.008 in)}$

3. If necessary, replace cylinder block.

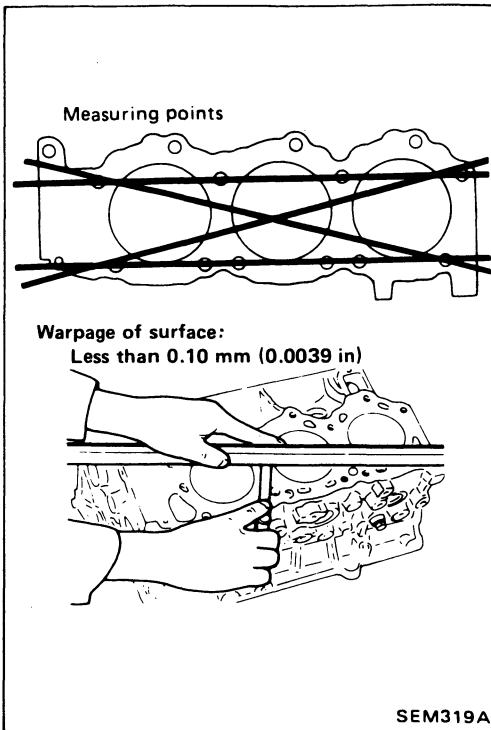

PISTON-TO-BORE CLEARANCE

Method A (Using bore gauge and micrometer)

1. Using a bore gauge, measure cylinder bore for wear, out-of-round and taper.

Standard inner diameter:

87.000 - 87.030 mm (3.4252 - 3.4264 in)

Wear limit:

0.20 mm (0.0079 in)

Out-of-round (X - Y) limit:

0.015 mm (0.0006 in)

Taper (A - B - C) limit:

0.015 mm (0.0006 in)

If it exceeds the limit, rebore all cylinders. Replace cylinder block if necessary.

2. Check for scratches and seizure. If seizure is found, hone it.

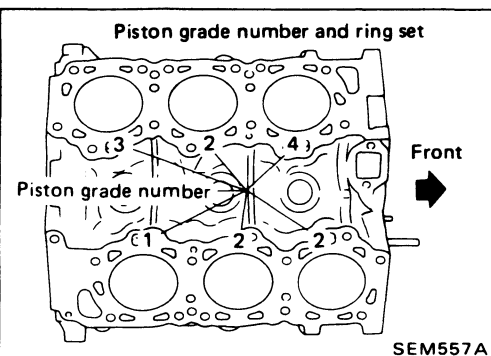
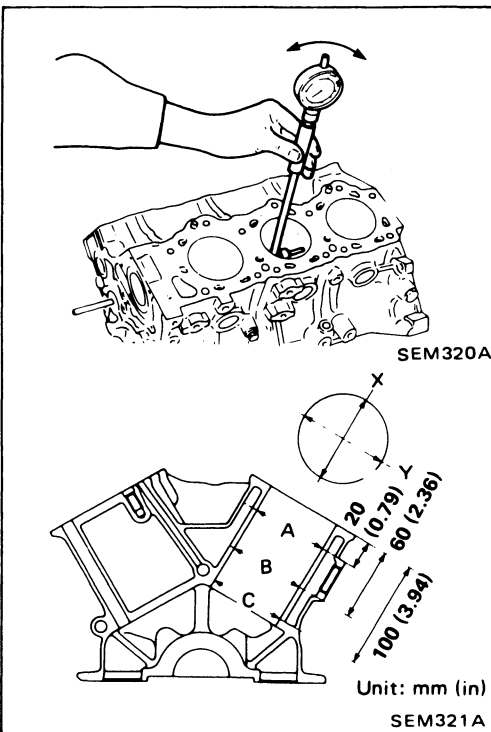

- If both cylinder block and piston are replaced with new ones, select piston of the same grade number punched on cylinder block upper surface.

CYLINDER BLOCK

Inspection (Cont'd)

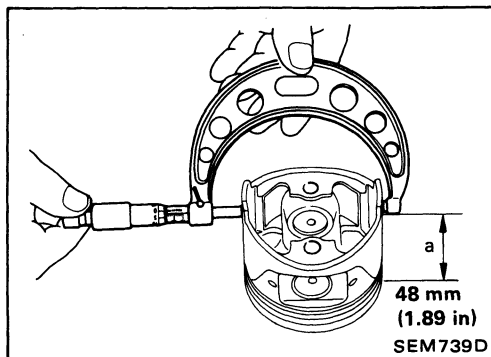

3. Measure piston skirt diameter.

Piston diameter "A":

Refer to S.D.S.

Measuring point "a" (Distance from the top):

48.0 mm (1.890 in)

4. Check that piston-to-bore clearance is within specification.

Piston-to-bore clearance "B":

Non-turbo

0.015 - 0.035 mm (0.0006 - 0.0014 in)

Turbo

0.025 - 0.045 mm (0.0010 - 0.0018 in)

5. Determine piston oversize according to amount of cylinder wear.

Oversize pistons are available for service. Refer to S.D.S.

6. Cylinder bore size is determined by adding piston-to-bore clearance to piston diameter "A".

Rebored size calculation:

$$D = A + B - C$$

where,

D: Bored diameter

A: Piston diameter as measured

B: Piston-to-bore clearance

C: Honing allowance 0.02 mm (0.0008 in)

7. Install main bearing caps, and tighten to the specified torque to prevent distortion of cylinder bores in final assembly.

8. Cut cylinder bores.

- **When any cylinder needs boring, all other cylinders must also be bored.**

- **Do not cut too much out of cylinder bore at a time. Do not cut more than 0.05 mm (0.0020 in) in diameter at a time.**

9. Hone cylinders to obtain specified piston-to-bore clearance.

10. Measure finished cylinder bore for out-of-round and taper.

- **Measurement should be done after cylinder bore cools down.**

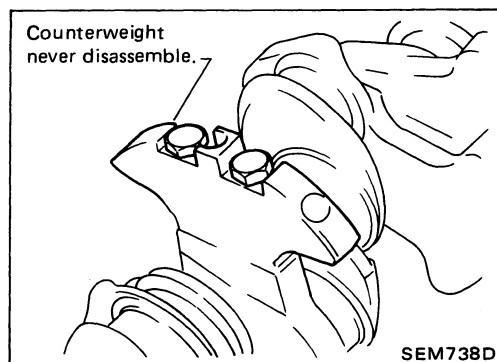

CRANKSHAFT

CAUTION:

Never attempt to disassemble crankshaft counter weight.

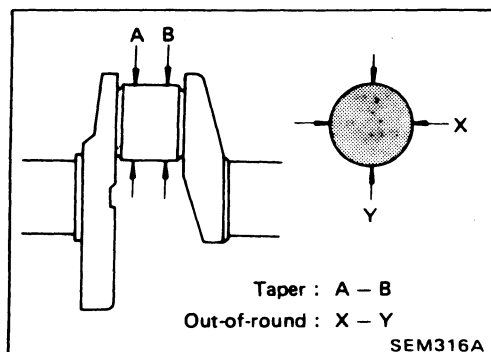

1. Check crankshaft main and pin journals for score, wear or cracks.

2. With a micrometer, measure journals for taper and out-of-round.

Out-of-round (X - Y):

Less than 0.005 mm (0.0002 in)

Taper (A - B):

Less than 0.005 mm (0.0002 in)

Limit:

0.02 mm (0.0008 in)

CYLINDER BLOCK

Inspection (Cont'd)

3. Measure crankshaft runout.

Runout (Total indicator reading):
Less than 0.10 mm (0.0039 in)

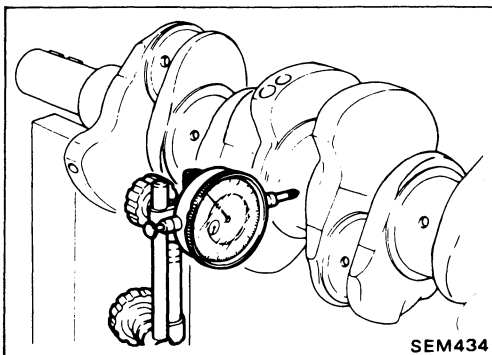

SEM434

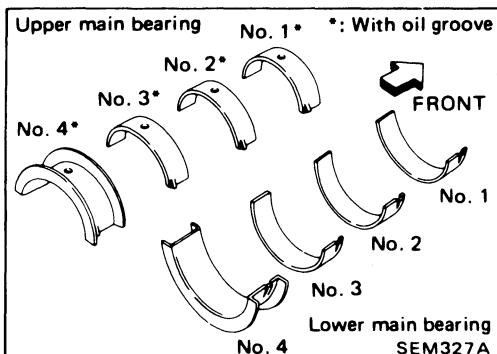

SEM327A

BEARING CLEARANCE

- Either of the following two methods may be used; however, method "A" gives more reliable results and is preferable.

Method A (Using bore gauge & micrometer)

Main bearing

1. Set main bearings in their proper positions on cylinder block and main bearing cap.

2. Install main bearing cap to cylinder block.

Tighten all bolts in correct order in two or three stages.

3. Measure inner diameter "A" of each main bearing.

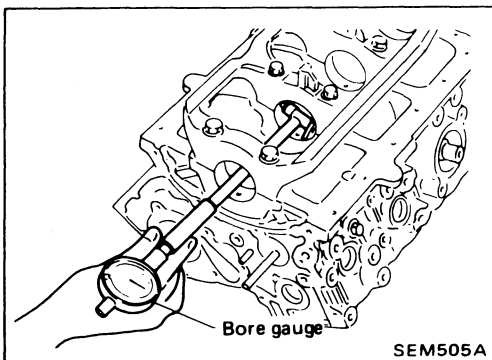

SEM505A

4. Measure outer diameter "Dm" of each crankshaft main journal.
5. Calculate main bearing clearance.

Main bearing clearance (A - Dm):

Standard

0.028 - 0.055 mm (0.0011 - 0.0022 in)

Limit

0.090 mm (0.0035 in)

6. If it exceeds the limit, replace bearing.
7. If clearance cannot be adjusted within the standard of any bearing, grind crankshaft journal and use undersized bearing.

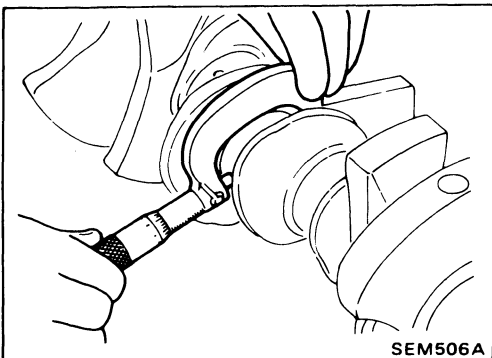

SEM506A

- a. When grinding crankshaft journal, confirm that "L" dimension in fillet roll is more than the specified limit.

"L": 0.1 mm (0.004 in)

- b. Refer to S.D.S. for grinding crankshaft and available service parts.

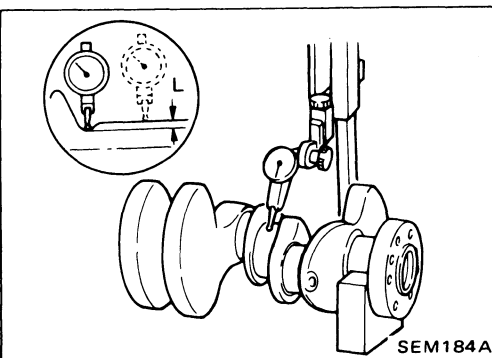

SEM184A

CYLINDER BLOCK

Inspection (Cont'd)

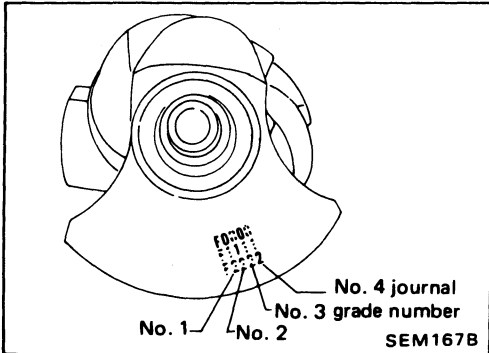
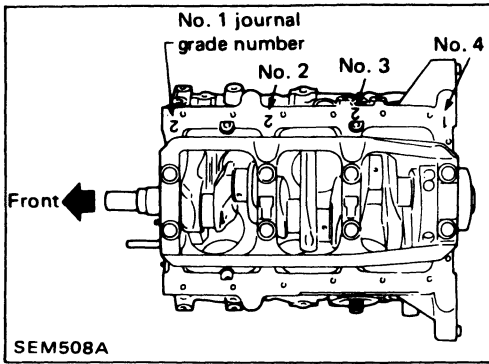

8. If crankshaft, cylinder block or main bearing is reused again, measure main bearing clearance.

If crankshaft, cylinder block and main bearings are replaced with new ones, it is necessary to select thickness of main bearings as follows:

a. Grade number of each cylinder block main journal is punched on the respective cylinder block.

b. Grade number of each crankshaft main journal is punched on the No. 1 counter weight of crankshaft.

c. Select main bearing with suitable thickness according to the following table.

Main bearing grade number:

Crankshaft journal grade number \ Main journal grade number	0	1	2
	0	0	1
1	1	2	3
2	2	3	4

For example:

Main journal grade number: 1

Crankshaft journal grade number: 2

Main bearing grade number = 1 + 2
= 3

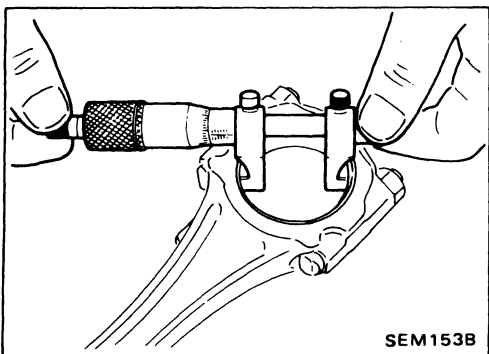

Connecting rod bearing (Big end)

1. Install connecting rod bearing to connecting rod and cap.
2. Install connecting rod cap to connecting rod.

Tighten bolts to the specified torque.

3. Measure inner diameter "C" of each bearing.

CYLINDER BLOCK

Inspection (Cont'd)

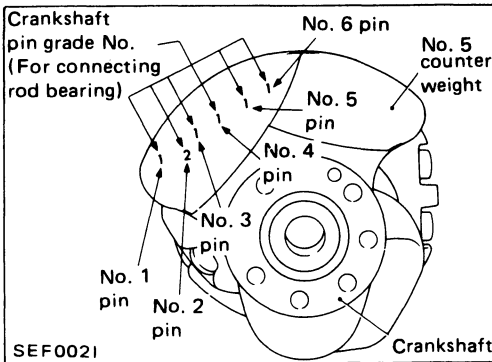
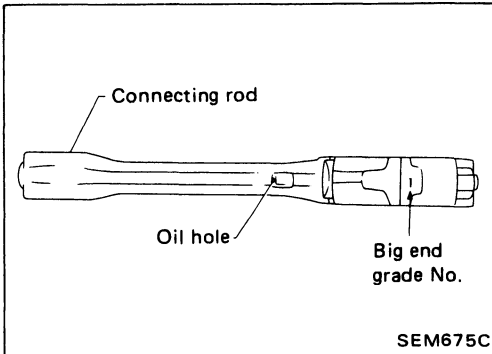
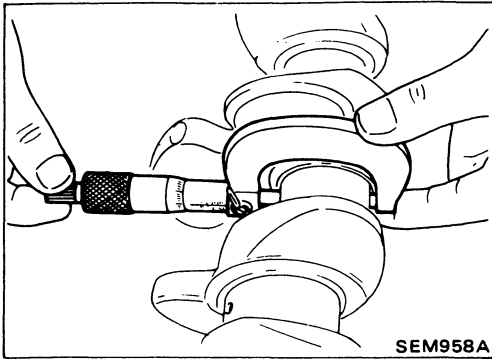

4. Measure outer diameter "Dp" of each crankshaft pin journal.
5. Calculate connecting rod bearing clearance.

Connecting rod bearing clearance (C - Dp):

Standard

0.028 - 0.048 mm (0.0011 - 0.0019 in)

Limit

0.090 mm (0.0035 in)

6. If it exceeds the limit, replace bearing.
7. If clearance cannot be adjusted within the standard of any bearing, grind crankshaft journal and use undersized bearing. Refer to step 7 of "BEARING CLEARANCE — Main bearing".

8. If crankshaft, connecting rods or bearings are replaced with new ones, it is necessary to select thickness of connecting rod bearings as follows:

- a. Grade number of each connecting rod big end is punched on the respective connecting rod.

- b. Grade number of each crankshaft pin journal is punched on the No. 5 counter weight of crankshaft.

- c. Select connecting rod bearing with suitable thickness according to the following table.

Connecting rod bearing grade number:

Crankshaft pin grade number	Connecting rod big end grade number	0	1 (I)
	0	0	1
	1 (I)	1	2
	2 (II)	2	3

For example:

Connecting rod big end grade number: 1

Crankshaft pin grade number: 2

$$\begin{aligned} \text{Connecting rod bearing grade number} &= 1 + 2 \\ &= 3 \end{aligned}$$

CYLINDER BLOCK

Inspection (Cont'd)

Method B (Using "plastigage")

CAUTION:

- Do not turn crankshaft or connecting rod while plastigage is being inserted.
- When bearing clearance exceeds the specified limit, ensure that the proper bearing has been installed. Then if excessive bearing clearance exists, use a thicker main bearing or undersized bearing so that the specified bearing clearance is obtained.

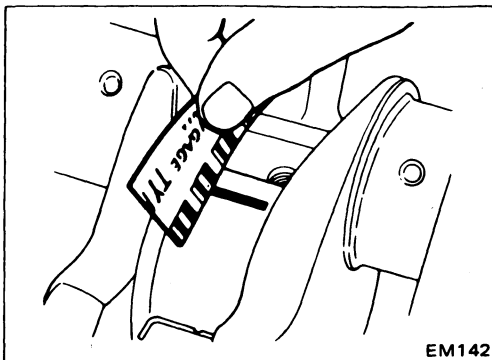

CONNECTING ROD BUSHING CLEARANCE (Small end)

1. Measure inner diameter "C" of bushing.

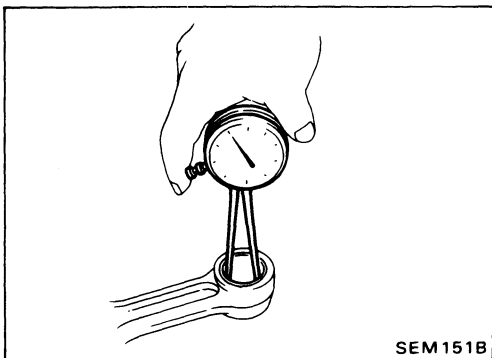

2. Measure outer diameter "Dp" of piston pin.
3. Calculate connecting rod bushing clearance.

$$C - Dp = 0.005 - 0.017 \text{ mm (0.0002 - 0.0007 in)}$$

$$\text{Limit: } 0.023 \text{ mm (0.0009 in)}$$

If it exceeds the specified value, replace connecting rod bushing and/or piston set with pin.

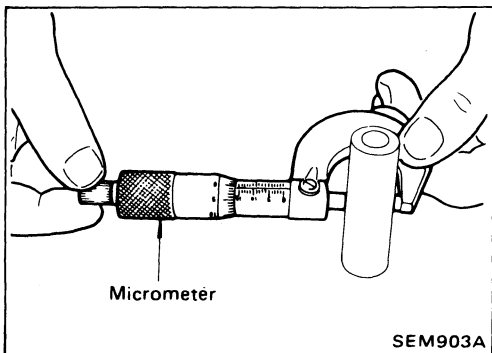

REPLACEMENT OF CONNECTING ROD BUSHING (Small end)

1. Drive in small end bushing until it is flush with end surface of rod.

Be sure to align the oil holes.

2. After driving in small end bushing, ream the bushing.

Small end bushing inside diameter:

Finished size

$$22.000 - 22.012 \text{ mm (0.8661 - 0.8666 in)}$$

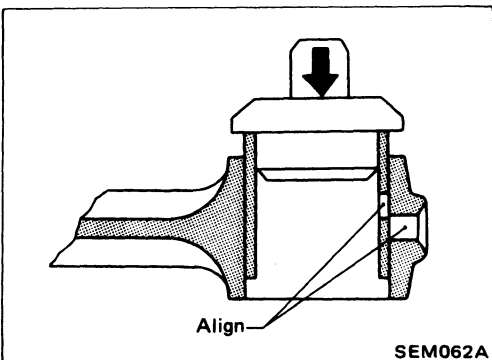

FLYWHEEL/DRIVE PLATE RUNOUT

Runout (Total indicator reading):

Flywheel (M/T model)

Less than 0.15 mm (0.0059 in)

Drive plate (A/T model)

Less than 0.15 mm (0.0059 in)

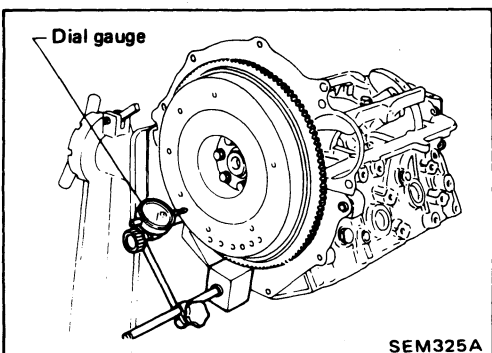

CYLINDER BLOCK

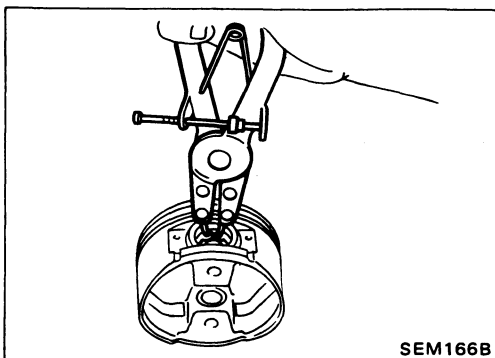

Assembly

PISTON

1. Install new snap ring on one side of piston pin hole.

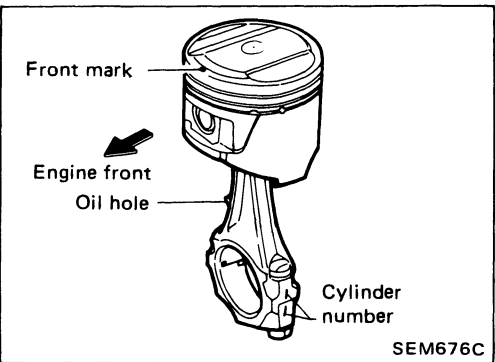
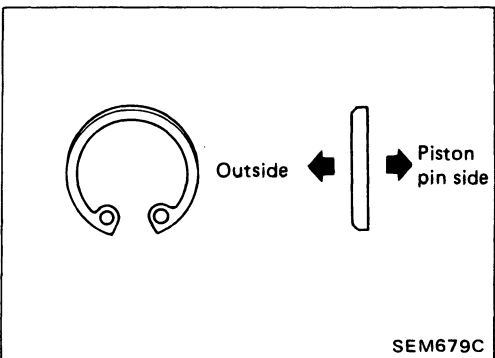

2. Heat piston to 60 to 70°C (140 to 158°F) and assemble piston, piston pin, connecting rod and new snap ring.

- Align the direction of piston and connecting rod.
- Numbers stamped on connecting rod and cap correspond to each cylinder.
- After assembly, make sure connecting rod swings smoothly.

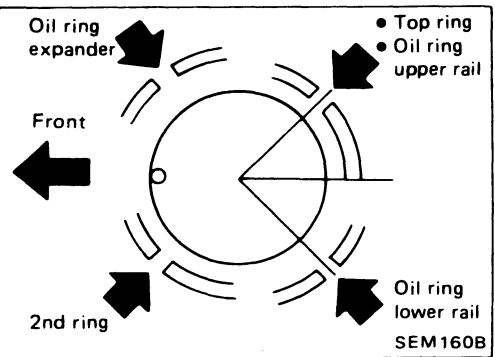

3. Set piston rings as shown.

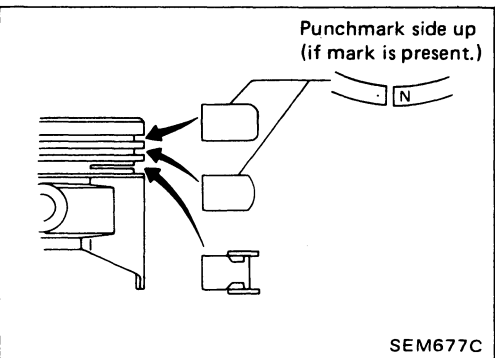

CYLINDER BLOCK

Assembly (Cont'd) CRANKSHAFT

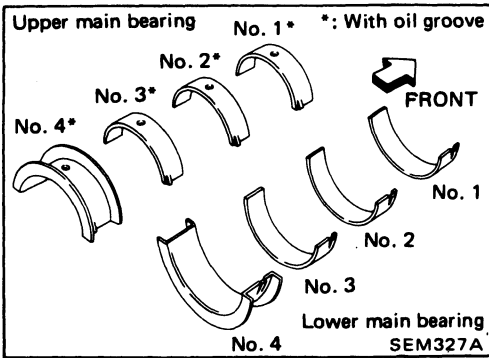

1. Set main bearings in their proper positions on cylinder block and main bearing cap.

- Confirm that correct main bearings are used. Refer to "Inspection".

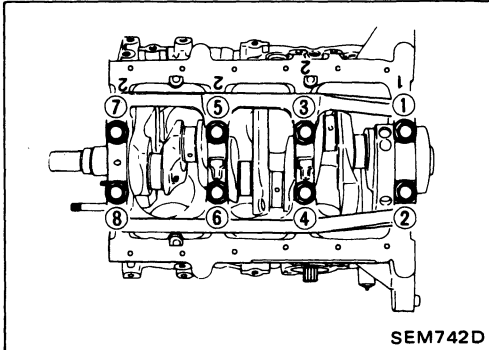

2. Install crankshaft and main bearing caps and tighten bolts to the specified torque.

- Prior to tightening bearing cap bolts, place bearing cap in its proper position by shifting crankshaft in the axial direction.
- Tighten bearing cap bolts gradually in two or three stages. Start with center bearing and move outward sequentially.
- After securing bearing cap bolts, make sure crankshaft turns smoothly by hand.

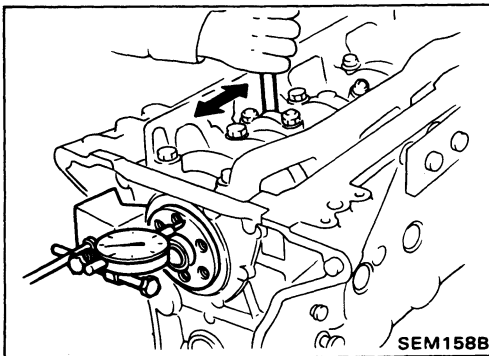

3. Measure crankshaft end play.

Crankshaft end play:

Standard

0.05 - 0.18 mm (0.0020 - 0.0071 in)

Limit

0.30 mm (0.0118 in)

If beyond the limit, replace bearing with a new one.

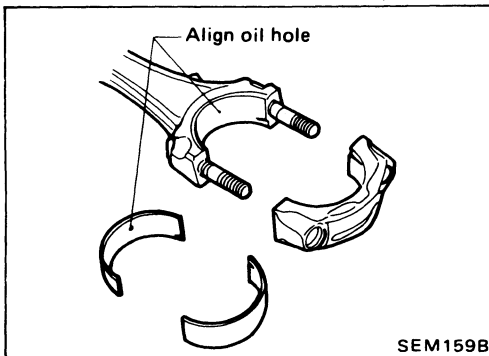

4. Install connecting rod bearings in connecting rods and connecting rod caps.

- Confirm that correct bearings are used.

Refer to "Inspection".

- Install bearings so that oil hole in connecting rod aligns with oil hole of bearing.

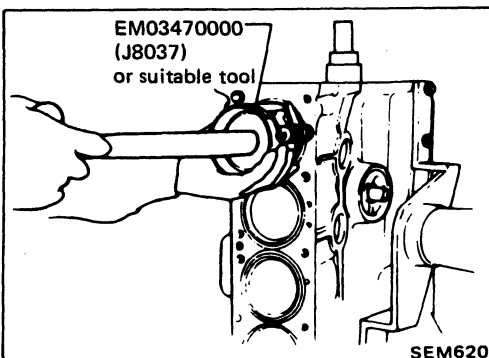

5. Install pistons with connecting rods.

- a. Install them into corresponding cylinders with Tool.

- Be careful not to scratch cylinder wall by connecting rod.
- Arrange so that front mark on piston head faces toward front of engine.

CYLINDER BLOCK

Assembly (Cont'd)

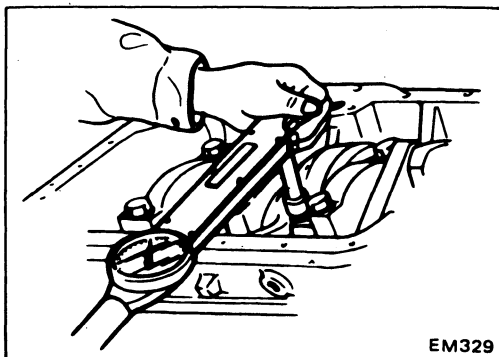

- b. Install connecting rod bearing caps.
Tighten connecting rod bearing cap nuts to the specified torque.

 **Connecting rod bearing nut**

- (1) Tighten to 14 to 16 N·m
(1.4 to 1.6 kg-m, 10 to 12 ft-lb).
- (2) Tighten to 59 to 65 N·m
(6.0 to 6.6 kg-m, 43 to 48 ft-lb)
or if you have an angle wrench, tighten bolts
60 to 65 degrees clockwise.

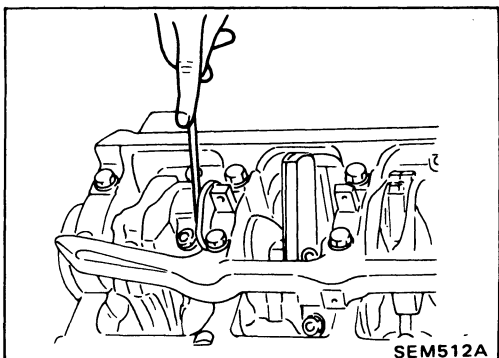

6. Measure connecting rod side clearance.

Connecting rod side clearance:

Standard

0.20 - 0.35 mm (0.0079 - 0.0138 in)

Limit

0.40 mm (0.0157 in)

If beyond the limit, replace connecting rod and/or crankshaft.

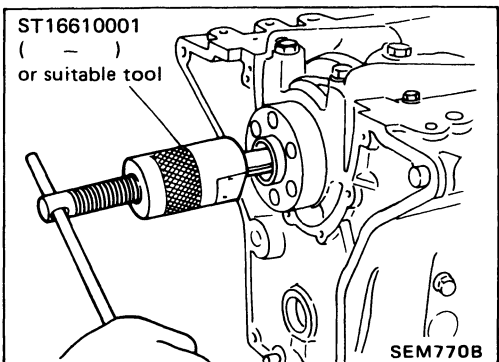

REPLACING PILOT BUSHING

1. Remove pilot bushing (M/T)/pilot converter (A/T).

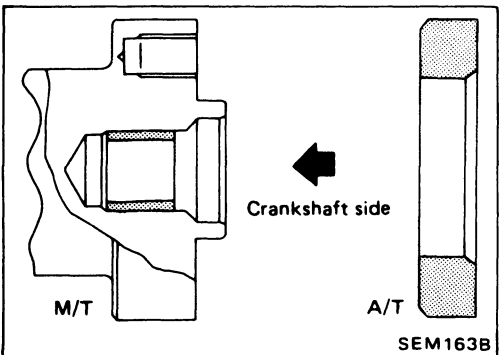

2. Install pilot bushing (M/T)/pilot converter (A/T).

SERVICE DATA AND SPECIFICATIONS (S.D.S.)

General Specifications

Cylinder arrangement	V-6	
Displacement	cm ³ (cu in)	2,960 (180.62)
Bore and stroke	mm (in)	87 x 83 (3.43 x 3.27)
Valve arrangement	D.O.H.C.	
Firing order	1-2-3-4-5-6	
Number of piston rings		
Compression	2	
Oil	1	
Number of main bearings	4	
Compression ratio (Non-turbo/Turbo)	10.5/8.5	

COMPRESSION PRESSURE

Unit: kPa (kg/cm², psi)/300 rpm

	Non-Turbo	Turbo
Compression pressure		
Standard	1,285 (13.1, 186)	1,177 (12.0, 171)
Minimum	981 (10.0, 142)	883 (9.0, 128)
Differential limit between cylinders	98 (1.0, 14)	

Cylinder number

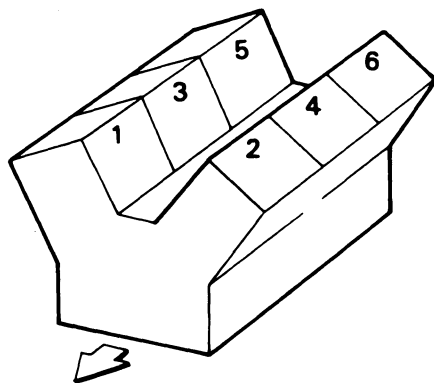

FRONT

SEM713A

SERVICE DATA AND SPECIFICATIONS (S.D.S.)

Inspection and Adjustment

CYLINDER HEAD

Unit: mm (in)

	Standard	Limit
Head surface distortion	Less than 0.05 (0.0020)	0.1 (0.004)

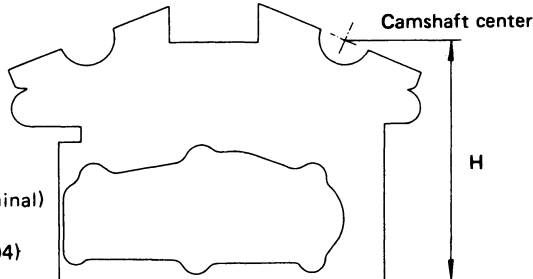

Height (nominal)
138±0.1
(5.433±0.004)

SEM570B

VALVE

Unit: mm (in)

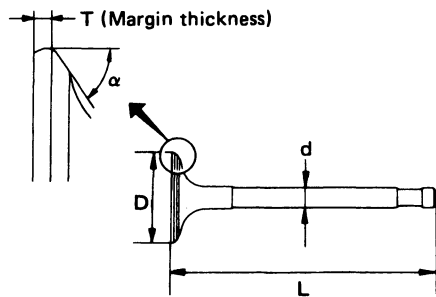

SEM188

Valve head diameter "D"		
Intake	34.0 - 34.2 (1.339 - 1.346)	
Exhaust	29.5 - 29.7 (1.161 - 1.169)	
Valve length "L"		
Intake	103.1 - 103.3 (4.059 - 4.067)	
Exhaust	103.6 - 103.8 (4.079 - 4.087)	
Valve stem diameter "d"		
Intake	5.965 - 5.980 (0.2348 - 0.2354)	
Exhaust	5.945 - 5.960 (0.2341 - 0.2346)	
Valve seat angle "α"		
Intake		45° 15' - 45° 45'
Exhaust		
Valve margin "T"		
Intake	1.15 - 1.45 (0.0453 - 0.0571)	
Exhaust	1.35 - 1.65 (0.0531 - 0.0650)	
Valve margin "T" limit	More than 0.5 (0.020)	
Valve stem end surface grinding limit	Less than 0.2 (0.008)	
Valve clearance		
Intake	0 (0)	
Exhaust	0 (0)	

Valve spring

Free height	mm (in)	43.1 (1.697)
Pressure N (kg, lb) at height mm (in)	Standard	536.4 (54.7, 120.6) at 26.5 (1.043)
	Limit	452.79 (46.17, 101.80) at 26.5 (1.043)
Out-of-square	mm (in)	Less than 1.8 (0.071)

Hydraulic valve lifter

Unit: mm (in)

Lifter outer diameter	30.955 - 30.965 (1.2187 - 1.2191)
Lifter guide inner diameter	31.000 - 31.020 (1.2205 - 1.2213)
Clearance between lifter and lifter guide	0.035 - 0.065 (0.0014 - 0.0026)

Valve guide

Unit: mm (in)

	Standard	Service
Valve guide		
Outer diameter	10.023 - 10.034 (0.3946 - 0.3950)	10.223 - 10.234 (0.4025 - 0.4029)
Valve guide		
Inner diameter (Finished size)	6.000 - 6.018 (0.2362 - 0.2369)	
Cylinder head valve guide hole diameter	9.975 - 9.996 (0.3927 - 0.3935)	10.175 - 10.196 (0.4006 - 0.4014)
Interference fit of valve guide	0.027 - 0.059 (0.0011 - 0.0023)	
	Standard	Max. tolerance
Stem to guide clearance	Intake 0.020 - 0.053 (0.0008 - 0.0021)	0.10 (0.0039)
	Exhaust 0.040 - 0.073 (0.0016 - 0.0029)	
Valve deflection limit	—	0.20 (0.0079)

SERVICE DATA AND SPECIFICATIONS (S.D.S.)

Inspection and Adjustment (Cont'd)

VALVE SEAT

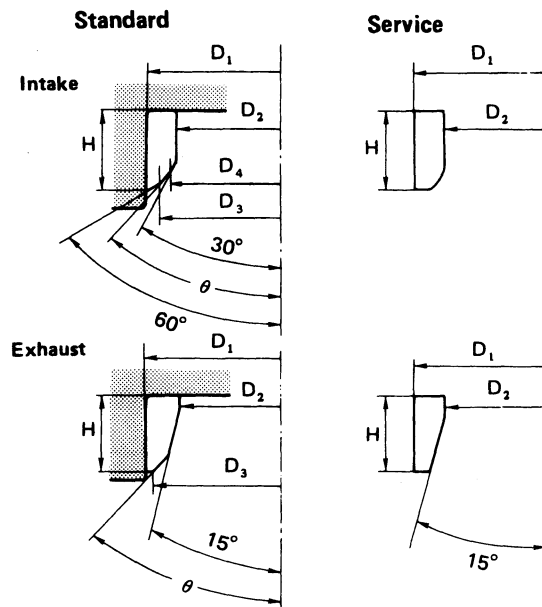

SEM529C

Unit: mm (in)

		Standard	Service*
Cylinder head seat recess diameter (D_1)	In.	36.000 - 36.016 (1.4173 - 1.4179)	36.500 - 36.516 (1.4370 - 1.4376)
	Ex.	31.500 - 31.516 (1.2402 - 1.2408)	32.000 - 32.016 (1.2598 - 1.2605)
Valve seat interference fit	In.	0.081 - 0.113 (0.0032 - 0.0044)	
	Ex.	0.064 - 0.096 (0.0025 - 0.0038)	
Valve seat outer diameter (D_1)	In.	36.097 - 36.113 (1.4211 - 1.4218)	36.597 - 36.613 (1.4408 - 1.4415)
	Ex.	31.580 - 31.596 (1.2433 - 1.2439)	32.080 - 32.096 (1.2630 - 1.2636)
Valve seat inner diameter (D_2)	In.	29.85 - 30.15 (1.1752 - 1.1870)	
	Ex.	24.35 - 24.65 (0.9587 - 0.9705)	
Height (H)	In.	5.9 - 6.0 (0.232 - 0.236)	5.35 - 5.45 (0.2106 - 0.2146)
	Ex.	5.9 - 6.0 (0.232 - 0.236)	5.9 - 6.0 (0.232 - 0.236)
Face angle (θ)	In.	45°	
	Ex.	45°	
Face inner diameter (D_4)	In.	31.5 (1.240)	*: Valve seat surface must be corrected to specified value.
Face outer diameter (D_3)	In.	33.6 - 33.8 (1.323 - 1.331)	
	Ex.	28.9 - 29.1 (1.138 - 1.146)	

SERVICE DATA AND SPECIFICATIONS (S.D.S.)

Inspection and Adjustment (Cont'd)

PISTON, PISTON RING AND PISTON PIN

Available piston

Unit: mm (in)

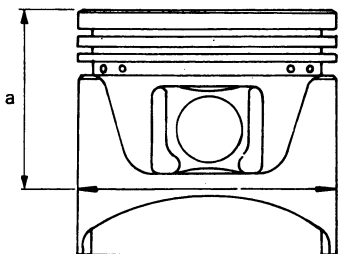

SEM740D

Piston skirt diameter "A"

Standard

Grade No. 1	86.975 - 86.985 (3.4242 - 3.4246)
Grade No. 2	86.985 - 86.995 (3.4246 - 3.4250)
Grade No. 3	86.995 - 87.005 (3.4250 - 3.4254)

0.25 (0.0098) oversize (Service)	87.225 - 87.275 (3.4340 - 3.4360)
-------------------------------------	-----------------------------------

0.50 (0.0197) oversize (Service)	87.475 - 87.525 (3.4439 - 3.4459)
-------------------------------------	-----------------------------------

"a" dimension	48.0 (1.890)
---------------	--------------

Piston pin hole diameter	21.987 - 21.999 (0.8656 - 0.8661)
--------------------------	-----------------------------------

Piston clearance to cylinder block

Non-turbo	0.015 - 0.035 (0.0006 - 0.0014)
Turbo	0.025 - 0.045 (0.0010 - 0.0018)

Piston ring

Unit: mm (in)

	Standard	Limit
Side clearance	0.040 - 0.073 (0.0016 - 0.0029)	0.1 (0.004)
2nd	0.030 - 0.063 (0.0012 - 0.0025)	
Oil	0.015 - 0.185 (0.0006 - 0.0073)	0.2 (0.0079)
End gap	0.21 - 0.40 (0.0083 - 0.0157)	1.0 (0.039)
2nd	0.50 - 0.76 (0.0197 - 0.0299)	
Oil (rail ring)	0.20 - 0.76 (0.0079 - 0.0299)	

Piston pin

Unit: mm (in)

Piston pin outer diameter	21.989 - 22.001 (0.8657 - 0.8662)
Interference fit of piston pin to piston	0 - 0.004 (0 - 0.0002)
Piston pin to connecting rod bushing clearance	0.005 - 0.017 (0.0002 - 0.0007)

* Values measured at ambient temperature of 20°C (68°F)

CONNECTING ROD

Unit: mm (in)

Center distance	154.1 - 154.2 (6.067 - 6.071)
Bend [per 100 (3.94)] Limit	0.15 (0.0059)
Torsion [per 100 (3.94)] Limit	0.3 (0.012)
Piston pin bushing inner diameter*	22.000 - 22.012 (0.8661 - 0.8666)
Connecting rod big end inner diameter	53.000 - 53.013 (2.0866 - 2.0871)
Side clearance	0.20 - 0.35 (0.0079 - 0.0138)

* After installing in connecting rod

SERVICE DATA AND SPECIFICATIONS (S.D.S.)

Inspection and Adjustment (Cont'd)

CAMSHAFT AND CAMSHAFT BEARING

Unit: mm (in)

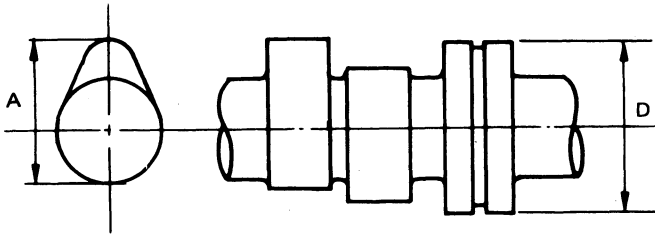

SEM568A

	Standard	Max. tolerance
Camshaft journal to bearing clearance	0.045 - 0.086 (0.0018 - 0.0034)	0.15 (0.0059)
Inner diameter of camshaft bearing	28.000 - 28.021 (1.1024 - 1.1032)	-
Outer diameter of camshaft journal	27.935 - 27.955 (1.0998 - 1.1006)	-
Camshaft runout [T.I.R.*]	Less than 0.04 (0.0016)	0.1 (0.004)
Camshaft end play	0.03 - 0.08 (0.0012 - 0.0031)	-

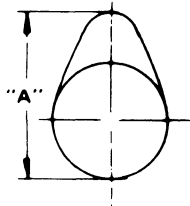

EM671

Cam height "A"	
Intake	40.405 - 40.595 (1.5907 - 1.5982)
Exhaust	
Wear limit of cam height	0.15 (0.0059)

*Total indicator reading

Valve timing

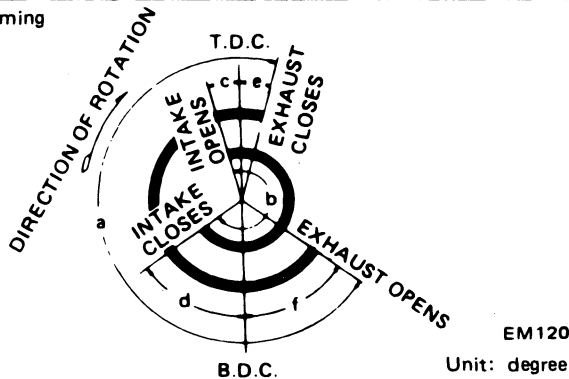

EM120

Unit: degree

a	b	c	d	e	f
248	248	-1	69	9	59

CYLINDER BLOCK

Unit: mm (in)

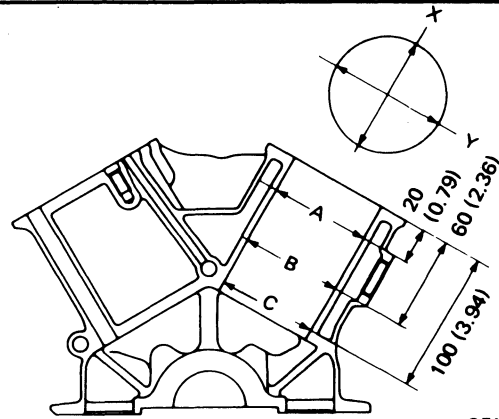

SEM321A

Surface flatness	
Standard	Less than 0.03 (0.0012)
Limit	0.10 (0.0039)
Cylinder bore	
Inner diameter	
Standard	
Grade No. 1	87.000 - 87.010 (3.4252 - 3.4256)
Grade No. 2	87.010 - 87.020 (3.4256 - 3.4260)
Grade No. 3	87.020 - 87.030 (3.4260 - 3.4264)
Wear limit	0.20 (0.0079)
Out-of-round (X - Y)	Less than 0.015 (0.0006)
Taper (A - B - C)	Less than 0.015 (0.0006)
Main journal inner diameter	
Grade No. 0	66.645 - 66.654 (2.6238 - 2.6242)
Grade No. 1	66.654 - 66.663 (2.6242 - 2.6245)
Grade No. 2	66.663 - 66.672 (2.6245 - 2.6249)
Difference in inner diameter between cylinders	
Standard	Less than 0.05 (0.0020)

SERVICE DATA AND SPECIFICATIONS (S.D.S.)

Inspection and Adjustment (Cont'd)

CRANKSHAFT

Unit: mm (in)

Main journal dia. "Dm"	
Grade No. 0	62.967 - 62.975 (2.4790 - 2.4793)
Grade No. 1	62.959 - 62.967 (2.4787 - 2.4790)
Grade No. 2	62.951 - 62.959 (2.4784 - 2.4787)
Pin journal dia. "Dp"	
Grade No. 0	49.968 - 49.974 (1.9672 - 1.9675)
Grade No. 1	49.962 - 49.968 (1.9670 - 1.9672)
Grade No. 2	49.955 - 49.962 (1.9667 - 1.9670)
Center distance "r"	
	41.47 - 41.53 (1.6327 - 1.6350)
Out-of-round (X - Y)	
Standard	Less than 0.005 (0.0002)
Limit	0.02 (0.0008)
Taper (A - B)	
Standard	Less than 0.005 (0.0002)
Limit	0.02 (0.0008)
Runout [T.I.R.]	
Standard	Less than 0.10 (0.0039)
Free end play	
Standard	0.05 - 0.18 (0.0020 - 0.0071)
Limit	0.30 (0.0118)

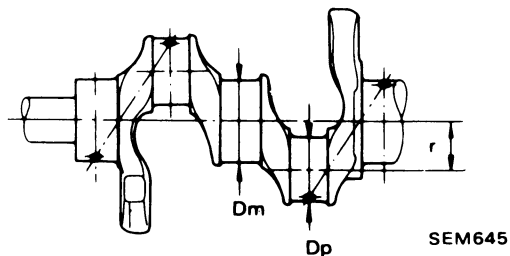

SEM645

Out-of-round X - Y
Taper A - B

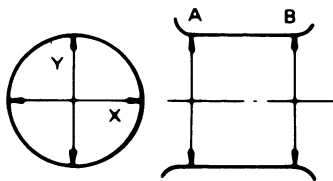

EM715

AVAILABLE MAIN BEARING

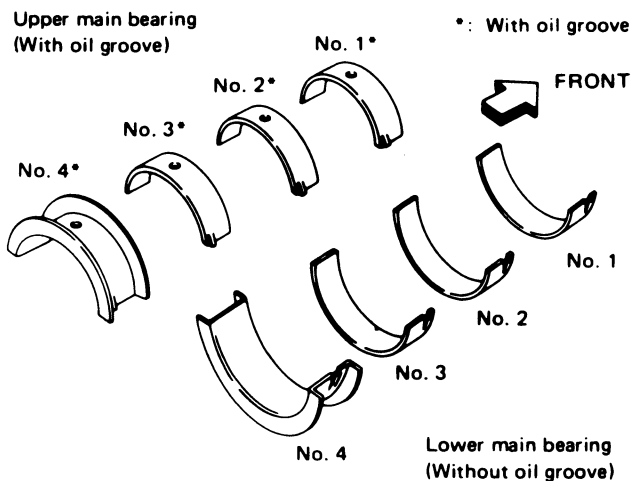

SEM327A

No. 1 main bearing

Grade number	Thickness "T" mm (in)	Width "W" mm (in)	Identification color
0	1.817 - 1.821 (0.0715 - 0.0717)		Black
1	1.821 - 1.825 (0.0717 - 0.0719)		Brown
2	1.825 - 1.829 (0.0719 - 0.0720)	22.4 - 22.6 (0.882 - 0.890)	Green
3	1.829 - 1.833 (0.0720 - 0.0722)		Yellow
4	1.833 - 1.837 (0.0722 - 0.0723)		Blue

No. 2 and 3 main bearing

Grade number	Thickness "T" mm (in)	Width "W" mm (in)	Identification color
0	1.817 - 1.821 (0.0715 - 0.0717)		Black
1	1.821 - 1.825 (0.0717 - 0.0719)		Brown
2	1.825 - 1.829 (0.0719 - 0.0720)	18.9 - 19.1 (0.744 - 0.752)	Green
3	1.829 - 1.833 (0.0720 - 0.0722)		Yellow
4	1.833 - 1.837 (0.0722 - 0.0723)		Blue

SERVICE DATA AND SPECIFICATIONS (S.D.S.)

Inspection and Adjustment (Cont'd)

No. 4 main bearing

Grade number	Thickness "T" mm (in)	Identification color
0	1.817 - 1.821 (0.0715 - 0.0717)	Black
1	1.821 - 1.825 (0.0717 - 0.0719)	Brown
2	1.825 - 1.829 (0.0719 - 0.0720)	Green
3	1.829 - 1.833 (0.0720 - 0.0722)	Yellow
4	1.833 - 1.837 (0.0722 - 0.0723)	Blue

Undersize

Unit: mm (in)

	Thickness	Main journal diameter "Dm"
0.25 (0.0098)	1.948 - 1.956 (0.0767 - 0.0770)	Grind so that bearing clearance is the specified value.

AVAILABLE CONNECTING ROD BEARING

Connecting rod bearing

Grade number	Thickness "T" mm (in)	Identification color
0	1.496 - 1.499 (0.0589 - 0.0590)	No paint
1	1.499 - 1.502 (0.0590 - 0.0591)	Brown
2	1.502 - 1.505 (0.0591 - 0.0593)	Green
3	1.505 - 1.508 (0.0593 - 0.0594)	Yellow

Undersize

Unit: mm (in)

	Thickness	Crank pin journal diameter "Dp"
0.08 (0.0031)	1.540 - 1.548 (0.0606 - 0.0609)	Grind so that bearing clearance is the specified value.
0.12 (0.0047)	1.560 - 1.568 (0.0614 - 0.0617)	
0.25 (0.0098)	1.625 - 1.633 (0.0640 - 0.0643)	

TURBOCHARGER

Unit: mm (in)

Rotor shaft	
Runout [T.I.R.] *	0.056 - 0.127 (0.0022 - 0.0050)
End play	0.013 - 0.096 (0.0005 - 0.0038)

*Total indicator reading

MISCELLANEOUS COMPONENTS

Unit: mm (in)

Flywheel	
Runout [T.I.R.] *	Less than 0.15 (0.0059)

*Total indicator reading

Bearing clearance

Unit: mm (in)

Main bearing clearance	
Standard	0.028 - 0.055 (0.0011 - 0.0022)
Limit	0.090 (0.0035)

Connecting rod bearing clearance	
Standard	0.028 - 0.048 (0.0011 - 0.0019)
Limit	0.090 (0.0035)

ENGINE LUBRICATION & COOLING SYSTEMS

SECTION **LC**

LC

CONTENTS

PREPARATION	LC- 2
PRECAUTIONS	LC- 3
ENGINE LUBRICATION SYSTEM	LC- 4
ENGINE COOLING SYSTEM	LC- 9
SERVICE DATA AND SPECIFICATIONS (S.D.S.)	LC-16

PREPARATION

SPECIAL SERVICE TOOLS

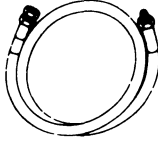
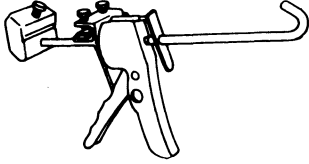
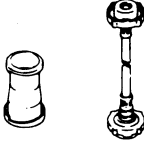
Tool number (Kent-Moore No.) Tool name	Description
ST25051001 (J25695-1) Oil pressure gauge	
ST25052000 (J25695-2) Hose	Adapting oil pressure gauge to cylinder block 
WS39930000 (-) Tube presser	Pressing the tube of liquid gasket 
EG17650301 (-) Radiator cap tester adapter	Adapting radiator cap tester to radiator filler neck 

PRECAUTIONS

Supplemental Restraint System "AIR BAG"

The Supplemental Restraint System "Air Bag" helps to reduce the risk or severity of injury to the driver in a frontal collision. The Supplemental Restraint System consists of an air bag (located in the center of the steering wheel), sensors, a control unit, warning lamp, wiring harness and spiral cable. Information necessary to service the system safely is included in the **BF** section of this Service Manual.

WARNING:

- a. To avoid rendering the SRS inoperative, which could lead to personal injury or death in the event of a severe frontal collision, all maintenance must be performed by an authorized NISSAN dealer.
- b. Improper maintenance, including incorrect removal and installation of the SRS, can lead to personal injury caused by unintentional activation of the system.
- c. All SRS electrical wiring harnesses and connectors are covered with yellow outer insulation. Do not use electrical test equipment on any circuit related to the SRS "Air Bag".

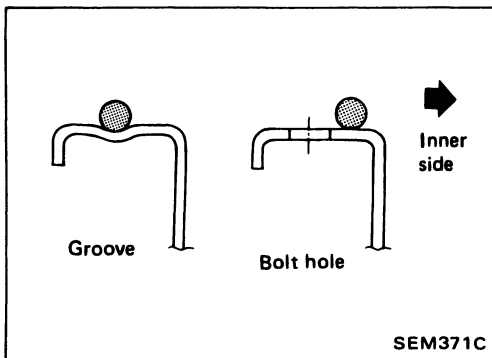

Liquid Gasket Application Procedure

- a. Before applying liquid gasket, use a scraper to remove all traces of old liquid gasket from mating surface.
- b. Apply a continuous bead of liquid gasket to mating surfaces. (Use Genuine Liquid Gasket or equivalent.)
 - Be sure liquid gasket is 3.5 to 4.5 mm (0.138 to 0.177 in) wide (for oil pan).
 - Be sure liquid gasket is 2.0 to 3.0 mm (0.079 to 0.118 in) wide (in areas except oil pan).
- c. Apply liquid gasket to inner sealing surface around hole perimeter area.
(Assembly should be done within 5 minutes after coating.)
- d. Wait at least 30 minutes before refilling engine oil and engine coolant.

ENGINE LUBRICATION SYSTEM

Lubrication Circuit

Valve timing control system

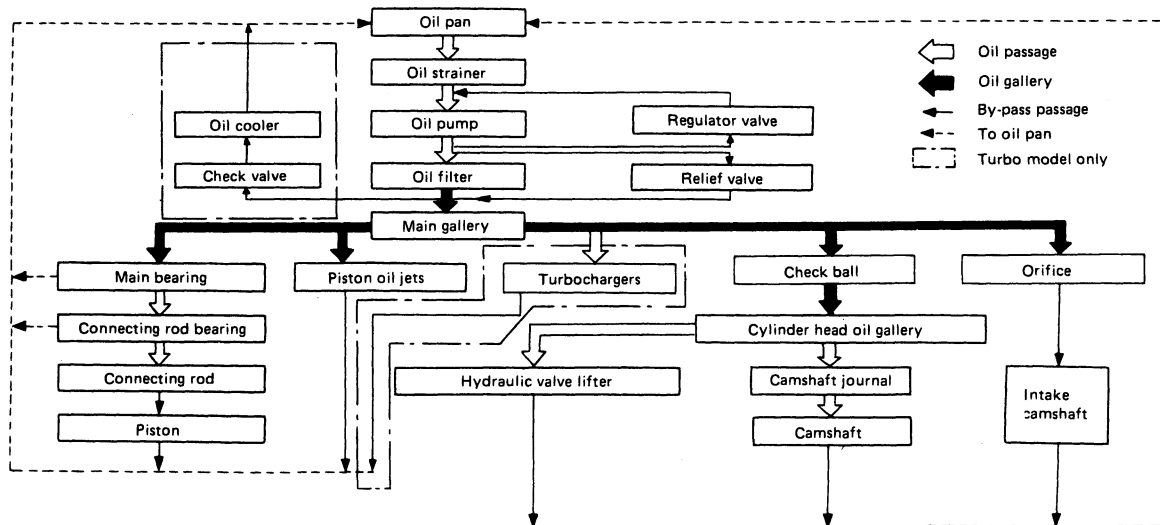
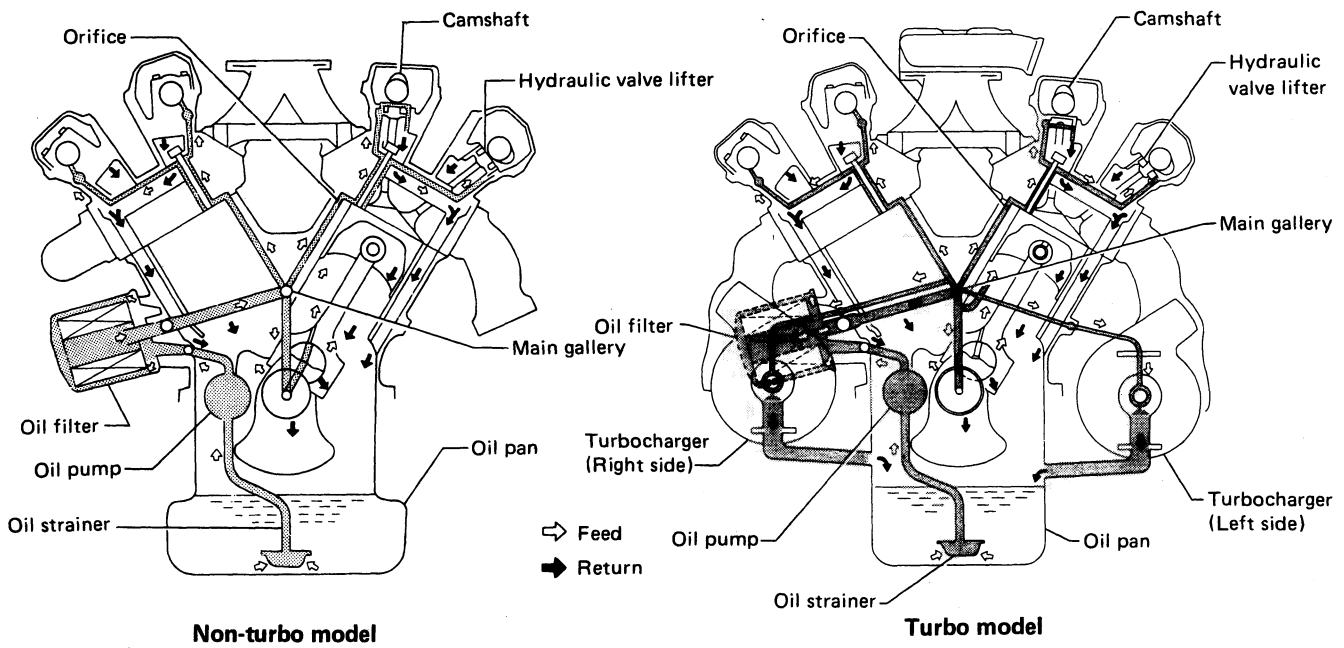
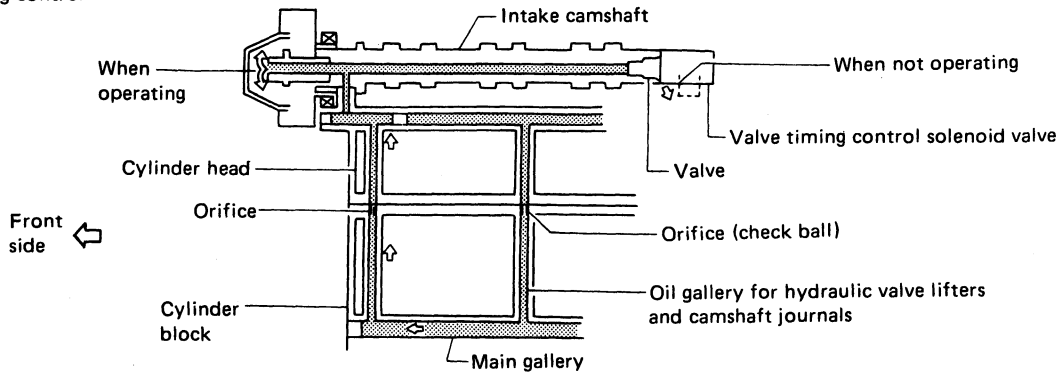

SLC580A

ENGINE LUBRICATION SYSTEM

Oil Pressure Check

WARNING:

- Be careful not to burn yourself, as the engine and oil may be hot.
- Oil pressure check should be done in "Neutral" gear position.

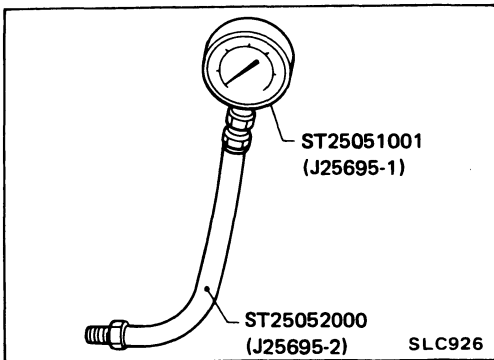
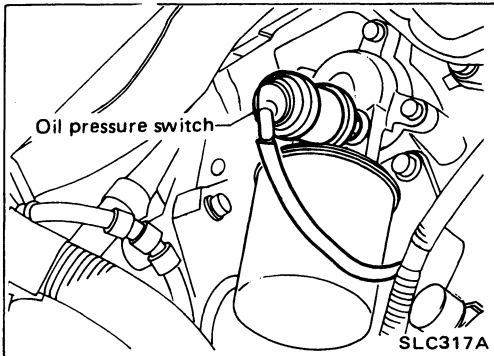

1. Check oil level.
2. Remove oil pressure switch.

3. Install pressure gauge.
4. Start engine and warm it up to normal operating temperature.
5. Check oil pressure with engine running under no-load.

Engine rpm	Approximate discharge pressure kPa (kg/cm ² , psi)
Idle speed	More than 78 (0.8, 11)
3,000	353 - 451 (3.6 - 4.6, 51 - 65)

If difference is extreme, check oil passage and oil pump for oil leaks.

6. Install oil pressure switch with sealant.

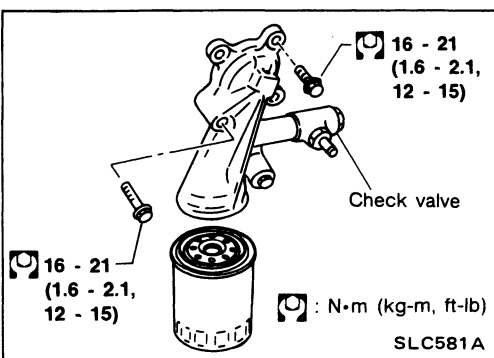

Oil Filter Bracket (Turbo model)

- Check oil cooler check valve for valve opening pressure.

Opening pressure:

324 - 363 kPa (3.3 - 3.7 kg/cm², 47 - 53 psi)

ENGINE LUBRICATION SYSTEM

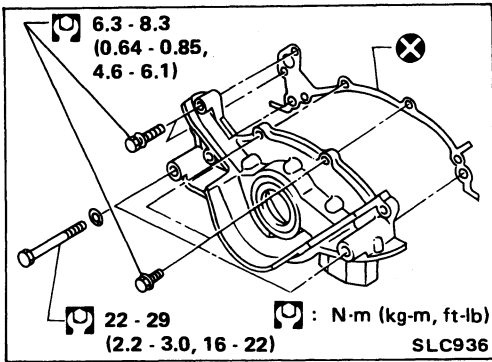

Oil Pump REMOVAL

1. Drain oil.
2. Remove oil pan. (Refer to "OIL PAN — Removal" in EM section.)
3. Remove oil pump assembly.

DISASSEMBLY AND ASSEMBLY

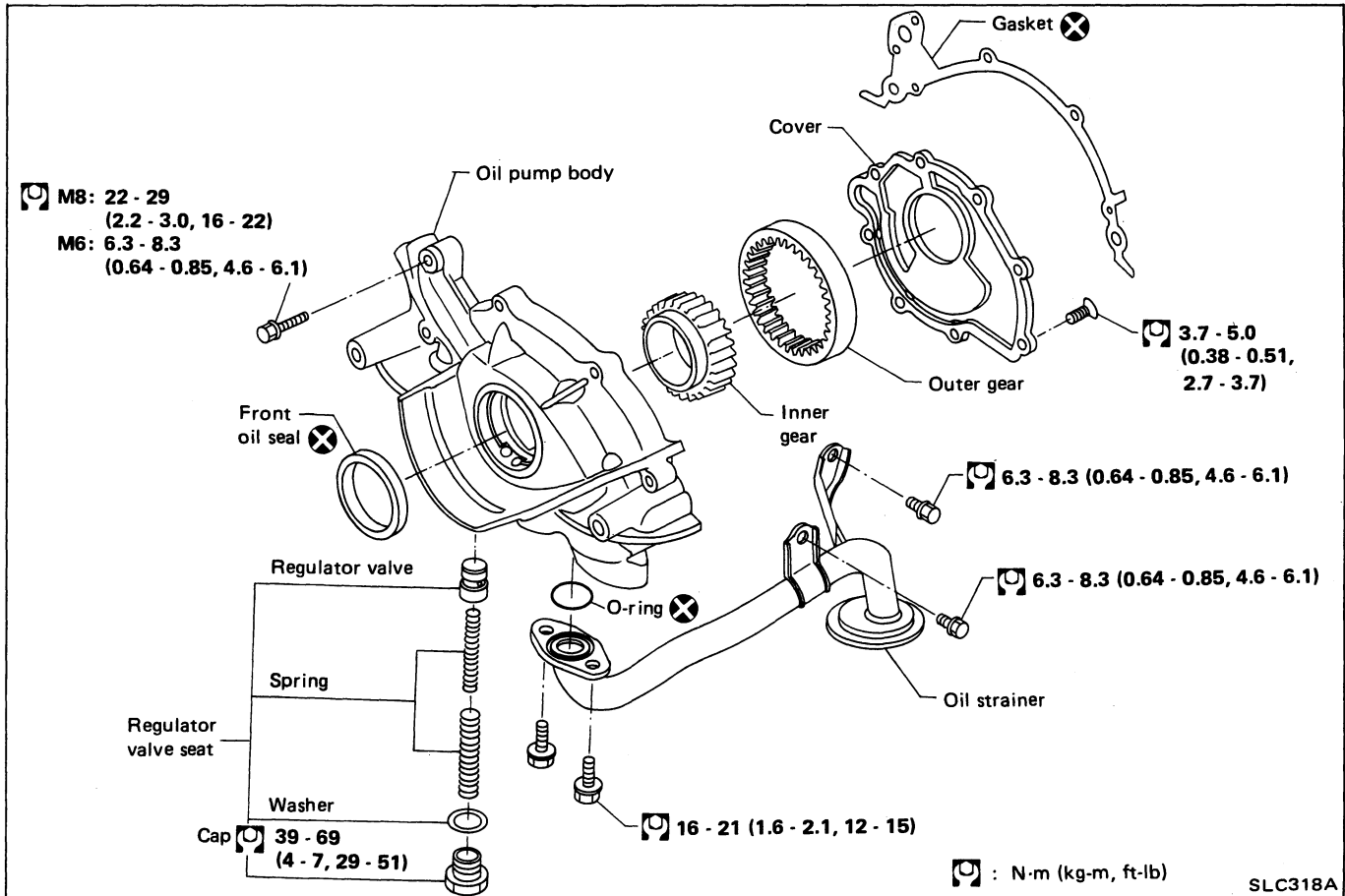

- Always replace with new oil seal and gasket.
- When installing oil pump, apply engine oil to inner and outer gears.
- Be sure that O-ring is properly installed.

ENGINE LUBRICATION SYSTEM

Oil Pump (Cont'd)

INSPECTION

Using a feeler gauge, check the following clearances:

Standard clearance:

Unit: mm (in)

Body to outer gear clearance ①	0.110 - 0.200 (0.0043 - 0.0079)
Inner gear to crescent clearance ②	0.223 - 0.333 (0.0088 - 0.0131)
Outer gear to crescent clearance ③	0.210 - 0.320 (0.0083 - 0.0126)
Housing to inner gear clearance ④	0.050 - 0.090 (0.0020 - 0.0035)
Housing to outer gear clearance ⑤	0.050 - 0.110 (0.0020 - 0.0043)

If any clearance exceeds the limit, replace gear set or entire oil pump assembly.

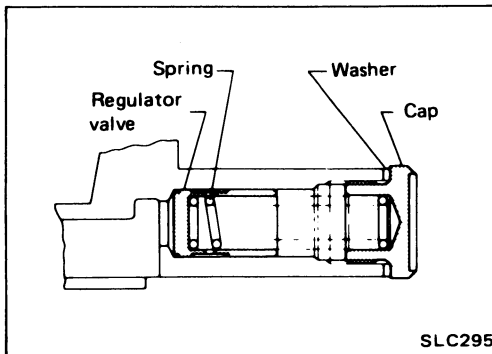
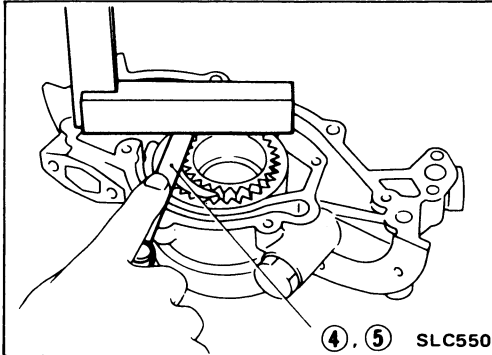
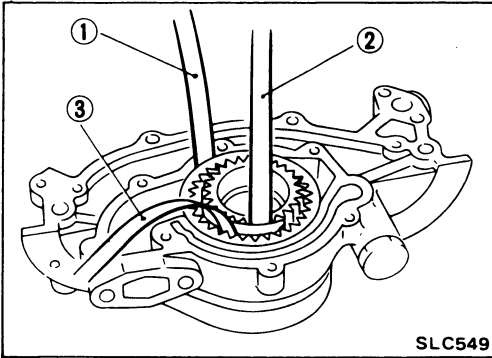

REGULATOR VALVE INSPECTION

1. Visually inspect components for wear and damage.
2. Check oil pressure regulator valve sliding surface and valve spring.
3. Coat regulator valve with engine oil and check to make sure that it falls smoothly into the valve hole by its own weight.

If damaged, replace regulator valve set or oil pump assembly.

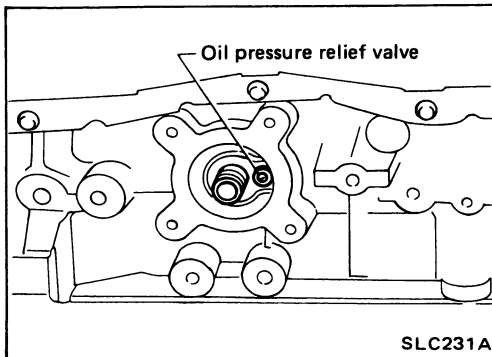

OIL PRESSURE RELIEF VALVE INSPECTION

Inspect oil pressure relief valve for movement, cracks and breaks by pushing the ball. If replacement is necessary, remove valve by prying it out with a suitable tool. Install a new valve by tapping it in place.

ENGINE LUBRICATION SYSTEM

Oil Cooler (Turbo model) DISASSEMBLY AND ASSEMBLY

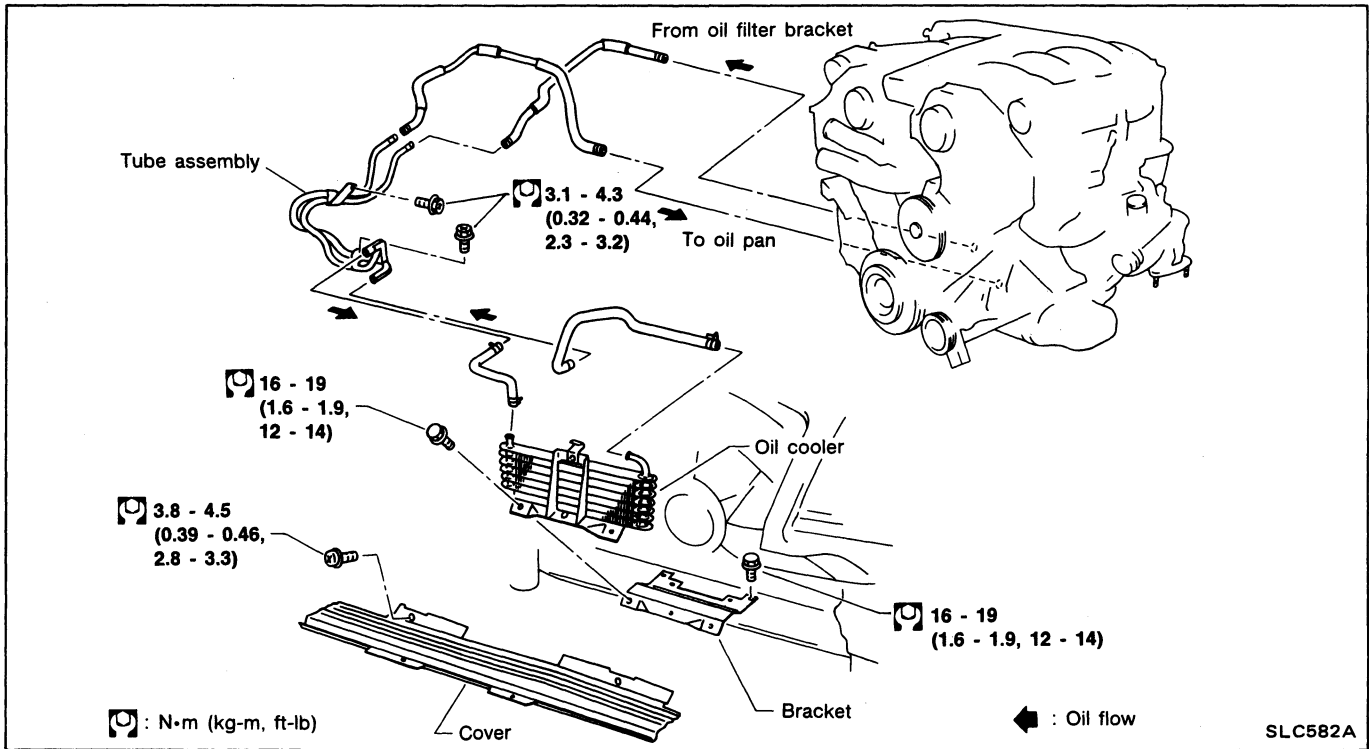

ENGINE COOLING SYSTEM

Cooling Circuit

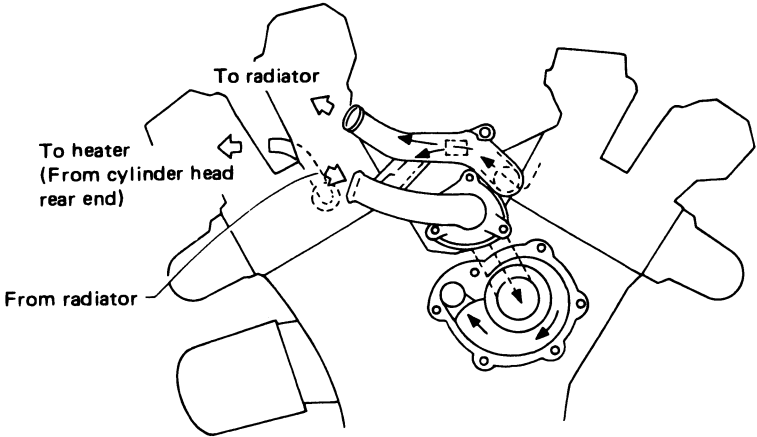
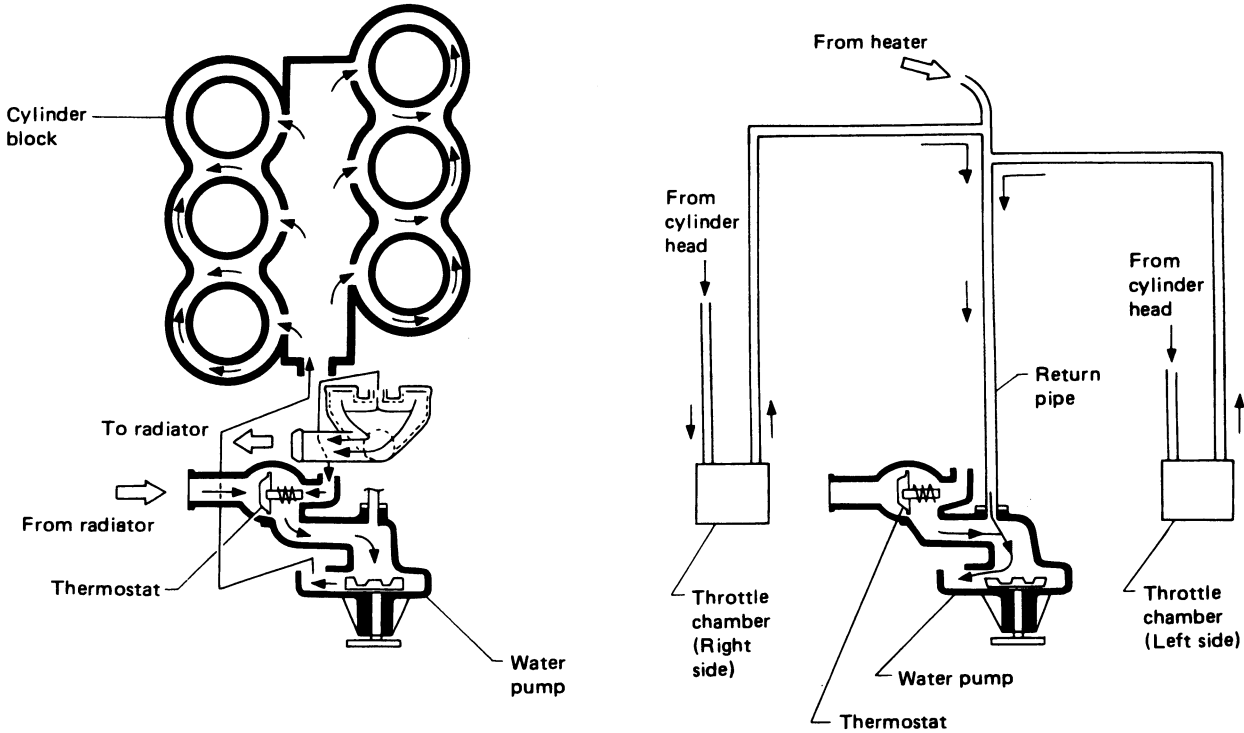

- ◄ : Thermostat open
- ◄ : Thermostat closed
- ◄ : Turbo model only

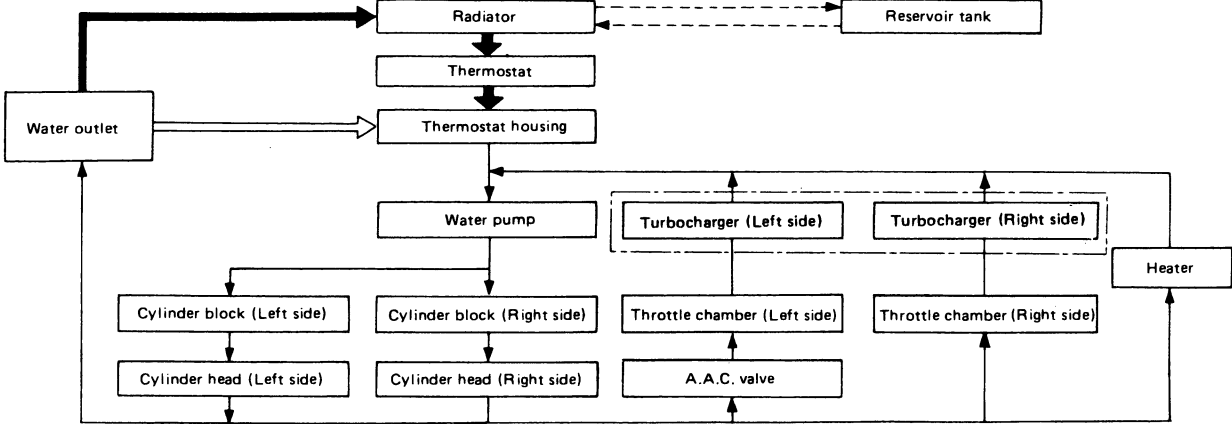

SLC343A

ENGINE COOLING SYSTEM

System Check

WARNING:

Never remove the radiator cap when the engine is hot; serious burns could be caused by high pressure fluid escaping from the radiator.

Wrap a thick cloth around the cap and carefully remove by turning it a quarter turn to allow built-up pressure to escape. Then continue to turn the cap until it can be removed safely.

CHECKING COOLING SYSTEM HOSES

Check hoses for improper attachment, leaks, cracks, damage, loose connections, chafing and deterioration.

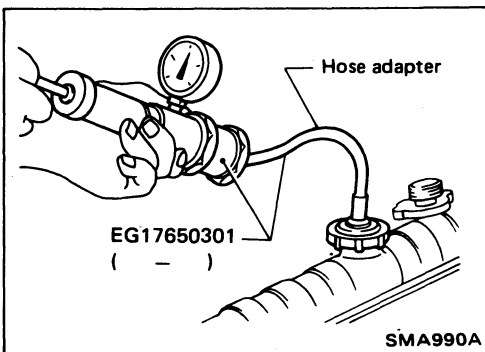

CHECKING COOLING SYSTEM FOR LEAKS

To check for leakage, apply pressure to the cooling system with a tester.

Testing pressure:

98 kPa (1.0 kg/cm², 14 psi)

CAUTION:

Higher than the specified pressure may cause radiator damage.

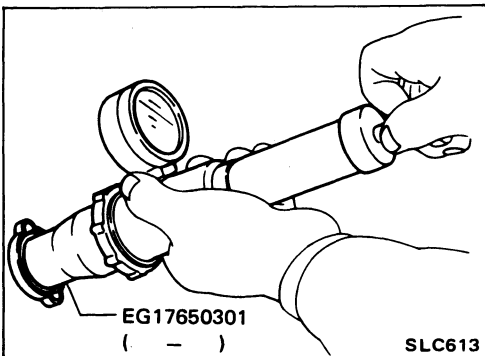

CHECKING RADIATOR CAP

To check radiator cap, apply pressure to cap with a tester.

Radiator cap relief pressure:

78 - 98 kPa (0.8 - 1.0 kg/cm², 11 - 14 psi)

Water Pump

REMOVAL AND INSTALLATION

1. Drain coolant from drain cocks on both sides of cylinder block and radiator.
2. Remove the following parts:
 - Under cover
 - Radiator
 - Drive belts
 - Cooling fan and coupling
 - Water inlet and outlet

ENGINE COOLING SYSTEM

Water Pump (Cont'd)

- Crank pulley
- Timing belt cover
- 3. Remove water pump
- 4. After repairing or replacing water pump, install any parts removed in reverse order of removal.

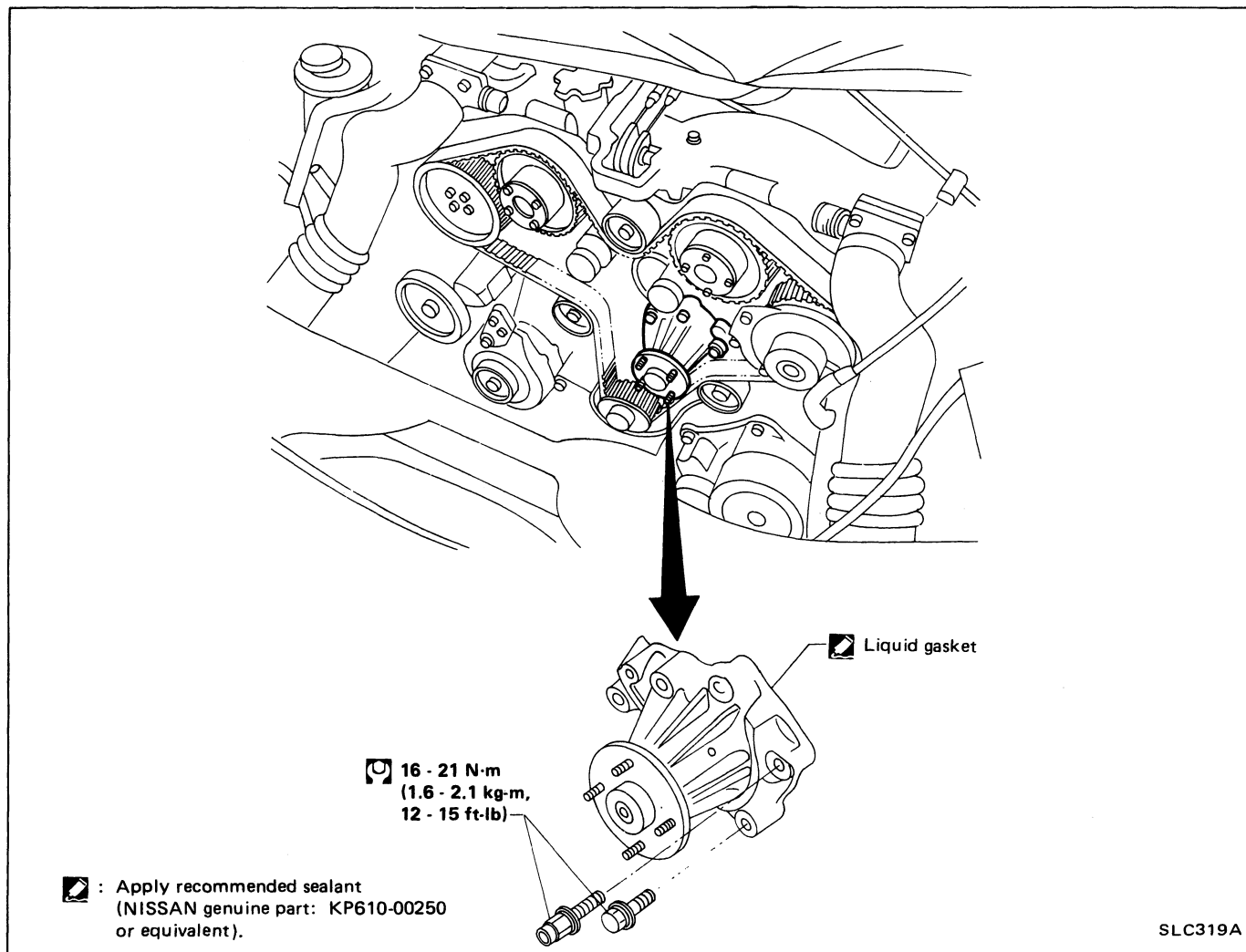

CAUTION:

- When removing water pump assembly, be careful not to get coolant on timing belt.
- Water pump cannot be disassembled and should be replaced as a unit.
- After installing water pump, connect hose and clamp securely, then check for leaks using radiator cap tester.

INSPECTION

1. Check for badly rusted or corroded vanes and body assembly.
2. Check for rough operation due to excessive end play.

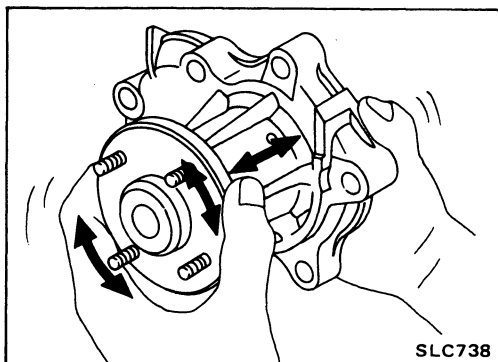

ENGINE COOLING SYSTEM

Thermostat

REMOVAL AND INSTALLATION

1. Drain coolant from drain cocks on both sides of cylinder block and radiator.
2. Remove the following parts:
 - Under cover
 - Radiator upper hose
 - Radiator shroud
 - Fan belt
 - Cooling fan and coupling
 - Water inlet
3. Remove thermostat.

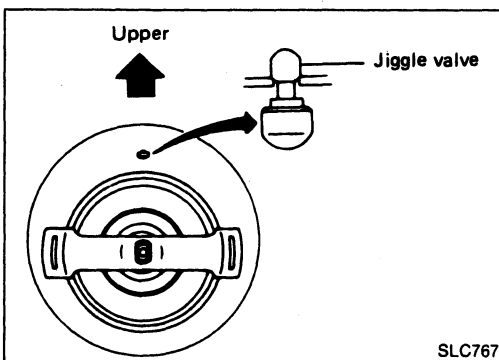
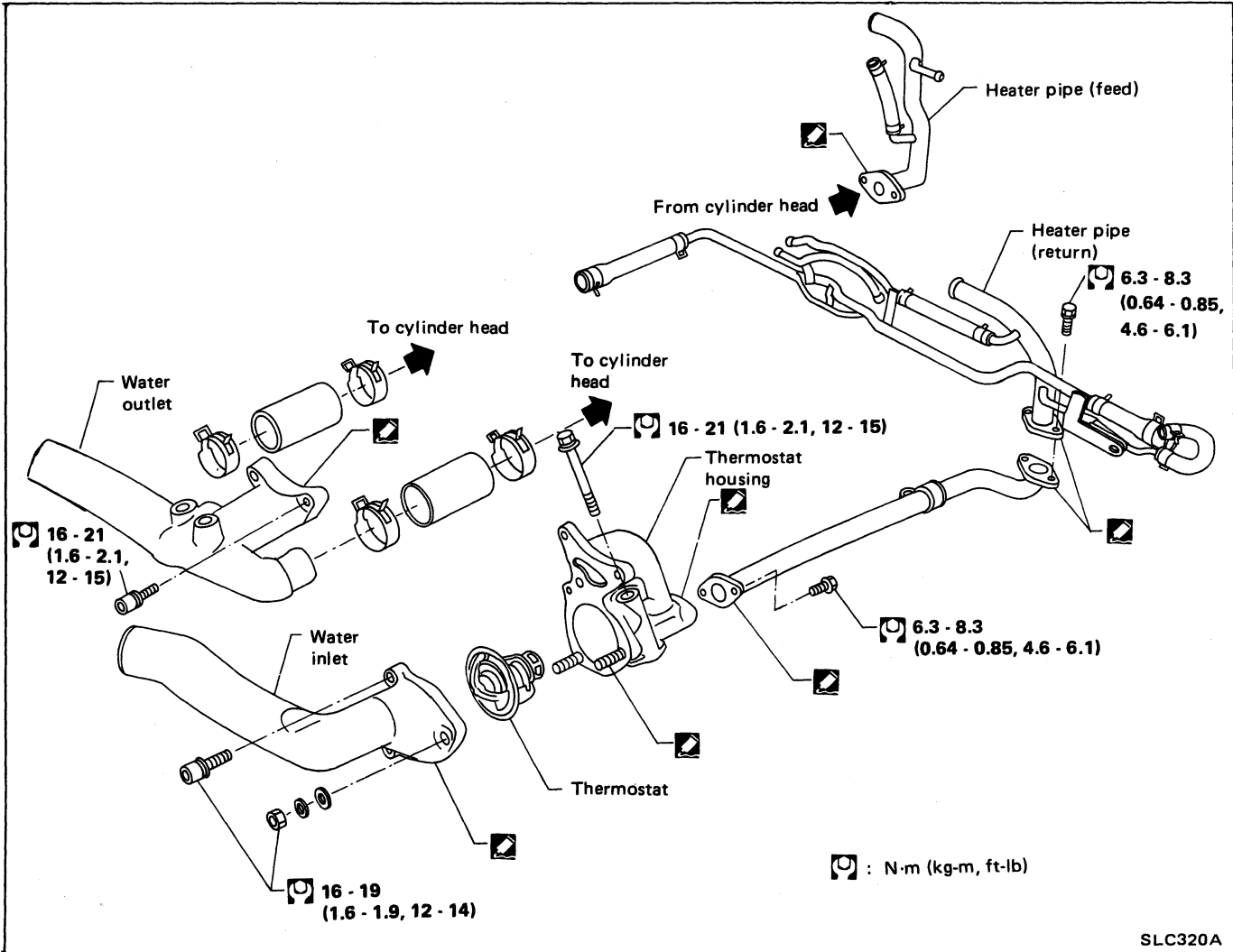

4. After repairing or replacing thermostat, install thermostat with jiggle valve facing upward.

ENGINE COOLING SYSTEM

Thermostat (Cont'd)

INSPECTION

1. Check valve seating condition at ordinary room temperatures. It should seat tightly.

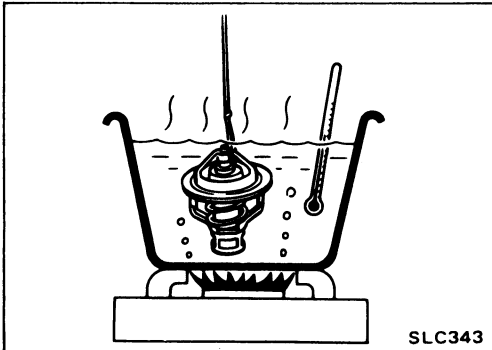

2. Check valve opening temperature and maximum valve lift.

		Standard
Valve opening temperature	°C (°F)	76.5 (170)
Maximum valve lift	mm/°C (in/°F)	10/90 (0.39/194)

3. Then check if valve is 5°C (9°F) below valve opening temperature.
 - After installation, run engine for a few minutes, and check for leaks.
 - Be careful not to spill coolant over engine compartment. Use a rag to absorb coolant.

ENGINE COOLING SYSTEM

Radiator

REMOVAL AND INSTALLATION

1. Drain coolant from radiator drain cock.
2. Remove under cover.
3. Disconnect radiator upper and lower hoses.
4. Remove A/T oil cooler hoses. (A/T model only)
5. Remove radiator lower shroud.
6. Remove radiator.
7. After repairing or replacing radiator, install any part removed in reverse order of removal.

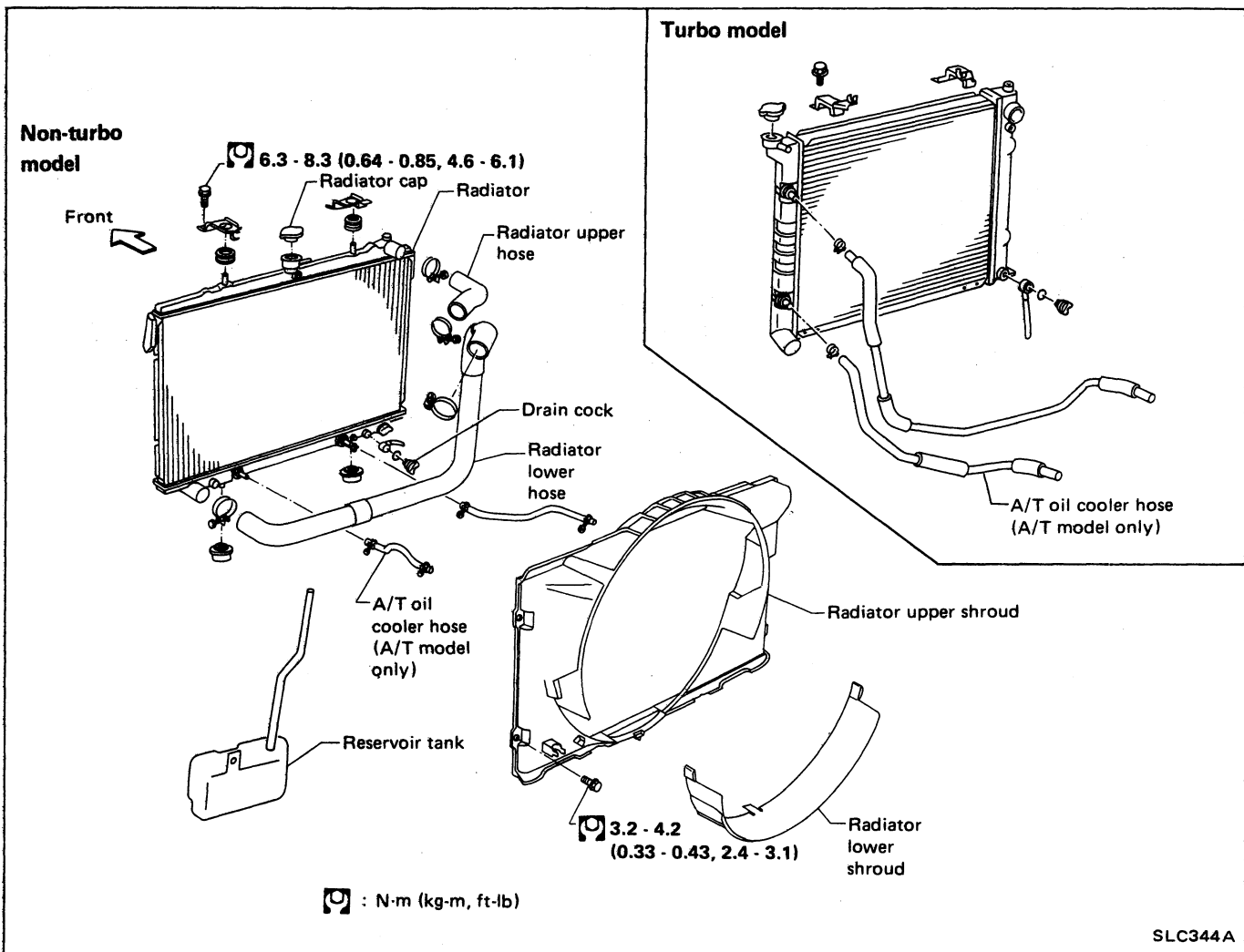

Electric Cooling Fan Control System

Radiator (Condenser) fan is controlled by E.C.C.S. control unit.
For details, refer to EF & EC section.

ENGINE COOLING SYSTEM

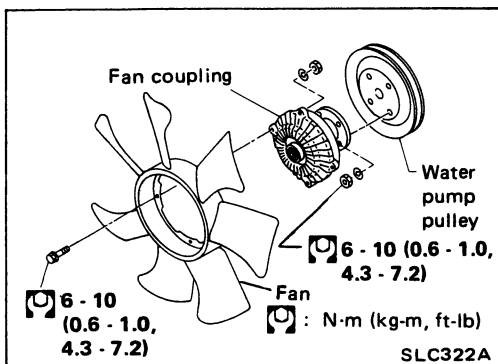

Cooling Fan DISASSEMBLY AND ASSEMBLY

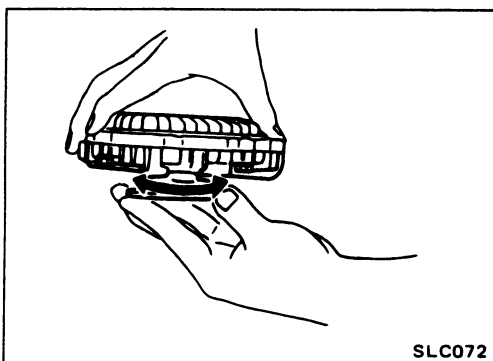

INSPECTION

Check fan coupling for rough operation, oil leakage or bent bimetal.

SERVICE DATA AND SPECIFICATIONS (S.D.S.)

Engine Lubrication System

Oil pressure check

Engine rpm	Approximate discharge pressure kPa (kg/cm ² , psi)
Idle speed	More than 78 (0.8, 11)
3,000	353 - 451 (3.6 - 4.6, 51 - 65)

Oil pump

	Unit: mm (in)
Body to outer gear clearance ①	0.110 - 0.200 (0.0043 - 0.0079)
Inner gear to crescent clearance ②	0.223 - 0.333 (0.0088 - 0.0131)
Outer gear to crescent clearance ③	0.210 - 0.320 (0.0083 - 0.0126)
Housing to inner gear side clearance ④	0.050 - 0.090 (0.0020 - 0.0035)
Housing to outer gear side clearance ⑤	0.050 - 0.110 (0.0020 - 0.0043)

Engine Cooling System

Thermostat

	Standard
Valve opening temperature °C (°F)	76.5 (170)
Maximum valve lift mm/°C (in/°F)	10/90 (0.39/194)

ENGINE FUEL & EMISSION CONTROL SYSTEM

SECTION **EF & EC**

EF & EC

CONTENTS

PREPARATION	EF & EC- 2
PRECAUTIONS	EF & EC- 3
ENGINE AND EMISSION CONTROL OVERALL SYSTEM	EF & EC- 4
ENGINE AND EMISSION CONTROL PARTS DESCRIPTION	EF & EC- 14
ENGINE AND EMISSION CONTROL SYSTEM DESCRIPTION	EF & EC- 21
IDLE SPEED/IGNITION TIMING/IDLE MIXTURE RATIO INSPECTION	EF & EC- 37
TROUBLE DIAGNOSES	EF & EC- 42
FUEL INJECTION CONTROL SYSTEM INSPECTION	EF & EC-191
EVAPORATIVE EMISSION CONTROL SYSTEM	EF & EC-193
CRANKCASE EMISSION CONTROL SYSTEM	EF & EC-195
SERVICE DATA AND SPECIFICATIONS (S.D.S.)	EF & EC-196

For assistance with wiring diagrams:

- Read G1 section, "HOW TO READ WIRING DIAGRAMS".
 - See EL section, "POWER SUPPLY ROUTING" for power distribution circuit.
- When you perform trouble diagnoses, read G1 section, "HOW TO FOLLOW FLOW CHART IN TROUBLE DIAGNOSES".

PREPARATION

SPECIAL SERVICE TOOLS

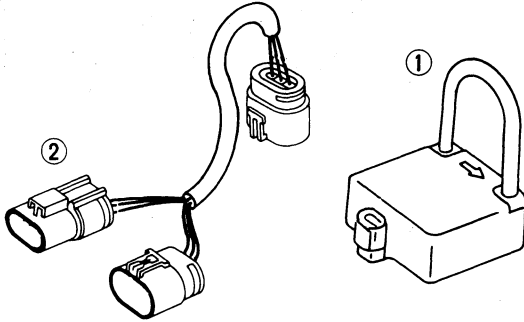
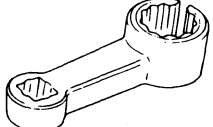
Tool number (Kent-Moore No.) Tool name	Description
① KV109D0010 (J-36777-1) Ignition timing adapter coil ② KV10114200 (J-38386) Adapter harness	 <p>Measuring ignition timing</p> <p>The diagram shows two tools. Tool 1 is a rectangular box with a curved handle on top and a cylindrical connector on the side. Tool 2 is a harness consisting of a black cable with a multi-pin connector at one end and a smaller cylindrical connector at the other. A separate cylindrical component is also shown, which is part of the ignition timing adapter coil.</p>
KV10114400 (J-38365) Exhaust gas sensor wrench	 <p>Loosening or tightening exhaust gas sensor</p> <p>The diagram shows a specialized wrench with a long handle and a circular head that has a series of vertical ridges or teeth on its inner surface, designed to grip the hexagonal base of an exhaust gas sensor.</p>

PRECAUTIONS

E.C.U.

- Do not disassemble E.C.C.S. control unit (E.C.U.).
- Do not turn diagnosis mode selector forcibly.
- If a battery terminal is disconnected, the memory will return to the ROM value. The E.C.C.S. will now start to self-control at its initial value. Engine operation can vary slightly when the terminal is disconnected. However, this is not an indication of a problem. Do not replace parts because of a slight variation.

BATTERY

- Always use a 12 volt battery as power source.
- Do not attempt to disconnect battery cables while engine is running.

INJECTOR

- Do not disconnect injector harness connectors with engine running.
- Do not apply battery power directly to injectors.

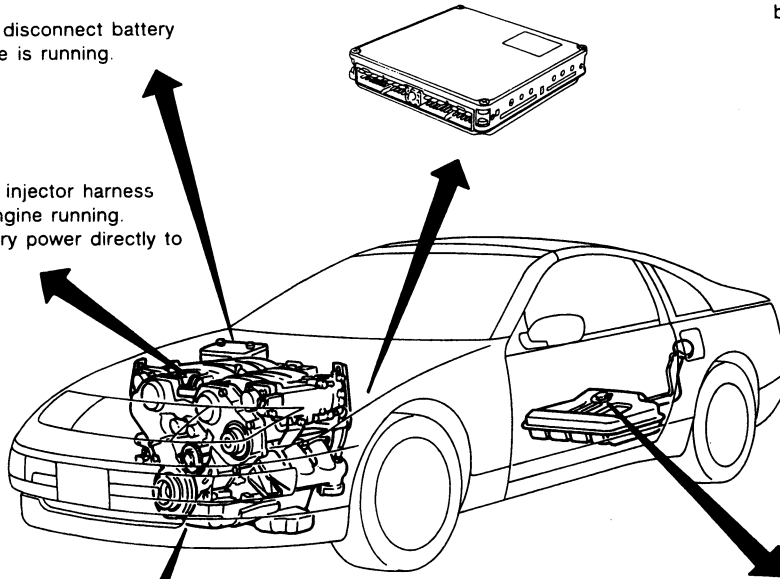

WIRELESS EQUIPMENT

- When installing C.B. ham radio or a mobile phone, be sure to observe the following as it may adversely affect electronic control systems depending on its installation location.
 - 1) Keep the antenna as far as possible from the electronic control units.
 - 2) Keep the antenna feeder line more than 20 cm (7.9 in) away from the harness of electronic controls. Do not let them run parallel for a long distance.
 - 3) Adjust the antenna and feeder line so that the standing-wave ratio can be kept smaller.
 - 4) Be sure to ground the radio to vehicle body.

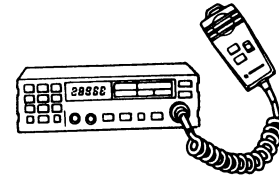

E.C.C.S. PARTS HANDLING

- Handle air flow meter carefully to avoid damage.
- Do not disassemble air flow meter.
- Do not clean air flow meter with any type of detergent.
- Do not disassemble auxiliary air control valve.
- Even a slight leak in the air intake system can cause serious problems.
- Do not shock or jar the crank angle sensor.



WHEN STARTING

- Do not depress accelerator pedal when starting.
- Immediately after starting, do not rev up engine unnecessarily.
- Do not rev up engine just prior to shutdown.

FUEL PUMP

- Do not operate fuel pump when there is no fuel in lines.
- Tighten fuel hose clamps to the specified torque.

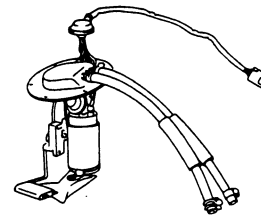

E.C.C.S. HARNESS HANDLING

- Securely connect E.C.C.S. harness connectors. A poor connection can cause an extremely high (surge) voltage to develop in coil and condenser, thus resulting in damage to ICs.
- Keep E.C.C.S. harness at least 10 cm (3.9 in) away from adjacent harnesses, to prevent an E.C.C.S. system malfunction due to receiving external noise, degraded operation of ICs, etc.
- Keep E.C.C.S. parts and harnesses dry.
- Before removing parts, turn off ignition switch and then disconnect battery ground cable.

SUPPLEMENTAL RESTRAINT SYSTEM "AIR BAG"

The Supplemental Restraint System "Air Bag" helps to reduce the risk or severity of injury to the driver in a frontal collision. The Supplemental Restraint System consists of an air bag (located in the center of the steering wheel), sensors, a control unit, warning lamp, wiring harness and spiral cable. Information necessary to service the system safely is included in the **BF** section of this Service Manual.

WARNING:

- To avoid rendering the SRS inoperative, which could lead to personal injury or death in the event of a severe frontal collision, all maintenance must be performed by an authorized NISSAN dealer.
- Improper maintenance, including incorrect removal and installation of the SRS, can lead to personal injury caused by unintentional activation of the system.
- All SRS electrical wiring harnesses and connectors are covered with yellow outer insulation. Do not use electrical test equipment on any circuit related to the SRS "Air Bag".

SEF3231

ENGINE AND EMISSION CONTROL OVERALL SYSTEM

E.C.C.S. Component Parts Location

NON-TURBO MODEL

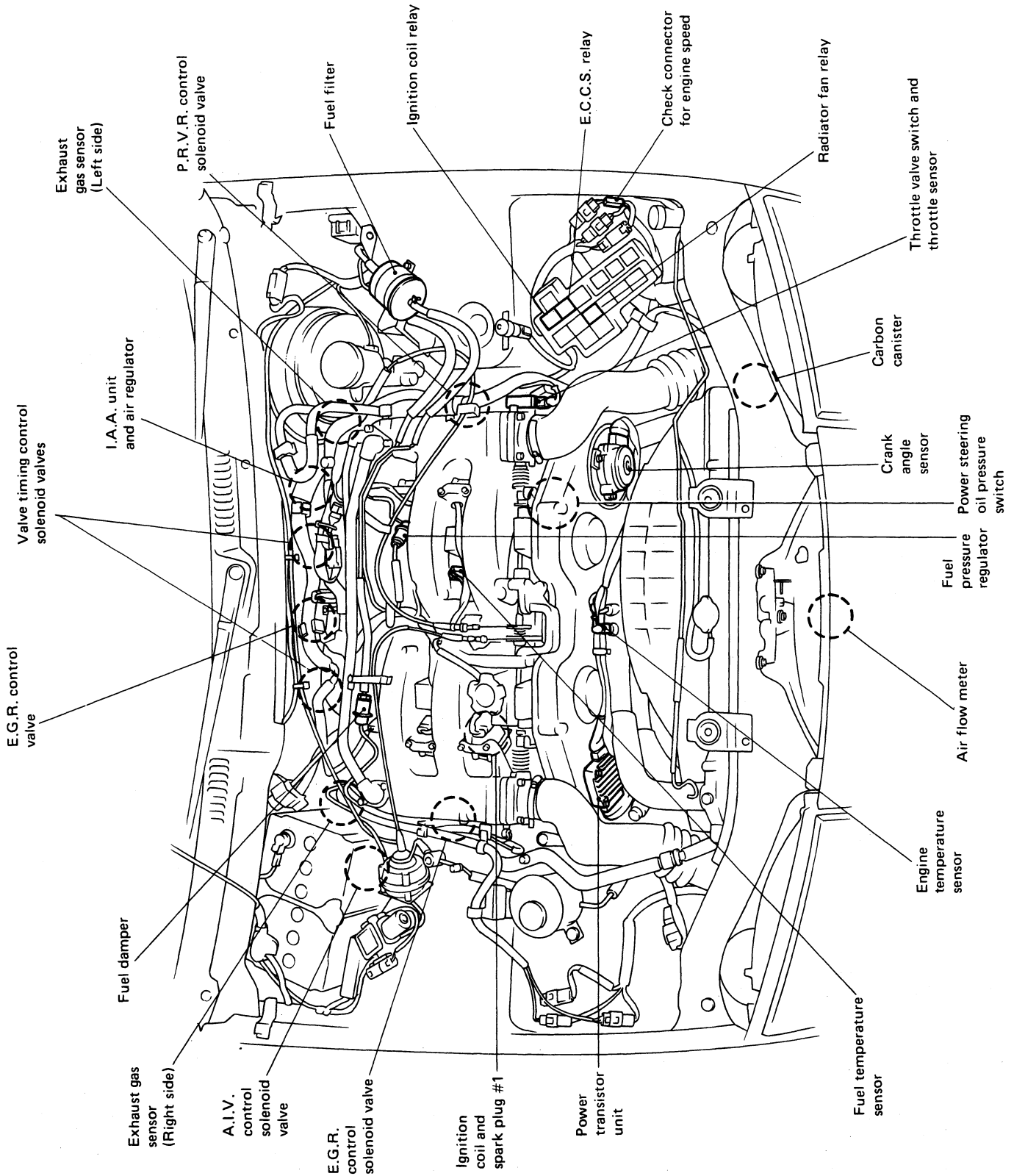

SEF193J

ENGINE AND EMISSION CONTROL OVERALL SYSTEM

E.C.C.S. Component Parts Location (Cont'd)

TURBO MODEL

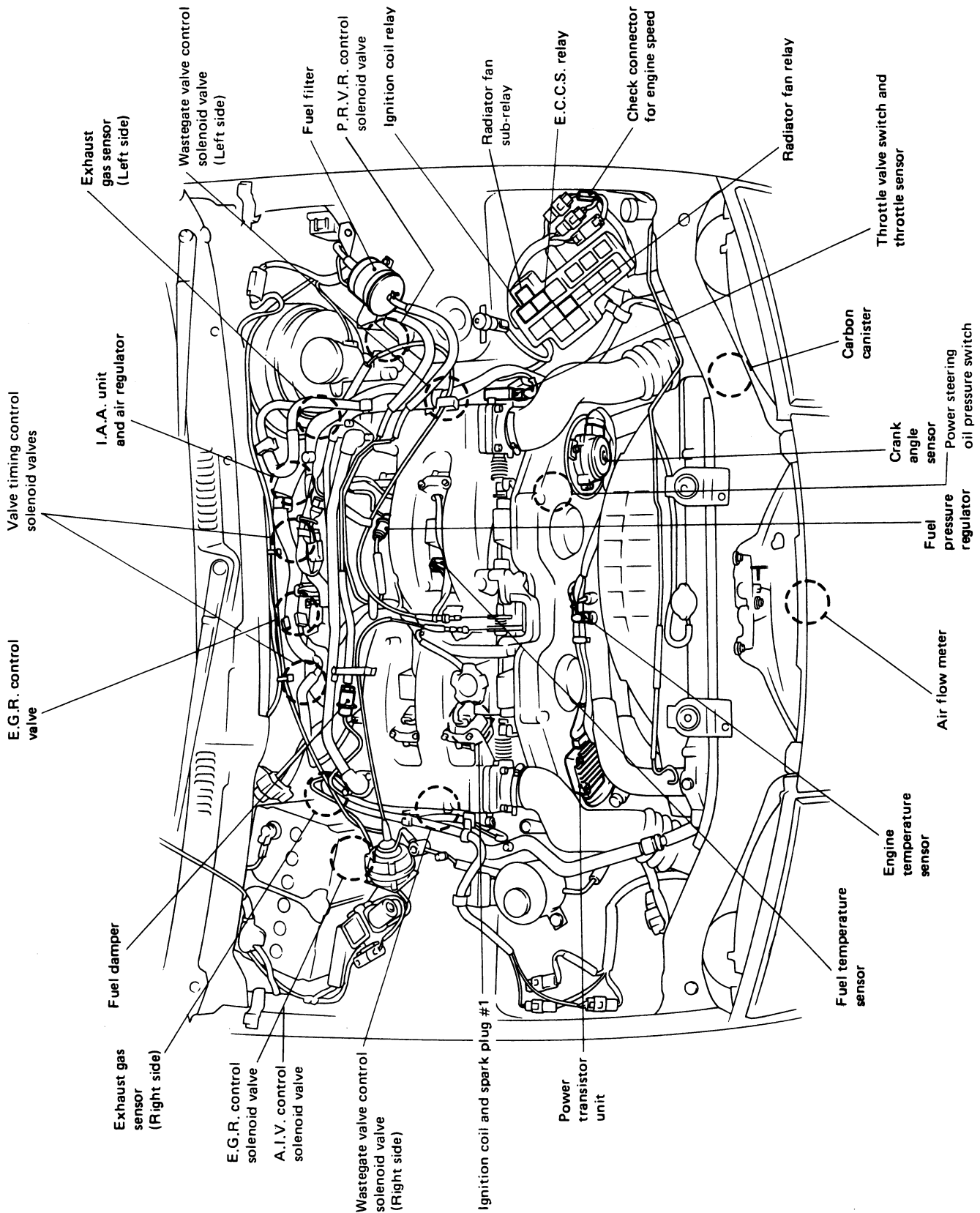

SEF194J

ENGINE AND EMISSION CONTROL OVERALL SYSTEM

E.C.C.S. Component Parts Location (Cont'd)

NON-TURBO MODEL

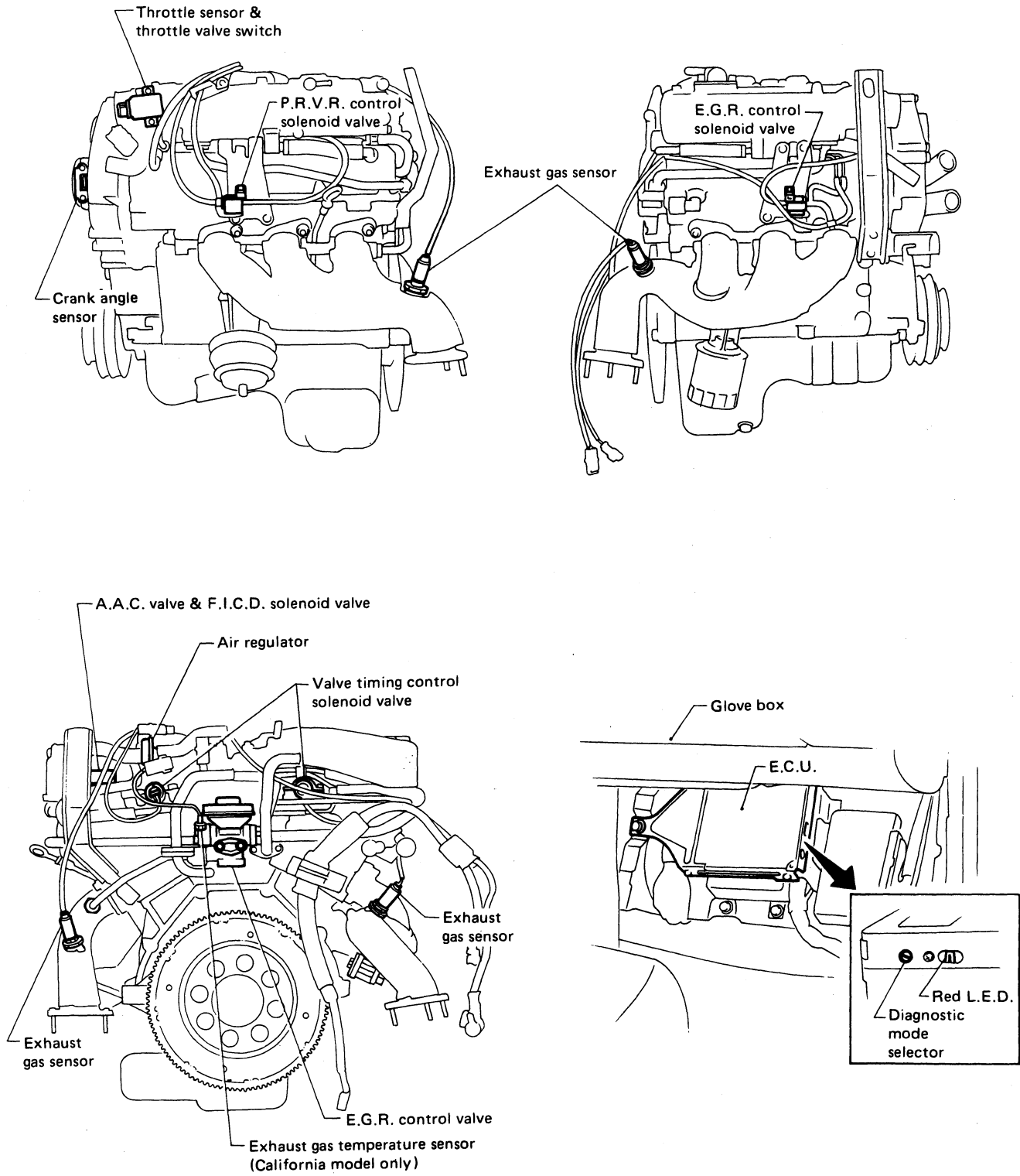

ENGINE AND EMISSION CONTROL OVERALL SYSTEM

E.C.C.S. Component Parts Location (Cont'd)

TURBO MODEL

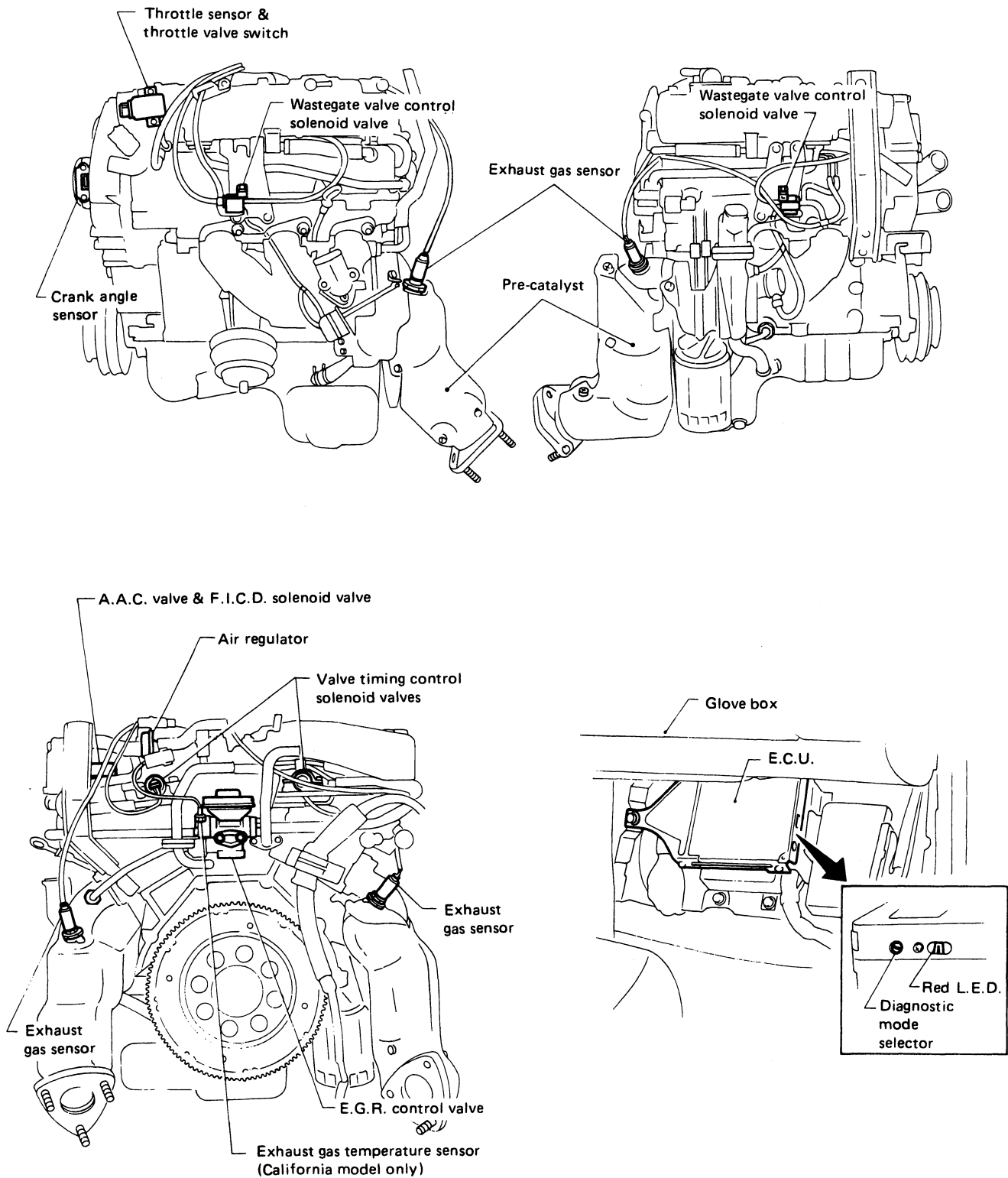

ENGINE AND EMISSION CONTROL OVERALL SYSTEM

System Diagram

NON-TURBO MODEL

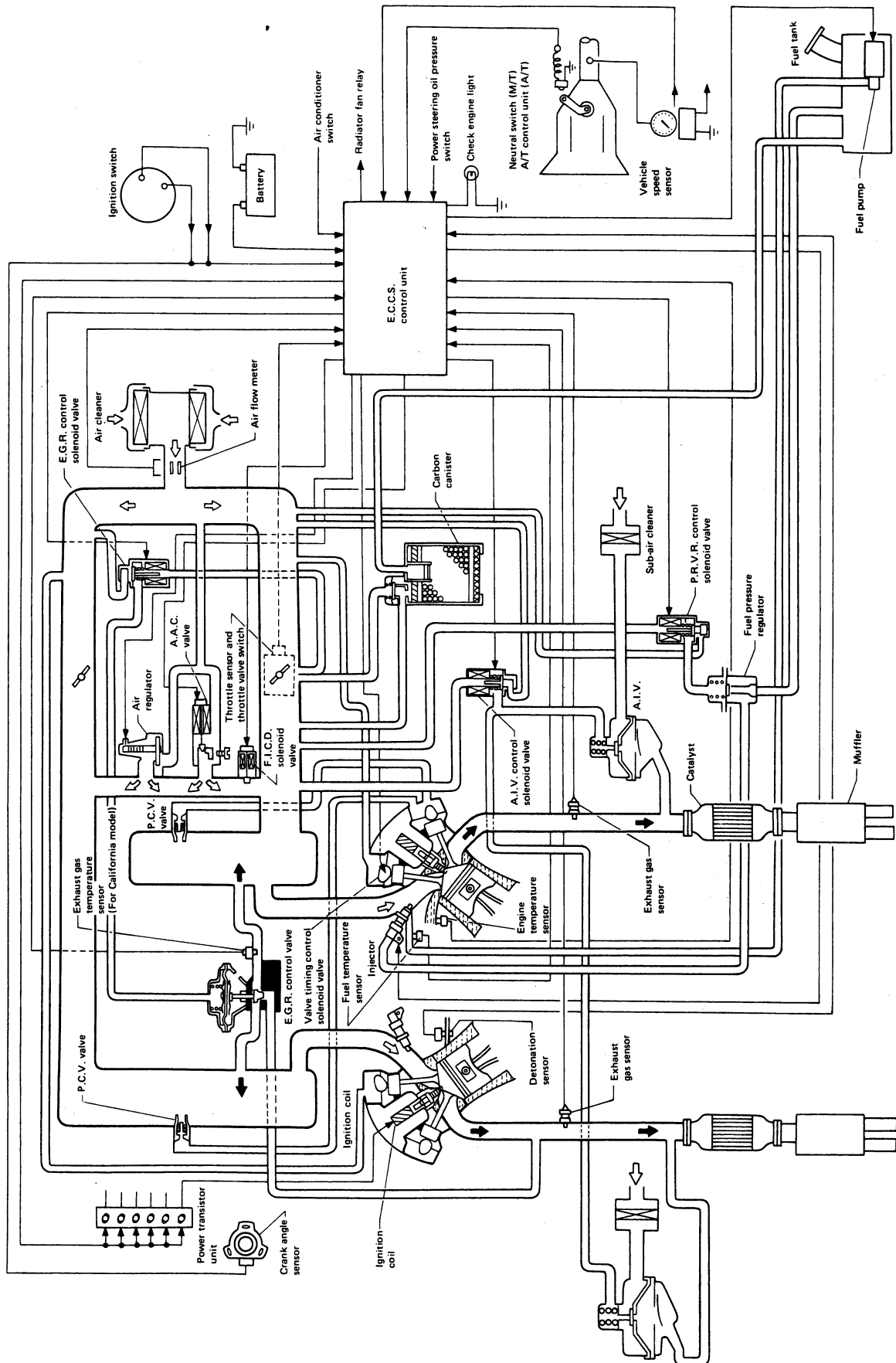

SEF406J

ENGINE AND EMISSION CONTROL OVERALL SYSTEM

System Diagram (Cont'd)

TURBO MODEL

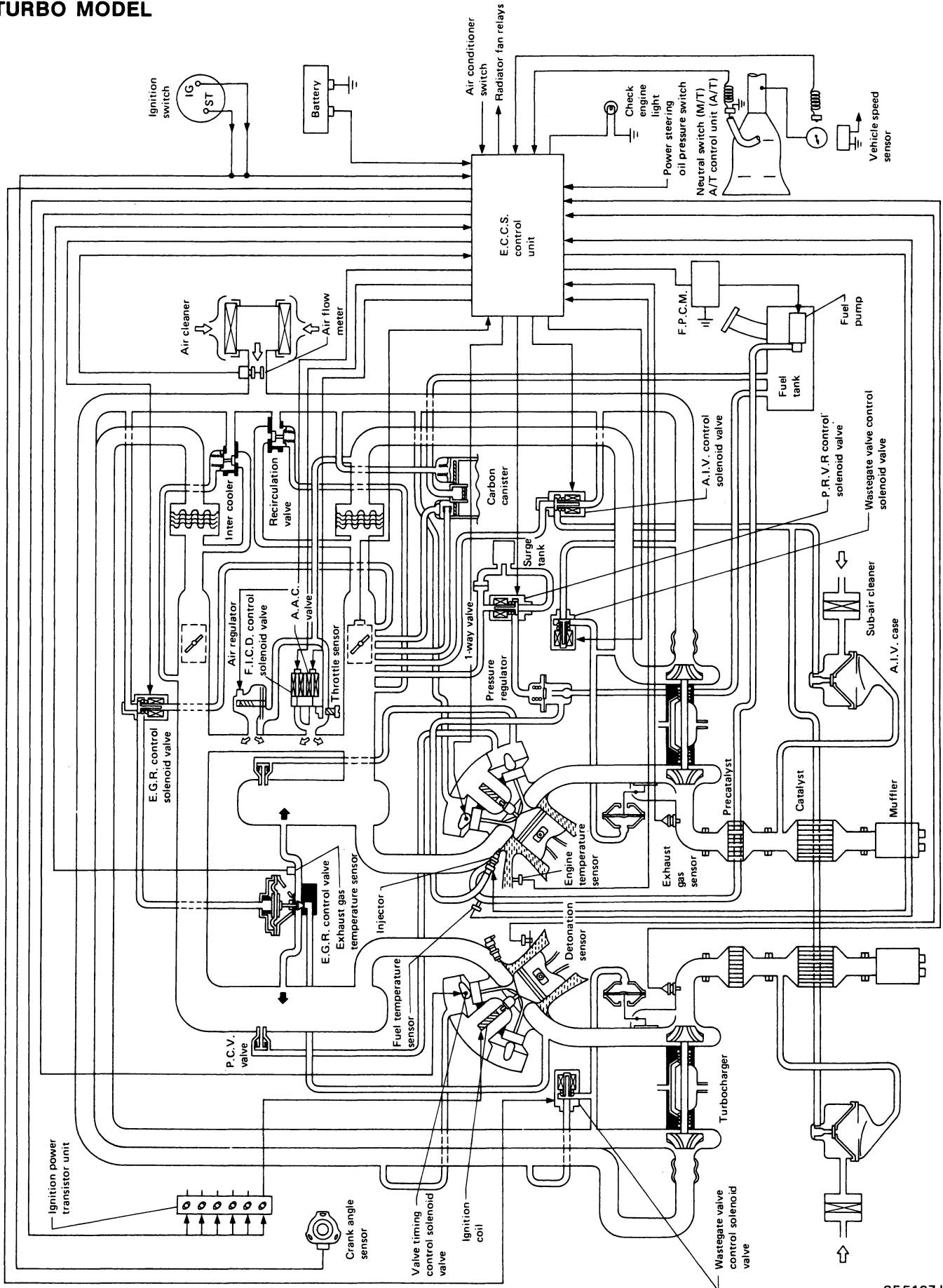

SEF197J

ENGINE AND EMISSION CONTROL OVERALL SYSTEM

System Chart

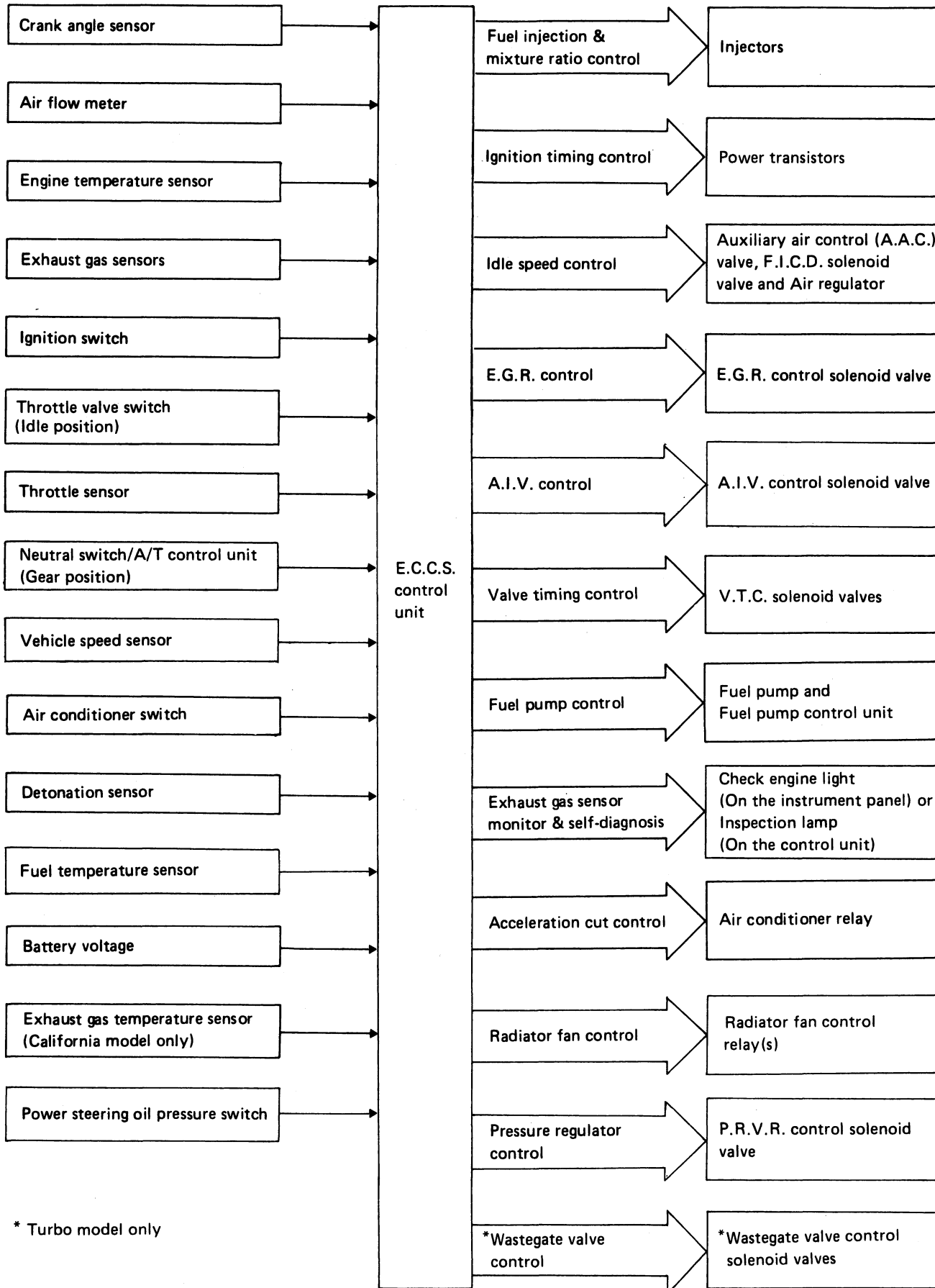

ENGINE AND EMISSION CONTROL OVERALL SYSTEM

Vacuum Hose Drawing

NON-TURBO MODEL

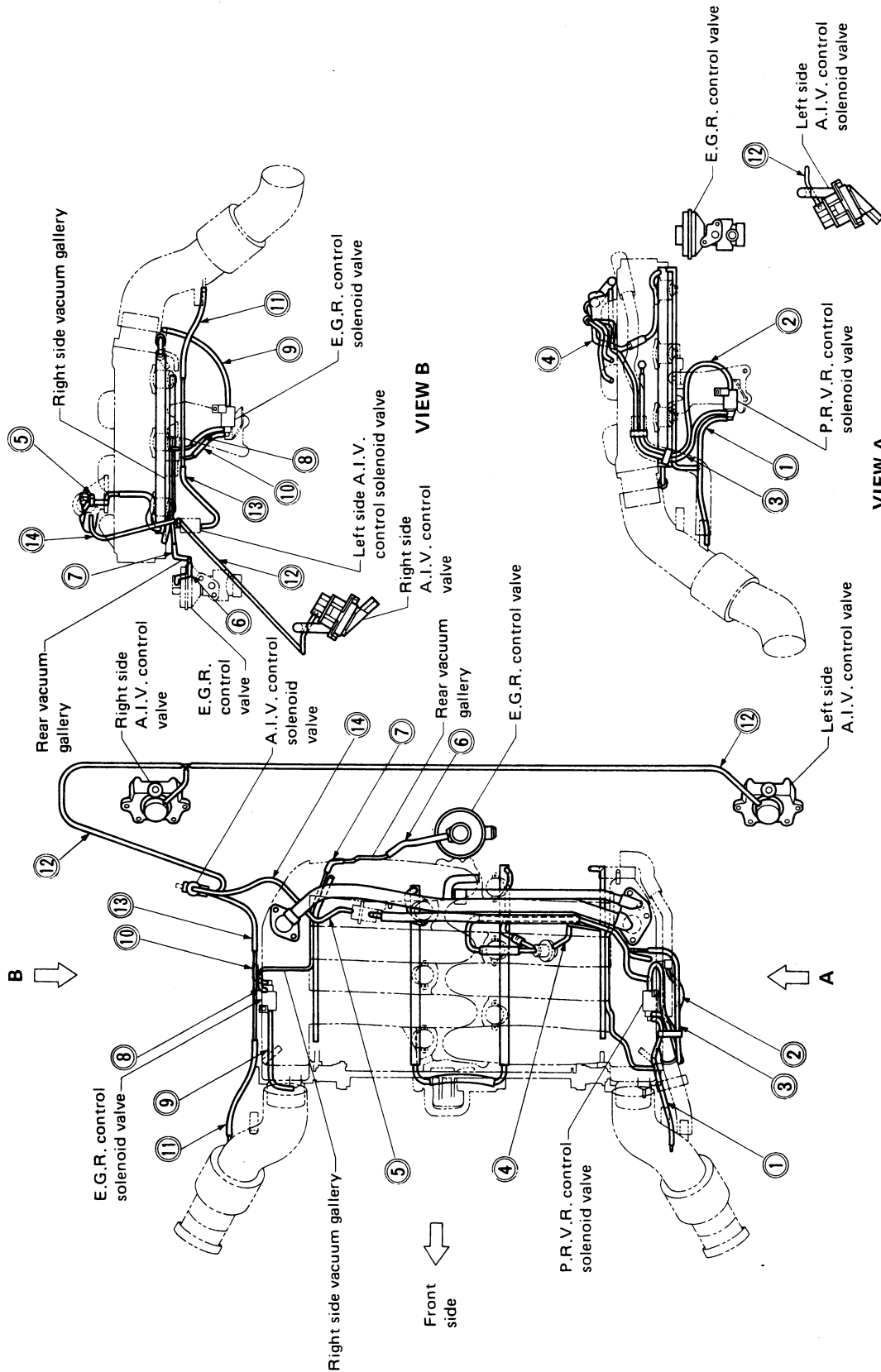

- ① P.R.V.R. control solenoid valve to Air duct
- ② P.R.V.R. control solenoid valve to Intake manifold collector
- ③ P.R.V.R. control solenoid valve to Fuel pressure regulator
- ④ Fuel pressure regulator to Vacuum gallery
- ⑤ Fuel damper to Balance tube
- ⑥ E.G.R. control valve to Rear side vacuum gallery
- ⑦ Rear side vacuum gallery to Right side vacuum gallery
- ⑧ E.G.R. control solenoid valve to Right side vacuum gallery
- ⑨ Throttle chamber to E.G.R. control solenoid valve
- ⑩ Air gallery to E.G.R. control solenoid valve
- ⑪ Air duct to Air gallery
- ⑫ A.I.V. control solenoid valve to A.I.V. control valve
- ⑬ A.I.V. control solenoid valve to Air gallery
- ⑭ A.I.V. control solenoid valve to Balance tube

- ① Left side A.I.V. control valve
- ② P.R.V.R. control solenoid valve
- ③ E.G.R. control valve
- ④ Right side A.I.V. control solenoid valve
- ⑤ Rear vacuum gallery
- ⑥ E.G.R. control valve
- ⑦ Right side A.I.V. control solenoid valve
- ⑧ E.G.R. control valve
- ⑨ Right side A.I.V. control valve
- ⑩ Rear vacuum gallery
- ⑪ E.G.R. control valve
- ⑫ A.I.V. control solenoid valve
- ⑬ Right side A.I.V. control solenoid valve
- ⑭ Rear vacuum gallery

ENGINE AND EMISSION CONTROL OVERALL SYSTEM

Vacuum Hose Drawing (Cont'd)

TURBO MODEL

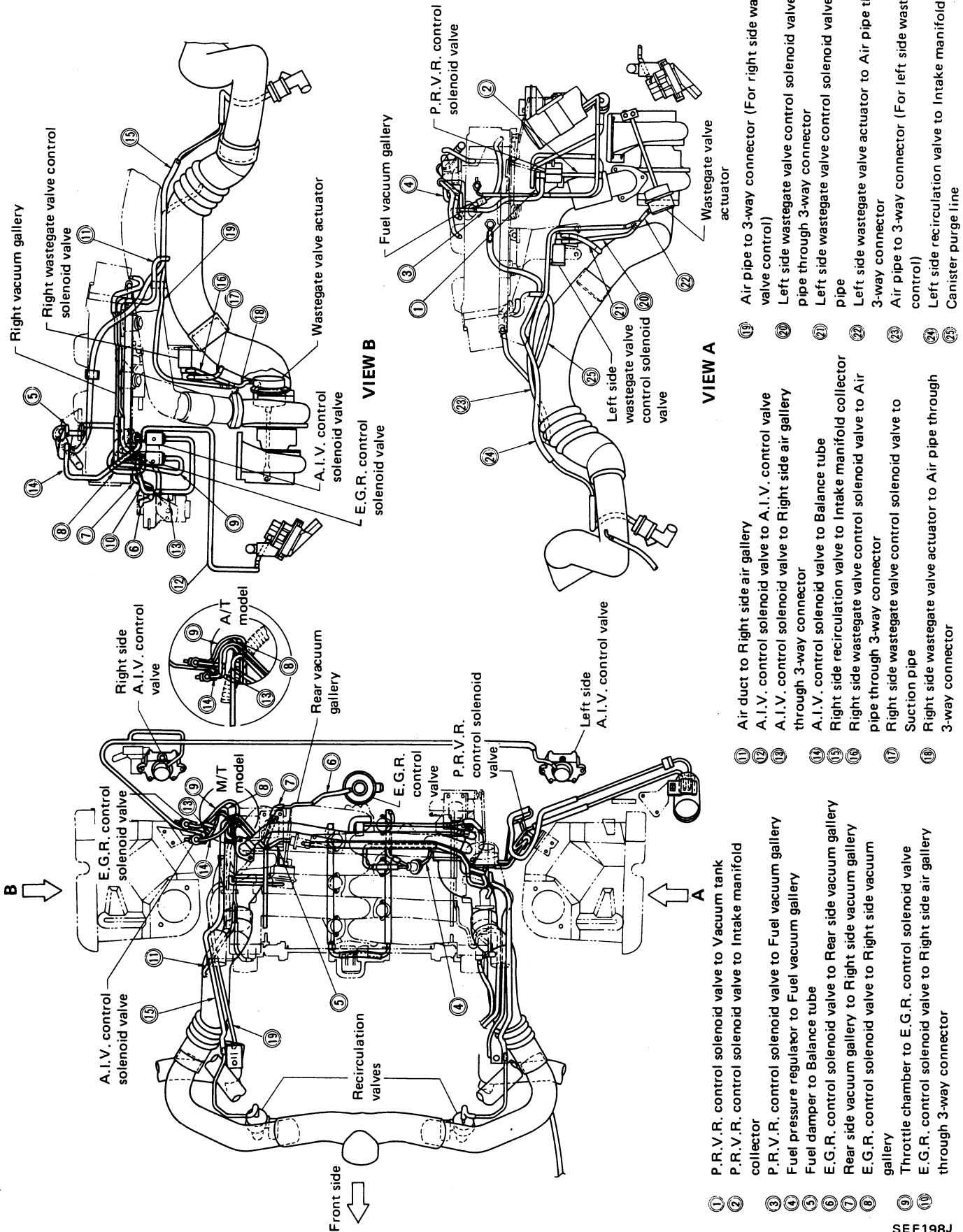

ENGINE AND EMISSION CONTROL OVERALL SYSTEM

Circuit Diagram

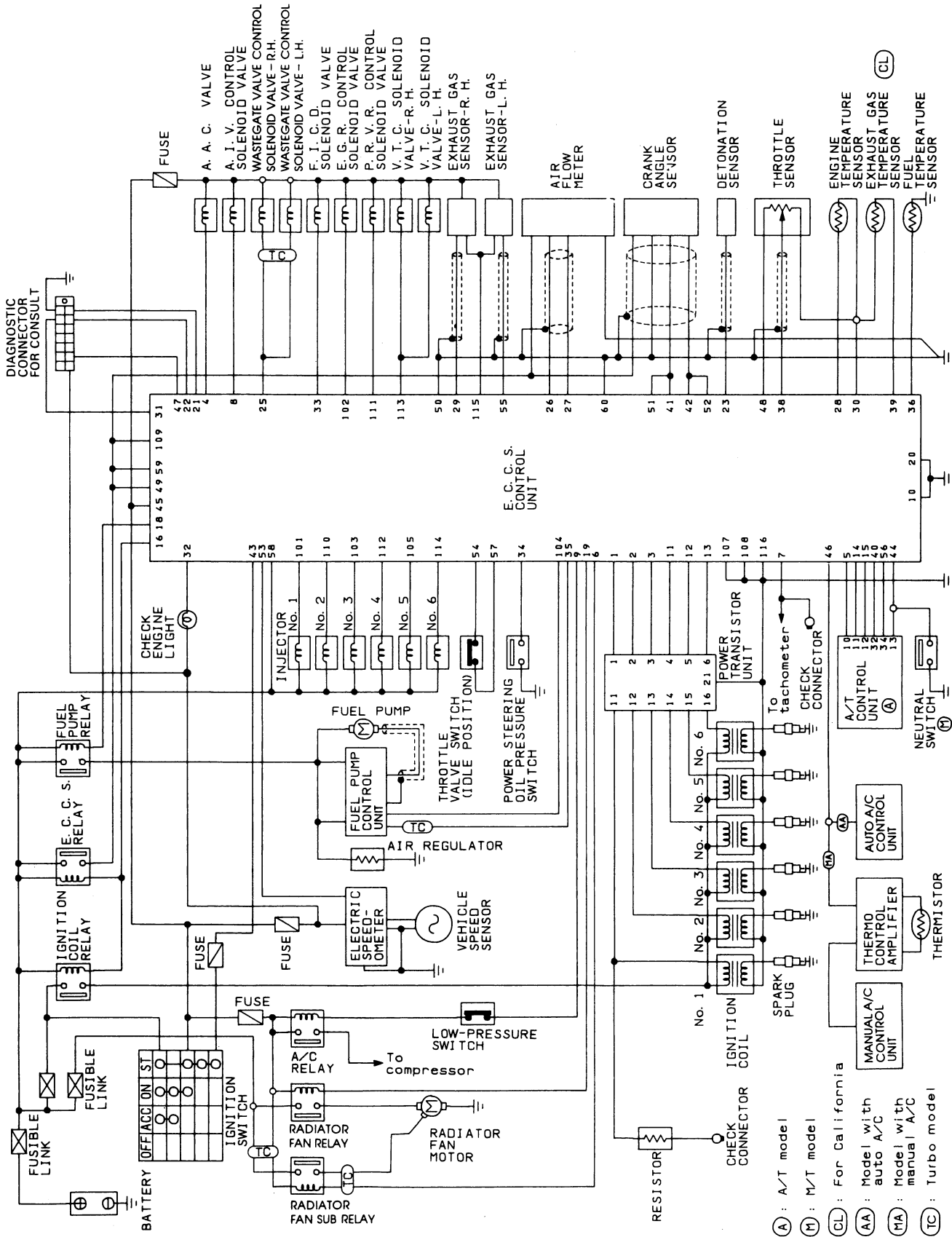

ENGINE AND EMISSION CONTROL PARTS DESCRIPTION

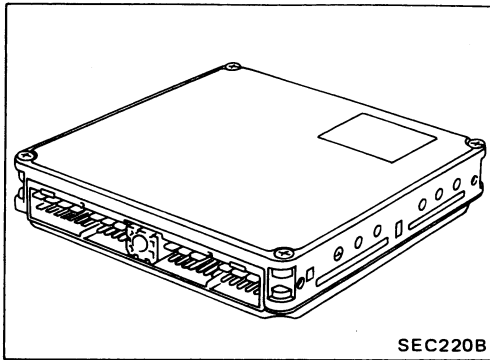

E.C.C.S. Control Unit (E.C.U.)

The E.C.U. consists of a microcomputer, an inspection lamp, a diagnostic mode selector, and connectors for signal input and output and for power supply. The unit controls the engine.

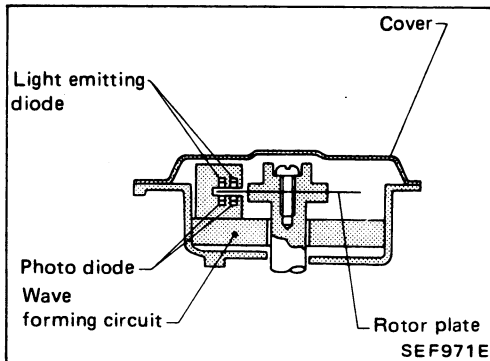

Crank Angle Sensor

The crank angle sensor is a basic component of the E.C.C.S. It monitors engine speed and piston position, and sends signals to the E.C.U. to control fuel injection, ignition timing and other functions.

The crank angle sensor has a rotor plate and a wave-forming circuit. The rotor plate has 360 slits for 1° signal and 6 slits for 120° signal. Light Emitting Diodes (L.E.D.) and photo diodes are built in the wave-forming circuit.

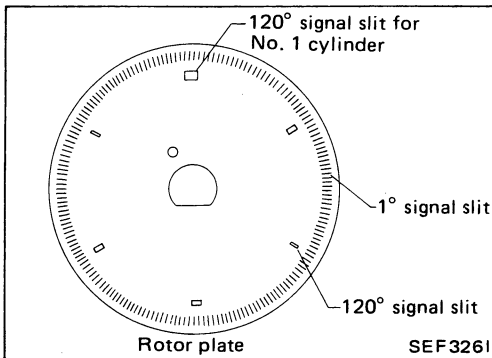

When the rotor plate passes between the L.E.D. and the photo diode, the slits in the rotor plate continually cut the light being transmitted to the photo diode from the L.E.D. This generates rough-shaped pulses which are converted into on-off pulses by the wave-forming circuit, which are sent to the E.C.U.

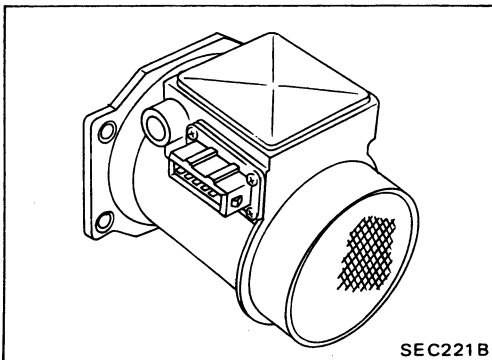

Air Flow Meter

The air flow meter measures the intake air flow rate by measuring a part of the entire flow. Measurements are made in such a way that the E.C.U. receives electrical output signals varied by the amount of heat emitting from the hot film placed in the stream of the intake air.

When intake air flows into the intake manifold through a route around the hot film, the heat generated from the hot film is taken away by the air. The amount of heat reduction depends on the air flow. The temperature of the hot film is automatically controlled to a certain number of degrees.

Therefore, it is necessary to supply the hot film with more electric current in order to maintain the temperature of the hot film. The E.C.U. detects the air flow by means of this current change.

ENGINE AND EMISSION CONTROL PARTS DESCRIPTION

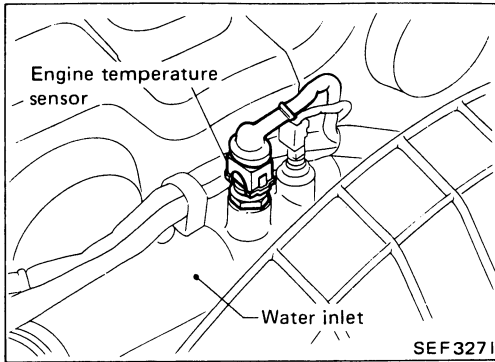

Engine Temperature Sensor

The engine temperature sensor, located on the top of water inlet housing, detects engine coolant temperature and transmits a signal to the E.C.U.

The temperature sensing unit employs a thermistor which is sensitive to the change in temperature. Electrical resistance of the thermistor decreases in response to the temperature rise.

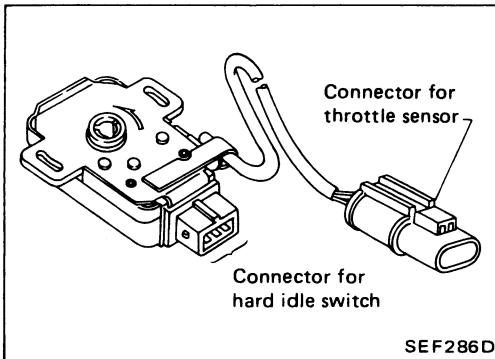

Throttle Sensor & Soft/Hard Idle Switch

The throttle sensor responds to accelerator pedal movement. This sensor is a kind of potentiometer which transforms the throttle valve position into output voltage, and emits the voltage signal to the E.C.U. In addition, the sensor detects the opening and closing speed of the throttle valve and feeds the voltage signal to the E.C.U.

Idle position of the throttle valve is determined by the E.C.U. receiving the signal from the throttle sensor. This system is called "soft idle switch". It controls engine operation such as fuel cut. On the other hand, "hard idle switch", which is built in the throttle sensor unit, is used for engine control when soft idle switch is malfunctioning.

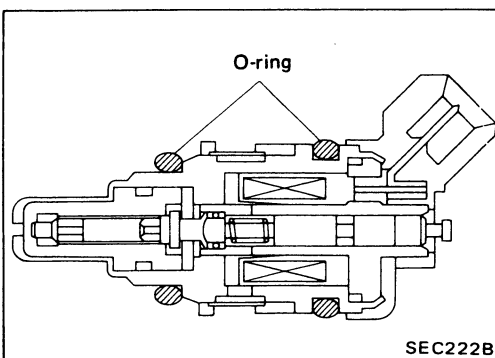
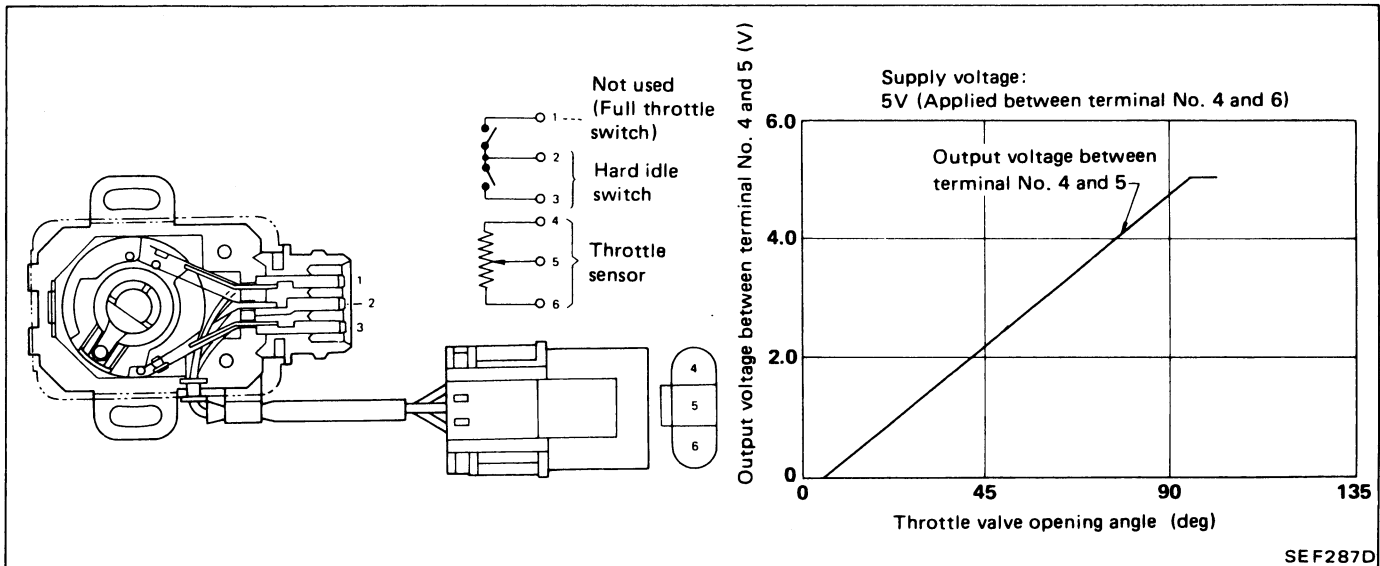

Fuel Injector

The fuel injector is a small, elaborate solenoid valve. As the E.C.U. sends injection signals to the injector, the coil in the injector pulls the needle valve back and fuel is released into the intake manifold through the nozzle. The injected fuel is controlled by the E.C.U. in terms of injection pulse duration.

ENGINE AND EMISSION CONTROL PARTS DESCRIPTION

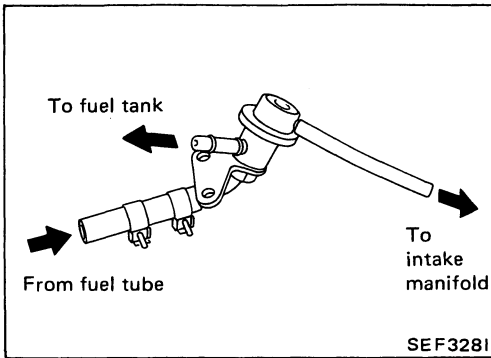

Pressure Regulator

The pressure regulator maintains the fuel pressure at 299.1 kPa (3.05 kg/cm², 43.4 psi). Since the injected fuel amount depends on injection pulse duration, it is necessary to maintain the pressure at the above value.

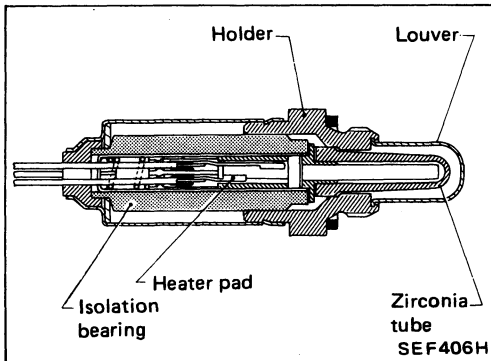

Exhaust Gas Sensor

The exhaust gas sensor, which is placed into the exhaust outlet, monitors the amount of oxygen in the exhaust gas. The sensor has a closed-end tube made of ceramic zirconia. The outer surface of the tube is exposed to exhaust gas, and the inner surface to atmosphere. The zirconia of the tube compares the oxygen density of exhaust gas with that of atmosphere, and generates electricity. In order to improve generating power of the zirconia, its tube is coated with platinum. The voltage is approximately 1V in a richer condition of the mixture ratio than the ideal air-fuel ratio, while approximately 0V in leaner conditions. The radical change from 1V to 0V occurs at around the ideal mixture ratio. In this way, the exhaust gas sensor detects the amount of oxygen in the exhaust gas and sends the signal of approximately 1V or 0V to the E.C.U. A heater is used to activate the sensor.

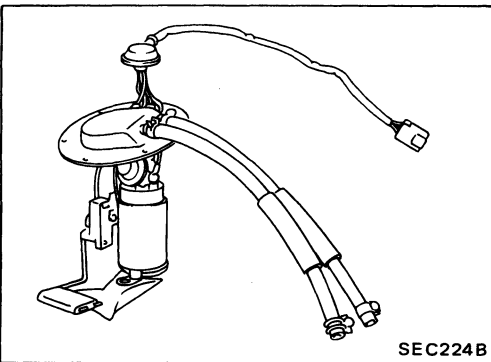
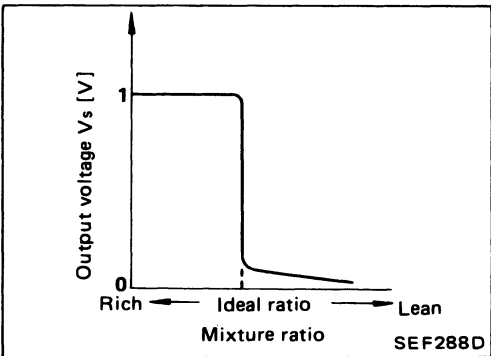

Fuel Pump

The fuel pump is an in-tank type with a fuel damper. Both the pump and damper are located in the fuel tank.

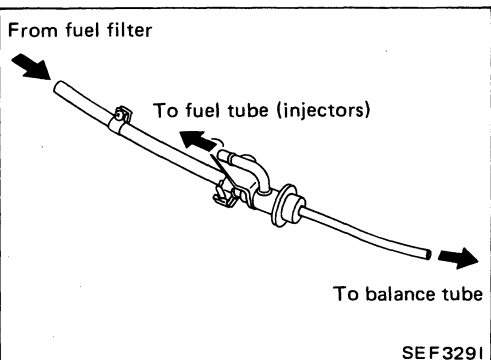

Fuel Damper

The fuel damper, which consists of a diaphragm, reduces fuel pressure pulsation in the fuel feed line between the fuel filter and injectors.

ENGINE AND EMISSION CONTROL PARTS DESCRIPTION

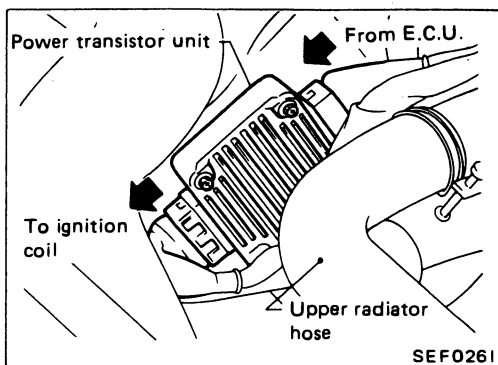

Power Transistor Unit & Ignition Coil

The ignition signal from the E.C.U. is amplified by the power transistor, which turns the ignition coil primary circuit on and off, inducing the proper high voltage in the secondary circuit. The ignition coil is a small, molded type.

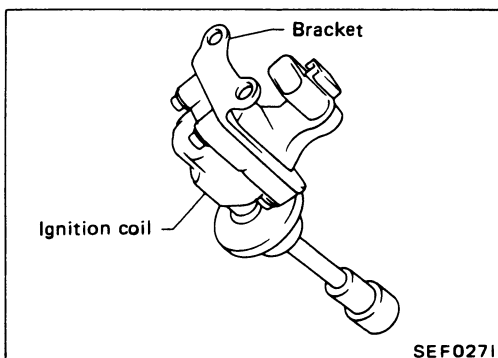

Air Regulator

The air regulator provides an air by-pass when the engine is cold for a fast idle during warm-up.

A bimetal, heater and rotary shutter are built into the air regulator. When the bimetal temperature is low, the air by-pass port opens. As the engine starts and electric current flows through a heater, the bimetal begins to turn the shutter to close the by-pass port. The air passage remains closed until the engine stops and the bimetal temperature drops.

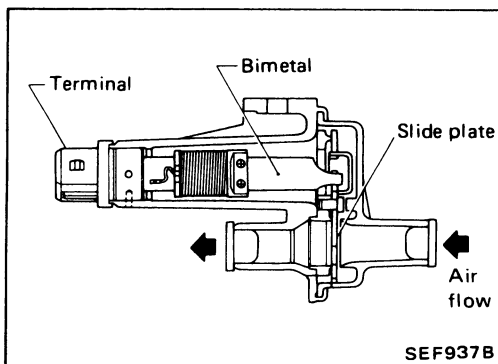

Idle Air Adjusting (I.A.A.) Unit

The I.A.A. unit is made up of the A.A.C. valve, F.I.C.D. solenoid valve and idle adjust screw. It receives the signal from the E.C.U. and controls the idle speed at the preset value.

The F.I.C.D. solenoid valve compensates for changes in idle speed caused by the operation of the air compressor.

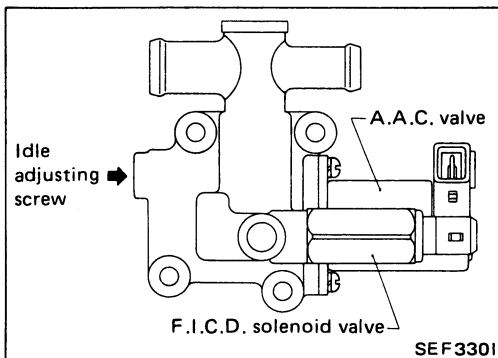

Auxiliary Air Control (A.A.C.) Valve

The E.C.U. actuates the A.A.C. valve by an ON/OFF pulse. The longer that ON duty is left on, the larger the amount of air that will flow through the A.A.C. valve.

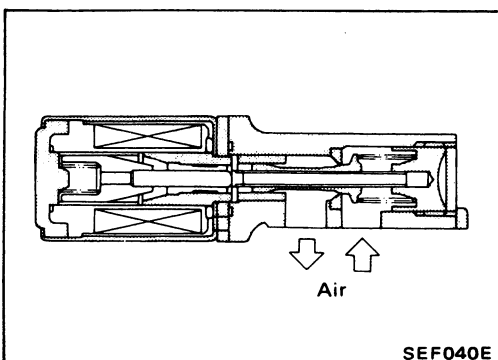

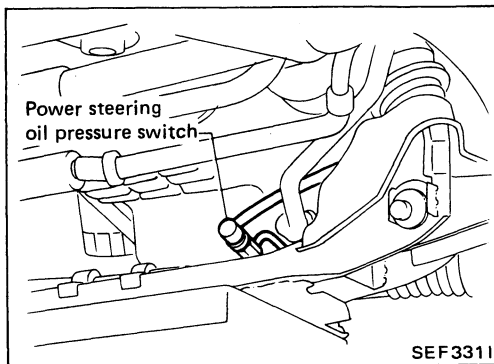

Power Steering Oil Pressure Switch

The power steering oil pressure switch is attached to the power steering high-pressure tube and detects the power steering load, sending the load signal to the E.C.U. The E.C.U. then sends the idle-up signal to the A.A.C valve.

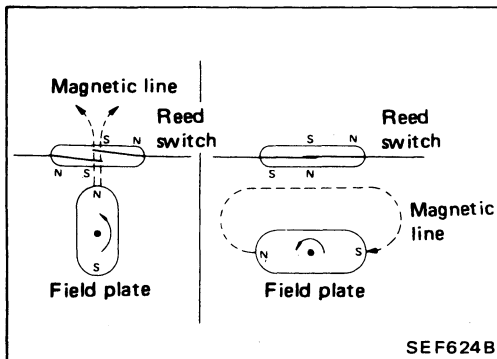

Vehicle Speed Sensor

The vehicle speed sensor provides a vehicle speed signal to the E.C.U.

The speed sensor consists of a reed switch, which is installed in the speedometer unit and transforms vehicle speed into a pulse signal.

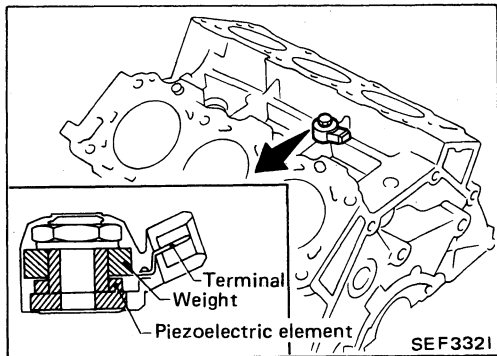

Detonation Sensor

The detonation sensor is attached to the cylinder block and senses engine knocking conditions.

A knocking vibration from the cylinder block is applied as pressure to the piezoelectric element. This vibrational pressure is then converted into a voltage signal which is sent to the E.C.U.

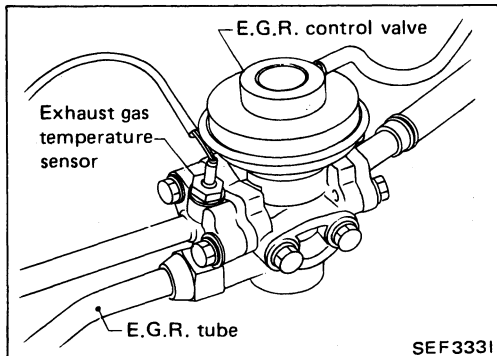

E.G.R. Control Valve

The E.G.R. control valve controls the quantity of exhaust gas to be diverted to the intake manifold through vertical movement of a taper valve connected to the diaphragm. Vacuum is applied to the diaphragm in response to the opening of the throttle valve.

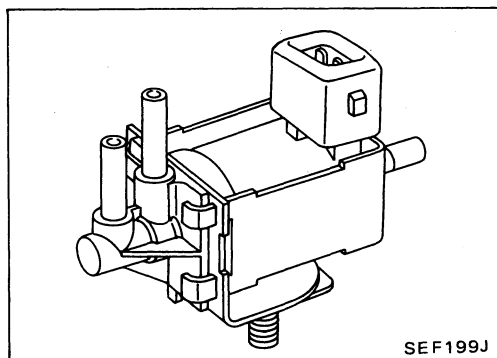

E.G.R. Control Solenoid Valve

The solenoid valve responds to the ON/OFF signal from the E.C.U. When it is off, a vacuum signal from the throttle chamber is fed into the E.G.R. control valve. When the control unit sends an ON signal, the coil pulls the plunger downward and cuts the vacuum signal.

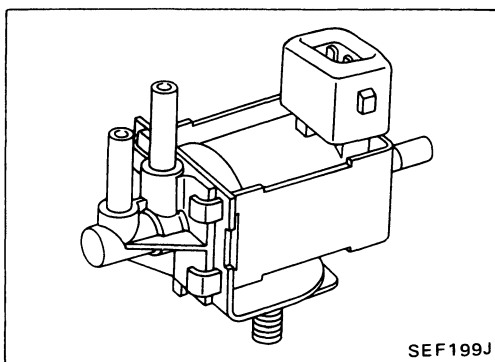

Pressure Regulator Vacuum Relief (P.R.V.R.) Control Solenoid Valve

The solenoid valve responds to the ON/OFF signal from the E.C.U. When it is off, a vacuum signal from the intake manifold is fed into the pressure regulator. When the control unit sends an ON signal, the coil pulls the plunger downward and cuts the vacuum signal.

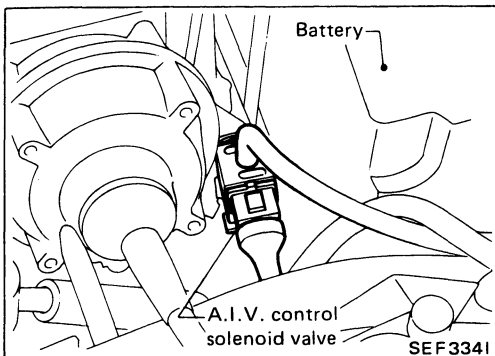

A.I.V. Control Solenoid Valve

The solenoid valve responds to the ON/OFF signal from the E.C.U. When it is ON, a vacuum signal from the intake manifold is fed into the A.I.V. control valve. When the control unit sends an OFF signal, the coil pulls the plunger downward and cuts the vacuum signal.

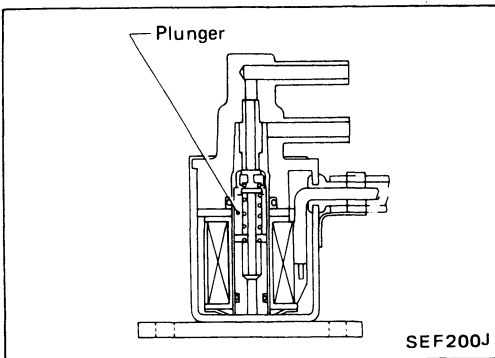

Wastegate Valve Control Solenoid Valve

The solenoid valve responds to the ON/OFF signal from the E.C.U. When it is ON, a vacuum signal from the suction pipe or compressor outlet is fed into the wastegate valve actuator. The actuator is hard to open at this time. When the control unit sends an OFF signal, the coil pulls the plunger upward and cuts the route to the suction pipe.

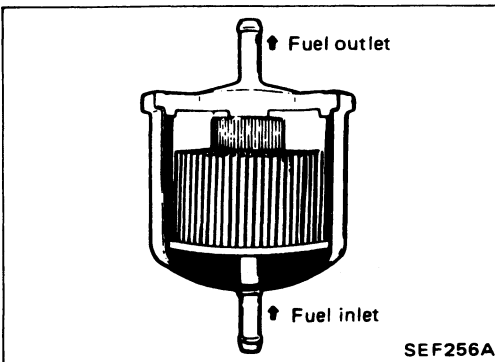

Fuel Filter

The specially designed fuel filter has a metal case in order to withstand high fuel pressure.

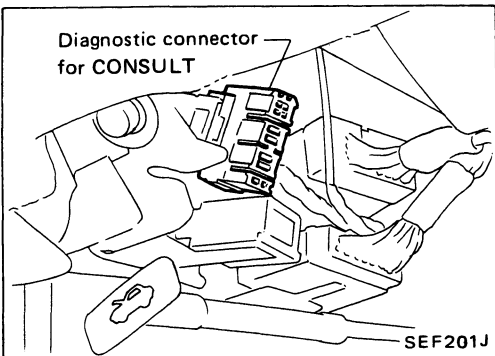

Diagnostic Connector for CONSULT

The diagnostic connector for CONSULT is located above the hood release handle.

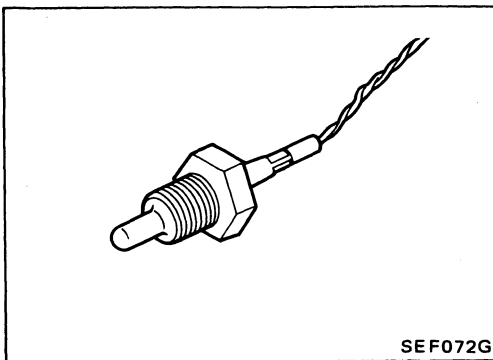

Exhaust Gas Temperature Sensor

The exhaust gas temperature sensor monitors the exhaust gas temperature and transmits a signal to the E.C.U. The temperature sensing unit employs a thermistor which is sensitive to the change in temperature. Electric resistance of the thermistor decreases in response to the temperature rise.

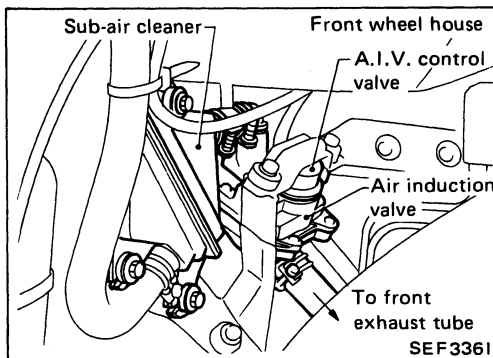

Air Induction Valve (A.I.V.)

The air induction valve sends secondary air to the exhaust manifold, using a vacuum created by exhaust pulsation in the exhaust manifold. When the exhaust pressure is below atmospheric pressure (negative pressure), secondary air is sent to the exhaust manifold. When the exhaust pressure is above atmospheric pressure, the reed valves prevent secondary air from being sent back to the sub-air cleaner.

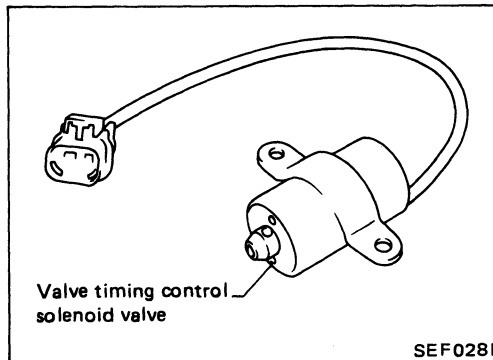

Valve Timing Control Solenoid Valve

The valve timing control solenoids are installed at the rear end of the intake camshafts, and control oil pressure which regulates the position of the intake camshafts.

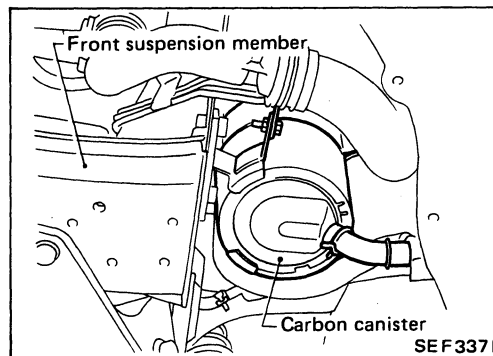

Carbon Canister

The carbon canister is filled with active charcoal to absorb evaporative gases produced in the fuel tank. These absorbed gases are then delivered to the intake manifold by manifold vacuum for combustion purposes.

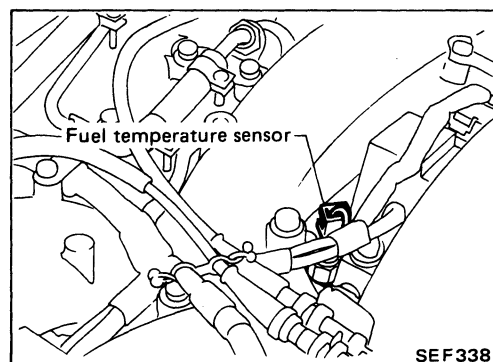

Fuel Temperature Sensor

The fuel temperature sensor, built into the fuel tube, senses fuel temperature. When the fuel temperature is higher than specified, the E.C.C.S. control unit turns the P.R.V.R. control solenoid valve ON and raises fuel pressure.

ENGINE AND EMISSION CONTROL SYSTEM DESCRIPTION

Fuel Injection Control

INPUT/OUTPUT SIGNAL LINE

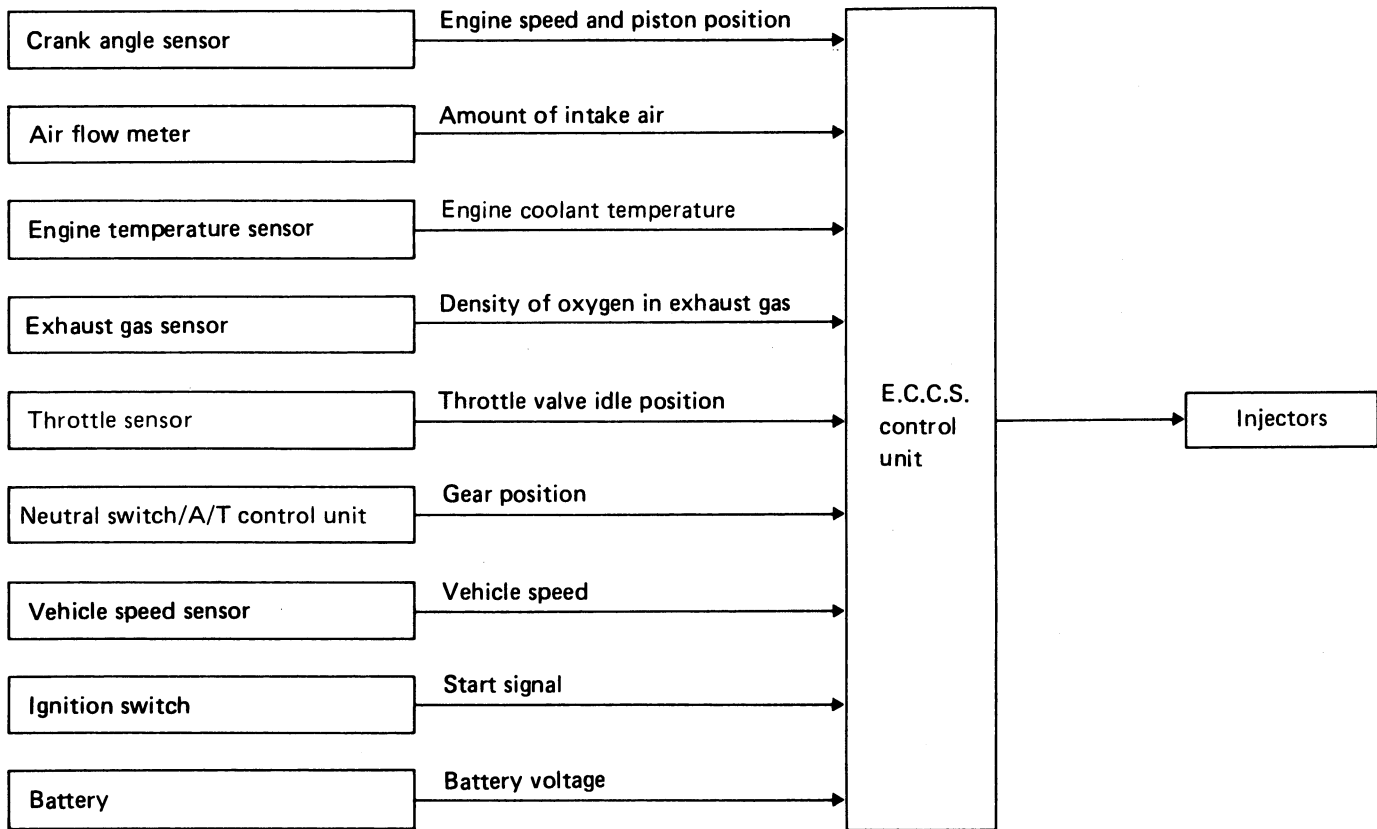

BASIC FUEL INJECTION CONTROL

The amount of fuel injected from the fuel injector, or the length of time the valve remains open, is determined by the E.C.U. The basic amount of fuel injected is a program value mapped in the E.C.U. ROM memory. In other words, the program value is preset by engine operating conditions determined by input signals (for engine rpm and air intake) from both the crank angle sensor and the air flow meter.

VARIOUS FUEL INJECTION

INCREASE/DECREASE COMPENSATION

In addition, the amount of fuel injection is compensated for to improve engine performance under various operating conditions as listed below.

<Fuel increase>

- 1) During warm-up
- 2) When starting the engine
- 3) During acceleration
- 4) Hot-engine operation

<Fuel decrease>

- 1) During deceleration

ENGINE AND EMISSION CONTROL SYSTEM DESCRIPTION

Fuel Injection Control (Cont'd)

MIXTURE RATIO FEEDBACK CONTROL

The mixture ratio feedback system is used for precise control of the mixture ratio to the stoichiometric point, so that the three-way catalyst can reduce CO, HC and NOx emissions. This system uses an exhaust gas sensor in the exhaust manifold to check the air-fuel ratio. The control unit adjusts the injection pulse width according to the sensor voltage so the mixture ratio will be within the range of the stoichiometric air-fuel ratio.

This stage refers to the closed-loop control condition. The open-loop control condition refers to that under which the E.C.U. detects any of the following conditions and feedback control stops in order to maintain stabilized fuel combustion.

- 1) Deceleration
- 2) High-load, high-speed operation
- 3) Engine idling
- 4) Malfunction of exhaust gas sensor or its circuit
- 5) Insufficient activation of exhaust gas sensor at low engine temperature
- 6) Engine starting
- 7) Exhaust gas sensor high output voltage

MIXTURE RATIO SELF-LEARNING CONTROL

The mixture ratio feedback control system monitors the mixture ratio signal transmitted from the exhaust gas sensor. This feedback signal is then sent to the E.C.U. to control the amount of fuel injection to provide a basic mixture ratio as close to the theoretical mixture ratio as possible. However, the basic mixture ratio is not necessarily controlled as originally designed. This is due to manufacturing errors (e.g., air flow meter hot wire) and changes during operation (injector clogging, etc.) of E.C.C.S. parts which directly affect the mixture ratio.

Accordingly, a difference between the basic and theoretical mixture ratios is monitored in this system. It is then computed in terms of "fuel injection duration" to automatically compensate for the difference between the two ratios.

FUEL INJECTION TIMING

Two types of fuel injection systems are used — simultaneous injection and sequential injection. In the former, fuel is injected into all six cylinders simultaneously twice each engine cycle.

In other words, pulse signals of the same width are simultaneously transmitted from the E.C.U. to the six injectors two times for each engine cycle.

In the sequential injection system, fuel is injected into each cylinder during each engine cycle according to the firing order.

When engine is starting, fuel is injected into all six cylinders simultaneously twice per cycle.

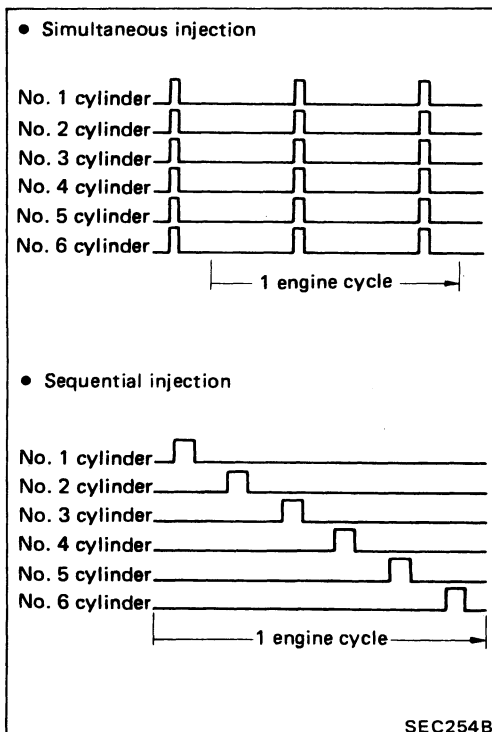
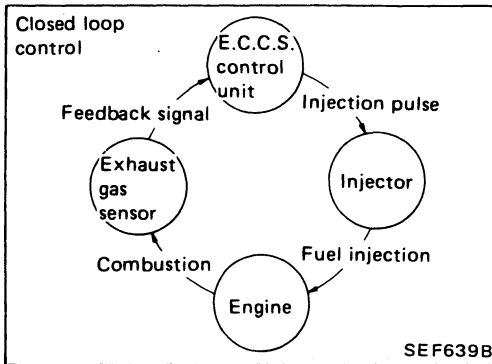

ENGINE AND EMISSION CONTROL SYSTEM DESCRIPTION

Fuel Injection Control (Cont'd)

FUEL SHUT-OFF

Fuel to each cylinder is cut off during deceleration or high-speed operation.

Ignition Timing Control

INPUT/OUTPUT SIGNAL LINE

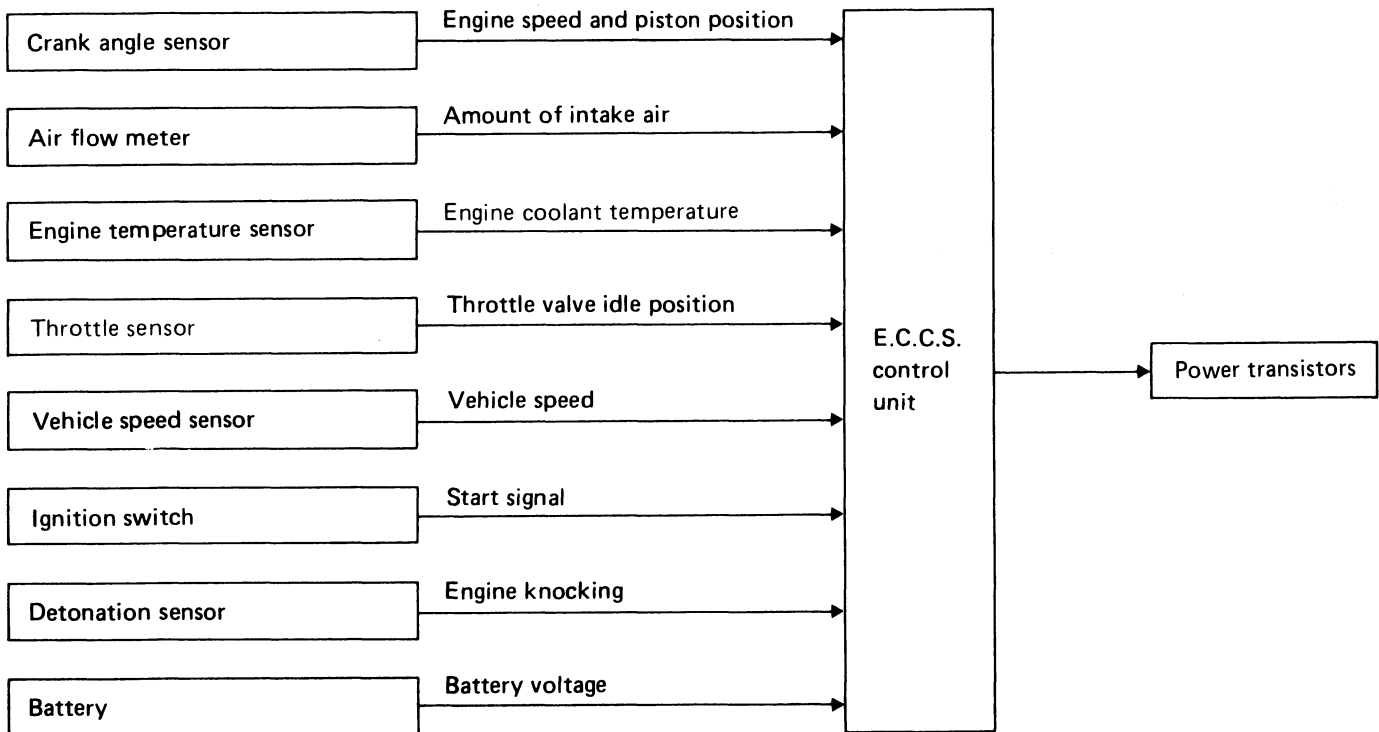

ENGINE AND EMISSION CONTROL SYSTEM DESCRIPTION

Ignition Timing Control (Cont'd)

SYSTEM DESCRIPTION

The ignition timing is controlled by the E.C.U. in order to maintain the best air-fuel ratio in response to every running condition of the engine.

The ignition timing data is stored in the ROM located in the E.C.U. This data forms the map shown below. The E.C.U. detects information such as the injection pulse width and crank angle sensor signal which varies every moment. Then responding to this information, ignition signals are transmitted to the power transistor.

e.g. N: 1,800 rpm, T_p : 1.50 msec
A °B.T.D.C.

In addition to this,

- 1) At starting
- 2) During warm-up
- 3) At idle
- 4) At low battery voltage

the ignition timing is revised by the E.C.U. according to the other data stored in the ROM.

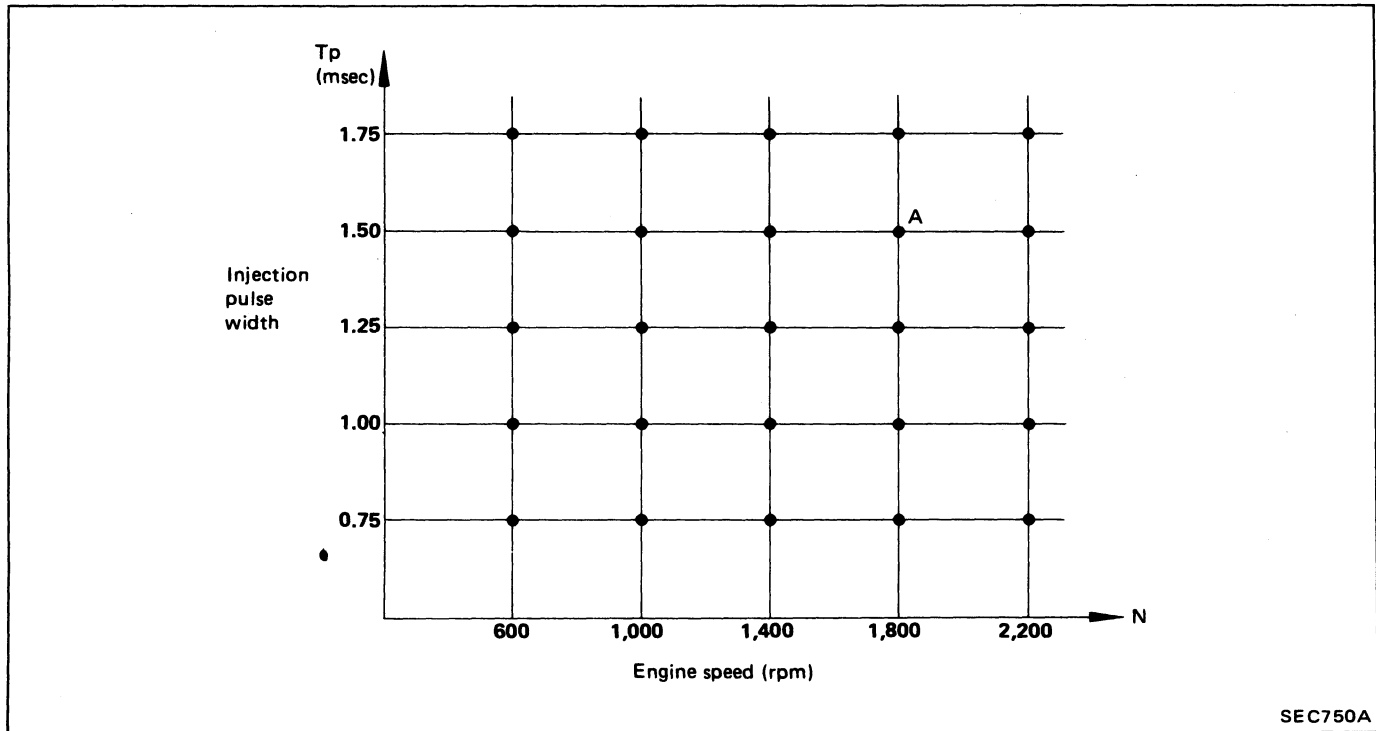

The retard system, actuated by the detonation sensor, is designed only for emergencies. The basic ignition timing is pre-programmed within the anti-knocking zone, even if recommended fuel is used under dry conditions. Consequently, the retard system does not operate under normal driving conditions.

However, if engine knocking occurs, the detonation sensor monitors the condition and the signal is transmitted to the E.C.C.S. control unit. After receiving it, the control unit retards the ignition timing to eliminate the knocking condition.

ENGINE AND EMISSION CONTROL SYSTEM DESCRIPTION

Idle Speed Control

INPUT/OUTPUT SIGNAL LINE

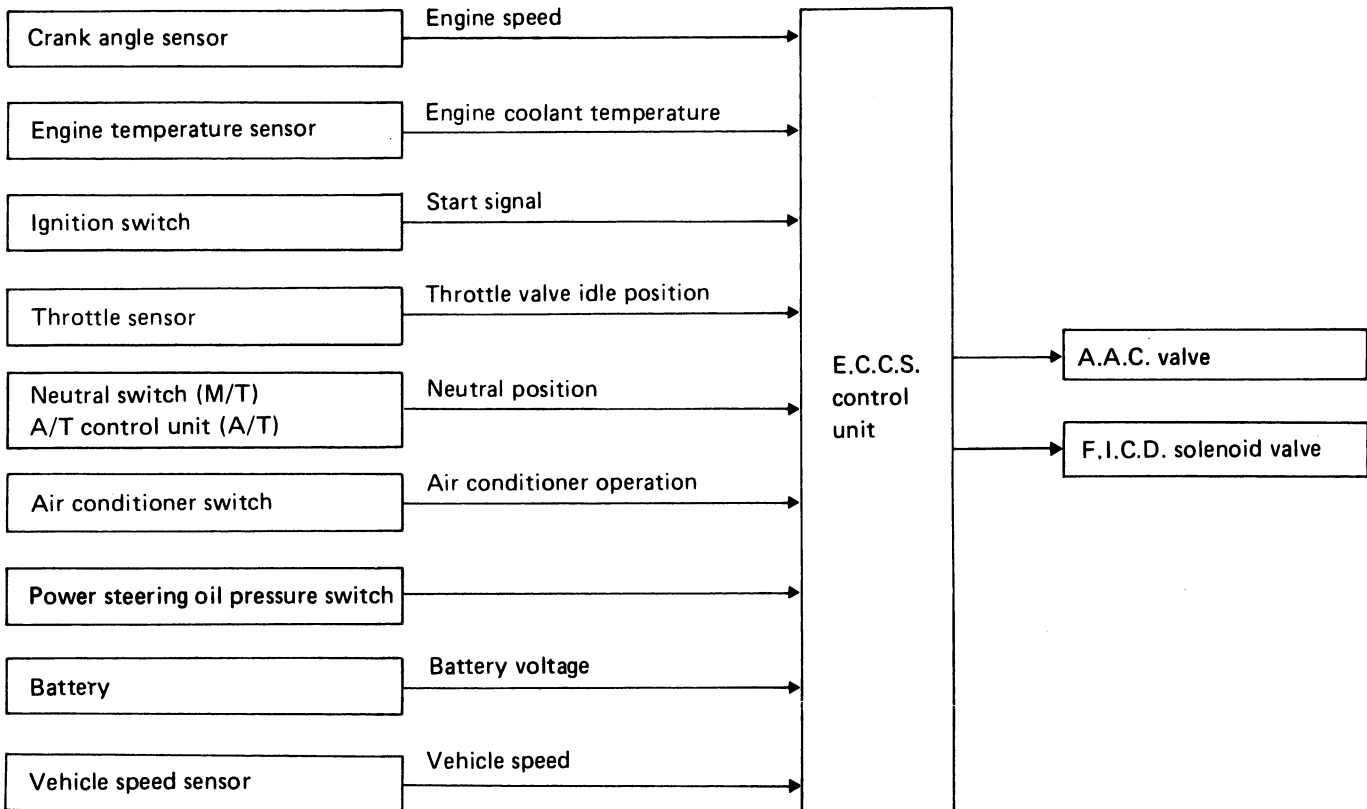

SYSTEM DESCRIPTION

This system automatically controls engine idle speed to a specified level. Idle speed is controlled through fine adjustment of the amount of air which by-passes the throttle valve via A.A.C. valve. The A.A.C. valve repeats ON/OFF operation according to the signal sent from the E.C.U. The crank angle sensor detects the actual engine speed and sends a signal to the E.C.U. The E.C.U. then controls the ON/OFF time of

the A.A.C. valve so that engine speed coincides with the target value memorized in ROM. The target engine speed is the lowest speed at which the engine can operate steadily. The optimum value stored in the ROM is determined by taking into consideration various engine conditions, such as noise and vibration transmitted to the vehicle interior, fuel consumption, and engine load.

ENGINE AND EMISSION CONTROL SYSTEM DESCRIPTION

Fuel Pump Control

INPUT/OUTPUT SIGNAL LINE

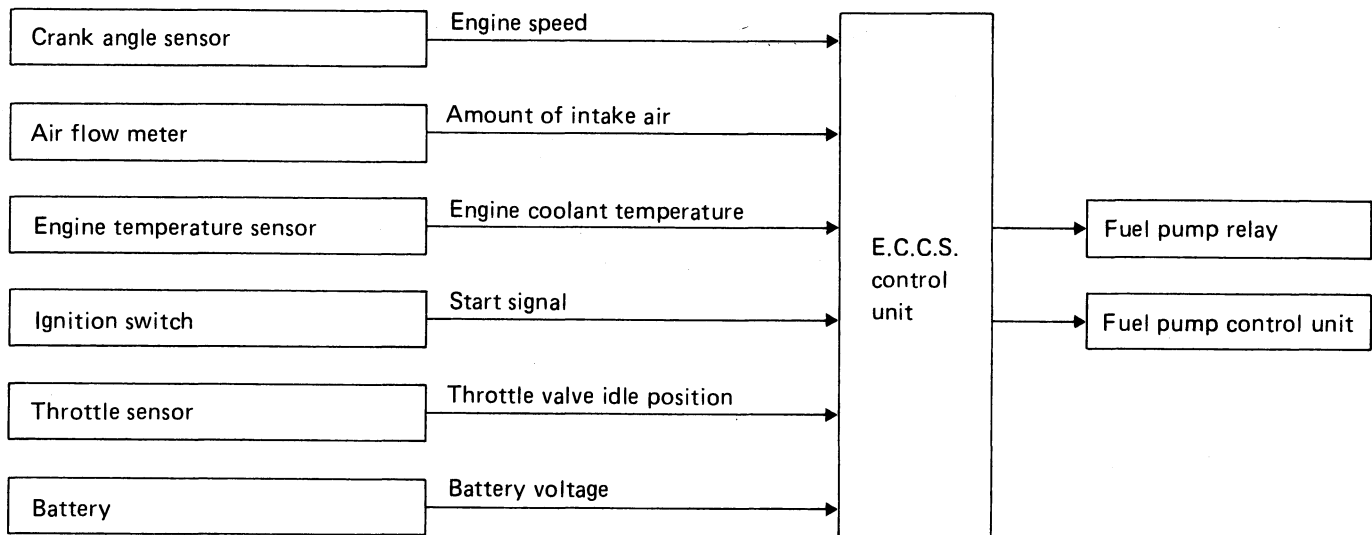

SYSTEM DESCRIPTION

Fuel pump and air regulator ON-OFF control

The E.C.U. activates the fuel pump for several seconds after the ignition switch is turned on to improve engine start-up. If the E.C.U. receives a 1° signal from the crank angle sensor, it knows that the engine is rotating, and causes the pump to activate. If the 1° signal is not received when the ignition switch is on, the engine stalls. The E.C.U. stops pump operation and prevents battery discharging, thereby improving safety. The E.C.U. does not directly drive the fuel pump. It controls the ON/OFF fuel pump relay, which in turn controls the fuel pump.

Condition	Fuel pump operation
Ignition switch is turned to ON.	Operates for 1 second
Engine running and cranking	Operates
When engine is stopped	Stops in 1.5 seconds
Except as shown above	Stops

Fuel pump voltage control

The fuel pump is controlled by the fuel pump control unit adjusting the voltage supplied to the fuel pump.

Conditions	Supplied voltage	
	Turbo model	Non-turbo model
<ul style="list-style-type: none"> 1 second after ignition switch is turned ON Engine cranking 30 (*NA)/5 (**TC) seconds after engine start [above 50°C (122°F)] Engine temperature below 0°C (32°F) Engine is running under heavy load conditions 	Battery voltage	Battery voltage
<ul style="list-style-type: none"> Engine is running under middle load conditions 	Approx. 7V	Battery voltage
<ul style="list-style-type: none"> Except the above 	Approx. 6V	Approx. 8V

*NA: Non-turbo model **TC: Turbo model

ENGINE AND EMISSION CONTROL SYSTEM DESCRIPTION

E.G.R. (Exhaust Gas Recirculation) Control

INPUT/OUTPUT SIGNAL LINE

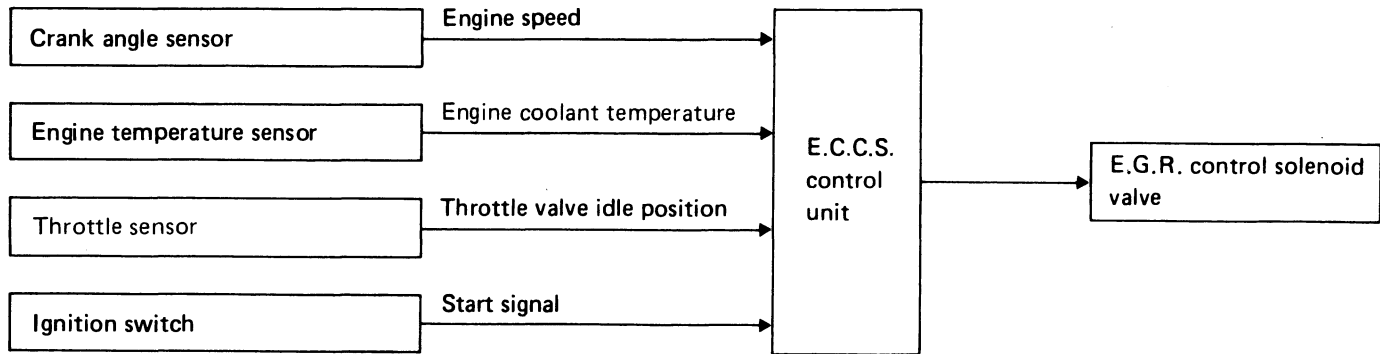

SYSTEM DESCRIPTION

In addition, a system is provided which precisely cuts and controls port vacuum applied to the E.G.R. valve to suit engine operating conditions. This cut-and-control operation is accomplished through the E.C.U. When the E.C.U. detects any of the following conditions, current flows through the solenoid valve in the E.G.R. control vacuum line.

This causes the port vacuum to be discharged into the atmosphere so that the E.G.R. control valve remains closed.

- 1) Low engine temperature
- 2) Engine starting
- 3) High-speed engine operation
- 4) Engine idling
- 5) Excessively high engine temperature

Air Induction Valve (A.I.V.) Control

INPUT/OUTPUT SIGNAL LINE

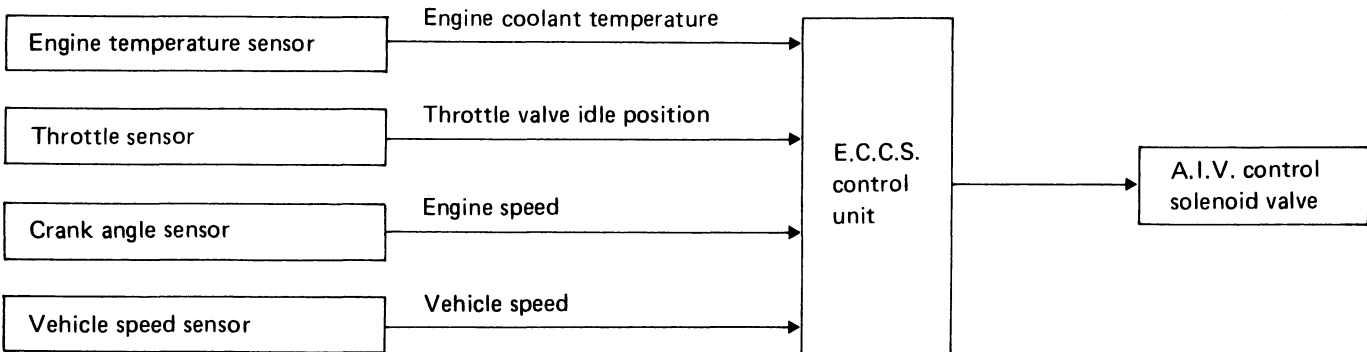

SYSTEM DESCRIPTION

The air induction system is designed to send secondary air to the exhaust manifold, utilizing the vacuum caused by exhaust pulsation in the exhaust manifold.

The exhaust pressure in the exhaust manifold usually pulsates in response to the opening and closing of the exhaust valve and decreases below atmospheric pressure periodically.

If a secondary air intake pipe is opened to the

atmosphere under vacuum conditions, secondary air can be drawn into the exhaust manifold in proportion to the vacuum.

The air induction valve is controlled by the E.C.C.S. control unit, corresponding to the engine temperature. When the engine is cold, the A.I.V. control system operates to reduce HC and CO.

This system also operates during deceleration for the purpose of blowing off water around the air induction valve.

Engine condition	Engine coolant temperature °C (°F)	Vehicle speed km/h (MPH)	A.I.V. control solenoid valve	A.I.V. control system
Throttle valve is at idle position	Below 64 (147)	Any condition	ON	Operates
	Above 65 (149)	Below 24 (15)		

ENGINE AND EMISSION CONTROL SYSTEM DESCRIPTION

Fuel Pressure Regulator Control

INPUT/OUTPUT SIGNAL LINE

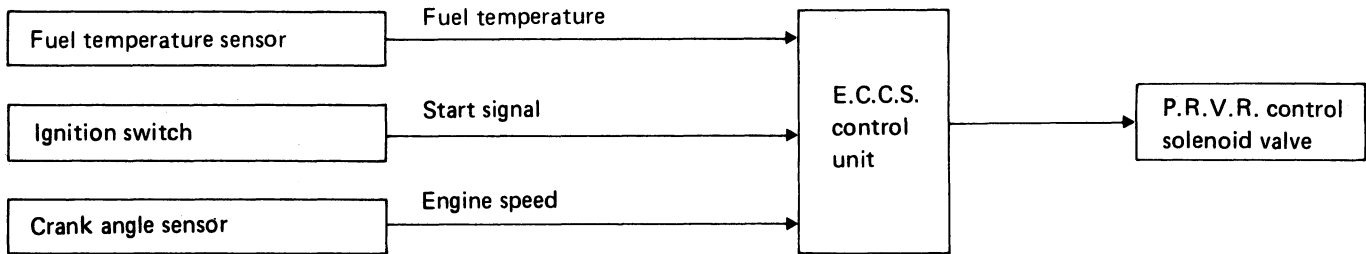

SYSTEM DESCRIPTION

The fuel "pressure-up" control system briefly increases fuel pressure for improved starting performance of a hot engine. Under normal operating conditions, manifold vacuum is applied to the fuel pressure regulator. When starting the engine, however, the E.C.U. allows current to flow through the ON/OFF solenoid valve in the control vacuum line, opening this line to the atmosphere. As a result, atmospheric pressure is applied, restricting the fuel return line so as to increase fuel pressure.

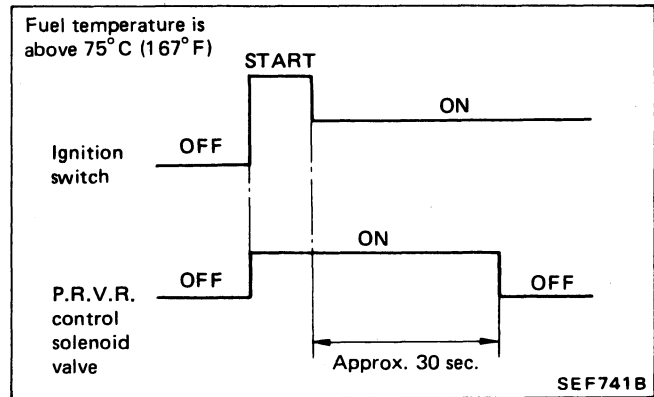

Acceleration Cut Control

INPUT/OUTPUT SIGNAL LINE

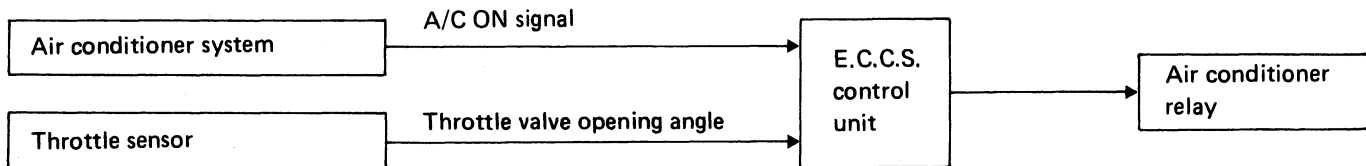

SYSTEM DESCRIPTION

When the accelerator pedal is fully depressed, the air conditioner is turned off for a few seconds. This system improves acceleration when the air conditioner is used.

ENGINE AND EMISSION CONTROL SYSTEM DESCRIPTION

Valve Timing Control

INPUT/OUTPUT SIGNAL LINE

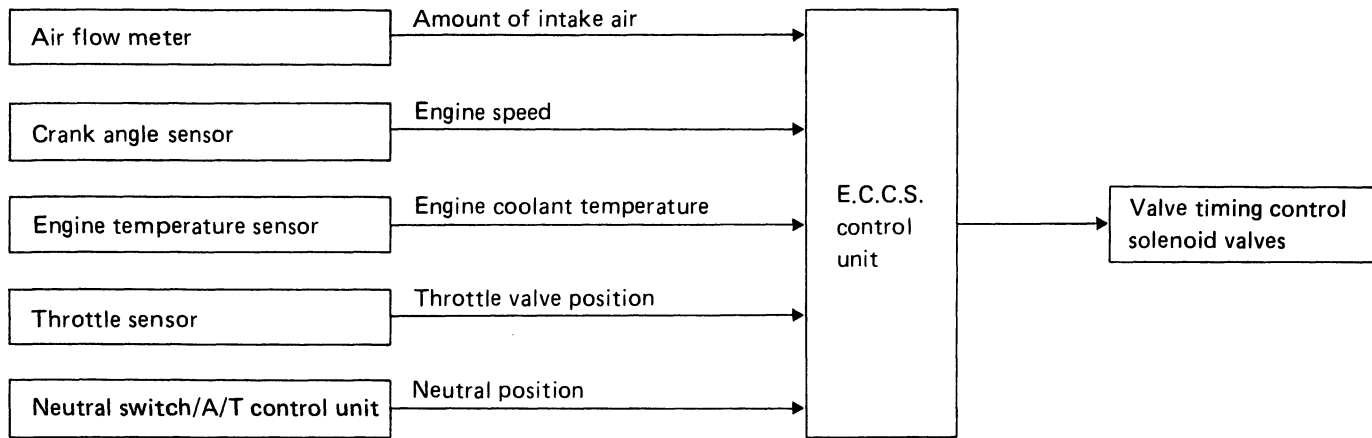

SYSTEM DESCRIPTION

The valve timing control system is utilized to increase engine performance. Intake valve opening and closing time is controlled, according to the engine operating conditions, by the E.C.U. Engine coolant temperature signals, engine speed,

amount of intake air, throttle valve position and gear position are used to determine intake valve timing. The intake camshaft pulley position is regulated by oil pressure, which is controlled by the valve timing control solenoid valve.

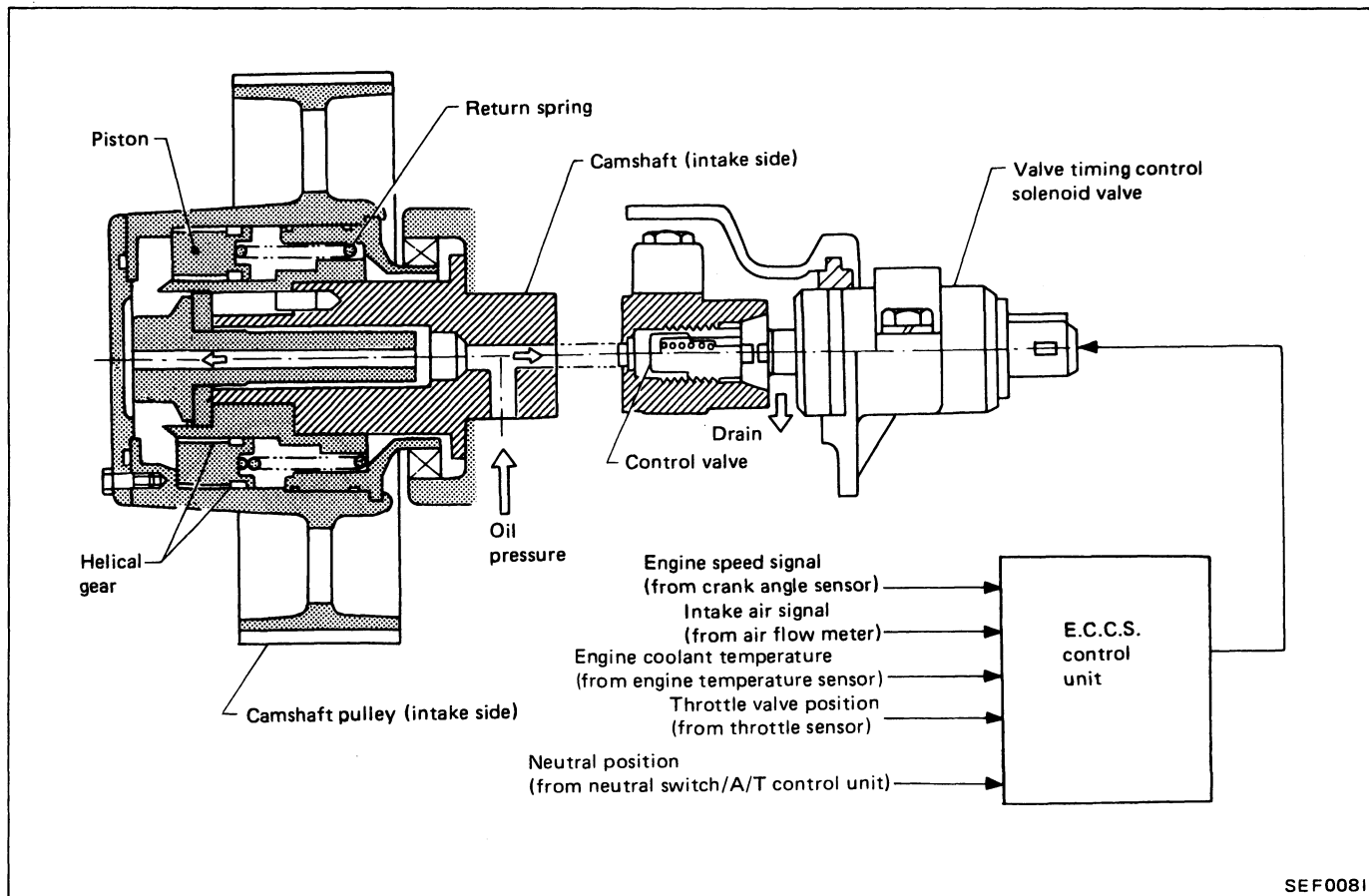

ENGINE AND EMISSION CONTROL SYSTEM DESCRIPTION

Valve Timing Control (Cont'd)

OPERATION

Engine operating condition	Valve timing control solenoid valve	Intake valve opening and closing time	Valve overlap	Engine torque curve
Idling, high speed	OFF	Retard	Decreased	Ⓘ
Low to medium speed	ON	Advance	Increased	Ⓜ

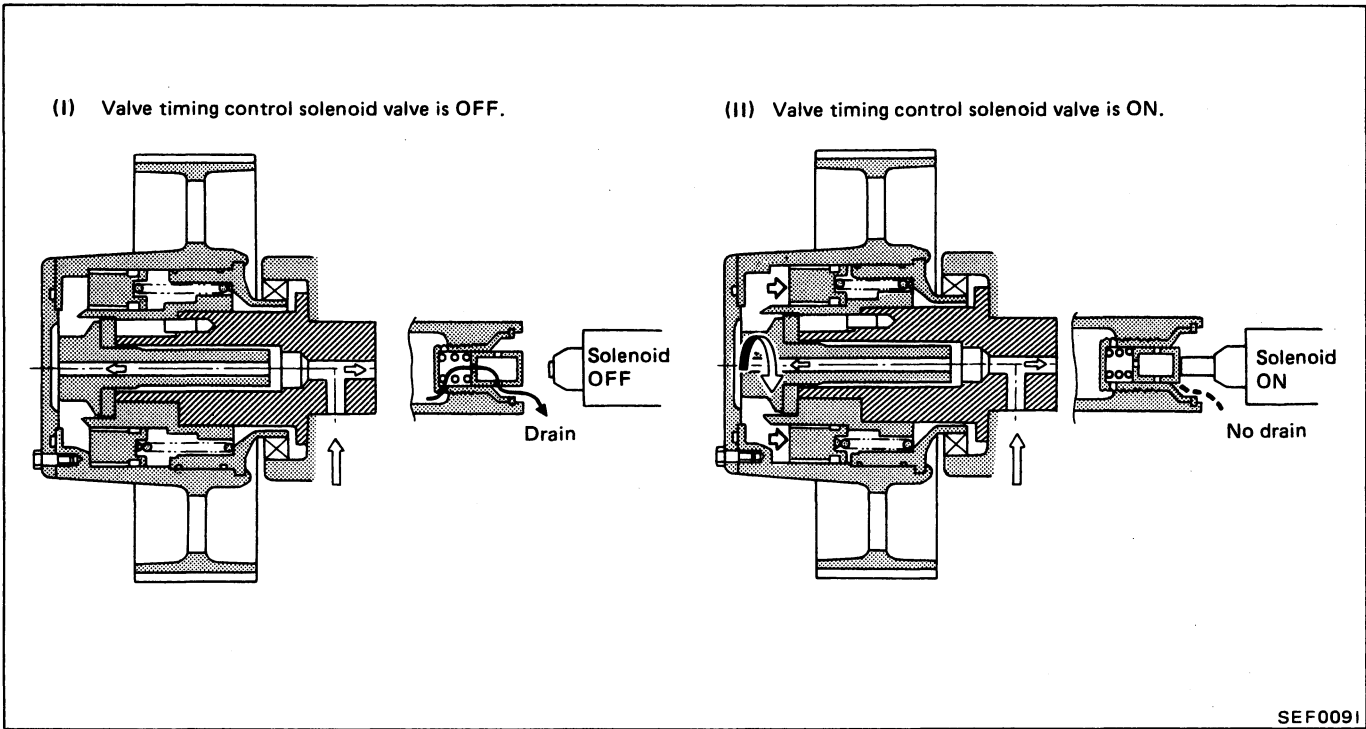

SEF0091

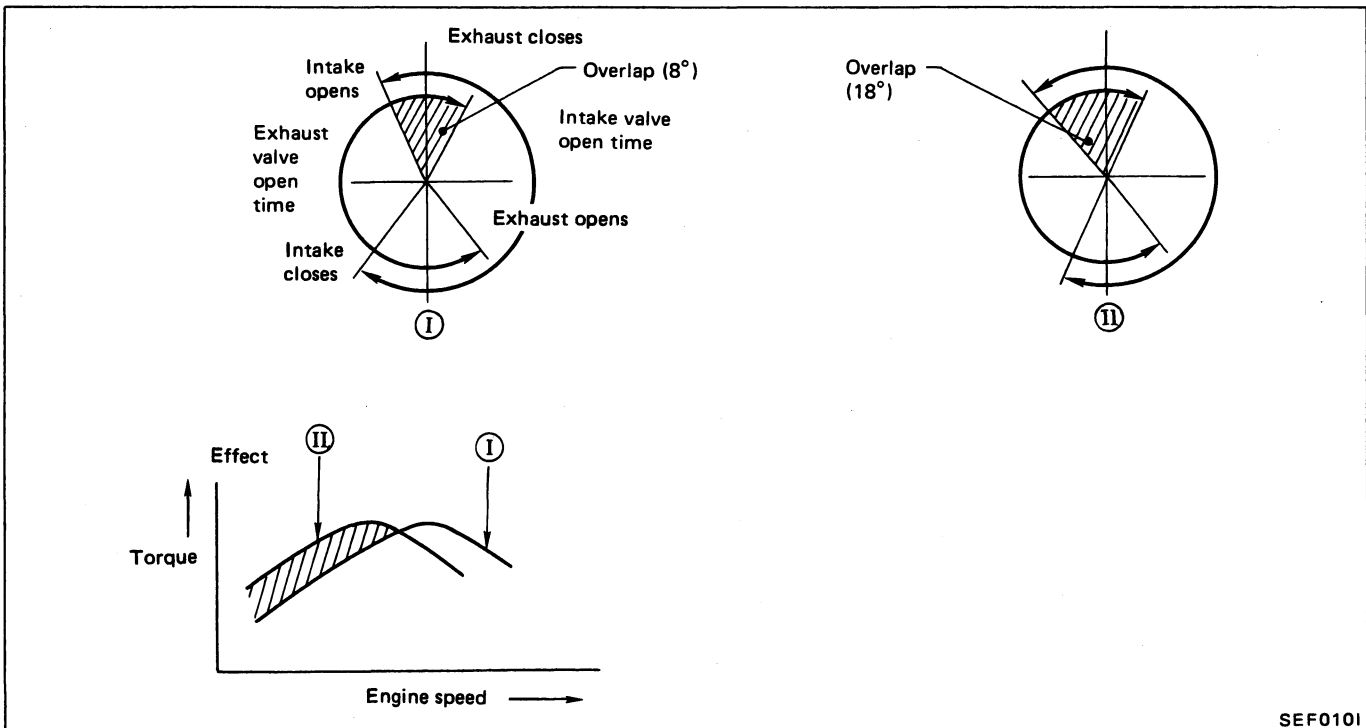

SEF0101

ENGINE AND EMISSION CONTROL SYSTEM DESCRIPTION

Radiator Fan Control

INPUT/OUTPUT SIGNAL LINE

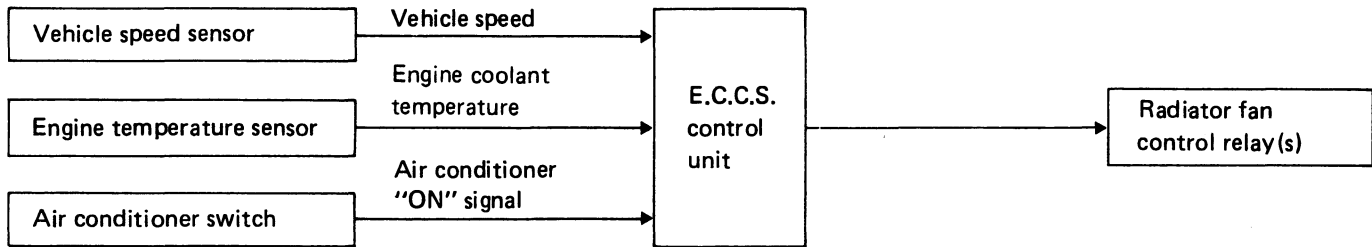

The E.C.U. controls the radiator fan corresponding to the vehicle speed, engine temperature, and air conditioner ON signal. The non-turbo model has 2-step control [ON (HIGH)/OFF], and the turbo model 3-step control [HIGH/LOW/OFF].

OPERATION

[Non-turbo model]

Air conditioner switch is "OFF"

Engine coolant temperature °C (°F)	Radiator fan
Below 104 (219)	OFF
Above 105 (221)	ON

Air conditioner switch is "ON"

Vehicle speed km/h (MPH)	Engine coolant temperature °C (°F)	Radiator fan
Below 39 (24)	Below 94 (201)	OFF
	Above 95 (203)	ON (HIGH)
Above 40 (25)	Below 104 (219)	OFF
	Above 105 (221)	ON (HIGH)

[Turbo model]

Air conditioner switch is "OFF"

Engine coolant temperature °C (°F)	Radiator fan
Below 104 (219)	OFF
Above 105 (221)	ON

Air conditioner switch is "ON"

Vehicle speed km/h (MPH)	Engine coolant temperature °C (°F)	Radiator fan
Below 39 (24)	Below 89 (192)	OFF
	Between 90 (194) and 99 (210)	LOW
	Above 100 (212)	HIGH
Above 40 (25)	Below 104 (219)	OFF
	Above 105 (221)	HIGH

ENGINE AND EMISSION CONTROL SYSTEM DESCRIPTION

Wastegate Valve Control

INPUT/OUTPUT SIGNAL LINE

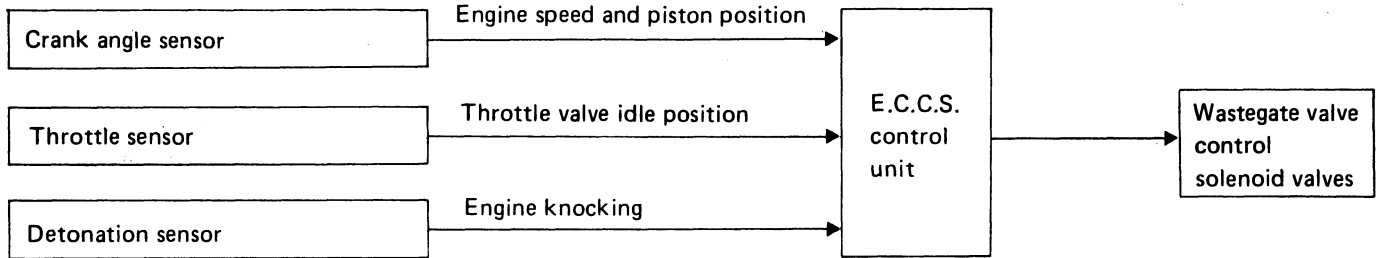

SYSTEM DESCRIPTION

The wastegate valve control solenoid valve changes the source vacuum which activates the actuator. This results in a suitable turbo-pressure.

When detonation signs are detected, which means a low octane fuel is being used, the solenoid valve turns OFF, and turbocharger pressure becomes low.

OPERATION

Engine conditions	Wastegate valve control solenoid valves	Wastegate valve actuators	Turbocharger pressure
<ul style="list-style-type: none"> • Engine running or cranking • Throttle sensor output voltage: more than 0.1V • Judged fuel quality: hi octane (Detecting no sign of detonation) 	ON	Lead to suction pipe or turbocharger compressor outlet	HIGH
<ul style="list-style-type: none"> • Except the above 	OFF	Lead to turbocharger compressor outlet	LOW

ENGINE AND EMISSION CONTROL SYSTEM DESCRIPTION

Fail-safe System

C.P.U. MALFUNCTION OF E.C.U.

Input/output signal line

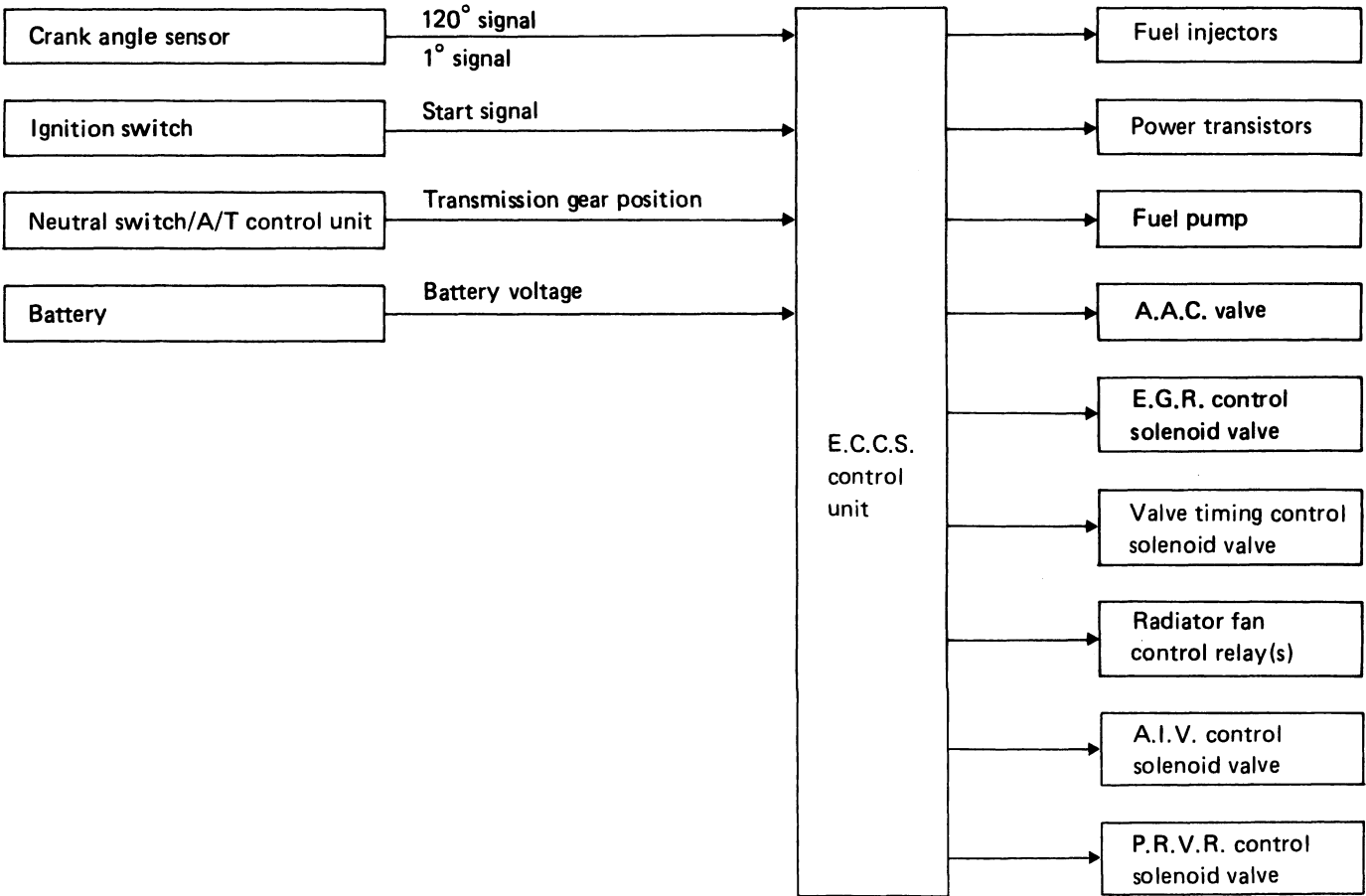

Outline

The fail-safe system makes engine starting possible if there is something malfunctioning in the E.C.U.'s C.P.U. circuit.

In general, engine starting was difficult under the previously mentioned conditions. But with the provisions in this fail-safe system, it is possible to start the engine.

ENGINE AND EMISSION CONTROL SYSTEM DESCRIPTION

Fail-safe System (Cont'd)

Fail-safe system activating condition when E.C.U. is malfunctioning

The fail-safe mode operation starts when the computing function of the E.C.U. is judged to be malfunctioning.

When the fail-safe system activates, i.e. if a malfunction condition is detected in the C.P.U. of the E.C.U., the CHECK ENGINE LIGHT on the instrument panel lights to warn the driver.

Engine control, with fail-safe system, operates when E.C.U. is malfunctioning

When the fail-safe system is operating, fuel injection, ignition timing, fuel pump operation, engine idle speed, E.G.R. operation, and so on are controlled under certain limitations.

Cancellation of fail-safe system when E.C.U. is malfunctioning

Activation of the fail-safe system is canceled each time the ignition switch is turned OFF. The system is reactivated if all of the activating conditions are satisfied after turning the ignition switch from OFF to ON.

AIR FLOW METER MALFUNCTION

If the air flow meter output voltage is above or below the specified value, the E.C.U. senses an air flow meter malfunction. In case of a malfunction, the throttle sensor substitutes for the air flow meter.

Although the air flow meter is malfunctioning, it is possible to start the engine and drive the vehicle. But engine speed will not rise more than 2,400 rpm in order to inform the driver of fail-safe system operation while driving.

Operation

Engine condition	Starter switch	Fail-safe system	Fail-safe functioning
Stopped	ANY	Does not operate	—
Cranking	ON	Operates	Engine will be started by a pre-determined injection pulse on E.C.U.
Running	OFF		Engine speed will not rise above 2,400 rpm

ENGINE TEMPERATURE SENSOR MALFUNCTION

When engine temperature sensor output voltage is below or above the specified value, engine coolant temperature signal is fixed at the preset value as follows:

Engine condition	Engine coolant temperature preset value °C (°F)
Start	20 (68)
Running	80 (176)

FUEL TEMPERATURE SENSOR MALFUNCTION

When fuel temperature sensor output voltage is below or above the specified value, fuel temperature signal is fixed at the preset value as follows:

Engine condition	Fuel temperature preset value °C (°F)
Start	20 (68)
Running	80 (176)

ENGINE AND EMISSION CONTROL SYSTEM DESCRIPTION

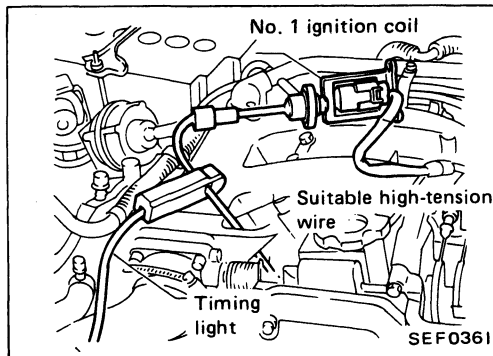
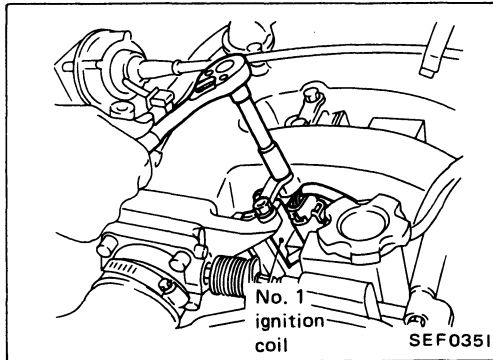
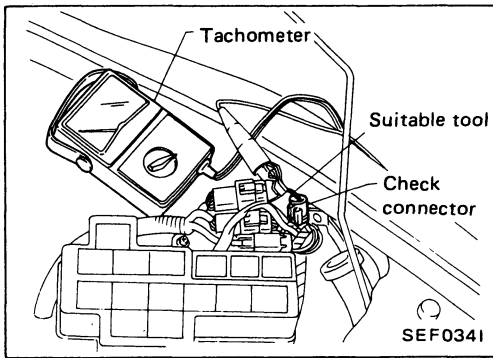
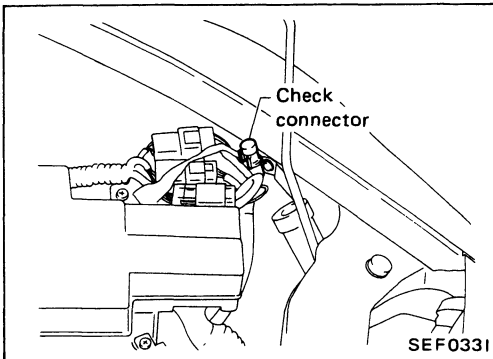
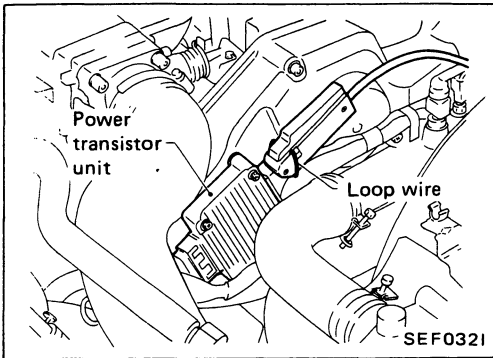

Direct Ignition System

CHECKING IDLE SPEED AND IGNITION TIMING

Idle speed

- **Method A (With pulse type tachometer)**
Clamp loop wire as shown.

- **Method B (With voltage type tachometer)**

1. Disconnect check connector (Harness color: Y/R) for tachometer.

2. Connect tachometer using suitable tool.

Ignition timing

- **Method A (Without S.S.T.)**
1. Remove No. 1 ignition coil.

2. Connect No. 1 ignition coil and No. 1 spark plug with suitable high-tension wire as shown, and attach timing light clamp to this wire.
3. Check ignition timing.

ENGINE AND EMISSION CONTROL SYSTEM DESCRIPTION

Direct Ignition System (Cont'd)

4. For above procedures, enlarge suitable high-tension wire end with insulating tape as shown.

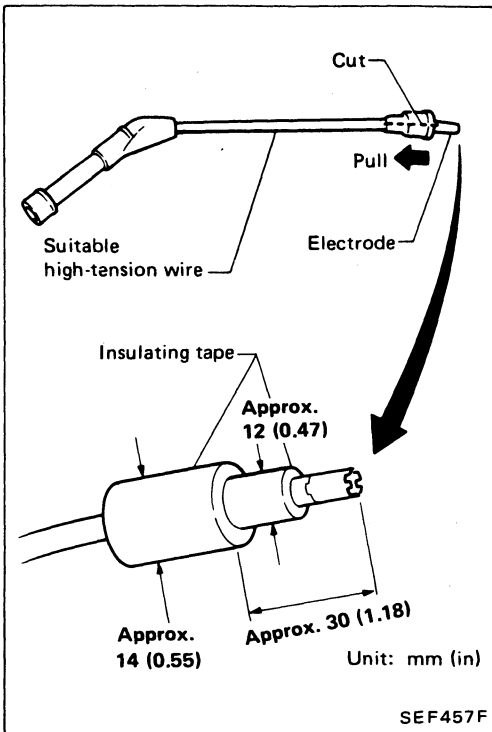

● Method B (With S.S.T.)

1. Disconnect connector of No. 1 ignition coil.

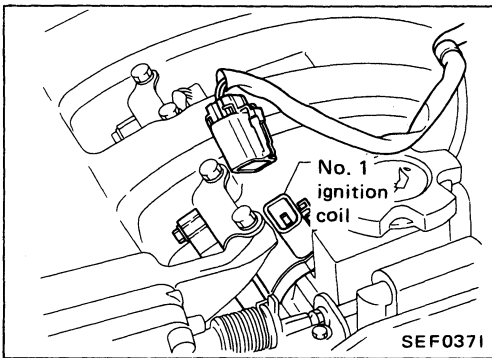

2. Connect S.S.T. and clamp wire with timing light as shown.
3. Check ignition timing.

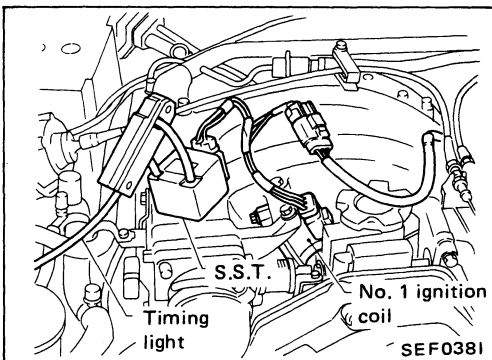

Align direction marks on S.S.T. and timing light clamp if aligning mark is punched.

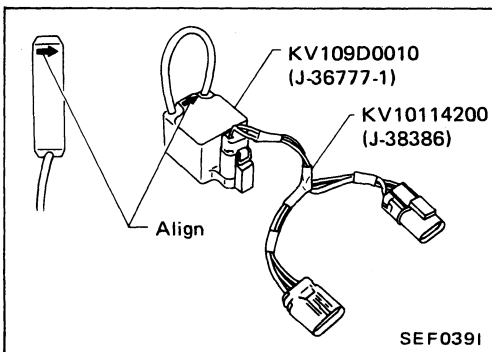

IDLE SPEED/IGNITION TIMING/IDLE MIXTURE RATIO INSPECTION

PREPARATION

1. Make sure that the following parts are in good order.

- Battery
- Ignition system
- Engine oil and coolant levels
- Fuses
- E.C.U. harness connector
- Vacuum hoses
- Air intake system
(Oil filler cap, oil level gauge, etc.)
- Fuel pressure
- Engine compression
- E.G.R. control valve operation
- Throttle valve

2. On air conditioner equipped models, checks should be carried out while the air conditioner is "OFF".

3. On automatic transmission equipped models, when checking idle rpm, ignition timing and mixture ratio, checks should be carried out while shift lever is in "N" position.

4. When measuring "CO" percentage, insert probe more than 40 cm (15.7 in) into tail pipe.

5. Turn off headlamps, heater blower, rear defogger.

6. Keep front wheels pointed straight ahead.

7. Make the check after the radiator fan has stopped.

Overall inspection sequence

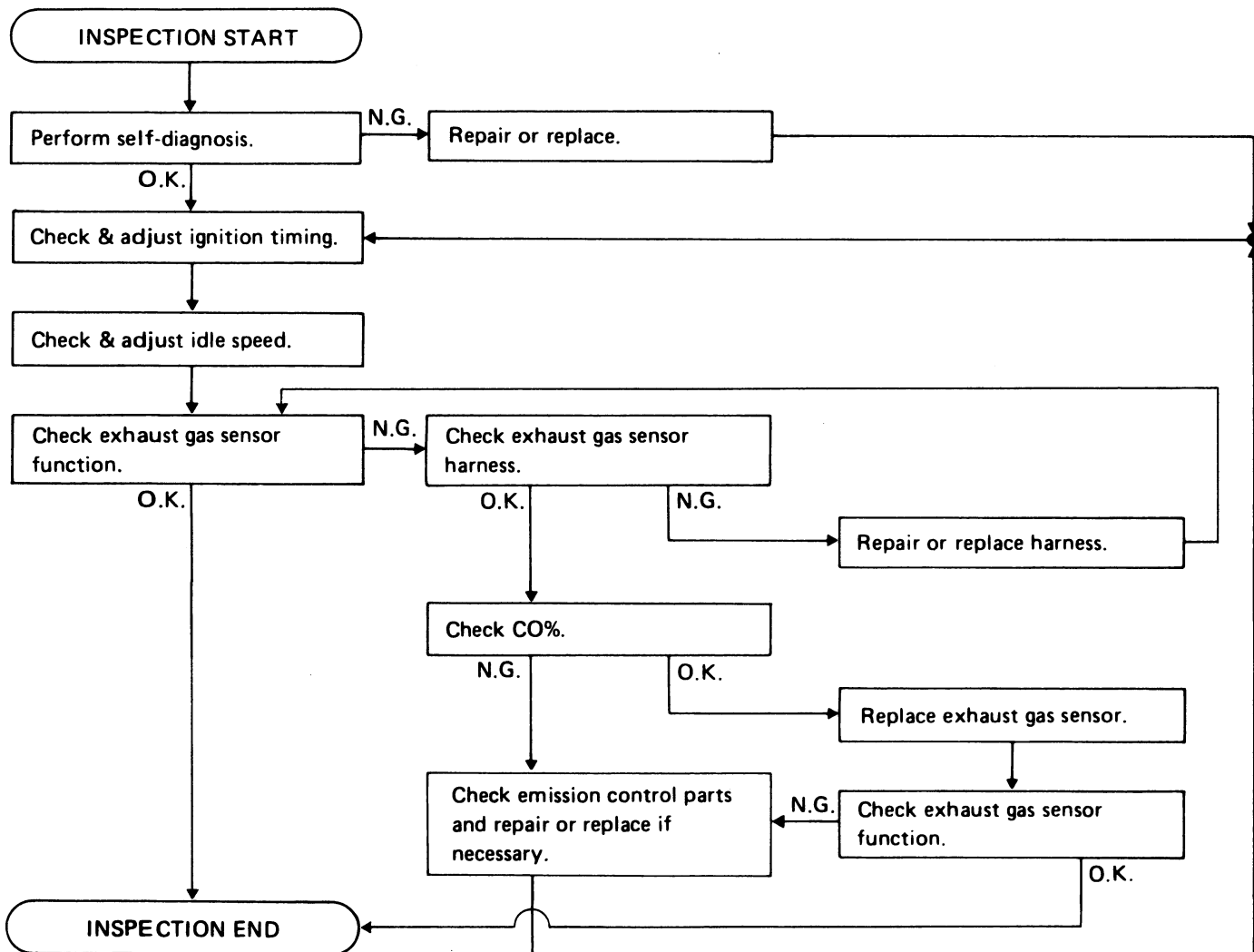

IDLE SPEED/IGNITION TIMING/IDLE MIXTURE RATIO INSPECTION

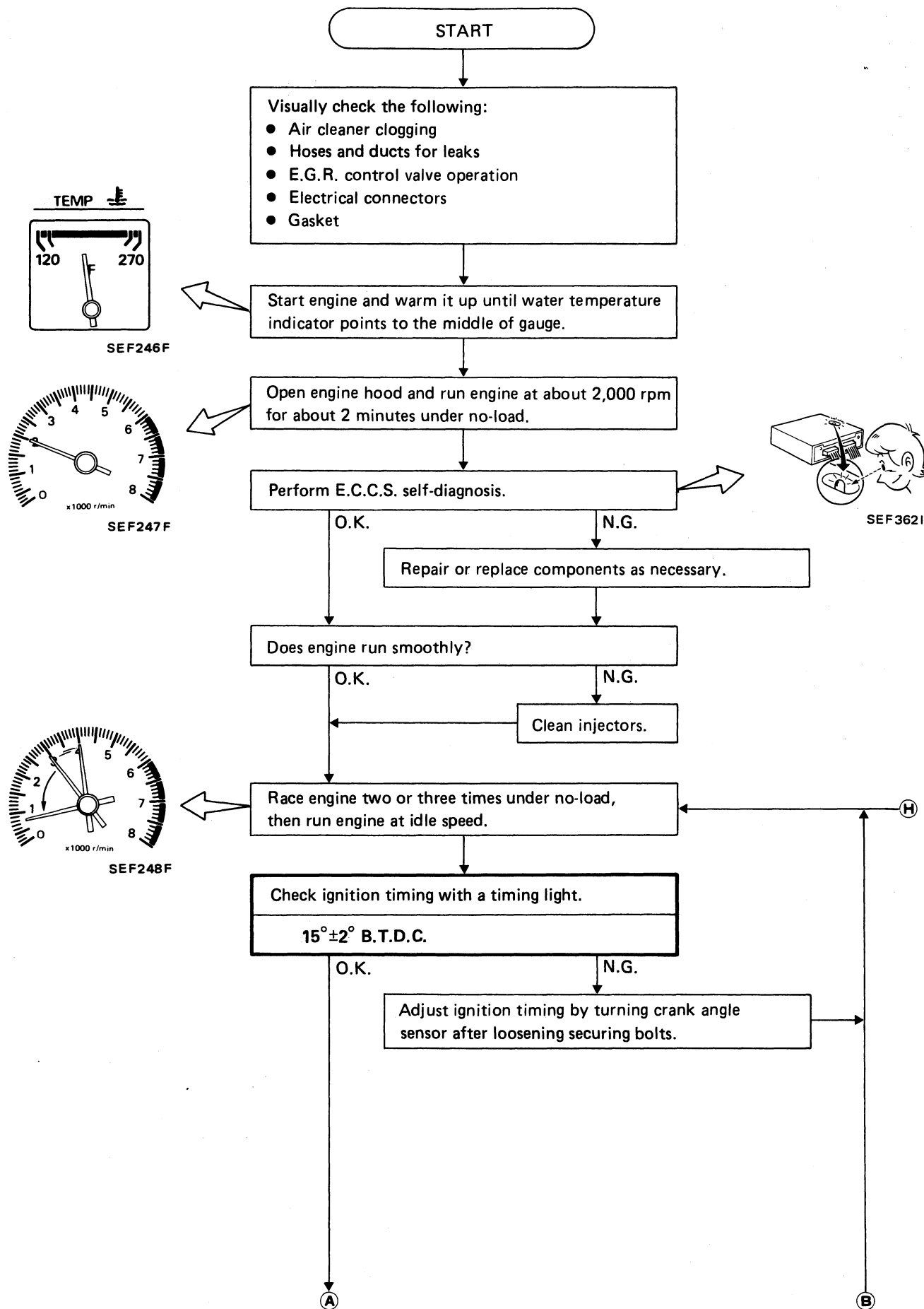

IDLE SPEED/IGNITION TIMING/IDLE MIXTURE RATIO INSPECTION

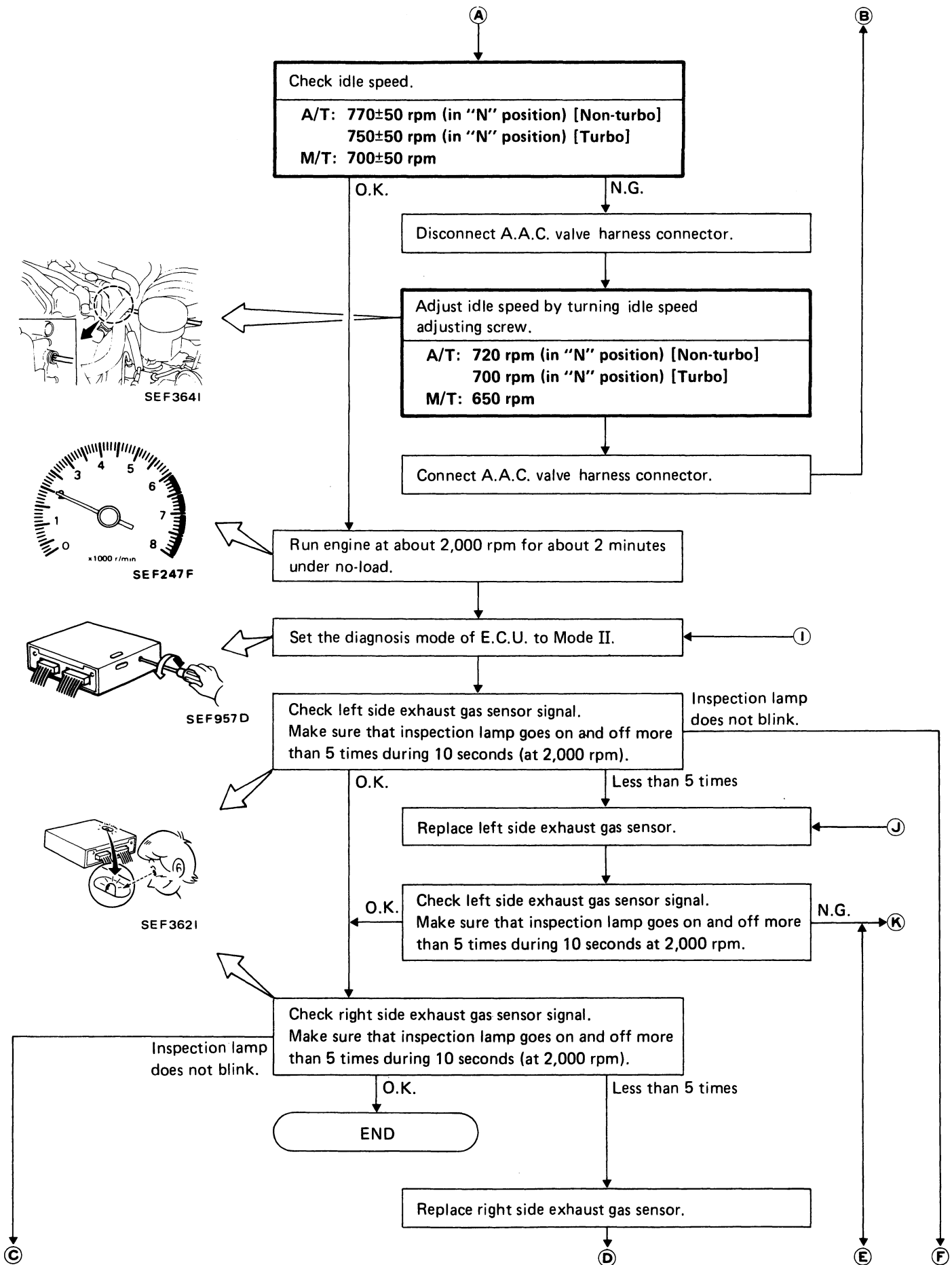

IDLE SPEED/IGNITION TIMING/IDLE MIXTURE RATIO INSPECTION

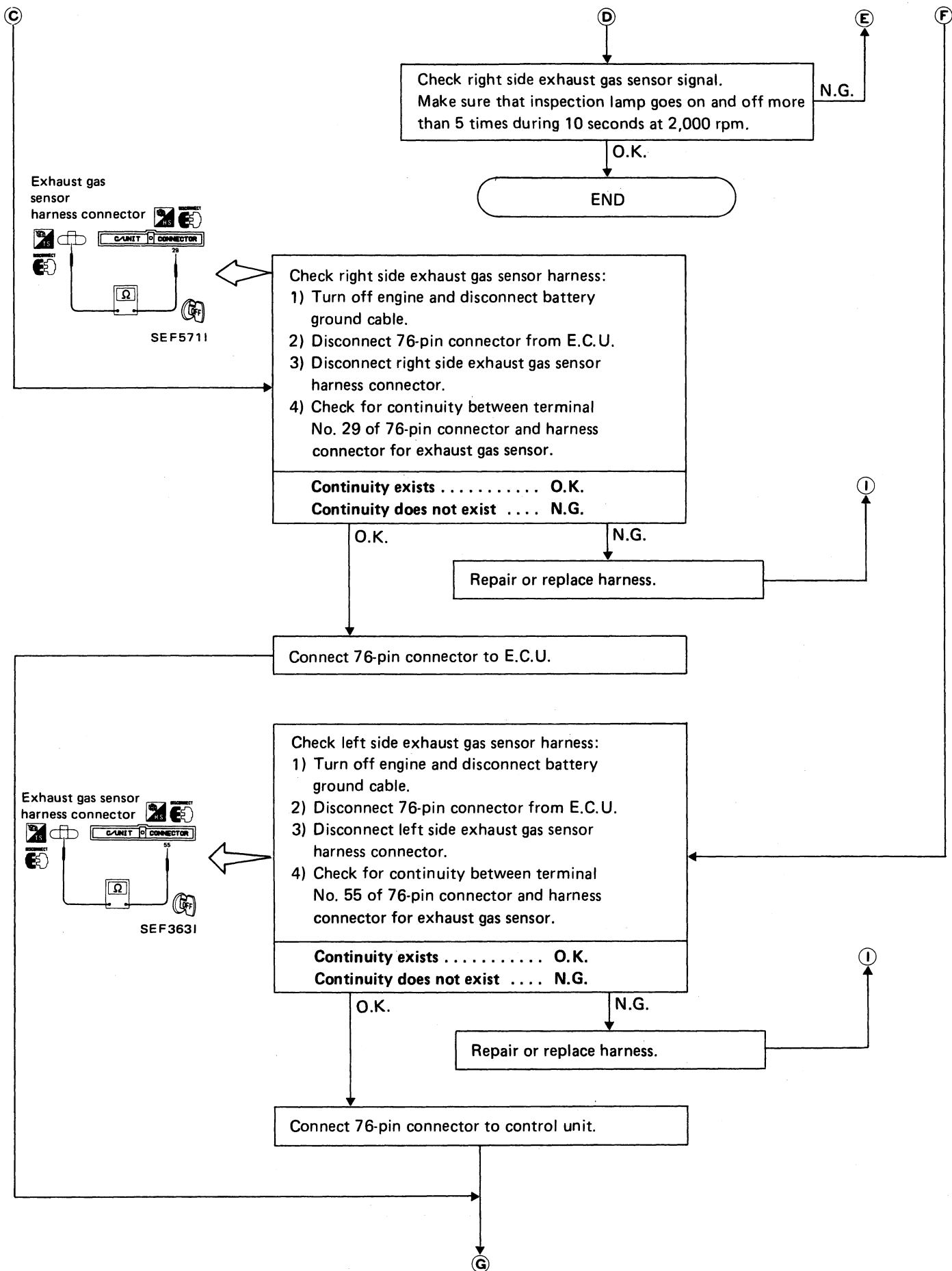

IDLE SPEED/IGNITION TIMING/IDLE MIXTURE RATIO INSPECTION

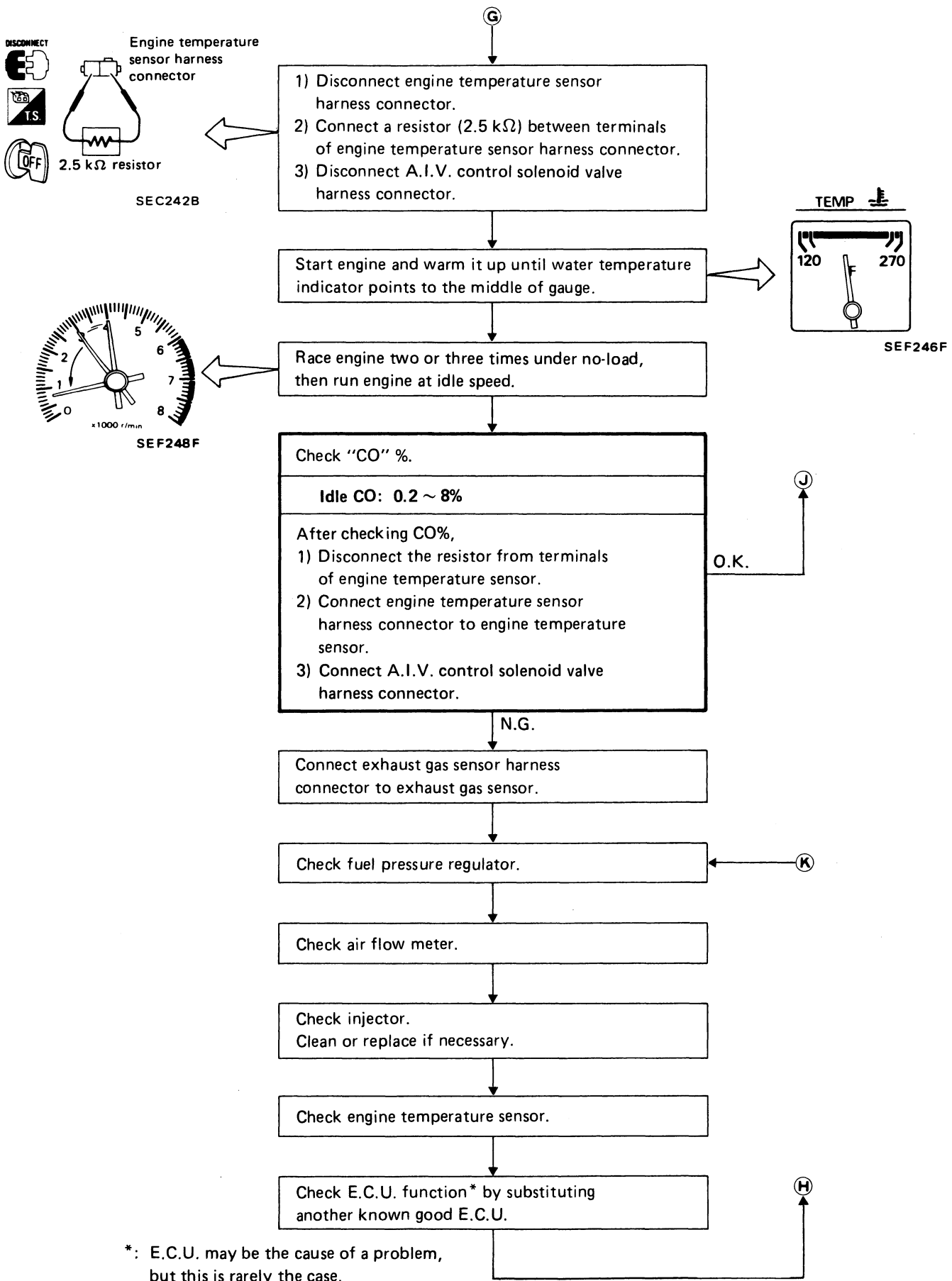

TROUBLE DIAGNOSES

Contents

How to Perform Trouble Diagnoses for Quick and Accurate Repair	EF & EC- 44
Self-diagnosis	EF & EC- 48
Self-diagnosis — Mode I	EF & EC- 50
Self-diagnosis — Mode II (Self-diagnostic results)	EF & EC- 51
Self-diagnosis — Mode II (Exhaust gas sensor monitor)	EF & EC- 54
Consult	EF & EC- 55
Basic Inspection	EF & EC- 63
Diagnostic Procedure 1 — High Idling after Warm-up	EF & EC- 66
Diagnostic Procedure 2 — Hunting	EF & EC- 67
Diagnostic Procedure 3 — Unstable Idle	EF & EC- 69
Diagnostic Procedure 4 — Hard to Start or Impossible to Start when the Engine is Cold	EF & EC- 73
Diagnostic Procedure 5 — Hard to Start or Impossible to Start when the Engine is Hot	EF & EC- 75
Diagnostic Procedure 6 — Hard to Start or Impossible to Start under Normal Conditions	EF & EC- 77
Diagnostic Procedure 7 — Hesitation when the Engine is Hot	EF & EC- 79
Diagnostic Procedure 8 — Hesitation when the Engine is Cold	EF & EC- 80
Diagnostic Procedure 9 — Hesitation under Normal Conditions	EF & EC- 81
Diagnostic Procedure 10 — Engine Stalls when Turning	EF & EC- 83
Diagnostic Procedure 11 — Engine Stalls when the Engine is Hot	EF & EC- 85
Diagnostic Procedure 12 — Engine Stalls when the Engine is Cold	EF & EC- 87
Diagnostic Procedure 13 — Engine Stalls when Stepping on the Accelerator Momentarily	EF & EC- 89
Diagnostic Procedure 14 — Engine Stalls after Decelerating	EF & EC- 91
Diagnostic Procedure 15 — Engine Stalls when Accelerating or Cruising	EF & EC- 95
Diagnostic Procedure 16 — Engine Stalls when the Electrical Load is Heavy	EF & EC- 98
Diagnostic Procedure 17 — Lack of Power and Stumble	EF & EC-100
Diagnostic Procedure 18 — Detonation	EF & EC-101
Diagnostic Procedure 19 — Surge	EF & EC-103
Diagnostic Procedure 20 — Backfire through the Intake	EF & EC-104
Diagnostic Procedure 21 — Backfire through the Exhaust	EF & EC-105
Diagnostic Procedure 22 MAIN POWER SUPPLY AND GROUND CIRCUIT	EF & EC-106
Diagnostic Procedure 23 CRANK ANGLE SENSOR	EF & EC-108
Diagnostic Procedure 24 AIR FLOW METER	EF & EC-112
Diagnostic Procedure 25 ENGINE TEMPERATURE SENSOR	EF & EC-116
Diagnostic Procedure 26 VEHICLE SPEED SENSOR	EF & EC-118
Diagnostic Procedure 27 IGNITION SIGNAL	EF & EC-120
Diagnostic Procedure 28 ENGINE CONTROL UNIT	EF & EC-124
Diagnostic Procedure 29 E.G.R. FUNCTION	EF & EC-126
Diagnostic Procedure 30 EXHAUST GAS SENSOR	EF & EC-130
Diagnostic Procedure 31 DETONATION SENSOR	EF & EC-134
Diagnostic Procedure 32 EXHAUST GAS TEMPERATURE SENSOR	EF & EC-136
Diagnostic Procedure 33 FUEL TEMPERATURE SENSOR	EF & EC-138
Diagnostic Procedure 34 THROTTLE SENSOR	EF & EC-140

TROUBLE DIAGNOSES

Contents (Cont'd)

Diagnostic Procedure 35	
INJECTOR LEAK	EF & EC-144
Diagnostic Procedure 36	
INJECTOR CIRCUIT	EF & EC-146
Diagnostic Procedure 37	
THROTTLE VALVE SWITCH	EF & EC-148
Diagnostic Procedure 38	
START SIGNAL	EF & EC-150
Diagnostic Procedure 39	
POWER STEERING OIL PRESSURE SWITCH	EF & EC-152
Diagnostic Procedure 40	
NEUTRAL SWITCH & A/T CONTROL UNIT (NEUTRAL SIGNAL) CIRCUIT	EF & EC-154
Diagnostic Procedure 41	
FUEL PUMP	EF & EC-156
Diagnostic Procedure 42	
AIR REGULATOR	EF & EC-160
Diagnostic Procedure 43	
A.A.C. VALVE	EF & EC-162
Diagnostic Procedure 44	
F.I.C.D. SOLENOID VALVE	EF & EC-164
Diagnostic Procedure 45	
A.I.V. CONTROL SOLENOID VALVE	EF & EC-166
Diagnostic Procedure 46	
P.R.V.R. CONTROL SOLENOID VALVE	EF & EC-168
Diagnostic Procedure 47	
V.T.C. SOLENOID VALVE	EF & EC-170
Diagnostic Procedure 48	
RADIATOR FAN CONTROL	EF & EC-172
Diagnostic Procedure 49	
WASTEGATE VALVE CONTROL SOLENOID VALVE	EF & EC-176
Electrical Components Inspection	EF & EC-178

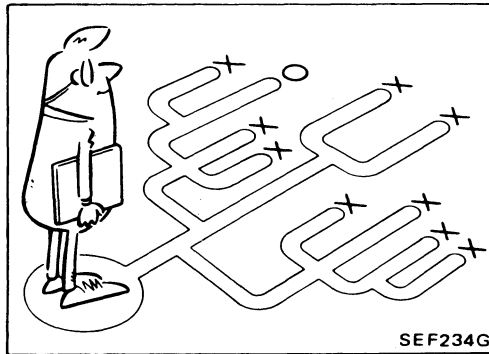
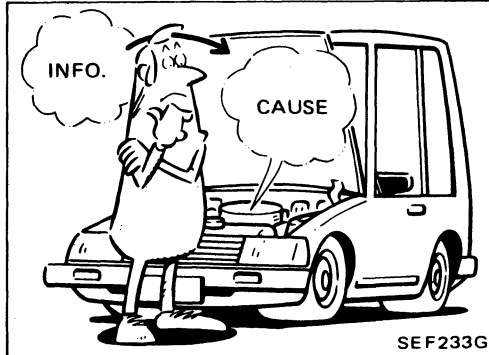
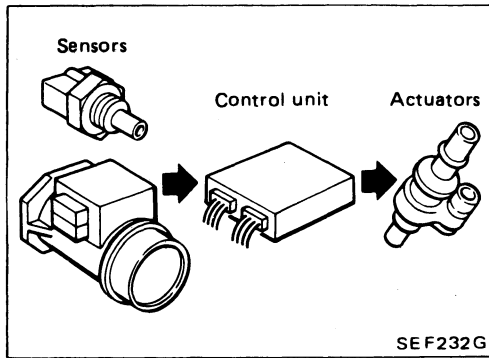

How to Perform Trouble Diagnoses for Quick and Accurate Repair

INTRODUCTION

The engine has an electronic control unit to control major systems such as fuel control, ignition control, idle speed control, etc. The control unit accepts input signals from sensors and instantly drives actuators. It is essential that both kinds of signals are proper and stable. At the same time, it is important that there are no conventional problems such as vacuum leaks, fouled spark plugs, or other problems with the engine.

It is much more difficult to diagnose a problem that occurs intermittently rather than continuously. Most intermittent problems are caused by poor electric connections or improper wiring. In this case, careful checking of suspected circuits may help prevent the replacement of good parts.

A visual check only may not find the cause of the problems, so a road test with a circuit tester connected to a suspected circuit should be performed.

Before undertaking actual checks, take just a few minutes to talk with a customer who approaches with a driveability complaint. The customer is a very good supplier of information on such problems, especially intermittent ones. Through interaction with the customer, find out what symptoms are present and under what conditions they occur.

Start your diagnosis by looking for "conventional" problems first. This is one of the best ways to troubleshoot driveability problems on an electronically controlled engine vehicle.

TROUBLE DIAGNOSES

How to Perform Trouble Diagnoses for Quick and Accurate Repair (Cont'd)

WORK FLOW

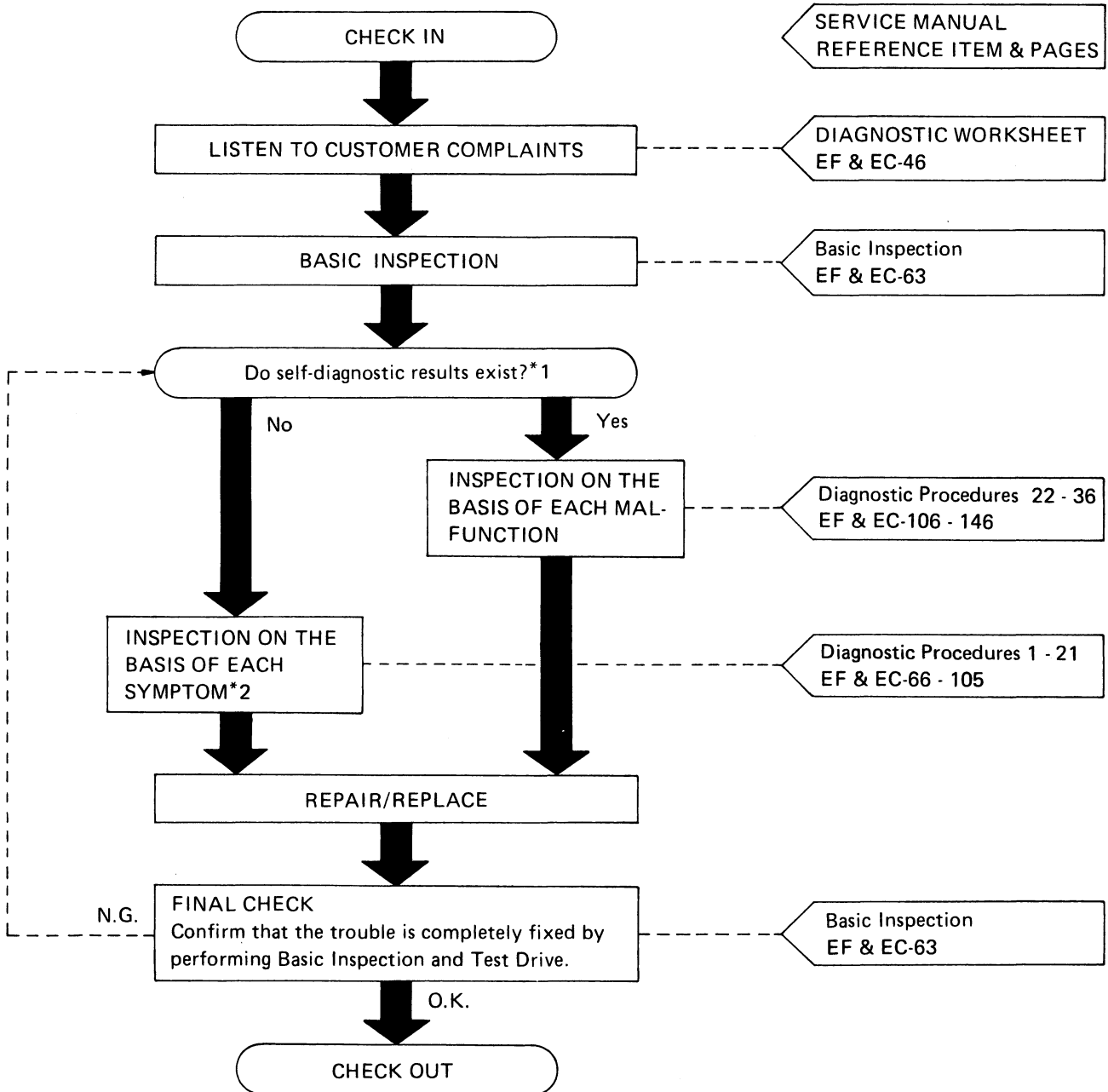

*1: If the self-diagnosis cannot be performed, check main power supply and ground circuit. (See Diagnostic Procedure 22.)

*2: If the trouble is not duplicated, see INTERMITTENT PROBLEM SIMULATION (EF & EC-47).

TROUBLE DIAGNOSES

How to Perform Trouble Diagnoses for Quick and Accurate Repair (Cont'd)

INTERMITTENT PROBLEM SIMULATION

In order to duplicate an intermittent problem, it is effective to create similar conditions for component parts, under which the problem might occur.

Perform the activity listed under Service procedure and note the result.

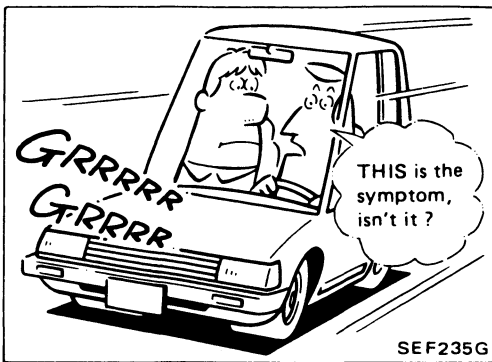

	Variable factor	Influential part	Target condition	Service procedure
1	Mixture ratio	Pressure regulator	Made lean	Remove vacuum hose and apply vacuum.
			Made rich	Remove vacuum hose and apply pressure.
2	Ignition timing	Crank angle sensor	Advanced	Rotate distributor counterclockwise.
			Retarded	Rotate distributor clockwise.
3	Mixture ratio feedback control	Exhaust gas sensor	Suspended	Disconnect exhaust gas sensor harness connector.
		Control unit	Operation check	Perform self-diagnosis (Mode II) at 2,000 rpm.
4	Idle speed	A.A.C. valve	Raised	Turn idle adjusting screw counterclockwise.
			Lowered	Turn idle adjusting screw clockwise.
5	Electrical connection (Electric continuity)	Harness connectors and wires	Poor electrical connection or improper wiring	Tap or wiggle.
				Race engine rapidly. See if the torque reaction of the engine unit causes electric breaks.
6	Temperature	Control unit	Cooled	Cool with an icing spray or similar device.
			Warmed	Heat with a hair drier. [WARNING: Do not overheat the unit.]
7	Moisture	Electric parts	Damp	Wet. [WARNING: Do not directly pour water on components. Use a mist sprayer.]
8	Electric loads	Load switches	Loaded	Turn on headlamps, air conditioner, rear defogger, etc.
9	Idle switch condition	Control unit	ON-OFF switching	Rotate throttle sensor body.
10	Ignition spark	Timing light	Spark power check	Try to flash timing light for each cylinder using ignition coil adapter (S.S.T.).

TROUBLE DIAGNOSES

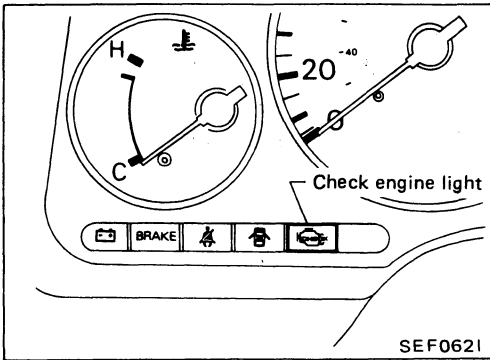

Self-diagnosis

CHECK ENGINE LIGHT

A check engine light has been adopted on the California, Federal and Canada models. This light blinks simultaneously with the RED L.E.D. on the E.C.U.

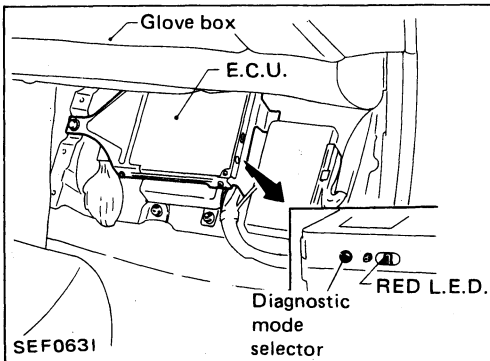

E.C.U. L.E.D.

In the E.C.U., the Green and Red L.E.D.'s have now been permanently changed to one RED L.E.D.

SELF-DIAGNOSTIC FUNCTION

		Mode	Mode I	Mode II
		Condition		
Ignition switch in "ON" position	Engine stopped 		BULB CHECK	SELF-DIAGNOSTIC RESULTS
	Engine running 		MALFUNCTION WARNING	EXHAUST GAS SENSOR MONITOR

TROUBLE DIAGNOSES

Self-diagnosis (Cont'd) HOW TO SWITCH MODES

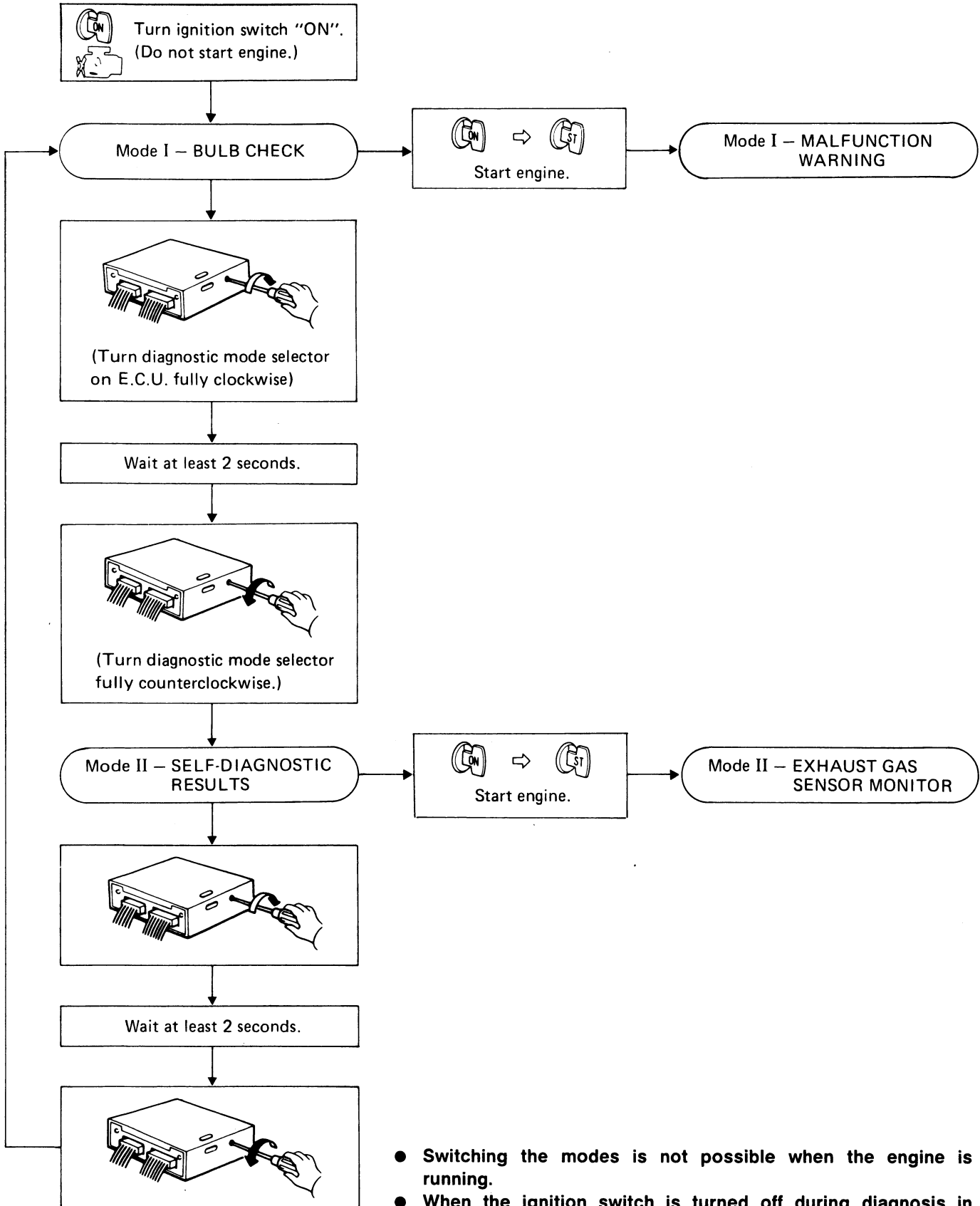

- Switching the modes is not possible when the engine is running.
- When the ignition switch is turned off during diagnosis in each mode, and then turned back on again after power to the E.C.U. has dropped off completely, the diagnosis will automatically return to Mode I.

TROUBLE DIAGNOSES

Self-diagnosis — Mode I

MODE I — BULB CHECK

In this mode, the RED L.E.D. in the E.C.U. and the CHECK ENGINE LIGHT in the instrument panel stay "ON".

If either remain "OFF", check the bulb in the CHECK ENGINE LIGHT or the RED L.E.D.

MODE I — MALFUNCTION WARNING

FOR CALIFORNIA MODEL

CHECK ENGINE LIGHT and RED L.E.D.	Condition
ON	When the following malfunction (check engine light item) is detected or the E.C.U.'s C.P.U. is malfunctioning.
OFF	O.K.

Code No.	Malfunction
12	Air flow meter circuit
13	Engine temperature sensor circuit
14	Vehicle speed sensor circuit
31	E.C.U. (E.C.C.S. control unit)
32	E.G.R. function
33	Exhaust gas sensor circuit (Left side)
35	Exhaust gas temperature sensor circuit
43	Throttle sensor circuit
45	Injector leak
51	Injector circuit
53	Exhaust gas sensor circuit (Right side)

- These Code Numbers are clarified in Mode II — SELF-DIAGNOSTIC RESULTS.
- The RED L.E.D. and the CHECK ENGINE LIGHT will turn off when normal condition is detected. At this time, the Mode II — SELF-DIAGNOSTIC RESULTS memory must be cleared as the contents remain stored.

FOR NON-CALIFORNIA MODEL

CHECK ENGINE LIGHT and RED L.E.D.	Condition
ON	When the E.C.U.'s C.P.U. is malfunctioning.
OFF	O.K.

TROUBLE DIAGNOSES

Self-diagnosis — Mode II (Self-diagnostic results)





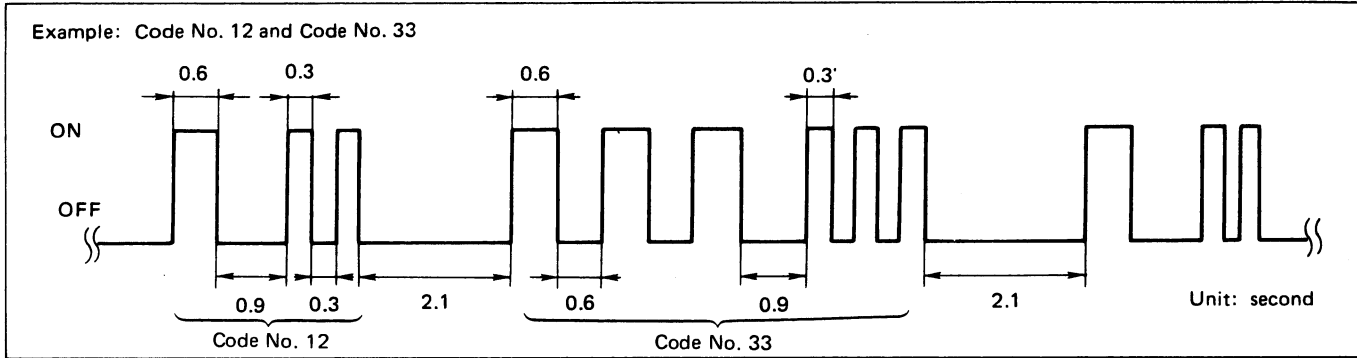





DESCRIPTION

In this mode, a malfunction code is indicated by the number of flashes from the RED L.E.D. or the CHECK ENGINE LIGHT as shown below:



Long (0.6 second) blinking indicates the number of ten digits and short (0.3 second) blinking indicates the number of single digits. For example, the red L.E.D. flashes once for 0.6 seconds and then it flashes twice for 0.3 seconds. This indicates the number "12" and refers to a malfunction in the air flow meter. In this way, all the problems are classified by their code numbers.

Display code table

Code No.	Detected items	California model	Non-California model
11	Crank angle sensor circuit	X	X
12	 Air flow meter circuit	X	X
13	 Engine temperature sensor circuit	X	X
14	 Vehicle speed sensor circuit	X	X
21	Ignition signal circuit	X	X
31	 E.C.U.	X	X
32	 E.G.R. function	X	—
33	 Exhaust gas sensor circuit (Left side)	X	X
34	Detonation sensor circuit	X	X
35	 Exhaust gas temperature sensor circuit	X	—
42	Fuel temperature sensor circuit	X	X
43	 Throttle sensor circuit	X	X
45	 Injector leak	X	—
51	 Injector circuit	X	—
53	 Exhaust gas sensor circuit (Right side)	X	X
54	Signal circuit from A/T control unit to E.C.U. (A/T only)	X	X
55	No malfunction in the above circuits	X	X

X: Available

—: Not available

 : Check engine light item

TROUBLE DIAGNOSES

Self-diagnosis — Mode II (Self-diagnostic results) (Cont'd)

Code No.	Detected items	Malfunction is detected when ...	Check item (remedy)
*11	Crank angle sensor circuit	<ul style="list-style-type: none"> ● Either 1° or 120° signal is not entered for the first few seconds during engine cranking. ● Either 1° or 120° signal is not input often enough while the engine speed is higher than the specified rpm. 	<ul style="list-style-type: none"> ● Harness and connector (If harness and connector are normal, replace crank angle sensor.)
12	Air flow meter circuit	<ul style="list-style-type: none"> ● The air flow meter circuit is open or shorted. (An abnormally high or low voltage is entered.) 	<ul style="list-style-type: none"> ● Harness and connector (If harness and connector are normal, replace air flow meter.)
13	Engine temperature sensor circuit	<ul style="list-style-type: none"> ● The engine temperature sensor circuit is open or shorted. (An abnormally high or low output voltage is entered.) 	<ul style="list-style-type: none"> ● Harness and connector ● Engine temperature sensor
14	Vehicle speed sensor circuit	<ul style="list-style-type: none"> ● The vehicle speed sensor circuit is open or shorted. 	<ul style="list-style-type: none"> ● Harness and connector ● Vehicle speed sensor (reed switch)
*21	Ignition signal circuit	<ul style="list-style-type: none"> ● The ignition signal in the primary circuit is not entered during engine cranking or running. 	<ul style="list-style-type: none"> ● Harness and connector ● Power transistor unit
31	E.C.U.	<ul style="list-style-type: none"> ● E.C.U. calculation function is malfunctioning. 	(Replace E.C.C.S. control unit.)
32	E.G.R. function	<ul style="list-style-type: none"> ● E.G.R. control valve does not operate. (E.G.R. control valve spring does not lift.) 	<ul style="list-style-type: none"> ● E.G.R. control valve ● E.G.R. control solenoid valve
33	Exhaust gas sensor circuit (Left side)	<ul style="list-style-type: none"> ● The exhaust gas sensor circuit is open or shorted. (An abnormally high or low output voltage is entered.) 	<ul style="list-style-type: none"> ● Harness and connector ● Exhaust gas sensor ● Fuel pressure ● Injectors ● Intake air leaks
53	Exhaust gas sensor circuit (Right side)		
34	Detonation sensor circuit	<ul style="list-style-type: none"> ● The detonation circuit is open or shorted. (An abnormally high or low voltage is entered.) 	<ul style="list-style-type: none"> ● Harness and connector ● Detonation sensor
35	Exhaust gas temperature sensor circuit	<ul style="list-style-type: none"> ● The exhaust gas temperature sensor circuit is open or shorted. (An abnormally high or low voltage is entered.) 	<ul style="list-style-type: none"> ● Harness and connector ● Exhaust gas temperature sensor
42	Fuel temperature sensor circuit	<ul style="list-style-type: none"> ● The fuel temperature sensor circuit is open or shorted. (An abnormally high or low voltage is entered.) 	<ul style="list-style-type: none"> ● Harness and connector ● Fuel temperature sensor
43	Throttle sensor circuit	<ul style="list-style-type: none"> ● The throttle sensor circuit is open or shorted. (An abnormally high or low voltage is entered.) 	<ul style="list-style-type: none"> ● Harness and connector ● Throttle sensor

*: Check items causing a malfunction of crank angle sensor circuit first, if both code No. 11 and 21 are displayed at the same time.

TROUBLE DIAGNOSES

Self-diagnosis — Mode II (Self-diagnostic results) (Cont'd)

Code No.	Detected items	Malfunction is detected when ...	Check item (remedy)
45	Injector leak	<ul style="list-style-type: none"> Fuel leaks from injector. 	<ul style="list-style-type: none"> Injector
51	Injector circuit	<ul style="list-style-type: none"> The injector circuit is open. 	<ul style="list-style-type: none"> Harness and connector Injector
54	Signal circuit from A/T control unit to E.C.U. (A/T only)	<ul style="list-style-type: none"> The A/T communication line is open or shorted. 	<ul style="list-style-type: none"> Harness and connector

RETENTION OF DIAGNOSTIC RESULTS

The diagnostic results will remain in E.C.U. memory until the starter is operated fifty times after a diagnostic item has been judged to be malfunctioning. The diagnostic result will then be cancelled automatically. If a diagnostic item which has been judged to be malfunctioning and stored in memory is again judged to be malfunctioning before the starter is operated fifty times, the second result will replace the previous one. It will be stored in E.C.U. memory until the starter is operated fifty times more.

RETENTION TERM CHART (Example)

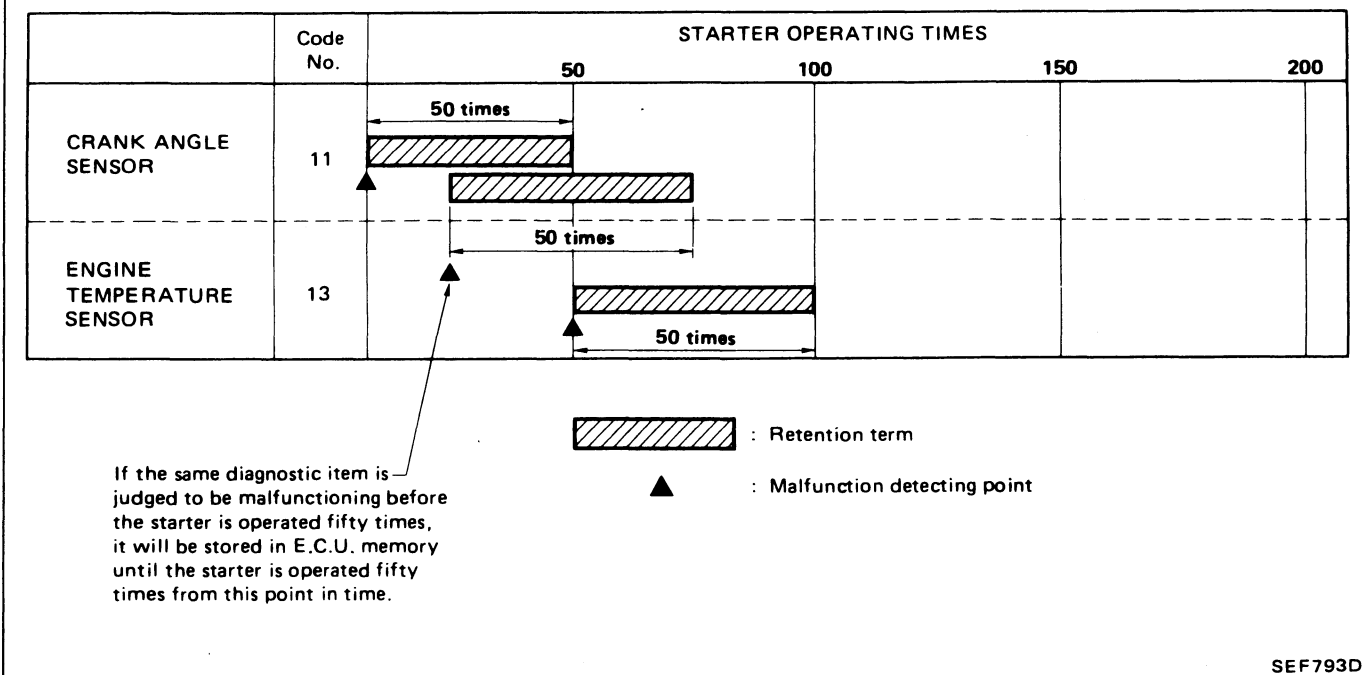

HOW TO ERASE SELF-DIAGNOSTIC RESULTS

The malfunction code is erased from the backup memory on the E.C.U. when the diagnostic mode is changed from Mode II to Mode I. (Refer to "HOW TO SWITCH MODES".)

- When the battery terminal is disconnected, the malfunction code will be lost from the backup memory within 24 hours.
- Before starting self-diagnosis, do not erase the stored memory before beginning self-diagnosis.

TROUBLE DIAGNOSES

Self-diagnosis — Mode II (Exhaust gas sensor monitor)

DESCRIPTION

In this mode, the CHECK ENGINE LIGHT and RED L.E.D. display the condition of the fuel mixture (lean or rich) which is monitored by the exhaust gas sensor.

CHECK ENGINE LIGHT and RED L.E.D.	Fuel mixture condition in the exhaust gas	Air fuel ratio feedback control condition
ON	Lean	Closed loop control
OFF	Rich	
*Remains ON or OFF	Any condition	Open loop control

*: Maintains conditions just before switching to open loop.

If two exhaust gas sensors (right side and left side) are fitted on the engine, the left side exhaust gas sensor monitor operates first, when selecting this mode.

HOW TO CHANGE MONITOR FROM LEFT SIDE (Right side) TO RIGHT SIDE (Left side)

1. Turn diagnostic mode selector on E.C.U. fully clockwise.
 2. Wait at least 2 seconds.
 3. Turn diagnostic mode selector on E.C.U. fully counterclockwise.
- These procedures should be carried out when the engine is running.

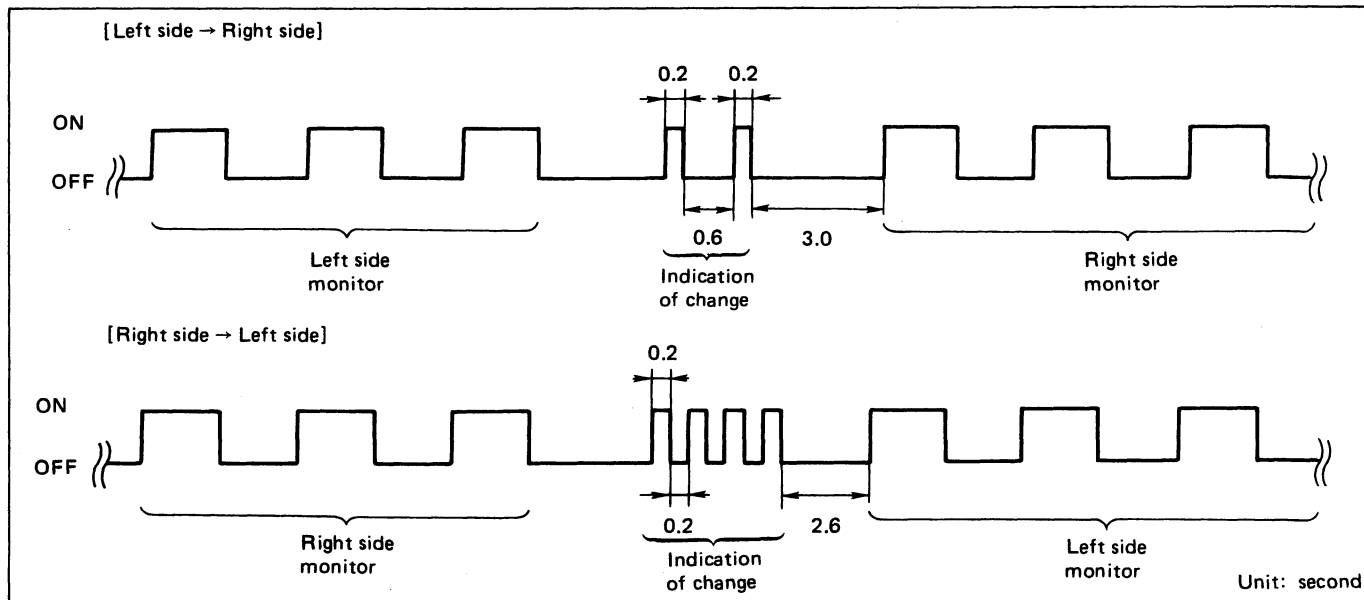

HOW TO CHECK EXHAUST GAS SENSOR

1. Set Mode II. (Refer to "HOW TO SWITCH MODES".)
2. Start engine and warm it up until engine coolant temperature indicator points to the middle of the gauge.
3. Run engine at about 2,000 rpm for about 2 minutes under no-load conditions.
4. Make sure RED L.E.D. or CHECK ENGINE LIGHT goes ON and OFF more than 5 times every 10 seconds; measured at 2,000 rpm under no-load.

TROUBLE DIAGNOSES

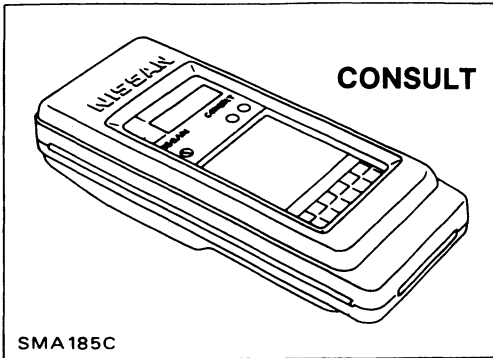

Consult

CONSULT INSPECTION PROCEDURE

1. Turn off ignition switch.
2. Connect "CONSULT" to diagnostic connector.
(Diagnostic connector is located in left dash side panel.)

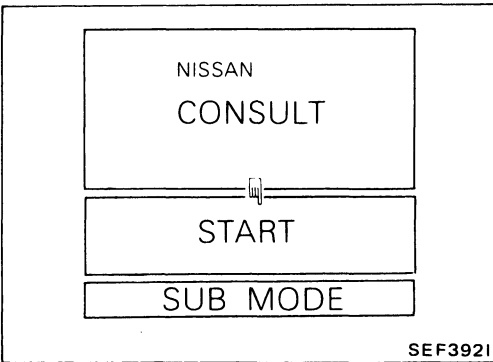
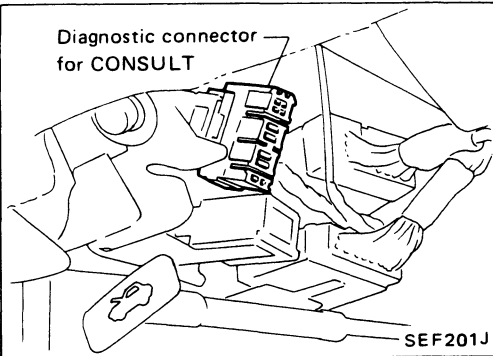

3. Turn on ignition switch.
4. Touch "START".

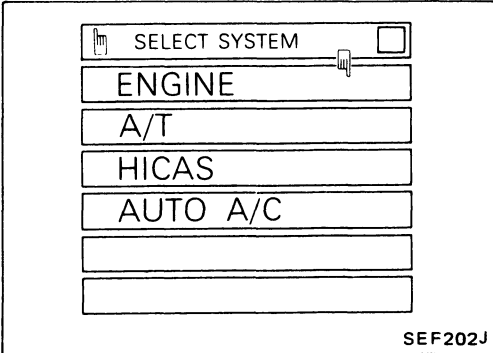

5. Touch "ENGINE".

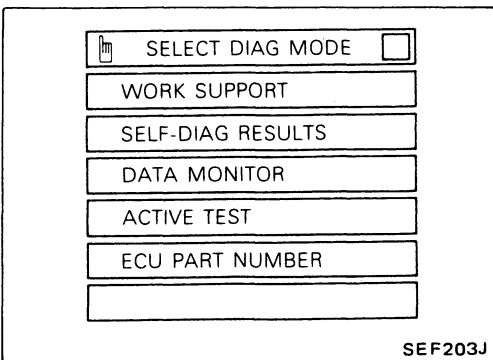

6. Perform each diagnostic mode according to the inspection sheet as follows:

For further information, see the CONSULT Operation Manual.

TROUBLE DIAGNOSES

Consult (Cont'd)

E.C.C.S. COMPONENT PARTS APPLICATION

MODE		WORK SUPPORT	SELF-DIAGNOSTIC RESULTS	DATA MONITOR	ACTIVE TEST
E.C.C.S. COMPONENT PARTS					
INPUT	Crank angle sensor		X	X	
	Air flow meter		X	X	
	Engine temperature sensor		X	X	X
	Exhaust gas sensors		X	X	
	Vehicle speed sensor		X	X	
	Throttle sensor	X	X	X	
	Fuel temperature sensor		X	X	
	Exhaust gas temperature sensor*		X	X	
	Detonation sensor		X		
	Ignition switch (start signal)			X	
	Air conditioner switch			X	
	Neutral switch			X	
	Power steering oil pressure switch			X	
	Battery			X	
	A/T signal			X	X
OUTPUT	Injectors		X	X	X
	Power transistors (ignition signal)		X	X (Ignition timing)	X
	A.A.C. valve	X		X	X
	F.I.C.D. solenoid valve			X	X
	Valve timing control solenoid valve			X	X
	A.I.V. control solenoid valve			X	X
	P.R.V.R. control solenoid valve			X	X
	E.G.R. control solenoid valve			X	X
	Wastegate valve control solenoid valves			X	
	Air conditioner relay			X	
	Fuel pump relay	X		X	X
	Radiator fan			X	X

*: The E.C.C.S. component part marked * is applicable to vehicles for California only.

X: Applicable

TROUBLE DIAGNOSES

Consult (Cont'd)

FUNCTION

Diagnostic mode	Function
Work support	This mode enables a technician to adjust some devices faster and more accurately by following the indications on the CONSULT unit.
Self-diagnostic results	Self-diagnostic results can be read and erased quickly.
Data monitor	Input/Output data in the control unit can be read.
Active test	Mode in which CONSULT drives some actuators apart from the control units and also shifts some parameters in a specified range.
E.C.U. part number	E.C.U. part number can be read.

WORK SUPPORT MODE

WORK ITEM	CONDITION	USAGE
THROTTLE SENSOR ADJUSTMENT	CHECK THE THROTTLE SENSOR SIGNAL. ADJUST IT TO THE SPECIFIED VALUE BY ROTATING THE SENSOR BODY UNDER THE FOLLOWING CONDITIONS. <ul style="list-style-type: none"> ● IGN SW "ON" ● ENG NOT RUNNING ● ACC PEDAL NOT PRESSED 	When adjusting throttle sensor initial position,
IGNITION TIMING ADJUSTMENT*	<ul style="list-style-type: none"> ● IGNITION TIMING FEEDBACK CONTROL WILL BE HELD BY TOUCHING "START". AFTER DOING SO, ADJUST IGNITION TIMING WITH A TIMING LIGHT BY TURNING THE CRANK ANGLE SENSOR. 	When adjusting initial ignition timing,
AAC VALVE ADJUSTMENT	SET ENGINE RPM AT THE SPECIFIED VALUE UNDER THE FOLLOWING CONDITIONS. <ul style="list-style-type: none"> ● ENGINE WARMED UP ● NO-LOAD 	When adjusting idle speed,
FUEL PRESSURE RELEASE	<ul style="list-style-type: none"> ● FUEL PUMP WILL STOP BY TOUCHING "START" DURING IDLING. CRANK A FEW TIMES AFTER ENGINE STALLS. 	When releasing fuel pressure from fuel line,

*: The ignition timing feedback control is not adopted on model 300ZX, so it is not necessary to perform IGNITION TIMING ADJUSTMENT.

TROUBLE DIAGNOSES

Consult (Cont'd)

SELF-DIAGNOSTIC RESULTS MODE

DIAGNOSTIC ITEM	DIAGNOSTIC ITEM IS DETECTED WHEN . . .	CHECK ITEM (REMEDY)
CRANK ANGLE SENSOR*	<ul style="list-style-type: none"> ● Either 1° or 120° signal is not entered for the first few seconds during engine cranking. ● Either 1° or 120° signal is not input often enough while the engine speed is higher than the specified rpm. 	<ul style="list-style-type: none"> ● Harness and connector (If harness and connector are normal, replace crank angle sensor.)
AIR FLOW METER	<ul style="list-style-type: none"> ● The air flow meter circuit is open or shorted. (An abnormally high or low voltage is entered.) 	<ul style="list-style-type: none"> ● Harness and connector (If harness and connector are normal, replace air flow meter.)
ENGINE TEMP SENSOR	<ul style="list-style-type: none"> ● The engine temperature sensor circuit is open or shorted. (An abnormally high or low output voltage is entered.) 	<ul style="list-style-type: none"> ● Harness and connector ● Engine temperature sensor
CAR SPEED SENSOR	<ul style="list-style-type: none"> ● The vehicle speed sensor circuit is open or shorted. 	<ul style="list-style-type: none"> ● Harness and connector ● Vehicle speed sensor (reed switch)
IGN SIGNAL-PRIMARY*	<ul style="list-style-type: none"> ● The ignition signal in primary circuit is not entered during engine cranking or running. 	<ul style="list-style-type: none"> ● Harness and connector ● Power transistor unit
CONTROL UNIT	<ul style="list-style-type: none"> ● E.C.U. calculation function is malfunctioning. 	(Replace E.C.C.S. control unit.)
EGR SYSTEM**	<ul style="list-style-type: none"> ● E.G.R. control valve does not operate. (E.G.R. control valve spring does not lift.) 	<ul style="list-style-type: none"> ● E.G.R. control valve ● E.G.R. control solenoid valve
EXH GAS SENSOR EXH GAS SENSOR-R	<ul style="list-style-type: none"> ● The exhaust gas sensor circuit is open or shorted. (An abnormally high or low output voltage is entered.) 	<ul style="list-style-type: none"> ● Harness and connector ● Exhaust gas sensor ● Fuel pressure ● Injectors ● Intake air leaks
DETONATION SENSOR	<ul style="list-style-type: none"> ● The detonation circuit is open or shorted. (An abnormally high or low voltage is entered.) 	<ul style="list-style-type: none"> ● Harness and connector ● Detonation sensor
EXH GAS TEMP SENSOR**	<ul style="list-style-type: none"> ● The exhaust gas temperature sensor circuit is open or shorted. (An abnormally high or low voltage is entered.) 	<ul style="list-style-type: none"> ● Harness and connector ● Exhaust gas temperature sensor
FUEL TEMP SENSOR	<ul style="list-style-type: none"> ● The fuel temperature sensor circuit is open or shorted. (An abnormally high or low voltage is entered.) 	<ul style="list-style-type: none"> ● Harness and connector ● Fuel temperature sensor
THROTTLE SENSOR	<ul style="list-style-type: none"> ● The throttle sensor circuit is open or shorted. (An abnormally high or low voltage is entered.) 	<ul style="list-style-type: none"> ● Harness and connector ● Throttle sensor

*: Check items causing a malfunction of crank angle sensor circuit first, if both "CRANK ANGLE SENSOR" and "IGN SIGNAL-PRIMARY" are displayed at the same time.

TROUBLE DIAGNOSES

Consult (Cont'd)

DIAGNOSTIC ITEM	DIAGNOSTIC ITEM IS DETECTED WHEN....	CHECK ITEM (REMEDY)
INJECTOR FUEL LEAK**	<ul style="list-style-type: none">● Fuel leaks from injector.	<ul style="list-style-type: none">● Injector
INJECTOR OPEN**	<ul style="list-style-type: none">● The injector circuit is open.	<ul style="list-style-type: none">● Injector
A/T COMM LINE	<ul style="list-style-type: none">● The A/T communication line is open or shorted.	<ul style="list-style-type: none">● Harness and connector

** : The diagnostic item marked ** is applicable to vehicles for California only.

TROUBLE DIAGNOSES

Consult (Cont'd)

DATA MONITOR MODE

- Remarks;
- The monitor item marked "*" is applicable to vehicles for California only.
 - Specification data are reference values.
 - Specification data are out-put/in-put values which are detected or supplied by E.C.U. at the connector.
 - * Specification data may not be directly related to their components signals/values/operations.
- ie. Adjust ignition timing with a timing light before monitoring IGN TIMING, because the monitor may show the specification data in spite of the ignition timing being not adjusted to the specification data. This IGN TIMING monitors the calculated data by E.C.U. according to the input signals from crank angle sensor and other ignition timing related sensors.

MONITOR ITEM	CONDITION		SPECIFICATION		CHECK ITEM WHEN OUTSIDE SPEC.
			Non-turbo	Turbo	
CAS-RPM (POS) CAS-RPM (REF)	<ul style="list-style-type: none"> • Tachometer: Connect • Run engine and compare tachometer indication with the CONSULT value. 		Almost the same speed as the CONSULT value.		<ul style="list-style-type: none"> • Harness and connector • Crank angle sensor
AIR FLOW MTR	<ul style="list-style-type: none"> • Engine: After warming up, idle the engine • A/C switch "OFF" • Shift lever "N" • No-load 	Idle	0.8 - 1.5V	0.9 - 1.4V	<ul style="list-style-type: none"> • Harness and connector • Air flow meter
		2,000 rpm	1.4 - 1.8V	1.4 - 1.8V	
ENG TEMP SEN	<ul style="list-style-type: none"> • Engine: After warming up 		More than 70°C (158°F)		<ul style="list-style-type: none"> • Harness and connector • Engine temperature sensor
EXH GAS SEN EXH GAS SEN-R M/R F/C MNT M/R F/C MNT-R	<ul style="list-style-type: none"> • Engine: After warming up 	Maintaining engine speed at 2,000 rpm	0 - 0.3V ↔ 0.6 - 1.0V		<ul style="list-style-type: none"> • Harness and connector • Exhaust gas sensor • Intake air leaks • Injectors
LEAN ↔ RICH Changes more than 5 times during 10 seconds.					
CAR SPEED SEN	<ul style="list-style-type: none"> • Turn drive wheels and compare speedometer indication with the CONSULT value 		Almost the same speed as the CONSULT value		<ul style="list-style-type: none"> • Harness and connector • Vehicle speed sensor
BATTERY VOLT	<ul style="list-style-type: none"> • Ignition switch: ON (Engine stopped) 		11 - 14V		<ul style="list-style-type: none"> • Battery • E.C.U. power supply circuit
THROTTLE SEN	<ul style="list-style-type: none"> • Ignition switch: ON (Engine stopped) 	Throttle valve fully closed	0.4 - 0.5V		<ul style="list-style-type: none"> • Harness and connector • Throttle sensor • Throttle sensor adjustment
		Throttle valve fully opened	Approx. 4.0V		
FUEL TEMP SEN	<ul style="list-style-type: none"> • Engine: After warming up 		20 - 60°C (68 - 140°F)		<ul style="list-style-type: none"> • Harness and connector • Fuel temp. sensor
EGR TEMP SEN*	<ul style="list-style-type: none"> • Engine: After warming up 		Less than 4.5V		<ul style="list-style-type: none"> • Harness and connector • Exhaust gas temperature sensor
START SIGNAL	<ul style="list-style-type: none"> • Ignition switch: ON → START 		OFF → ON		<ul style="list-style-type: none"> • Harness and connector • Starter switch
IDLE POSITION	<ul style="list-style-type: none"> • Ignition switch: ON (Engine stopped) 	Throttle valve: Idle position	ON		<ul style="list-style-type: none"> • Harness and connector • Throttle sensor • Throttle sensor adjustment
		Throttle valve: Slightly open	OFF		
AIR COND SIG	<ul style="list-style-type: none"> • Engine: After warming up, idle the engine 	A/C switch "OFF"	OFF		<ul style="list-style-type: none"> • Harness and connector • Air conditioner switch
		A/C switch "ON"	ON		
NEUTRAL SW	<ul style="list-style-type: none"> • Ignition switch: ON 	Shift lever "P" or "N"	ON		<ul style="list-style-type: none"> • Harness and connector • Neutral switch
		Except above	OFF		

TROUBLE DIAGNOSES

Consult (Cont'd)

MONITOR ITEM	CONDITION		SPECIFICATION		CHECK ITEM WHEN OUTSIDE SPEC.
			Non-turbo	Turbo	
PW/ST SIGNAL	<ul style="list-style-type: none"> Engine: After warming up, idle the engine 	Steering wheel in neutral (forward direction)	OFF		<ul style="list-style-type: none"> Harness and connector Power steering oil pressure switch
		The steering wheel is turned	ON		
INJ PULSE	<ul style="list-style-type: none"> Engine: After warming up A/C switch "OFF" Shift lever "N" No-load 	Idle	2.0 - 3.0 msec.	1.8 - 2.5 msec.	<ul style="list-style-type: none"> Harness and connector Injector Air flow meter Intake air system
INJ PULSE-R		2,000 rpm	2.0 - 3.0 msec.	1.8 - 2.2 msec.	
IGN TIMING	ditto	Idle	15° B.T.D.C.	15° B.T.D.C.	<ul style="list-style-type: none"> Harness and connector Crank angle sensor
		2,000 rpm	More than 25° B.T.D.C.	More than 25° B.T.D.C.	
AAC VALVE	ditto	Idle	15 - 40%	15 - 35%	<ul style="list-style-type: none"> Harness and connector A.A.C. valve
		2,000 rpm	—	—	

TROUBLE DIAGNOSES

Consult (Cont'd)

ACTIVE TEST MODE

TEST ITEM	CONDITION	JUDGEMENT	CHECK ITEM (REMEDY)
FUEL INJECTION TEST	<ul style="list-style-type: none"> Engine: Return to the original trouble condition Change the amount of fuel injection with the CONSULT. 	If trouble symptom disappears, see CHECK ITEM.	<ul style="list-style-type: none"> Harness and connector Fuel injectors Exhaust gas sensors
AAC/V OPENING TEST	<ul style="list-style-type: none"> Engine: After warming up, idle the engine. Change the AAC valve opening percent with the CONSULT. 	Engine speed changes according to the opening percent.	<ul style="list-style-type: none"> Harness and connector AAC valve
ENGINE TEMP TEST	<ul style="list-style-type: none"> Engine: Return to the original trouble condition Change the engine coolant temperature with the CONSULT. 	If trouble symptom disappears, see CHECK ITEM.	<ul style="list-style-type: none"> Harness and connector Engine temperature sensor Fuel injectors
IGN TIMING TEST	<ul style="list-style-type: none"> Engine: Return to the original trouble condition Timing light: Set Retard the ignition timing with the CONSULT. 	If trouble symptom disappears, see CHECK ITEM.	<ul style="list-style-type: none"> Adjust initial ignition timing
POWER BALANCE TEST	<ul style="list-style-type: none"> Engine: After warming up, idle the engine. A/C switch "OFF" Shift lever "N" Cut off each injector signal one at a time with the CONSULT. 	Engine runs rough or dies.	<ul style="list-style-type: none"> Harness and connector Compression Injectors Power transistor Spark plugs Ignition coils
RADIATOR FAN TEST	<ul style="list-style-type: none"> Ignition switch: ON Turn the radiator fan "ON" and "OFF" with the CONSULT. 	Radiator fan moves and stops.	<ul style="list-style-type: none"> Harness and connector Radiator fan motor
FICD SOL/V TEST	<ul style="list-style-type: none"> Engine: After warming up, idle the engine. A/C switch "OFF" Shift lever "N" Turn the FICD solenoid valve "ON" with the CONSULT. 	Engine speed will increase momentarily by approx. 200 rpm.	<ul style="list-style-type: none"> Harness and connector FICD solenoid valve
FUEL PUMP RLY TEST	<ul style="list-style-type: none"> Ignition switch: ON (Engine stopped) Turn the fuel pump relay "ON" and "OFF" with the CONSULT and listen to operating sound. 	Fuel pump relay makes the operating sound.	<ul style="list-style-type: none"> Harness and connector Fuel pump relay
EGR CONT SOL/V TEST	<ul style="list-style-type: none"> Ignition switch: ON Turn solenoid valve "ON" and "OFF" with the CONSULT and listen to operating sound. 	Each solenoid valve makes an operating sound.	<ul style="list-style-type: none"> Harness and connector Solenoid valve
PRVR CONT SOL/V TEST			
AIV CONT SOL/V TEST			
VALVE TIM SOL TEST			
SELF-LEARN CONT TEST	<ul style="list-style-type: none"> In this test, the coefficient of self-learning control mixture ratio returns to the original coefficient by touching "CLEAR" on the screen. 		

TROUBLE DIAGNOSES

Basic Inspection

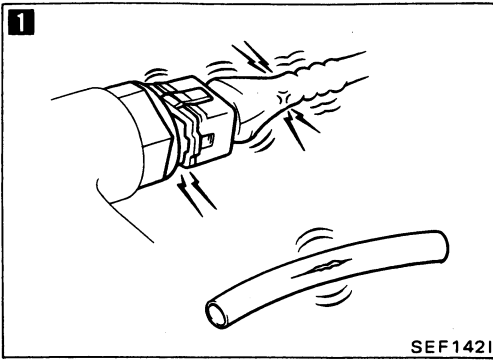

1

BEFORE STARTING

1. Check service records for any recent repairs that may indicate a related problem, or the current need for scheduled maintenance.
2. Open engine hood and check the following:
 - Harness connectors for proper connections
 - Vacuum hoses for splits, kinks, and proper connections
 - Wiring for proper connections, pinches, and cuts

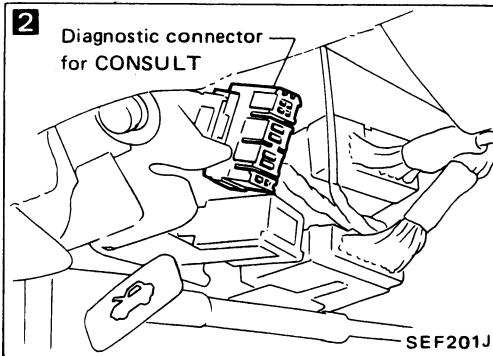

2

CONNECT CONSULT TO THE VEHICLE

Connect "CONSULT" to the diagnostic connector and select "ENGINE" from the menu. (Refer to page EF & EC-55.)

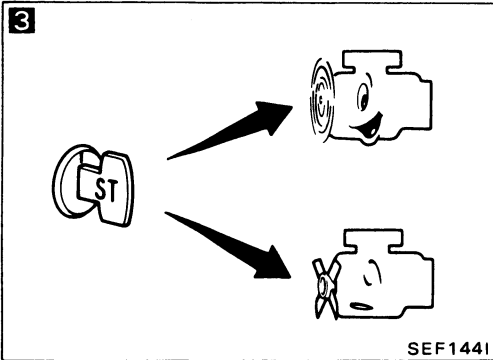

3

DOES ENGINE START?

No

GO TO 6

Yes

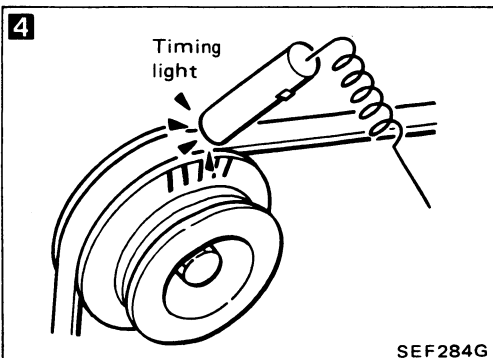

4

CHECK IGNITION TIMING.

Warm up engine sufficiently and check ignition timing at idle using timing light. (Refer to page EF & EC-35.)

Ignition timing: $15^{\circ} \pm 2^{\circ}$
B.T.D.C.

N.G.

Adjust ignition timing by turning crank angle sensor.

O.K.

(Go to **A** on next page.)

TROUBLE DIAGNOSES

Basic Inspection (Cont'd)

5

■ AAC VALVE ADJ ■

SET ENGINE RPM AT THE SPECIFIED VALUE UNDER THE FOLLOWING CONDITION

- ENG WARMED UP
- NO LOAD

START

SEF372I

5

SEF146I

5

CHECK IDLE ADJ. SCREW INITIAL SET RPM.

1. Select "A.A.C. VALVE ADJ" in "WORK SUPPORT" mode.

2. When touching "START", does engine rpm fall to;

M/T: 650 ± 50 rpm
A/T: 720 ± 50 rpm (Non-turbo)
 700 ± 50 rpm (Turbo)
[in "N" position]?

—OR—

When disconnecting A.A.C. valve harness connector, does engine rpm fall to;

M/T: 650 ± 50 rpm
A/T: 720 ± 50 rpm (Non-turbo)
 700 ± 50 rpm (Turbo)
[in "N" position]?

No → Adjust engine rpm by turning idle adjusting screw.

6

■ THROTTLE SEN ADJ ■

**** ADJ MONITOR ****

THROTTLE SEN 0.46V

=== MONITOR ===

CAS-RPM (POS) 800rpm
IDLE POSITION ON

SEF147I

6

SEF148I

6

CHECK THROTTLE SENSOR IDLE POSITION.

1. Perform "THROTTLE SEN. ADJ." in "WORK SUPPORT" mode.

2. Check that output voltage of throttle sensor is 0.4 to 0.5V. (Throttle valve fully closes.) and "IDLE POSITION" stays "ON".

—OR—

Measure output voltage of throttle sensor using voltmeter, and check that it is 0.4 to 0.5V. (Throttle valve fully closed.)

N.G. →

1. Adjust output voltage by rotating throttle sensor body.
2. Disconnect throttle sensor harness connector for a few seconds and then reconnect it.
3. Confirm that "IDLE POSITION" stays "ON".

O.K. ↓

(Go to **B** on next page.)

TROUBLE DIAGNOSES

Basic Inspection (Cont'd)

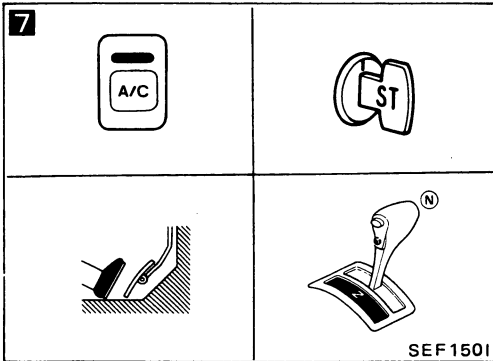
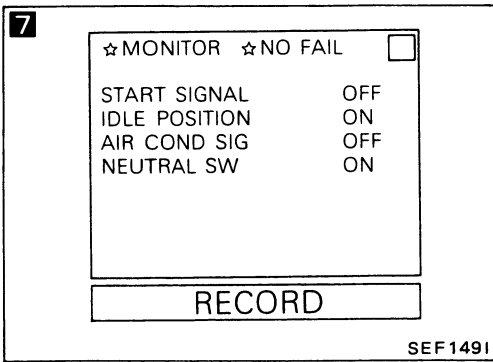

7

CHECK SWITCH INPUT SIGNAL.

Select the following switches in "DATA MONITOR" mode,

- Start signal,
- Idle position,
- Air conditioner signal,
- Neutral (Parking) switch,

and check the switches' ON-OFF operation.

N.G. → Repair or replace the malfunctioning switch or its circuit.

OR

Remove E.C.U. from front floor panel and check the above switches' ON-OFF operation using voltmeter at each E.C.U. terminal.

Switch	Condition	Voltage (V)
Start signal	IGN → IGN ON → START	0 → Battery voltage
Idle position	—	—
A/C signal	A/C OFF → ON (Engine running)	Battery voltage → 0.5 - 0.7
Neutral (Parking) switch	Shift lever is "N" or "P" position → Except "N" and "P"	0 → 8.0 - 9.0

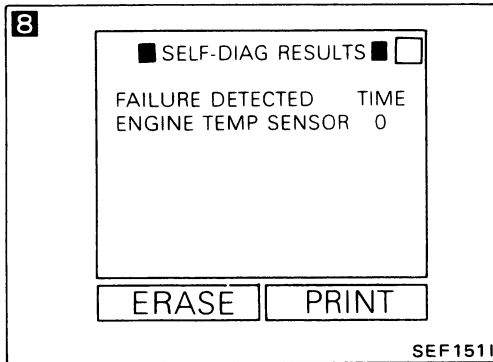

8

READ SELF-DIAGNOSTIC RESULTS.

- Perform "SELF-DIAG RESULTS" mode.
- Read out self-diagnostic results.
- Is a failure detected?

Yes → Go to the relevant inspection procedure.

OR

- Set "Self-diagnostic results mode" in Mode II. (Refer to page EF & EC-49.)
- Count the number of RED L.E.D. flashes and read out the codes.
- Are the codes being output?

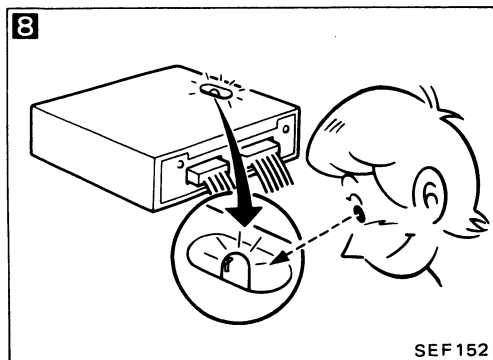

No

INSPECTION END

TROUBLE DIAGNOSES

Diagnostic Procedure 1 — High Idling after Warm-up

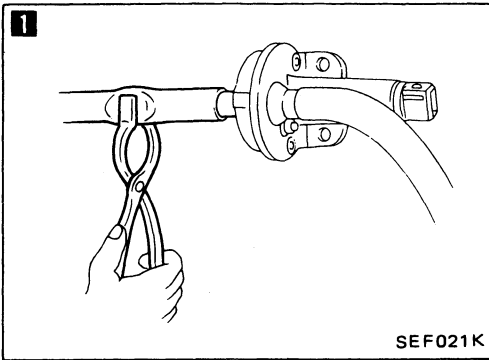

1
CHECK AIR REGULATOR.
When pinching the air regulator hose, does the engine speed drop?

Yes → Check air regulator and circuit.

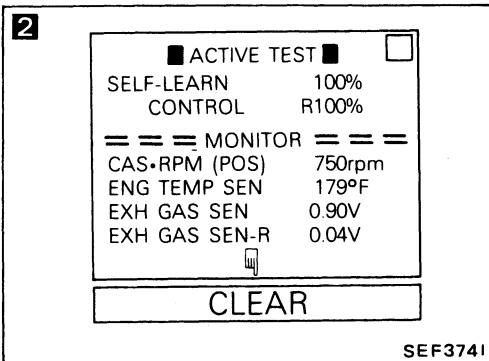

2
CHECK INTAKE AIR LEAK.

1. Select "SELF-LEARNING CONT" in "ACTIVE TEST" mode.
2. Clear the self-learning control coefficient by touching "CLEAR".
3. Does the engine speed drop?

Yes → Discover air leak location and repair.

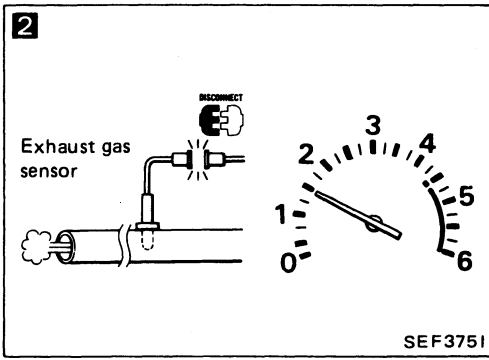

OR

1. Disconnect exhaust gas sensor harness connectors.
2. After racing engine at 1,500 rpm under no load for about 30 seconds, does the engine speed drop?

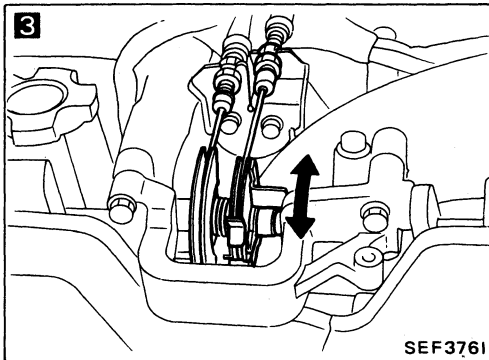

3
CHECK THROTTLE LINKAGE.
1. Check that throttle linkage moves smoothly.
2. Confirm that throttle valve both fully opens and fully closes.

N.G. → Repair throttle linkage or sticking of throttle valve.

O.K.

INSPECTION END

TROUBLE DIAGNOSES

Diagnostic Procedure 2 — Hunting

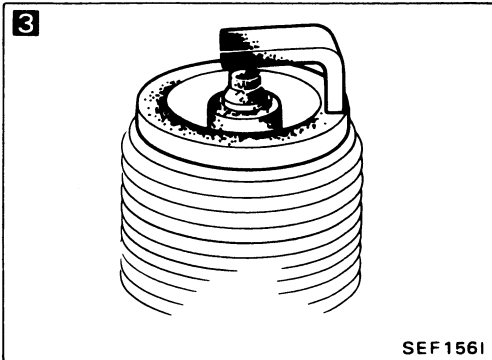
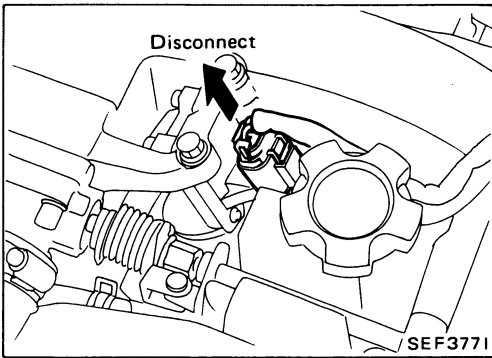
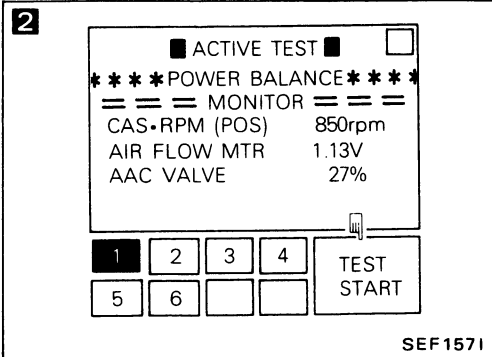
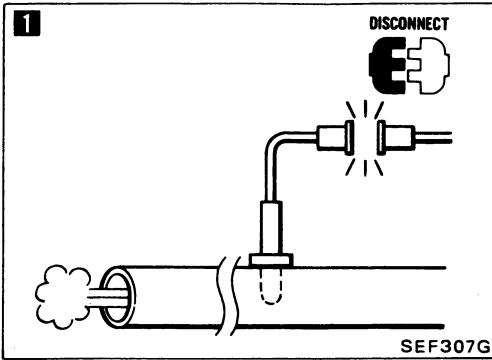

1
CHECK EXHAUST GAS SENSORS.
 When disconnecting exhaust gas sensor harness connectors, is the hunting fixed?

Check exhaust gas sensor(s). (See page EF & EC-130.)

No

2
PERFORM POWER BALANCE TEST.

1. Perform "POWER BALANCE" in "ACTIVE TEST" mode.

2. Is there any cylinder which does not produce a momentary engine speed drop?

No

Go to **4**.

OR

When disconnecting each ignition coil harness connector one at a time, is there any cylinder which does not produce a momentary engine speed drop?

Yes

3
CHECK SPARK PLUGS.
 Remove the spark plugs and check for fouling, etc.

N.G.

Repair or replace spark plug(s).

O.K.

(Go to **A** on next page.)

TROUBLE DIAGNOSES

Diagnostic Procedure 2 — Hunting (Cont'd)

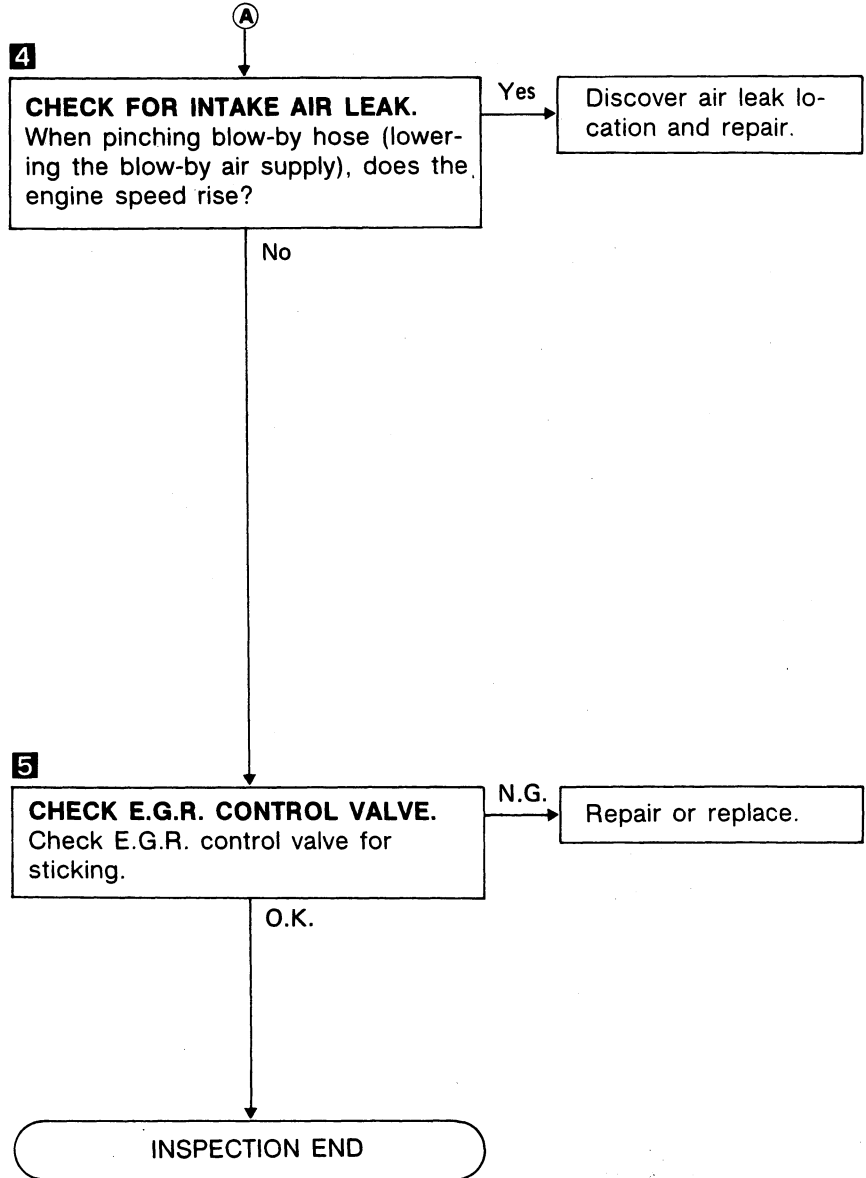
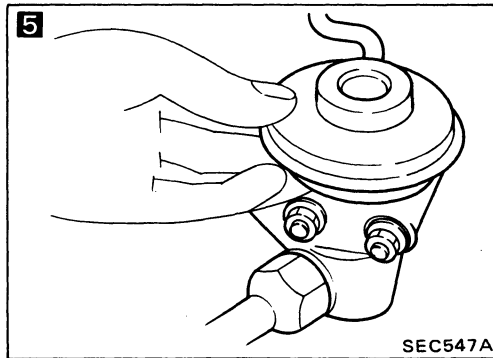
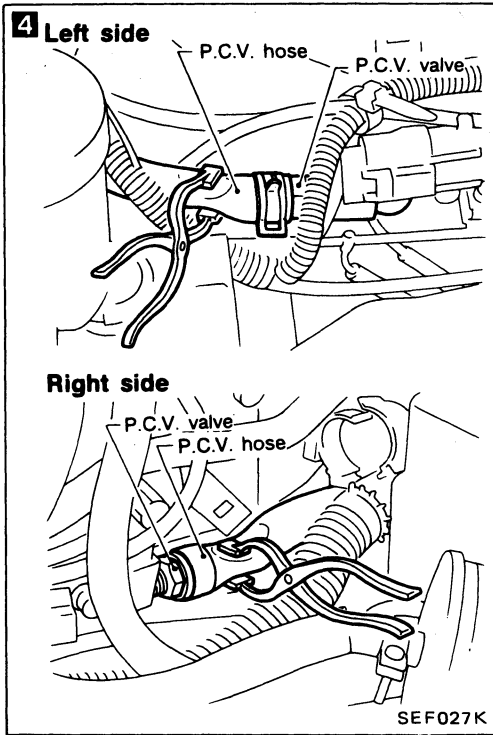

TROUBLE DIAGNOSES

Diagnostic Procedure 3 — Unstable Idle

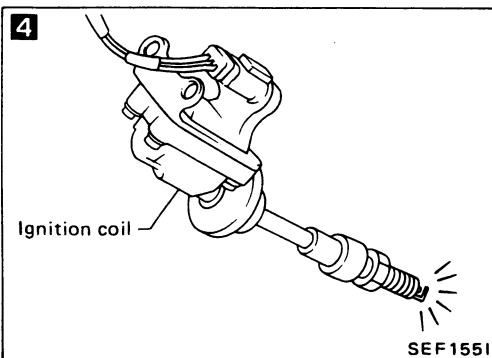
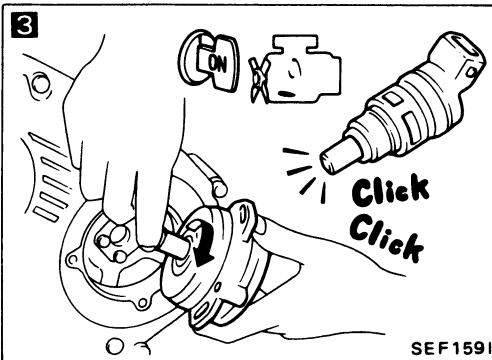
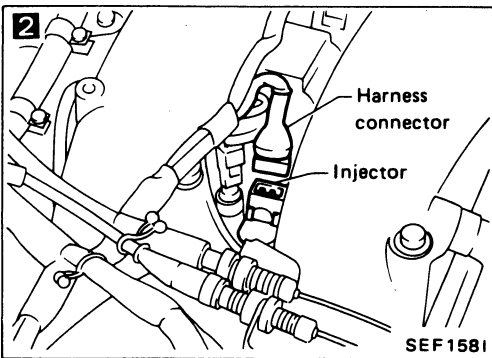
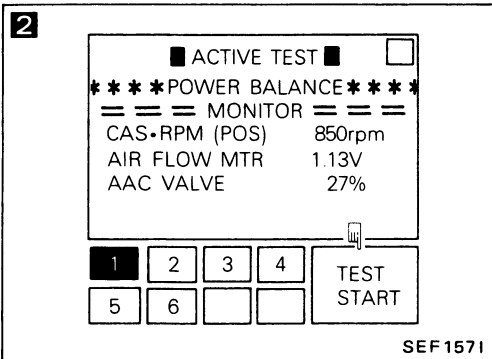
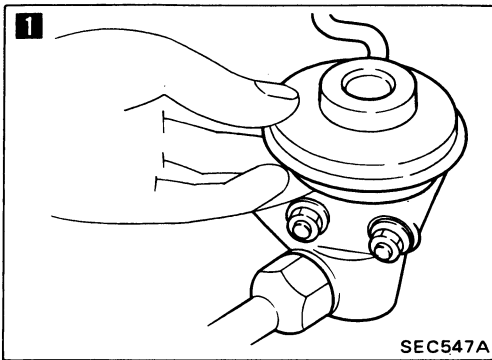

1
CHECK E.G.R. CONTROL VALVE.
Check E.G.R. control valve for sticking.

N.G.

Repair or replace.

O.K.

2
PERFORM POWER BALANCE TEST.

1. Perform "POWER BALANCE" in "ACTIVE TEST" mode.
2. Is there any cylinder which does not produce a momentary engine speed drop?

— OR —

No

Go to **6**

 When disconnecting each injector harness connector one at a time, is there any cylinder which does not produce a momentary engine speed drop?

Yes

3
CHECK INJECTOR.

1. Remove crank angle sensor from engine. (Harness connector should remain connected.)
2. Turn ignition switch ON. (Do not start engine.)
3. When rotating crank angle sensor shaft, does each injector make an operating sound?

No

Check injector(s) and circuit(s).

Yes

4
CHECK IGNITION SPARK.

1. Disconnect ignition coil assembly from collector.
2. Connect a known good spark plug to the ignition coil assembly.
3. Place end of spark plug against a suitable ground and crank engine.
4. Check for spark.

N.G.

Check ignition coil, power transistor unit and their circuits. (See page EF & EC-120.)

O.K.

(Go to **A** on next page.)

TROUBLE DIAGNOSES

Diagnostic Procedure 3 — Unstable Idle (Cont'd)

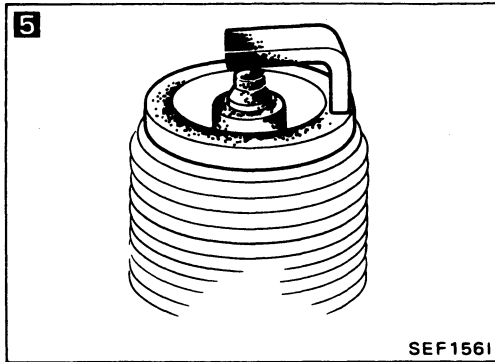

5

CHECK SPARK PLUGS.
Remove the spark plugs and check for fouling, etc.

N.G. → Repair or replace spark plug(s).

O.K.

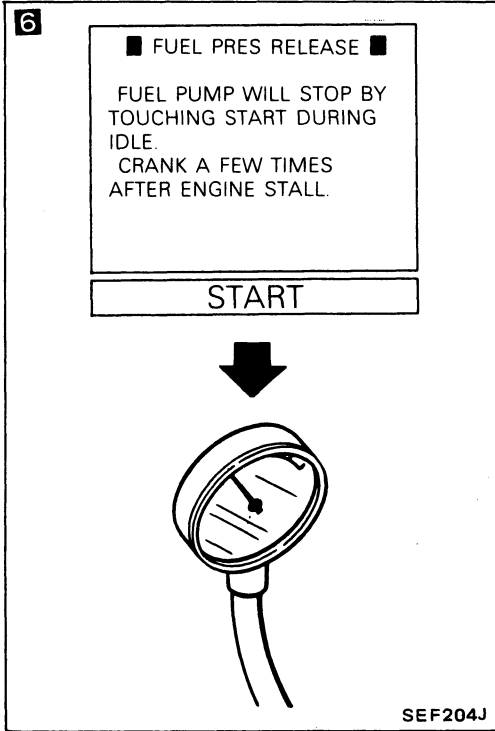

6

CHECK FUEL PRESSURE.

1. Perform "FUEL PRESSURE RELEASE" in "WORK SUPPORT" mode in order to release fuel pressure to zero.

2. Install fuel pressure gauge and check fuel pressure.
At idle approx. 255 kPa (2.6 kg/cm², 37 psi)

— OR —

N.G. → Check fuel pump and circuit.

1. Release fuel pressure to zero. (Refer to page EF & EC-191.)

2. Install fuel pressure gauge and check fuel pressure.

O.K.

(Go to ② on next page.)

TROUBLE DIAGNOSES

Diagnostic Procedure 3 — Unstable Idle (Cont'd)

7

☆ MONITOR	☆ NO FAIL	<input type="checkbox"/>
CAS•RPM(POS)	2087rpm	
M/R F/C MNT	LEAN	
M/R F/C MNT-R	RICH	

RECORD

SEF160I

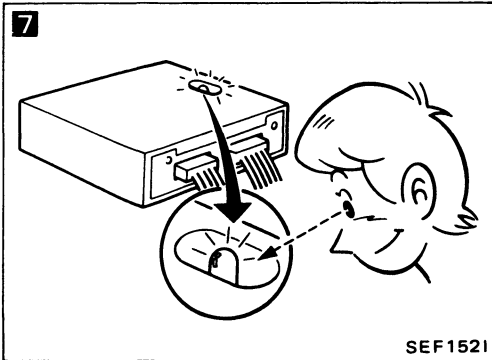

7

CHECK EXHAUST GAS SENSOR.

1. See "M/R F/C MNT (right and left sides)" in "Data monitor" mode.
2. Maintaining engine at 2,000 rpm under no-load (engine is warmed up sufficiently.), check that the monitor fluctuates between "LEAN" and "RICH" more than 5 times during 10 seconds.
RICH→LEAN→RICH→
 1 time 2 times
LEAN→RICH.....

OR

1. Set "Exhaust gas sensor monitor" in the self-diagnostic Mode II. (See page EF & EC-54.)
2. Maintaining engine at 2,000 rpm under no-load, check to make sure that RED LED on the E.C.U. goes ON and OFF more than 5 times during 10 seconds.

N.G. → Replace exhaust gas sensor(s).

O.K.

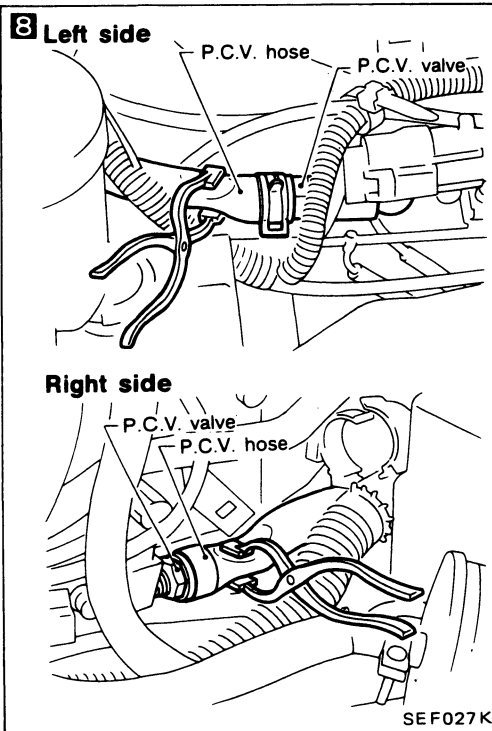

8

CHECK FOR INTAKE AIR LEAK.
 When pinching blow-by hose (lowering the blow-by air supply), does the engine speed rise?

Yes → Discover air leak location and repair.

No

(Go to © on next page.)

TROUBLE DIAGNOSES

Diagnostic Procedure 3 — Unstable Idle (Cont'd)

9

■ AAC VALVE ADJ ■

**** ADJ MONITOR ****
CAS-RPM (POS) 712rpm

— — CONDITION SETTING — —
AAC VALVE FIXED

=== MONITOR ===
ENG TEMP SEN 177°C
IDLE POSITION ON
AIR COND SIG OFF

SEF1451

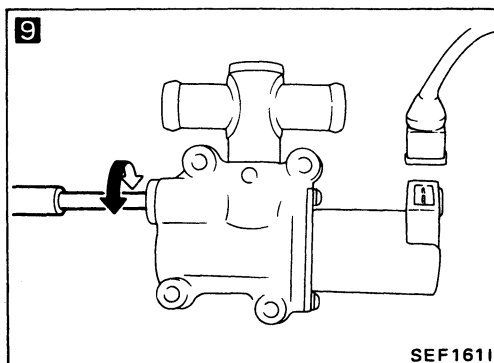

10

COMPRESSION PRESSURE

SEF309G

9

Ⓢ

CHECK IDLE ADJ. SCREW CLOGGING.

1. Perform "AAC VALVE ADJ" in "WORK SUPPORT" mode.
2. Can you set engine rpm as follows by turning idle adjusting screw?
M/T: 650 ± 50 rpm
A/T: 720 ± 50 rpm (Non-turbo)
 700 ± 50 rpm (Turbo) [in "N" position]

OR

1. Disconnect A.A.C. valve harness connector.
2. Can you set engine rpm as follows by turning idle adjusting screw?
M/T: 650 ± 50 rpm
A/T: 720 ± 50 rpm (Non-turbo)
 700 ± 50 rpm (Turbo) [in "N" position]

No

Check for IAS clogging or throttle valve clogging.

10

Yes

CHECK COMPRESSION PRESSURE.

- Check compression pressure.
Standard: kPa (kg/cm², psi)/300 rpm
1,285 (13.1, 186)
Minimum: kPa (kg/cm², psi)/300 rpm
981 (10.0, 142)
Difference between each cylinder: kPa (kg/cm²,psi)/300 rpm
98 (1.0, 14)

N.G.

Check pistons, piston rings, valves, valve seats and cylinder head gaskets.

11

O.K.

CHECK E.C.U. HARNESS CONNECTOR.
Check the E.C.U. pin terminals for damage or poor connection of E.C.U. harness connector.

N.G.

Repair or replace.

12

O.K.

TRY A KNOWN GOOD E.C.U.

O.K.

INSPECTION END

TROUBLE DIAGNOSES

Diagnostic Procedure 4 — Hard to Start or Impossible to Start when the Engine is Cold

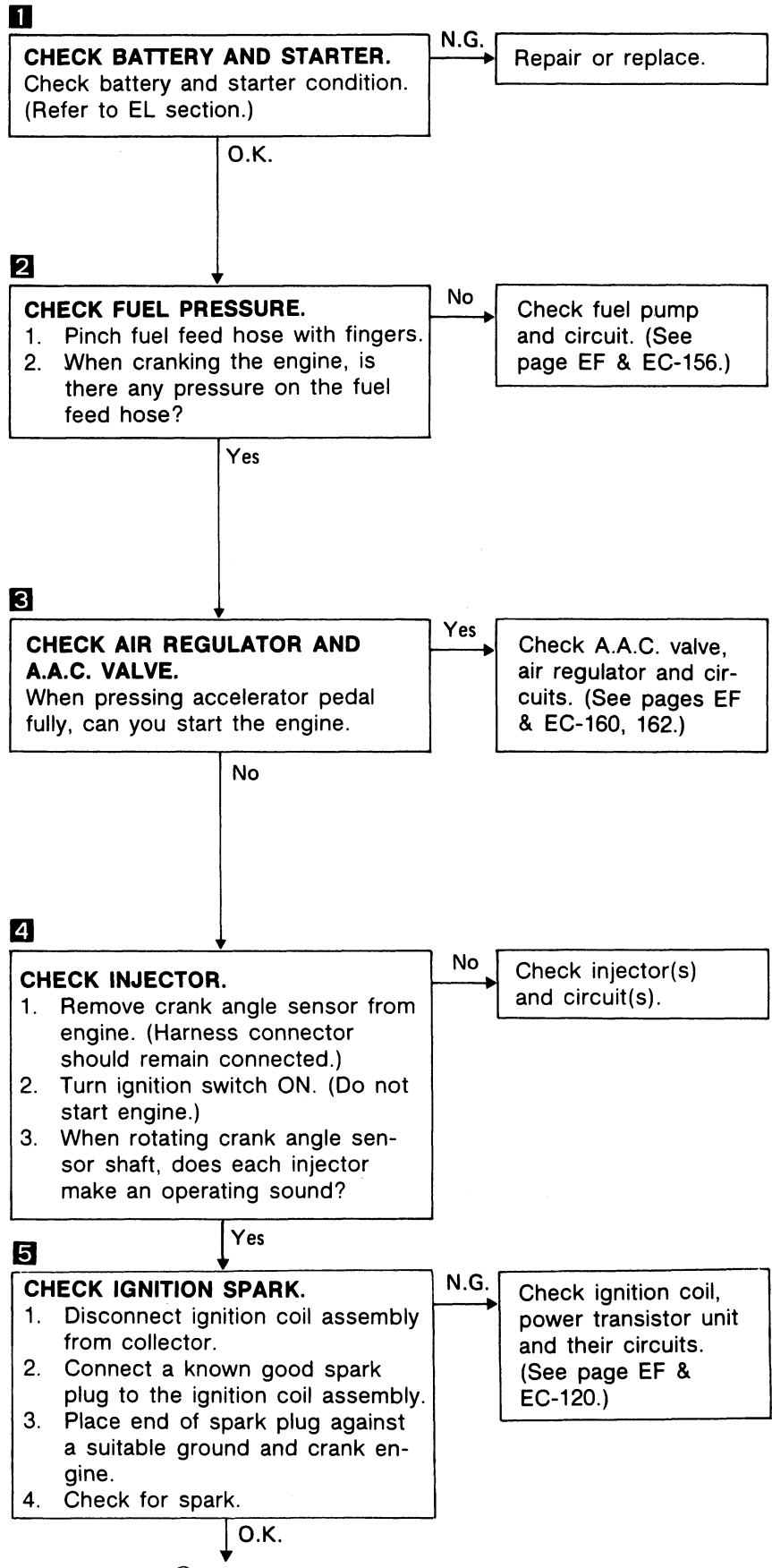
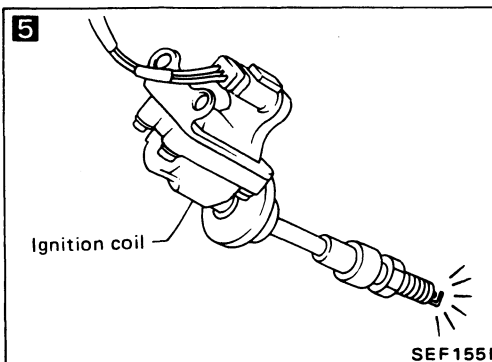
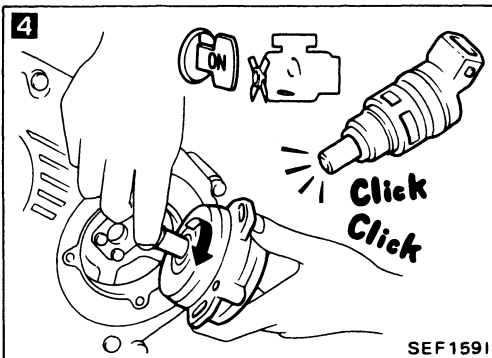
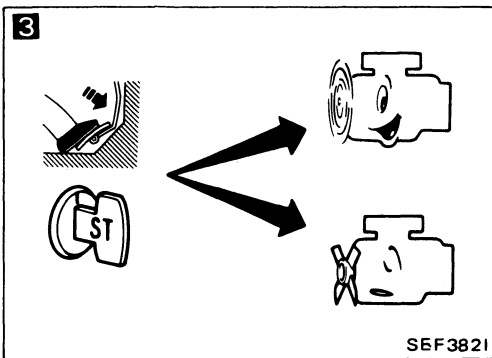
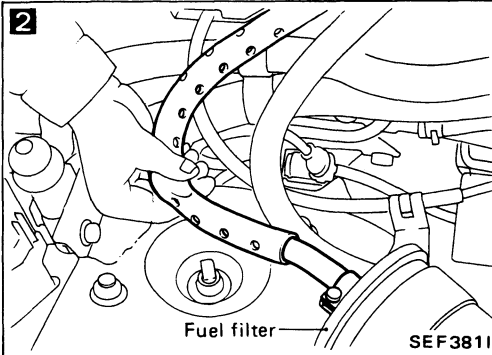
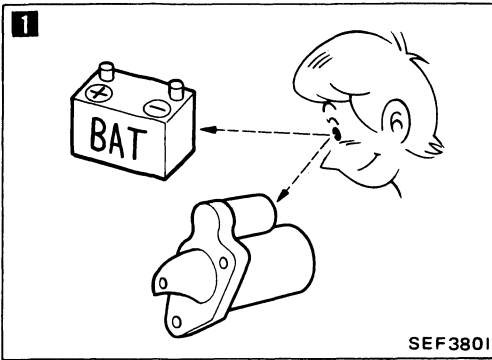

TROUBLE DIAGNOSES

Diagnostic Procedure 4 — Hard to Start or Impossible to Start when the Engine is Cold (Cont'd)

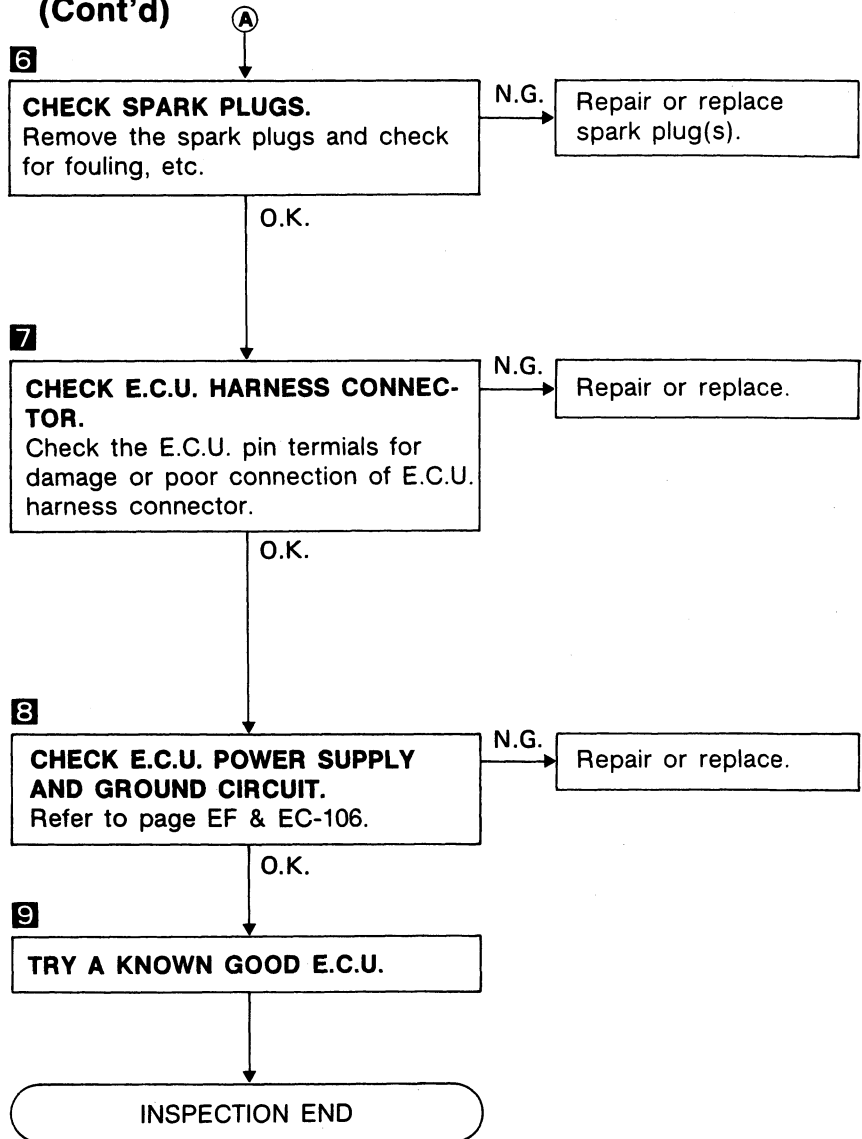
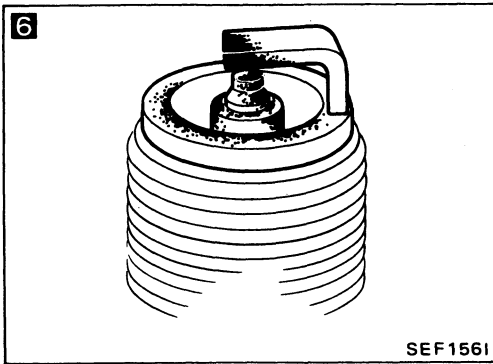

TROUBLE DIAGNOSES

Diagnostic Procedure 5 — Hard to Start or Impossible to Start when the Engine is Hot

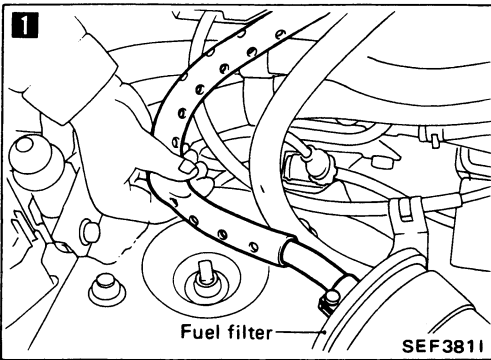

1

CHECK FUEL PRESSURE.

1. Pinch fuel feed hose with fingers.
2. When cranking the engine, is there any pressure on the fuel feed hose?

No

Check fuel pump and circuit. (See page EF & EC-156.)

Yes

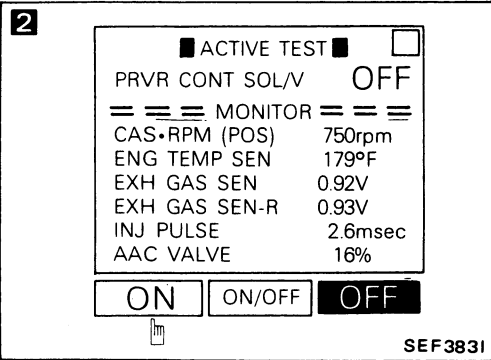

2

CHECK FUEL VAPOR.

1. Select "PRVR CONT SOL VALVE" in "ACTIVE TEST" mode.
2. After touching "ON", can you start the engine?

Yes

Check fuel properties.

OR

1. Disconnect fuel pressure regulator vacuum hose and plug hose.
2. Can you start engine?

No

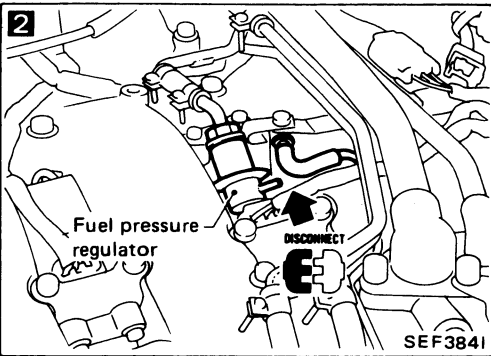

3

CHECK INJECTOR.

1. Remove crank angle sensor from engine. (Harness connector should remain connected.)
2. Turn ignition switch ON. (Do not start engine.)
3. When rotating crank angle sensor shaft, does each injector make an operating sound?

No

Check injector(s) and circuit(s).

Yes

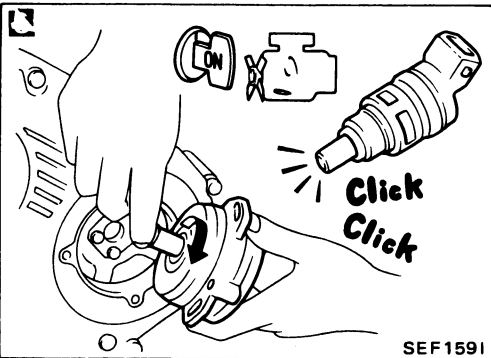

4

CHECK IGNITION SPARK.

1. Disconnect ignition coil assembly from collector.
2. Connect a known good spark plug to the ignition coil assembly.
3. Place end of spark plug against a suitable ground and crank engine.
4. Check for spark.

N.G.

Check ignition coil, power transistor unit and circuits. (See page EF & EC-120.)

O.K.

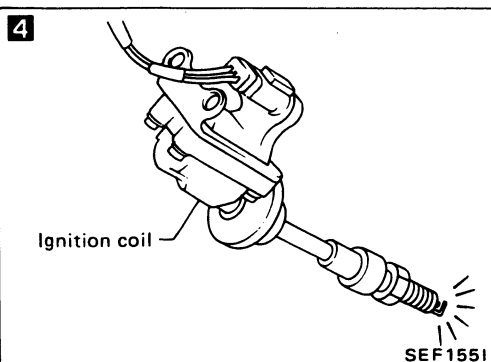

(Go to **A** on next page.)

TROUBLE DIAGNOSES

Diagnostic Procedure 5 — Hard to Start or Impossible to Start when the Engine is Hot (Cont'd)

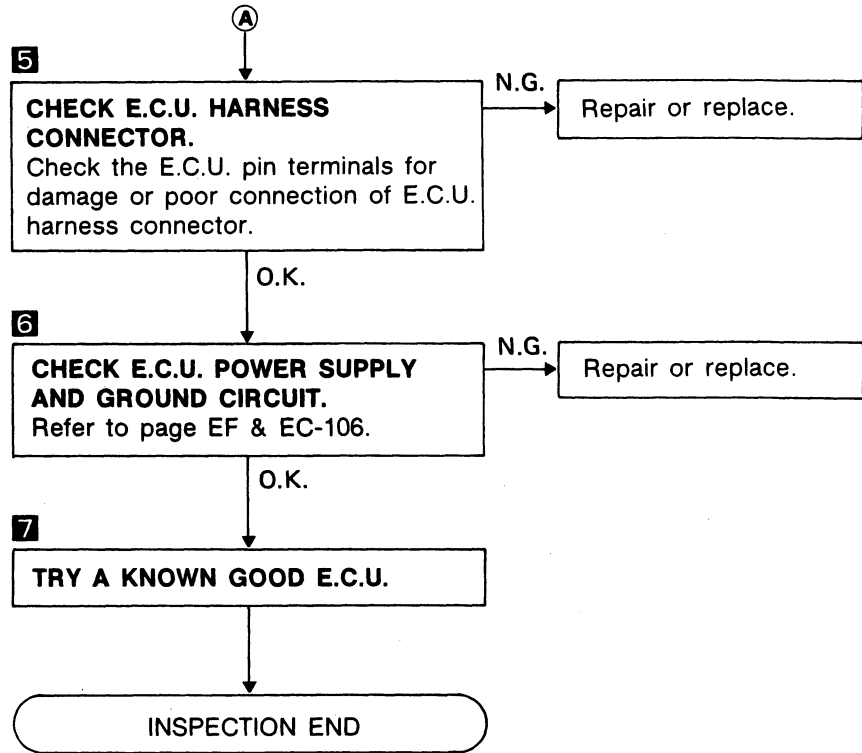

TROUBLE DIAGNOSES

Diagnostic Procedure 6 — Hard to Start or Impossible to Start under Normal Conditions

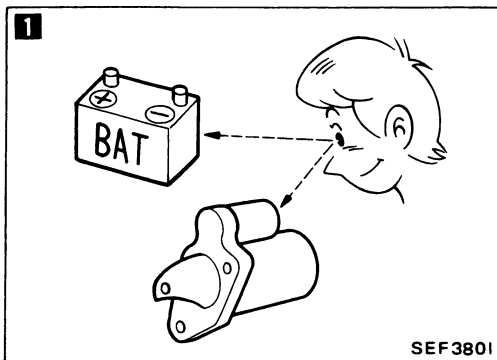

1
CHECK BATTERY AND STARTER.
Check battery and starter operation.
(Refer to EL section.)

N.G. → Repair or replace.

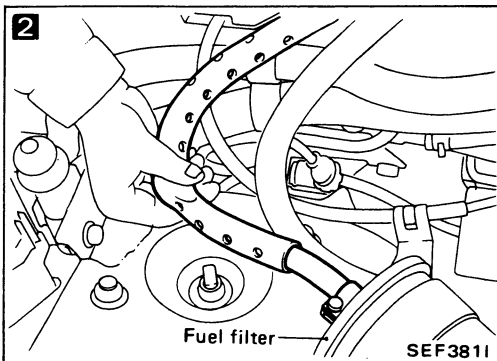

2
CHECK FUEL PRESSURE.
1. Pinch fuel feed hose with fingers.
2. When cranking the engine, is there any pressure on the fuel feed hose?

No → Check fuel pump and circuit. (See page EF & EC-156.)

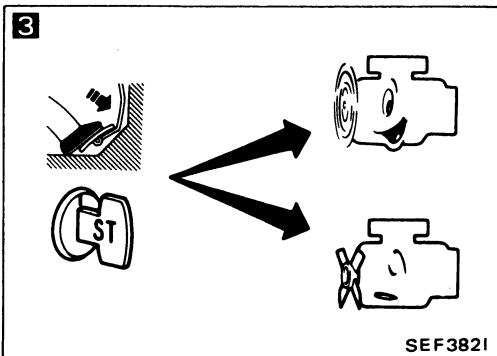

3
CHECK INJECTOR FOR LEAKAGE.
When pressing accelerator pedal fully, can you start the engine.

Yes → Check injector(s) for leakage.

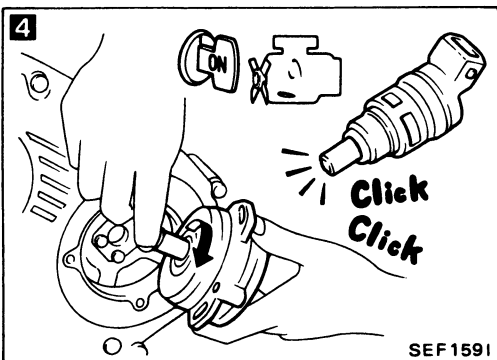

4
CHECK INJECTOR.
1. Remove crank angle sensor from engine. (Harness connector should remain connected.)
2. Turn ignition switch ON. (Do not start engine.)
3. When rotating crank angle sensor shaft, does each injector make an operating sound?

No → Check injectors and circuits.

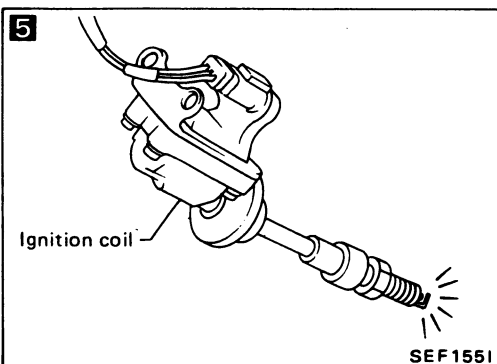

5
CHECK IGNITION SPARK.
1. Disconnect ignition coil assembly from collector.
2. Connect a known good spark plug to the ignition coil assembly.
3. Place end of spark plug against a suitable ground and crank engine.
4. Check for spark.

N.G. → Check ignition coil, power transistor unit and circuits. (See page EF & EC-120.)

O.K. → (Go to **A** on next page.)

TROUBLE DIAGNOSES

Diagnostic Procedure 6 — Hard to Start or Impossible to Start under Normal Conditions (Cont'd)

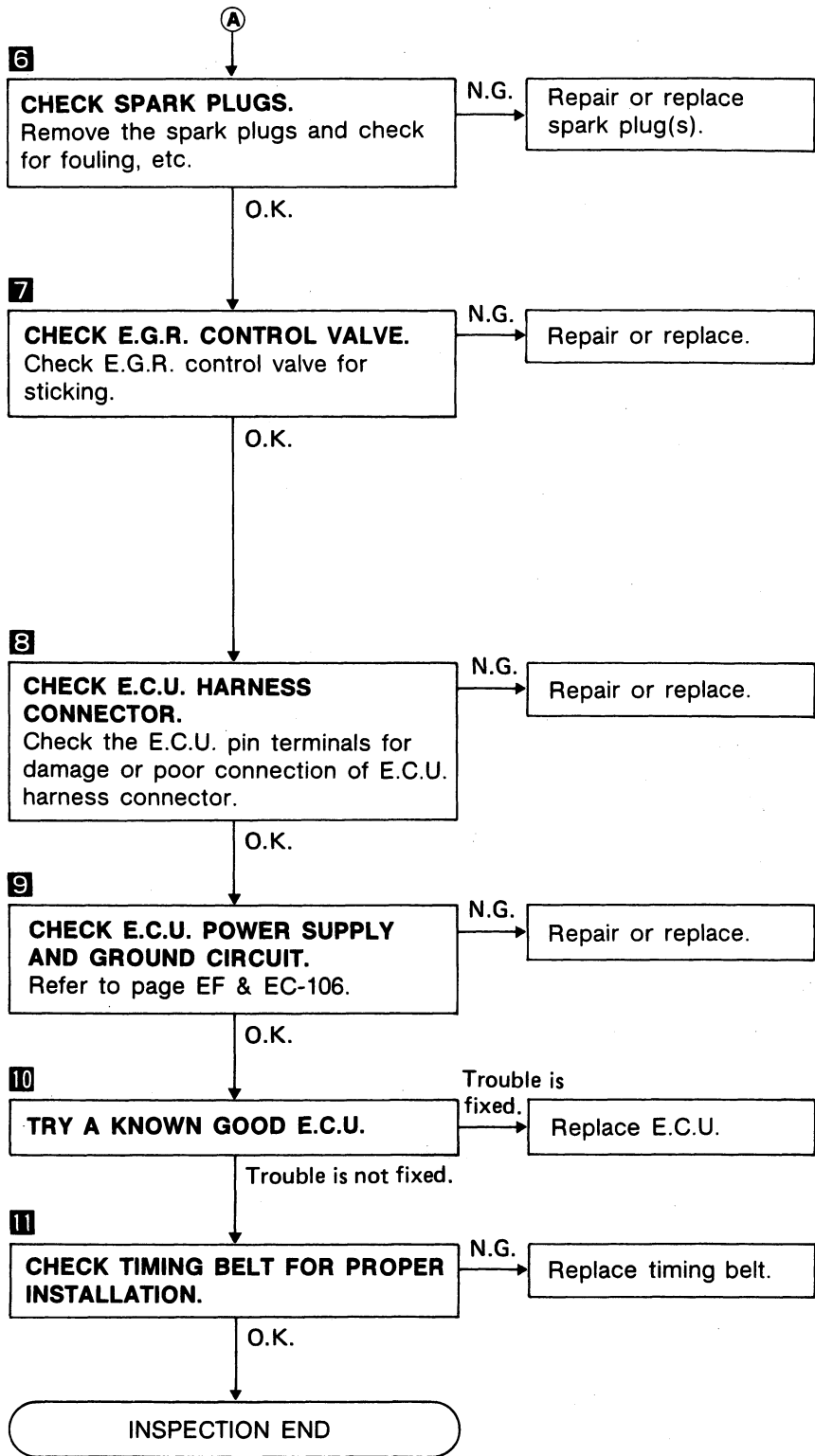
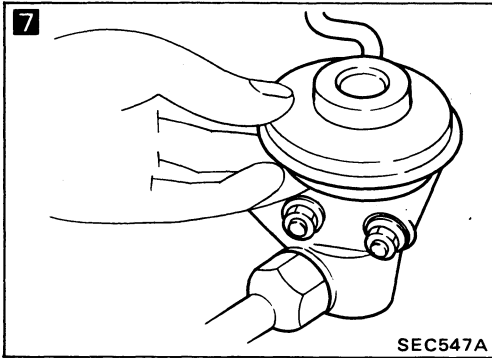
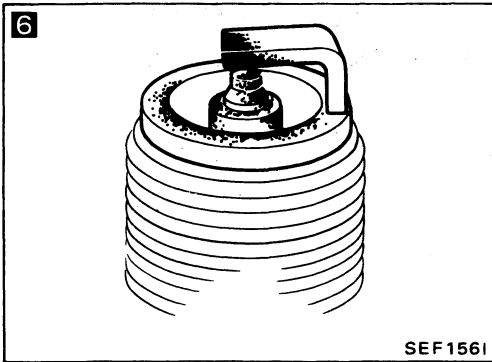

TROUBLE DIAGNOSES

Diagnostic Procedure 7 — Hesitation when the Engine is Hot

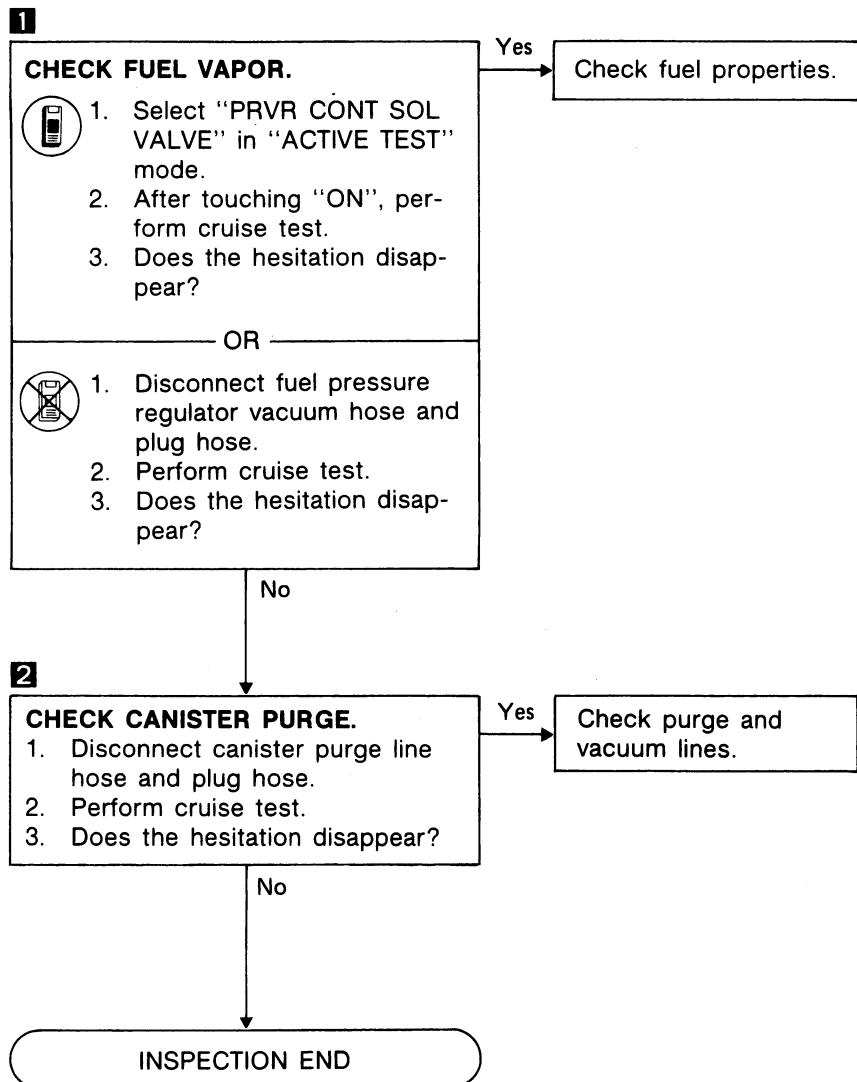
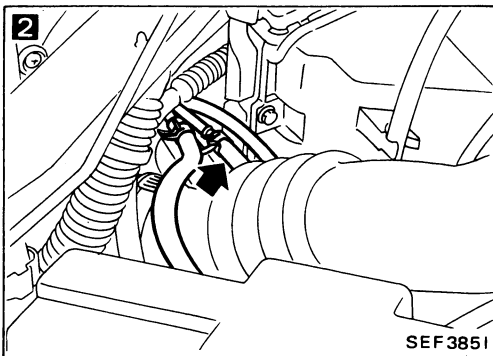
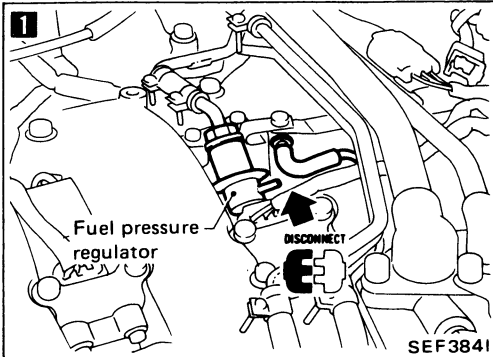
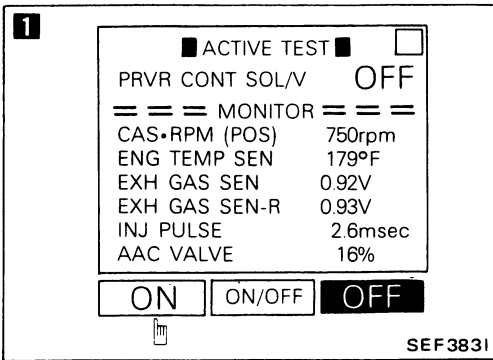

TROUBLE DIAGNOSES

Diagnostic Procedure 8 — Hesitation when the Engine is Cold

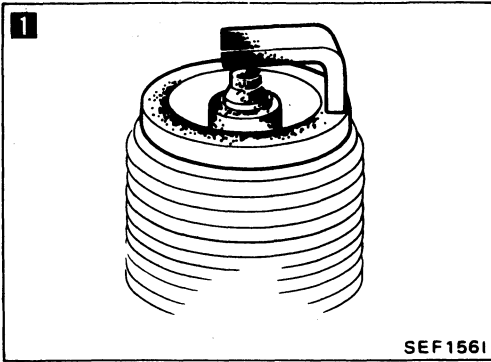

1

CHECK SPARK PLUGS.
Remove spark plugs and check for fouling, etc.

N.G. → Repair or replace spark plug(s).

O.K.

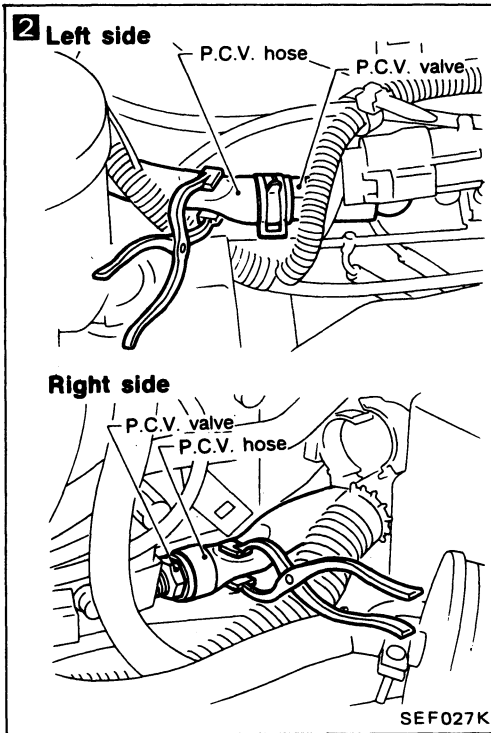

2

CHECK FOR INTAKE AIR LEAK.
When pinching blow-by hose (lowering the blow-by air supply), does the engine speed rise?

Yes → Discover air leak location and repair.

No

3

TRY A KNOWN GOOD AIR FLOW METER.

Trouble is fixed. → Replace air flow meter.

Trouble is not fixed.

4

CHECK FOR INTAKE VALVE DEPOSITS.
If there are deposits on intake valves, remove them.

INSPECTION END

TROUBLE DIAGNOSES

Diagnostic Procedure 9 — Hesitation under Normal Conditions

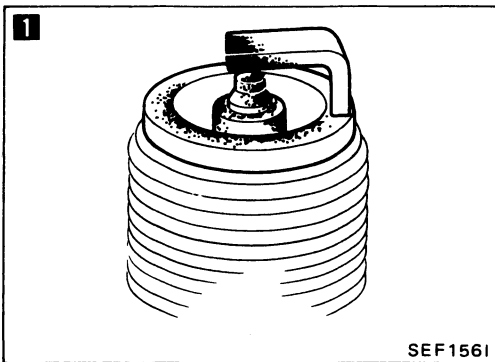

1

CHECK SPARK PLUGS.
Remove spark plugs and check for fouling, etc.

N.G. → Repair or replace spark plug(s).

O.K.

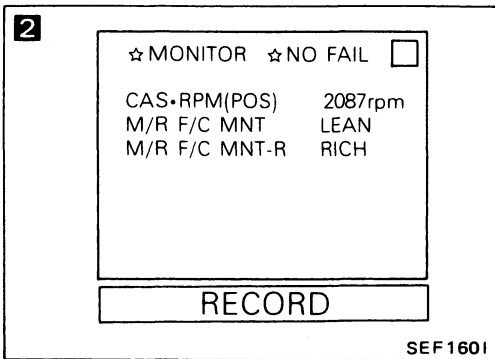

2

CHECK EXHAUST GAS SENSOR.

1. See "M/R F/C MNT (right and left sides)" in "DATA MONITOR" mode.

2. Maintaining engine at 2,000 rpm under no-load (with engine warmed up sufficiently), check to make sure that the monitor fluctuates between "LEAN" and "RICH" more than 5 times during 10 seconds.

RICH→LEAN→RICH→
1 time 2 times
LEAN→RICH.....

Yes → Replace exhaust gas sensor(s).

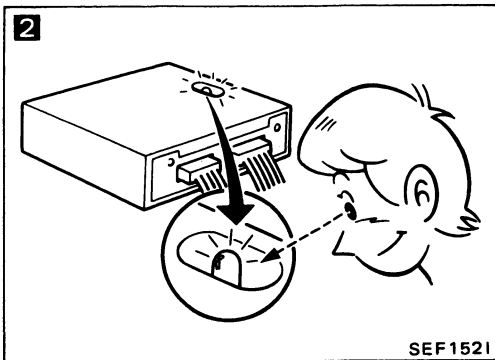

OR

1. Set "Exhaust gas sensor monitor" in the self-diagnostic Mode II. (See page EF & EC-54.)

2. Maintaining engine at 2,000 rpm under no load, check that RED LED on the E.C.U. goes ON and OFF more than 5 times during 10 seconds.

No

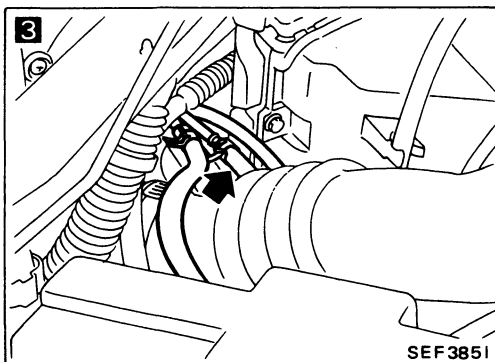

3

CHECK CANISTER PURGE.

1. Disconnect canister purge line hose and plug hose.

2. Perform cruise test.

3. Does the hesitation disappear?

Yes → Check purge and vacuum lines.

No

(Go to (A) on next page.)

TROUBLE DIAGNOSES

Diagnostic Procedure 9 — Hesitation under Normal Conditions (Cont'd)

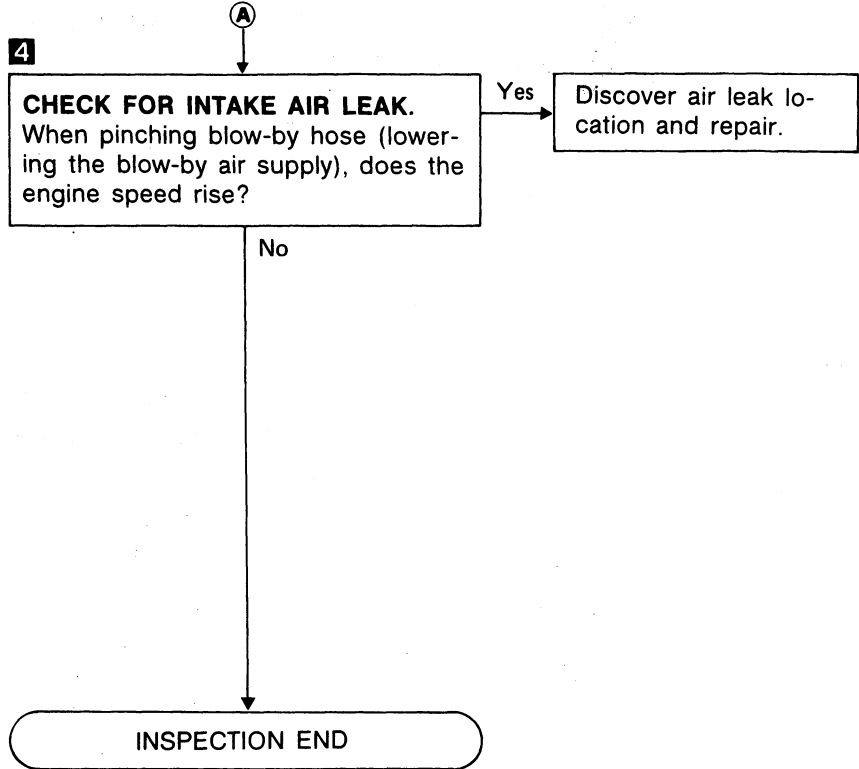
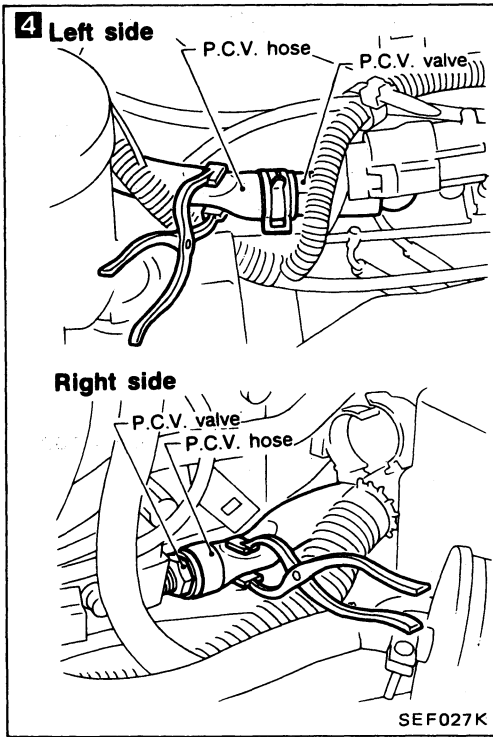

TROUBLE DIAGNOSES

Diagnostic Procedure 10 — Engine Stalls when Turning

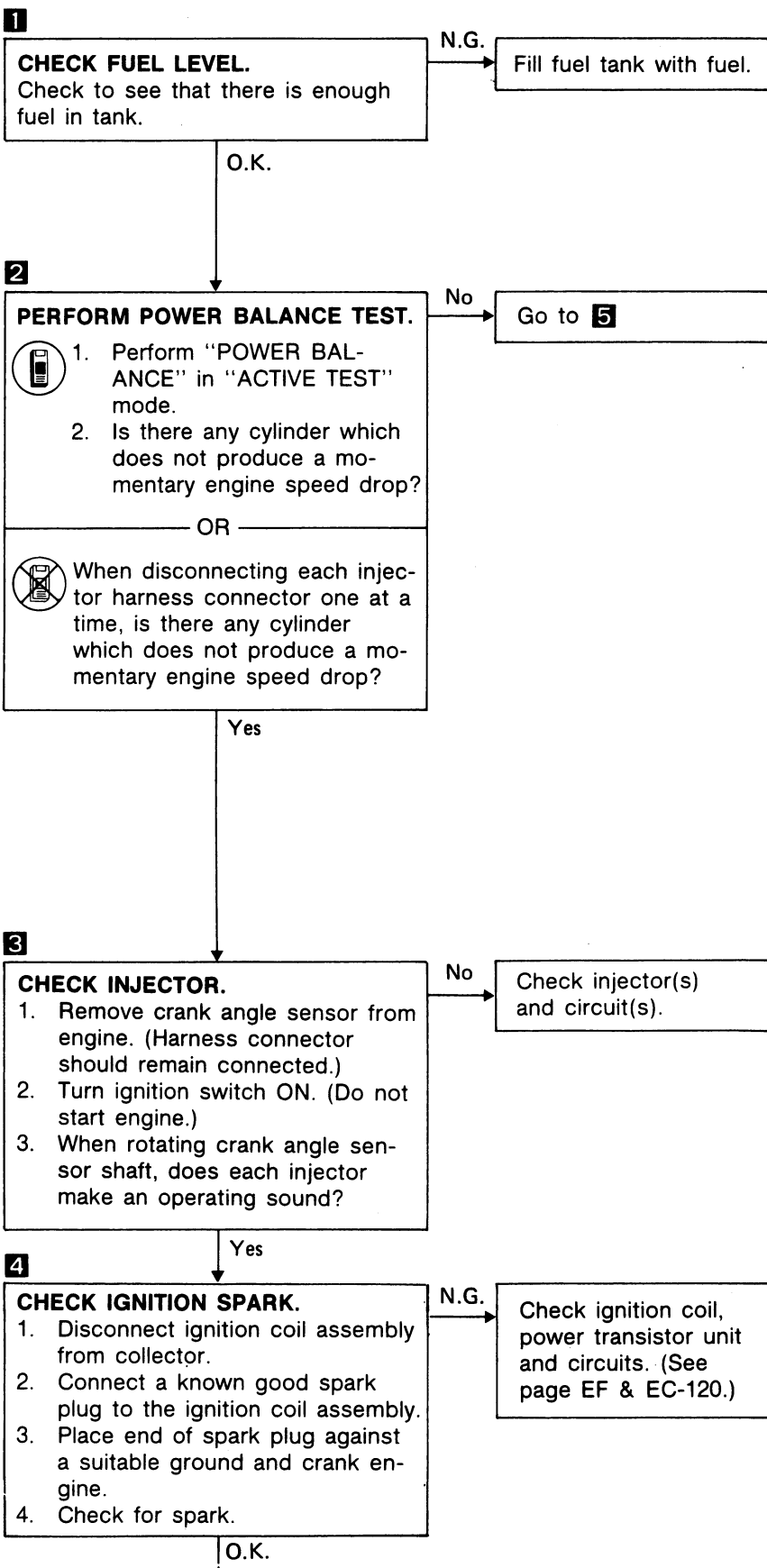
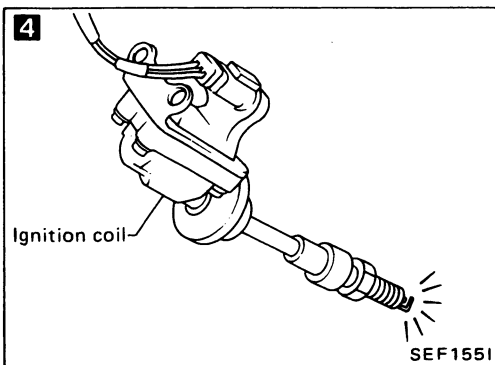
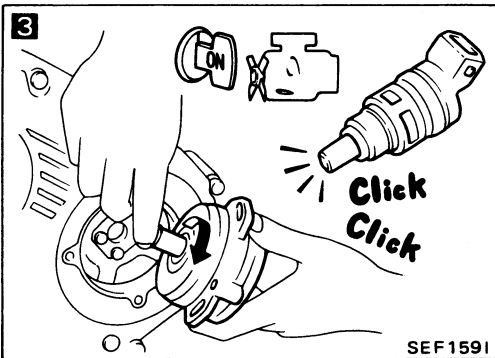
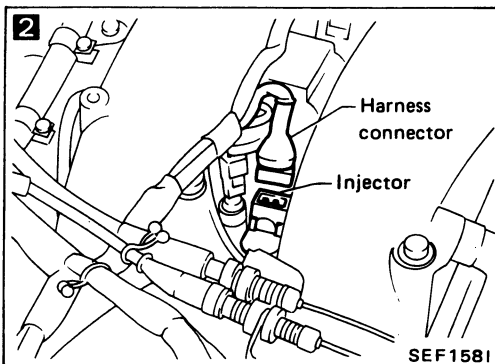
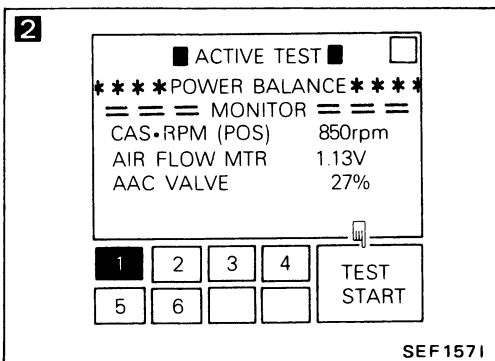
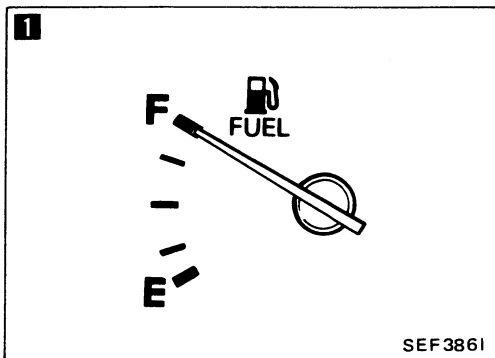

(Go to **A** on next page.)

TROUBLE DIAGNOSES

Diagnostic Procedure 10 — Engine Stalls when Turning (Cont'd)

5

■ FUEL PRES RELEASE ■

FUEL PUMP WILL STOP BY TOUCHING START DURING IDLE.
CRANK A FEW TIMES AFTER ENGINE STALL.

START



SEF204J

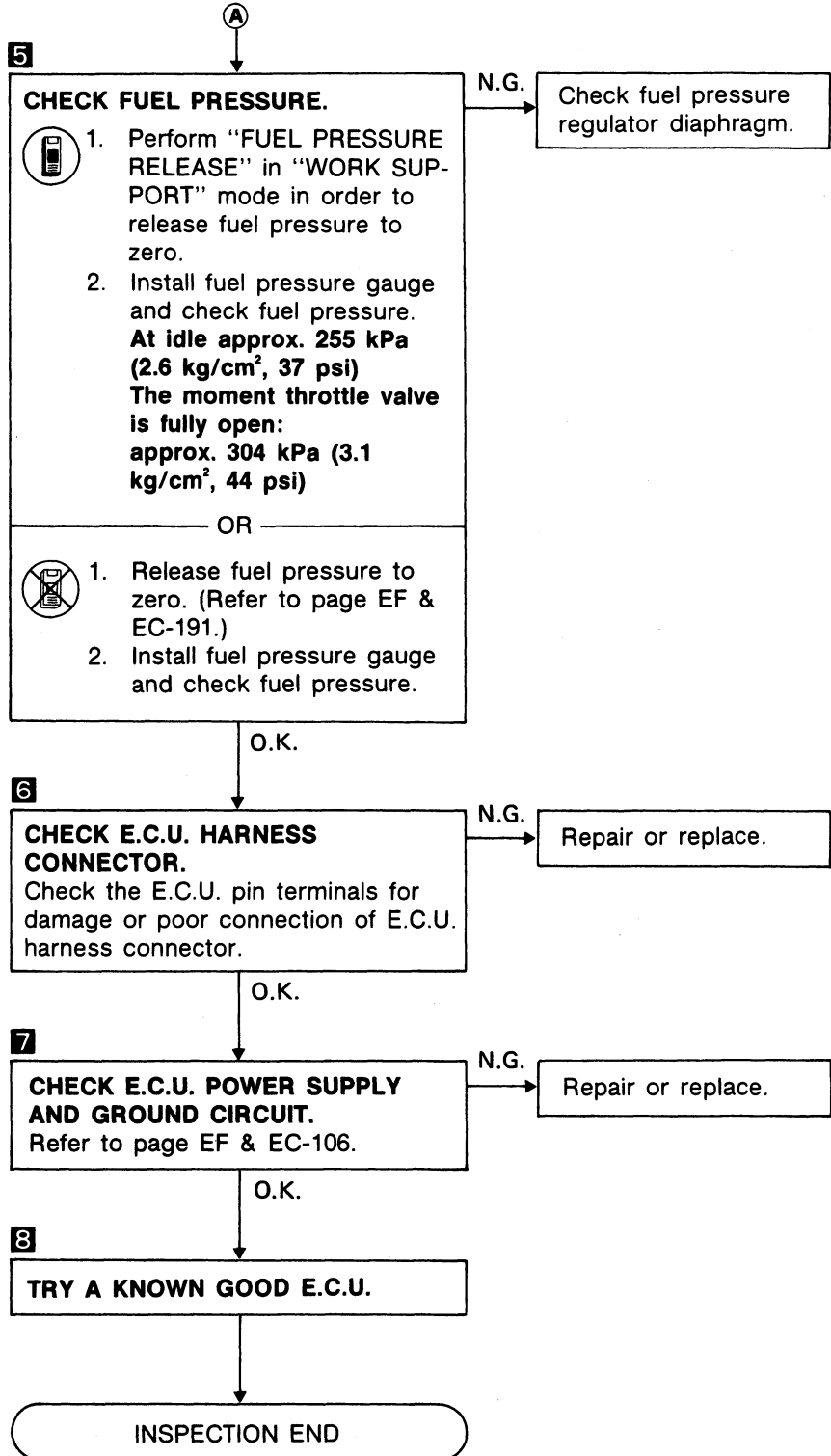

TROUBLE DIAGNOSES

Diagnostic Procedure 11 — Engine Stalls when the Engine is Hot

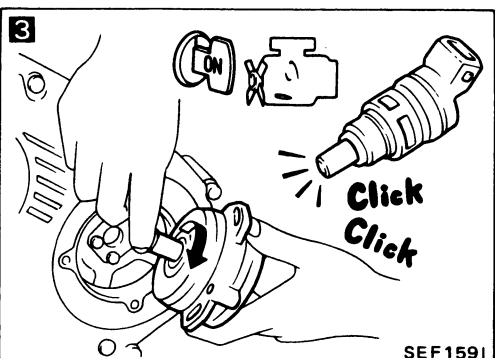
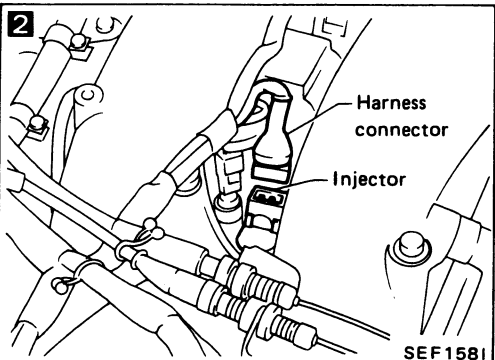
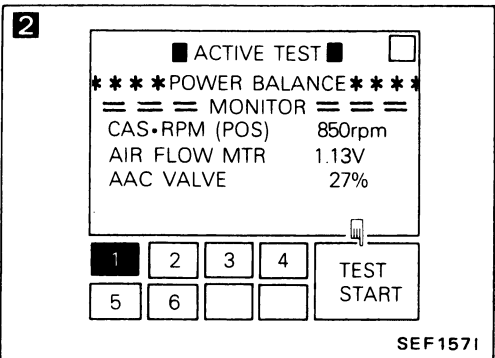
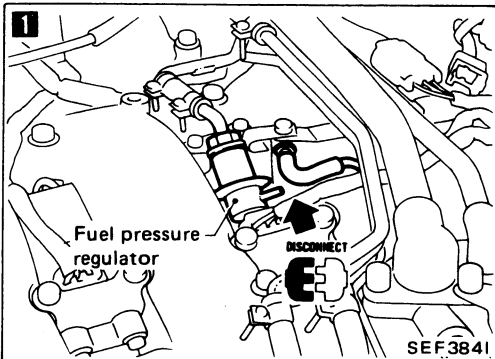
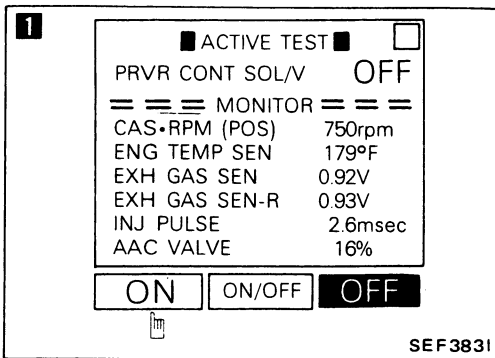

1

CHECK FUEL VAPOR.

1. Select "PRVR CONT SOL VALVE" in "ACTIVE TEST" mode.

2. After touching "ON", perform cruise test.

3. Does the engine stall disappear?

OR

1. Disconnect fuel pressure regulator vacuum hose and plug hose.

2. Perform cruise test.

3. Does the engine stall disappear?

Yes → Check fuel properties.

No

2

PERFORM POWER BALANCE TEST.

1. Perform "POWER BALANCE" in "ACTIVE TEST" mode.

2. Is there any cylinder which does not produce a momentary engine speed drop?

OR

When disconnecting each injector harness connector one at a time, is there any cylinder which does not produce a momentary engine speed drop?

No → Go to **5**

Yes

3

CHECK INJECTOR.

1. Remove crank angle sensor from engine. (Harness connector should remain connected.)

2. Turn ignition switch ON. (Do not start engine.)

3. When rotating crank angle sensor shaft, does each injector make an operating sound?

No → Check injector(s) and circuit(s).

Yes → (Go to **A** on next page.)

TROUBLE DIAGNOSES

Diagnostic Procedure 11 — Engine Stalls when the Engine is Hot (Cont'd)

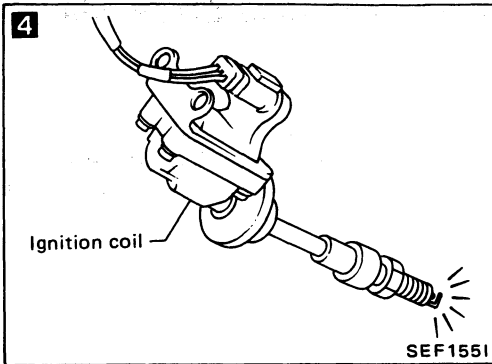

- 4**
- CHECK IGNITION SPARK.**
1. Disconnect ignition coil assembly from collector.
 2. Connect a known good spark plug to the ignition coil assembly.
 3. Place end of spark plug against a suitable ground and crank engine.
 4. Check for spark.

N.G. → Check ignition coil, power transistor unit and their circuits. (See page EF & EC-120.)

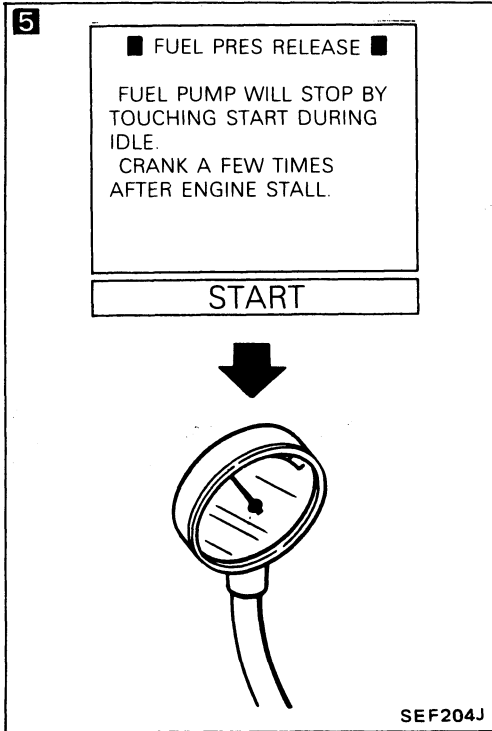

- 5**
- CHECK FUEL PRESSURE.**
1. Perform "FUEL PRESSURE RELEASE" in "WORK SUPPORT" mode in order to release fuel pressure to zero.
 2. Install fuel pressure gauge and check fuel pressure.
At idle approx. 255 kPa (2.6 kg/cm², 37 psi)
The moment throttle valve is fully open: approx. 304 kPa (3.1 kg/cm², 44 psi)
- OR
1. Release fuel pressure to zero. (Refer to page EF & EC-191.)
 2. Install fuel pressure gauge and check fuel pressure.

N.G. → Check fuel pressure regulator diaphragm.

- 6**
- CHECK E.C.U. HARNESS CONNECTOR.**
- Check the E.C.U. pin terminals for damage or poor connection of E.C.U. harness connector.

N.G. → Repair or replace.

- 7**
- CHECK E.C.U. POWER SUPPLY AND GROUND CIRCUIT.**
- Refer to page EF & EC-106.

N.G. → Repair or replace.

- 8**
- TRY A KNOWN GOOD E.C.U.**

O.K. → Trouble is fixed.

N.G. → Replace E.C.U.

- 9**
- CHECK TIMING BELT FOR PROPER INSTALLATION.**

N.G. → Replace timing belt.

O.K. → INSPECTION END

TROUBLE DIAGNOSES

Diagnostic Procedure 12 — Engine Stalls when the Engine is Cold

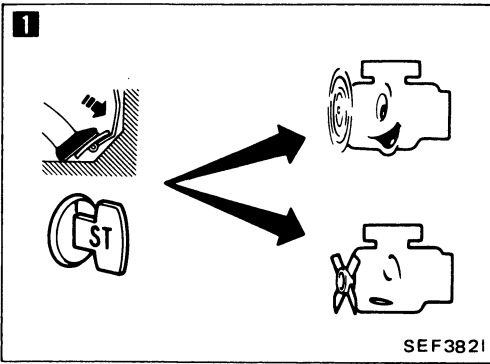

1

CHECK AIR REGULATOR AND A.A.C. VALVE.
When the engine is cold, can you start the engine when pressing accelerator pedal fully?

N.G.

Check A.A.C. valve, air regulator and circuits. (See pages EF & EC-160, 162.)

O.K.

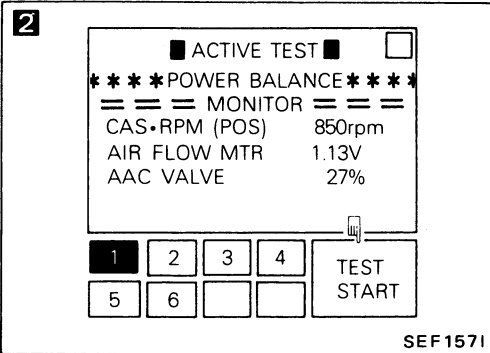

2

PERFORM POWER BALANCE TEST.

1. Perform "POWER BALANCE" in "ACTIVE TEST" mode.
2. Is there any cylinder which does not produce a momentary engine speed drop?

OR

N.G.

Go to **6**

 When disconnecting each injector harness connector one at a time, is there any cylinder which does not produce a momentary engine speed drop?

O.K.

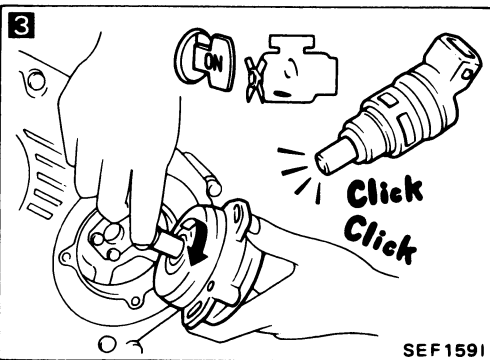
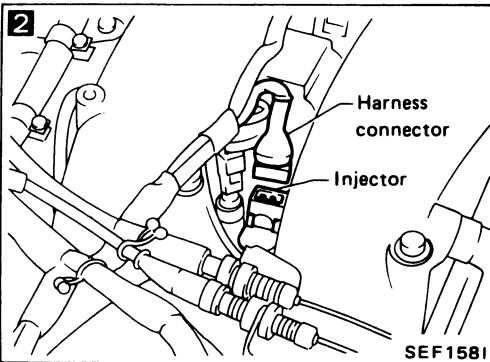

3

CHECK INJECTOR.

1. Remove crank angle sensor from engine. (Harness connector should remain connected.)
2. Turn ignition switch ON. (Do not start engine.)
3. When rotating crank angle sensor shaft, does each injector make an operating sound?

N.G.

Check injector(s) and circuit(s).

O.K.

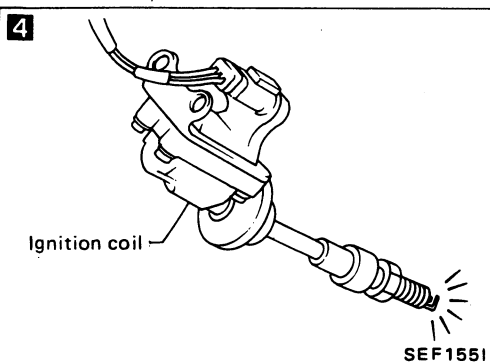

4

CHECK IGNITION SPARK.

1. Disconnect ignition coil assembly from collector.
2. Connect a known good spark plug to the ignition coil assembly.
3. Place end of spark plug against a suitable ground and crank engine.
4. Check for spark.

N.G.

Check ignition coil, power transistor unit and circuits. (See page EF & EC-120.)

O.K.

(Go to **A** on next page.)

TROUBLE DIAGNOSES

Diagnostic Procedure 12 — Engine Stalls when the Engine is Cold (Cont'd)

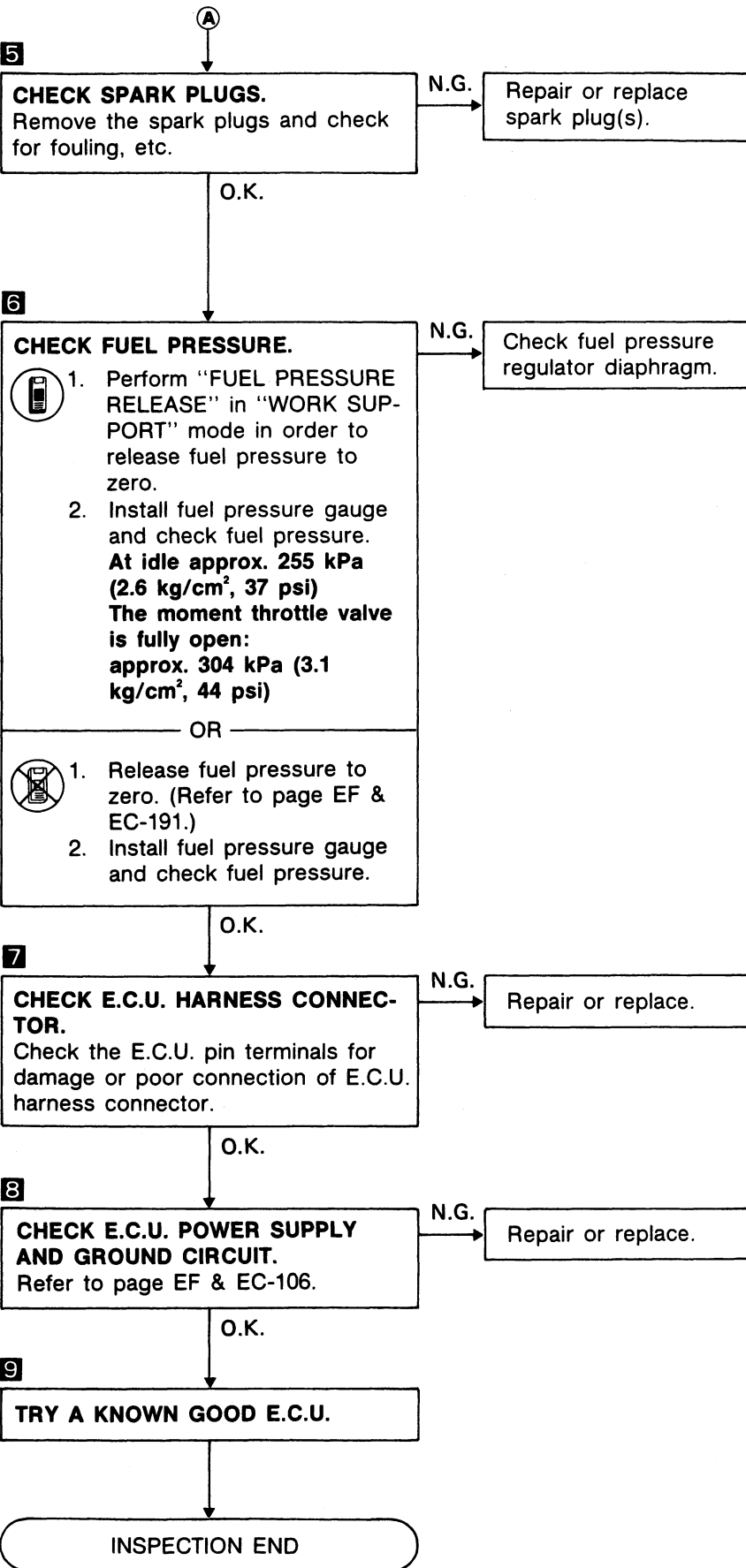
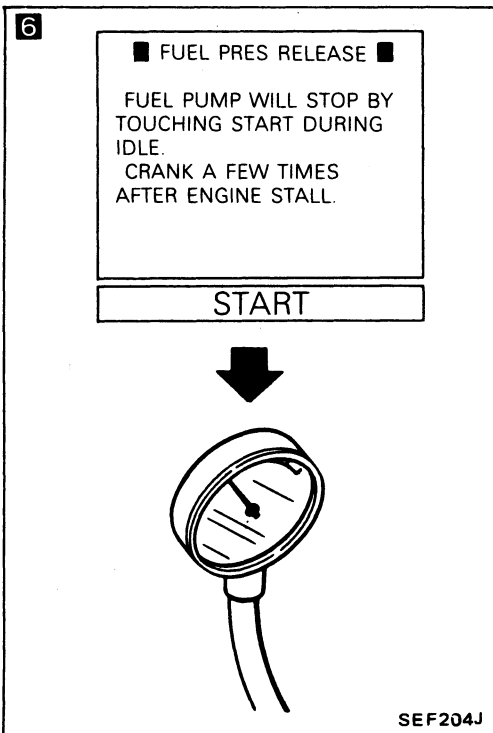
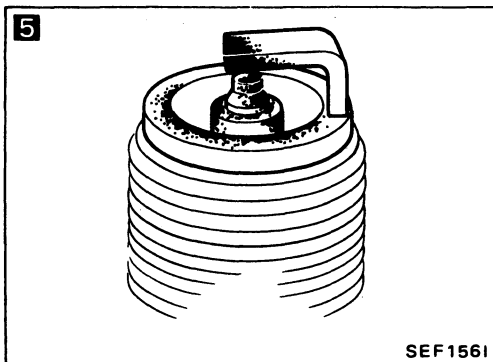

Diagnostic Procedure 13 — Engine Stalls when Stepping on the Accelerator Momentarily

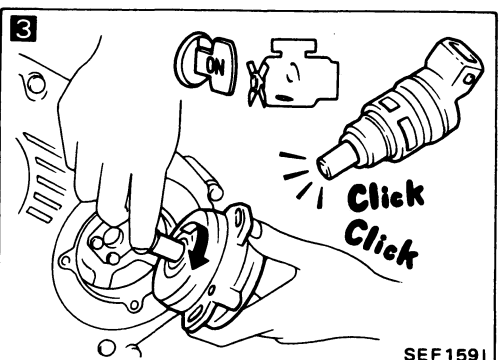
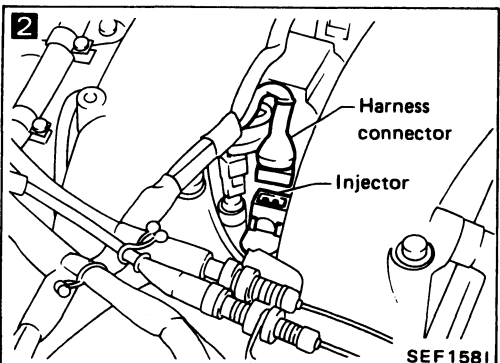
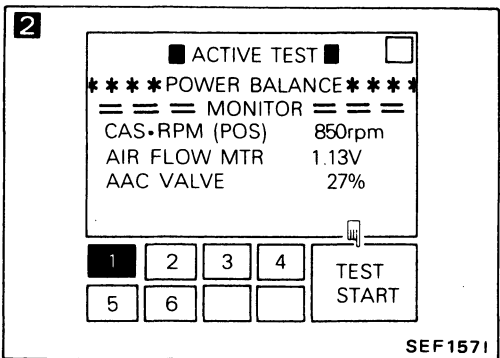
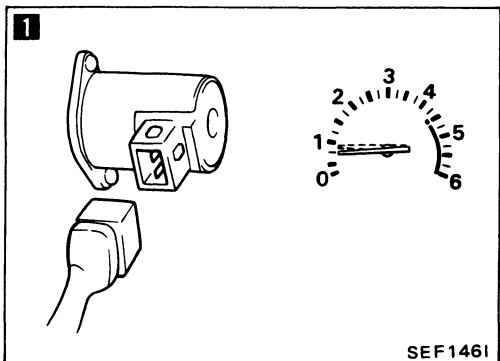
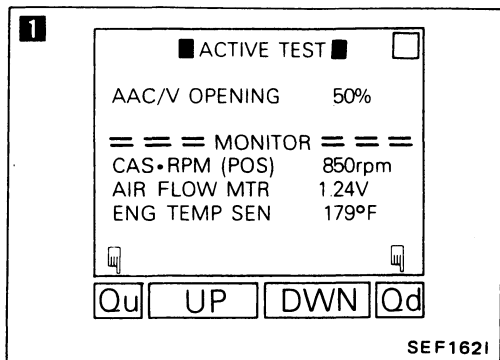

1

CHECK A.A.C. VALVE.

1. Select "A.A.C. VALVE OPENING" in "ACTIVE TEST" mode.
2. When touching "Qu" and "Qd", does the engine speed change according to the percent of A.A.C. valve opening?

— OR —

When disconnecting A.A.C. valve harness connector, does the engine speed drop?

No → Check A.A.C. valve and circuit. (See page EF & EC-162.)

Yes ↓

2

PERFORM POWER BALANCE TEST.

1. Perform "POWER BALANCE" in "ACTIVE TEST" mode.
2. Is there any cylinder which does not produce a momentary engine speed drop?

— OR —

When disconnecting each injector harness connector one at a time, is there any cylinder which does not produce a momentary engine speed drop?

No → Go to **5**

Yes ↓

3

CHECK INJECTOR.

1. Remove crank angle sensor from engine. (Harness connector should remain connected.)
2. Turn ignition switch ON. (Do not start engine.)
3. When rotating crank angle sensor shaft, does each injector make an operating sound?

No → Check injector(s) and their circuit(s).

Yes → (Go to **A** on next page.)

TROUBLE DIAGNOSES

Diagnostic Procedure 13 — Engine Stalls when Stepping on the Accelerator Momentarily (Cont'd)

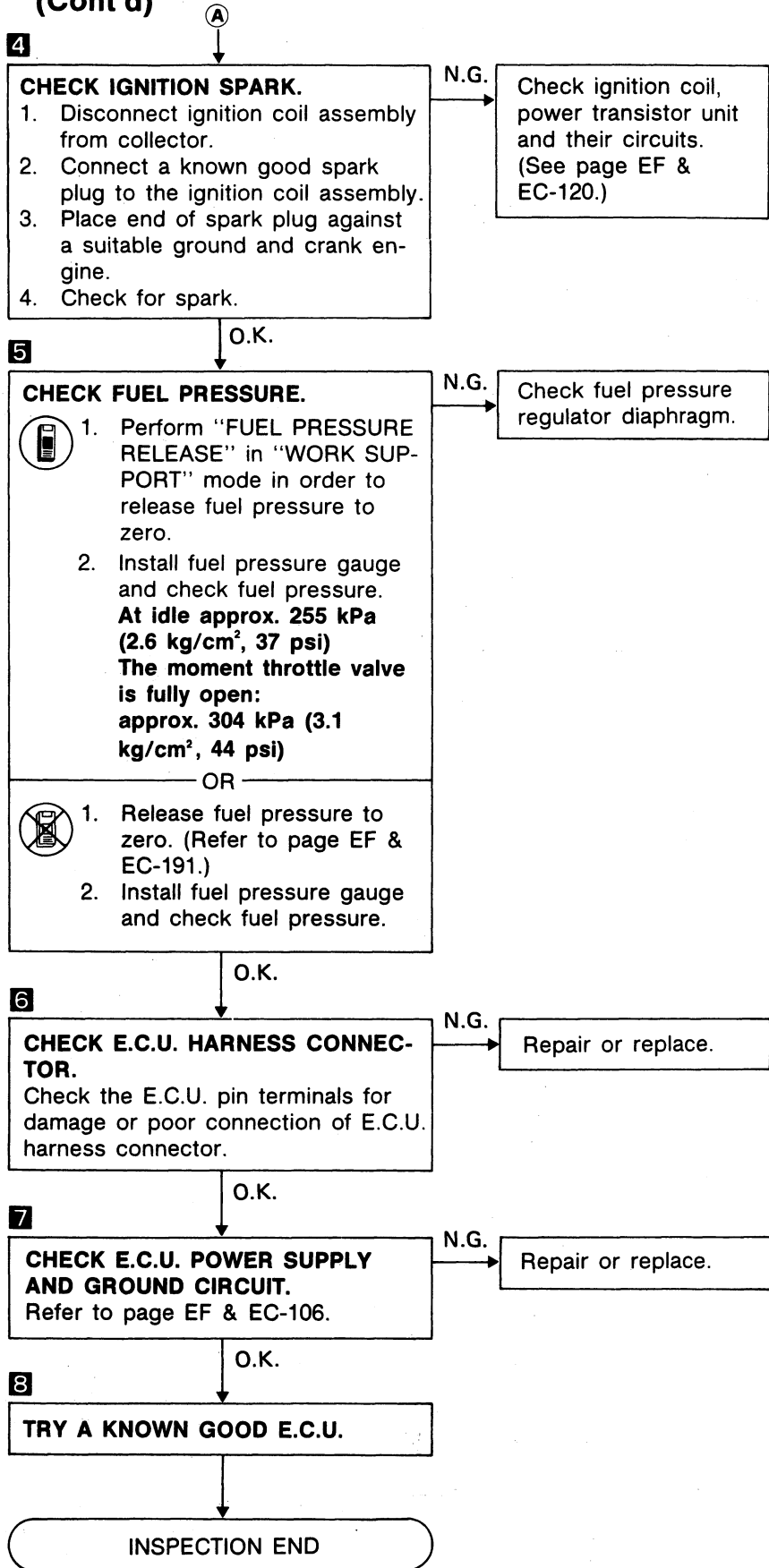
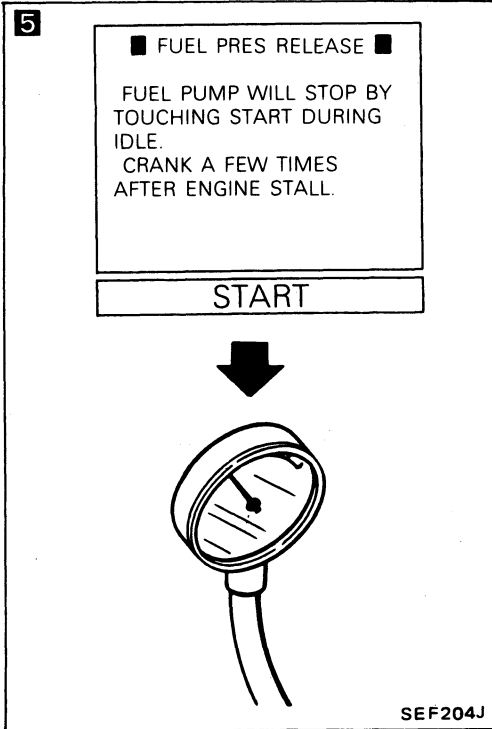
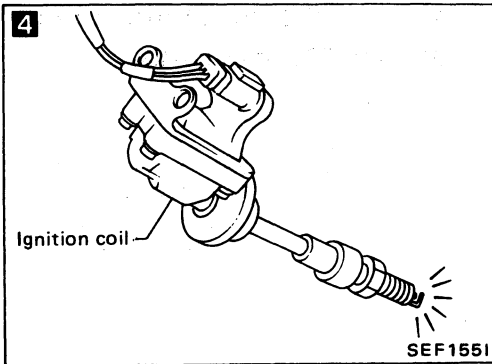

TROUBLE DIAGNOSES

Diagnostic Procedure 14 — Engine Stalls after Decelerating

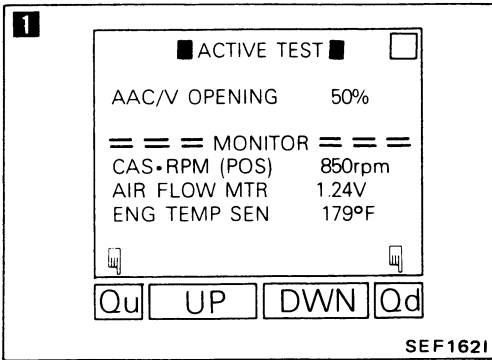

1

CHECK A.A.C. VALVE.

1. Select "A.A.C. VALVE OPENING" in "ACTIVE TEST" mode.
2. When touching "Qu" and "Qd", does the engine speed change according to the percent of A.A.C. valve opening?

No → Check A.A.C. valve and circuit. (See page EF & EC-162.)

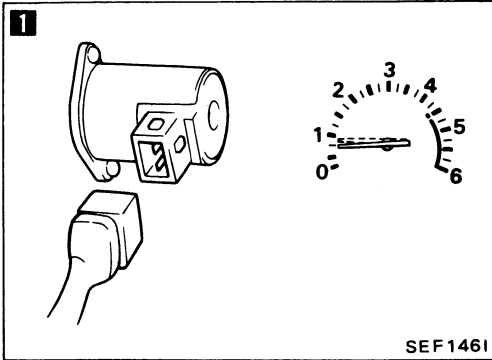

OR

1. When disconnecting A.A.C. valve harness connector, does the engine speed drop?

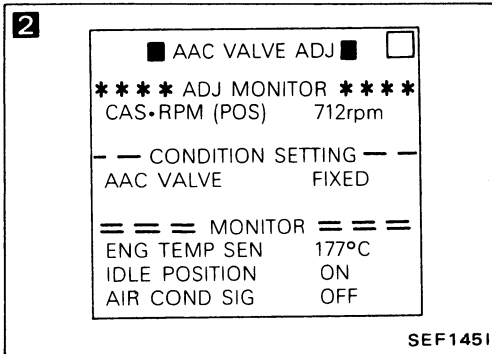

2

CHECK IDLE ADJ. SCREW CLOGGING.

1. Perform "A.A.C. VALVE ADJ" in "WORK SUPPORT" mode.
2. Can you set engine rpm as follows by turning idle adjusting screw?
M/T: 650 ± 50 rpm
A/T: 720 ± 50 rpm (Non-turbo)
 700 ± 50 rpm (Turbo) [in "N" position]

No → Check for IAS clogging or throttle chamber clogging.

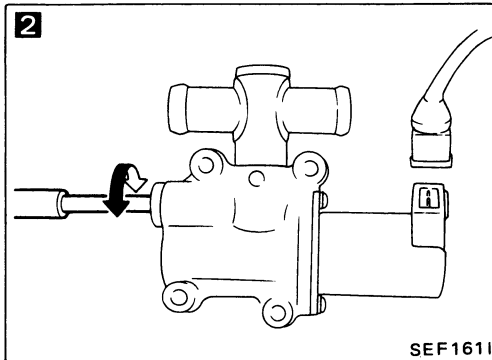

OR

1. Disconnect A.A.C. valve harness connector
2. Can you set engine rpm as follows by turning idle adjusting screw?
M/T: 650 ± 50 rpm
A/T: 720 ± 50 rpm (Non-turbo)
 700 ± 50 rpm (Turbo) [in "N" position]

Yes → (Go to **A** on next page.)

TROUBLE DIAGNOSES

Diagnostic Procedure 14 — Engine Stalls after Decelerating (Cont'd)

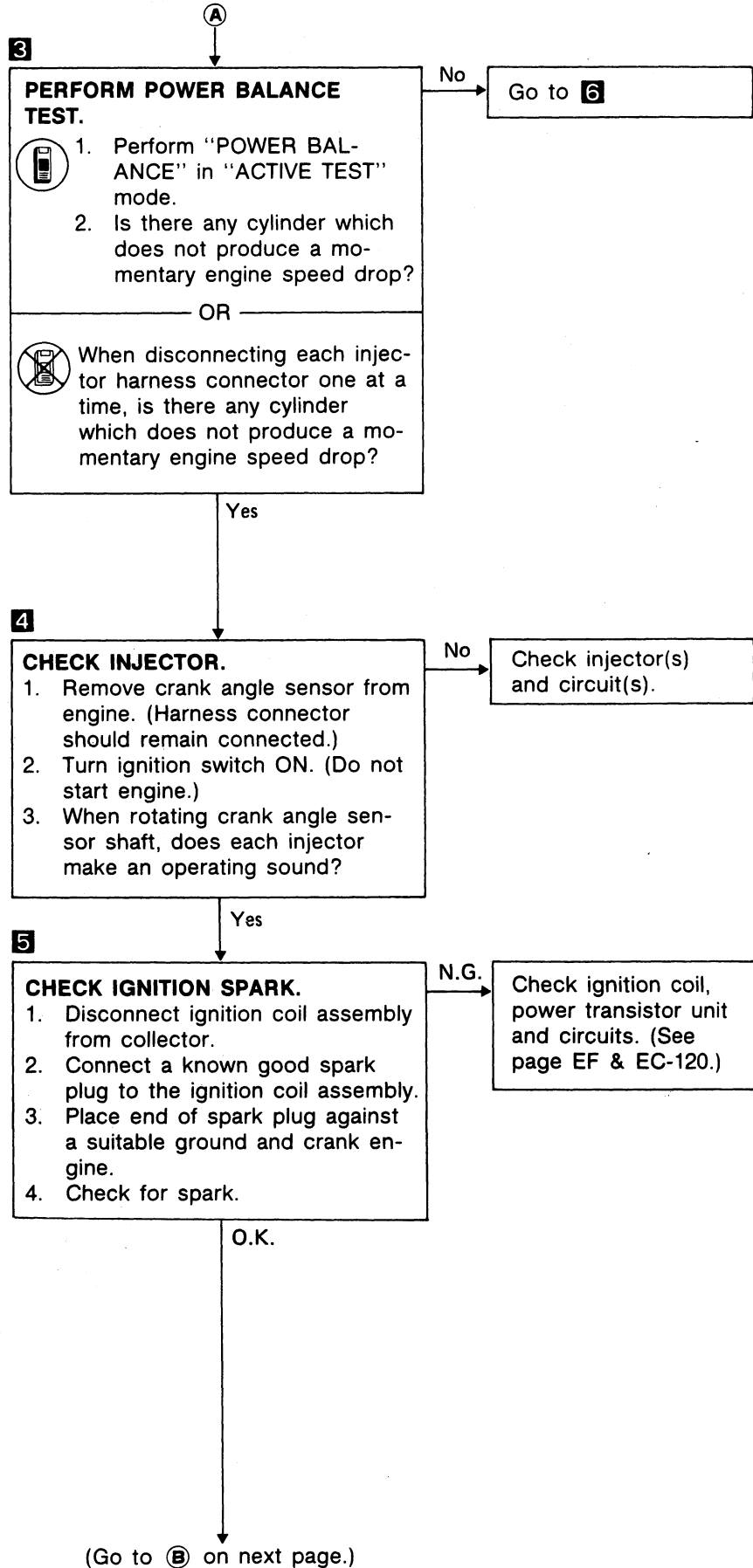
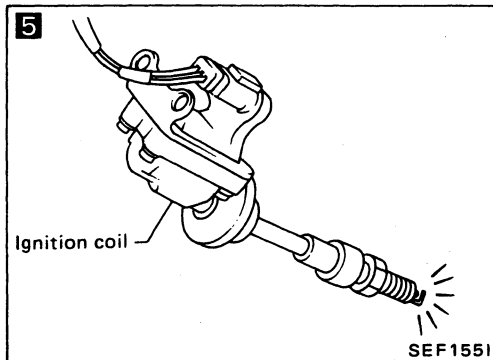
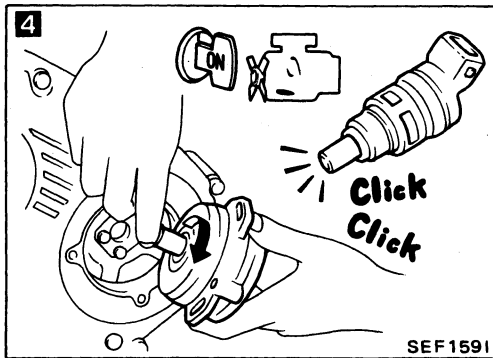
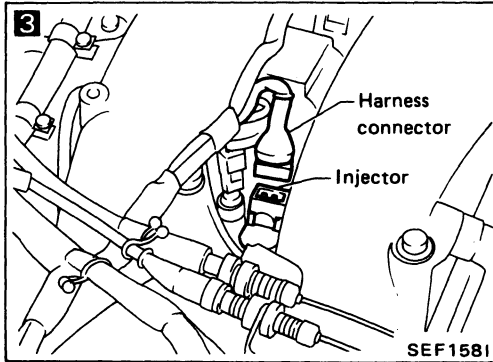
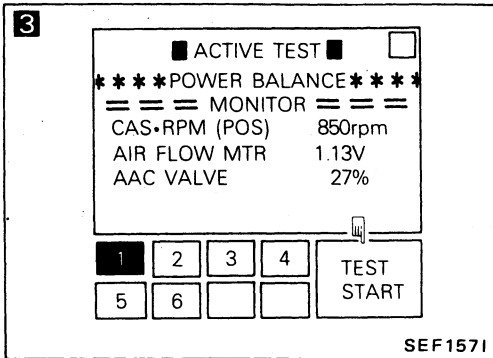

TROUBLE DIAGNOSES

Diagnostic Procedure 14 — Engine Stalls after Decelerating (Cont'd)

6

■ FUEL PRES RELEASE ■

FUEL PUMP WILL STOP BY TOUCHING START DURING IDLE. CRANK A FEW TIMES AFTER ENGINE STALL.

START



SEF204J

7

☆ MONITOR ☆ NO FAIL

CAS-RPM(POS)	2087rpm
M/R F/C MNT	LEAN
M/R F/C MNT-R	RICH

RECORD

SEF160I

7

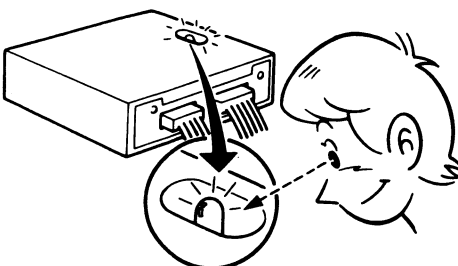

SEF152I

6

CHECK FUEL PRESSURE.

1. Perform "FUEL PRESSURE RELEASE" in "WORK SUPPORT" mode in order to release fuel pressure to zero.

2. Install fuel pressure gauge and check fuel pressure.
At idle approx. 255 kPa (2.6 kg/cm², 37 psi)
The moment throttle valve is fully open: approx. 304 kPa (3.1 kg/cm², 44 psi)

OR

1. Release fuel pressure to zero. (Refer to page EF & EC-191.)

2. Install fuel pressure gauge and check fuel pressure.

N.G. Check fuel pressure regulator diaphragm.

O.K.

7

CHECK EXHAUST GAS SENSOR.

1. See "M/R F/C MNT (right and left sides)" in "DATA MONITOR" mode.

2. Maintaining engine at 2,000 rpm under no-load (with engine warmed up sufficiently), check to make sure that the monitor fluctuates between "LEAN" and "RICH" more than 5 times during 10 seconds.

RICH → LEAN → RICH →
1 time 2 times
LEAN → RICH.....

OR

1. Set "Exhaust gas sensor monitor" in the self-diagnostic Mode II. (See page EF & EC-54.)

2. Maintaining engine at 2,000 rpm under no load, check that RED LED on the E.C.U. goes ON and OFF more than 5 times during 10 seconds.

N.G. Replace exhaust gas sensor(s).

O.K.
 (Go to © on next page.)

TROUBLE DIAGNOSES

Diagnostic Procedure 14 — Engine Stalls after Decelerating (Cont'd)

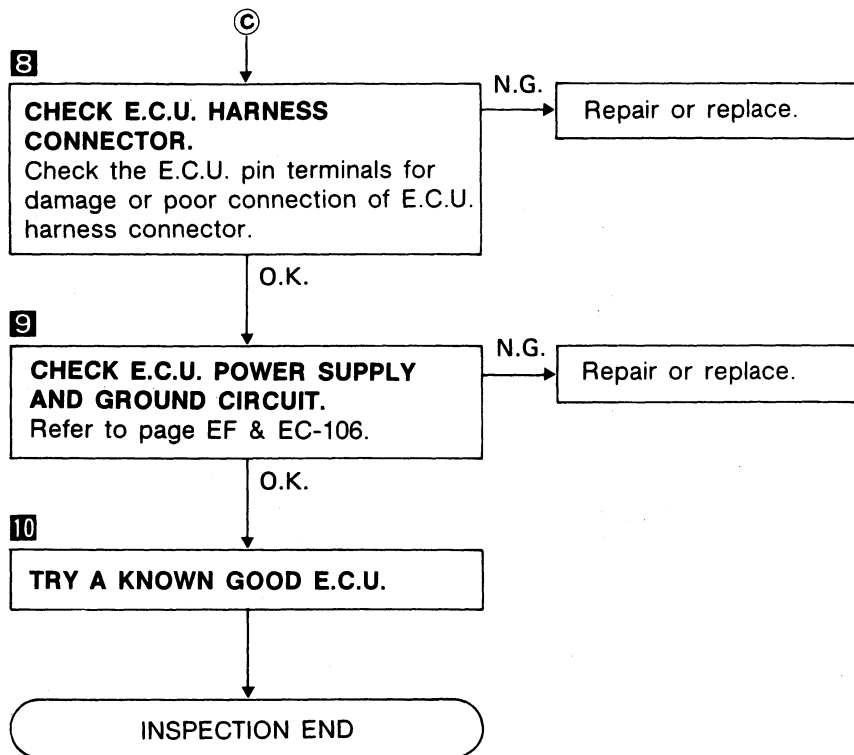

TROUBLE DIAGNOSES

Diagnostic Procedure 15 — Engine Stalls when Accelerating or Cruising

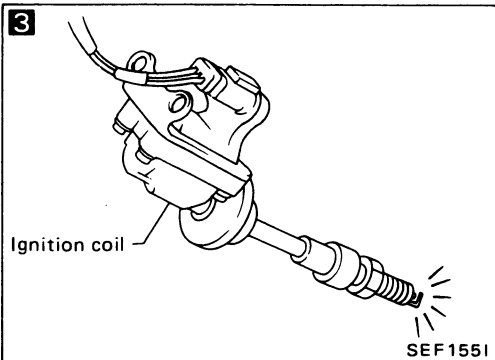
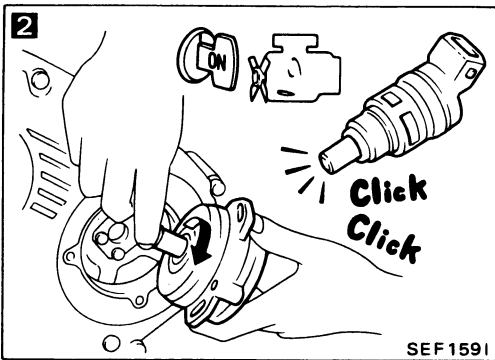
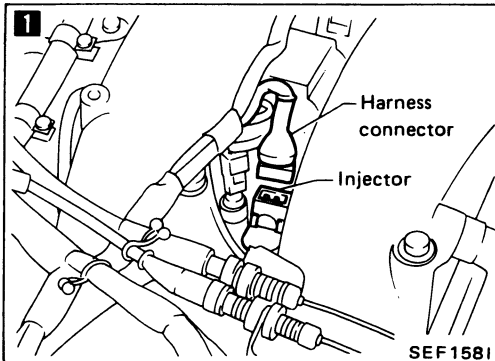
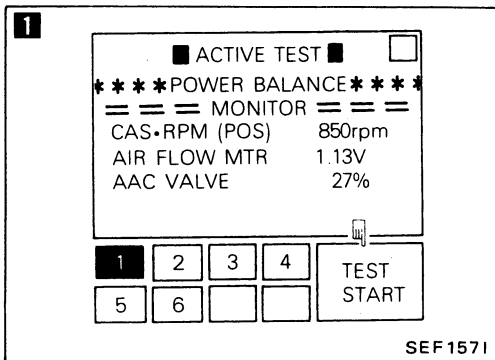

1

PERFORM POWER BALANCE TEST.

1. Perform "POWER BALANCE" in "ACTIVE TEST" mode.
2. Is there any cylinder which does not produce a momentary engine speed drop?

No → Go to **4**

OR

When disconnecting each injector harness connector one at a time, is there any cylinder which does not produce a momentary engine speed drop?

Yes

2

CHECK INJECTOR.

1. Remove crank angle sensor from engine. (Harness connector should remain connected.)
2. Turn ignition switch ON. (Do not start engine.)
3. When rotating crank angle sensor shaft, does each injector make an operating sound?

No → Check injector(s) and circuit(s).

Yes

3

CHECK IGNITION SPARK.

1. Disconnect ignition coil assembly from collector.
2. Connect a known good spark plug to the ignition coil assembly.
3. Place end of spark plug against a suitable ground and crank engine.
4. Check for spark.

N.G. → Check ignition coil, power transistor unit and circuits. (See page EF & EC-120.)

O.K.

(Go to **A** on next page.)

TROUBLE DIAGNOSES

Diagnostic Procedure 15 — Engine Stalls when Accelerating or Cruising (Cont'd)

4

■ FUEL PRES RELEASE ■

FUEL PUMP WILL STOP BY TOUCHING START DURING IDLE. CRANK A FEW TIMES AFTER ENGINE STALL.

START



SEF204J

4

CHECK FUEL PRESSURE.

1. Perform "FUEL PRESSURE RELEASE" in "WORK SUPPORT" mode in order to release fuel pressure to zero.

2. Install fuel pressure gauge and check fuel pressure.
At idle approx. 255 kPa (2.6 kg/cm², 37 psi)
The moment throttle valve is fully open: approx. 304 kPa (3.1 kg/cm², 44 psi)

OR

1. Release fuel pressure to zero. (Refer to page EF & EC-191.)

2. Install fuel pressure gauge and check fuel pressure.

N.G. → Check fuel pump, circuit and fuel pressure regulator.

5

Left side

P.C.V. hose P.C.V. valve

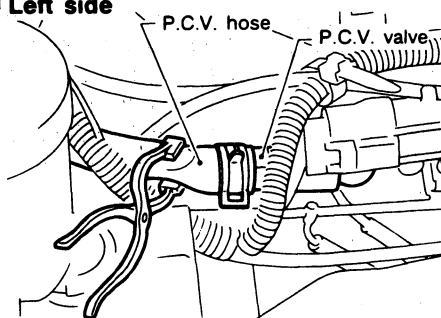

Right side

P.C.V. valve P.C.V. hose

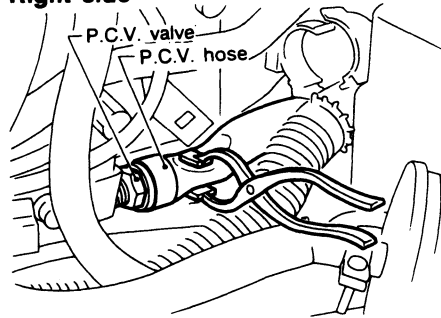

SEF027K

O.K.

5

CHECK FOR INTAKE AIR LEAK.
 When pinching blow-by hose (lowering the blow-by air supply), does the engine speed rise?

Yes → Discover air leak location and repair.

No

(Go to **B** on next page.)

TROUBLE DIAGNOSES

Diagnostic Procedure 15 — Engine Stalls when Accelerating or Cruising (Cont'd)

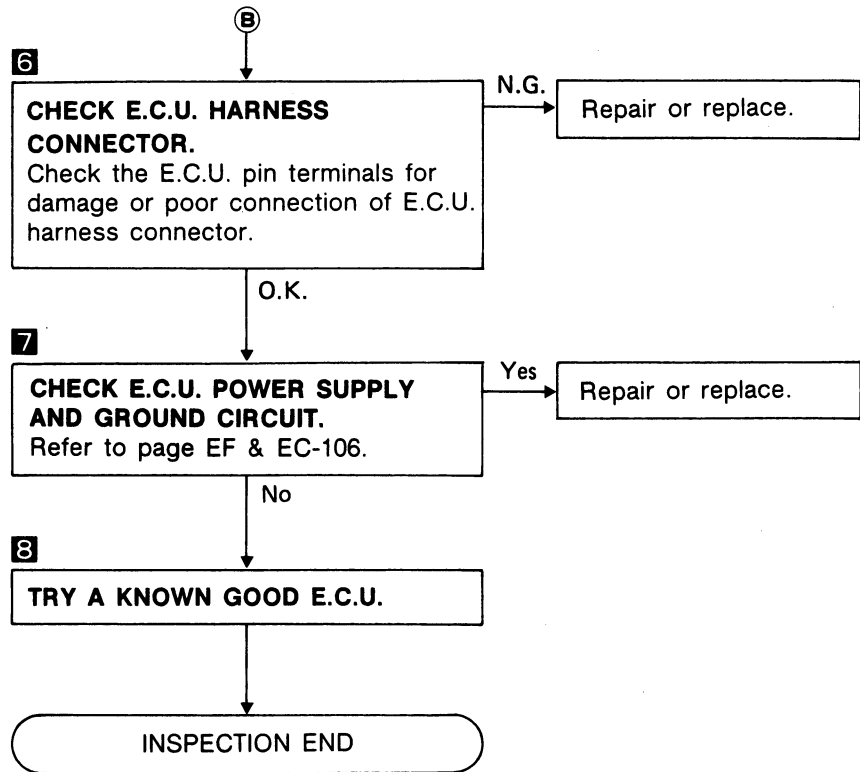

TROUBLE DIAGNOSES

Diagnostic Procedure 16 — Engine Stalls when the Electrical Load is Heavy

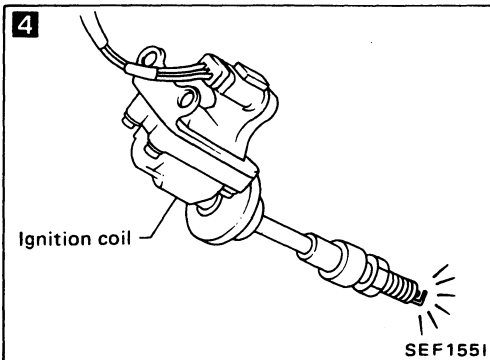
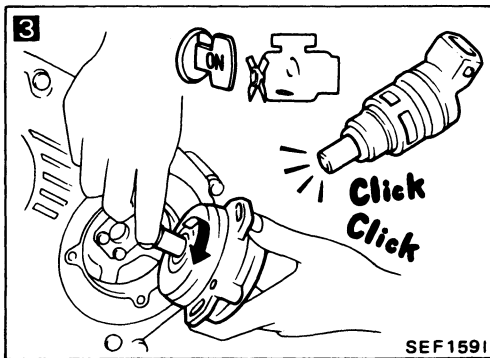
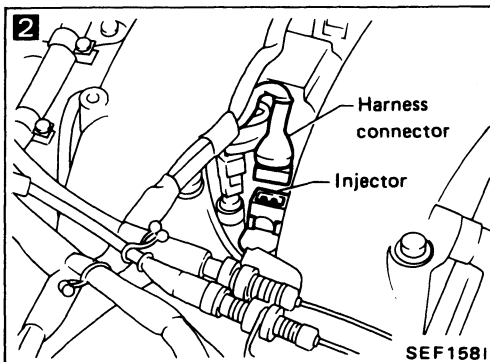
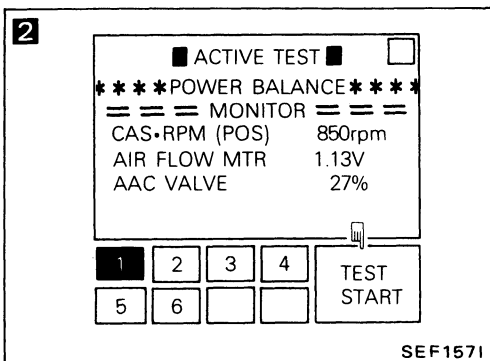
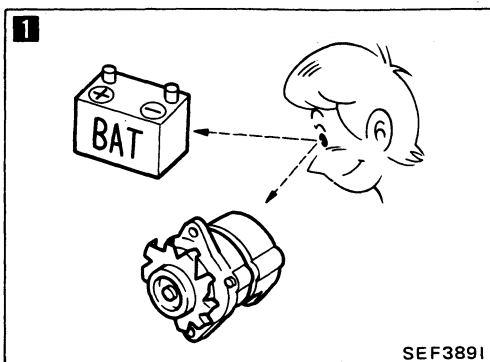

1

CHECK BATTERY AND ALTERNATOR.
Check battery and alternator condition. (Refer to EL section.)

N.G. → Repair or replace.

O.K.

2

PERFORM POWER BALANCE TEST.

1. Perform "POWER BALANCE" in "ACTIVE TEST" mode.

2. Is there any cylinder which does not produce a momentary engine speed drop?

OR

No → Go to **5**

When disconnecting each injector harness connector one at a time, is there any cylinder which does not produce a momentary engine speed drop?

Yes

3

CHECK INJECTOR.

1. Remove crank angle sensor from engine. (Harness connector should remain connected.)

2. Turn ignition switch ON. (Do not start engine.)

3. When rotating crank angle sensor shaft, does each injector make an operating sound?

No → Check injector(s) and circuit(s).

Yes

4

CHECK IGNITION SPARK.

1. Disconnect ignition coil assembly from collector.

2. Connect a known good spark plug to the ignition coil assembly.

3. Place end of spark plug against a suitable ground and crank engine.

4. Check for spark.

N.G. → Check ignition coil, power transistor unit and circuits. (See page EF & EC-120.)

O.K.

(Go to **A** on next page.)

TROUBLE DIAGNOSES

Diagnostic Procedure 16 — Engine Stalls when the Electrical Load is Heavy (Cont'd)

5

■ FUEL PRES RELEASE ■

FUEL PUMP WILL STOP BY TOUCHING START DURING IDLE.
CRANK A FEW TIMES AFTER ENGINE STALL.

START



SEF204J

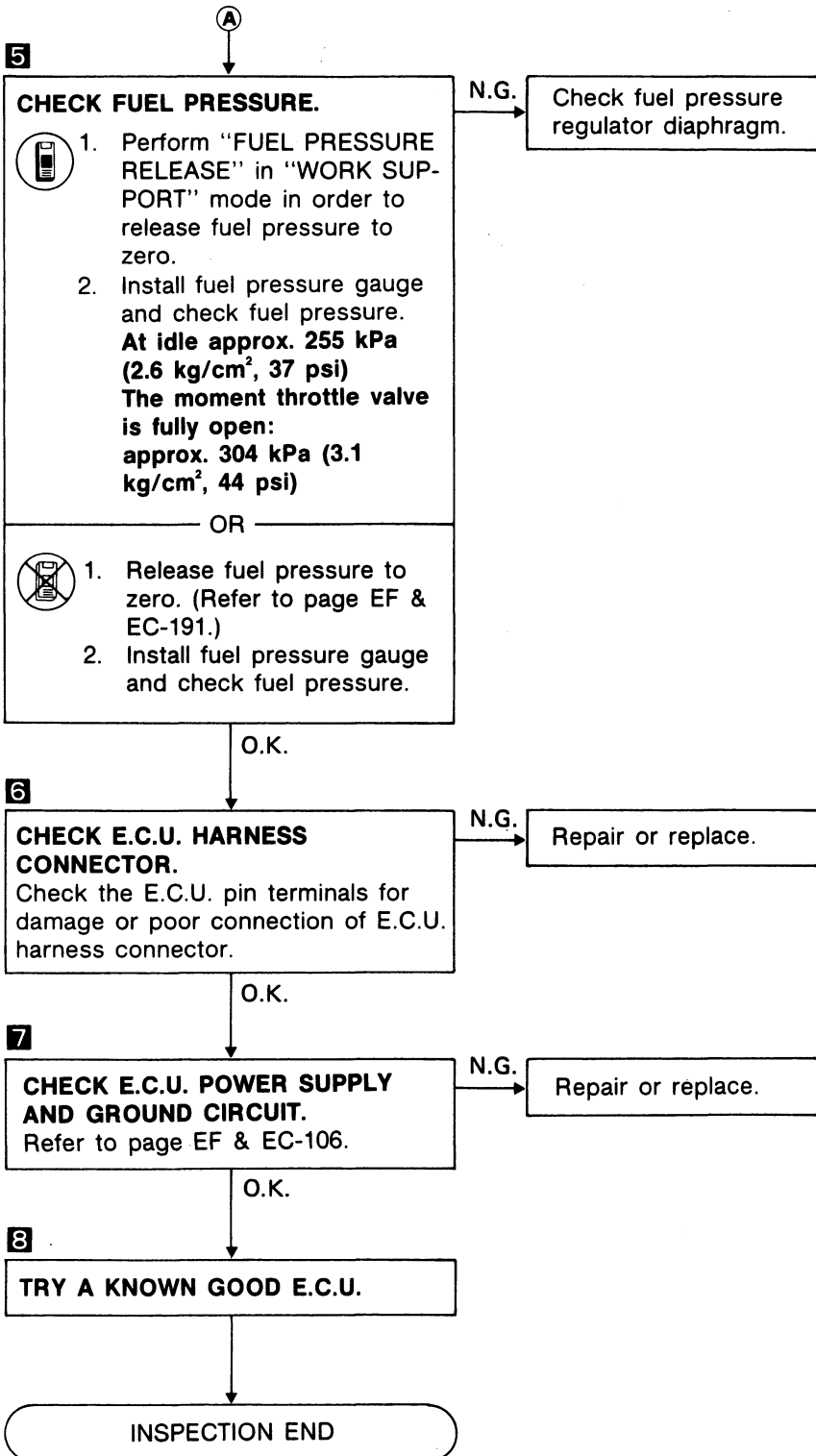

TROUBLE DIAGNOSES

Diagnostic Procedure 17 — Lack of Power and Stumble

1

■ FUEL PRES RELEASE ■

FUEL PUMP WILL STOP BY TOUCHING START DURING IDLE.
CRANK A FEW TIMES AFTER ENGINE STALL.

START



SEF204J

2 Left side

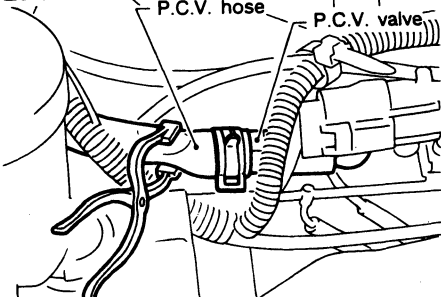

P.C.V. hose P.C.V. valve

Right side

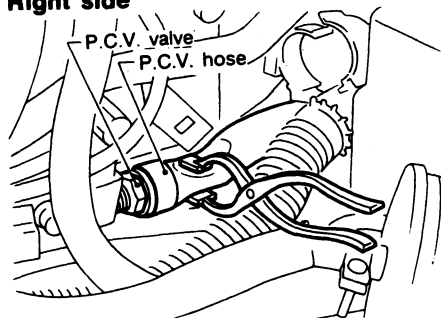

P.C.V. valve P.C.V. hose

SEF027K

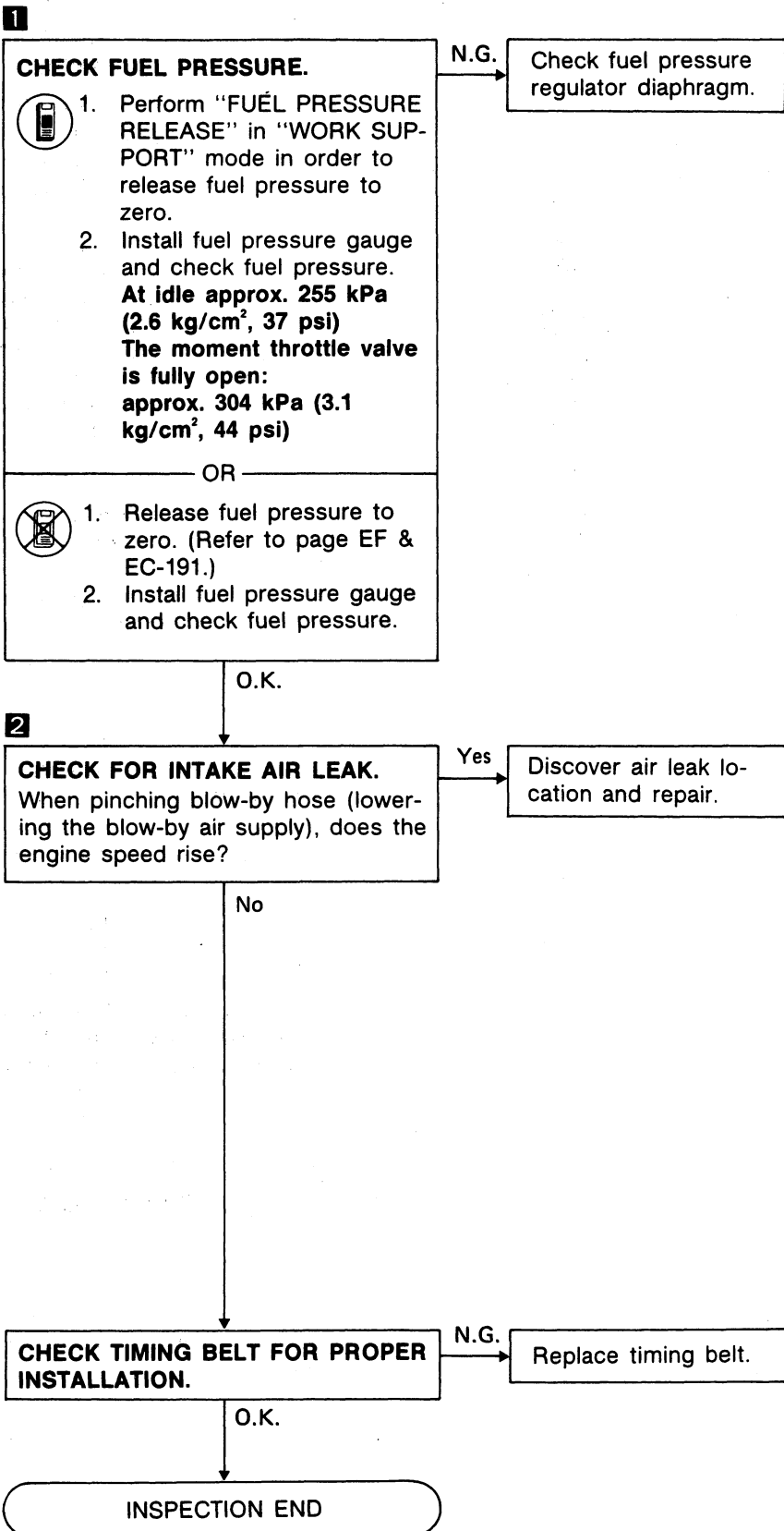

TROUBLE DIAGNOSES

Diagnostic Procedure 18 — Detonation

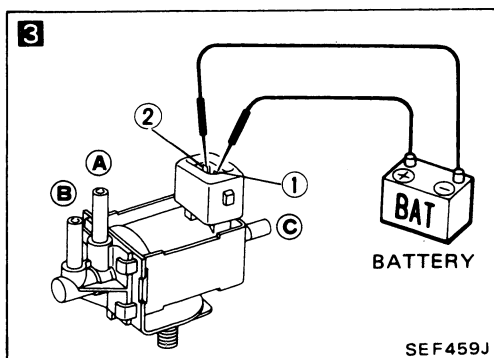
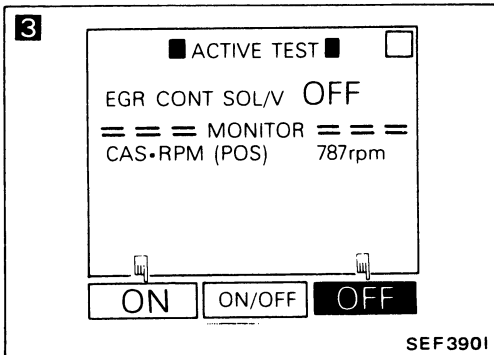
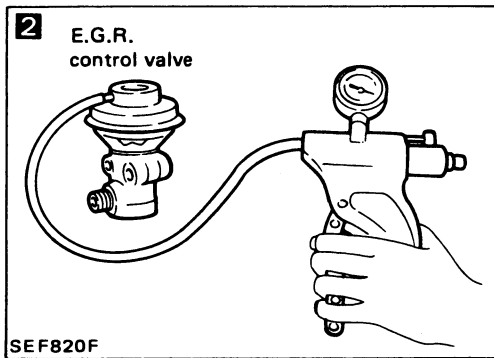
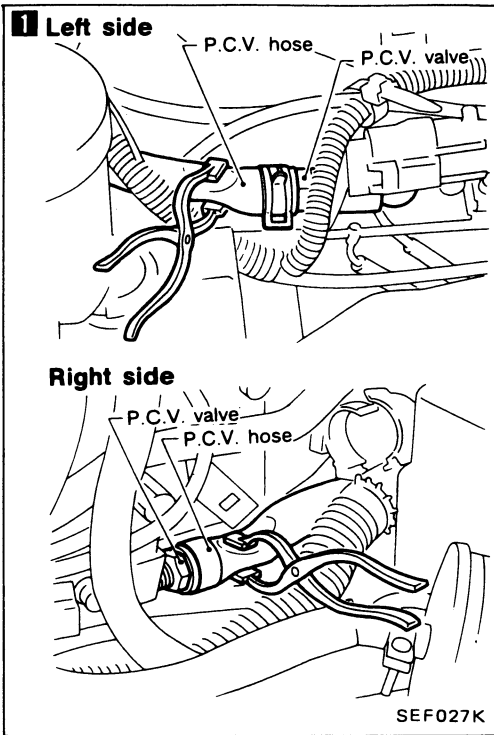

1

CHECK FOR INTAKE AIR LEAK.
When pinching blow-by hose (lowering the blow-by air supply), does the engine rpm rise?

Yes → Discover air leak location and repair.

No

2

CHECK E.G.R. OPERATION.
1. Apply vacuum directly to the E.G.R. valve using a handy vacuum pump.
2. Check to see that the engine runs rough or dies.

No → Check E.G.R. valve for sticking.

Yes

3

CHECK E.G.R. CONTROL SOLENOID VALVE.

1. Select "E.G.R. CONT SOL VALVE" in "ACTIVE TEST" mode.
2. Turn E.G.R. control solenoid valve ON and OFF.
3. Check operating sound.

OR

1. Disconnect E.G.R. control solenoid valve harness connector.
2. Supply E.G.R. control solenoid valve terminals with battery current and check operating sound.

N.G. → Check solenoid valve and circuit.

O.K.

(Go to **A** on next page.)

TROUBLE DIAGNOSES

Diagnostic Procedure 18 — Detonation (Cont'd)

A

4

CHECK VACUUM HOSES.

Check the following vacuum hoses for clogging, cracks and poor connection.

- a) Vacuum hose between E.G.R. control valve and E.G.R. control solenoid valve.
- b) Vacuum hose between E.G.R. control solenoid valve and throttle chamber port.
- c) Vacuum hose between E.G.R. control solenoid valve and air duct.

N.G.

Repair or replace.

O.K.

5

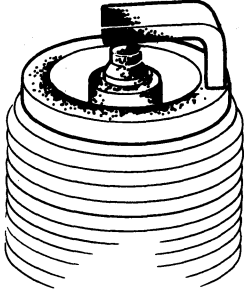

SEF 1561

5

CHECK FOR OIL LEAK TO COMBUSTION CHAMBER.

Remove spark plugs and check for fouling with oil.

Yes

Check pistons, piston rings, valves, valve seats, valve oil seal, engine oil level, etc.

No

INSPECTION END

TROUBLE DIAGNOSES

Diagnostic Procedure 19 — Surge

1

☆ MONITOR ☆ NO FAIL <input type="checkbox"/>
CAS-RPM(POS) 2087rpm
M/R F/C MNT LEAN
M/R F/C MNT-R RICH

RECORD

SEF1601

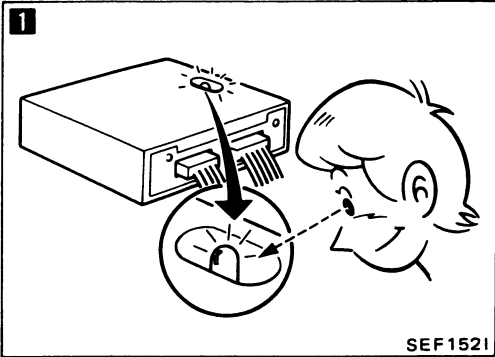

1

CHECK EXHAUST GAS SENSOR.

1. See "M/R F/C MNT (right and left sides)" in "DATA MONITOR" mode.
2. Maintaining engine at 2,000 rpm under no-load (with engine warmed up sufficiently), check to make sure that the monitor fluctuates between "LEAN" and "RICH" more than 5 times during 10 seconds.

RICH → LEAN → RICH →
1 time 2 times
LEAN → RICH.....

— OR —

N.G. → Replace exhaust gas sensor(s).

1. Set "Exhaust gas sensor monitor" in the self-diagnostic Mode II. (See page EF & EC-54.)
2. Maintaining engine at 2,000 rpm under no load, check that RED LED on the E.C.U. goes ON and OFF more than 5 times during 10 seconds.

O.K.

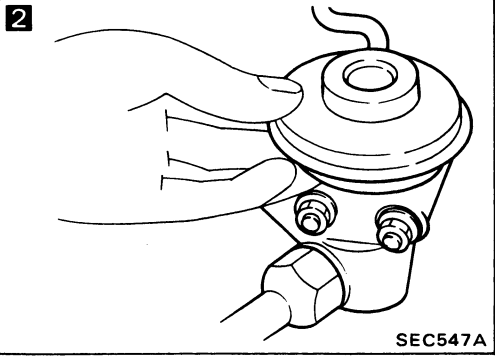

2

CHECK E.G.R. CONTROL VALVE.
 Check E.G.R. control valve for sticking.

N.G. → Repair or replace.

O.K.

3

TRY A KNOWN GOOD E.C.U.

O.K.

INSPECTION END

TROUBLE DIAGNOSES

Diagnostic Procedure 20 — Backfire through the Intake

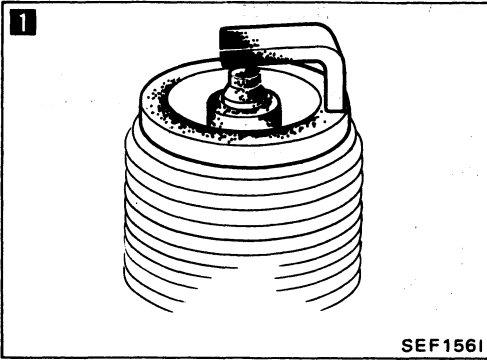

1
CHECK SPARK PLUGS.
Remove the spark plugs and check for fouling, etc.

N.G. → Repair or replace spark plug(s).

O.K.

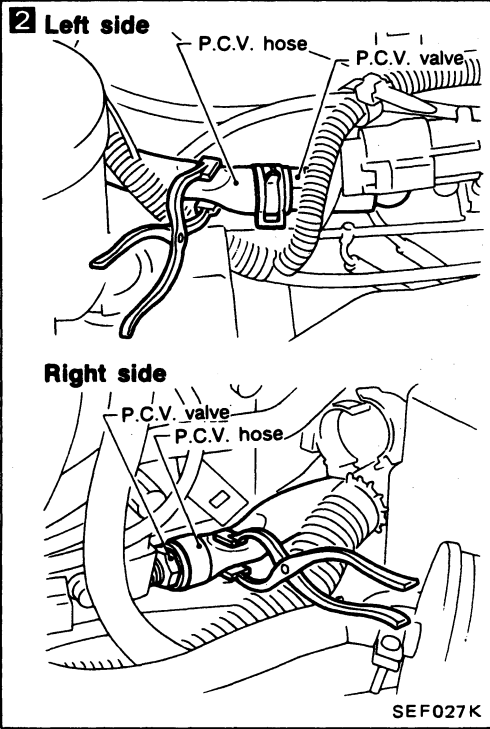

2
CHECK INTAKE AIR LEAK.
When pinching blow-by hose (lowering the blow-by air supply), does the engine speed rise?

Yes → Discover air leak location and repair.

No

3
CHECK FOR INTAKE VALVE DEPOSITS.
If there are deposits on intake valves, remove them.

INSPECTION END

TROUBLE DIAGNOSES

Diagnostic Procedure 21 — Backfire through the Exhaust

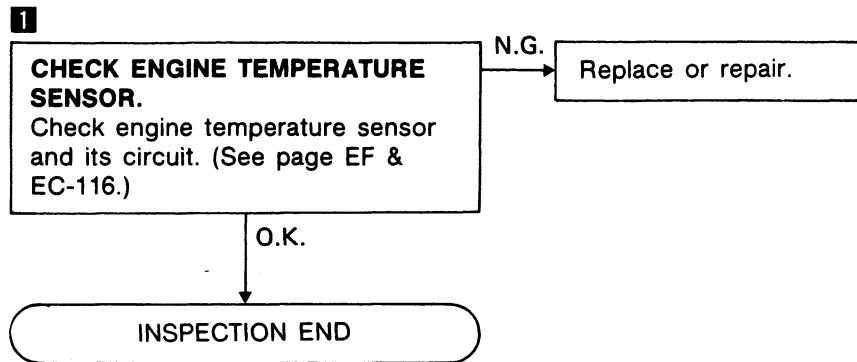

TROUBLE DIAGNOSES

Diagnostic Procedure 22

MAIN POWER SUPPLY AND GROUND CIRCUIT

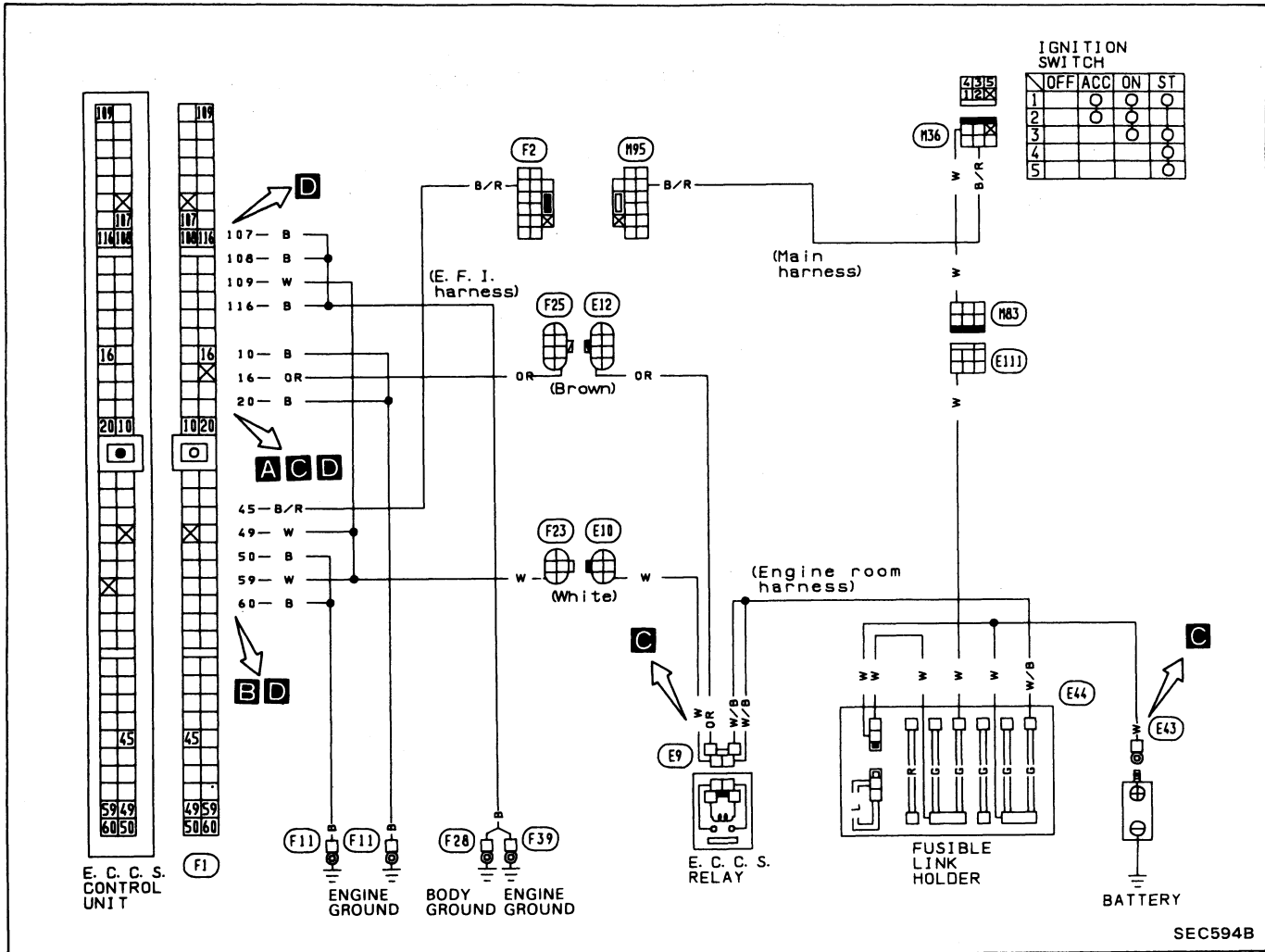

Harness layout

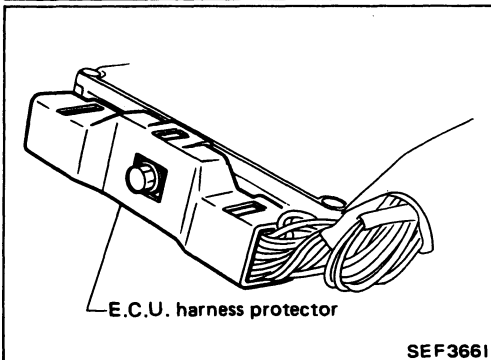
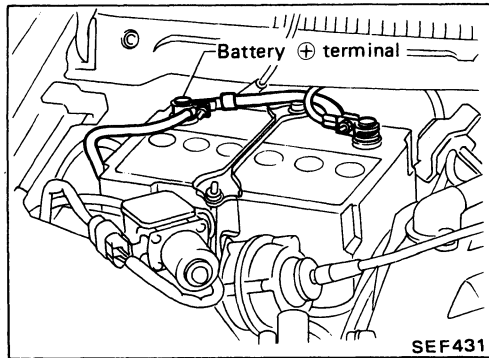
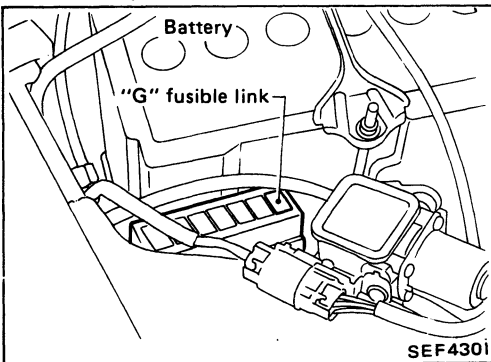

TROUBLE DIAGNOSES

Diagnostic Procedure 22 (Cont'd)

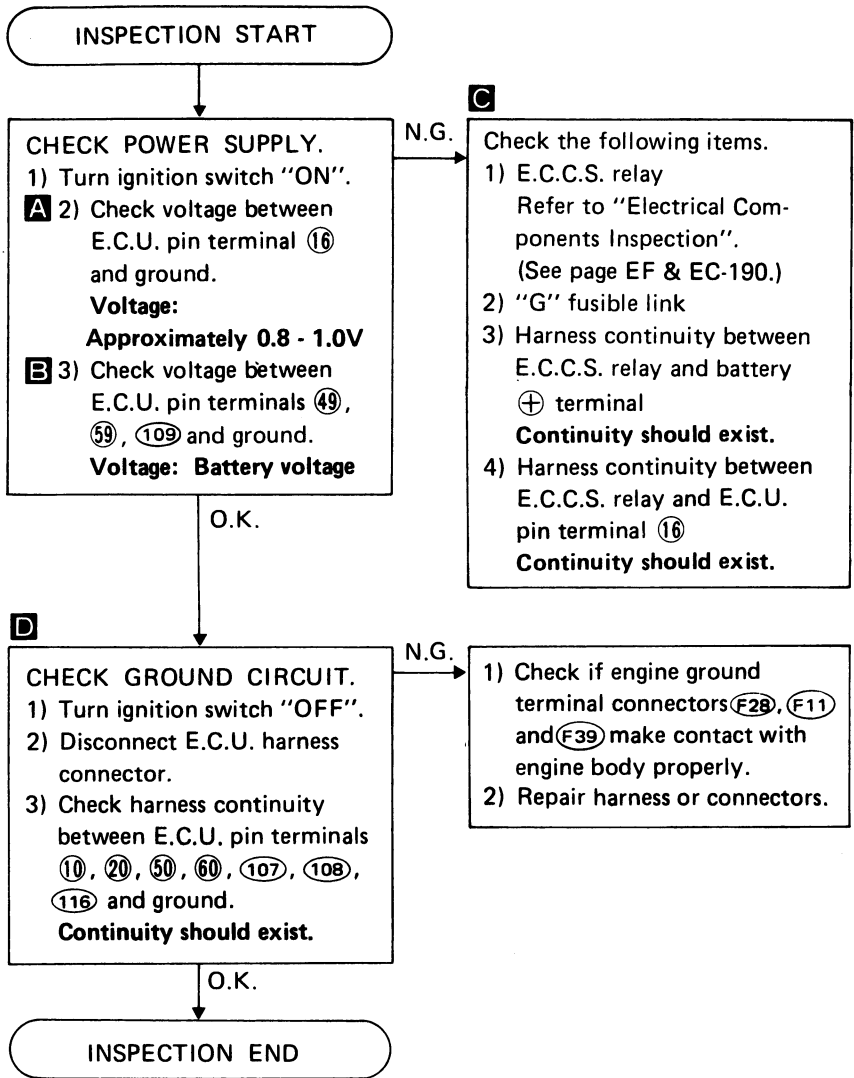
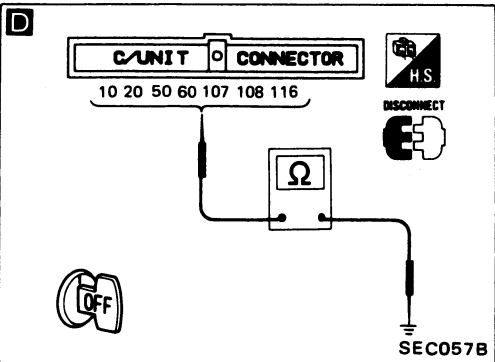
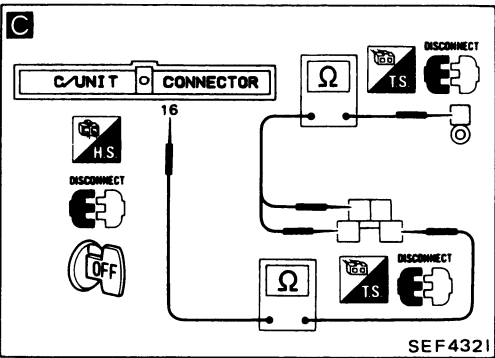
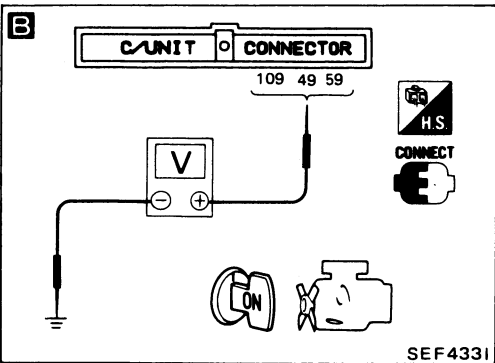
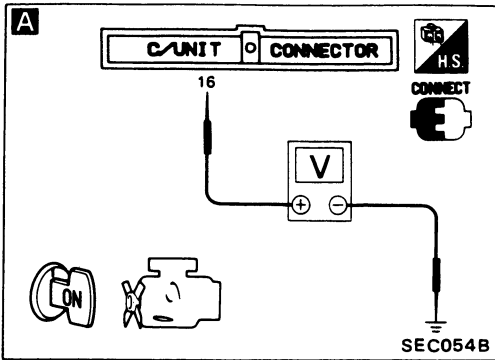

TROUBLE DIAGNOSES

Diagnostic Procedure 23

CRANK ANGLE SENSOR (Code No. 11)

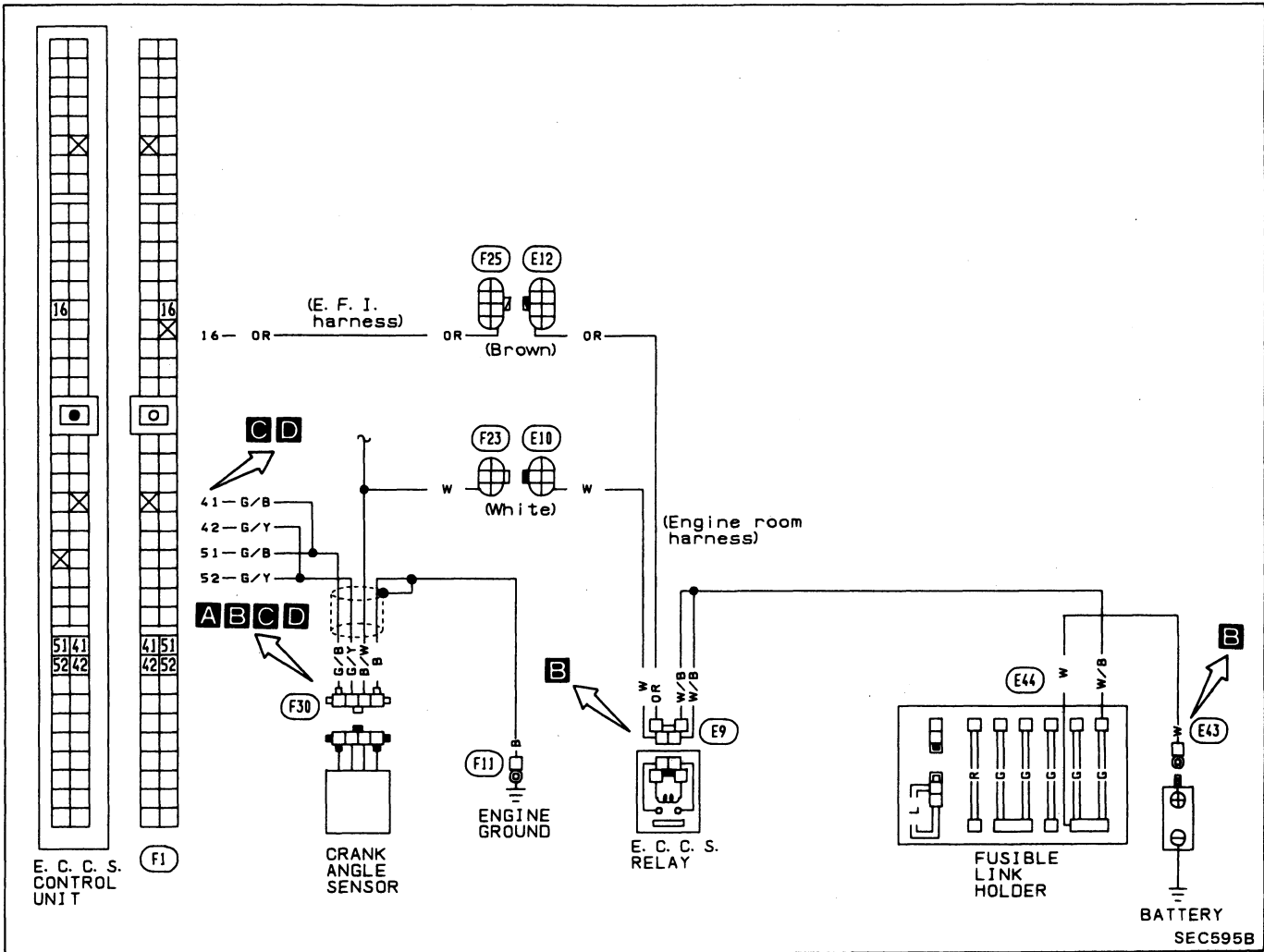

Harness layout

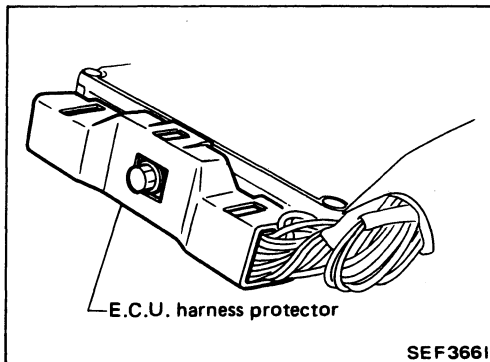
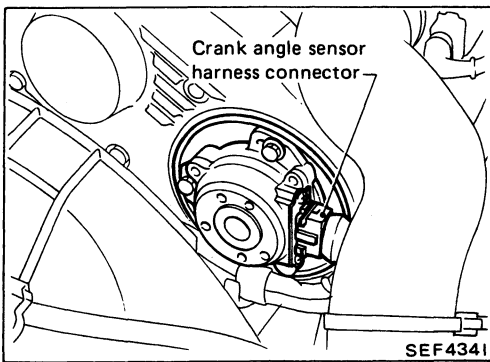

TROUBLE DIAGNOSES

Diagnostic Procedure 23 (Cont'd)

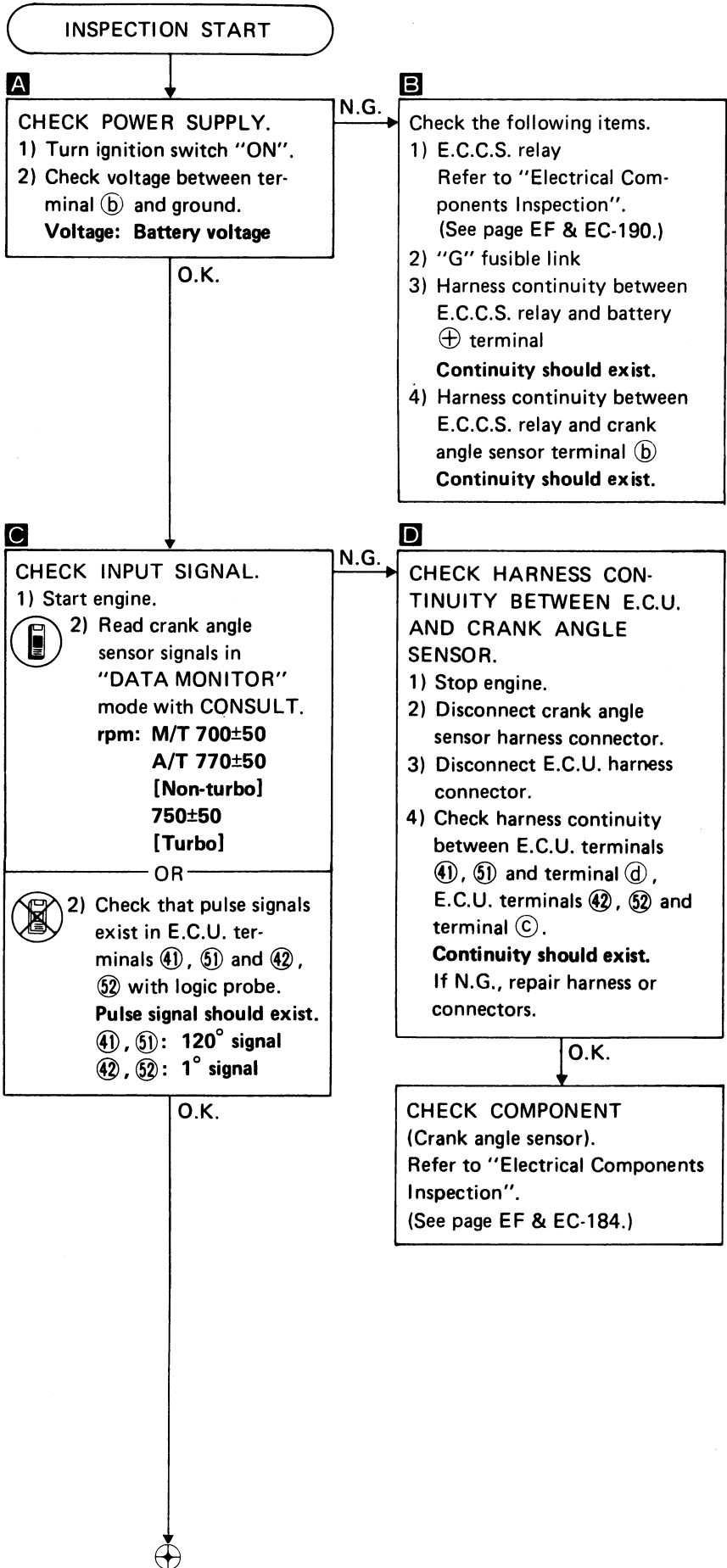
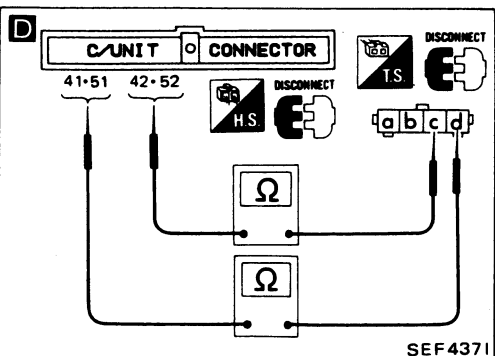
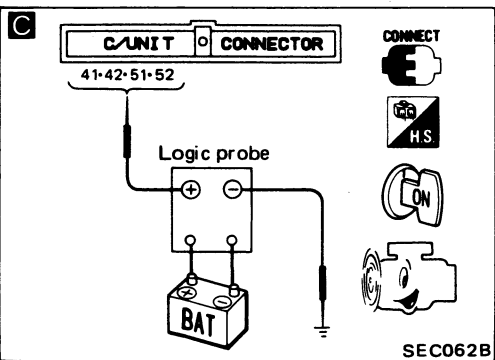
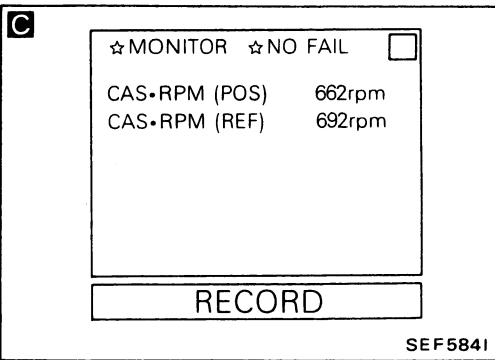
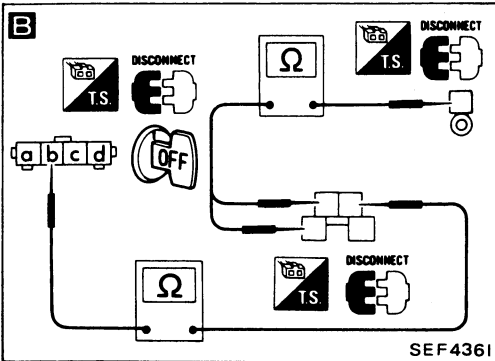
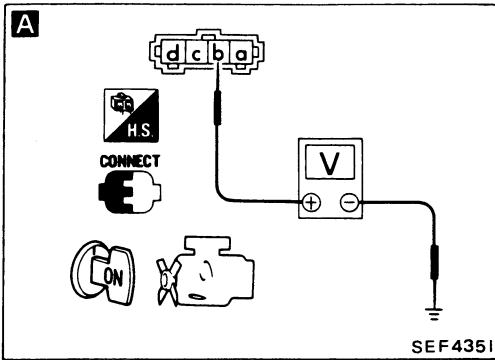

TROUBLE DIAGNOSES

Diagnostic Procedure 23 (Cont'd)

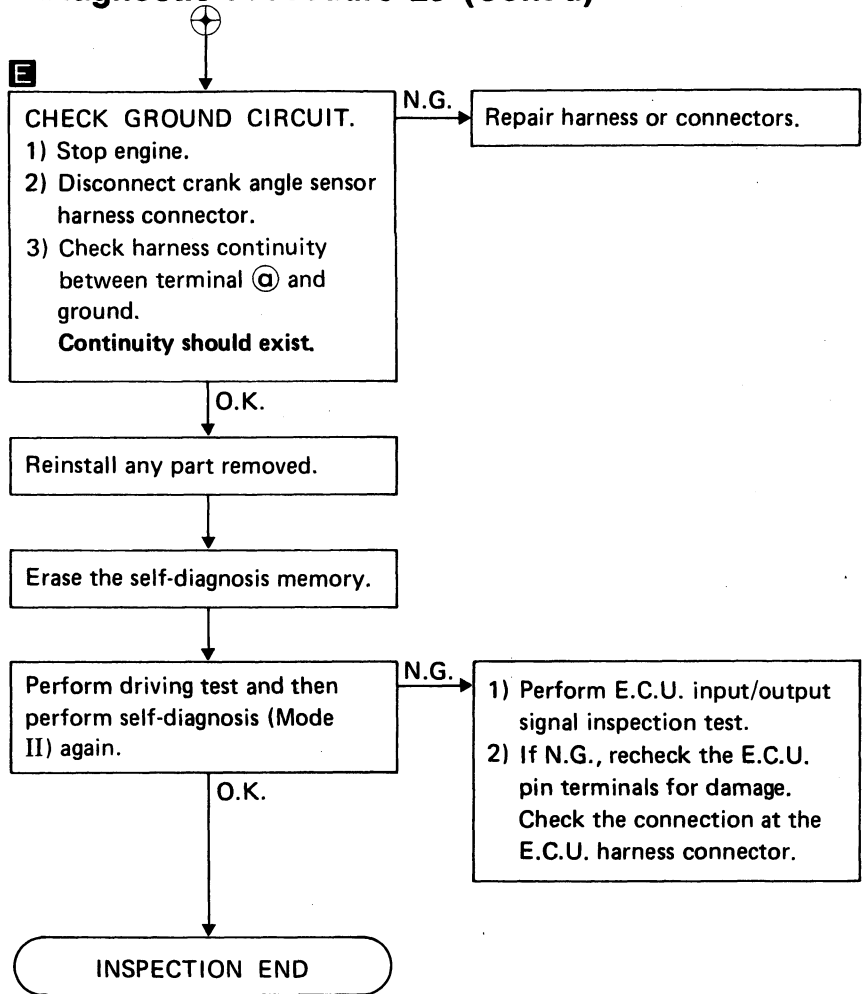
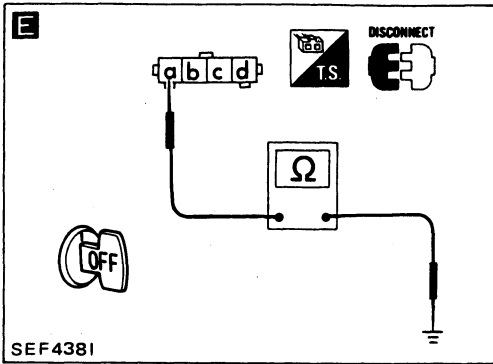

TROUBLE DIAGNOSES

NOTE

TROUBLE DIAGNOSES

Diagnostic Procedure 24

AIR FLOW METER (Code No. 12) (CHECK ENGINE LIGHT ITEM)

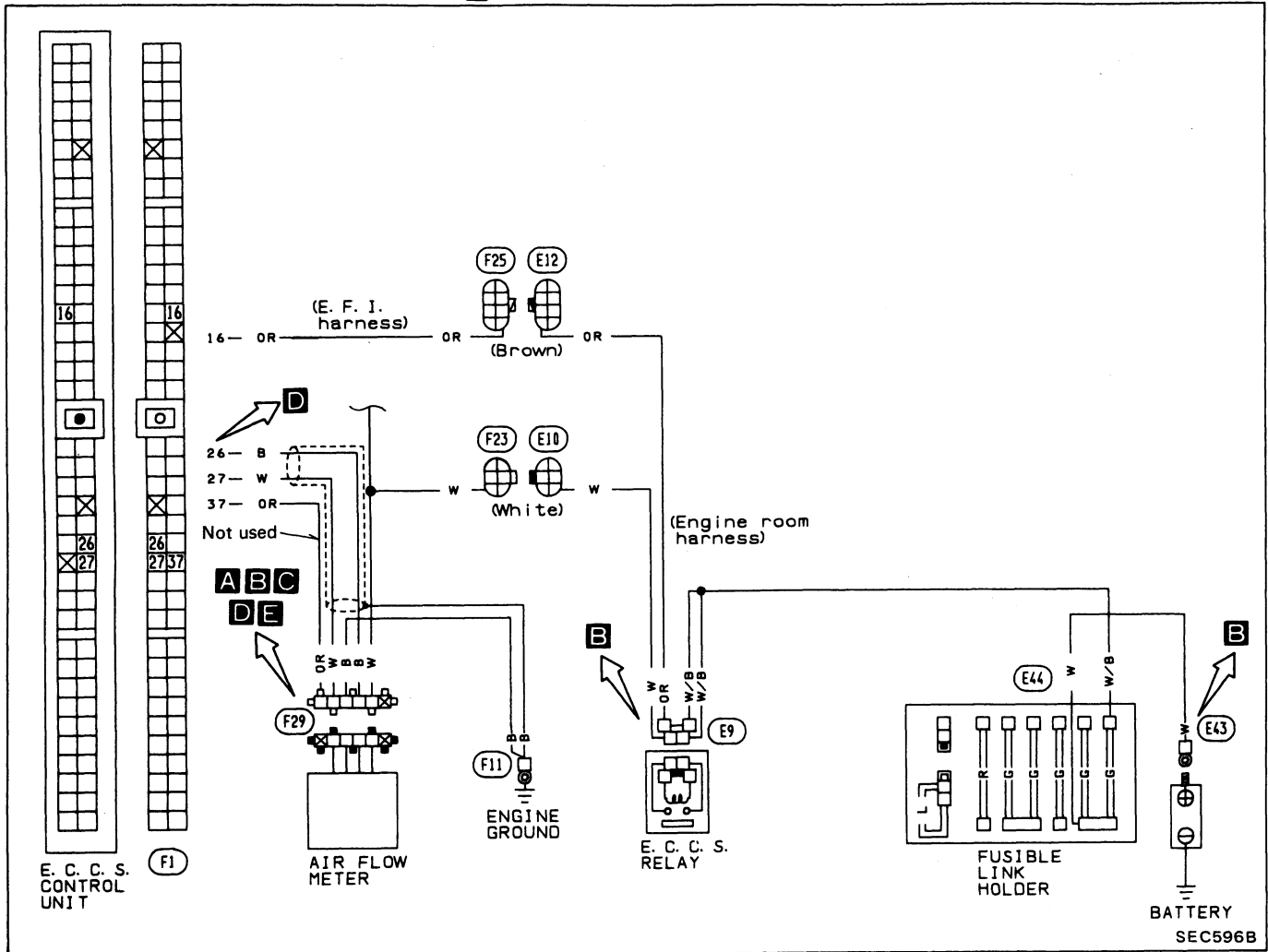

Harness layout

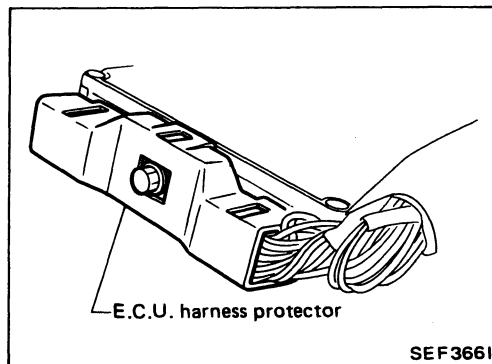
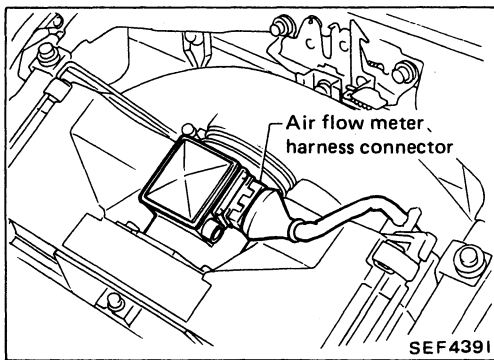

TROUBLE DIAGNOSES

Diagnostic Procedure 24 (Cont'd)

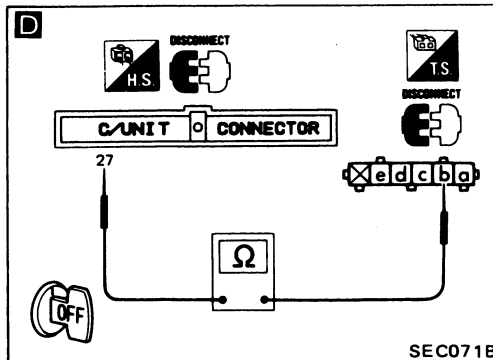
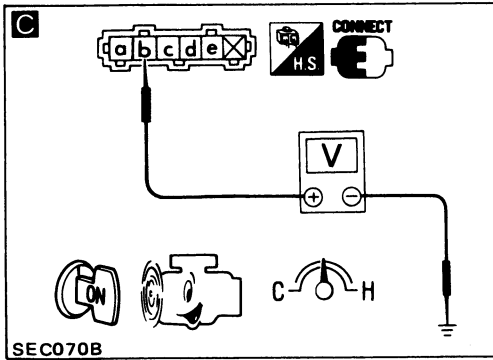
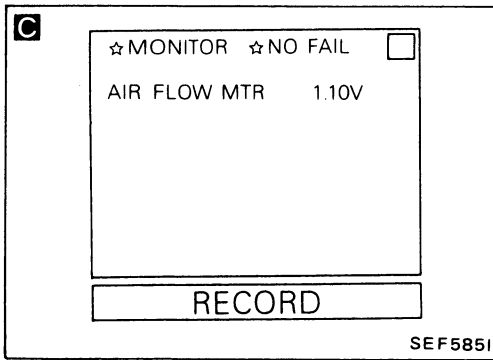
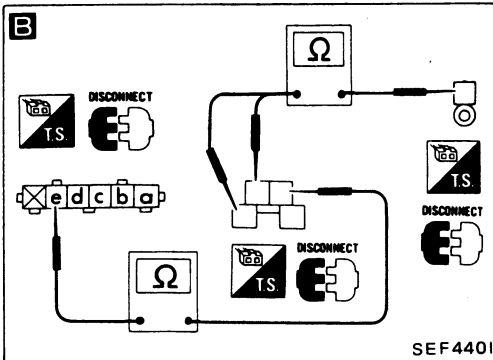
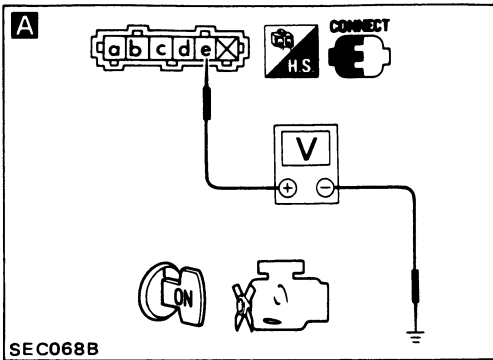

INSPECTION START

A
CHECK POWER SOURCE.
 1) Turn ignition switch "ON".
 2) Check voltage between terminal ⑤ and ground.
Voltage: Battery voltage

B
 Check the following items.
 1) E.C.C.S. relay
 Refer to "Electrical Components Inspection".
 (See page EF & EC-190.)
 2) "G" fusible link
 3) Harness continuity between E.C.C.S. relay and battery ⊕ terminal
Continuity should exist.
 4) Harness continuity between E.C.C.S. relay and air flow meter terminal ⑤.
Continuity should exist.

O.K.

C
CHECK INPUT SIGNAL.
 1) Start engine and warm it up sufficiently.
 2) Read air flow meter signal in "DATA MONITOR" mode with CONSULT.
Voltage: 0.8 - 1.5V

D
CHECK HARNESS CONTINUITY BETWEEN AIR FLOW METER AND E.C.U.
 1) Stop engine.
 2) Disconnect air flow meter harness connector.
 3) Disconnect E.C.U. harness connector.
 4) Check harness continuity between E.C.U. terminal ⑳ and terminal ㉑.
Continuity should exist.
 If N.G., repair harness or connectors.

OR
 2) Check voltage between terminal ㉑ and ground at idle under no-load.
Voltage: 0.8 - 1.5V

O.K.
CHECK COMPONENT
 (Air flow meter).
 Refer to "Electrical Components Inspection".
 (See page EF & EC-184.)

O.K.

E
CHECK GROUND CIRCUIT.
 1) Stop engine.
 2) Disconnect air flow meter harness connector.
 3) Check harness continuity between terminal ㉑ and ground.
Continuity should exist.

N.G. Repair harness or connectors.

O.K.
 ⊕

TROUBLE DIAGNOSES

Diagnostic Procedure 24 (Cont'd)

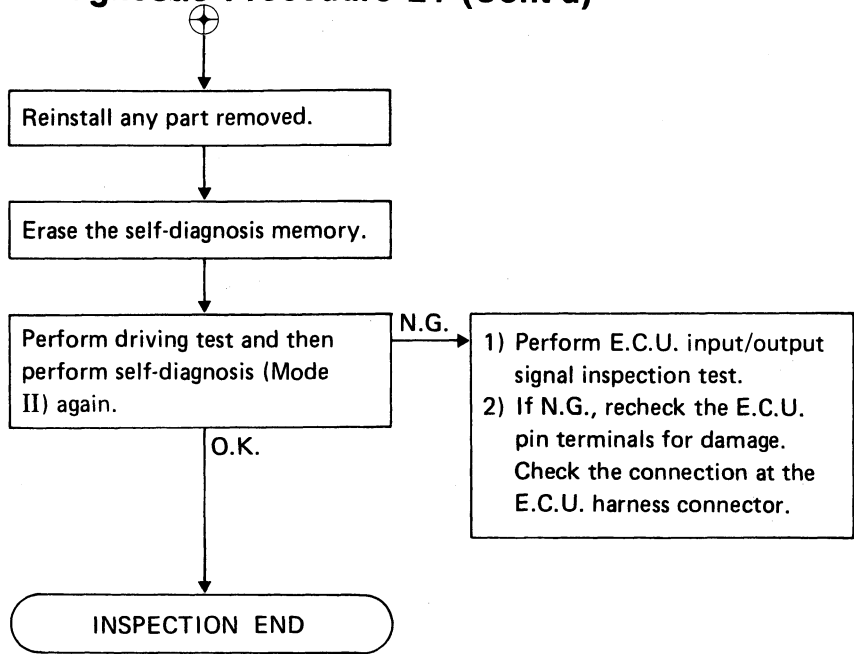
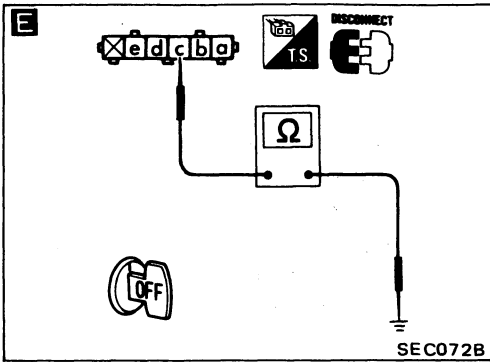

TROUBLE DIAGNOSES

NOTE

TROUBLE DIAGNOSES

Diagnostic Procedure 25

ENGINE TEMPERATURE SENSOR (Code No. 13)  (CHECK ENGINE LIGHT ITEM)

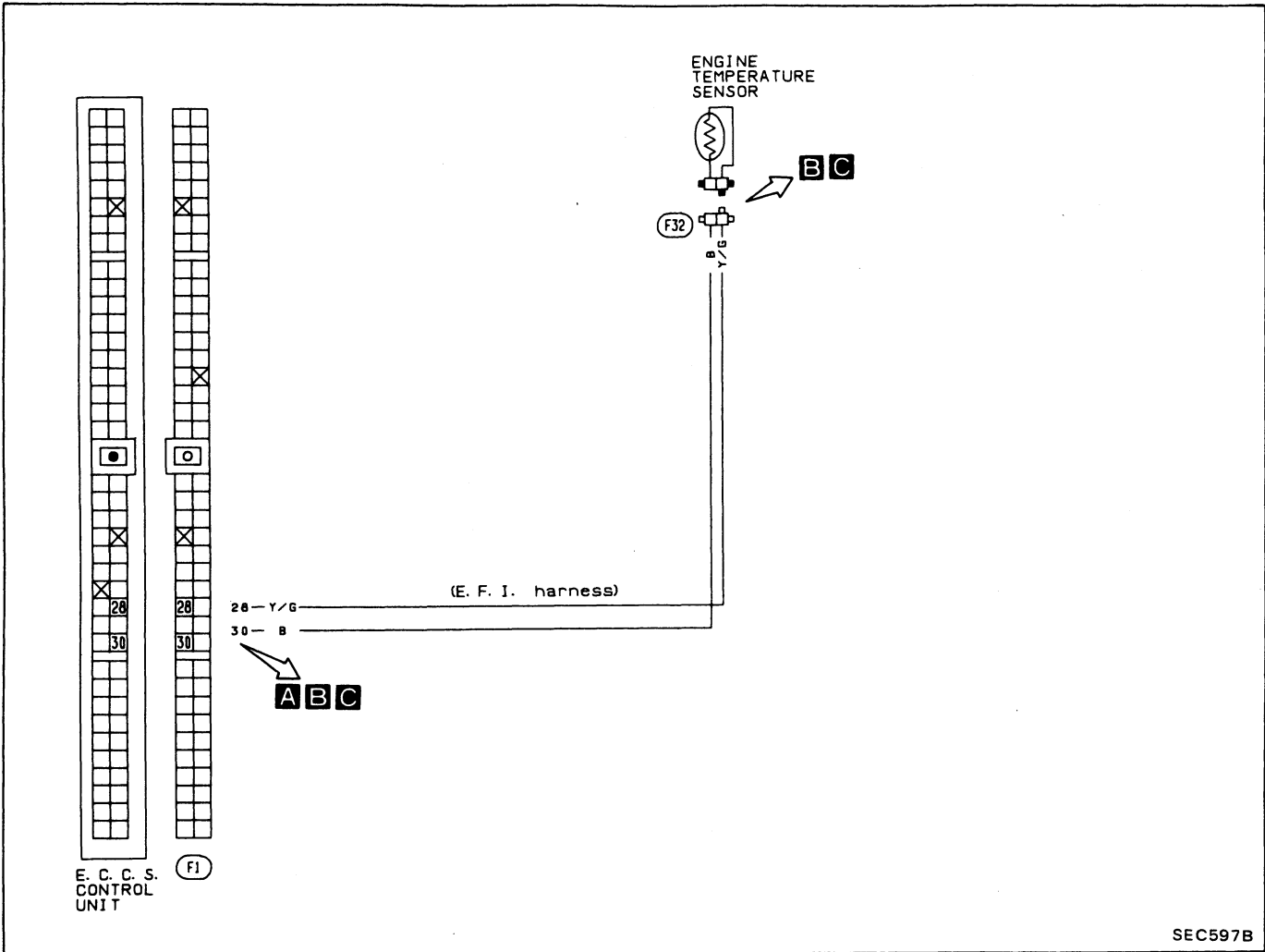

Harness layout

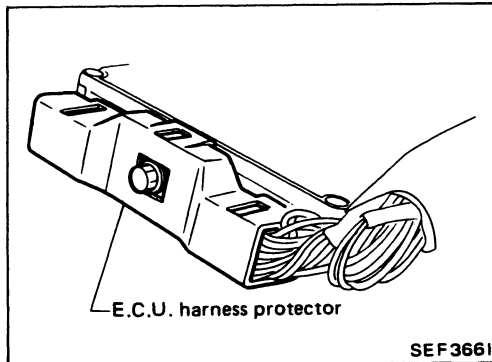
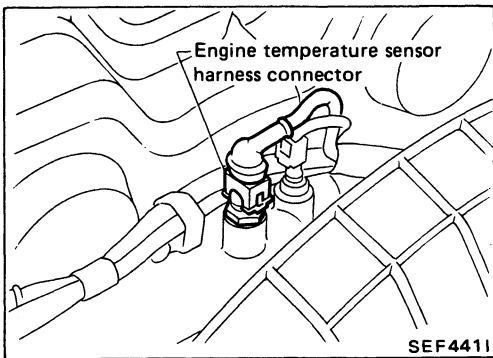

TROUBLE DIAGNOSES

Diagnostic Procedure 25 (Cont'd)

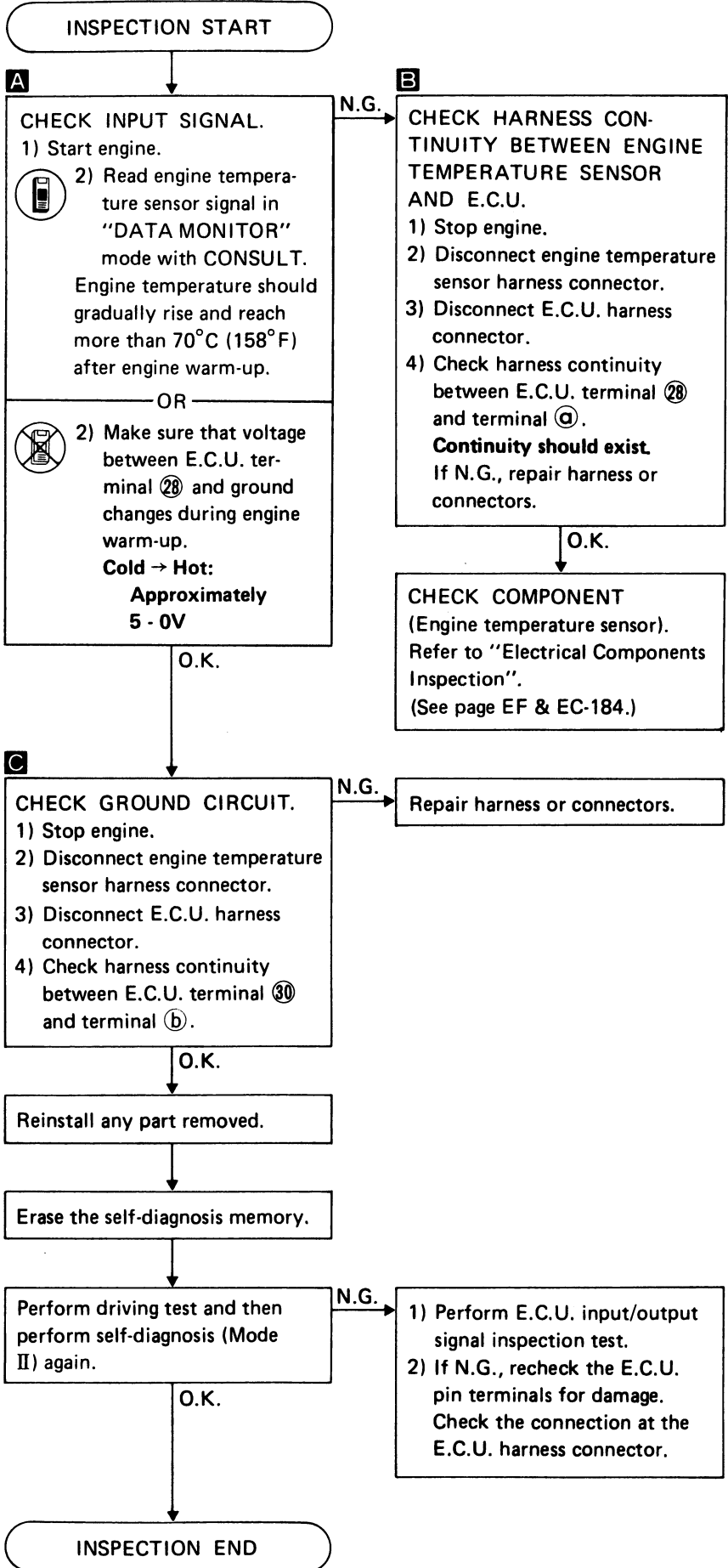
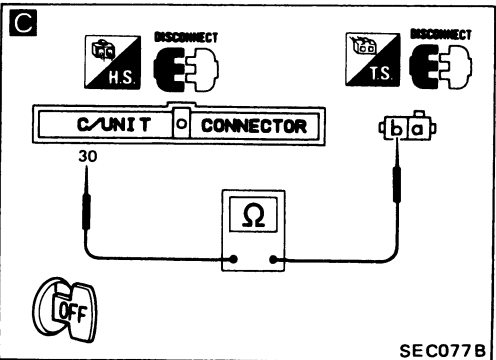
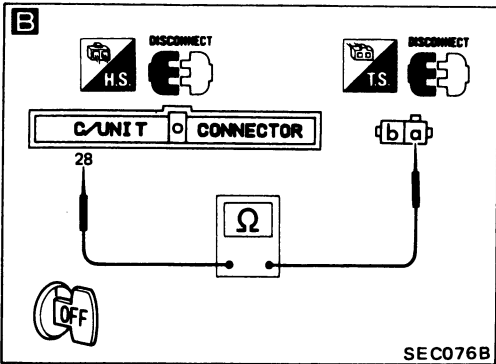
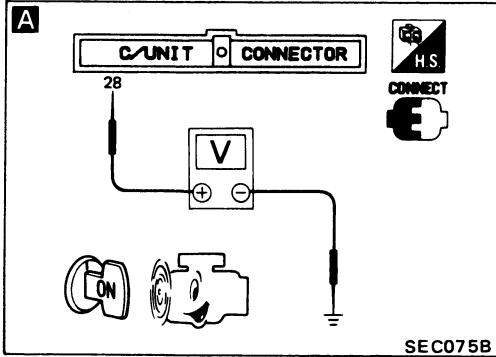
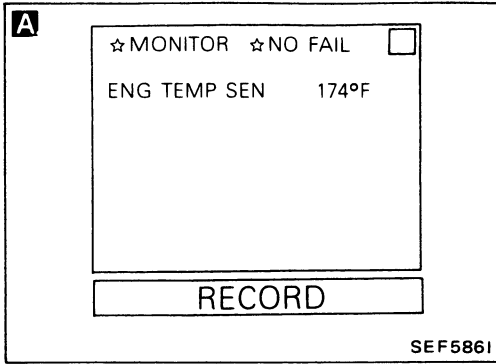

TROUBLE DIAGNOSES

Diagnostic Procedure 26

VEHICLE SPEED SENSOR (Code No. 14) (CHECK ENGINE LIGHT ITEM)

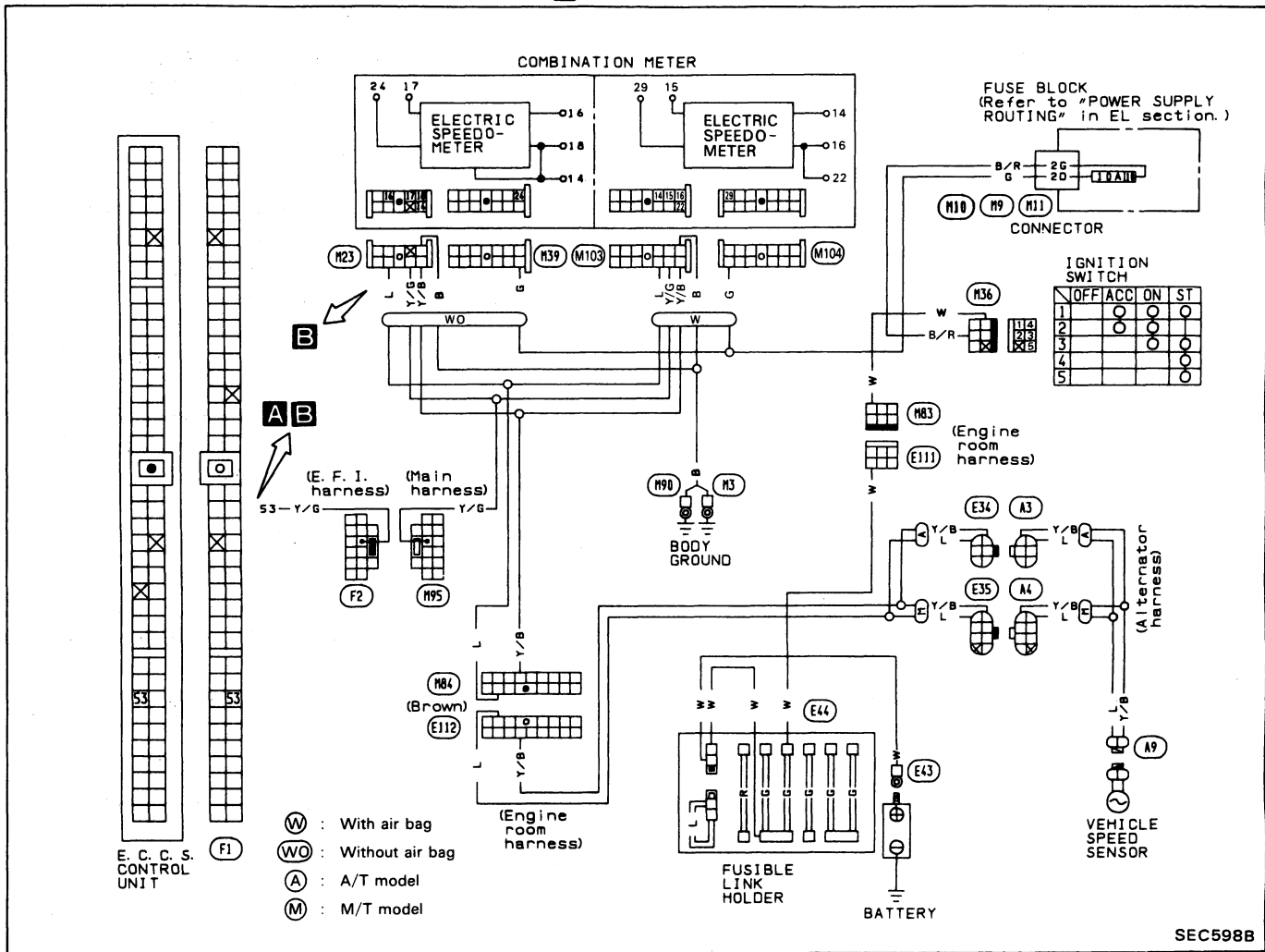

SEC598B

Harness layout

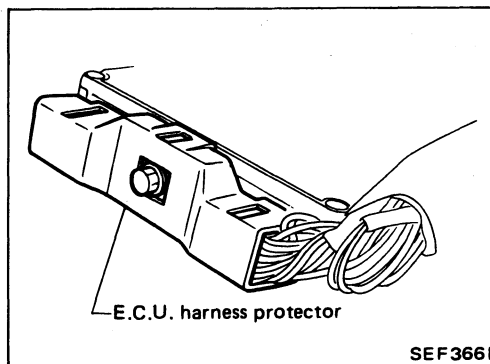
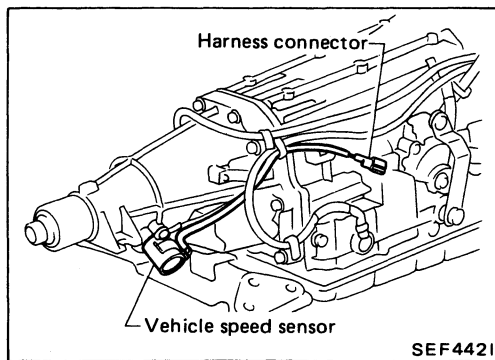

TROUBLE DIAGNOSES

Diagnostic Procedure 26 (Cont'd)

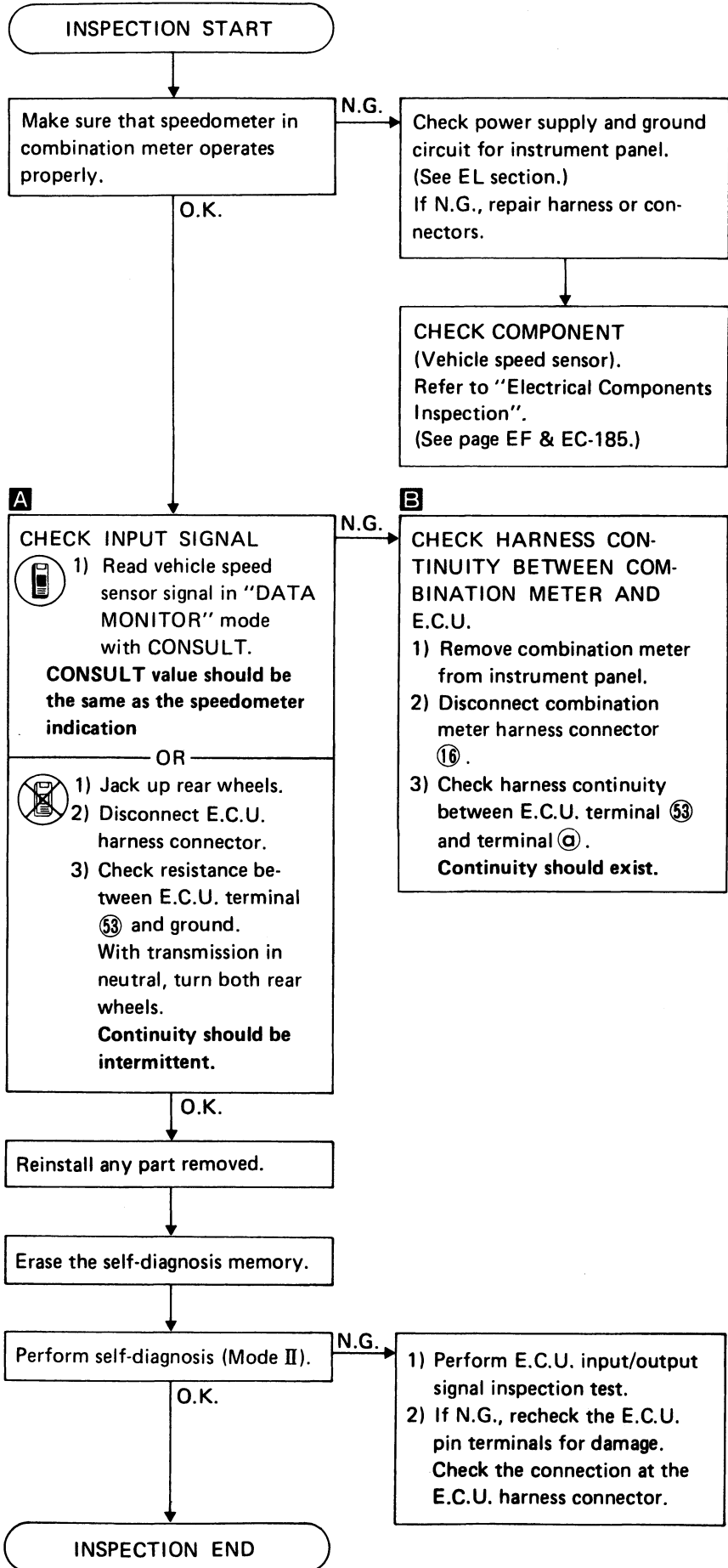
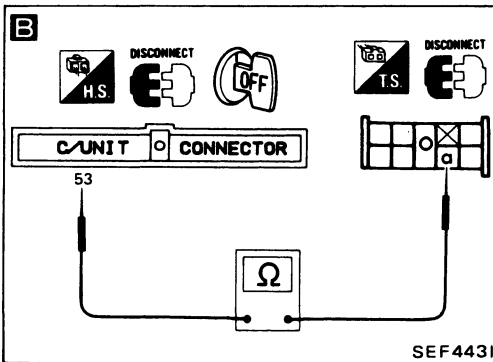
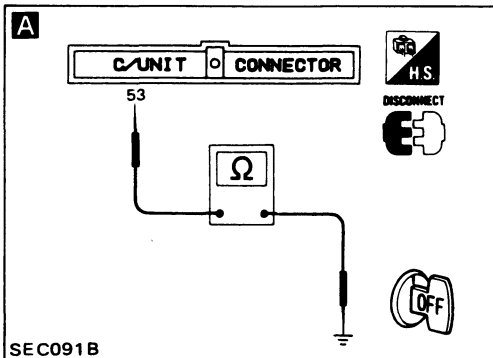
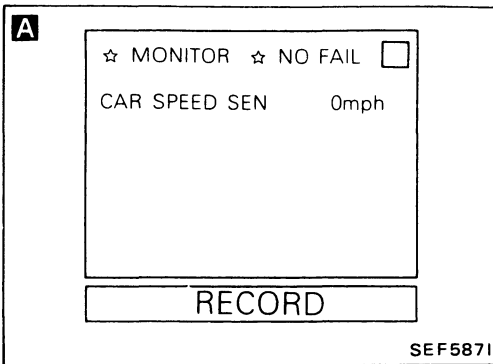

TROUBLE DIAGNOSES

Diagnostic Procedure 27

IGNITION SIGNAL (Code No. 21)

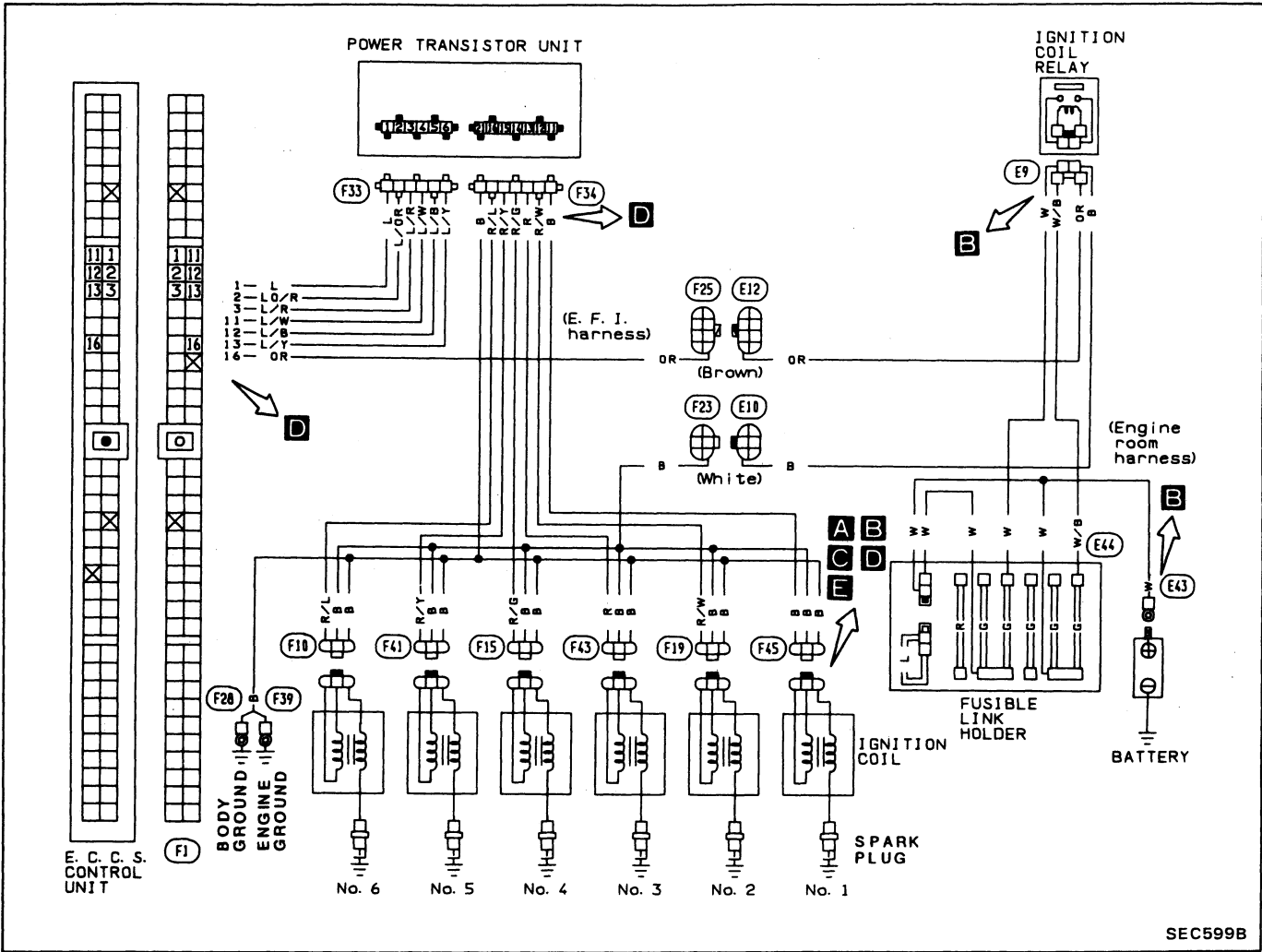

Harness layout

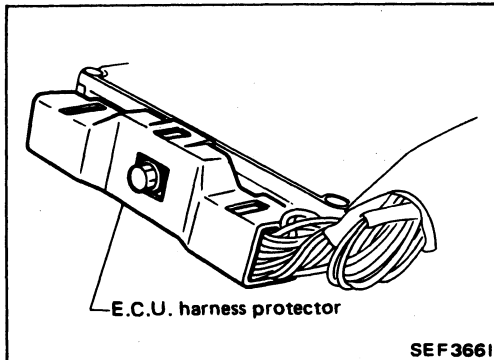
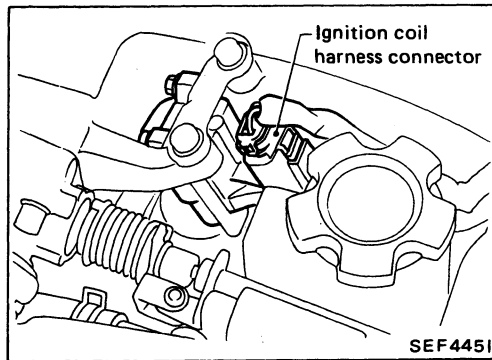
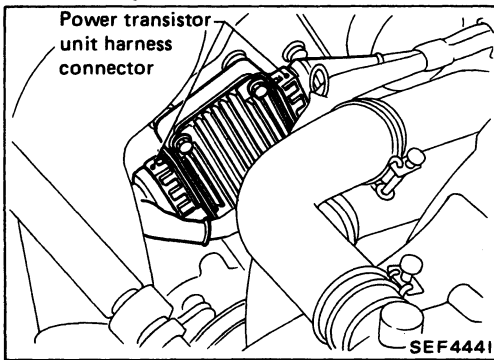

TROUBLE DIAGNOSES

Diagnostic Procedure 27 (Cont'd)

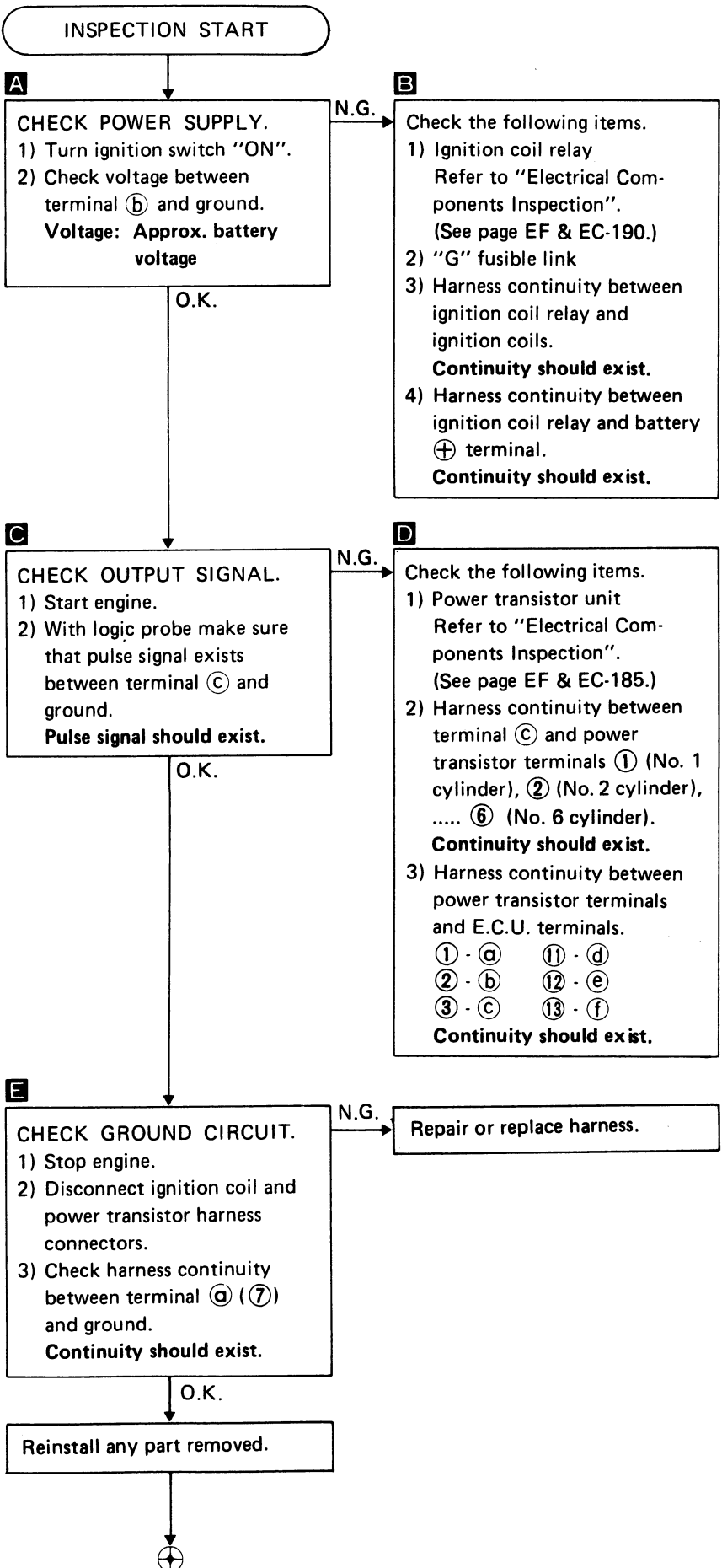
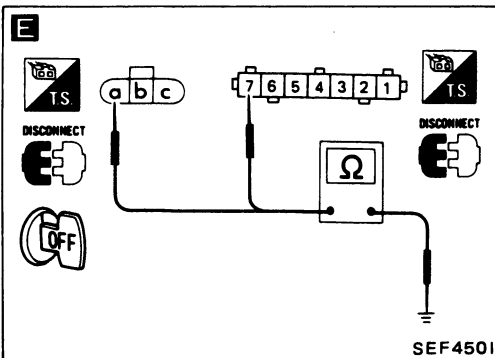
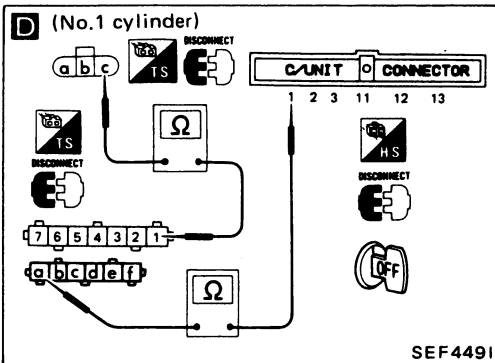
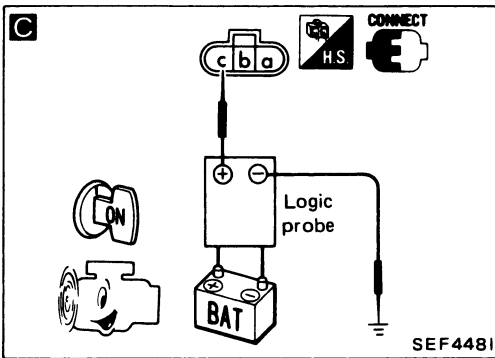
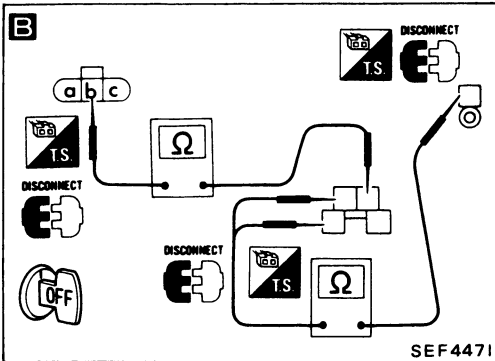
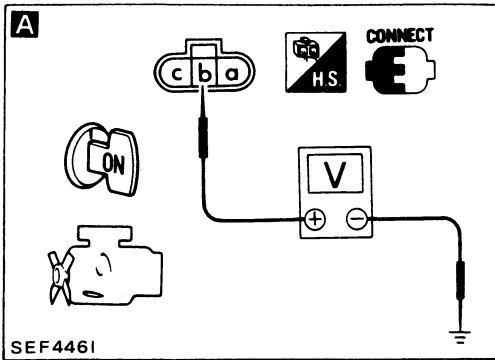

TROUBLE DIAGNOSES

Diagnostic Procedure 27 (Cont'd)

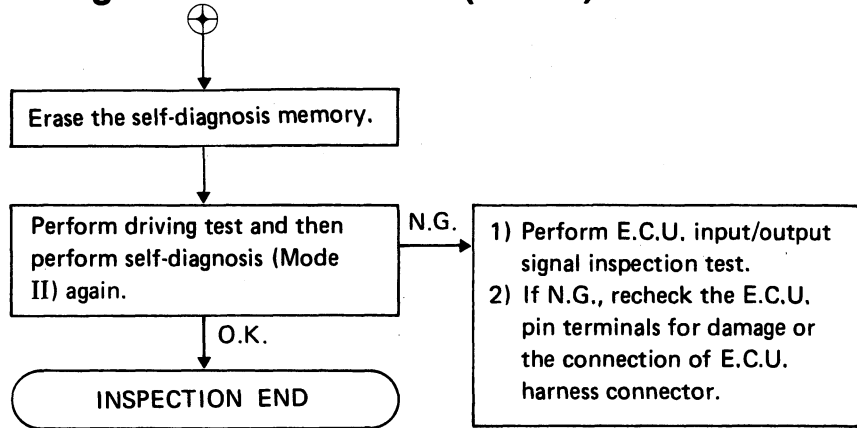

TROUBLE DIAGNOSES

NOTE

TROUBLE DIAGNOSES

Diagnostic Procedure 28

ENGINE CONTROL UNIT (Code No. 31)  (CHECK ENGINE LIGHT ITEM)

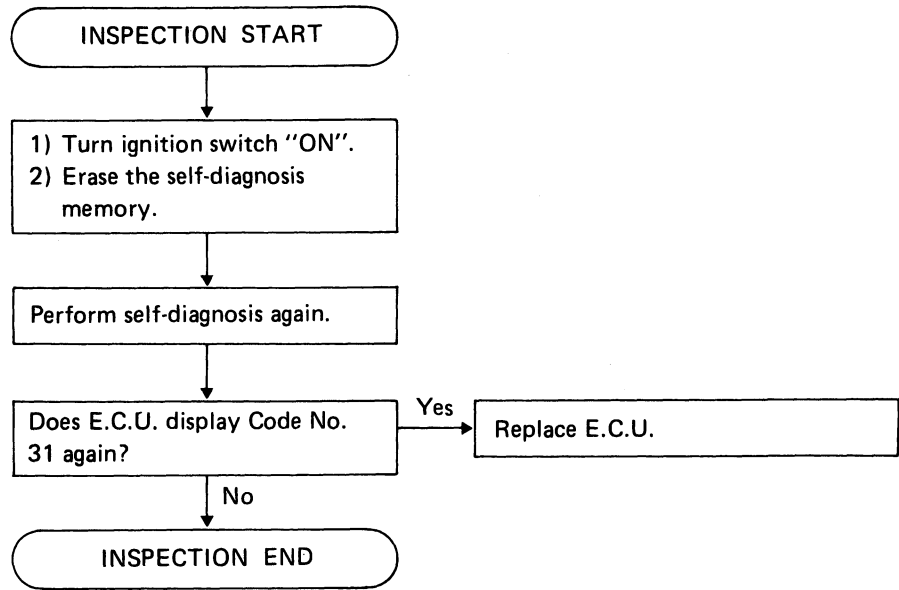

TROUBLE DIAGNOSES

NOTE

TROUBLE DIAGNOSES

Diagnostic Procedure 29

E.G.R. FUNCTION (Code No. 32)  (CHECK ENGINE LIGHT ITEM): For California model (Not self-diagnostic item): For Non-California model

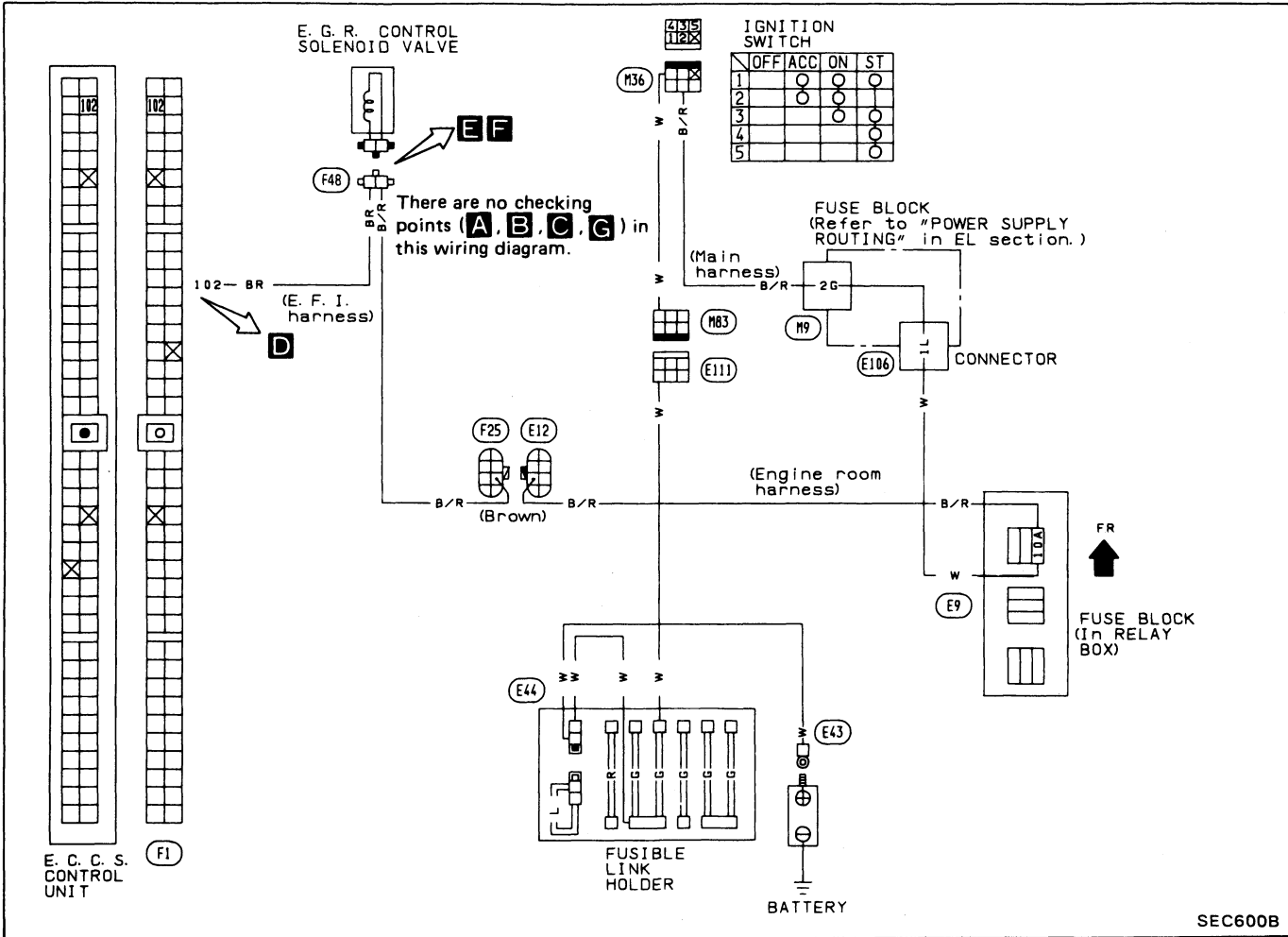

Harness layout

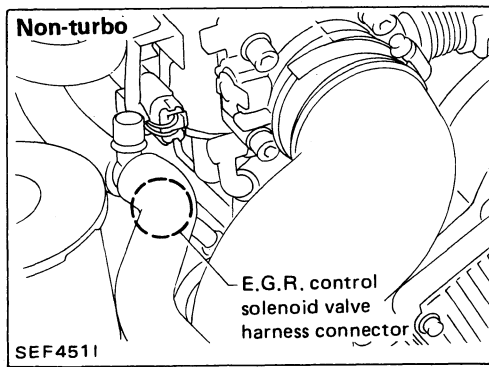
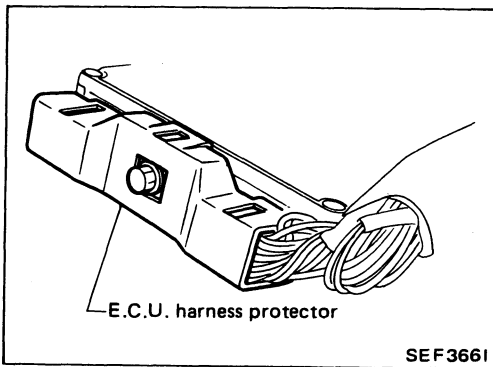

TROUBLE DIAGNOSES

Diagnostic Procedure 29 (Cont'd)

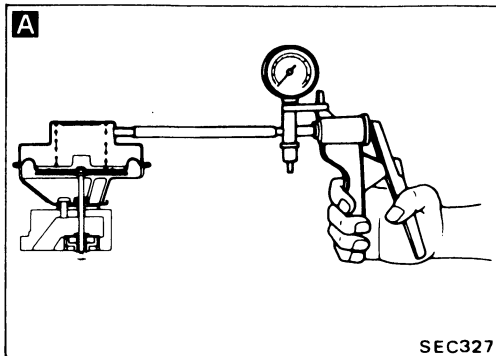

INSPECTION START

A CHECK E.G.R. CONTROL VALVE OPERATION.
Make sure that E.G.R. control valve lifts up when applying vacuum.

N.G. Replace or repair E.G.R. control valve.

O.K.

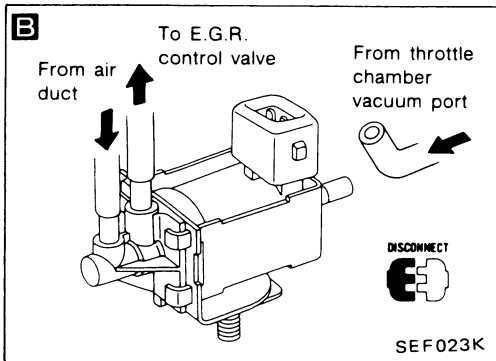

B CHECK VACUUM SOURCE TO E.G.R. CONTROL VALVE.
1) Disconnect vacuum hose connected to E.G.R. control solenoid valve.
2) Make sure vacuum exists when racing engine.

N.G. CHECK THROTTLE CHAMBER VACUUM PORT FOR CLOGGING.

O.K.

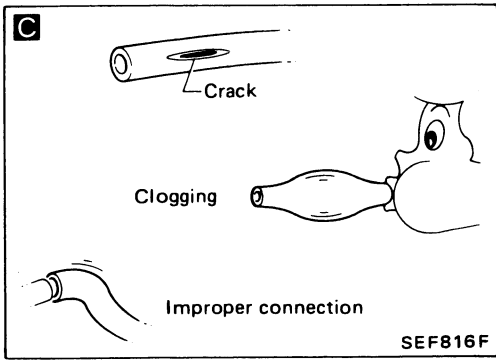

C CHECK VACUUM HOSE.
Check vacuum hose for clogging, cracks or improper connections.

N.G. If necessary, replace vacuum hose or reconnect vacuum hose firmly.

O.K.

D CHECK E.C.U. OUTPUT SIGNAL.
1) Check voltage between E.C.U. terminal (102) and ground under the following conditions:

Engine condition	Voltage
Idle	0.7 - 0.8V
Racing (Less than approx. 3,000 rpm)	Battery voltage

N.G. **E** CHECK POWER SOURCE TO E.G.R. CONTROL SOLENOID VALVE.

1) Stop engine.
2) Turn ignition switch "ON".
3) Check voltage between terminal (b) and ground.
Voltage: Battery voltage

F CHECK GROUND CIRCUIT.

1) Turn ignition switch "OFF".

2) Disconnect E.C.U. harness connector.

3) Disconnect E.G.R. control solenoid valve harness connector.

4) Check resistance between E.C.U. terminal (102) and terminal (b).

Resistance: Approximately 0Ω
If N.G., repair or replace harness.

O.K.

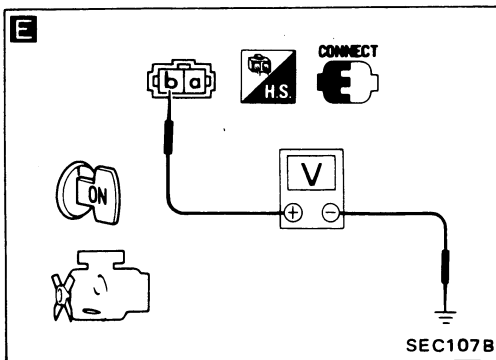
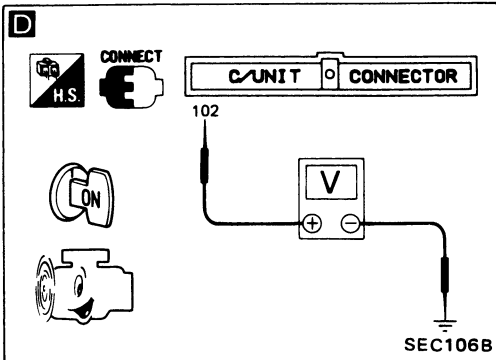

TROUBLE DIAGNOSES

Diagnostic Procedure 29 (Cont'd)

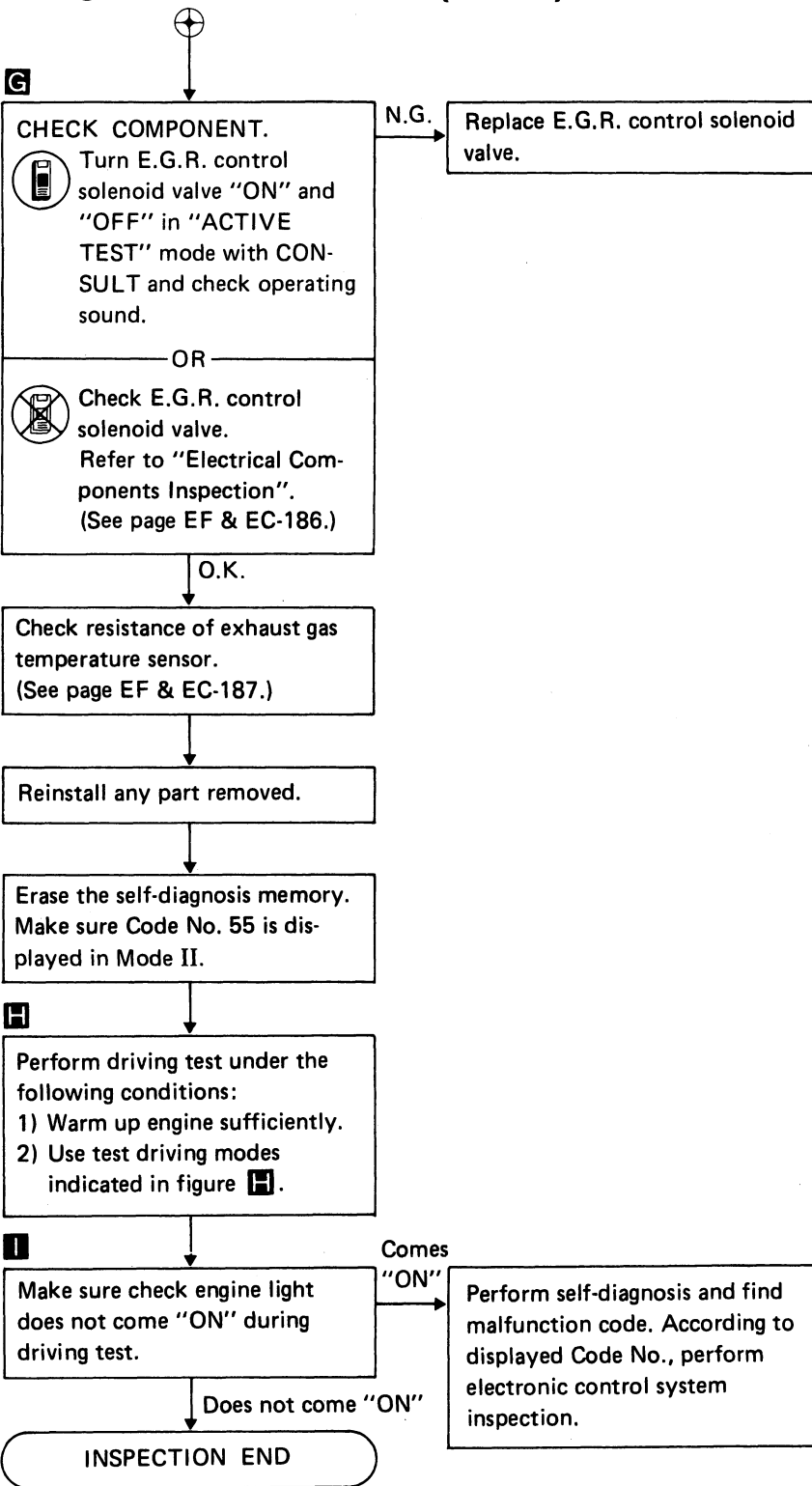
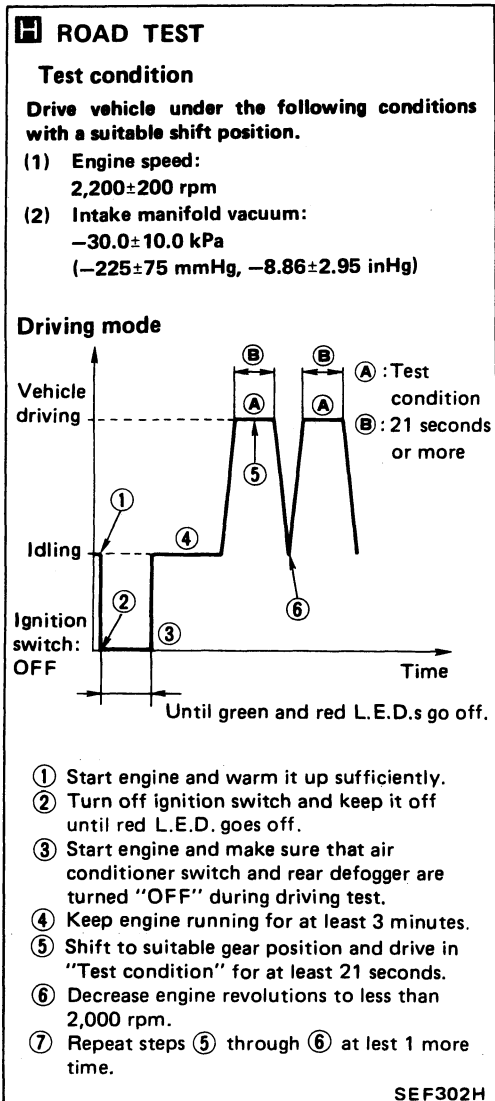
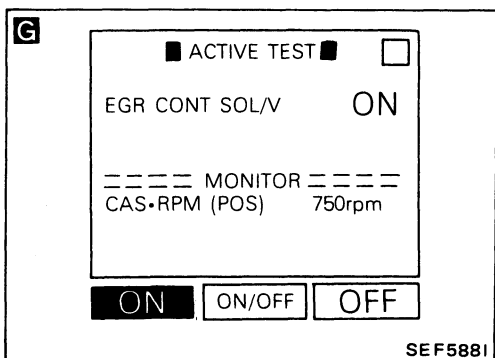
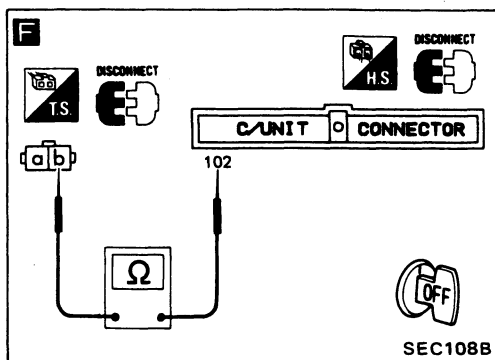

TROUBLE DIAGNOSES

Diagnostic Procedure 29 (Cont'd)

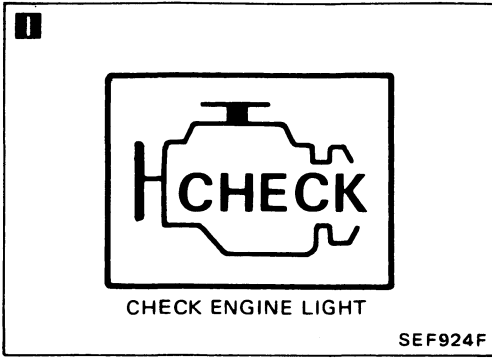

TROUBLE DIAGNOSES

Diagnostic Procedure 30

EXHAUST GAS SENSOR (Code No. 33 and 53)  (CHECK ENGINE LIGHT ITEM)

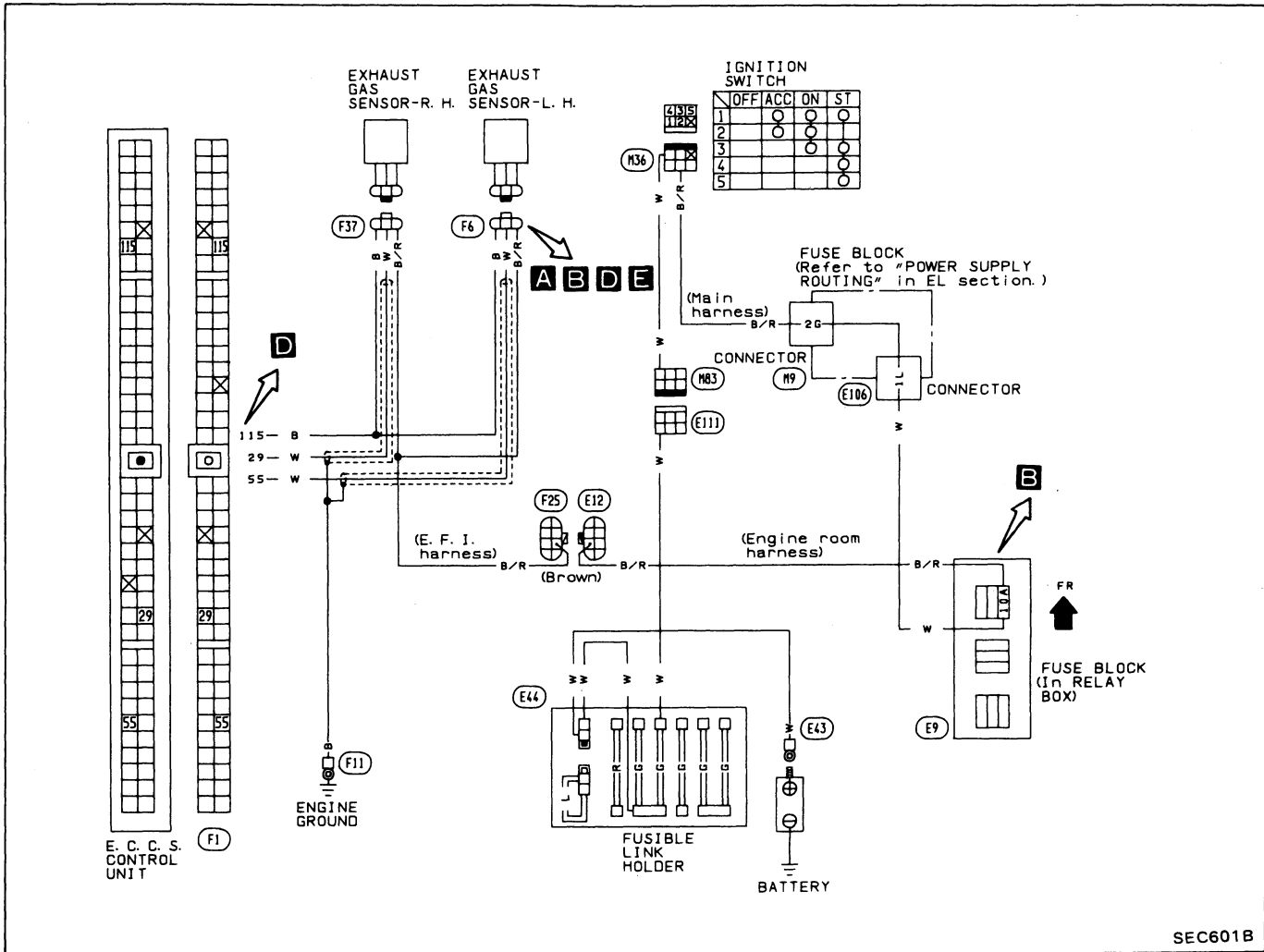

SEC601B

Harness layout

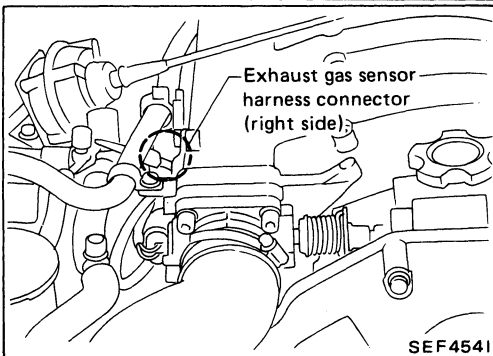
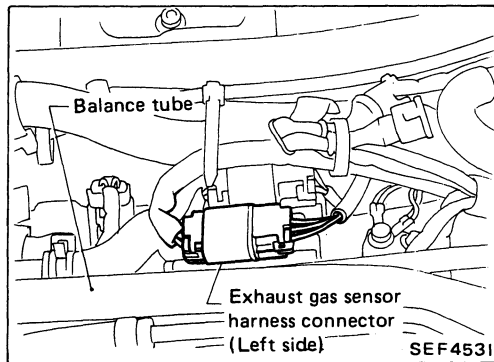
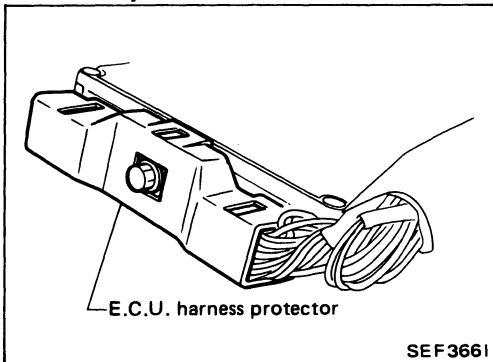

TROUBLE DIAGNOSES

Diagnostic Procedure 30 (Cont'd)

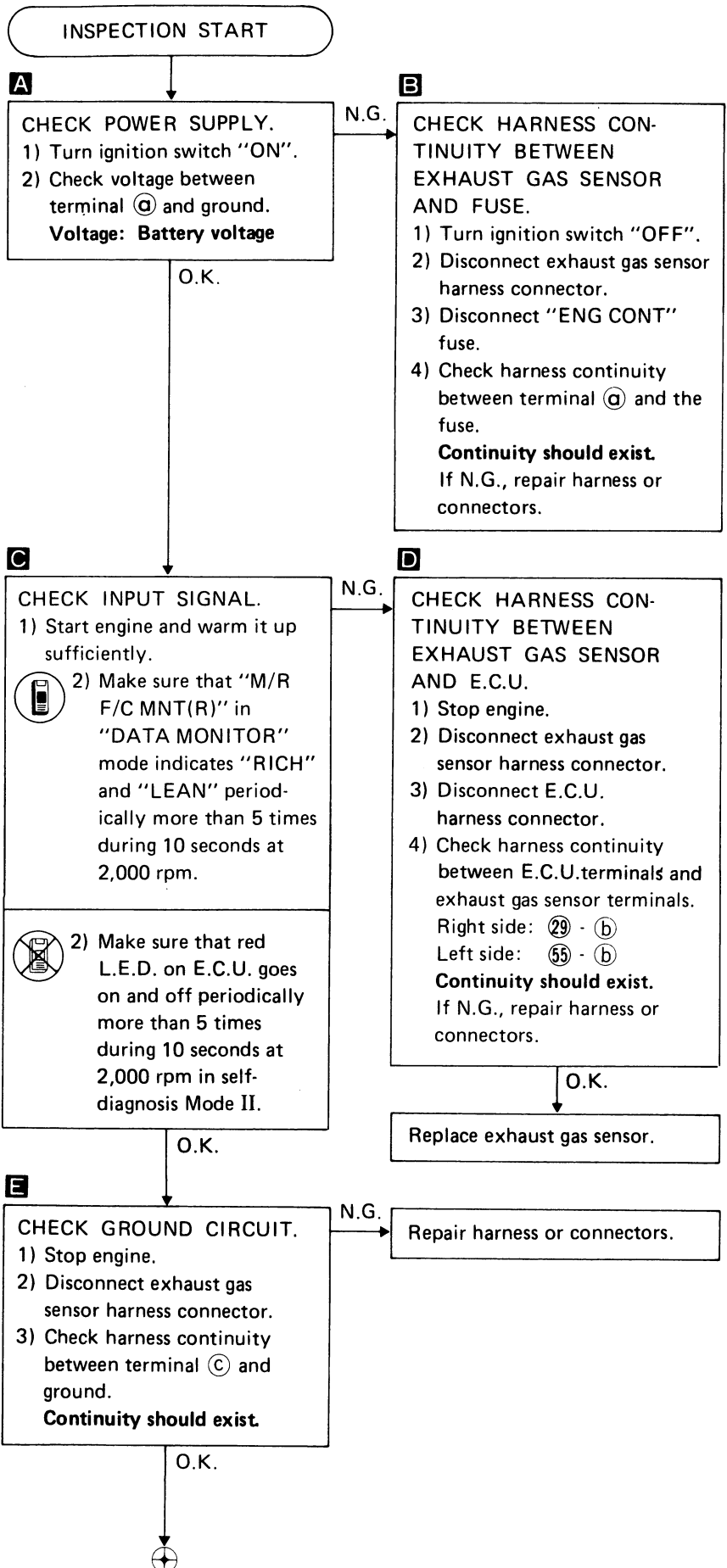
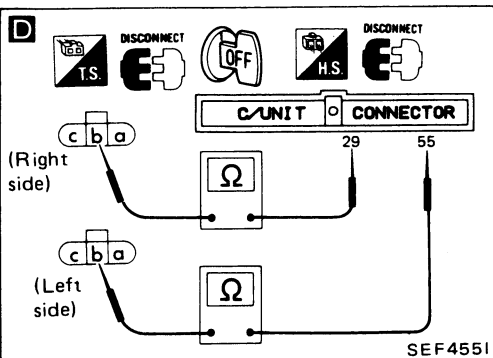
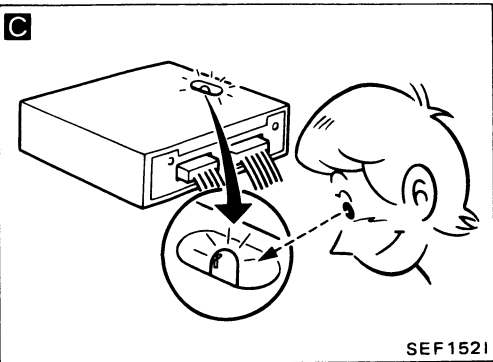
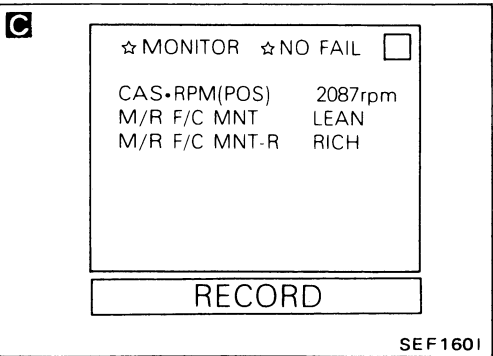
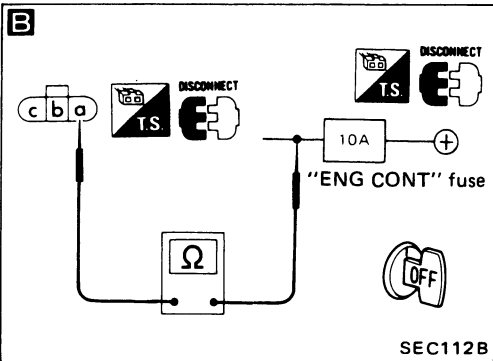
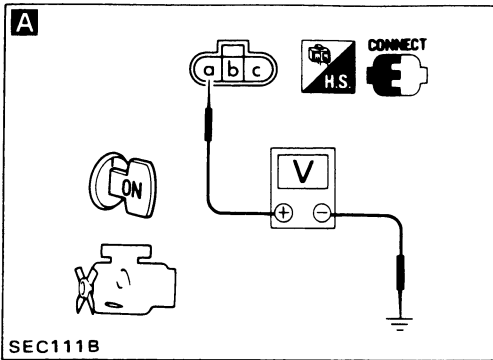

TROUBLE DIAGNOSES

Diagnostic Procedure 30 (Cont'd)

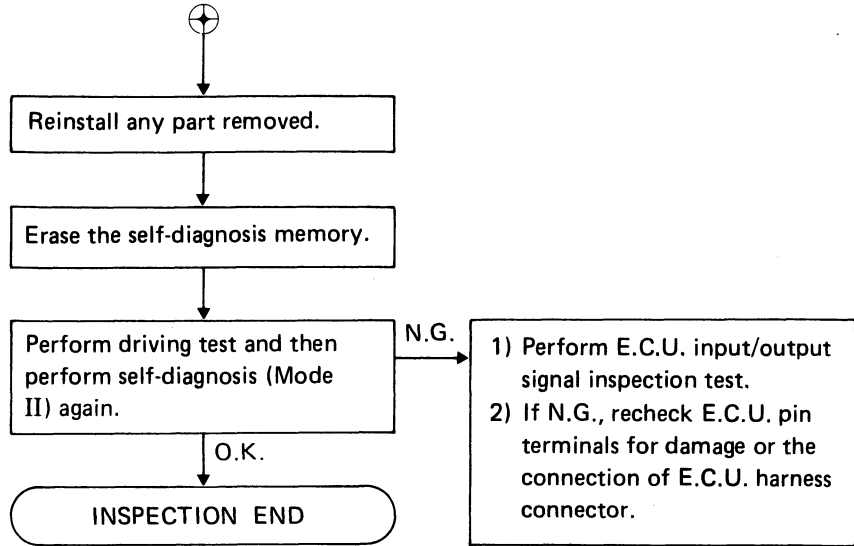
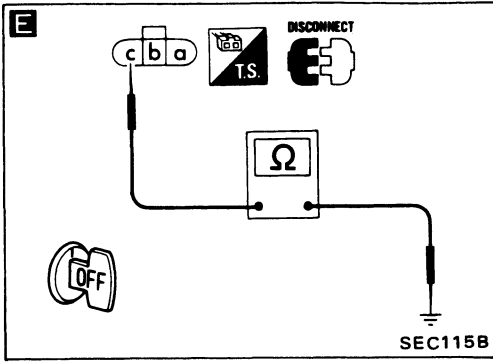

TROUBLE DIAGNOSES

NOTE

TROUBLE DIAGNOSES

Diagnostic Procedure 31

DETONATION SENSOR (Code No. 34)

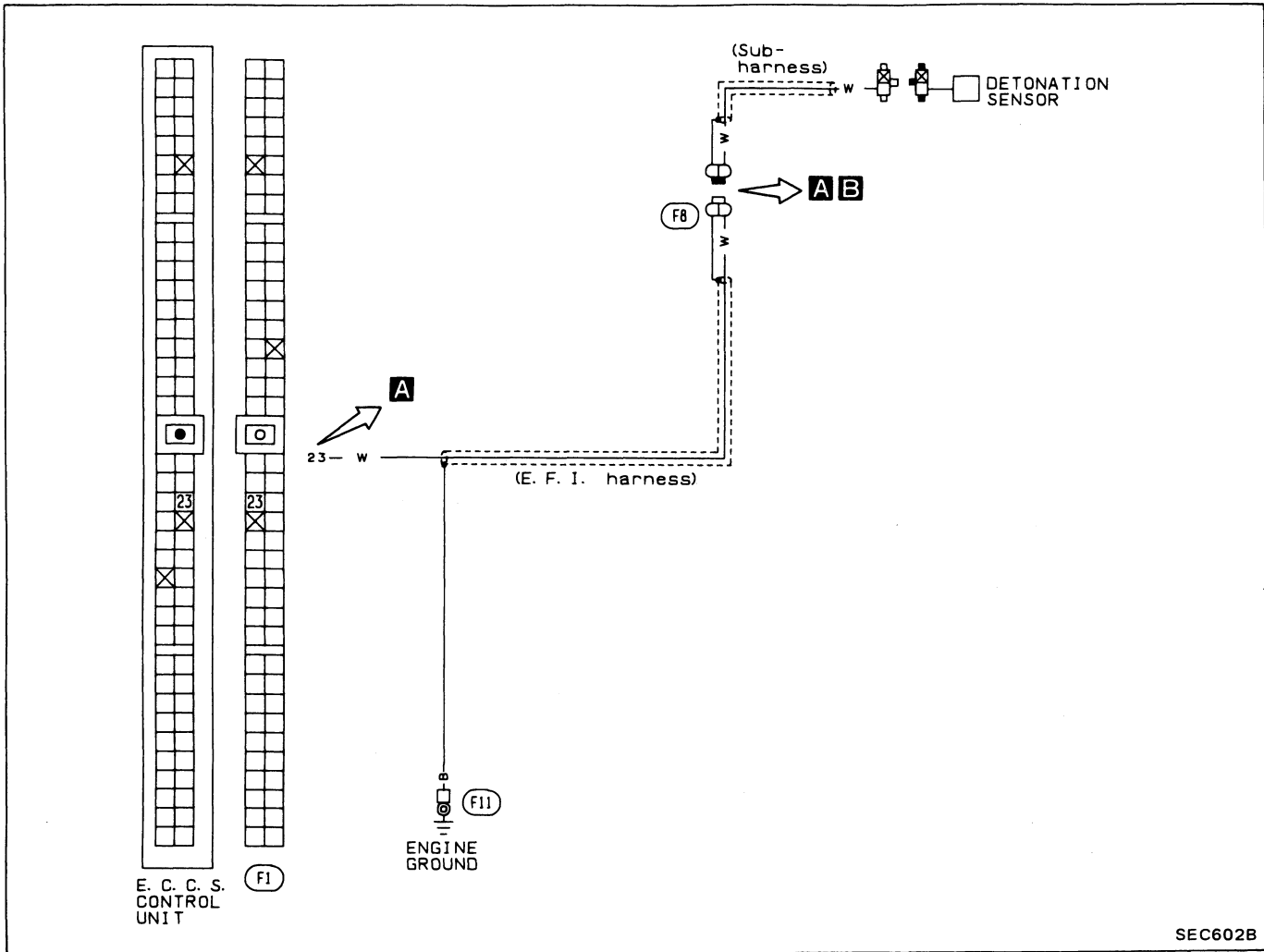

SEC602B

Harness layout

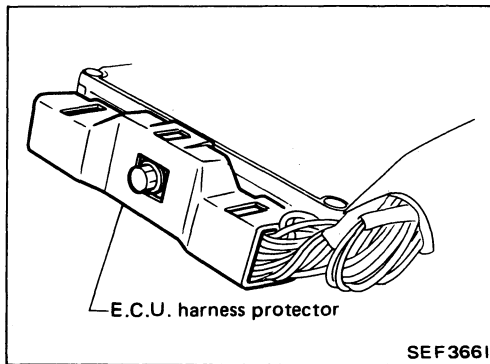
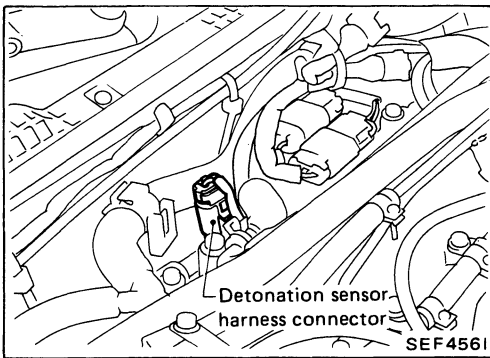

TROUBLE DIAGNOSES

Diagnostic Procedure 31 (Cont'd)

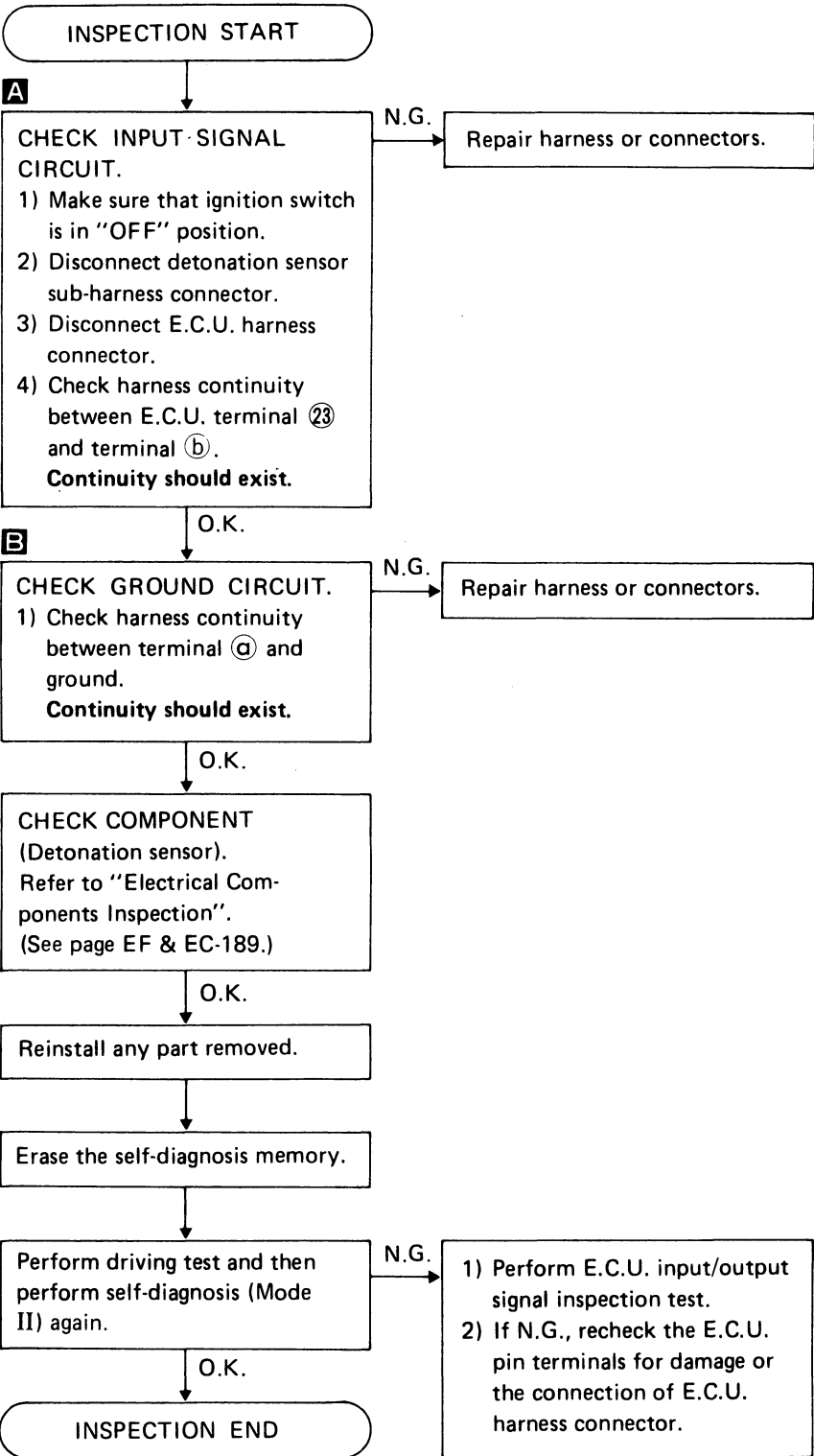
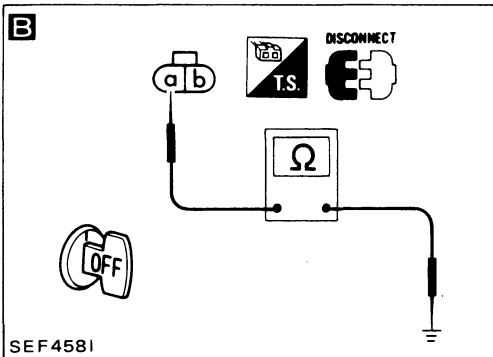
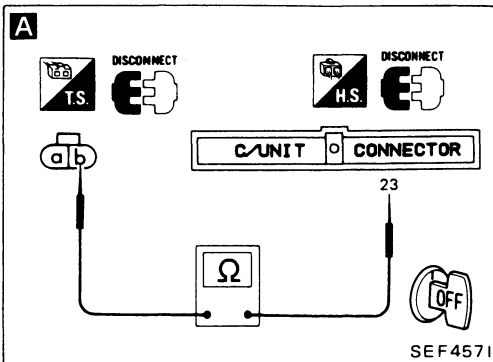

TROUBLE DIAGNOSES

Diagnostic Procedure 32

EXHAUST GAS TEMPERATURE SENSOR (Code No. 35)  (CHECK ENGINE LIGHT ITEM); CALIFORNIA MODEL ONLY

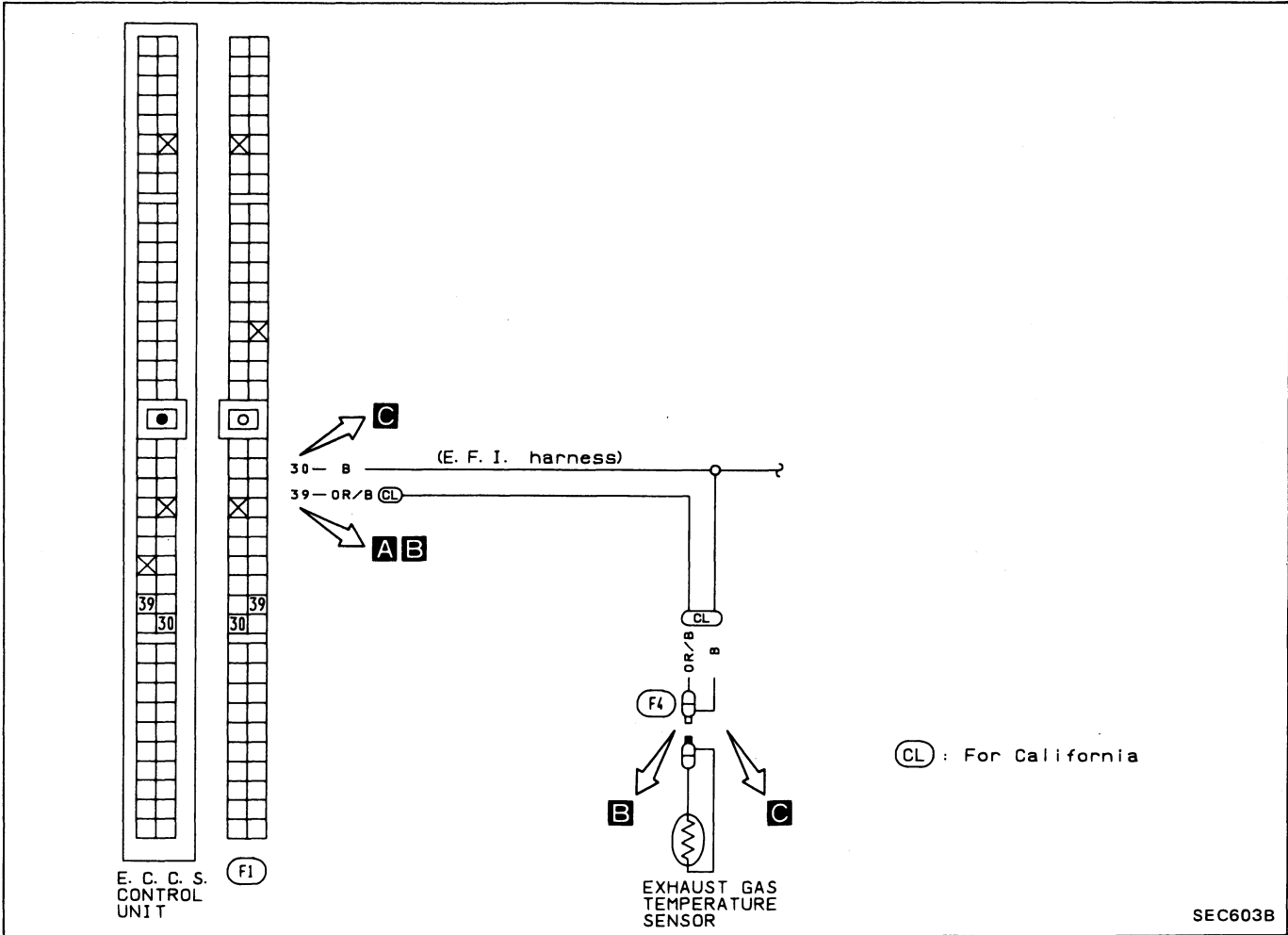

Harness layout

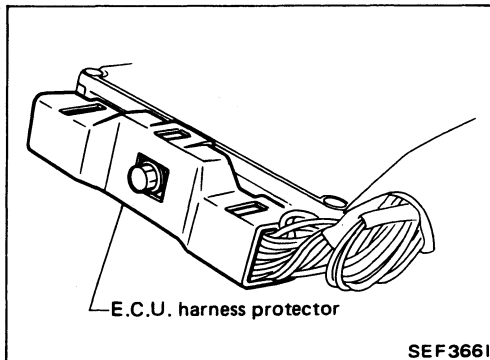
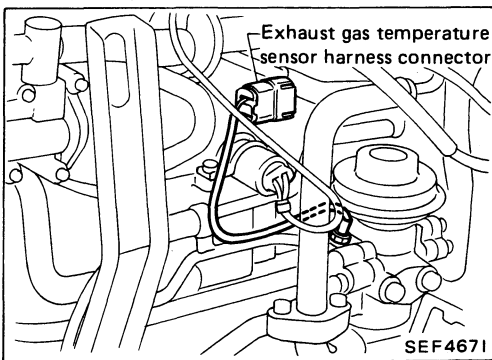

TROUBLE DIAGNOSES

Diagnostic Procedure 32 (Cont'd)

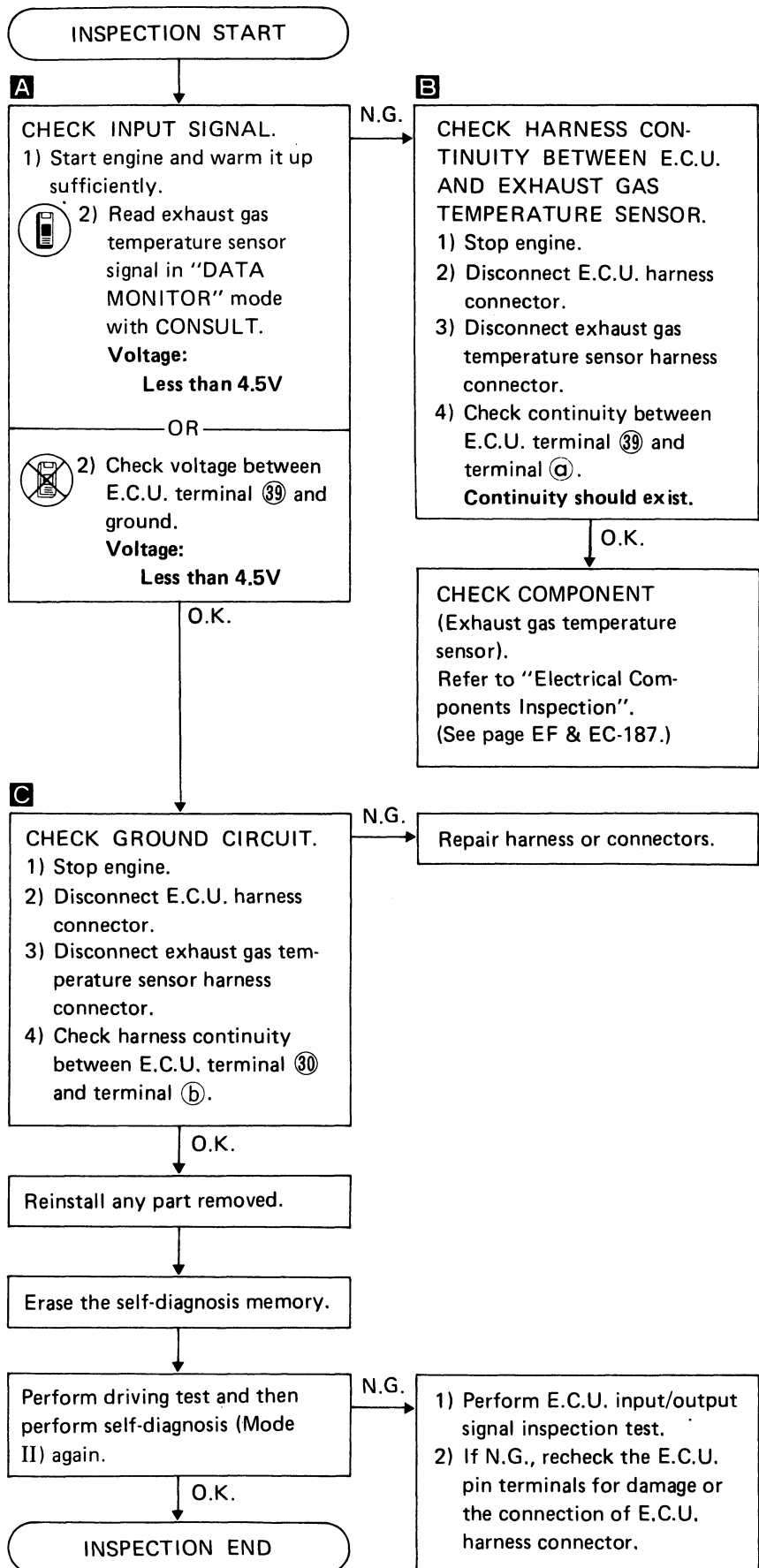
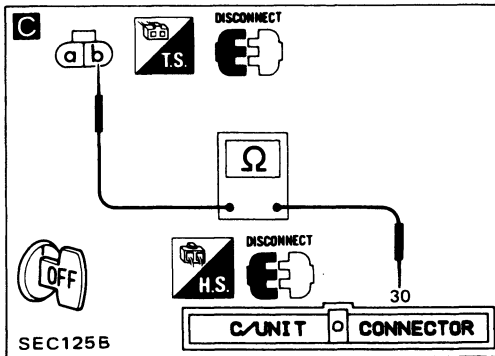
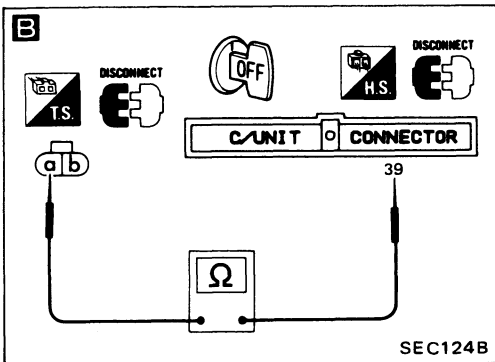
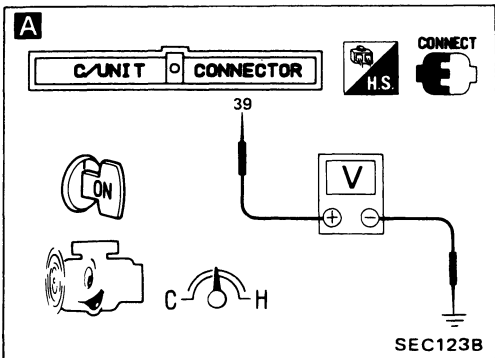
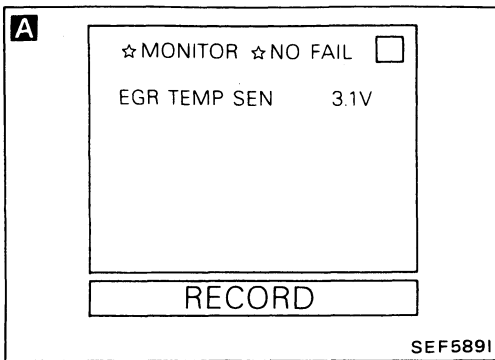

TROUBLE DIAGNOSES

Diagnostic Procedure 33

FUEL TEMPERATURE SENSOR (Code No. 42)

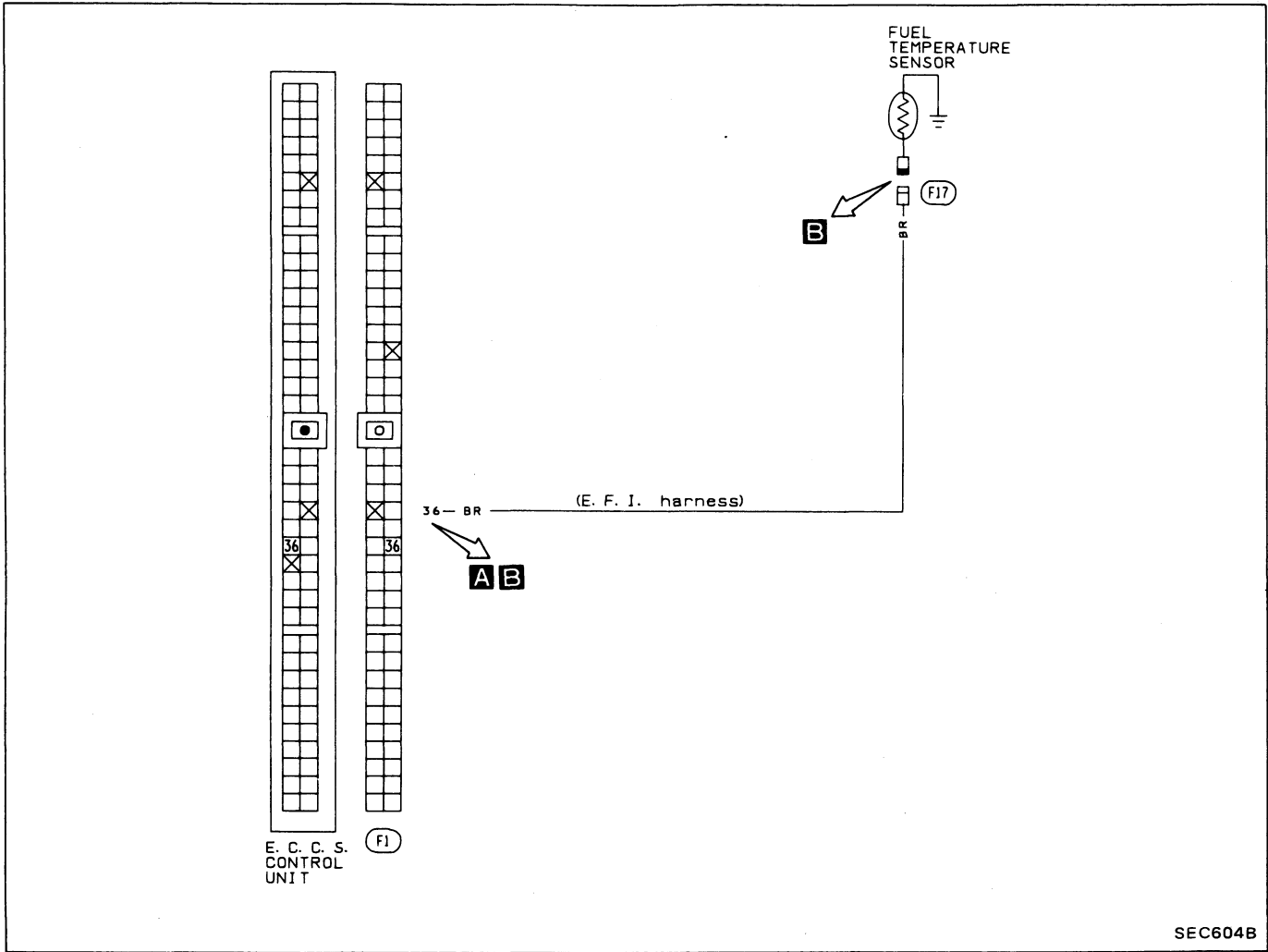

Harness layout

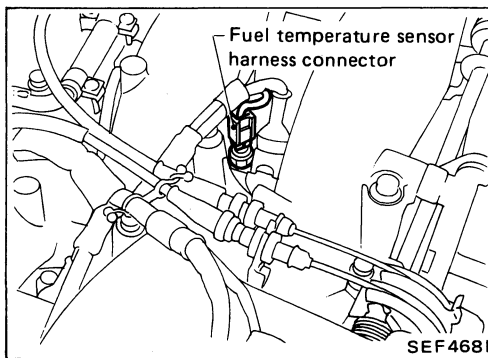
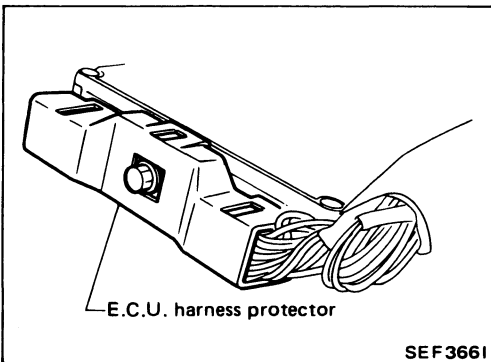

TROUBLE DIAGNOSES

Diagnostic Procedure 33 (Cont'd)

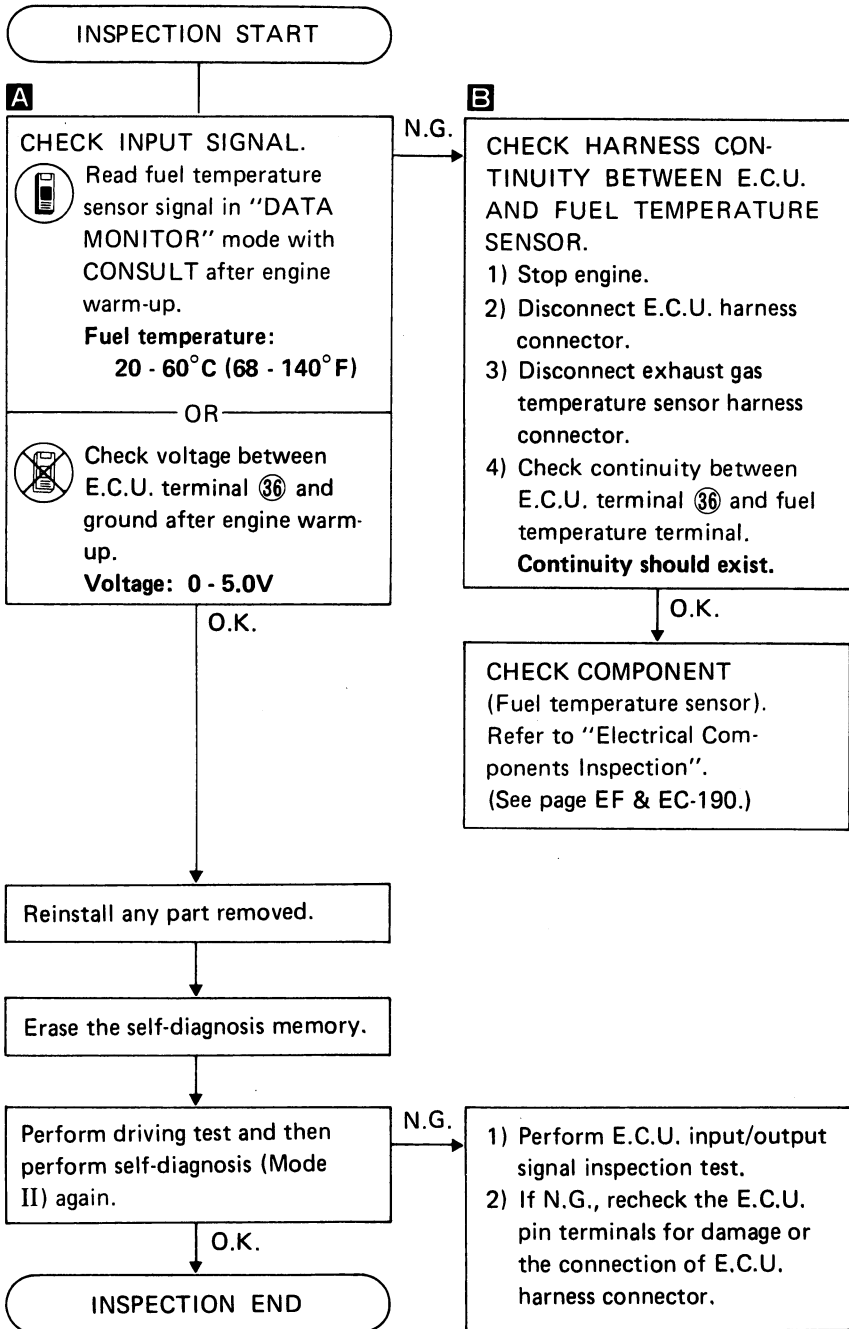
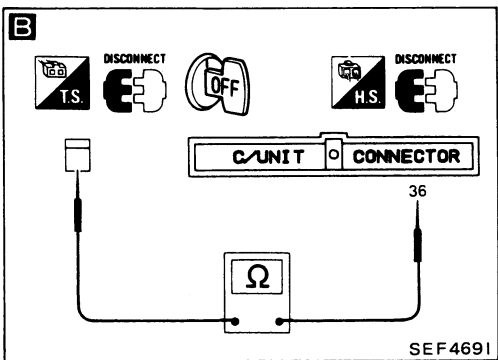
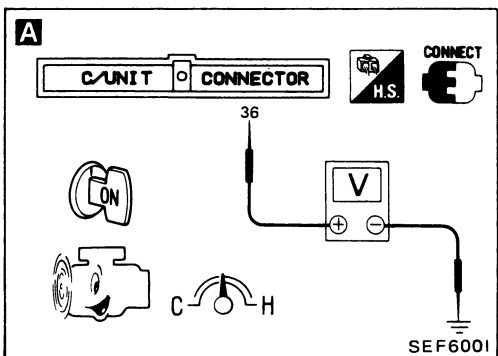
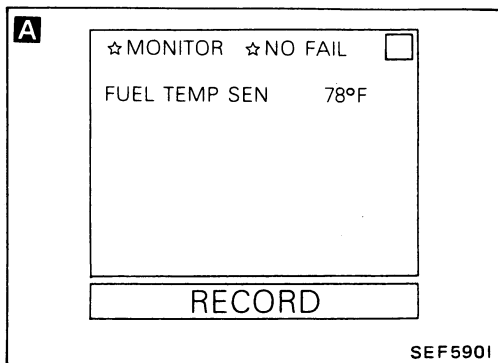

TROUBLE DIAGNOSES

Diagnostic Procedure 34

THROTTLE SENSOR (Code No. 43)  (CHECK ENGINE LIGHT ITEM)

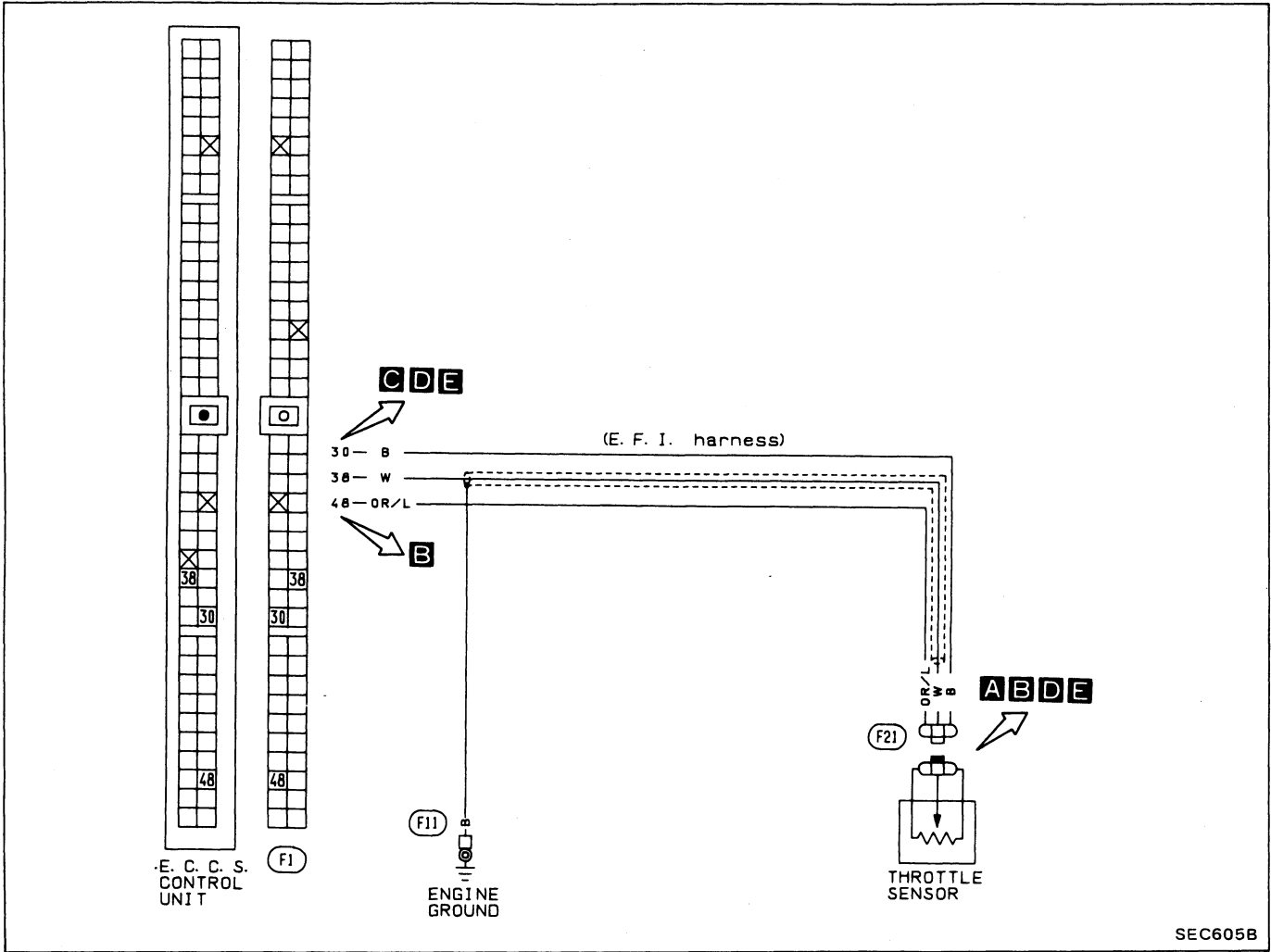

Harness layout

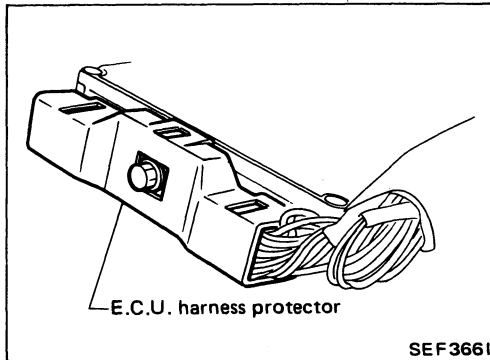
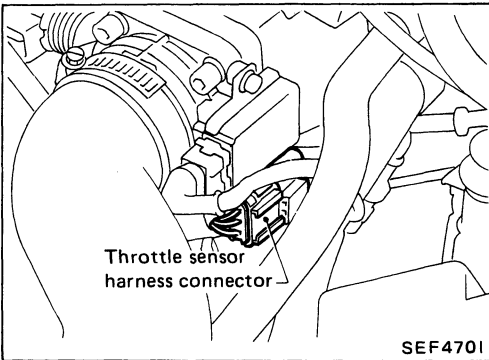

TROUBLE DIAGNOSES

Diagnostic Procedure 34 (Cont'd)

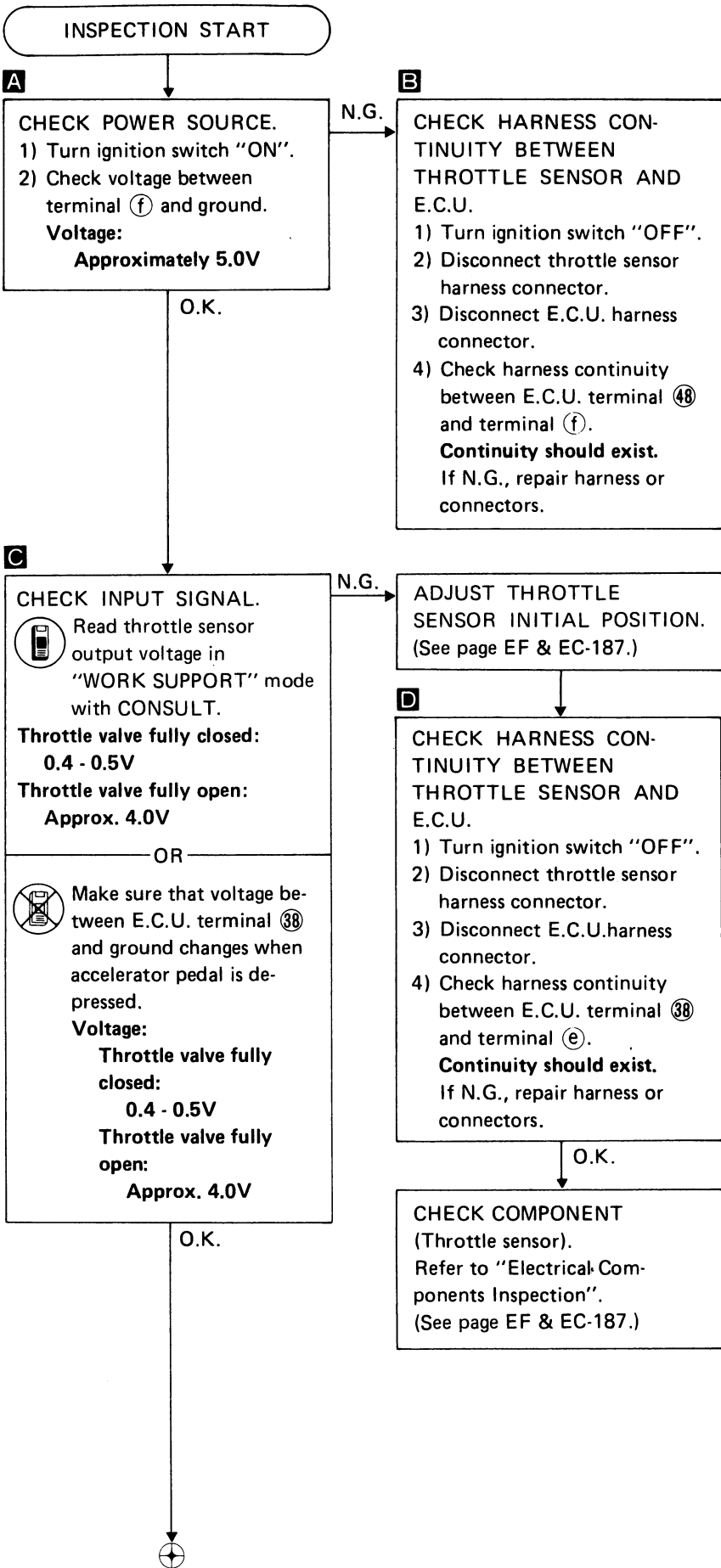
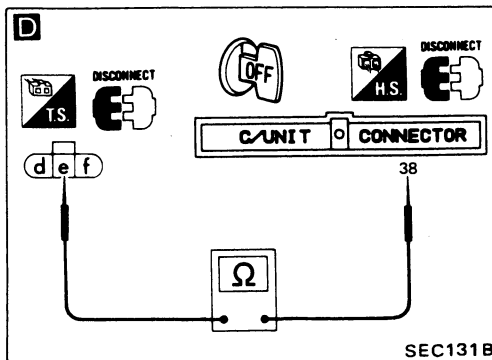
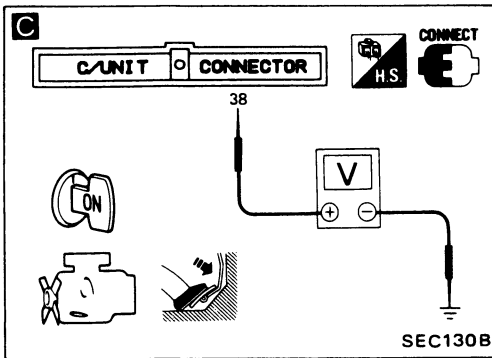
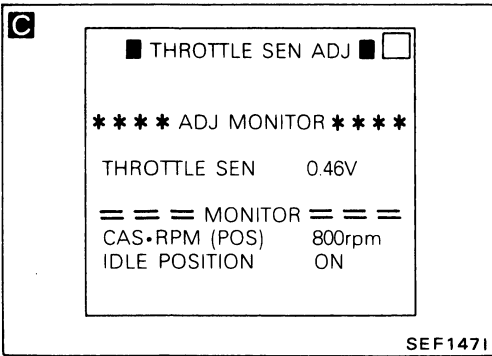
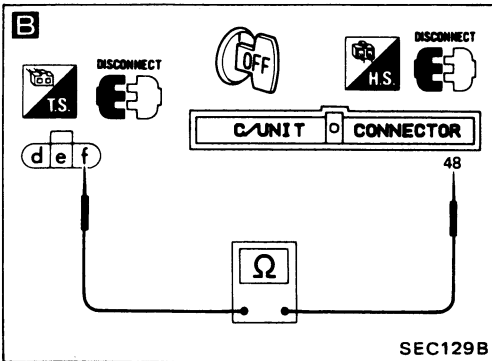
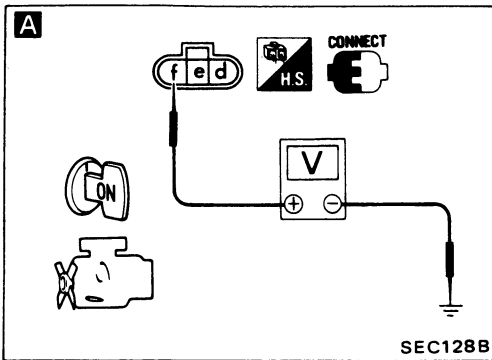

TROUBLE DIAGNOSES

Diagnostic Procedure 34 (Cont'd)

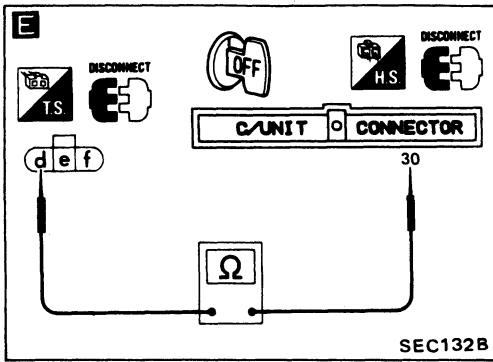

CHECK GROUND CIRCUIT.

- 1) Turn ignition switch "OFF".
 - 2) Disconnect E.C.U. harness connector.
 - 3) Disconnect throttle sensor harness connector.
 - 4) Check resistance between E.C.U. terminal ③⑩ and terminal ①.
- Continuity should exist.**

N.G.

- 1) Check harness continuity between throttle sensor and ground.
- 2) E.C.U. ground circuit.

O.K.

Reinstall any part removed.

Erase the self-diagnosis memory.

Perform driving test and then perform self-diagnosis (Mode II) again.

N.G.

- 1) Perform E.C.U. input/output signal inspection test.
- 2) If N.G., recheck the E.C.U. pin terminals damage or the connection of E.C.U. harness connector.

O.K.

INSPECTION END

TROUBLE DIAGNOSES

NOTE

TROUBLE DIAGNOSES

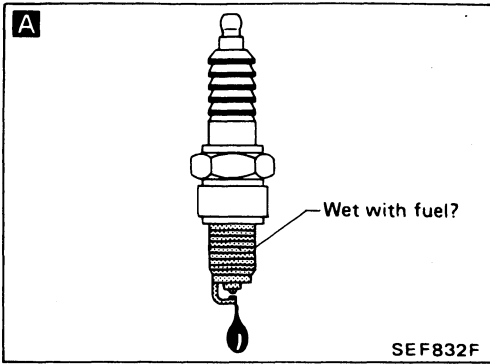

Diagnostic Procedure 35

INJECTOR LEAK (Code No. 45)  (CHECK ENGINE LIGHT ITEM); CALIFORNIA MODEL ONLY

B ROAD TEST

Test condition
 Drive vehicle under the following conditions with a suitable shift position.
 (1) Engine speed: $2,200 \pm 200$ rpm
 (2) Intake manifold vacuum: -38.7 ± 9.3 kPa (-290 ± 70 mmHg, -11.42 ± 2.76 inHg)

Driving mode

A : 40 seconds or more
 B : 5 seconds or more
 C : 10 seconds or more

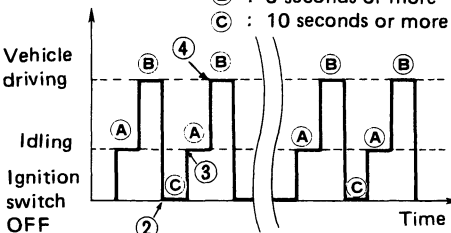

- ① Start engine and warm it up sufficiently.
- ② Turn ignition switch OFF and wait for at least 10 seconds.
- ③ Start engine and keep it at idle speed for at least 40 seconds.
- ④ Shift to a suitable gear position and drive in "Test condition" for at least 5 seconds.
- ⑤ Repeat steps ② through ④ at least 5 times.

SEF5831

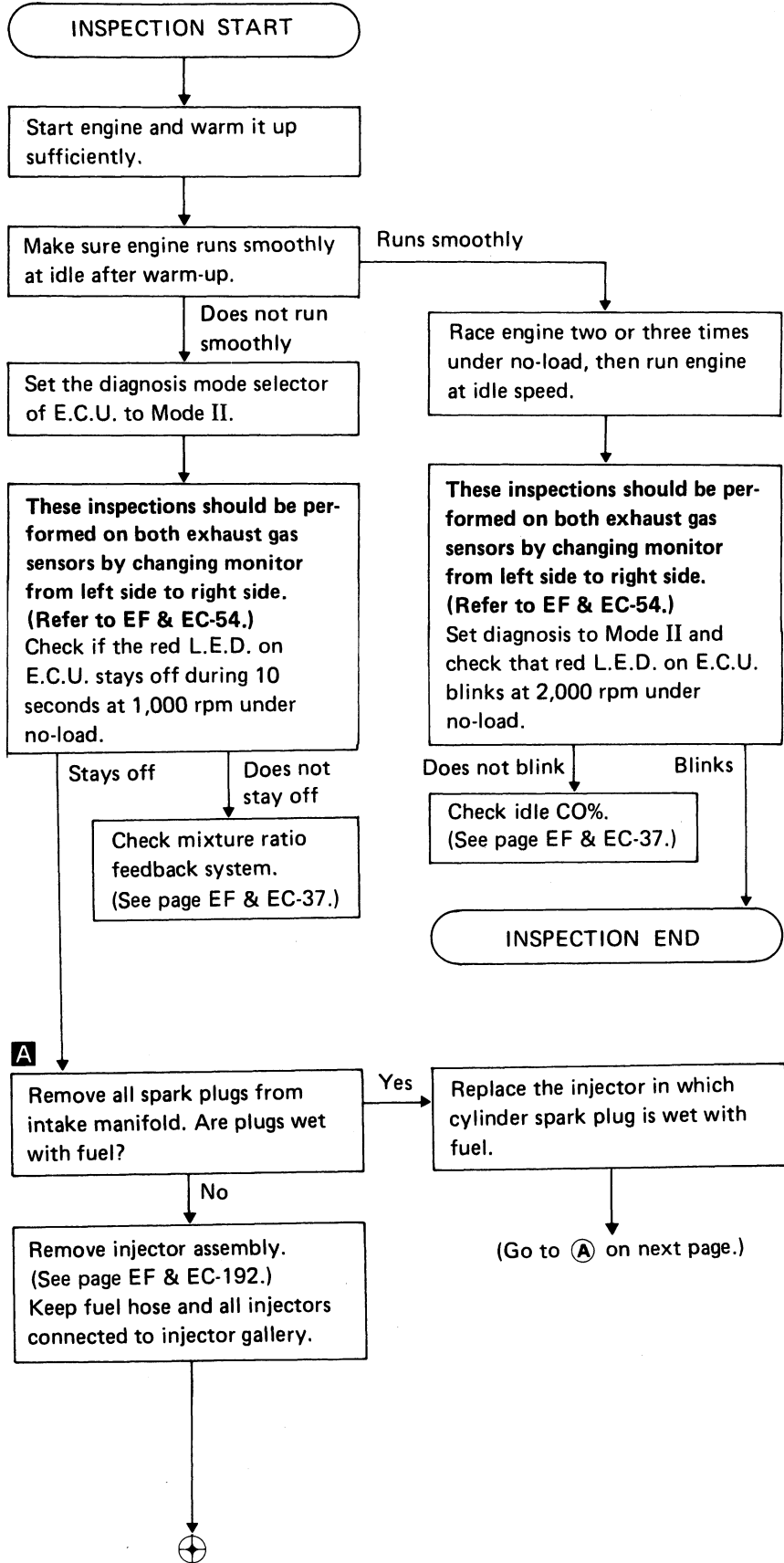
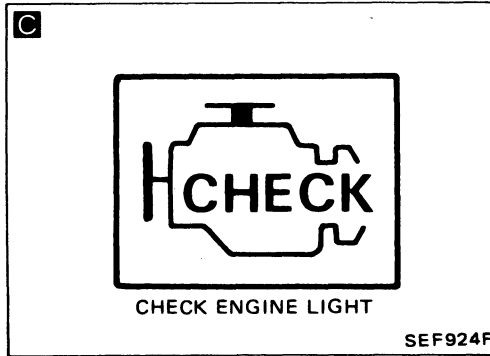

TROUBLE DIAGNOSES

Diagnostic Procedure 35 (Cont'd)

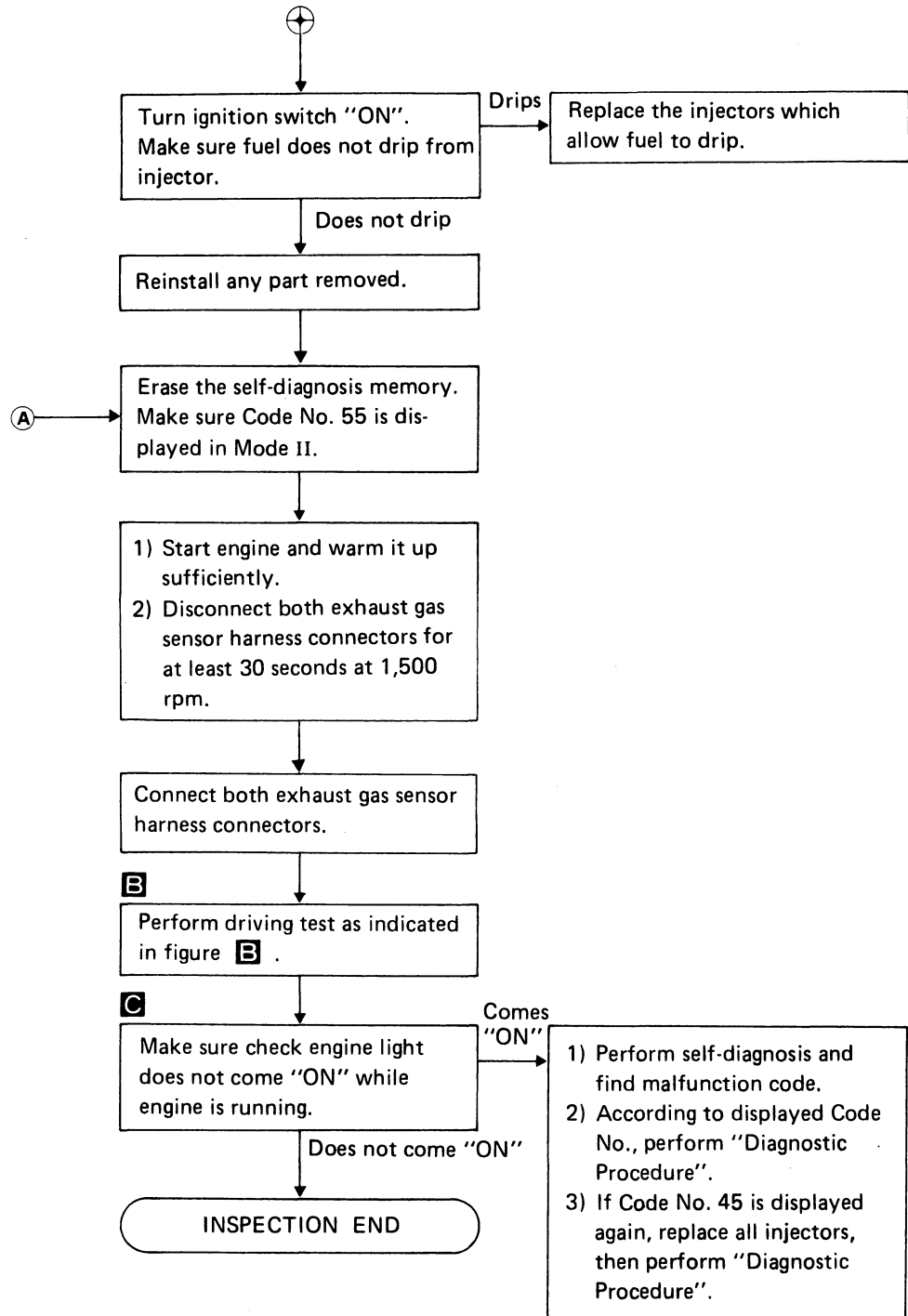

TROUBLE DIAGNOSES

Diagnostic Procedure 36

INJECTOR CIRCUIT (Code No. 51)  (CHECK ENGINE LIGHT ITEM): For California model
(Not self-diagnostic item): For Non-California model

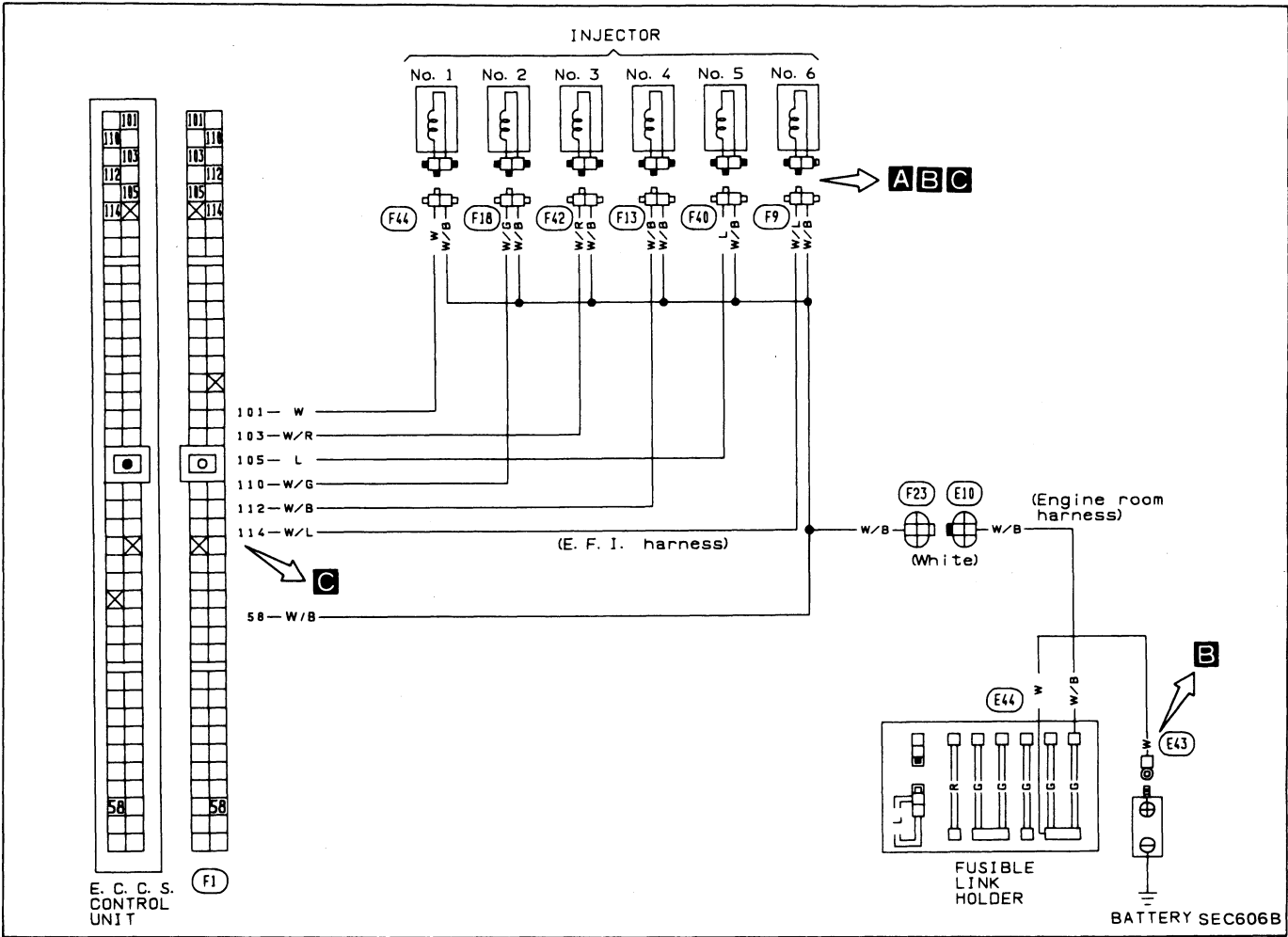

Harness layout

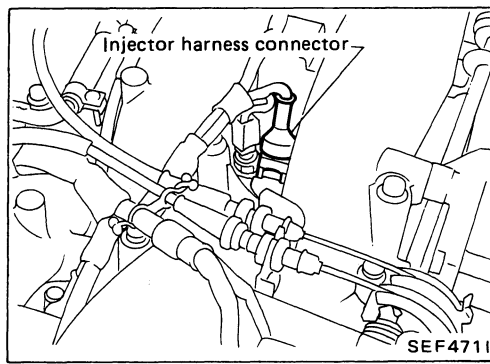
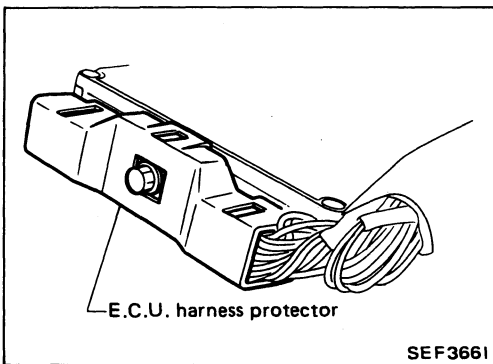

TROUBLE DIAGNOSES

Diagnostic Procedure 36 (Cont'd)

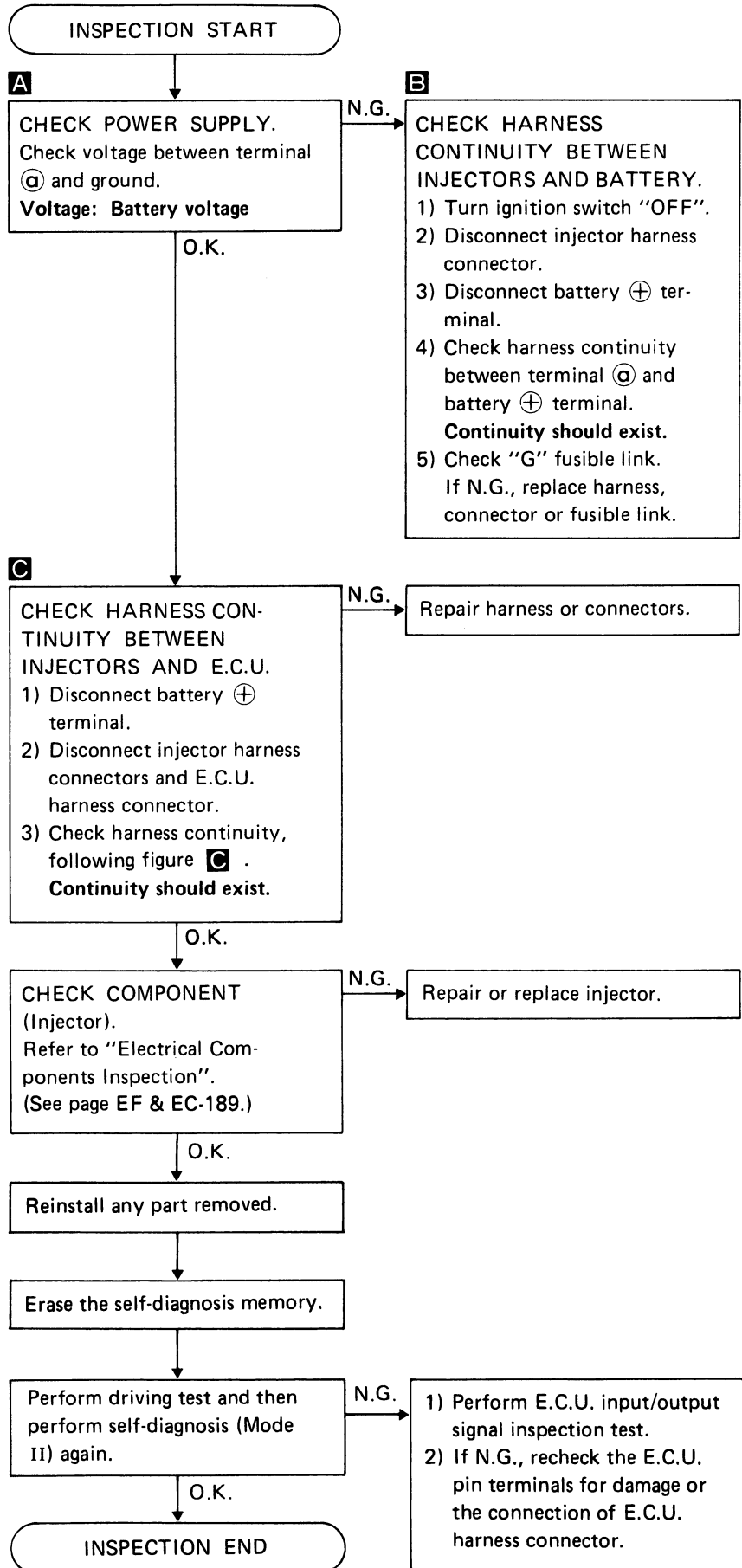
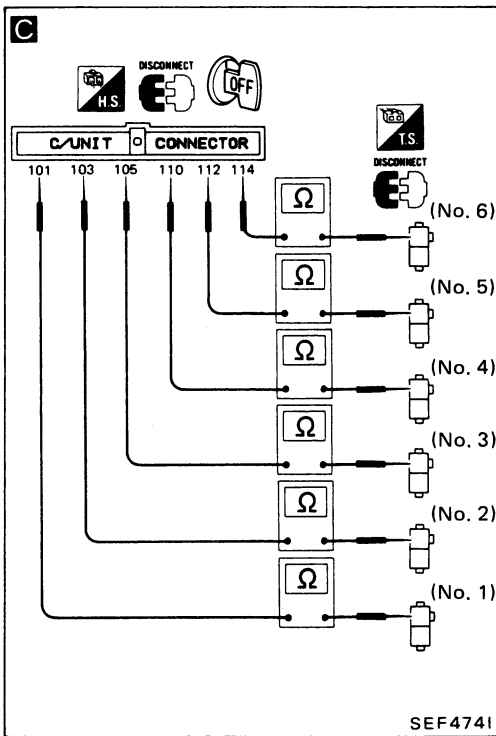
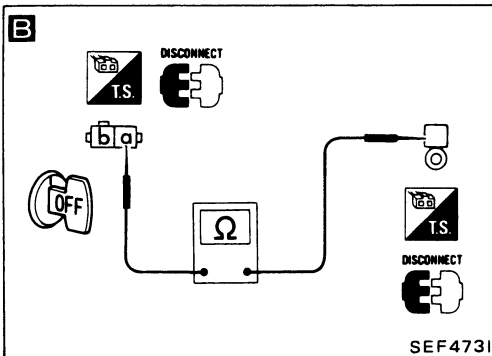
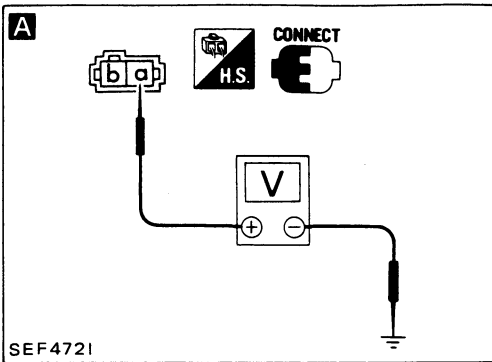

TROUBLE DIAGNOSES

Diagnostic Procedure 37

THROTTLE VALVE SWITCH (Idle position) (Not self-diagnostic item)

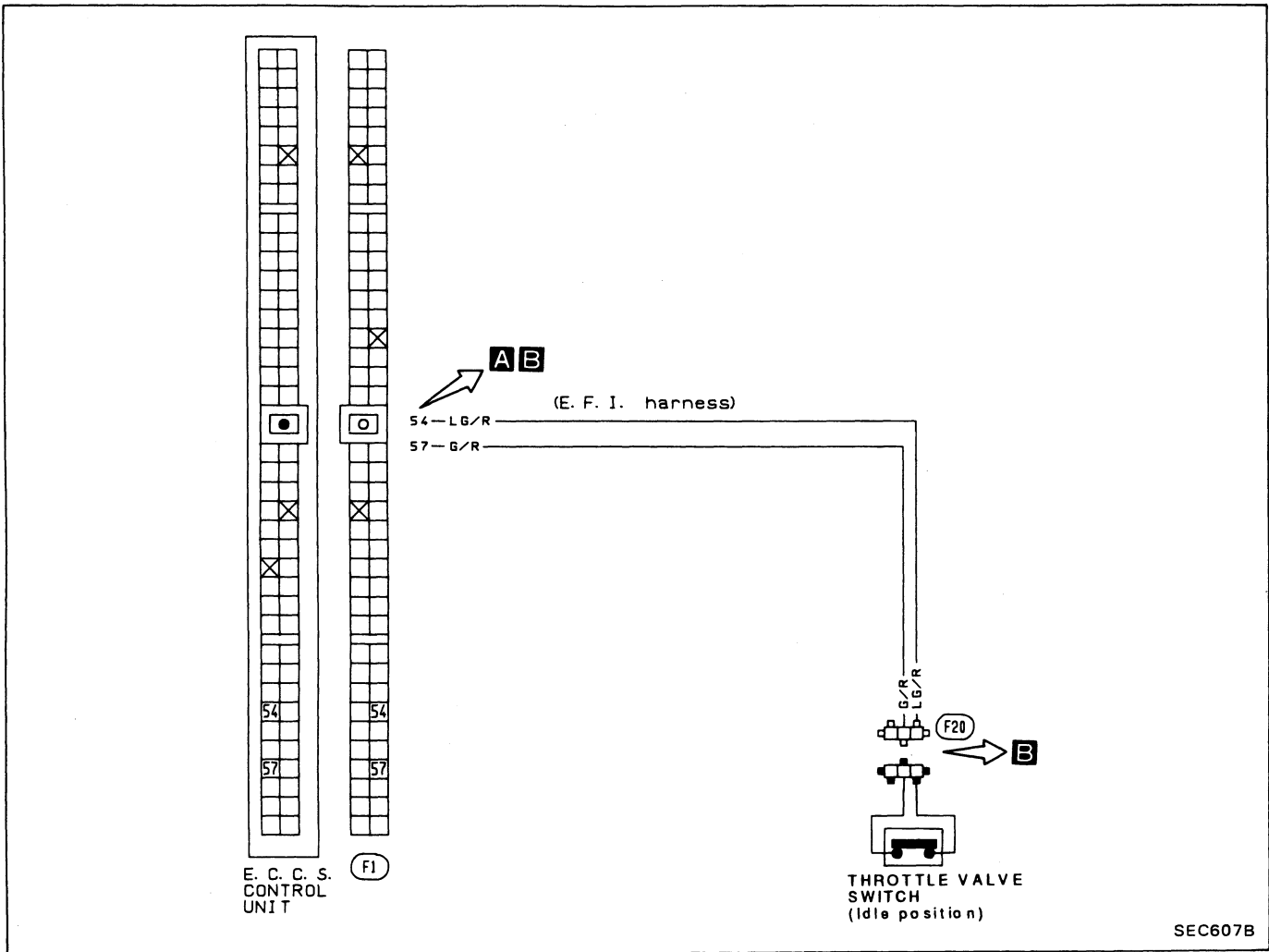

Harness layout

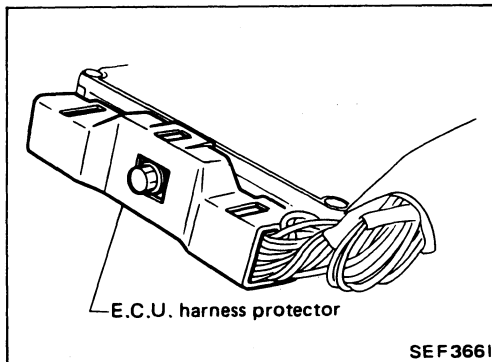
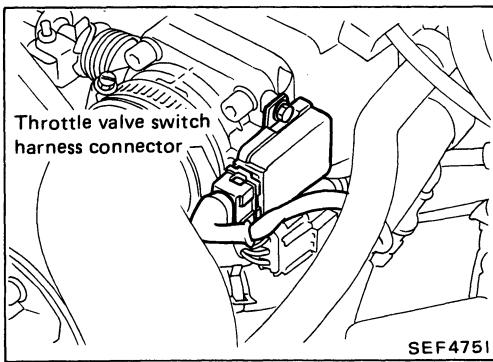

TROUBLE DIAGNOSES

Diagnostic Procedure 37 (Cont'd)

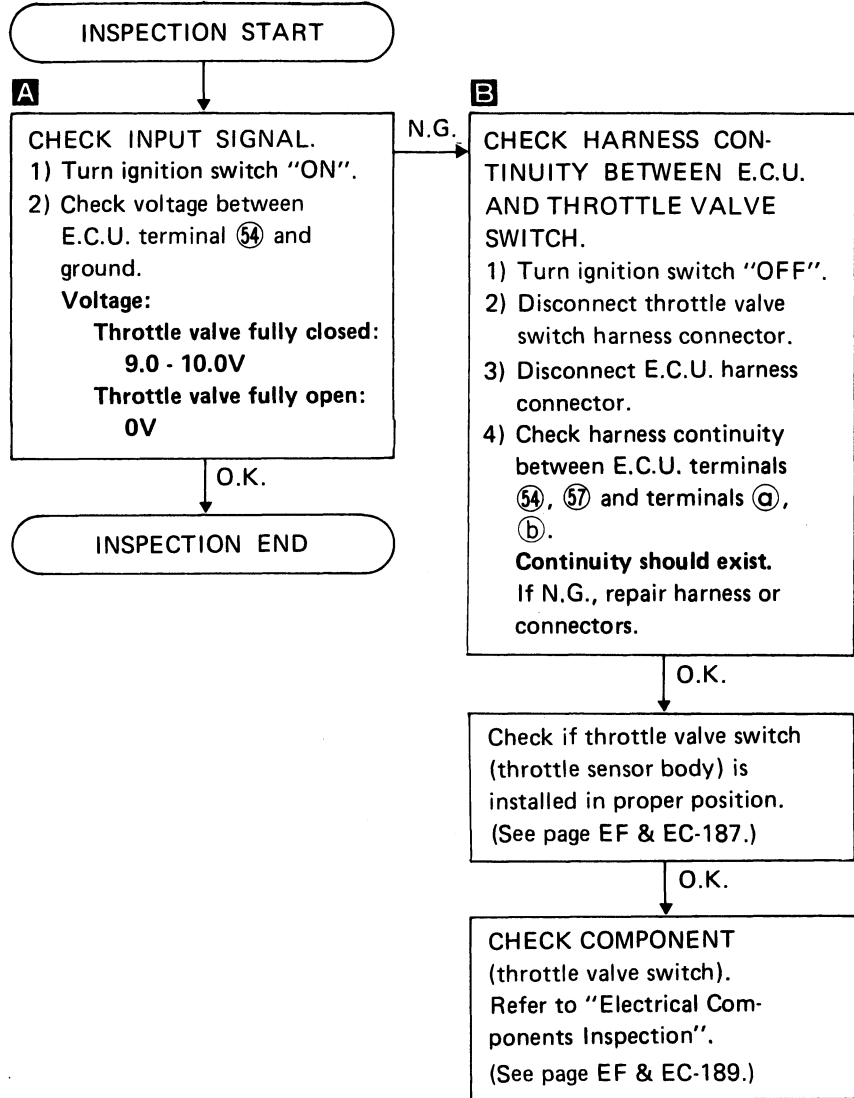
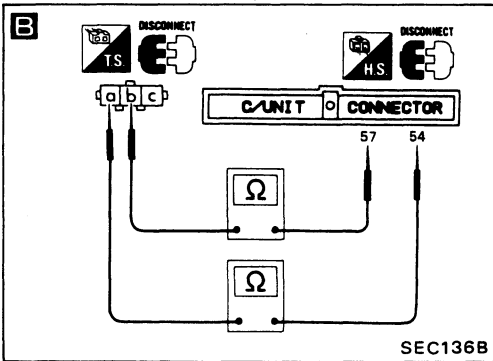
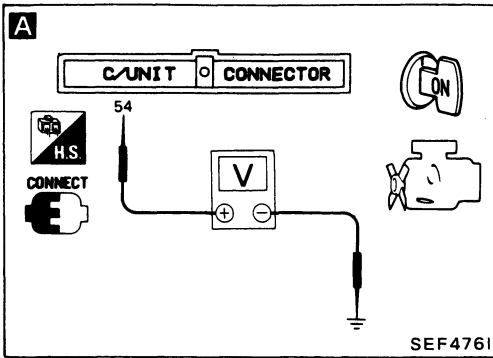

TROUBLE DIAGNOSES

Diagnostic Procedure 38

START SIGNAL (Not self-diagnostic item)

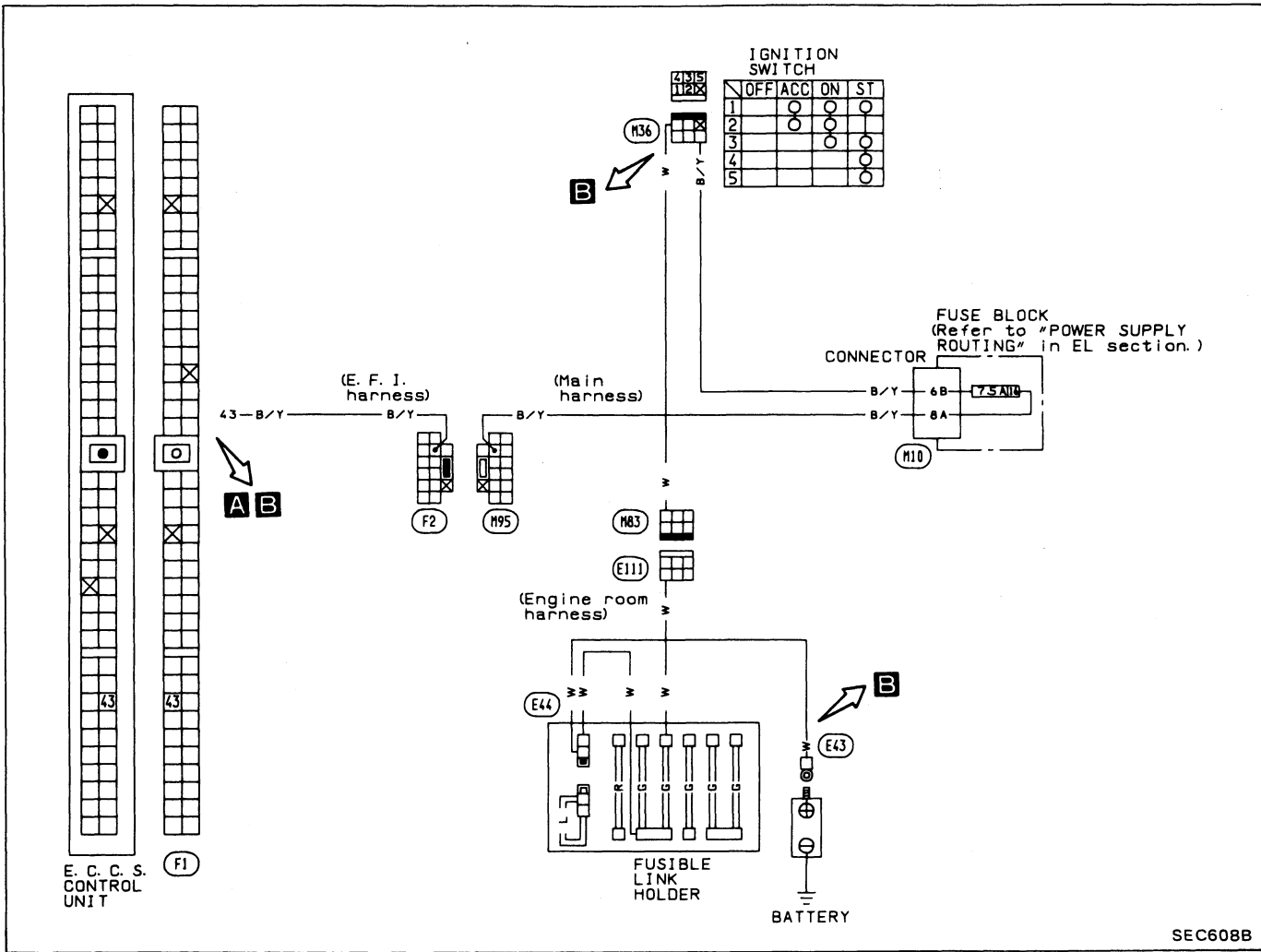

SEC608B

Harness layout

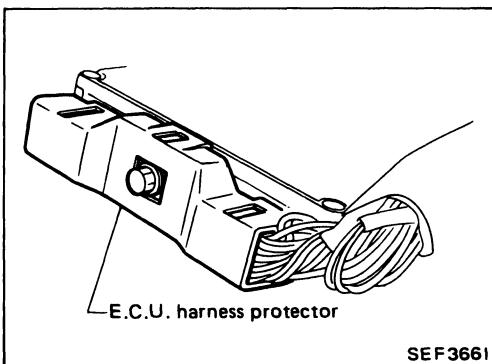

TROUBLE DIAGNOSES

Diagnostic Procedure 38 (Cont'd)

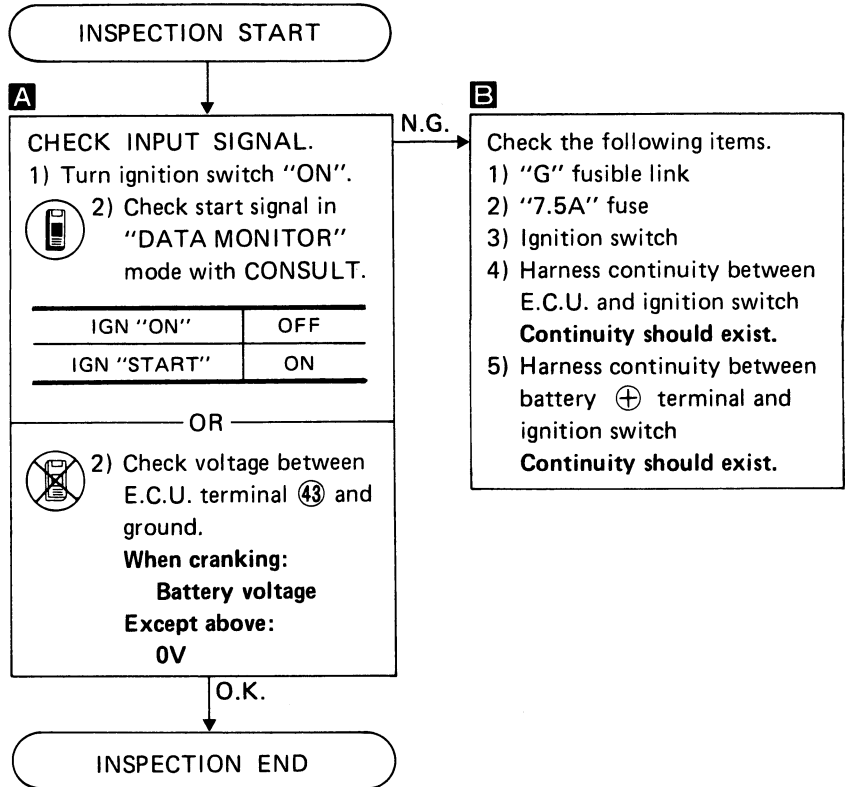
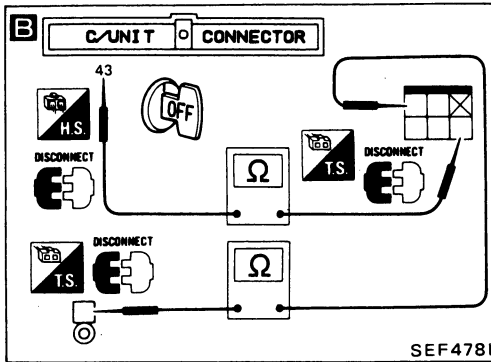
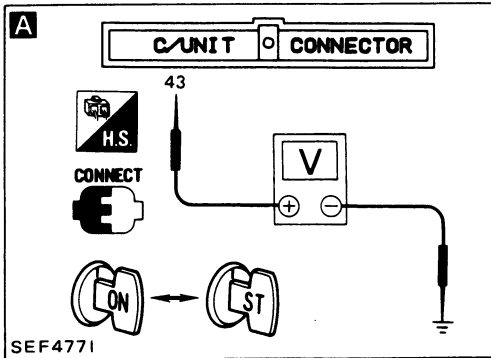
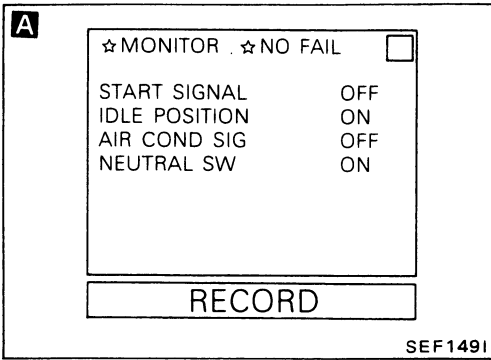

TROUBLE DIAGNOSES

Diagnostic Procedure 39

POWER STEERING OIL PRESSURE SWITCH (Not self-diagnostic item)

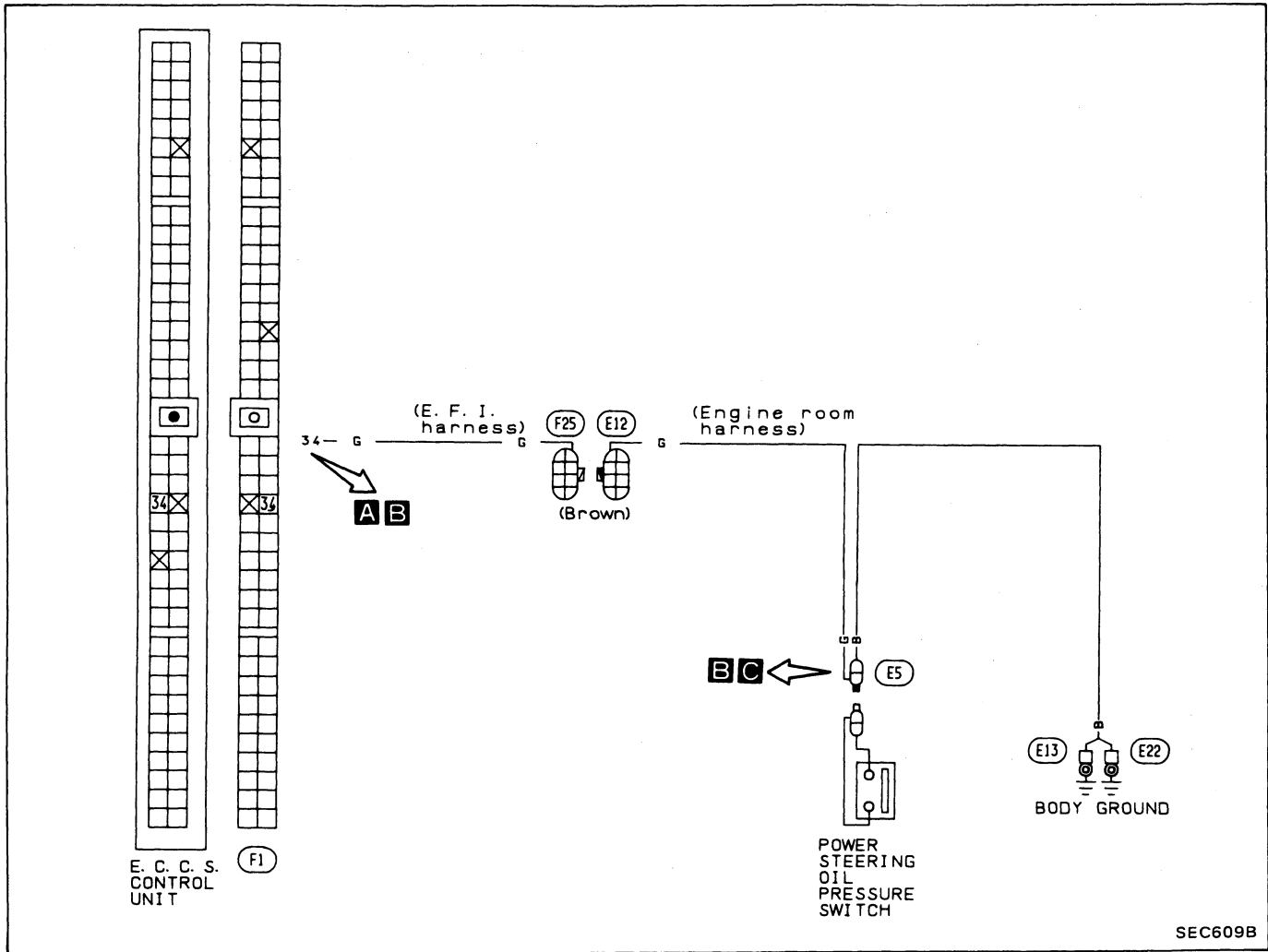

Harness layout

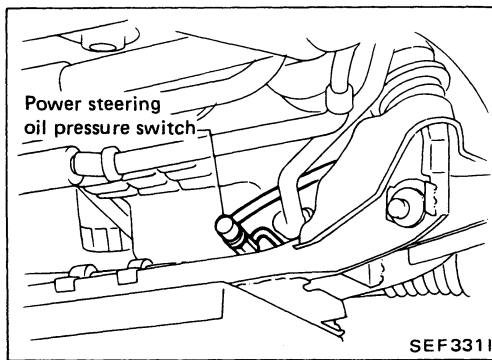
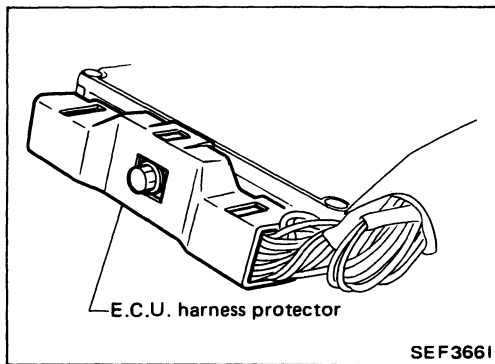

TROUBLE DIAGNOSES

Diagnostic Procedure 39 (Cont'd)

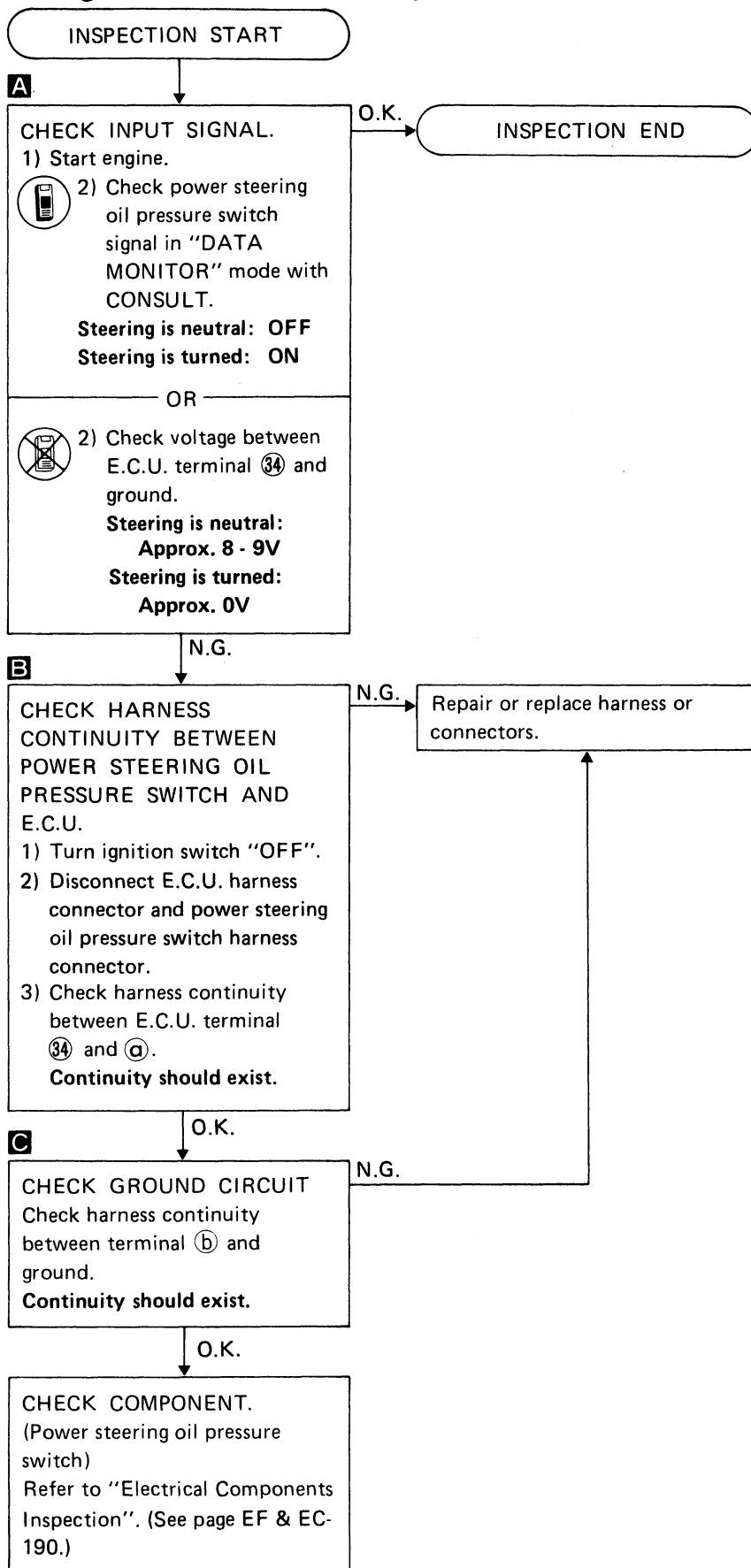
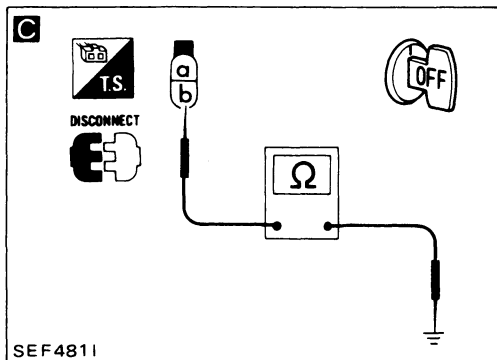
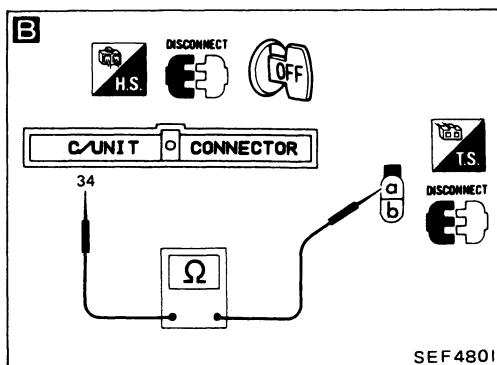
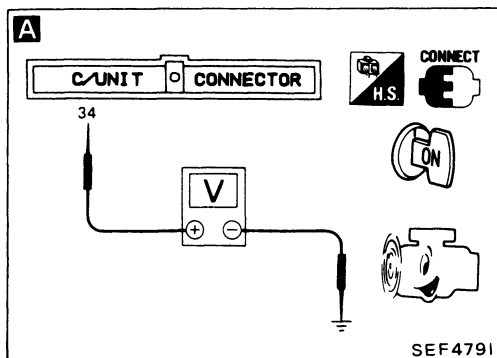
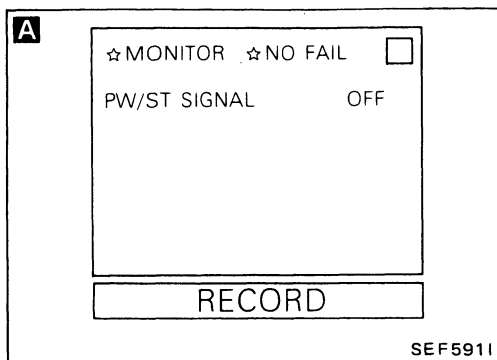

TROUBLE DIAGNOSES

Diagnostic Procedure 40

NEUTRAL SWITCH & A/T CONTROL UNIT (NEUTRAL SIGNAL) CIRCUIT

(Not self-diagnostic item)

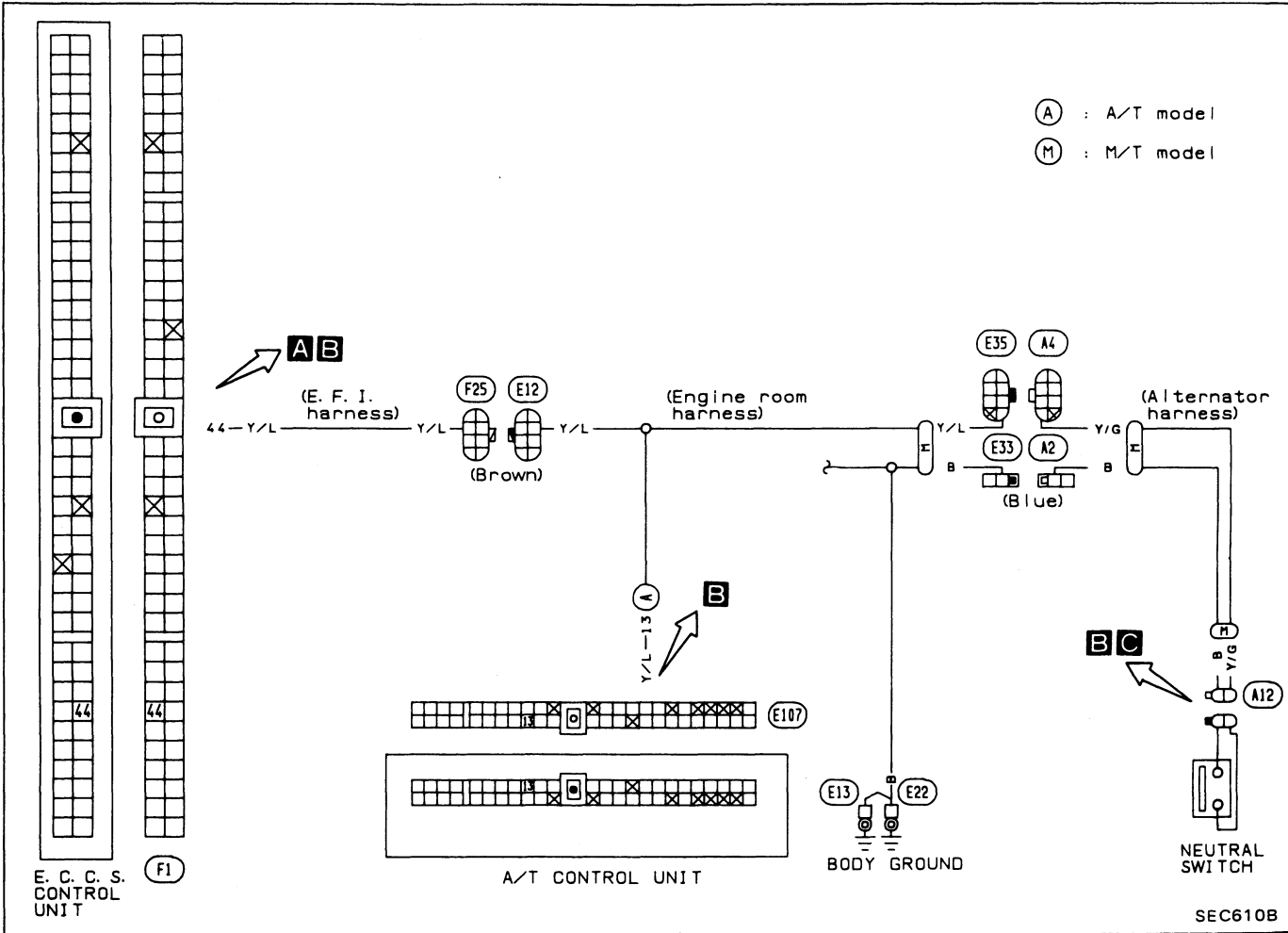

Harness layout

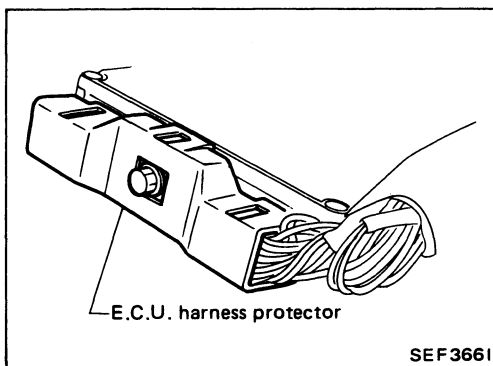

TROUBLE DIAGNOSES

Diagnostic Procedure 40 (Cont'd)

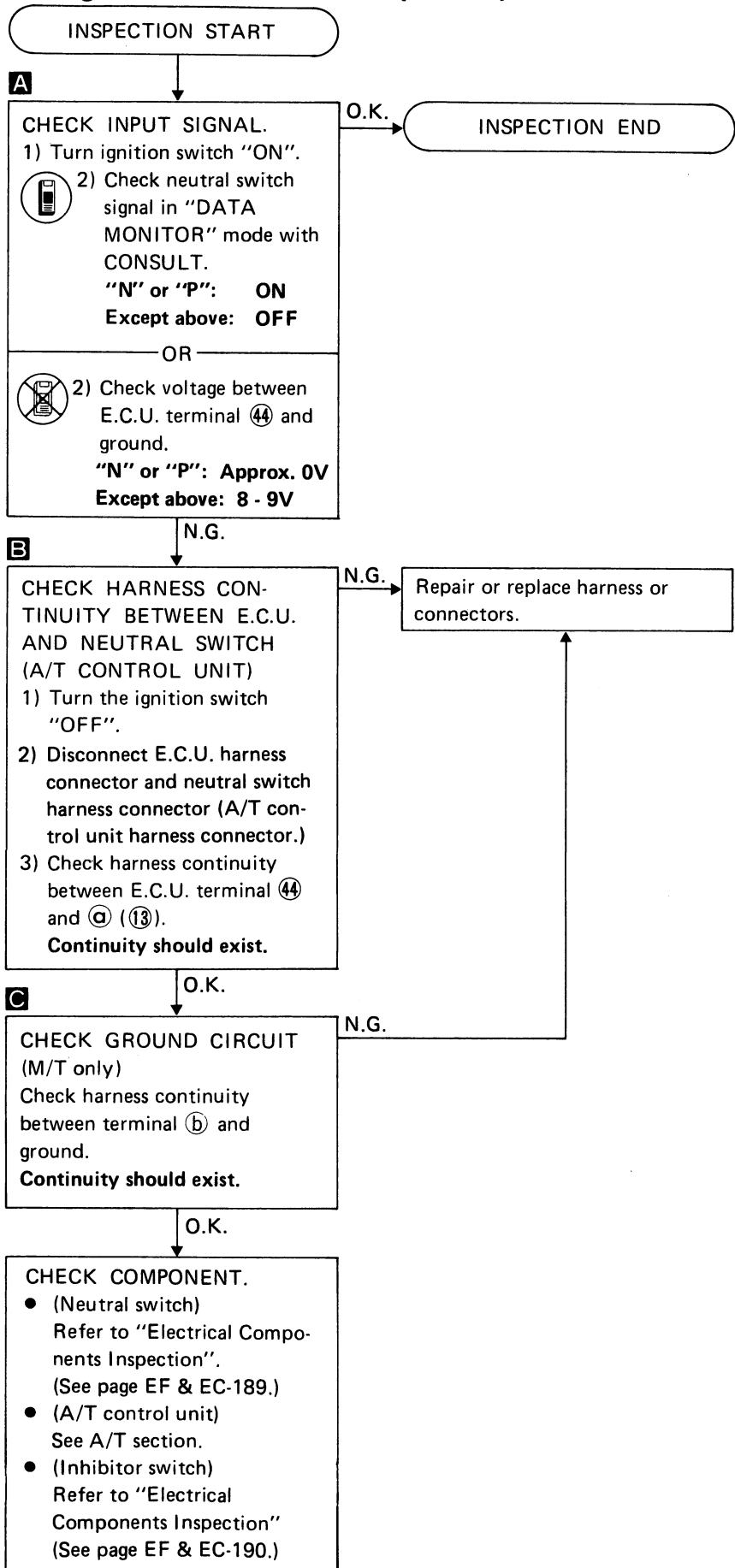
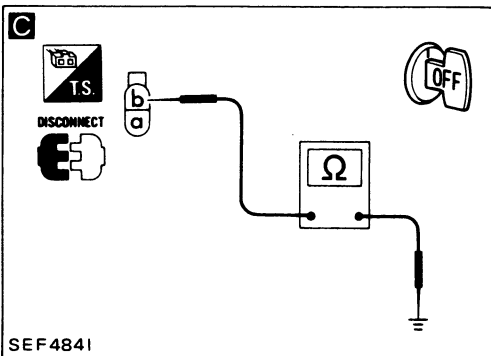
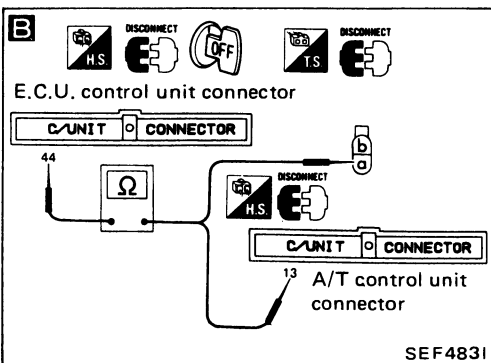
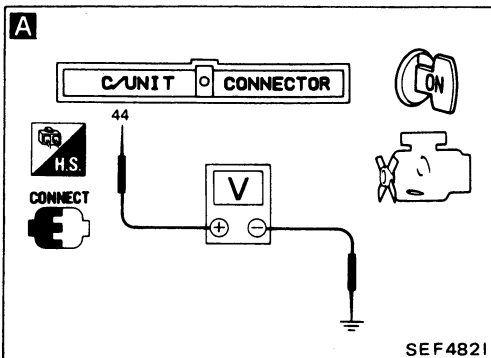
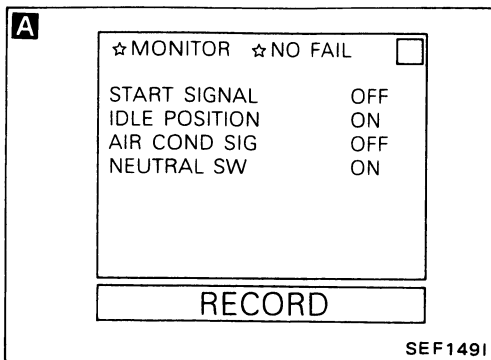

TROUBLE DIAGNOSES

Diagnostic Procedure 41

FUEL PUMP (Not self-diagnostic item)

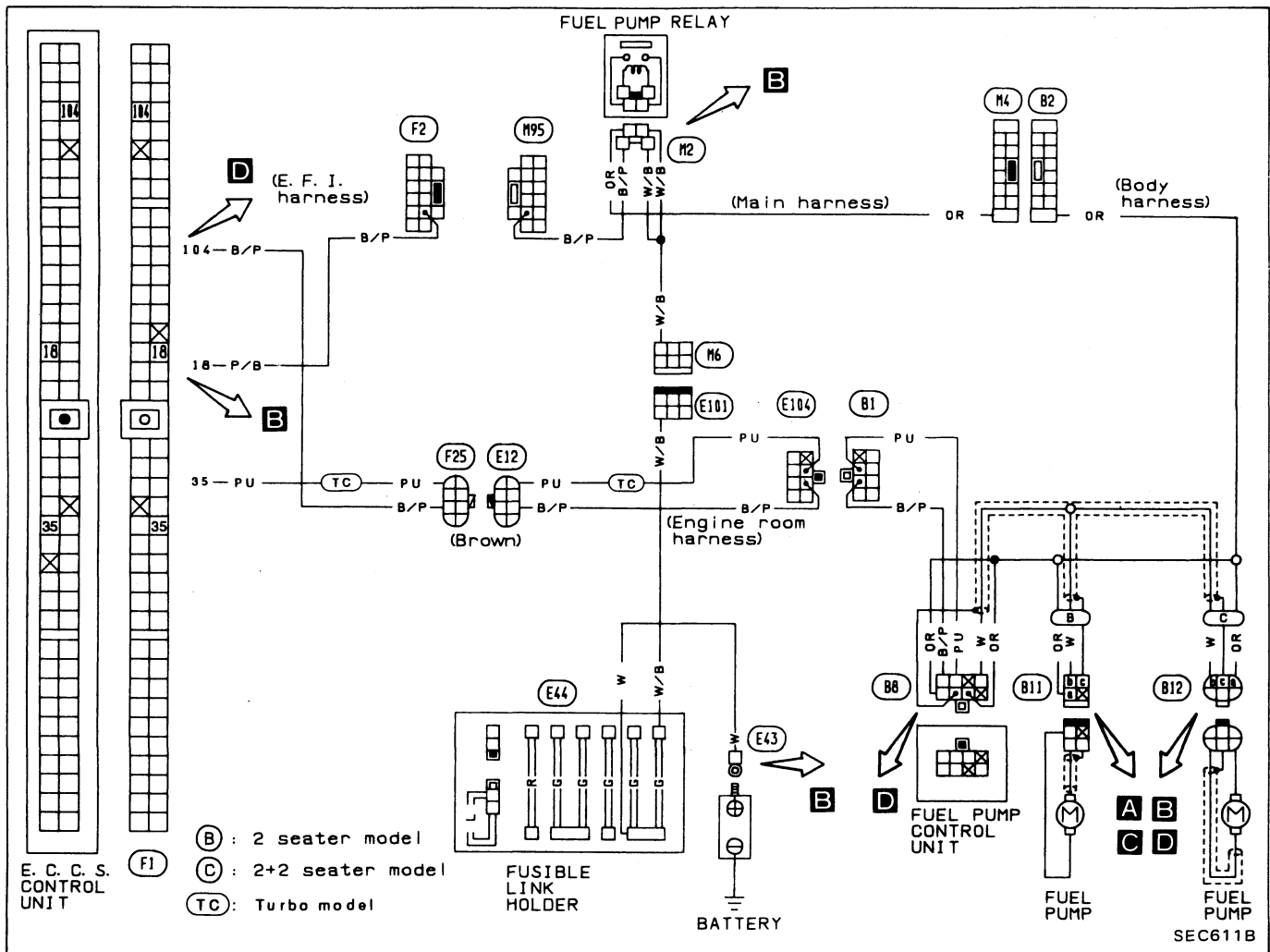

Harness layout

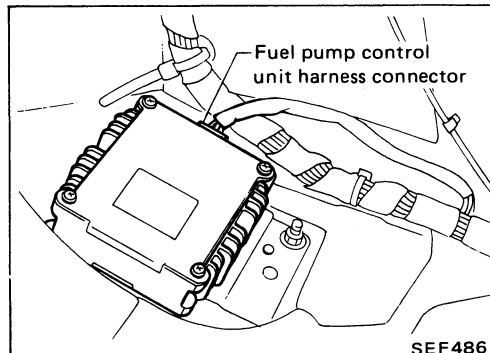
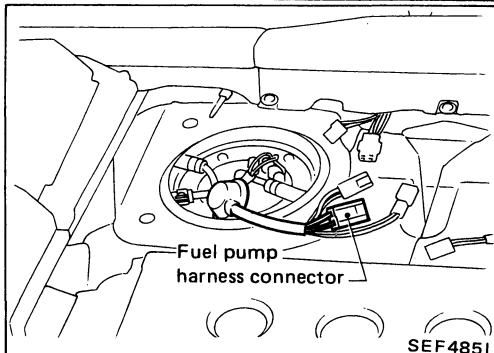
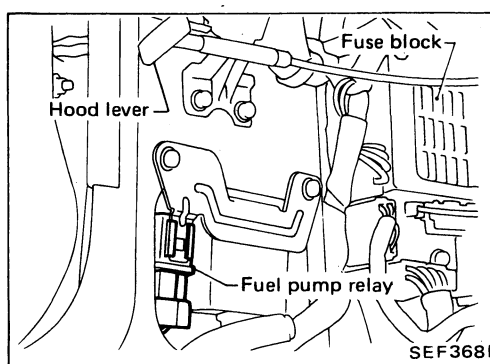
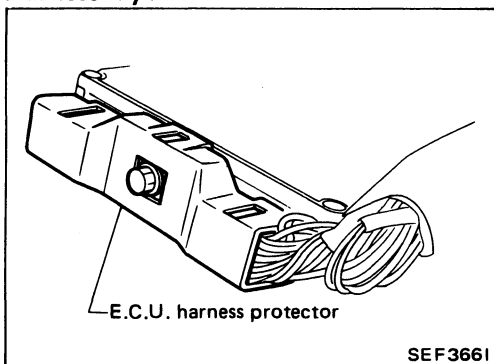

TROUBLE DIAGNOSES

Diagnostic Procedure 41 (Cont'd)

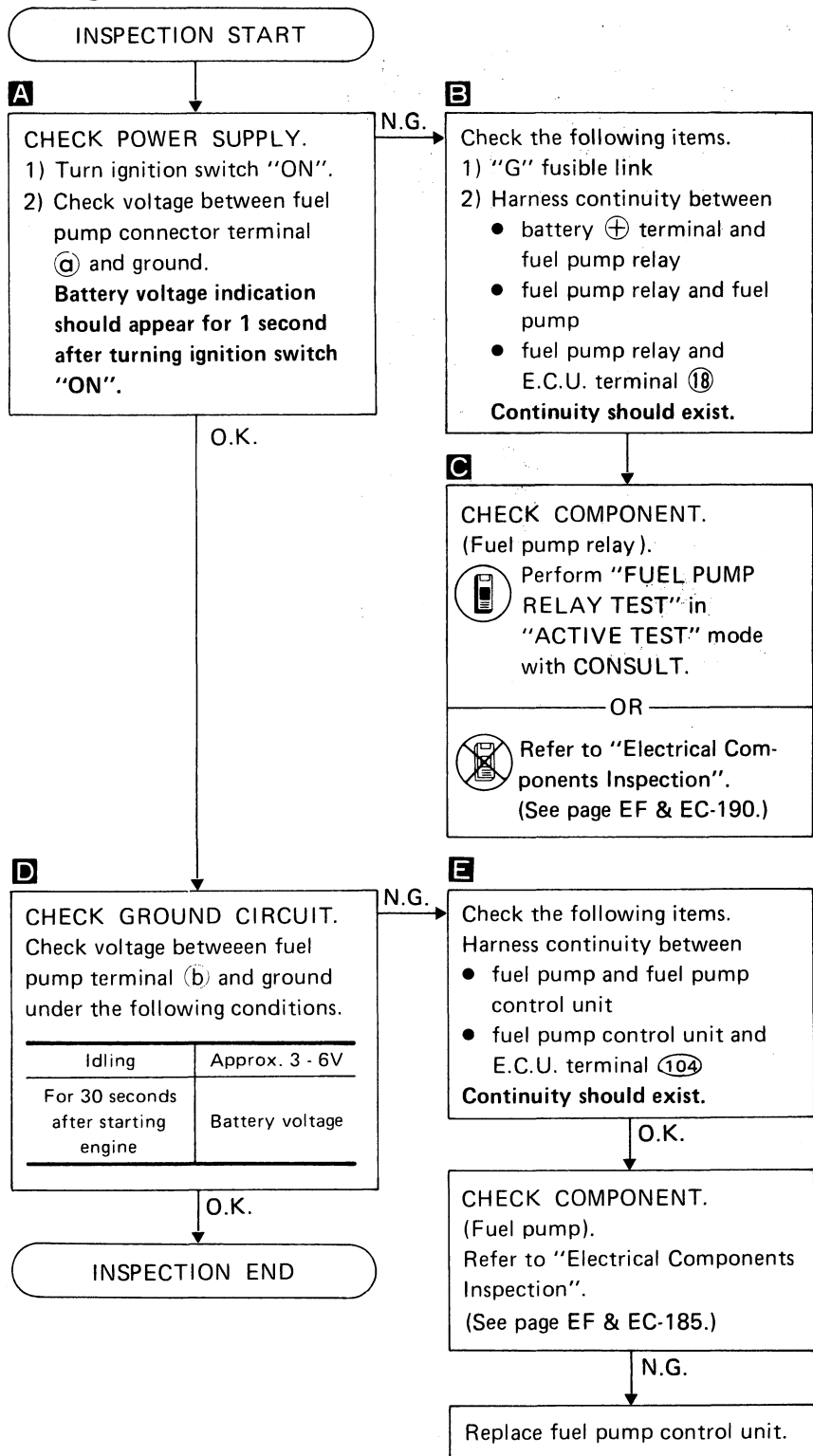
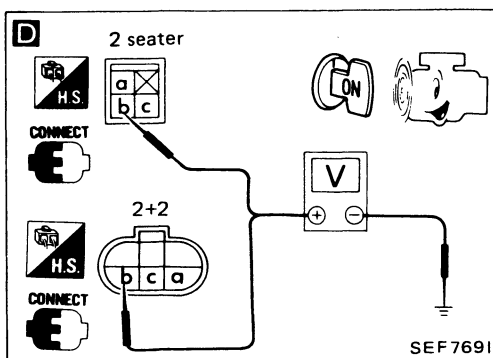
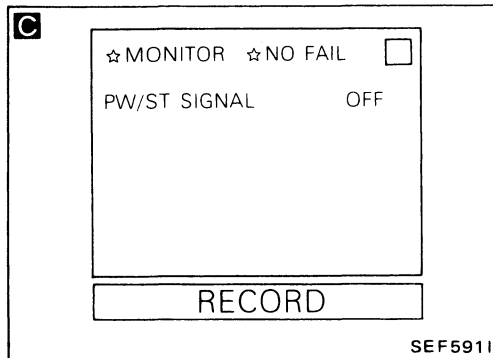
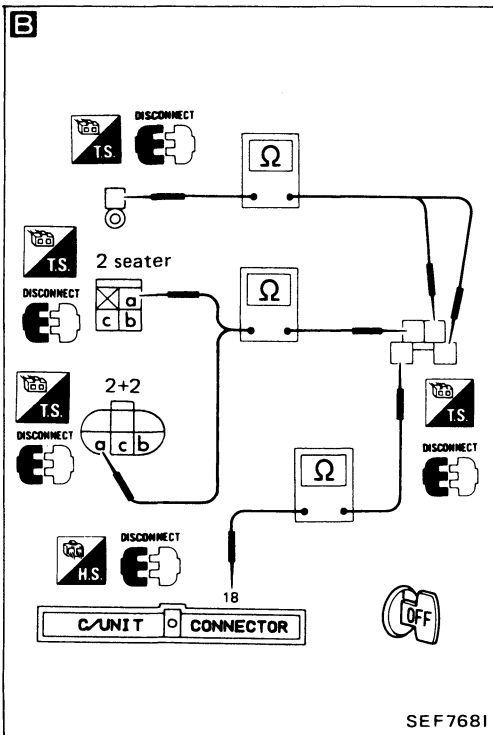
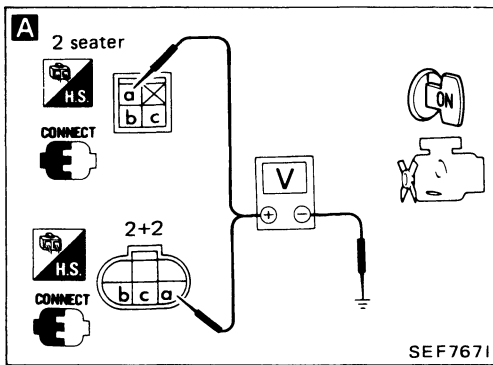

TROUBLE DIAGNOSES

Diagnostic Procedure 41 (Cont'd)

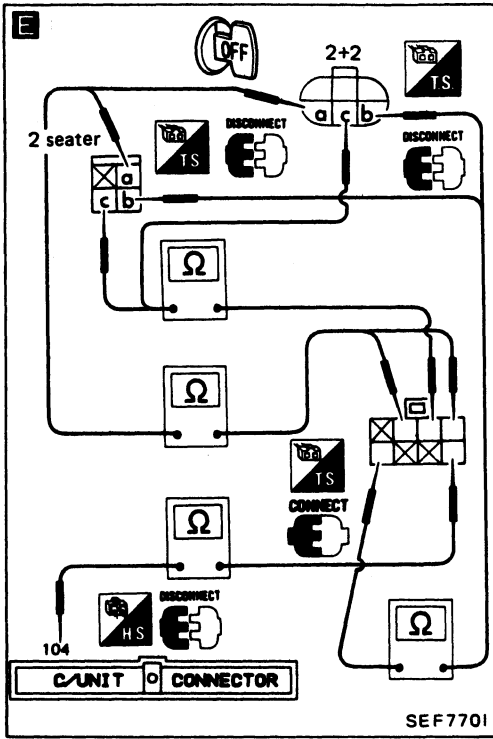

TROUBLE DIAGNOSES

NOTE

TROUBLE DIAGNOSES

Diagnostic Procedure 42

AIR REGULATOR (Not self-diagnostic item)

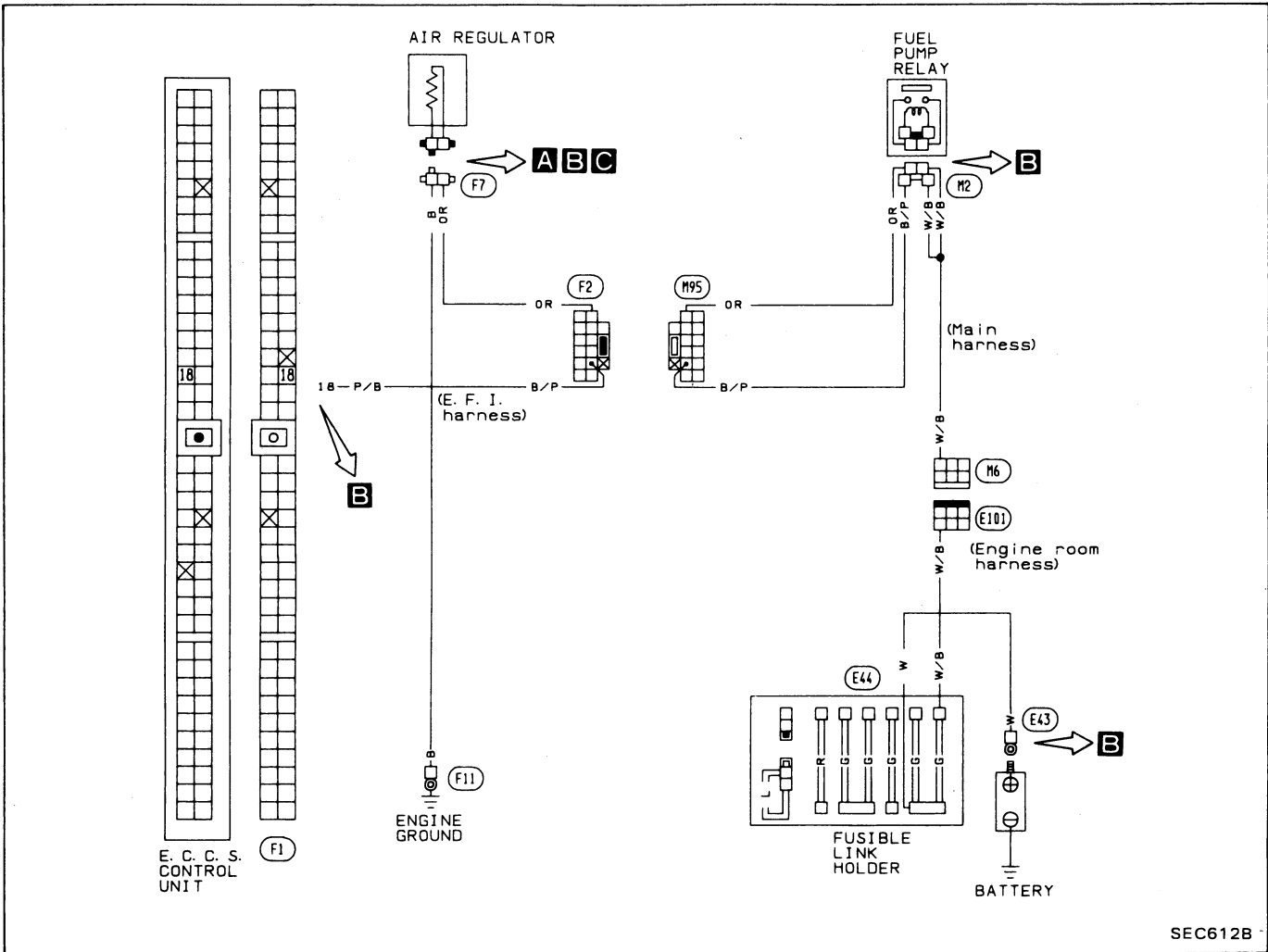

SEC612B

Harness layout

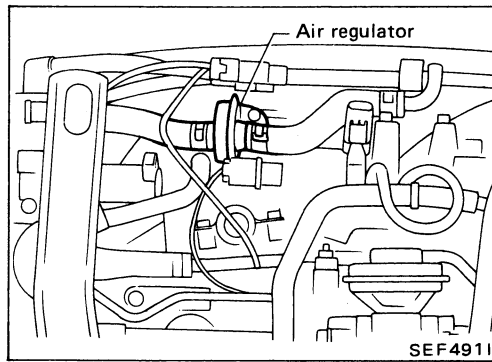
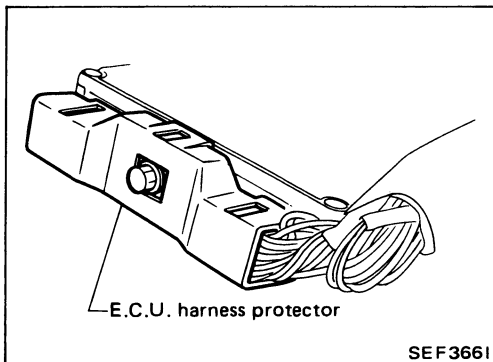

TROUBLE DIAGNOSES

Diagnostic Procedure 42 (Cont'd)

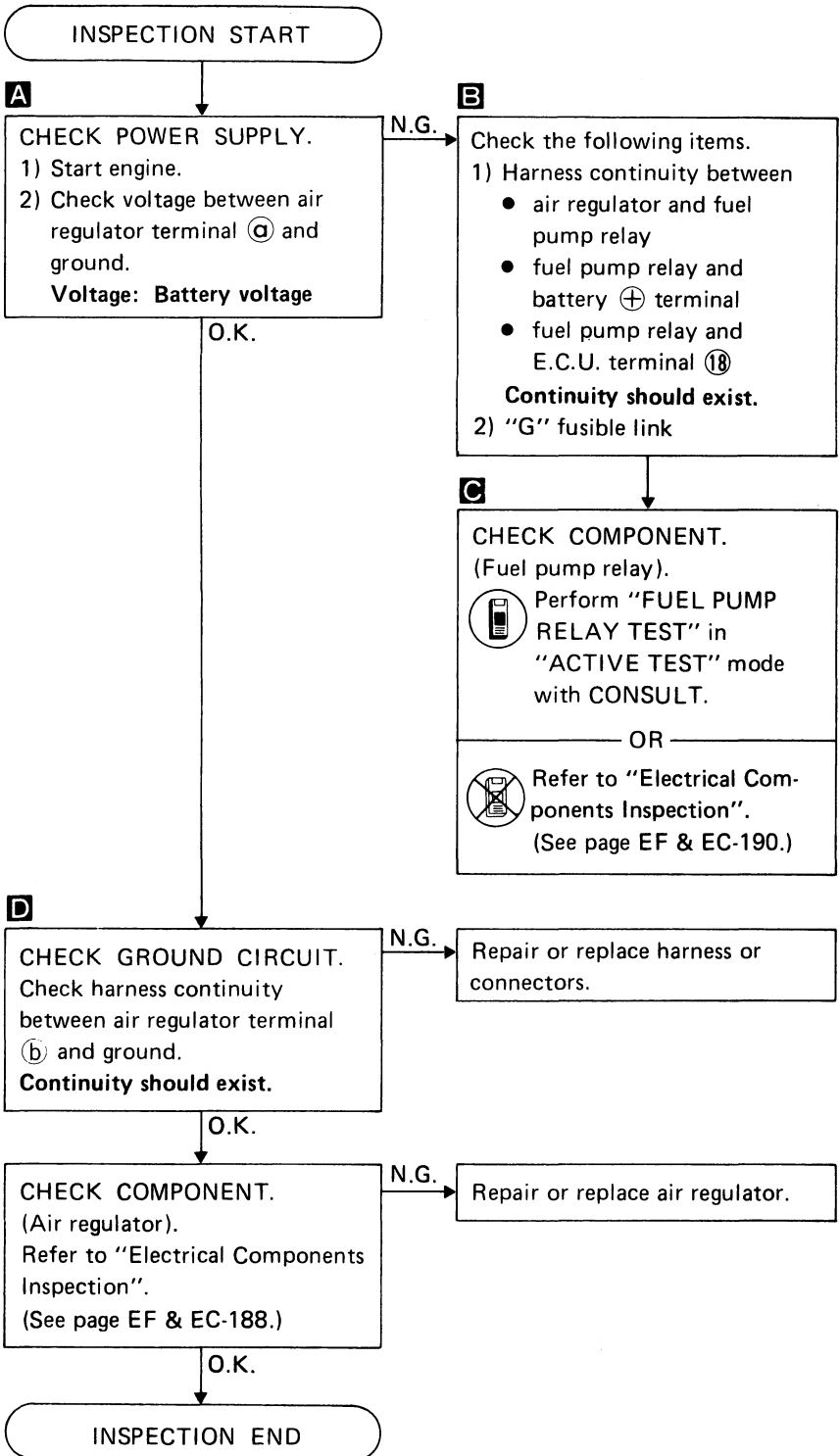
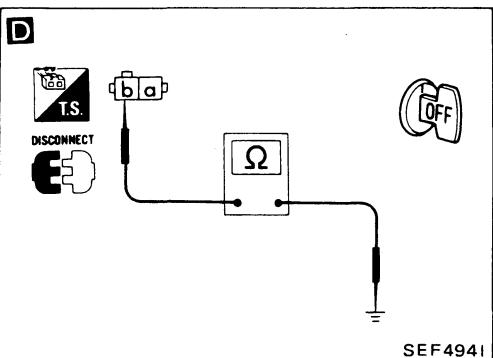
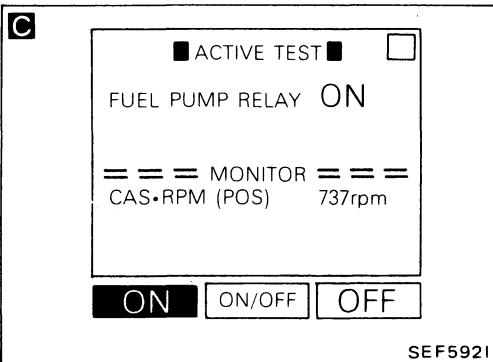
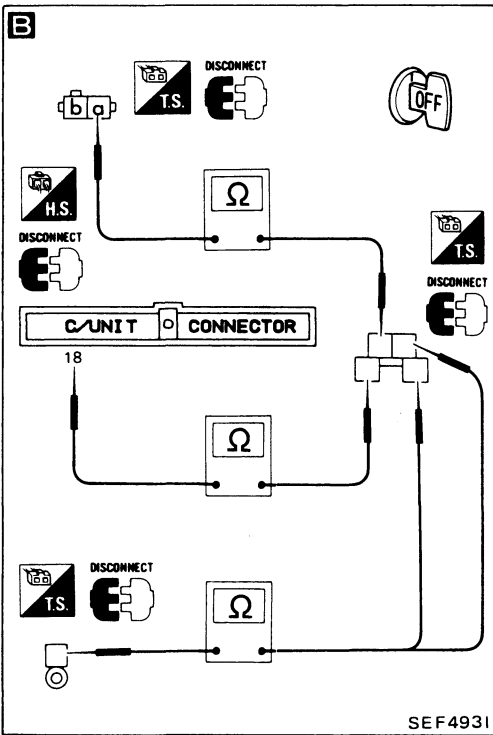
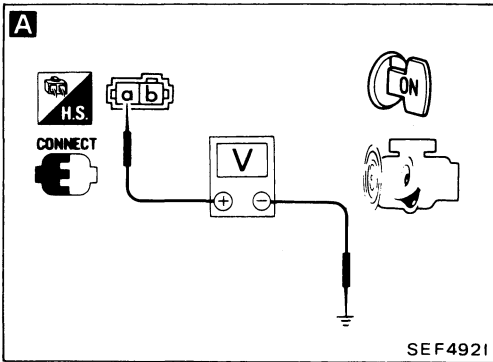

TROUBLE DIAGNOSES

Diagnostic Procedure 43

A.A.C. VALVE (Not self-diagnostic item)

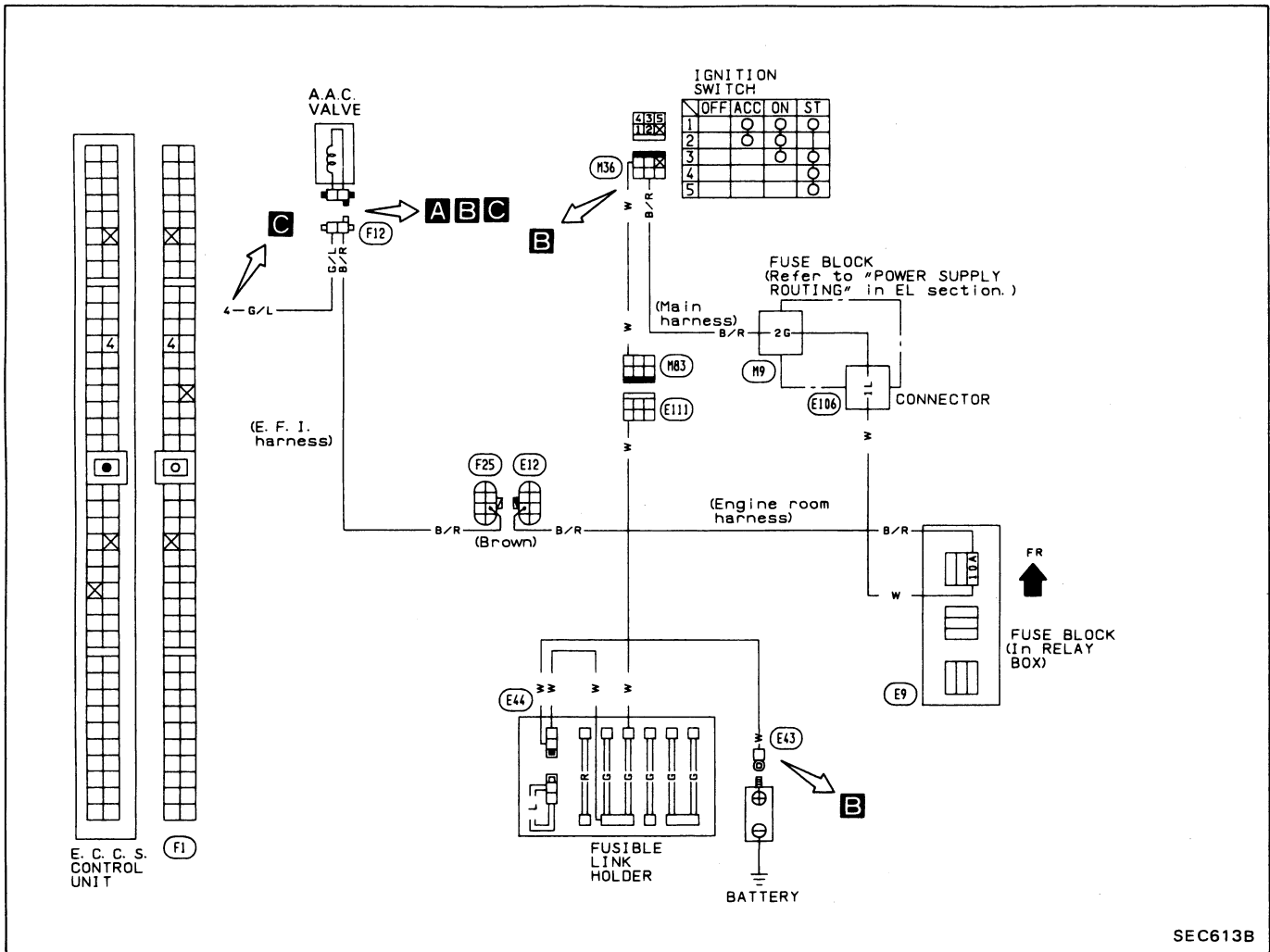

SEC613B

Harness layout

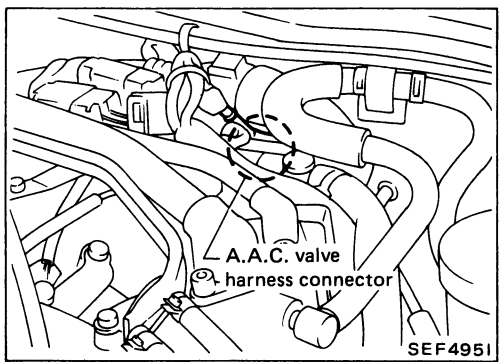
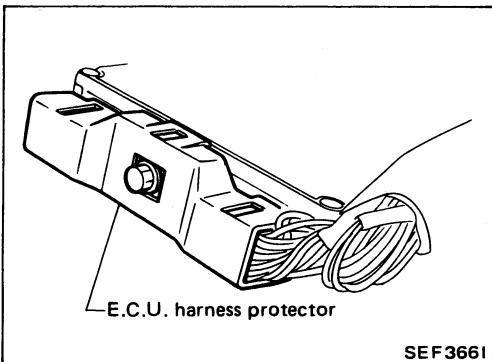

TROUBLE DIAGNOSES

Diagnostic Procedure 43 (Cont'd)

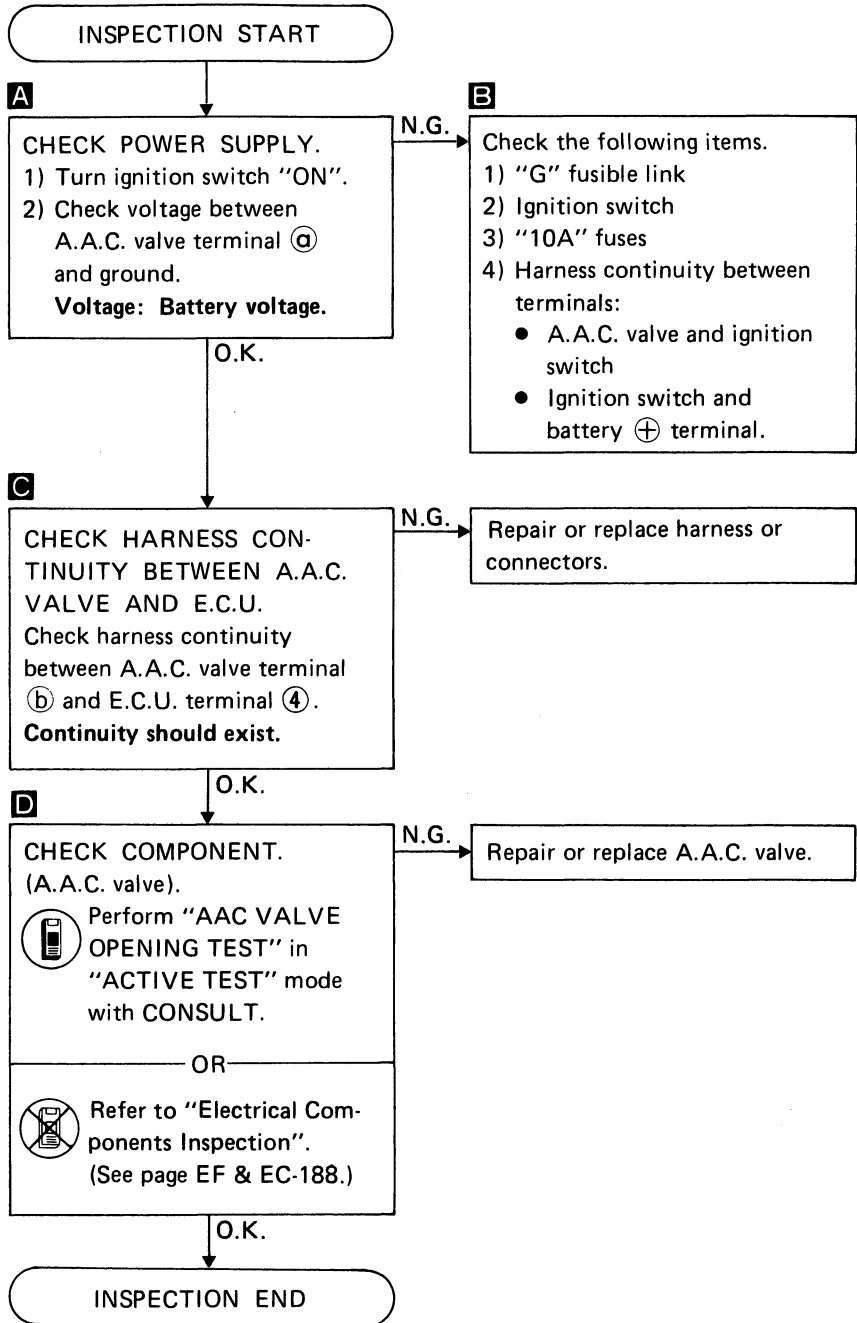
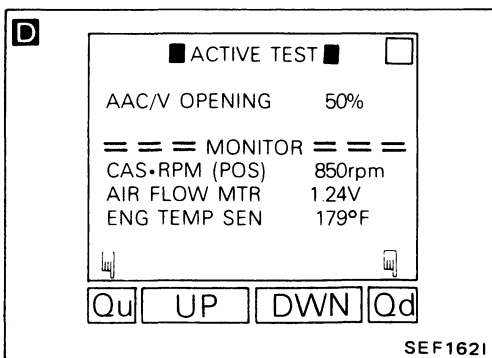
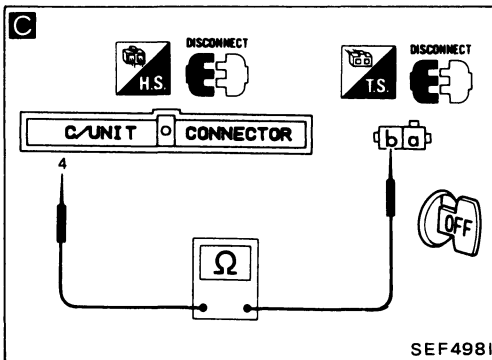
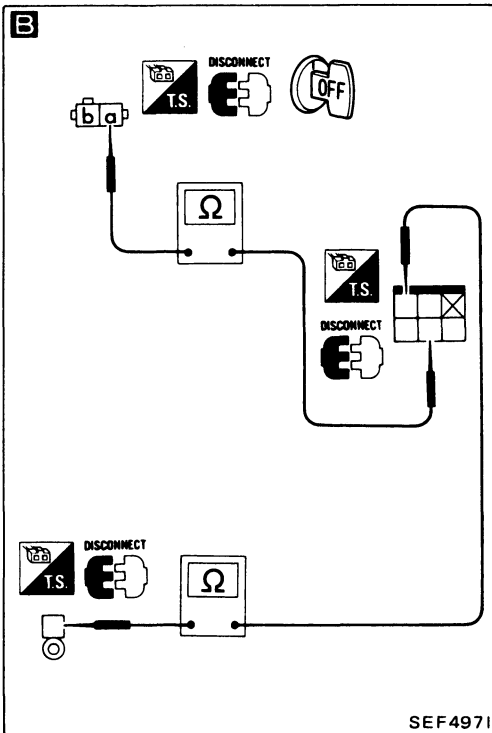
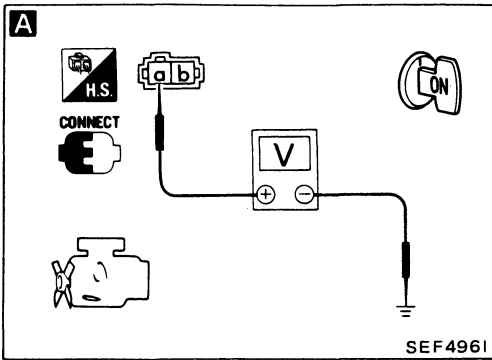

TROUBLE DIAGNOSES

Diagnostic Procedure 44

F.I.C.D. SOLENOID VALVE

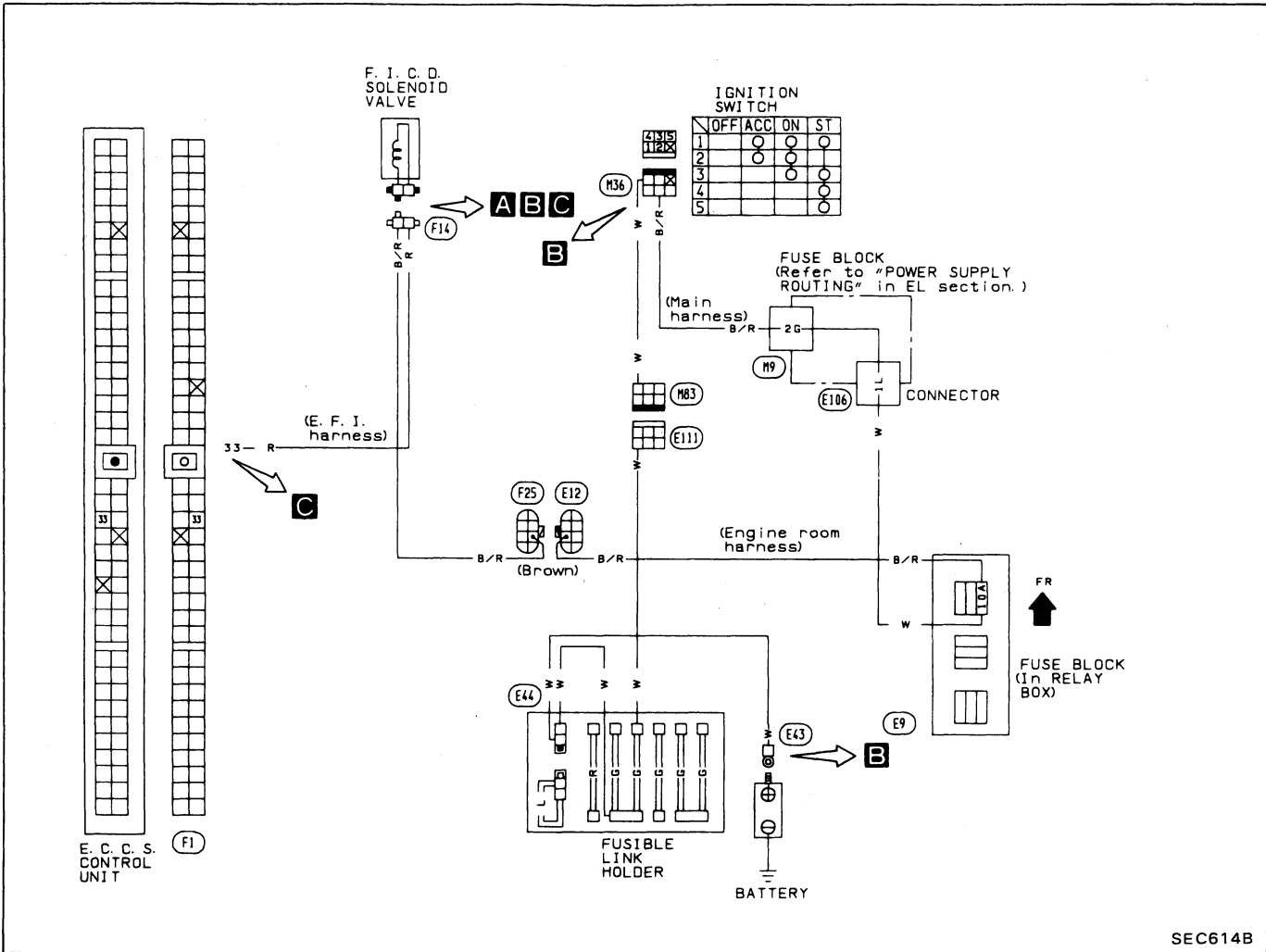

Harness layout

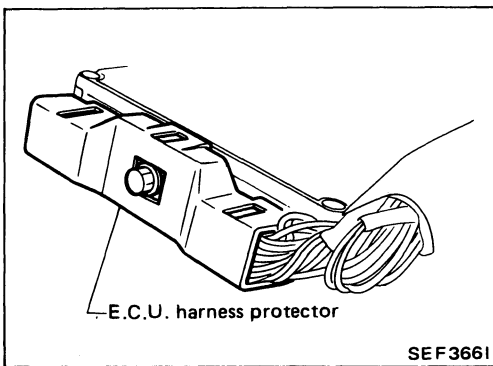

F.I.C.D. solenoid valve harness connector is located near A.A.C. valve harness connector.

TROUBLE DIAGNOSES

Diagnostic Procedure 44 (Cont'd)

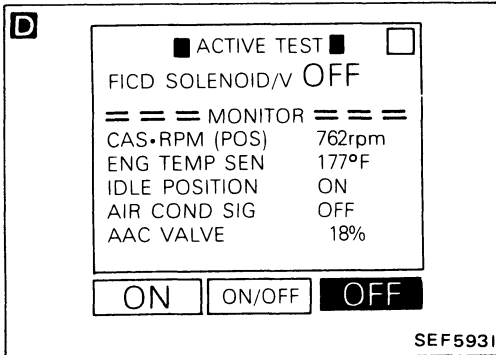
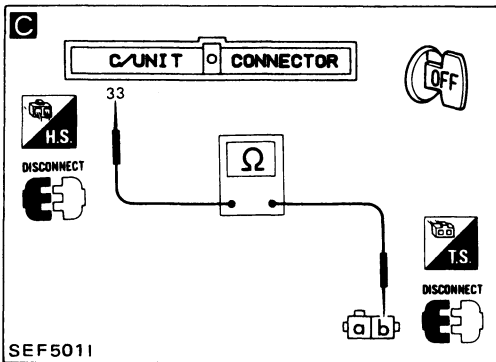
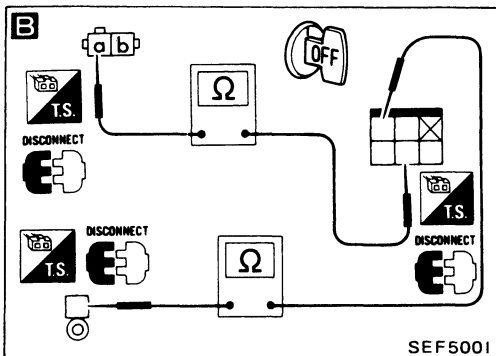
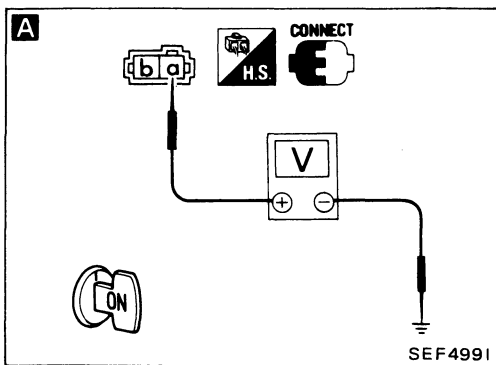

INSPECTION START

A
CHECK POWER SUPPLY.
1) Turn ignition switch "ON".
2) Check voltage between F.I.C.D. solenoid valve terminal ① and ground.
Voltage: Battery voltage.

B
Check the following items.
1) "G" fusible link.
2) "10A" fuses.
3) Ignition switch.
4) Harness continuity between terminals:
• F.I.C.D. solenoid valve and ignition switch
• Ignition switch and battery ⊕ terminal.
Continuity should exist.

O.K.

C
CHECK HARNESS CONTINUITY BETWEEN F.I.C.D. SOLENOID VALVE AND E.C.U.
Check harness continuity between F.I.C.D. solenoid valve terminal ② and E.C.U. terminal ③③.
Continuity should exist.

N.G. → Repair or replace harness or connectors.

O.K.

D
CHECK COMPONENT (F.I.C.D. solenoid valve).
Perform "F.I.C.D. SOLENOID VALVE TEST" in "ACTIVE TEST" mode with CONSULT.

N.G. → Repair or replace F.I.C.D. solenoid valve.

OR
Refer to "Electrical Components Inspection".
(See page EF & EC-188.)

O.K.

INSPECTION END

TROUBLE DIAGNOSES

Diagnostic Procedure 45

A.I.V. CONTROL SOLENOID VALVE (Not self-diagnostic item)

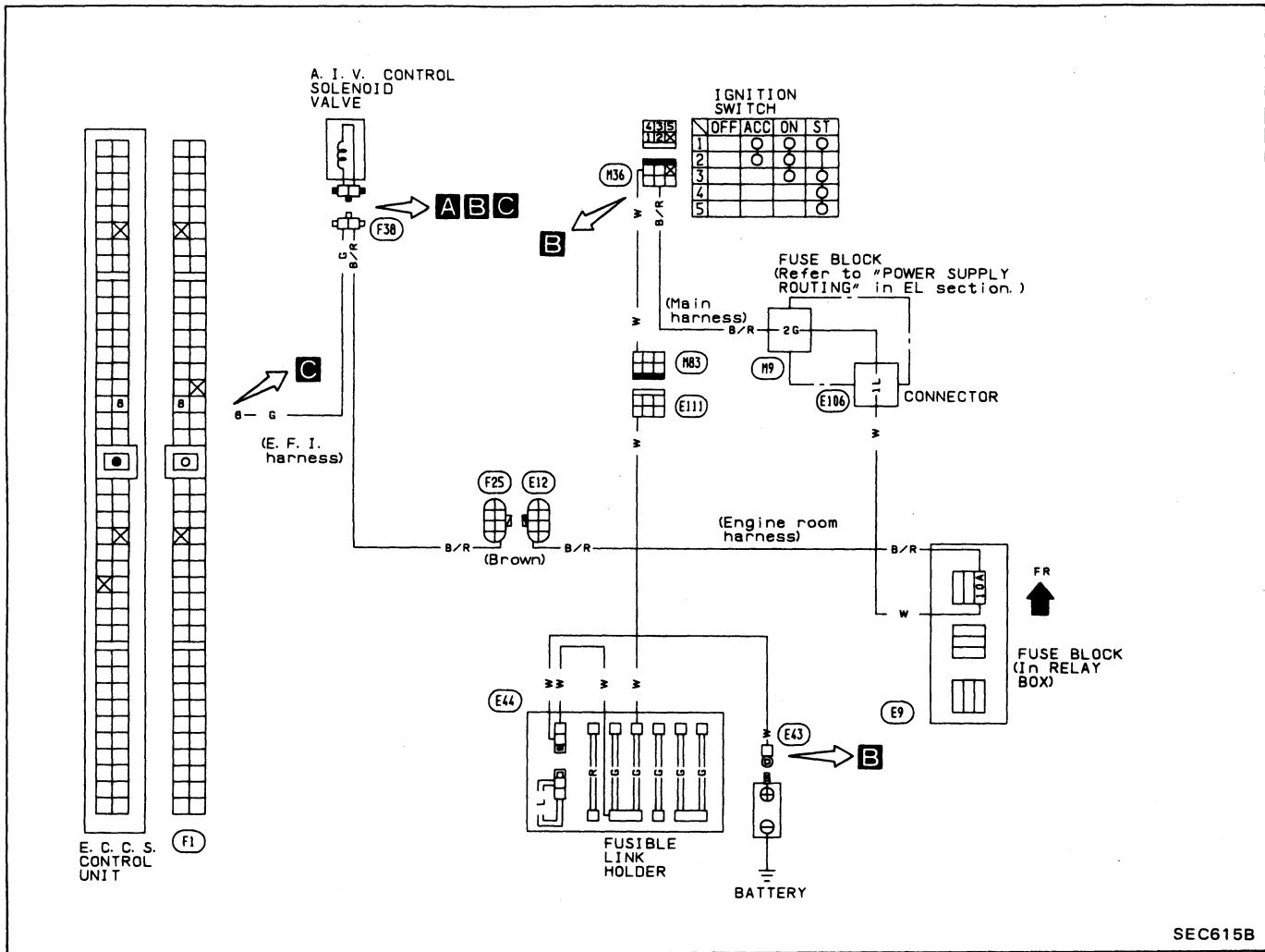

Harness layout

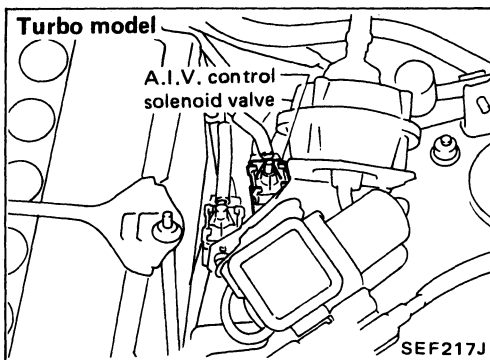
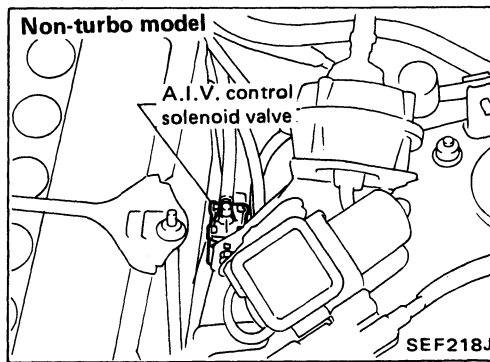
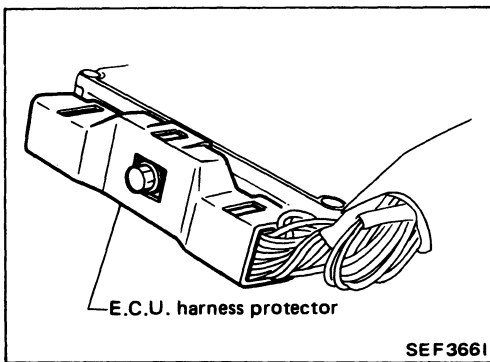

TROUBLE DIAGNOSES

Diagnostic Procedure 45 (Cont'd)

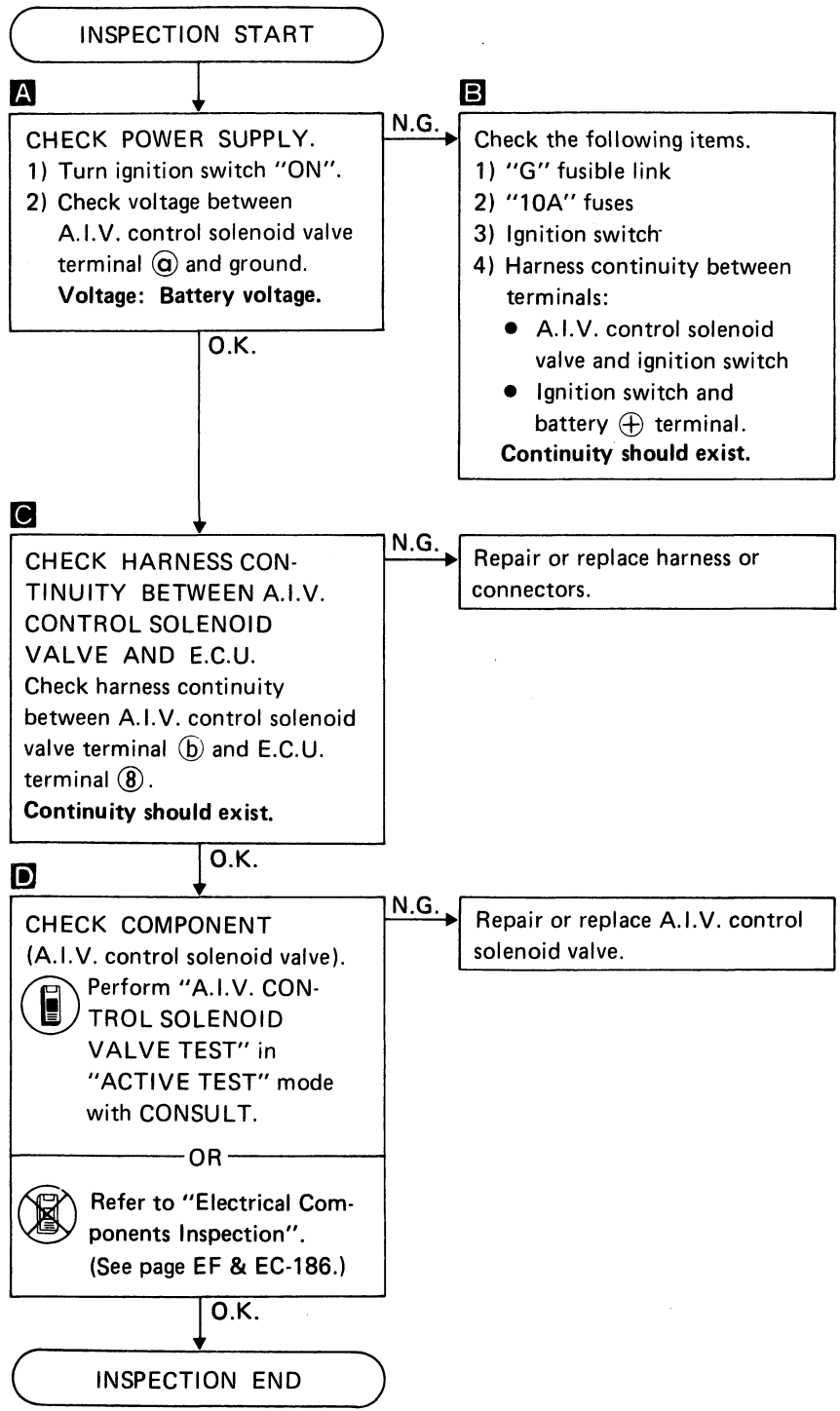
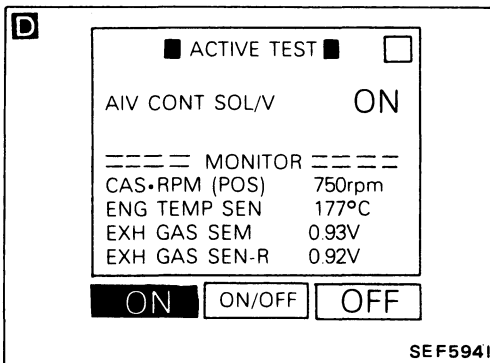
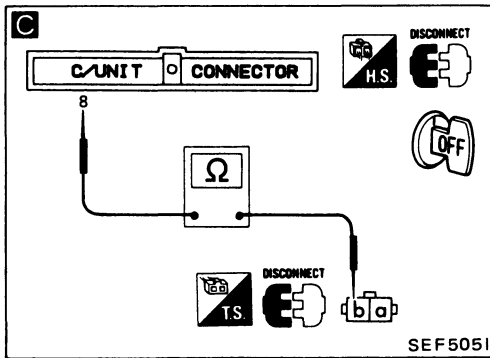
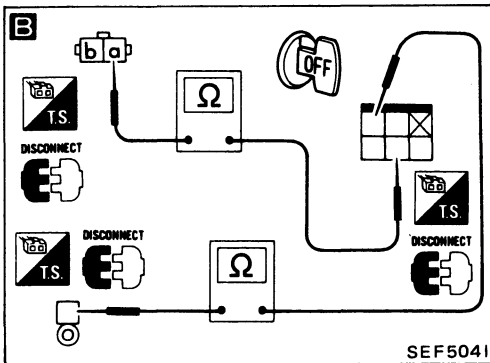
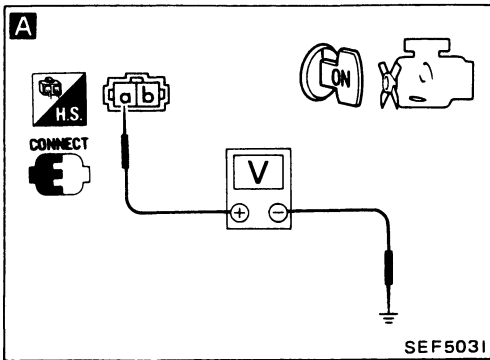

TROUBLE DIAGNOSES

Diagnostic Procedure 46

P.R.V.R. CONTROL SOLENOID VALVE (Not self-diagnostic item)

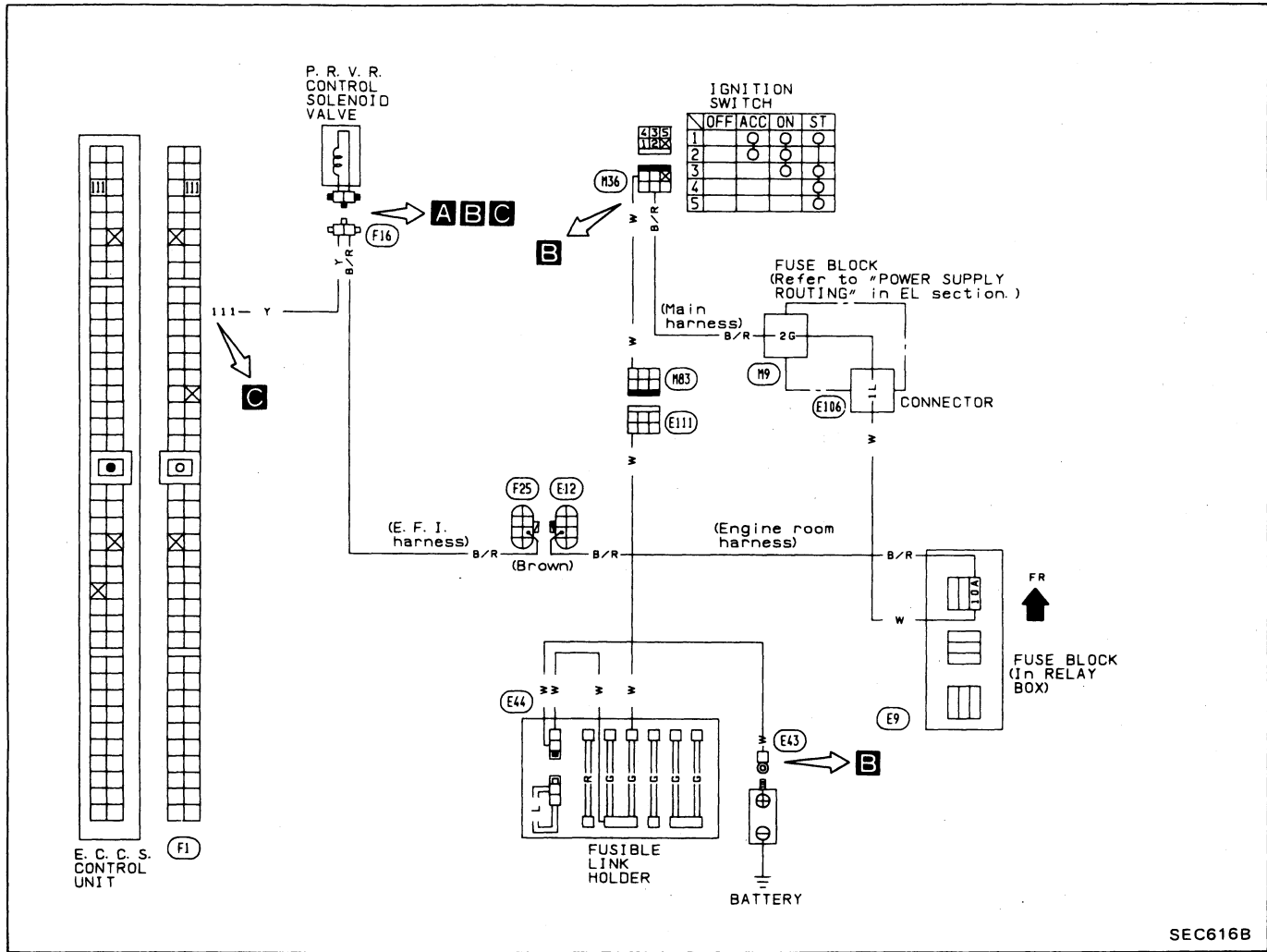

SEC616B

Harness layout

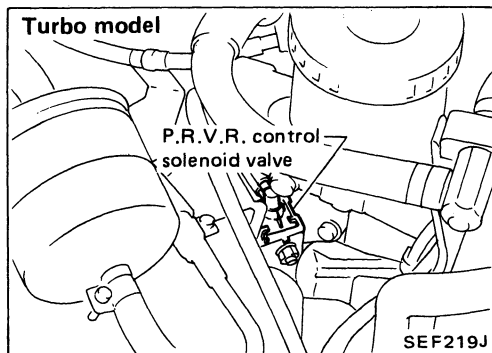
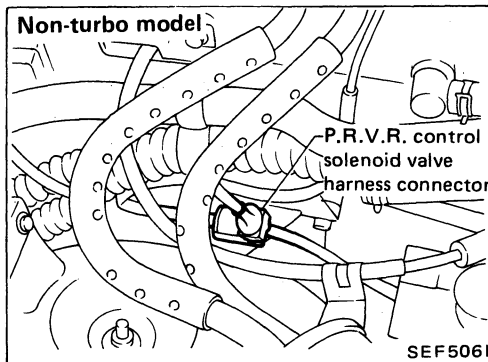
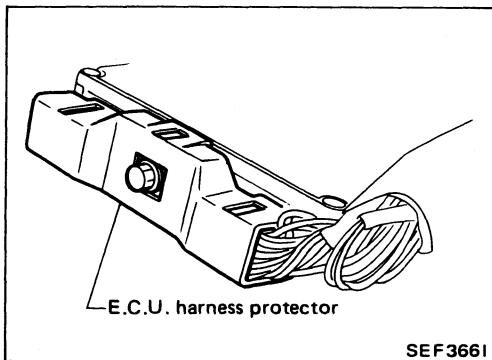

TROUBLE DIAGNOSES

Diagnostic Procedure 46 (Cont'd)

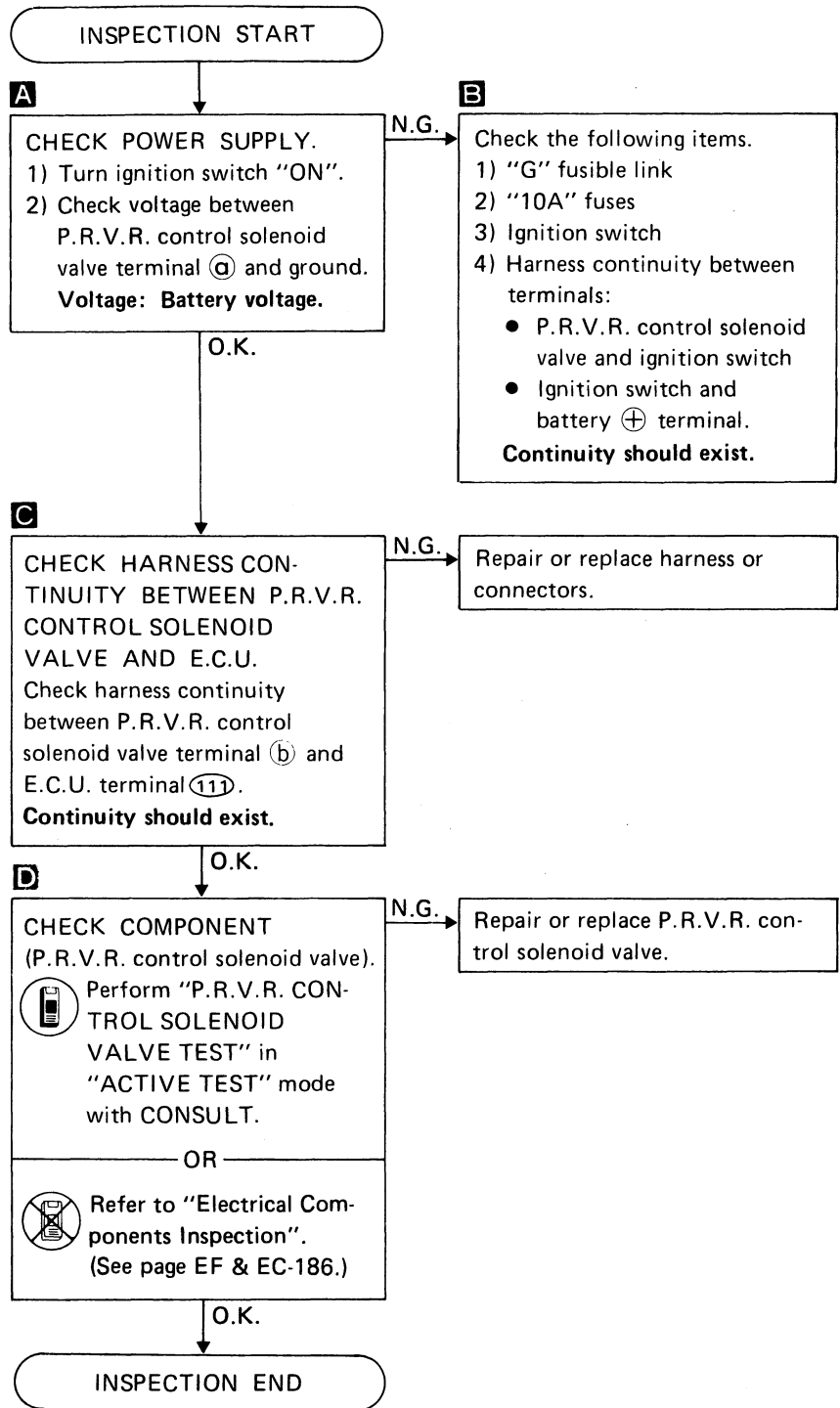
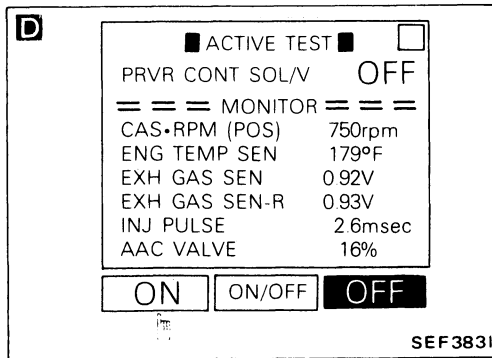
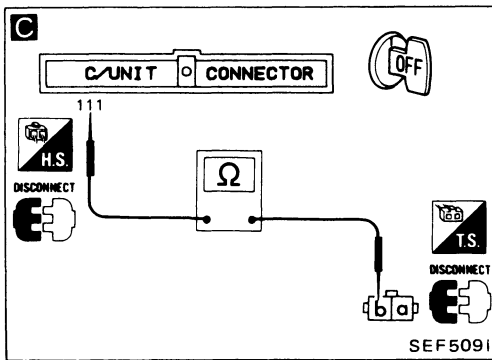
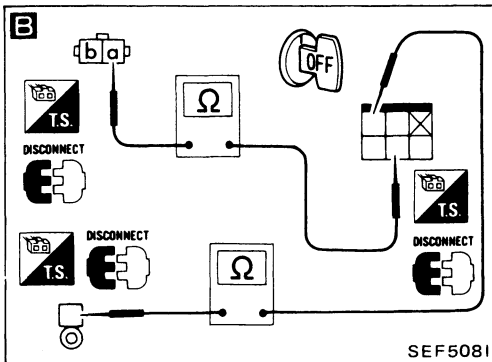
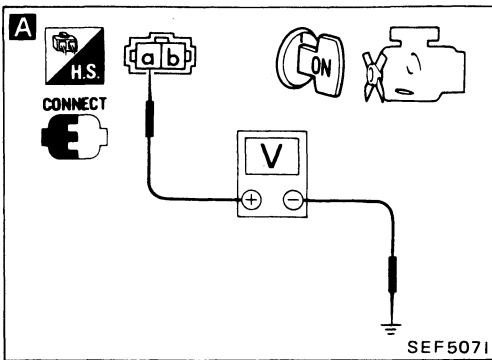

TROUBLE DIAGNOSES

Diagnostic Procedure 47

V.T.C. SOLENOID VALVE (Not self-diagnostic item)

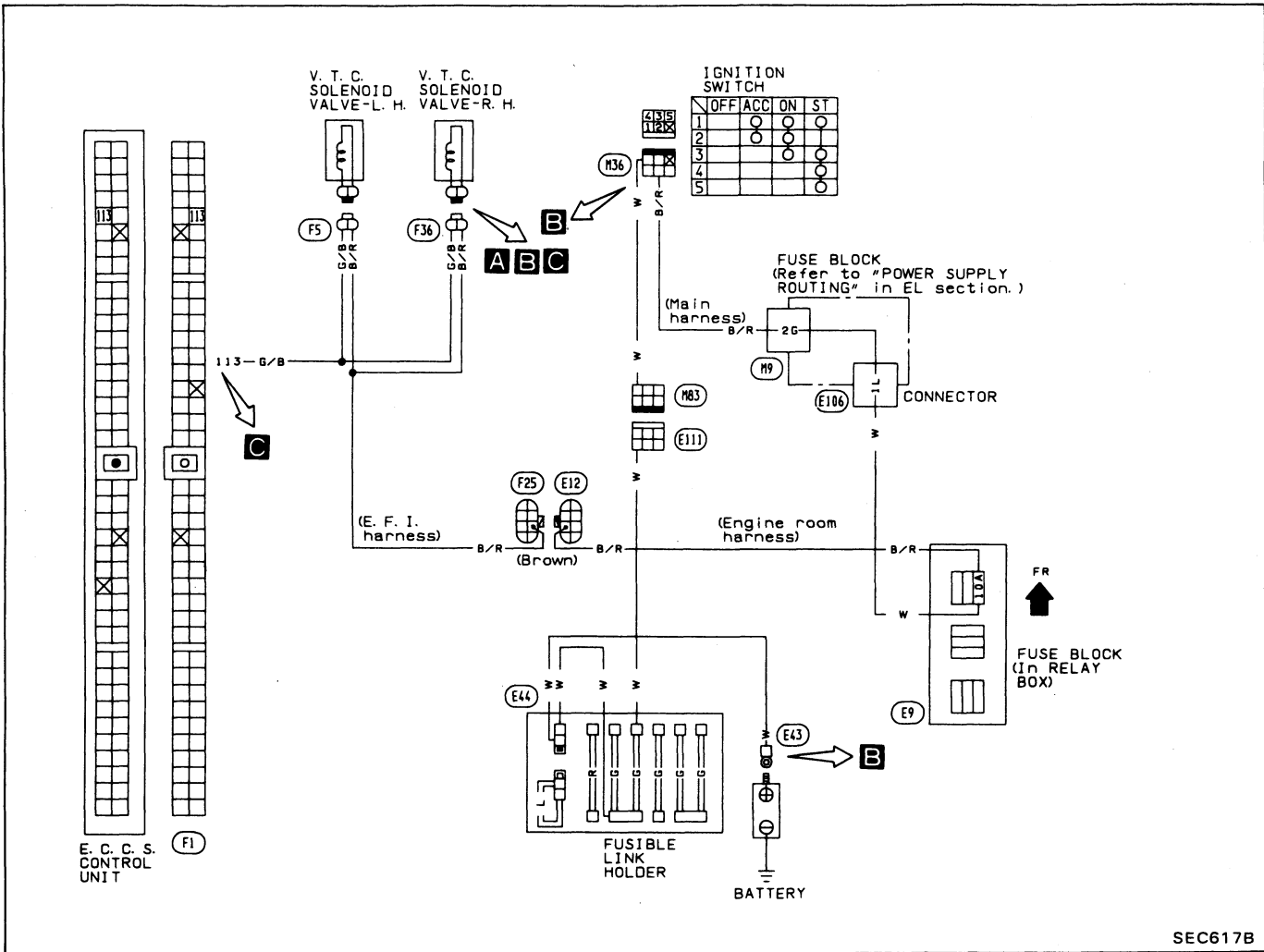

SEC617B

Harness layout

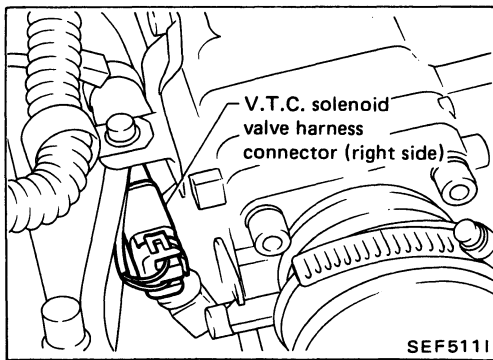
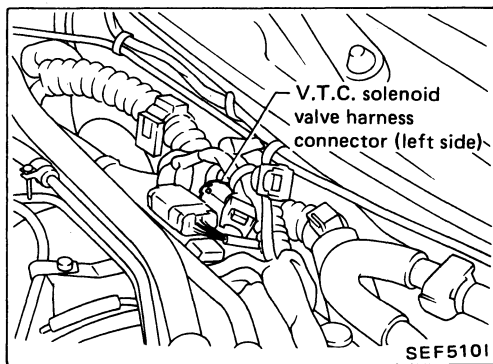
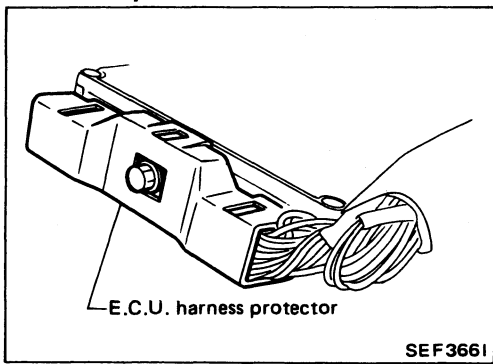

TROUBLE DIAGNOSES

Diagnostic Procedure 47 (Cont'd)

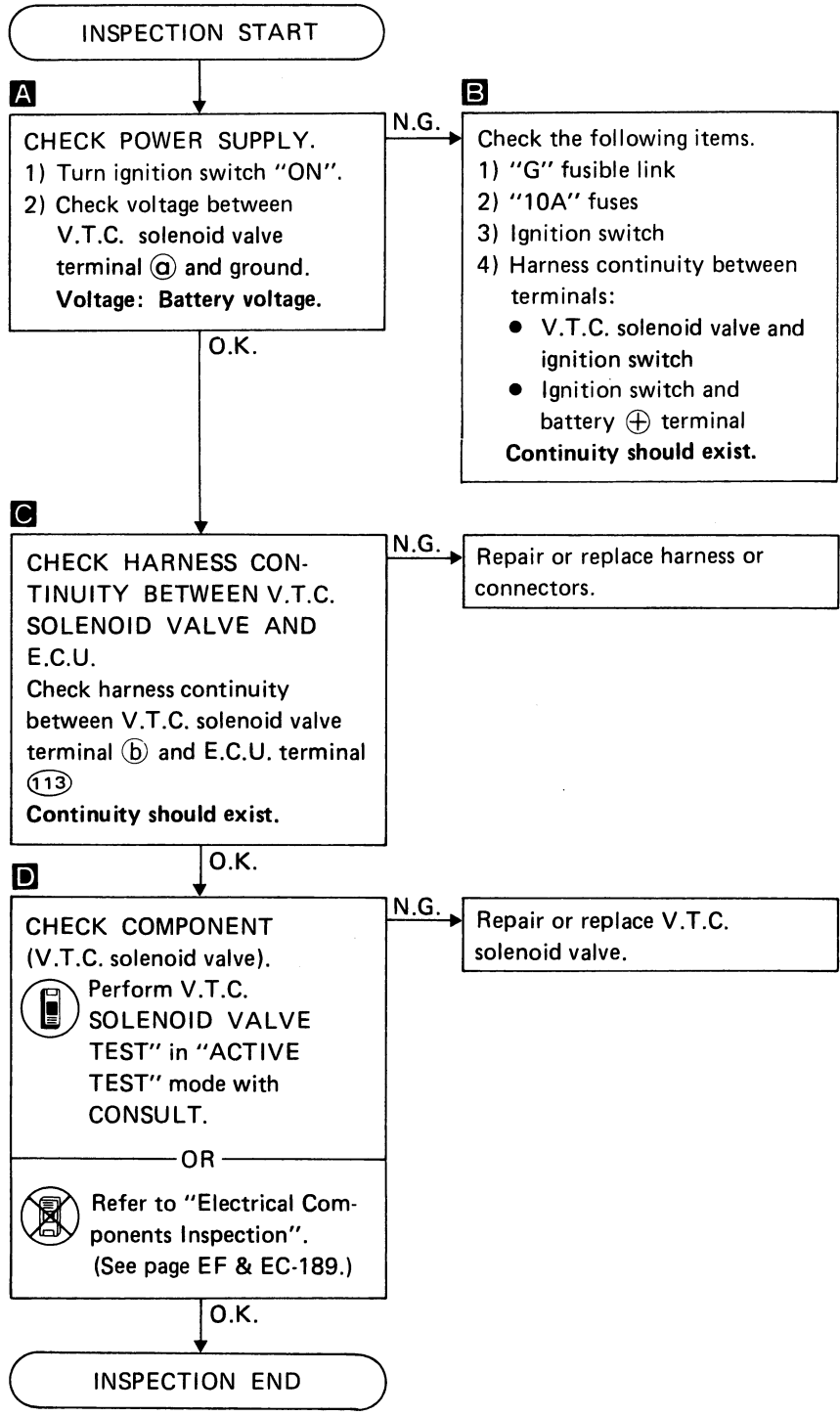
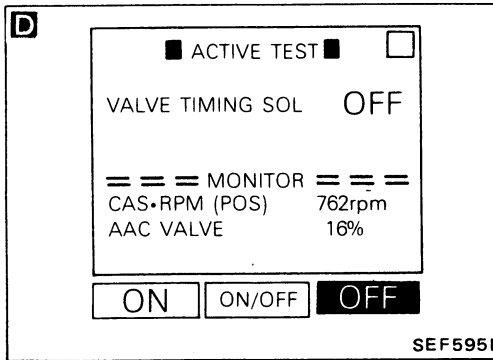
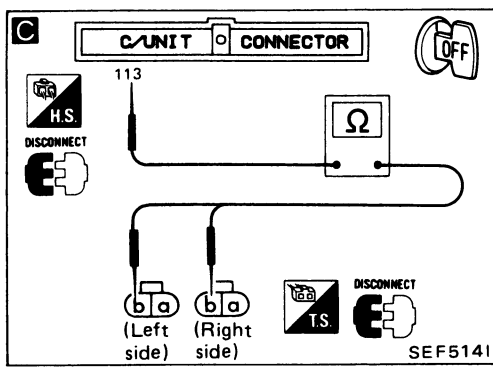
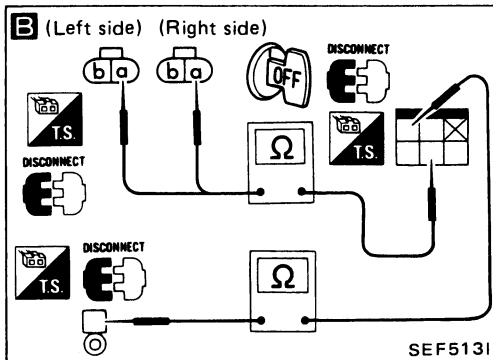
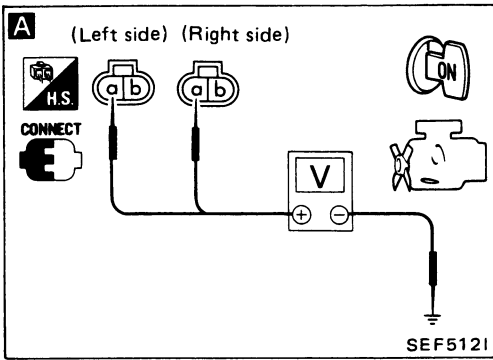

TROUBLE DIAGNOSES

Diagnostic Procedure 48

RADIATOR FAN CONTROL (Not self-diagnostic item)

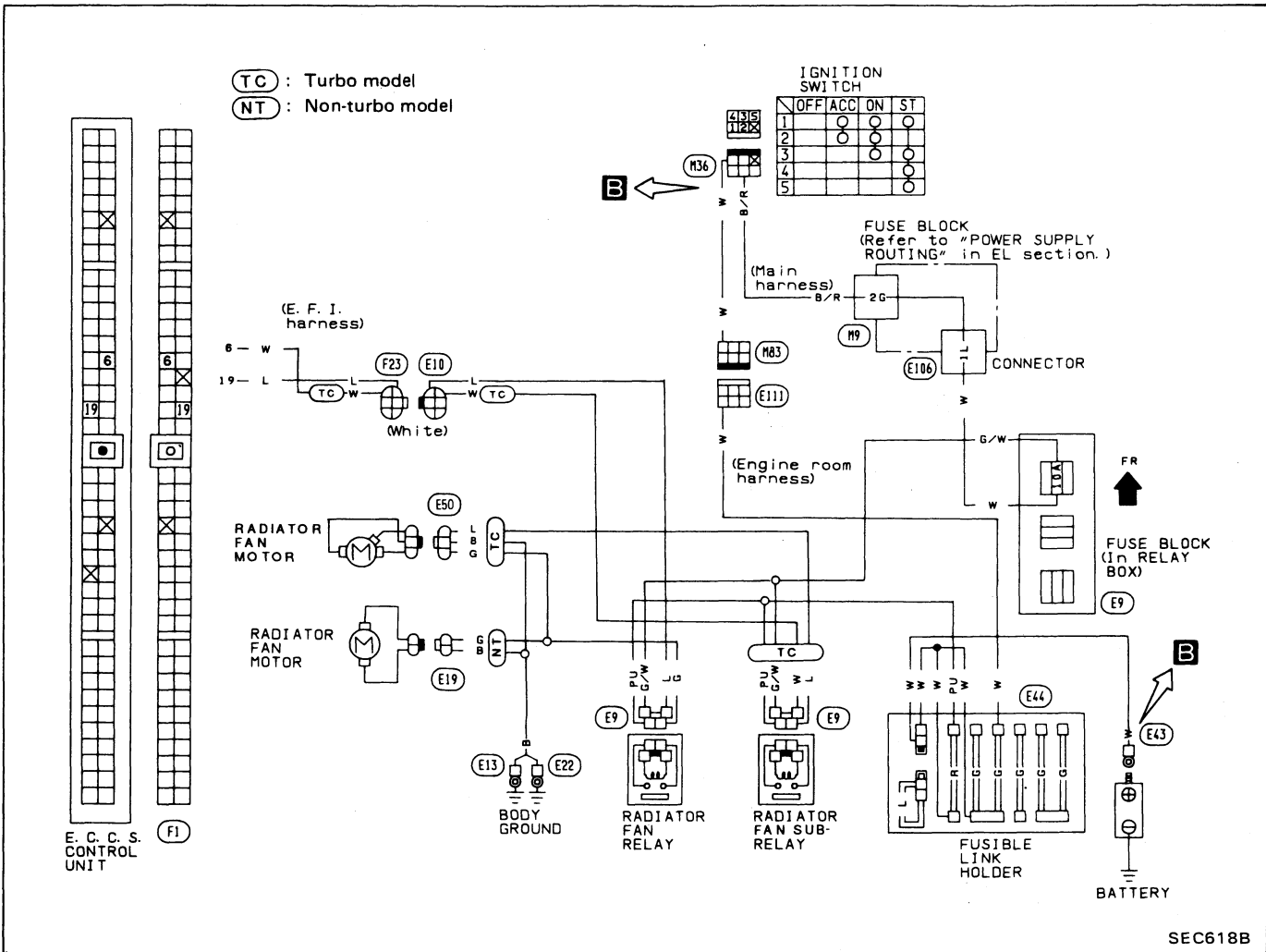

SEC618B

Harness layout

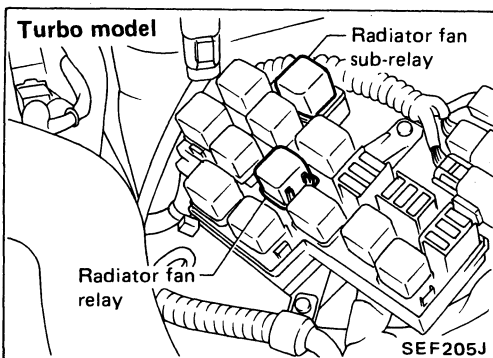
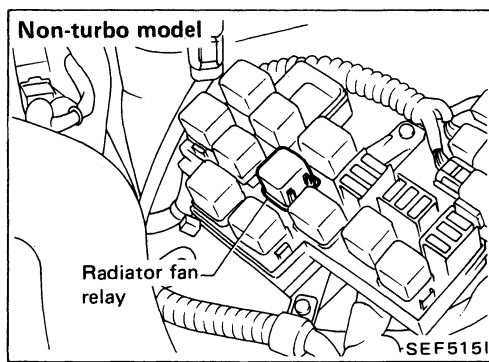
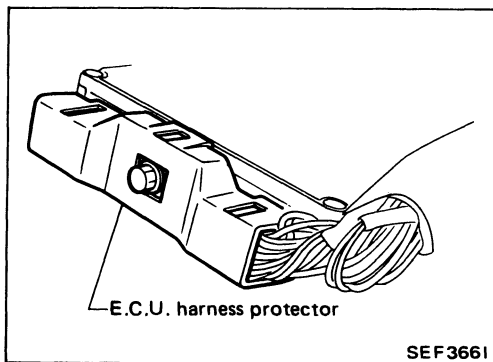

For radiator fan motor harness connector, see "HARNES LAY-OUT" in EL section.

TROUBLE DIAGNOSES

Diagnostic Procedure 48 (Cont'd)

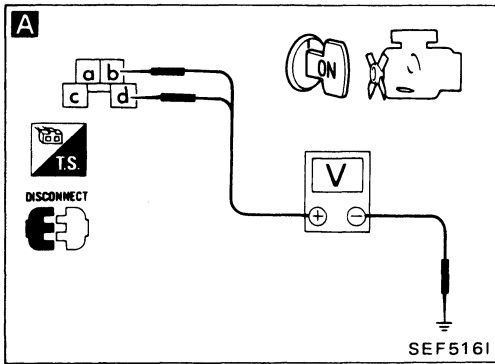

INSPECTION START

A

CHECK POWER SUPPLY (1).

- 1) Turn ignition switch "ON".
- 2) Check voltage between radiator fan relay terminals (b), (d) and ground.

Voltage: Battery voltage.

B

Check the following items.

- 1) "G", "R" and "L" fusible links.
- 2) "10A" fuses
- 3) Ignition switch
- 4) Harness continuity between
 - radiator fan relay terminal (b) and battery (+) terminal
 - radiator fan relay terminal (d) and ignition switch
 - ignition switch and battery (+) terminal

Continuity should exist.

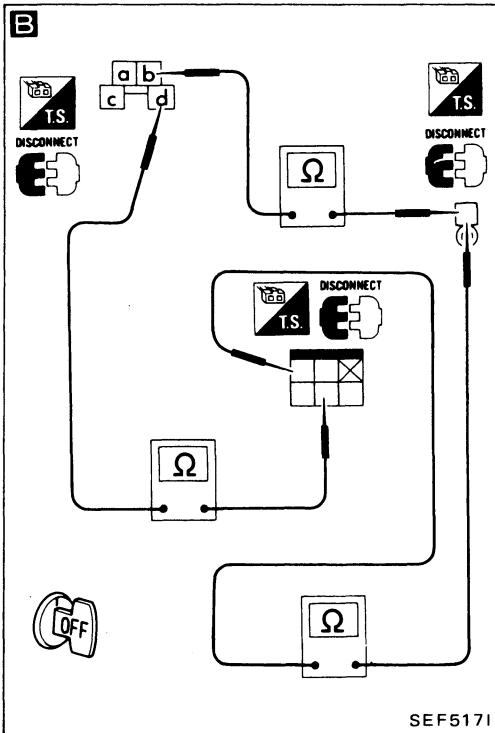

C

CHECK POWER SUPPLY (2).

- 1) Turn radiator fan relay "ON" in "ACTIVE TEST" mode with CONSULT.
- 2) Check voltage between radiator fan motor terminal (a) and ground.

Voltage: Battery voltage.

D

Check the following items.

Harness continuity between

- radiator fan motor and radiator fan relay
- radiator fan relay and E.C.U. terminal (19)

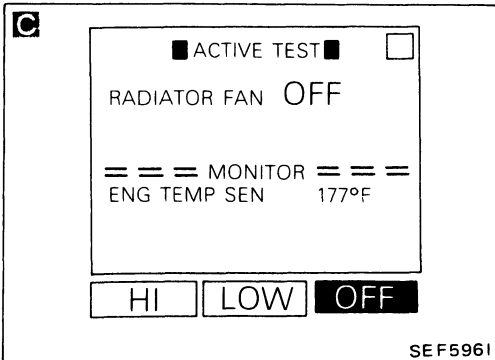

E

CHECK COMPONENT (Radiator fan relay).

Perform "RADIATOR FAN TEST" in "ACTIVE TEST" mode with CONSULT.

Refer to "Electrical Components Inspection". (See page EF & EC-190.)

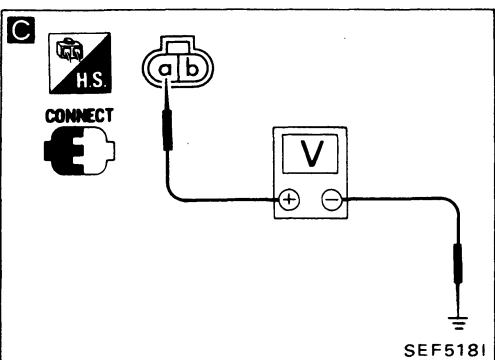

E

CHECK GROUND CIRCUIT.

Check harness continuity between radiator fan motor terminal (b) and ground.

Continuity should exist.

Repair or replace harness or connectors.



TROUBLE DIAGNOSES

Diagnostic Procedure 48 (Cont'd)

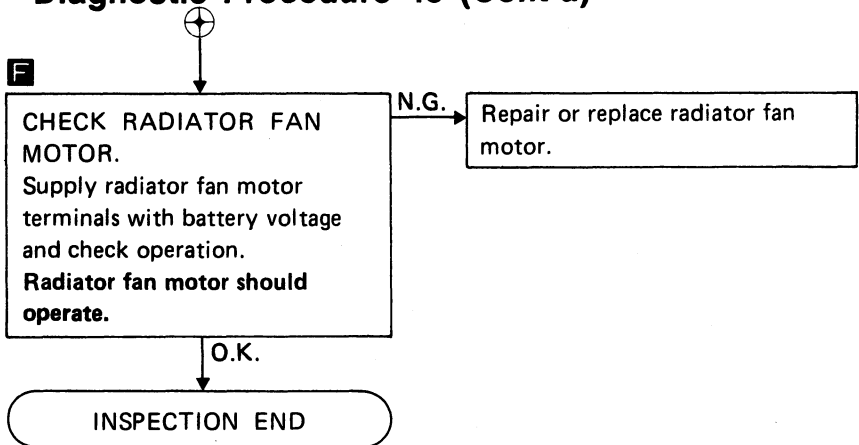
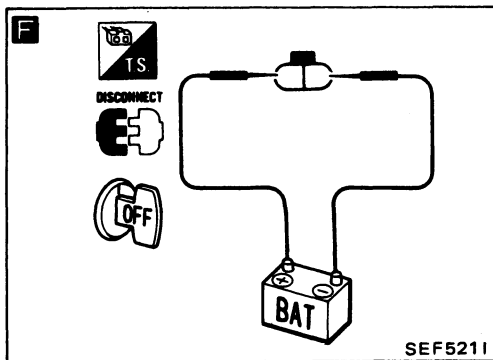
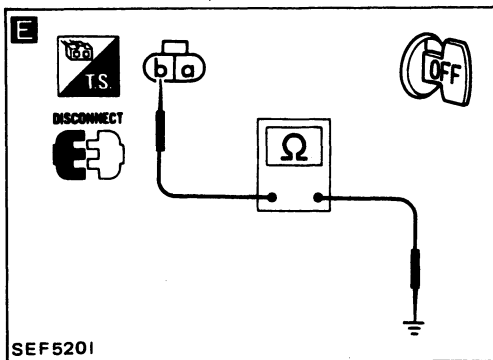
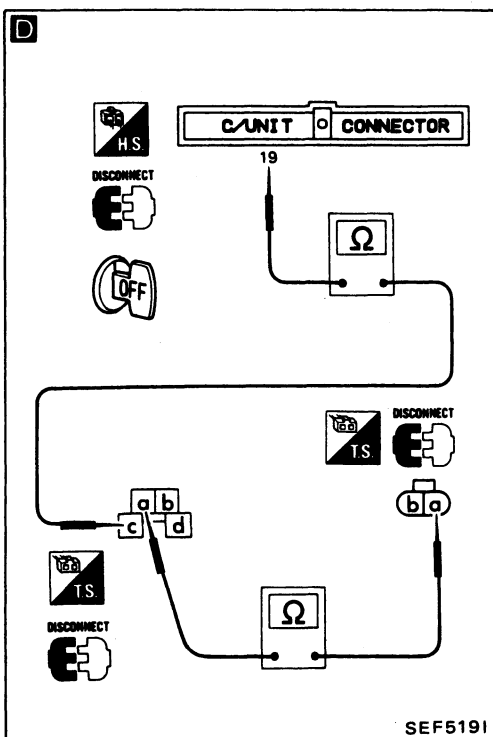

TROUBLE DIAGNOSES

NOTE

TROUBLE DIAGNOSES

Diagnostic Procedure 49

WASTEGATE VALVE CONTROL SOLENOID VALVE (Not self-diagnostic item): Turbo model only

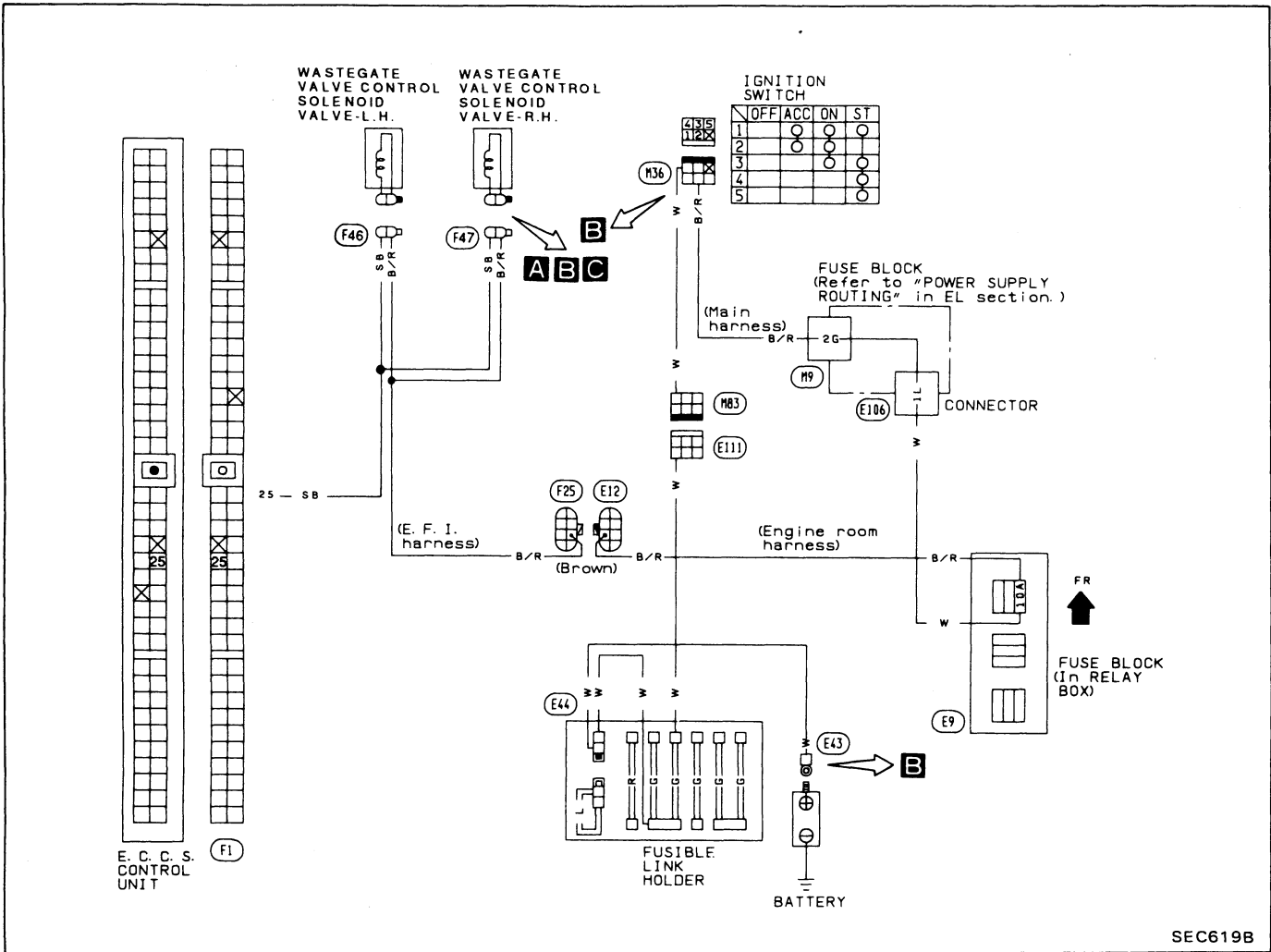

SEC619B

Harness layout

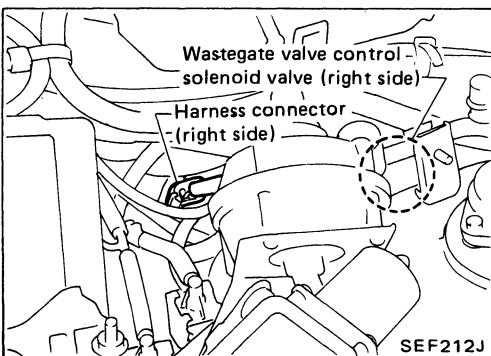
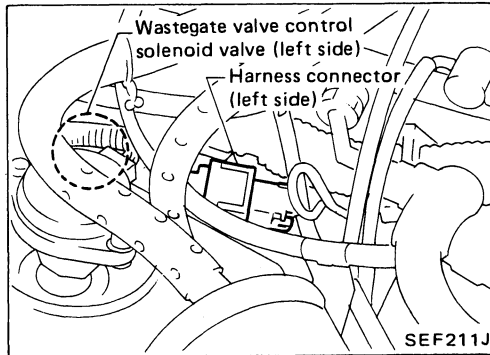
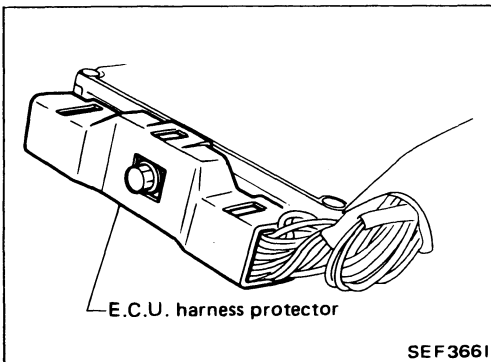

TROUBLE DIAGNOSES

Diagnostic Procedure 49 (Cont'd)

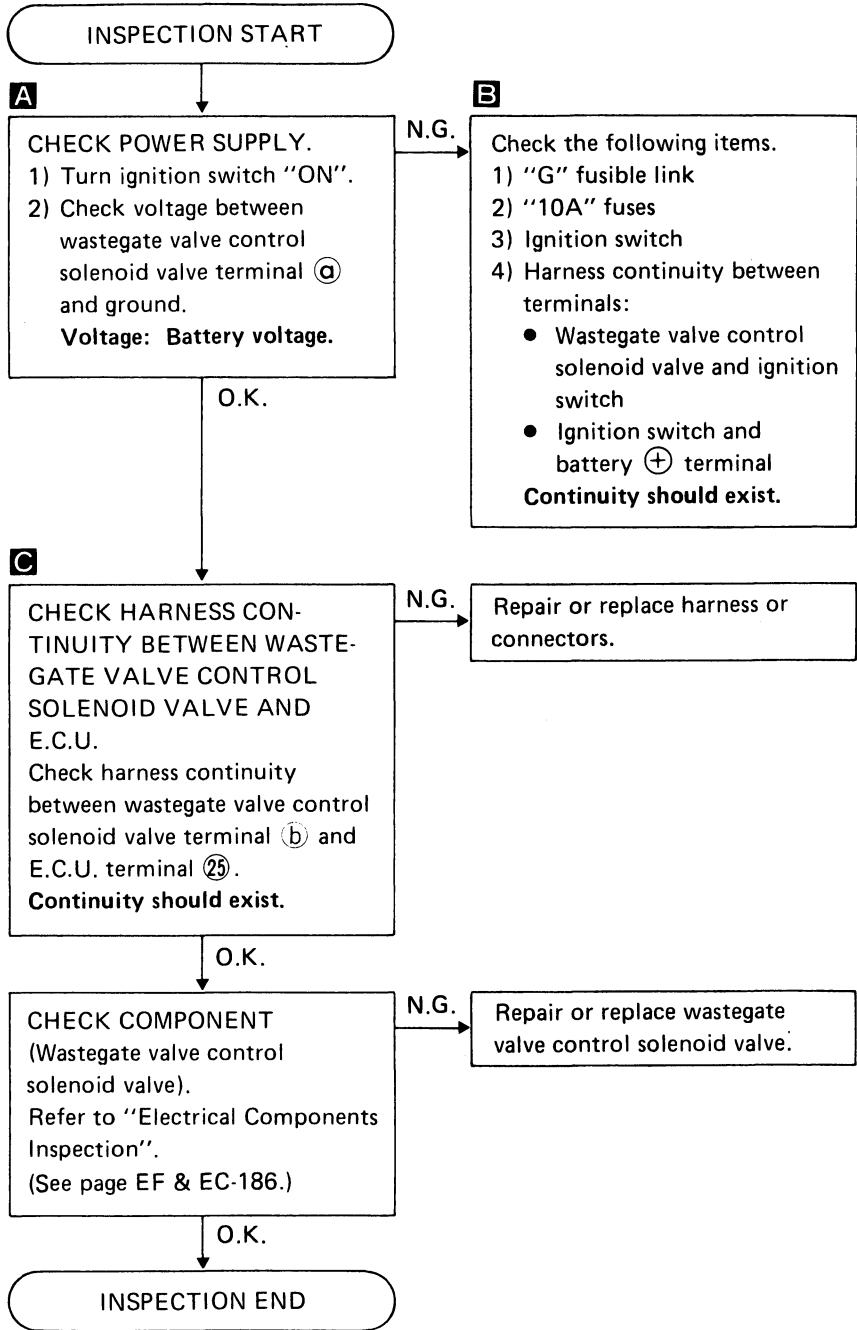
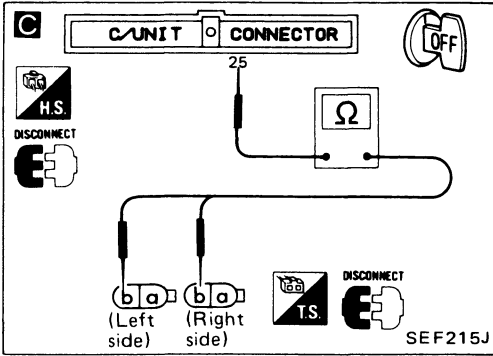
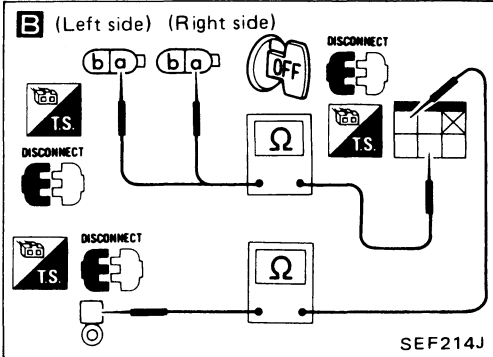
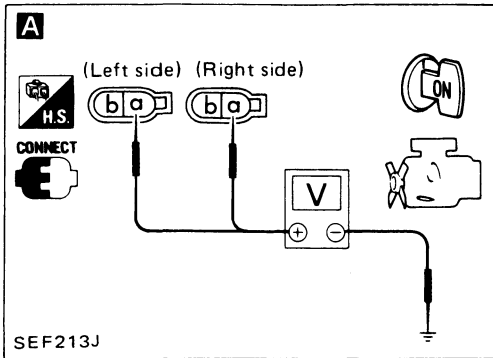

TROUBLE DIAGNOSES

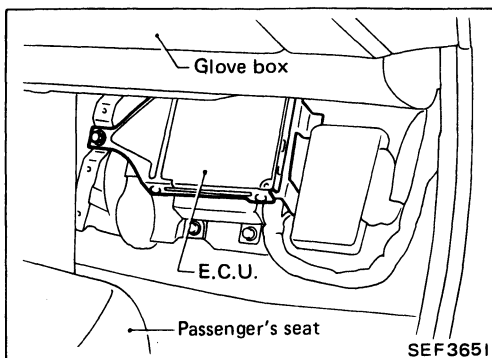

Electrical Components Inspection

E.C.U. INPUT/OUTPUT SIGNAL INSPECTION

1. E.C.U. is located behind front passenger side floor board. For this inspection, remove the front passenger side floor board.

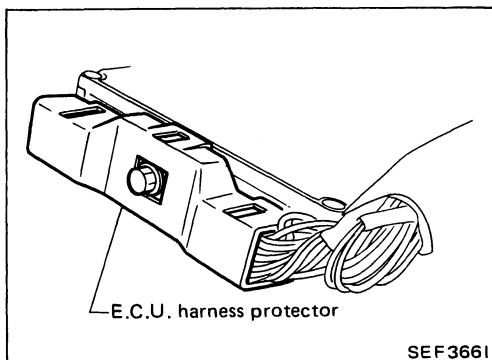

2. Remove E.C.U. harness protector.

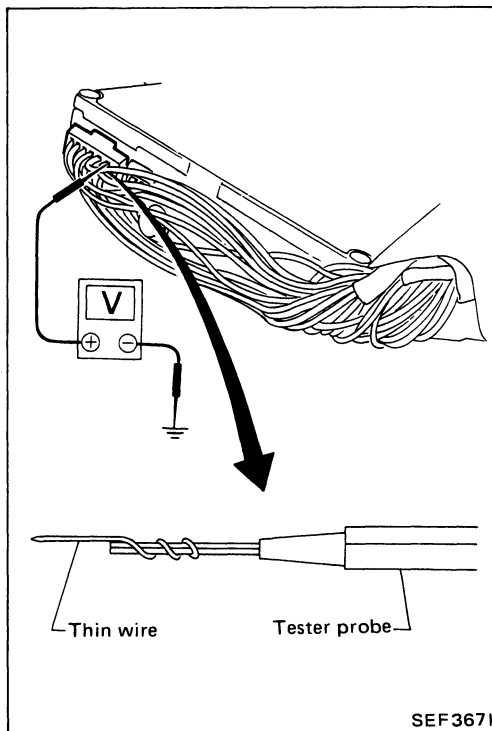

3. Perform all voltage measurements with the connectors connected.

Extend tester probe as shown to perform tests easily.

TROUBLE DIAGNOSES

Electrical Components Inspection (Cont'd)

E.C.U. inspection table

*Data are reference values.

TERMI- NAL NO.	ITEM	CONDITION	*DATA
1 2 3 11 12 13	Ignition signal	<div style="border: 1px solid black; padding: 2px; display: inline-block;">Engine is running.</div> └ Idle speed	Approx. 0.1V
		<div style="border: 1px solid black; padding: 2px; display: inline-block;">Engine is running.</div> └ Engine speed is 2,000 rpm.	Approx. 0.14V
4	A.A.C. valve	<div style="border: 1px solid black; padding: 2px; display: inline-block;">Engine is running.</div> └ Racing condition	Voltage briefly decreases from battery voltage (11 - 14V).
6	Radiator fan sub-relay (Turbo model)	<div style="border: 1px solid black; padding: 2px; display: inline-block;">Engine is running.</div> └ Radiator fan is not operating.	BATTERY BOLTAGE (11 - 14V)
		<div style="border: 1px solid black; padding: 2px; display: inline-block;">Engine is running.</div> └ Radiator fan is operating.	0.1 - 0.3V
7	Tachometer	<div style="border: 1px solid black; padding: 2px; display: inline-block;">Engine is running.</div> └ Idle speed	Approx. 0.7V
		<div style="border: 1px solid black; padding: 2px; display: inline-block;">Engine is running.</div> └ Engine speed is 2,000 rpm.	Approx. 1.2V
8	A.I.V. control solenoid valve	<div style="border: 1px solid black; padding: 2px; display: inline-block;">Engine is running.</div> └ Idle speed	Approx. 0V
		<div style="border: 1px solid black; padding: 2px; display: inline-block;">Engine is running.</div> └ Engine speed is 2,000 rpm.	BATTERY VOLTAGE (11 - 14V)
9	Air conditioner relay	<div style="border: 1px solid black; padding: 2px; display: inline-block;">Engine is running.</div> └ Air conditioner switch "OFF"	BATTERY VOLTAGE (11 - 14V)
		<div style="border: 1px solid black; padding: 2px; display: inline-block;">Engine is running.</div> └ Air conditioner switch "ON"	Approx. 0V
16	E.C.U. power source (Self-shutoff)	<div style="border: 1px solid black; padding: 2px; display: inline-block;">Engine is running.</div> └ Idle speed	0.8 - 1.0V
		<div style="border: 1px solid black; padding: 2px; display: inline-block;">Engine is not running.</div> └ For a few seconds after turning ignition switch "OFF"	BATTERY VOLTAGE (11 - 14V)

TROUBLE DIAGNOSES

Electrical Components Inspection (Cont'd)

*Data are reference values.

TERMI- NAL NO.	ITEM	CONDITION	*DATA
18	Fuel pump relay	<div style="border: 1px solid black; padding: 2px; display: inline-block;">Ignition switch "ON"</div> └ For 5 seconds after turning ignition switch "ON"	0.7 - 0.9V
		<div style="border: 1px solid black; padding: 2px; display: inline-block;">Engine is running.</div>	
19	Radiator fan relay	<div style="border: 1px solid black; padding: 2px; display: inline-block;">Ignition switch "ON"</div> └ In 5 seconds after turning ignition switch "ON"	BATTERY VOLTAGE (11 - 14V)
		<div style="border: 1px solid black; padding: 2px; display: inline-block;">Engine is running.</div> └ Radiator fan is not operating.	BATTERY VOLTAGE (11 - 14V)
23	Detonation sensor	<div style="border: 1px solid black; padding: 2px; display: inline-block;">Engine is running.</div> └ Radiator fan is operating.	0.1 - 0.3V
		<div style="border: 1px solid black; padding: 2px; display: inline-block;">Engine is running.</div> └ Idle speed	Approx. 2.5V
25	Wastegate valve control solenoid valves (Turbo model)	<div style="border: 1px solid black; padding: 2px; display: inline-block;">Ignition switch "ON"</div>	BATTERY VOLTAGE (11 - 14V)
		<div style="border: 1px solid black; padding: 2px; display: inline-block;">Engine is running.</div>	
		<div style="border: 1px solid black; padding: 2px; display: inline-block;">Engine is racing.</div> └ Engine speed is up to 2,000 rpm	Approx. 0.2V
27	Air flow meter	<div style="border: 1px solid black; padding: 2px; display: inline-block;">Engine is running.</div> (Warm-up condition) └ Idle speed	0.8 - 1.5V
		<div style="border: 1px solid black; padding: 2px; display: inline-block;">Engine is running.</div> (Warm-up condition) └ Engine speed is 2,000 rpm.	1.0 - 1.6V
28	Engine temperature sensor	<div style="border: 1px solid black; padding: 2px; display: inline-block;">Engine is running.</div>	0 - 5.0V Output voltage varies with engine temperature.
29	Right side exhaust gas sensor	<div style="border: 1px solid black; padding: 2px; display: inline-block;">Engine is running.</div>	0 ↔ Approx. 1.0V
55	Left side exhaust gas sensor	└ After warming up sufficiently and engine speed is 2,000 rpm.	
33	F.I.C.D. solenoid valve	<div style="border: 1px solid black; padding: 2px; display: inline-block;">Engine is running.</div> └ A/C compressor is not operating.	BATTERY VOLTAGE (11 - 14V)
		<div style="border: 1px solid black; padding: 2px; display: inline-block;">Engine is running.</div> └ A/C compressor is operating.	0.7 - 0.8V

TROUBLE DIAGNOSES

Electrical Components Inspection (Cont'd)

*Data are reference values.

TERMI- NAL NO.	ITEM	CONDITION	*DATA
34	Power steering oil pressure switch	<div style="border: 1px solid black; padding: 2px; display: inline-block;">Engine is running.</div> ↳ Steering wheel is in the "straight ahead" position.	8.0 - 9.0V
		<div style="border: 1px solid black; padding: 2px; display: inline-block;">Engine is running.</div> ↳ Steering wheel is turned.	Approx. 0V
36	Fuel temperature sensor	<div style="border: 1px solid black; padding: 2px; display: inline-block;">Engine is running.</div>	0 - 5.0V Output voltage varies with fuel temperature.
38	Throttle sensor	<div style="border: 1px solid black; padding: 2px; display: inline-block;">Ignition switch "ON"</div>	0.4 - 4.0V Output voltage varies with throttle valve opening angle.
39	Exhaust gas temperature sensor	<div style="border: 1px solid black; padding: 2px; display: inline-block;">Engine is running.</div> (Warm-up condition) ↳ Idle speed	Less than 4.5V
		<div style="border: 1px solid black; padding: 2px; display: inline-block;">Engine is running.</div> (Warm-up condition) ↳ E.G.R. system is operating.	0 - 1.0V
41 51	Crank angle sensor (Reference signal)	<div style="border: 1px solid black; padding: 2px; display: inline-block;">Engine is running.</div> Do not run engine at high speed under no-load.	1.2 - 1.4V Output voltage varies slightly with engine speed.
42 52	Crank angle sensor (Position signal)	<div style="border: 1px solid black; padding: 2px; display: inline-block;">Engine is running.</div> Do not run engine at high speed under no-load.	2.5 - 2.7V Output voltage varies slightly with engine speed.
43	Start signal	<div style="border: 1px solid black; padding: 2px; display: inline-block;">Ignition switch "ON"</div>	Approx. 0V
		<div style="border: 1px solid black; padding: 2px; display: inline-block;">Ignition switch "START"</div>	BATTERY VOLTAGE (11 - 14V)
44	Neutral switch (M/T model) A/T control unit (A/T model)	<div style="border: 1px solid black; padding: 2px; display: inline-block;">Ignition switch "ON"</div> ↳ Gear position is "Neutral" (M/T model). ↳ Gear position is "N" or "P" (A/T model).	Approx. 0V
		<div style="border: 1px solid black; padding: 2px; display: inline-block;">Ignition switch "ON"</div> ↳ Except the above conditions	8.0 - 9.0V
45	Ignition switch	<div style="border: 1px solid black; padding: 2px; display: inline-block;">Ignition switch "ON"</div> ↳ Engine stopped	BATTERY VOLTAGE (11 - 14V)

TROUBLE DIAGNOSES

Electrical Components Inspection (Cont'd)

*Data are reference values.

TERMI- NAL NO.	ITEM	CONDITION	*DATA
46	Air conditioner switch	<div style="border: 1px solid black; padding: 2px; display: inline-block;">Engine is running.</div> └ Air conditioner switch "OFF"	BATTERY VOLTAGE (11 - 14V)
		<div style="border: 1px solid black; padding: 2px; display: inline-block;">Engine is running.</div> └ Air conditioner switch "ON"	0.5 - 0.7V
48	Power source for sensors	<div style="border: 1px solid black; padding: 2px; display: inline-block;">Ignition switch "ON"</div> └ Engine stopped	Approximately 5.0V
49	Battery source	<div style="border: 1px solid black; padding: 2px; display: inline-block;">Ignition switch "ON"</div> └ Engine stopped	BATTERY VOLTAGE (11 - 14V)
54	Throttle valve switch (Idle position)	<div style="border: 1px solid black; padding: 2px; display: inline-block;">Ignition switch "ON"</div> └ Accelerator pedal is fully released (engine running).	9.0 - 10.0V
		<div style="border: 1px solid black; padding: 2px; display: inline-block;">Ignition switch "ON"</div> └ Accelerator pedal is depressed (engine running).	0V
57	Power source for throttle valve switch	<div style="border: 1px solid black; padding: 2px; display: inline-block;">Ignition switch "ON"</div> └ Engine running	BATTERY VOLTAGE (11 - 14V)
59	Power supply	<div style="border: 1px solid black; padding: 2px; display: inline-block;">Ignition switch "ON"</div> └ Engine running	BATTERY VOLTAGE (11 - 14V)
101 103 105 110 112 114	Injectors	<div style="border: 1px solid black; padding: 2px; display: inline-block;">Ignition switch "OFF"</div>	BATTERY VOLTAGE (11 - 14V)
102	E.G.R. control solenoid valve	<div style="border: 1px solid black; padding: 2px; display: inline-block;">Engine is running.</div> (Warm-up condition) └ Idle speed	0.7 - 0.8V
		<div style="border: 1px solid black; padding: 2px; display: inline-block;">Engine is running.</div> (Warm-up condition) └ Engine speed is 2,000 rpm.	BATTERY VOLTAGE (11 - 14V)

TROUBLE DIAGNOSES

Electrical Components Inspection (Cont'd)

*Data are reference values.

TERMI- NAL NO.	ITEM	CONDITION	*DATA
35 104	Fuel pump voltage control (35: Turbo model)	Ignition switch "ON" └ Engine stopped	BATTERY VOLTAGE (11 - 14V)
		Engine is running. (Warm-up condition) └ Idle speed	Approx. 0V
111	P.R.V.R. control solenoid valve	Stop and restart engine after warming it up. └ Fuel temperature is above 75°C (167°F)	0 - 1.0V (for 30 seconds after ignition switch is turned off.) BATTERY VOLTAGE (After 30 seconds)
		Stop and restart engine after warming it up. └ Fuel temperature is below 75°C (167°F)	BATTERY VOLTAGE (11 - 14V)
113	Valve timing control solenoid valves	Engine is running. └ Idle speed	BATTERY VOLTAGE (11 - 14V)
		Engine is running. └ Engine speed is 3,000 rpm.	0.2 - 0.5V

E.C.U. HARNESS CONNECTOR TERMINAL LAYOUT

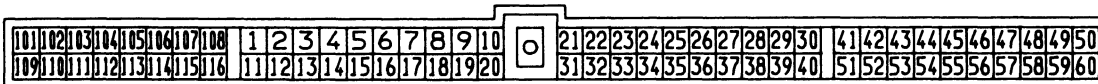

SEC250B

TROUBLE DIAGNOSES

Electrical Components Inspection (Cont'd) CRANK ANGLE SENSOR

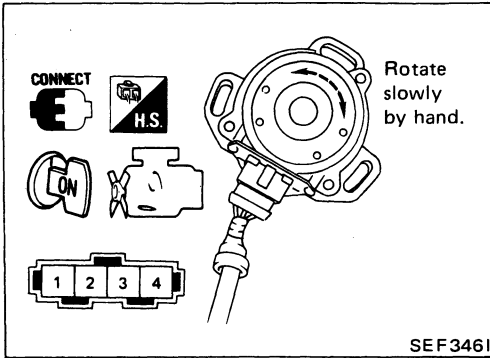

1. Remove crank angle sensor from engine. (Crank angle sensor harness connector should remain connected.)
2. Turn ignition switch "ON".
3. Rotate crank angle sensor shaft slowly by hand and check voltage between terminals ①, ② and ground.

Terminal	Voltage
② (120° signal)	Voltage fluctuates between 5V and 0V.
① (1° signal)	

If N.G., replace crank angle sensor.

After this inspection, malfunction code No. 11 might be displayed though the crank angle sensor is functioning properly. In this case erase the stored memory.

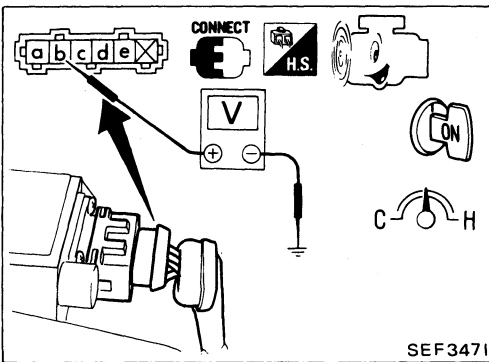

AIR FLOW METER

1. Fold back air flow meter harness connector rubber as shown in the figure if the harness connector is connected.
2. Turn ignition switch "ON".
3. Start engine and warm it up sufficiently.
4. Check voltage between terminal ① and ground.

Conditions	Voltage V
Ignition switch "ON" (Engine stopped.)	Approximately 0.8
Idle (Engine is warm-up sufficiently.)	Approximately 0.8 - 1.5

5. If N.G., remove air flow meter from air duct. Check hot wire for damage or dust.

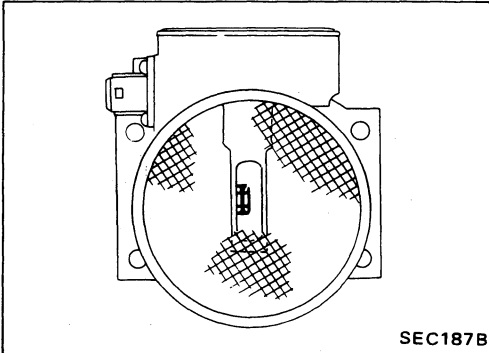

ENGINE TEMPERATURE SENSOR

1. Disconnect engine temperature sensor harness connector.
2. Check resistance as shown in the figure.

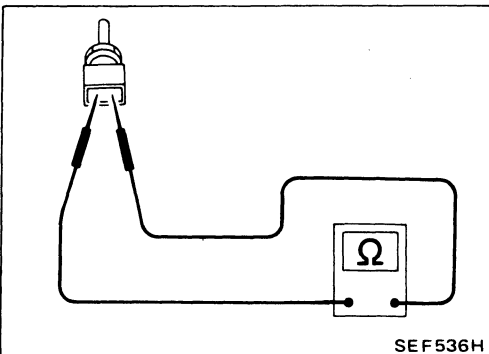

Temperature °C (°F)	Resistance kΩ
20 (68)	2.1 - 2.9
50 (122)	0.68 - 1.00
80 (176)	0.30 - 0.33

If N.G., replace engine temperature sensor.

TROUBLE DIAGNOSES

Electrical Components Inspection (Cont'd)

IGNITION COIL

1. Disconnect ignition coil harness connector.
2. Check resistance as shown in the figure.

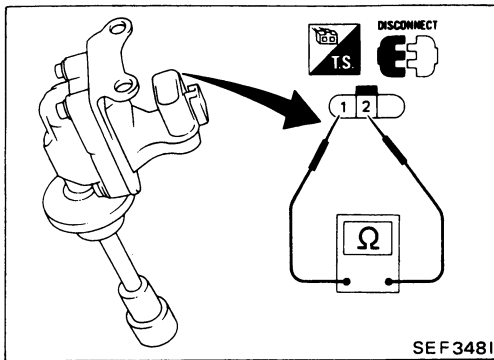

Terminal	Resistance
① - ②	Approximately 0.7Ω

If N.G., replace ignition coil.

POWER TRANSISTOR

1. Disconnect power transistor harness connector.
2. Check power transistor continuity between terminals as shown in the figure.

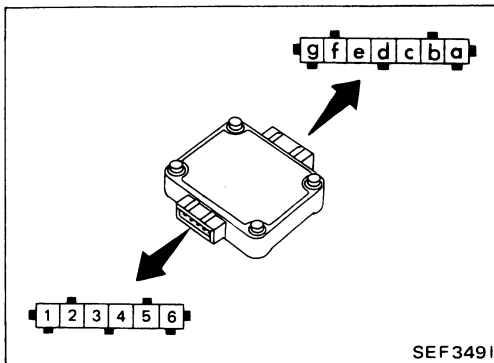

Terminal combination						Tester polarity	Con-tinuity	Tester polarity	Con-tinuity
g	g	g	g	g	g	⊕	No	⊖	Yes
a	b	c	d	e	f	⊖		⊕	
g	g	g	g	g	g	⊕	Yes	⊖	Yes
1	2	3	4	5	6	⊖		⊕	
a	b	c	d	e	f	⊕	Yes	⊖	No
1	2	3	4	5	6	⊖		⊕	

If N.G., replace power transistor.

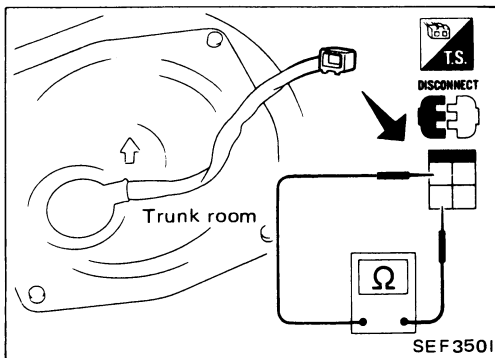

FUEL PUMP

1. Disconnect fuel pump harness connector.
2. Check resistance between terminals Ⓐ and Ⓒ.

Resistance: Approximately 0.5Ω

If N.G., replace fuel pump.

VEHICLE SPEED SENSOR

1. Jack up rear wheels. Use stands to support vehicle.
2. Disconnect vehicle speed sensor harness connector.
3. Check continuity between terminals Ⓐ and Ⓑ while rotating rear wheel by hand.

Continuity should come and go.

If N.G. replace vehicle speed sensor.

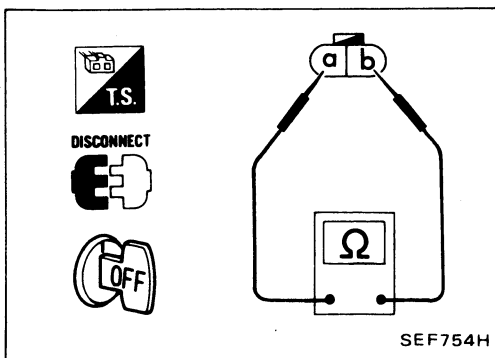

TROUBLE DIAGNOSES

Electrical Components Inspection (Cont'd) WASTEGATE VALVE CONTROL SOLENOID VALVE

Check air passage continuity.

Condition	Air passage continuity between (A) and (B)
12V direct current supply between terminals (a) and (b)	Yes
No supply	No

If N.G., replace solenoid valve.

E.G.R. CONTROL SOLENOID VALVE A.I.V. CONTROL SOLENOID VALVE P.R.V.R. CONTROL SOLENOID VALVE

Check air passage continuity.

Condition	Air passage continuity between (A) and (B)	Air passage continuity between (A) and (C)
12V direct current supply between terminals (1) and (2)	Yes	No
No supply	No	Yes

If N.G., replace solenoid valve.

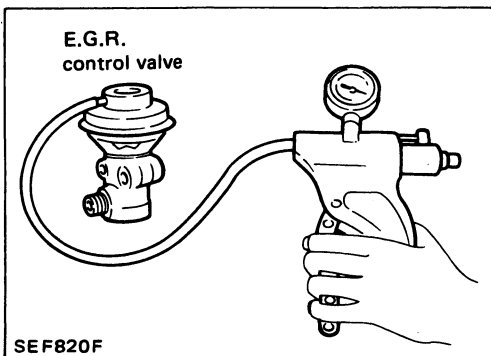
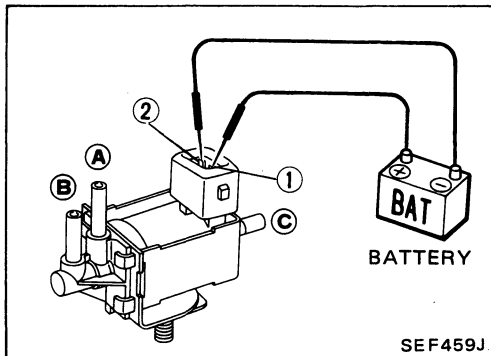
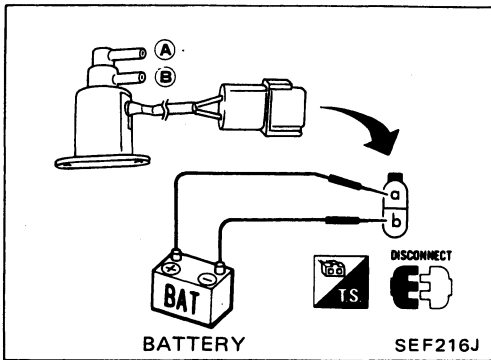

E.G.R. CONTROL VALVE

Apply vacuum to E.G.R. vacuum port with a hand vacuum pump.

E.G.R. control valve spring should lift.

If N.G., replace E.G.R. control valve.

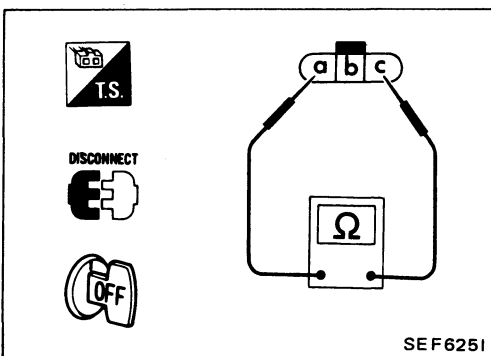

EXHAUST GAS SENSOR

Refer to "Diagnostic Procedure 30".
(See page EF & EC-130.)

EXHAUST GAS SENSOR HEATER

Check resistance between terminals (a) and (c).

Resistance: 3 - 1,000 Ω

If N.G., replace exhaust gas sensor.

TROUBLE DIAGNOSES

Electrical Components Inspection (Cont'd)

EXHAUST GAS TEMPERATURE SENSOR

Check resistance change and resistance value at 100°C (212°F).

- Resistance should decrease in response to temperature increase.

Resistance: 100°C (212°F)

85.3 ± 8.53 kΩ

If N.G., replace exhaust gas temperature sensor.

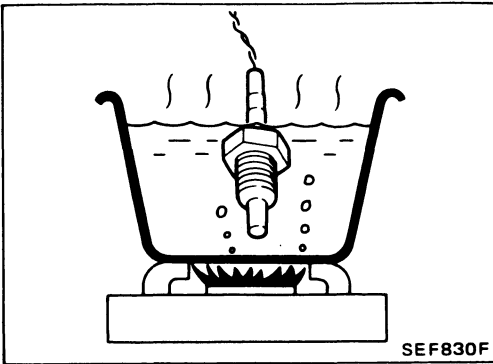

THROTTLE SENSOR

1. Disconnect throttle sensor harness connector.
2. Make sure that resistance between terminals (b) and (c) changes when opening throttle valve manually.

Accelerator pedal conditions	Resistance kΩ
Completely released	Approximately 1
Partially released	1 - 9
Completely depressed	Approximately 9

If N.G., replace throttle sensor.

Adjustment

If throttle sensor is replaced or removed, it is necessary to install it in the proper position, by following the procedure as shown below:

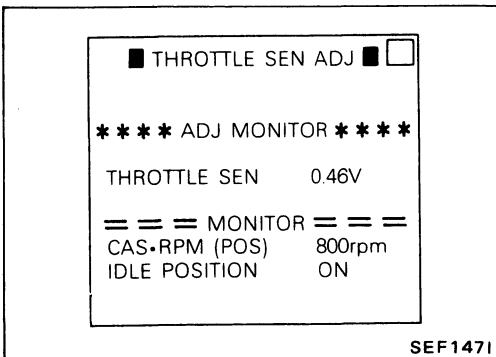
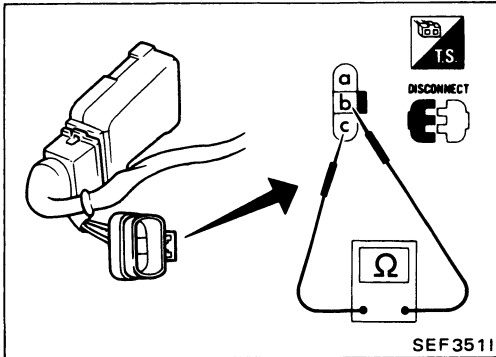

1. Install throttle sensor body in throttle chamber. Do not tighten bolts.
2. Connect throttle sensor and idle switch harness connector.
3. Start engine and warm it up sufficiently.
4.  Perform "THROTTLE SEN ADJ" in "WORK SUPPORT" mode.



Measure output voltage of throttle sensor using voltmeter.

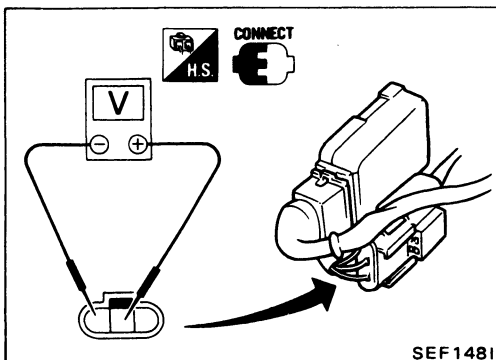

5. Adjust by rotating throttle sensor body so that output voltage is 0.4 to 0.5V.
6. Tighten mounting bolts.
7. Disconnect throttle sensor harness connector for a few seconds and then reconnect it.

TROUBLE DIAGNOSES

Electrical Components Inspection (Cont'd)

A.A.C. VALVE

- Check A.A.C. valve resistance.

Resistance:

Approximately 10Ω

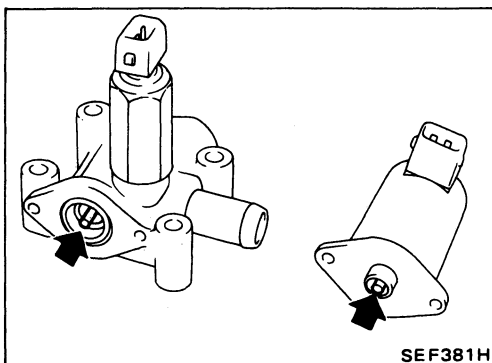
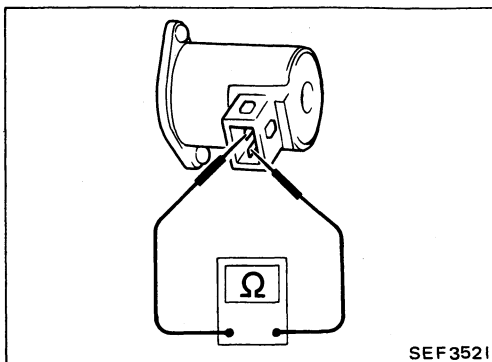

- Check plunger for seizing or sticking.
- Check for broken spring.

F.I.C.D. SOLENOID VALVE

- Check for clicking sound when applying 12V direct current to terminals.

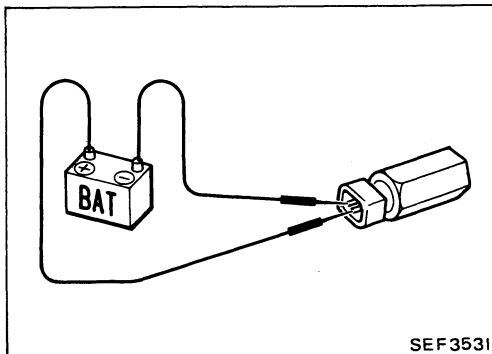

- Check plunger for seizing or sticking.
- Check for broken spring.

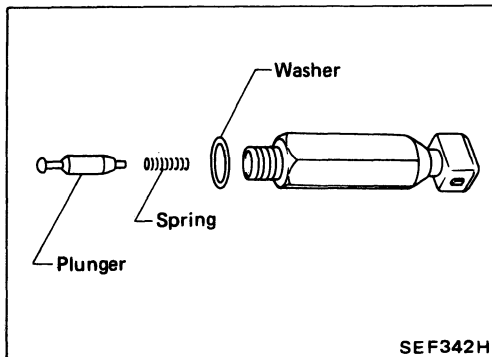

AIR REGULATOR

- Check air regulator resistance.

Resistance:

Approximately $70 - 80\Omega$

- Check air regulator for clogging.

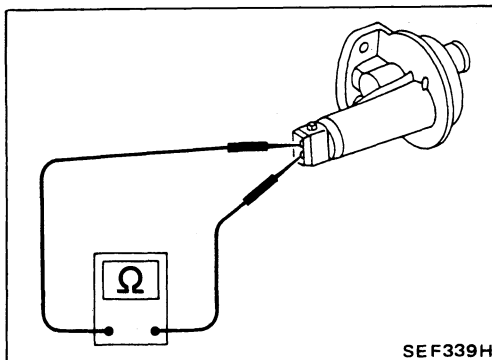

TROUBLE DIAGNOSES

Electrical Components Inspection (Cont'd)

DETONATION SENSOR

1. Disconnect detonation sensor sub-harness connector.
 2. Check continuity between terminal Ⓐ and ground.
- Continuity should exist.

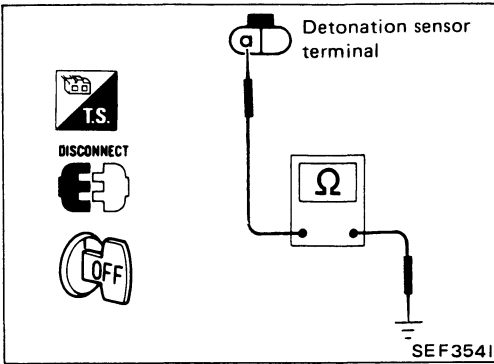

INJECTOR

1. Disconnect injector harness connector.
 2. Check resistance between terminals as shown in the figure.
- Resistance: 10 - 14 Ω**
If N.G., replace injector.

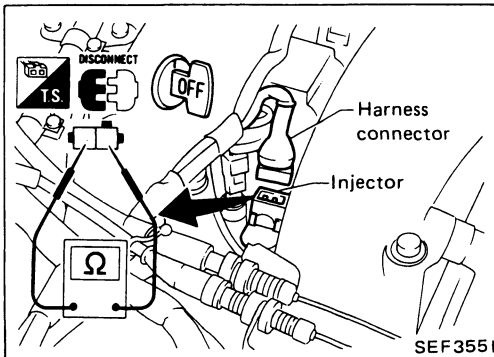

VALVE TIMING CONTROL SOLENOID VALVE

- Check valve timing control solenoid valve for normal operation by supplying it with battery voltage between terminals Ⓐ and Ⓑ.
- If N.G., replace solenoid valve.

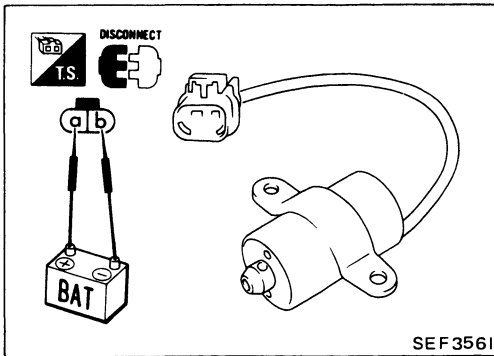

THROTTLE VALVE SWITCH (Idle position)

1. Disconnect idle switch harness connector.
2. Check continuity between terminals Ⓐ and Ⓑ.

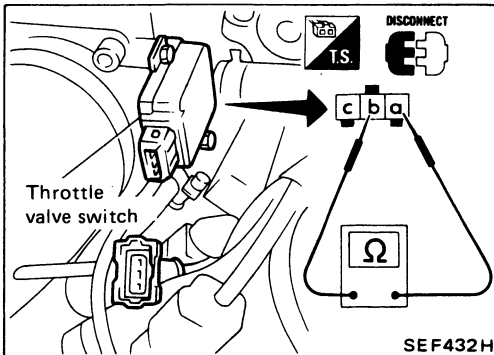

Accelerator pedal condition	Continuity
Released	Yes
Depressed	No

If N.G., replace throttle valve switch.

NEUTRAL SWITCH

Check continuity between terminals Ⓐ and Ⓑ.

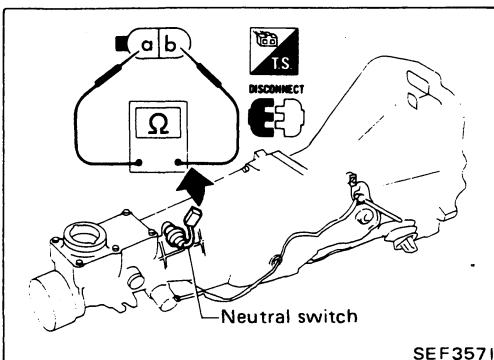

Conditions	Continuity
Shift to Neutral	Yes
Shift to other position	No

If N.G., replace neutral switch.

TROUBLE DIAGNOSES

Electrical Components Inspection (Cont'd)

INHIBITOR SWITCH

Check continuity between terminals ① and ②, ③.

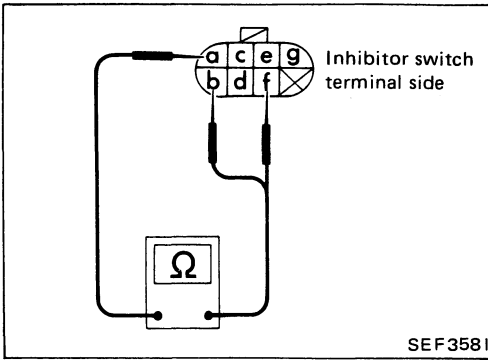

Conditions	Continuity between terminals ① and ②	Continuity between terminals ① and ③
Shift to "P" position	Yes	No
Shift to "N" position	No	Yes
Shift to positions other than "P" and "N"	No	No

E.C.C.S. RELAY, FUEL PUMP RELAY, RADIATOR FAN RELAY AND IGNITION COIL RELAY

Check continuity between terminals ④ and ⑤.

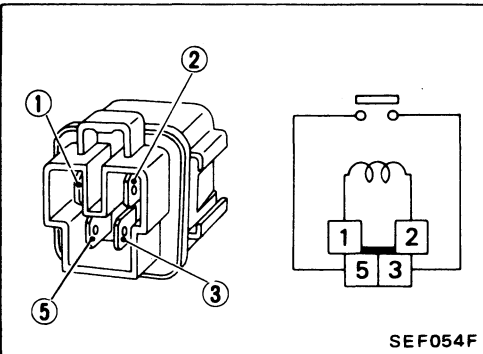

Conditions	Continuity
12V direct current supply between terminals ④ and ⑤	Yes
No current supply	No

If N.G., replace relay.

POWER STEERING OIL PRESSURE SWITCH

1. Disconnect power steering oil pressure switch harness connector.
2. Check resistance between terminals.

Resistance: Approximately 2 - 3 Ω

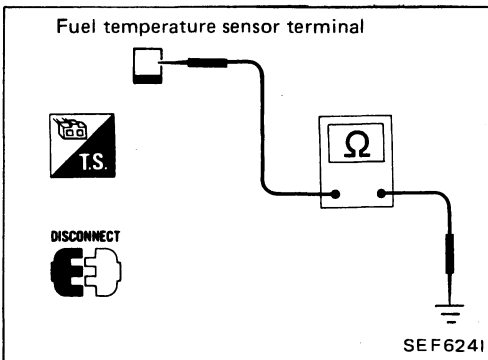

FUEL TEMPERATURE SENSOR

1. Disconnect fuel temperature sensor harness connector.
2. Check resistance between terminal and ground as shown in the figure.

Temperature °C (°F)	Resistance kΩ
20 (68)	2.1 - 2.9
50 (122)	0.68 - 1.00
80 (176)	0.30 - 0.33

If N.G., replace fuel inhibitor switch.

FUEL INJECTION CONTROL SYSTEM INSPECTION

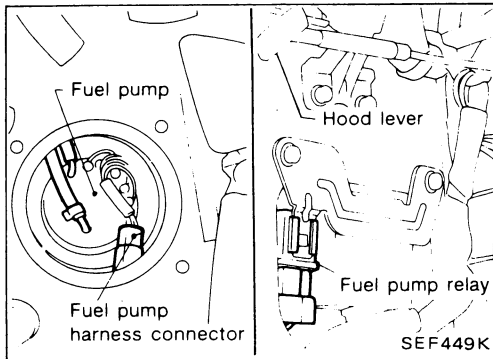
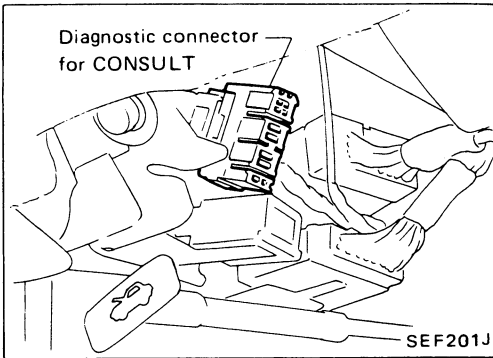

Releasing Fuel Pressure

Before disconnecting fuel line, release fuel pressure from fuel line to eliminate danger.



Perform "FUEL PRESSURE RELEASE" in "WORK SUPPORT" mode with CONSULT.



1. Remove fuel pump relay or disconnect fuel pump connector.
2. Start engine.
3. After engine stalls, crank it two or three times to release all fuel pressure.
4. Turn ignition switch off and reconnect fuel pump relay or fuel pump connector.

Fuel Pressure Check

- a. When reconnecting fuel line, always use new clamps.
 - b. Make sure that clamp screw does not contact adjacent parts.
 - c. Use a torque driver to tighten clamps.
 - d. Use Pressure Gauge to check fuel pressure.
 - e. Do not perform fuel pressure check while fuel pressure regulator control system is operating; otherwise, fuel pressure gauge might indicate incorrect readings.
1. Release fuel pressure to zero.
 2. Disconnect fuel hose between fuel filter and fuel tube (engine side).
 3. Install pressure gauge between fuel filter and fuel tube.
 4. Start engine and check for fuel leakage.

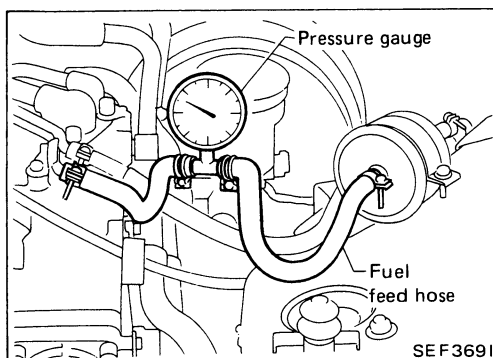

5. Read the indication of fuel pressure gauge.

At idling:

When fuel pressure regulator valve vacuum hose is connected.

Approximately 250.1 kPa
(2.55 kg/cm², 36.3 psi)

When fuel pressure regulator valve vacuum hose is disconnected.

Approximately 299.1 kPa
(3.05 kg/cm², 43.4 psi)

FUEL INJECTION CONTROL SYSTEM INSPECTION

Fuel Pressure Check (Cont'd)

6. Stop engine and disconnect fuel pressure regulator vacuum hose from intake manifold.
7. Plug intake manifold with a rubber cap.
8. Connect variable vacuum source to fuel pressure regulator.

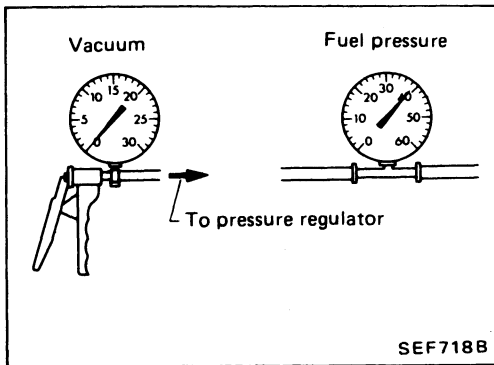

9. Start engine and read indication of fuel pressure gauge as vacuum is changed.

Fuel pressure should decrease as vacuum increases. If results are unsatisfactory, replace fuel pressure regulator.

Injector Removal and Installation

1. Release fuel pressure to zero.
2. Drain coolant from radiator drain cock.
3. Remove or disconnect the following:
 - Related harnesses, wires and tubes
 - Intake manifold collectorFor details, refer to EM section.
4. Remove injectors with fuel tube assembly.
5. Remove injectors from fuel tube assembly.
6. Install injectors as follows:
 - 1) Clean exterior of injector tail piece.
 - 2) Use new O-rings.

CAUTION:

After properly connecting injectors to fuel tube assembly, check connections for fuel leakage.

7. Assemble injectors with fuel tube assembly to intake manifold.

EVAPORATIVE EMISSION CONTROL SYSTEM

Description

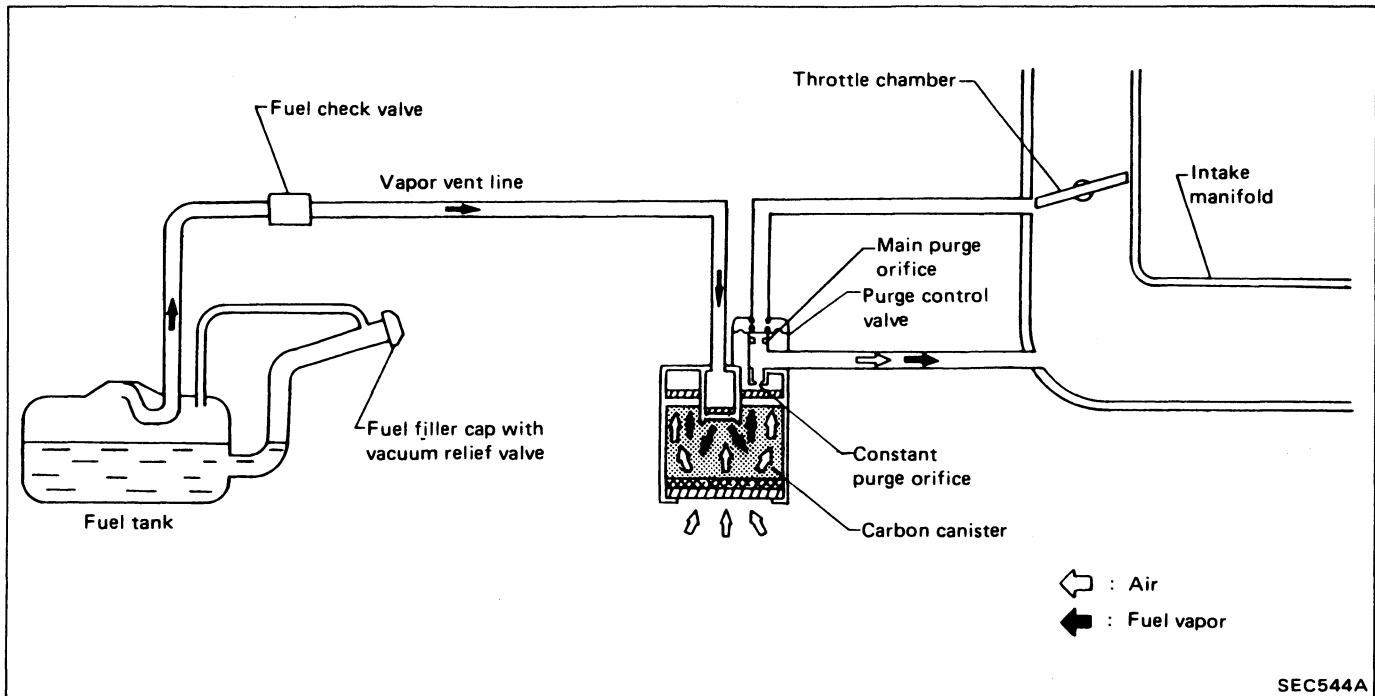

The evaporative emission control system is used to reduce hydrocarbons emitted into the atmosphere from the fuel system. This reduction of hydrocarbons is accomplished by activated charcoals in the carbon canister.

The fuel vapor from the sealed fuel tank is led into the canister which contains activated carbon and the vapor is stored there when the engine is not running.

The canister retains the fuel vapor until the canister is purged by the air drawn through the bottom of the canister to the intake manifold when the engine is running. When the engine runs at idle, the purge control valve is closed.

Only a small amount of stored vapor flows into the intake manifold through the constant purge orifice. As the engine speed increases, and the throttle vacuum rises higher, the purge control valve opens and the vapor is sucked into the intake manifold through both the main purge orifice and the constant purge orifice.

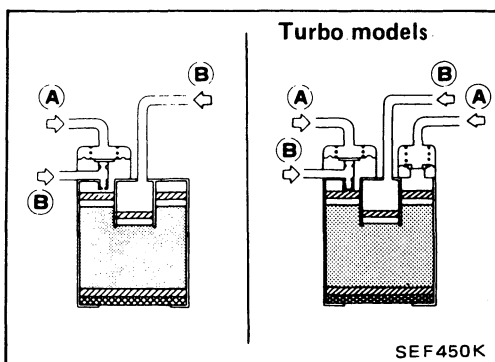

Inspection

CARBON CANISTER

Check carbon canister as follows:

- Ⓐ : Blow air and ensure that there is no leakage.
- Ⓑ : Blow air and ensure that there is leakage.

EVAPORATIVE EMISSION CONTROL SYSTEM

Inspection (Cont'd)

FUEL TANK VACUUM RELIEF VALVE

1. Wipe clean valve housing.
2. Suck air through the cap. A slight resistance accompanied by valve clicks indicates that valve is in good mechanical condition. Note also that, by further sucking air, the resistance should disappear with valve clicks.
3. If valve is clogged or if no resistance is felt, replace cap as an assembly.

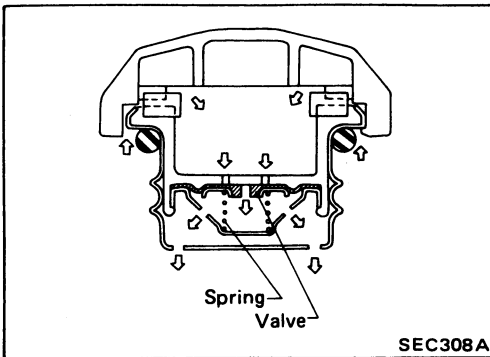

FUEL CHECK VALVE

1. Blow air through connector on fuel tank side. A considerable resistance should be felt and a portion of air flow should be directed toward the canister.
2. Blow air through connector on canister side. Air flow should be smoothly directed toward fuel tank.
3. If fuel check valve is suspected of not properly functioning in steps 1 and 2 above, replace it.

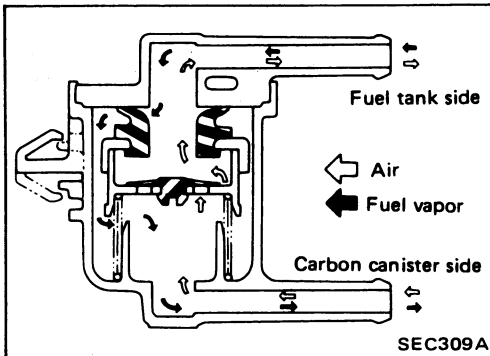

CRANKCASE EMISSION CONTROL SYSTEM

Description

This system returns blow-by gas to both the intake manifold and air inlet tubes.

The positive crankcase ventilation (P.C.V.) valve is provided to conduct crankcase blow-by gas to the intake manifold.

During partial throttle operation of the engine, the intake manifold sucks the blow-by gas through the P.C.V. valve.

Normally, the capacity of the valve is sufficient to handle any blow-by and a small amount of ventilating air.

The ventilating air is then drawn from the air inlet tubes, through the hose connecting air inlet tubes to rocker cover, into the crankcase.

Under full-throttle condition, the manifold vacuum is insufficient to draw the blow-by flow through the valve, and its flow goes through the hose connection in the reverse direction.

On vehicles with an excessively high blow-by some of the flow will go through the hose connection to the air inlet tubes under all conditions.

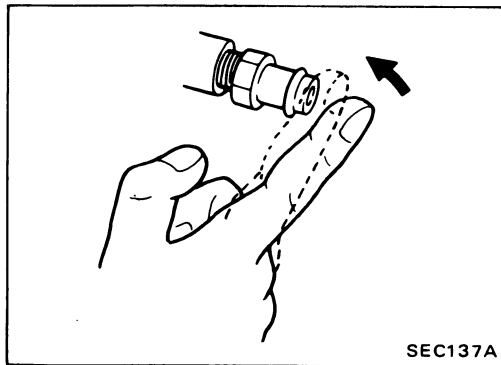
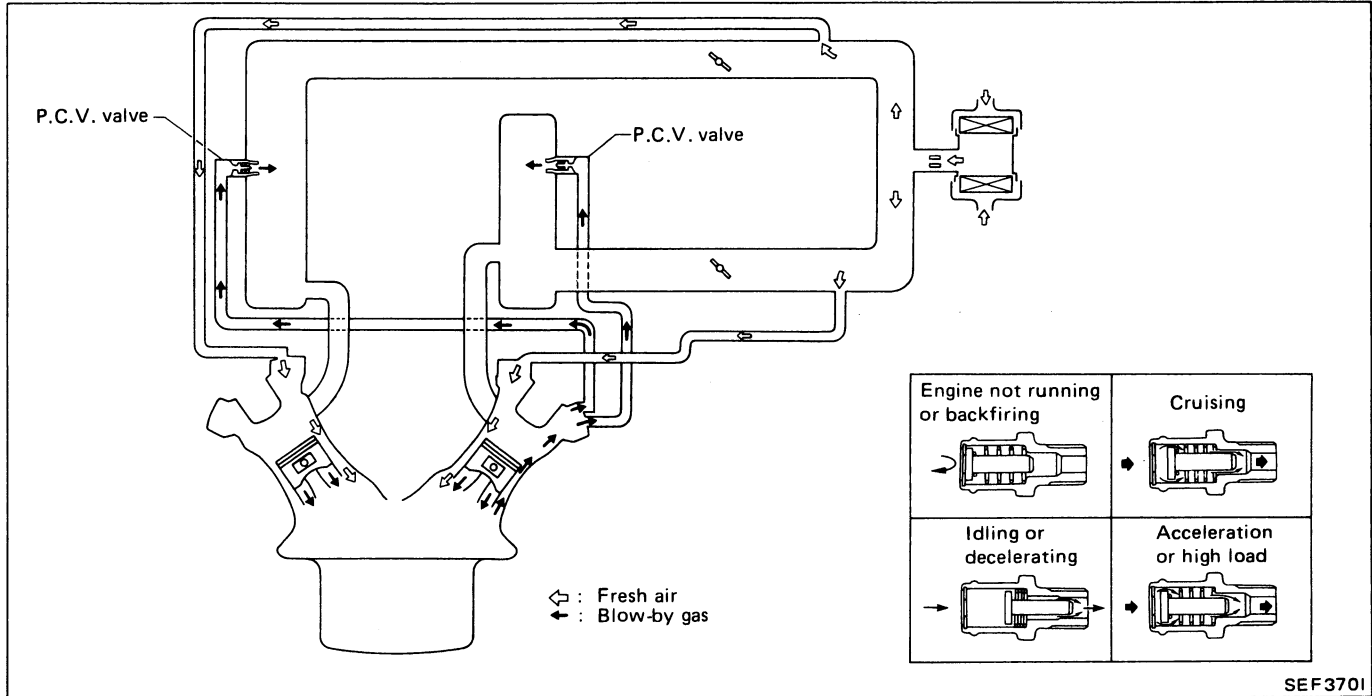

Inspection

P.C.V. (Positive Crankcase Ventilation)

With engine running at idle, remove ventilation hose from P.C.V. valve; if the valve is working properly, a hissing noise will be heard as air passes through it and a strong vacuum should be felt immediately when a finger is placed over valve inlet.

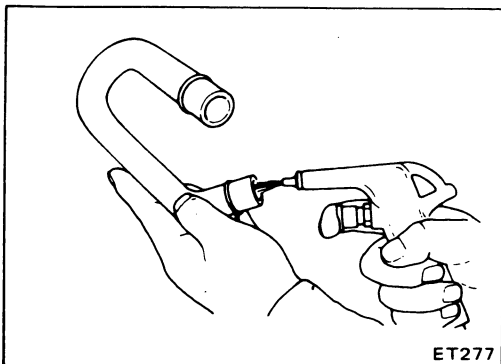

VENTILATION HOSE

1. Check hoses and hose connections for leaks.
2. Disconnect all hoses and clean with compressed air. If any hose cannot be freed of obstructions, replace.

SERVICE DATA AND SPECIFICATIONS (S.D.S.)

General Specifications

PRESSURE REGULATOR

Regulated pressure kPa (kg/cm ² , psi)	299.1 (3.05, 43.4)
--	--------------------

Inspection and Adjustment

Idle speed*1	rpm	
No-load*2		
M/T		700±50
A/T (in "N" position)		
Non-turbo		770±50
Turbo		750±50
Air conditioner: ON		
Non-turbo		800±50
Turbo		850±50
Ignition timing	degree	15±2 B.T.D.C.
Throttle sensor idle position	V	0.4 - 0.5

*1: Feedback controlled and needs no adjustments

*2: Under the following conditions:

- Air conditioner switch: OFF
- Steering wheel: Kept straight
- Electric load: OFF (Lights, heater, fan & rear defogger)
- Radiator fan: OFF

IGNITION COIL

Primary voltage	V	12
Primary resistance [at 20°C (68°F)]	Ω	Approximately 0.7
Secondary resistance [at 20°C (68°F)]	kΩ	Approximately 8

ENGINE TEMPERATURE SENSOR AND FUEL TEMPERATURE SENSOR

Temperature °C (°F)	Resistance kΩ
20 (68)	2.1 - 2.9
50 (122)	0.68 - 1.00
80 (176)	0.30 - 0.33

FUEL PUMP

Resistance	Ω	Approximately 0.5
------------	---	-------------------

EXHAUST GAS TEMPERATURE SENSOR

Resistance [at 100°C (212°F)]	kΩ	85.3±8.53
----------------------------------	----	-----------

EXHAUST GAS SENSOR HEATER

Resistance	Ω	3 - 1,000
------------	---	-----------

A.A.C. VALVE

Resistance	Ω	Approximately 10
------------	---	------------------

INJECTOR

Resistance	Ω	10 - 14
------------	---	---------

THROTTLE SENSOR

Accelerator pedal conditions	Resistance kΩ
Completely released	Approximately 1
Partially released	1 - 9
Completely depressed	Approximately 9

AIR REGULATOR

Resistance	Ω	70 - 80
------------	---	---------

POWER STEERING OIL PRESSURE SWITCH

Resistance	Ω	Approximately 2 - 3
------------	---	---------------------

ACCELERATOR CONTROL, FUEL & EXHAUST SYSTEMS

SECTION **FE**

CONTENTS

ACCELERATOR CONTROL SYSTEM	FE-2
FUEL SYSTEM	FE-3
EXHAUST SYSTEM	FE-5

FE

ACCELERATOR CONTROL SYSTEM

- When removing accelerator cable, make a mark to indicate lock nut's initial position.
- Check that throttle valve opens fully when accelerator pedal is fully depressed and that it returns to idle position when pedal is released.
- Adjust accelerator cable according to the following procedure.
Tighten "adjusting nut" until "throttle drum" starts to move.
From that position turn back "adjusting nut" 1.5 to 2 turns, and fasten it with a lock nut.
- Check accelerator control parts for improper contact with any adjacent parts.
- When connecting accelerator cable, be careful not to twist or scratch its inner wire.

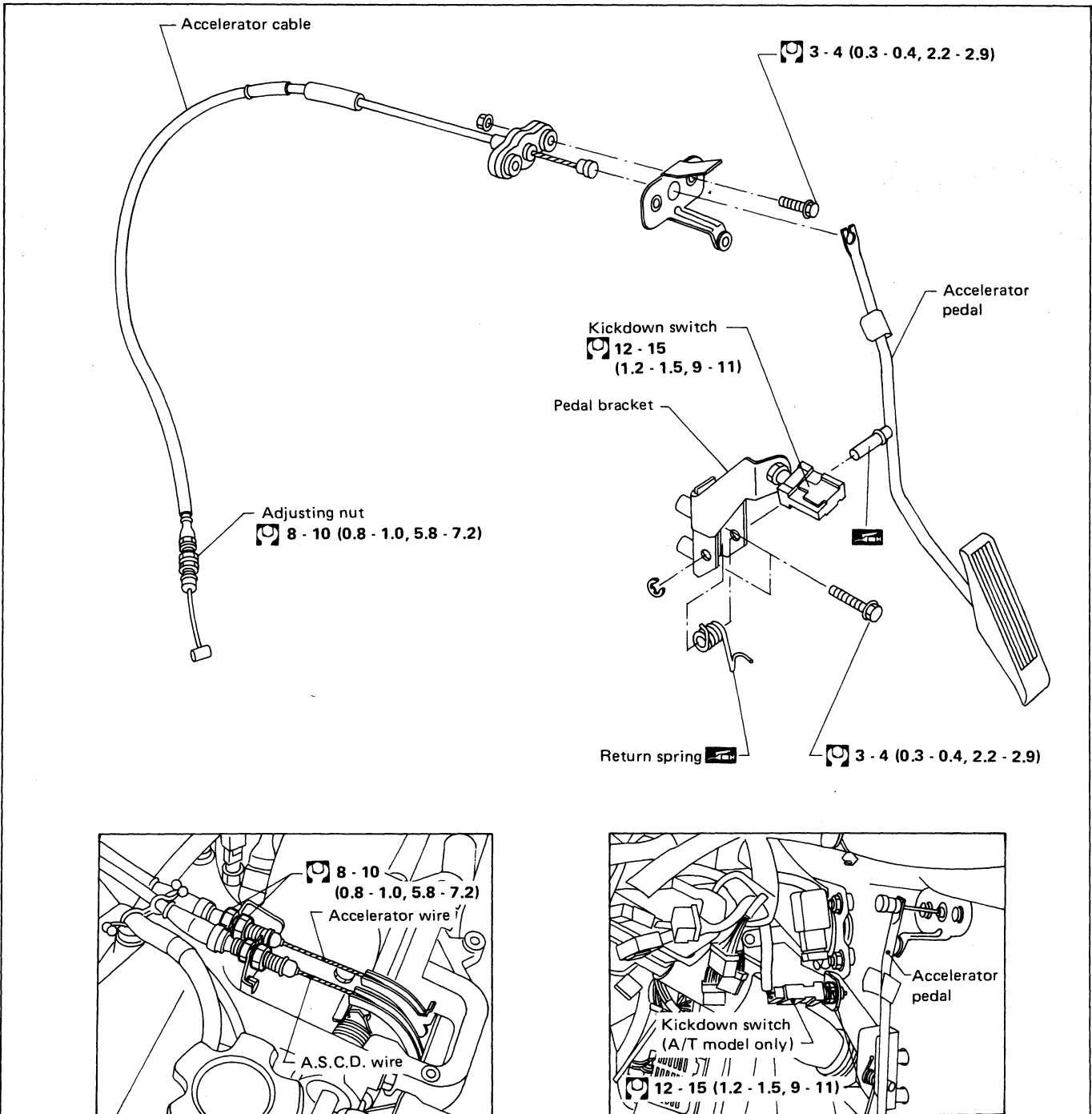

: N.m (kg-m, ft-lb)

SFE059A

FUEL SYSTEM

WARNING:

When replacing fuel line parts, be sure to observe the following:

- Put a "CAUTION: INFLAMMABLE" sign in workshop.
- Be sure to furnish workshop with a CO₂ fire extinguisher.
- Do not smoke while servicing fuel system. Keep open flames and sparks away from work area.
- Be sure to disconnect battery ground cable before conducting operations.
- Put drained fuel in an explosion-proof container and put lid on securely.

CAUTION:

- Before disconnecting fuel hose, release fuel pressure from fuel line. Refer to "Changing Fuel Filter" in MA section.
- Do not disconnect any fuel line unless absolutely necessary.
- Plug hose and pipe openings to prevent entry of dust or dirt.
- Always replace O-ring and clamps with new ones.
- Do not kink or twist hose and tube when they are installed.
- Do not tighten hose clamps excessively.
- When installing fuel check valve, be careful of its designated direction. (Refer to section EF & EC.)
- After assembly, run engine and check for fuel leaks at connections.

2 seater model

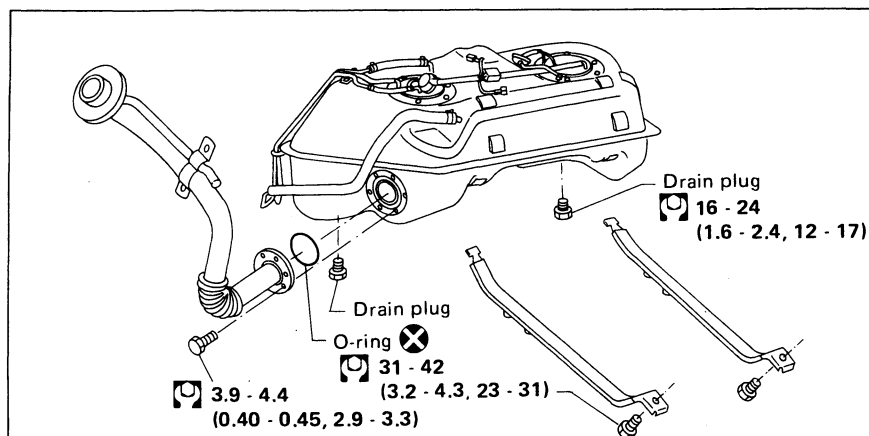
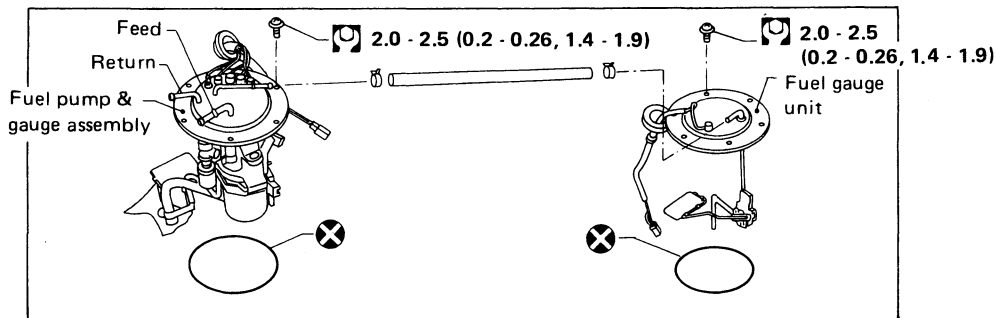
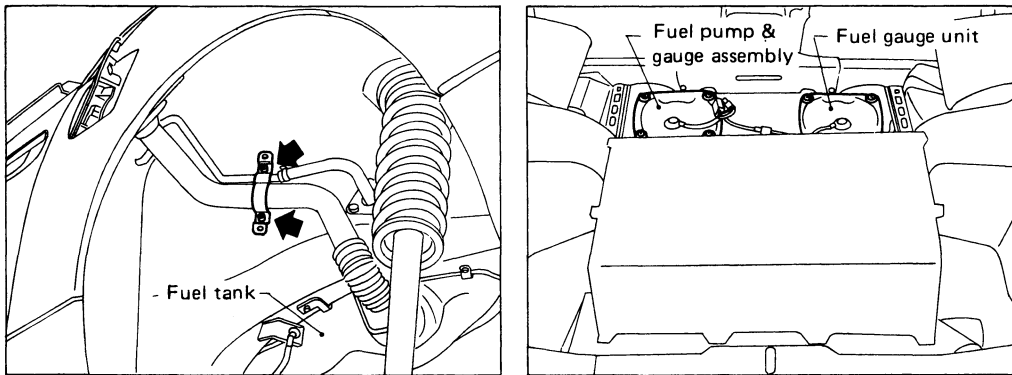

: N-m (kg-m, ft-lb)

SFE060A

FUEL SYSTEM

2 + 2 seater model

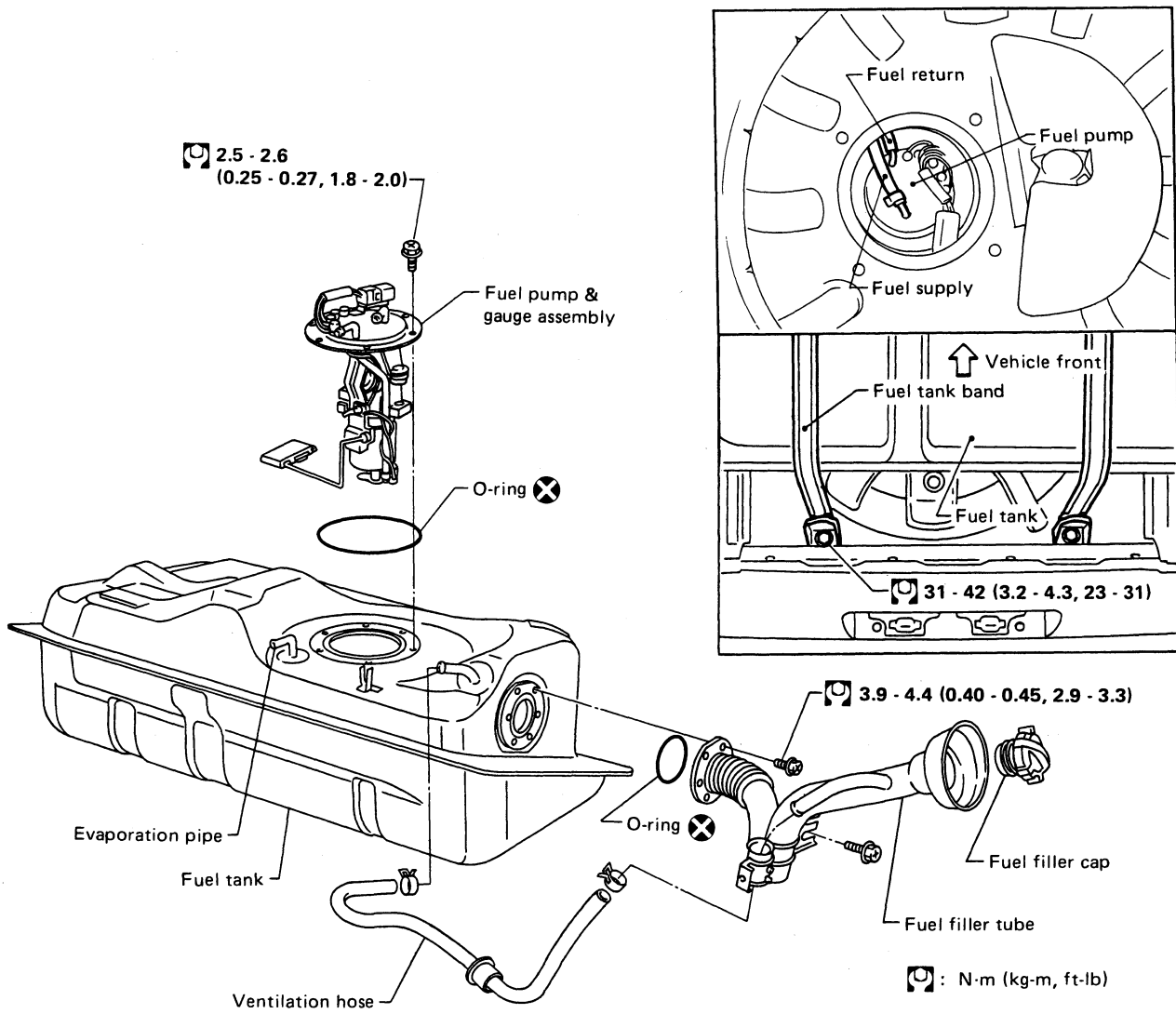

SFE070A

EXHAUST SYSTEM

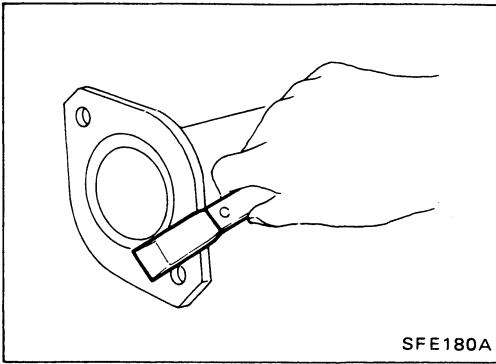

CAUTION:

- Always replace exhaust gaskets with new ones when reassembling.
If gasket is left on flange surface, scrape off completely as shown at left.
- With engine running, check all tube connections for exhaust gas leaks, and entire system for unusual noises.
- After installation, check to ensure that mounting brackets and mounting insulators are free from undue stress. If any of the above parts are not installed properly, excessive noise or vibration may be transmitted to the vehicle body.

2 seater model

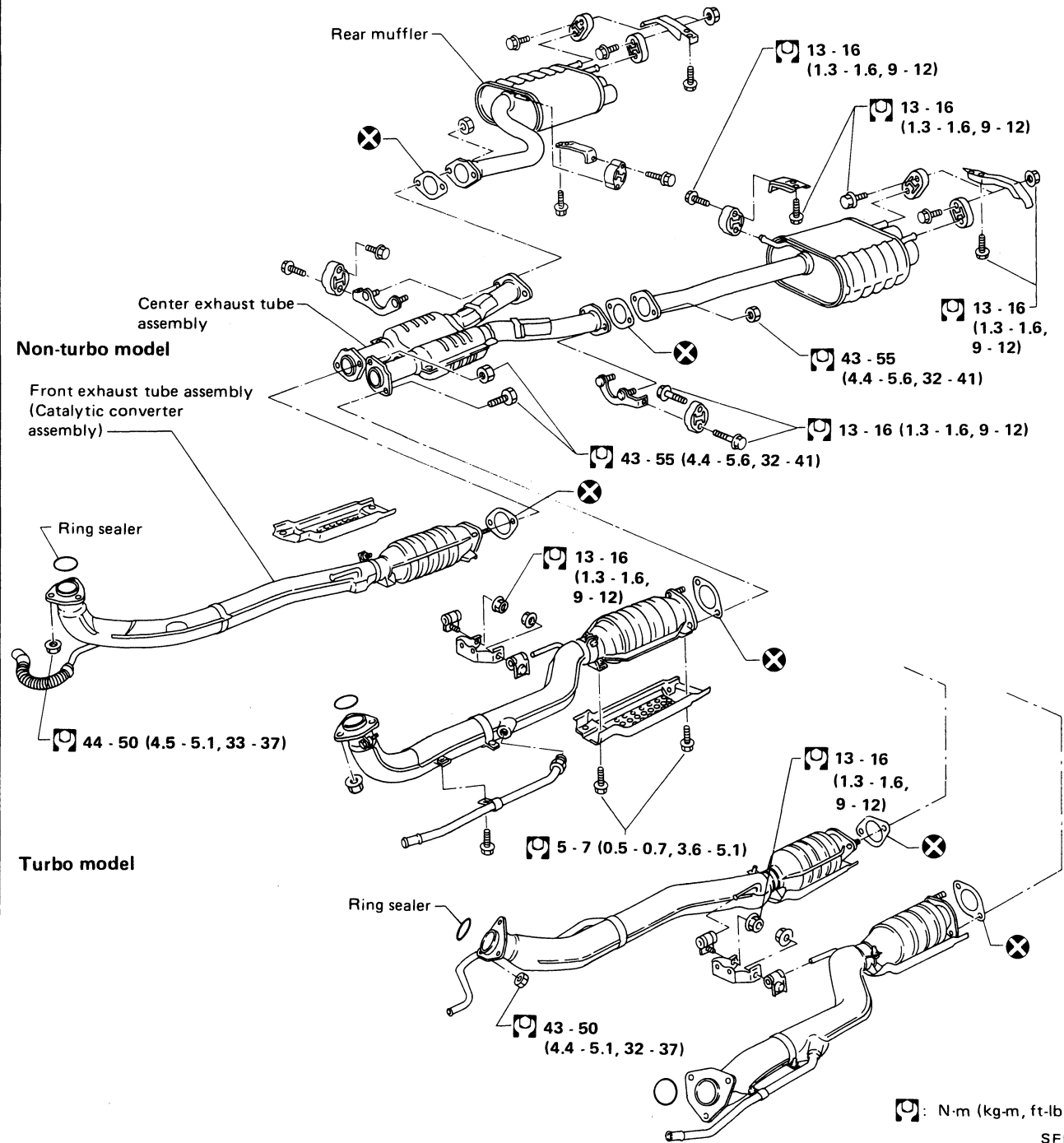

EXHAUST SYSTEM

2 + 2 seater model

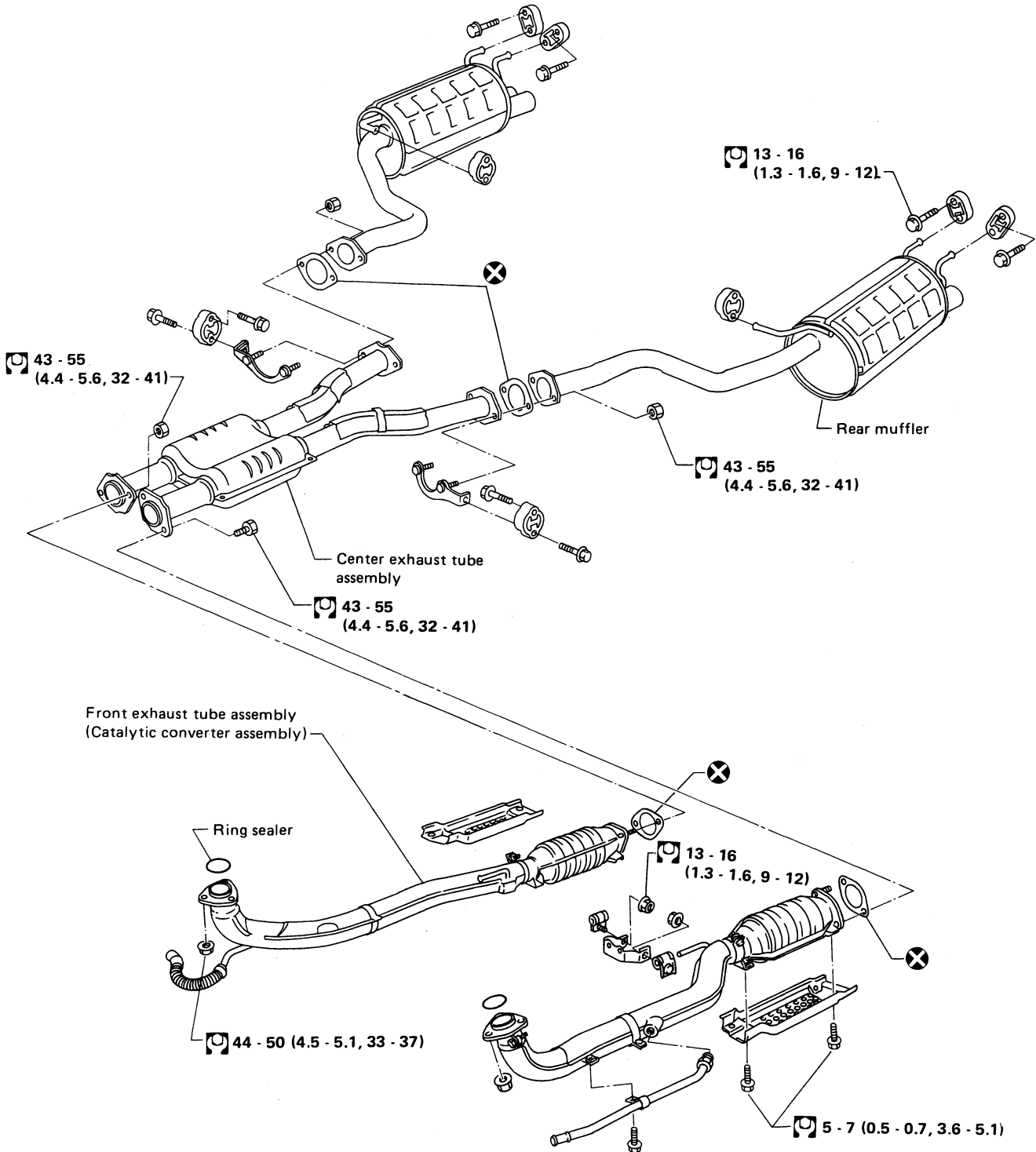

: N-m (kg-m, ft-lb)

SFE063A

SECTION CL

CONTENTS

PRECAUTIONS AND PREPARATION CL- 2
CLUTCH SYSTEM CL- 4
INSPECTION AND ADJUSTMENT CL- 7
HYDRAULIC CLUTCH CONTROL CL- 9
CLUTCH RELEASE MECHANISM CL-13
CLUTCH DISC AND CLUTCH COVER CL-15
SERVICE DATA AND SPECIFICATIONS (S.D.S.) CL-18



PRECAUTIONS AND PREPARATION

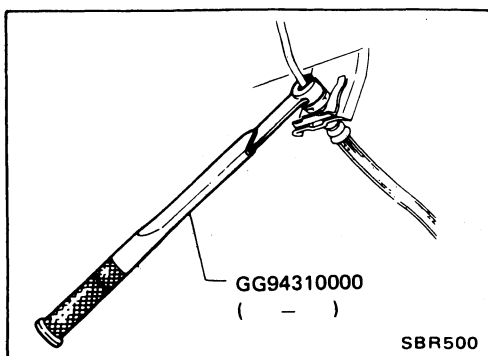

Precautions



- Recommended fluid is brake fluid "DOT 3".
- Never reuse drained brake fluid.
- Be careful not to splash brake fluid on painted areas.
- When removing and installing clutch piping, use Tool.
- Use new brake fluid to clean or wash all parts of master cylinder, operating cylinder and clutch damper.
- Never use mineral oils such as gasoline or kerosene. It will ruin the rubber parts of the hydraulic system.

WARNING:

After cleaning the clutch disc, wipe it with a dust collector. Do not use compressed air.

Preparation

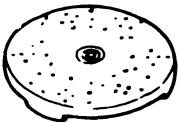
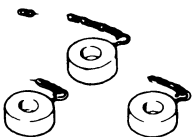
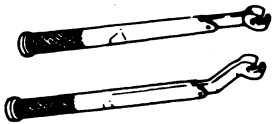
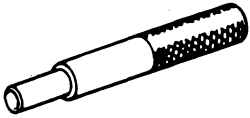
SPECIAL SERVICE TOOLS

Tool number (Kent-Moore No.) Tool name	Description	
ST20050010 (-) Base plate		Inspecting diaphragm spring of clutch cover
ST20050100 (-) Distance piece		Inspecting diaphragm spring of clutch cover
GG94310000 (-) Flare nut torque wrench		Removing and installing each clutch piping
ST20600000 (J26366) Clutch aligning bar		Installing clutch cover and clutch disc
ST20050240 (-) Diaphragm spring adjusting wrench		Adjusting unevenness of diaphragm spring of clutch cover

PRECAUTIONS AND PREPARATION

Preparation (Cont'd)

COMMERCIAL SERVICE TOOLS

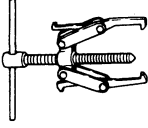
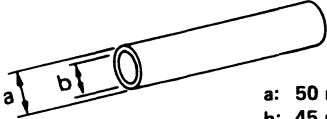
Tool name	Description
Bearing puller	 Removing release bearing
Bearing drift	 <p>a: 50 mm (1.97 in) dia. b: 45 mm (1.77 in) dia.</p> Installing release bearing

CLUTCH SYSTEM

VG30DE engine model

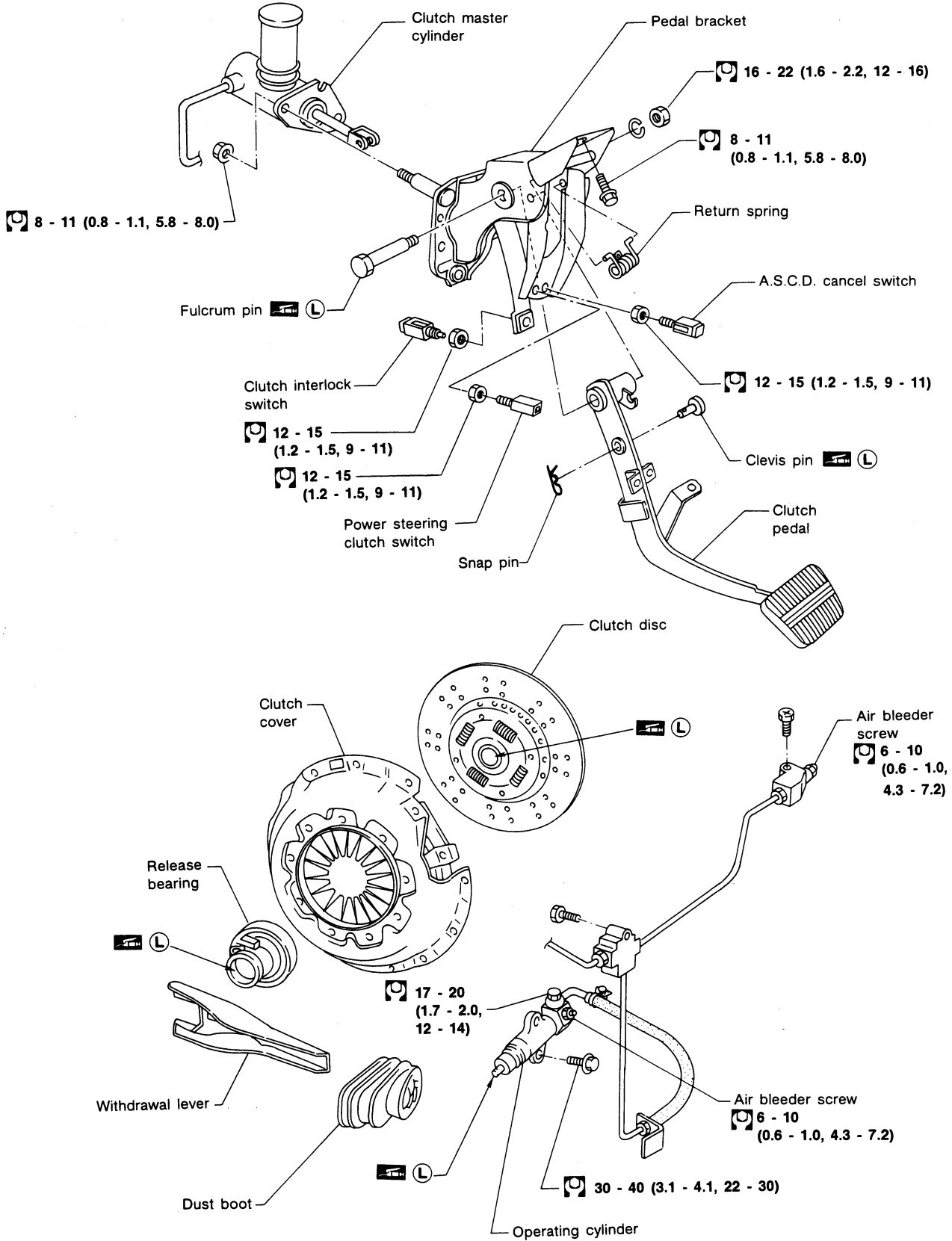

- : N·m (kg-m, ft-lb)
- : Apply lithium-based grease including molybdenum disulphide.

CLUTCH SYSTEM

VG30DETT engine model

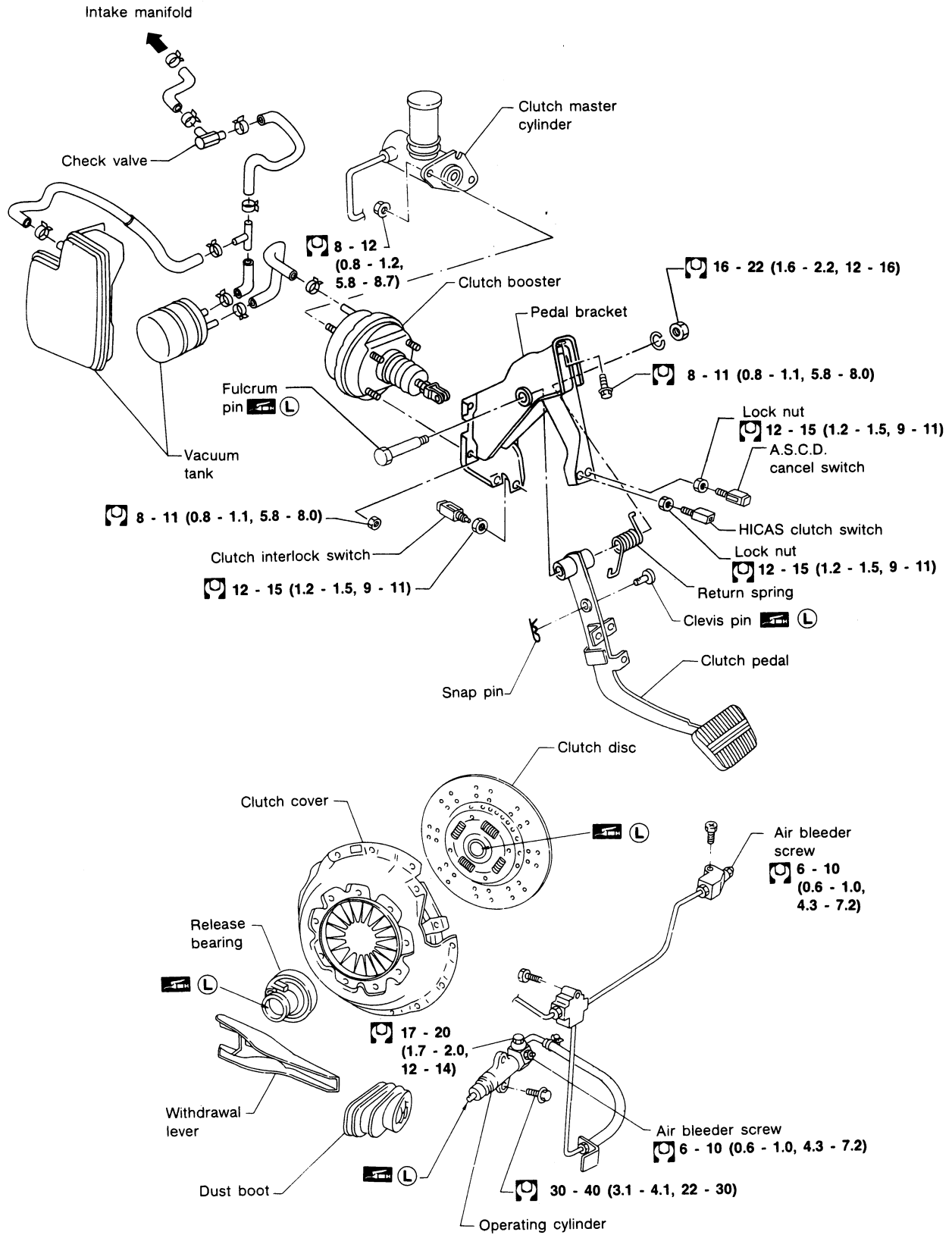

: N·m (kg·m, ft·lb)
 L : Apply lithium-based grease including molybdenum disulphide.

SCL437

CLUTCH SYSTEM

Vacuum Hose Layout — VG30DETT Engine Model

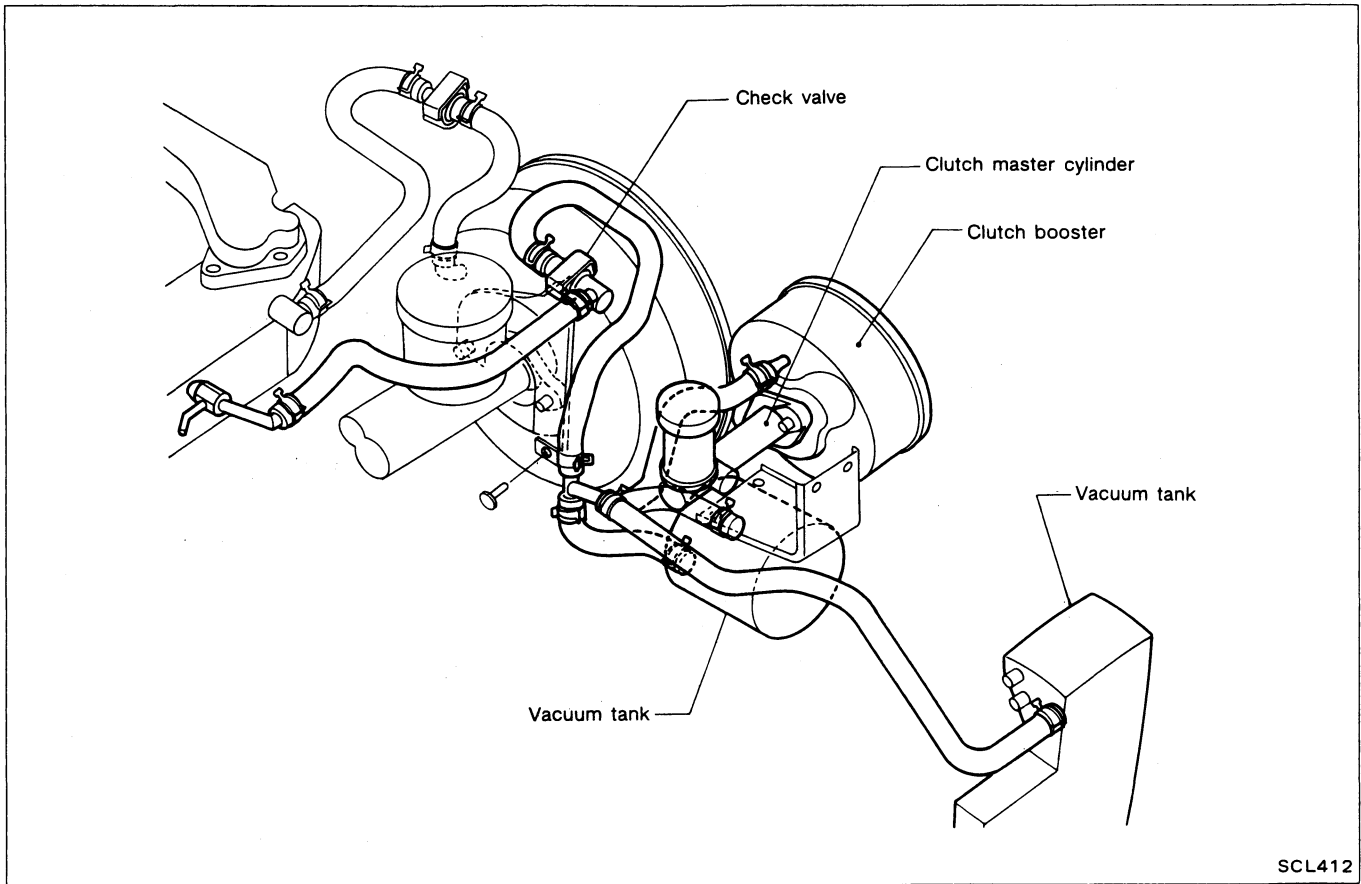

Adjusting Clutch Pedal

1. Adjust pedal height with A.S.C.D. cancel switch and HICAS clutch switch or power steering clutch switch.

Pedal height "H":

VG30DE engine

197 - 207 mm (7.76 - 8.15 in)

VG30DETT engine

183 - 193 mm (7.20 - 7.60 in)

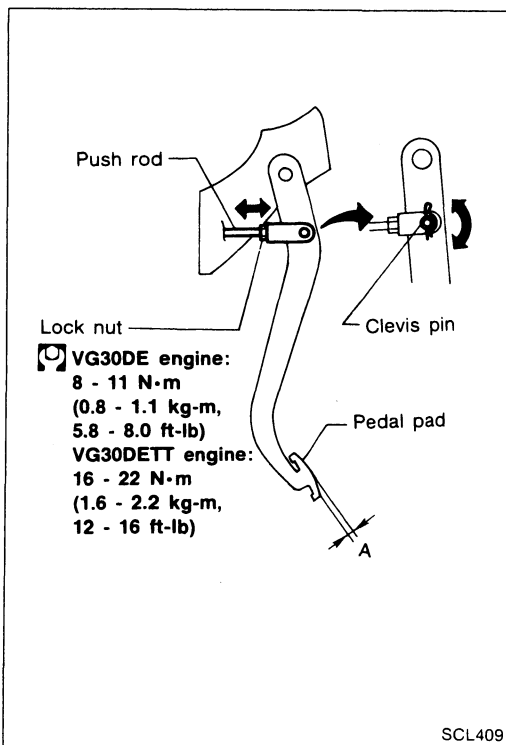
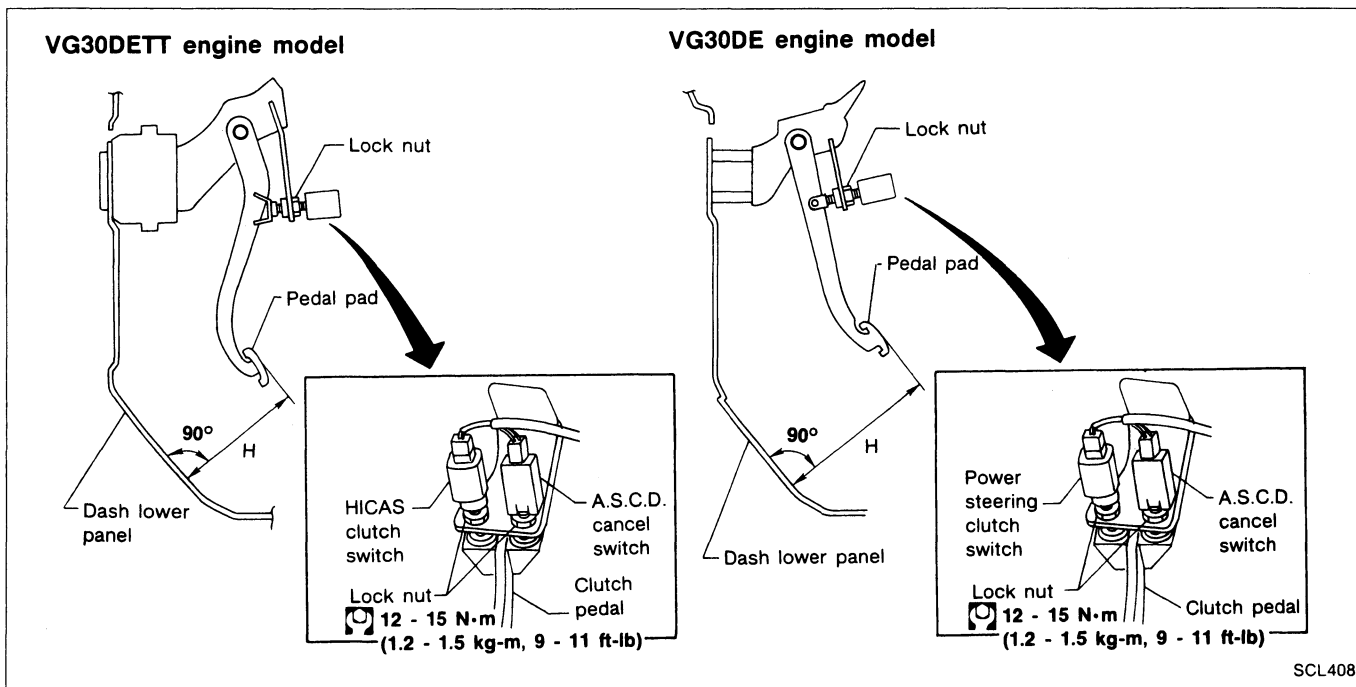

2. Adjust pedal free play with master cylinder push rod. Then tighten lock nut.

Pedal free play "A":

1.0 - 3.0 mm (0.039 - 0.118 in)

Pedal free play means the following measured at position of pedal pad:

- Play due to clevis pin and clevis pin hole in clutch pedal.
3. Make sure that clevis pin can be rotated smoothly. If not, readjust pedal free play with master cylinder push rod.

INSPECTION AND ADJUSTMENT

Adjusting Clutch Pedal (Cont'd)

— U.S.A. model only —

- Adjust clearance "C" between pedal stopper rubber and threaded end of clutch interlock switch while depressing clutch pedal fully.

Clearance C:

1.0 - 2.0 mm (0.039 - 0.079 in)

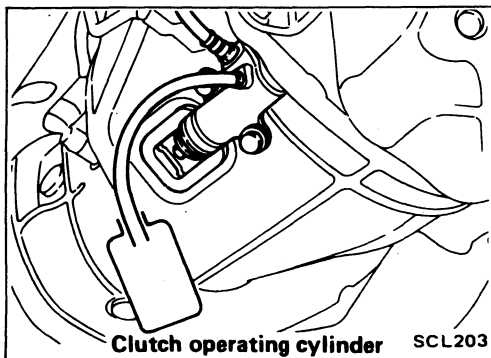
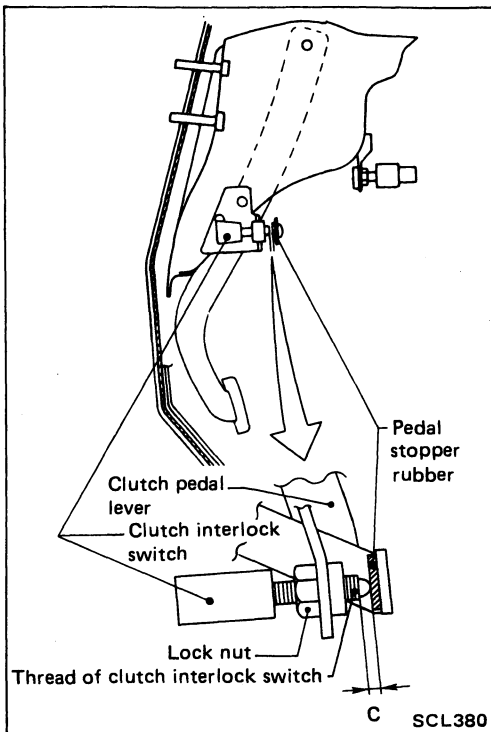

Bleeding Procedure

- Bleed air from clutch operating cylinder according to the following procedure.

Carefully monitor fluid level at master cylinder during bleeding operation.

- Top up reservoir with recommended brake fluid.
 - Connect a transparent vinyl tube to air bleeder valve.
 - Fully depress clutch pedal several times.
 - With clutch pedal depressed, open bleeder valve to release air.
 - Close bleeder valve.
 - Repeat steps c through e above until brake fluid flows from air bleeder valve without air bubbles.
- Bleed air from clutch piping connector according to the above same procedure.
 - Repeat the above bleeding procedures 1 and 2 several times.

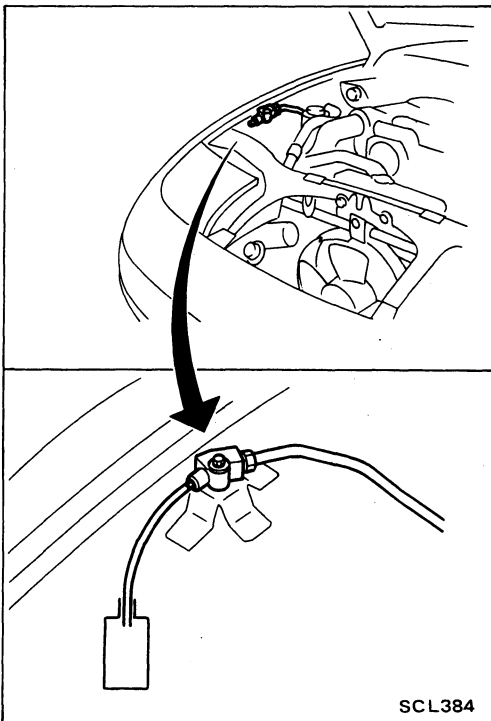

HYDRAULIC CLUTCH CONTROL

Clutch Master Cylinder

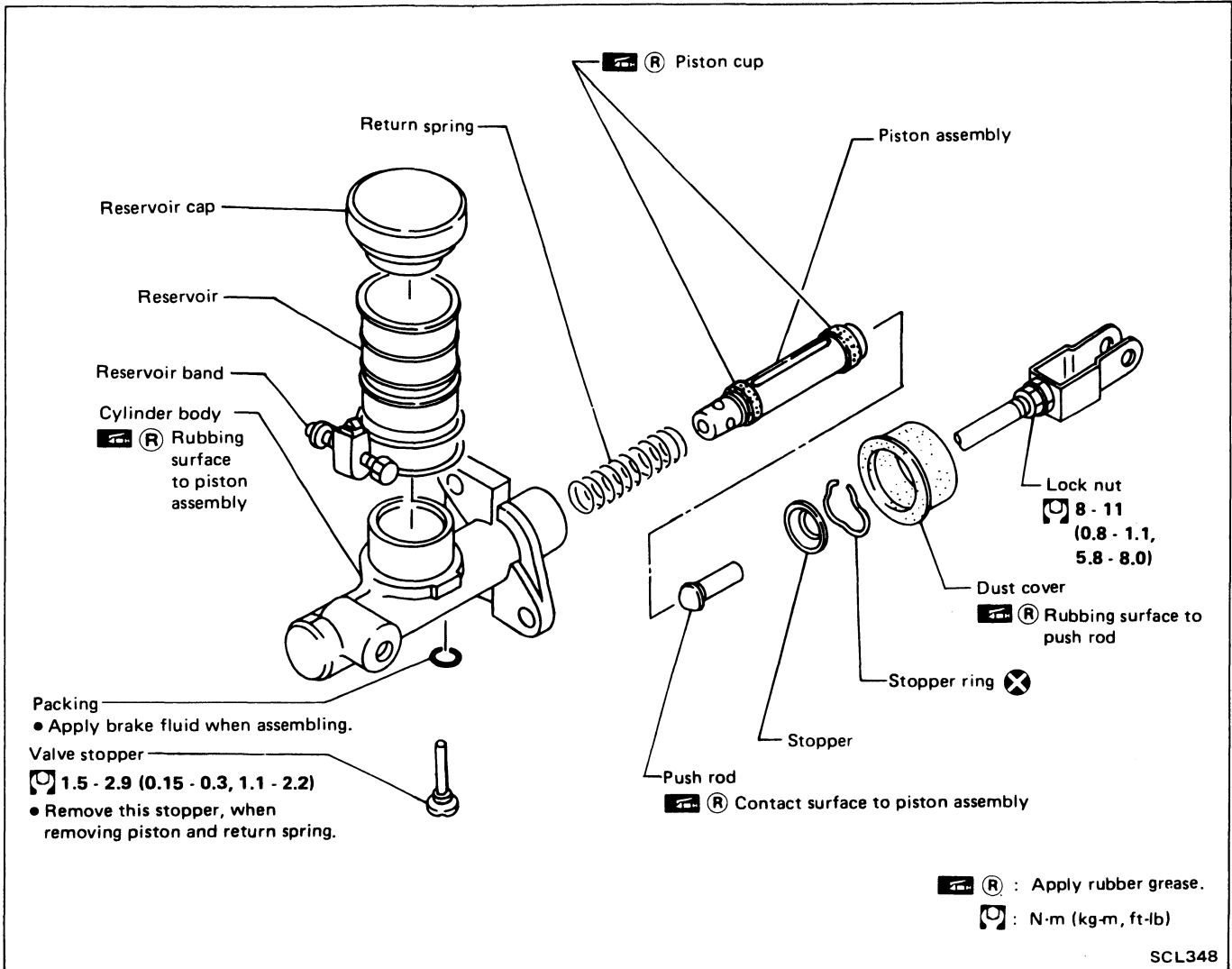

DISASSEMBLY AND ASSEMBLY

- Push piston into cylinder body with screwdriver when removing and installing valve stopper.

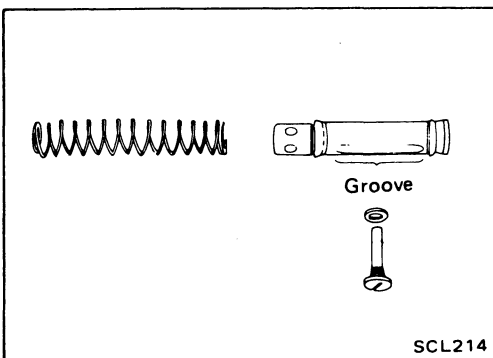

- Align groove of piston assembly and valve stopper when installing valve stopper.
- Check direction of piston cups.

HYDRAULIC CLUTCH CONTROL

Clutch Master Cylinder (Cont'd)

INSPECTION

- Check cylinder and piston rubbing surface for uneven wear, rust or damage. Replace if necessary.
- Check piston with piston cup for wear or damage. Replace if necessary.
- Check return spring for wear or damage. Replace if necessary.
- Check reservoir for deformation or damage. Replace if necessary.
- Check dust cover for cracks, deformation or damage. Replace if necessary.

Operating Cylinder

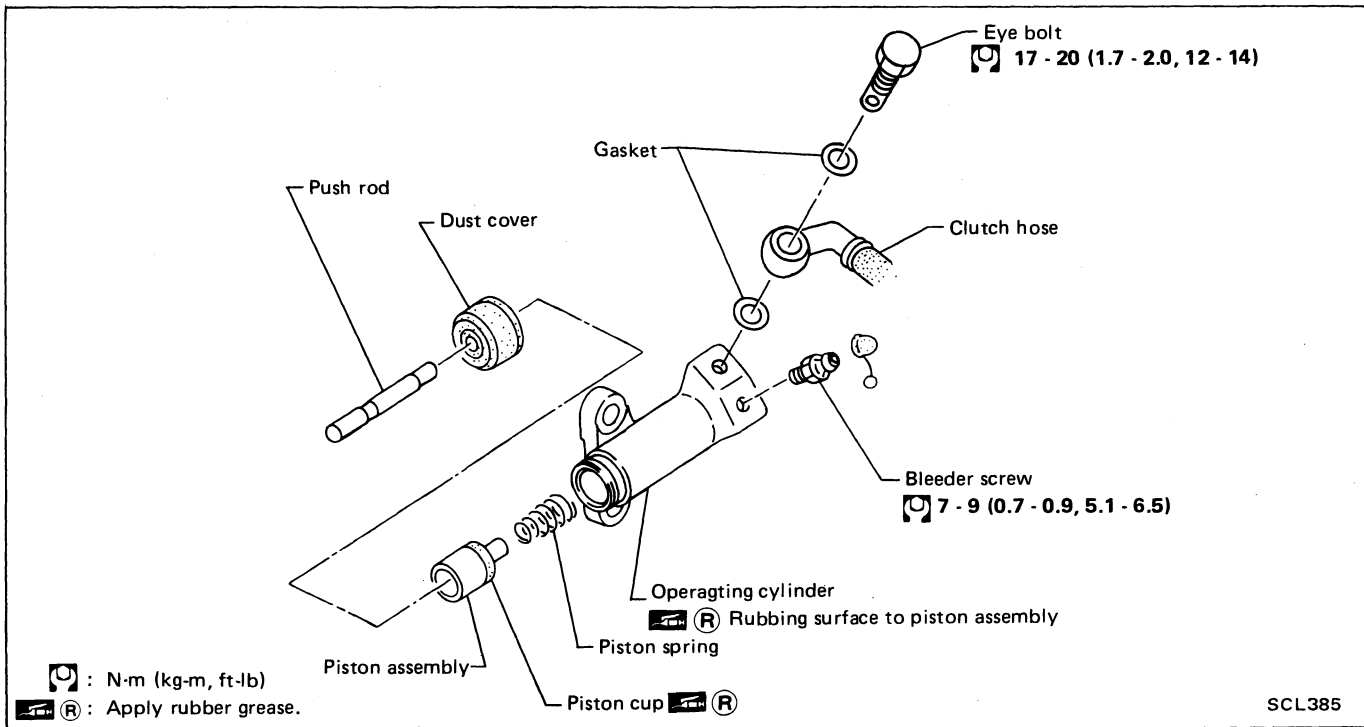

INSPECTION

- Check rubbing surface of cylinder for wear, rust or damage. Replace if necessary.
- Check piston with piston cup for wear or damage. Replace if necessary.
- Check piston spring for wear or damage. Replace if necessary.
- Check dust cover for cracks, deformation or damage. Replace if necessary.

HYDRAULIC CLUTCH CONTROL

Clutch Booster

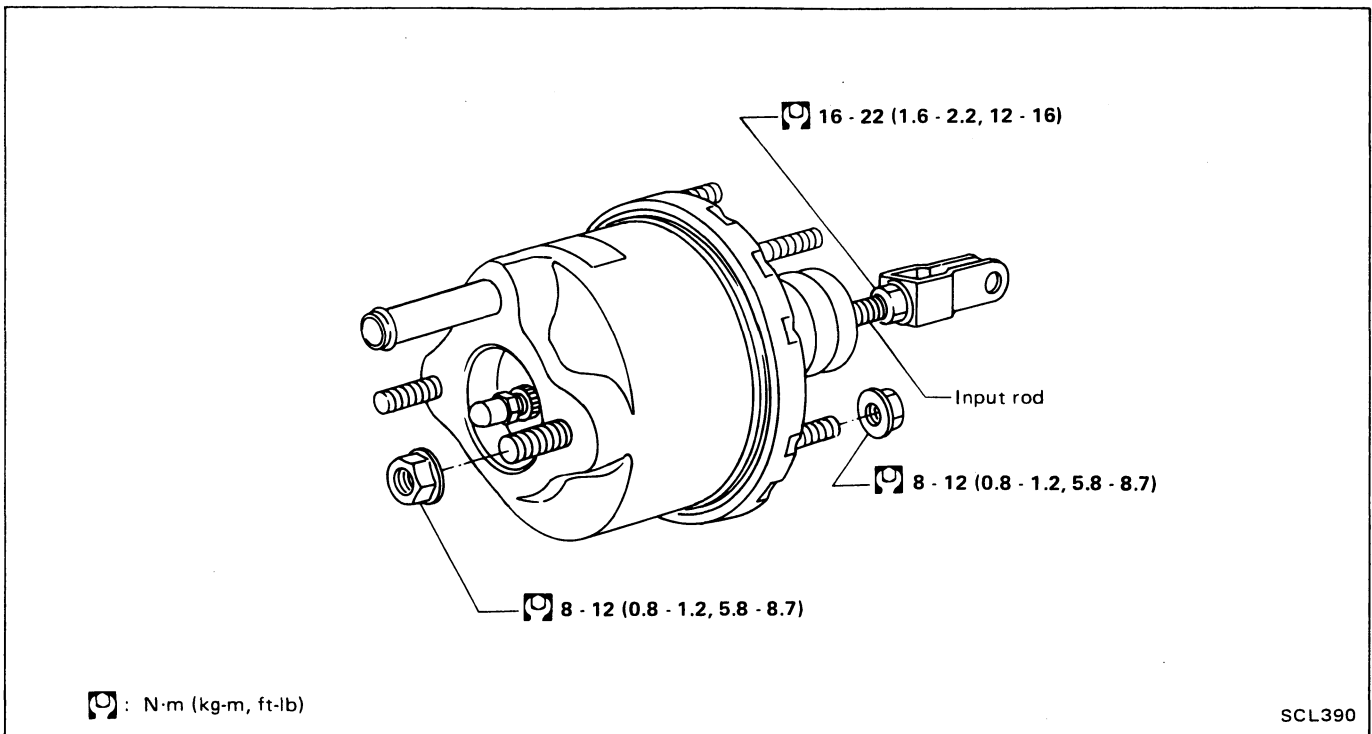

INSPECTION

Hoses and connectors

- Check condition of vacuum hoses and connections.
- Check vacuum hoses and check valve for air tightness.

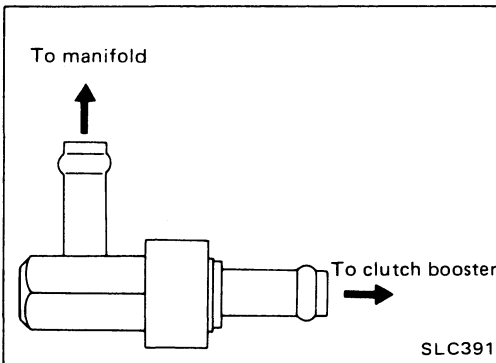

Check valve

- Install check valve properly paying attention to its direction.

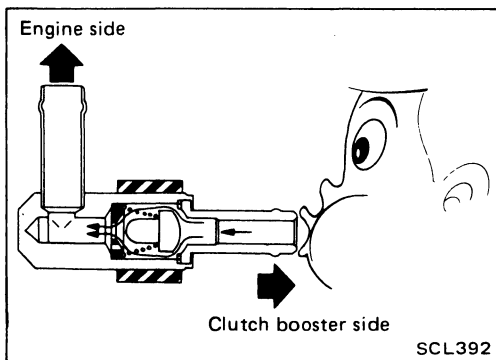

- When pressure is applied to the clutch booster side of check valve and valve does not open, replace check valve with a new one.

HYDRAULIC CLUTCH CONTROL

Clutch Booster (Cont'd) - ADJUSTMENT

Output rod length "A":
13.35 - 13.60 mm (0.5256 - 0.5354 in)

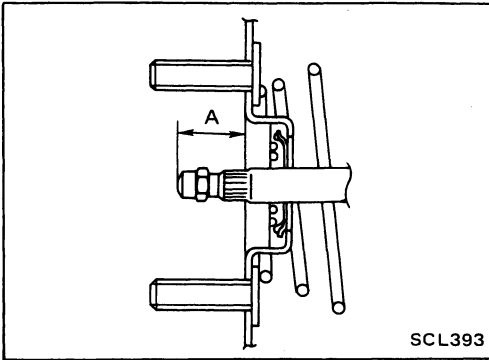

If amount of adjustment required exceeds 0.5 mm (0.020 in), reaction disc may have either been dislocated or fallen off. Replace clutch booster assembly.

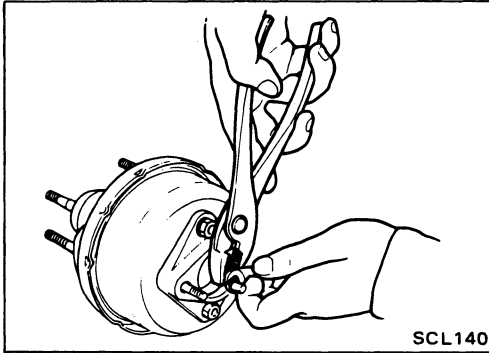

Input rod length "B":
113 mm (4.45 in)

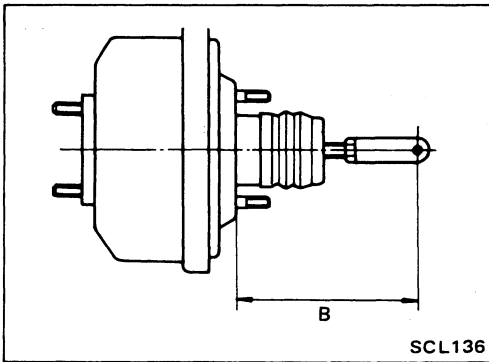

CLUTCH RELEASE MECHANISM

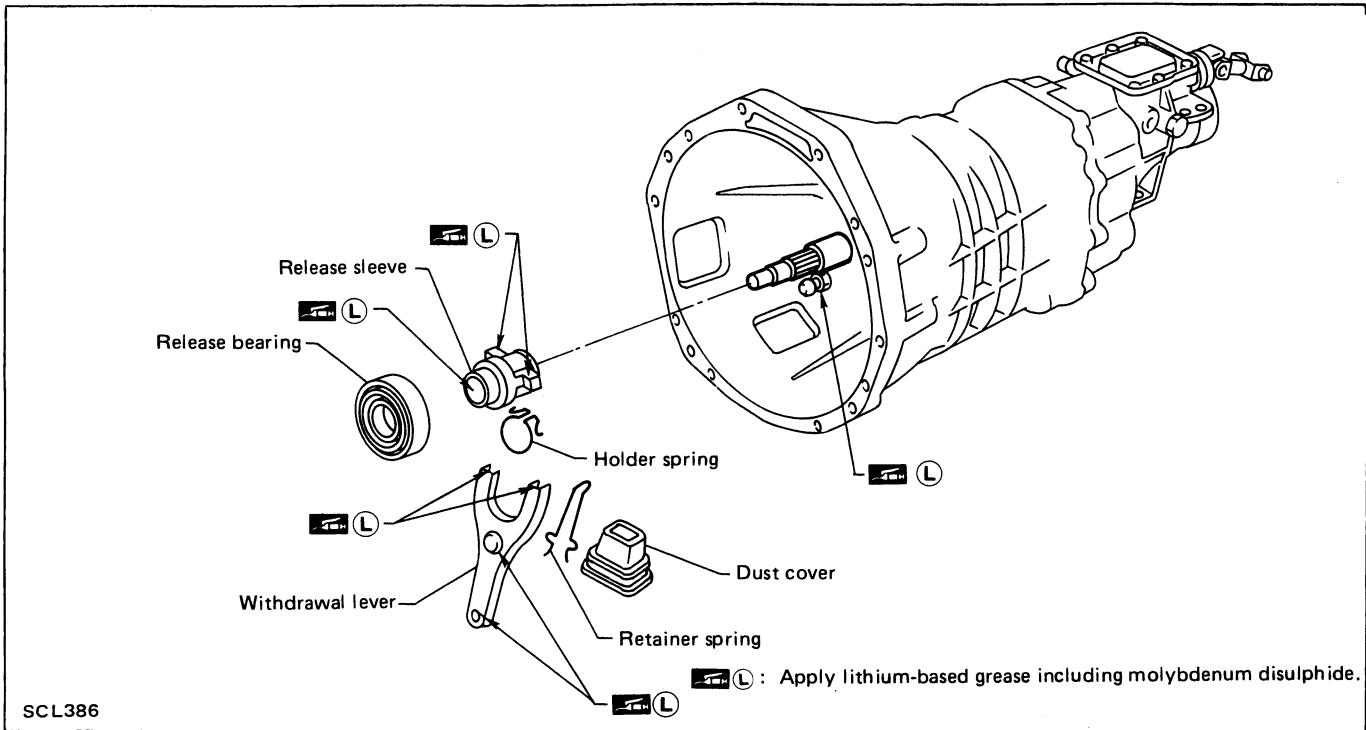

REMOVAL AND INSTALLATION

- Install retainer spring and holder spring.

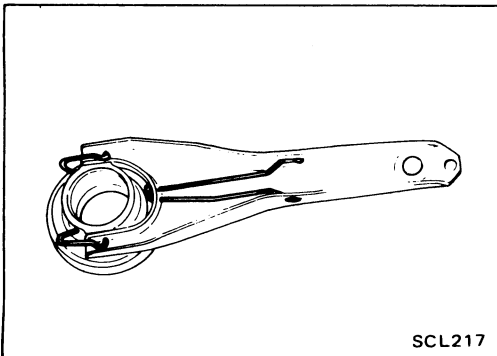

- Remove release bearing

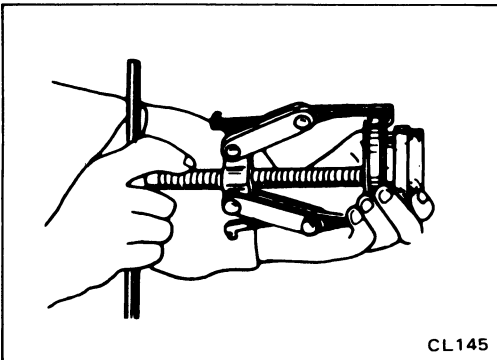

- Install release bearing with suitable drift.

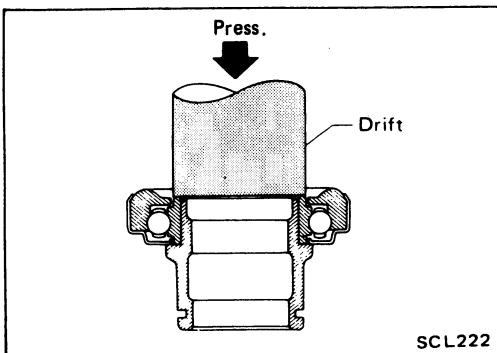

CLUTCH RELEASE MECHANISM

INSPECTION

- Check release bearing to see that it rolls freely and is free from noise, cracks, pitting or wear. Replace if necessary.
- Check release sleeve and withdrawal lever rubbing surface for wear, rust or damage. Replace if necessary.

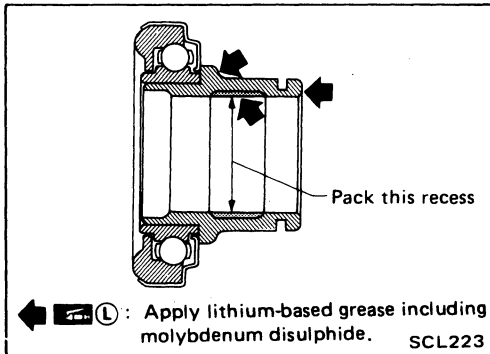

LUBRICATION

- Apply recommended grease to contact surface and rubbing surface.

Too much lubricant might damage clutch disc facing.

CLUTCH DISC AND CLUTCH COVER

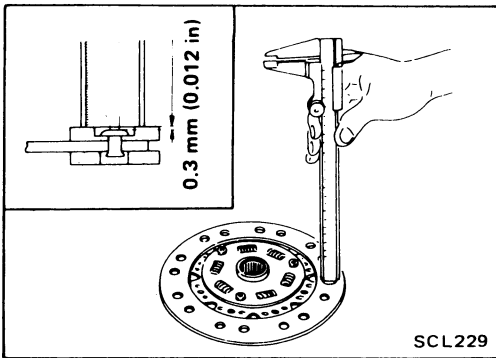
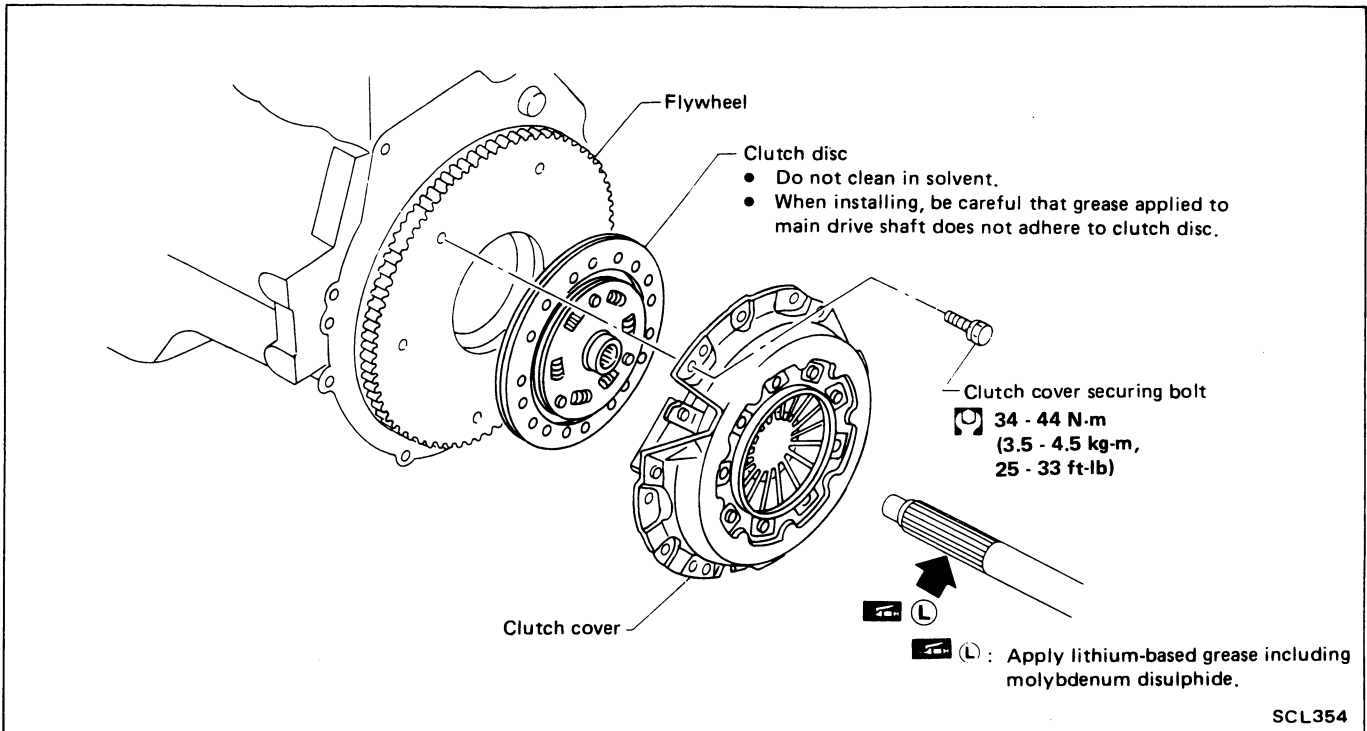

Clutch Disc

INSPECTION

- Check clutch disc for wear of facing.
**Wear limit of facing surface to rivet head:
 0.3 mm (0.012 in)**

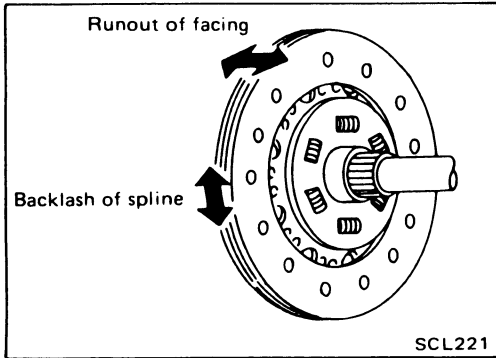

- Check clutch disc for backlash of spline and runout of facing.
**Maximum backlash of spline (at outer edge of disc):
 1.0 mm (0.039 in)**
**Runout limit:
 1.0 mm (0.039 in)**
Distance of runout check point (from hub center):
**VG30DE engine
 115 mm (4.53 in)**
**VG30DETT engine
 120 mm (4.72 in)**
- Check clutch disc for burns, discoloration or oil or grease leakage. Replace if necessary.

INSTALLATION

- Apply recommended grease to contact surface of spring portion.
Too much lubricant might damage clutch disc facing.

CLUTCH DISC AND CLUTCH COVER

Clutch Cover and Flywheel INSPECTION AND ADJUSTMENT

- Set Tool and check height and unevenness of diaphragm spring.

Diaphragm spring height "A":

VG30DE engine

37.5 - 39.5 mm (1.476 - 1.555 in)

VG30DETT engine

36.5 - 38.5 mm (1.437 - 1.516 in)

- Set 0.5 mm (0.020 in) feeler gauges on distance pieces (ST20050100) when checking diaphragm spring height.
- Check thrust rings for wear or damage by shaking cover assembly and listening for chattering noise, or lightly hammering on rivets for a slightly cracked noise. Replace clutch cover assembly if necessary.
- Check pressure plate and clutch disc contact surface for slight burns or discoloration. Repair pressure plate with emery paper.
- Check pressure plate and clutch disc contact surface for deformation or damage. Replace if necessary.

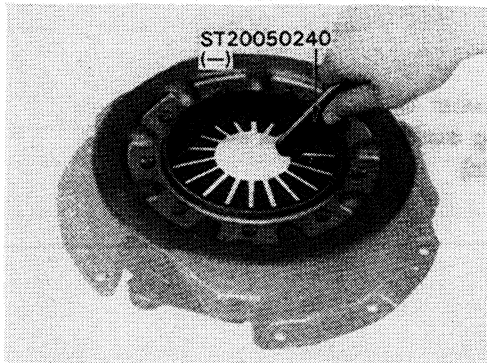
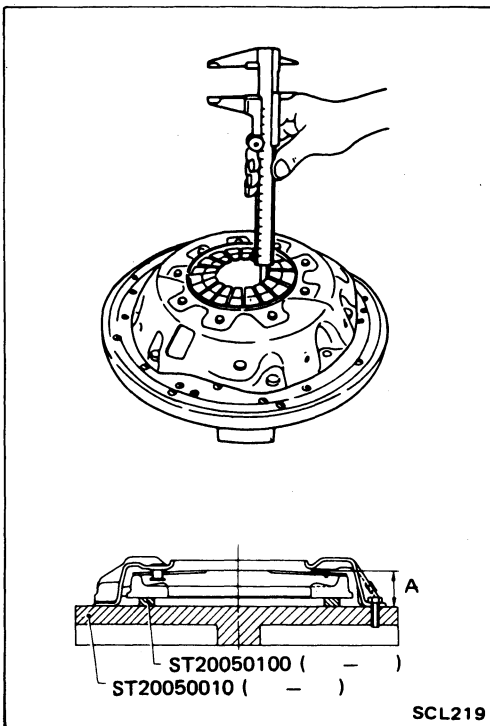

- Adjust unevenness of diaphragm spring with Tool.

Uneven limit:

0.5 mm (0.020 in)

FLYWHEEL INSPECTION

- Check contact surface of flywheel for slight burns or discoloration. Repair flywheel with emery paper.
- Check flywheel runout.

Runout (Total indicator reading):

Less than 0.15 mm (0.0059 in)

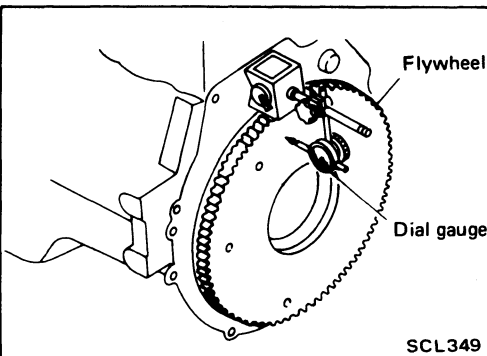

INSTALLATION

- Insert Tool into clutch disc hub when installing clutch cover and disc.

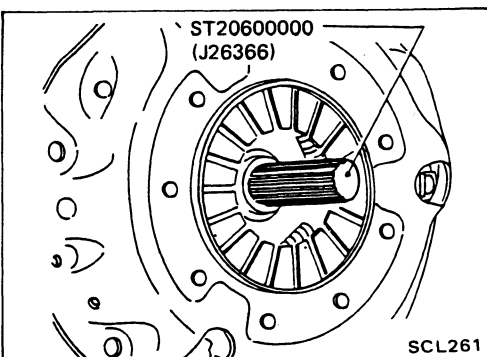

CLUTCH DISC AND CLUTCH COVER

Clutch Cover and Flywheel (Cont'd)

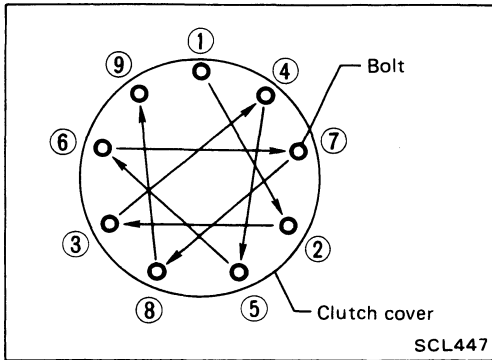

- Tighten clutch cover fixing bolts.
- Tighten bolts in crisscross order as shown in illustration, in two steps.

Tightening torque:

First step

20 N·m (2.0 kg-m, 14 ft-lb)

Final step

22 - 29 N·m (2.2 - 3.0 kg-m, 16 - 22 ft-lb)

SERVICE DATA AND SPECIFICATIONS (S.D.S.)

General Specifications

CLUTCH CONTROL SYSTEM

Type of clutch control	Hydraulic
------------------------	-----------

CLUTCH MASTER CYLINDER

Inner diameter	mm (in)	15.87 (5/8)
----------------	---------	-------------

CLUTCH OPERATING CYLINDER

Inner diameter	mm (in)	19.05 (3/4)
----------------	---------	-------------

CLUTCH DISC

Model	240TBL	250TBL
Engine	VG30DE	VG30DETT
Facing size (Outer dia. x inner dia. x thickness) mm (in)	240 x 160 x 3.5 (9.45 x 6.30 x 0.138)	250 x 160 x 3.5 (9.84 x 6.30 x 0.138)
Thickness of disc assembly With load mm (in)	8.1 - 8.5 (0.319 - 0.335) with 4,904 N (500 kg, 1,103 lb)	

CLUTCH COVER

Model	C240S	C250S
Engine	VG30DE	VG30DETT
Full load N (kg, lb)	5,688 (580, 1,279)	7,846 (800, 1,764)

CLUTCH BOOSTER (VG30DETT engine model)

Model	M45
Diaphragm diameter mm (in)	114.3 (4.50)

Inspection and Adjustment

CLUTCH PEDAL

	Unit: mm (in)	
Engine	VG30DE	VG30DETT
Pedal height "H"	197 - 207 (7.76 - 8.15)	183 - 193 (7.20 - 7.60)
Pedal free play (Backlash at clevis)	1.0 - 3.0 (0.039 - 0.118)	
Clearance between pedal stopper rubber and threaded end of clutch interlock	1.0 - 2.0 (0.039 - 0.079)	

*: Measured from surface of dash lower panel to pedal pad

CLUTCH COVER

	Unit: mm (in)	
Model	C240S	C250S
Diaphragm spring height	37.5 - 39.5 (1.476 - 1.555)	36.5 - 38.5 (1.437 - 1.516)
Uneven limit of diaphragm spring toe height	0.5 (0.020)	

CLUTCH BOOSTER

	Unit: mm (in)	
Output rod length "A"	13.35 - 13.60 (0.5256 - 0.5354)	
Input rod length "B"	113 (4.45)	

CLUTCH DISC

	Unit: mm (in)	
Model	240TBL	250TBL
Wear limit of facing surface to rivet head	0.3 (0.012)	
Runout limit of facing	1.0 (0.039)	
Distance of runout check point (from the hub center)	115 (4.53)	120 (4.72)
Maximum backlash of spline (at outer edge of disc)	1.0 (0.039)	

MANUAL TRANSMISSION

SECTION **MT**



CONTENTS

PREPARATION	MT- 2
ON-VEHICLE SERVICE	MT- 5
REMOVAL AND INSTALLATION	MT- 6
MAJOR OVERHAUL	MT- 7
DISASSEMBLY	MT-12
INSPECTION	MT-20
ASSEMBLY	MT-22
SERVICE DATA AND SPECIFICATIONS (S.D.S.)	MT-34

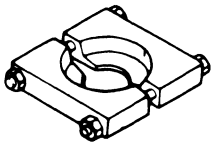

PREPARATION

SPECIAL SERVICE TOOLS — for FS5R30A

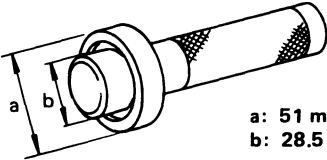
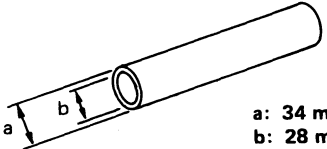
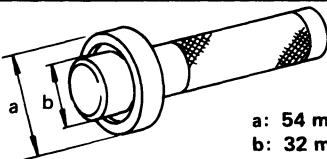
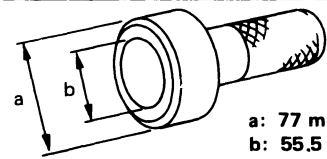
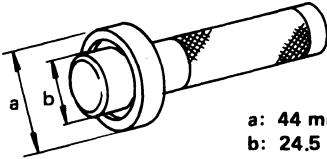
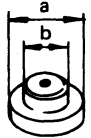
Tool number (Kent-Moore No.) Tool name	Description
ST23540000 (J25689-A) Pin punch	 <p style="text-align: right;">Removing and installing retaining pin</p>
ST30031000 (J22912-01) Puller	 <p style="text-align: right;">Removing 1st & 2nd synchronizer assembly Removing counter gear rear thrust bearing Removing main drive bearing Measuring 2nd & 3rd inner baulk ring</p>
ST33290001 (J25810-A) Puller	 <p style="text-align: right;">Removing rear oil seal</p>
ST33230000 (-) Drift	 <p style="text-align: right;">a: 51 mm (2.01 in) dia. b: 28.5 mm (1.122 in) dia.</p> <p style="text-align: right;">Removing mainshaft and counter gear</p>
ST22350000 (J25678-01) Drift	 <p style="text-align: right;">a: 34 mm (1.34 in) dia. b: 28 mm (1.10 in) dia.</p> <p style="text-align: right;">Removing counter gear front bearing (Use with KV38100300)</p>
KV38100300 (J25523) Drift	 <p style="text-align: right;">a: 54 mm (2.13 in) dia. b: 32 mm (1.26 in) dia.</p> <p style="text-align: right;">Removing counter gear front bearing (Use with ST22350000) Installing counter gear rear bearing</p>
ST30720000 ① (J34286) ② (J34331) Drift	 <p style="text-align: right;">a: 77 mm (3.03 in) dia. b: 55.5 mm (2.185 in) dia.</p> <p style="text-align: right;">① Removing mainshaft front bearing ② Installing mainshaft front bearing</p>
ST33210000 ① (J25523) ② (J25803-01) Drift	 <p style="text-align: right;">a: 44 mm (1.73 in) dia. b: 24.5 mm (0.965 in) dia.</p> <p style="text-align: right;">① Installing counter gear front bearing ② Installing front cover oil seal</p>
ST30613000 (J25742-3) Drift	 <p style="text-align: right;">a: 72 mm (2.83 in) dia. b: 48 mm (1.89 in) dia.</p> <p style="text-align: right;">Installing main drive gear bearing</p>

PREPARATION

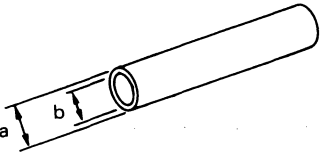
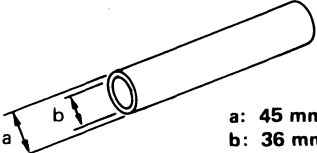
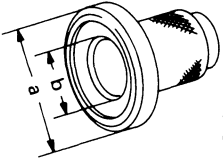
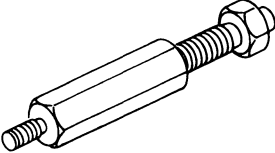
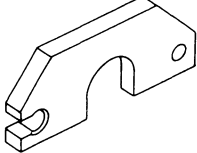
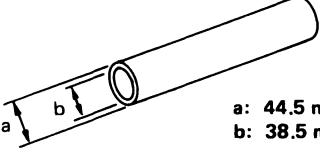
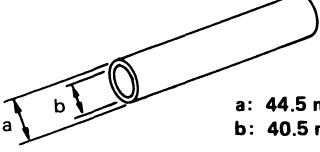
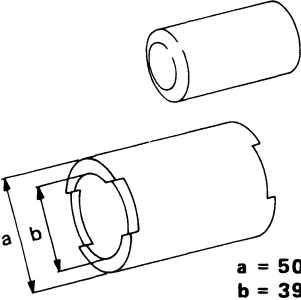
Tool number (Kent-Moore No.) Tool name	Description	
ST37750000 ① (J34286) ② (J34332) ③ (J34334) ④ (J25679-01) Drift	 <p style="text-align: center;">a: 40 mm (1.57 in) dia. b: 31 mm (1.22 in) dia.</p>	① Removing counter gear rear bearing ② Installing O.D. gear bushing ② Installing reverse cone ③ Installing reverse counter gear ④ Installing counter gear rear end bearing
ST22452000 (J34337) Drift	 <p style="text-align: center;">a: 45 mm (1.77 in) dia. b: 36 mm (1.42 in) dia.</p>	Installing reverse hub Installing mainshaft rear bearing
ST33400001 (J26082) Drift	 <p style="text-align: center;">a: 60 mm (2.36 in) dia. b: 47 mm (1.85 in) dia.</p>	Installing rear oil seal
(J26349-3) Puller leg		Installing mainshaft and counter gear (Use with J34328)
(J34328) Puller		Installing mainshaft and counter gear (Use with J26349-3)
(J26092) Drift	 <p style="text-align: center;">a: 44.5 mm (1.752 in) dia. b: 38.5 mm (1.516 in) dia.</p>	Installing sub-gear snap ring
(J34342) Drift	 <p style="text-align: center;">a: 44.5 mm (1.752 in) dia. b: 40.5 mm (1.594 in) dia.</p>	Installing O.D. main gear Installing reverse gear bushing
ST36730000 (-) Drift	 <p style="text-align: center;">a = 50 mm (1.97 in) dia. b = 39 mm (1.54 in) dia.</p>	Installing sub-gear on reverse idler gear

PREPARATION

COMMERCIAL SERVICE TOOL — for FS5R30A

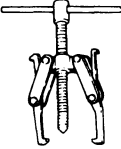
Tool name	Description
Puller	 <ul style="list-style-type: none">Removing counter gear rear end bearingRemoving mainshaft rear bearingRemoving reverse synchronizer hubRemoving reverse counter gear

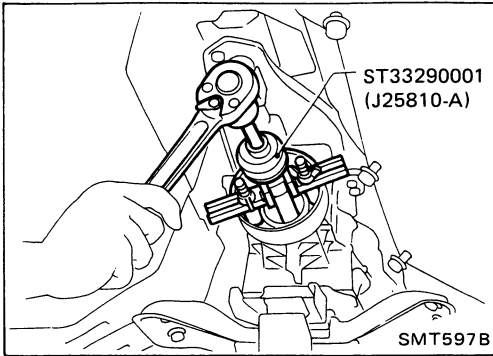

Replacing Rear Oil Seal
REMOVAL

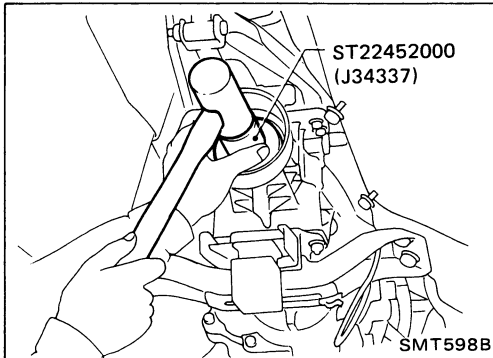

INSTALLATION

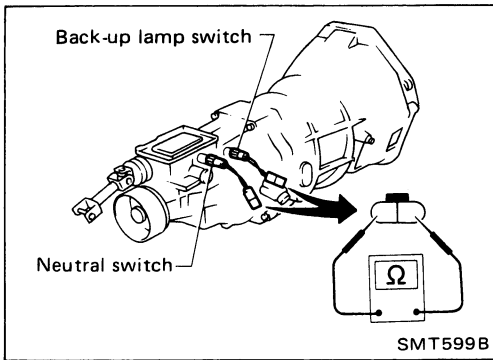

Position Switch Check
BACK-UP LAMP SWITCH

- Check continuity.

Gear position	Continuity
Reverse	Yes
Except reverse	No

NEUTRAL SWITCH

- Check continuity.

Gear position	Continuity
Neutral	Yes
Except neutral	No

REMOVAL AND INSTALLATION

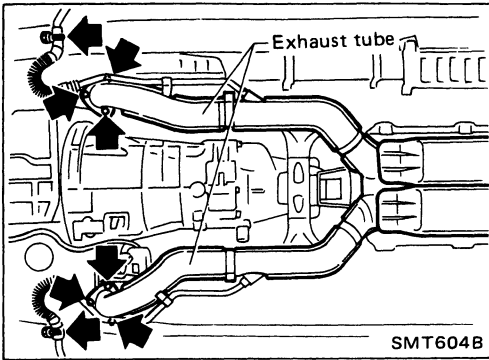

Removal

- Remove exhaust tube.

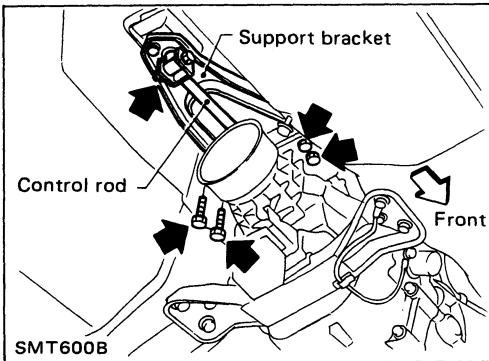

- Remove support bracket from M/T assembly.
- Remove control rod from shift lever.

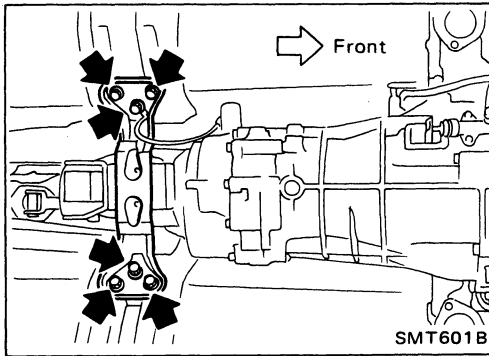

- Remove propeller shaft — Refer to section PD.
- **Insert plug into rear oil seal after removing propeller shaft.**
- **Be careful not to damage spline, sleeve yoke and rear oil seal when removing propeller shaft.**
- Disconnect back-up lamp switch and neutral switch harness connectors.
- Support manual transmission with a jack.
- Remove rear mounting.

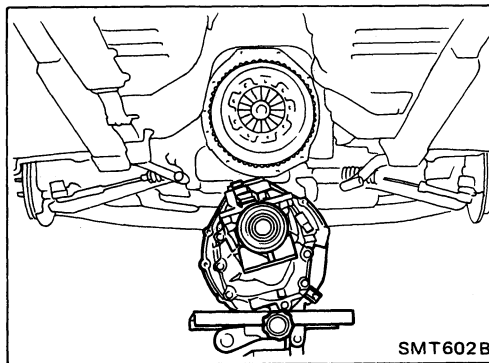

- Lower manual transmission.

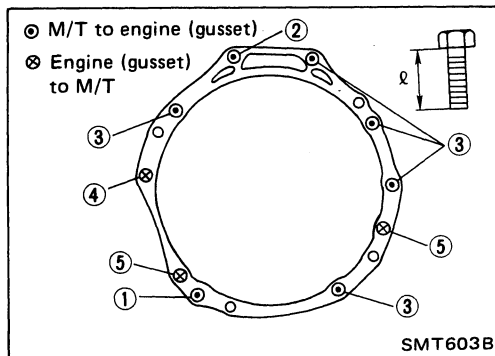

Installation

- Tighten all transmission bolts.

Bolt No.	Tightening torque	N·m (kg·m, ft·lb)	ℓ mm (in)
①	39 - 49	(4.0 - 5.0, 29 - 36)	100 (3.94)
②	39 - 49	(4.0 - 5.0, 29 - 36)	65 (2.56)
③	39 - 49	(4.0 - 5.0, 29 - 36)	60 (2.36)
④	29 - 39	(3.0 - 4.0, 22 - 29)	55 (2.17)
⑤	29 - 39	(3.0 - 4.0, 22 - 29)	25 (0.98)

MAJOR OVERHAUL

Case Components

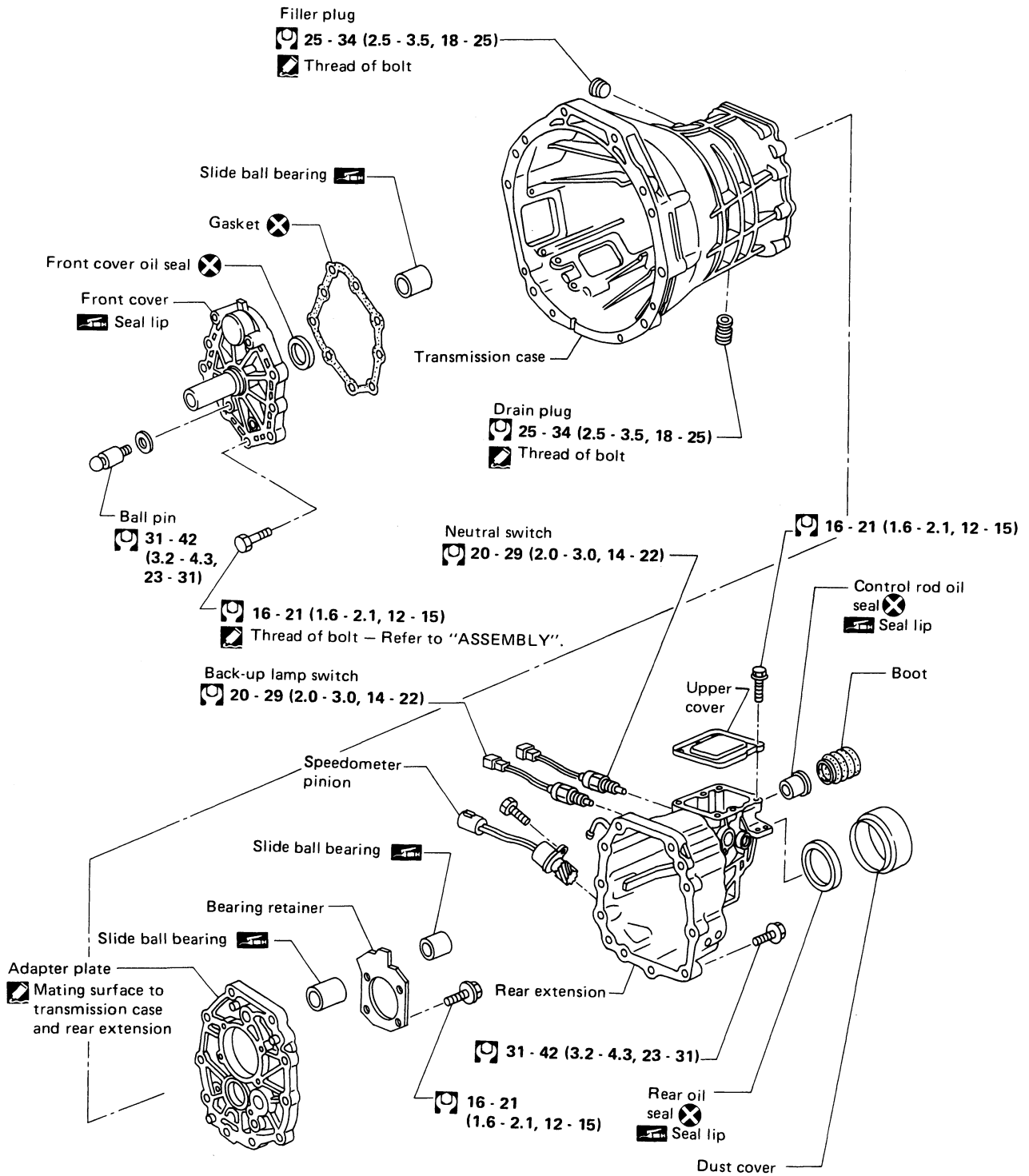

: N·m (kg-m, ft-lb)
 : Apply recommended sealant (Nissan genuine Part: KP610-00250) or equivalent.

SMT606B

MAJOR OVERHAUL

Gear Components

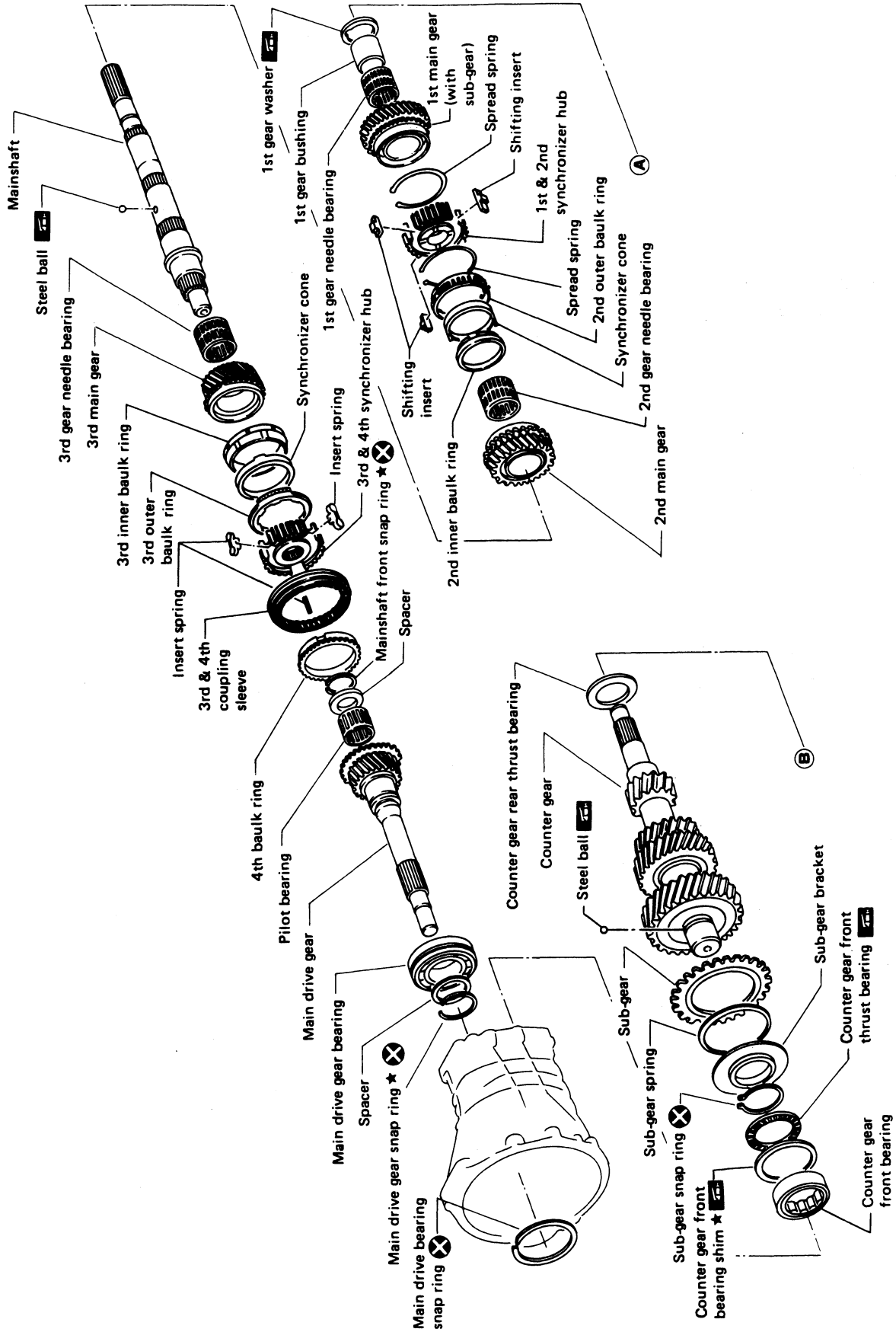

MAJOR OVERHAUL

Gear Components (Cont'd)

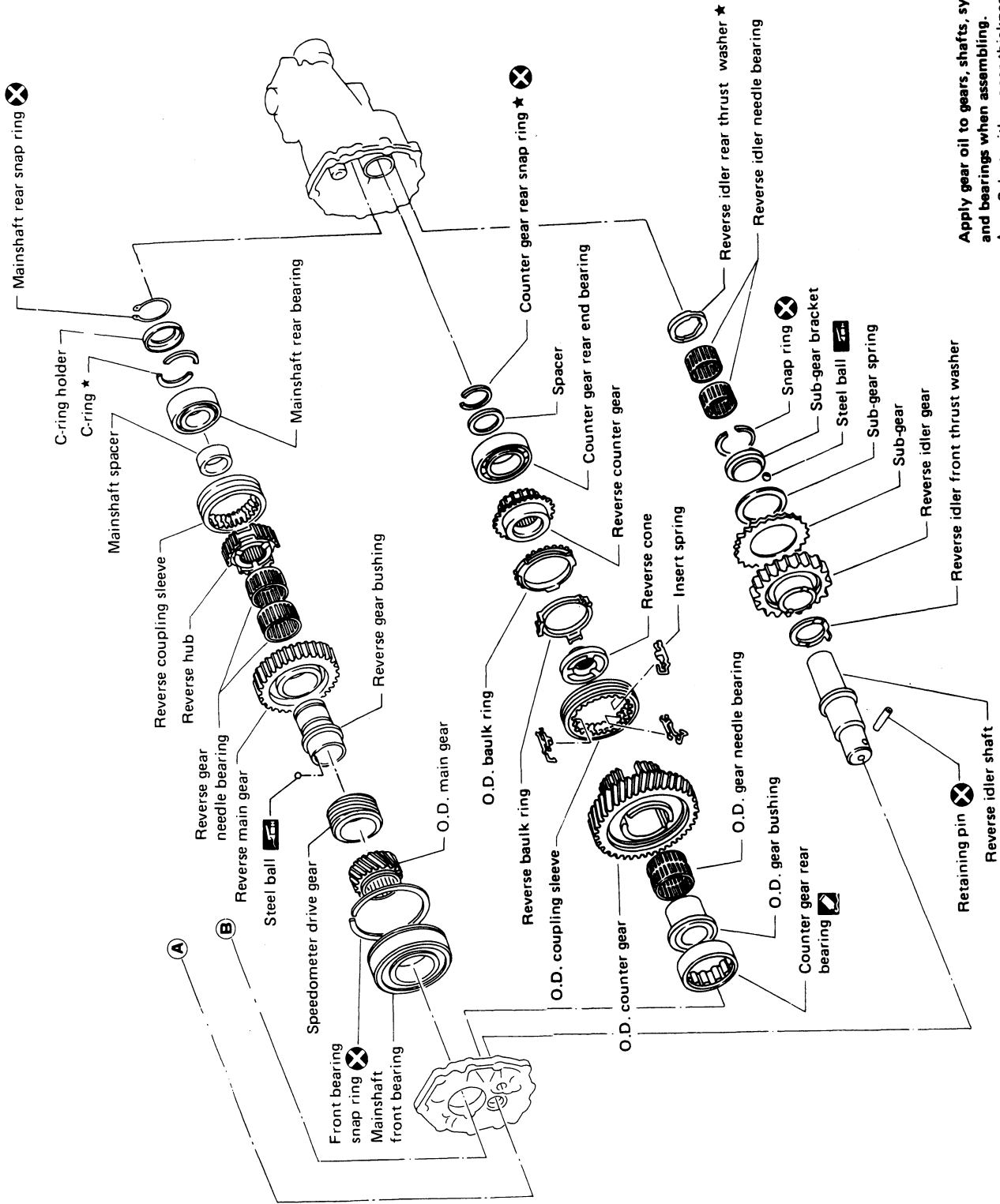

Apply gear oil to gears, shafts, synchronizers and bearings when assembling.
 ★ : Select with proper thickness.

MAJOR OVERHAUL

Shift Control Components

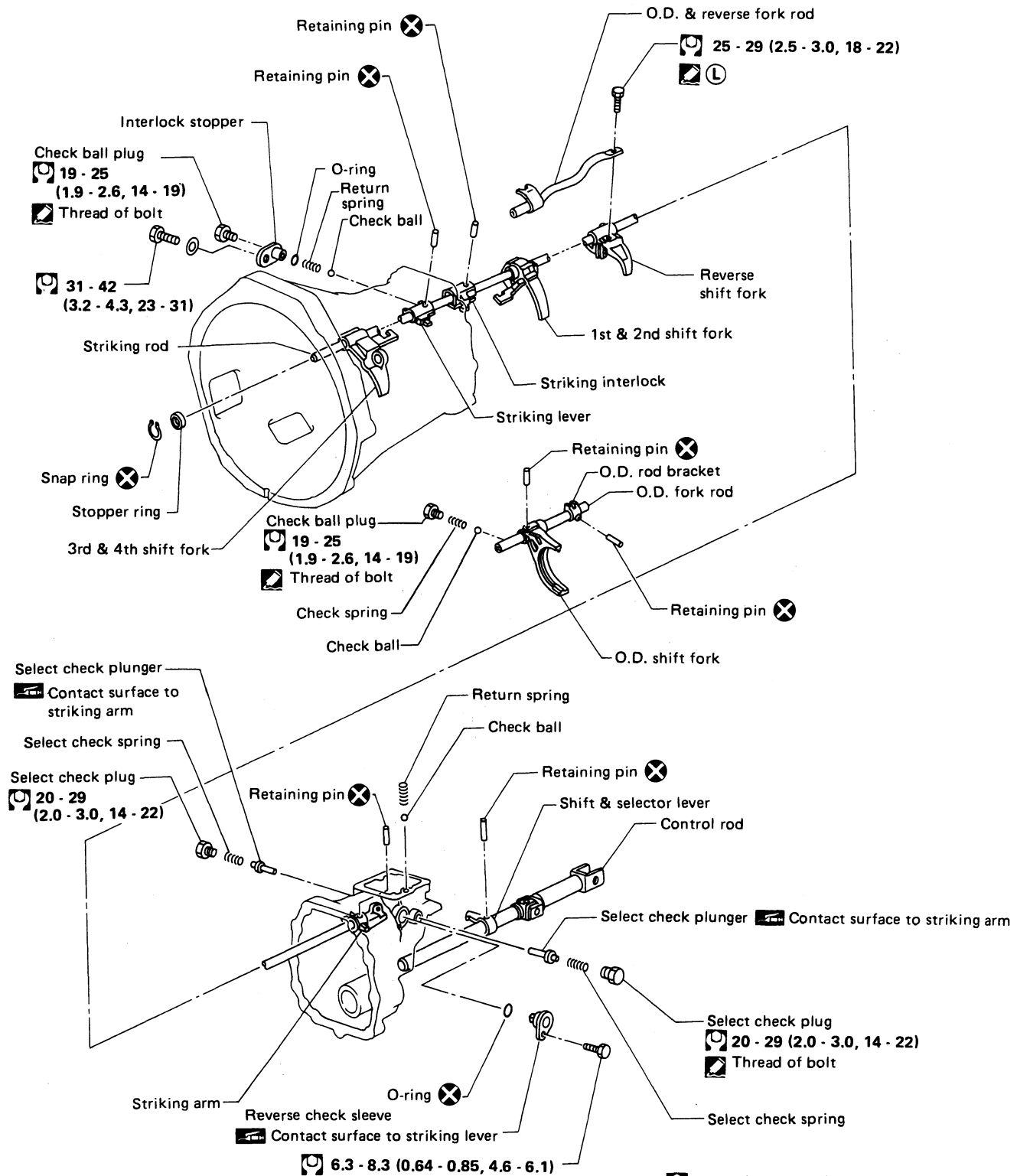

- ⊗ : N.m (kg-m, ft-lb)
- ☒ : Apply recommended sealant (Nissan genuine part: KP610-00250) or equivalent.
- Ⓛ : Apply locking sealant.

SMT607B

MAJOR OVERHAUL

Shift Control Components (Cont'd)

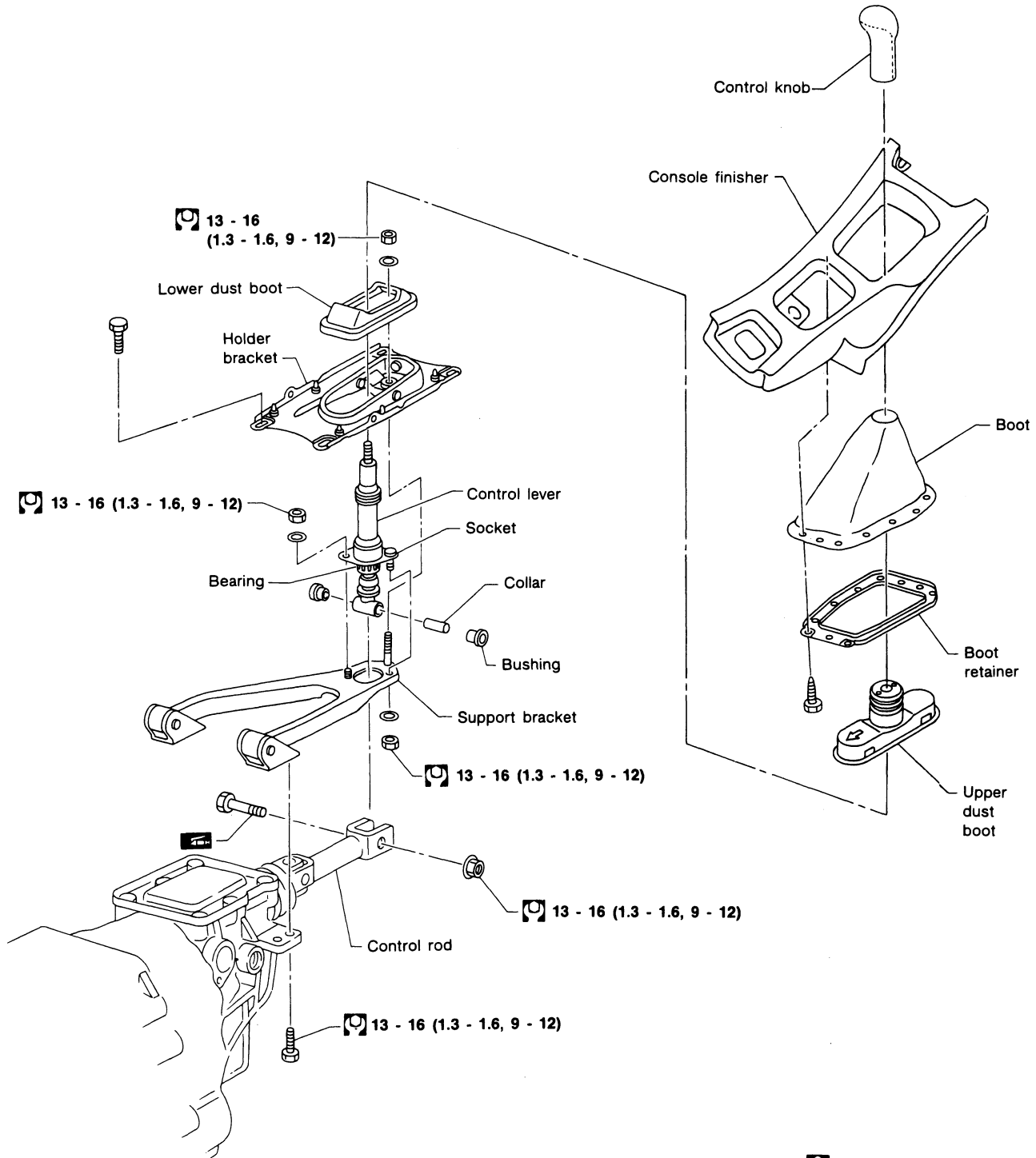

DISASSEMBLY

Case Components

1. Remove check ball plug, check spring and check ball. Then remove interlock stopper.

If interlock assembly is removed as a unit, the check ball can fall into transmission case.

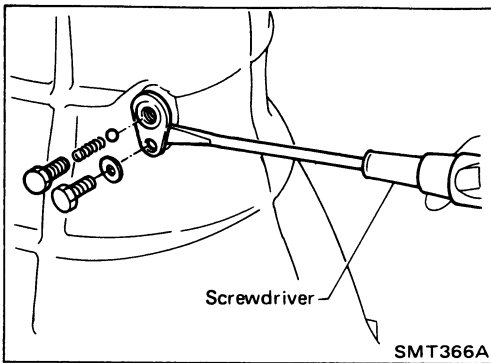

2. Remove upper cover, return spring and check ball.

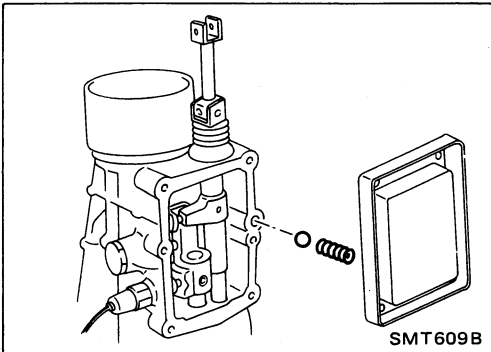

3. Drive out retaining pin from shift & selector lever.

4. Remove control rod from M/T assembly.

Be careful not to damage control rod oil seal and dust cover.

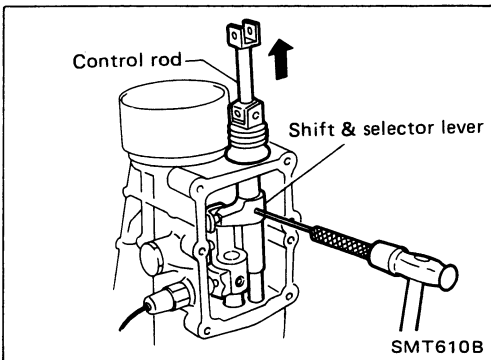

5. Drive out retaining pin from striking arm.

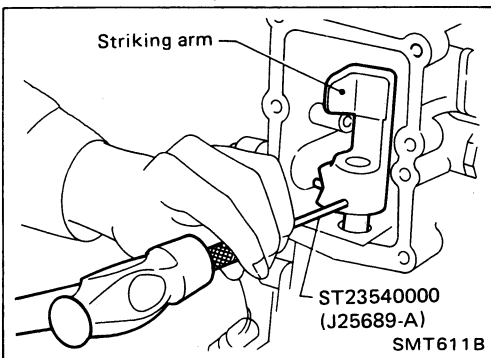

DISASSEMBLY

Case Components (Cont'd)

6. Remove rear extension together with striking arm by tapping lightly.

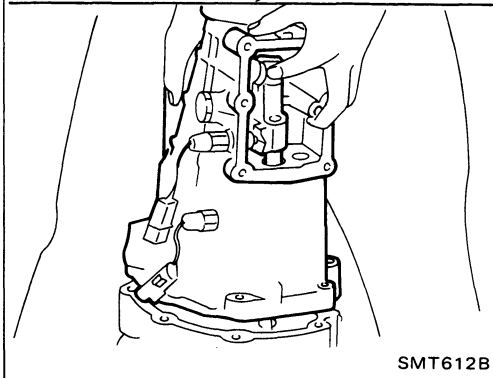
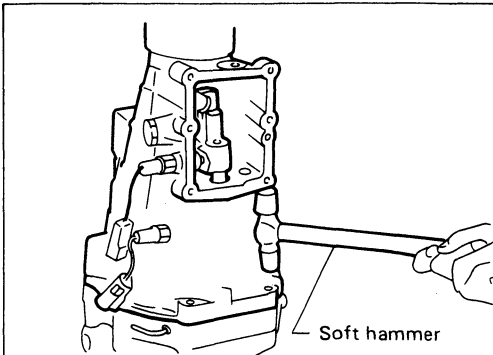

SMT612B

7. Remove front cover and gasket.

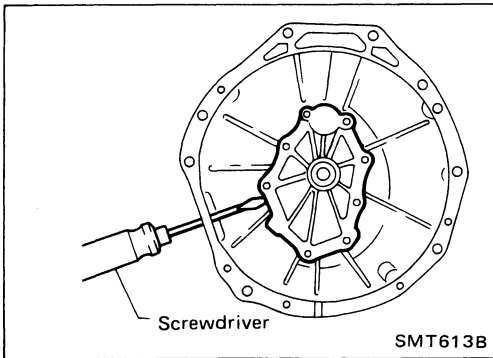

SMT613B

8. Remove stopper ring and main drive bearing snap ring.

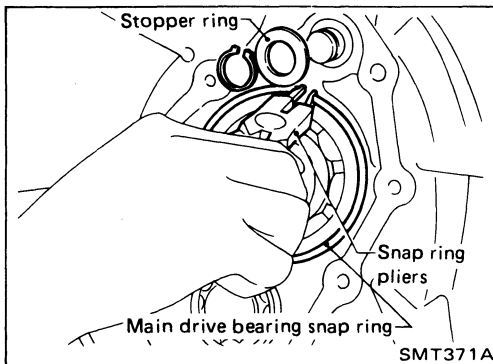

SMT371A

9. Remove transmission case by tapping lightly.

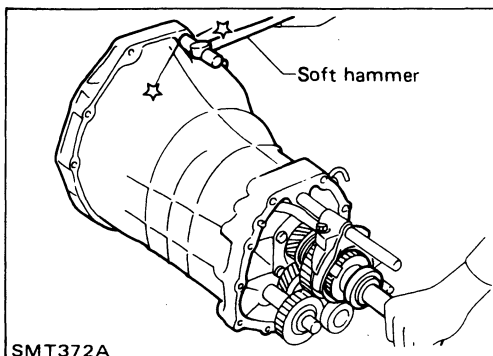

SMT372A

DISASSEMBLY

Case Components (Cont'd)

10. Remove front cover oil seal.

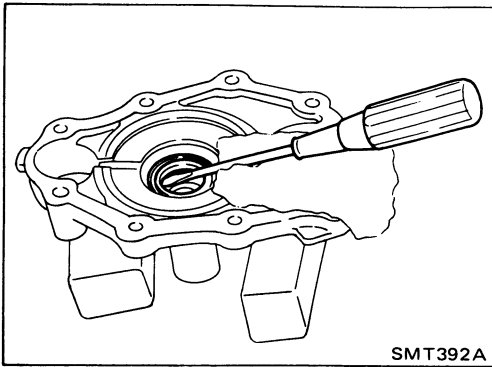

Shift Control Components

1. Mount adapter plate on vise.
2. Remove O.D. & reverse fork rod.

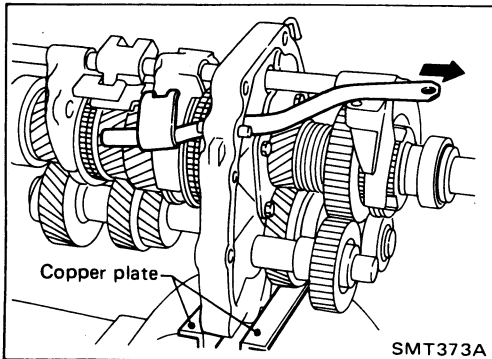

3. Remove check ball plug, check ball and return spring.

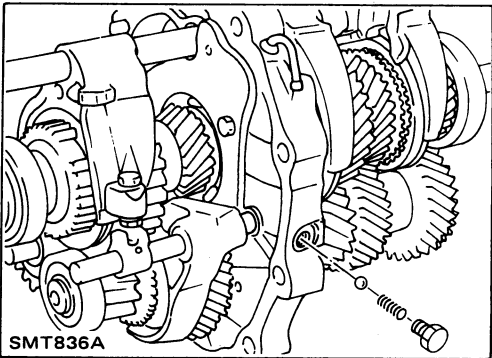

4. Drive out retaining pin from striking lever.
5. While pulling out striking rod, remove striking lever and striking interlock. Then remove 1st & 2nd, 3rd & 4th and reverse shift forks.

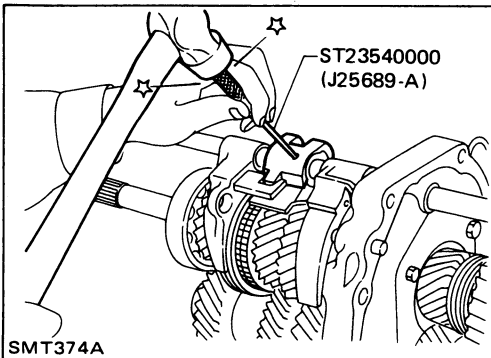

6. Drive out retaining pin from O.D. shift fork.
7. Pull out O.D. fork rod and then remove O.D. shift fork.

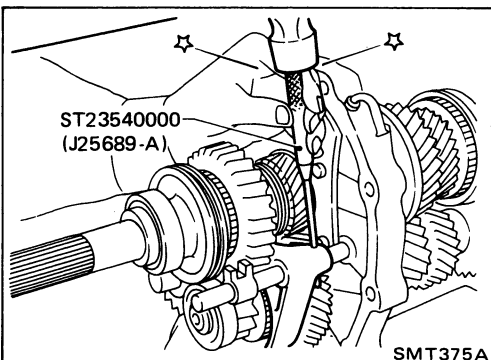

DISASSEMBLY

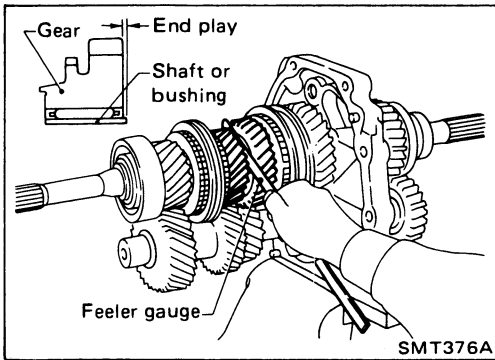

Gear Components

1. Before removing gears and shafts, measure each gear end play.

Gear	End play mm (in)
1st main gear	0.23 - 0.33 (0.0091 - 0.0130)
2nd main gear	0.23 - 0.33 (0.0091 - 0.0130)
3rd main gear	0.23 - 0.33 (0.0091 - 0.0130)
O.D. counter gear	0.23 - 0.33 (0.0091 - 0.0130)
Reverse main gear	0.33 - 0.43 (0.0130 - 0.0169)

- If not within specification, disassemble and check contact surface of gear to hub, washer, bushing, needle bearing and shaft.

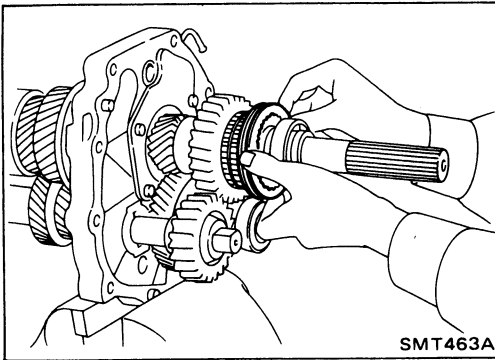

2. Remove rear side components on mainshaft and counter gear.
 - a. Remove snap ring, speedometer drive gear and steel ball.
 - b. Remove reverse coupling sleeve.

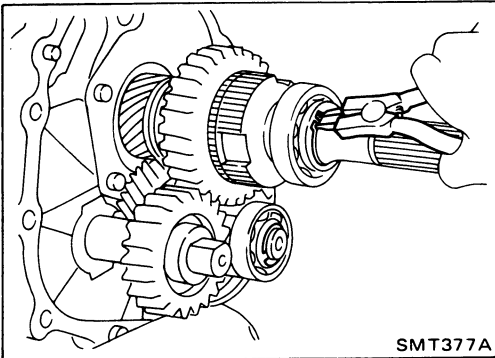

- c. Remove mainshaft rear snap ring and counter gear rear snap ring.
- d. Remove C-ring holder and mainshaft C-rings from mainshaft. Use punch and hammer to remove C-rings.

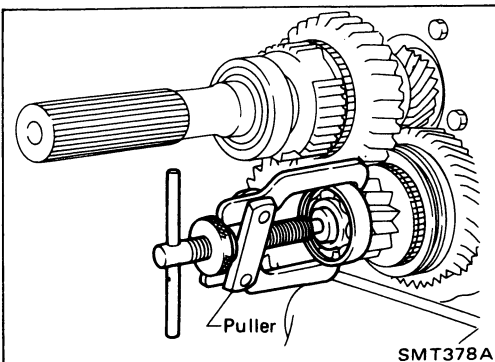

- e. Pull out counter gear rear end bearing.
- f. Remove reverse idler gear and reverse idler thrust washers.

DISASSEMBLY

Gear Components (Cont'd)

g. Remove sub-gear from reverse idler gear.

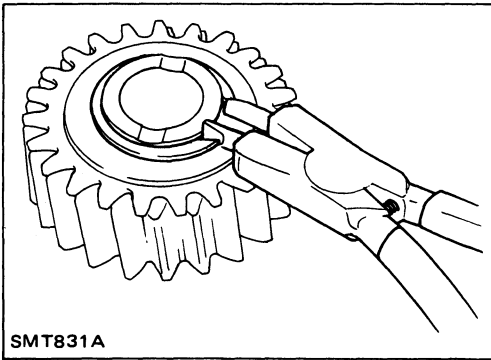

h. Pull out mainshaft rear bearing.

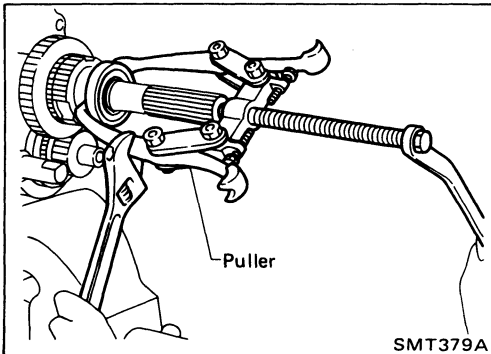

i. Pull out reverse main gear together with mainshaft spacer and reverse synchronizer hub. Then remove reverse gear needle bearings.

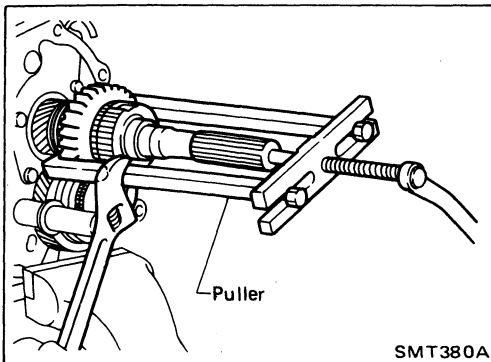

j. Pull out reverse counter gear.
k. Remove O.D. coupling sleeve together with O.D. baulk ring, reverse baulk ring and spring inserts.

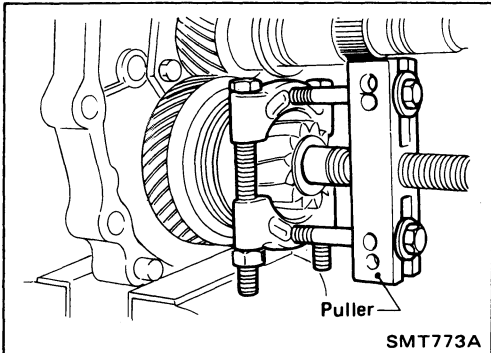

l. Pull out reverse gear bushing.

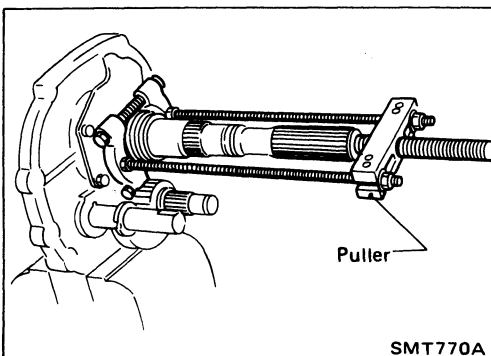

DISASSEMBLY

Gear Components (Cont'd)

m. Pull out O.D. counter gear together with reverse cone.

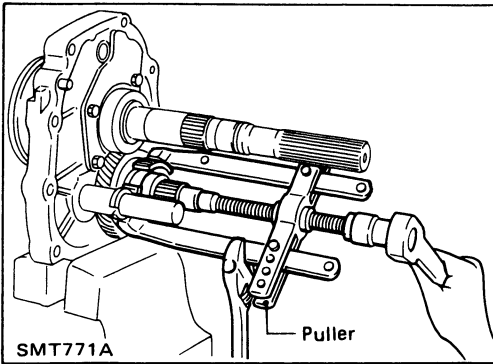

3. Press out mainshaft and counter gear alternately.

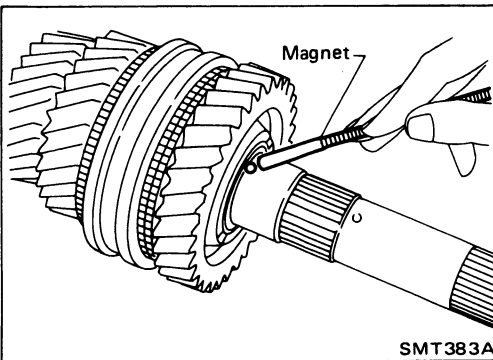
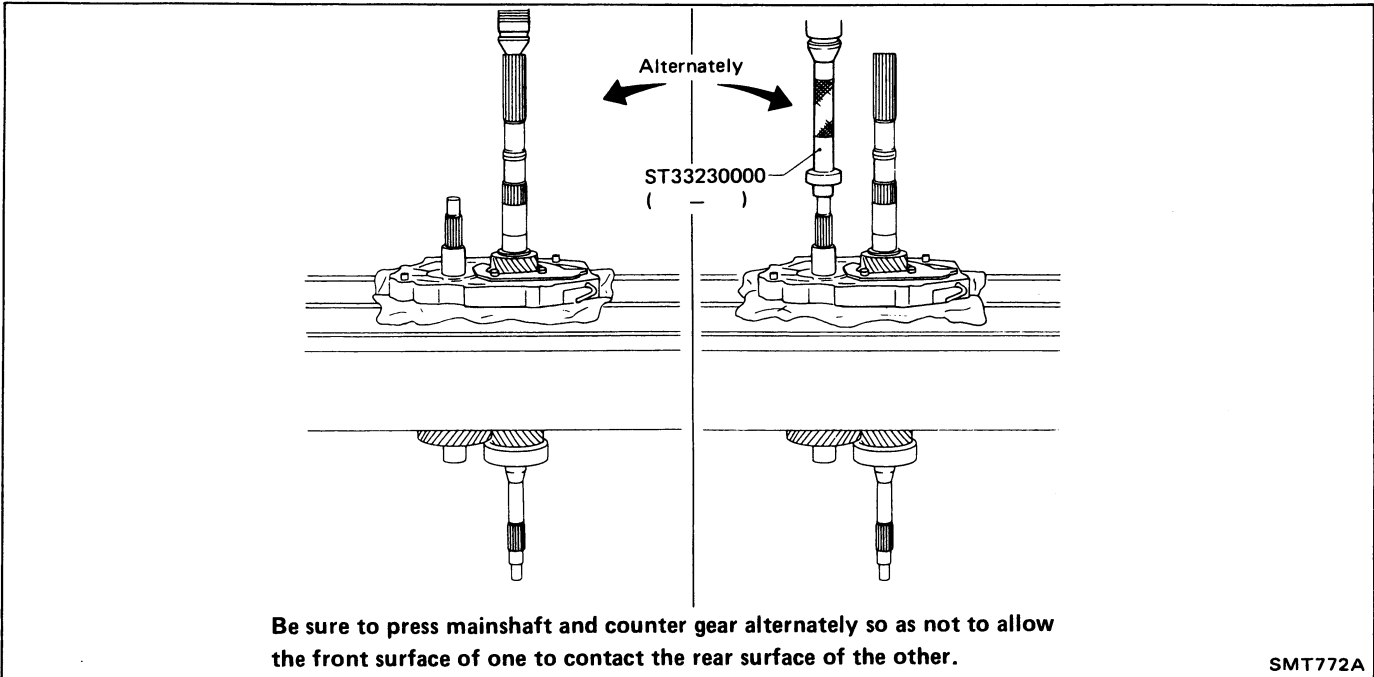

4. Remove front side components on mainshaft.
 - a. Remove 1st gear washer and steel ball.
 - b. Remove 1st main gear and 1st gear needle bearing.

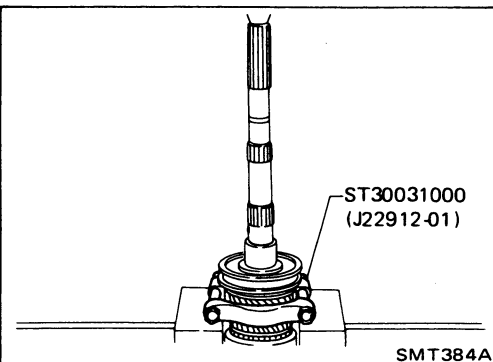

- c. Press out 2nd main gear together with 1st gear bushing and 1st & 2nd synchronizer assembly.
 - d. Remove mainshaft front snap ring.

DISASSEMBLY

Gear Components (Cont'd)

- e. Press out 3rd main gear together with 3rd & 4th synchronizer assembly and 3rd gear needle bearing.

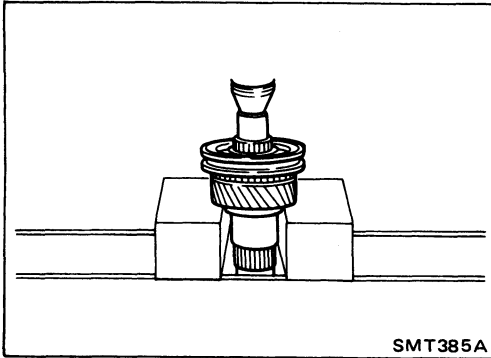

5. Remove front side components on counter gear.
 - a. Remove counter gear rear thrust bearing.

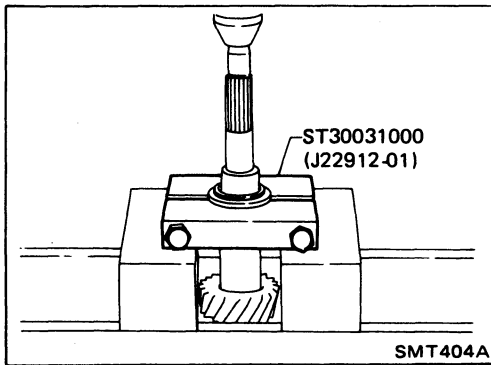

- b. Remove sub-gear components.

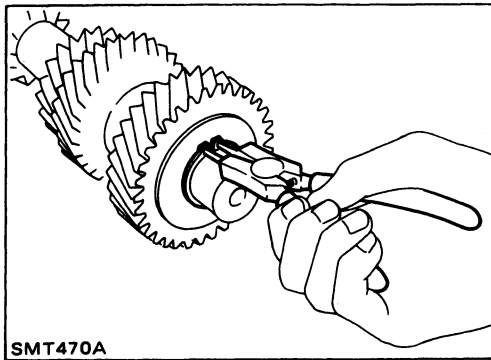

6. Remove main drive gear bearing.
 - a. Remove main drive gear snap ring and spacer.
 - b. Press out main drive gear bearing.

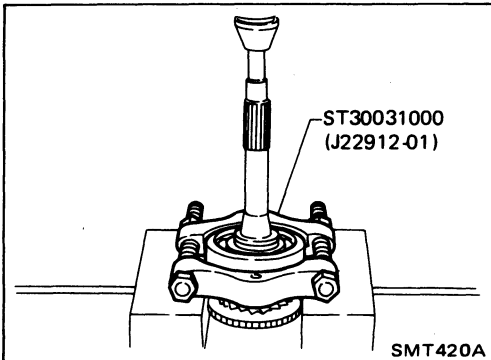

DISASSEMBLY

Gear Components (Cont'd)

7. Remove bearings from case components.

Counter gear front bearing in transmission case

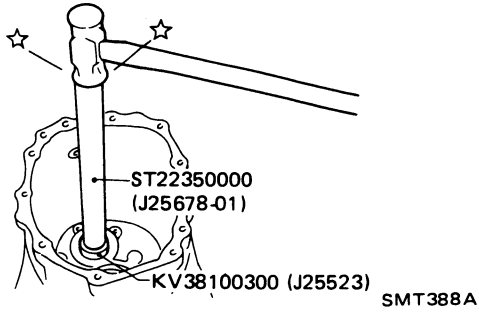

Mainshaft front bearing in adapter plate

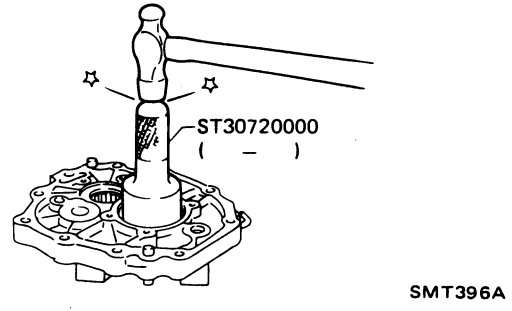

Counter gear rear bearing in adapter plate

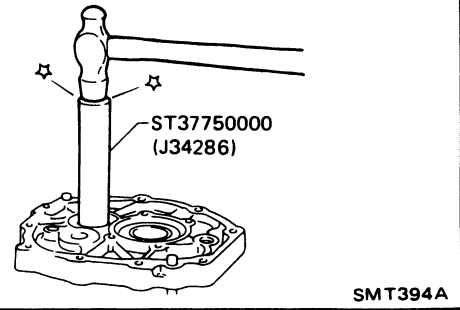

INSPECTION

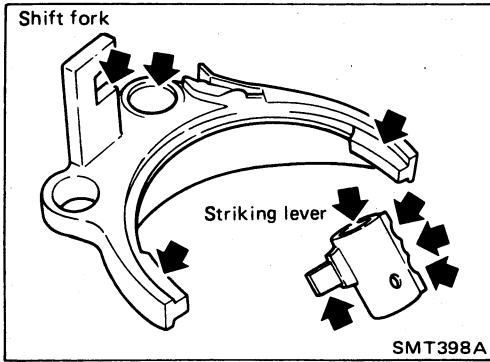

Shift Control Components

- Check contact surface and sliding surface for wear, scratches, projections or other damage.

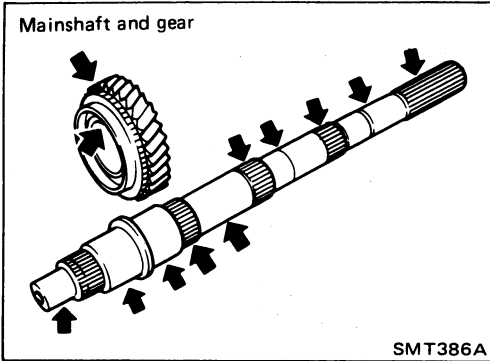

Gear Components GEARS AND SHAFTS

- Check shafts for cracks, wear or bending.
- Check gears for excessive wear, chips or cracks.

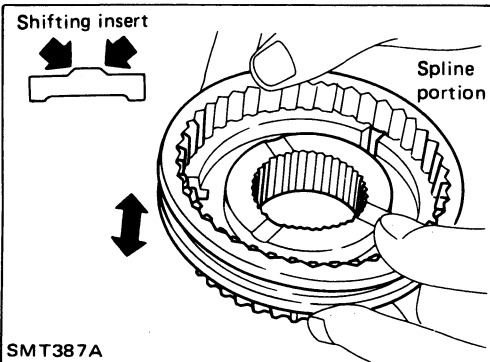
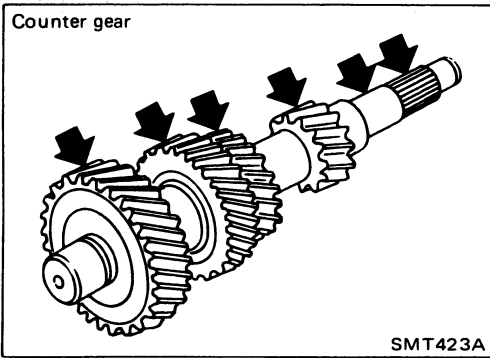

SYNCHRONIZERS

- Check spline portion of coupling sleeves, hubs, and gears for wear or cracks.
- Check baulk rings for cracks or deformation.
- Check shifting inserts for wear or deformation.
- Check insert springs for deformation.

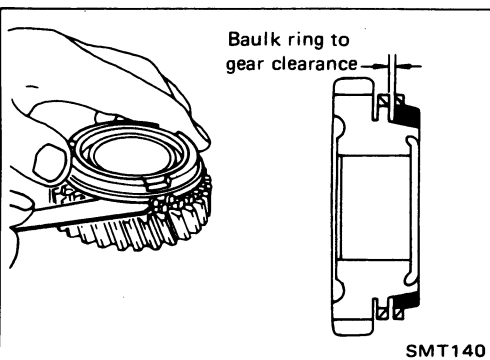

Clearance between baulk ring and gear

- Measure wear of main drive, 1st and O.D. baulk rings.

		Unit: mm (in)
	Standard	Wear limit
1st	1.05 - 1.3 (0.0413 - 0.0512)	0.7 (0.028)
Main drive	1.05 - 1.3 (0.0413 - 0.0512)	0.7 (0.028)
O.D.	1.05 - 1.3 (0.0413 - 0.0512)	0.7 (0.028)

If the clearance is smaller than the wear limit, replace baulk ring.

INSPECTION

Gear Components (Cont'd)

- Measure wear of 2nd and 3rd baulk rings.
 - a. Place baulk rings in position on synchronizer cone.
 - b. While holding baulk rings against synchronizer cone as far as it will go, measure dimensions "A" and "B".

Unit: mm (in)

Dimension	Standard	Wear limit
A	0.6 - 1.1 (0.024 - 0.043)	0.2 (0.008)
B	0.7 - 0.9 (0.028 - 0.035)	

- c. If dimension "A" or "B" is smaller than the wear limit, replace baulk ring.

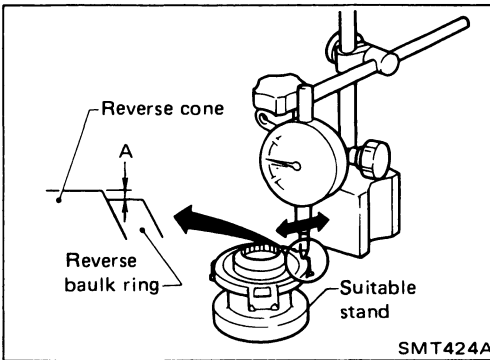
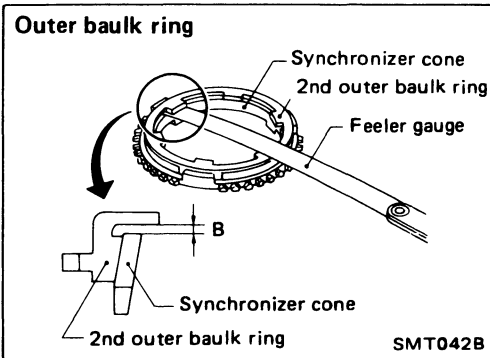
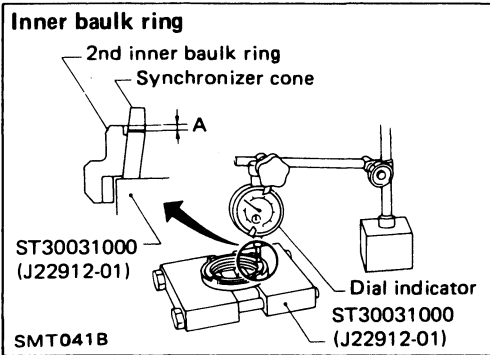

- Measure wear of reverse baulk ring.
 - a. Place baulk ring in position on reverse cone.
 - b. While holding baulk ring against reverse cone as far as it will go, measure dimension "A" with dial indicator.

Unit: mm (in)

	Standard	Wear limit
Dimension "A"	-0.1 to 0.35 (-0.0039 to 0.0138)	0.7 (0.028)

- c. If dimension "A" is larger than the wear limit, replace baulk ring.

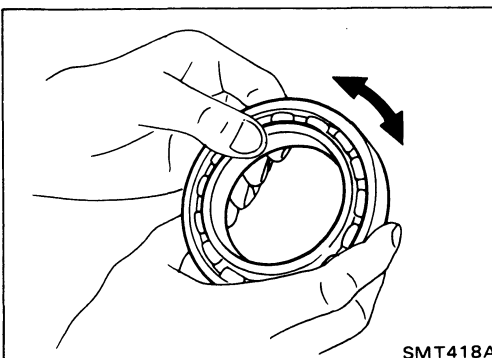

BEARINGS

- Make sure bearings roll freely and are free from noise, crack, pitting or wear.

ASSEMBLY

Gear Components (Cont'd)

1. Install bearings into case components.

Counter gear front bearing in transmission case

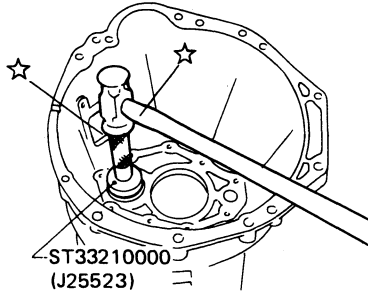

SMT389A

Mainshaft front bearing in adapter plate

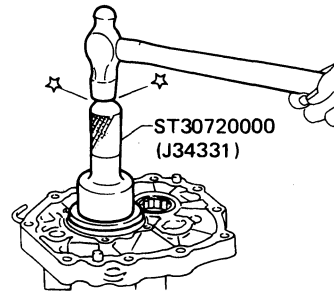

SMT397A

Counter gear rear bearing in adapter plate

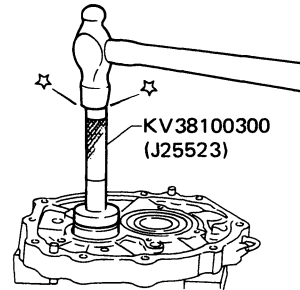

SMT395A

2. Install main drive gear bearing.
 - a. Press main drive gear bearing.
 - b. Install main drive gear spacer.

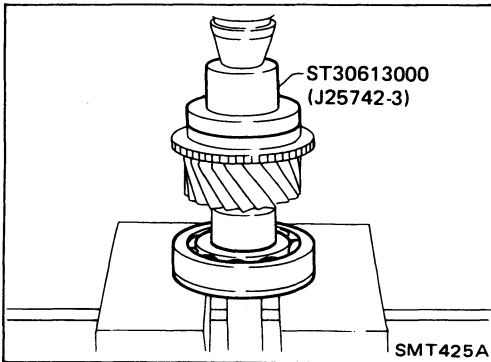

SMT425A

- c. Select proper main drive gear snap ring to minimize clearance of groove.

Allowable clearance of groove:

0 - 0.1 mm (0 - 0.004 in)

Main drive gear snap ring

Thickness mm (in)	Part number
1.89 (0.0744)	32204-01G00
1.98 (0.0780)	32204-01G01
2.05 (0.0807)	32204-01G02
2.12 (0.0835)	32204-01G03
2.19 (0.0862)	32204-01G04

- d. Install selected snap ring on main drive gear.

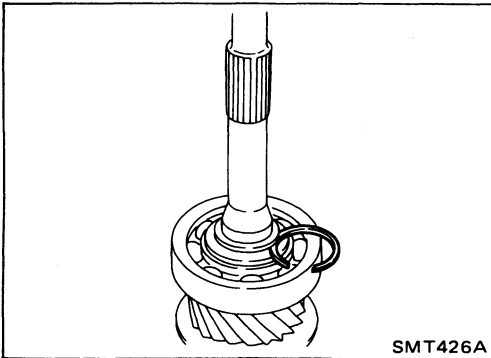

SMT426A

ASSEMBLY

Gear Components (Cont'd)

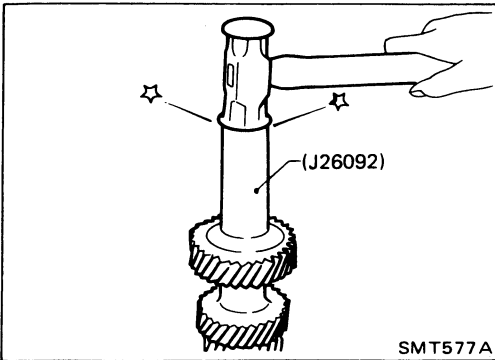

3. Install components on counter gear.

a. Install sub-gear components.

When installing sub-gear snap ring, tap sub-gear snap ring into position on counter gear.

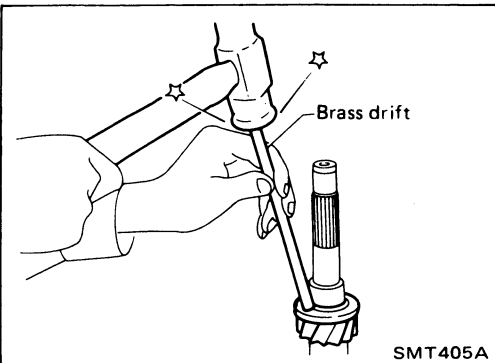

b. Install counter gear rear thrust bearing.

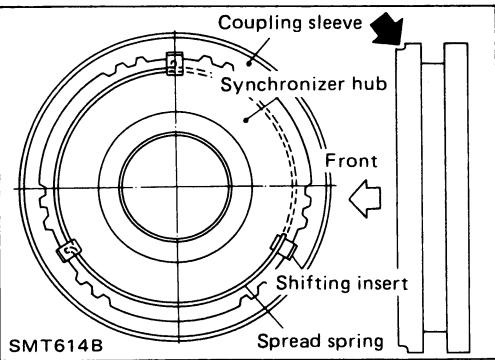

4. Install front side components on mainshaft.

a. Assemble 1st & 2nd synchronizer.

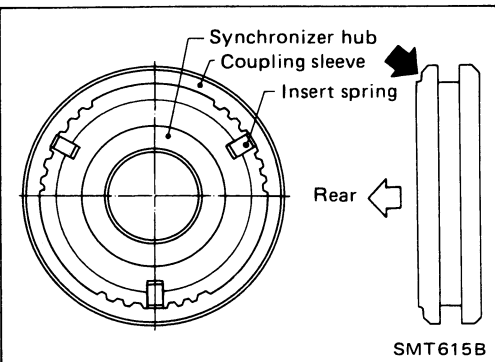

b. Assemble 3rd & 4th synchronizer.

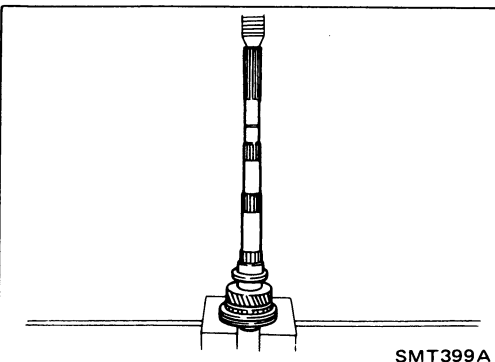

c. Press on 3rd & 4th synchronizer assembly together with 3rd main gear and 3rd gear needle bearing.

Pay attention to direction of synchronizer assembly.

ASSEMBLY

Gear Components (Cont'd)

d. Select proper snap ring to minimize clearance of groove.

Allowable clearance of groove:

0 - 0.1 mm (0 - 0.004 in)

Mainshaft front snap ring

Thickness mm (in)	Part number
1.89 (0.0744)	32204-01G00
1.98 (0.0780)	32204-01G01
2.05 (0.0807)	32204-01G02
2.12 (0.0835)	32204-01G03
2.19 (0.0862)	32204-01G04

e. Install selected snap ring on mainshaft.

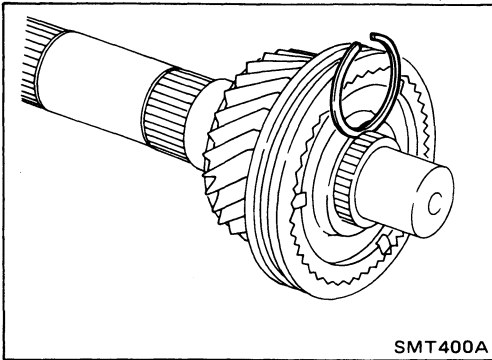

f. Press on 1st & 2nd synchronizer assembly together with 2nd main gear and 2nd gear needle bearing.

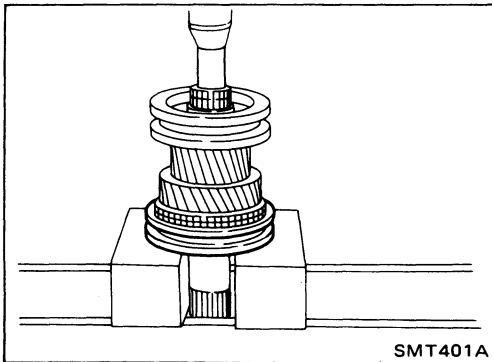

g. Press on 1st gear bushing using 1st gear washer.

h. Install 1st main gear and needle bearing.

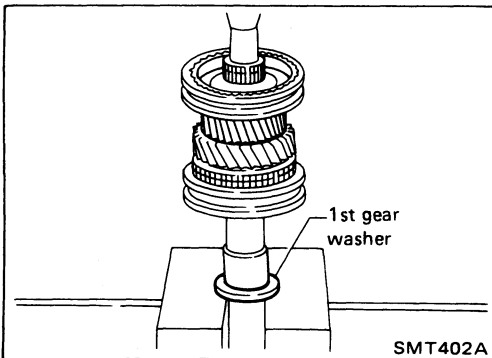

i. Install steel ball and 1st gear washer.

Apply multi-purpose grease to steel ball and 1st gear washer before installing.

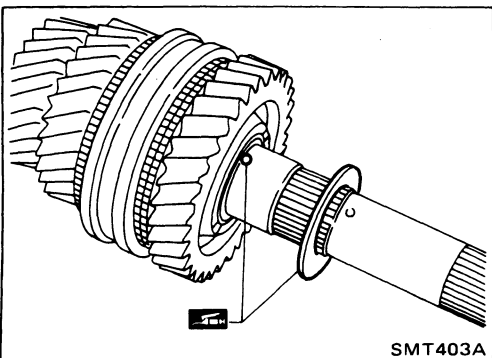

ASSEMBLY

Gear Components (Cont'd)

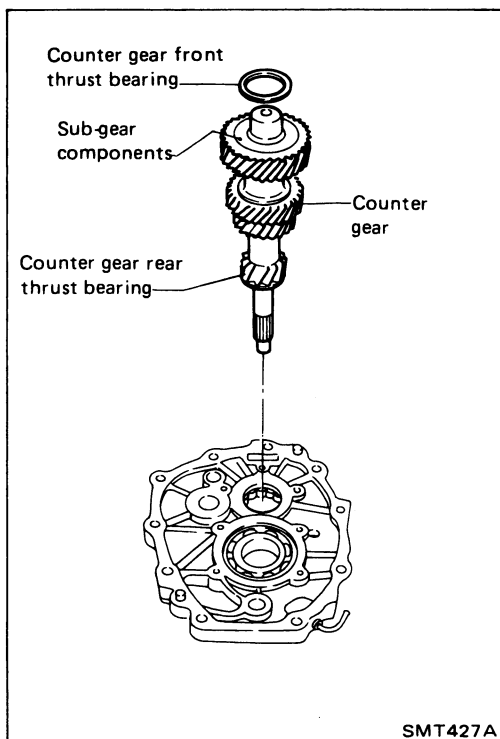

5. Select proper counter gear front bearing shim when replacing transmission case, counter gear, counter gear thrust bearing or sub-gear components.
 - a. Install counter gear with sub-gear components, counter gear front and rear thrust bearing on adapter plate.
 - b. Remove counter gear front bearing shim from transmission case.
 - c. Place adapter plate and counter gear assembly in transmission case (case inverted).

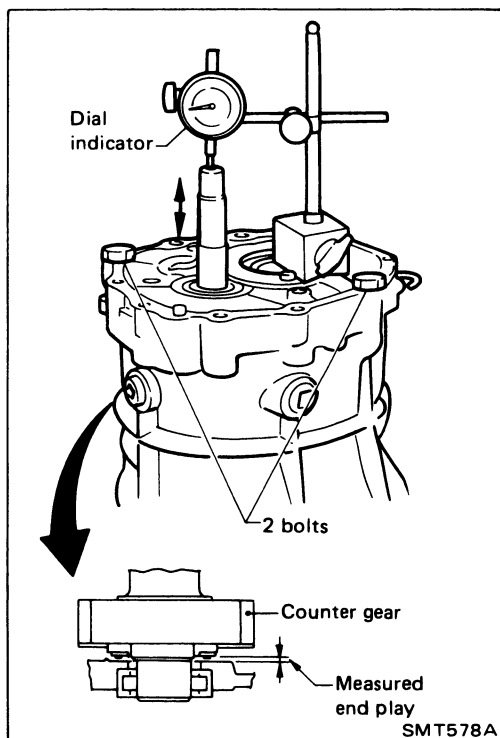

- d. Tighten adapter plate to transmission case using 2 bolts.
- e. Place dial indicator on rear end of counter gear.
- f. Move counter gear up and down and measure dial indicator deflection.
- g. Select proper shim using table below as a guide.

Counter gear end play:

0.10 - 0.25 mm (0.0039 - 0.0098 in)

Table for selecting proper counter gear front bearing shim

Dial indicator deflection mm (in)	Thickness of proper washer mm (in)	Part number
0.93 - 1.02 (0.0366 - 0.0402)	0.8 (0.031)	32218-01G00
1.03 - 1.12 (0.0406 - 0.0441)	0.9 (0.035)	32218-01G01
1.13 - 1.22 (0.0445 - 0.0480)	1.0 (0.039)	32218-01G02
1.23 - 1.32 (0.0484 - 0.0520)	1.1 (0.043)	32218-01G03
1.33 - 1.42 (0.0524 - 0.0559)	1.2 (0.047)	32218-01G04
1.43 - 1.52 (0.0563 - 0.0598)	1.3 (0.051)	32218-01G05
1.53 - 1.62 (0.0602 - 0.0638)	1.4 (0.055)	32218-01G06

ASSEMBLY

Gear Components (Cont'd)

6. Select proper reverse idler rear thrust washer when replacing rear extension, reverse idler gear, reverse idler shaft or reverse idler thrust washer.

a. Install reverse idler gear, reverse idler needle bearings, reverse idler thrust washers and reverse idler shaft into rear extension.

When replacing reverse idler rear washer, install either A or B.

Reverse idler rear thrust washer

	Thickness mm (in)	Part number
A	1.97 (0.0776)	32284-01G10
B	2.07 (0.0815)	32284-01G11

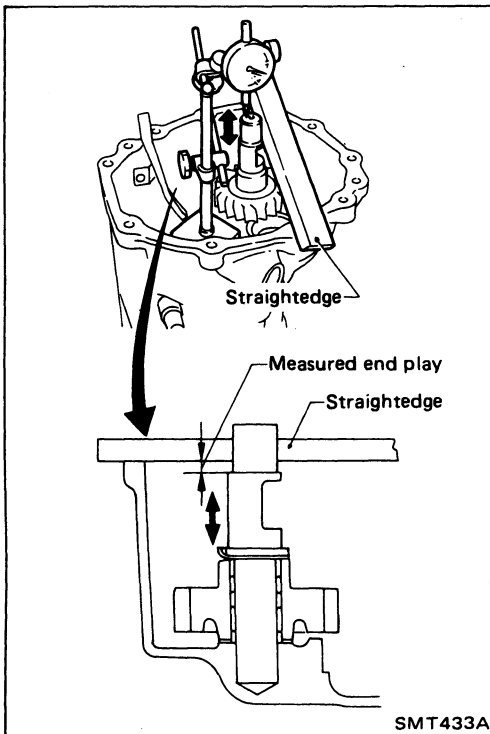
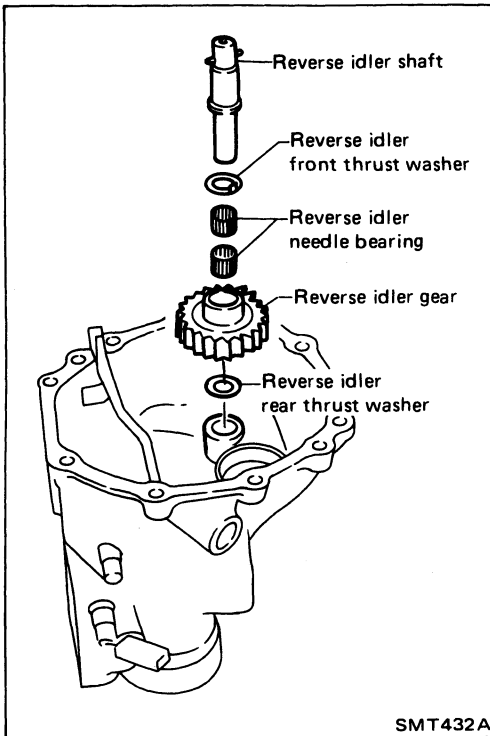

b. Place dial indicator on front end of reverse idler shaft.

c. Put straightedge on front surface of rear extension as a stopper of reverse idler shaft.

d. Move reverse idler shaft up and down and measure reverse idler gear end play.

Reverse idler gear end play:

0.30 - 0.53 mm (0.0118 - 0.0209 in)

e. If not within specification, replace reverse idler rear thrust washer with the other (A or B) and check again.

ASSEMBLY

Gear Components (Cont'd)

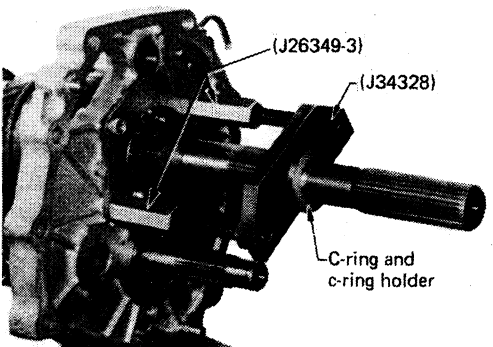
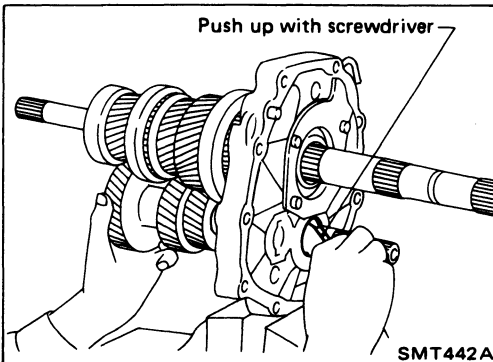
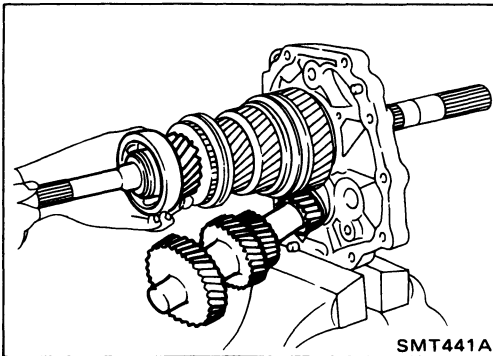
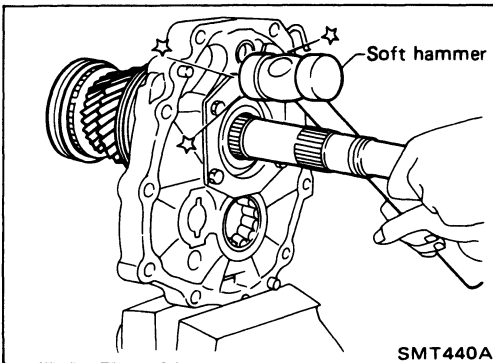
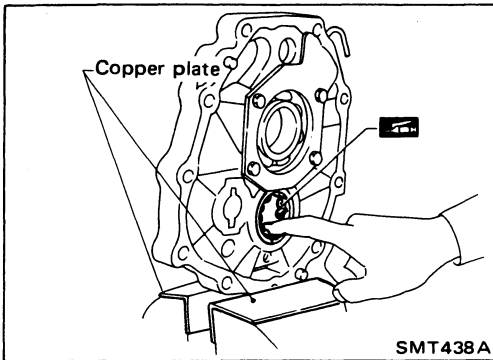

7. Install mainshaft and counter gear on adapter plate and main drive gear on mainshaft.
 - a. Mount adapter plate on vise and apply multi-purpose grease to counter gear rear bearing.

- b. Install mainshaft a little on mainshaft front bearing.
To allow for installation of counter gear, do not install mainshaft completely.

- c. Install counter gear on counter gear rear bearing and install main drive gear, pilot bearing and spacer on mainshaft.

When installing counter gear into counter gear rear bearing, push up on upper roller of counter gear rear bearing with screwdriver.

- d. Install Tools (J26349-3) onto adapter plate and C-ring and C-ring holder on mainshaft.
 - e. Install Tool (J34328) on mainshaft.

ASSEMBLY

Gear Components (Cont'd)

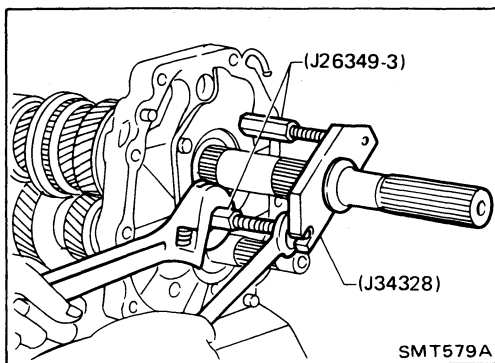

- f. Install mainshaft and counter gear completely by extending length of J26349-3.

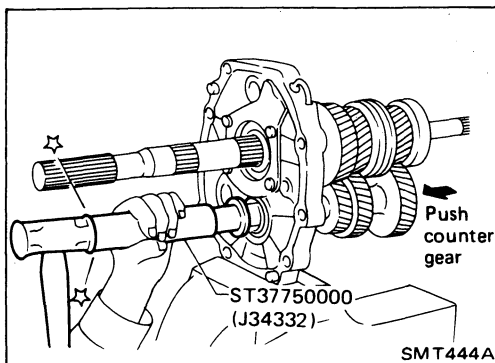

8. Install rear side components on mainshaft and counter gear.
a. Install O.D. gear bushing while pushing on the front of counter gear.

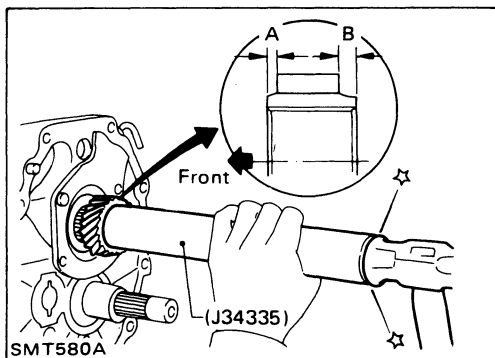

- b. Install O.D. main gear.
Pay attention to direction of O.D. main gear. (B is wider than A as shown at left.)
c. Install adapter plate with gear assembly onto transmission case.
d. Install O.D. gear needle bearing and then install O.D. counter gear and reverse idler shaft.

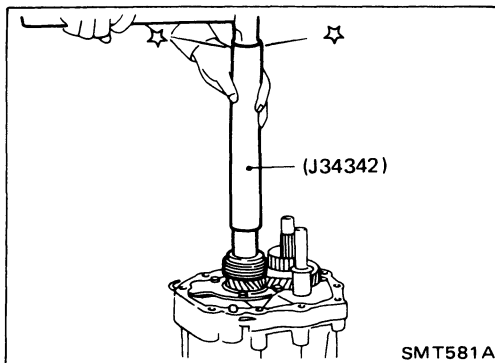

- e. Install reverse gear bushing.

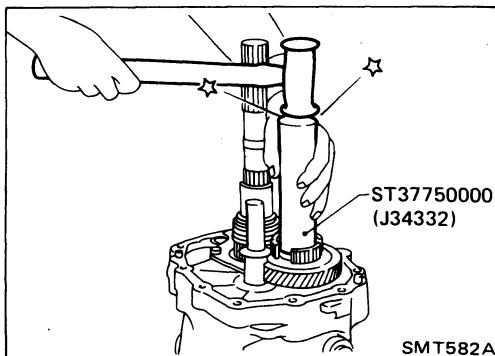

- f. Install reverse cone.

ASSEMBLY

Gear Components (Cont'd)

- g. Install insert springs and reverse baulk ring on O.D. coupling sleeve. Then install them and O.D. baulk ring on O.D. counter gear.

Pay attention to direction of O.D. coupling sleeve.

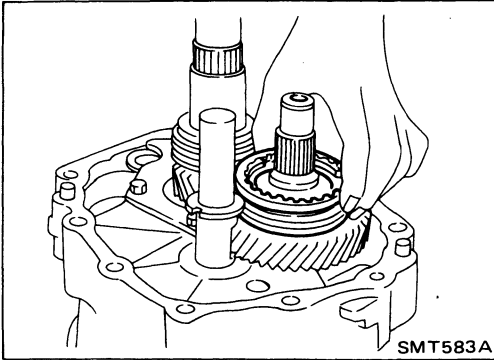
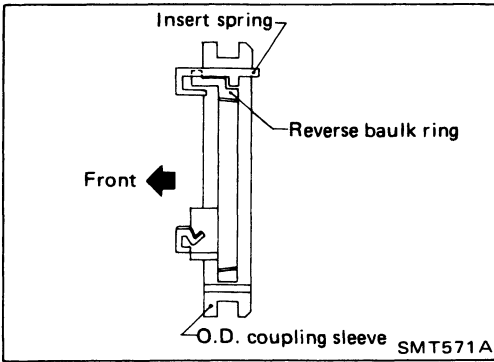

- h. Install reverse counter gear.

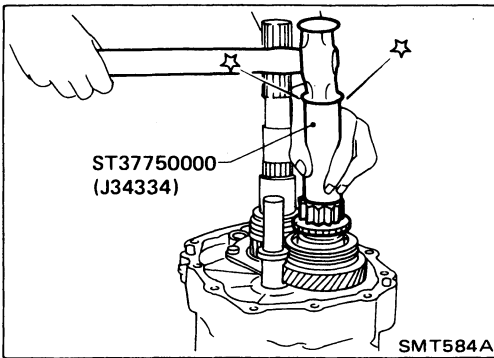

- i. Install sub-gear on reverse idler gear.
j. Install reverse gear needle bearing and then install reverse main gear, reverse idler gear and reverse idler thrust washers.

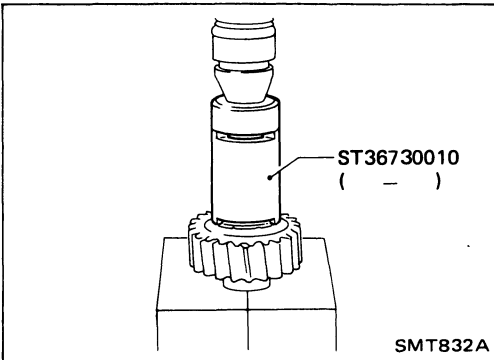

- k. Install reverse hub.
Pay attention to its direction.

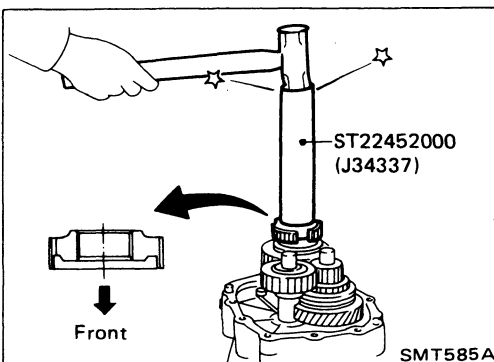

ASSEMBLY

Gear Components (Cont'd)

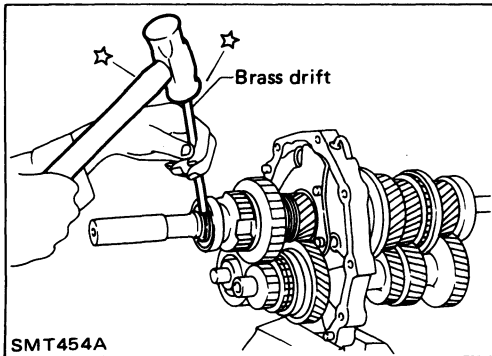
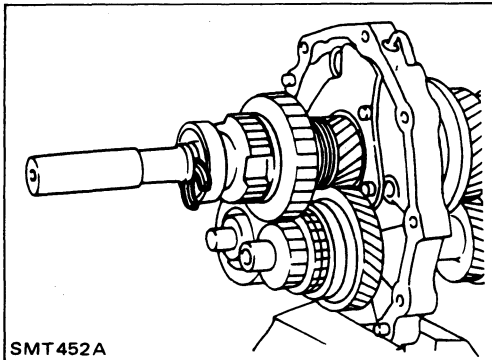
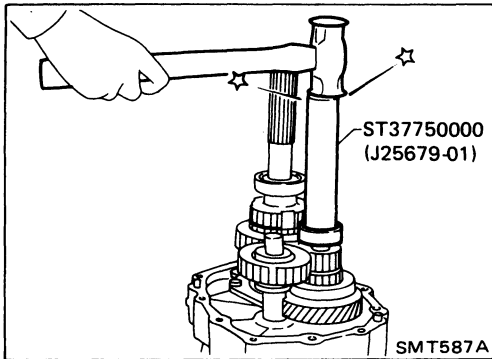
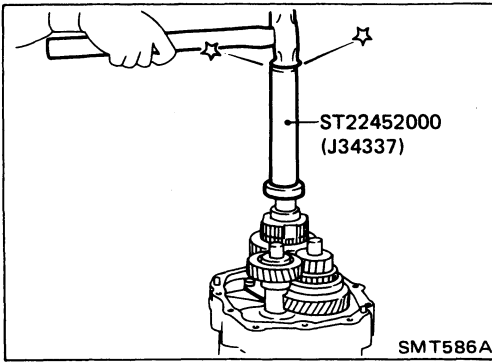

- l. Install mainshaft spacer and mainshaft rear bearing.
- m. Install speedometer drive gear.

- n. Install counter gear rear end bearing.
- o. Separate adapter plate from transmission case and Mount adapter plate on vise again.

- p. Select proper mainshaft C-ring to minimize clearance of groove.

Allowable clearance of groove:

0 - 0.1 mm (0 - 0.004 in)

Mainshaft C-ring

Thickness mm (in)	Part number	Thickness mm (in)	Part number
2.63 (0.1035)	32348-01G15	3.19 (0.1256)	32348-01G07
2.70 (0.1063)	32348-01G00	3.26 (0.1283)	32348-01G08
2.77 (0.1091)	32348-01G01	3.33 (0.1311)	32348-01G09
2.84 (0.1118)	32348-01G02	3.40 (0.1339)	32348-01G10
2.91 (0.1146)	32348-01G03	3.47 (0.1366)	32348-01G11
2.98 (0.1173)	32348-01G04	3.54 (0.1394)	32348-01G12
3.05 (0.1201)	32348-01G05	3.61 (0.1421)	32348-01G13
3.12 (0.1228)	32348-01G06	3.68 (0.1449)	32348-01G14

- q. Install selected C-ring, C-ring holder and mainshaft rear snap ring.

ASSEMBLY

Gear Components (Cont'd)

- r. Install spacer and then select proper counter gear rear snap ring to minimize clearance of groove.

Allowable clearance of groove:

0 - 0.1 mm (0 - 0.004 in)

Counter gear rear snap ring

Thickness mm (in)	Part number
1.26 (0.0496)	32236-01G08
1.32 (0.0520)	32236-01G00
1.38 (0.0543)	32236-01G01
1.44 (0.0567)	32236-01G02
1.50 (0.0591)	32236-01G03
1.56 (0.0614)	32236-01G04
1.62 (0.0638)	32236-01G05
1.68 (0.0661)	32236-01G06
1.74 (0.0685)	32236-01G07

- s. Install selected counter gear rear snap ring.

- t. Install reverse coupling sleeve.

Pay attention to its direction.

- u. Measure each gear end play as a final check — Refer to "DISASSEMBLY".

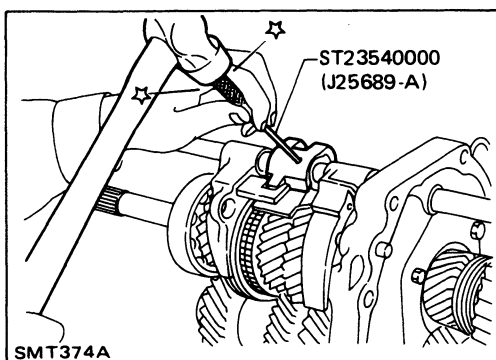
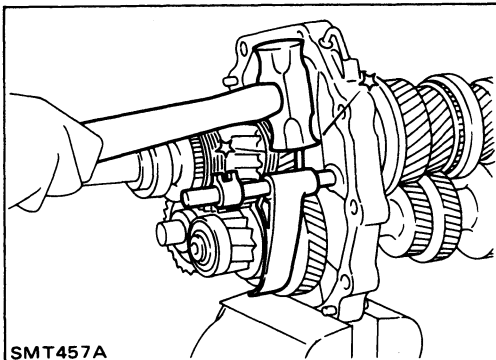
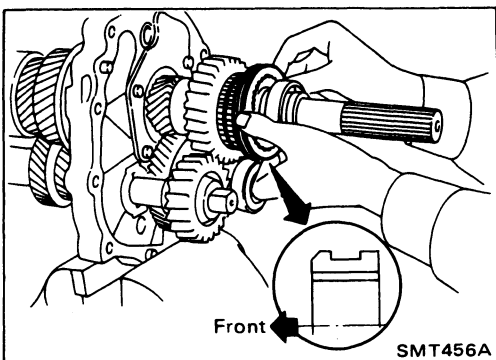
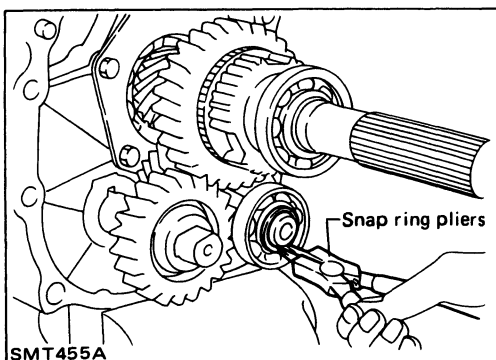
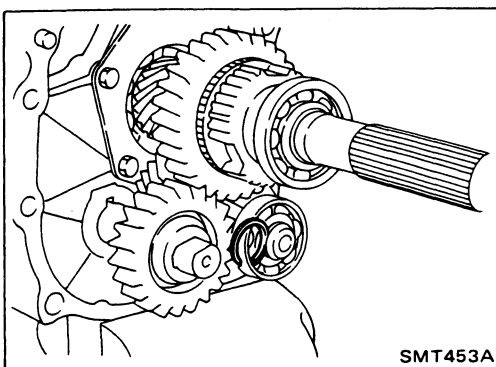

Shift Control Components

1. Install O.D. fork rod and O.D. shift fork. Then install retaining pin into O.D. shift fork.
2. Install 1st & 2nd, 3rd & 4th and reverse shift forks onto coupling sleeve.

3. Install striking rod into hole of shift forks, striking lever and interlock and then install retaining pin into striking lever.

Make sure that striking rod moves smoothly.

ASSEMBLY

Shift Control Components (Cont'd)

4. Install check ball, return spring and check ball plug.
Apply sealant to thread of check ball plug.

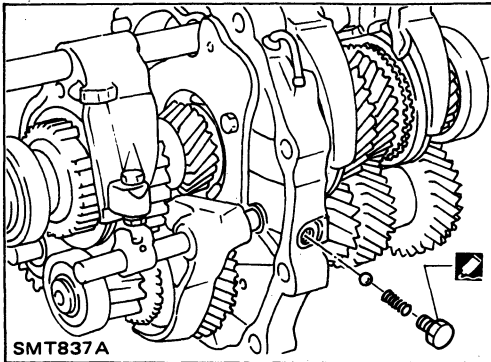

Case Components

1. Install front cover oil seal.
Apply multi-purpose grease to seal lip.
2. Install selected counter gear front bearing shim onto transmission case.
Apply multi-purpose grease.
3. Apply sealant to mating surface of transmission case.

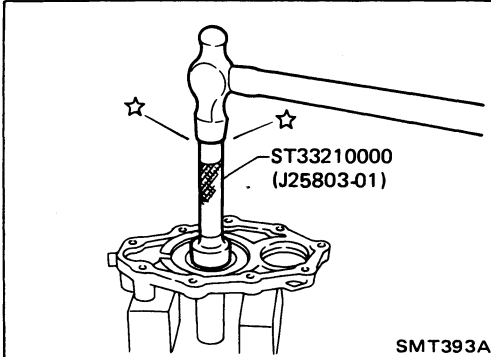

4. Install gear assembly onto transmission case.
5. Install check spring and check ball into interlock stopper.
Apply multi-purpose grease to check ball.

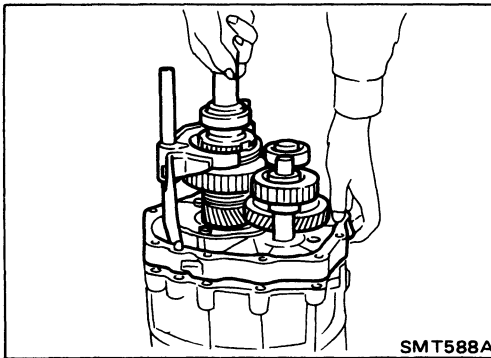

6. Install interlock stopper assembly and then tighten check ball plug.
Apply sealant to thread of check ball plug.

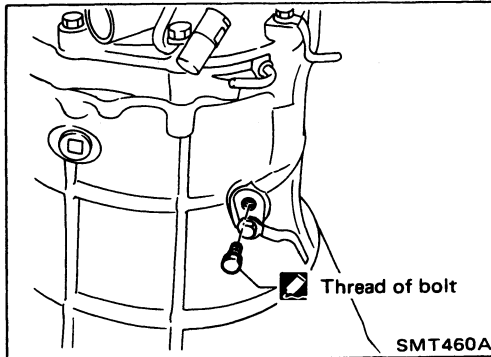

7. Install stopper ring and main drive bearing snap ring.

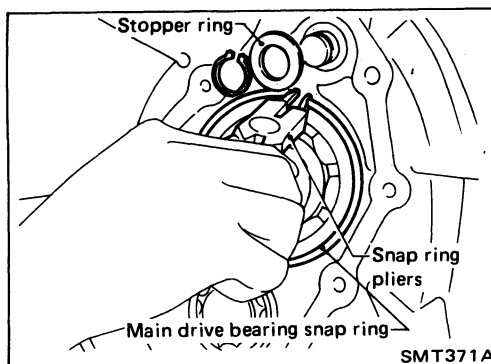

ASSEMBLY

Case Components (Cont'd)

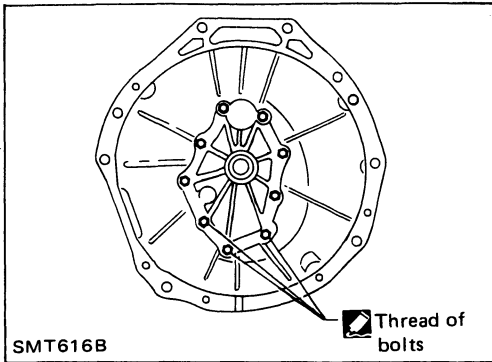

8. Install front cover and gasket.
Apply sealant to thread of 3 bolts shown left.
9. Apply sealant to mating surface of adapter plate.

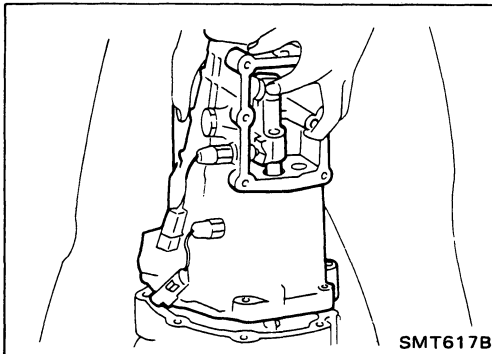

10. Install rear extension together with striking arm.

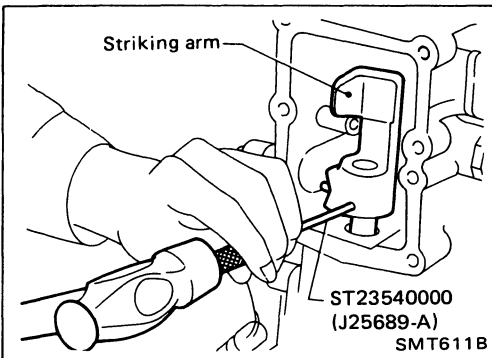

11. Install retaining pin into striking arm.

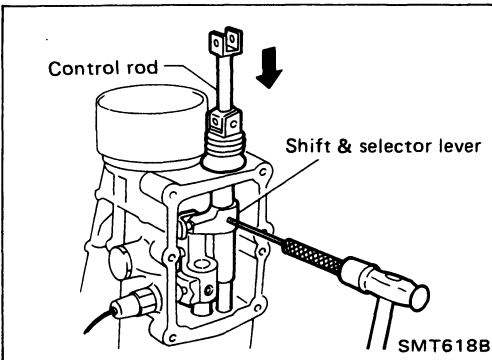

12. Install control rod.
Be careful not to damage control rod oil seal and dust cover.
13. Install retaining pin into shift & selector lever.

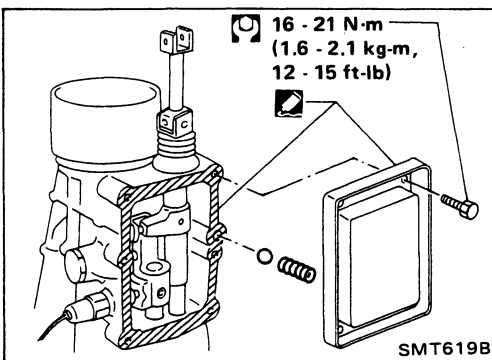

14. Install return spring and check ball and then install control housing.
Apply sealant to mating surface of rear extension.
15. Tighten control housing bolts.

SERVICE DATA AND SPECIFICATIONS (S.D.S.)

General Specifications

Engine	VG30DE, VG30DETT	
Transmission model	RS5R30A	
Shift pattern		
Synchromesh type	Warner	
Gear ratio		
	1st	3.214
	2nd	1.925
	3rd	1.302
	4th	1.000
	O.D.	0.752
	Reverse	3.369
Number of teeth		
	Main drive gear	23
	Main gear	
	1st	31
	2nd	30
	3rd	29
	O.D.	24
	Reverse	30
	Counter drive gear	31
	Counter gear	
	1st	13
	2nd	21
	3rd	30
	O.D.	43
	Reverse	12
	Reverse idler gear	22
Oil capacity	liter (US pt, Imp pt)	2.8 (5-7/8, 4-7/8)

SERVICE DATA AND SPECIFICATIONS (S.D.S.)

Inspection and Adjustment

GEAR END PLAY

Gear	End play mm (in)
1st main gear	0.23 - 0.33 (0.0091 - 0.0130)
2nd main gear	0.23 - 0.33 (0.0091 - 0.0130)
3rd main gear	0.23 - 0.33 (0.0091 - 0.0130)
O.D. counter gear	0.23 - 0.33 (0.0091 - 0.0130)
Reverse main gear	0.33 - 0.43 (0.0130 - 0.0169)
Counter gear	0.10 - 0.25 (0.0039 - 0.0098)
Reverse idler gear	0.30 - 0.53 (0.0118 - 0.0209)

CLEARANCE BETWEEN BAULK RING AND GEAR

1st, main drive and O.D. baulk ring

Unit: mm (in)

	Standard	Wear limit
1st	1.05 - 1.3 (0.0413 - 0.0512)	0.7 (0.028)
Main drive	1.05 - 1.3 (0.0413 - 0.0512)	0.7 (0.028)
O.D.	1.05 - 1.3 (0.0413 - 0.0512)	0.7 (0.028)

2nd and 3rd baulk ring

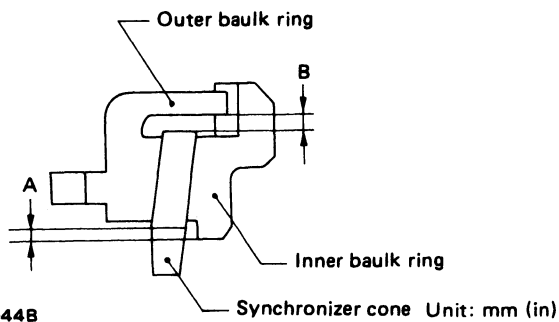

Dimension	Standard	Wear limit
A	0.6 - 1.1 (0.024 - 0.043)	0.2 (0.008)
B	0.7 - 0.9 (0.028 - 0.035)	0.2 (0.008)

DISTANCE BETWEEN REAR SURFACE OF REVERSE CONE AND REVERSE BAULK RING

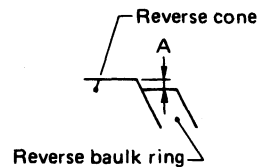

Unit: mm (in)

	Standard	Wear limit
Dimension "A"	-0.1 to 0.35 (-0.0039 to 0.0138)	0.7 (0.028)

AVAILABLE SNAP RING

Main drive gear snap ring

Allowable clearance 0 - 0.1 mm (0 - 0.004 in)

Thickness mm (in)	Part number
1.89 (0.0744)	32204-01G00
1.98 (0.0780)	32204-01G01
2.05 (0.0807)	32204-01G02
2.12 (0.0835)	32204-01G03
2.19 (0.0862)	32204-01G04

Mainshaft front snap ring

Allowable clearance 0 - 0.1 mm (0 - 0.004 in)

Thickness mm (in)	Part number
1.89 (0.0744)	32204-01G00
1.98 (0.0780)	32204-01G01
2.05 (0.0807)	32204-01G02
2.12 (0.0835)	32204-01G03
2.19 (0.0862)	32204-01G04

Counter gear rear snap ring

Allowable clearance 0 - 0.1 mm (0 - 0.004 in)

Thickness mm (in)	Part number
1.26 (0.0496)	32236-01G08
1.32 (0.0520)	32236-01G00
1.38 (0.0543)	32236-01G01
1.44 (0.0567)	32236-01G02
1.50 (0.0591)	32236-01G03
1.56 (0.0614)	32236-01G04
1.62 (0.0638)	32236-01G05
1.68 (0.0661)	32236-01G06
1.74 (0.0685)	32236-01G07

SERVICE DATA AND SPECIFICATIONS (S.D.S.)

Inspection and Adjustment (Cont'd)

AVAILABLE C-RING

Mainshaft C-ring

Allowable clearance 0 - 0.1 mm (0 - 0.004 in)

Thickness mm (in)	Part number	Thickness mm (in)	Part number
2.63 (0.1035)	32348-01G15	3.19 (0.1256)	32348-01G07
2.70 (0.1063)	32348-01G00	3.26 (0.1283)	32348-01G08
2.77 (0.1091)	32348-01G01	3.33 (0.1311)	32348-01G09
2.84 (0.1118)	32348-01G02	3.40 (0.1339)	32348-01G10
2.91 (0.1146)	32348-01G03	3.47 (0.1366)	32348-01G11
2.98 (0.1173)	32348-01G04	3.54 (0.1394)	32348-01G12
3.05 (0.1201)	32348-01G05	3.61 (0.1421)	32348-01G13
3.12 (0.1228)	32348-01G06	3.68 (0.1449)	32348-01G14

AVAILABLE SHIM AND WASHER

Table for selecting proper counter gear front bearing shim

Dial indicator deflection mm (in)	Thickness of proper washer mm (in)	Part number
0.93 - 1.02 (0.0366 - 0.0402)	0.8 (0.031)	32218-01G00
1.03 - 1.12 (0.0406 - 0.0441)	0.9 (0.035)	32218-01G01
1.13 - 1.22 (0.0445 - 0.0480)	1.0 (0.039)	32218-01G02
1.23 - 1.32 (0.0484 - 0.0520)	1.1 (0.043)	32218-01G03
1.33 - 1.42 (0.0524 - 0.0559)	1.2 (0.047)	32218-01G04
1.43 - 1.52 (0.0563 - 0.0598)	1.3 (0.051)	32218-01G05
1.53 - 1.62 (0.0602 - 0.0638)	1.4 (0.055)	32218-01G06

Reverse idler rear thrust washer

Thickness mm (in)	Part number
1.97 (0.0776)	32284-01G10
2.07 (0.0815)	32284-01G11

AUTOMATIC TRANSMISSION

SECTION **AT**

CONTENTS

PREPARATION	AT- 2
PRECAUTIONS	AT- 4
A/T CONTROL DIAGRAM	AT- 5
ON-VEHICLE SERVICE	AT- 8
TROUBLE DIAGNOSES	AT- 11
REMOVAL AND INSTALLATION	AT-108
MAJOR OVERHAUL	AT-110
DISASSEMBLY	AT-118
REPAIR FOR COMPONENT PARTS	AT-130
ASSEMBLY	AT-179
SERVICE DATA AND SPECIFICATIONS (S.D.S.)	AT-198

AT

When you read wiring diagrams:

- Read G1 section, "HOW TO READ WIRING DIAGRAMS".
- See EL section, "POWER SUPPLY ROUTING" for power distribution circuit.

When you perform trouble diagnoses, read G1 section, "HOW TO FOLLOW FLOW CHART IN TROUBLE DIAGNOSES".

PREPARATION

SPECIAL SERVICE TOOLS

Tool number (Kent-Moore No.) Tool name	Description	
ST2505S001 (J25695-A) Oil pressure gauge set ① ST25051001 (-) Oil pressure gauge ② ST25052000 (-) Hose ③ ST25053000 (-) Joint pipe ④ ST25054000 (-) Adapter ⑤ ST25055000 (-) Adapter		Measuring line pressure
KV31101201 (-) Oil pressure gauge adapter		Measuring line pressure
ST07870000 (J37068) Transmission case stand		Disassembling and assembling A/T
KV31102100 (J37065) Torque converter one-way clutch check tool		Checking one-way clutch in torque converter
ST25850000 (J25721-A) Sliding hammer		Removing oil pump assembly
KV31102400 (J34285 and J34285-87) Clutch spring compressor		Removing and installing clutch return springs
ST33200000 (J26082) Drift	<p>a: 60 mm (2.36 in) dia. b: 44.5 mm (1.752 in) dia.</p>	Installing oil pump housing oil seal Installing rear oil seal

PREPARATION

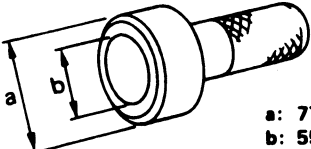
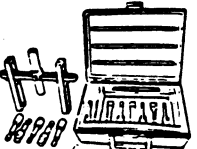
Tool number (Kent-Moore No.) Tool name	Description
ST30720000 (J34331) Drift	 <p>a: 77 mm (3.03 in) dia. b: 55.5 mm (2.185 in) dia.</p> <p>Installing rear oil seal</p>
(J34291) Shim setting gauge set	 <p>Selecting oil pump cover bearing race and oil pump thrust washer</p>

PRECAUTIONS

Service Notice

- Before proceeding with disassembly, thoroughly clean the outside of the transmission. It is important to prevent the internal parts from becoming contaminated by dirt or other foreign matter.
- Disassembly should be done in a clean work area.
- Use lint-free cloth or towels for wiping parts clean. Common shop rags can leave fibers that could interfere with the operation of the transmission.
- When disassembling parts, place them in order in a parts rack so that they can be put back into the unit in their proper positions.
- All parts should be carefully cleaned with a general purpose, non-flammable solvent before inspection or reassembly.
- Gaskets, seals and O-rings should be replaced any time the transmission is disassembled.
- It is very important to perform functional tests whenever they are indicated.
- The valve body contains precision parts and requires extreme care when parts are removed and serviced. Place removed parts in order on a parts rack so they can be put back in the valve body in the same positions and sequences. Care will also prevent springs and small parts from becoming scattered or lost.
- Properly installed valves, sleeves, plugs, etc. will slide along their bores in the valve body under their own weight.
- Before assembly, apply a coat of recommended A.T.F. to all parts. Petroleum jelly may be applied to O-rings and seals and used to hold small bearings and washers in place during reassembly. Do not use grease.
- Extreme care should be taken to avoid damage to O-rings, seals and gaskets when assembling.
- After overhaul, refill the transmission with new A.T.F.

A/T CONTROL DIAGRAM

Hydraulic Control Circuits

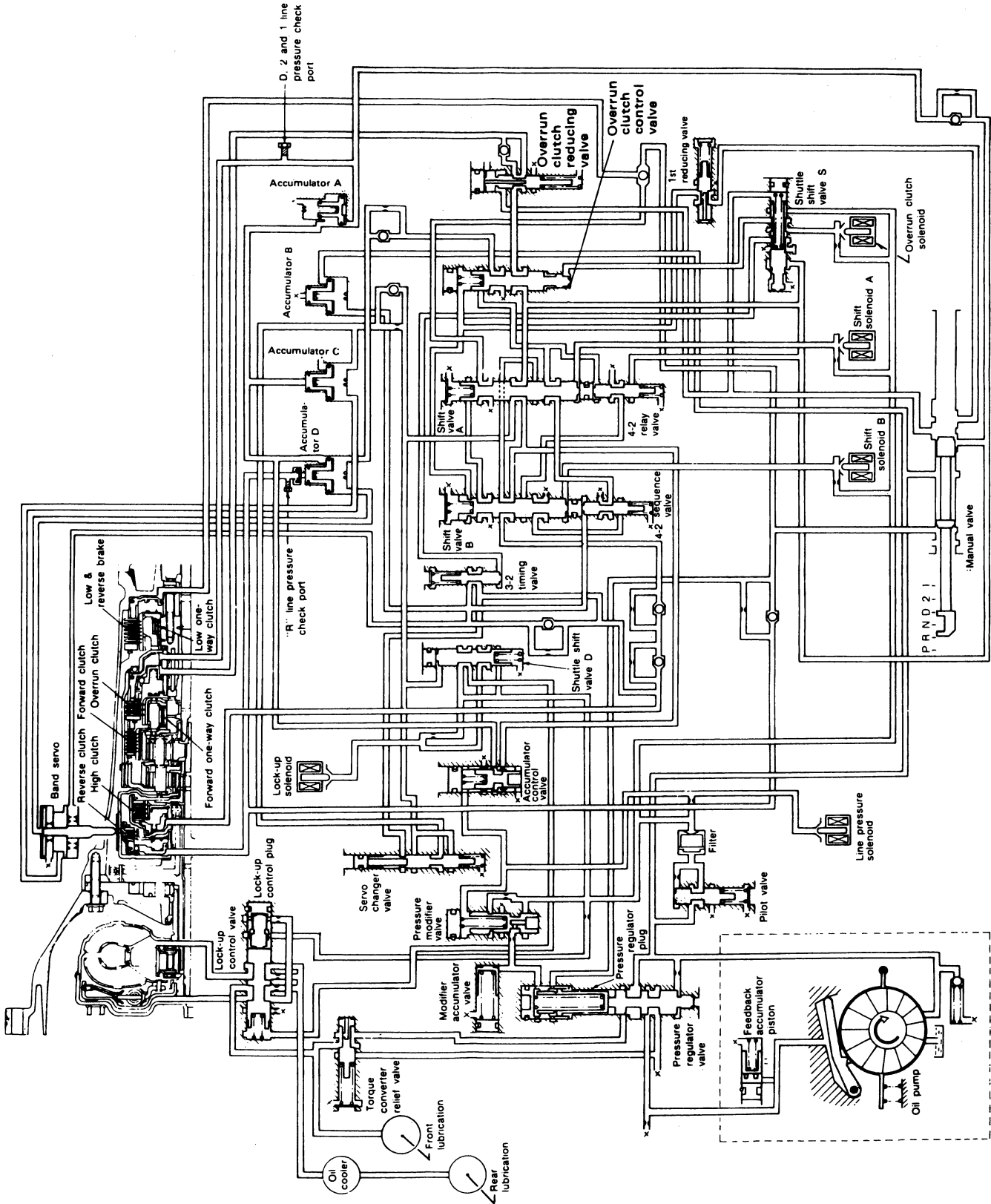

SAT123B

A/T CONTROL DIAGRAM

Electrical Control Chart

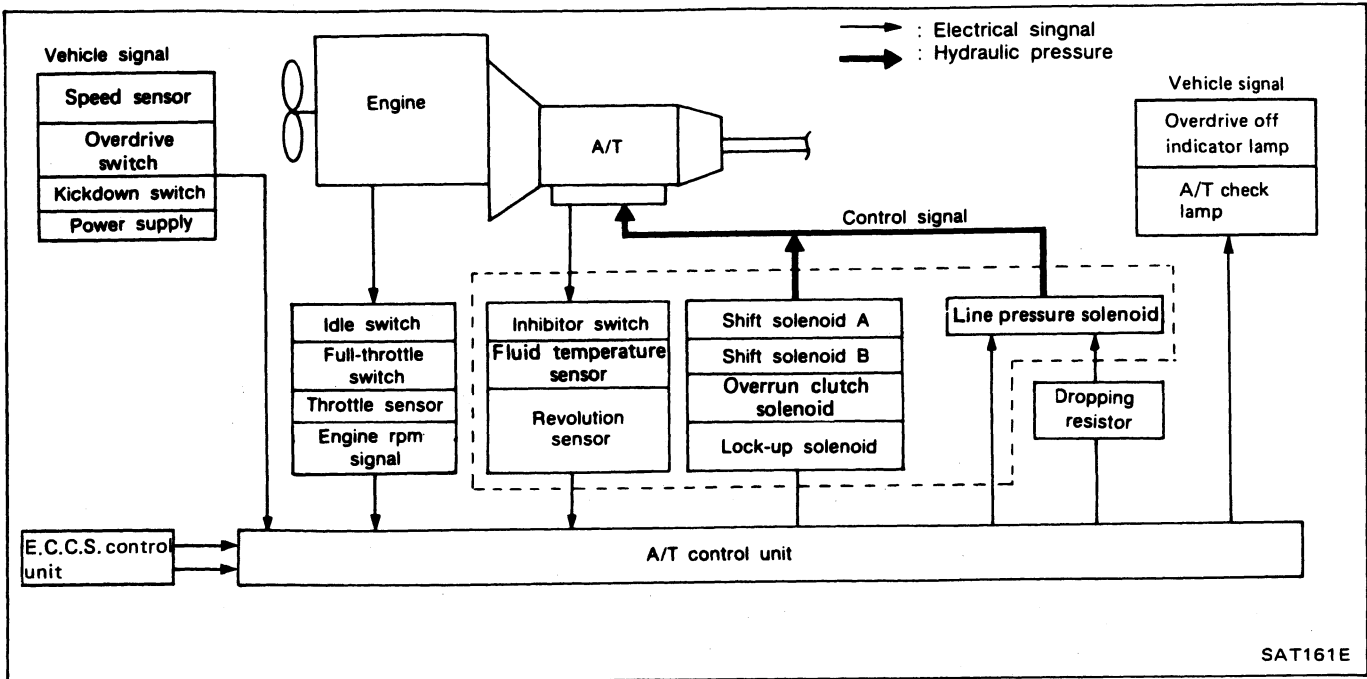

Mechanical Operation

Shift position	Reverse clutch	High clutch	Forward clutch	Overrun clutch	Band servo			Forward one-way clutch	Low one-way clutch	Low & reverse brake	Lock-up	Remarks
					2nd apply	3rd release	4th apply					
P												PARK
R	○									○		REVERSE
N												NEUTRAL
D *4	1st		○	⊗				●	●			Automatic shift 1 → 2 → 3 → 4
	2nd		○	○ ^{*1}	○			●				
	3rd		○	○	○	*2⊗	⊗	●				
	4th		○	⊗		*3⊗	⊗	○			○	
2	1st		○	⊗				●	●			Automatic shift 1 → 2
	2nd		○	○	○			●				
1	1st		○	○				●		○		Locks (held stationary) in 1st speed 1 → 2
	2nd		○	○	○			●				

*1. Operates when overdrive switch is set in "OFF" position.

*2. Oil pressure is applied to both 2nd "apply" side and 3rd "release" side of band servo piston. However, because oil pressure area on the "release" side is greater than that on the "apply" side, brake band does not contract.

*3. Oil pressure is applied to 4th "apply" side in condition *2 above, and brake band contracts.

*4. A/T will not shift to 4th when overdrive switch is set in "OFF" position.

○ : Operates.

○ : Operates when throttle opening is less than 1/16. Engine brake activates.

● : Operates during "progressive" acceleration.

⊗ : Operates but does not affect power transmission.

⊗ : Operates when throttle opening is less than 1/16 but does not affect engine brake.

A/T CONTROL DIAGRAM

Cross-Sectional View

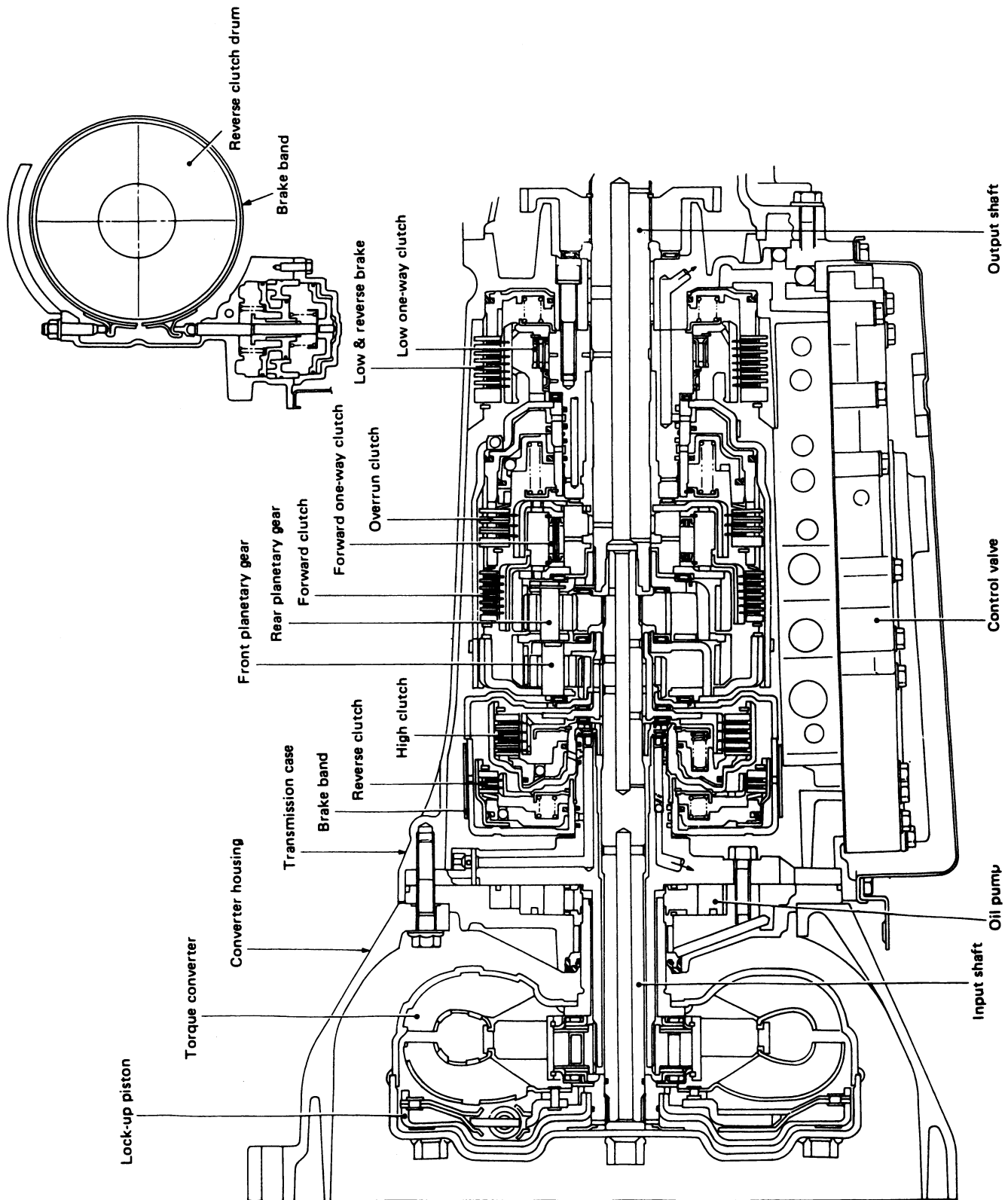

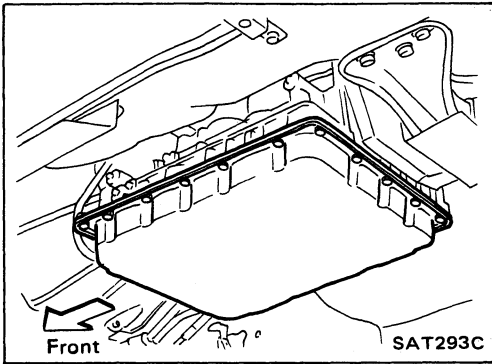

Control Valve Assembly and Accumulators Inspection

1. Remove oil pan and gasket and drain A.T.F.

2. Remove oil strainer.

3. Remove control valve assembly by removing fixing bolts and disconnecting harness connector.

Bolt length and location

Bolt symbol	ℓ mm (in)	 ℓ
(A)	33 (1.30)	
(B)	45 (1.77)	

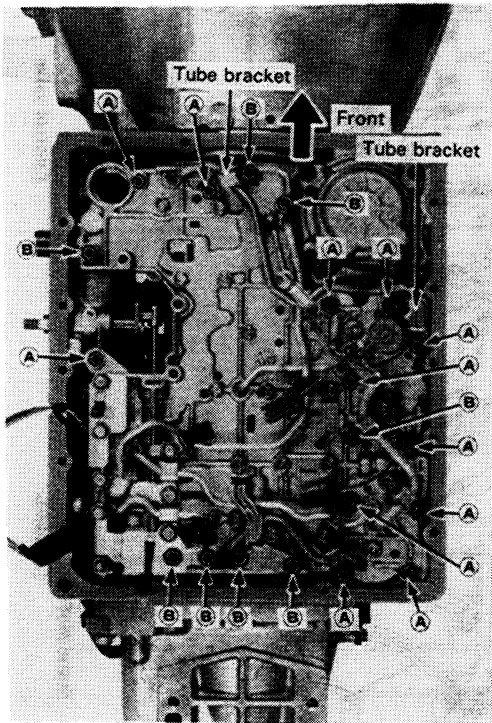

4. Remove solenoids and valves from valve body if necessary.
5. Remove terminal cord assembly if necessary.

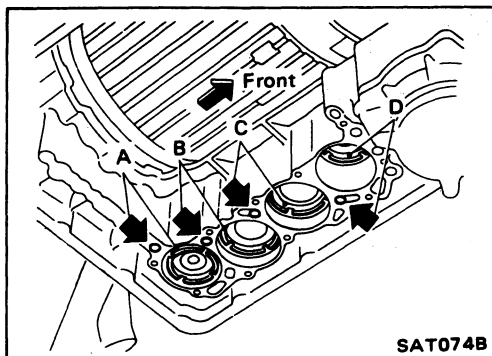

6. Remove accumulators A, B, C and D by applying compressed air if necessary.

- Hold each piston with rag.
- 7. Reinstall any part removed.
- Always use new sealing parts.

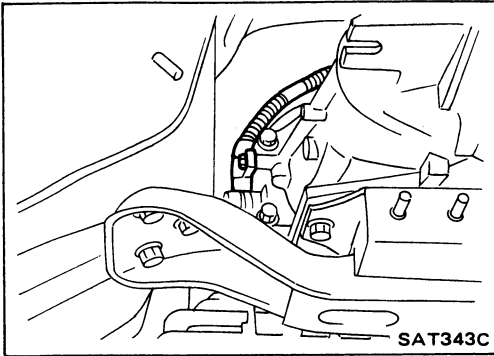

Revolution Sensor Replacement

1. Remove exhaust tube.
 2. Remove revolution sensor from A/T assembly.
 3. Reinstall any part removed.
- Always use new sealing parts.

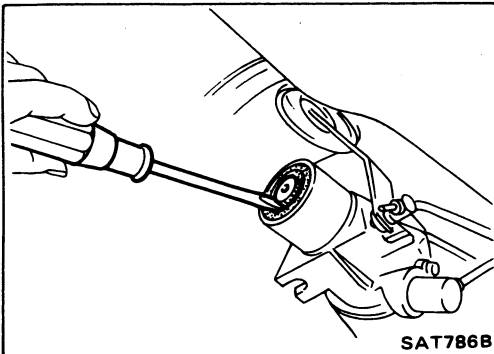

Rear Oil Seal Replacement

1. Remove propeller shaft from vehicle. — Refer to section PD.
2. Remove rear oil seal.

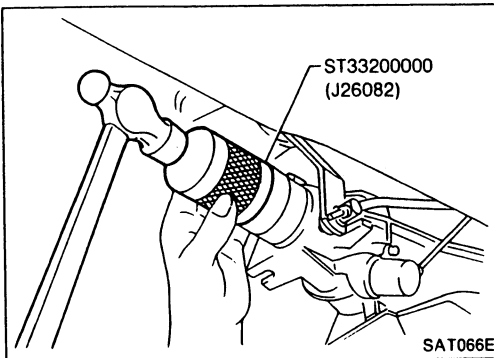

3. Install rear oil seal.
- Apply A.T.F. before installing.
4. Reinstall any part removed.

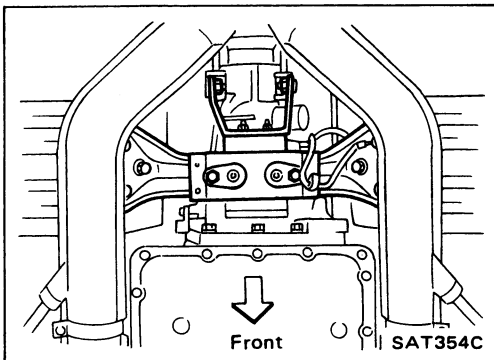

Parking Components Inspection

1. Remove exhaust tube.
2. Remove propeller shaft from vehicle. — Refer to section PD.
3. Remove rear engine mounting member from A/T assembly while supporting A/T with jack.

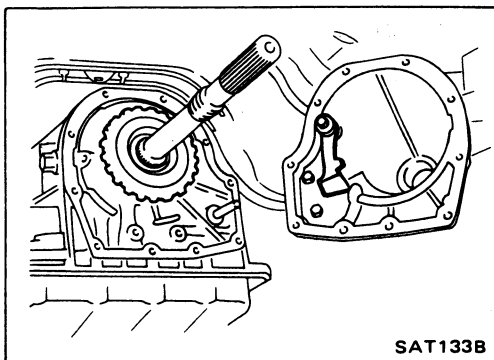

4. Remove rear extension from transmission case.
 5. Replace parking components if necessary.
 6. Reinstall any part removed.
- Always use new sealing parts.

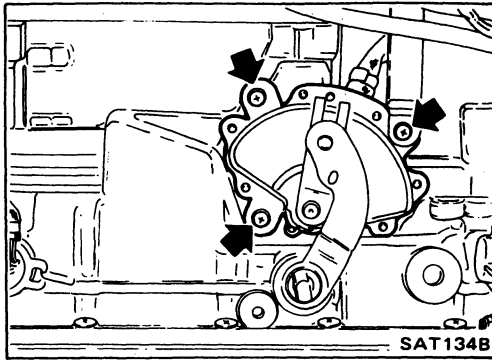

Inhibitor Switch Adjustment

1. Remove manual control linkage from manual shaft of A/T assembly.
2. Set manual shaft of A/T assembly in "N" position.
3. Loosen inhibitor switch fixing bolts.

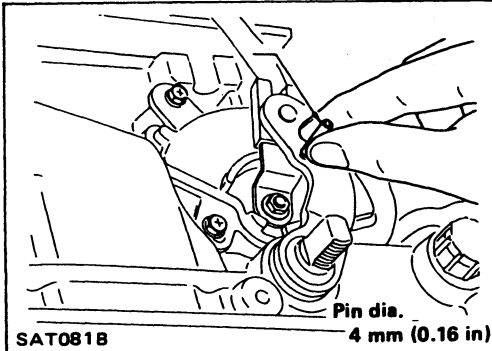

4. Insert pin into adjustment holes in both inhibitor switch and manual shaft of A/T assembly as near vertical as possible.
5. Reinstall any part removed.
6. Check continuity of inhibitor switch. — Refer to "Electrical Components Inspection".

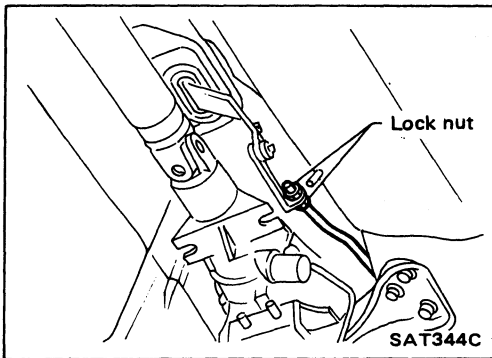

Manual Control Linkage Adjustment

Move selector lever from "P" range to "1" range. You should be able to feel the detents in each range.

If the detents cannot be felt or the pointer indicating the range is improperly aligned, the linkage needs adjustment.

1. Place selector lever in "P" range.
2. Loosen lock nuts.

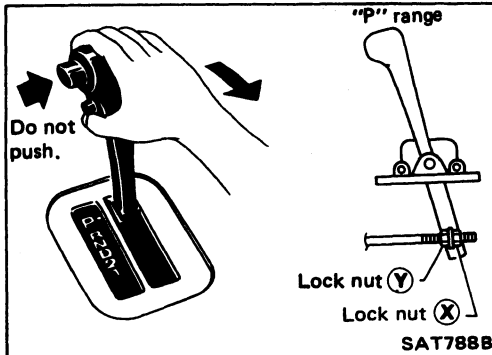

3. Tighten lock nut (X) until it touches trunnion pulling selector lever toward "R" range side without pushing button.
4. Back off lock nut (X) 1 turn and tighten lock nut (Y) to the specified torque.

Lock nut:

Ⓚ: 11 - 15 N·m (1.1 - 1.5 kg-m, 8 - 11 ft-lb)

5. Move selector lever from "P" range to "1" range. Make sure that selector lever can move smoothly.

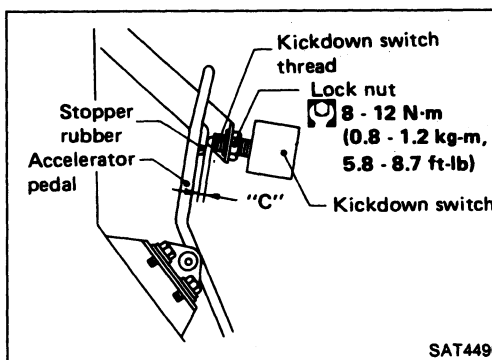

Kickdown Switch Adjustment

1. Adjust accelerator cable — Refer to section FE.
2. Adjust clearance "C" between stopper rubber and end of kickdown switch thread while depressing accelerator pedal fully.
Clearance "C": 0.3 - 1.0 mm (0.012 - 0.039 in)

TROUBLE DIAGNOSES

Contents

How to Perform Trouble Diagnoses for Quick and Accurate Repair	AT- 13
Preliminary Check	AT- 14
Diagnosis by CONSULT	AT- 32
A/T Electrical Parts Location	AT- 35
Circuit Diagram for Quick Pinpoint Check	AT- 37
Wiring Diagram	AT- 38
Self-diagnosis	AT- 40
SELF-DIAGNOSTIC PROCEDURE (With CONSULT)	AT- 40
SELF-DIAGNOSTIC PROCEDURE (Without CONSULT)	AT- 41
JUDGEMENT OF SELF-DIAGNOSIS CODE	AT- 43
REVOLUTION SENSOR CIRCUIT CHECK	AT- 47
SPEED SENSOR CIRCUIT CHECK	AT- 48
THROTTLE SENSOR CIRCUIT CHECK	AT- 49
SHIFT SOLENOID A CIRCUIT CHECK	AT- 50
SHIFT SOLENOID B CIRCUIT CHECK	AT- 51
OVERRUN CLUTCH SOLENOID CIRCUIT CHECK	AT- 52
LOCK-UP SOLENOID CIRCUIT CHECK	AT- 53
FLUID TEMPERATURE SENSOR CIRCUIT AND A/T CONTROL UNIT POWER SOURCE CIRCUIT CHECKS	AT- 54
ENGINE REVOLUTION SIGNAL CIRCUIT CHECK	AT- 56
LINE PRESSURE SOLENOID CIRCUIT CHECK	AT- 57
INHIBITOR, OVERDRIVE, KICKDOWN AND IDLE SWITCH CIRCUIT CHECKS	AT- 58
Diagnostic Procedure 1 (SYMP TOM: A/T CHECK lamp does not come on for about 2 seconds when turning ignition switch to "ON".)	AT- 62
Diagnostic Procedure 2 (SYMP TOM: Engine cannot be started with selector lever in "P" or "N" range or engine can be started with selector lever in "D", "2", "1" or "R" range.)	AT- 63
Diagnostic Procedure 3 (SYMP TOM: Vehicle moves when it is pushed forward or backward with selector lever in "P" range.)	AT- 63
Diagnostic Procedure 4 (SYMP TOM: Vehicle moves forward or backward when selecting "N" range.)	AT- 64
Diagnostic Procedure 5 (SYMP TOM: There is large shock when changing from "N" to "R" range.)	AT- 65
Diagnostic Procedure 6 (SYMP TOM: Vehicle does not creep backward when selecting "R" range.)	AT- 66
Diagnostic Procedure 7 (SYMP TOM: Vehicle does not creep forward when selecting "D", "2" or "1" range.)	AT- 67
Diagnostic Procedure 8 (SYMP TOM: Vehicle cannot be started from D ₁ on Cruise test — Part 1.)	AT- 68
Diagnostic Procedure 9 (SYMP TOM: A/T does not shift from D ₁ to D ₂ at the specified speed. A/T does not shift from D ₄ to D ₂ when depressing accelerator pedal fully at the specified speed.)	AT- 69
Diagnostic Procedure 10 (SYMP TOM: A/T does not shift from D ₂ to D ₃ at the specified speed.)	AT- 70
Diagnostic Procedure 11 (SYMP TOM: A/T does not shift from D ₃ to D ₄ at the specified speed.)	AT- 71
Diagnostic Procedure 12 (SYMP TOM: A/T does not perform lock-up at the specified speed.)	AT- 72
Diagnostic Procedure 13 (SYMP TOM: A/T does not hold lock-up condition for more than 30 seconds.)	AT- 73
Diagnostic Procedure 14 (SYMP TOM: Lock-up is not released when accelerator pedal is released.)	AT- 73

TROUBLE DIAGNOSES

Contents (Cont'd)

Diagnostic Procedure 15

(SYMPTOM: Engine speed does not return to idle smoothly when A/T is shifted from D₄ to D₃ with accelerator pedal released.

Vehicle does not decelerate by engine brake when changing overdrive switch to "OFF" position with accelerator pedal released.

Vehicle does not decelerate by engine brake when changing selector lever from "D" to "2" range with accelerator pedal released.)

AT- 74

Diagnostic Procedure 16

(SYMPTOM: Vehicle does not start from D₁ on Cruise test — Part 2.)

AT- 75

Diagnostic Procedure 17

(SYMPTOM: A/T does not shift from D₄ on D₃ when changing overdrive switch to "OFF" position.)

AT- 75

Diagnostic Procedure 18

(SYMPTOM: A/T does not shift from D₃ on 2₂ when changing selector lever from "D" to "2" range.)

AT- 76

Diagnostic Procedure 19

(SYMPTOM: A/T does not shift from 2₂ to 1₁ when changing selector lever from "2" to "1" range.)

AT- 76

Diagnostic Procedure 20

(SYMPTOM: Vehicle does not decelerate by engine brake when shifting from 2₂ (1₂) to 1₁.)

AT- 76

Electrical Components Inspection

AT- 77

Final Check

AT- 84

Symptom Chart

AT- 89

A/T Shift Lock System

AT- 92

TROUBLE DIAGNOSES

How to Perform Trouble Diagnoses for Quick and Accurate Repair

WORK FLOW

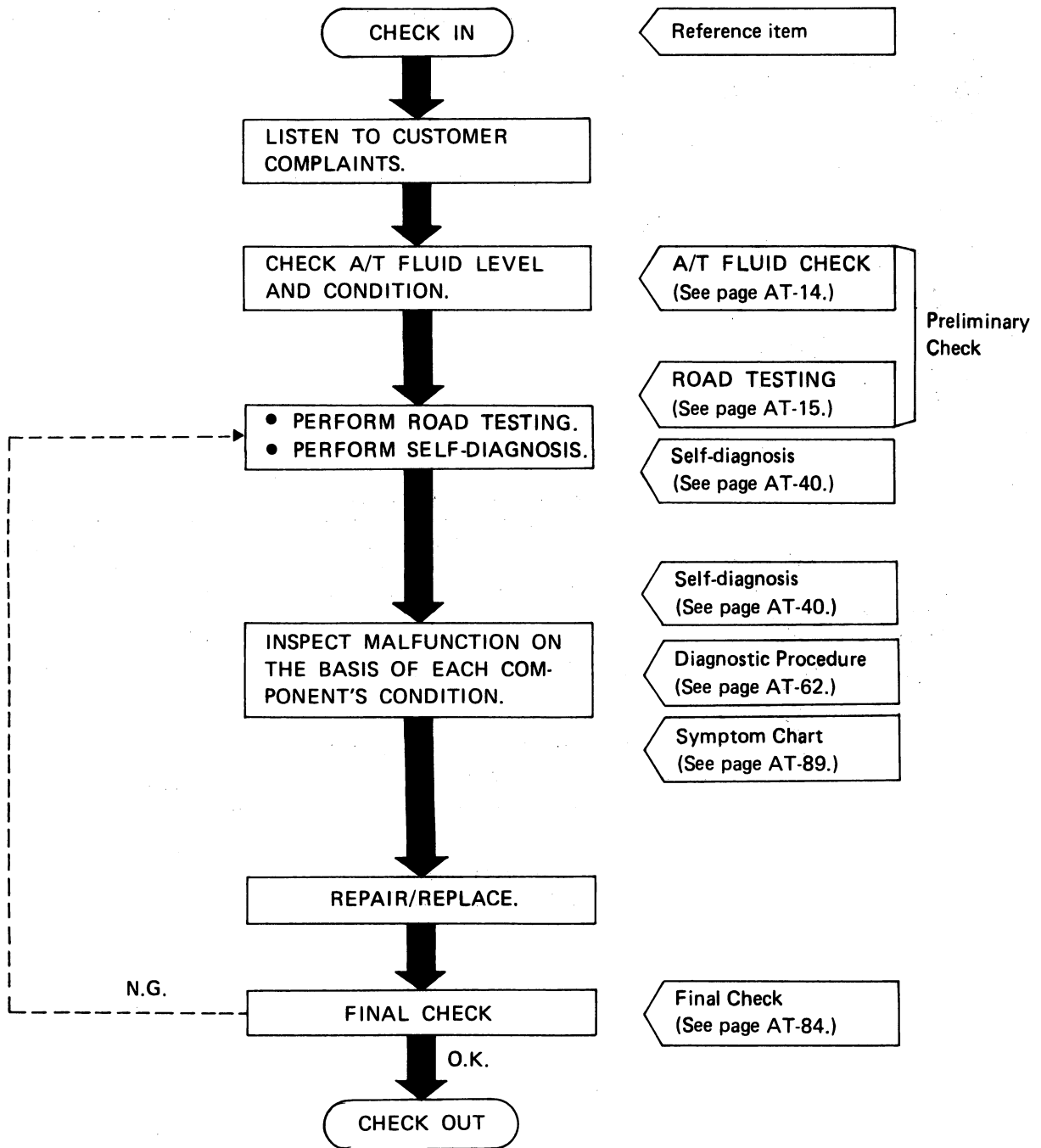

TROUBLE DIAGNOSES

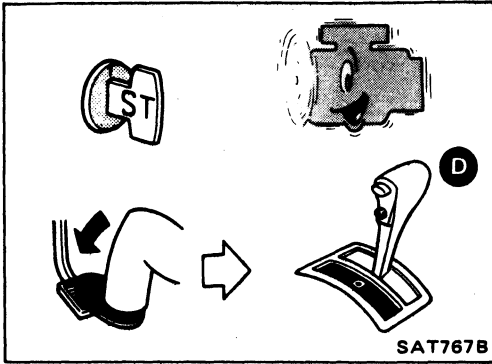

Preliminary Check

A/T FLUID CHECK

Fluid leakage check

1. Clean area suspected of leaking, — for example, mating surface of converter housing and transmission case.
2. Start engine, apply foot brake, place selector lever in "D" range and wait a few minutes.
3. Stop engine.

4. Check for fresh leakage.

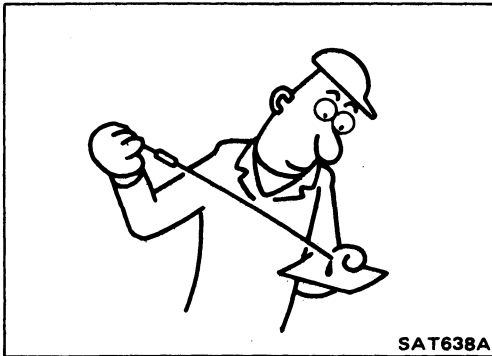
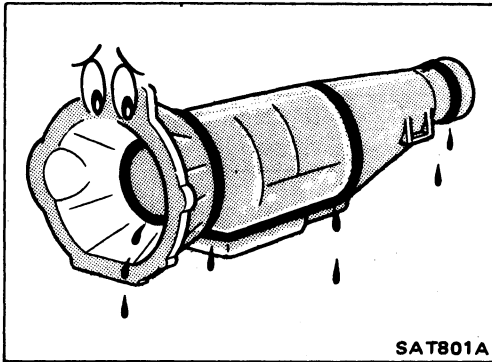

Fluid condition check

Fluid color	Suspected problem
Dark or black with burned odor	Wear of frictional material
Milky pink	Water contamination — Road water entering through filler tube or breather
Varnished fluid, light to dark brown and tacky	Oxidation — Over or under filling — Overheating

Fluid level check

Refer to section MA.

TROUBLE DIAGNOSES

ROAD TEST PROCEDURE

1. Check before engine is started.



2. Check at idle.



3. Cruise test.

SAT786A

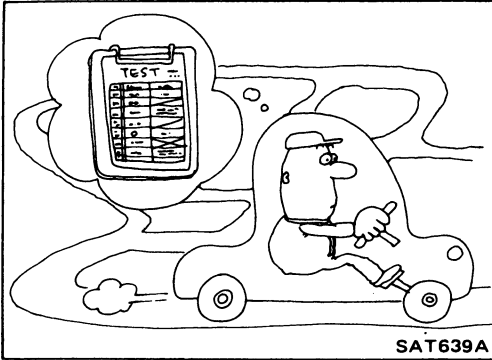

SAT639A

Preliminary Check (Cont'd)

ROAD TESTING

Description

- The purpose of this road test is to determine overall performance of automatic transmission and analyze causes of problems.
- The road test consists of the following three parts:
 1. Check before engine is started
 2. Check at idle
 3. Cruise test
- Before road test, familiarize yourself with all test procedures and items to check.
- Conduct tests on all items. Troubleshoot items which check out No Good after road test. Refer to "Self-diagnosis" and "Diagnostic Procedure".

TROUBLE DIAGNOSES

Preliminary Check (Cont'd)

1. Check before engine is started

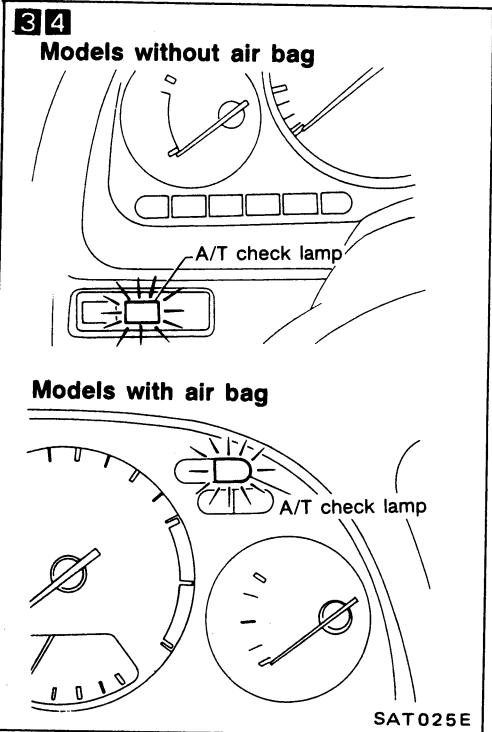
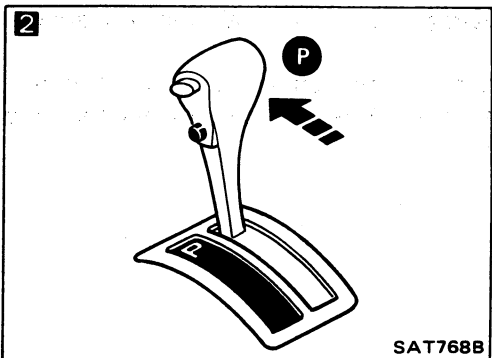
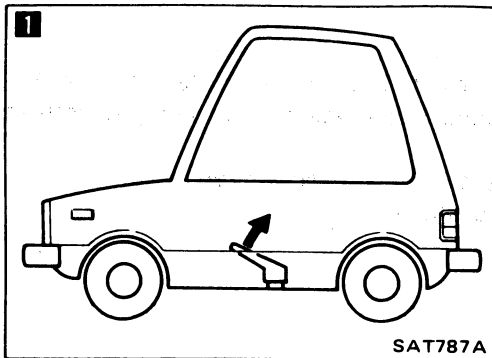

1

Park vehicle on flat surface.

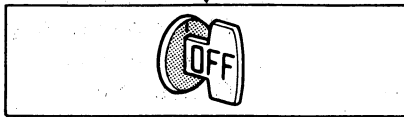

2

Move selector lever to "P" range.



3

Does A/T check lamp come on for about 2 seconds?

No

Go to Diagnostic Procedure 1.

Yes

4

Does A/T check lamp flicker for about 8 seconds?

Yes

Perform self-diagnosis.
— Refer to SELF-DIAGNOSIS PROCEDURE.

No

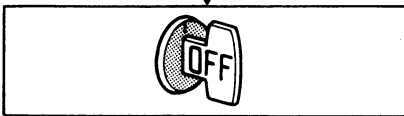

Perform self-diagnosis.
— Refer to SELF-DIAGNOSIS PROCEDURE and note N.G. items.

Go to "ROAD TESTING
— 2. Check at idle".

TROUBLE DIAGNOSES

Preliminary Check (Cont'd)

2. Check at idle

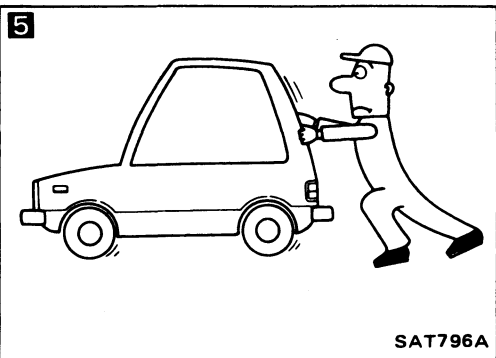
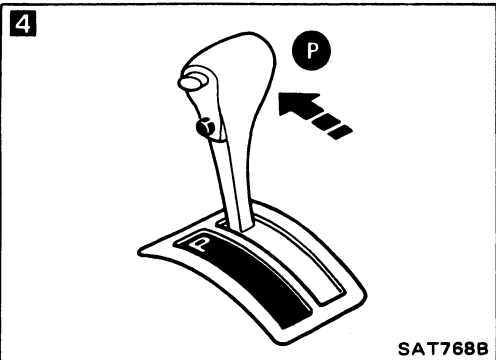
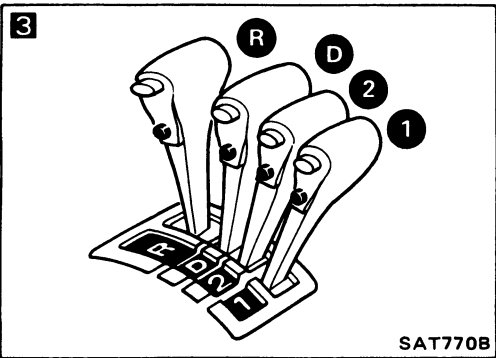
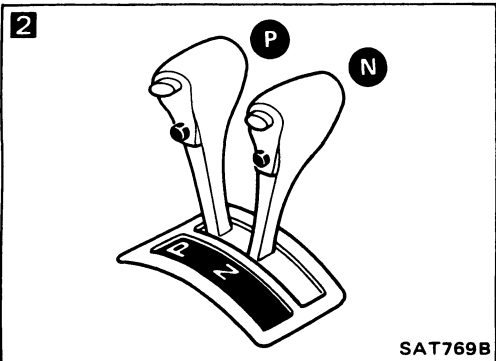
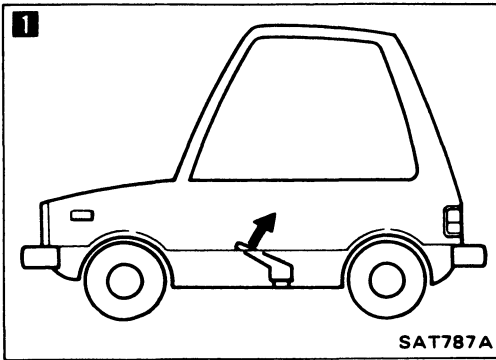

1
Park vehicle on flat surface.

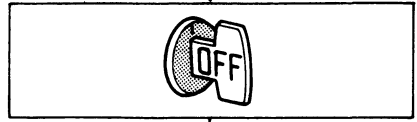

2
Move selector lever to "P" or "N" range.



Is engine started?

No → Go to Diagnostic Procedure 2.



3
Move selector lever to "D", "1", "2" or "R" range.



Is engine started?

Yes → Go to Diagnostic Procedure 2.
No



4
Move selector lever to "P" range.

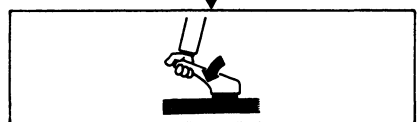

5
Push vehicle forward or backward.

Does vehicle move when it is pushed forward or backward?

Yes → Go to Diagnostic Procedure 3.

No
↓
A

TROUBLE DIAGNOSES

Preliminary Check (Cont'd)

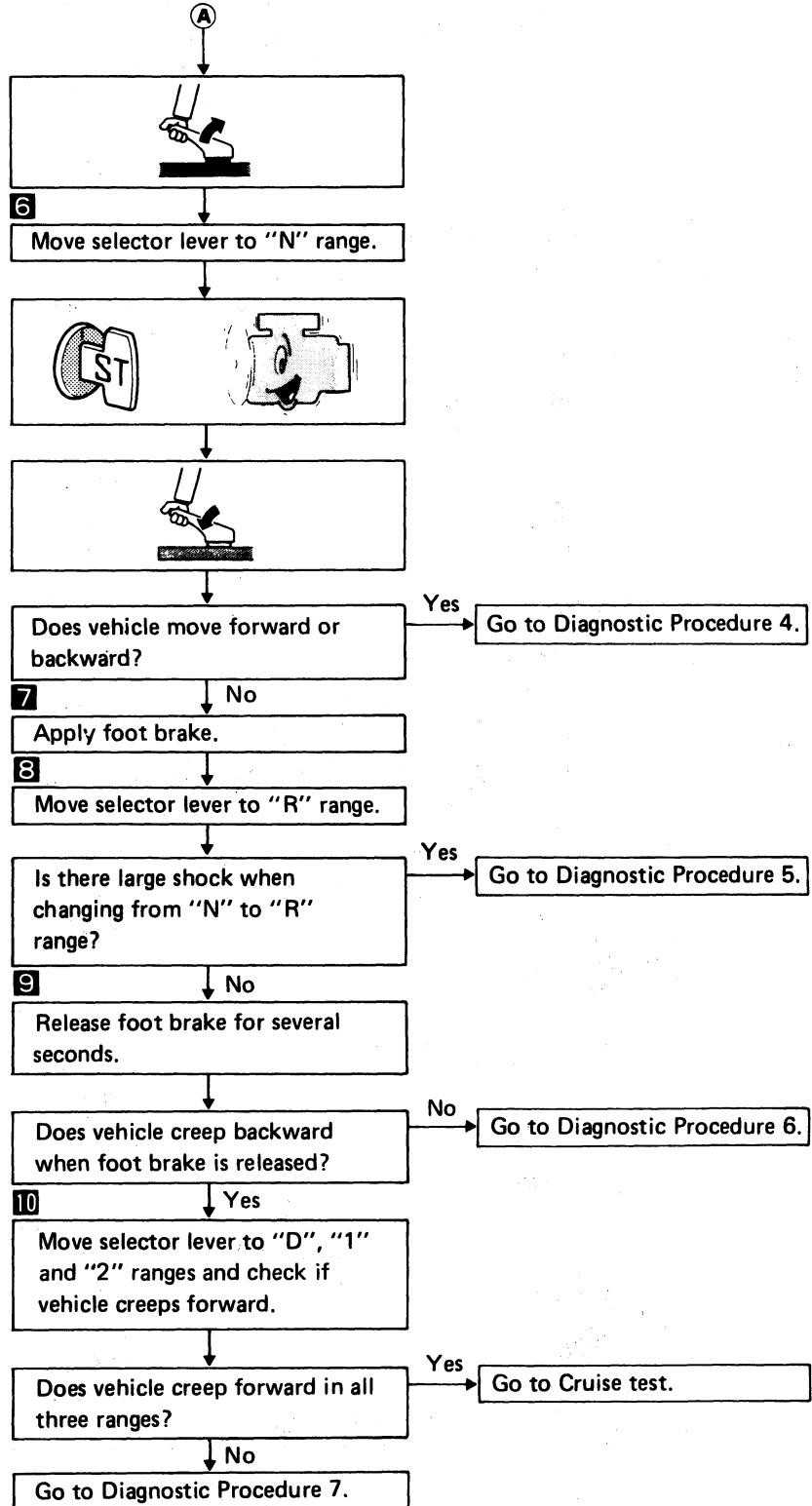
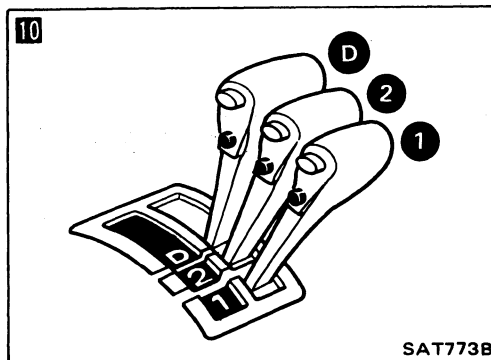
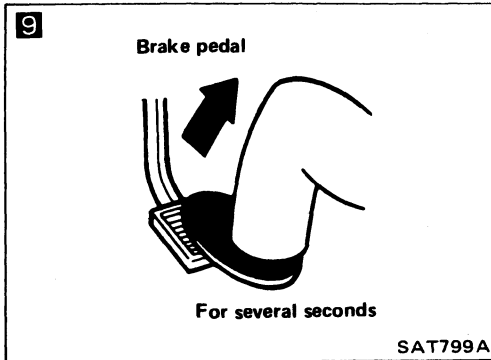
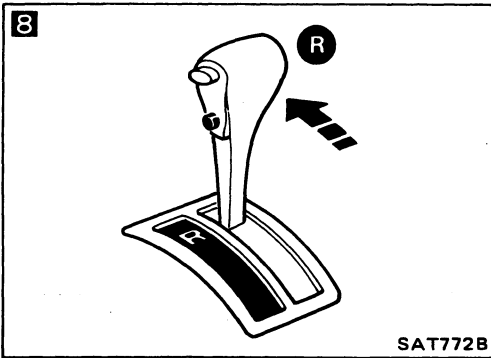
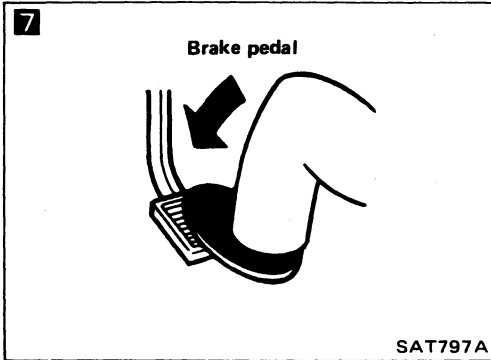
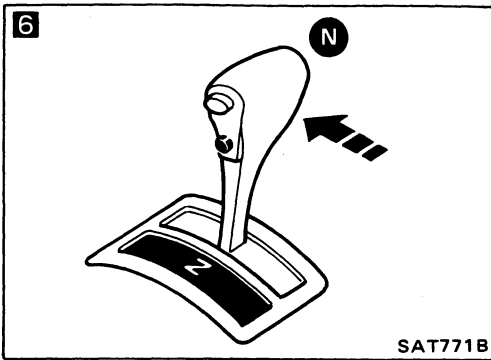

TROUBLE DIAGNOSES

Preliminary Check (Cont'd)

3. Cruise test

With CONSULT

- Using CONSULT, conduct a cruise test and record the result.
- Print the result and ensure that shifts and lock-ups take place as per "Shift Schedule."
- Check all items listed in Parts 1 through 3.

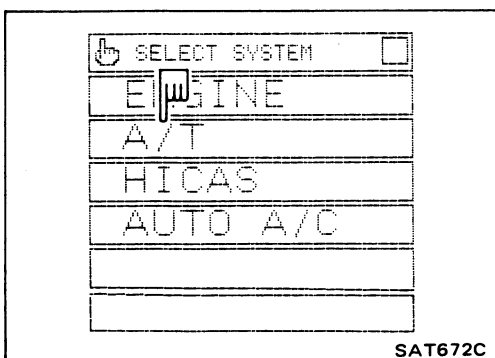
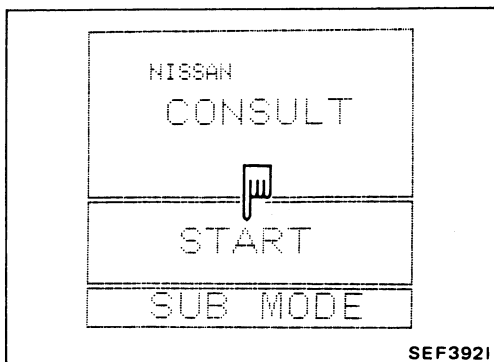
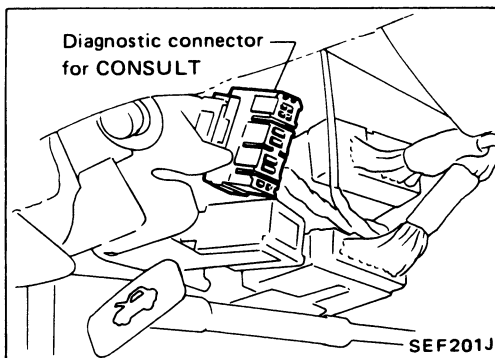
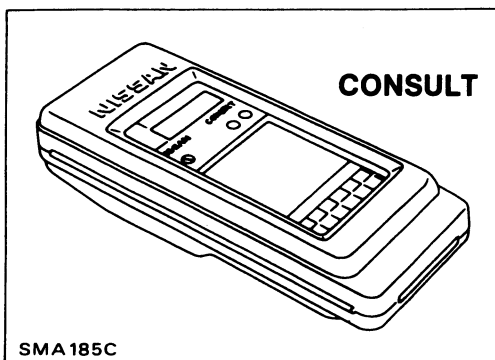

CONSULT setting procedure

1. Turn off ignition switch.
2. Connect "CONSULT" to diagnostic connector. (Diagnostic connector is located in left dash side panel.)

3. Turn on ignition switch.
4. Touch "START".

5. Touch "A/T".

TROUBLE DIAGNOSES

Preliminary Check (Cont'd)

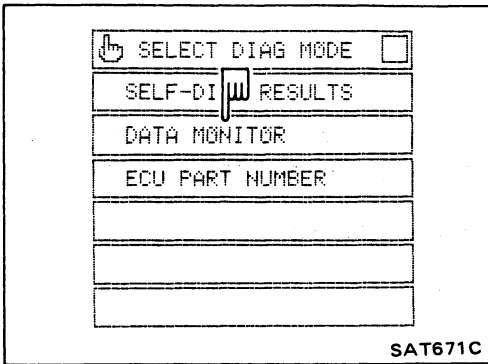

6. Touch "DATA MONITOR".

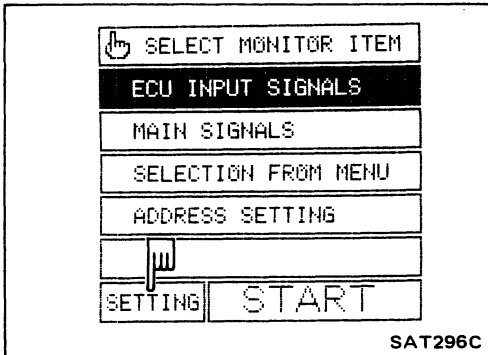

7. Touch "SETTING" to set recording condition.

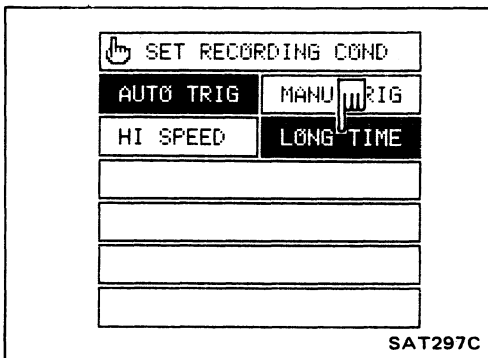

8. Touch "LONG TIME" and "ENTER" key.

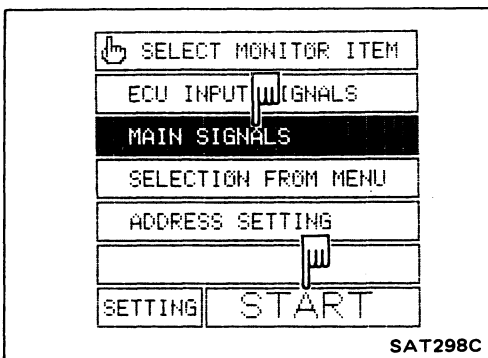

9. Go back to SELECT MONITOR ITEM and touch "MAIN SIGNALS".

10. Touch "START".

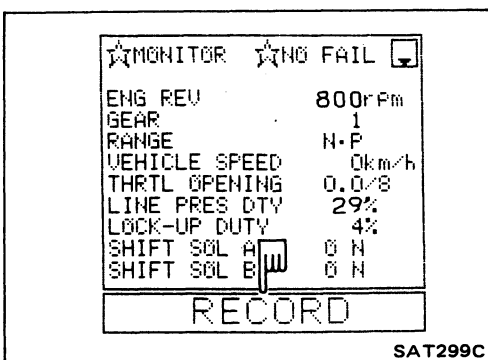

11. When performing cruise test, touch "RECORD".

TROUBLE DIAGNOSES

Preliminary Check (Cont'd)

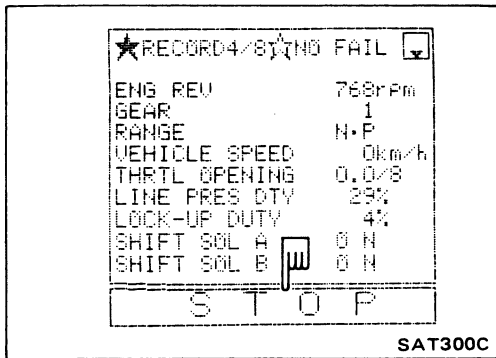

12. After finishing cruise test part 1, touch "STOP".

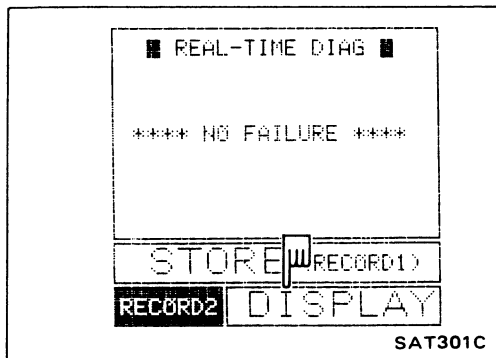

13. Touch "DISPLAY".

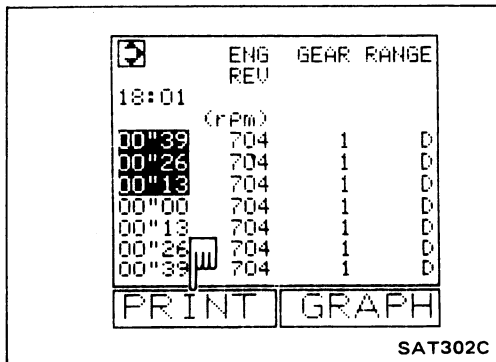

14. Touch "PRINT".

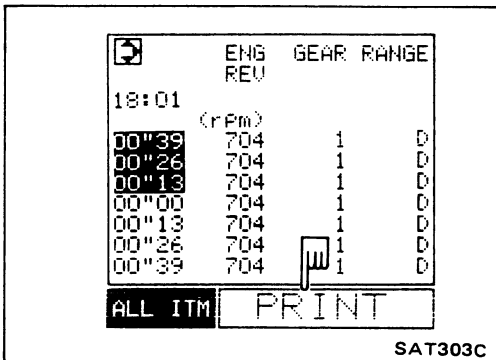

15. Touch "PRINT" again.

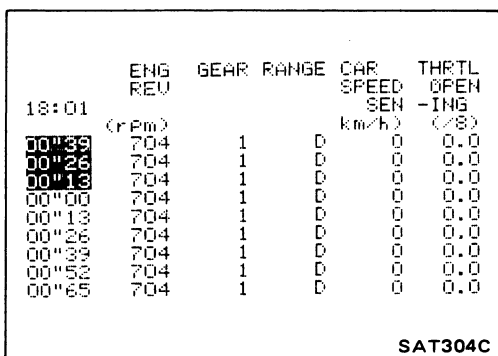

16. Check the monitor data printed out.

17. Continue cruise test part 2 and 3.

TROUBLE DIAGNOSES

Preliminary Check (Cont'd)

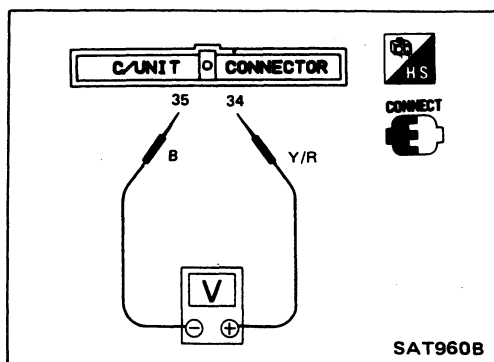

Without CONSULT

- Throttle position can be controlled by voltage across terminals ③④ and ③⑤ of A/T control unit.

TROUBLE DIAGNOSES

Preliminary Check (Cont'd)

Cruise test – Part 1

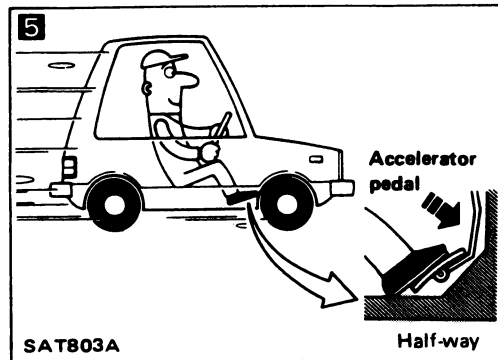
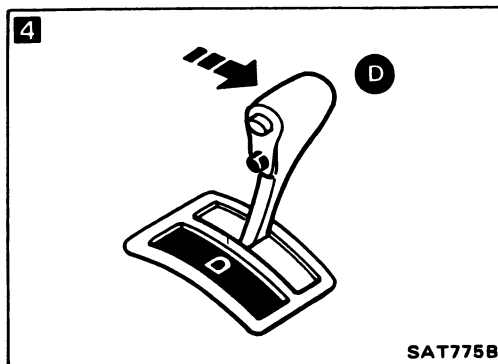
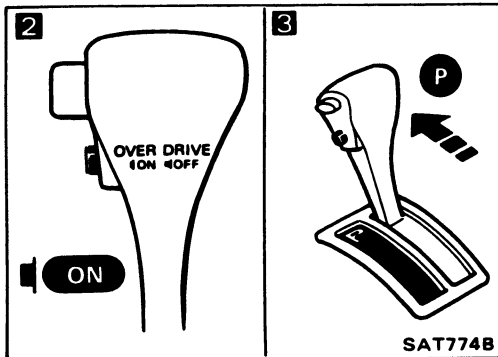
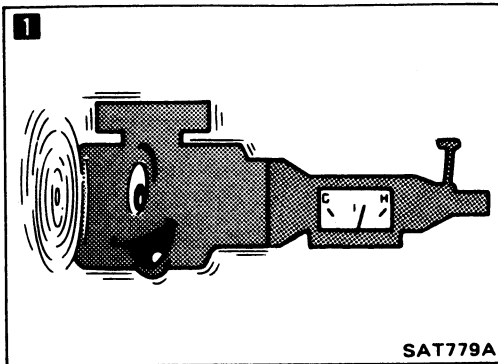

1

Warm up engine until engine oil and A.T.F. reach operating temperature after vehicle has been driven approx. 10 minutes.

A.T.F. operating temperature:
50 - 80°C (122 - 176°F)

Park vehicle on flat surface.

2

Set overdrive switch in "ON" position.

3

Move selector lever to "P" range.

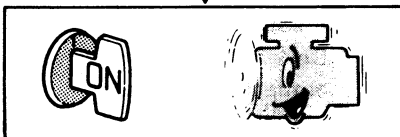

4

Move selector lever to "D" range.

5

Accelerate vehicle to half throttle.

Does vehicle start from D₁? No → Go to Diagnostic Procedure 8.

Read gear position.

Yes

↓

Ⓐ

TROUBLE DIAGNOSES

Preliminary Check (Cont'd)

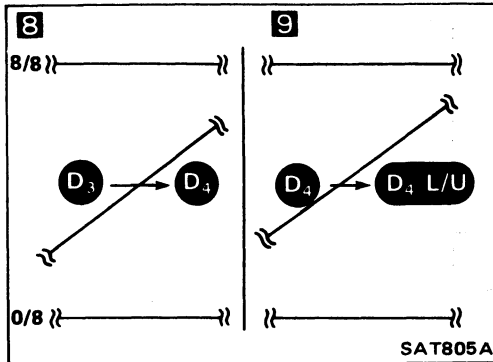
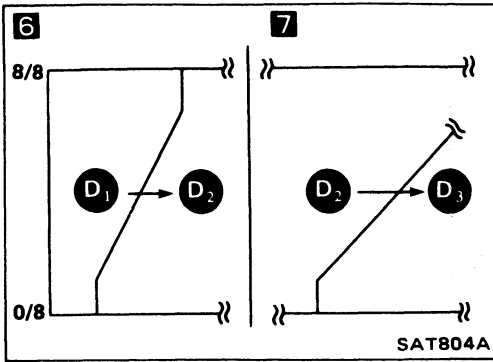

6

Does A/T shift from D₁ to D₂ at the specified speed?

Read gear position, throttle opening and vehicle speed.

Specified speed when shifting from D₁ to D₂:
Refer to Shift schedule.

No → Go to Diagnostic Procedure 9.

Yes →

7

Does A/T shift from D₂ to D₃ at the specified speed?

Read gear position, throttle opening and vehicle speed.

Specified speed when shifting from D₂ to D₃:
Refer to Shift schedule.

No → Go to Diagnostic Procedure 10.

Yes →

8

Does A/T shift from D₃ to D₄ at the specified speed?

Read gear position, throttle opening and vehicle speed.

Specified speed when shifting from D₃ to D₄:
Refer to Shift schedule.

No → Go to Diagnostic Procedure 11.

Yes →

9

Does A/T perform lock-up at the specified speed?

Read vehicle speed, throttle opening when lock-up duty becomes 94%.

Specified speed when lock-up occurs:
Refer to Shift schedule.

No → Go to Diagnostic Procedure 12.

Yes →

Does A/T hold lock-up condition for more than 30 seconds?

No → Go to Diagnostic Procedure 13.

Yes →

B

TROUBLE DIAGNOSES

Preliminary Check (Cont'd)

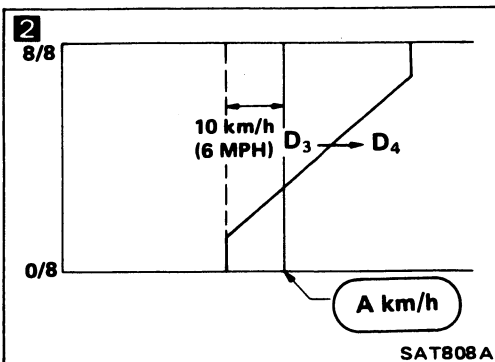
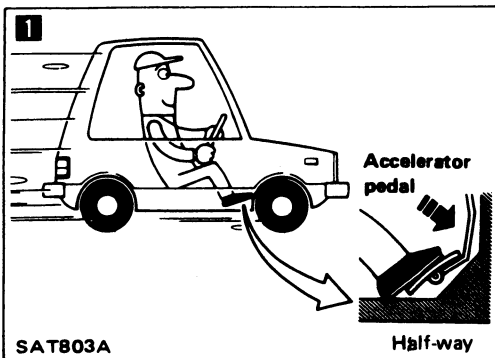
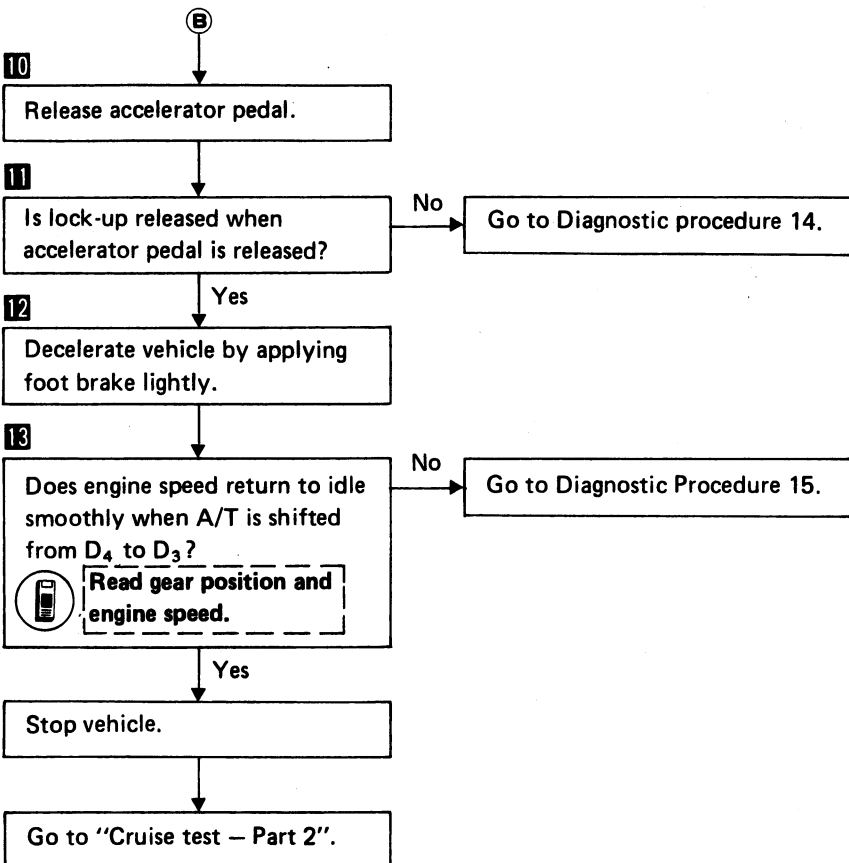
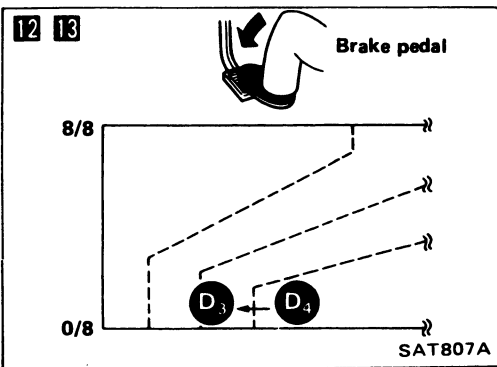
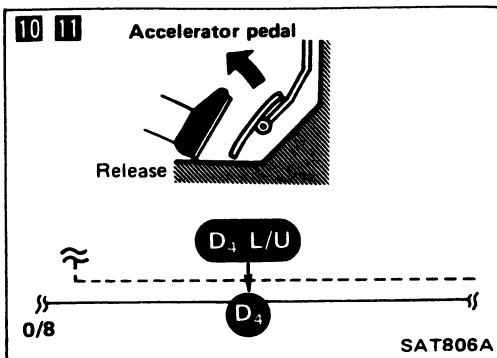

Cruise test — Part 2

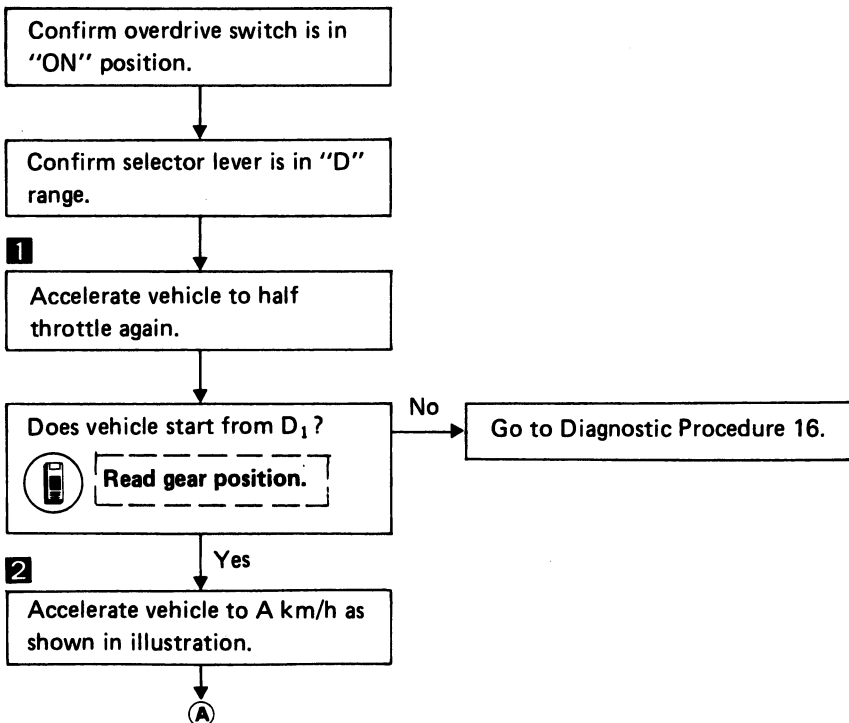

TROUBLE DIAGNOSES

Preliminary Check (Cont'd)

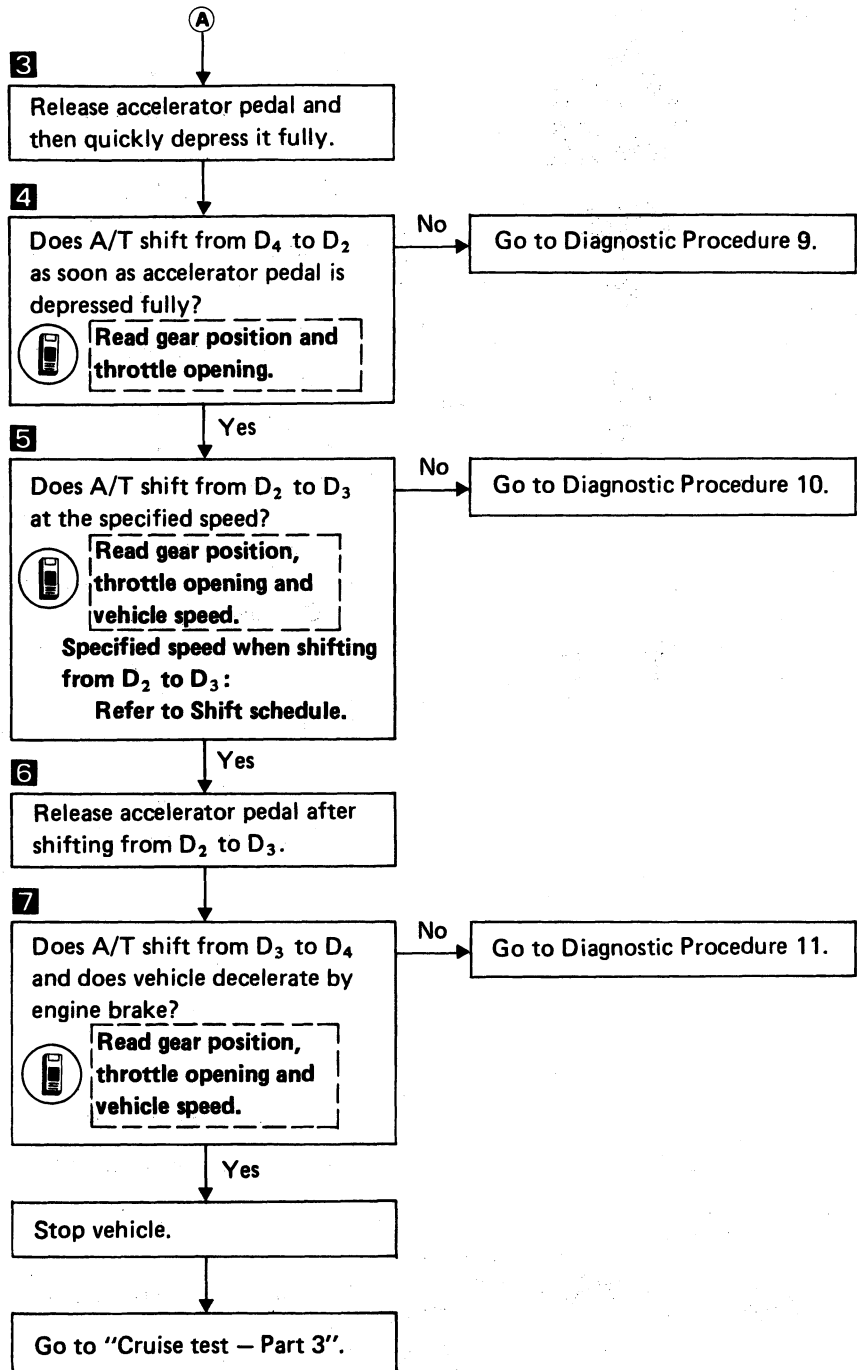
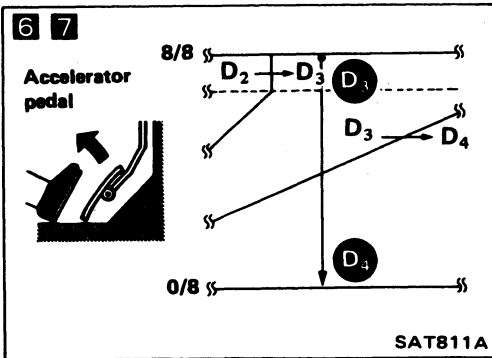
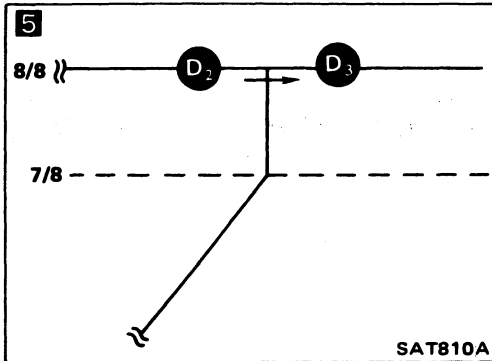
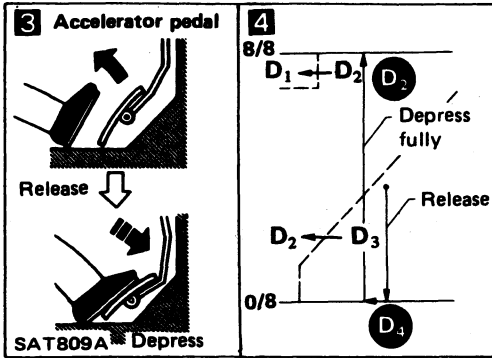

TROUBLE DIAGNOSES

Preliminary Check (Cont'd)

Cruise test — Part 3

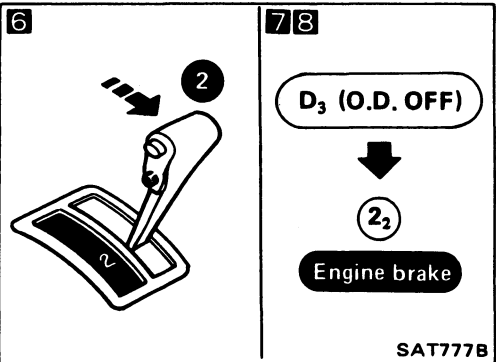
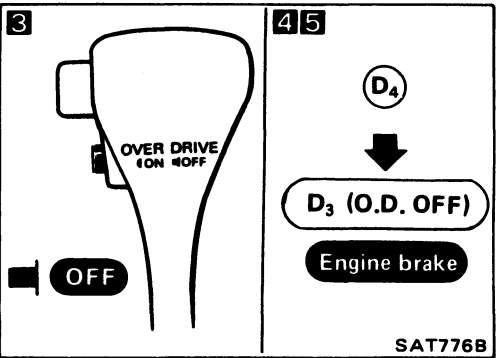
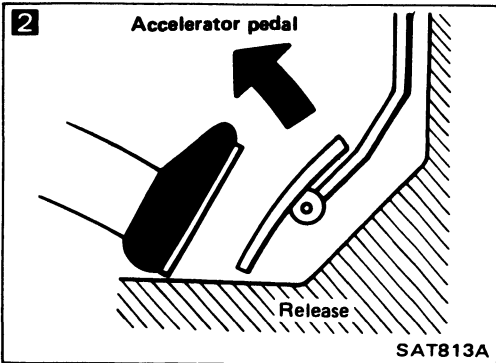
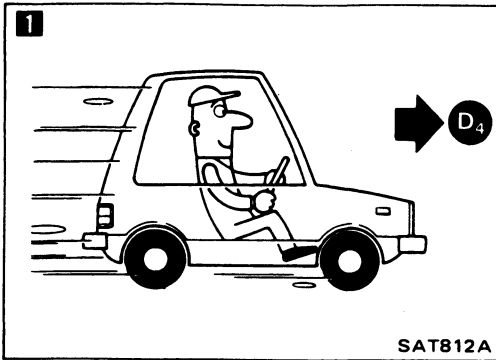

Confirm overdrive switch is in "ON" position.

Confirm selector lever is in "D" range.

1 Accelerate vehicle, using half-throttle, to D₄.

2 Release accelerator pedal.

3 Set overdrive switch in "OFF" position while driving in D₄ range.

4 Does A/T shift from D₄ to D₃?
 Read gear position and vehicle speed.

No → Go to Diagnostic Procedure 17.

5 Does vehicle decelerate by engine brake?

No → Go to Diagnostic Procedure 15.

6 Move selector lever from "D" to "2" range while driving in D₃.

7 Does A/T shift from D₃ to 2₂?
 Read gear position.

No → Go to Diagnostic Procedure 18.

8 Does vehicle decelerate by engine brake?

No → Go to Diagnostic Procedure 15.

Yes → A

TROUBLE DIAGNOSES

Preliminary Check (Cont'd)

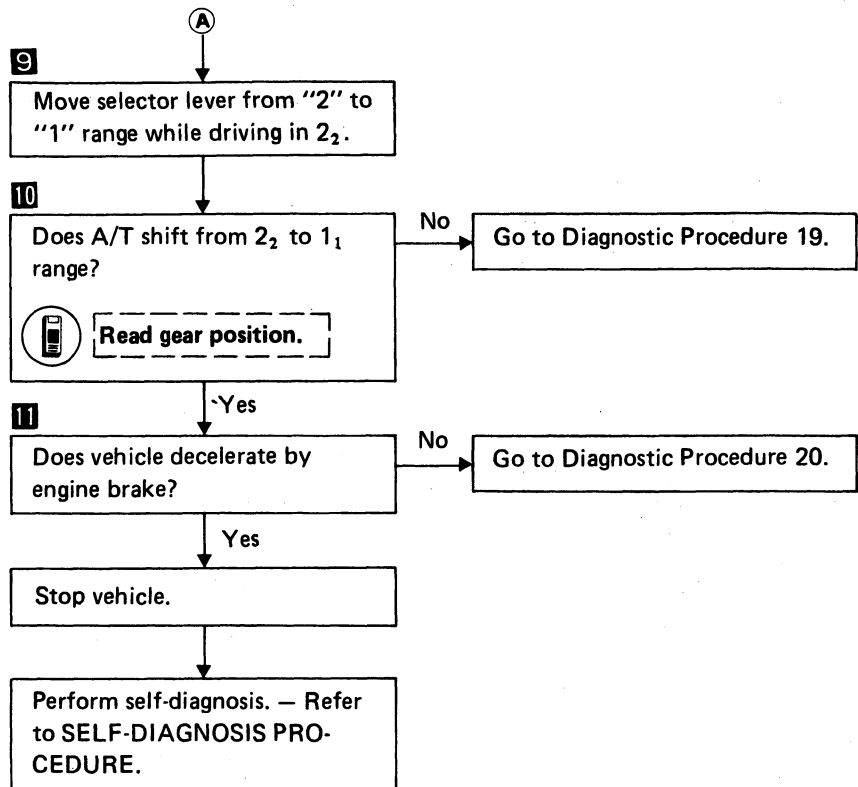
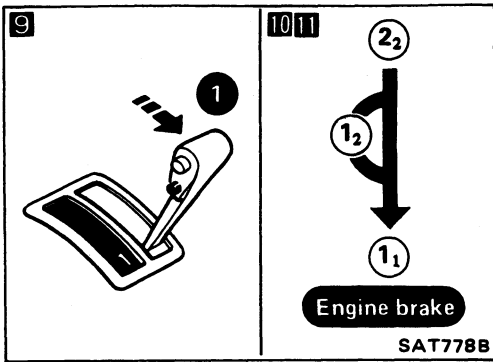

TROUBLE DIAGNOSES

Preliminary Check (Cont'd)

Vehicle speed when shifting gears

RE4R01A

Throttle position	Vehicle speed km/h (MPH)					
	D ₁ → D ₂	D ₂ → D ₃	D ₃ → D ₄	D ₄ → D ₃	D ₃ → D ₂	D ₂ → D ₁
Full throttle	60 - 64 (37 - 40)	107 - 115 (66 - 71)	166 - 176 (103 - 109)	161 - 169 (100 - 105)	96 - 104 (60 - 65)	44 - 48 (27 - 30)
Half throttle	45 - 49 (28 - 30)	83 - 89 (52 - 55)	119 - 127 (74 - 79)	80 - 88 (50 - 55)	33 - 39 (21 - 24)	10 - 14 (6 - 9)

RE4R03A

Throttle position	Vehicle speed km/h (MPH)					
	D ₁ → D ₂	D ₂ → D ₃	D ₃ → D ₄	D ₄ → D ₃	D ₃ → D ₂	D ₂ → D ₁
Full throttle	68 - 72 (42 - 45)	120 - 128 (75 - 80)	183 - 193 (114 - 120)	177 - 187 (110 - 116)	109 - 117 (68 - 73)	33 - 37 (21 - 23)
Half throttle	47 - 51 (29 - 32)	89 - 95 (55 - 59)	136 - 144 (85 - 89)	78 - 86 (48 - 53)	28 - 34 (17 - 21)	10 - 14 (6 - 9)

Vehicle speed when performing and releasing lock-up

RE4R01A

Throttle position	O.D. switch [Shift range]	Vehicle speed km/h (MPH)	
		Lock-up "ON"	Lock-up "OFF"
Full throttle	ON [D ₄]	167 - 175 (104 - 109)	161 - 169 (100 - 105)
	OFF [D ₃]	107 - 115 (66 - 71)	96 - 104 (60 - 65)
Half throttle	ON [D ₄]	120 - 128 (75 - 80)	84 - 92 (52 - 57)
	OFF [D ₃]	91 - 99 (57 - 62)	86 - 94 (53 - 58)

RE4R03A

Throttle position	O.D. switch (Shift range)	Vehicle speed km/h (MPH)	
		Lock-up "ON"	Lock-up "OFF"
Full throttle	ON [D ₄]	184 - 192 (114 - 119)	178 - 186 (111 - 116)
	OFF [D ₃]	120 - 128 (75 - 80)	109 - 117 (68 - 73)
Half throttle	ON [D ₄]	184 - 192 (114 - 119)	117 - 125 (73 - 78)
	OFF [D ₃]	88 - 96 (55 - 60)	74 - 82 (46 - 51)

TROUBLE DIAGNOSES

Preliminary Check (Cont'd)

Shift schedule (Overdrive ON) — RE4R01A

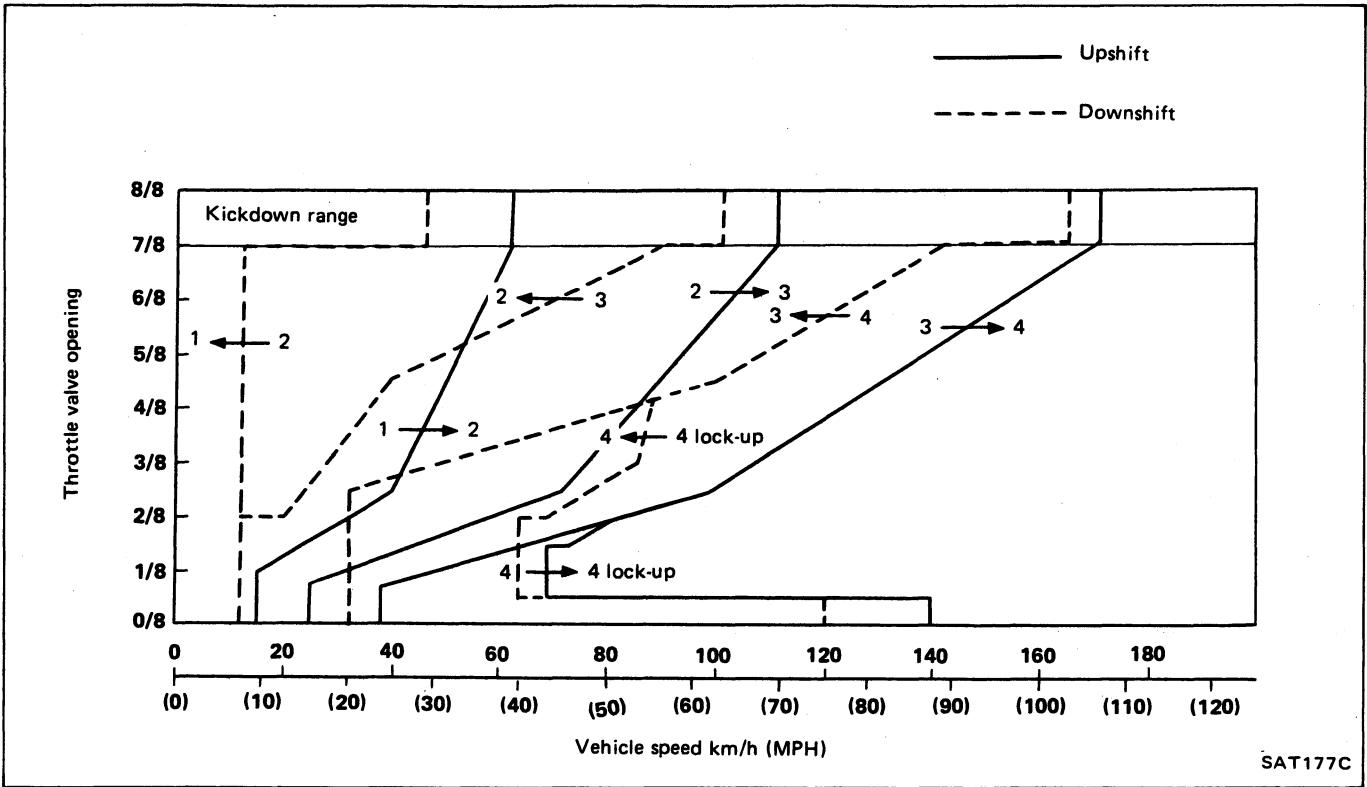

Shift schedule (Overdrive OFF) — RE4R01A

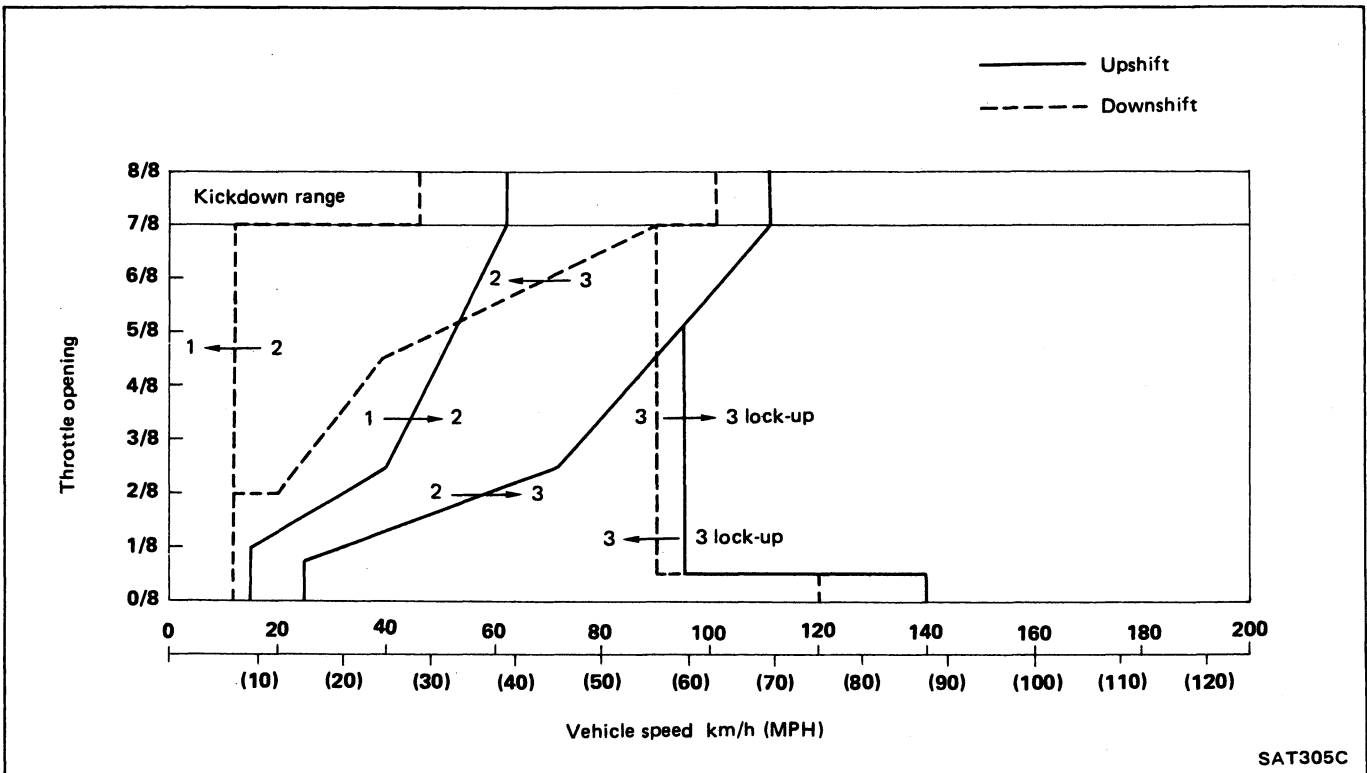

TROUBLE DIAGNOSES

Preliminary Check (Cont'd)

Shift schedule (Overdrive ON) — RE4R03A

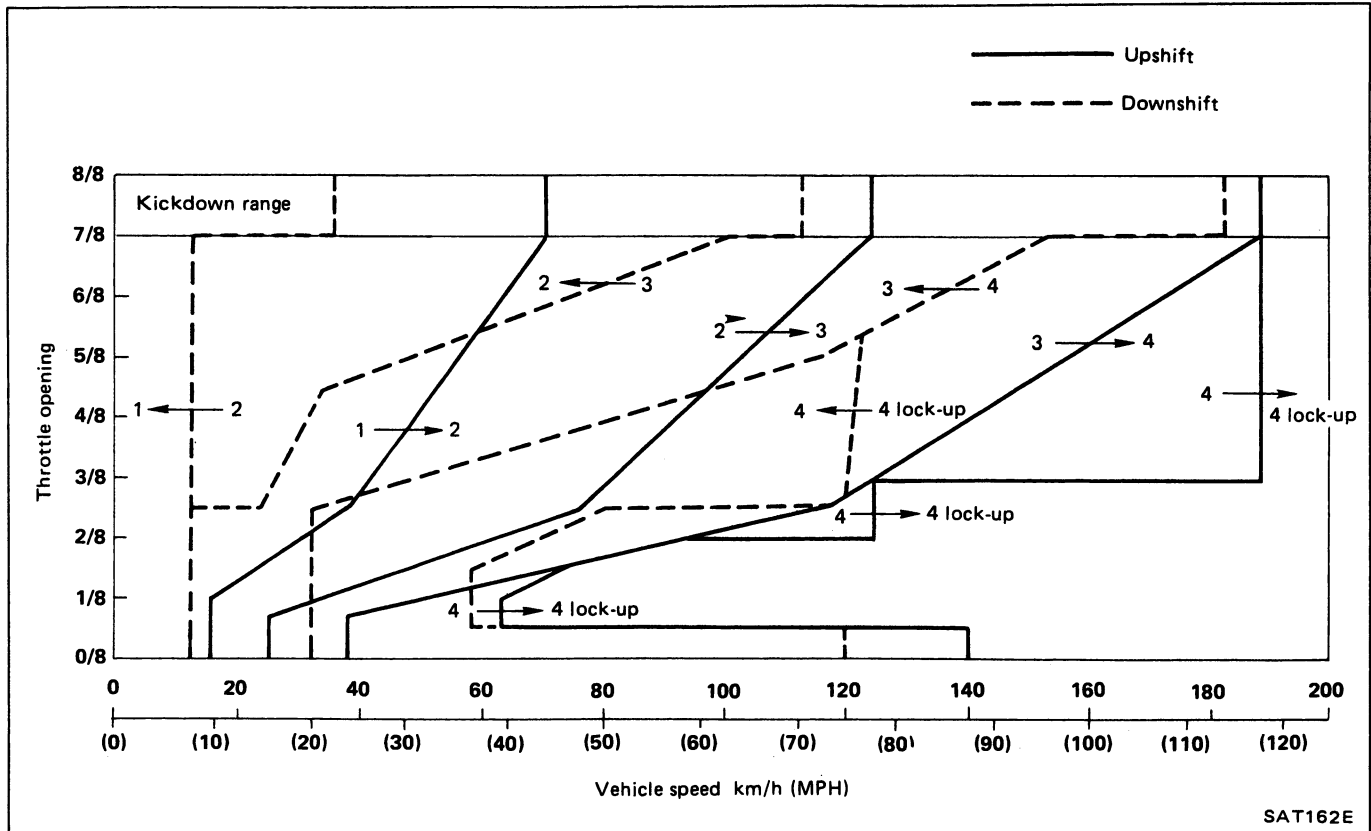

Shift schedule (Overdrive OFF) — RE4R03A

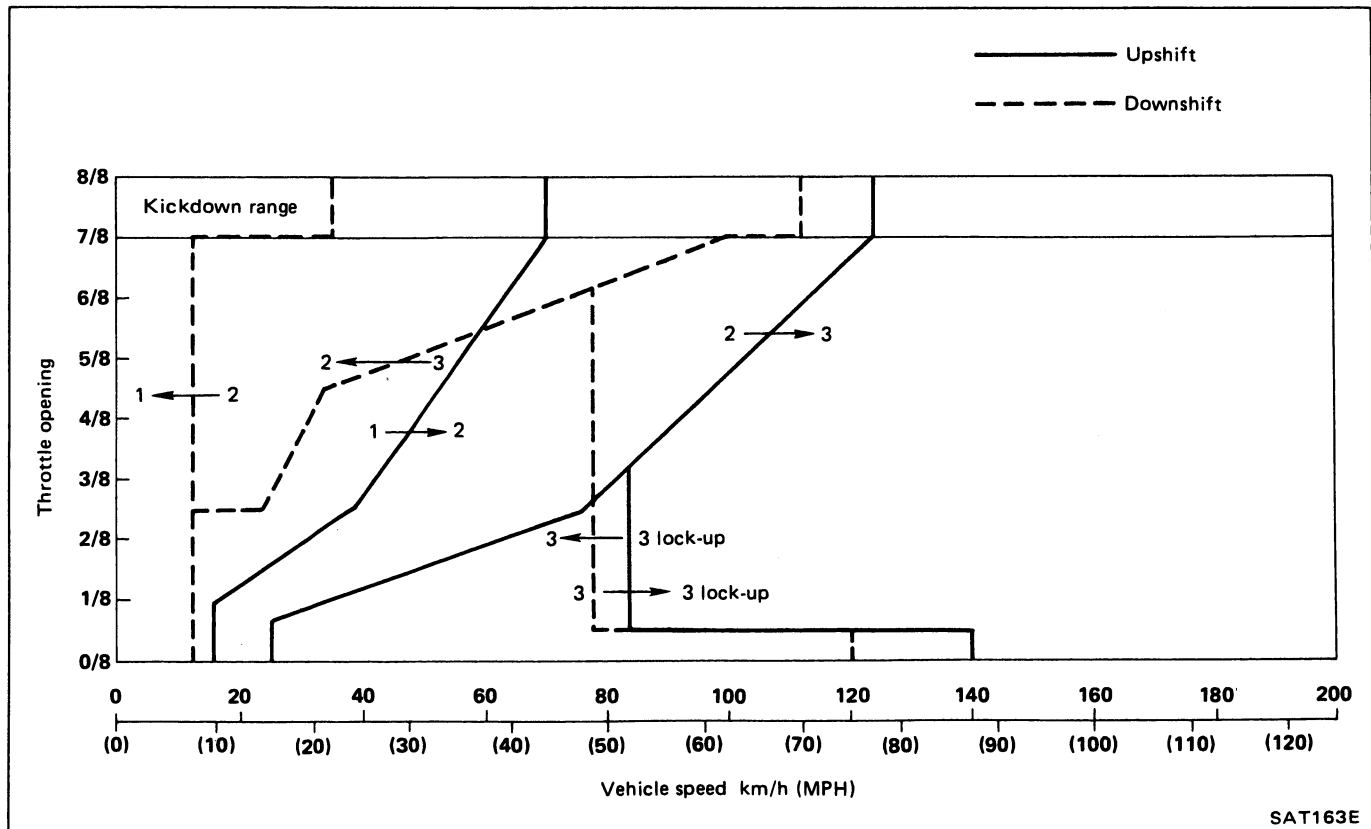

TROUBLE DIAGNOSES

Diagnosis by CONSULT

NOTICE

1. The CONSULT electrically displays shift timing and lock-up timing (that is, operation timing of each solenoid). When a noticeable time difference occurs between shift timing which is manifested by shift shock and the CONSULT display, mechanical parts (except solenoids, sensors, etc.) are considered to be malfunctioning. Check mechanical parts using applicable diagnostic procedures.
2. Shift schedule (which implies gear position) displayed on CONSULT and that indicated in Service Manual may differ slightly. This occurs because of the following reasons:
 - Actual shift schedule has more or less tolerance or allowance,
 - Shift schedule indicated in Service Manual refers to the point where shifts starts, and
 - Gear position displayed on CONSULT indicates the point where shifts are completed.
3. Shift solenoid "A" or "B" is displayed on CONSULT at the start of shifting while gear position is displayed upon completion of shifting (which is computed by A/T control unit).

TROUBLE DIAGNOSES

Diagnosis by CONSULT (Cont'd)

DATA MONITOR APPLICATION

Item	Application
Vehicle speed sensor 1 (A/T)	X
Vehicle speed sensor 2 (meter)	X
Throttle sensor	X
Fluid temperature sensor	X
Battery voltage	X
Engine rpm	X
Selector lever switch (O.D. switch)	X
A.S.C.D. — cruise signal	X
A.S.C.D. — O.D. cut signal	X
Kickdown switch	X
Power shift switch	—
Idle switch	X
Full throttle switch	X
Shift solenoid A	X
Shift solenoid B	X
Overrun clutch solenoid	X
*Shift solenoid A (feedback)	X
*Shift solenoid B (feedback)	X
*Overrun clutch solenoid (feedback)	X
Hold mode switch	—
1 range switch	X
2 range switch	X
D range switch	X
N range switch	X
R range switch	X
Gear position	X
Range position	X
Vehicle speed	X
Throttle opening	X
Line-pressure solenoid	X
Lock-up solenoid	X

X: Applicable —: Not applicable

TROUBLE DIAGNOSES

Diagnosis by CONSULT (Cont'd)

DATA ANALYSIS

Item	Display	Condition
Lock-up duty	Approximately 4% ↓ Approximately 94%	Lock-up "OFF" ↓ Lock-up "ON"
Line pressure duty	Approximately 29% ↓ Approximately 94%	Low line-pressure (Small throttle opening) ↓ High line-pressure (Large throttle opening)
Throttle sensor	Approximately 0.5V	Fully-closed throttle
	Approximately 4V	Fully-open throttle
Fluid temperature sensor	Approximately 1.5V ↓ Approximately 0.5V	Cold [20°C (68°F)] ↓ Hot [80°C (176°F)]

Gear position	1	2	3	4
Shift solenoid A	ON	OFF	OFF	ON
Shift solenoid B	ON	ON	OFF	OFF

TROUBLE DIAGNOSES

A/T Electrical Parts Location

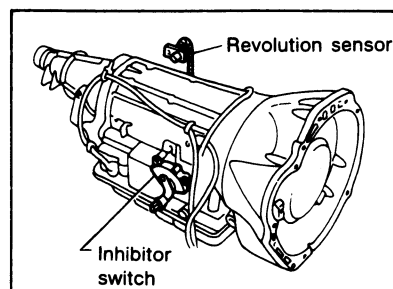
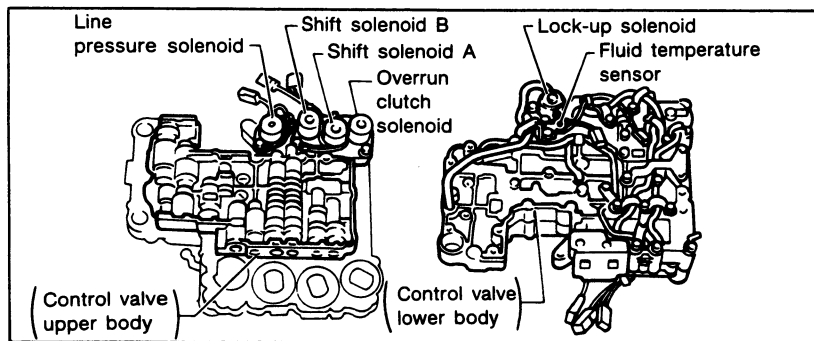
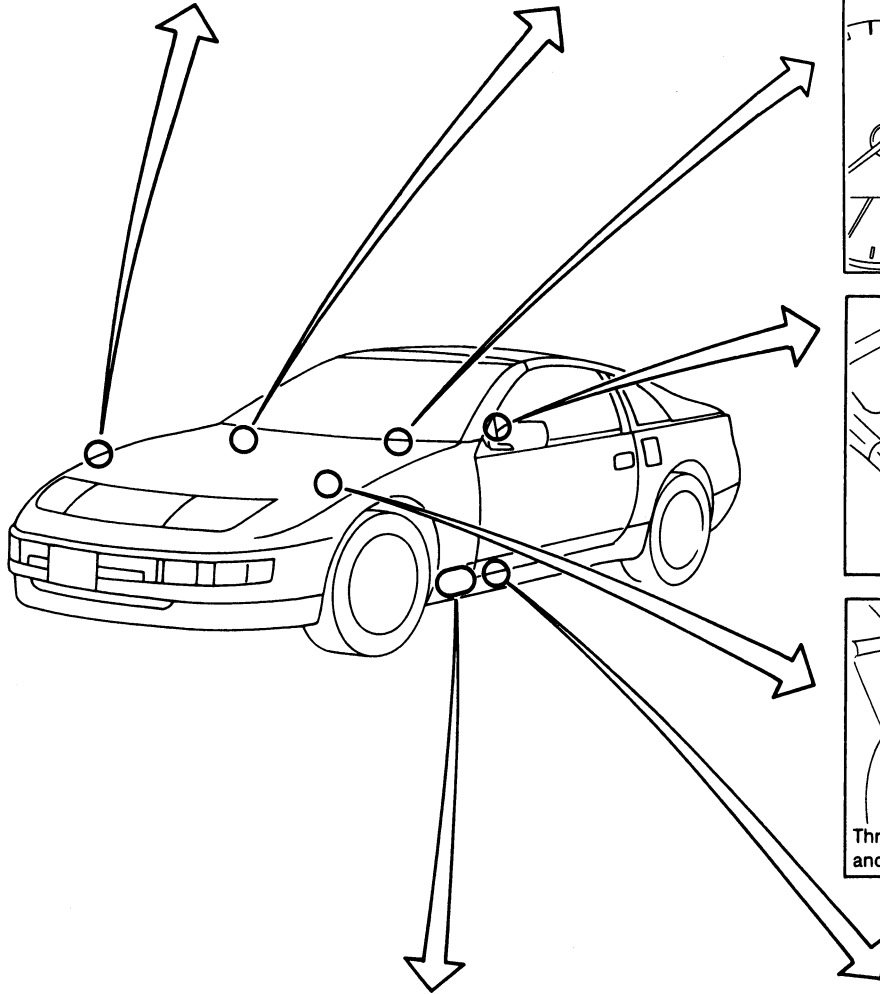
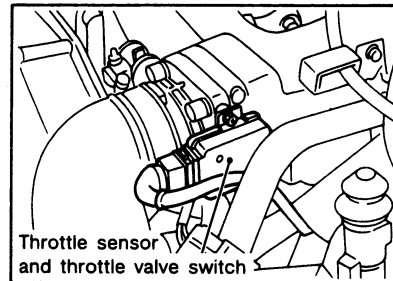
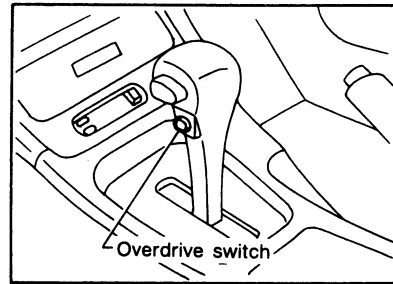
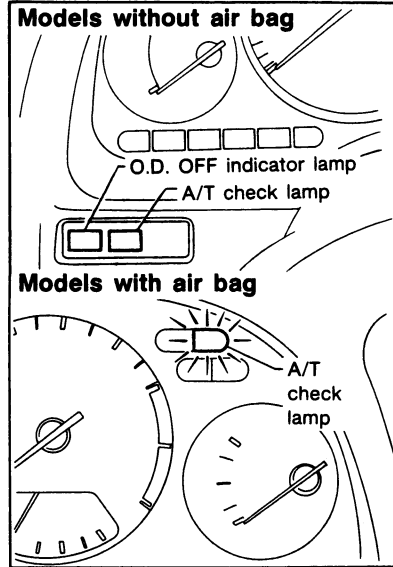
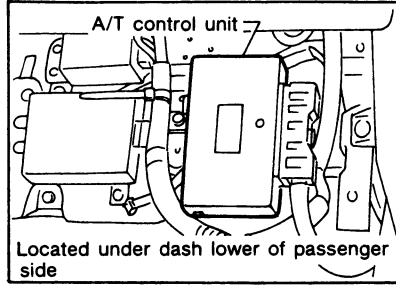
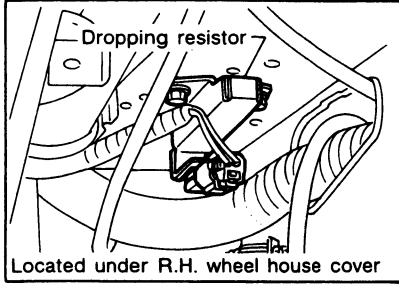

SAT026E

TROUBLE DIAGNOSES

A/T Electrical Parts Location (Cont'd)

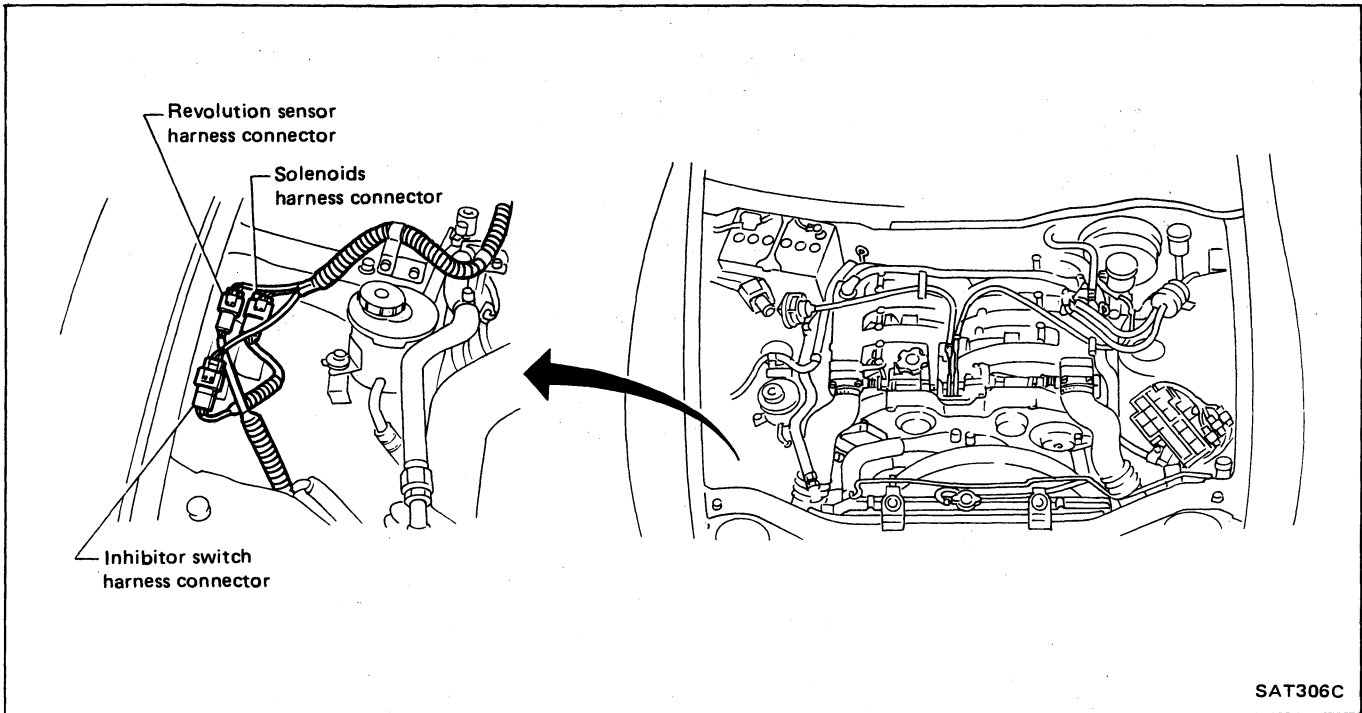

TROUBLE DIAGNOSES

Circuit Diagram for Quick Pinpoint Check

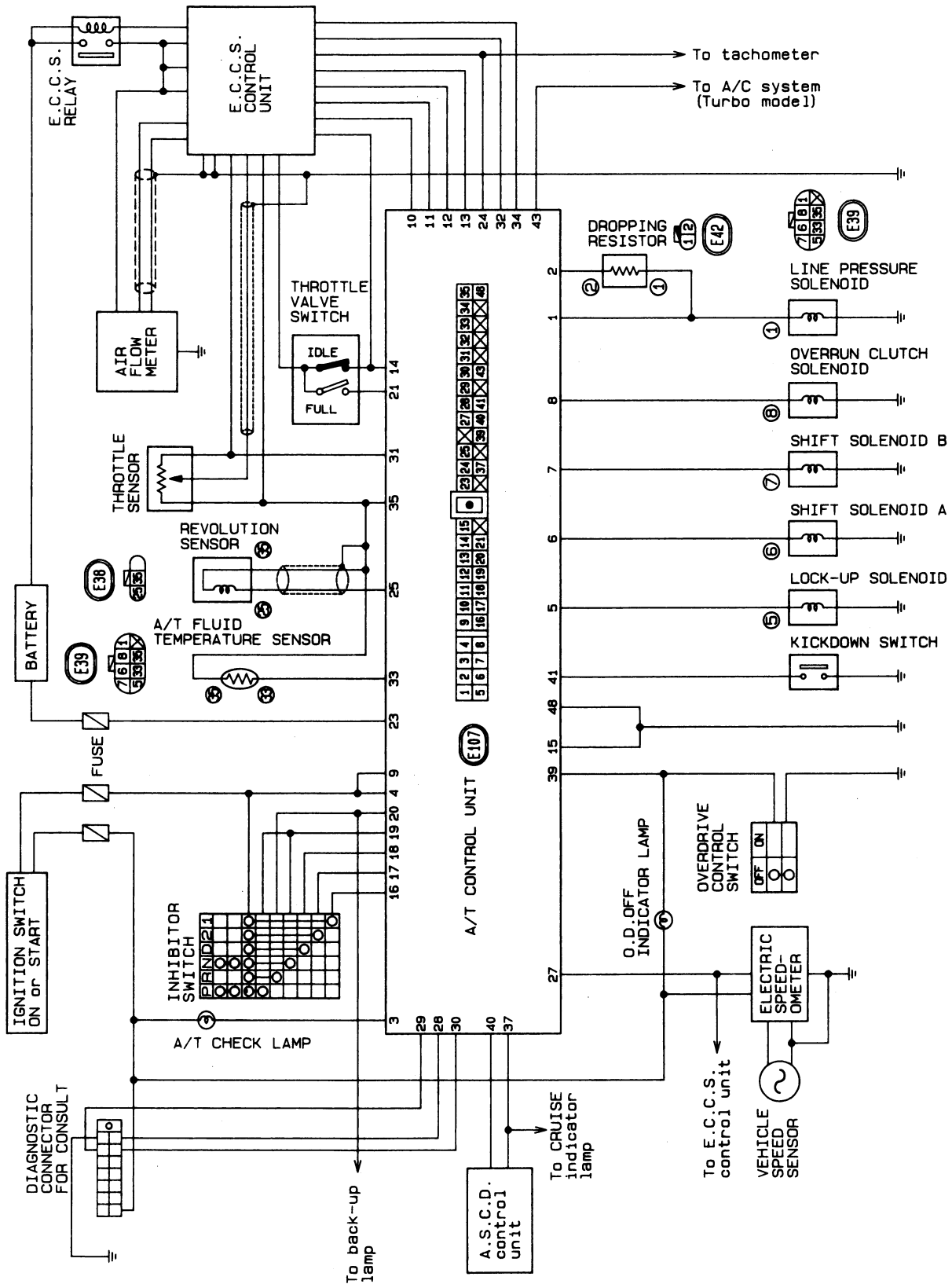

TROUBLE DIAGNOSES

Wiring Diagram

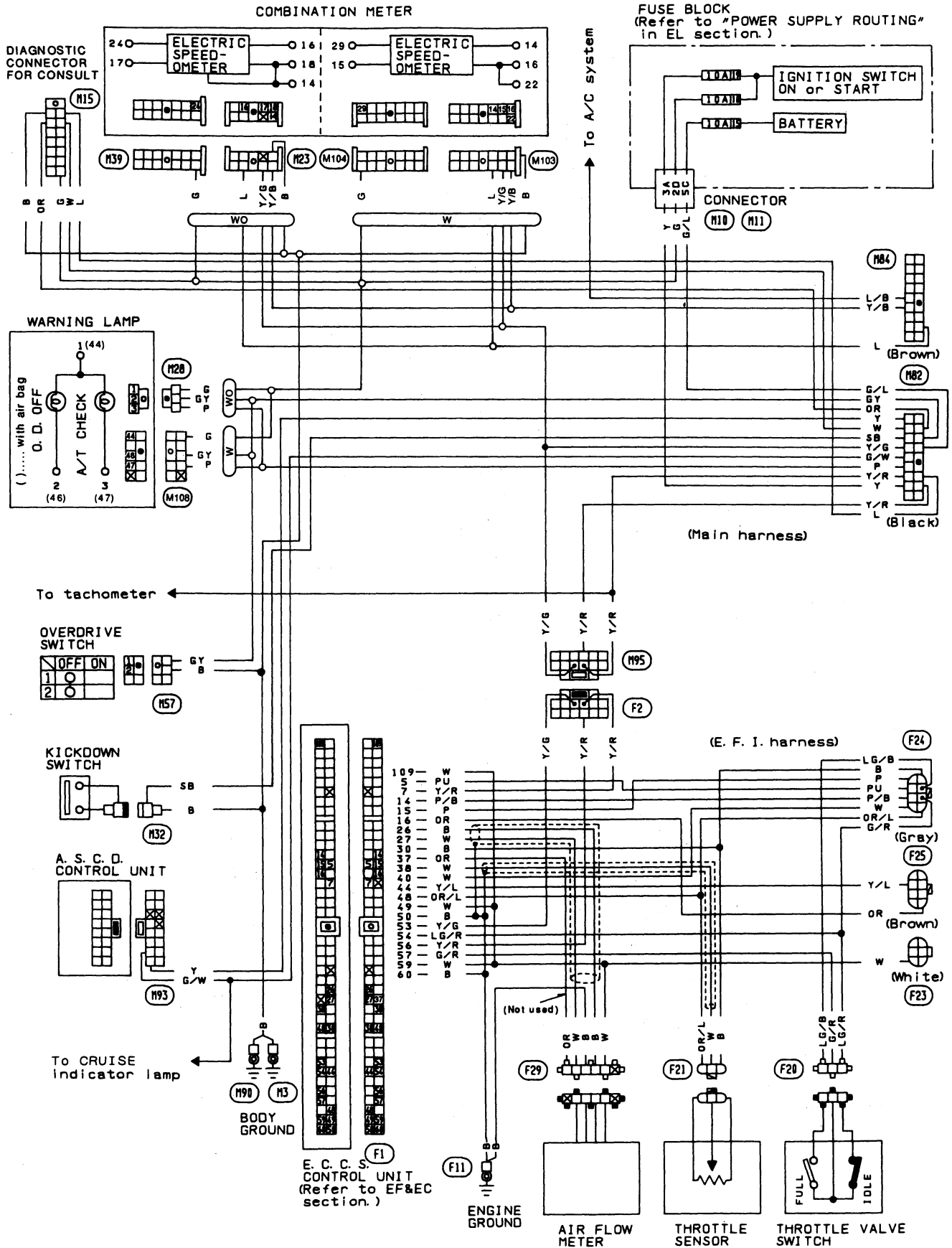

TROUBLE DIAGNOSES

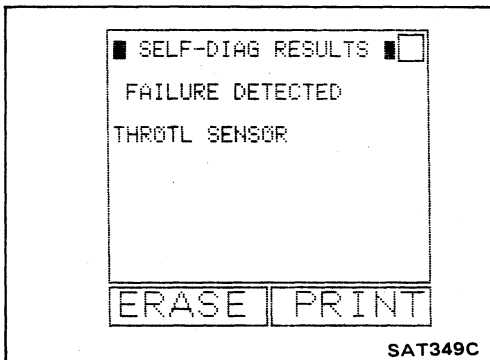
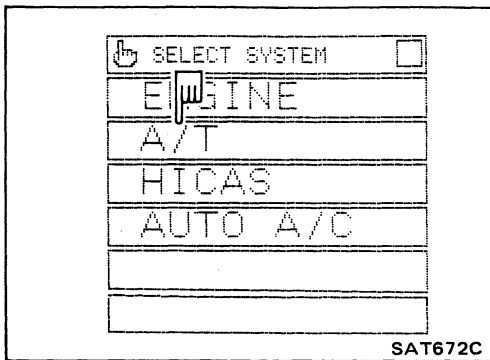

Self-diagnosis

SELF-DIAGNOSTIC PROCEDURE (With CONSULT)

1. Turn on CONSULT.
2. Touch "A/T".
3. Touch "SELF-DIAGNOSIS".
CONSULT performs REAL-TIME SELF-DIAGNOSIS.

TROUBLE DIAGNOSES

Self-diagnosis (Cont'd)

SELF-DIAGNOSTIC PROCEDURE (⌚ Without CONSULT)

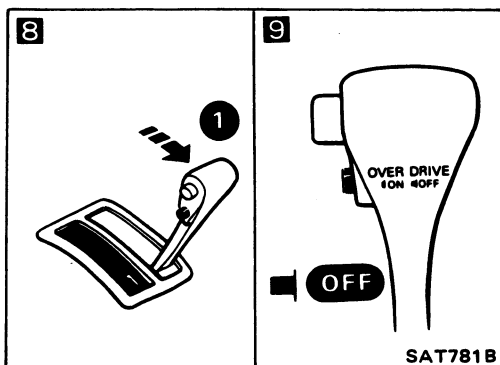
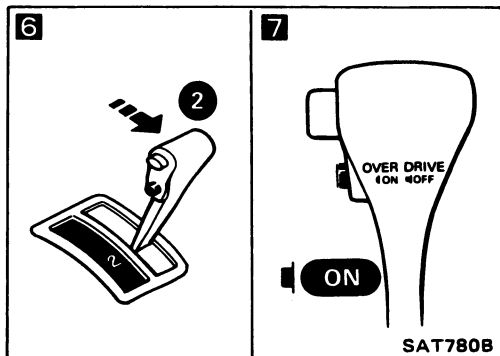
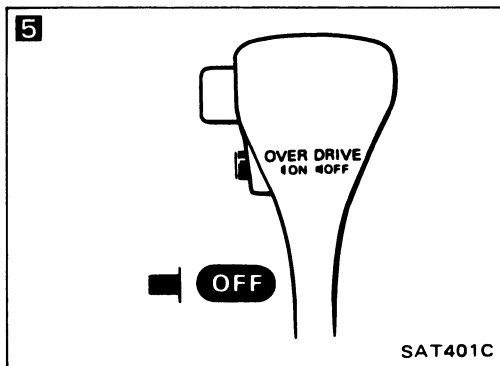
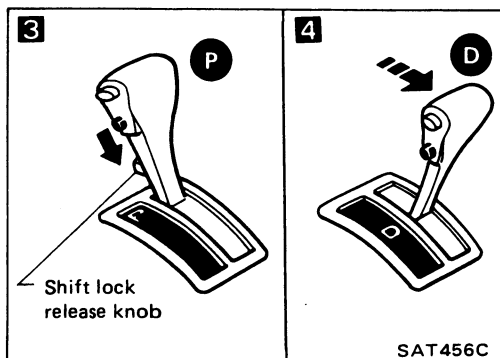
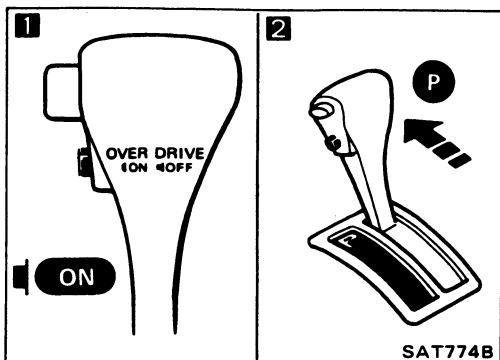

DIAGNOSIS START

Start engine and warm it up to normal engine operating temperature.



1 Set overdrive switch in "ON" position.

2 Move selector lever to "P" range.



Does A/T check lamp come on for about 2 seconds?

Yes

No

Go to Diagnostic Procedure 1.



3 Push shift lock release knob (if equipped).

4 Move selector lever to "D" range.

5 Set overdrive switch in "OFF" position.



Wait for more than 2 seconds after ignition switch "ON".

6 Move selector lever to "2" range.

7 Set overdrive switch in "ON" position.

8 Move selector lever to "1" range.

9 Set overdrive switch in "OFF" position.

A

TROUBLE DIAGNOSES

Self-diagnosis (Cont'd)

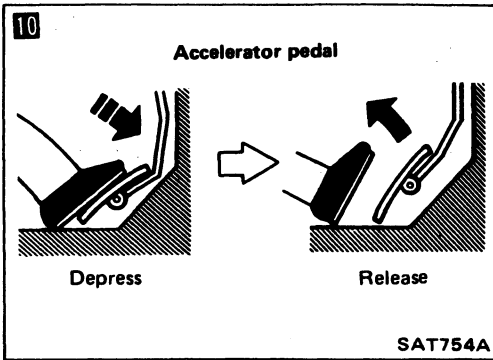

10

A

Depress accelerator pedal fully and release it.

Check A/T check lamp.
Refer to JUDGEMENT OF SELF-DIAGNOSIS CODE on next page.

DIAGNOSIS END

TROUBLE DIAGNOSES

Self-diagnosis (Cont'd)

JUDGEMENT OF SELF-DIAGNOSIS CODE

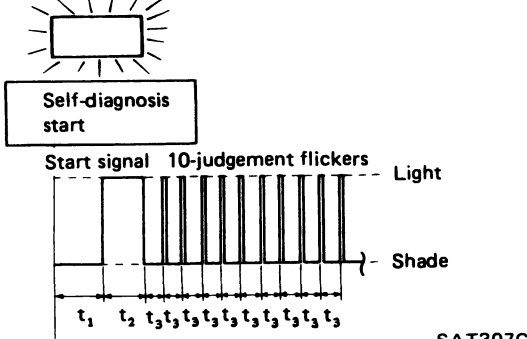
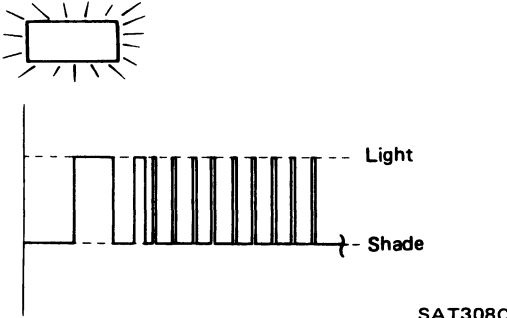
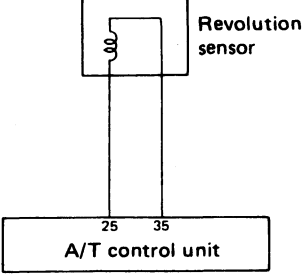
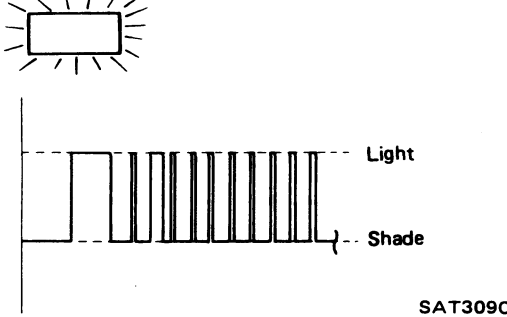
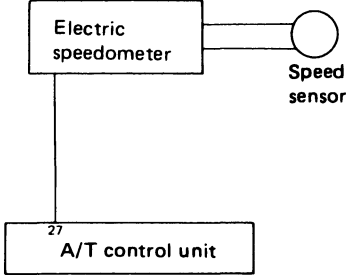
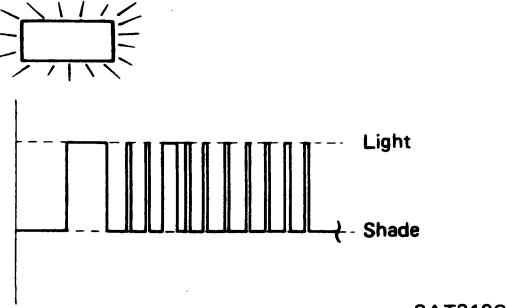
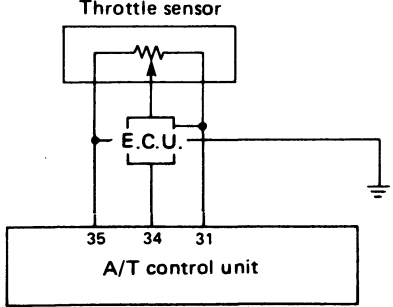
A/T check lamp	Damaged circuit
<p>All judgement flickers are same.</p>  <p style="text-align: right;">SAT307C</p>	<p>All circuits that can be confirmed by self-diagnosis are O.K.</p>
<p>1st judgement flicker is longer than others.</p>  <p style="text-align: right;">SAT308C</p>	<p>Revolution sensor circuit is short-circuited or disconnected.</p>  <p>➡ Go to revolution sensor circuit check. SAT965B</p>
<p>2nd judgement flicker is longer than others.</p>  <p style="text-align: right;">SAT309C</p>	<p>Speed sensor circuit is short-circuited or disconnected.</p>  <p>➡ Go to speed sensor circuit check. SAT029E</p>
<p>3rd judgement flicker is longer than others.</p>  <p style="text-align: right;">SAT310C</p>	<p>Throttle sensor circuit is short-circuited or disconnected.</p>  <p>➡ Go to throttle sensor circuit check. SAT967B</p>

$t_1 = 2.5$ seconds $t_2 = 2.0$ seconds $t_3 = 1.0$ second

TROUBLE DIAGNOSES

Self-diagnosis (Cont'd)

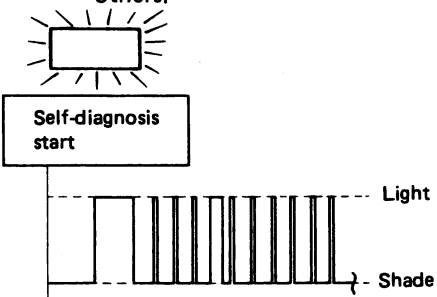
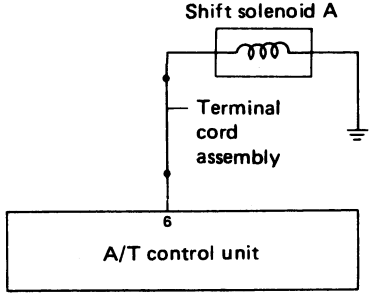
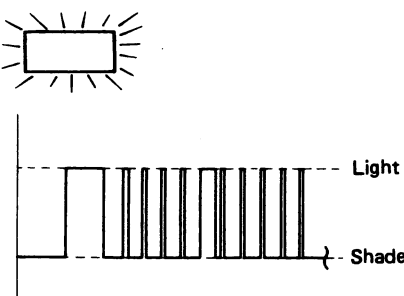
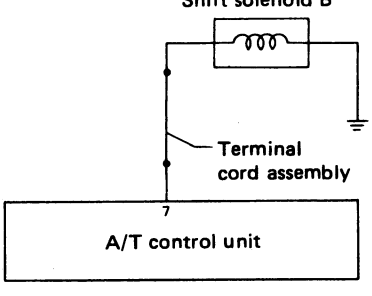
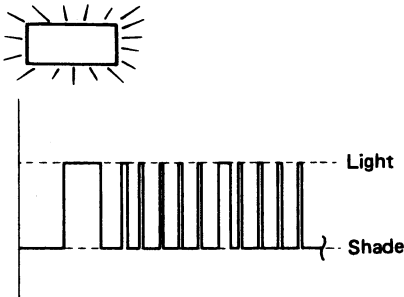
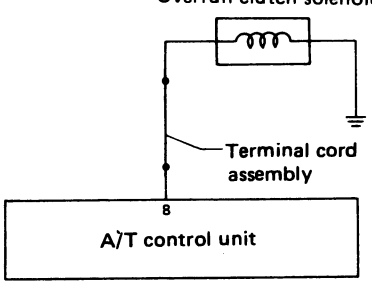
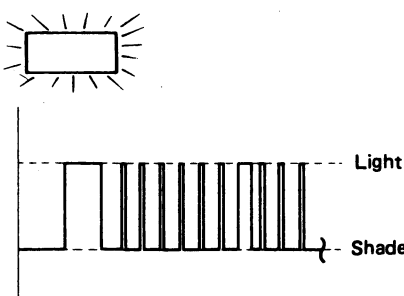
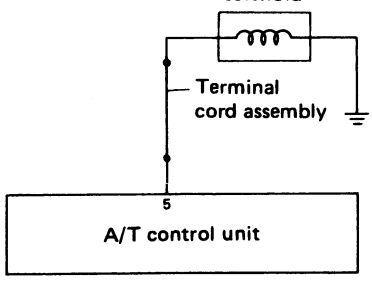
A/T check lamp	Damaged circuit
<p>4th judgement flicker is longer than others.</p>  <p>SAT311C</p>	<p>Shift solenoid A circuit is short-circuited or disconnected.</p>  <p>➡ Go to shift solenoid A circuit check. SAT968B</p>
<p>5th judgement flicker is longer than others.</p>  <p>SAT312C</p>	<p>Shift solenoid B circuit is short-circuited or disconnected.</p>  <p>➡ Go to shift solenoid B circuit check. SAT969B</p>
<p>6th judgement flicker is longer than others.</p>  <p>SAT313C</p>	<p>Overrun clutch solenoid circuit is short-circuited or disconnected.</p>  <p>➡ Go to overrun clutch solenoid circuit check. SAT970B</p>
<p>7th judgement flicker is longer than others.</p>  <p>SAT314C</p>	<p>Lock-up solenoid circuit is short-circuited or disconnected.</p>  <p>➡ Go to lock-up solenoid circuit check. SAT971B</p>

TROUBLE DIAGNOSES

Self-diagnosis (Cont'd)

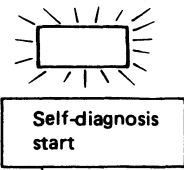
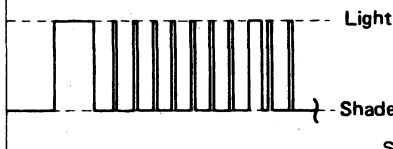
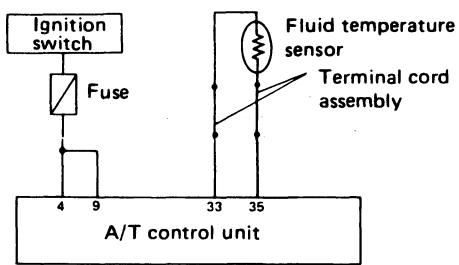
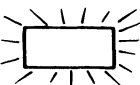
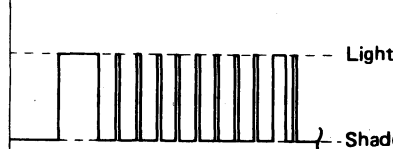
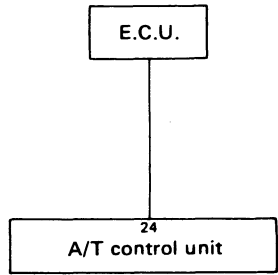
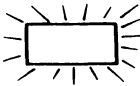
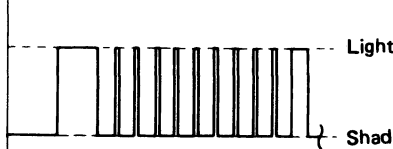
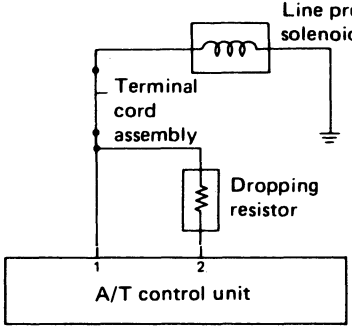
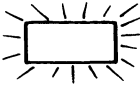
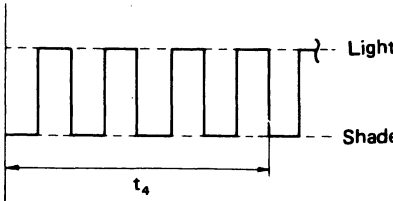
A/T check lamp	Damaged circuit
<p style="text-align: center;">8th judgement flicker is longer than others.</p> <div style="text-align: center;">  </div> <div style="text-align: center;">  </div> <p style="text-align: right;">SAT315C</p>	<p>Fluid temperature sensor is disconnected or A/T control unit power source circuit is damaged.</p> <div style="text-align: center;">  </div> <p>➡ Go to fluid temperature sensor and A/T control unit power source circuit check. SAT972B</p>
<p style="text-align: center;">9th judgement flicker is longer than others.</p> <div style="text-align: center;">  </div> <div style="text-align: center;">  </div> <p style="text-align: right;">SAT316C</p>	<p>Engine revolution signal circuit is short-circuited or disconnected.</p> <div style="text-align: center;">  </div> <p>➡ Go to engine revolution signal circuit check. SAT973B</p>
<p style="text-align: center;">10th judgement flicker is longer than others.</p> <div style="text-align: center;">  </div> <div style="text-align: center;">  </div> <p style="text-align: right;">SAT317C</p>	<p>Line pressure solenoid circuit is short-circuited or disconnected.</p> <div style="text-align: center;">  </div> <p>➡ Go to line pressure solenoid circuit check. SAT974B</p>
<p style="text-align: center;">Flickers as shown below.</p> <div style="text-align: center;">  </div> <div style="text-align: center;">  </div> <p style="text-align: right;">SAT318C</p>	<p>Battery power is low. Battery has been disconnected for a long time. Battery is connected conversely. (When reconnecting A/T control unit connectors. — This is not a problem.)</p>

t₄ = 1.0 second

TROUBLE DIAGNOSES

Self-diagnosis (Cont'd)

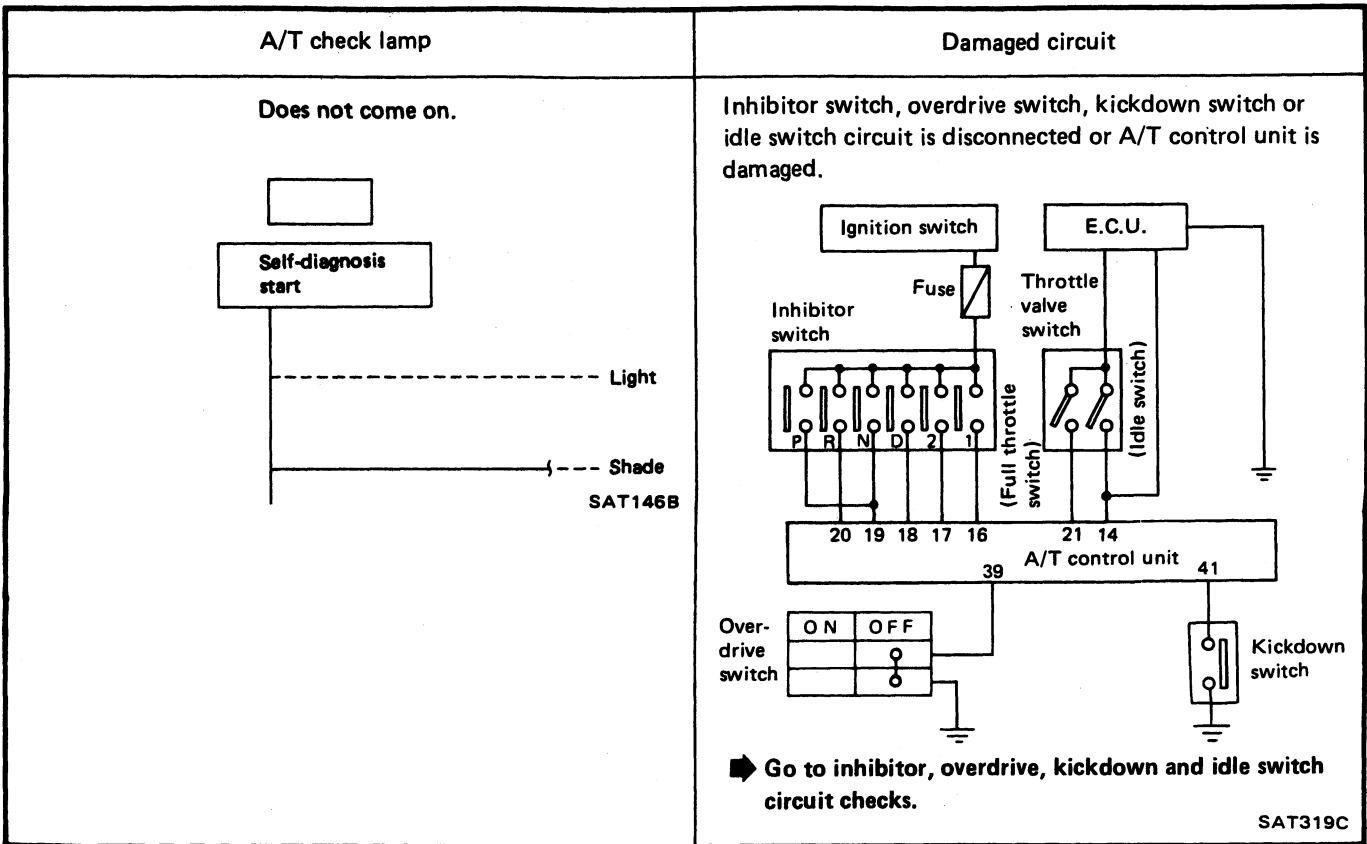

TROUBLE DIAGNOSES

Self-diagnosis (Cont'd)

REVOLUTION SENSOR CIRCUIT CHECK

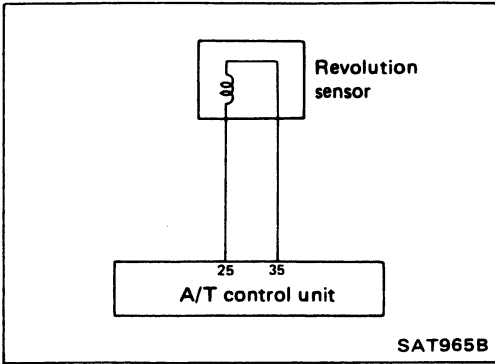

A

☆MONITOR	☆NO FAIL	
CAR/S SE1-A/T	0km/h	
CAR/S SE2-MTR	5km/h	
THROTTLE SEN	0.4V	
FLUID TEMP SE	1.2V	
BATTERY VOLT	13.4V	
ENG REV	1024rpm	
SLCT LEVER SW	0 N	
R-RANGE SW	OFF	
N-RANGE SW	0 N	
RECORD		

SAT320C

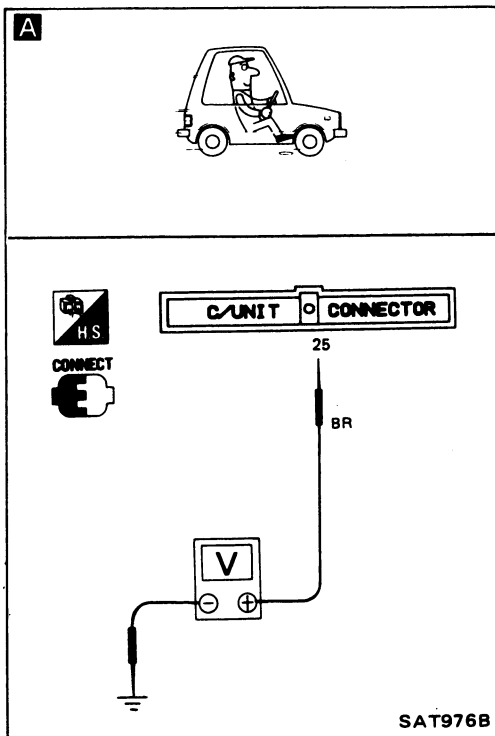

CHECK REVOLUTION SENSOR. — Refer to "Electrical Components Inspection".

N.G.

Repair or replace revolution sensor.

O.K.

A

CHECK INPUT SIGNAL.

1.

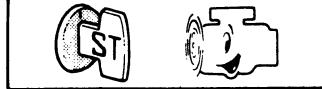

2.



- Select "E.C.U. INPUT SIGNALS".
- Read out the value of "CAR SPEED SENSOR 1" while driving.
- Check the value changes according to driving speed.

N.G.

Check harness continuity between A/T control unit and revolution sensor.

OR



Check voltage between A/T control unit terminal ②⑤ and ground while driving.
(Measure with A.C. range.)

Voltage:

At 0 km/h (0 MPH):
0V

At 30 km/h (19 MPH):
1V or more

(Voltage rises gradually in response to vehicle speed.)

O.K.

Perform self-diagnosis again after driving for a while.

N.G.

1. Perform A/T control unit input/output signal inspection.
2. If N.G., recheck A/T control unit pin terminals for damage or connection of A/T control unit harness connector.

O.K.

INSPECTION END

TROUBLE DIAGNOSES

Self-diagnosis (Cont'd)

SPEED SENSOR CIRCUIT CHECK

A



MONITOR	NO FAIL
CAR/S SE1·A/T	0km/h
CAR/S SE2·MTR	5km/h
THROTTLE SEN	0.4V
FLUID TEMP SE	1.2V
BATTERY VOLT	13.4V
ENG REV	1024rpm
SLCT LEVER SW	0 N
R-RANGE SW	OFF
N-RANGE SW	0 N

RECORD

SAT320C

A

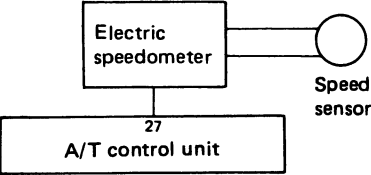

At 2 - 3 km/h (1 - 2 MPH)

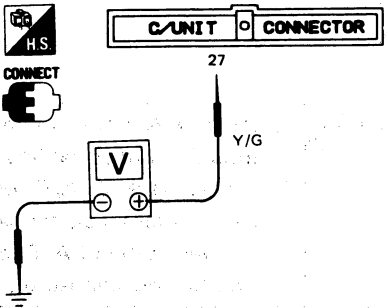



SAT030E

A

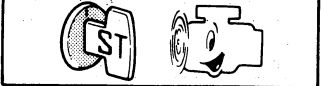
CHECK INPUT SIGNAL.

1. 

2.  • Select "E.C.U. INPUT SIGNALS".

- Read out the value of "CAR SPEED SENSOR 2" while driving.
- Check the value changes according to driving speed.

OR

 • Check voltage between A/T control unit terminal ②7 and ground while driving at 2 to 3 km/h (1 to 2 MPH) for 1 m (3 ft) or more.

Voltage: Varies from 0V to 5V

N.G. → Check the following items.

- Speed sensor and ground circuit for speed sensor – Refer to section EL.
- Harness continuity between A/T control unit and speed sensor

O.K. → Perform self-diagnosis again after driving for a while.

N.G. →

1. Perform A/T control unit input/output signal inspection.
2. If N.G., recheck A/T control unit pin terminals for damage or connection of A/T control unit harness connector.

O.K. → **INSPECTION END**

TROUBLE DIAGNOSES

Self-diagnosis (Cont'd)

THROTTLE SENSOR CIRCUIT CHECK

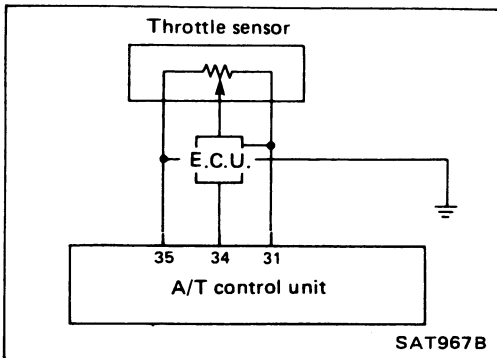

A

Depress slowly.

```

MONITOR  NO FAIL
CAR/S SE1·A/T      0km/h
CAR/S SE2·MTR     5km/h
THROTTLE SEN      0.4V
FLUID TEMP SE     1.2V
BATTERY VOLT     13.4V
ENG REV           1024rPm
SLCT LEVER SW     0 N
R-RANGE SW       OFF
N-RANGE SW       0 N
    
```

RECORD

SAT321C

A

Depress slowly.

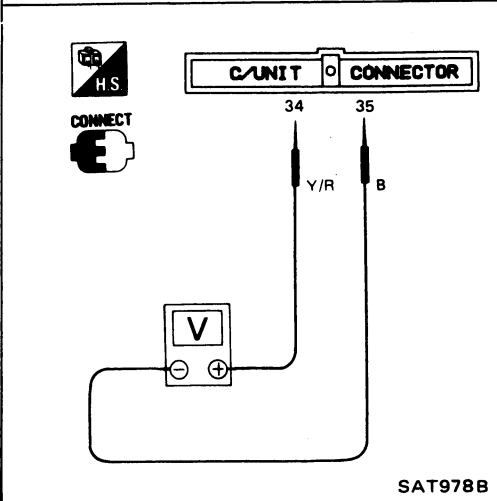

Perform self-diagnosis (Mode III) for engine control.

N.G.

Check throttle sensor circuit for engine control. — Refer to section EF & EC.

O.K.

A

CHECK INPUT SIGNAL.

1.



N.G.

Check harness continuity between E.C.U. and A/T control unit regarding throttle sensor circuit.

2.



- Select "E.C.U. INPUT SIGNALS".
- Read out the value of "THROTTLE SENSOR".

Voltage:

Fully-closed throttle:

Approximately
0.5V

Fully-open throttle:

Approximately
4V

OR



- Check voltage between A/T control unit terminals ③④ and ③⑤ while accelerator pedal is depressed slowly.

Voltage:

Fully-closed throttle:

Approximately
0.5V

Fully-open throttle:

Approximately
4V

(Voltage rises gradually in response to throttle valve opening.)

O.K.

Perform self-diagnosis again after driving for a while.

N.G.

1. Perform A/T control unit input/output signal inspection.
2. If N.G., recheck A/T control unit pin terminals for damage or connection of A/T control unit harness connector.

O.K.

INSPECTION END

TROUBLE DIAGNOSES

Self-diagnosis (Cont'd)

SHIFT SOLENOID A CIRCUIT CHECK

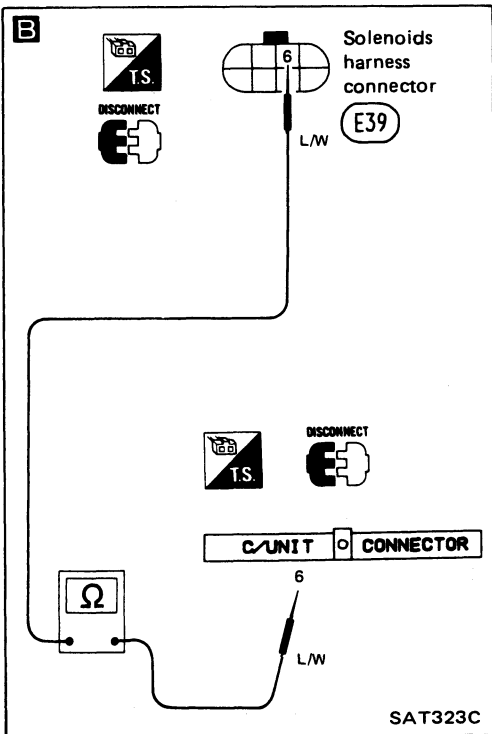
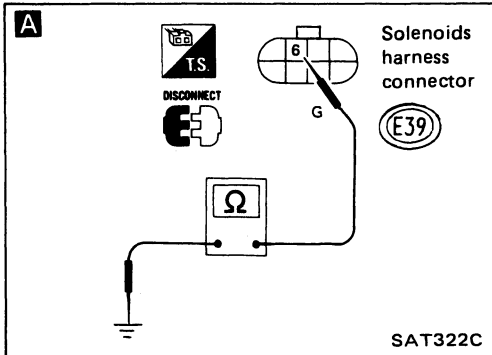
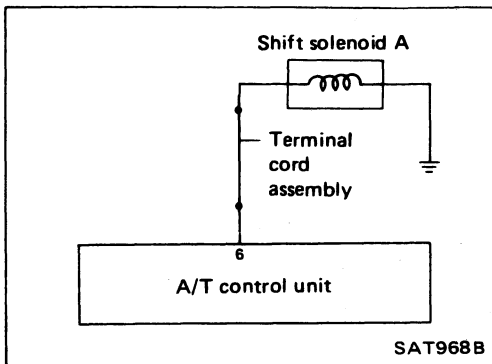

A

CHECK GROUND CIRCUIT.

- 1.
2. Disconnect terminal cord assembly connector in engine compartment.
3. Check resistance between terminal ⑥ and ground.
Resistance: 20 - 40Ω

N.G.

1. Remove control valve assembly. — Refer to "ON-VEHICLE SERVICE".
2. Check the following items.
 - Shift solenoid A — Refer to "Electrical Components Inspection".
 - Harness continuity of terminal cord assembly

O.K.

B

CHECK POWER SOURCE CIRCUIT.

- 1.
2. Disconnect A/T control unit connector.
3. Check resistance between terminal ⑥ and A/T control unit terminal ⑥.
Resistance: Approximately 0Ω
4. Reinstall any part removed.

N.G.

- Repair or replace harness between A/T control unit and terminal cord assembly.

O.K.

Perform self-diagnosis after driving for a while.

N.G.

1. Perform A/T control unit input/output signal inspection.
2. If N.G., recheck A/T control unit pin terminals for damage or connection of A/T control unit harness connector.

O.K.

INSPECTION END

TROUBLE DIAGNOSES

Self-diagnosis (Cont'd)

SHIFT SOLENOID B CIRCUIT CHECK

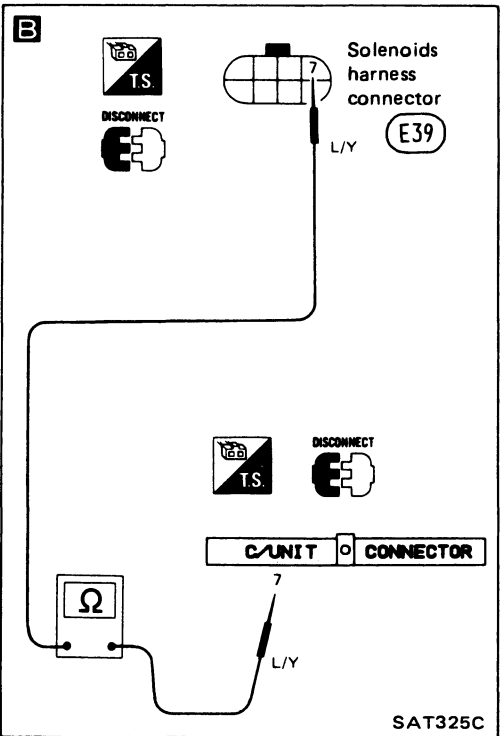
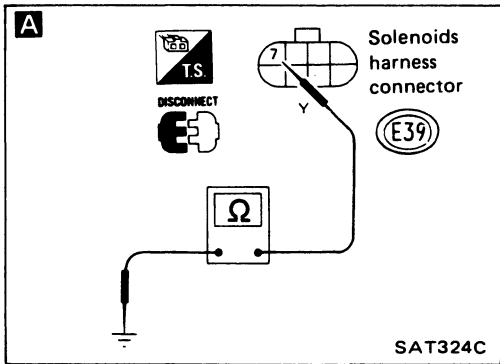
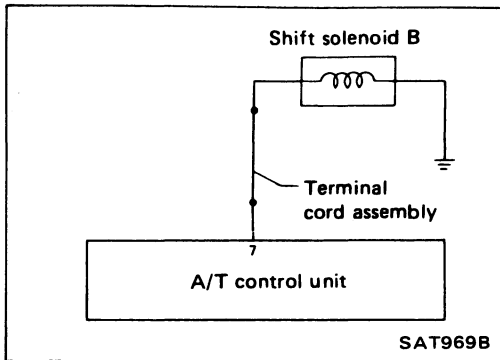

A

CHECK GROUND CIRCUIT.

- 1.
2. Disconnect terminal cord assembly connector in engine compartment.
3. Check resistance between terminal ⑦ and ground.
Resistance: 20 - 40Ω

N.G.

1. Remove control valve assembly. — Refer to "ON-VEHICLE SERVICE".
2. Check the following items.
 - Shift solenoid B — Refer to "Electrical Components Inspection".
 - Harness continuity of terminal cord assembly

B

CHECK POWER SOURCE CIRCUIT.

- 1.
2. Disconnect A/T control unit connector.
3. Check resistance between terminal ⑦ and A/T control unit terminal ⑦.
Resistance: Approximately 0Ω
4. Reinstall any part removed.

N.G.

Repair or replace harness between A/T control unit and terminal cord assembly.

O.K.

Perform self-diagnosis after driving for a while.

N.G.

1. Perform A/T control unit input/output signal inspection.
2. If N.G., recheck A/T control unit pin terminals for damage or connection of A/T control unit harness connector.

O.K.

INSPECTION END

TROUBLE DIAGNOSES

Self-diagnosis (Cont'd)

OVERRUN CLUTCH SOLENOID CIRCUIT CHECK

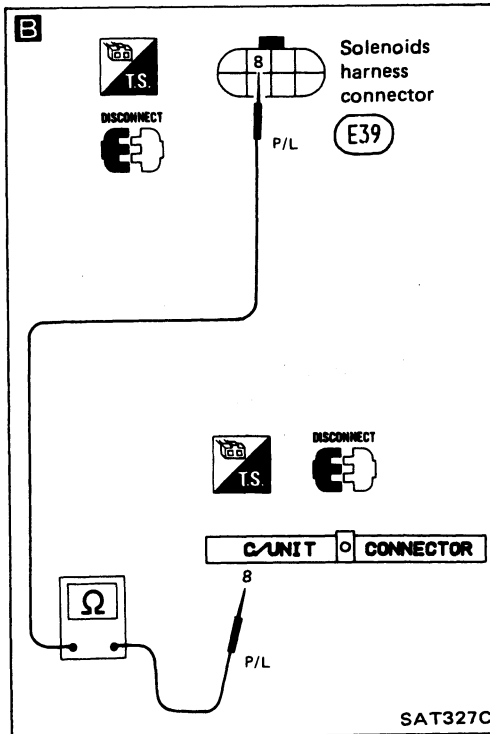
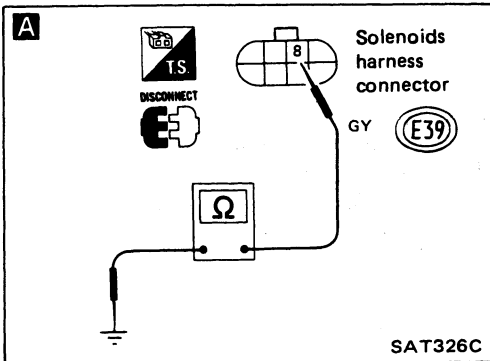
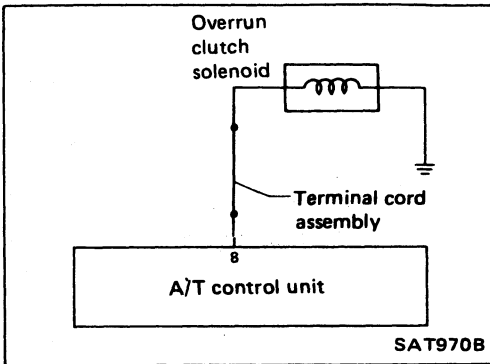

A

CHECK GROUND CIRCUIT.

- 1.
2. Disconnect terminal cord assembly connector in engine compartment.
3. Check resistance between terminal ⑧ and ground.
Resistance: 20 - 40Ω

- N.G.
1. Remove control valve assembly. — Refer to "ON-VEHICLE SERVICE".
 2. Check the following items.
 - Overrun clutch solenoid. — Refer to "Electrical Components Inspection".
 - Harness continuity of terminal cord assembly

O.K.

B

CHECK POWER SOURCE CIRCUIT.

- 1.
2. Disconnect A/T control unit connector.
3. Check resistance between terminal ⑧ and A/T control unit terminal ⑧.
Resistance: Approximately 0Ω
4. Reinstall any part removed.

- N.G.
- Repair or replace harness between A/T control unit and terminal cord assembly.

O.K.

Perform self-diagnosis after driving for a while.

O.K.

INSPECTION END

- N.G.
1. Perform A/T control unit input/output signal inspection.
 2. If N.G., recheck A/T control unit pin terminals for damage or connection of A/T control unit harness connector.

TROUBLE DIAGNOSES

Self-diagnosis (Cont'd)

LOCK-UP SOLENOID CIRCUIT CHECK

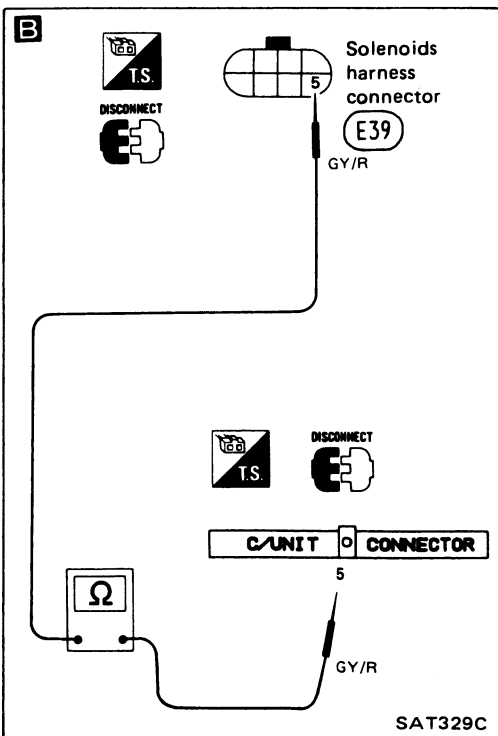
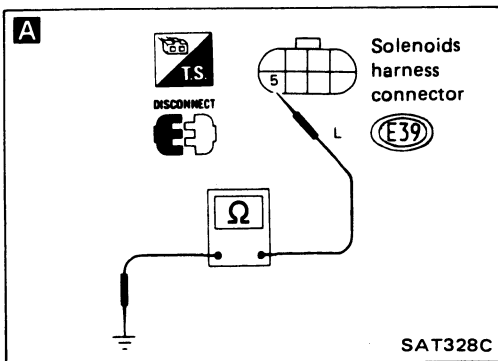
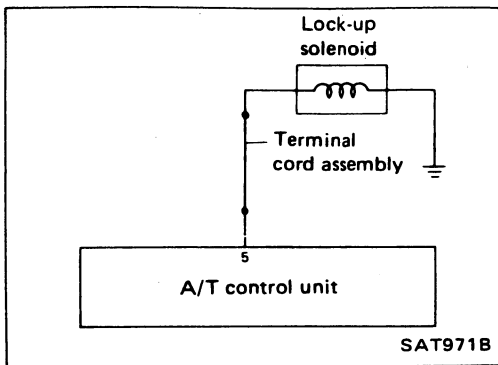

A

CHECK GROUND CIRCUIT.

- 1.
2. Disconnect terminal cord assembly connector in engine compartment.
3. Check resistance between terminal ⑤ and ground.
Resistance: 10 - 20 Ω

N.G.

1. Remove oil pan.
– Refer to "ON-VEHICLE SERVICE".
2. Check the following items.
 - Lock-up solenoid – Refer to "Electrical Components Inspection".
 - Harness continuity of terminal cord assembly.

B

CHECK POWER SOURCE CIRCUIT.

- 1.
2. Disconnect A/T control unit connector.
3. Check resistance between terminal ⑤ and A/T control unit terminal ⑤.
Resistance: Approximately 0 Ω
4. Reinstall any part removed.

N.G.

Repair or replace harness between A/T control unit and terminal cord assembly.

O.K.

Perform self-diagnosis after driving for a while.

O.K.

INSPECTION END

N.G.

1. Perform A/T control unit input/output signal inspection.
2. If N.G., recheck A/T control unit pin terminals for damage or connection of A/T control unit harness connector.

TROUBLE DIAGNOSES

Self-diagnosis (Cont'd)

FLUID TEMPERATURE SENSOR CIRCUIT AND A/T CONTROL UNIT POWER SOURCE CIRCUIT CHECKS

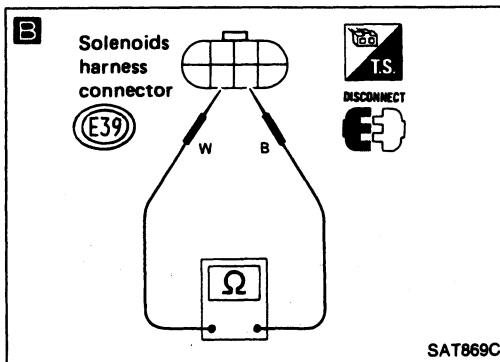
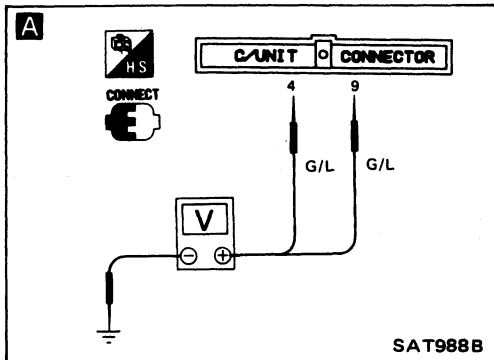
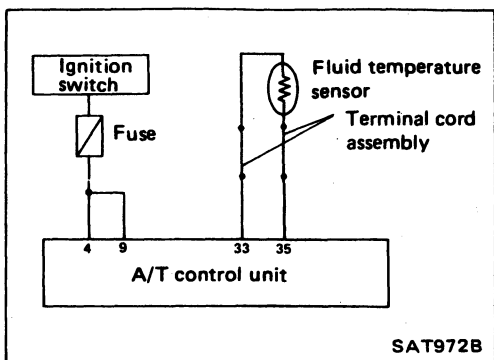

A

CHECK A/T CONTROL UNIT POWER SOURCE.

-
- Check voltage between A/T control unit terminals ④, ⑨ and ground.
Battery voltage should exist.

N.G.

Check the following items.

- Harness continuity between ignition switch and A/T control unit
- Ignition switch and fuse – Refer to section EL.

B

O.K.

CHECK FLUID TEMPERATURE SENSOR WITH TERMINAL CORD ASSEMBLY

-
- Disconnect terminal cord assembly connector in engine compartment.
- Check resistance between terminals ③③ and ③⑤ when A/T is cold.
Resistance:
Cold [20°C (68°F)]
Approximately 2.5 kΩ
- Reinstall any part removed.

N.G.

1. Remove control valve cover.
2. Check the following items.
 - Fluid temperature sensor – Refer to "Electrical Components Inspection".
 - Harness continuity of terminal cord assembly

O.K.

↓

Ⓐ

TROUBLE DIAGNOSES

Self-diagnosis (Cont'd)

C

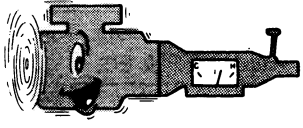

```

    ☆MONITOR ☆NO FAIL
    CAR/S SE1·A/T      0km/h
    CAR/S SE2·MTR      5km/h
    THROTTLE SEN       0.4V
    FLUID TEMP SE      1.2V
    BATTERY VOLT       13.4V
    ENG REV            1024rPm
    SLOT LEVER SW      0 N
    R-RANGE SW         OFF
    N-RANGE SW         0 N
    
```

RECORD

SAT330C

C

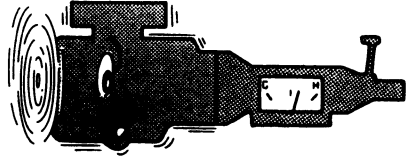
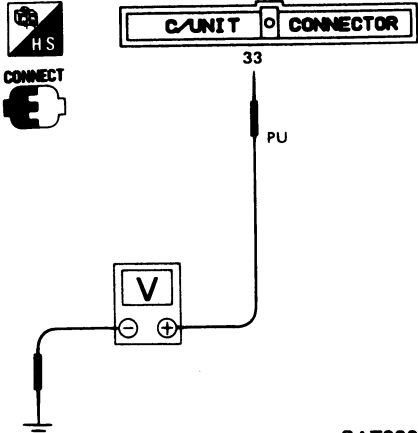



SAT990B

C

CHECK INPUT SIGNAL OF FLUID TEMPERATURE SENSOR.

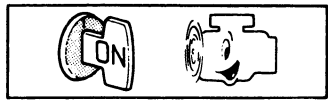
N.G. → Check harness continuity between A/T control unit and terminal cord assembly.

- 
- Select "E.C.U. INPUT SIGNALS".
 - Read out the value of "FLUID TEMPERATURE SENSOR".

Voltage:
 Cold [20°C (68°F)] →
 Hot [80°C (176°F)]:
 Approximately
 1.5V → 0.5V

OR

- Check voltage between A/T control unit terminal ③③ and ground while warming up A/T.

Voltage:
 Cold [20°C (68°F)] →
 Hot [80°C (176°F)]:
 Approximately
 1.5V → 0.5V

O.K. → Perform self-diagnosis after driving for a while.

N.G. → 1. Perform A/T control unit input/output signal inspection.
 2. If N.G., recheck A/T control unit pin terminals for damage or connection of A/T control unit harness connector.

O.K. → **INSPECTION END**

TROUBLE DIAGNOSES

Self-diagnosis (Cont'd)

ENGINE REVOLUTION SIGNAL CIRCUIT CHECK

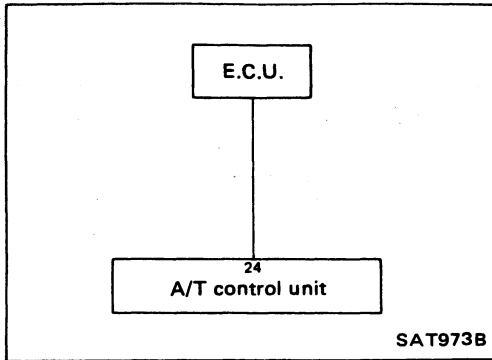

A

☆MONITOR	☆NO FAIL	
CAR/S SE1-A/T	0km/h	
CAR/S SE2-MTR	5km/h	
THROTTLE SEN	0.4V	
FLUID TEMP SE	1.2V	
BATTERY VOLT	13.4V	
ENG REV	1024rPm	
SLCT LEVER SW	0 N	
R-RANGE SW	0FF	
N-RANGE SW	0 N	

RECORD

SAT331C

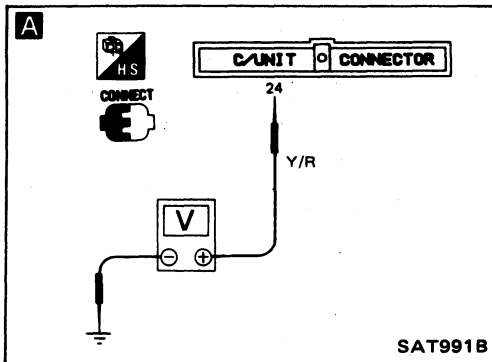

Check ignition circuit condition for engine.

N.G.

Repair or replace. — Refer to section EF & EC.

O.K.

A

CHECK INPUT SIGNAL.

1.



2.



- Select "E.C.U. INPUT SIGNALS".
- Read out the value of "ENGINE REVOLUTION".
- Check engine revolution changes according to throttle opening.

OR



- Check voltage between A/T control unit terminal 24 and ground.
Voltage: 0.9 - 4.5V

N.G.

Check harness continuity between A/T control unit and E.C.C.S. control unit.

O.K.

Perform self-diagnosis again after driving for a while.

N.G.

1. Perform A/T control unit input/output signal inspection.
2. If N.G., recheck A/T control unit pin terminals for damage or connection of A/T control unit harness connector.

O.K.

INSPECTION END

TROUBLE DIAGNOSES

Self-diagnosis (Cont'd)

LINE PRESSURE SOLENOID CIRCUIT CHECK

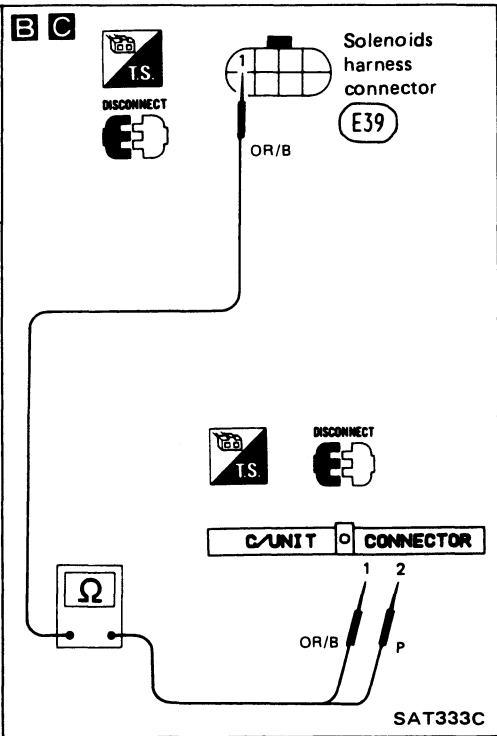
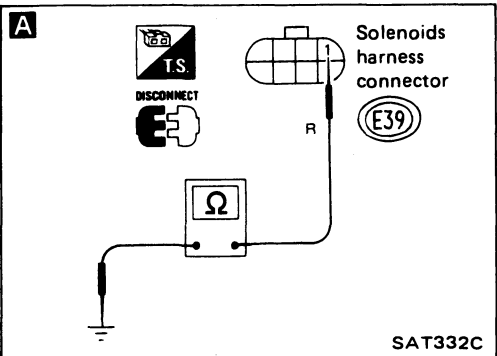
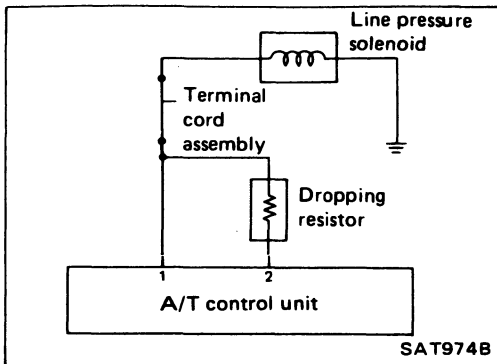

A

CHECK GROUND CIRCUIT.

- 1.
2. Disconnect terminal cord assembly connector in engine compartment.
3. Check resistance between terminal ① and ground.
Resistance: 2.5 - 5Ω

N.G.

1. Remove control valve assembly. – Refer to "ON-VEHICLE SERVICE".
2. Check the following items.
 - Line pressure solenoid – Refer to "Electrical Components Inspection".
 - Harness continuity of terminal cord assembly

O.K.

B

CHECK POWER SOURCE CIRCUIT.

- 1.
2. Disconnect A/T control unit connector.
3. Check resistance between terminal ① and A/T control unit terminal ②.
Resistance: 11.2 - 12.8Ω

N.G.

Check the following items.

- Dropping resistor – Refer to "Electrical Components Inspection".
- Harness continuity between A/T control unit ② and terminal cord assembly

O.K.

C

CHECK POWER SOURCE CIRCUIT

- 1.
2. Check resistance between terminal ① and A/T control unit terminal ①.
Resistance: Approximately 0Ω
3. Reinstall any part removed.

N.G.

Repair or replace harness between A/T control unit ① and terminal cord assembly.

O.K.

Perform self-diagnosis after driving for a while.

N.G.

1. Perform A/T control unit input/output signal inspection.
2. If N.G., recheck A/T control unit pin terminals for damage or connection of A/T control unit harness connector.

INSPECTION END

TROUBLE DIAGNOSES

Self-diagnosis (Cont'd)

INHIBITOR, OVERDRIVE, KICKDOWN AND IDLE SWITCH CIRCUIT CHECKS

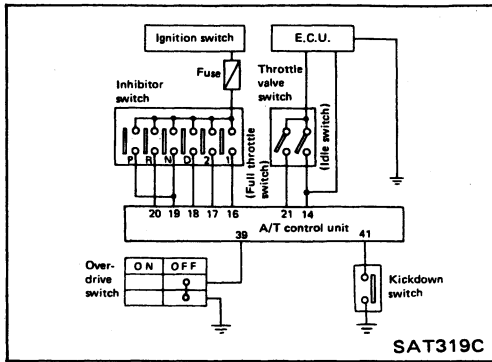

A

```

    *MONITOR *NO FAIL
    CAR/S SE1-A/T      0km/h
    CAR/S SE2-MTR     5km/h
    THROTTLE SEN      0.4V
    FLUID TEMP SE     1.2V
    BATTERY VOLT     13.4V
    ENG REV           1024rpm
    SLCT LEVER SW     0 N
    R-RANGE SW        OFF
    N-RANGE SW        0 N
    
```

RECORD

SAT334C

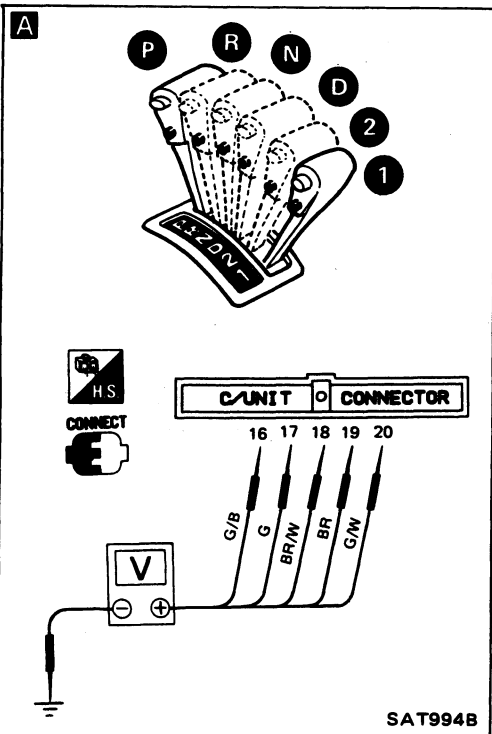

A

CHECK INHIBITOR SWITCH CIRCUIT.

1.



2.



- Select "E.C.U. INPUT signals".
- Read out "R, N, D, 1 and 2 range switches" moving selector lever to each range.
- Check the selector lever position is indicated properly.

OR



- Check voltage between A/T control unit terminals 16, 17, 18, 19, 20 and ground while moving selector lever through each range.

Voltage:

- B:** Battery voltage
- 0:** 0V

Terminal No.	19	20	18	17	16
Lever position					
P, N	B	0	0	0	0
R	0	B	0	0	0
D	0	0	B	0	0
2	0	0	0	B	0
1	0	0	0	0	B

O.K.



N.G.

Check the following items.

- Inhibitor switch – Refer to "Electrical Components Inspection".
- Harness continuity between ignition switch and inhibitor switch
- Harness continuity between inhibitor switch and A/T control unit

TROUBLE DIAGNOSES

Self-diagnosis (Cont'd)

B

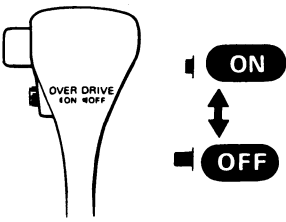

OVER DRIVE
ON OFF

ON
OFF

```

MONITOR  NO FAIL
CAR/S SE1·A/T      0km/h
CAR/S SE2·MTR      5km/h
THROTTLE SEN       0.4V
FLUID TEMP SE      1.2V
BATTERY VOLT       13.4V
ENG REV            1024rPm
SLCT LEVER SW      0 N
R-RANGE SW         OFF
N-RANGE SW         0 N
    
```

RECORD

SAT335C

B

CHECK OVERDRIVE SWITCH CIRCUIT.

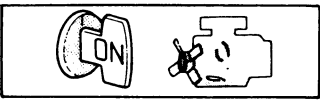
1. 

2. 

- Select "E.C.U. INPUT SIGNALS".
- Read out "SELECTOR LEVER SWITCH (Overdrive switch)".
- Check the selector lever switch position is indicated properly. (Selector lever switch "ON" displayed on CONSULT means overdrive "OFF".)

N.G. →

Check the following items.

- Overdrive switch – Refer to "Electrical Components Inspection".
- Harness continuity between A/T control unit and overdrive switch
- Harness continuity of ground circuit for overdrive switch

OR



- Check voltage between A/T control unit terminal ③9 and ground when overdrive switch is in "ON" position and in "OFF" position.

Switch position	Voltage
ON	Battery voltage
OFF	1V or less

B

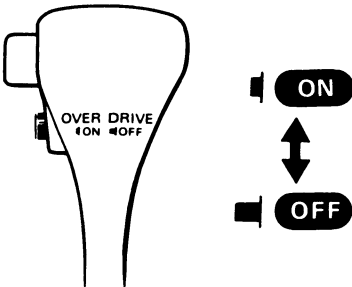

OVER DRIVE
ON OFF

ON
OFF

 HS
CONNECT

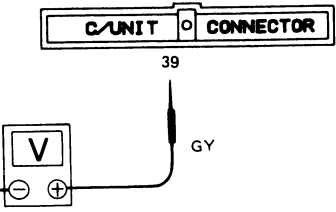

C/UNIT CONNECTOR

39

GY

V

SAT995B

O.K.

B

TROUBLE DIAGNOSES

Self-diagnosis (Cont'd)

C



MONITOR	NO FAIL
D-RANGE SW	OFF
1-RANGE SW	OFF
2-RANGE SW	OFF
ASCD-CRUISE	OFF
ASCD-OD CUT	OFF
KICKDOWN SW	OFF
POWERSHIFT SW	OFF
IDLE SW	ON
FULL THRTL SW	OFF

RECORD

SAT336C

C

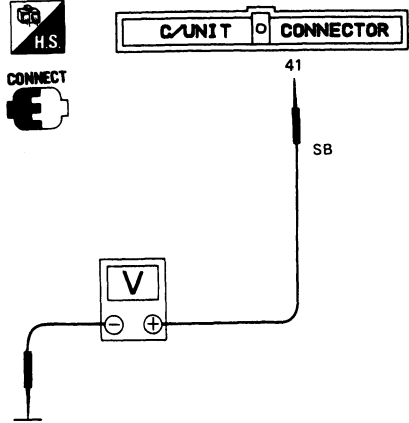
CONNECT

V

41

SB

SAT337C

B

C

CHECK KICKDOWN SWITCH CIRCUIT.

1. 

2. 

- Select "E.C.U. INPUT SIGNALS".
- Read out "KICKDOWN SWITCH" depressing accelerator pedal fully.
- Check Kickdown switch position is indicated properly.

N.G.

Check the following items.

- Kickdown switch
- Harness continuity between A/T control unit and kick-down switch
- Harness continuity of ground circuit for kickdown switch
- Adjust kickdown switch — Refer to "ON-VEHICLE SERVICE".

OR



- Check voltage between A/T control unit terminal ④ and ground while depressing accelerator pedal slowly. (after warming up engine)

Voltage:

When releasing accelerator pedal: 3 - 8V

When depressing accelerator pedal fully:

1V or less

O.K.

C

TROUBLE DIAGNOSES

Self-diagnosis (Cont'd)

D



☆MONITOR	☆NO FAIL	↕
D-RANGE SW	OFF	
1-RANGE SW	OFF	
2-RANGE SW	OFF	
ASCD-CRUISE	OFF	
ASCD-OD CUT	OFF	
KICKDOWN SW	OFF	
POWERSHIFT SW	OFF	
IDLE SW	ON	
FULL THRTL SW	OFF	
RECORD		

SAT338C

D

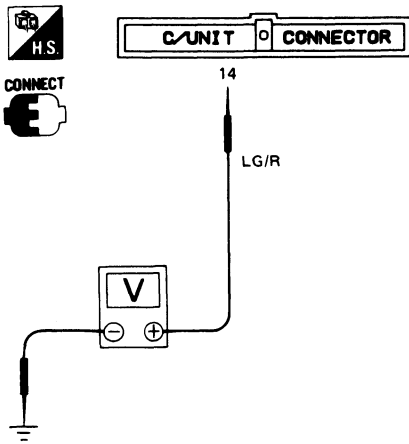



SAT339C

D

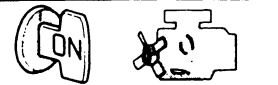
CHECK IDLE SWITCH CIRCUIT.

1. 

2.  • Select "E.C.U. INPUT SIGNALS".

- Read out "IDLE SWITCH" depressing and releasing accelerator pedal.
- Check idle switch changes ON or OFF.

OR

 • Check voltage between A/T control unit terminal ⑭ and ground while depressing accelerator pedal slowly.

Voltage:

- When releasing accelerator pedal:**
8 - 15V
- When depressing accelerator pedal fully:**
1V or less

O.K. → Perform self-diagnosis again after driving for a while.

O.K. → **INSPECTION END**

N.G. → Perform self-diagnosis (Mode IV) for engine control. Check idle switch circuit.

O.K. → Check harness continuity between A/T control unit and idle switch.

N.G. → Check idle switch circuit for engine control. — Refer to section EF & EC.

N.G. → 1. Perform A/T control unit input/output signal inspection.
2. If N.G., recheck A/T control unit pin terminals for damage or connection of A/T control unit harness connector.

TROUBLE DIAGNOSES

Diagnostic Procedure 1

SYMPTOM: A/T CHECK lamp does not come on for about 2 seconds when turning ignition switch to "ON".

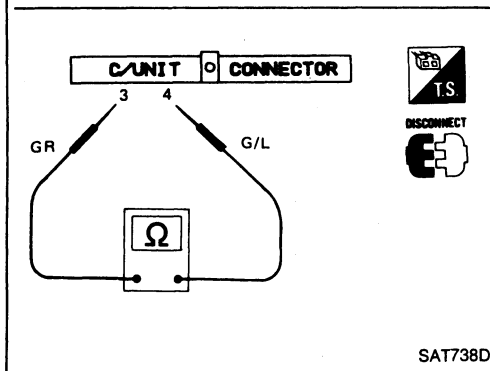
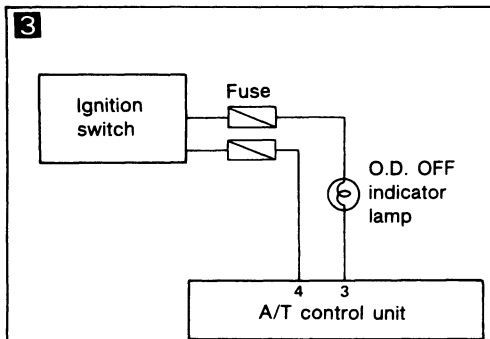
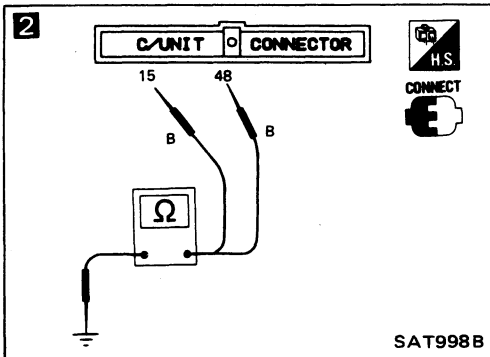
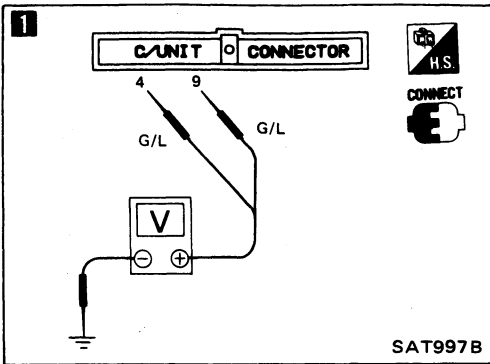

1

CHECK A/T CONTROL UNIT POWER SOURCE.

1.

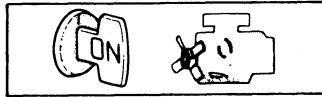

2. Check voltage between A/T control unit terminals (4), (9) and ground.

Battery voltage should exist.

N.G.

Check the following items.

- Harness continuity between ignition switch and A/T control unit
- Ignition switch and fuse – Refer to section EL.

O.K.

2

CHECK A/T CONTROL UNIT GROUND CIRCUIT.

1.



2. Disconnect A/T control unit connector.

3. Check resistance between A/T control unit terminals (15), (48) and ground.

Resistance:

Approximately 0Ω

N.G.

Check harness continuity between A/T control unit and ground.

O.K.

3

CHECK LAMP CIRCUIT.

1.

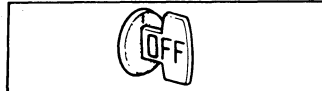

2. Disconnect A/T control unit connector.

3. Check resistance between A/T control unit terminals (3) and (4).

Resistance: 50 - 100Ω

4. Reinstall any part removed.

N.G.

Check the following items.

- A/T check lamp
- Harness continuity between ignition switch and A/T check lamp
- Harness continuity between A/T check lamp and A/T control unit

O.K.

Check again.

N.G.

1. Perform A/T control unit input/output signal inspection.
2. If N.G., recheck A/T control unit pin terminals for damage or connection of A/T control unit harness connector.

O.K.

INSPECTION END

TROUBLE DIAGNOSES

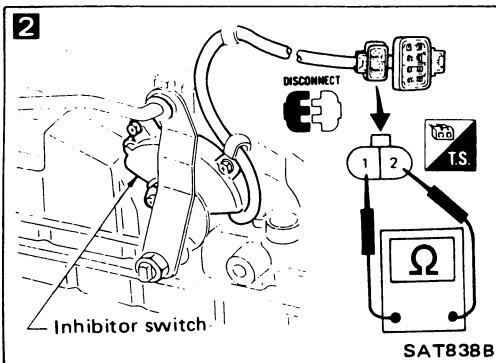
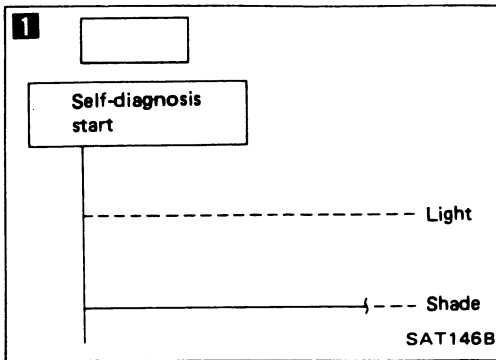

Diagnostic Procedure 2

SYMPTOM: Engine cannot be started with selector lever in "P" or "N" range or engine can be started with selector lever in "D", "2", "1" or "R" range.

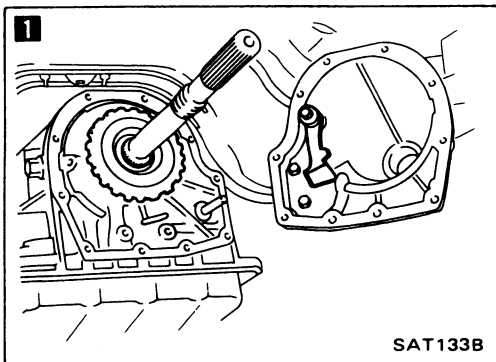
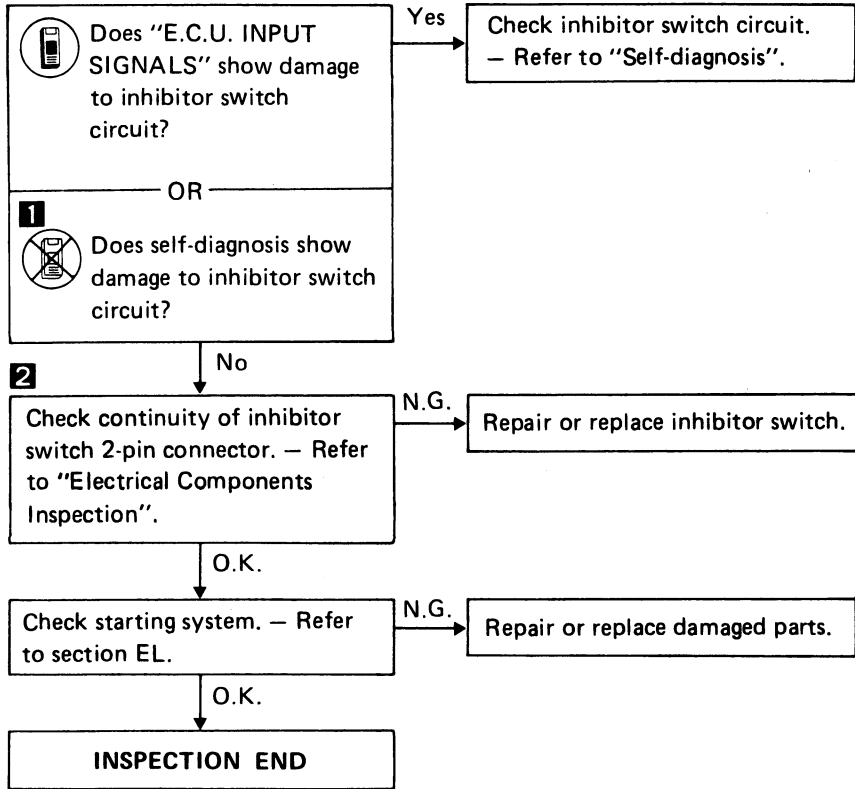

Diagnostic Procedure 3

SYMPTOM: Vehicle moves when it is pushed forward or backward with selector lever in "P" range.

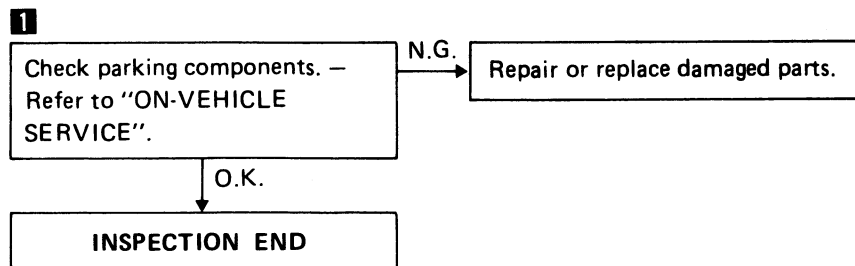

TROUBLE DIAGNOSES

Diagnostic Procedure 4

SYMPTOM: Vehicle moves forward or backward when selecting "N" range.

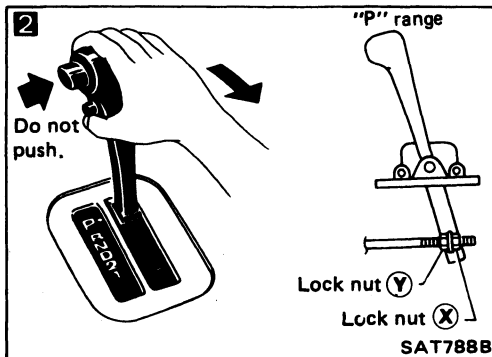
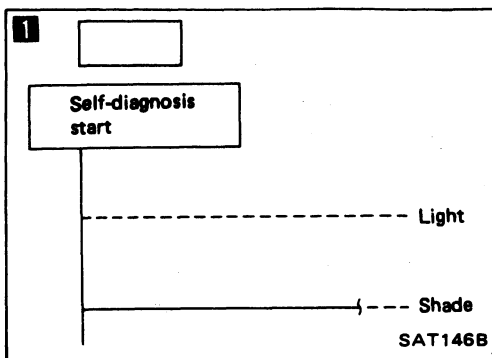

SAT638A

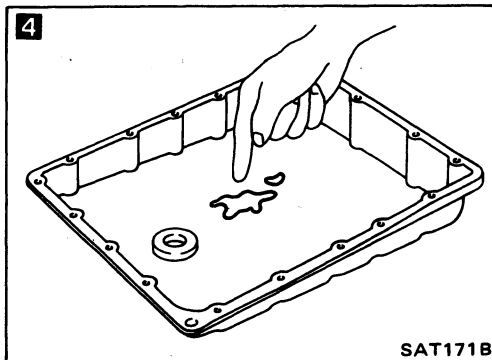

SAT171B

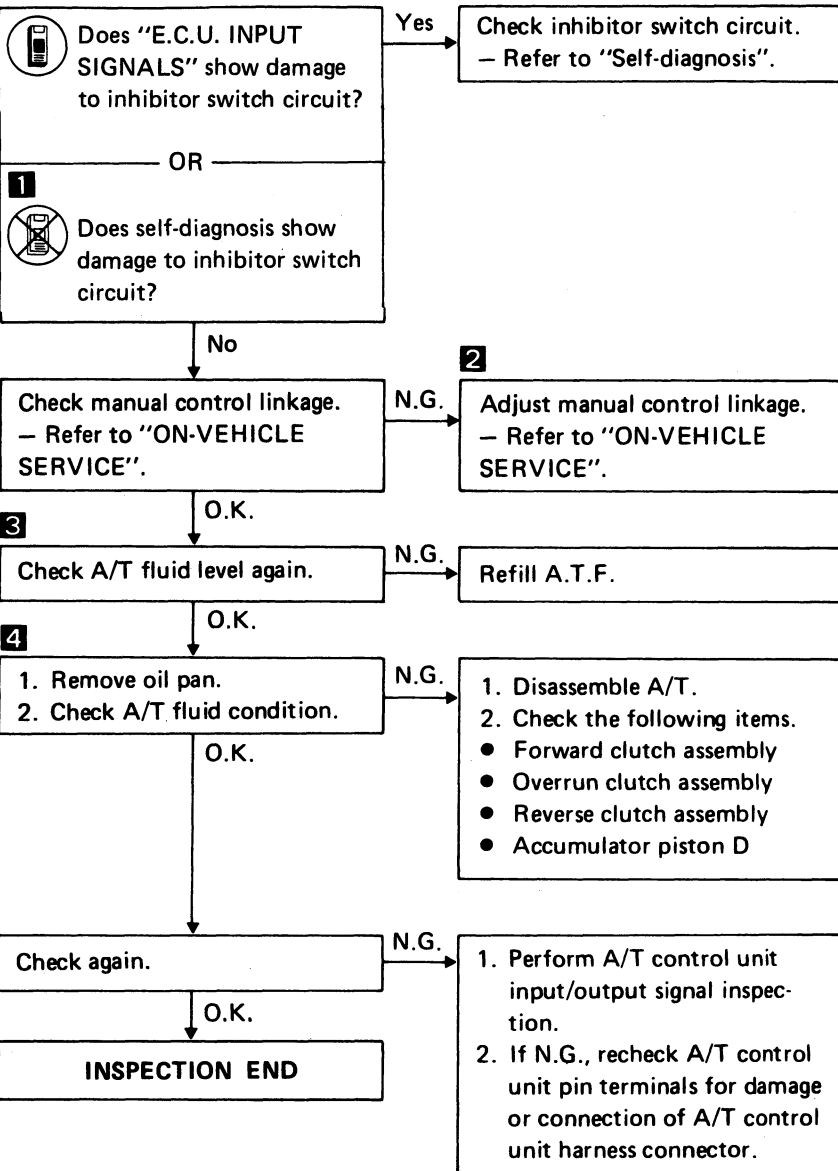

TROUBLE DIAGNOSES

Diagnostic Procedure 5

SYMPTOM: There is large shock when changing from "N" to "R" range.

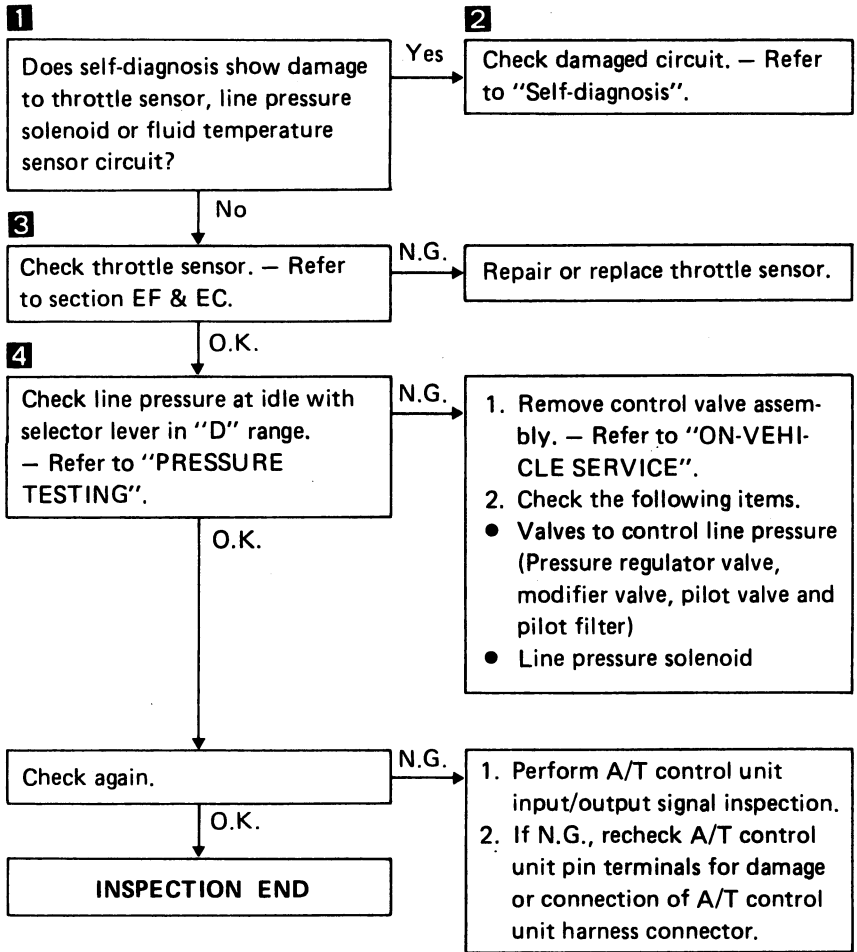
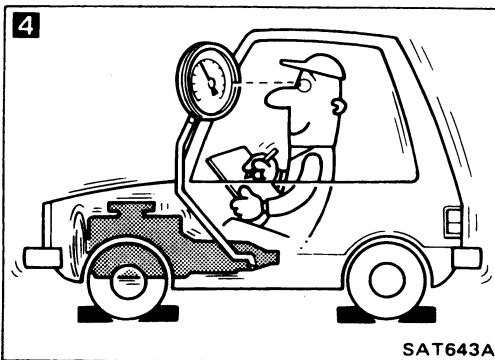
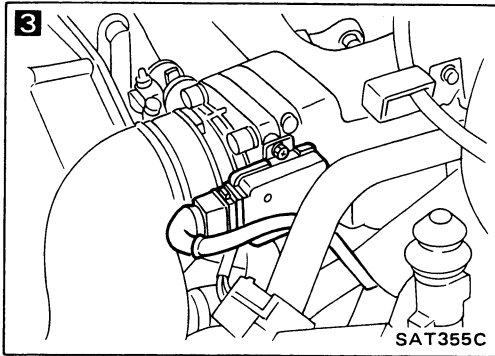
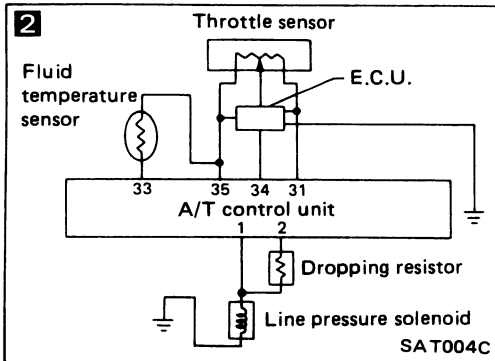
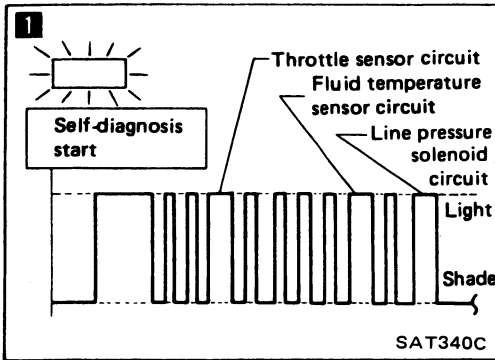

TROUBLE DIAGNOSES

Diagnostic Procedure 6

SYMPTOM: Vehicle does not creep backward when selecting "R" range.

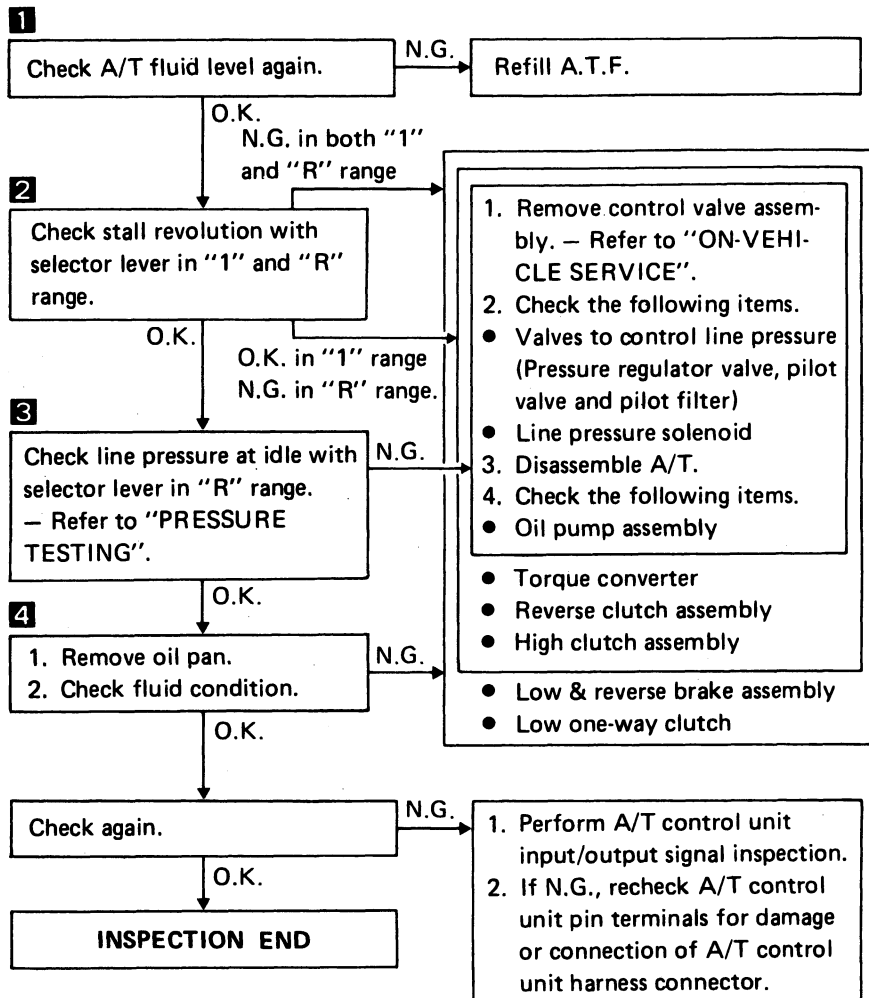
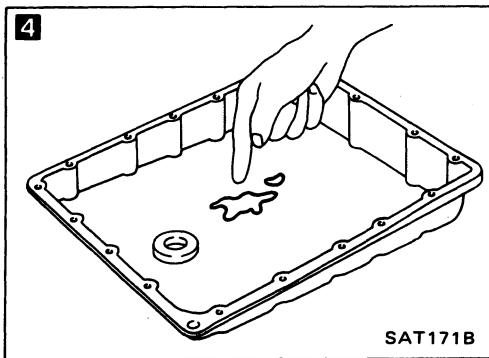
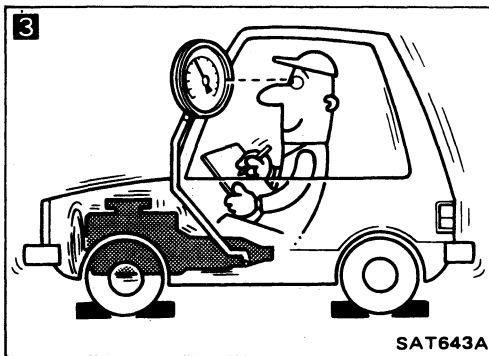
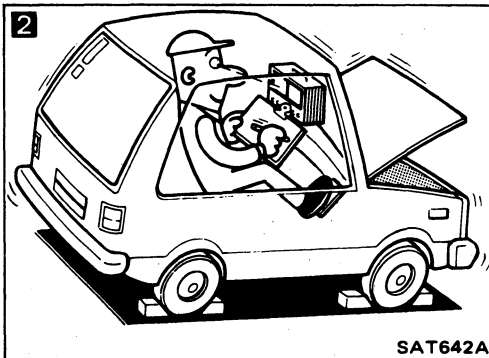
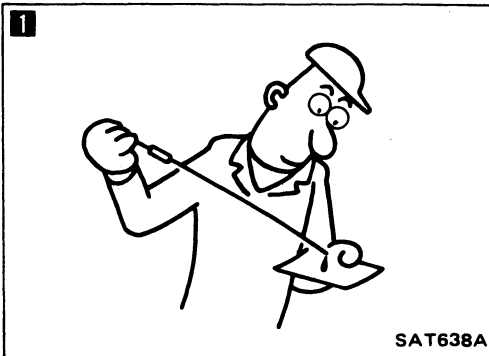

TROUBLE DIAGNOSES

Diagnostic Procedure 7

SYMPTOM: Vehicle does not creep forward when selecting "D", "2" or "1" range.

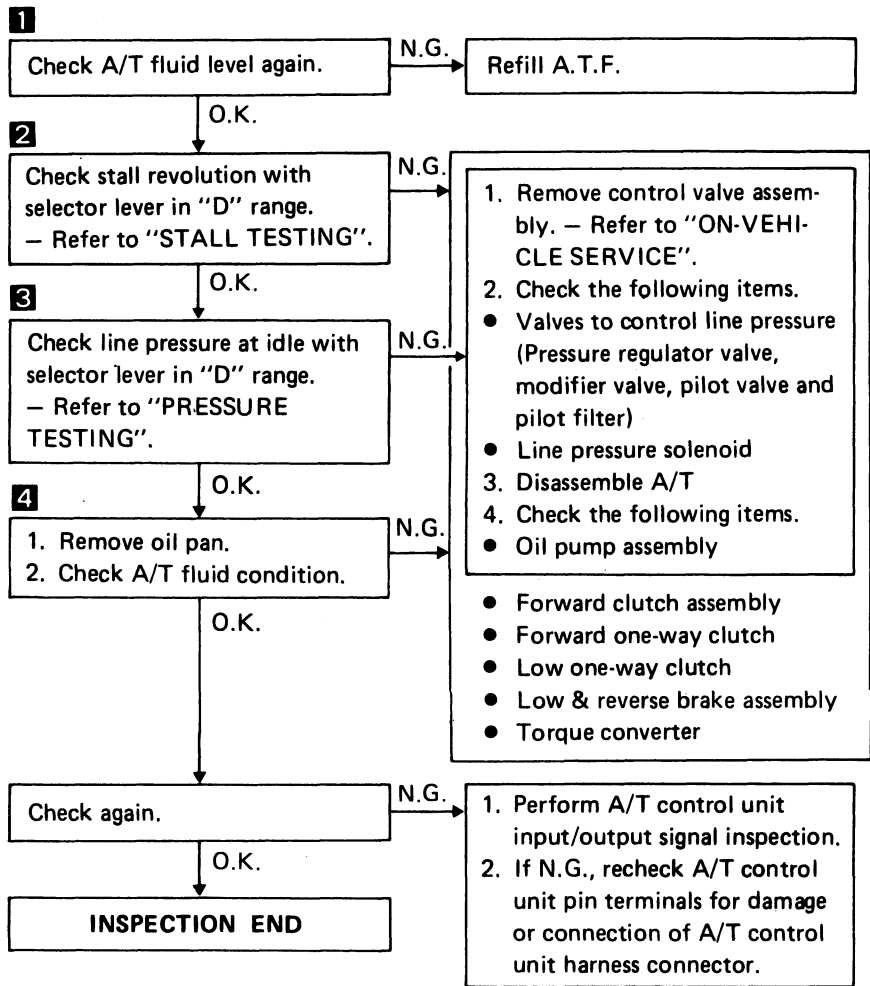
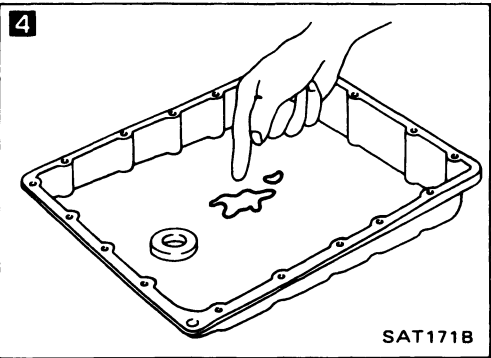
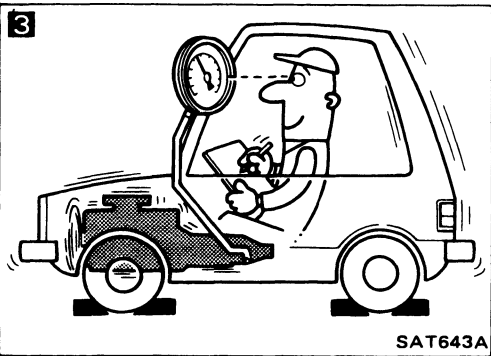
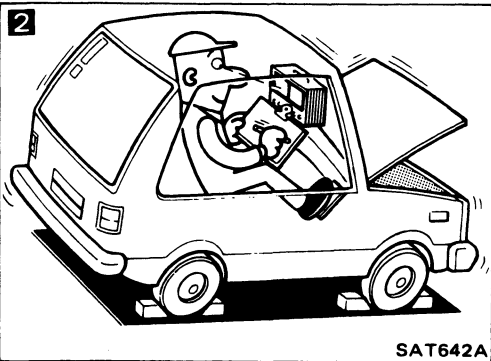
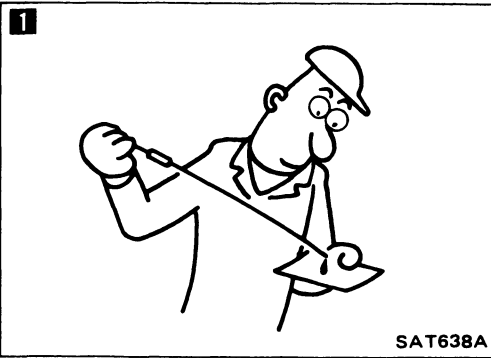

TROUBLE DIAGNOSES

Diagnostic Procedure 8

SYMPTOM: Vehicle cannot be started from D₁ on Cruise test — Part 1.

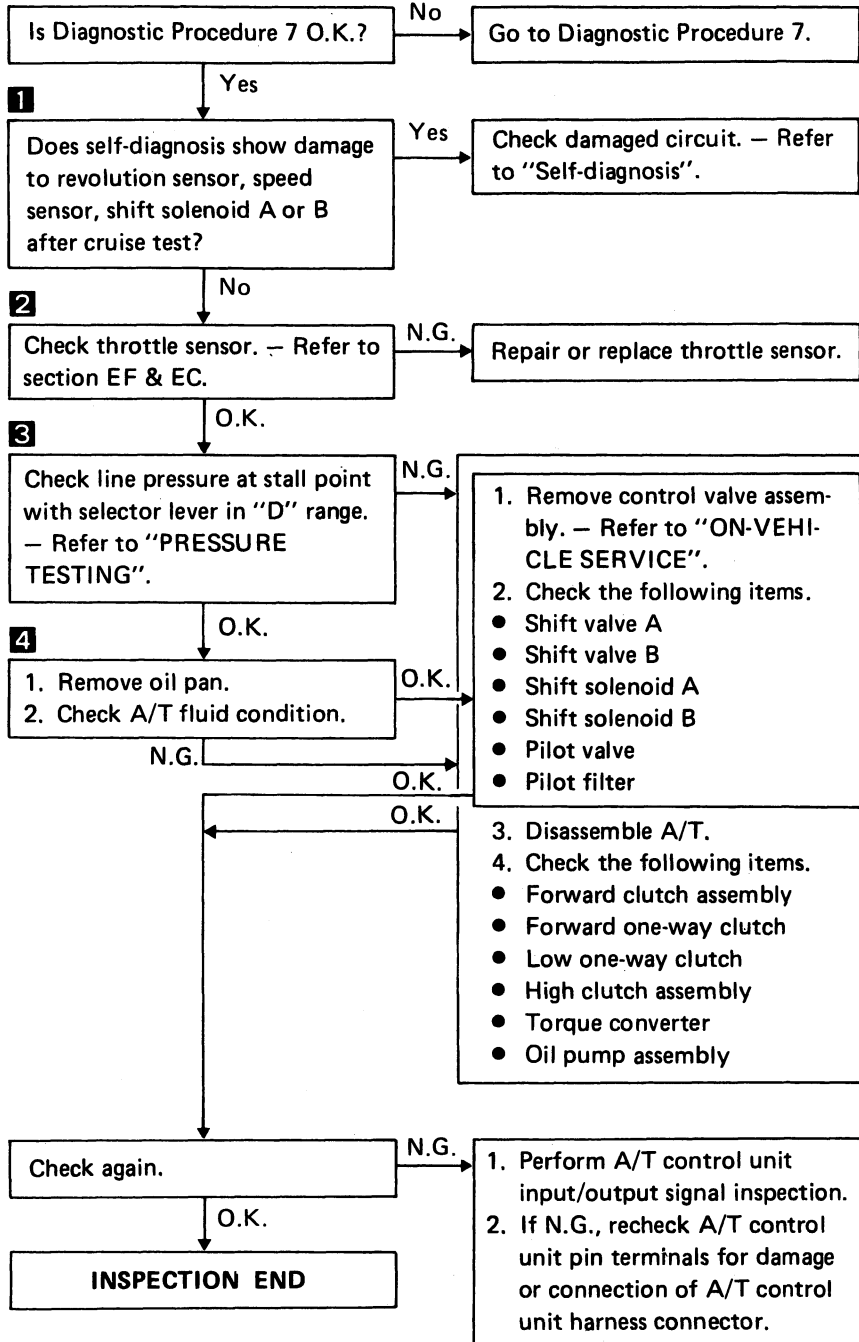
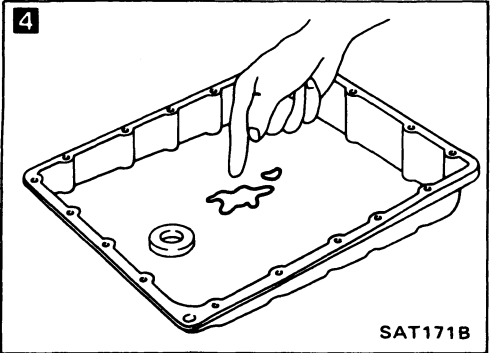
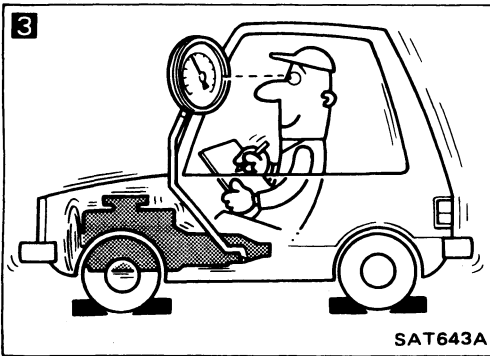
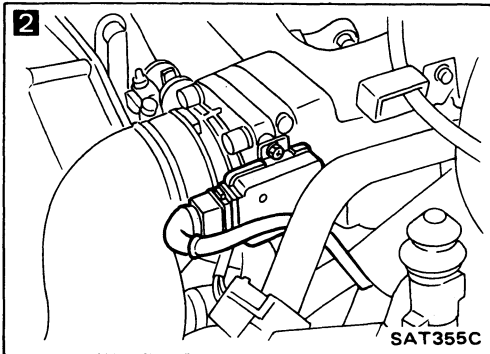
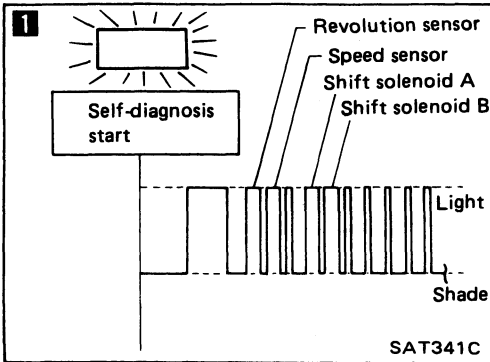

TROUBLE DIAGNOSES

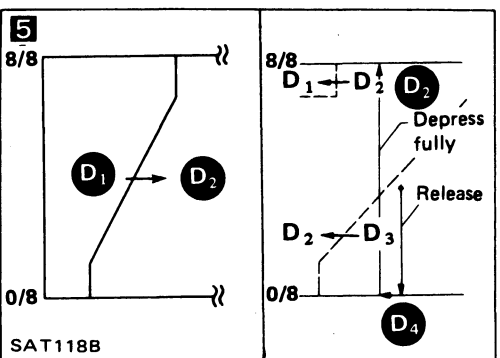
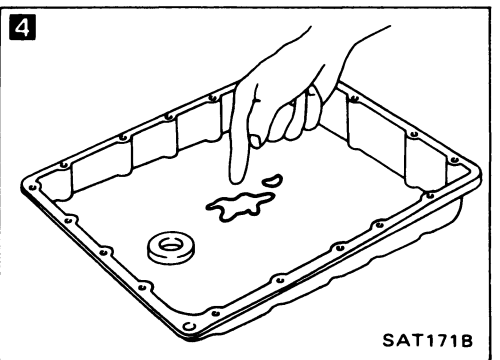
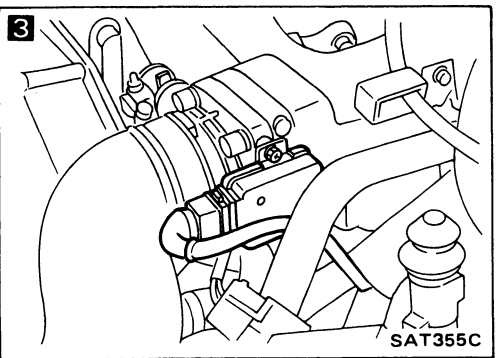
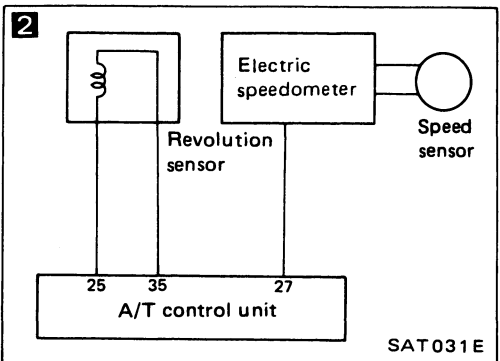
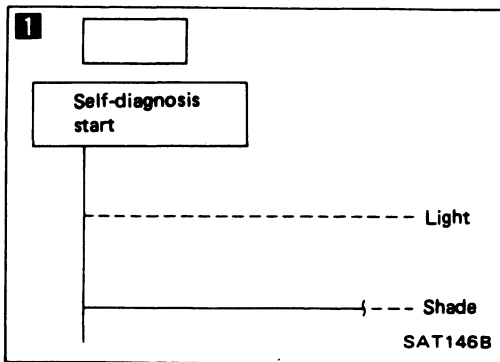

Diagnostic Procedure 9

SYMPTOM: A/T does not shift from D₁ to D₂ at the specified speed.

A/T does not shift from D₄ to D₂ when depressing accelerator pedal fully at the specified speed.

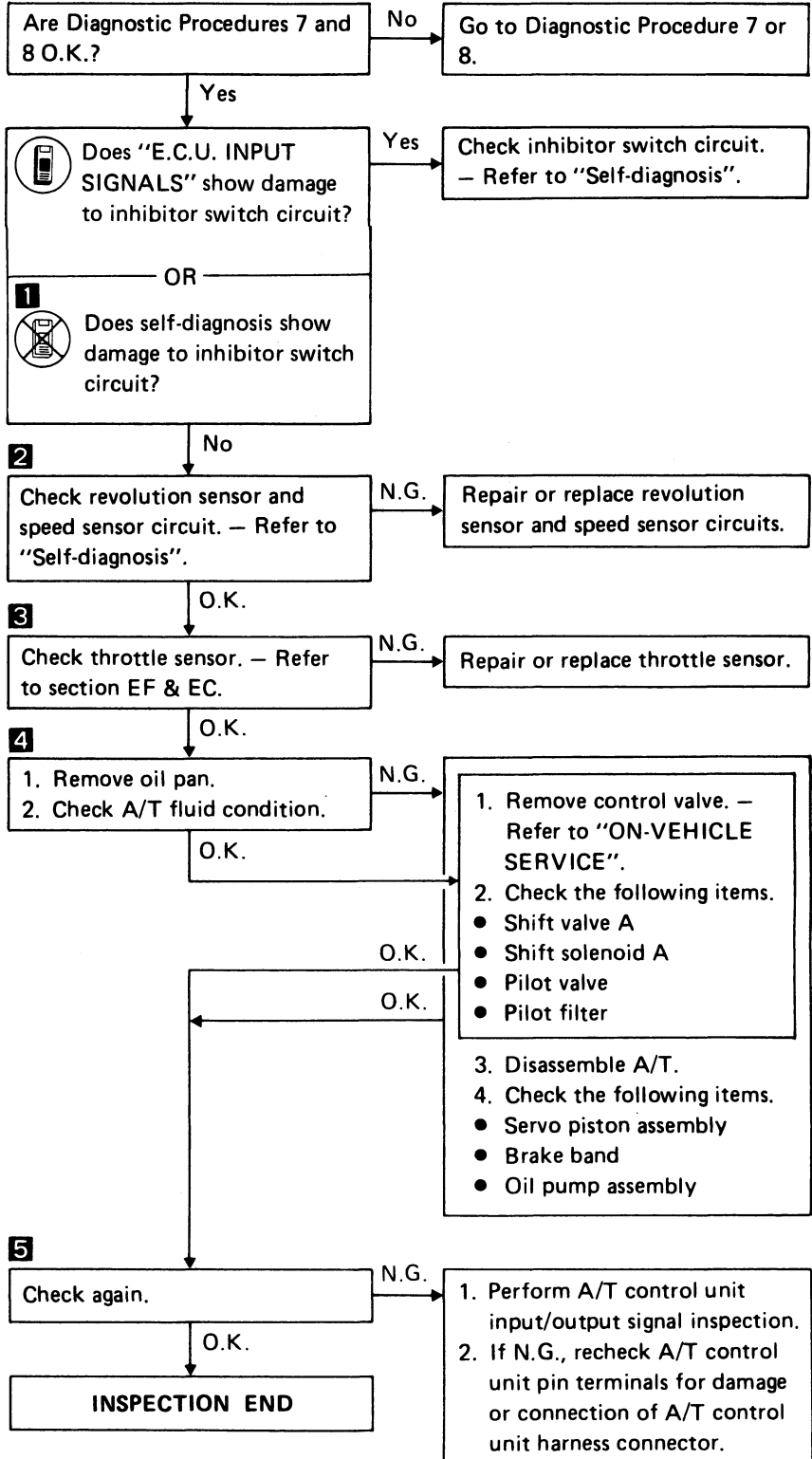

TROUBLE DIAGNOSES

Diagnostic Procedure 10

SYMPTOM: A/T does not shift from D₂ to D₃ at the specified speed.

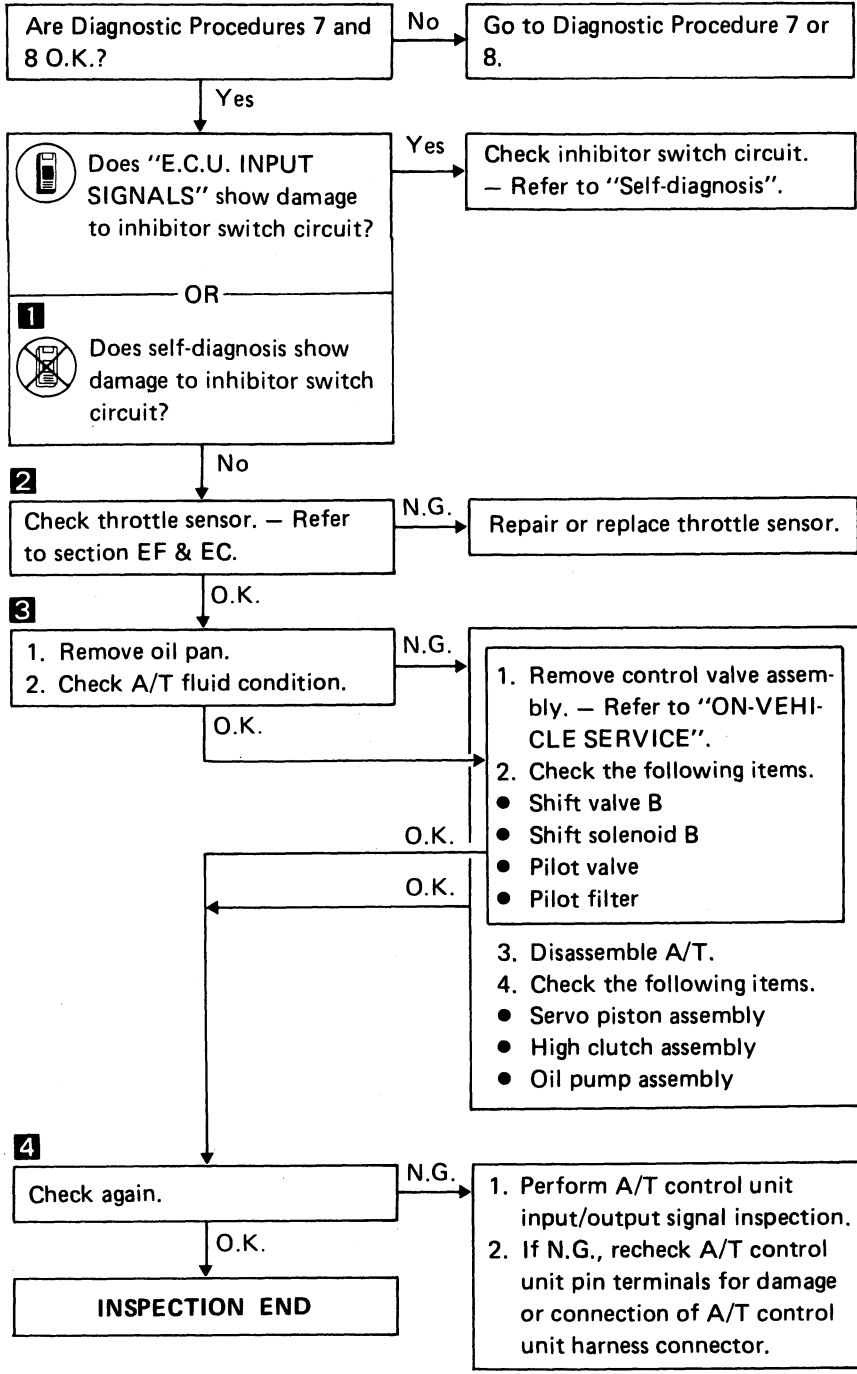
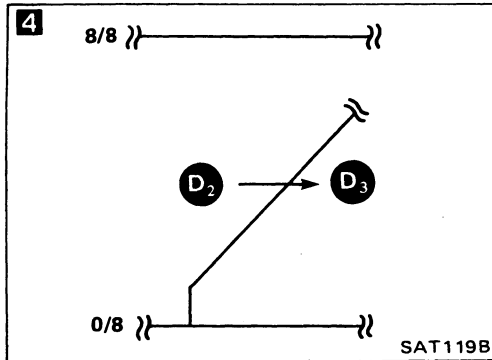
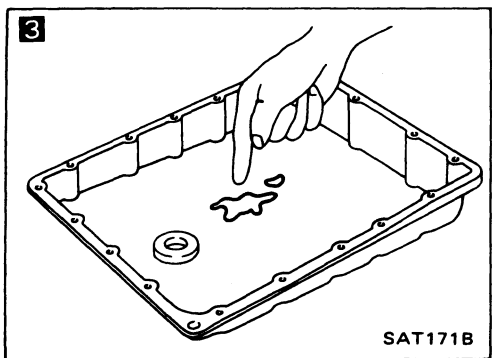
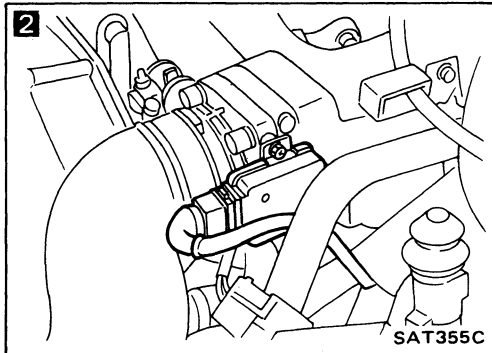
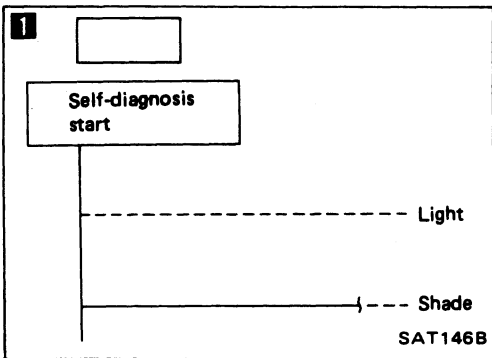

TROUBLE DIAGNOSES

Diagnostic Procedure 11

SYMPTOM: A/T does not shift from D₃ to D₄ at the specified speed.

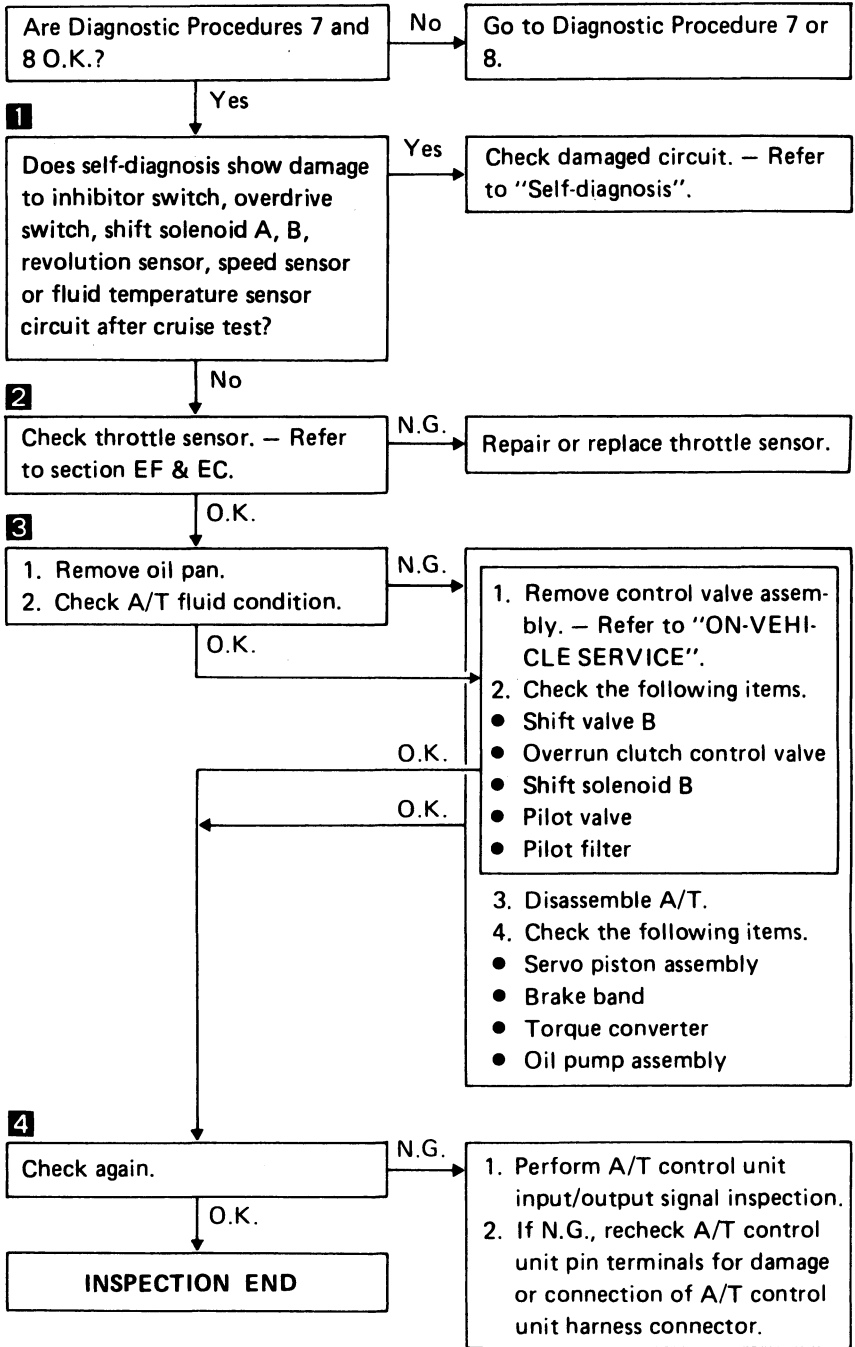
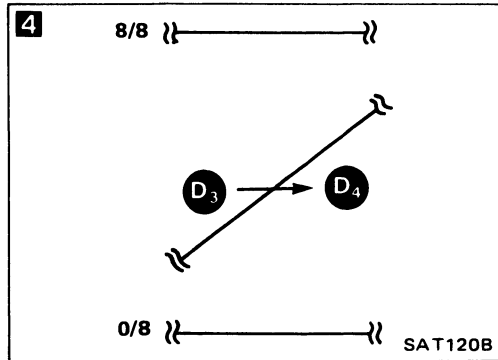
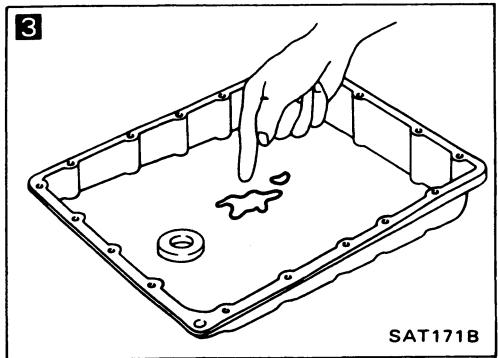
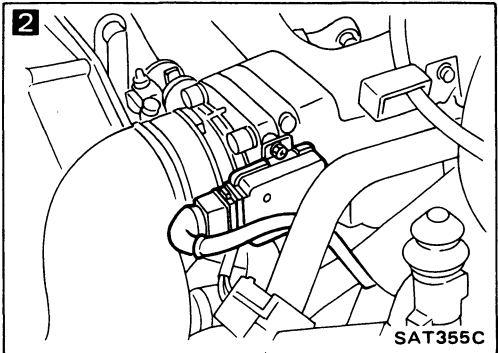
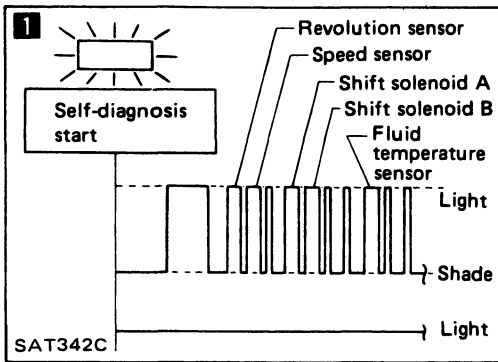

TROUBLE DIAGNOSES

Diagnostic Procedure 12

SYMPTOM: A/T does not perform lock-up at the specified speed.

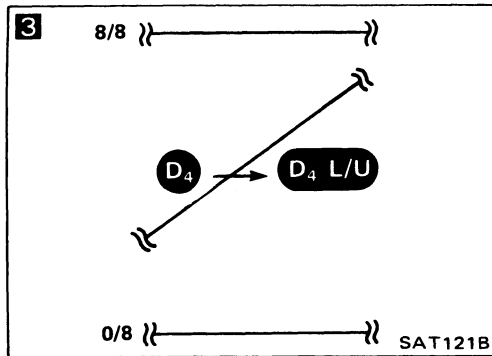
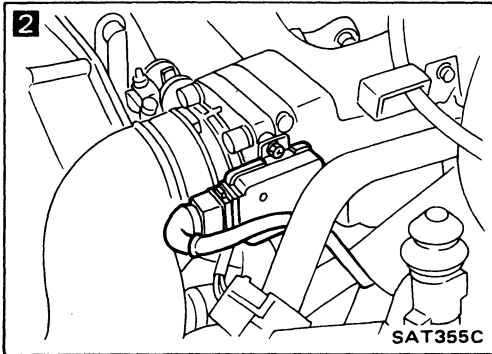
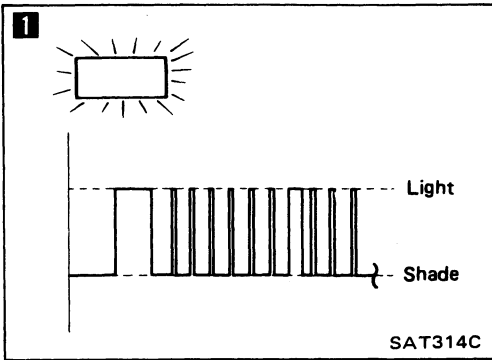

1

Does self-diagnosis show damage to lock-up solenoid circuit after cruise test?

Yes

Check lock-up solenoid circuit.
— Refer to "Self-diagnosis".

No

2

Check throttle sensor. — Refer to section EF & EC.

N.G.

Repair or replace throttle sensor.

O.K.

1. Remove control valve. — Refer to "ON-VEHICLE SERVICE".
2. Check following items.

- Lock-up control valve
- Shuttle shift valve D
- Torque converter relief valve
- Lock-up solenoid
- Pilot valve
- Pilot filter

N.G.

Repair or replace damaged parts.

O.K.

3

Check again.

N.G.

1. Perform A/T control unit input/output signal inspection.
2. If N.G., recheck A/T control unit pin terminals for damage or connection of A/T control unit harness connector.

O.K.

INSPECTION END

TROUBLE DIAGNOSES

Diagnostic Procedure 13

SYMPTOM: A/T does not hold lock-up condition for more than 30 seconds.

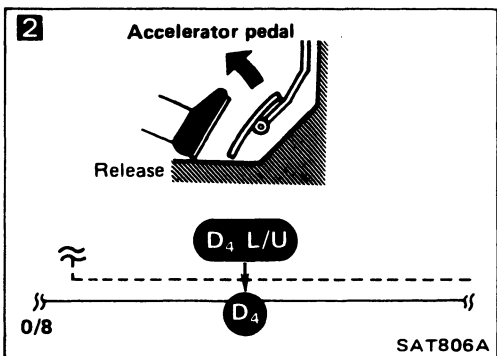
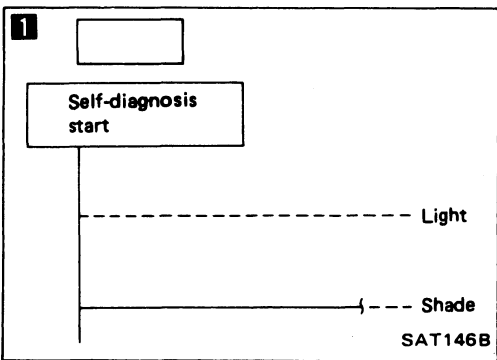
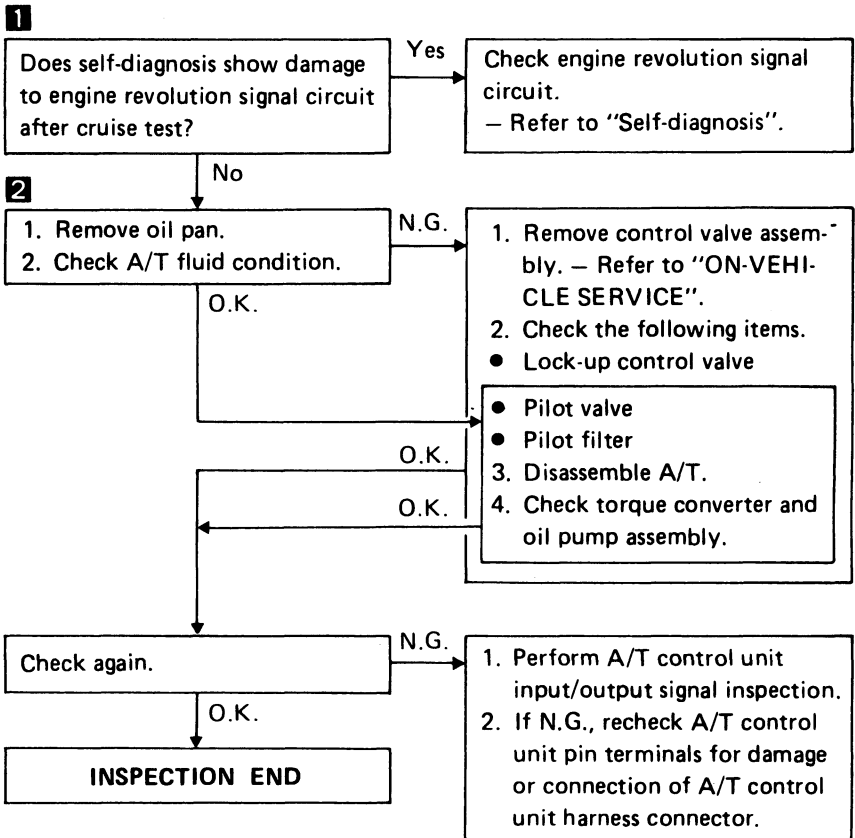
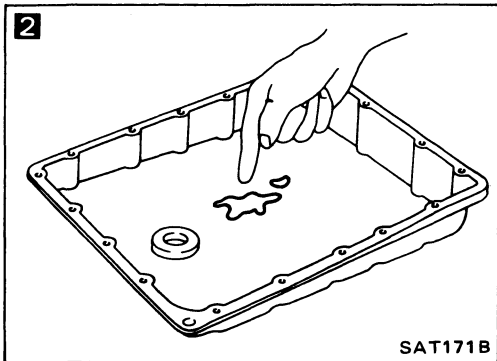
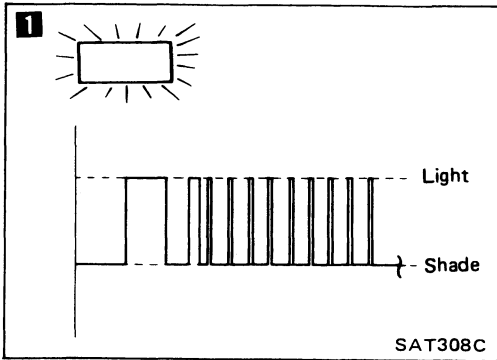

Diagnostic Procedure 14

SYMPTOM: Lock-up is not released when accelerator pedal is released.

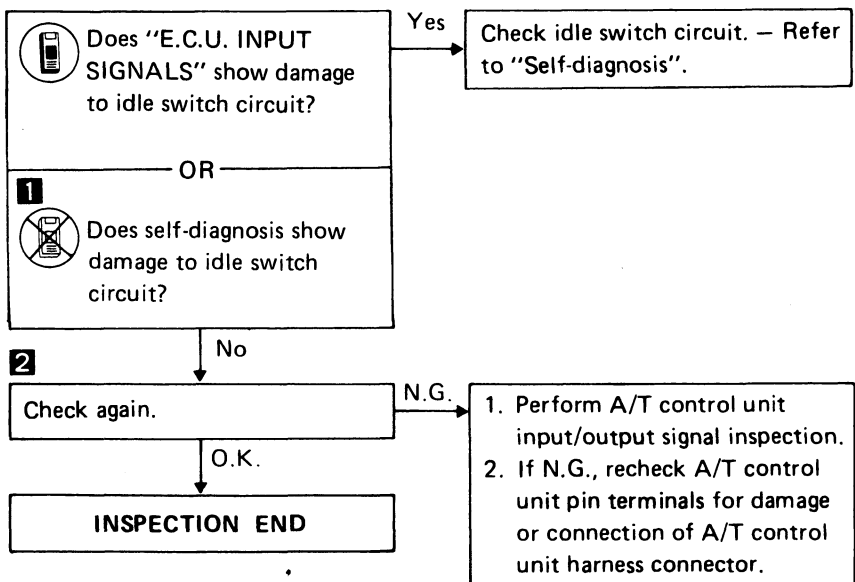

TROUBLE DIAGNOSES

Diagnostic Procedure 15

SYMPTOM: Engine speed does not return to idle smoothly when A/T is shifted from D₄ to D₃ with accelerator pedal released.

Vehicle does not decelerate by engine brake when changing overdrive switch to "OFF" position with accelerator pedal released.

Vehicle does not decelerate by engine brake when changing selector lever from "D" to "2" range with accelerator pedal released.

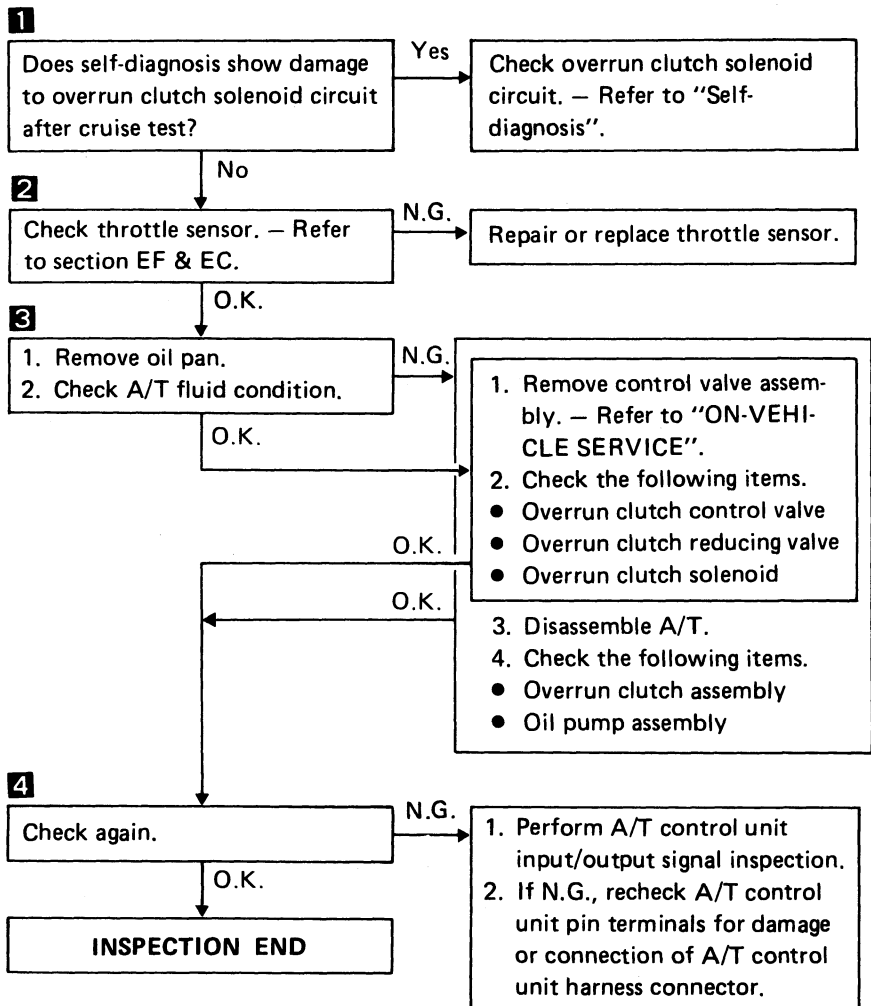
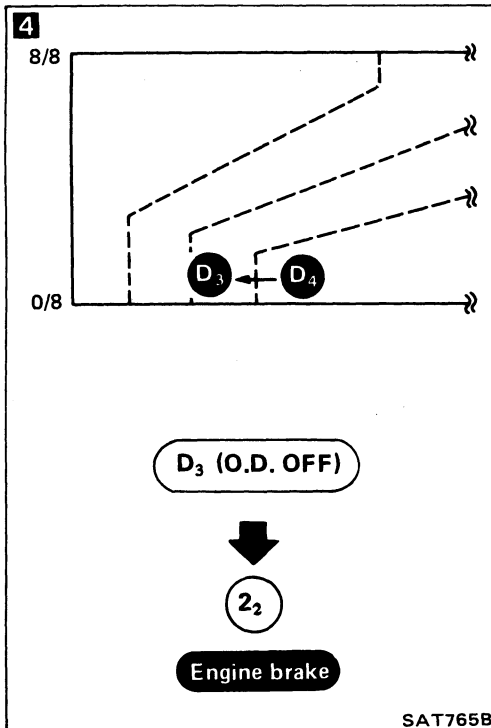
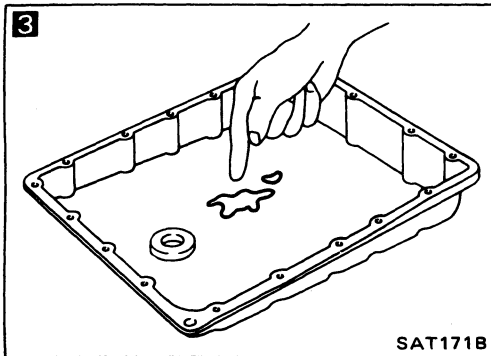
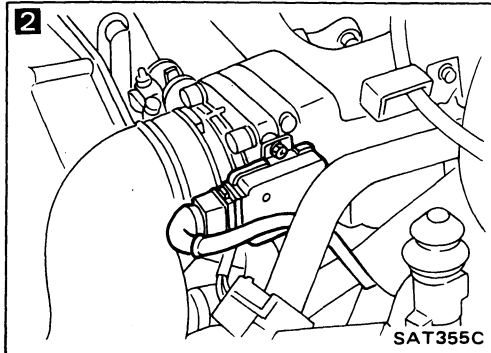
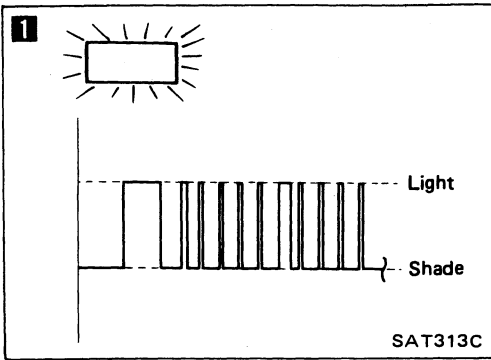

TROUBLE DIAGNOSES

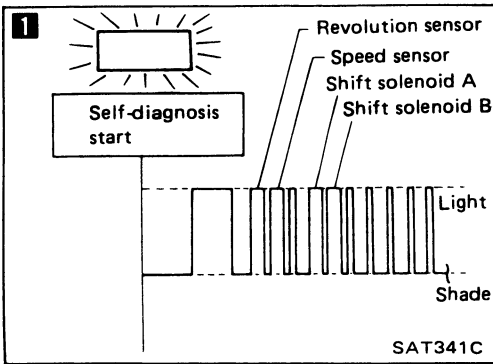

Diagnostic Procedure 16

SYMPTOM: Vehicle does not start from D₁ on Cruise test — Part 2.

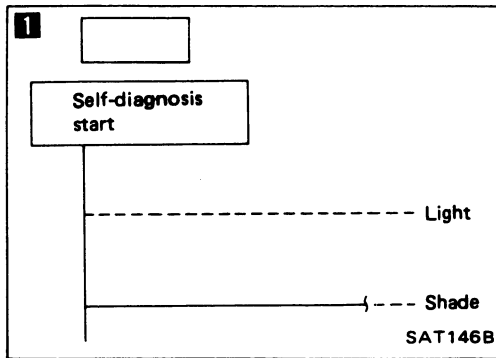
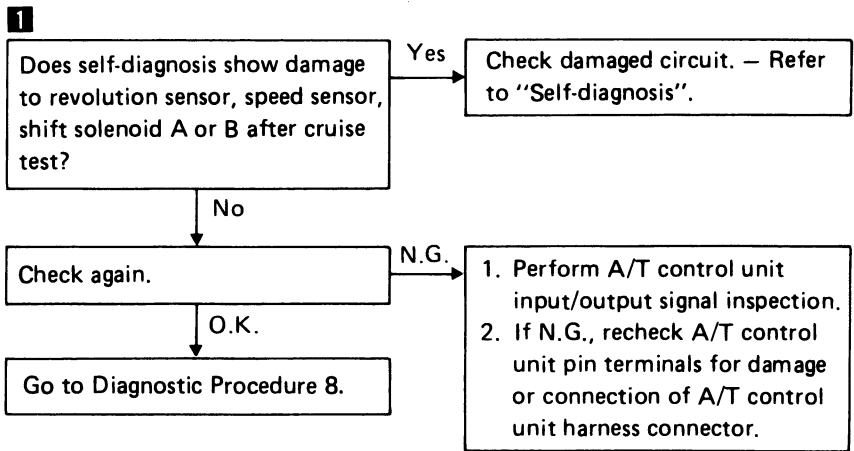

Diagnostic Procedure 17

SYMPTOM: A/T does not shift from D₄ to D₃ when changing overdrive switch to "OFF" position.

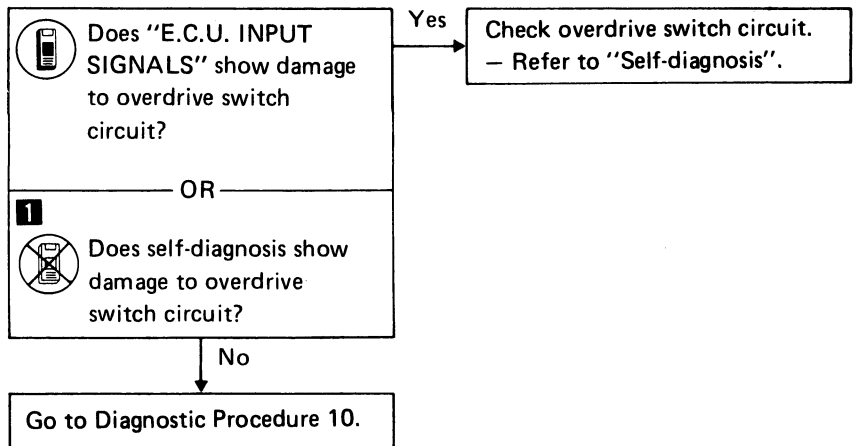

TROUBLE DIAGNOSES

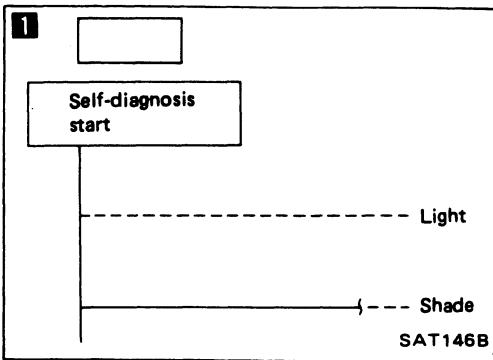

Diagnostic Procedure 18

SYMPTOM: A/T does not shift from D_3 to 2_2 when changing selector lever from "D" to "2" range.

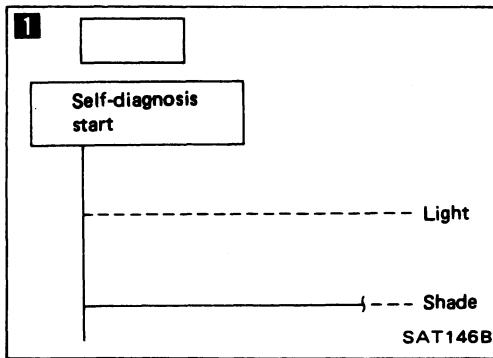
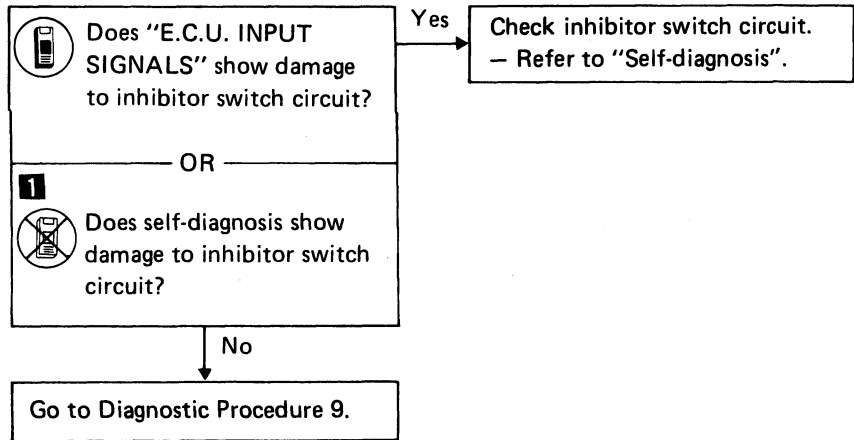

Diagnostic Procedure 19

SYMPTOM: A/T does not shift from 2_2 to 1_1 when changing selector lever from "2" to "1" range.

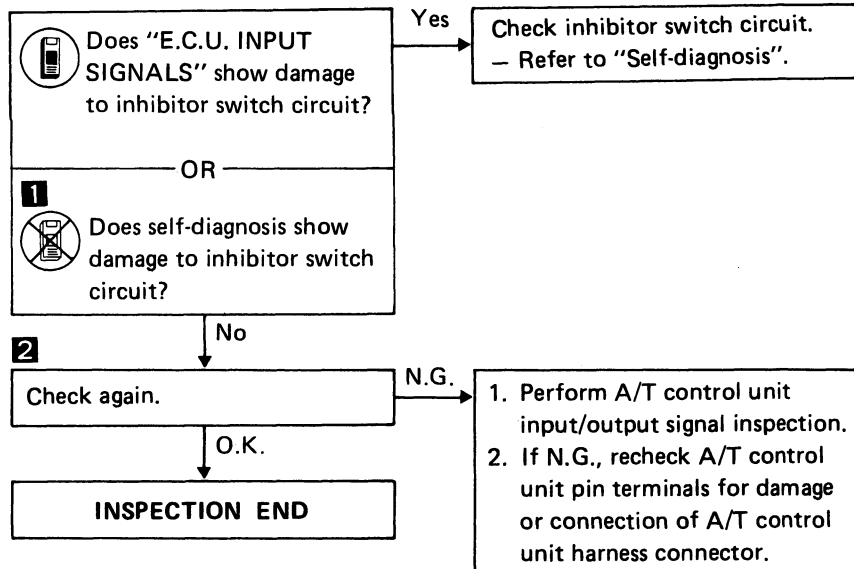
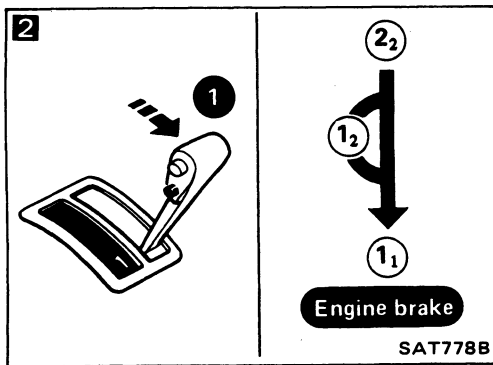

Diagnostic Procedure 20

SYMPTOM: Vehicle does not decelerate by engine brake when shifting from 2_2 (1_2) to 1_1 .

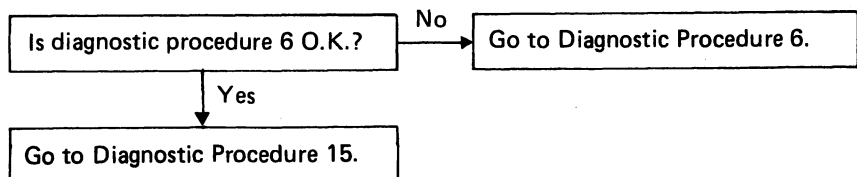

TROUBLE DIAGNOSES

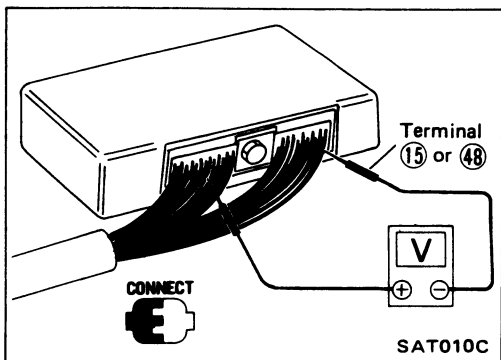

Electrical Components Inspection

INSPECTION OF A/T CONTROL UNIT

- Measure voltage between each terminal and terminal ⑮ or ④⑧ by following "A/T CONTROL UNIT INSPECTION TABLE".

- Pin connector terminal layout.

1	2	3	4	9	10	11	12	13	14	15	●	23	24	25	×	27	28	29	30	31	32	33	34	35
5	6	7	8	16	17	18	19	20	21	×	×	37	×	39	40	41	×	43	×	×	×	×	×	48



SAT032E

TROUBLE DIAGNOSES

Electrical Components Inspection (Cont'd)

A/T CONTROL UNIT INSPECTION TABLE

(Data are reference values.)

Terminal No.	Item	Condition	Judgement standard
1	Line pressure solenoid	When accelerator pedal is released after warming up engine.	1.5 - 2.5V
		When accelerator pedal is depressed fully after warming up engine.	0.5V or less
2	Line pressure solenoid (with dropping resistor)	When accelerator pedal is released after warming up engine.	5 - 14V
		When accelerator pedal is depressed fully after warming up engine.	0.5V or less
3	A/T check lamp	When A/T check lamp is on.	1V or less
		When A/T check lamp is not on.	Battery voltage
4	Power source	When ignition switch is turned to "ON".	Battery voltage
		When ignition switch is turned to "OFF".	1V or less
5	Lock-up solenoid	When A/T is performing lock-up.	8 - 15V
		When A/T is not performing lock-up.	1V or less
6	Shift solenoid A	When shift solenoid A is operating. (When driving in "D ₁ " or "D ₄ ".)	Battery voltage
		When shift solenoid A is not operating. (When driving in "D ₂ " or "D ₃ ".)	1V or less
7	Shift solenoid B	When shift solenoid B is operating. (When driving in "D ₁ " or "D ₂ ".)	Battery voltage
		When shift solenoid B is not operating. (When driving in "D ₃ " or "D ₄ ".)	1V or less
8	Overrun clutch solenoid	When timing solenoid is operating. (When driving in "D ₁ " or "D ₄ ".)	Battery voltage
		When timing solenoid is not operating. (When driving in "D ₂ " or "D ₃ ".)	1V or less



TROUBLE DIAGNOSES



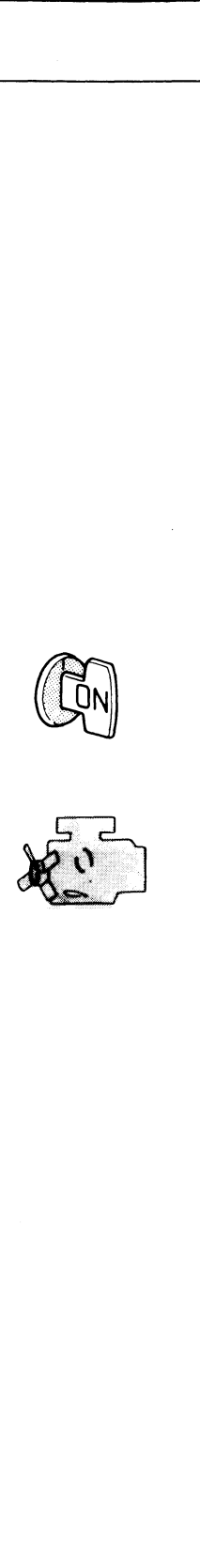

Electrical Components Inspection (Cont'd)

Terminal No.	Item	Condition	Judgement standard	
9	Power source		Same as No. 4	
10*	—		—	
11	—		—	
12	—		—	
13	—		—	
14	Idle switch (in throttle valve switch)		When accelerator pedal is released after warming up engine.	8 - 15V
			When accelerator pedal is depressed after warming up engine.	1V or less
15	Ground		—	—
16	Inhibitor "1" range switch		When selector lever is set to "1" range.	Battery voltage
			When selector lever is set to other ranges.	1V or less
17	Inhibitor "2" range switch	When selector lever is set to "2" range.	Battery voltage	
		When selector lever is set to other ranges.	1V or less	
18	Inhibitor "D" range switch	When selector lever is set to "D" range.	Battery voltage	
		When selector lever is set to other ranges.	1V or less	
19	Inhibitor "N" or "P" range switch	When selector lever is set to "N" range.	Battery voltage	
		When selector lever is set to other ranges.	1V or less	
20	Inhibitor "R" range switch	When selector lever is set to "R" range.	Battery voltage	
		When selector lever is set to other ranges.	1V or less	
21	Full throttle switch (in throttle valve switch)	When accelerator pedal is depressed more than half-way after warming up engine.	8 - 15V	
		When accelerator pedal is released after warming up engine.	1V or less	
22	—	—	—	

*: This terminal is connected to terminal No. 36 of E.C.C.S. control unit.
When code No. 54 appears during engine self-diagnosis, check line between above terminals for proper continuity.

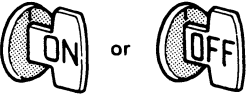
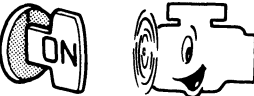

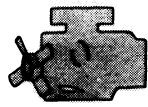

TROUBLE DIAGNOSES

Electrical Components Inspection (Cont'd)

Terminal No.	Item	Condition	Judgement standard	
23	Power source (Back-up)		When ignition switch is turned to "OFF".	Battery voltage
			When ignition switch is turned to "ON".	Battery voltage
24	Engine revolution signal		When engine is running at idle speed.	0.9V
			When engine is running at 3,000 rpm.	Approximately 3.7V
25	Revolution sensor (Measure in AC range)		When vehicle is cruising at 30 km/h (19 MPH).	1V or more Voltage rises gradually in response to vehicle speed.
			When vehicle is parked.	0V
26	—	—	—	
27	Speed sensor	—	—	
28	—	—	—	
29	—	—	—	
30	—	—	—	
31	Throttle sensor (Power source)	—	4.5 - 5.5V	
32	—	—	—	
33	Fluid temperature sensor		When A.T.F. temperature is 20°C (68°F).	Approximately 1.5V
			When A.T.F. temperature is 80°C (176°F).	Approximately 0.5V
34	Throttle sensor		When accelerator pedal is depressed slowly after warming up engine. Voltage rises gradually in response to throttle opening angle.	Fully-closed throttle: Approximately 0.5V Fully-open throttle: Approximately 4V
35	Throttle sensor (Ground)	—	—	
36	—	—	—	
37	A.S.C.D. cruise signal		When A.S.C.D. cruise is being performed. ("CRUISE" light comes on.)	Battery voltage
			When A.S.C.D. cruise is not being performed. ("CRUISE" light does not come on.)	1V or less

TROUBLE DIAGNOSES

Electrical Components Inspection (Cont'd)

Terminal No.	Item	Condition	Judgement standard
38	—	—	—
39	Overdrive switch	 When overdrive switch is set in "ON" position.	Battery voltage
		 When overdrive switch is set in "OFF" position.	1V or less
40	A.S.C.D. O.D. cut signal	 When "ACCEL" set switch on A.S.C.D. cruise is released.	5 - 8V
		When "ACCEL" set switch on A.S.C.D. cruise is applied.	1V or less
41	Kickdown switch	When accelerator pedal is released after warming up engine.	3 - 8V
		When accelerator pedal is depressed fully after warming up engine.	1V or less
42	—	—	—
43	A/C switch (Turbo model)	 When A/C switch is set in "ON" position.	8 - 16V
		 When A/C switch is set in "OFF" position.	2V or less
44	—	—	—
45	—	—	—
46	—	—	—
47	—	—	—
48	Ground	—	—

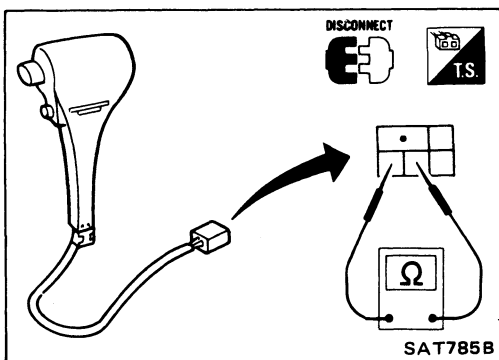

OVERDRIVE SWITCH

- Check continuity between two terminals.

O.D. switch position	Continuity
ON	No
OFF	Yes

TROUBLE DIAGNOSES

Electrical Components Inspection (Cont'd) INHIBITOR SWITCH

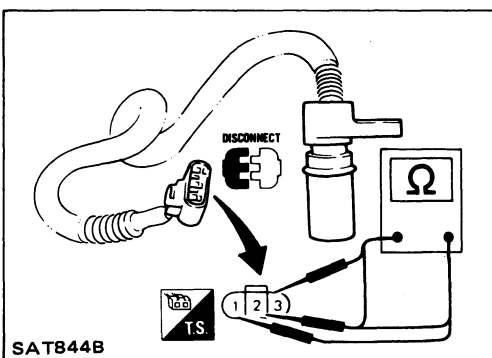
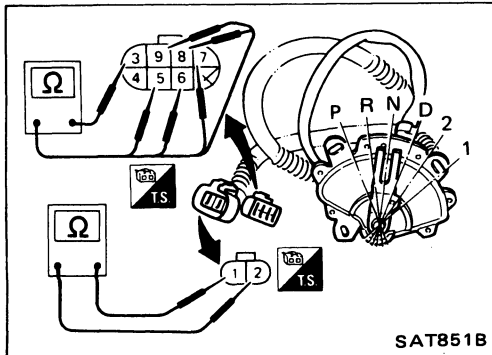
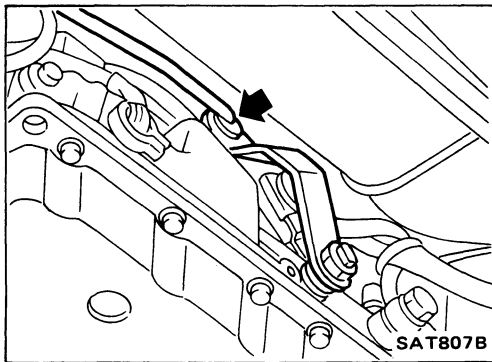
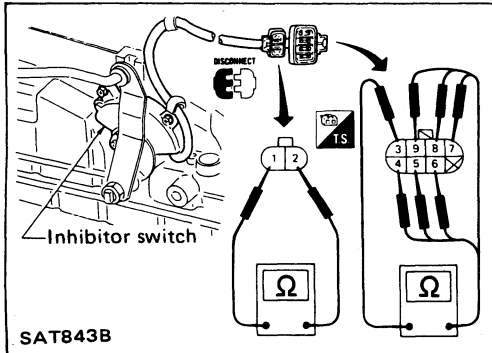
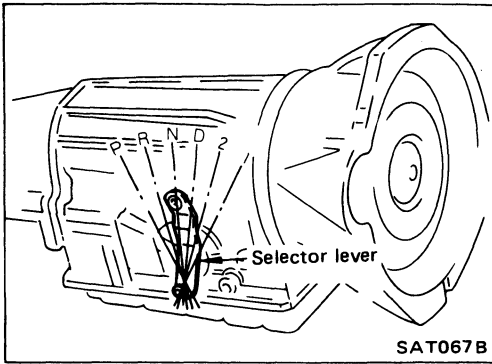

1. Check continuity between terminals ① and ② and between terminals ③ and ④, ⑤, ⑥, ⑦, ⑧, ⑨ while moving selector lever through each range.

Terminal No. / Lever position	①	②	③	④	⑤	⑥	⑦	⑧	⑨
P	○—○		○—○						
R			○—○	○—○					
N	○—○		○—○		○—○				
D			○—○				○—○		
2			○—○					○—○	
1			○—○						○—○

2. If N.G., check again with manual control linkage disconnected from manual shaft of A/T assembly. — Refer to step 1.
3. If O.K. on step 2, adjust manual control linkage. — Refer to "ON-VEHICLE SERVICE".
4. If N.G. on step 2, remove inhibitor switch from A/T and check continuity of inhibitor switch terminal. — Refer to step 1.
5. If O.K. on step 4, adjust inhibitor switch. — Refer to "ON-VEHICLE SERVICE".
6. If N.G. on step 4, replace inhibitor switch.

REVOLUTION SENSOR

- For removal and installation, refer to "ON-VEHICLE SERVICE".
- Check resistance between terminals ①, ② and ③.

Terminal No.		Resistance
①	②	500 - 650Ω
②	③	No continuity
①	③	No continuity

TROUBLE DIAGNOSES

Electrical Components Inspection (Cont'd)

FLUID TEMPERATURE SENSOR

- For removal and installation, refer to "ON-VEHICLE SERVICE".
- Check resistance between two terminals while changing temperature as shown at left.

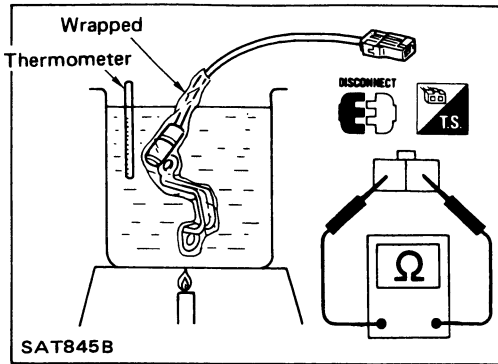

Temperature °C (°F)	Resistance
20 (68)	Approximately 2.5 kΩ
80 (176)	Approximately 0.3 kΩ

LOCK-UP SOLENOID

- For removal and installation, refer to "ON-VEHICLE SERVICE".
- Check resistance between two terminals.

Resistance:

Lock-up solenoid 10 - 20Ω

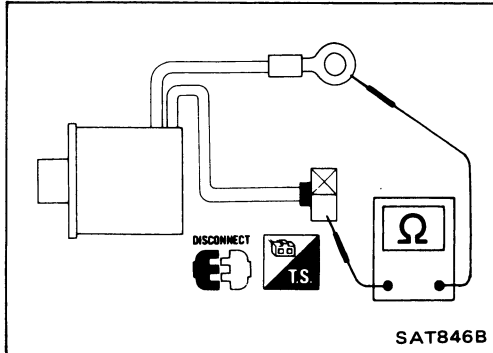

3-UNIT SOLENOID ASSEMBLY (Shift solenoids A, B and overrun clutch solenoid) AND LINE PRESSURE SOLENOID

- For removal and installation, refer to "ON-VEHICLE SERVICE".
- Check resistance between terminals of each solenoid.

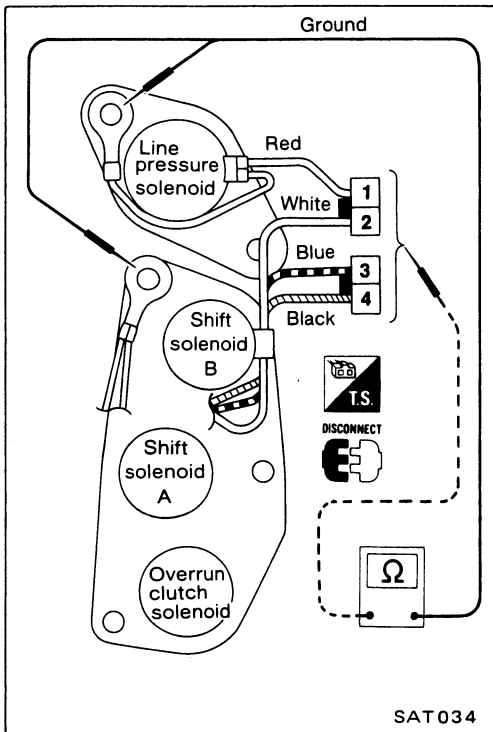

Solenoid	Terminal No.	Resistance
Shift solenoid A	③	20 - 40Ω
Shift solenoid B	②	
Overrun clutch solenoid	④	
Line pressure solenoid	①	2.5 - 5Ω

Ground terminal

DROPPING RESISTOR

- Check resistance between two terminals.

Resistance: 11.2 - 12.8Ω

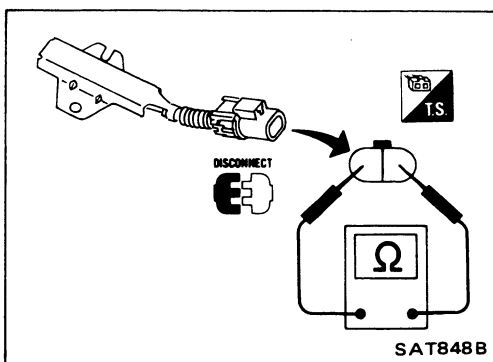

TROUBLE DIAGNOSES

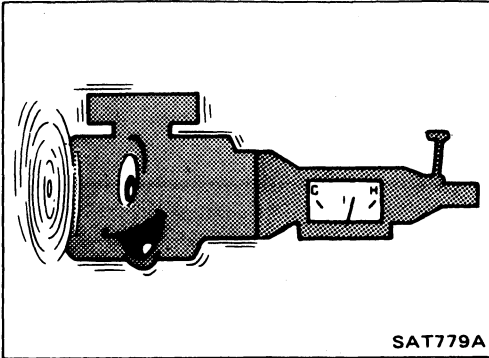

Final Check

STALL TESTING

Stall test procedure

1. Check A/T and engine fluid levels. If necessary, add.
2. Warm up engine until engine oil and A.T.F. reach operating temperature after vehicle has been driven approx. 10 minutes.

A.T.F. operating temperature:
50 - 80°C (122 - 176°F)

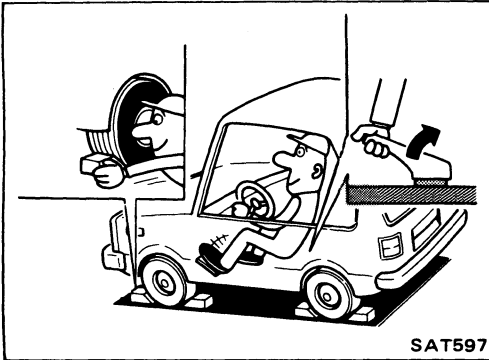

3. Set parking brake and block wheels.
4. Install a tachometer where it can be seen by driver during test.

- It is good practice to put a mark on point of specified engine rpm on indicator.

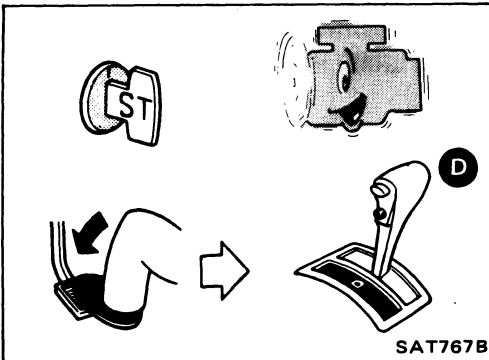

5. Start engine, apply foot brake, and place selector lever in "D" range.

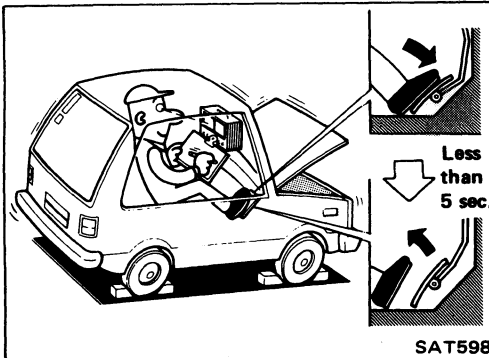

6. Accelerate to wide-open throttle gradually while applying foot brake.
7. Quickly note the engine stall revolution and immediately release throttle.

- During test, never hold throttle wide-open for more than 5 seconds.

Stall revolution:

2,450 - 2,650 rpm (RE4R01A)

2,950 - 3,200 rpm (RE4R03A)

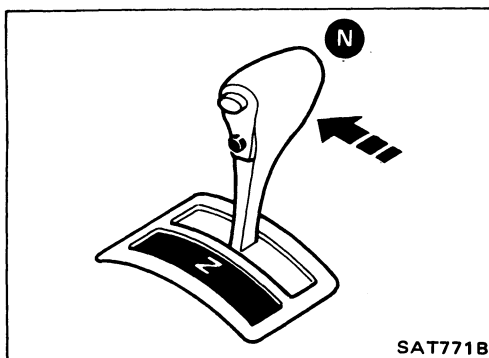

8. Shift selector lever to "N".

9. Cool off A.T.F.

- Run engine at idle for at least one minute.

10. Perform stall tests in the same manner as in steps 5 through 9 with selector lever in "2", "1" and "R", respectively.

TROUBLE DIAGNOSES

Final Check (Cont'd)

Judgement of stall test

Selector lever position	Judgement		
D	L	O	H
2	L	O	H
1	L	O	O
R	L	H	H

- O : Stall revolution is normal.
- H : Stall revolution is higher than specified.
- L : Stall revolution is lower than specified.

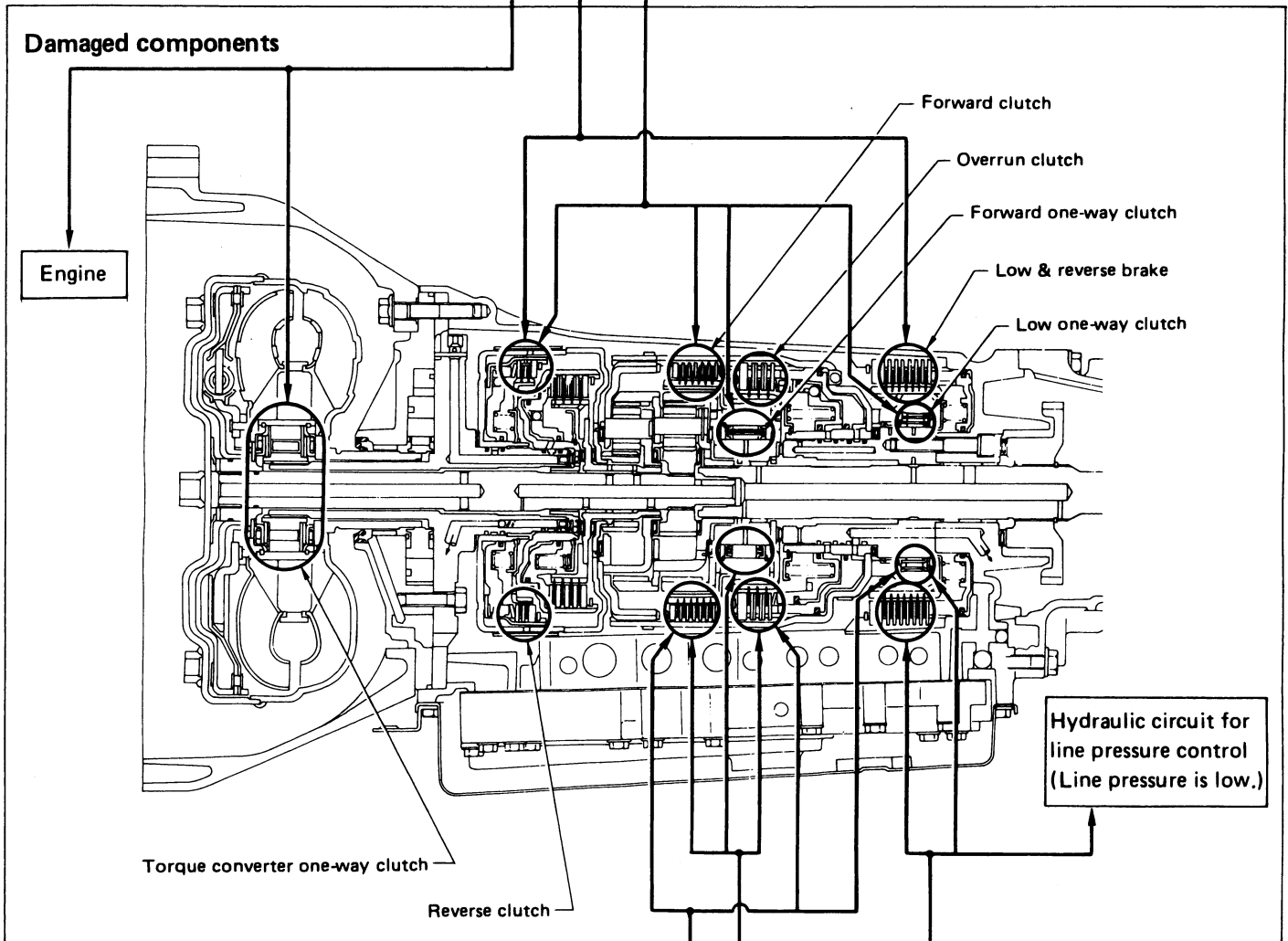

Clutches and brakes except high clutch and brake band are O.K. (Condition of high clutch and brake band cannot be confirmed by stall test.)

D	H	H	H	O
2	H	H	H	O
1	O	H	H	O
R	O	O	H	O
Selector lever position	Judgement			

TROUBLE DIAGNOSES

Final Check (Cont'd)

PRESSURE TESTING

- Location of line pressure test port
- Line pressure plugs are hexagon headed bolts.
- Always replace line pressure plugs as they are self-sealing bolts.

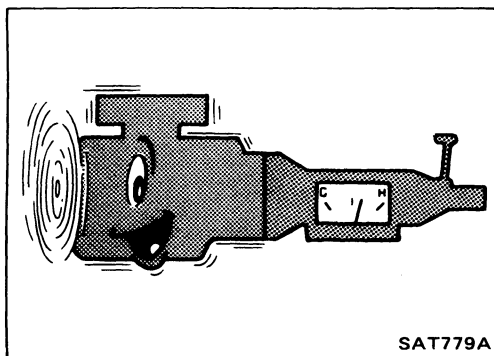
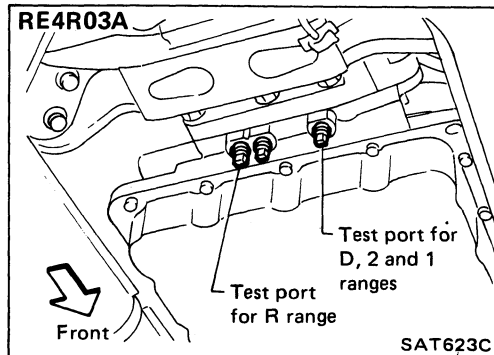
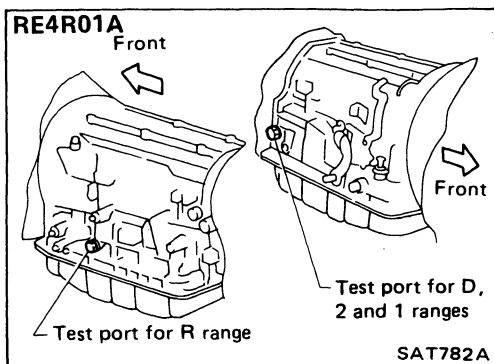

Line pressure test procedure

1. Check A/T and engine fluid levels. If necessary, add.
2. Warm up engine until engine oil and A.T.F. reach operating temperature after vehicle has been driven approx. 10 minutes.

A.T.F. operating temperature:

50 - 80°C (122 - 176°F)

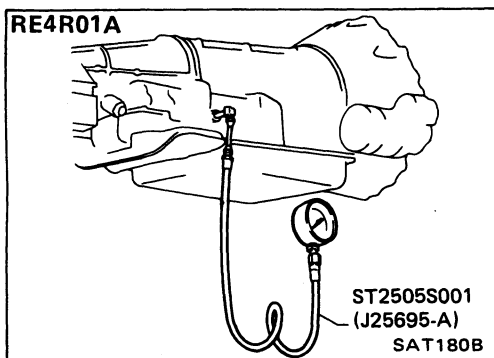

3. Install pressure gauge to line pressure port.

— D, 2 and 1 ranges —

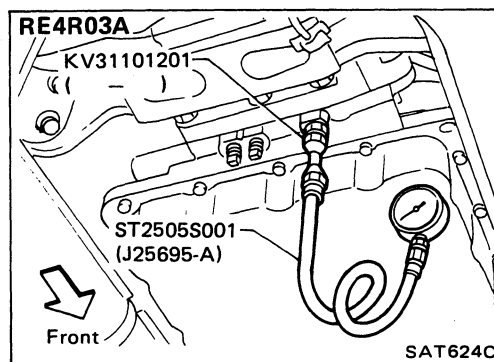

TROUBLE DIAGNOSES

Final Check (Cont'd)

— R range —

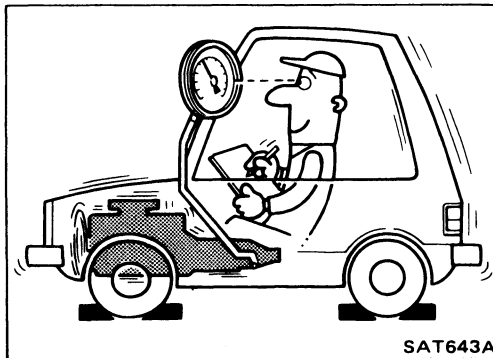
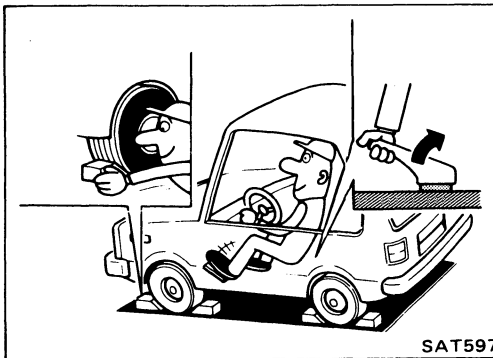
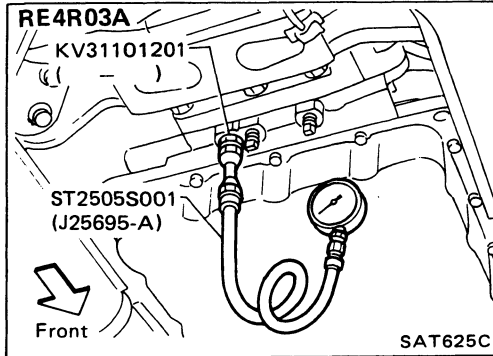
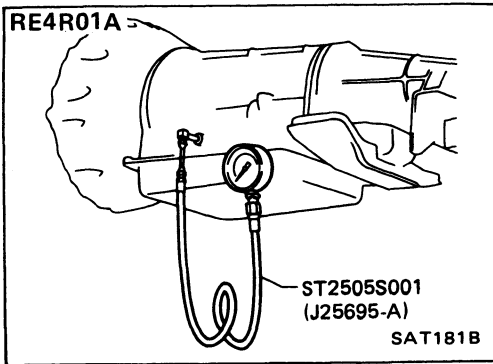

4. Set parking brake and block wheels.

- Continue to depress brake pedal fully while line pressure test at stall speed is performed.

5. Start engine and measure line pressure at idle and stall speed.

- When measuring line pressure at stall speed, follow the stall test procedure.

Line pressure:

Engine speed rpm	Line pressure kPa (kg/cm ² , psi)	
	D, 2 and 1 ranges	R range
Idle	422 - 461 (4.3 - 4.7, 61 - 67)	667 - 706 (6.8 - 7.2, 97 - 102)
Stall	1,020 - 1,098 (10.4 - 11.2, 148 - 159)	1,422 - 1,500 (14.5 - 15.3, 206 - 218)

TROUBLE DIAGNOSES

Final Check (Cont'd)

JUDGEMENT OF LINE PRESSURE TEST

Judgement		Suspected parts
At idle	Line pressure is low in all ranges.	<ul style="list-style-type: none"> ● Oil pump wear ● Control piston damage ● Pressure regulator valve or plug sticking ● Spring for pressure regulator valve damaged ● Fluid pressure leakage between oil strainer and pressure regulator valve
	Line pressure is low in particular range.	<ul style="list-style-type: none"> ● Fluid pressure leakage between manual valve and particular clutch. ● For example; If line pressure is low in "R" and "1" ranges but is normal in "D" and "2" range, fluid leakage exists at or around low & reverse brake circuit.
	Line pressure is high.	<ul style="list-style-type: none"> ● Mal-adjustment of throttle sensor ● Fluid temperature sensor damaged ● Line pressure solenoid sticking ● Short circuit of line pressure solenoid circuit ● Pressure modifier valve sticking ● Pressure regulator valve or plug sticking
At stall speed	Line pressure is low.	<ul style="list-style-type: none"> ● Mal-adjustment of throttle sensor ● Control piston damaged ● Line pressure solenoid sticking ● Short circuit of line pressure solenoid circuit ● Pressure regulator valve or plug sticking ● Pressure modifier valve sticking ● Pilot valve sticking

TROUBLE DIAGNOSES

Symptom Chart

Reference page (AT-)		ON vehicle											OFF vehicle																				
		10, 14	82	82	86	83, 135	83	83	8, 83	8	8	118, 130	149, 153	155, 170	155	159	177																
Reference page (AT-)	Numbers are arranged in order of probability. Perform inspections starting with number one and work up. Circled numbers indicate that the transmission must be removed from the vehicle.	Fluid level	Control linkage	Inhibitor switch	Throttle sensor (Adjustment)	Revolution sensor and speed sensor	Engine revolution signal	Engine idling rpm	Line pressure	Control valve assembly	Shift solenoid A	Shift solenoid B	Line pressure solenoid	Lock-up solenoid	Overrun clutch solenoid	Fluid temperature sensor	Accumulator N-D	Accumulator 1-2	Accumulator 2-3	Accumulator 3-4 (N-R)	Ignition switch and starter	Torque converter	Oil pump	Reverse clutch	High clutch	Forward clutch	Forward one-way clutch	Overrun clutch	Low one-way clutch	Low & reverse brake	Brake band	Parking components	
63	Engine does not start in "N", "P" ranges.	2	3																	1													
63	Engine starts in range other than "N" and "P".	1	2																														
-	Transmission noise in "P" and "N" ranges.	1		3	4	5		2														7	6										
63	Vehicle moves when changing into "P" range or parking gear does not disengage when shifted out of "P" range.	1																													2		
64	Vehicle runs in "N" range.	1																						3		2		5					
66	Vehicle will not run in "R" range (but runs in "D", "2" and "1" ranges). Clutch slips. Very poor acceleration.	1					2		4			3												5	6	7		8		9			
-	Vehicle braked when shifting into "R" range.	1	2					3		5			4												6		8		9			7	
-	Sharp shock in shifting from "N" to "D" range.			2		5	1	3		7			6			4	8										9						
-	Vehicle will not run in "D" and "2" ranges (but runs in "1" and "R" range).	1																											2				
67	Vehicle will not run in "D", "1", "2" ranges (but runs in "R" range). Clutch slips. Very poor acceleration.	1					2		4			3												6	7	8	9		10				
-	Clutches or brakes slip somewhat in starting.	1	2		3			4		6		5											13	12	10		9				11		
-	Excessive creep.						1																										
66, 67	No creep at all.	1						2		3													6	5			4						
-	Failure to change gear from "D ₁ " to "D ₂ ".	2	1		5				4	3																					6		
-	Failure to change gear from "D ₂ " to "D ₃ ".	2	1		5				4	3															6						7		
-	Failure to change gear from "D ₃ " to "D ₄ ".	2	1		4					3					5																6		
69, 70, 71	Too high a gear change point from "D ₁ " to "D ₂ ", from "D ₂ " to "D ₃ ", from "D ₃ " to "D ₄ ".			1	2					3	4																						
-	Gear change directly from "D ₁ " to "D ₃ " occurs.	1																2													3		
-	Engine stops when shifting lever into "R", "D", "2" and "1".						1		3					2								4											
-	Too sharp a shock in change from "D ₁ " to "D ₂ ".			1				2		4						5		3													6		
-	Too sharp a shock in change from "D ₂ " to "D ₃ ".			1				2		4									3												6		

TROUBLE DIAGNOSES

Symptom Chart (Cont'd)

Reference page (AT-)	Reference page (AT-)	ON vehicle										OFF vehicle																				
		10, 14	82	82	86	83, 135	83	83	8, 83	8	8	118, 130	149, 153	155, 170	155	159	177															
		Fluid level	Control linkage	Inhibitor switch	Throttle sensor (Adjustment)	Revolution sensor and speed sensor	Engine revolution signal	Engine idling rpm	Line pressure	Control valve assembly	Shift solenoid A	Shift solenoid B	Line pressure solenoid	Lock-up solenoid	Overrun clutch solenoid	Fluid temperature sensor	Accumulator N-D	Accumulator 1-2	Accumulator 2-3	Accumulator 3-4 (N-R)	Ignition switch and starter	Torque converter	Oil pump	Reverse clutch	High clutch	Forward clutch	Forward one-way clutch	Overrun clutch	Low one-way clutch	Low & reverse brake	Brake band	Parking components
-	Too sharp a shock in change from "D ₃ " to "D ₄ ".	.	.	1	.	.	.	2	4	3	6	.	5	.	.	
-	Almost no shock or clutches slipping in change from "D ₁ " to "D ₃ ".	1	.	2	.	.	.	3	5	4	6	.	.
-	Almost no shock or slipping in change from "D ₂ " to "D ₃ ".	1	.	2	.	.	.	3	5	4	6	.	.	.	7	.	.
-	Almost no shock or slipping in change from "D ₃ " to "D ₄ ".	1	.	2	.	.	.	3	5	4	6	.	.	.	7	.	.
-	Vehicle braked by gear change from "D ₁ " to "D ₃ ".	1	2	4	.	.	5	3	.	.	.
-	Vehicle braked by gear change from "D ₂ " to "D ₃ ".	1	2	.	.
-	Vehicle braked by gear change from "D ₃ " to "D ₄ ".	1	4	.	3	2
-	Maximum speed not attained. Acceleration poor.	1	.	2	5	3	4	11	10	6	7	.	.	9	8	.	.
-	Failure to change gear from "D ₄ " to "D ₃ ".	1	.	2	6	4	5	3	8	7	.	.	.	
-	Failure to change gear from "D ₃ " to "D ₁ " or from "D ₄ " to "D ₁ ".	1	.	2	5	3	4	6	.	.	.	7	.	.	
-	Failure to change gear from "D ₂ " to "D ₁ " or from "D ₃ " to "D ₁ ".	1	.	2	5	3	4	7	.	6	8	.	.	.	
-	Gear change shock felt during deceleration by releasing accelerator pedal.	.	.	1	.	.	.	2	4	3
-	Too high a change point from "D ₄ " to "D ₃ ", from "D ₃ " to "D ₂ ", from "D ₂ " to "D ₁ ".	.	.	1	2
-	Kickdown does not operate when depressing pedal in "D ₄ " within kickdown vehicle speed.	.	.	1	2	.	.	.	3	4
-	Kickdown operates or engine overruns when depressing pedal in "D ₄ " beyond kickdown vehicle speed limit.	.	.	2	1	.	.	.	3	4
-	Races extremely fast or slips in changing from "D ₄ " to "D ₃ " when depressing pedal.	1	.	2	.	.	3	5	4	6	7
-	Races extremely fast or slips in changing from "D ₄ " to "D ₂ " when depressing pedal.	1	.	2	.	.	3	6	5	4	8	.	.	7	.	.	.
-	Races extremely fast or slips in changing from "D ₃ " to "D ₂ " when depressing pedal.	1	.	2	.	.	3	5	4	8	10	9	7	.	.	6	.	.	.
-	Races extremely fast or slips in changing from "D ₄ " or "D ₃ " to "D ₁ " when depressing pedal.	1	.	2	.	.	3	5	4	6	7	8
-	Vehicle will not run in any range.	1	2	.	.	.	3	.	4	9	5	6	.	.	8	7	10	.	.
-	Transmission noise in "D", "2", "1" and "R" ranges.	1	2

TROUBLE DIAGNOSES

Symptom Chart (Cont'd)

Reference page (AT-)		ON vehicle										OFF vehicle																					
		10, 14	82	82	86	83, 135	83	83	8, 83	8	8	118, 130	149, 153	155, 170	155	159	177																
Reference page (AT-)	Reference page (AT-)	Fluid level	Control linkage	Inhibitor switch	Throttle sensor (Adjustment)	Revolution sensor and speed sensor	Engine revolution signal	Engine idling rpm	Line pressure	Control valve assembly	Shift solenoid A	Shift solenoid B	Line pressure solenoid	Lock-up solenoid	Overrun clutch solenoid	Fluid temperature sensor	Accumulator N-D	Accumulator 1-2	Accumulator 2-3	Accumulator 3-4 (N-R)	Ignition switch and starter	Torque converter	Oil pump	Reverse clutch	High clutch	Forward clutch	Forward one-way clutch	Overrun clutch	Low one-way clutch	Low & reverse brake	Brake band	Parking components	
76	Failure to change from "D ₃ " to "2 ₁ " when changing lever into "2" range.	.	7	1	2	6	5	4	.	.	3	9	.	8	.	.	
-	Gear change from "2 ₁ " to "2 ₂ " in "2" range.	.	.	1	
76	Engine brake does not operate in "1" range.	.	2	1	3	4	.	.	.	6	5	.	.	7	8	.	9	.	.		
-	Gear change from "1 ₁ " to "1 ₂ " in "1" range.	.	2	1	
-	Does not change from "1 ₂ " to "1 ₁ " in "1" range.	.	.	1	.	2	.	.	.	4	3	.	.	5	6	.	7	.	.		
-	Large shock changing from "1 ₂ " to "1 ₁ " in "1" range.	1	2	.	.		
-	Transmission overheats.	1	.	.	3	.	.	2	4	6	.	5	19	7	8	9	11	.	12	.	13	10	.	
-	A.T.F. shoots out during operation. White smoke emitted from exhaust pipe during operation.	1	2	3	5	.	6	.	7	4	.	
-	Offensive smell at fluid charging pipe.	1	2	3	4	5	7	.	8	.	9	6	.
-	Torque converter is not locked up.	.	.	3	1	2	4	.	6	8	.	.	7	.	5	9	
-	Lock-up piston slip	1	.	.	2	.	.	3	6	.	5	4	7	
72	Lock-up point is extremely high or low.	.	.	.	1	2	.	.	4	.	.	3	
-	A/T does not shift to "D ₄ " when driving with overdrive switch "ON".	.	.	2	1	3	.	8	6	4	.	.	5	7	10	.	9	.	.	
-	Engine is stopped at "R", "D", "2" and "1" ranges.	1	5	4	3	.	2	

TROUBLE DIAGNOSES

A/T Shift Lock System

SHIFT LOCK SYSTEM ELECTRICAL PARTS LOCATION

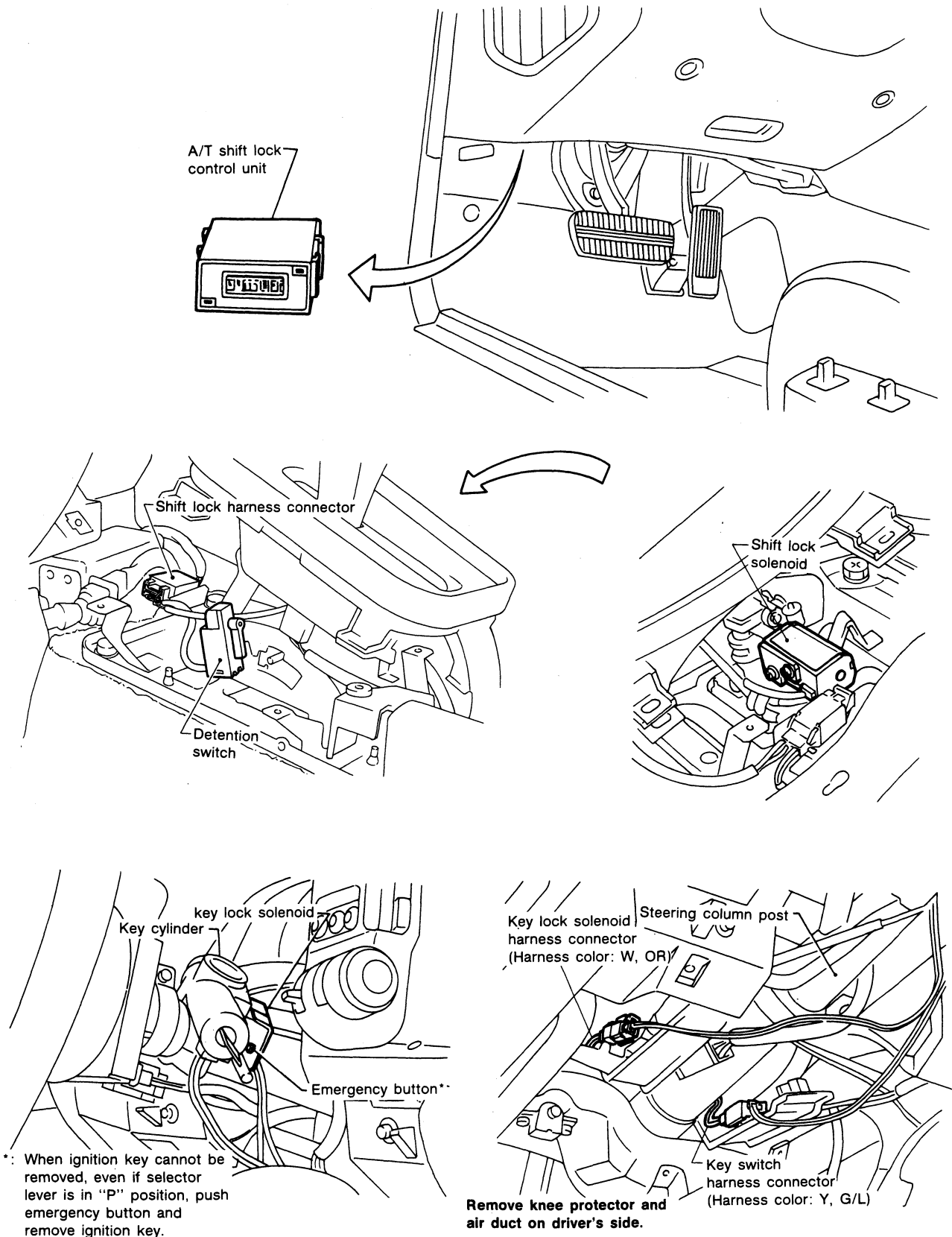

** : When ignition key cannot be removed, even if selector lever is in "P" position, push emergency button and remove ignition key.

SAT033E

TROUBLE DIAGNOSES

A/T Shift Lock System (Cont'd)

CIRCUIT DIAGRAM FOR QUICK PINPOINT CHECK

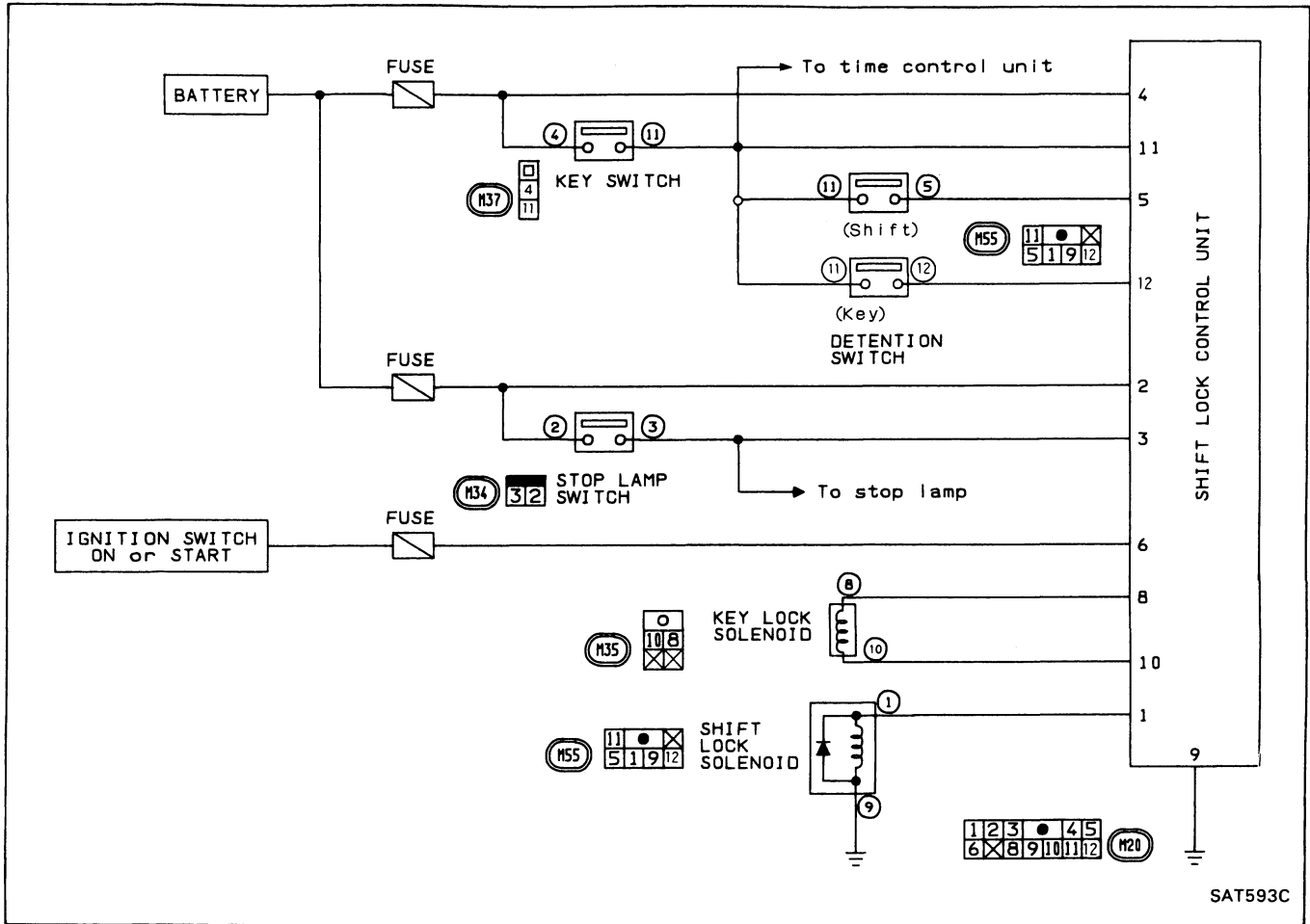

TROUBLE DIAGNOSES

A/T Shift Lock System (Cont'd)

WIRING DIAGRAM

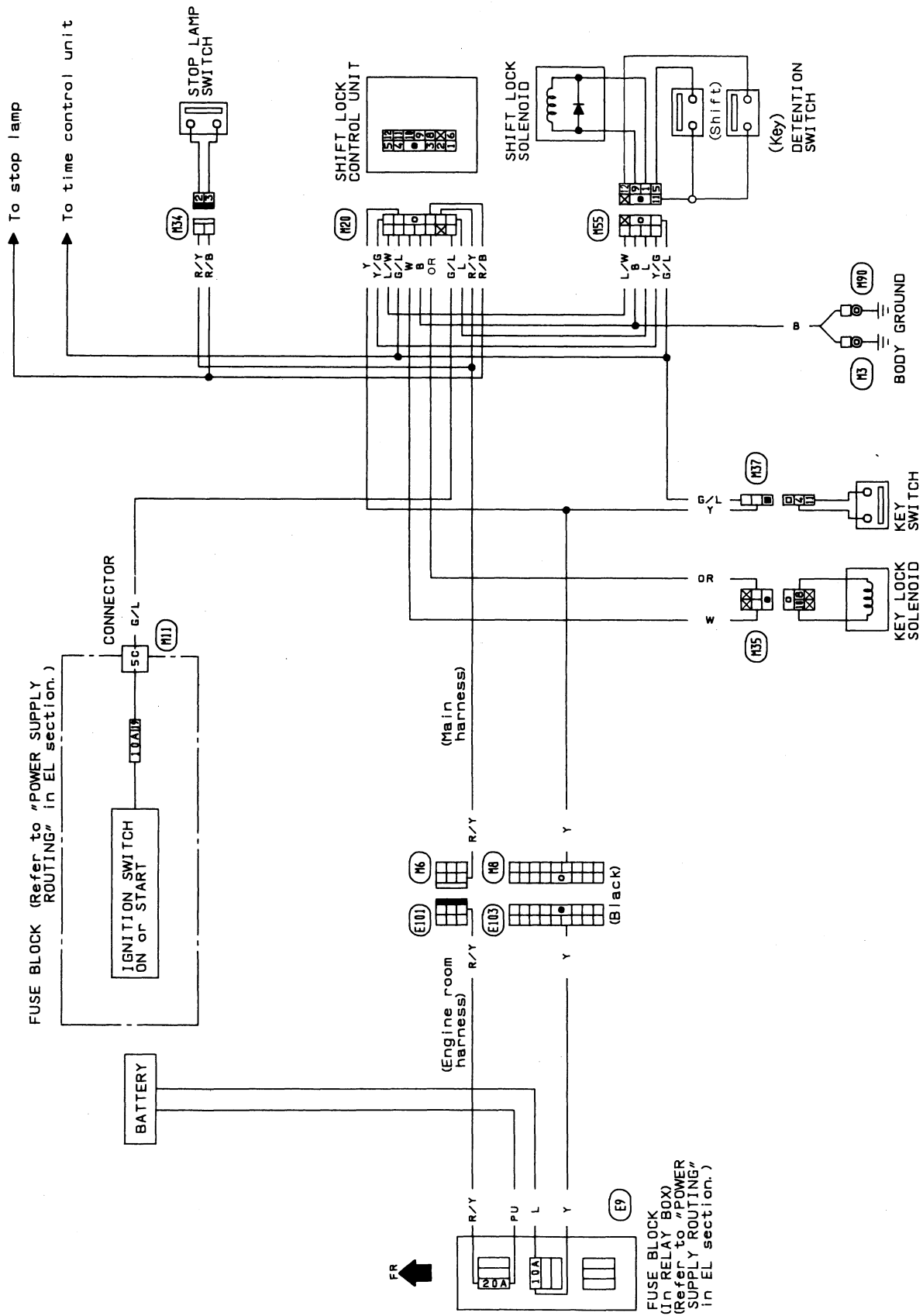

TROUBLE DIAGNOSES

A/T Shift Lock System (Cont'd)

DIAGNOSTIC PROCEDURE 1

SYMPTOM:

Selector lever cannot be moved from "P" range when applying brake pedal or can be moved when releasing brake pedal.
Selector lever can be moved from "P" range when key is removed from key cylinder.

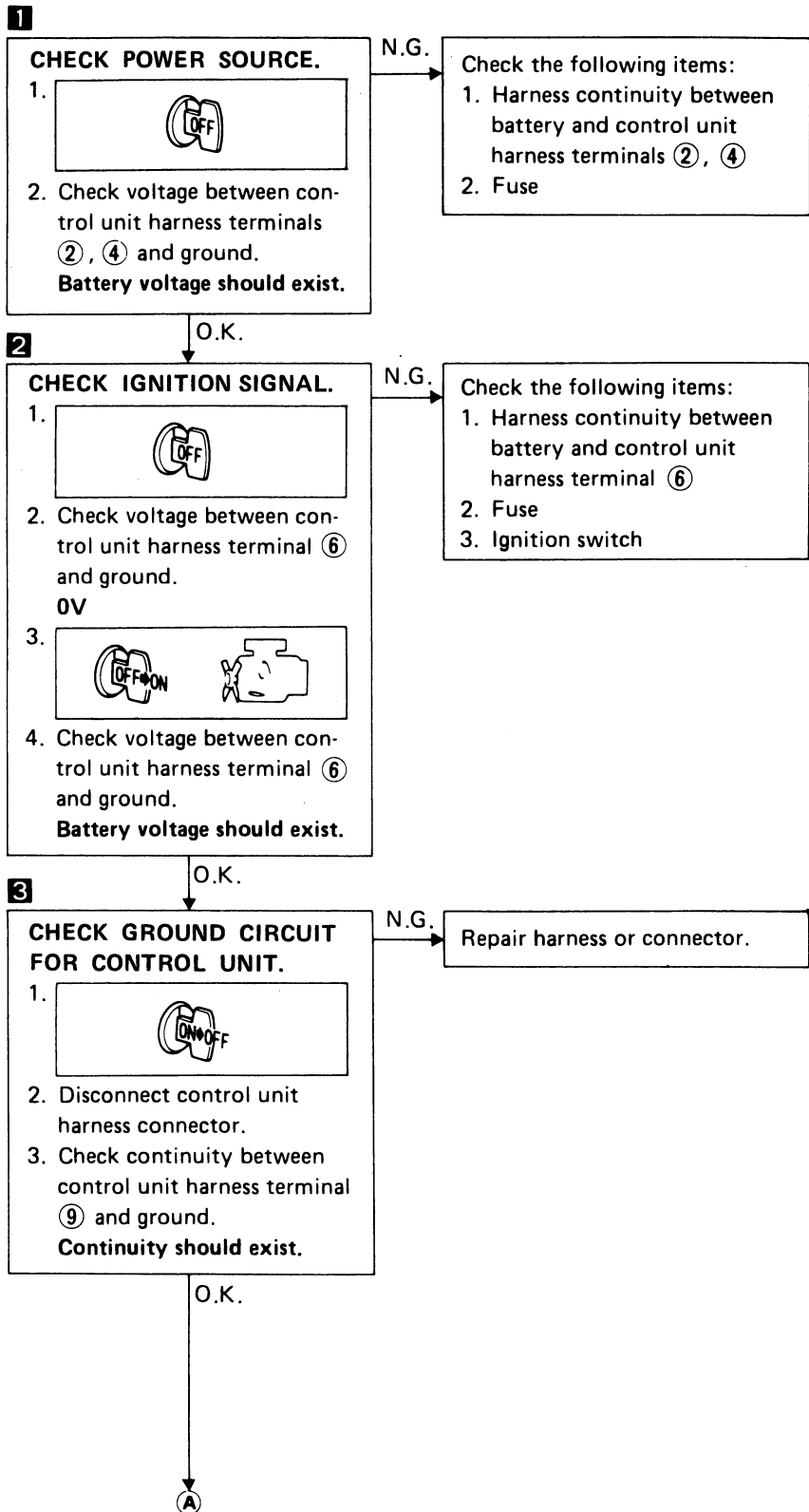
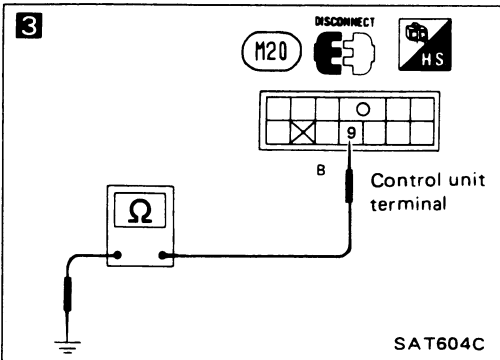
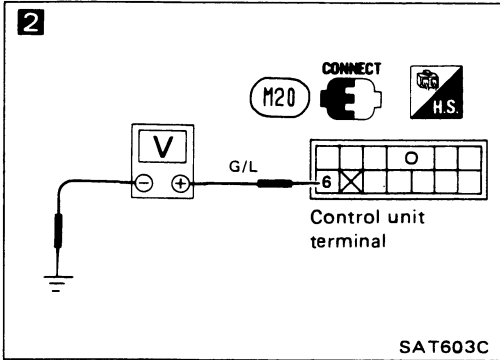
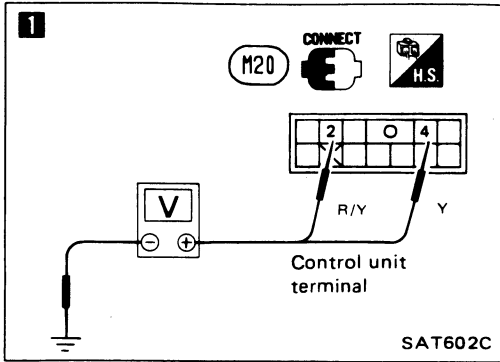

TROUBLE DIAGNOSES

A/T Shift Lock System (Cont'd)

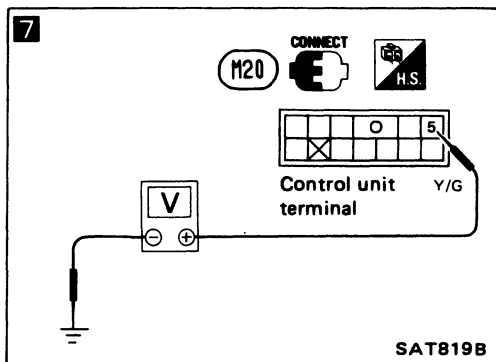
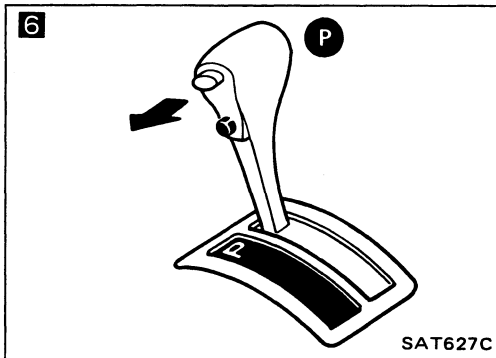
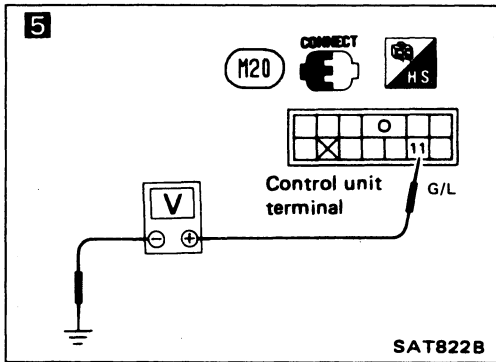
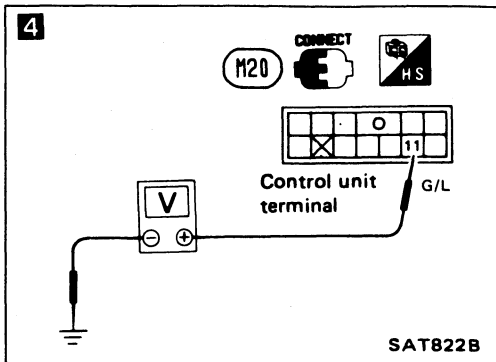

4

CHECK INPUT SIGNAL (KEY SWITCH).

1. Reconnect control unit harness connector.
- 2.
3. Check voltage between control unit terminal ① and ground.
0V

N.G. Check key switch.
(Refer to "COMPONENT CHECK".)

O.K.

5

- 1.
2. Check voltage between control unit harness terminal ① and ground.
Battery voltage should exist.

N.G. Check the following items:

1. Harness continuity between control unit harness terminal ① and key switch harness terminal ①.
2. Harness continuity between key switch harness terminal ④ and fuse
3. Key switch (Refer to "COMPONENT CHECK".)

O.K.

CHECK INPUT SIGNAL (DETENTION SWITCH-SHIFT).

- 1.
2. Set selector lever in "P" position and release selector lever button.
3. Check voltage between control unit harness terminal ⑤ and ground.
0V

N.G. Check detention switch-shift.
(Refer to "COMPONENT CHECK".)

O.K.

B

TROUBLE DIAGNOSES

A/T Shift Lock System (Cont'd)

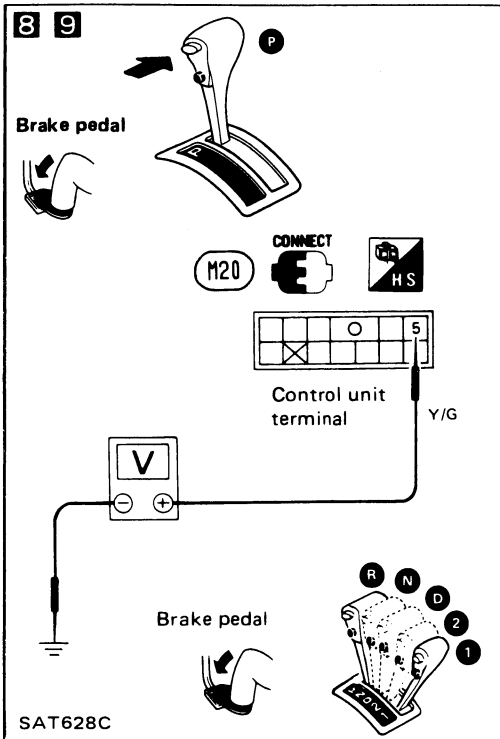

CHECK INPUT SIGNAL (DETENTION SWITCH-SHIFT).

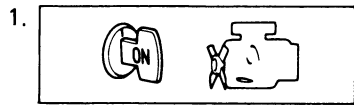

8 2. Check voltage between control unit harness terminal ⑤ and ground with brake pedal depressed and selector lever button pushed.
Battery voltage should exist.

9 3. Check voltage between control unit harness terminal ⑤ and ground with selector lever set in any position except "P".
When selector lever cannot be moved from "P" position with brake pedal depressed, push shift lock release knob.
Battery voltage should exist.

N.G.

Check the following items:

1. Harness continuity between control unit harness terminal ⑤ and detention switch harness terminal ⑤
2. Harness continuity between detention switch harness terminal ⑪ and key switch harness terminal ⑪
3. Detention switch-shift (Refer to "COMPONENT CHECK".)

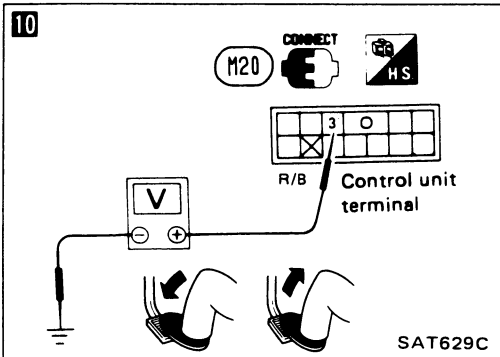

CHECK INPUT SIGNAL (STOP LAMP SWITCH).

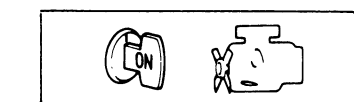

- Check voltage between control unit harness terminal ③ and ground.

Brake pedal	Voltage
Depressed	Battery voltage
Released	0V

N.G.

Check the following items:

1. Harness continuity between control unit harness terminal ③ and stop lamp switch harness terminal ③
2. Harness continuity between stop lamp switch harness terminal ② and fuse
3. Stop lamp switch (Refer to "COMPONENT CHECK".)

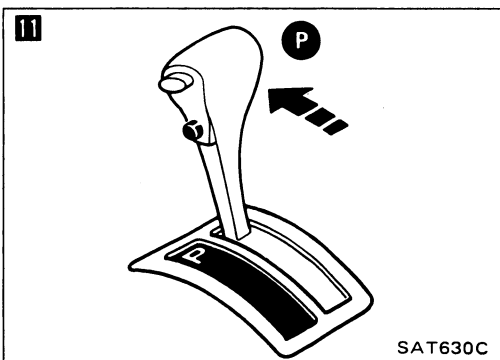

11 Set selector lever in "P" position.

©

TROUBLE DIAGNOSES

A/T Shift Lock System (Cont'd)

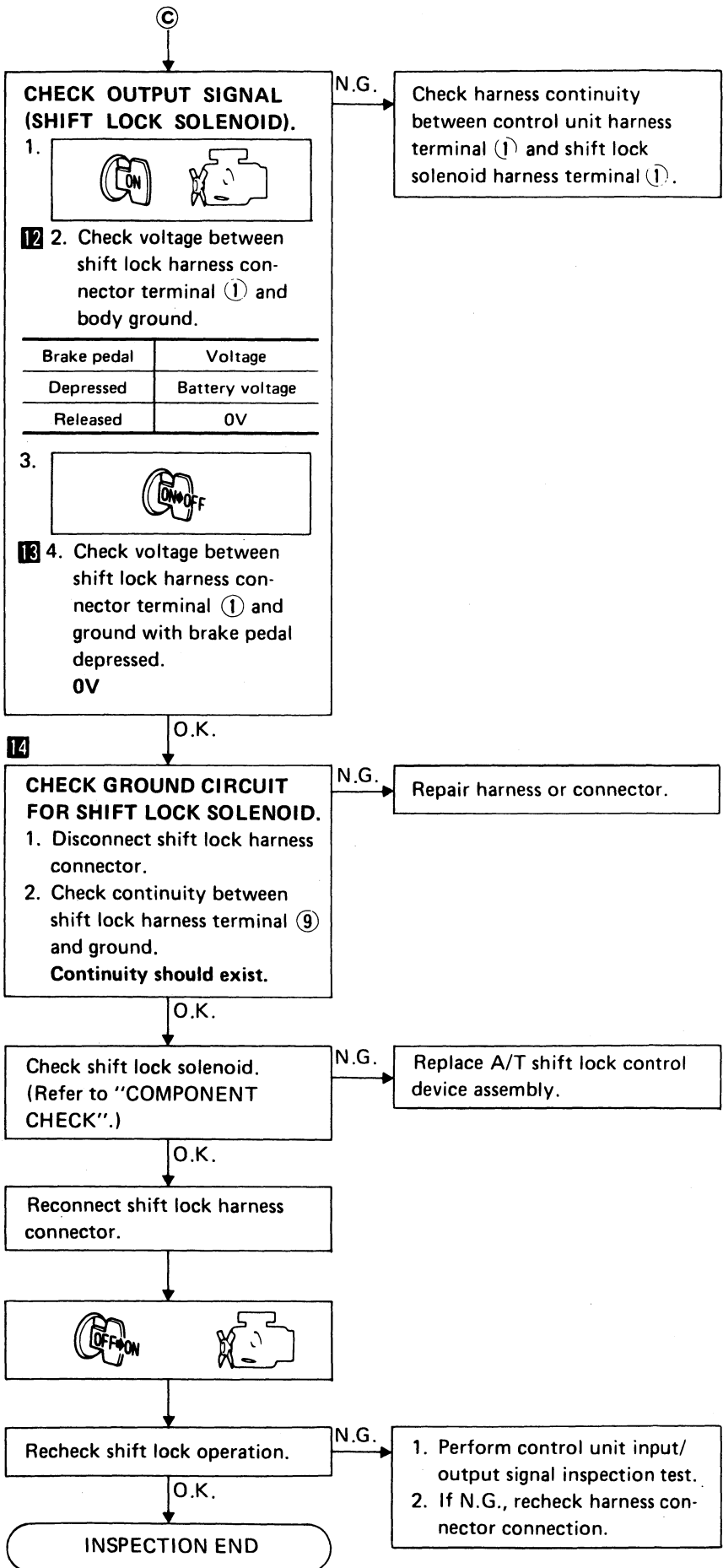
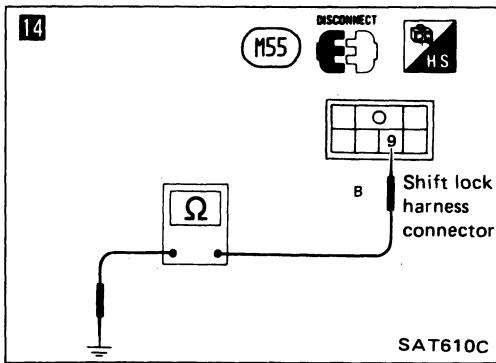
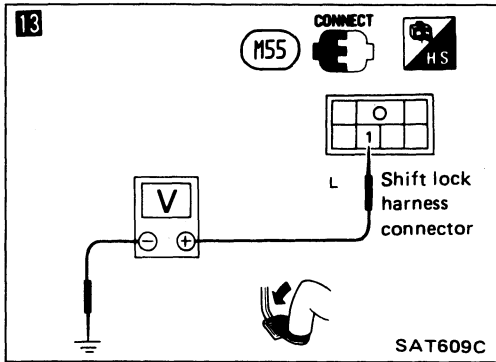
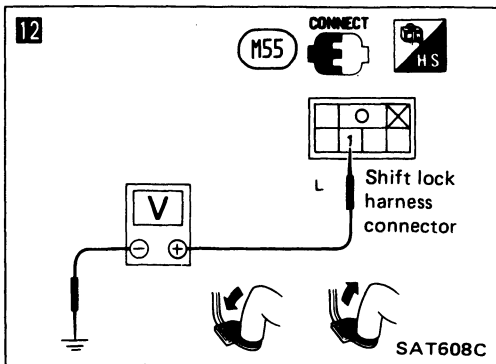

TROUBLE DIAGNOSES

A/T Shift Lock System (Cont'd)

DIAGNOSTIC PROCEDURE 2

SYMPTOM:

Ignition key cannot be removed when selector lever is set to "P" position or can be removed when selector lever is set to any position except "P".

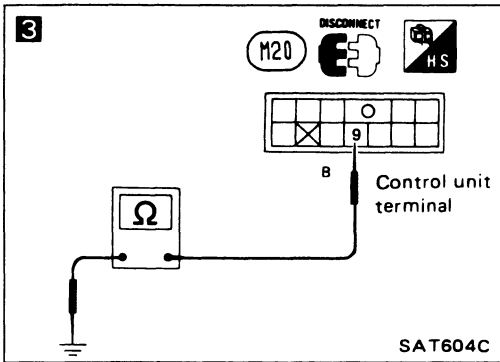
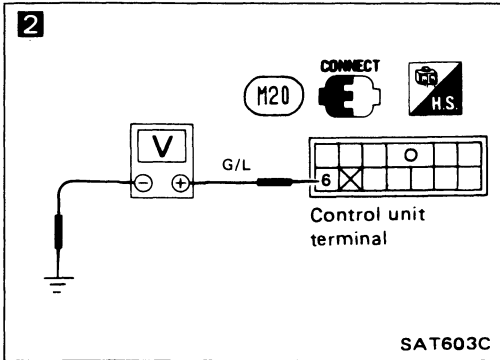
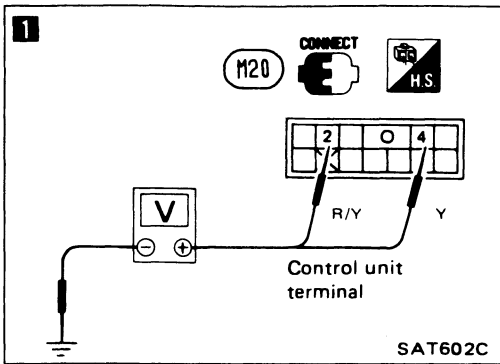

1

CHECK POWER SOURCE.

1. 

2. Check voltage between control unit harness terminals ②, ④ and ground.
Battery voltage should exist.

N.G. → Check the following items:
1. Harness continuity between battery and control unit harness terminals ②, ④
2. Fuse

2

O.K. ↓

CHECK IGNITION SIGNAL.

1. 

2. Check voltage between control unit harness terminal ⑥ and ground.
0V

3. 

4. Check voltage between control unit harness terminal ⑥ and ground.
Battery voltage should exist.

N.G. → Check the following items:
1. Harness continuity between battery and control unit harness terminal ⑥
2. Fuse
3. Ignition switch

3

O.K. ↓

CHECK GROUND CIRCUIT FOR CONTROL UNIT.

1. 

2. Disconnect control unit harness connector.

3. Check continuity between control unit harness terminal ⑨ and ground.
Continuity should exist.

N.G. → Repair harness or connector.

O.K. ↓

A

TROUBLE DIAGNOSES

A/T Shift Lock System (Cont'd)

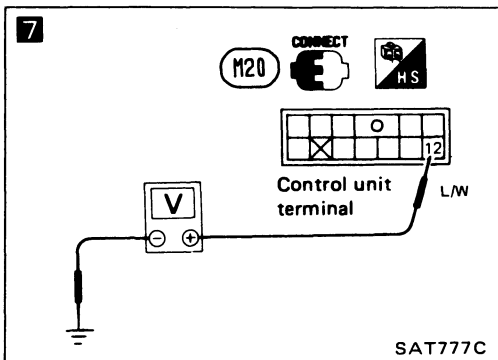
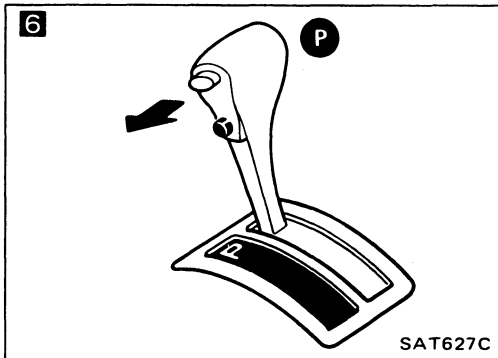
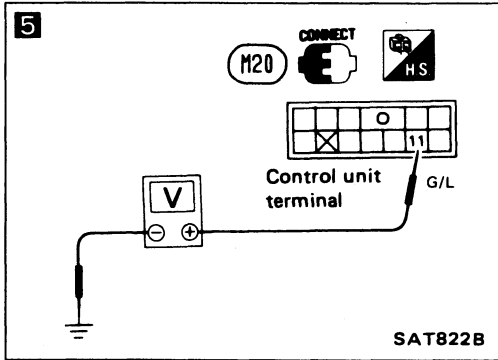
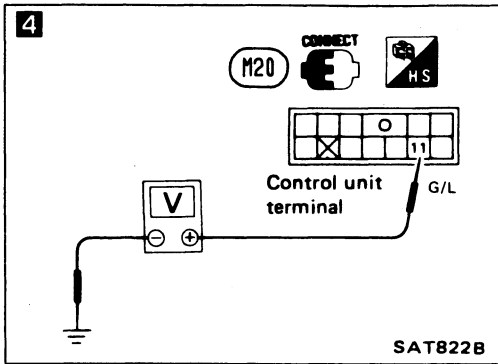

4

CHECK INPUT SIGNAL (KEY SWITCH).

1. Reconnect control unit harness connector.
2. 

When ignition key cannot be removed, even if selector lever is in "P" position, use emergency button.

3. Check voltage between control unit terminal ① and ground.
0V

N.G. → Check key switch. (Refer to "COMPONENT CHECK".)

O.K.

5

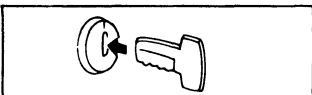
1. 
2. Check voltage between control unit harness terminal ① and ground.
Battery voltage should exist.

N.G. → Check the following items:

1. Harness continuity between control unit harness terminal ① and key switch harness terminal ①.
2. Harness continuity between key switch harness terminal ④ and fuse
3. Key switch (Refer to "COMPONENT CHECK".)

O.K.

CHECK INPUT SIGNAL (DETENTION SWITCH-KEY).

1. 
2. Set selector lever in "P" position and release selector lever button.
3. Check voltage between control unit harness terminal ② and ground.
0V

N.G. → Check detention switch-key. (Refer to "COMPONENT CHECK".)

O.K.

↓

B

TROUBLE DIAGNOSES

A/T Shift Lock System (Cont'd)

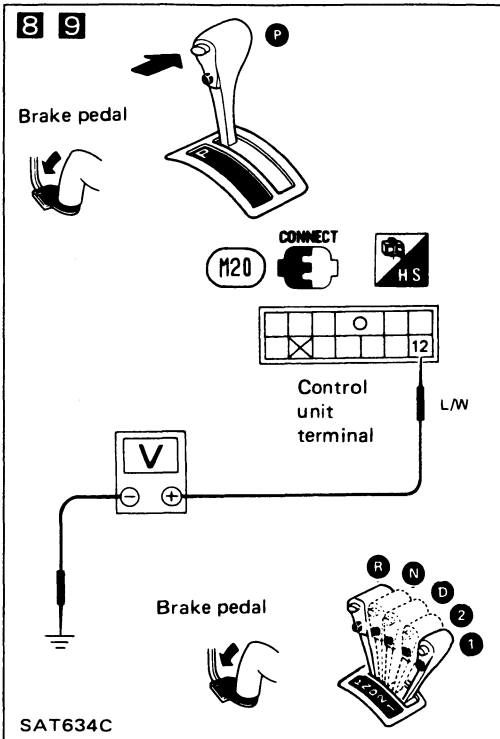

Ⓑ

CHECK INPUT SIGNAL (DETENTION SWITCH-KEY).

8 1. Check voltage between control unit harness terminal ⑫ and ground with brake pedal depressed and selector lever button pushed.
Battery voltage should exist.

9 2. Check voltage between control unit harness terminal ⑫ and ground with selector lever set in any position except "P".
Battery voltage should exist.

N.G.

Check the following items:

1. Harness continuity between control unit harness terminal ⑫ and detention switch harness terminal ⑫
2. Harness continuity between detention switch harness terminal ⑪ and key switch harness terminal ⑪
3. Detention switch-key (Refer to "COMPONENT CHECK".)

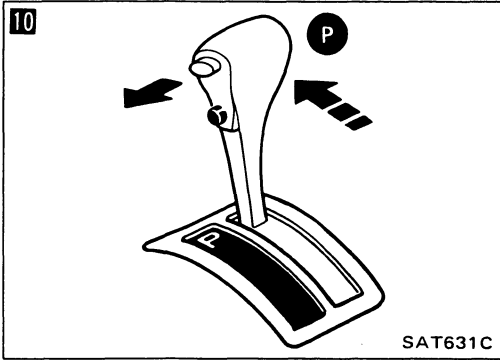

O.K.

10

Set selector lever in "P" position and release selector lever button.

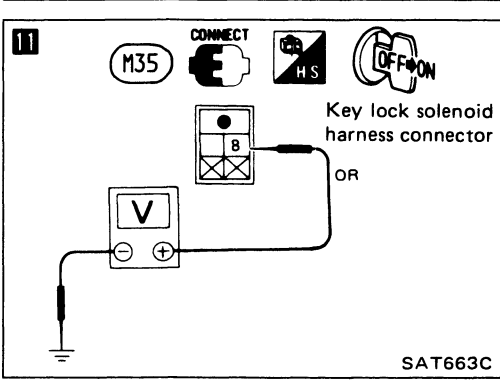

Ⓒ

11

CHECK OUTPUT SIGNAL (KEY LOCK SIGNAL).

Check voltage between key lock solenoid harness terminal ⑧ and ground at the moment ignition key is turned from OFF to ON.
Battery voltage should exist for approximately 0.1 seconds.

N.G.

Check harness continuity between shift lock solenoid harness terminal ⑧ and control unit harness terminal ⑧.

O.K. → Replace control unit.

N.G. → Repair harness or connector.

TROUBLE DIAGNOSES

A/T Shift Lock System (Cont'd)

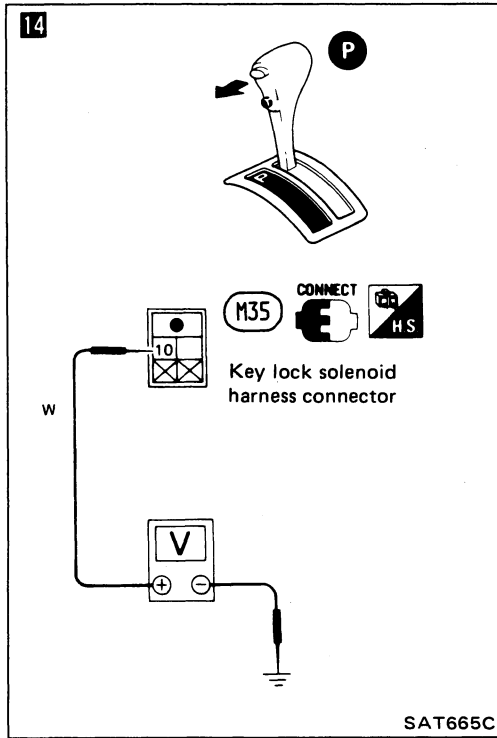
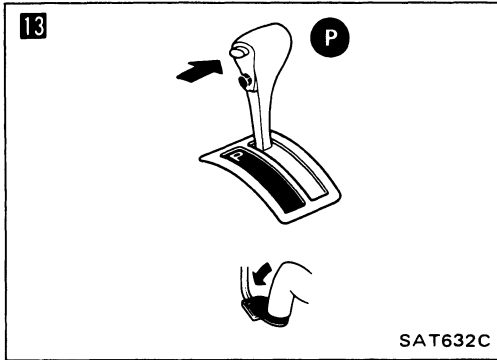
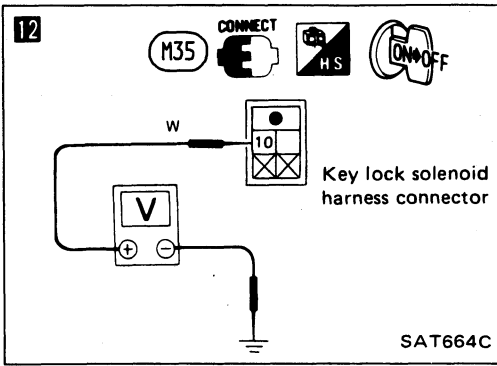

12

Ⓒ

CHECK OUTPUT SIGNAL (KEY UNLOCK SIGNAL CAUSED BY IGNITION SIGNAL).

Check voltage between key lock solenoid harness terminal ⑩ and ground at the moment ignition key is turned from ON to OFF. **Battery voltage should exist for approximately 0.1 seconds.**

N.G. →

Check harness continuity between shift lock solenoid harness terminal ⑩ and control unit harness terminal ⑩.

O.K. ↓

N.G. ↓

Repair harness or connector.

Replace control unit.

O.K. ↓

13

1. Push selector lever button with brake pedal depressed.
- 2.

When turning ignition key, keep selector lever button pushed and brake pedal depressed.

14

CHECK OUTPUT SIGNAL (KEY UNLOCK SIGNAL CAUSED BY DETENTION SWITCH-KEY).

Check voltage between key lock solenoid harness terminal ⑩ and ground at the moment selector lever button is released. **Battery voltage should exist for approximately 0.1 seconds.**

N.G. →

Replace control unit.

O.K. ↓

Ⓓ

TROUBLE DIAGNOSES

A/T Shift Lock System (Cont'd)

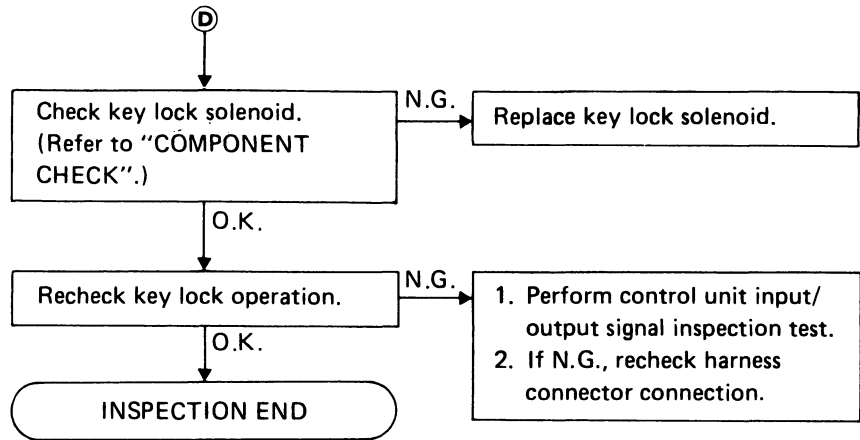

TROUBLE DIAGNOSES

A/T Shift Lock System (Cont'd)

SHIFT LOCK CONTROL UNIT INSPECTION



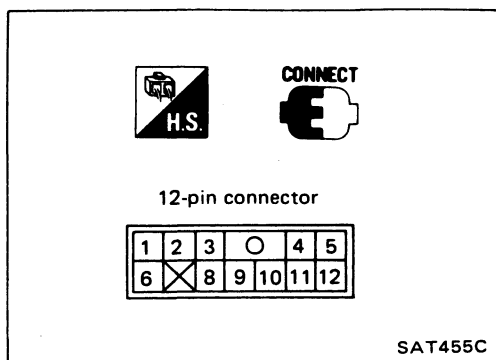

- Measure voltage between each terminal and terminal ⑨ by following "SHIFT LOCK CONTROL UNIT INSPECTION TABLE".
- Pin connector terminal layout.



TROUBLE DIAGNOSES

A/T Shift Lock System (Cont'd)

SHIFT LOCK CONTROL UNIT INSPECTION TABLE (Data are reference values.)

Terminal No.		Item	Condition	Judgement standard
⊕	⊖			
1	9	Shift lock signal	 When selector lever is set in "P" position and brake pedal is depressed	Battery voltage
			Except above	0V
2		Power source		Battery voltage
3		Stop lamp switch	When brake pedal is depressed	Battery voltage
			When brake pedal is released	0V
4		Power source		Battery voltage
5		Detention switch (Shift)	When key is inserted into key cylinder, selector lever is set in "P" position and selector lever button is released	0V
			Except above	Battery voltage
6	Ignition signal		Battery voltage	
8	10	Key lock signal	When ignition switch is turned from LOCK, OFF or ACC to ON	Battery voltage (Approximately 0.1 seconds)
			Except above	0V
9	—	Ground	—	—
10	8	Key unlock signal	When ignition switch is turned from ON to LOCK, OFF, or ACC, selector lever is set in "P" position and selector lever button is released	Battery voltage (Approximately 0.1 seconds)
			Except above	0V
11	9	Key switch	When key is inserted into key cylinder	Battery voltage
			When key is removed from key cylinder	0V
12		Detention switch (Key)	When key is inserted into key cylinder, selector lever is set in "P" position and selector lever button is released	0V
			Except above	Battery voltage

TROUBLE DIAGNOSES

A/T Shift Lock System (Cont'd)

COMPONENT CHECK

Shift lock solenoid

- Check operation by applying battery voltage to shift lock harness connector.

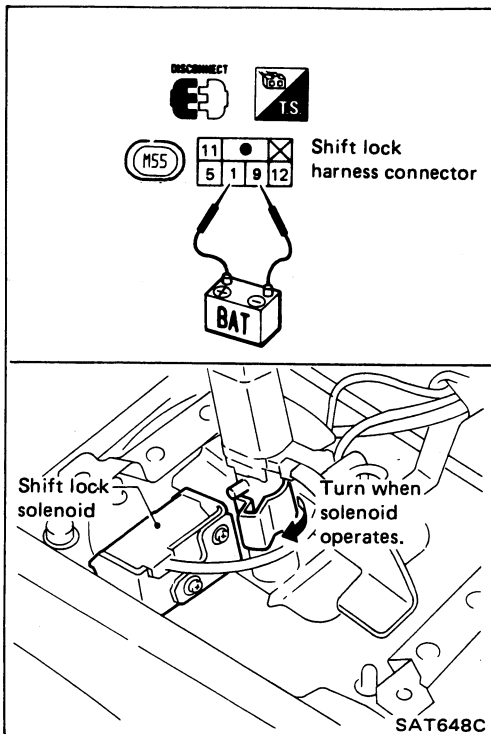

SAT648C

Detention switch — shift

- Check continuity between terminals ⑤ and ⑪ of shift lock harness connector.

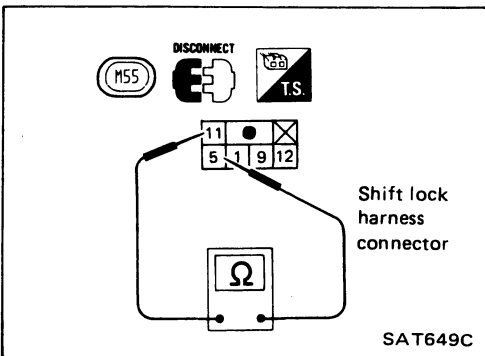

SAT649C

Condition	Continuity
When selector lever is set in "P" position and selector lever button is released	No
Except the above	Yes

Detention switch — key

- Check continuity between terminals ⑪ and ⑫ of shift lock harness connector.

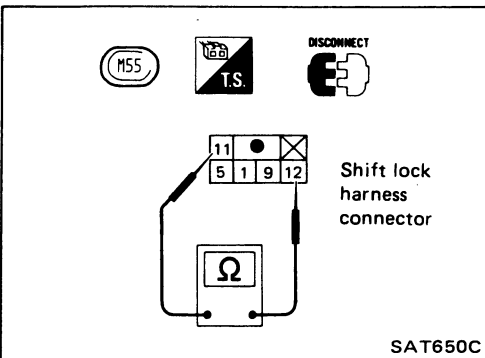

SAT650C

Condition	Continuity
When selector lever is set in "P" position and selector lever button is released	No
Except the above	Yes

Key lock solenoid

- Check operation by applying battery voltage to key lock solenoid harness connector.

Operating sound must be emitted.

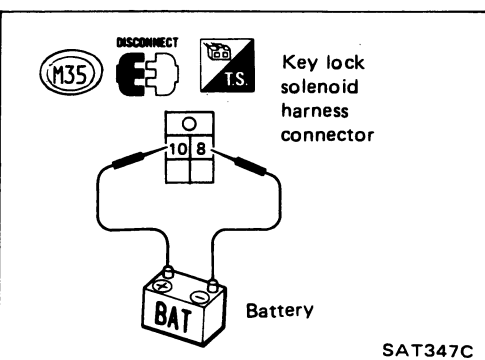

SAT347C

TROUBLE DIAGNOSES

A/T Shift Lock System (Cont'd)

Key switch

- Check continuity between terminals ④ and ⑪ of key switch harness connector.

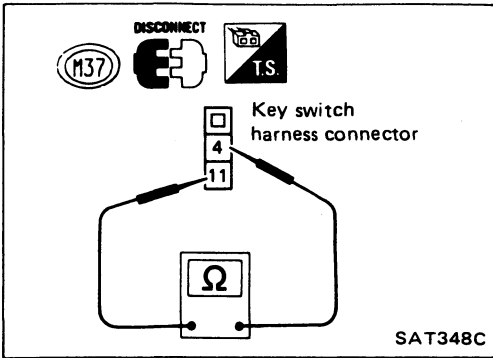

Condition	Continuity
When key is inserted into key cylinder	Yes
When key is removed from key cylinder	No

Stop lamp switch

- Check continuity between terminals ② and ③ of stop lamp switch harness connector.

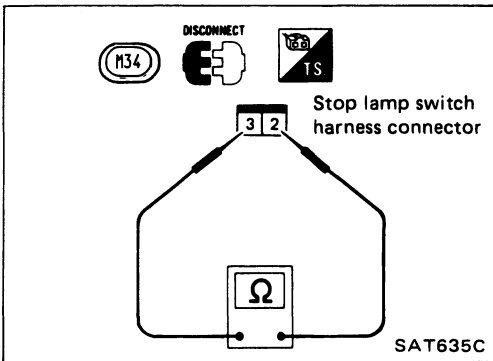

Condition	Continuity
When brake pedal is depressed	Yes
When brake pedal is released	No

Check stop lamp switch after adjusting brake pedal — refer to section BR.

REMOVAL AND INSTALLATION

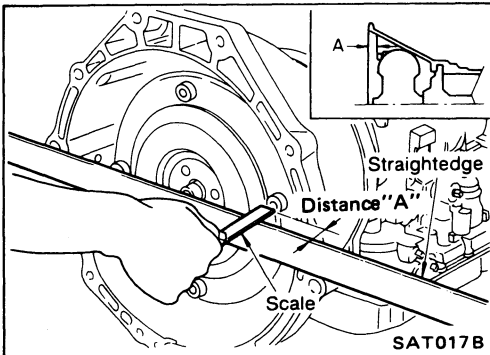
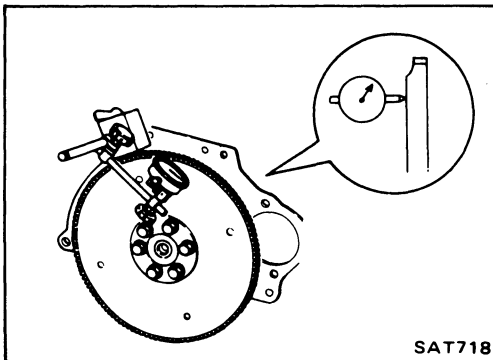
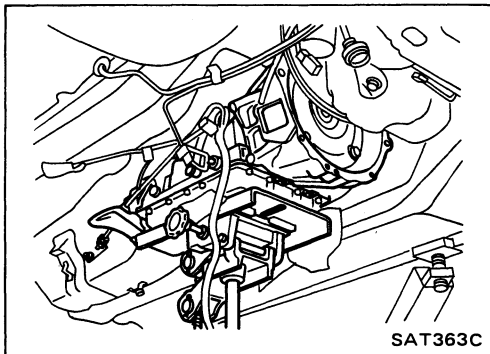
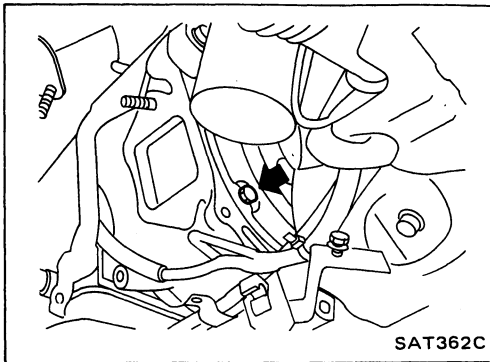

Removal

- Remove exhaust tube.
- Remove fluid charging pipe from A/T assembly.
- Remove oil cooler pipe from A/T assembly.
- Remove control linkage from selector lever.
- Disconnect inhibitor switch and solenoid harness connectors.
- Remove speedometer cable from A/T assembly.
- Plug up openings such as the oil charging pipe hole, etc.
- Remove propeller shaft. — Refer to section PD.
- **Insert plug into rear oil seal after removing propeller shaft.**
- **Be careful not to damage spline, sleeve yoke and rear oil seal, when removing propeller shaft.**
- Remove starter motor.
- Remove gusset securing engine to A/T assembly.
- Remove bolts securing torque converter to drive plate.
- **Remove the bolts by turning crankshaft.**
- Support engine by placing a jack under oil pan.
- **Do not place jack under oil pan drain plug.**
- Remove transmission from engine.
- **Support automatic transmission, while removing it.**

Installation

- Drive plate runout
Maximum allowable runout:
0.5 mm (0.020 in)
If this runout is out of allowance, replace drive plate with ring gear.
- When connecting torque converter to transmission, measure distance "A" to be certain that they are correctly assembled.
Distance "A":
RE4R01A
26 mm (1.02 in) or more
RE4R03A
25 mm (0.98 in) or more
- Install converter to drive plate.
- Reinstall any part removed.
- **After converter is installed to drive plate, rotate crankshaft several turns and check to be sure that transmission rotates freely without binding.**

REMOVAL AND INSTALLATION

Installation (Cont'd)

- Tighten bolts securing transmission.

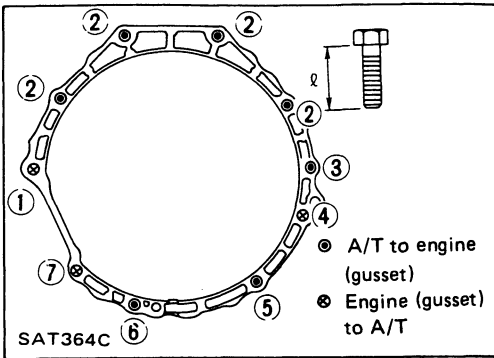

RE4R01A

Bolt No.	Tightening torque N·m (kg·m, ft·lb)	Bolt length "L" mm (in)
1	39 - 49 (4.0 - 5.0, 29 - 36)	60 (2.36)
2	39 - 49 (4.0 - 5.0, 29 - 36)	50 (1.97)
3	39 - 49 (4.0 - 5.0, 29 - 36)	45 (1.77)
4	29 - 39 (3.0 - 4.0, 22 - 29)	25 (0.98)
5	29 - 39 (3.0 - 4.0, 22 - 29)	60 (2.36)
6	39 - 49 (4.0 - 5.0, 29 - 36)	65 (2.56)
7	39 - 49 (4.0 - 5.0, 29 - 36)	25 (0.98)
Gusset to engine	29 - 39 (3.0 - 4.0, 22 - 29)	20 (0.98)

RE4R03A

Bolt No.	Tightening torque N·m (kg·m, ft·lb)	Bolt length "L" mm (in)
1	39 - 49 (4.0 - 5.0, 29 - 36)	60 (2.36)
2	39 - 49 (4.0 - 5.0, 29 - 36)	60 (2.36)
3	39 - 49 (4.0 - 5.0, 29 - 36)	65 (2.56)
4	29 - 39 (3.0 - 4.0, 22 - 29)	25 (0.98)
5	29 - 39 (3.0 - 4.0, 22 - 29)	60 (2.36)
6	39 - 49 (4.0 - 5.0, 29 - 36)	65 (2.56)
7	39 - 49 (4.0 - 5.0, 29 - 36)	25 (0.98)
Gusset to engine	29 - 39 (3.0 - 4.0, 22 - 29)	20 (0.98)





- Reinstall any part removed.



- Check fluid level in transmission.
- Move selector lever through all positions to be sure that transmission operates correctly.
With parking brake applied, rotate engine at idling. Move selector lever through "N" to "D", to "2", to "1" and to "R". A slight shock should be felt by hand gripping selector each time transmission is shifted.
- Perform road test. — Refer to "ROAD TESTING".

MAJOR OVERHAUL

RE4R01A

-  : N-m (kg-m, ft-lb)
-  : Apply recommended sealant (Nissan genuine part: KP610-00250) or equivalent.
-  : Apply A.T.F.
-  : Apply petroleum jelly
- ★ : Select with proper thickness.
- ☆ : Adjustment is required.

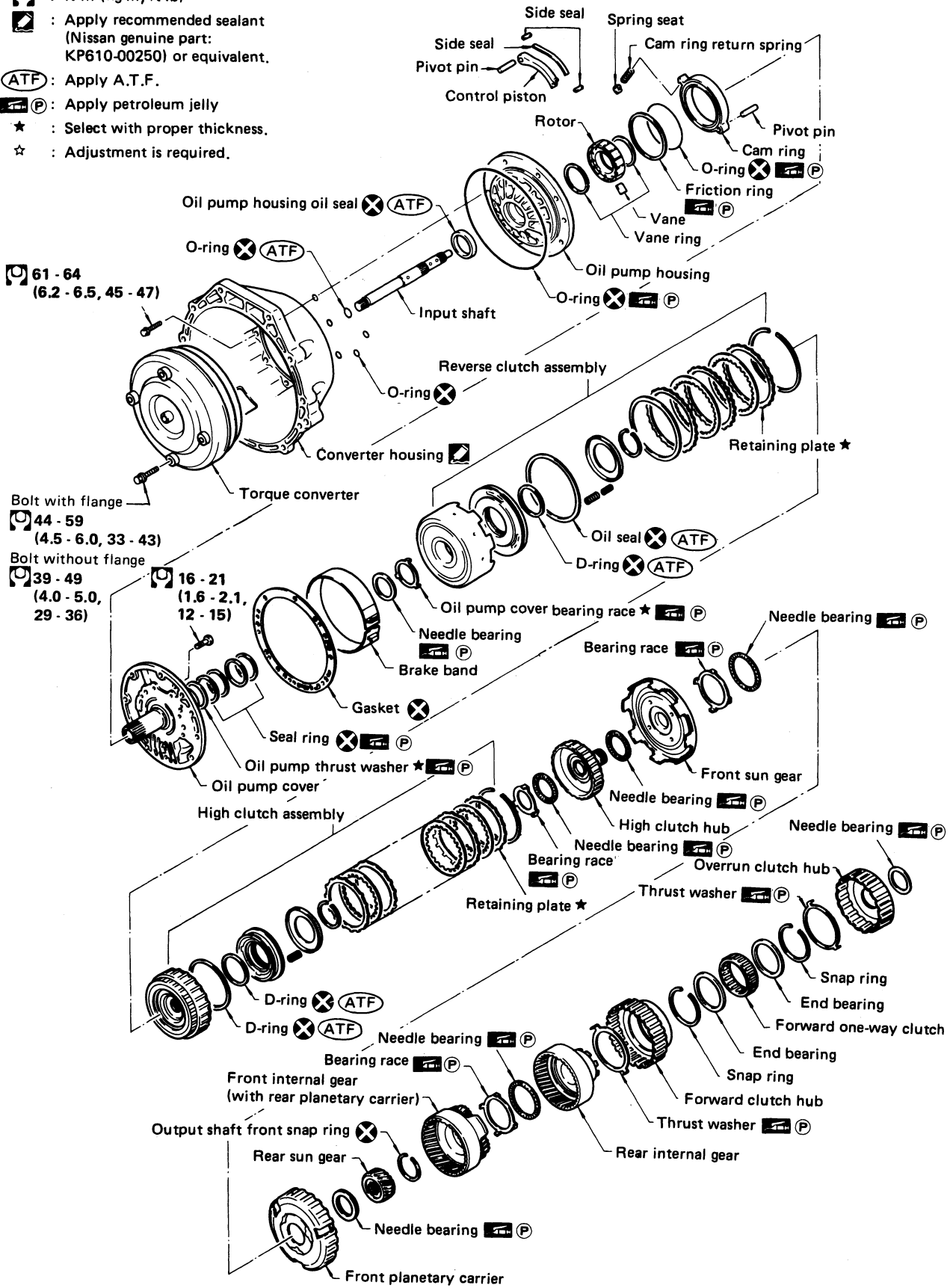

MAJOR OVERHAUL



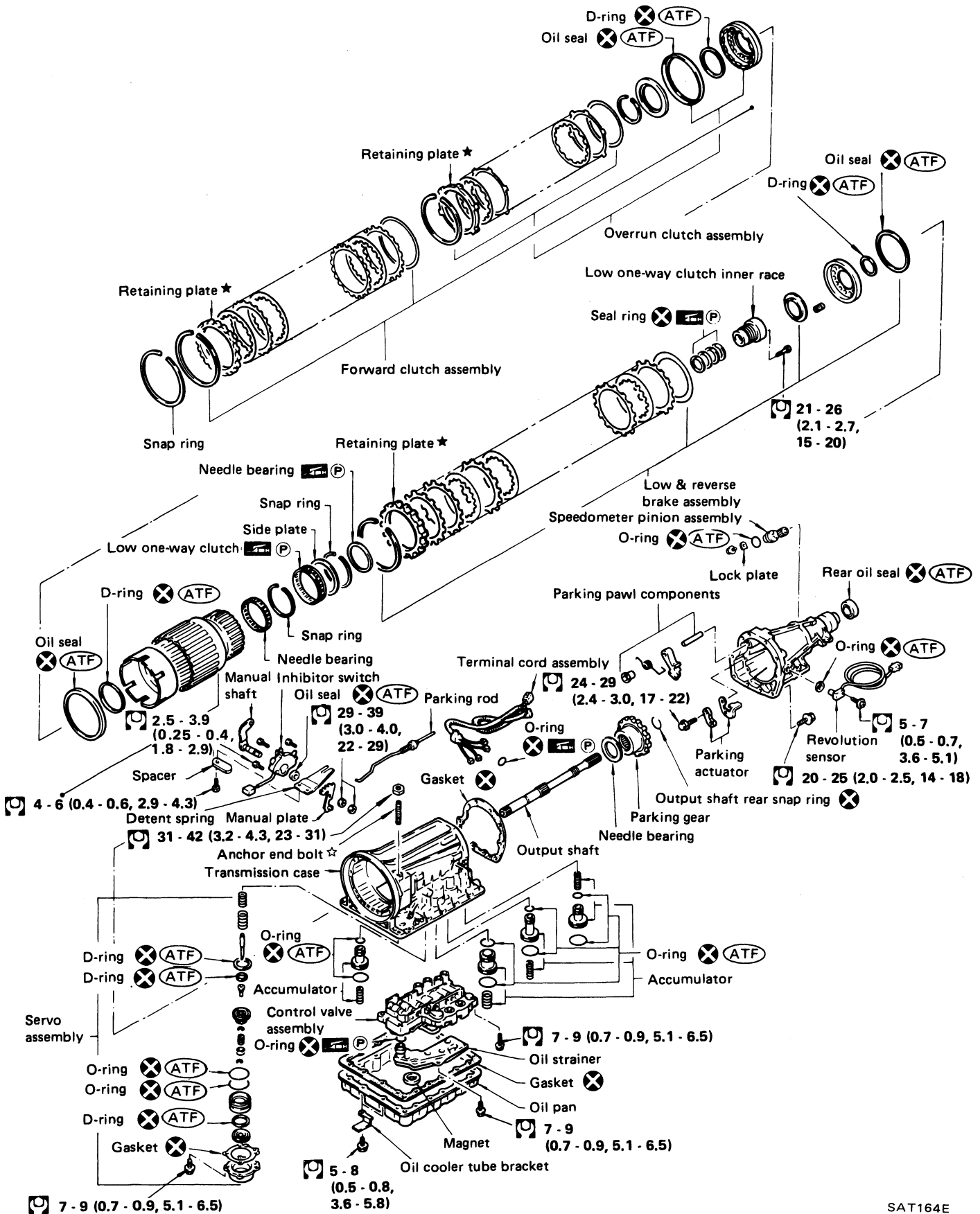



RE4R01A (Cont'd)



SAT164E

MAJOR OVERHAUL

RE4R03A

-  : N-m (kg-m, ft-lb)
-  : Apply recommended sealant (Nissan genuine part: KP610-00250) or equivalent.
-  : Apply A.T.F.
-  : Apply petroleum jelly
-  : Select with proper thickness.
-  : Adjustment is required.

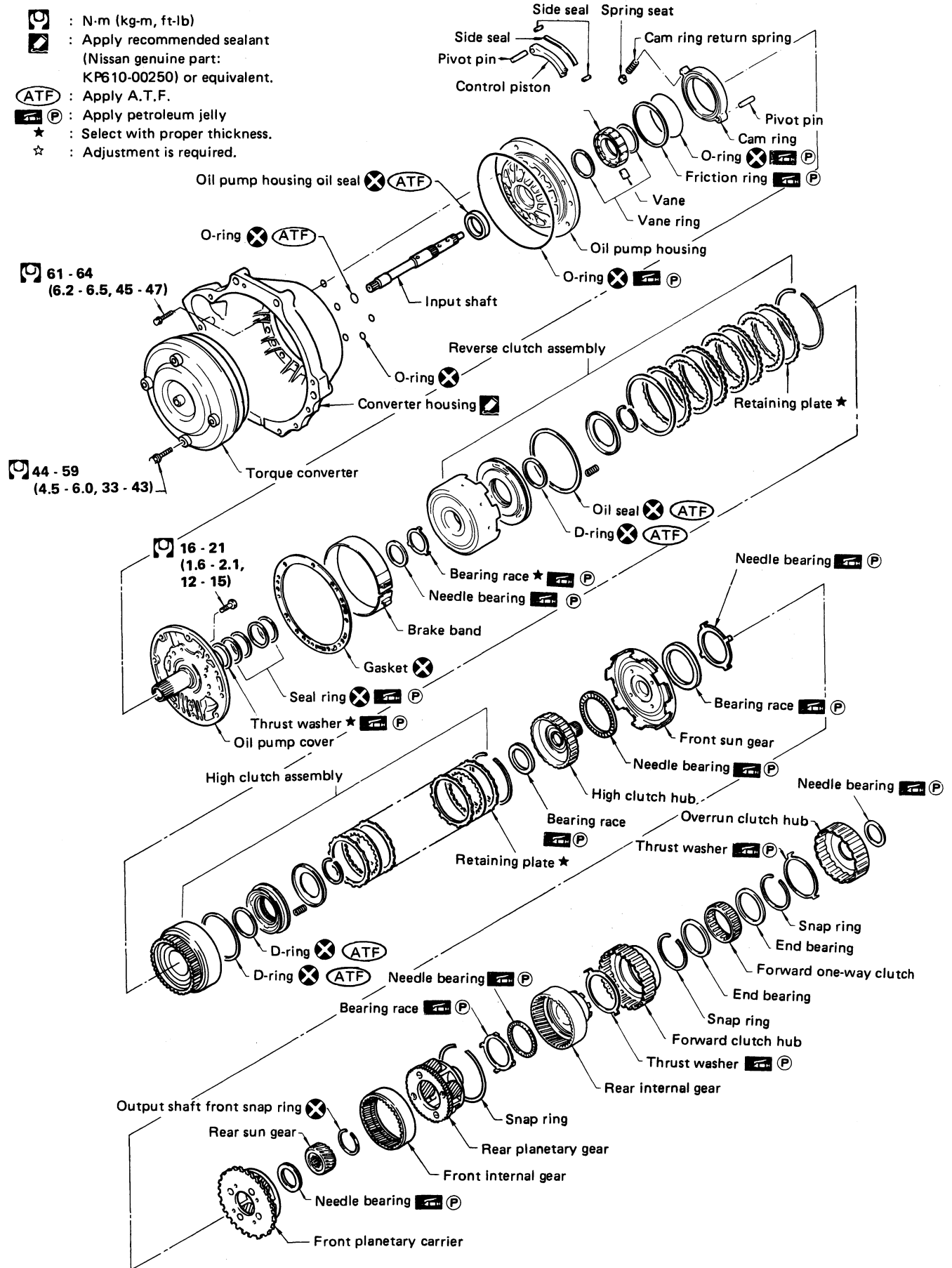

MAJOR OVERHAUL

RE4R03A (Cont'd)

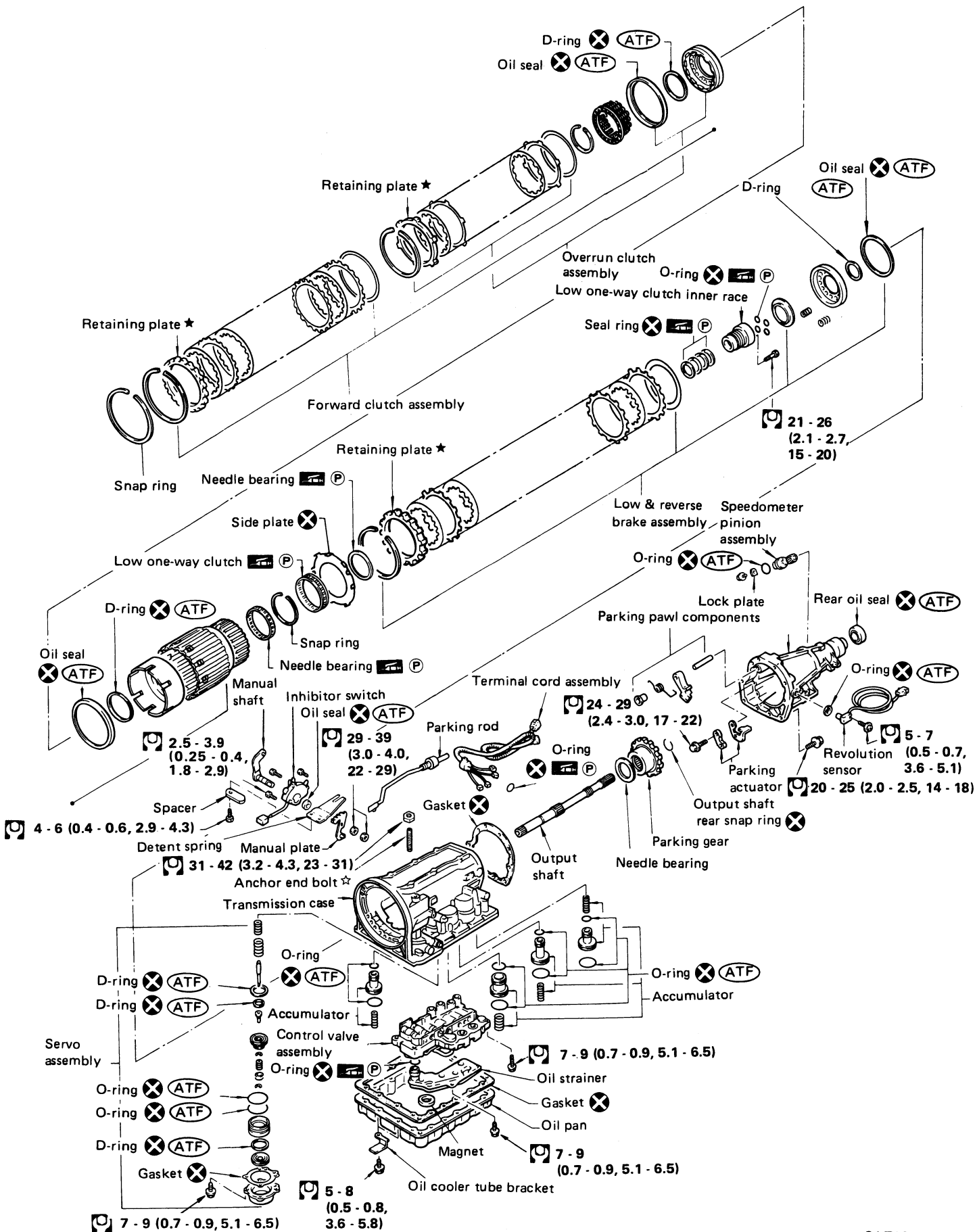

SAT165E

MAJOR OVERHAUL

Oil Channel — RE4R01A

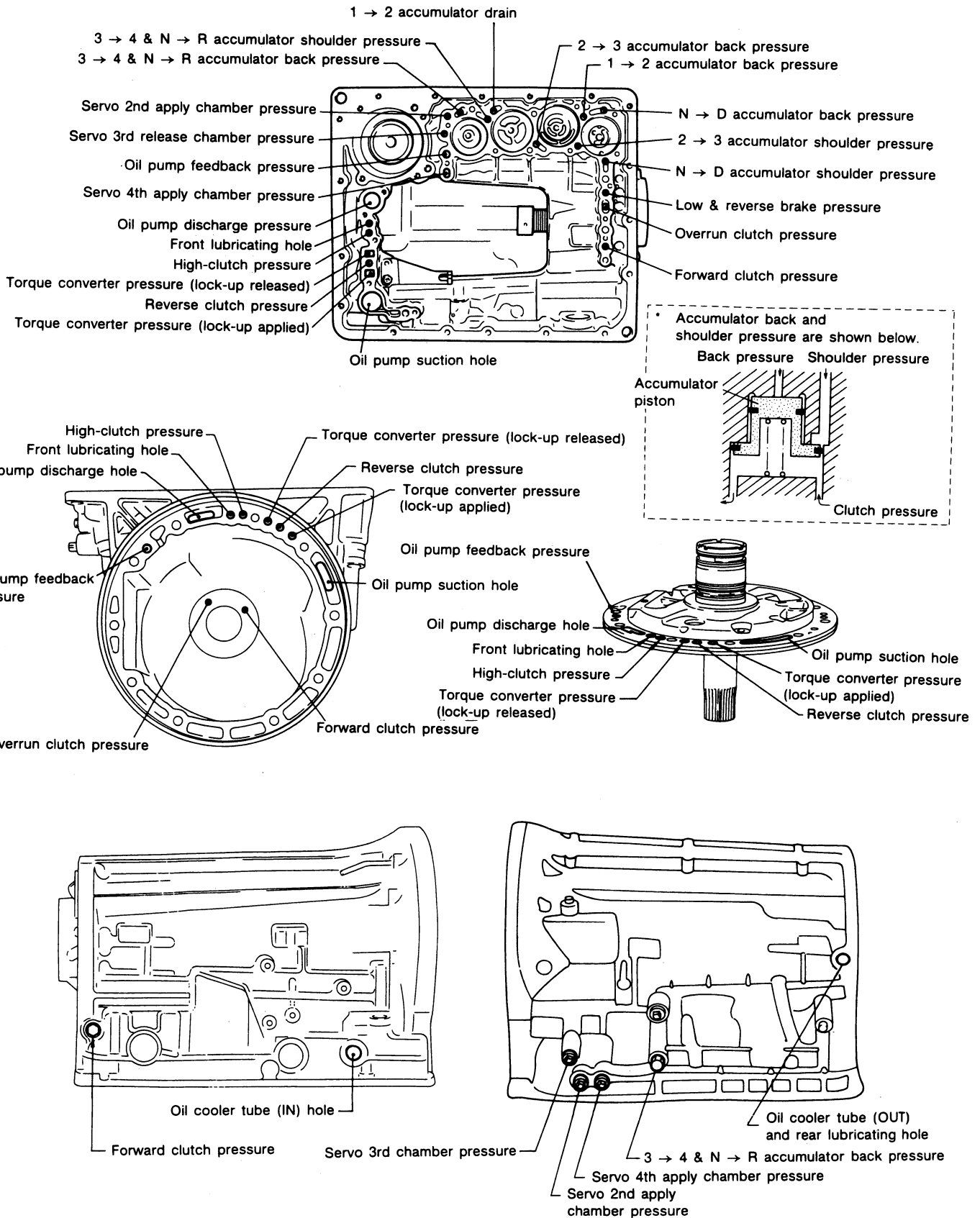

SAT185B

MAJOR OVERHAUL

Oil Channel — RE4R03A

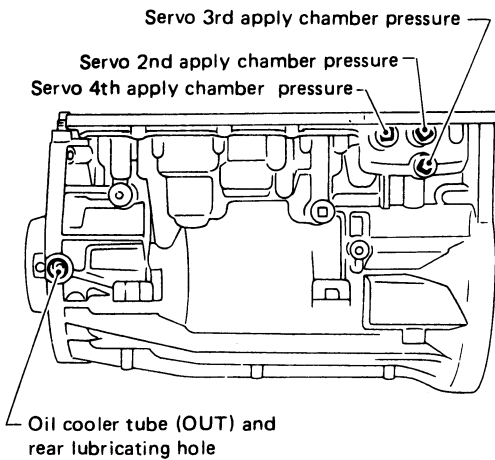
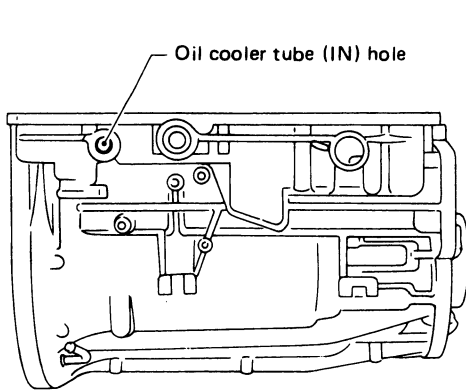
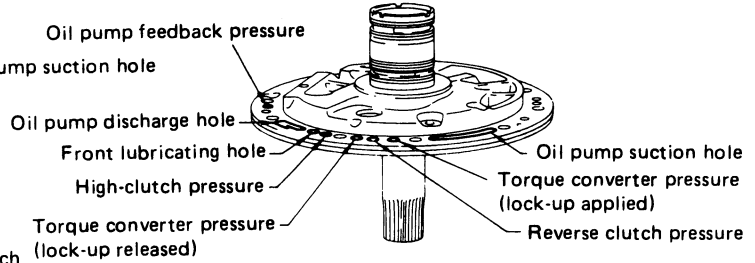
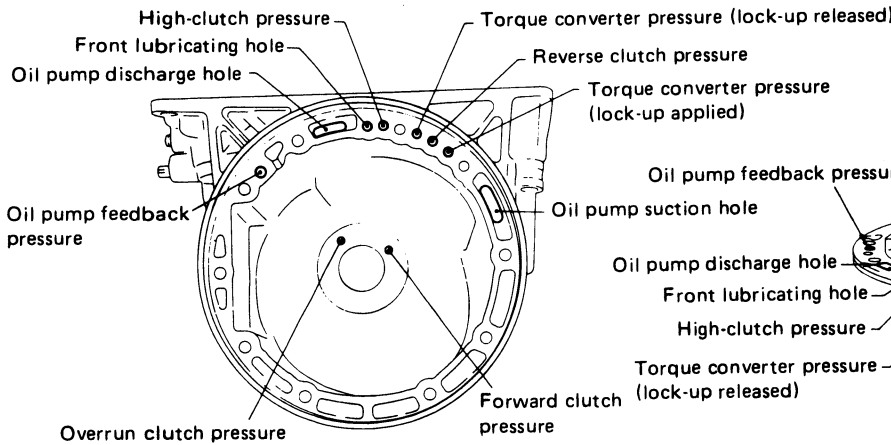
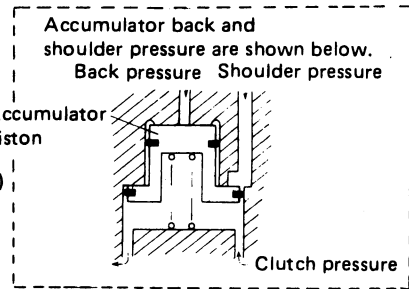
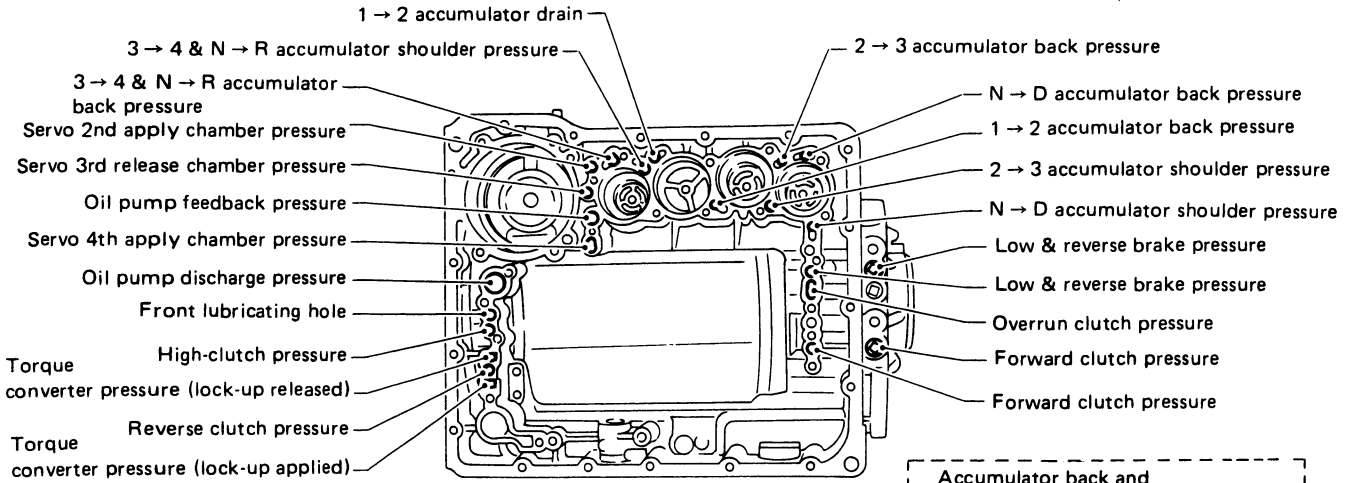

MAJOR OVERHAUL

Locations of Needle Bearings, Thrust Washers and Snap Rings — RE4R01A

Outer diameter of snap rings

Item number	Outer diameter mm (in)
②	161.0 (6.34)
③	140.1 (5.52)
④	156.4 (6.16)
⑥	142.0 (5.59)
⑦	159.2 (6.27)

Thrust washers

Item number	Color
①	Black
⑤	White

Outer diameter of needle bearings

Item number	Outer diameter mm (in)
⑧	47 (1.85)
⑨	53 (2.09)
⑩	53 (2.09)
⑪	78 (3.07)
⑫	53 (2.09)
⑬	78 (3.07)
⑭	59 (2.32)
⑮	78 (3.07)
⑯	64 (2.52)

Inner diameter of bearing races

Item number	Outer diameter mm (in)
⑪	58 (2.28)
⑬	58.8 (2.315)

Installation of one-piece bearings

Item number	Bearing race (black) location
⑫	Front
⑮	Rear side
⑯	Rear side

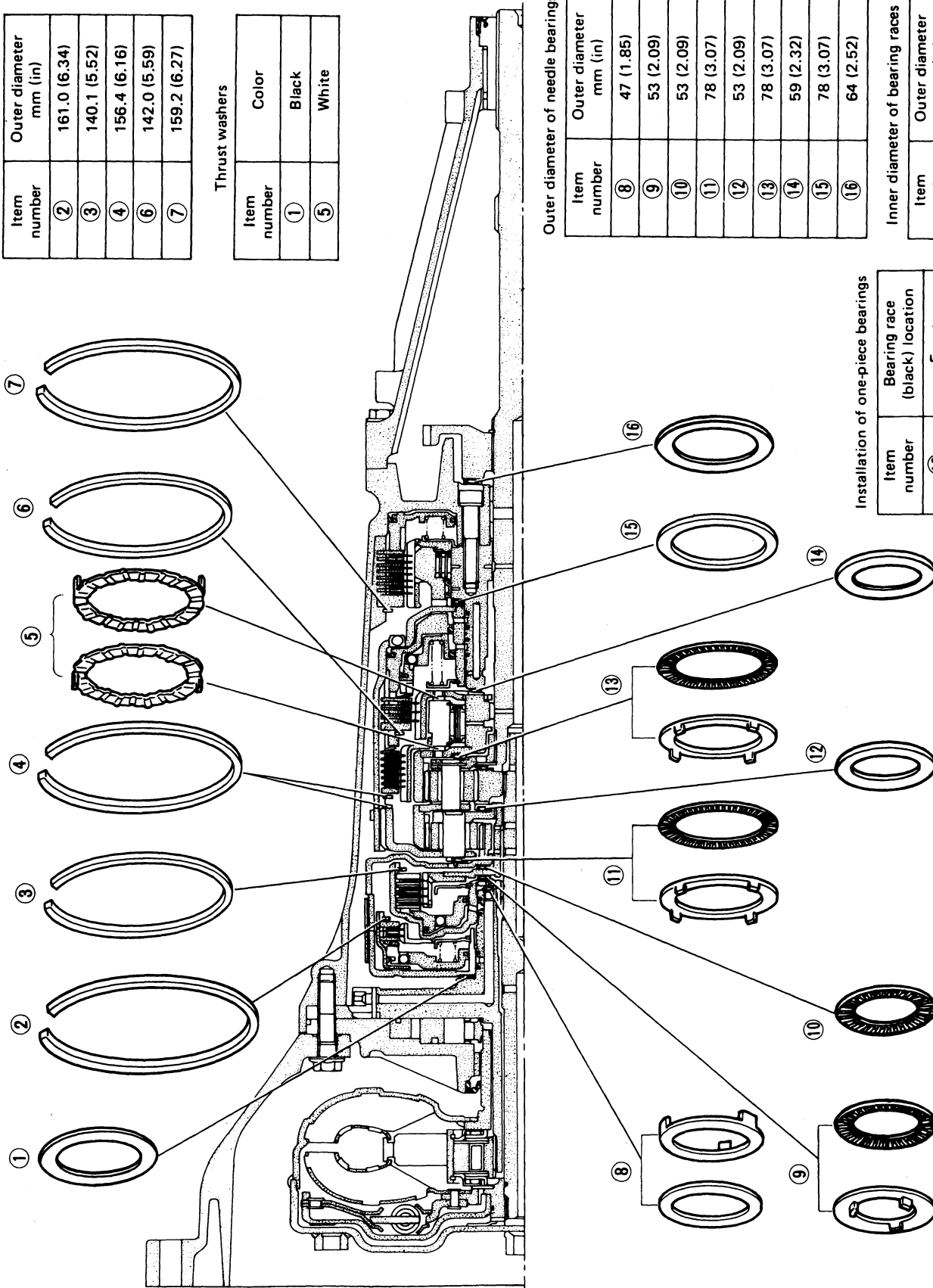

MAJOR OVERHAUL

Locations of Needle Bearings, Thrust Washers and Snap Rings — RE4R03A

Outer diameter of snap rings

Item number	Outer diameter mm (in)
②, ⑤	164.0 (6.46)
③	176.0 (6.93)
⑥	172.0 (6.77)

Thrust washers

Item number	Color
①	Black
④	White

Outer diameter of bearing races

Item number	Outer diameter mm (in)
⑦	43.5 (1.713)
⑩	82.0 (3.228)
⑬	63.2 (2.488)

Installation of one-piece bearings

Item number	Bearing race (black) location
⑮	Rear side
⑯	Rear side

Inner and outer diameter of needle bearings

Item number	Outer diameter mm (in)	Inner diameter mm (in)	Number of needles
⑦	47.0 (1.850)	30.0 (1.181)	—
⑧	53.0 (2.087)	35.1 (1.382)	—
⑨, ⑩	85.0 (3.346)	62.7 (2.468)	—
⑪, ⑫	64.0 (2.520)	45.0 (1.772)	52
⑬	64.0 (2.520)	45.0 (1.772)	50
⑭	64.0 (2.520)	44.0 (1.732)	34
⑮	78.1 (3.075)	—	—
⑯	64.0 (2.520)	—	—

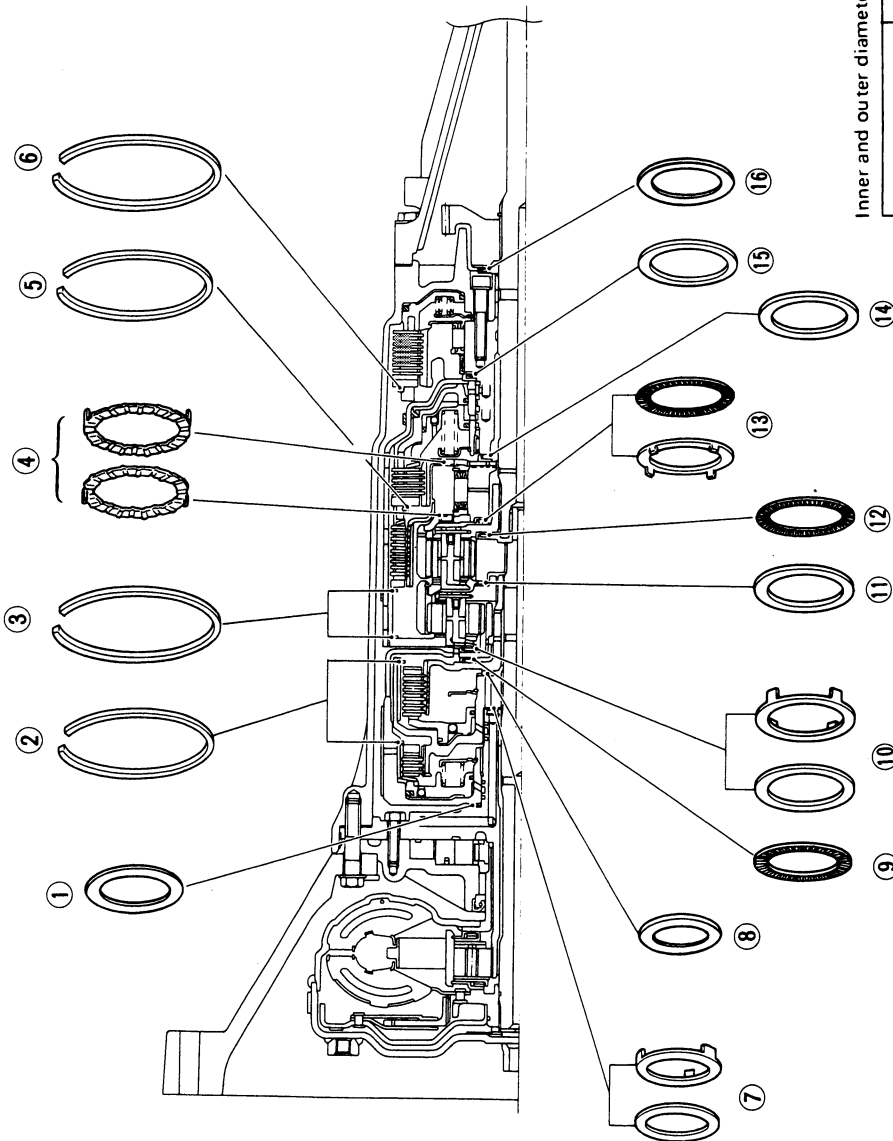

DISASSEMBLY

Disassembly

1. Remove torque converter by holding it firmly and turning while pulling straight out.

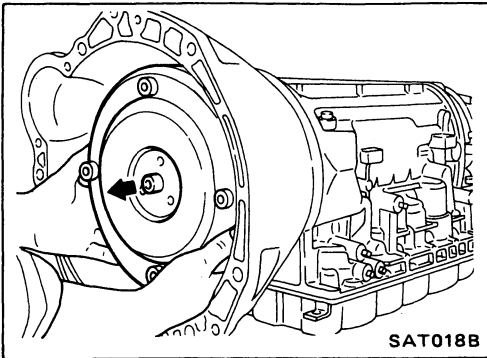

2. Check torque converter one-way clutch.
 - a. Insert Tool into spline of one-way clutch inner race.
 - b. Hook bearing support unitized with one-way clutch outer race with suitable wire.
 - c. Check that one-way clutch inner race rotates only clockwise with Tool while holding bearing support with wire.

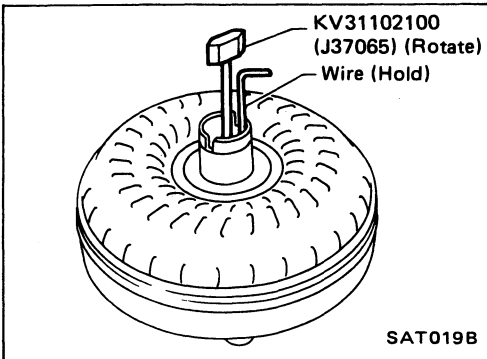

3. Remove inhibitor switch from transmission case.

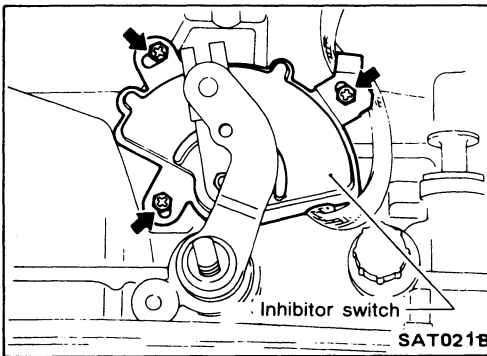

4. Remove oil pan.
 - a. Drain A.T.F. from rear extension.
 - b. Raise oil pan by placing wooden blocks under converter housing and rear extension.
 - c. Separate the oil pan and transmission case.
 - Always place oil pan straight down so that foreign particles inside will not move.

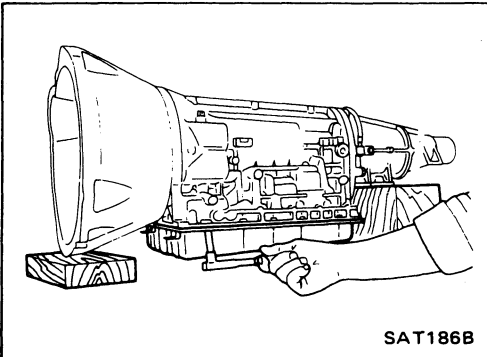

5. Place transmission into Tool with the control valve facing up.

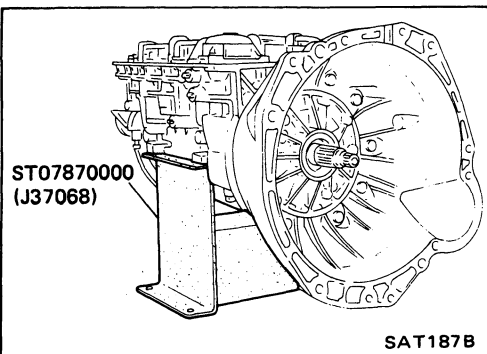

DISASSEMBLY

Disassembly (Cont'd)

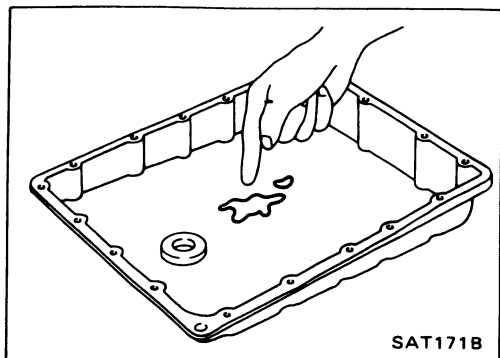

6. Check oil pan and oil strainer for accumulation of foreign particles.
 - If materials of clutch facing are found, clutch plates may be worn.
 - If metal filings are found, clutch plates, brake bands, etc. may be worn.
 - If aluminum filings are found, bushings or aluminum cast parts may be worn.

In above cases, replace torque converter and check unit for cause of particle accumulation.

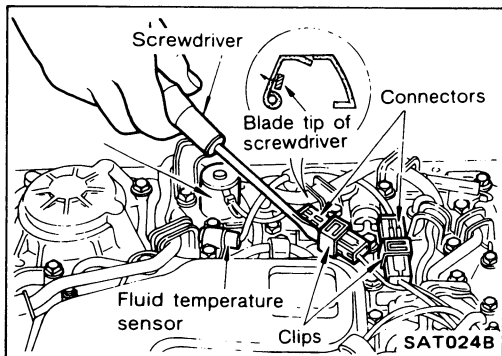

7. Remove lock-up solenoid and fluid temperature sensor connectors.
 - **Be careful not to damage connector.**

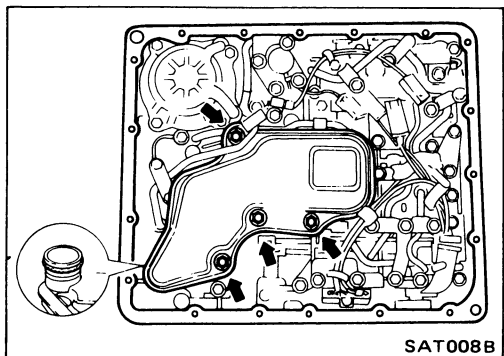

8. Remove oil strainer.
 - a. Remove oil strainer from control valve assembly. Then remove O-ring from oil strainer.

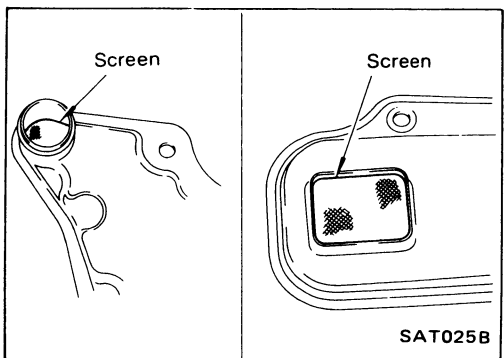

- b. Check oil strainer screen for damage.

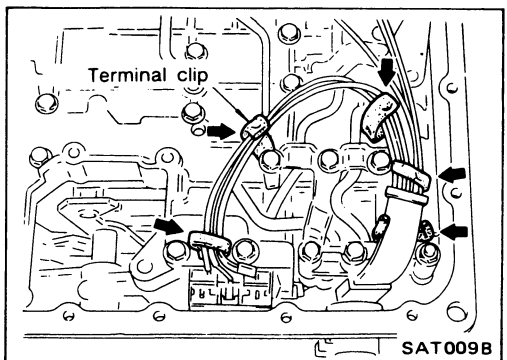



9. Remove control valve assembly.
 - a. Straighten terminal clips to free terminal cords then remove terminal clips.

DISASSEMBLY

Disassembly (Cont'd)

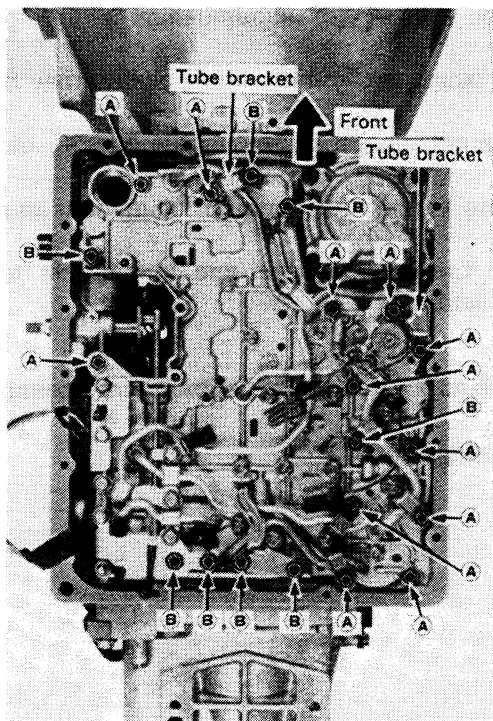
- b. Remove bolts **(A)** and **(B)**, and remove control valve assembly from transmission.



Bolt symbol	ℓ mm (in)	 ℓ
(A)	33 (1.30)	
(B)	45 (1.77)	

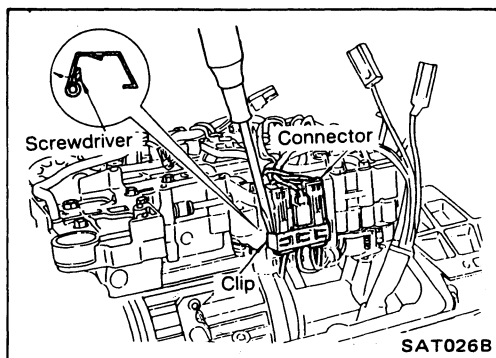

- c. Remove solenoid connector.
 ● **Be careful not to damage connector.**

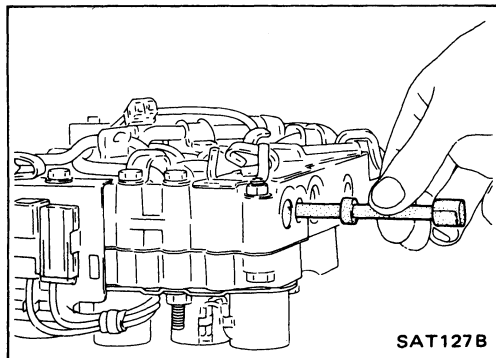

- d. Remove manual valve from control valve assembly.

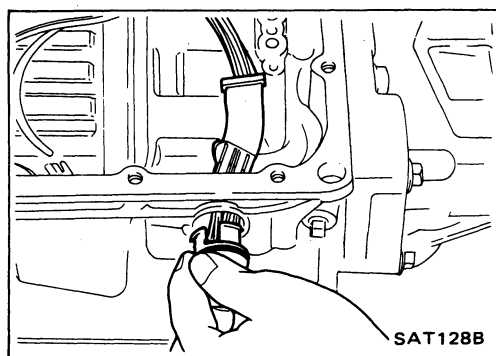

10. Remove terminal cord assembly from transmission case while pushing on stopper.
 ● **Be careful not to damage cord.**
 ● **Do not remove terminal cord assembly unless it is damaged.**

DISASSEMBLY

Disassembly (Cont'd)

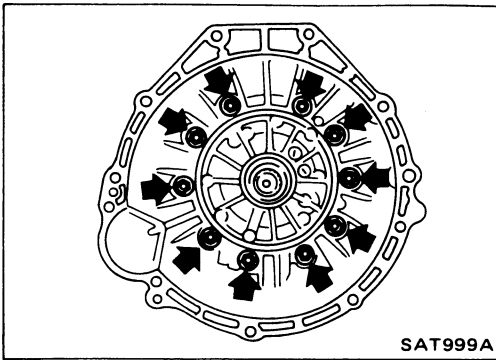

11. Remove converter housing from transmission case.

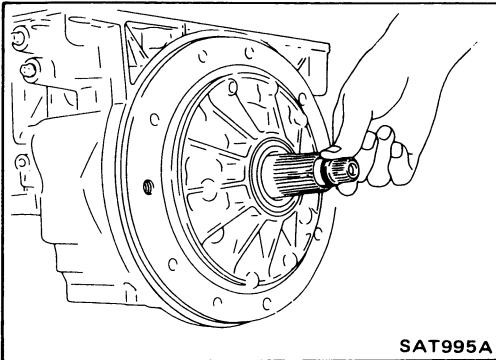

12. Remove O-ring from input shaft.

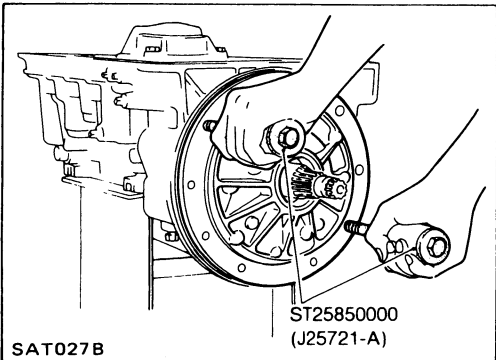

13. Remove oil pump assembly.

a. Attach Tool to oil pump assembly and extract it evenly from transmission case.

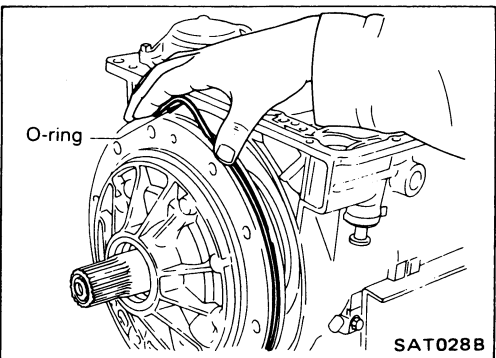

b. Remove O-ring from oil pump assembly.

c. Remove traces of sealant from oil pump housing.

● **Be careful not to scratch pump housing.**

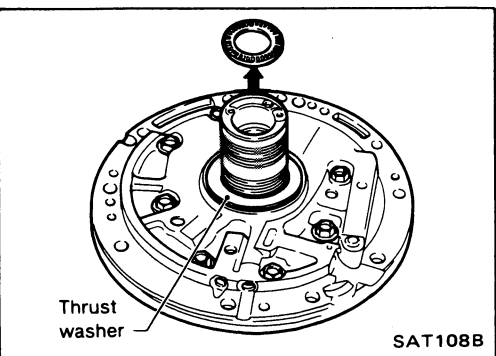

d. Remove needle bearing and thrust washer from oil pump assembly.

DISASSEMBLY

Disassembly (Cont'd)

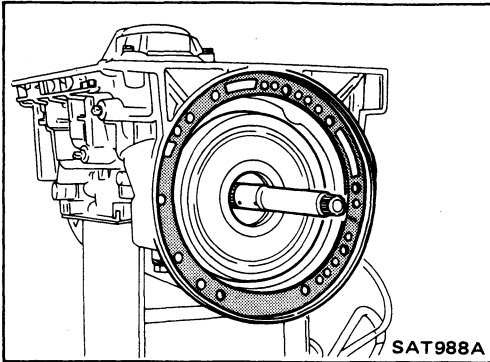

14. Remove input shaft and oil pump gasket.

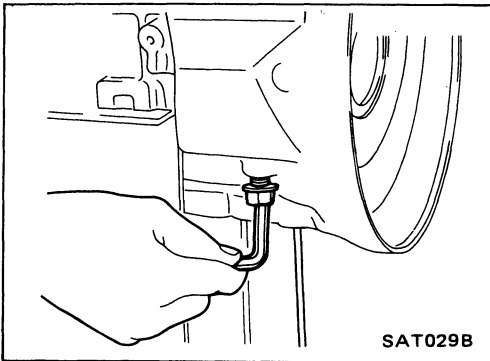

15. Remove brake band and band strut.

a. Loosen lock nut and remove band servo anchor end pin from transmission case.

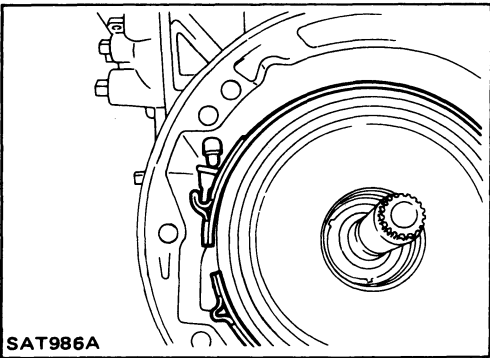

b. Remove brake band and band strut from transmission case.

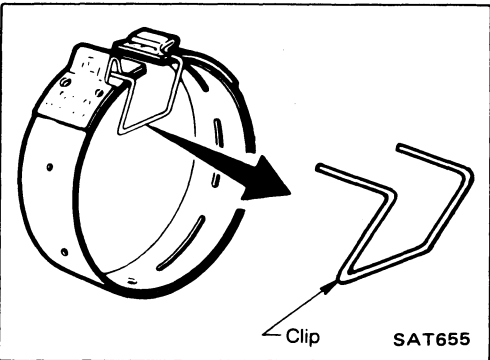

c. Hold brake band in a circular shape with clip.

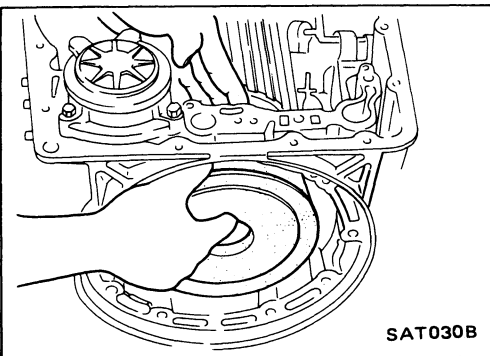

16. Remove front side clutch and gear components.

a. Remove clutch pack (reverse clutch, high clutch and front sun gear) from transmission case.

DISASSEMBLY

Disassembly (Cont'd)

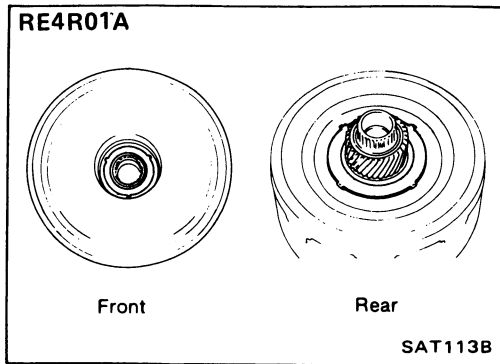

- b. Remove front bearing race from clutch pack.
- c. Remove rear bearing race or front needle bearing from clutch pack.

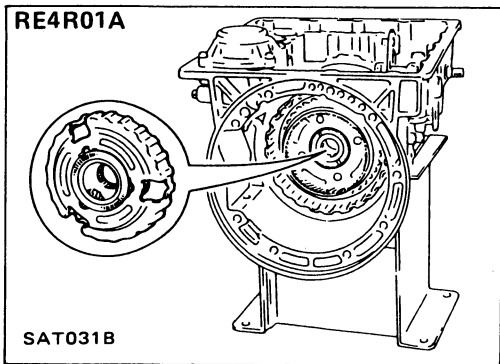
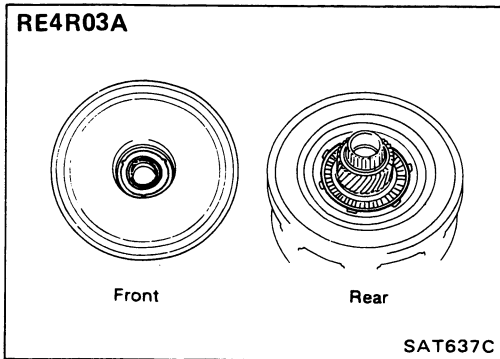

- d. Remove front planetary carrier from transmission case.

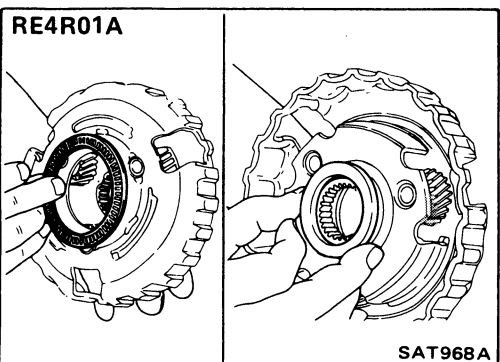
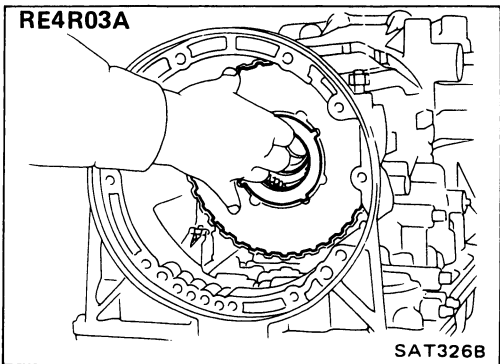

- e. Remove front needle bearing or front bearing race from front planetary carrier.
- f. Remove rear needle bearing from front planetary carrier.

DISASSEMBLY

Disassembly (Cont'd)

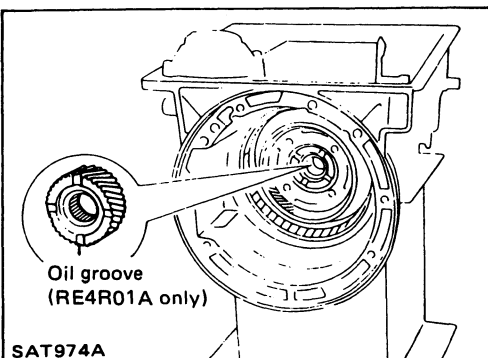
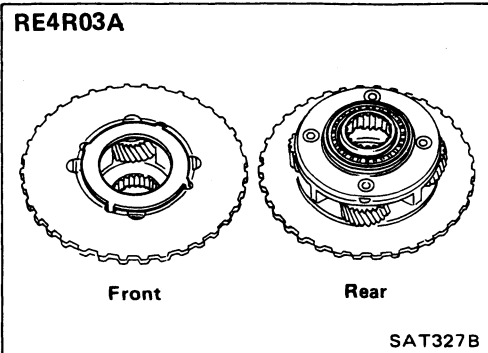

g. Remove rear sun gear from transmission case.

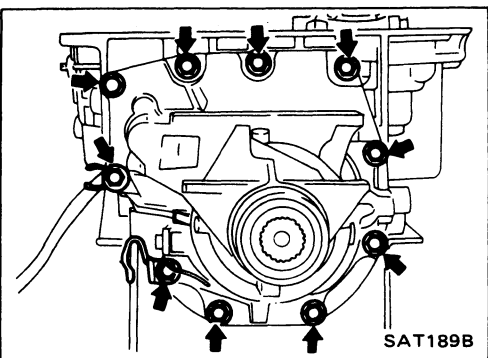

17. Remove rear extension.

a. Remove rear extension from transmission case.

b. Remove rear extension gasket from transmission case.

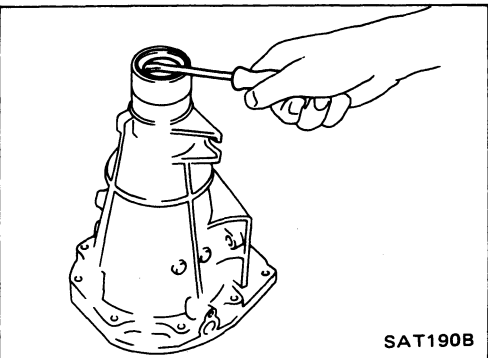

c. Remove oil seal from rear extension.

● Do not remove oil seal unless it is to be replaced.

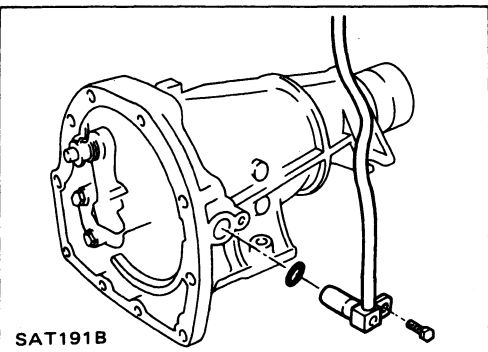

d. Remove revolution sensor from rear extension.

e. Remove O-ring from revolution sensor.

DISASSEMBLY

Disassembly (Cont'd)

18. Remove output shaft and parking gear.
a. Remove rear snap ring from output shaft.

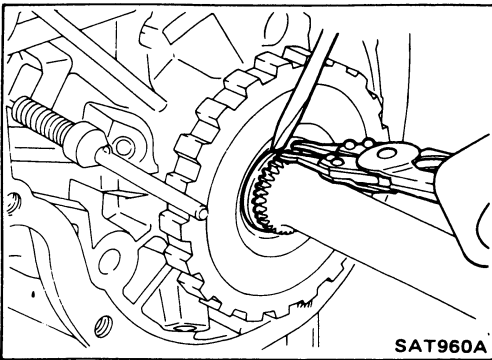

- b. Slowly push output shaft all the way forward.
● **Do not use excessive force.**
c. Remove snap ring from output shaft.

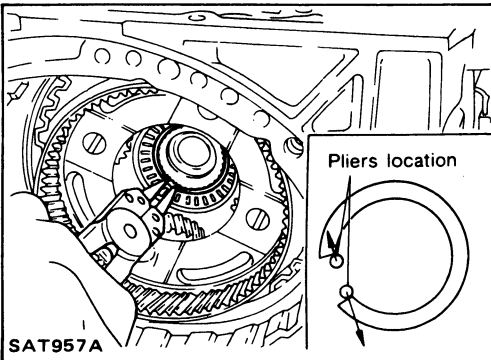

- d. Remove output shaft and parking gear as a unit from transmission case.
e. Remove parking gear from output shaft.

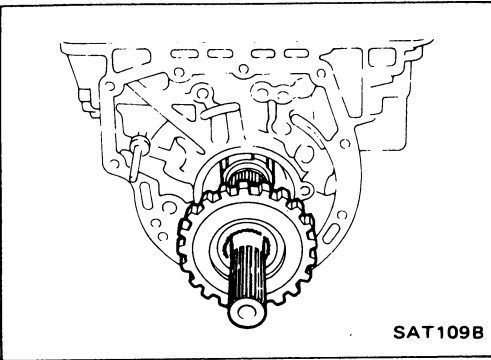

- f. Remove needle bearing from transmission case.

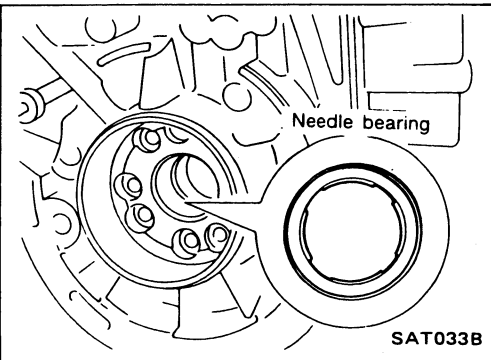

19. Remove rear side clutch and gear components.
a. Remove front internal gear.

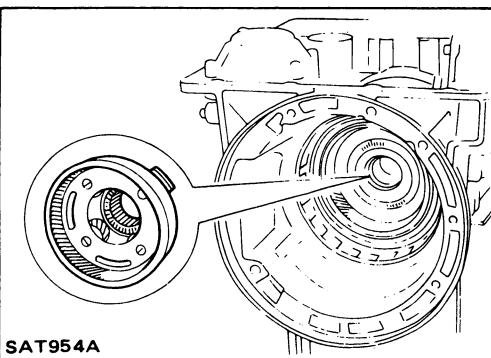

DISASSEMBLY

Disassembly (Cont'd)

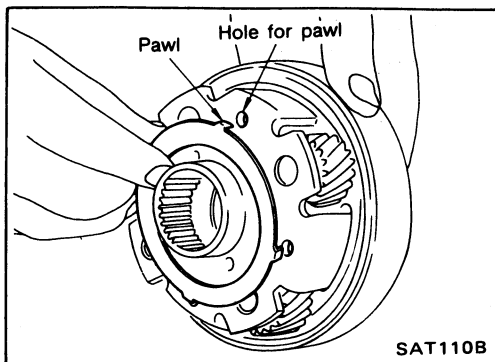

b. Remove bearing race from front internal gear.

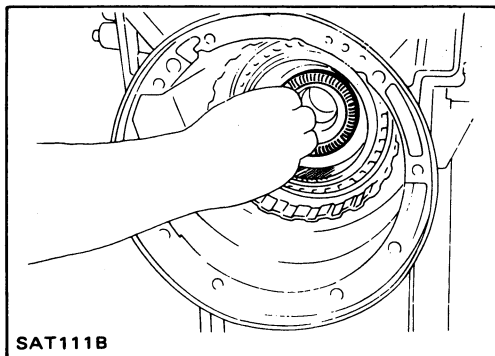

c. Remove needle bearing from rear internal gear.

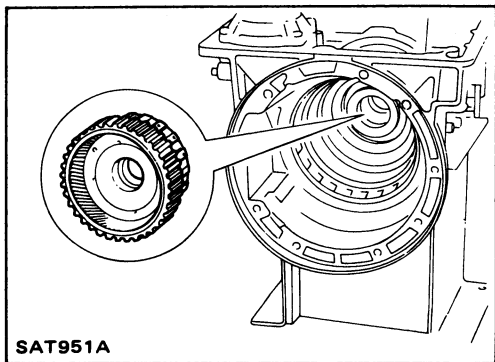

d. Remove rear internal gear, forward clutch hub and overrun clutch hub as a set from transmission case.

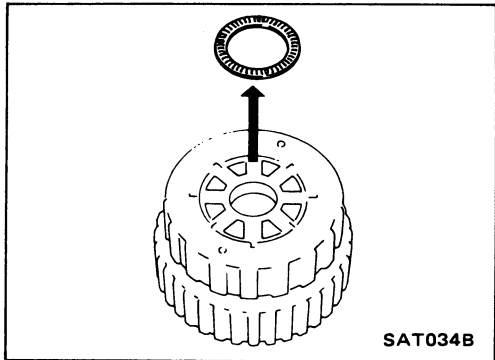

e. Remove needle bearing from overrun clutch hub.

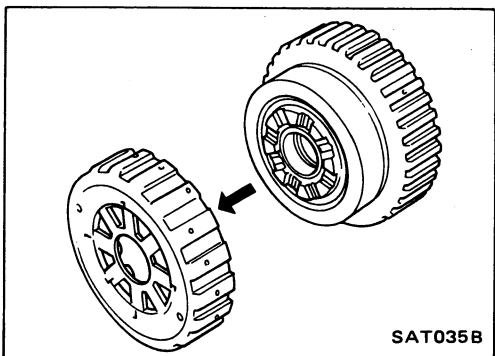

f. Remove overrun clutch hub from rear internal gear and forward clutch hub.

DISASSEMBLY

Disassembly (Cont'd)

g. Remove thrust washer from overrun clutch hub.

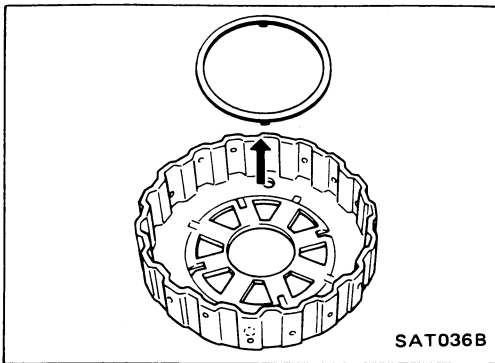

h. Remove forward clutch assembly from transmission case.

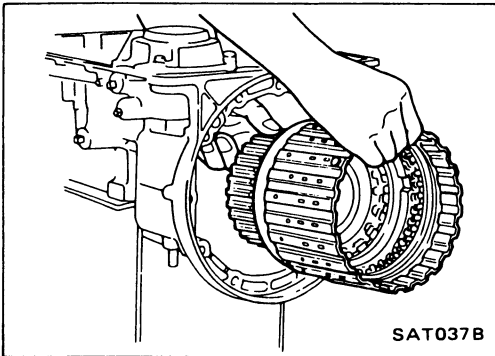

20. Remove band servo and accumulator components.

a. Remove band servo retainer from transmission case.

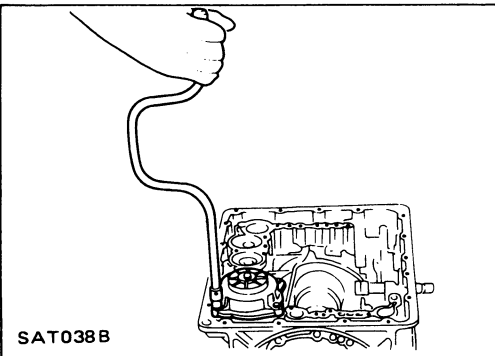

b. Apply compressed air to oil hole until band servo piston comes out of transmission case.

● **Hold piston with a rag and gradually direct air to oil hole.**

c. Remove return springs.

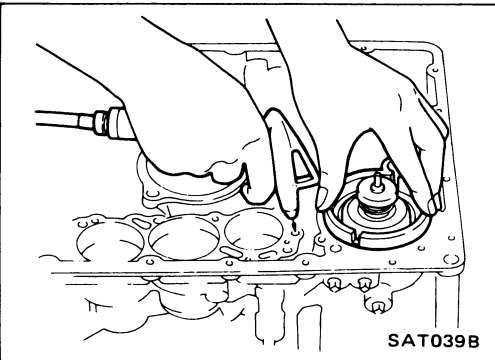

d. Remove springs from accumulator pistons B, C and D.

e. Apply compressed air to each oil hole until piston comes out.

● **Hold piston with a rag and gradually direct air to oil hole.**

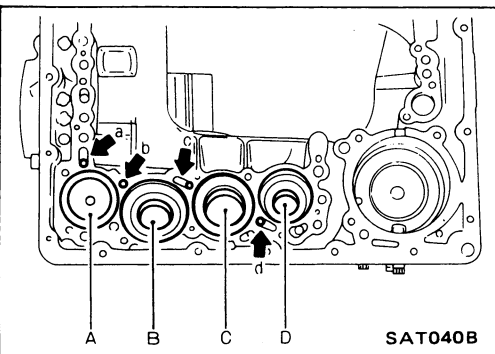

Identification of accumulator pistons	A	B	C	D
Identification of oil holes	a	b	c	d

DISASSEMBLY

Disassembly (Cont'd)

f. Remove O-ring from each piston.

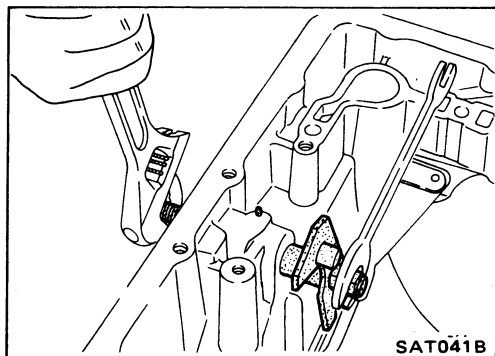
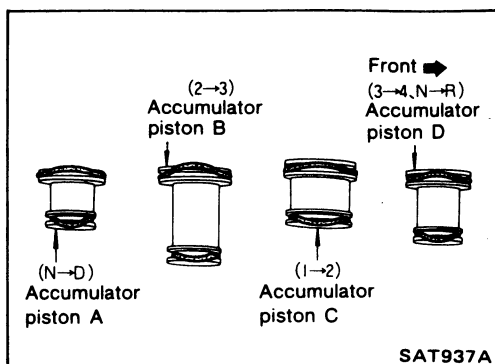

21. Remove manual shaft components, if necessary.

a. Hold width across flats of manual shaft (outside the transmission case) and remove lock nut from shaft.

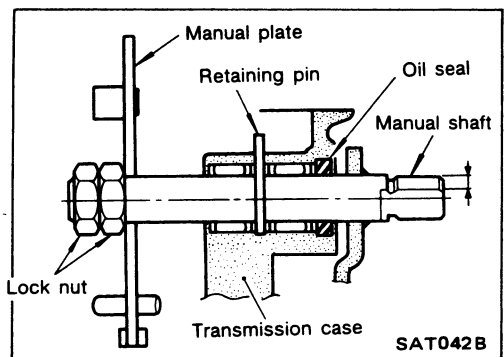

b. Remove retaining pin from transmission case.

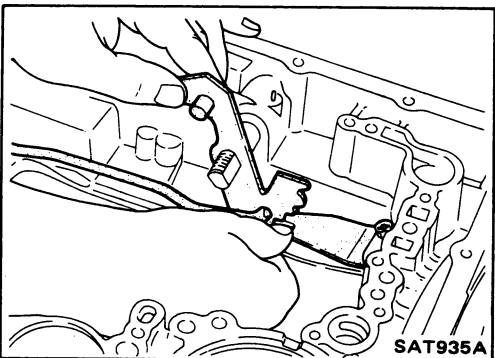

c. While pushing detent spring down, remove manual plate and parking rod from transmission case.

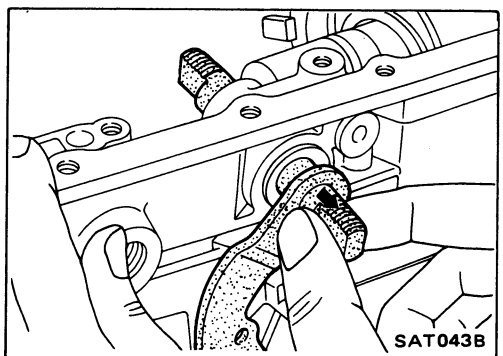

d. Remove manual shaft from transmission case.

DISASSEMBLY

Disassembly (Cont'd)

- e. Remove spacer and detent spring from transmission case.

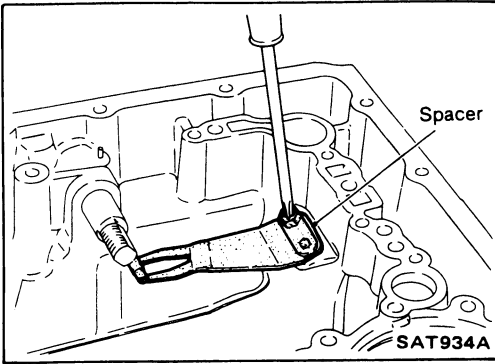

- f. Remove oil seal from transmission case.

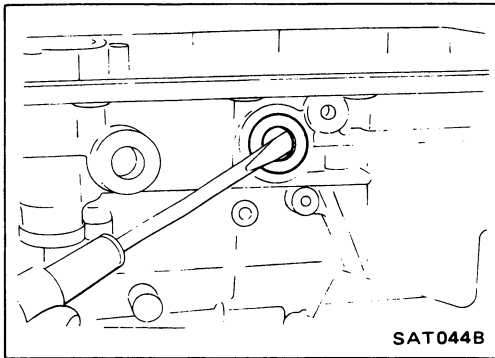

Oil Pump

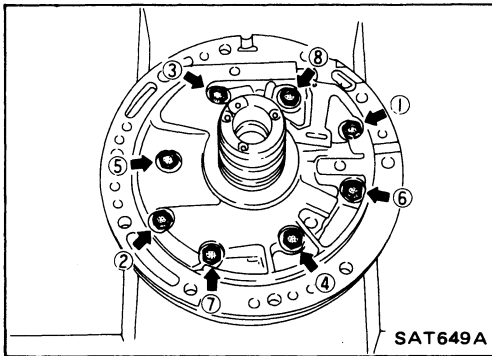
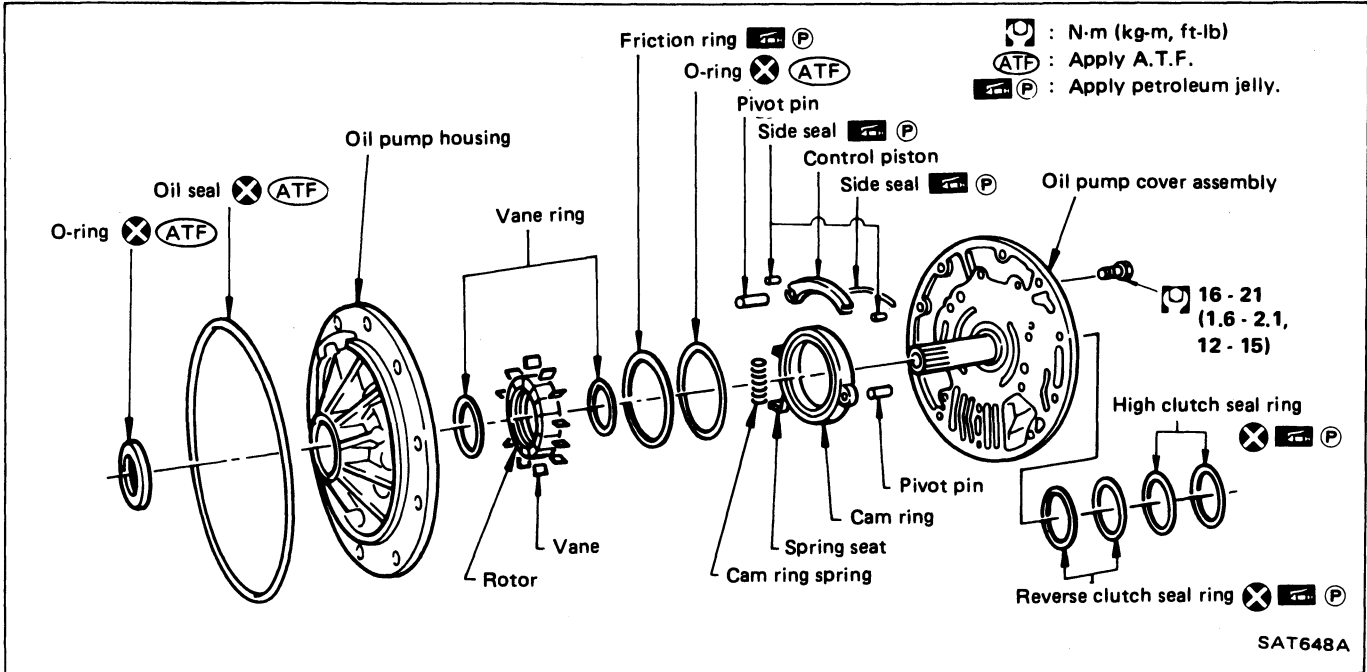

DISASSEMBLY

1. Loosen bolts in numerical order and remove oil pump cover.

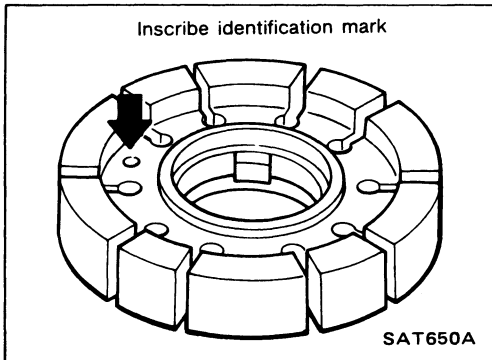

2. Remove rotor, vane rings and vanes.

- Inscribe a mark on back of rotor for identification of fore-aft direction when reassembling rotor. Then remove rotor.

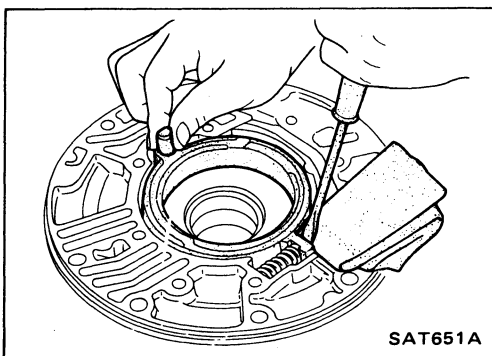

3. While pushing on cam ring remove pivot pin.

- Be careful not to scratch oil pump housing.

REPAIR FOR COMPONENT PARTS

Oil Pump (Cont'd)

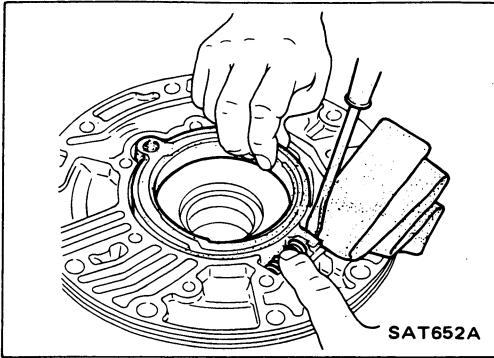

4. While holding cam ring and spring lift out cam ring spring.
 - Be careful not to damage oil pump housing.
 - Hold cam ring spring to prevent it from jumping.

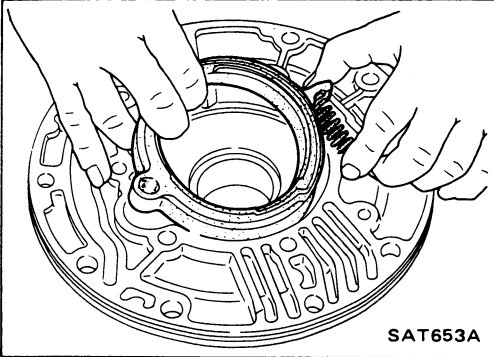

5. Remove cam ring and cam ring spring from oil pump housing.

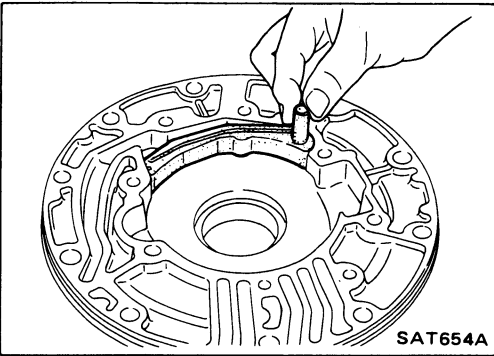

6. Remove pivot pin from control piston and remove control piston assembly.

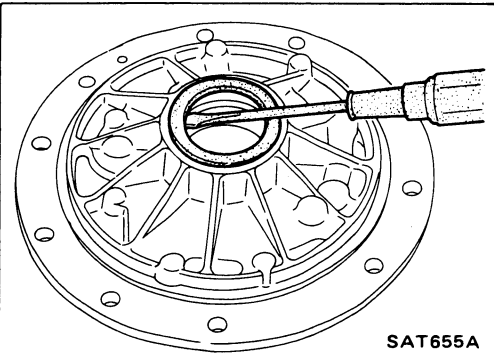

7. Remove oil seal from oil pump housing.
 - Be careful not to scratch oil pump housing.

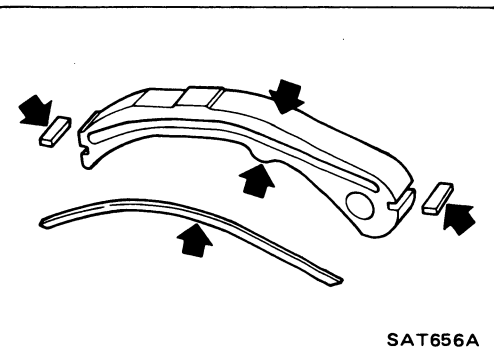

INSPECTION

Oil pump cover, rotor, vanes, control piston, side seals, cam ring and friction ring

- Check for wear or damage.

REPAIR FOR COMPONENT PARTS

Oil Pump (Cont'd)

Side clearances

- Measure side clearances between end of oil pump housing and cam ring, rotor, vanes and control piston in at least four places along their circumferences. Maximum measured values should be within specified ranges.
- **Before measuring side clearance, check that friction rings, O-ring, control piston side seals and cam ring spring are removed.**

Standard clearance:

Cam ring

0.01 - 0.024 mm (0.0004 - 0.0009 in)

Rotor, vanes, control piston

0.03 - 0.044 mm (0.0012 - 0.0017 in)

- If not within standard clearance, replace oil pump assembly except oil pump cover assembly.

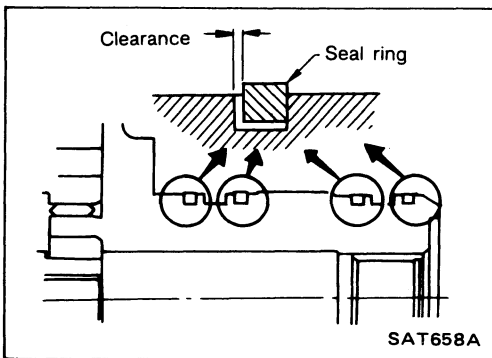
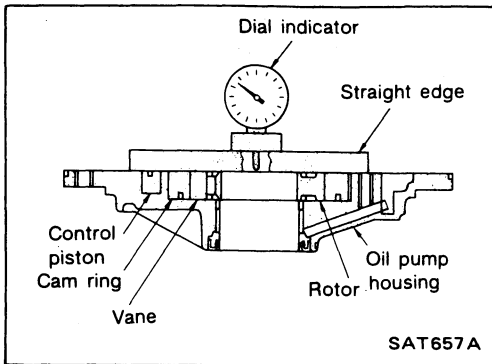

Seal ring clearance

- Measure clearance between seal ring and ring groove.

Standard clearance:

0.10 - 0.25 mm (0.0039 - 0.0098 in)

Wear limit:

0.25 mm (0.0098 in)

- If not within wear limit, replace oil pump cover assembly.

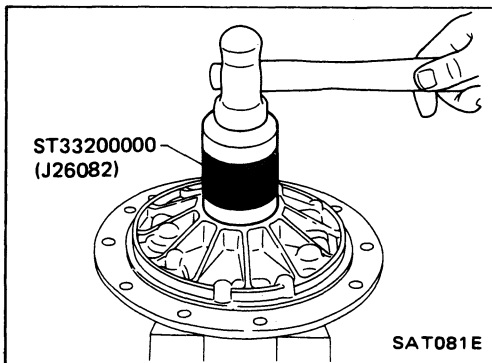

ASSEMBLY

1. Drive oil seal into oil pump housing.

- Apply A.T.F. to outer periphery and lip surface.

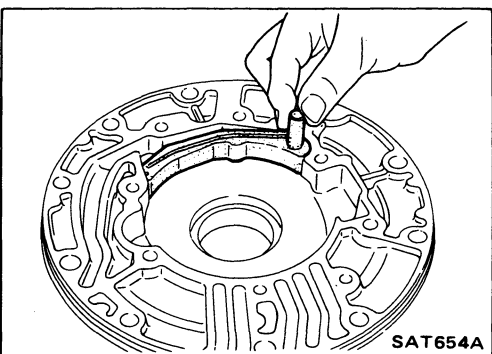

2. Install cam ring in oil pump housing by the following steps.

- a. Install side seal on control piston.

- Pay attention to its direction — Black surface goes toward control piston.

- Apply petroleum jelly to side seal.

- b. Install control piston on oil pump.

REPAIR FOR COMPONENT PARTS

Oil Pump (Cont'd)

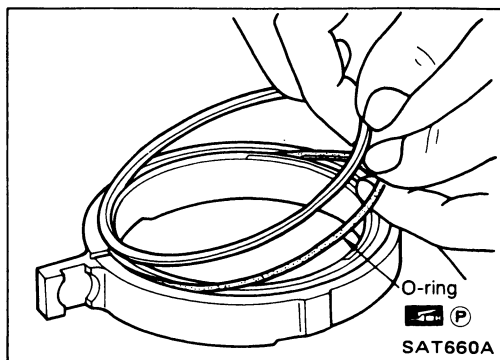

- c. Install O-ring and friction ring on cam ring.
 - Apply petroleum jelly to O-ring.

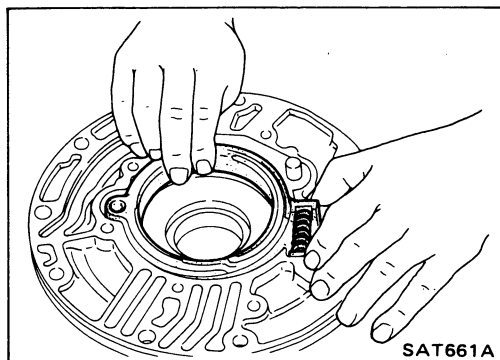

- d. Assemble cam ring, cam ring spring and spring seat. Install spring by pushing it against pump housing.

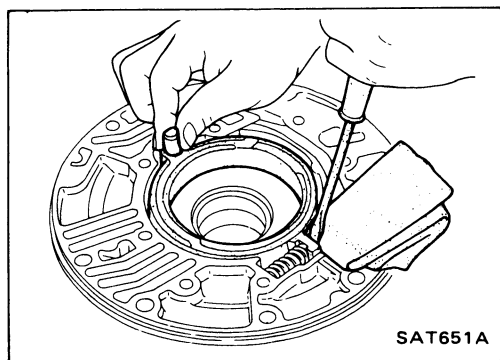

- e. While pushing on cam ring install pivot pin.

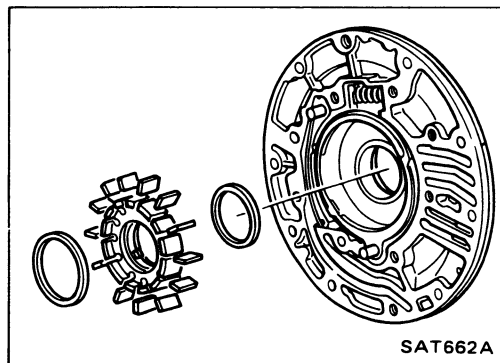

3. Install rotor, vanes and vane rings.
 - Pay attention to direction of rotor.

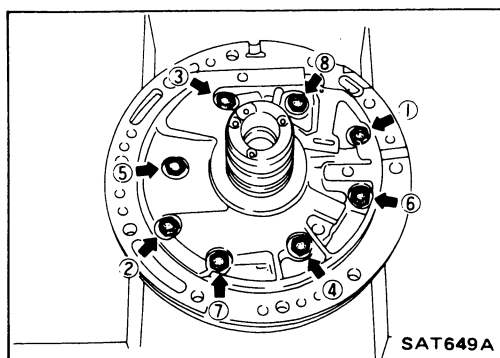

4. Install oil pump housing and oil pump cover.
 - a. Wrap masking tape around splines of oil pump cover assembly to protect seal. Position oil pump cover assembly in oil pump housing assembly, then remove masking tape.
 - b. Tighten bolts in a criss-cross pattern.

REPAIR FOR COMPONENT PARTS

Oil Pump (Cont'd)

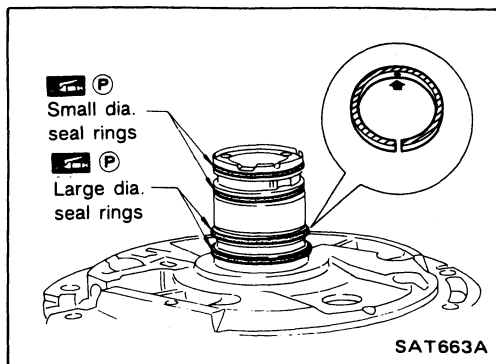

5. Install seal rings carefully after packing ring grooves with petroleum jelly. Press rings down into jelly to a close fit.

- Seal rings come in two different diameters. Check fit carefully in each groove.

Small dia. seal ring:

No mark

Large dia. seal ring:

Yellow mark in area shown by arrow

- Do not spread gap of seal ring excessively while installing. It may deform ring.

REPAIR FOR COMPONENT PARTS

Control Valve Assembly (Cont'd)

DISASSEMBLY

1. Remove solenoids.
 - a. Remove lock-up solenoid and side plate from lower body.
 - b. Remove O-ring from solenoid.

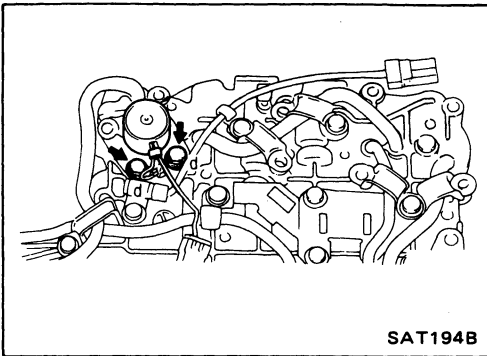

- c. Remove line pressure solenoid from upper body.
 - d. Remove O-ring from solenoid.

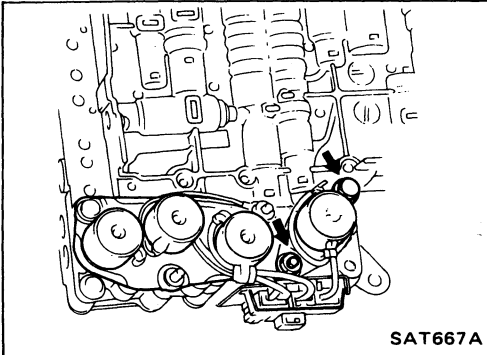

- e. Remove 3-unit solenoid assembly from upper body.
 - f. Remove O-rings from solenoids.

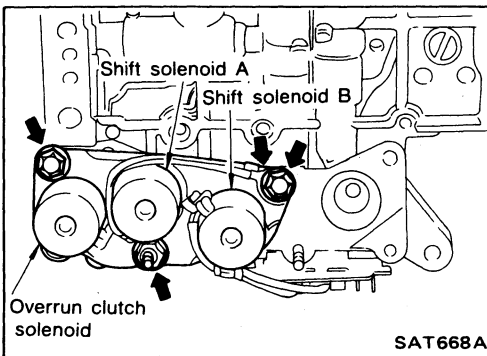

2. Disassemble upper and lower bodies.
 - a. Place upper body facedown, and remove bolts, reamer bolts and support plates.
 - b. Remove lower body, separator plate and separate gasket as a unit from upper body.
 - **Be careful not to drop pilot filter, orifice check valve, spring and steel balls.**

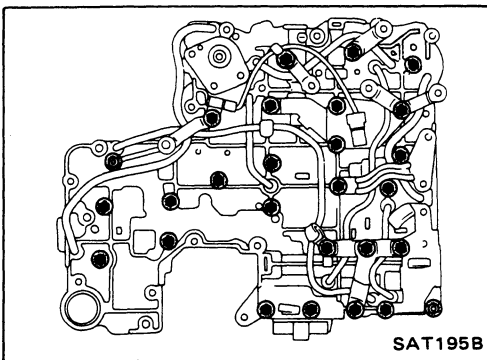

- c. Place lower body facedown, and remove separate gasket and separator plate.
 - d. Remove pilot filter, orifice check valve and orifice check spring.

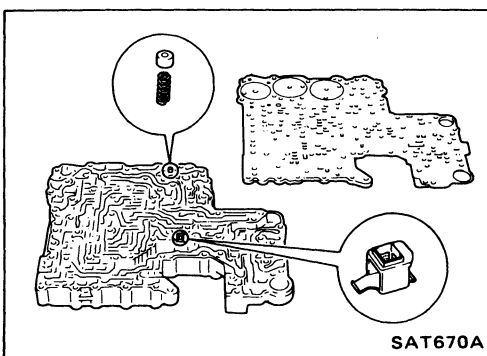

REPAIR FOR COMPONENT PARTS

Control Valve Assembly (Cont'd)

- e. Check to see that steel balls are properly positioned in upper body and then remove them from upper body.

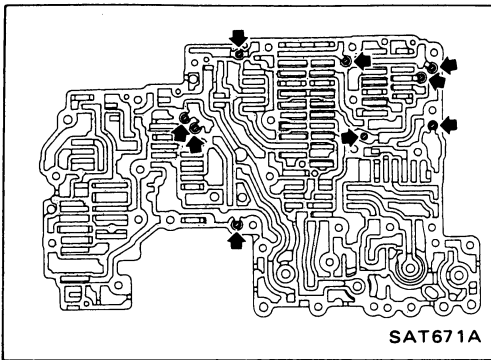

INSPECTION

Lower and upper bodies

- Check to see that there are pins and retainer plates in lower body.

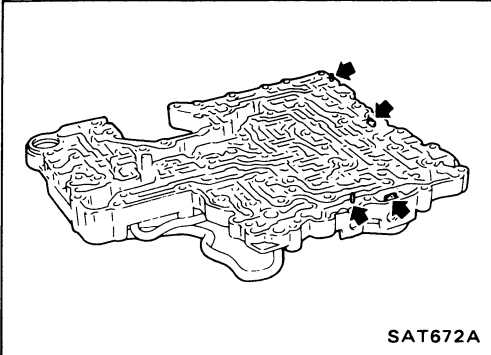

- Check to see that there are pins and retainer plates in upper body.

- **Be careful not to lose these parts.**

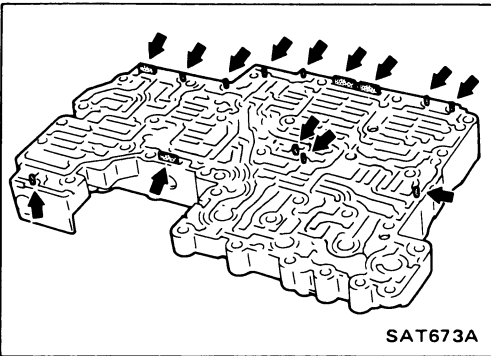

- Check to make sure that oil circuits are clean and free from damage.

- Check tube brackets and tube connectors for damage.

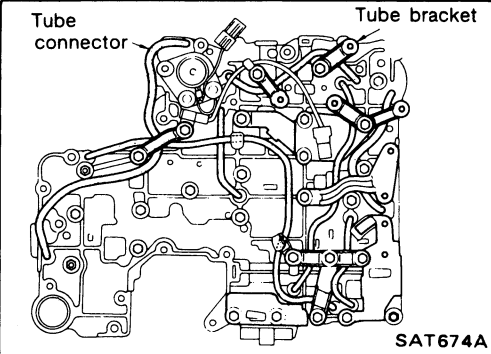

Separator plates

- Check to make sure that separator plate is free of damage and not deformed and oil holes are clean.

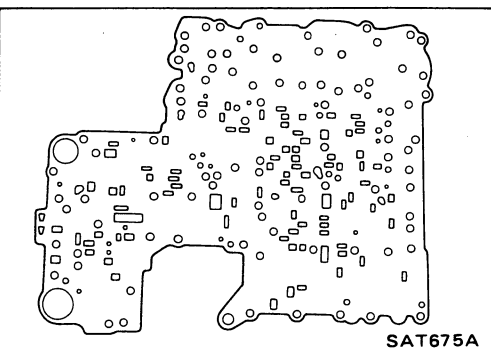

REPAIR FOR COMPONENT PARTS

Control Valve Assembly (Cont'd)

Pilot filter

- Check to make sure that filter is not clogged or damaged.

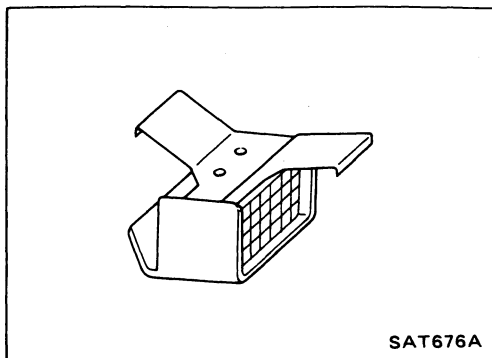

SAT676A

Lock-up solenoid

- Check that filter is not clogged or damaged.
- Measure resistance. — Refer to "Electrical Components Inspection".

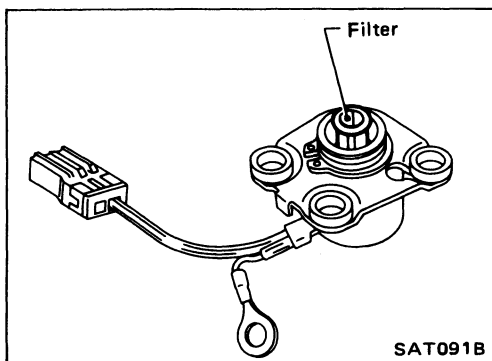

SAT091B

Line pressure solenoid

- Check that filter is not clogged or damaged.
- Measure resistance. — Refer to "Electrical Components Inspection".

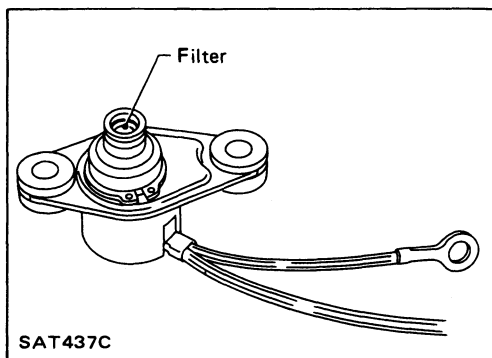

SAT437C

3-unit solenoid assembly (Overrun clutch solenoid and shift solenoids A and B)

- Measure resistance of each solenoid. — Refer to "Electrical Components Inspection".

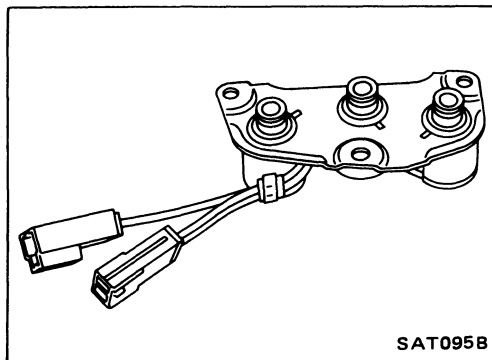

SAT095B

Fluid temperature sensor

- Measure resistance. — Refer to "Electrical Components Inspection".

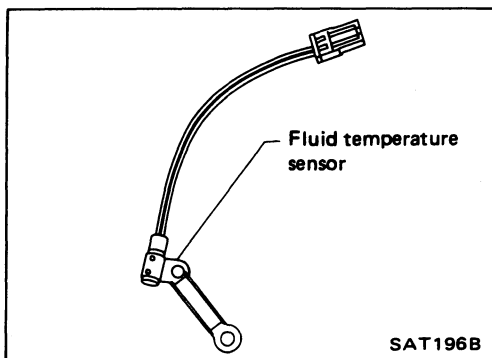

SAT196B

REPAIR FOR COMPONENT PARTS

Control Valve Assembly (Cont'd) ASSEMBLY

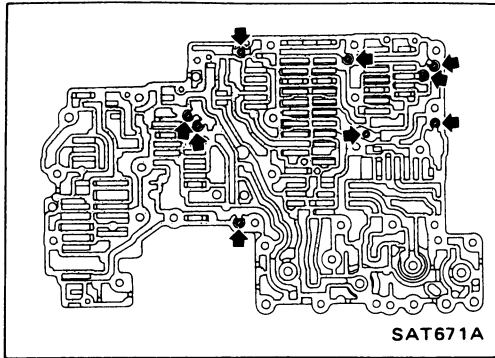

1. Install upper and lower bodies.
 - a. Place oil circuit of upper body face up. Install steel balls in their proper positions.

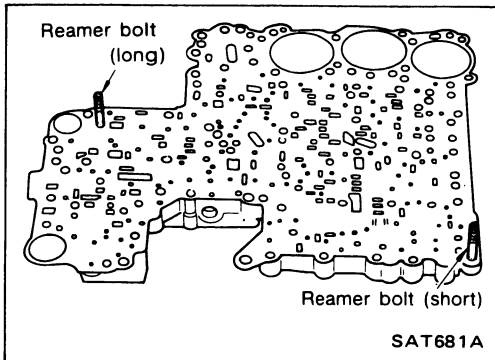

- b. Install reamer bolts from bottom of upper body and install separate gaskets.

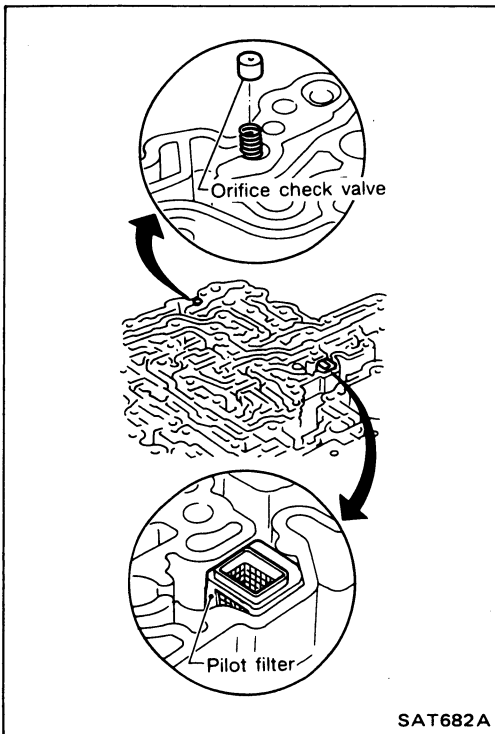

- c. Place oil circuit of lower body face up. Install orifice check spring, orifice check valve and pilot filter.

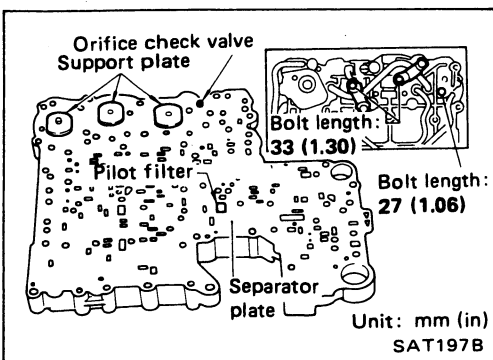

- d. Install lower separate gaskets and separator plates on lower body.
 - e. Install and temporarily tighten support plates, fluid temperature sensor and tube brackets.

REPAIR FOR COMPONENT PARTS

Control Valve Assembly (Cont'd)

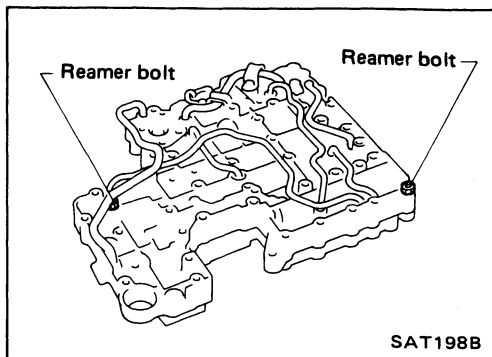

- f. Temporarily assemble lower and upper bodies, using reamer bolt as a guide.
- Be careful not to dislocate or drop steel balls, orifice check spring, orifice check valve and pilot filter.

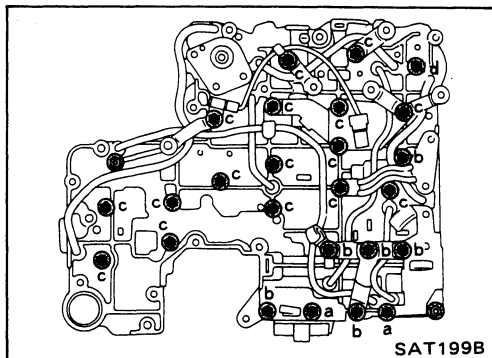

- g. Install and temporarily tighten bolts and tube brackets in their proper locations.

Bolt length and location:

Item	Bolt symbol	a	b	c	d
		Bolt length	mm (in)	70 (2.76)	50 (1.97)

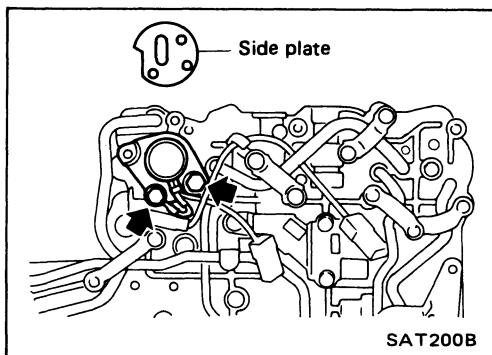

2. Install solenoids.
- a. Attach O-ring and install lock-up solenoid and side plates onto lower body.

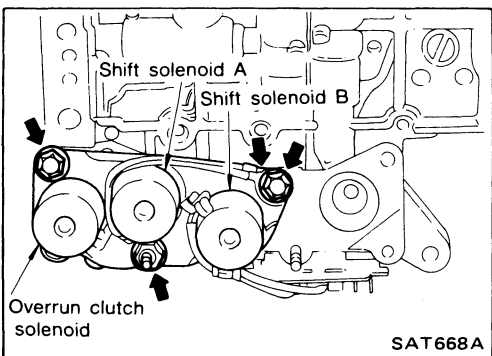

- b. Attach O-rings and install 3-unit solenoids assembly onto upper body.

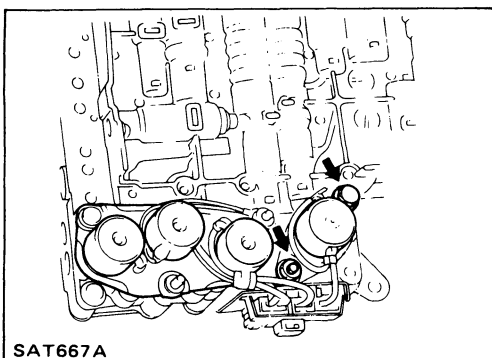

- c. Attach O-ring and install line pressure solenoid onto upper body.
3. Tighten all bolts.

Control Valve Upper Body

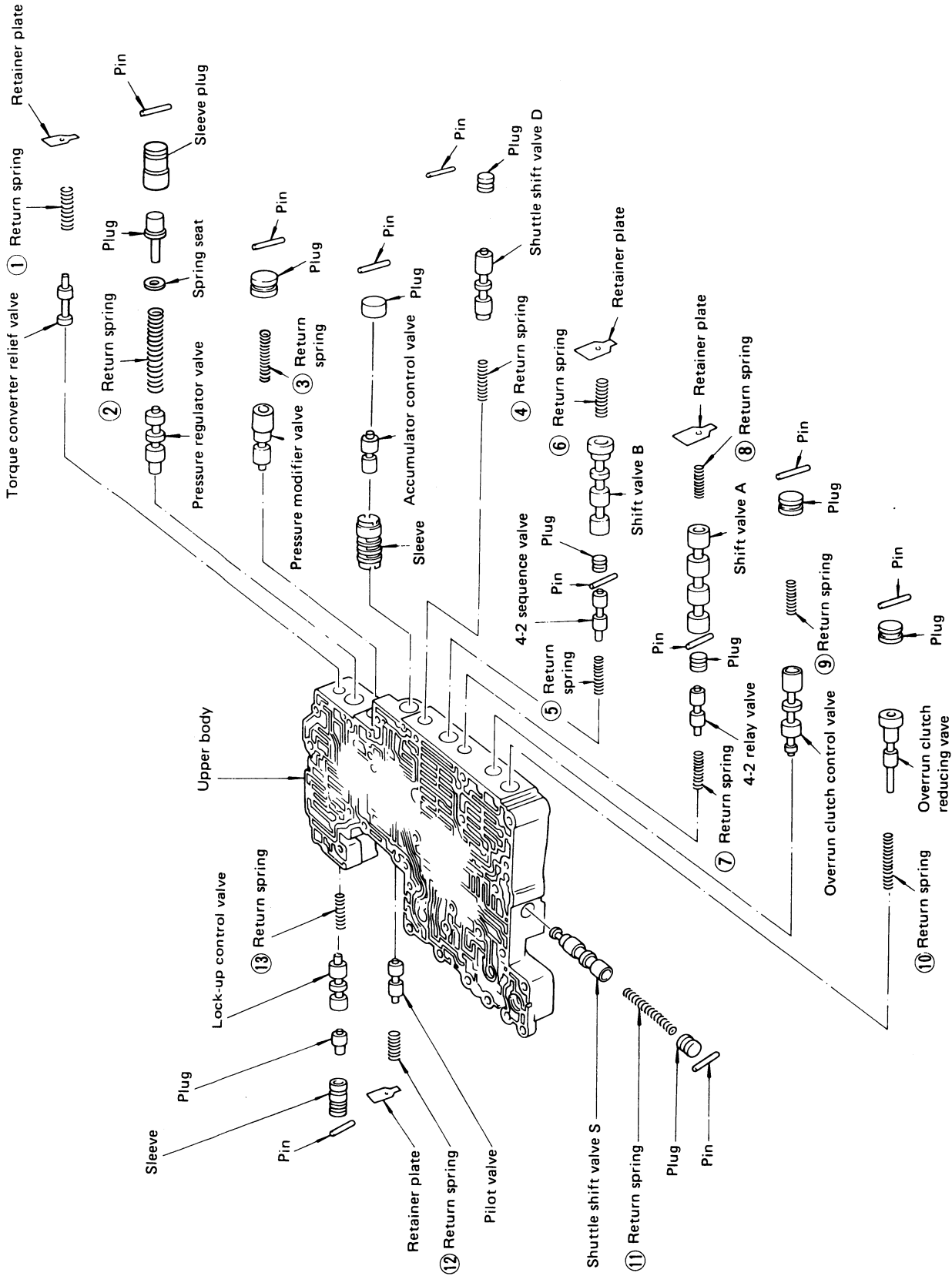

Numbers preceding valve springs correspond with those shown in Spring Chart on page AT-144.

Apply A.T.F. to all components before their installation.

REPAIR FOR COMPONENT PARTS

Control Valve Upper Body (Cont'd) DISASSEMBLY

1. Remove valves at parallel pins.
 - Do not use a magnetic hand.

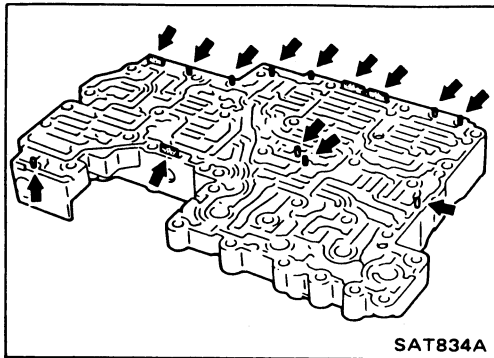

- a. Use a wire paper clip to push out parallel pins.

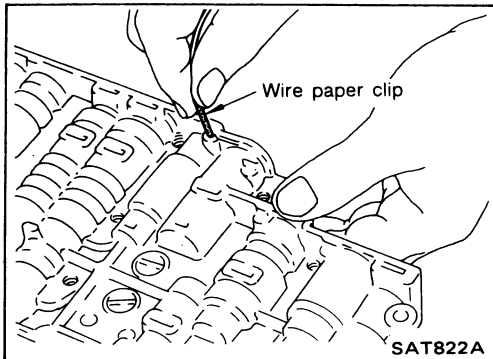

- b. Remove parallel pins while pressing their corresponding plugs and sleeves.
 - Remove plug slowly to prevent internal parts from jumping out.

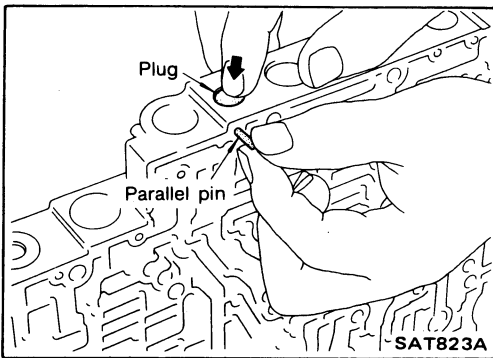

- c. Place mating surface of valve facedown, and remove internal parts.
 - If a valve is hard to remove, place valve body facedown and lightly tap it with a soft hammer.
 - Be careful not to drop or damage valves and sleeves.

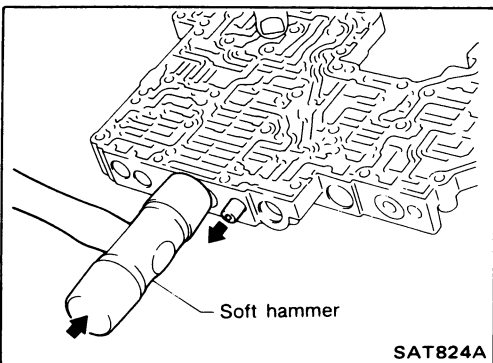

2. Remove valves at retainer plates.
 - a. Pry out retainer plate with wire paper clip.

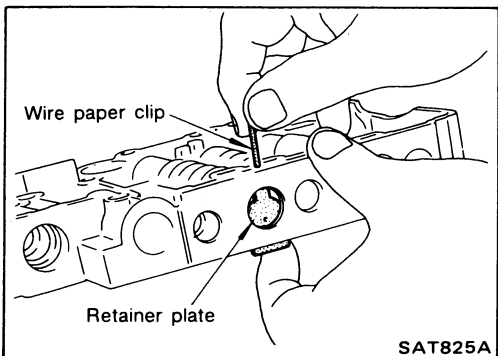

REPAIR FOR COMPONENT PARTS

Control Valve Upper Body (Cont'd)

b. Remove retainer plates while holding spring.

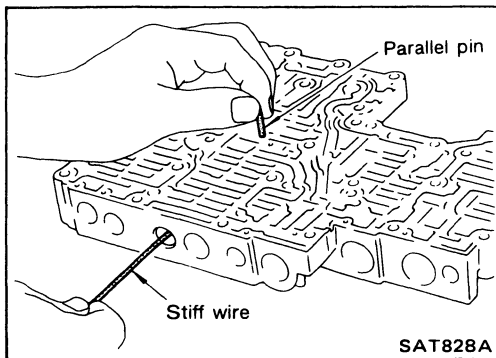
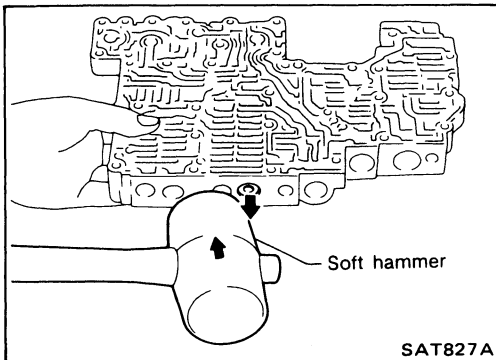
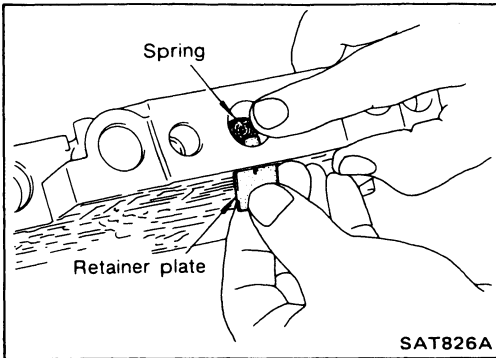

c. Place mating surface of valve facedown, and remove internal parts.

- If a valve is hard to remove, lightly tap valve body with a soft hammer.
- Be careful not to drop or damage valves, sleeves, etc.

● 4-2 sequence valve and relay valve are located far back in upper body. If they are hard to remove, carefully push them out using stiff wire.

- Be careful not to scratch sliding surface of valve with wire.

REPAIR FOR COMPONENT PARTS

Control Valve Upper Body (Cont'd)

INSPECTION

Valve springs

- Measure free length and outer diameter of each valve spring. Also check for damage or deformation.
- Numbers of each valve spring listed in table below are the same as those in the figure on AT-141.

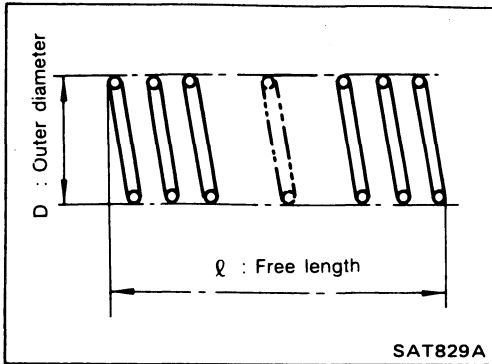

Inspection standard

Unit: mm (in)

Parts	Item	Part No.	l	D
①	Torque converter relief valve spring	31742-41X23	38.0 (1.496)	9.0 (0.354)
②	Pressure regulator valve spring	31742-41X24	44.02 (1.7331)	14.0 (0.551)
③	Pressure modifier valve spring	31742-41X19	31.95 (1.2579)	6.8 (0.268)
④	Shuttle shift valve D spring	31762-41X00	26.5 (1.043)	6.0 (0.236)
⑤	4-2 sequence valve spring	31756-41X00	29.1 (1.146)	6.95 (0.2736)
⑥	Shift valve B spring	31762-41X01	25.0 (0.984)	7.0 (0.276)
⑦	4-2 relay valve spring	31756-41X00	29.1 (1.146)	6.95 (0.2736)
⑧	Shift valve A spring	31762-41X01	25.0 (0.984)	7.0 (0.276)
⑨	Overrun clutch control valve spring	31762-41X03	23.6 (0.929)	7.0 (0.276)
⑩	Overrun clutch reducing valve spring	31742-41X20	32.5 (1.280)	7.0 (0.276)
⑪	Shuttle shift valve S spring	31762-41X04	51.0 (2.008)	5.65 (0.2224)
⑫	Pilot valve spring	31742-41X13	25.7 (1.012)	9.1 (0.358)
⑬	Lock-up control valve spring	31742-41X22	18.5 (0.728)	13.0 (0.512)

- Replace valve springs if deformed or fatigued.

Control valves

- Check sliding surfaces of valves, sleeves and plugs.

REPAIR FOR COMPONENT PARTS

Control Valve Upper Body (Cont'd) ASSEMBLY

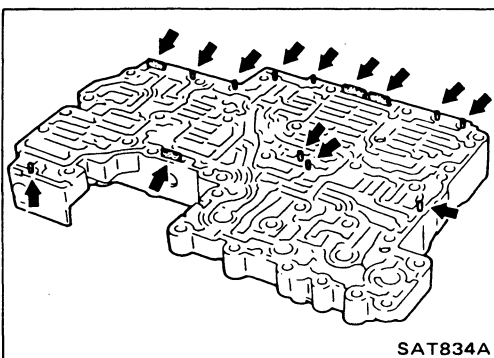
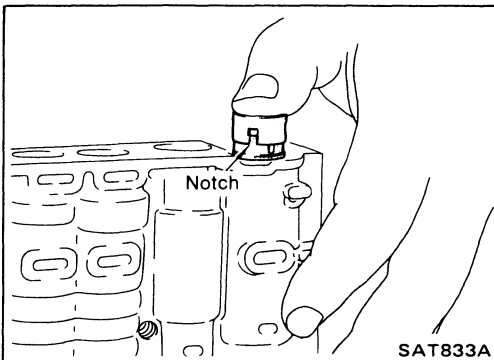
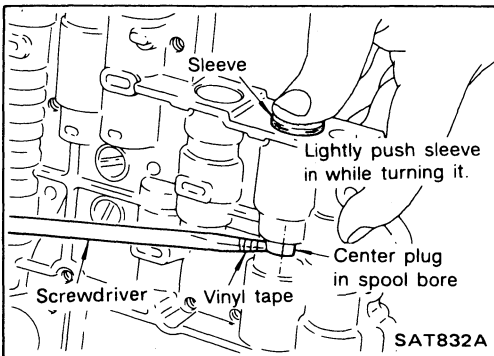
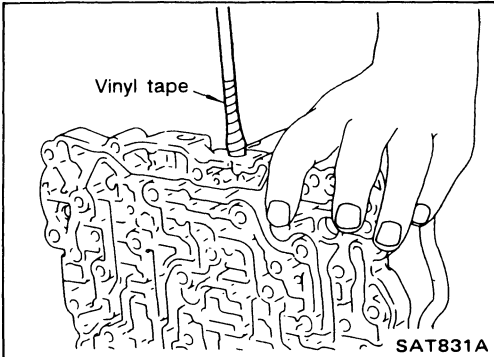
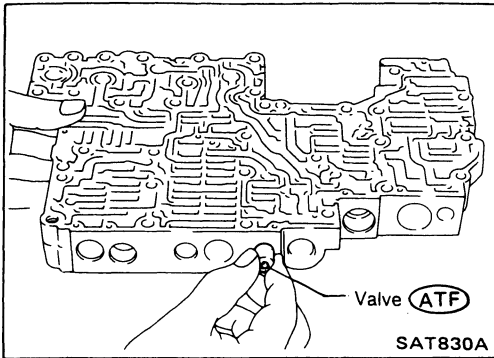

1. Lubricate the control valve body and all valves with A.T.F. Install control valves by sliding them carefully into their bores.

- Be careful not to scratch or damage valve body.

- Wrap a small screwdriver with vinyl tape and use it to insert the valves into proper position.

Pressure regulator valve

- If pressure regulator plug is not centered properly, sleeve cannot be inserted into bore in upper body. If this happens, use vinyl tape wrapped screwdriver to center sleeve until it can be inserted.
- Turn sleeve slightly while installing.

Accumulator control plug

- Align protrusion of accumulator control sleeve with notch in plug.
- Align parallel pin groove in plug with parallel pin, and install accumulator control valve.

2. Install parallel pins and retainer plates.

REPAIR FOR COMPONENT PARTS

Control Valve Upper Body (Cont'd)

- While pushing plug, install parallel pin.

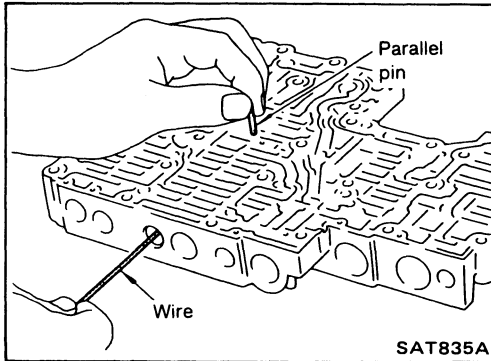
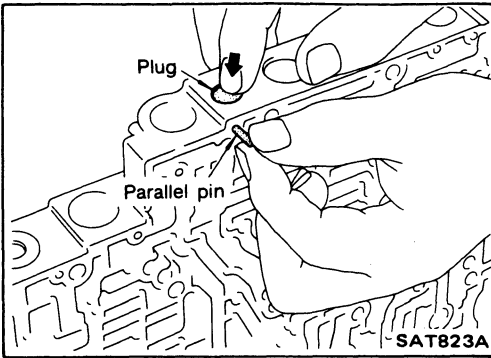

4-2 sequence valve and relay valve

- Push 4-2 sequence valve and relay valve with wire wrapped in vinyl tape to prevent scratching valve body. Install parallel pins.

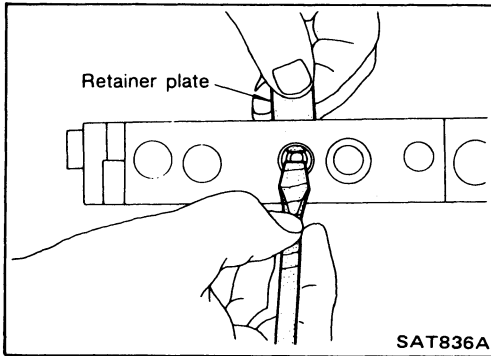

- Insert retainer plate while pushing spring.

Control Valve Lower Body

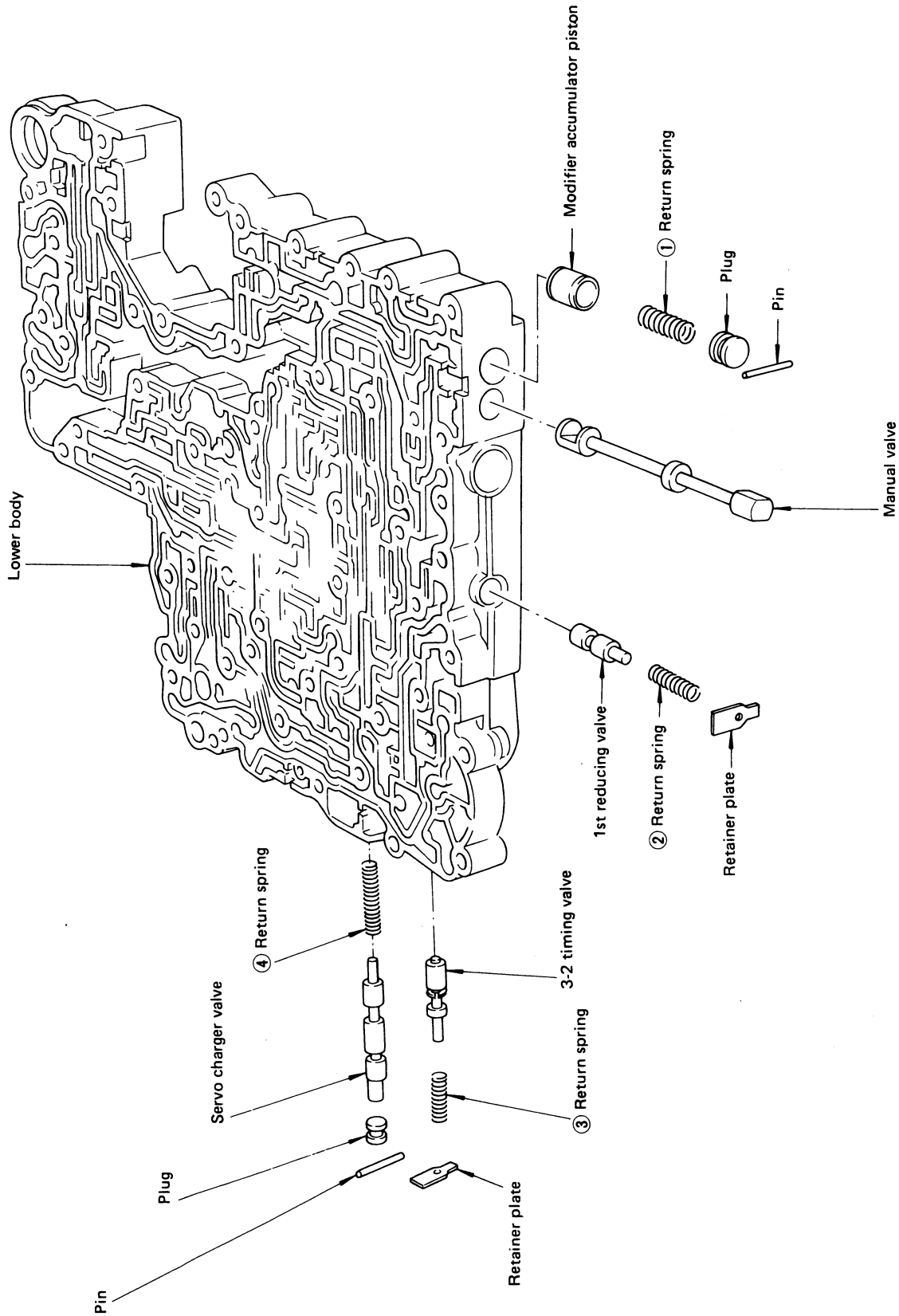

Numbers preceding valve springs correspond with those shown in Spring Chart on the next page.

Apply A.T.F. to all components before their installation.

REPAIR FOR COMPONENT PARTS

Control Valve Lower Body (Cont'd)

DISASSEMBLY

1. Remove valves at parallel pins.
2. Remove valves at retainer plates.

For removal procedures, refer to "DISASSEMBLY" of Control Valve Upper Body.

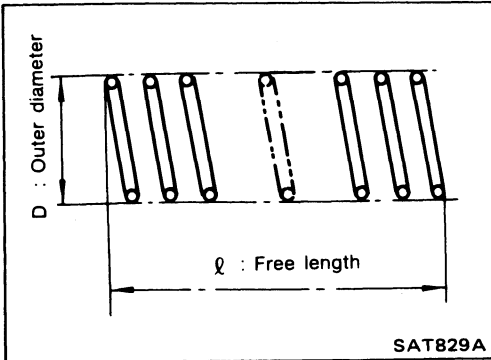
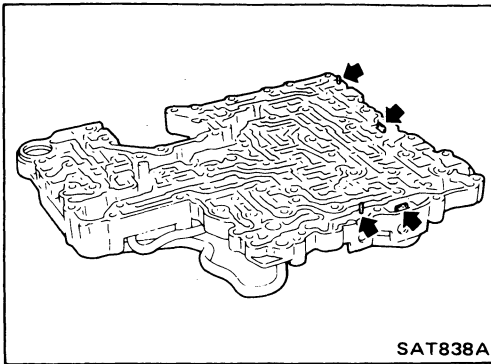

INSPECTION

Valve springs

- Check each valve spring for damage or deformation. Also measure free length and outer diameter.
- Numbers of each valve spring listed in table below are the same as those in the figure on AT-147.

Inspection standard:

Unit: mm (in)

Parts	Item	Part No.	ℓ	D
①	Modifier accumulator piston spring	31742-41X15	30.5 (1.201)	9.8 (0.386)
②	1st reducing valve spring	31756-41X05	25.4 (1.000)	6.75 (0.2657)
③	3-2 timing valve spring	31742-41X08	20.55 (0.8091)	6.75 (0.2657)
④	Servo charger valve spring	31742-41X06	23.0 (0.906)	6.7 (0.264)

- Replace valve springs if deformed or fatigued.

Control valves

- Check sliding surfaces of control valves, sleeves and plugs for damage.

ASSEMBLY

- Install control valves.
For installation procedures, refer to "ASSEMBLY" of Control Valve Upper Body.

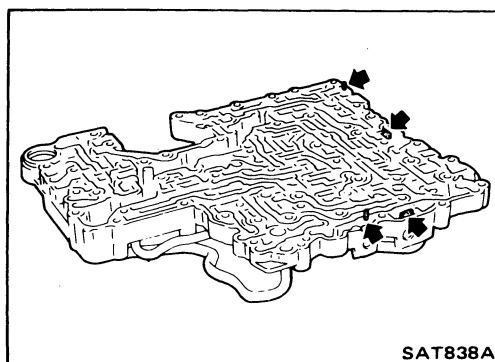

Reverse Clutch

☆ For the number of clutch sheets (drive plate and driven plate), refer to the below cross-section.

(ATF) : Apply A.T.F.
 ☆ : Select with proper thickness.

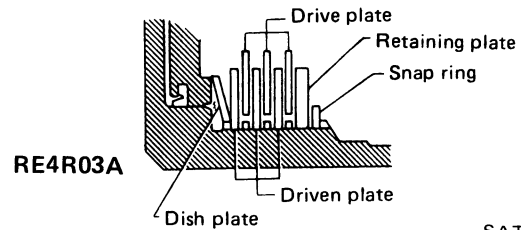
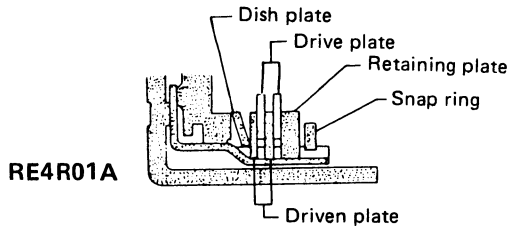
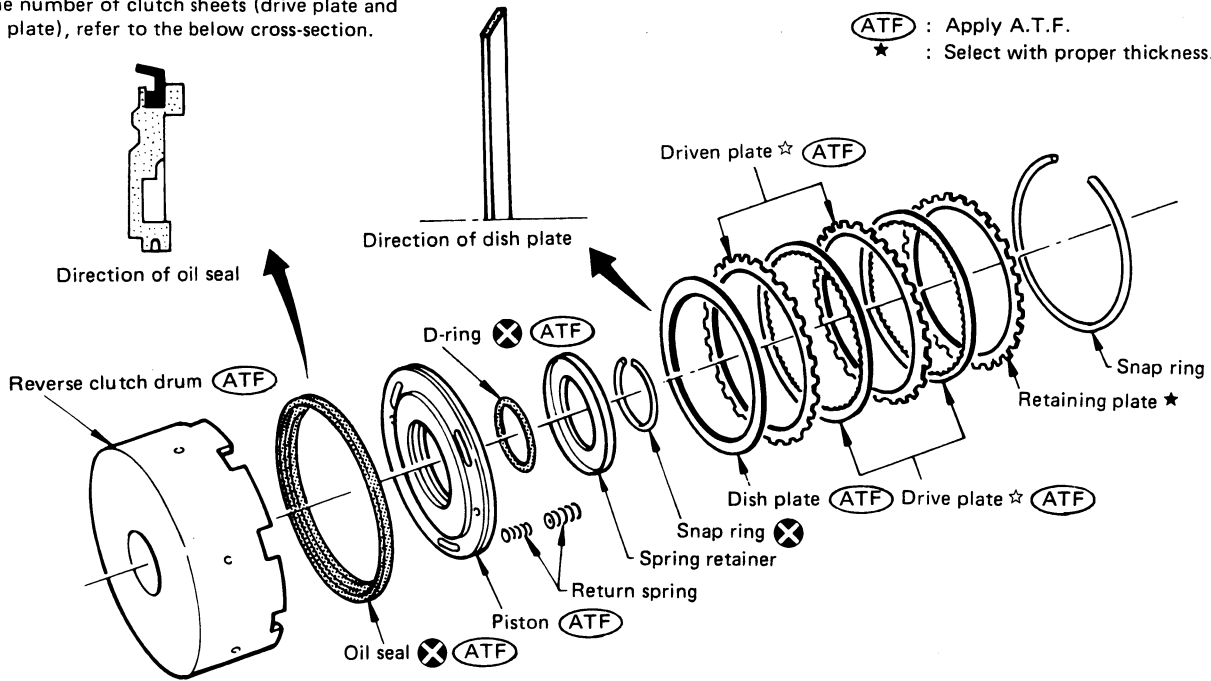

SAT641C

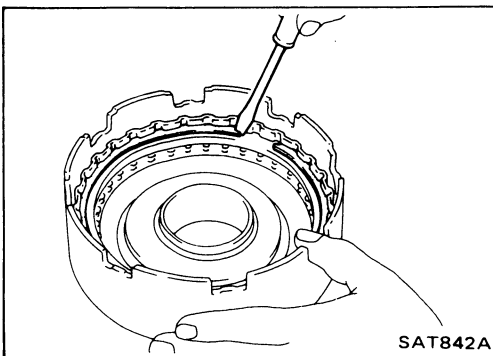
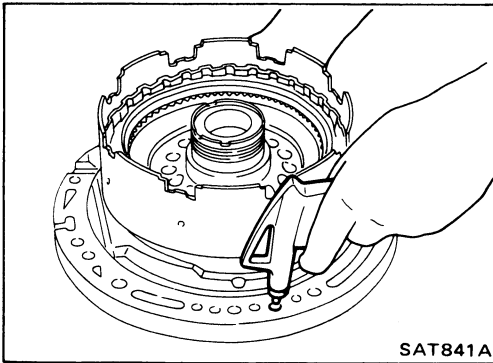

DISASSEMBLY

1. Check operation of reverse clutch.
 - a. Install seal ring onto oil pump cover and install reverse clutch. Apply compressed air to oil hole.
 - b. Check to see that retaining plate moves to snap ring.
 - c. If retaining plate does not move to snap ring, D-ring or oil seal may be damaged or fluid may be leaking at piston check ball.
2. Remove drive plates, driven plates, retaining plate, dish plate and snap ring.

REPAIR FOR COMPONENT PARTS

Reverse Clutch (Cont'd)

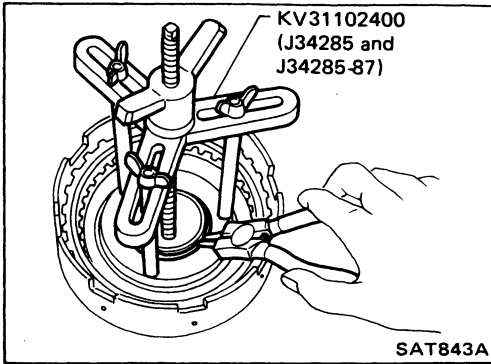

3. Remove snap ring from clutch drum while compressing clutch springs.
 - Do not expand snap ring excessively.
4. Remove spring retainer and return spring.

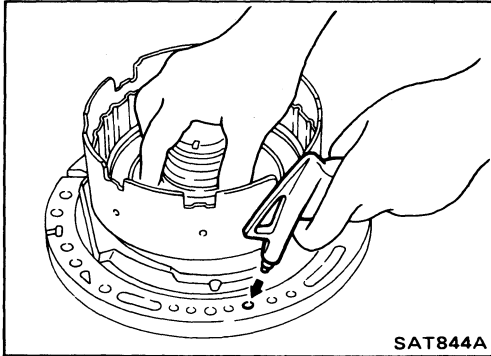

5. Install seal ring onto oil pump cover and install reverse clutch drum. While holding piston, gradually apply compressed air to oil hole until piston is removed.
 - Do not apply compressed air abruptly.
6. Remove D-ring and oil seal from piston.

INSPECTION

Reverse clutch snap ring and spring retainer

- Check for deformation, fatigue or damage.

Reverse clutch return springs

- Check for deformation or damage. Also measure free length and outside diameter.

Inspection standard:

Unit: mm (in)

Model	Part No.	ℓ	D
RE4R01A	31505-41X02	19.69 (0.7752)	11.6 (0.457)
RE4R03A	31505-51X00	37.8 (1.488)	14.8 (0.583)

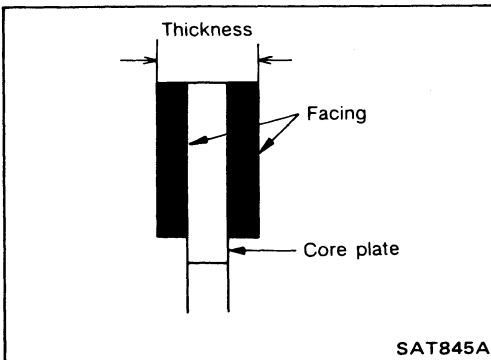
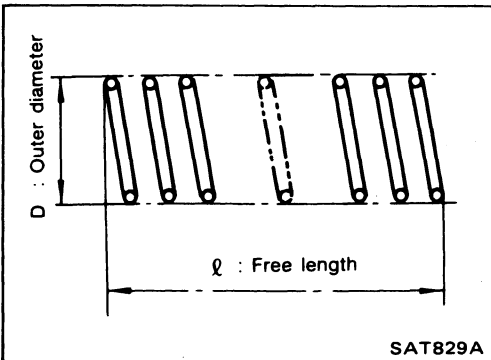

Reverse clutch drive plates

- Check facing for burns, cracks or damage.
- Measure thickness of facing.

Thickness of drive plate:

Standard value: 2.0 mm (0.079 in)

Wear limit: 1.8 mm (0.071 in)

- If not within wear limit, replace.

Reverse clutch dish plate

- Check for deformation or damage.

Reverse clutch piston

- Shake piston to assure that balls are not seized.
- Apply compressed air to check ball oil hole opposite the return spring to assure that there is no air leakage.
- Also apply compressed air to oil hole on return spring side to assure that air leaks past ball.

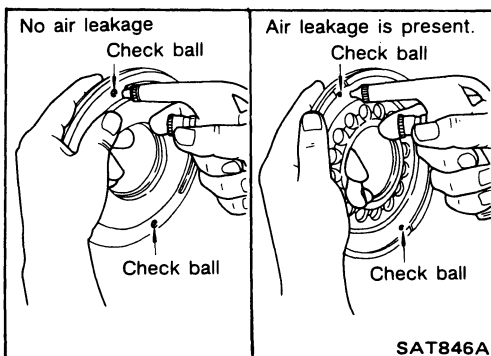

REPAIR FOR COMPONENT PARTS

Reverse Clutch (Cont'd)

ASSEMBLY

1. Install D-ring and oil seal on piston.
 - Apply A.T.F. to both parts.

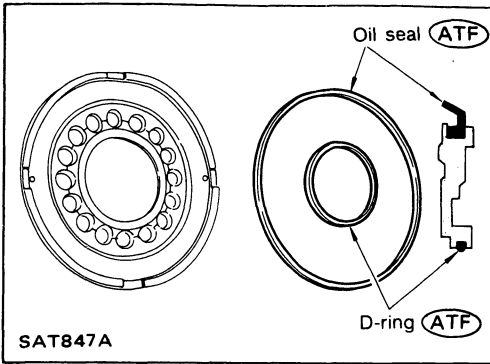

2. Install piston assembly by turning it slowly and evenly.
 - Apply A.T.F. to inner surface of drum.

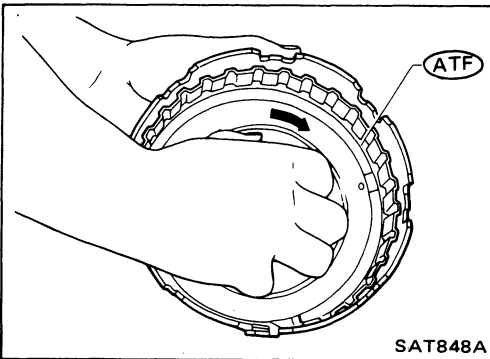

3. Install return springs and spring retainer.

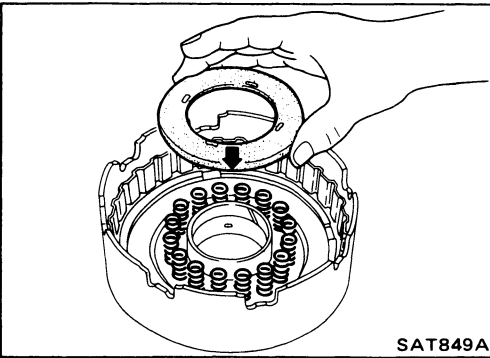

4. Install snap ring while compressing clutch springs.

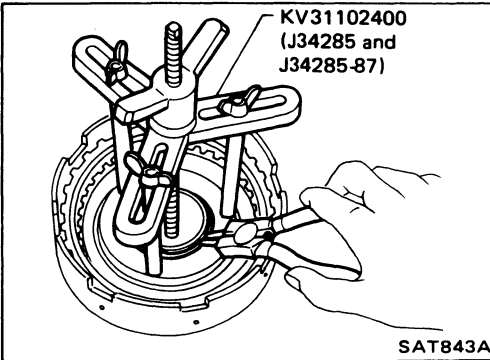

- Do not align snap ring gap with spring retainer stopper.

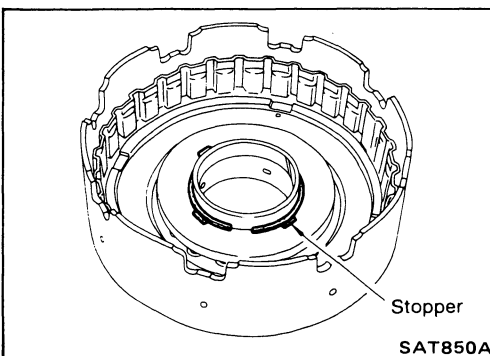

REPAIR FOR COMPONENT PARTS

Reverse Clutch (Cont'd)

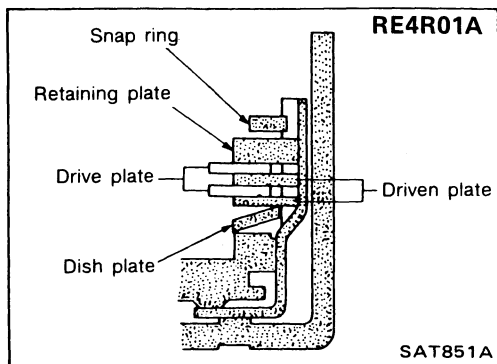

5. Install drive plates, driven plates, retaining plate and dish plate.

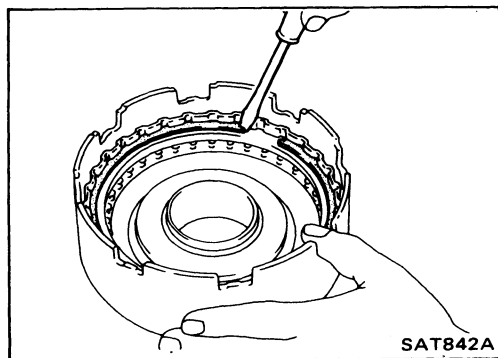
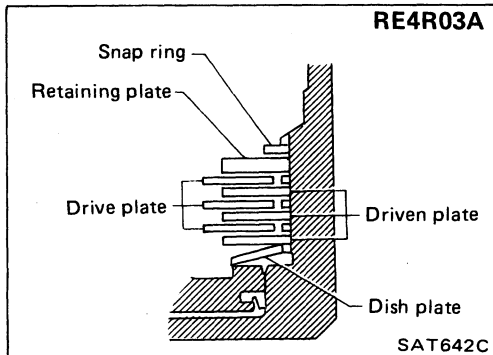

6. Install snap ring.

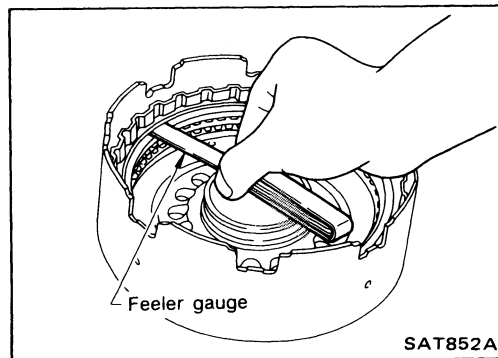

7. Measure clearance between retaining plate and snap ring. If not within allowable limit, select proper retaining plate.

Specified clearance:

Standard

0.5 - 0.8 mm (0.020 - 0.031 in)

Allowable limit

1.2 mm (0.047 in) (RE4R01A)

1.4 mm (0.055 in) (RE4R03A)

Retaining plate:

Refer to S.D.S.

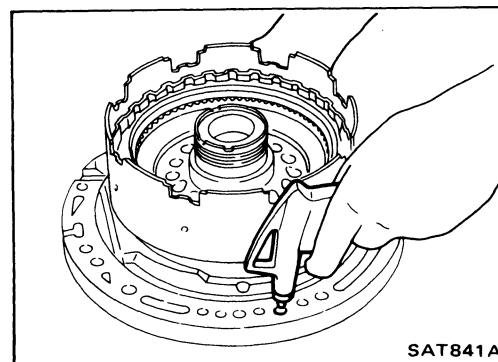

8. Check operation of reverse clutch.
Refer to "DISASSEMBLY" of Reverse Clutch.

REPAIR FOR COMPONENT PARTS

High Clutch

RE4R01A

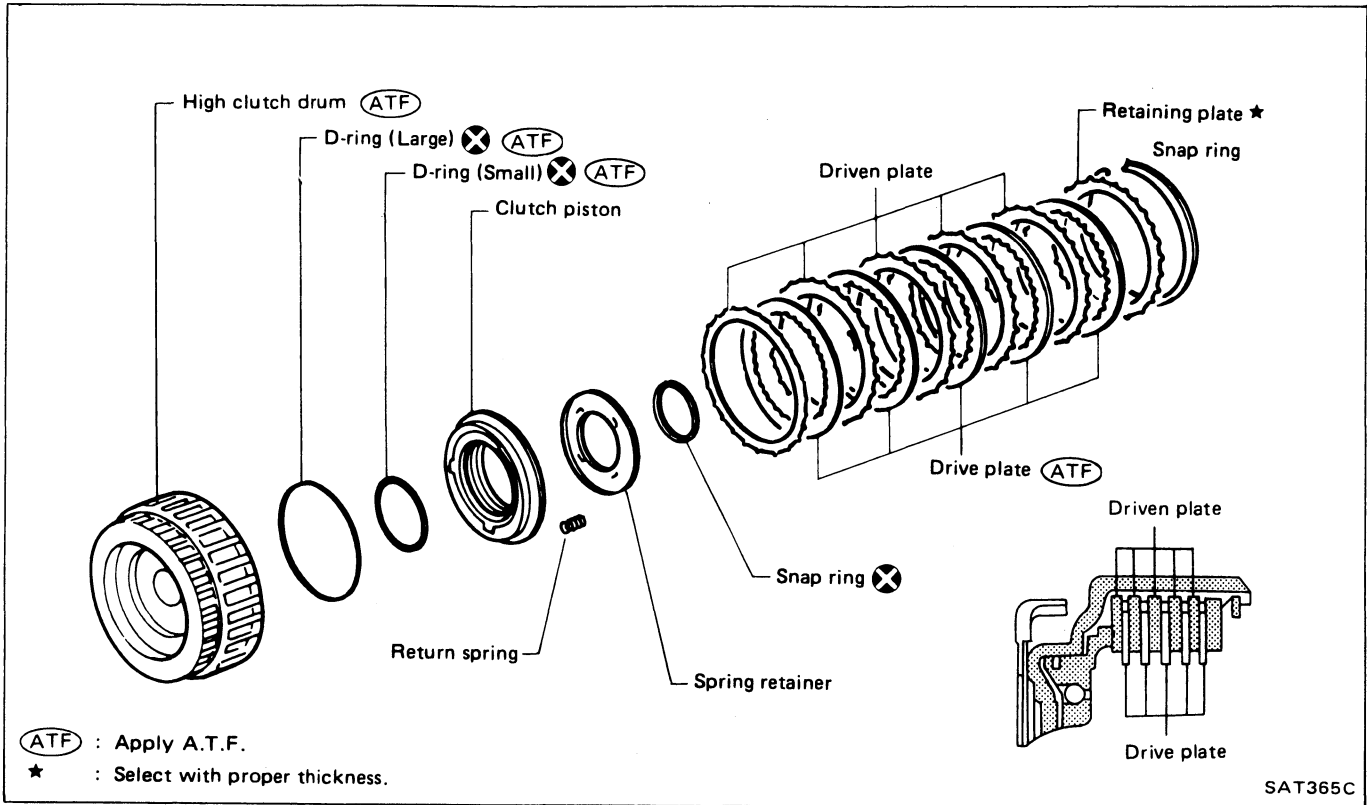

RE4R03A

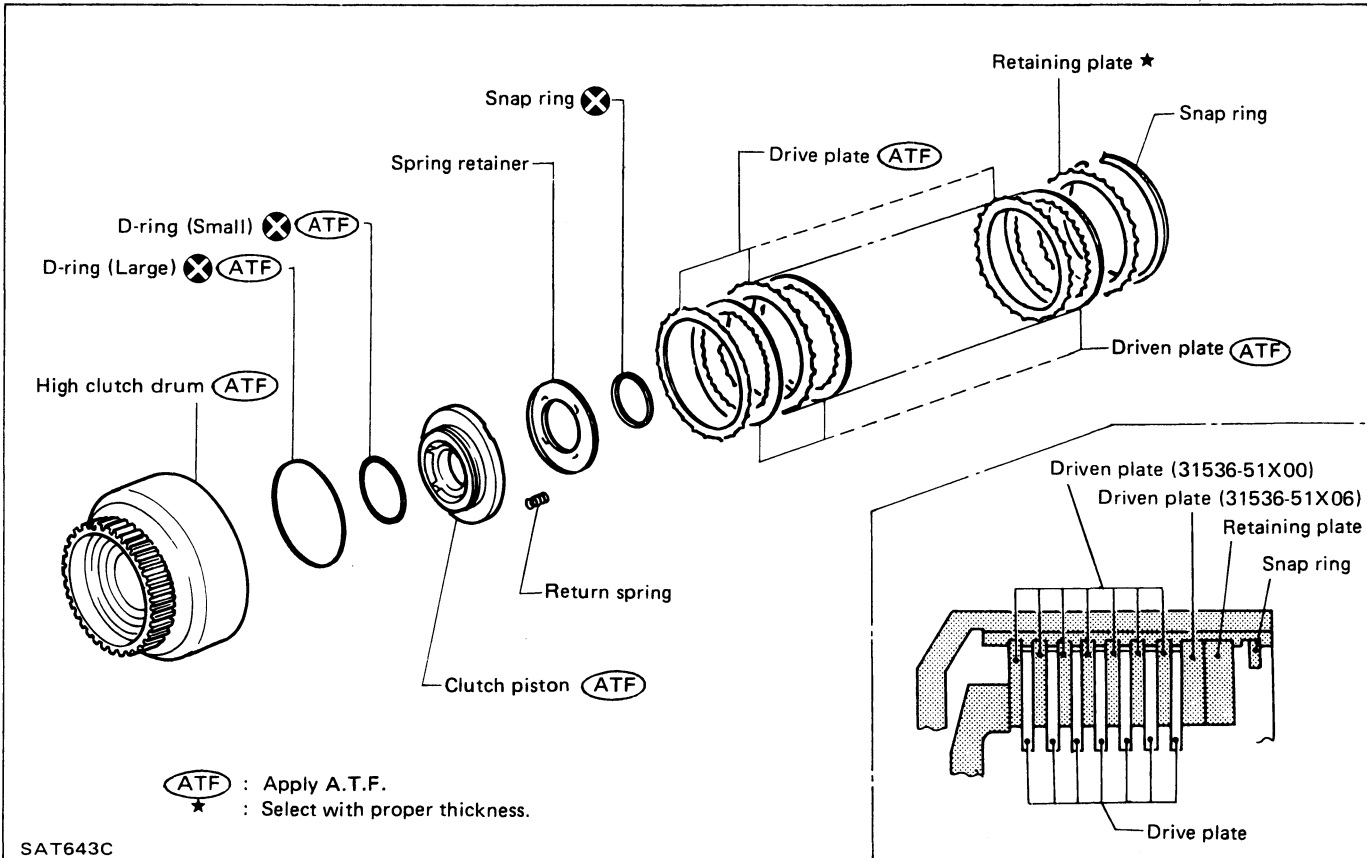

REPAIR FOR COMPONENT PARTS

High Clutch (Cont'd)

Service procedures for high clutch are essentially the same as those for reverse clutch, with the following exception:

- Check of high clutch operation

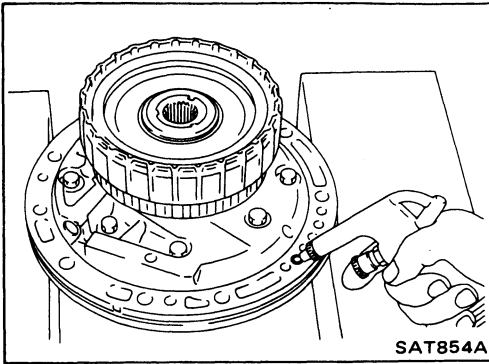

- Removal and installation of return spring

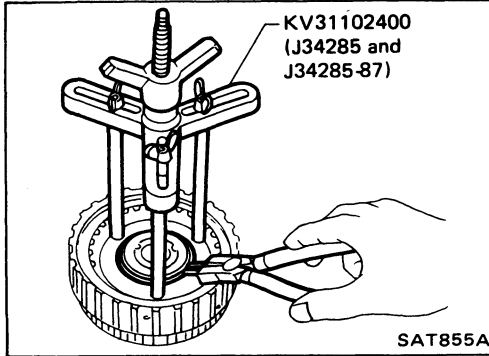

- Inspection of high clutch return springs

Inspection standard:

Unit: mm (in)

Part No.	ℓ	D
31505-21X03	22.06 (0.8685)	11.6 (0.457)

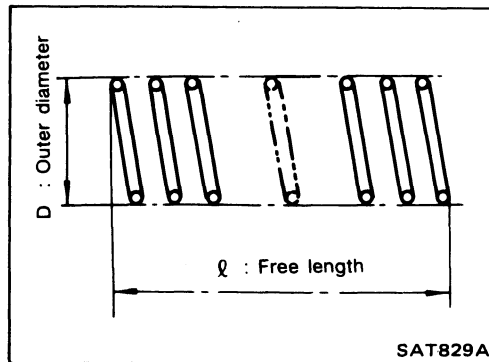

- Inspection of high clutch drive plate

Thickness of drive plate:

Standard

1.6 mm (0.063 in)

Wear limit

1.4 mm (0.055 in)

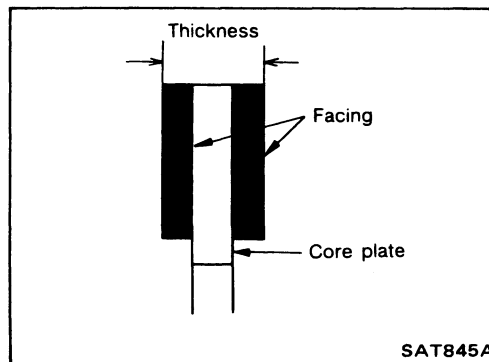

- Measurement of clearance between retaining plate and snap ring

Specified clearance:

Standard

1.8 - 2.2 mm (0.071 - 0.087 in)

Allowable limit

3.2 mm (0.126 in) (RE4R01A)

3.0 mm (0.118 in) (RE4R03A)

Retaining plate:

Refer to S.D.S.

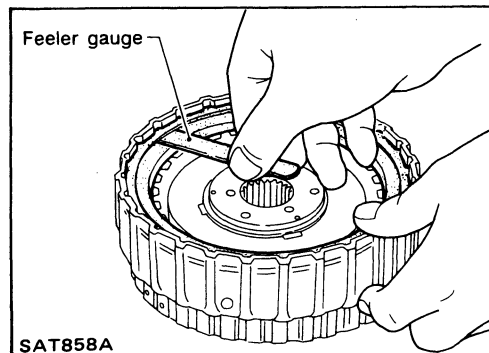

REPAIR FOR COMPONENT PARTS

Forward and Overrun Clutches

For the number of clutch sheets (drive plate and driven plate), refer to the below cross-section.

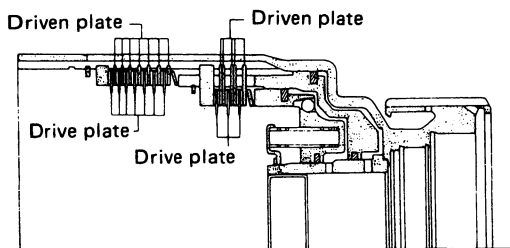
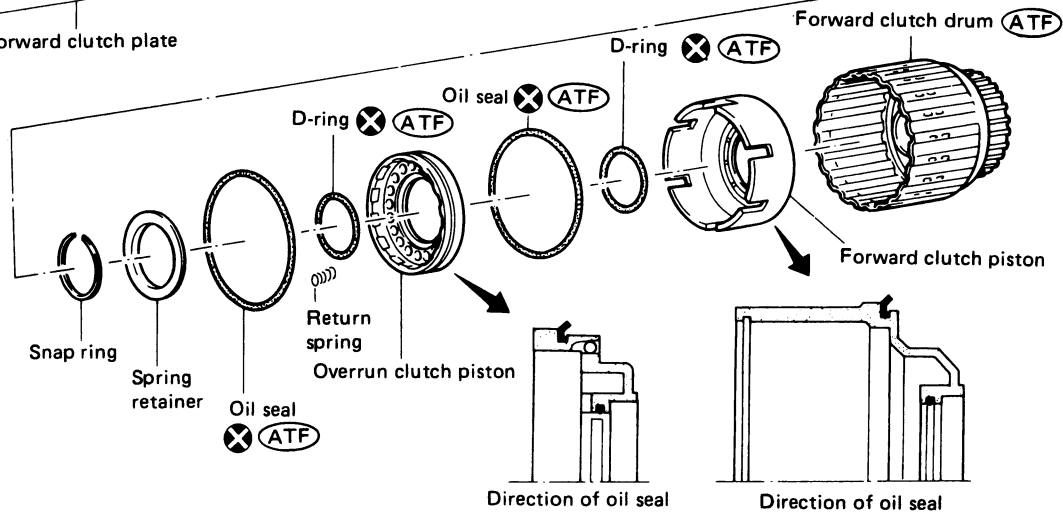
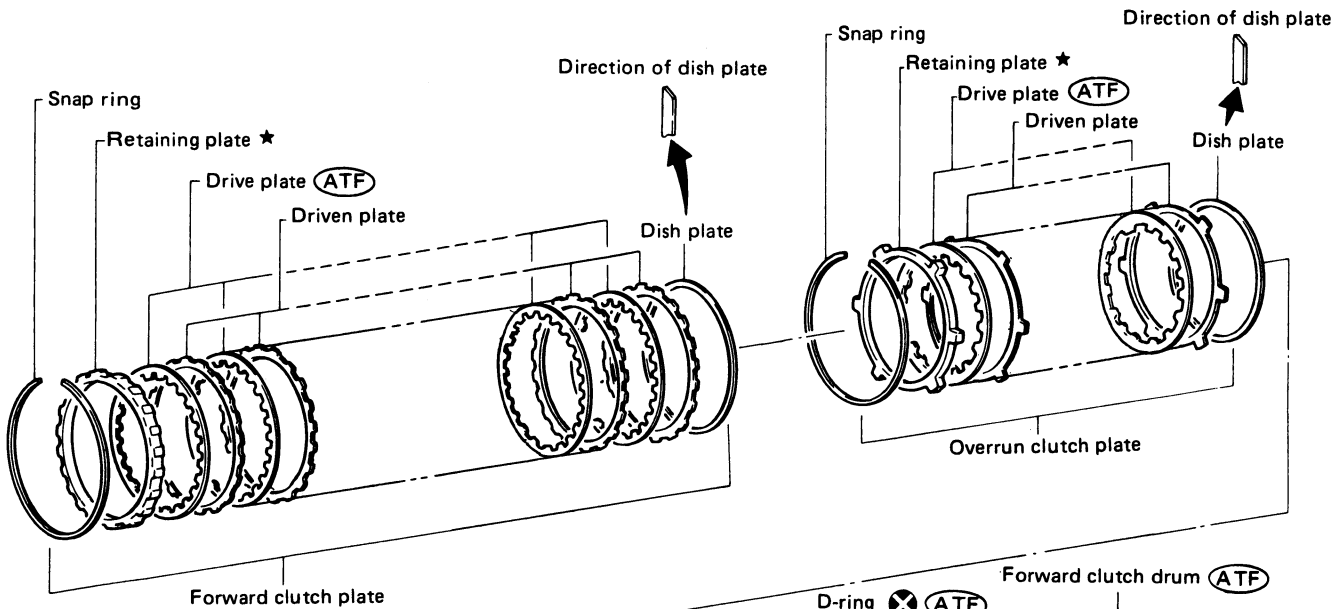

RE4R01A

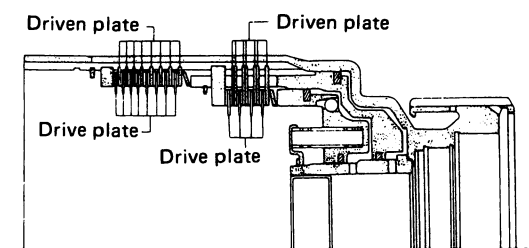

RE4R03A

(ATF): Apply A.T.F.
★: Select with proper thickness.

REPAIR FOR COMPONENT PARTS

Forward and Overrun Clutches (Cont'd)

Service procedures for forward and overrun clutches are essentially the same as those for reverse clutch, with the following exception:

- Check of forward clutch operation.

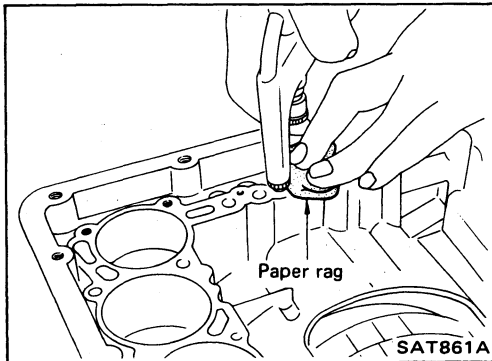
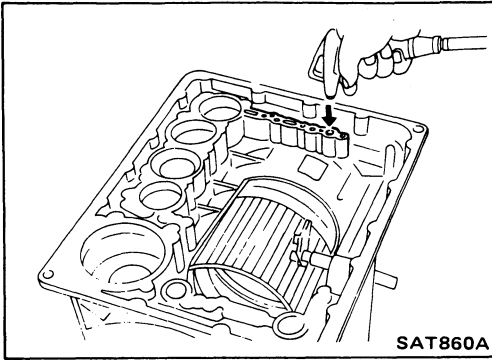

- Check of overrun clutch operation.

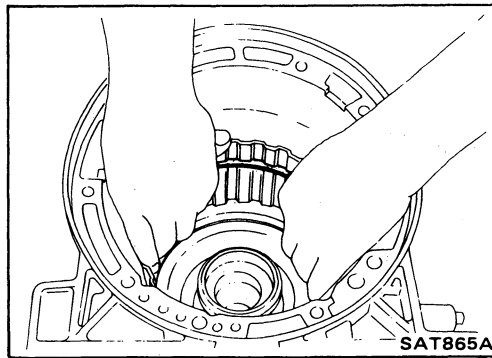

- Removal of forward clutch drum
Remove forward clutch drum from transmission case by holding snap ring.

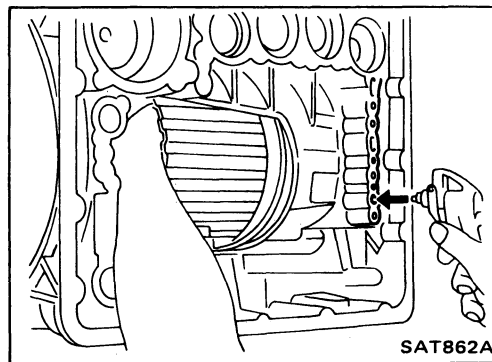

- Removal of forward clutch and overrun clutch pistons
1. While holding overrun clutch piston, gradually apply compressed air to oil hole.

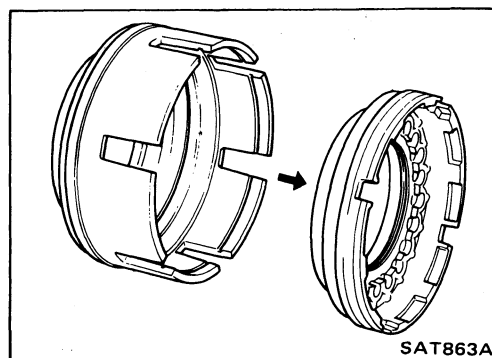

2. Remove overrun clutch from forward clutch.

REPAIR FOR COMPONENT PARTS

Forward and Overrun Clutches (Cont'd)

- Removal and installation of return springs

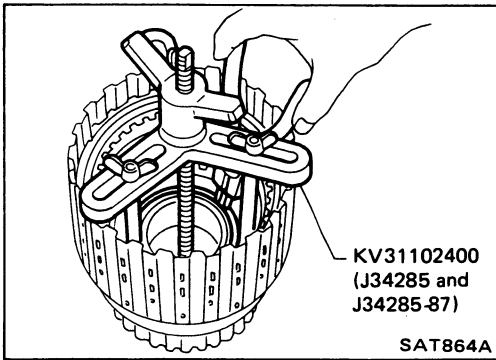

- Inspection of forward clutch and overrun clutch return springs

Inspection standard:

Unit: mm (in)

Model	Part No.	ℓ	D
RE4R01A	31505-41X01	35.77 (1.4083)	9.7 (0.382)
RE4R03A	31505-51X04	36.8 (1.449)	9.8 (0.386)

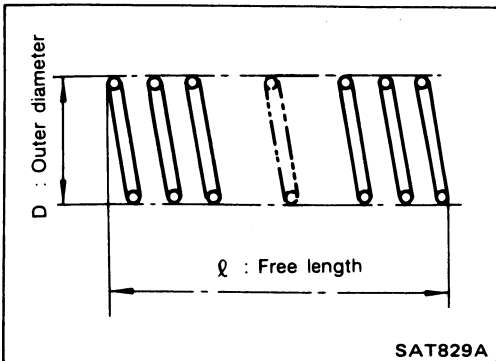

- Inspection of forward clutch drive plates

Thickness of drive plate:

Standard

1.6 mm (0.063 in) (RE4R01A)

2.0 mm (0.079 in) (RE4R03A)

Wear limit

1.4 mm (0.055 in) (RE4R01A)

1.8 mm (0.071 in) (RE4R03A)

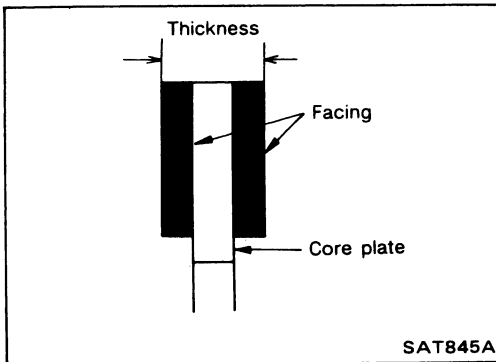

- Inspection of overrun clutch drive plates

Thickness of drive plate:

Standard

2.0 mm (0.079 in) (RE4R01A)

1.6 mm (0.063 in) (RE4R03A)

Wear limit

1.8 mm (0.071 in) (RE4R01A)

1.4 mm (0.055 in) (RE4R03A)

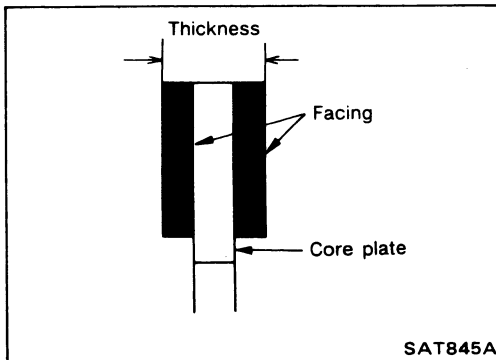

- Installation of forward clutch piston and overrun clutch piston

1. Install forward clutch piston by turning it slowly and evenly.

- Apply A.T.F. to inner surface of clutch drum.

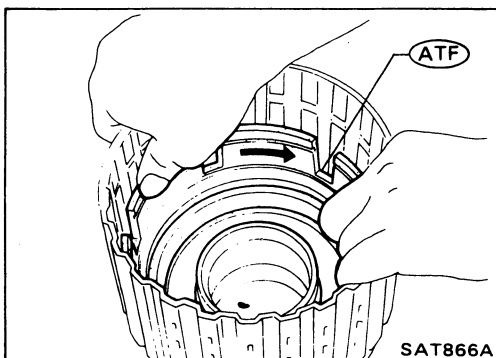

REPAIR FOR COMPONENT PARTS

Forward and Overrun Clutches (Cont'd)

- Align notch in forward clutch piston with groove in forward clutch drum.

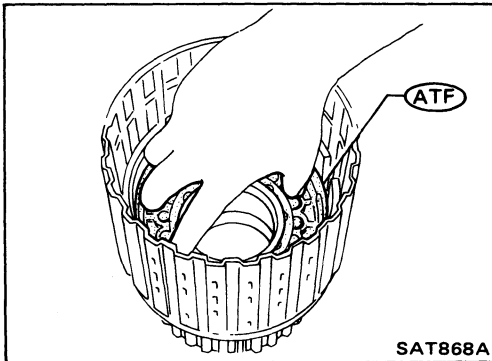
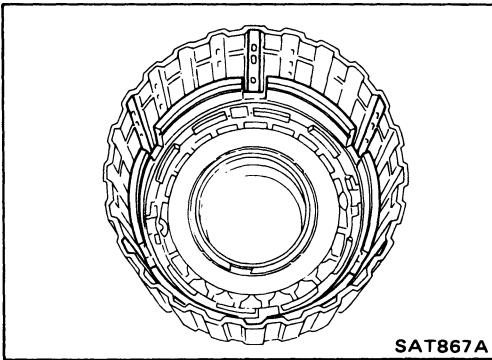

2. Install overrun clutch by turning it slowly and evenly.
- Apply A.T.F. to inner surface of forward clutch piston.

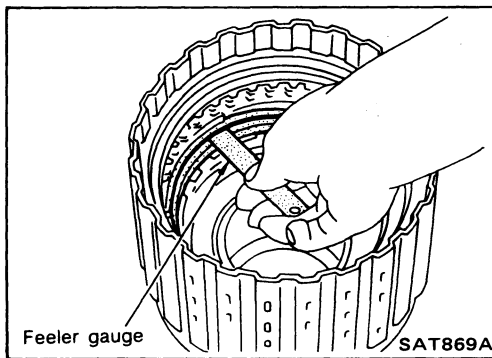

- Measurement of clearance between retaining plate and snap ring of overrun clutch

Specified clearance:

Standard

1.0 - 1.4 mm (0.039 - 0.055 in)

Allowable limit

2.0 mm (0.079 in) (RE4R01A)

2.2 mm (0.087 in) (RE4R03A)

Retaining plate:

Refer to S.D.S.

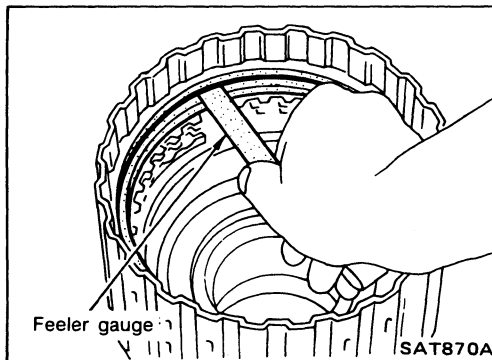

- Measurement of clearance between retaining plate and snap ring of forward clutch

Specified clearance:

Standard

0.45 - 0.85 mm (0.0177 - 0.0335 in)

Allowable limit

2.25 mm (0.0886 in) (RE4R01A)

2.45 mm (0.0965 in) (RE4R03A)

Retaining plate:

Refer to S.D.S.

Low & Reverse Brake

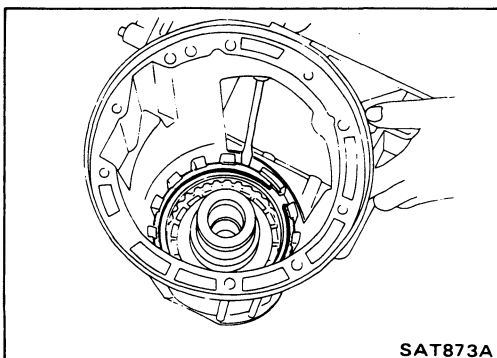
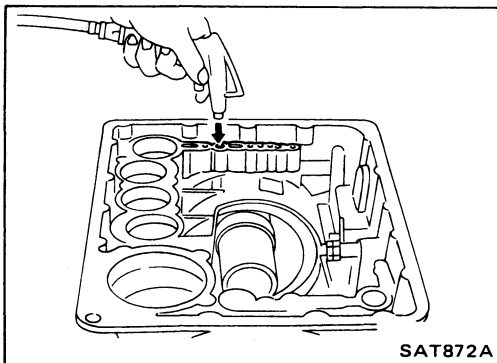
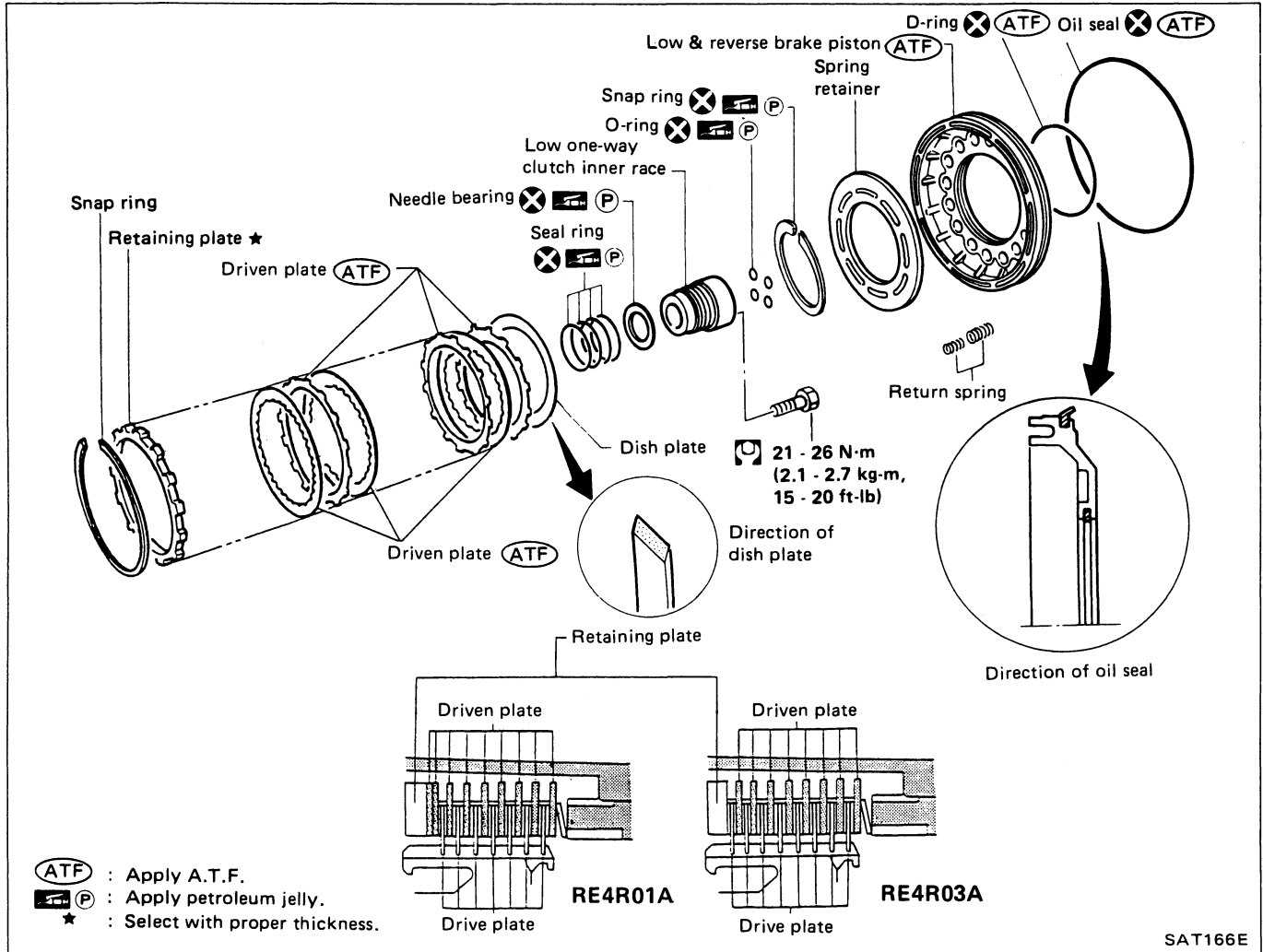

DISASSEMBLY

1. Check operation of low and reverse brake.
 - a. Install seal ring onto oil pump cover and install reverse clutch. Apply compressed air to oil hole.
 - b. Check to see that retaining plate moves to snap ring.
 - c. If retaining plate does not move to snap ring, D-ring or oil seal may be damaged or fluid may be leaking at piston check ball.
2. Remove snap ring, low and reverse brake drive plates, driven plates and dish plate.

REPAIR FOR COMPONENT PARTS

Low & Reverse Brake (Cont'd)

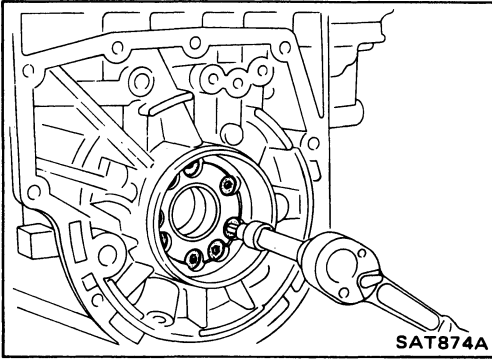

- Remove low one-way clutch inner race, spring retainer and return spring from transmission case.

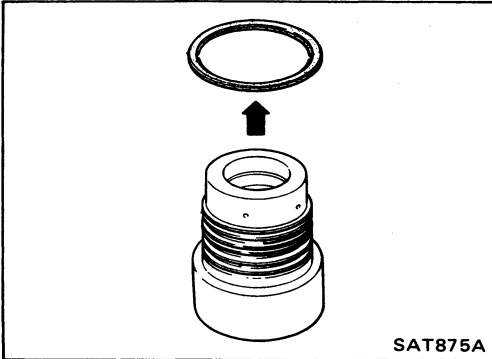

- Remove seal rings from low one-way clutch inner race.
- Remove needle bearing from low one-way clutch inner race.

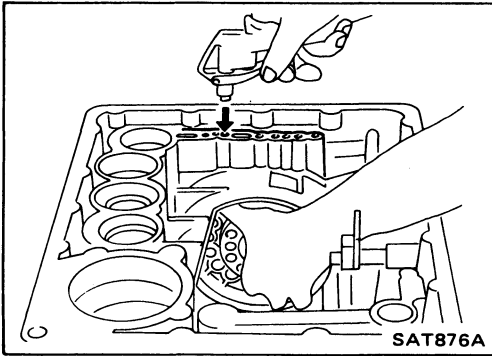

- Remove low and reverse brake piston using compressed air.
- Remove oil seal and D-ring from piston.

INSPECTION

Low and reverse brake snap ring and spring retainer

- Check for deformation, or damage.

Low and reverse brake return springs

- Check for deformation or damage. Also measure free length and outside diameter.

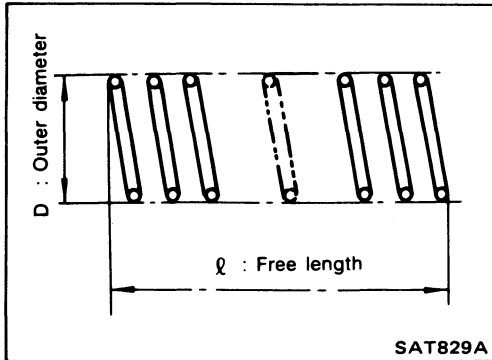

Inspection standard:

Unit: mm (in)

Model	Part No.	ℓ	D
RE4R01A	31521-21X00	23.7 (0.933)	11.6 (0.457)
RE4R03A	31505-51X06 (Inner)	20.43 (0.8043)	10.3 (0.406)
	31505-51X05 (Outer)	20.35 (0.8012)	13.0 (0.512)

REPAIR FOR COMPONENT PARTS

Low & Reverse Brake (Cont'd)

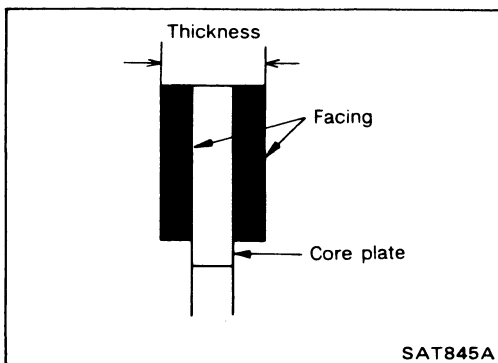

Low and reverse brake drive plates

- Check facing for burns, cracks or damage.
- Measure thickness of facing.

Thickness of drive plate:

Standard value

2.0 mm (0.079 in) (RE4R01A)

1.6 mm (0.063 in) (RE4R03A)

Wear limit

1.8 mm (0.071 in) (RE4R01A)

1.4 mm (0.055 in) (RE4R03A)

- If not within wear limit, replace.

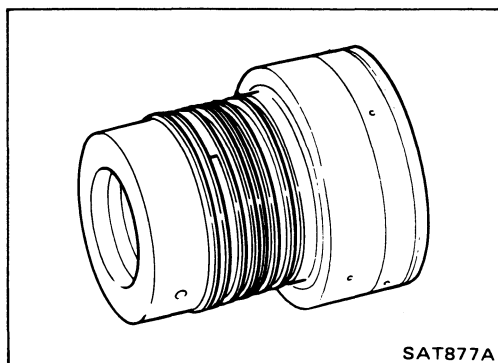

Low one-way clutch inner race

- Check frictional surface of inner race for wear or damage.

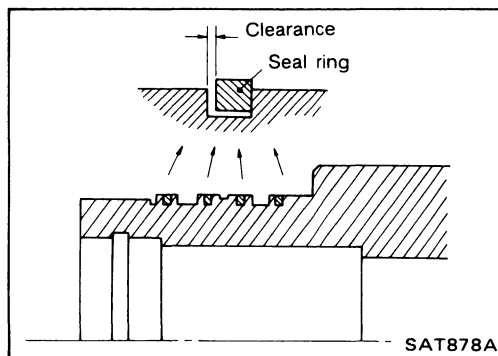

- Install a new seal rings onto low one-way clutch inner race.
- **Be careful not to expand seal ring gap excessively.**
- Measure seal ring-to-groove clearance.

Inspection standard:

Standard value: 0.10 - 0.25 mm (0.0039 - 0.0098 in)

Allowable limit: 0.25 mm (0.0098 in)

- If not within allowable limit, replace low one-way clutch inner race.

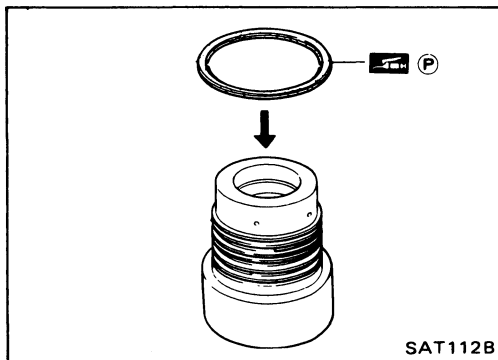

ASSEMBLY

1. Install bearing onto one-way clutch inner race.

- Pay attention to its direction — **Black surface goes to rear side.**
- Apply petroleum jelly to needle bearing.

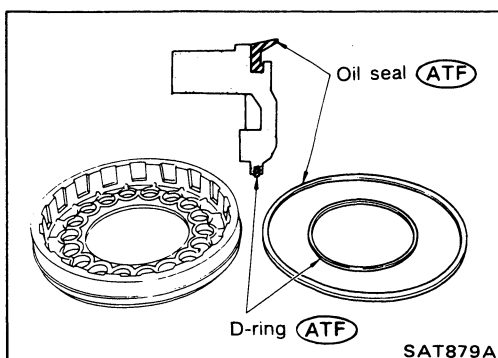

2. Install oil seal and D-ring onto piston.

- Apply A.T.F. to oil seal and D-ring.

REPAIR FOR COMPONENT PARTS

Low & Reverse Brake (Cont'd)

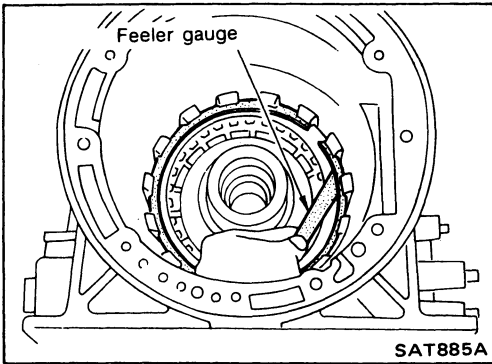

8. Measure clearance between retaining plate and snap ring. If not within allowable limit, select proper retaining plate.

Specified clearance:

Standard

1.1 - 1.5 mm (0.043 - 0.059 in)

Allowable limit

2.9 mm (0.114 in) (RE4R01A)

3.1 mm (0.122 in) (RE4R03A)

Retaining plate:

Refer to S.D.S.

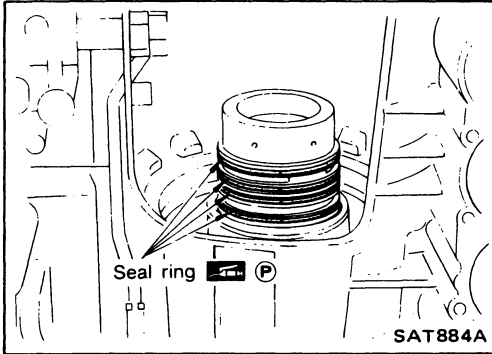

9. Install low one-way clutch inner race seal ring.

- Apply petroleum jelly to seal ring.
- Make sure seal rings are pressed firmly into place and held by petroleum jelly.

REPAIR FOR COMPONENT PARTS

Low & Reverse Brake (Cont'd)

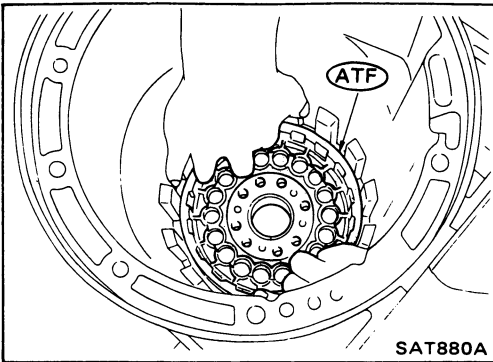

3. Install piston by rotating it slowly and evenly.
 - Apply A.T.F. to inner surface of transmission case.



4. Install return springs, spring retainer and low one-way clutch inner race onto transmission case.

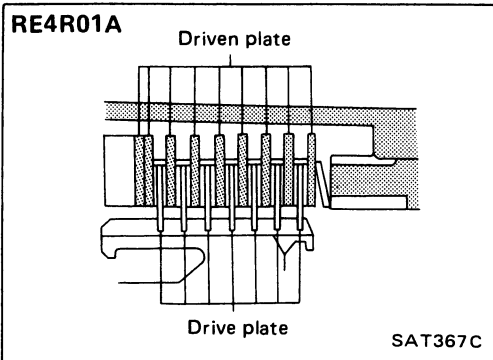

5. Install dish plate, low and reverse brake drive plates, driven plates and retaining plate.
 - Two types of drive plates are used on the RE4R03A transmission. One type uses a "waving" design and the other type uses a "flat" design. Either one can be installed first since they are interchangeable.
6. Install snap ring on transmission case.

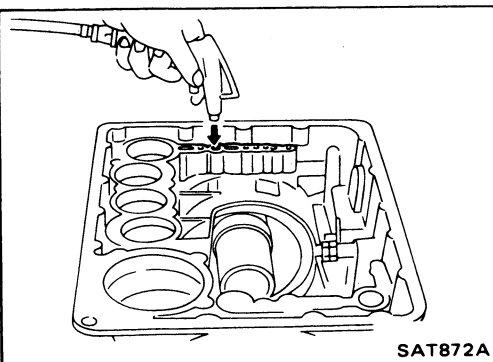
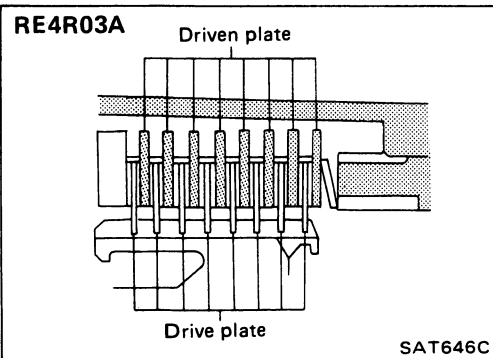

7. Check operation of low and reverse brake clutch piston. Refer to "DISASSEMBLY".

Forward Clutch Drum Assembly — RE4R01A

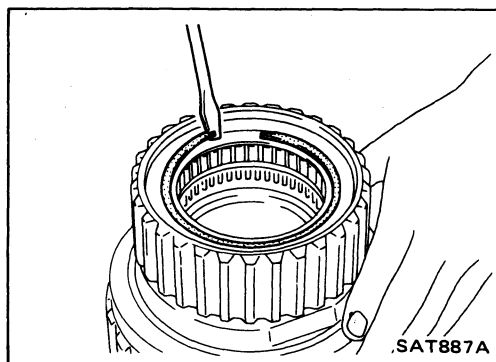
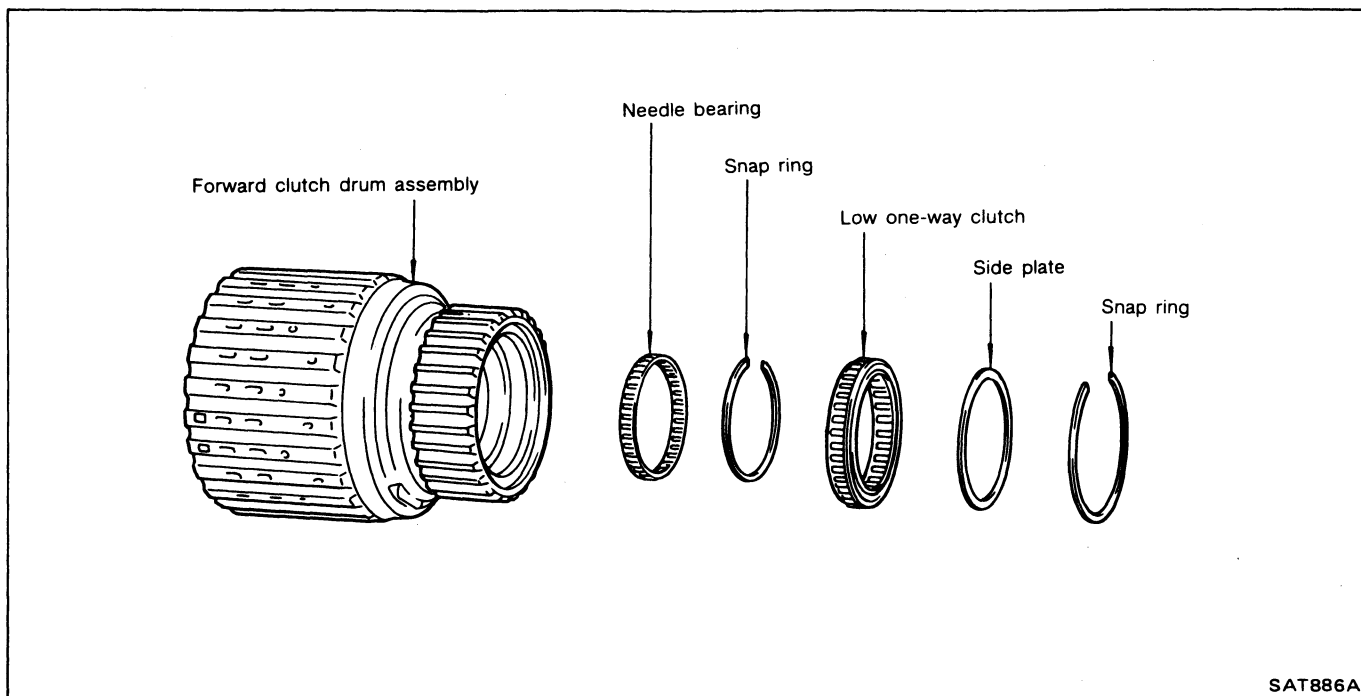

DISASSEMBLY

1. Remove snap ring from forward clutch drum.

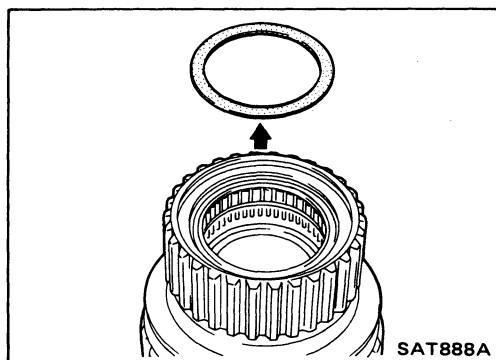

2. Remove side plate from forward clutch drum.

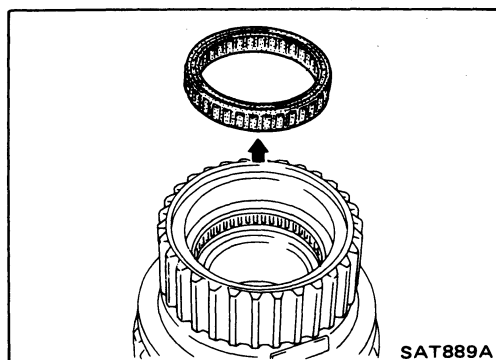

3. Remove low one-way clutch from forward clutch drum.

REPAIR FOR COMPONENT PARTS

Forward Clutch Drum Assembly — RE4R01A (Cont'd)

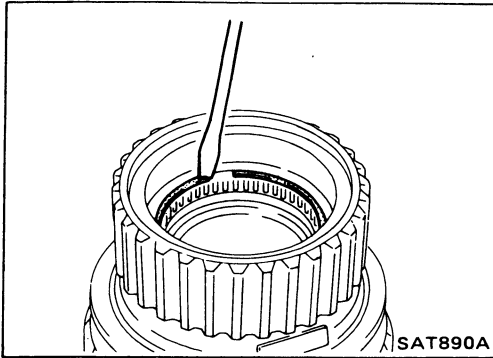

4. Remove snap ring from forward clutch drum.

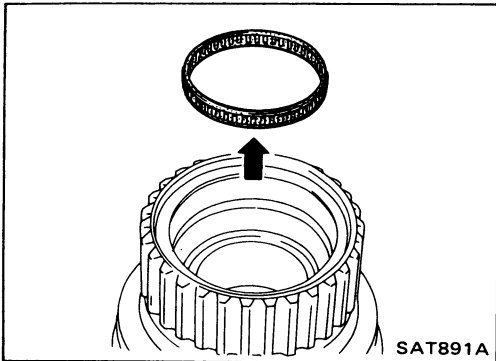

5. Remove needle bearing from forward clutch drum.

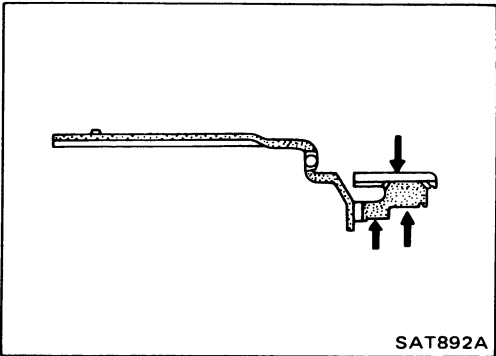

INSPECTION

Forward clutch drum

- Check spline portion for wear or damage.
- Check frictional surfaces of low one-way clutch and needle bearing for wear or damage.

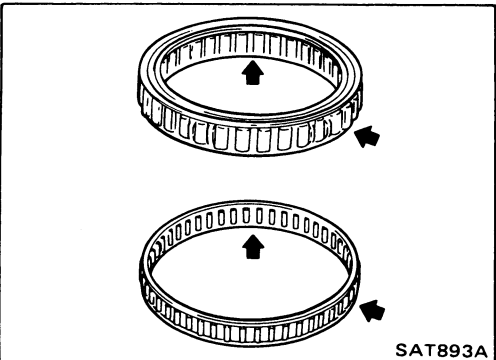

Needle bearing and low one-way clutch

- Check frictional surface for wear or damage.

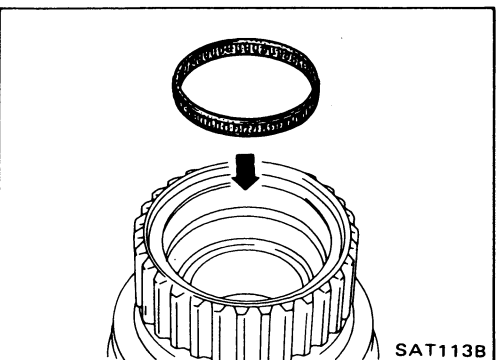

ASSEMBLY

1. Install needle bearing in forward clutch drum.

REPAIR FOR COMPONENT PARTS

Forward Clutch Drum Assembly — RE4R01A (Cont'd)

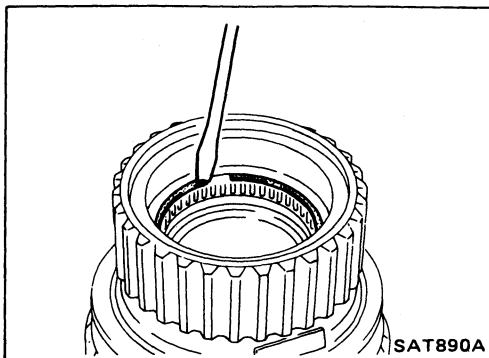

2. Install snap ring onto forward clutch drum.

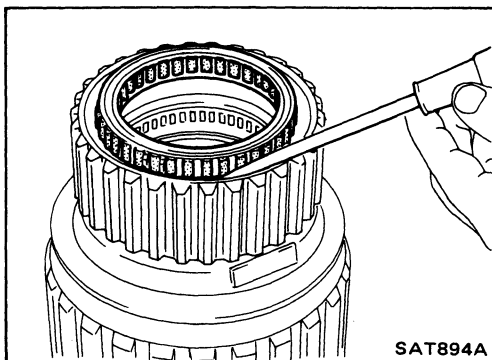

3. Install low one-way clutch onto forward clutch drum by pushing the roller in evenly.

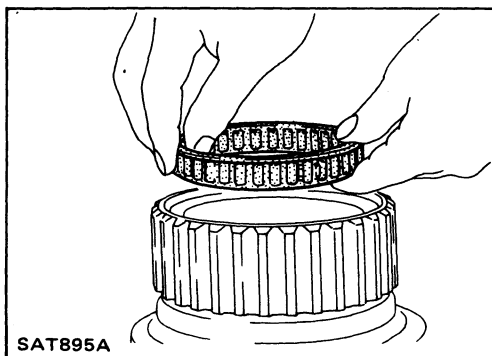

- Install low one-way clutch with flange facing rearward.

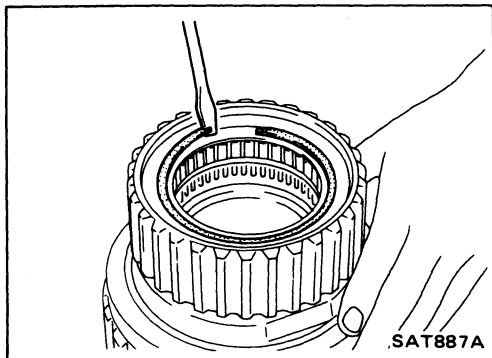

4. Install side plate onto forward clutch drum.
5. Install snap ring onto forward clutch drum.

Forward Clutch Drum Assembly — RE4R03A

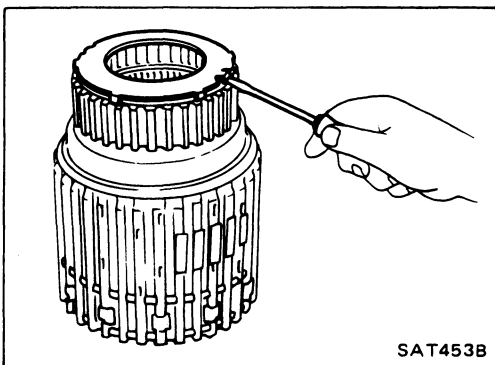
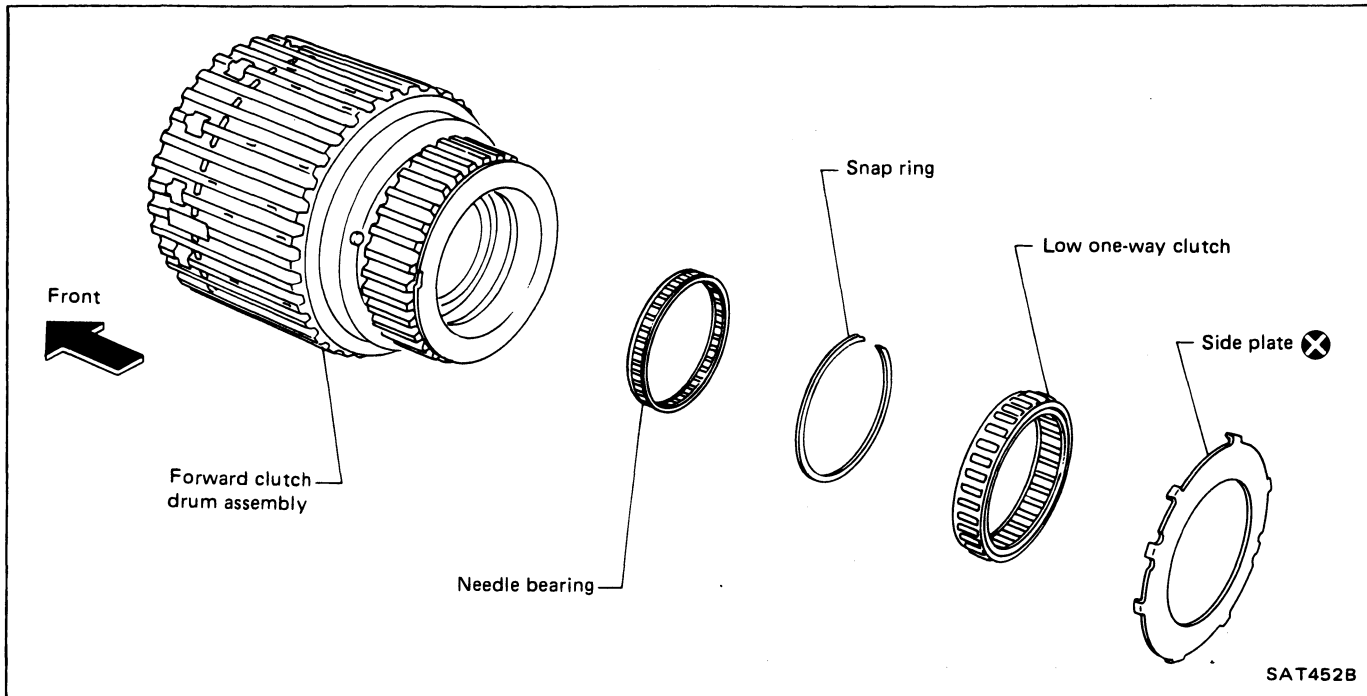

DISASSEMBLY

1. Remove side plate from forward clutch drum.

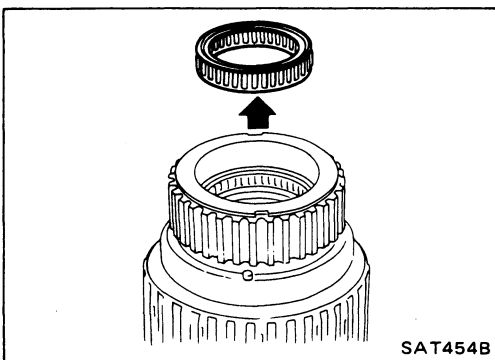

2. Remove low one-way clutch from forward clutch drum.

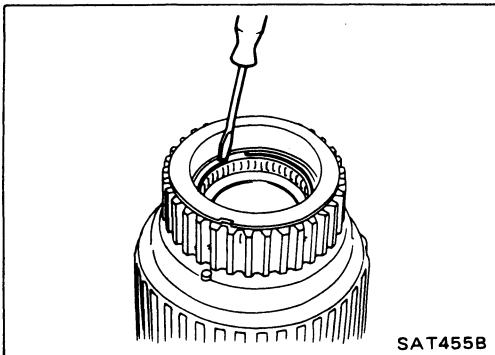

3. Remove snap ring from forward clutch drum.

REPAIR FOR COMPONENT PARTS

Forward Clutch Drum Assembly — RE4R03A (Cont'd)

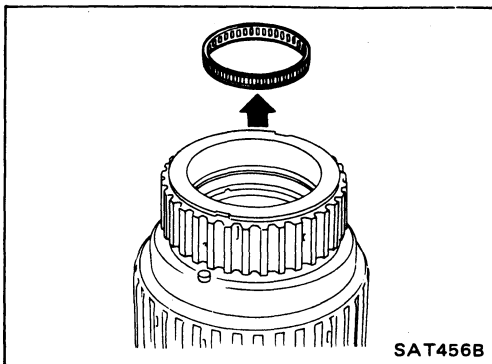

4. Remove needle bearing from forward clutch drum.

INSPECTION

Forward clutch drum

- Check spline portion for wear or damage.
- Check frictional surfaces of low one-way clutch and needle bearing for wear or damage.

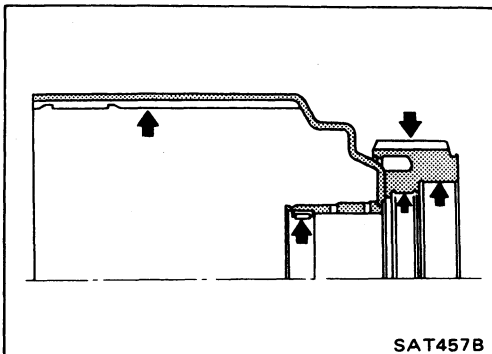

Needle bearing and low one-way clutch

- Check frictional surface for wear or damage.

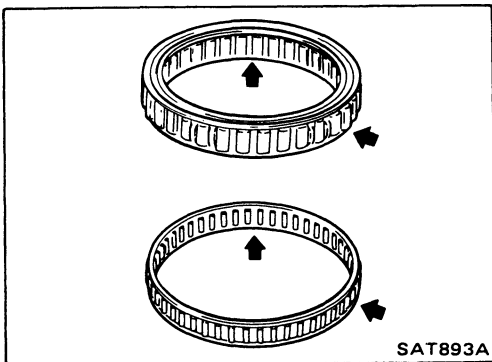

ASSEMBLY

1. Install needle bearing in forward clutch drum.

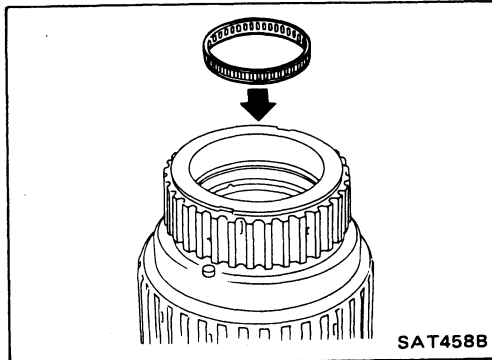

2. Install snap ring onto forward clutch drum.

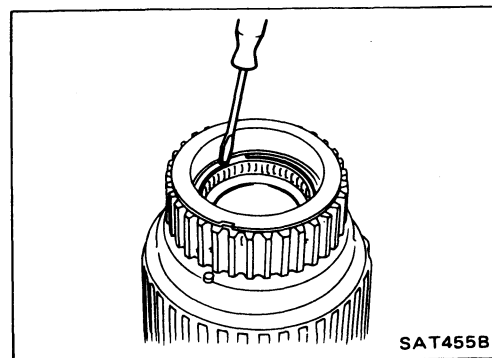

REPAIR FOR COMPONENT PARTS

Forward Clutch Drum Assembly — RE4R03A (Cont'd)

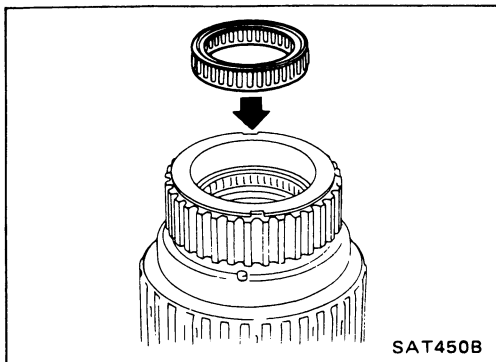

3. Install low one-way clutch onto forward clutch drum by pushing the roller in evenly.

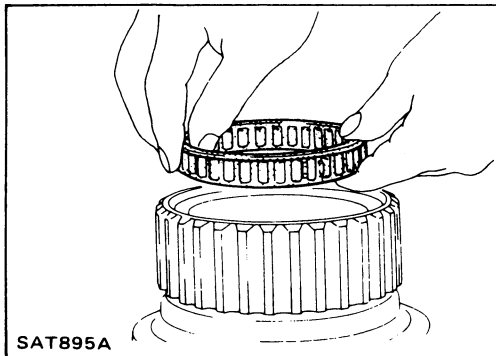

- Install low one-way clutch with flange facing rearward.

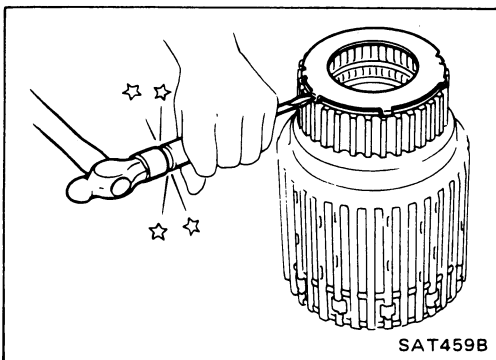

4. Install side plate onto forward clutch drum.

REPAIR FOR COMPONENT PARTS

Rear Internal Gear and Forward Clutch Hub

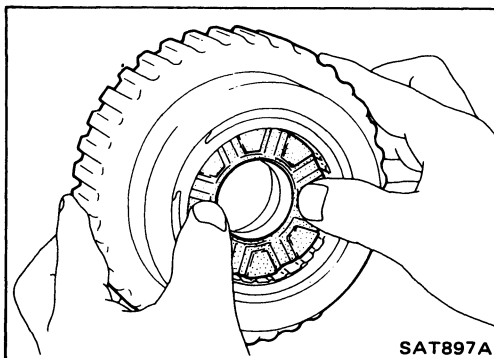
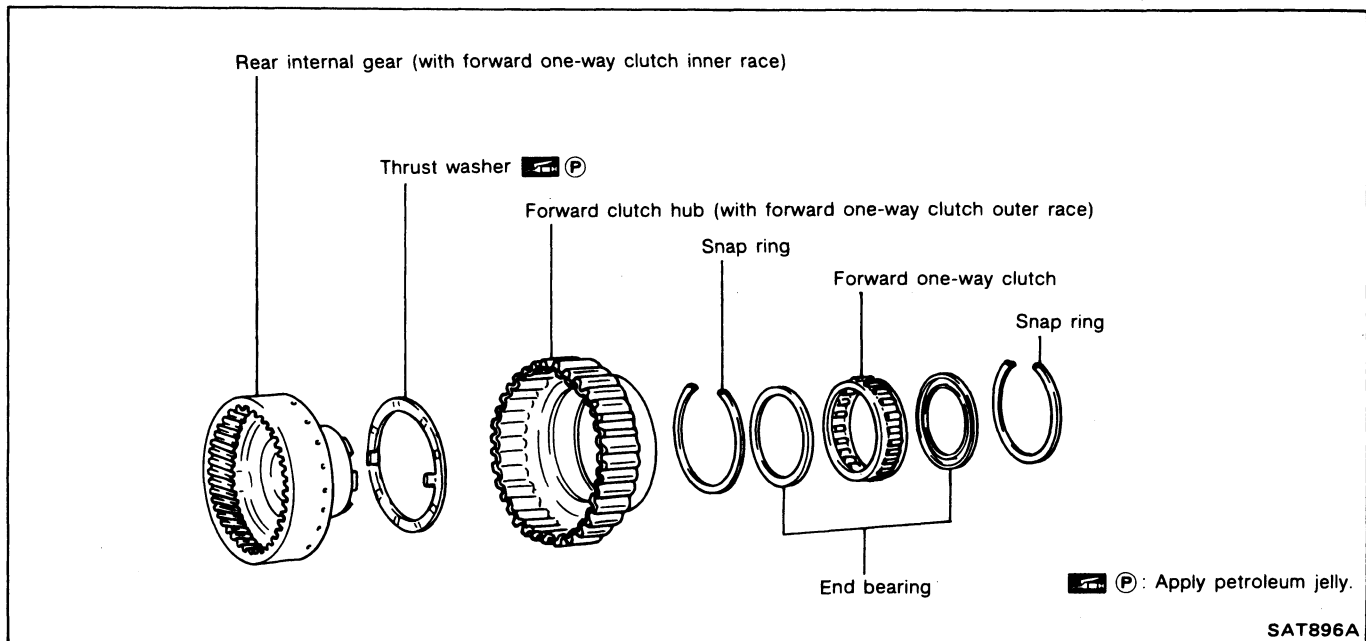

DISASSEMBLY

1. Remove rear internal gear by pushing forward clutch hub forward.

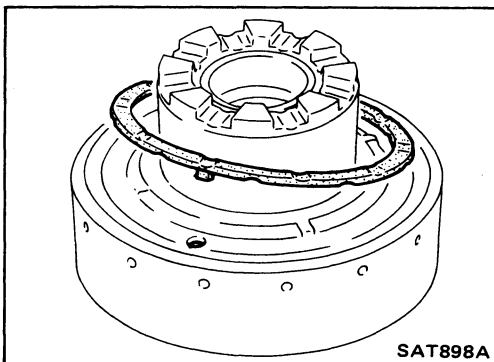

2. Remove thrust washer from rear internal gear.

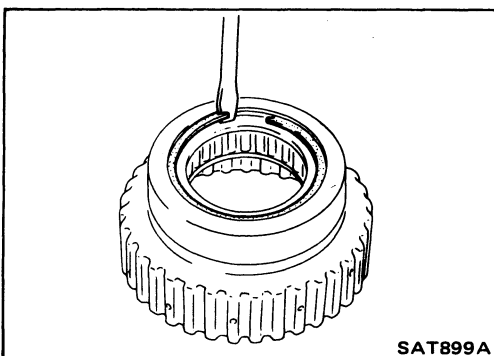

3. Remove snap ring from forward clutch hub.

REPAIR FOR COMPONENT PARTS

Rear Internal Gear and Forward Clutch Hub (Cont'd)

4. Remove end bearing.

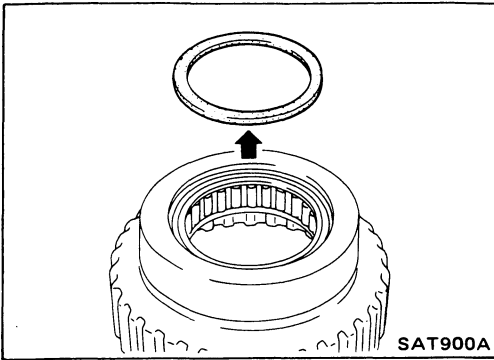

5. Remove forward one-way clutch and end bearing as a unit from forward clutch hub.

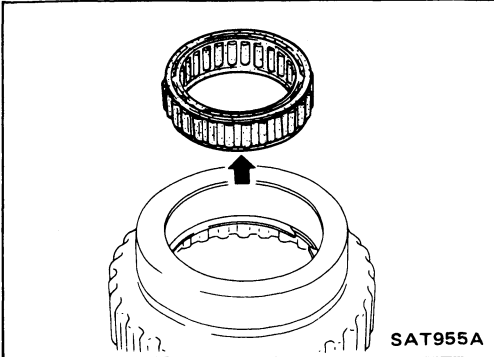

6. Remove snap ring from forward clutch hub.

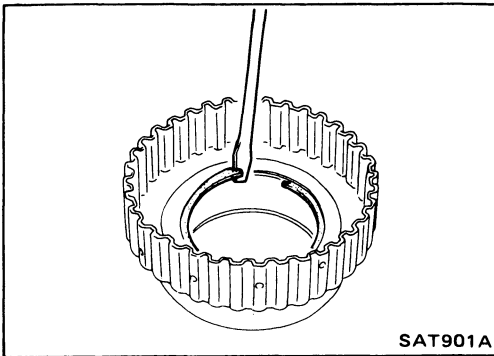

INSPECTION

Rear internal gear and forward clutch hub

- Check gear for excessive wear, chips or cracks.
- Check frictional surfaces of forward one-way clutch and thrust washer for wear or damage.
- Check spline for wear or damage.

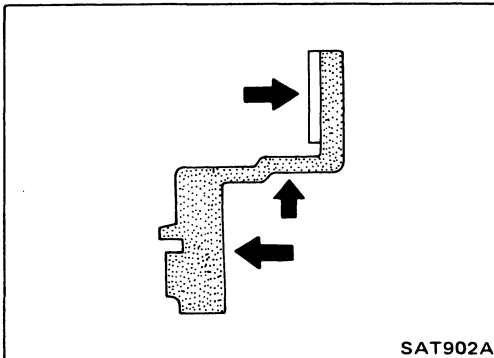

Snap ring and end bearing

- Check for deformation or damage.

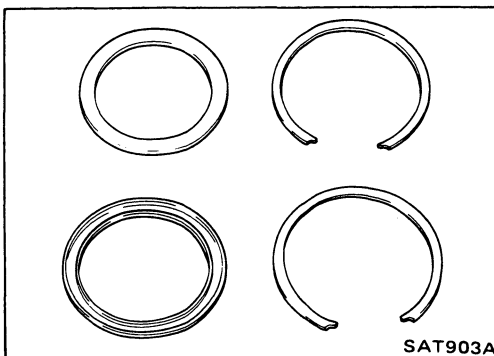

REPAIR FOR COMPONENT PARTS

Rear Internal Gear and Forward Clutch Hub (Cont'd)

ASSEMBLY

1. Install snap ring onto forward clutch hub.
2. Install end bearing.

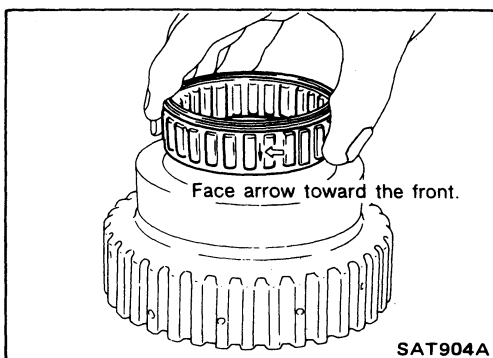
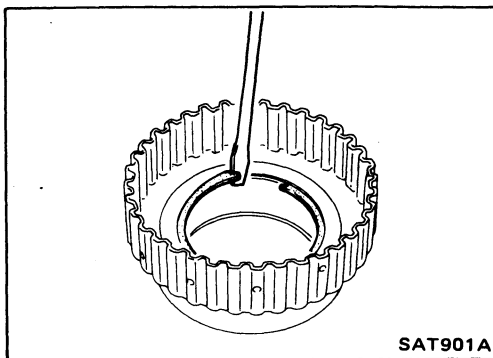

3. Install forward one-way clutch onto clutch hub.
 - **Install forward one-way clutch with flange facing rearward.**
4. Install end bearing.
5. Install snap ring onto forward clutch hub.

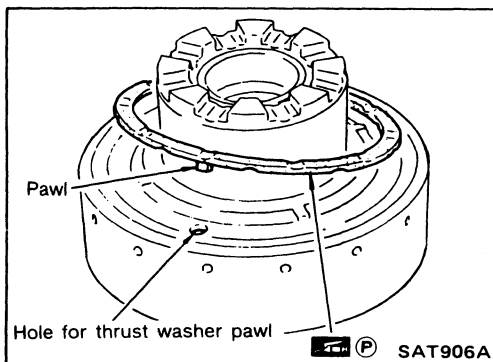

6. Install thrust washer onto rear internal gear.
 - **Apply petroleum jelly to thrust washer.**
 - **Securely insert pawls of thrust washer into holes in rear internal gear.**

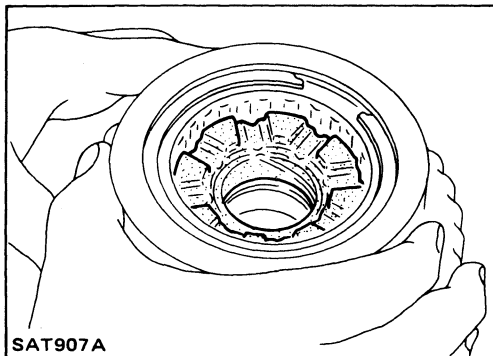

7. Position forward clutch hub in rear internal gear.

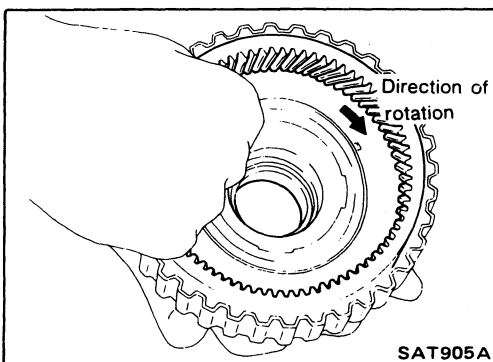

8. After installing, check to assure that forward clutch hub rotates clockwise.

Band Servo Piston Assembly

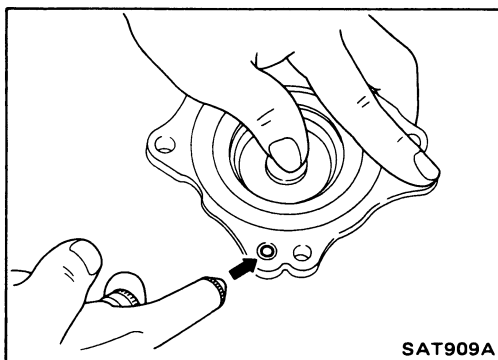
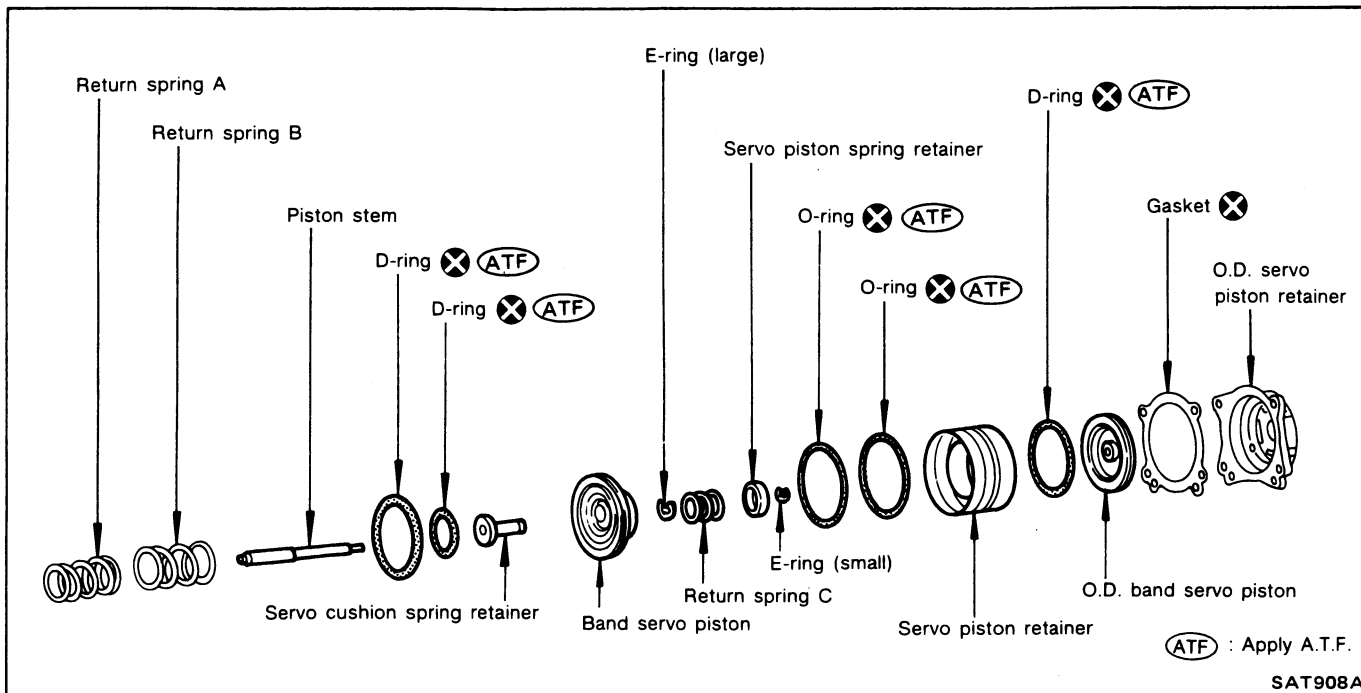

DISASSEMBLY

1. Block one oil hole in O.D. servo piston retainer and the center hole in O.D. band servo piston.
2. Apply compressed air to the other oil hole in piston retainer to remove O.D. band servo piston from retainer.
3. Remove D-ring from O.D. band servo piston.

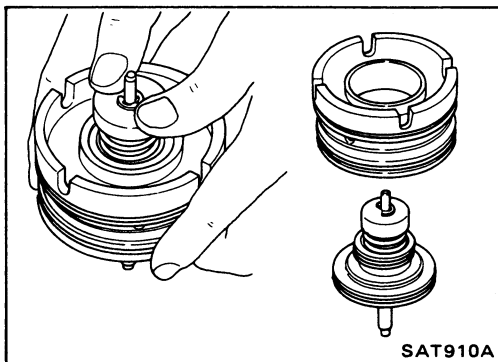

4. Remove band servo piston assembly from servo piston retainer by pushing it forward.

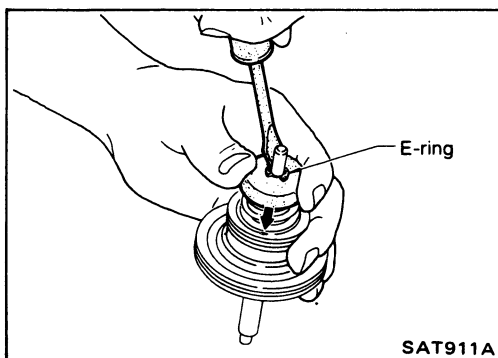

5. Place piston stem end on a wooden block. While pushing servo piston spring retainer down, remove E-ring.

REPAIR FOR COMPONENT PARTS

Band Servo Piston Assembly (Cont'd)

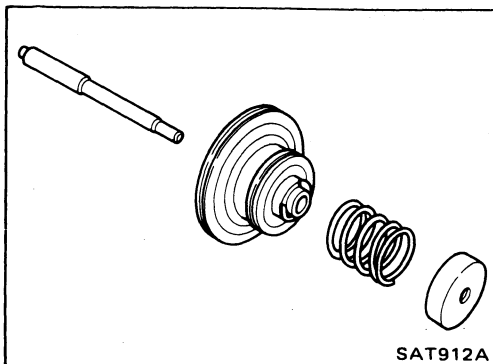

6. Remove servo piston spring retainer, return spring C and piston stem from band servo piston.

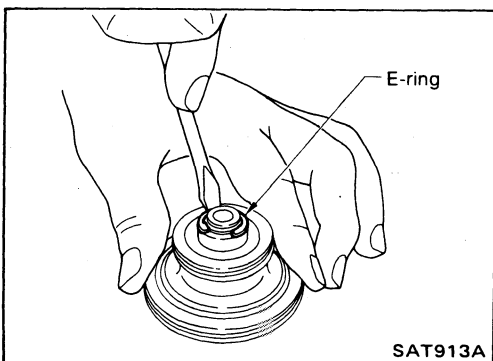

7. Remove E-ring from band servo piston.

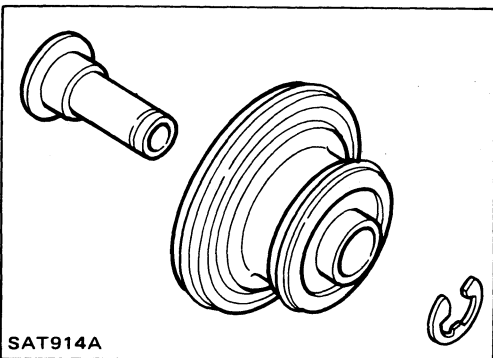

8. Remove servo cushion spring retainer from band servo piston.
9. Remove D-rings from band servo piston.
10. Remove O-rings from servo piston retainer.

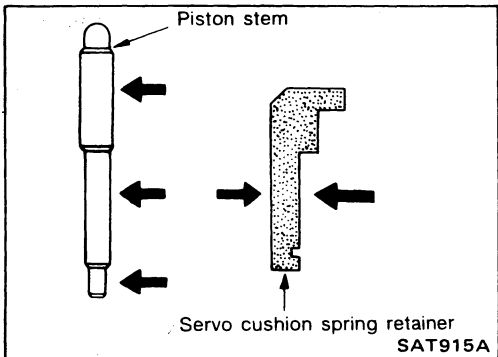

INSPECTION

Pistons, retainers and piston stem

- Check frictional surfaces for abnormal wear or damage.

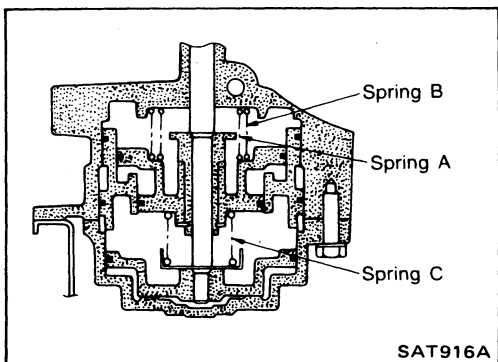

Return springs

- Check for deformation or damage. Measure free length and outer diameter.

Inspection standard:

Unit: mm (in)

Parts	Free length	Outer diameter
Spring A	45.6 (1.795)	34.3 (1.350)
Spring B	53.8 (2.118)	40.3 (1.587)
Spring C	29.7 (1.169)	27.6 (1.087)

REPAIR FOR COMPONENT PARTS

Band Servo Piston Assembly (Cont'd)

ASSEMBLY

1. Install O-rings onto servo piston retainer.
 - Apply A.T.F. to O-rings.
 - Pay attention to position of each O-ring.

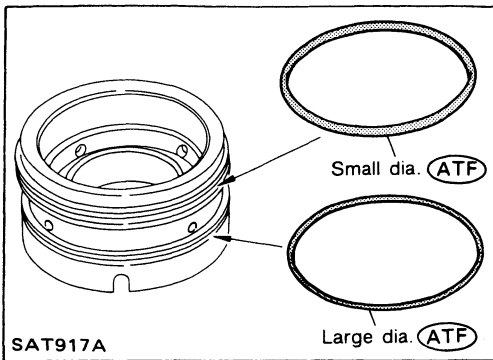

2. Install servo cushion spring retainer onto band servo piston.

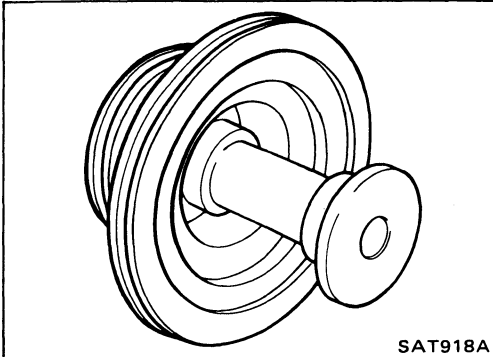

3. Install E-ring onto servo cushion spring retainer.

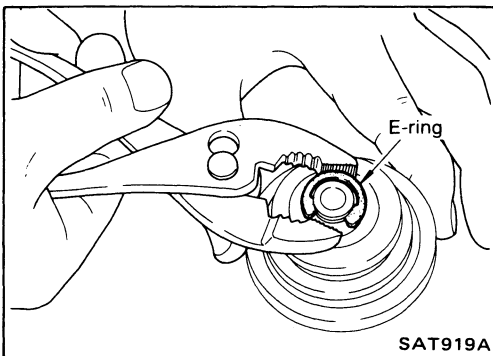

4. Install D-rings onto band servo piston.
 - Apply A.T.F. to D-rings.

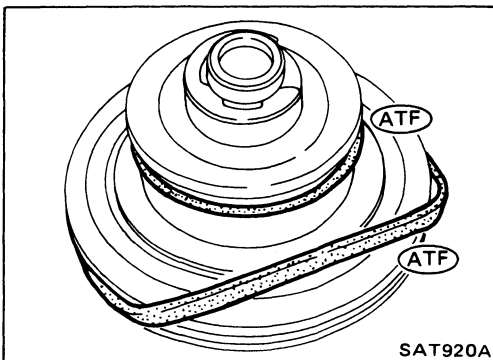

5. Install servo piston spring retainer, return spring C and piston stem onto band servo piston.

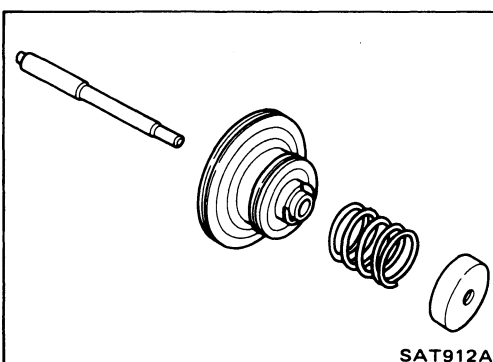

REPAIR FOR COMPONENT PARTS

Band Servo Piston Assembly (Cont'd)

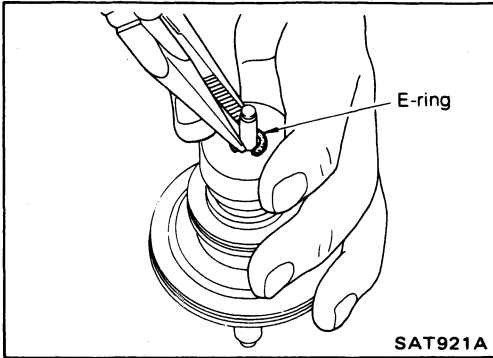

6. Place piston stem end on a wooden block. While pushing servo piston spring retainer down, install E-ring.

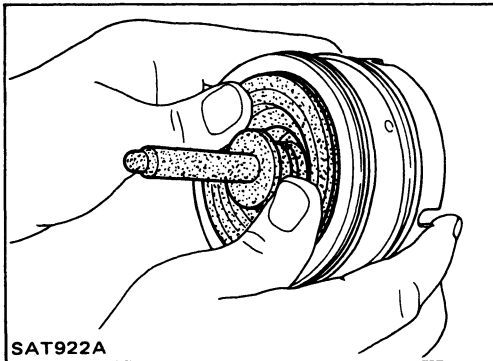

7. Install band servo piston assembly onto servo piston retainer by pushing it inward.

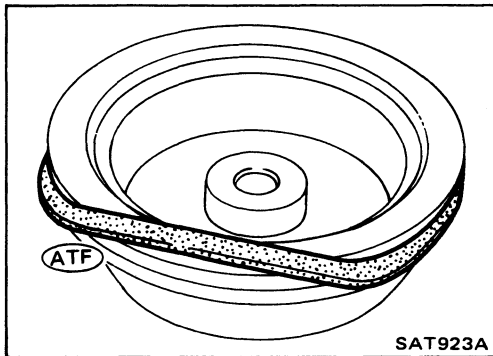

8. Install D-ring on O.D. band servo piston.
 - Apply A.T.F. to D-ring.

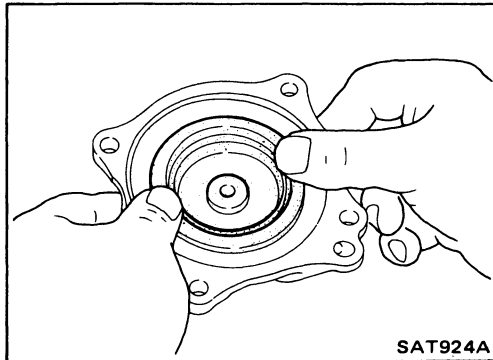

9. Install O.D. band servo piston onto servo piston retainer by pushing it inward.

Parking Pawl Components

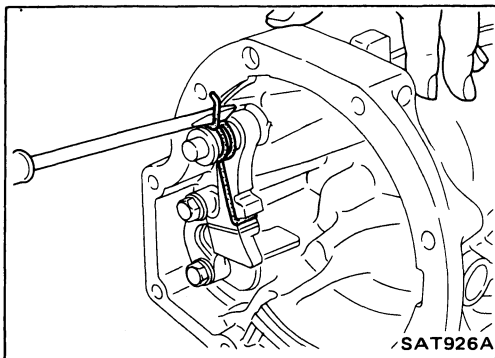
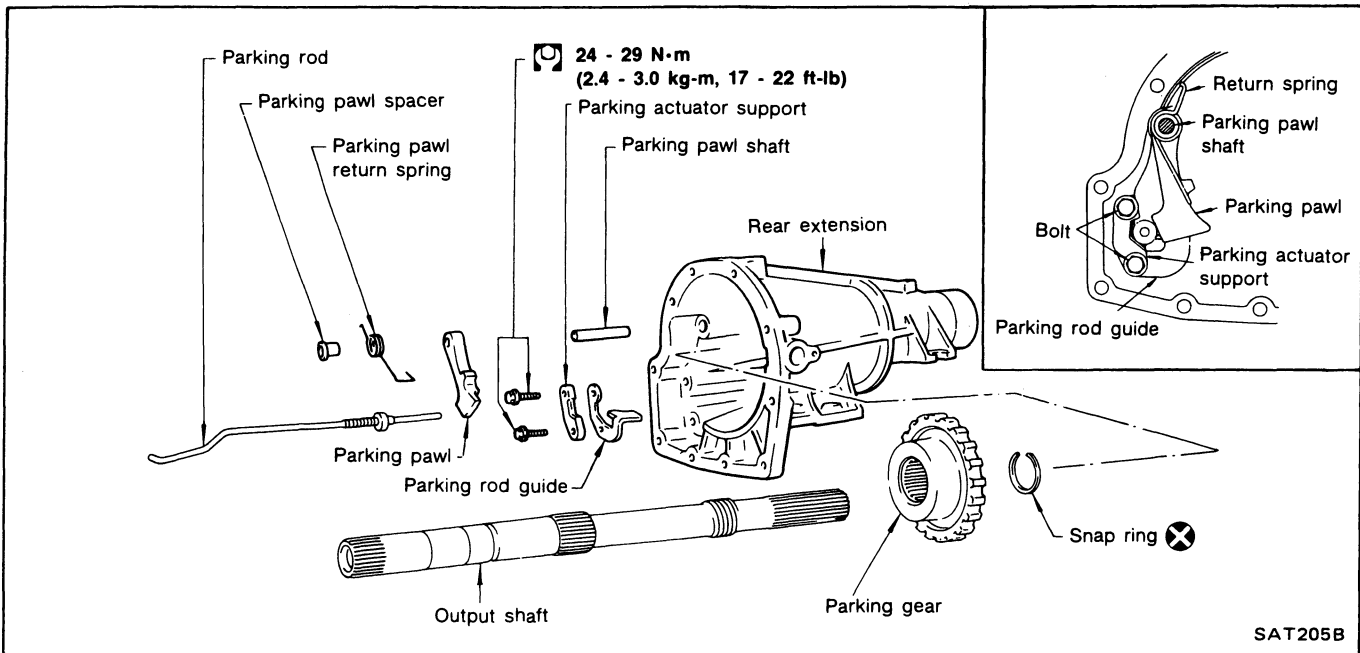

DISASSEMBLY

1. Slide return spring to the front of rear extension flange.

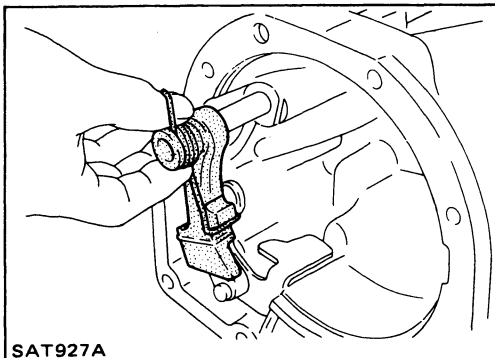

2. Remove return spring, pawl spacer and parking pawl from rear extension.
3. Remove parking pawl shaft from rear extension.

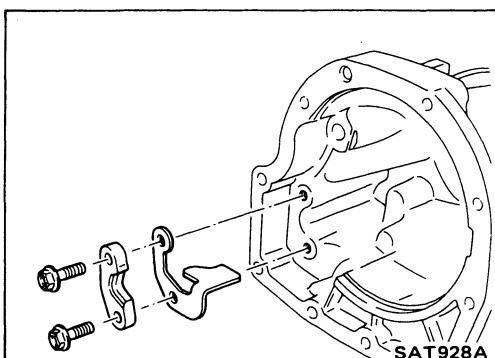

4. Remove parking actuator support and rod guide from rear extension.

REPAIR FOR COMPONENT PARTS

Parking Pawl Components (Cont'd)

INSPECTION

Parking pawl and parking actuator support

- Check contact surface of parking rod for wear.

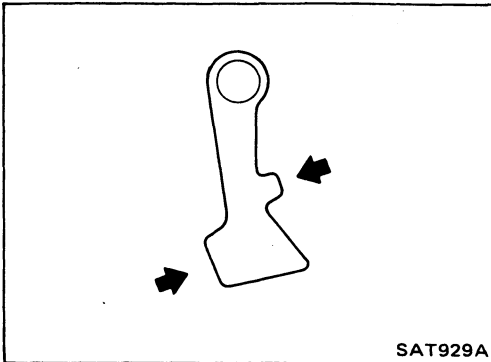

ASSEMBLY

1. Install rod guide and parking actuator support onto rear extension.
2. Insert parking pawl shaft into rear extension.

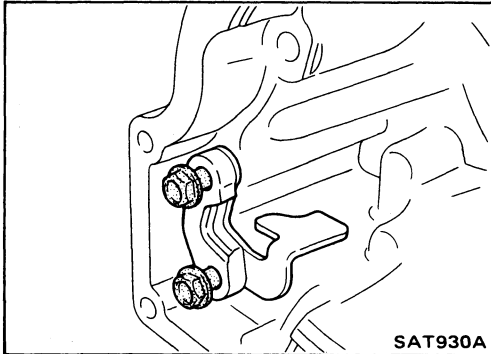

3. Install return spring, pawl spacer and parking pawl onto parking pawl shaft.

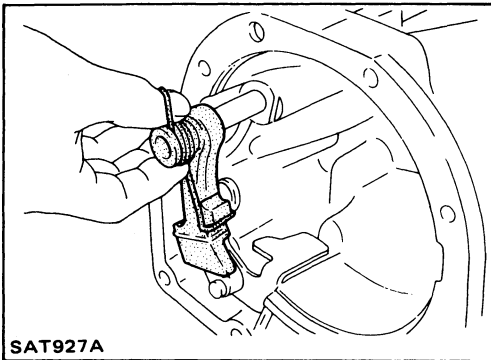

4. Bend return spring upward and install it onto rear extension.

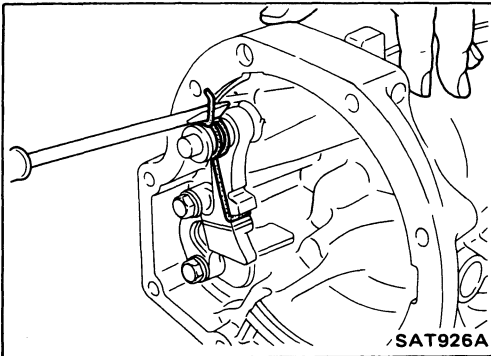

ASSEMBLY

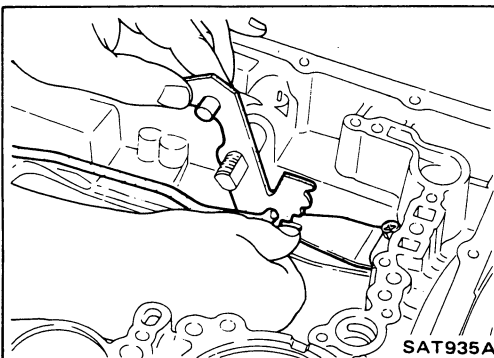
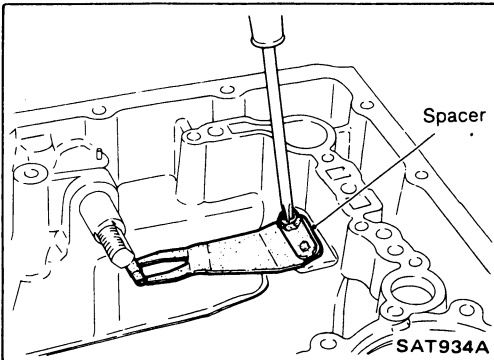
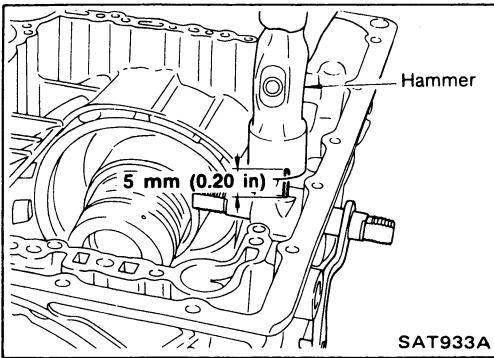
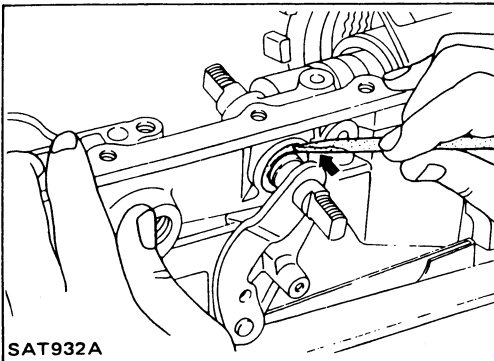
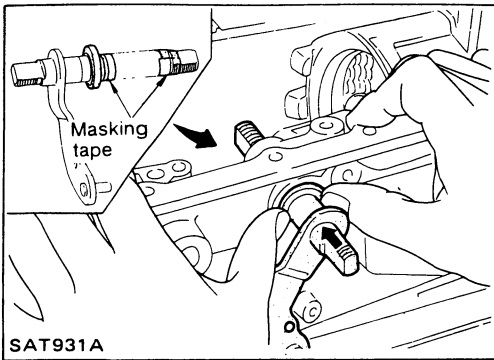

Assembly

1. Install manual shaft components.
 - a. Install oil seal onto manual shaft.
 - **Apply A.T.F. to oil seal.**
 - **Wrap threads of manual shaft with masking tape.**
 - b. Insert manual shaft and oil seal as a unit into transmission case.
 - c. Remove masking tape.
- d. Push oil seal evenly and install it onto transmission case.
- e. Align groove in shaft with drive pin hole, then drive pin into position as shown in figure at left.
- f. Install detent spring and spacer.
- g. While pushing detent spring down, install manual plate onto manual shaft.

ASSEMBLY

Assembly (Cont'd)

h. Install lock nuts onto manual shaft.

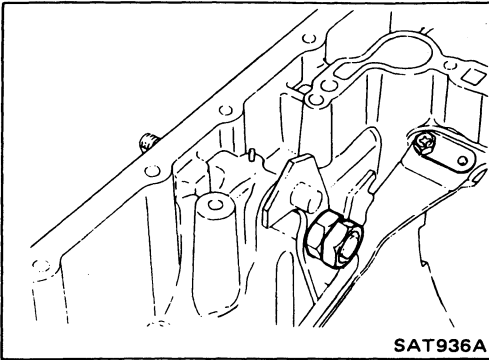

SAT936A

2. Install accumulator piston.
 - a. Install O-rings onto accumulator piston.
 - **Apply A.T.F. to O-rings.**

Accumulator piston O-rings:

Unit: mm (in)

Accumulator	A	B	C	D
Small diameter end	29 (1.14)	32 (1.26)	45 (1.77)	29 (1.14)
Large diameter end	45 (1.77)	50 (1.97)	50 (1.97)	45 (1.77)

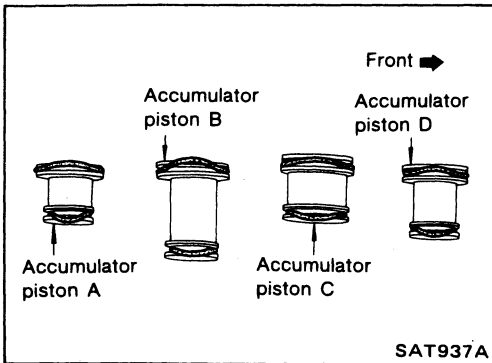

SAT937A

- b. Install return spring for accumulator A onto transmission case.

Free length of return spring:

Unit: mm (in)

Accumulator	A
Free length	43 (1.69)

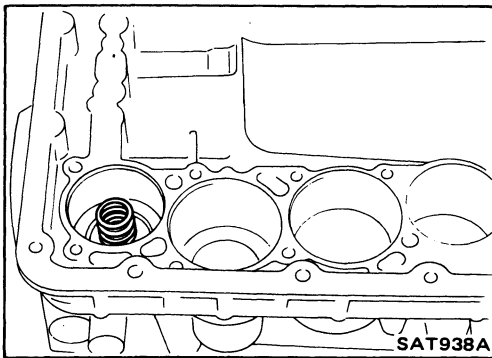

SAT938A

- c. Install accumulator pistons A, B, C and D.
 - **Apply A.T.F. to transmission case.**

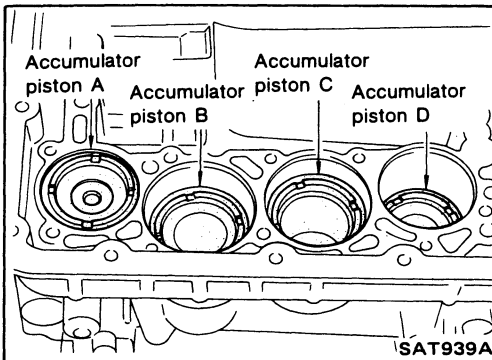

SAT939A

3. Install band servo piston.
 - a. Install return springs onto servo piston.

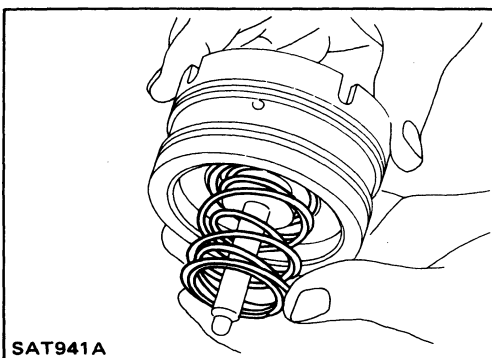

SAT941A

ASSEMBLY

Assembly (Cont'd)

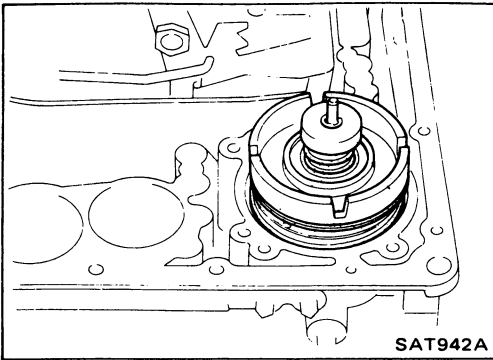

- b. Install band servo piston onto transmission case.
 - Apply A.T.F. to O-ring of band servo piston and transmission case.
- c. Install gasket for band servo onto transmission case.

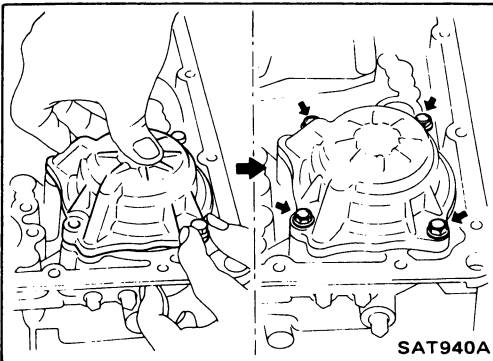

- d. Install band servo retainer onto transmission case.

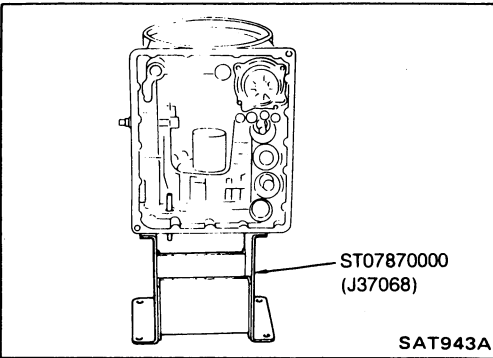

- 4. Install rear side clutch and gear components.
 - a. Place transmission case in vertical position.

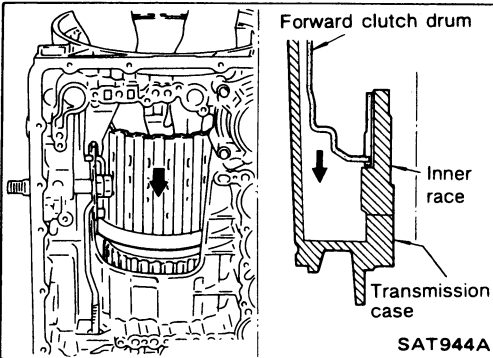

- b. Slightly lift forward clutch drum assembly and slowly rotate it clockwise until its hub passes fully over the clutch inner race inside transmission case.

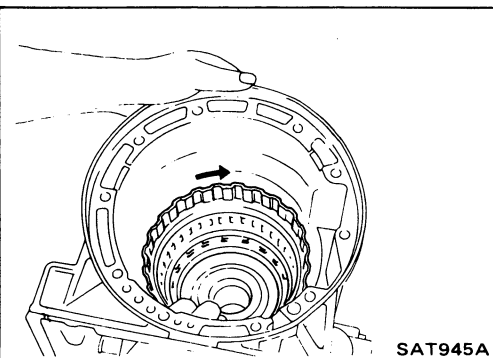

- c. Check to be sure that rotation direction of forward clutch assembly is correct.

ASSEMBLY

Assembly (Cont'd)

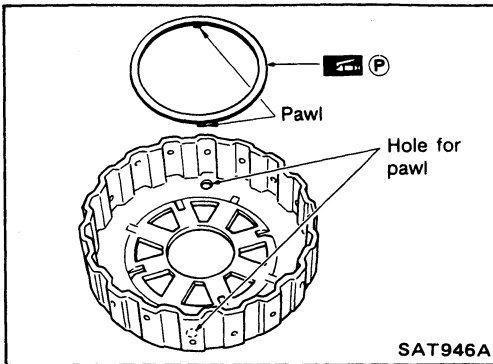

- d. Install thrust washer onto front of overrun clutch hub.
- Apply petroleum jelly to the thrust washer.
 - Insert pawls of thrust washer securely into holes in overrun clutch hub.

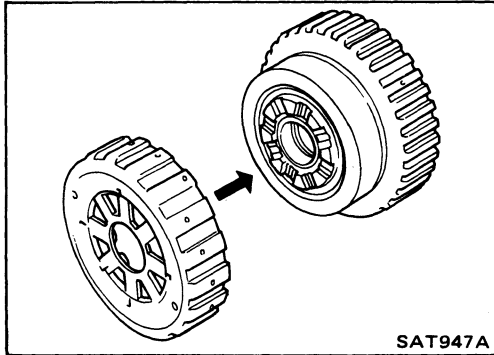

- e. Install overrun clutch hub onto rear internal gear assembly.

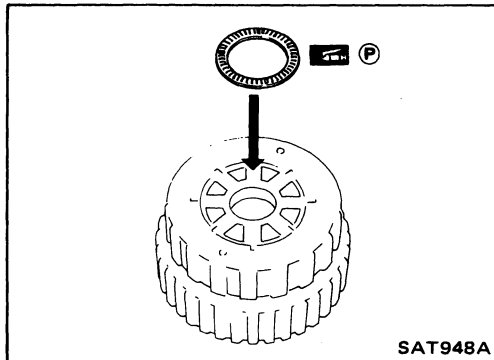

- f. Install needle bearing onto rear of overrun clutch hub.
- Apply petroleum jelly to needle bearing.

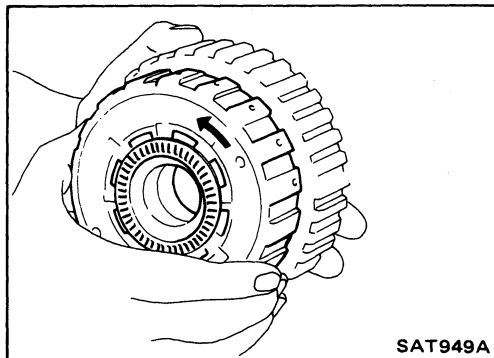

- g. Check that overrun clutch hub rotates as shown while holding forward clutch hub.

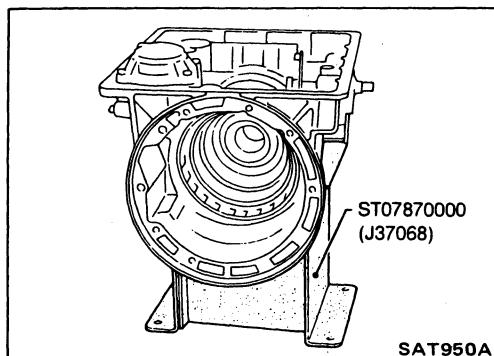

- h. Place transmission case into horizontal position.

ASSEMBLY

Assembly (Cont'd)

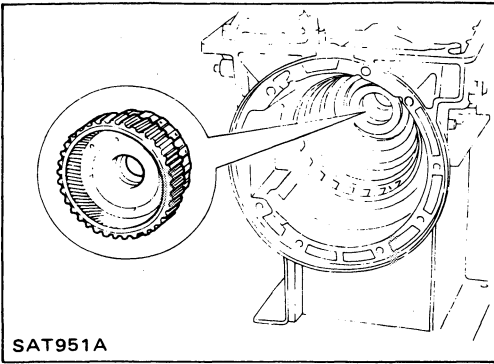

- i. Install rear internal gear, forward clutch hub and overrun clutch hub as a unit onto transmission case.

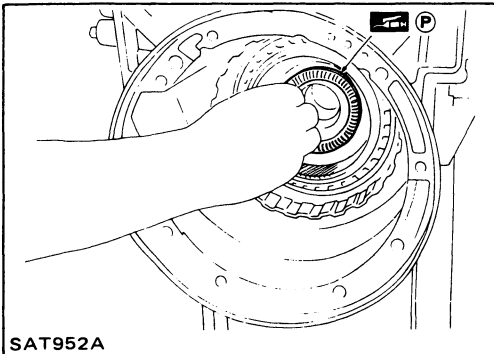

- j. Install needle bearing onto rear internal gear.
● Apply petroleum jelly to needle bearing.

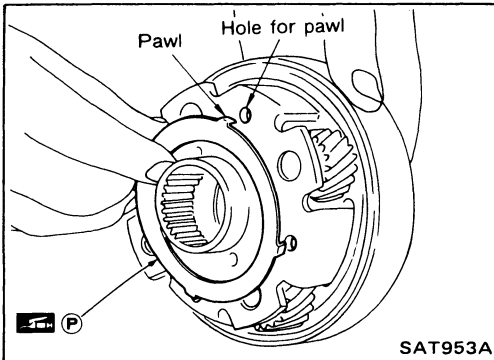

- k. Install bearing race onto rear of front internal gear.
● Apply petroleum jelly to bearing race.
● Securely engage pawls of bearing race with holes in front internal gear.

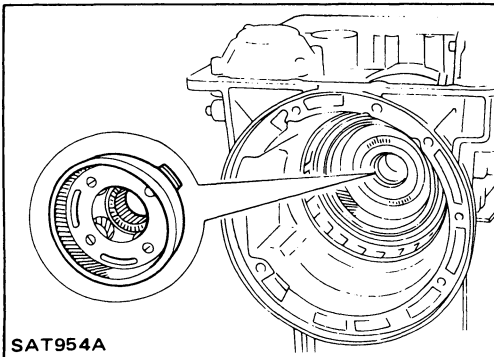

- l. Install front internal gear on transmission case.

ASSEMBLY

Adjustment

When any parts listed in the following table are replaced, total end play or reverse clutch end play must be adjusted.

Part name	Item	Total end play	Reverse clutch end play
Transmission case		●	●
Low one-way clutch inner race		●	●
Overrun clutch hub		●	●
Rear internal gear		●	●
Rear planetary carrier		●	●
Rear sun gear		●	●
Front planetary carrier		●	●
Front sun gear		●	●
High clutch hub		●	●
High clutch drum		●	●
Oil pump cover		●	●
Reverse clutch drum		—	●

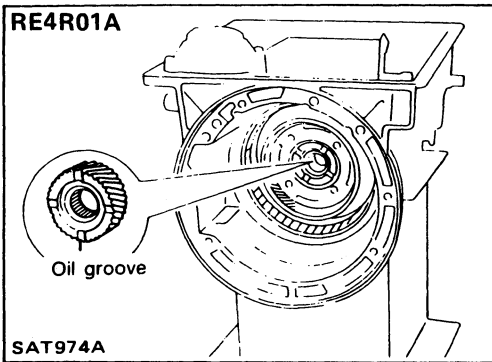

1. Install front side clutch and gear components.
 - a. Install rear sun gear on transmission case.
 - Pay attention to its direction.

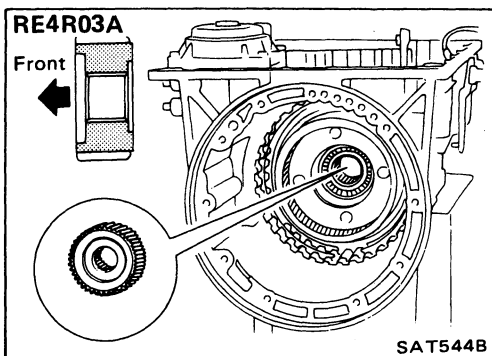

ASSEMBLY

Adjustment (Cont'd)

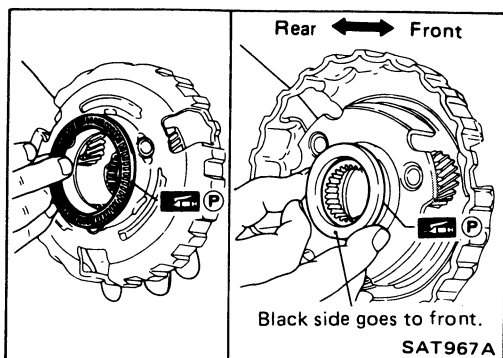

- b. Install needle bearing on front of front planetary carrier.
 - Apply petroleum jelly to needle bearing.
- c. Install needle bearing on rear of front planetary carrier.
 - Apply petroleum jelly to bearing.
 - Pay attention to its direction — Black side goes to front.

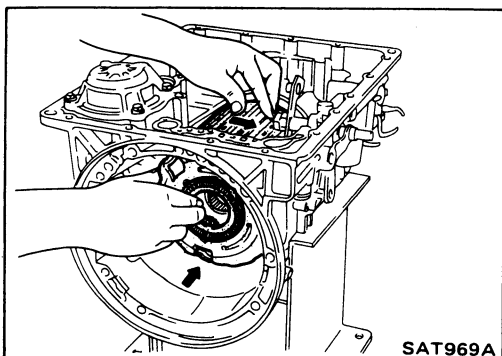

- d. While rotating forward clutch drum clockwise, install front planetary carrier on forward clutch drum.

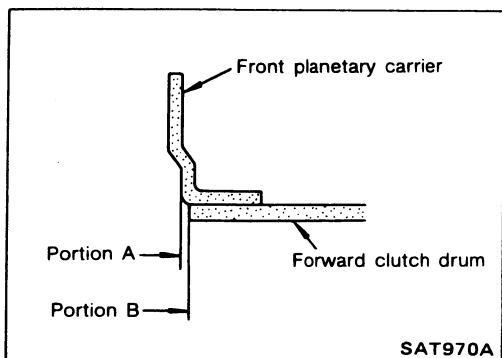

- Check that portion A of front planetary carrier protrudes approximately 2 mm (0.08 in) beyond portion B of forward clutch assembly. (RE4R01A only)

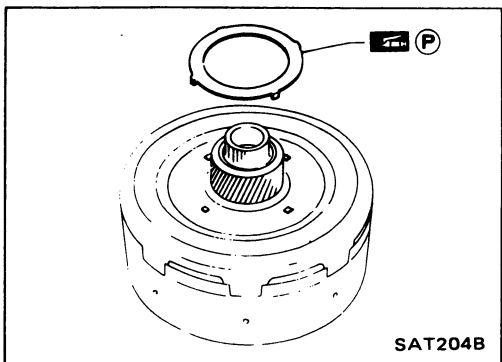

- e. Install bearing race (RE4R01A) or needle bearing (RE4R03A) on rear of clutch pack.
 - Apply petroleum jelly to bearing races.
 - Securely engage pawls of bearing race with hole in clutch pack.

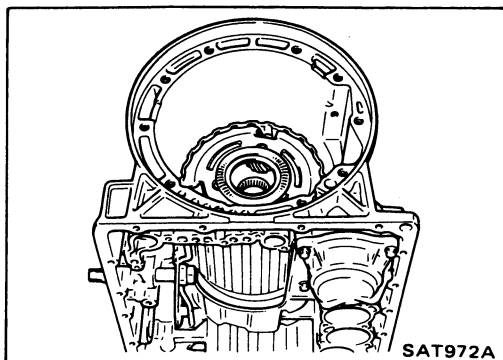

- f. Place transmission case in vertical position.

ASSEMBLY

Adjustment (Cont'd)

g. Install clutch pack into transmission case.

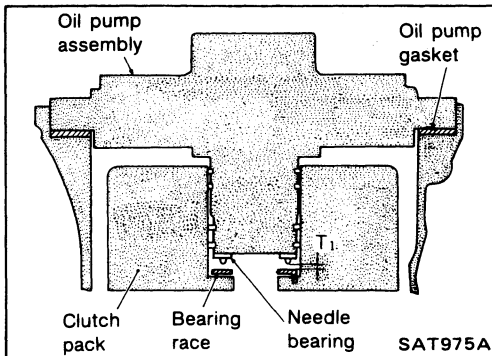
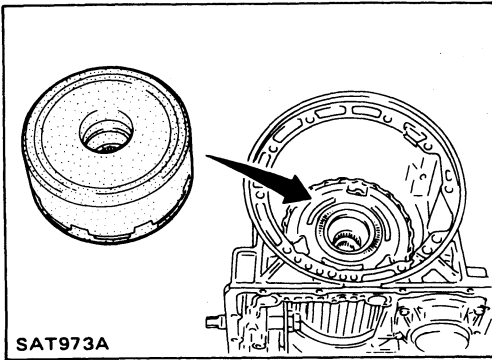

2. Adjust total end play.
Total end play "T₁":
0.25 - 0.55 mm (0.0098 - 0.0217 in)

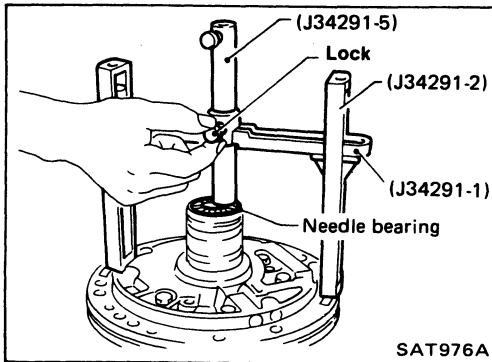

a. With needle bearing installed, place J34291-1 (bridge), J34291-2 (legs) and the J34291-5 (gauging cylinder) onto oil pump. The long ends of legs should be placed firmly on machined surface of oil pump assembly and gauging cylinder should rest on top of the needle bearing. Lock gauging cylinder in place with set screw.

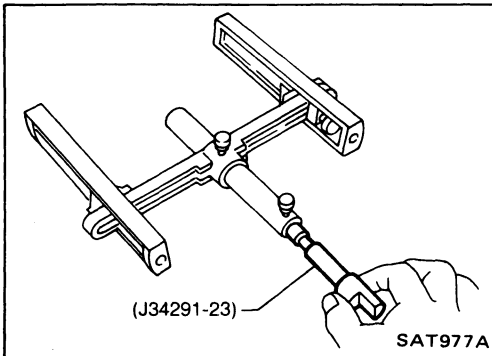

b. Install J34291-23 (gauging plunger) into gauging cylinder.

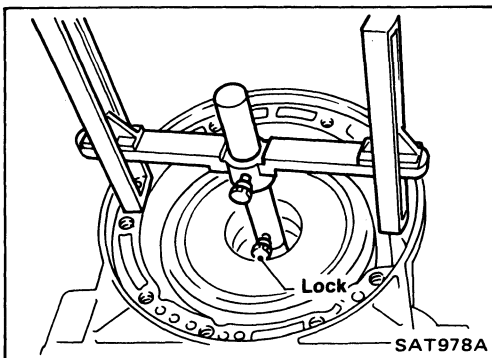

c. With original bearing race installed inside reverse clutch drum, place shim selecting gauge with its legs on machined surface of transmission case (no gasket) and allow gauging plunger to rest on bearing race. Lock gauging plunger in place with set screw.

ASSEMBLY

Adjustment (Cont'd)

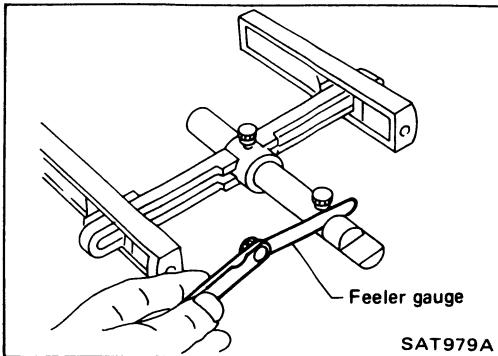

- d. Remove Tool and use feeler gauge to measure gap between gauging cylinder and gauging plunger. This measurement should give exact total end play.

Total end play "T₁":

0.25 - 0.55 mm (0.0098 - 0.0217 in)

- If end play is out of specification, decrease or increase thickness of oil pump cover bearing race as necessary.

Available oil pump cover bearing race:

Refer to S.D.S.

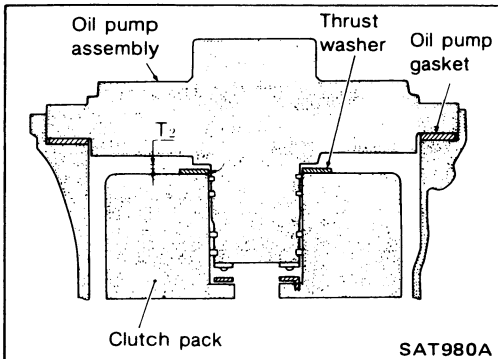

3. Adjust reverse clutch drum end play.
- Reverse clutch drum end play "T₂":**
0.55 - 0.90 mm (0.0217 - 0.0354 in)

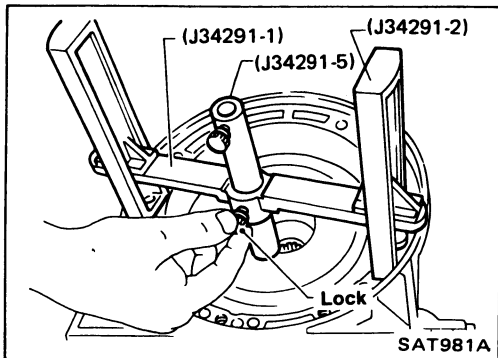

- a. Place J34291-1 (bridge), J34291-2 (legs) and J34291-5 (gauging cylinder) on machined surface of transmission case (no gasket) and allow gauging cylinder to rest on front thrust surface of reverse clutch drum. Lock cylinder in place with set screw.

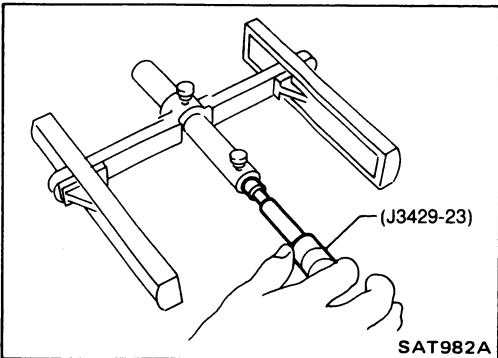

- b. Install J34291-23 (gauging plunger) into gauging cylinder.

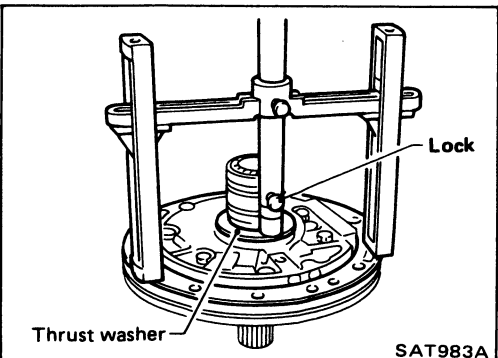

- c. With original thrust washer installed on oil pump, place shim setting gauge legs onto machined surface of oil pump assembly and allow gauging plunger to rest on thrust washer. Lock plunger in place with set screw.

ASSEMBLY

Adjustment (Cont'd)

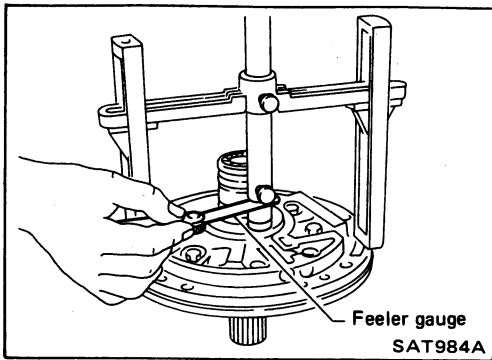

- d. Use feeler gauge to measure gap between gauging plunger and gauging cylinder. This measurement should give you exact reverse clutch drum and play.

Reverse clutch drum end play "T₂":

0.55 - 0.90 mm (0.0217 - 0.0354 in)

- If end play is out of specification, decrease or increase thickness of oil pump thrust washer as necessary.

Available oil pump thrust washer:

Refer to S.D.S.

Assembly

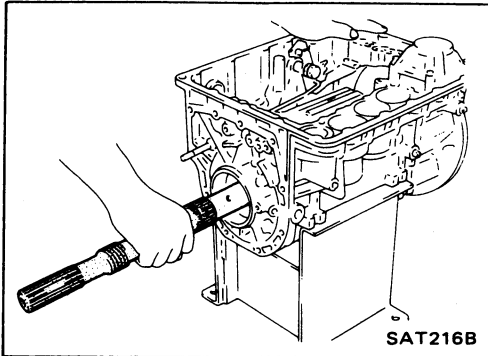

1. Install output shaft and parking gear.
 - a. Insert output shaft from rear of transmission case while slightly lifting front internal gear.
- **Do not force output shaft against front of transmission case.**

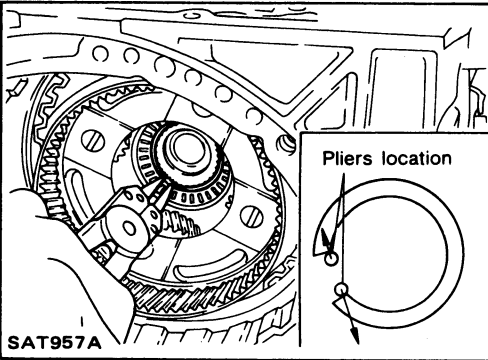

- b. Carefully push output shaft against front of transmission case. Install snap ring on front of output shaft.
- **Check to be sure output shaft cannot be removed in rear direction.**

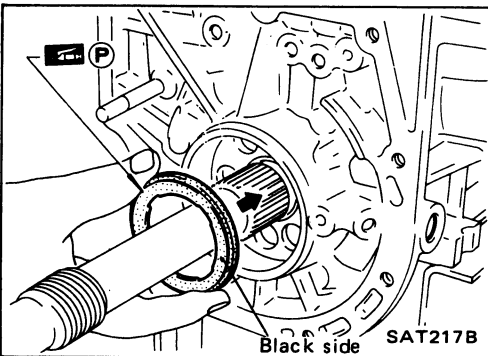

- c. Install needle bearing on transmission case.
- **Pay attention to its direction — Black side goes to rear.**
- **Apply petroleum jelly to needle bearing.**

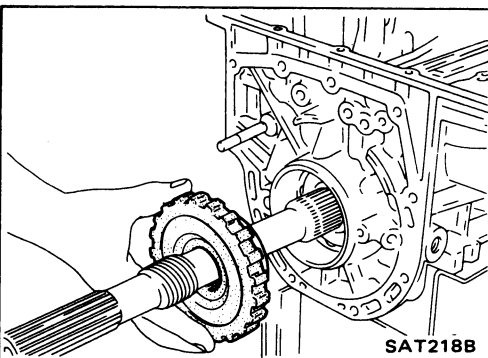

- d. Install parking gear on transmission case.

ASSEMBLY

Assembly (Cont'd)

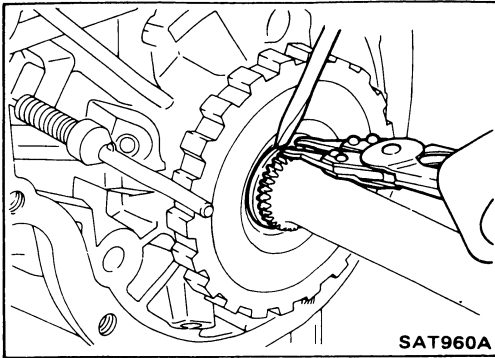

- e. Install snap ring on rear of output shaft.
 - Check to be sure output shaft cannot be removed in forward direction.

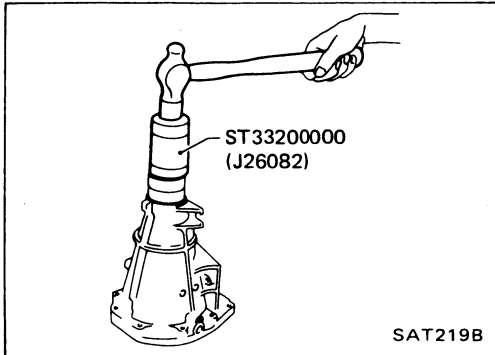

- 2. Install rear extension.
 - a. Install oil seal on rear extension.
 - Apply A.T.F. to oil seal.

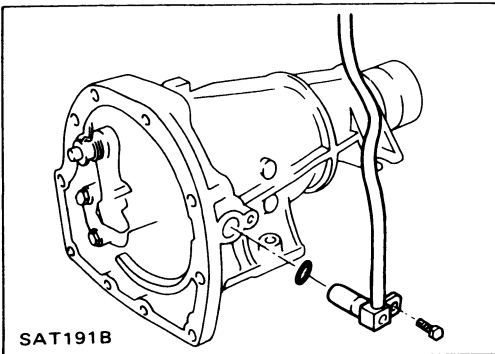

- b. Install O-ring on revolution sensor.
 - Apply A.T.F. to O-ring.
 - c. Install revolution sensor on rear extension.

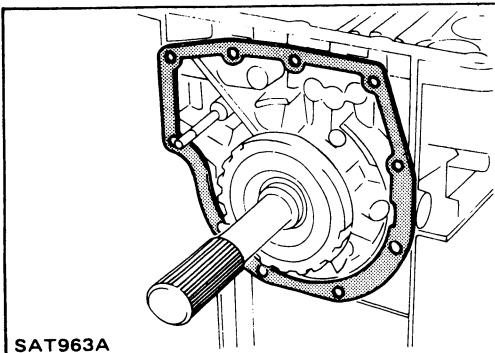

- d. Install rear extension gasket on transmission case.

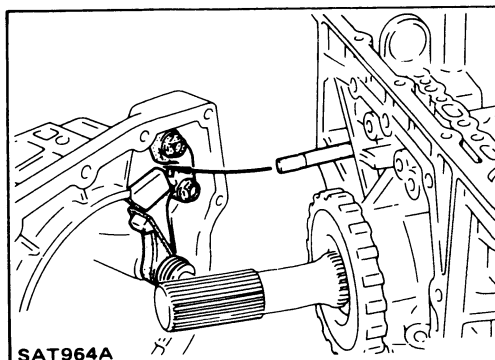

- e. Install parking rod on transmission case.

ASSEMBLY

Assembly (Cont'd)

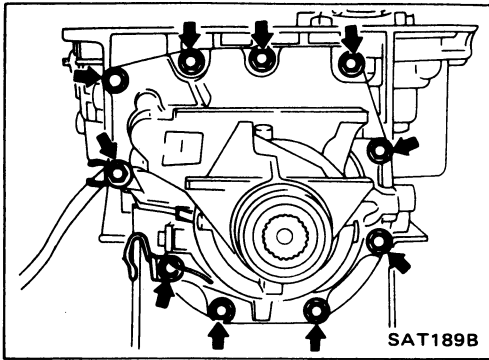

f. Install rear extension on transmission case.

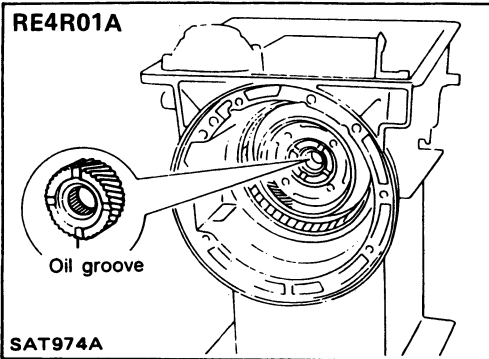

3. Install front side clutch and gear components.

a. Install rear sun gear on transmission case.

● Pay attention to its direction.

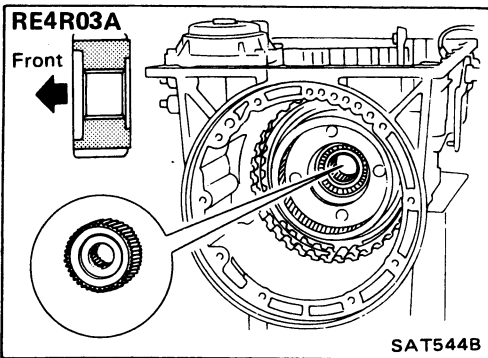

b. Make sure needle bearing is on front of front planetary carrier.

● Apply petroleum jelly to needle bearing.

c. Make sure needle bearing is on rear of front planetary carrier.

● Apply petroleum jelly to bearing.

● Pay attention to its direction — Black side goes to front.

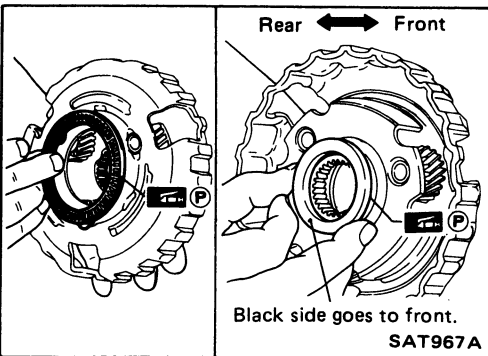

d. While rotating forward clutch drum clockwise, install front planetary carrier on forward clutch drum.

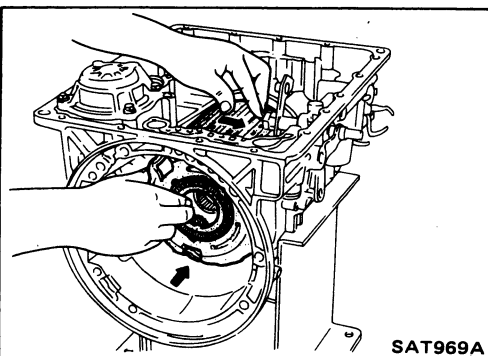

ASSEMBLY

Assembly (Cont'd)

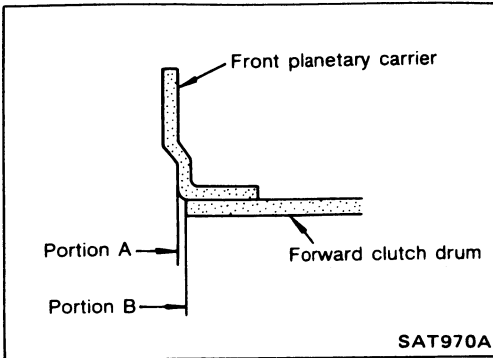

- Check that portion A of front planetary carrier protrudes approximately 2 mm (0.08 in) beyond portion B of forward clutch assembly. (RE4R01A only)

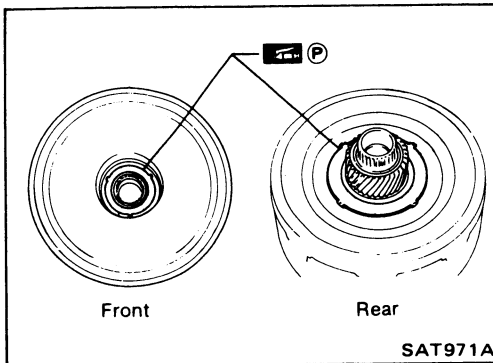

- e. Make sure bearing race (RE4R01A) or needle bearing (RE4R03A) are on front and rear of clutch pack.
- Apply petroleum jelly to bearing races.
- Securely engage pawls of bearing races with holes in clutch pack.

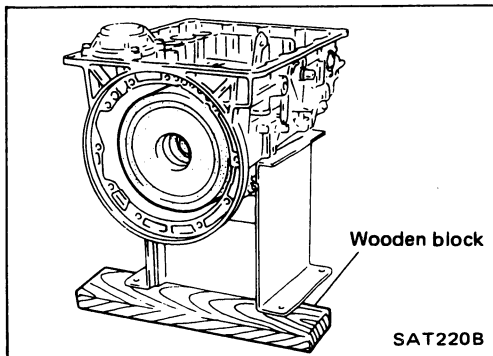

- f. Install clutch pack into transmission case.

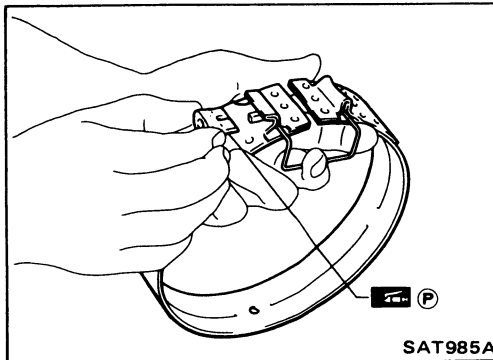

- 4. Install brake band and band strut.
- a. Install band strut on brake band.
- Apply petroleum jelly to band strut.

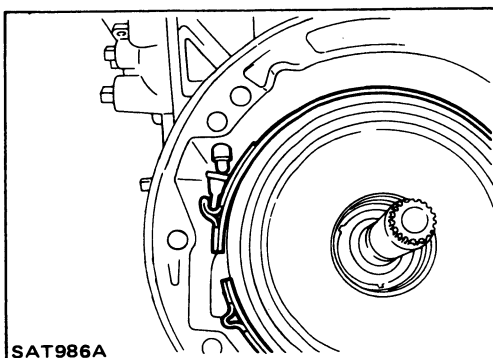

- b. Place brake band on periphery of reverse clutch drum, and insert band strut into end of band servo piston stem.

ASSEMBLY

Assembly (Cont'd)

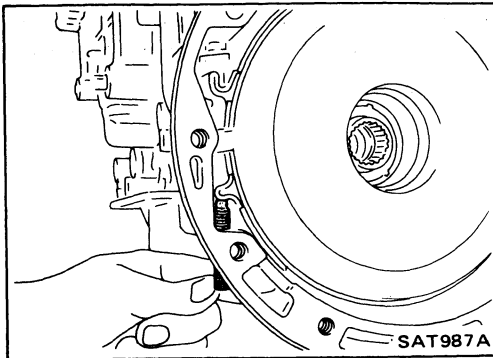

- c. Install anchor end bolt on transmission case. Then, tighten anchor end bolt just enough so that reverse clutch drum (clutch pack) will not tilt forward.

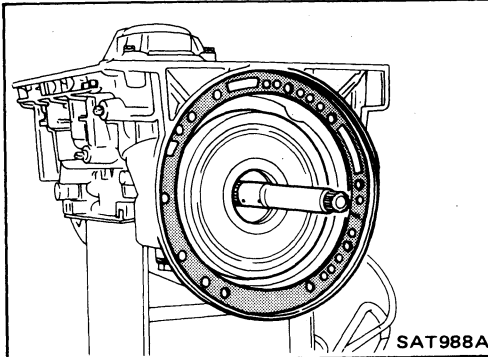

5. Install input shaft on transmission case.
 - **Pay attention to its direction — O-ring groove side is front.**
6. Install gasket on transmission case.

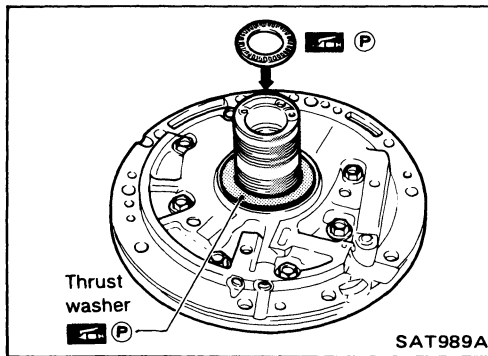

7. Install oil pump assembly.
 - a. Install needle bearing on oil pump assembly.
 - **Apply petroleum jelly to the needle bearing.**
 - b. Install selected thrust washer on oil pump assembly.
 - **Apply petroleum jelly to thrust washer.**

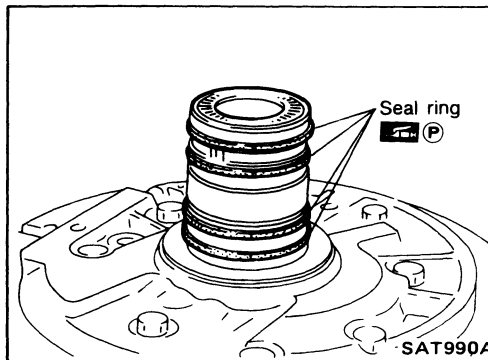

- c. Carefully install seal rings into grooves and press them into the petroleum jelly so that they are a tight fit.

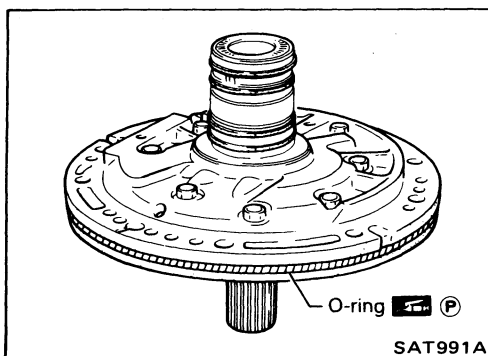

- d. Install O-ring on oil pump assembly.
 - **Apply petroleum jelly to O-ring.**

ASSEMBLY

Assembly (Cont'd)

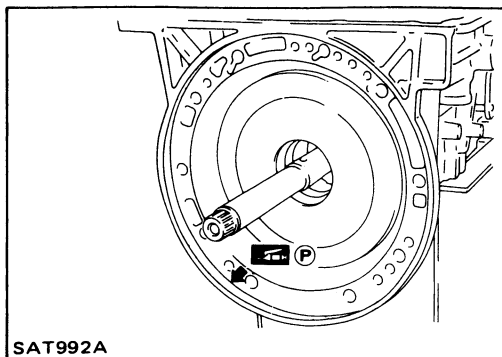

- e. Apply petroleum jelly to mating surface of transmission case and oil pump assembly.

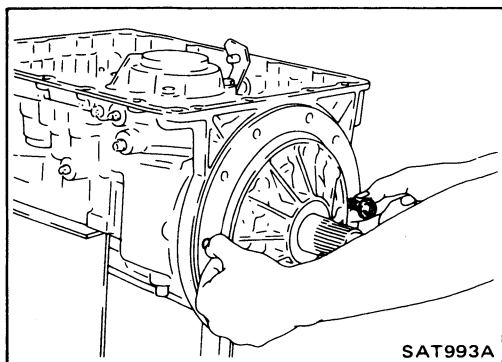

- f. Install oil pump assembly.
- Install two converter housing securing bolts in bolt holes in oil pump assembly as guides.

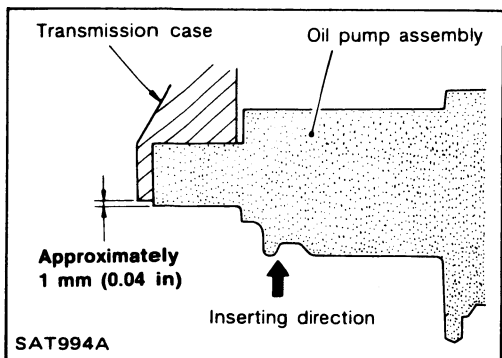

- Insert oil pump assembly to the specified position in transmission, as shown at left.

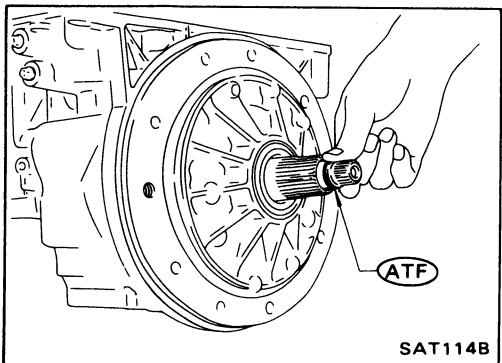

8. Install O-ring on input shaft.
- Apply A.T.F. to O-rings.

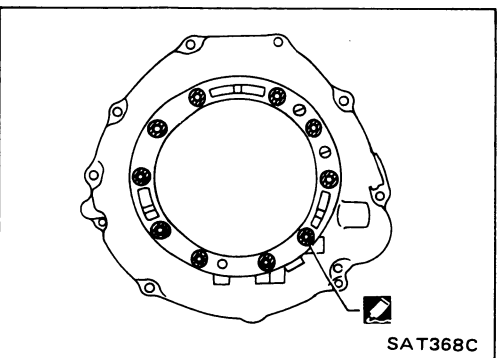

9. Install converter housing.
- a. Apply recommended sealant (Nissan genuine part: KP610-00250 or equivalent) to outer periphery of bolt holes in converter housing.
- Do not apply too much sealant.

ASSEMBLY

Assembly (Cont'd)

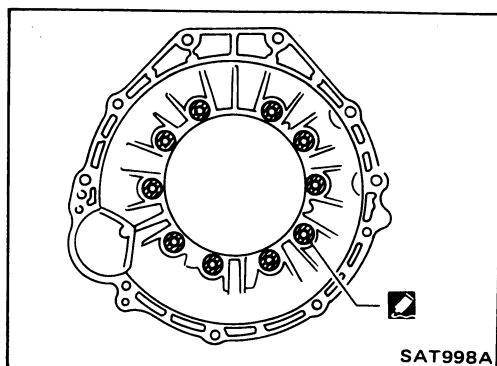

- b. Apply recommended sealant (Nissan genuine part: KP610-00250 or equivalent) to seating surfaces of bolts that secure front of converter housing.

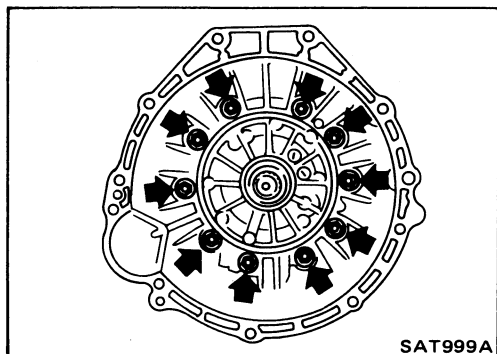

- c. Install converter housing on transmission case.

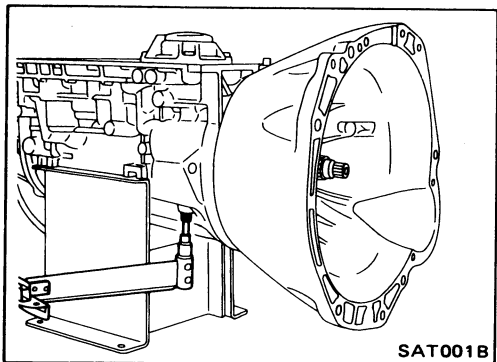

10. Adjust brake band.
- a. Tighten anchor end bolt to specified torque.
- Anchor end bolt:**
☐: 4 - 6 N·m
(0.4 - 0.6 kg-m, 2.9 - 4.3 ft-lb)
- b. Back off anchor end bolt two and a half turns.

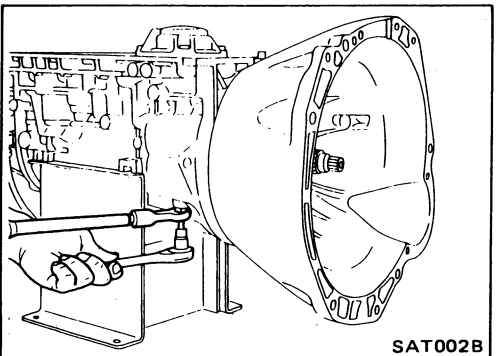

- c. While holding anchor end pin, tighten lock nut.

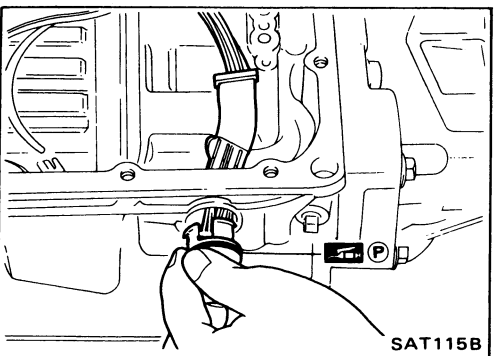

11. Install terminal cord assembly.
- a. Install O-ring on terminal cord assembly.
- **Apply petroleum jelly to O-ring.**
- b. Compress terminal cord assembly stopper and install terminal cord assembly on transmission case.

ASSEMBLY

Assembly (Cont'd)

12. Install control valve assembly.

a. Install accumulator piston return springs B, C and D.

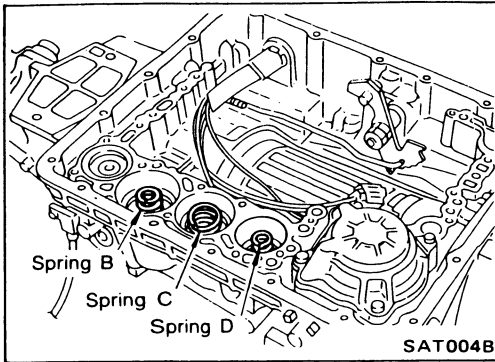

Free length of return springs:

Unit: mm (in)

Item	Accumulator	B	C	D
Free length		66 (2.60)	45 (1.77)	58.4 (2.299)

b. Install manual valve on control valve.

● Apply A.T.F. to manual valve.

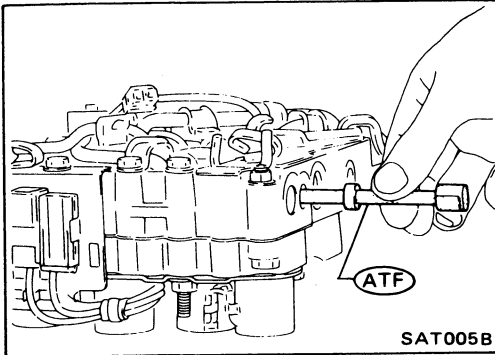

c. Place control valve assembly on transmission case. Connect solenoid connector for upper body.

d. Install connector clip.

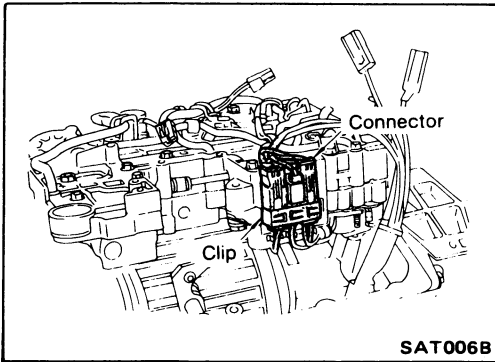

e. Install control valve assembly on transmission case.

f. Install connector, tube brackets and tighten bolts (A) and (B).

● Check that terminal assembly harness does not catch.

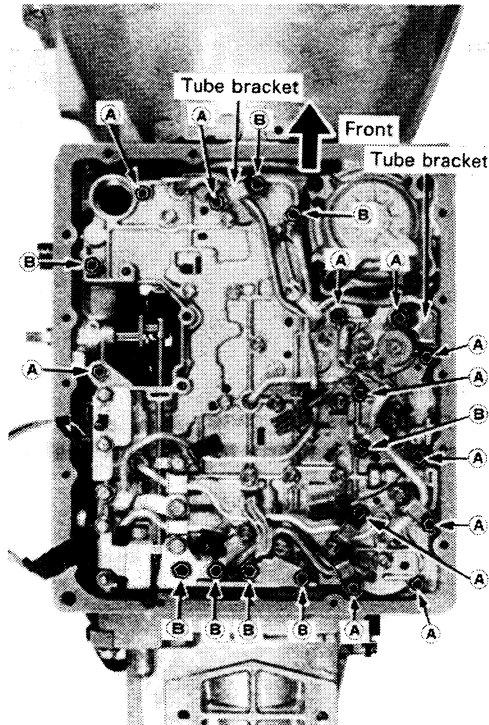

Bolt symbol	ℓ mm (in)	 ℓ
(A)	33 (1.30)	
(B)	45 (1.77)	

ASSEMBLY

Assembly (Cont'd)

- g. Install O-ring on oil strainer.
 - **Apply petroleum jelly to O-ring.**
- h. Install oil strainer on control valve.

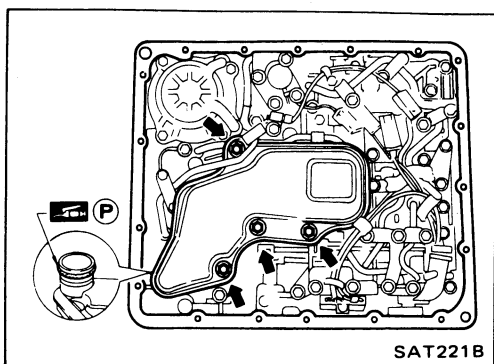

- i. Securely fasten terminal harness with clips.

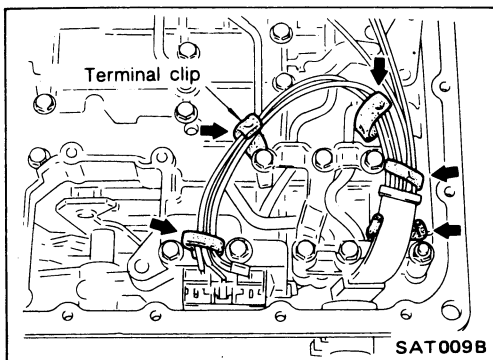

- j. Install lock-up solenoid and fluid temperature sensor connectors.

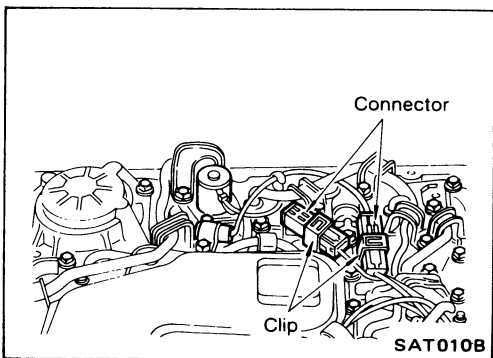

- 13. Install oil pan.
 - a. Attach a magnet to oil pan.

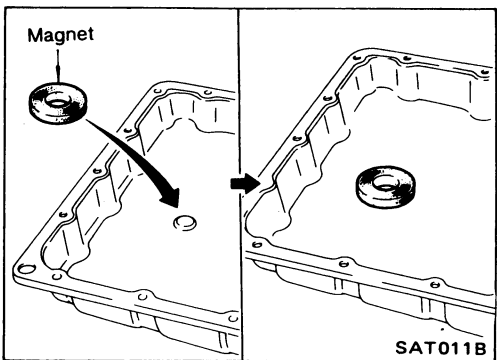

- b. Install oil pan gasket on transmission case.
- c. Install oil pan and bracket on transmission case.
 - **Tighten four bolts in a criss-cross pattern to prevent dislocation of gasket.**

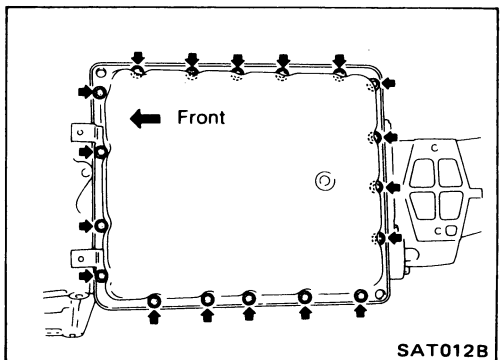

ASSEMBLY

Assembly (Cont'd)

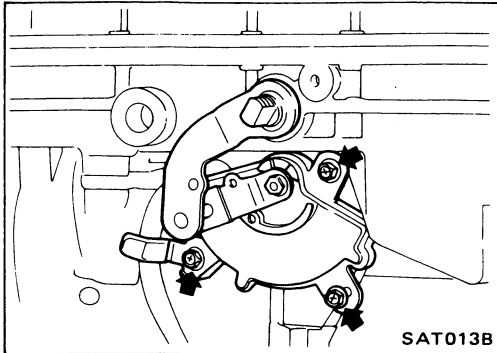

14. Install inhibitor switch.
 - a. Check that manual shaft is in "1" range.
 - b. Temporarily install inhibitor switch on manual shaft.
 - c. Move manual shaft to "N".

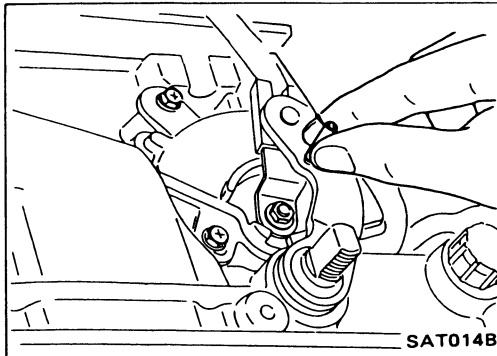

- d. Tighten bolts while inserting 4.0 mm (0.157 in) dia. pin vertically into locating holes in inhibitor switch and manual shaft.

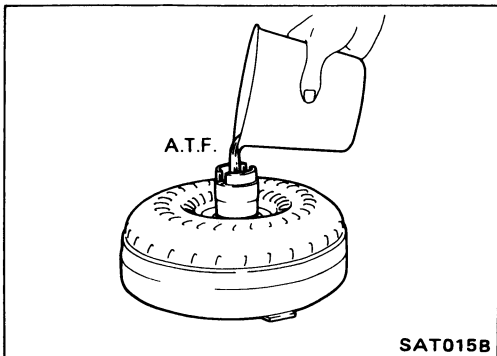

15. Install torque converter.
 - a. Pour A.T.F. into torque converter.
 - Approximately 2 liters (2-1/8 US qt, 1-3/4 Imp qt) of fluid are required for a new torque converter.
 - When reusing old torque converter, add the same amount of fluid as was drained.

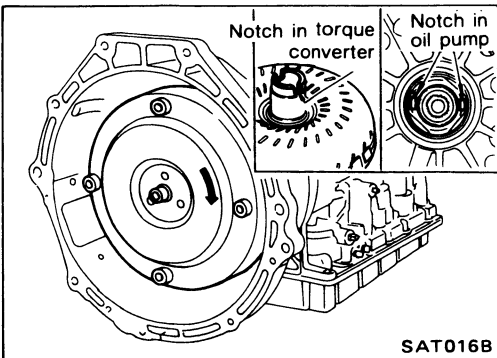

- b. Install torque converter while aligning notches and oil pump.

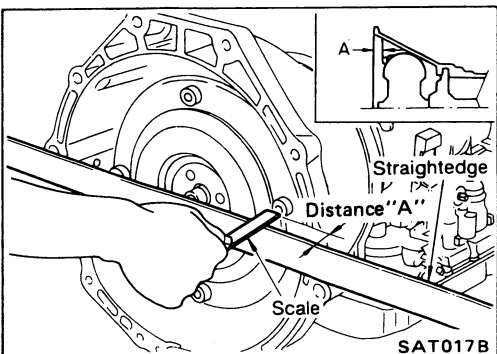

- c. Measure distance A to check that torque converter is in proper position.

Distance "A":

RE4R01A

26 mm (1.02 in) or more

RE4R03A

25 mm (0.98 in) or more

SERVICE DATA AND SPECIFICATIONS (S.D.S.)

General Specifications

Engine	VG30DE	VG30DETT
Automatic transmission model	RE4R01A	RE4R03A
Transmission model code number	45 x 65	51 x 08
Stall torque ratio	2.0 : 1	
Transmission gear ratio		
1st	2.785	2.784
2nd	1.545	1.544
Top	1.000	1.000
O.D.	0.694	0.694
Reverse	2.272	2.275
Recommended oil	Automatic transmission fluid Type DEXRON™	
Oil capacity ℓ (US qt, Imp qt)	8.3 (8-3/4, 7-1/4)	8.2 (8-5/8, 7-1/4)

Specifications and Adjustment — RE4R01A

VEHICLE SPEED WHEN SHIFTING GEARS

Throttle position	Vehicle speed km/h (MPH)					
	D ₁ → D ₂	D ₂ → D ₃	D ₃ → D ₄	D ₄ → D ₃	D ₃ → D ₂	D ₂ → D ₁
Full throttle	60 - 64 (37 - 40)	107 - 115 (66 - 71)	166 - 176 (103 - 109)	161 - 169 (100 - 105)	96 - 104 (60 - 65)	44 - 48 (27 - 30)
Half throttle	45 - 49 (28 - 30)	83 - 89 (52 - 55)	119 - 127 (74 - 79)	80 - 88 (50 - 55)	33 - 39 (21 - 24)	10 - 14 (6 - 9)

VEHICLE SPEED WHEN PERFORMING AND RELEASING LOCK-UP

Throttle position	O.D. switch [Shift range]	Vehicle speed km/h (MPH)	
		Lock-up "ON"	Lock-up "OFF"
Full throttle	ON [D ₄]	167 - 175 (104 - 109)	161 - 169 (100 - 105)
	OFF [D ₃]	107 - 115 (66 - 71)	96 - 104 (60 - 65)
Half throttle	ON [D ₄]	120 - 128 (75 - 80)	84 - 92 (52 - 57)
	OFF [D ₃]	91 - 99 (57 - 62)	86 - 94 (53 - 58)

STALL REVOLUTION

Stall revolution rpm
2,450 - 2,650

LINE PRESSURE



Engine speed rpm	Line pressure kPa (kg/cm ² , psi)	
	D, 2 and 1 ranges	R range
Idle	422 - 461 (4.3 - 4.7, 61 - 67)	667 - 706 (6.8 - 7.2, 97 - 102)
Stall	1,020 - 1,098 (10.4 - 11.2, 148 - 159)	1,422 - 1,500 (14.5 - 15.3, 206 - 218)

SERVICE DATA AND SPECIFICATIONS (S.D.S.)

Specifications and Adjustment — RE4R01A (Cont'd)

RETURN SPRINGS

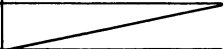
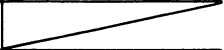
Unit: mm (in)

Parts	Item	Part No.	Free length	Outer diameter	
Control valve	Upper body	Torque converter relief valve spring	31742-41X23	38.0 (1.496)	9.0 (0.354)
		Pressure regulator valve spring	31742-41X24	44.02 (1.7331)	14.0 (0.551)
		Pressure modifier valve spring	31742-41X19	31.95 (1.2579)	6.8 (0.268)
		Shuttle shift valve D spring	31762-41X00	26.5 (1.043)	6.0 (0.236)
		4-2 sequence valve spring	31756-41X00	29.1 (1.146)	6.95 (0.2736)
		Shift valve B spring	31762-41X01	25.0 (0.984)	7.0 (0.276)
		4-2 relay valve spring	31756-41X00	29.1 (1.146)	6.95 (0.2736)
		Shift valve A spring	31762-41X01	25.0 (0.984)	7.0 (0.276)
		Overrun clutch control valve spring	31762-41X03	23.6 (0.929)	7.0 (0.276)
		Overrun clutch reducing valve spring	31742-41X20	32.5 (1.280)	7.0 (0.276)
		Shuttle shift valve S spring	31762-41X04	51.0 (2.008)	5.65 (0.2224)
		Pilot valve spring	31742-41X13	25.7 (1.012)	9.1 (0.358)
		Lock-up control valve spring	31742-41X22	18.5 (0.728)	13.0 (0.512)
	Lower body	Modifier accumulator piston spring	31742-41X15	30.5 (1.201)	9.8 (0.386)
		1st reducing valve spring	31756-41X05	25.4 (1.000)	6.75 (0.2657)
3-2 timing valve spring		31742-41X08	20.55 (0.8091)	6.75 (0.2657)	
Servo charger valve spring		31742-41X06	23.0 (0.906)	6.7 (0.264)	
Reverse clutch	16 pcs	31505-41X02	19.69 (0.7752)	11.6 (0.457)	
High clutch	16 pcs	31505-21X03	22.06 (0.8685)	11.6 (0.457)	
Forward clutch (Overrun clutch)	20 pcs	31505-41X01	35.77 (1.4083)	9.7 (0.382)	
Low & reverse brake	18 pcs	31521-21X00	23.7 (0.933)	11.6 (0.457)	
Band servo	Spring A	31605-41X05	45.6 (1.795)	34.3 (1.350)	
	Spring B	31605-41X00	53.8 (2.118)	40.3 (1.587)	
	Spring C	31605-41X01	29.7 (1.169)	27.6 (1.087)	
Accumulator	Accumulator A	31605-41X02	43.0 (1.693)		
	Accumulator B	31605-41X10	66.0 (2.598)		
	Accumulator C	31605-41X09	45.0 (1.772)		
	Accumulator D	31605-41X06	58.4 (2.299)		

SERVICE DATA AND SPECIFICATIONS (S.D.S.)

Specifications and Adjustment — RE4R01A (Cont'd)

ACCUMULATOR O-RING

Accumulator	Diameter mm (in)			
	A	B	C	D
Small diameter end	29 (1.14)	32 (1.26)	45 (1.77)	29 (1.14)
Large diameter end	45 (1.77)	50 (1.97)	50 (1.97)	45 (1.77)

CLUTCHES AND BRAKES

Reverse clutch		
Number of drive plates	2	
Number of driven plates	2	
Thickness of drive plate mm (in)		
Standard	2.0 (0.079)	
Wear limit	1.8 (0.071)	
Clearance mm (in)		
Standard	0.5 - 0.8 (0.020 - 0.031)	
Allowable limit	1.2 (0.047)	
Thickness of retaining plate	Thickness mm (in)	Part number
	4.6 (0.181)	31537-21X00
	4.8 (0.189)	31537-21X01
	5.0 (0.197)	31537-21X02
	5.2 (0.205)	31537-21X03
	5.4 (0.213)	31537-21X04
	5.6 (0.220)	31567-21X13
	5.8 (0.228)	31567-21X14
High clutch		
Number of drive plates	5	
Number of driven plates	5	
Thickness of drive plate mm (in)		
Standard	1.6 (0.063)	
Wear limit	1.4 (0.055)	
Clearance mm (in)		
Standard	1.8 - 2.2 (0.071 - 0.087)	
Allowable limit	3.2 (0.126)	
Thickness of retaining plate	Thickness mm (in)	Part number
	3.4 (0.134)	31537-41X71
	3.6 (0.142)	31537-41X61
	3.8 (0.150)	31537-41X62
	4.0 (0.157)	31537-41X63
	4.2 (0.165)	31537-41X64
	4.4 (0.173)	31537-41X65
	4.6 (0.181)	31537-41X66
4.8 (0.189)	31537-41X67	

Forward clutch		
Number of drive plates	7	
Number of driven plates	7	
Thickness of drive plate mm (in)		
Standard	1.6 (0.063)	
Wear limit	1.4 (0.055)	
Clearance mm (in)		
Standard	0.45 - 0.85 (0.0177 - 0.0335)	
Allowable limit	2.25 (0.0886)	
Thickness of retaining plate	Thickness mm (in)	Part number
	4.0 (0.157)	31537-41X07
	4.2 (0.165)	31537-41X08
	4.4 (0.173)	31537-41X09
	4.6 (0.181)	31537-41X10
	4.8 (0.189)	31537-41X11
	5.0 (0.197)	31537-41X12
	5.2 (0.205)	31537-41X13
Overrun clutch		
Number of drive plates	3	
Number of driven plates	5	
Thickness of drive plate mm (in)		
Standard	2.0 (0.079)	
Wear limit	1.8 (0.071)	
Clearance mm (in)		
Standard	1.0 - 1.4 (0.039 - 0.055)	
Allowable limit	2.0 (0.079)	
Thickness of retaining plate	Thickness mm (in)	Part number
	4.0 (0.157)	31537-41X79
	4.2 (0.165)	31537-41X80
	4.4 (0.173)	31537-41X81
	4.6 (0.181)	31537-41X82
	4.8 (0.189)	31537-41X83
	5.0 (0.197)	31537-41X84
	5.2 (0.205)	31537-41X20

SERVICE DATA AND SPECIFICATIONS (S.D.S.)

Specifications and Adjustment — RE4R01A (Cont'd)

Low & reverse brake		
Number of drive plates	7	
Number of driven plates	9	
Thickness of drive plate mm (in)		
Standard	2.0 (0.079)	
Wear limit	1.8 (0.071)	
Clearance mm (in)		
Standard	1.1 - 1.5 (0.043 - 0.059)	
Allowable limit	2.9 (0.114)	
Thickness of retaining plate	Thickness mm (in)	Part number
	7.2 (0.283)	31667-41X13
	7.4 (0.291)	31667-41X14
	7.6 (0.299)	31667-41X07
	7.8 (0.307)	31667-41X08
	8.0 (0.315)	31667-41X00
	8.2 (0.323)	31667-41X01
Brake band		
Anchor end bolt tightening torque N·m (kg·m, ft·lb)	4 - 6 (0.4 - 0.6, 2.9 - 4.3)	
Number of returning revolutions for anchor end bolt	2.5	

REVERSE CLUTCH DRUM END PLAY

Reverse clutch drum end play "T ₂ "	0.55 - 0.90 mm (0.0217 - 0.0354 in)	
Thickness of oil pump thrust washer	Thickness mm (in)	Part number
	0.7 (0.028)	31528-21X00
	0.9 (0.035)	31528-21X01
	1.1 (0.043)	31528-21X02
	1.3 (0.051)	31528-21X03
	1.5 (0.059)	31528-21X04
	1.7 (0.067)	31528-21X05
1.9 (0.075)	31528-21X06	

REMOVAL AND INSTALLATION

Manual control linkage Number of returning revolutions for lock nut	1
Lock nut tightening torque	11 - 15 N·m (1.1 - 1.5 kg·m, 8 - 11 ft·lb)
Distance between end of conver- ter housing and torque converter	26.0 mm (1.024 in) or more
Drive plate runout limit	0.5 mm (0.020 in)

OIL PUMP AND LOW ONE-WAY CLUTCH

Oil pump clearance Cam ring — oil pump housing Standard	mm (in) 0.01 - 0.024 (0.0004 - 0.0009)
Rotor, vanes and control piston — oil pump housing Standard	mm (in) 0.03 - 0.044 (0.0012 - 0.0017)
Seal ring clearance Standard Allowable limit	mm (in) 0.10 - 0.25 (0.0039 - 0.0098) 0.25 (0.0098)

TOTAL END PLAY

Total end play "T ₁ "	0.25 - 0.55 mm (0.0098 - 0.0217 in)	
Thickness of oil pump cover bearing race	Thickness mm (in)	Part number
	0.8 (0.031)	31429-21X00
	1.0 (0.039)	31429-21X01
	1.2 (0.047)	31429-21X02
	1.4 (0.055)	31429-21X03
	1.6 (0.063)	31429-21X04
	1.8 (0.071)	31429-21X05
	2.0 (0.079)	31429-21X06

SERVICE DATA AND SPECIFICATIONS (S.D.S.)

Specifications and Adjustment — RE4R03A

VEHICLE SPEED WHEN SHIFTING GEARS

Throttle position	Vehicle speed km/h (MPH)					
	D ₁ → D ₂	D ₂ → D ₃	D ₃ → D ₄	D ₄ → D ₃	D ₃ → D ₂	D ₂ → D ₁
Full throttle	68 - 72 (42 - 45)	120 - 128 (75 - 80)	183 - 193 (114 - 120)	177 - 187 (110 - 116)	109 - 117 (68 - 73)	33 - 37 (21 - 23)
Half throttle	47 - 51 (29 - 32)	89 - 95 (55 - 59)	136 - 144 (85 - 89)	78 - 86 (48 - 53)	28 - 34 (17 - 21)	10 - 14 (6 - 9)

VEHICLE SPEED WHEN PERFORMING AND RELEASING LOCK-UP

Throttle position	O.D. switch [Shift range]	Vehicle speed km/h (MPH)	
		Lock-up "ON"	Lock-up "OFF"
Full throttle	ON [D ₄]	184 - 192 (114 - 119)	178 - 186 (111 - 116)
	OFF [D ₃]	120 - 128 (75 - 80)	109 - 117 (68 - 73)
Half throttle	ON [D ₄]	184 - 192 (114 - 119)	117 - 125 (73 - 78)
	OFF [D ₃]	88 - 96 (55 - 60)	74 - 82 (46 - 51)

STALL REVOLUTION

Stall revolution rpm
2,950 - 3,200

LINE PRESSURE

Engine speed rpm	Line pressure kPa (kg/cm ² , psi)	
	D, 2 and 1 ranges	R range
Idle	422 - 461 (4.3 - 4.7, 61 - 67)	667 - 706 (6.8 - 7.2, 97 - 102)
Stall	1,020 - 1,098 (10.4 - 11.2, 148 - 159)	1,422 - 1,500 (14.5 - 15.3, 206 - 218)

SERVICE DATA AND SPECIFICATIONS (S.D.S.)

Specifications and Adjustment — RE4R03A (Cont'd)

RETURN SPRINGS

Unit: mm (in)

Parts	Item	Part No.	Free length	Outer diameter	
Control valve	Upper body	Torque converter relief valve spring	31742-41X23	38.0 (1.496)	9.0 (0.354)
		Pressure regulator valve spring	31742-41X24	44.02 (1.7331)	14.0 (0.551)
		Pressure modifier valve spring	31742-41X19	31.95 (1.2579)	6.8 (0.268)
		Shuttle shift valve D spring	31762-41X00	26.5 (1.043)	6.0 (0.236)
		4-2 sequence valve spring	31756-41X00	29.1 (1.146)	6.95 (0.2736)
		Shift valve B spring	31762-41X01	25.0 (0.984)	7.0 (0.276)
		4-2 relay valve spring	31756-41X00	29.1 (1.146)	6.95 (0.2736)
		Shift valve A spring	31762-41X01	25.0 (0.984)	7.0 (0.276)
		Overrun clutch control valve spring	31762-41X03	23.6 (0.929)	7.0 (0.276)
		Overrun clutch reducing valve spring	31742-41X20	32.5 (1.280)	7.0 (0.276)
		Shuttle shift valve S spring	31762-41X04	51.0 (2.008)	5.65 (0.2224)
		Pilot valve spring	31742-41X13	25.7 (1.012)	9.1 (0.358)
		Lock-up control valve spring	31742-41X22	18.5 (0.728)	13.0 (0.512)
	Lower body	Modifier accumulator piston spring	31742-41X15	30.5 (1.201)	9.8 (0.386)
		1st reducing valve spring	31756-41X05	25.4 (1.000)	6.75 (0.2657)
3-2 timing valve spring		31742-41X08	20.55 (0.8091)	6.75 (0.2657)	
Servo charger valve spring		31742-41X06	23.0 (0.906)	6.7 (0.264)	
Reverse clutch	16 pcs	31505-51X00	37.8 (1.488)	14.8 (0.583)	
High clutch	16 pcs	31505-21X03	22.06 (0.8685)	11.6 (0.457)	
Forward clutch (Overrun clutch)	20 pcs	31505-51X04	36.8 (1.449)	9.8 (0.386)	
Low & reverse brake	Inner 16 pcs	31505-51X06	20.43 (0.8043)	10.3 (0.406)	
	Outer 16 pcs	31505-51X05	20.35 (0.8012)	13.0 (0.512)	
Band servo	Spring A	31605-41X05	45.6 (1.795)	34.3 (1.350)	
	Spring B	31605-41X00	53.8 (2.118)	40.3 (1.587)	
	Spring C	31605-41X01	29.7 (1.169)	27.6 (1.087)	
Accumulator	Accumulator A	31605-41X02	43.0 (1.693)		
	Accumulator B	31605-41X10	66.0 (2.598)		
	Accumulator C	31605-41X09	45.0 (1.772)		
	Accumulator D	31605-41X06	58.4 (2.299)		

SERVICE DATA AND SPECIFICATIONS (S.D.S.)

Specifications and Adjustment — RE4R03A (Cont'd)

ACCUMULATOR O-RING

Accumulator	Diameter mm (in)			
	A	B	C	D
Small diameter end	29 (1.14)	32 (1.26)	45 (1.77)	29 (1.14)
Large diameter end	45 (1.77)	50 (1.97)	50 (1.97)	45 (1.77)

CLUTCHES AND BRAKES

Reverse clutch		
Number of drive plates	3	
Number of driven plates	3	
Thickness of drive plate mm (in)		
Standard	2.0 (0.079)	
Wear limit	1.8 (0.071)	
Clearance mm (in)		
Standard	0.5 - 0.8 (0.020 - 0.031)	
Allowable limit	1.4 (0.055)	
Thickness of retaining plate	Thickness mm (in)	Part number
	4.4 (0.173)	31537-57X61
	4.6 (0.181)	31537-51X00
	4.8 (0.189)	31537-51X01
	5.0 (0.197)	31537-51X02
High clutch		
Number of drive plates	7	
Number of driven plates	7 + 1	
Thickness of drive plate mm (in)		
Standard	1.6 (0.063)	
Wear limit	1.4 (0.055)	
Clearance mm (in)		
Standard	1.8 - 2.2 (0.071 - 0.087)	
Allowable limit	3.0 (0.118)	
Thickness of retaining plate	Thickness mm (in)	Part number
	4.0 (0.157)	31537-51X19
	4.2 (0.165)	31537-51X60
	4.4 (0.173)	31537-51X61
	4.6 (0.181)	31537-51X00
	4.8 (0.189)	31537-51X01
5.0 (0.197)	31537-51X02	

Forward clutch		
Number of drive plates	8	
Number of driven plates	8	
Thickness of drive plate mm (in)		
Standard	2.0 (0.079)	
Wear limit	1.8 (0.071)	
Clearance mm (in)		
Standard	0.45 - 0.85 (0.0177 - 0.0335)	
Allowable limit	2.45 (0.0965)	
Thickness of retaining plate	Thickness mm (in)	Part number
	4.2 (0.165)	31537-51X67
	4.4 (0.173)	31537-51X05
	4.6 (0.181)	31537-51X06
	4.8 (0.189)	31537-51X07
	5.0 (0.197)	31537-51X08
	5.2 (0.205)	31537-51X09
Overrun clutch		
Number of drive plates	4	
Number of driven plates	7	
Thickness of drive plate mm (in)		
Standard	1.6 (0.063)	
Wear limit	1.4 (0.055)	
Clearance mm (in)		
Standard	1.0 - 1.4 (0.039 - 0.055)	
Allowable limit	2.2 (0.087)	
Thickness of retaining plate	Thickness mm (in)	Part number
	3.8 (0.150)	31537-51X11
	4.0 (0.157)	31537-51X12
	4.2 (0.165)	31537-51X13
	4.4 (0.173)	31537-51X14
	4.6 (0.181)	31537-51X15
4.8 (0.189)	31537-51X64	

SERVICE DATA AND SPECIFICATIONS (S.D.S.)

Specifications and Adjustment — RE4R03A (Cont'd)

Low & reverse brake		
Number of drive plates	2 + 6	
Number of driven plates	8	
Thickness of drive plate mm (in)		
Standard	1.6 (0.063)	
Wear limit	1.4 (0.055)	
Clearance mm (in)		
Standard	1.1 - 1.5 (0.043 - 0.059)	
Allowable limit	3.1 (0.122)	
Thickness of retaining plate	Thickness mm (in)	Part number
	4.2 (0.165)	31667-51X10
	4.4 (0.173)	31667-51X00
	4.6 (0.181)	31667-51X01
	4.8 (0.189)	31667-51X02
	5.0 (0.197)	31667-51X03
Brake band		
Anchor end bolt tightening torque N-m (kg-m, ft-lb)	4 - 6 (0.4 - 0.6, 2.9 - 4.3)	
Number of returning revolutions for anchor end bolt	2.5	

REVERSE CLUTCH DRUM END PLAY

Reverse clutch drum end play "T ₂ "	0.55 - 0.90 mm (0.0217 - 0.0354 in)	
Thickness of oil pump thrust washer	Thickness mm (in)	Part number
	0.7 (0.028)	31528-21X00
	0.9 (0.035)	31528-21X01
	1.1 (0.043)	31528-21X02
	1.3 (0.051)	31528-21X03
	1.5 (0.059)	31528-21X04
	1.7 (0.067)	31528-21X05
	1.9 (0.075)	31528-21X06

REMOVAL AND INSTALLATION

Manual control linkage Number of returning revolutions for lock nut	1
Lock nut tightening torque	11 - 15 N-m (1.1 - 1.5 kg-m, 8 - 11 ft-lb)
Distance between end of clutch housing and torque converter	25.0 mm (0.984 in) or more
Drive plate runout limit	0.5 mm (0.020 in)

OIL PUMP AND LOW ONE-WAY CLUTCH

Oil pump clearance Cam ring — oil pump housing Standard	mm (in) 0.01 - 0.024 (0.0004 - 0.0009)
Rotor, vanes and control piston — oil pump housing Standard	mm (in) 0.03 - 0.044 (0.0012 - 0.0017)
Seal ring clearance Standard Allowable limit	mm (in) 0.10 - 0.25 (0.0039 - 0.0098) 0.25 (0.0098)

TOTAL END PLAY

Total end play "T ₁ "	0.25 - 0.55 mm (0.0098 - 0.0217 in)	
Thickness of oil pump cover bearing race	Thickness mm (in)	Part number
	0.8 (0.031)	31429-21X00
	1.0 (0.039)	31429-21X01
	1.2 (0.047)	31429-21X02
	1.4 (0.055)	31429-21X03
	1.6 (0.063)	31429-21X04
	1.8 (0.071)	31429-21X05
	2.0 (0.079)	31429-21X06

PROPELLER SHAFT & DIFFERENTIAL CARRIER

SECTION **PD**

CONTENTS

PREPARATION	PD- 2
PROPELLER SHAFT	PD- 7
ON-VEHICLE SERVICE (Final drive)	PD-12
REMOVAL AND INSTALLATION	PD-14
FINAL DRIVE	PD-15
DISASSEMBLY	PD-17
INSPECTION	PD-22
ADJUSTMENT (R200V)	PD-23
ADJUSTMENT (R230V)	PD-30
ASSEMBLY	PD-35
SERVICE DATA AND SPECIFICATIONS (S.D.S.)	PD-41



PD

PREPARATION

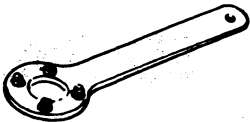
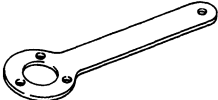
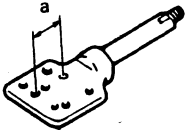
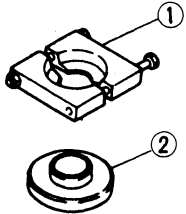
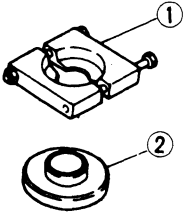

SPECIAL SERVICE TOOLS

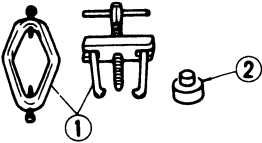
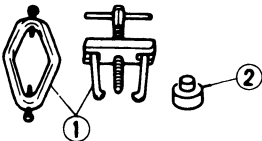
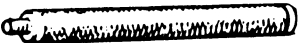
Tool number (Kent-Moore No.) Tool name	Description	Unit application	
		R200V	R230V
ST38060002 (J34311) Drive pinion flange wrench	 <p>Removing and installing propeller shaft lock nut, and drive pinion lock nut.</p> <p>Use two holes and propeller shaft connecting bolt to hold companion flange</p>	X	-
xxxxxxxxxx (-) Drive pinion flange wrench	 <p>Removing and installing propeller shaft lock nut, and drive pinion lock nut</p>	-	X
KV38100800 (-) Equivalent tool (J25604-01) Differential attachment	 <p>Mounting final drive (To use, make a new hole.)</p> <p>a: 156 mm (6.14 in) – R200V 178 mm (7.01 in) – R230V</p>	X	X
ST3090S000 (-) Drive pinion rear inner race puller set ① ST30031000 (J22912-01) Puller ② ST30901000 (-) Equivalent tool (J26010-01) Base	 <p>Removing and installing drive pinion rear cone</p>	X	-
ST3002S000 (-) Drive pinion rear inner race puller set ① ST30021000 (-) Puller ② ST30022000 (-) Base	 <p>Removing and installing drive pinion rear cone</p>	-	X

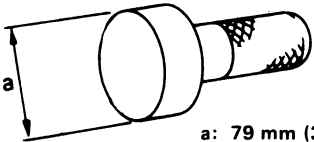
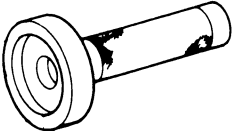

PREPARATION

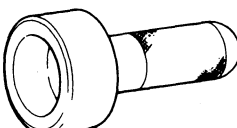
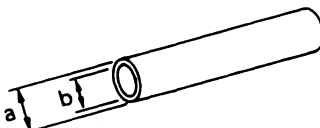
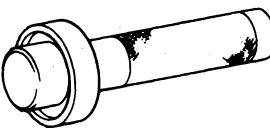
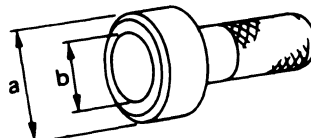
Tool number (Kent-Moore No.) Tool name	Description	Unit application		
		R200V	R230V	
ST3306S001 (-) Differential side bearing puller set ① ST33051001 (-) Equivalent tool (J22888) Body ② ST33061000 (J8107-2) Equivalent tool (J26010-01) Adapter		Removing and installing differential side bearing inner cone	X	-
ST3306S001 (-) Differential side bearing puller set ① ST33051001 (-) Equivalent tool (J22888) Body ② xxxxxxxxxxxx (-) Adapter		Removing and installing differential side bearing inner cone	-	X
ST30611000 (J25742-1) Drift		Installing pinion rear bearing outer race	X	X
ST30613000 (J25742-3) Drift		Installing pinion front bearing outer race	X	-
xxxxxxxxxxxx (-) Drift	 <p style="text-align: center;">a: 79 mm (3.11 in) dia.</p>	Installing pinion front bearing outer race	-	X
KV38100200 (J26233) Oil seal drift		Installing side oil seal	X	-

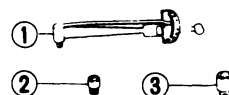
PREPARATION

Tool number (Kent-Moore No.) Tool name	Description	Unit application		
		R200V	R230V	
KV38102510 (-) Oil seal drift		Installing side oil seal	-	X
KV38100500 (-) Oil seal drift		Installing front oil seal	X	-
xxxxxxxxxx (-) Oil seal drift		Installing front oil seal a: 85 mm (3.35 in) dia. b: 69 mm (2.72 in) dia.	-	X
KV38100300 (J25523) Drift		Installing side bearing inner cone	X	-
xxxxxxxxxx (-) Drift		Installing side bearing inner cone a: 64 mm (2.52 in) dia. b: 55.5 mm (2.185 in) dia.	-	X
KV38100600 (J25267) Side bearing spacer drift		Installing side bearing spacer	X	-
xxxxxxxxxx (-) Side bearing spacer drift		Installing side bearing spacer	-	X
ST3127S000 (See J5765-A) Preload gauge ① GG91030000 (J25765) Torque wrench ② HT62940000 (-) Socket adapter ③ HT62900000 (-) Socket adapter		Measuring pinion bearing preload and total preload	X	X

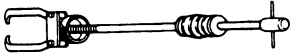
PREPARATION

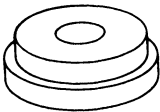
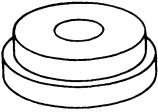
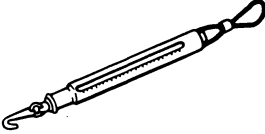
Tool number (Kent-Moore No.) Tool name	Description	Unit application		
		R200V	R230V	
HT72400000 (-) Slide hammer		Removing differential case assembly	X	X
(J34309) Differential shim selector		Adjusting bearing preload and gear height	X	-
(xxxxxxx) Differential shim selector		Adjusting bearing preload and gear height	-	X
(J25269-4) Side bearing discs (2 Req'd)		Selecting pinion height adjusting washer	X	-
(xxxxxxx) Side bearing discs (2 Req'd)		Selecting pinion height adjusting washer	-	X
(J8129) Spring gauge		Measuring carrier turning torque	X	X

PREPARATION

COMMERCIAL SERVICE TOOL

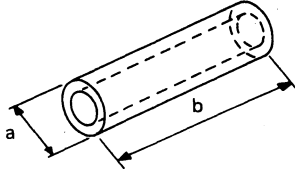
Tool name	Description	Unit application	
		R200V	R230V
Drift	 <p>Installing pinion rear bearing outer race</p> <p>a: 89 mm (3.50 in) dia. – R200V 99 mm (3.90 in) dia. – R230V b: 200 mm (7.87 in)</p>	X	X

PROPELLER SHAFT

3S71A

Washer
Apply a coat of multi-purpose lithium grease containing molybdenum disulfide to the end face of the center bearing and both sides of the washer.

A/T model

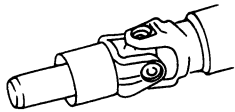

M/T model

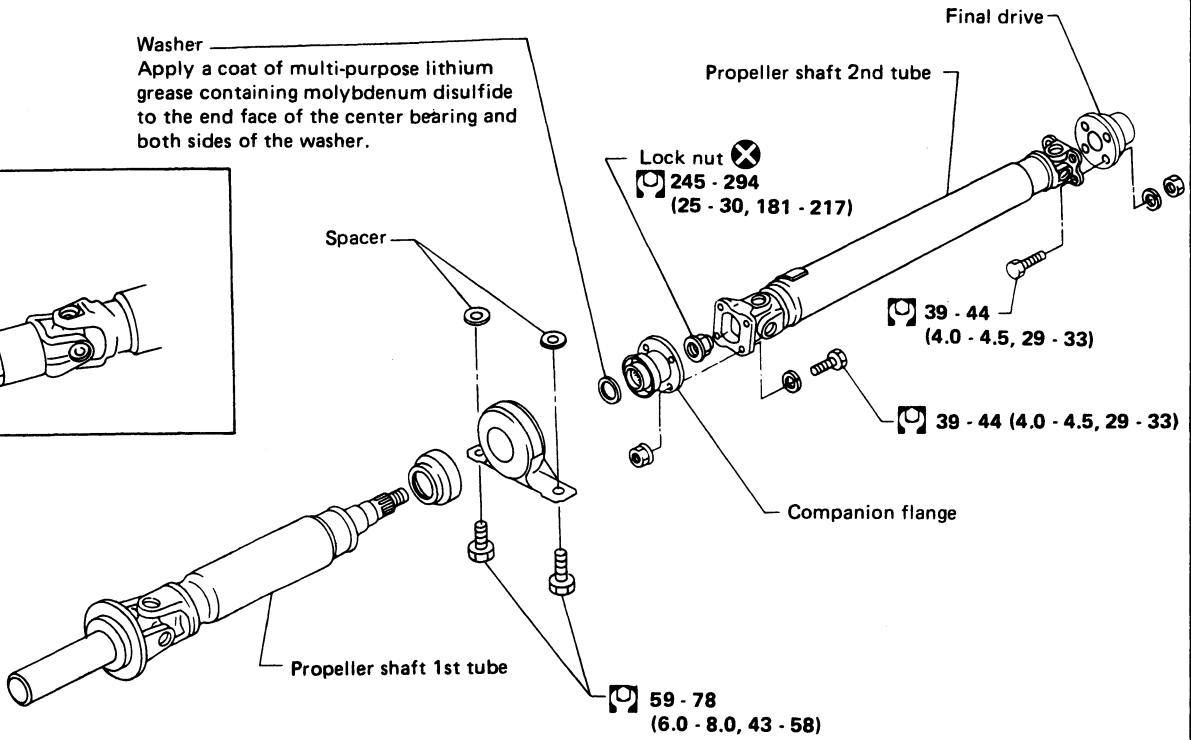

: N·m (kg·m, ft·lb)

SPD965

3S80A-VL107

Washer
Apply a coat of multi-purpose lithium grease containing molybdenum disulfide to the end face of the center bearing and both sides of the washer.

A/T model

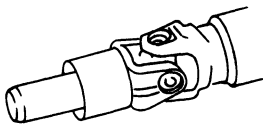

M/T model

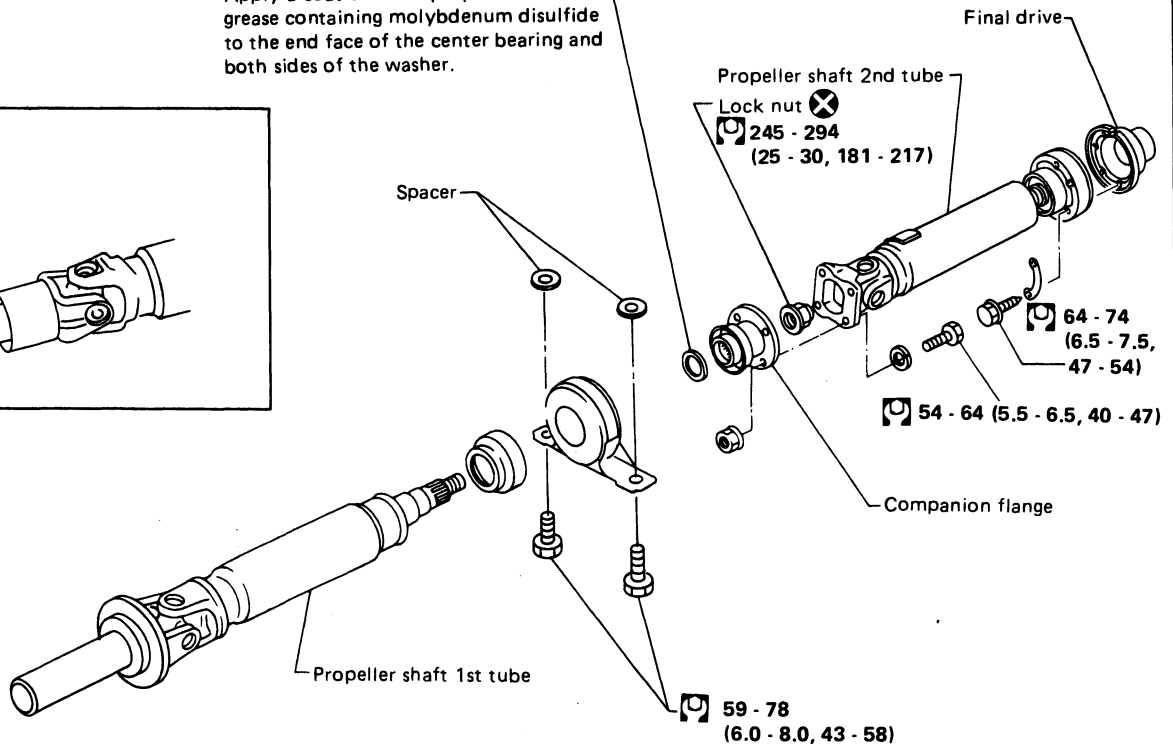

: N·m (kg·m, ft·lb)

SPD982

PROPELLER SHAFT

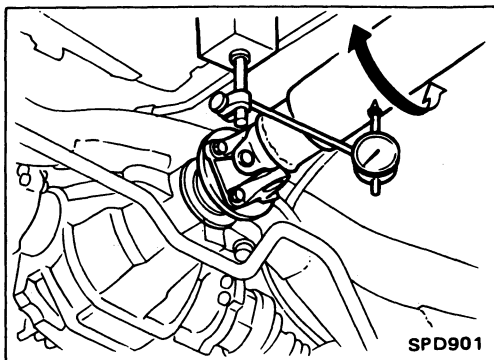

On-vehicle Service

PROPELLER SHAFT VIBRATION

If vibration is present at high speed, inspect propeller shaft runout first.

1. Raise rear wheels.
2. Measure propeller shaft runout at indicated points by rotating final drive companion flange with hands.

Runout limit: 0.6 mm (0.024 in)

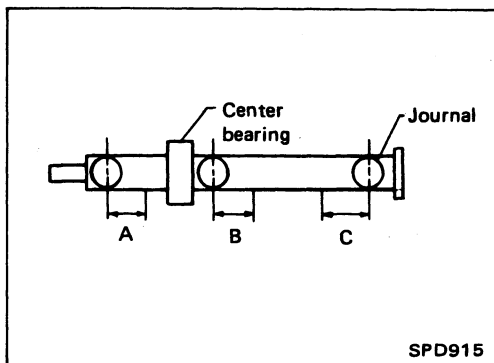

Propeller shaft runout measuring points:

Distance "A":

162 mm (6.38 in)

Distance "B":

3S71A: 172 mm (6.77 in)

3S80A-VL107: 200 mm (7.87 in)

Distance "C":

3S71A: 192 mm (7.56 in)

3S80A-VL107: 200 mm (7.87 in)

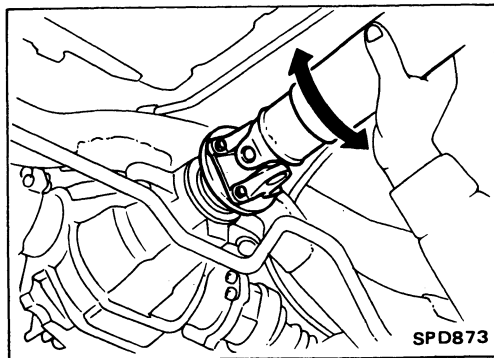

3. If runout exceeds specifications, disconnect propeller shaft at final drive companion flange. Rotate companion flange 90° (3S71A) or 60° (3S80A-VL107), and reconnect propeller shaft and check runout.

Repeat above operation when companion flange is rotated 180° (3S71A) or 120° (3S80A-VL107) and 270° (3S71A) or 180° (3S80A-VL107), respectively. Also, for 3S80A-VL107, the operation should be repeated at 240° and 300°. Securely connect propeller shaft at the point where the smallest runout of the three measurements occurs.

Runout limit: 0.6 mm (0.024 in)

4. Check runout again. If runout still exceeds specifications, replace propeller shaft assembly.
5. Perform road test.

APPEARANCE CHECKING

- Inspect propeller shaft tube surface for dents or cracks. If damaged, replace propeller shaft assembly.
- If center bearing is noisy or damaged, replace center bearing.

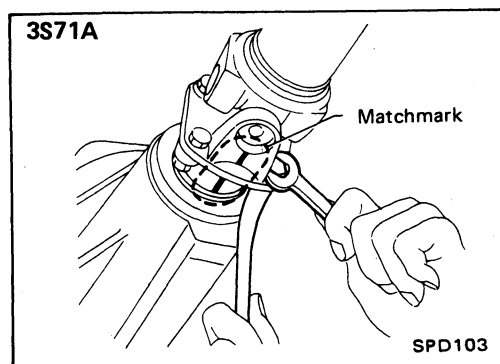

Removal

- Put matchmarks on flanges and separate propeller shaft from final drive.

PROPELLER SHAFT

Removal (Cont'd)

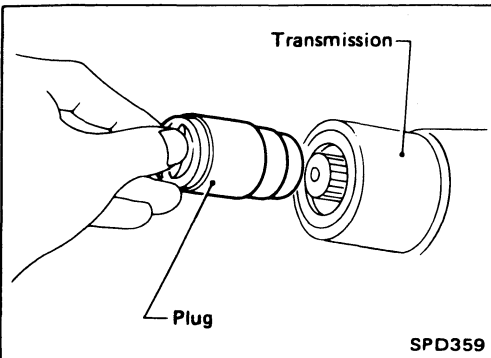
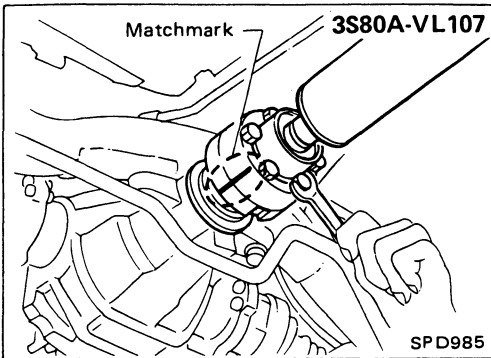

- Draw out propeller shaft from transmission and plug up rear end of transmission rear extension housing.

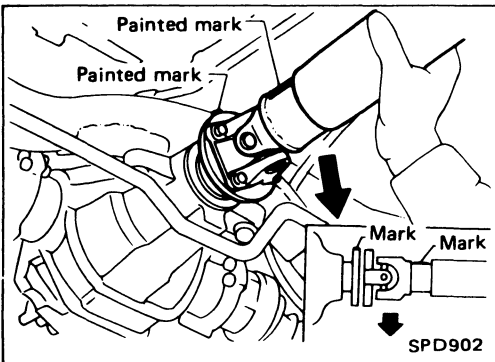

Installation

- Temporarily install differential companion flange and flange yoke so that their alignment marks (original marks) are located as close to each other as possible.
- Turn propeller shaft until alignment marks face straight upward. Securely fasten propeller shaft so that lower side wall of concave flange yoke will touch lower side wall of convex companion flange.

Inspection

- Inspect propeller shaft runout. If runout exceeds specifications, replace propeller shaft assembly.

Runout limit: 0.6 mm (0.024 in)

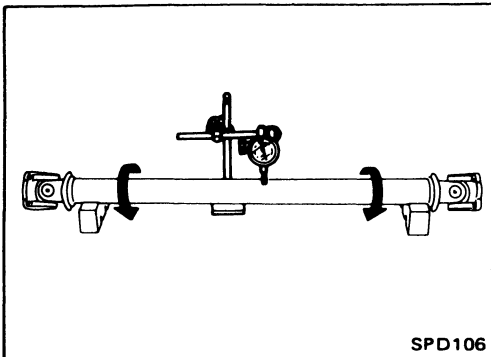

- Inspect journal axial play. If the play exceeds specifications, replace propeller shaft assembly.

Journal axial play:

0 mm (0 in)

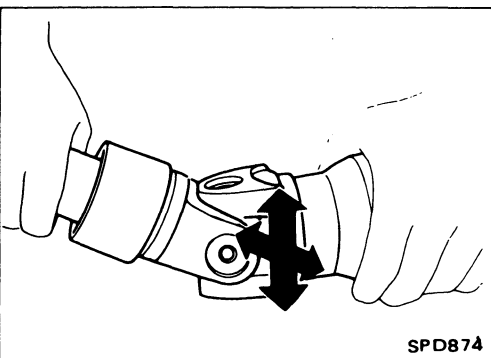

PROPELLER SHAFT

Disassembly

CENTER BEARING

1. Put matchmarks on flanges, and separate 2nd tube from 1st tube.

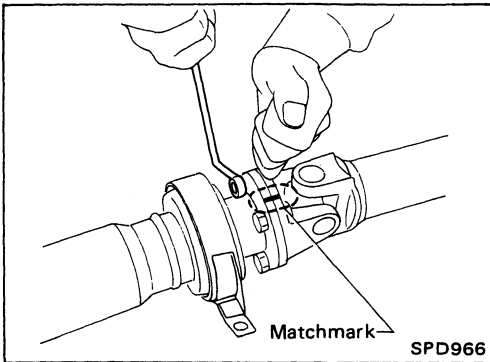

2. Put matchmarks on the flange and shaft.

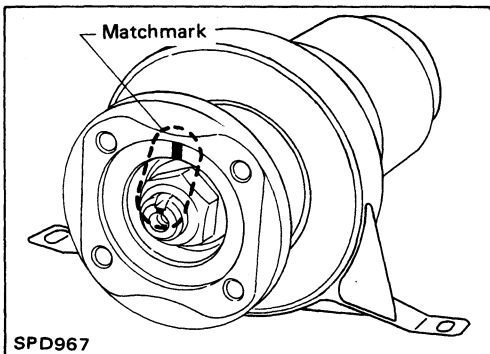

3. Remove locking nut with Tool.

Tool number:
ST38060002 (J34311)

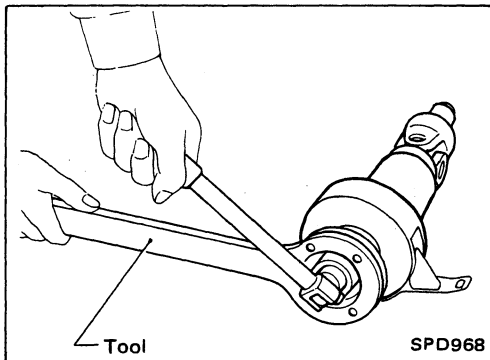

4. Remove companion flange with puller.

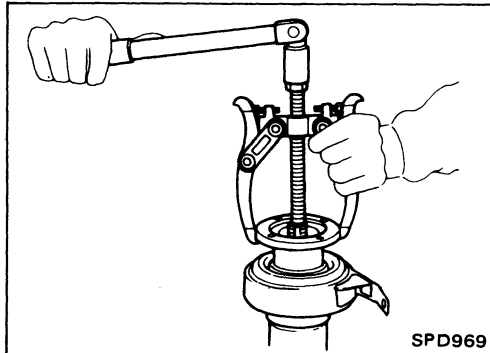

5. Remove center bearing with Tool and press.

Tool number: ST30031000 (J22912-01)

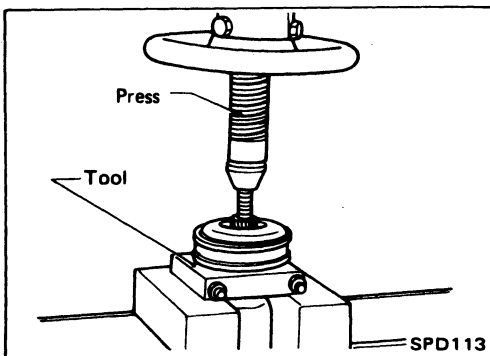

PROPELLER SHAFT

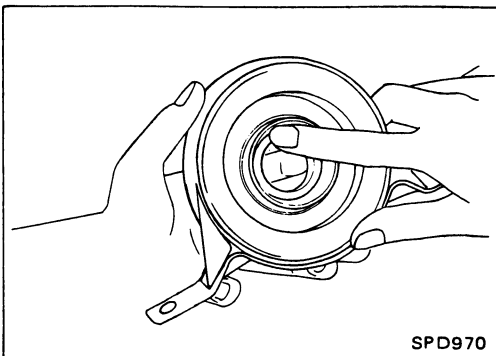

Assembly

CENTER BEARING

- Install center bearing with insulator's protrusion side facing front of vehicle.
- Apply a coat of multi-purpose lithium grease containing molybdenum disulfide to the end face of the center bearing and both sides of the washer.

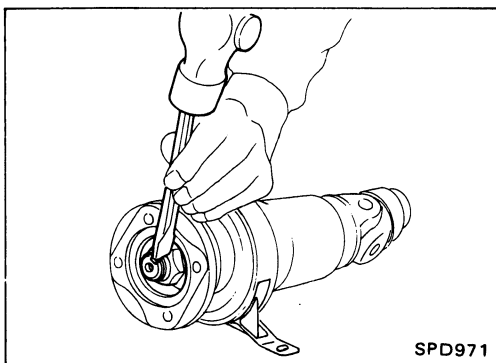

- Stake the nut. Always use new one.
- Align matchmarks when assembling tubes.

Front Oil Seal Replacement (R200V)

CAUTION:

For final drive models using collapsible spacer (R230V), bearing preload must be adjusted whenever companion flange is removed. In order to do this adjustment correctly, final drive overhaul is required.

1. Remove propeller shaft.
2. Loosen drive pinion nut with Tool.

Tool number: **ST38060002 (J34311)**

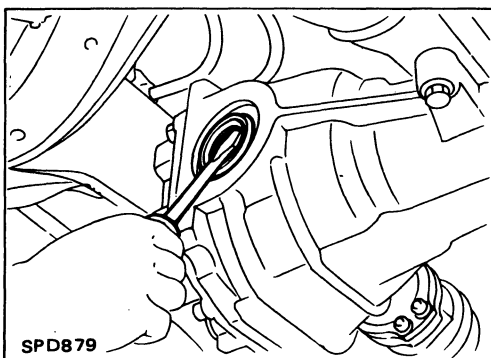
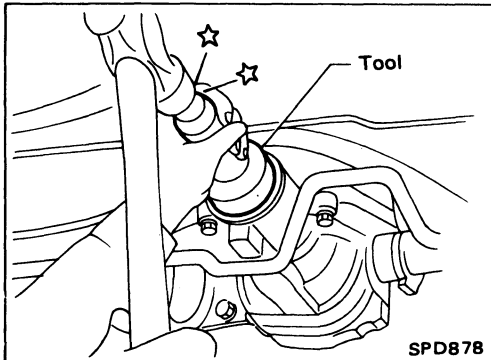
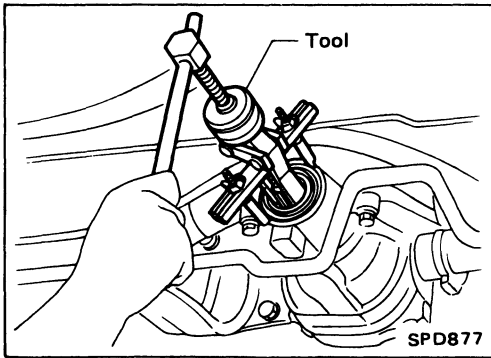
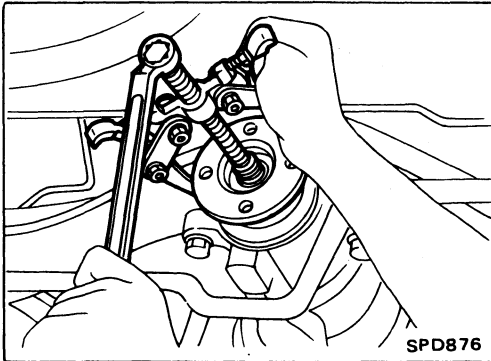
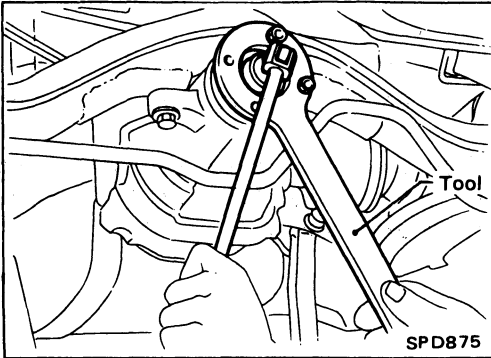

3. Remove companion flange.

4. Remove front oil seal.

5. Apply multi-purpose grease to sealing lips of oil seal. Press front oil seal into carrier.
6. Install companion flange and drive pinion nut.
7. Install propeller shaft.

Side Oil Seal Replacement

1. Remove drive shafts.
Refer to RA section.
2. Remove final drive side flange.
3. Remove oil seal.

Side Oil Seal Replacement (Cont'd)

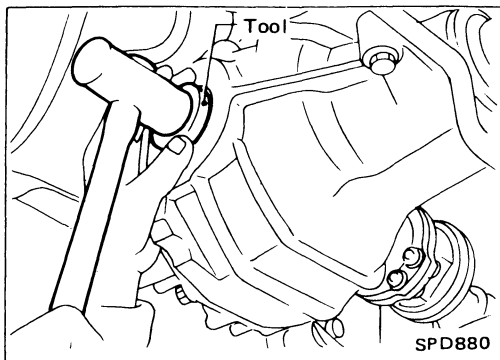

4. Apply multi-purpose grease to sealing lips of oil seal. Press-fit oil seal into carrier with Tool.

Tool number:

KV38100200 (J26233) — R200V —

xxxxxxxxxx (—) — R230V —

5. Install final drive side flange and drive shaft.

REMOVAL AND INSTALLATION

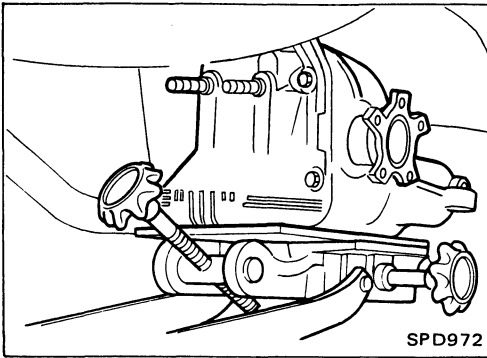

Removal

- Remove exhaust tube.
- Remove propeller shaft.

Plug up rear end of transmission rear extension housing.

- Remove drive shafts.
Refer to RA section.
- Remove nuts securing final drive rear cover to suspension member.
- Support weight of final drive using jack.
- Remove final drive mounting member from front of final drive.
- Move final drive forward together with jack. Remove rear cover stud bolts from suspension member.
- Lower final drive using jack. Remove jack from rear of vehicle.

CAUTION:

- Be careful not to damage spline, sleeve yoke and front oil seal, when removing propeller shaft.
- After final drive is removed, support suspension member on a stand to prevent its insulators from being twisted or damaged.

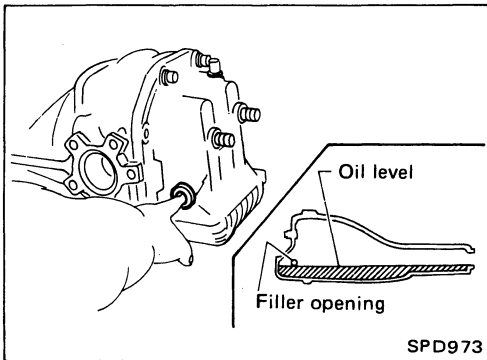

Installation

- Fill final drive with recommended gear oil.

FINAL DRIVE

Model R200V

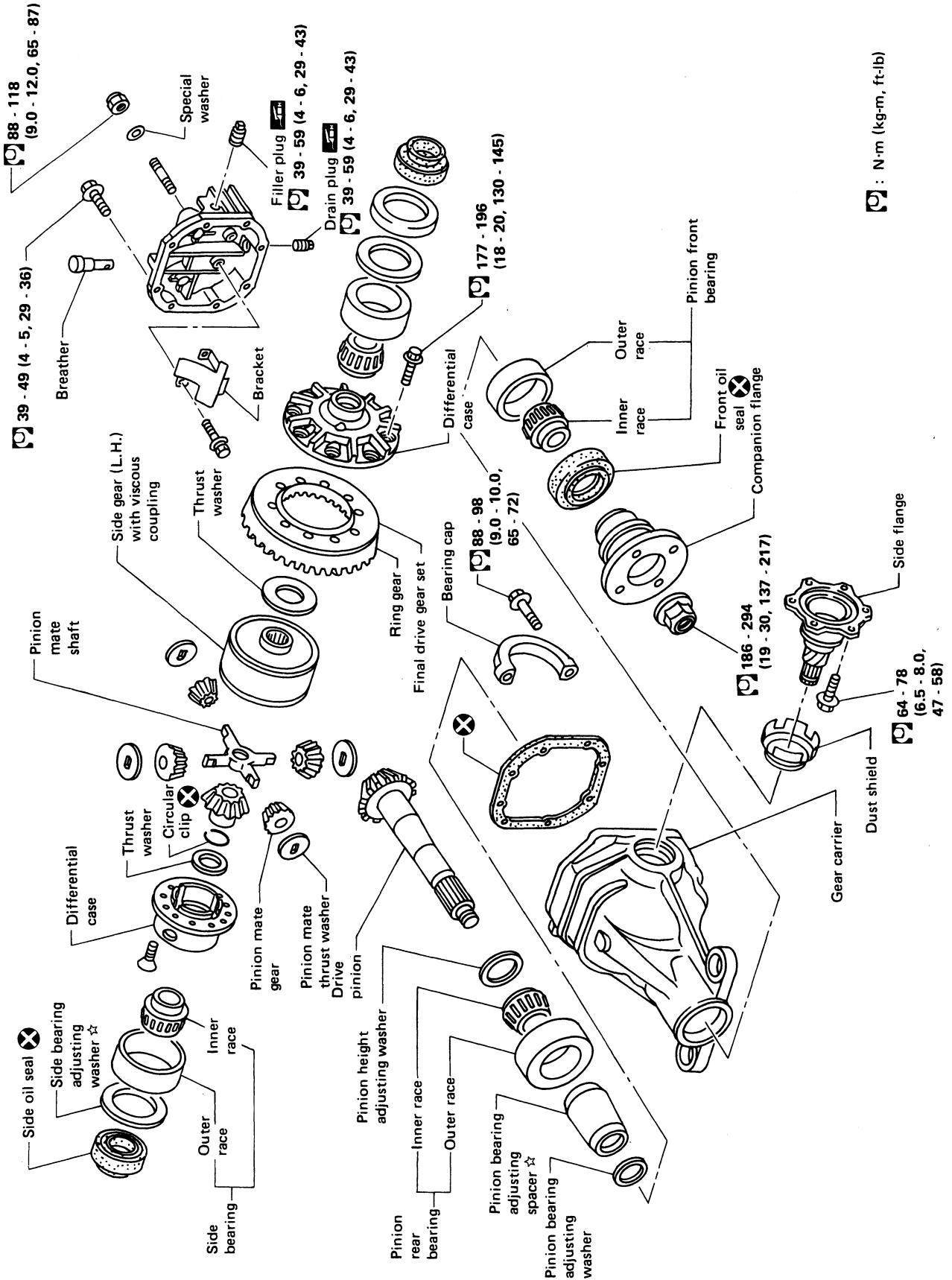

☐ : N·m (kg·m, ft·lb)

FINAL DRIVE

Model R230V

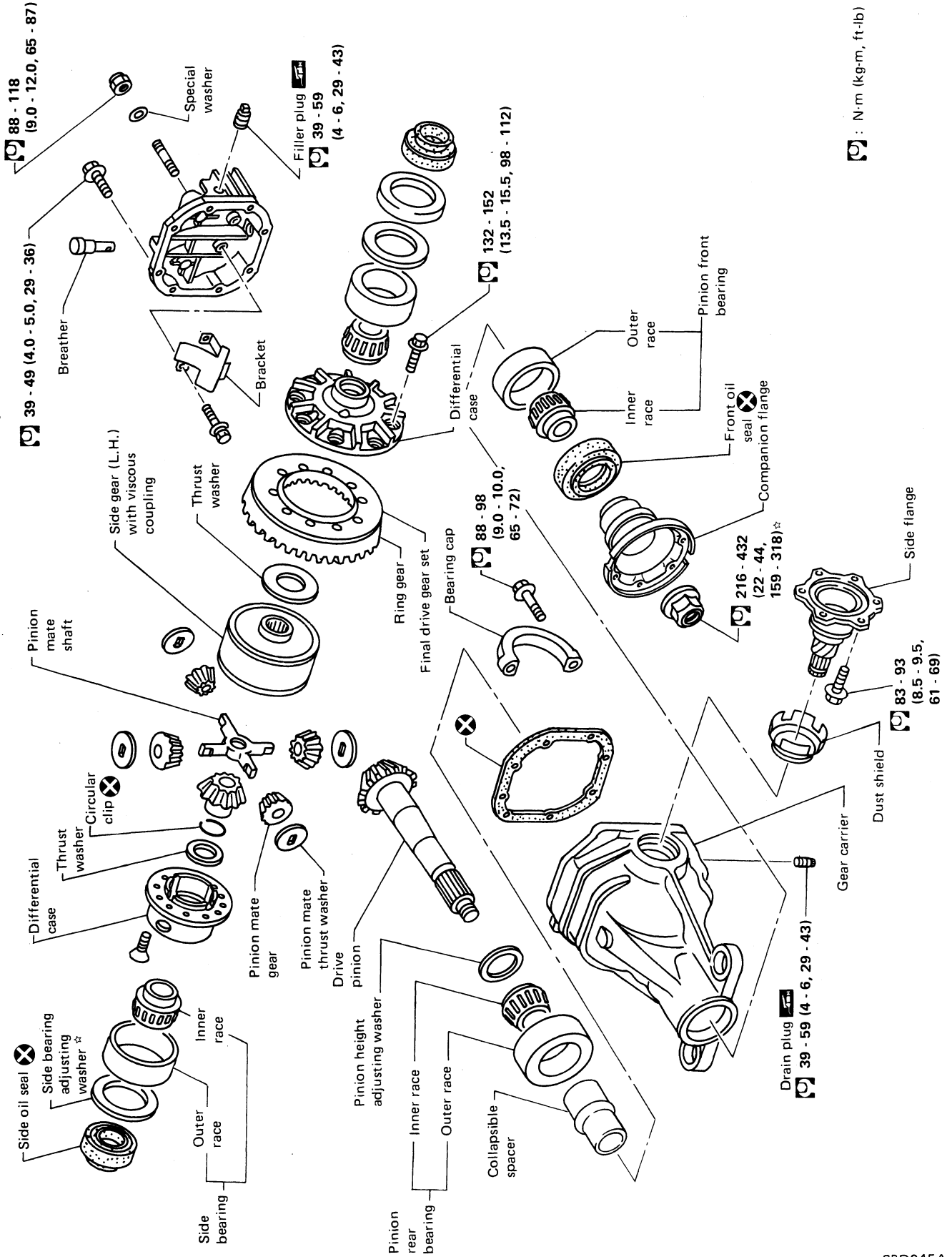

☆ : N·m (kg·m, ft·lb)

DISASSEMBLY

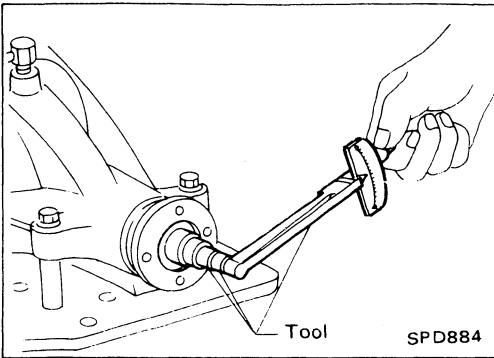

Pre-inspection

Before disassembling final drive, perform the following inspection.

- Total preload
 - 1) Turn drive pinion in both directions several times to set bearing rollers.
 - 2) Check total preload with Tool.

Tool number: ST3127S000 (See J25765-A)

Total preload:

1.4 - 1.7 N·m

(14 - 17 kg-cm, 12 - 15 in-lb)

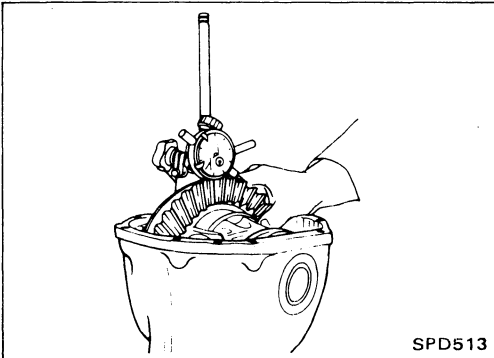

- Ring gear to drive pinion backlash
Check ring gear-to-drive pinion backlash with a dial indicator at several points.

Ring gear-to-drive pinion backlash:

0.10 - 0.15 mm (0.0039 - 0.0059 in)

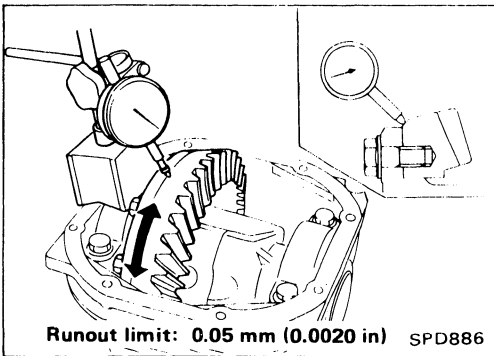

- Ring gear runout
Check runout of ring gear with a dial indicator.

Runout limit:

0.05 mm (0.0020 in)

- Tooth contact
Check tooth contact. (Refer to Adjustment.)

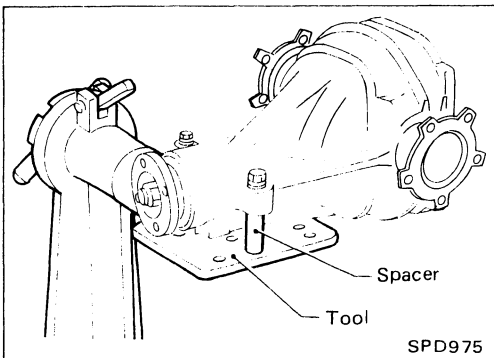

Differential Carrier

1. Using two 45 mm (1.77 in) spacers, mount carrier on Tool.

Tool number: KV38100800 (—)

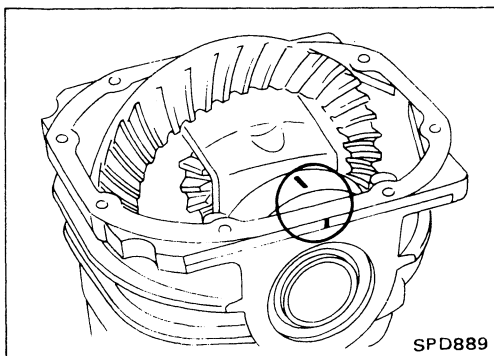

2. Paint or punch matchmarks on one side of the side bearing cap so it can be properly reinstalled.

Bearing caps are line-bored during manufacture. Replace them in their proper positions.

DISASSEMBLY

Differential Carrier (Cont'd)

3. Remove side bearing caps.

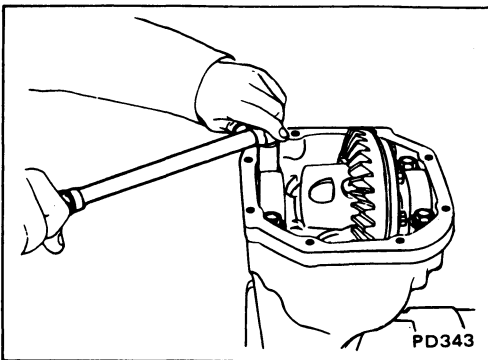

4. Lift differential case assembly out with Tool.

Tool number: HT72400000 (—)

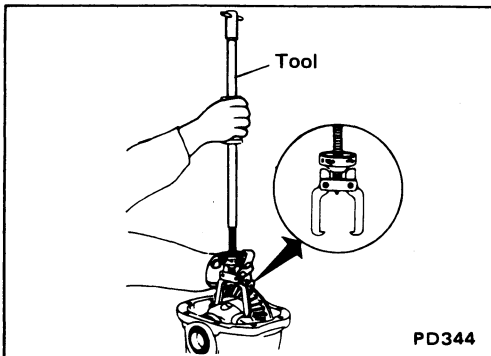

Keep the side bearing outer races together with inner cone — do not mix them up.

Also, keep side bearing spacer and adjusting shims together with bearings.

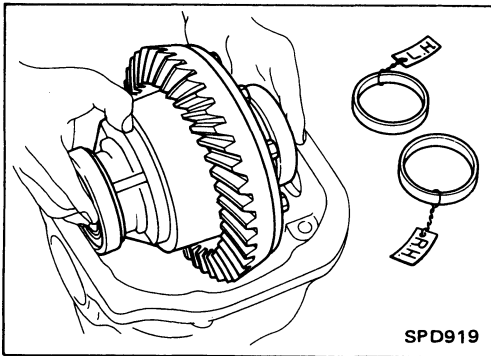

5. Loosen drive pinion nut and pull off companion flange.

Tool number:

ST38060002 (J34311) — R200V —

xxxxxxxxxx (—) — R230V —

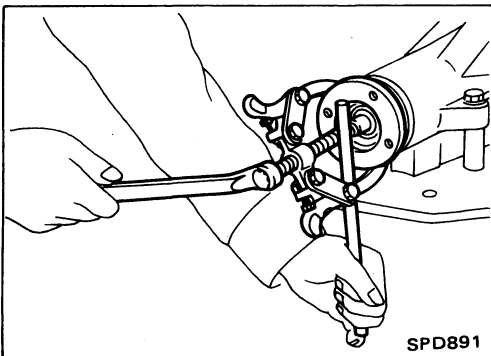
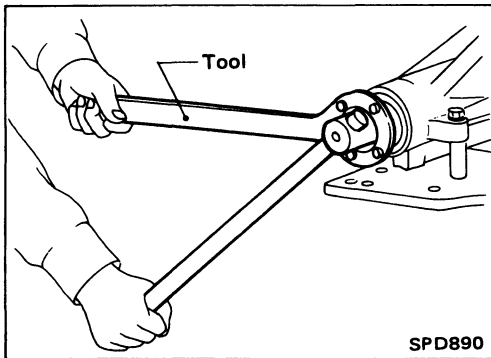

DISASSEMBLY

Differential Carrier (Cont'd)

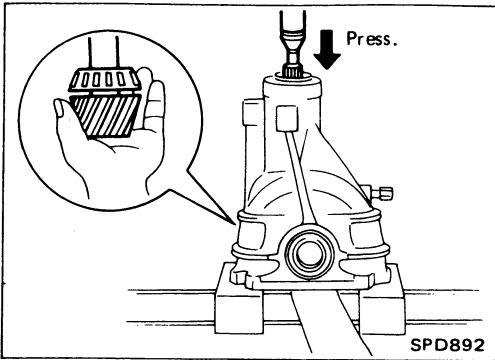

6. Take out drive pinion (together with rear bearing inner race, bearing spacer and adjusting washer).
7. Remove oil seal.
8. Remove front bearing inner race.
9. Remove side oil seal.

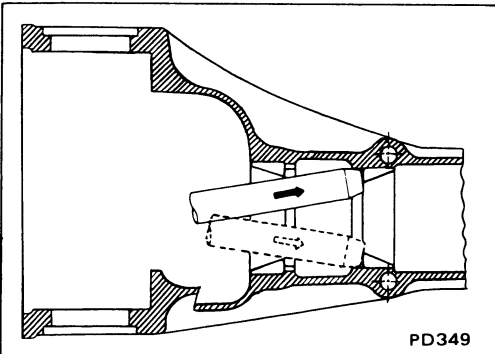

10. Remove pinion bearing outer races with a brass drift.

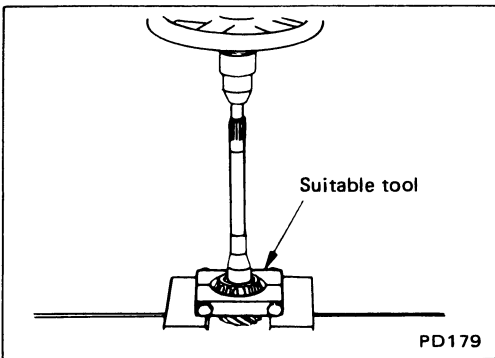

11. Remove pinion rear bearing inner race and drive pinion height adjusting washer with suitable tool.

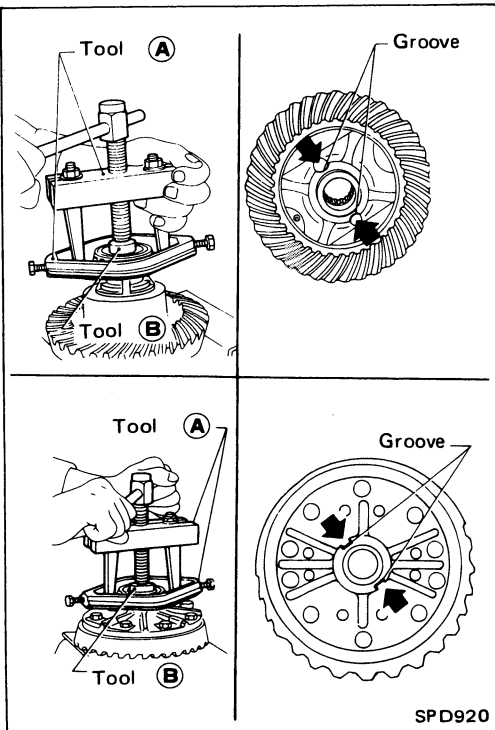

Differential Case

1. Remove side bearing inner cones.
To prevent damage to bearing, engage puller jaws in groove.

Tool number:

- (A) ST33051001 (—)
- (B) ST33061000 (J8107-2) — R200V —
xxxxxxxxxx (—) — R230V —

DISASSEMBLY

Differential Case (Cont'd)

Be careful not to confuse left- and right-hand parts.

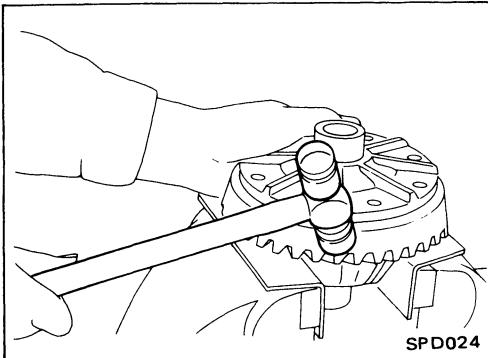
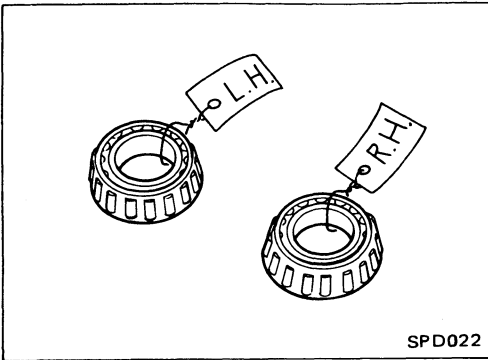

2. Loosen ring gear bolts in a criss-cross fashion.
3. Tap ring gear off the differential case with a soft hammer. Tap evenly all around to keep ring gear from binding.

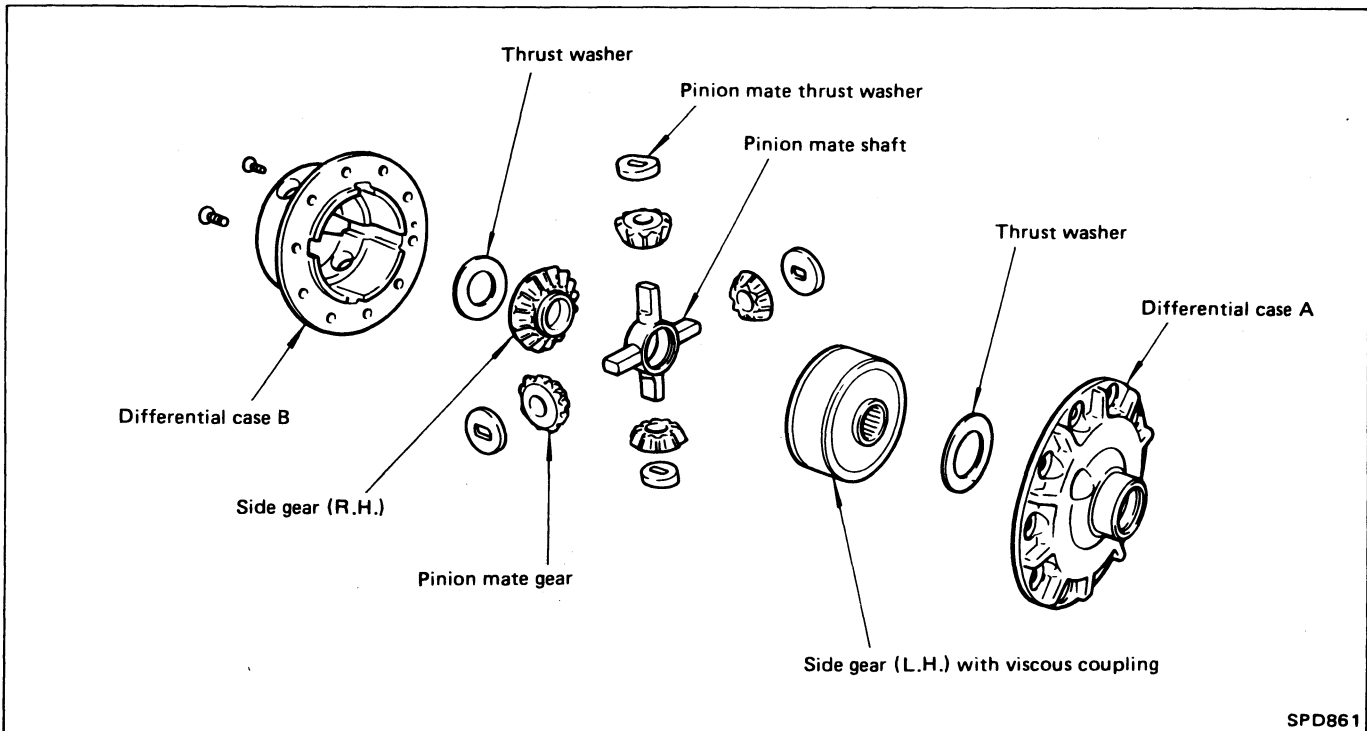

DISASSEMBLY

Differential Case (Cont'd)

4. Loosen screws on differential cases A and B.
5. Separate differential cases A and B.

CAUTION:

Assemble differential case firmly.

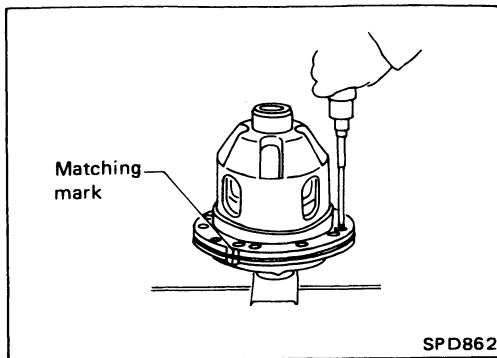

INSPECTION

Contact Surfaces

1. Clean the disassembled parts in suitable solvent and blow dry with compressed air.
2. If following surfaces are found to be burred or scratched, smooth with oil stone.
 - Differential case A
 - Differential case B
 - Side gear
 - Pinion mate gear
 - Pinion mate shaft
3. Check viscous coupling for oil leakage. If necessary, replace it with new one.

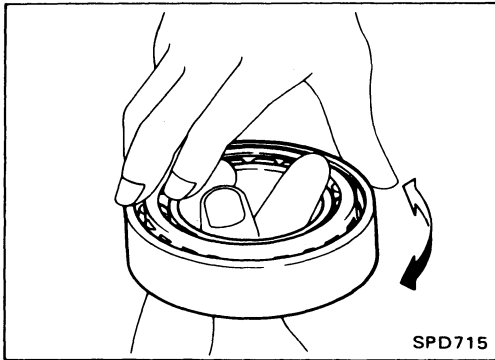

Bearing

1. Thoroughly clean bearing.
2. Check bearings for wear, scratches, pitting or flaking. Check tapered roller bearing for smooth rotation. If damaged, replace outer race and inner cone as a set.

ADJUSTMENT (R200V)

For quiet and reliable final drive operation, the following five adjustments must be made correctly.

1. Side bearing preload
2. Pinion gear height
3. Pinion bearing preload
4. Ring gear-to-pinion backlash (Refer to ASSEMBLY.)
5. Ring and pinion gear tooth contact pattern

Side Bearing Preload

A selection of carrier side bearing preload shims is required for successful completion of this procedure.

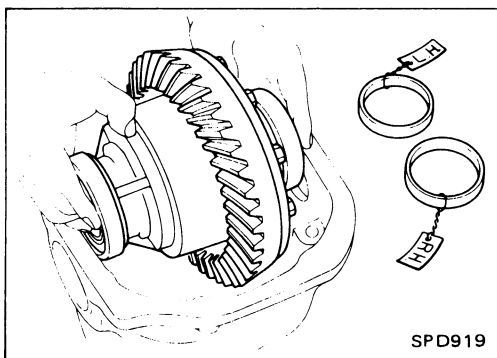

1. Make sure all parts are clean and that the bearings are well lubricated with light oil or Dexron™ type automatic transmission fluid.
2. Place the differential carrier, with side bearings and bearing races installed, into the final drive housing.

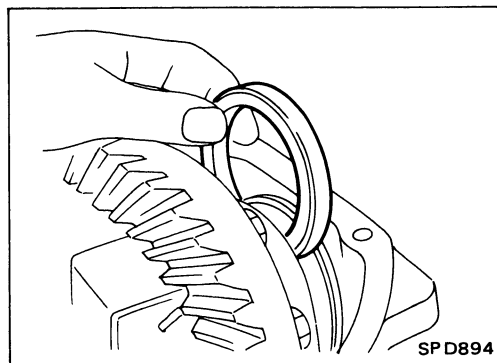

3. Put the side bearing spacer in place on the ring gear end of the carrier.

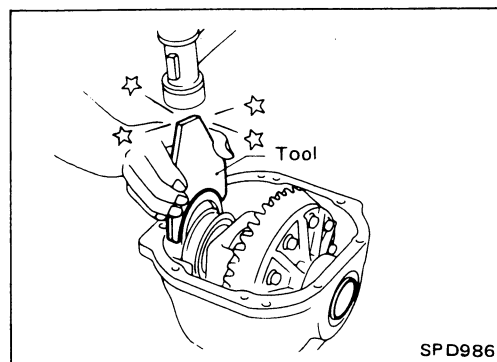

4. Using the J-25267 side bearing spacer drift, place both of the original carrier side bearing preload shims on the carrier end, opposite the ring gear.

ADJUSTMENT (R200V)

Side Bearing Preload (Cont'd)

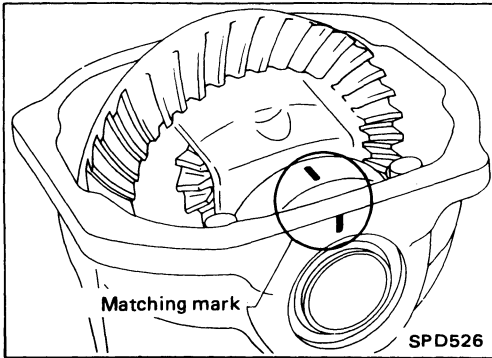

5. Install the side bearing caps in their correct locations and torque the bearing cap retaining bolts.

Specification:

88 - 98 N·m

(9 - 10 kg-m, 65 - 72 ft-lb)

6. Turn the carrier several times to seat the bearings.

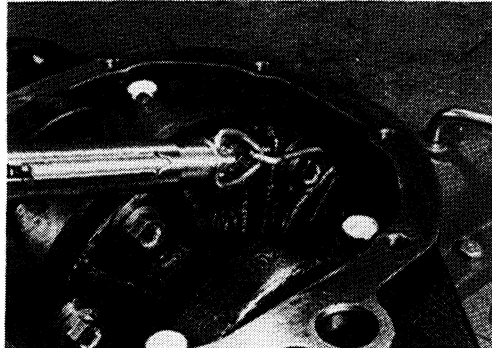

7. Measure the turning torque of the carrier at the ring gear retaining bolts with a spring gauge, J-8129.

Specification:

34.3 - 39.2 N

(3.5 - 4 kg, 7.7 - 8.8 lb)

of pulling force at the ring gear bolt.

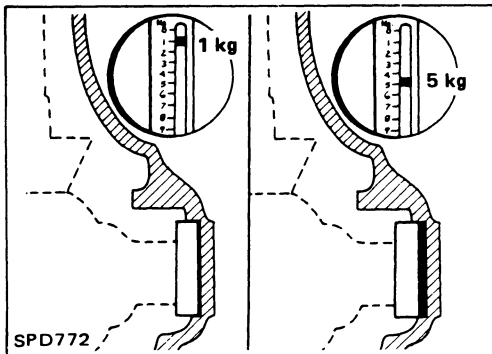

8. If the carrier turning torque is not within the specification range, increase or decrease the total thickness of the side bearing adjusting washers until the turning torque is correct. If the turning torque is less than the specified range, install washers of greater thickness; if the turning torque is greater than the specification, install thinner washers. See the S.D.S. section for washer dimensions and part numbers.

9. Record the total amount of washer thickness required for the correct carrier side bearing preload.

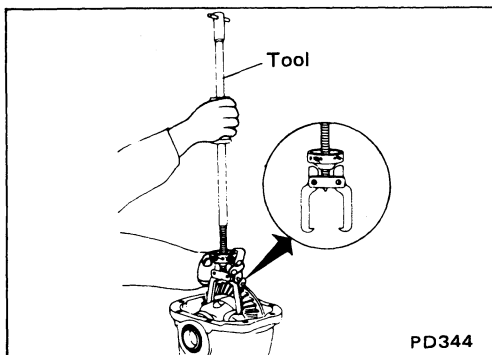

10. Remove the carrier from the final drive housing, saving the selected preload washers for later use during the assembly of the final drive unit.

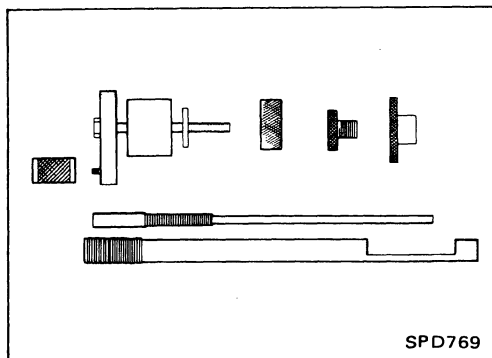

Pinion Gear Height and Pinion Bearing Preload

1. Make sure all parts are clean and that the bearings are well lubricated.
2. Assemble the pinion gear bearings into the pinion preload shim selector Tool, J-34309.

ADJUSTMENT (R200V)

Pinion Gear Height and Pinion Bearing Preload (Cont'd)

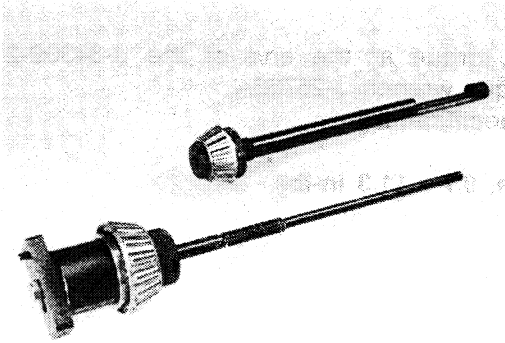

- **Front pinion bearing** — make sure the J-34309-3 front pinion bearing seat is secured tightly against the J-34309-2 gauge anvil. Then turn the front pinion bearing pilot, J-34309-5, to secure the bearing in its proper position.
- **Rear pinion bearing** — the rear pinion bearing pilot, J-34309-8, is used to center the rear pinion bearing only. The rear pinion bearing locking seat, J-34309-4, is used to lock the bearing to the assembly.
- **Installation of J-34309-9 and J-34309-16** — place a suitable 2.5 mm (0.098 in) thick plain washer between J-34309-9 and J-34309-16. Both surfaces of J-34309-9 and J-34309-16 must be parallel with a clearance of 2.5 mm (0.098 in).

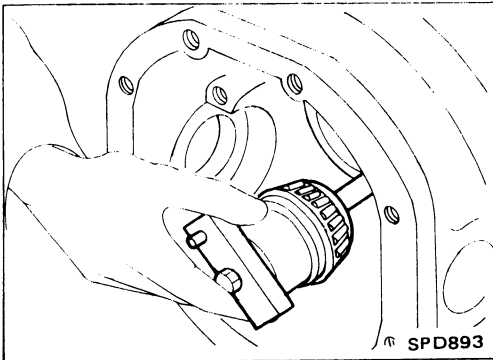

3. Place the pinion preload shim selector Tool, J-34309-1, gauge screw assembly with the pinion rear bearing inner cone installed into the final drive housing.

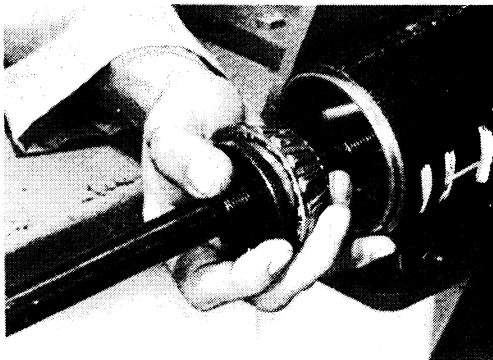

4. Assemble the front pinion bearing inner cone and the J-34309-2 gauge anvil together with the J-34309-1 gauge screw in the final drive housing. Make sure that the pinion height gauge plate, J-34309-16, will turn a full 360 degrees, and tighten the two sections together by hand.

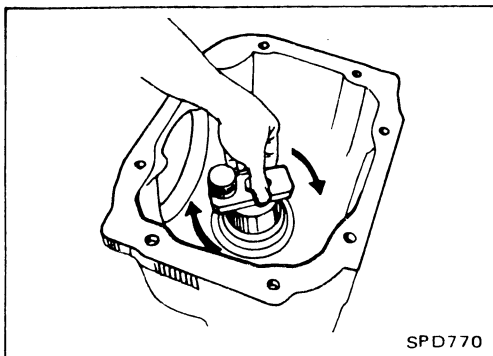

5. Turn the assembly several times to seat the bearings.

ADJUSTMENT (R200V)

Pinion Gear Height and Pinion Bearing Preload (Cont'd)

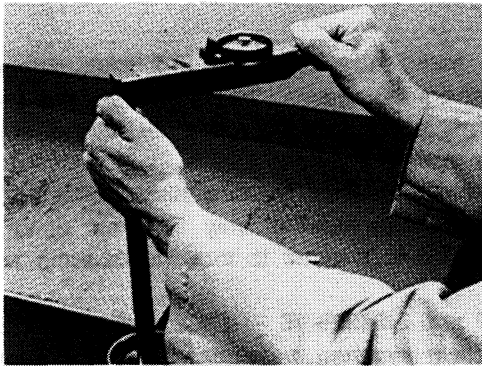

6. Measure the turning torque at the end of the J-34309-2 gauge anvil using torque wrench J-25765A.

Turning torque specification:

1.0 - 1.3 N·m

(10 - 13 kg-cm, 8.7 - 11.3 in-lb)

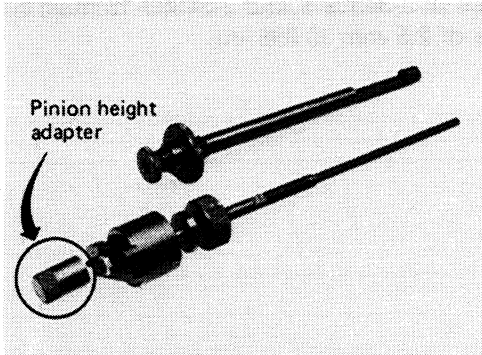

7. Place the J-34309-11 "R200A" pinion height adapter onto the gauge plate and tighten it by hand.

CAUTION:

Make sure all machined surfaces are clean.

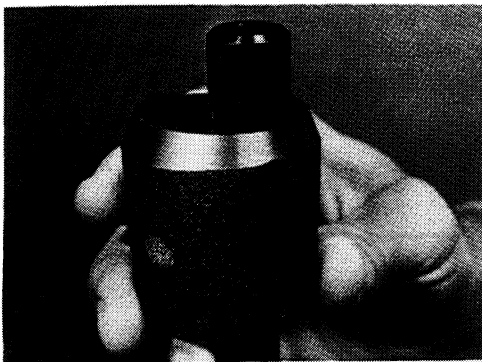

— PINION BEARING PRELOAD WASHER SELECTION —

8. Place the solid pinion bearing spacer, small end first, over the J-34309-2 gauge anvil and seat the small end squarely against the tip of the J-34309-1 gauge screw in the tool recessed portion.

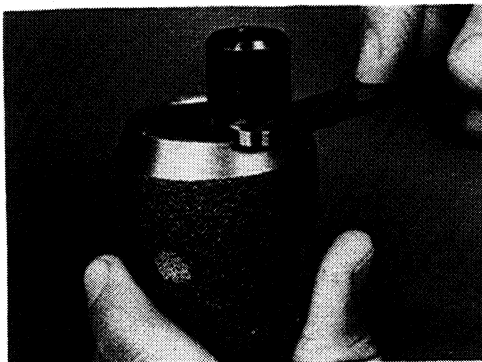
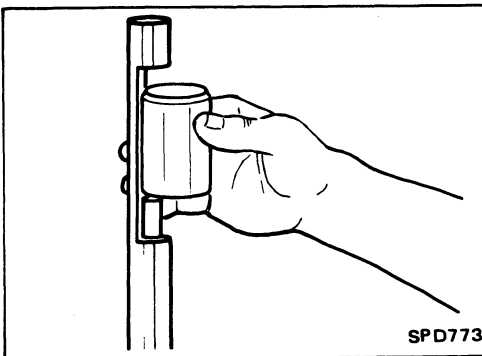

9. Select the correct thickness of pinion bearing preload adjusting washer using a standard gauge of 3.5 mm (0.138 in) and your J-34309-101 feeler gauge. *The exact measurement you get with your gauges is the thickness of the adjusting washer required.* Select the correct washer.

Drive pinion bearing preload adjusting washer:

Refer to S.D.S.

ADJUSTMENT (R200V)

Pinion Gear Height and Pinion Bearing Preload (Cont'd)

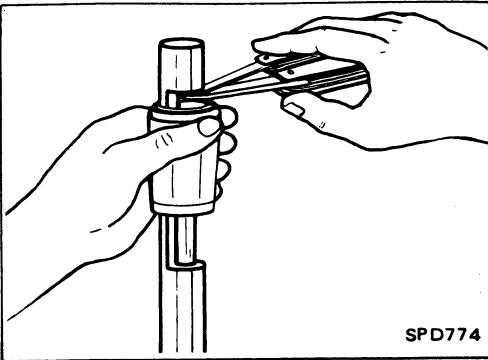

10. Set your selected, correct pinion bearing preload adjusting washer aside for use when assembling the pinion gear and bearings into the final drive.

— PINION HEIGHT ADJUSTING WASHER SELECTION —

11. Now, position the side bearing discs, J-25269-4, and arbor firmly into the side bearing bores. Install the side bearing caps and tighten the cap bolts to proper torque.

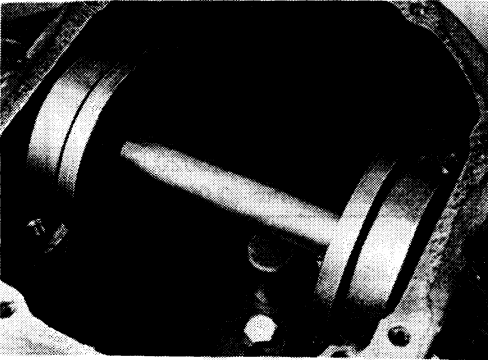

12. Select the correct *standard* pinion height adjusting washer thickness using a standard gauge of 3 mm (0.12 in) and your J-34309-101 feeler gauge. Measure the distance between the J-34309-11 pinion height adapter including the standard gauge and the arbor.

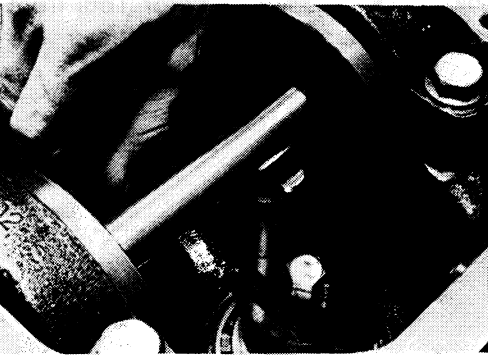

13. Write down your exact measurement (the value of feeler gauge).

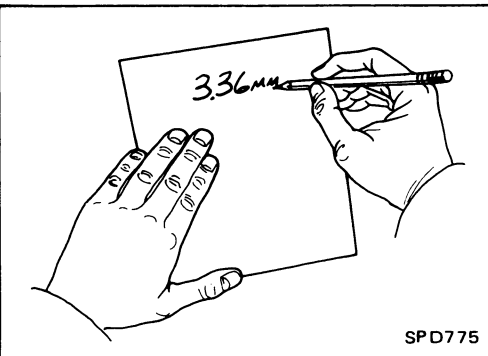

14. Correct the pinion height washer size by referring to the "pinion head number."

There are two numbers painted on the pinion gear. The first one refers to the pinion and ring gear as a matched set and should be the same as the number on the ring gear. The second number is the "pinion head height number," and it refers to the ideal pinion height from standard for quietest operation. Use the following chart to determine the correct pinion height washer.

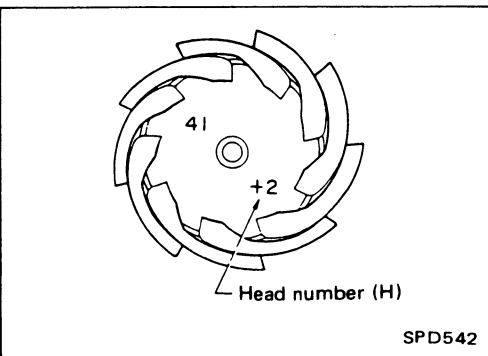

ADJUSTMENT (R200V)

Pinion Gear Height and Pinion Bearing Preload (Cont'd)

Pinion head height number	Add or remove from the standard pinion height washer thickness measurement
-6	Add 0.06 mm (0.0024 in)
-5	Add 0.05 mm (0.0020 in)
-4	Add 0.04 mm (0.0016 in)
-3	Add 0.03 mm (0.0012 in)
-2	Add 0.02 mm (0.0008 in)
-1	Add 0.01 mm (0.0004 in)
0	Use the selected washer thickness
+1	Subtract 0.01 mm (0.0004 in)
+2	Subtract 0.02 mm (0.0008 in)
+3	Subtract 0.03 mm (0.0012 in)
+4	Subtract 0.04 mm (0.0016 in)
+5	Subtract 0.05 mm (0.0020 in)
+6	Subtract 0.06 mm (0.0024 in)

15. Select the correct pinion height washer from the following chart.

Drive pinion height adjusting washer:

Refer to S.D.S.

16. Remove the J-34309 pinion preload shim selector Tool from the final drive housing and disassemble to retrieve the pinion bearings.

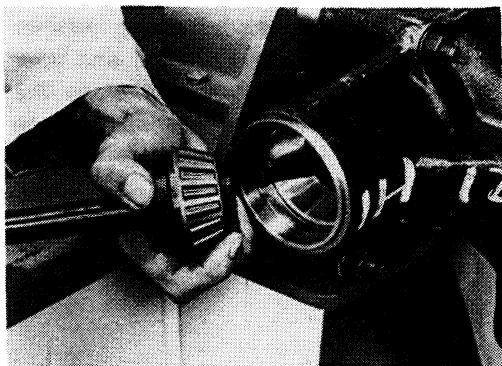

Tooth Contact

Checking gear tooth contact pattern is necessary to verify correct relationship between ring gear and drive pinion.

Hypoid gears which are not positioned properly in relation to one another may be noisy, or have short life or both. With the checking of gear tooth contact pattern, the most desirable contact for low noise level and long life can be assured.

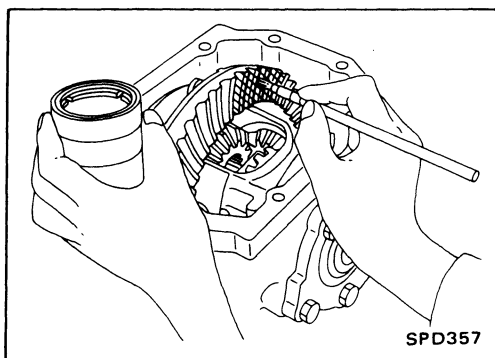

1. Thoroughly clean ring gear and drive pinion teeth.
2. Sparingly apply a mixture of powdered titanium oxide and oil or equivalent to 3 or 4 teeth of ring gear drive side.

ADJUSTMENT (R200V)

Tooth Contact (Cont'd)

3. Hold companion flange steady by hand and rotate the ring gear in both directions.

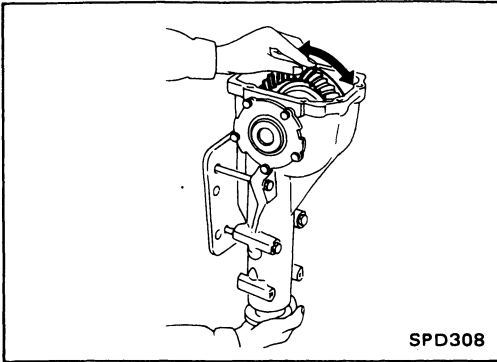

Usually the pattern will be correct if you have calculated the shims correctly and the backlash is correct. However, in rare cases you may have to use trial-and-error processes until you get a good tooth contact pattern. The tooth pattern is the best indication of how well the final drive has been set up.

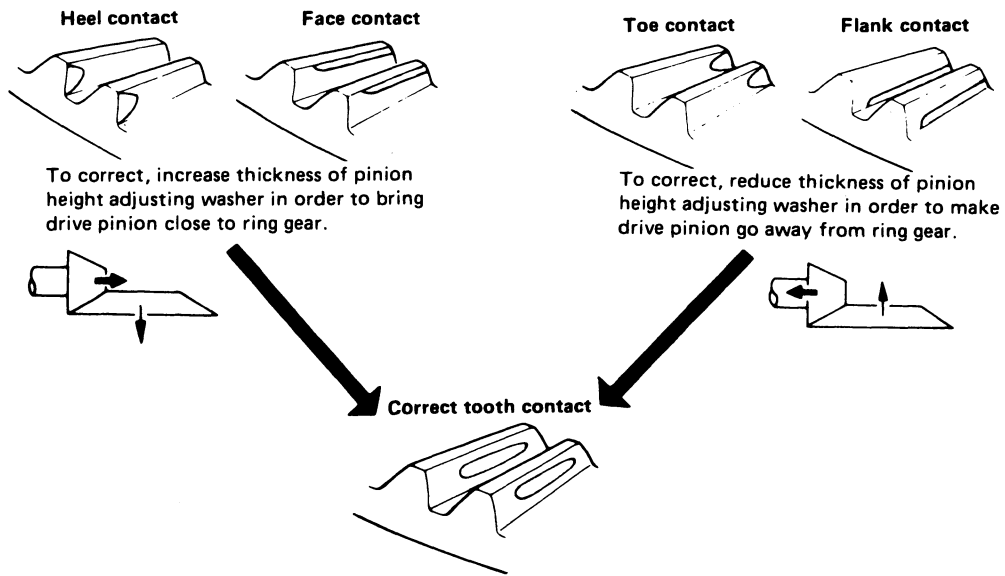

SPD007

ADJUSTMENT (R230V)

For quiet and reliable final drive operation, the following five adjustments must be made correctly.

1. Side bearing preload
2. Pinion gear height
3. Ring gear-to-pinion backlash (Refer to ASSEMBLY.)
4. Ring and pinion gear tooth contact pattern

Side Bearing Preload

A selection of carrier side bearing preload shims is required for successful completion of this procedure.

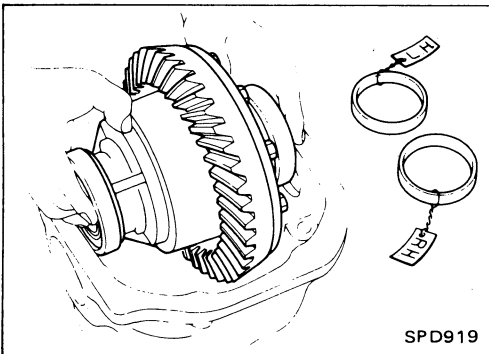

1. Make sure all parts are clean and that the bearings are well lubricated with light oil or Dexron™ type automatic transmission fluid.
2. Place the differential carrier, with side bearings and bearing races installed, into the final drive housing.

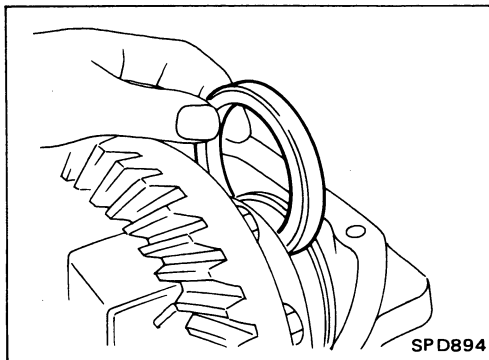

3. Put the side bearing spacer in place on the ring gear end of the carrier.

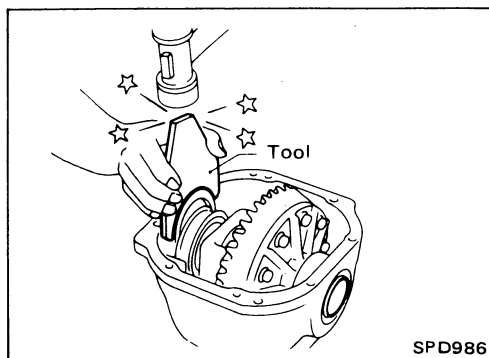

4. Using the xxxxx side bearing spacer drift, place both of the original carrier side bearing preload shims on the carrier end, opposite the ring gear.

ADJUSTMENT (R230V)

Side Bearing Preload (Cont'd)

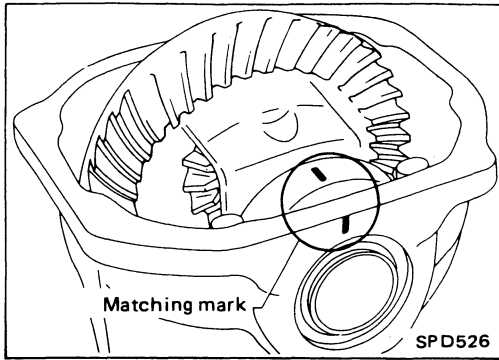

5. Install the side bearing caps in their correct locations and torque the bearing cap retaining bolts.

Specification:

88 - 98 N·m

(9 - 10 kg-m, 65 - 72 ft-lb)

6. Turn the carrier several times to seat the bearings.

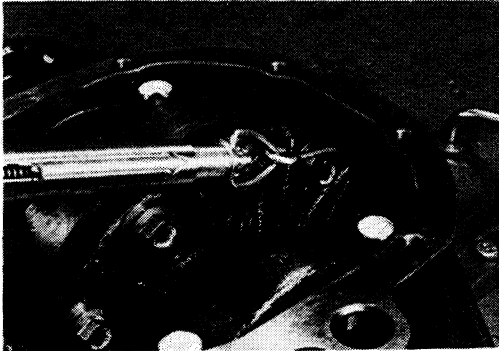

7. Measure the turning torque of the carrier at the ring gear retaining bolts with a spring gauge, J-8129.

Specification:

34.3 - 39.2 N

(3.5 - 4 kg, 7.7 - 8.8 lb)

of pulling force at the ring gear bolt.

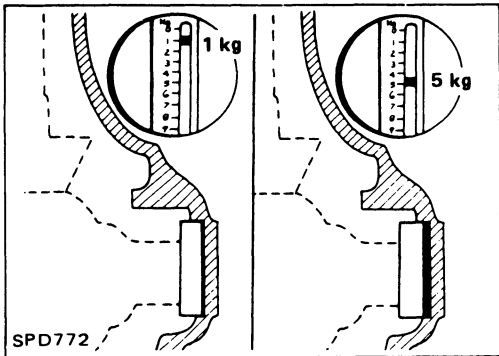

8. If the carrier turning torque is not within the specification range, increase or decrease the total thickness of the side bearing adjusting washers until the turning torque is correct. If the turning torque is less than the specified range, install washers of greater thickness; if the turning torque is greater than the specification, install thinner washers. See the S.D.S. section for washer dimensions and part numbers.
9. Record the total amount of washer thickness required for the correct carrier side bearing preload.

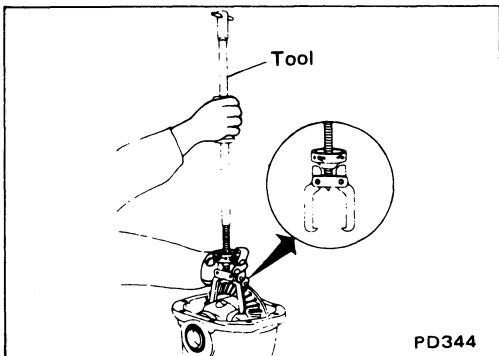

10. Remove the carrier from the final drive housing, saving the selected preload washers for later use during the assembly of the final drive unit.

Pinion Gear Height

1. Make sure all parts are clean and that the bearings are well lubricated.
2. Assemble the pinion gear bearings into the pinion preload shim selector Tool, xxxxxx.

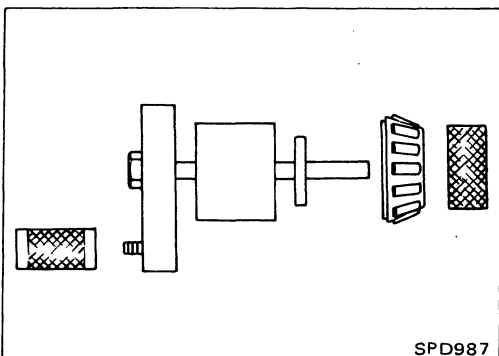

ADJUSTMENT (R230V)

Pinion Gear Height (Cont'd)

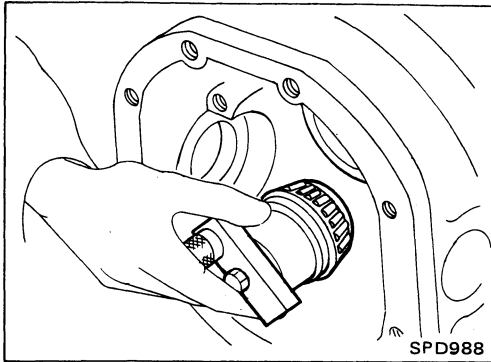

3. Place the pinion preload shim selector Tool, xxxxxxx, gauge screw assembly with the pinion rear bearing inner cone installed into the final drive housing.

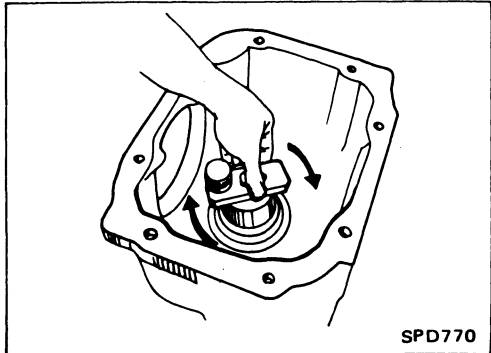

4. Turn the assembly several times to seat the bearings.

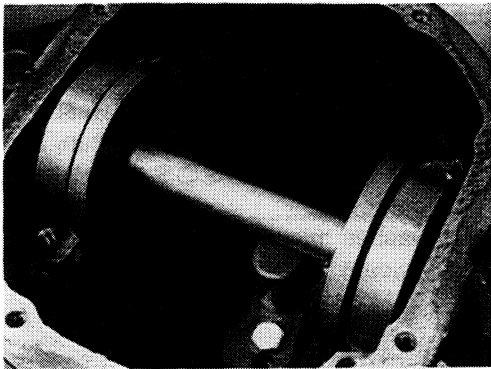

5. Now, position the side bearing discs, xxxxxxx, and arbor firmly into the side bearing bores. Install the side bearing caps and tighten the cap bolts to proper torque.

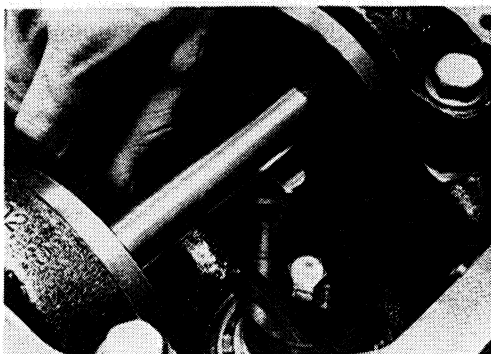

6. Select the correct *standard* pinion height adjusting washer thickness using a standard gauge of 3 mm (0.12 in) and your xxxxxxxx feeler gauge. Measure the distance between the xxxxxxxx pinion height adapter including the standard gauge and the arbor.

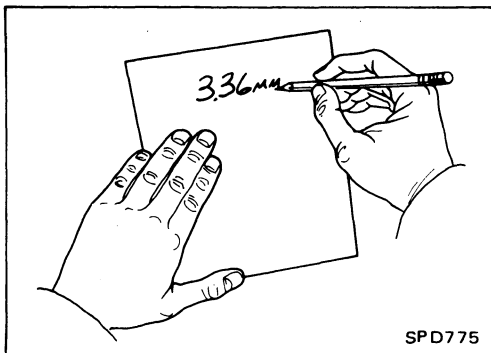

7. Write down your exact measurement (the value of feeler gauge).

ADJUSTMENT (R230V)

Pinion Gear Height (Cont'd)

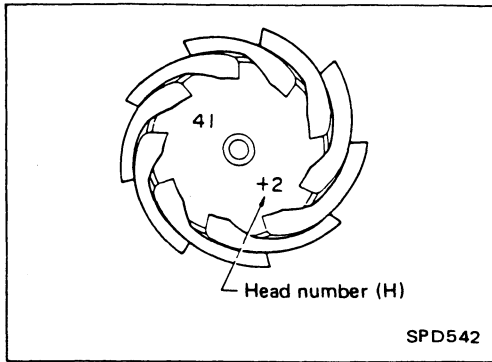

8. Correct the pinion height washer size by referring to the "pinion head number."

There are two numbers painted on the pinion gear. The first one refers to the pinion and ring gear as a matched set and should be the same as the number on the ring gear. The second number is the "pinion head height number," and it refers to the ideal pinion height from standard for quietest operation. Use the following chart to determine the correct pinion height washer.

Pinion head height number	Add or remove from the standard pinion height washer thickness measurement
-6	Add 0.06 mm (0.0024 in)
-5	Add 0.05 mm (0.0020 in)
-4	Add 0.04 mm (0.0016 in)
-3	Add 0.03 mm (0.0012 in)
-2	Add 0.02 mm (0.0008 in)
-1	Add 0.01 mm (0.0004 in)
0	Use the selected washer thickness
+1	Subtract 0.01 mm (0.0004 in)
+2	Subtract 0.02 mm (0.0008 in)
+3	Subtract 0.03 mm (0.0012 in)
+4	Subtract 0.04 mm (0.0016 in)
+5	Subtract 0.05 mm (0.0020 in)
+6	Subtract 0.06 mm (0.0024 in)

9. Select the correct pinion height washer from the following chart.

Drive pinion height adjusting washer:

Refer to S.D.S.

Tooth Contact

Checking gear tooth contact pattern is necessary to verify correct relationship between ring gear and drive pinion.

Hypoid gears which are not positioned properly in relation to one another may be noisy, or have short life or both. With the checking of gear tooth contact pattern, the most desirable contact for low noise level and long life can be assured.

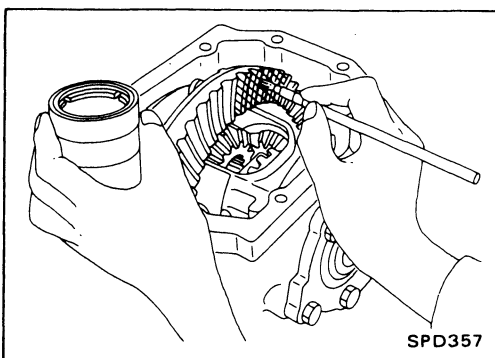

1. Thoroughly clean ring gear and drive pinion teeth.
2. Sparingly apply a mixture of powdered titanium oxide and oil or equivalent to 3 or 4 teeth of ring gear drive side.

ADJUSTMENT (R230V)

Tooth Contact (Cont'd)

3. Hold companion flange steady by hand and rotate the ring gear in both directions.

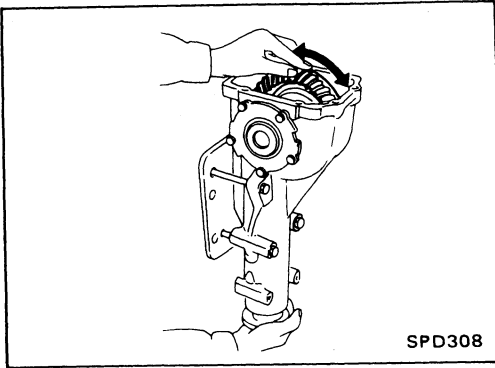

Usually the pattern will be correct if you have calculated the shims correctly and the backlash is correct. However, in rare cases you may have to use trial-and-error processes until you get a good tooth contact pattern. The tooth pattern is the best indication of how well the final drive has been set up.

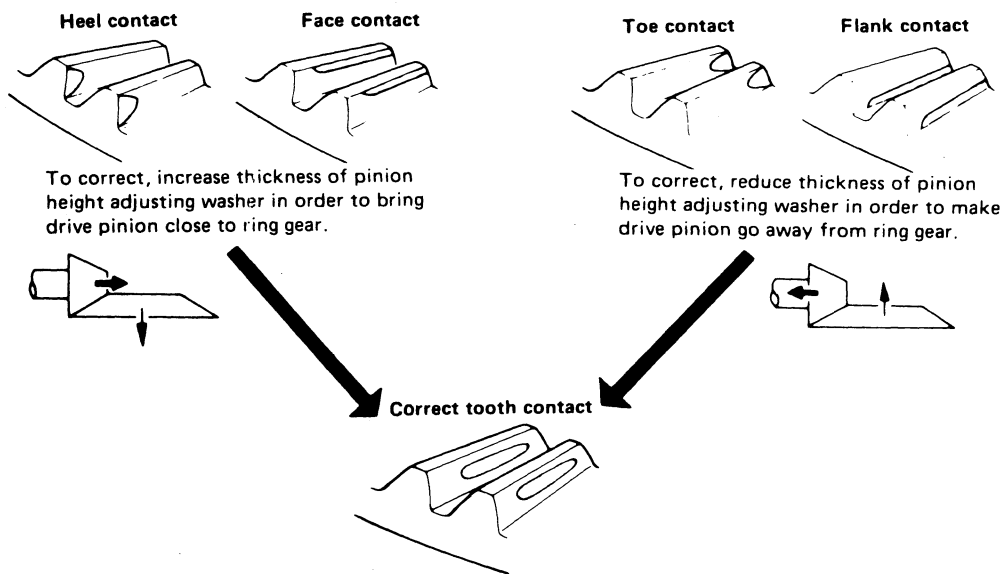

SPD007

ASSEMBLY

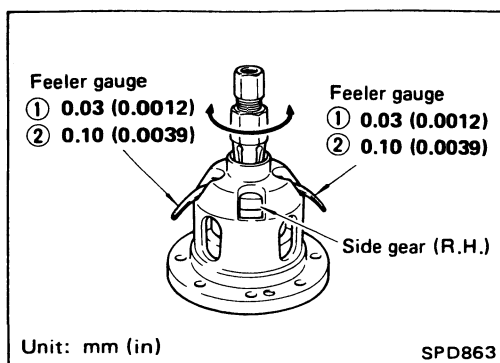

Differential Case THRUST WASHER SELECTION

Whenever side gears or pinion mate gears are replaced, select suitable thrust washers as follows:

1. Clean side gears and pinion mate gears using white gasoline.
2. Before assembling gears, apply hypoid gear oil to frictional surfaces.
3. Install the previously removed thrust washer on right side gear. On left side gear, install a suitable thrust washer. Temporarily tighten differential cases using two screws.
4. Position differential assembly so that right side gear is on the upper side. Place a 0.03 mm (0.0012 in) feeler gauge (for example) between right side gear and thrust washer.

Do not insert feeler gauge in oil groove portion of differential case.

5. Also place a 0.03 mm (0.0012 in) additional feeler gauge between right side gear and thrust washer so that it is positioned diagonal to (180° apart from) the feeler gauge described previously.
6. Rotate right side gear with a suitable tool attached to splines. If right side gear cannot be rotated, replace thrust washer used on left side gear with a thinner one.
7. Replace both 0.03 mm (0.0012 in) feeler gauges with 0.10 mm (0.0039 in) gauges. At this point, make sure right side gear does not rotate. If it does, replace thrust washer on left side gear with a thicker one so that right side gear does not rotate.
8. As explained in above example, select suitable thrust washers to ensure that:
 - a) Both side gears rotate. [0.03 mm (0.0012 in) feeler gauges are used in this case.]
 - b) Side gear is held stationary. [0.10 mm (0.0039 in) feeler gauges are used in this case.](Refer to S.D.S.)

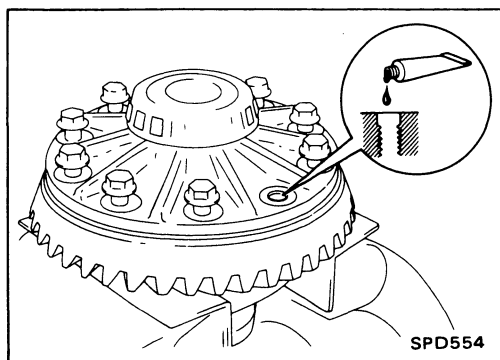
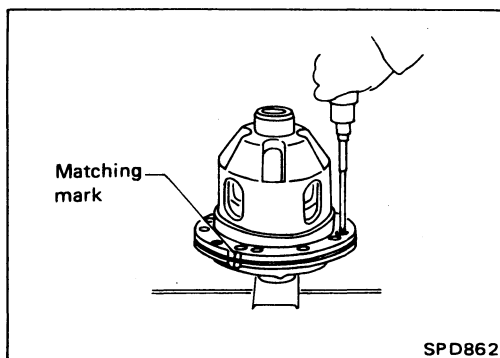

ASSEMBLY

1. Install differential case A and B.

2. Place differential case on ring gear.
3. Apply locking sealant to ring gear bolts, and install them.

Tighten bolts in a criss-cross fashion, lightly tapping bolt head with a hammer.

ASSEMBLY

Differential Case (Cont'd)

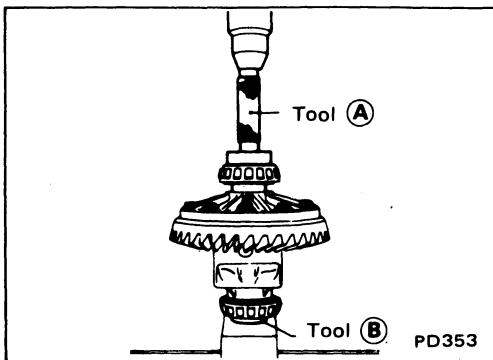

4. Press-fit side bearing inner cones on differential case with Tool.

Tool number:

- Ⓐ KV38100300 (J25523) — R200V —
xxxxxxxxxx (—) — R230V —
- Ⓑ ST33061000 (J8107-2) — R200V —
xxxxxxxxxx (—) — R230V —

Differential Carrier

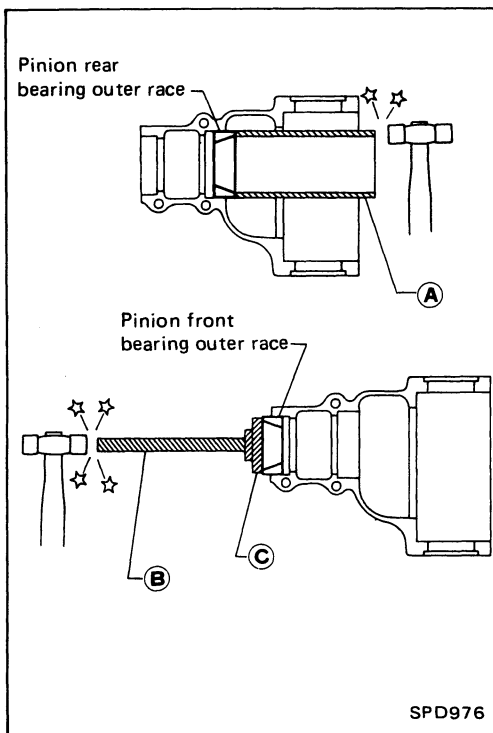

1. Press-fit front and rear bearing outer races with Tools.

Tool number:

- Ⓐ suitable tool
- Ⓑ ST30611000 (J25742-1)
- Ⓒ ST30613000 (J25742-3) — R200V —
xxxxxxxxxx (—) — R230V —

2. Select pinion bearing adjusting washer and drive pinion bearing spacer, referring to ADJUSTMENT.

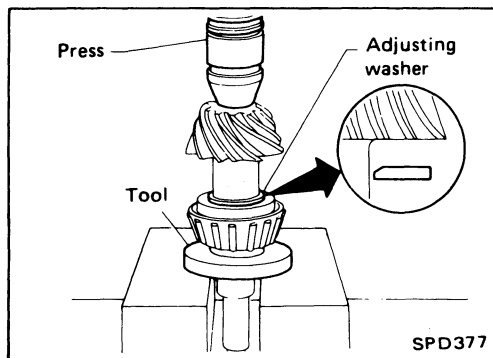

3. Install selected drive pinion height adjusting washer in drive pinion, and press-fit pinion rear bearing inner cone in it, using press and Tool.

Tool number:

- ST30901000 (—) — R200V —
- ST30022000 (—) — R230V —

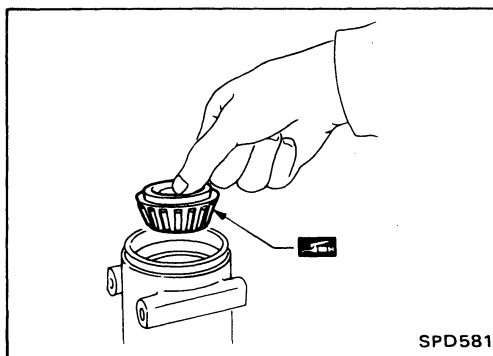

4. Place pinion front bearing inner cone in final drive housing.

ASSEMBLY

Differential Carrier (Cont'd)

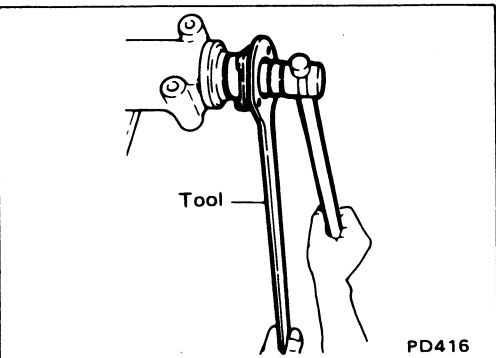
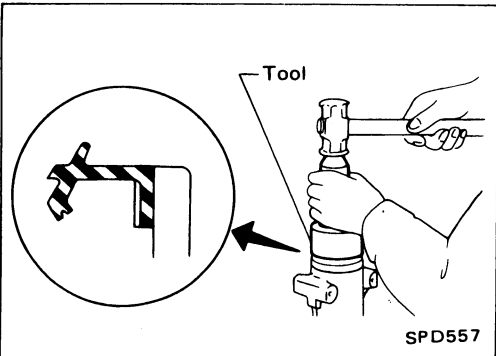
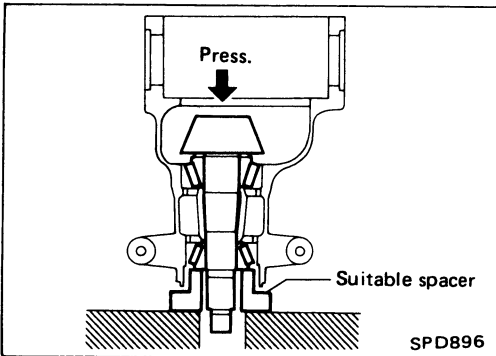
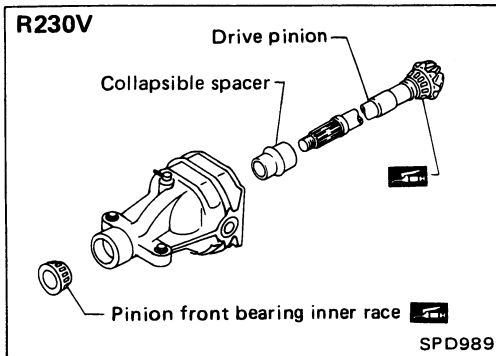
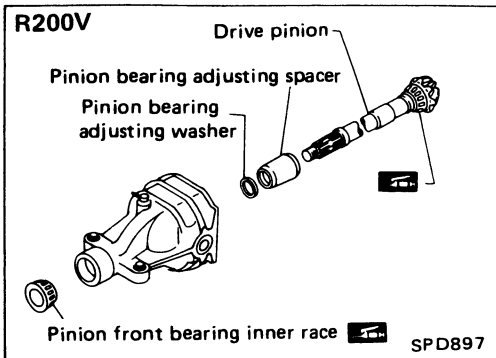

5. Set drive pinion assembly (as shown in figure at left) in differential carrier and install drive pinion, with press and suitable tool.

Stop when drive pinion touches bearing.

Apply multi-purpose grease to pinion rear bearing inner race, pinion front bearing inner race and front pilot bearing.

6. Apply multi-purpose grease to cavity at sealing lips of oil seal. Install front oil seal with Tool.

Tool number:

KV38100500 (—) — R200V —

xxxxxxxxxx (—) — R230V —

7. Install companion flange.

— R200V —

Tighten pinion nut to specified torque with Tool.

— R230V —

Tighten pinion nut to 127 N·m (13 kg·m, 94 ft·lb).

Make sure that threaded portion of drive pinion and pinion nut are free from oil or grease.

Tool number:

ST38060002 (J34311) — R200V —

xxxxxxxxxx (—) — R230V —

ASSEMBLY

Differential Carrier (Cont'd)

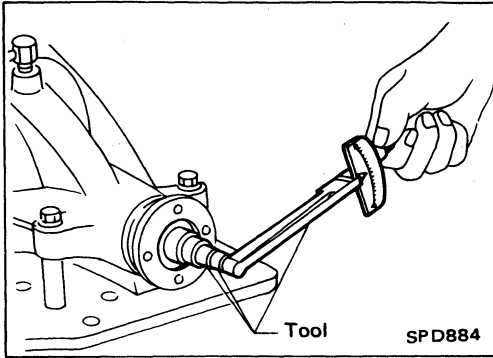

8.

— R200V —

Turn drive pinion in both directions several times, and measure pinion bearing preload.

Pinion bearing preload:

1.1 - 1.4 N·m

(11 - 14 kg-cm, 9.5 - 12.2 in-lb)

When pinion bearing preload is outside the specifications, replace pinion bearing adjusting washer and spacer with a different thickness.

— R230V —

Tighten the pinion nut by very small degrees until the specified preload is achieved. When checking the preload, turn the drive pinion in both directions several times to set the bearing rollers.

Pinion bearing preload:

1.8 - 2.6 N·m

(18 - 27 kg-cm, 16 - 23 in-lb)

This procedure will have to be repeated if:

- Maximum preload is achieved before the minimum pinion nut torque is reached.
- Minimum preload is not achieved before maximum pinion nut torque is reached.

9. Install differential case assembly with side bearing outer races into gear carrier.

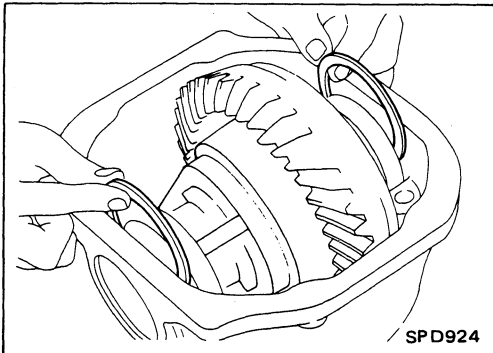
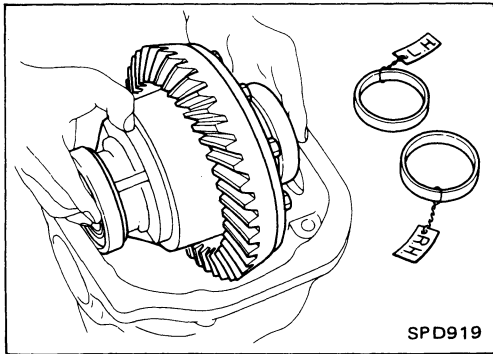

10. Insert left and right side bearing adjusting washers in place between side bearings and carrier.

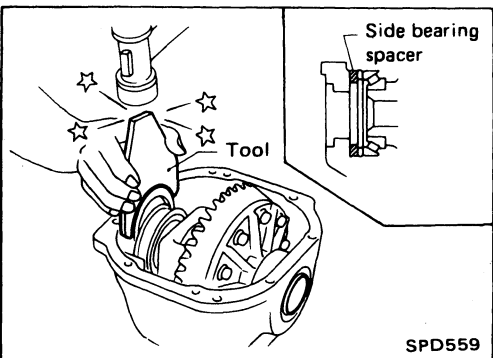

11. Drive in side bearing spacer with Tool.

Tool number:

KV38100600 (J25267) — R200V —

xxxxxxxxxx (—) — R230V —

ASSEMBLY

Differential Carrier (Cont'd)

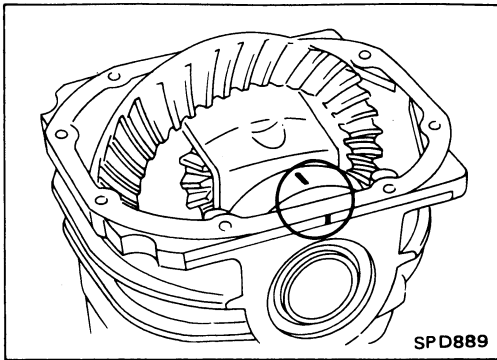

12. Align mark on bearing cap with that on gear carrier and install bearing cap on gear carrier.

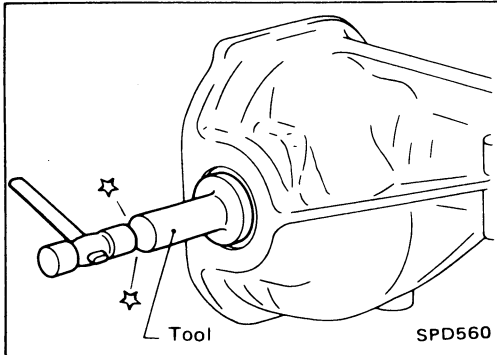

13. Apply multi-purpose grease to cavity at sealing lips of oil seal. Install side oil seal.

Tool number:

KV38100200 (J26233) — R200V —

KV38102510 (—) — R230V —

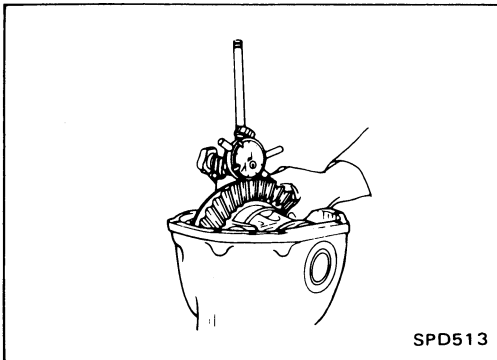

14. Measure ring gear-to-drive pinion backlash with a dial indicator.

Ring gear-to-drive pinion backlash:

0.10 - 0.15 mm

(0.0039 - 0.0059 in)

- If backlash is too small, decrease thickness of left shim and increase thickness of right shim by the same amount.

If backlash is too great, reverse the above procedure.

Never change the total amount of shims as it will change the bearing preload.

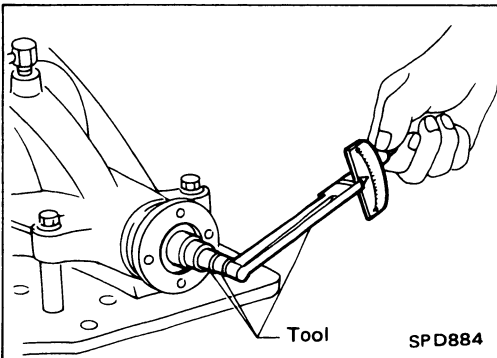

15. Check total preload with Tool.

When checking preload, turn drive pinion in both directions several times to seat bearing rollers correctly.

Total preload:

Value more than 0.29 N·m (3.0 kg-cm, 2.6 in-lb) added on measured value of drive pinion preload

- If preload is too great, remove the same amount of shim from each side.
- If preload is too small, add the same amount of shim to each side.

Never add or remove a different number of shims for each side as it will change ring gear-to-drive pinion backlash.

16. Recheck ring gear-to-drive pinion backlash because increase or decrease in thickness of shims will cause change of ring gear-to-pinion backlash.

ASSEMBLY

Differential Carrier (Cont'd)

17. Check runout of ring gear with a dial indicator.

Runout limit:

0.05 mm (0.0020 in)

- If backlash varies excessively in different places, foreign matter may be caught between the ring gear and the differential case.
 - If the backlash varies greatly when the ring gear runout is within a specified range, replace the hypoid gear set or differential case.
18. Check tooth contact.
Refer to ADJUSTMENT.
19. Install rear cover and gasket.

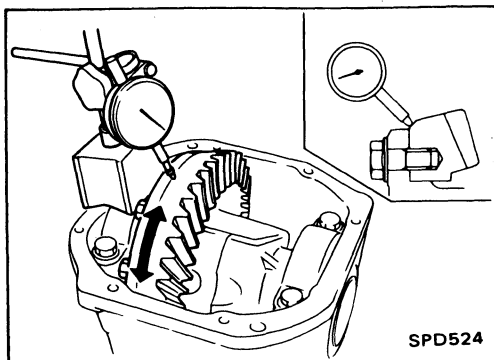

SERVICE DATA AND SPECIFICATIONS (S.D.S.)

Propeller Shaft

GENERAL SPECIFICATIONS

Vehicle model	2 seater				2+2 seater				
Engine	VG30DETT				VG30DE				
Transmission	M/T	A/T	M/T	A/T	M/T	A/T	M/T	A/T	
Propeller shaft model	3S80A-VL107				3S71A				
Number of joints	3								
Coupling method with transmission	Sleeve type								
Types of journal bearings	Shell type (non-disassembly type) x 2, CVJ* x 1				Shell type (non-disassembly type)				
Distance between yokes	mm (in)	80.0 (3.150)				71.0 (2.795)			
Shaft length (Spider to spider)	mm (in)								
1st		606 (23.86)	489 (19.25)	606 (23.86)	510 (20.08)	606 (23.86)	510 (20.08)		
2nd		388 (15.28)		419 (16.50)		539 (21.22)			
Shaft outer diameter	mm (in)								
1st		82.6 (3.252)				75 (2.95)			
2nd		75.2 (2.961)				75 (2.95)			

*: Constant velocity joint

INSPECTION AND ADJUSTMENT

Unit: mm (in)

Propeller shaft model	3S71A	3S80A-VL107
Journal axial play	0 (0)	
Propeller shaft runout limit	0.6 (0.024)	

SERVICE DATA AND SPECIFICATIONS (S.D.S.)

Final Drive

GENERAL SPECIFICATIONS

Final drive model	R200V	R230V
Ring gear pitch diameter mm (in)	205 (8.07)	230 (9.06)
Gear ratio	4.083	3.692
Number of teeth (Ring gear/Drive pinion)	49/12	48/13
Oil capacity (approx.) ℓ (US pt, Imp pt)	1.5 (3-1/8, 2-5/8)	1.8 (3-7/8, 3-1/8)

INSPECTION AND ADJUSTMENT (R200V)

Ring gear runout

Ring gear runout limit mm (in)	0.05 (0.0020)
-----------------------------------	---------------

Side gear adjustment

Side gear backlash (Clearance between side gear and differential case) mm (in)	0 - 0.15 (0 - 0.0059)
--	-----------------------

Available side gear thrust washers

Thickness mm (in)	Part number
0.80 (0.0315)	38424-40F60
0.83 (0.0327)	38424-40F61
0.86 (0.0339)	38424-40F62
0.89 (0.0350)	38424-40F63
0.92 (0.0362)	38424-40F64
0.95 (0.0374)	38424-40F65
0.98 (0.0386)	38424-40F66
1.01 (0.0398)	38424-40F67
1.04 (0.0409)	38424-40F68
1.07 (0.0421)	38424-40F69
1.10 (0.0433)	38424-40F70
1.13 (0.0445)	38424-40F71
1.16 (0.0457)	38424-40F72
1.19 (0.0469)	38424-40F73
1.22 (0.0480)	38424-40F74
1.25 (0.0492)	38424-40F75
1.28 (0.0504)	38424-40F76
1.31 (0.0516)	38424-40F77
1.34 (0.0528)	38424-40F78
1.37 (0.0539)	38424-40F79
1.40 (0.0551)	38424-40F80
1.43 (0.0563)	38424-40F81
1.46 (0.0575)	38424-40F82
1.49 (0.0587)	38424-40F83

Side bearing adjustment

Side bearing preload measured at ring gear retaining bolt N (kg, lb)	34.3 - 39.2 (3.5 - 4.0, 7.7 - 8.8)
--	---------------------------------------

Available side bearing adjusting washers

Thickness mm (in)	Part number
2.00 (0.0787)	38453-N3100
2.05 (0.0807)	38453-N3101
2.10 (0.0827)	38453-N3102
2.15 (0.0846)	38453-N3103
2.20 (0.0866)	38453-N3104
2.25 (0.0886)	38453-N3105
2.30 (0.0906)	38453-N3106
2.35 (0.0925)	38453-N3107
2.40 (0.0945)	38453-N3108
2.45 (0.0965)	38453-N3109
2.50 (0.0984)	38453-N3110
2.55 (0.1004)	38453-N3111
2.60 (0.1024)	38453-N3112
2.65 (0.1043)	38453-N3133

Drive pinion height adjustment

Available pinion height adjusting washers

Thickness mm (in)	Part number
3.09 (0.1217)	38154-P6017
3.12 (0.1228)	38154-P6018
3.15 (0.1240)	38154-P6019
3.18 (0.1252)	38154-P6020
3.21 (0.1264)	38154-P6021
3.24 (0.1276)	38154-P6022
3.27 (0.1287)	38154-P6023
3.30 (0.1299)	38154-P6024
3.33 (0.1311)	38154-P6025
3.36 (0.1323)	38154-P6026
3.39 (0.1335)	38154-P6027
3.42 (0.1346)	38154-P6028
3.45 (0.1358)	38154-P6029
3.48 (0.1370)	38154-P6030
3.51 (0.1382)	38154-P6031
3.54 (0.1394)	38154-P6032
3.57 (0.1406)	38154-P6033
3.60 (0.1417)	38154-P6034
3.63 (0.1429)	38154-P6035
3.66 (0.1441)	38154-P6036

Drive pinion preload adjustment

Drive pinion preload with front oil seal N·m (kg·cm, in·lb)	1.1 - 1.4 (11 - 14, 9.5 - 12.2)
---	---------------------------------

SERVICE DATA AND SPECIFICATIONS (S.D.S.)

Final Drive (Cont'd)

Available drive pinion bearing preload adjusting washers

Thickness mm (in)	Part number
3.80 - 3.82 (0.1496 - 0.1504)	38125-61001
3.82 - 3.84 (0.1504 - 0.1512)	38126-61001
3.84 - 3.86 (0.1512 - 0.1520)	38127-61001
3.86 - 3.88 (0.1520 - 0.1528)	38128-61001
3.88 - 3.90 (0.1528 - 0.1535)	38129-61001
3.90 - 3.92 (0.1535 - 0.1543)	38130-61001
3.92 - 3.94 (0.1543 - 0.1551)	38131-61001
3.94 - 3.96 (0.1551 - 0.1559)	38132-61001
3.96 - 3.98 (0.1559 - 0.1567)	38133-61001
3.98 - 4.00 (0.1567 - 0.1575)	38134-61001
4.00 - 4.02 (0.1575 - 0.1583)	38135-61001
4.02 - 4.04 (0.1583 - 0.1591)	38136-61001
4.04 - 4.06 (0.1591 - 0.1598)	38137-61001
4.06 - 4.08 (0.1598 - 0.1606)	38138-61001
4.08 - 4.10 (0.1606 - 0.1614)	38139-61001

Available side gear thrust washers

Thickness mm (in)	Part number
0.80 (0.0315)	38424-40F00
0.85 (0.0335)	38424-40F08
0.90 (0.0354)	38424-40F01
0.95 (0.0374)	38424-40F09
1.00 (0.0394)	38424-40F02
1.05 (0.0413)	38424-40F10
1.10 (0.0433)	38424-F4G03
1.15 (0.0453)	38424-40F11
1.20 (0.0472)	38424-40F04
1.25 (0.0492)	38424-40F12
1.30 (0.0512)	38424-40F05
1.35 (0.0531)	38424-40F13
1.40 (0.0551)	38424-40F06
1.45 (0.0571)	38424-40F14
1.50 (0.0591)	38424-40F07

Available drive pinion bearing preload adjusting spacers

Length mm (in)	Part number
45.60 (1.7953)	38165-10V05
45.90 (1.8071)	38165-10V06
46.20 (1.8189)	38165-10V07
46.50 (1.8307)	38165-10V00
46.80 (1.8425)	38165-10V01

Side bearing adjustment

Side bearing preload measured at ring gear retaining bolt N (kg, lb)	34.3 - 39.2 (3.5 - 4.0, 7.7 - 8.8)
---	---------------------------------------

Available side bearing adjusting washers

Thickness mm (in)	Part number
2.00 (0.0787)	38453-40P00
2.05 (0.0807)	38453-40P01
2.10 (0.0827)	38453-40P02
2.15 (0.0846)	38453-40P03
2.20 (0.0866)	38453-40P04
2.25 (0.0886)	38453-40P05
2.30 (0.0906)	38453-40P06
2.35 (0.0925)	38453-40P07
2.40 (0.0945)	38453-40P08
2.45 (0.0965)	38453-40P09
2.50 (0.0984)	38453-40P10
2.55 (0.1004)	38453-40P11
2.60 (0.1024)	38453-40P12

Total preload

Total preload	Value of more than 0.29 N·m (3.0 kg·cm, 2.6 in·lb) added on to measured value of drive pinion preload
Ring gear backlash mm (in)	0.10 - 0.15 (0.0039 - 0.0059)

INSPECTION AND ADJUSTMENT (R230V)

Ring gear runout

Ring gear runout limit mm (in)	0.05 (0.0020)
--------------------------------	---------------

Side gear adjustment

Side gear backlash (Clearance between side gear and differential case) mm (in)	0 - 0.15 (0 - 0.0059)
--	--------------------------

SERVICE DATA AND SPECIFICATIONS (S.D.S.)

Final Drive (Cont'd)

Drive pinion height adjustment

Available pinion height adjusting washers

Thickness mm (in)	Part number
2.59 (0.1020)	38154-40P00
2.61 (0.1028)	38154-40P01
2.63 (0.1035)	38154-40P02
2.65 (0.1043)	38154-40P03
2.67 (0.1051)	38154-40P04
2.69 (0.1059)	38154-40P05
2.71 (0.1067)	38154-40P06
2.73 (0.1075)	38154-40P07
2.75 (0.1083)	38154-40P08
2.77 (0.1091)	38154-40P09
2.79 (0.1098)	38154-40P10
2.81 (0.1106)	38154-40P11
2.83 (0.1114)	38154-40P12
2.85 (0.1122)	38154-40P13
2.87 (0.1130)	38154-40P14
2.89 (0.1138)	38154-40P15
2.91 (0.1146)	38154-40P16
2.93 (0.1154)	38154-40P17
2.95 (0.1161)	38154-40P18
2.97 (0.1169)	38154-40P19

Drive pinion preload adjustment

Drive pinion preload with front oil seal N-m (kg-cm, in-lb)	1.8 - 2.6 (18 - 27, 16 - 23)
--	---------------------------------

Total preload adjustments

Total preload	Value of more than 0.29 N-m (3.0 kg-cm, 2.6 in-lb) added on to measured value of drive pinion preload
Ring gear backlash mm (in)	0.13 - 0.18 (0.0051 - 0.0071)

FRONT AXLE & FRONT SUSPENSION

SECTION **FA**

CONTENTS

PRECAUTIONS AND PREPARATION	FA- 2
FRONT AXLE AND FRONT SUSPENSION	FA- 4
CHECK AND ADJUSTMENT — On-vehicle	FA- 5
FRONT AXLE	FA- 9
FRONT AXLE — Wheel Hub and Steering Knuckle	FA-10
FRONT SUSPENSION	FA-14
FRONT SUSPENSION — Coil Spring and Shock Absorber	FA-15
FRONT SUSPENSION — Third Link and Upper Link	FA-17
FRONT SUSPENSION — Transverse Link and Lower Ball Joint	FA-20
FRONT SUSPENSION — Tension Rod and Stabilizer Bar	FA-21
ADJUSTABLE SHOCK ABSORBER	FA-22
ADJUSTABLE SHOCK ABSORBER — Trouble Diagnoses	FA-23
SERVICE DATA AND SPECIFICATIONS (S.D.S.)	FA-29

FA

PRECAUTIONS AND PREPARATION

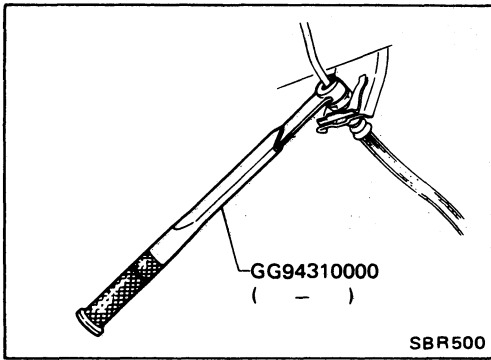

Precautions

- When installing each rubber part, final tightening must be carried out under unladen condition* with tires on ground.
- * Fuel, radiator coolant and engine oil full. Spare tire, jack, hand tools and mats in designated positions.
- When removing each suspension part, check wheel alignment and adjust if necessary.
- Use Tool when removing or installing brake lines.

Preparation

SPECIAL SERVICE TOOLS

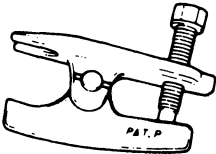
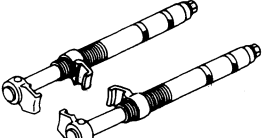
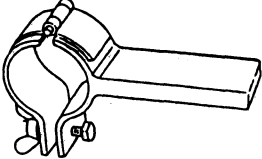
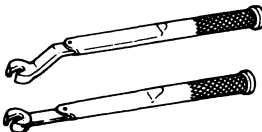
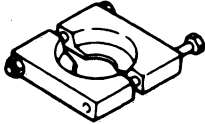
Tool number (Kent-Moore No.) Tool name	Description
HT72750000 (-) Ball joint remover	 <p>Removing tie-rod outer end and lower ball joint</p>
HT71780000 (-) Spring compressor	 <p>Removing and installing coil spring</p>
ST35652000 (-) Shock absorber attachment	 <p>Fixing shock absorber</p>
GG94310000 (-) Flare nut torque wrench	 <p>Removing and installing brake piping</p>
ST30031000 (J22912-01) Bearing inner race puller	 <p>Removing bearing inner race</p>

PRECAUTIONS AND PREPARATION

Preparation (Cont'd)

COMMERCIAL SERVICE TOOLS

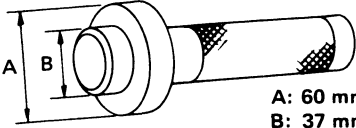
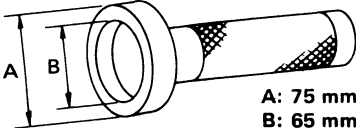
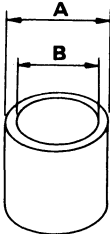
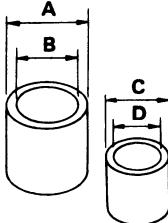
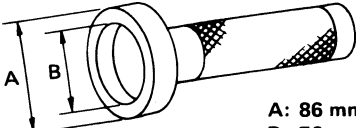
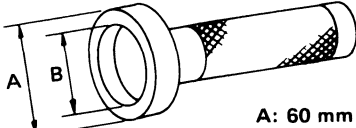
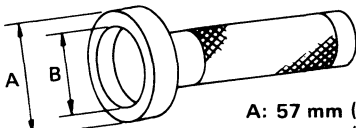
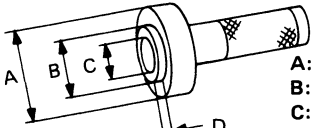
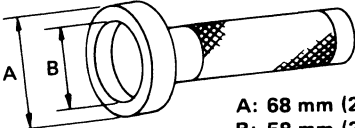
Tool name	Description
Wheel bearing drift	 <p>A: 60 mm (2.36 in) dia. B: 37 mm (1.46 in) dia.</p>
Wheel bearing drift	 <p>A: 75 mm (2.95 in) dia. B: 65 mm (2.56 in) dia.</p>
Baffle plate drift	 <p>A: 125 mm (4.92 in) dia. B: 106 mm (4.17 in) dia.</p>
Tension rod bushing drift	 <p>A: 78 mm (3.07 in) dia. B: 66 mm (2.60 in) dia. C: 62 mm (2.44 in) dia. D: 25 - 55 mm (0.98 - 2.17 in) dia.</p>
Grease seal drift	 <p>A: 86 mm (3.39 in) dia. B: 76 mm (2.99 in) dia.</p>
Cap drift	 <p>A: 60 mm (2.36 in) dia. B: 52 mm (2.05 in) dia.</p>
Bearing drift	 <p>A: 57 mm (2.24 in) dia. B: 50 mm (1.97 in) dia.</p>
Bearing drift	 <p>A: 57 mm (2.24 in) dia. B: 46 mm (1.81 in) dia. C: 40 mm (1.57 in) dia. D: 2.5 mm (0.098 in)</p>
Grease seal drift	 <p>A: 68 mm (2.68 in) dia. B: 58 mm (2.28 in) dia.</p>

FRONT AXLE AND FRONT SUSPENSION

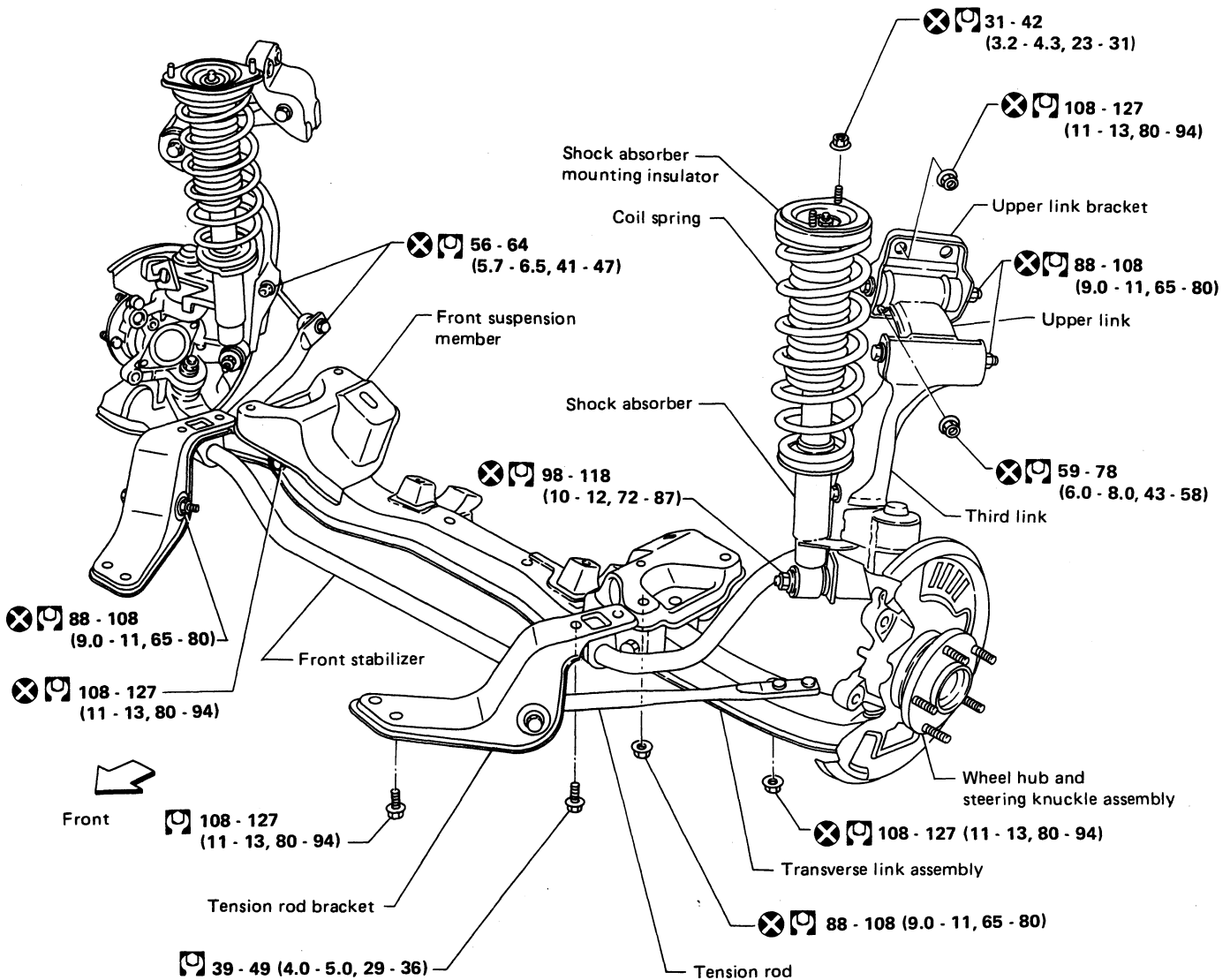

When installing stabilizer bar, tension rod and transverse link, final tightening must be done with vehicle under unladen condition*, with tires on the ground.

*; Fuel, radiator coolant and engine oil full. Spare tire, jack, hand tools and mats in designated position.

□ : N·m (kg-m, ft-lb)

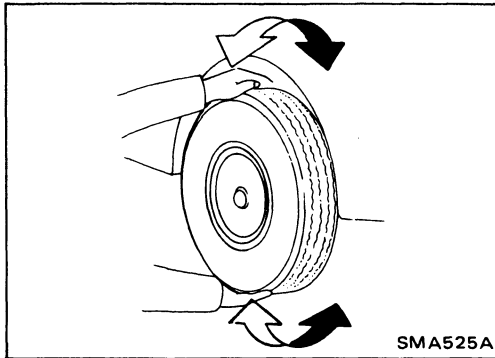

Front Axle and Front Suspension Parts

- Check front axle and front suspension parts for looseness, cracks, wear or other damage.

(1) Shake each front wheel to check for excessive play.

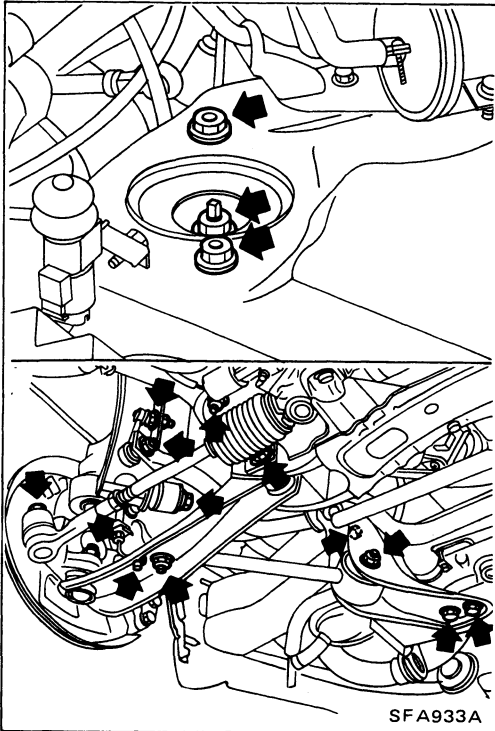

(2) Retighten all nuts and bolts to the specified torque.

Tightening torque: Refer to pages FA-4 and FA-14.

(3) Make sure that cotter pin is inserted.

(4) Check front axle and front suspension parts for wear, cracks or other damage.

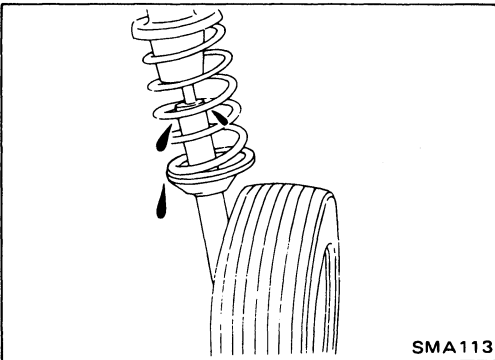

- Check shock absorber for oil leakage or other damage.

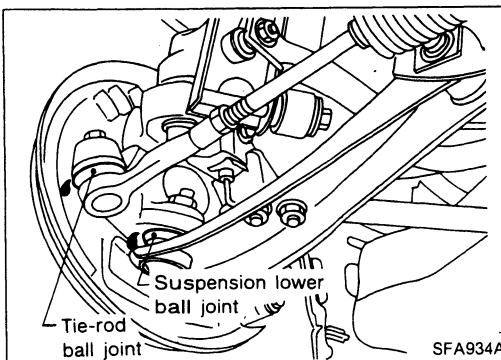

- Check suspension lower ball joint and tie-rod ball joint for grease leakage, and dust cover for cracks or other damage.

CHECK AND ADJUSTMENT — On-vehicle

Front Axle and Front Suspension Parts (Cont'd)

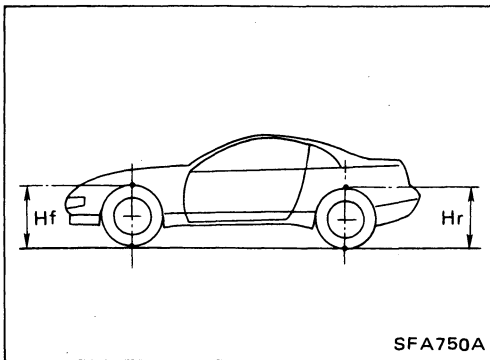

SFA750A

- Check spring height from the top of the wheelarch to the ground.
- (1) Vehicle must be unladen*, parked on a level surface, and tires checked for proper inflation and wear (tread wear indicator must not be showing).
 - * Fuel, radiator coolant and engine oil full. Spare tire, jack, hand tools and mats in designated positions.
- (2) Bounce the vehicle up and down several times before measuring.

Unit: mm (in)

	Standard	
	2 seater	2+2 seater
Front (Hf)	675 (26.57)	676 (26.61)
Rear (Hr)	676 (26.61)	675 (26.57)

- (3) Spring height is not adjustable. If out of specification, check for worn springs or suspension parts.

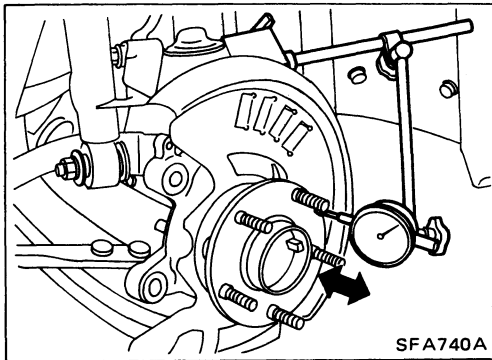

SFA740A

Front Wheel Bearing

- Check tightening torque of wheel bearing lock nut.
 - ☐: 206 - 284 N·m
(21 - 29 kg-m, 152 - 210 ft-lb)
- Check wheel bearings for smooth operation.
- Check axial end play.
 - Axial end play: 0.05 mm (0.0020 in) or less**
- If axial end play is not within specification or wheel bearing does not turn smoothly, replace wheel bearing assembly. Refer to FRONT AXLE — Wheel Hub and Knuckle.

Front Wheel Alignment

Before checking front wheel alignment, be sure to make a preliminary inspection.

PRELIMINARY INSPECTION

Make the following checks. Adjust, repair or replace if necessary.

- Check tires for wear and improper inflation.
- Check front wheel bearings for looseness.
- Check wheel runout.

Refer to S.D.S.

- Check front suspension for looseness.
- Check steering linkage for looseness.
- Check that front shock absorbers work properly.
- Check vehicle posture (Unladen).
("Unladen": Fuel, radiator coolant and engine oil full. Spare tire, jack, hand tools and mats in designated positions.)

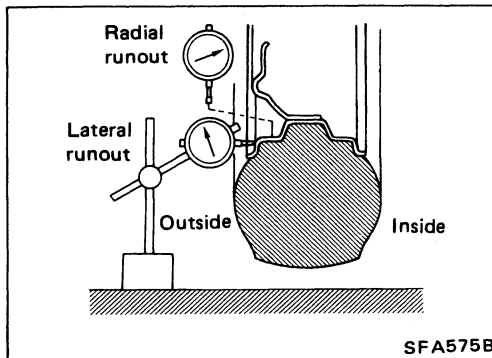

SFA575B

CHECK AND ADJUSTMENT — On-vehicle

Front Wheel Alignment (Cont'd) CAMBER, CASTER AND KINGPIN INCLINATION

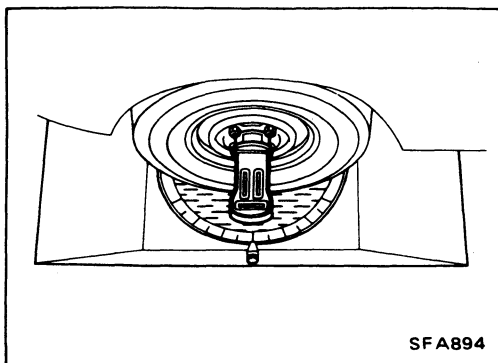

- Camber, caster and kingpin inclination are preset at factory and cannot be adjusted.
- Measure camber, caster and kingpin inclination of both right and left wheels with a suitable alignment gauge.

Camber:

$-1^{\circ}35'$ to $-0^{\circ}05'$

Caster:

$9^{\circ}00'$ - $10^{\circ}30'$

Kingpin inclination:

$12^{\circ}10'$ - $13^{\circ}40'$

- If camber, caster and kingpin inclination are not within specification, inspect and replace any damaged or worn front suspension parts.

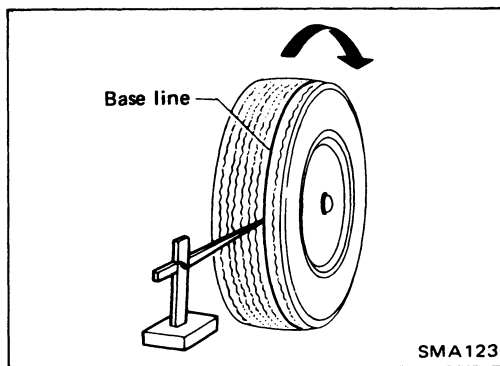

TOE-IN

1. Draw a base line on tread surface of tires.

After lowering front of vehicle, move it up and down to eliminate friction, and set wheels in straight-ahead position.

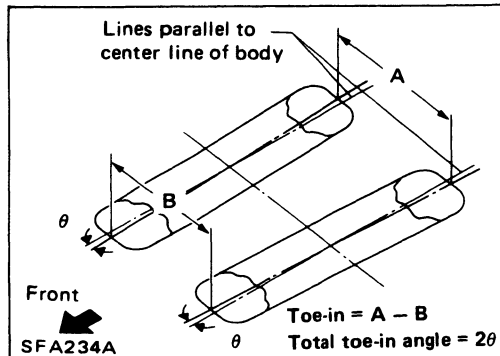

2. Measure toe-in.

Measure distance "A" and "B" at same height as hub center.

Toe-in:

$A - B$ $0 - 2$ mm ($0 - 0.08$ in)

2θ (Total toe-in angle) $0' - 11'$

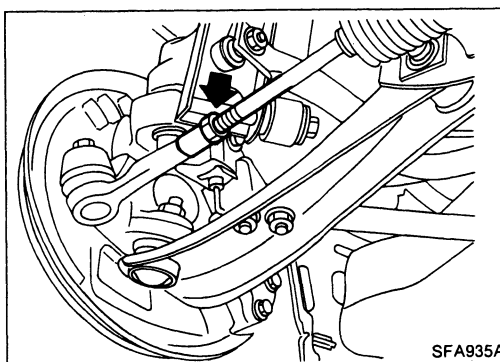

3. Adjust toe-in by varying length of steering tie-rods.

(1) Loosen lock nuts.

(2) Adjust toe-in by turning tie-rod forward or backward.

CHECK AND ADJUSTMENT — On-vehicle

Front Wheel Alignment (Cont'd)

Make sure both tie-rods are the same length.

Standard length "L":

155 mm (6.10 in)

(3) Tighten lock nuts to the specified torque.

: 78 - 98 N·m

(8.0 - 10.0 kg-m, 58 - 72 ft-lb)

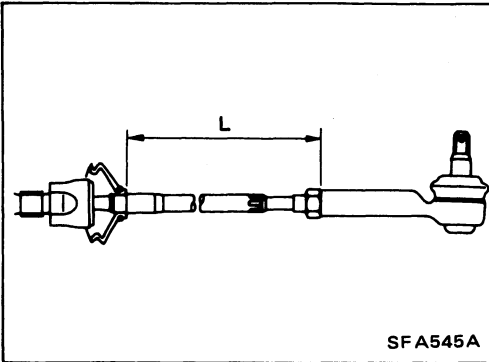

FRONT WHEEL TURNING ANGLE

1. Set wheels in straight-ahead position and then move vehicle forward until front wheels rest on turning radius gauge properly.

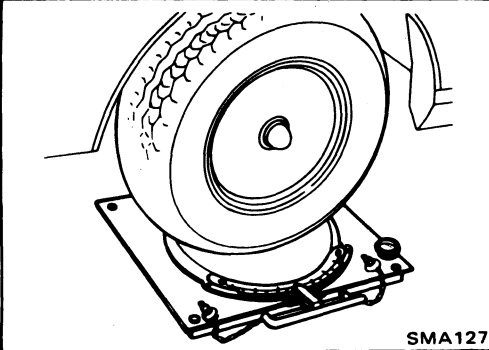

2. Rotate steering wheel fully to the right or left; measure turning angle.

Wheel turning angle:

Full turn	Inside wheel: A	32°20' - 36°20'
	Outside wheel: B	26°30' - 30°30'

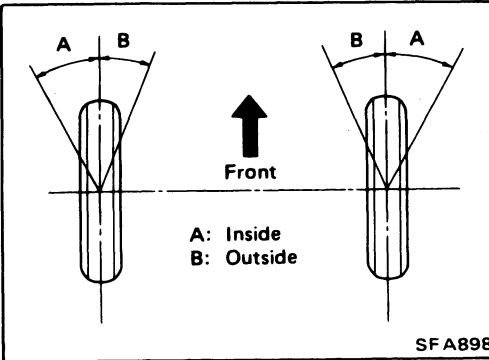

FRONT AXLE

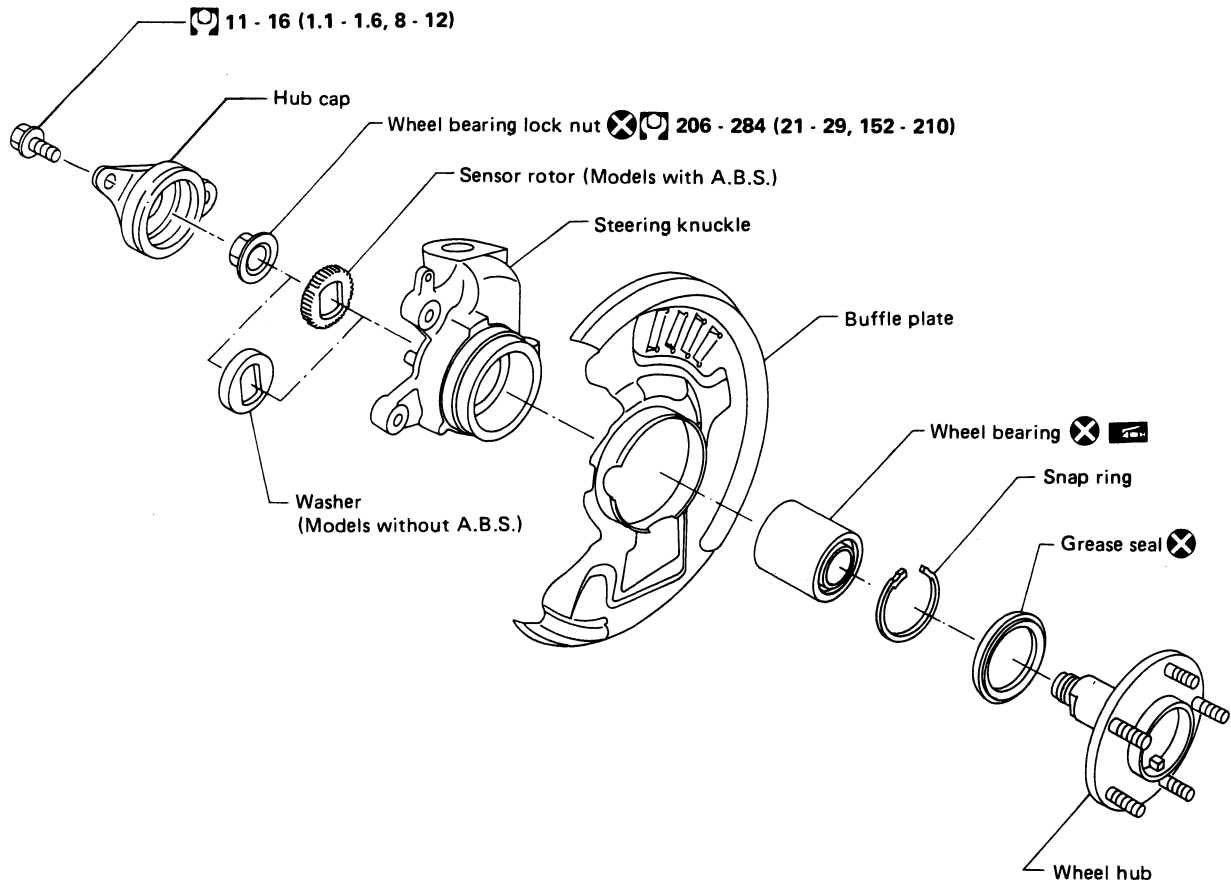

\otimes : N·m (kg·m, ft·lb)

FRONT AXLE — Wheel Hub and Steering Knuckle

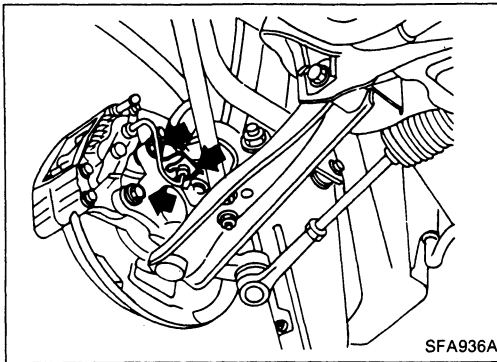

Removal

CAUTION:

Wheel bearing usually does not require maintenance. If any of the following symptoms are noted, replace wheel bearing assembly.

- Growling noise is emitted from wheel bearing during operation.
- Wheel bearing drags or turns roughly when hub is turned by hand.
- Remove brake caliper assembly and rotor.

Brake line need not be disconnected from brake caliper. Be careful not to depress brake pedal, or piston will pop out. Make sure brake line is not twisted.

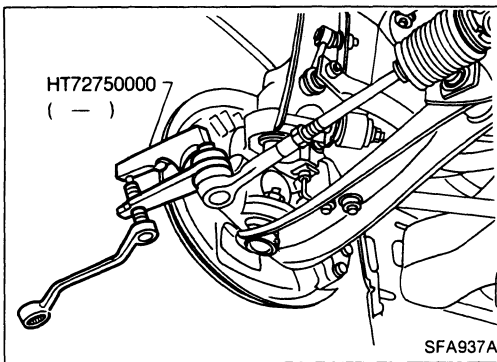

- Remove tie-rod ball joint and lower ball joint with Tool.

CAUTION:

Steering knuckle is made from aluminum alloy. Be careful not to hit steering knuckle.

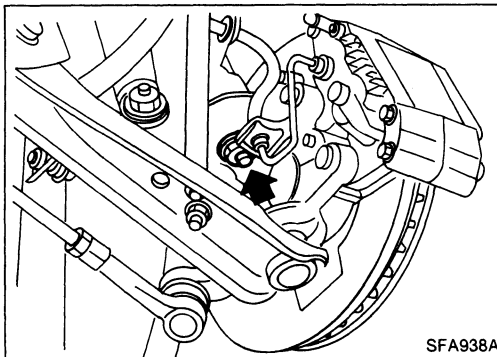

- Remove kingpin lower nut then remove steering knuckle assembly.

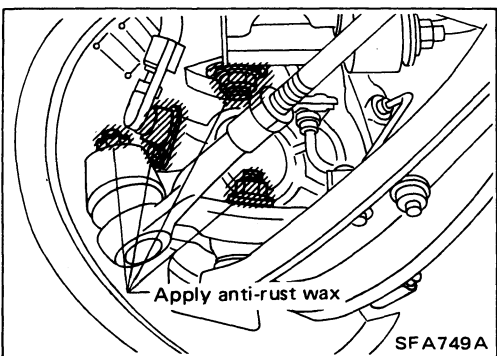

Installation

- Install steering knuckle assembly.
- Apply anti-rust wax as follows:
 - Portions around lower ball joint connections
 - Portions around tie-rod ball joint connections
 - Portions around kingpin lower nut location
 - Portions around A.B.S. sensor connection

Disassembly

CAUTION:

When removing wheel bearing from steering knuckle, replace wheel bearing assembly (outer race, inner races and grease seal) with a new one.

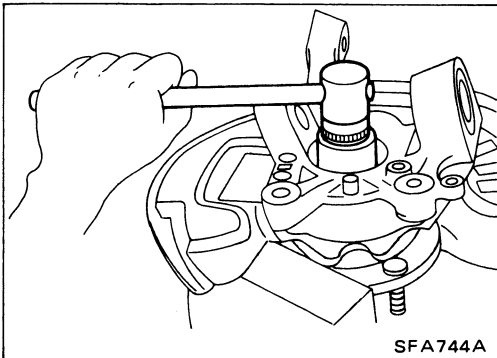

- Remove hub cap and wheel bearing lock nut.

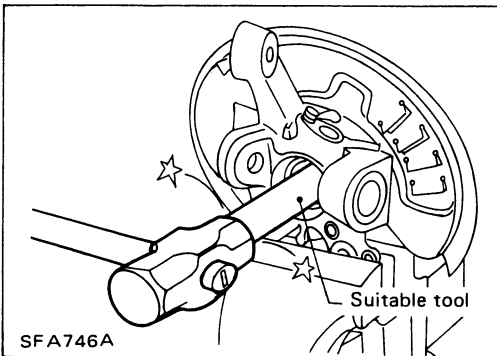

- Remove wheel hub with a suitable tool.

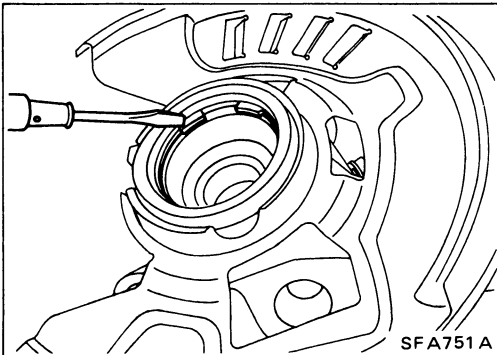

- Remove circular clip with a suitable tool.

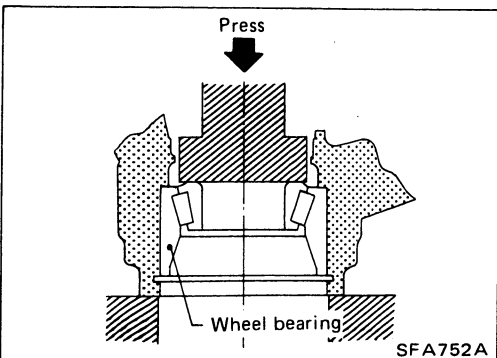

- Press out wheel bearing assembly from steering knuckle.

FRONT AXLE — Wheel Hub and Steering Knuckle

Disassembly (Cont'd)

- Drive out wheel bearing inner race (to outside) from wheel hub, then remove grease seal.

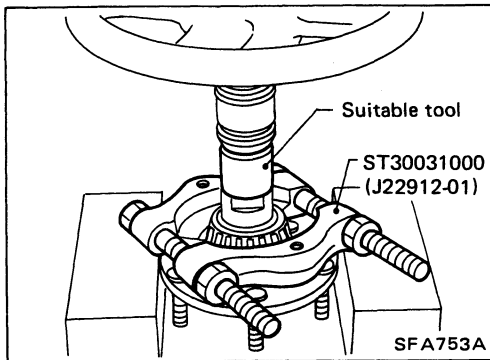

Inspection

WHEEL HUB AND STEERING KNUCKLE

- Check wheel hub and steering knuckle for any cracks.

CIRCULAR CLIP

- Check circular clip for wear or cracks.
Replace if necessary.

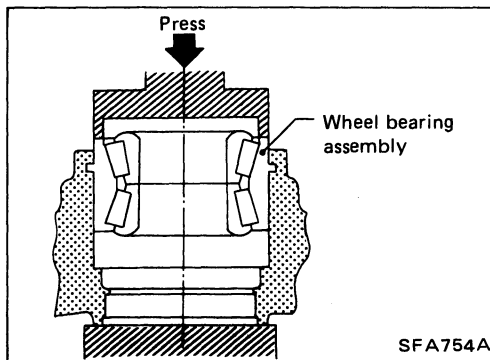

Assembly

1. Press new wheel bearing assembly into steering knuckle from outside of steering knuckle.

Maximum load P:

34.3 kN (3.5 t, 3.9 US ton, 3.44 Imp ton)

CAUTION:

- Do not press inner race of wheel bearing assembly.
- Do not apply oil or grease to mating surfaces of wheel bearing outer race and wheel hub.

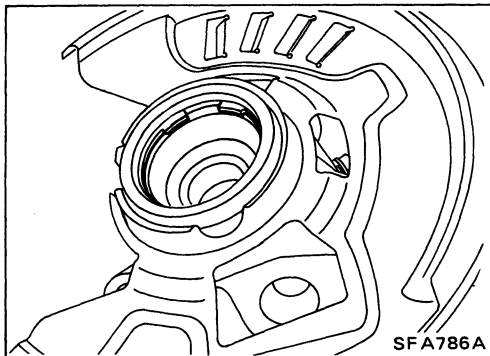

2. Install circular clip into groove of steering knuckle.

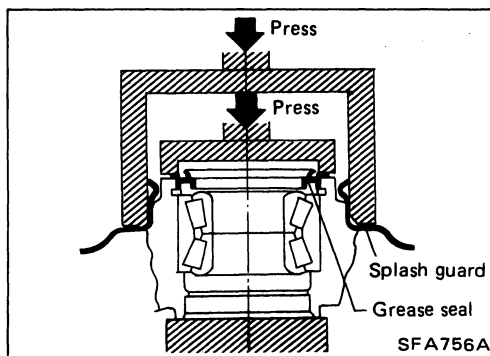

3. Apply multi-purpose grease to sealing lip.
4. Install grease seal.
Maximum load P:
10 kN (1 t, 1.1 US ton, 1.0 Imp ton)
5. Install splash guard.

FRONT AXLE — Wheel Hub and Steering Knuckle

Assembly (Cont'd)

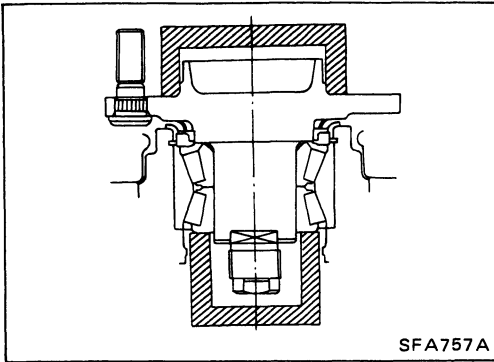

6. Press wheel hub into steering knuckle.
Maximum load P:
29 kN (3 t, 3.3 US ton, 3.0 Imp ton)
7. Tighten wheel bearing lock nut to the specified torque.
☞ : 206 - 284 N·m (21 - 29 kg-m, 152 - 210 ft-lb)

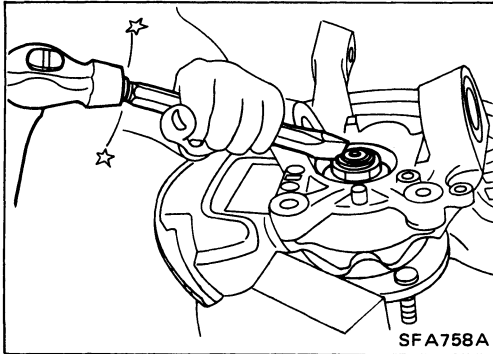

8. Stake wheel bearing lock nut.

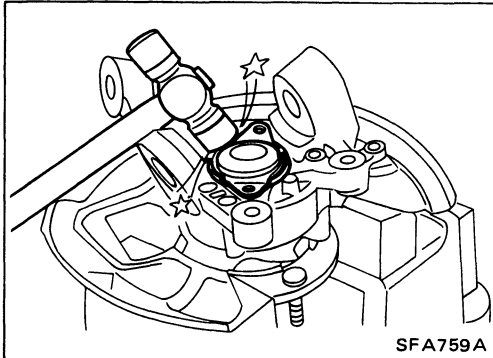

9. Install hub cap.
Drive hub cap onto steering knuckle by lightly tapping with a plastic hammer. After hub cap is in close contact with steering knuckle, tighten bolts.

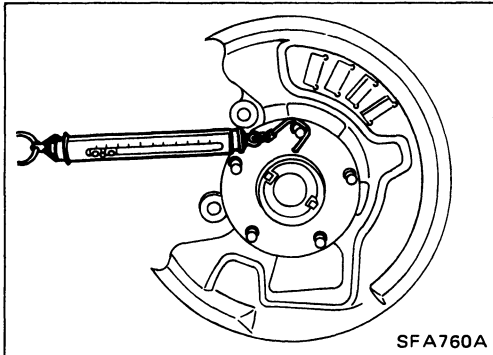

10. Check wheel bearing preload and axial end play.
Before checking, spin wheel hub at least 10 revolutions in both directions.

Turning torque:

0.34 - 2.16 N·m (3.5 - 22.0 kg-cm, 3.0 - 19.1 in-lb)

(NSK bearing)

0.44 - 3.33 N·m (4.5 - 34.0 kg-cm, 3.9 - 29.5 in-lb)

(NTN bearing)

As measured at wheel hub bolt:

5.9 - 37.3 N (0.6 - 3.8 kg, 1.3 - 8.4 lb)

(NSK bearing)

7.8 - 57.9 N (0.8 - 5.9 kg, 1.8 - 13.0 lb)

(NTN bearing)

Axial end play:

0.05 mm (0.0020 in) or less

FRONT SUSPENSION

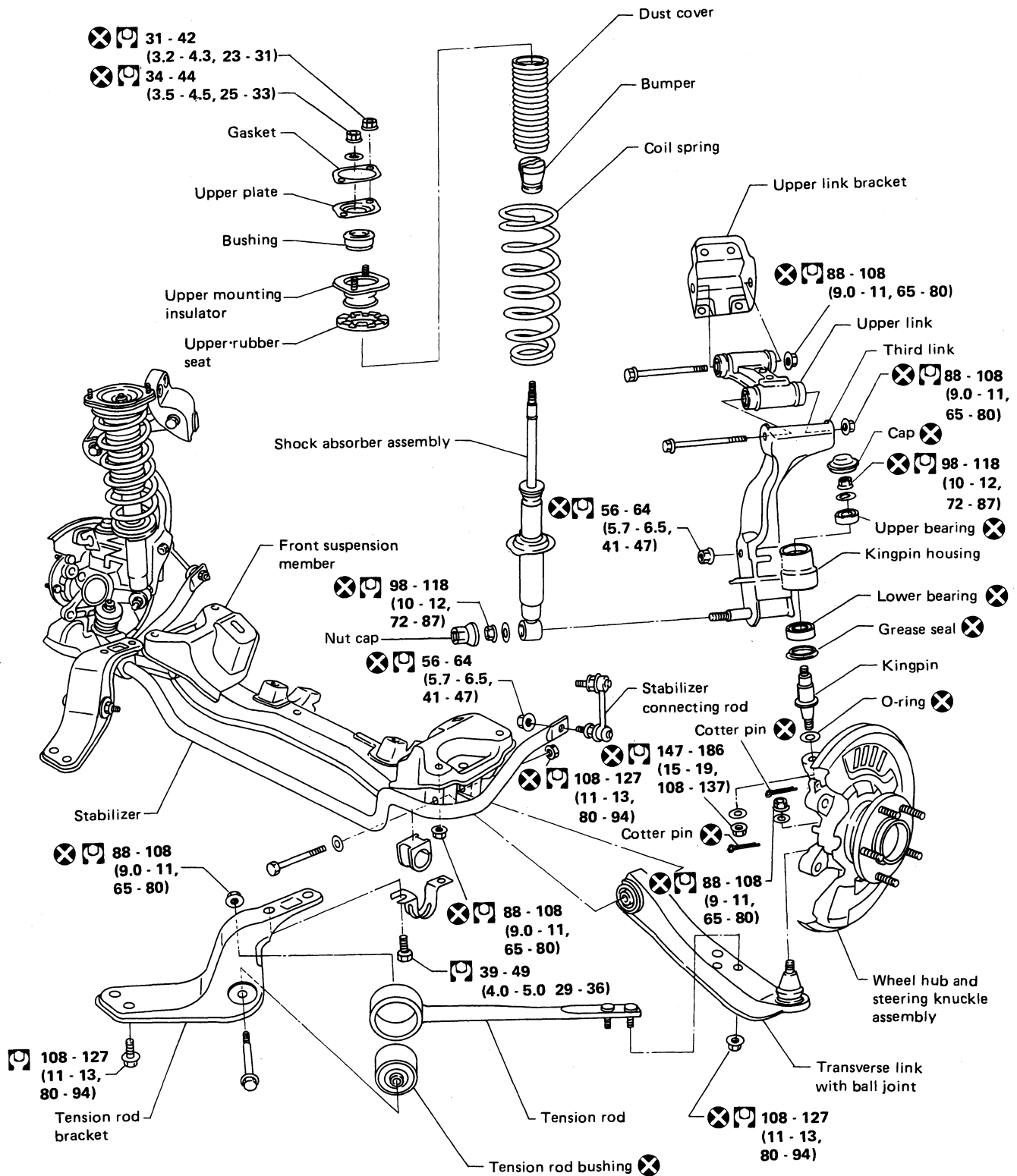

Final tightening for rubber parts must be done under unladen condition*, with tires on ground.
 * Fuel, radiator coolant and engine oil full.
 Spare tire, jack, hand tools and mats in designated positions.

: N.m (kg-m, ft-lb)

SFA761A

FRONT SUSPENSION — Coil Spring and Shock Absorber

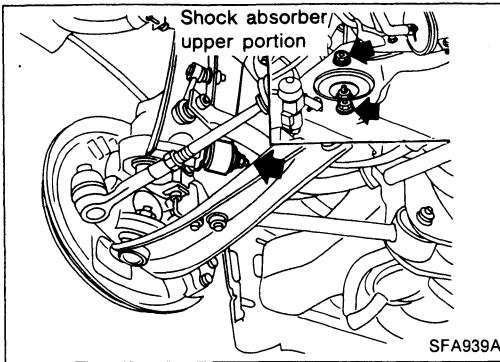

Removal

- Remove shock absorber fixing bolt and nut (to hoodledge).
- Do not remove piston rod lock nut.

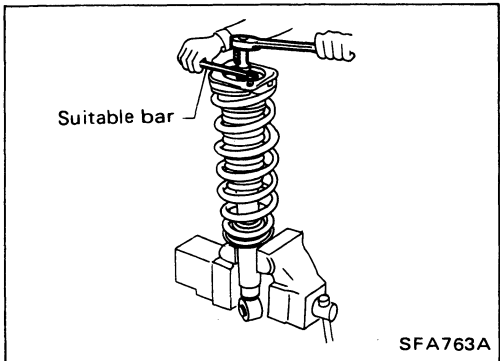

Disassembly

1. Set shock absorber on vise with Tool, then loosen piston rod lock nut.
 - Do not remove piston rod lock nut.

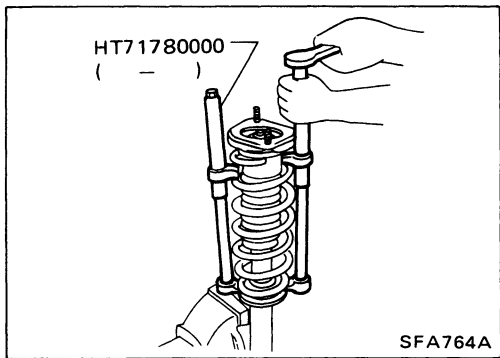

2. Compress spring with Tool so that shock absorber mounting insulator can be turned by hand.

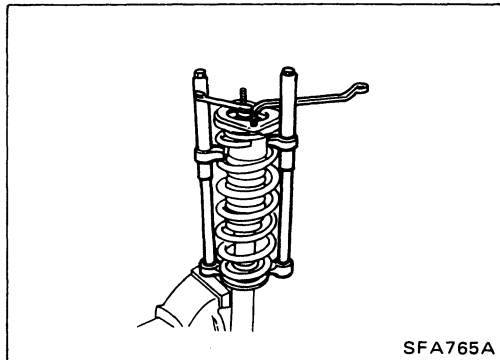

3. Remove piston rod lock nut.

Inspection

SHOCK ABSORBER ASSEMBLY

- Check for smooth operation through a full stroke, both compression and extension.
- Check for oil leakage occurring on welded or gland packing portions.
- Check piston rod for cracks, deformation or other damage. Replace if necessary.

FRONT SUSPENSION — Coil Spring and Shock Absorber

Inspection (Cont'd)

MOUNTING INSULATOR AND RUBBER PARTS

- Check cemented rubber-to-metal portion for separation or cracks. Check rubber parts for deterioration. Replace if necessary.

COIL SPRING

- Check for cracks, deformation or other damage. Replace if necessary.

Assembly

- When installing coil spring, be careful not to reverse top and bottom direction. (Top end is flat.)

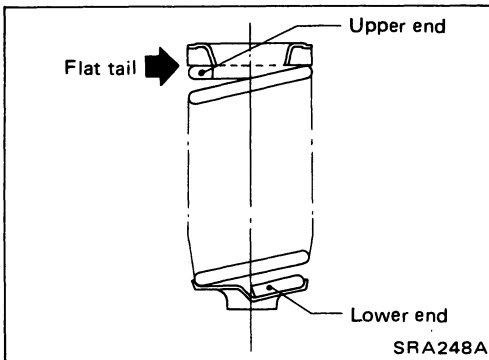
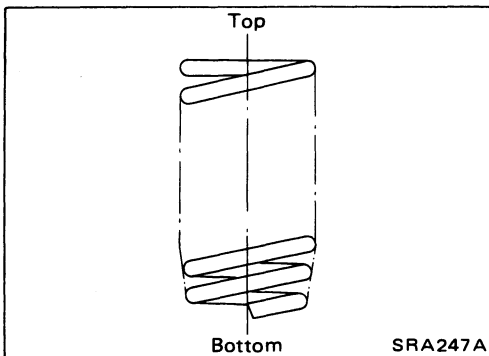

- When installing coil spring on shock absorber, it must be positioned as shown in figure at left.

Removal

CAUTION:

Kingpin bearing usually does not require maintenance. If any of the following symptoms are noted, replace kingpin bearing assembly.

- Growling noise is emitted from kingpin bearing during operation.
- Kingpin bearing drags or turns roughly when steering knuckle is turned by hand.

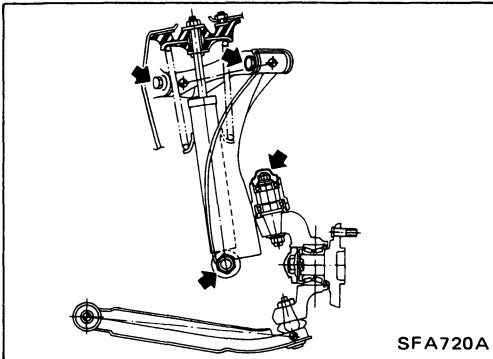

1. Remove cap and kingpin upper nut.
- **Do not remove kingpin lower nut.**
2. Remove shock absorber fixing nut and upper link fixing bolts.
3. Remove third link and upper link.

Installation

THIRD LINK

- Pack kingpin housing and cap with multi-purpose grease.

Grease capacity:

Kingpin housing	10 g (0.35 oz)
Cap	5 g (0.18 oz)

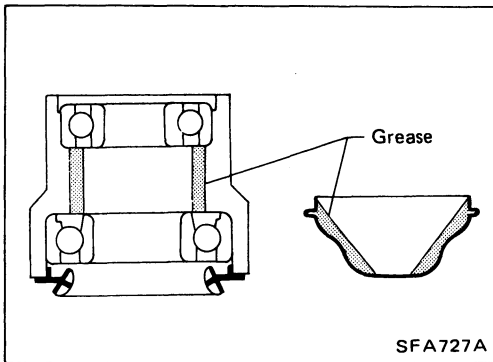

- Install third link and cap.

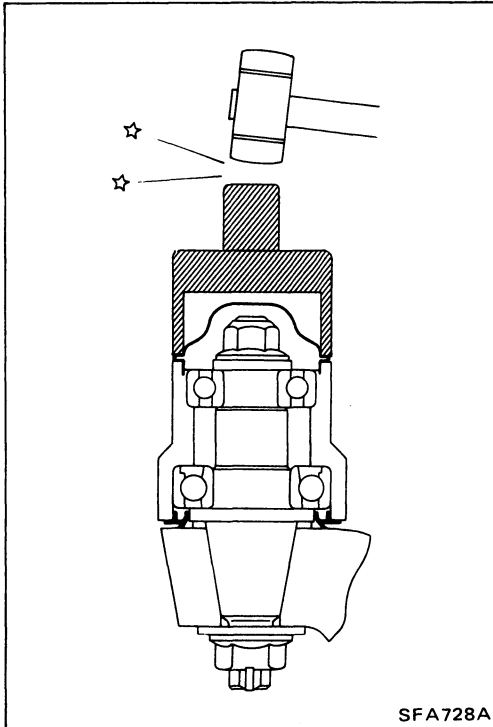

FRONT SUSPENSION — Third Link and Upper Link

Installation (Cont'd)

UPPER LINK

- Upper link has characters "A" and "L" (or "R") on it as shown. Always install upper link with "A" side facing axle and side without a character facing vehicle body.

Upper link bushings cannot be disassembled.

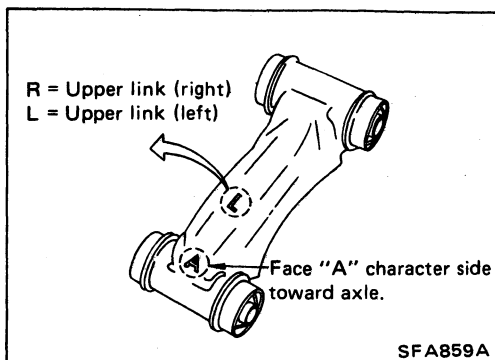

Disassembly

- Remove upper bearing (inner race and ball).

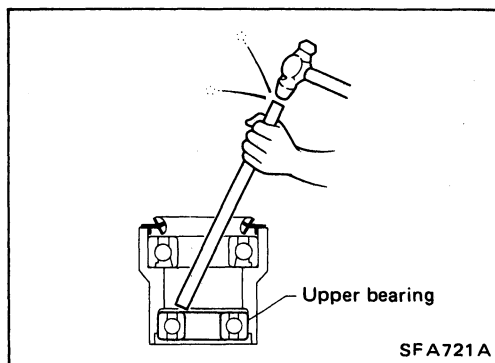

- Remove kingpin grease seal.
- Remove lower bearing (inner race and ball).

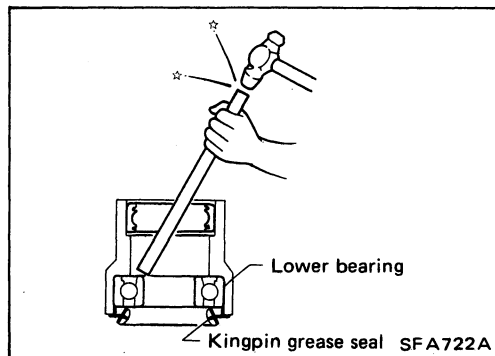

- Remove upper and lower outer race.
- **Be careful not to damage kingpin housing.**

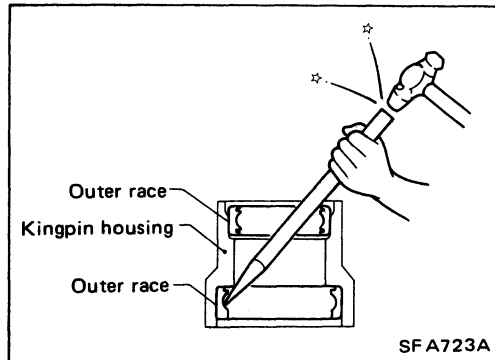

Assembly

- Install lower bearing.

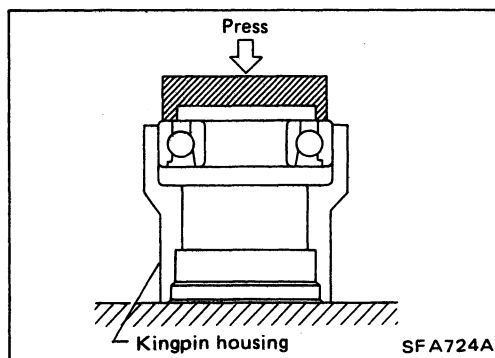

FRONT SUSPENSION — Third Link and Upper Link

Assembly (Cont'd)

- Install upper bearing.

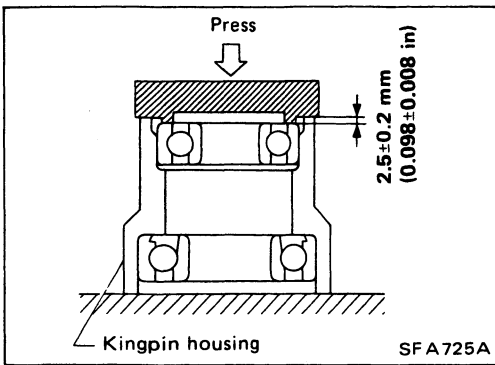

- Install lower oil seal.
- Apply multi-purpose grease to oil seal lip.

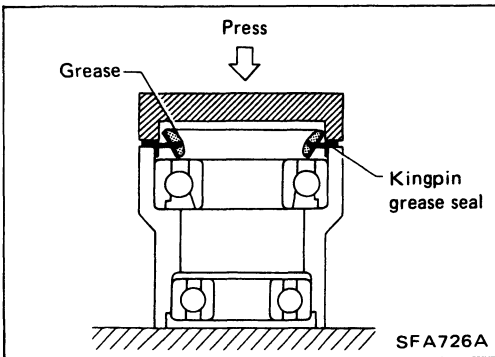

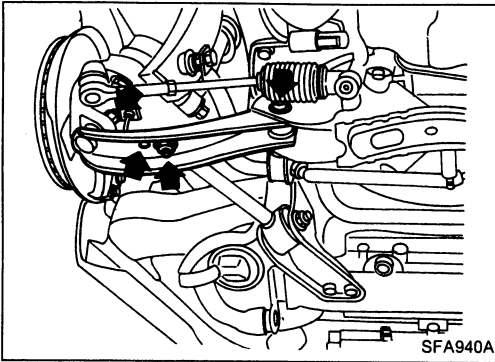

Removal and Installation

- Remove tension rod, ball joint and transverse link assembly.
- During installation, final tightening must be done at curb weight with tires on ground.
- After installation, check wheel alignment.
Refer to "Front Wheel Alignment" of CHECK AND ADJUSTMENT — On-vehicle.

Inspection

TRANSVERSE LINK

- Check transverse link for damage, cracks or deformation. Replace it if necessary.
- Check rubber bushing for damage, cracks and deformation. Replace transverse link if necessary.

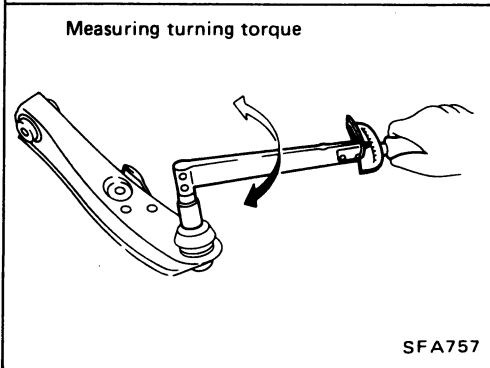
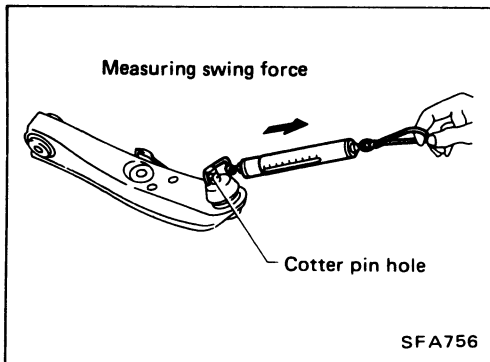

LOWER BALL JOINT

- Check ball joint for play. If ball stud is worn, play in axial direction is excessive or joint is hard to swing, replace transverse link assembly.

Swing force and turning torque

Before checking, turn ball joint at least 10 revolutions so that ball joint is properly broken in.

Swing force:

(measuring point: cotter pin hole of ball stud)

7.8 - 53.0 N (0.8 - 5.4 kg, 1.8 - 11.9 lb)

Turning torque:

0.49 - 3.43 N·m (5.0 - 35 kg-cm, 4.3 - 30.4 in-lb)

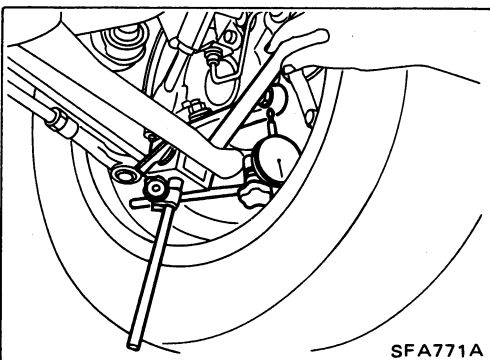

Vertical end play (On-vehicle)

- (1) Jack up front of vehicle and set the stands.
- (2) Clamp dial indicator onto transverse link and place indicator tip on lower edge of brake caliper.
- (3) Make sure front wheels are straight and brake pedal is depressed.
- (4) Place a pry bar between transverse link and inner rim of road wheel.
- (5) While pushing and releasing pry bar, observe maximum dial indicator value.

Vertical end play: 0 mm (0 in)

- (6) If not to above specification, replace transverse link.

FRONT SUSPENSION — Tension Rod and Stabilizer Bar

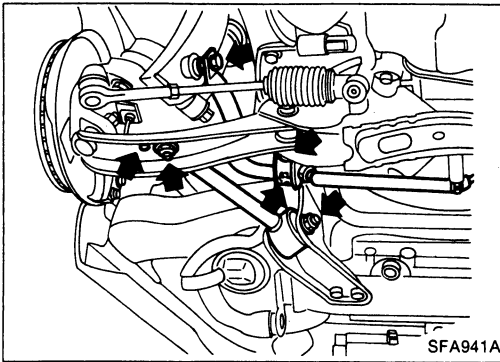

Removal and Installation

- Remove tension rod and stabilizer bar.

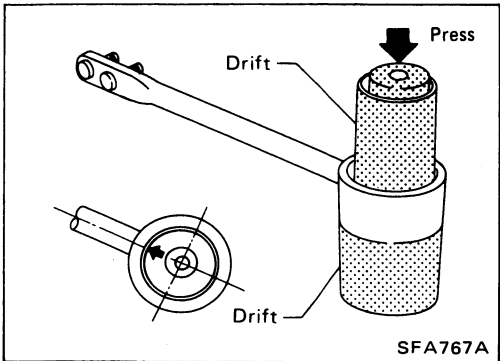

- When removing tension rod bushing, place one drift on lower side of bushing and the other on upper side, and press bushing out.
- Place arrow mark on bushing facing tension rod before installing bushing.

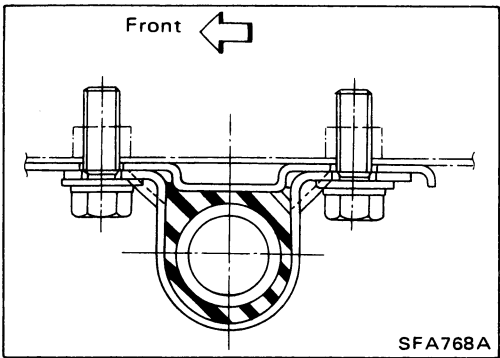

- When installing stabilizer, make sure that paint mark and clamp face in the correct direction.

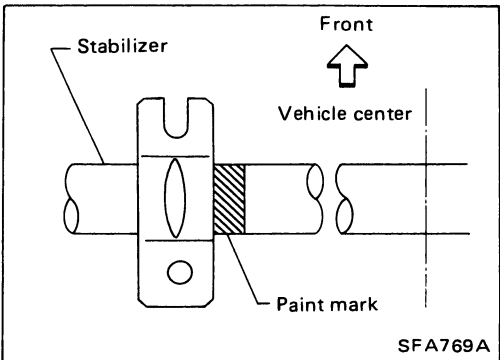

ADJUSTABLE SHOCK ABSORBER

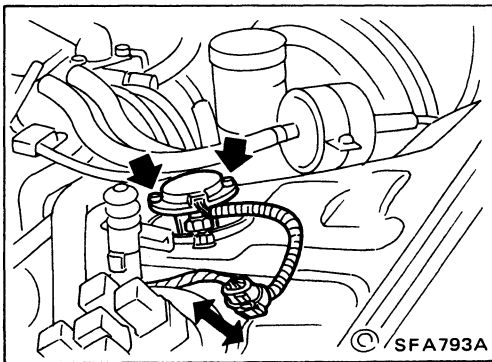
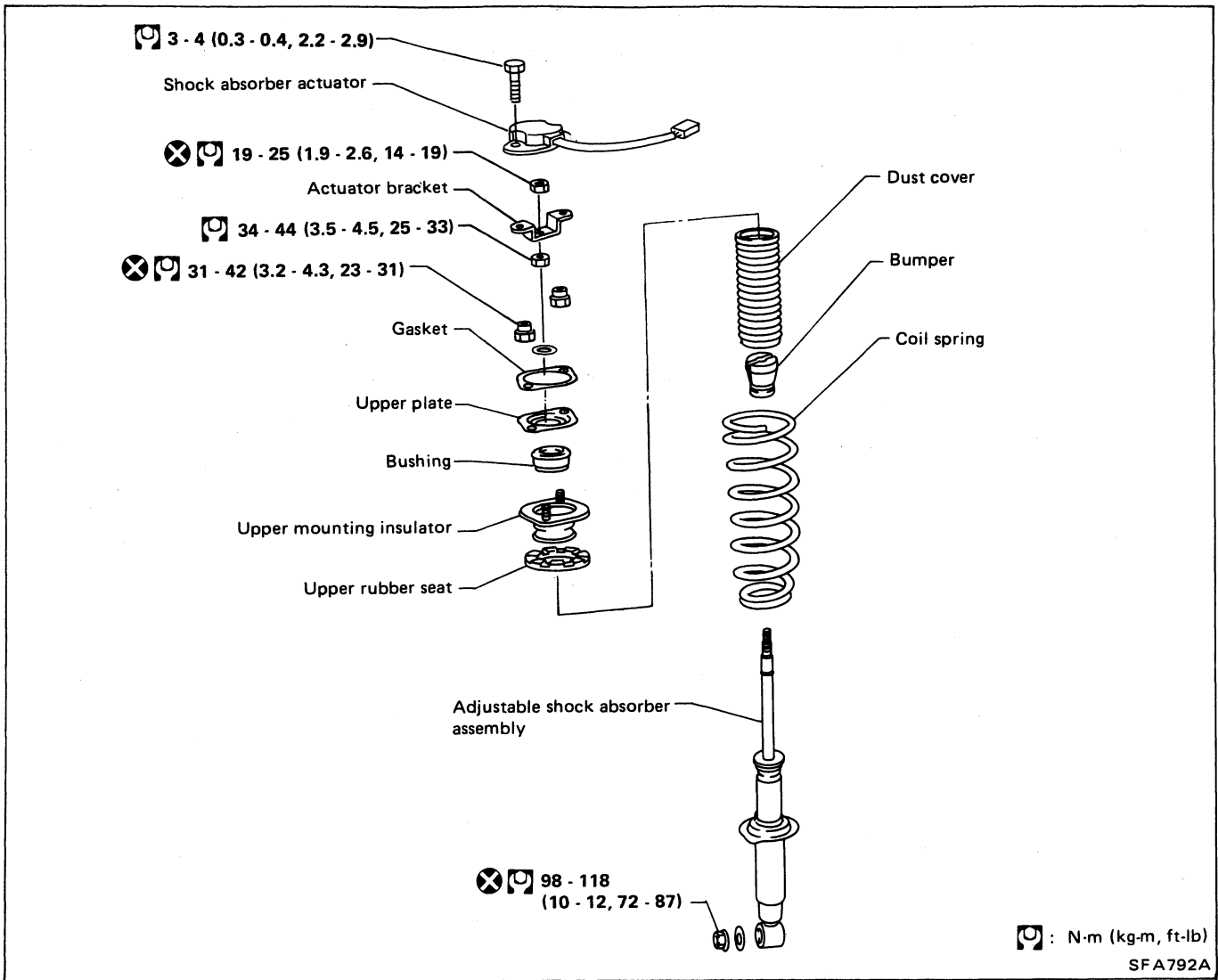

Removal and Installation

- Disconnect sub-harness connector.
- Remove shock absorber actuator fixing bolts.

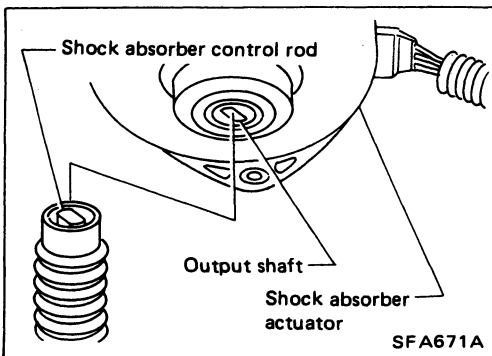

- Before installing actuator, ensure shock absorber control rod is aligned with actuator output shaft. Otherwise, actuator may be damaged.
- Refer to FRONT SUSPENSION for other procedures.

Inspection

- Replace shock absorber assembly if it is damaged. Refer to FRONT SUSPENSION — Coil Spring and Shock Absorber.

ADJUSTABLE SHOCK ABSORBER — Trouble Diagnoses

Component Parts and Harness Connector Location

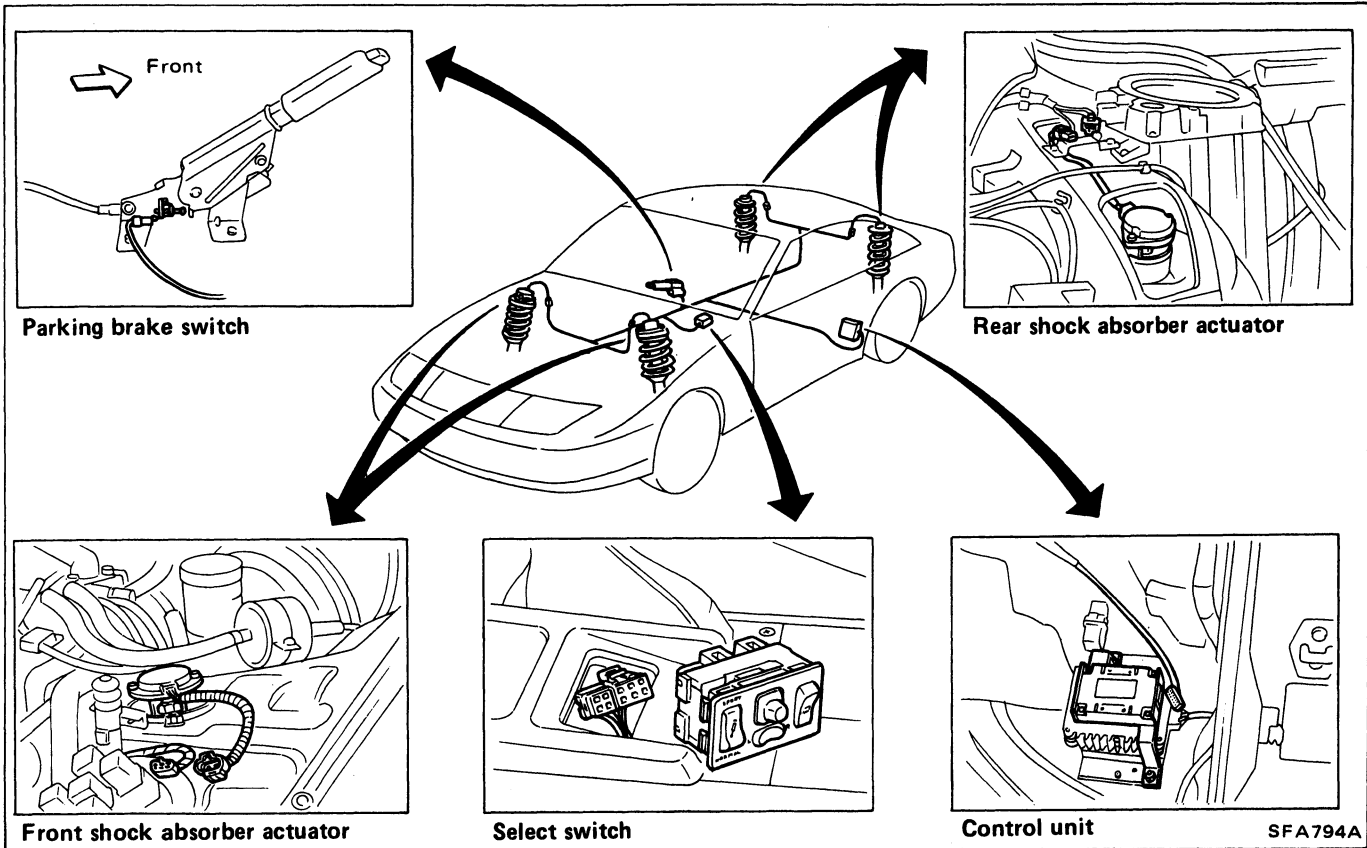

Circuit Diagram for Quick Pinpoint Check

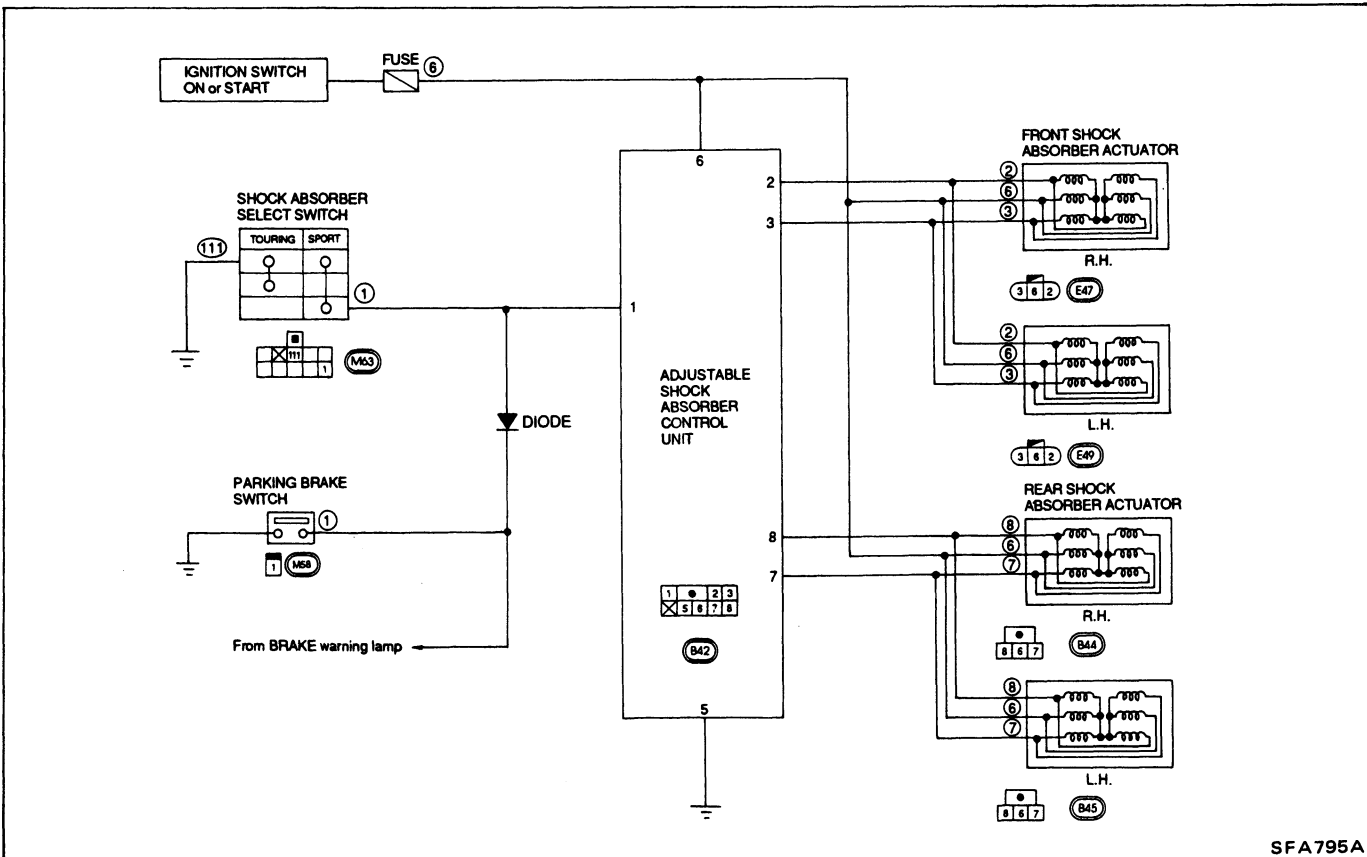

Wiring Diagram

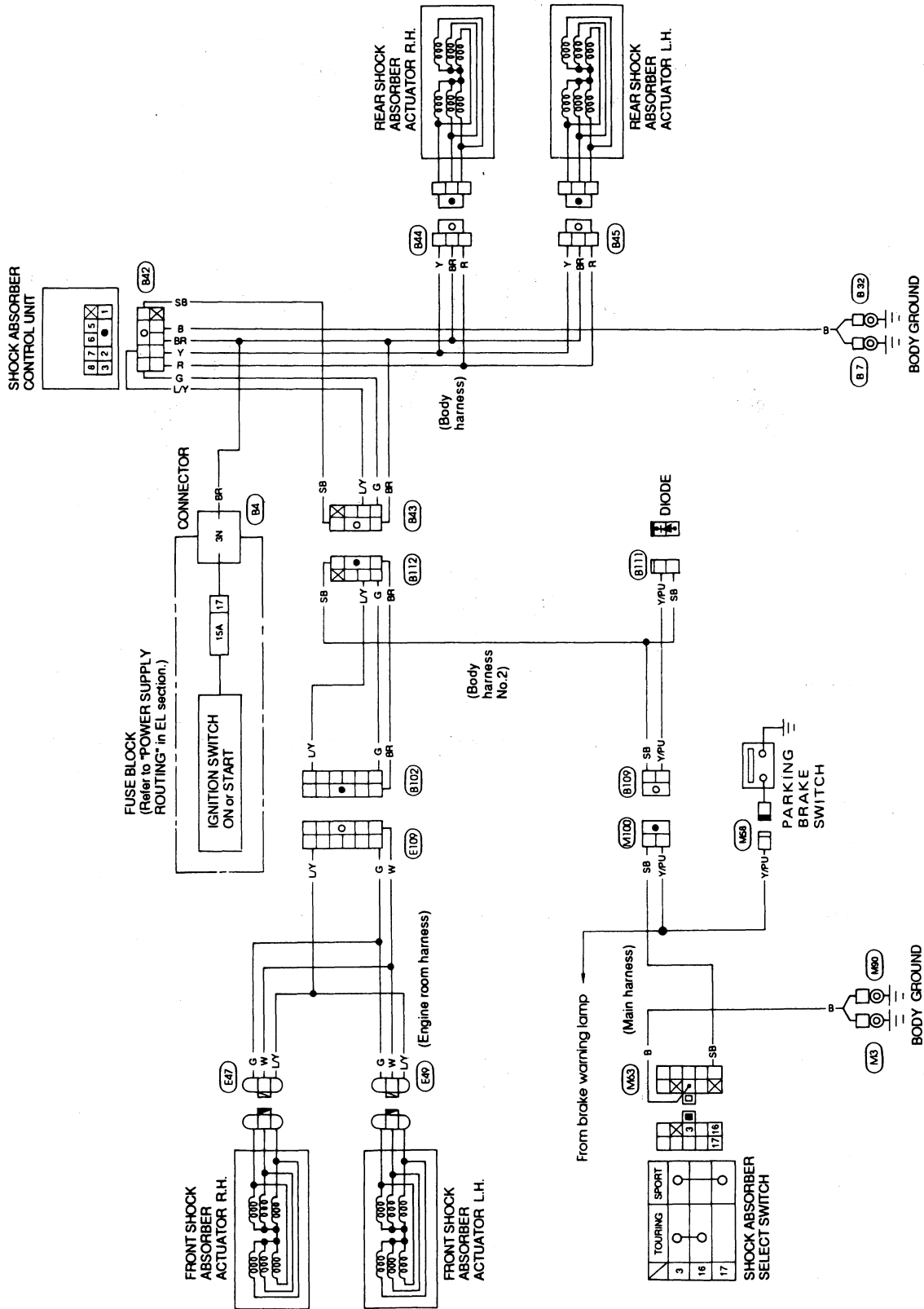

ADJUSTABLE SHOCK ABSORBER — Trouble Diagnoses

Diagnostic Procedure

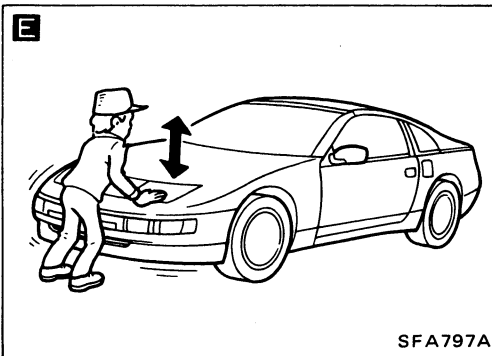
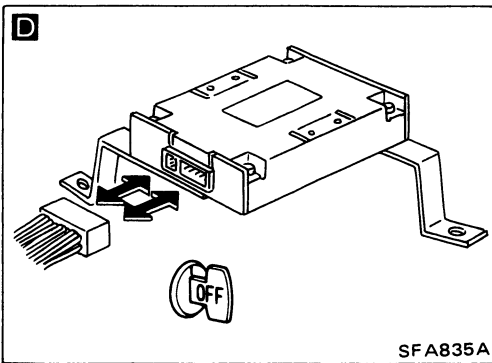
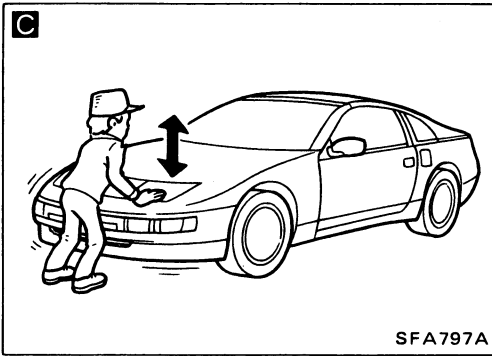
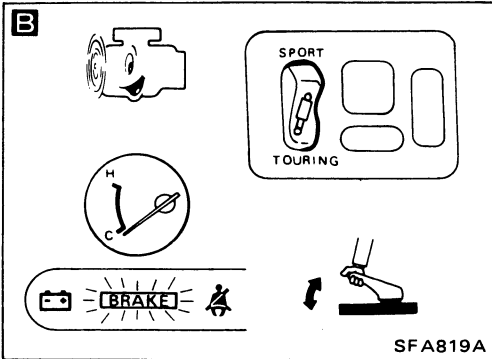
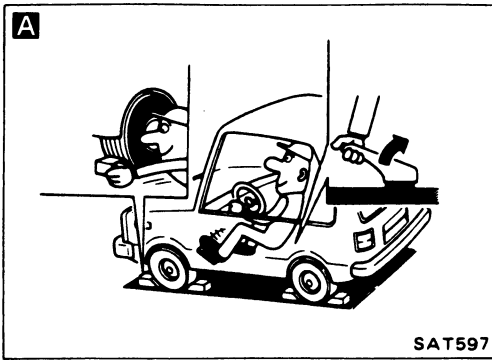

START

A
Engage parking brake and chock all four wheels.

B
CHECK PARKING BRAKE WARNING LAMP.
1) Set shift lever to "P" (A/T model) or "N" (M/T model).
2) Set select switch to "TOURING".
3) Start engine.
4) Check that parking brake warning lamp comes on when engine starts.

No
Repair or replace parking brake switch, warning lamp or harness.

Yes

C
CHECK SWITCHING OF SHOCK ABSORBER ACTUATOR.
• Release and engage parking brake.
• Push down on body above each wheel with your hand to check damping force of shock absorber.
• Release parking brake. Push down on body above each wheel to check if damping force of shock absorber changes.

Damping force of all shock absorber does not change.

D
CHECK CONNECTOR CONTINUITY.
Disconnect control unit and select switch connectors and reconnect them firmly.

A

Damping force of one or more shock absorbers changes.

E
CHECK SWITCHING OF SHOCK ABSORBER ACTUATOR.
• Release parking brake.
• Move select switch from "TOURING" to "SPORT".
• Push down on body above each wheel with your hand to see if damping force of each shock absorber changes.

B
Damping force of all shock absorbers does not change.

C
Damping force of some shock absorbers does not change.

Damping force of all shock absorbers changes.

END

ADJUSTABLE SHOCK ABSORBER — Trouble Diagnoses

Diagnostic Procedure (Cont'd)

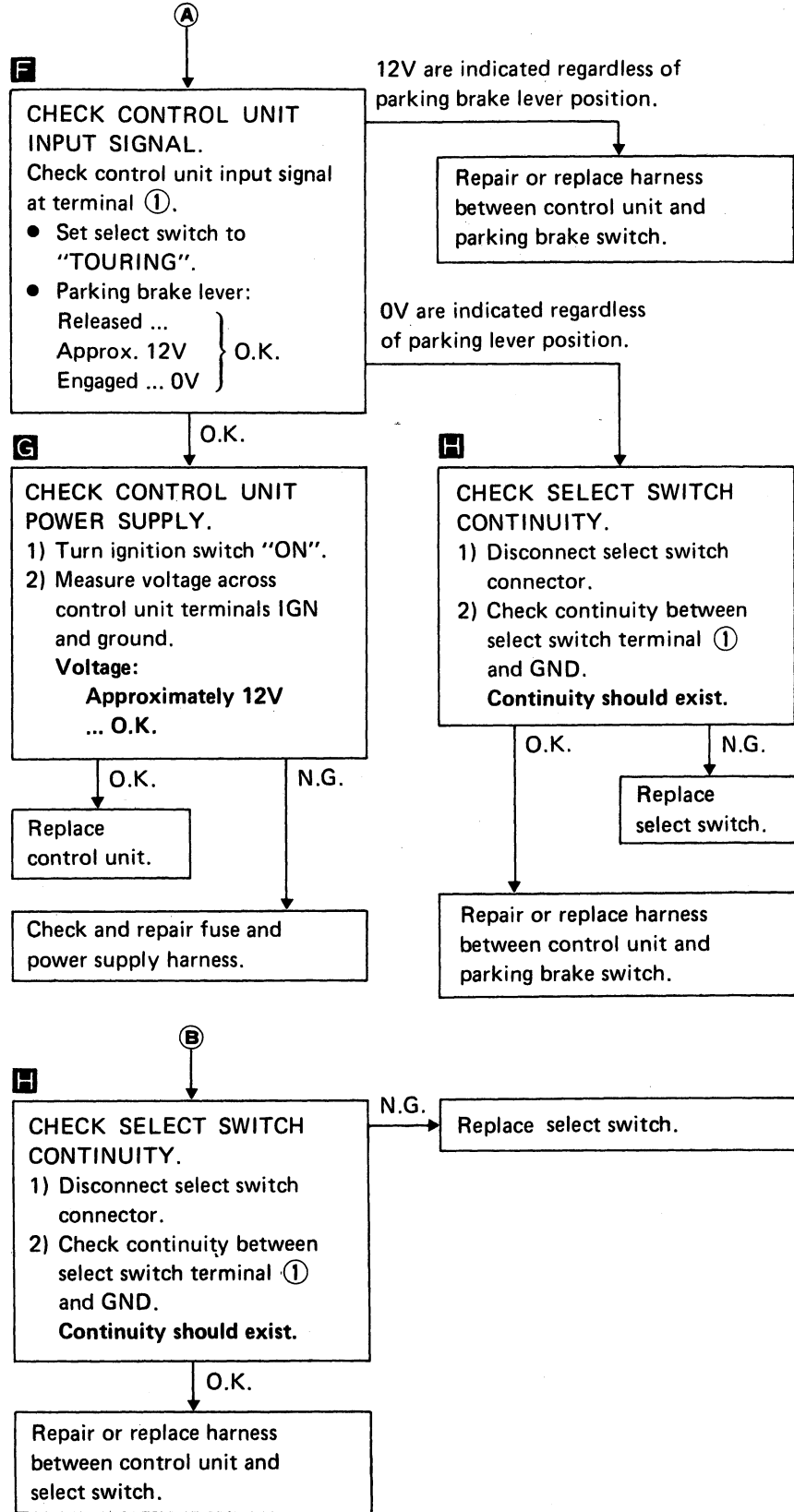
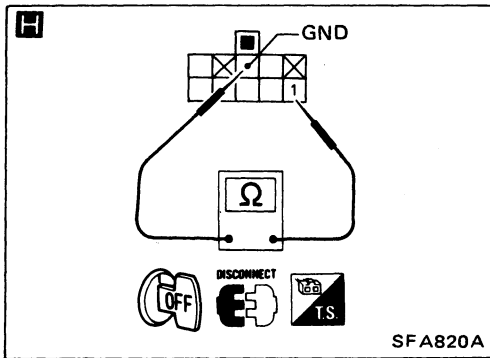
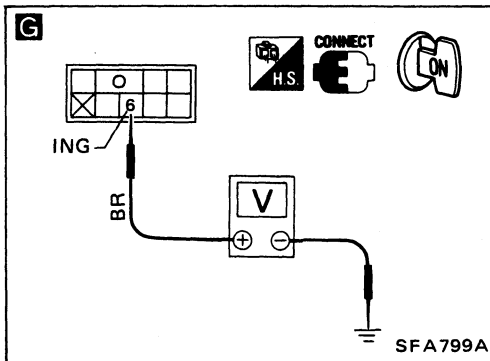
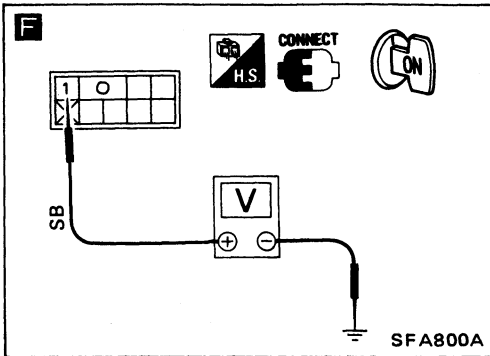

ADJUSTABLE SHOCK ABSORBER — Trouble Diagnoses

Diagnostic Procedure (Cont'd)

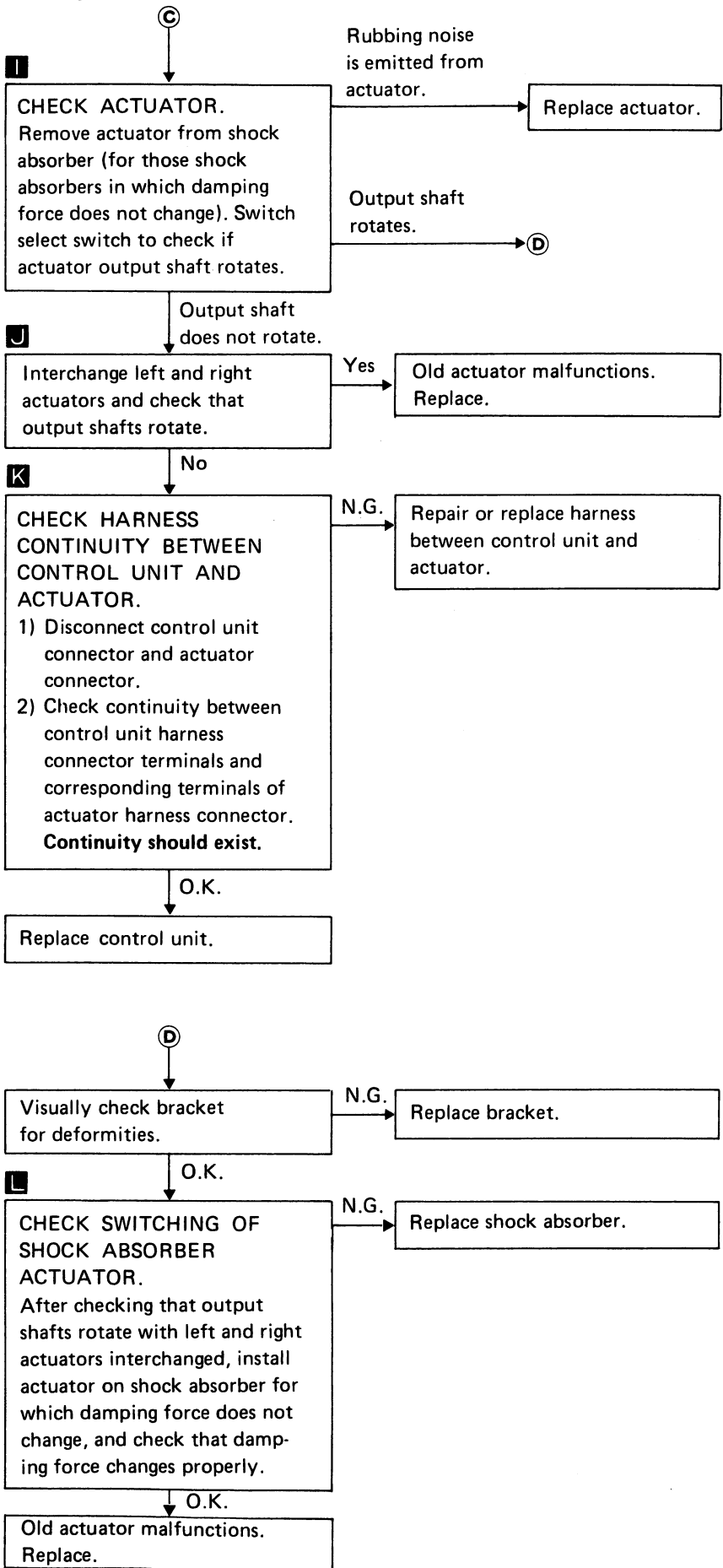
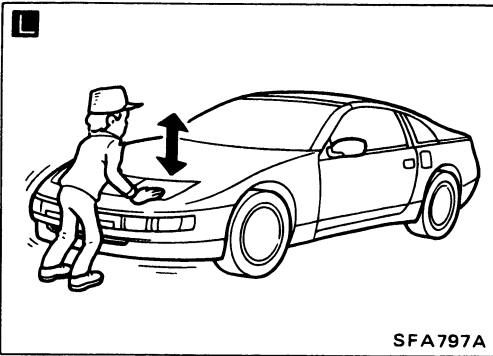
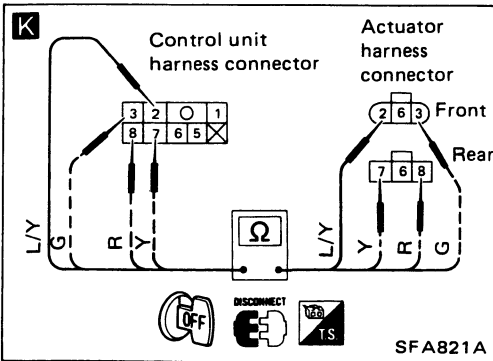
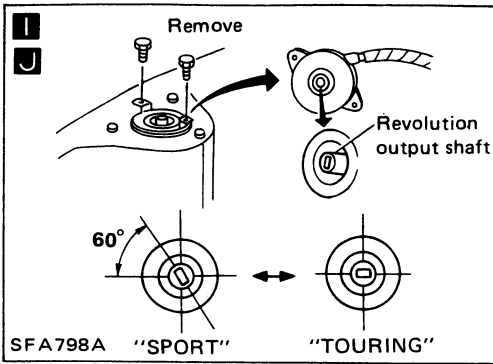

ADJUSTABLE SHOCK ABSORBER — Trouble Diagnoses

Diagnostic Procedure (Cont'd) CONTROL AND OPERATION OF SHOCK ABSORBER DAMPING FORCE

Select switch	TOURING	SPORT
Parking brake lever released	Soft	Firm
Parking brake lever engaged	Firm	Firm

CONTROL UNIT INSPECTION TABLE

Terminal No.	Connected to	Standard value
①	Select switch and parking brake switch	0V ("SPORT"); 12V ("TOURING") ^{*1}
		0V (parking brake lever released); ^{*2} 12V (parking brake lever engaged)
②	Front actuator "Firm"	When select signal is emitted, 12V ^{*1} (approx.) instantaneously drops to 2 - 3V.
③	Front actuator "Soft"	When select signal is emitted, 12V ^{*1} (approx.) instantaneously drops to 2 - 3V.
⑤	GND	0V
⑥	IGN	Approx. 12V
⑦	Rear actuator "Firm"	When select signal is emitted, 12V ^{*1} (approx.) instantaneously drops to 2 - 3V.
⑧	Rear actuator "Soft"	When select signal is emitted, 12V ^{*1} (approx.) instantaneously drops to 2 - 3V.

*1: Measure with parking brake released.

*2: Measure with select switch set to "TOURING".

SERVICE DATA AND SPECIFICATIONS (S.D.S.)

General Specifications

COIL SPRING

Item	Engine	VG30DE		VG30DETT
		2 seater	2+2 seater	
Wire diameter	mm (in)	12.1 (0.476)	11.9 (0.469)	12.1 (0.476)
Coil diameter	mm (in)	100.1 (3.94)	99.9 (3.933)	100.1 (3.94)
Free length	mm (in)	360 (14.17)	370 (14.57)	
Spring constant	N/mm (kg/mm, lb/in)	29.4 (3.0, 168)	27.5 (2.8, 157)	29.4 (3.0, 168)
Identification color		Light blue x 1, Pink x 1	Light blue x 2	Light blue x 1, Orange x 2

SHOCK ABSORBER

Item	Engine	VG30DE	VG30DETT	
			Firm	Soft
Shock absorber type		Double acting gas type		
Piston rod diameter	mm (in)	12.5 (0.492)	14.0 (0.551)	
Inner cylinder bore diameter	mm (in)	25.0 (0.984)	30.0 (1.181)	
Damping force [at 0.3 m (1.0 ft)/sec.]	N (kg, lb)			
Expansion		1,177 - 1,569 (120 - 160, 265 - 353)	1,608 - 2,118 (164 - 216, 362 - 476)	1,138 - 1,510 (116 - 154, 256 - 340)
Compression		559 - 814 (57 - 83, 126 - 183)	1,138 - 1,608 (116 - 164, 256 - 362)	686 - 981 (70 - 100, 154 - 221)

FRONT STABILIZER BAR

Stabilizer diameter	mm (in)	27.2 (1.071)
Identification color		White

TENSION ROD

Item	Engine	VG30DE	VG30DETT
		Rod diameter	mm (in)

Inspection and Adjustment

WHEEL ALIGNMENT (Unladen*1)

Camber	degree	-1°35' to -0°05'
Caster	degree	9°00' - 10°30'
Toe-in (Total)	mm (in)	0 - 2 (0 - 0.08)
	degree	0' - 11'
Kingpin inclination	degree	12°10' - 13°40'
Front wheel turning angle		
Full turn*2 inside/outside	degree	32°20' - 36°20'/26°30' - 30°30'

*1: Fuel, radiator coolant and engine oil full. Spare tire, jack, hand tools and mats in designated positions.

*2: On power steering models, wheel turning force (at circumference of steering wheel) of 98 to 147 N (10 to 15 kg, 22 to 33 lb) with engine idle.

WHEEL BEARING

Wheel bearing axial end play mm (in)	0.05 (0.0020) or less
Wheel bearing lock nut Tightening torque N·m (kg·m, ft·lb)	206 - 284 (21 - 29, 152 - 210)
Wheel bearing turning resistance N·m (kg·cm, in·lb)	0.34 - 2.16 (3.5 - 22.0, 3.0 - 19.1)
NSK bearing	
NTN bearing	0.44 - 3.33 (4.5 - 34.0, 3.9 - 29.5)
At wheel hub bolt N (kg, lb)	
NSK bearing	5.9 - 37.3 (0.6 - 3.8, 1.3 - 8.4)
NTN bearing	7.8 - 57.9 (0.8 - 5.9, 1.8 - 13.0)

LOWER BALL JOINT

Swing force (Measuring point: cotter pin hole of ball stud)	N (kg, lb)	7.8 - 53.0 (0.8 - 5.4, 1.8 - 11.9)
Turning torque	N·m (kg·cm, in·lb)	0.49 - 3.43 (5.0 - 35, 4.3 - 30.4)
Vertical end play	mm (in)	0 (0)

WHEEL RUNOUT (Radial and lateral)

Wheel type	Radial runout	Lateral runout
Aluminum wheel mm (in)	0.3 (0.012) or less	

WHEELARCH HEIGHT

Unit: mm (in)

	Standard	
	2 seater	2+2 seater
Front (Hf)	675 (26.57)	676 (26.61)
Rear (Hr)	676 (26.61)	675 (26.57)

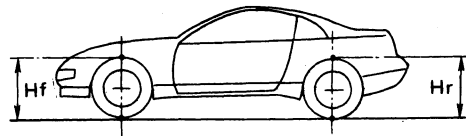

SFA750A

REAR AXLE & REAR SUSPENSION

SECTION **RA**

CONTENTS

PRECAUTIONS AND PREPARATION	RA- 2
REAR AXLE AND REAR SUSPENSION	RA- 4
CHECK AND ADJUSTMENT — On-vehicle	RA- 5
REAR AXLE AND REAR SUSPENSION ASSEMBLY	RA- 8
REAR AXLE — Wheel Hub and Axle Housing	RA- 9
REAR AXLE — Drive Shaft	RA-13
REAR SUSPENSION	RA-18
REAR SUSPENSION — Coil Spring and Shock Absorber	RA-19
REAR SUSPENSION — Multi-link and Lower Ball Joint	RA-21
REAR SUSPENSION — Stabilizer Bar	RA-22
ADJUSTABLE SHOCK ABSORBER	RA-23
SUPER HICAS	RA-25
SERVICE DATA AND SPECIFICATIONS (S.D.S.)	RA-27

RA

PRECAUTIONS AND PREPARATION

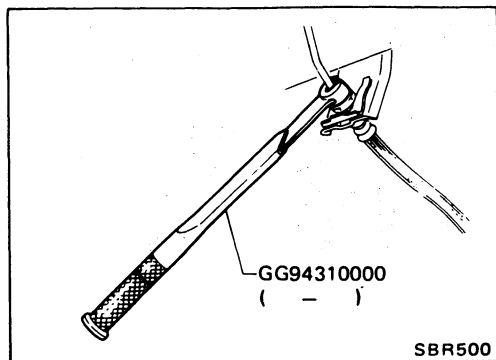

Precautions

- When installing each rubber part, final tightening must be carried out under unladen condition* with tires on ground.
- * Fuel, radiator coolant and engine oil full. Spare tire, jack, hand tools, and mats in designated positions.
- Use Tool when removing or installing brake lines.
- When removing each suspension part, check wheel alignment and adjust if necessary.
- Do not jack up at the lower arm.

Preparation

SPECIAL SERVICE TOOLS

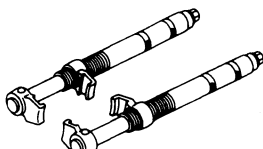
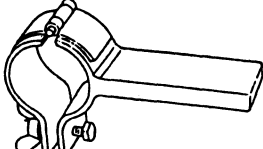
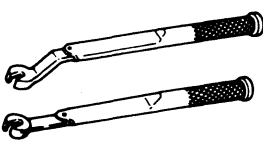
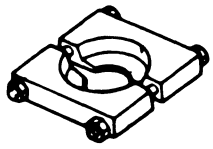
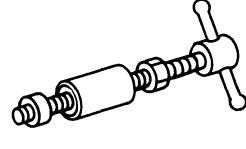
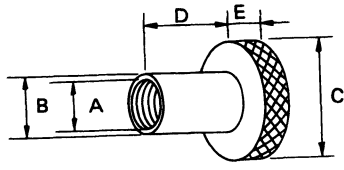
Tool number (Kent-Moore No.) Tool name	Description
HT71780000 (-) Spring compressor	 <p style="text-align: right;">Removing and installing coil spring</p>
ST35652000 (-) Shock absorber attachment	 <p style="text-align: right;">Fixing strut assembly</p>
GG94310000 (-) Flare nut torque wrench	 <p style="text-align: right;">Removing and installing brake piping</p>
ST30031000 (J22912-01) Bearing puller	 <p style="text-align: right;">Removing inner race of wheel bearing</p>
ST38280000 (-) Arm bushing remover	 <p style="text-align: right;">Removing and installing bushing of rear axle housing</p>
IM23600800 (-) Attachment Wheel alignment	 <p style="text-align: right;">Measure rear wheel alignment</p> <p style="text-align: right;"> A: Screw M24 x 1.5 B: 35 (1.38) dia. C: 65 (2.56) dia. D: 56 (2.20) E: 12 (0.47) </p> <p style="text-align: right;">Unit: mm (in)</p>

PRECAUTIONS AND PREPARATION

Preparation (Cont'd)

COMMERCIAL SERVICE TOOLS

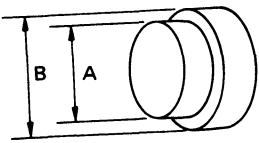
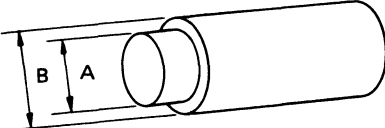
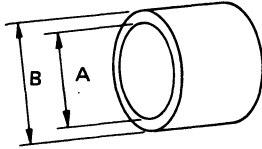
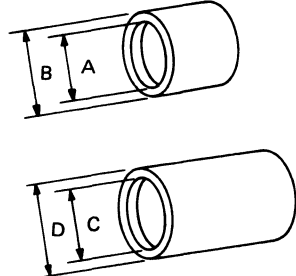
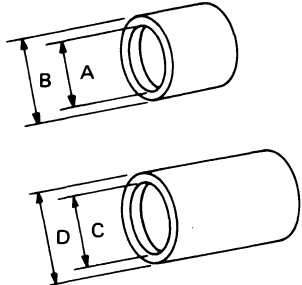
Tool name	Description
Rear wheel hub drift	<div style="display: flex; align-items: center;">  <div style="margin-left: 20px;"> <p>Installing wheel bearing</p> <p>A: 41 mm (1.61 in) dia. B: 49 mm (1.93 in) dia.</p> </div> </div>
Wheel bearing drift	<div style="display: flex; align-items: center;">  <div style="margin-left: 20px;"> <p>Removing rear wheel hub</p> <p>A: 26 mm (1.02 in) dia. B: 40 mm (1.57 in) dia.</p> </div> </div>
Rear drive shaft plug seal drift	<div style="display: flex; align-items: center;">  <div style="margin-left: 20px;"> <p>Installing rear drive shaft plug seal</p> <p>A: 67 mm (2.64 in) dia. B: 85 mm (3.35 in) dia.</p> </div> </div>
Rear axle housing ball joint drift	<div style="display: flex; align-items: center;">  <div style="margin-left: 20px;"> <p>Removing ball joint</p> <p>A: 20 (0.79) dia. B: 28 (1.10) dia. C: 40 (1.57) dia. D: 43 (1.69) dia.</p> <p style="text-align: right;">Unit: mm (in)</p> </div> </div>
Rear axle housing ball joint drift	<div style="display: flex; align-items: center;">  <div style="margin-left: 20px;"> <p>Installing ball joint</p> <p>A: 33 (1.30) dia. B: 43 (1.69) dia. C: 30 (1.18) dia. D: 40 (1.57) dia.</p> <p style="text-align: right;">Unit: mm (in)</p> </div> </div>

REAR AXLE AND REAR SUSPENSION

Final tightening for rubber parts must be done under unladen condition*, with tires on ground.

* Fuel, radiator coolant and engine oil full.

Spare tire, jack, hand tools and mats in designated positons.

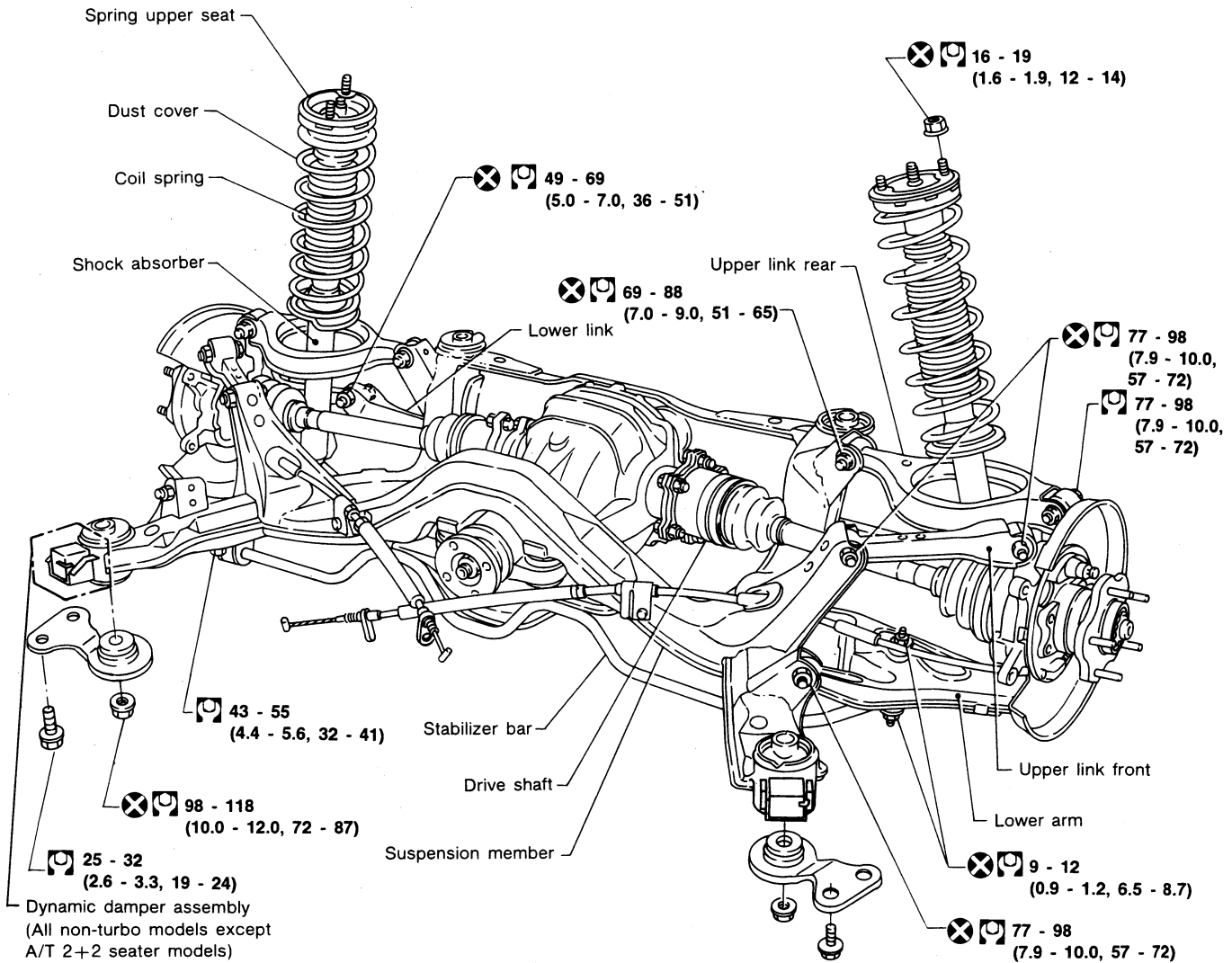

: N·m (kg·m, ft·lb)

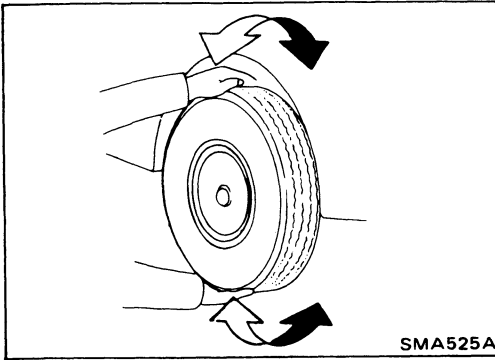

Rear Axle and Rear Suspension Parts

Check axle and suspension parts for looseness, wear or damage.

- Shake each rear wheel to check for excessive play.

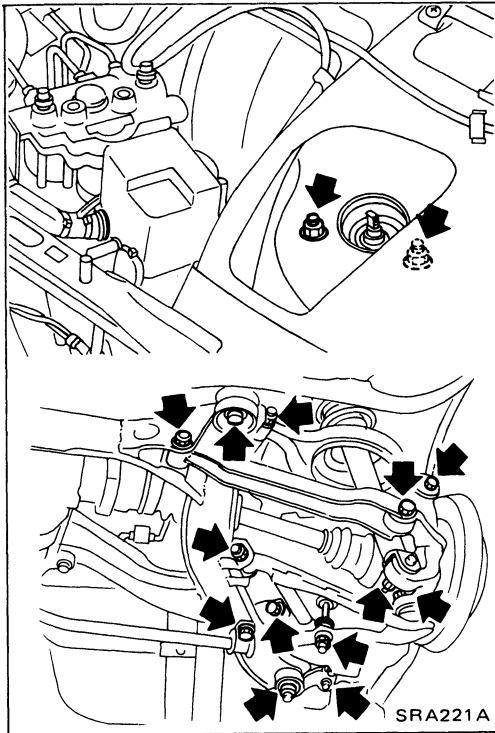

- Retighten all nuts and bolts to the specified torque.

Tightening torque:

Refer to pages RA-4 and RA-18.

- Make sure that cotter pin is inserted.
- Check rear axle and rear suspension parts for wear, cracks or other damage.

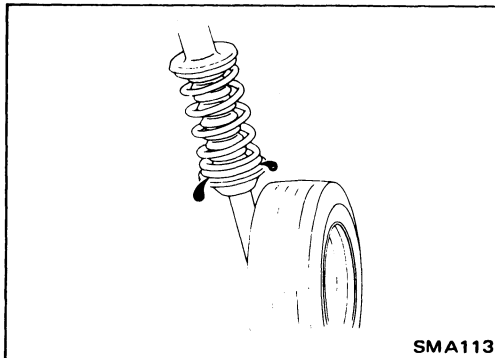

- Check shock absorber for oil leakage or other damage.
- Check wheelarch height. Refer to section FA.

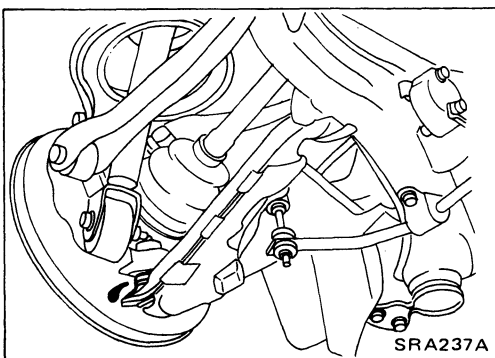

- Check suspension ball joint for grease leakage and ball joint dust cover for cracks or other damage.

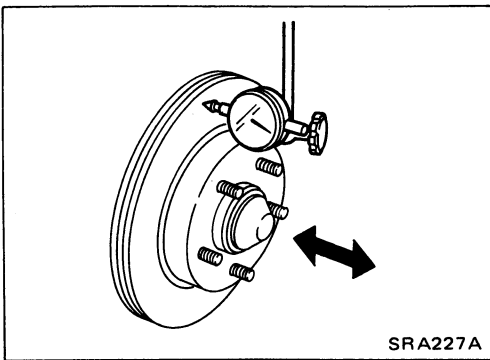

SRA227A

Rear Wheel Bearing

- Check tightening torque of wheel bearing lock nut.
 \square : 206 - 275 N·m
 (21 - 28 kg-m, 152 - 203 ft-lb)
- Check wheel bearings for smooth operation.
- Check axial end play.

Axial end play:
0.05 mm (0.0020 in) or less

If axial end play is not within specification or wheel bearing does not turn smoothly, replace wheel bearing assembly. Refer to REAR AXLE — Wheel Hub and Axle Housing.

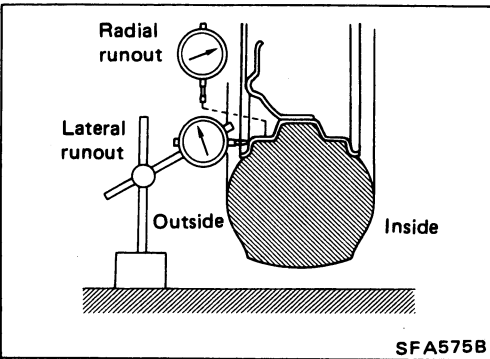

SFA575B

Rear Wheel Alignment

Before checking rear wheel alignment, be sure to make a preliminary inspection.

PRELIMINARY INSPECTION

Make the following checks. Adjust, repair or replace if necessary.

- Check tires for wear and for improper inflation.
 - Check rear wheel bearings for looseness.
 - Check wheel runout.
- Refer to S.D.S.**
- Check that rear shock absorber works properly.
 - Check rear axle and rear suspension parts for looseness.
 - Check vehicle posture (Unladen).
 ("Unladen": Fuel tank, radiator and engine oil full. Spare tire, jack, hand tools and mats in designated positions.)

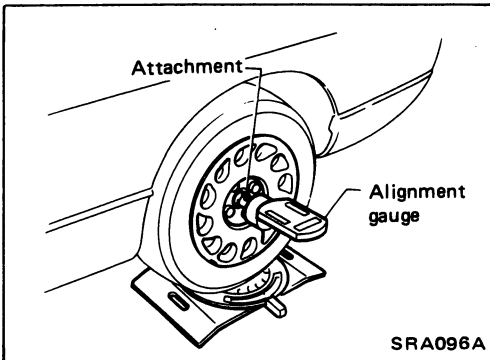

SRA096A

CAMBER

- Measure camber of both right and left wheels with a suitable alignment gauge and adjust in accordance with the following procedures.

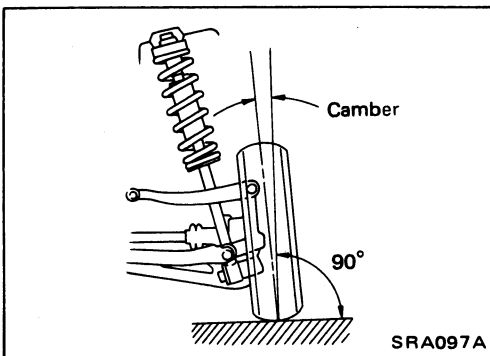

SRA097A

Camber:
-1°36' to -0°36'

CHECK AND ADJUSTMENT — On-vehicle

Rear Wheel Alignment (Cont'd)

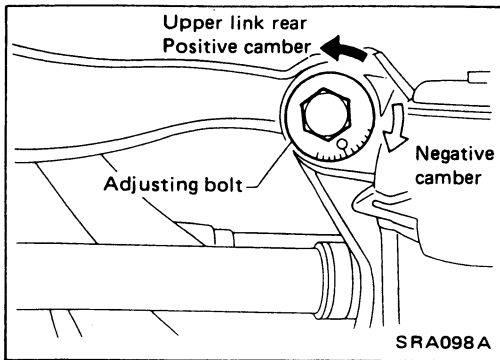

If camber is not within specification, adjust by turning the adjusting pin.

(1) Turn the adjusting pin to adjust.

Camber changes about 5' with each graduation of the adjusting pin.

(2) Tighten to the specified torque.

\square : 69 - 88 N·m

(7.0 - 9.0 kg-m, 51 - 65 ft-lb)

TOE-IN

1. Draw a base line across the tread.

After lowering rear of vehicle, move it up and down to eliminate friction.

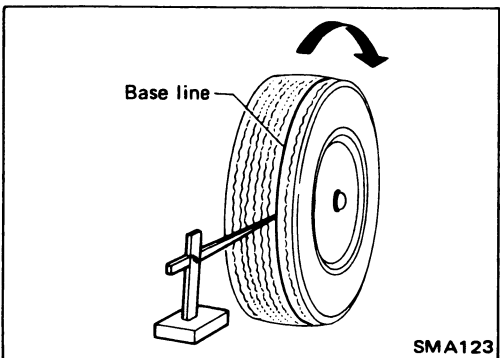

2. Measure toe-in.

Measure distance "A" and "B" at the same height as hub center.

Toe-in:

A - B

0 - 4 mm (0 - 0.16 in)

2 θ (Total toe-in angle)

0' - 23'

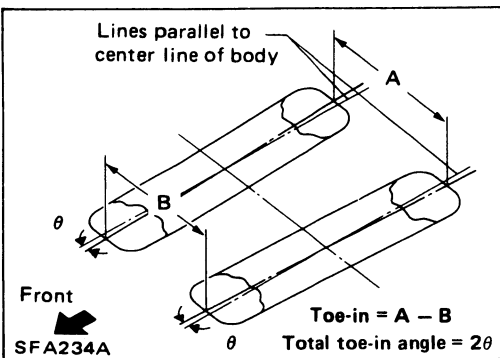

3. Adjust toe-in by turning adjusting pins.

Toe changes about 1.5 mm (0.059 in) [One side] with each graduation of the adjusting pin.

4. Tighten to the specified torque.

\square : 69 - 88 N·m

(7.0 - 9.0 kg-m, 51 - 65 ft-lb)

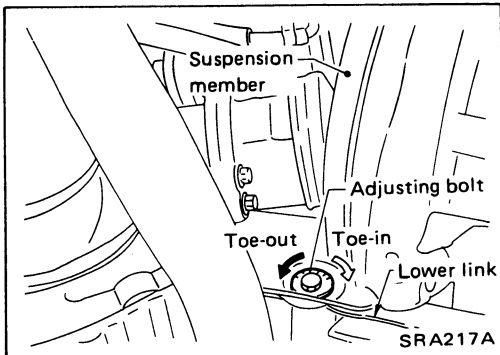

Drive Shaft

Check boot and drive shaft for cracks, wear, damage or grease leakage.

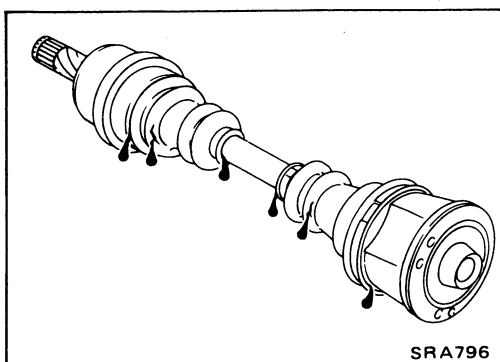

REAR AXLE AND REAR SUSPENSION ASSEMBLY

Removal and Installation

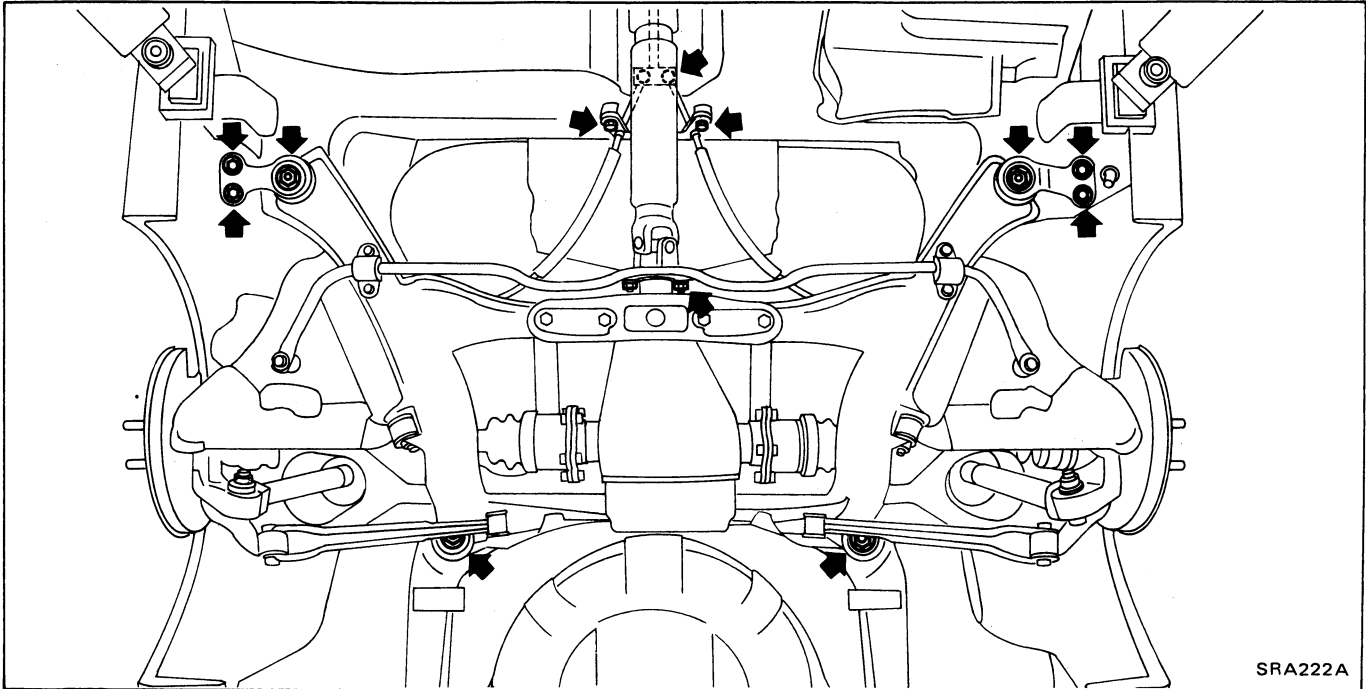

- Remove exhaust tube.
- Disconnect propeller shaft rear end.
- Disconnect hand brake wire front end.

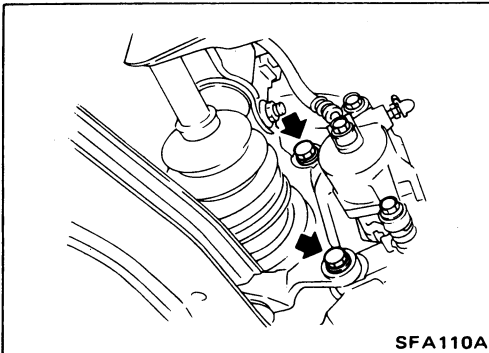

- Remove brake caliper assembly.
Brake line need not be disconnected from brake caliper.
Be careful not to depress brake pedal, or piston will pop out.
Make sure brake line is not twisted.

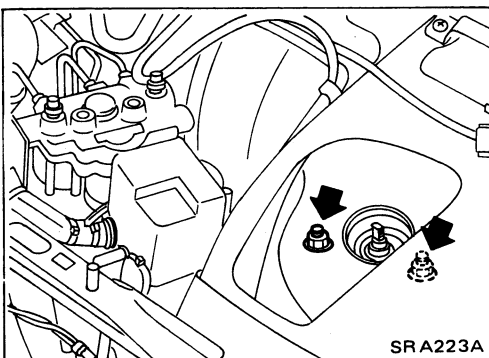

- Remove upper end nuts of shock absorber.
Do not remove piston rod lock nut.
- Remove suspension member fixing nuts. Then draw out rear axle and rear suspension assembly.

REAR AXLE — Wheel Hub and Axle Housing

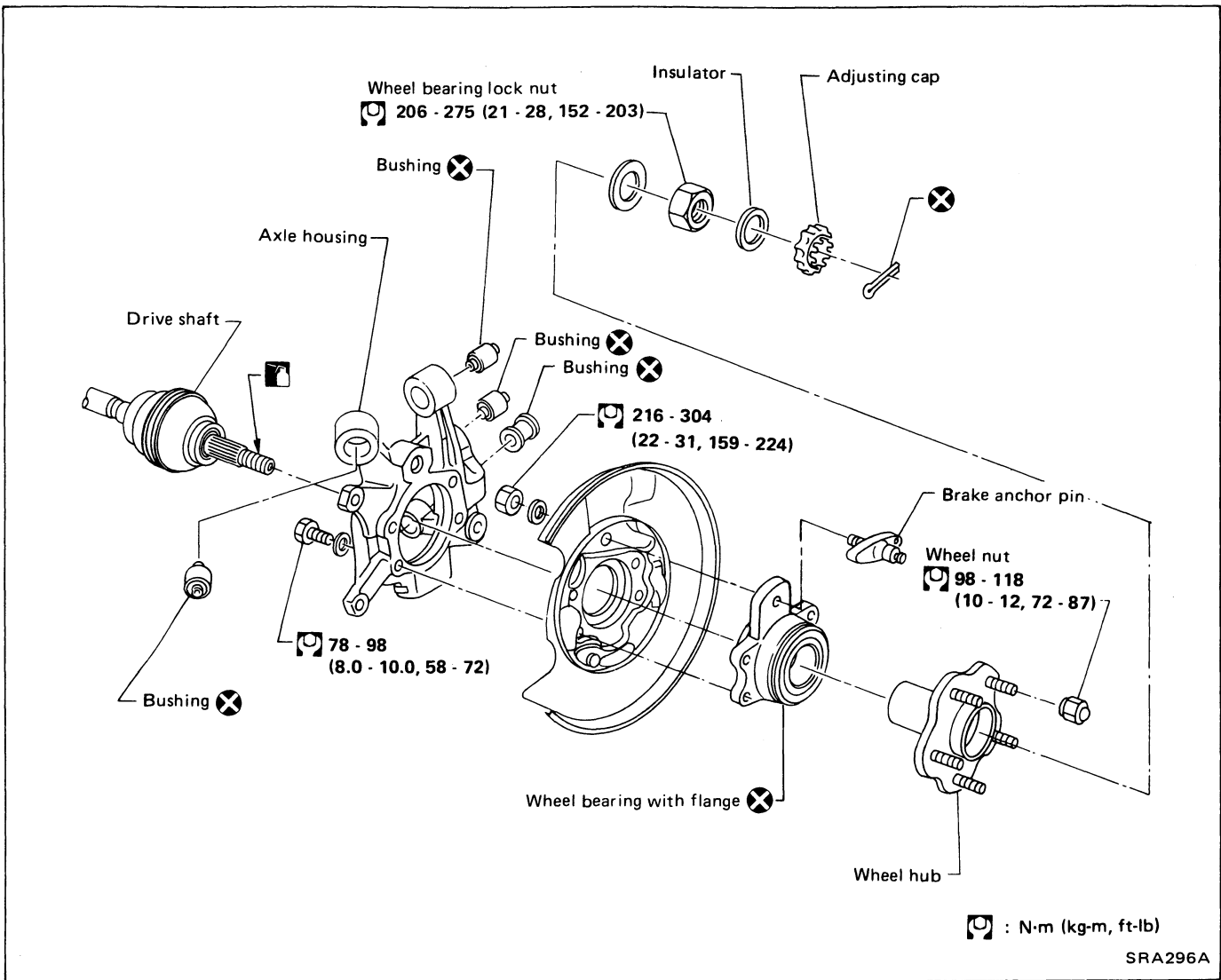

Removal

- Remove wheel bearing lock nut.

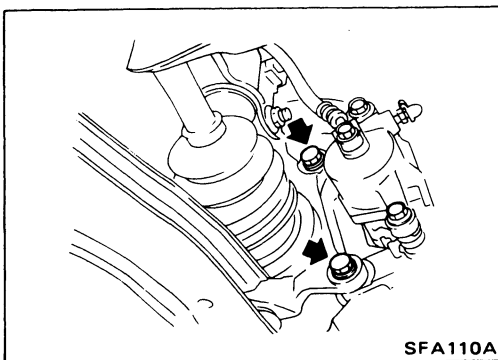

- Remove brake caliper assembly and rotor. Brake line need not be disconnected from brake caliper. Be careful not to depress brake pedal, or piston will pop out. Make sure brake line is not twisted.

REAR AXLE — Wheel Hub and Axle Housing

Removal (Cont'd)

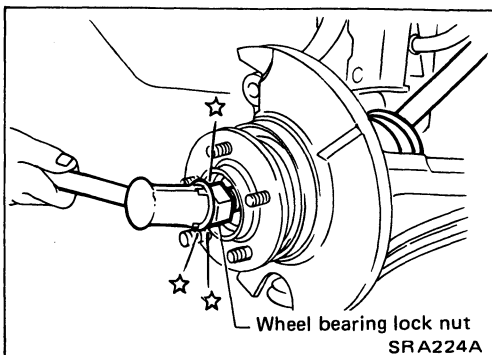

- Separate drive shaft from axle housing by slightly tapping it. When removing drive shaft, cover boots with waste cloth to prevent them from being damaged.

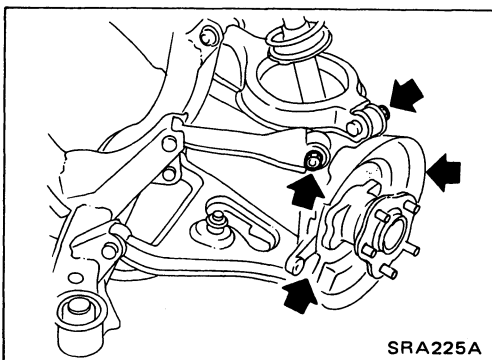

- Remove axle housing.

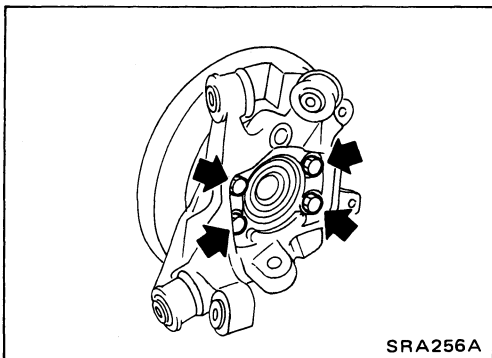

- Remove wheel bearing with flange, and wheel hub from axle housing.

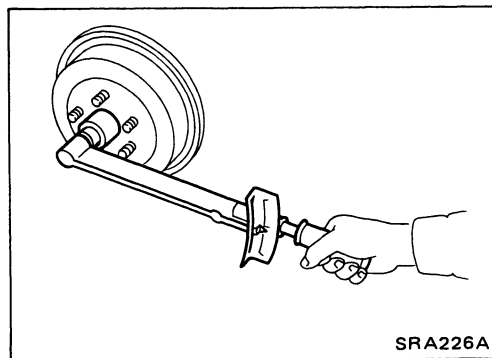

Installation

- Install axle housing with wheel hub.
- Tighten wheel bearing lock nut.
□: 206 - 275 N·m
(21 - 28 kg-m, 152 - 203 ft-lb)

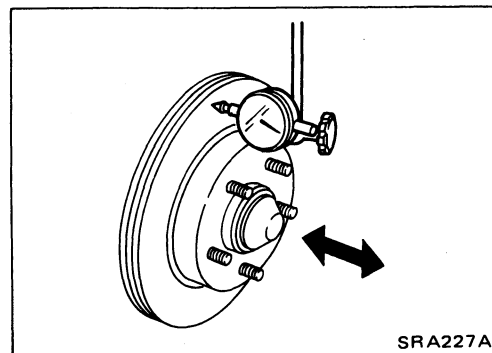

- Check wheel bearing axial end play.
Axial end play: 0.05 mm (0.0020 in) or less

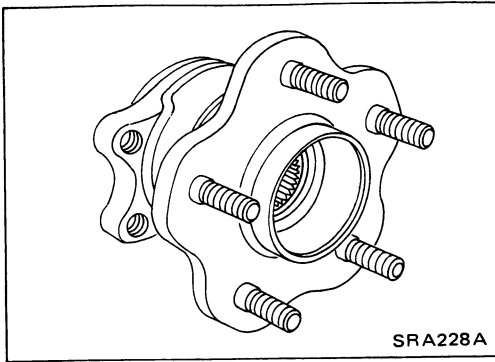

Disassembly

CAUTION:

Wheel bearing with flange usually does not require maintenance. If any of the following symptoms are noted, replace wheel bearing assembly (including flange, and inner and outer seals).

- Growling noise is emitted from wheel bearing during operation.
- Wheel bearing drags or turns roughly when hub is turned with your hand after bearing lock nut is tightened to specified torque.
- After wheel bearing is removed from hub.

WHEEL HUB

- Remove wheel bearing (with flange) and wheel hub as one unit from axle housing before disassembling.

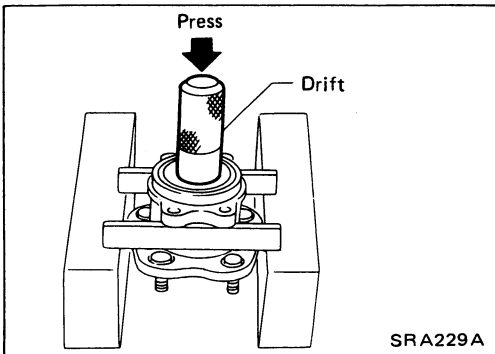

WHEEL BEARING

- Using a press and drift as shown in figure at left, press wheel bearing out.
- Discard old wheel bearing assembly. Replace with a new wheel assembly.

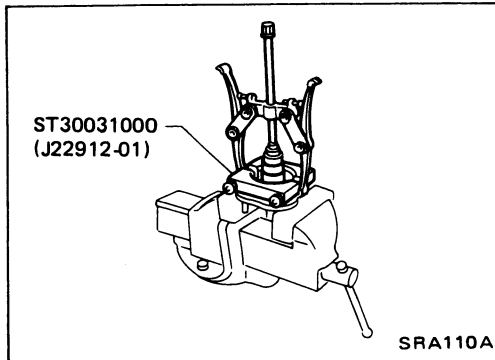

- Remove inner race from hub using a bearing replacer/puller.

CAUTION:

- a. Do not reuse old inner race although it is of the same brand as the bearing assembly.
- b. Do not replace grease seals as single parts.

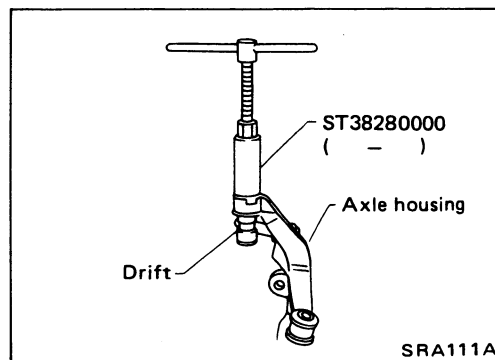

AXLE HOUSING

- Attach a drift on outer shell of bushing as shown in figure at left, remove bushing using arm bushing remover.

When placing axle housing in a vise, use wooden blocks or copper plates as pads.

REAR AXLE — Wheel Hub and Axle Housing

Disassembly (Cont'd)

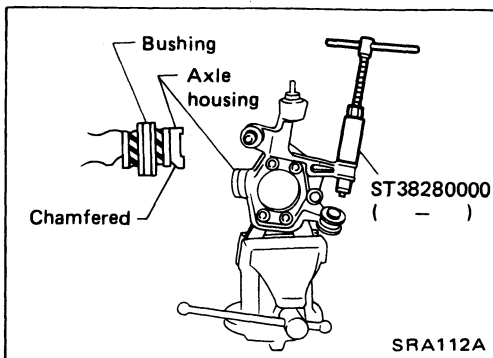

- Ensure axle housing bore is free from scratches or deformities before pressing bushing into it.
- Attach bushing to chamfered bore end of axle housing and press it until it is flush with end face of axle housing.

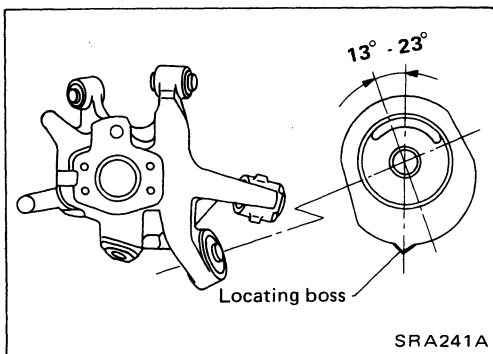

- When installing shock absorber bushing, make sure that it is positioned as shown.

Inspection

WHEEL HUB AND AXLE HOUSING

- Check wheel hub and axle housing for cracks by using a magnetic exploration or dyeing test.
- Check wheel bearing for damage, seizure, rust or rough operation.
- Check rubber bushing for wear or other damage.

Replace if necessary.

Assembly

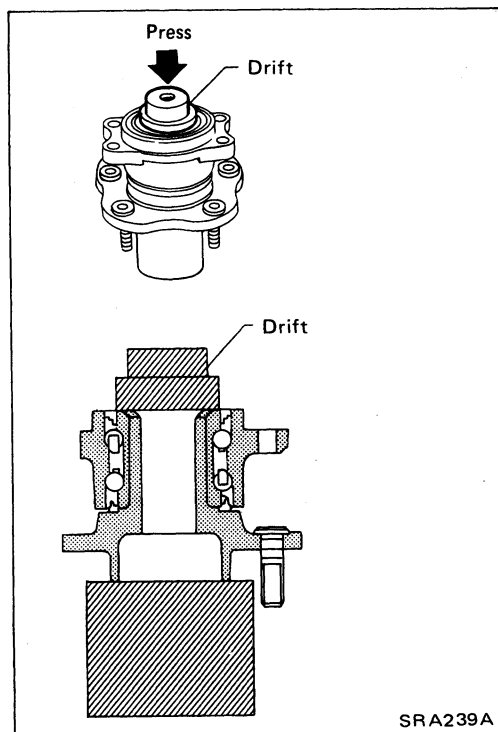

- Place hub on a block. Attach a drift to inner race of wheel bearing and press it into hub as shown in figure at left.
- Be careful not to damage grease seal.**

REAR AXLE — Drive Shaft

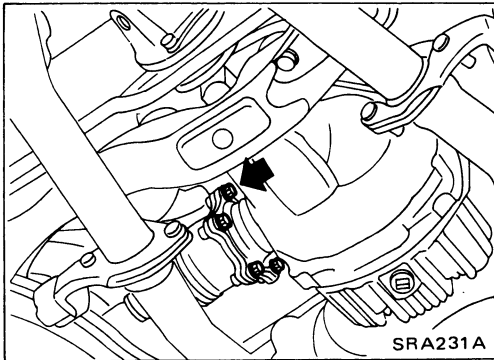
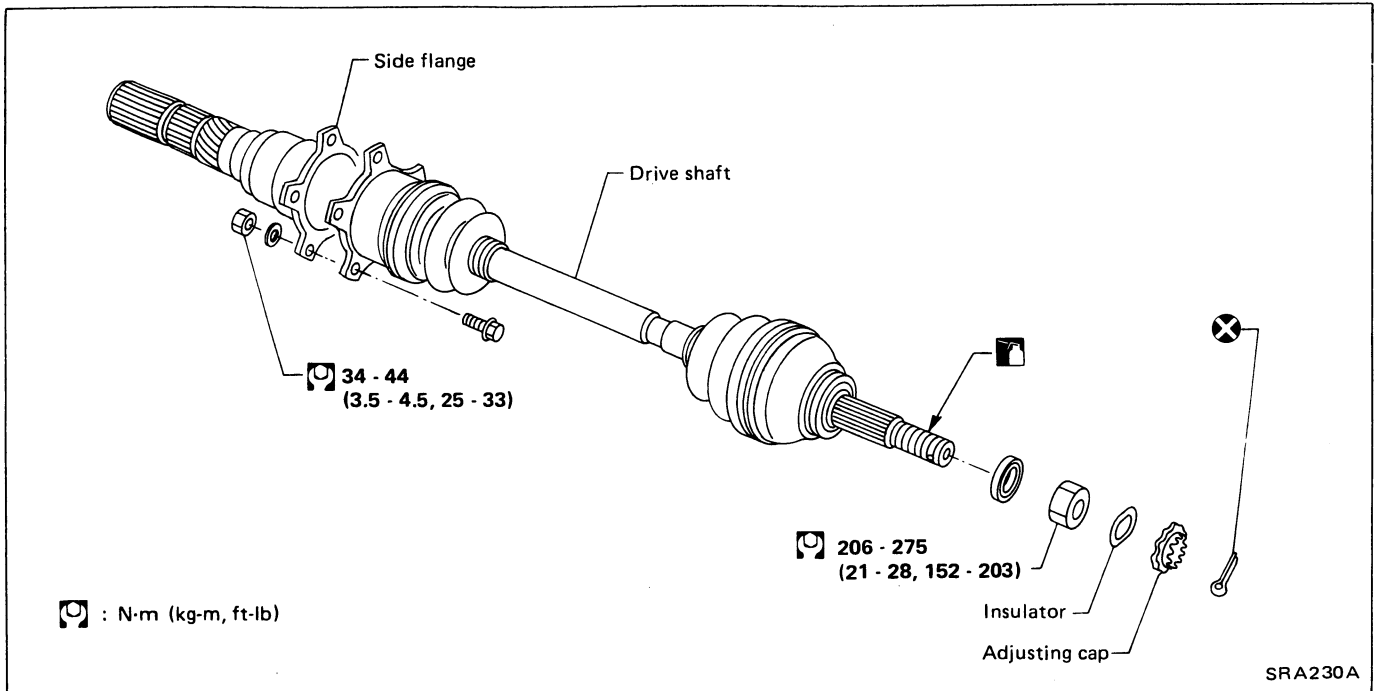

Removal

When removing drive shaft, cover boots with waste cloth to prevent damage to them.

FINAL DRIVE SIDE

- Remove side flange mounting bolt and separate shaft.

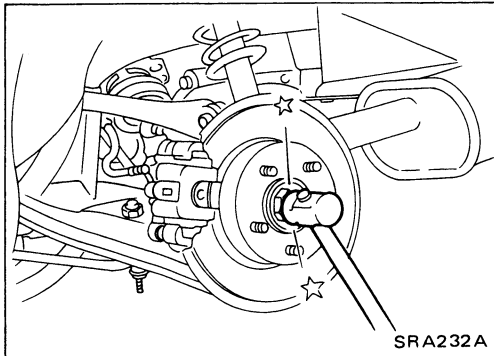

WHEEL SIDE

- Remove drive shaft by lightly tapping it with a copper hammer.

To avoid damaging threads of drive shaft, install a nut while removing drive shaft.

Installation

- Insert drive shaft from wheel hub and temporarily tighten wheel bearing lock nut.
- Tighten side flange mounting bolts to specified torque.
- Tighten wheel bearing lock nut to specified torque.

Components

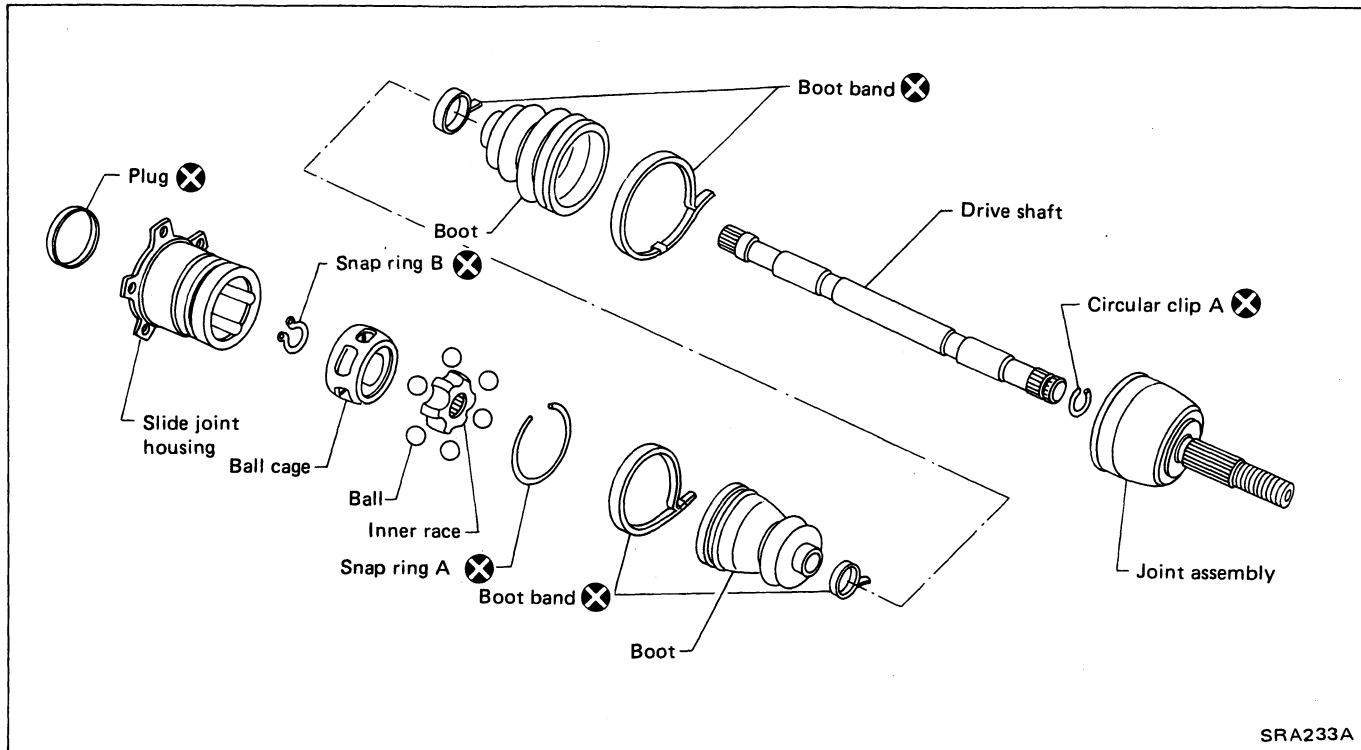

SRA233A

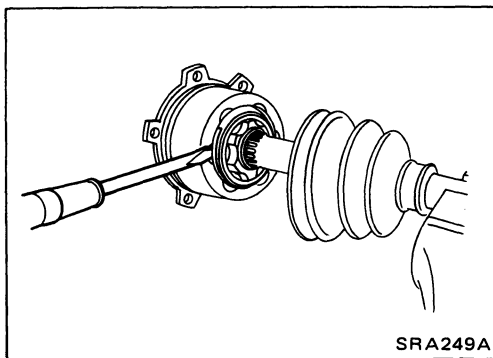

SRA249A

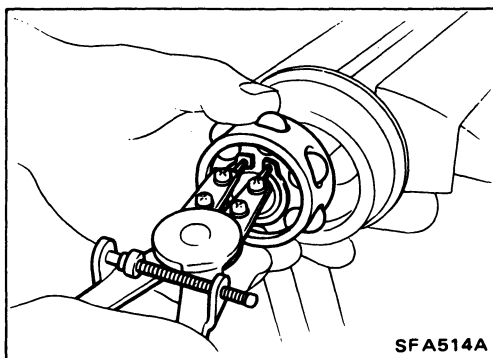

SFA514A

Disassembly

FINAL DRIVE SIDE

1. Remove boot bands.
2. Put matching marks on slide joint housing and inner race, before separating joint assembly.
3. Pry off snap ring "A" with a screwdriver, and pull out slide joint housing.

4. Put matching marks on inner race and drive shaft.
5. Pry off snap ring "B", then remove ball cage, inner race and balls as a unit.
6. Draw out boot.

Cover drive shaft serration with tape so as not to damage the boot.

REAR AXLE — Drive Shaft

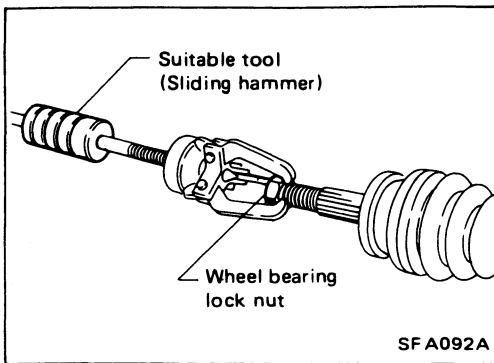

Disassembly (Cont'd)

WHEEL SIDE

CAUTION:

The joint on the wheel side cannot be disassembled.

- Before separating joint assembly, put matching marks on drive shaft and joint assembly.
 - Separate joint assembly with a suitable tool.
- Be careful not to damage threads on drive shaft.**
- Remove boot bands.

Inspection

Thoroughly clean all parts in cleaning solvent, and dry with compressed air. Check parts for evidence of deformation or other damage.

DRIVE SHAFT

Replace drive shaft if it is twisted or cracked.

BOOT

Check boot for fatigue, cracks, or wear. Replace boot with new boot bands.

JOINT ASSEMBLY (Final drive side)

- Replace any parts of double offset joint which show signs of scorching, rust, wear or excessive play.
- Check serration for deformation. Replace if necessary.
- Check slide joint housing for any damage. Replace if necessary.

JOINT ASSEMBLY (Wheel side)

Replace joint assembly if it is deformed or damaged.

Assembly

- After drive shaft has been assembled, ensure that it moves smoothly over its entire range without binding.
- Use **NISSAN GENUINE GREASE** or equivalent after every overhaul.

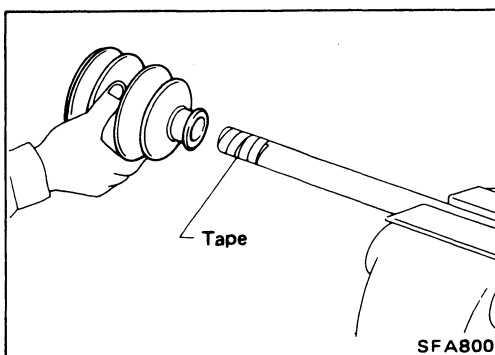

WHEEL SIDE

1. Install boot and new small boot band on drive shaft. **Cover drive shaft serration with tape so as not to damage boot during installation.**

REAR AXLE — Drive Shaft

Assembly (Cont'd)

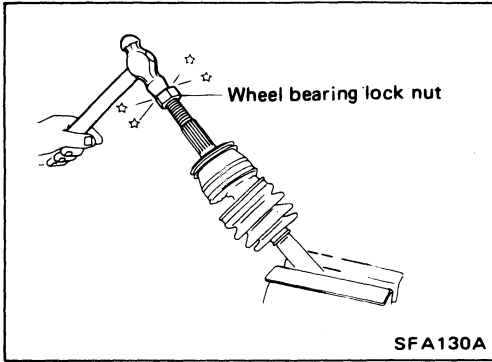

2. Set joint assembly onto drive shaft by lightly tapping it. Install joint assembly securely, ensuring marks which were made during disassembly are properly aligned.

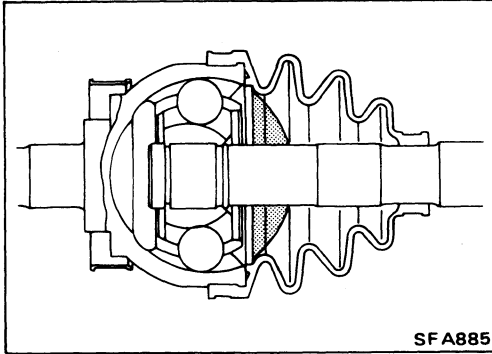

3. Pack drive shaft with specified amount of grease.
Specified amount of grease:

Without turbo

165 - 175 g (5.82 - 6.17 oz)

With turbo

170 - 190 g (6.00 - 6.70 oz)

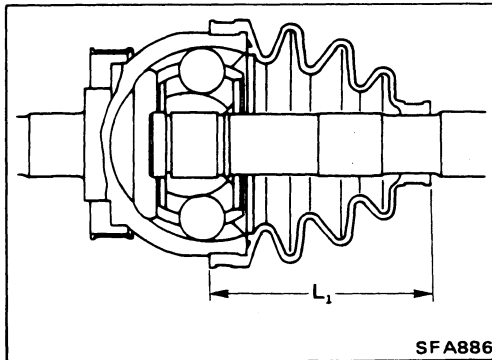

4. Set boot so that it does not swell and deform when its length is "L₁".

Make sure that boot is properly installed on the drive shaft groove.

Length "L₁":

Without turbo

96 - 98 mm (3.78 - 3.86 in)

With turbo

101 - 103 mm (3.98 - 4.06 in)

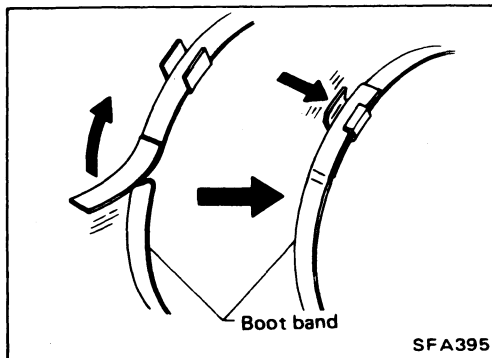

5. Lock new larger and smaller boot bands securely with a suitable tool.

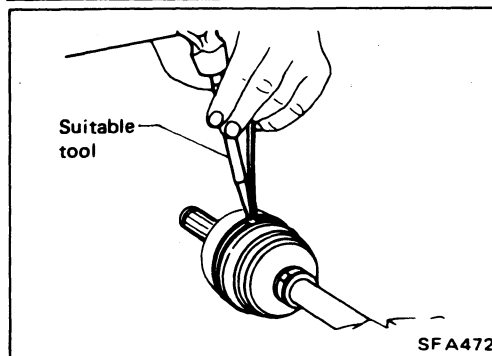

REAR AXLE — Drive Shaft

Assembly (Cont'd)

FINAL DRIVE SIDE

1. Install boot and new small boot band on drive shaft.
Cover drive shaft serration with tape so as not to damage boot during installation.

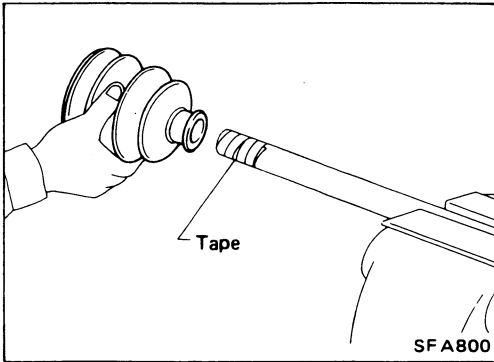

2. Securely install ball cage, inner race and balls as a unit, making sure the marks which were made during disassembly are properly aligned.
3. Install new snap ring "B".

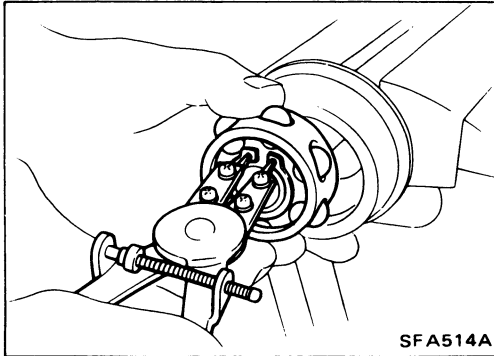

4. Pack drive shaft with specified amount of grease.

Specified amount of grease:

Without turbo

165 - 175 g (5.82 - 6.17 oz)

With turbo

180 - 200 g (6.35 - 7.05 oz)

5. Install slide joint housing, then install new snap ring "A".
6. Set boot so that it does not swell and deform when its length is "L₂".

Make sure that boot is properly installed on the drive shaft groove.

Length "L₂":

Without turbo

93 - 95 mm (3.66 - 3.74 in)

With turbo

102.5 - 104.5 mm (4.04 - 4.11 in)

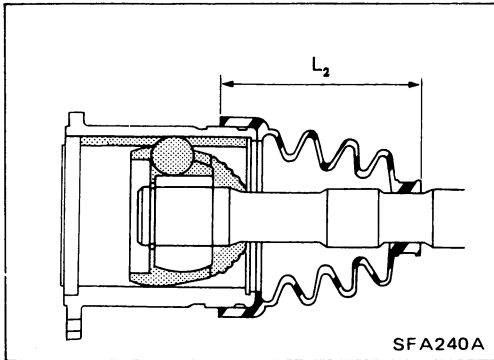

7. Lock new larger and smaller boot bands securely with a suitable tool.

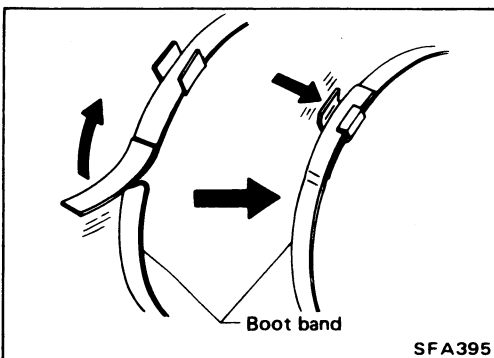

REAR SUSPENSION

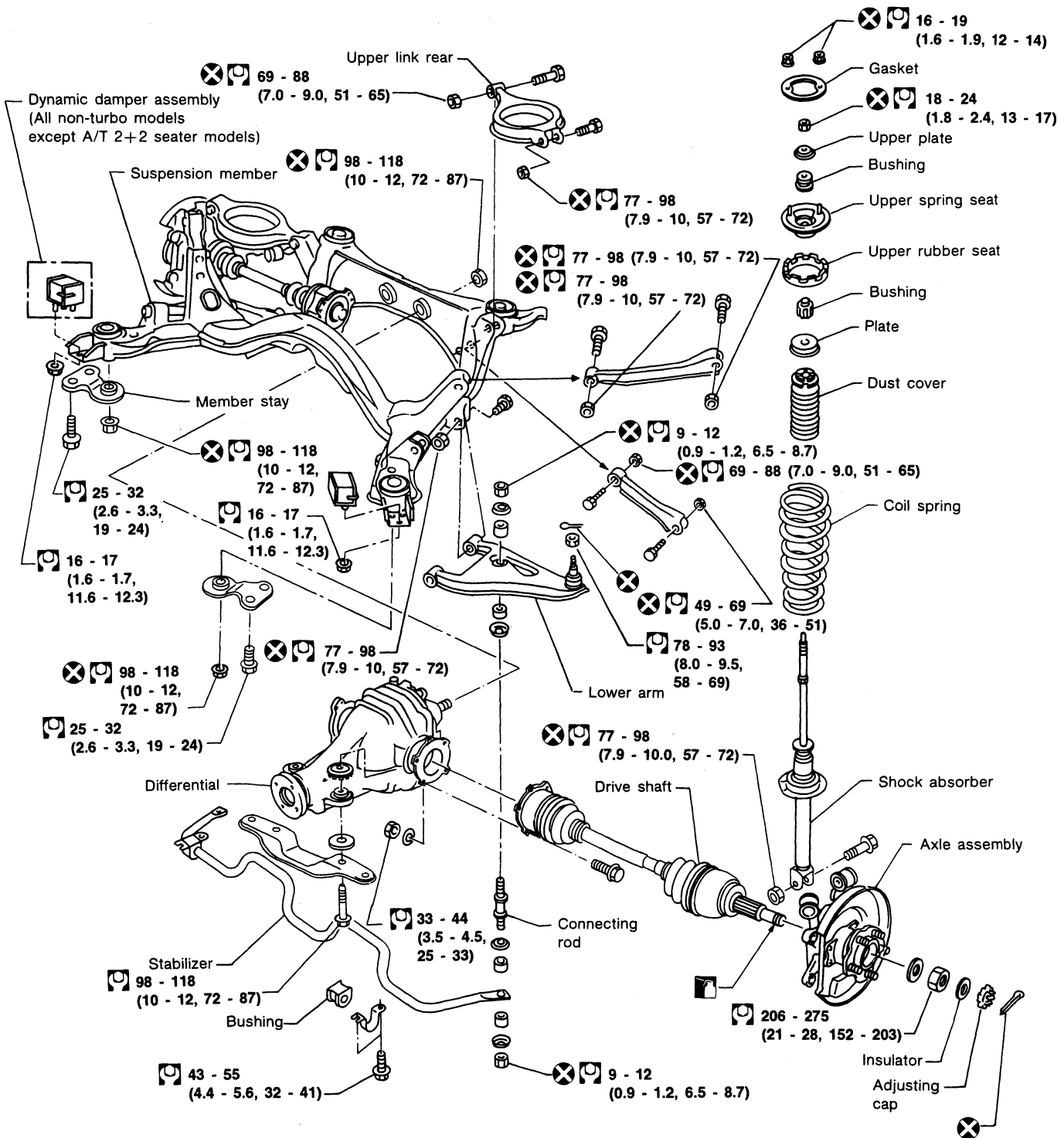

CAUTION:

Do not jack up lower arm.

Final tightening for rubber parts must be done under unladen condition*, with tires on ground.

* Fuel, radiator coolant and engine oil full.

Spare tire, jack, hand tools and mats in designated positons.

: N·m (kg-m, ft-lb)

SRA234A

Removal

- Remove shock absorber upper and lower fixing nuts.
- Do not remove piston rod lock nut on vehicle.

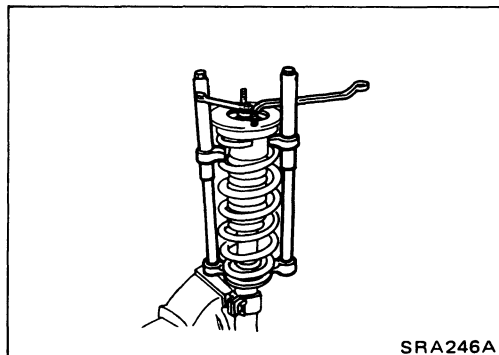
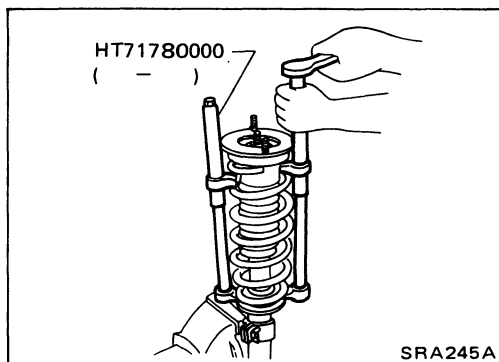
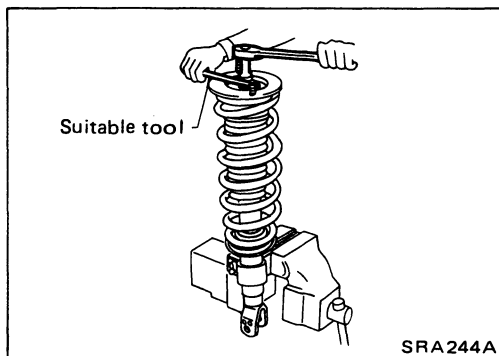

Disassembly

1. Set shock absorber on vise with attachment, then loosen piston rod lock nut.
 - Do not remove piston rod lock nut.
2. Compress spring with Tool so that the strut upper spring seat can be turned by hand.
3. Remove piston rod lock nut.

Inspection

SHOCK ABSORBER ASSEMBLY

- Check for smooth operation through a full stroke, both compression and extension.
- Check for oil leakage occurring on welded or gland packing portions.
- Check piston rod for cracks, deformation or other damage.
Replace if necessary.

UPPER RUBBER SEAT AND BUSHING

- Check rubber parts for deterioration or cracks.
Replace if necessary.

REAR SUSPENSION — Coil Spring and Shock Absorber

Inspection (Cont'd)

COIL SPRING

- Check for cracks, deformation or other damage. Replace if necessary.

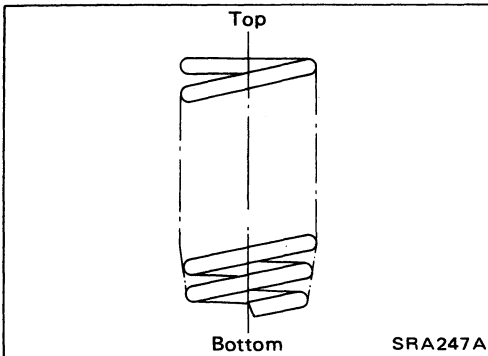

Assembly

- When installing coil spring, be careful not to reverse top and bottom direction. (Top end is flat.)

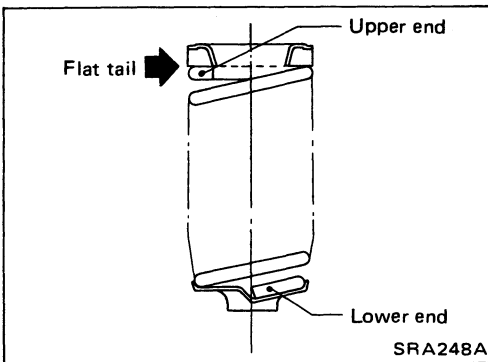

- When installing coil spring on strut, it must be positioned as shown in figure at left.

Removal and Installation

- Refer to "Removal and Installation" of REAR AXLE AND REAR SUSPENSION ASSEMBLY.

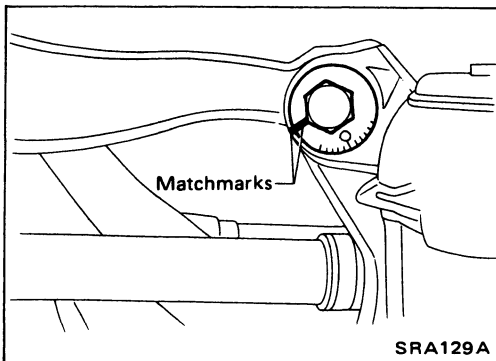

Before removing, put matchmarks on adjusting pin.

- When installing, final tightening must be done at curb weight with tires on ground.
- After installation, check wheel alignment. Refer to "Rear Wheel Alignment" of CHECK AND ADJUSTMENT — On vehicle.

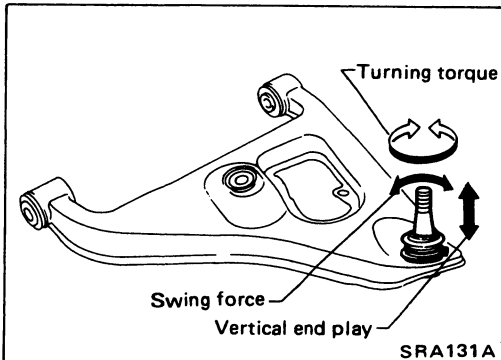
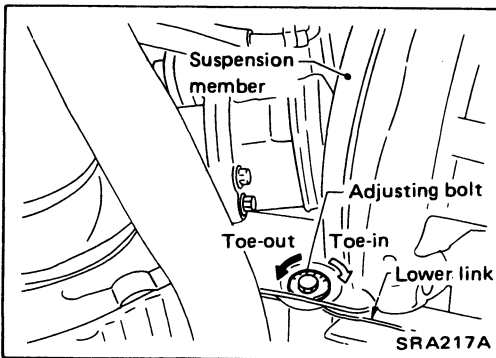

Inspection

REAR SUSPENSION MEMBER

- Replace suspension member assembly if cracked or deformed or if any part (insulator, for example) is damaged.

UPPER AND LOWER LINKS

- Replace upper or lower link as required if cracked or deformed or if bushing is damaged.

SUSPENSION LOWER BALL JOINT

- Measure swing force, turning torque and vertical end play in axial direction. (Use same measurement procedures as that of FA section.)
- If ball stud is worn, play in axial direction is excessive, or joint is hard to swing, replace lower arm.

Ball joint specifications	Swing force	7.8 - 54.9 N (0.8 - 5.6 kg, 1.8 - 12.3 lb)
	Turning torque	0.5 - 3.4 N·m (5 - 35 kg·cm, 4.3 - 30.4 in·lb)
	Vertical end play	0 mm (0 in)

REAR SUSPENSION — Stabilizer Bar

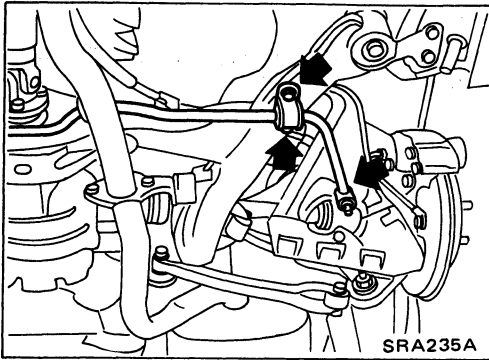

Removal

- Remove connecting rod and clamp.

Inspection

- Check stabilizer bar for deformation or cracks. Replace if necessary.
- Check rubber bushings for deterioration or cracks. Replace if necessary.

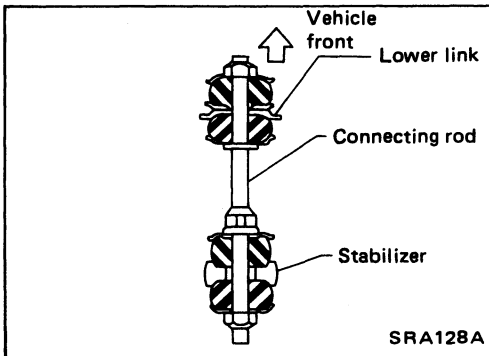

Installation

- When installing connecting rod, make sure direction is correct (as shown at left).

ADJUSTABLE SHOCK ABSORBER

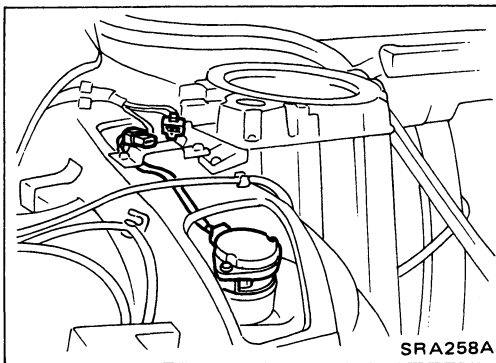
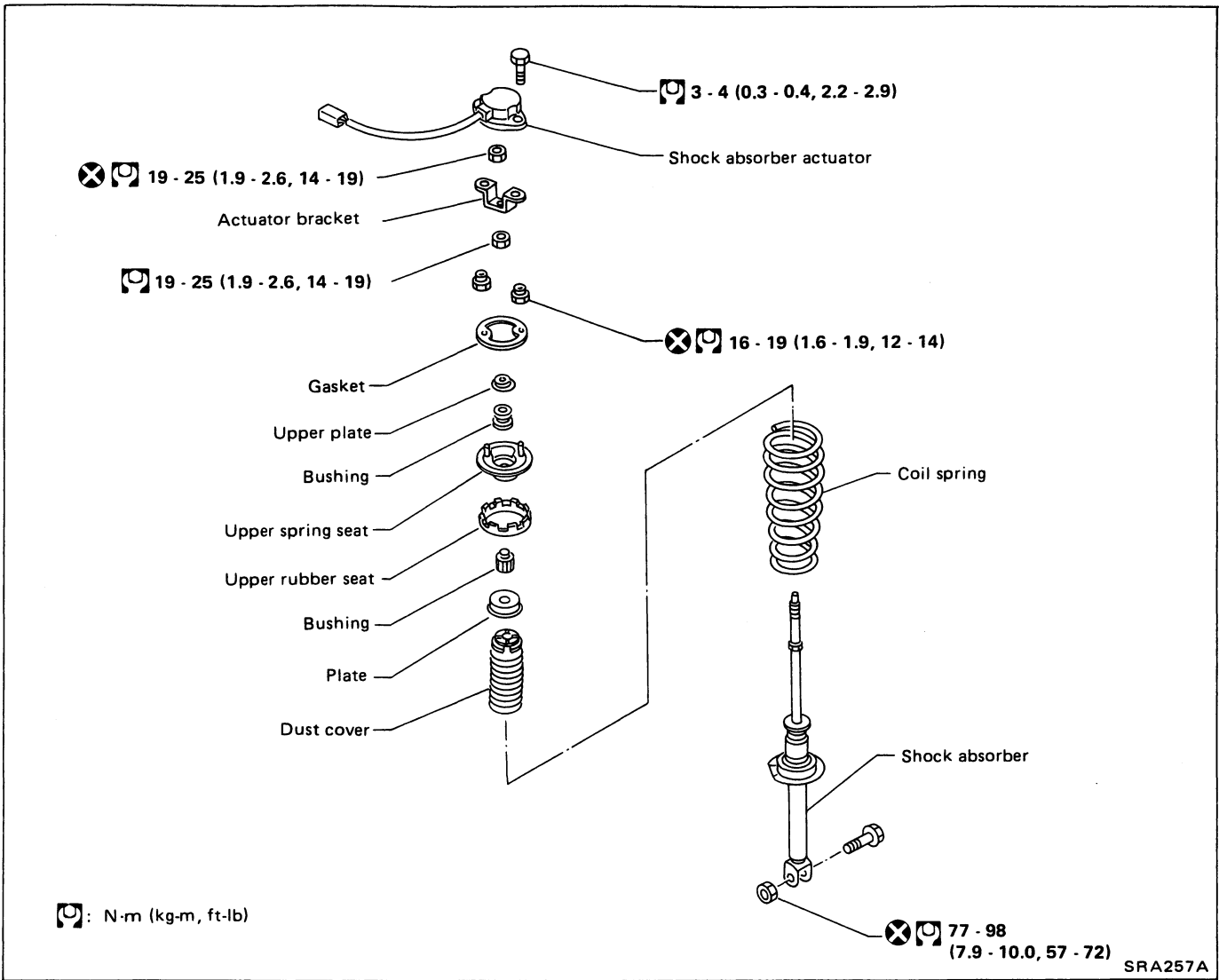

Removal and Installation

- Remove room trim. Refer to section BF.
- Disconnect sub-harness connector.
- Remove shock absorber actuator fixing bolts.

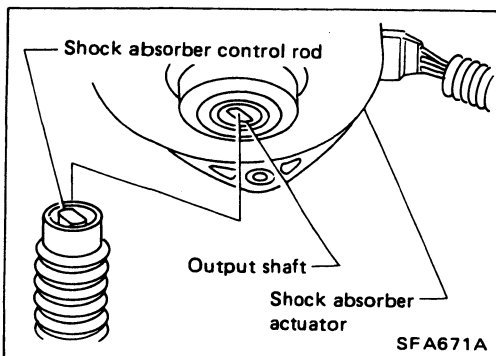

- Before installing actuator, ensure angle of shock absorber control rod is aligned with that of actuator output shaft. Otherwise, actuator may be damaged.
- Refer to REAR SUSPENSION for other procedures.

ADJUSTABLE SHOCK ABSORBER

Inspection

- Replace shock absorber assembly if it is damaged.
Refer to REAR SUSPENSION — Coil Spring and Shock Absorber.

Trouble Diagnosis

Refer to ADJUSTABLE SHOCK ABSORBER — Trouble Diagnoses in section FA.

Rear Wheel Alignment

TOE-IN

1. Draw a base line across the tread.
After lowering rear of vehicle, move it up and down to eliminate friction.

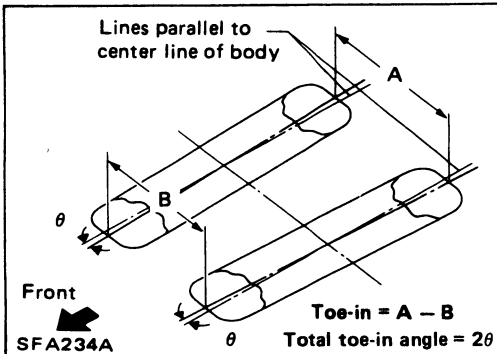
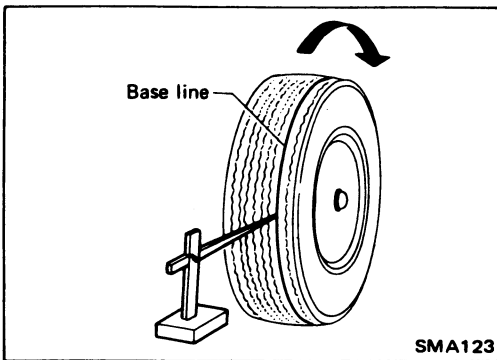

2. Measure toe-in.

Measure distance "A" and "B" at the same height as hub center.

Toe-in:

$$A - B$$

$$0 - 4 \text{ mm (0 - 0.16 in)}$$

$$2 \theta \text{ (Total toe-in angle)}$$

$$0' - 23'$$

3. Adjust toe-in by varying length of power cylinder lower links.

- (1) Loosen lock nuts.
- (2) Adjust toe-in by turning lower links forward or backward.

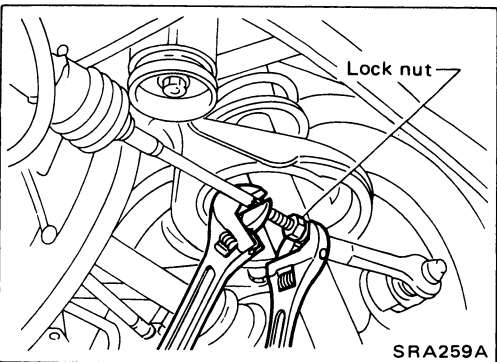

Make sure both lower links are the same length.

Standard length "L":

$$185.5 \text{ mm (7.30 in)}$$

(3) Tighten lock nuts to the specified torque.

$$\square: 37 - 46 \text{ N}\cdot\text{m}$$

$$(3.8 - 4.7 \text{ kg}\cdot\text{m, } 27 - 34 \text{ ft}\cdot\text{lb})$$

● Refer to CHECK AND ADJUSTMENT for other procedures.

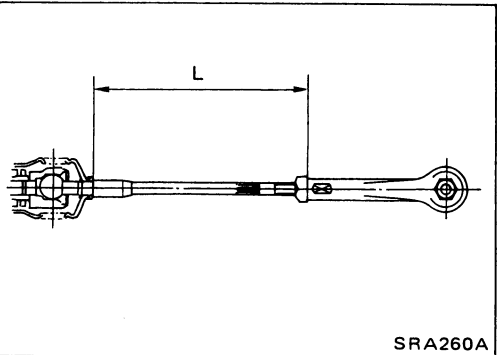

Rear Axle Housing Ball Joint

INSPECTION

- Measure swing force, turning torque and vertical end play in axial direction.
- If ball joint is worn, play in axial direction is excessive, or joint is hard to swing, replace ball joint.

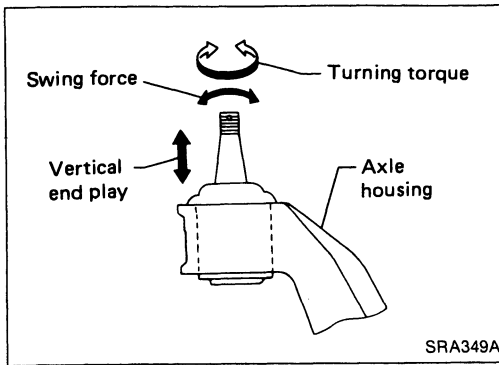

Ball joint specifications	Swing force	6.9 - 68.6 N (0.7 - 7.0 kg, 1.5 - 15.4 lb)
	Turning torque	0.3 - 2.9 N·m (3 - 30 kg-cm, 2.6 - 26.0 in-lb)
	Vertical end play	0 mm (0 in)

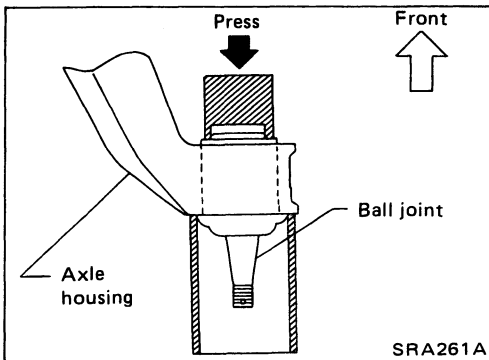

REMOVAL

- Remove ball joint snap ring.
- Press out ball joint from axle housing.

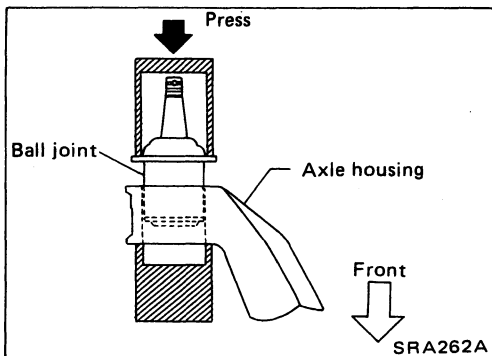

ASSEMBLY

- Press new ball joint assembly into axle housing.
- Install snap ring into groove of ball joint.
- Refer to REAR AXLE — Wheel Hub and Axle Housing for other procedures.
- Refer to ST section for power cylinder and SUPER HICAS — Trouble Diagnoses.

SERVICE DATA AND SPECIFICATIONS (S.D.S.)

General Specifications

COIL SPRING

Item	Model	VG30DE		VG30DETT
		2 seater	2+2 seater	2 seater
Wire diameter	mm (in)	11.4 (0.449)		11.2 (0.441)
Coil diameter	mm (in)	100 (3.94)		
Free length	mm (in)	371.5 (14.63)	380 (14.96)	370 (14.57)
Spring constant	N/mm (kg/mm, lb/in)	21.6 (2.2, 123)		23.5 (2.4, 134)
Identification color		White x 1, Yellow x 1	Purple x 1, Pink x 1	Purple x 1, Light green x 1

SHOCK ABSORBER

Item	Engine	VG30DE	VG30DETT	
			Firm	Soft
Piston rod diameter	mm (in)	12.5 (0.492)	14.0 (0.551)	
Damping force [at 0.3 m (1.0 ft)/sec.]	N (kg, lb)			
Expansion		873 - 1,187 (89 - 121, 196 - 267)	1,432 - 1,903 (146 - 194, 322 - 428)	834 - 1,128 (85 - 115, 187 - 254)
Compression		520 - 755 (53 - 77, 117 - 170)	971 - 1,383 (99 - 141, 218 - 311)	481 - 696 (49 - 71, 108 - 157)

DRIVE SHAFT

Item	Engine	VG30DE	VG30DETT
		Joint type	
Final drive side		DS90	DS100
Wheel side		ZF100	BF100
Diameter	mm (in)		
Wheel side D_1		30 (1.18)	33 (1.30)
Grease		Nissan genuine grease or equivalent	
Specified amount of grease	g (oz)		
Final drive side		165 - 175 (5.82 - 6.17)	180 - 200 (6.35 - 7.05)
Wheel side		165 - 175 (5.82 - 6.17)	170 - 190 (6.00 - 6.70)
Boot length	mm (in)		
Final drive side (L_1)		93 - 95 (3.66 - 3.74)	102.5 - 104.5 (4.04 - 4.11)
Wheel side (L_2)		96 - 98 (3.78 - 3.86)	101 - 103 (3.98 - 4.06)

Final drive side

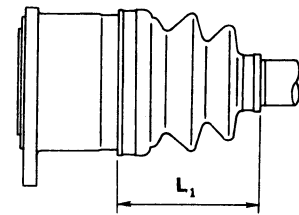

Wheel drive side

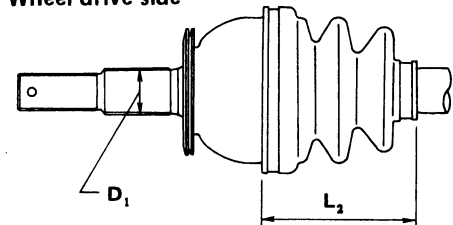

SRA236A

SERVICE DATA AND SPECIFICATIONS (S.D.S.)

General Specifications (Cont'd)

REAR STABILIZER BAR

Item	Engine	VG30DE		VG30DETT
		2 seater	2+2 seater	
Stabilizer diameter mm (in)	Outer	15.9 (0.626)	21.0 (0.827)	25.4 (1.000)
	Inner	12.3 (0.484)	15.8 (0.622)	19.4 (0.764)

Inspection and Adjustment

WHEEL ALIGNMENT (Unladen*)

Camber	degree	-1°36' to -0°36'
Toe-in	mm (in)	0 - 4 (0 - 0.16)
	(Total) degree	0' - 23'

* Tankful of fuel, radiator coolant and engine oil full.
Spare tire, jack, hand tools, mats in designated position.

WHEEL BEARING

Wheel bearing axial end play	mm (in)	0.05 (0.0020) or less
Wheel bearing lock nut Tightening torque	N-m (kg-m, ft-lb)	206 - 275 (21 - 28, 152 - 203)

WHEEL RUNOUT (Radial and lateral)

Wheel type	Radial runout	Lateral runout
Aluminum wheel	mm (in)	0.3 (0.012) or less

LOWER BALL JOINT

Swing force (Measuring point: cotter pin hole of ball stud)	N (kg, lb)	7.8 - 54.9 (0.8 - 5.6, 1.8 - 12.3)
Turning torque	N-m (kg-cm, in-lb)	0.5 - 3.4 (5 - 35, 4.3 - 30.4)
Vertical end play	mm (in)	0 (0)

LOWER LINK BALL JOINT (SUPER HICAS)

Swing force (at cotter pin hole)	N (kg, lb)	6.9 - 68.6 (0.7 - 7.0, 1.5 - 15.4)
Turning torque	N-m (kg-cm, in-lb)	0.3 - 2.9 (3 - 30, 2.6 - 26.0)
Vertical end play	mm (in)	0 (0)

BRAKE SYSTEM

SECTION **BR**

CONTENTS

PRECAUTIONS AND PREPARATION	BR- 2
CHECK AND ADJUSTMENT	BR- 3
BRAKE HYDRAULIC LINE	BR- 4
BRAKE PEDAL AND BRACKET	BR- 6
BRAKE BOOSTER	BR- 8
VACUUM PIPING	BR- 9
MASTER CYLINDER	BR-11
FRONT DISC BRAKE (OPZ25VA) — Caliper	BR-12
FRONT DISC BRAKE (OPZ25VA) — Rotor	BR-15
REAR DISC BRAKE (OPZ11VB) — Caliper	BR-16
REAR DISC BRAKE (OPZ11VB) — Rotor	BR-20
PARKING BRAKE CONTROL	BR-21
PARKING DRUM BRAKE (DS17HD)	BR-23
ANTI-LOCK BRAKING SYSTEM	BR-25
TROUBLE DIAGNOSES	BR-29
SERVICE DATA AND SPECIFICATIONS (S.D.S.)	BR-54

BR

PRECAUTIONS AND PREPARATION

Precautions

- Recommended fluid is brake fluid "DOT 3".
- Never reuse drained brake fluid.
- Be careful not to splash brake fluid on painted areas.
- To clean or wash all parts of master cylinder, disc brake caliper and wheel cylinder, use clean brake fluid.
- Never use mineral oils such as gasoline or kerosene. They will ruin rubber parts of hydraulic system.

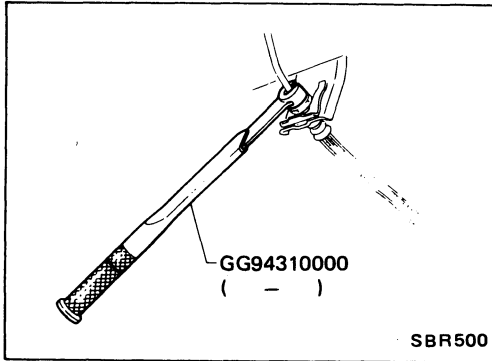

- Use Tool when removing and installing brake tube.

WARNING:

- Clean brake pads and shoes with a waste cloth, then collect dust with a dust collector.

Preparation SPECIAL SERVICE TOOL

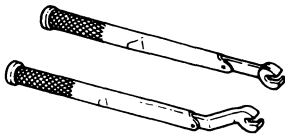
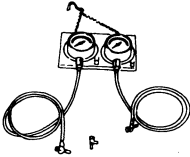
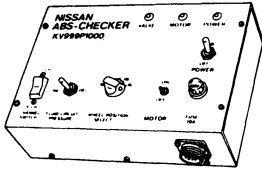
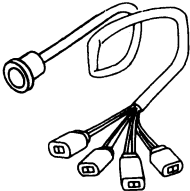
Tool number (Kent-Moore No.) Tool name	Description
GG94310000 (-) Flare nut torque wrench	 <p>Removing and installing each brake piping</p>
KV991V0010 (-) Brake fluid pressure gauge	 <p>Measuring brake fluid pressure</p>
KV999P1000 (-) A.B.S. checker	 <p>Checking brake fluid pressure of A.B.S. actuator</p>
KV999P1020 (-) A.B.S. checker adapter harness	 <p>Checking brake fluid pressure of A.B.S. actuator</p>

CHECK AND ADJUSTMENT

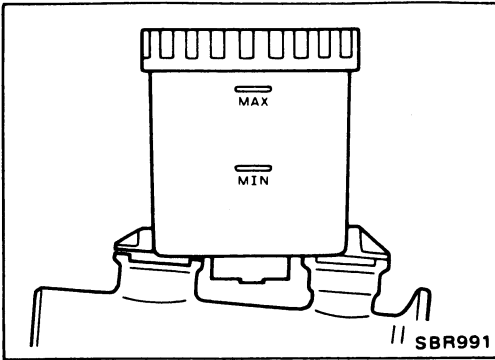

Checking Brake Fluid Level

- Check fluid level in reservoir tank. It should be between Max. and Min. lines on reservoir tank.
- If fluid level is extremely low, check brake system for leaks.

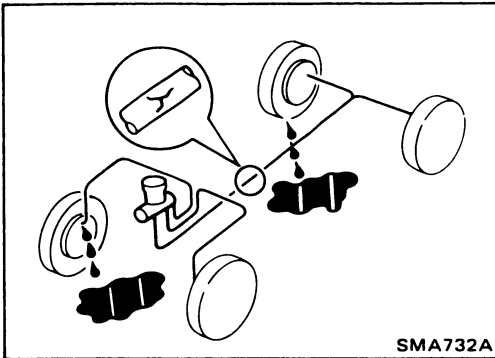

Checking Brake System

- Check brake lines (lines and flexible hoses) for cracks, deterioration or other damage. Replace any damaged parts. If leakage occurs around joints, retighten or, if necessary, replace damaged parts.
- Check for oil leakage by fully depressing brake pedal.

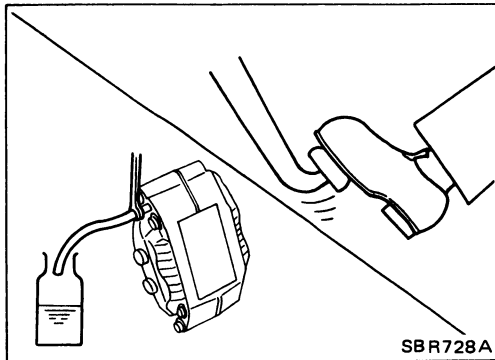

Changing Brake Fluid

1. Drain brake fluid in each air bleeder valve.
 2. Refill until new brake fluid comes out of each air bleeder valve.
- Use same procedure as in bleeding hydraulic system to refill brake fluid.
Refer to Bleeding Procedure.
- **Refill with recommended brake fluid "DOT 3".**
 - **Never reuse drained brake fluid.**
 - **Be careful not to splash brake fluid on painted areas.**

BRAKE HYDRAULIC LINE

Models with A.B.S.

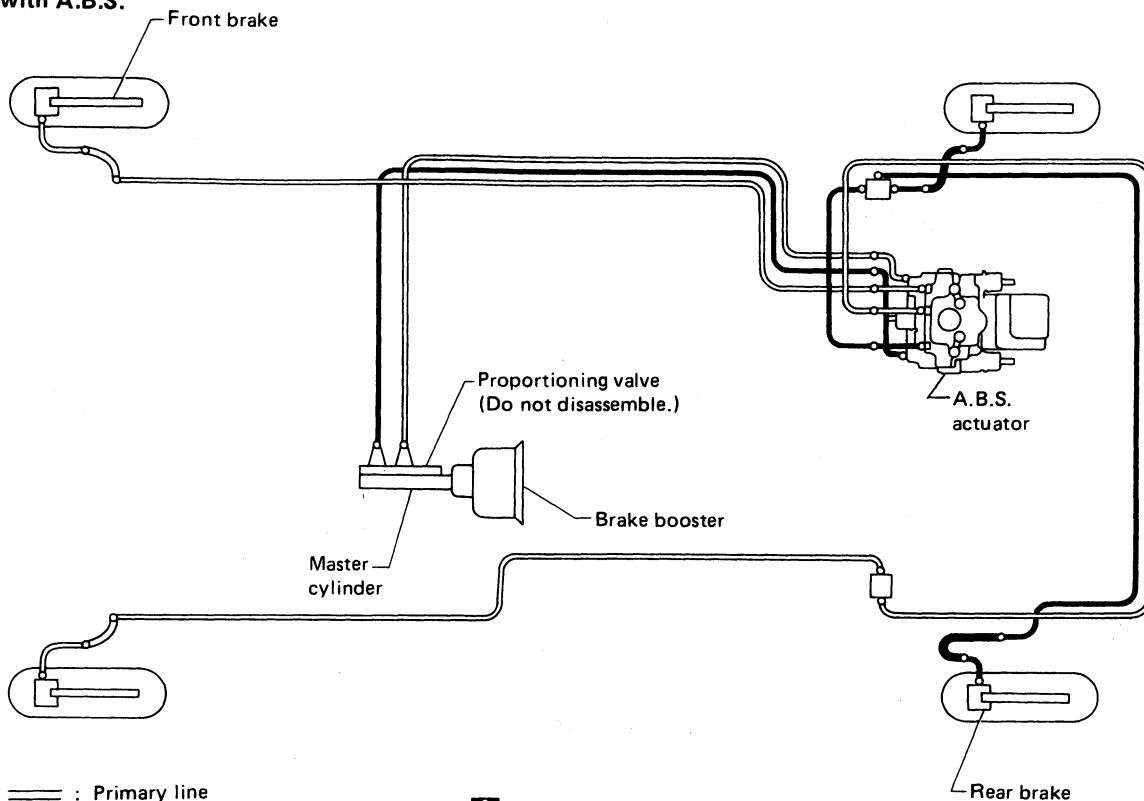

== : Primary line
 — : Secondary line



o : Flare nut
 15 - 18 N·m (1.5 - 1.8 kg·m, 11 - 13 ft·lb)

SBR729A

Models without A.B.S.

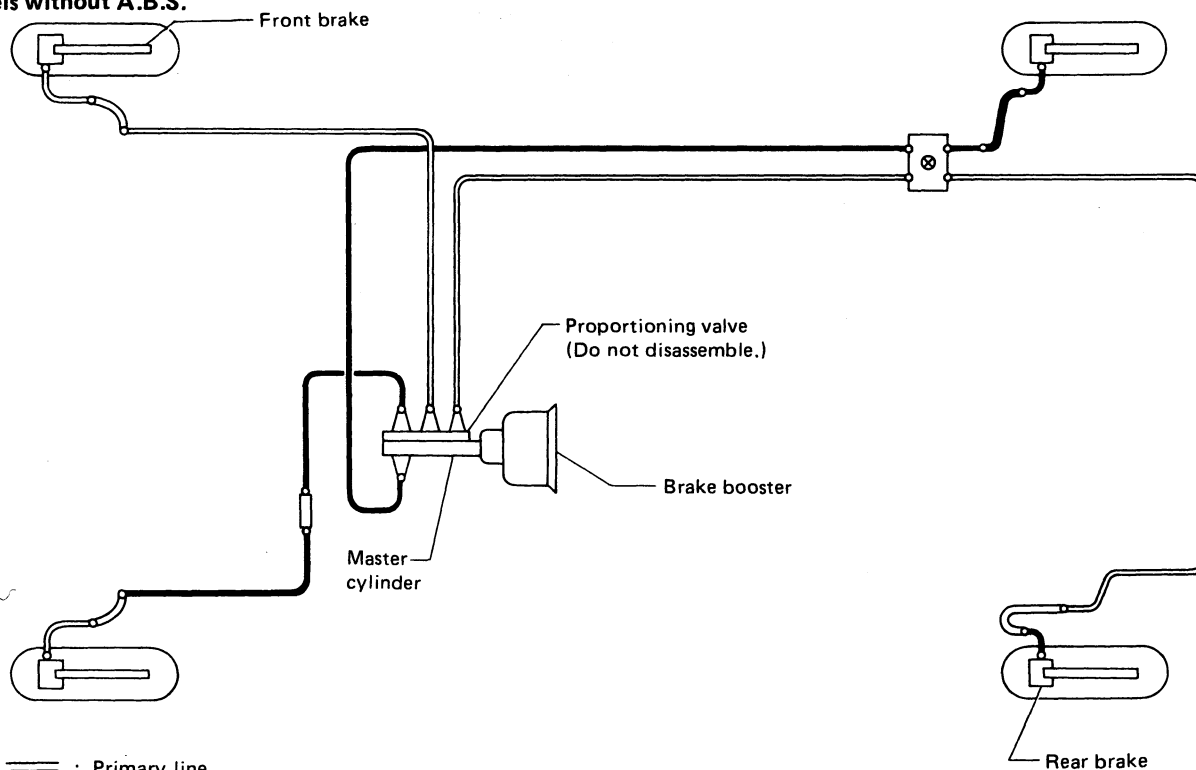

== : Primary line
 — : Secondary line



o : Flare nut
 15 - 18 N·m (1.5 - 1.8 kg·m, 11 - 13 ft·lb)

SBR481B

BRAKE HYDRAULIC LINE

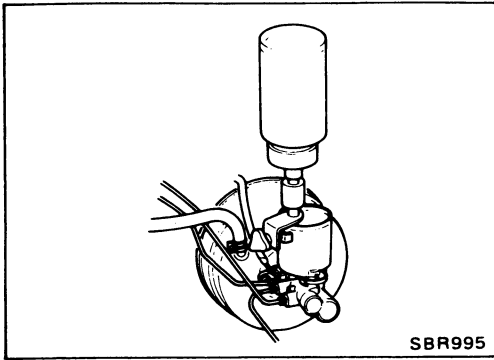

Bleeding Procedure

CAUTION:

- Carefully monitor brake fluid level at master cylinder during bleeding operation.
- Fill reservoir with recommended brake fluid. Make sure it is full at all times while bleeding air out of system.
- Place a container beneath master cylinder to avoid spillage of brake fluid.

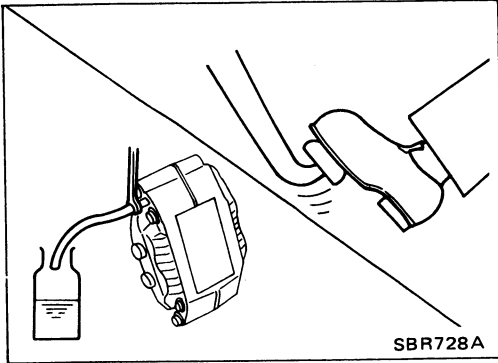

- Bleed air according to the following procedure.
Left rear caliper
↓
Right rear caliper
↓
Left front caliper
↓
Right front caliper
↓
Front side air bleeder on A.B.S. actuator (Models with A.B.S.)
↓
Rear side air bleeder on A.B.S. actuator (Models with A.B.S.)

- **To bleed air out of lines, wheel cylinders and calipers, use the following procedure.**

- 1) Connect a transparent vinyl tube to air bleeder valve.
- 2) Fully depress brake pedal several times.
- 3) With brake pedal depressed, open air bleeder valve to release air.
- 4) Close air bleeder valve.
- 5) Release brake pedal slowly.
- 6) Repeat steps 2) through 5) until clear brake fluid comes out of air bleeder valve.

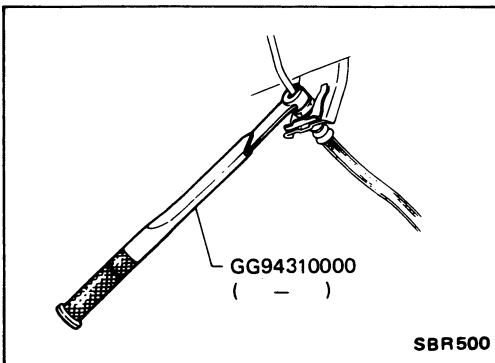

Removal and Installation

1. To remove brake flexible hose, first remove flare nut securing brake line to hose, then withdraw lock spring.
2. Cover openings to prevent entrance of dirt whenever disconnecting hydraulic line.
3. All hoses must be free from excessive bending, twisting and pulling.
4. After installing brake lines, check for oil leakage by fully depressing brake pedal.

Inspection

Check brake lines (lines and flexible hoses) for cracks, deterioration or other damage. Replace any damaged parts.

If leakage occurs around joints, retighten or, if necessary, replace damaged parts.

BRAKE PEDAL AND BRACKET

Removal and Installation

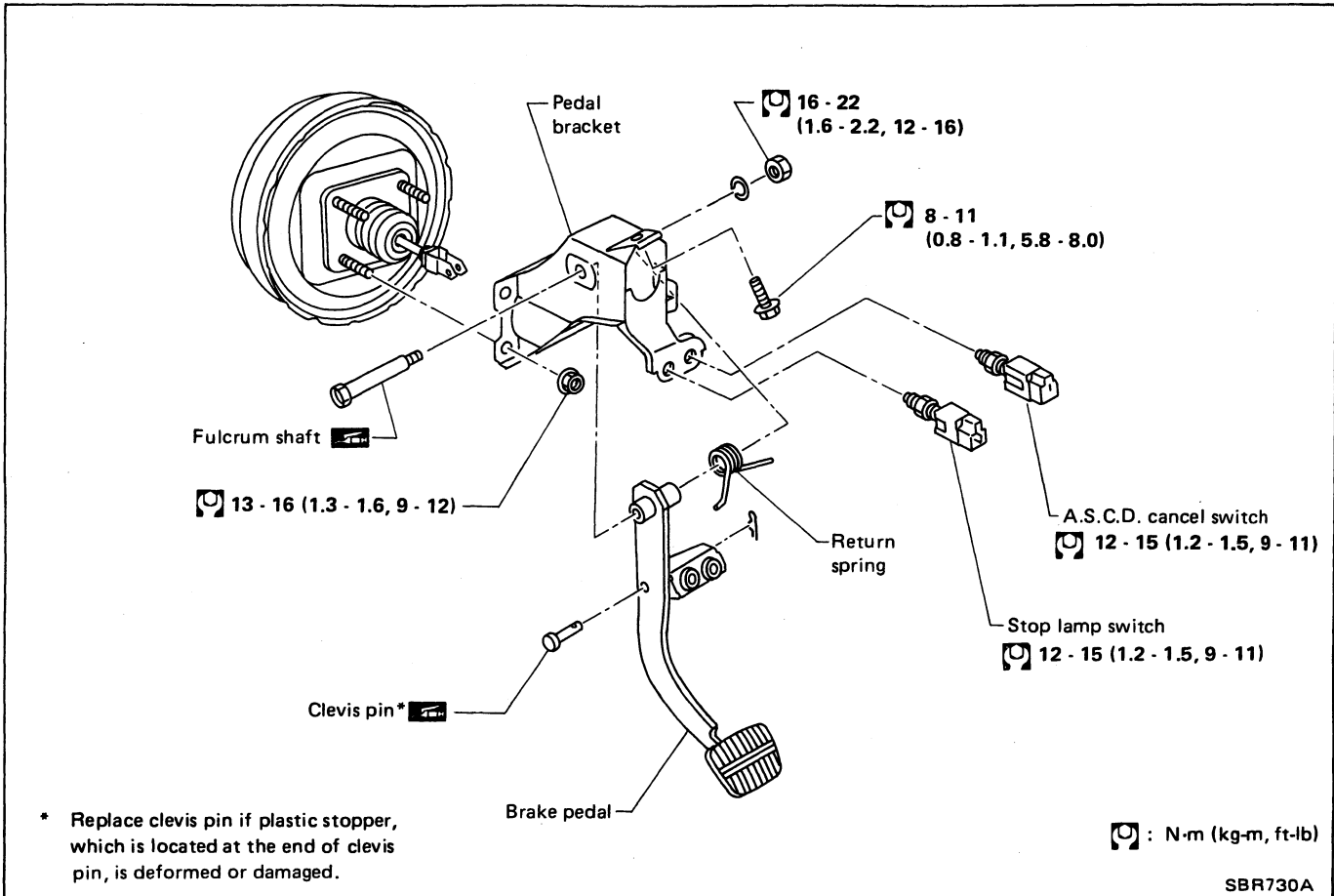

Inspection

Check brake pedal for following items.

- Brake pedal bend
- Clevis pin deformation
- Crack of any welded portion

BRAKE PEDAL AND BRACKET

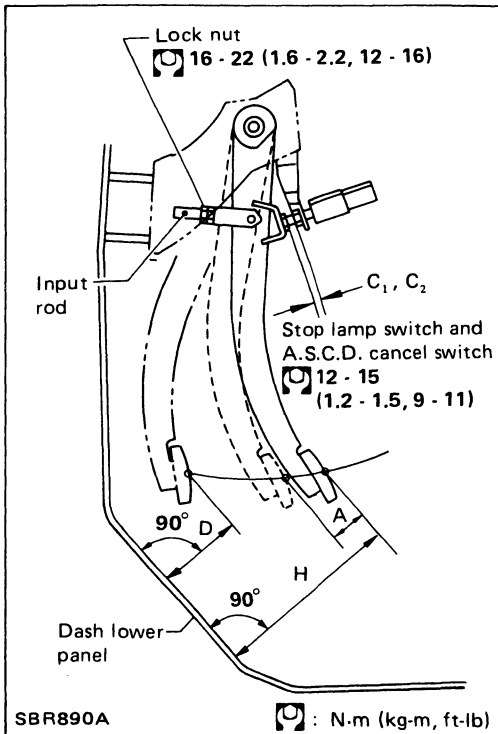

Adjustment

Check brake pedal free height from dash reinforcement panel. Adjust if necessary.

- H:** Free height
Refer to S.D.S.
- D:** Depressed height
Refer to S.D.S.
Under force of 490 N (50 kg, 110 lb)
- C₁:** Clearance between pedal stopper and threaded end of stop lamp switch
0.3 - 1.0 mm (0.012 - 0.039 in)
- C₂:** Clearance between pedal stopper and threaded end of A.S.C.D. switch
0.3 - 1.0 mm (0.012 - 0.039 in)
- A:** Pedal free play
1 - 3 mm (0.04 - 0.12 in)

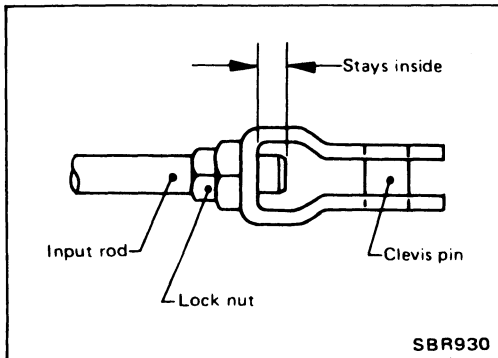

1. Adjust pedal free height with brake booster input rod. Then tighten lock nut.

Make sure that tip of input rod stays inside.

2. Adjust clearance "C₁" and "C₂" with stop lamp switch and A.S.C.D. switch respectively. Then tighten lock nuts.
3. Check pedal free play.

Make sure that stop lamp is off when pedal is released.

4. Check brake pedal's depressed height while engine is running.

If depressed height is below specified value, check brake system for leaks, accumulation of air or any damage to components (master cylinder, wheel cylinder, etc.); then make necessary repairs.

BRAKE BOOSTER

Removal and Installation

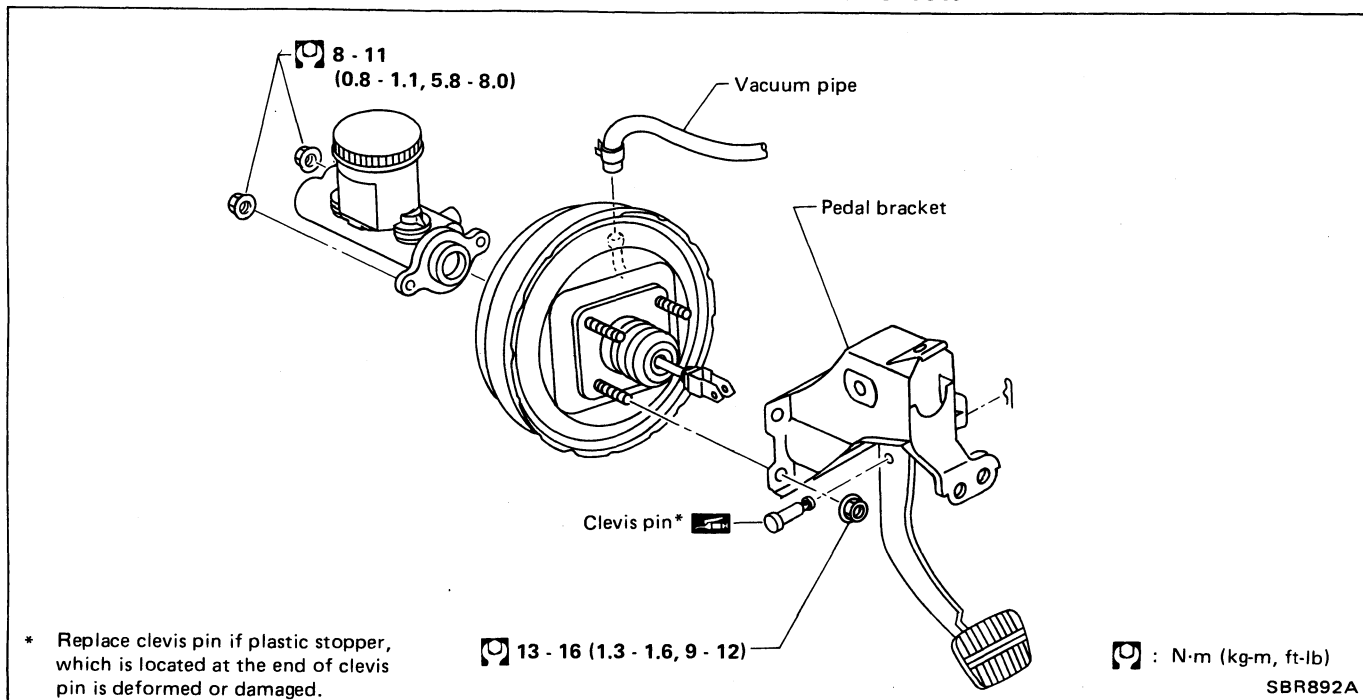

Inspection

OPERATING CHECK

- Depress brake pedal several times with engine off, and check that there is no change in pedal stroke.
- Depress brake pedal, then start engine. If pedal goes down slightly, operation is normal.

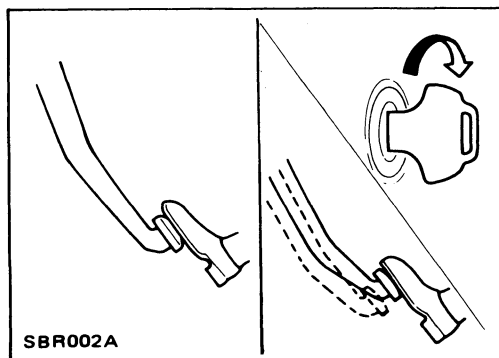

AIRTIGHT CHECK

- Start engine, and stop it after one or two minutes. Depress brake pedal several times slowly. If pedal goes further down the first time and gradually rises after second or third time, booster is airtight.
- Depress brake pedal while engine is running, and stop engine with pedal depressed. If there is no change in pedal stroke after holding pedal down **30 seconds**, brake booster is airtight.

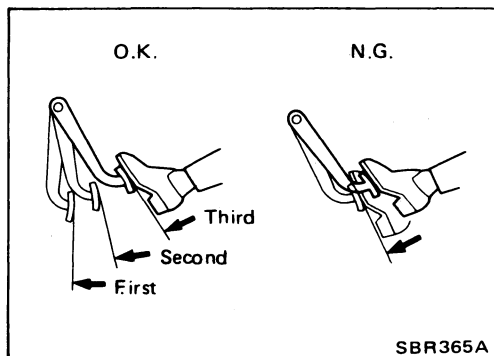

OUTPUT ROD LENGTH CHECK

1. Supply brake booster with vacuum of -66.7 kPa (-500 mmHg, -19.69 inHg) using a handy vacuum pump.
2. Check output rod length.
Specified length:
10.275 - 10.525 mm (0.4045 - 0.4144 in)
3. Adjust rod length if necessary.
4. If rod length is without specification, replace brake booster.

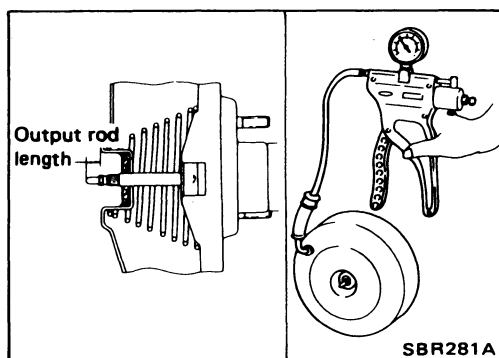

VACUUM PIPING

Removal and Installation

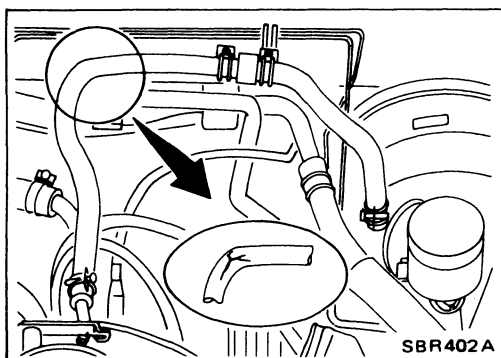
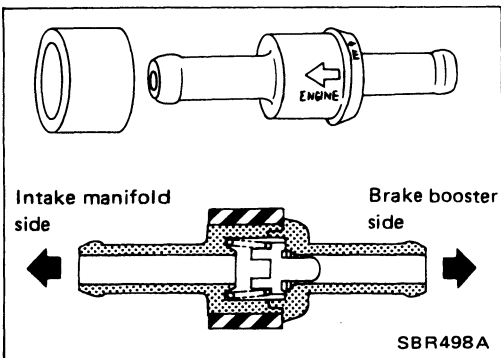
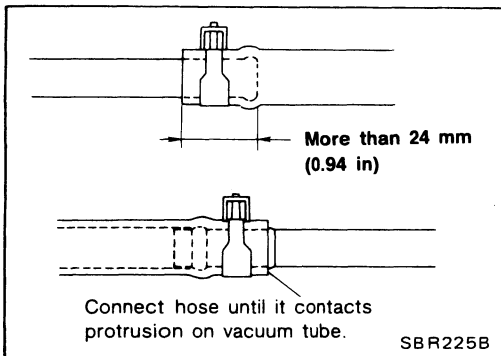
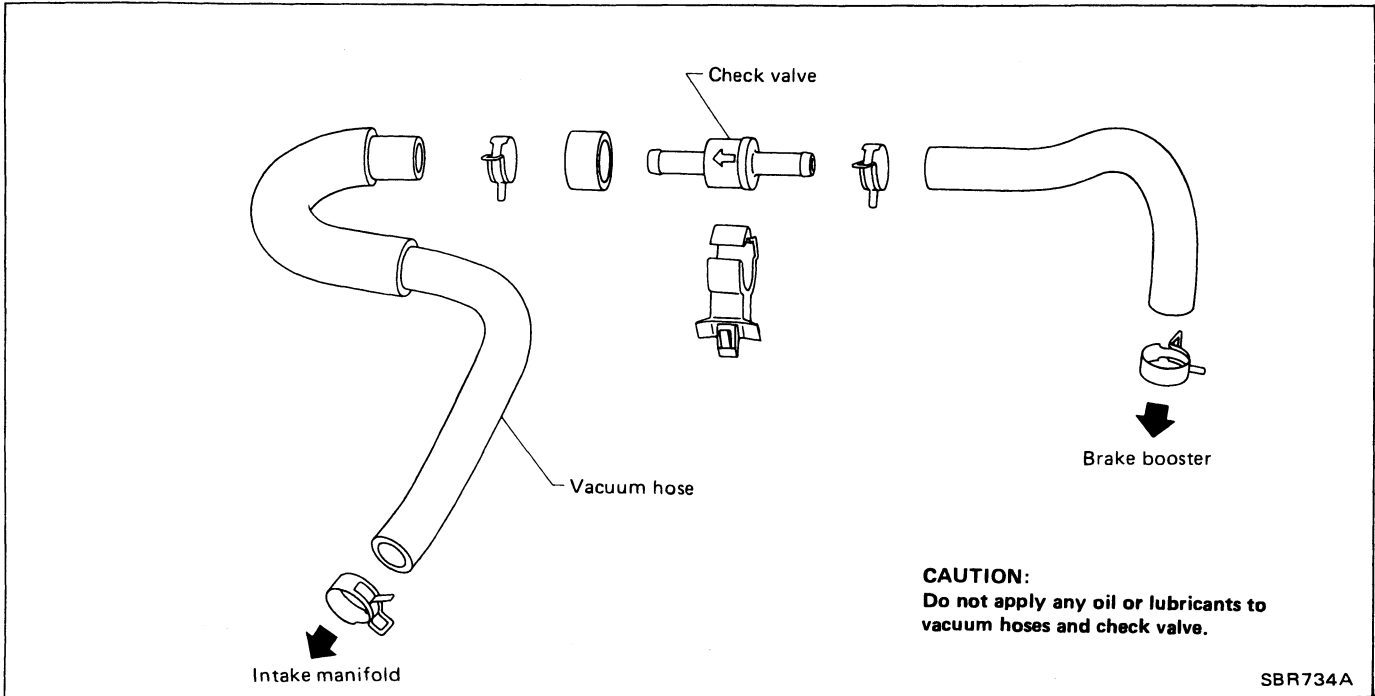

CAUTION:

When installing vacuum hoses, pay attention to the following points.

- Do not apply any oil or lubricants to vacuum hose and check valve.
- Insert vacuum tube into vacuum hoses as shown.
- Install check valve, paying attention to its direction.

Inspection

HOSES AND CONNECTORS

- Check vacuum lines, connections and check valve for airtightness, improper attachment chafing and deterioration.

VACUUM PIPING

Inspection (Cont'd) CHECK VALVE

- When pressure is applied to brake booster side of check valve and valve does not open, replace check valve with a new one.

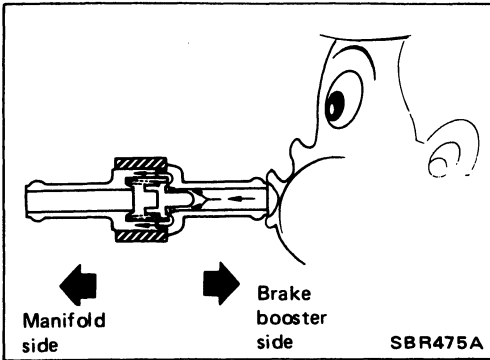

MASTER CYLINDER

Removal and Installation

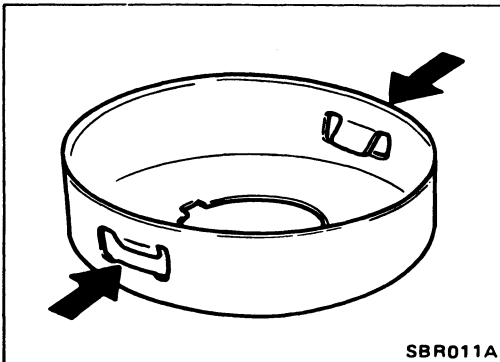
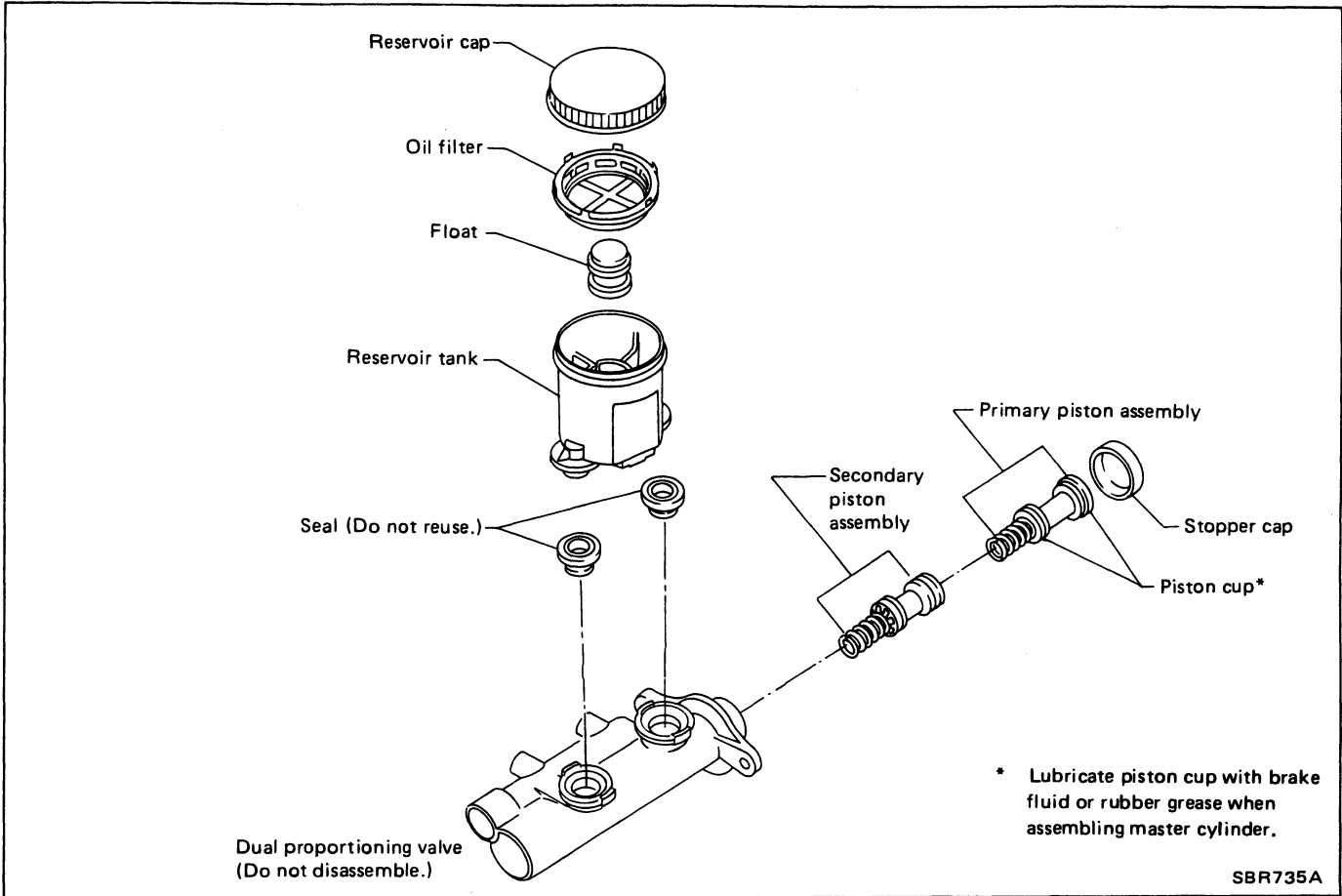

- Replace stopper cap if claw is damaged or deformed.
- Bend claws inward when installing stopper cap.

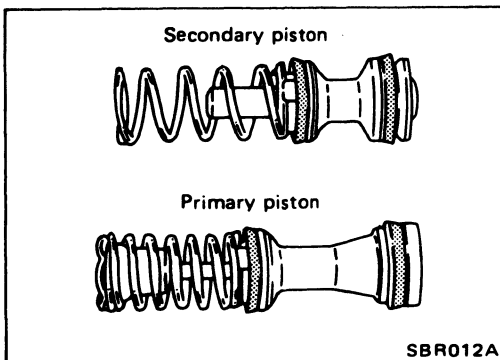

- Pay attention to direction of piston cups in figure at left.
- Check parts for wear or damage. Replace if necessary.

FRONT DISC BRAKE (OPZ25VA) — Caliper

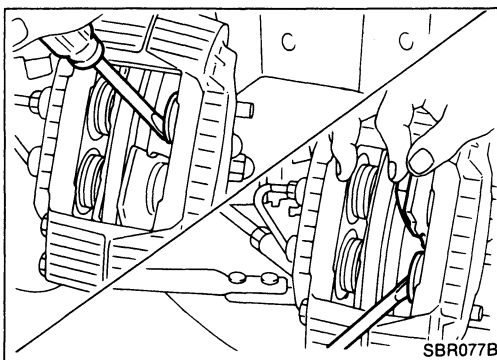
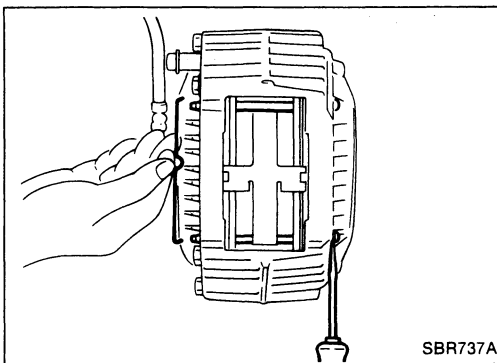
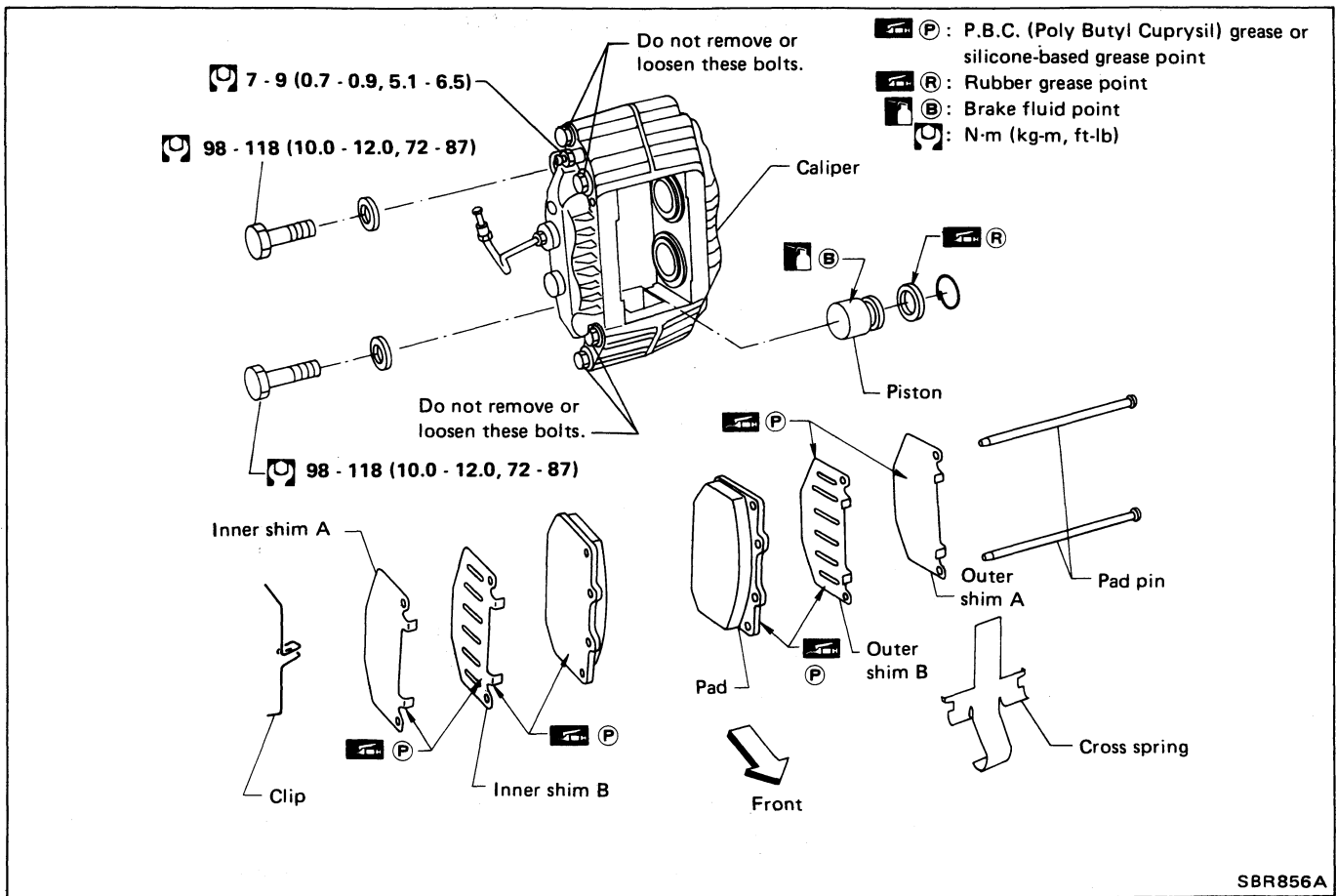

Pad Replacement

CAUTION:

- When pads are removed, do not depress brake pedal because piston will pop out.
- Be careful not to damage dust seal or get oil on rotor. Always replace shims when replacing pads.

1. Remove clip from pad pin and then remove pad pin.
2. Remove cross spring.

3. Pull out outer pad and insert it temporarily between lower piston and rotor as shown.
4. Push back upper piston with a suitable tool and insert new pad so it contacts upper piston as shown.
5. Pull out old pad.
6. Push back lower piston with a suitable tool.
7. Pull out new pad and reinstall it in the proper position.
8. Repeat step 3 to 7 for inner pad.
9. Install cross spring, pad pin and clip.

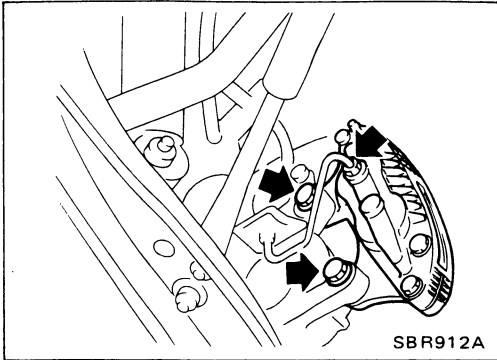

Removal and Installation

1. Disconnect brake tube.
2. Remove brake pad.
3. Remove brake caliper mounting bolts.

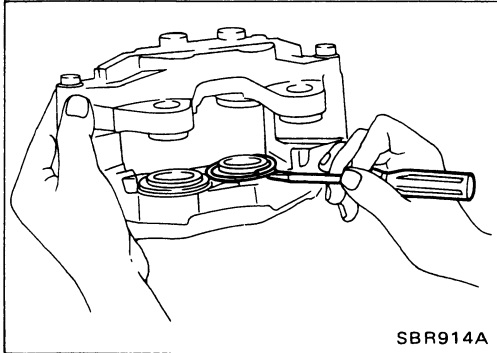

Disassembly

1. Remove retaining ring.

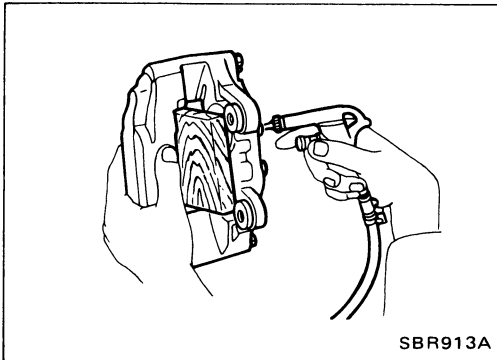

2. Push out piston with dust seal using compressed air.

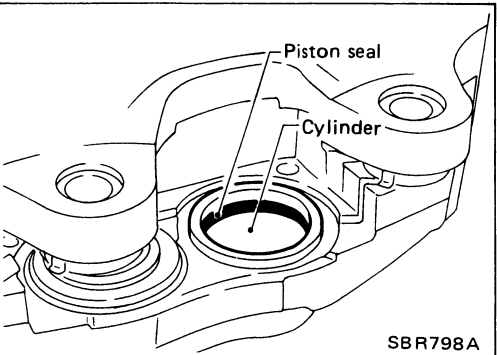

3. Remove piston seal.

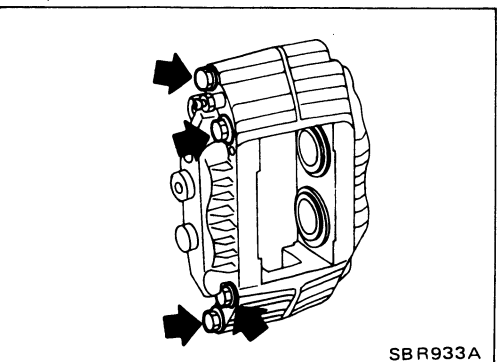

CAUTION:

Be careful not to loosen or remove bolts joining both sides of caliper.

If there is any fluid leakage, replace caliper assembly.

Inspection

CALIPER

- Check dust seals for damage.
- Check calipers for damage, rust or foreign materials.
- Check inside surface of cylinder for scoring, rust, wear, damage or foreign materials. Replace if any such condition exists.
- Eliminate minor damage from rust or foreign materials by polishing surface with fine emery paper.

CAUTION:

Use brake fluid to clean.

PISTON

Check piston for scoring, rust, wear, damage or foreign materials. Replace if any condition exists.

CAUTION:

Piston sliding surface is plated. Do not polish with emery paper even if rust or foreign materials are stuck to sliding surface.

PAD PIN AND CLIPS

Check for wear, cracks deformation, deterioration, rust or other damage. Replace if any such condition exists.

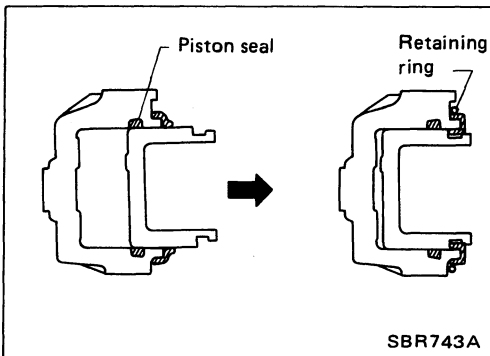

Assembly

1. Insert piston seal into groove on cylinder body,
2. With dust seal fitted to piston, install piston into cylinder body.
3. Secure dust seal properly.
4. Install retaining ring.

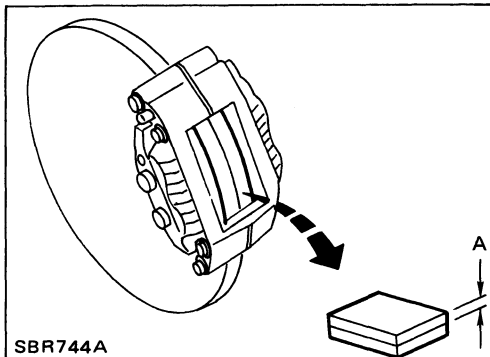

Inspection (On-vehicle)

DISC PAD

- Check pad shims for deformation or damage.
- Check disc pad for wear or damage.

Pad standard thickness (A):

10.0 mm (0.394 in)

Pad wear limit (A):

2.0 mm (0.079 in)

Inspection

RUBBING SURFACE

Check rotor for roughness, cracks or chips.

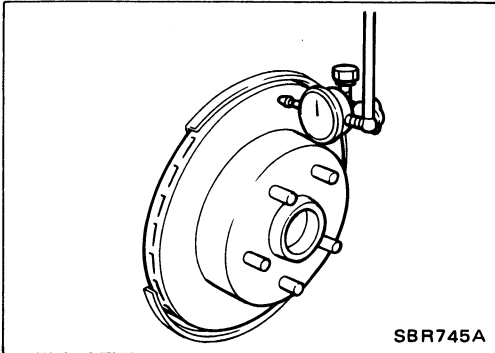

RUNOUT

Check runout using a dial indicator. Make sure that axial end play is within the specifications before measuring. Refer to section FA.

Rotor repair limit:

Maximum runout

(Total indicator reading at center of rotor pad contact surface)

0.07 mm (0.0028 in)

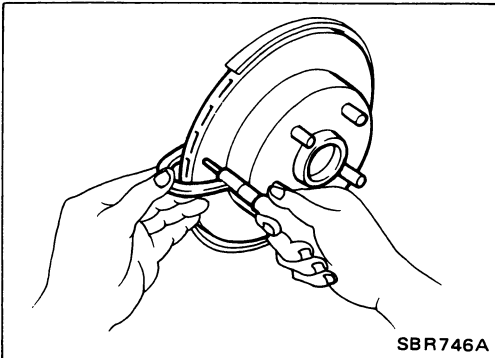

THICKNESS

Standard thickness:

30.0 mm (1.181 in)

Minimum thickness:

28.0 mm (1.102 in)

REAR DISC BRAKE (OPZ11VB) — Caliper

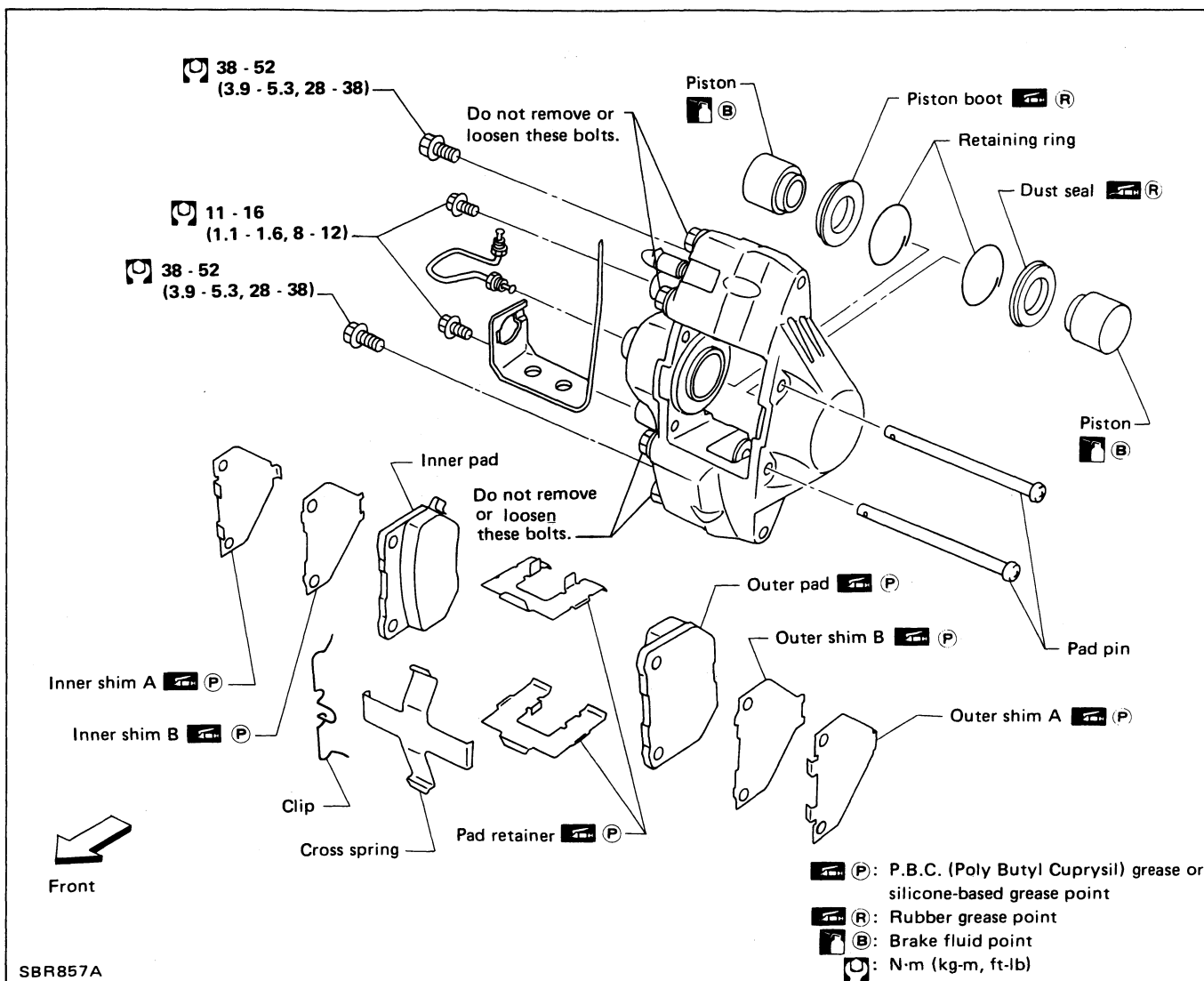

SBR857A

Pad Replacement

CAUTION:

When pads are removed, do not depress brake pedal because piston will pop out.

1. Remove clip from pad pin and then remove pad pin.
2. Remove cross spring.

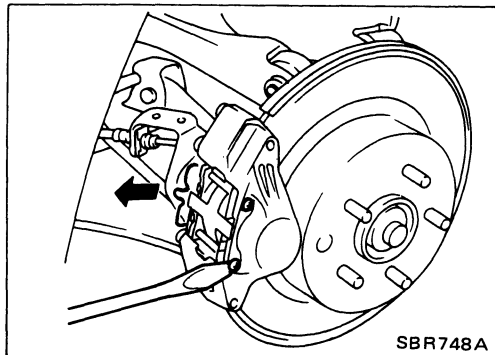

3. Pull out inner and outer pads.

CAUTION:

Be careful not to damage dust seal or get oil on rotor. Always replace shims when replacing pads.

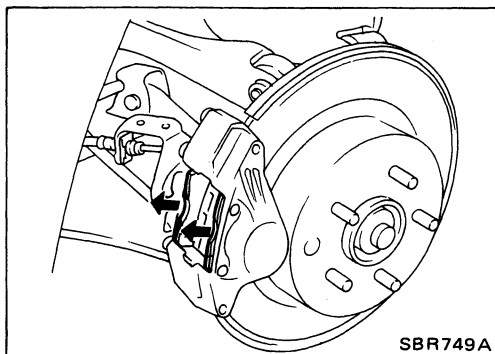

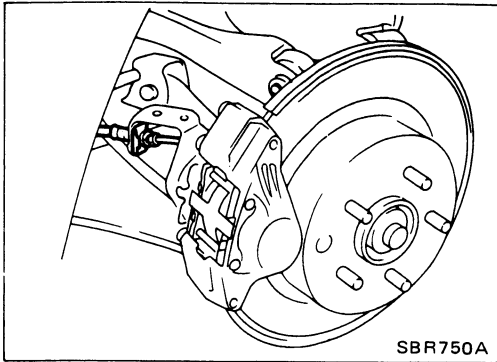

Removal and Installation

1. Disconnect brake tube.
2. Remove brake pad.

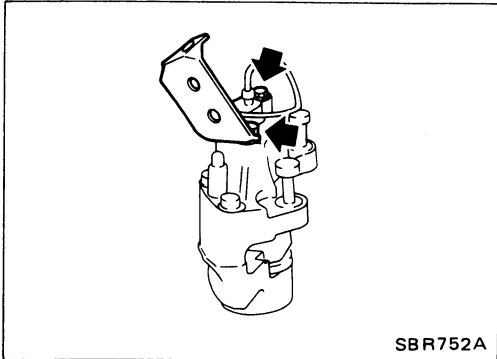

3. Remove brake cable and bracket.

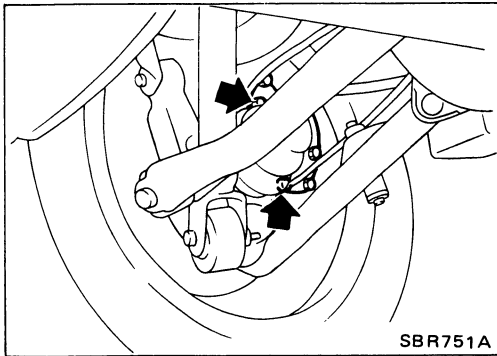

4. Remove axle housing fixing bolts.

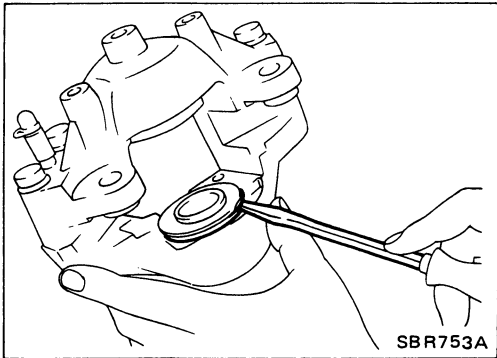

Disassembly

1. Remove retaining ring.

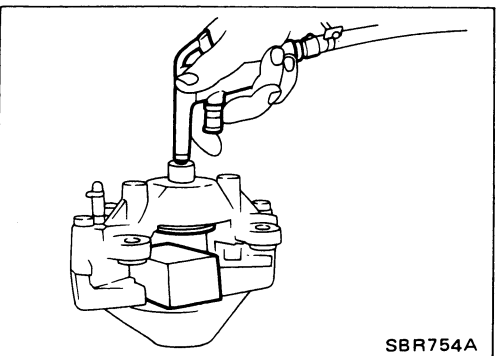

2. Push out piston with dust seal using compressed air.

REAR DISC BRAKE (OPZ11VB) — Caliper

Disassembly (Cont'd)

3. Remove piston seal.

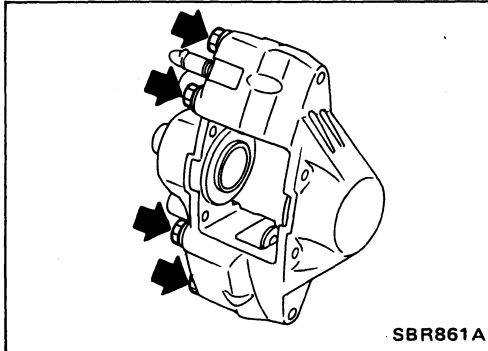
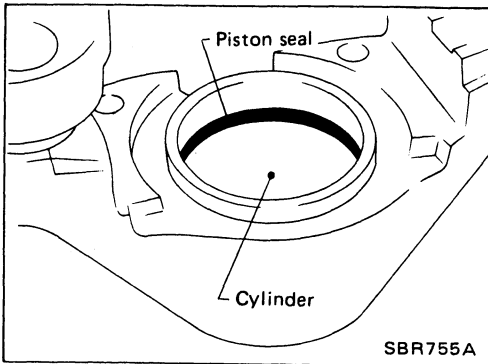

CAUTION:

Be careful not to loosen or remove bolts joining both sides of caliper.

If there is any fluid leakage, replace caliper assembly.

Inspection

CALIPER

- Check dust seals for damage.
- Check calipers for damage, rust or foreign materials.
- Check inside surface of cylinder for score, rust, wear or other damage.
- Minor damage from rust or foreign materials may be eliminated by polishing surface with a fine emery paper. Replace if necessary.

CAUTION:

Use brake fluid to clean.

PISTON

Check piston for score, rust, wear or other damage. Replace if necessary.

CAUTION:

Piston sliding surface is plated. Do not polish with emery paper even if rust or foreign matter is stuck to sliding surface.

PAD PIN AND CLIP

Check for wear, cracks deformation, deterioration, rust or other damage. Replace if necessary.

REAR DISC BRAKE (OPZ11VB) — Caliper

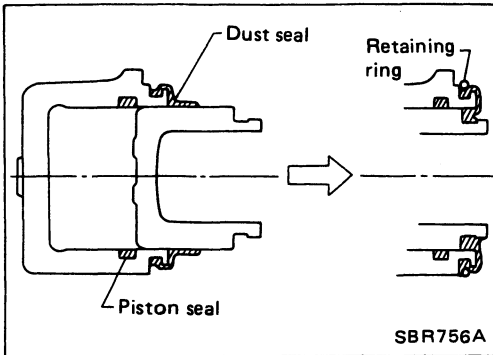

Assembly

1. Insert piston seal into groove on cylinder body.
2. With dust seal fitted to piston, install piston into cylinder body.
3. Secure dust seal properly.
4. Install retaining ring.

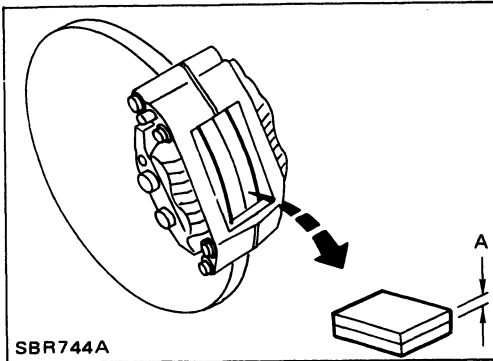

Inspection (On-vehicle)

DISC PAD

- Check pad shims for deformation or damage.
- Check disc pad for wear or damage.

Standard thickness (A):

11.5 mm (0.453 in)

Pad wear limit (A):

2.0 mm (0.079 in)

Inspection

RUBBING SURFACE

Check rotor for roughness, cracks or chips.

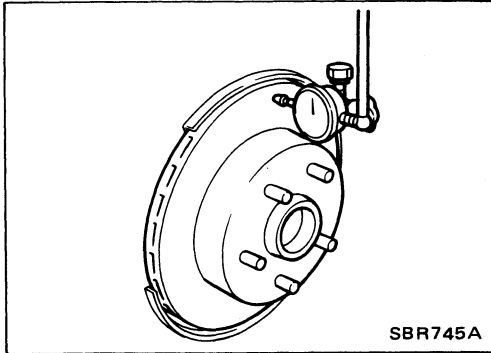

RUNOUT

- Check runout using a dial indicator.
- Make sure that axial end play is within the specifications before measuring. Refer to section RA.

Rotor repair limit:

Maximum runout

(Total indicator reading at center of rotor pad contact surface)

0.07 mm (0.0028 in)

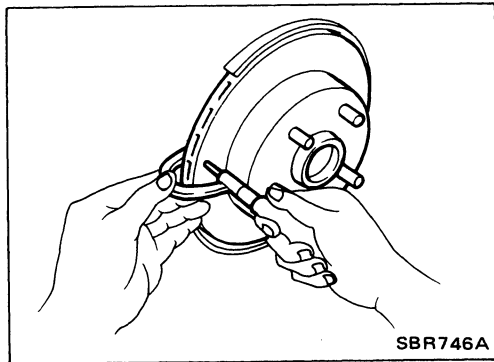

THICKNESS

Standard thickness:

18 mm (0.71 in)

Minimum thickness:

16 mm (0.63 in)

PARKING BRAKE CONTROL

Removal and Installation

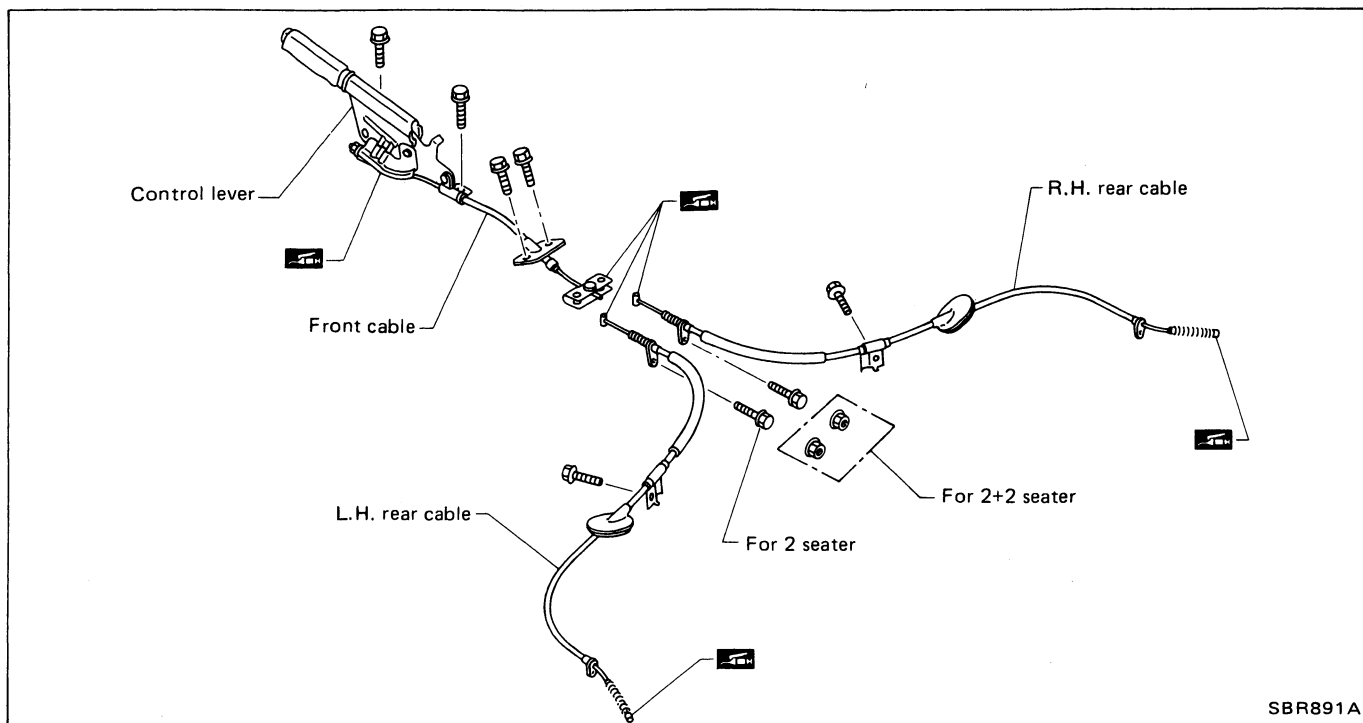

- Before removing parking brake control, remove console box.
- Loosen cable using control lever adjuster, and separate front and rear cables.

Apply multi-purpose grease to areas between control lever drum and cables.

Be careful not to damage boot and inner cable.

Inspection

1. Check control lever for wear or other damage. Replace if necessary.
2. Check parking brake cables, lamp and switch. Replace if necessary.
3. Check parts at each connecting portion for deformation or damage. If found, replace.

Adjustment

Perform shoe clearance adjustment before adjusting control lever stroke.

1. Turn adjusting nut.

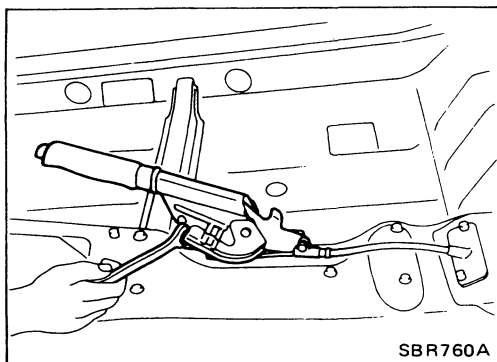

PARKING BRAKE CONTROL

Adjustment (Cont'd)

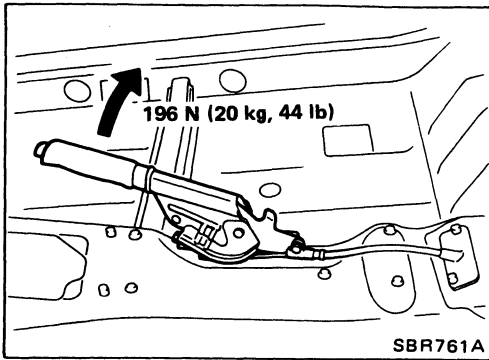

2. Pull control lever with specified amount of force. Check lever stroke and ensure smooth operation.

Number of notches: 6 - 7

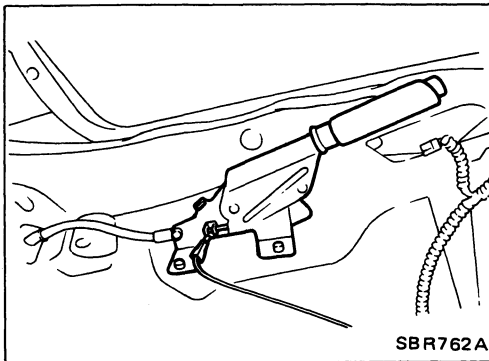

3. Bend parking brake warning lamp switch plate so that brake warning light comes on when ratchet at parking brake lever is pulled "A" notches and goes out when fully released.

Number of notches "A": 1

PARKING DRUM BRAKE (DS17HD)

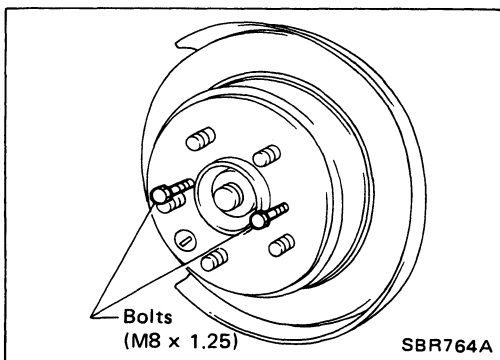
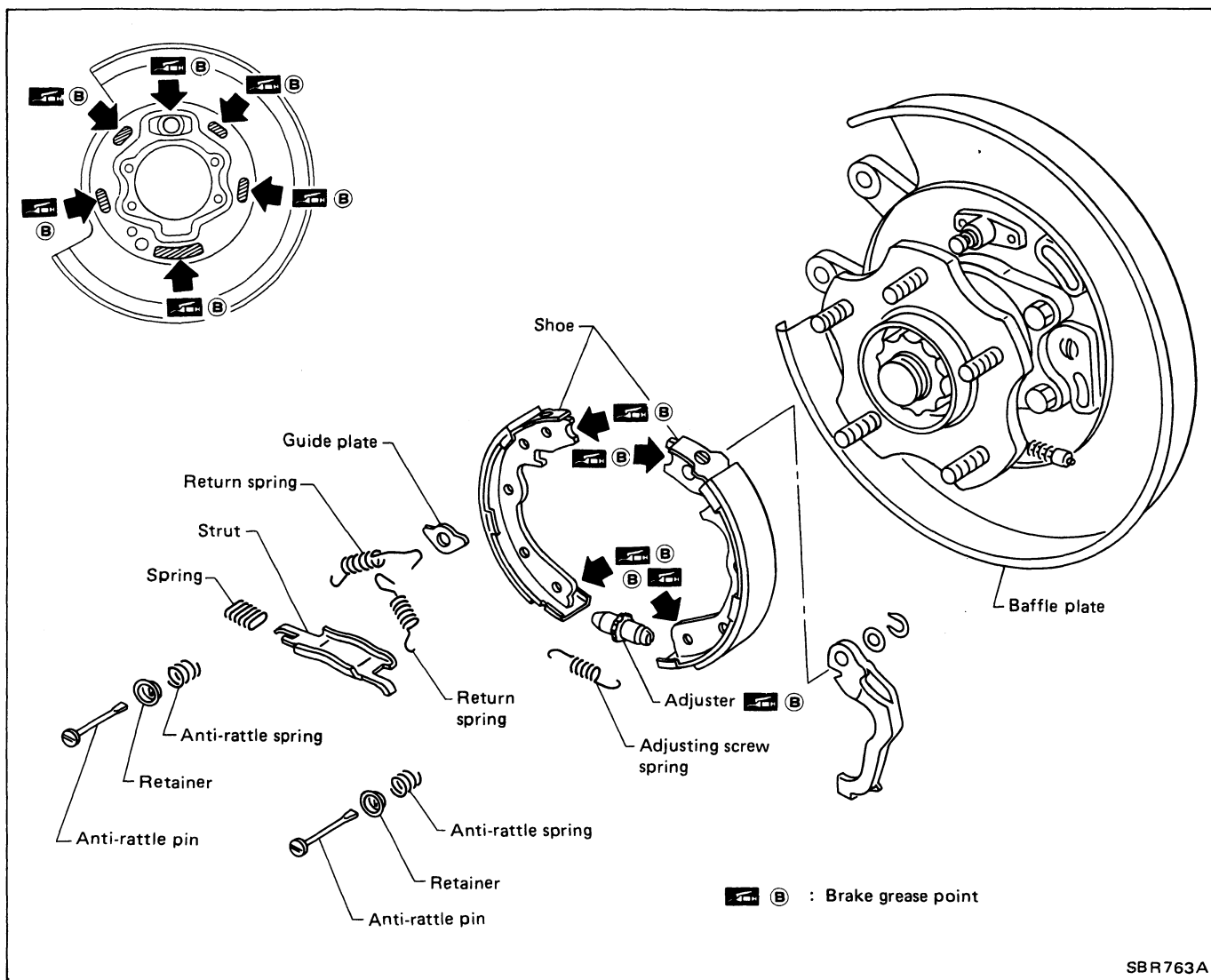

Shoe Replacement

1. Remove disc rotor (With parking drum brake).
Tighten two bolts gradually if disc rotor is hard to remove.

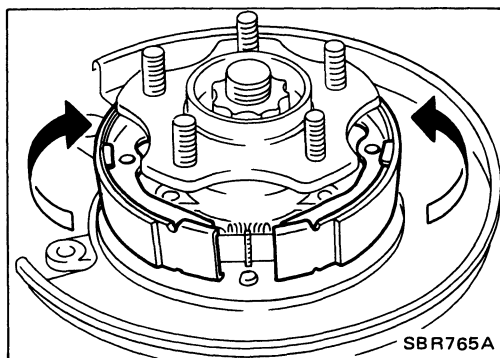

2. After removing anti-rattle pin, remove spring by rotating shoes.
Be careful not to damage parking brake cable when separating it.

PARKING DRUM BRAKE (DS17HD)

Shoe Replacement (Cont'd)

3. Apply brake grease to the contact areas shown at left.

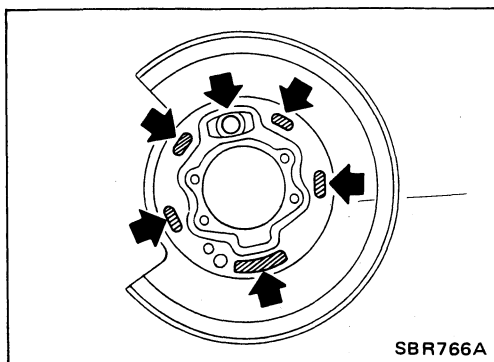

Shoe Clearance Adjustment

1. Remove adjuster hole plug, and turn adjuster wheel with a screwdriver until shoe touches brake drum.

Make sure that parking control lever is released completely.

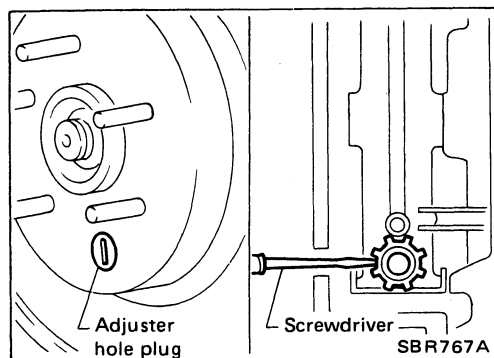

2. Return adjuster wheel 5 to 6 latches.
3. Install adjuster hole plug, and make sure that there is no drag between shoes and brake drum when rotating disc rotor.

Breaking in Drum and Lining

1. Using either low or 2nd transmission speed, drive the unloaded vehicle on a safe, level and dry road.
2. Depress the release button of parking brake lever, then pull the lever with a force of 98 N (10 kg, 22 lb).
3. While holding the lever, continue to drive the vehicle forward 100 m (328 ft) at approximately 35 km/h (22 MPH).
4. While holding the lever, drive the vehicle in reverse 10 m (33 ft) at approximately 10 km/h (6 MPH).
5. Repeat steps 1 through three times and then repeat only step 4 one more time.

Drum Inspection

Standard inner diameter:

172.0 mm (6.77 in)

Maximum inner diameter:

173.0 mm (6.81 in)

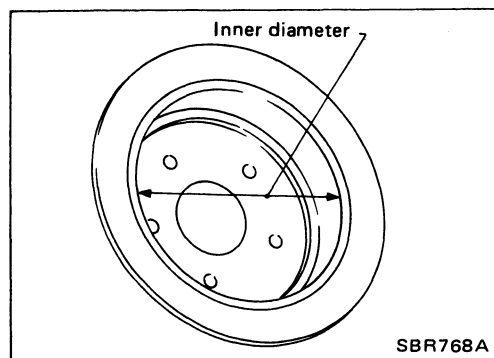

ANTI-LOCK BRAKING SYSTEM

System Components

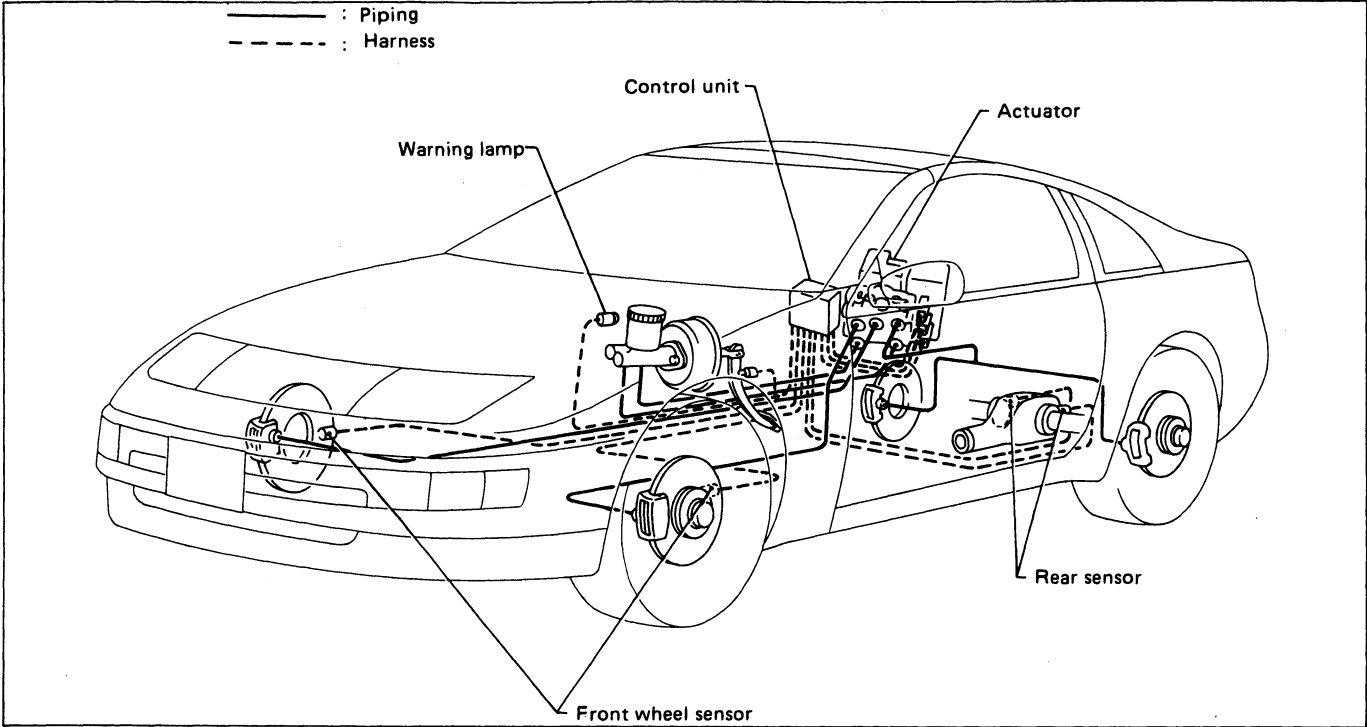

Hydraulic Circuit

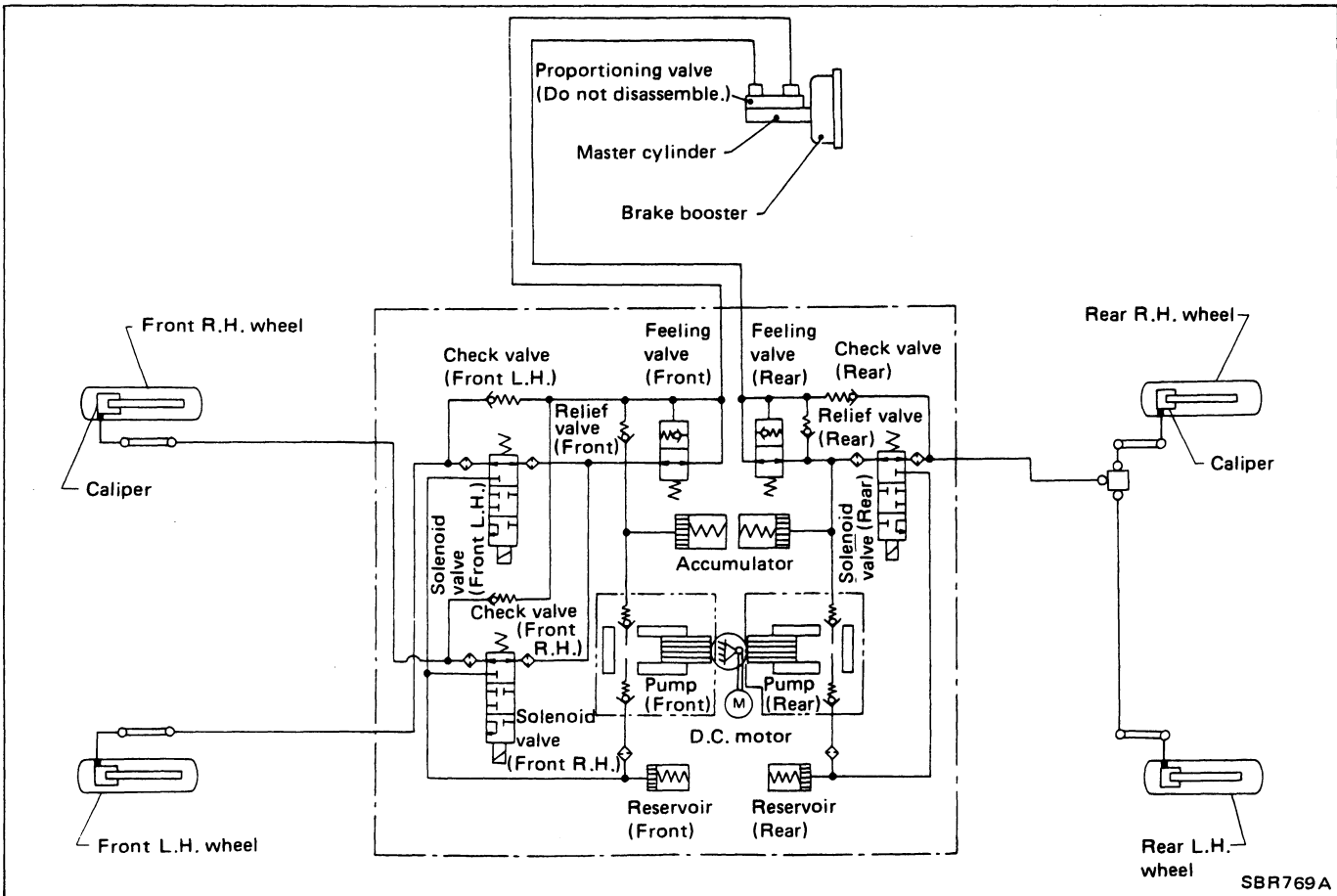

ANTI-LOCK BRAKING SYSTEM

Removal and Installation

CAUTION:

Be careful not to damage sensor edge and sensor rotor teeth.
FRONT WHEEL SENSOR

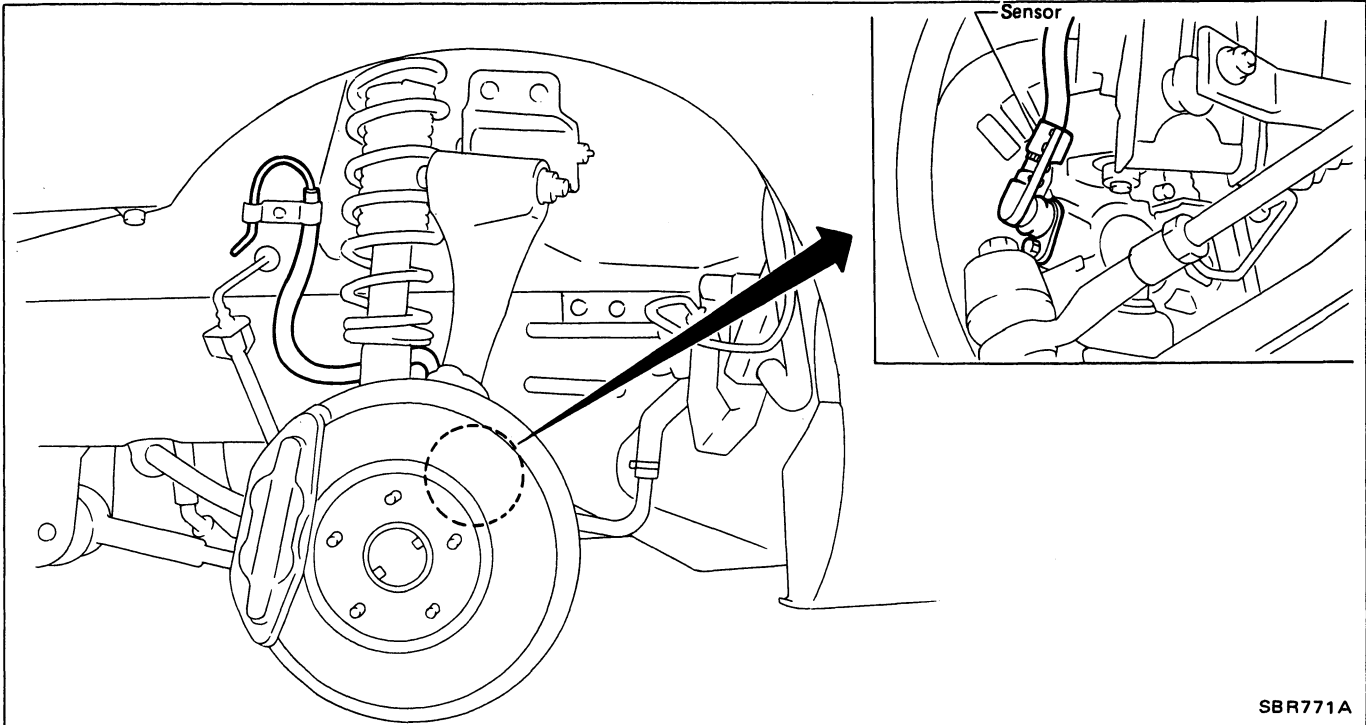

SBR771A

REAR SENSOR

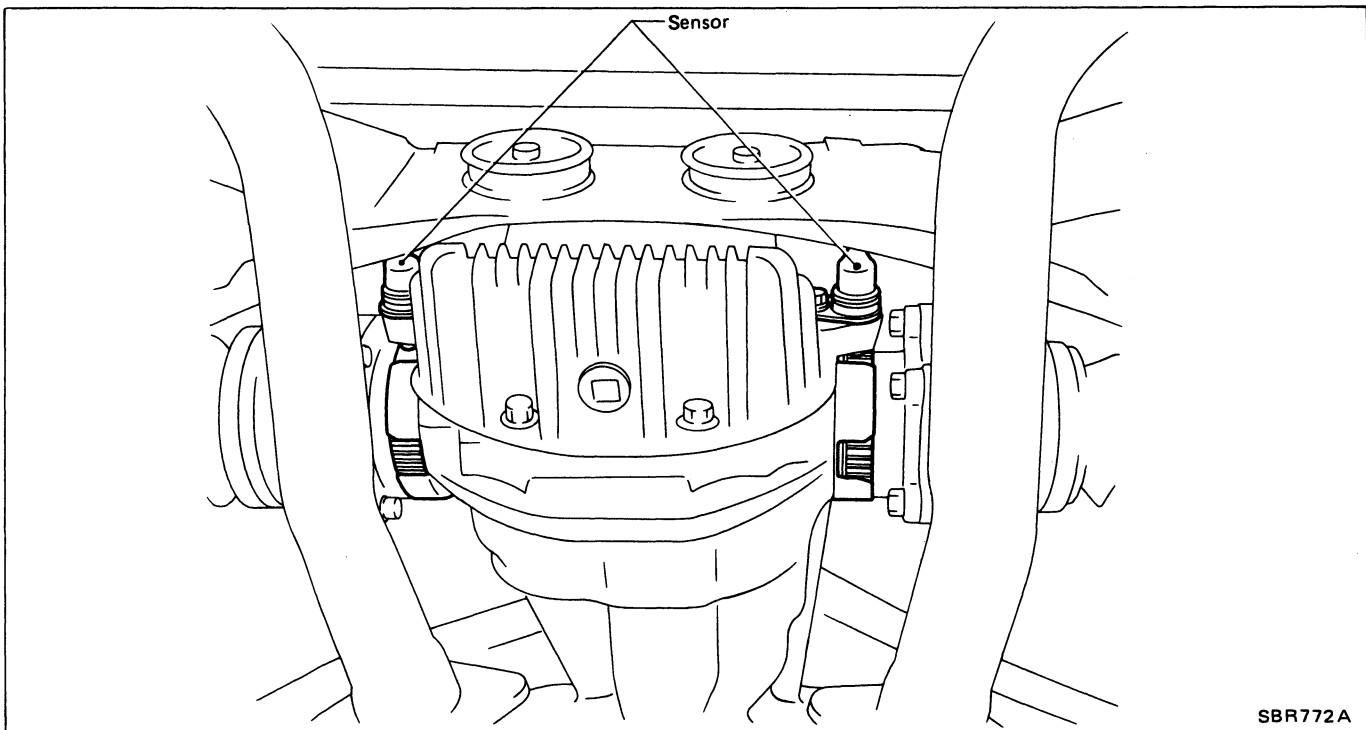

SBR772A

- Remove rear sensor rotor with differential side flange after drive shaft removal. Refer to RA section.

ANTI-LOCK BRAKING SYSTEM

Removal and Installation (Cont'd)

ACTUATOR

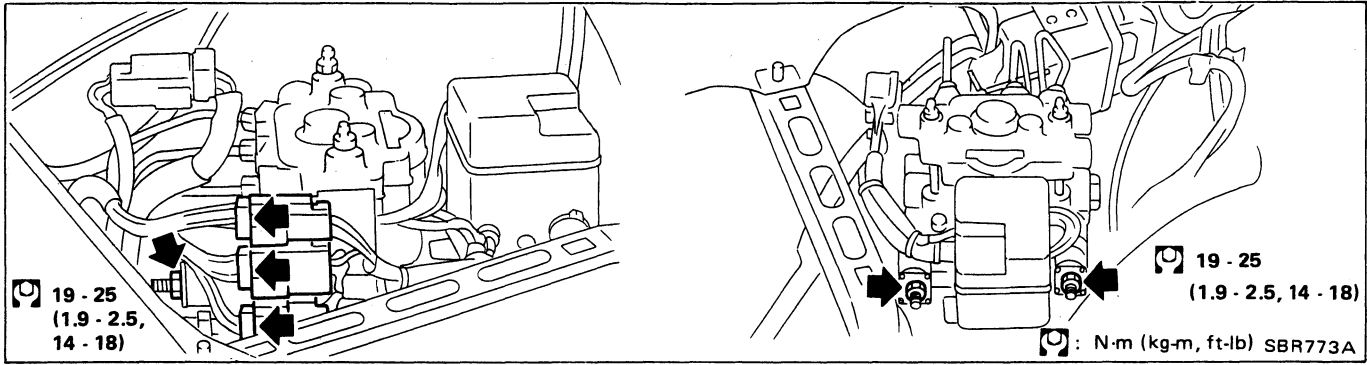

- Disconnect 3 connectors and brake tubes.
- Remove 3 nuts fixing actuator to bracket.

TROUBLE DIAGNOSES

Contents

How to Perform Trouble Diagnoses for Quick and Accurate Repair	BR-30
Symptom Chart	BR-33
Preliminary Check 1	BR-34
Preliminary Check 2	BR-35
Preliminary Check 3, 4	BR-36
Self-diagnosis	BR-37
Component Parts Location	BR-38
Harness Connector Location	BR-39
Ground Circuit Check	BR-40
Circuit Diagram for Quick Pinpoint Check	BR-41
Diagnostic Procedure 1	BR-42
Diagnostic Procedure 2	BR-43
Diagnostic Procedure 3	BR-44
Diagnostic Procedure 4	BR-44
Diagnostic Procedure 5	BR-45
Diagnostic Procedure 6	BR-45
Diagnostic Procedure 7	BR-46
Diagnostic Procedure 8	BR-47
Diagnostic Procedure 9	BR-48
Diagnostic Procedure 10	BR-49
Diagnostic Procedure 11	BR-50
Diagnostic Procedure 12	BR-51
Electrical Components Inspection	BR-52

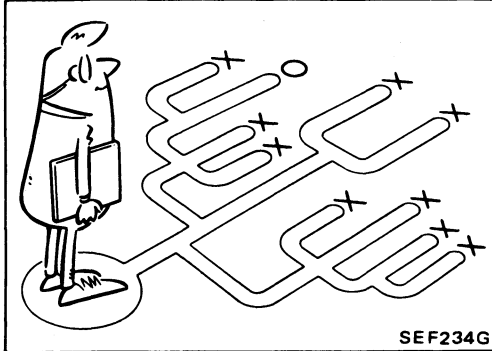
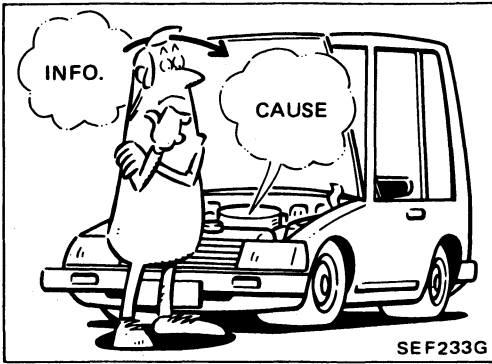

How to Perform Trouble Diagnoses for Quick and Accurate Repair

INTRODUCTION

The A.B.S. system has an electronic control unit to control major functions. The control unit accepts input signals from sensors and instantly drives actuators. It is essential that both kinds of signals are proper and stable. At the same time, it is important that there are no conventional problems such as air leaks in the booster or lines, lack of brake fluid, or other problems with brake system.

It is much more difficult to diagnose a problem that occurs intermittently rather than continuously. Most intermittent problems are caused by poor electric connections or faulty wiring. In this case, careful checking of suspicious circuits may help prevent the replacement of good parts.

A visual check only may not find the cause of the problems, so a road test should be performed.

Before undertaking actual checks, take just a few minutes to talk with a customer who approaches with a A.B.S. complaint. The customer is a very good source of information on such problems; especially intermittent ones. Through the talks with the customer, find out what symptoms are present and under what conditions they occur.

Start your diagnosis by looking for "conventional" problems first. This is one of the best ways to troubleshoot brake problems on an A.B.S. controlled vehicle.

TROUBLE DIAGNOSES

How to Perform Trouble Diagnoses for Quick and Accurate Repair (Cont'd)

WORK FLOW

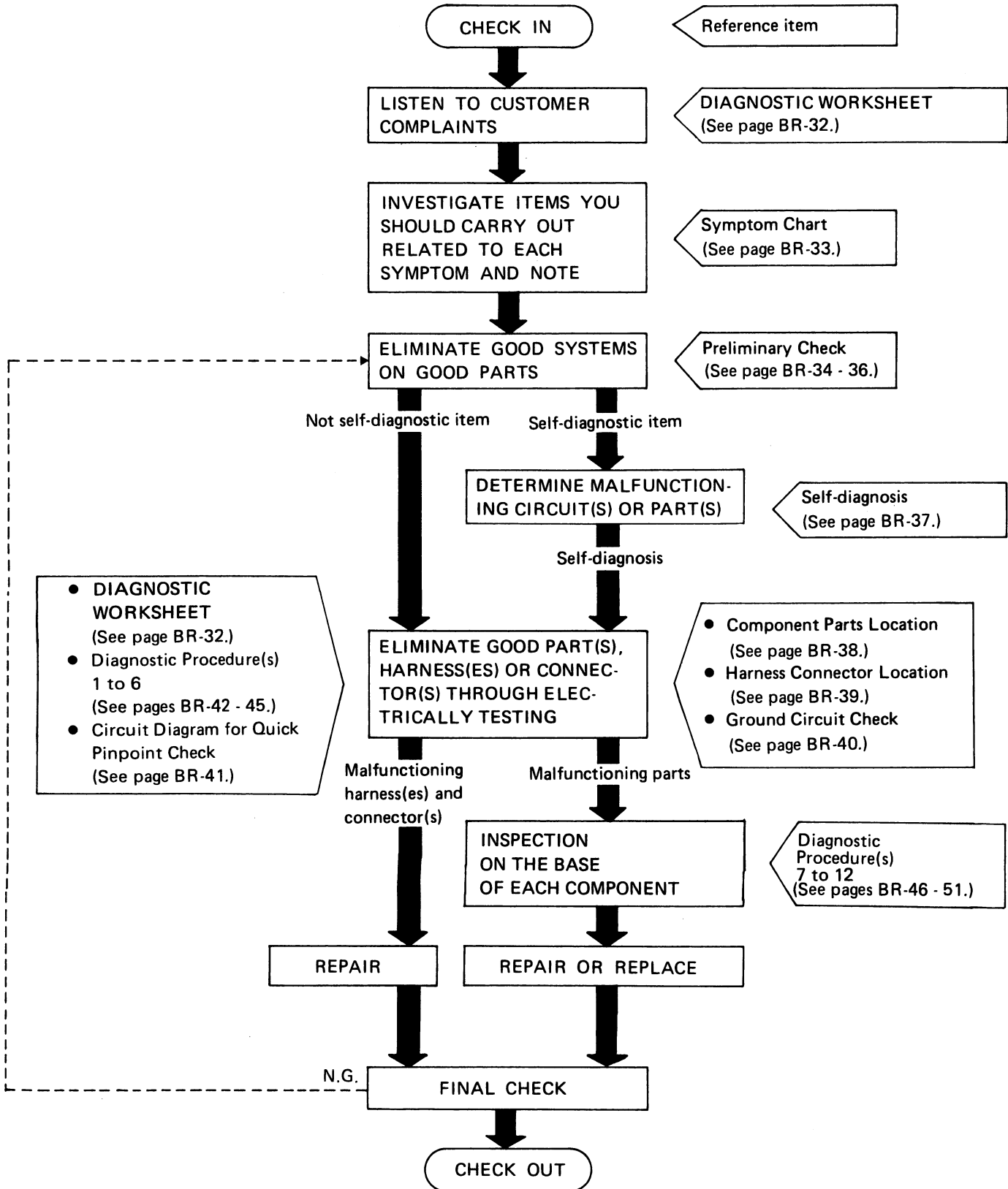

TROUBLE DIAGNOSES

Symptom Chart

PROCEDURE	REFERENCE PAGE	SYMPTOM	Pedal vibration & noise	Warning activates	Long stopping distance	Abnormal pedal action	A.B.S. doesn't work	A.B.S. works but warning activates	A.B.S. works frequently
Electrical Components Inspection	BR-52	Actuator inspection					○		
	BR-40	Motor ground					○		
Ground Circuit Check	BR-40	Sensor shield	○						○
	BR-51	L.E.D. comes off	○	○	○	○	○	○	
Diagnostic Procedure (Select inspection with L.E.D. flashing No.)	BR-50	L.E.D. flashing 16	○	○	○	○	○	○	
	BR-49	L.E.D. flashing 10	○	○	○	○	○	○	
	BR-48	L.E.D. flashing 9	○	○	○	○	○	○	
	BR-47	L.E.D. flashing 5 - 8	○	○	○	○	○	○	
	BR-46	L.E.D. flashing 1 - 4	○	○	○	○	○	○	
	Diagnostic Procedure	BR-45	Diagnostic Procedure 6						
BR-45		Diagnostic Procedure 5					○		
BR-44		Diagnostic Procedure 4					○		
BR-44		Diagnostic Procedure 3				○			
BR-43		Diagnostic Procedure 2			○				
BR-42		Diagnostic Procedure 1	○						
Preliminary Check	BR-36	Preliminary Check 4	○	○	○	○	○	○	
	BR-36	Preliminary Check 3	○	○					
	BR-35	Preliminary Check 2		○			○		○
	BR-34	Preliminary Check 1			○	○			○

TROUBLE DIAGNOSES

Preliminary Check 1

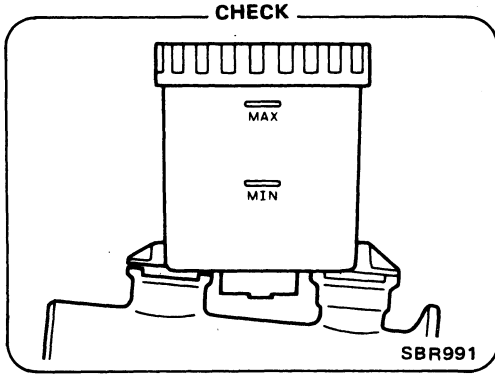

Check brake fluid level in reservoir tank.

N.G. → Fill up brake fluid.

O.K. →

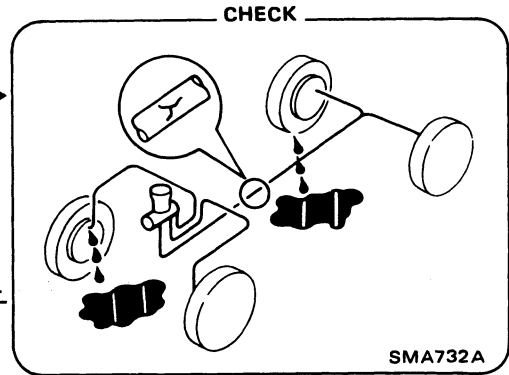

Check brake system.
Refer to CHECK AND ADJUSTMENT.

Repair brake system. ← N.G.

O.K. ↓

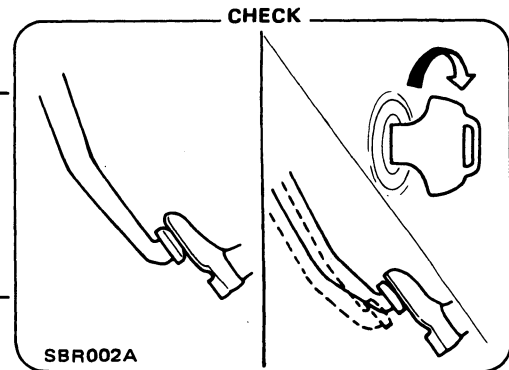

Check brake booster operation and airtightness.
Refer to "Inspection" of BRAKE BOOSTER.

Repair or replace booster system. ← N.G.

O.K. →

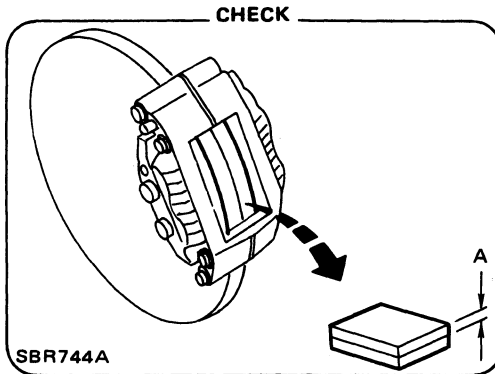

Check brake pads and rotor.
Refer to "Inspection" of FRONT and REAR DISC BRAKE.

Replace malfunctioning parts. ← N.G.

TROUBLE DIAGNOSES

Preliminary Check 2

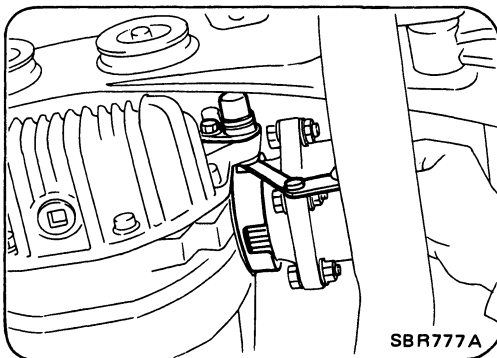
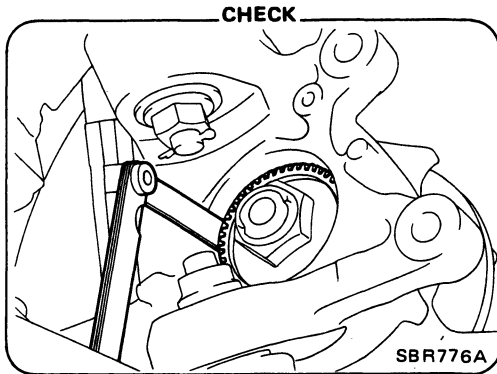

Check sensor clearance.

	Clearance mm (in)
Front wheel sensor	0.22 - 0.71 (0.0087 - 0.0280)
Rear sensor	0.06 - 0.93 (0.0024 - 0.0366)

O.K.

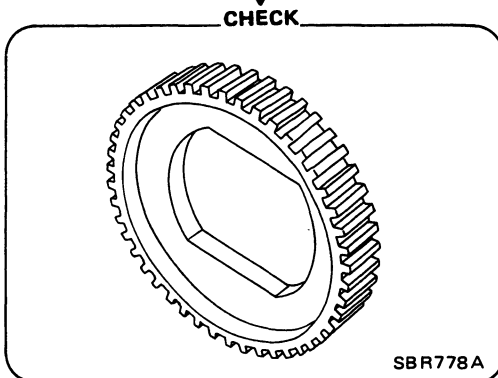

Check sensor rotor for teeth damage.

Number of teeth:

Front: 46

Rear: 46

N.G.

Check sensor for the following items:

- Dust, foreign materials, etc., at fastening portion
- Improper installation
- Breakage

O.K.

N.G.

Repair or replace malfunctioning sensor.

N.G.

Replace sensor rotor.

TROUBLE DIAGNOSES

Preliminary Check 3 CHECK

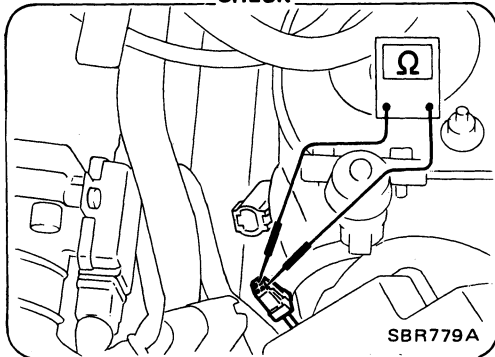

N.G. → Replace.

O.K. →

Measure each sensor resistance.
0.8 - 1.2 kΩ

Preliminary Check 3, 4

Preliminary Check 4 CHECK

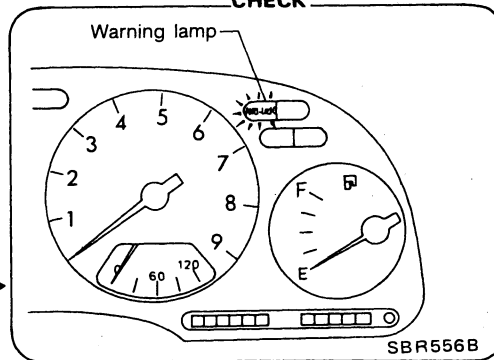

Check warning lamp activation.
When ignition switch is turned on, warning lamp turns on.

O.K. →

N.G. ↓

Check fuse.
Check bulb condition and remedy.

CHECK

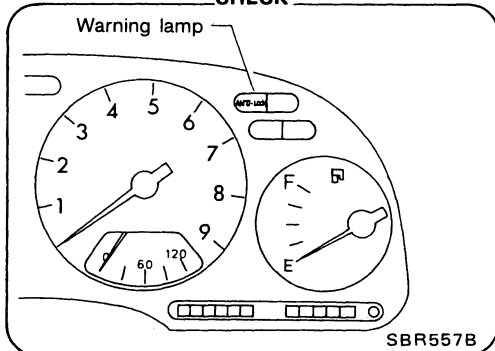

Check warning lamp for deactivation.
When engine starts, warning lamp deactivates.

O.K. ↓

DRIVE

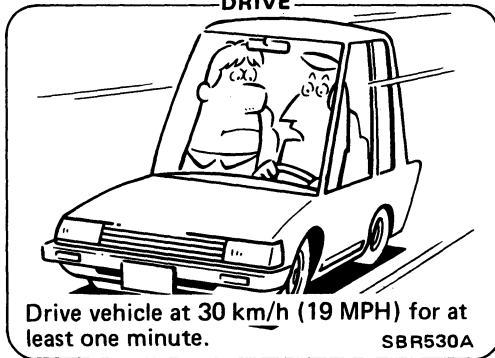

Drive vehicle at 30 km/h (19 MPH) for at least one minute.

CHECK

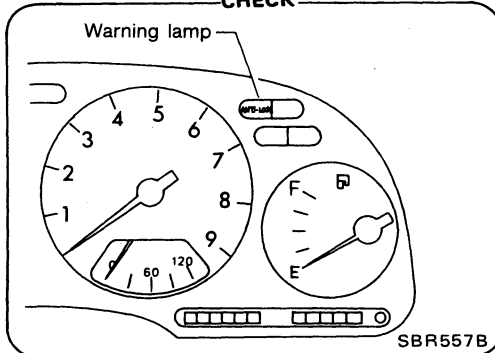

Ensure warning lamp remains off while driving.

N.G. →

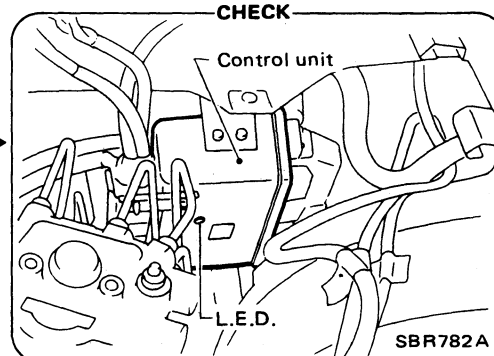

- Keep engine on and running.
- Count the number of L.E.D. flashes during 5 to 10 second "OFF" period.

Go to Self-diagnosis.
(See page BR-37.)

N.G. →

O.K. → If Preliminary Check 2 is not performed and there is abnormal A.B.S. operation, perform Preliminary Check 2.

TROUBLE DIAGNOSES

Self-diagnosis

CHECKING THE NUMBER OF L.E.D. FLASHES

When a problem occurs in the A.B.S., the warning light on the instrument panel comes on. As shown in the Table, the control unit performs self-diagnosis.

To obtain satisfactory self-diagnosing results, the vehicle must be driven above 30 km/h (19 MPH) for at least one minute before the self-diagnosis is performed. After the vehicle is stopped, the number of L.E.D. flashes is counted while the engine is running.

The L.E.D. is located on the control unit, identifying a malfunctioning part or unit by the number of flashes. Both the warning light and the L.E.D. persistently activate, even after a malfunctioning part or unit has been repaired, unless the ignition switch is turned "OFF". After repairs, turn the ignition switch "OFF". Then start the engine and drive the vehicle over 30 km/h (19 MPH) for at least one minute to ensure that the malfunctioning part or unit has been repaired properly.

If more than two circuits malfunction at the same time, the L.E.D. will flash to indicate one of the malfunctioning circuits. After the circuit has been repaired, the L.E.D. will then flash to indicate that the other circuit is malfunctioning.

No. of L.E.D. flashes	Malfunctioning part or unit
1	Left front actuator solenoid circuit
2	Right front actuator solenoid circuit
3 or 4	Rear actuator solenoid circuit
5	Left front rotor sensor circuit
6	Right front rotor sensor circuit
7	Right rear rotor sensor circuit
8	Left rear wheel sensor circuit
9	Actuator motor, motor relay circuit
10	Actuator solenoid valve relay
16	Control unit
Warning activates and L.E.D. "OFF"	Power supply or ground circuit for control unit

Example

Improper operation of left front rotor sensor circuit

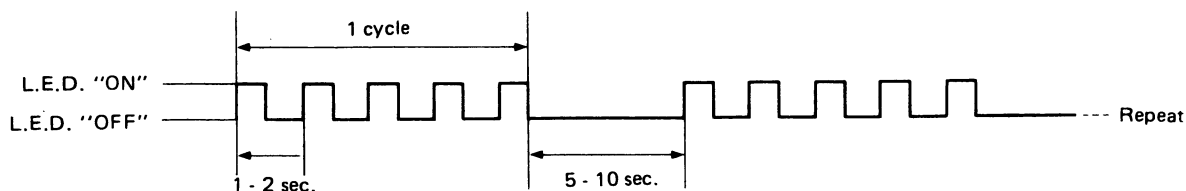

SBR531A

Go to Diagnostic Procedure from 7 to 10, where malfunction portion is concerned.

TROUBLE DIAGNOSES

Component Parts Location

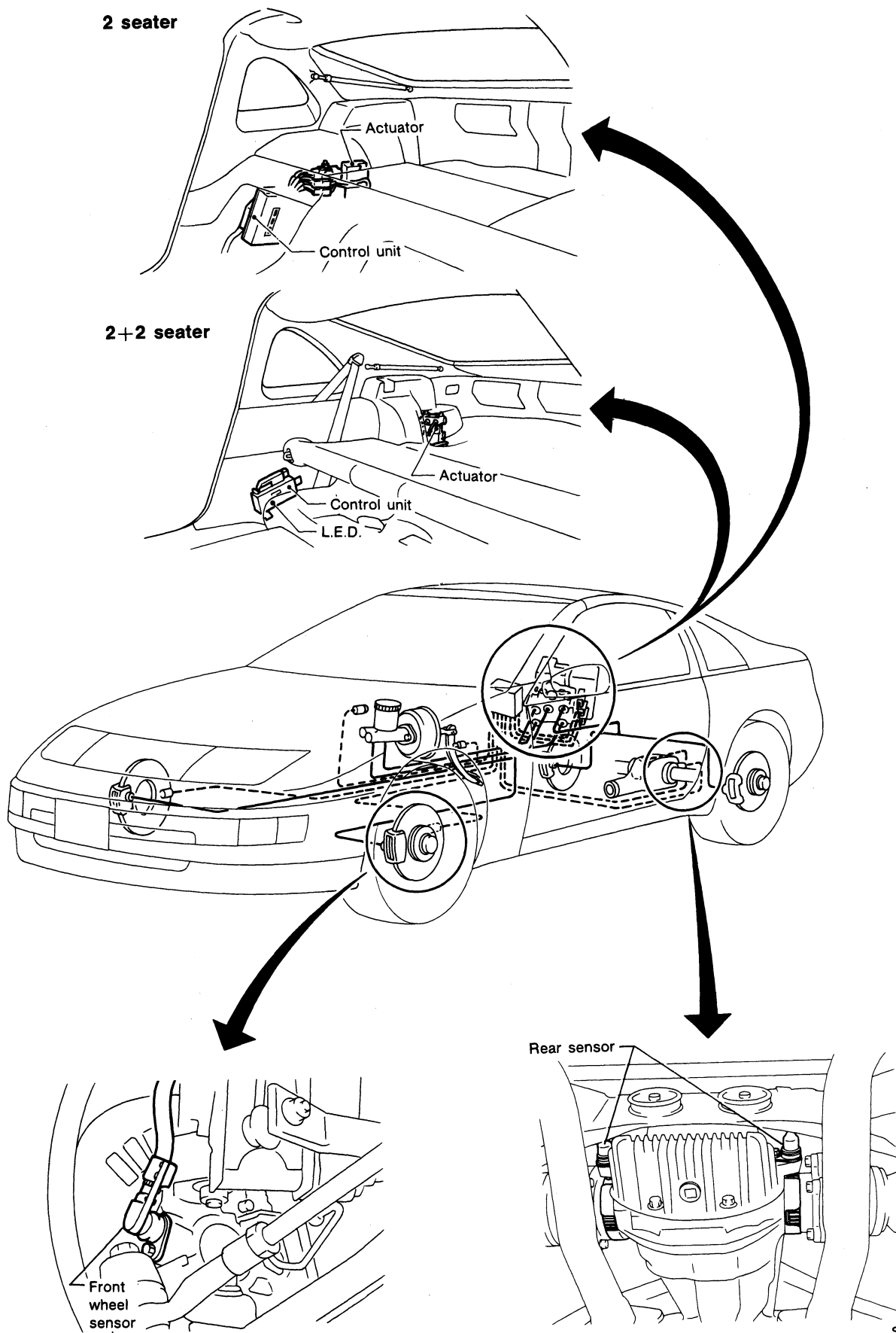

SBR555B

TROUBLE DIAGNOSES

Harness Connector Location

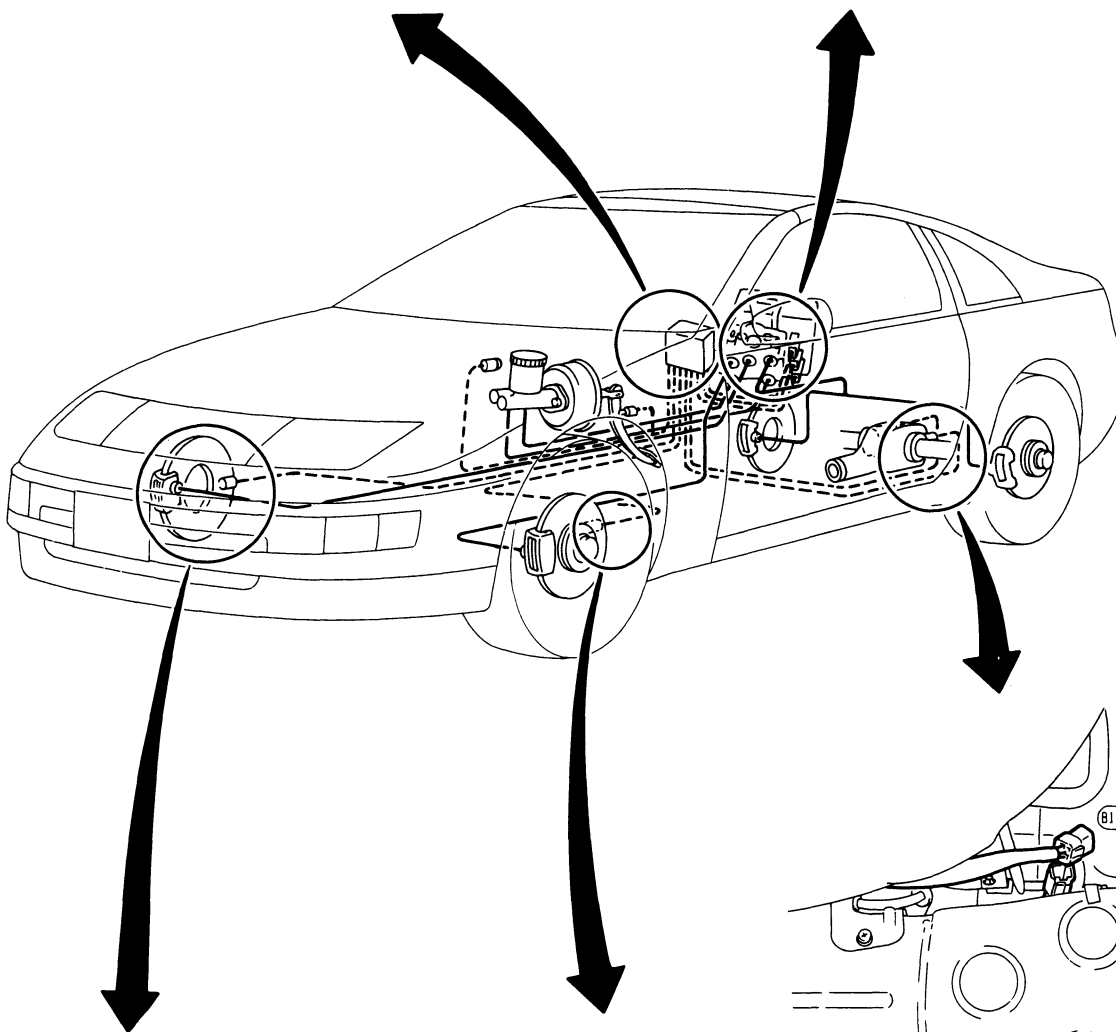
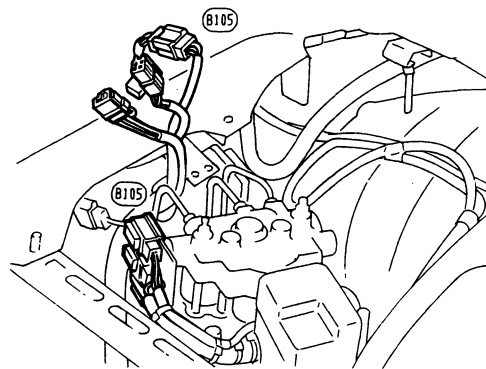
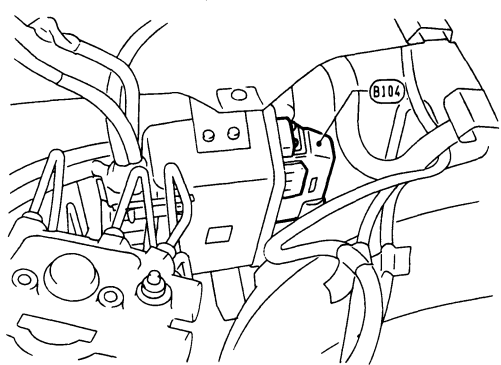

Front wheel sensor R.H.

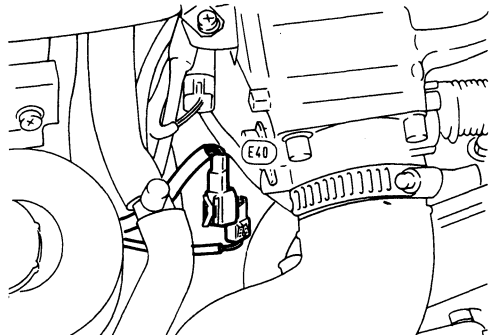

Front wheel sensor L.H.

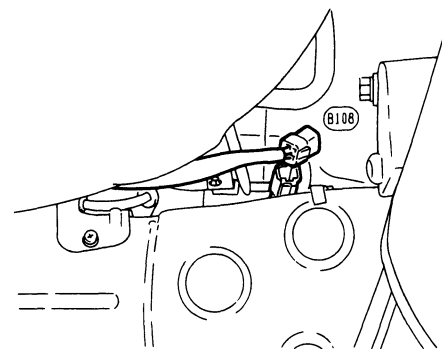
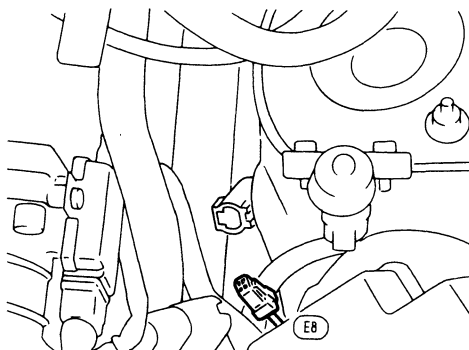

SBR785A

TROUBLE DIAGNOSES

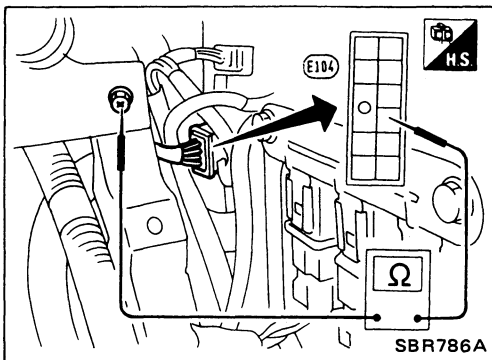

Ground Circuit Check

FRONT WHEEL SENSOR L.H. SHIELDED WIRE GROUND

- Check resistance between both terminals.
Resistance: approx. 0Ω

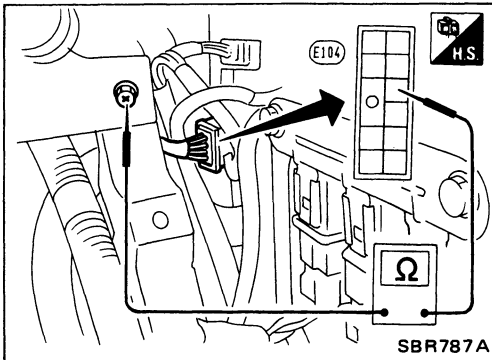

FRONT WHEEL SENSOR R.H. SHIELDED WIRE GROUND

- Check resistance between both terminals.
Resistance: approx. 0Ω

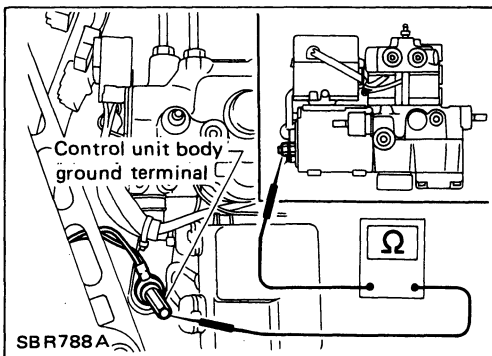

ACTUATOR MOTOR GROUND

- Check resistance between both terminals.
Resistance: approx. 0Ω

TROUBLE DIAGNOSES

Circuit Diagram for Quick Pinpoint Check

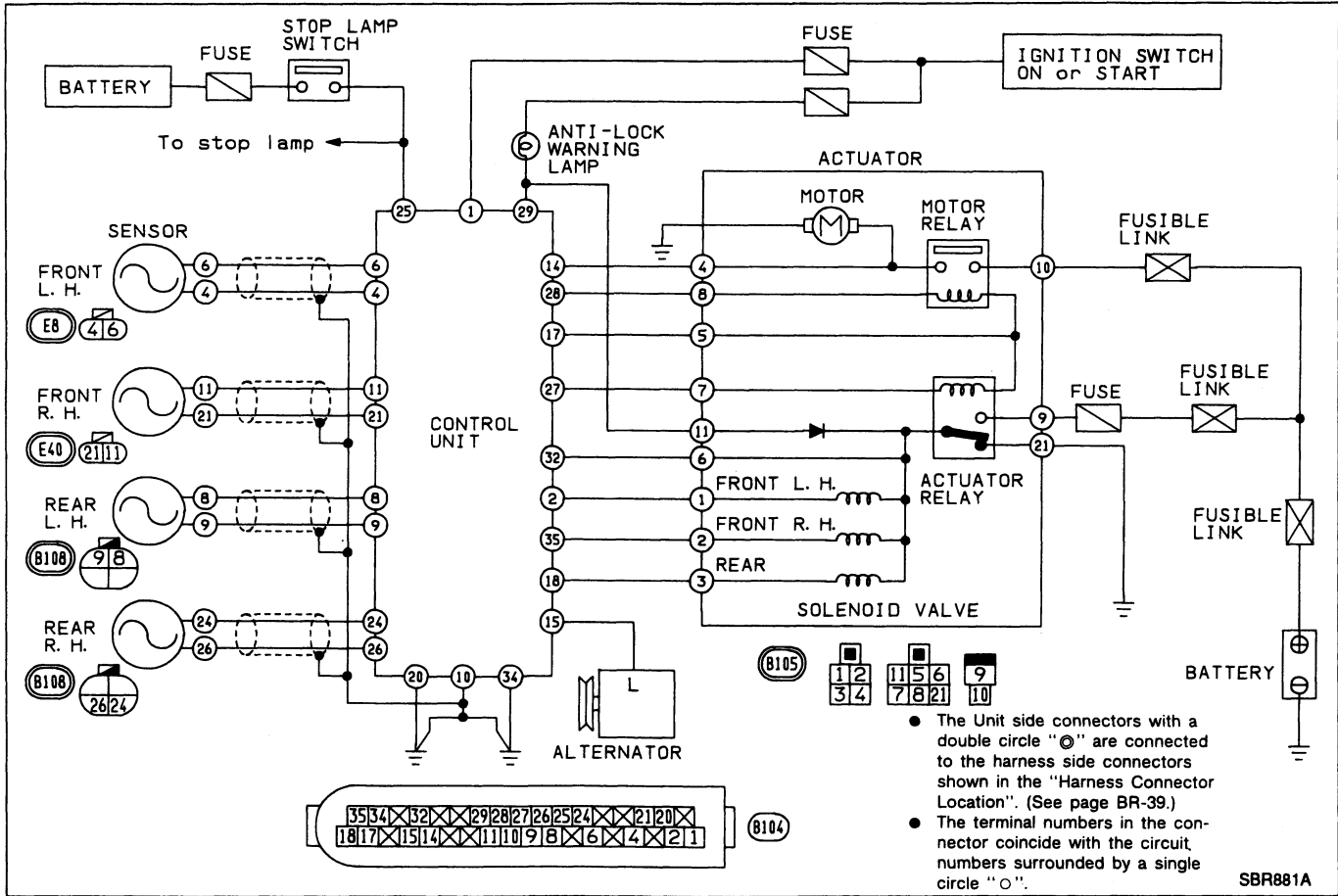

TROUBLE DIAGNOSES

Diagnostic Procedure 1

SYMPTOM: Pedal vibration and noise

Refer to worksheet result.

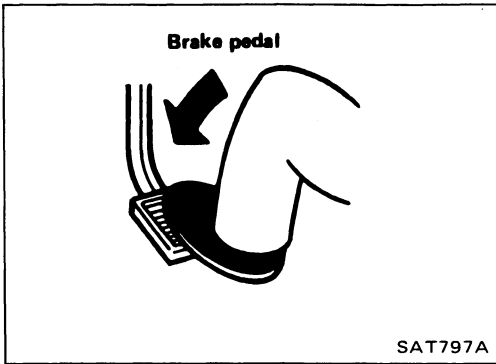

Check whether the symptom appears only when brake is applied suddenly.

Yes → When brake is normally applied, A.B.S. works and produces pedal vibration or noise.

No ↓

Check whether the symptom appears only when engine is started.

Yes → Refer to Preliminary Check 4 result.

No ↓

Check whether the symptom appears only when the vehicle speed is within 10 km/h (6 MPH) after starting engine.

Yes → Check whether the symptom disappears within 5 seconds.

No ↓

No → (A)

Yes ↓

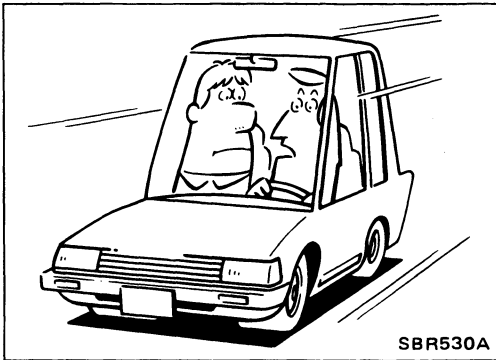

A.B.S. may sometimes operate when load is high and voltage is low due to insufficient alternator output.

Check whether the symptom appears while the vehicle is being driven.

No → (A)

Yes ↓

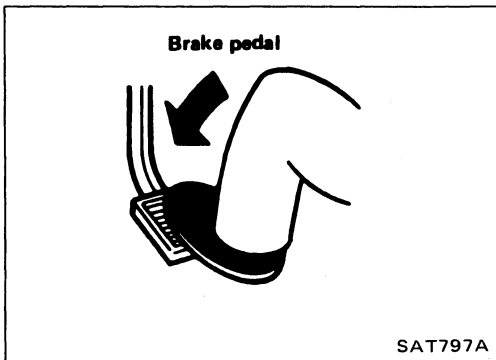

Check whether the symptom appears when brake is applied gradually.

Yes → (B)

No (Appears when brake is not applied.) → Check if there are any conditions, among those listed below, when symptom appears.

- Shifting
- Operating clutch
- Passing protrusion

No ↓ (B)

Yes ↓

Under these conditions individual wheel speed can change suddenly. This may sometimes cause the A.B.C. to operate.

TROUBLE DIAGNOSES

Diagnostic Procedure 1 (Cont'd)

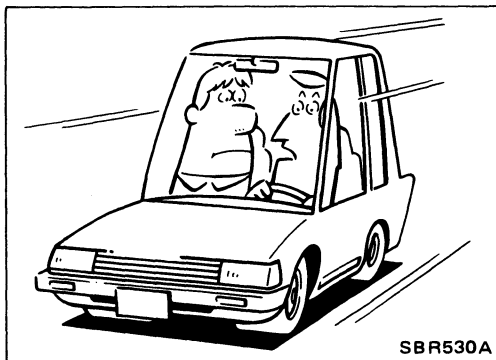
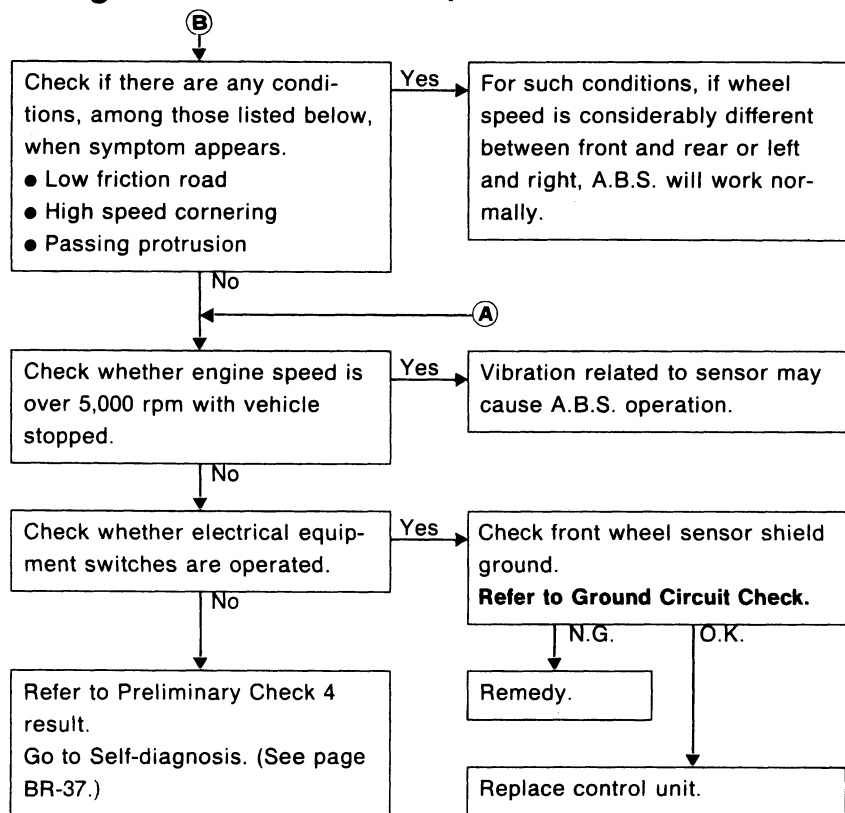

Diagnostic Procedure 2

SYMPTOM: Long stopping distance

Refer to worksheet results.

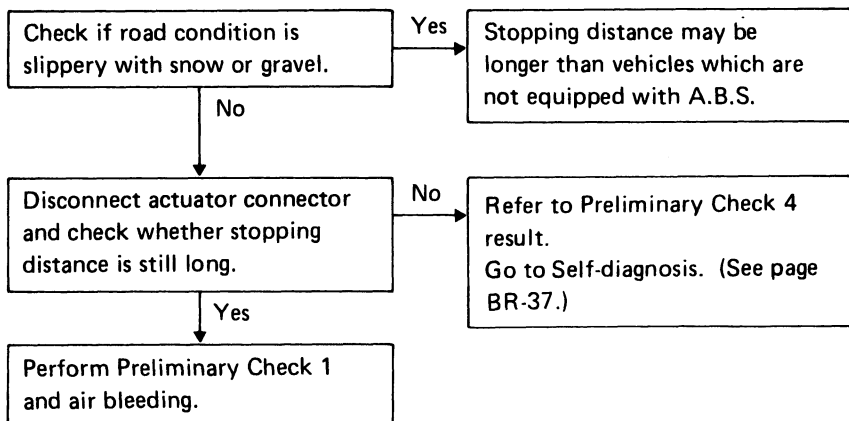

TROUBLE DIAGNOSES

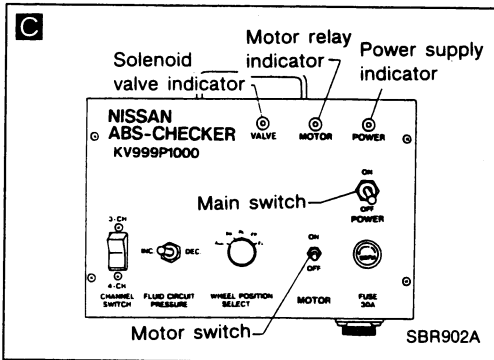
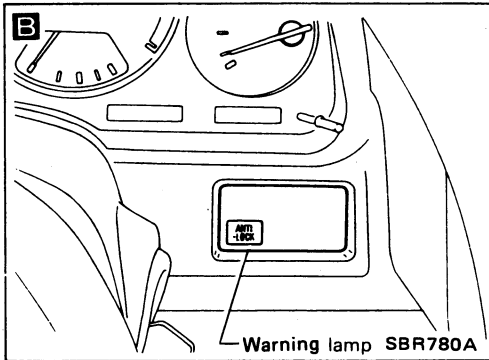
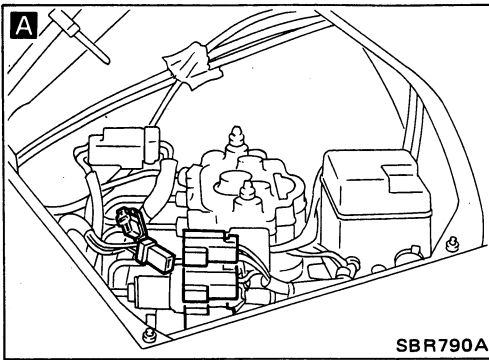

Diagnostic Procedure 3

SYMPTOM: Abnormal pedal action

Refer to worksheet results.

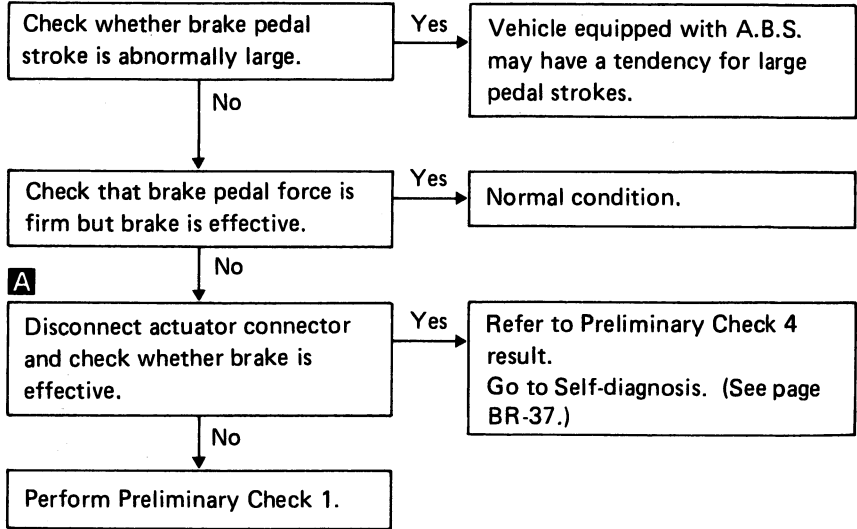

Diagnostic Procedure 4

SYMPTOM: A.B.S. doesn't work.

Refer to worksheet results.

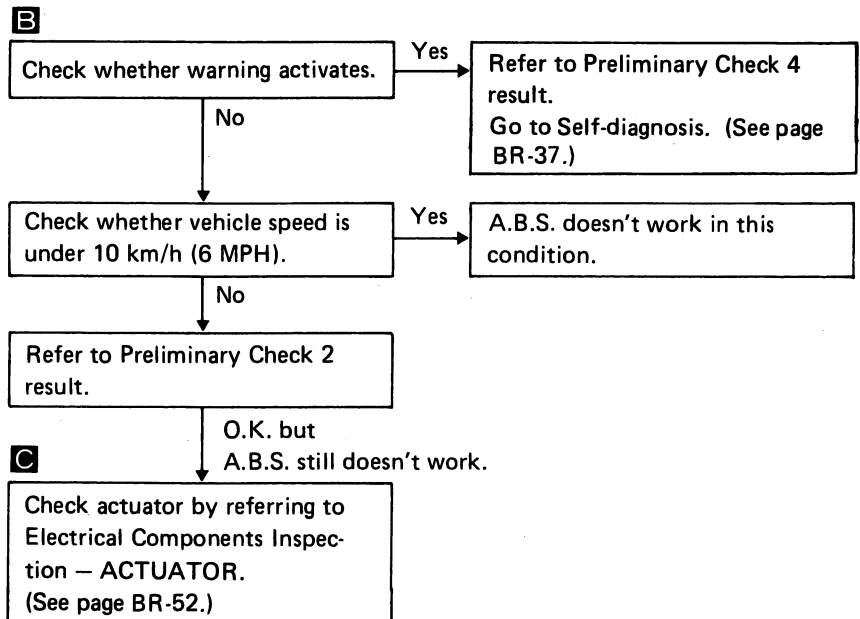

TROUBLE DIAGNOSES

Diagnostic Procedure 5

SYMPTOM: A.B.S. works but warning activates.

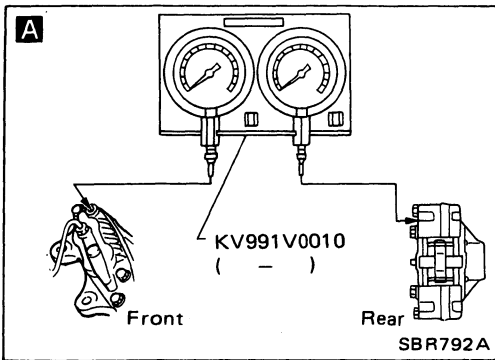
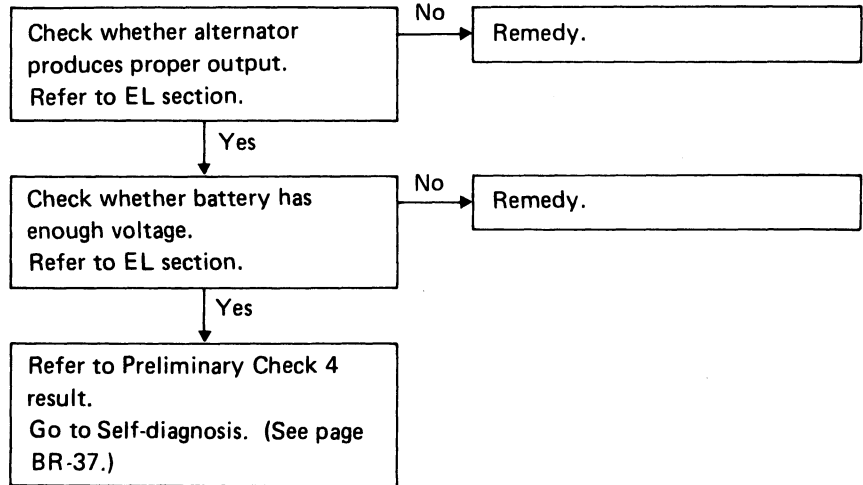

Diagnostic Procedure 6

SYMPTOM: A.B.S. works frequently.

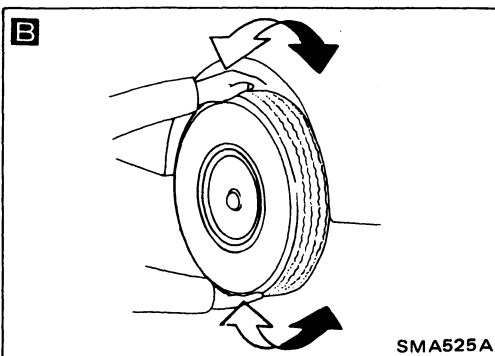
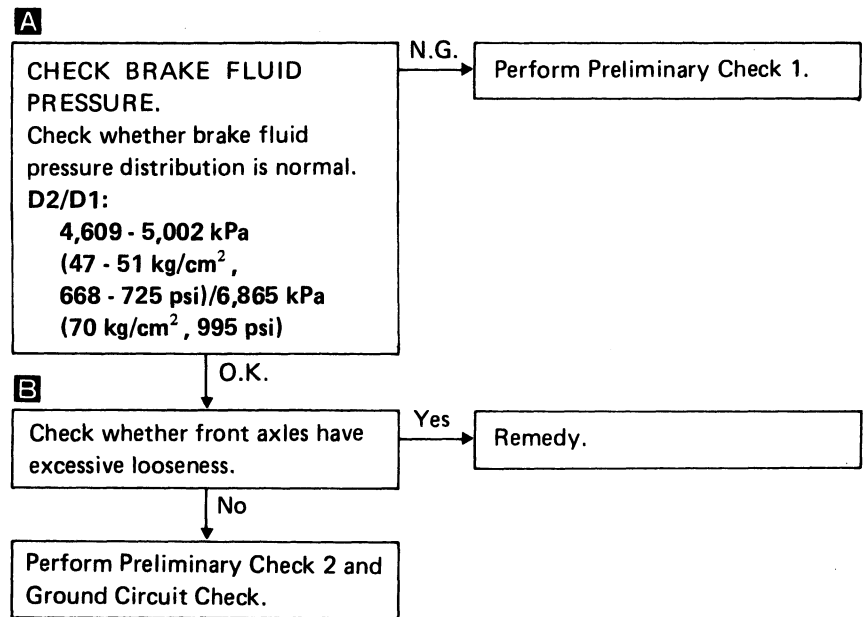
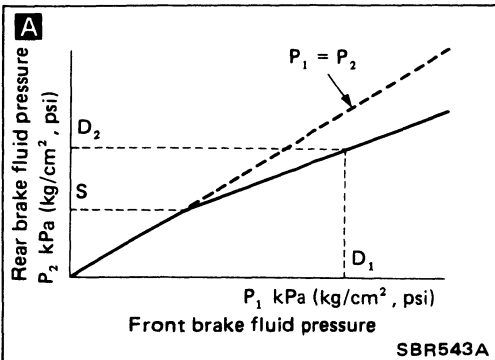

TROUBLE DIAGNOSES

Diagnostic Procedure 7 ACTUATOR SOLENOID (L.E.D. flashing number 1 - 4)

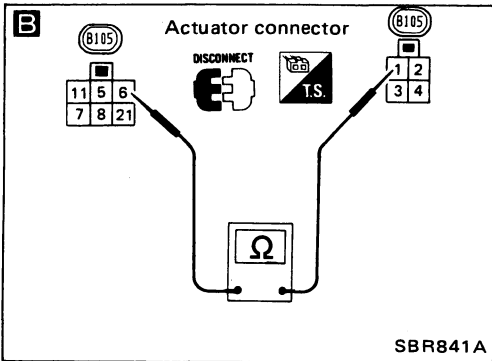
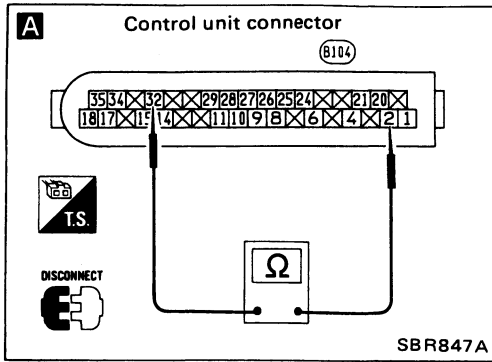

INSPECTION START
Remove battery negative terminal connector.

A CHECK SOLENOID VALVE RESISTANCE. O.K. → Replace control unit.

Disconnect control unit connector.
Check resistance between control unit connector (vehicle side) terminals.
Flashing number 1:
Terminals ③② and ②
Flashing number 2:
Terminals ③② and ③⑤
Flashing number 3 or 4:
Terminals ③② and ①⑧
Resistance: 0.7 - 1.6Ω

B N.G. → O.K. → Repair harness between actuator connector and control unit connector.

Disconnect actuator connector.
Check resistance between actuator connector (actuator side) terminals.
Flashing number 1:
Terminals ⑥ and ①
Flashing number 2:
Terminals ⑥ and ②
Flashing number 3 or 4:
Terminals ⑥ and ③
Resistance: 0.7 - 1.6Ω

N.G. → Replace actuator.

TROUBLE DIAGNOSES

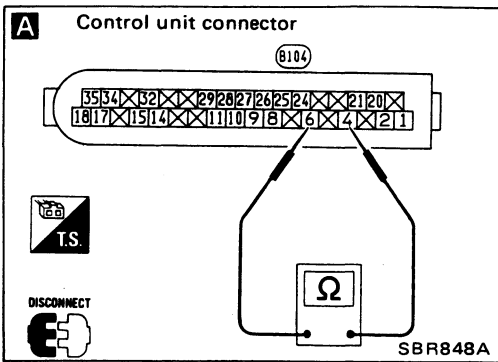

Diagnostic Procedure 8

WHEEL SPEED SENSOR (L.E.D. flashing number 5 - 8)

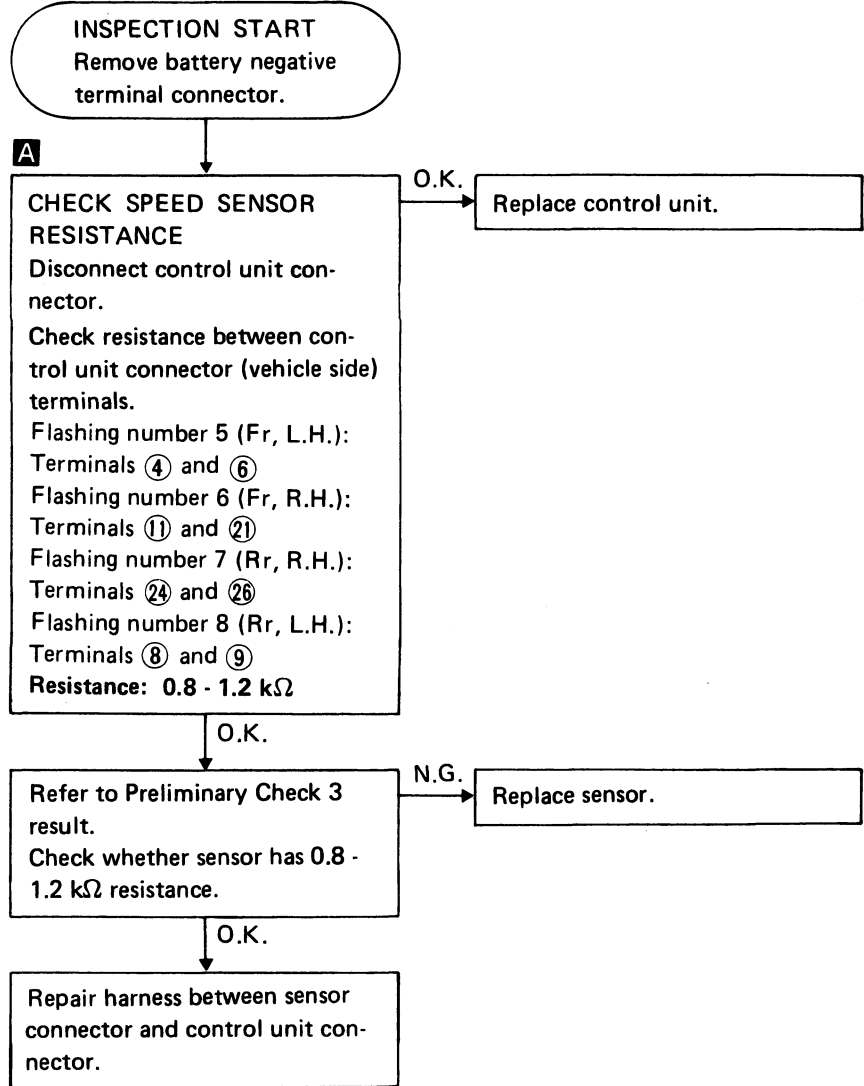

TROUBLE DIAGNOSES

Diagnostic Procedure 9 ACTUATOR MOTOR RELAY (L.E.D. flashing number 9)

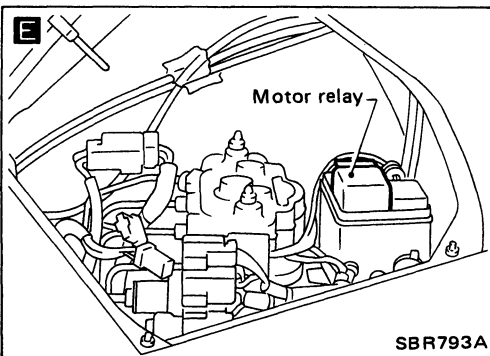
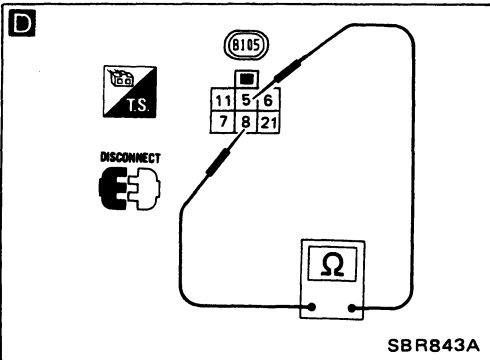
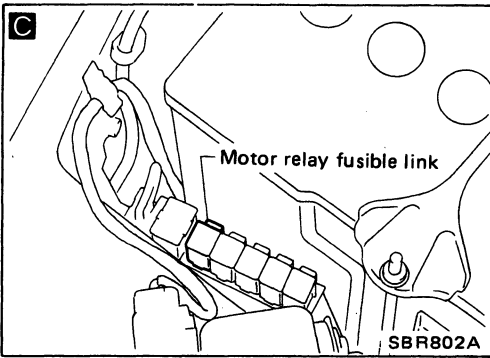
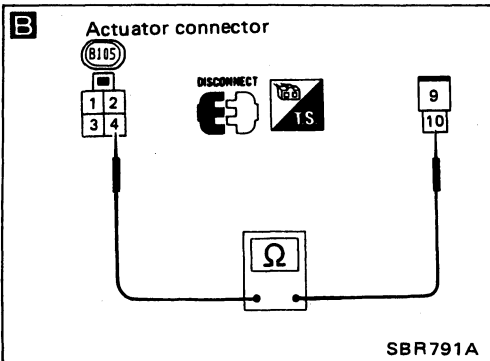
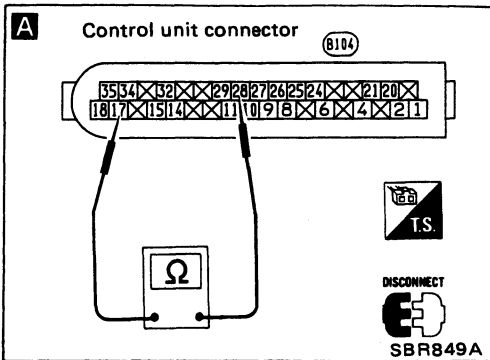

INSPECTION START
Remove battery negative terminal connector.

```

    graph TD
      Start([INSPECTION START  
Remove battery negative terminal connector.]) --> A[A]
      A[A] --> B[B]
      A -- N.G. --> D[D]
      B -- O.K. --> C[C]
      B -- No --> E[E]
      C -- Yes --> E
      C -- No --> F[F]
      D -- O.K. --> G[G]
      D -- N.G. --> H[H]
      F -- O.K. --> I[I]
      F -- N.G. --> J[J]
  
```

A CHECK MOTOR RELAY SOLENOID RESISTANCE. Disconnect control unit connector. Check resistance between control unit connector (vehicle side) terminals ⑰ and ⑳. Resistance: 45 - 55Ω

B CHECK MOTOR RELAY DEACTIVATION. Disconnect actuator connector. Check continuity between actuator connector (actuator side) terminals ④ and ⑩.

C Check visually if motor's fusible link is blown. Resistance: Approximately 0Ω

D Disconnect actuator connector. Check resistance between actuator connector (actuator side) terminals ⑧ and ⑤. Resistance: 45 - 55Ω

E Replace motor relay.

F Replace fusible link.

G Repair harness between actuator and control unit.

H Replace motor relay.

I Replace control unit.

J Replace actuator.

TROUBLE DIAGNOSES

Diagnostic Procedure 10

ACTUATOR SOLENOID VALVE RELAY (L.E.D. flashing number 10)

INSPECTION START
Remove battery negative terminal connector.

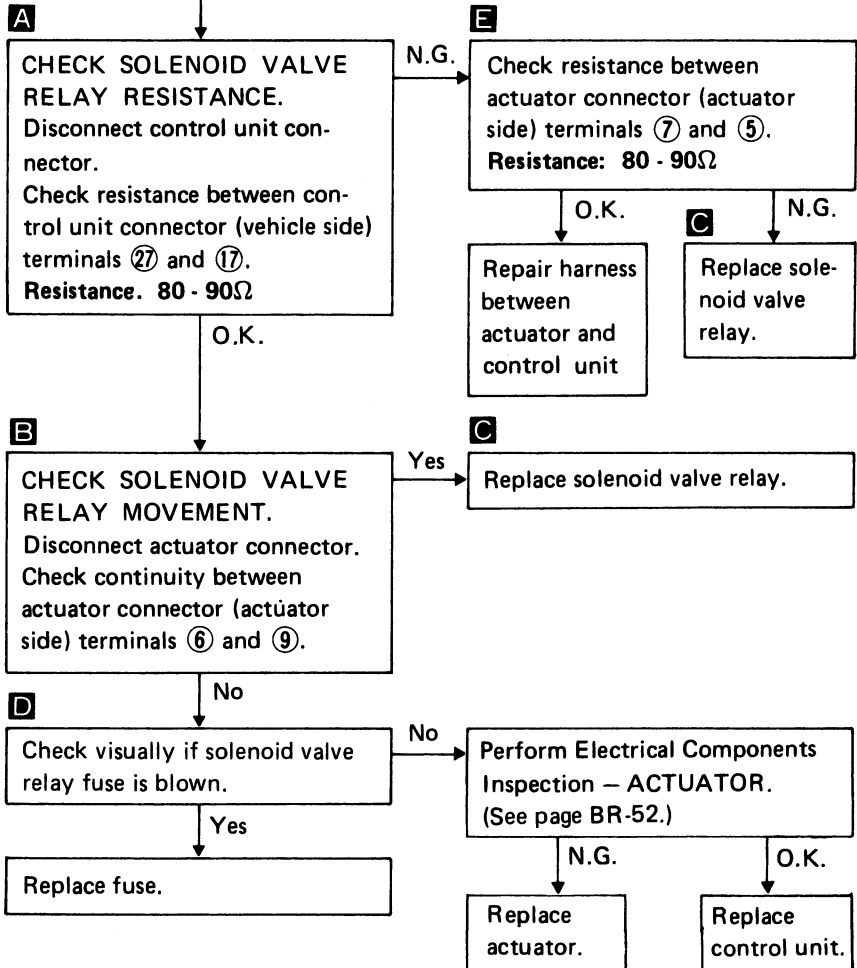
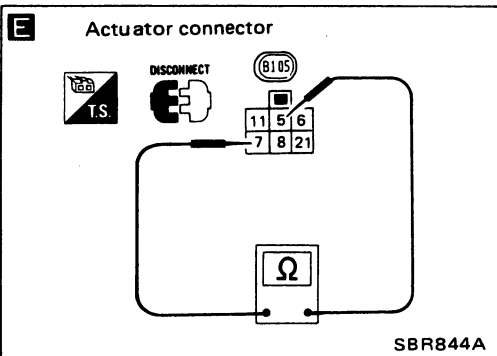
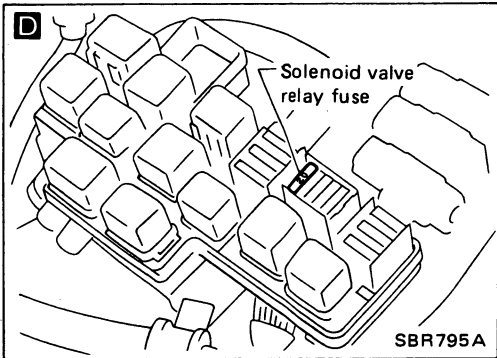
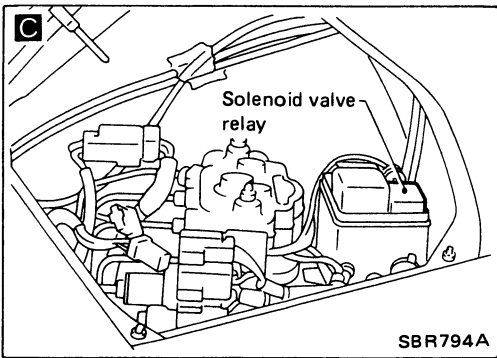
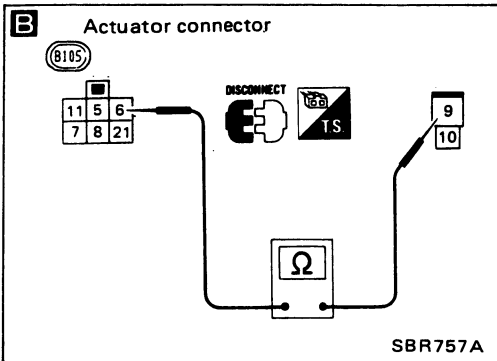
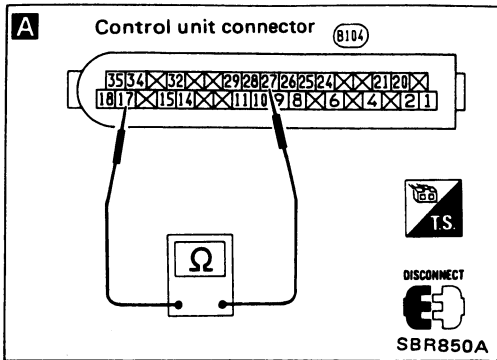

TROUBLE DIAGNOSES

Diagnostic Procedure 11 CONTROL UNIT (L.E.D. flashing number 16)

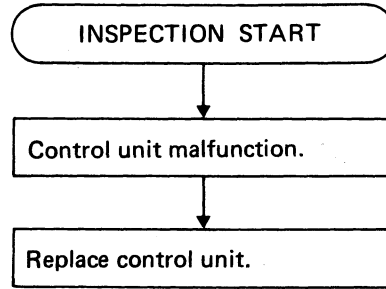

TROUBLE DIAGNOSES

Diagnostic Procedure 12

CONTROL UNIT OR POWER SUPPLY AND GROUND CIRCUIT (Warning activates but L.E.D. comes off.)

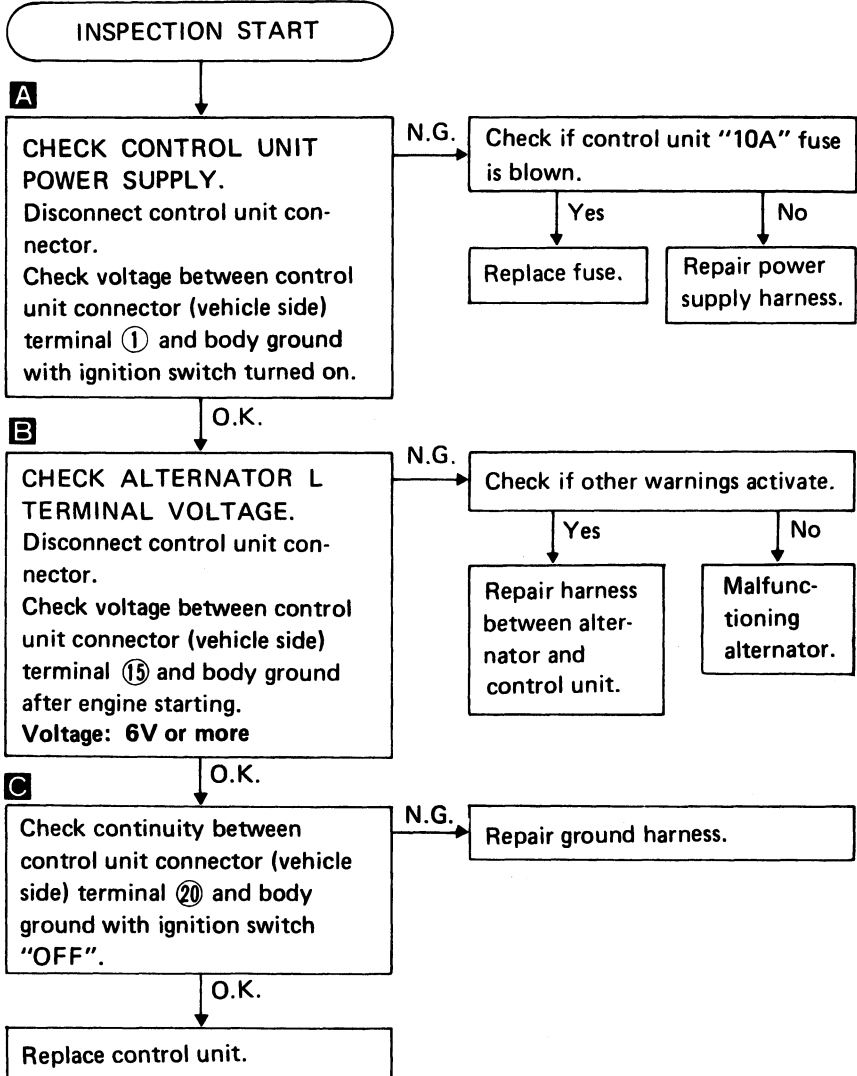
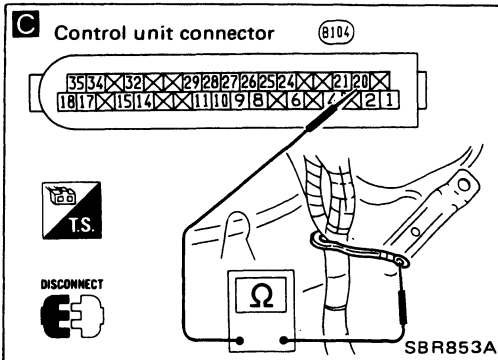
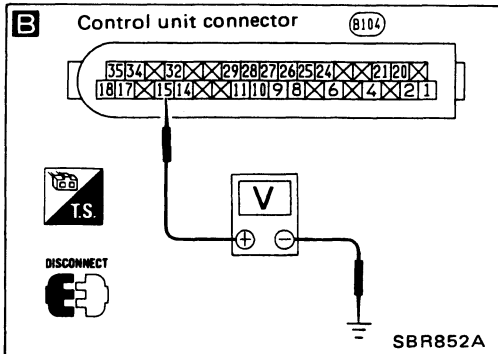
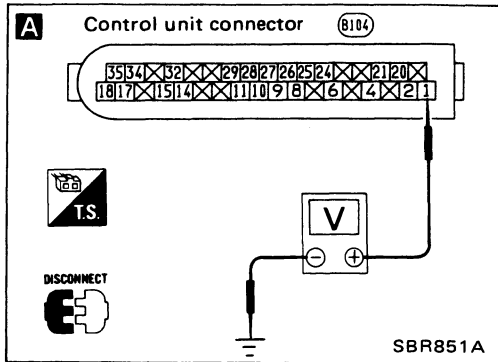

Electrical Components Inspection

ACTUATOR (Not self-diagnostic item)

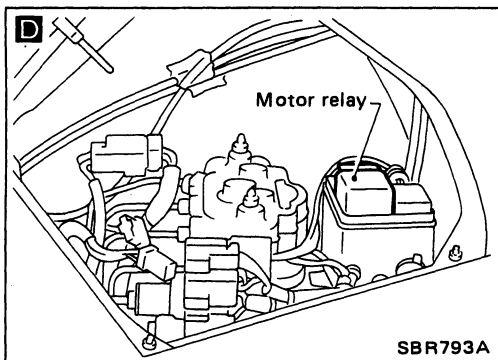
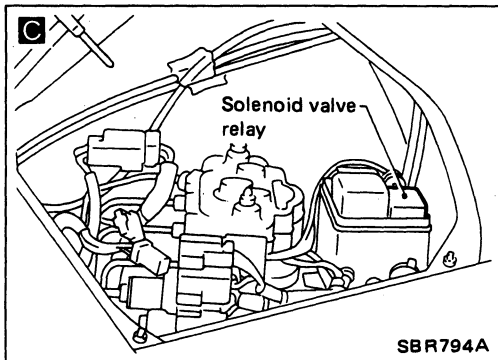
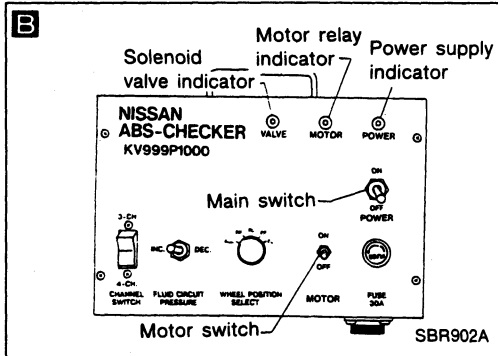
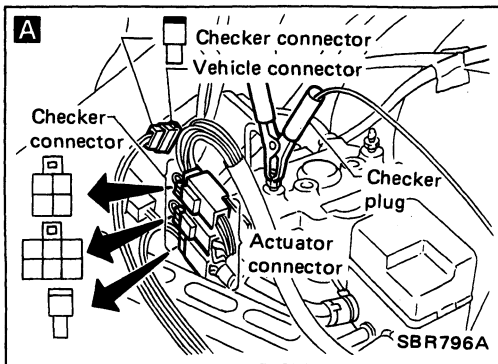

INSPECTION START

A Connect A.B.S. checker to actuator connector and vehicle harness with battery terminal connected and all checker switch turning off. Use harness for 3 channel. Set channel select switch to 3 channel.

B Turn checker main switch on. Check power supply indicator for coming on.

No → Replace battery with fully charged new one, if checker connection is correct.

B Check checker valve relay indicator for coming on.

No → **C** Replace solenoid valve relay, if checker connection is correct.

B step **A** Select one valve — FL, FR or RR. (valves corresponding to each wheel position.) Select brake circuit pressure decreasing position by switch then turn motor switch on. Select pressure increasing position.

B Check motor relay indicator for coming on while motor switch is turned on.

No → **D** Replace motor relay, if checker connection is correct.

Check motor for operational sound beside the actuator in a quiet place.

No → Replace actuator as assembly, if Diagnostic Procedures 7 - 12 are already performed and checker connection is correct.

⑤

TROUBLE DIAGNOSES

Electrical Components Inspection (Cont'd)

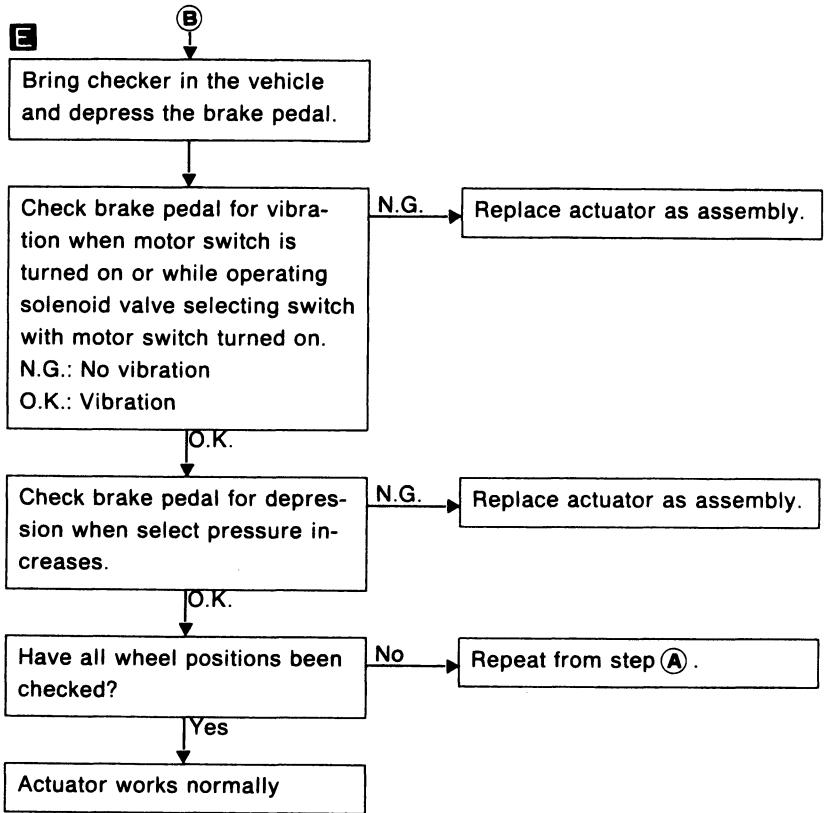
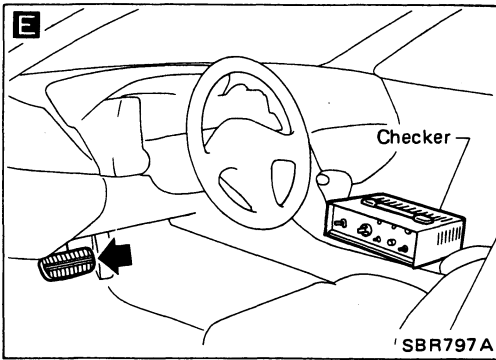

CAUTION:

Do not set checker at pressure decrease position for more than 5 seconds at a time. Actuator solenoid valve may be damaged.

SERVICE DATA AND SPECIFICATIONS (S.D.S.)

General Specifications

Applied model	VG30DE		VG30DETT
	Without A.B.S.	With A.B.S.	-
Front brake			
Brake model	OPZ25VA		
Cylinder bore diameter mm (in)	40.45 (1.5925) x 4		
Pad length x width x thickness mm (in)	116 x 50 x 10 (4.57 x 1.97 x 0.39)		
Rotor outer diameter x thickness mm (in)	280 x 30 (11.02 x 1.18)		
Rear brake			
Brake model	OPZ11VB		
Cylinder bore diameter mm (in)	38.1 (1.500) x 2		
Pad length x width x thickness mm (in)	71.8 x 36.5 x 11.5 (2.827 x 1.437 x 0.453)		
Rotor outer diameter x thickness mm (in)	297 x 18 (11.69 x 0.71)		
Master cylinder			
Cylinder bore diameter mm (in)	23.81 (15/16)	26.99 (17/16)	
Control valve			
Valve model	Proportioning valve (within master cylinder)		
Split point x reducing ratio kPa (kg/cm ² , psi)	3,432 (35, 498) x 0.4	2,452 (25, 356) x 0.4	
Brake booster			
Booster model	M215T		
Diaphragm diameter mm (in)	Primary: 230 (9.06) Secondary: 205 (8.07)		
Brake fluid			
Recommended brake fluid	DOT 3		
Parking drum brake			
Brake model	DS17HD		
Lining Width x thickness x length mm (in)	154.1 x 25.0 x 3.0 (6.07 x 0.984 x 0.118)		
Drum inner diameter mm (in)	172.0 (6.77)		

SERVICE DATA AND SPECIFICATIONS (S.D.S.)

Inspection and Adjustment BRAKE PEDAL

FRONT DISC BRAKE

Unit: mm (in)

Brake model	OPZ25VA
Pad wear limit Minimum thickness	2.0 (0.079)
Rotor repair limit Minimum thickness	28.0 (1.102)
Maximum runout	0.07 (0.0028)

REAR DISC BRAKE

Unit: mm (in)

Brake model	OPZ11VB
Pad wear limit Minimum thickness	2.0 (0.079)
Rotor repair limit Minimum thickness	16.0 (0.630)
Maximum runout	0.07 (0.0028)

PARKING DRUM BRAKE

Unit: mm (in)

Brake model	DS17HD
Lining replacement limit Minimum thickness	1.5 (0.059)
Drum repair limit Maximum inner diameter	173.0 (6.81)

Unit: mm (in)

Applied model	M/T	A/T
Free height	186 - 196 (7.32 - 7.72)	195 - 205 (7.68 - 8.07)
Depressed height [under force of 490 N (50 kg, 110 lb) with engine running] With A.B.S.	105 (4.13)	110 (4.33)
Without A.B.S.	95 (3.74)	105 (4.13)
Clearance between pedal stopper and threaded end of switches	0.3 - 1.0 (0.012 - 0.039)	
Pedal free play at clevis	1 - 3 (0.04 - 0.12)	

PARKING BRAKE

Number of notches [under force of 196 N (20 kg, 44 lb)]	6 - 7
Number of notches (when warning switch comes on)	1

STEERING SYSTEM

SECTION **ST**

CONTENTS

PRECAUTIONS	ST- 2
PREPARATION	ST- 3
ON-VEHICLE INSPECTION	ST- 5
ON-VEHICLE INSPECTION (Power steering)	ST- 7
STEERING WHEEL AND STEERING COLUMN	ST-10
POWER STEERING GEAR AND LINKAGE (Model PR26SE)	ST-14
POWER STEERING OIL PUMP	ST-26
TWIN ORIFICE POWER STEERING SYSTEM	ST-30
TWIN ORIFICE POWER STEERING SYSTEM — Trouble Diagnoses	ST-32
SUPER HICAS SYSTEM	ST-43
SUPER HICAS SYSTEM — On-vehicle Inspection	ST-44
SUPER HICAS SYSTEM — Repair of Component Parts	ST-48
SUPER HICAS SYSTEM — Trouble Diagnoses	ST-60
SERVICE DATA AND SPECIFICATIONS (S.D.S.)	ST-96

ST

PRECAUTIONS

Supplemental Restraint System "AIR BAG"

The Supplemental Restraint System "Air Bag" helps to reduce the risk or severity of injury to the driver in a frontal collision. The Supplemental Restraint System consists of an air bag (located in the center of the steering wheel), five sensors, a control unit, warning lamp, wiring harness and spiral cable. Information necessary to service the system safely is included in the **BF section** of this Service Manual.

WARNING:

- a. To avoid rendering the SRS inoperative, which could lead to personal injury or death in the event of a severe frontal collision, all maintenance must be performed by an authorized NISSAN dealer.
- b. Improper maintenance, including incorrect removal and installation of the SRS, can lead to personal injury caused by unintentional activation of the system.
- c. All SRS electrical wiring harnesses and connectors are covered with yellow outer insulation. Do not use electrical test equipment on any circuit related to the SRS "Air Bag".

Steering System

- Before disassembly, thoroughly clean the outside of the unit.
- Disassembly should be done in a clean work area. It is important to prevent the internal parts from becoming contaminated by dirt or other foreign matter.
- When disassembling parts, be sure to place them in order in a parts rack so they can be reinstalled in their proper positions.
- Use nylon cloths or paper towels to clean the parts; common shop rags can leave lint that might interfere with their operation.
- Before inspection or reassembly, carefully clean all parts with a general purpose, non-flammable solvent.
- Before assembly, apply a coat of recommended A.T.F.* to hydraulic parts. Vaseline may be applied to O-rings and seals. Do not use any grease.
- Replace all gaskets, seals and O-rings. Avoid damaging O-rings, seals and gaskets during installation. Perform functional tests whenever designated.

*: Automatic transmission fluid

PREPARATION

SPECIAL SERVICE TOOLS

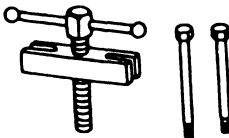
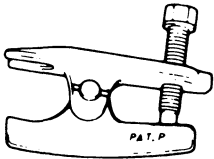
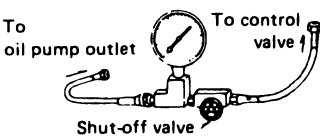
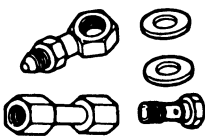
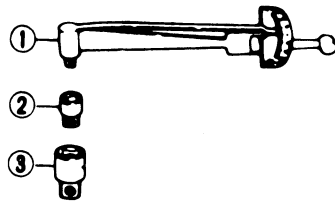
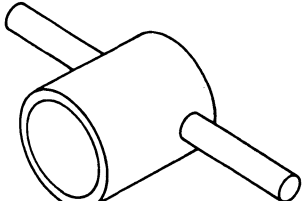
Tool number (Kent-Moore No.) Tool name	Description	
KV48100700 (J26364) Torque adapter		Measuring pinion rotating torque
ST27180001 (J25726-A) Steering wheel puller		Removing steering wheel
HT72750000 (—) Ball joint remover		Removing ball joint
ST27091000 (J26357) Pressure gauge		Measuring oil pressure
KV48102500 (—) Pressure gauge adapter		Measuring oil pressure
ST3127S000 (See J25765-A) ① GG91030000 (J25765-A) Torque wrench ② HT6294000 (—) Socket adapter ③ HT62900000 (—) Socket adapter		Measuring turning torque
KV48104400 (—) Rack seal ring reformer		Reforming teflon ring

PREPARATION

SPECIAL SERVICE TOOLS (Cont'd)

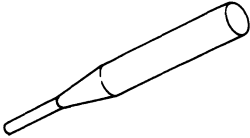
Tool number (Kent-Moore No.) Tool name	Description	
KV32101100 (—) Pin punch		Removing and installing tube seat

COMMERCIAL SERVICE TOOLS

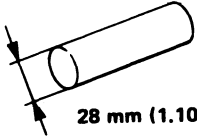
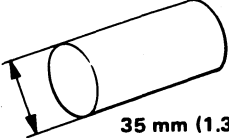
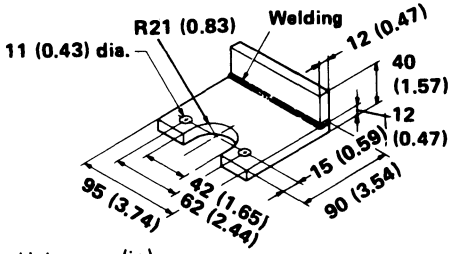
Tool name	Description	
Rear oil seal drift	 <p style="text-align: center;">28 mm (1.10 in) dia.</p>	Installing rear oil seal
Pinion oil seal drift	 <p style="text-align: center;">35 mm (1.38 in) dia.</p>	Installing pinion oil seal
Oil pump attachment	 <p style="text-align: center;">Unit: mm (in) SST481A</p>	Disassembling and assembling oil pump

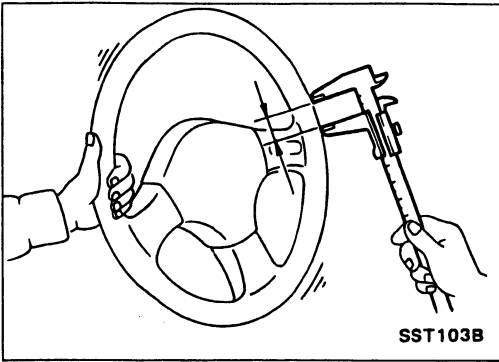

Checking Steering Wheel Play

- With wheels in a straight-ahead position, check steering wheel play.

Steering wheel play:

35 mm (1.38 in) or less

- If it is not within specification, check steering gear assembly when front suspension and axle, steering gear assembly and steering column are mounted correctly.

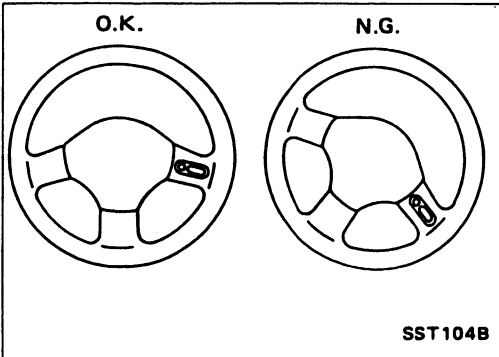

Checking Neutral Position on Steering Wheel

Pre-checking

- Make sure that wheel alignment is correct.

Wheel alignment:

Refer to section FA for S.D.S.

- Verify that the steering gear is centered before removing the steering wheel.

Checking

1. Check that the steering wheel is in the neutral position when driving straight ahead.
2. If it is not in the neutral position, remove the steering wheel and reinstall it correctly.
3. If the neutral position is between two serrated teeth, loosen tie-rod lock nut and move tie-rod in the opposite direction by the same amount on both left and right sides to compensate for error in the neutral position.

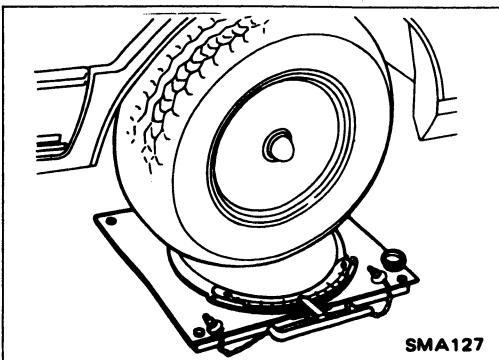

Front Wheel Turning Angle

1. Rotate steering wheel all the way right and left; measure turning angle.

Turning angle of full turns:

Refer to section FA for S.D.S.

2. If it is not within specification, check rack stroke.

Rack stroke "L":

Refer to S.D.S.

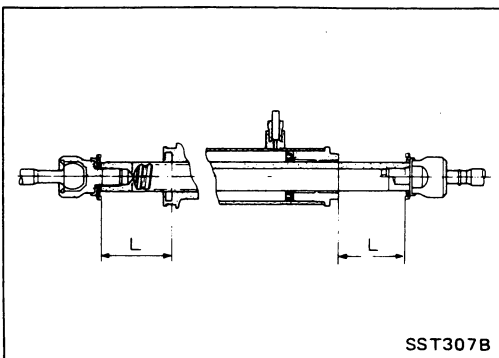

ON-VEHICLE INSPECTION

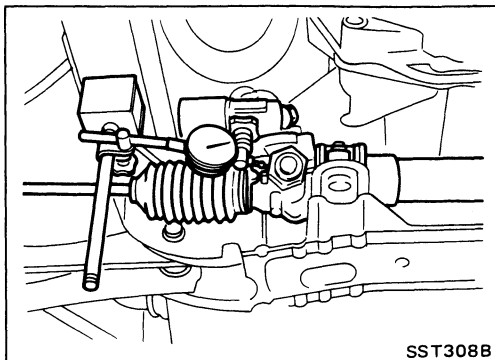

Checking Gear Housing Movement

1. Check the movement of steering gear housing during stationary steering on a dry paved surface.
 - Apply a force of 49 N (5 kg, 11 lb) to steering wheel to check the gear housing movement.
- Turn off ignition key while checking.

Movement of gear housing:

$\pm 2 \text{ mm } (\pm 0.08 \text{ in})$ or less

2. If movement exceeds the limit, replace mount insulator after confirming proper installation of gear housing clamps.

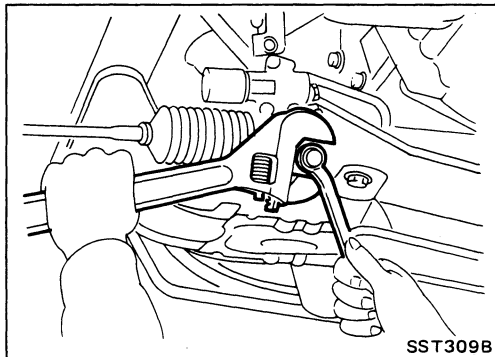

Adjusting Rack Retainer

- Perform this driving test on a flat road.
1. Check whether vehicle moves in a straight line when steering wheel is released.
 2. Check whether steering wheel returns to neutral position when steering wheel is released from a slightly turned (approx. 20°) position.
- If any abnormality is found, correct it by resetting adjusting screw.

Checking and Adjusting Drive Belts

Refer to section MA for Drive Belt Inspection.

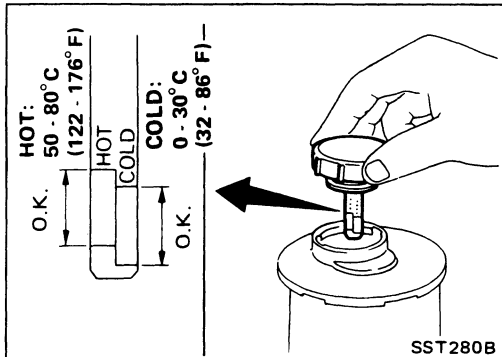

Checking Fluid Level

Check fluid level.

Fluid level should be checked using "HOT" range on dipstick at fluid temperatures of 50 to 80°C (122 to 176°F) or using "COLD" range on dipstick at fluid temperatures of 0 to 30°C (32 to 86°F).

CAUTION:

- Do not overfill.
- Recommended fluid is Automatic Transmission Fluid "DEXRON™ Type".

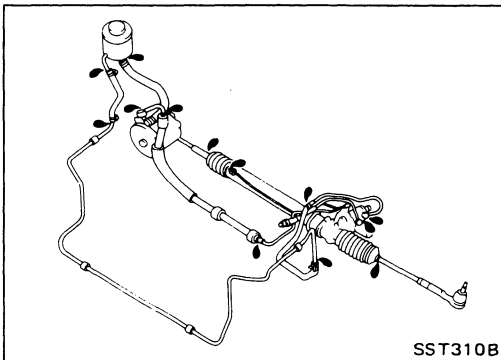

Checking Fluid Leakage

Check the lines for improper attachment and for leaks, cracks, damage, loose connections, chafing or deterioration.

1. Run engine at idle speed or 1,000 rpm.

Make sure temperature of fluid in oil tank rises to 60 to 80°C (140 to 176°F).

2. Turn steering wheel right-to-left several times.
3. Hold steering wheel at each "lock" position for five seconds and carefully check for fluid leakage.

CAUTION:

Do not hold the steering wheel in a locked position for more than 15 seconds.

4. If fluid leakage at connectors is noticed, loosen flare nut and then retighten.

Do not overtighten connector as this can damage O-ring, washer and connector.

Bleeding Hydraulic System

1. Raise front end of vehicle until wheels clear ground.
 2. Add fluid into oil tank to specified level. Meanwhile, quickly turn steering wheel fully to right and left and lightly touch steering stoppers.
Repeat steering wheel operation until fluid level no longer decreases.
 3. Start engine.
Repeat step 2 above.
- Incomplete air bleeding will cause the following to occur.
When this happens, bleed air again.

ON-VEHICLE INSPECTION (Power steering)

Bleeding Hydraulic System (Cont'd)

- Generation of air bubbles in reservoir tank
- Generation of clicking noise in oil pump
- Excessive buzzing in oil pump

While the vehicle is stationary or while turning the steering wheel slowly, fluid noise may occur in the valve or oil pump. This noise is inherent in this steering system, and it will not affect performance or durability of the system.

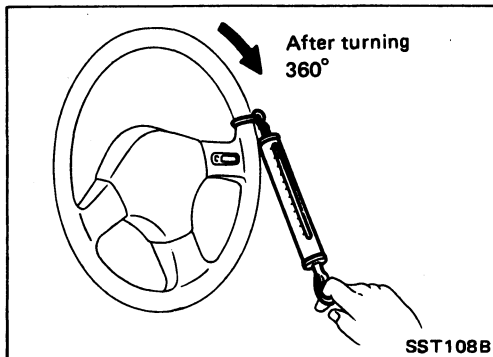

Checking Steering Wheel Turning Force

- Park vehicle on a level, dry surface and set parking brake.
- Start engine.
- Bring power steering fluid up to adequate operating temperature. [Make sure temperature of fluid is approximately 60 to 80°C (140 to 176°F).]

Tires need to be inflated to normal pressure.

- Check steering wheel turning force when steering wheel has been turned 360° from the neutral position.

Steering wheel turning force:

39 N (4 kg, 9 lb) or less

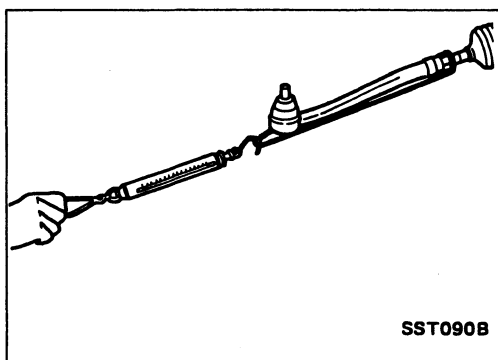

- If steering wheel turning force is out of specifications, check rack sliding force to detect condition of steering gear assembly.
 - Disconnect steering column lower joint and knuckle arms from the gear.
 - Start and run engine at idle to make sure steering fluid has reached normal operating temperature.
 - While pulling tie-rod slowly in the ± 11.5 mm (± 0.453 in) range from the neutral position, make sure rack sliding force is within specification.

Average rack sliding force:

Without HICAS

206 - 265 N (21 - 27 kg, 46 - 60 lb)

With HICAS

201.0 - 250.1 N (20.5 - 25.5 kg, 45.2 - 56.2 lb)

- Check sliding force outside above range.

Maximum rack sliding force:

Not more than 39 N (4 kg, 9 lb) beyond above value

- If rack sliding force is not within specification, overhaul steering gear assembly.

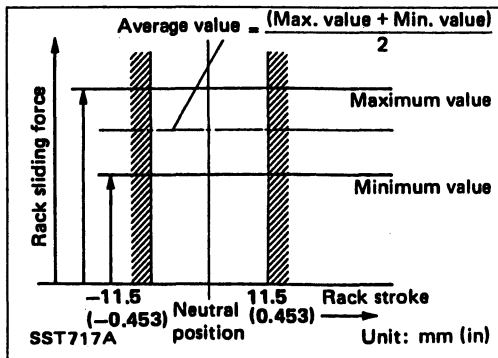

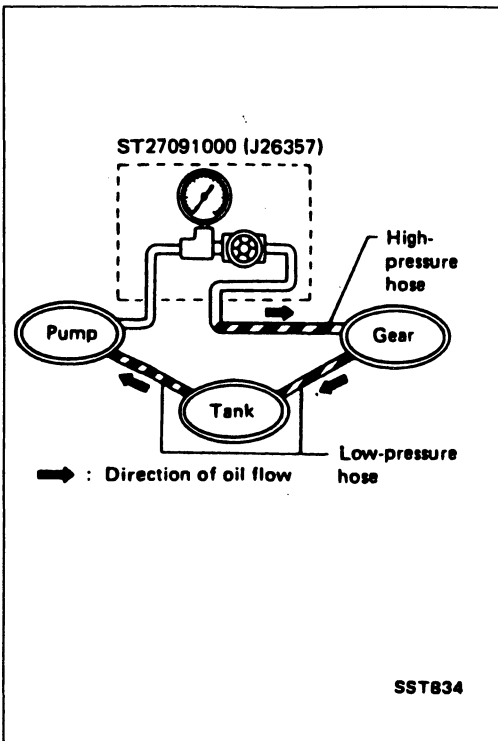

Checking Hydraulic System

Before starting, check belt tension, driving pulley and tire pressure.

1. Set Tool. Open shut-off valve. Then bleed air. (See "Bleeding Hydraulic System".)

2. Run engine.

Make sure temperature of fluid in tank rises to 60 to 80°C (140 to 176°F).

WARNING:

Warm up engine with shut-off valve fully opened. If engine is started with shut-off valve closed, oil pressure in oil pump will increase to relief pressure, resulting in an abnormal rise in oil temperature.

3. Check pressure with steering wheel fully turned to left and right positions with engine idling at 1,000 rpm.

CAUTION:

Do not hold the steering wheel in a locked position for more than 15 seconds.

Oil pump maximum standard pressure:

7,649 - 8,238 kPa (78 - 84 kg/cm², 1,109 - 1,194 psi)

4. If oil pressure is below the standard pressure, slowly close shut-off valve and check pressure.

- When pressure reaches standard pressure, gear is damaged.
- When pressure remains below standard pressure, pump is damaged.

CAUTION:

Do not close shut-off valve for more than 15 seconds.

5. If oil pressure is higher than standard pressure, check oil pump flow control valve.

6. After checking hydraulic system, remove Tool and add fluid as necessary, then completely bleed air out of system.

STEERING WHEEL AND STEERING COLUMN

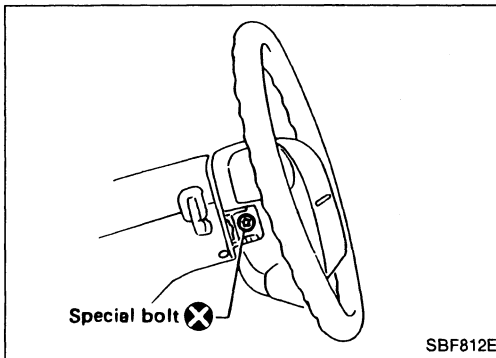
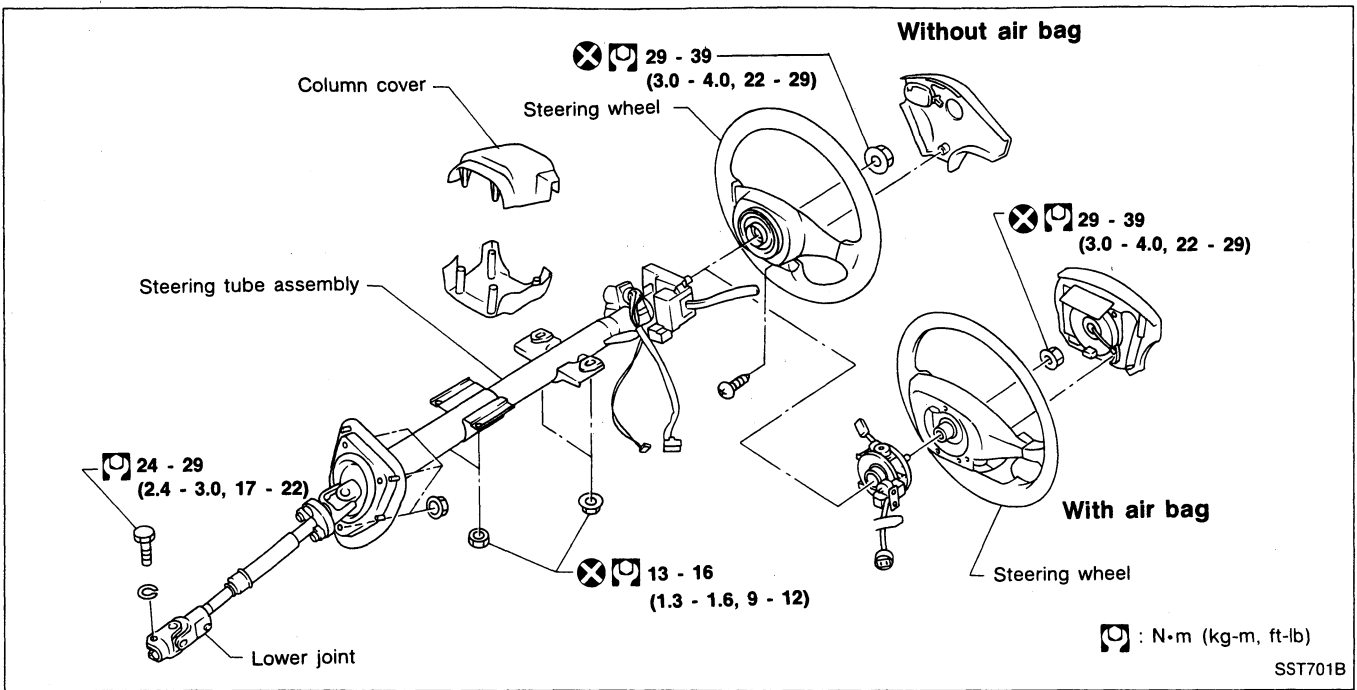

Removal

STEERING WHEEL (With air bag)

- Remove screws from both sides of steering wheel and pull out horn pad. Refer to section BF for Air Bag Module and Spiral Cable Removal.

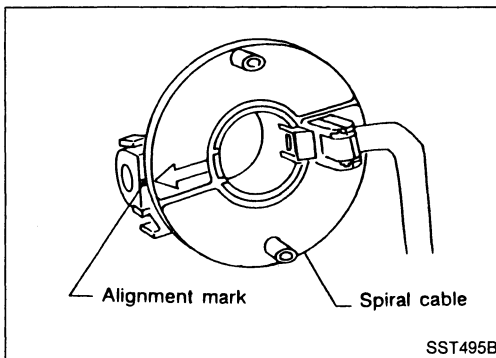

- Align spiral cable correctly when installing steering wheel.

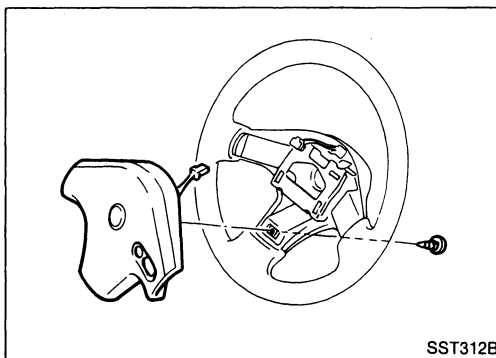

STEERING WHEEL (Without air bag)

- Remove screw from rear of steering wheel and pull out horn pad.

STEERING WHEEL AND STEERING COLUMN

Removal (Cont'd)

- Remove steering wheel with Tool.

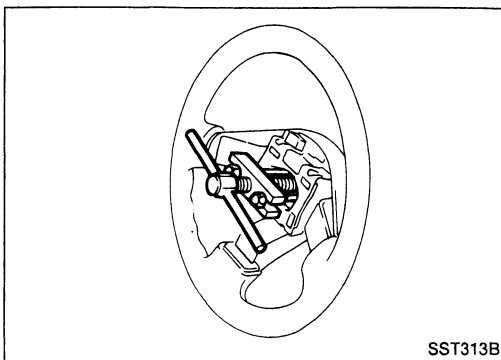

SST313B

Installation

STEERING WHEEL

When installing steering wheel, apply multi-purpose grease to entire surface of turn signal cancel pin (both portions) and also to horn contact slip ring.

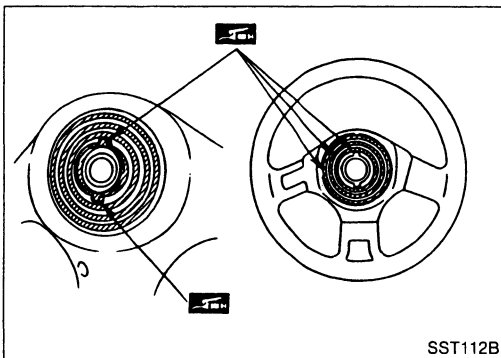

SST112B

STEERING COLUMN

- When installing steering column, fingertighten all lower bracket and clamp retaining bolts; then tighten them securely. Do not apply undue stress to steering column.
- When attaching coupling joint, be sure tightening bolt faces cutout portion.

CAUTION:

After installing steering column, turn steering wheel to make sure it moves smoothly and that the number of turns from the straight forward position to left and right locks are equal.

Be sure that the steering wheel is in a neutral position when driving straight ahead.

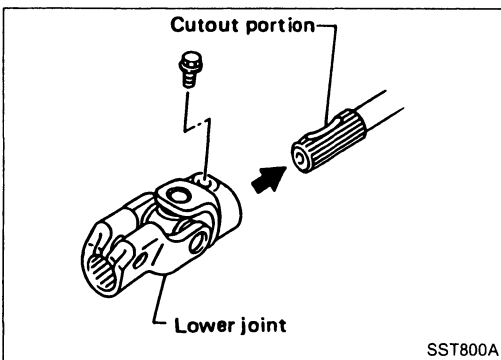

SST800A

STEERING WHEEL AND STEERING COLUMN

Disassembly and Assembly

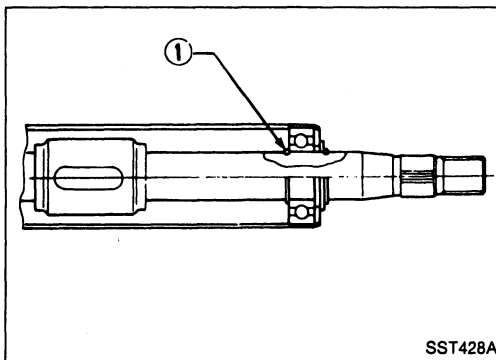
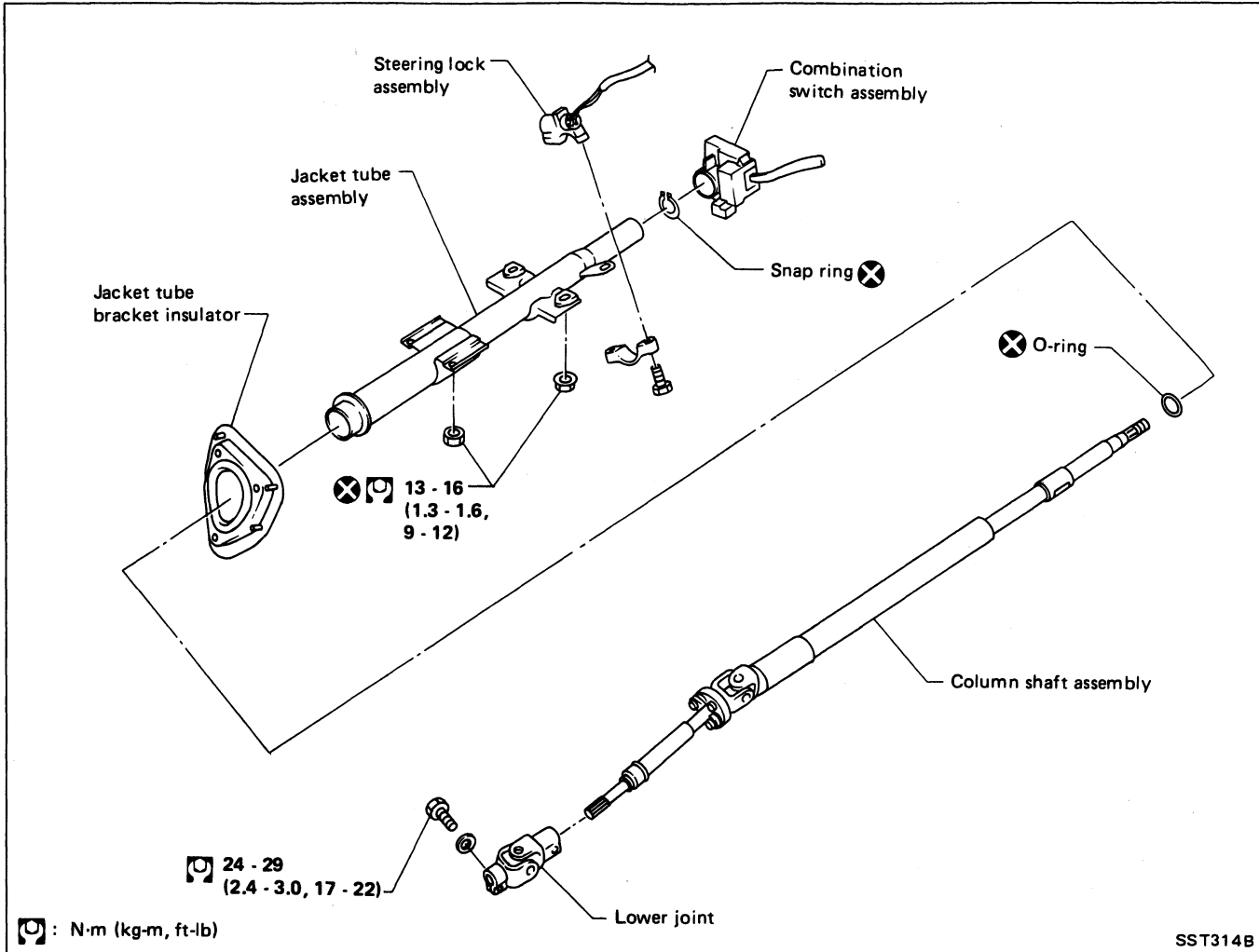

- When disassembling and assembling, unlock steering lock with key.
- Install O-ring ① before inserting shaft into jacket tube. Ensure that rounded surface of snap ring faces toward bearing when snap ring is installed.

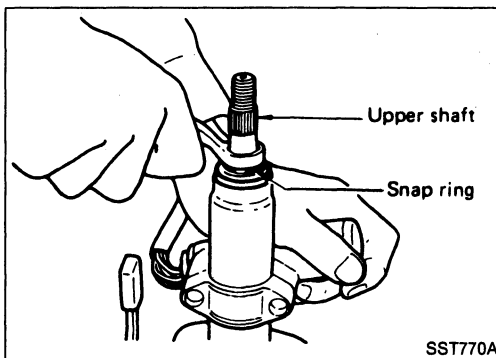

- Install snap ring on upper shaft with box wrench.

STEERING WHEEL AND STEERING COLUMN

Disassembly and Assembly (Cont'd)

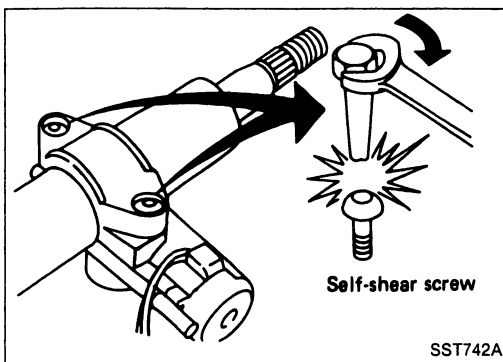

- Steering lock
- a) Break self-shear type screws with a drill or other appropriate tool.
- b) Install self-shear type screws and then cut off self-shear type screw heads.

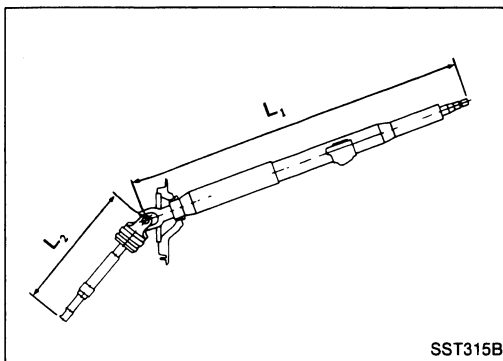

Inspection

- When steering wheel can not be rotated smoothly, check the steering column for the following matters and replace damaged parts.
 - a. Check column bearings for damage or unevenness. Lubricate with recommended multi-purpose grease or replace steering column as an assembly, if necessary.
 - b. Check steering column lower shaft for deformation or breakage. Replace if necessary.
- When the vehicle is involved in a light collision, check steering column length " L_1 " and steering column lower shaft length " L_2 ". If it is not within specifications, replace steering column as an assembly.

Steering column length " L_1 ":

Without air bag

745.9 - 747.5 mm (29.37 - 29.43 in)

With air bag

749.4 - 751.0 mm (29.50 - 29.57 in)

Steering column lower shaft length " L_2 ":

280.6 - 282.2 mm (11.05 - 11.11 in)

POWER STEERING GEAR AND LINKAGE (Model PR26SE)

Removal and Installation

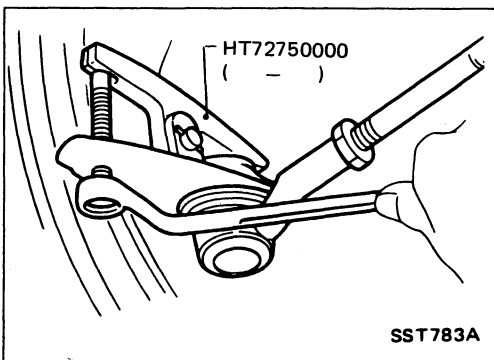
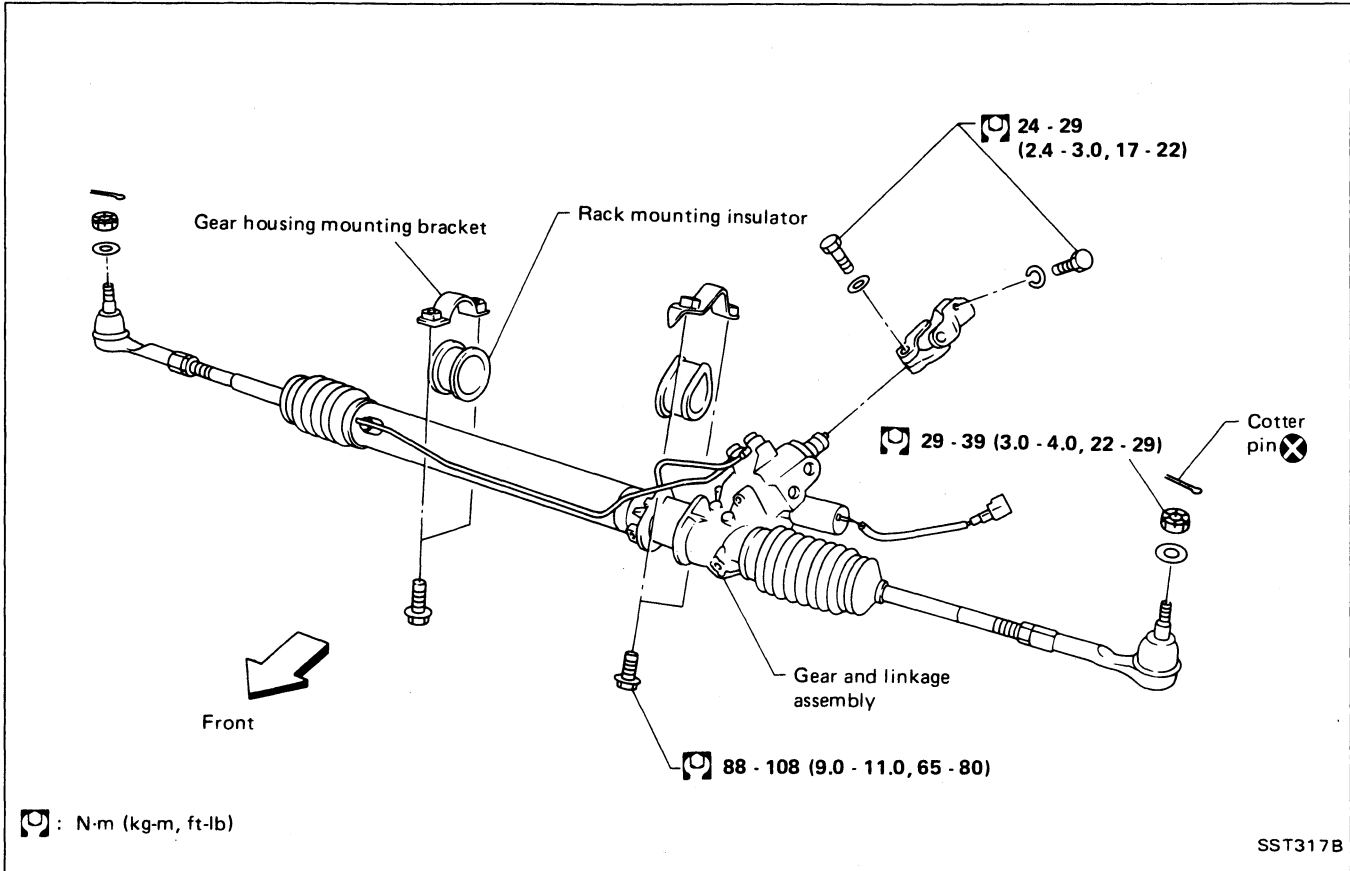

- Detach tie-rod outer sockets from knuckle arms with Tool.

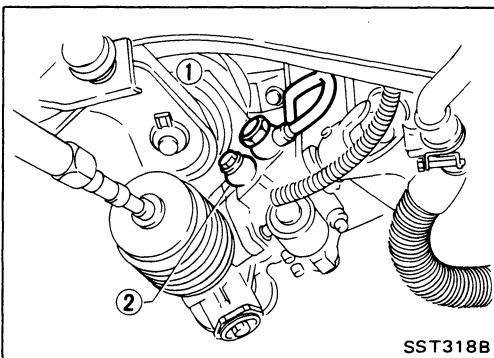

- Install pipe connector.
 - ① Low-pressure side
[Wrench icon]: 36 - 40 N·m (3.7 - 4.1 kg-m, 27 - 30 ft-lb)
 - ② High-pressure side
[Wrench icon]: 30 - 35 N·m (3.1 - 3.6 kg-m, 22 - 26 ft-lb)

POWER STEERING GEAR AND LINKAGE (Model PR26SE)

Removal and Installation (Cont'd)

- Observe specified tightening torque when tightening high-pressure and low-pressure pipe connectors. Excessive tightening can damage threads or damaged connector O-ring.
- The O-ring in low-pressure pipe connector is larger than that in high-pressure connector. Take care to install the proper O-ring.

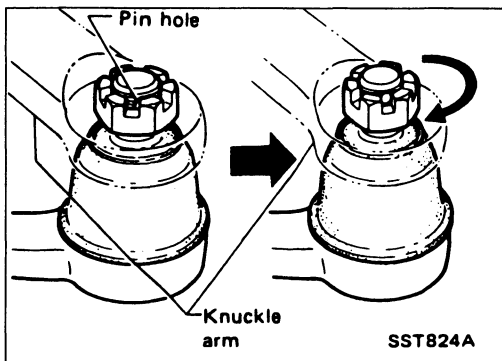

- Initially, tighten nut on tie-rod outer socket and knuckle arm to 29 to 39 N·m (3 to 4 kg-m, 22 to 29 ft-lb). Then tighten further to align nut groove with first pin hole so that cotter pin can be installed.

CAUTION:

Tightening torque must not exceed 49 N·m (5 kg-m, 36 ft-lb).

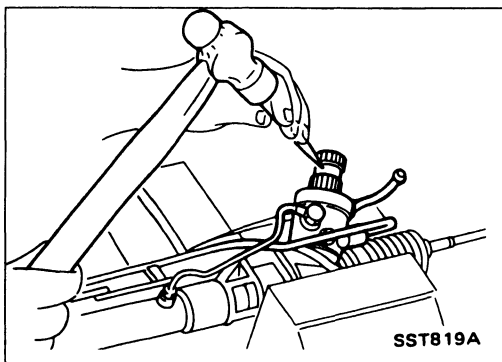

- Before removing lower joint from gear, set gear in neutral (wheels in straight-ahead position). After removing lower joint, put matching mark on pinion shaft and pinion housing to record neutral position of gear.
- To install, set left and right dust boots to equal deflection, and attach lower joint by aligning matching marks of pinion shaft and pinion housing.

POWER STEERING GEAR AND LINKAGE (Model PR26SE)

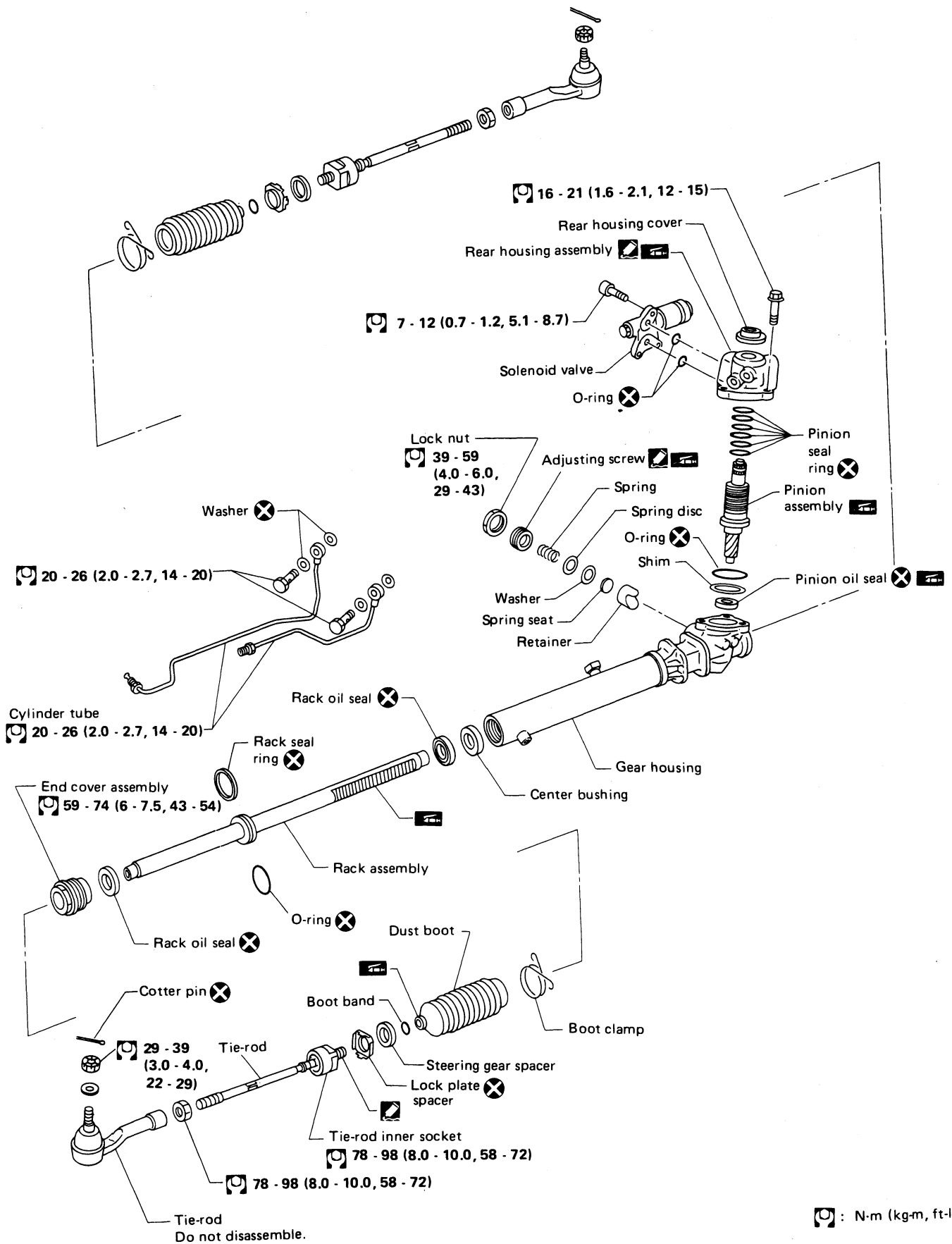

: N-m (kg-m, ft-lb)

SST319B

POWER STEERING GEAR AND LINKAGE (Model PR26SE)

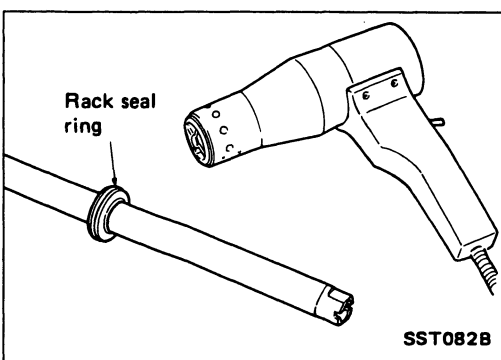
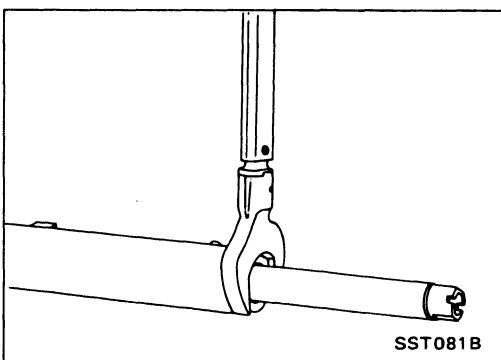
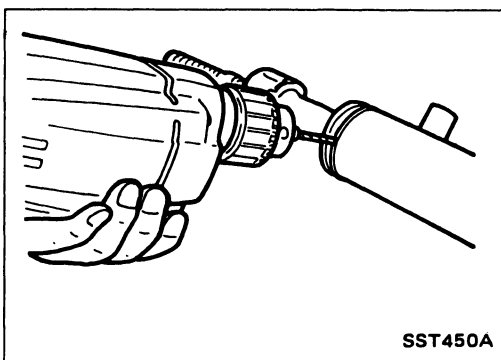
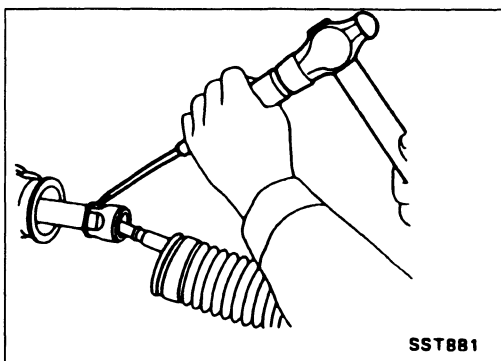
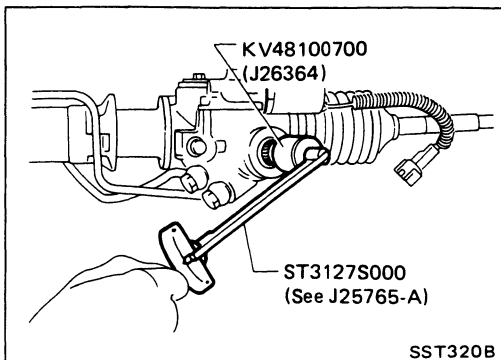

Disassembly

1. Prior to disassembling, measure pinion rotating torque. Record the pinion rotating torque as a reference.

- Before measuring, disconnect cylinder tube and drain fluid.
- Use soft jaws when holding steering gear housing. Handle gear housing carefully, as it is made of aluminum. Do not grip cylinder in a vise.

2. Remove pinion gear.

- Be careful not to damage pinion gear when removing pinion seal ring.

3. Remove tie-rod outer sockets and boots.

4. Loosen tie-rod inner socket by prying up staked portion, and remove socket.

5. Remove retainer.

6. Remove pinion assembly.

7. Drill staked portion of cylinder end cover with drill of 2 to 2.5 mm (0.079 to 0.098 in) diameter, until the staking is eliminated.

8. Remove gear housing end cover assembly with Tool.

9. Draw out rack assembly.

10. Remove rack seal ring.

- Using a heat gun, heat rack seal to approximately 40°C (104°F).

- Remove rack seal ring.

- Replace rack seal ring and O-ring with new ones.

Be careful not to damage rack.

POWER STEERING GEAR AND LINKAGE (Model PR26SE)

Disassembly (Cont'd)

11. Remove center bushing and rack oil seal using tape wrapped socket and extension bar.

Do not scratch inner surfaces of pinion housing.

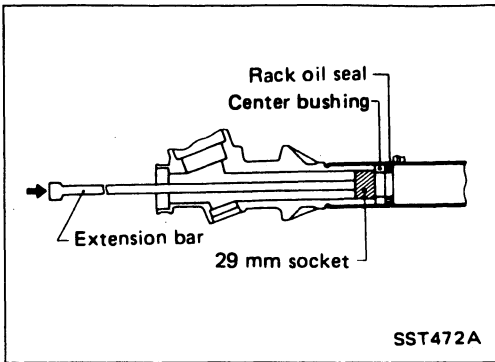

Inspection

Thoroughly clean all parts in cleaning solvent or automatic transmission fluid "DEXRON™" type, and blow dry with compressed air, if available.

BOOT

Check condition of boot. If cracked excessively, replace it.

RACK

Thoroughly examine rack gear. If damaged, cracked or worn, replace it.

PINION ASSEMBLY

- Thoroughly examine pinion gear. If pinion gear is damaged, cracked or worn, replace it.
- Inspect bearings to see that they roll freely and are free from cracked, pitted, or worn balls, rollers and races. Replace if necessary.

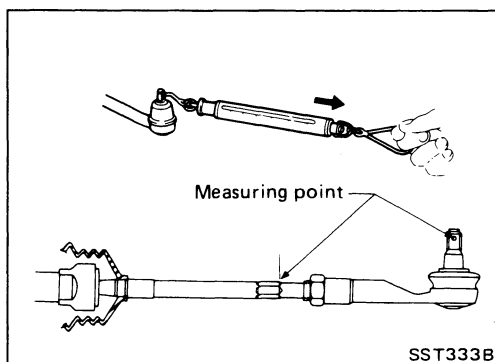

TIE-ROD OUTER AND INNER SOCKET

- Check ball joint for swinging force.

Tie-rod outer ball joint:

4.61 - 46.1 N

(0.47 - 4.7 kg, 1.04 - 10.4 lb)

Tie-rod inner ball joint:

8.8 - 78.5 N

(0.9 - 8.0 kg, 2.0 - 17.6 lb)

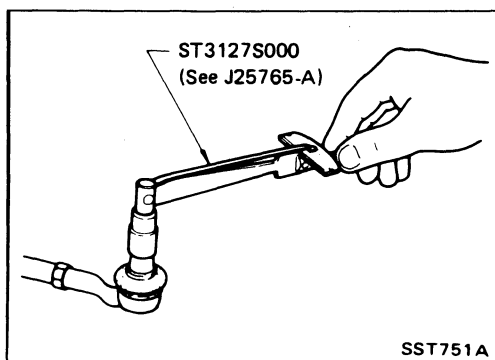

- Check ball joint for rotating torque.

Tie-rod outer ball joint:

0.29 - 2.94 N·m

(3.0 - 30.0 kg-cm, 2.6 - 26.0 in-lb)

Tie-rod inner ball joint:

1.0 - 8.8 N·m (10 - 90 kg-cm, 8.7 - 78.1 in-lb)

POWER STEERING GEAR AND LINKAGE (Model PR26SE)

Inspection (Cont'd)

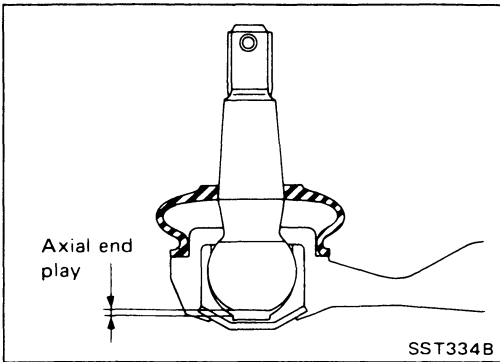

- Check ball joint for axial end play.
Tie-rod outer ball joint:
0 mm (0 in)
Tie-rod inner ball joint:
0 mm (0 in)
- Check condition of dust cover. If cracked excessively, replace it.

CYLINDER TUBES

Check cylinder tubes for scratches or other damage. Replace if necessary.

Assembly

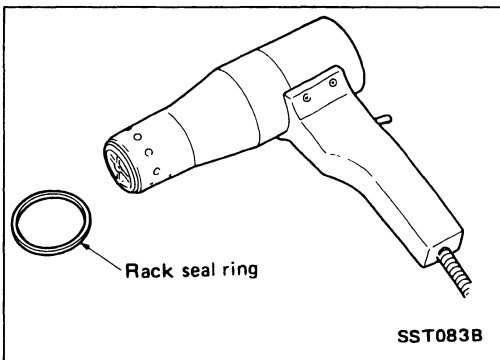

1. Using a heat gun, heat rack seal ring (made of Teflon) to approximately 40°C (104°F) and install it onto rack with your hand.

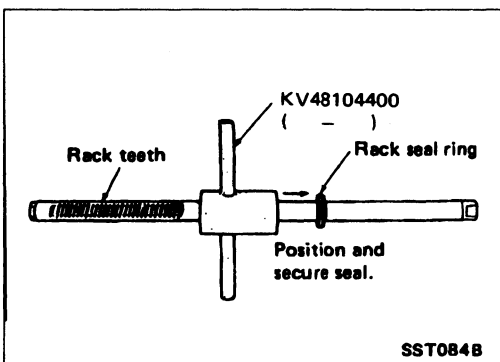

- Using Tool, compress periphery of rack seal ring (made of Teflon) to position and secure it on rack.

Always insert the tool from the rack gear side.

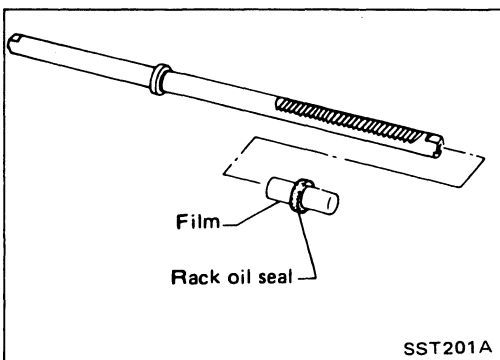

2. Insert rack oil seal.
 - Place plastic film into rack oil seal to prevent damage by rack teeth.
 - Always remove plastic film after rack oil seal is positioned properly.
 - Make sure lips of rack oil seal face each other.

POWER STEERING GEAR AND LINKAGE (Model PR26SE)

Assembly (Cont'd)

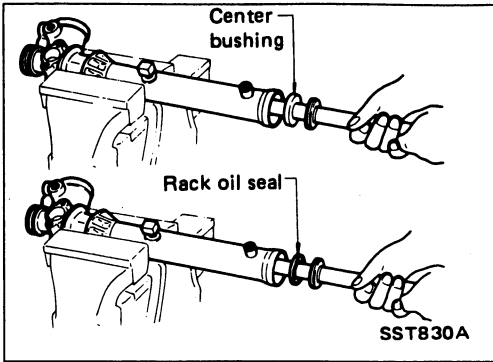

3. Install center bushing and rack oil seal with rack assembly.

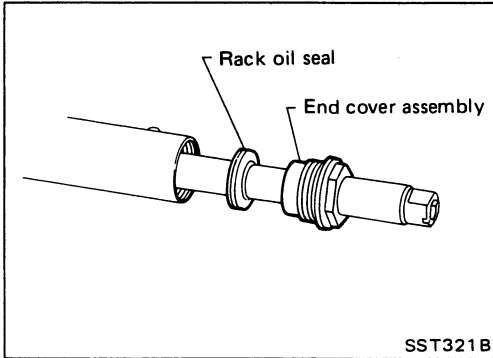

4. Insert rack oil seal and end cover assembly to rack then tighten end cover assembly.

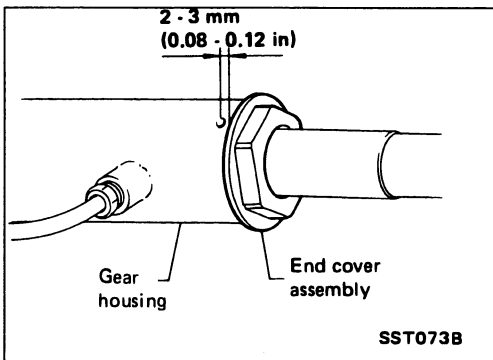

5. Fasten cylinder end cover assembly to gear housing by staking.

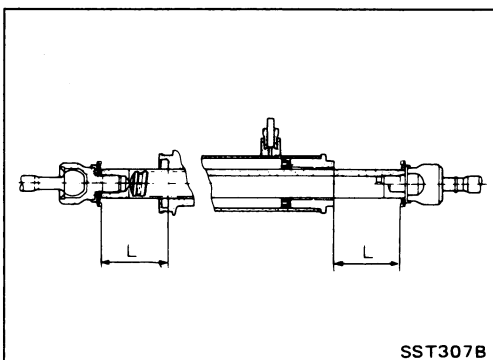

6. Set rack gear in neutral position.
Rack stroke "L":
Refer to S.D.S.

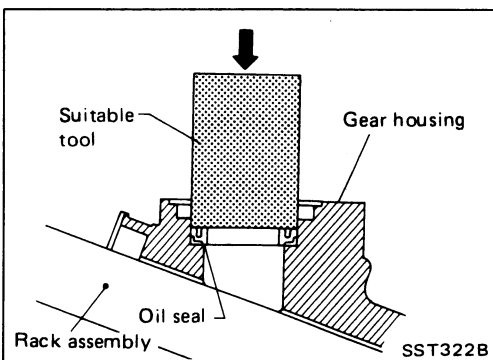

7. Coat seal lip of oil seal with multi-purpose grease and install new pinion oil seal to pinion housing with a suitable tool.
 - Make sure lip of oil seal faces up when installed.

POWER STEERING GEAR AND LINKAGE (Model PR26SE)

Assembly (Cont'd)

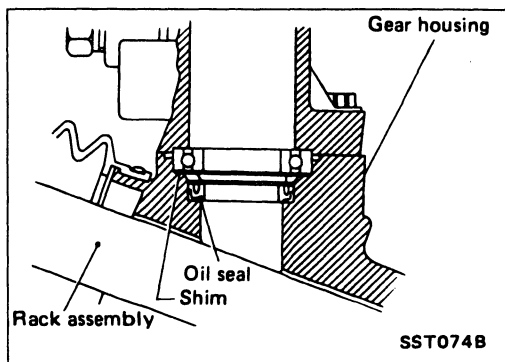

8. Install pinion bearing adjusting shim(s).
- Whenever pinion assembly, gear housing and rear housing are disassembled, replace shim(s) with new ones. Always use the same number of shim(s) when replacing.

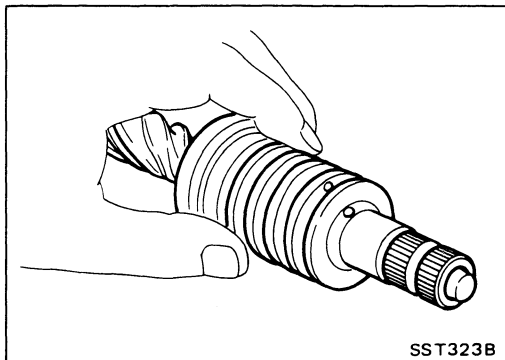

9. Install pinion seal ring on pinion gear assembly.
- Using a heat gun, heat pinion seal ring to approximately 40°C (104°F) before installing it onto pinion gear assembly.
 - Make sure pinion seal ring is properly settled in valve groove.

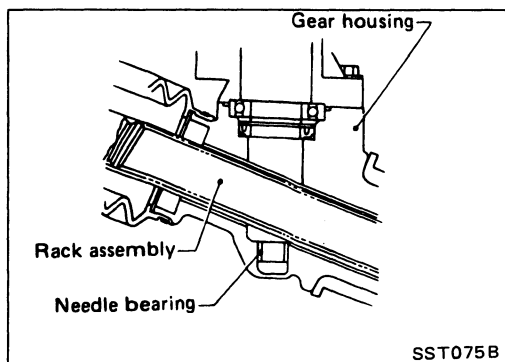

10. Apply a coat of multi-purpose grease to needle bearing roller and oil seal lip before installing pinion assembly in gear housing.

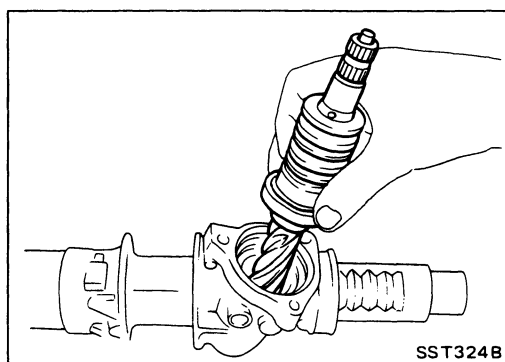

11. Install pinion assembly to pinion housing.
Be careful not to damage pinion oil seal.

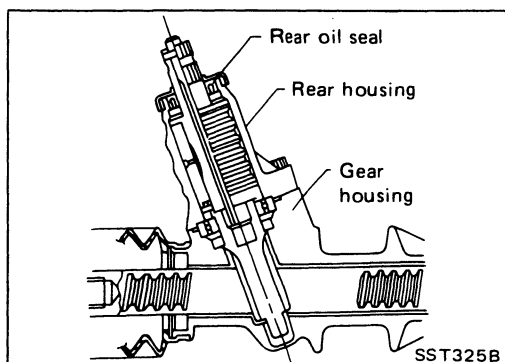

12. Apply a coat of multi-purpose grease to rear oil seal lip before installing rear housing.

POWER STEERING GEAR AND LINKAGE (Model PR26SE)

Assembly (Cont'd)

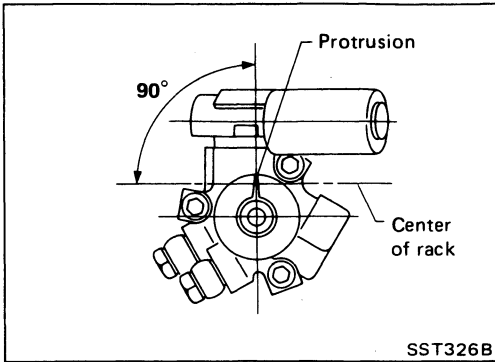

13. Install rear cover cap so that protrusion of rear housing cover is positioned as shown in figure at left.

Be careful not to damage worm ring and oil seal.

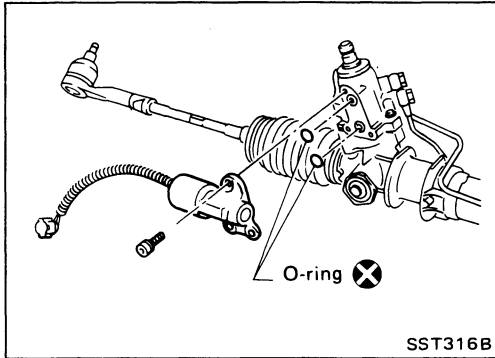

14. Install solenoid valve.

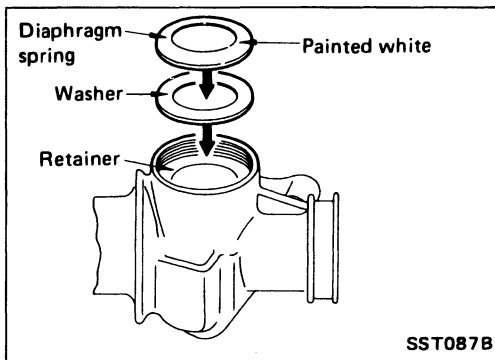

15. Install diaphragm spring at retainer.

- Always install retainer, spring washer and diaphragm spring in that order.
- Make sure convex end (painted white) of diaphragm spring faces outward when installing.

16. Install retainer spring and adjusting screw temporarily.

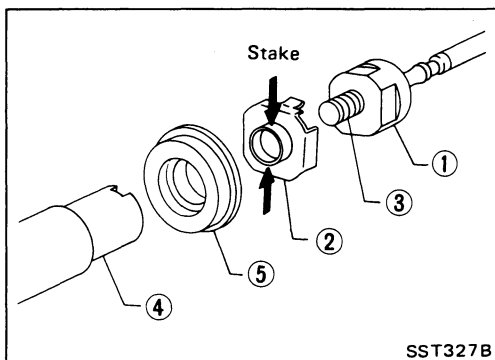

CAUTION:

Ensure steering gear spacer is installed with rubber side facing rack.

- Attach lock plate ② to side rod inner socket ①.
- Insert steering gear spacer ⑤ to rack ④.
- Apply locking sealant to inner socket threads ③. Screw inner socket into rack ④ and tighten to specified torque.
- Stake lock plate at two places.

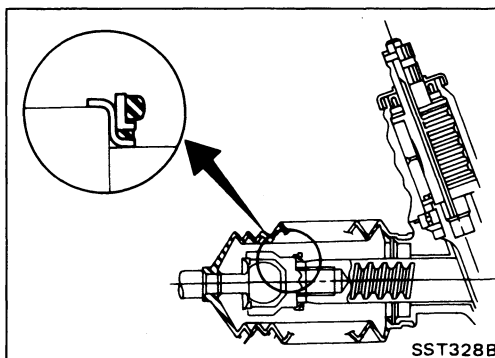

17. Install steering gear spacer ⑤ to lock plate ②.

POWER STEERING GEAR AND LINKAGE (Model PR26SE)

Assembly (Cont'd)

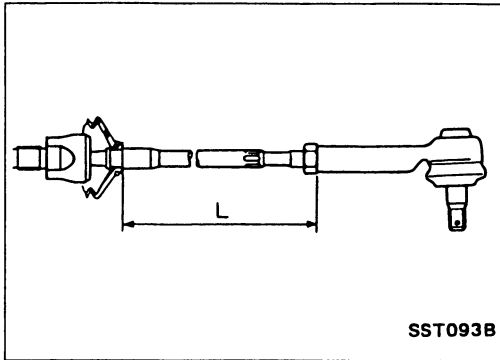

18. Tighten outer socket lock nut.
Tie-rod length "L":
Refer to S.D.S.

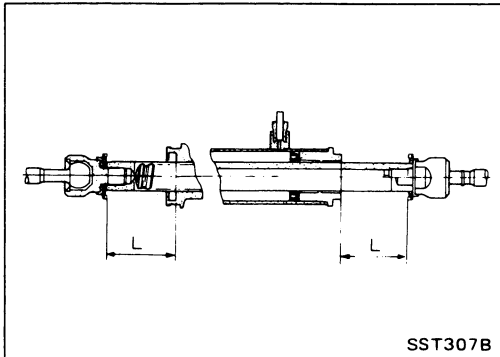

19. Measure rack stroke.
Rack stroke "L":
Refer to S.D.S.

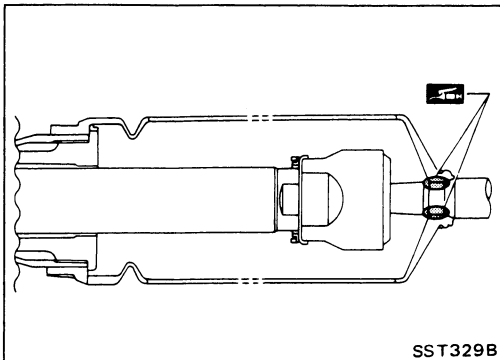

20. Before installing boot, coat the contact surfaces between boot and tie-rod with grease.

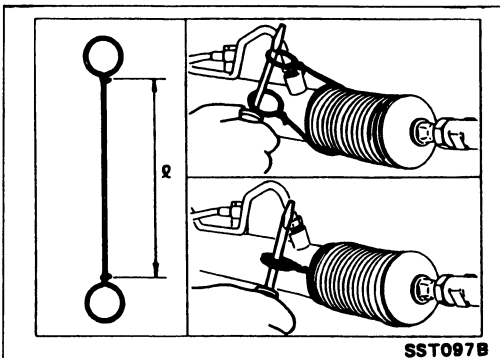

21. Install boot clamps.
- To install, wrap boot clamp around boot groove twice. Tighten clamp by twisting rings at both ends 4 to 4-1/2 turns with screwdriver while pulling with a force of approx. 98 N (10 kg, 22 lb).

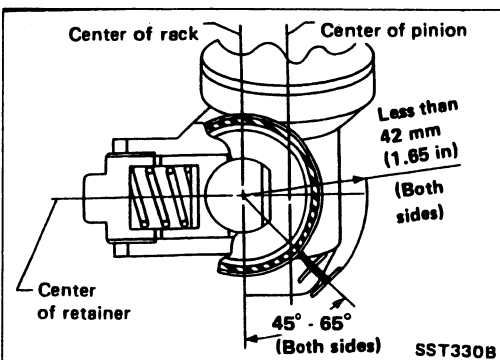

- Install boot clamp so that it is to the rear of the vehicle when gear housing is attached to the body. (This will prevent interference with other parts.)

POWER STEERING GEAR AND LINKAGE (Model PR26SE)

Assembly (Cont'd)

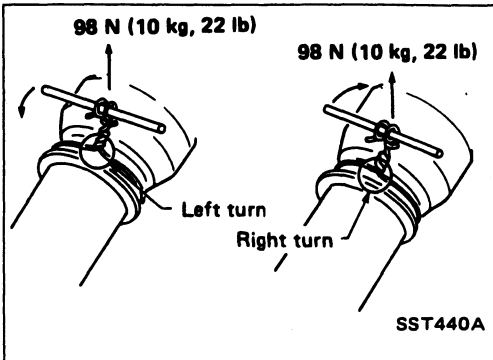

- Twist boot clamp in the direction shown in figure at left.

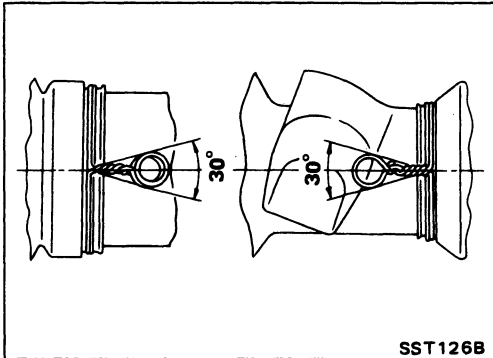

- After twisting boot clamp, bend twisted and diagonally so it does not contact boot.

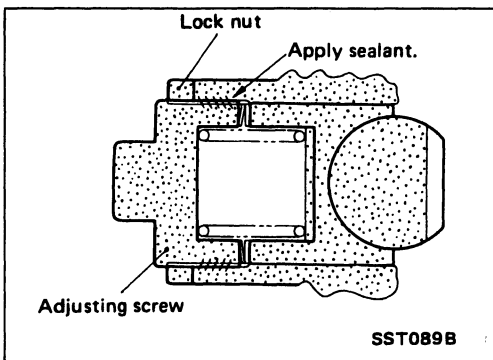

Adjustment

Adjust pinion rotating torque as follows:

1. Set gears to Neutral without fluid in the gear.
2. Coat the adjusting screw with locking sealant and screw it in.
3. Lightly tighten lock nut.
4. Tighten adjusting screw to a torque of 4.9 to 5.9 N·m (50 to 60 kg-cm, 43 to 52 in-lb).
5. Loosen adjusting screw, then retighten it to 0.05 to 0.20 N·m (0.5 to 2 kg-cm, 0.43 to 1.74 in-lb).
6. Move rack over its entire stroke several times.
7. Measure pinion rotating torque within the range of 180° from neutral position.
Stop the gear at the point of maximum torque.
8. Loosen adjusting screw, then retighten it to 4.9 N·m (50 kg-cm, 43 in-lb).
9. Loosen adjusting screw by 60° to 100°.

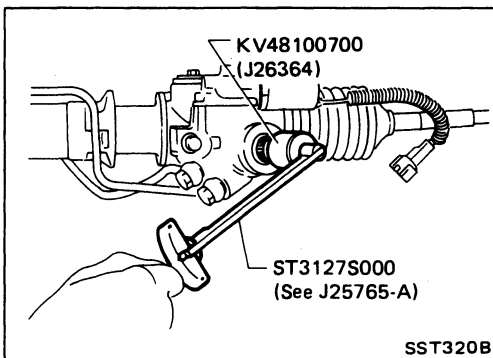

10. Prevent adjusting screw from turning, and tighten lock nut to specified torque.

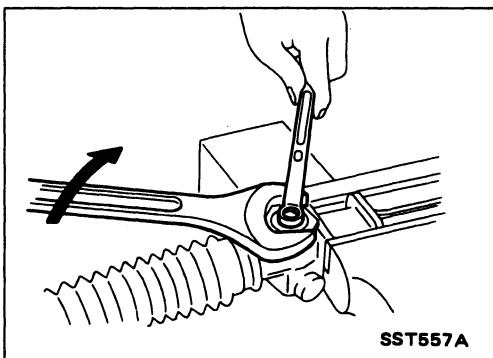

POWER STEERING GEAR AND LINKAGE (Model PR26SE)

Adjustment (Cont'd)

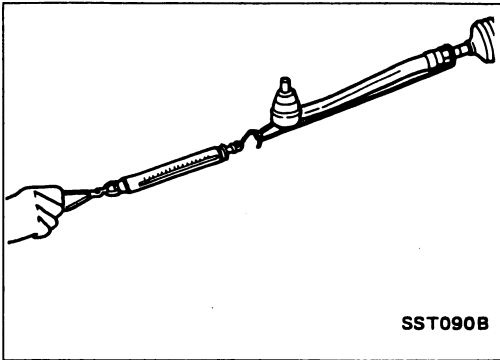

11. Check steering gear for rack sliding frictional force.

Around neutral point of rack stroke

$\pm 5.5 \text{ mm } (\pm 0.217 \text{ in})$:

122.6 - 166.7 N (12.5 - 17 kg, 27.6 - 37.5 lb)

Except for neutral point:

122.6 - 186.3 N (12.5 - 19 kg, 27.6 - 41.9 lb)

- If sliding frictional force is out of specification, repeat the adjustment procedure, starting from No. 4.
- After the readjustment, if sliding force is still out of specification, steering gear is damaged.

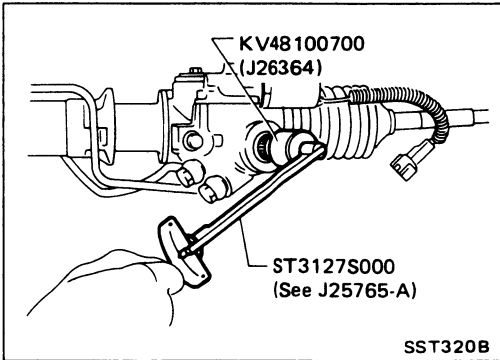

12. Measure pinion rotating torque within the range of $\pm 100^\circ$ from the neutral point.

Average rotating torque

$[(\text{Max. measured value} + \text{Min. measured value}) \times 0.5]$:

0.8 - 1.3 N·m (8 - 13 kg-cm, 6.9 - 11.3 in-lb)

Maximum torque increment:

Less than 0.4 N·m (4 kg-cm, 3.5 in-lb)

Except for above mentioned measuring range:

Maximum rotating torque

1.9 N·m (19 kg-cm, 16 in-lb)

Maximum torque increment

Less than 0.6 N·m (6 kg-cm, 5.2 in-lb)

- If pinion rotating torque is not within specification, readjust it.
- After the readjustment, if pinion rotating torque is still out of specification, steering gear is damaged.

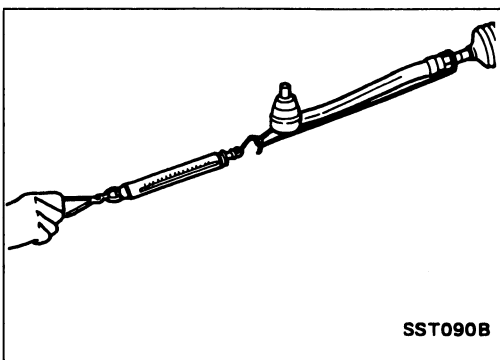

13. Check rack sliding force on vehicle as follows:

- Install steering gear onto vehicle, but do not connect tie-rod to knuckle arm.
- Connect all piping and fill with steering fluid.
- Start engine and bleed air completely.
- Disconnect steering column lower joint from the gear.
- Keep engine at idle and make sure steering fluid has reached normal operating temperature.
- While pulling tie-rod slowly in the $\pm 11.5 \text{ mm } (\pm 0.453 \text{ in})$ range from the neutral position, make sure rack sliding force is within specification.

Average rack sliding force:

Without HICAS

206 - 265 N (21 - 27 kg, 46 - 60 lb)

With HICAS

201.0 - 250.1 N (20.5 - 25.5 kg, 45.2 - 56.2 lb)

- Check sliding force outside above range.

Maximum rack sliding force:

Not more than 39 N (4 kg, 9 lb) beyond above value

- If rack sliding force is not within specification, readjust by repeating adjustment procedure from the beginning.
- If rack sliding force is still out of specification after readjustment, gear assembly needs to be replaced.

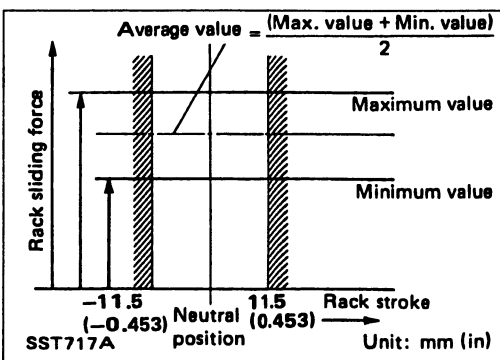

POWER STEERING OIL PUMP

Disassembly and Assembly

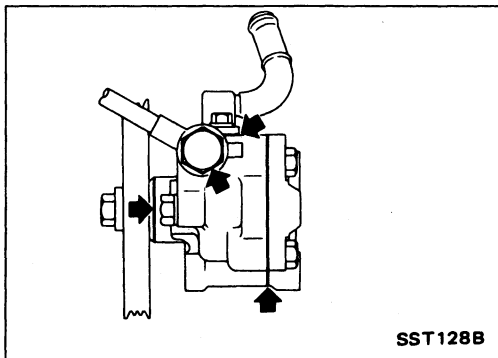
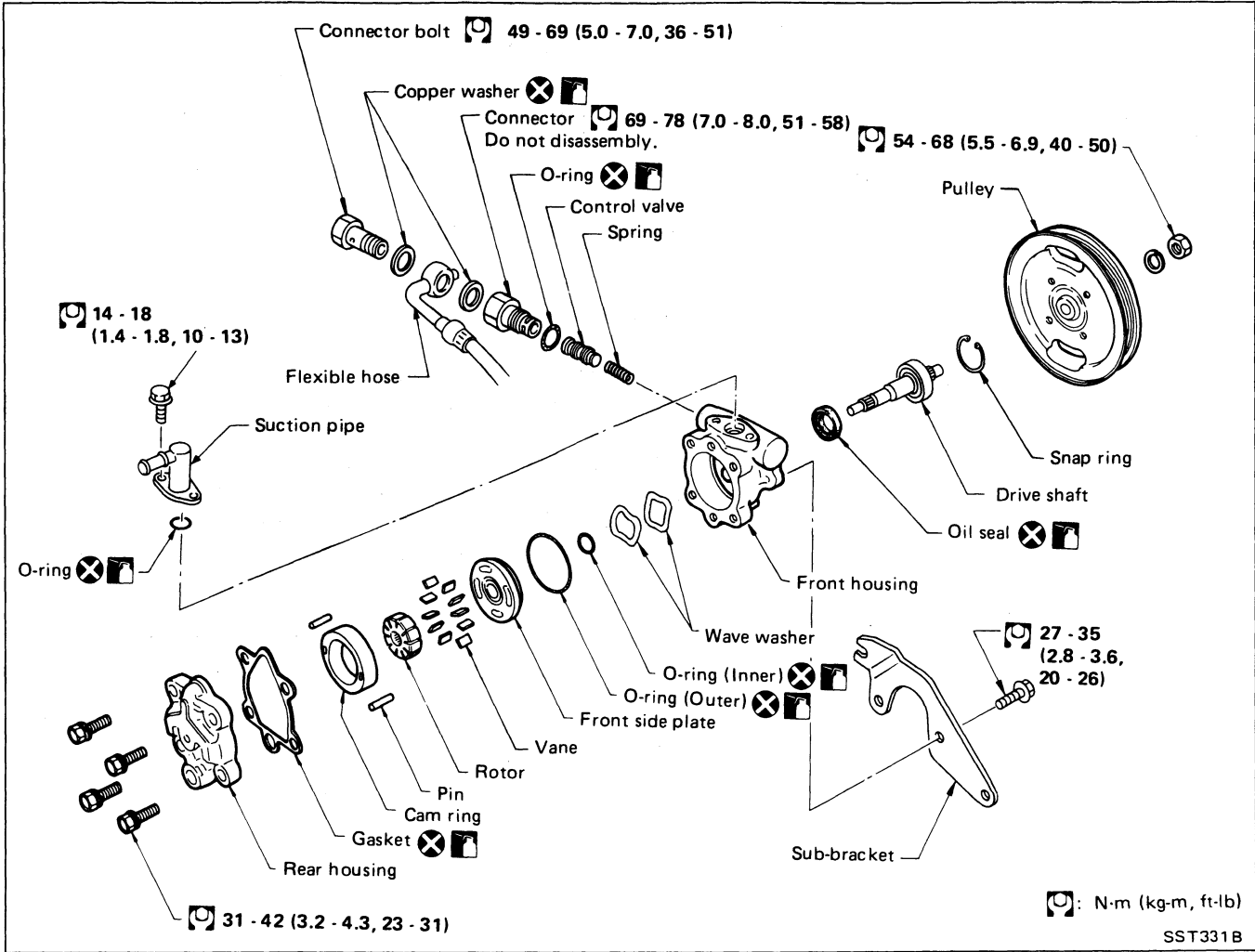

Pre-disassembly Inspection

Disassemble the power steering oil pump only if the following items are found.

- Oil leak from any point shown in the figure.
- Deformed or damaged pulley.
- Poor performance

POWER STEERING OIL PUMP

Disassembly

CAUTION:

- Parts which can be disassembled are strictly limited. Never disassemble parts other than those specified.
- Disassemble in as clean a place as possible.
- Clean your hands before disassembly.
- Do not use rags; use nylon cloths or paper towels.
- Follow the procedures and cautions in the Service Manual.
- When disassembling and reassembling, do not let foreign matter enter or contact the parts.

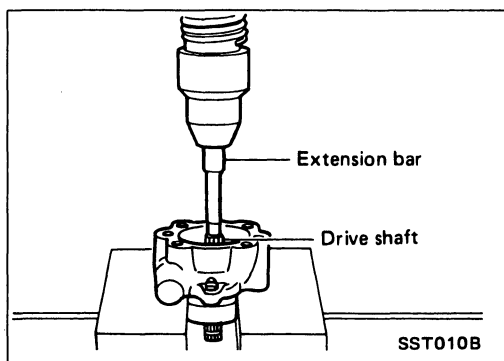

- Remove snap ring, then draw drive shaft out.
Be careful not to drop drive shaft.

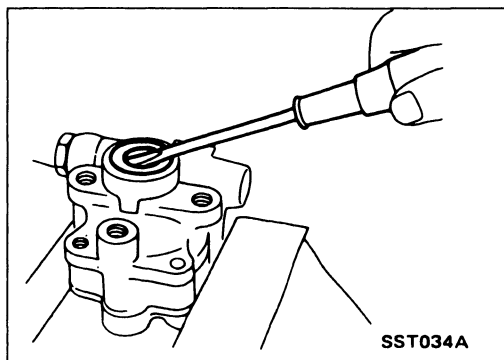

- Remove oil seal.
Be careful not to damage front housing.

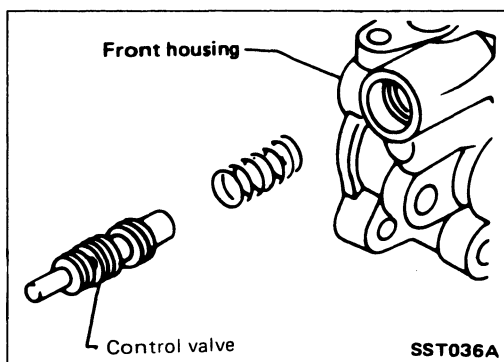

- Remove connector.
Be careful not to drop control valve.

Inspection

Inspect each component part for wear, deformation, scratches, and cracks. If damage is found, replace the part.

POWER STEERING OIL PUMP

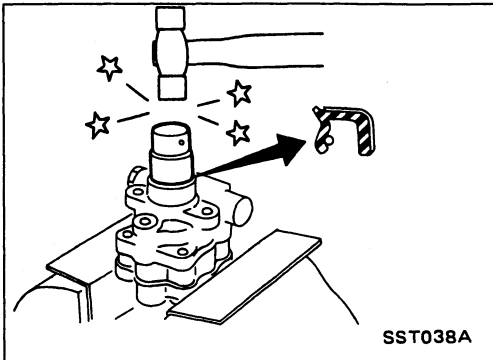

Assembly

Assemble oil pump, noting the following instructions.

- Make sure O-rings and oil seal are properly installed.
- Always install new O-rings and oil seal.
- Be careful of oil seal direction.
- Cam ring, rotor and vanes must be replaced as a set if necessary.
- Coat each part with A.T.F. when assembling.

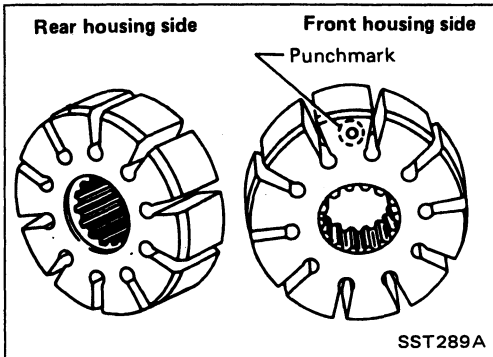

- Pay attention to rotor direction.

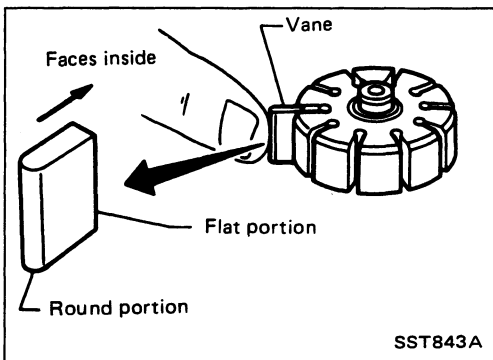

- When assembling vanes to rotor, rounded surfaces of vanes must face cam ring side.

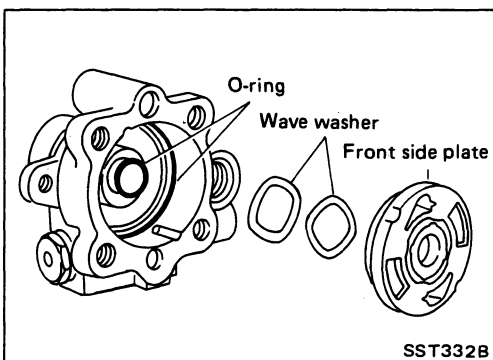

- Apply A.T.F. to O-ring.

POWER STEERING OIL PUMP

Assembly (Cont'd)

- Insert pin ② into pin groove ① of front housing and front side plate. Then install cam ring ③ as shown at left.

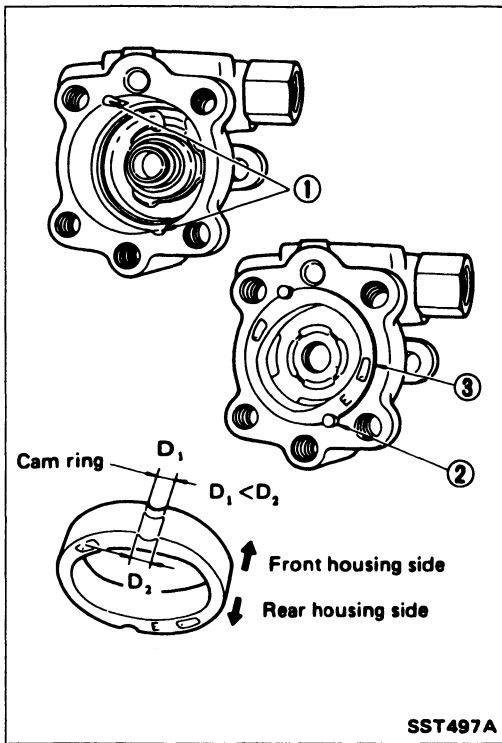

TWIN ORIFICE POWER STEERING SYSTEM

Hydraulic Circuit

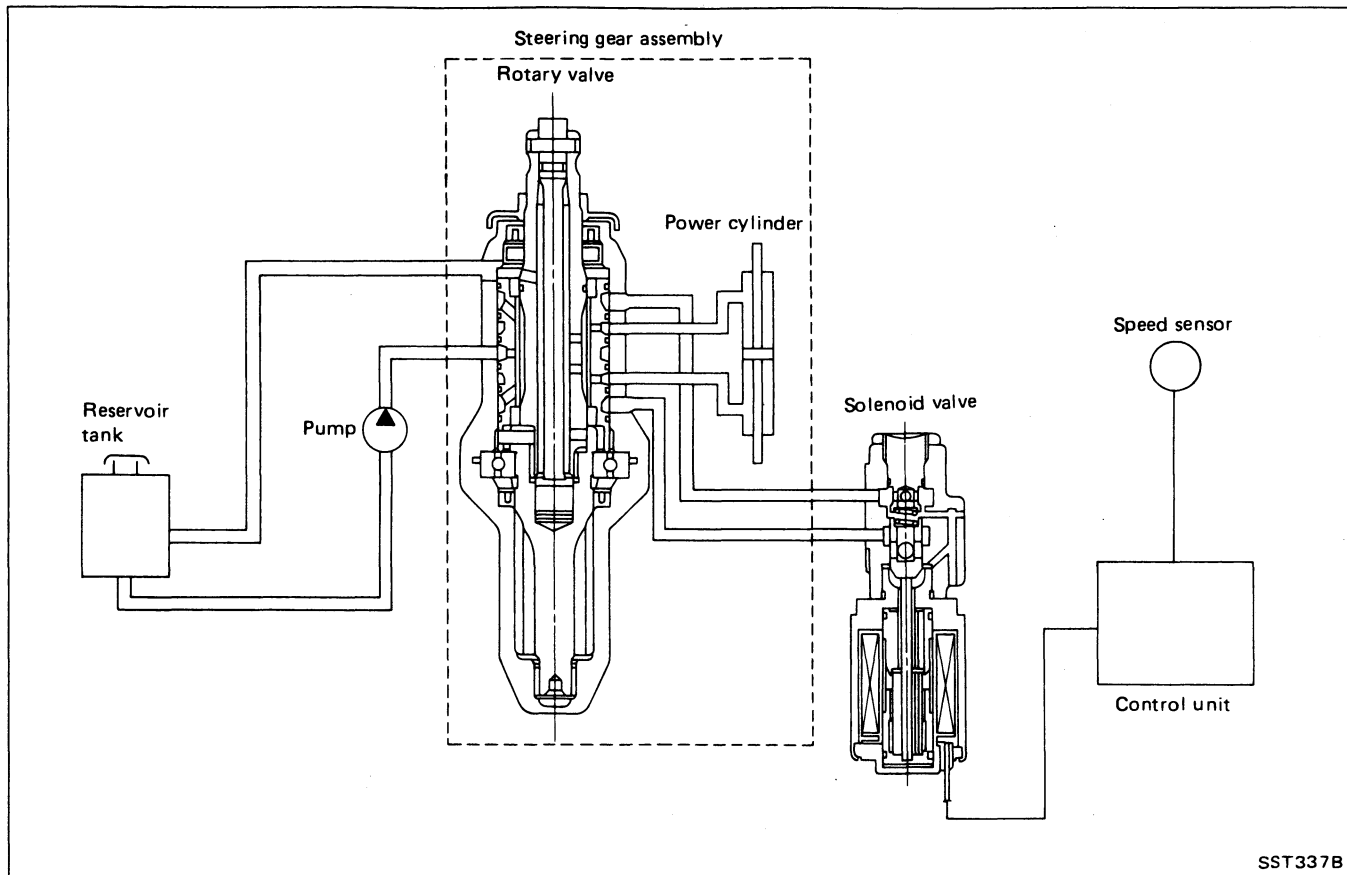

SST337B

Schematic

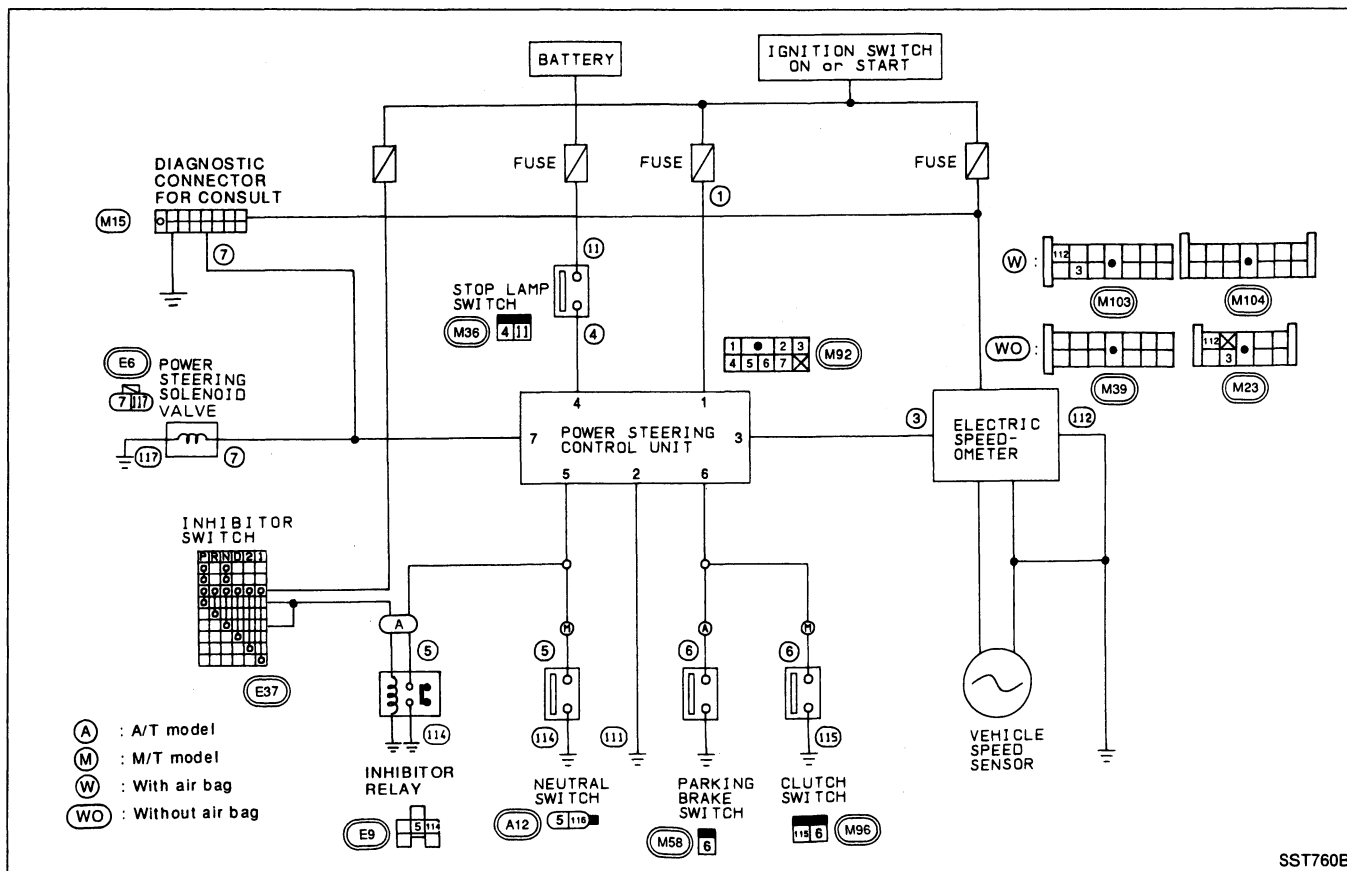

SST760B

TWIN ORIFICE POWER STEERING SYSTEM

Wiring Diagram

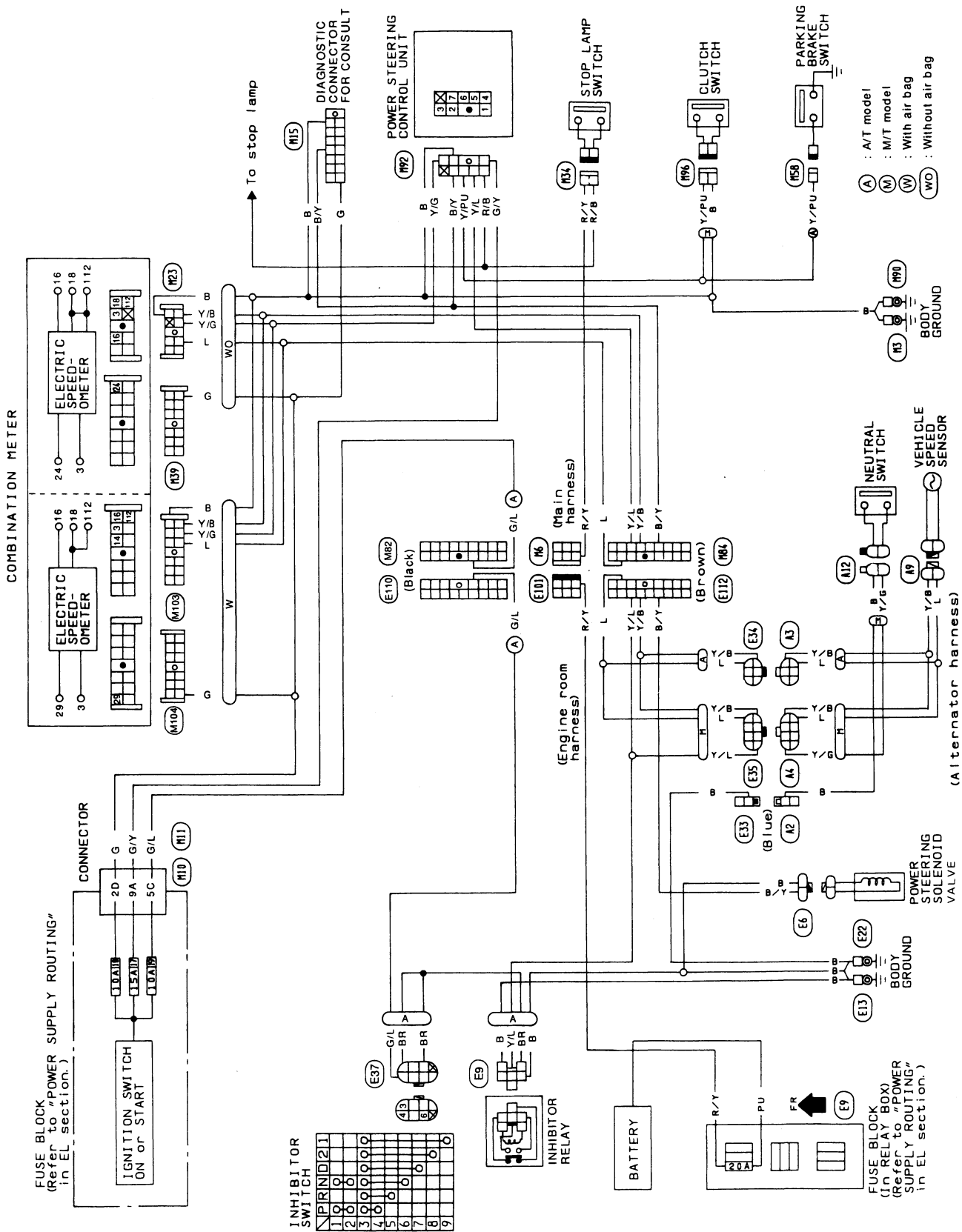

Precautions

BEFORE DIAGNOSING THE POWER STEERING SYSTEM, ENSURE THAT:

Vehicle stopped

- Power steering components (gears, oil pump, pipes, etc.) are free from leakage, and that oil level is correct.
- Tires are inflated to specified pressure and are of specified size, and that steering wheel is a genuine Nissan part.
- Wheel alignment is adjusted properly.
- Suspension utilizes the original design, and is free of modifications which increase vehicle weight.

Vehicle in operation

- Understand the trouble symptoms.
- Engine is operating properly.

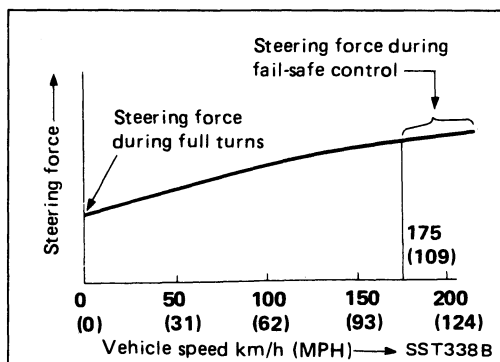

PRELIMINARY KNOWLEDGE HELPFUL IN CONDUCTING DIAGNOSES

The power steering system is a twin orifice type, which uses a vehicle-speed sensing, electronic control design. Valve sensitivity is controlled in response to vehicle speed to achieve optimum steering effort. When a vehicle-speed signal is not entered into the power steering control unit for approximately 10 seconds during normal operation (see NOTE below), a fail-safe system activates to maintain the steering effort at a level similar to that experienced during high-speed operation. More precisely, if a foot-brake signal, parking-brake signal and/or transmission position signal (N or P-range signal on automatic transmission models and a neutral or clutch signal on manual transmission models) are not entered, the power steering system is held in a "fail-safe" control state. When this happens, a symptom referred to as "heavy steering during stationary turns" sometimes occurs.

NOTE:

Normal operation refers to a driving condition in which the foot brake pedal and parking brake lever are released, the shift lever is in any position other than "P" or "N" (automatic transmission models), the shift lever set in any position except "N" (manual transmission models) and the clutch pedal is not depressed.

Diagnostic Procedure 1

SYMPTOM:

Heavy steering operation during stationary turns

START

1) CHECK STOP LAMP SIGNAL.
Turn ignition switch "ON" (with engine OFF), release foot brake pedal and parking brake lever. Set shift lever to any position except "P" and "N" on automatic transmission models or set shift lever to any position except "N" on manual transmission models, and ensure clutch pedal is released.

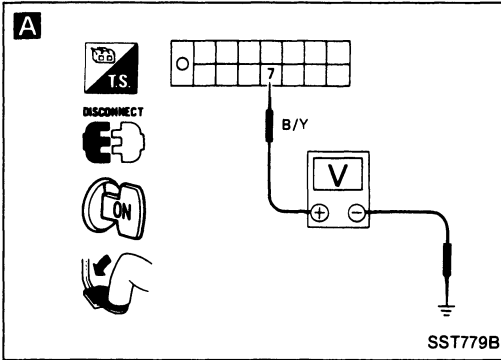

Depress brake pedal and measure voltage between solenoid valve terminals of diagnostic connector for CONSULT.

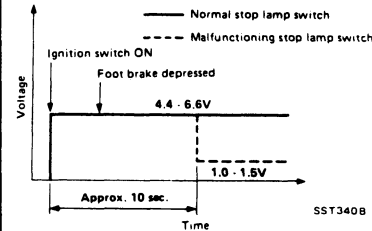

Voltage:

4.4 - 6.6 volts (constant)

... O.K.

Outside the above range or voltage fluctuations

... N.G.

O.K. → Go to 2).

N.G.

Check if terminal voltage drops to 1 - 1.5V range approx. 10 seconds after ignition switch is turned ON.

No change (outside 4.4 - 6.6V range) ... O.K.

Voltage drop ... N.G.

O.K. → Go to 5).

N.G.

Ⓐ

TWIN ORIFICE POWER STEERING SYSTEM — Trouble Diagnoses

Diagnostic Procedure 1 (Cont'd)

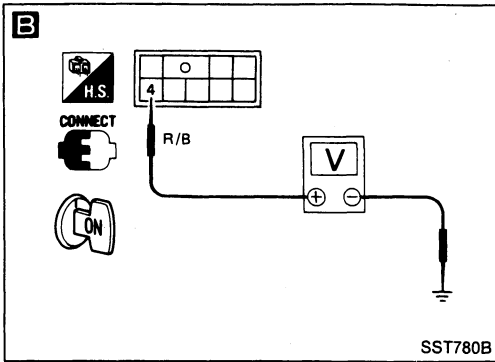

B

Check if stop lamp switch signal is present at power steering control unit.

YES (12 volts — Brake pedal depressed.) ... O.K.
NO (0 volts) ... N.G.

N.G. → Malfunctioning stop lamp switch system

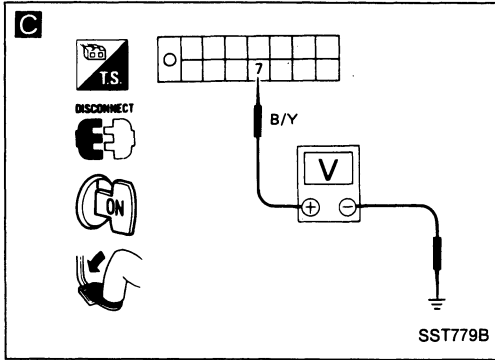

Ensure that power steering control unit connector is connected properly.

C

After ignition switch is turned "ON", depress brake pedal and measure voltage between solenoid valve terminals of diagnostic connector for CONSULT.

4.4 - 6.6 volts (constant) ... O.K.
Voltage fluctuations ... N.G.

N.G. → Malfunctioning power steering control unit.

Check if heavy steering operation occurs during stationary turns.

YES ... N.G.
NO (Lighter steering operation) ... O.K.

N.G. → Go to 4).

O.K. → END

TWIN ORIFICE POWER STEERING SYSTEM — Trouble Diagnoses

Diagnostic Procedure 1 (Cont'd)

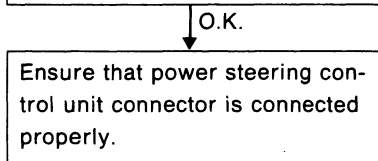
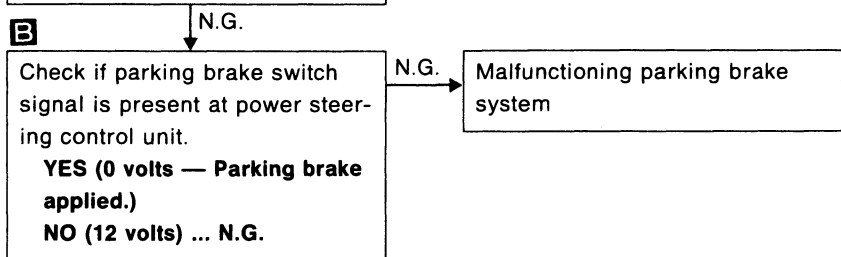
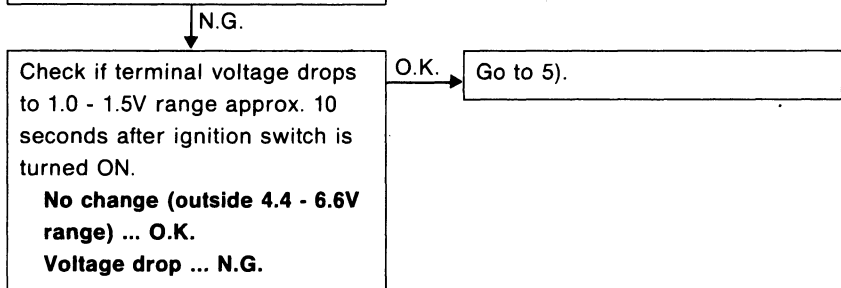
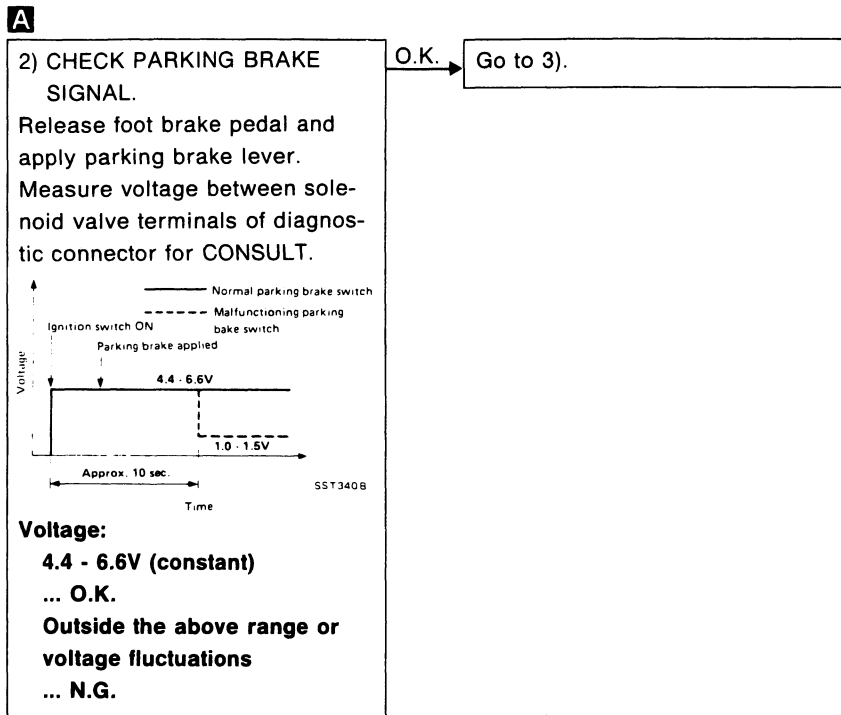
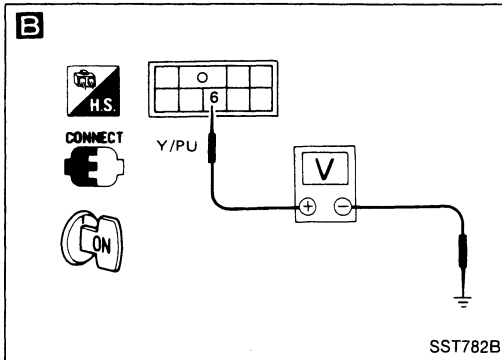
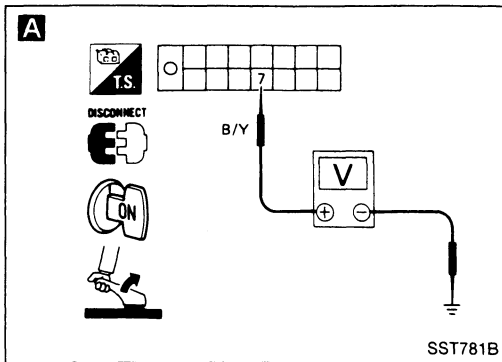

ⓑ

TWIN ORIFICE POWER STEERING SYSTEM — Trouble Diagnoses

Diagnostic Procedure 1 (Cont'd)

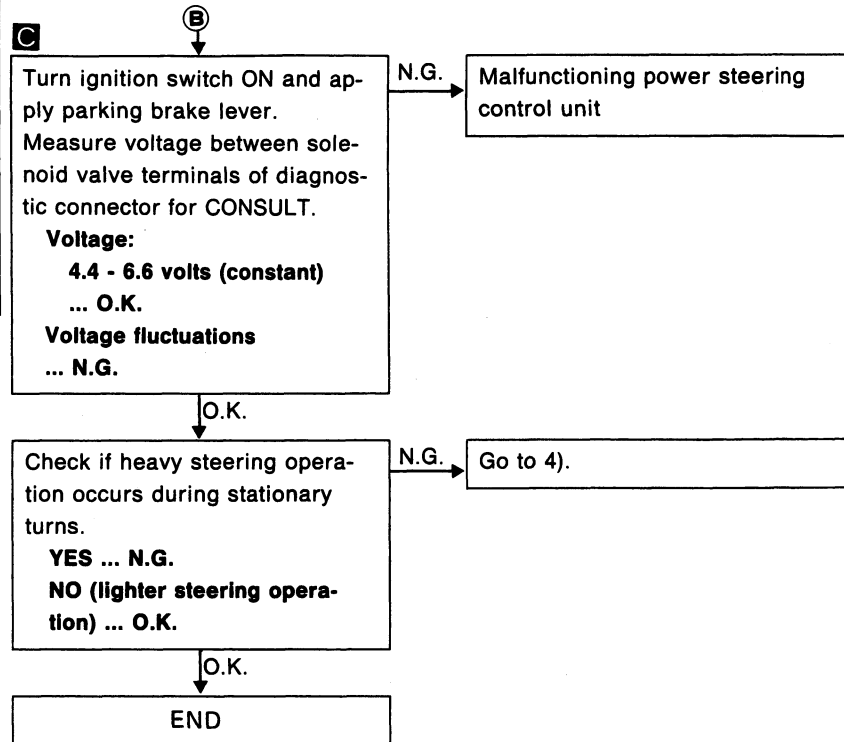
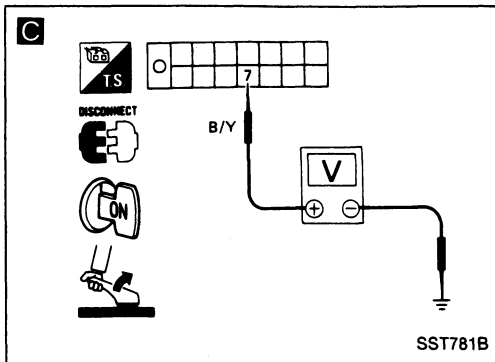

TWIN ORIFICE POWER STEERING SYSTEM — Trouble Diagnoses

Diagnostic Procedure 1 (Cont'd)

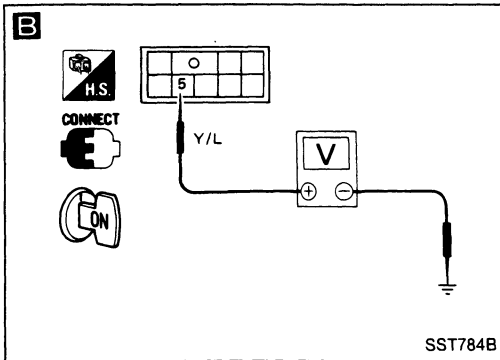
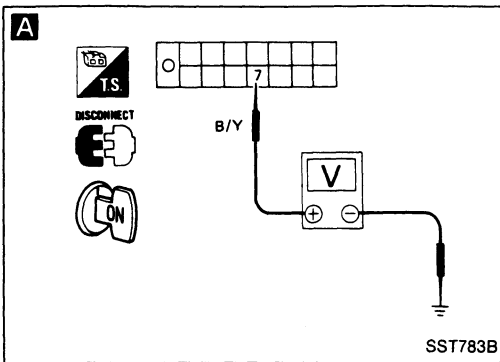

A

3) CHECK NEUTRAL POSITION SIGNAL.
 Release parking brake lever.
 Move shift lever to Neutral (A/T and M/T models). Measure voltage between solenoid valve terminals of diagnostic connector for CONSULT.

Voltage:
4.4 - 6.6V (constant) ... O.K.
Outside the 4.4 - 6.6V range or Voltage fluctuations ... N.G.

O.K. → Depress clutch pedal (M/T model) and move shift lever to "P" (A/T model). Measure voltage between solenoid valve terminals at diagnostic connector for CONSULT.
Voltage:
4.4 - 6.6V (constant) ... O.K.
Outside the above range or voltage fluctuations ... N.G.

N.G. → O.K. → Go to 4).

N.G. → Check if terminal voltage drops to 1.0 - 1.5V range approx. 10 seconds after ignition switch is turned ON.
No change (outside 4.4 - 6.6V range) ... O.K.
Voltage drop ... N.G.

O.K. → Go to 5).

N.G. → **B** Check if position switch signal is present at power steering control unit.
YES (0 volts, when position switch is ON) ... O.K.
NO (4 - 5 volts) ... N.G.

N.G. → Malfunctioning position switch system

O.K. → Ensure that power steering control unit connector is connected properly.

©

TWIN ORIFICE POWER STEERING SYSTEM — Trouble Diagnoses

Diagnostic Procedure 1 (Cont'd)

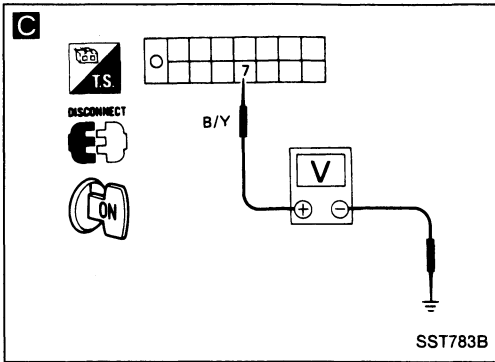

C

Turn ignition switch ON, depress clutch pedal (M/T model) and move shift lever to "P" (A/T model). Measure voltage between solenoid valve terminals of diagnostic connector for CONSULT.

Voltage:
4.4 - 6.6V (constant) ... O.K.
Voltage fluctuations ... N.G.

N.G. → Malfunctioning power steering control unit

O.K. ↓

Check if heavy steering operation occurs during stationary turns.

YES ... N.G.
NO (Lighter steering operation) ... O.K.

N.G. → Go to 1).

O.K. ↓

END

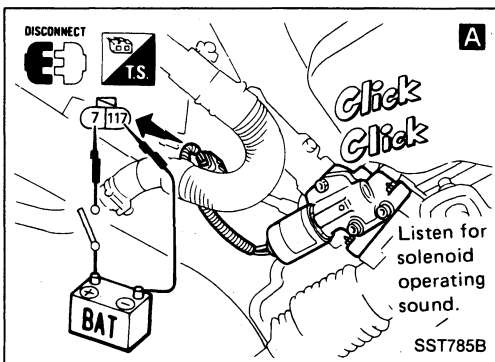

A

4) CHECK POWER STEERING SOLENOID VALVE FOR PROPER OPERATION. Disconnect solenoid valve connector. Check if plunger clicks when voltage is applied between connector terminals (on solenoid valve side).

Clicks ... O.K.
NO clicks ... N.G.

N.G. → Malfunctioning power steering solenoid valve

O.K. ↓

- Malfunctioning steering gear assembly
- Malfunctioning oil pump

TWIN ORIFICE POWER STEERING SYSTEM — Trouble Diagnoses

Diagnostic Procedure 1 (Cont'd)

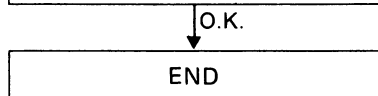
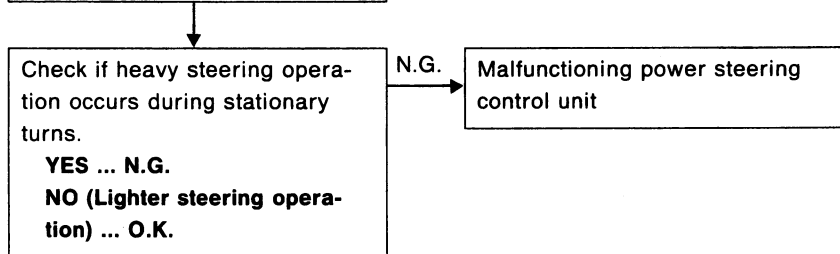
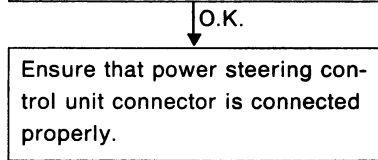
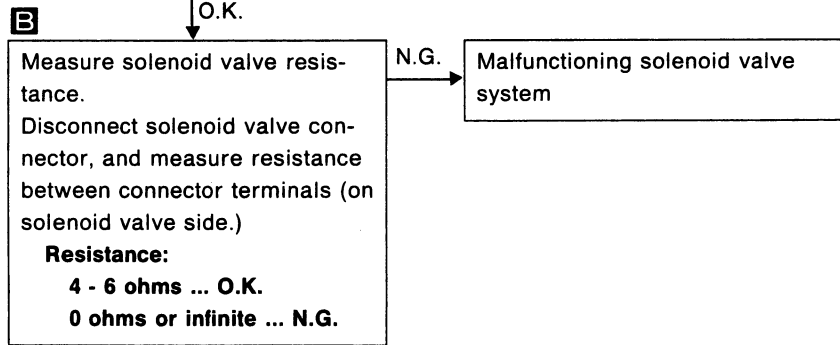
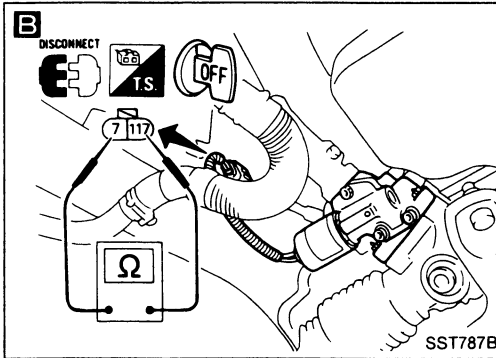
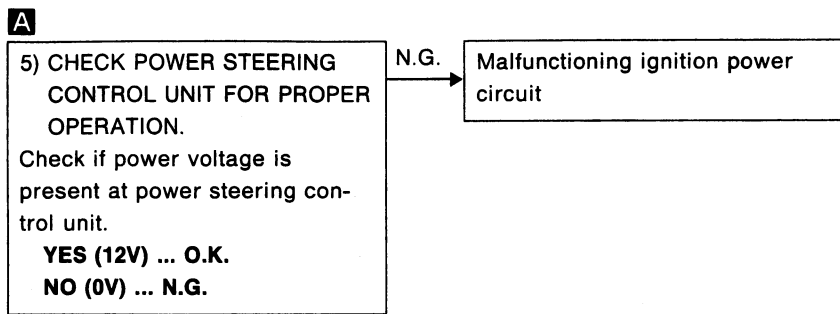
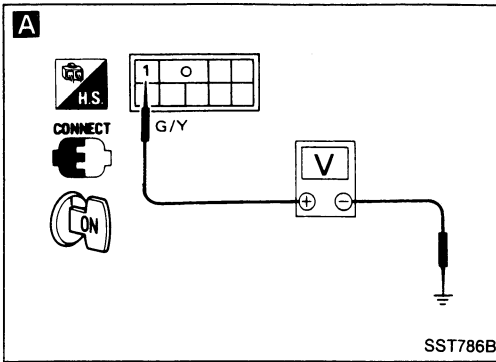

TWIN ORIFICE POWER STEERING SYSTEM — Trouble Diagnoses

Diagnostic Procedure 2

SYMPTOM:

Light steering operation during high-speed driving

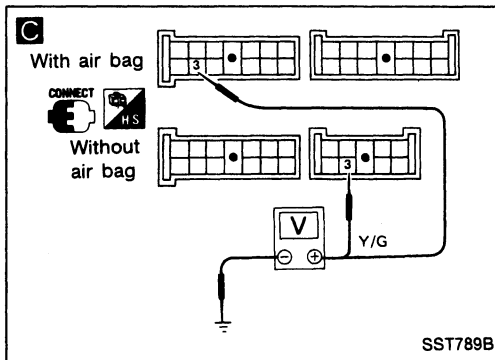
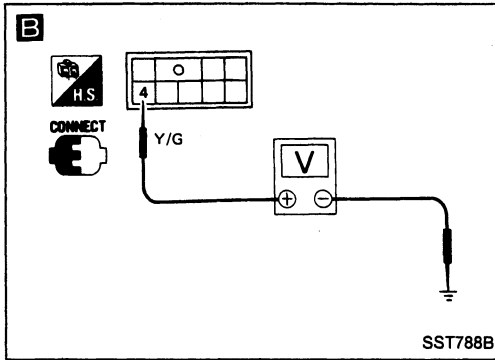
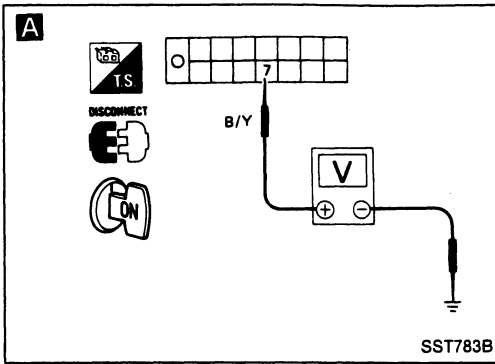

Raise rear wheels off ground and start engine.

A Measure voltage between solenoid valve terminals of diagnostic connector for CONSULT while driving vehicle from 0 to 100 km/h (0 to 62 MPH).
Voltage:
 0 km/h (0 MPH):
 4.4 - 6.6V ... O.K.
 100 km/h (62 MPH):
 1.8 - 2.8V ... O.K.
 Constant voltage ... N.G.

N.G.
 Check speedometer for proper operation.
YES ... O.K.
NO ... N.G.

O.K. → **C**
 Malfunctioning vehicle speed sensor or speedometer

O.K.
 Check A.S.C.D. and vehicle speed-sensing door lock for proper operation.
YES ... O.K.
NO ... N.G.

N.G. → **C**
 Check if vehicle speed signal is present at speedometer. Disconnect speedometer from vehicle to facilitate work. Reconnect wiring. Measure voltage between speedometer terminals while driving vehicle at very slow speeds.
1 volt (Min.) and 5 volts (Max.) are alternately repeated ... O.K.
No voltage is present ... N.G.

O.K.
B Check if vehicle speed signal is present at power steering control unit. While driving at very slow speeds, connect power steering unit connector. Measure terminal voltage.
1 volt (Min.) and 5 volts (Max.) are alternately repeated ... O.K.
No voltage is present ... N.G.

N.G. → Malfunctioning speedometer

O.K.
 Ensure that power steering control unit connector is connected properly.

O.K. → Improper connection between speedometer and power steering control unit

TWIN ORIFICE POWER STEERING SYSTEM — Trouble Diagnoses

Diagnostic Procedure 2 (Cont'd)

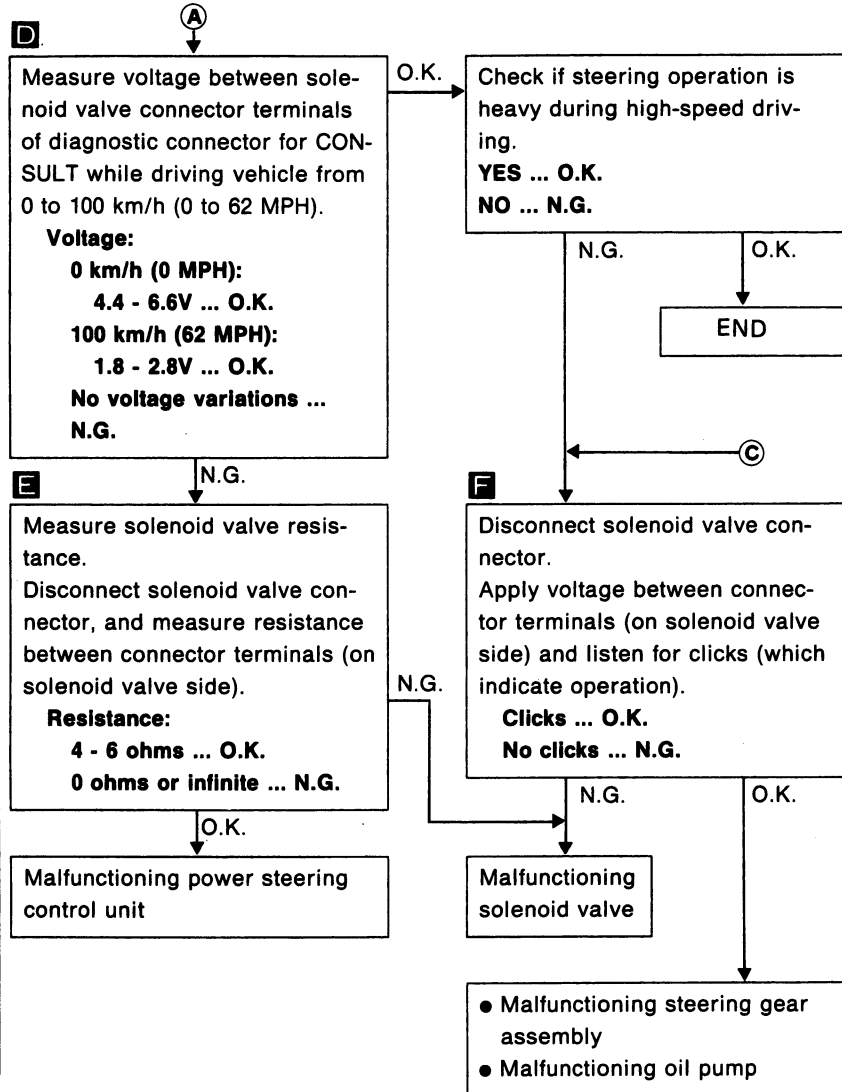
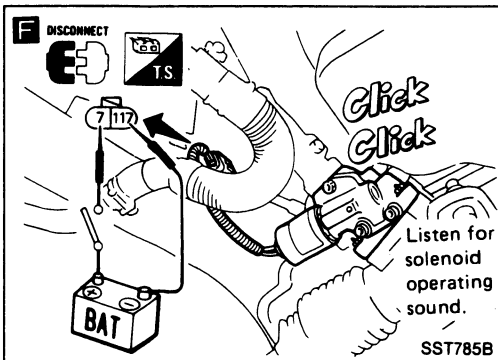
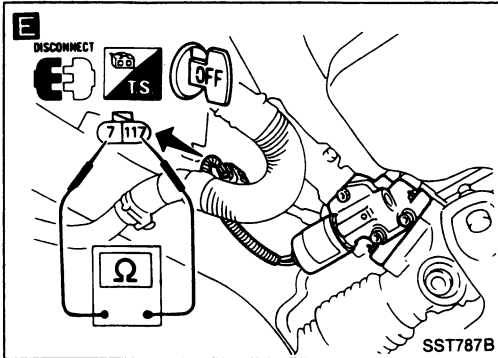
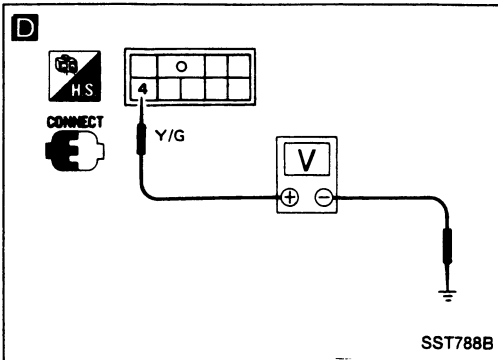

TWIN ORIFICE POWER STEERING SYSTEM — Trouble Diagnoses

Control Unit Inspection Table

The standard values (voltage), measured with an analog tester in contact with the control unit terminal, are shown below:

Terminal No.	Application	Standard value
1	Power	Approx. 12V
2	Ground	0V
3	Vehicle speed sensor input	1 volt (min.) and 5 volts (max.) are alternately repeated when vehicle is driven at very slow speeds.
4	Stop lamp switch input	Pressed: Approx. 12V Released: 0V
5	Neutral switch input	0V (clutch engaged and shift lever in "N") ... M/T models 0V (selector lever in "N" or "P") ... A/T models 4 - 5V (except for the above)
6	Parking brake switch input	Applied: 0V Released: Approx. 12V
7	Power steering solenoid valve output	0 km/h 4.4 - 6.6V 100 km/h 1.8 - 2.8V Fail-safe 1.0 - 1.5V

Performance of Controller

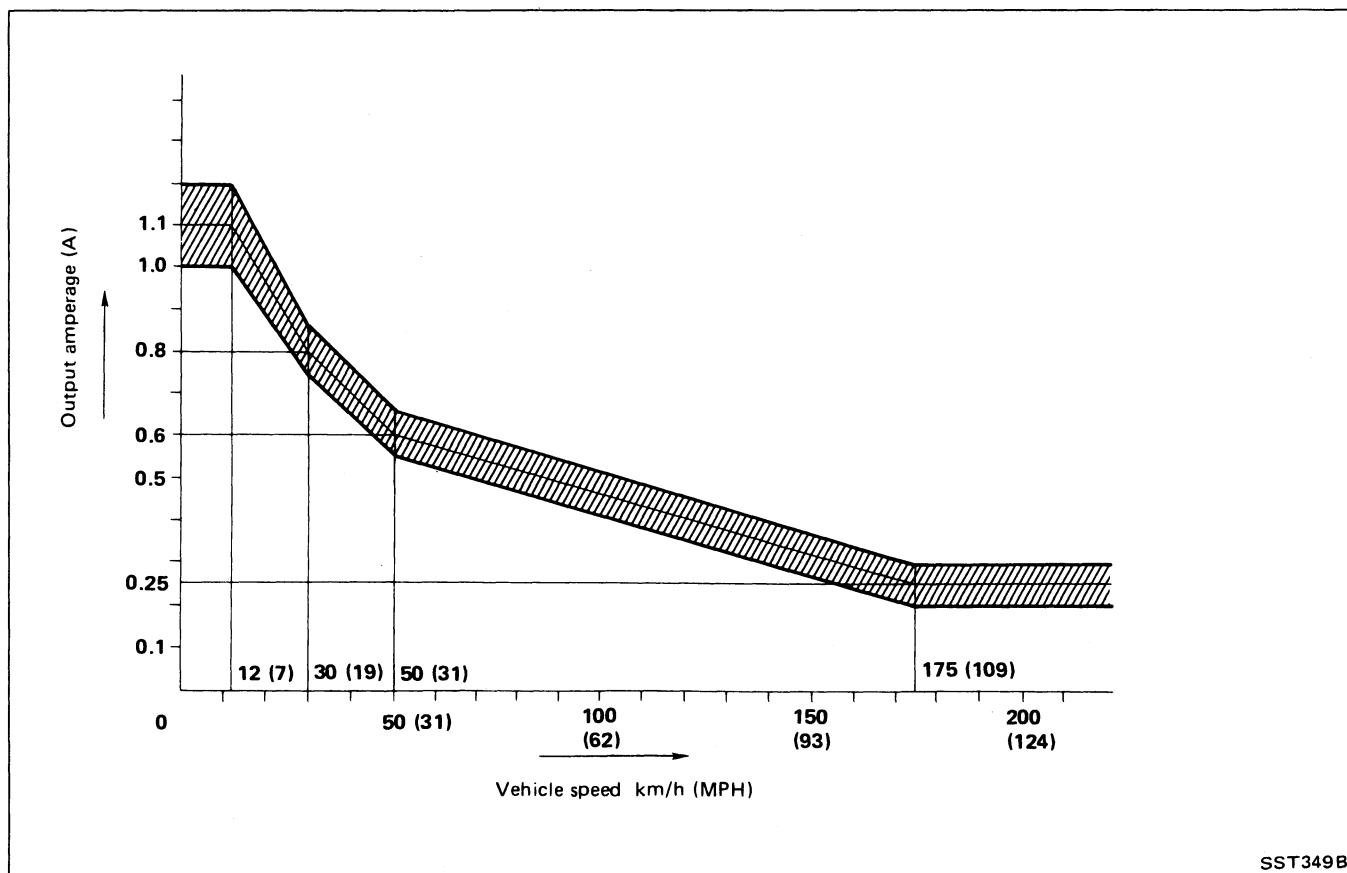

SST349B

SUPER HICAS SYSTEM

HICAS Component Parts Location

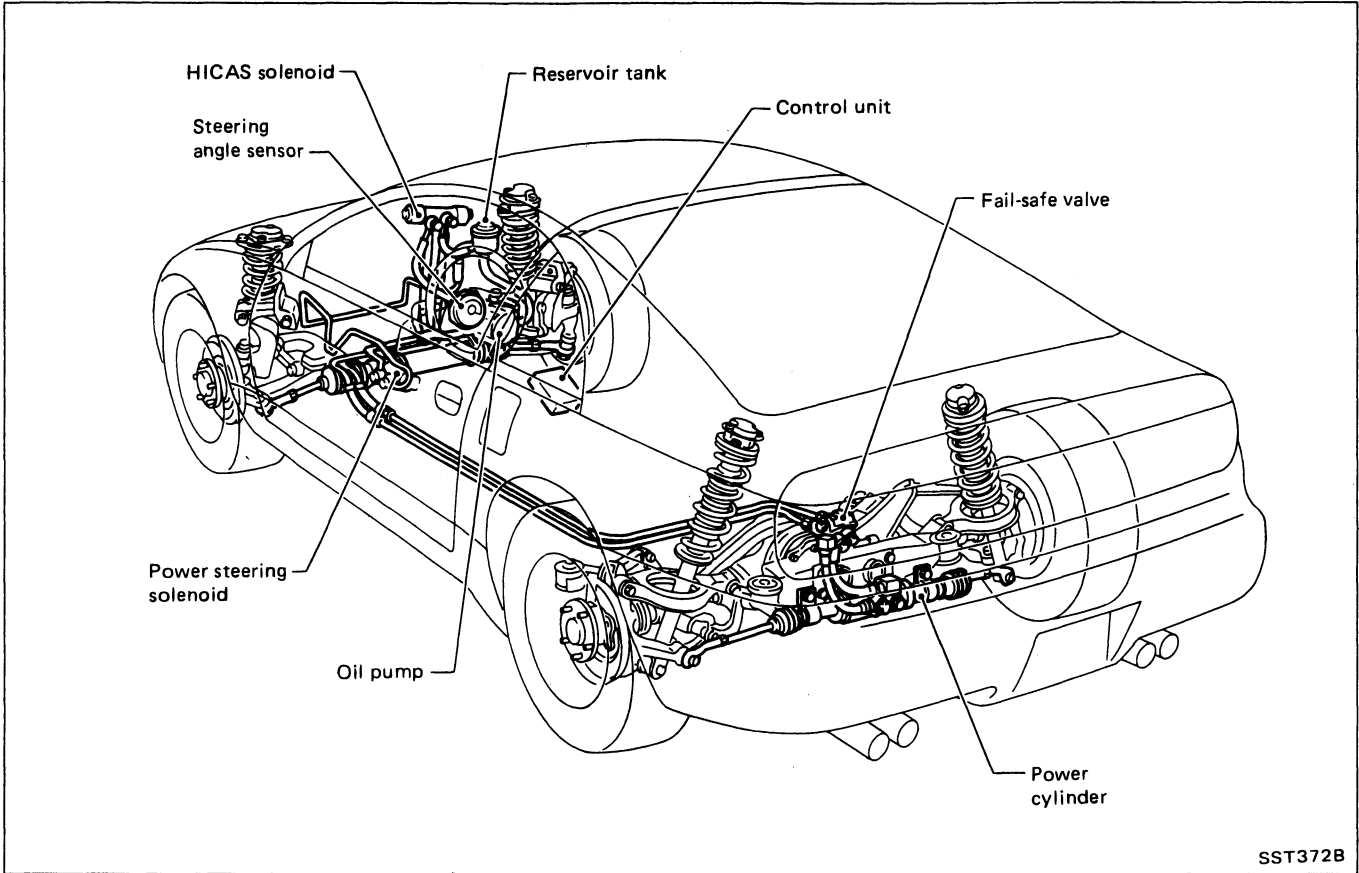

SST372B

System Diagram

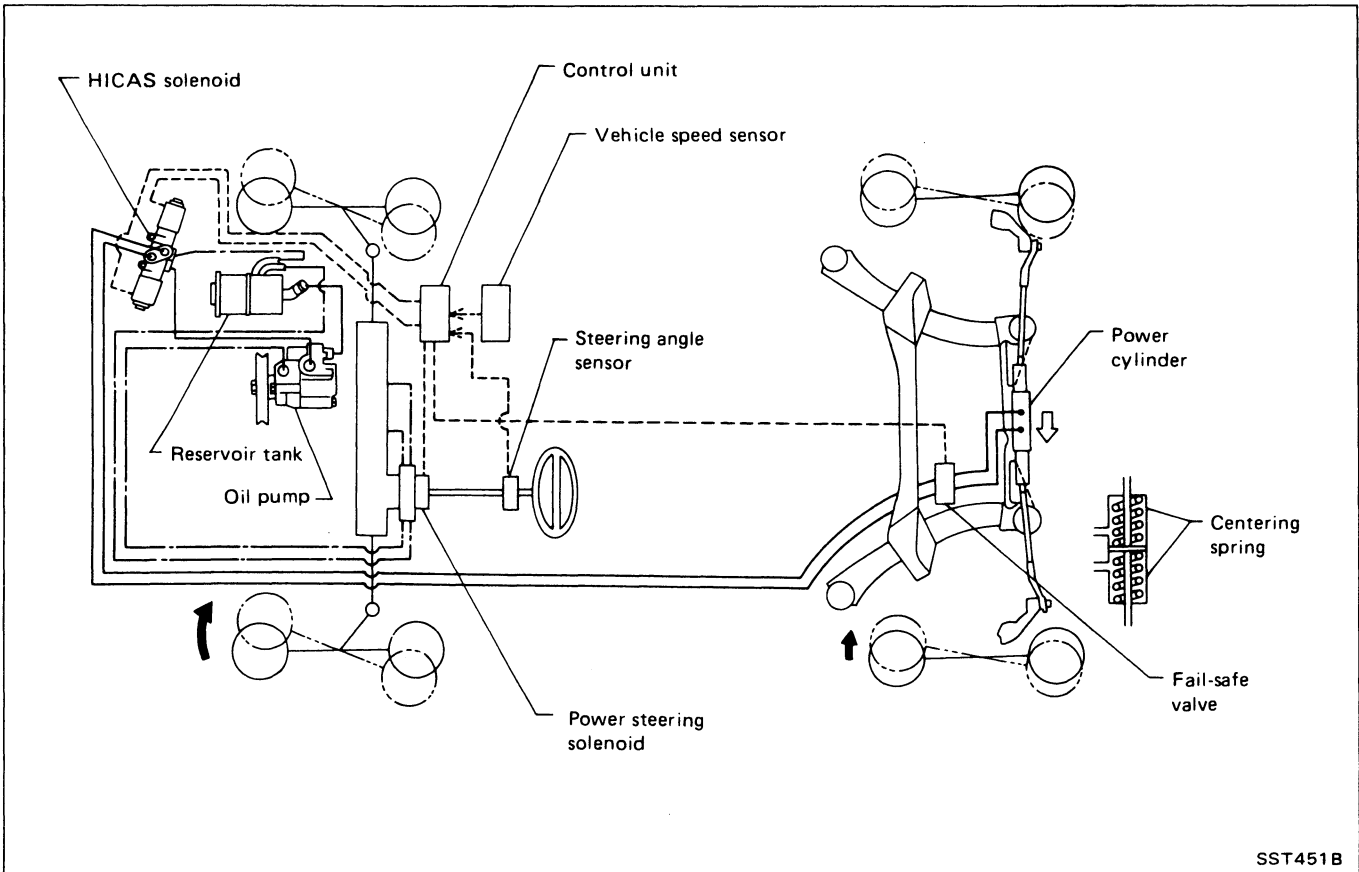

SST451B

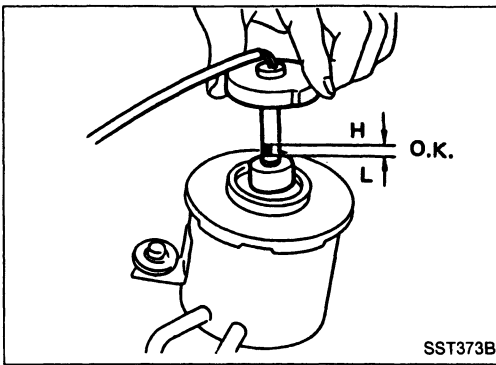

Checking Fluid Level

Maintain the fluid level so that the lower surface of the float is maintained between the "L" and "H" marks on the gauge rod. The fluid level should be checked when the engine is stopped and the fluid temperature is about 30°C (86°F).

CAUTION:

- Do not overfill.
- Recommended fluid is Automatic Transmission Fluid "Dexron™" type.
- Note that fluid level will vary with fluid temperature by approx. 1 mm/5°C (0.04 in/9°F) due to changes in fluid volume.

Checking Fluid Leakage

Check lines for proper attachment, leaks, cracks, damage, loose connections, chafing and deterioration.

Fluid leakage should be checked for when the oil temperature is normal with the engine idling.

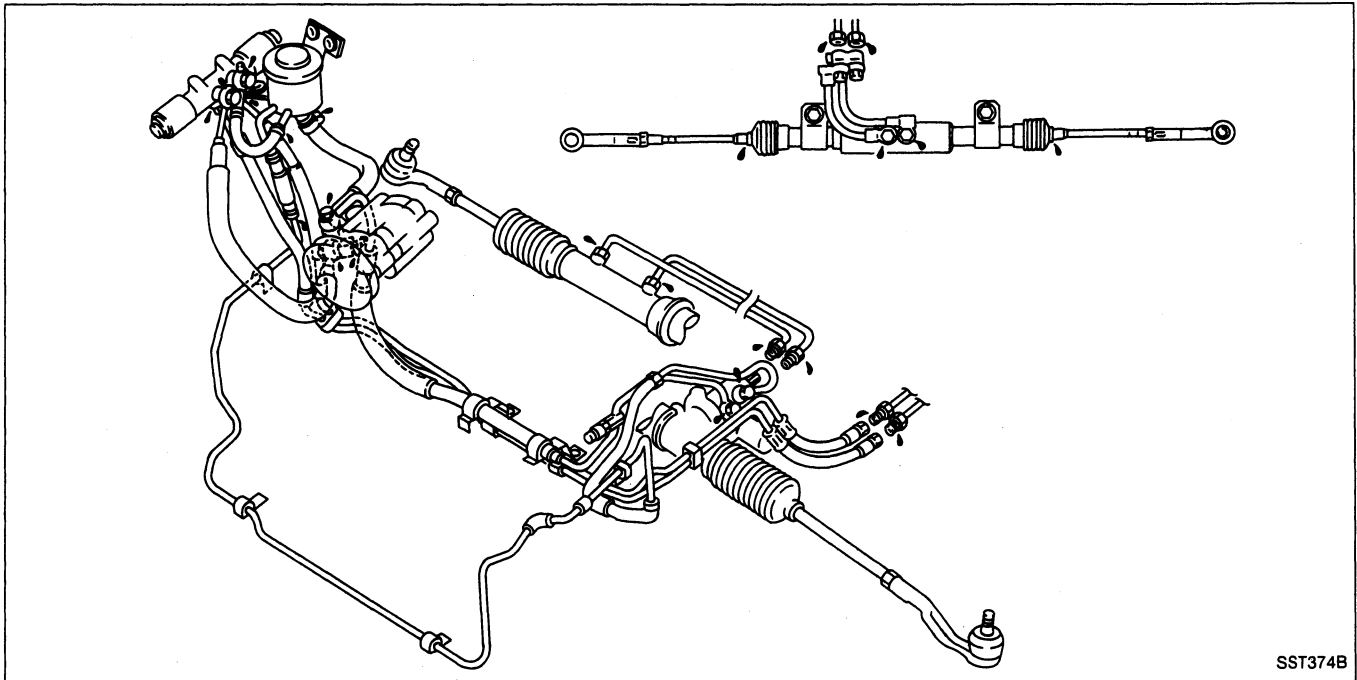

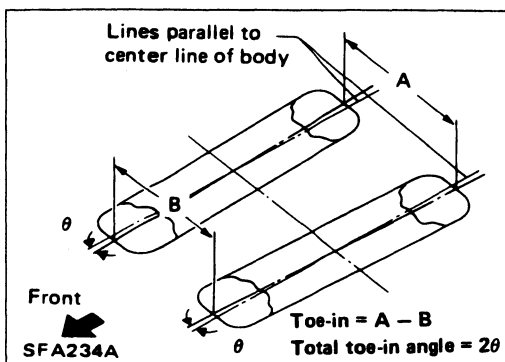

Measuring Rear Toe-in

Measure distance “A” and “B” at the same height as hub center.

Toe-in:

A - B

0 - 4 mm (0 - 0.16 in)

2θ (Total toe-in angle)

0' - 23'

Refer to “SUPER HICAS” in RA section.

Inspection of HICAS System Operation

CAUTION:

Ensure that shift lever is set to “P” (A/T model) or “Neutral” (M/T model) before checking HICAS system operation.

When CONSULT is used:



1. Have a helper sit in the driver's compartment and raise vehicle.
(Use a two-pole lift or a center pole lift so that the four wheels are free to rotate.)
2. Connect CONSULT unit to diagnostic connector and start engine.
3. Touch “START” on CONSULT display.
4. Touch “HICAS”, “ACTIVE TEST” and “SIMULATED DRIVE” in that order.

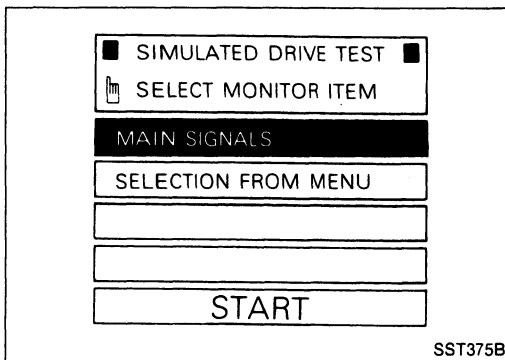

5. Touch “START” when MAIN SIGNALS display is reversed.

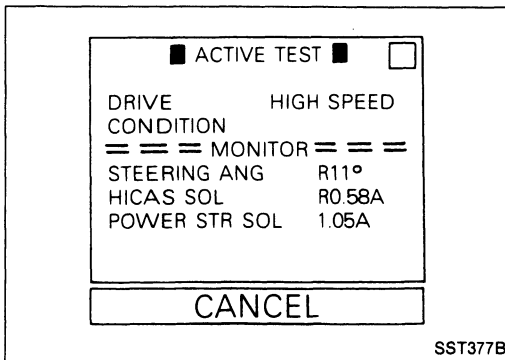

6. Touch “START.”

After simulated drive condition has continued for 5 minutes, it will automatically cancel and CONSULT unit will then show “TEST IS INTERRUPTED TO AVOID OIL TEMP. RISE” display. To cancel this mode during self-diagnosis, simply touch “CANCEL”.

SUPER HICAS SYSTEM — On-vehicle Inspection

Inspection of HICAS System Operation (Cont'd)

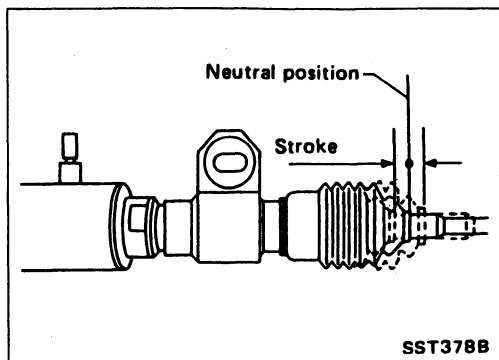

- Operate engine at speeds greater than 2,000 rpm, and turn steering wheel 180° in one direction from the neutral position. Measure extension value of one power cylinder rod and retraction value of the other. Then, turn steering wheel 180° in the other direction from the neutral position, and measure extension value of one cylinder rod and retraction value of the other. Determine strokes of respective power cylinders by adding (measured) extension and retraction values.

Measure rod strokes in as short a period of time as possible.

Specifications:

When turned to the right

3 mm (0.12 in)

When turned to the left

3 mm (0.12 in)

Total stroke

6 mm (0.24 in)

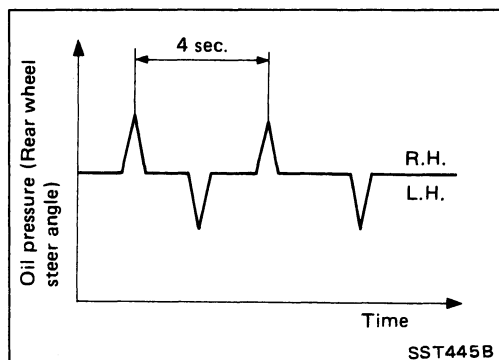

When CONSULT is not used:



- Have a helper sit in the driver's compartment and raise vehicle.
(Use a 2-pole lift or a center pole lift so that the four wheels are free to rotate.)
- Set HICAS system in self-diagnosis mode.
 - Turn ignition switch "OFF".
 - Set shift lever to "P" or "N" position (A/T model), or "Neutral" position (M/T model).
 - Turn ignition switch "ON".
 - Immediately start engine.
 - Turn steering wheel from left to right (at least 20° from the neutral position) 5 times or more, then depress foot brake pedal at least 5 times all within 10 seconds after ignition switch has been turned "ON".
- Set steering wheel to a point approximately 10° from the neutral position and check to ensure that rear wheels turn to the left and right alternately.

SUPER HICAS SYSTEM — On-vehicle Inspection

Inspection of HICAS System Operation (Cont'd)

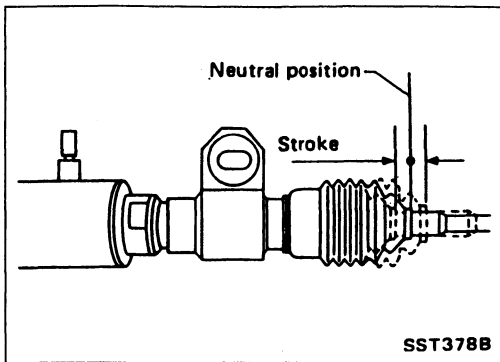

4. Operate engine at speeds greater than 2,000 rpm, and turn steering wheel 180° in one direction from the neutral position. Measure extension value of one power cylinder rod and retraction value of the other. Then, turn steering wheel 180° in the other direction from the neutral position, and measure extension value of one cylinder rod and retraction value of the other. Determine strokes of respective power cylinder rods by adding (measured) extension and retraction values.

Measure rod strokes in as short a period of time as possible.

Specifications:

When turned to the right

3 mm (0.12 in)

When turned to the left

3 mm (0.12 in)

Total stroke

6 mm (0.24 in)

Do not depress foot brake pedal during operation check, otherwise the operation will be stopped.

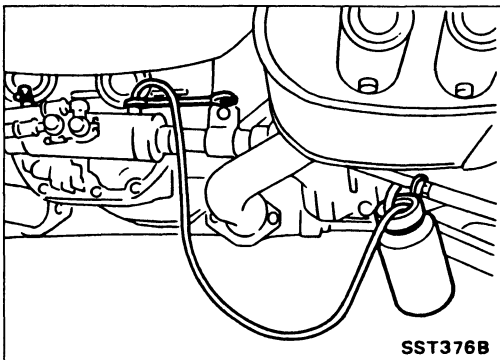

Bleeding Hydraulic System

Before bleeding air from the HICAS system, be sure to bleed air from the power steering system.

Refer to "SUPER HICAS SYSTEM — Repair of Component Parts".

Power Cylinder

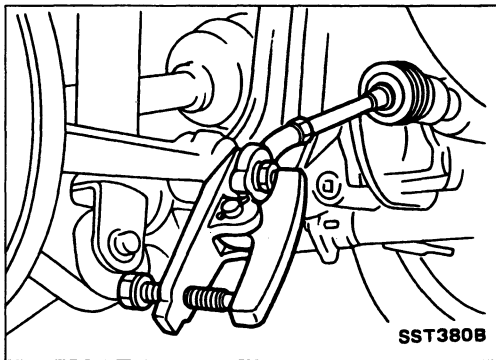
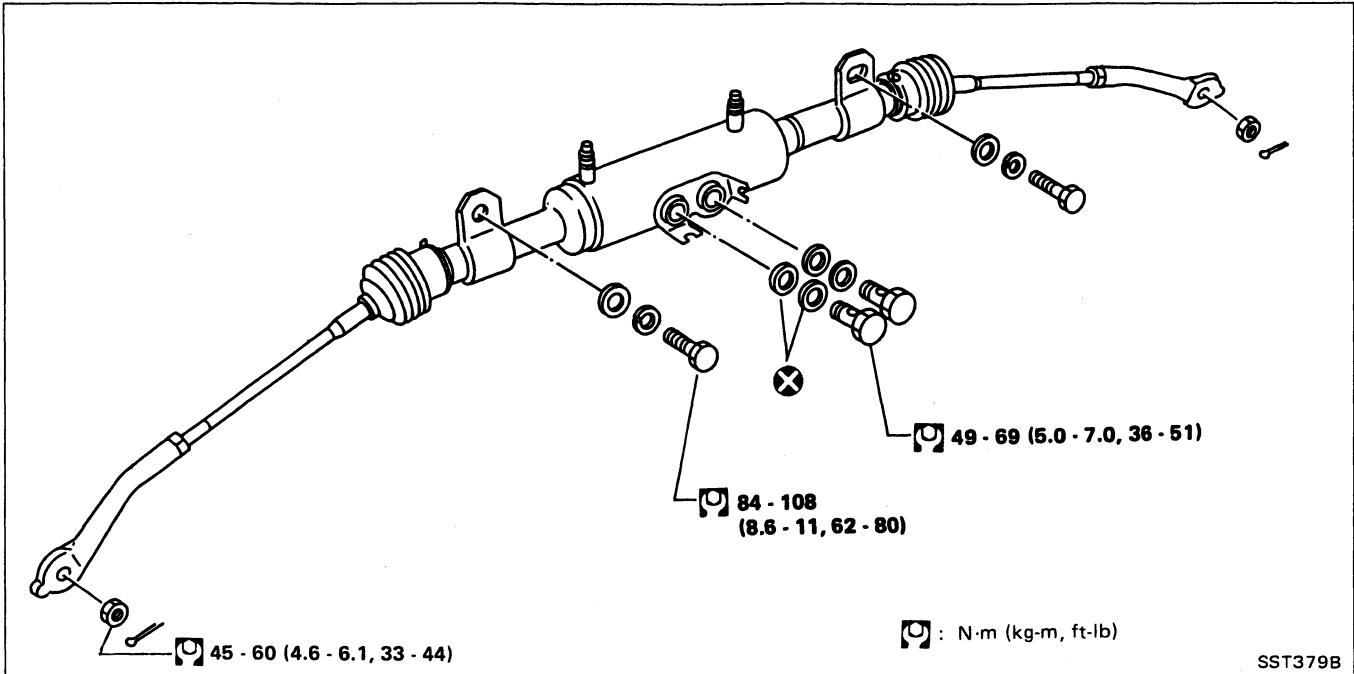

REMOVAL

- Detach power cylinder lower links from axle housing sockets with Tool.

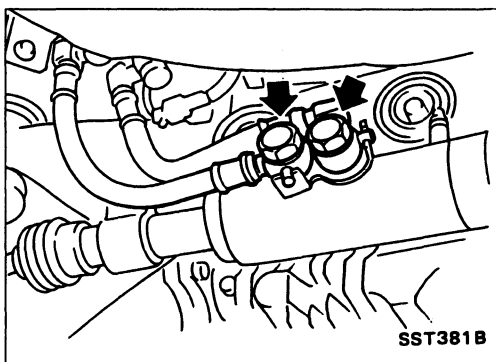

- Disconnect oil pipes from power cylinders and remove power cylinders.

CAUTION:

Plug openings of oil pipes and power cylinders to prevent entry of foreign particles after removal.

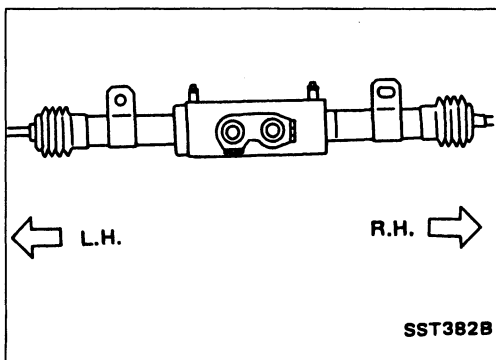

INSTALLATION

1. Before installing power cylinder on suspension member, wipe power cylinder bracket and mating surface of suspension member. Using the left side of the bracket as a reference point, locate the right side (oblong hole side) and install power cylinder.

CAUTION:

- a. To prevent entry of foreign particles, clean oil pipes and connectors using dry compressed air.
- b. Ensure that your hands are clean and free from foreign particles when connecting oil pipes.

SUPER HICAS SYSTEM — Repair of Component Parts

Power Cylinder (Cont'd)

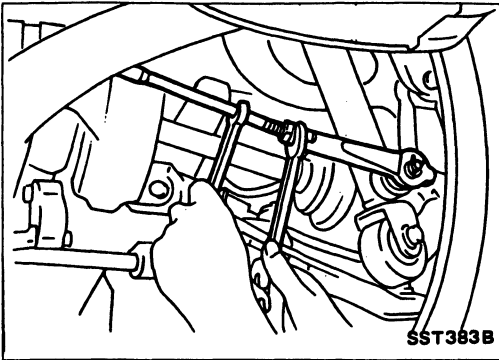

2. Install power cylinders and oil pipes.
3. After installing lower link assemblies, check toe-in to ensure that it is within specifications. If it is not within specifications, perform proper adjustments. Refer to "SUPER HICAS" in section RA.

BLEEDING HYDRAULIC SYSTEM

Before bleeding air from the HICAS system, be sure to bleed air from the power steering system.

CAUTION:

Ensure that shift lever is set to "P" (A/T model) or "Neutral" (M/T model).

When CONSULT is used:



1. Connect CONSULT unit to diagnosis connector on body side.
2. Have a helper sit in the driver's compartment and raise vehicle.

Use a two-pole lift or a center pole lift so that the four wheels are free to rotate.

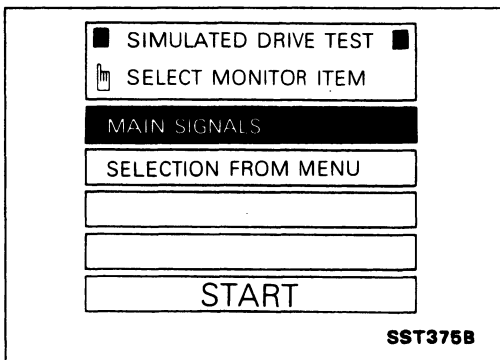

3. Start engine.
4. Touch "START" on CONSULT display. (Display will then change.)
5. Touch "HICAS", "ACTIVE TEST", "SIMULATED DRIVE" and "START" in that order.

Before touching "START", ensure that MAIN SIGNALS display is reversed.

6. Touch "START".

SUPER HICAS SYSTEM — Repair of Component Parts

Power Cylinder (Cont'd)

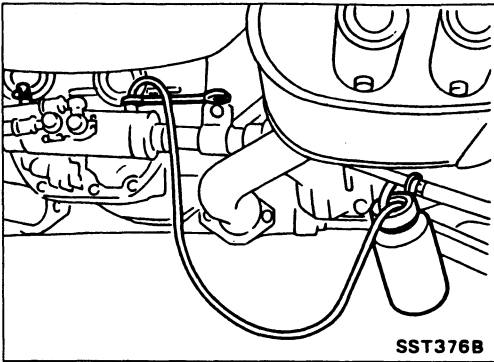

7. Operate engine at speeds greater than 2,000 rpm, and turn steering wheel 180° to the right from the neutral position. Loosen right power cylinder bleeder valve to bleed air, then retighten. Return steering wheel to the neutral position.
8. Operate engine at speeds greater than 2,000 rpm, and turn steering wheel 180° to the left from the neutral position. Loosen left power cylinder bleeder valve to bleed air, then retighten. Return steering wheel to the neutral position.
9. Repeat steps 7. and 8. until there are no air bubbles in fluid. While bleeding air from power cylinders, never allow fluid level to drop below inlet port of reservoir tank (by adding fluid as required).
10. Touch "CANCEL" on CONSULT display and turn ignition switch OFF.

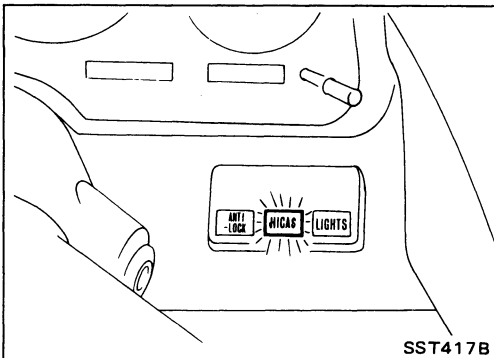

When CONSULT is not used:



1. Have a helper sit in the driver's compartment, and raise vehicle.

Use a two-pole lift or center pole lift so that the four wheels are free to rotate.

2. Set HICAS system in self-diagnosis mode.
 - (1) Turn ignition switch "OFF".
 - (2) Set shift lever to "P" or "N" position (A/T model), or "Neutral" position (M/T model).
 - (3) Turn ignition switch "ON".
 - (4) Immediately start engine.
 - (5) Turn steering wheel from left to right (at least 20° from the neutral position) 5 times or more, then depress foot brake pedal at least 5 times all within 10 seconds after ignition switch has been turned "ON".
3. Set steering wheel within 10° from the neutral position. Ensure that rear wheels turn to the left and right alternately.
4. Operate engine at idling speed, and turn steering wheel 180° to the right from the neutral position. Loosen right power cylinder bleeder valve to bleed air, then retighten. Return steering wheel to the neutral position.
5. Operate engine at idling speed, and turn steering wheel 180° to the left from the neutral position. Loosen left power cylinder bleeder valve to bleed air, then retighten. Return steering wheel to the neutral position.
6. Repeat steps 4. and 5. above until there are no air bubbles in fluid. While bleeding air from power cylinders, never allow fluid level to drop below inlet port of reservoir tank (by adding fluid as required).
7. Turn ignition switch OFF to complete self-diagnosis operation.

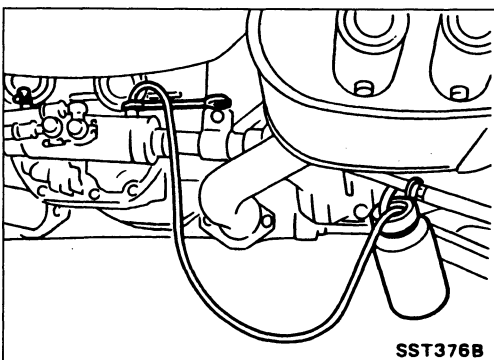

SUPER HICAS SYSTEM — Repair of Component Parts

Power Cylinder (Cont'd) DISASSEMBLY AND ASSEMBLY

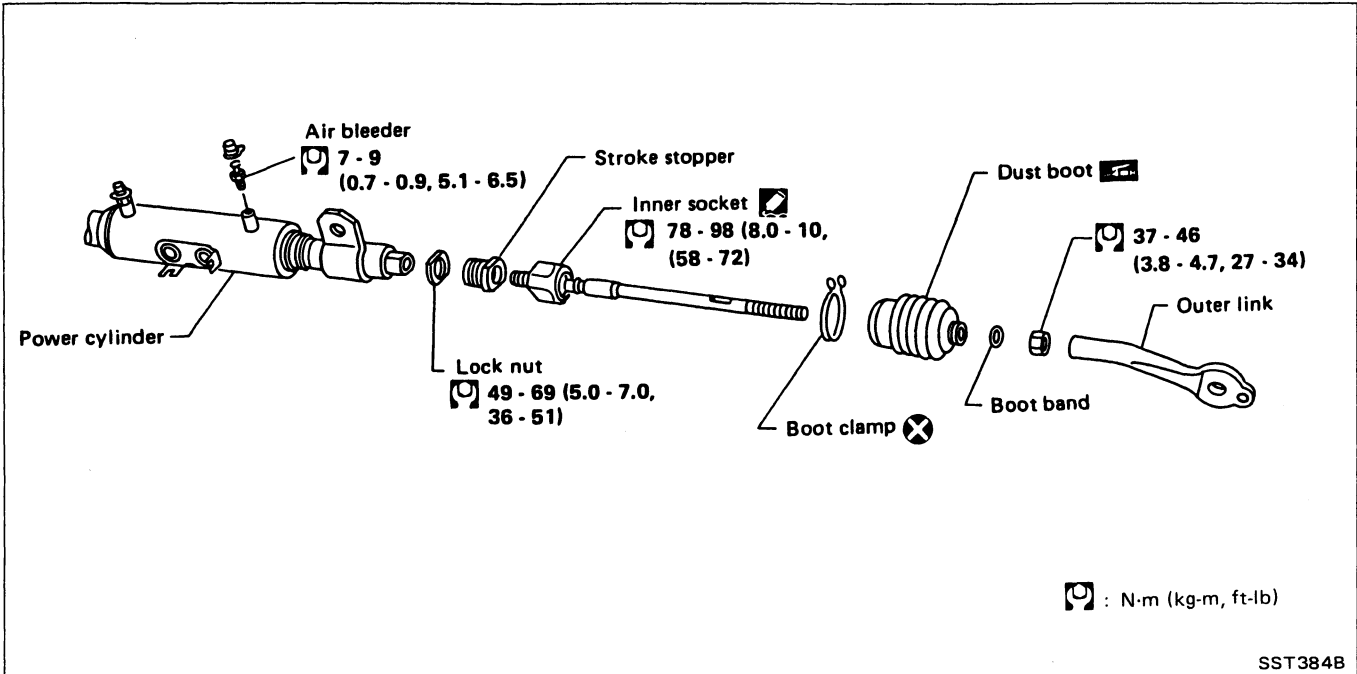

Power cylinder assembly cannot be disassembled. When it is malfunctioning, replace power cylinder as an assembly.

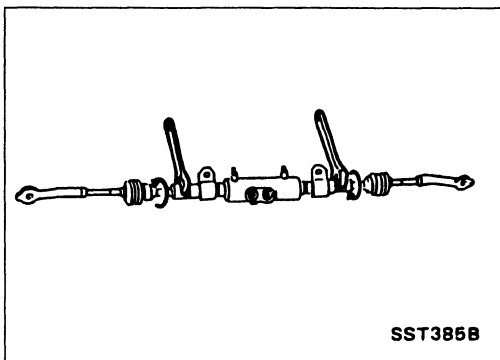

DISASSEMBLY

1. Remove clamps from left and right dust boots, and move dust boots toward outer links.
2. Attach wrenches to left and right ball joint sockets, and turn in directions that loosen lower links. Remove one of loosened lower link assemblies.

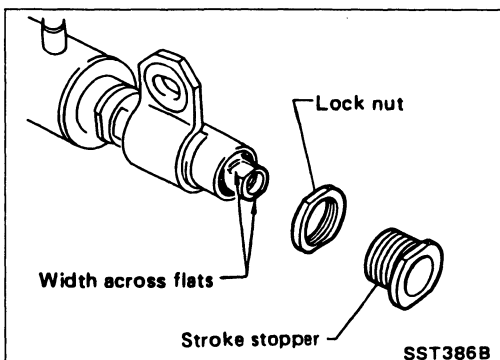

3. Loosen stroke stopper lock nut from which lower link assembly was removed, and remove stroke stopper.

SUPER HICAS SYSTEM — Repair of Component Parts

Power Cylinder (Cont'd)

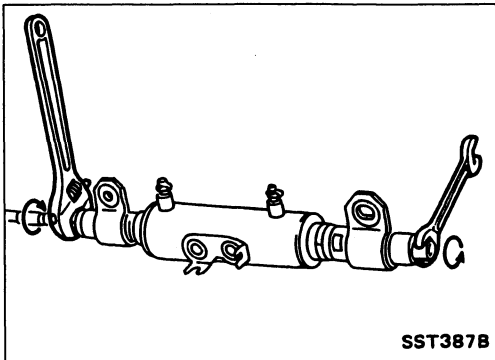

- While attaching a wrench to "width across flats" section of rod end from which stroke stopper was removed, remove the other lower link assembly.

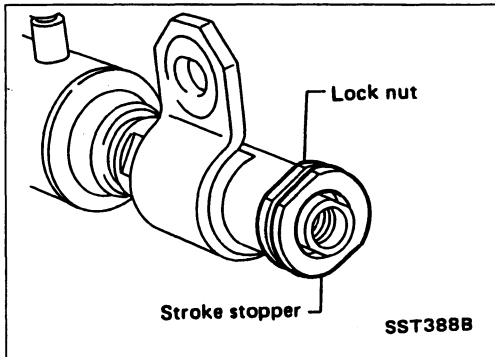

ASSEMBLY

1. Install stroke stopper and lock nut on the lower link assembly to be assembled.

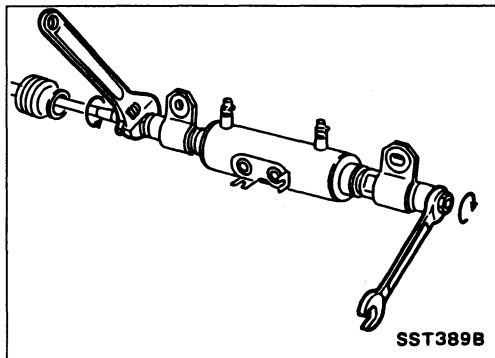

2. Apply Locktite to inner ball joint thread. Attach a wrench to "width across flats" section of piston rod (located on the other side) to prevent rod from turning. Install lower link assembly.

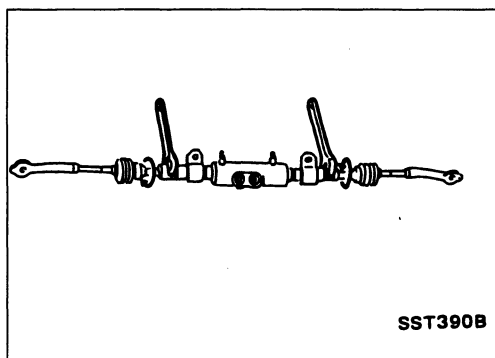

3. After installing stroke stopper and lock nut on the other lower link assembly, install lower link assembly. Attach a wrench to inner ball joint (to prevent it from turning), tighten inner socket to specified torque.

Inner socket:

\square : 78 - 98 N·m (8 - 10 kg-m, 58 - 72 ft-lb)

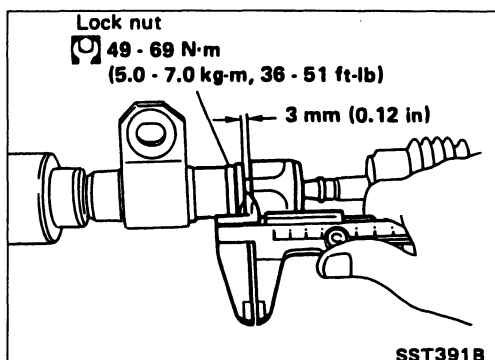

4. If stroke stopper was moved during removal of lower link, adjust it after installation, as described below:

- (1) Loosen lock nut which secures stroke stopper.
- (2) Turn stroke stopper until clearance between inner ball joint and stroke stopper is 3 mm (0.12 in) on each side.
- (3) Tighten lock nut securely.

Lock nut:

\square : 49 - 69 N·m (5.0 - 7.0 kg-m, 36 - 51 ft-lb)

- (4) Recheck clearance between inner ball joint and stroke stopper on each side.

SUPER HICAS SYSTEM — Repair of Component Parts

Power Cylinder (Cont'd)

5. Install dust boot using new boot band and clamp.
 - Apply a coat of grease to grooves at boot location.

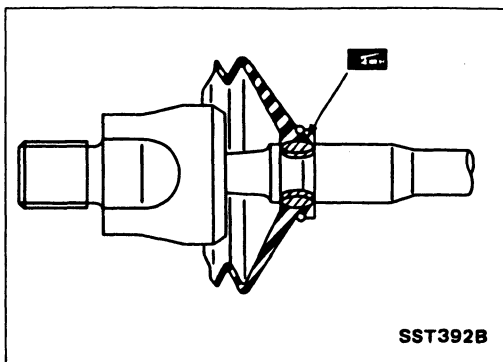

Oil Pump

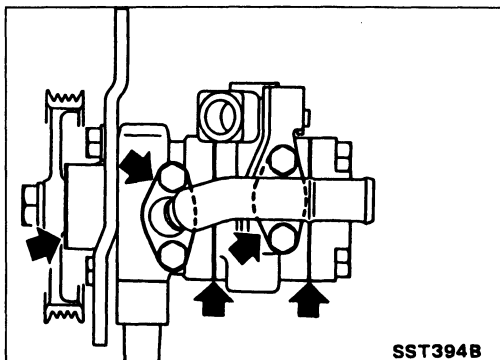
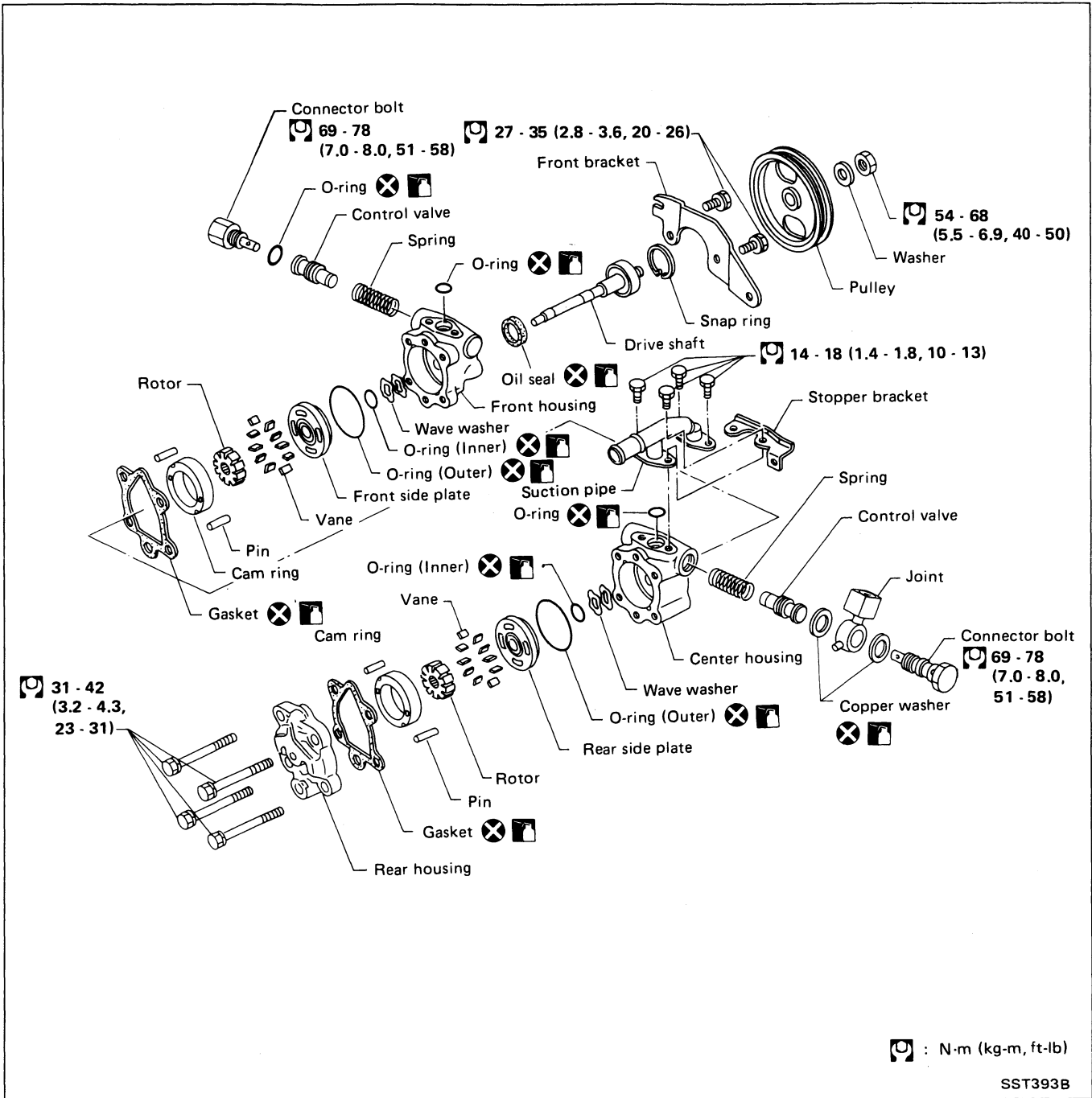

PRE-DISASSEMBLY INSPECTION

Disassemble the power steering oil pump only if the following items are found.

- Oil leak from any point shown in the figure.
- Deformed or damaged pulley.

Procedures for disassembly and assembly are the same as those for the power steering oil pump.

Oil Pump (Cont'd)

Disassembly

CAUTION:

- Parts which can be disassembled are strictly limited. Never disassemble parts other than those specified.
- Disassemble in as clean a place as possible.
- Clean your hands before disassembly.
- Do not use rags; use nylon cloths or paper towels.
- Follow the procedures and cautions in the Service Manual.
- When disassembling and reassembling, do not let foreign matter enter or contact the parts.

1. Remove connector.

Be careful not to drop control valve.

Be careful not to confuse main side with sub side.

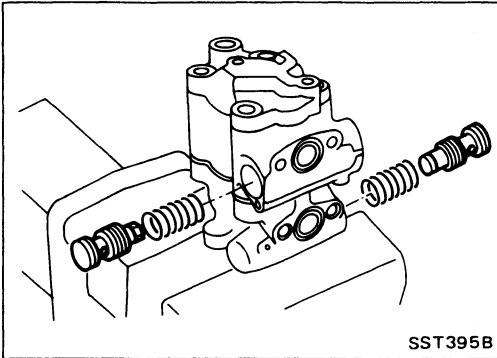

2. Remove rear housing.
3. Remove center housing.
4. Remove cam ring, rotor and other parts from center housing (sub side).

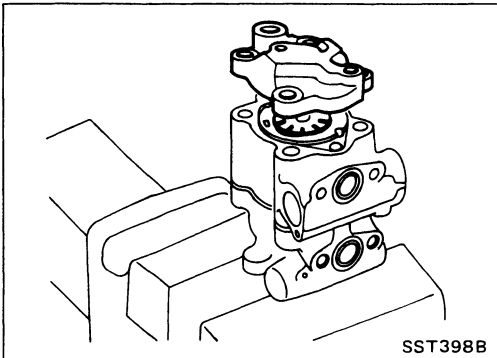

5. Remove cam ring, rotor and other parts from front housing (main side).

Be careful not to confuse main side with sub side.

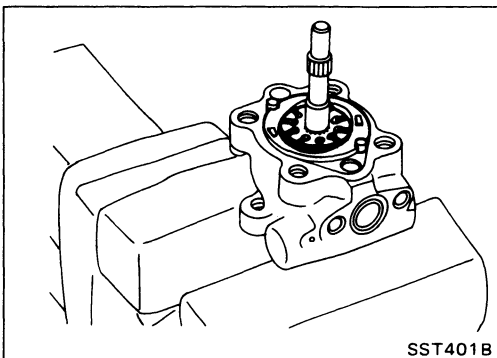

6. Remove snap ring, then draw drive shaft out.
Be careful not to drop drive shaft.

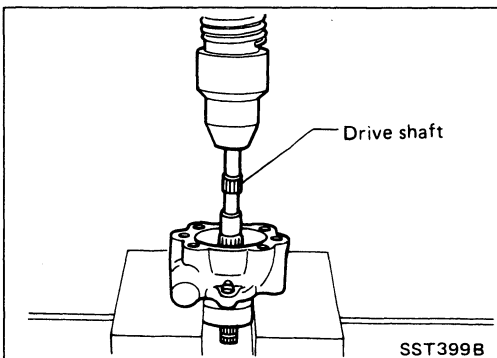

SUPER HICAS SYSTEM — Repair of Component Parts

Disassembly (Cont'd)

7. Remove oil seal.

Be careful not to damage front housing.

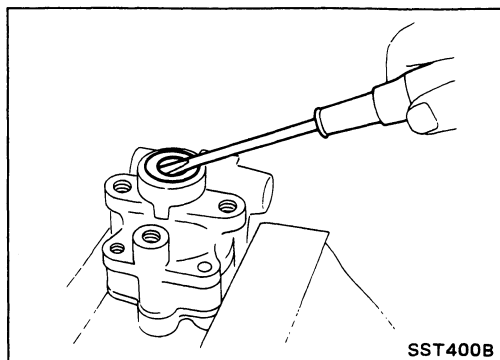

Inspection

If any of the following parts are scratched or damaged, replace oil pump assembly.

- Mating surfaces of front housing and cam center housing
- Mating surfaces of rear housing and cam center housing
- Front housing bushing (at drive shaft support location)
- Flow control valve
- Drive shaft
- Rotor

Assembly

Assemble oil pump in the reverse order of disassembly, noting the following instructions.

- Before installation, coat the O-rings and oil seal with A.T.F.
- Make sure O-rings and oil seal are properly installed.
- When assembling vanes to rotor, rounded surfaces of vanes must face cam case side.
- Always install new O-rings and oil seal.
- Be careful of oil seal direction.

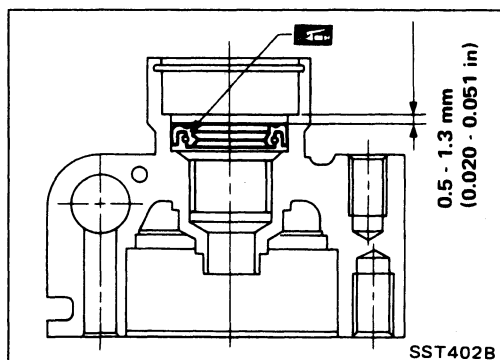

1. Press oil seal into front housing and apply grease to sealing lips.

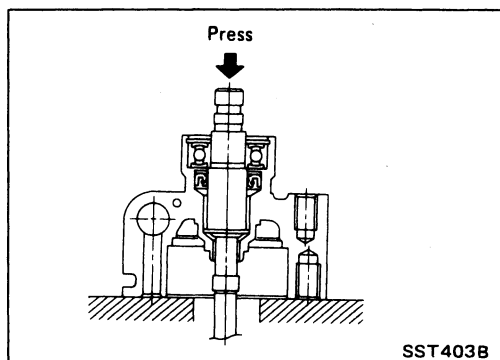

2. Press shaft assembly into front housing and install snap ring.

SUPER HICAS SYSTEM — Repair of Component Parts

Assembly (Cont'd)

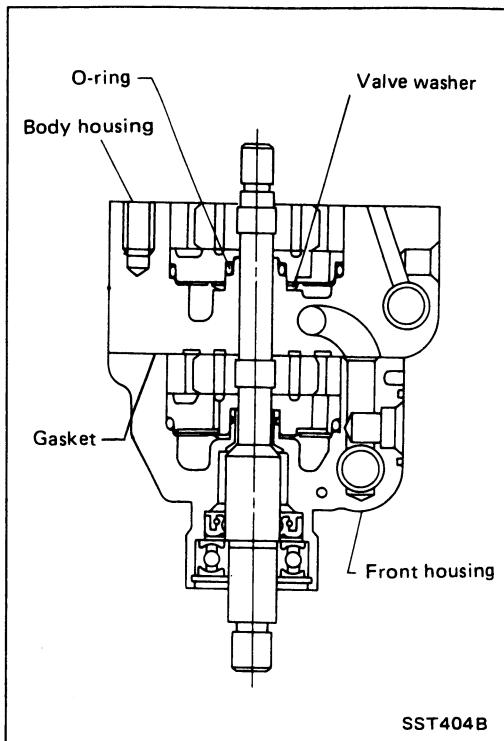

3. Install component parts on front housing in the order indicated below:

- 1) O-ring x 2
 - 2) Wave washer
 - 3) Side plate
 - 4) Rotor [thickness: 16.25 mm (0.6398 in) (main side); 13 mm (0.51 in) (sub side)]
 - 5) Vane
 - 6) Pin
 - 7) Cam ring [thickness: 16.25 mm (0.6398 in) (main side); 13 mm (0.51 in) (sub side)]
4. Place packing on front housing and position center housing on the packing. In the manner similar to step 3. above, install component parts on front housing (sub side).

CAUTION:

- Ensure that O-rings are positioned properly.
- Ensure that vane is installed with curved side facing cam ring.
- Use cam, rotor vane as original single unit.
- Ensure that control valve moves smoothly.

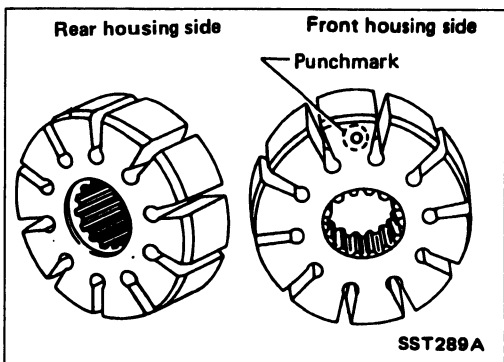

- Pay attention to rotor direction.

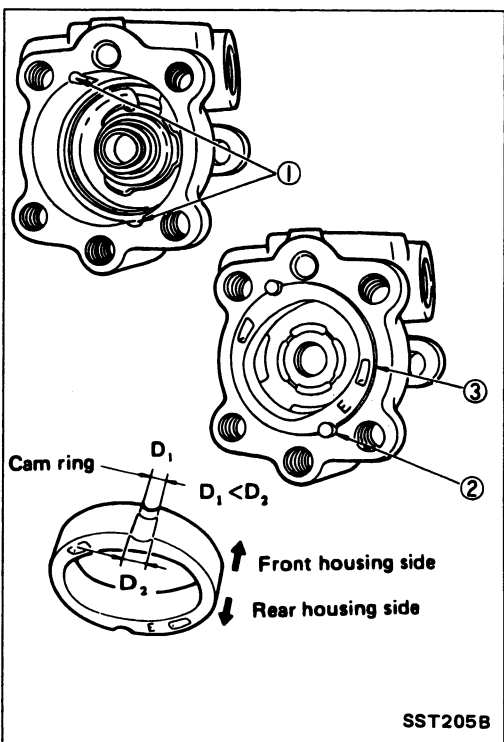

- Pay attention to cam ring direction.

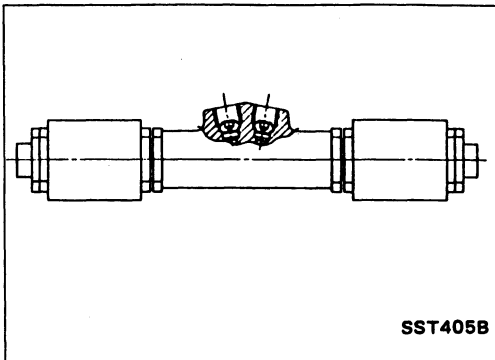

HICAS Solenoid and Fail-safe Valve

- Do not loosen lock nut which secures solenoid since HICAS solenoid fail-safe valves are of types that should not be disassembled.
- If any part is found to be malfunctioning, always replace as a valve assembly.

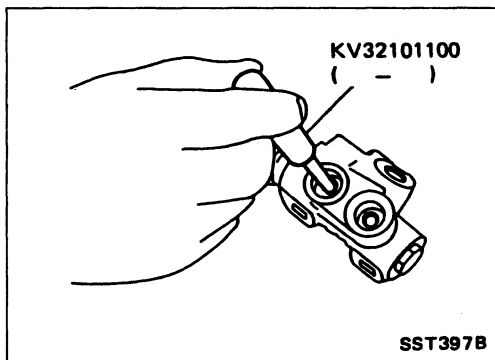
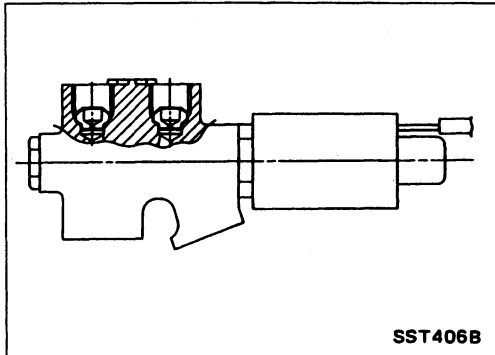

- Whenever tubes are disconnected, check tube seat for scratches or damage. A scratched or cracked tube seat may cause oil leakage. Replace it using pin punch.

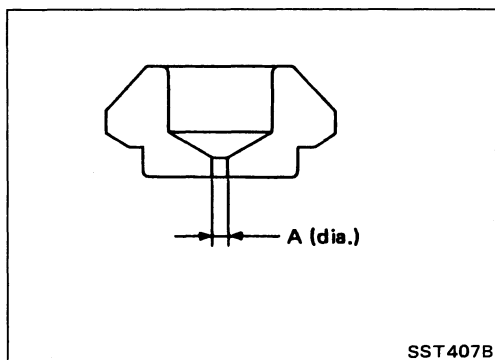

	Control valve	Cut-off valve
Part No.	49528-31P10	49528-52L10
A (dia.)	mm (in)	6.5 (0.256)

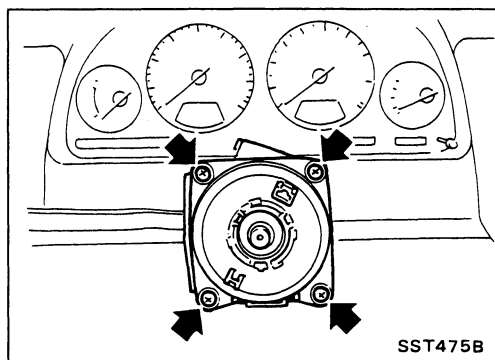

Steering Angle Sensor

- Ensure that steering angle sensor bolts are secure and tight.
- If any part of steering angle sensor is malfunctioning, replace steering angle sensor assembly.

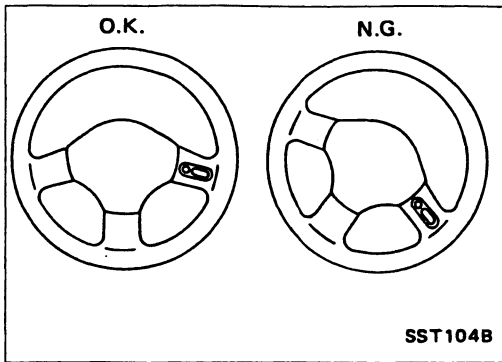

Steering Wheel

CHECKING NEUTRAL POSITION

- Check that the steering wheel is in the neutral position when driving straight ahead at a speed of at least 70 km/h (43 MPH).
- If it is not in the neutral position, remove the steering wheel and reinstall it correctly.
- If the neutral position is between two serrated teeth, loosen tie-rod lock nut and move tie-rod in the opposite direction by the same amount on both left and right sides to compensate for error in the neutral position.

Contents

How to Perform Trouble Diagnoses for Quick and Accurate Repair	ST-61
Symptom Chart	ST-62
Preliminary Check	ST-63
Component Parts and Harness Connector Locations	ST-66
Circuit Diagram for Quick Pinpoint Check	ST-67
Wiring Diagram	ST-68
Self-diagnosis	ST-69
Diagnostic Procedure 1	ST-75
Diagnostic Procedure 2	ST-76
Diagnostic Procedure 3	ST-78
Diagnostic Procedure 4	ST-79
Diagnostic Procedure 5	ST-85
Diagnostic Procedure 6	ST-87
Diagnostic Procedure 7	ST-88
Diagnostic Procedure 8	ST-89
Diagnostic Procedure 9	ST-90
Diagnostic Procedure 10	ST-91
Diagnostic Procedure 11	ST-93
Diagnostic Procedure 12	ST-94
Control Unit Inspection Table	ST-95

How to Perform Trouble Diagnoses for Quick and Accurate Repair

WORK FLOW

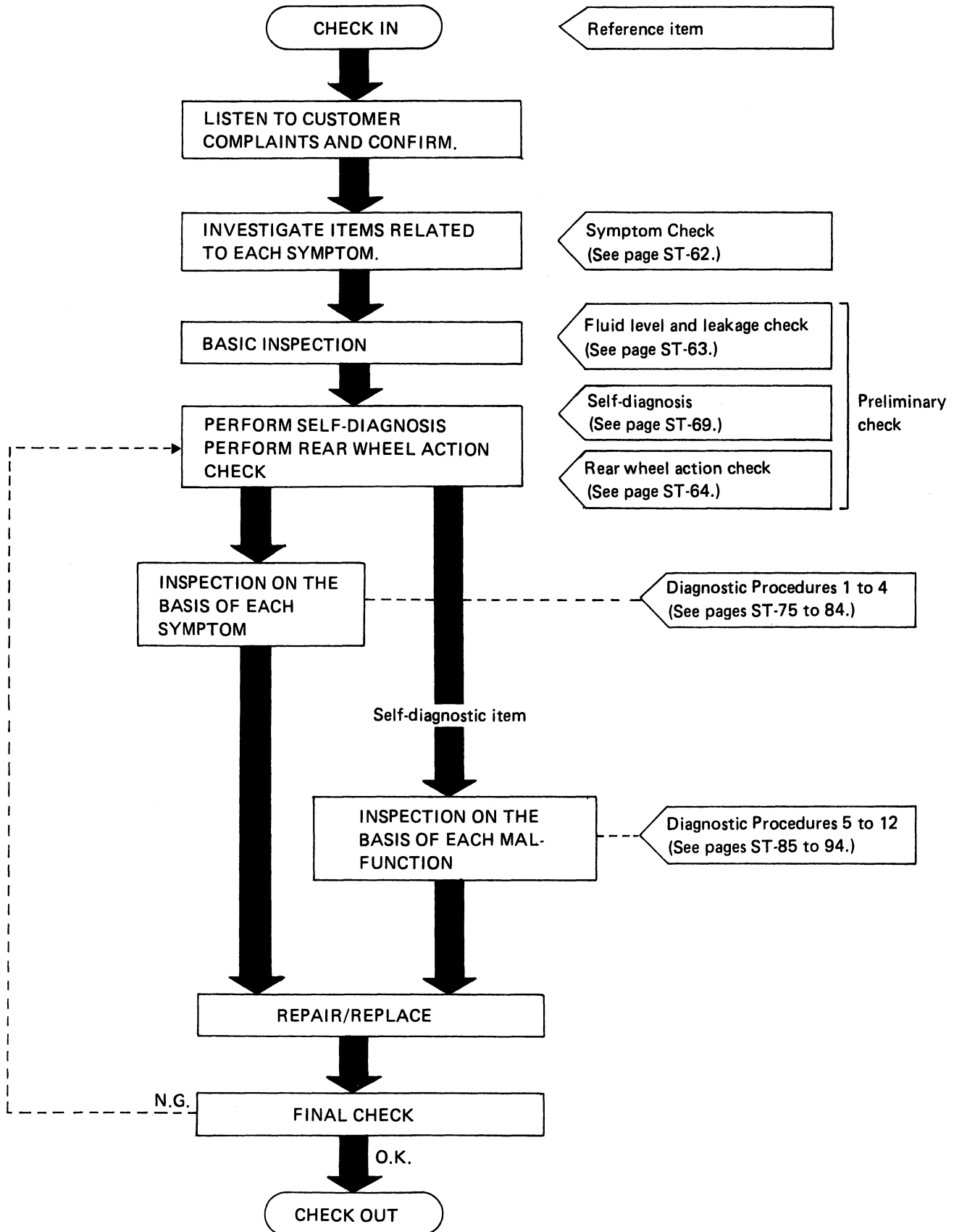

SUPER HICAS SYSTEM — Trouble Diagnoses

Symptom Chart

DIAGNOSTIC TABLE

PROCEDURE	Preliminary Check			Diagnostic Procedure												
REFERENCE PAGE (ST-)	63	63	64	75	76	78	79	85	87	88	89	90	91	93	94	
SYMPTOM	Preliminary check 1	Preliminary check 2	Preliminary check 3	Diagnostic procedure 1	Diagnostic procedure 2	Diagnostic procedure 3	Diagnostic procedure 4	Diagnostic procedure 5	Diagnostic procedure 6	Diagnostic procedure 7	Diagnostic procedure 8	Diagnostic procedure 9	Diagnostic procedure 10	Diagnostic procedure 11	Diagnostic procedure 12	
No warning lamp comes on when ignition switch is turned "ON"	○			○												
Warning lamp comes on when engine is running	○	○	○		○		○	○	○	○	○	○	○	○	○	
Abnormal noise is emitted.	○	○	○			○										
Vehicle behavior is unusual (due to malfunctioning HICAS system.)	○	○	○				○	○	○	○	○	○	○	○	○	
System is not set in self-diagnosis mode.								○								
Self-diagnostic results	Self-diagnosis code No.	Diagnosed part	CONSULT indication													
	1	HICAS solenoid (RH) output is not present.	HICAS SOLENOID-R [ABNORMAL SIGNAL]						○							
	2	HICAS solenoid (LH) output is not present.	HICAS SOLENOID-L [ABNORMAL SIGNAL]						○							
	3	Fail-safe valve output is not present.	FAIL-SAFE VALVE [ABNORMAL SIGNAL]							○						
	4	Power steering solenoid output is not present.	POWER STEERING SOL [ABNORMAL SIGNAL]								○					
	5	Vehicle speed signal is not present.	VEHICLE SPEED SENSOR [NO SIGNAL] (-a) CAR SPEED SENSOR [SIG-SUDDEN TURN] (-b)										○			
	6	Steering angle sensor input is not present.	STEERING ANGLE SEN [NO ANG SIGNAL] (-a) STEERING ANGLE SEN [NO NEUT SIGNAL] (-b)											○		
	7		STEERING ANGLE SEN [NEUT SIG-360° OFF] (-c) STEERING ANGLE SEN [NEUT SIG-30° ON] (-d)											○		
	8	Parking brake (AT) or clutch switch (MT) input is not present.	—												○	
	9	Inhibitor switch (AT) or neutral switch (MT) input is not present.	—													○

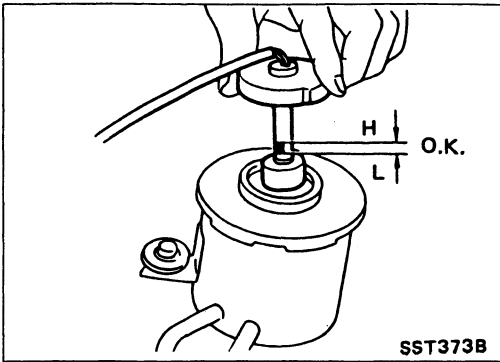

Preliminary Check

CHECK 1

Checking fluid level and fluid leakage

Refer to "SUPER HICAS SYSTEM — On-vehicle Inspection" on page ST-44.

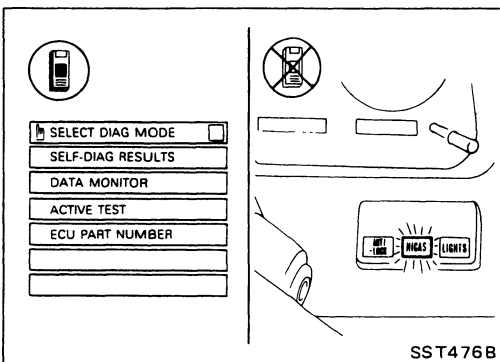
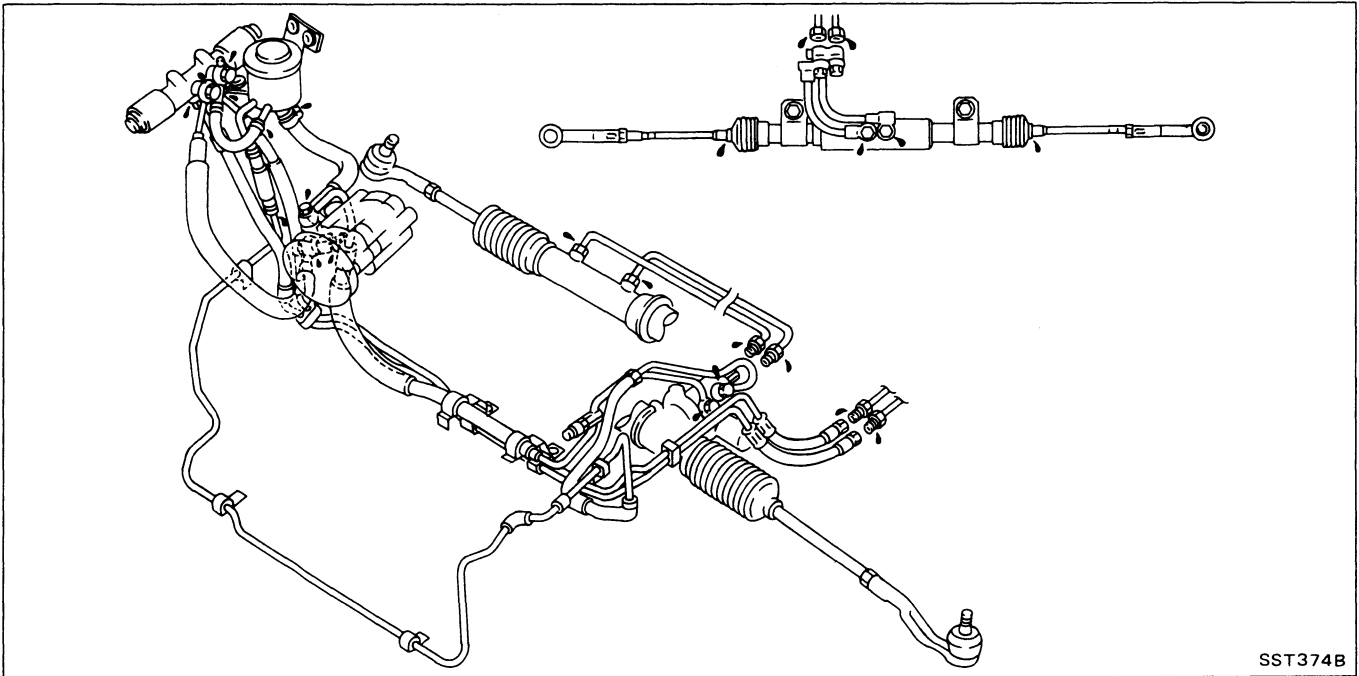

CHECK 2

Perform self-diagnosis.

Refer to "Self-diagnosis" on page ST-69.

Preliminary Check (Cont'd)

CHECK 3

Perform rear wheel action check.

When CONSULT is used:

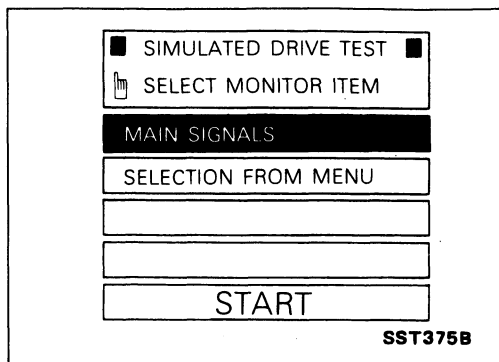

1. Have a helper sit in the driver's compartment, and raise vehicle.
(Use a two-pole lift or a center pole lift so that the four wheels are free to rotate.)
2. Connect CONSULT unit to diagnosis connector and start engine.
3. Touch "START" on CONSULT display.
4. Touch "HICAS", "ACTIVE TEST" and "SIMULATED DRIVE" in that order.
5. Touch "START" when "MAIN SIGNALS" display is reversed.

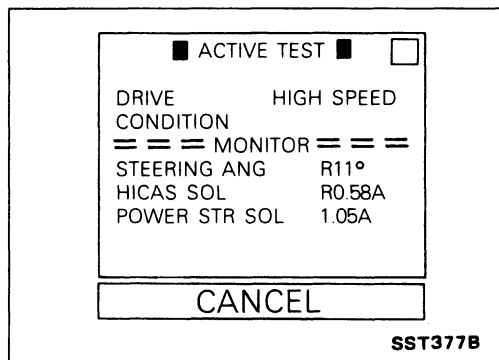

6. Touch "START."

After simulated drive condition has continued for 5 minutes, it will automatically cancel and CONSULT unit will then show "TEST IS INTERRUPTED TO AVOID OIL TEMP RISE" display. To cancel this mode during self-diagnosis, simply touch "CANCEL".

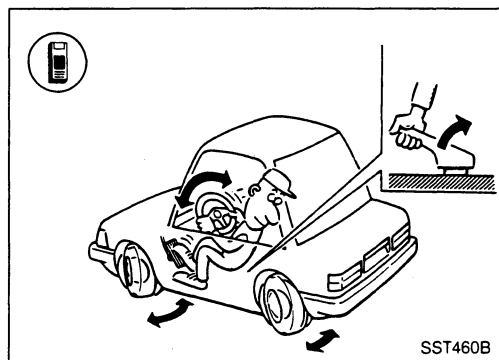

7. While running engine at speeds greater than 2,000 rpm, turn steering wheel 180° to the left and right from the neutral position. Ensure that rear wheels steer in response to rotation of steering wheel.

SUPER HICAS SYSTEM — Trouble Diagnoses

Preliminary Check (Cont'd)

When **CONSULT** is not used: 

1. Turn key switch "OFF".
2. Set HICAS system in self-diagnosis mode.
 - (1) Turn ignition switch "OFF".
 - (2) Set shift lever to "P" or "N" position (A/T model), or "Neutral" position (M/T model).
 - (3) Turn ignition switch "ON".
 - (4) Immediately start engine.
 - (5) Turn steering wheel from left to right (at least 20° from the neutral position) 5 times or more, then depress foot brake pedal at least 5 times all within 10 seconds after ignition switch has been turned "ON".
3. Set steering wheel to a point approximately 10° from the neutral position and check to ensure that rear wheels turn to the left and right alternately.

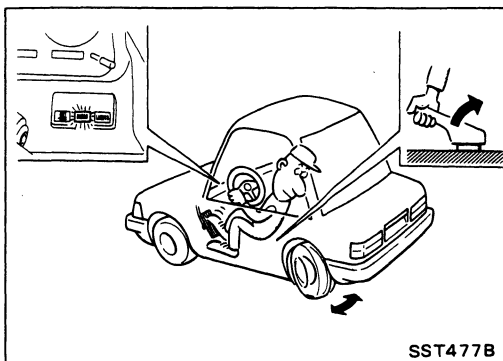
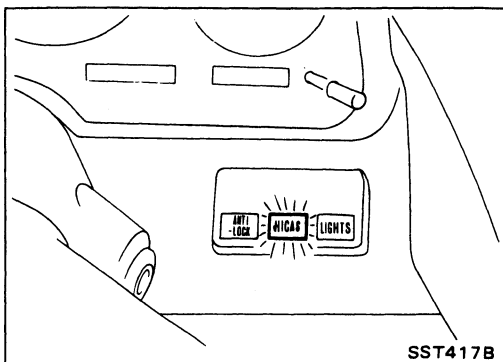

Component Parts and Harness Connector Location

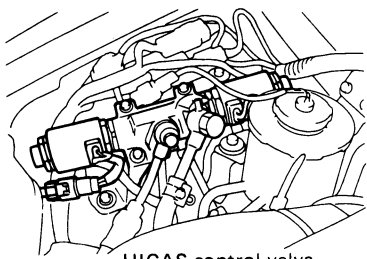

HICAS control valve

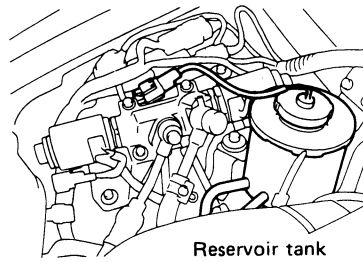

Reservoir tank

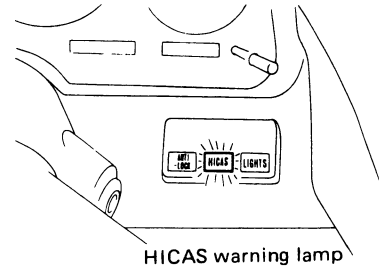

HICAS warning lamp

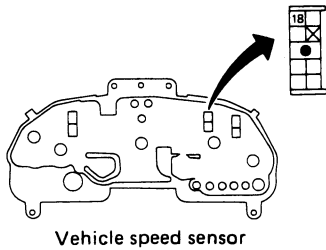

Vehicle speed sensor

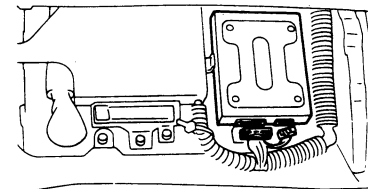

Control unit

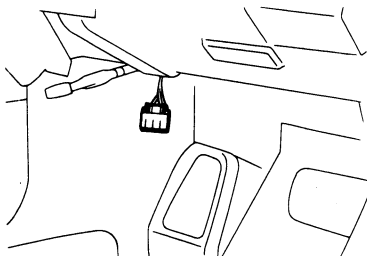

Diagnostic connector for CONSULT

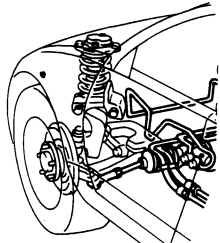
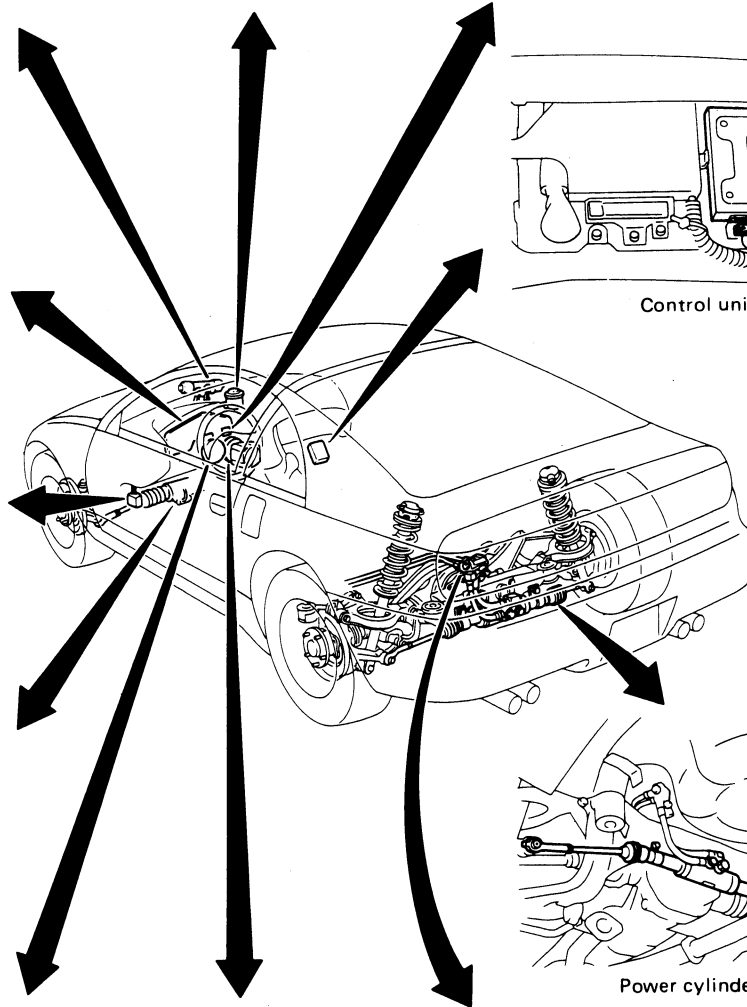

Power steering solenoid

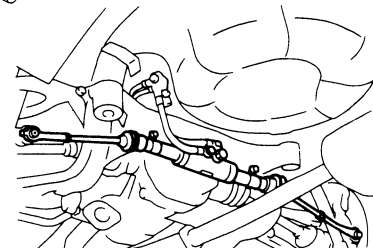

Power cylinder

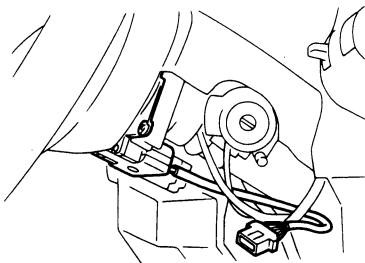

Steering angle sensor

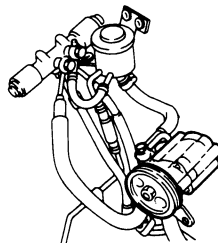

Oil pump

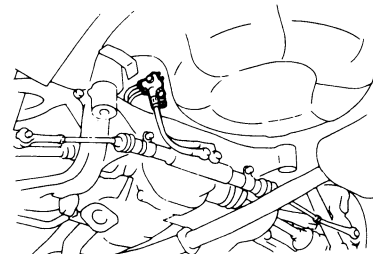

Fail-safe valve

Circuit Diagram for Quick Pinpoint Check

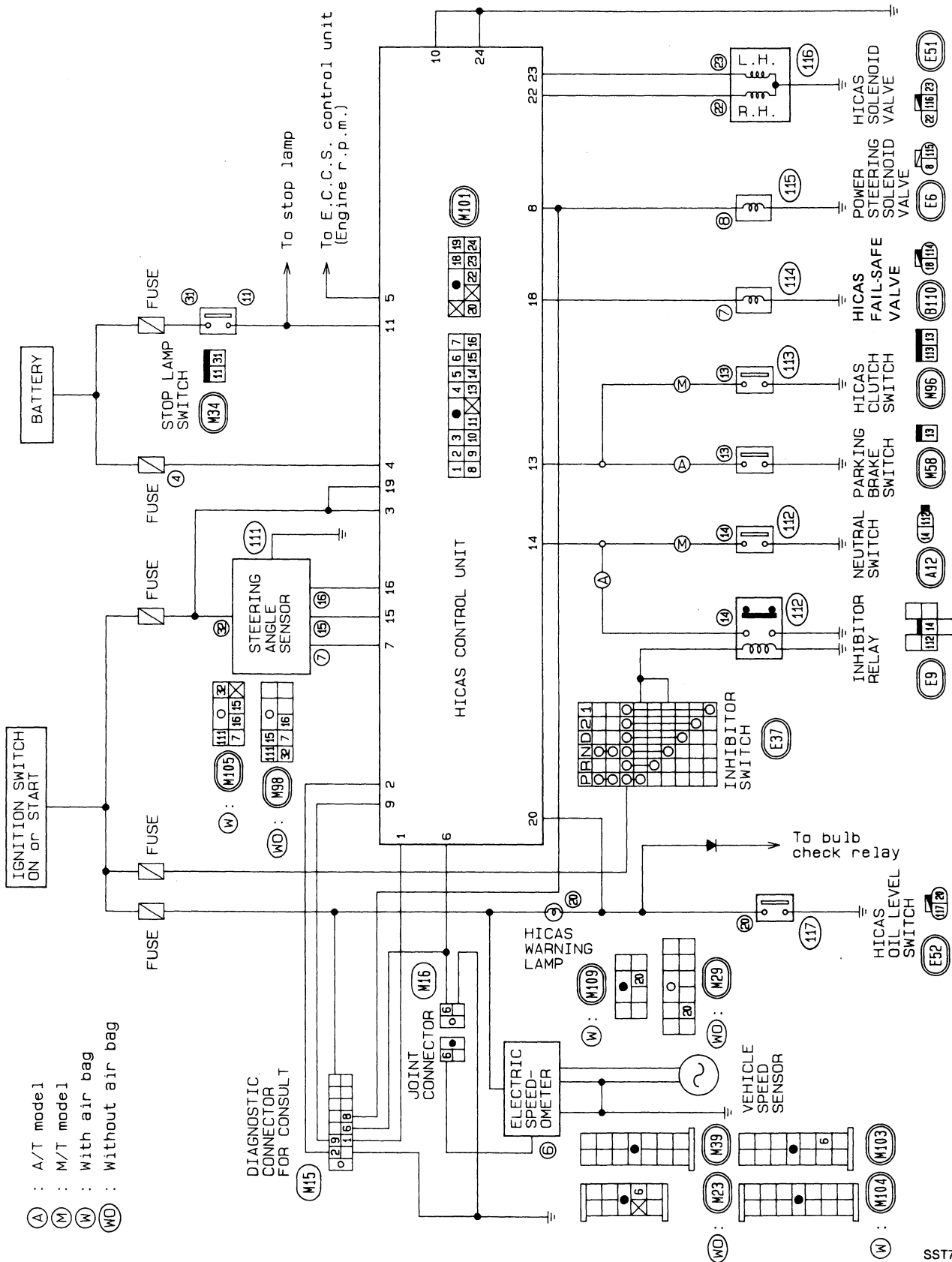

SST762B

Wiring Diagram

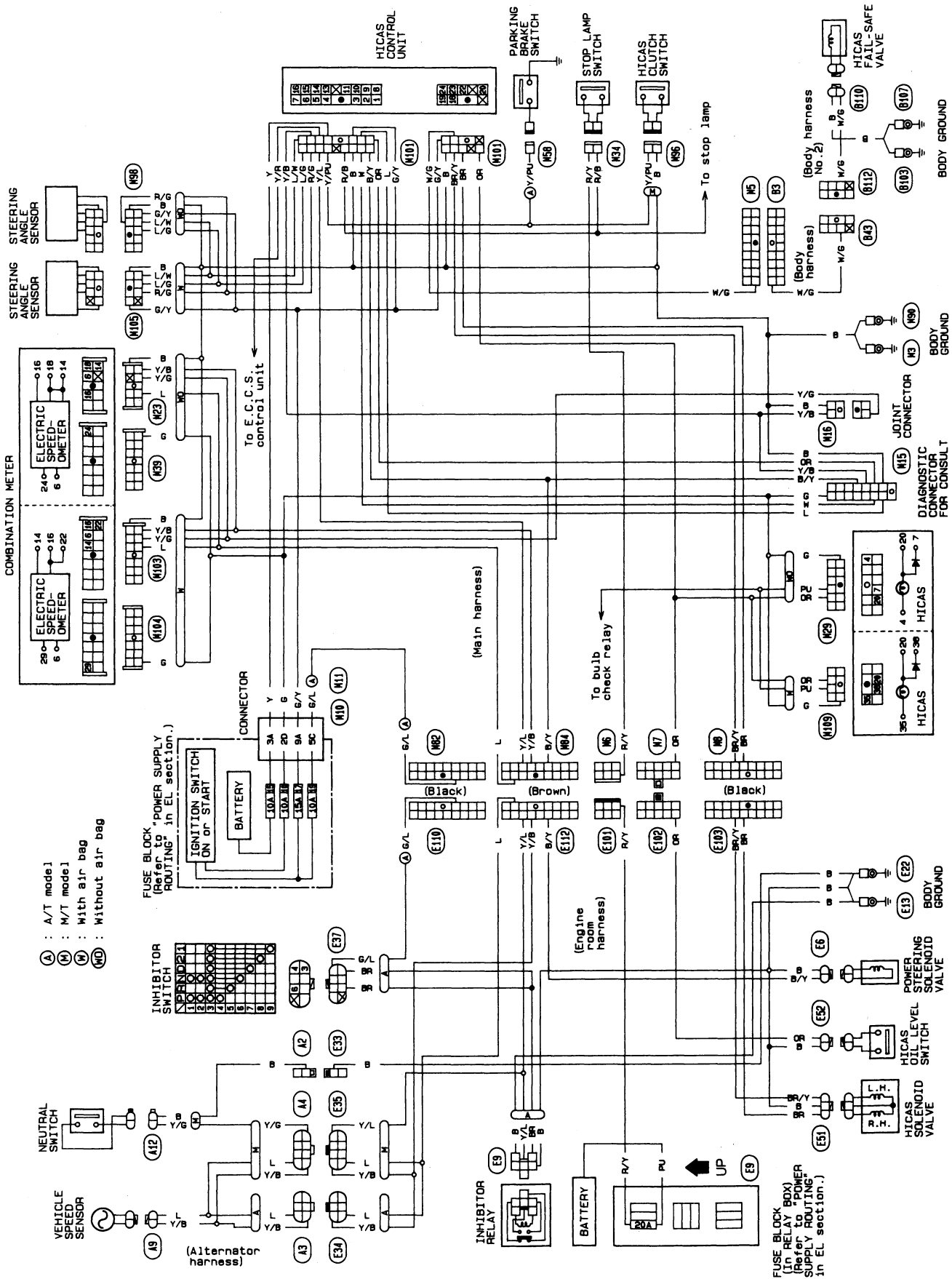

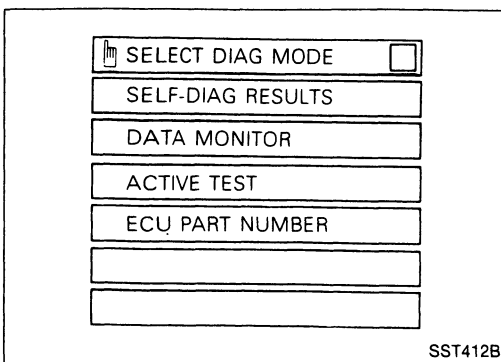

Self-diagnosis (When CONSULT is used)

- Start engine.
- Touch START (on CONSULT display).
- Touch HICAS.
- Touch SELF-DIAG RESULTS.

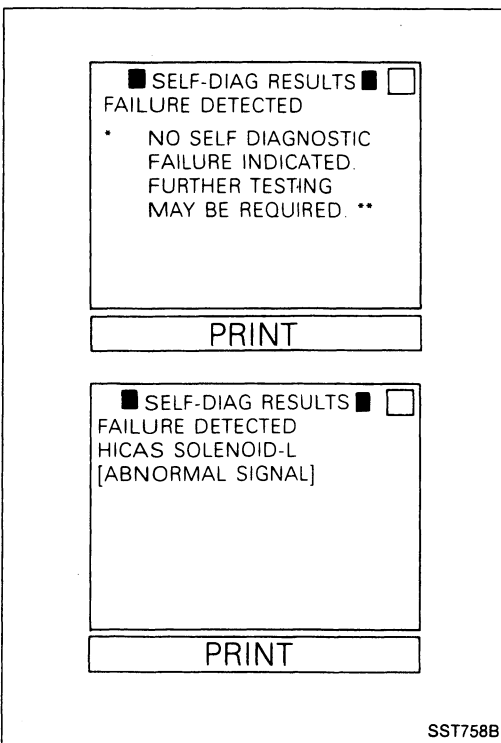

- Self-diagnostic results are shown on display. Refer to Table on page ST-70.

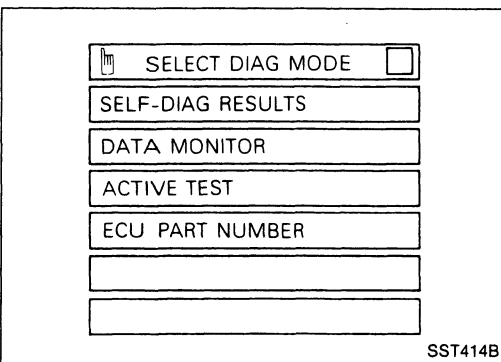

For reference:

Recording input/output signals using data monitor function

- Start engine.
- Touch START (on CONSULT display).
- Touch HICAS.
- Touch DATA MONITOR.

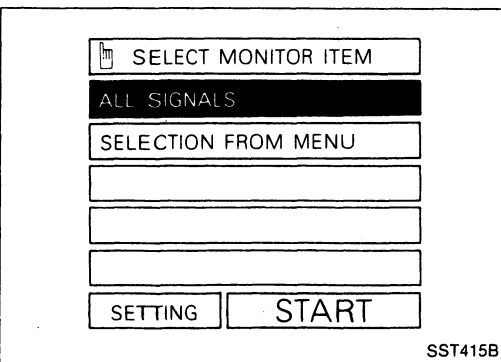

- Check to ensure that the ALL SIGNALS display is reversed. Touch START. Refer to Table on page ST-71.

SUPER HICAS SYSTEM — Trouble Diagnoses

Self-diagnosis (When CONSULT is used) (Cont'd)

☆ MONITOR ☆ NO FAIL ▼ CAR SPEED (REF) 0km/h STEERING ANG L8° NEUTRAL SIG ON STOP LAMP SW OFF PKB/CLUTCH SW ON NEUTRAL SW ON ENG REV UNDER 1500 HICAS SOL R0.00A POWER STR SOL 1.05A	
RECORD	
☆ MONITOR ☆ NO FAIL ▲ FAILSAFE/V OFF FAILSAFE NON WARNING LAMP OFF	
RECORD	

SST416B

- Touch RECORD to record data.
- Ensure that ON-OFF signal is produced when signal is entered from each sensor while monitoring.
- To cancel data recording during operation, touch CANCEL.**

Self-diagnosis items

Diagnostic item	Description
* NO SELF DIAGNOSTIC FAILURE INDICATED. FURTHER TESTING MAY BE REQUIRED. **	● Even if no self diagnostic failure is indicated, further testing may be required as far as the customer complains.
VEHICLE SPEED SENSOR [NO SIGNAL] (-a)	● No vehicle speed signal is entered after vehicle has been operated.
VEHICLE SPEED SENSOR [SIG-SUDDEN TURN] (-b)	● Vehicle speed signal abruptly changes during operation.
STEERING ANGLE SEN [NO ANG SIGNAL] (-a)	● Steering angle has not been changed while driving at a speed of at least 60 km/h (37 MPH).
STEERING ANGLE SEN [NO NEUT SIGNAL] (-b)	● Neutral (ON) signal is not entered after vehicle has been driven.
STEERING ANGLE SEN [NEUT SIG-360° OFF] (-c)	● Neutral (ON) signal is not entered even after steering wheel has been turned at least 360°.
STEERING ANGLE SEN [NEUT SIG-30° ON] (-d)	● Neutral (ON) signal is continually shown at steering angle of at least 30°.
FAILSAFE VALVE [ABNORMAL SIGNAL]	● Output terminal voltage is abnormal due to broken or shorted HICAS fail-safe valve circuit.
HICAS SOLENOID-R [ABNORMAL SIGNAL]	● Output terminal voltage is abnormal due to broken or shorted HICAS solenoid (RH) circuit.
HICAS SOLENOID-L [ABNORMAL SIGNAL]	● Output terminal voltage is abnormal due to broken or shorted HICAS solenoid (LH) circuit.
POWER STEERING SOL [ABNORMAL SIGNAL]	● Output terminal voltage is abnormal due to broken or shorted power steering solenoid circuit.

SUPER HICAS SYSTEM — Trouble Diagnoses

Self-diagnosis (When CONSULT is used) (Cont'd)

Data monitoring items

○: Standard
△: Optional selection

Item	Monitor item selection		Remarks
	All items	Item menu	
Vehicle speed sensor (km/h)	○	△	—
Steering angle sensor (deg)	○	△	Abnormal value is shown before straight-ahead position ("0") is set and after battery is disconnected and reconnected.
Neutral signal (ON-OFF display)	○	△	—
Stop lamp switch signal (ON-OFF display)	○	△	—
Parking brake/Clutch switch (ON-OFF display)	○	△	Clutch switch signal for M/T model and parking brake switch signal for A/T model.
Neutral switch (ON-OFF display)	○	△	Neutral switch signal for M/T model and inhibitor relay (N or P) signal for A/T model.
Engine rpm ("OVER 1,500" or "UNDER 1,500" is shown.)	○	△	Engine speed greater than/less than 1,500 rpm is shown.
HICAS solenoid (R/L) (A)	○	△	Controlled current flow from control unit to HICAS solenoid and direction of current control are shown.
Power steering solenoid (A)	○	△	Controlled current flow from control unit to power steering solenoid is shown.
Fail-safe valve (ON-OFF display)	○	△	ON (when connected) or OFF (when disconnected) is shown.
Fail-safe system (CUT-NON display)	○	△	NON (fail-safe valve ON) referring to "normal" conditioner CUT (fail-safe valve OFF) when in "fail-safe" condition are shown.
Warning lamp (ON-OFF display)	○	△	Illumination control of control unit's HICAS warning lamp is shown.
■ Voltage (V)	—	△	Voltage measured with voltage probes is shown.
■ Pulse (ms, Hz or)	—	△	Value measured with pulse probes is shown. If pulse cannot be measured, "#" is shown. "#" is also shown at left of final data until measurement results are determined.

Self-diagnosis (When CONSULT is not used)

SELF-DIAGNOSIS PROCEDURES

1. Input starting conditions for self-diagnosis.
 - (1) Turn ignition switch "OFF".
 - (2) Set shift lever to "P" or "N" position (A/T model), or "Neutral" position (M/T model).
 - (3) Turn ignition switch "ON".
 - (4) Immediately start engine.
 - (5) Turn steering wheel from left to right (at least 20° from the neutral position) 5 times or more, then depress foot brake pedal at least 5 times all within 10 seconds after ignition switch has been turned "ON".
2. Input self-diagnosis item.
 - (1) Depress and release foot brake pedal.
 - (2) Turn steering wheel from left to right (at least 20°) from the neutral position.
 - (3) (M/T model)
Depress clutch pedal and move gear shift lever to any position other than Neutral and return to Neutral. Release clutch pedal.
(A/T model)
Disengage and engage parking brake lever. Move shift lever to any position other than Neutral or Parking and return to Parking.
 - (4) Move car at least 3 meters (10 ft) forward and proceed at an indicated speed of at least 2 km/h (1 MPH) in self-diagnosis mode.

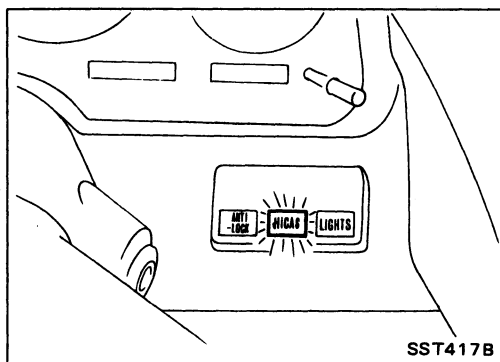

3. The self-diagnosis mode will then appear in the "HICAS" warning lamp.

When all systems are normal:

HICAS warning lamp flashes at 0.25-second intervals.

SUPER HICAS SYSTEM — Trouble Diagnoses

Self-diagnosis (When CONSULT is not used) (Cont'd)

When there is a system malfunction:

Example: When ② HICAS solenoid LH, ④ power steering solenoid and ⑤ vehicle speed sensor have experienced a malfunction.

The warning lamp displays abnormal mode (1 sec. ON).

A If fail-safe system was operated (fail-safe valve is operating) when ignition switch was turned OFF for the last time, fail-safe items will be displayed in numerical order in modes indicated. After all items are displayed, display is repeated again.

- To change the display mode to **A**, turn OFF ignition switch after mode **B** is displayed.
- When battery charge is insufficient, mode **B** is displayed.

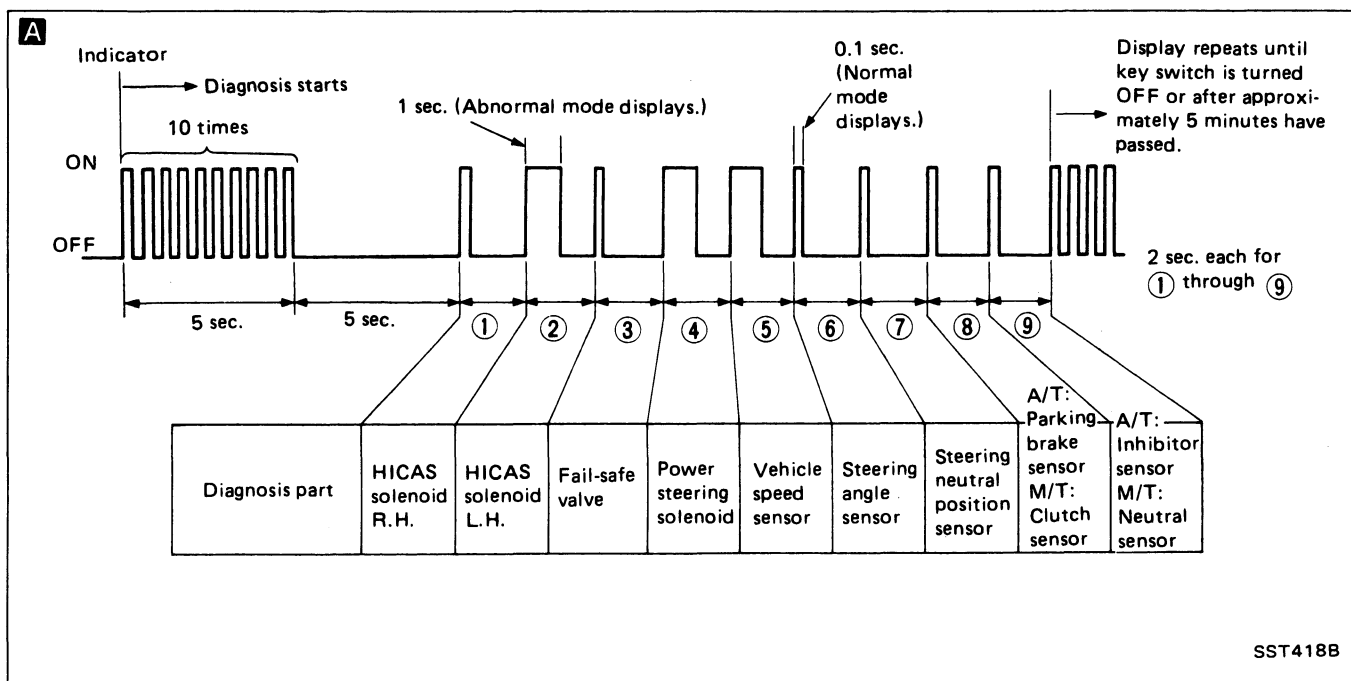

SUPER HICAS SYSTEM — Trouble Diagnoses

Self-diagnosis (When CONSULT is not used) (Cont'd)

B If fail-safe system was not operated when ignition switch was turned OFF for the last time, display will show self-diagnosis results in numerical sequence in modes indicated below. After all self-diagnosis results are shown, display is repeated again.

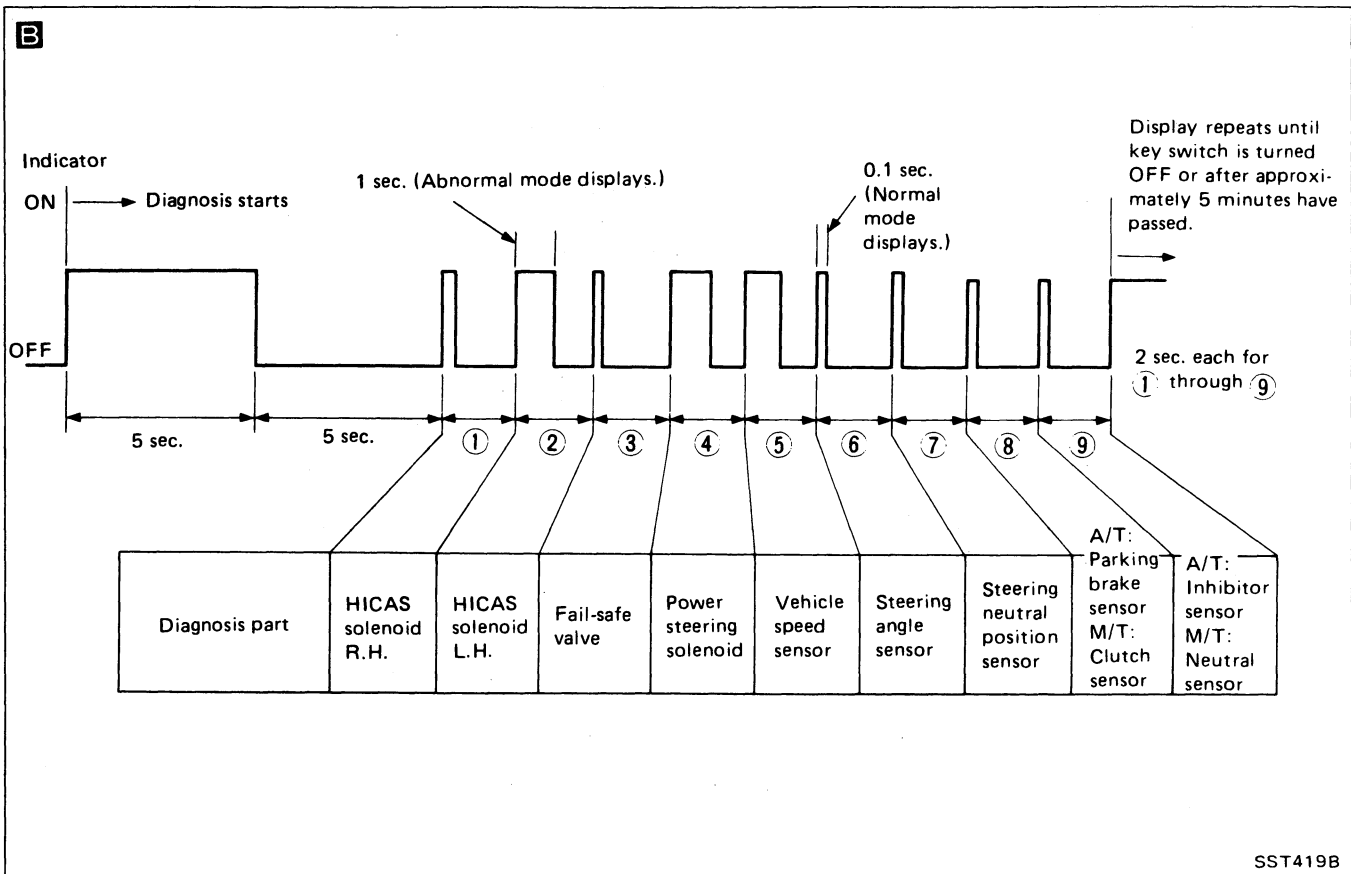

CANCELING THE SELF-DIAGNOSIS FUNCTION

There are three methods for canceling the self-diagnosis function, as described below:

- The self-diagnosis system is canceled by the turning ignition switch "OFF".
- After self-diagnosing has been operated for approximately 5 minutes, the self-diagnosis system will be automatically canceled.
- The self-diagnosis system is canceled by a vehicle speed of 30 km/h (19 MPH) or over.

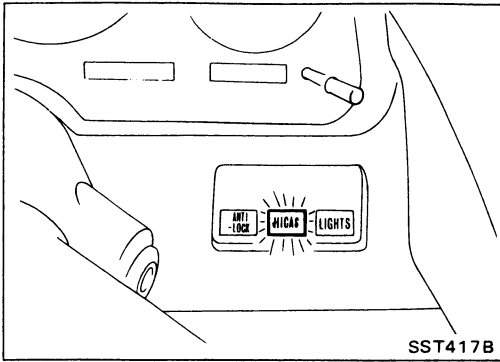

Diagnostic Procedure 1

SYMPTOM:

No warning lamp comes on when ignition switch is turned "ON".

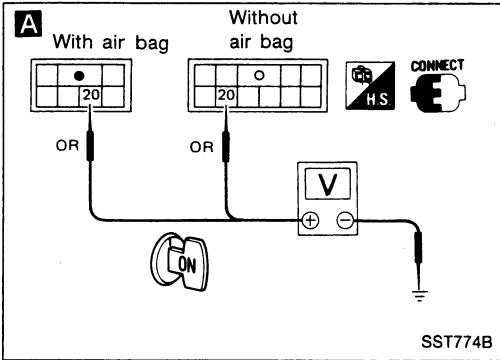
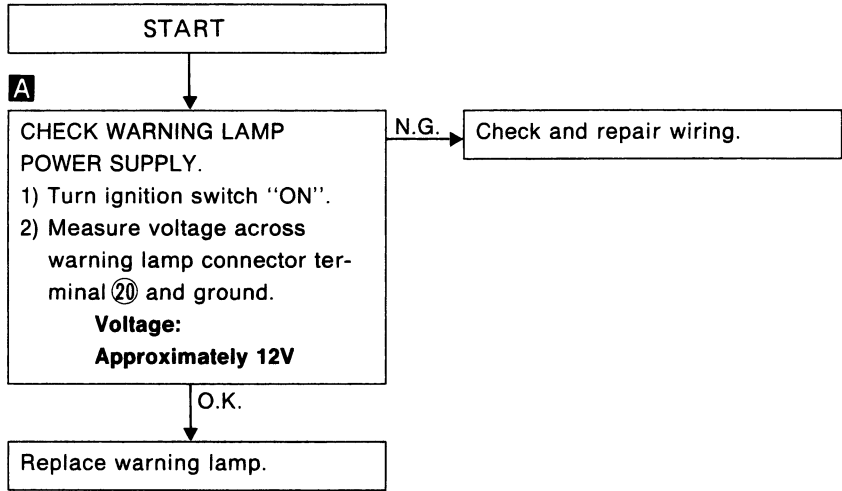

Diagnostic Procedure 2

SYMPTOM (A):

Warning lamp comes on during operation.

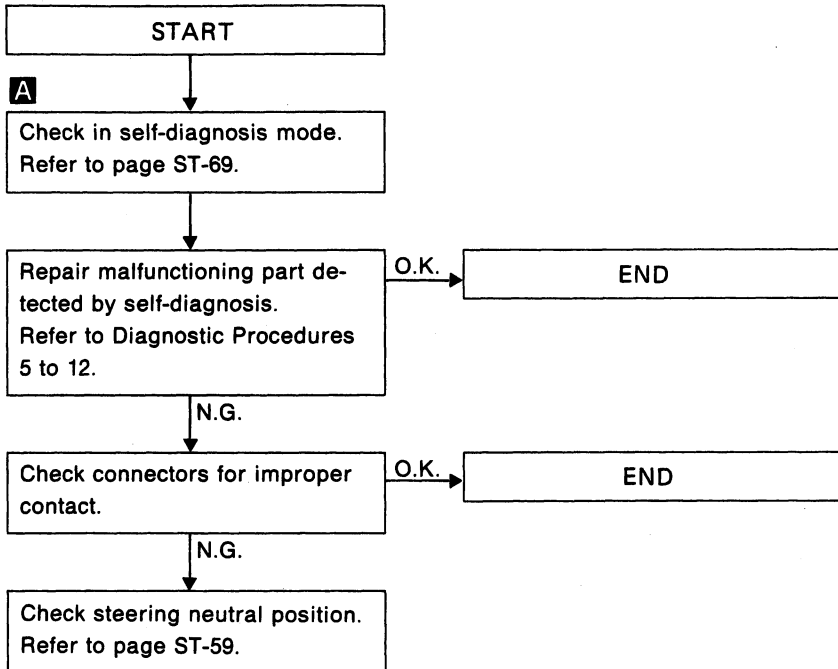
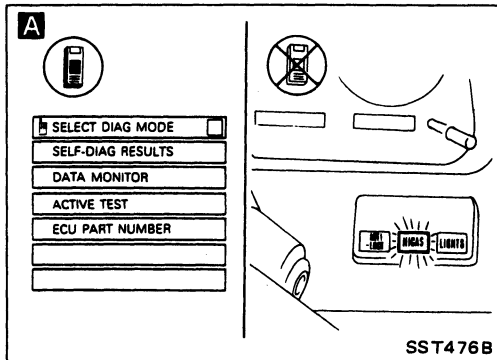
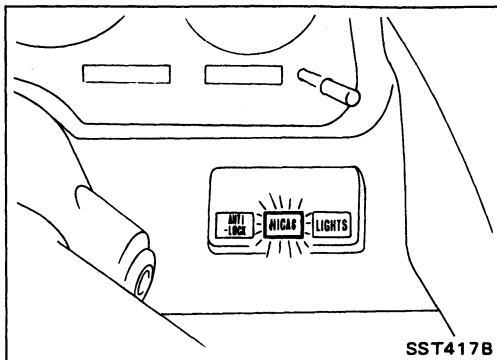

SUPER HICAS SYSTEM — Trouble Diagnoses

Diagnostic Procedure 2 (Cont'd)

SYMPTOM (B):

Warning lamp comes on when ignition switch is turned ON; however, it does not go out after engine start.

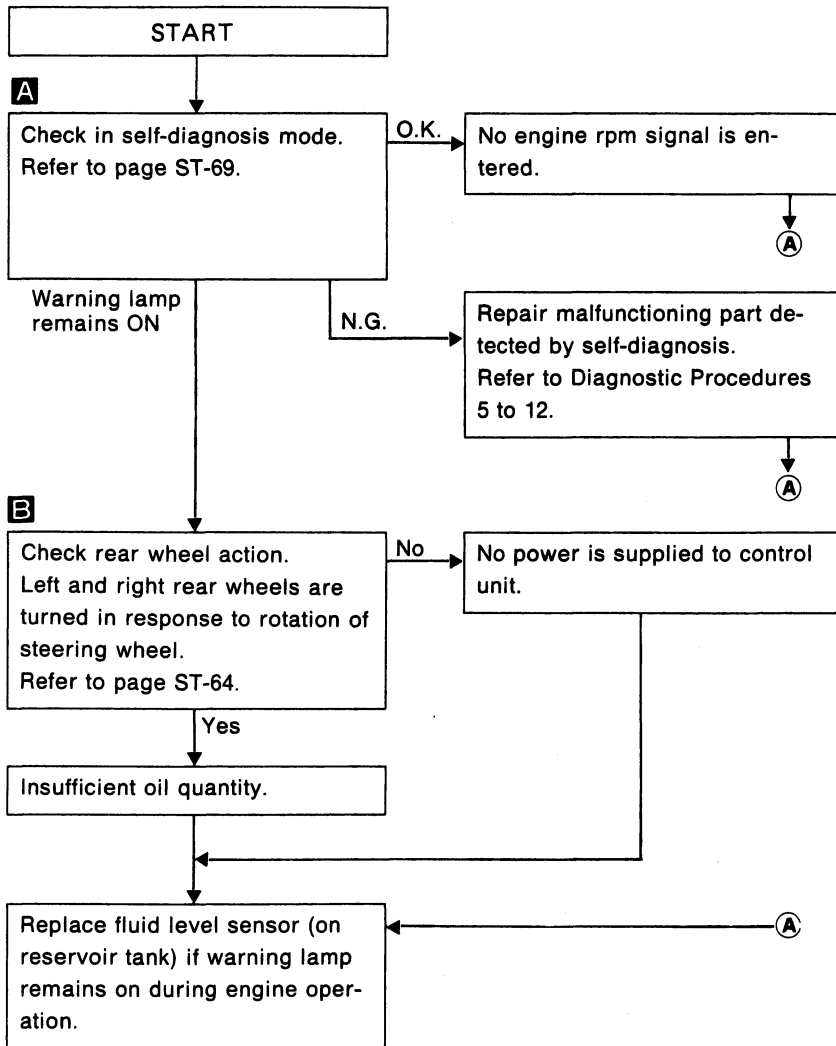
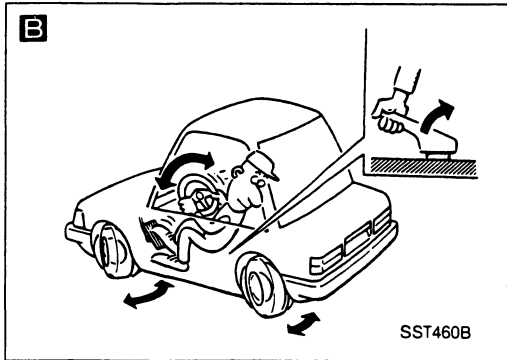
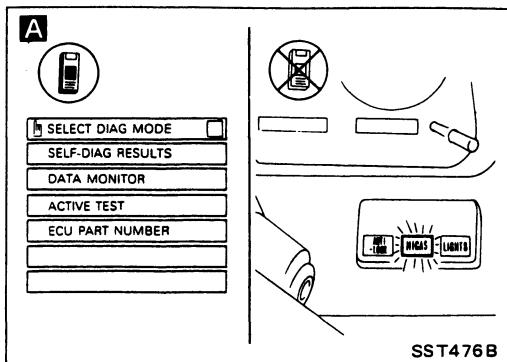

Diagnostic Procedure 3

SYMPTOM:
Abnormal noise occurs.

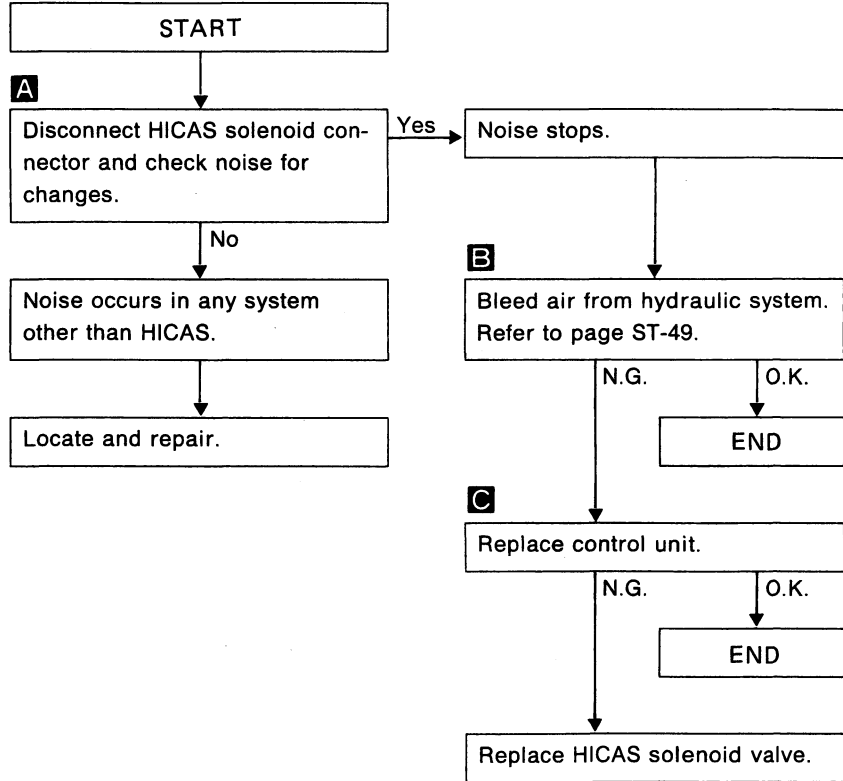
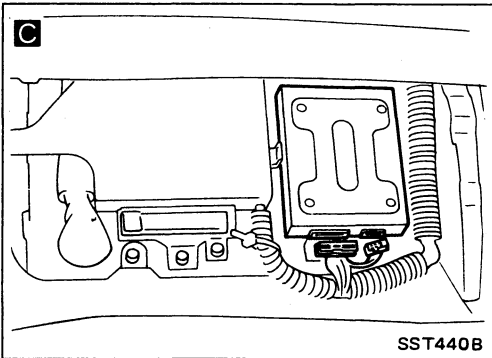
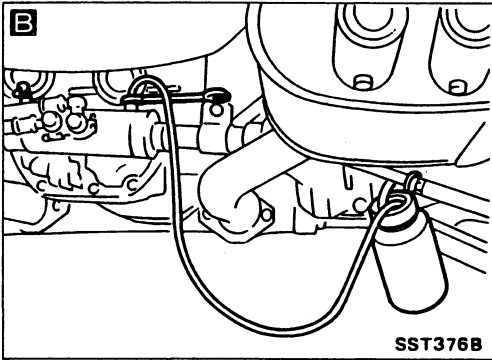
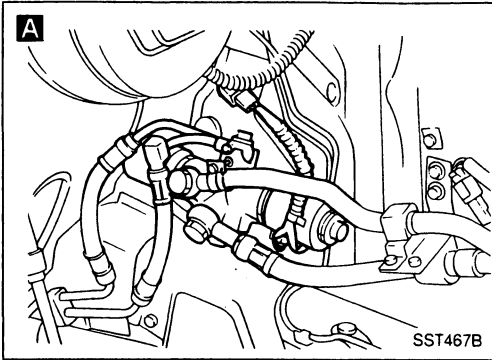

Diagnostic Procedure 4

SYMPTOM:

Vehicle behavior is abnormal. (Vehicle sways or jerks.)

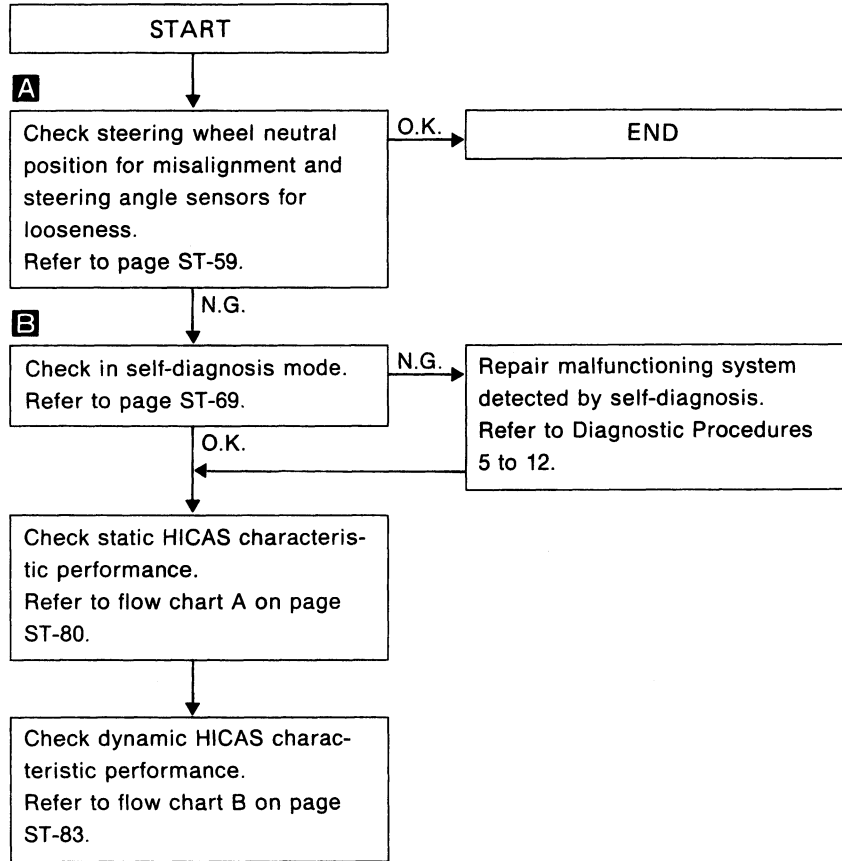
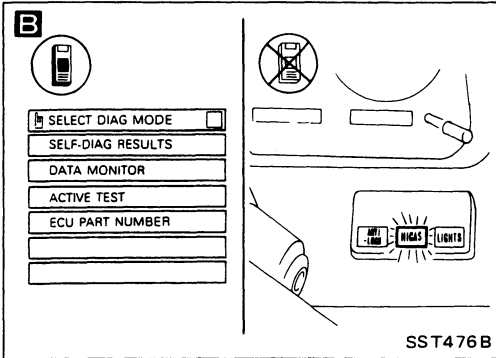
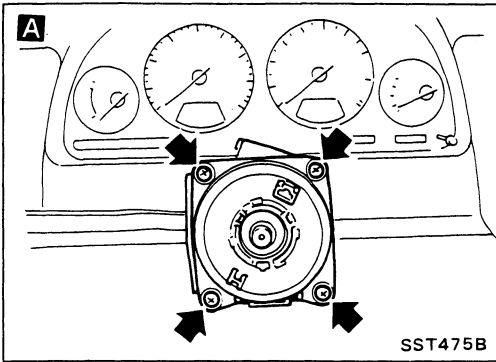

SUPER HICAS SYSTEM — Trouble Diagnoses

Diagnostic Procedure 4 (Cont'd)

A. Static HICAS characteristic performance check

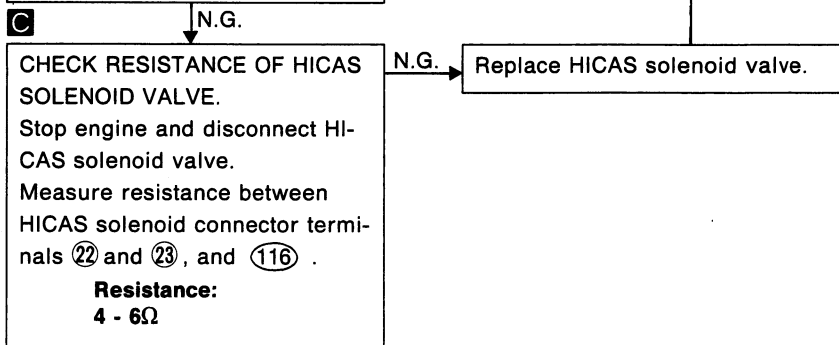
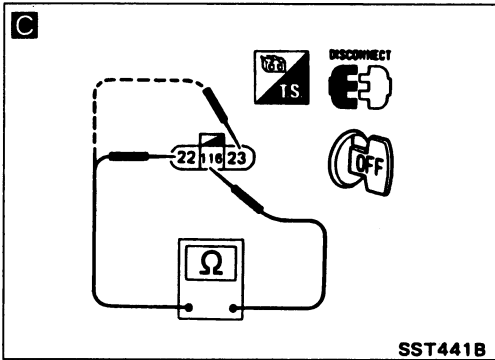
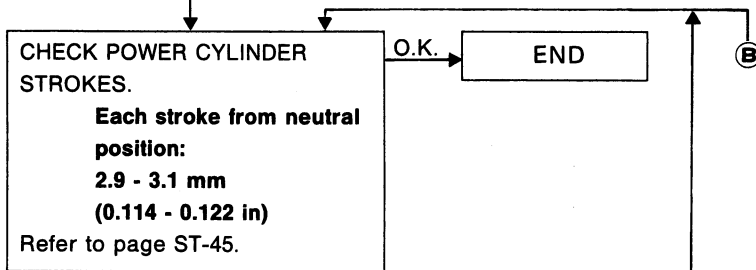
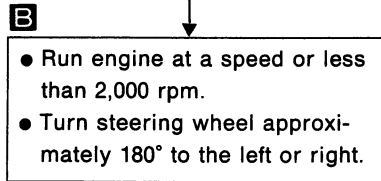
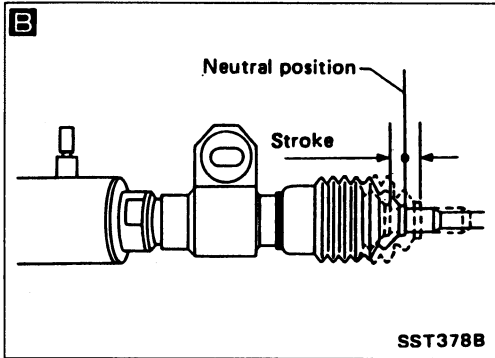
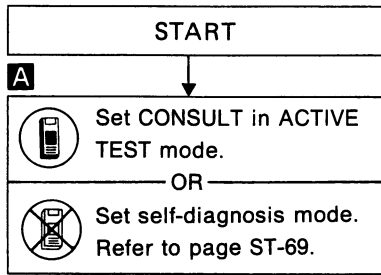
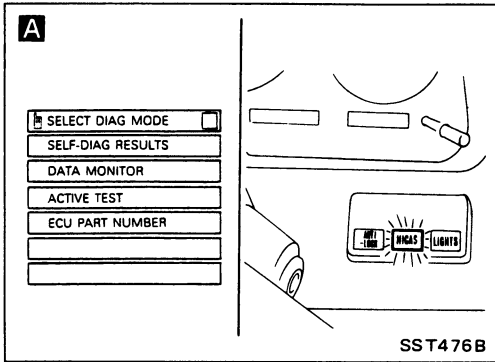

SUPER HICAS SYSTEM — Trouble Diagnoses

Diagnostic Procedure 4 (Cont'd)

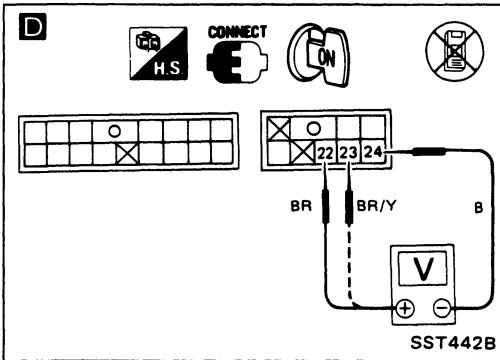
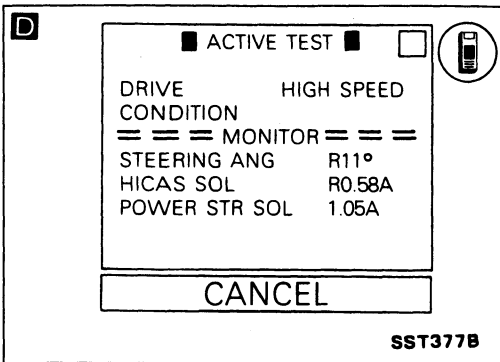

D

A

CHECK CONTROL UNIT OUTPUT VOLTAGE.

Set CONSULT in ACTIVE TEST mode.

HICAS solenoid valve output amperes:
1.1 - 1.2A

OR

Set self-diagnosis mode.

- Run engine at a speed of more than 2,000 rpm.
- Turn steering wheel approximately 180°.
- Measure voltage across control unit connector terminals ②② and ②③, and ②④.

Output voltage:
More than 4.4V

N.G. → Replace control unit. **B**

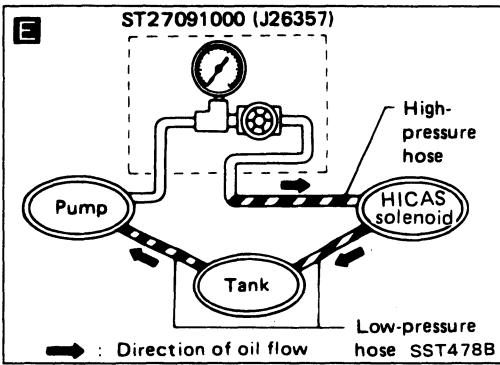

E

O.K.

CHECK HICAS OIL PUMP RELIEF PRESSURE.

- Cancel self-diagnosis mode.
- Check HICAS oil pump relief pressure with engine running at a speed of more than 2,000 rpm.

Relief pressure:
More than 5,884 kPa (60 kg/cm², 853 psi)

N.G. → Replace oil pump. **B**

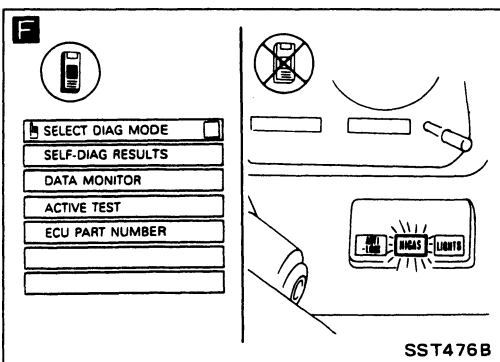

F

O.K.

CHECK OIL PRESSURE AT FAIL-SAFE VALVE.

Set CONSULT in ACTIVE TEST mode.

OR

Set self-diagnosis mode.

Ⓢ

Diagnostic Procedure 4 (Cont'd)

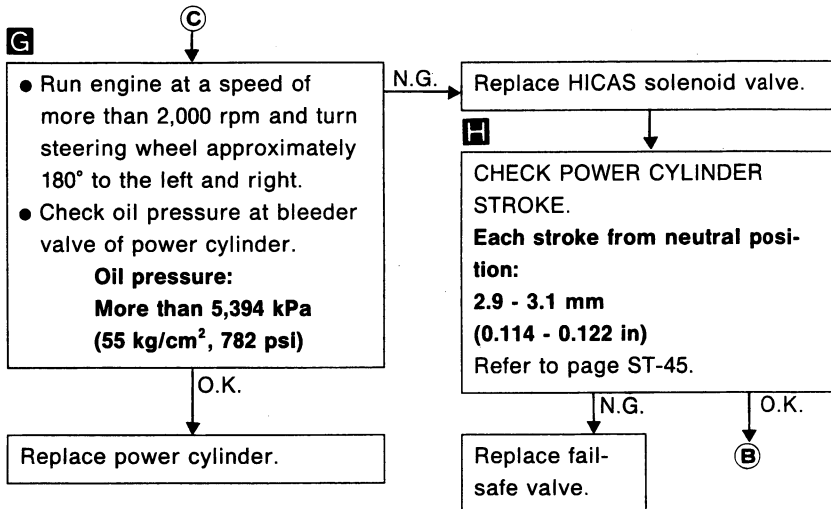
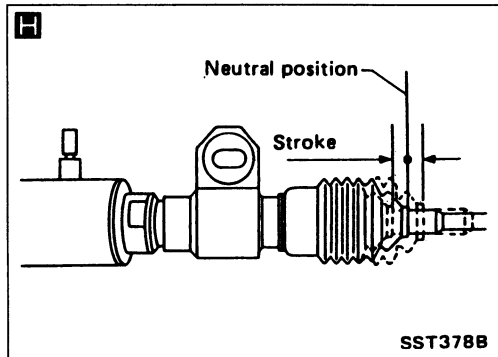
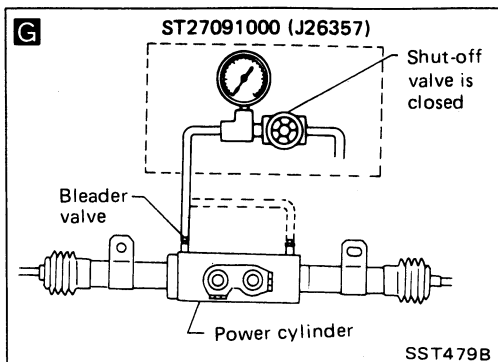

SUPER HICAS SYSTEM — Trouble Diagnoses

Diagnostic Procedure 4 (Cont'd)

B. Dynamic HICAS characteristic performance check

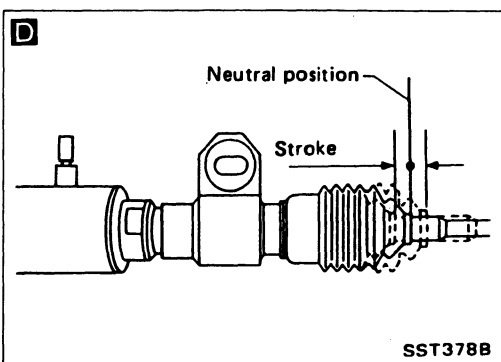
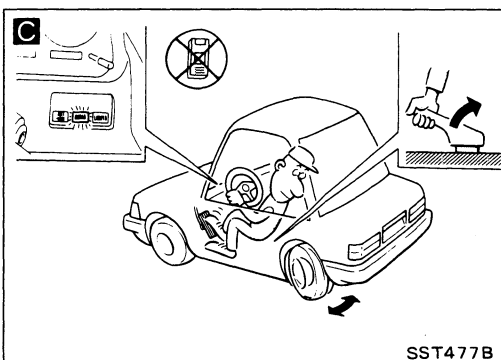
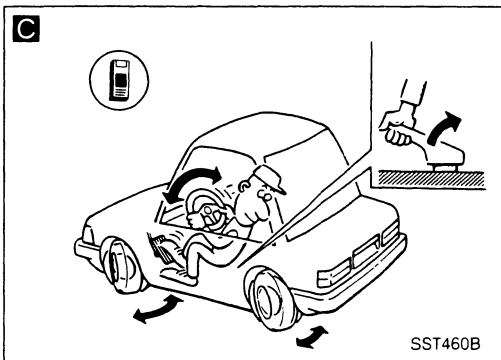
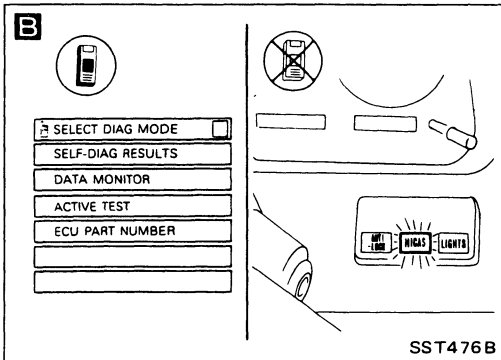
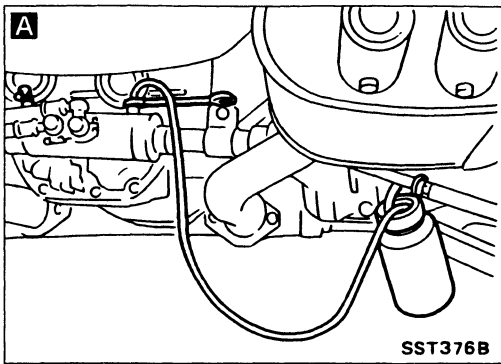

START

A
CHECK PIPING AND CONNECTIONS. ALSO BLEED AIR FROM HYDRAULIC SYSTEM.

- Replace piping or connectors which are found to be damaged.
- Bleed air from hydraulic system. Refer to page ST-49.

B
Set CONSULT in ACTIVE TEST mode.
OR
Set in self-diagnosis mode. Refer to page ST-69.

Run engine at a speed of more than 2,000 rpm.

C
CHECK REAR WHEELS FOR PROPER MOVEMENT.

Ensure that rear wheel turns to the left or right when steering wheel is turned to the left or right.

OR

Ensure that rear wheels intermittently turn to the left and right when steering wheel is set to the neutral position.

D
CHECK POWER CYLINDER STROKES.
Each stroke from neutral position:
More than 2.0 mm (0.079 in)

O.K. → END

N.G. → **A**

SUPER HICAS SYSTEM — Trouble Diagnoses

Diagnostic Procedure 4 (Cont'd)

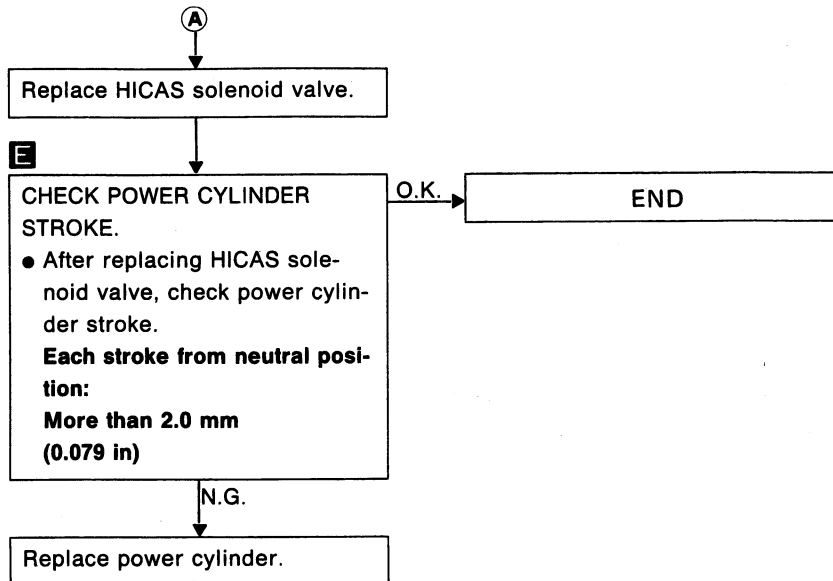
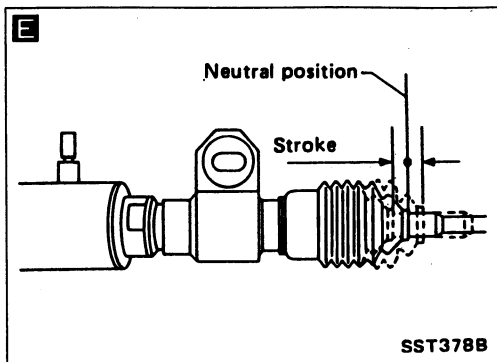

Diagnostic Procedure 5

SYMPTOM:
System is not set in self-diagnosis mode.

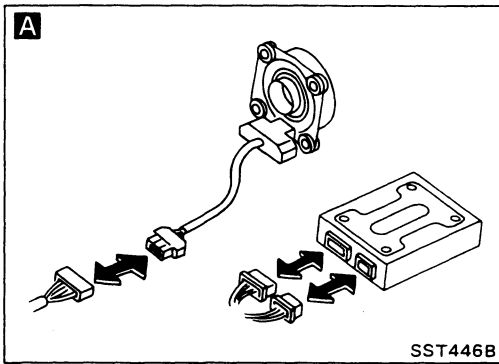

B

☆ MONITOR	☆ NO FAIL	
CAR SPEED (REF)	0km/h	
STEERING ANG	L8°	
NEUTRAL SIG	ON	
STOP LAMP SW	OFF	
PKB/CLUTCH SW	ON	
NEUTRAL SW	ON	
ENG REV	UNDER 1500	
HICAS SOL	R0.00A	
POWER STR SOL	1.05A	

RECORD

☆ MONITOR	☆ NO FAIL	
FAILSAFE/V	OFF	
FAILSAFE	NON	
WARNING LAMP	OFF	

RECORD

SST416B

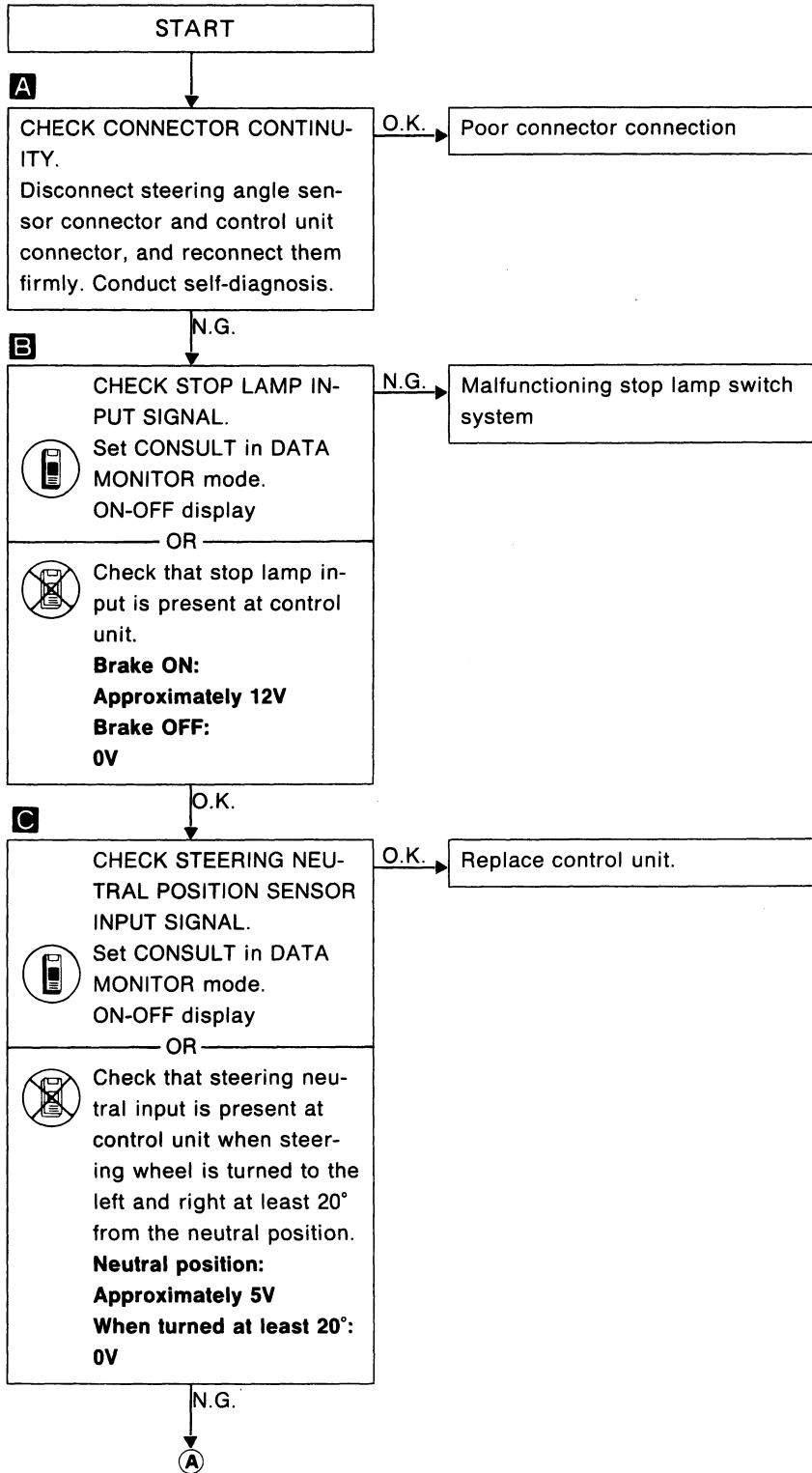
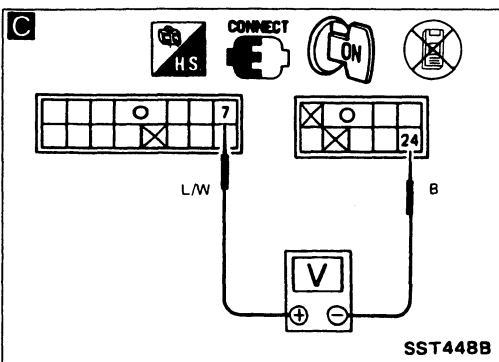
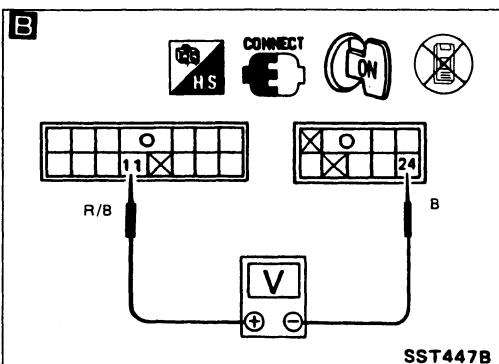

SUPER HICAS SYSTEM — Trouble Diagnoses

Diagnostic Procedure 5 (Cont'd)

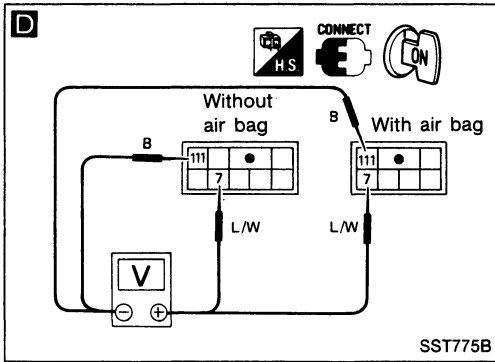

D

CHECK STEERING NEUTRAL POSITION SENSOR OUTPUT SIGNAL.
 Check that steering neutral output is present when steering wheel is turned to the left and right at least 20° from the neutral position.

Neutral position:
Approximately 5V
When turned at least 20°:
0V

O.K. → Repair or replace harness between control unit and steering angle sensor.

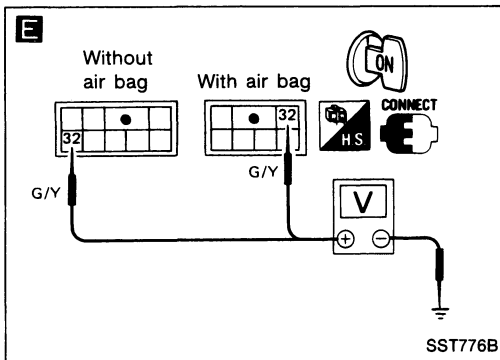

E **CHECK STEERING ANGLE SENSOR POWER SUPPLY.**
 1) Turn ignition switch "ON".
 2) Measure voltage across steering angle sensor connector terminal IGN and ground.

Voltage:
Approximately 12V

F **CHECK STEERING ANGLE SENSOR GROUND CIRCUIT.**
 Check continuity between steering angle sensor terminal GND and body metal (ground).

Continuity should exist.

O.K. → Replace steering angle sensor.

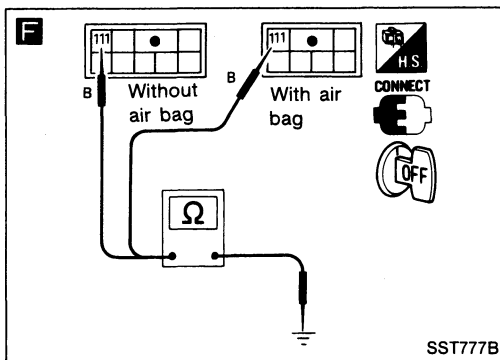

N.G. → Check and repair power supply harness or ground harness.

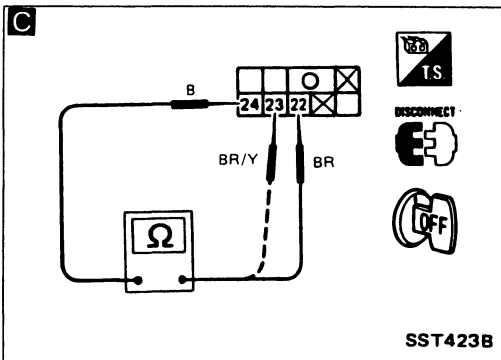
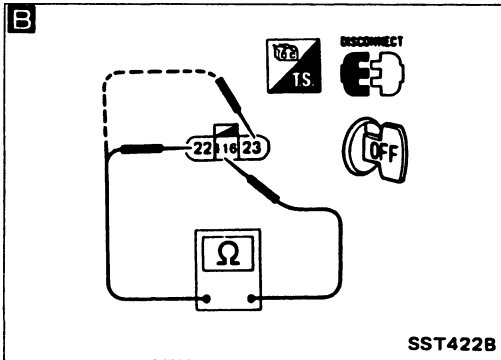
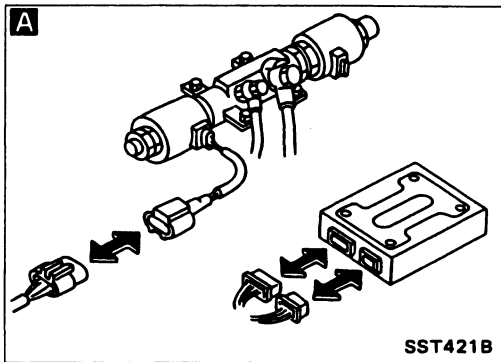

Diagnostic Procedure 6

SYMPTOM:

HICAS solenoid (left and right) output is not present.

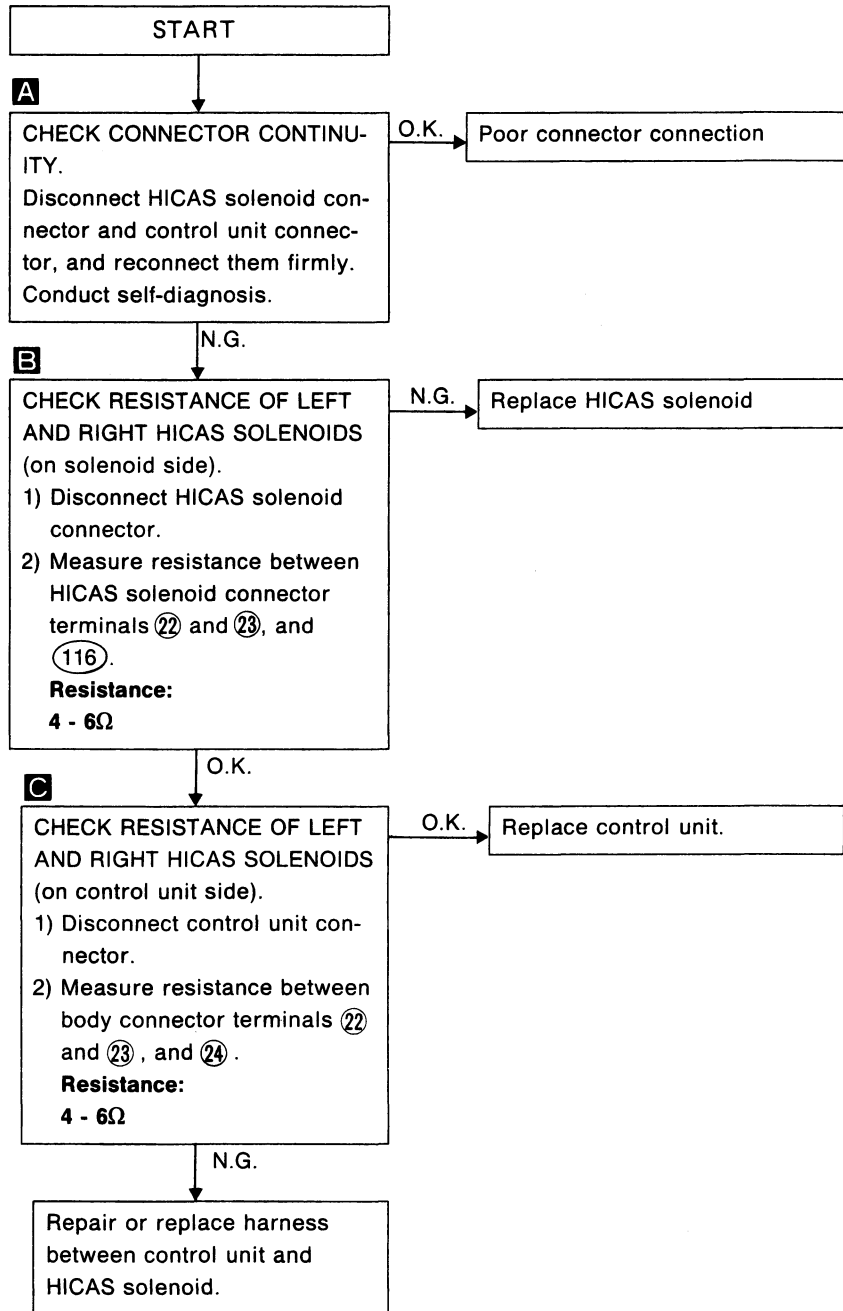

Diagnostic Procedure 7

SYMPTOM:

Fail-safe valve output is not present.

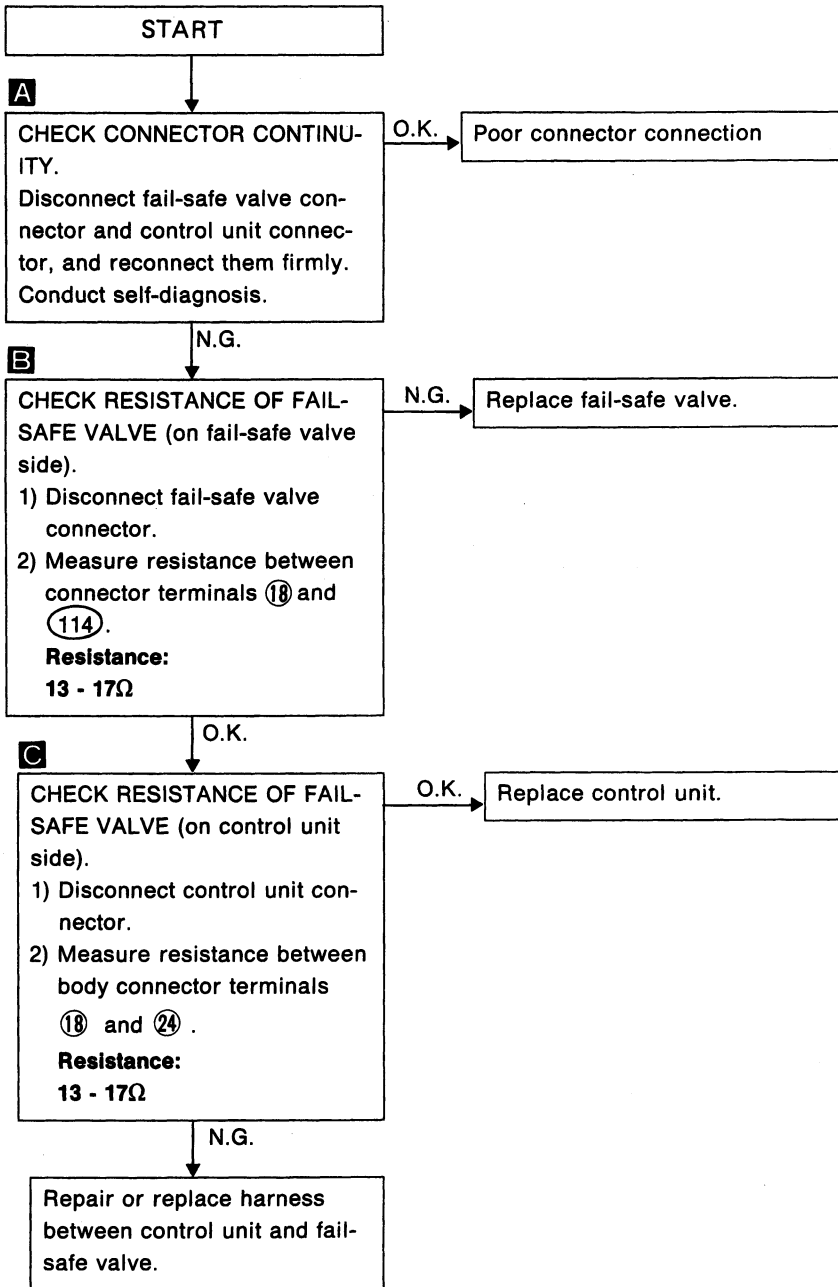
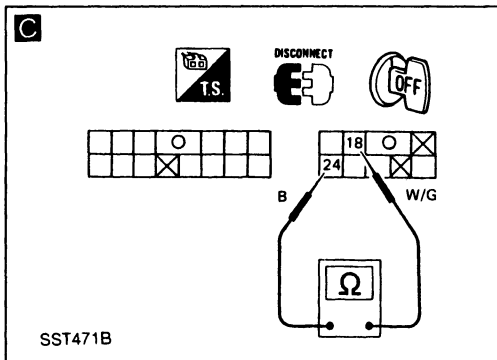
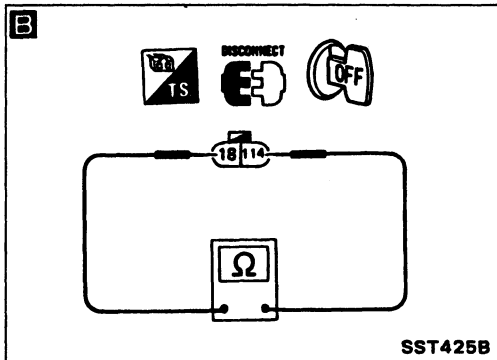
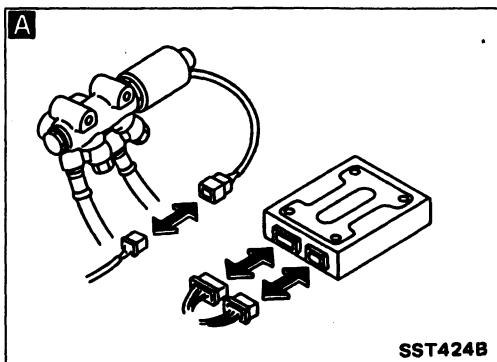

Diagnostic Procedure 8

SYMPTOM:

Power steering solenoid output is not present.

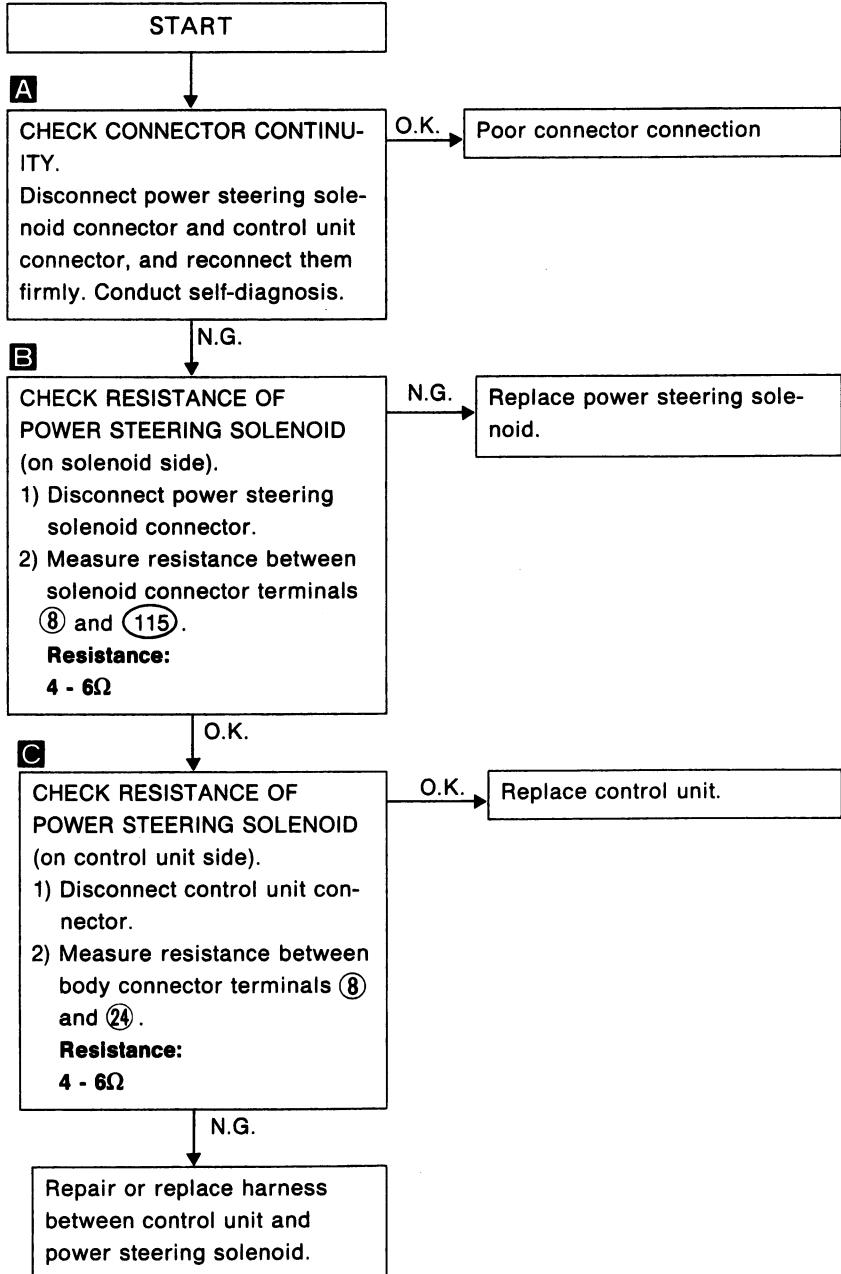
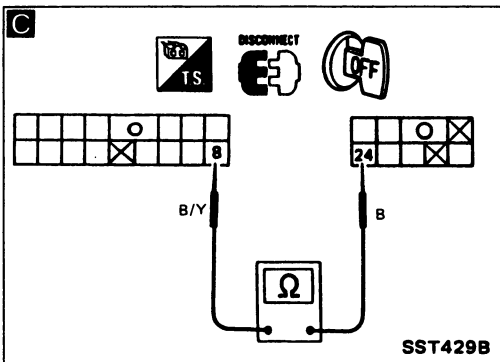
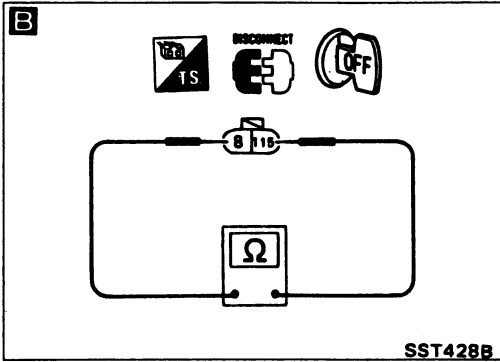
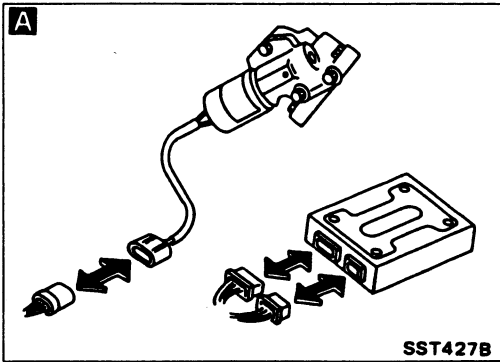

Diagnostic Procedure 9

SYMPTOM:

Vehicle speed signal is not present.

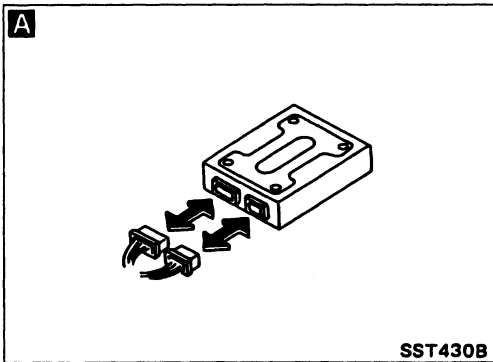

B

☆ MONITOR ☆ NO FAIL	▼
CAR SPEED (REF)	0km/h
STEERING ANG	L8°
NEUTRAL SIG	ON
STOP LAMP SW	OFF
PKB/CLUTCH SW	ON
NEUTRAL SW	ON
ENG REV UNDER 1500	
HICAS SOL	R0.00A
POWER STR SOL	1.05A

RECORD

☆ MONITOR ☆ NO FAIL	▲
FAILSAFE/V	OFF
FAILSAFE	NON
WARNING LAMP	OFF

RECORD

SST416B

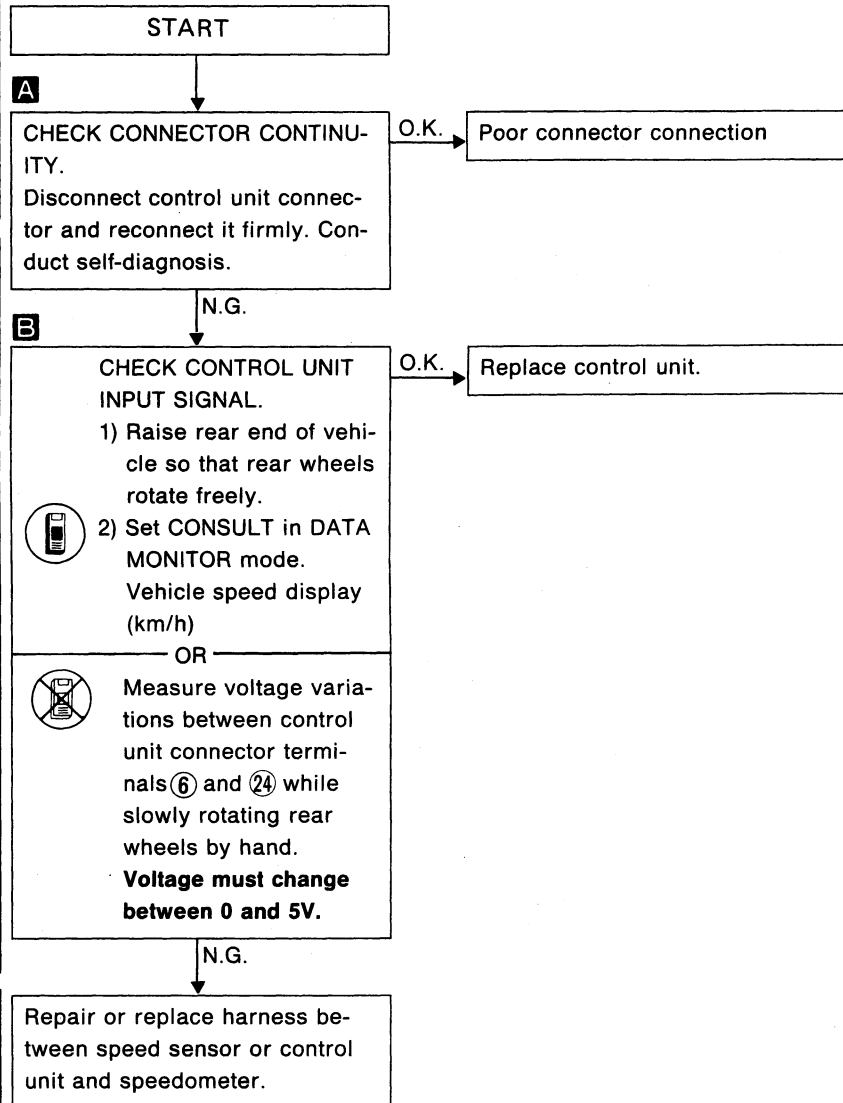
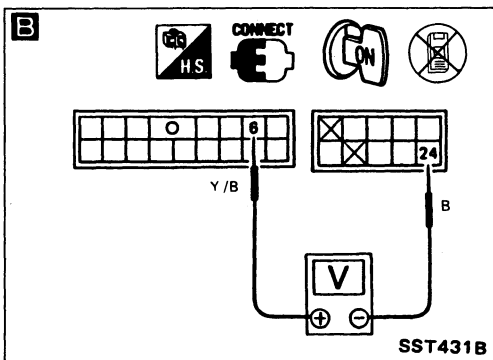

Diagnostic Procedure 10

SYMPTOM:

Steering angle sensor input is not present.

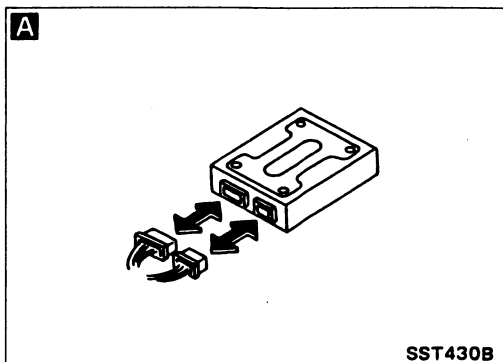

B

☆ MONITOR ☆ NO FAIL	▼
CAR SPEED (REF)	0km/h
STEERING ANG	L8°
NEUTRAL SIG	ON
STOP LAMP SW	OFF
PKB/CLUTCH SW	ON
NEUTRAL SW	ON
ENG REV UNDER 1500	
HICAS SOL	R0.00A
POWER STR SOL	1.05A
RECORD	

☆ MONITOR ☆ NO FAIL	▲
FAILSAFE/V	OFF
FAILSAFE	NON
WARNING LAMP	OFF
RECORD	

SST416B

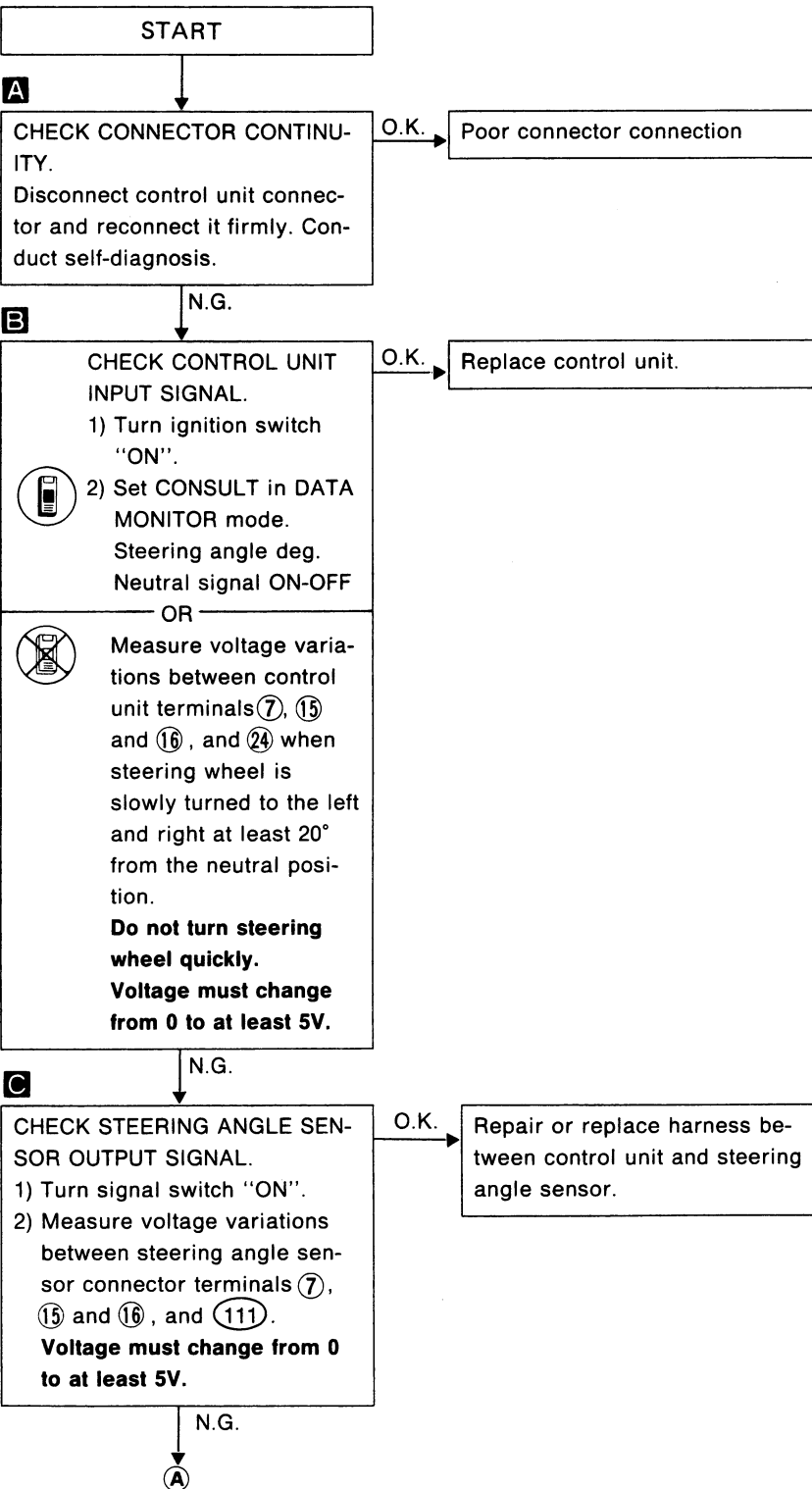
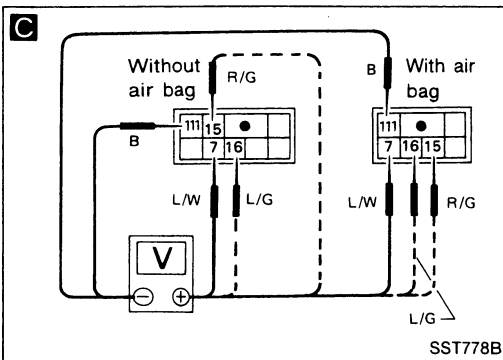
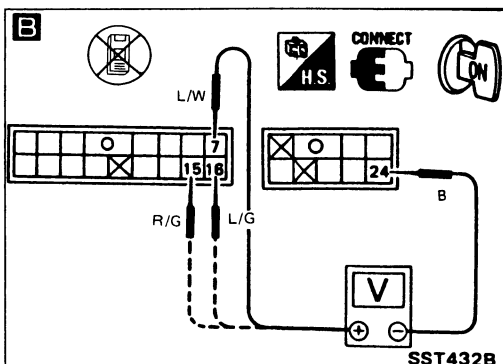

Diagnostic Procedure 10 (Cont'd)

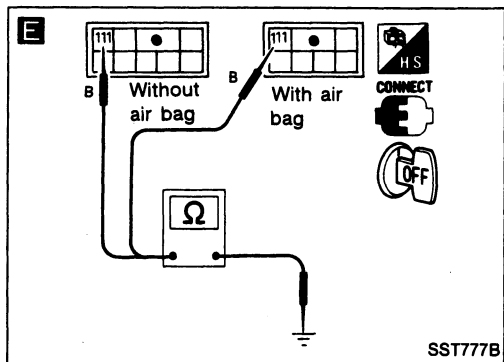
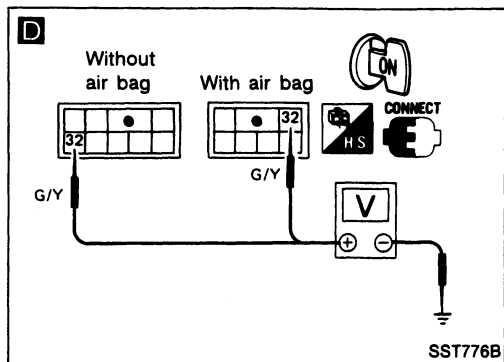

D CHECK STEERING ANGLE SENSOR POWER SUPPLY.

- 1) Turn ignition switch "ON".
- 2) Measure voltage across steering angle sensor connector terminal 32 and ground.

Voltage:
Approximately 12V

E CHECK STEERING ANGLE SENSOR GROUND CIRCUIT.

Check continuity between steering angle sensor terminal 111 and body metal (ground).

Continuity should exist.

O.K. → Replace steering angle sensor.

N.G.

Repair or replace power supply harness or ground harness.

Diagnostic Procedure 11

SYMPTOM:

Parking brake (A/T) or clutch switch (M/T) input is not present.

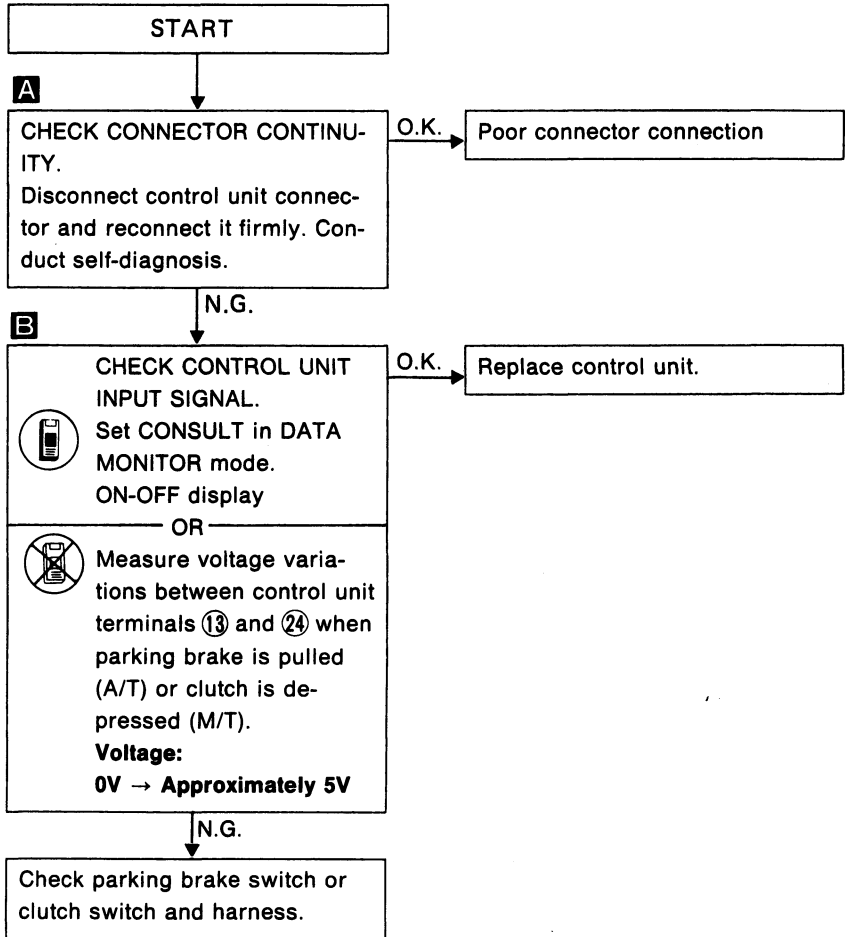
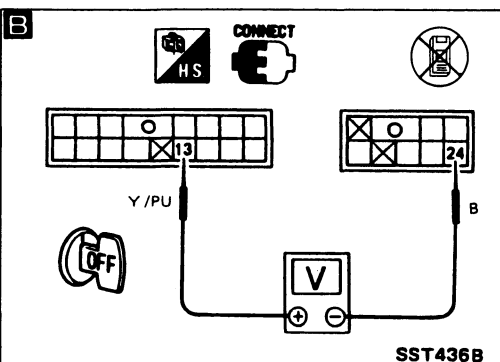
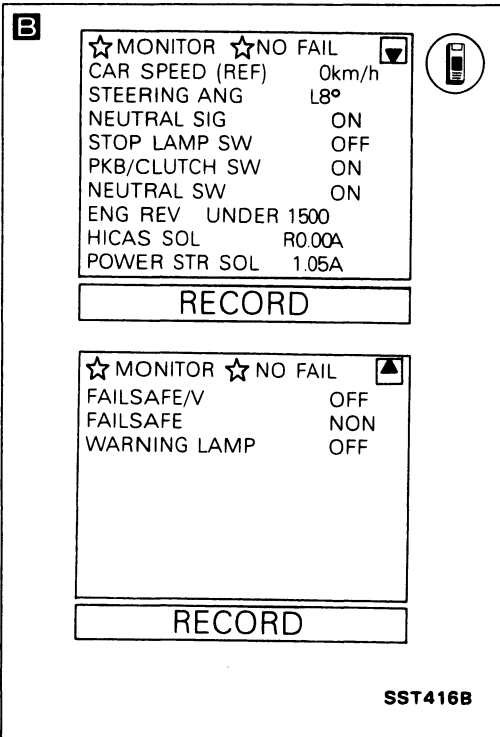
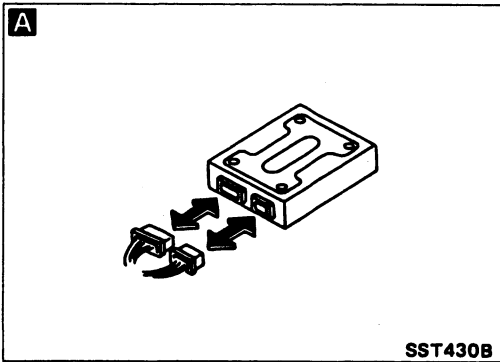

Diagnostic Procedure 12

SYMPTOM:

Inhibitor switch (A/T) or neutral switch (M/T) input is not present.

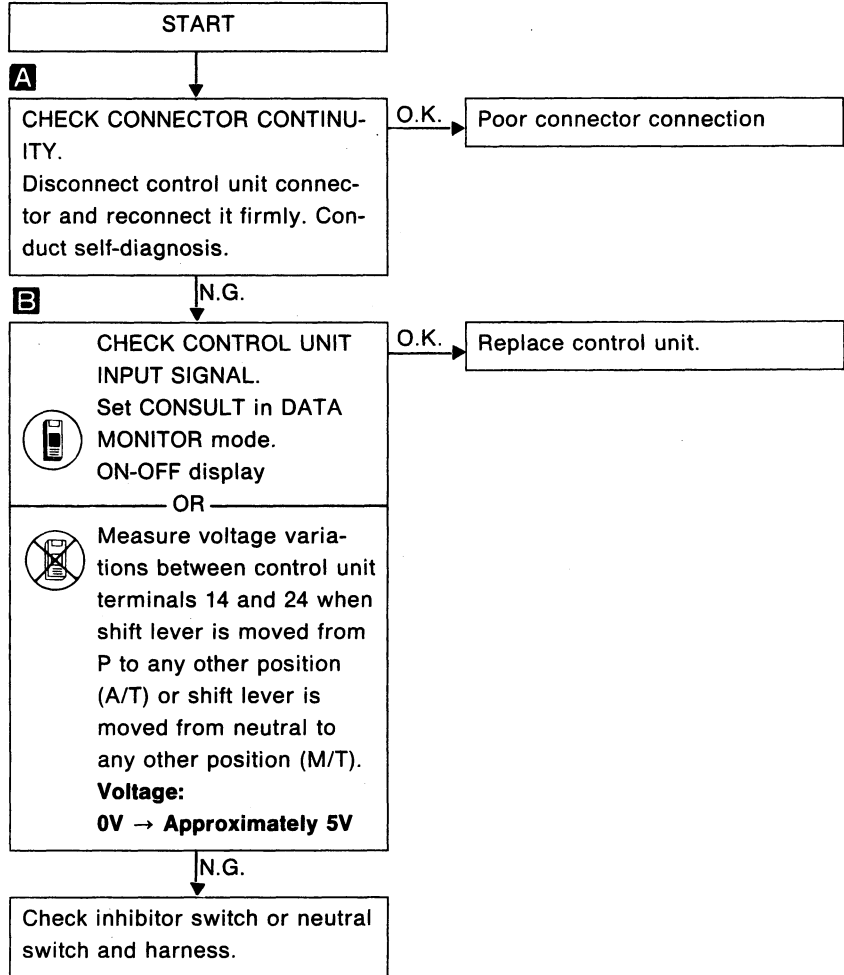
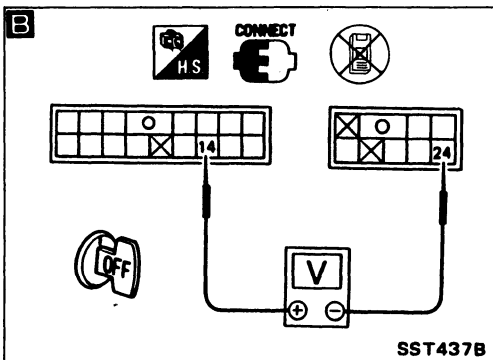
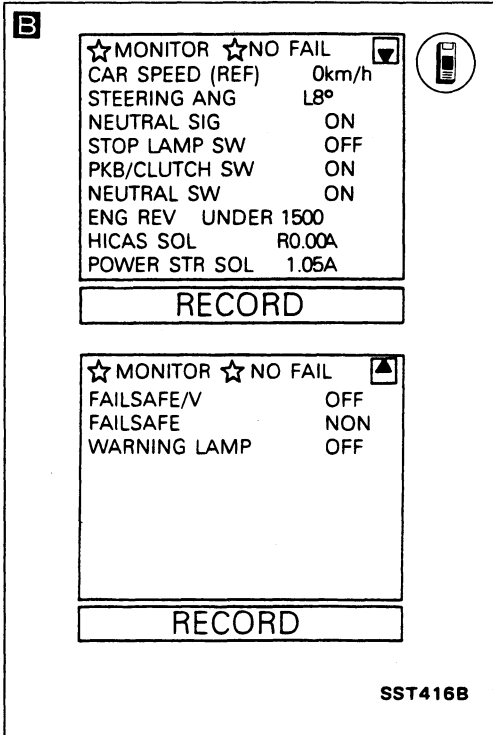
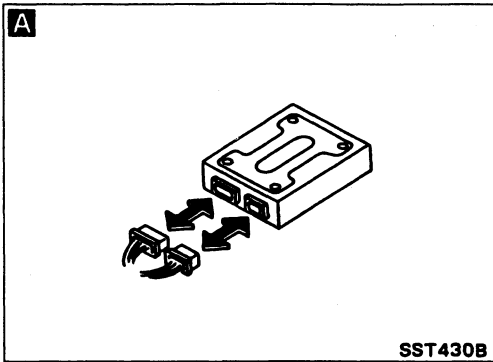

SUPER HICAS SYSTEM — Trouble Diagnoses

Control Unit Inspection Table

The standard values (voltage) measured with an analog tester, in contact with the control unit terminal, are shown below:

Terminal No.	Application	Standard value
1	Service support CLK input	—
2	Service support RX output	—
3	IGN power supply	Key switch ON: Approximately 12V Key switch in other position: 0V
4	Battery	Approximately 12V
5	E.C.C.S. revolution signal	—
6	Vehicle speed signal	Rear wheel rotating 0V ← → greater than 5V (approx.), intermittent
7	Steering neutral position sensor	Approximately 5V (Neutral position)
8	Resistance of power steering solenoid	4 - 6Ω
9	Service support TX output	—
10	Ground	0V
11	Stop lamp switch signal	Brake ON: Approximately 12V Brake OFF: 0V
13	Parking brake signal (A/T), Clutch signal (M/T)	Parking brake engaged (A/T)/ clutch disengaged (M/T): Approximately 5V
14	Inhibitor signal (A/T), Neutral signal (M/T)	Shift lever in any position other than Parking (A/T) or neutral (M/T): Approximately 5V
15	Steering angle sensor-1 signal	Steering wheel turned 0 ← → Approximately 5V, intermittent
16	Steering angle sensor-2 signal	Steering wheel turned 0 ← → Approximately 5V, intermittent
18	Resistance of fail-safe valve	13 - 17Ω
19	IGN power supply	Ignition switch ON: Approximately 12V Ignition switch in other position: 0V
20	HICAS warning lamp	Lamp ON: 0V Lamp OFF: Approximately 12V
22	Resistance of HICAS solenoid (R.H.)	4 - 6Ω
23	Resistance of HICAS solenoid (L.H.)	4 - 6Ω
24	Ground	0V

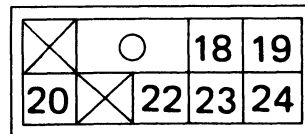
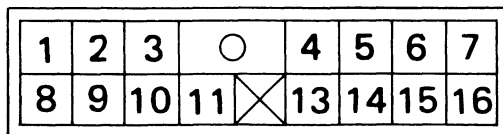

SST438B

SERVICE DATA AND SPECIFICATIONS (S.D.S.)

General Specifications

	Without SUPER HICAS	With SUPER HICAS
Steering model	Power steering	
Steering gear type	PR26SE	
Steering overall gear ratio	16.9	14.8
Turn of steering wheel (Lock to lock)	2.7	2.4
Steering column type	Collapsible	

Inspection and Adjustment

STEERING WHEEL

Steering wheel axial play mm (in)	0 (0)
Steering wheel play mm (in)	0 - 35 (0 - 1.38)

STEERING COLUMN

	Without air bag	With air bag
Steering column length "L ₁ " mm (in)	745.9 - 747.5 (29.37 - 29.43)	749.4 - 751.0 (29.50 - 29.57)
Steering column lower shaft length "L ₂ " mm (in)	280.6 - 282.2 (11.05 - 11.11)	

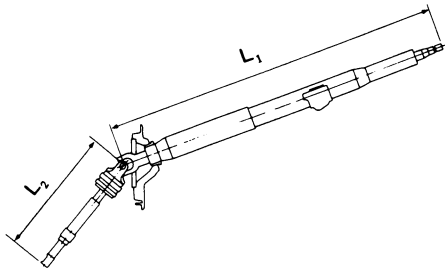

SST315B

STEERING GEAR AND LINKAGE

Item	Steering gear type	PR26SE
Tie-rod outer ball joint		
Swinging force (at cotter pin hole) N (kg, lb)		4.61 - 46.09 (0.47 - 4.7, 1.04 - 10.36)
Rotating torque N-m (kg-cm, in-lb)		0.29 - 2.94 (3.0 - 30.0, 2.6 - 26.0)
Axial end play mm (in)		0 (0)
Tie-rod inner ball joint		
Swinging force* N (kg, lb)		8.8 - 78.5 (0.9 - 8.0, 2.0 - 17.6)
Rotating torque N-m (kg-cm, in-lb)		1.0 - 8.8 (10 - 90, 8.7 - 78.1)
Axial end play mm (in)		0 (0)
Tie-rod standard length "L" mm (in)		155 (6.10)

*: Measuring point

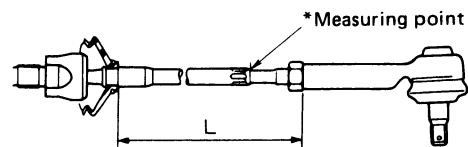

SST304B

Rack stroke "L"	mm (in)	59.5 (2.343)
-----------------	---------	--------------

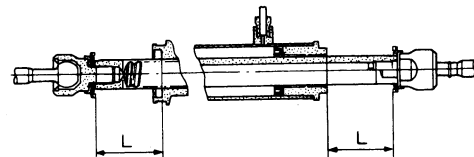

SST307B

SERVICE DATA AND SPECIFICATIONS (S.D.S.)

Inspection and Adjustment (Cont'd)

POWER STEERING

	Without SUPER HICAS	With SUPER HICAS
Rack sliding force N (kg, lb)		
Under normal operating oil pressure		
Range within ± 11.5 mm (± 0.453 in) from the neutral position	206 - 265 (21 - 27, 46 - 60)	201.0 - 250.1 (20.5 - 25.5, 45.2 - 56.2)
Except above range	Not more than 39 (4, 9) beyond above value	
Retainer adjustment		
Adjusting screw		
Initial tightening torque N·m (kg-cm, in-lb)	4.9 - 5.9 (50 - 60, 43 - 52)	
Retightening torque after loosening	0.2 (2, 1.7)	
Tightening torque after gear has settled	4.9 (50, 43)	
Returning angle degree	60° - 100°	
Steering wheel turning force (Measured at one full turn from the neutral position) N (kg, lb)	39 (4, 9) or less	
Fluid capacity (Approximate) ℓ (US qt, Imp qt)	1.3 (1-3/8, 1-1/8)	2.0 (2-1/8, 1-3/4)
Oil pump maximum pressure kPa (kg/cm ² , psi)	7,649 - 8,238 (78 - 84, 1,109 - 1,194)	Main: 7,649 - 8,238 (78 - 84, 1,109 - 1,194) Sub: 6,375 - 6,865 (65 - 70, 924 - 995)

POWER CYLINDER LOWER LINK (SUPER HICAS)

Power cylinder lower link ball joint		
Swinging force*	N (kg, lb)	2.9 - 41.2 (0.3 - 4.2, 0.7 - 9.3)
Axial end play	mm (in)	0 (0)
Power cylinder lower link standard length "L"	mm (in)	309.5 (12.19)
Stroke	mm (in)	3.0 (0.118)

*: Measuring point

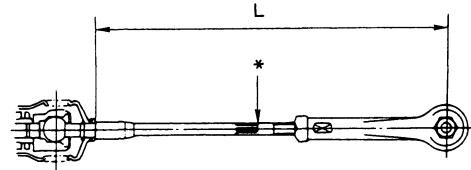

SST486B

SECTION BF**CONTENTS**

GENERAL SERVICING	
(Including all clips & fasteners)	BF- 2
BODY END	BF- 5
DOOR	
(Including "Power Window" & "Power Door Lock")	BF-10
INSTRUMENT PANEL	BF-16
INTERIOR AND EXTERIOR	
(In EXTERIOR, including "Weatherstrips")	BF-18
T-BAR ROOF	BF-30
SEAT	BF-32
WINDSHIELD AND WINDOWS	BF-35
AUTOMATIC SEAT BELT SYSTEM	BF-40
REAR AIR SPOILER	BF-45
MIRROR	BF-46
BODY ALIGNMENT	BF-48
SUPPLEMENTAL RESTRAINT SYSTEM (SRS)	BF-55
TROUBLE DIAGNOSES – Supplemental Restraint System (SRS)	BF-63

When you read wiring diagrams:

- Read GI section, "HOW TO READ WIRING DIAGRAMS".
- See EL section, "POWER SUPPLY ROUTING" for power distribution circuit.

BF

★ For conventional seat belt, refer to MA section.

Precautions

- When removing or installing various parts, place a cloth or padding onto the vehicle body to prevent scratches.
- Handle trim, molding, instruments, grille, etc. carefully during removing or installation. Be careful not to soil or damage them.
- Apply sealing compound where necessary when installing parts.
- When applying sealing compound, be careful that the sealing compound does not protrude from parts.
- When replacing any metal parts (for example body outer panel, members, etc.), be sure to take rust prevention measures.

Supplemental Restraint System "AIR BAG"

The Supplemental Restraint System "Air Bag" helps to reduce the risk or severity of injury to the driver in a frontal collision. The Supplemental Restraint System consists of an air bag (located in the center of the steering wheel), sensors, a control unit, warning lamp, wiring harness and spiral cable. Information necessary to service the system safely is included in the **BF** section of this Service Manual.

WARNING:

- To avoid rendering the SRS inoperative, which could lead to personal injury or death in the event of a severe frontal collision, all maintenance must be performed by an authorized NISSAN dealer.**
- Improper maintenance, including incorrect removal and installation of the SRS, can lead to personal injury caused by unintentional activation of the system.**
- All SRS electrical wiring harnesses and connectors are covered with yellow outer insulation. Do not use electrical test equipment on any circuit related to the SRS "Air Bag".**

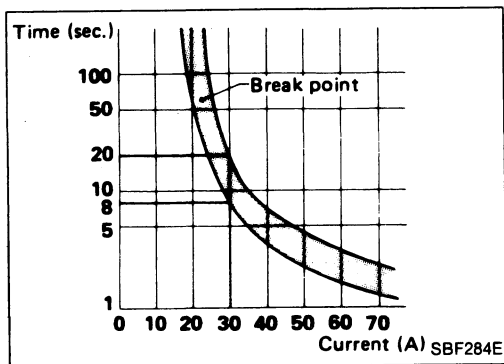

Circuit Breaker Inspection

For example, when current is 30A, the circuit is broken within 8 to 20 seconds.





Circuit breakers are used in the following systems.

- Power window & power door lock
- Power seat

GENERAL SERVICING



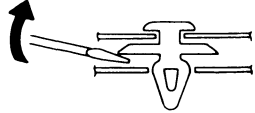
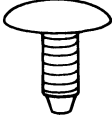
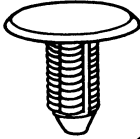
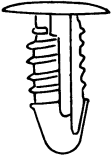
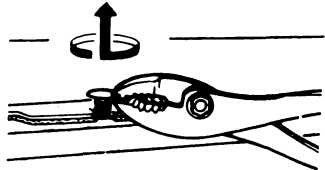
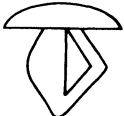
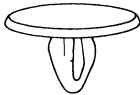
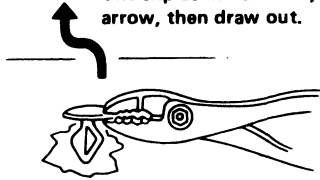
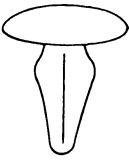
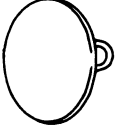
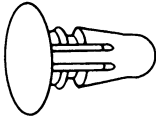

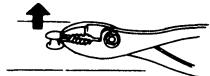
Clip and Fastener

- Clips and fasteners in BF section correspond to the following numbers and symbols.
- Replace any clips and/or fasteners which are damaged during removal or installation.

No.	Symbol	Shape	Removal & Installation
C101	 SBF092B	 SBF109B	Removal: Remove by bending up with a flat-bladed screwdriver.  SBF094B
C102	 SBF113B	 SBF114B  SBF137B	 Removal: Pull up while rotating. SBF115B
C105	 SBF141B	 SBF142B	Removal: Tilt clip as indicated by arrow, then draw out.  SBF143B
C106	 SBF089B	   SBF090B	Removal: Remove with flat-bladed screwdriver or pliers   SBF091B

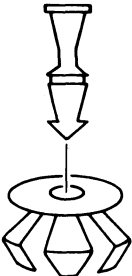
GENERAL SERVICING

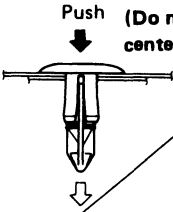
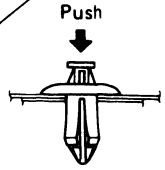
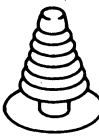
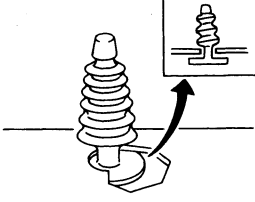
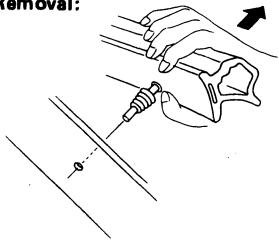
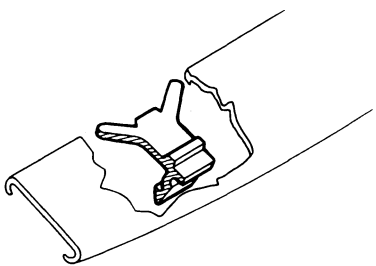
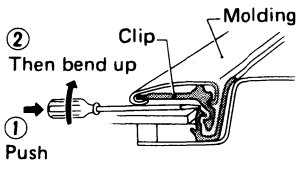
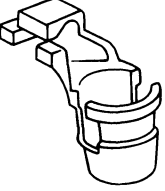
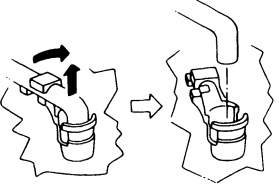
Clip and Fastener (Cont'd)

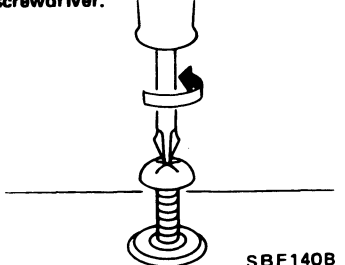
No.	Symbol	Shape	Removal & Installation
C203	 <p>SBF318C</p>	 <p>SBF319C</p>	<p>Removal:</p>  <p>Installation:</p>  <p>Push center pin to catching position. (Do not remove center pin by hitting it.)</p> <p>SBF708E</p>
CE103	 <p>SBF103B</p>	 <p>SBF104B</p>	<p>Removal:</p>  <p>SBF147B</p>
CE106	 <p>SBF653B</p>		<p>Removal:</p>  <p>SBF654B</p>
CR103	 <p>SBF768B</p>		<p>Removal: Holder portion of clip must be spread out to remove rod.</p>  <p>SBF770B</p>
CS102	 <p>SBF138B</p>	 <p>SBF139B</p>	<p>Removal: Screw out with a Phillips screwdriver.</p>  <p>SBF140B</p>

BODY END

Body Front End

- Hood adjustment: Adjust at hinge portion.
- Hood lock adjustment: After adjusting, check hood lock control operation. Apply a coat of grease to hood lock engaging mechanism.
- Hood opener: Do not attempt to bend cable forcibly.

Bumper shock absorber inspection

1. Check shock absorber for oil leakage, cracks or deformation.
2. Function of shock absorber;
 - (1) Place vehicle in front of a wall.
Apply parking brake and place tire stoppers securely.
 - (2) Place a jack between bumper and wall; jack is positioned squarely with bumper, directly in line with shock absorber to be checked.
 - (3) Apply pressure to compress shock absorber at least 10.0 mm (0.394 in).

Use a jack with capacity of more than 600 kg (1,323 lb).

- (4) Make sure bumper returns to its original position when jack is retracted. Replace if necessary.

CAUTION:

It is not recommended to confirm proper installation by driving into walls or other barriers as this could cause personal injury or damage to the vehicle.

When replacing shock absorbers, make sure they are of the same type and rating, and manufactured by the same maker.

BODY END

Body Front End (Cont'd)

Hood lock adjustment

- Adjust lock so that hood primary lock meshes at a position where hood is 1 to 1.5 mm (0.039 to 0.059 in) lower than fender.
- After hood lock adjustment, adjust bumper rubber.
- When securing hood lock, ensure it does not tilt. Striker must be positioned at the center of hood primary lock.
- After adjustment, ensure that hood primary and secondary lock operate properly.

Hood lock secondary latch hooking length

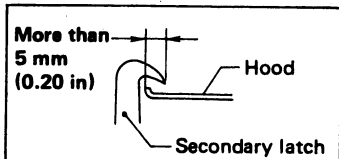

Hood adjustment **A**

Bumper rubber adjustment

- Adjust so that hood is aligned with fender. [Bumper rubber free height is approx. 15 mm (0.59 in).]

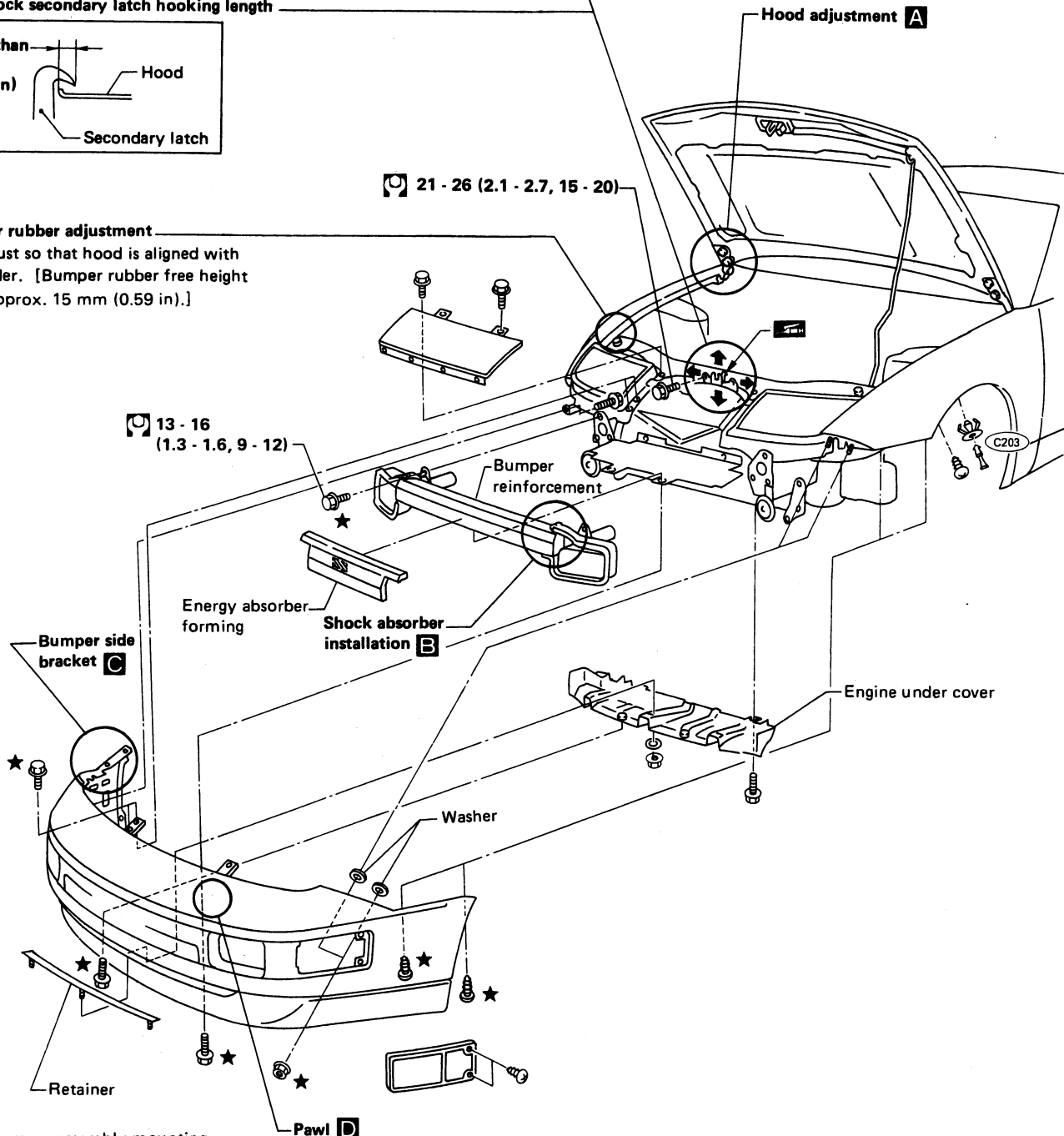

★ : Bumper assembly mounting bolts, nuts and screws

C : N-m (kg-m, ft-lb)

 : Double-faced adhesive tape

BODY END

Body Front End (Cont'd)

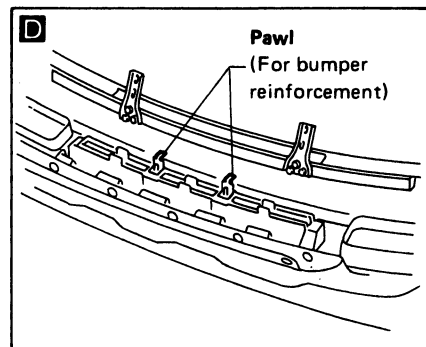
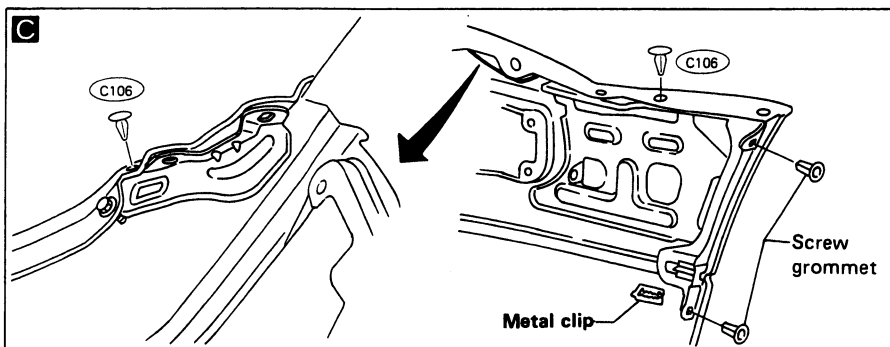
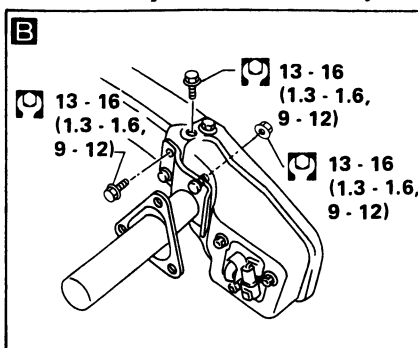
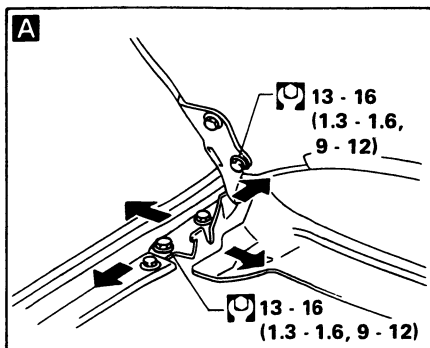

SBF856E

Service Notice

- Be sure to enlarge hood hinge holes (hinge to hood side) less than 10 mm (0.39 in) dia. for easy hood adjustment at hood-hinge portion.
- Be sure to take rust prevention measures after enlargement of holes.

BODY END

Body Rear End and Opener

- Back door adjustment: Adjust at hinge-body portion for proper back door fit.
- Back door lock system adjustment: Adjust lock & striker so that they are in the center. After adjustment, check back door lock operation.

WARNING:

- a. Be careful not to scratch back door stay when installing back door. A scratched stay may cause gas leakage.
 - b. The contents of the back door are under pressure. Do not take apart, puncture, apply heat or allow fire near it.
- Opener cable: do not attempt to bend cable using excessive force.
 - After installation, make sure that trunk lid/back door and fuel filler lid open smoothly.
 - Remove washer tank (located at left of luggage compartment) before removing or installing bumper.

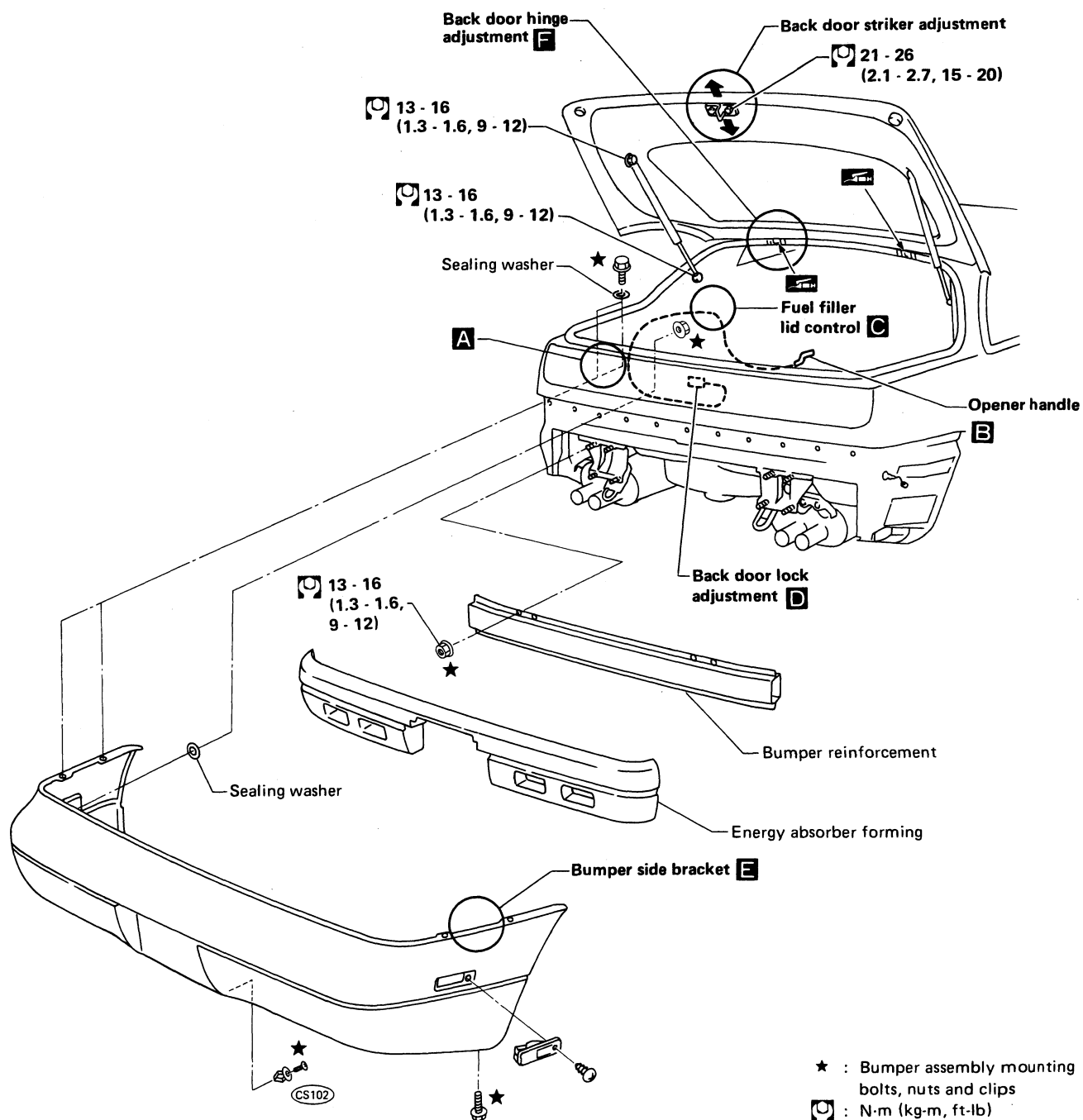

BODY END

Body Rear End and Opener (Cont'd)

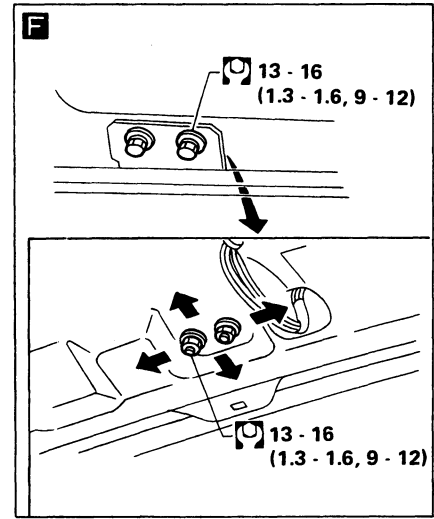
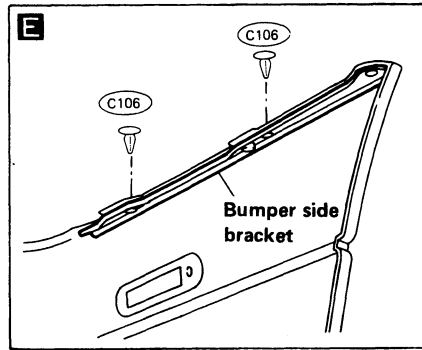
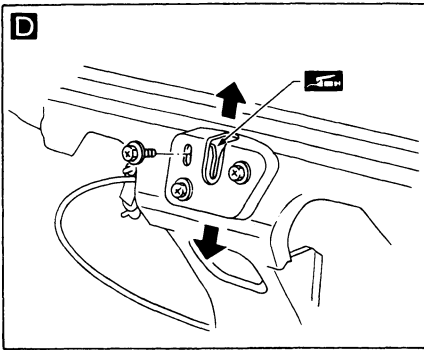
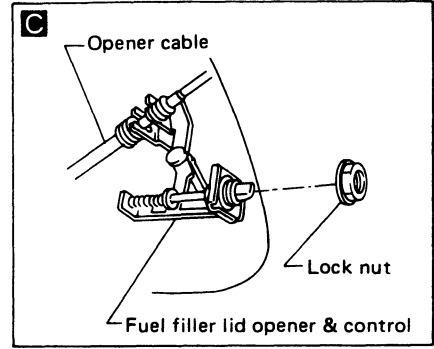
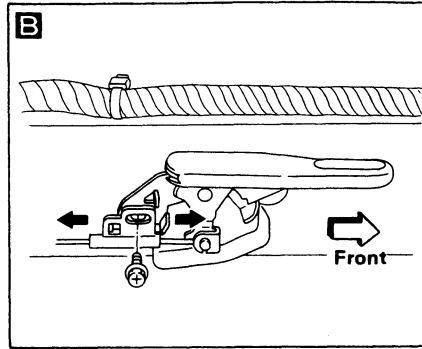
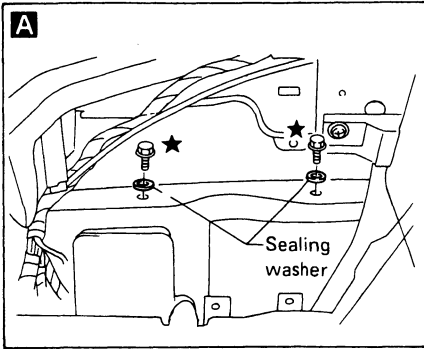

DOOR

- After adjusting door or door lock, check door lock operation.

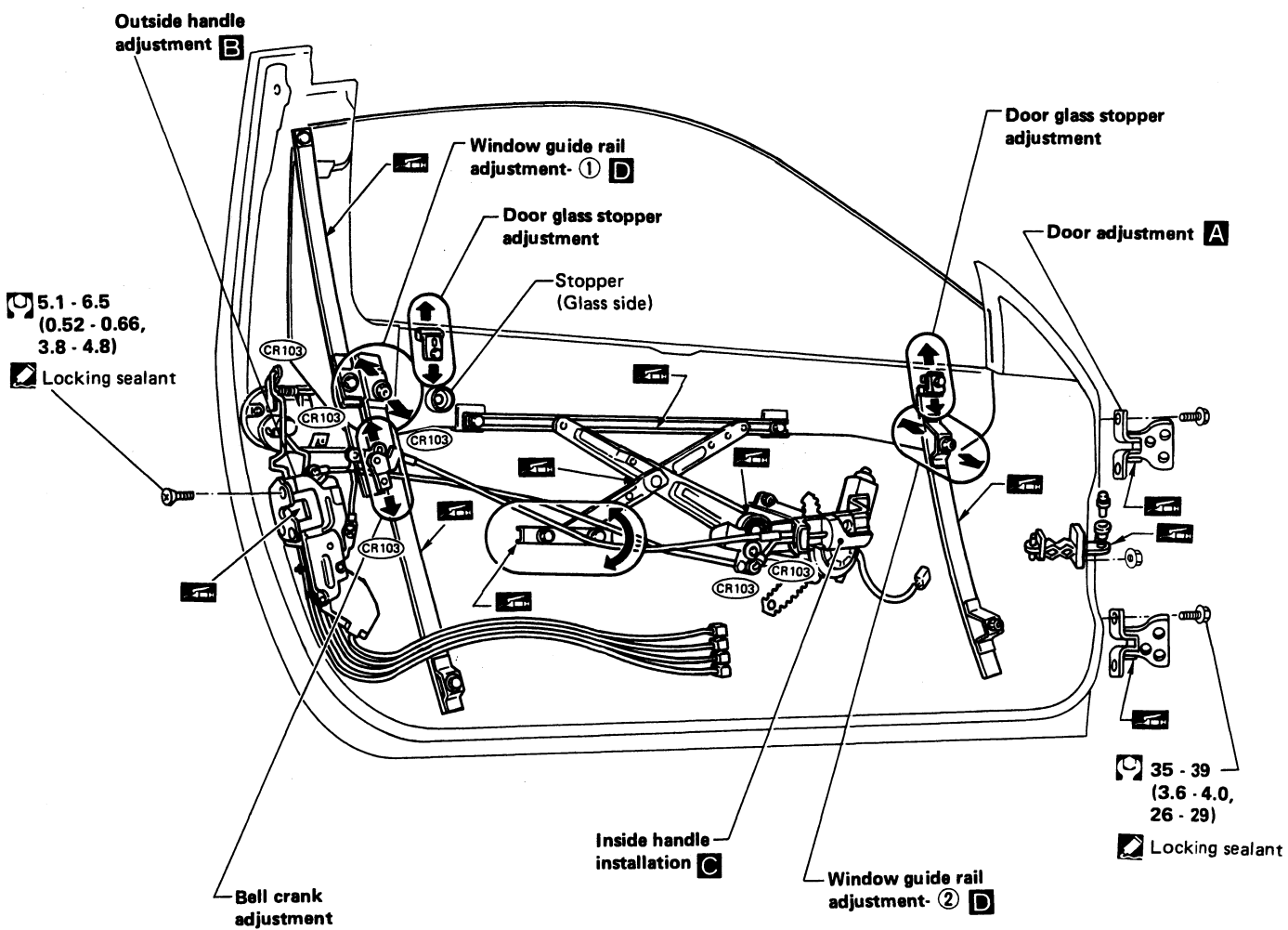

: N·m (kg-m, ft-lb)

DOOR

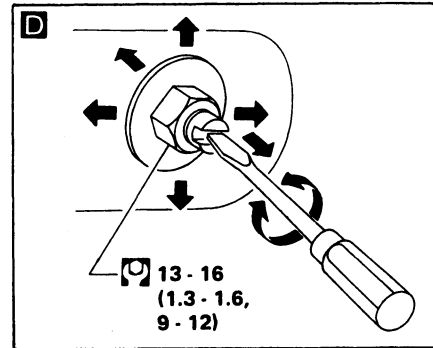
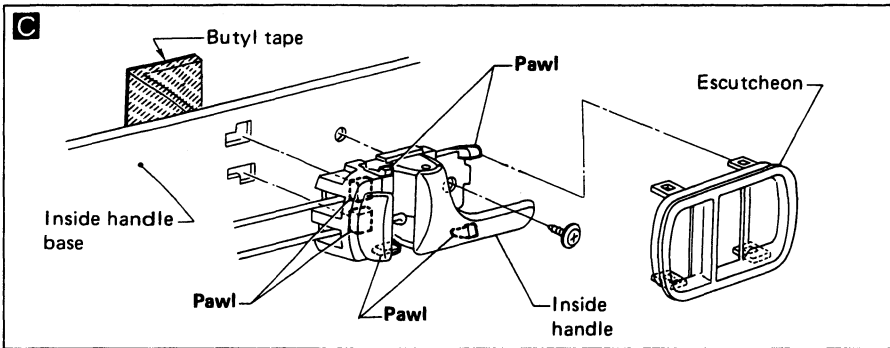
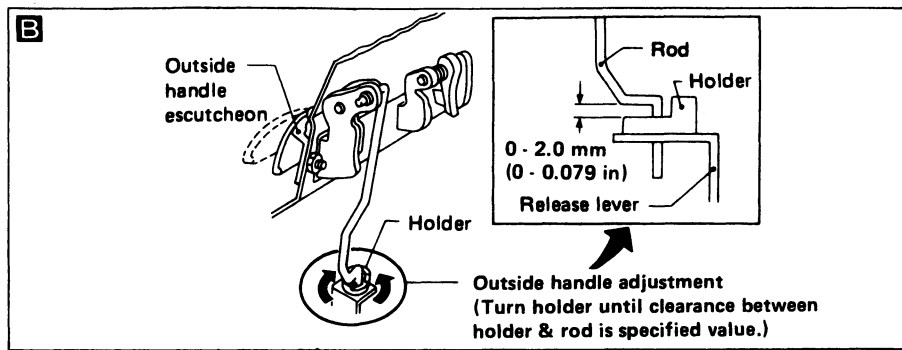
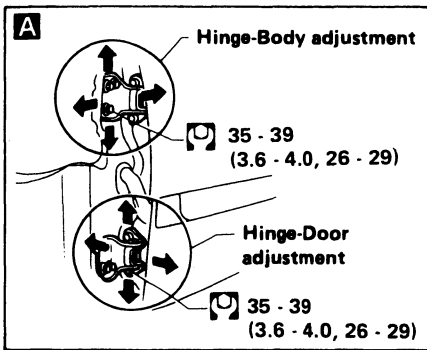

Striker adjustment

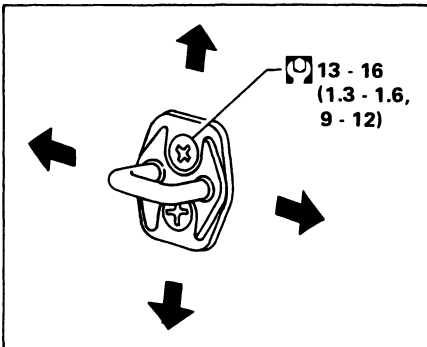

DOOR

Power Window

WIRING DIAGRAM

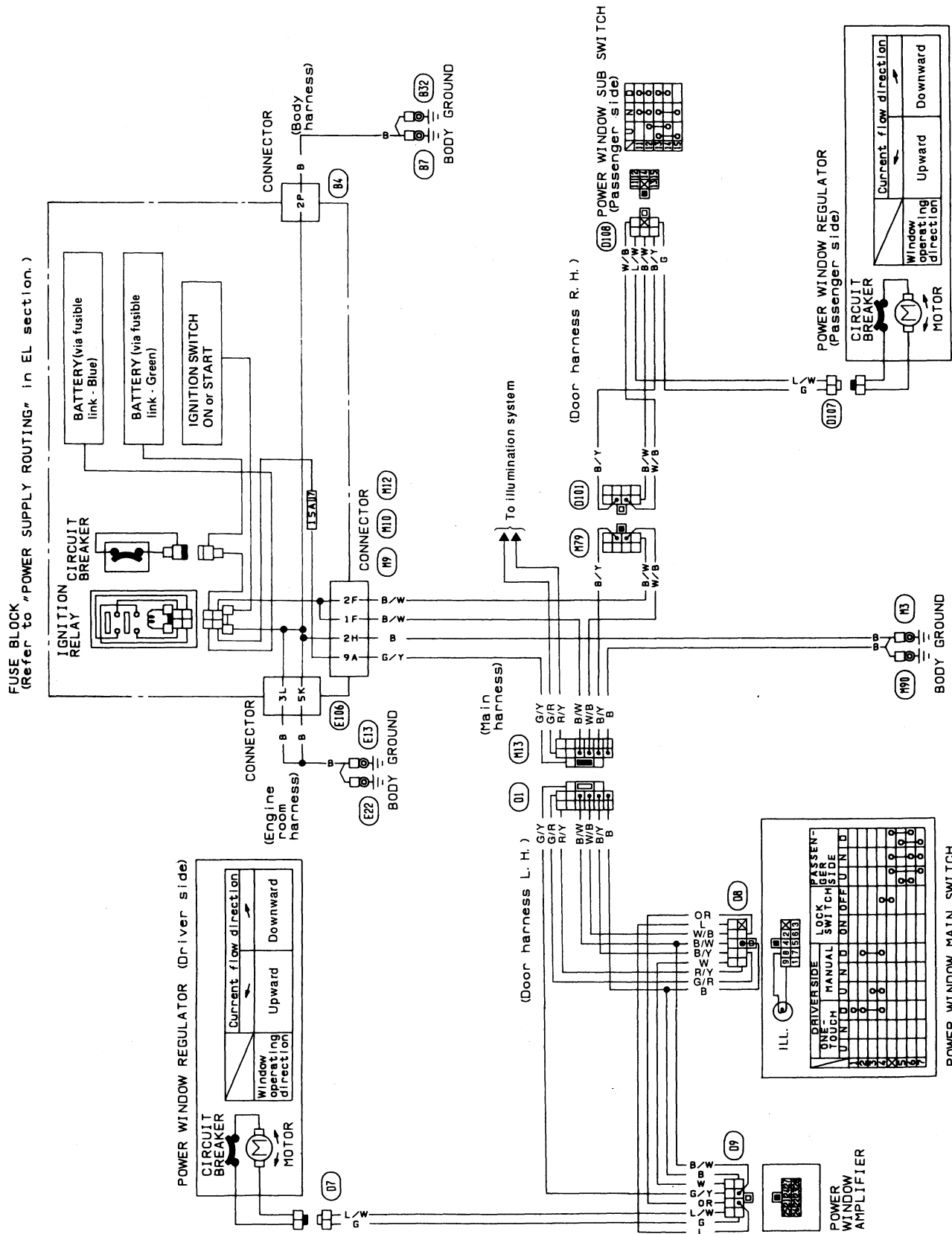

DOOR

Power Window (Cont'd)

POWER WINDOW AMP. INSPECTION

FRONT DRIVER SIDE POWER WINDOW SWITCH

	FR Drive side						Connections
	One-touch (Auto)			Manual			
	U	N	D	U	N	D	
1							From power window AMP (28)
2				○			From power window AMP (22)
3					○		From power window AMP (21)
4				○	○		Ground

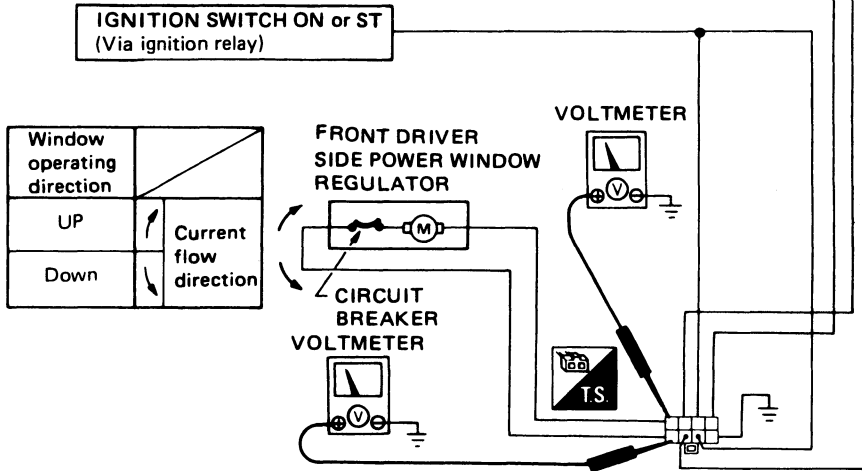

Window operating direction	Current flow direction
UP	↗
Down	↘

AMP. OPERATION

	Connections	Operations					
		Manual operation			One-touch (Auto) Operation		
		12V	12V	12V	12V	12V	12V
24	Power source (IGN)	12V	12V	12V	12V	12V	12V
27	Ground	Ground	Ground	Ground	Ground	Ground	Ground
23	From ignition SW (ON or ST)	ON or ST	ON or ST	ON or ST	ON or ST	ON or ST	ON or ST
28	To FR driver side power window SW (AUTO) (1)	OFF	OFF	OFF	OFF	ON	OFF
	To FR driver side power window SW (UP) (3)	OFF	ON	OFF	OFF	OFF	OFF
	To FR driver side power window SW (DOWN) (2)	OFF	OFF	ON	OFF	ON	OFF
25	FR driver side regulator ("Up" power source)	Approx. 0V	Approx. over 9V	Approx. 0V	Approx. 0V	Approx. 0V	Approx. 0V
	FR driver side regulator ("Down" power source)	Approx. 0V	Approx. 0V	Approx. over 9V	Approx. 0V	Approx. over 9V	Approx. over 9V

Regulator Operating Condition	Stop	Upward operation	Downward operation	Stop	Keeps operating until fully open, then stops automatically.	
					Starting	Downward operation

Carry out this operation check in this chart from left to right

POWER WINDOW AMP. – Front driver side door (Behind door trim)

SBF219F

DOOR

Power Door Lock

WIRING DIAGRAM

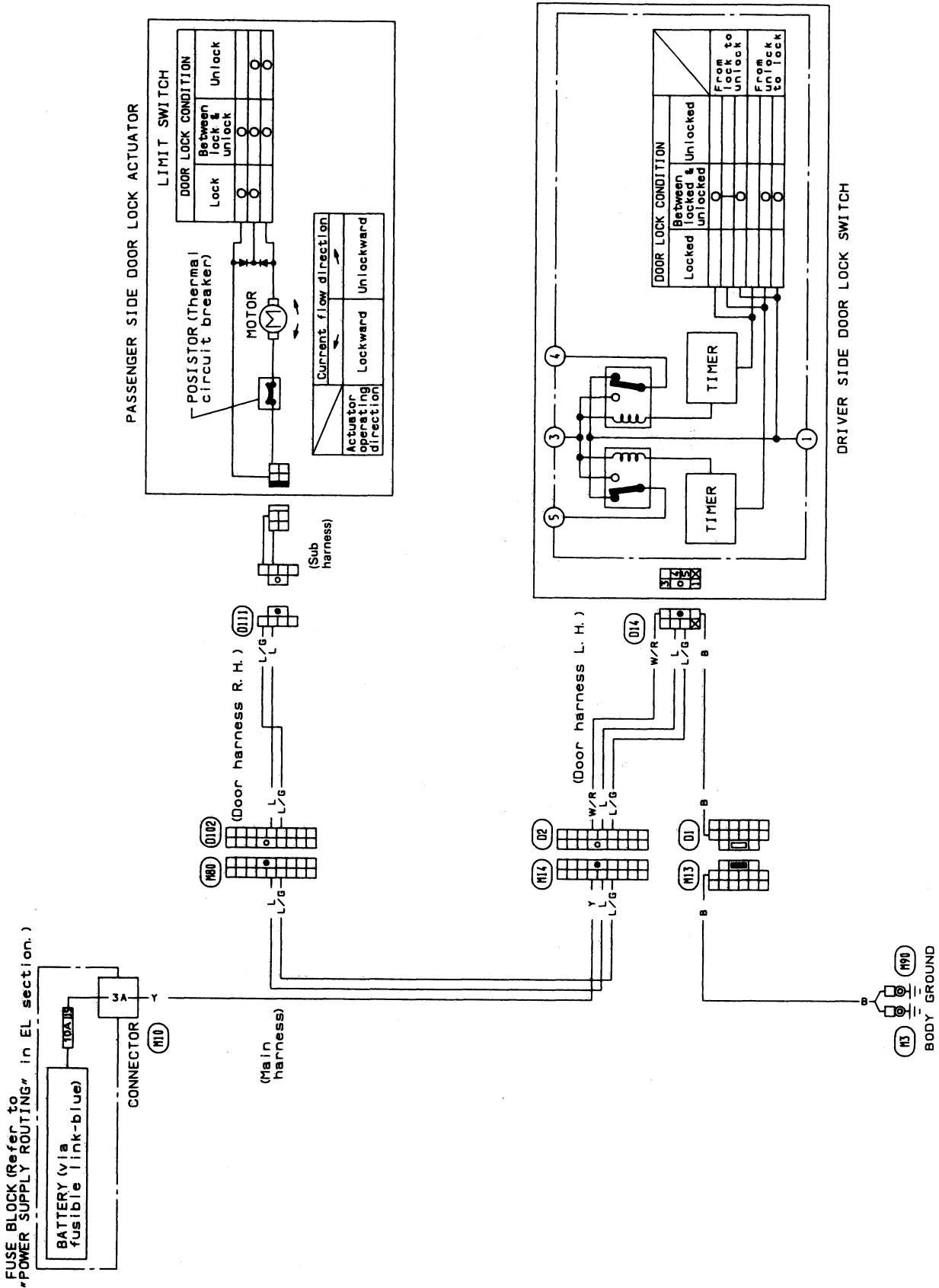



DOOR

NOTE

INSTRUMENT PANEL

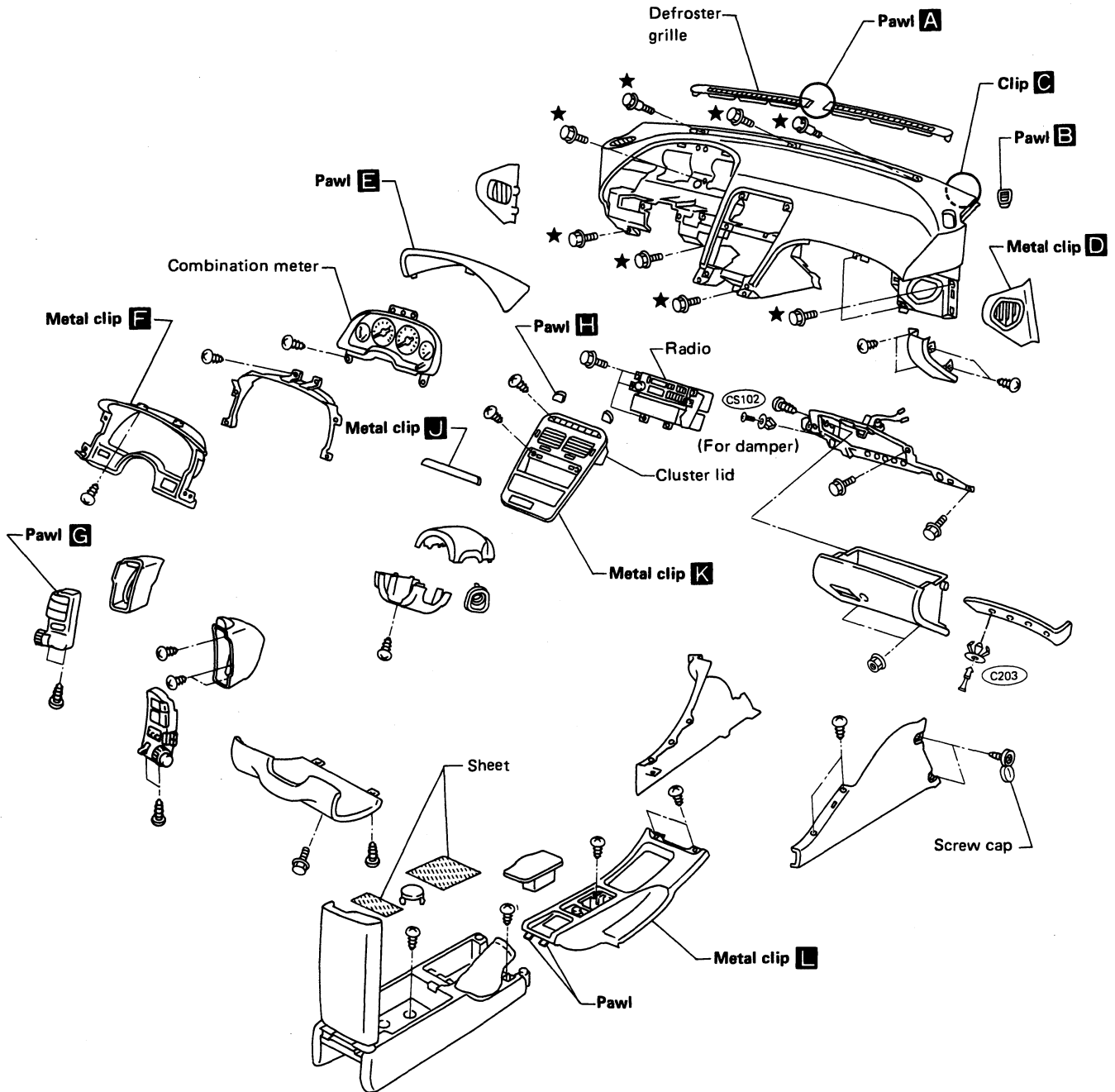
- When removing instrument panel assembly, remove defroster grille, combination meter, cluster lid and radio first.



 : Double-faced adhesive tape

INSTRUMENT PANEL

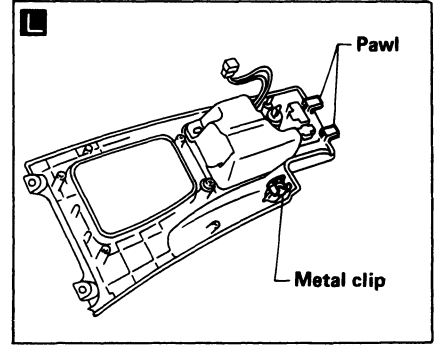
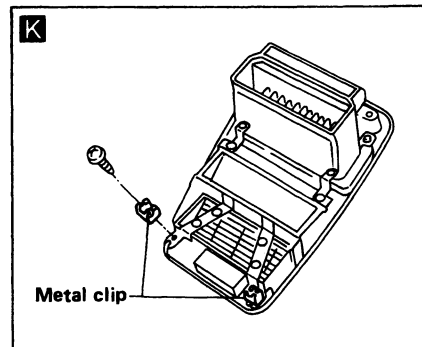
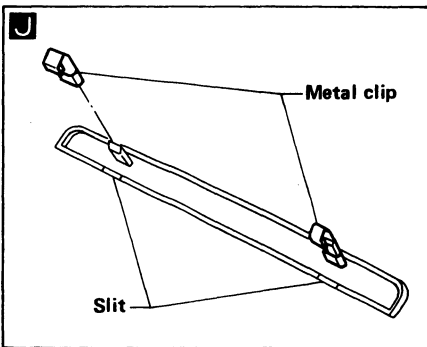
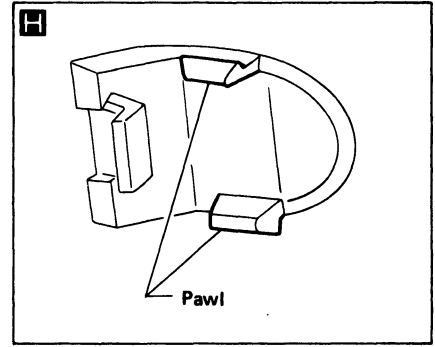
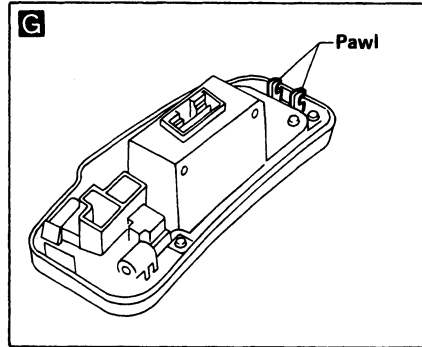
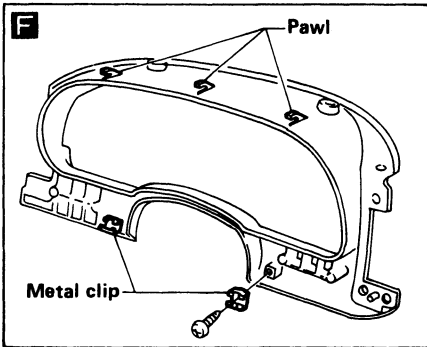
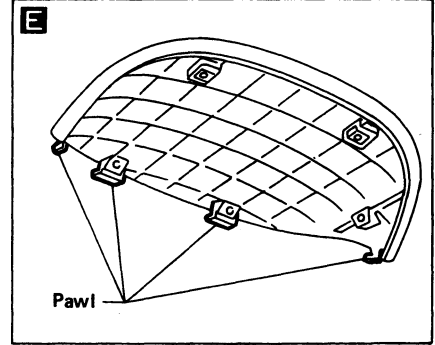
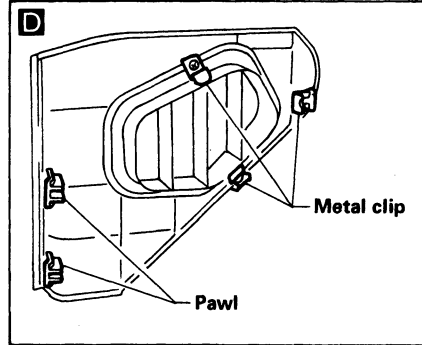
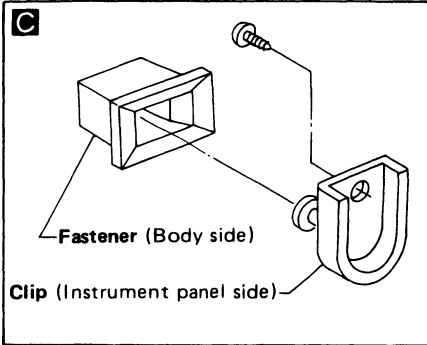
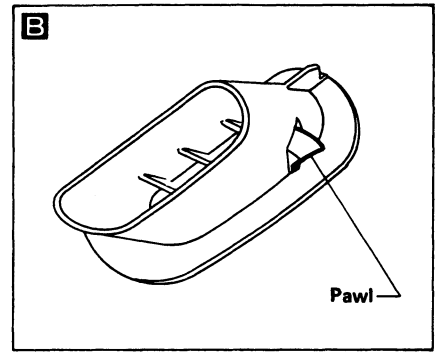
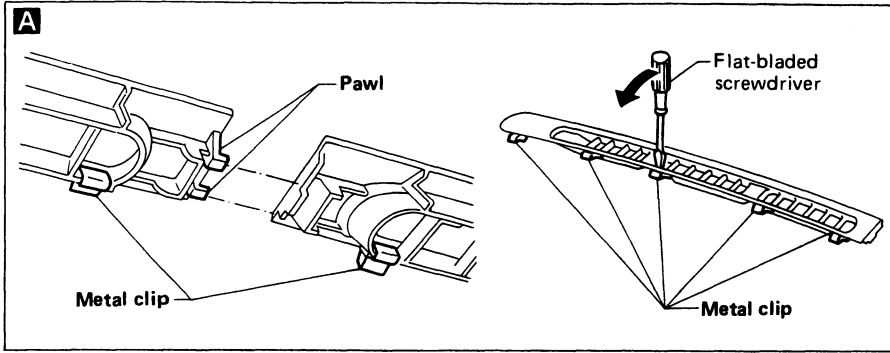

INTERIOR AND EXTERIOR

Interior

SIDE, LUGGAGE AND FLOOR TRIM

2 seater model

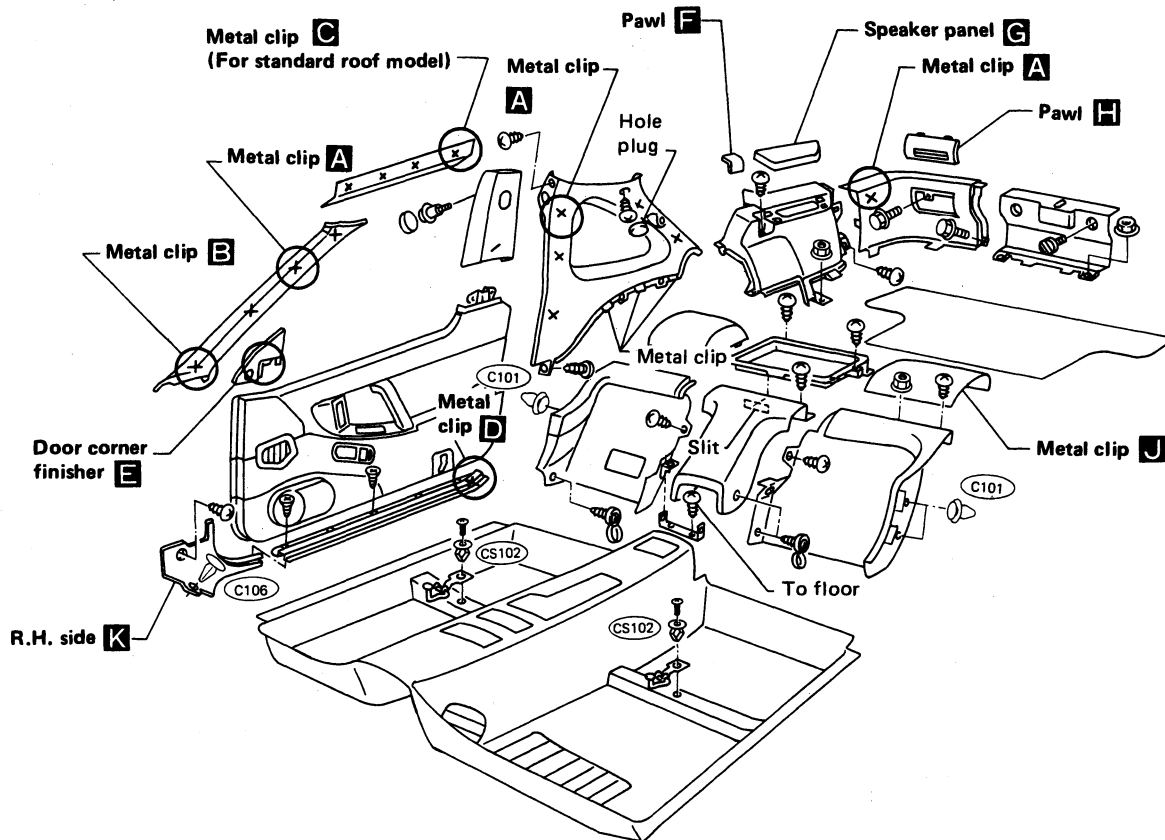

2+2 seater model

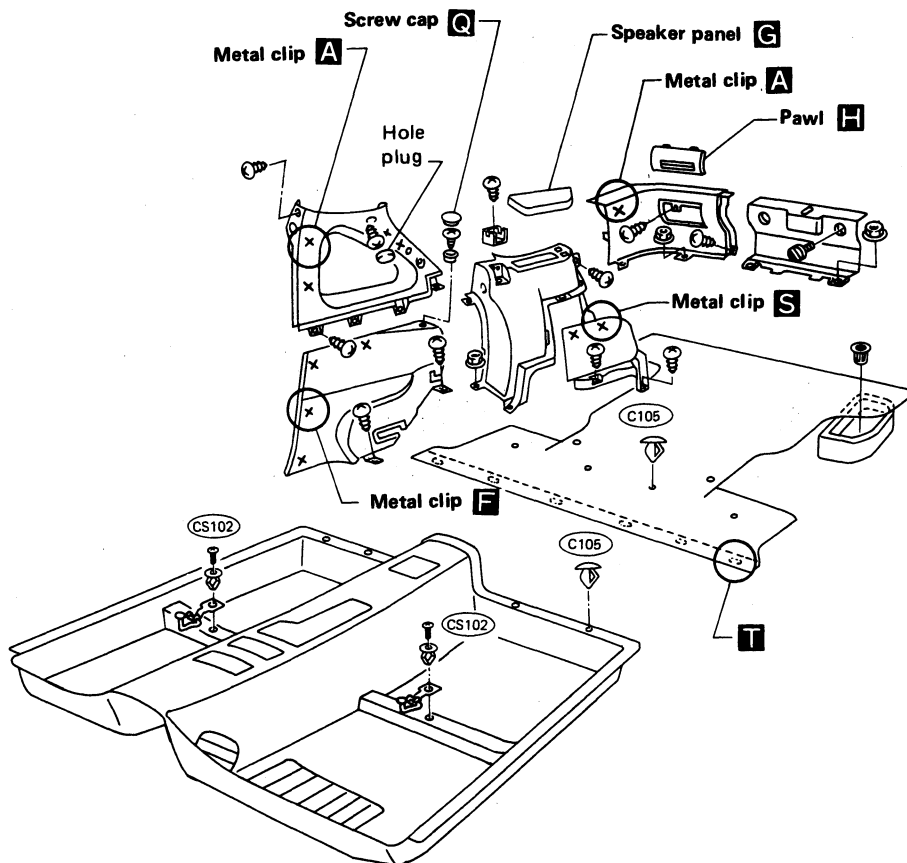

INTERIOR AND EXTERIOR

Interior (Cont'd)

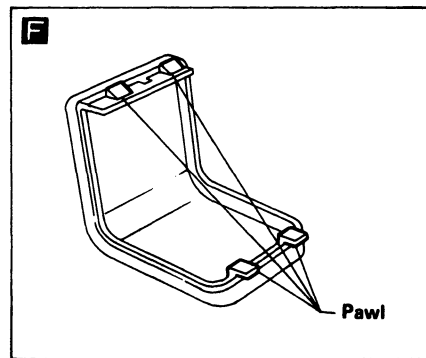
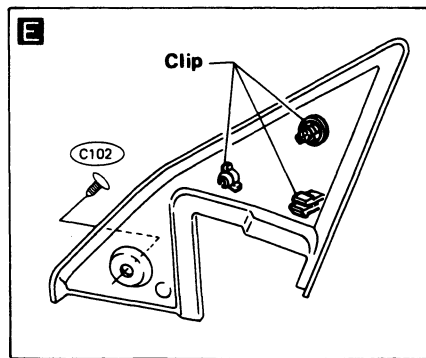
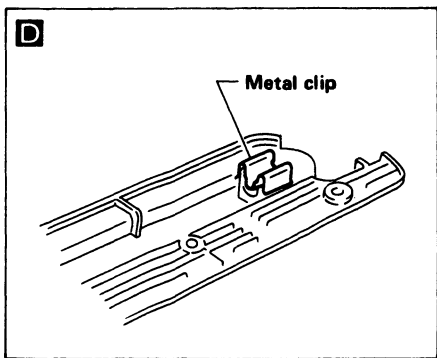
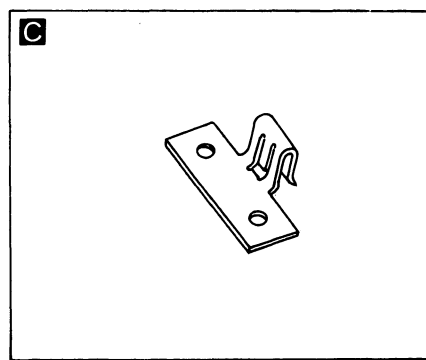
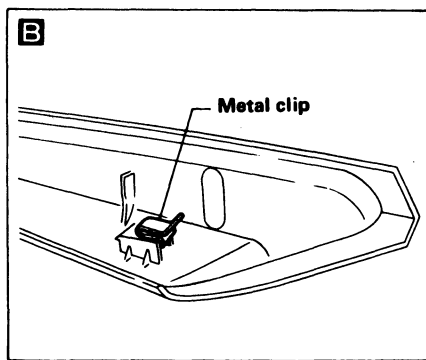
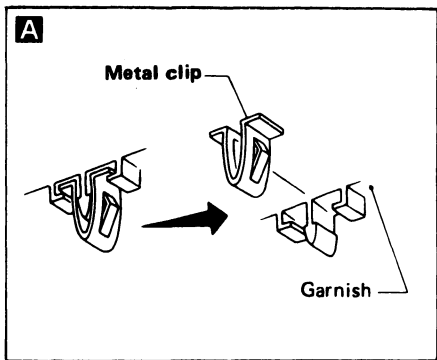
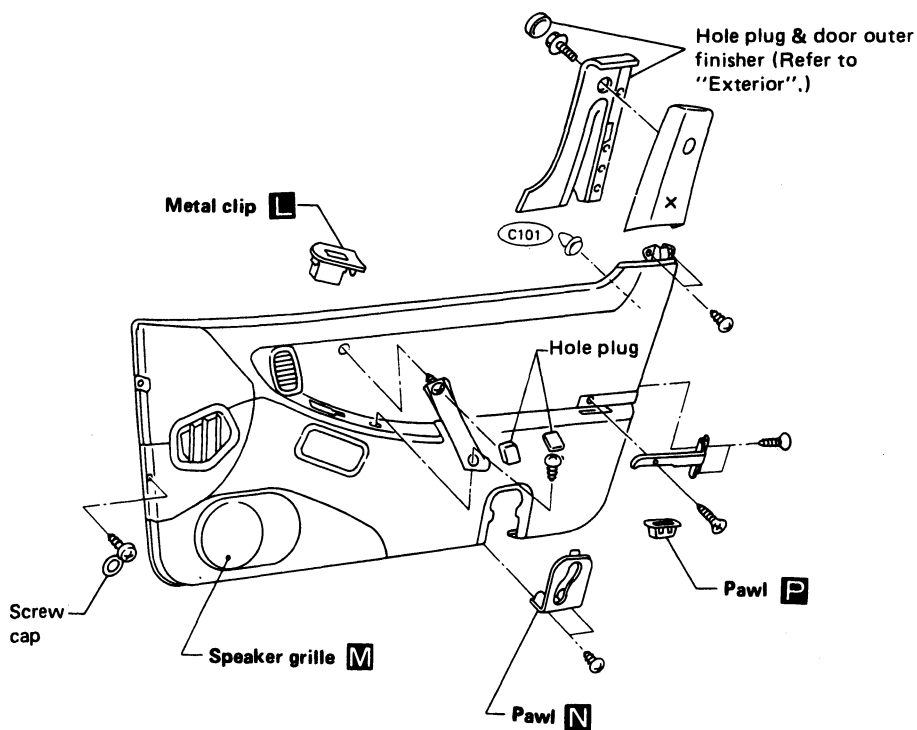

INTERIOR AND EXTERIOR

Interior (Cont'd)

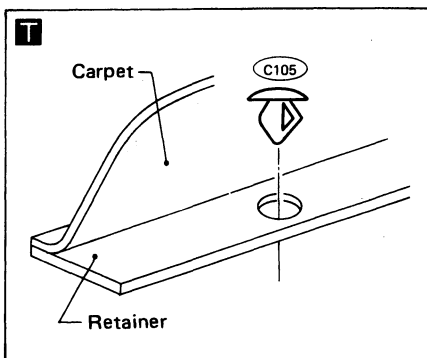
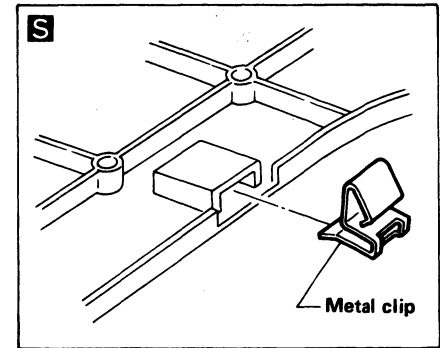
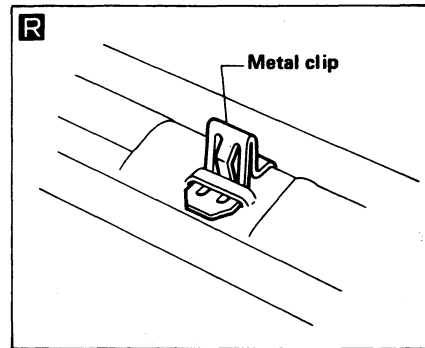
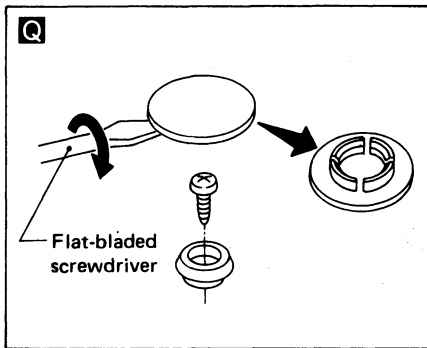
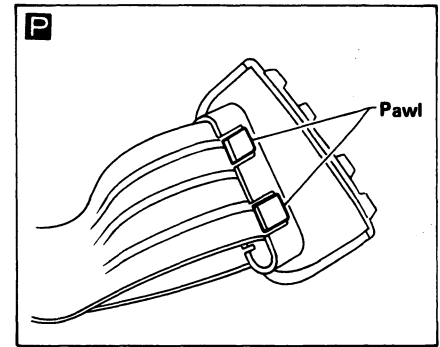
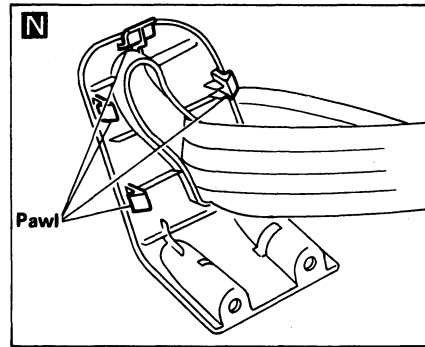
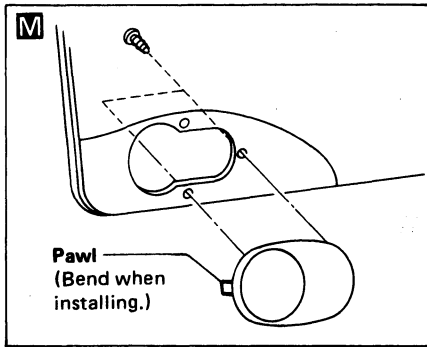
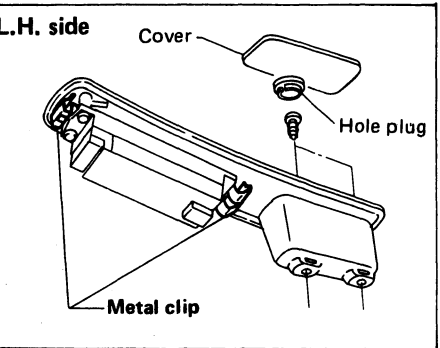
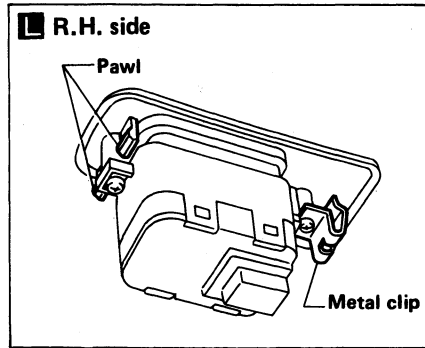
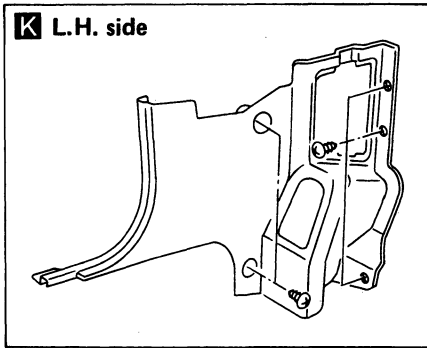
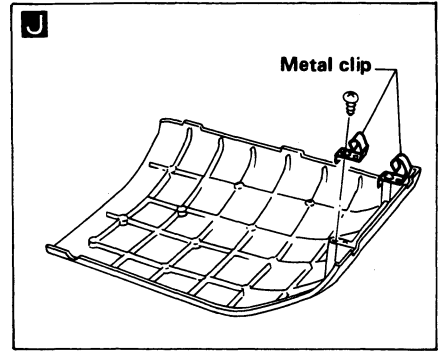
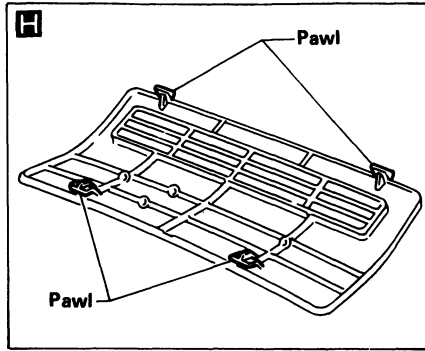
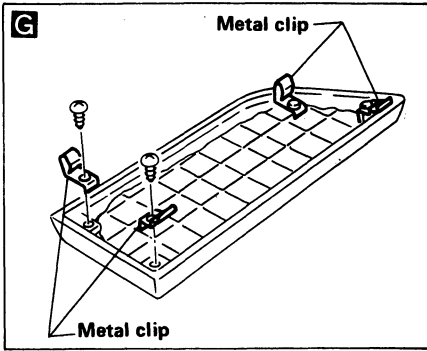

INTERIOR AND EXTERIOR

NOTE

INTERIOR AND EXTERIOR

Interior (Cont'd)

BACK DOOR TRIM

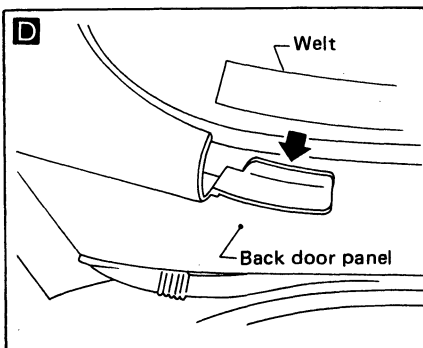
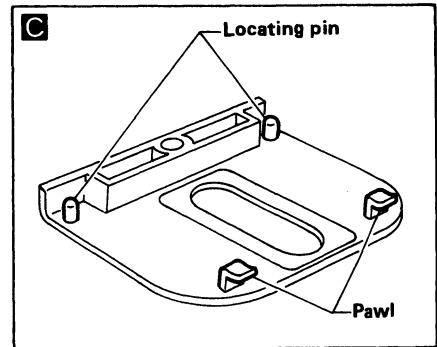
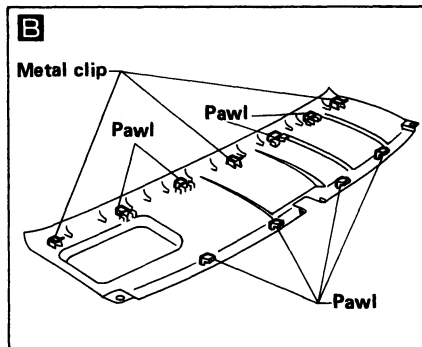
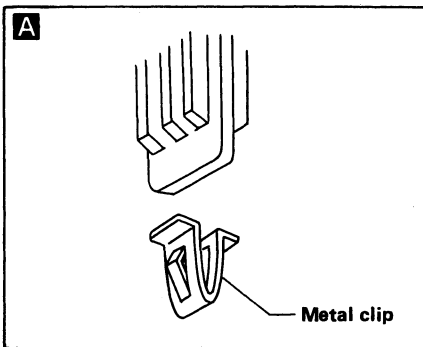
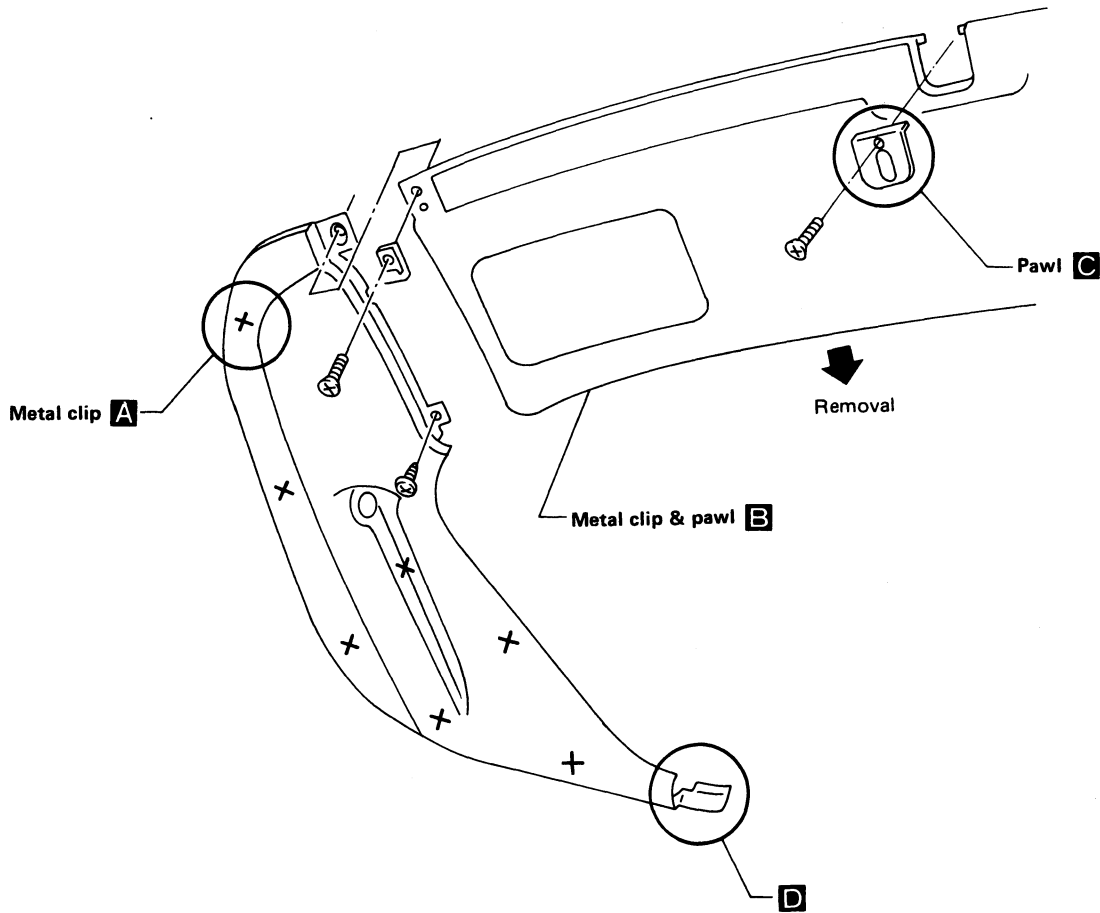

INTERIOR AND EXTERIOR

Interior (Cont'd)

ROOF TRIM

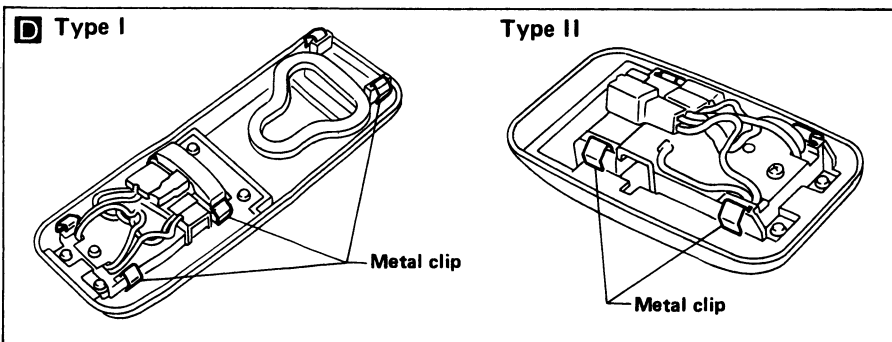
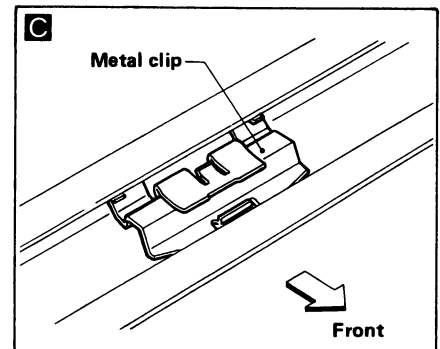
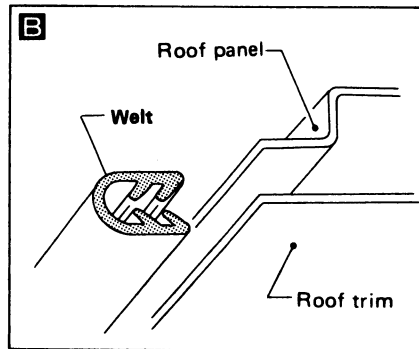
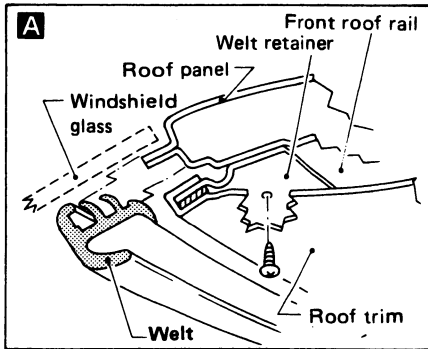
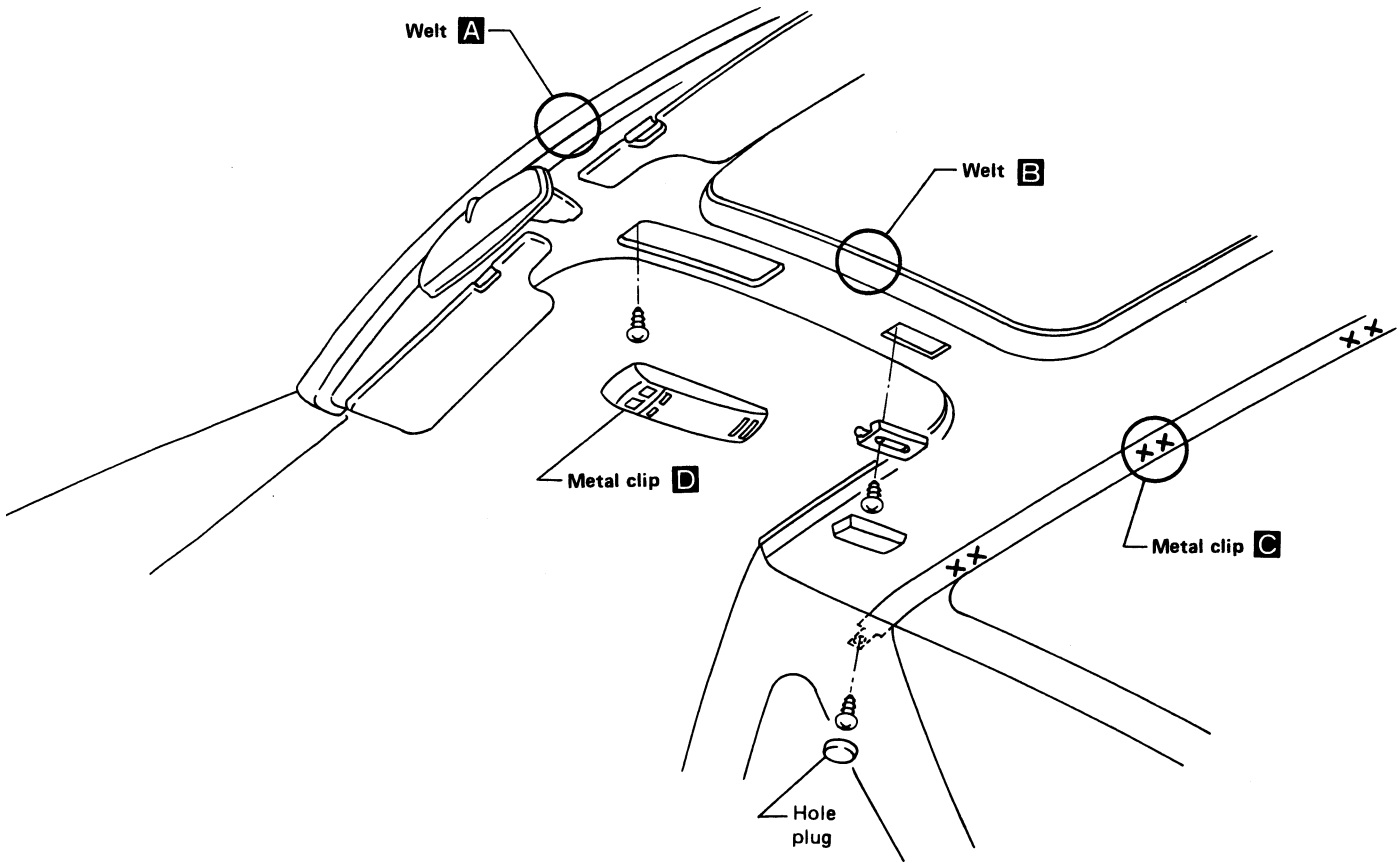

INTERIOR AND EXTERIOR

Exterior

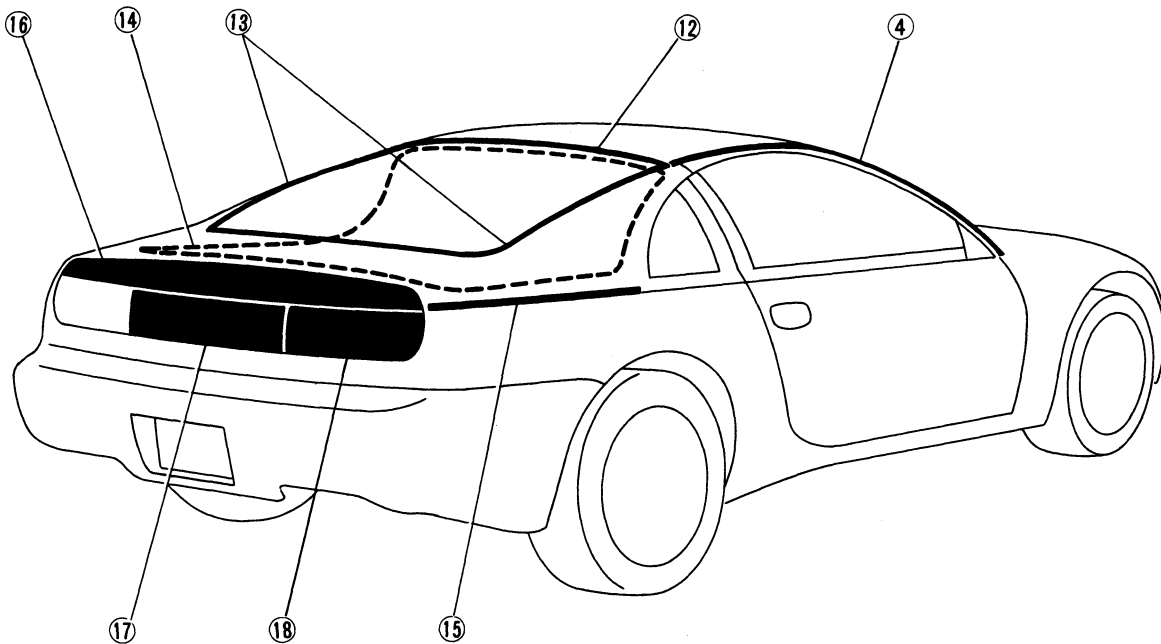
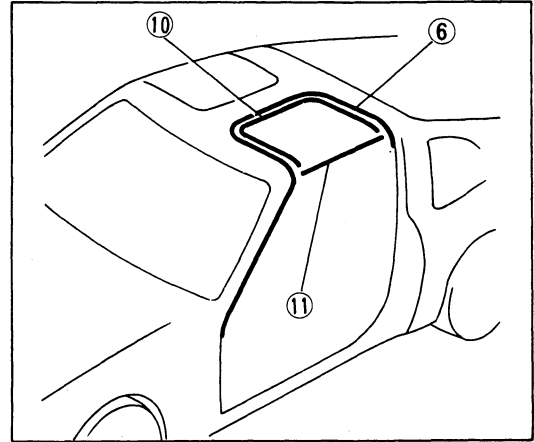
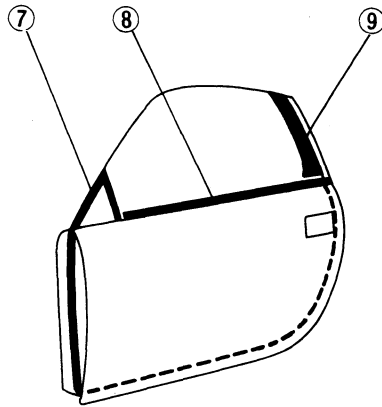
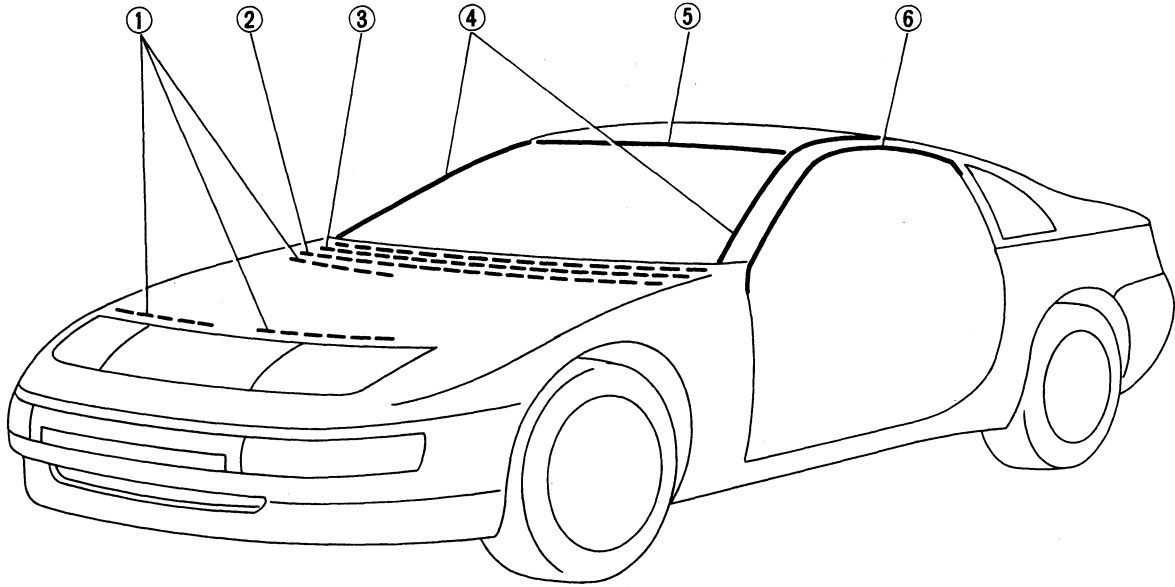

INTERIOR AND EXTERIOR

Exterior (Cont'd)

① Hood front and rear seal

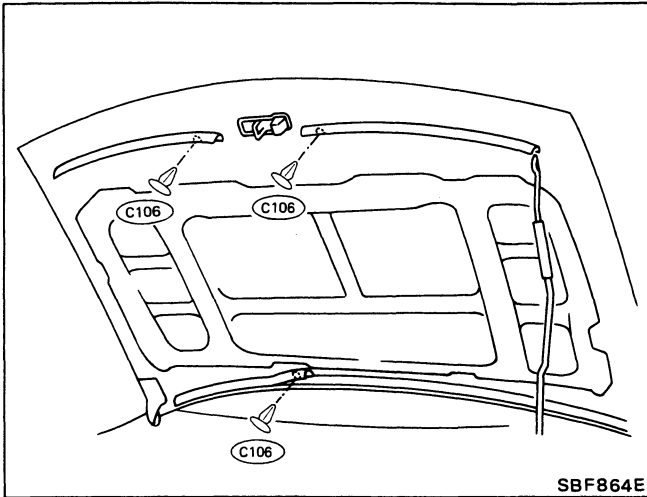

② ③ Cowl top seal and cowl top grille

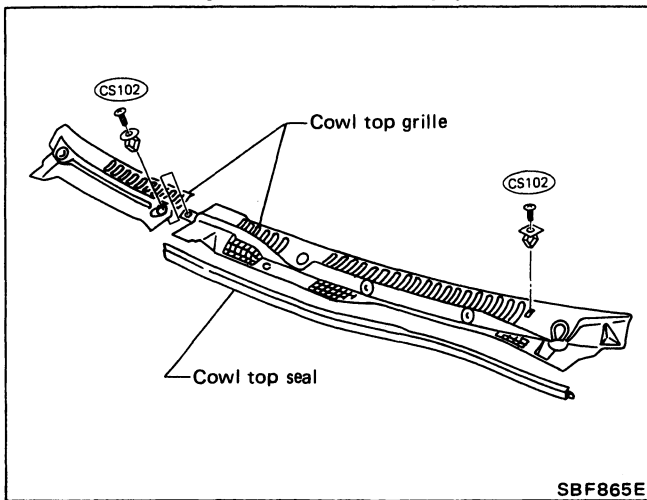

④ Windshield side molding

Standard roof model

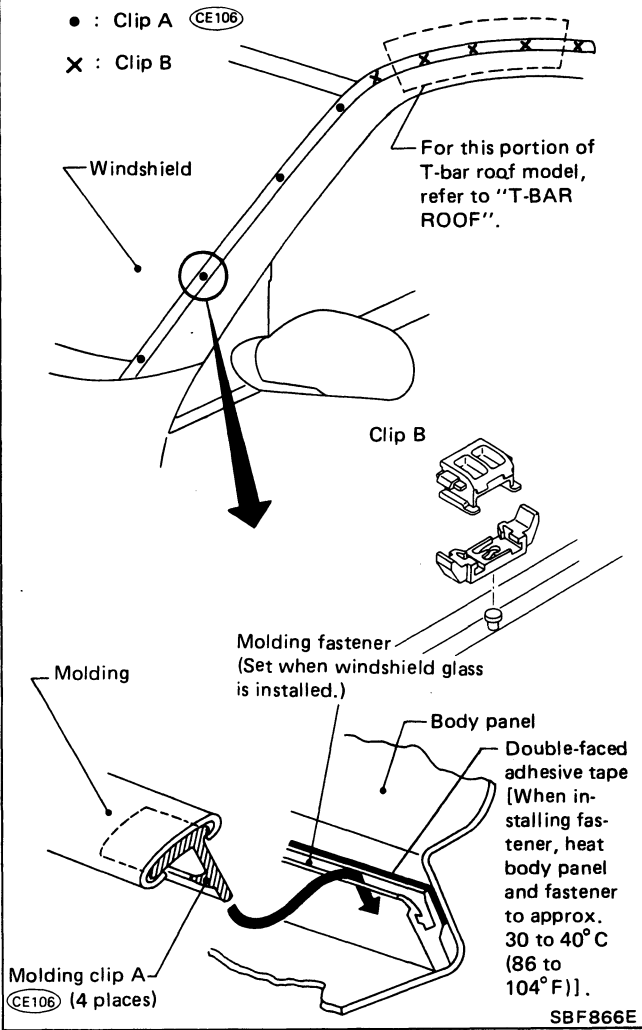

⑤ Windshield upper molding

Method 1

Cut off top portion of molding and clean glass and panel surfaces.

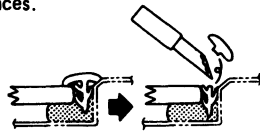

Apply sealant to top portion of molding.



Cut off lower portion of new molding



Finish well to give it a good appearance.

Method 2

1. Cut off sealant at glass end.
2. Clean the side on which panel was mounted.
3. Set molding fastener and apply sealant & primer to body panel, and apply primer to molding.

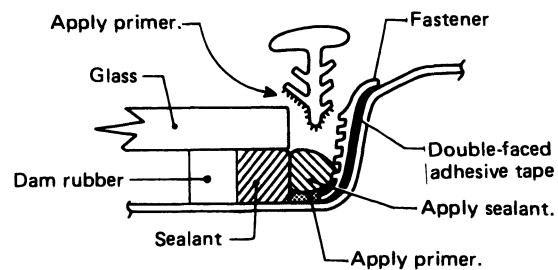

4. Install molding by aligning the molding mark located on center with vehicle center. Be sure to install tightly so that there is no gap around the corner.

SBF301C

INTERIOR AND EXTERIOR

Exterior (Cont'd)

⑥ Body side weatherstrip

T-bar roof model

Basically the same as the standard roof model

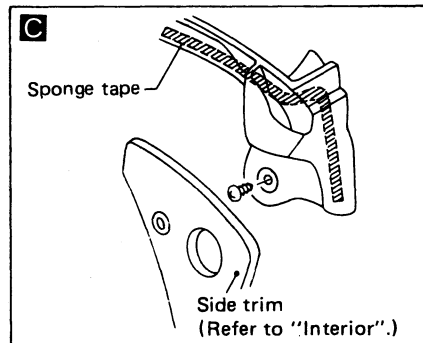
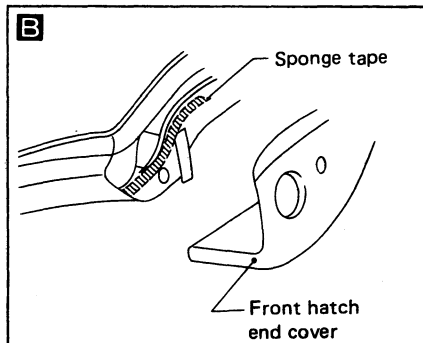
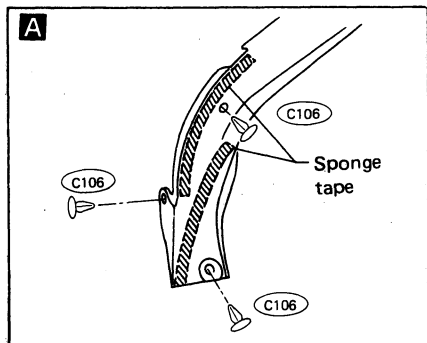
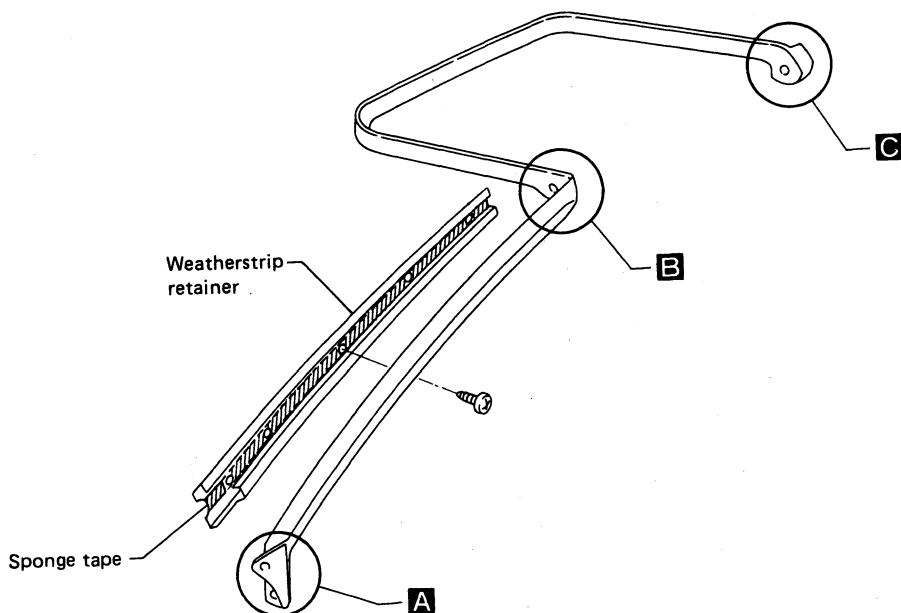

SBF868E

⑦ Door weatherstrip

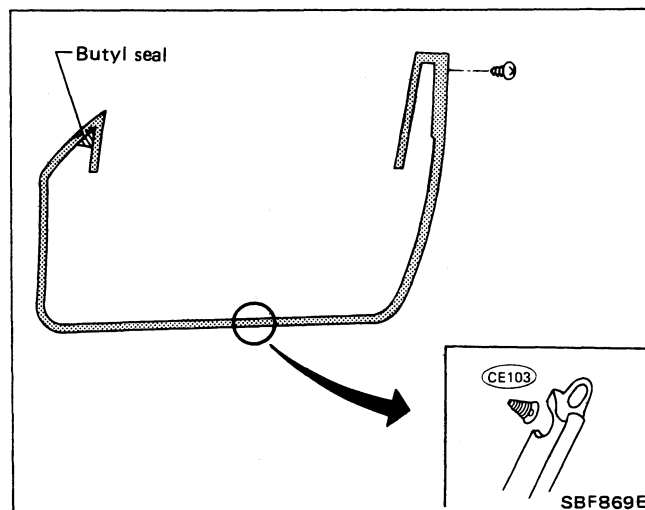

SBF869E

INTERIOR AND EXTERIOR

Exterior (Cont'd)

⑧ Door out side molding

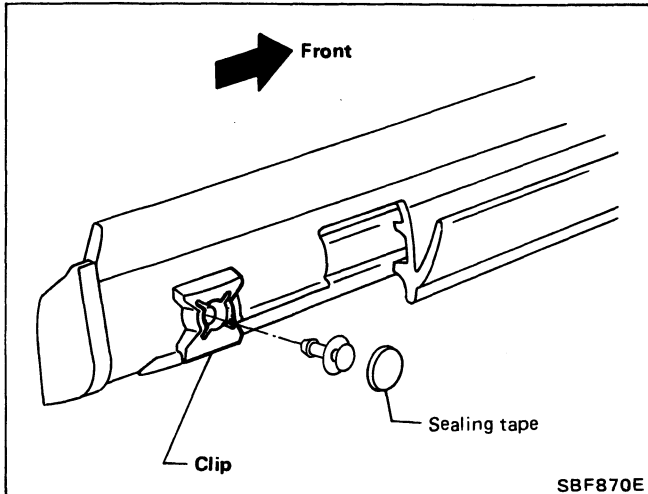

⑪ T-bar roof side weatherstrip

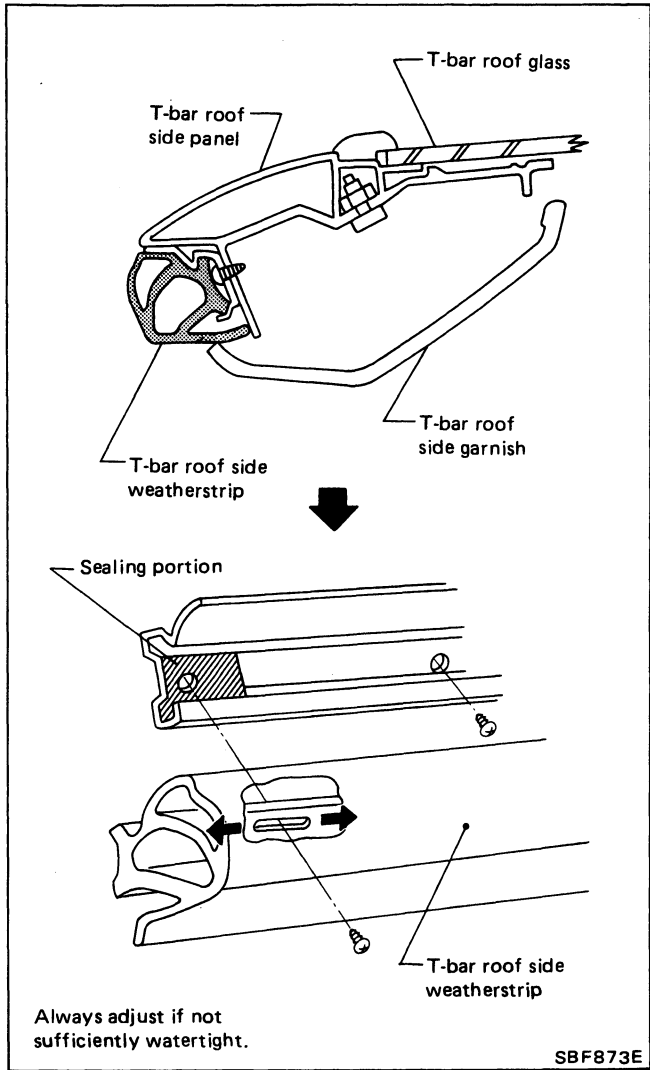

⑨ Door outer finisher

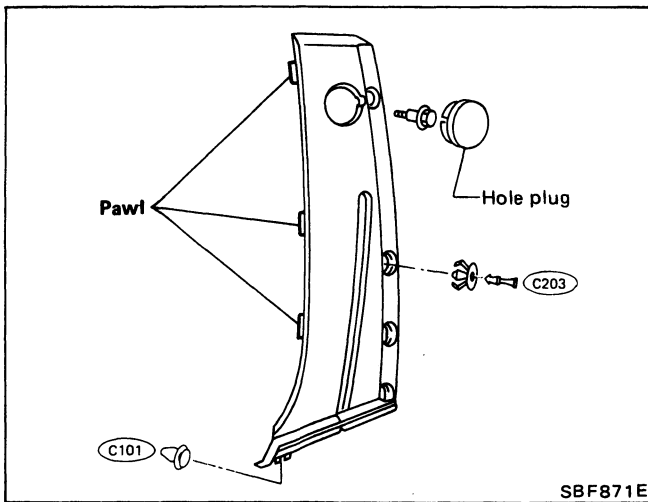

⑩ T-bar roof sash and T-bar roof weatherstrip

These are part of the T-bar roof glass and cannot be removed. (Refer to T-BAR ROOF.)

If they are damaged, replace entire T-bar roof glass assembly.

⑫ Back door glass upper molding

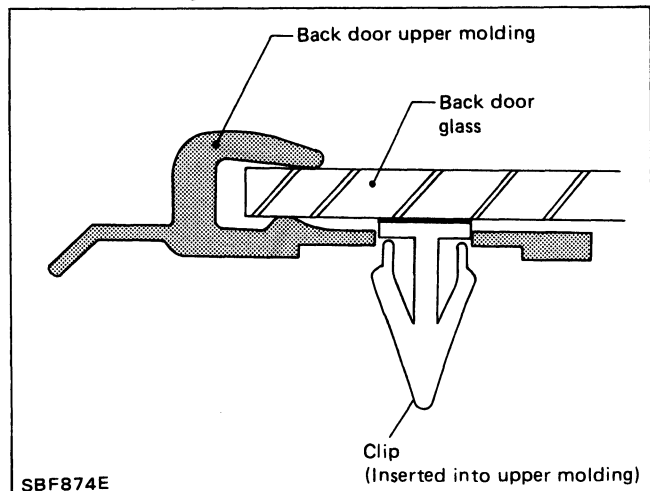

INTERIOR AND EXTERIOR

Exterior (Cont'd)

13 Back door glass side molding

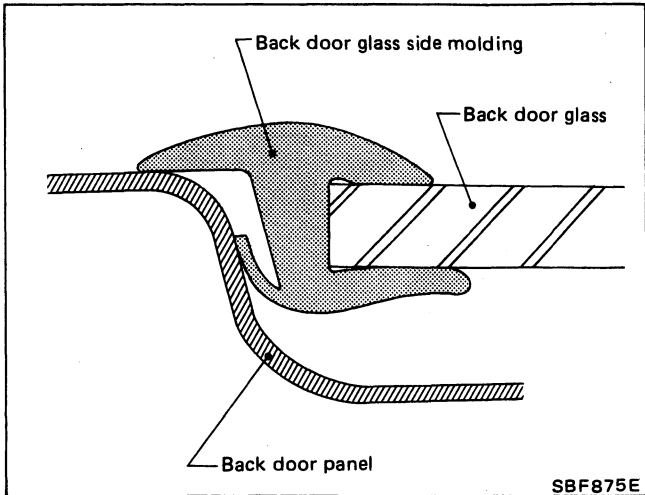

16 Back door finisher

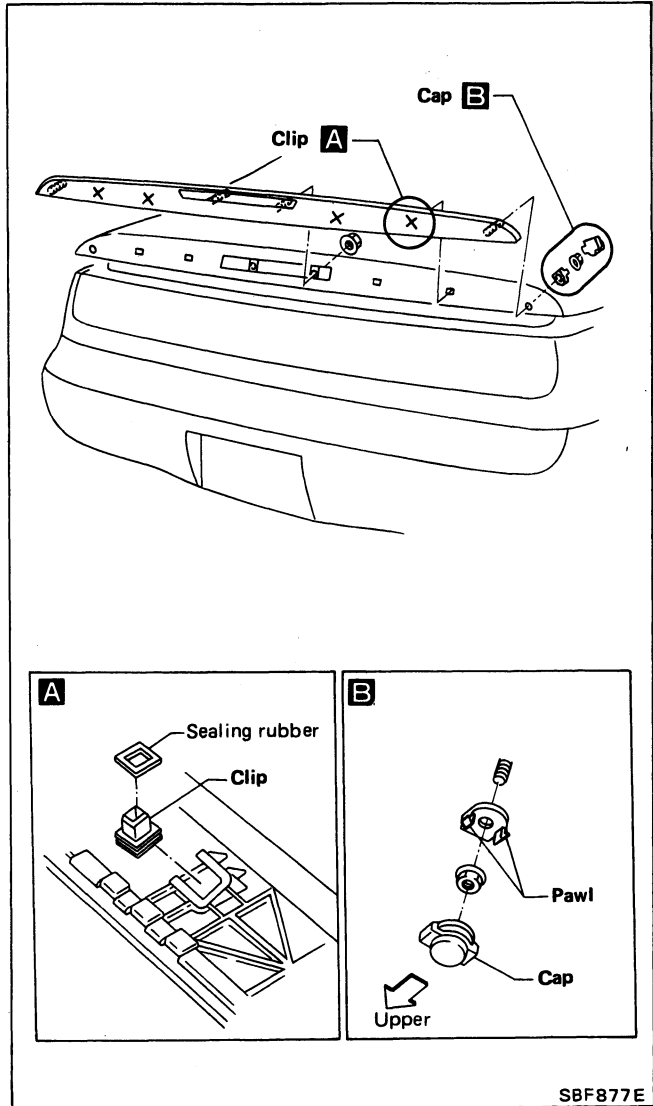

14 Back door weatherstrip

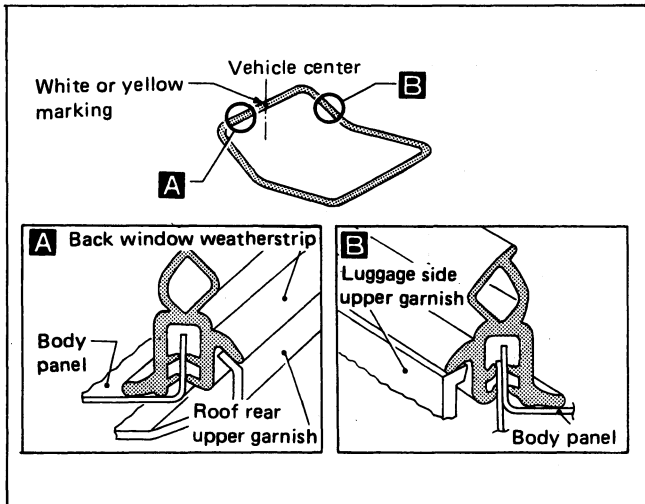

15 Back door molding

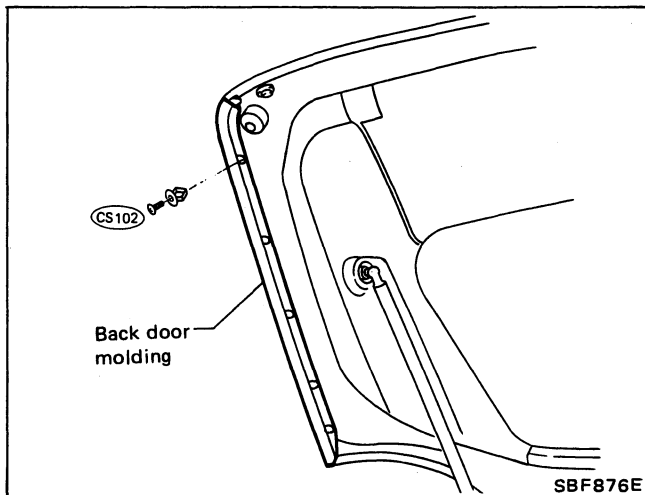

17 Rear panel finisher

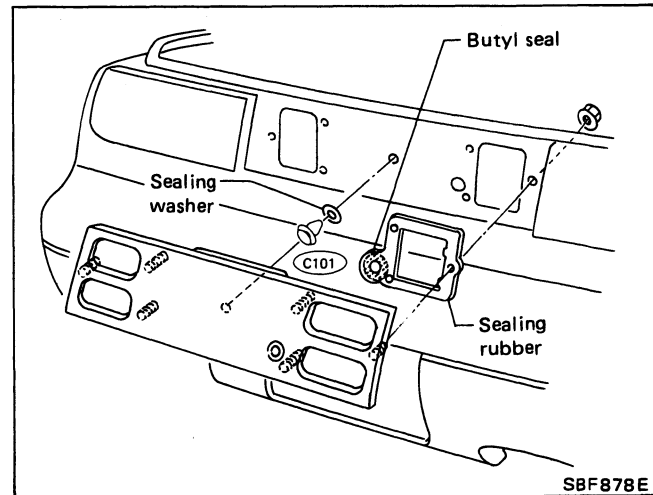

INTERIOR AND EXTERIOR

Exterior (Cont'd)

18 Rear combination lamp

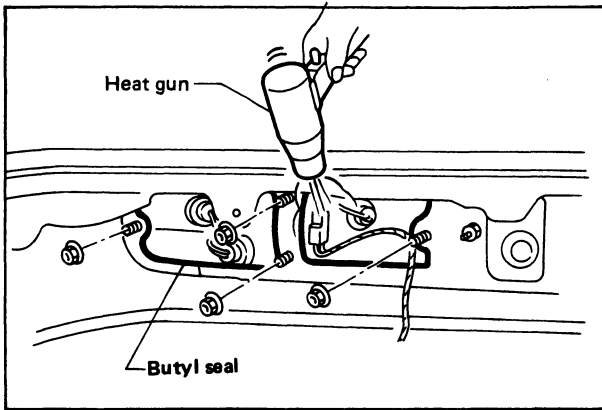

- Warm up lamp assembly area to a temperature a little below 60°C (140°F).

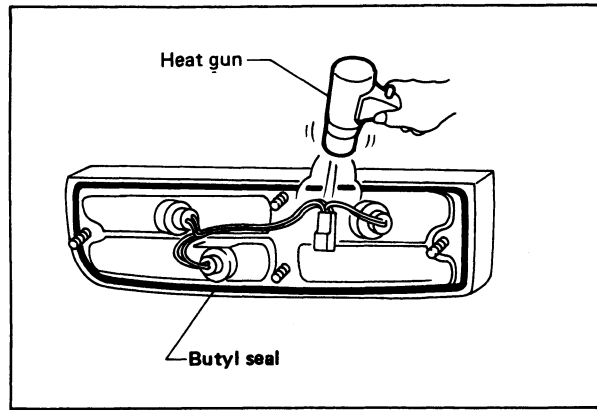

- Apply butyl seal evenly as it tends to become thin in the corners.
- Warm up lamp assembly area to a temperature a little below 60°C (140°F).

SBF886E

T-BAR ROOF

- Handle T-bar roof glass with care so not to damage it.
- Apply sealant to portions susceptible to water leakage if necessary.
- Side molding, sash, lock basement and glass of T-bar roof constitute one unit and cannot be disassembled.

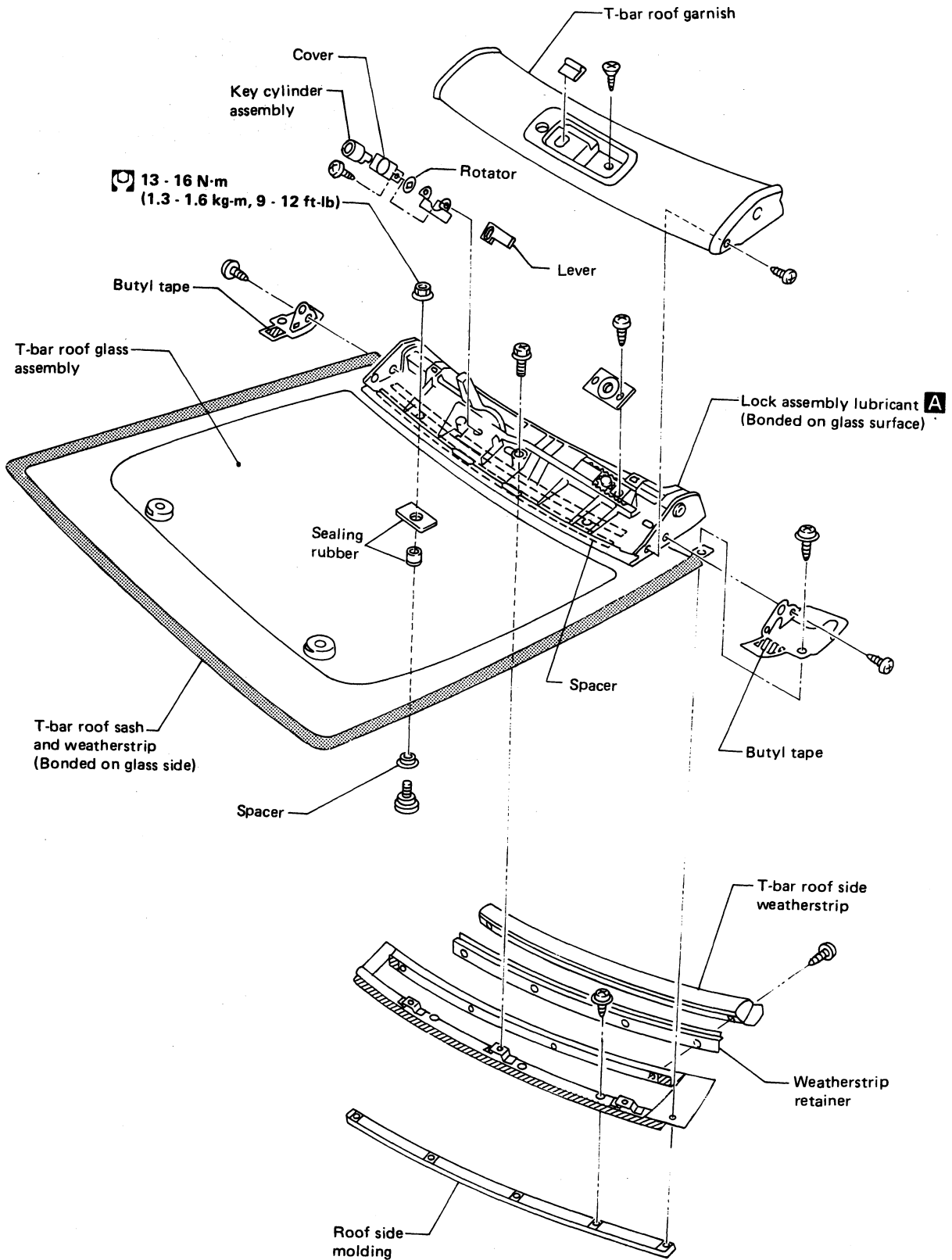

T-BAR ROOF

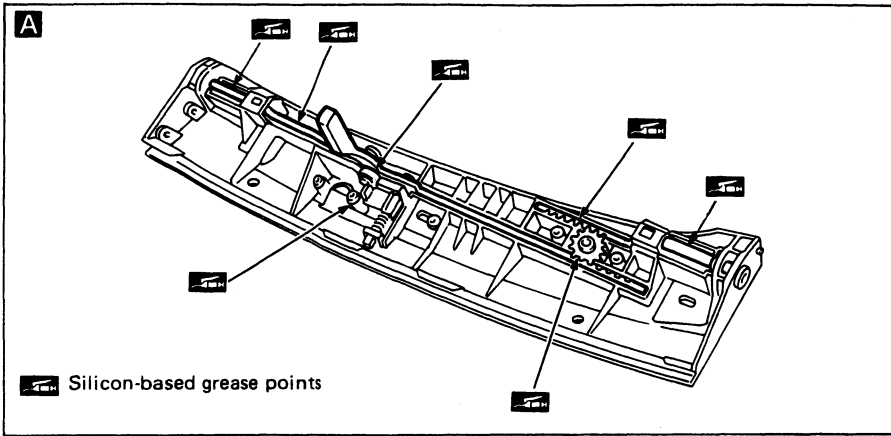

T-bar roof hook

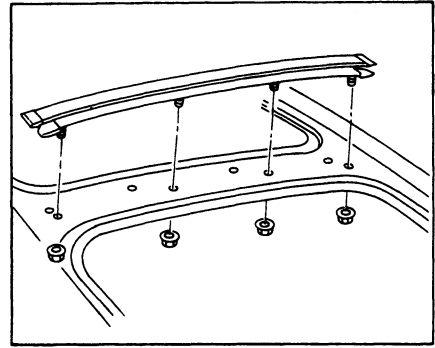

T-bar roof female lock adjustment

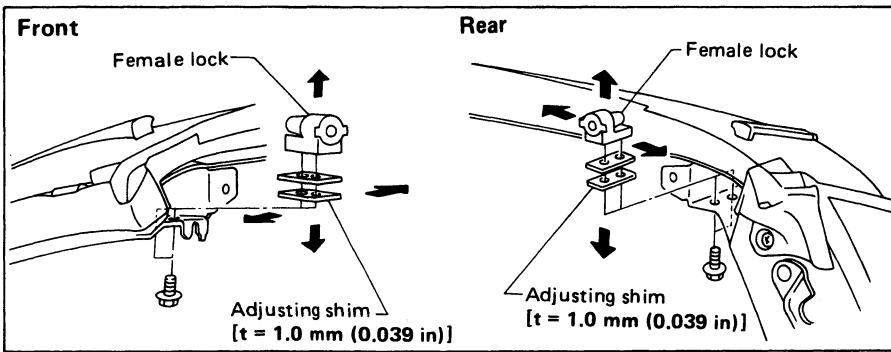

SEAT

- When removing or installing the seat trim, handle it carefully to keep it from becoming dirty and to avoid damage.

FRONT SEAT

For power seat

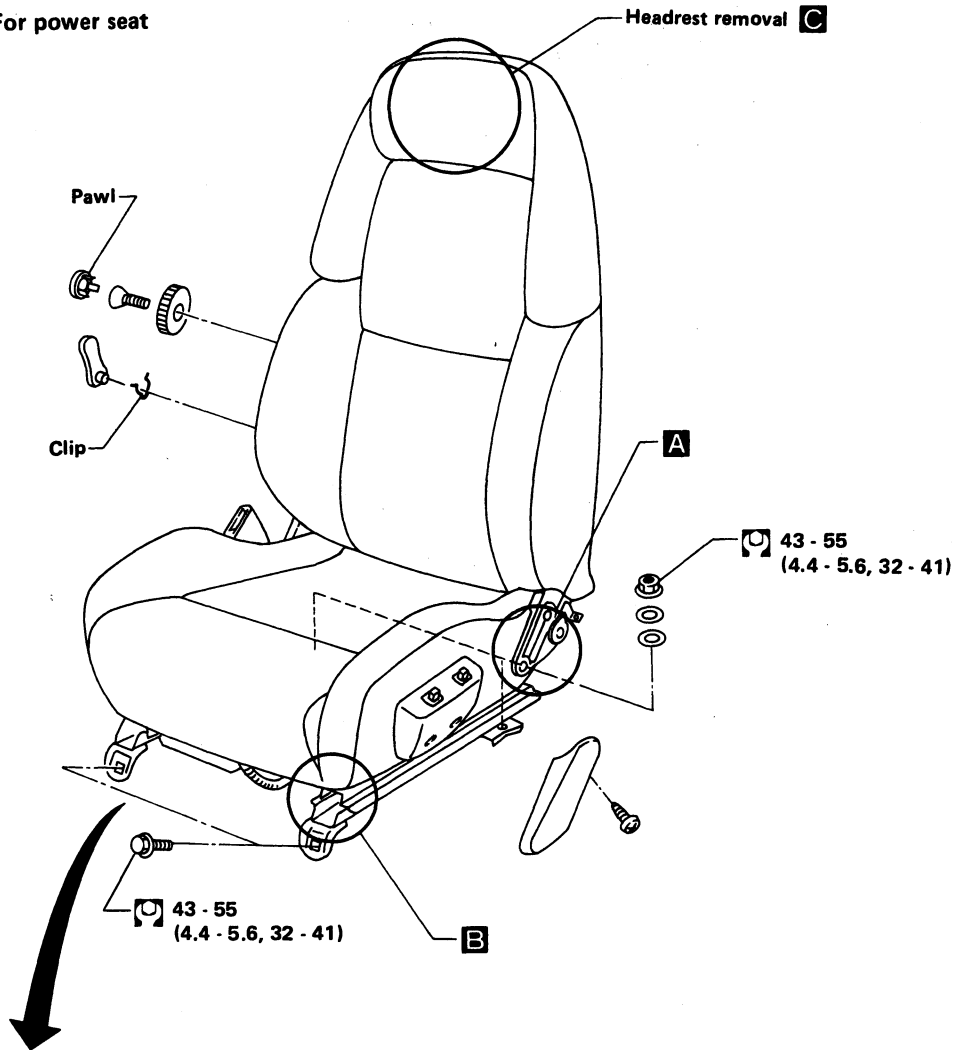

For manual seat

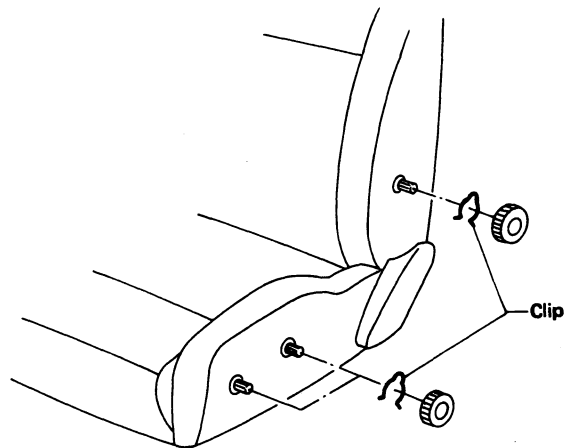
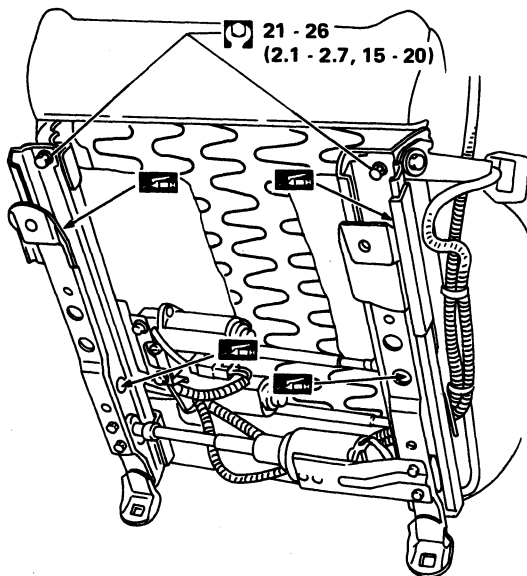

 : N·m (kg·m, ft·lb)

SEAT

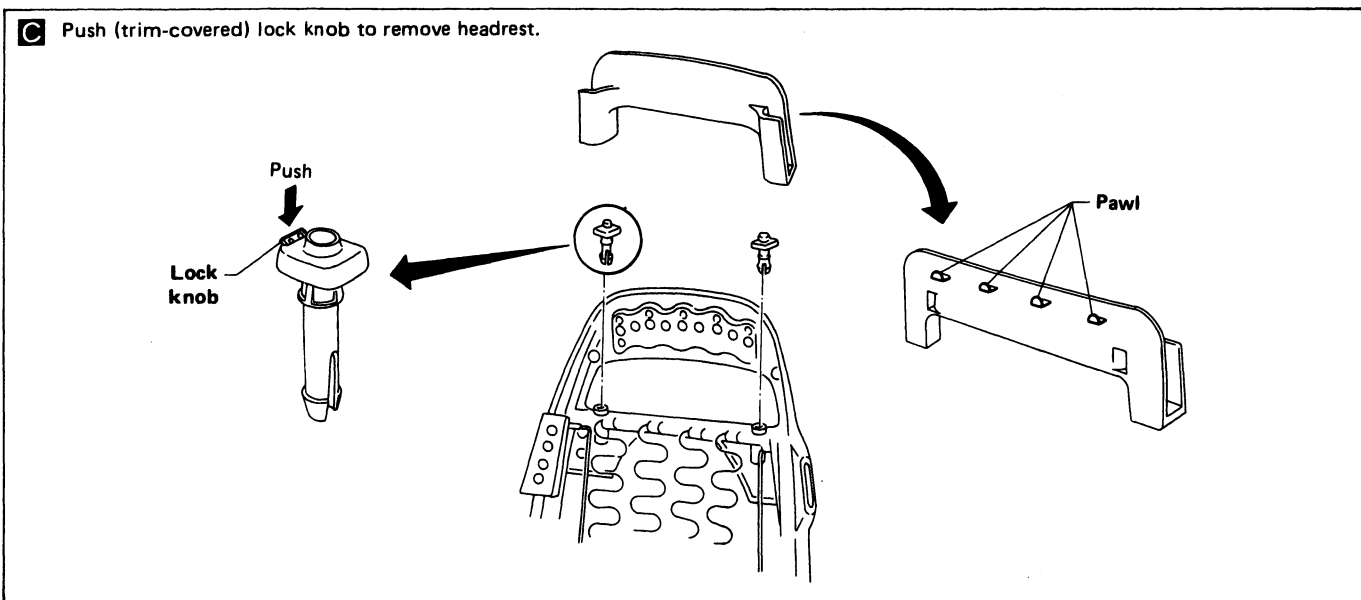
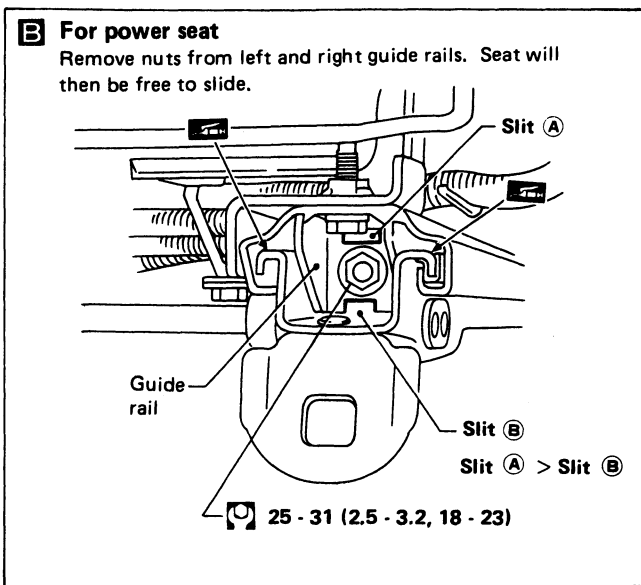
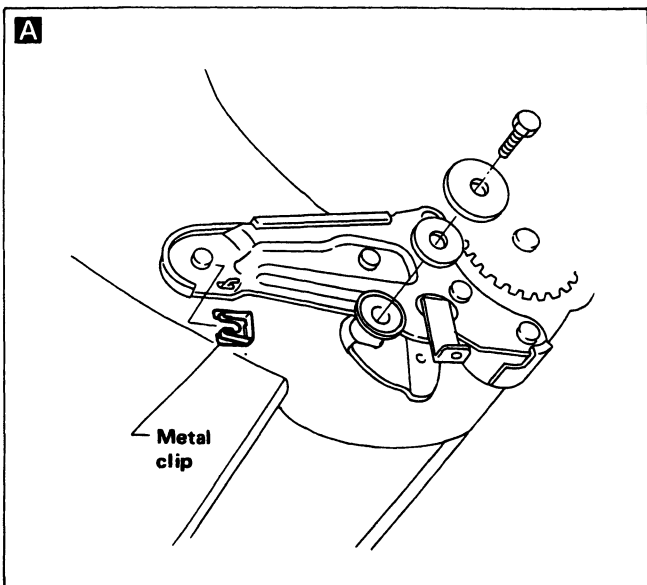

SBF879E

REAR SEAT

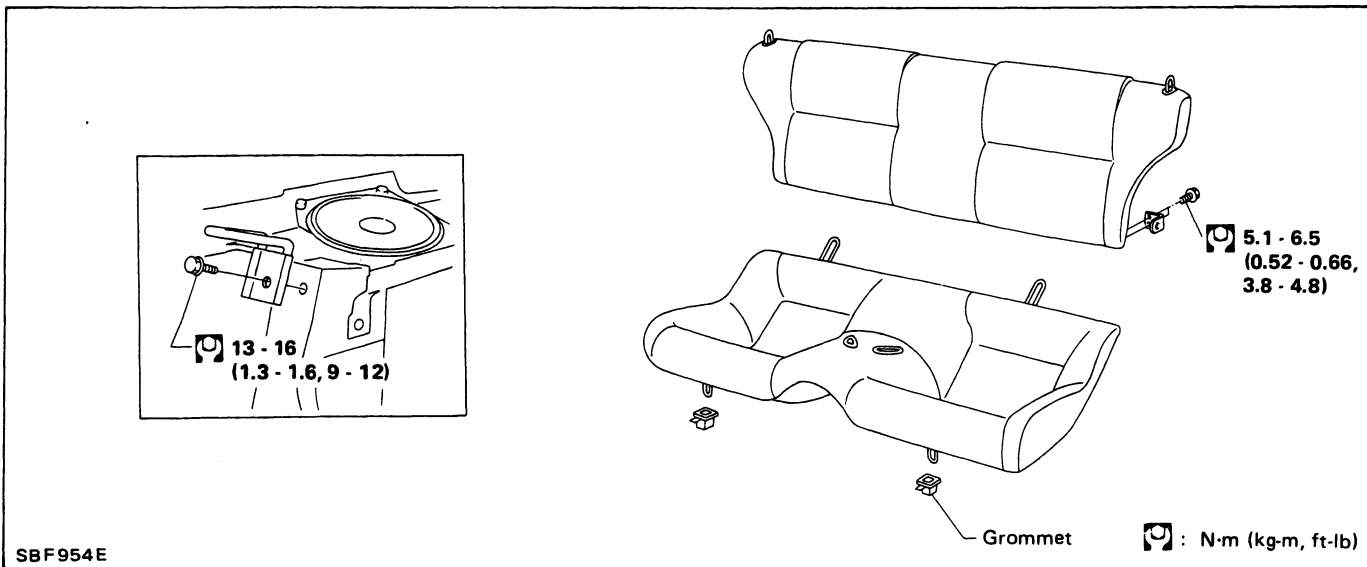

SBF954E

POWER SEAT/WIRING DIAGRAM

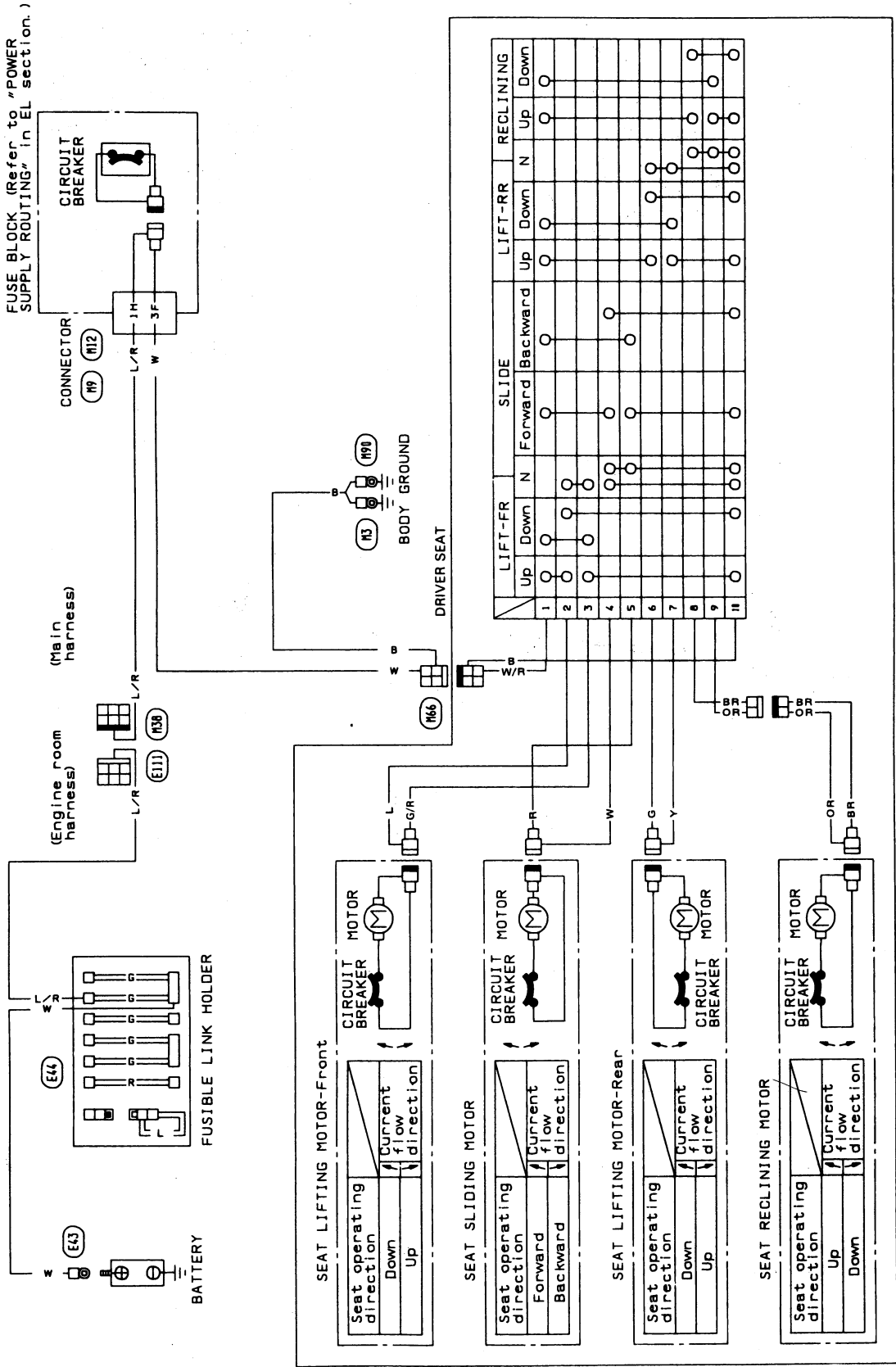

WINDSHIELD AND WINDOWS

Windshield

REMOVAL

After removing moldings, remove glass.

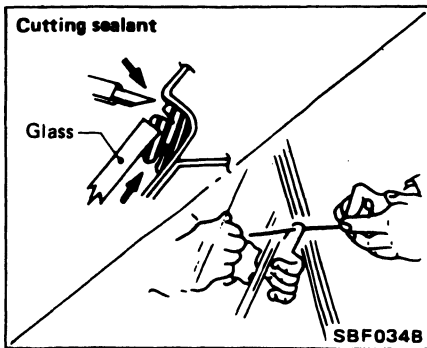

CAUTION:

Be careful not to scratch glass when removing.

INSTALLATION

- Use genuine Nissan Sealant kit or equivalent. Follow instructions provided with each kit.
- After installation, the vehicle should remain stationary for about 24 hours.
- Do not use sealant which is more than 12 months past its production date.
- Do not leave cartridge unattended with its cap open.
- Keep primers and sealant in a cool, dry place. Nissan recommends that they are stored in a refrigerator.
- Be sure to install moldings.

WARNING:

Keep heat or open flames away as primers are flammable.

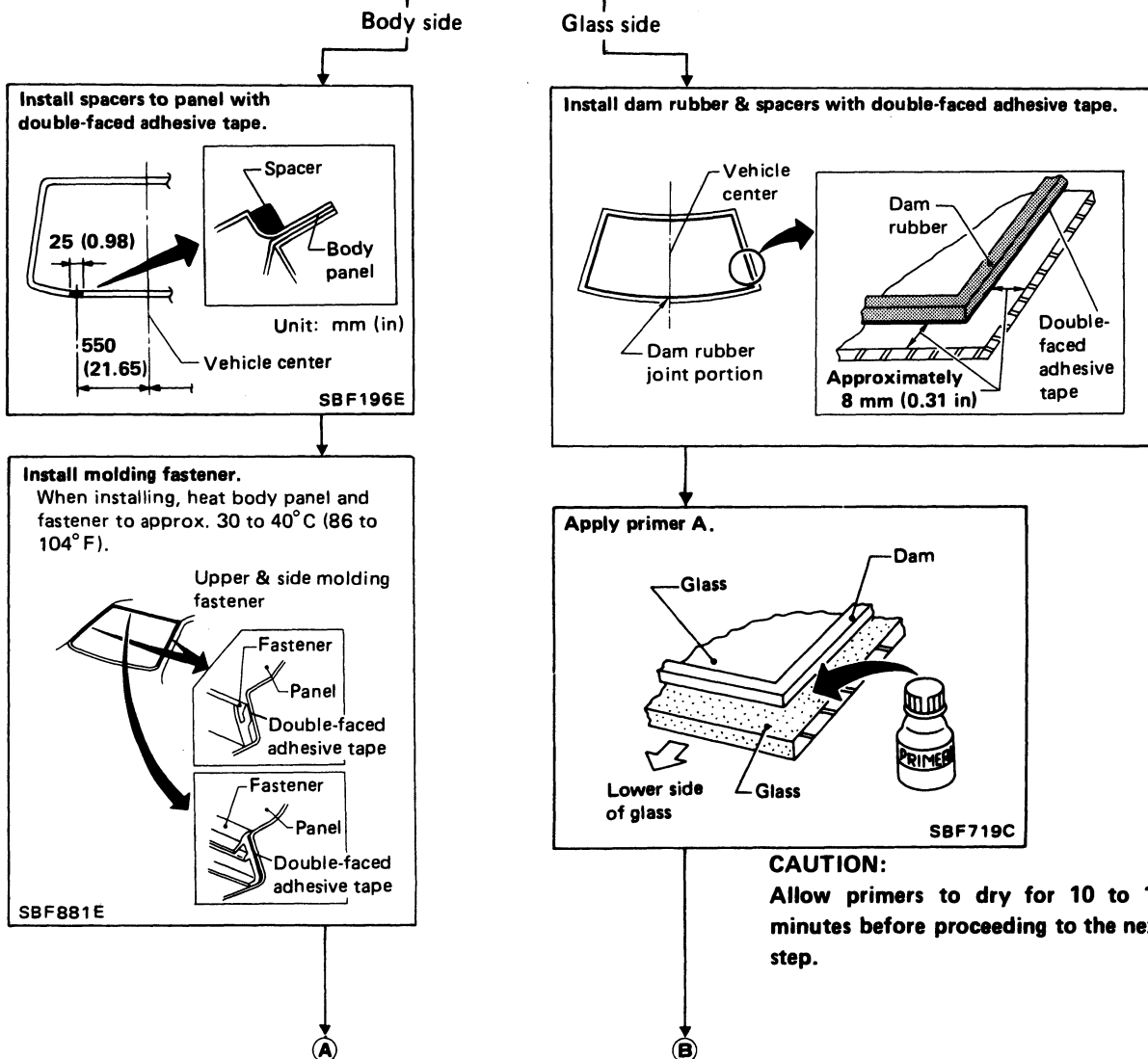
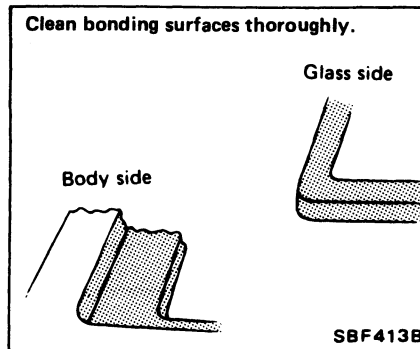

WINDSHIELD AND WINDOWS

Windshield (Cont'd)

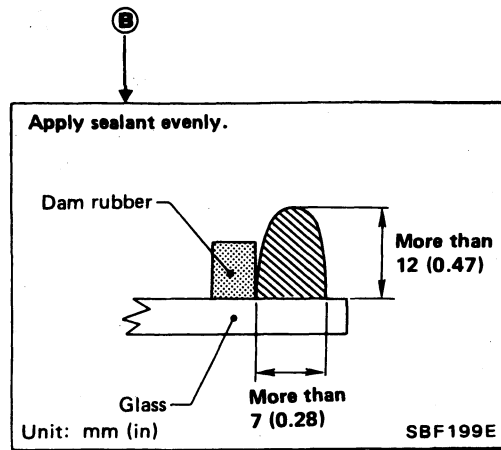
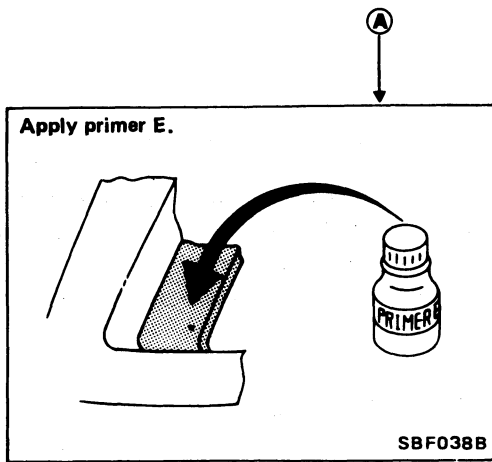

CAUTION:
Allow primers to dry for 10 to 15 minutes before proceeding to the next step.

CAUTION:
Windshield glass should be installed within 15 minutes of applying sealant: sealant starts to harden 15 minutes after it is applied.

Set glass in position and press glass lightly and evenly.

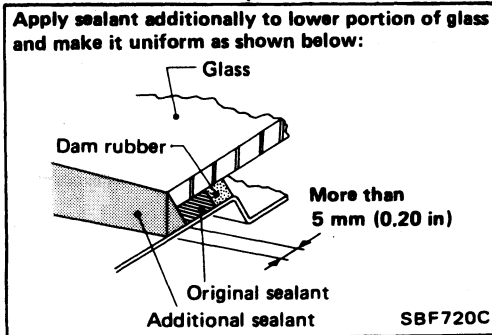

Check for water leakage.

CAUTION:
For sealant drying period, refer to "Drying Time for Sealant".

Apply sealant to upper & side molding fixing portion.

Set upper and side moldings.

CAUTION:
Molding must be installed securely so that it is in position and leaves no gap.

Install lower molding.

For details of moldings, refer to "Exterior".

WINDSHIELD AND WINDOWS

Side Window

2 seater model

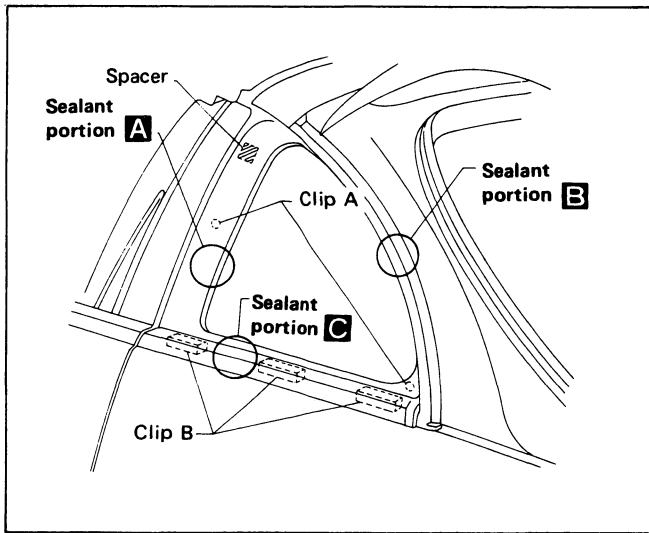

2+2 seater model

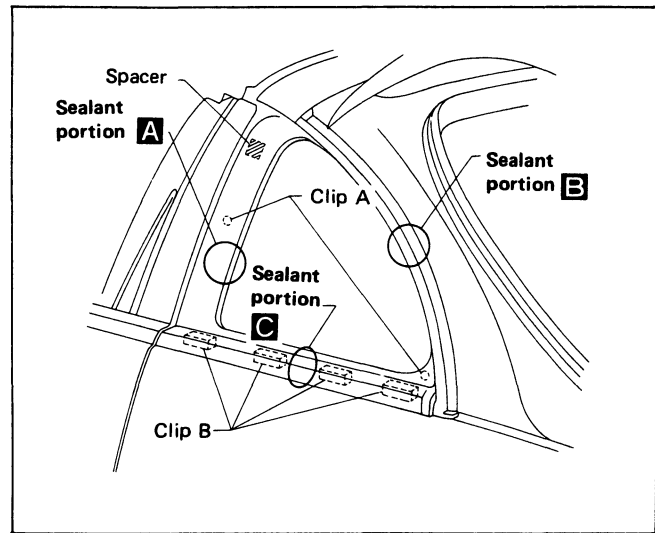

Spacer and clip portion

Unit: mm (in)

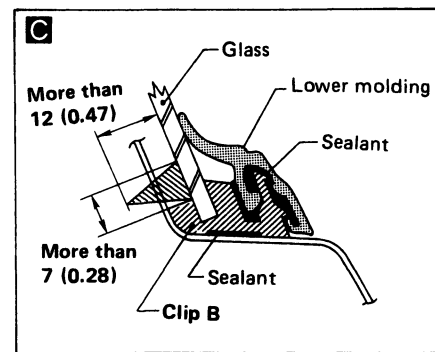
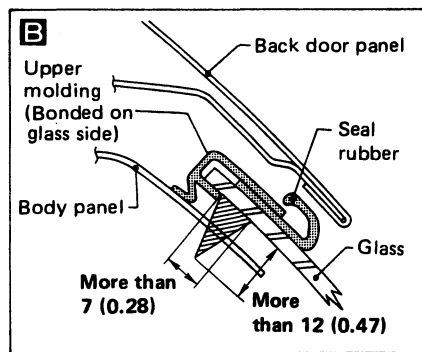
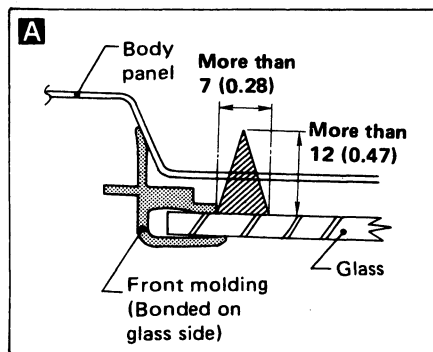
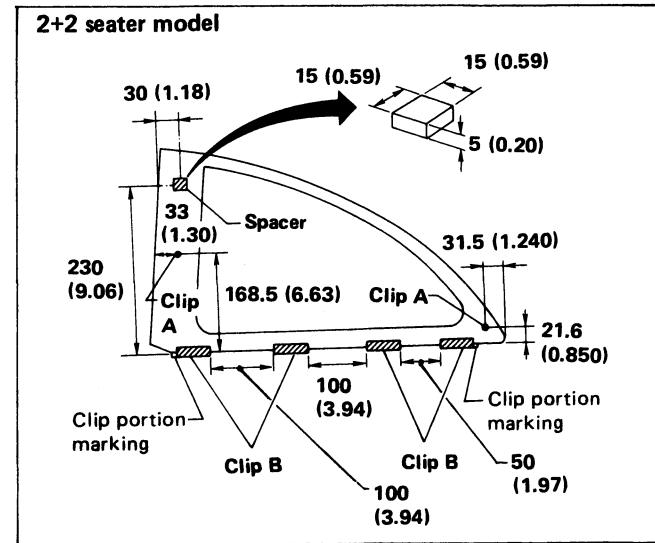
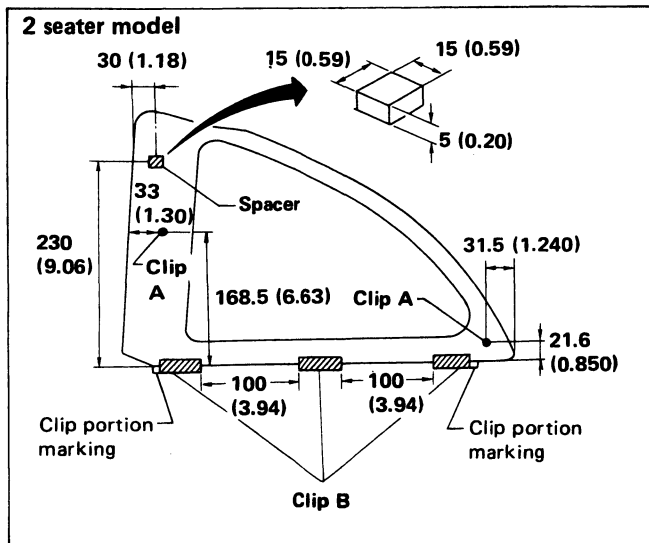

SBF010F

WINDSHIELD AND WINDOWS

Back Door Window

- Construction and removal/reinstallation method of back door window are basically the same as those of windshield.
- For sealant drying time, refer to "Drying Time for Sealant".
- For details of moldings, refer to "Exterior".

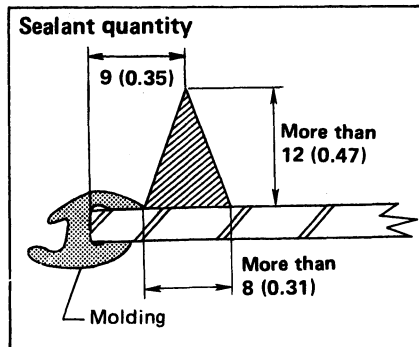
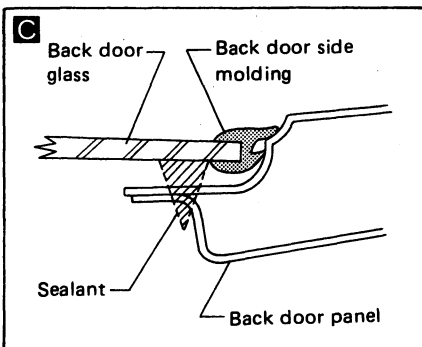
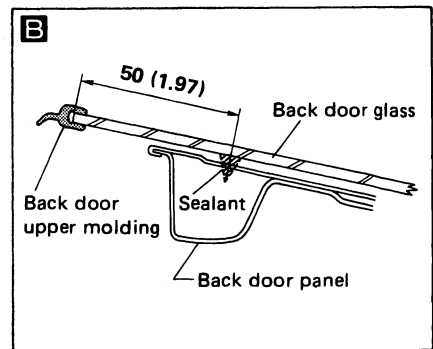
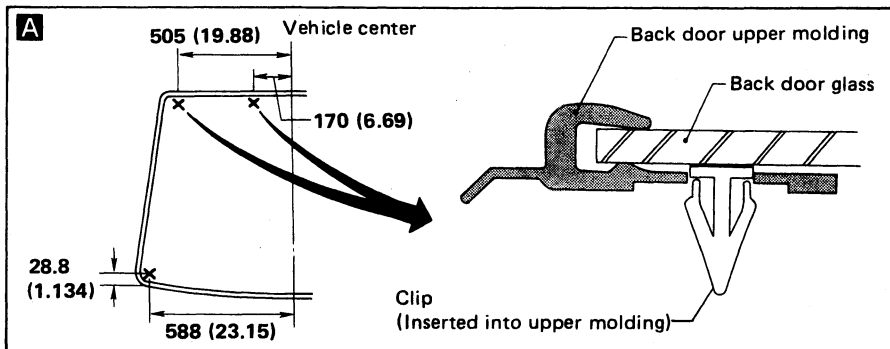
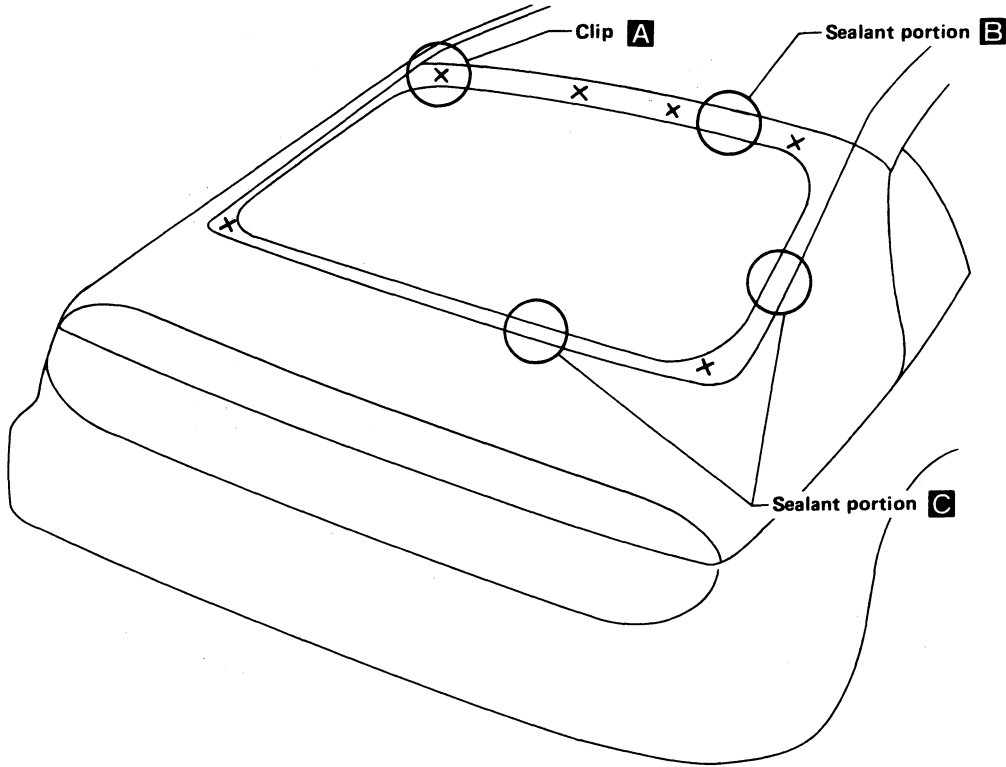

Unit: mm (in)

SBF884E

WINDSHIELD AND WINDOWS

Drying Time for Sealant

Reference: Time required for sealant to dry to desired hardness.

Unit: days

Relative humidity %	90	50	25
Temperature °C (°F)			
40 (104)	1.0	1.5	3.0
25 (77)	1.5	2.5	5.0
5 (41)	3.0	8.0	13.0

CAUTION:

Advise the user of the fact that vehicle should not be driven on rough roads or surfaces until sealant has properly vulcanized.

Repairing Water Leaks for Windshield, Side Window and Back Door Window

Leaks can be repaired without removing and reinstalling glass.

If water is leaking between caulking material and body or between glass and caulking material, determine the extent of the leak by applying water while pushing glass outward.

To stop the leak, apply primer and then sealant to the leak point.

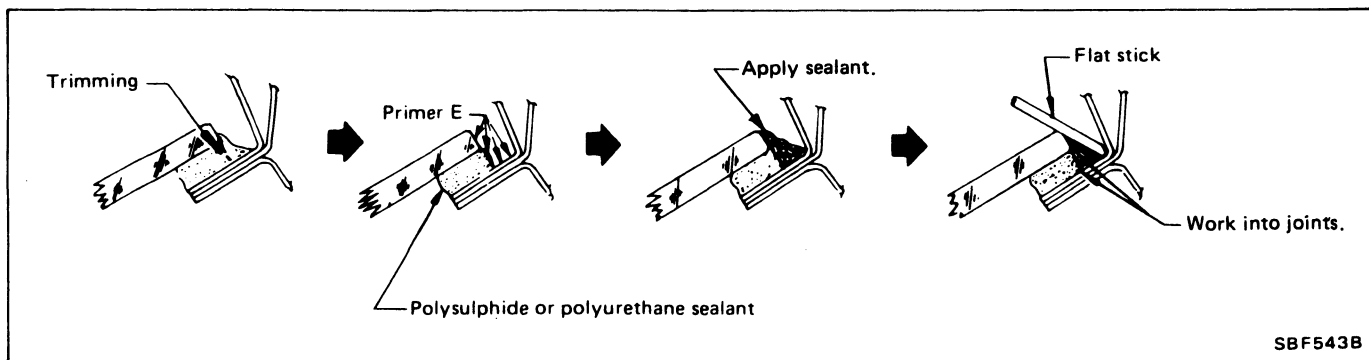

Afterwards, install molding securely.

AUTOMATIC SEAT BELT SYSTEM

Unit Location

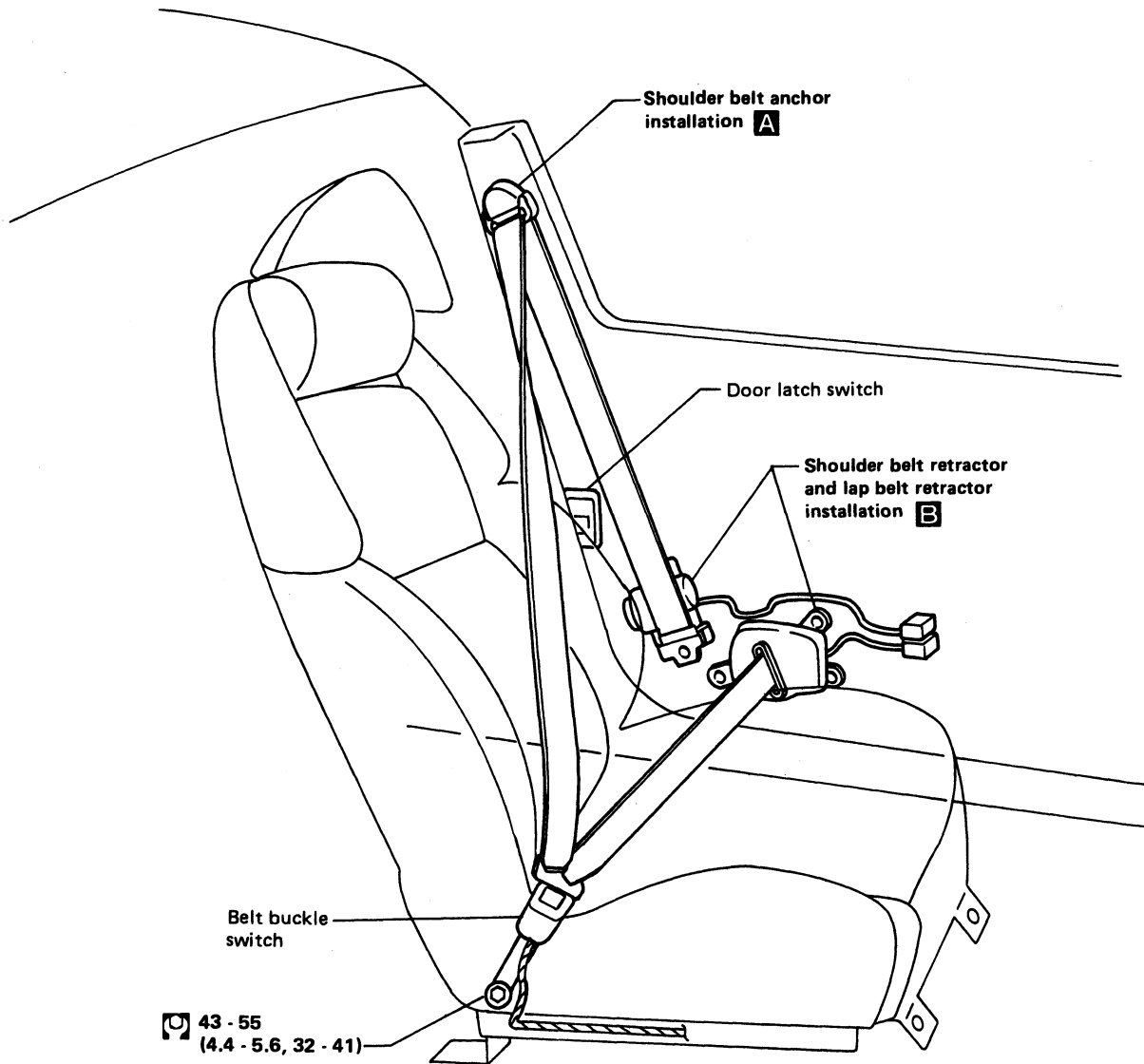

Control unit

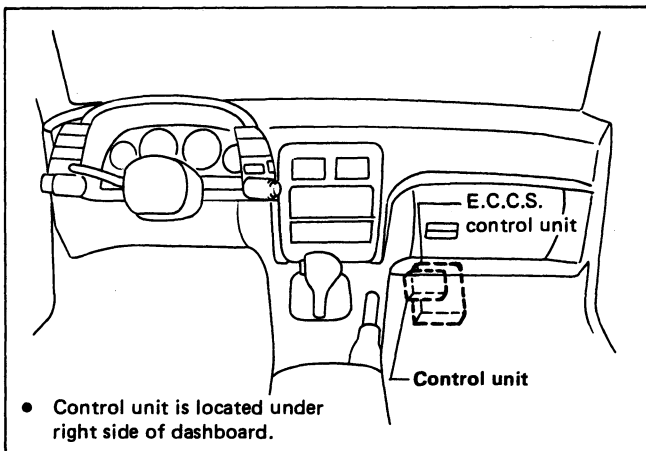

: N·m (kg·m, ft·lb)

AUTOMATIC SEAT BELT SYSTEM

Unit Location (Cont'd)

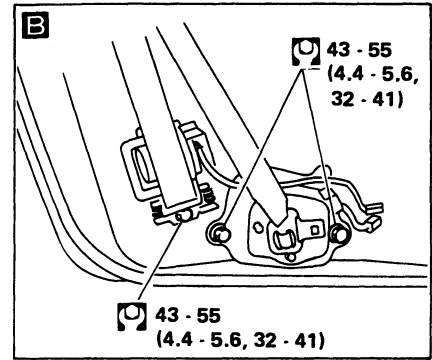
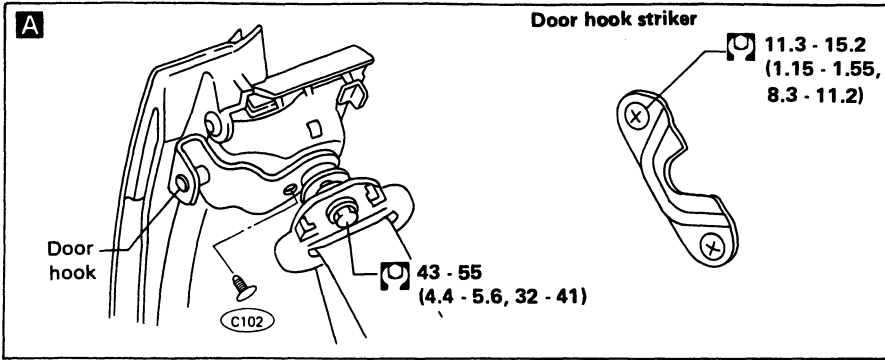

AUTOMATIC SEAT BELT SYSTEM

Wiring Diagram

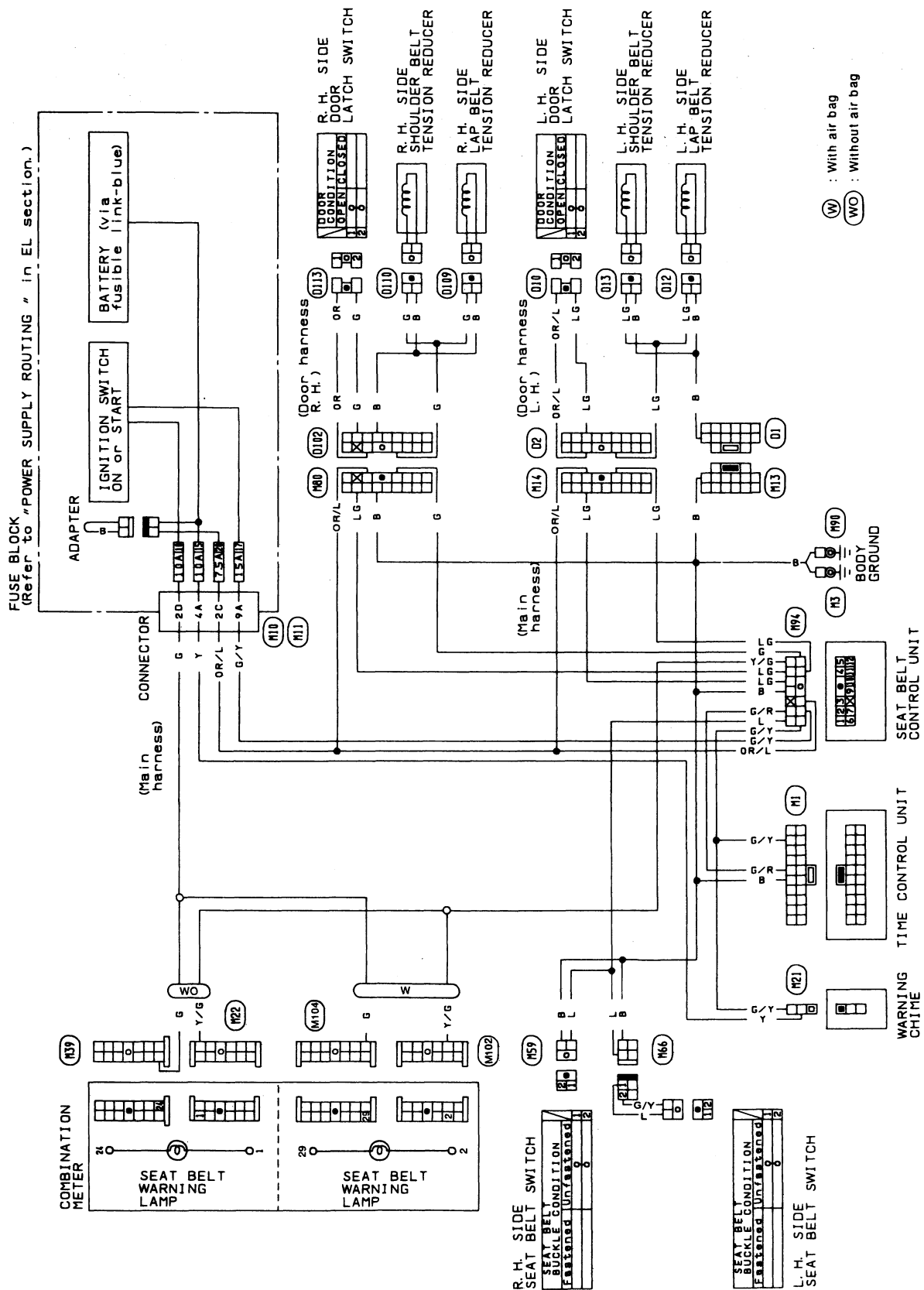

AUTOMATIC SEAT BELT SYSTEM

Preparation for Trouble Diagnoses

1. Remove floor board located in front of passenger leg space.
2. Disconnect harness connector.

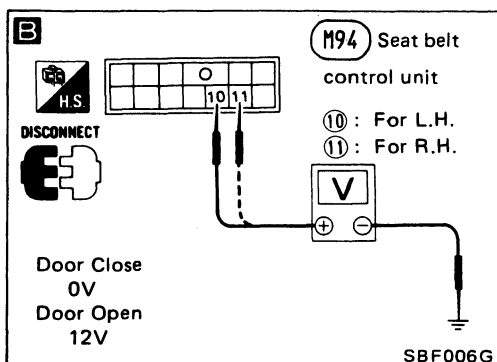
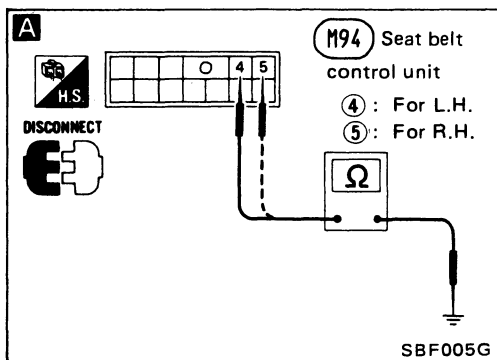
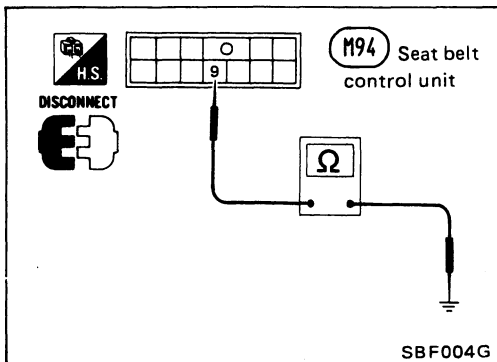
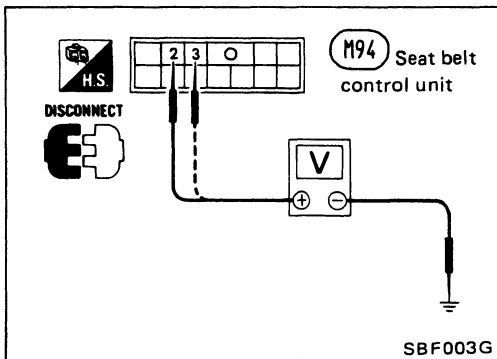

Power Supply Circuit Check

Terminals		Ignition switch	
⊕	⊖	OFF or ACC	ON
②	Ground	0V	12V
③	Ground	12V	12V

Ground Circuit Check

Terminals	Continuity
⑨ -Ground	Yes

Trouble Diagnoses

SYMPTOM:

Warning lamp flashes continuously.

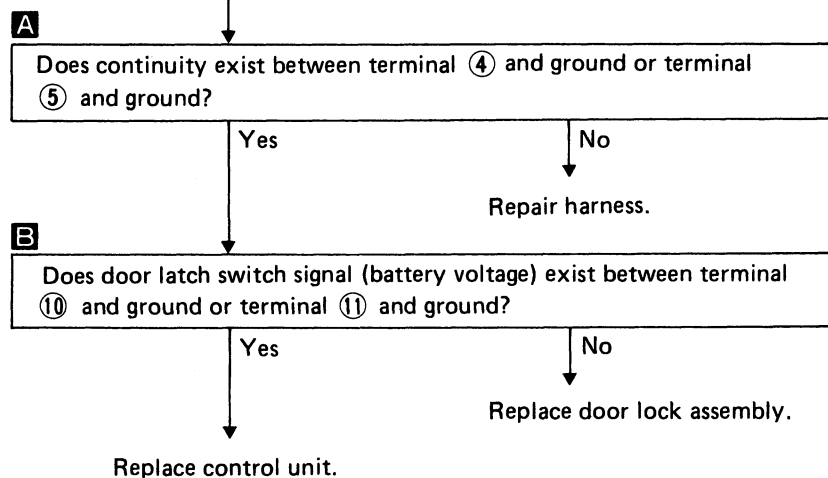

AUTOMATIC SEAT BELT SYSTEM

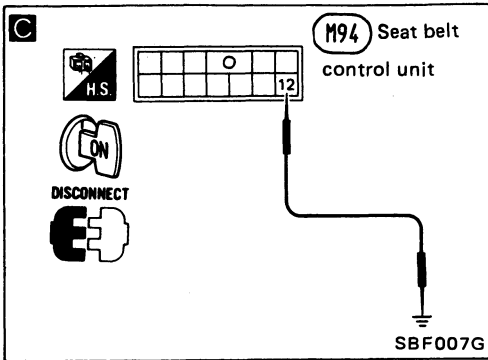

Trouble Diagnoses (Cont'd)

SYMPTOM:

Warning lamp does not flash when ignition switch is "ON".

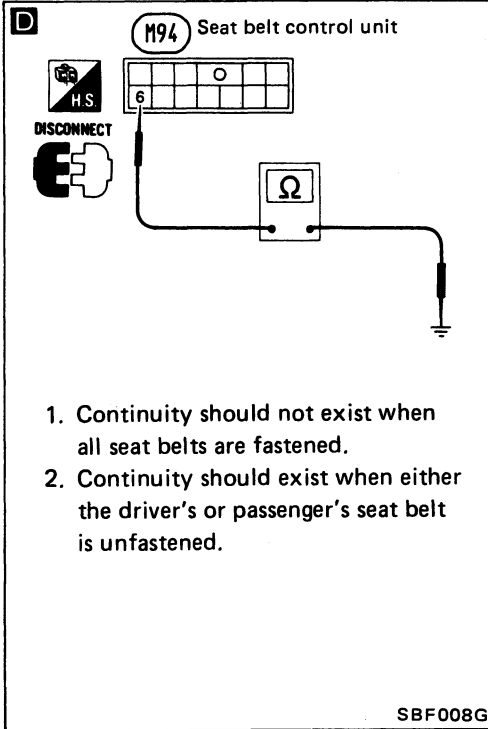
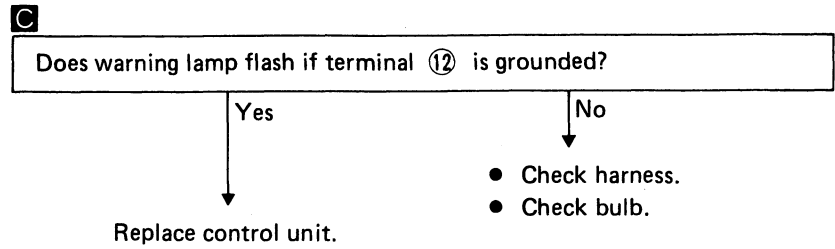

SYMPTOM:

Warning chime does not operate for 6 seconds after ignition switch is ON, when releasing belt from buckle.

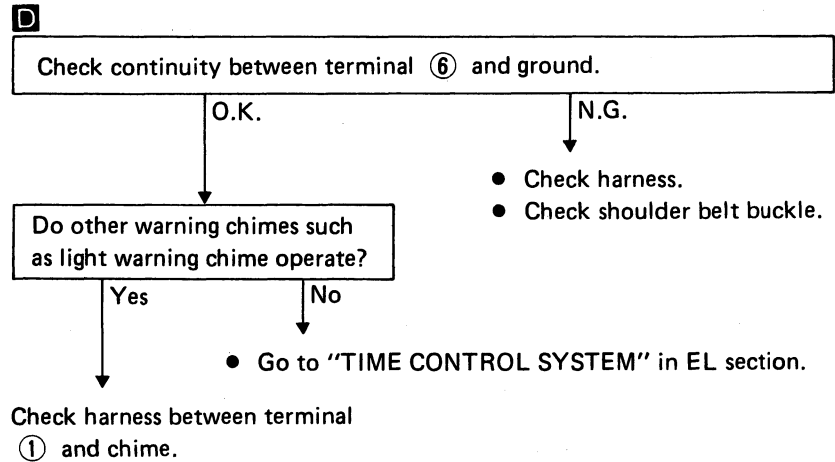

REAR AIR SPOILER

- When installing, make sure that there are not gaps or waves at ends of air spoiler.
- Before installing spoiler, clean and remove oil from surface where spoiler will be mounted.

REAR AIR SPOILER

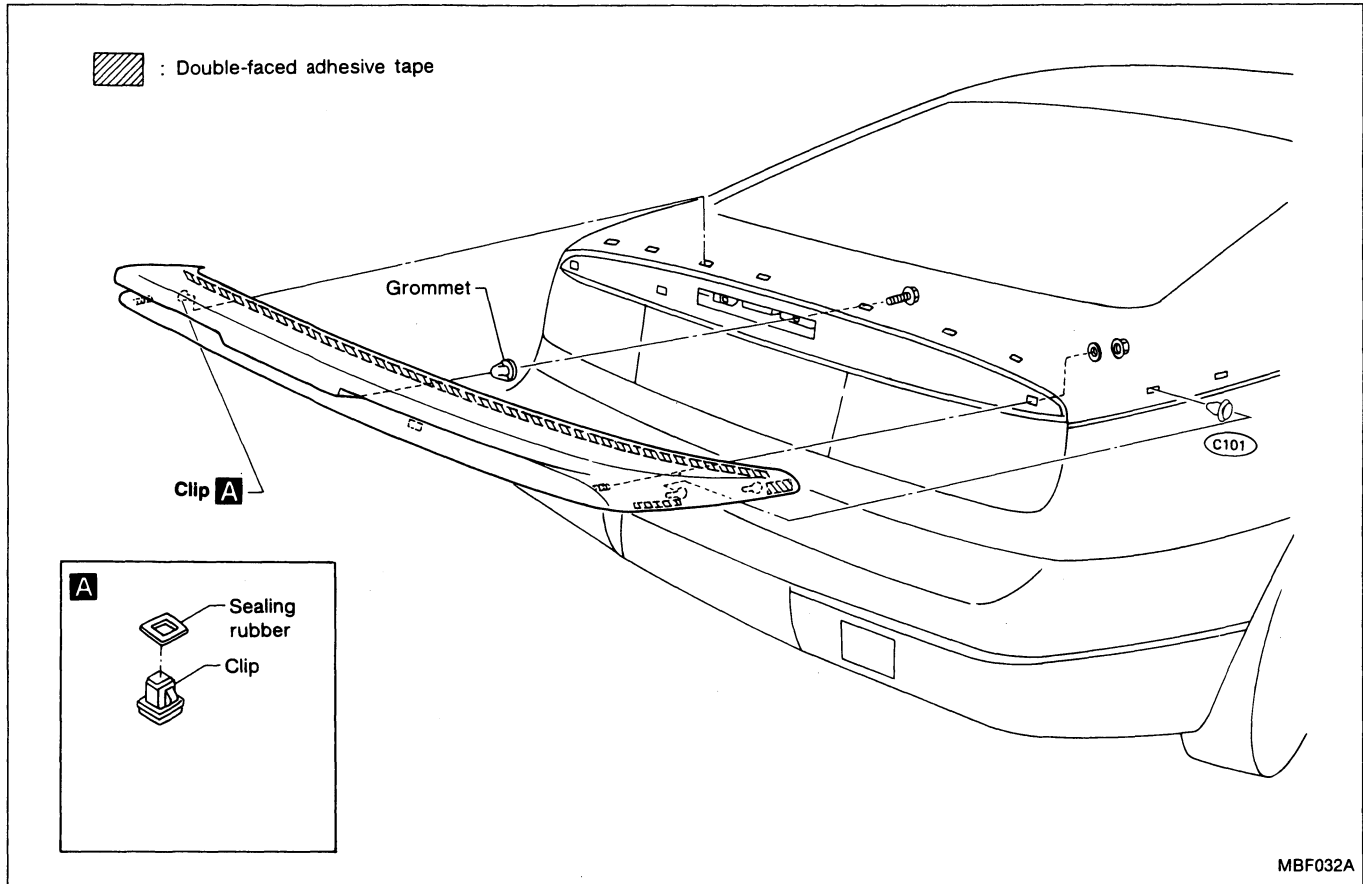

MBF032A

MIRROR

Door Mirror

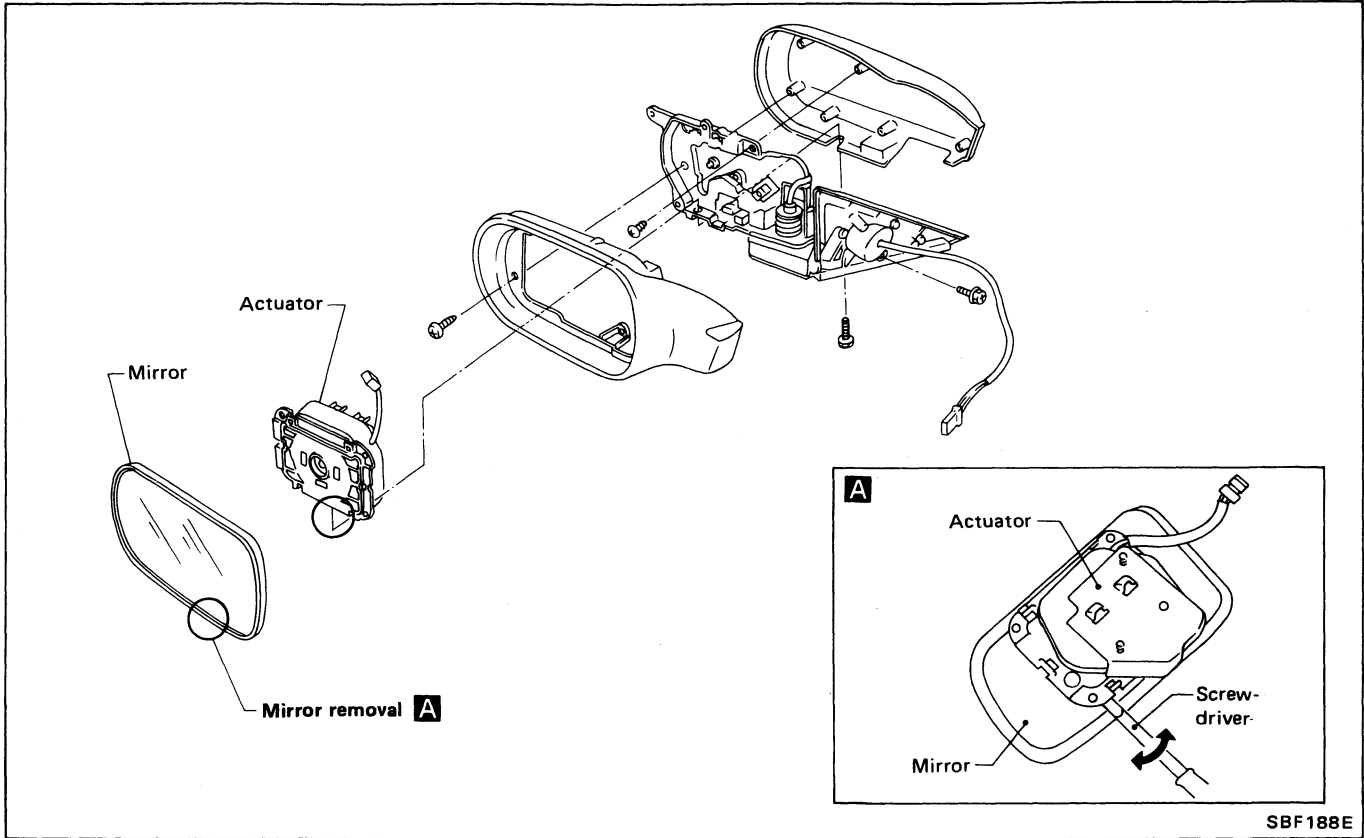

SBF188E

BODY ALIGNMENT

- All dimensions indicated in figures are actual ones.
- When a tram tracking gauge is used, adjust both pointers to equal length and check the pointers and gauge itself to make sure there is no free play.
- When a measuring tape is used, check to be sure there is no elongation, twisting or bending.
- Measurements should be taken at the center of the mounting holes.
- An asterisk (*) following the value at the measuring point indicates that the measuring point on the other side is the same value.
- The coordinates of the measurement points are the distances measured from the standard line of "X", "Y" and "Z".

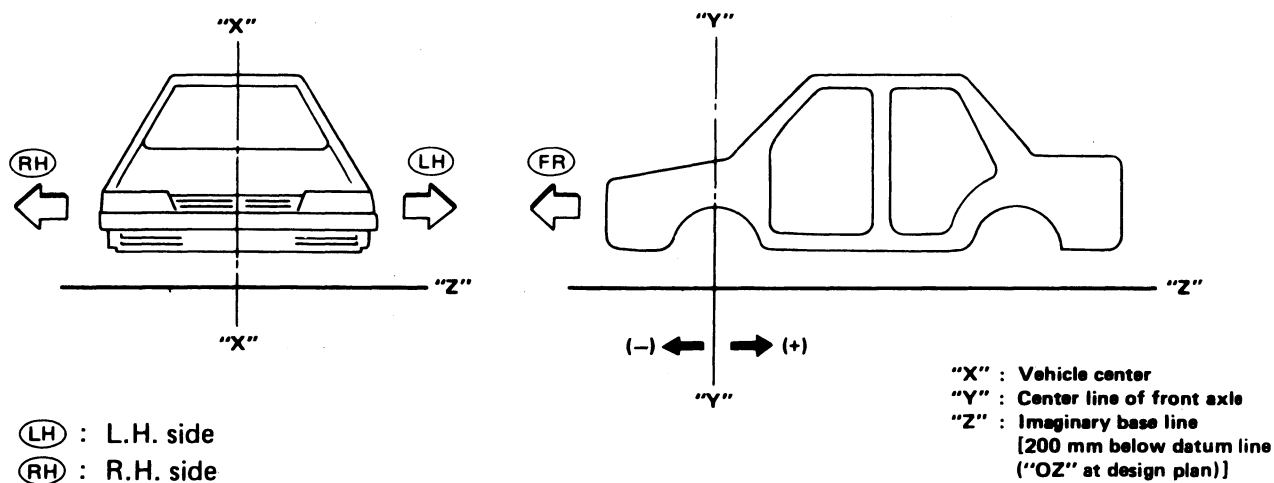

Engine Compartment

MEASUREMENT

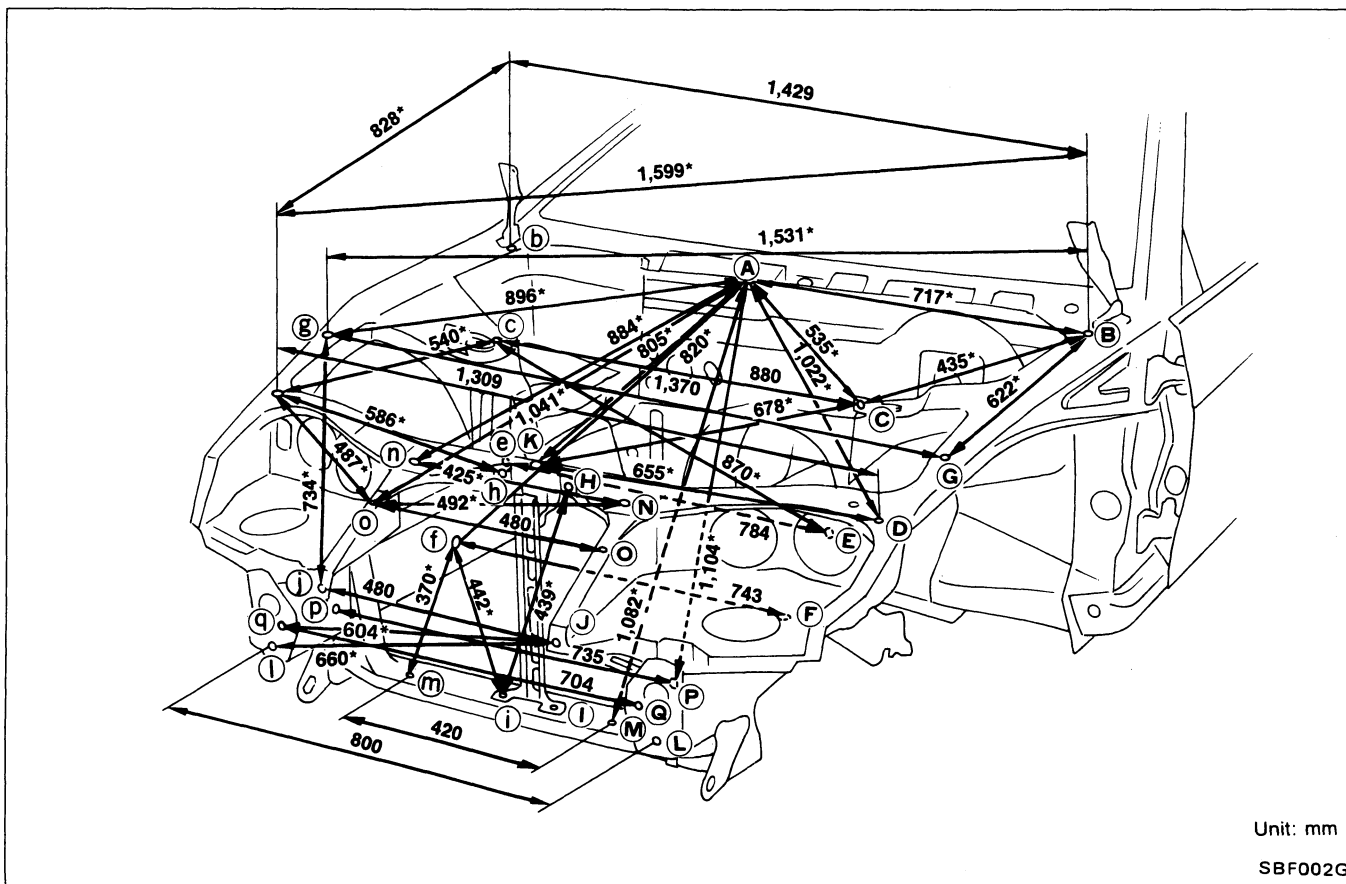

BODY ALIGNMENT

Engine Compartment (Cont'd)

MEASUREMENT POINTS

Unit: mm

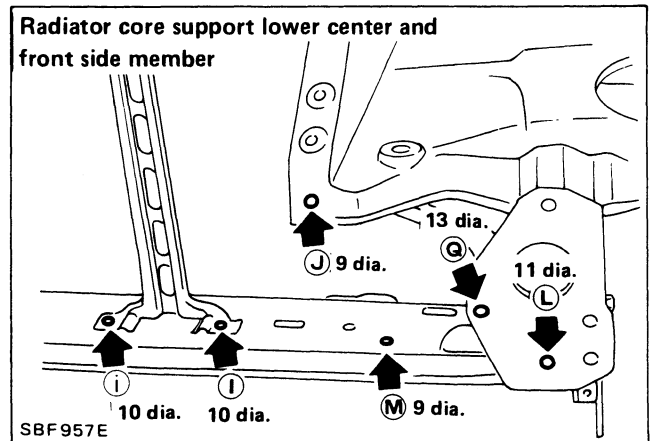
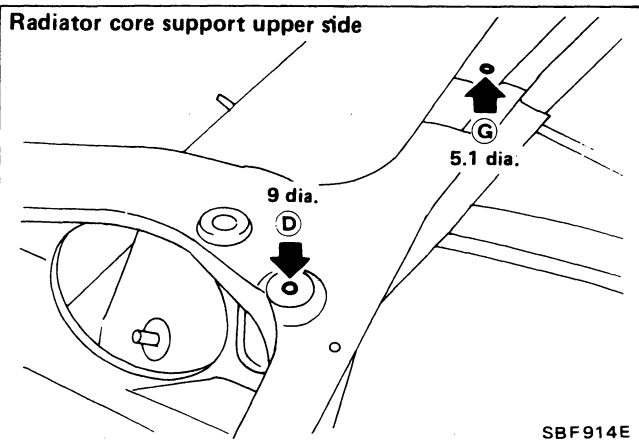
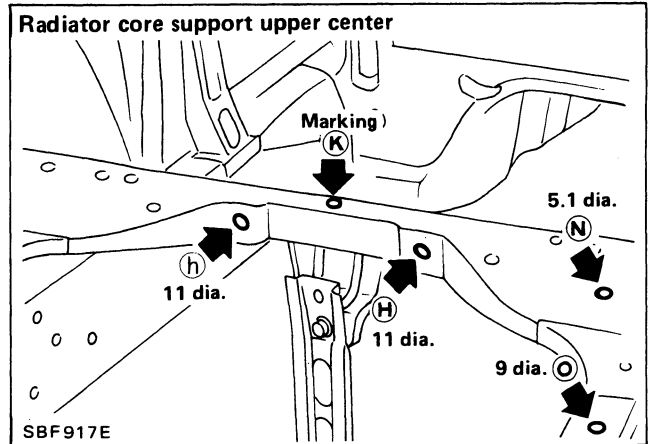
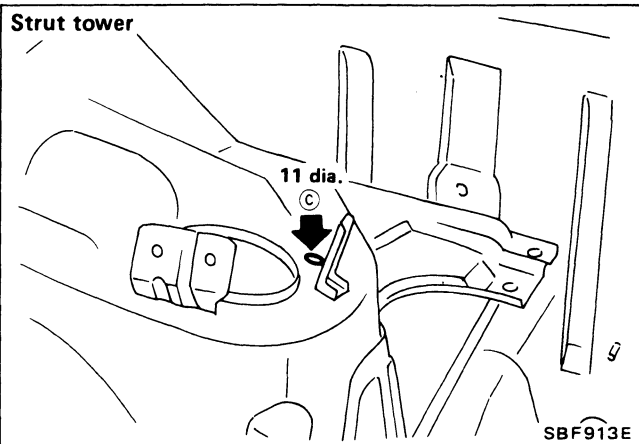
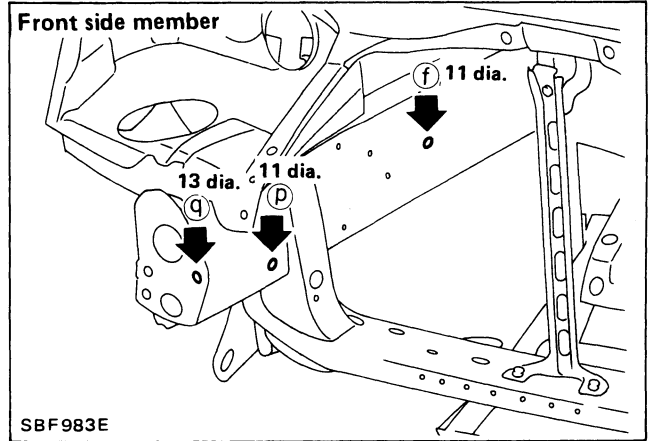
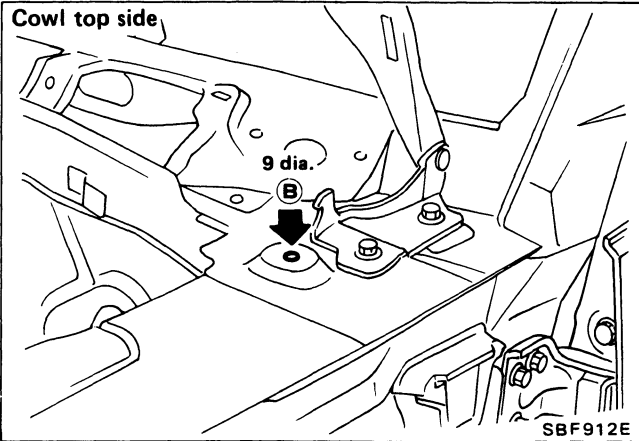
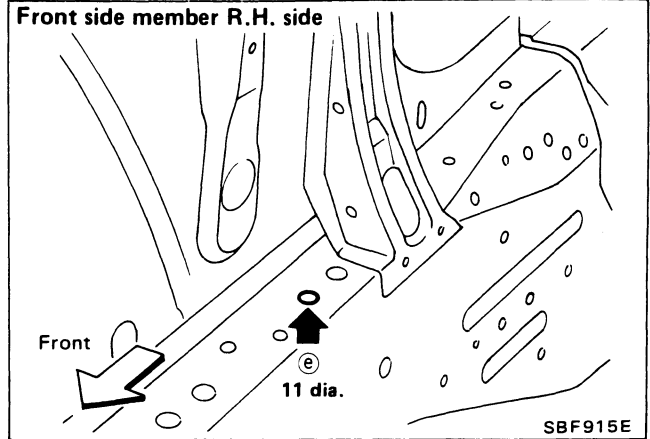
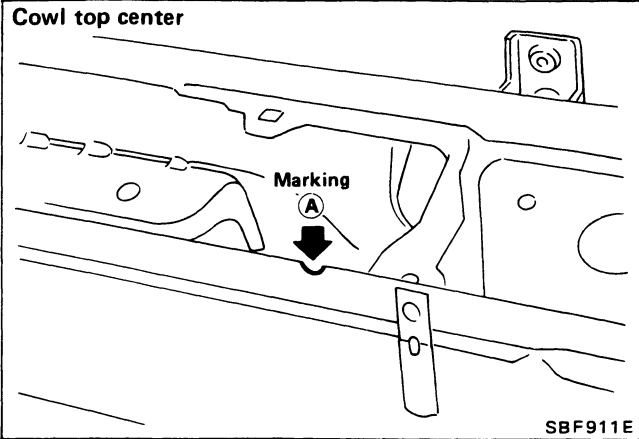

BODY ALIGNMENT

Underbody

MEASUREMENT

2 seater model

Unit: mm

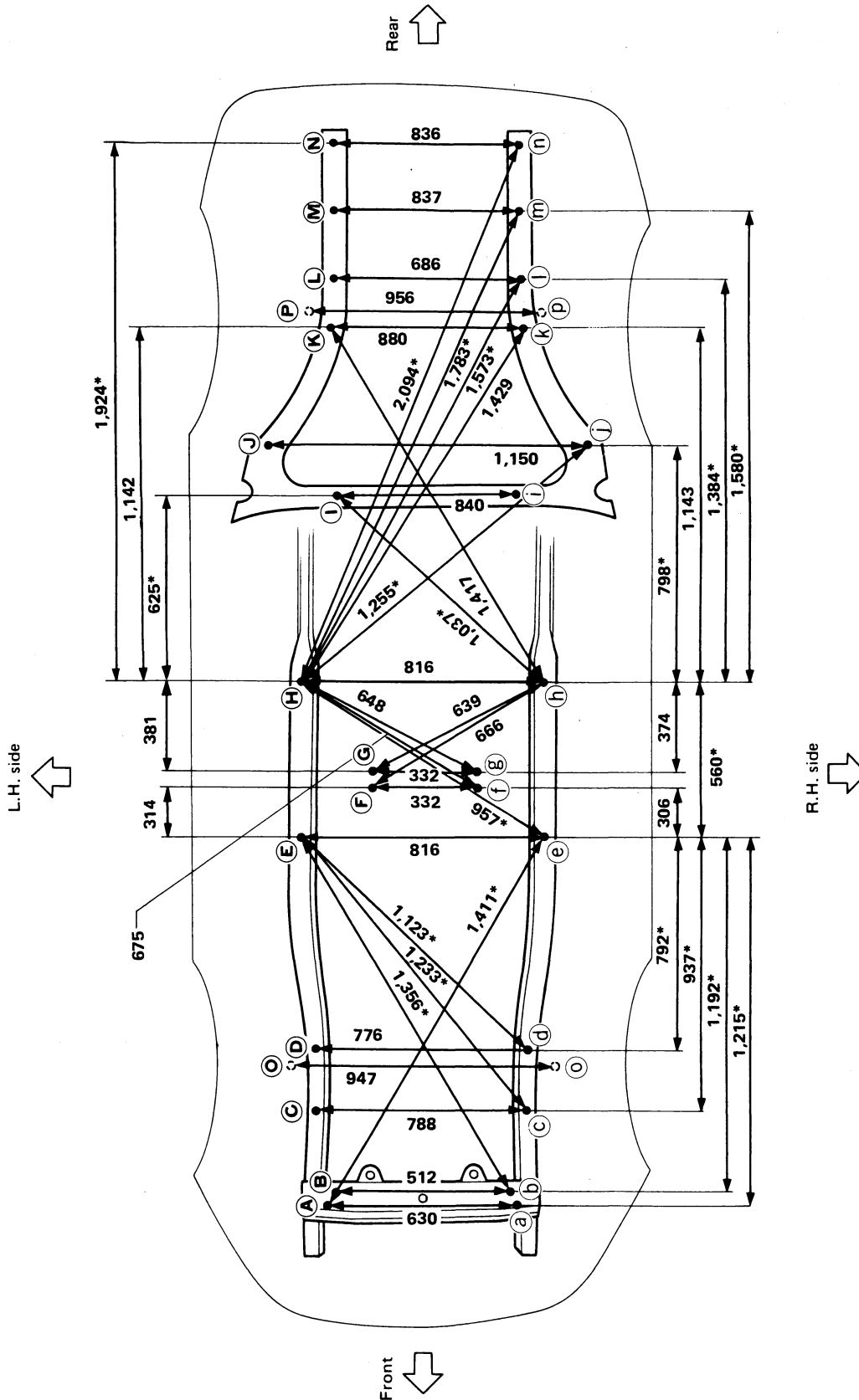

All dimensions indicated in this figure are actual ones. (There are no projected dimensions.)

BODY ALIGNMENT

Underbody (Cont'd)

MEASUREMENT POINTS

2 seater model

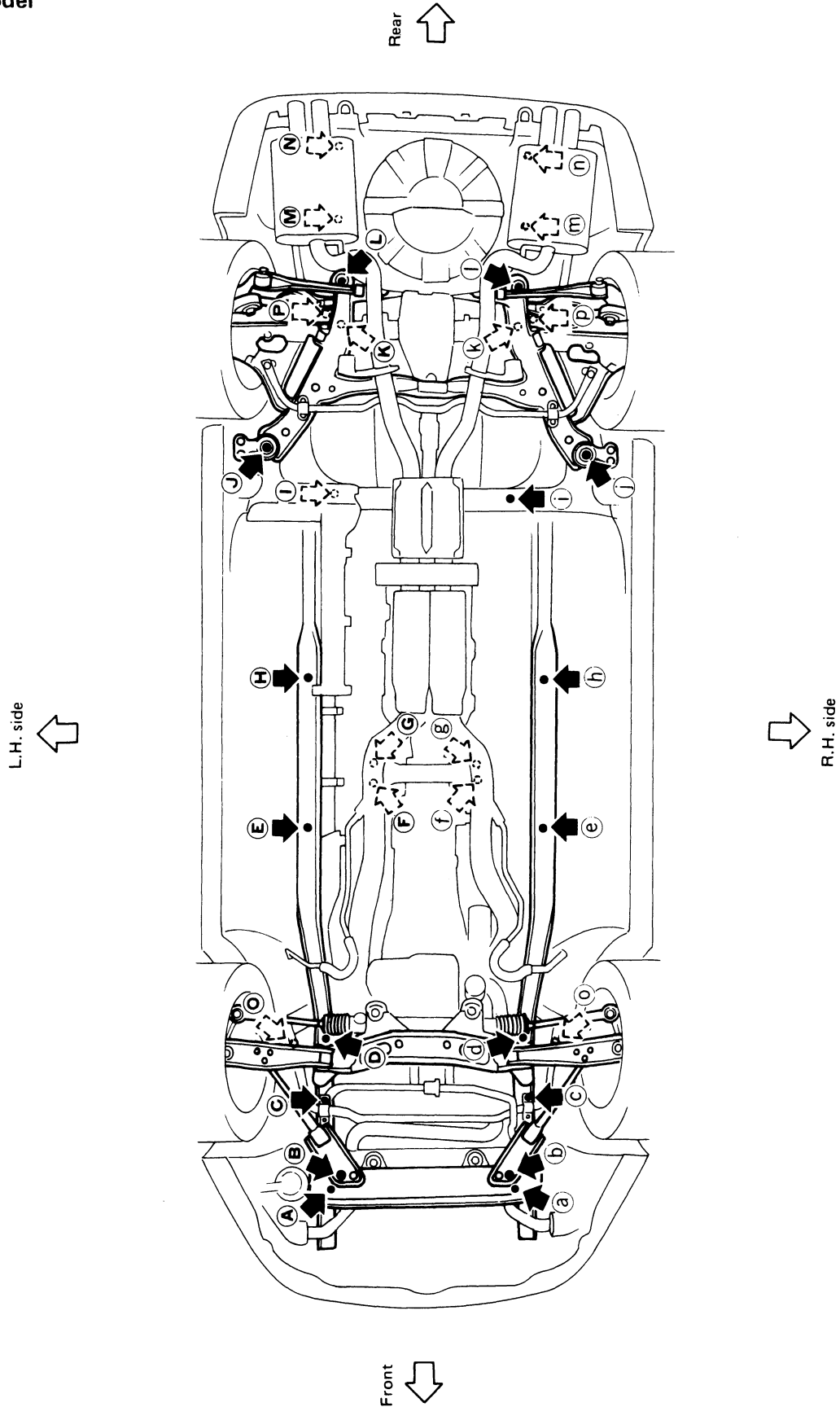

BODY ALIGNMENT

Underbody (Cont'd)

MEASUREMENT

2+2 seater model

Unit: mm

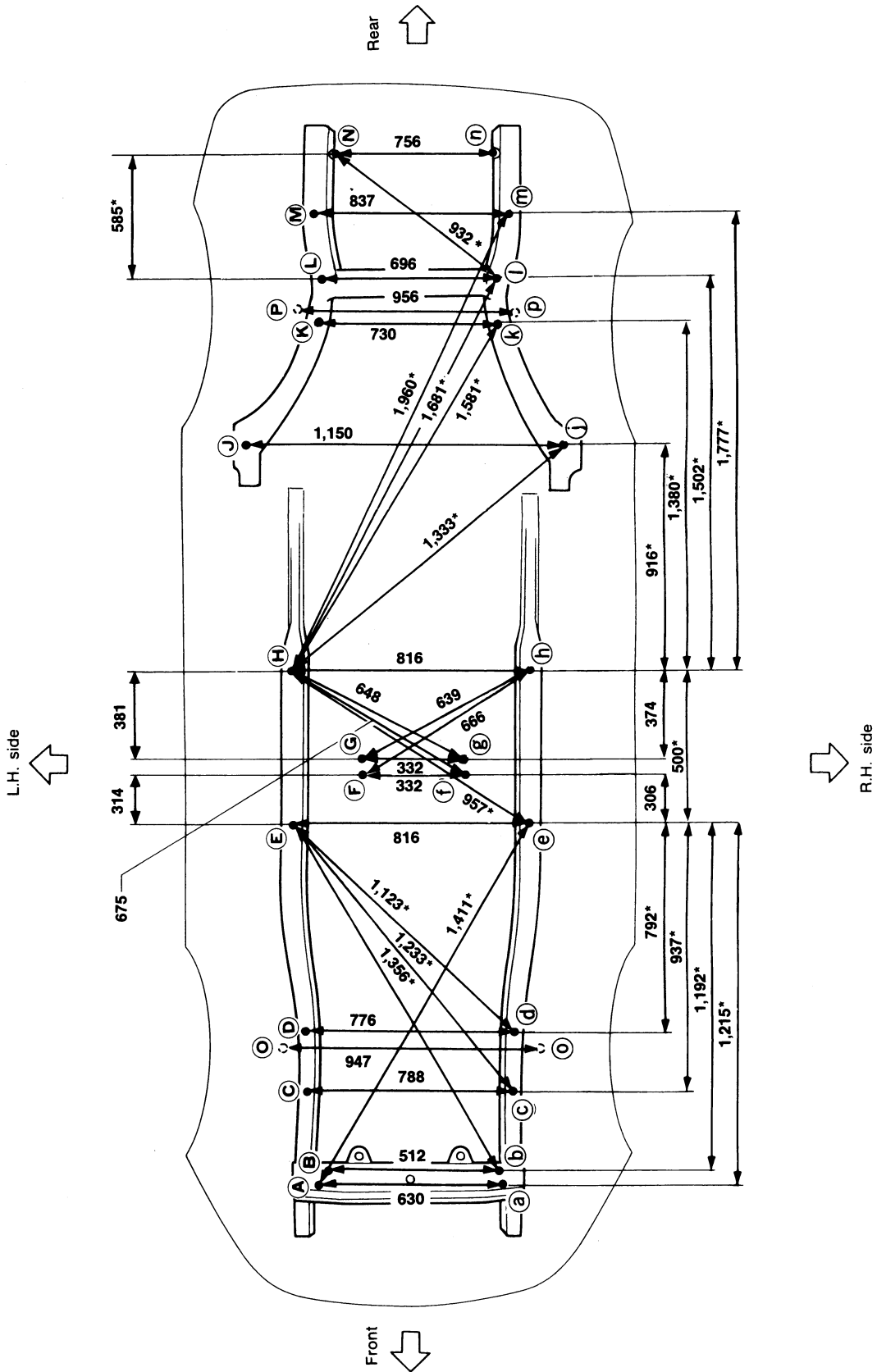

All dimensions indicated in this figure are actual ones. (There are no projected dimensions.)

BODY ALIGNMENT

Underbody (Cont'd)

MEASUREMENT POINTS

2+2 seater model

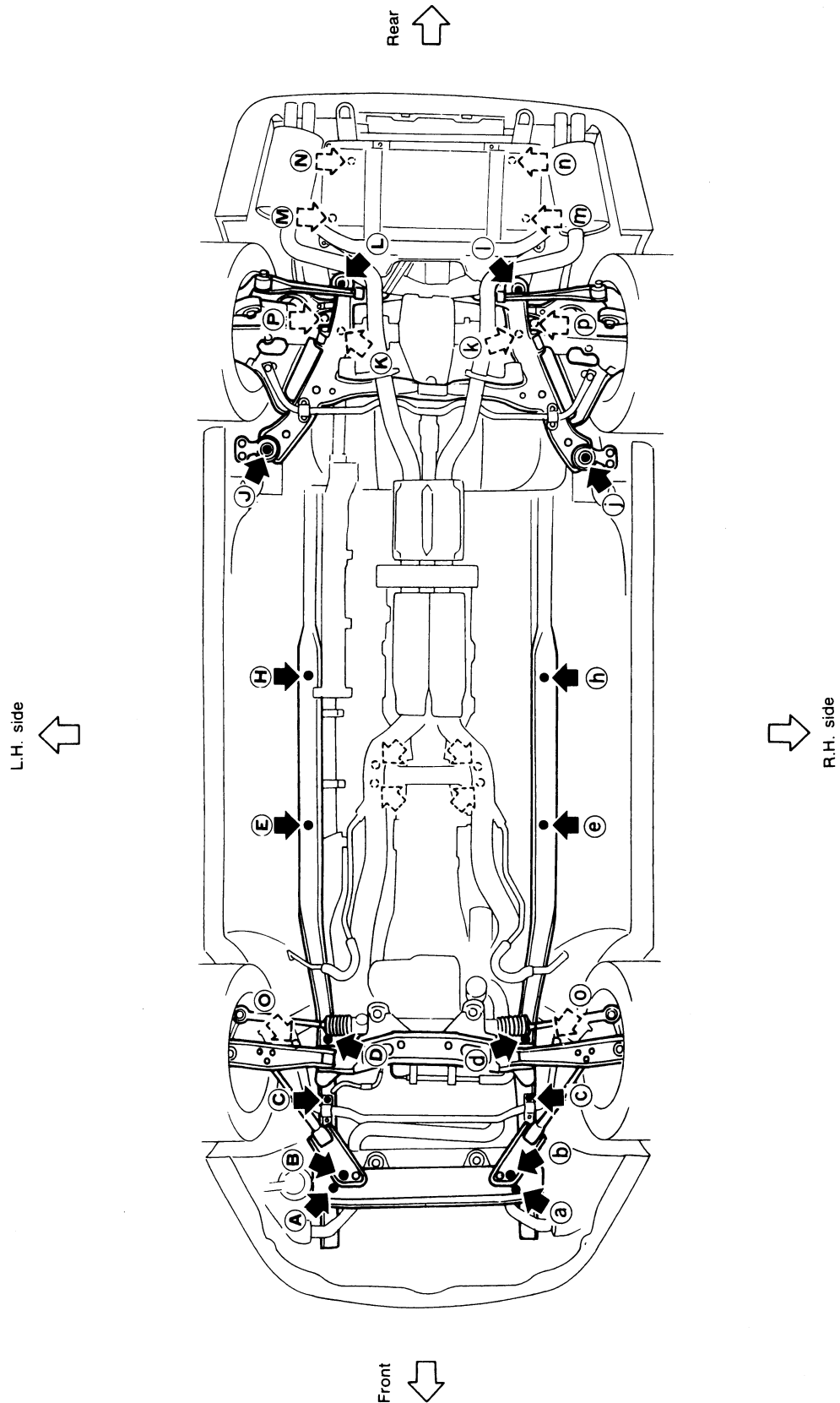

BODY ALIGNMENT

Underbody (Cont'd)

Unit: mm

Front and rear strut tower centers

Coordinates:

(K, k)

X: 473.4

Y: 52.3

Z: 727.2

(L, l)

X: 477.9

Y: 2,489.3

(2 seater model)

2,609.3

(2+2 seater model)

Z: 727.8

Front: (K, k) 82.6 dia.

Rear: (L, l) 46 dia.

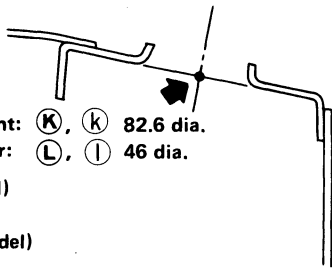

MBF052A

Front side member and front extension

Coordinates:

(A, a)

X: 315

Y: -460

Z: 205.1

(B, b)

X: 255.8

Y: -431

Z: 205.1

(C, c)

X: 394

Y: -170

Z: 330

(D, d)

X: 388

Y: -22

Z: 330

(E, e)

X: 408.2

Y: 750

Z: 152.6

(F)

Y: 161

Y: 917

Z: 249

(f)

X: 171

Y: 917

Z: 249

(G)

X: 161

Y: 977

Z: 249

(g)

X: 171

Y: 977

Z: 249

(H, h)

X: 408.2

Y: 1,250

Z: 152.6

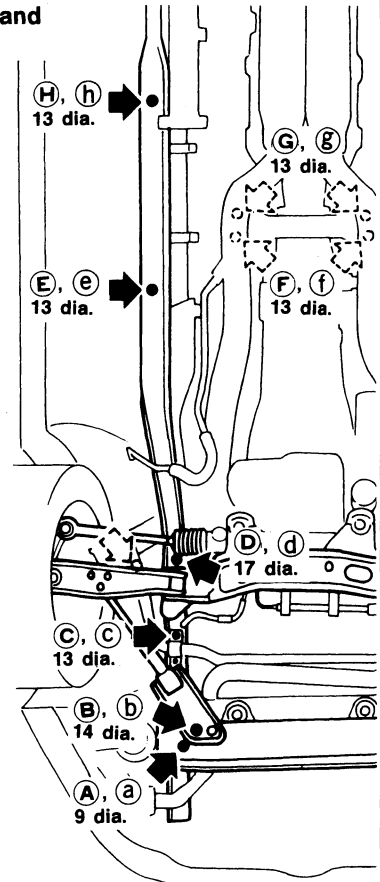

SBF566F

Rear side member and rear extension (2 seater model)

Coordinates:

(I, i)

X: 420

Y: 1,860

Z: 286.1

(J, j)

X: 575

Y: 2,030

Z: 179.1

(K)

X: 430

Y: 2,350

Z: 459.6

(k)

X: 450

Y: 2,350

Z: 459.6

(M, m)

X: 418.5

Y: 2,800

Z: 460

(L, l)

X: 343

Y: 2,620

Z: 334.3

(N, n)

X: 418

Y: 3,153.1

Z: 434.1

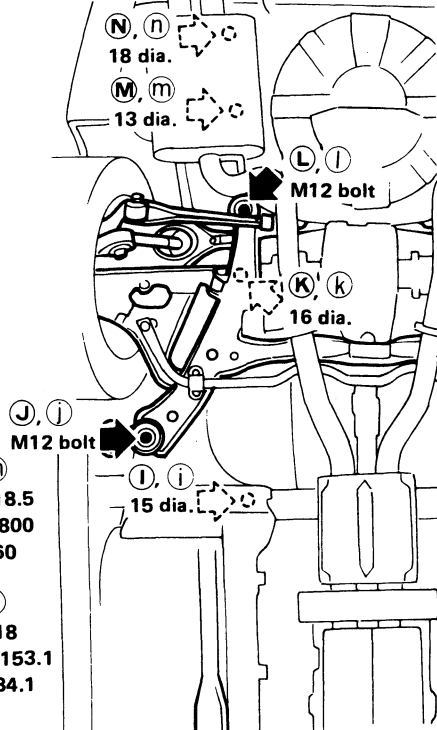

SBF963E

Rear side member and rear extension (2+2 seater model)

Coordinates:

(J, j)

X: 575

Y: 2,150

Z: 180.7

(K, k)

X: 365

Y: 2,625

Z: 259.6

(L, l)

X: 348

Y: 2,740

Z: 334.3

(M, m)

X: 418.5

Y: 3,000

Z: 459.8

(N, n)

X: 378

Y: 3,290

Z: 530

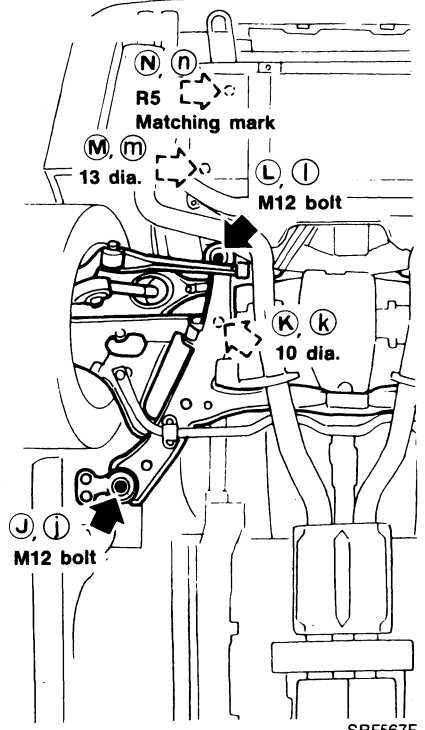

SBF567F

SUPPLEMENTAL RESTRAINT SYSTEM (SRS)

SRS Component Parts Location

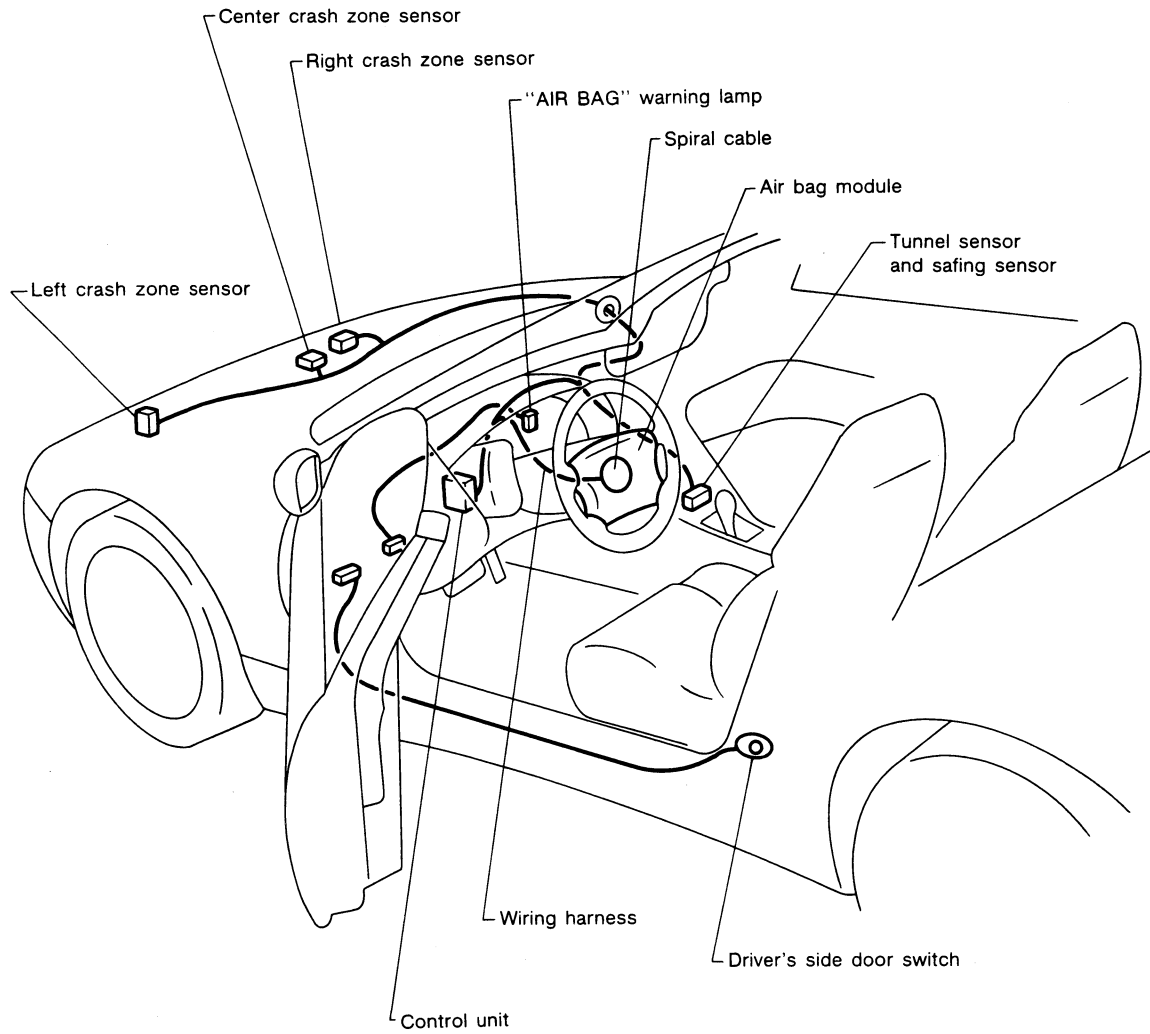

SUPPLEMENTAL RESTRAINT SYSTEM (SRS)

Caution Labels

The CAUTION LABELS are important when servicing air bags in the field. If they are dirty or damaged, replace them with new ones.

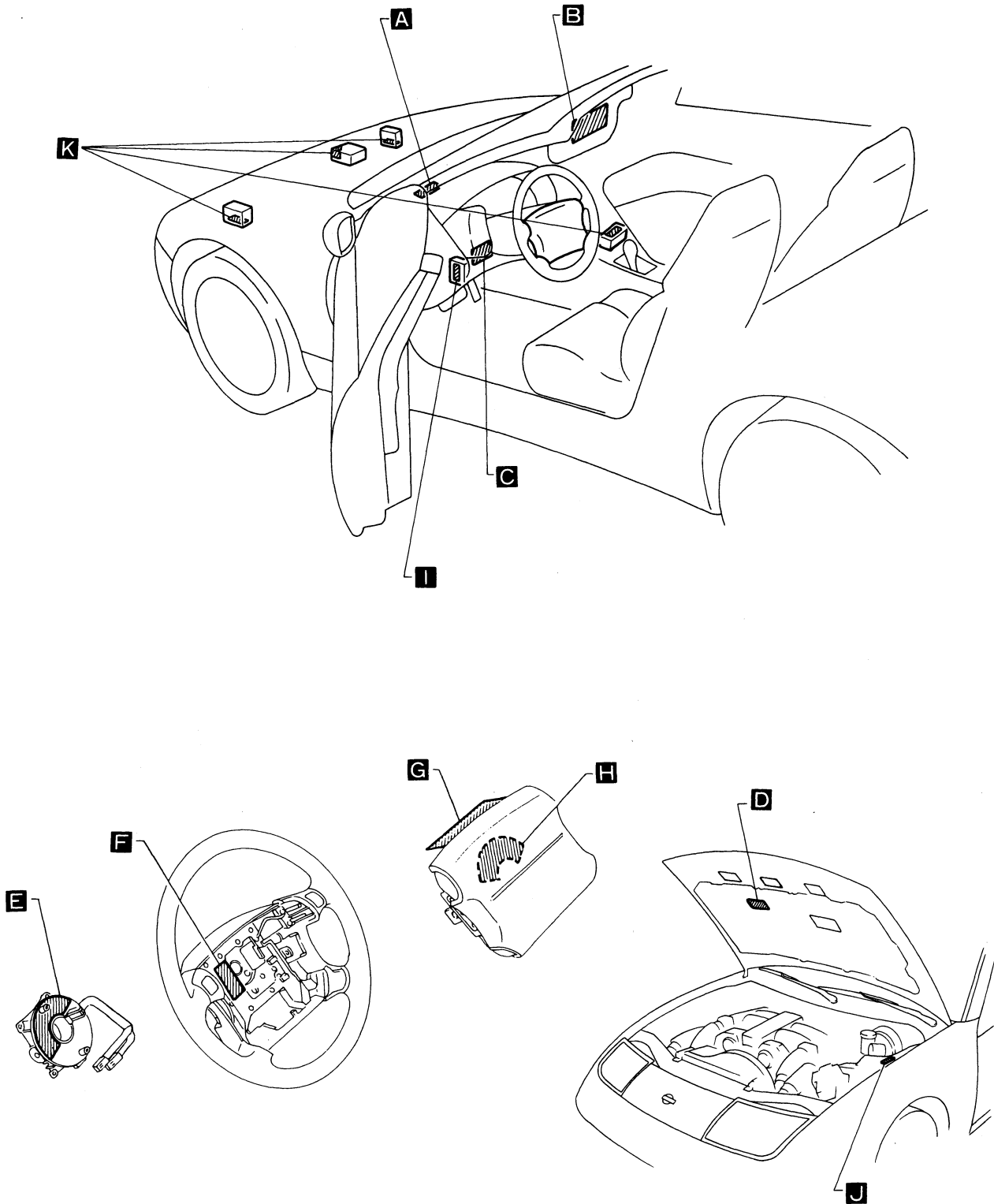

SUPPLEMENTAL RESTRAINT SYSTEM (SRS)

Caution Labels (Cont'd)

A

DRIVER-AIRBAG

B

INFORMATION SRS AIRBAG

- THIS CAR IS EQUIPPED WITH A DRIVER AIR BAG AS A SUPPLEMENTAL RESTRAINT SYSTEM (S.R.S.) TO REDUCE INJURY TO THE DRIVER IN A FRONTAL COLLISION.
- THE SYSTEM IS DESIGNED TO SUPPLEMENT THE ACCIDENT PROTECTION PROVIDED BY THE DRIVER'S SEAT BELT. BUT IT IS NOT A SUBSTITUTE FOR THE BELT SYSTEM.
- ALWAYS WEAR YOUR SEAT BELT WHEN THE CAR IS IN USE.
- THE SYSTEM MUST BE INSPECTED 10 YEARS AFTER DATE OF MANUFACTURE, AS NOTED ON THE CERTIFICATION LABEL LOCATED ON THE LEFT FRONT DOOR.
- THE "AIRBAG" LAMP WILL LIGHT MOMENTARILY WHEN THE IGNITION KEY IS TURNED TO THE "ON" OR "START" POSITION. THIS MEANS THE SYSTEM IS OPERATIONAL.
- HOWEVER, IF ANY OF THE FOLLOWING CONDITIONS OCCUR, THE SYSTEM MUST BE SERVICED:
 1. THE "AIR BAG" LAMP DOES NOT GO ON AS DESCRIBED ABOVE.
 2. THE "AIRBAG" LAMP FLASHES INTERMITTENTLY OR REMAINS ON.
 3. ANY PORTION OF THE FRONT END OF THE CAR IS DAMAGED.
 4. THE AIR BAG HAS DEPLOYED.
- SEE YOUR OWNER'S MANUAL FOR DETAILS ABOUT THE FUNCTIONING, SERVICE, AND DISPOSAL PROCEDURES FOR THE SYSTEM.

C

NOTICE SRS AIRBAG

- THIS CAR IS EQUIPPED WITH A DRIVER AIR BAG AS A SUPPLEMENTAL RESTRAINT SYSTEM (S.R.S.)
- IT IS DESIGNED TO SUPPLEMENT THE SEAT BELT.
- ALWAYS WEAR YOUR SEAT BELT.

D

WARNING SRS AIRBAG

- THIS CAR IS EQUIPPED WITH A DRIVER AIR BAG AS A SUPPLEMENTAL RESTRAINT SYSTEM (S.R.S.)
- ALL S.R.S. ELECTRICAL WIRING AND CONNECTORS ARE COLORED YELLOW.
- DO NOT USE ELECTRICAL TEST EQUIPMENT ON THESE CIRCUITS.
- TAMPERING WITH OR DISCONNECTING THE S.R.S. WIRING AND CONNECTORS COULD RESULT IN ACCIDENTAL DEPLOYMENT OF THE AIR BAG OR MAKE THE SYSTEM INOPERATIVE, WHICH MAY RESULT IN SERIOUS INJURY.

E

CAUTION SRS AIRBAG

- BEFORE ASSEMBLY;
 - LINE UP THE FRONT WHEELS STRAIGHT AHEAD.
 - ALIGN THE ARROW WITH THE YELLOW MARK ON THE SIDE GEAR.
 - READ SERVICE MANUAL.
- NO SERVICEABLE PARTS INSIDE.
- DO NOT DISASSEMBLE OR TAMPER.

F

WARNING SRS AIRBAG

- BEFORE MOUNTING STEERING WHEEL;
- MAKE SURE THAT THE FRONT WHEELS ARE IN STRAIGHT-AHEAD POSITION.
 - ALIGN THE ARROW WITH THE YELLOW MARK ON THE SIDE GEAR. (SPIRAL CABLE)
 - READ SERVICE MANUAL.

SUPPLEMENTAL RESTRAINT SYSTEM (SRS)

Caution Labels (Cont'd)

G

WARNING

SRS AIRBAG

- THIS AIRBAG MODULE CANNOT BE REPAIRED.
- USE DIAGNOSTIC INSTRUCTIONS TO DETERMINE IF THE UNIT IS OPERATIONAL.
- IF NOT OPERATIONAL, REPLACE AND DISPOSE OF THE ENTIRE UNIT AS DIRECTED IN THE INSTRUCTIONS.
- UNDER NO CIRCUMSTANCES SHOULD A DIAGNOSIS BE PERFORMED USING ELECTRICALLY POWERED TEST EQUIPMENT OR PROBING DEVICES.
- TAMPERING OR MISHANDLING CAN RESULT IN PERSONAL INJURY.
- STORE THE REMOVED AIRBAG MODULE WITH THE PAD SURFACE UP.
- FOR SPECIAL HANDLING OR STORAGE REFER TO SERVICE MANUAL.

I

CAUTION SRS AIRBAG

- NO SERVICEABLE PARTS INSIDE.
- DO NOT DISASSEMBLE OR TAMPER.
- DO NOT DROP; KEEP DRY.
- WHILE REMOVED, STORE IN A CLEAN AND DRY AREA.
- IF WET CONDITION OCCURS, THIS UNIT MUST BE SERVICED.

J

CAUTION SRS AIRBAG

- TO AVOID DAMAGING THE S.R.S. SPIRAL CABLE, WHICH COULD MAKE THE SYSTEM INOPERATIVE, REMOVE THE STEERING WHEEL BEFORE REMOVING THE STEERING LOWER JOINT.

H

DANGER POISON

- KEEP OUT OF THE REACH OF CHILDREN.
- CONTAINS SODIUM AZIDE AND POTASSIUM NITRATE.
- CONTENTS ARE POISONOUS AND EXTREMELY FLAMMABLE.
- CONTACT WITH ACID, WATER OR HEAVY METALS MAY PRODUCE HARMFUL AND IRRITATING GASES OR EXPLOSIVE COMPOUNDS.
- DO NOT DISMANTLE, INCINERATE, OR BRING INTO CONTACT WITH ELECTRICITY OR STORE AT TEMPERATURES EXCEEDING 200°F.
- FIRST AID: IF CONTENTS ARE SWALLOWED, INDUCE VOMITING;
 - FOR EYE CONTACT, FLUSH EYES WITH WATER FOR 15 MINUTES
 - IF GASES FROM ACID OR WATER CONTACT ARE INHALED, SEEK FRESH AIR
 - IN EVERY CASE, GET PROMPT MEDICAL ATTENTION
- FOR ADDITIONAL INFORMATION, SEE MATERIAL SAFETY DATA SHEET (MSDS) FOR THIS PRODUCT.

K

WARNING

SRS AIRBAG

- DO NOT DISASSEMBLE OR TAMPER.
- DISMANTLING AND INSTALLATION SHOULD ONLY BE PERFORMED BY TRAINED PERSONNEL.

SUPPLEMENTAL RESTRAINT SYSTEM (SRS)

**AIR
BAG**

SBF806E

Maintenance Items

1. Check "AIR BAG" warning lamp
When the ignition key is in the "ON" or "START" position, the "AIR BAG" warning lamp will illuminate for about 7 seconds and then turn off. This means that the system is operational.

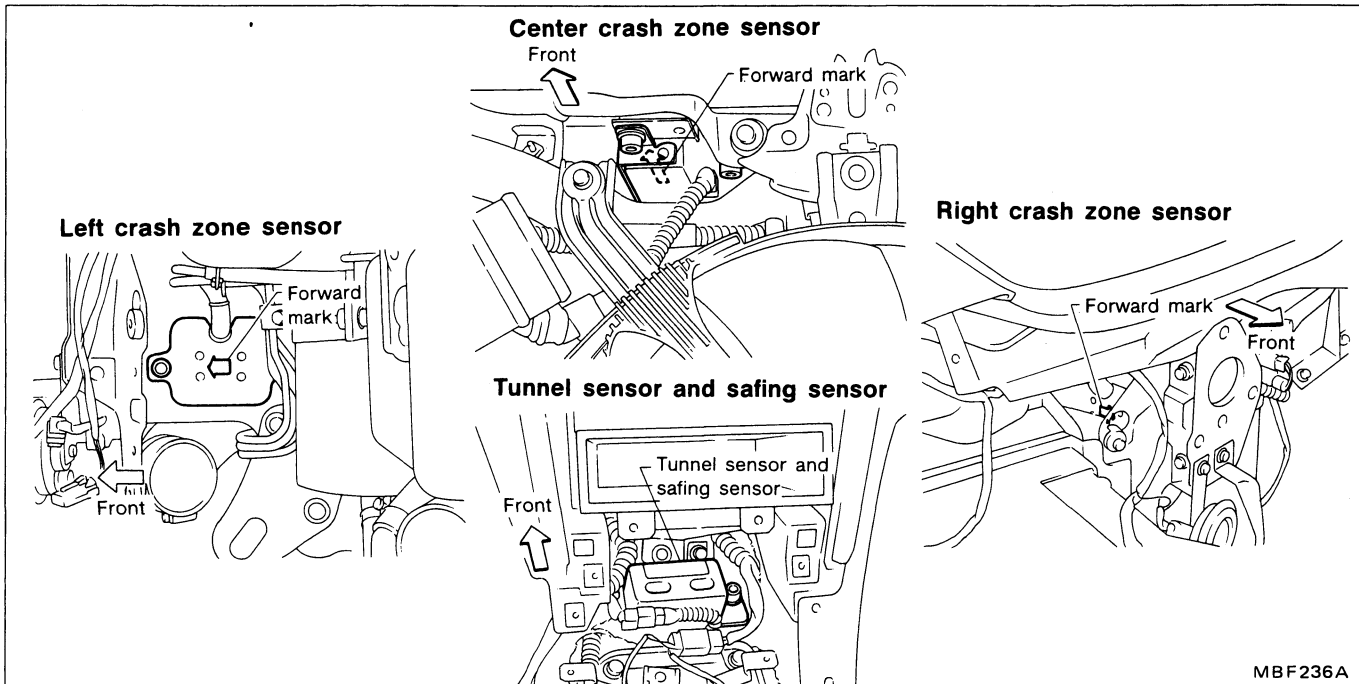

MBF236A

2. Visually check SRS components
 - (1) Sensors
 - Check sensors to ensure the arrow marks face the front of the vehicle.
 - Check body and sensor brackets for deformities or rust.
 - Check sensor case for dents, cracks, deformities or rust.
 - Check sensor harness for binds, connector for damage, and terminals for deformities.
 - (2) Control unit — Airbag
 - Check case and bracket for dents, cracks or deformities.
 - Check connectors for damage, and terminals for deformities.
 - (3) Main harness and instrument harness
 - Check connectors for poor connections.
 - Check harnesses for binds, connectors for damage, and terminals deformities.
 - (4) Spiral cable
 - Visually check lock (engagement) pins and combination switch for damage.
 - Check connectors, flat cable and protective tape for damage.
 - Check steering wheel for noise, binds or difficult operation.

SUPPLEMENTAL RESTRAINT SYSTEM (SRS)

Maintenance Items (Cont'd)

(5) Steering wheel

- Check harness (built into steering wheel) and connectors for damage, and terminals for deformities.
- Install air bag module to check fit or alignment with steering wheel.
- Check steering wheel for excessive free play.

(6) Air bag module

- Remove air bag module from steering wheel. Check harness cover and connectors for damage, terminals for deformities, and harness for binds.
- Install air bag module to steering wheel to check fit or alignment with the wheel.

CAUTION:

Replace previously used screws with new ones.

SUPPLEMENTAL RESTRAINT SYSTEM (SRS)

Removal and Installation — Control Unit and Sensors

CAUTION:

- Before servicing SRS, turn the ignition switch off, disconnect battery ground cable and wait for at least 10 minutes.
- The special bolts are coated with bonding agent. Discard old ones after removal; replace with new ones.
- Check all sensors for proper installation.
- Check all sensors to ensure they are free of deformities, dents, cracks or rust. If they show any visible signs of damage, replace them with new ones.
- Check sensor brackets to ensure they are free of deformities or rust.

Center crash zone sensor

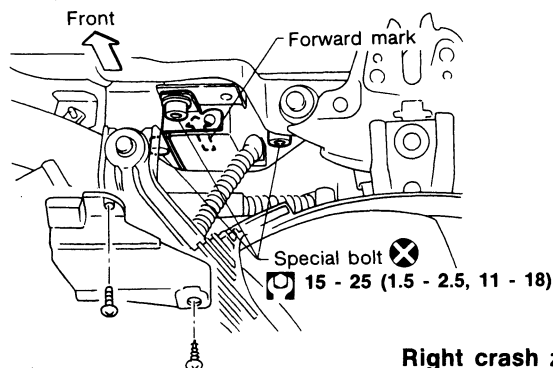

Left crash zone sensor

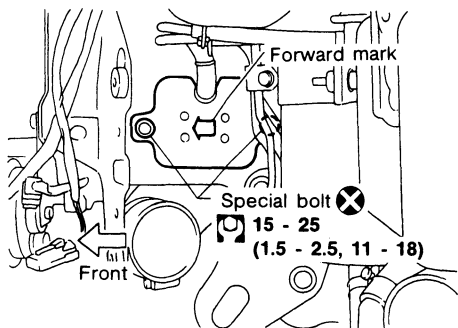

Right crash zone sensor

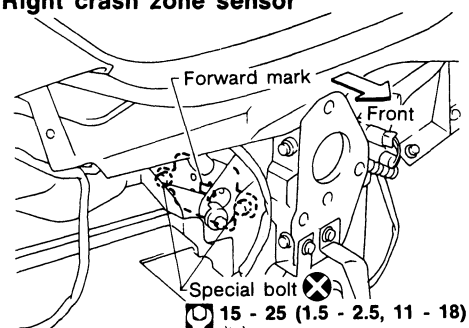

Control unit

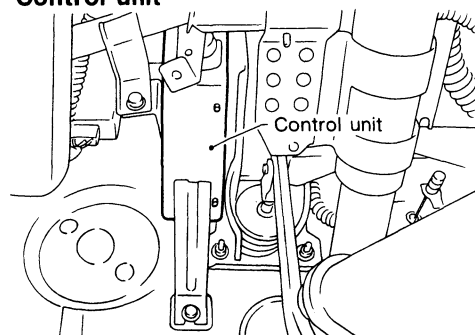

Tunnel sensor and safing sensor

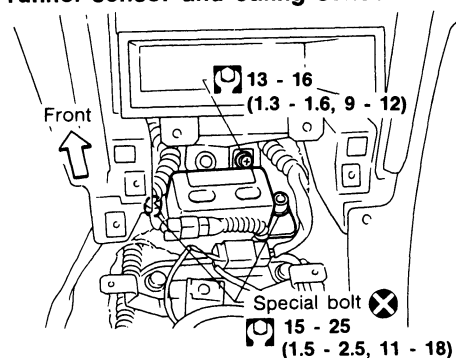

 : N·m (kg-m, ft-lb)

SUPPLEMENTAL RESTRAINT SYSTEM (SRS)

Removal — Air Bag Module and Spiral Cable

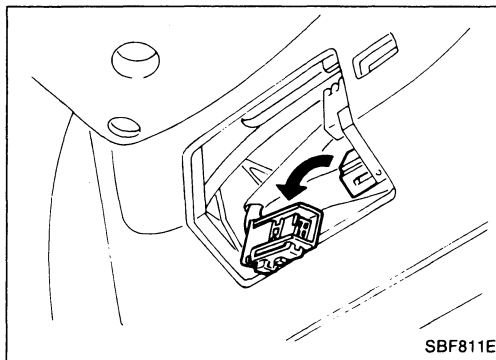
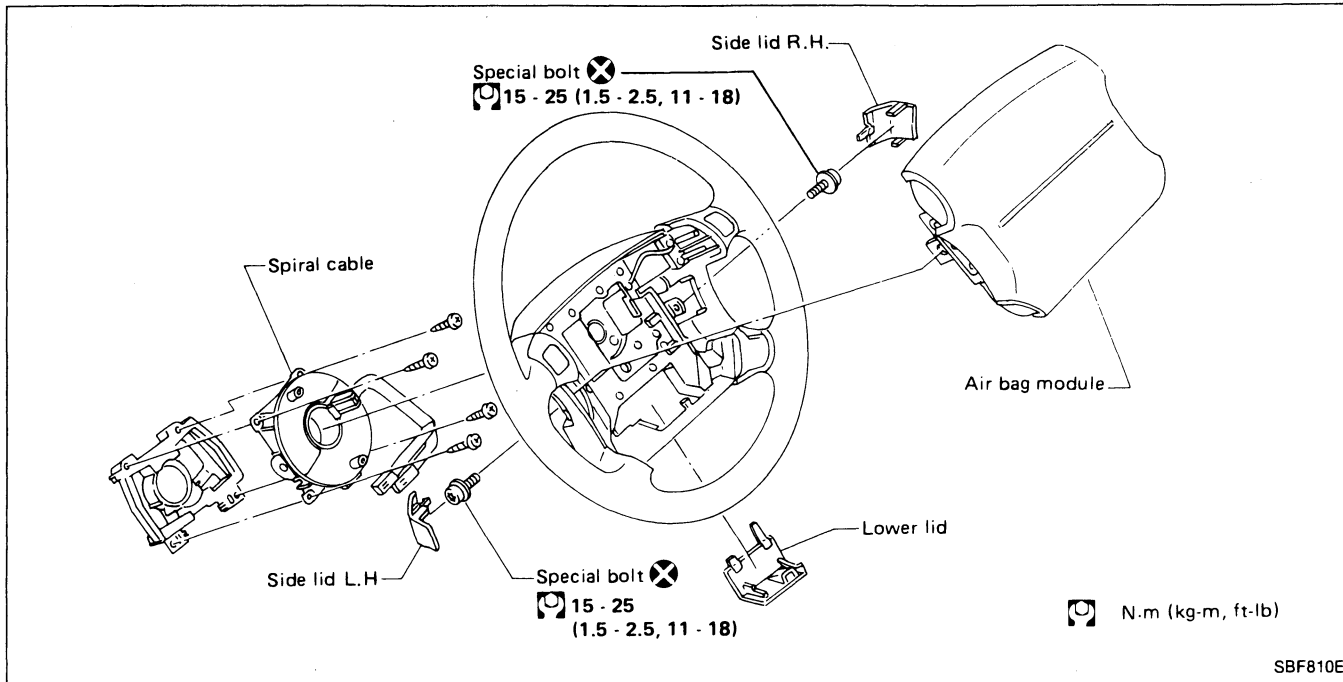

CAUTION:

Before servicing SRS, turn the ignition switch off, disconnect battery ground cable and wait for at least 10 minutes.

1. Remove lower lid from steering wheel, and disconnect air bag module connector.

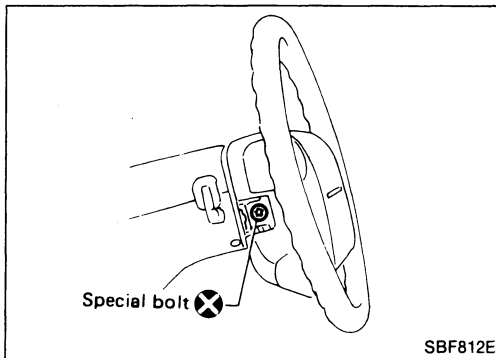

2. Remove side lid. Using the T50H torx bit, remove left and right special bolts. Air bag module can then be removed.

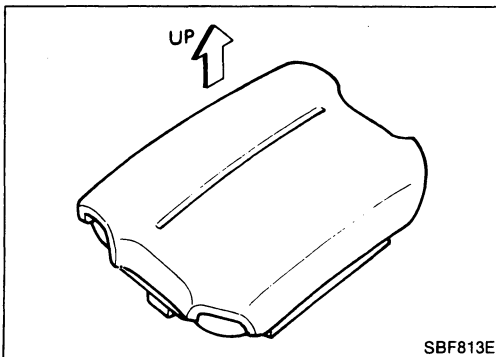

CAUTION:

- Always place air bag module with pad side facing upward.
- Do not attempt to disassemble air bag module.
- The special bolts are coated with bonding agent. Discard old ones after removal; replace with new ones.

Contents

Schematic	BF-64
Wiring Diagram	BF-65
Self-diagnosis	BF-66
USING CONSULT	BF-66
USING THE WARNING LAMP	BF-69
Diagnostic Procedure 1	BF-72
SYMPTOM: Warning lamp flashes.	
Diagnostic Procedure 2	BF-72
SYMPTOM: Warning lamp does not come on.	
Diagnostic Procedure 3	BF-73
SYMPTOM: Warning lamp does not go off.	
Collision Diagnosis	BF-74

Schematic

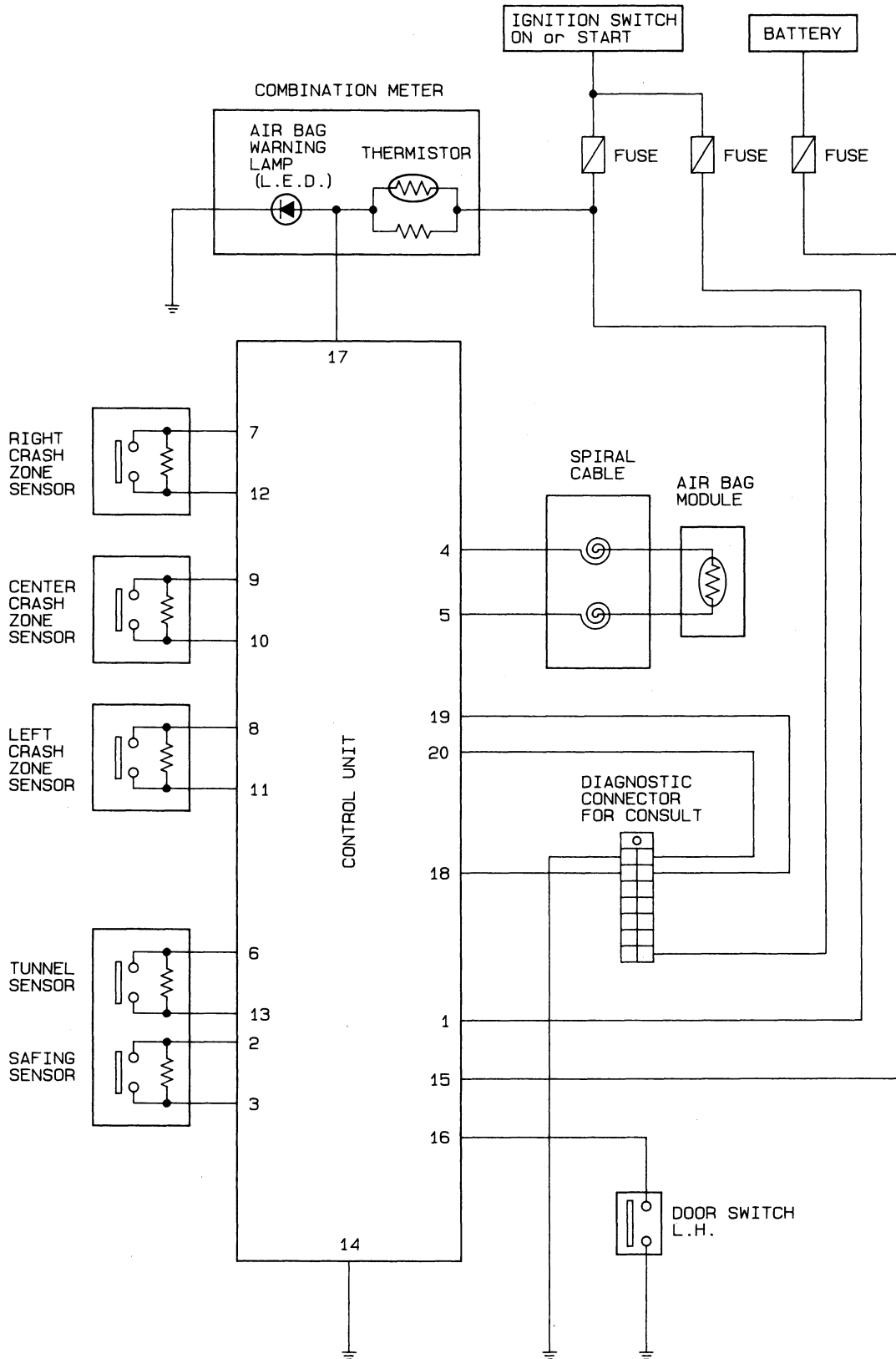

Wiring Diagram

CAUTION:

- Do not use a circuit tester to check SRS "Air Bag" harness connectors. The wiring harness and connectors have yellow outer insulation for easy identification.
- Do not attempt to repair, splice or modify the SRS "Air Bag" wiring harness. If the harness is damaged, replace it with a new one.
- Keep ground portion clean.

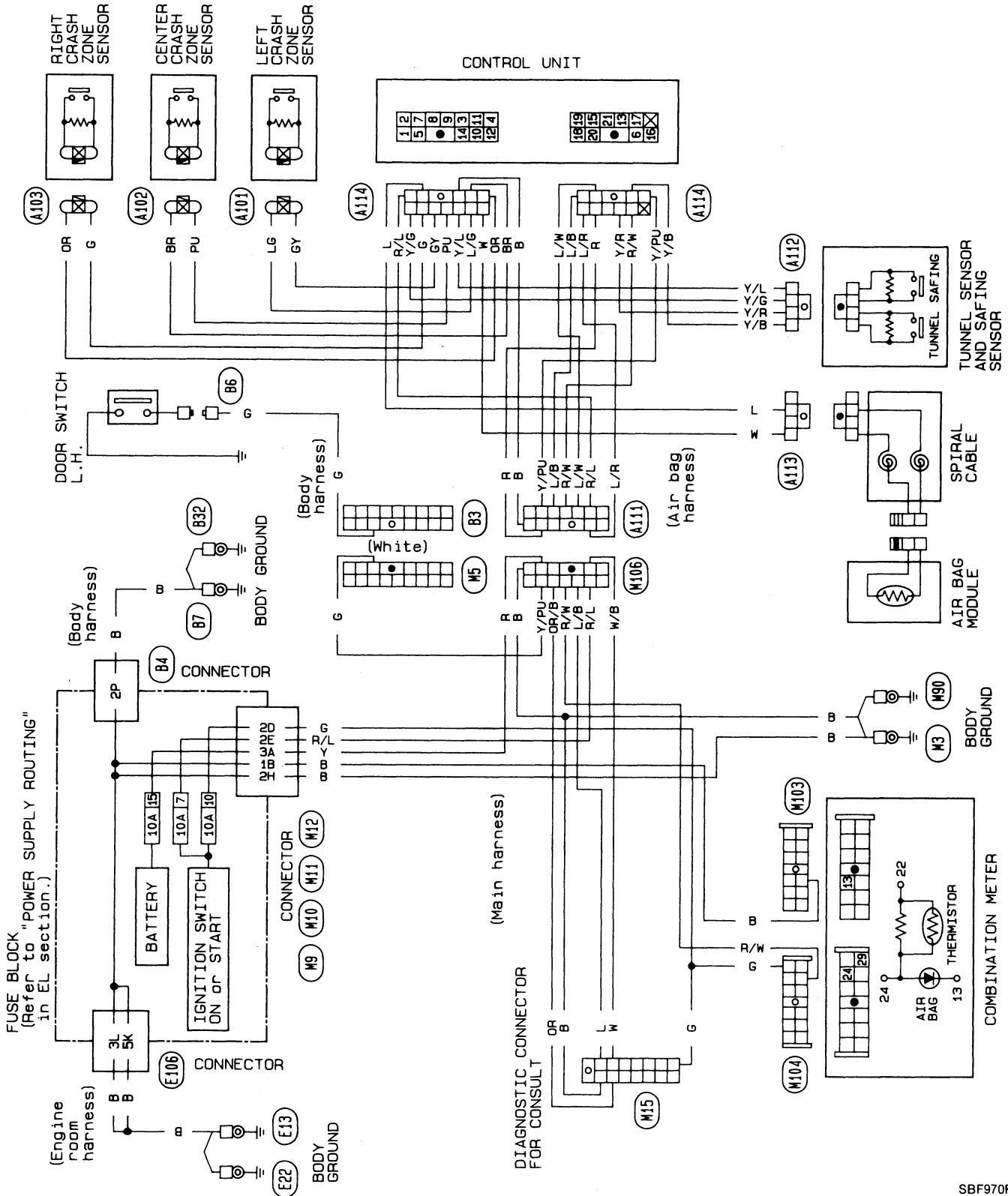

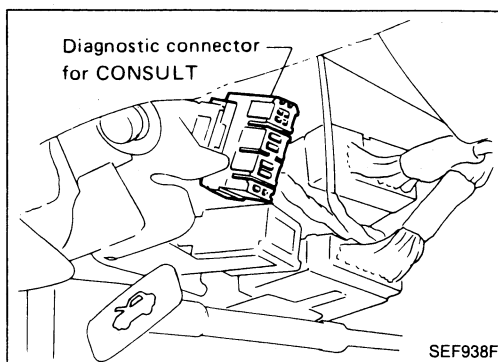

Self-diagnosis

USING CONSULT

The self-diagnosis results can be read by CONSULT, as follows:

1. Connect "CONSULT" to vehicle harness connector.



2. Turn ignition switch to "ON". (When CONSULT is connected, the "AIR BAG" warning lamp will be turned to present diagnosis mode.)



3. Touch "START" to operate "CONSULT".



4. Touch "AIR BAG" to choose air bag system.



5. Touch "SELF DIAG RESULTS" to read self-diagnosis results.



6. Problem codes are displayed on "SELF DIAG RESULT 1" (first page — present mode). The problem code last indicated is displayed on "SELF DIAG RESULT 2" (second page — initial mode).



7. When "PRINT" is pressed, information displayed on "SELF DIAG RESULTS 1 and 2" is printed out.



8. After repairing malfunctioning parts, press "ERASE" to clear self-diagnosis results.

- **After repairing malfunctioning parts, attempt to clear self-diagnosis results from memory.**
- **If malfunctioning parts are not completely repaired, self-diagnosis results remain stored in memory.**



9. Push Back Key of CONSULT until SELECT SYSTEM mode appears to make "SELF-DIAGNOSIS" user mode.



10. Push the power off switch.



11. Turn off ignition switch.

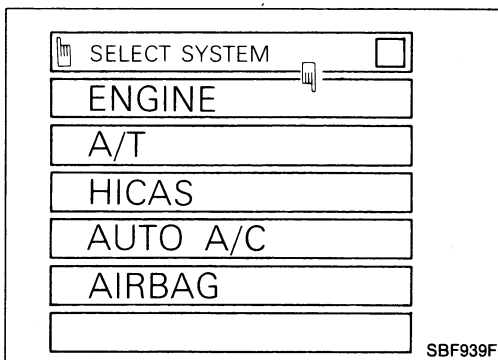

TROUBLE DIAGNOSES — Supplemental Restraint System (SRS)

Self-diagnosis (Cont'd)

Self-diagnosis results

Failure parts group [Present] and [Initial]	Explanation	Repair order * Recheck SRS at each replacement.
**** NO SELF DIAGNOSTIC FAILURE ****	Normal. The SRS "Air Bag" is in good order.	—
SAFING SENSOR [OPEN/LWR-GND-SHORT]	The circuit for the safing sensor is open or the wire from the safing sensor to the control unit (terminal No. 3) is shorted.	1. Visually check the wiring harness connections. 2. Replace the safing sensor.
SAFING SENSOR [SHORT/LWR-VB-SHORT]	Both the wires for the safing sensor are shorted or the wire from the safing sensor to the control unit (terminal No. 3) is shorted to some power supply circuit.	(safing sensor and tunnel sensor unit) 3. Replace the control unit. 4. Replace the main harness.
AIRBAG MODULE [OPEN]	The circuit for the air bag module is open. (including the spiral cable)	1. Visually check the wiring harness connections. 2. Replace the spiral cable.
AIRBAG MODULE [VB-SHORT]	The circuit for the air bag module is shorted to some power supply circuit. (including the spiral cable)	3. Replace the air bag module. (Before disposing of it, it must be deployed.)
AIRBAG MODULE [GND-SHORT]	The circuit for the air bag module is shorted. (including the spiral cable)	4. Replace the control unit. 5. Replace the main harness.
TUNNEL SENSOR [OPEN/UPR-VB-SHORT]	The circuit for the tunnel sensor is open or the wire from the control unit (terminal No. 6) to the tunnel sensor is shorted to some power supply circuit.	1. Visually check the wiring harness connections. 2. Replace the tunnel sensor.
TUNNEL SENSOR [SHORT]	The circuits for the tunnel sensor are shorted to each other.	(safing sensor and tunnel sensor unit) 3. Replace the control unit. 4. Replace the main harness.
CRASH ZONE SEN-RH [OPEN/UPR-VB-SHORT]	The circuit for the right crash zone sensor is open or the wire from the control unit (terminal No. 7) to the right crash zone sensor is shorted to some power supply circuit.	1. Visually check the wiring harness connections. 2. Replace the right crash zone sensor.
CRASH ZONE SEN-RH [SHORT]	The circuits for the right crash zone sensor are shorted to each other.	3. Replace the control unit. 4. Replace the main harness.
CRASH ZONE SEN-LH [OPEN/UPR-VB-SHORT]	The circuit for the left crash zone sensor is open or the wire from the control unit (terminal No. 8) to the left crash zone sensor is shorted to some power supply circuit.	1. Visually check the wiring harness connections. 2. Replace the left crash zone sensor.
CRASH ZONE SEN-LH [SHORT]	The circuits for the left crash zone sensor are shorted to each other.	3. Replace the control unit. 4. Replace the main harness.
CRASH ZONE SEN-CTR [OPEN/UPR-VB-SHORT]	The circuit for the center crash zone sensor is open or the wire from the control unit (terminal No. 9) to the center crash zone sensor is shorted to some power supply circuit.	1. Visually check the wiring harness connections. 2. Replace the center crash zone sensor.
CRASH ZONE SEN-CTR [SHORT]	The circuits for the center crash zone sensor are shorted to each other.	3. Replace the control unit. 4. Replace the main harness.
CONTROL UNIT	The control unit (diagnostic unit) is out of order.	1. Visually check the wiring harness connections. 2. Replace the control unit. 3. Replace the main harness.

TROUBLE DIAGNOSES — Supplemental Restraint System (SRS)

Self-diagnosis (Cont'd)

Failure parts group [Present] and [Initial]	Explanation	Repair order * Recheck SRS at each replacement.
INDEFINITE FAILURES	A problem which cannot be specified occurs because more than two parts are out of order.	<ol style="list-style-type: none">1. See the SELF-DIAGNOSIS RESULT 2 failure parts group [initial], then repair as necessary.2. Visually check the wiring harness connections.3. Replace the control unit.4. Replace all sensors, the spiral cable and air bag module.5. Replace the main harness.

TROUBLE DIAGNOSES — Supplemental Restraint System (SRS)

Self-diagnosis (Cont'd)

USING THE WARNING LAMP

Self-diagnosis results can be also read by using the "AIR BAG" warning lamp.

The "Air bag" warning lamp operates as shown below:

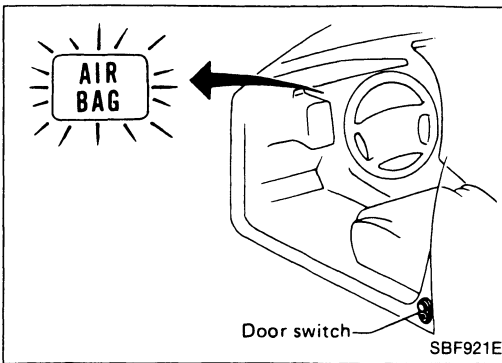

How to alternate self-diagnosis

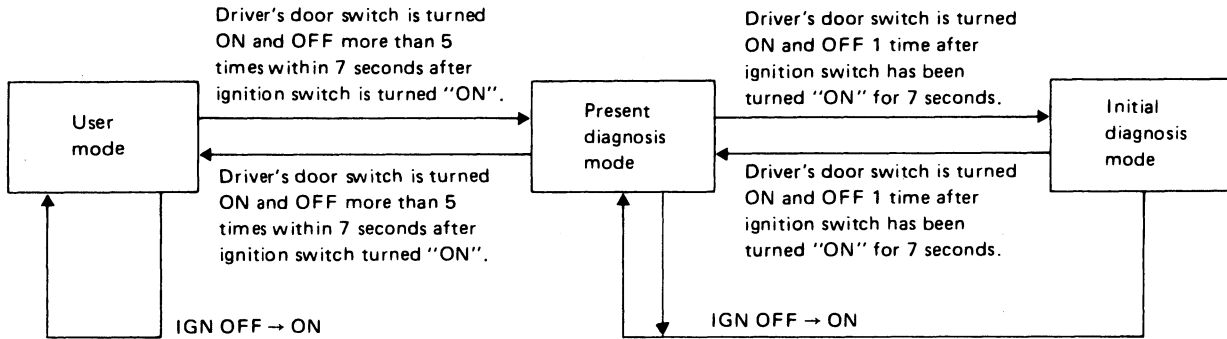

Problem codes are displayed in present diagnosis mode (self-diagnosis result 1). The problem code last indicated is displayed in initial diagnosis mode (self-diagnosis result 2).

After the malfunctioning parts have been repaired and the system is returned to the user mode, the present diagnosis mode information, displayed as self-diagnosis results, is automatically cleared from memory.

- After repairing malfunctioning part, attempt to clear self-diagnosis results from memory.
- If a malfunctioning part is not completely repaired, information stored in memory will not be cleared.

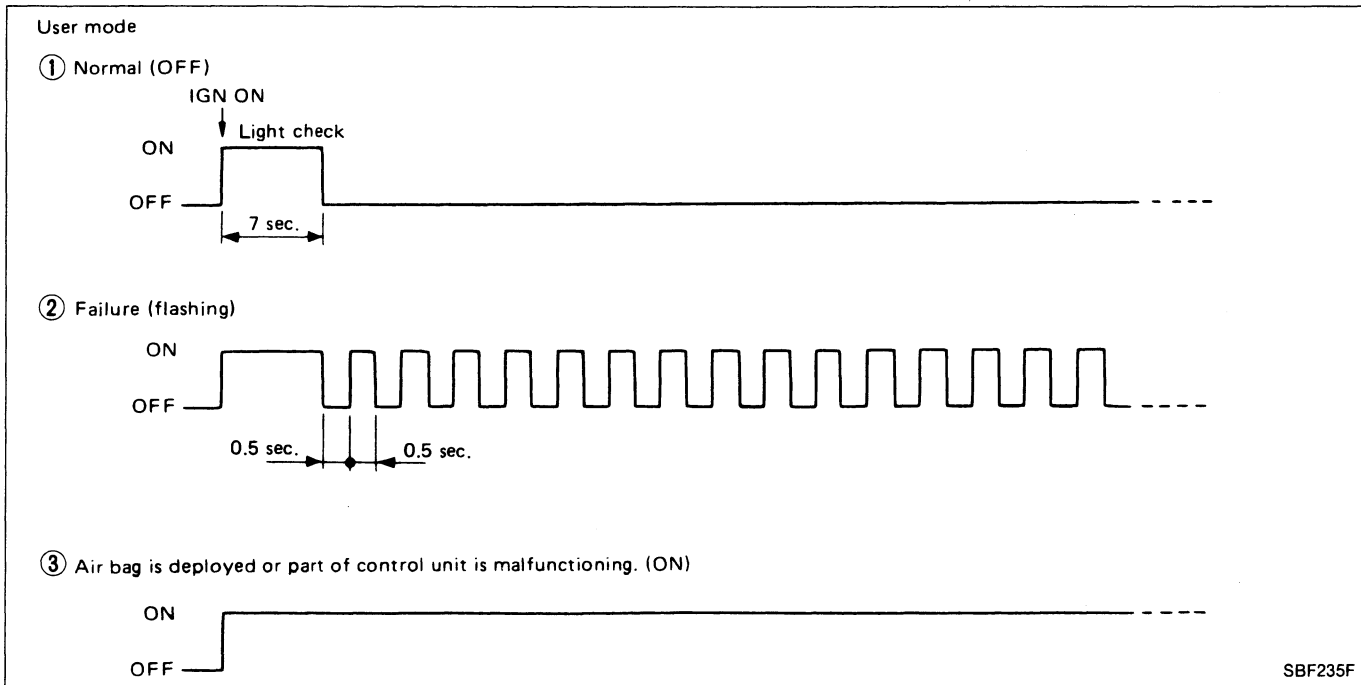

TROUBLE DIAGNOSES — Supplemental Restraint System (SRS)

Self-diagnosis (Cont'd)

Present diagnosis mode (self-diagnosis result 1)

(b) Start signal; Start signal identifies display modes.

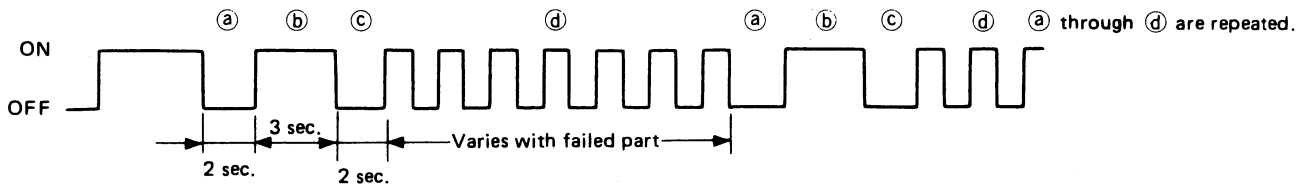

• No failure (or intermittent failure/repair completion)

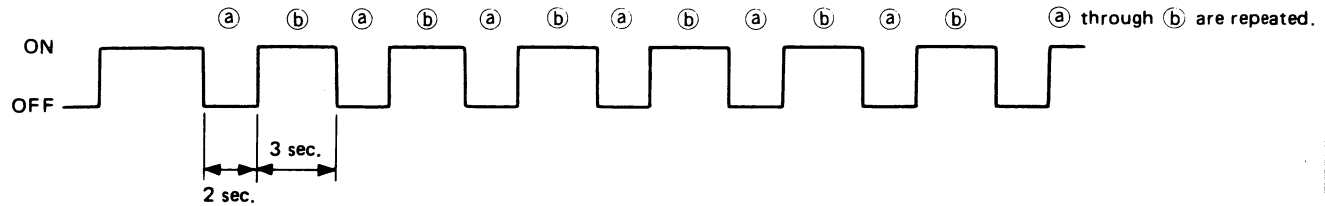

SBF236F

Initial diagnosis mode (self-diagnosis result 2)

(b) Start signal; Start signal identifies display modes.

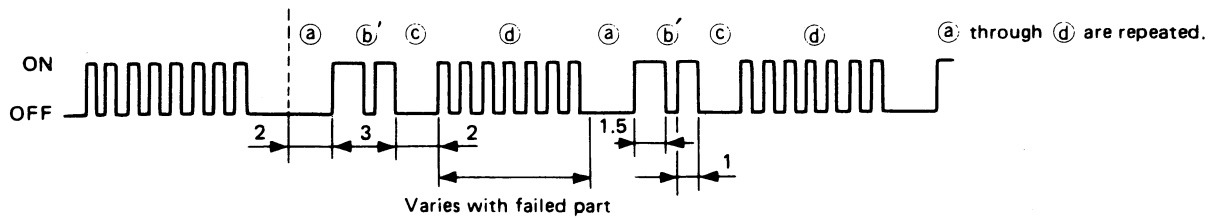

Unit: sec.

• No failure

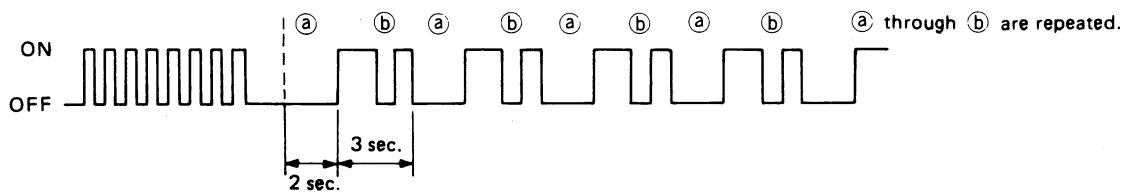

SBF237F

Self-diagnosis results in present- and initial-diagnosis modes can be identified by number of flashes (d). Refer to Table on next page for failed parts.

TROUBLE DIAGNOSES — Supplemental Restraint System (SRS)

Self-diagnosis (Cont'd)

Warning lamp flashing times and repair

Flash code ④ (# of flashes)	Explanation	Repair order * Recheck SRS at each replacement.
0	Normal. The SRS "Air Bag" is in good order.	—
1	The circuit for the safing sensor is out of order.	<ol style="list-style-type: none"> 1. Visually check the wiring harness connections. 2. Replace the safing sensor. (safing sensor and tunnel sensor unit) 3. Replace the control unit. 4. Replace the main harness.
2	The circuit for the air bag module is out of order.	<ol style="list-style-type: none"> 1. Visually check the wiring harness connections. 2. Replace the spiral cable. 3. Replace the air bag module. (Before disposing of it, it must be deployed.) 4. Replace the control unit. 5. Replace the main harness.
3	The circuit for the tunnel sensor is out of order.	<ol style="list-style-type: none"> 1. Visually check the wiring harness connections. 2. Replace the tunnel sensor. (safing sensor and tunnel sensor unit) 3. Replace the control unit. 4. Replace the main harness.
4	The circuit for the right crash zone sensor is out of order.	<ol style="list-style-type: none"> 1. Visually check the wiring harness connections. 2. Replace the right crash sensor. 3. Replace the control unit. 4. Replace the main harness.
5	The circuit for the left crash zone sensor is out of order.	<ol style="list-style-type: none"> 1. Visually check the wiring harness connections. 2. Replace the left crash zone sensor. 3. Replace the control unit. 4. Replace the main harness.
6	The circuit for the center crash zone sensor is out of order.	<ol style="list-style-type: none"> 1. Visually check the wiring harness connections. 2. Replace the center crash zone sensor. 3. Replace the control unit. 4. Replace the main harness.
7	The control unit (diagnostic unit) is out of order.	<ol style="list-style-type: none"> 1. Visually check the wiring harness connections. 2. Replace the control unit. 3. Replace the main harness.
8	More than two parts groups are out of order.	<ol style="list-style-type: none"> 1. See the SELF-DIAGNOSIS RESULT 2 failure parts group [Initial], then repair it. 2. Visually check the wiring harness connections. 3. Replace the control unit. 4. Replace all sensors, spiral cable and air bag module. 5. Replace the main harness.

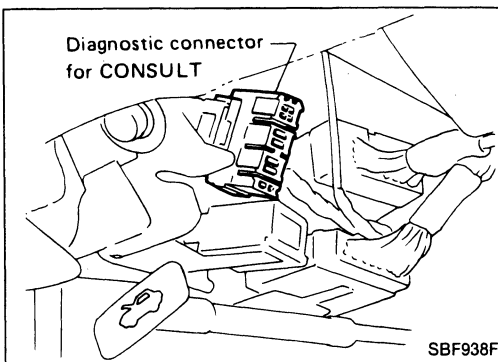

Diagnostic Procedure 1

SYMPTOM: Warning lamp flashes.

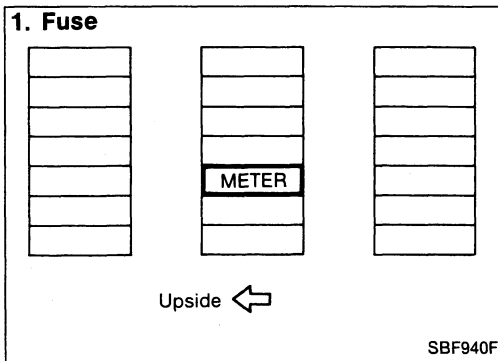
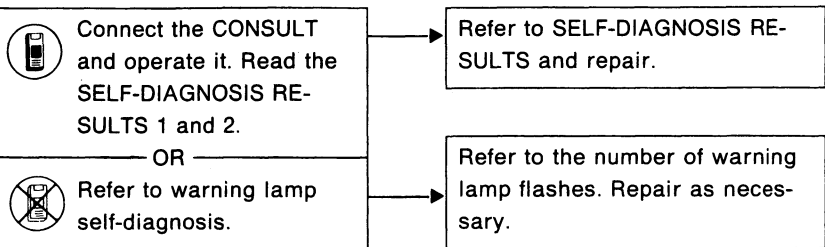

Diagnostic Procedure 2

SYMPTOM: Warning lamp does not come on.

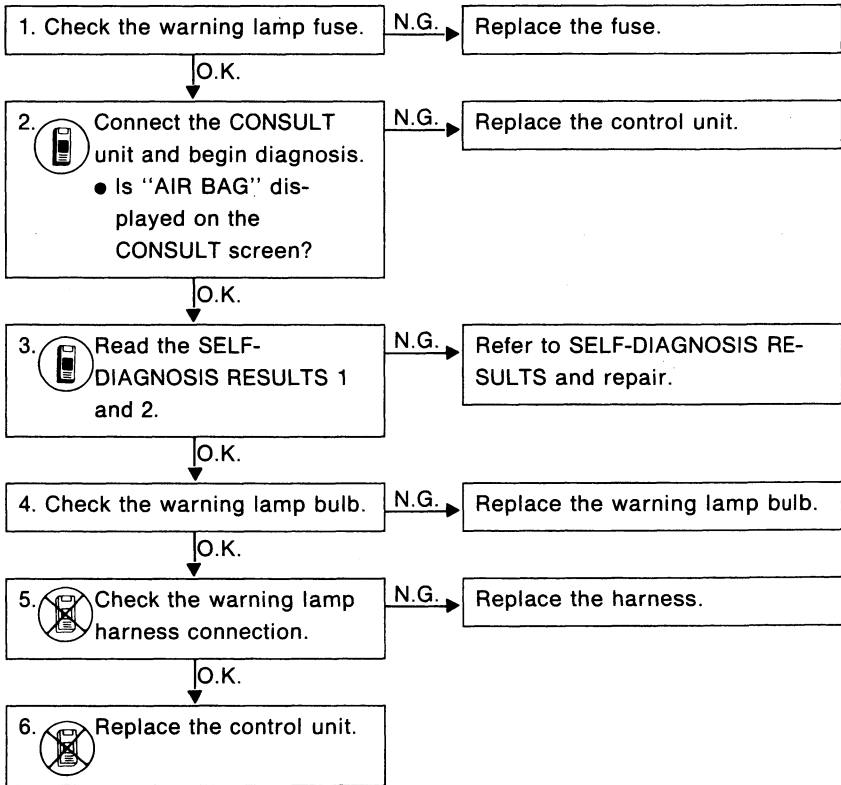
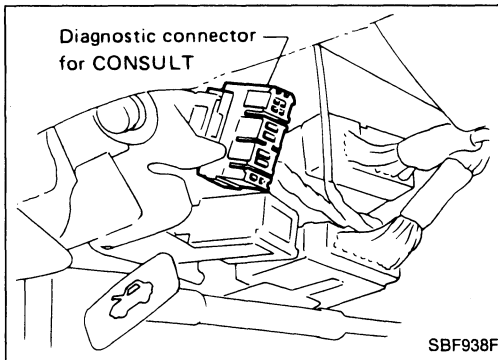

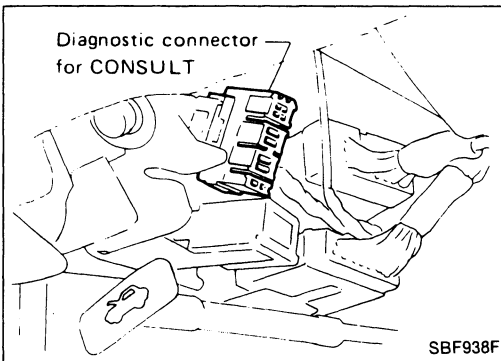
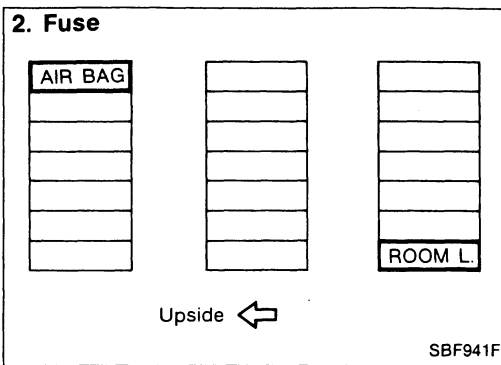

Diagnostic Procedure 3

SYMPTOM: Warning lamp does not go off.

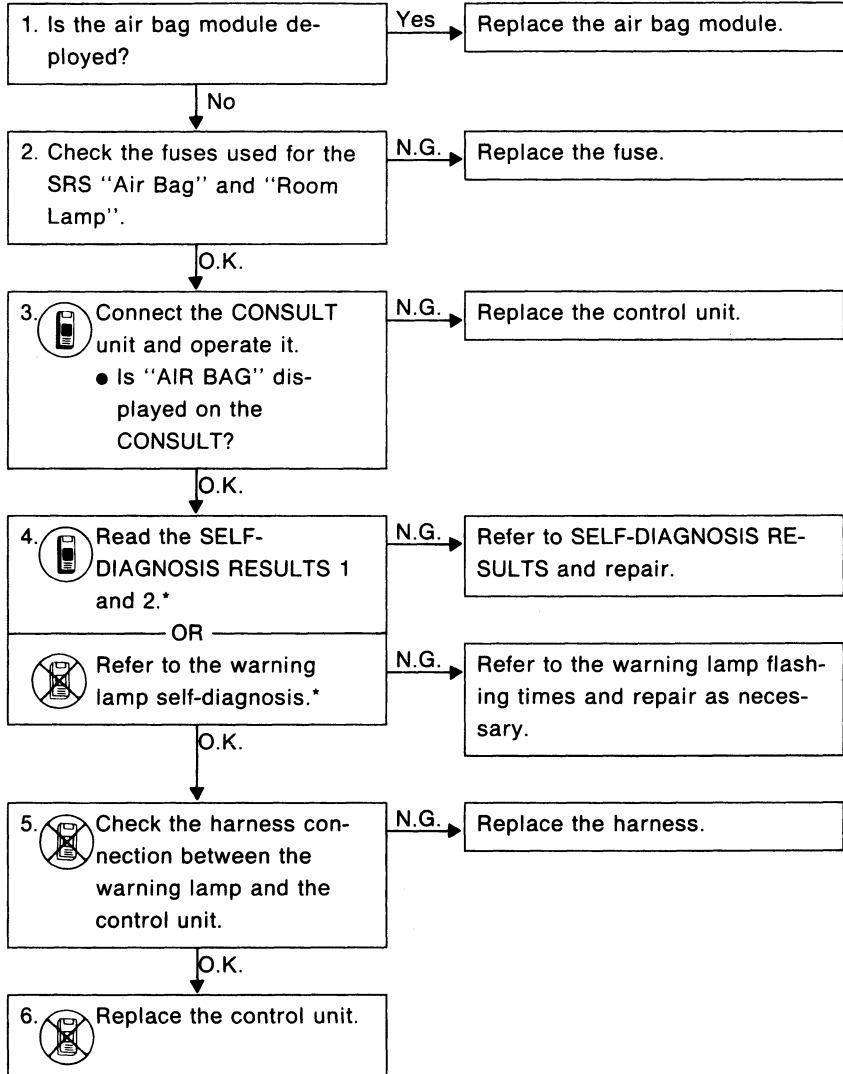

* Recheck SRS after each replacement.

Collision Diagnosis

To repair the SRS "AIR BAG", perform the following steps.

- ① Check the control unit (diagnostic unit).
 - Connect CONSULT and then erase the memory. (However, the memory may not be cleared.)

OR

- Check "AIR BAG" warning lamp and perform the following twice: turn driver's door switch ON and OFF 5 times within 7 seconds after ignition switch turned "ON".

↓
If "AIR BAG" warning lamp comes on continuously.

Replace the control unit.

- ② Remove the deployed air bag module.
- ③ Check the SRS components using the table shown below:
 - If the SRS components are showing any visible damage such as dents, cracks, or deformation, replace them with new ones.
- ④ Conduct self-diagnosis using CONSULT or "AIR BAG" warning lamp to ensure entire SRS operates properly except open circuit of air bag module.
- ⑤ Install new air bag module.

	Inspection (when air bag deploys in collision)	Inspection (when air bag does not deploy in low-speed collision)
Steering wheel	(1) Check harness (built into steering wheel) and connectors for damage, and terminals for deformities. (2) Install air bag module to check fit or alignment with steering wheel. (3) Check steering wheel for excessive free play.	
In-compartment sensor	(1) Check body and sensor brackets for deformities or rust. (2) Check sensor case for dents, cracks, deformities or rust. (3) Check sensor harness for binds, connector for damage, and terminals for deformities.	
All sensors (except those affected by collision)		
Air bag module	Replace air bag module.	(1) Remove air bag module from steering wheel. Check harness cover and connectors for damage, terminals for deformities, and harness for binds. (2) Install air bag module to steering wheel to check fit or alignment with the wheel. (3) Replace screws with new ones.
Harness connector (Main and Instrument harness)	(1) Check connectors for poor connections. (2) Check harness for binding, connectors for damage, and terminals for deformities.	
Spiral cable	(1) Visually check lock (engagement) pins and combination switch for damage. (2) Check connectors, flat cable and protective tape for damage. (3) Check steering wheel for noise, binds or heavy operation.	
Control unit	Replace control unit (diagnostic unit).	(1) Check case and bracket for dents, cracks or deformities. (2) Check connectors for damage, and terminals for deformities.

HEATER & AIR CONDITIONER

SECTION **HA**

CONTENTS

PRECAUTIONS — Supplemental Restraint System “AIR BAG”	HA- 2
DESCRIPTION — Overall System	HA- 3
DESCRIPTION — Refrigeration System	HA- 10
PRECAUTIONS	HA- 12
PREPARATION	HA- 15
DISCHARGING, EVACUATING, CHARGING AND CHECKING	HA- 22
SERVICE PROCEDURES	HA- 34
COMPRESSOR OIL — Checking and Adjusting	HA- 38
COMPRESSOR — Model DKS-16H (DIESEL-KIKI make)	HA- 40
DIAGNOSES — Overall System	HA- 43
TROUBLE DIAGNOSES — Manual Air Conditioner	HA- 55
TROUBLE DIAGNOSES — Auto Air Conditioner	HA- 90
SYSTEM DESCRIPTION — Manual Air Conditioner	HA-150
SYSTEM DESCRIPTION — Auto Air Conditioner	HA-154
SERVICE DATA AND SPECIFICATIONS (S.D.S.)	HA-164

When you read wiring diagrams:

- Read GI section, “HOW TO READ WIRING DIAGRAMS”.
- See EL section, “POWER SUPPLY ROUTING” for power distribution circuit.

When you perform trouble diagnoses, read GI section, “HOW TO FOLLOW FLOW CHART IN TROUBLE DIAGNOSES”.

Supplemental Restraint System “AIR BAG”

The Supplemental Restraint System “Air Bag” helps to reduce the risk or severity injury to the driver in a frontal collision. The Supplemental Restraint System consists of an air bag (located in the center of the steering wheel), sensors, a control unit, warning lamp, wiring harness and spiral cable. Information necessary to service the system safely is included in the **BF section** of this Service Manual.

WARNING:

- a. **To avoid rendering the SRS inoperative, which could lead to personal injury or death in the event of a severe frontal collision, all maintenance must be performed by an authorized NISSAN dealer.**
- b. **Improper maintenance, including incorrect removal and installation of the SRS, can lead to personal injury caused by unintentional activation of the system.**
- c. **All SRS electrical wiring harnesses and connectors are covered with yellow outer insulation. Do not use electrical test equipment on any circuit related to the SRS “Air Bag”.**

Features — Auto Air Conditioner

OUTLET AIR TEMPERATURE CONTROL (Air mix door control)

When the desired temperature is set on the control panel, the automatic temperature control system determines both the head and foot target temperatures, as well as target upper (VENT and DEF) and lower (FOOT) outlet air temperatures. This computation is accomplished in relation to the desired temperature, and outside conditions (ambient temperature and sunload). The automatic temperature control system then controls the air mix door position so that the outlet air temperatures meet target* outlet air temperatures.

A summary of the automatic temperature control system is as follows:

1. The upper and lower air temperatures are independently controlled to provide a comfortable ride.
2. Optimum outlet air temperatures can be set to the passenger's preference.
3. Outlet air temperature feedback control through duct sensors permits a "potentiometerless" air mix door design. It requires no adjustment, increases service life and improves performance reliability.

FAN SPEED CONTROL

The A.T.C. system continuously regulates fan speed according to the difference between the target temperature and the temperatures detected at the upper and lower in-vehicle sensors. The greater the difference between the temperatures the higher the blower speed. If the cabin sunload or ambient temperature is high, fan speed will be increased.

INTAKE DOOR CONTROL

The A.T.C. system adjusts the intake door position once every thirty seconds. The system is programmed to take in outside air as much as possible.

OUTLET DOOR CONTROL

The A.T.C. system controls distribution of air through the VENT, DEF and FOOT outlets based on the cabin sunload, ambient temperature and the set temperature.

COMPRESSOR MAGNET CLUTCH CONTROL

The A.T.C. system automatically shuts off the compressor at temperatures lower than 0°C (32°F).

SELF-DIAGNOSTIC SYSTEM

The A.T.C. system contains an on-board diagnostic system which can be used to check the A.T.C. system sensors and motors and any trouble data stored in the memory.

Pushing the "AUTO" and "OFF" switches at the same time for more than 5 seconds will give the self-diagnostic mode. There are 4 kinds of self-diagnostic systems (STEP 1 to STEP 4). Each step can be accessed by pushing the "AUTO" switch. The functions of each step are as follows:

- STEP 1 — Monitor diagnosis
- STEP 2 — Actuator test
- STEP 3 — Change of difference between upper and lower target temperature
- STEP 4 — Readout of trouble data memory

*: Target temperature

When a temperature for the cabin is set using the TEMP. SET switch, the A.T.C. system calculates an initial target temperature based on information from the various A.T.C. system sensors. This target temperature is continuously updated to bring the cabin temperature to the set temperature in the most comfortable way possible for the occupants. (The program for this was made after careful study of comfort levels related to car interiors).

Acceleration Cut System

This system is controlled by the E.C.C.S. control unit. When the engine is heavily overloaded, the compressor is turned off for several seconds to reduce overloading.

Water Cock Control System

The water cock is connected to the air mix doors with a cable. When the air mix doors are at the full-cold position, the water cock is fully closed, and when the air mix doors are at the full-hot position, the water cock is fully opened.

Control Operation — Manual Air Conditioner

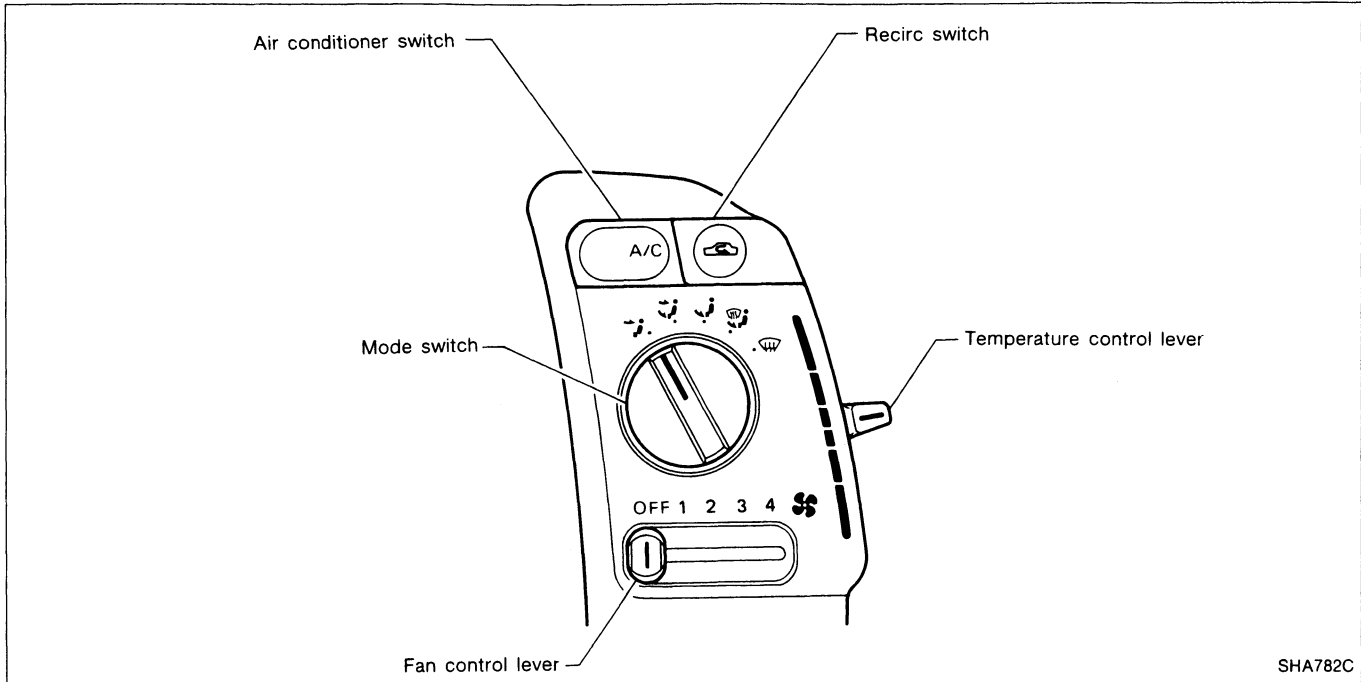

FAN CONTROL LEVER

This lever turns the fan ON and OFF, and controls fan speed.

MODE SWITCH

This switch allows you to select the outlet air flow.

In the "DEF" mode, the intake door is set to "FRE". The compressor turns on in "DEF" or "F/D" mode.

TEMPERATURE CONTROL LEVER

This lever allows you to adjust the temperature of the outlet air.

RECIRC SWITCH

OFF position:

Outside air is drawn into the passenger compartment when this switch is OFF.

ON position:

Interior air is recirculated inside the vehicle. This switch does not work in the "DEF" mode.

AIR CONDITIONER SWITCH

Start the engine, move the fan control lever to the desired (1 to 4) position and push the air conditioner switch to turn ON the air conditioner. The indicator light will come on when the air conditioner is ON. To stop the air conditioner, push the switch again to return it to the original position.

The air conditioner cooling function operates only when the engine is running.

DESCRIPTION — Overall System

Control Operation — Auto Air Conditioner

AUTO SWITCH	
INTAKE DOOR POSITION	AUTOMATIC CONTROL
OUTLET DOOR POSITION	
AIR MIX DOOR POSITION	
FAN SPEED	
COMPRESSOR	ON [outside air temperature above 0°C (32°F)]
REMARKS	Fan speed can be set at 4 speeds. Outlet mode can be set at 4 modes.

OFF SWITCH	
INTAKE DOOR POSITION	OUTSIDE AIR
OUTLET DOOR POSITION	AUTOMATIC CONTROL
AIR MIX DOOR POSITION	OFF
FAN SPEED	OFF
COMPRESSOR	REC switch and MODE switch can be set.
REMARKS	Outlet mode can be set at 4 modes.

ECON SWITCH	
INTAKE DOOR POSITION	OUTSIDE AIR
OUTLET DOOR POSITION	AUTOMATIC CONTROL
AIR MIX DOOR POSITION	OFF
FAN SPEED	OFF
COMPRESSOR	Fan speed can be set at 4 speeds. Outlet mode can be set at 4 modes.
REMARKS	

DEF SWITCH	
INTAKE DOOR POSITION	OUTSIDE AIR
OUTLET DOOR POSITION	DEFROSTER
AIR MIX DOOR POSITION	AUTOMATIC CONTROL
FAN SPEED	AUTOMATIC CONTROL
COMPRESSOR	ON [outside air temperature above 0°C (32°F)]
REMARKS	Fan speed can be set at 4 speeds.

TEMP. SET SWITCH

Each time corresponding switch is pressed, set temperature is increased or decreased by 1°F. When it is pressed for more than 0.5 seconds, set temperature can be continuously changed.

MODE SWITCH	
VENT	B/L → FOOT → D/F

"DEF" mode is canceled when MODE switch is pressed.

FAN SWITCH	
LO	M1 → M2 → HI

Fan speed can be set at 4 speeds in any mode.

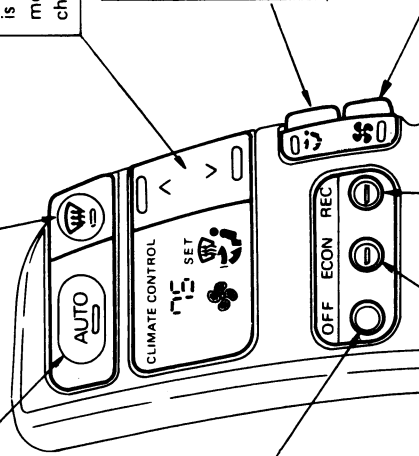

RECIRC SWITCH	
INDICATOR	ON OFF
INTAKE DOOR POSITION	RECIRCULATED AIR AUTOMATIC CONTROL
REMARKS	Recirculation mode changes to automatic control mode ten minutes after "RECIRC" switch is turned "ON". "RECIRC" switch does not function when it is in "DEF" mode. Recirculation function is canceled when "RECIRC" switch is pressed again.

Component Layout

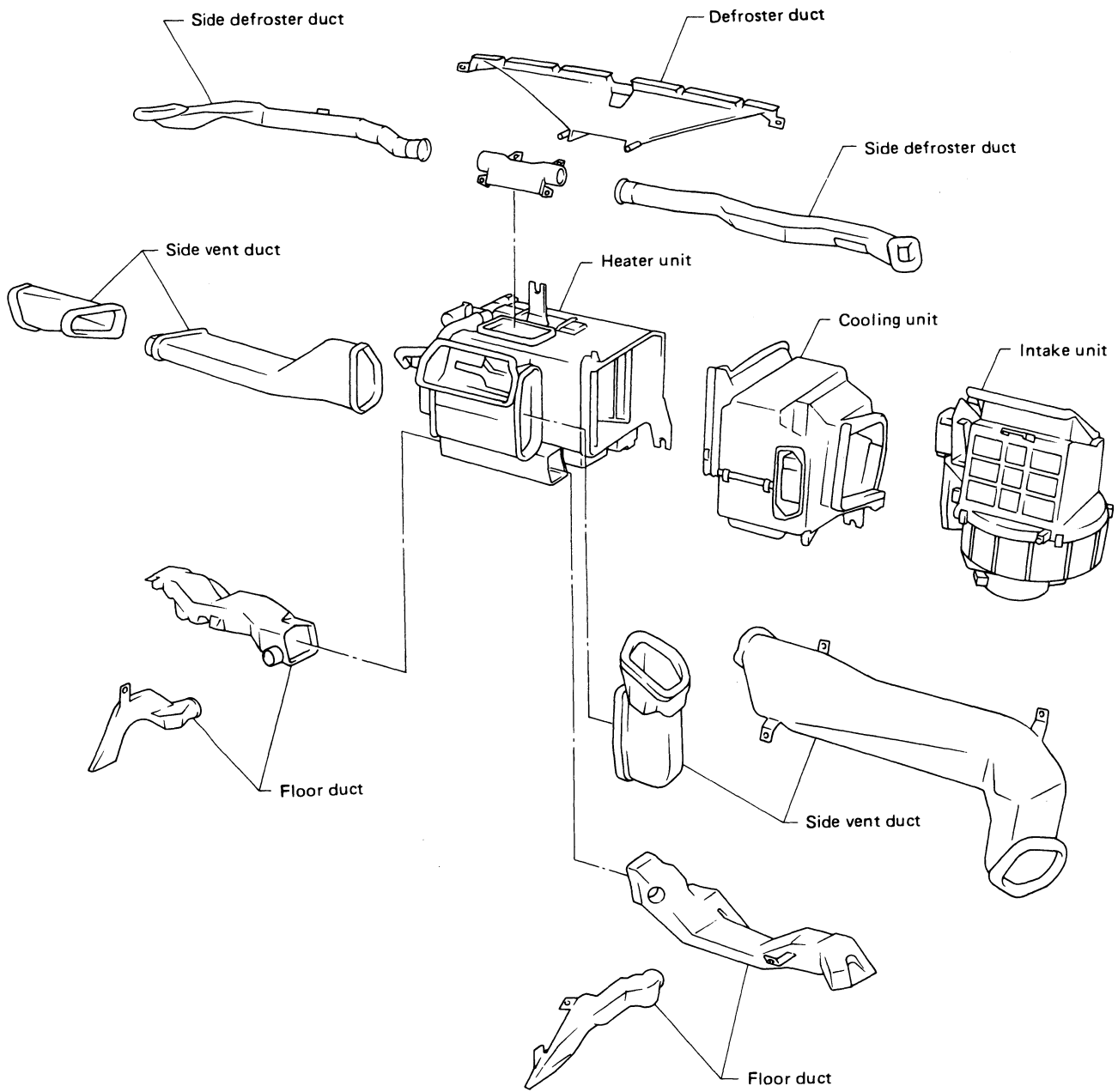

DESCRIPTION — Overall System

Air Flow

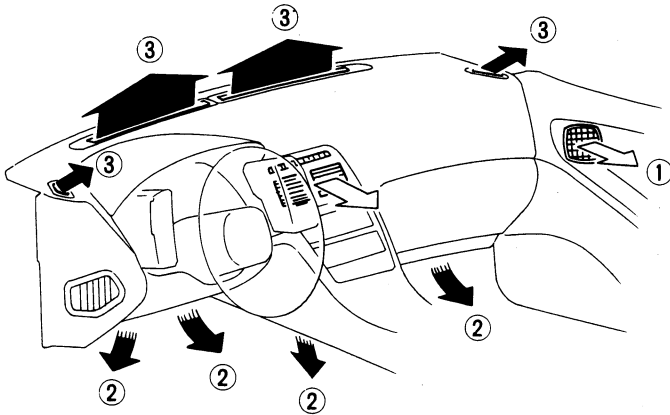

Ventilation

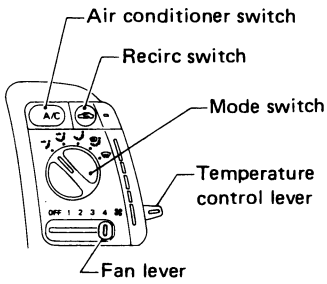

- ① ... To ventilator
- ② ... To floor
- ③ ... To defroster

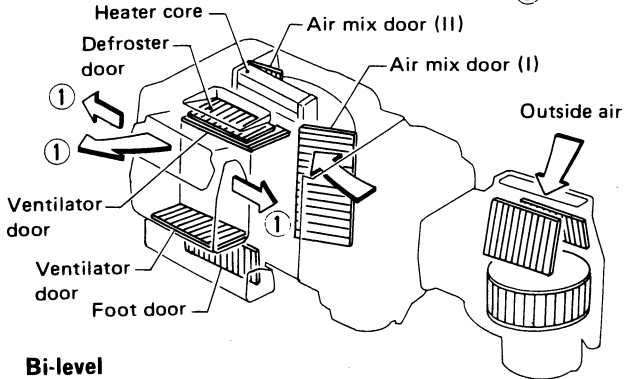

Bi-level

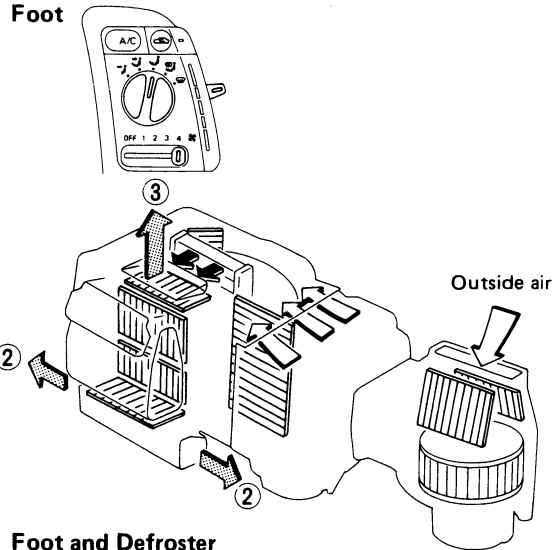
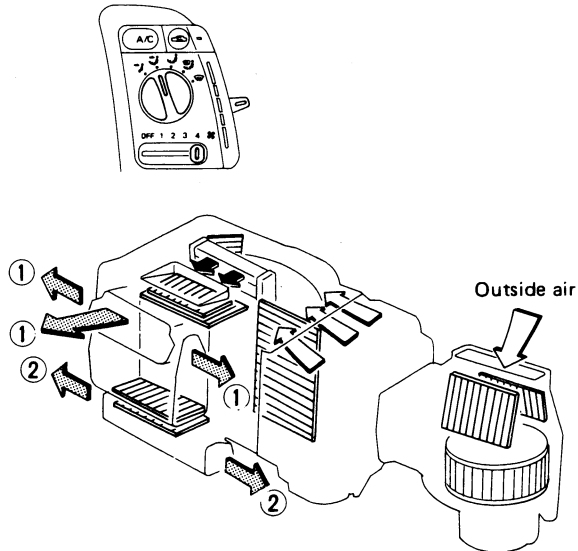

Foot and Defroster

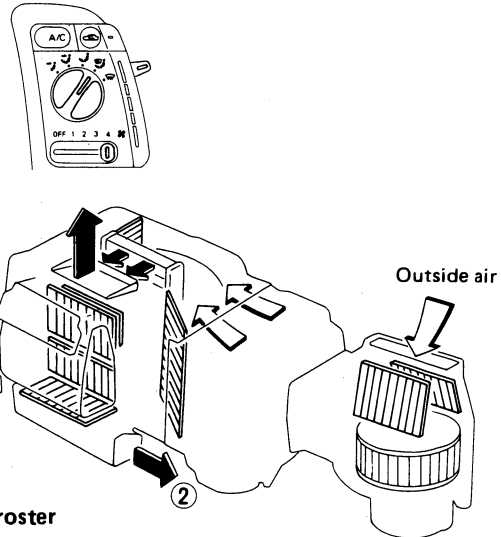

Defroster

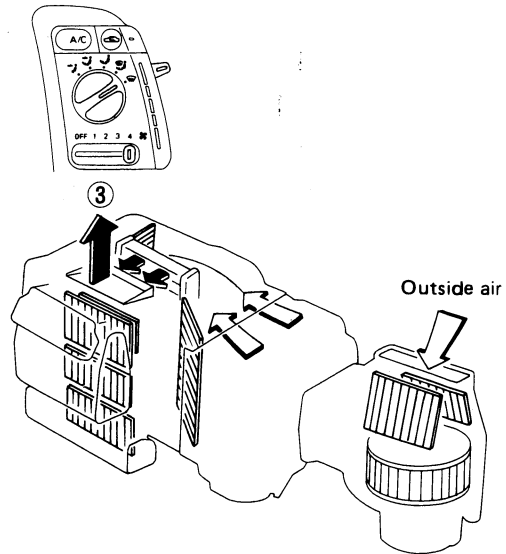

- ← : Air passed through heater core
- ← + ← : Mixed air
- ← : Air not passed through heater core

DESCRIPTION — Overall System

Air Flow (Cont'd)

AIR DISTRIBUTION RATIOS

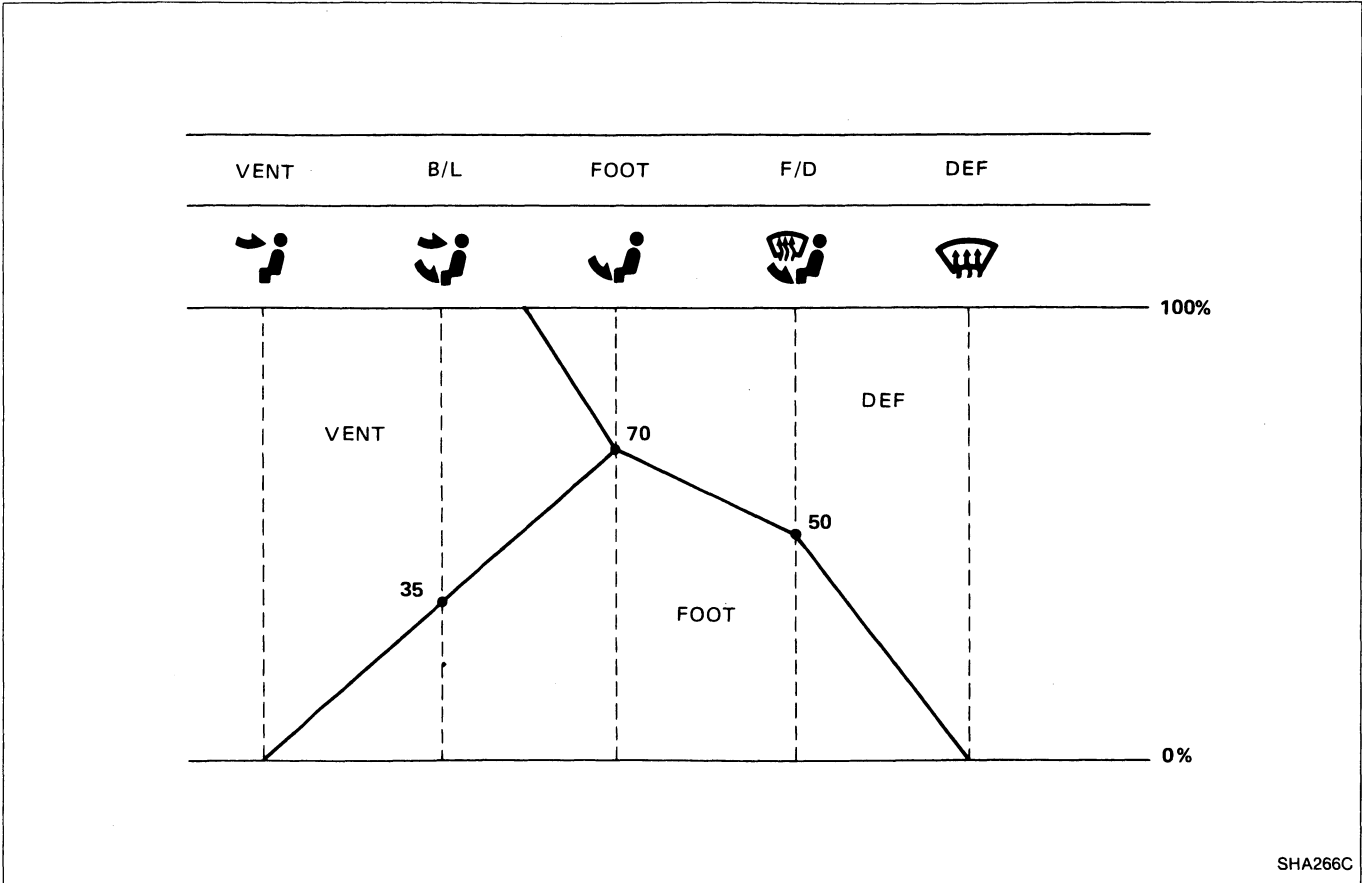

SHA266C

Refrigeration Cycle

REFRIGERANT FLOW

The refrigerant flows in the standard pattern, that is, through the compressor, the condenser, the receiver drier, through the evaporator, and back to the compressor.

Refrigerant evaporation through the evaporator coil is controlled by an externally equalized expansion valve, located inside the evaporator case.

FREEZE PROTECTION (For manual air conditioner)

The compressor cycles on and off to maintain the evaporator temperature within a specified range. When the evaporator coil temperature falls below a specified point, the thermo control amplifier interrupts the compressor operation. When the evaporator coil temperature rises above the specified point, the thermo control amplifier allows compressor operation.

FREEZE PROTECTION (For auto air conditioner)

When the A/C is switched on, the compressor runs continuously, and the evaporator pressure is controlled by a suction throttle valve (S.T.V.) to prevent freeze up.

REFRIGERANT SYSTEM PROTECTION

Low-pressure switch

The refrigerant system is protected against excessively low pressures by the low-pressure switch, located on the receiver drier. If the system pressure falls below the specifications, the low-pressure switch opens to interrupt compressor operation.

Fusible plug

Opens at temperature above 105°C (221°F), thereby discharging refrigerant to the atmosphere. If this plug is melted and opened, check the refrigerant line and replace the receiver drier.

Pressure relief valve

The refrigerant system is also protected by a pressure relief valve, located on the end of the high pressure flexible hose near the compressor. When the pressure of refrigerant in the system increases to an abnormal level [more than 3,727 kPa (38 kg/cm², 540 psi)], the release port on the pressure relief valve automatically opens and releases refrigerant into the atmosphere.

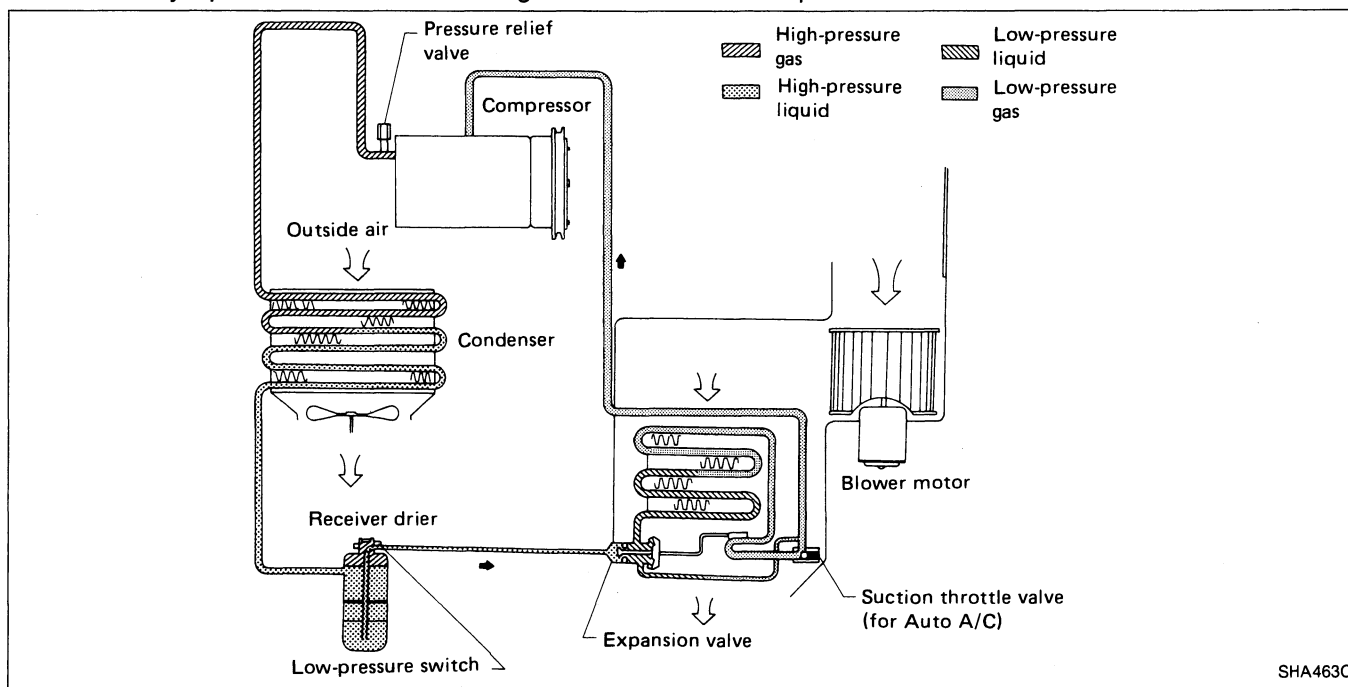

DESCRIPTION — Refrigerant System

Refrigerant System

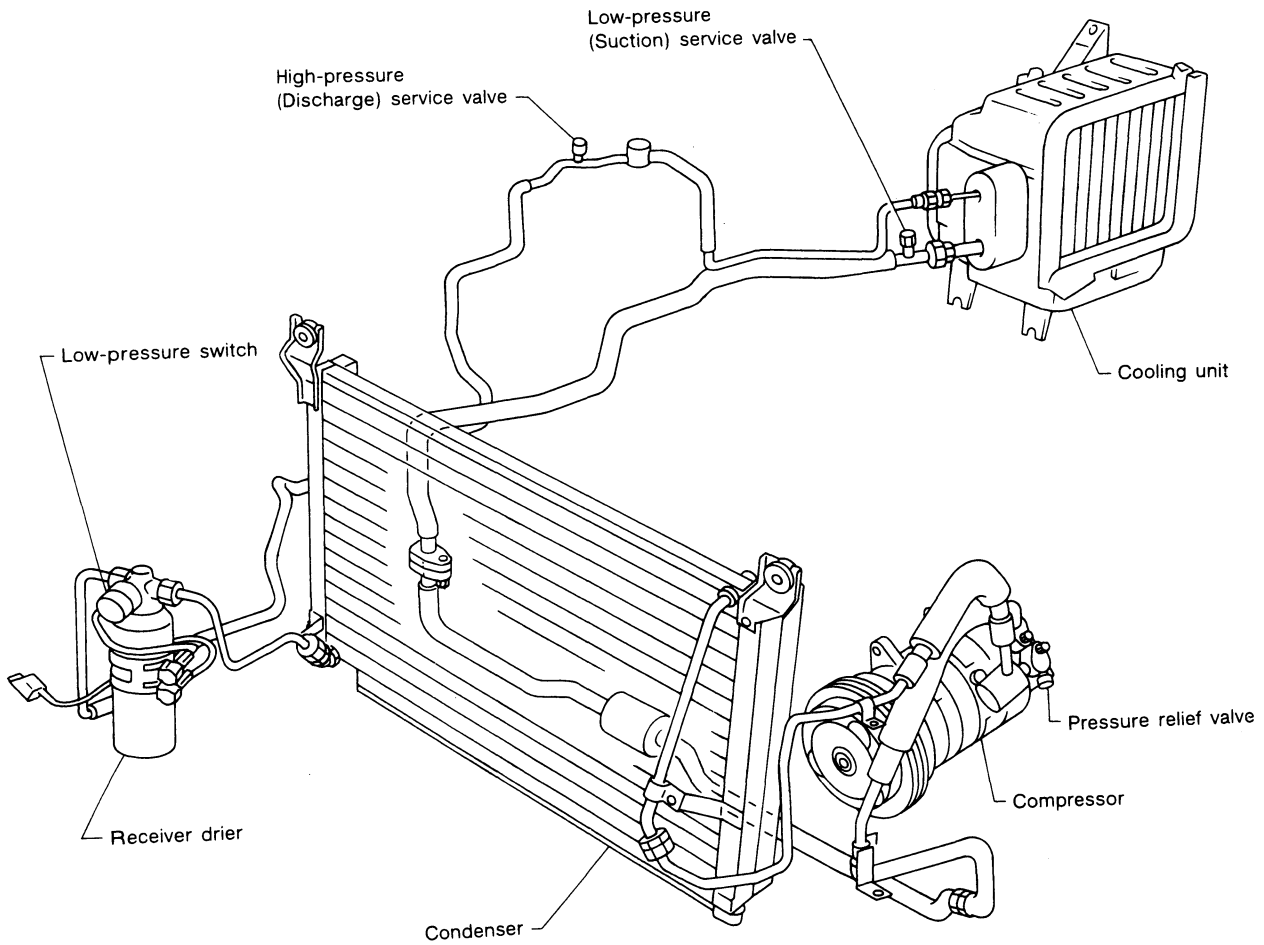
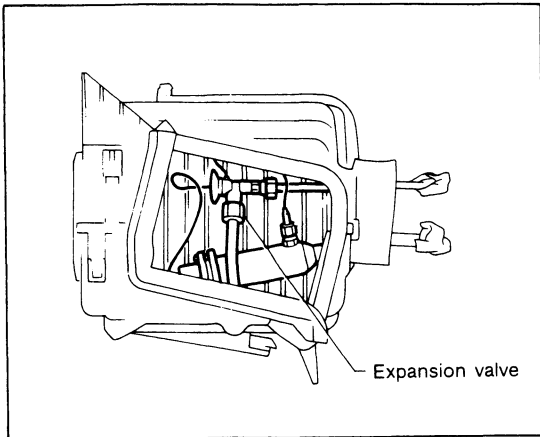

PRECAUTIONS

Goggles

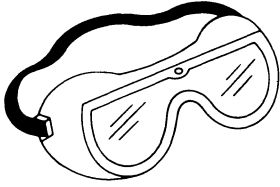

RHA260B

Gloves

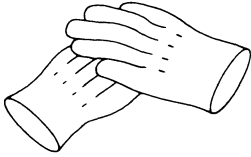

RHA261B

Avoid Open Flame

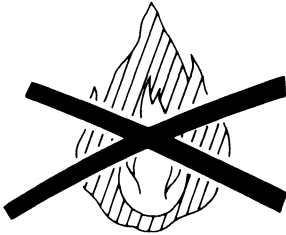

RHA262B

No Direct Heat
on Container

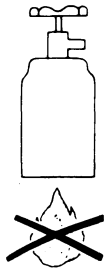

RHA263B

PRECAUTIONS FOR THE HANDLING OF REFRIGERANT

- Always wear eye protection when working around the system.
- Always be careful that refrigerant does not come in contact with your skin.
- Keep refrigerant containers stored below 40°C (104°F) and never drop from high places.
- Work in well-ventilated area because refrigerant gas evaporates quickly and breathing may become difficult due to the lack of oxygen.
- Keep refrigerant away from open flames because poisonous gas will be produced if it burns.
- Do not increase can temperature beyond 40°C (104°F) in charging.
- Do not heat refrigerant container with an open flame. There is a danger that container will explode.

CAUTION:

- Do not use steam to clean surface of condenser or evaporator. Be sure to use cold water or compressed air.
- Compressed air must never be used to clean a dirty line.

No Direct Heat
on Container

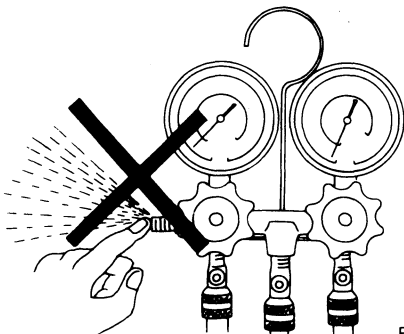

RHA676B

- Do not release refrigerant into the atmosphere.

PRECAUTIONS

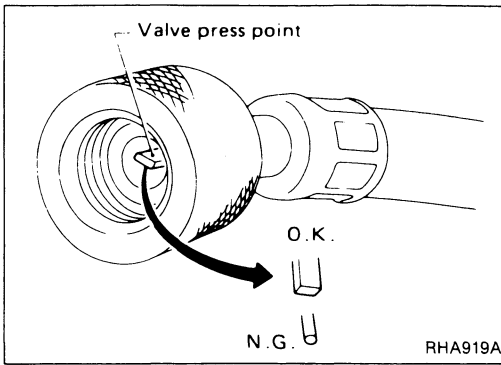

- Do not use manifold gauge whose press point shape is different from that shown. Otherwise, insufficient evacuating may occur.

- Do not over-tighten service valve cap.
- Do not allow refrigerant to rush out. Otherwise, compressor oil will be discharged along with refrigerant.

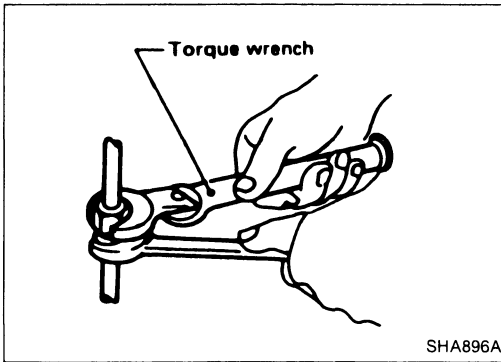

PRECAUTIONS FOR REFRIGERANT CONNECTIONS

WARNING:

Gradually loosen discharge side hose fitting, and remove it after remaining pressure has been released.

CAUTION:

When replacing or cleaning refrigerant cycle components, observe the following.

- Do not leave compressor on its side or upside down for more than 10 minutes, as compressor oil will enter low pressure chamber.
- When connecting tubes, always use a torque wrench and a back-up wrench.

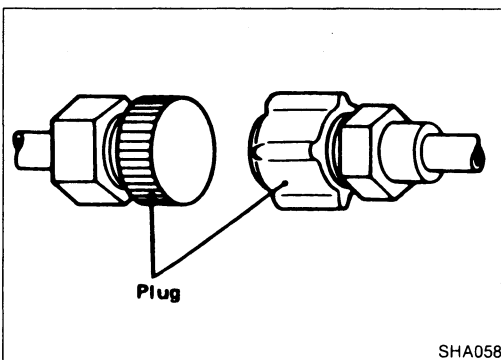

- After disconnecting tubes, plug all openings immediately to prevent entrance of dirt and moisture.

PRECAUTIONS

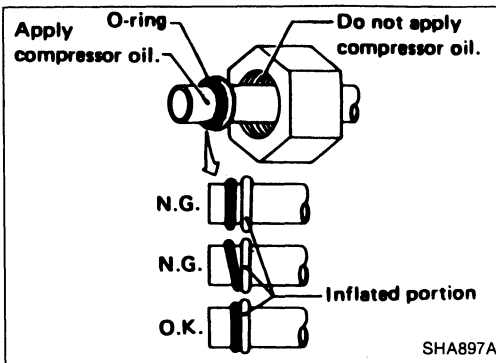

- Always replace used O-rings.
- When connecting tube, apply compressor oil to portions shown in illustration. Be careful not to apply oil to threaded portion.
- O-ring must be closely attached to inflated portion of tube.

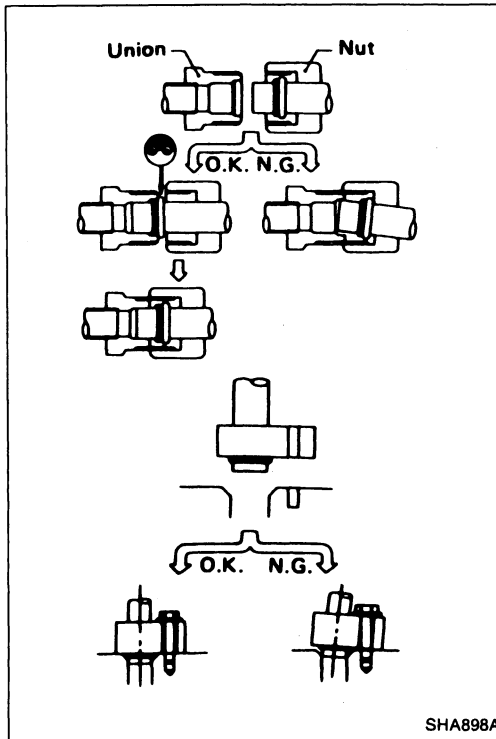





- After inserting tube into union until O-ring is no longer visible, tighten nut to specified torque.
- After connecting line, conduct leak test and make sure that there is no leakage from connections. When the gas leaking point is found, disconnect that line and replace the O-ring. Then tighten connections of seal seat to the specified torque.

PRECAUTIONS FOR SERVICING COMPRESSOR

- Plug all openings to prevent moisture and foreign matter from entering.
- Do not leave compressor on its side or upside down for more than 10 minutes.
- When replacing or repairing compressor, check compressor oil level in system.
- When replacing with a new compressor, drain specified oil from new compressor. Refer to COMPRESSOR OIL.
- Be sure there is no oil or dirt on frictional surface of clutch disc and pulley.
- When replacing compressor clutch, be careful not to scratch shaft or bend pulley.
- When replacing compressor clutch assembly, do not forget BREAK-IN OPERATION.
- Replace shaft seal, seal seat, oil seal and O-ring as a set.
- When installing shaft seal, Seal seat, oil seal, O-ring and gaskets, apply compressor oil sparingly to the contact surface. Do not reuse them.
- After replacement or repairs, conduct a Leak Test.

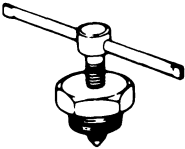
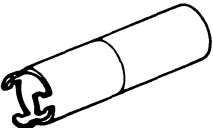
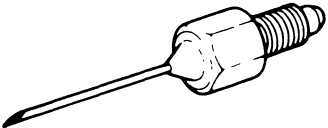

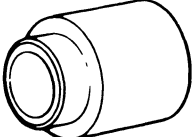
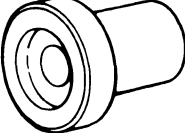
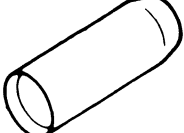
PREPARATION

SPECIAL SERVICE TOOLS

Tool number (Kent-Moore No.) Tool name	Description
KV99232022 (J26571-A) Clutch disc puller	 A mechanical tool with a central threaded shaft and a hexagonal base, used for pulling a clutch disc. Removing clutch disc
KV99235140 (J37876) Shaft seal remover and installer	 A cylindrical tool with a hook-like end, used for removing and installing shaft seals. Removing and installing shaft seal
KV994C1552 (J37880) Charge nozzle	 A tool with a long, thin needle-like tip and a threaded handle, used for charging refrigerant. Charging refrigerant
KV99231010 (J37877) Clutch disc wrench	 A long, thin metal tool with a hook-like end, used for removing the shaft nut and clutch disc. Removing shaft nut and clutch disc
KV99233040 (J26720-A) Puller pilot	 A cylindrical tool with a flange at one end, used for removing a pulley. Removing pulley
KV99234160 (J37879) Pulley installer	 A cylindrical tool with a flange at one end, used for installing a pulley. Installing pulley
KV99267420 (J37878) Shaft seal guide	 A cylindrical tool with a slightly tapered end, used for installing a shaft seal. Installing shaft seal
KV99235160 (J37882) Nut wrench	 A tool with a hook-like end and a central opening, used for removing a lock nut. Removing lock nut

PREPARATION

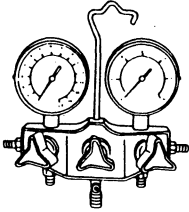
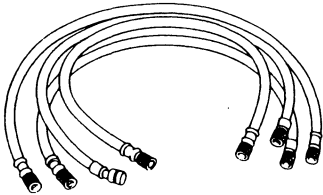
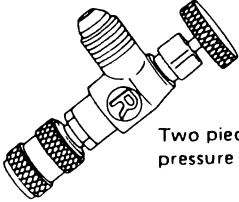
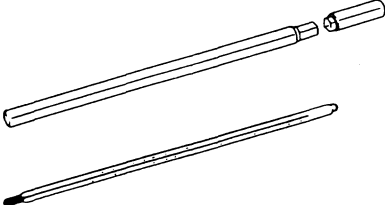
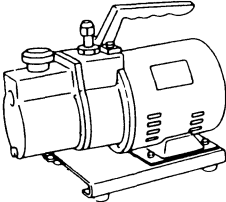
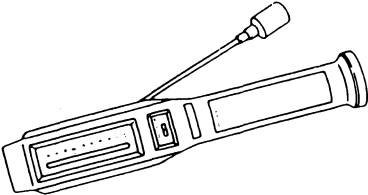
Service Tools

Tool name	Description
Manifold gauge (3-valve type)	 <p>Discharging, evacuating and charging refrigerant</p> <p>RHA570B</p>
Charging hose (Four)	 <p>Discharging, evacuating and charging refrigerant</p> <p>RHA571B</p>
Adapter valve	 <p>Two pieces on each high pressure and low pressure line</p> <p>Discharging, evacuating and charging refrigerant</p> <p>RHA573B</p>
Thermometer	 <p>Checking temperature</p> <p>RHA574B</p>
Vacuum pump	 <p>Evacuating</p> <p>RHA575B</p>
Gas leak detector	 <p>Checking refrigerant leaks</p> <p>RHA577B</p>
Charging cylinder	 <p>Checking amount of refrigerant and charging refrigerant</p> <p>RHA578B</p>

PREPARATION

Service Tools (Cont'd)

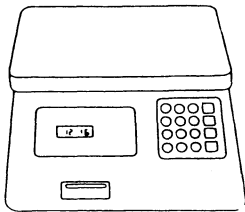
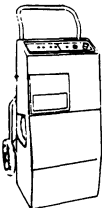
Tool name	Description
Weight scale	 Checking amount of refrigerant RHA579B
Refrigerant recycling equipment	 Capturing and recycling refrigerant SHA732C

For details of such handling methods, refer to the Instruction Manual attached to each of the service tools.

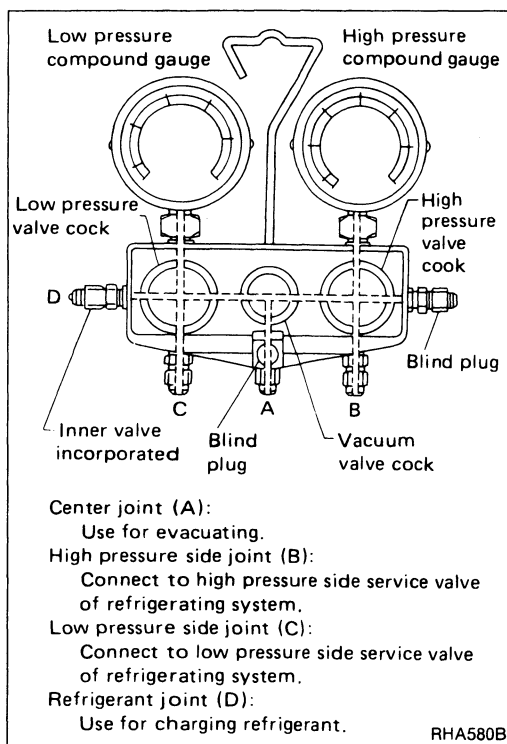

HANDLING METHOD AND STRUCTURE

Manifold gauge

The manifold gauge is used to measure the operating pressure accurately in the high pressure and low pressure lines of the refrigerating system. The high pressure gauge measures from -101.3 kPa (-760 mmHg , -29.92 inHg) to $2,942 \text{ kPa}$ (30 kg/cm^2 , 427 psi), and the low pressure gauge measures generally from -101.3 kPa (-760 mmHg , -29.92 inHg) to $1,471 \text{ kPa}$ (15 kg/cm^2 , 213 psi).

CAUTION:

- When installing the gauge to the refrigerating system, use utmost care not to mistake high pressure and low pressure line connections. (Wrong connections will lead to a damaged gauge.)
- Before evacuating, confirm that the gauge has a negative pressure scale. (If not, the gauge will be damaged.)

PREPARATION

Service Tools (Cont'd)

Charging hose

1. Completely tighten the high pressure valve, low pressure valve and vacuum pump valve cocks of the gauge manifold.
2. Connect the charging hoses to the high and low pressure lines.
3. Connect the charging hose fitted with a valve core to the charging cylinder.
4. Connect the vacuum pump hose to the vacuum pump.

The high and low pressure hoses are color coded to prevent wrong connection.

High pressure line hose	Red
Low pressure line hose	Yellow
Charging hose	Blue or green (with valve core)
Vacuum pump hose	Blue or green

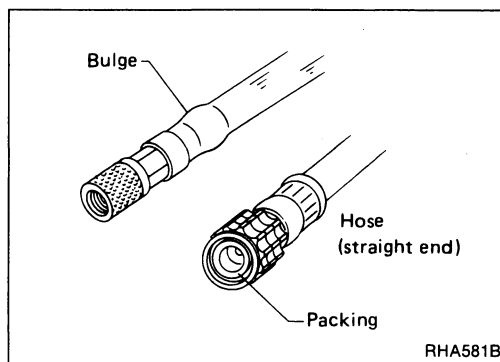

CAUTION:

- Check each hose for cracks. If found, discard the hose.
- Do not use any hose if bulges are found.
- Check the rubber packing. If any deterioration or cracks are found, replace it with a new one.

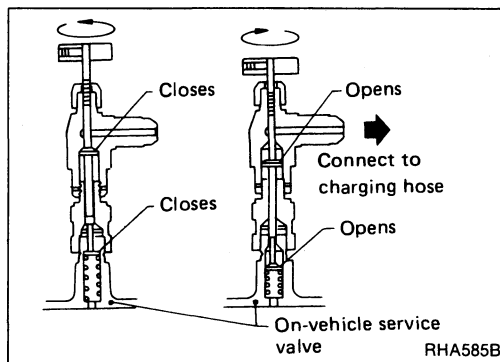

Installing the adapter valve

Install the adapter valve to each of the high pressure and low pressure service valves so that air purging from the charging hose can be omitted. This also ensures that refrigerant leakage upon disconnection of the hose can be prevented.

1. Before connecting the adapter valve to the on-vehicle service valve, turn the adapter valve handle fully counter-clockwise to retract the pin.

CAUTION:

Check the packing for any sign of deterioration or cracks. If any abnormality is found, replace the packing with new.

2. Connect the high and low pressure hoses to the adapter valves.

Turning the handle clockwise will cause the on-vehicle service valve pin to be pushed open by the adapter valve pin, thus opening the refrigerant passage. Turning the handle counter-clockwise will close the passage. Before removing the adapter valve from the on-vehicle service valve, be sure to fully turn the handle counterclockwise to shut off the refrigerant passage.

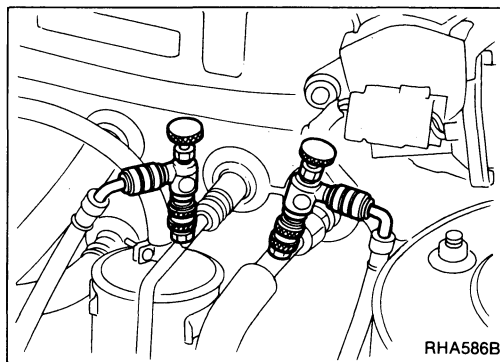

PREPARATION

Service Tools (Cont'd)

Vacuum pump

The vacuum pump is used to purge air and moisture from the inside of the refrigeration system by evacuation, thereby ensuring proper functioning of the air conditioner system.

Check the vacuum pump to see that the vacuum pump capacity is greater than -100.0 kPa (-750 mmHg, -29.53 inHg).

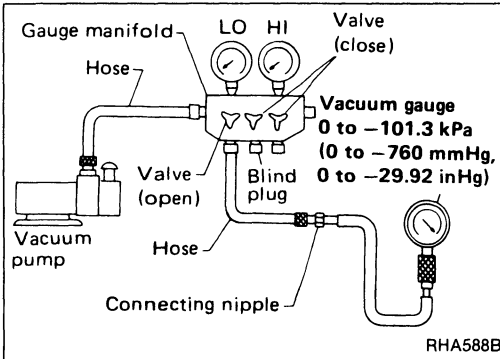
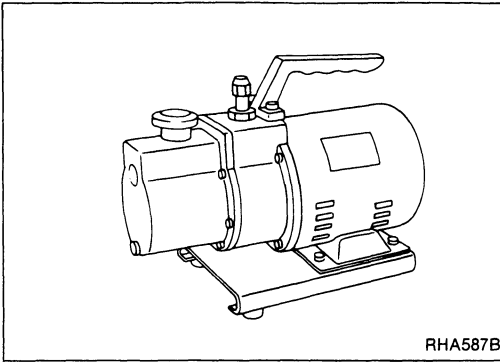

Vacuum pump performance check procedure

1. Connect the vacuum gauge to the system.
2. Run the vacuum pump, and check to see that the needle pointers of the gauge manifold and vacuum gauge move smoothly, indicating a similar value.
3. After running the vacuum pump for two or three minutes, read the vacuum gauge. The measured value indicates the capacity of the vacuum pump.

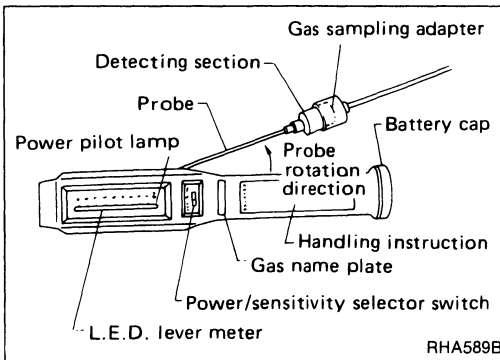

Gas leak detector

The gas leak detector is used to check whether the refrigeration system is leaking. The detector is available in two types; halide torch or electrical. The features of these gas leak detectors are listed below. We recommend the electrical type because of its greater detection ability and ease of handling.

PREPARATION

Service Tools (Cont'd)

Type		Detection ability	Features
Halide torch		200 g (7.05 oz)/year (thin green)	<ul style="list-style-type: none"> ● Low price ● Low sensitivity ● Less safe because of the use of flame for detection
Electrical	Discharge type (Suction type)	3 - 50 g (0.11 - 1.76 oz)/year	<ul style="list-style-type: none"> ● Easy handling ● Medium sensitivity ● Each point needs two or more seconds for detection.
	Positive ion emission type (Suction type)	2 g (0.07 oz)/year	<ul style="list-style-type: none"> ● High sensitivity ● High price ● Warm-up time is needed because a heater is incorporated.
Other simple checking method: Changing in vacuum when evacuating		1 kg (2 lb)/month; if 13.3 kPa (100 mmHg, 3.94 inHg) change in vacuum is detected in 10 minutes.	<ul style="list-style-type: none"> ● Can be used easily in refrigerant charging operation. ● Detection ability is very low with vacuum gauge in gauge manifold.

- Leakage inspection of a refrigeration system needs a sensitivity greater than 20 g (0.71 oz)/year.
- The actual amount of leak is estimated at 5 to 10 times the detected amount.
- Insufficient cooling may be felt if leakage exceeds 150 to 200 g (5.29 to 7.05 oz).

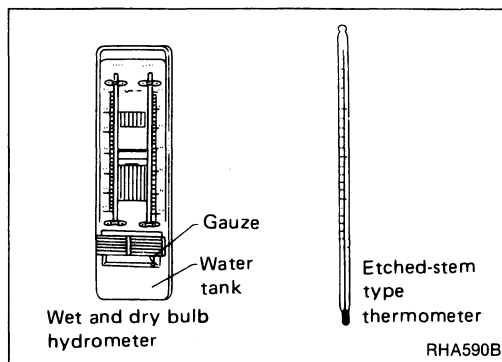

Temperature gauge

Use to check the air conditioner performance. An etched stem type thermometer may be used. A hydrometer must also be used because the air conditioner performance depends on the humidity.

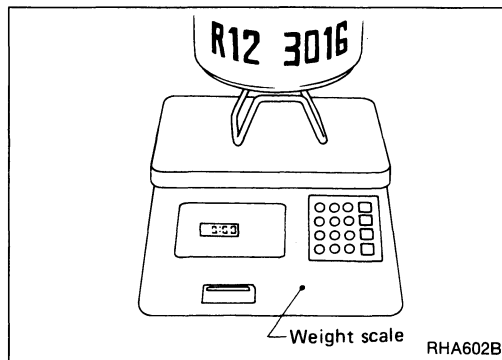

Scale

Measure the weight of the refrigerant to determine how much the refrigerant is charged.

PREPARATION

Service Tools (Cont'd)

Charging cylinder

The charging cylinder is used to correctly measure the amount of refrigerant to be charged.

Features

- With the charging cylinder, the operator can measure correctly the amount of refrigerant to be charged into the system.
- Change in the refrigerant volume due to a change in temperature and pressure can be supplemented, and this ensures correct charging of refrigerant.

CAUTION:

- **Never attempt to carry the charging cylinder containing refrigerant.**
- **Do not put the charging cylinder in a hot place. If the temperature and pressure of the refrigerant in the cylinder increase, the safety valve will be pushed open and the refrigerant will be released into the atmosphere.**
- **Do not expose the cylinder to the direct sunlight.**
- **Do not over-charge the refrigerant so that it exceeds the maximum limit of the cylinder.**
- **Do not charge the cylinder with more refrigerant than is needed.**

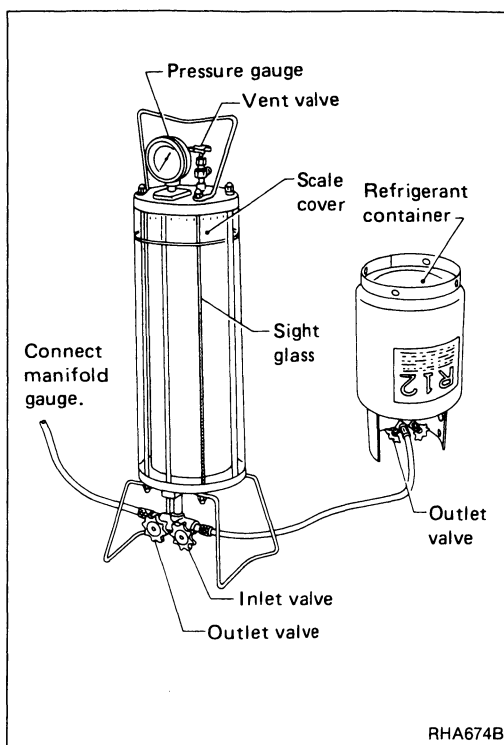

DISCHARGING, EVACUATING, CHARGING AND CHECKING

Work Procedure

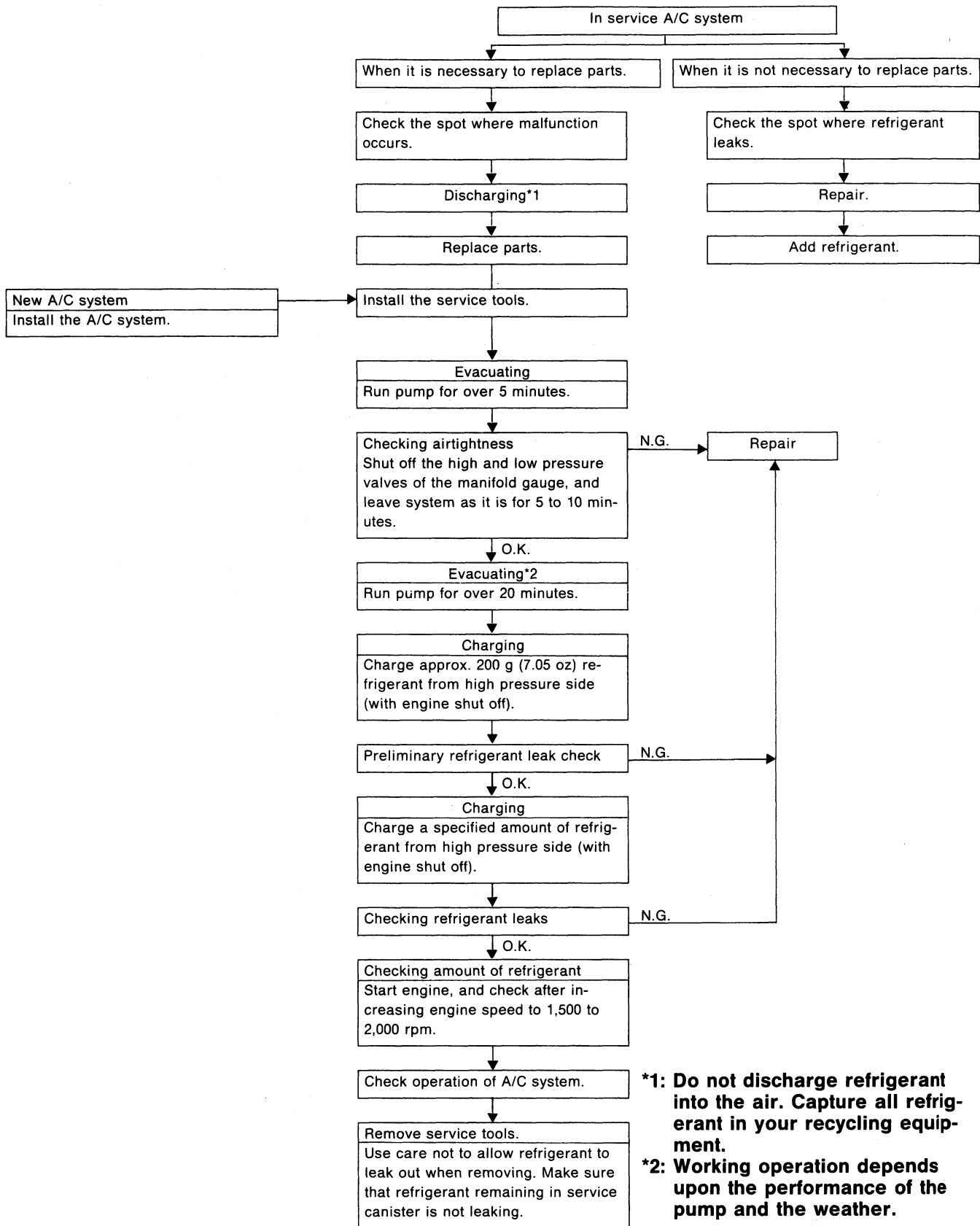

***1: Do not discharge refrigerant into the air. Capture all refrigerant in your recycling equipment.**

***2: Working operation depends upon the performance of the pump and the weather.**

DISCHARGING, EVACUATING, CHARGING AND CHECKING

Setting of Service Tools

Make sure that the service tools are set as indicated below and that no refrigerant is leaking.

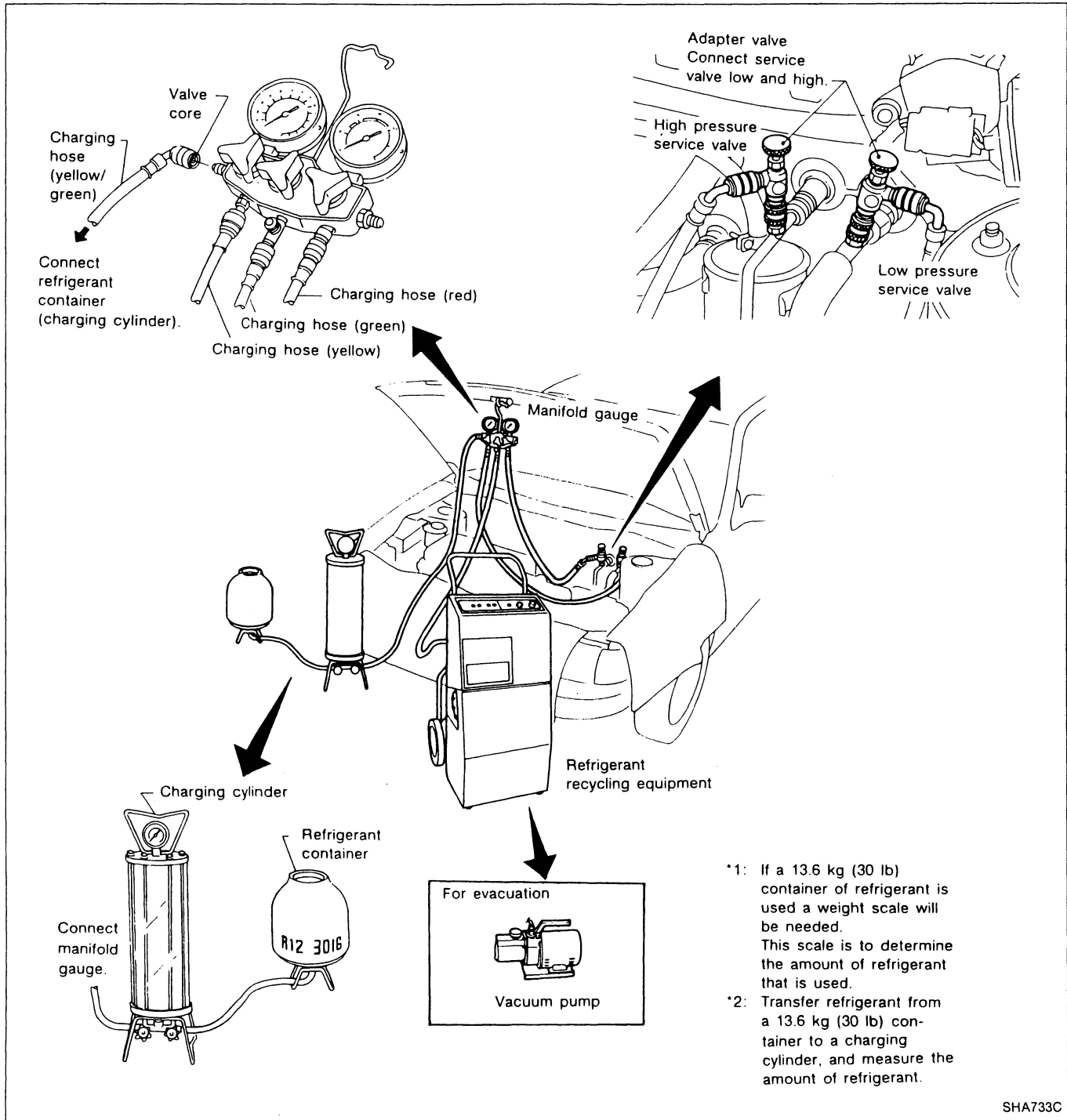

SHA733C

DISCHARGING, EVACUATING, CHARGING AND CHECKING

Setting of Service Tools (Cont'd)

When a 3-valve type manifold gauge is unavailable, use a 2-valve type manifold gauge with one additional valve at the end of the charging hose.

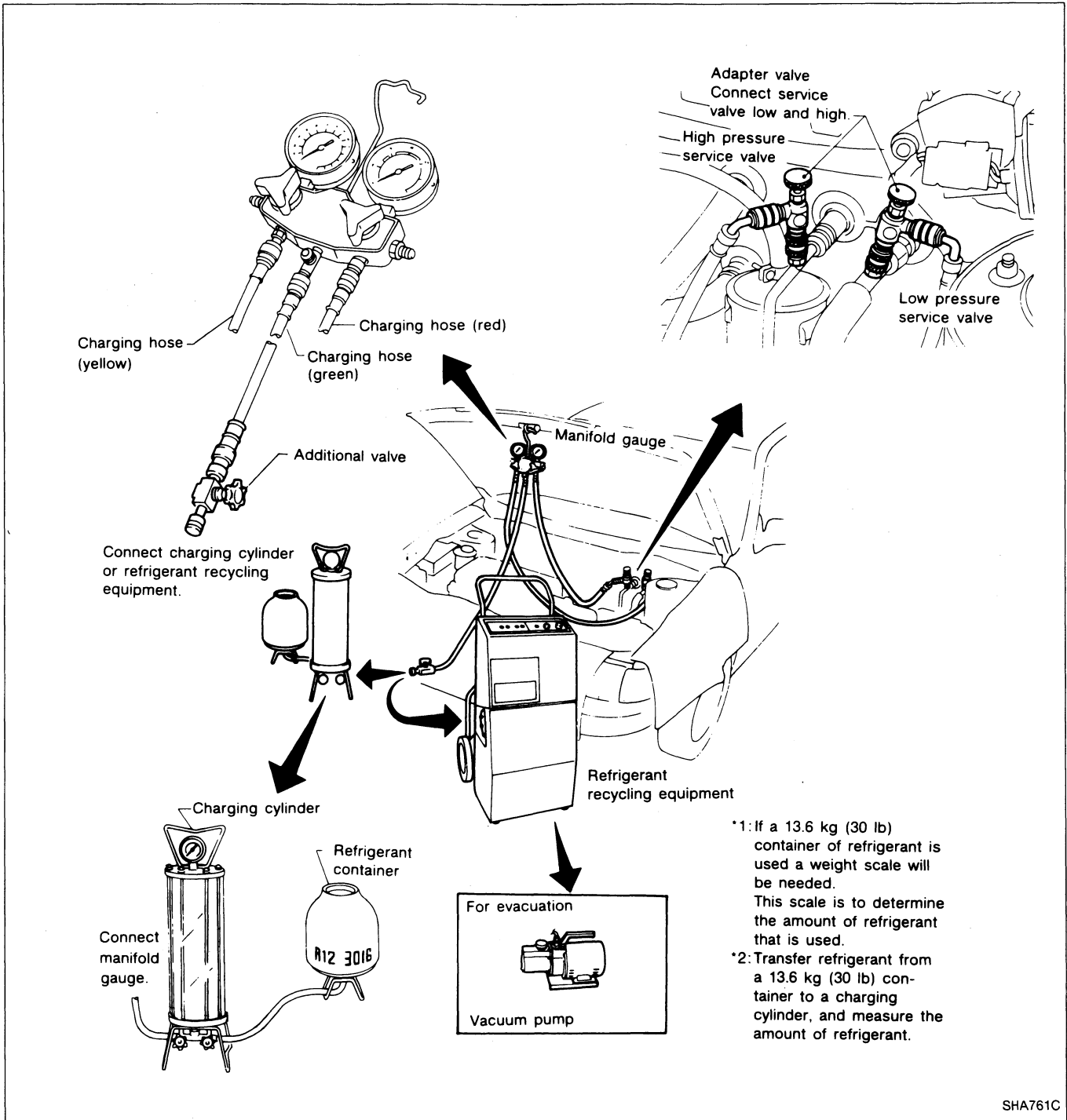

SHA761C

DISCHARGING, EVACUATING, CHARGING AND CHECKING

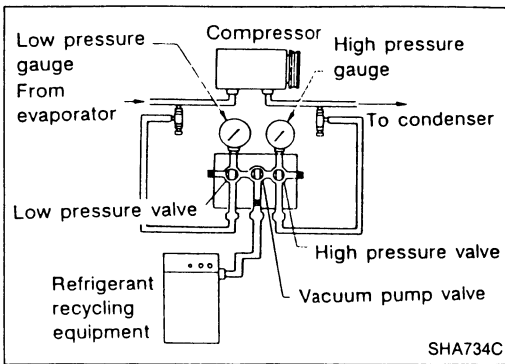

Discharging

WARNING:

**Discharge only into your recycling equipment.
Do not release refrigerant into the air.**

Slowly open the valves to discharge the refrigerant. If they are opened quickly, compressor oil will also be discharged.

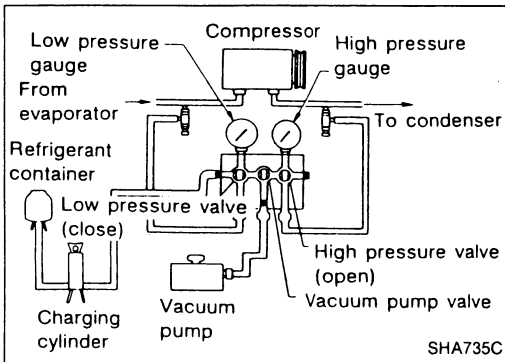

Evacuation

EVACUATION PROCEDURE

1. Completely tighten the low pressure and high pressure adapter valves.
Turn on the high and low pressure service valves.
2. Open the high and low pressure valves and vacuum pump valve of the manifold gauge set.
3. Run the vacuum pump.
4. Perform evacuation for more than five minutes to stabilize the vacuum inside the system. Check to ensure that the low pressure gauge indicates -98.6 to -101.3 kPa (-740 to -760 mmHg, -29.13 to -29.92 inHg).
5. Shut off the high and low pressure valves and vacuum pump valve of the manifold gauge set.

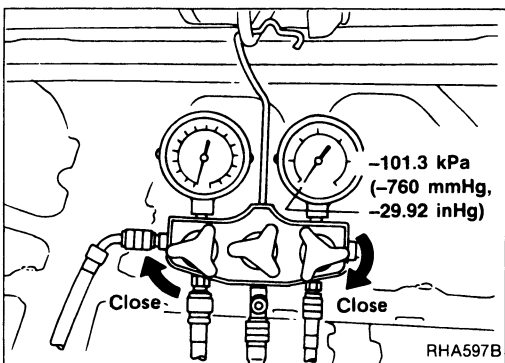

CHECKING AIRTIGHTNESS

1. Shut off the high and low pressure valves and vacuum pump valve of the manifold gauge set, and leave the system as it is for 5 to 10 minutes.
2. Make sure that the needle of the low pressure gauge will not move back toward the atmospheric pressure side (gauge pressure 0).

If any reverse movement is noted, it indicates poor system airtightness. Service the system until airtightness is complete. If pressure changes approx. 13.3 kPa (100 mmHg, 3.94 inHg) in 10 minutes, the refrigerant in the system will be exhausted in about one month.

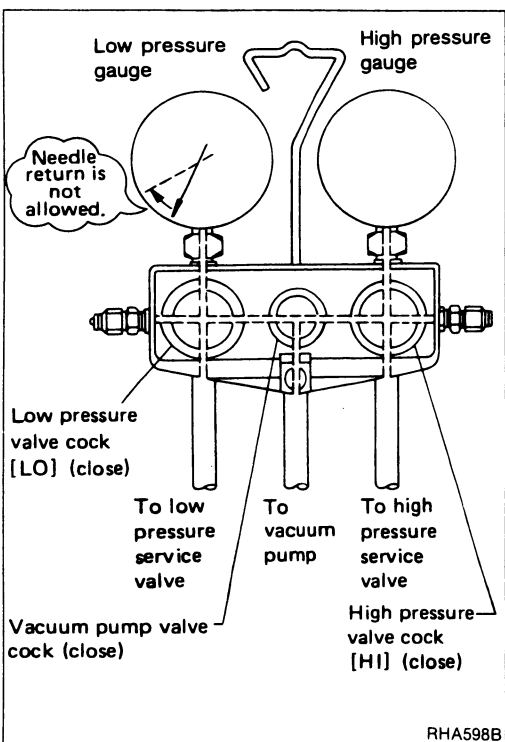

DISCHARGING, EVACUATING, CHARGING AND CHECKING

Evacuation (Cont'd)

MAINTENANCE

If inadequate airtightness is detected, check and service the following portions:

Leak from pipe joints	Leak from manifold gauge set
<ul style="list-style-type: none">● Contaminated, damaged, or deformed O-ring● No oil applied when connecting pipe● Excessive or insufficient tightening of pipe joint	<ul style="list-style-type: none">● Malfunctioning hose● Improper installation of manifold● Malfunctioning valve● Malfunctioning packing

EVACUATION

If no abnormality is found during the airtightness check, perform evacuation again for more than 20 minutes.

1. Run the vacuum pump.
2. Open the high and low pressure valve and vacuum pump valve of the manifold gauge set.
3. Evacuate for more than 20 minutes.
4. Close the high and low pressure valves and vacuum pump valve of the manifold gauge set.

Charging Refrigerant

Install the charging cylinder correctly to the vehicle. Refer to "Setting of Service Tools".

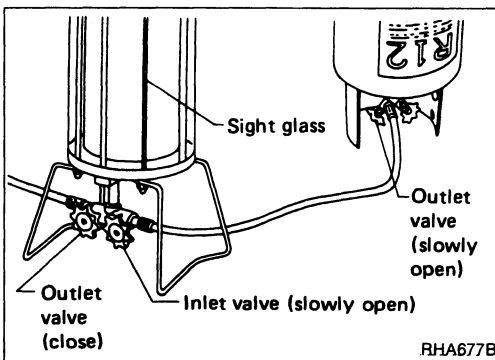

PRELIMINARY CHARGING OF REFRIGERANT-1

1. Make sure that the inlet and outlet valves of the charging cylinder are closed.
2. Slowly open the outlet valve of a refrigerant container [13.6 kg (30 lb)].
3. Slowly open the inlet valve of the charging cylinder.

The refrigerant will flow into the sight glass of the charging cylinder as the valve is opened.

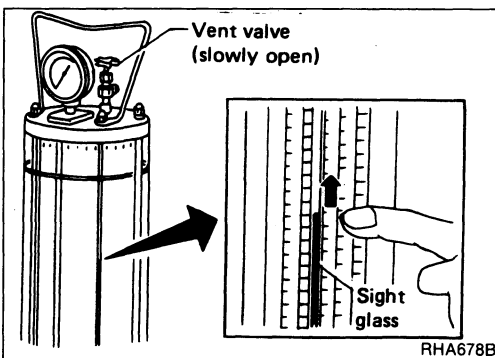

4. Slowly open the upper vent valve to release pressure from the charging cylinder. While doing so, continue charging until the required amount of refrigerant is reached.

The refrigerant volume changes with the temperature and pressure. It is necessary to charge refrigerant with a little more than the required amount (indicated on the sight glass). Refer to the CAUTION label attached on the vehicle, or to the Service Manual.

5. Close the inlet valve and upper vent valve of the charging cylinder.

DISCHARGING, EVACUATING, CHARGING AND CHECKING

Charging Refrigerant (Cont'd)

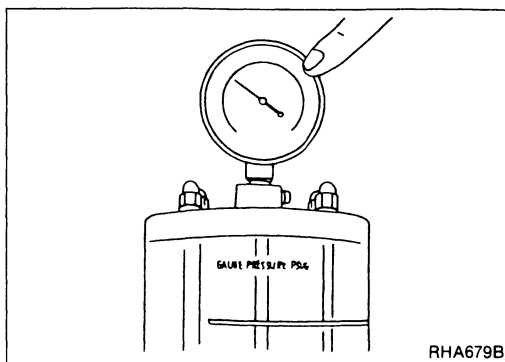

6. Turn on the heater switch (the charging cylinder is provided with a heater.)

The refrigerant charging time can be reduced by heating the refrigerant to increase its pressure. In this case, do not allow the pressure in the cylinder to rise higher than 1,030 kPa (10.5 kg/cm², 150 psi). (If pressure rises above this level, turn off the heater.)

The pressure in the charging cylinder can be measured by the upper pressure gauge.

EVACUATION AND AIRTIGHTNESS CHECK

Refer to "EVACUATION PROCEDURE" and "CHECKING AIRTIGHTNESS" in "Evacuation".

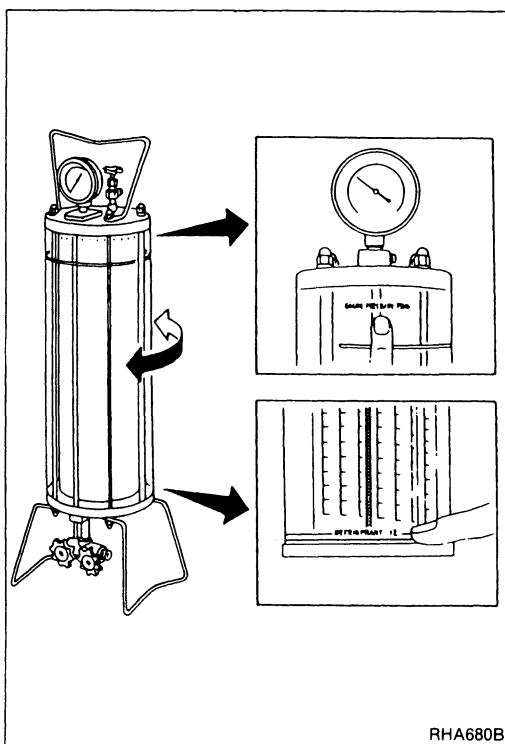

SETTING OF FLOW METER

1. Rotate the charging cylinder main body until the scale for R12 is at the correct position on the sight glass.
2. Read the charging cylinder pressure gauge.
3. Rotate the charging cylinder so that the scale of the charging cylinder agrees with the pressure value indicated on the pressure gauge.
4. Open the outlet valve of the charging cylinder.

DISCHARGING, EVACUATING, CHARGING AND CHECKING

Charging Refrigerant (Cont'd)

CALCULATING CHARGING AMOUNT OF REFRIGERANT

1. Record the amount of refrigerant in the sight glass before charging.
2. Subtract the required amount of refrigerant (charge quantity specified for the vehicle) from the amount of refrigerant recorded in step 1. Charge refrigerant into the system until the remaining value equals to the value indicated on the sight glass.

Example:

Level in sight glass: 3 lb 8 oz

Charge specification (from S.D.S.) 2.0 - 2.4 lb.

Calculate charge quantity into lb and oz as follows: 1 lb = 16 oz, and 0.1 lb = 1.6 oz, so that 2.0 lb = 32 oz, 2.4 lb = 32 + (4 x 1.6) = 32 + 6.4 = 38.4, round off to 38. Therefore our charge quantity will be between 32 and 38 oz, or 2 lb 0 oz to 2 lb 6 oz. Subtract 2 lb 6 oz from the level in the sight glass (3 lb 8 oz) = 1 lb 2 oz.

This will be our ending point.

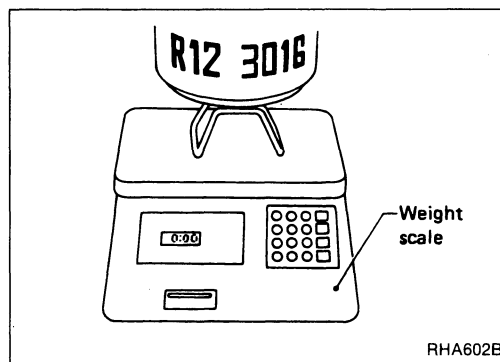
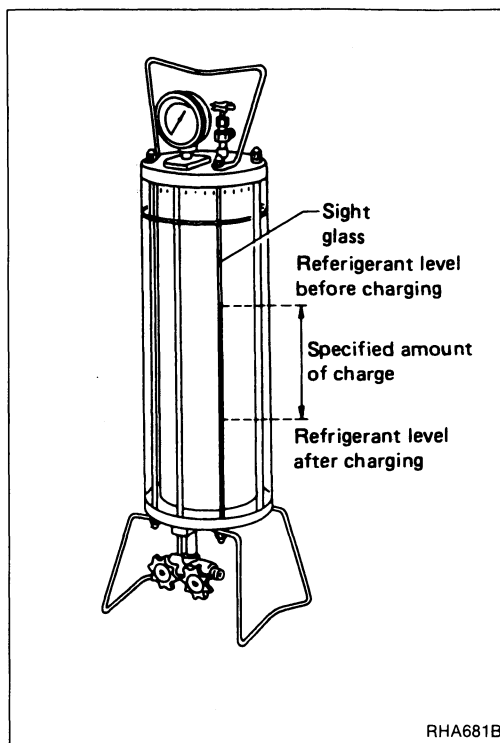

If a flow meter is not available, the amount of charged refrigerant also can be determined by subtracting the weight of the canister measured after charging from its weight measured before charging.

DISCHARGING, EVACUATING, CHARGING AND CHECKING

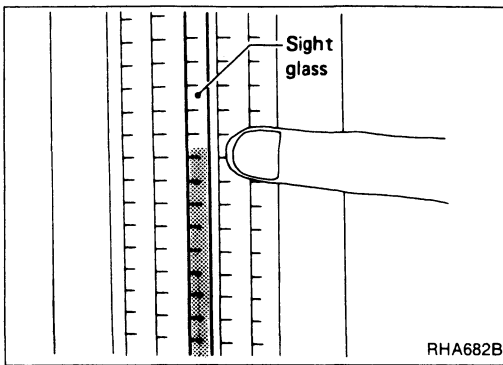

Charging Refrigerant (Cont'd)

PRELIMINARY CHARGING OF REFRIGERANT-2

1. Slowly open the high pressure side valve of the manifold gauge to charge refrigerant from the high pressure side.
2. Close the high pressure valve after charging approx. 200 g (7.05 oz) refrigerant.

CAUTION:

The refrigerant in the charging cylinder is kept in the liquid state, so the refrigerant should be charged from high pressure side. Do not start the engine with the high pressure valve kept open.

PRELIMINARY CHECK FOR REFRIGERANT LEAKS

Refer to "PRELIMINARY CHECK FOR REFRIGERANT LEAKS" in "Charging Refrigerant".

CHARGING REFRIGERANT

1. Slowly open the high pressure valve of the manifold gauge, and charge the calculated amount of refrigerant in "CALCULATING CHARGING AMOUNT OF REFRIGERANT".

CAUTION:

The refrigerant in the charging cylinder is kept in the liquid state, so the refrigerant should be charged from high pressure side. Do not start the engine with the high pressure valve kept open.

2. Close the high pressure valve of the manifold gauge.
3. Make sure that the calculated amount of refrigerant is in the sight glass.
4. Close the charging cylinder outlet valve.
5. Turn off the heater if it is on (when using heater equipped type).

Inspection for Refrigerant Leaks

WORK PROCEDURE

To facilitate inspection for refrigerant leaks, establish the following conditions:

- Start the engine.
- Run the air conditioner.
- Set the blower fan control to MAX.
- Set the temperature control to FULL COLD.
- Run the refrigerant system for more than 5 minutes after setting the above-mentioned conditions (to circulate the refrigerant through the system).

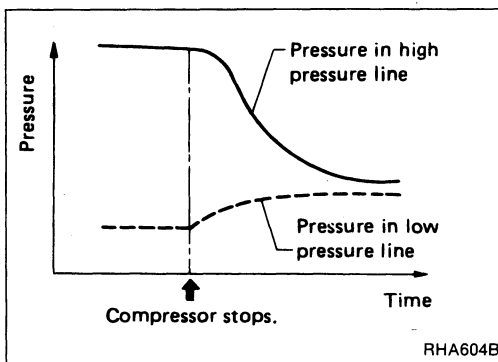

Refrigerant leaks should be checked immediately after stopping the engine, beginning with the high pressure line, using a gas leak detector. This is because the pressure in the high pressure line drops gradually after the refrigerant circulation stops while the pressure in the low pressure line rises gradually as shown in the graph. Leaks can be detected easily when pressure is high.

To prevent detecting errors, make sure that there is no refrigerant vapor or tobacco smoke in the vicinity of the vehicle. It is also necessary to shield the vehicle from the wind so that the leaking refrigerant is not blown away.

DISCHARGING, EVACUATING, CHARGING AND CHECKING

Inspection for Refrigerant Leaks (Cont'd)

INSPECTION POINTS

Check carefully each of the tube joints. To check, wipe the portion to be checked with waste cloth, and move the tester probe all around the joint.

Compressor

Check the shaft seals and bolt holes, and also around the magnet clutch.

Receiver drier

Check the pressure valve, safety valve and the fusible plug mounts.

Service valve

Check all around the service valves.

Ensure that the valve core is not loose.

The service valve cap must be attached to the valve (to prevent leak).

Also check that there are no foreign objects inside the cap.

Inside of cooling unit

To check, insert the leak tester probe into the drain hose immediately after stopping the engine. (Keep the probe inserted for more than 10 seconds.)

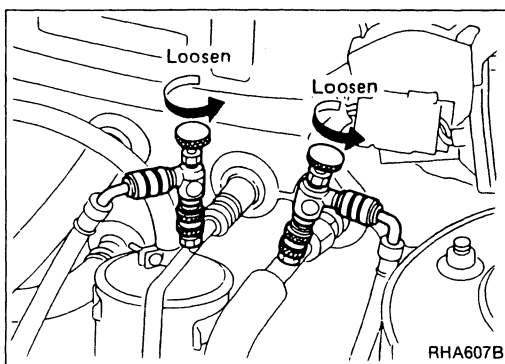
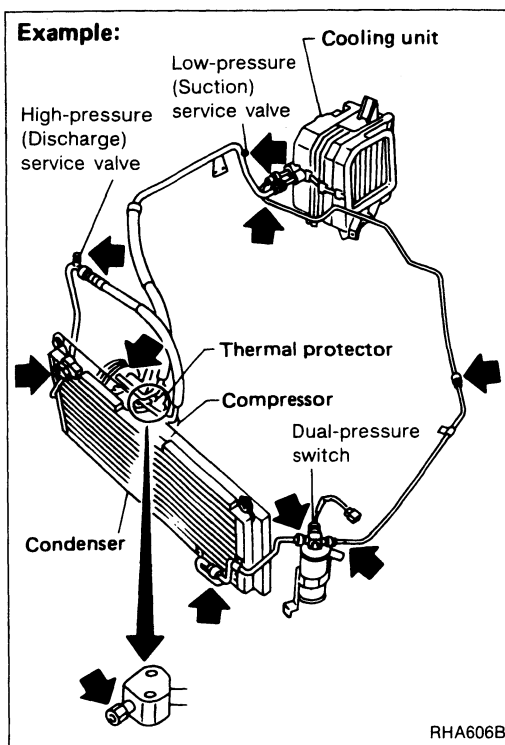

Recovery Procedure

REMOVAL OF REFRIGERANT CHARGING DEVICE

1. Completely loosen the adapter valves of the low pressure and high pressure lines. The inner valve of the adapter valve will prevent the refrigerant from leaking out.
2. Remove both the high-pressure and low-pressure side adapter valves from the on-vehicle service valve.

If adapter valve is not used for charging, proceed as follows to minimize the refrigerant discharge into the atmosphere.

3. Loosen the nut of the low pressure charging hose while pressing it against the service valve to prevent refrigerant leakage.
4. After loosening the nut, quickly remove the charge valve from the service valve.
5. Wait until the high pressure gauge indication drops to below 981 kPa (10 kg/cm², 142 psi), then similarly disconnect the high pressure charging hose.

DISCHARGING, EVACUATING, CHARGING AND CHECKING

Confirmation of Amount of Charged Refrigerant

The amount of refrigerant charged into the system can be observed through the sight glass by watching the flow of the refrigerant and by reading the high pressure and low pressure manifold gauges under the following conditions:

CONDITIONS

- Doors:
Close completely.
- Window glasses:
Close completely.
- Intake door position:
RECIRC
- Mode door position:
VENT
- Blower fan:
HI
- TEMP control:
Optional (Set so that intake air temperature is 30 to 35°C (86 to 95°F).
- AIR CON switch:
ON
- Engine speed:
Approx. 1,500 rpm

WORK PROCEDURE

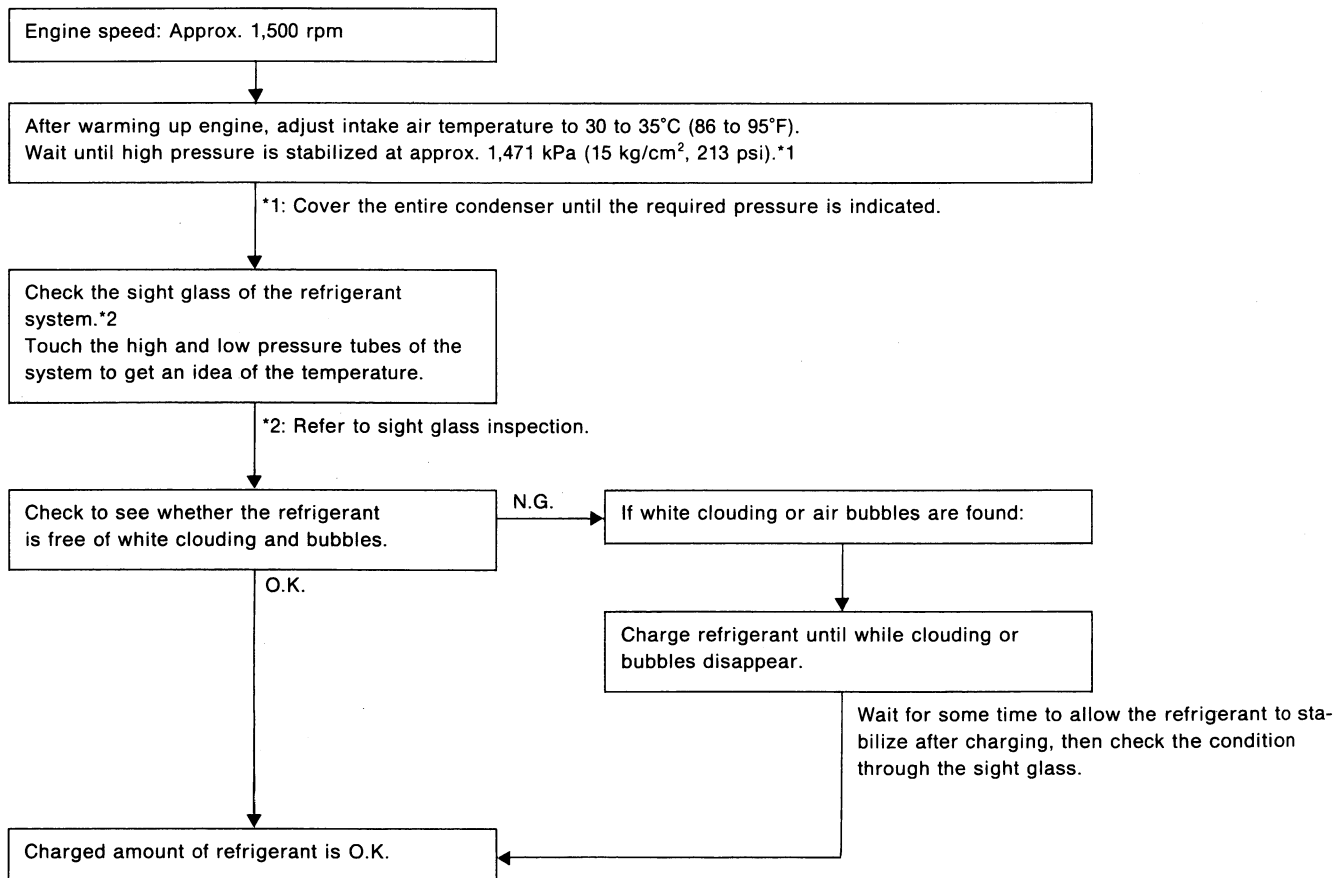

DISCHARGING, EVACUATING, CHARGING AND CHECKING

Confirmation of Amount of Charged Refrigerant (Cont'd)

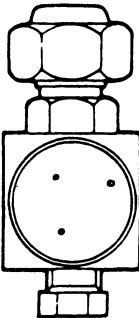
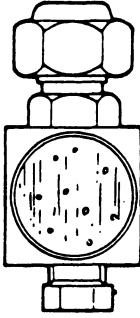
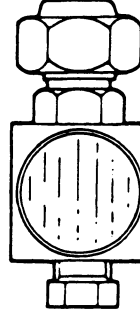
Amount of charge Check item	Appropriate	Refrigerant is insufficient	Almost no refrigerant	Overcharged, or air in system
Temperature of high and low pressure pipes	High pressure side is hot while low pressure side is cold.	High pressure side is warm and low pressure side is somewhat cold.	No difference is felt between high and low pressure sides.	High pressure side is very hot.
Flow of refrigerant viewed through sight glass	Mostly transparent. Occasionally some bubbles are seen when engine rpm is increased or decreased. 	Bubbles are always flowing. Refrigerant is cloudy. 	Nothing is visible. 	If overcharged, no bubbles are seen. If there is air in the system, large bubbles are seen.
Pressure	Normal high pressure: 1,373 - 1,765 kPa (14 - 18 kg/cm ² , 199 - 256 psi) Normal low pressure: 147 - 294 kPa (1.5 - 3 kg/cm ² , 21 - 43 psi)	Both high and low pressure values are insufficient.	High pressure value is very small.	Both high and low pressure values are excessive.
Action to take	Air bubbles may be generated when the receiver drier strainer is clogged, or when the expansion valve is opened excessively.	Add refrigerant after checking for leaks.	Check the refrigerant system.	Stop the compressor and extract excessive refrigerant. If air is found, perform evacuation, then charge the specified amount of refrigerant.

CAUTION:

The condition of bubbles seen through the sight glass as well as the intake and discharge pressures are influenced by the ambient temperature, wind velocity, weather, and by the air temperature in front of the condenser, etc.

SERVICE PROCEDURES

Refrigerant Lines

VG30DE ENGINE MODEL

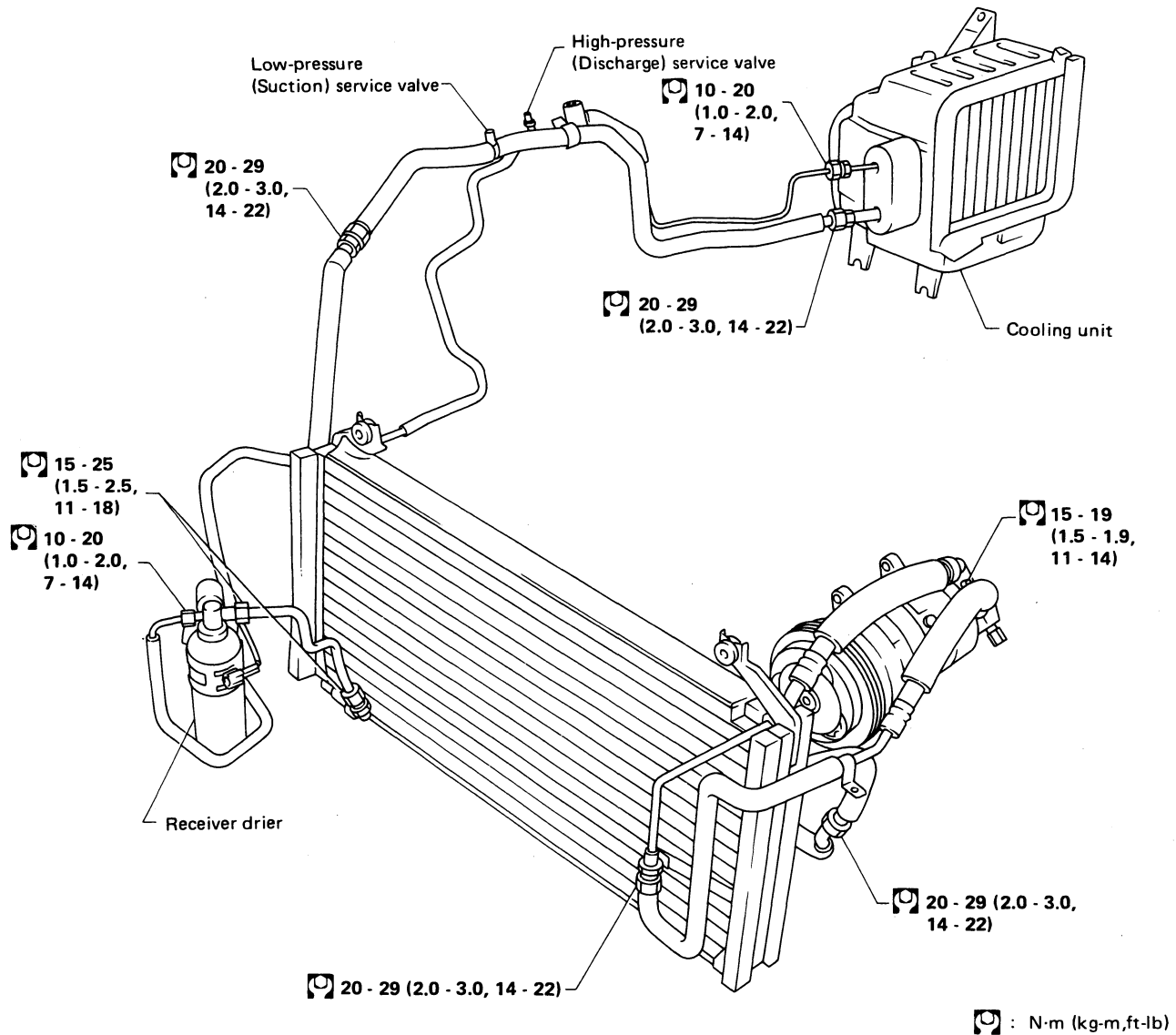
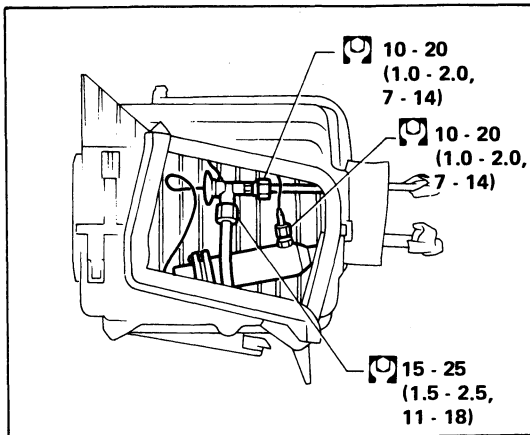

SERVICE PROCEDURES

Refrigerant Lines (Cont'd)

VG30DETT ENGINE MODEL

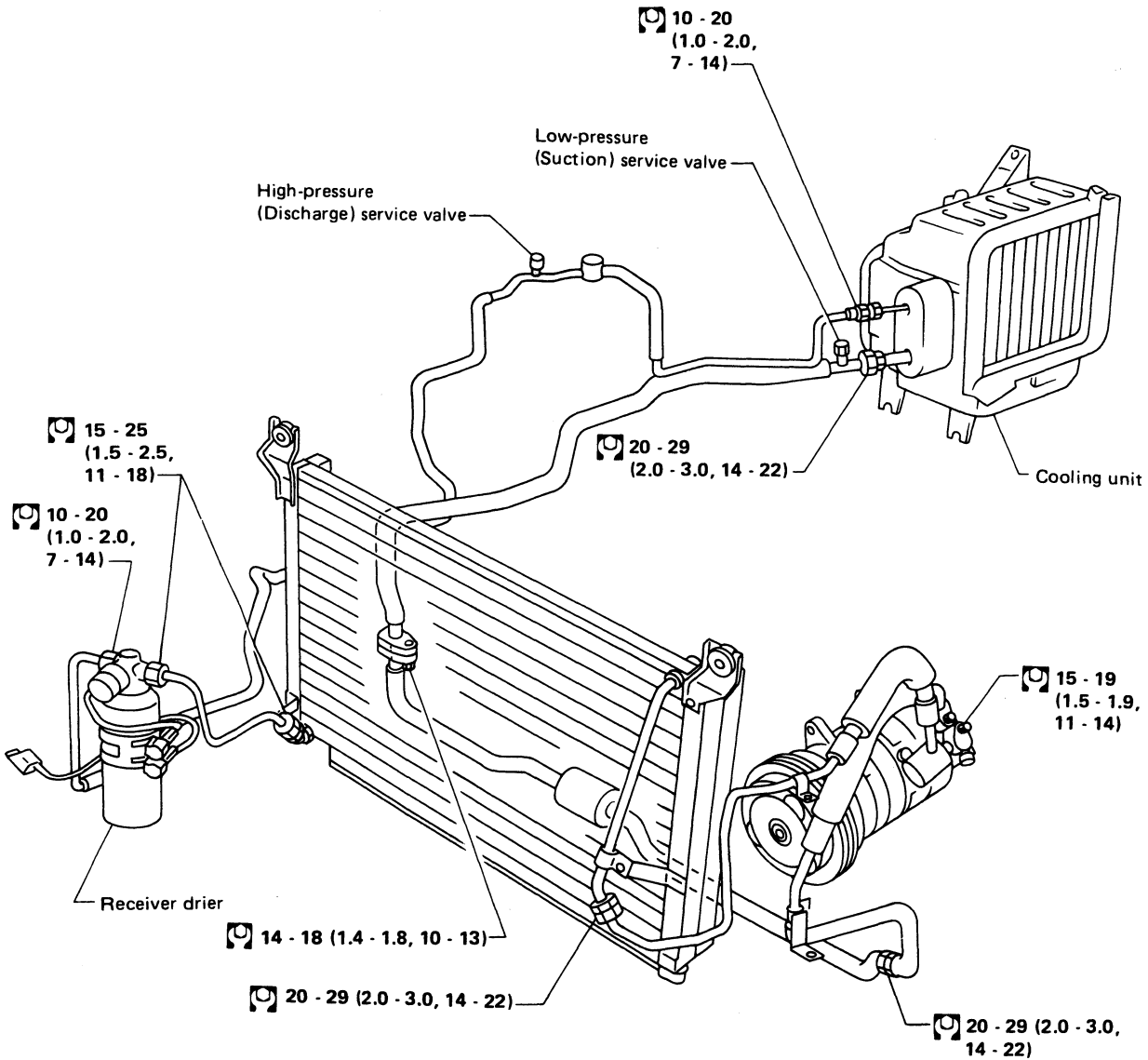
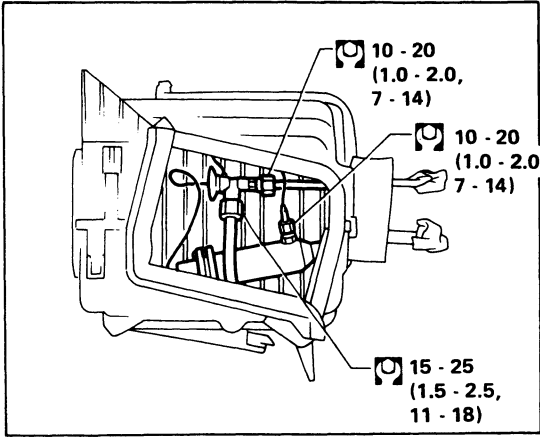

: N·m (kg-m, ft-lb)

SERVICE PROCEDURES

Compressor Mounting

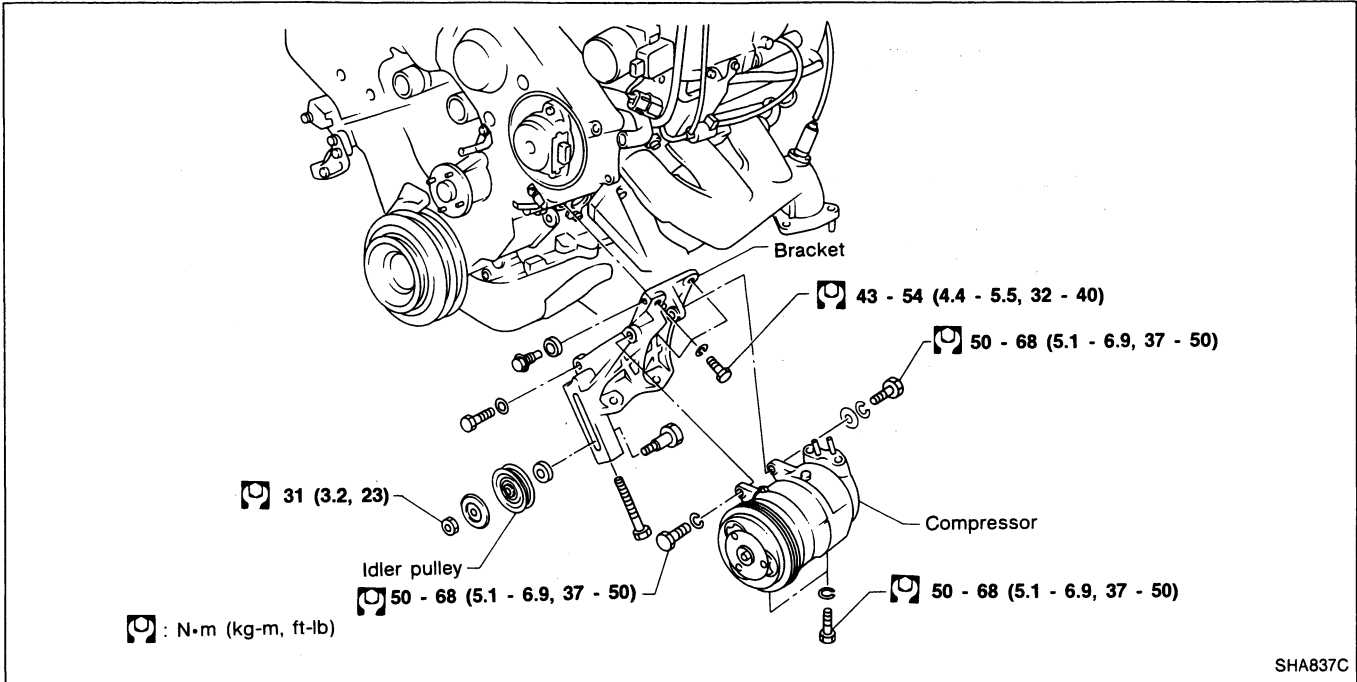

Belt Tension

- Refer to section MA.

Fast Idle Control Device (F.I.C.D.)

- Refer to section EF & EC.

SERVICE PROCEDURES

Removal and Installation — Compressor

REMOVAL

1. Remove battery cable.
2. Discharge refrigerant into your refrigerant recycling equipment.
3. Remove under cover.

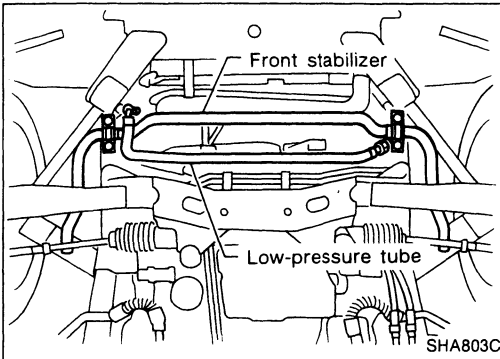

4. Remove low pressure tube, front stabilizer bar and its clamps.
5. Loosen idler pulley nut and adjusting bolt. Remove idler pulley.

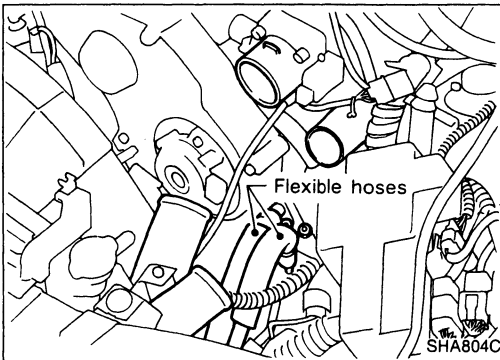

6. Remove air pipes and hoses to make room.
7. Remove two nuts to separate high and low pressure flexible hoses from compressor.
8. Disconnect compressor harness connector.
9. Remove two compressor fixing bolts (upper).

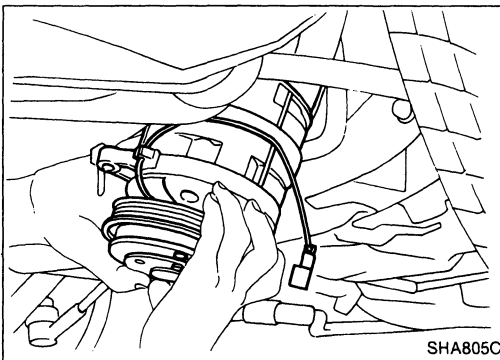

10. Remove two compressor fixing bolts (lower).
11. Remove the compressor as shown in the left-hand figure.

INSTALLATION

Installation is the reverse order of removal. Tightening torque related to front stabilizer: refer to FA section.

Maintenance of Oil Quantity in Compressor

The oil used to lubricate the compressor circulates through the system with the refrigerant. Whenever any component of the system is replaced or a large amount of gas leakage occurs, add oil to the compressor to maintain the specified amount. If oil quantity is not maintained properly, the following malfunctions may result:

- Lack of oil: May lead to a seized compressor
- Excessive oil: Inadequate cooling (thermal exchange impeded)

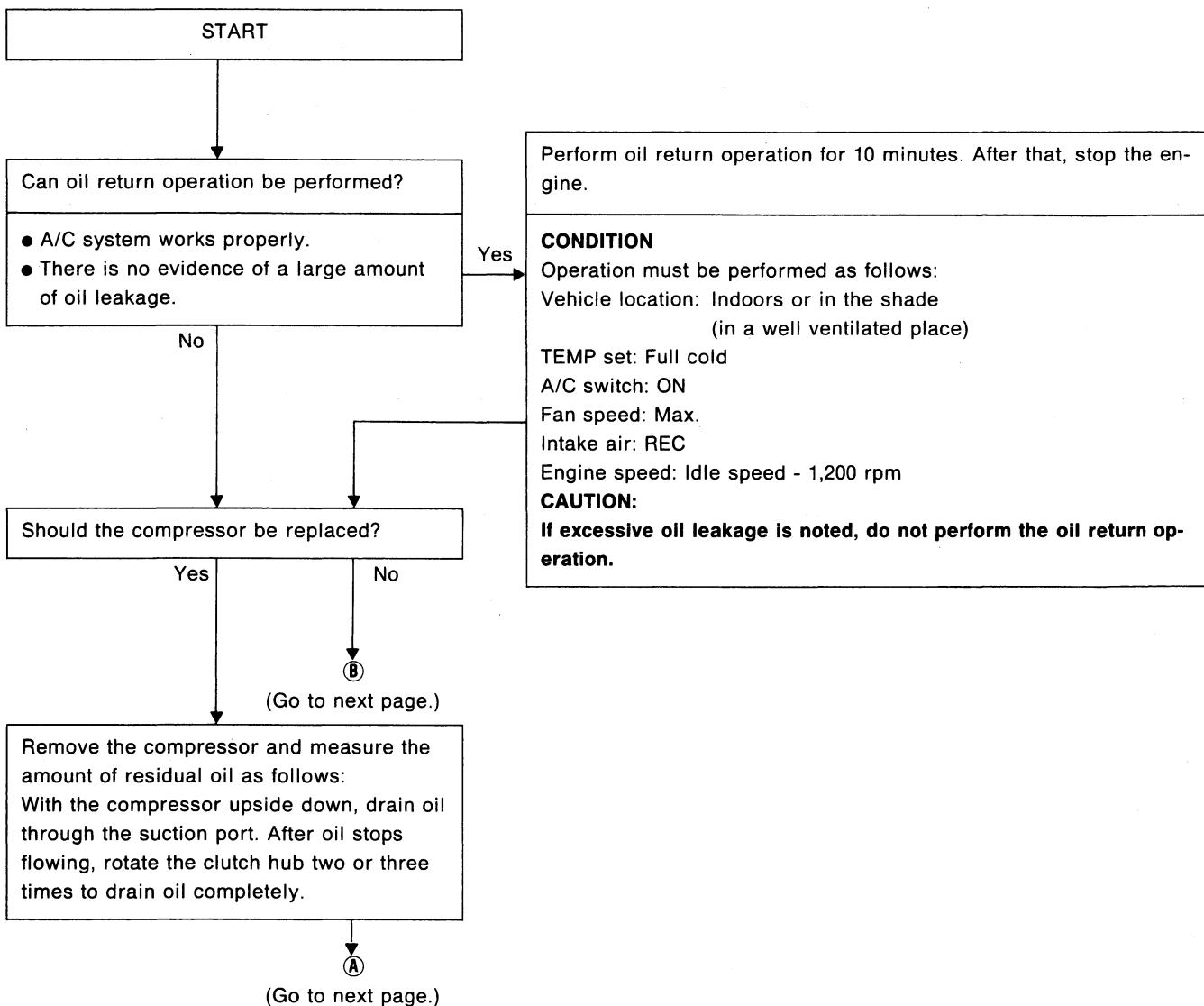

COMPRESSOR OIL — Checking and Adjusting

Maintenance of Oil Quantity in Compressor (Cont'd)

Ⓐ

Decide on the amount of oil to be drained from the new compressor in accordance with the table on the right.

Extract as much oil as necessary from the new compressor.
(refer to the table at right.)

Ⓑ

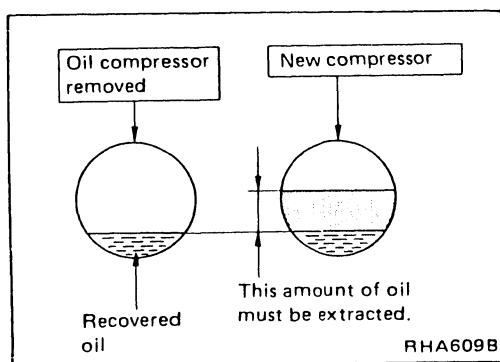

A new compressor is charged with the specified amount of oil (the overall amount needed in the system). So some oil needs to be drained from a new compressor to ensure that the amount of oil in the compressor is the same as was in the old compressor.

Amount of oil to be extracted from new compressor

Unit: mℓ (US fl oz, Imp fl oz)

Type	Pre-charged amount of oil in new compressor	Recovered amount of oil from old compressor	Amount of oil to be drained from new compressor
DKV14B DKV14C	200 (6.8, 7.0)	Less than 70 (2.4, 2.5)	110 (3.7, 3.9)
		Greater than 70 (2.4, 2.5)	200 (6.8, 7.0) - [Recovered amount + 20 (0.7, 0.7)]
NVR140 NVR140S	200 (6.8, 7.0)	Less than 90 (3.0, 3.2)	90 (3.0, 3.2)
		Greater than 90 (3.0, 3.2)	200 (6.8, 7.0) - [Recovered amount + 20 (0.7, 0.7)]
DKS16H DKS16N	250 (8.5, 8.8)	Less than 190 (6.4, 6.7)	60 (2.0, 2.1)
		Greater than 190 (6.4, 6.7)	250 (8.5, 8.8) - [Recovered amount + 20 (0.7, 0.7)]
MJS130 MJS170	150 (5.1, 5.3)	—	80 (2.7, 2.8)
V-5	236 (8.0, 8.3)	Less than 95 (3.2, 3.3)	150 (5.1, 5.3)
		Greater than 95 (3.2, 3.3)	236 (8.0, 8.3) - [Recovered amount + 20 (0.7, 0.7)]

Ⓑ

Is there any part to be replaced? (Evaporator, condenser, receiver drier or in case there is evidence of a large amount of oil leakage.)

Yes

After replacing any of the following major components of the system, be sure to add the correct amount of oil to the system.

Amount of oil to be added

Part replaced	Oil to be added to system		Remarks
	Amount of oil mℓ (US fl oz, Imp fl oz)	Ratio (%)	
Evaporator	45 - 75 (1.5 - 2.5, 1.6 - 2.6)	30	—
Condenser	30 - 50 (1.0 - 1.7, 1.1 - 1.8)	20	—
Receiver drier	15 - 25 (0.5 - 0.8, 0.5 - 0.9)	10	—
In case of refrigerant leak	30 - 50 (1.0 - 1.7, 1.1 - 1.8)	—	Large leak
	—	—	Small leak*

No

Carry out the A/C performance test.

*: If refrigerant leak is small, no addition of oil is needed.
"Ratio" in this table indicates the ratio of added oil to the overall amount of oil needed in the system.

COMPRESSOR — Model DKS-16H (DIESEL-KIKI make)

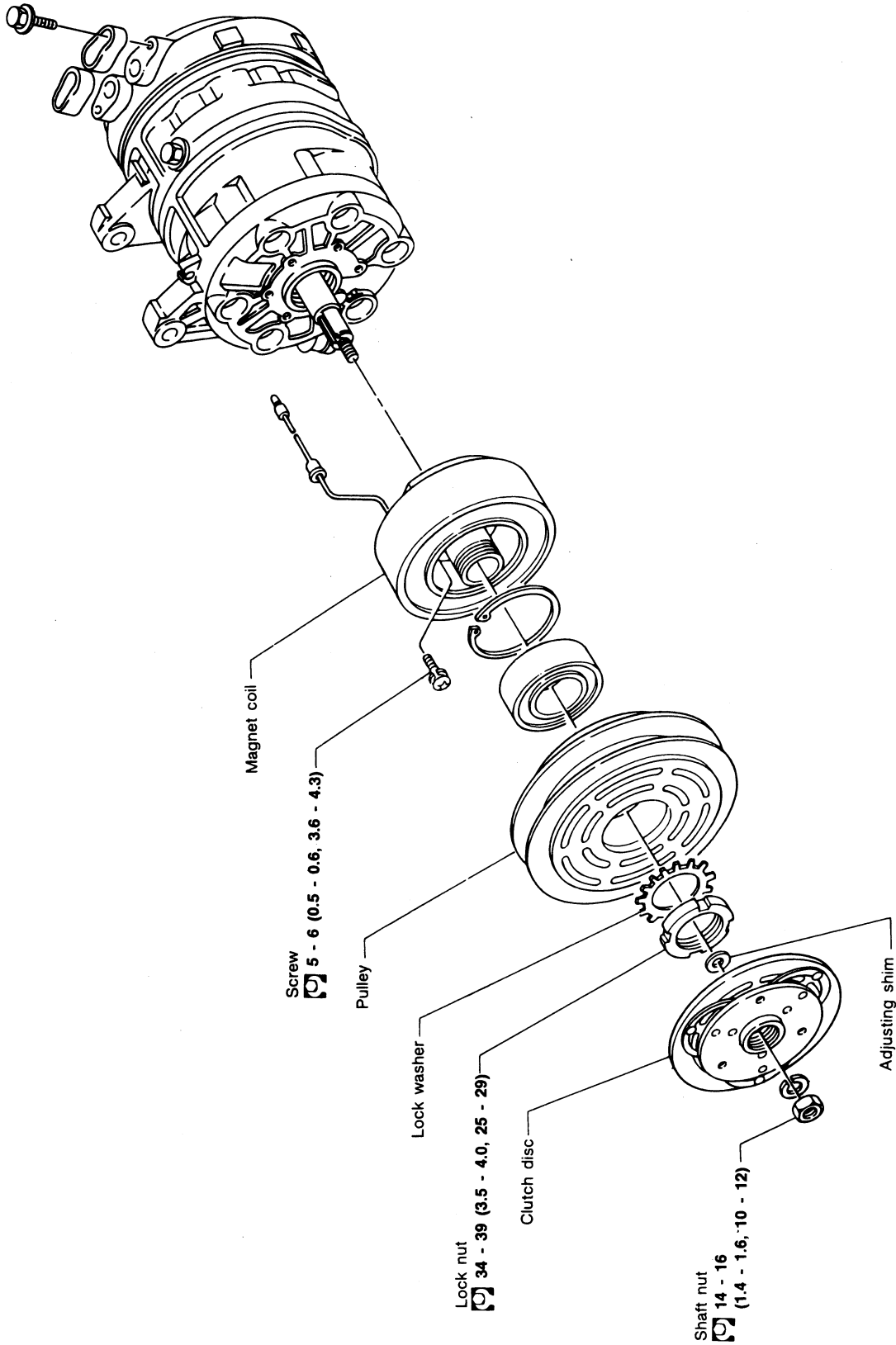

: N·m (kg·m, ft·lb)

Compressor Clutch

REMOVAL

- When removing shaft nut, hold clutch disc with clutch disc wrench.

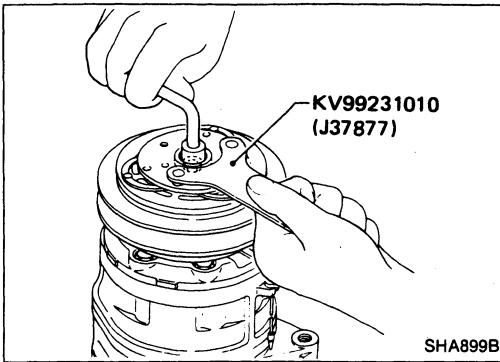

- Using clutch disc puller, clutch disc can be removed easily.

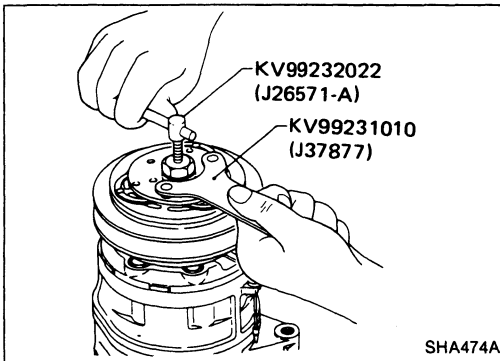

- Bend down pawl of lock washer.
- When removing pulley, remove lock nut with nut wrench.

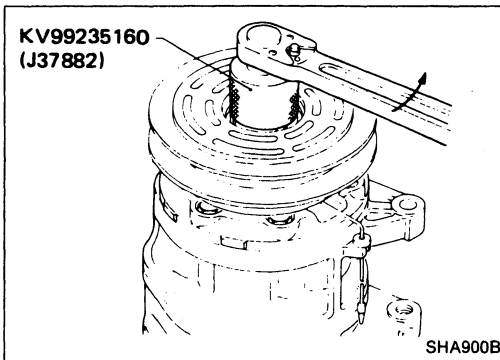

- Remove the pulley by hand. If difficult, use puller pilot.

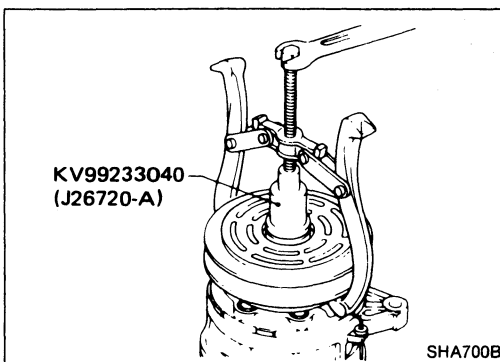

COMPRESSOR — Model DKS-16H (DIESEL-KIKI make)

Compressor Clutch (Cont'd)

INSPECTION

Clutch disc

If the contact surface shows signs of damage due to excessive heat, the drive plate and pulley should be replaced.

Pulley

Check the appearance of the pulley assembly. If the contact surface of the pulley shows signs of excessive grooving due to slippage, both the pulley and drive plate should be replaced. The contact surfaces of the pulley assembly should be cleaned with a suitable solvent before reinstallation.

Coil

Check coil for loose connection or cracked insulation.

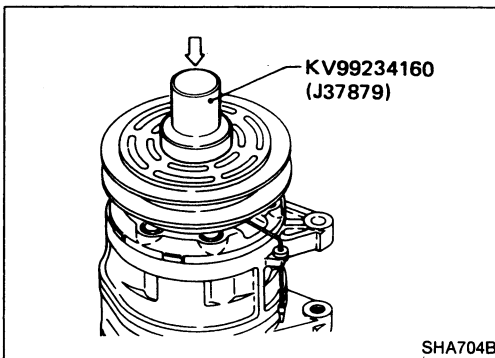
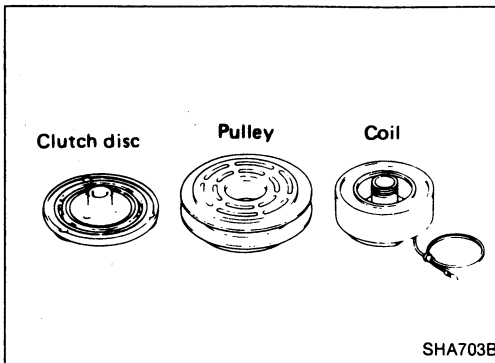

INSTALLATION

- Install the key in the keyway on the compressor drive shaft.
- Install the coil to compressor (lead wire up) and tighten the mounting screws.
- Install the lead wire into the holder correctly.

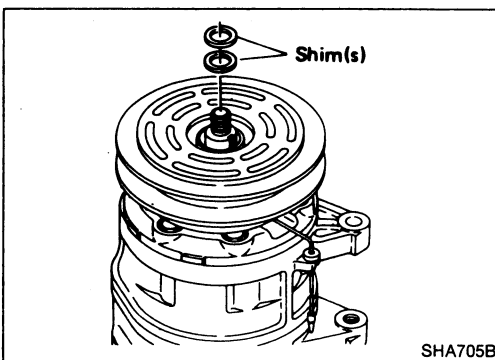

- Install lock washer and nut with nut wrench.
- Bend one pawl of the lock washer up against the nut to prevent the nut from loosening.

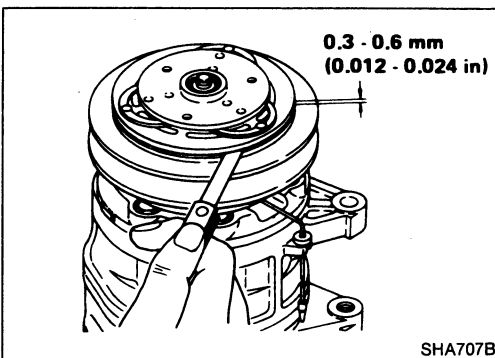

- Check to ensure that the clutch clearance is between 0.3 to 0.6 mm (0.012 to 0.024 in). Adjust the clearance using shim(s) as necessary.

BREAK-IN OPERATION

When replacing compressor clutch assembly, do not forget break-in operation, accomplished by engaging and disengaging the clutch about thirty times.

Break-in operation raises the level of transmitted torque.

How to Perform Trouble Diagnoses for Quick and Accurate Repair — Manual Air Conditioner

WORK FLOW

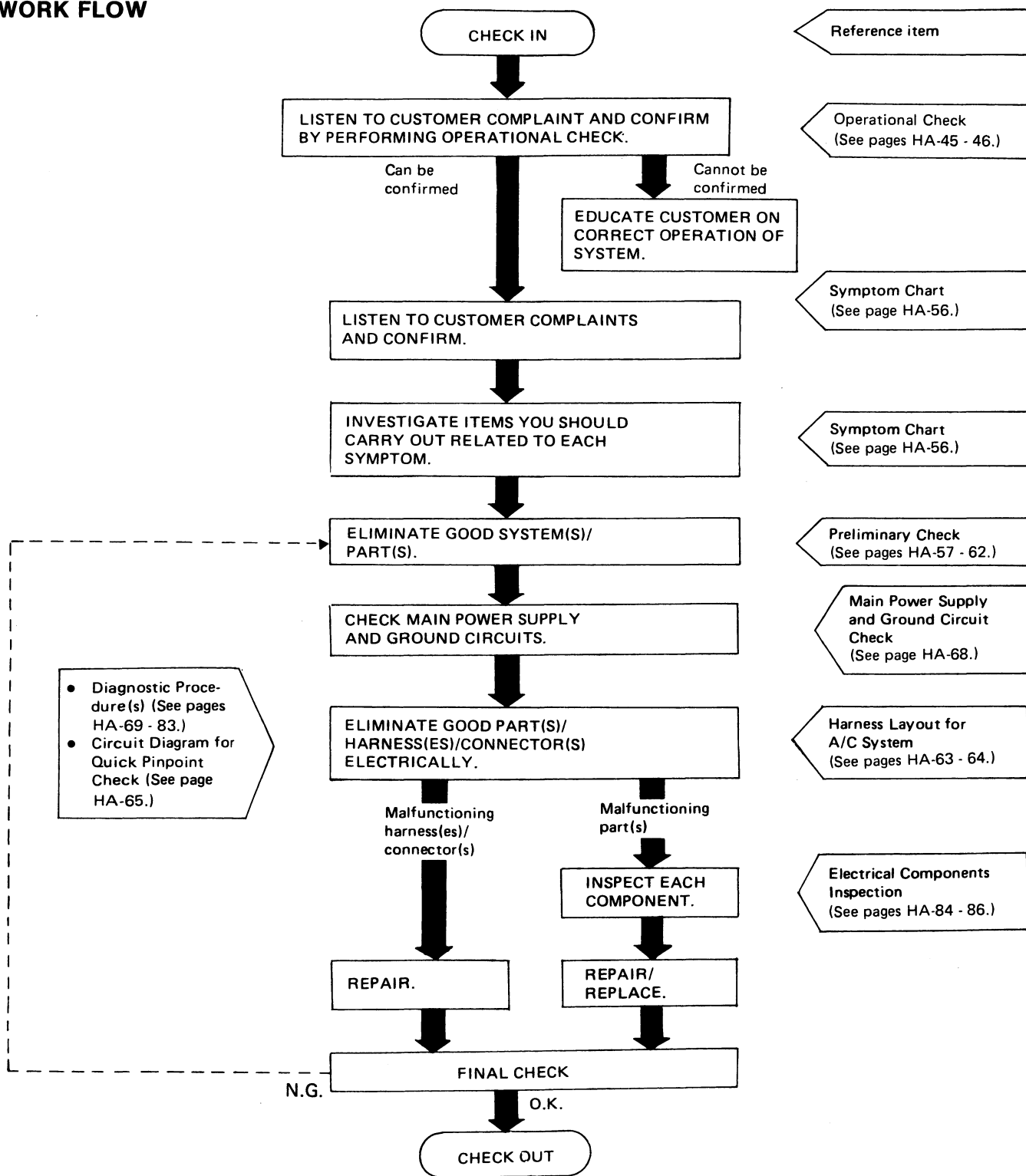

How to Perform Trouble Diagnoses for Quick and Accurate Repair — Auto Air Conditioner

WORK FLOW

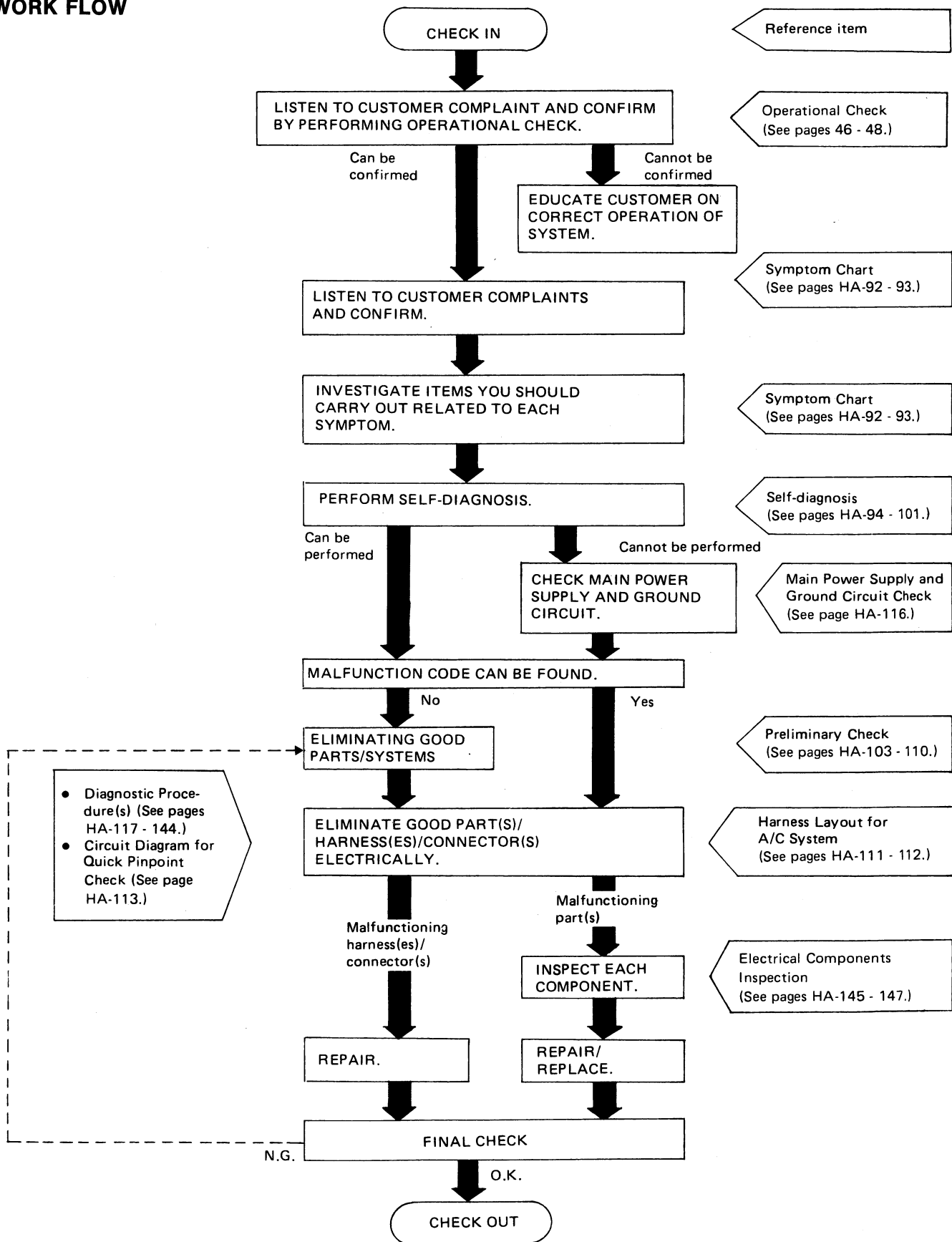

Operational Check — Manual Air Conditioner

The purpose of the operational check is to confirm that the system operates as it should. The systems which are checked are the blower, mode (discharge air), intake air, temperature decrease, temperature increase.

CONDITIONS:

Engine running at normal operating temperature.

PROCEDURE:

1. Check blower

- 1) Slide Fan lever to 1-speed.
Blower should operate on 1-speed.
- 2) Then slide Fan Lever to 2-speed.
- 3) Continue checking blower speed until all four speeds are checked.
- 4) Leave blower on 4-speed.

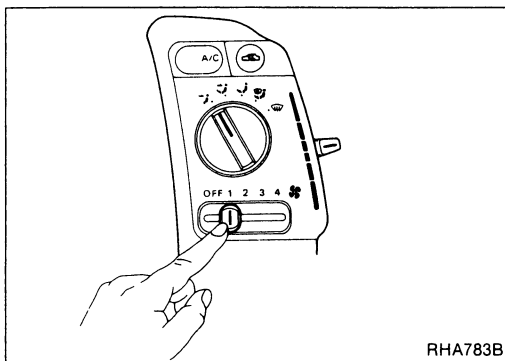

2. Check discharge air

- 1) Set Mode switch at VENT position.
- 2) Confirm that all discharge air comes out of face vents.
- 3) Set Mode switch at B/L position.
- 4) Confirm that discharge air comes out of face vents and foot vents.
- 5) Set Mode switch at FOOT position.
- 6) Confirm that discharge air comes out of foot vents, with some air from defroster vents.
- 7) Set Mode switch at F/D position.
- 8) Confirm that discharge air comes out of foot vents and defroster vents, and that compressor turns ON.
- 9) Set Mode switch at DEF position.
- 10) The discharge air should be coming only from defroster vents. At the same time intake door position should be at FRE.

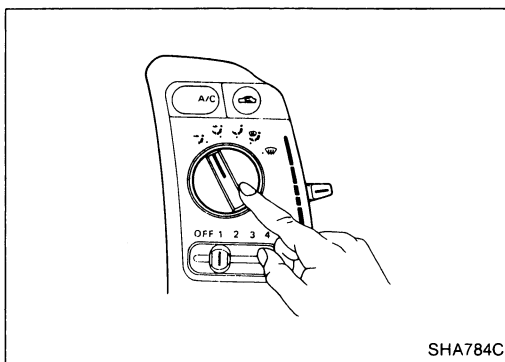

3. Check recirc

- 1) Press RECIRC button.
RECIRC indicator should light.
- 2) Listen for intake door position change (you should hear blower sound change slightly).

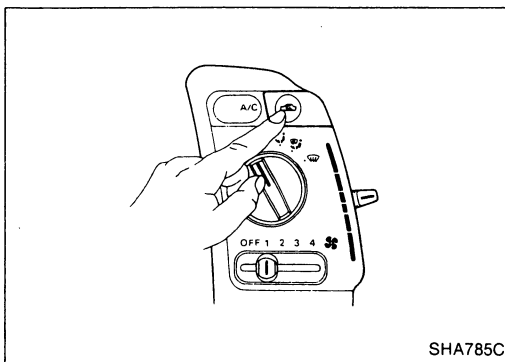

DIAGNOSES — Overall System

Operational Check — Manual Air Conditioner (Cont'd)

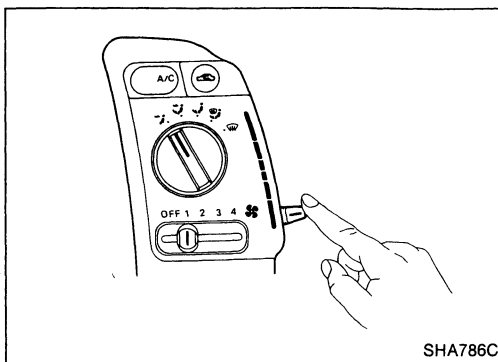

4. Check temperature decrease

- 1) Slide temperature control lever to full cold.
- 2) Check for cold air at discharge air outlets.

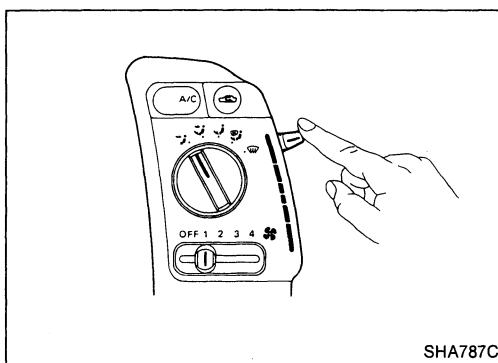

5. Check temperature increase

- 1) Slide temperature control lever to full hot.
- 2) Check for hot air at discharge air outlets.

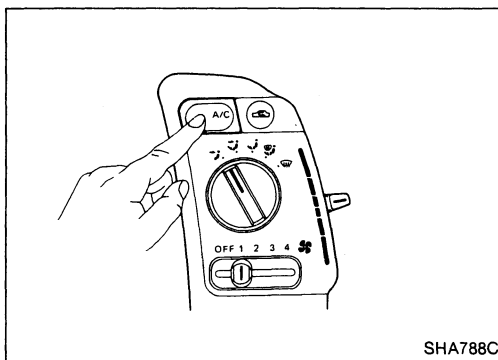

6. Check air conditioner switch

Move fan control lever to the desired (1 to 4-speed) position and push the air conditioner button to turn ON the air conditioner.

The indicator light should come on when air conditioner is ON.

Operational Check — Auto Air Conditioner

The purpose of the operational check is to confirm that the system operates as it should. The systems which will be checked are the blower, mode (discharge air), ambient display, intake air, defrost, econ, auto, temperature decrease, temperature increase, and the memory function.

CONDITIONS:

Engine running at normal operating temperature.

PROCEDURE:

1. Check blower

- 1) Press FAN switch one time.
ECON indicator should light.
Blower should operate on low speed, and the fan symbol should have one blade lit ().
- 2) Press FAN switch one more time.
- 3) Continue checking blower speed and fan symbol until all four speeds have been checked.
- 4) Leave blower on high speed.

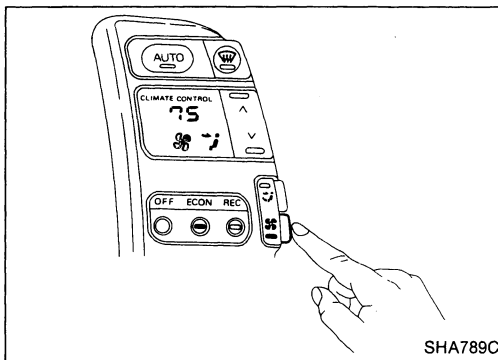



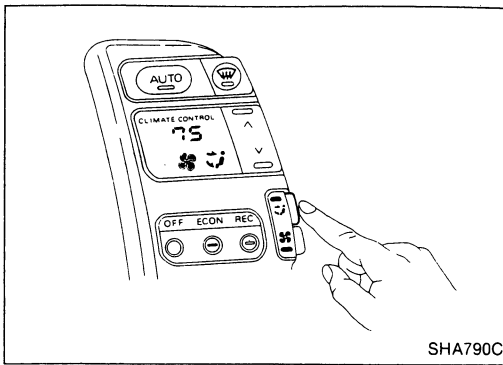

DIAGNOSES — Overall System

Operational Check — Auto Air Conditioner (Cont'd)



2. Check discharge air

- 1) Press MODE switch one time.
Display should show air to face ().
- 2) Confirm that all discharge air comes out of face vents.
- 3) Press MODE switch one more time.
Display should show air to face and foot (bi-level) ().
- 4) Confirm that discharge air comes out of face and foot vents.
- 5) Press MODE switch one more time.
Display should show air to foot ().
- 6) Confirm that discharge air comes mostly from foot outlets, with some air from defroster outlets.
- 7) Press MODE switch one more time.
Display should show air to foot and defroster ().
- 8) Confirm that discharge air comes out of foot vents and defroster vents.
- 9) Leave system in F/D mode.

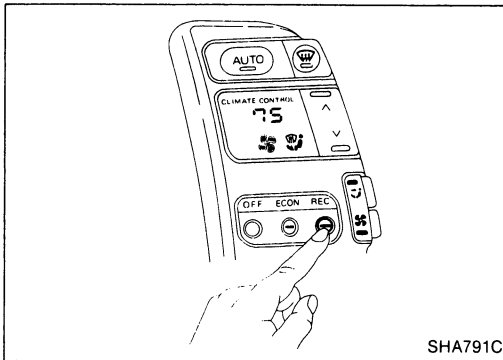

3. Check recirc

- 1) Press RECIRC switch.
RECIRC indicator should light.
- 2) Listen for intake door position change (you should hear blower sound change slightly).

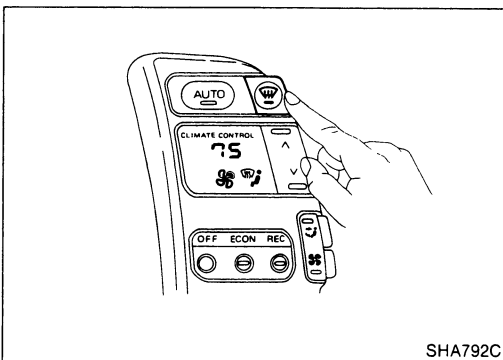

4. Check defrost

- 1) Press DEF switch.
- 2) Check that RECIRC, ECON, MODE and Fan are canceled.
The discharge air should be coming only from defrost vents.
- 3) Confirm that compressor clutch is engaged (visual inspection).
Display should show air to defroster ().

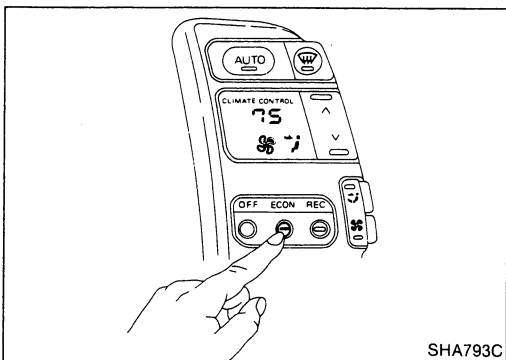

5. Check ECON mode

- 1) Press ECON switch.
Defrost should be canceled.
Discharge air outlet will depend on ambient, in-vehicle, and set temperatures.
- 2) Confirm that the compressor clutch is not engaged (visual inspection).

DIAGNOSES — Overall System

Operational Check — Auto Air Conditioner (Cont'd)

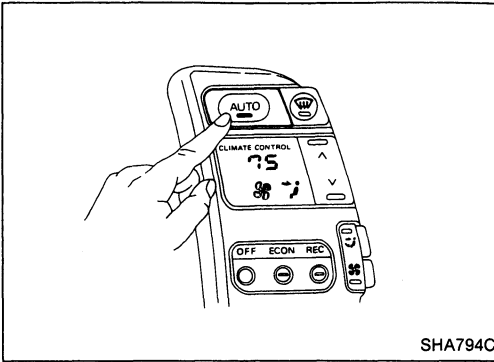

6. Check AUTO mode

- 1) Press AUTO switch.
- 2) Confirm that compressor clutch engages (audio or visual inspection).
Discharge air will depend on ambient, in-vehicle, and set temperatures.

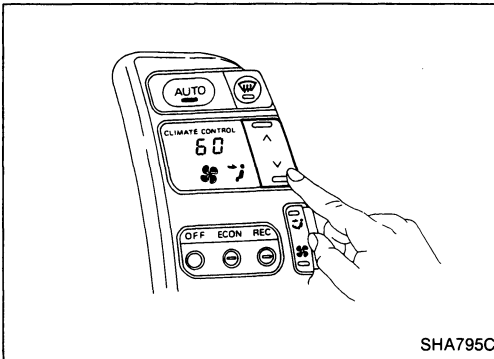

7. Check temperature decrease

- 1) Press temperature set switch until 10°C (60°F) is displayed.
- 2) Listen for changes in blower speed as set temperature changes.
- 3) Check for cold air at discharge air outlets.

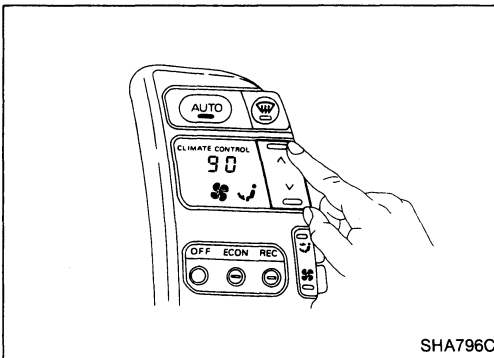

8. Check temperature increase

- 1) Press temperature set switch until 10°C (90°F) is displayed.
- 2) Listen for changes in blower speed as set temperature changes.
- 3) Check for hot air at discharge air outlets.

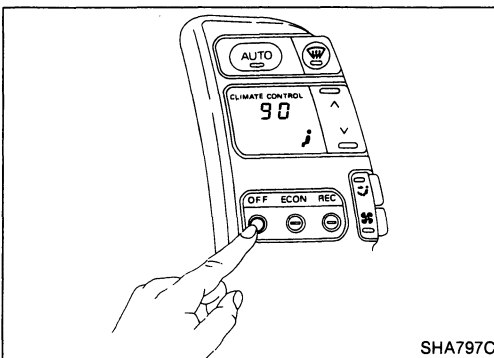

9. Check memory function

- 1) Press off button.
- 2) Turn ignition off.
- 3) Wait 15 seconds.
- 4) Turn ignition on.
- 5) Press AUTO button.
- 6) Confirm that the set temperature remained at 40°C (90°F).

Performance Chart

TEST CONDITION — For Manual Air Conditioner

Testing must be performed as follows:

Vehicle location: Indoors or in the shade (in a well ventilated place)

Doors: Closed

Door windows: Open

Hood: Open

TEMP. lever position: Max. COLD

Mode switch:  (Ventilation) set

REC switch:  (Recirculation) set

FAN level position: Max. position

Engine speed: 1,500 rpm

Time required before starting testing after air conditioner starts operating: More than 10 minutes

TEST CONDITION — For Auto Air Conditioner

Testing must be performed as follows:

Vehicle location: Indoors or in the shade (in a well ventilated place)

Doors: Closed

Door windows: Open

Hood: Open



Set up ACTIVE-TEST with CONSULT and set each component as follows:

Mode door: VENT

Intake door: REC

Air mix door: Full-cold

Compressor: ON

Blower motor: 12V



Set up self-diagnosis STEP 2 and set code .

DIAGNOSES — Overall System

Performance Chart (Cont'd)

TEST READING

Recirculating-to-discharge air temperature table

Inside air(Recirculating air) at blower assembly inlet		Discharge air temperature at center ventilator °C (°F)
Relative humidity %	Air temperature °C (°F)	
50 - 60	20 (68)	5.9 - 7.8 (43 - 46)
	25 (77)	8.0 - 10.7 (46 - 51)
	30 (86)	11.0 - 14.4 (52 - 58)
	35 (95)	14.8 - 19.4 (59 - 67)
60 - 70	20 (68)	7.8 - 9.9 (46 - 50)
	25 (77)	10.7 - 13.6 (51 - 56)
	30 (86)	14.4 - 18.2 (58 - 65)
	35 (95)	19.4 - 24.8 (67 - 77)

Ambient air temperature-to-compressor pressure table

Ambient air		High-pressure (Discharge side) kPa (kg/cm ² , psi)	Low-pressure (Suction side) kPa (kg/cm ² , psi)
Relative humidity %	Air temperature °C (°F)		
50 - 70	20 (68)	608 - 912 (6.2 - 9.3, 88 - 132)	177 - 245 (1.8 - 2.5, 26 - 36)
	25 (77)	814 - 1,147 (8.3 - 11.7, 118 - 166)	186 - 255 (1.9 - 2.6, 27 - 37)
	30 (86)	1,020 - 1,402 (10.4 - 14.3, 148 - 203)	196 - 265 (2.0 - 2.7, 28 - 38)
	35 (95)	1,236 - 1,638 (12.6 - 16.7, 179 - 237)	226 - 314 (2.3 - 3.2, 33 - 46)

DIAGNOSES — Overall System

Performance Test Diagnoses

Characteristics revealed by the manifold gauge readings for the air conditioning system are shown in the following. For how to do the performance test, refer to the item "Performance Chart".

In the following table, the portion smeared with ink on each gauge scale indicates the range showing that the air conditioning system is in good order. This range is described in Performance Chart.

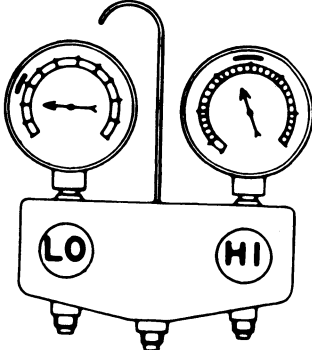
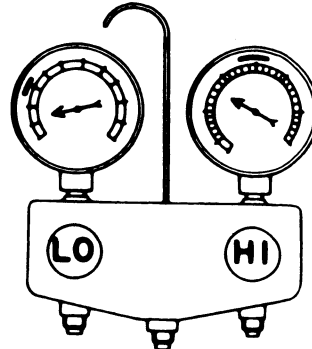
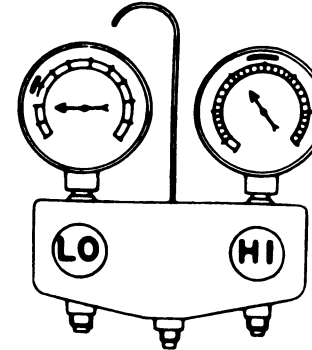
Condition	Probable cause	Corrective action
<p>INSUFFICIENT REFRIGERANT CHARGE</p>  <p>AC352A</p>	<p>Insufficient cooling. Bubbles appear in sight glass.</p> <p>Refrigerant is low, or leaking slightly.</p>	<p>1. Leak test. 2. Repair leak. 3. Charge system. Evacuate, as necessary, and recharge system.</p>
<p>ALMOST NO REFRIGERANT</p>  <p>AC353A</p>	<p>No cooling action. A lot of bubbles or something like mist appears in sight glass.</p> <p>Serious refrigerant leak.</p>	<p>Stop compressor immediately.</p> <p>1. Leak test. 2. Discharge system. 3. Repair leak(s). 4. Replace receiver drier if necessary. 5. Check oil level. 6. Evacuate and recharge system.</p>
<p>MALFUNCTIONING EXPANSION VALVE</p>  <p>AC354A</p>	<p>Slight cooling. Sweat or frosting on expansion valve inlet.</p> <p>Expansion valve restricts refrigerant flow.</p> <ul style="list-style-type: none"> ● Expansion valve is clogged. ● Expansion valve is inoperative. <p>Valve stuck closed. Thermal bulb has lost charge.</p>	<p>If valve inlet reveals sweat or frost:</p> <p>1. Discharge system. 2. Remove valve and clean it. Replace it if necessary. 3. Evacuate system. 4. Charge system.</p> <p>If valve does not operate:</p> <p>1. Discharge system. 2. Replace valve. 3. Evacuate and charge system.</p>

DIAGNOSES — Overall System

Performance Test Diagnoses (Cont'd)

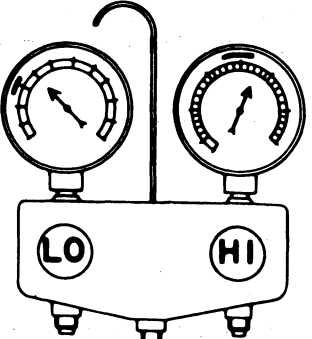
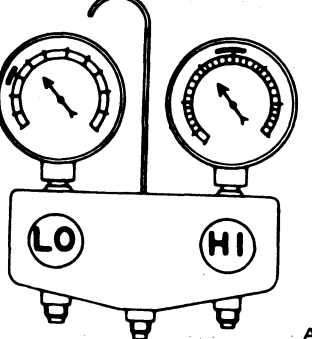
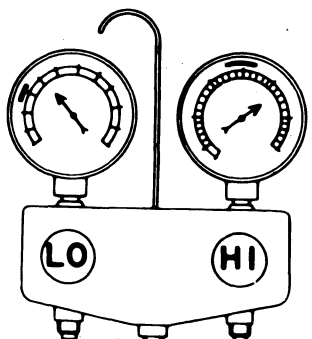
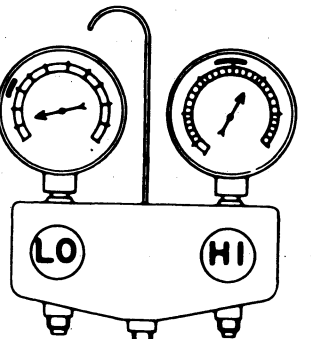
Condition	Probable cause	Corrective action
 <p>AC355A</p>	<p>Insufficient cooling. Sweat on suction line.</p>	<p>Expansion valve allows too much refrigerant through evaporator.</p> <p>Check valve for operation. If suction side does not show a pressure decrease, replace valve.</p>
 <p>AC356A</p>	<p>No cooling. Sweat or frosting on suction line.</p>	<p>Malfunctioning expansion valve.</p> <ol style="list-style-type: none"> 1. Discharge system. 2. Replace valve. 3. Evacuate and charge system.
<p>AIR IN SYSTEM</p>		
 <p>AC359A</p>	<p>Insufficient cooling. Sight glass shows occasional bubbles.</p>	<p>Air mixed with refrigerant in system.</p> <ol style="list-style-type: none"> 1. Discharge system. 2. Replace receiver drier. 3. Evacuate and charge system.
<p>MOISTURE IN SYSTEM</p>		
 <p>AC360A</p>	<p>After short operation, suction side may show vacuum pressure reading. During this condition, discharge air will be warm. As a warning of this, reading vibrates around 39 kPa (0.4 kg/cm², 6 psi).</p>	<p>Drier is saturated with moisture. Moisture has frozen in expansion valve. Refrigerant flow is restricted.</p> <ol style="list-style-type: none"> 1. Discharge system. 2. Replace receiver drier (twice if necessary). 3. Evacuate system completely. (Repeat 30-minutes evacuating three times.) 4. Recharge system.

DIAGNOSES — Overall System

Performance Test Diagnoses (Cont'd)

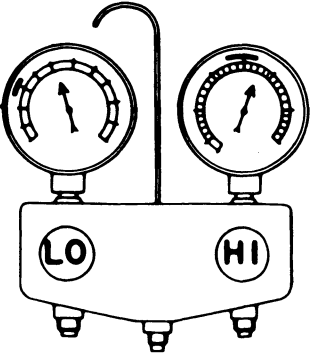
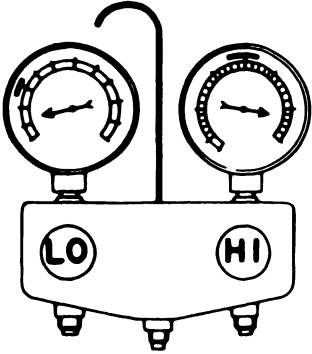
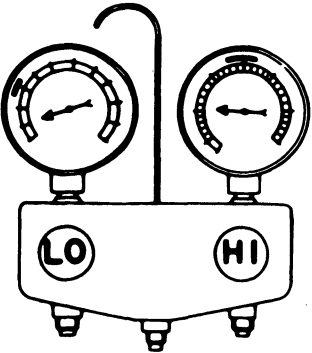
Condition	Probable cause	Corrective action
<p>MALFUNCTIONING CONDENSER</p>  <p>AC361 A</p>	<p>No cooling action: engine may overheat. Bubbles appear in sight glass of drier. Suction line is very hot.</p>	<p>Usually a malfunctioning condenser.</p> <ul style="list-style-type: none"> ● Check radiator fan motors. ● Check condenser for dirt accumulation. ● Check engine cooling system for overheating. ● Check for refrigerant overcharging. <p>If pressure remains high in spite of all above actions taken, remove and inspect the condenser for possible oil clogging.</p>
<p>HIGH PRESSURE LINE BLOCKED</p>  <p>AC362 A</p>	<p>Insufficient cooling. Frosted high pressure liquid line.</p>	<p>Drier clogged, or restriction in high pressure line.</p> <ol style="list-style-type: none"> 1. Discharge system. 2. Remove receiver drier or strainer and replace it. 3. Evacuate and charge system.
<p>MALFUNCTIONING COMPRESSOR</p>  <p>AC363 A</p>	<p>Insufficient cooling.</p>	<p>Internal problem in compressor, or damaged gasket and valve.</p> <ol style="list-style-type: none"> 1. Discharge system. 2. Remove and check compressor. 3. Repair or replace compressor. 4. Check oil level. 5. Replace receiver drier. 6. Evacuate and charge system.

DIAGNOSES — Overall System

Performance Test Diagnoses (Cont'd)

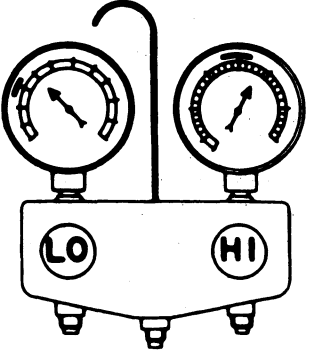
Condition	Probable cause	Corrective action
<p data-bbox="105 205 544 235">TOO MUCH OIL IN SYSTEM (Excessive)</p>  <p data-bbox="397 655 479 682">AC364A</p>	<p data-bbox="511 247 722 277">Insufficient cooling.</p> <p data-bbox="820 247 1112 373">Too much oil circulates with refrigerant, causing the cooling capacity of the system to be reduced.</p>	<p data-bbox="1136 247 1437 310">Refer to COMPRESSOR OIL for correcting oil level.</p>

Contents

Symptom Chart	HA-56
Preliminary Check	HA-57
PRELIMINARY CHECK 1	
(Intake door is not set at "FRESH" in DEF mode)	HA-57
PRELIMINARY CHECK 2	
(A/C does not blow cold air)	HA-58
PRELIMINARY CHECK 3	
(Magnet clutch does not engage in FOOT & DEF or DEF mode)	HA-59
PRELIMINARY CHECK 4	
(Air outlet does not change)	HA-60
PRELIMINARY CHECK 5	
(Noise)	HA-61
PRELIMINARY CHECK 6	
(Insufficient heating)	HA-62
Harness Layout for A/C system	HA-63
Circuit Diagram for Quick Pinpoint Check	HA-65
Wiring Diagram	HA-66
Main Power Supply and Ground Circuit check	HA-68
Diagnostic Procedure 1	
(Blower motor does not rotate)	HA-69
Diagnostic Procedure 2	
(Air outlet does not change)	HA-71
Diagnostic Procedure 3	
(Intake door does not charge in VENT, B/L or FOOT modes)	HA-73
Diagnostic Procedure 4	
(Magnet clutch does not engage when A/C switch and fan switch are ON)	HA-74
Diagnostic Procedure 5	
(Illumination or control panel indicators do not come on)	HA-78
Diagnostic Procedure 6	
(Temperature of air outlet does not change)	HA-82
Electrical Component Inspection	HA-84
Control Rod Adjustment	HA-87

Symptom Chart

DIAGNOSTIC TABLE

PROCEDURE	Preliminary check						Diagnostic Procedure						Main power supply and Ground circuit check		Electrical components inspection												
	HA-57	HA-58	HA-59	HA-60	HA-61	HA-62	HA-69 - 70	HA-71 - 72	HA-73	HA-74 - 77	HA-78 - 81	HA-82 - 83	HA-68	HA-68	HA-84	HA-84	HA-84	HA-85	HA-85	HA-85	HA-85	HA-86	HA-86	-	-	-	-
REFERENCE PAGE																											
SYMPTOM	Preliminary check 1	Preliminary check 2	Preliminary check 3	Preliminary check 4	Preliminary check 5	Preliminary check 6	Diagnostic procedure 1	Diagnostic procedure 2	Diagnostic procedure 3	Diagnostic procedure 4	Diagnostic procedure 5	Diagnostic procedure 6	Control amp.	Fuses	Fan switch	Blower motor	Blower resistor	A/C switch	Low pressure switch	RELAYS	MODE switch	THERMO CONTROL AMP.	Air mix door motor	Mode door motor	Intake door motor	Compressor	Harness
A/C does not blow cold air.	①						○		○		○	○	○	○		○	○	○	○	○						○	○
Insufficient heating						①	○					○	○			○	○						○				○
Blower motor does not rotate.	①						②						○	○		○	○										○
Air outlet does not change.				①				②					○	○								○		○			○
Intake door does not change in VENT, B/L or FOOT modes.									①				○	○											○		○
Intake door is not set at "FRESH" in DEF mode.	①								○				○	○											○		○
Magnet clutch does not engage when A/C switch and fan switch are ON.		①								②								○	○			○					○
Magnet clutch does not engage in FOOT & DEF or DEF mode.		①	②						○					○	○			○	○	○						○	○
Illumination or indicators on switch panel do not come on.											①			○													○
Noise					①																						○

Preliminary Check

PRELIMINARY CHECK 1

Intake door is not set at "FRESH" in DEF mode.

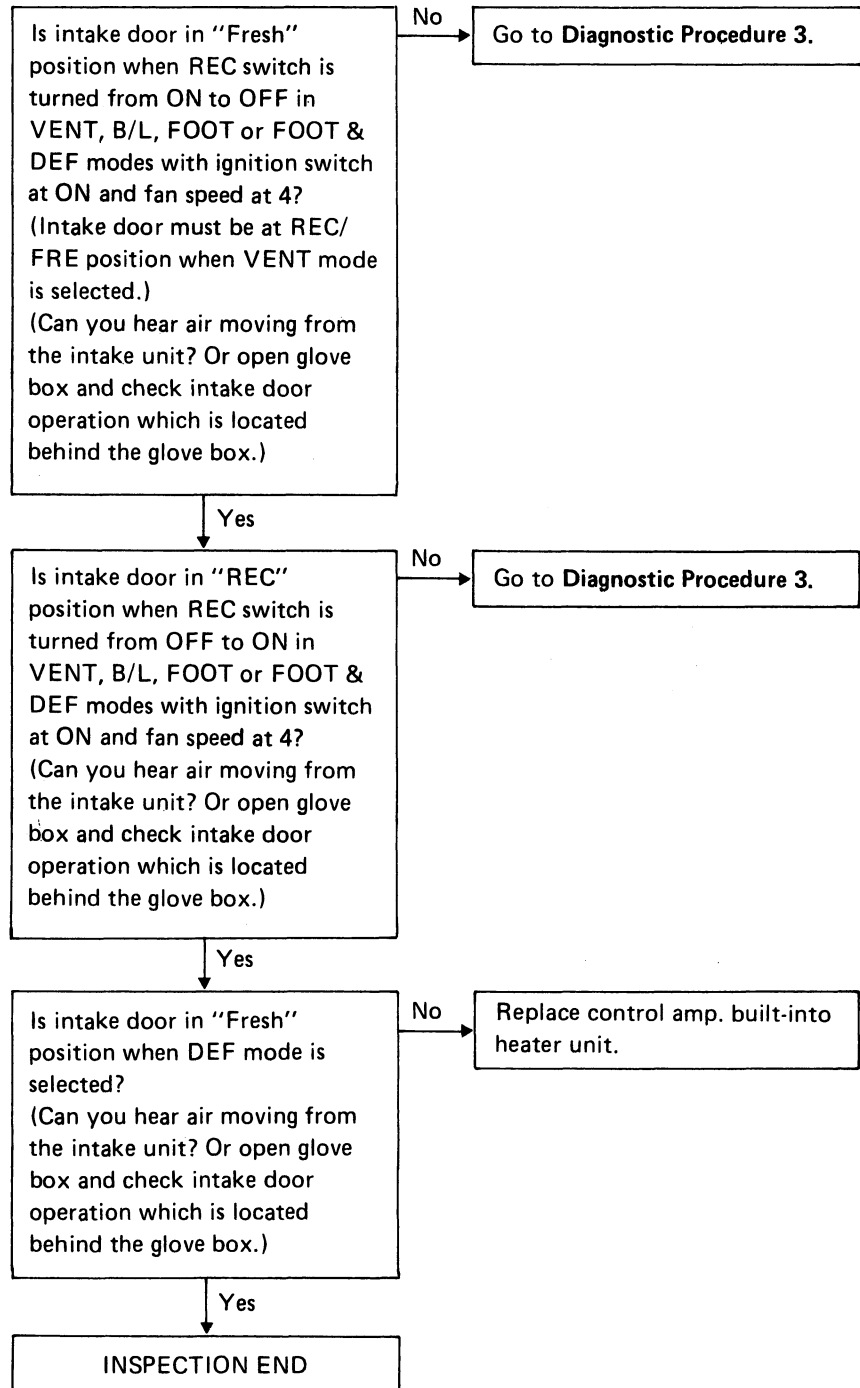

TROUBLE DIAGNOSES — Manual Air Conditioner

Preliminary Check (Cont'd)

PRELIMINARY CHECK 2

A/C does not blow cold air.

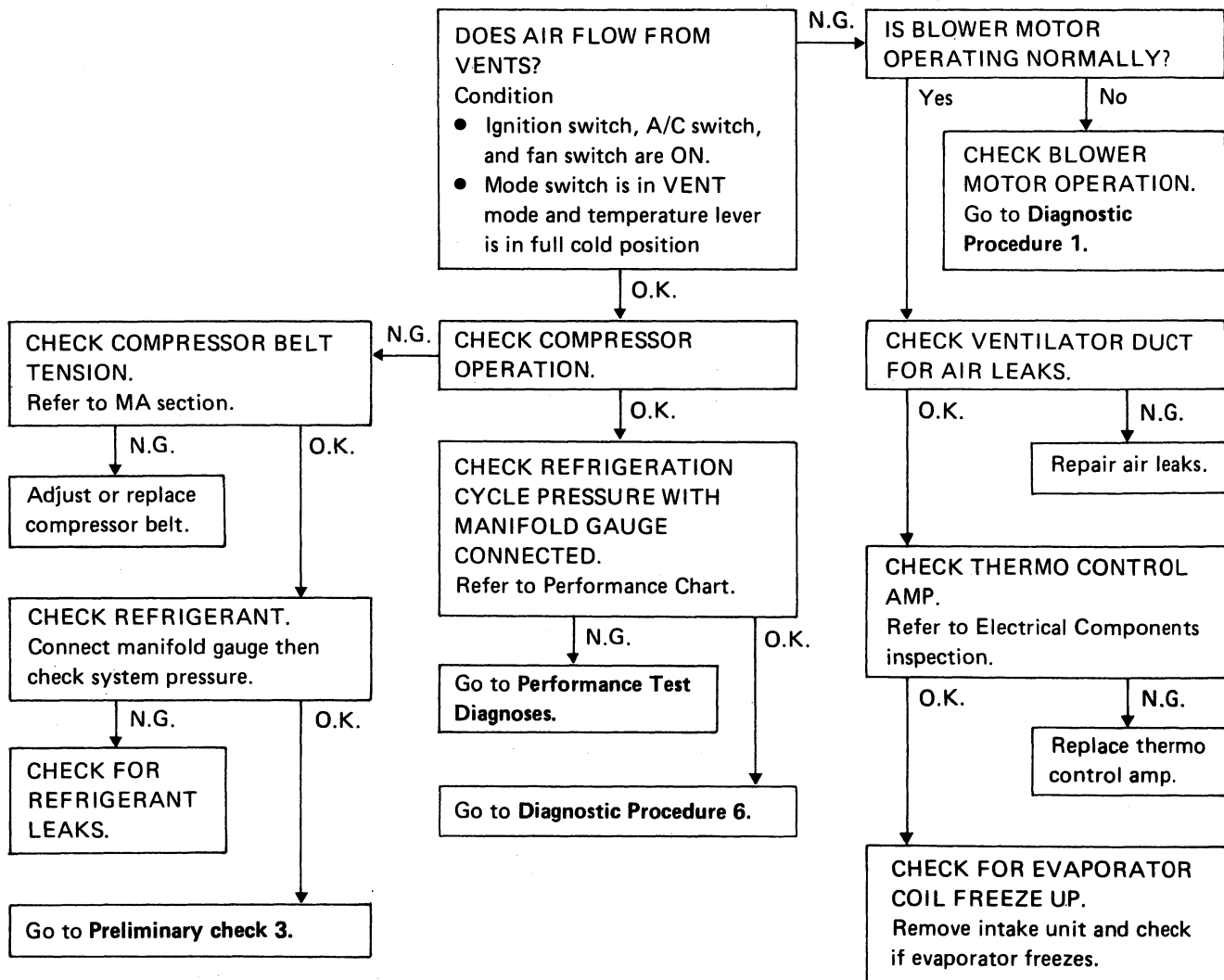

Preliminary Check (Cont'd)

PRELIMINARY CHECK 3

Magnet clutch does not engage in FOOT & DEF or DEF modes.

- Perform PRELIMINARY CHECK 2 and 4 before referring to the following flow chart.

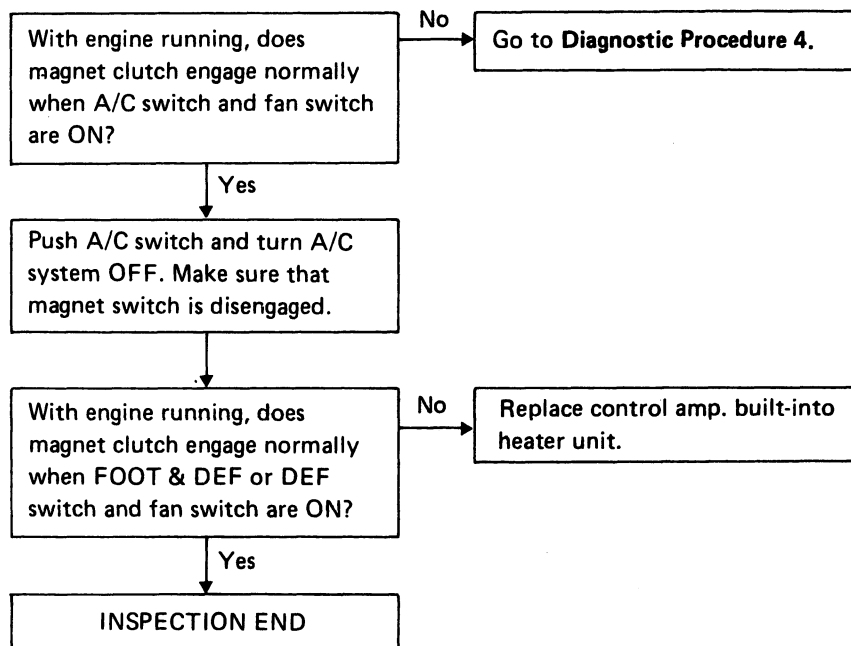

TROUBLE DIAGNOSES — Manual Air Conditioner

Preliminary Check (Cont'd)

PRELIMINARY CHECK 4

Air outlet does not change.

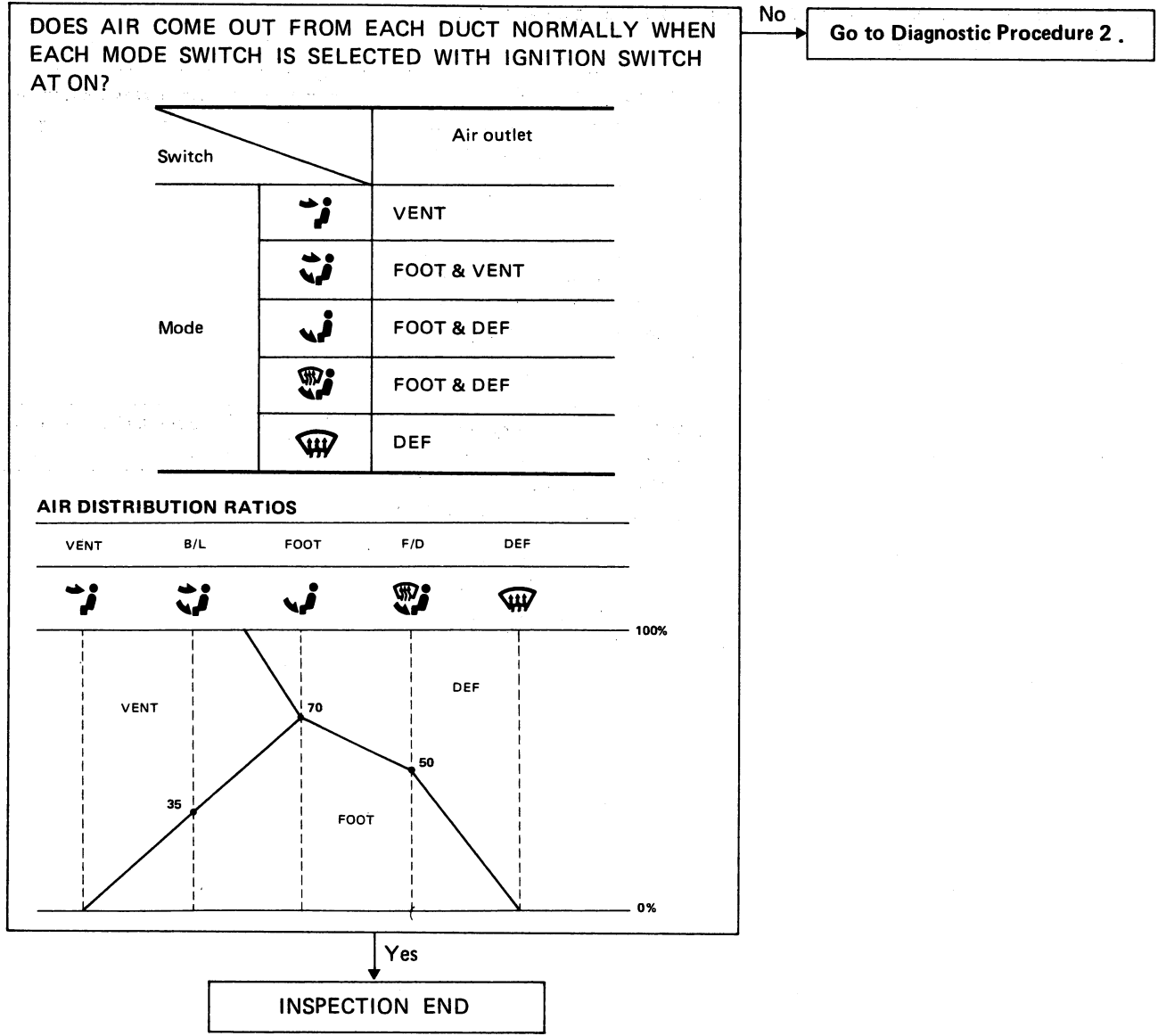

TROUBLE DIAGNOSES — Manual Air Conditioner

Preliminary Check (Cont'd)

PRELIMINARY CHECK 5

Noise

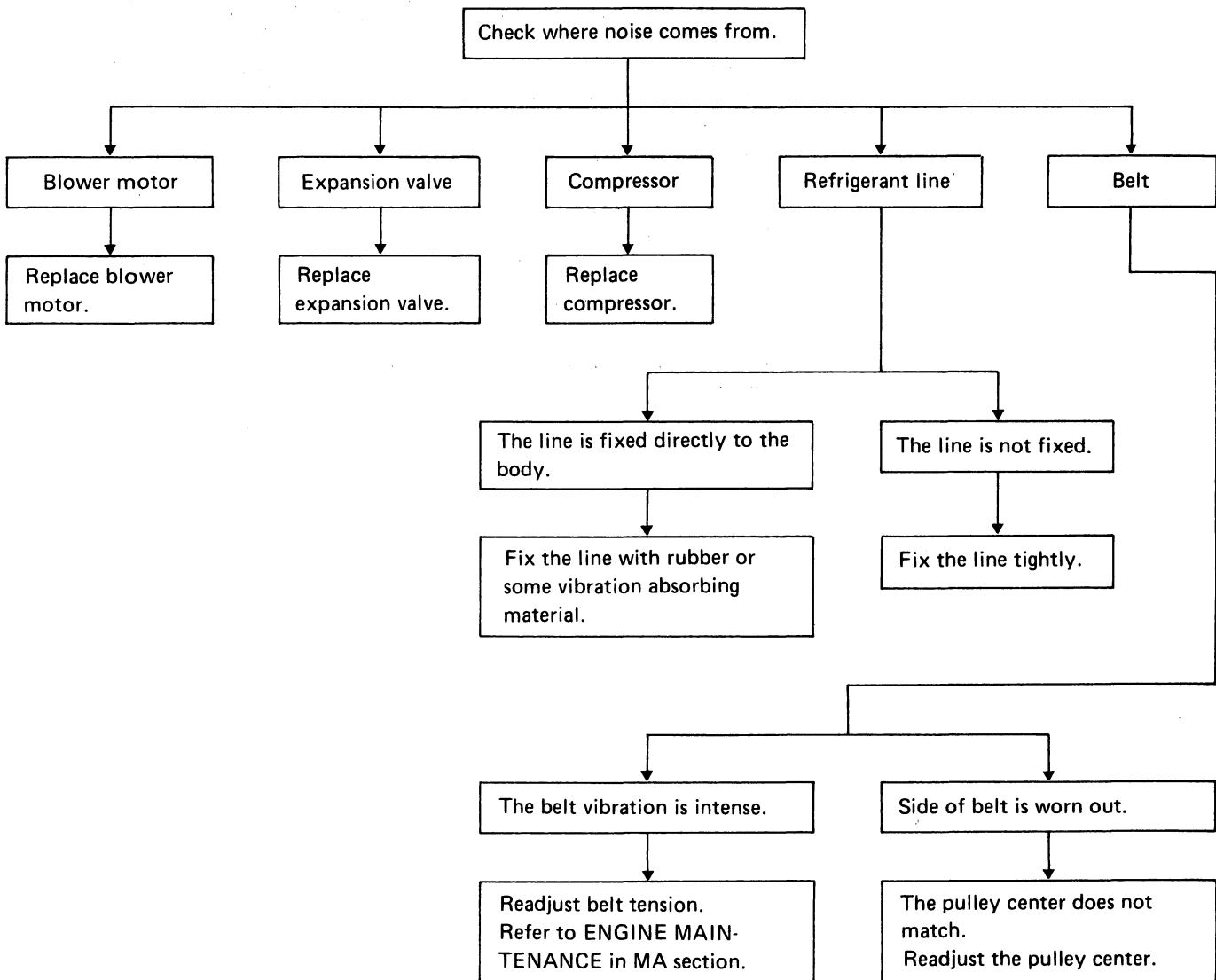

Preliminary Check (Cont'd)

PRELIMINARY CHECK 6

Insufficient heating

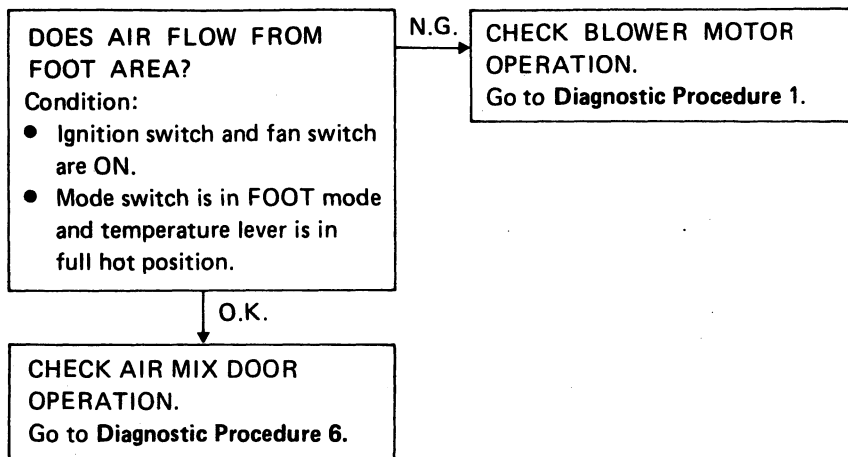

Harness Layout for A/C System

ENGINE COMPARTMENT

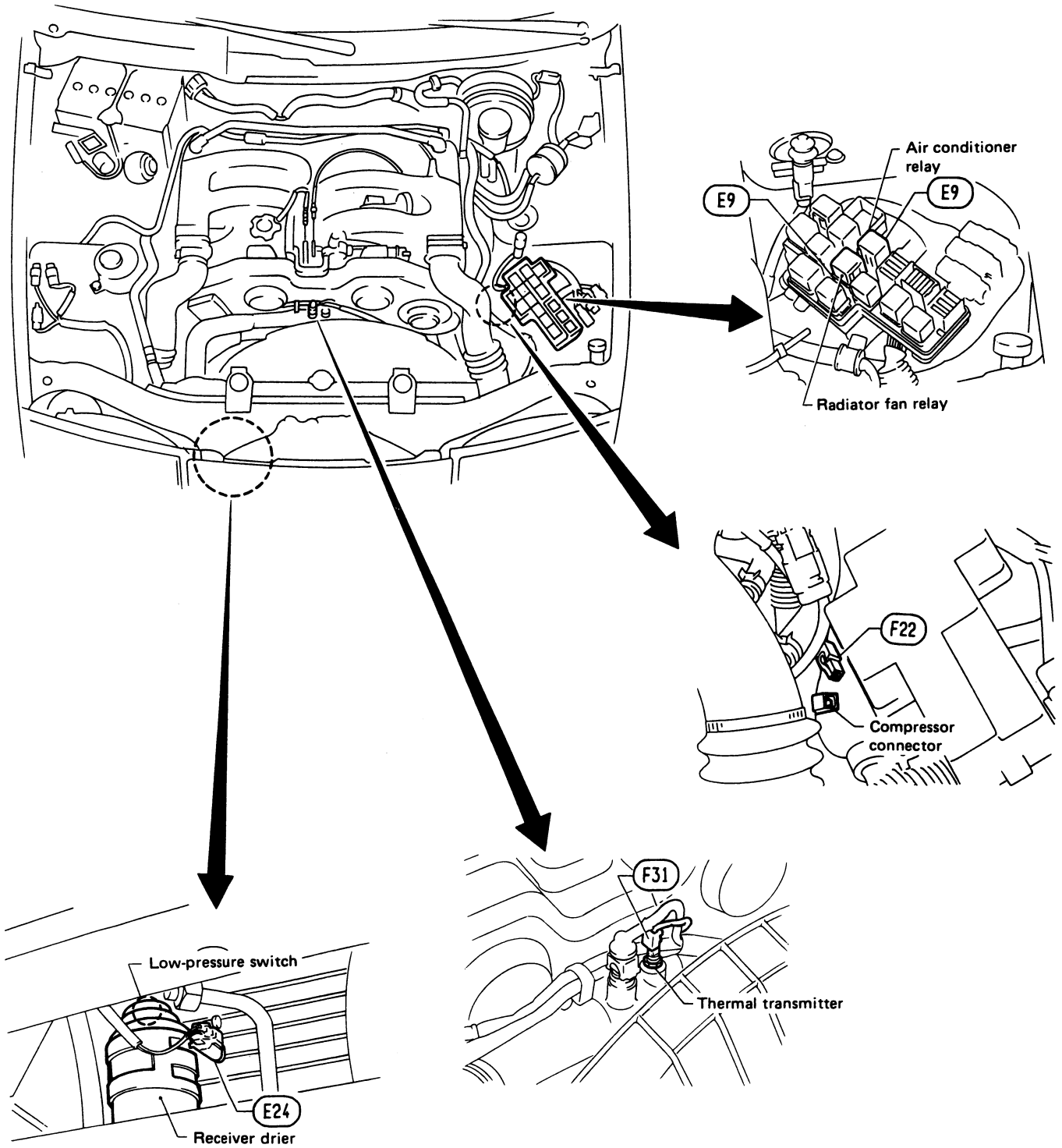

Harness Layout for A/C System (Cont'd)

PASSENGER COMPARTMENT

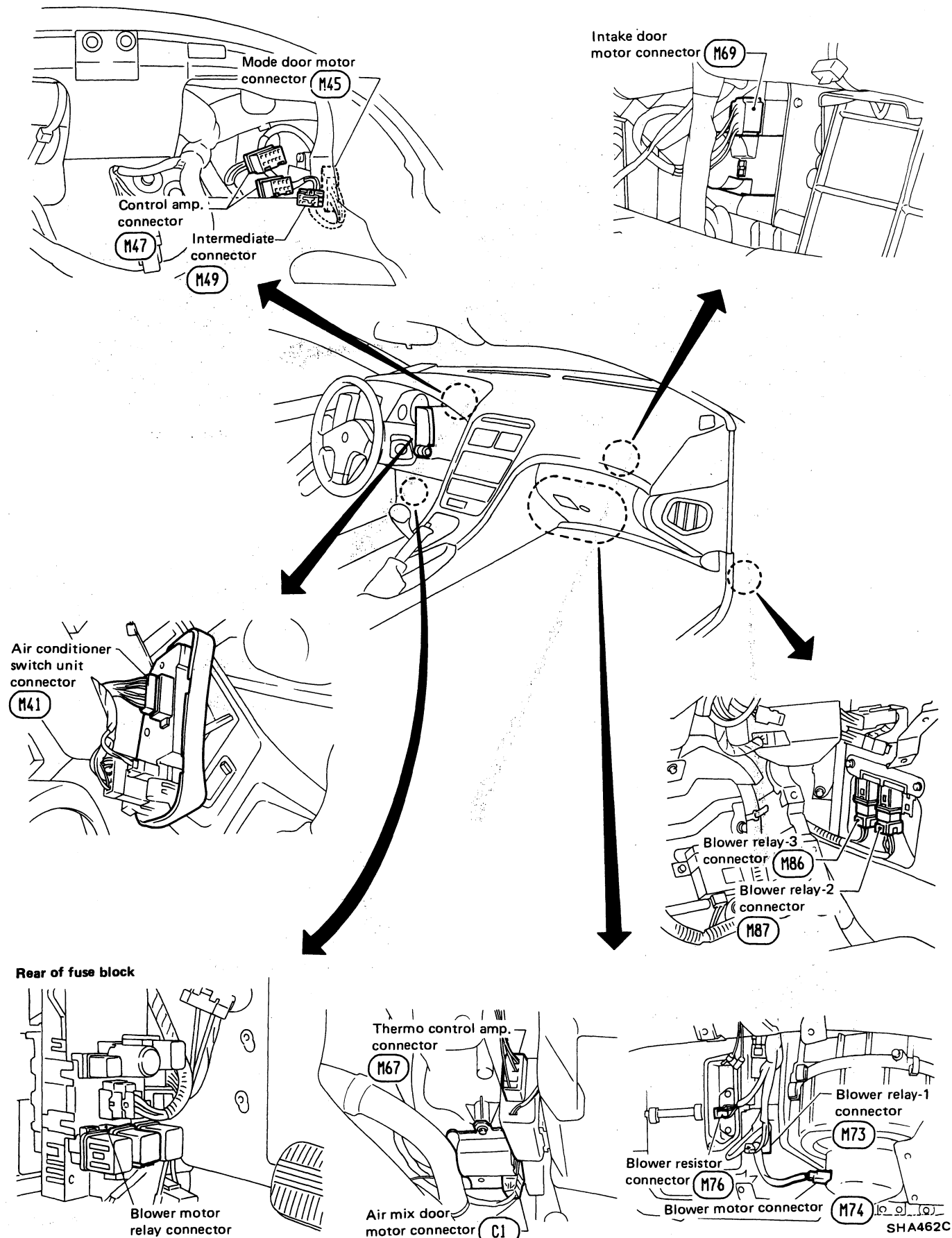

SHA462C

Circuit Diagram for Quick Pinpoint Check

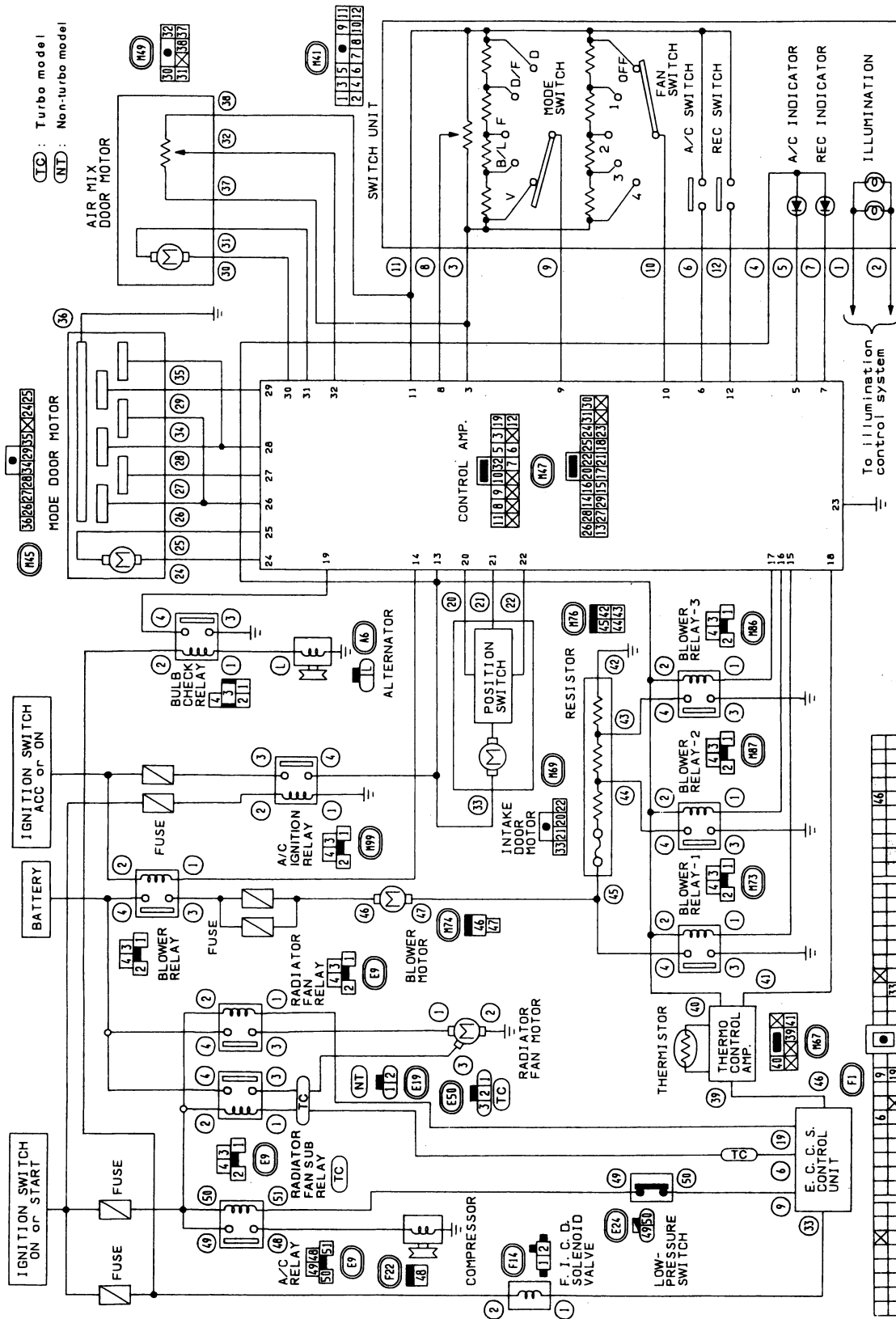

- All connectors shown in this illustration are unit side connectors.
- The unit side connectors with a double circle "○" are connected to the harness side connectors shown in the "Harness Layout for A/C System". (See pages HA-63 - HA-64.)
- The terminal numbers in the connector coincide with the circuit numbers surrounded by a single circle "○".

Wiring Diagram

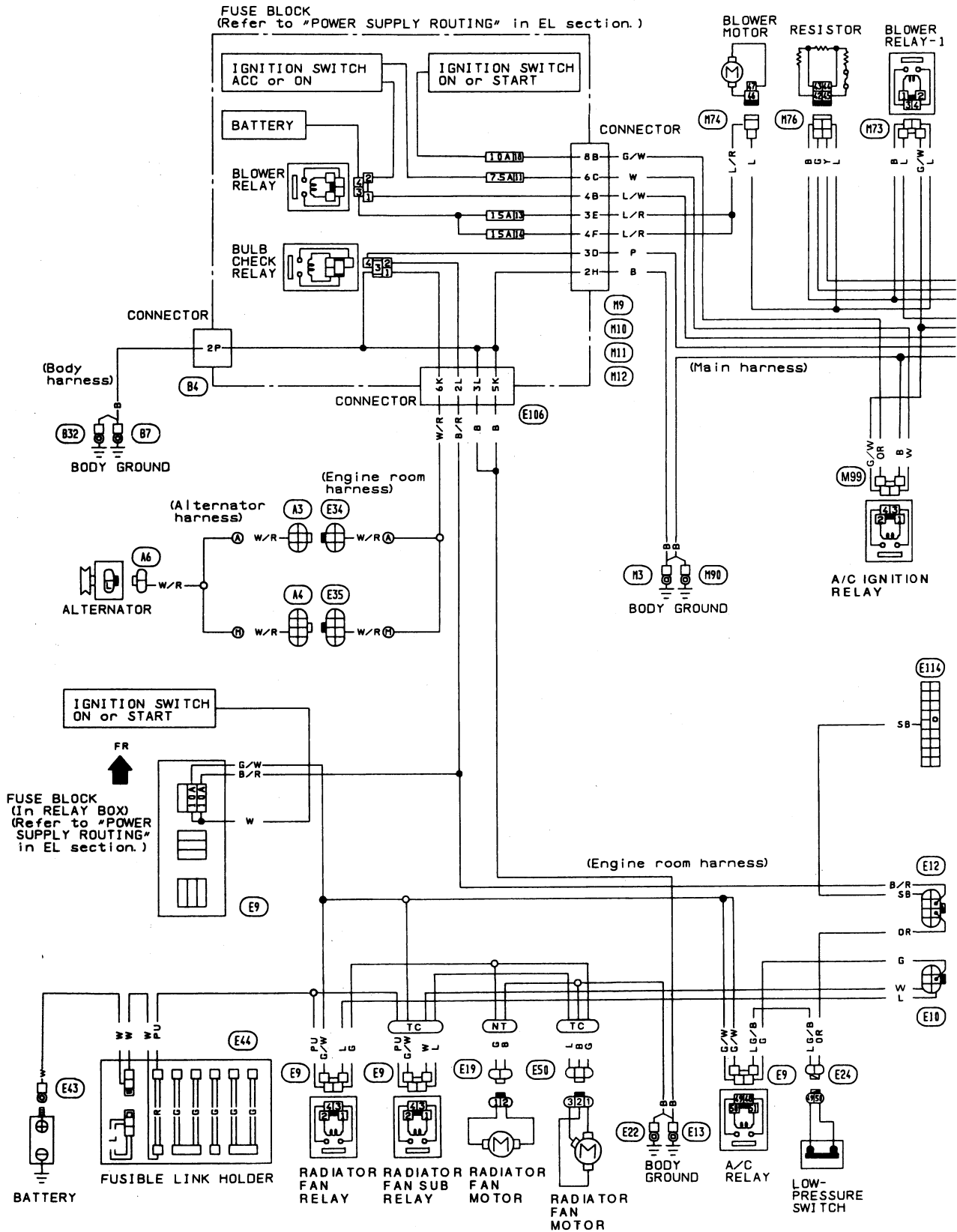

TROUBLE DIAGNOSES — Manual Air Conditioner

Wiring Diagram (Cont'd)

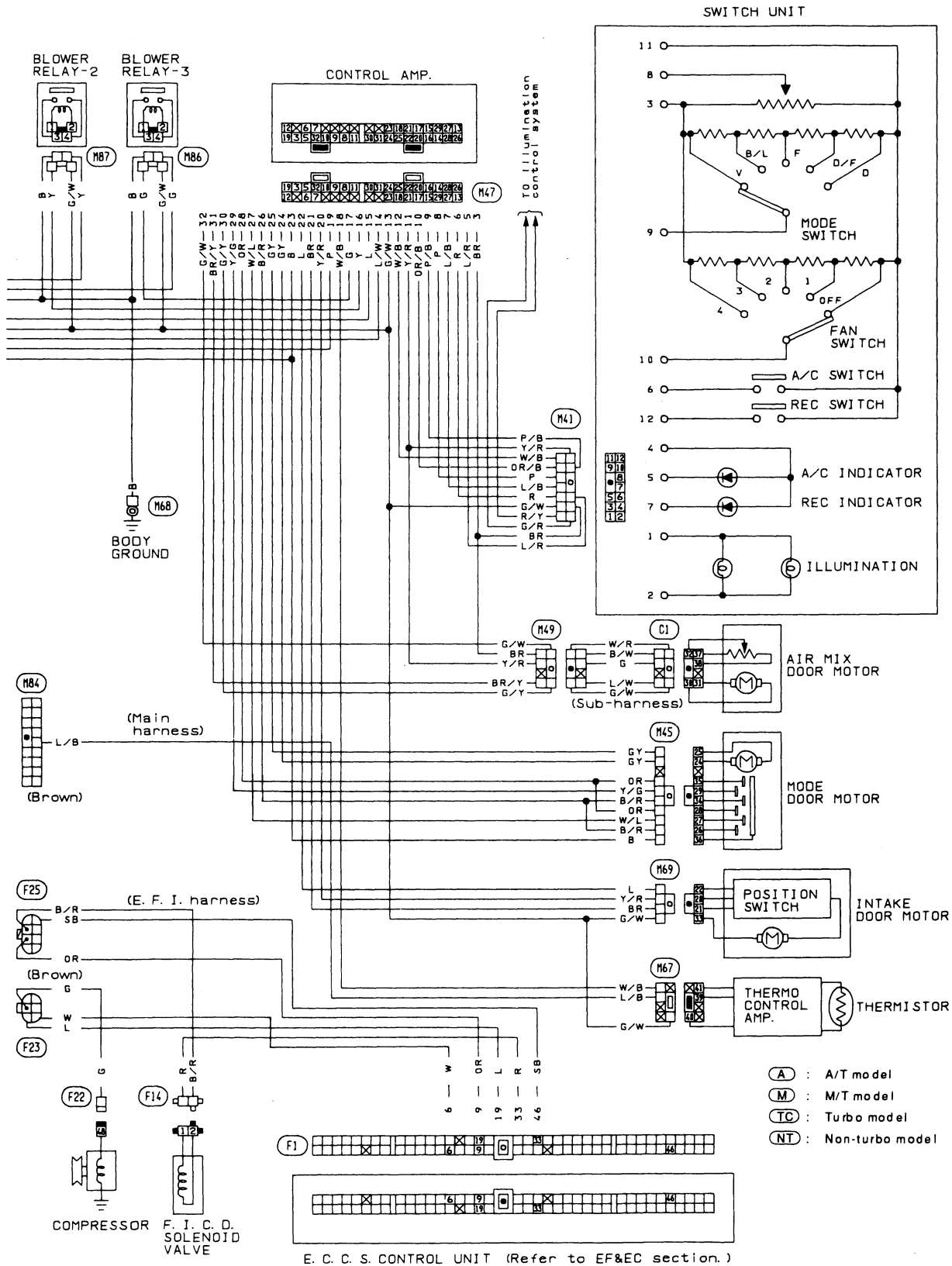

Main Power Supply and Ground Circuit Check

POWER SUPPLY CIRCUIT CHECK FOR A/C SYSTEM

Check power supply circuit for air conditioning system.

Refer to "POWER SUPPLY ROUTING" in section EL and A/C ELECTRICAL CIRCUIT.

CONTROL AMP. REMOVAL

1. Remove driver side instrument lower lid.
2. Remove vent duct.
3. Remove control amp. with harness connected.

CONTROL AMP. CHECK

1. Disconnect control amp. harness connector.
2. Connect voltmeter from harness side.
3. Measure voltage across terminal No. ⑬ or No. ⑭ and body ground.

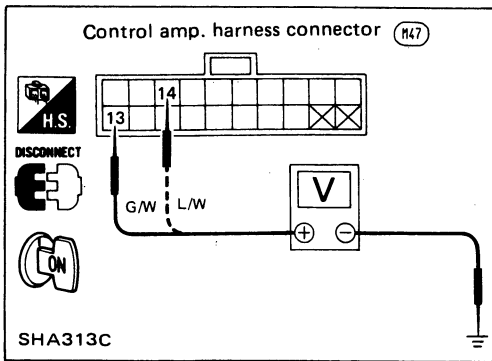

Voltmeter terminal		Voltage
⊕	⊖	
⑬	Body ground	Approximately 12V
⑭		

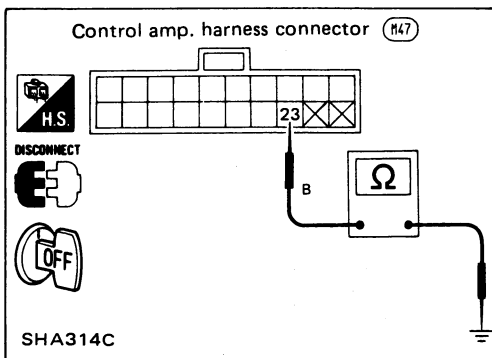

Check body ground circuit for control amp. with ignition switch OFF.

1. Disconnect control amp. harness connector.
2. Connect ohmmeter from harness side.
3. Check continuity between terminal No. ⑳ and body ground.

	INCIDENT	Flow chart No.
1	Fan fails to rotate	1
2	Fan does not rotate at speed 1.	2
3	Fan does not rotate at speed 2.	3
4	Fan does not rotate at speed 3.	4
5	Fan does not rotate at speed 4.	5

Diagnostic Procedure 1

SYMPTOM: Blower motor does not rotate.

- Perform **PRELIMINARY CHECK 2** before referring to the following flow chart.

Check if blower motor rotates properly at each fan speed. Conduct checks as per flow chart.

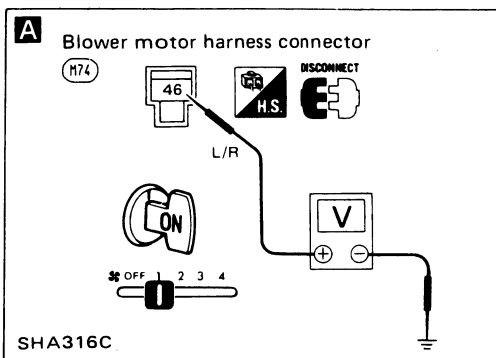
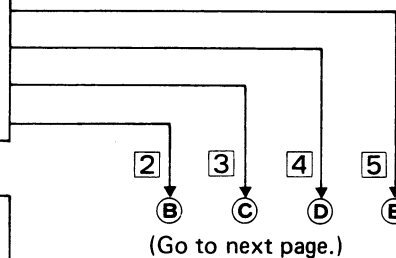

A

CHECK POWER SUPPLY FOR BLOWER MOTOR.
Disconnect blower motor harness connector. Do approximately 12 volts exist between blower motor harness terminal No. (46) and body ground?

N.G. Check fuses at fuse block. (Refer to "POWER SUPPLY ROUTING" in EL section and A/C ELECTRICAL CIRCUIT.)

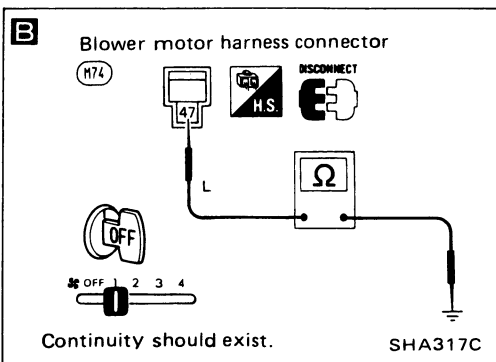

O.K.

B

Check circuit continuity between blower motor harness terminal No. (47) and body ground.

N.G. Reconnect blower motor harness connector.

O.K.

CHECK BLOWER MOTOR.
(Refer to Electrical Components Inspection.)

N.G. Replace blower motor.

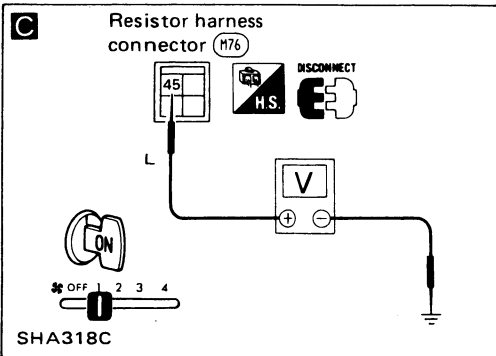

C

CHECK BLOWER MOTOR CIRCUIT BETWEEN BLOWER MOTOR AND RESISTOR.
Do approximately 12 volts exist between resistor harness terminal No. (45) and body ground?

N.G. Disconnect blower motor and resistor harness connectors.

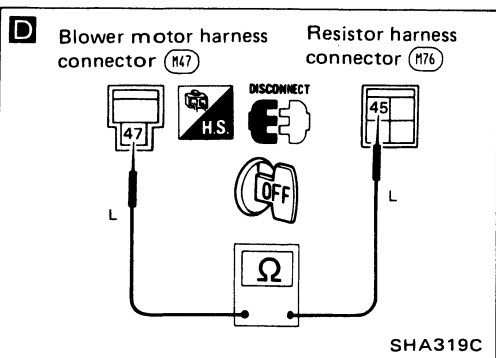

D Note

Check circuit continuity between blower motor harness terminal No. (47) and resistor terminal No. (45).

O.K. (Go to next page.)

Note:
If the result is N.G. after checking circuit continuity, repair harness or connector.

TROUBLE DIAGNOSES — Manual Air Conditioner

Diagnostic Procedure 1 (Cont'd)

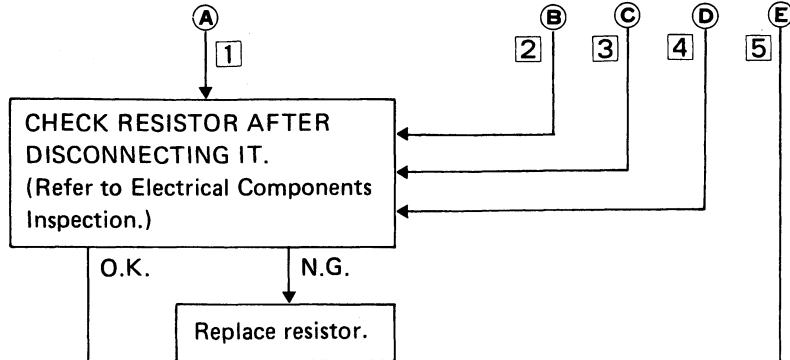
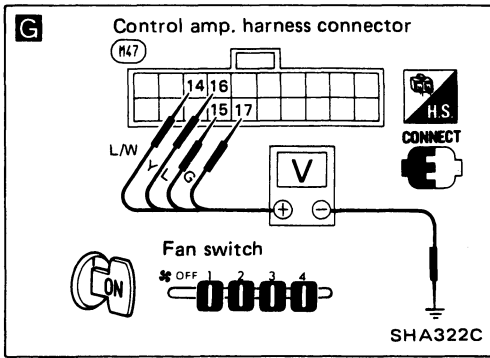
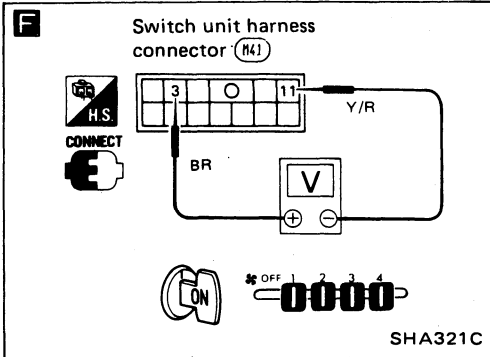
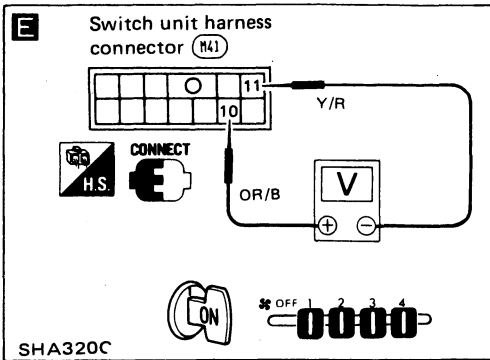

Reconnect resistor harness connector.

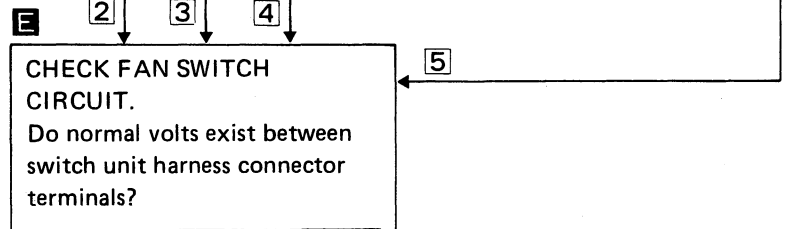

Flow chart No. (Fan SW position)	Terminal No.		Normal voltage (Approx.)
	+	-	
2 (1)	10	11	2V
3 (2)			3V
4 (3)			4V
5 (4)			5V

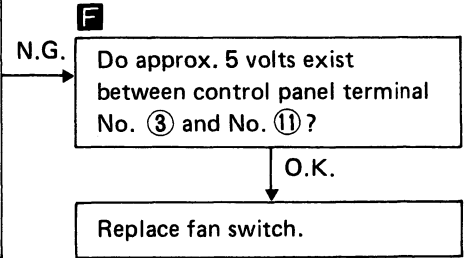

G **CHECK CONTROL AMP. HARNESS TERMINAL VOLTAGE.**
Do approximately 12 volts or 0 volts exist between control amp. harness terminal No. ⑭, ⑮, ⑯, or ⑰ and body ground?

Flow chart No.	Terminal No.	Fan SW operation	
		ON	OFF
2	14	0V	Approx. 12V
3	17	0V	Approx. 12V
4	16	0V	Approx. 12V
5	15	0V	Approx. 12V

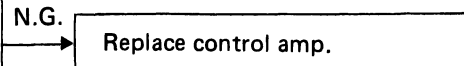

O.K. → Replace blower motor.

Diagnostic Procedure 2

SYMPTOM: Air outlet does not change.

- Perform **PRELIMINARY CHECK 4** and **Main Power Supply and Ground Circuit Check** before referring to the following flow chart.

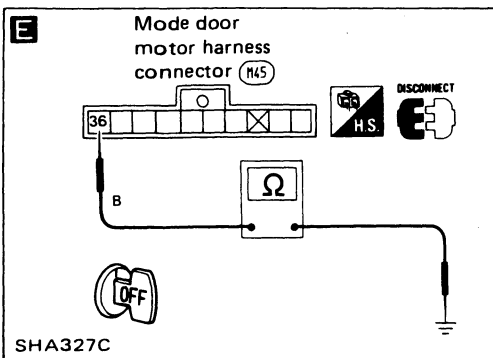
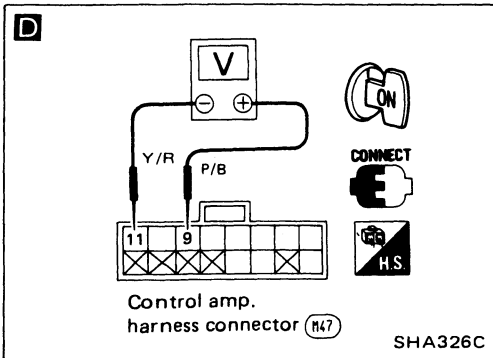
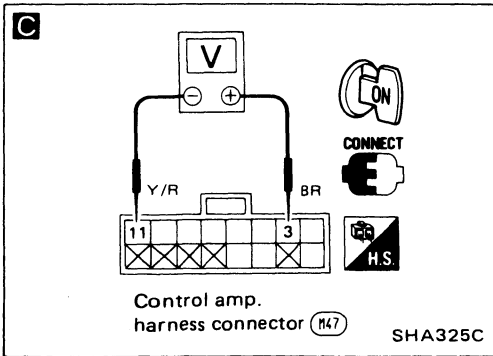
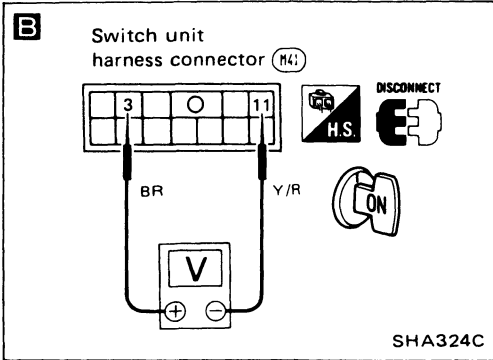
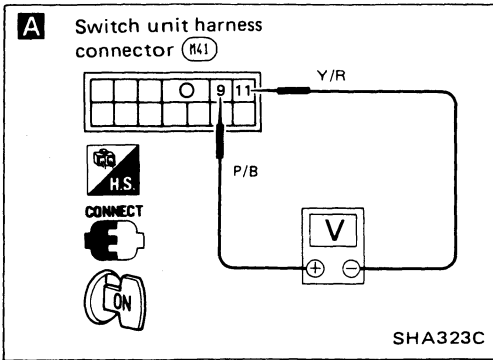

A

CHECK MODE DOOR MOTOR POSITION SWITCH.
Measure voltage between switch unit harness connector terminal No. ⑨ and ⑪.

Mode switch	Terminal No.		Voltage (Approx.)
	+	-	
VENT			5V
B/L			4V
FOOT	⑨	⑪	3V
F/D			2V
DEF			0V

N.G. Disconnect switch unit harness connector.

B Do approximately 5 volts exist between switch unit harness connector terminal No. ③ and ⑪.

N.G. O.K.

Replace switch unit.

C Do approximately 5 volts exist between control amp. harness connector No. ③ and ⑪.

N.G. O.K.

Repair harness or connector.

Replace control amp.

D

Measure voltage between control amp. harness connector terminal No. ⑨ and ⑪.

Mode switch	Terminal No.		Voltage (Approx.)
	+	-	
VENT			5V
B/L			4V
FOOT	⑨	⑪	3V
F/D			2V
DEF			0V

N.G. Repair harness or connector.

E

CHECK BODY GROUND CIRCUIT FOR MODE DOOR MOTOR.
Does continuity exist between mode door motor harness connector terminal No. ⑶ and body ground?

N.G. Repair harness or connector.

O.K. **A**

TROUBLE DIAGNOSES — Manual Air Conditioner

Diagnostic Procedure 2 (Cont'd)

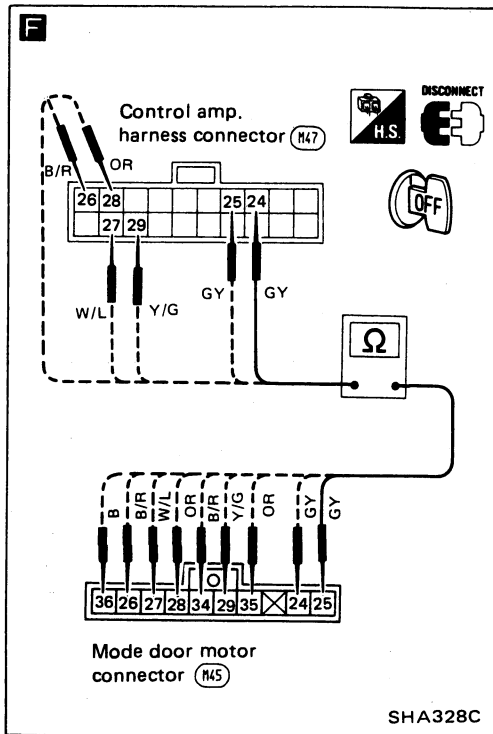

F

Check circuit continuity between each terminal on control amp. and mode door motor.

Terminal No.		Continuity
Control amp.	Mode door motor	
24	24	Yes
25	25	
26	26 and 34	
27	27	
28	28 and 35	
29	29	

N.G. → Repair harness or connector.

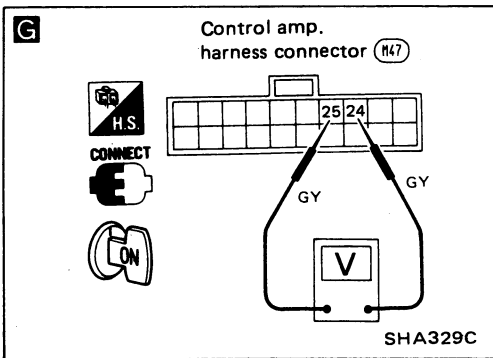

G

CHECK FOR OUTPUT OF CONTROL AMP.

Do approximately 12 volts exist between control amp. harness terminal No. 24 and 25 when mode is switched from "VENT" to "DEF" or when mode is switched from "DEF" to "VENT"?

Terminal No.		Mode door motor	
24	25	Mode door operation	Direction of linkage rotation
⊖	⊖	Stop	Stop
⊖	⊕	VENT → DEF	Clockwise
⊕	⊖	DEF → VENT	Counter-clockwise

N.G. → Replace control amp.

O.K. → Replace mode door motor.

Diagnostic Procedure 3

SYMPTOM: Intake door does not change in VENT, B/L, or FOOT mode.

- Perform **PRELIMINARY CHECK 1**, and Main Power Supply and Ground Circuit Check before referring to the following flow chart.

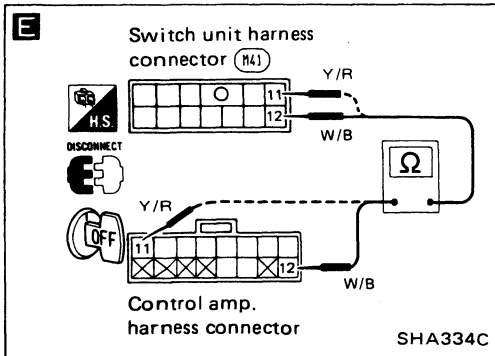
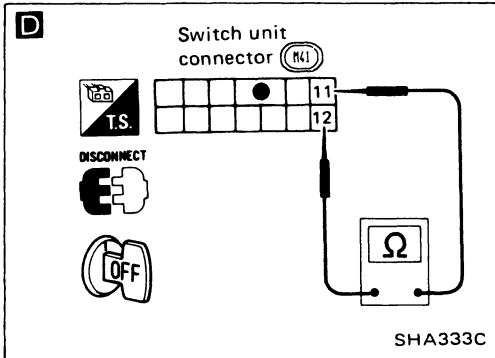
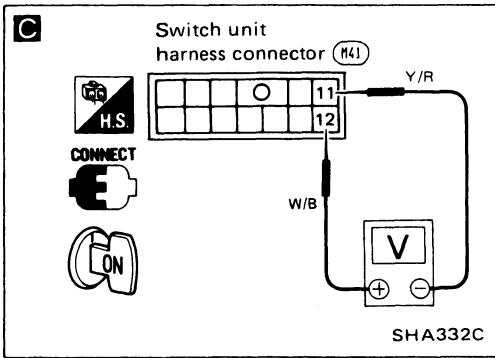
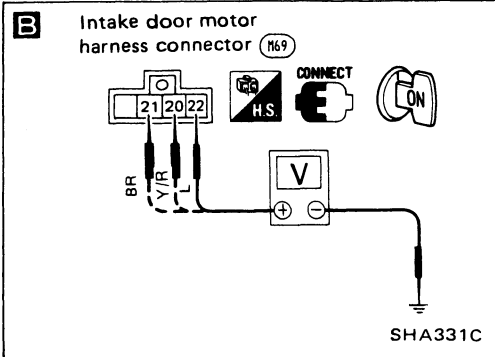
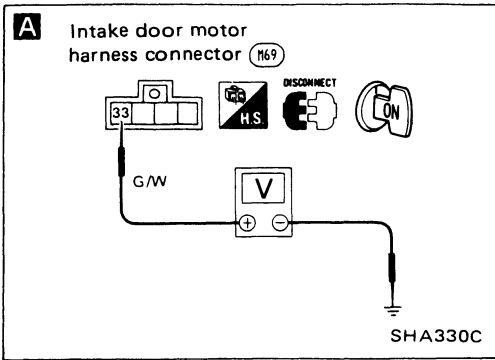

A

CHECK POWER SUPPLY FOR INTAKE DOOR MOTOR.
Disconnect intake door motor harness connector.
Do approximately 12 volts exist between intake door motor harness terminal No. ③③ and body ground?

N.G. → Check intake door motor power supply circuit continuity.

B

Select VENT mode and check the voltage between intake door motor harness terminal No. ②①, ②② and body ground.

A/C switch	REC switch	Mode	Terminal voltage (Approx.)		
			②①	②②	②③
ON	ON	REC	12V	12V	0V
ON	OFF	REC/FRE	12V	0V	12V
OFF	OFF	FRE	0V	12V	12V

O.K. → Replace intake door motor.

C

Check the voltage between control panel harness connector terminal No. ①② and ①①.

A/C switch	Terminal No.		Voltage (Approx.)
	①②	①①	
Switch pressed	+	-	0V
Switch free	+	-	5V

N.G. → Disconnect control panel connector.

O.K. → Replace control amp.

D

Check circuit continuity between control panel terminal No. ①② and ①①.

REC switch	Continuity between terminal No. ①② and ①①
Switch pressed	Yes
Switch free	No

N.G. → Replace control panel.

E

Check circuit continuity between control panel harness terminal No. ①② (①①) and control amp. harness terminal No. ①② (①①).

N.G. → Repair harness or connector.

O.K. → Replace control amp.

Diagnostic Procedure 4

SYMPTOM: Magnet clutch does not engage with A/C switch and fan switch ON.

- Perform PRELIMINARY CHECK 2 before referring to the following flow chart.

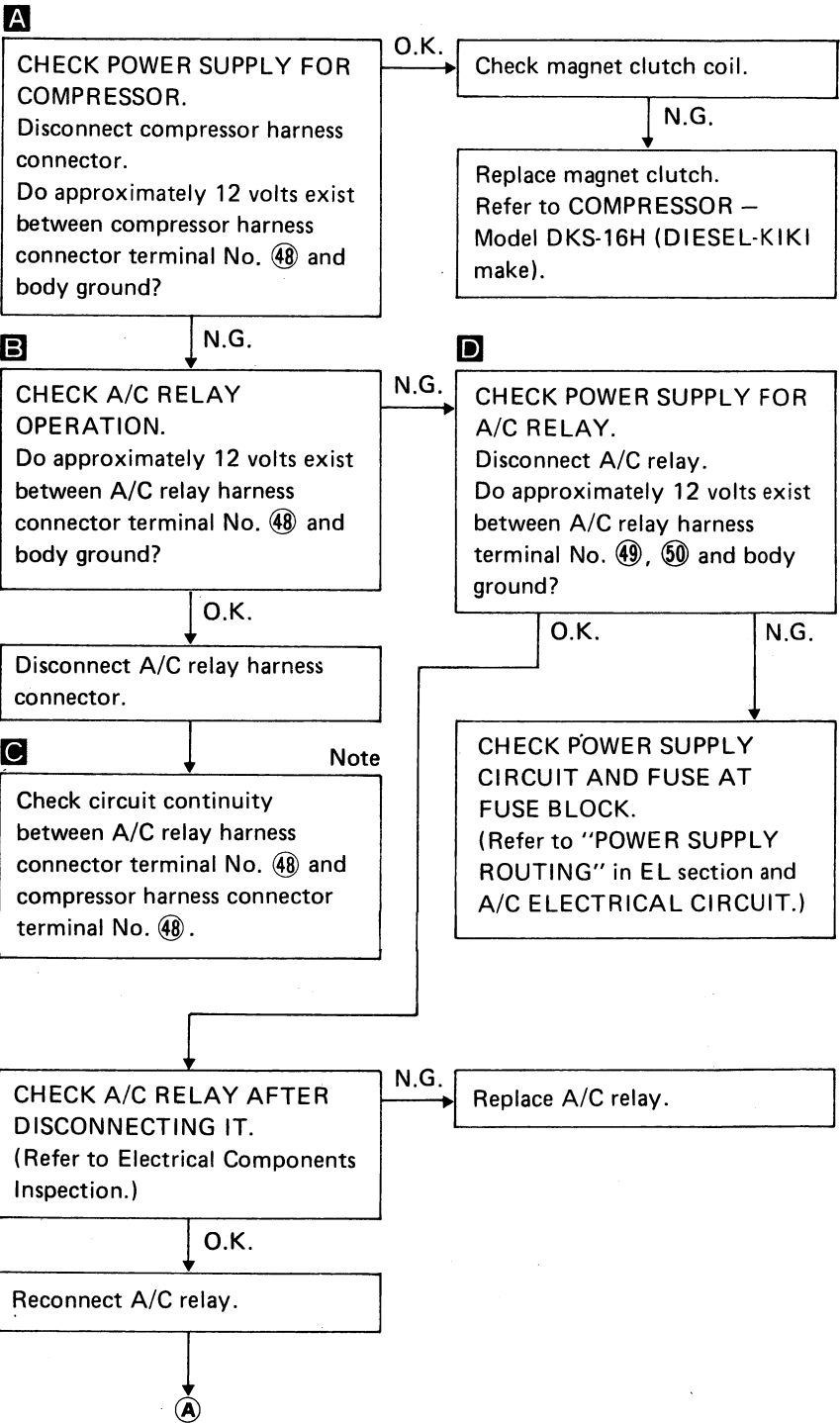
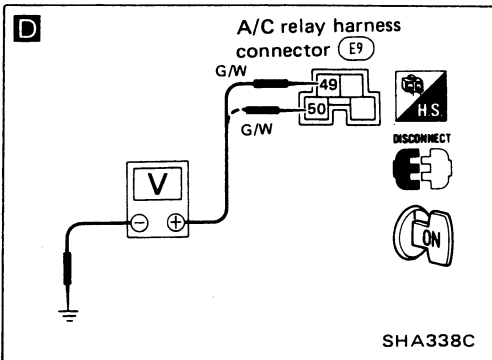
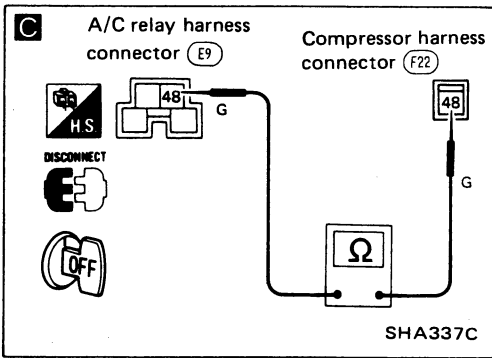
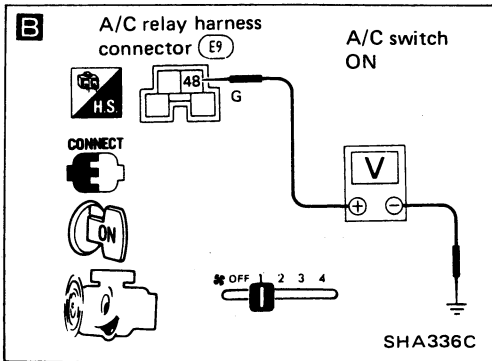
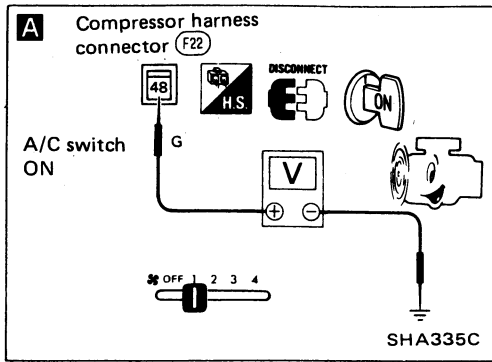

Note:

If the result is N.G. after checking circuit continuity, repair harness or connector.

TROUBLE DIAGNOSES — Manual Air Conditioner

Diagnostic Procedure 4 (Cont'd)

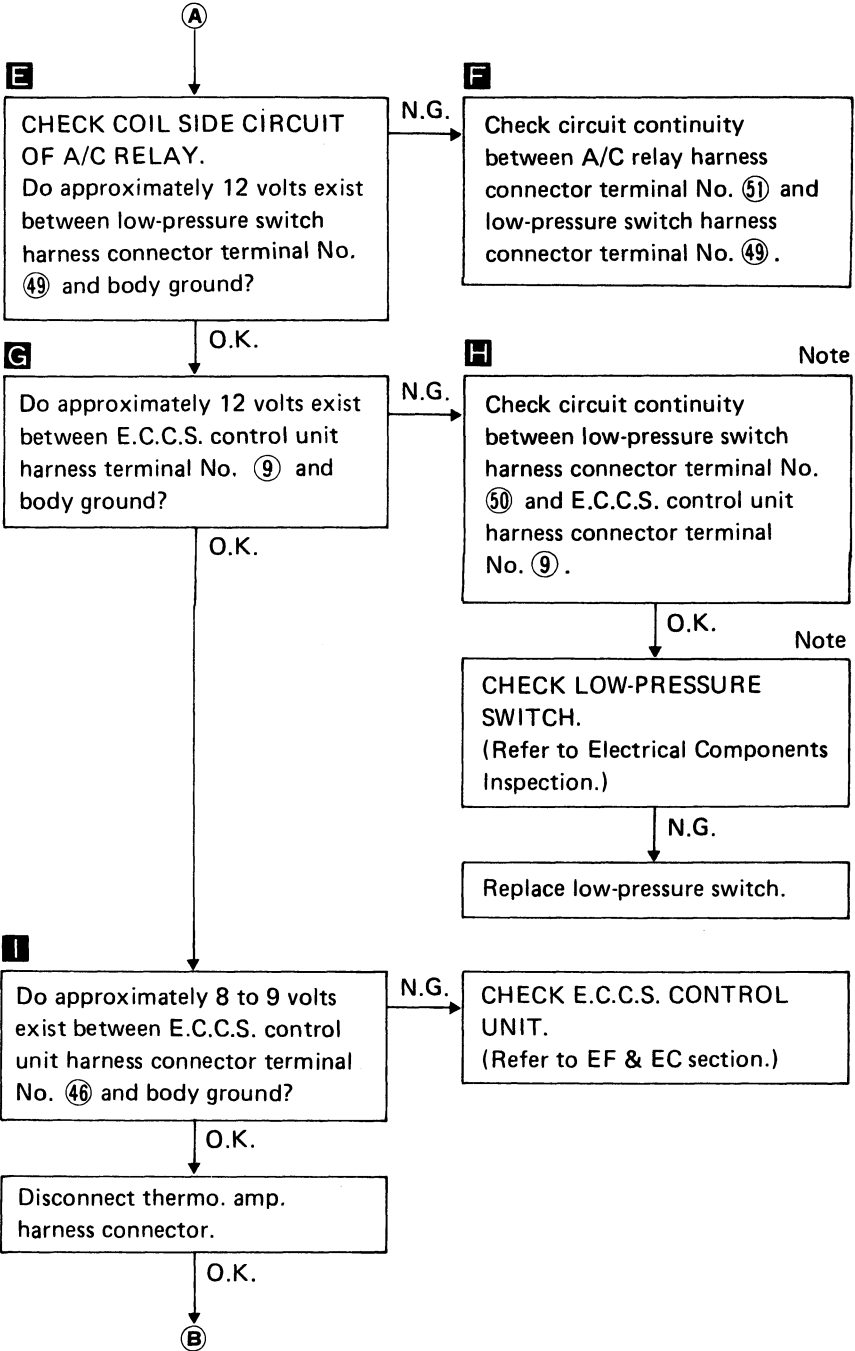
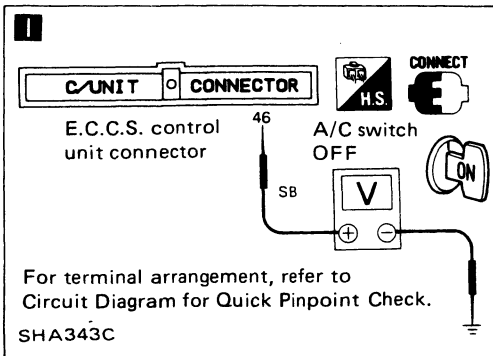
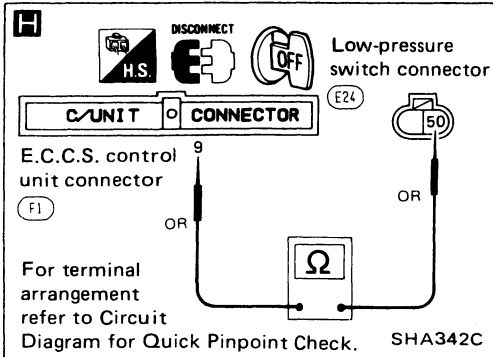
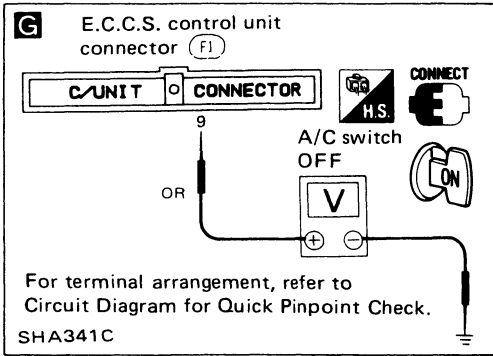
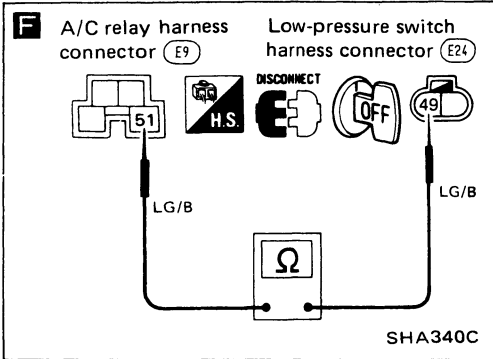
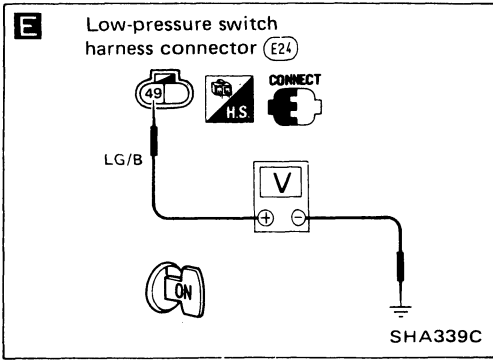

Note:

If the result is N.G. after checking circuit continuity, repair harness or connector.

Diagnostic Procedure 4 (Cont'd)

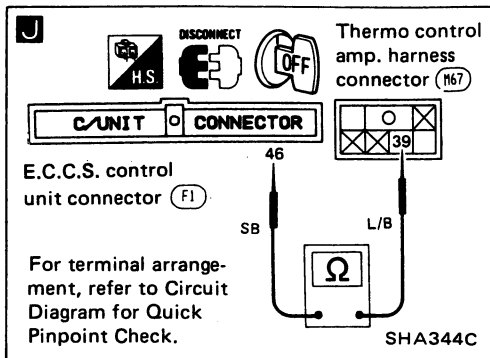

B

J Note

Check circuit continuity between thermo. control amp. harness connector terminal No. 39 and E.C.C.S. control unit harness connector terminal No. 46.

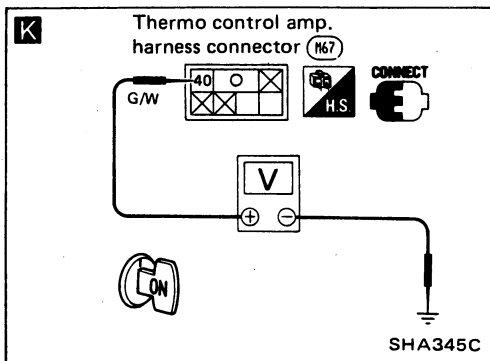

K O.K.

K CHECK POWER SUPPLY FOR THERMO. AMP.
Do approximately 12 volts exist between thermo. amp. harness connector terminal No. 40 and body ground?

N.G. CHECK POWER SUPPLY CIRCUIT AND FUSE AT FUSE BLOCK.
(Refer to "POWER SUPPLY ROUTING" in EL section and A/C ELECTRICAL CIRCUIT.)

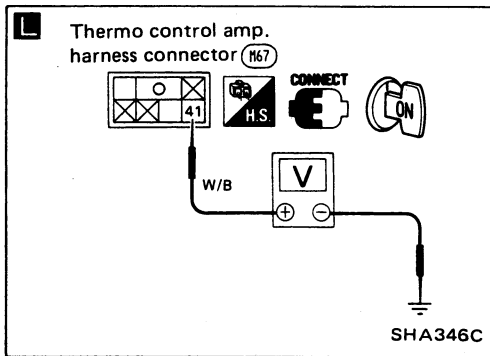

L O.K.

L Is the voltage between thermo. amp. harness connector terminal No. 41 and body ground less than 1V?

N.G. Replace thermo. control amp.

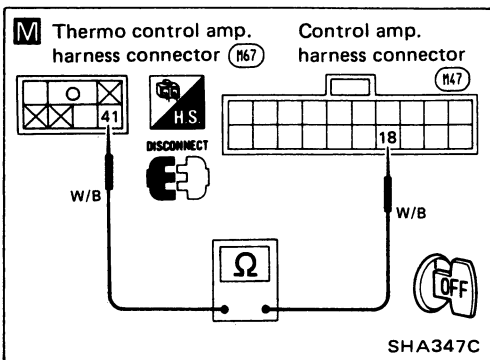

M O.K. Note

M Check continuity between thermo. control amp. harness connector terminal No. 41 and control amp. harness connector terminal No. 18.

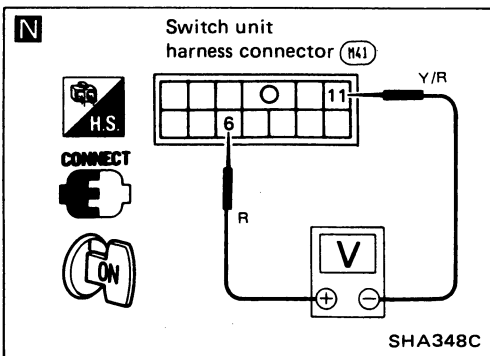

N O.K.

N CHECK A/C SWITCH OF SWITCH UNIT.
Check the voltage between switch unit harness connector terminal No. 6 and 11.

REC switch	Terminal No.		Voltage (Approx.)
	⑫	⑪	
Switch pressed	+	-	0V
Switch free	+	-	5V

N.G. Disconnect switch unit connector.

O.K. Replace control amp.

Note:
If the result is N.G. after checking circuit continuity, repair harness or connector.

Diagnostic Procedure 4 (Cont'd)

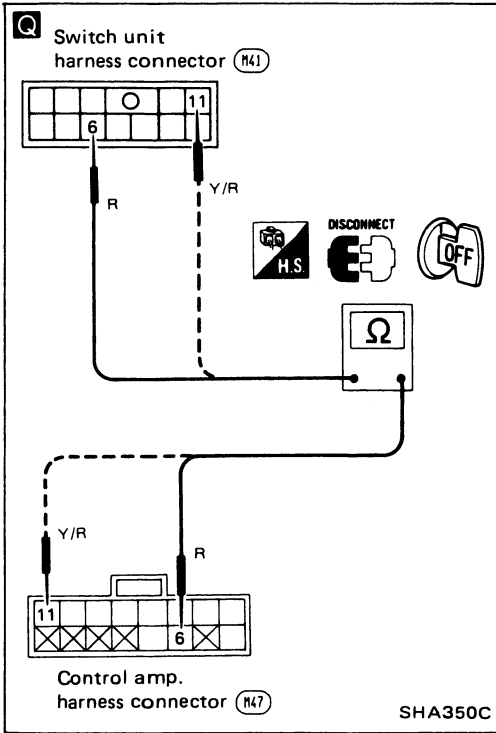
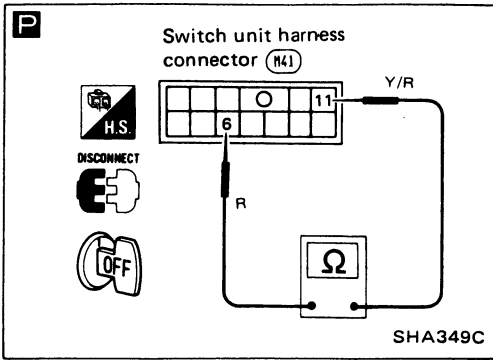

C

P

Check circuit continuity between switch unit harness connector terminal No. ⑥ and ⑪.

A/C switch	Continuity between terminal No. ⑥ and ⑪
Switch pressed	Yes
Switch free	No

N.G. → Replace switch unit.

O.K. Note

Q

Check circuit continuity between switch unit harness connector terminal No. ⑥ (⑪) and control amp. harness connector terminal No. ⑥ (⑪).

O.K.

Replace control amp.

Note:

If the result is N.G. after checking circuit continuity, repair harness or connector.

Diagnostic Procedure 5

SYMPTOM: Illumination or control panel indicators do not come on.

- Perform Main Power Supply and Ground Circuit check before referring to the following flow chart.

Turn ignition switch and lighting switch ON.

↓

CHECK ILLUMINATION AND INDICATORS.

- Turn A/C, REC and fan ON.
- Rotary VENT, B/L, FOOT, F/D and DEF switches in order.
- Check for incidents and follow the repairing methods as shown.

INCIDENT			How to repair
ILL	A/C	REC	
Control panel			
X	○	○	Go to DIAGNOSTIC PROCEDURE 5-1.
○	X	○	Go to DIAGNOSTIC PROCEDURE 5-2.
○	○	X	Go to DIAGNOSTIC PROCEDURE 5-3.
○	X	X	Go to DIAGNOSTIC PROCEDURE 5-4.

○: Illumination or indicator comes on.
X: Illumination or indicator does not come on.

**Diagnostic Procedure 5 (Cont'd)
DIAGNOSTIC PROCEDURE 5-1**

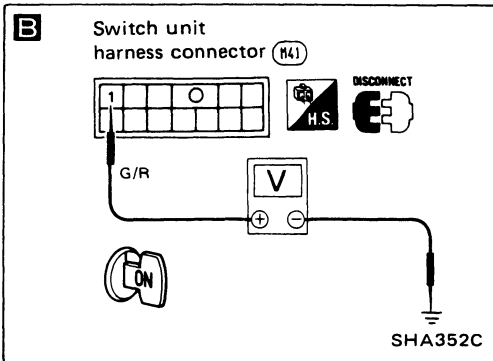
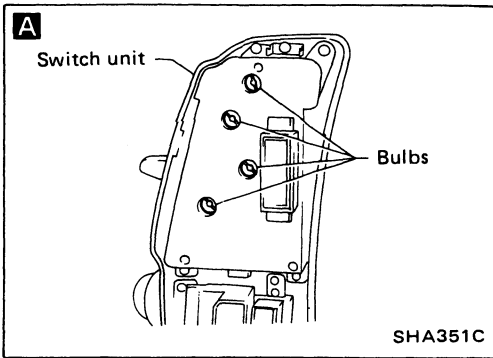

CHECK THE OTHER ILLUMINATION SYSTEMS EXCEPT FOR A/C SYSTEM.
Do the other illuminations come on with ignition switch and lighting switch ON?

N.G. → **CHECK ILLUMINATION SYSTEM.**
Refer to Illumination/Wiring Diagram in EL section.

O.K.

Turn ignition switch and lighting switch OFF.

A **CHECK ILLUMINATION BULB.**
Remove switch unit and disconnect harness connectors. Remove illumination bulb(s) and check them.

N.G. → Replace illumination bulb(s).

O.K.

B **CHECK POWER SUPPLY FOR ILLUMINATION WITH LIGHTING SWITCH ON.**
Do approximately 12 volts exist between switch unit connector harness terminal No. ① and body ground?

N.G. → **CHECK POWER SUPPLY FOR ILLUMINATION SYSTEM.**
Refer to Illumination/Wiring Diagram in EL section.

O.K.

CHECK TIME CONTROL SYSTEM.
Refer to TIME CONTROL SYSTEM in EL section.

TROUBLE DIAGNOSES — Manual Air Conditioner

Diagnostic Procedure 5 (Cont'd)

DIAGNOSTIC PROCEDURE 5-2

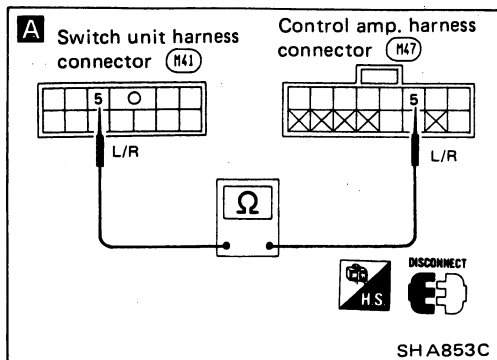

CHECK MAGNET CLUTCH OPERATION.
Does magnet clutch operate normally when engine is ON and A/C switch, fan switch are ON?

N.G. → Go to Diagnostic Procedure 4.

A O.K.
Check continuity between switch unit harness connector terminal No. ⑤ and control amp. harness connector terminal No. ⑤.

N.G.

Replace switch unit.

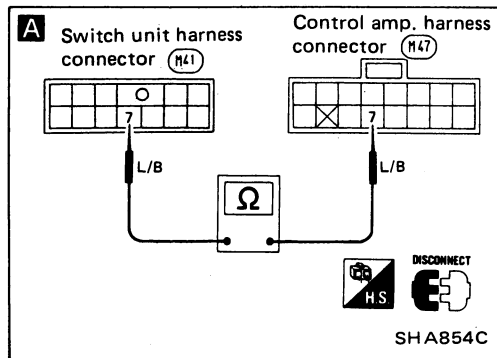

DIAGNOSTIC PROCEDURE 5-3

CHECK INTAKE DOOR OPERATION.
Does intake door operate normally when engine is ON and A/C switch, fan switch are ON?

N.G. → Do to Diagnostic Procedure 3.

A O.K.
Check continuity between switch unit harness connector terminal No. ⑦ and control amp. harness connector terminal No. ⑦.

N.G.

Replace switch unit.

**Diagnostic Procedure 5 (Cont'd)
DIAGNOSTIC PROCEDURE 5-4**

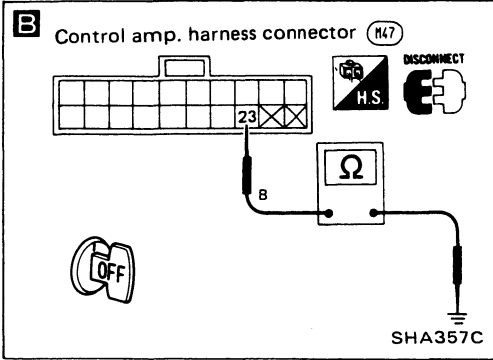
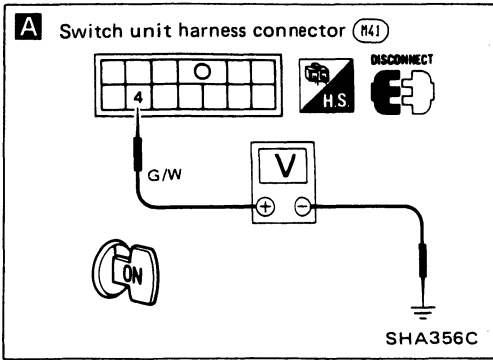

Turn ignition switch and lighting switch OFF.

Disconnect switch unit harness connector.

A
CHECK POWER SUPPLY FOR SWITCH UNIT
Do approximately 12 volts exist between switch unit harness connector terminal No. ④ and body ground?

N.G. Check harness of switch unit power supply circuit. (Refer to "POWER SUPPLY ROUTING" in EL section and A/C ELECTRICAL CIRCUIT.)

O.K.
B
CHECK BODY GROUND CIRCUIT FOR CONTROL AMP.
Does continuity exist between control amp. harness connector terminal No. ⑳ and body ground?

O.K.
Replace control amp.

Diagnostic Procedure 6

SYMPTOM: Temperature of air outlet does not change.

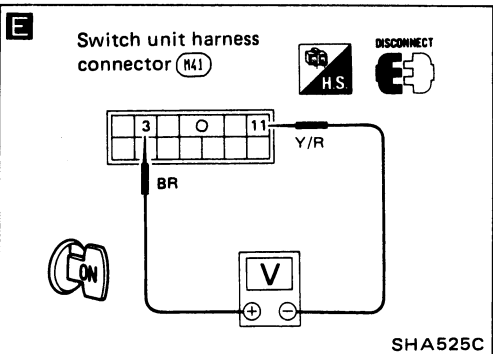
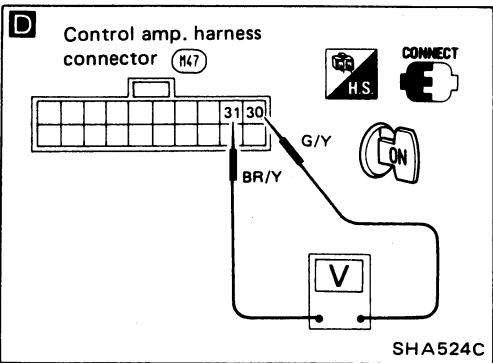
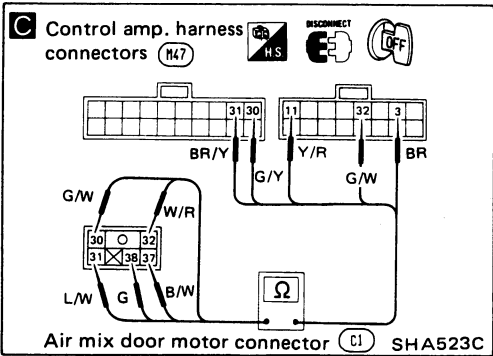
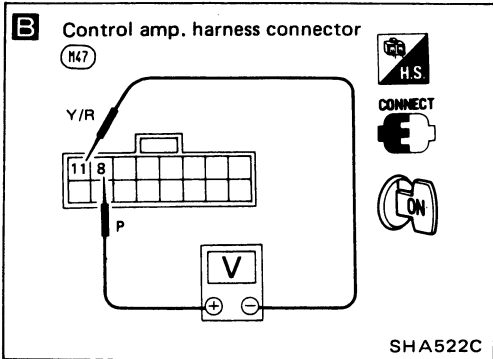
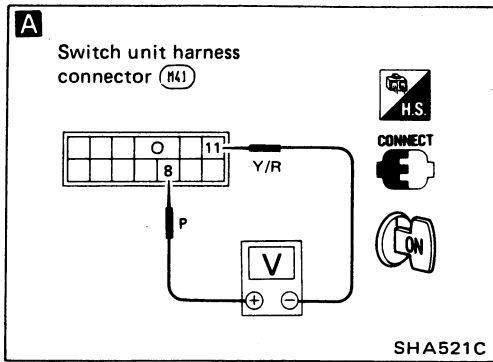

A

CHECK TEMPERATURE CONTROL LEVER.
Measure voltage between control panel harness connector terminals No. ⑧ and ⑪.

Temp. control lever	Terminal No.		Voltage (approx.)
	+	-	
Full hot	⑧	⑪	5V
Full cold			0V

N.G. → Disconnect control amp. harness connector.

E

Check if approximately 5 volts exist between control panel harness connector terminals No. ③ and ⑪.

N.G. → (Go to next page.)

O.K. → Replace control amp.

B

Measure voltage between control amp. harness connector terminals No. ⑧ and ⑪.

Temp. control lever	Terminal No.		Voltage (approx.)
	+	-	
Full hot	⑧	⑪	5V
Full cold			0V

O.K. → (Go to next page.)

C

Check continuity between each terminal of control amp. and air mix door motor.

Terminal No.		Continuity
Control amp.	Air mix door motor	
⑩	⑩	Yes
⑪	⑪	
③	④	
②	②	
①	③	

N.G. → Repair harness or connector.

D

CHECK FOR CONTROL AMP. OUTPUT.
Check if 12 volts exist between control amp. harness connector terminals No. ⑩ and ⑪ when temp. control lever is moved.

N.G. → Replace control amp.

O.K. → Replace air mix door motor.

Terminal No.	Air mix door motor	Direction of linkage rotation
⑩	⑩	Stop
-	+	Cold→Hot
+	-	Hot→Cold
-	-	Stop
+	+	Clockwise
-	-	Counter-clockwise

TROUBLE DIAGNOSES — Manual Air Conditioner

Diagnostic Procedure 6 (Cont'd)

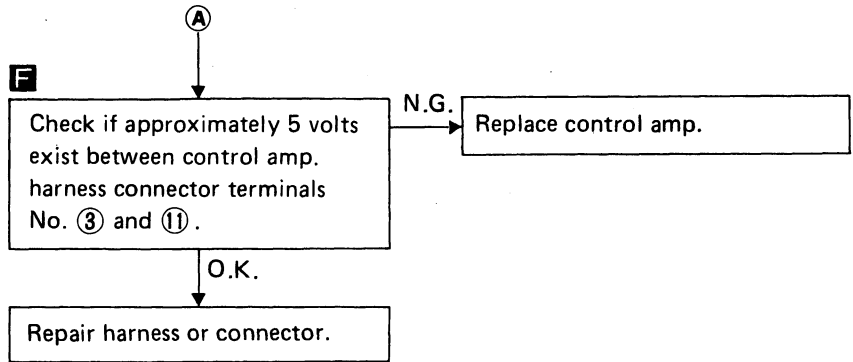
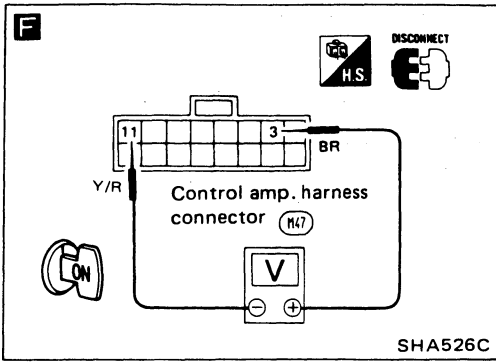

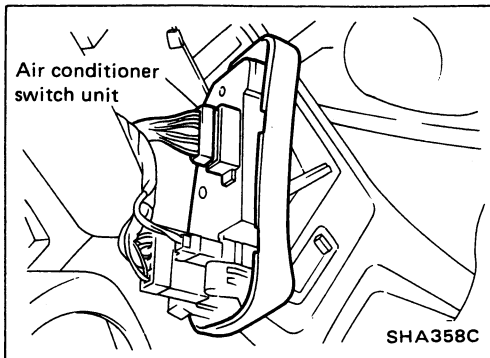

Electrical Components Inspection

FAN SWITCH

Check resistance between terminals at each switch position.

Switch position	Resistance between terminals No. ③ and ⑩ (Approx. Ω)
OFF	710
1	1,140
2	460
3	270
4	0

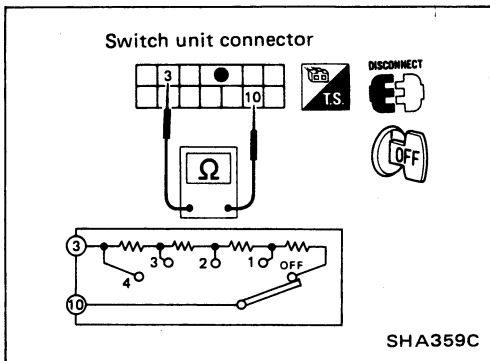

BLOWER MOTOR

Confirm smooth rotation of the blower motor.

- Ensure that there are no foreign particles inside the intake unit.

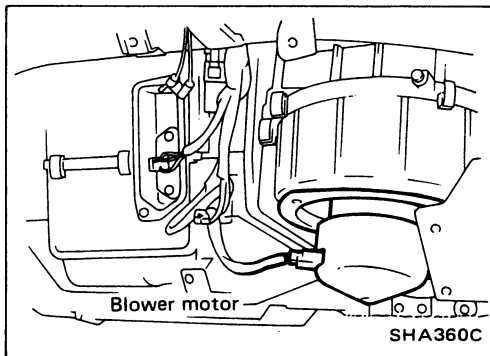

BLOWER RESISTOR

Check continuity between terminals.

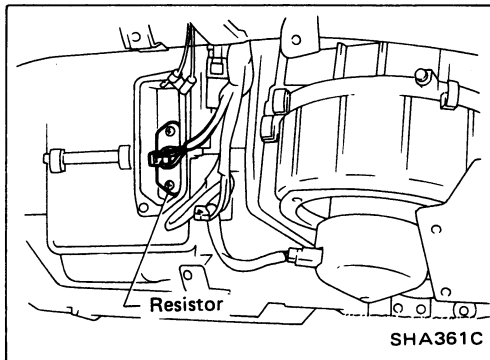

Electrical Components Inspection (Cont'd)

A/C SWITCH

Check continuity between terminals at each switch position.

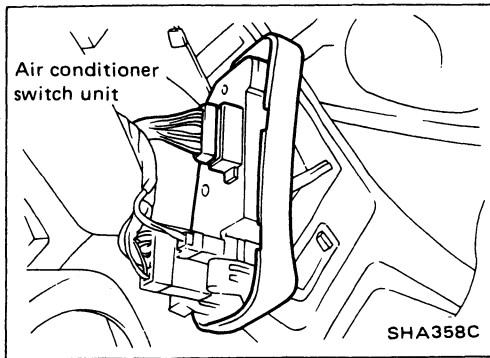

Switch condition	Terminal No.		Continuity
While A/C switch is pushed	⑥	⑪	Yes
While REC switch is pushed	⑫	⑪	Yes

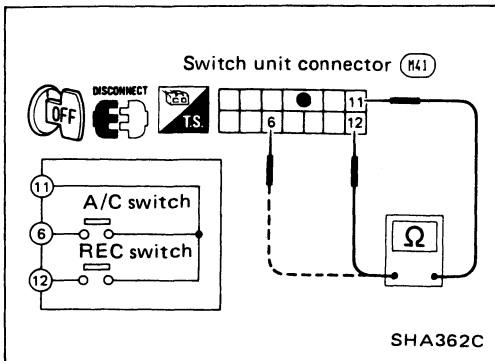

LOW-PRESSURE SWITCH

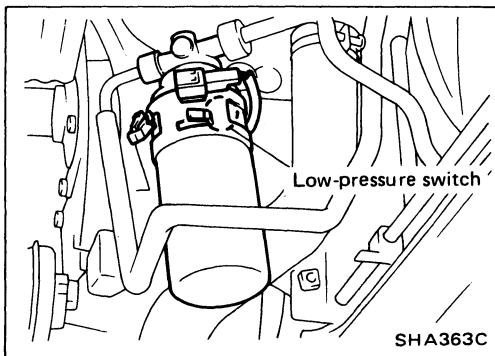

High-pressure side line pressure kPa (kg/cm ² , psi)	Operation	Continuity
196 (2.0, 28)	Turn OFF	Does not exist
206 (2.1, 30)	Turn ON	Exist

RELAYS

Check circuit continuity between terminals by supplying 12 volts to coil side terminal of relay.

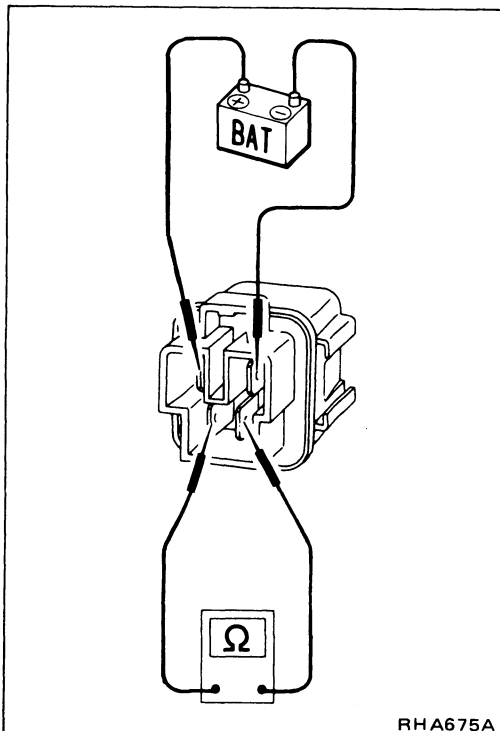

TROUBLE DIAGNOSES — Manual Air Conditioner

Electrical Components Inspection (Cont'd)

MODE SWITCH

Check resistance between terminals at each switch position.

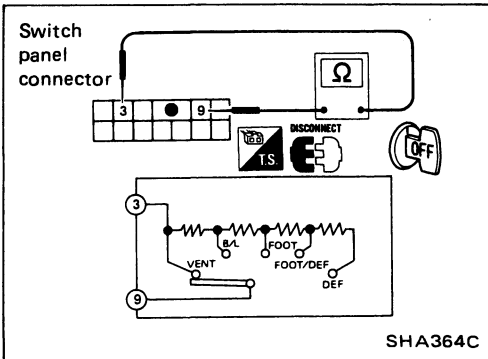
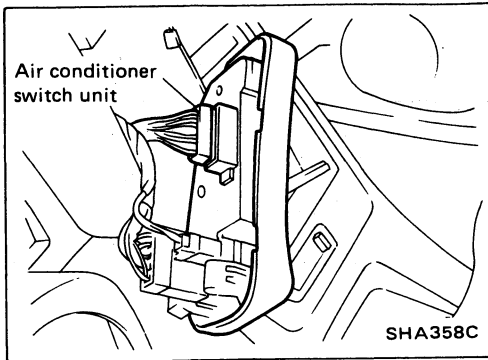

Switch position	Resistance between terminals No. ⑨ and No. ③ (Ω)
VENT	0
B/L	270
FOOT	460
FOOT/DEF	1,140
DEF	710

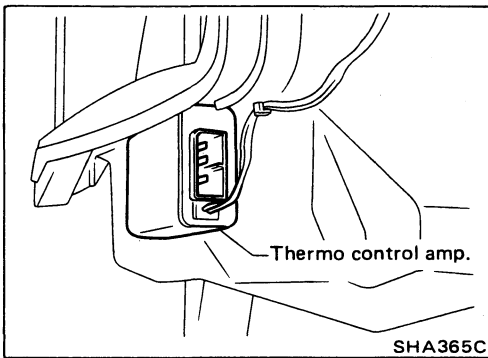

THERMO CONTROL AMP.

1. Run engine and operate A/C system.
2. Connect the voltmeter from harness side.
3. Check thermo control amp. operation shown in the table.

Evaporator outlet air temperature °C (°F)	Thermo amp. operation	Voltage (Approx.)
Decreasing to 3.0 (37)	Turn OFF	12V
Increasing to 4.5 (40)	Turn ON	0V

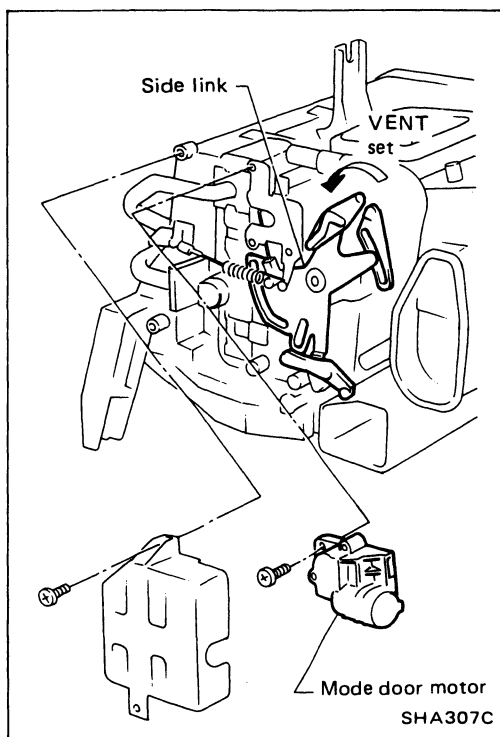

Control Rod Adjustment

MODE DOOR

1. Move side link by hand and hold mode door in VENT mode.
2. Install mode door motor on heater unit and connect it to harness.
3. Turn ignition switch to ON.
4. Turn VENT switch ON.
5. Attach mode door rod to side link rod holder.
6. Check that when DEF position is selected, only DEF door is at full-open position, and when VENT position is selected, only VENT door is at full-open position.

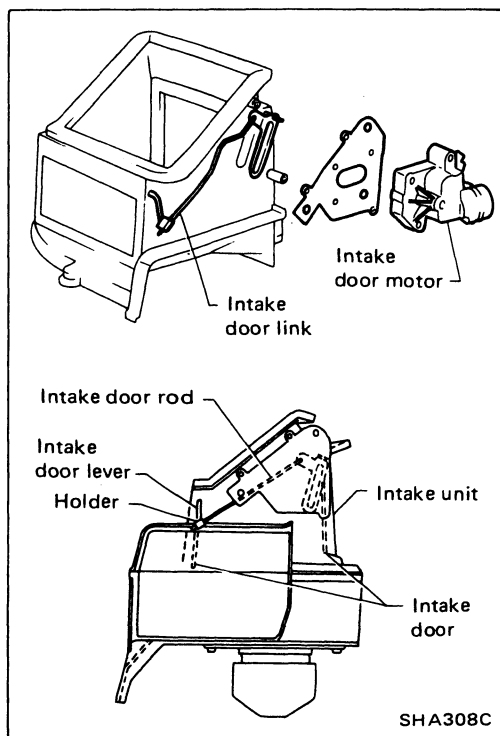

INTAKE DOOR

1. Install intake door motor on intake unit.
2. Connect intake door motor harness connector.
3. Turn ignition switch to ON.
4. Turn REC switch ON.
5. Install intake door lever.
6. Set intake door rod in REC position and fasten intake door rod to holder on intake door lever.
7. Check that intake door operates properly when REC switch is turned ON and OFF.

Control Rod Adjustment (Cont'd)

AIR MIX DOOR

1. Connect harness to air mix door motor and set temperature control lever at full-cold position.
2. Set air mix doors I and II at full-cold position and fasten door rod.
3. Check that when temperature control lever is at full-cold, both doors are at full-cold position, and when temperature control lever is at full-hot, both doors are at full-hot position.

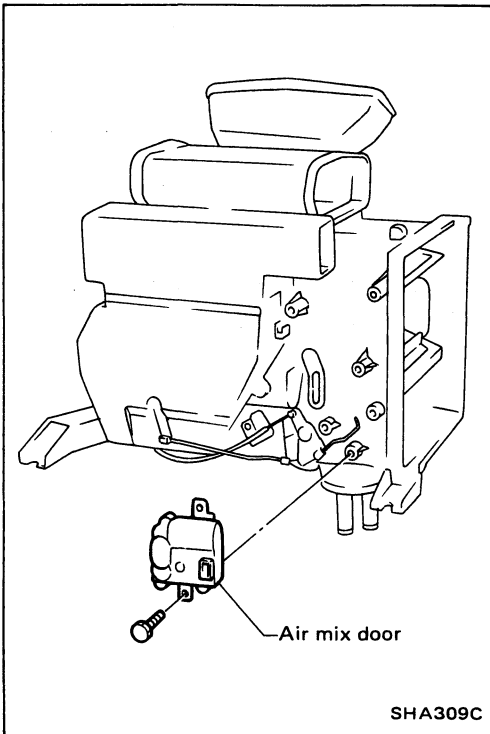

WATER COCK CONTROL CABLE

Clamp cable at full-close position when air mix doors I and II are at full-cold position, and full-open position when air mix doors I and II are at full-hot position.

NOTE

Contents

Symptom Chart	HA- 92
Self-diagnosis	HA- 94
CHECKING PROCEDURE	HA- 96
STEP 1: MONITOR DIAGNOSIS	HA- 98
STEP 2: ACTUATOR TEST	HA- 99
STEP 3: AUXILIARY MECHANISM	HA-100
STEP 4: READOUT OF TROUBLE DATA STORED IN MEMORY	HA-101
Consult	HA-102
Preliminary Check	HA-103
PRELIMINARY CHECK 1 (Air outlet does not change)	HA-103
PRELIMINARY CHECK 2 (Intake door does not change)	HA-104
PRELIMINARY CHECK 3 (Insufficient cooling)	HA-105
PRELIMINARY CHECK 4 (Insufficient heating)	HA-107
PRELIMINARY CHECK 5 (Blower motor operation is malfunctioning)	HA-108
PRELIMINARY CHECK 6 (Magnet clutch does not engage)	HA-109
PRELIMINARY CHECK 7 (Discharged air temperature does not change)	HA-110
PRELIMINARY CHECK 8 (Noise)	HA-110
Harness Layout for A/C System	HA-111
Circuit Diagram for Quick Pinpoint Check	HA-113
Wiring Diagram	HA-114
Main Power Supply and Ground Circuit Check	HA-116
Diagnostic Procedure 1 (SYMPTOM: Self-diagnosis detects intermittent short or open circuit in each sensor circuit)	HA-117
Diagnostic Procedure 2 (SYMPTOM: Ambient sensor circuit is open)	HA-118
Diagnostic Procedure 3 (SYMPTOM: Ambient sensor circuit is shorted)	HA-119
Diagnostic Procedure 4 (SYMPTOM: Upper in-vehicle sensor circuit is open)	HA-120
Diagnostic Procedure 5 (SYMPTOM: Upper in-vehicle sensor circuit is shorted)	HA-121
Diagnostic Procedure 6 (SYMPTOM: Lower in-vehicle sensor circuit is open)	HA-122
Diagnostic Procedure 7 (SYMPTOM: Lower in-vehicle sensor circuit is shorted)	HA-123
Diagnostic Procedure 8 (SYMPTOM: Def. duct sensor circuit is open)	HA-124
Diagnostic Procedure 9 (SYMPTOM: Def. duct sensor circuit is shorted)	HA-125
Diagnostic Procedure 10 (SYMPTOM: Vent duct sensor circuit is open)	HA-126
Diagnostic Procedure 11 (SYMPTOM: Vent duct sensor circuit is shorted)	HA-127
Diagnostic Procedure 12 (SYMPTOM: Floor duct sensor circuit is open)	HA-128
Diagnostic Procedure 13 (SYMPTOM: Floor duct sensor circuit is shorted)	HA-129

TROUBLE DIAGNOSES — Auto Air Conditioner

Contents (Cont'd)

Diagnostic Procedure 14	
(SYMPTOM: Sunload sensor circuit is shorted)	HA-130
Diagnostic Procedure 15	
(SYMPTOM: Air mix door does not operate normally)	HA-131
Diagnostic Procedure 16	
(SYMPTOM: Intake door does not operate normally)	HA-132
Diagnostic Procedure 17	
(SYMPTOM: Mode door does not operate normally)	HA-133
Diagnostic Procedure 18	
(SYMPTOM: Mode door does not move at all)	HA-134
Diagnostic Procedure 19	
(SYMPTOM: Magnet clutch does not engage)	HA-135
Diagnostic Procedure 20	
(SYMPTOM: Air conditioner control switch panel illumination does not come on)	HA-137
Diagnostic Procedure 21	
(SYMPTOM: Set temperature and mode display do not appear on display window)	HA-138
Diagnostic Procedure 22	
(SYMPTOM: When air conditioner switch is operated it does not beep)	HA-139
Diagnostic Procedure 23	
(SYMPTOM: Figures of set temperature do not appear on the display window and indicator lamp (L.E.D.) does not come on)	HA-140
Diagnostic Procedure 24	
(SYMPTOM: Switches do not work)	HA-141
Diagnostic Procedure 25	
(SYMPTOM: Blower motor operation is malfunctioning)	HA-142
Electrical Components Inspection	HA-145
Control Rod Adjustment	HA-148

TROUBLE DIAGNOSES — Auto Air Conditioner

Symptom Chart

DIAGNOSTIC TABLE

Symptom	Possible cause	Diagnostic procedure
Air outlet does not change	<ul style="list-style-type: none"> ● Mode door motor not operating correctly ● Inaccurate sensor input ● No output to mode door motor from auto amplifier 	Proceed to Preliminary check 1, then to Diagnostic procedures 17 and 18 if air mix door is malfunctioning.
Intake door does not change	<ul style="list-style-type: none"> ● Intake door motor or mechanism malfunctioning ● Inaccurate sensor input ● No output to intake door motor from auto amplifier 	Proceed to Preliminary check 2. If intake door is at fault, go to Diagnostic procedure 16.
Insufficient cooling	<ul style="list-style-type: none"> ● Compressor clutch not engaged ● Air mix door motors not working properly ● Condenser fan inoperative ● Low freon level 	Proceed to Preliminary check 3. If air mix doors do not operate properly, go to Diagnostic procedure 15. Check compressor clutch operation and freon level of system.
Discharged air temperature does not change	<ul style="list-style-type: none"> ● Air mix doors do not operate correctly ● Incorrect sensor input 	Proceed to Preliminary check 7.
Noise	<ul style="list-style-type: none"> ● Compressor belt tension ● Compressor component malfunction ● Blower motor interference ● Radiator cooling fan interference 	Proceed to Preliminary check 8.
Air conditioner control switch panel illumination does not come on	<ul style="list-style-type: none"> ● Blown fuse ● Loose or open in harness ● Blown bulb 	Proceed to Diagnostic procedure 20.
Insufficient heating	<ul style="list-style-type: none"> ● Coolant temperature is low ● Air mix doors not in correct position ● Incorrect sensor input 	Proceed to Preliminary check 4. If air mix doors do not operate correctly, go to Diagnostic procedure 15.
Blower motor operation is malfunctioning	<ul style="list-style-type: none"> ● Blower motor is not receiving power ● Vents may be obstructed ● Motor does not spin freely ● Air intake obstructed ● Blown fuse ● Malfunctioning blower relay 	Proceed to Preliminary check 5. If blower motor is malfunctioning, go to Diagnostic procedure 25.
Magnet clutch does not engage	<ul style="list-style-type: none"> ● Blown fuse ● A/C relay inoperative ● Open in wiring ● Open ambient sensor circuit ● Low freon level ● Malfunctioning clutch assembly 	Proceed to Preliminary check 6, then Diagnostic procedure 19 if clutch is at fault.

TROUBLE DIAGNOSES — Auto Air Conditioner

Symptom Chart (Cont'd)

Symptom	Possible cause	Diagnostic procedure
No display on A/C switch panel	<ul style="list-style-type: none">● Blown fuse● Malfunctioning bulb	Proceed to Diagnostic procedure 20.
Set temperature and mode indication do not appear on display window	<ul style="list-style-type: none">● Malfunctioning switch unit● Open in circuit● Malfunctioning auto amplifier	Proceed to Diagnostic procedure 21.
When air conditioner switch is operated, it does not beep	<ul style="list-style-type: none">● Malfunctioning A/C switch● Open in harness or connector● Malfunctioning auto amplifier	Proceed to Diagnostic procedure 22.
Set temperature and mode indication do not appear in display and indicator lamp (L.E.D.) does not come on	<ul style="list-style-type: none">● Open in harness● Malfunctioning switch panel● Malfunctioning auto amplifier	Proceed to Diagnostic procedure 23.
Switches do not work	<ul style="list-style-type: none">● Malfunctioning switch panel● Open in harness● Malfunctioning auto amplifier	Proceed to Diagnostic procedure 24.

TROUBLE DIAGNOSES — Auto Air Conditioner

Self-diagnosis

CONSULT AND ONBOARD SELF-DIAGNOSTIC SYSTEM

Function of CONSULT and ONBOARD SELF-DIAGNOSTIC SYSTEM are as follows:

ITEM	MONITOR		CHANGE PARAMETER		READOUT OF TROUBLE DATA STORED IN MEMORY	
	CONSULT	ONBOARD	CONSULT	ONBOARD	CONSULT	ONBOARD
Ambient temp.	○	○			○	○
In-vehicle temp. (Upper)	○	○			○	○
In-vehicle temp. (Lower)	○	○			○	○
Duct temp. (Defroster)	○	○			○	○
Duct temp. (Ventilator)	○	○			○	○
Duct temp. (Floor)	○	○			○	○
Sunload	○	○			○	○
Water temp.	○	○				
Mode door P.B.R.	○	○				
In-vehicle target temp. (Upper)	○					
In-vehicle target temp. (Lower)	○					
Outlet air target temp. (Upper)	○		○	*○		
Outlet air target temp. (Lower)	○		○	*○		
Mode door target position	○		○	*○		
Intake door target position	○		○	*○		
Blower motor target voltage	○		○	*○		
Difference between upper and lower target temp.	○		○	*○		
Output signal to compressor	○		○	*○		
Set temp.	○					
Selected mode	○					
Operated switches status	○					
Manual select status	○					

*: These can be set by self-diagnosis step II; their combinations are as follows:

Actuator test

Code	Intake	Outlet	A/M door	Comp.
	Outside air	DEF	Full Hot	OFF
	Outside air	FOOT	Full Hot	OFF
	Partial outside air	B/L	30°C (86°F)	ON
	Recirculation air	VENT	Full Cool	ON

Press MODE SW. ↓

Code	Voltage
	4V
	6V
	9V
	12V

Press FAN SW. ↓

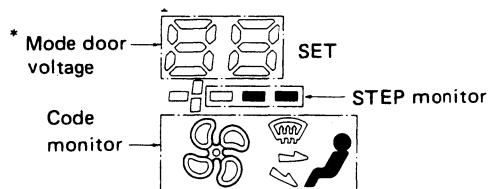

*: Mode door voltage: 0 = VENT, 5 = DEF
Ten times the value in V.

SHA755C

Self-diagnosis (Cont'd)

The self-diagnostic system diagnoses the sensors, door motors, blower motor, etc. by system line. Refer to applicable sections (items) for details. Shifting from normal control to the self-diagnostic system is accomplished by starting the engine (turning ignition switch from "OFF" to "ON"), and pressing both the (AUTO) and (OFF) switch for at least 5 seconds. This system will be cancelled by either pressing the (OFF) switch or turning the ignition switch "OFF". Shifting from one step to another is accomplished by means of pushing the (AUTO) switch, as required.

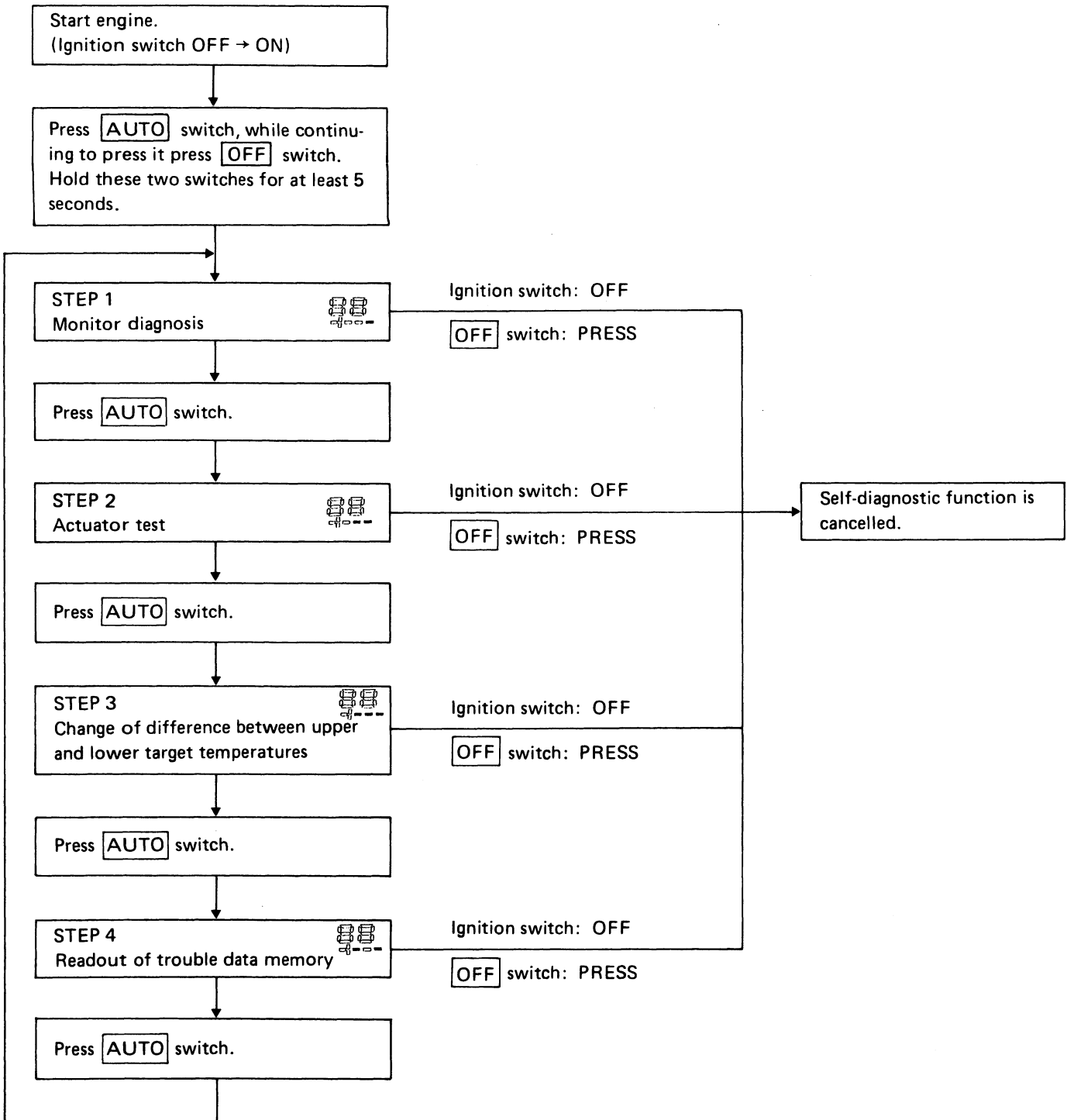

TROUBLE DIAGNOSES — Auto Air Conditioner

Self-diagnosis (Cont'd)

CHECKING PROCEDURE

Note

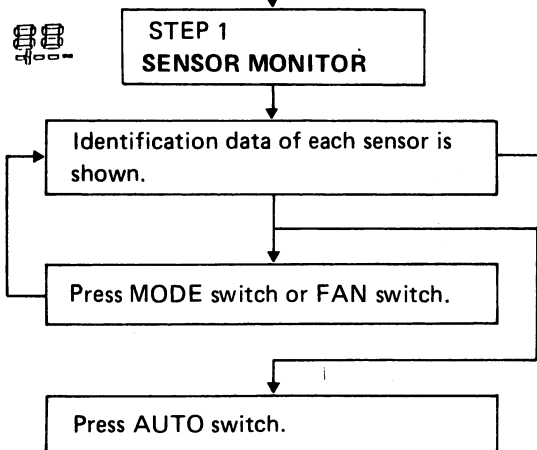
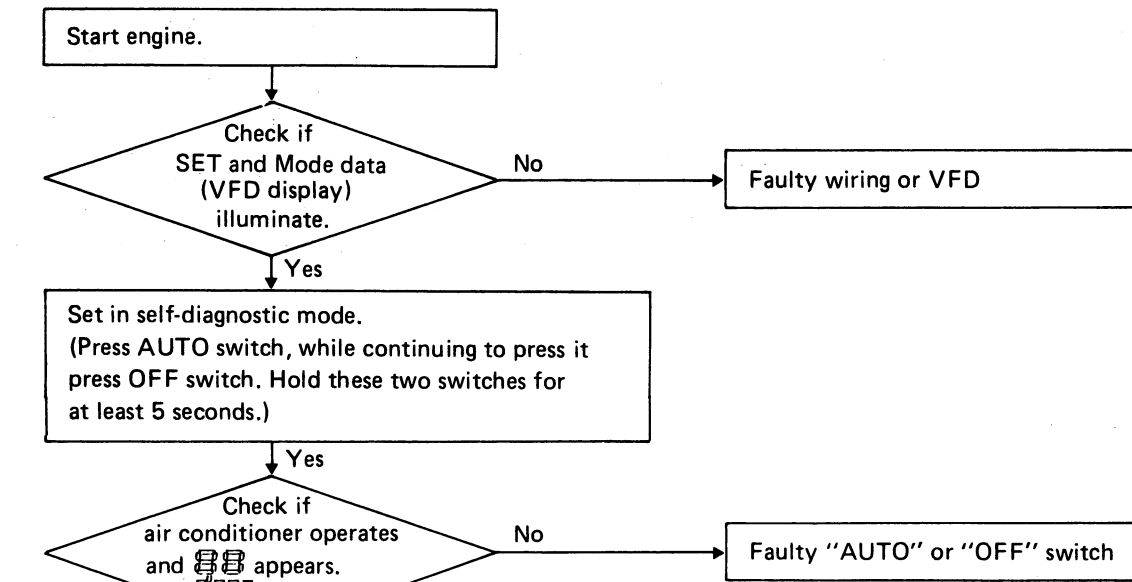

Sensor monitor

Code	Item	Unit	Code	Item	Unit
	Ambient temperature	°C (°F)		Internal data	-
	Upper compartment temperature				
	Lower compartment temperature				
	DEF outlet air temperature				
	VENT outlet air temperature				
	FOOT outlet air temperature				
	Sunload	*1		Difference between upper and lower target temperatures	°C (°F)
	Water temperature *3	°C (°F)		Internal data	-
	Mode door voltage*4	*2			

*1: One tenth of the value in kcal/h·m³ unit
 *2: Ten times of the value in V
 *3: When coolant temperature is below 40°C (104°F), indicates 20°C (68°F)
 When coolant temperature is above 40°C (104°F), indicates 80°C (176°F)
 *4: Mode door voltage: 0 = VENT, 5 = DEF

SHA754C

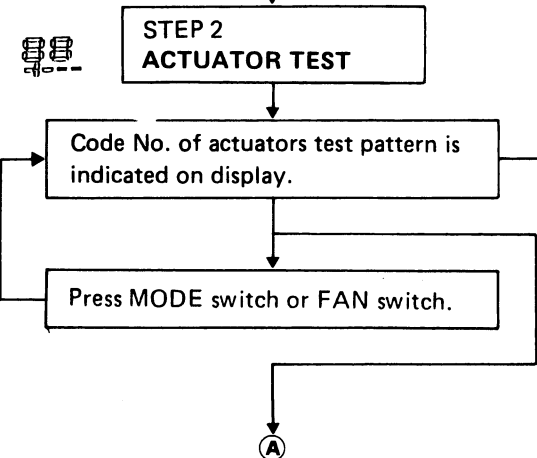

Actuator test

Code	Intake	Outlet	A/M door	Comp.
	Outside air	DEF	Full Hot	OFF
	Outside air	FOOT	Full Hot	OFF
	Partial outside air	B/L	30°C (86°F)	ON
	Recirculation air	VENT	Full Cool	ON

Code	Voltage
	4V
	6V
	9V
	12V

* Mode door voltage: 0 = VENT, 5 = DEF
 Ten times the value in V.

SHA755C

Note:
 1. Without engine running, STEP 1 and 2 are not useful for some case because compressor not operate.

TROUBLE DIAGNOSES — Auto Air Conditioner

Self-diagnosis (Cont'd)

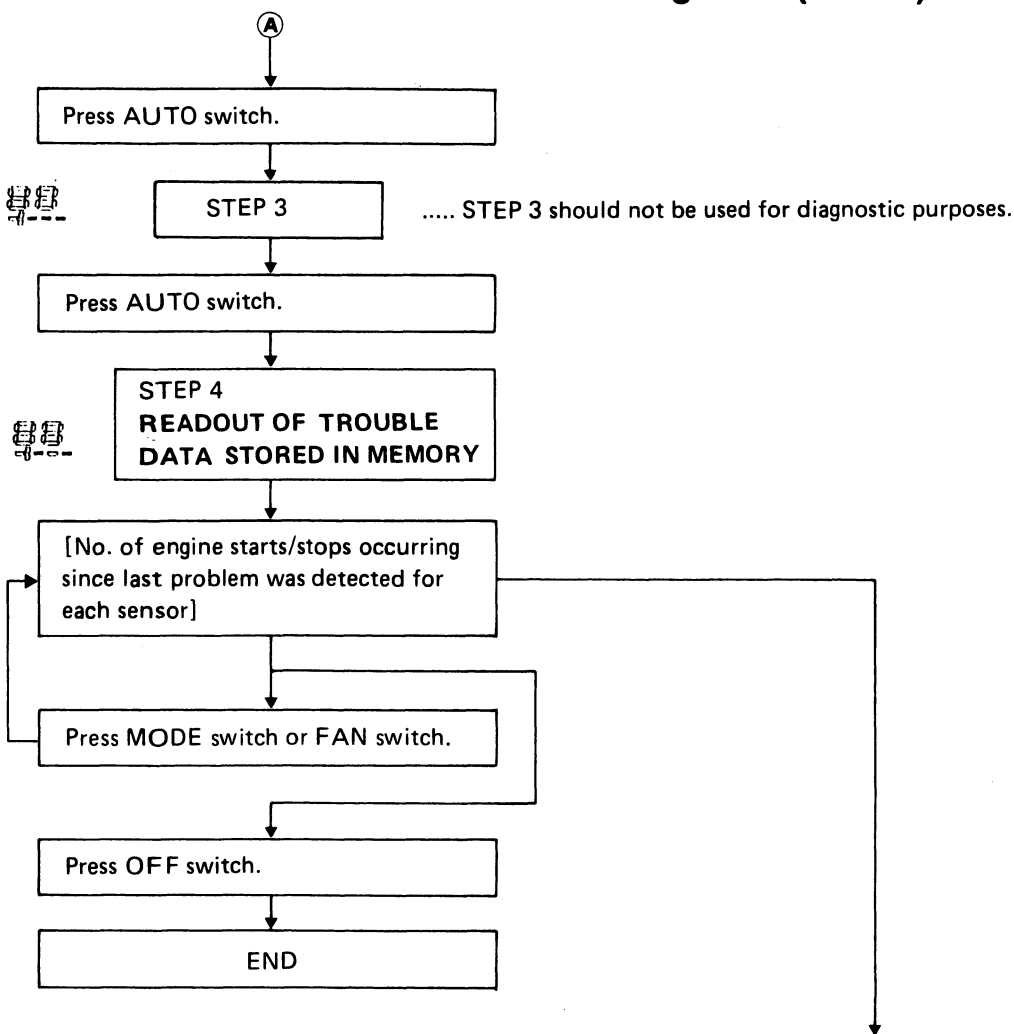

Readout of trouble data stored in memory

Code	Item	Trouble diagnosis criteria	Remarks
	Ambient sensor trouble data	Less than -70°C (-94°F) Greater than 141°C (286°F)	
	Upper in-vehicle sensor trouble data		
	Lower in-vehicle sensor trouble data		
	DEF Duct sensor trouble data		Less than -38°C (-36°F) Greater than 141°C (286°F)
	VENT Duct sensor trouble data		
	FOOT Duct sensor trouble data		
	Sunload sensor trouble data	-	Detects only short circuit

Press FAN SW. ↑
 Press MODE SW. ↓

Trouble data:

Open circuit:

Short circuit:

SET

STEP monitor

Code monitor

Trouble data

No. of IGN ON/OFF operations since last trouble was detected.

50: No problem

49 - 01: Problem existed

0: Problem exists

SHA756C

TROUBLE DIAGNOSES — Auto Air Conditioner

Self-diagnosis (Cont'd)

STEP 1: MONITOR DIAGNOSIS

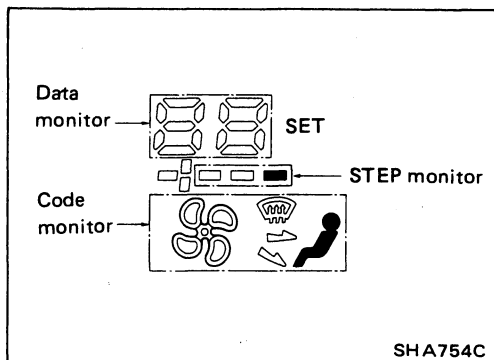

By setting in self-diagnostic mode, VFD display shows that Step 1 mode has begun.

In this mode, each time the FAN or MODE SW is pressed, the code monitor changes in turn, and data corresponding with each code appears in the data monitor.

If the temperature shown on the display greatly differs from the actual temperature, check the sensor circuit first, then inspect the sensor itself according to the procedures described in Electrical Components Inspection.

* For cross-reference of code and corresponding data, refer to "Sensor monitor" in "Checking procedure".

	Code	Item	Unit	Code	Item	Unit
Press FAN SW. ↑		Ambient temperature	°C (°F)		Internal data	—
		Upper compartment temperature				—
		Lower compartment temperature				—
		DEF outlet air temperature				—
		VENT outlet air temperature				—
Press MODE SW. ↓		FOOT outlet air temperature				—
		Sunload	*1		Difference between upper and lower target temperatures	°C (°F)
		Water temperature *3	°C (°F)		Internal data	—
		Mode door voltage*4	*2			

*1: One tenth of the value in kcal/h·m² unit

*2: Ten times of the value in V

*3: When coolant temperature is below 40°C (104°F), indicates 20°C (68°F)
When coolant temperature is above 40°C (104°F), indicates 80°C (176°F)

*4: Mode door voltage: 0 = VENT, 5 = DEF

TROUBLE DIAGNOSES — Auto Air Conditioner

Self-diagnosis (Cont'd)

STEP 2: ACTUATOR TEST

By pushing the AUTO SW once, self-diagnosis is changed from step 1 to step 2.

During inspection in STEP 2 mode, the auto amplifier will forcefully transmit an output to the affected actuators in response to the code shown on the display, as indicated in the table below. Each operating condition can be set in turn by pressing FAN or MODE SW.

Checks must be made for improper operation visually, by listening to any noise, or by touching air outlets with your hand, etc.

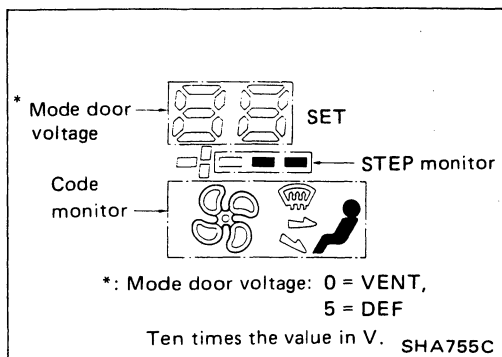

	Press MODE SW. →			
Display				
Actuator				
Mode door	DEF	D/FOOT	B/L	VENT
Intake door	FRE	FRE	50% FRE	REC
Air mix door	Full Hot	Full Hot	30°C (86°F)	Full Cold
Compressor	OFF	OFF	ON	ON

	Press FAN SW. →			
Display				
Blower motor				
Voltage	4V	6V	9V	12V

Operating condition of each actuator cannot be checked by indicators.

- * 1) Mode and fan speed can be set independently.
- 2) When appears, air mix door activates.
A stabilized outlet temperature 30°C (86°F) is reached after air mix door has been operating for approximately one minute.

TROUBLE DIAGNOSES — Auto Air Conditioner

Self-diagnosis (Cont'd)

STEP 3: AUXILIARY MECHANISM

Changes of difference between upper and lower target temperatures.

* Figures in parentheses "()" refer to values for "°F" specifications.

Each time the "MODE" switch is pressed, the number in the SET section advances. This number will increase up to 20 for °C specifications and 36 for °F specifications. Each time the "FAN" switch is pressed, the number decreases. This number decreases to -20 for °C specifications and -36 for °F specifications.

For °C specifications, pressing the "MODE" or "FAN" switch each time increases or decreases the data number by "1" degree (and by "1" through "3" degrees for °F specifications).

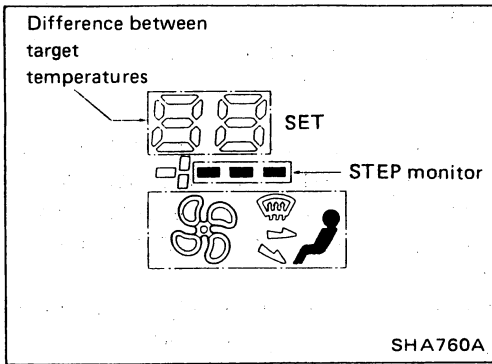

← Press FAN SW. Press MODE SW. →

°C specifications	Data	-20	-----	-1	0	1	-----	20
	Difference between upper and lower target temperatures	-2.0°C	-----	-1°C	0°C	0.1°C	-----	2.0°C
°F specifications	Data	-36	-----	-2	0	2°C	-----	36
	Difference between upper and lower target temperatures	-3.6°F	-----	-0.2°F	0°F	0.2°F	-----	3.6°F

Difference between upper and lower target temperatures changed in the preceding procedure is kept until the next change is done or the battery cable is removed.

Self-diagnosis (Cont'd)

STEP 4: READOUT OF TROUBLE DATA STORED IN MEMORY

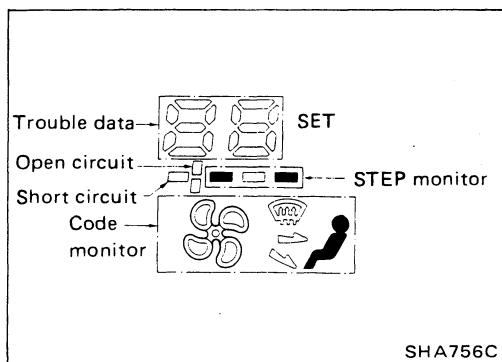

By pushing the AUTO SW once in step 3, self-diagnosis is changed to step 4.

In this mode, each time the FAN or MODE SW is pressed, the code monitor changes in turn, and data or status of each sensor appears in the data monitor.

When the sensor becomes inoperative, the number of IGN ON/OFF operations occurring since the last trouble was detected appears in the SET section.

Open circuit or short circuit is indicated by "□" or "□".

Conditions for open or short circuit

Code	Sensor	Open circuit	Short circuit
	Ambient sensor	Less than -70°C (-94°F)	Greater than 141°C (286°F)
	Room upper sensor	Less than -38°C (-36°F)	Greater than 141°C (286°F)
	Room lower sensor	Less than -38°C (-36°F)	Greater than 141°C (286°F)
	DEF duct sensor	Less than -38°C (-36°F)	Greater than 141°C (286°F)
	VENT duct sensor	Less than -38°C (-36°F)	Greater than 141°C (286°F)
	Floor duct sensor	Less than -38°C (-36°F)	Greater than 141°C (286°F)
	Sunloaded sensor	Open circuit can not be detected by self-diagnosis.	Greater than 1.784 kW ($1,534\text{ kcal/h}$, $6,087\text{ BTU/h}/\text{m}^2$ [19.19 kW ($16,506\text{ kcal/h}$, $65,502\text{ BTU/h}/\text{sq ft}$)]

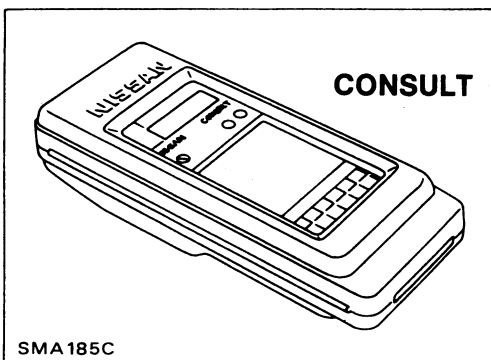

Consult

CONSULT INSPECTION PROCEDURE

1. Turn off ignition switch.
2. Connect "CONSULT" to diagnostic connector.
(Diagnostic connector is located in left dash side panel.)

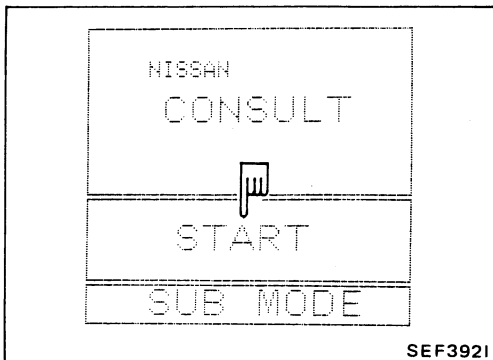
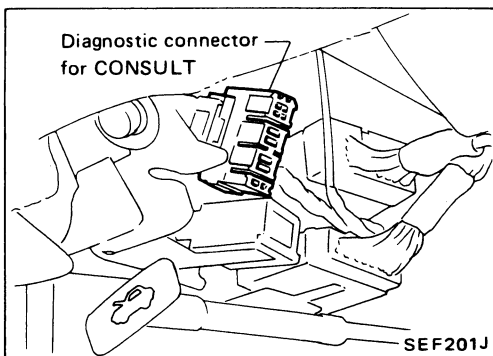

3. Turn on ignition switch.
4. Touch "START".

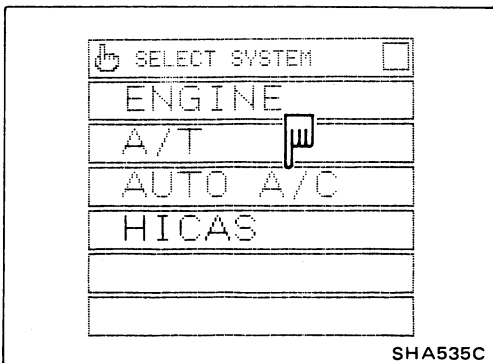

5. Touch "AUTO A/C".

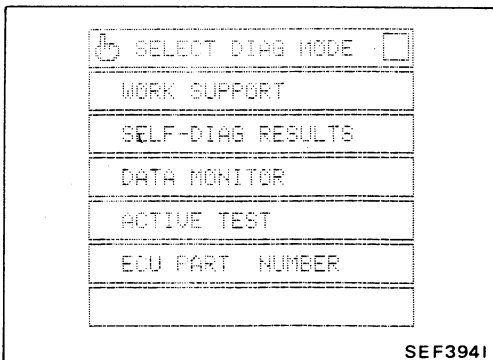

6. Perform each diagnostic mode according to the inspection sheet as follows:

For further information, read the CONSULT Operation Manual.

Preliminary Check

PRELIMINARY CHECK 1

Air outlet does not change.

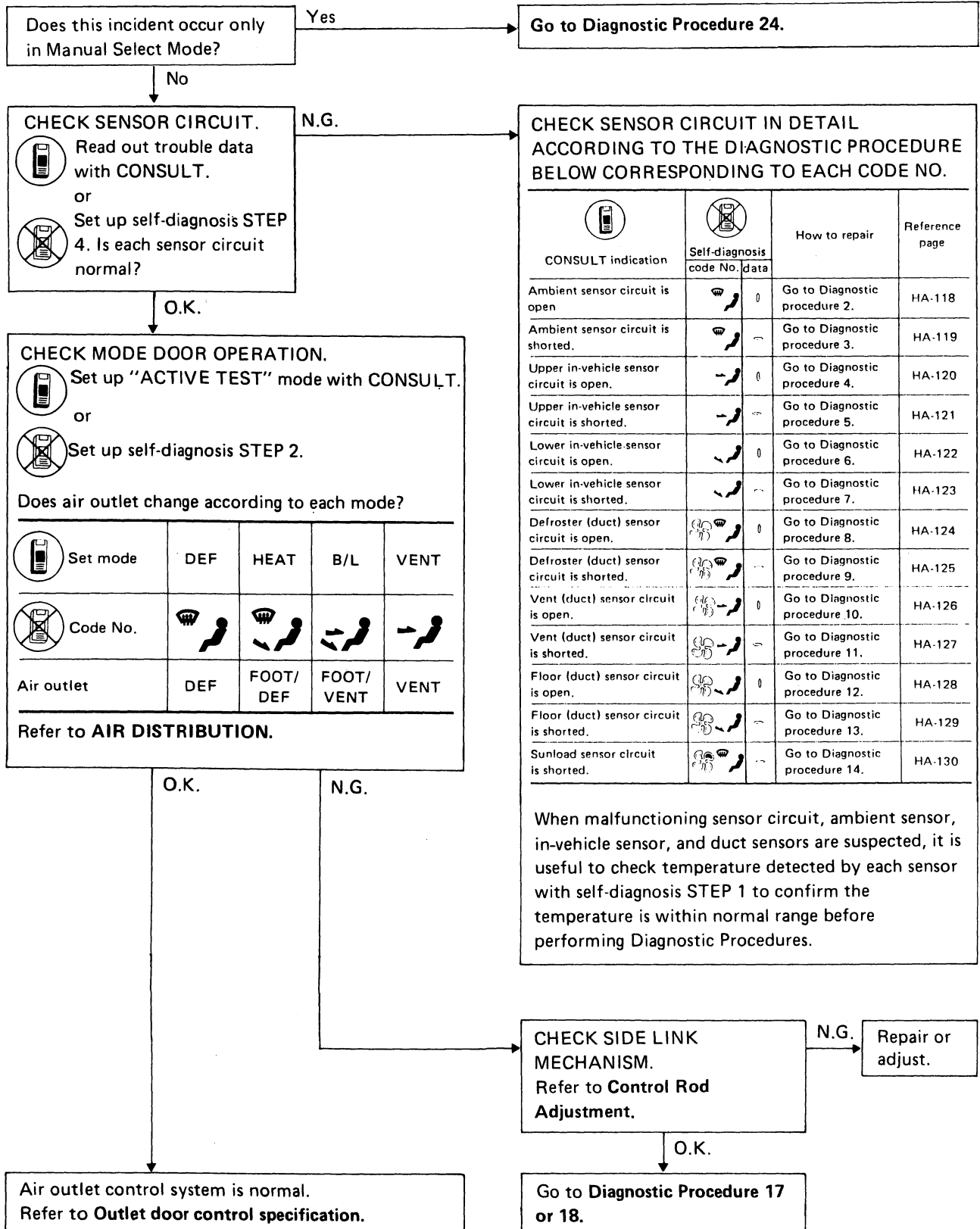

TROUBLE DIAGNOSES — Auto Air Conditioner

Preliminary Check (Cont'd)

PRELIMINARY CHECK 2

Intake door does not change.

CHECK SENSOR CIRCUIT.

Read out trouble data with CONSULT.
or
 Set up self-diagnosis STEP 4. Is each sensor circuit normal?

N.G.

**CHECK SENSOR CIRCUIT IN DETAIL
ACCORDING TO DIAGNOSTIC PROCEDURE
BELOW CORRESPONDING TO EACH CODE NO.**

CONSULT indication	Self-diagnosis code No. data	How to repair	Reference page
Ambient sensor circuit is open	0	Go to Diagnostic procedure 2.	HA-118
Ambient sensor circuit is shorted.	-	Go to Diagnostic procedure 3.	HA-119
Upper in-vehicle sensor circuit is open.	0	Go to Diagnostic procedure 4.	HA-120
Upper in-vehicle sensor circuit is shorted.	-	Go to Diagnostic procedure 5.	HA-121
Lower in-vehicle sensor circuit is open.	0	Go to Diagnostic procedure 6.	HA-122
Lower in-vehicle sensor circuit is shorted.	-	Go to Diagnostic procedure 7.	HA-123
Defroster (duct) sensor circuit is open.	0	Go to Diagnostic procedure 8.	HA-124
Defroster (duct) sensor circuit is shorted.	-	Go to Diagnostic procedure 9.	HA-125
Vent (duct) sensor circuit is open.	0	Go to Diagnostic procedure 10.	HA-126
Vent (duct) sensor circuit is shorted.	-	Go to Diagnostic procedure 11.	HA-127
Floor (duct) sensor circuit is open.	0	Go to Diagnostic procedure 12.	HA-128
Floor (duct) sensor circuit is shorted.	-	Go to Diagnostic procedure 13.	HA-129
Sunload sensor circuit is shorted.	-	Go to Diagnostic procedure 14.	HA-130

When malfunctioning sensor circuit, ambient sensor, in vehicle sensor, and duct sensors are suspected, it is useful to check temperature detected by each sensor with self-diagnosis STEP 1 to confirm the temperature is within normal range before performing Diagnostic Procedures.

CHECK INTAKE DOOR MOTOR.

Set up "ACTIVE TEST" mode with CONSULT.
or
 Set up self-diagnosis STEP 2.

Does intake air change according to each ordered position?

Set position	FRE	FRE/REC	REC
Code No.			
Air intake	FRE	FRE/REC	REC

O.K.

N.G.

Intake door control system is normal.
Refer to Intake door control specification.

CHECK INTAKE DOOR ROD or LEVER MECHANISM.
Refer to Control Rod Adjustment.

N.G.

Repair or adjust.

O.K.

Go to Diagnostic Procedure 16.

TROUBLE DIAGNOSES — Auto Air Conditioner

Preliminary Check (Cont'd)

PRELIMINARY CHECK 3

Insufficient cooling

- Read out self-diagnosis result with CONSULT or perform self-diagnosis STEP 4 before referring to the following flow chart.

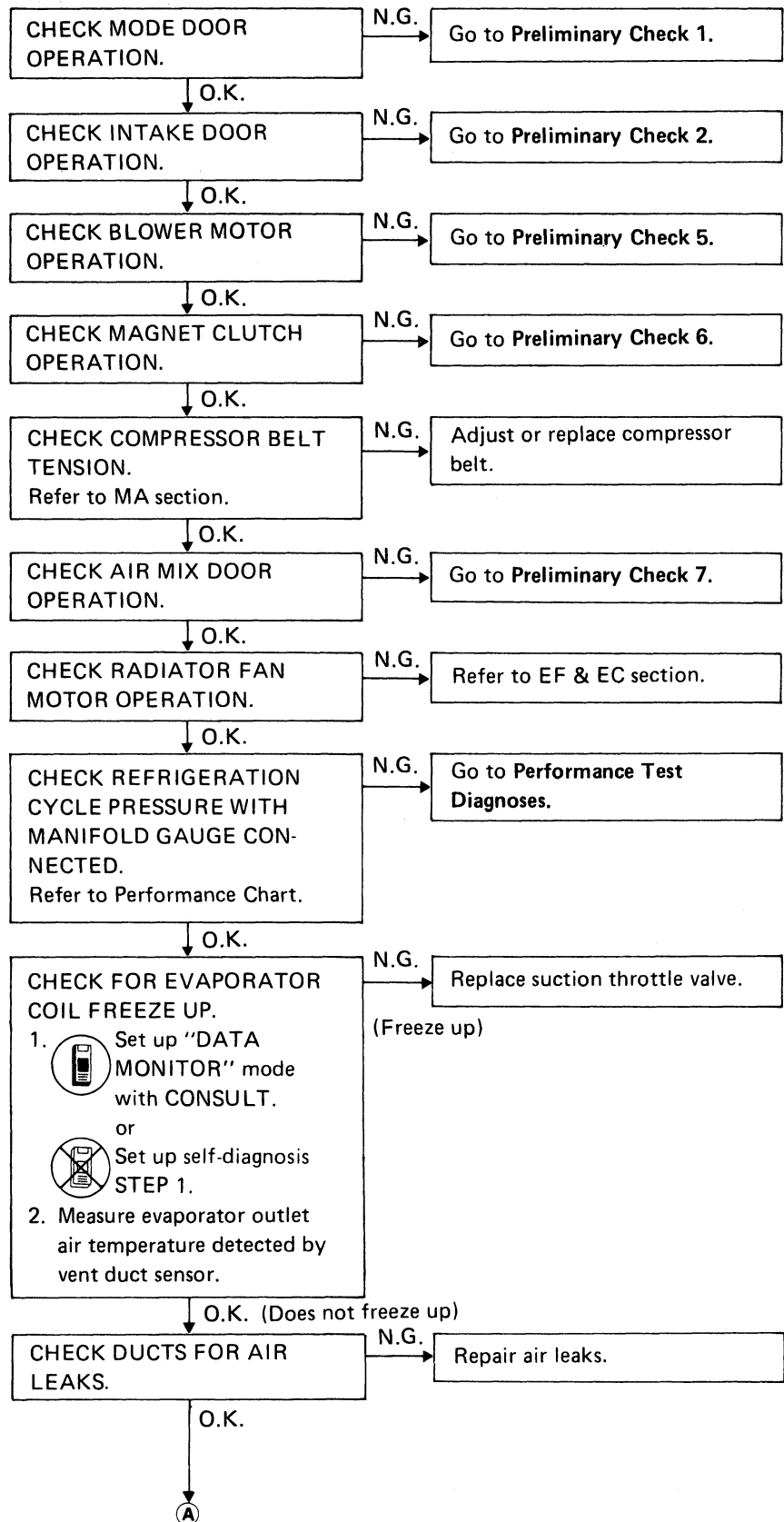



Preliminary Check (Cont'd)

A



**PERFORM TEMPERATURE
SETTING (Upper and lower).**

1.  Set up "WORK SUPPORT" mode with CONSULT.
or
 Set up self-diagnosis STEP 3.
2. Adjust difference between upper and lower target temperatures.

Preliminary Check (Cont'd)

PRELIMINARY CHECK 4

Insufficient heating

- Check coolant level, engine temperature and heater hoses, and read out self-diagnosis result with CONSULT or perform self-diagnosis STEP 4 before referring to the following flow chart.

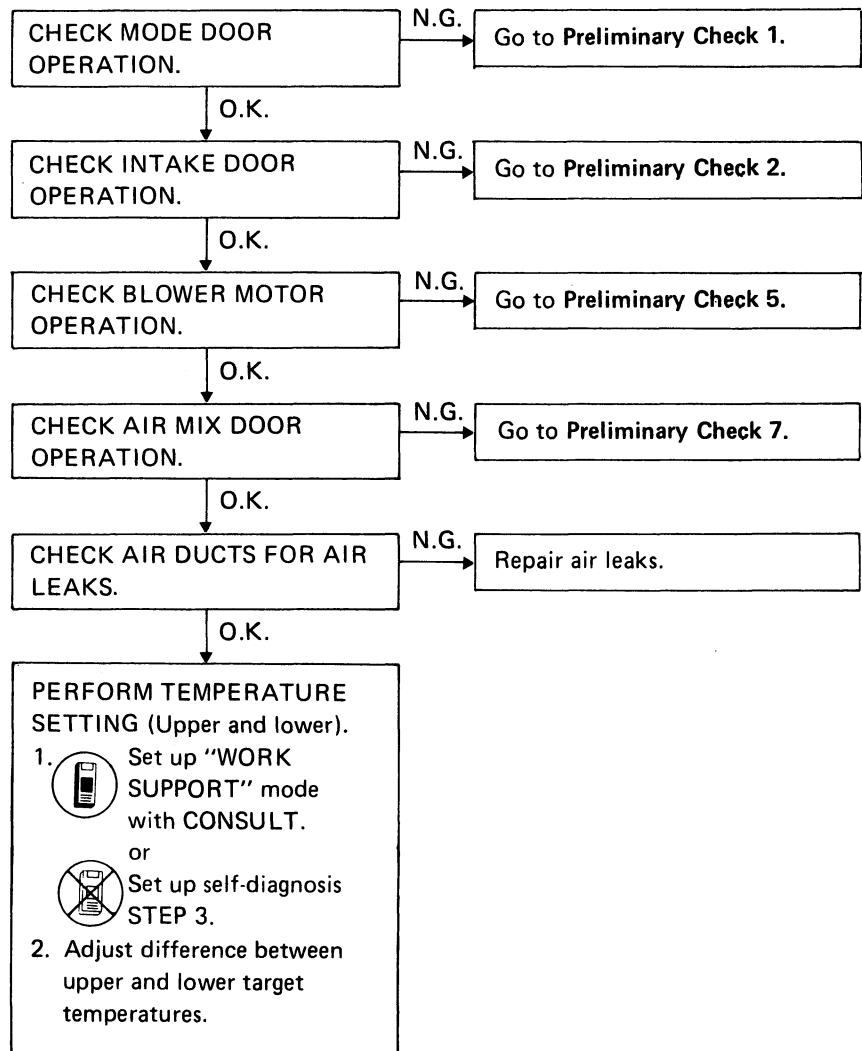

TROUBLE DIAGNOSES — Auto Air Conditioner

Preliminary Check (Cont'd)

PRELIMINARY CHECK 5

Blower motor operation is malfunctioning.

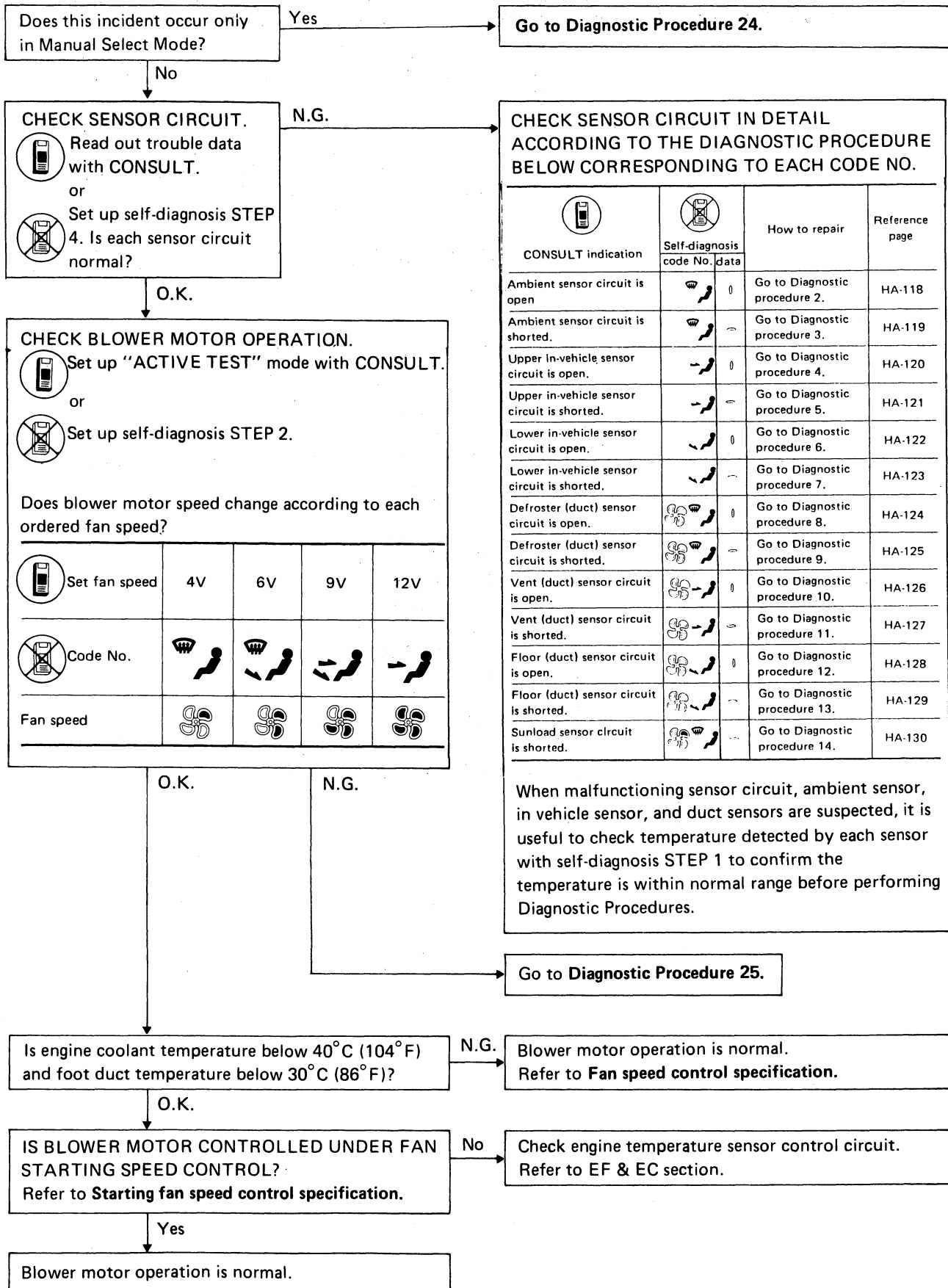

Preliminary Check (Cont'd)

PRELIMINARY CHECK 6

Magnet clutch does not engage.

CHECK SENSOR CIRCUIT.

Read out trouble data with CONSULT.
or
 Set up self-diagnosis STEP 4. Is each sensor circuit normal?

N.G.

CHECK SENSOR CIRCUIT IN DETAIL ACCORDING TO THE DIAGNOSTIC PROCEDURE BELOW CORRESPONDING TO EACH CODE NO.

CONSULT indication	Self-diagnosis code No. data	How to repair	Reference page
Ambient sensor circuit is open	0	Go to Diagnostic procedure 2.	HA-118
Ambient sensor circuit is shorted.	-	Go to Diagnostic procedure 3.	HA-119
Upper in-vehicle sensor circuit is open.	0	Go to Diagnostic procedure 4.	HA-120
Upper in-vehicle sensor circuit is shorted.	-	Go to Diagnostic procedure 5.	HA-121
Lower in-vehicle sensor circuit is open.	0	Go to Diagnostic procedure 6.	HA-122
Lower in-vehicle sensor circuit is shorted.	-	Go to Diagnostic procedure 7.	HA-123
Defroster (duct) sensor circuit is open.	0	Go to Diagnostic procedure 8.	HA-124
Defroster (duct) sensor circuit is shorted.	-	Go to Diagnostic procedure 9.	HA-125
Vent (duct) sensor circuit is open.	0	Go to Diagnostic procedure 10.	HA-126
Vent (duct) sensor circuit is shorted.	-	Go to Diagnostic procedure 11.	HA-127
Floor (duct) sensor circuit is open.	0	Go to Diagnostic procedure 12.	HA-128
Floor (duct) sensor circuit is shorted.	-	Go to Diagnostic procedure 13.	HA-129
Sunload sensor circuit is shorted.	-	Go to Diagnostic procedure 14.	HA-130

When malfunction sensor circuit, ambient sensor, in vehicle sensor, and duct sensors are suspected, it is useful to check temperature detected by each sensor with self-diagnosis STEP 1 to confirm the temperature is with normal range before performing Diagnostic Procedures.

CHECK MAGNET CLUTCH OPERATION.

Set up "ACTIVE TEST" mode with CONSULT.
or
 Set up self-diagnosis STEP 2.

Check if magnet clutch engages according to order from CONSULT or each code No.

Set magnet clutch operation	OFF	ON
Code No.		
Magnet clutch operation	OFF	ON

O.K.

N.G.

Magnet clutch control system is normal.
Refer to **MAGNET CLUTCH CONTROL.**

CHECK REFRIGERANT.
Connect manifold gauge then check system pressure.

N.G.

Check for refrigerant leaks.

O.K.

Go to **Diagnostic Procedure 19.**



TROUBLE DIAGNOSES — Auto Air Conditioner

Preliminary Check (Cont'd)

PRELIMINARY CHECK 7

Discharged air temperature does not change.



CHECK SENSOR CIRCUIT.

 Read out trouble data with CONSULT.
or
 Set up self-diagnosis STEP 4. Is each sensor circuit normal?





N.G.

O.K.

CHECK AIR MIX DOOR OPERATION.

 Set up "ACTIVE TEST" mode with CONSULT.
or
 Set up self-diagnosis STEP 2.

Check if discharge air temperature changes as in following chart.

 Set discharge air temperature	Full Hot	30° C (86° F)	Full Cool
 Code No.			
Discharge air temperature	Full Hot	30° C (86° F)	Full Cool

O.K.

N.G.

Air mix door control system is normal.
Refer to **Specification of air mix door control.**

CHECK AIR MIX DOOR MECHANISM.
Refer to **DOOR CONTROL.**















N.G.

Repair or adjust.

O.K.

Go to **Diagnostic Procedure 15.**

CHECK SENSOR CIRCUIT IN DETAIL
ACCORDING TO THE DIAGNOSTIC PROCEDURE BELOW CORRESPONDING TO EACH CODE NO.

 CONSULT indication	 Self-diagnosis code No.	data	How to repair	Reference page
Ambient sensor circuit is open		0	Go to Diagnostic procedure 2.	HA-118
Ambient sensor circuit is shorted.		-	Go to Diagnostic procedure 3.	HA-119
Upper in-vehicle sensor circuit is open.		0	Go to Diagnostic procedure 4.	HA-120
Upper in-vehicle sensor circuit is shorted.		-	Go to Diagnostic procedure 5.	HA-121
Lower in-vehicle sensor circuit is open.		0	Go to Diagnostic procedure 6.	HA-122
Lower in-vehicle sensor circuit is shorted.		-	Go to Diagnostic procedure 7.	HA-123
Defroster (duct) sensor circuit is open.		0	Go to Diagnostic procedure 8.	HA-124
Defroster (duct) sensor circuit is shorted.		-	Go to Diagnostic procedure 9.	HA-125
Vent (duct) sensor circuit is open.		0	Go to Diagnostic procedure 10.	HA-126
Vent (duct) sensor circuit is shorted.		-	Go to Diagnostic procedure 11.	HA-127
Floor (duct) sensor circuit is open.		0	Go to Diagnostic procedure 12.	HA-128
Floor (duct) sensor circuit is shorted.		-	Go to Diagnostic procedure 13.	HA-129
Sunload sensor circuit is shorted.		-	Go to Diagnostic procedure 14.	HA-130

When malfunction sensor circuit, ambient sensor, in vehicle sensor, and duct sensors are suspected, it is useful to check temperature detected by each sensor with self-diagnosis STEP 1 to confirm the temperature is with normal range before performing Diagnostic Procedures.

PRELIMINARY CHECK 8

Noise

Refer to page HA-61.

Engine compartment

Harness Layout for A/C System

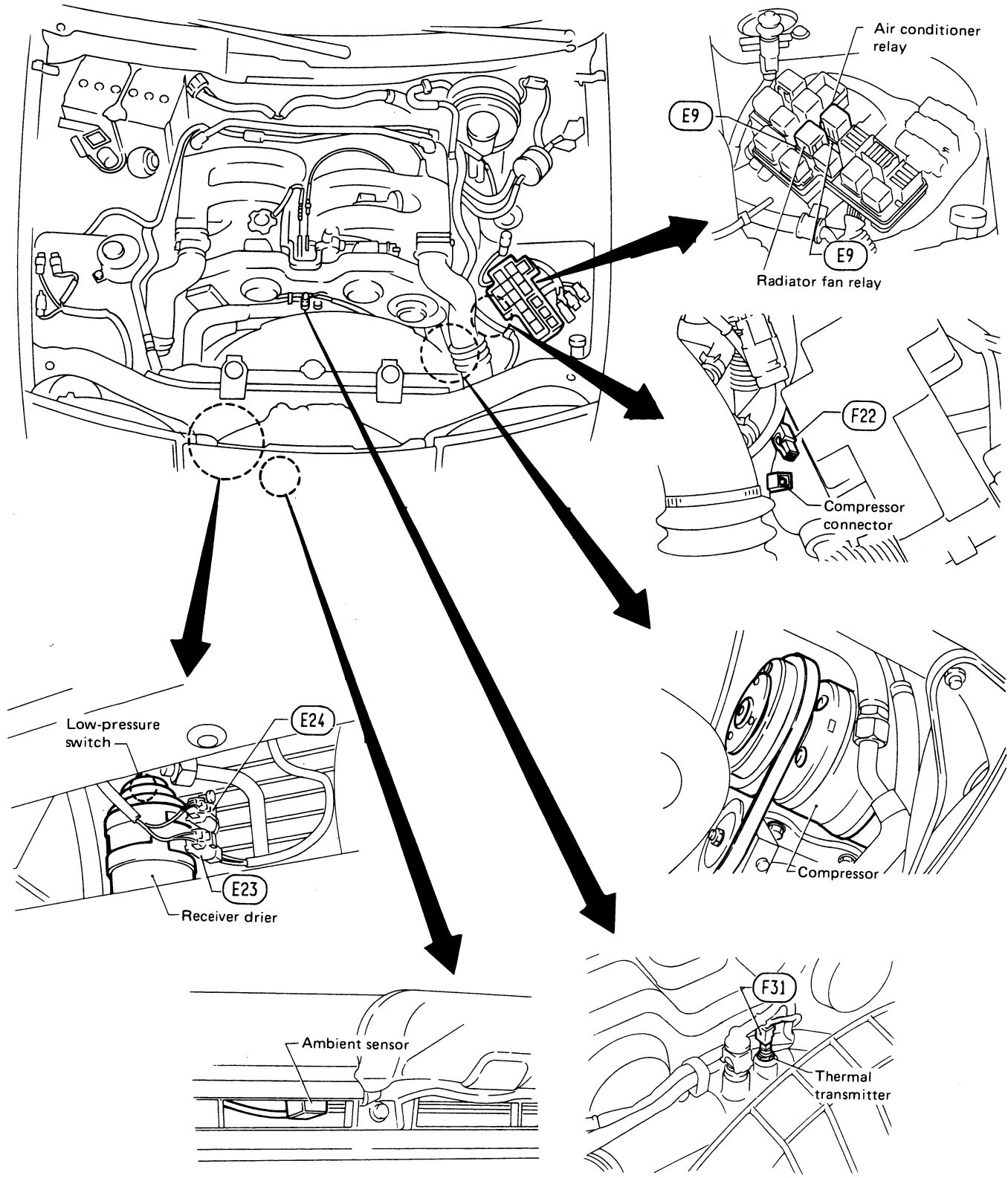

TROUBLE DIAGNOSES — Auto Air Conditioner

Harness Layout for A/C System (Cont'd)

Passenger compartment

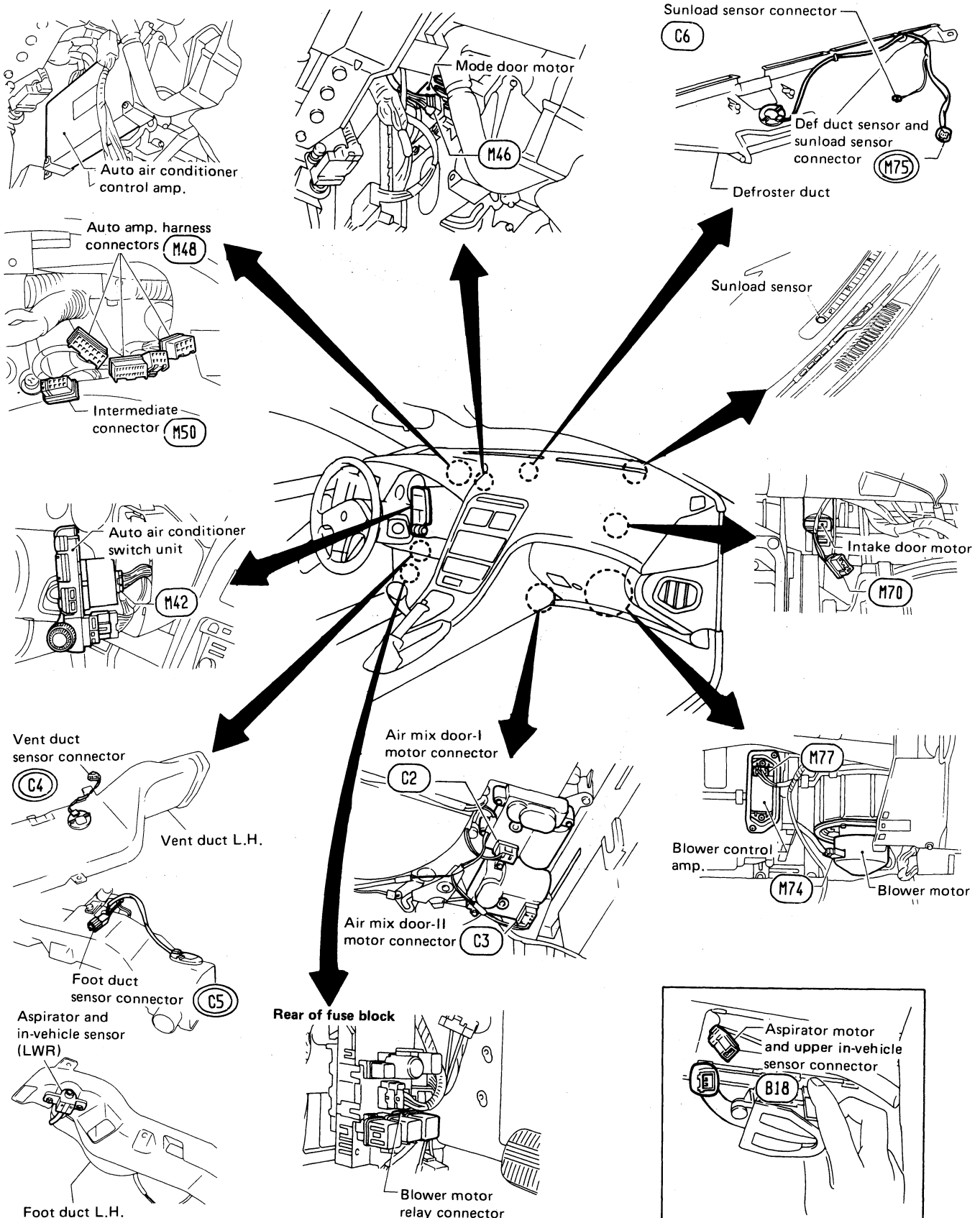

Circuit Diagram for Quick Pinpoint Check

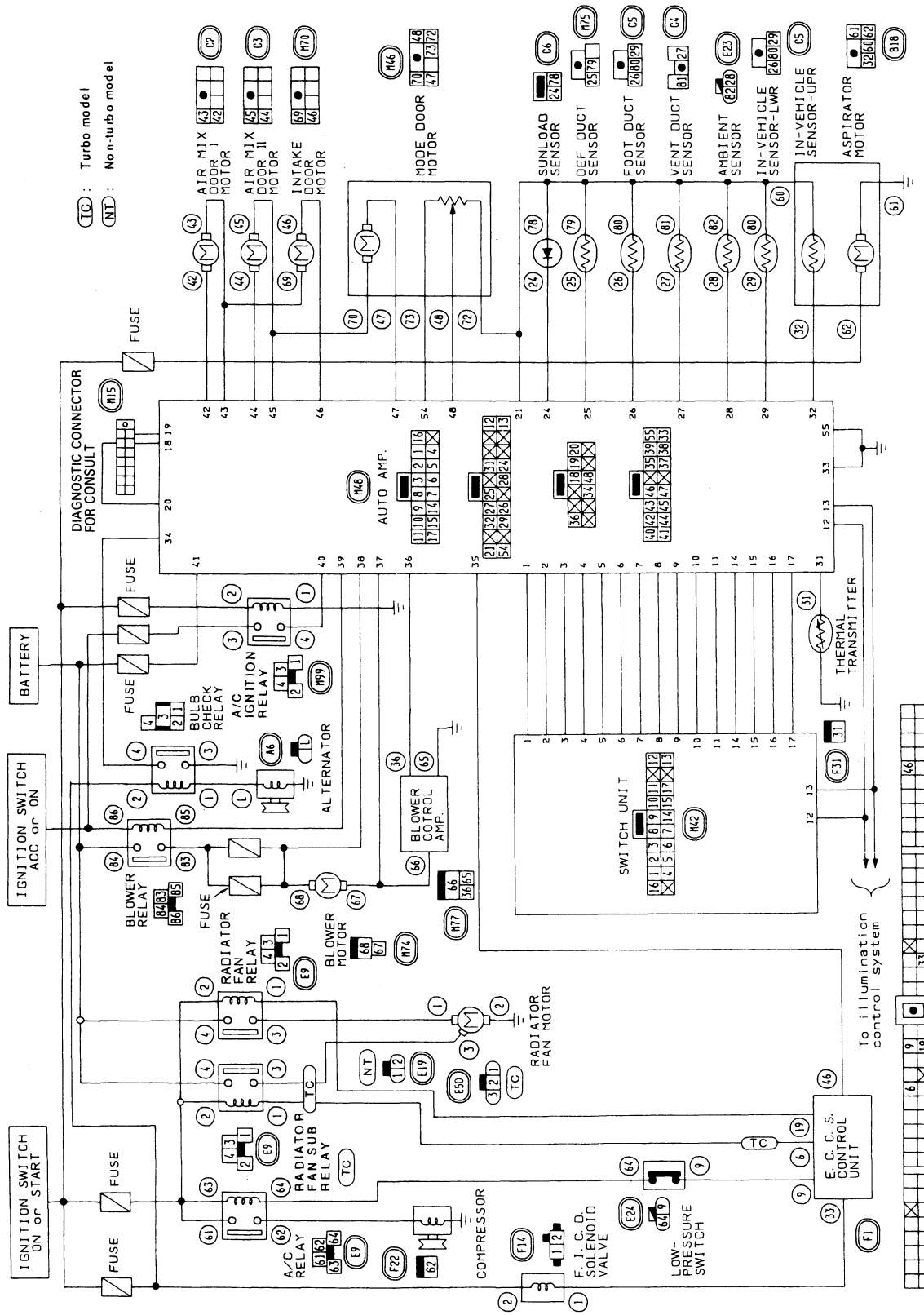

- All connectors shown in this illustration are unit side connectors.
- The unit side connectors with a double circle "⊖" are connected to the harness side connectors shown in the "Harness Layout for A/C System". (See pages HA-111 - HA-112.)
- The terminal numbers in the connector coincide with the circuit numbers surrounded by a single circle "○".

TROUBLE DIAGNOSES — Auto Air Conditioner

Wiring Diagram

(TC) : Turbo model
 (NT) : Non-turbo model

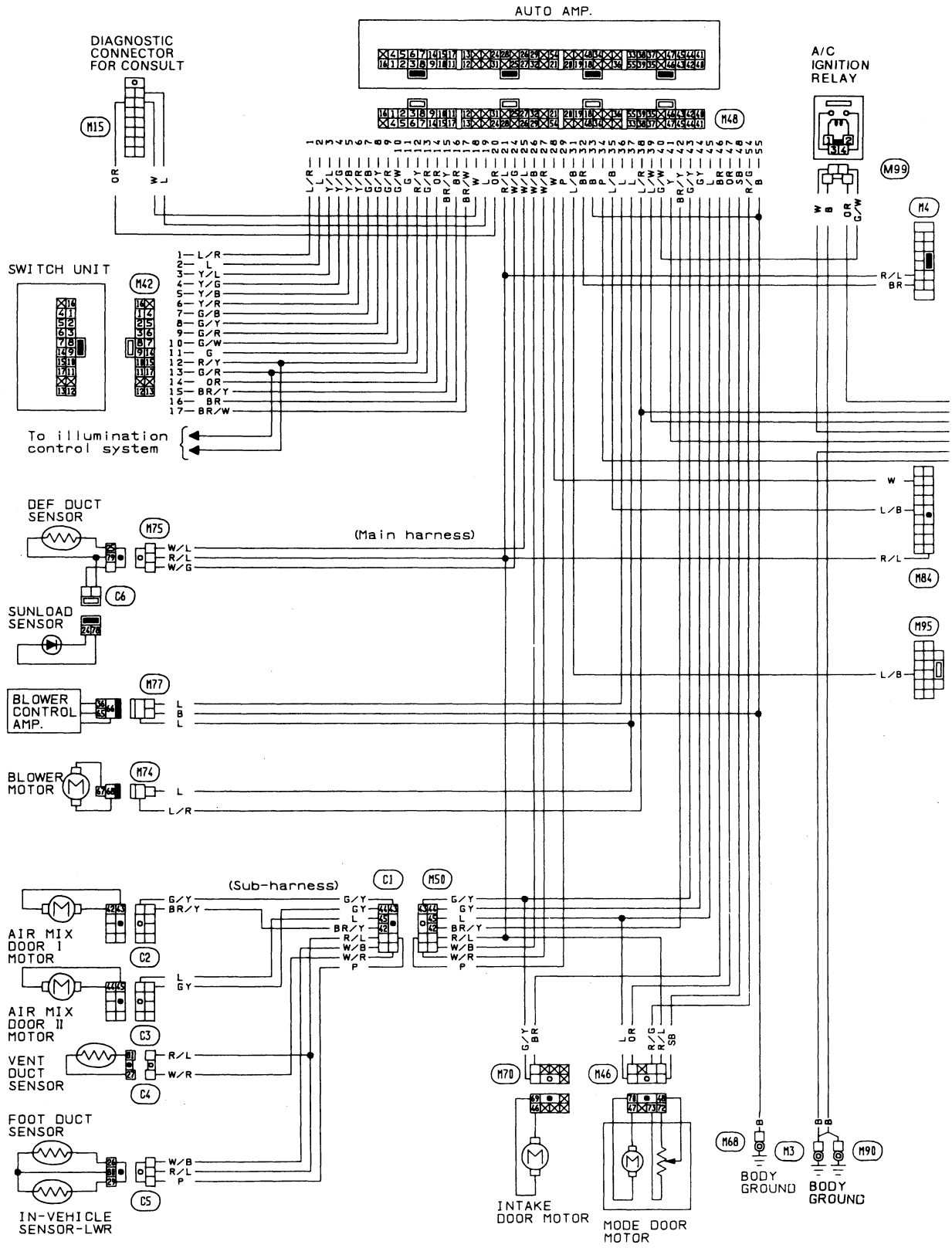

Main Power Supply and Ground Circuit Check POWER SUPPLY CIRCUIT CHECK FOR A/C SYSTEM

Check power supply circuit for air conditioning system.
Refer to "POWER SUPPLY ROUTING" in section EL and A/C ELECTRICAL CIRCUIT — Auto Air Conditioner.

AUTO AMP. REMOVAL

1. Remove driver side instrument lower lid.
2. Remove vent duct.
3. Remove auto amp. with harness connected.

AUTO AMP. CHECK

1. Disconnect auto amp. harness connectors.
2. Connect voltmeter from harness side.
3. Measure voltage across terminal No. ④⑩ or No. ④① and body ground.

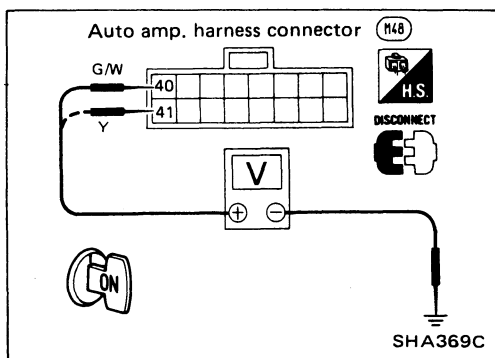

Voltmeter terminal		Voltage (Approx.)
⊕	⊖	
④⑩	Body ground	12V
④①		

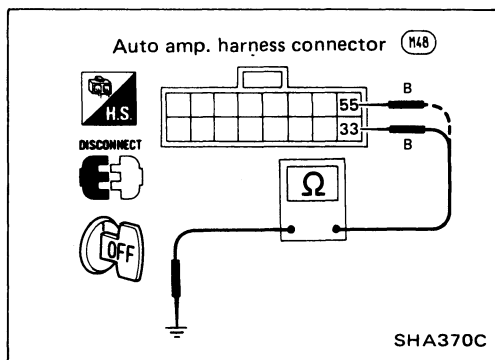

Check body ground circuit for control unit with ignition switch OFF

1. Disconnect auto amp. harness connector.
2. Connect ohmmeter from harness side.
3. Check continuity between terminal No. ③③ or ⑤⑤ and body ground.

TROUBLE DIAGNOSES — Auto Air Conditioner

Diagnostic Procedure 1

SYMPTOM: Self-diagnosis detects intermittent short or open circuit in each sensor circuit.

Check each connector connection as shown in the following table, and check each line's condition.

Malfunctioning circuit	Connector No. to be checked			
	Main harness	Engine room harness	Body harness	A/C sub-harness
Ambient sensor	(M48)	(E23) (E112)		
Upper in-vehicle sensor	(M4) (M48)		(B2) (B18)	
Lower in-vehicle sensor	(M48) (M50)			(C5) (C1)
DEF duct sensor	(M48) (M75)			
VENT duct sensor	(M48) (M50)			(C1) (C4)
Floor duct sensor	(M48) (M50)			(C5) (C1)
Sunload sensor	(M48) (M75)			(C6)

Diagnostic Procedure 2

SYMPTOM: Ambient sensor circuit is open. (CONSULT or self-diagnosis STEP 4 indicates this.)

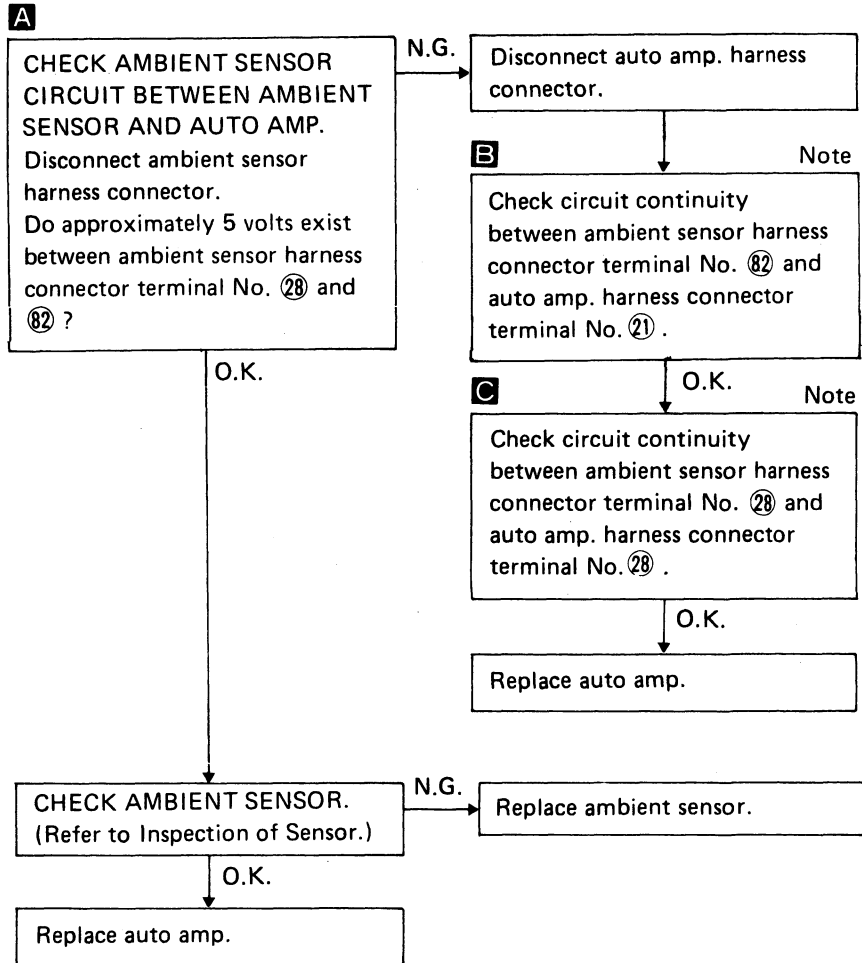
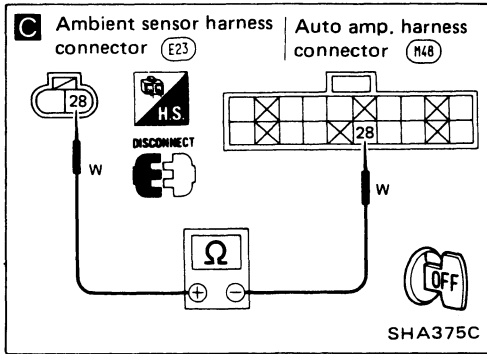
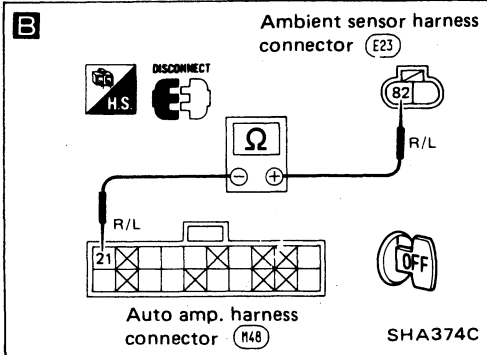
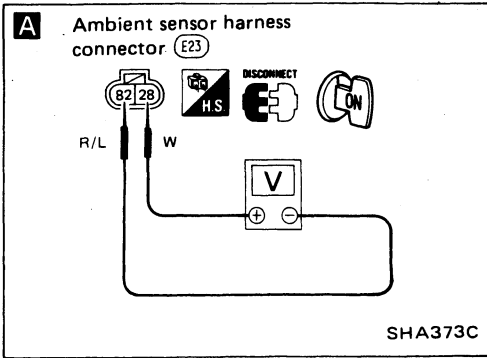

Note:
If the result is N.G. after checking circuit continuity, repair harness or connector.

Diagnostic Procedure 3

SYMPTOM: Ambient sensor circuit is shorted. (CONSULT or self-diagnosis STEP 4 indicates this.)

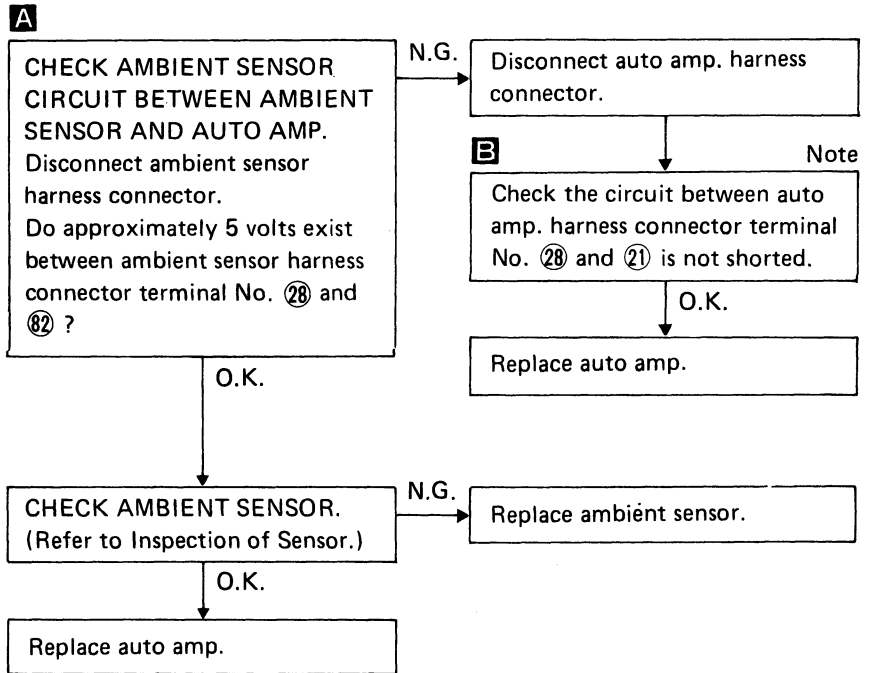
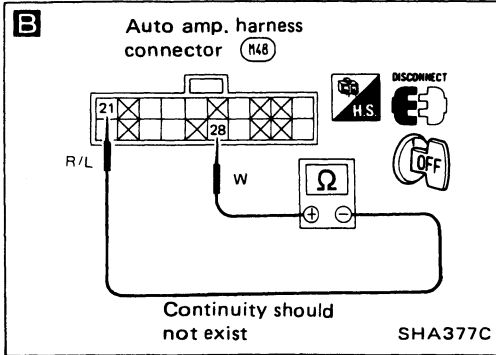
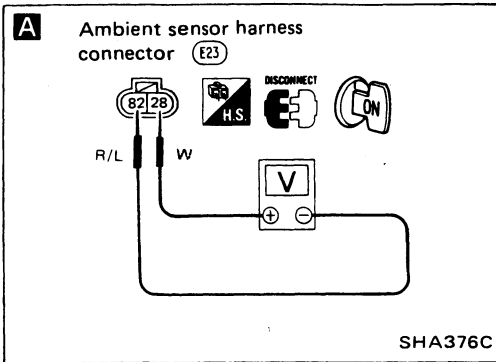

Note:

If the result is N.G. after checking insulation of each terminal, repair harness or connector.

Diagnostic Procedure 4

SYMPTOM: Upper in-vehicle sensor circuit is open. (CONSULT or self-diagnosis STEP 4 indicates this.)

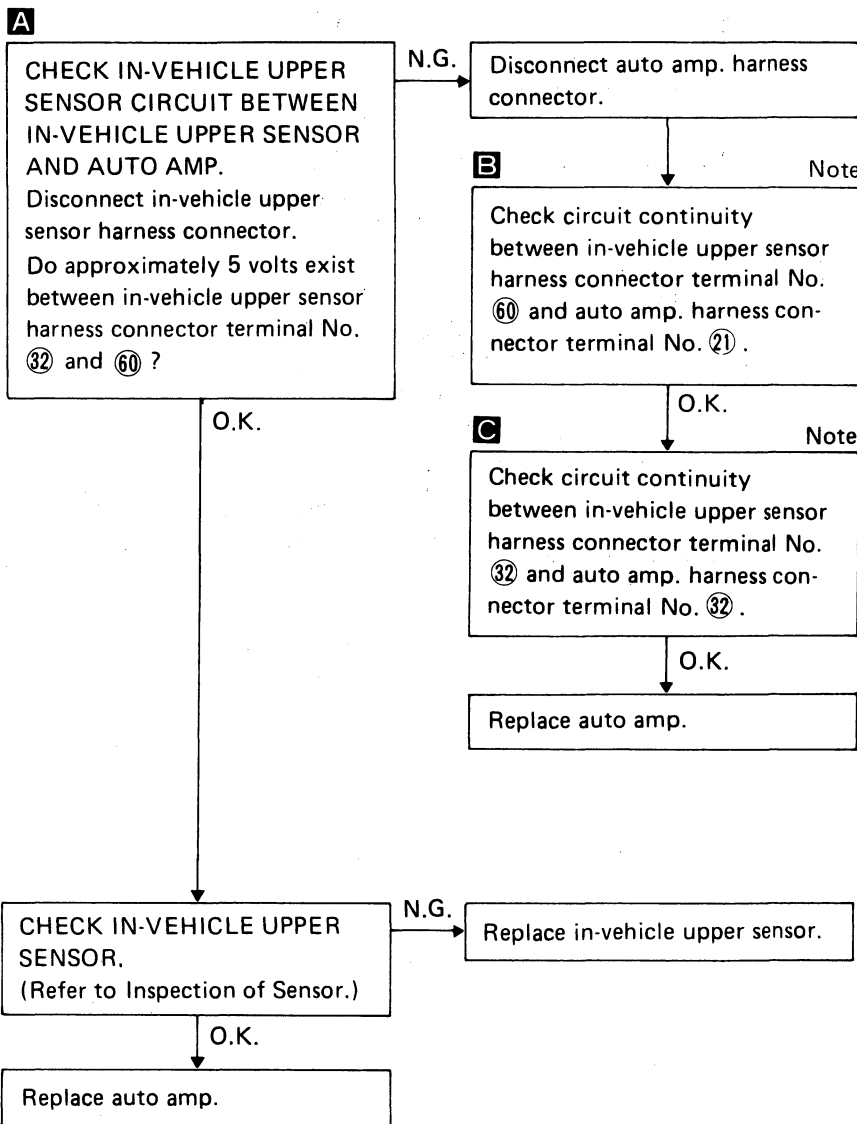
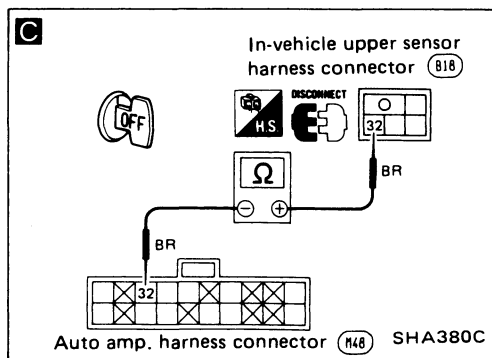
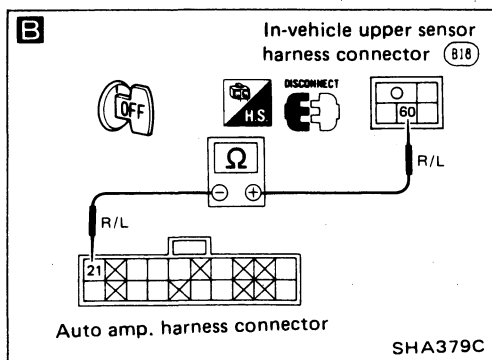
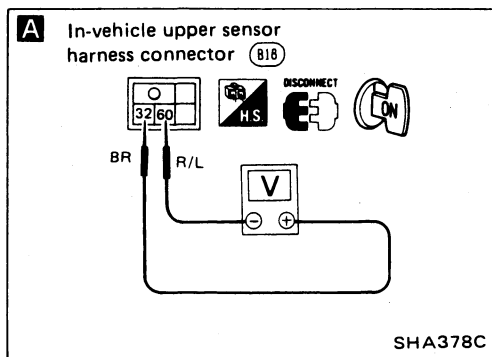

Note:

If the result is N.G. after checking circuit continuity, repair harness or connector.

Diagnostic Procedure 5

SYMPTOM: Upper in-vehicle sensor circuit is shorted. (CONSULT or self-diagnosis STEP 4 indicates this.)

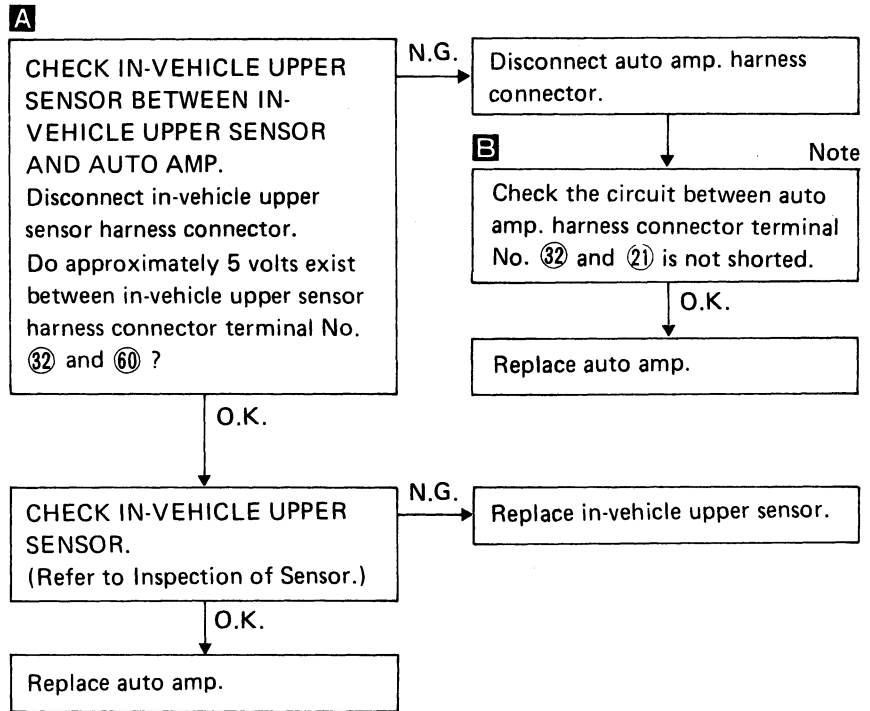
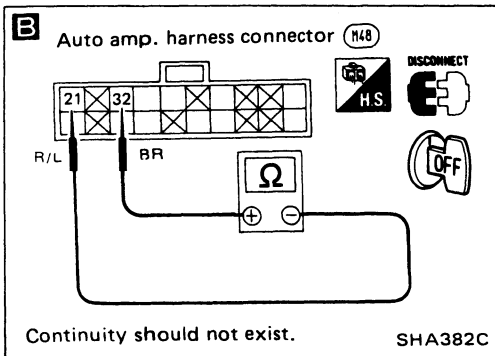
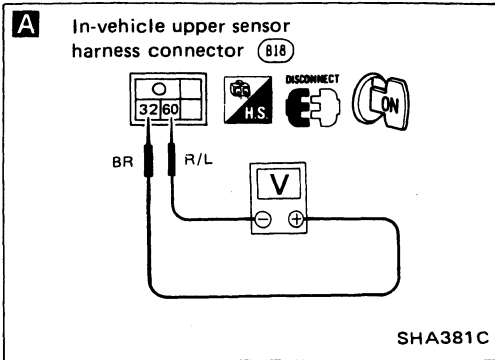

Note:

If the result is N.G. after checking insulation of each terminal, repair harness or connector.

Diagnostic Procedure 6

SYMPTOM: Lower in-vehicle sensor circuit is open. (CONSULT or self-diagnosis STEP 4 indicates this.)

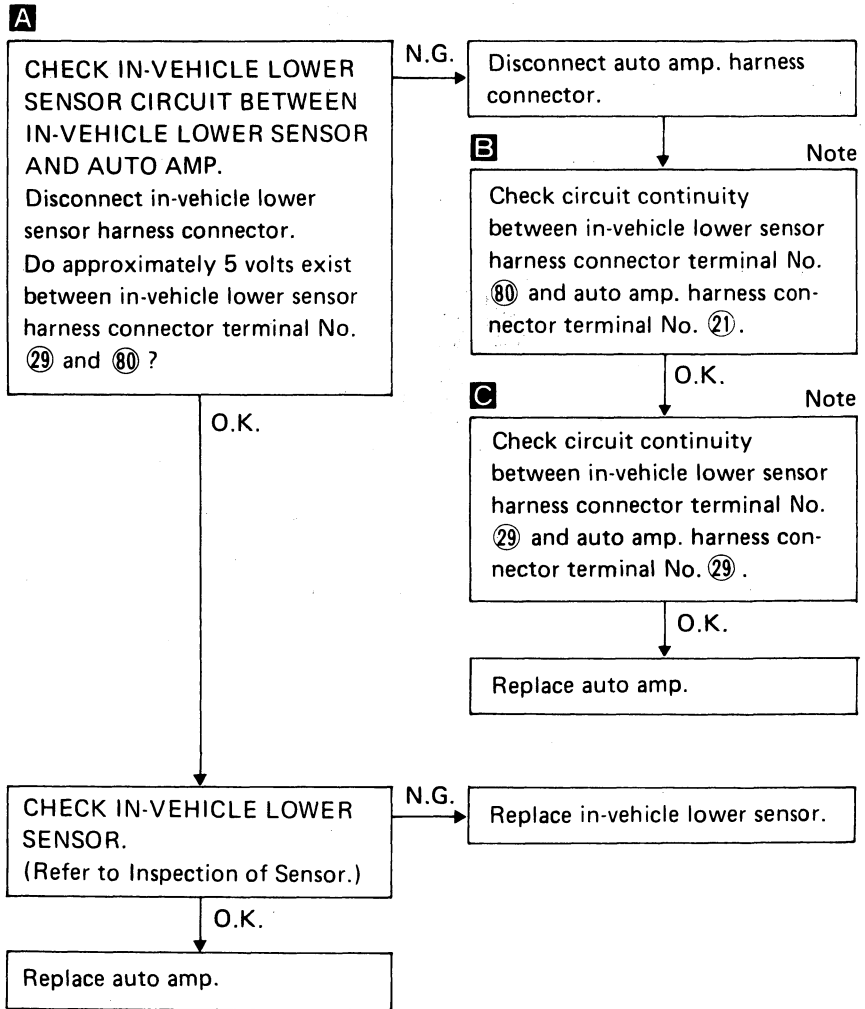
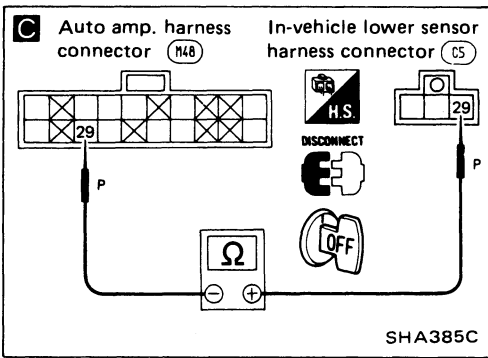
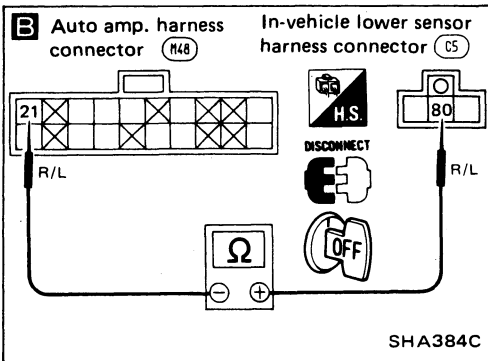
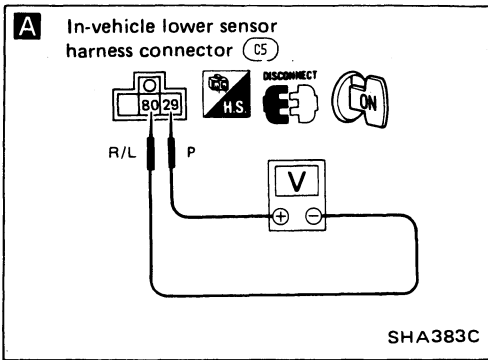

Note:

If the result is N.G. after checking circuit continuity, repair harness or connector.

Diagnostic Procedure 7

SYMPTOM: Lower in-vehicle sensor circuit is shorted. (CONSULT or self-diagnosis STEP 4 indicates this.)

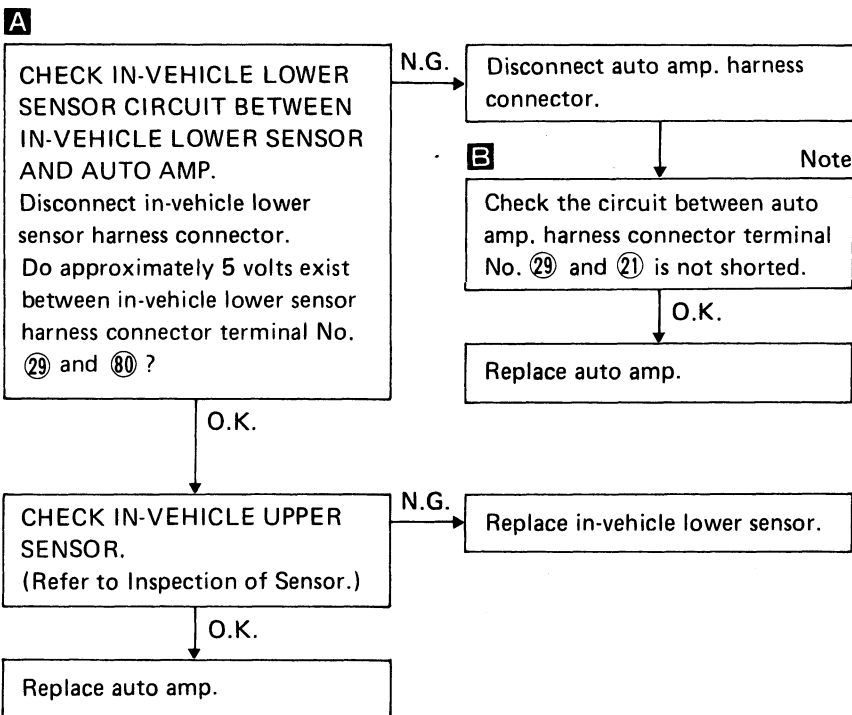
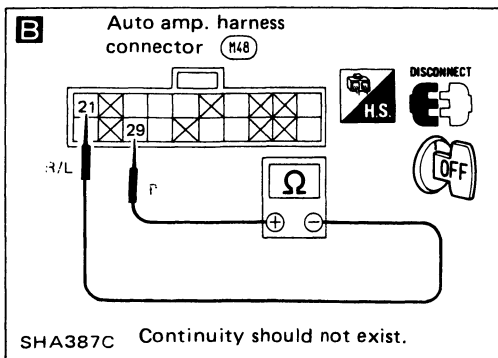
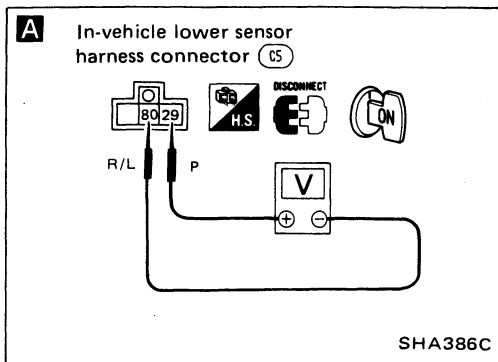

Note:

If the result is N.G. after checking insulation of each terminal, repair harness or connector.

Diagnostic Procedure 8

SYMPTOM: Def. duct sensor circuit is open. (CONSULT or self-diagnosis STEP 4 indicates this.)

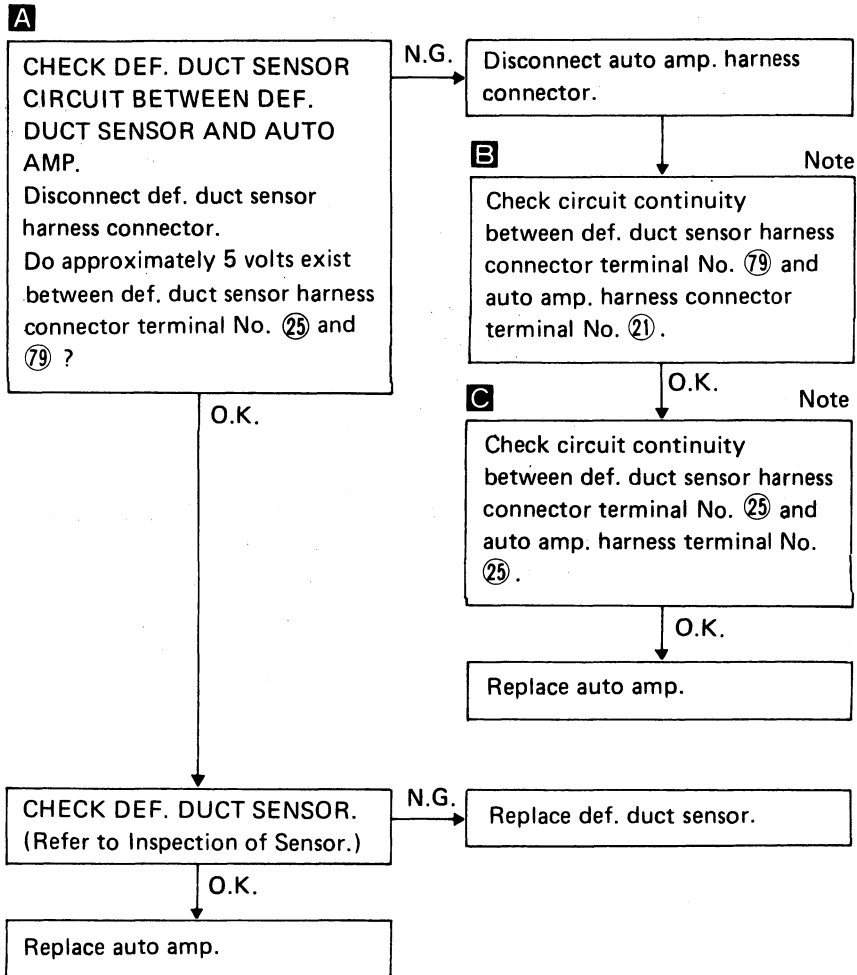
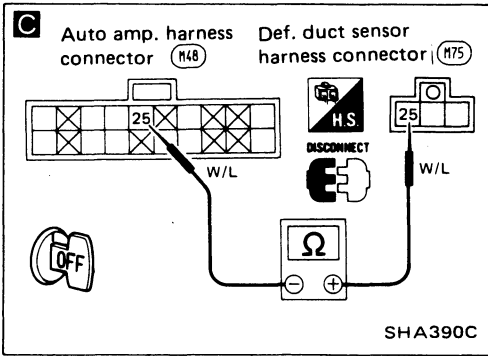
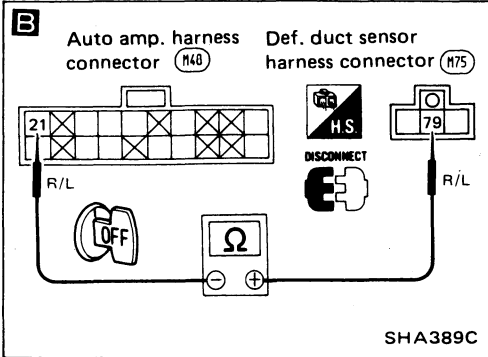
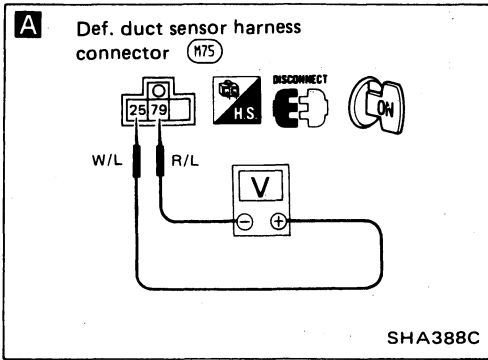

Note:

If the result is N.G. after checking circuit continuity, repair harness or connector.

Diagnostic Procedure 9

SYMPTOM: Def. duct sensor circuit is shorted. (CONSULT or self-diagnosis STEP 4 indicates this.)

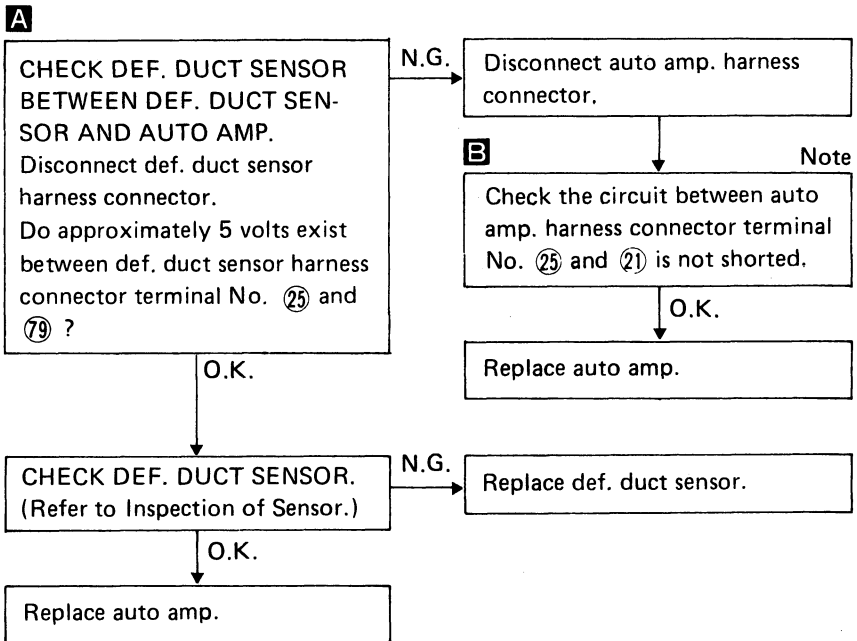
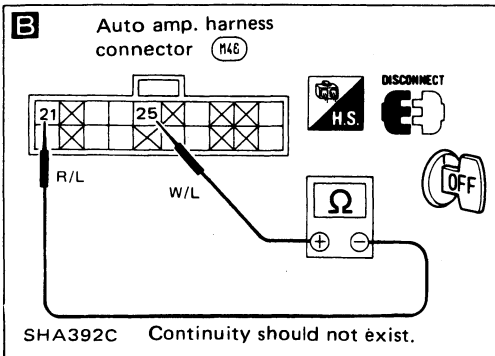
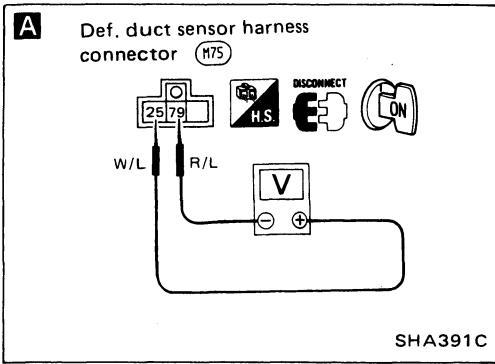

Note:

If the result is N.G. after checking insulation of each terminal, repair harness or connector.

Diagnostic Procedure 10

SYMPTOM: Vent duct sensor circuit is open. (CONSULT or self-diagnosis STEP 4 indicates this.)

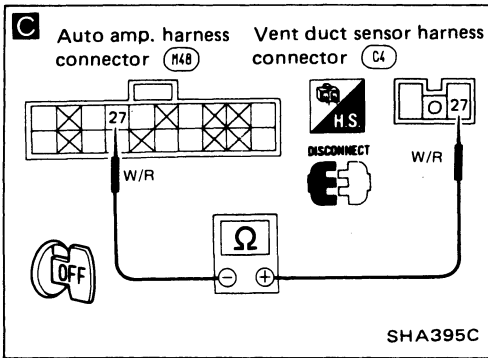
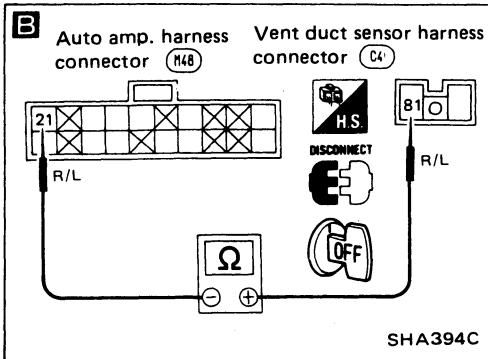
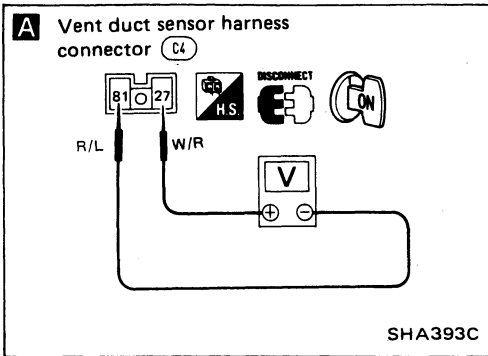

A

CHECK VENT DUCT SENSOR CIRCUIT BETWEEN VENT DUCT SENSOR AND AUTO AMP.
Disconnect vent duct sensor harness connector.
Do approximately 5 volts exist between vent duct sensor harness connector terminal No. ②⑦ and ⑧① ?

N.G. → Disconnect auto amp. harness connector.

O.K. → **CHECK VENT DUCT SENSOR.** (Refer to Inspection of Sensor.)

N.G. → Replace def. duct sensor.

O.K. → Replace auto amp.

B Note

Check circuit continuity between vent duct sensor harness connector terminal No. ⑧① and auto amp. harness connector terminal No. ②① .

O.K. → **C** Note

Check circuit continuity between vent duct sensor harness connector terminal No. ②⑦ and auto amp. harness connector terminal No. ②⑦ .

O.K. → Replace auto amp.

Note:

If the result is N.G. after checking circuit continuity, repair harness or connector.

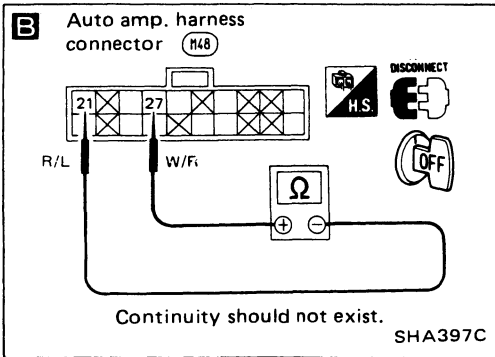
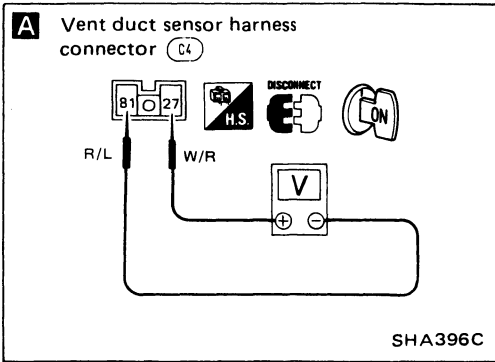

Diagnostic Procedure 11

SYMPTOM: Vent duct sensor circuit is shorted. (CONSULT or self-diagnosis STEP 4 indicates this.)

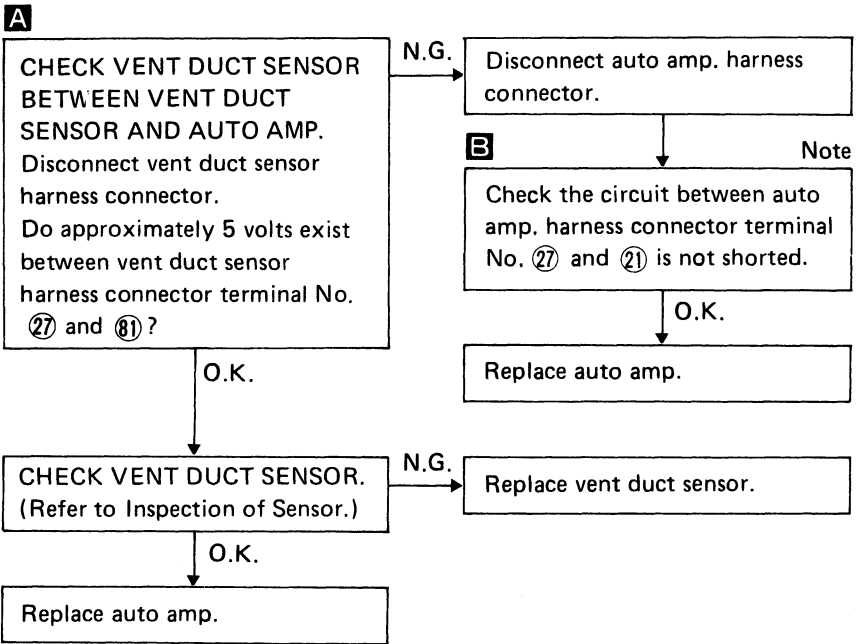

Note:

If the result is N.G. after checking insulation of each terminal, repair harness or connector.

Diagnostic Procedure 12

SYMPTOM: Floor duct sensor circuit is open. (CONSULT or self-diagnosis STEP 4 indicates this.)

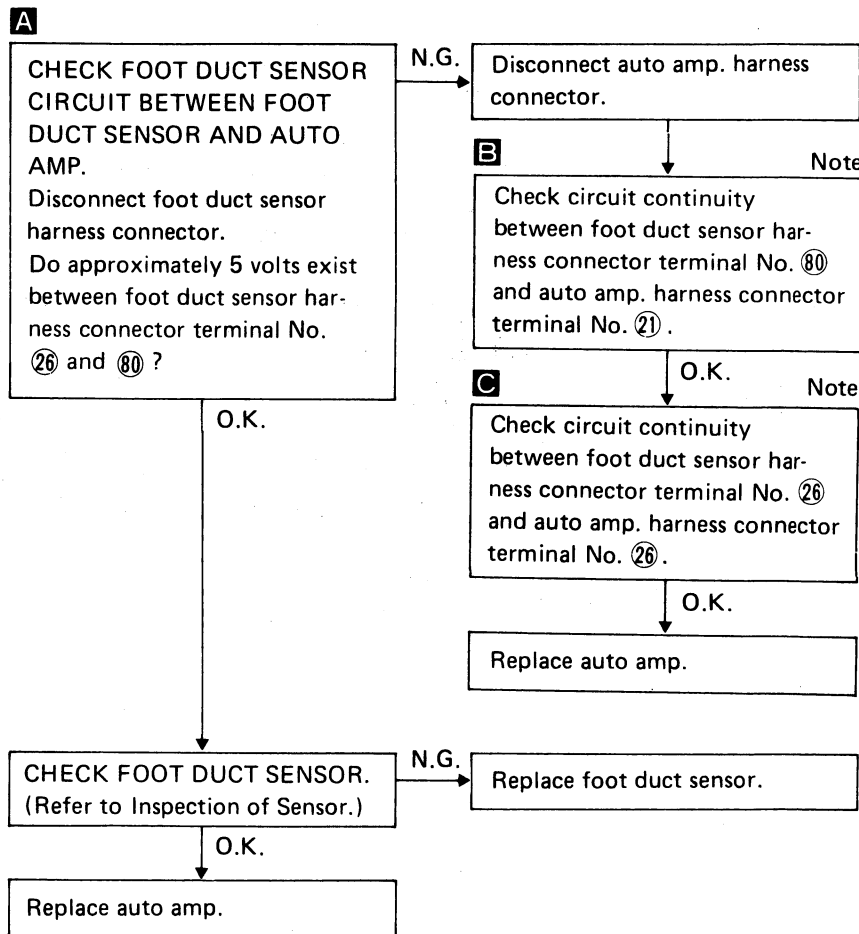
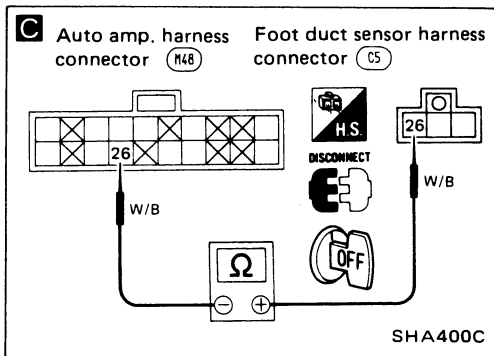
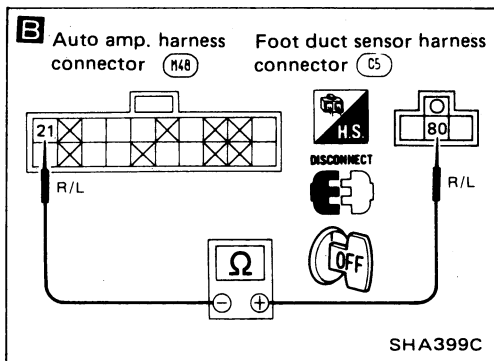
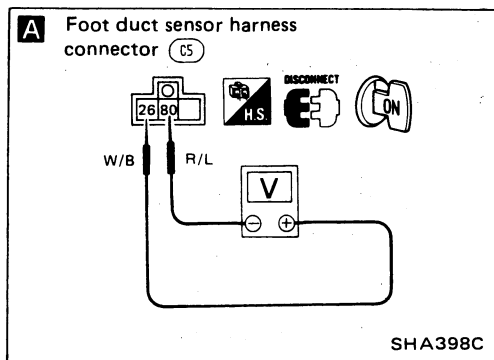

Note:

If the result is N.G. after checking circuit continuity, repair harness or connector.

Diagnostic Procedure 13

SYMPTOM: Floor duct sensor circuit is shorted. (CONSULT or self-diagnosis STEP 4 indicates this.)

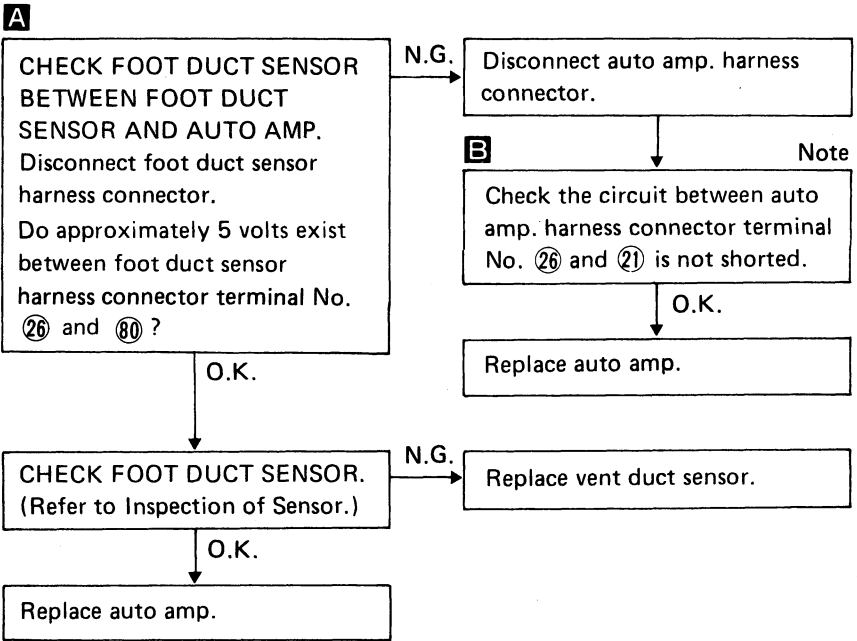
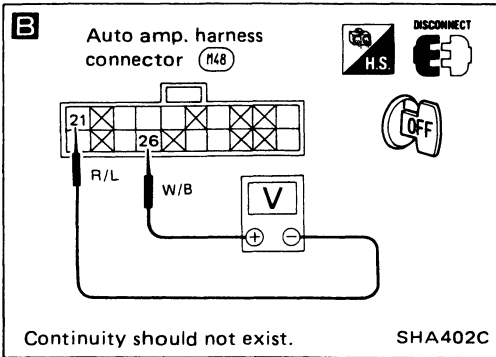
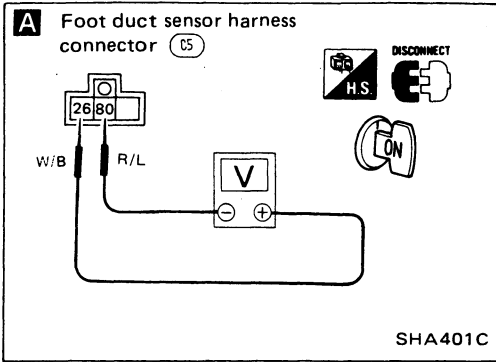

Note:

If the result is N.G. after checking insulation of each terminal, repair harness or connector.

Diagnostic Procedure 14

SYMPTOM: Sunload sensor circuit is shorted. (CONSULT or self-diagnosis STEP 4 indicates this.)

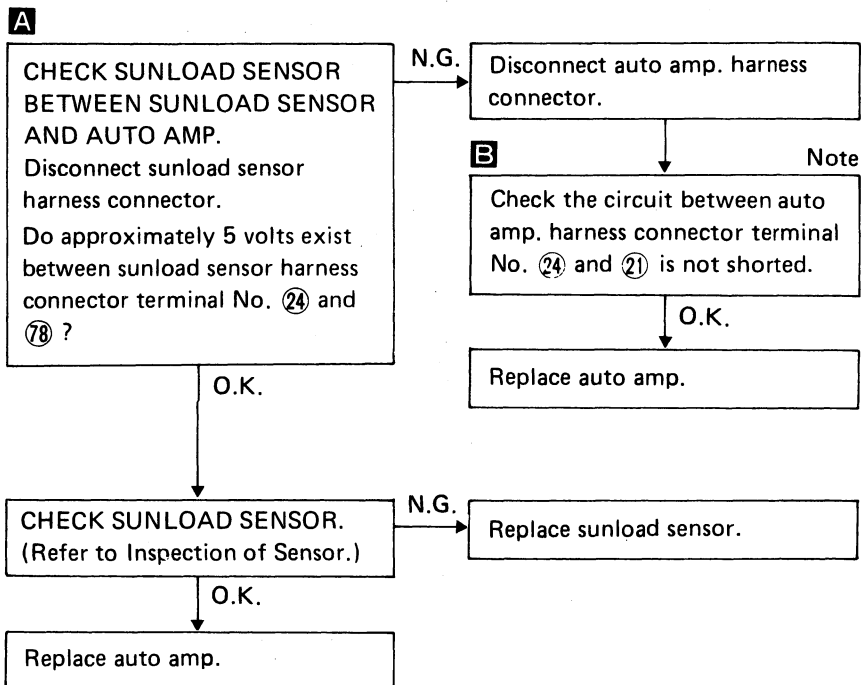
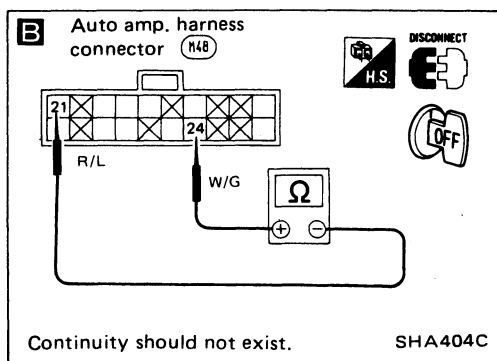
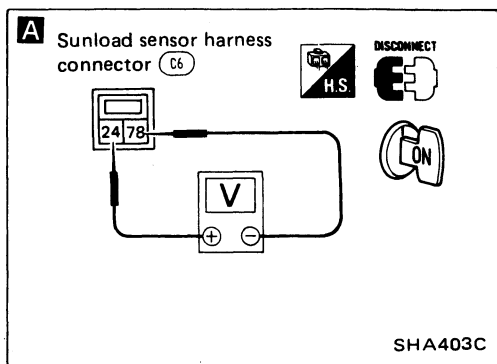

Note:

If the result is N.G. after checking insulation of each terminal, repair harness or connector.

Diagnostic Procedure 15

SYMPTOM: Air mix door does not operate normally.

- Read out self-diagnosis result with CONSULT or perform self-diagnosis STEP 4 before referring to the following flow chart.
- Remove combination meter assembly to make working space and reconnect air conditioner switch connector.

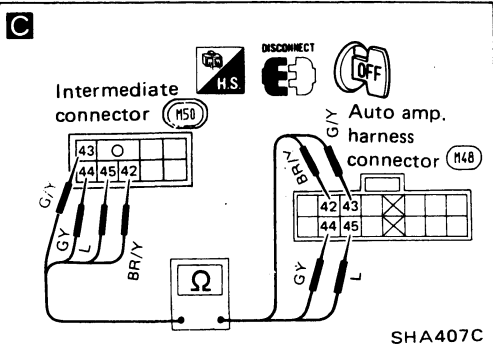
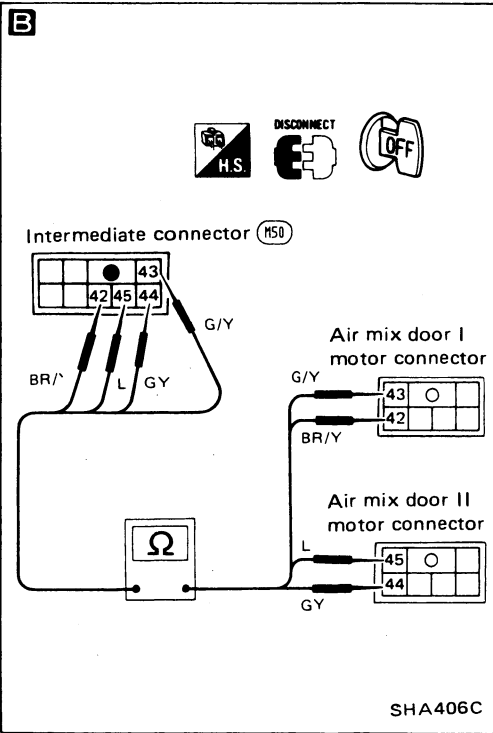
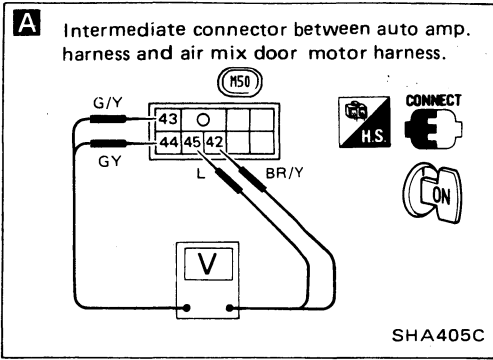

A CHECK FOR SIGNALS TO AIR MIX DOOR MOTOR.

Set up "ACTIVE TEST" mode with CONSULT.
 Set up self-diagnosis STEP 2.

Set air mix door position as shown in the following chart. Check if approximately 10V exists for 3 seconds every 10 seconds between each terminal.*

Air mix door position	Code No.	Terminal No.			
		Air mix door I		Air mix door II	
		+	-	+	-
Full-Hot		43	42	45	44
Full-Cool		42	43	44	45

O.K. → * : After two minutes power supply is automatically cut off.

N.G. →

C Check circuit continuity between auto amp. harness connector terminals and intermediate connector terminals.

Inter-mediate connector	Auto amp. connector	Continuity
42	42	Yes
43	43	Yes
44	44	Yes
45	45	Yes

O.K. → Replace auto amp.
N.G. → Repair harness or connector.

O.K. →

B Check continuity between intermediate connector terminal and each air mix door motor harness connector terminal.

Inter-mediate connector	Air mix door I motor connector	Continuity
42	42	Yes
43	43	Yes

Inter-mediate connector	Air mix door II motor connector	Continuity
44	44	Yes
45	45	Yes

O.K. → Replace air mix door motor.
N.G. → Repair harness or connector.

Diagnostic Procedure 16

SYMPTOM: Intake door does not operate normally.

- Read out self-diagnosis result with CONSULT or perform self-diagnosis STEP 4 before referring to the following flow chart.

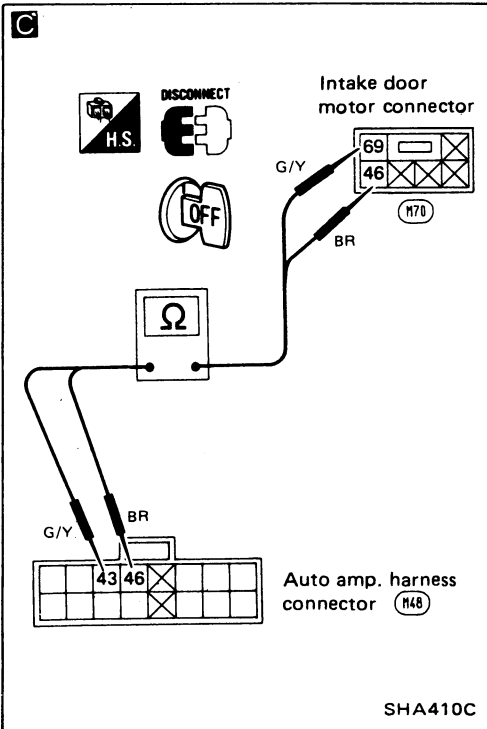
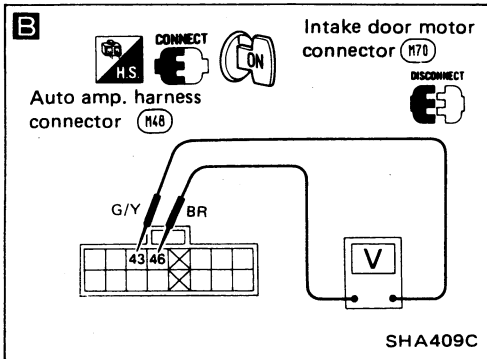
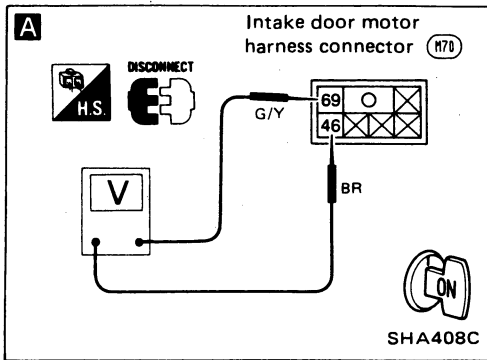

A

CHECK FOR SIGNALS TO INTAKE DOOR MOTOR.
Disconnect intake door motor harness connector.

- Set up "ACTIVE TEST" mode with CONSULT.
- Set up self-diagnosis STEP 2.

Set intake door position as shown in the following chart. Check if approximately 10V exists for 2.5 seconds between each terminal.

Intake door position	Code No.	Terminal No.	
		+	-
FRE/REC → REC		46	69
REC → FRE		69	46

O.K. → Replace intake door motor.

B

CHECK OUTPUT OF AUTO AMP.

- Set up "ACTIVE TEST" mode with CONSULT.
- Set up self-diagnosis STEP 2.

Set intake door position as shown in the following chart. Check if approximately 10V exists for 2.5 seconds between each terminal.

Intake door position	Code No.	Terminal No.	
		+	-
FRE/REC → REC		46	43
REC → FRE		43	46

O.K. → [Flow to C]
N.G. → Replace auto amp.

C

Check continuity between auto amp. harness connector terminal No. 46 and intake door motor harness connector terminal No. 46.

Check auto amp. harness connector terminal No. 43 and intake door motor harness connector terminal No. 69.

N.G. → Repair harness or connector.

Diagnostic Procedure 17

SYMPTOM: Mode door does not operate normally.

- Read out self-diagnosis result with CONSULT or perform self-diagnosis STEP 4 before referring to the following flow chart.

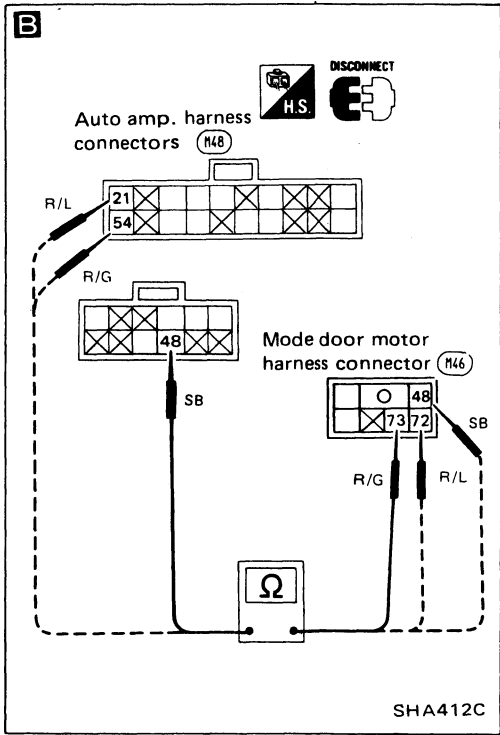
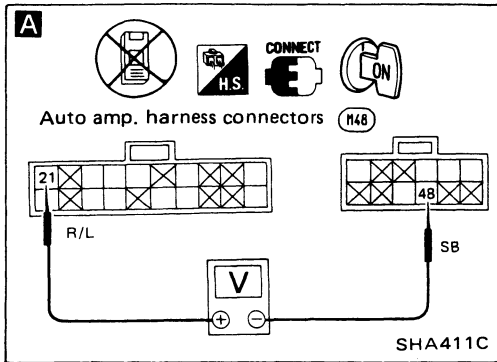

A

CHECK P.B.R. CIRCUIT

- Set up "ACTIVE TEST" mode with CONSULT.
- Set up self-diagnosis STEP 2.

Set mode door motor as shown in the following chart.

- Check P.B.R. voltage with data monitor function in "ACTIVE TEST" mode.

Mode door position	P.B.R. voltage (approx.)
DEF	4.8V
FOOT/DEF	2.5V
B/L	1.1V
VENT	0V

- Check if voltage between auto amp. harness connector terminals ④⑧ and ②① varies from approximately 5V to approximately 0V according to mode door position varies.

Code No.	Voltage	
	④⑧ (-)	②① (+)
⚡	4.8V	
⚡	2.5V	
⚡	1.1V	
⚡	0V	

N.G. → **CHECK MODE DOOR MOTOR.**
Refer to Electrical Components Inspection.

O.K. → []
N.G. → **Replace mode door motor.**

B

CHECK HARNESS BETWEEN AUTO AMP. AND MODE DOOR MOTOR.

Auto amp. harness connector terminal	Mode door motor harness connector terminal	Continuity
②①	④⑧	No
	⑦②	Yes
	⑦③	No
④⑧	④⑧	Yes
	⑦②	No
	⑦③	No
⑤④	④⑧	No
	⑦②	No
	⑦③	Yes

O.K. → []
N.G. → **Repair harness or connector.**

O.K. → **Go to diagnostic procedure 18.**

Diagnostic Procedure 18

SYMPTOM: Mode door does not move at all.

- Read out self-diagnosis result with CONSULT or perform self-diagnosis STEP 4 before referring to the following flow chart.

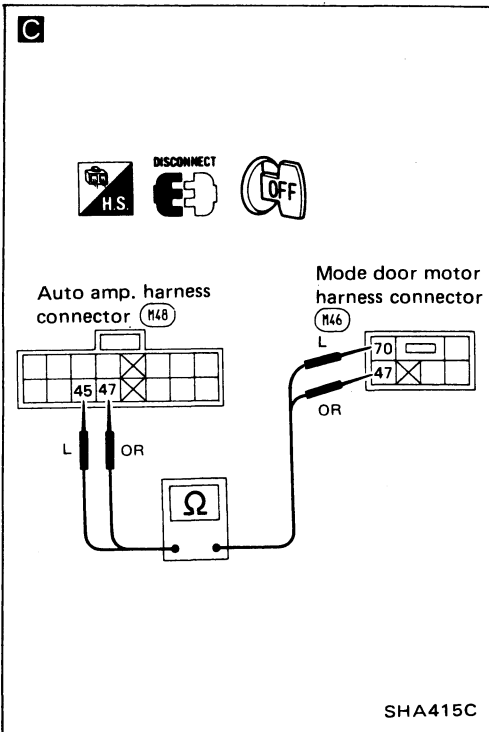
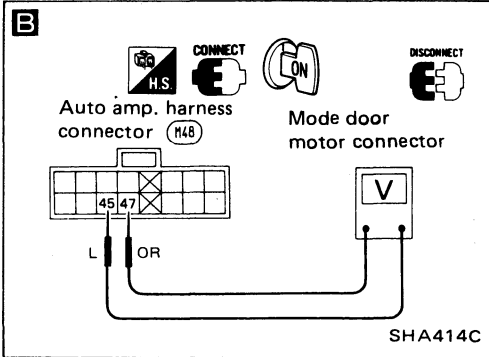
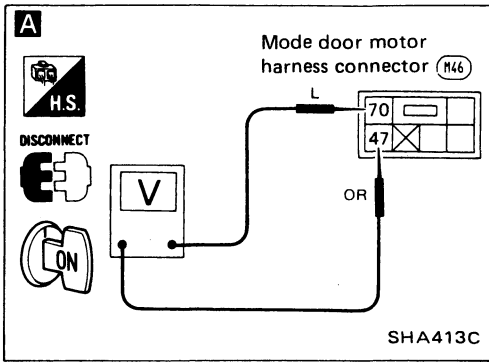

A

CHECK FOR SIGNALS TO MODE DOOR MOTOR.

- Set up "ACTIVE TEST" mode with CONSULT.
- Set up self-diagnosis STEP 2.

Set mode door position as shown in the following chart. Check if approximately 10V exists between mode door motor harness connector terminals 47 and 70 for approximately 1.3 second every 10 seconds.

Mode door position	Code No.	Terminal No.	
		+	-
DEF	↗	70	47
VENT	↘	47	70

O.K. → Replace mode door motor.

B

CHECK OUTPUT OF AUTO AMP.

- Set up "ACTIVE TEST" mode with CONSULT.
- Set up self-diagnosis STEP 2.

Set mode door position as shown in the following chart. Check if approximately 10V exists between mode door motor harness connector terminals 47 and 45 for approximately 1.3 second every 10 seconds.

Mode door position	Code No.	Terminal No.	
		+	-
DEF	↗	45	47
VENT	↘	47	45

O.K. → []

N.G. → Replace auto amp.

C

Check continuity between auto amp. harness connector terminal No. 47, 45 and mode door motor harness connector terminal No. 47, 70 respectively.

O.K. → []

N.G. → Repair harness or connector.

INSPECTION END

Diagnostic Procedure 19

SYMPTOM: Magnet clutch does not engage.

- Perform Preliminary check 6 before referring to the following flow chart.

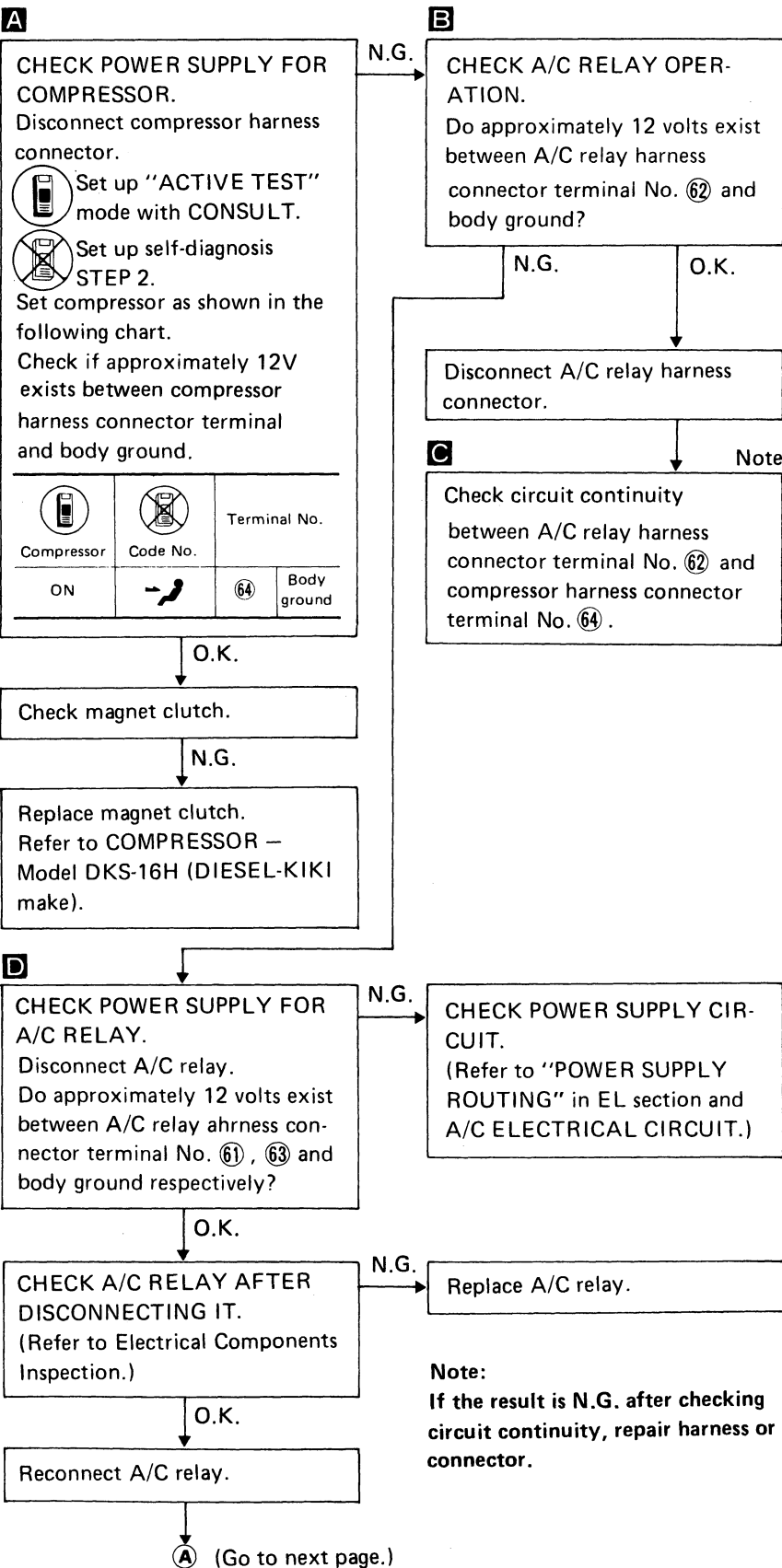
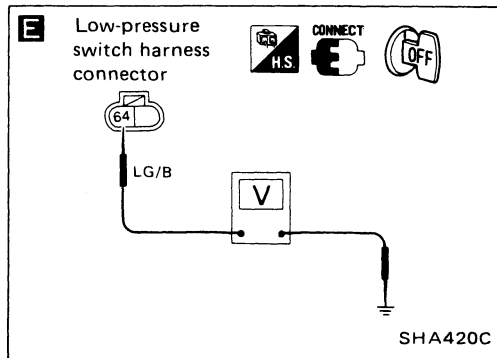
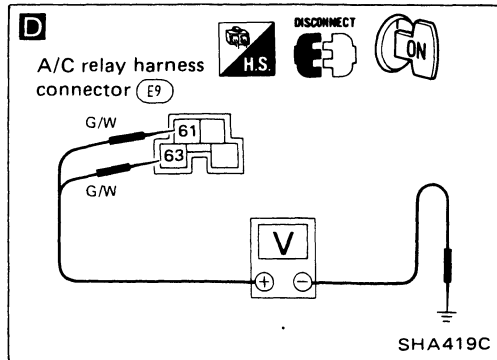
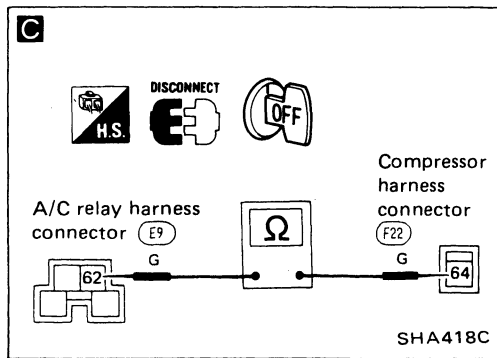
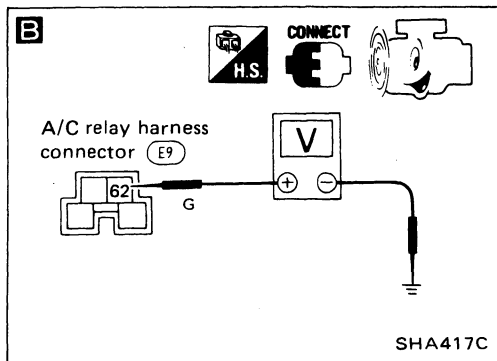
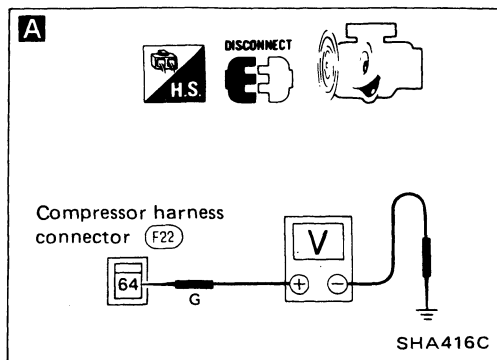

Note:
If the result is N.G. after checking circuit continuity, repair harness or connector.

TROUBLE DIAGNOSES — Auto Air Conditioner

Diagnostic Procedure 19 (Cont'd)

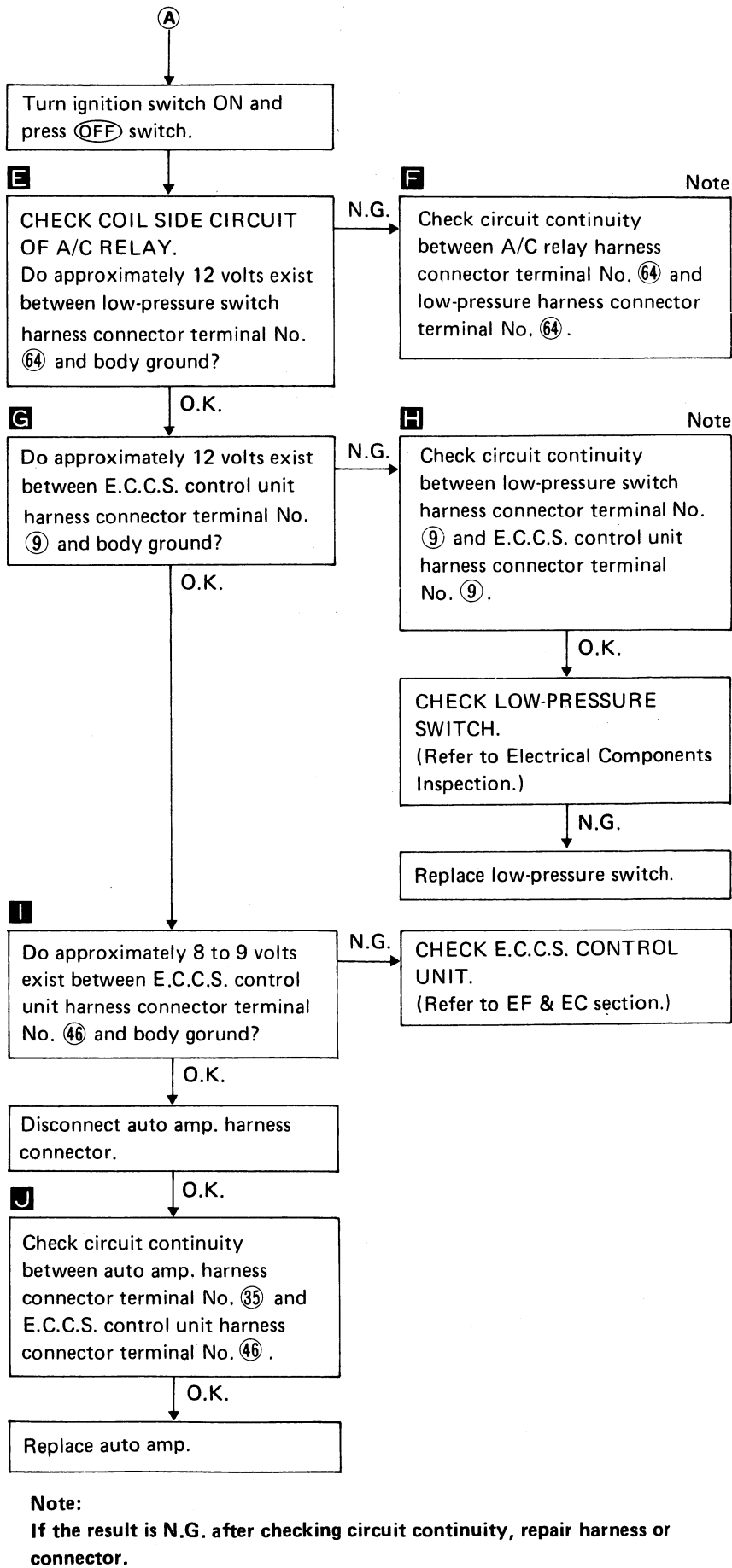
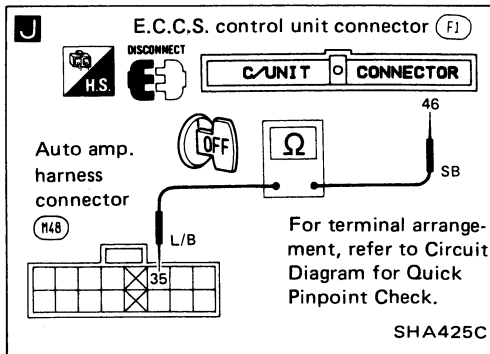
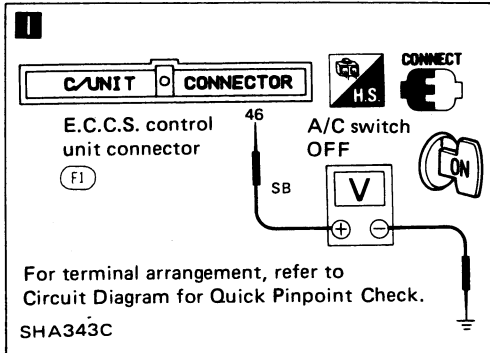
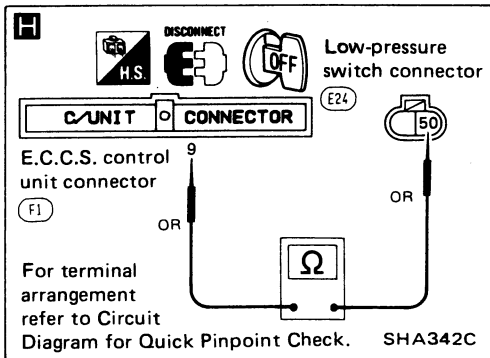
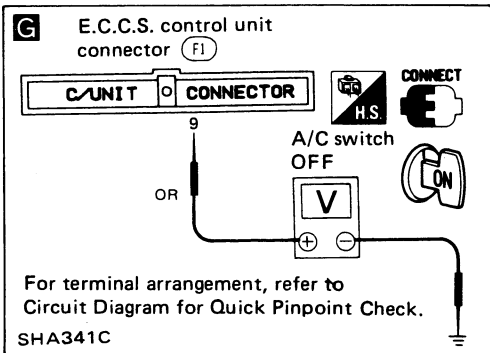
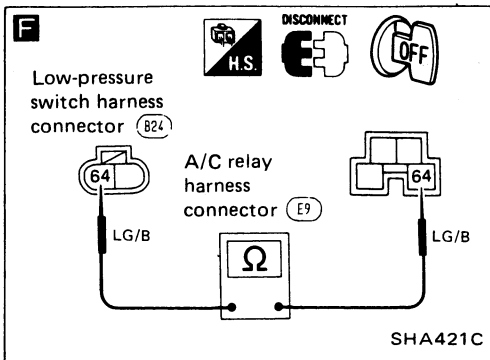

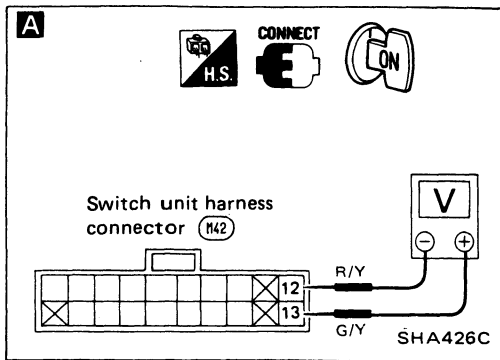

Diagnostic Procedure 20

SYMPTOM: Air conditioner control switch panel illumination does not come on.

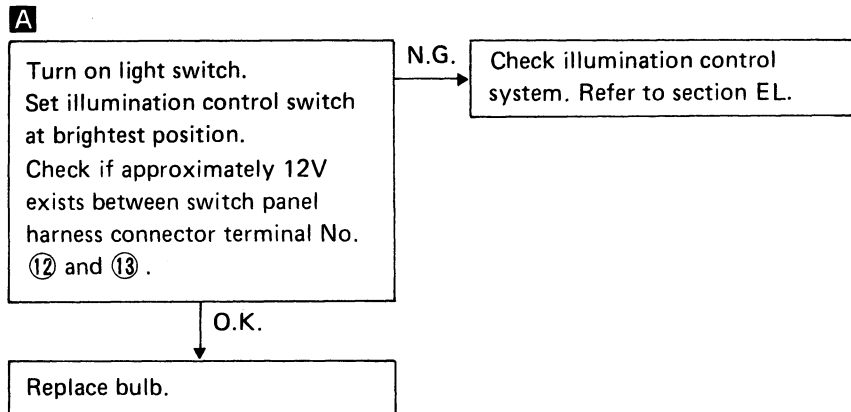

Diagnostic Procedure 21

SYMPTOM: Set temperature and mode display do not appear on display window.

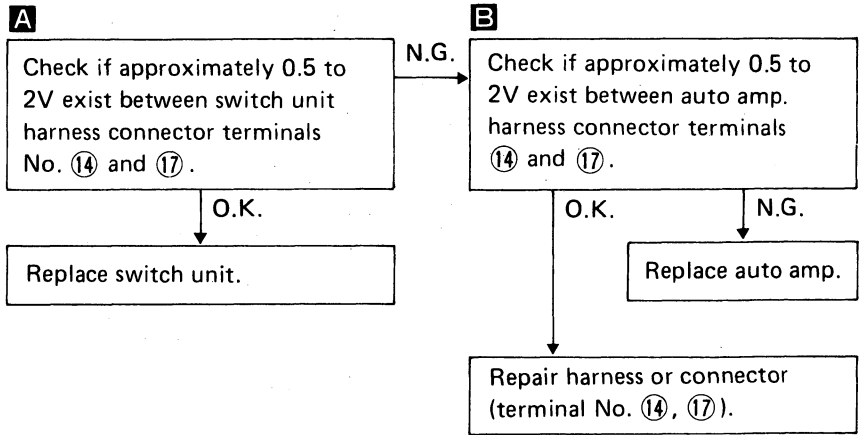
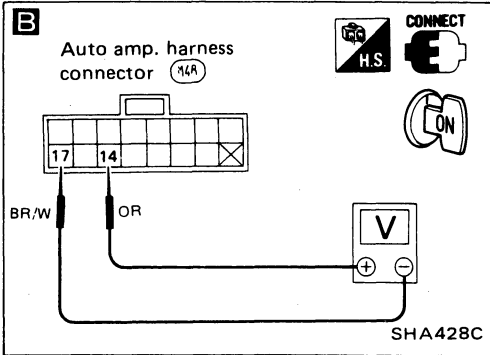
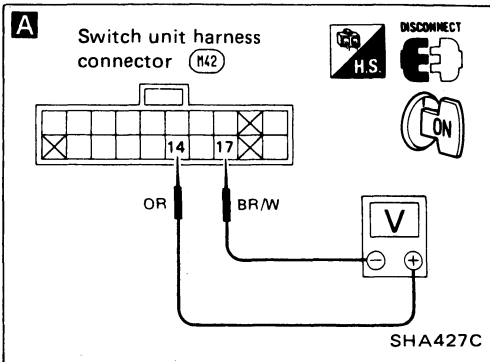

Diagnostic Procedure 22

SYMPTOM: When air conditioner switch is operated it does not beep.

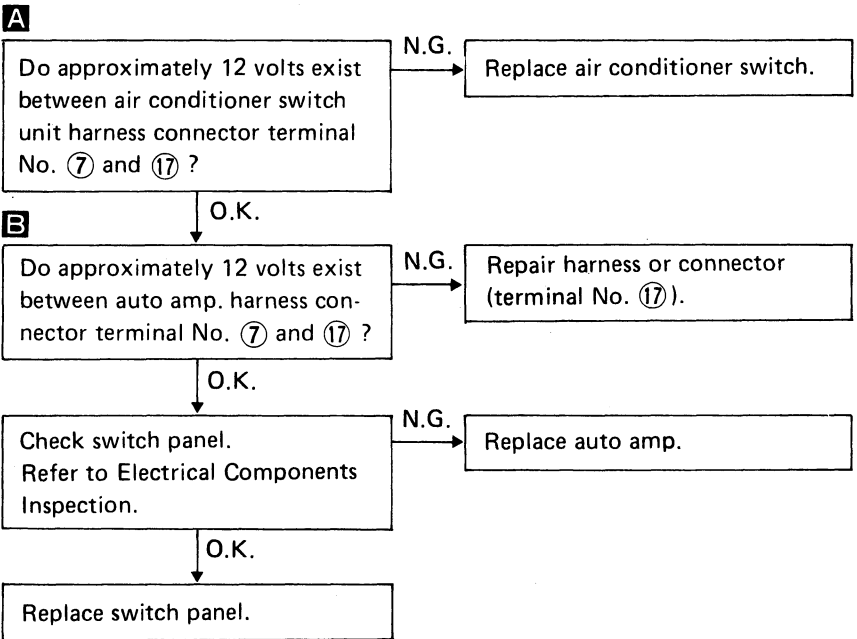
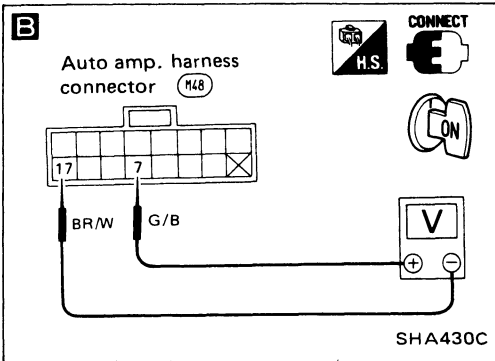
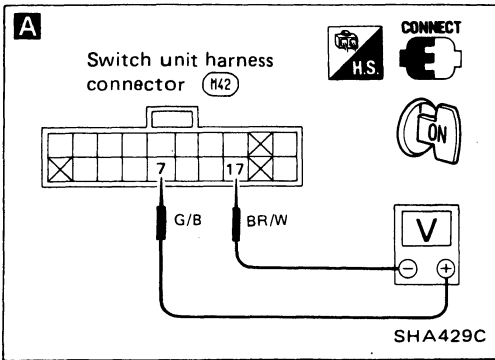

Diagnostic Procedure 23

SYMPTOM: Figures of set temperature do not appear on the display window and Indicator lamp (L.E.D.) does not come on.

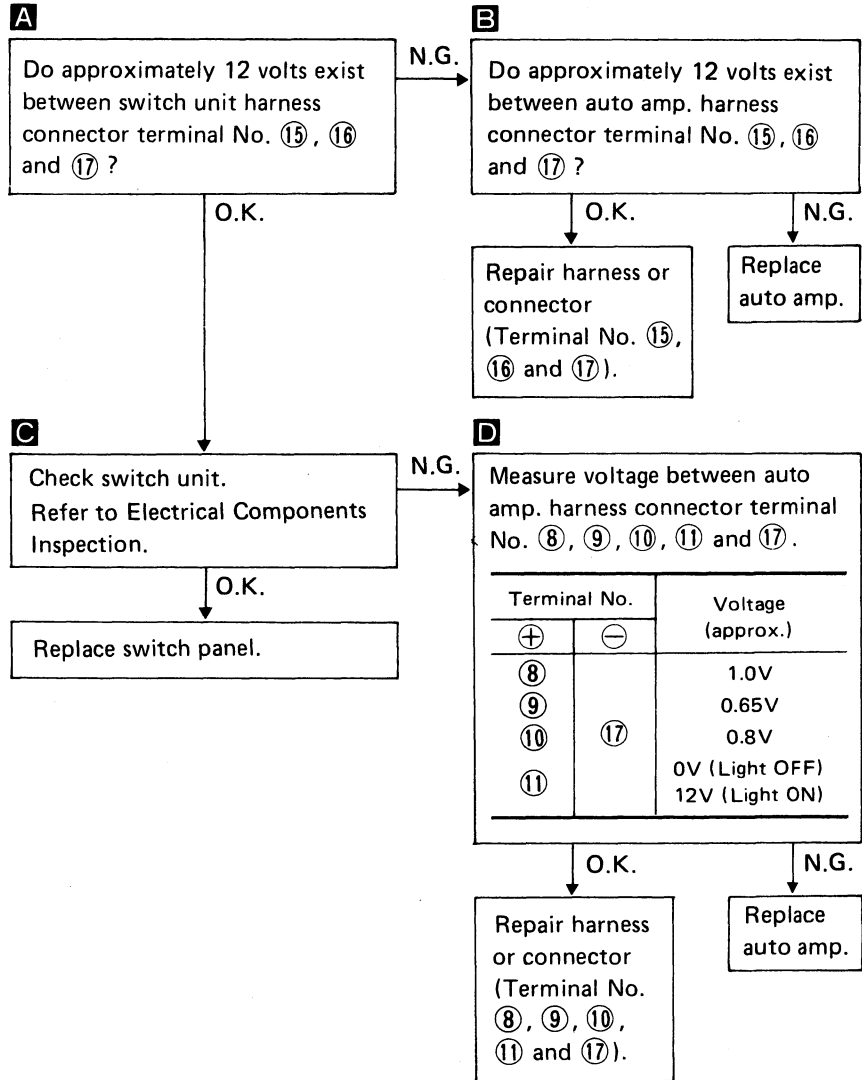
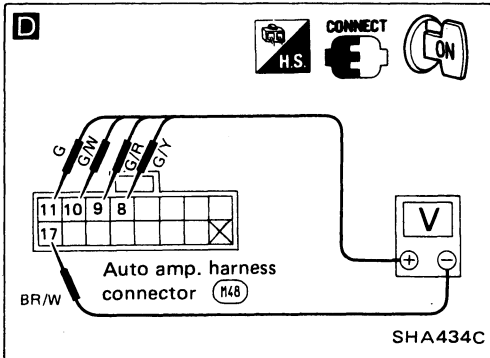
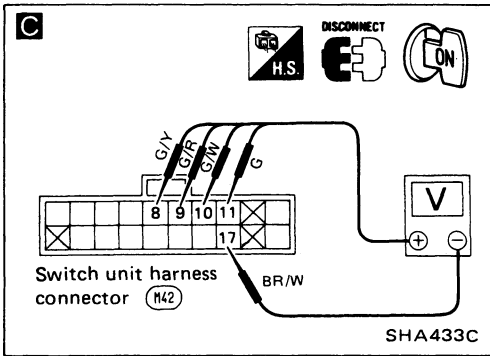
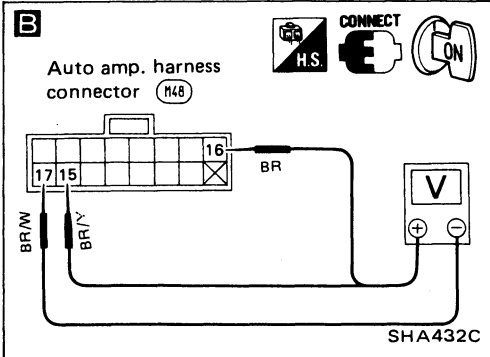
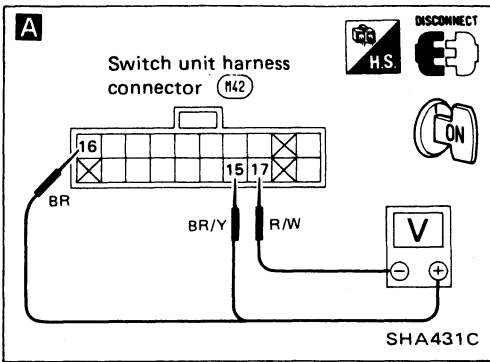

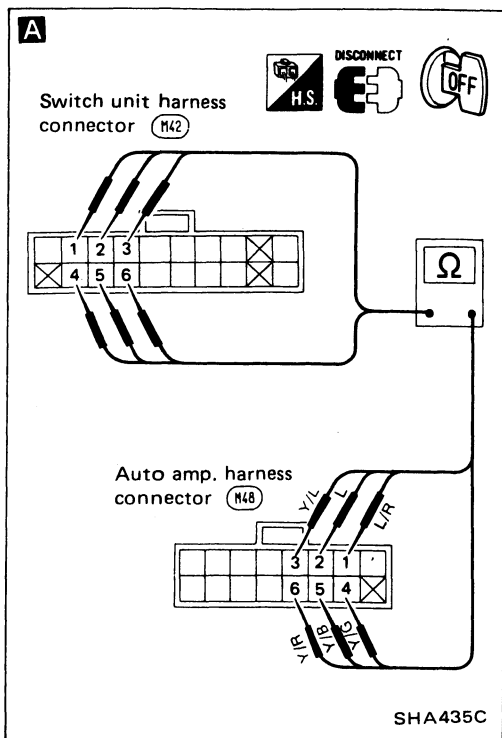

Diagnostic Procedure 24

SYMPTOM: Switches do not work.

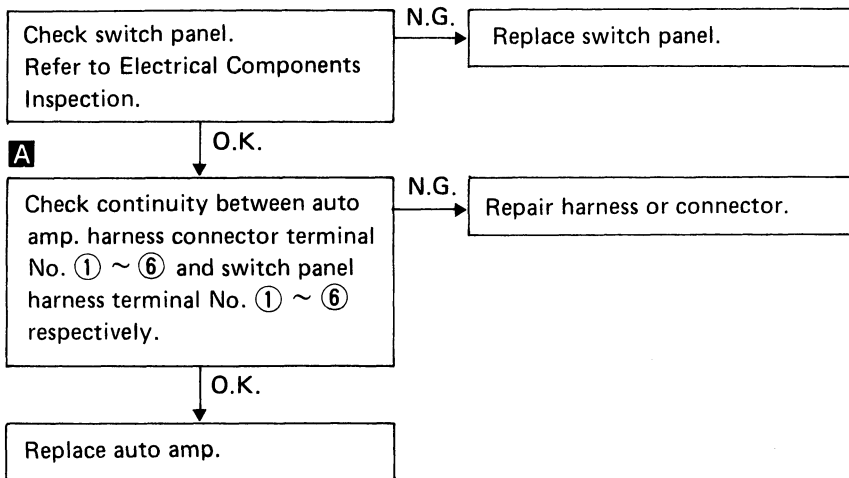

Diagnostic Procedure 25

SYMPTOM: Blower motor operation is malfunctioning.

- Perform Preliminary check 5 before referring to the of flowing flow chart.

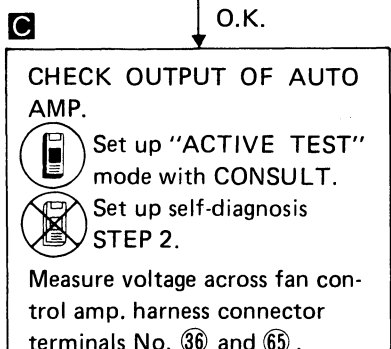
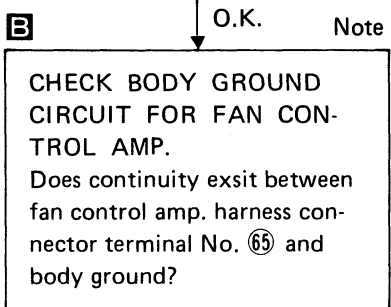
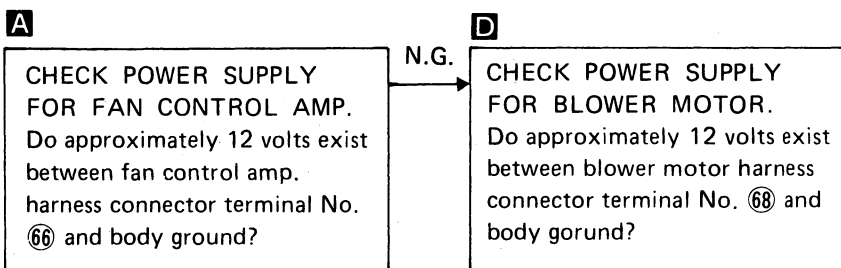
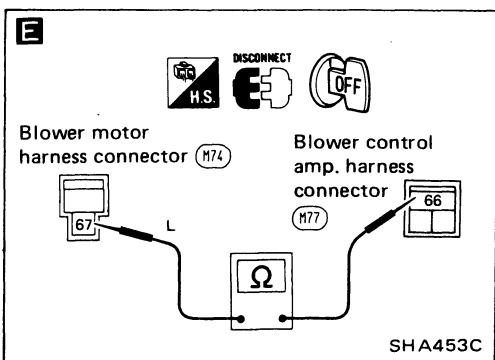
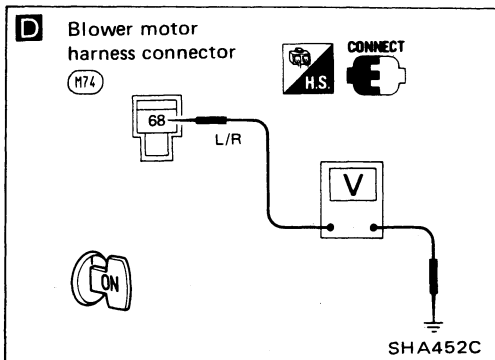
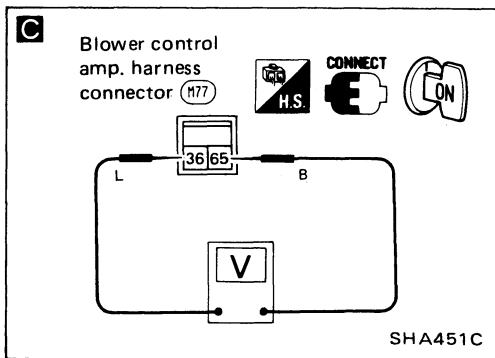
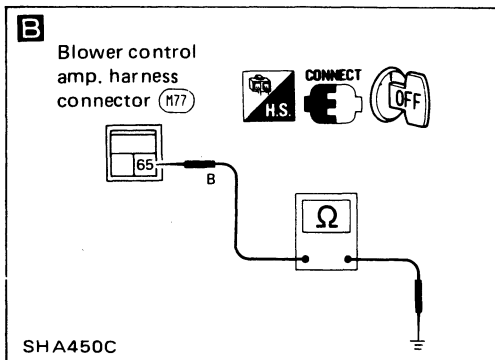
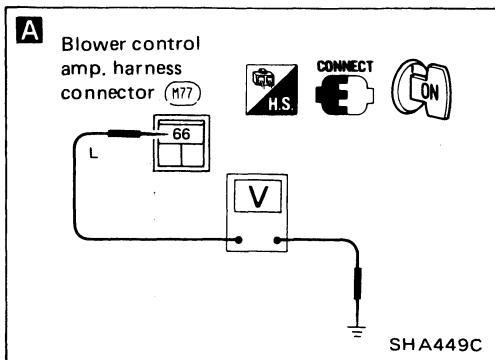

Blower motor voltage (V)	Code No.	Terminal No.		Voltage (Approx.) (V)
		+	-	
4				1.2
6				1.3
9		36	65	1.4
12				1.6

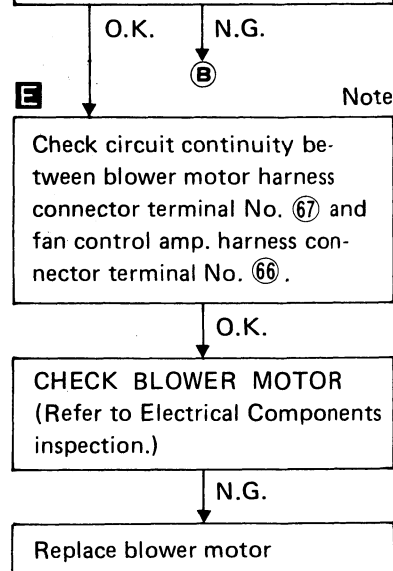
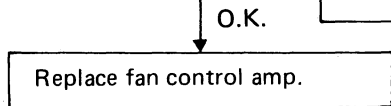

Diagnostic Procedure 25 (Cont'd)

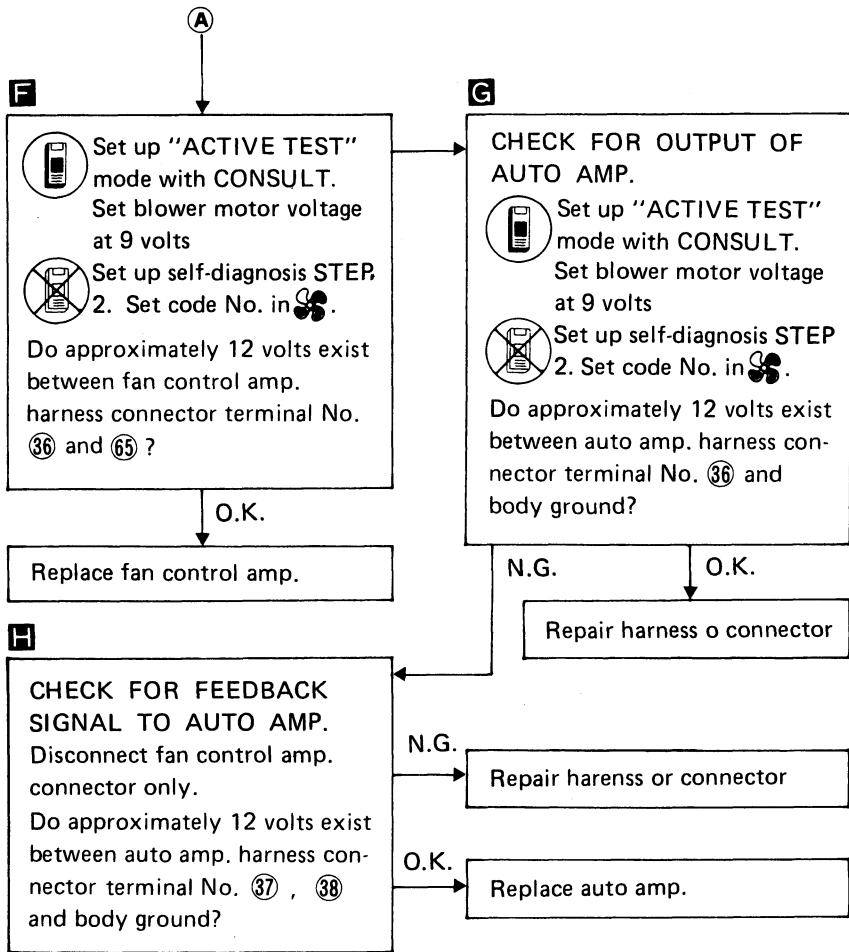
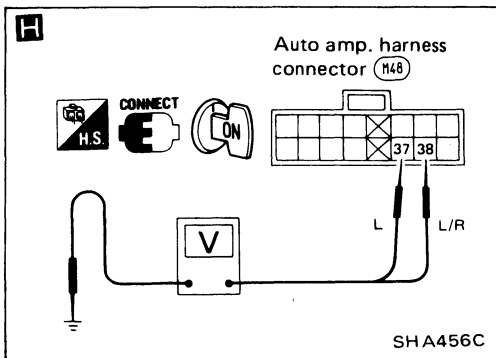
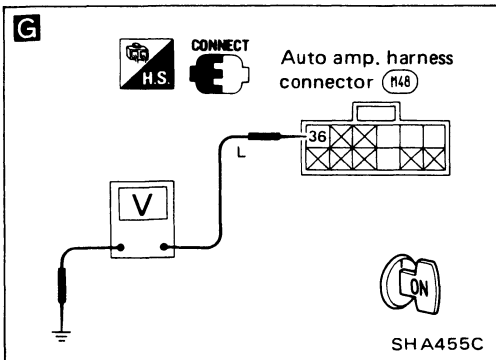
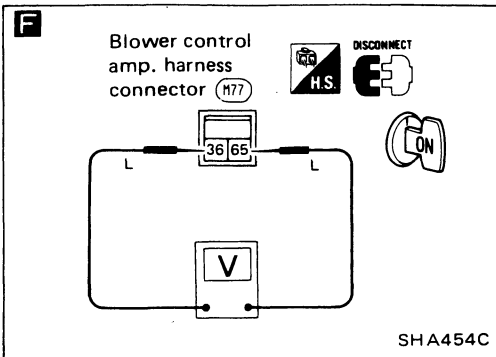

Diagnostic Procedure 25 (Cont'd)

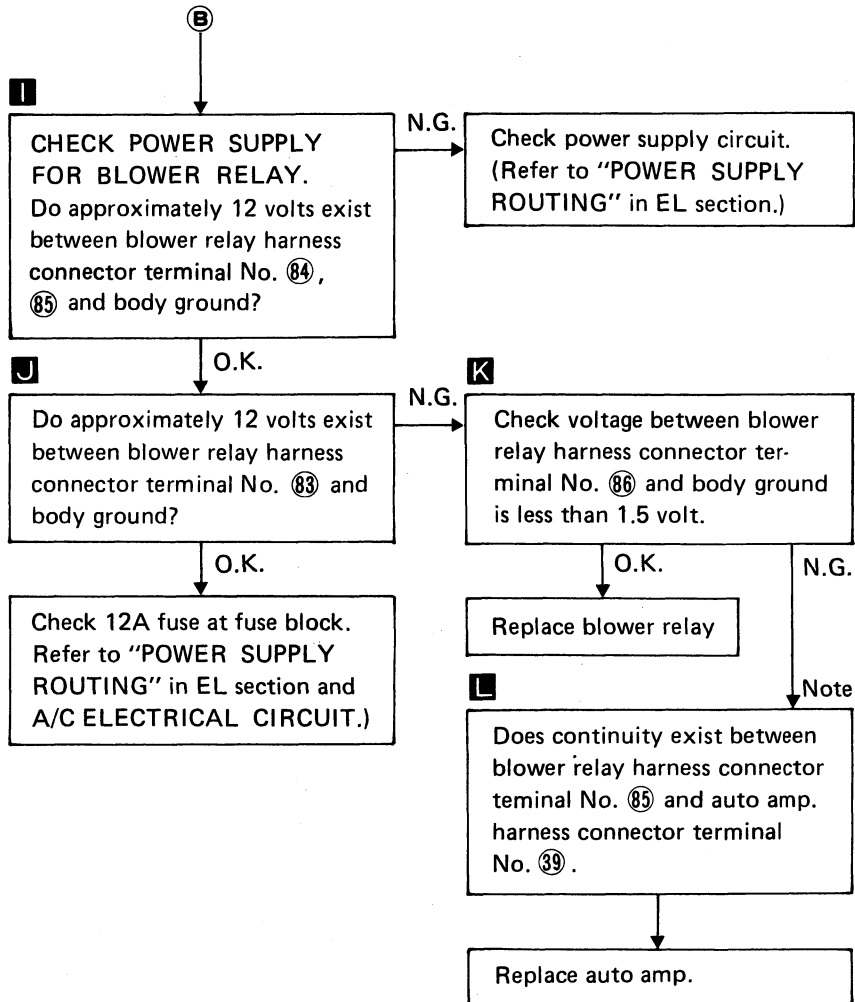
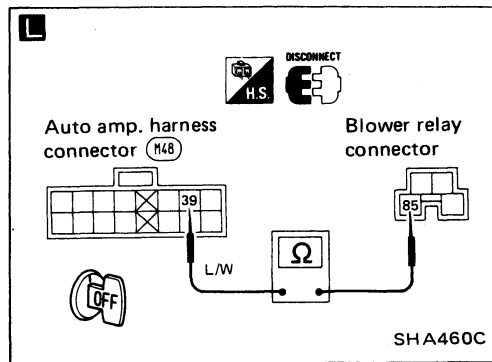
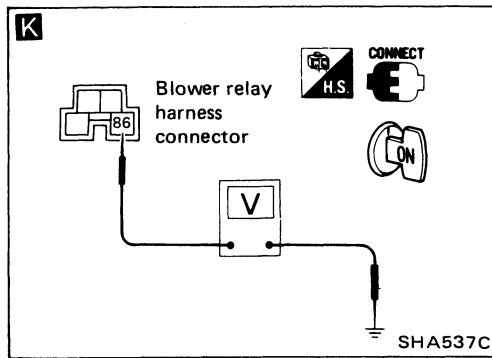
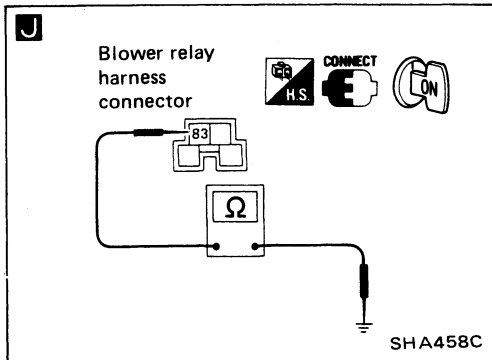
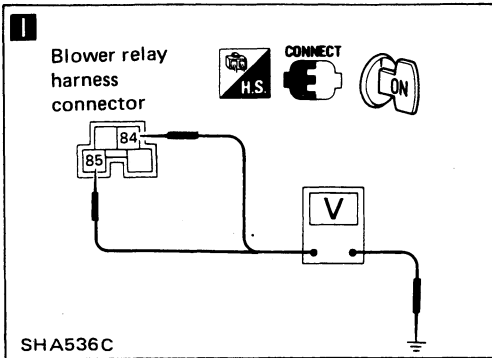

Note:
If the result is N.G. after checking circuit continuity, repair harness on connector.

Electrical Components Inspection

TEMPERATURE SENSORS

After disconnecting temperature sensors harness connector measure resistance between terminals of each sensor, using the table below.

Temperature °C (°F)	Resistance kΩ
-40 (-40)	210.55
-35 (-31)	146.86
-30 (-22)	103.97
-25 (-13)	74.63
-20 (-4)	54.28
-15 (5)	39.97
-10 (14)	29.77
-5 (23)	22.43
0 (32)	17.07
5 (41)	13.11
10 (50)	10.18
15 (59)	7.96
20 (68)	6.29
25 (77)	5.00
30 (86)	4.01
35 (95)	3.24
40 (104)	2.63
45 (113)	2.15
50 (122)	1.77
55 (131)	1.47
60 (140)	1.22
65 (149)	1.02
70 (158)	0.86
75 (167)	0.73
80 (176)	0.62

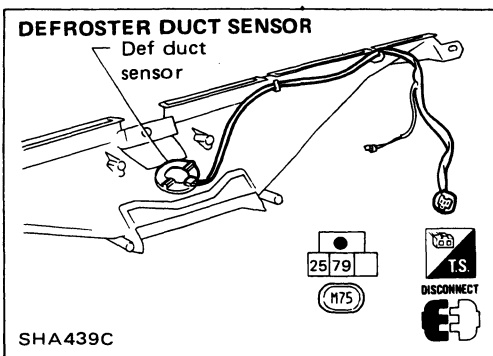
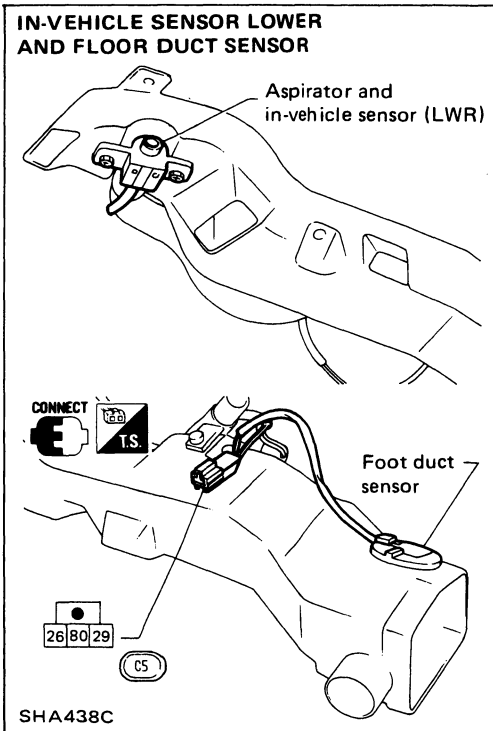
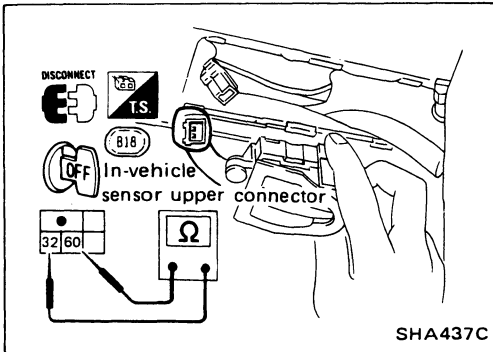
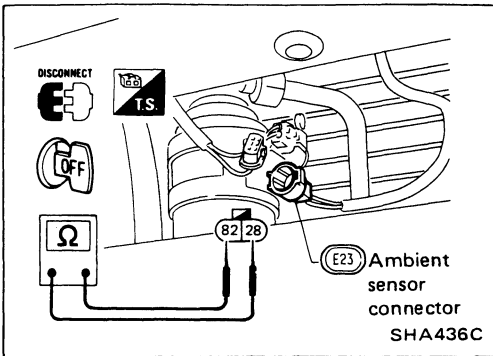

TROUBLE DIAGNOSES — Auto Air Conditioner

Electrical Components Inspection (Cont'd)

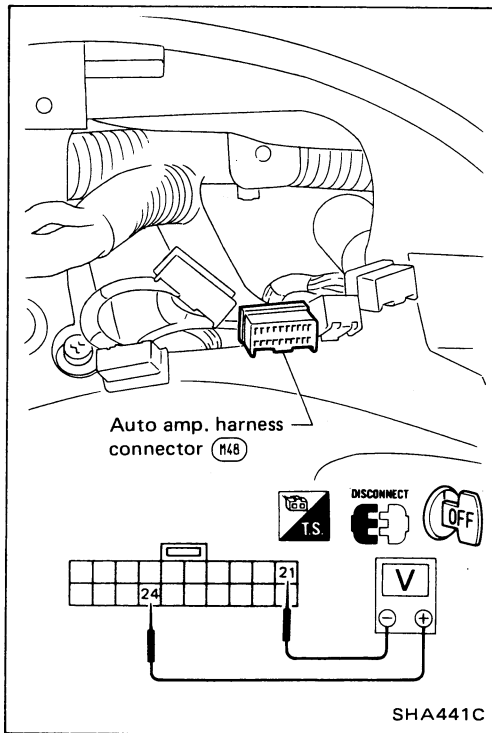
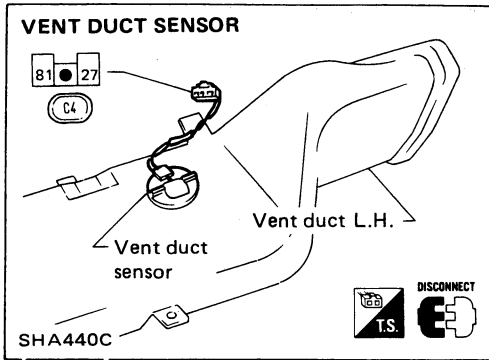

SUNLOAD SENSOR

Measure voltage between terminals ②① and ②④ at vehicle harness side using the table below.

Input current mA	Output voltage (V)
0	5
0.1	4
0.2	3
0.3	2
0.4	1
0.5	0

- When checking sunload sensor, select a place where sun shines on it directly.

MODE DOOR MOTOR

Check to see if motor rotates when 12V is applied across mode door motor connector terminals No. ④⑦ and No. ⑦⑩.

Terminal No.		Mode door operation
④⑦	⑦⑩	
⊖	⊕	VENT → DEF
⊖	⊖	STOP
⊕	⊖	DEF → VENT

Check to see if mode door P.B.R. resistance is varied according to mode door position, as shown in the following table.

Mode door position	Resistance between terminal No. ④⑧ and ⑦⑩
DEF	3 kΩ
FOOT/DEF	1.6 kΩ
B/L	0.7 kΩ
VENT	0Ω

Electrical Components Inspection (Cont'd)

AIR CONDITIONER SWITCH UNIT

Check the resistance between switch unit connector terminals as follows:

Switch condition	Resistance
Press	Less than 500Ω
Free	∞

Example:

When Auto switch is pressed, the resistance between terminal No. ① and ④ is less than 500Ω.

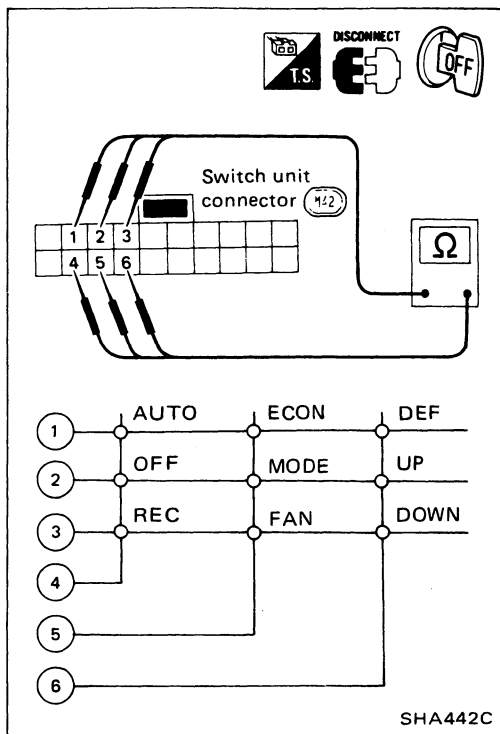

BLOWER MOTOR

- Refer to page HA-84.

RELAY

- Refer to page HA-85.

LOW-PRESSURE SWITCH

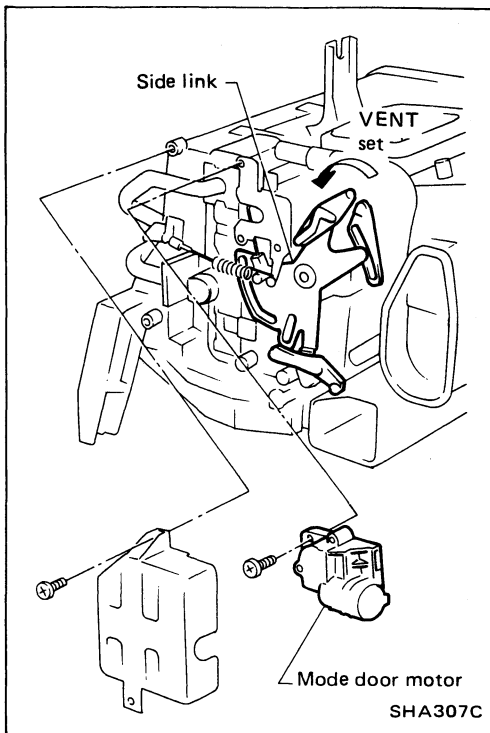

- Refer to page HA-85.









Control Rod Adjustment

MODE DOOR

1. Move side link by hand and hold mode door in VENT mode.
2. Install mode door motor on heater unit and connect it to harness.
3. Turn ignition switch to ON.
4. Set up "ACTIVE TEST" mode with CONSULT or set up self-diagnosis STEP 2.
5. Set MODE DOOR position as in the following table.

 MODE DOOR POSITION	 Code No.
VENT	

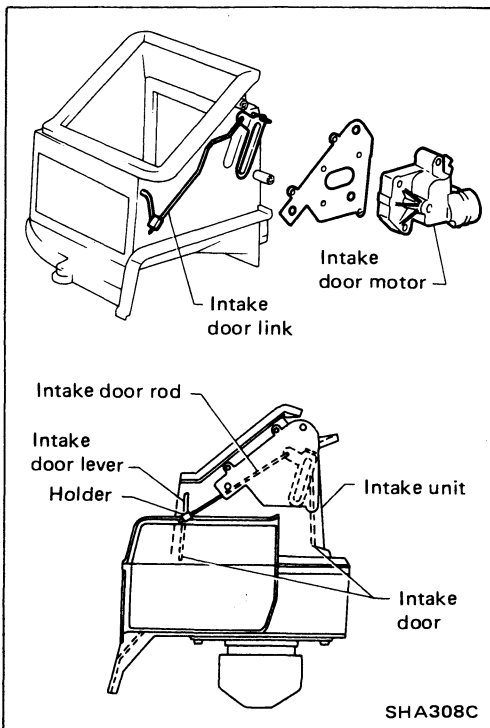

6. Attach mode door rod to side link rod holder.
7. Check mode door operates when position is changed with CONSULT or when code No.  is changed to others.

 Code No.				
Mode door position	DEF	HEAT	B/L	VENT







INTAKE DOOR

1. Install intake door motor on intake unit.
2. Connect intake door motor to harness.
3. Turn ignition switch to ON.
4. Set up "ACTIVE TEST" mode with CONSULT or set up self-diagnosis STEP 2.
5. Set INTAKE DOOR position as in the following table.

 INTAKE DOOR POSITION	 Code No.
REC	

6. Install intake door lever.
7. Set intake door rod in REC position and fasten intake door rod to holder intake door lever.
8. Check intake door operates properly when position is changed with CONSULT or when code No.  is changed to others.

 Code No.			
Intake door position	Outside air	Partial outside air	Recirculation

Control Rod Adjustment (Cont'd)

AIR MIX DOOR



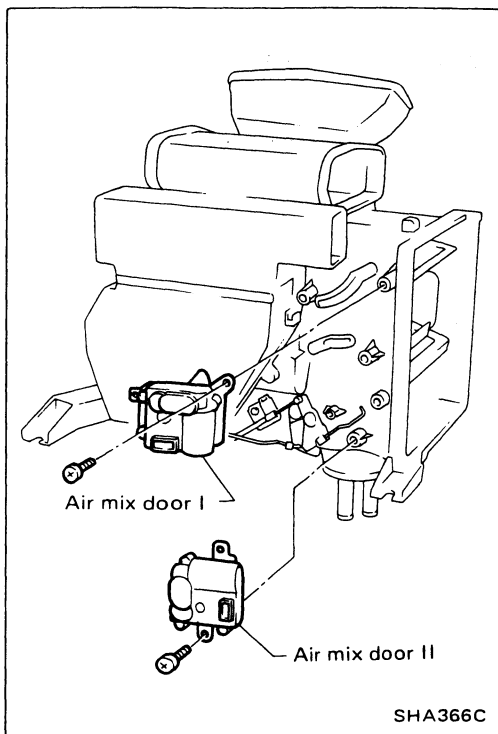



1. Connect harness to air mix door motors I and II and set temperature control lever at full-cold position.
2. Set air mix doors I and II at full-cold position and fasten door rod.
3. Check that when temperature control lever is at full-cold, both doors are at full-cold position, and when temperature control lever is at full-hot, both doors are at full-hot position.



WATER COCK CONTROL CABLE

Clamp cable at full-close position when air mix door II is at full-cold position, and full-open position when air mix door II is at full-hot position.

**Control Switches
SWITCHES AND THEIR CONTROL FUNCTIONS**

Switch		Indicator illuminates		Air outlet	Intake air	Compressor
		A/C				
A/C		○				ON*1
Mode				VENT	*3	*1*4
				B/L	*5	*1*4
				FOOT	*5	*1*4
				F/D	*5	ON*1
				DEF	FRE	ON*1
			○		REC*2	ON*1

*1: Compressor is operated by thermo control amp. and E.C.C.S. control unit.

*2: Depending on mode switch position.

*3: When vent mode is selected, REC switch function is as in the following chart:

*4: Depending on A/C switch position.

*5: Depending on REC switch position.

		REC	
		ON	OFF
A/C SW	ON	REC	REC/FRE
	OFF	REC	FRE

SHA267C

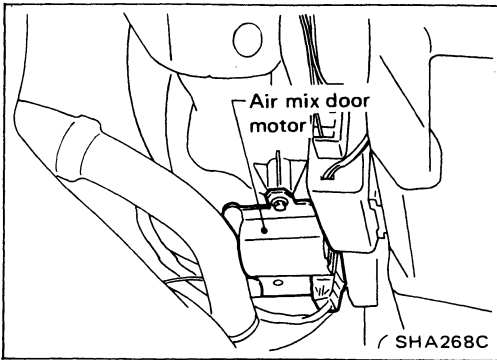

Specifications

AIR MIX DOOR MOTOR

The air mix door motor is attached to the heater unit. It rotates, opening the air mix door to the position set by the temperature control lever.

Motor rotation is conveyed through shafts and linkages. The air mix door position is fed back to the control amplifier by the Potentiometer Balance Resistor (P.B.R.) built into the air mix door motor.

Air mix door motor operation

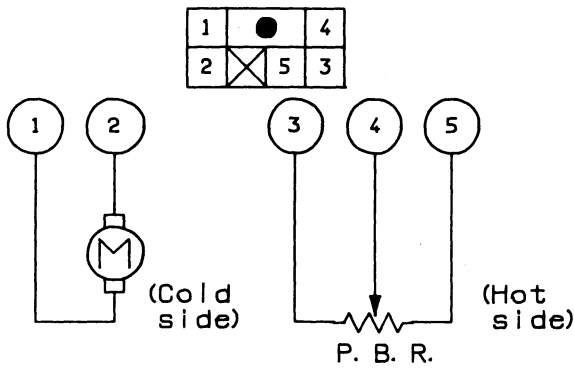

1	2	Air mix door operation	Direction of lever movement
⊕	⊖	COLD → HOT	Clockwise (Toward passenger compartment)
⊖	⊖	STOP	STOP
⊖	⊕	HOT → COLD	Counterclockwise (Toward engine compartment)

SHA269C

Characteristics of P.B.R.

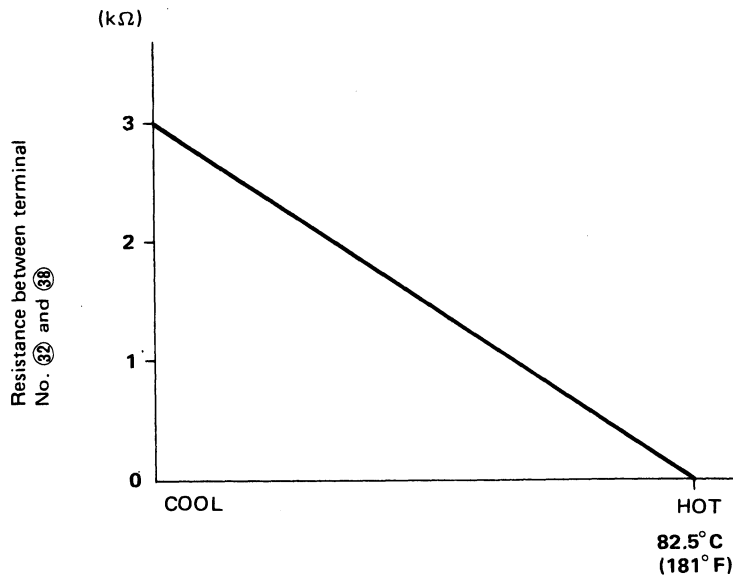

SHA270C

SYSTEM DESCRIPTION — Manual Air Conditioner

Specifications (Cont'd)

MODE DOOR MOTOR

When a mode switch is selected, the position switch built into it reads the corresponding mode to determine the direction of motor rotation. As soon as the desired mode is set, the position switch stops the motor.

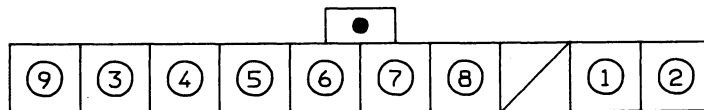
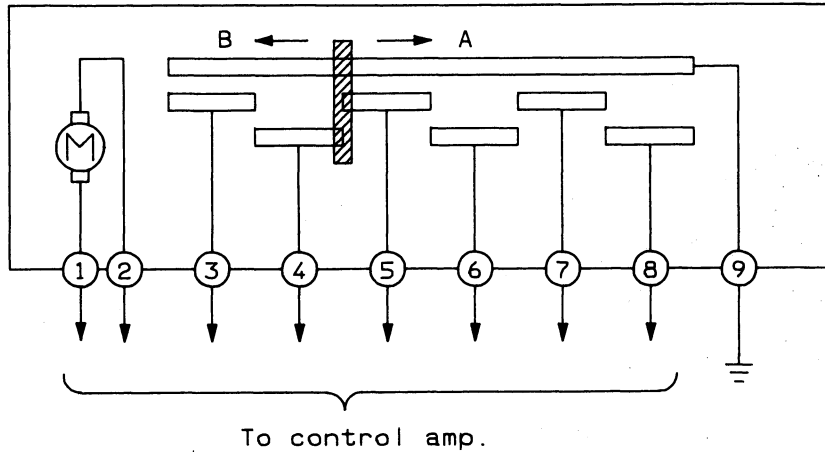
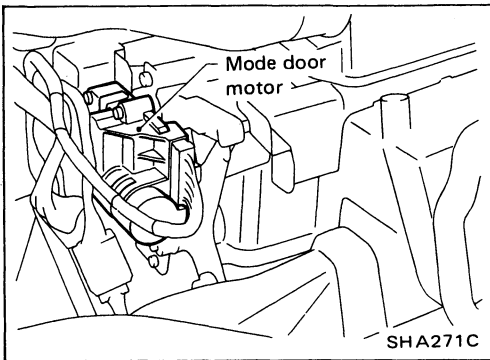

SHA272C

Specifications (Cont'd)

INTAKE DOOR MOTOR

The intake door motor is installed on the side portion of the intake unit. Using a rod and link it opens and closes the intake door. When the REC switch is ON (OFF), the ground line of the intake door motor is switched from terminal 20 to 22 (22 to 20). This causes the motor to start because the position switch contacts built into it are now set to the current flow position.

The contacts turn along with the motor. When they reach the non-current flow position, the motor will stop. The motor always turns in the same direction. (FRE→REC→REC/FREC)

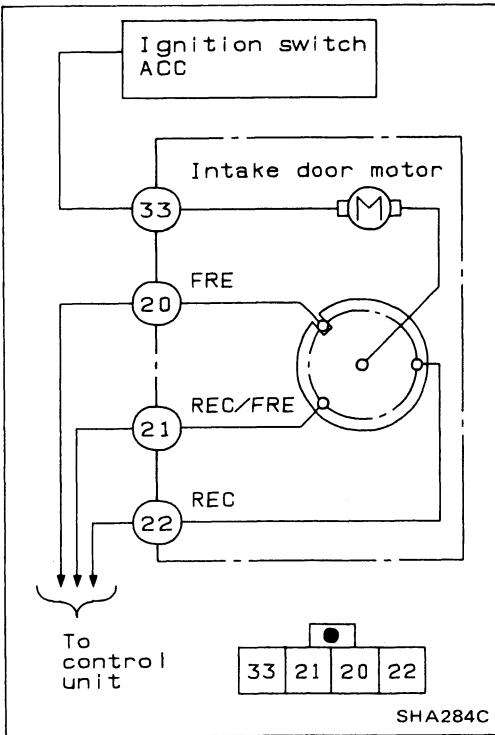
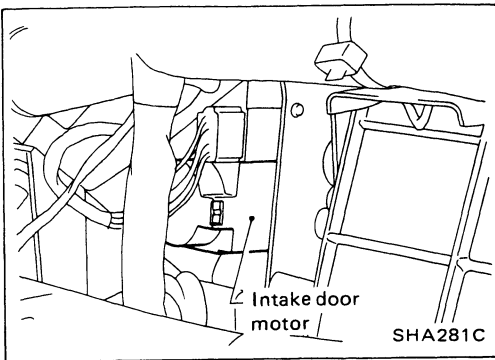

Specifications

AUTO AMPLIFIER

The auto amplifier has a built-in microcomputer which processes information from the A.T.C. system sensors. Signals are sent from the auto amplifier to activate the A.T.C. system depending upon the information sent by these sensors and the set temperature selected on the switch panel.

The A.T.C. system's self-diagnostic capabilities are built into the auto amplifier.

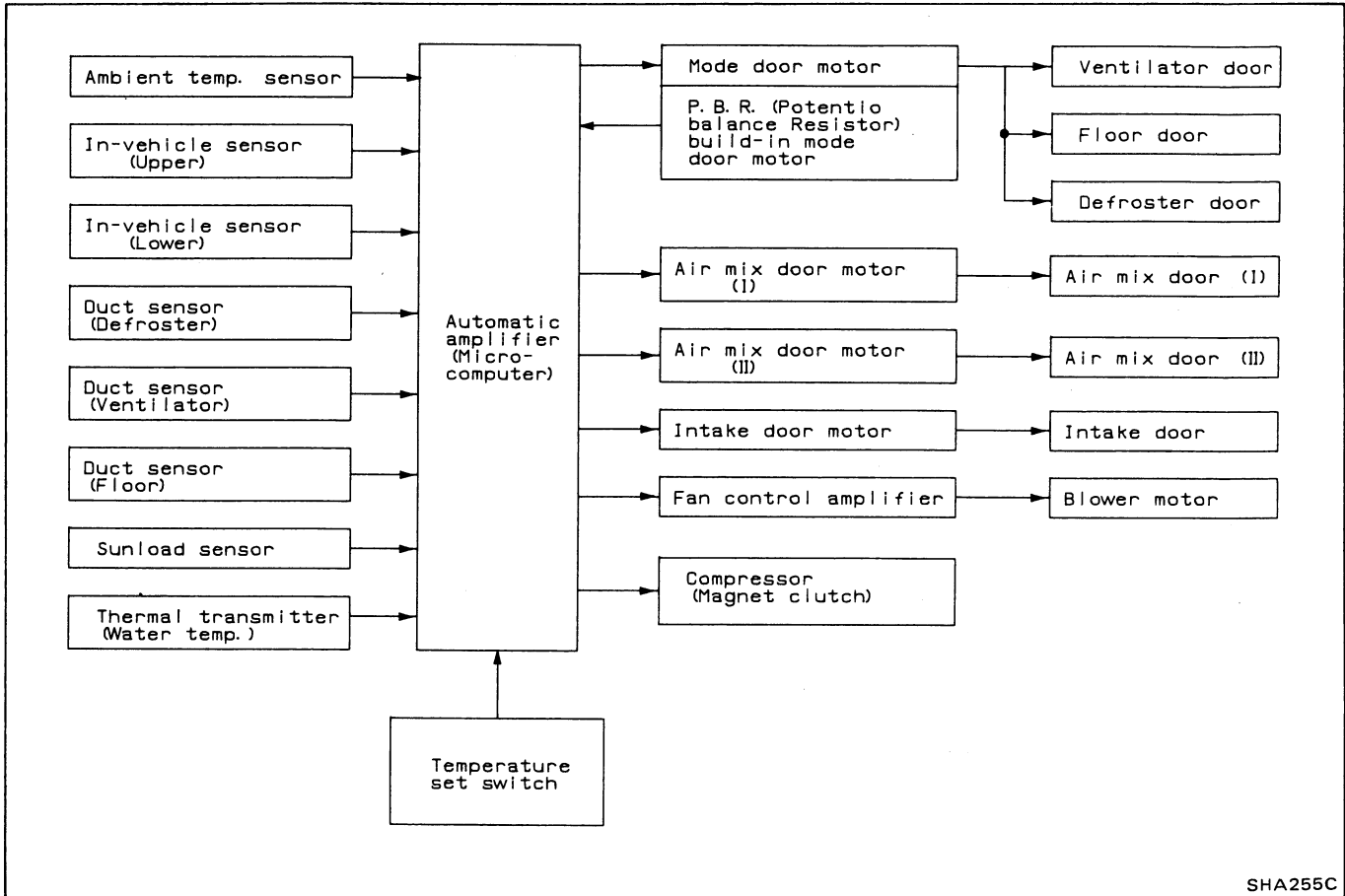

SHA255C

SYSTEM DESCRIPTION — Auto Air Conditioner

Specifications (Cont'd)

AIR MIX DOOR I and II MOTORS

Component and related parts

- Auto amplifier
- Air mix door motors
- In-vehicle sensors (upper and lower)
- Duct sensors (vent, floor, defroster)
- Ambient sensor
- sunload sensor

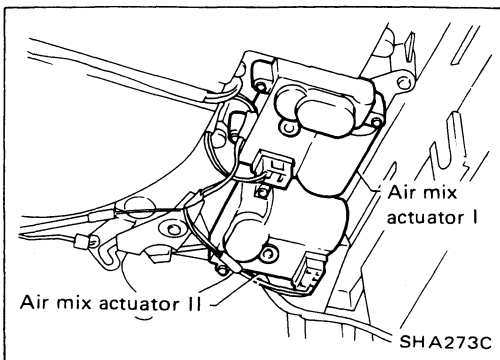

Operation of air mix door I and II motors

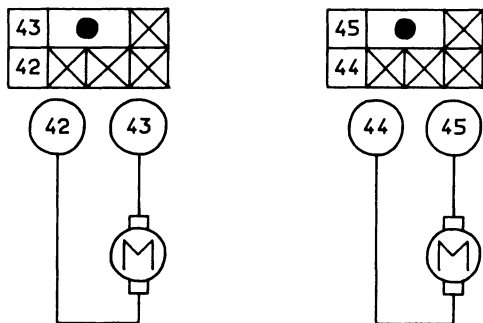

Air mix door I Air mix door II

④② ④④	④③ ④⑤	Air mix door I and II operation	Direction of lever movement
⊖	⊕	COLD → HOT	*Clockwise
⊖	⊖	STOP	STOP
⊕	⊖	HOT → COLD	*Counterclockwise

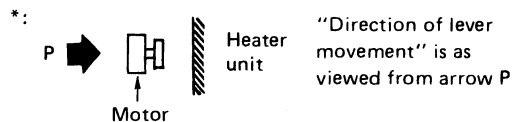

SHA274C

System operation

The air mix door motors are attached to the bottom of the heater unit. The motors rotate, moving a lever system which varies the air mix door position to heat or cool the inlet air. Outlet air temperature is measured by the duct sensors, signals from which are sent to the auto amplifier which uses them to modify the air mix door position to achieve the current target temperature.

- It takes about 1 minute to stabilize duct air temperature.
- When ambient temperature is below 5°C (41°F) or above 60°C (140°F), air mix door position is fixed.

SYSTEM DESCRIPTION — Auto Air Conditioner

Specifications (Cont'd)

MODE DOOR MOTOR

Component and related parts

- Auto amplifier
- Mode door motor with potential ballast resistor (P.B.R.)
- Lower in-vehicle sensor
- Ambient sensor
- Sunload sensor

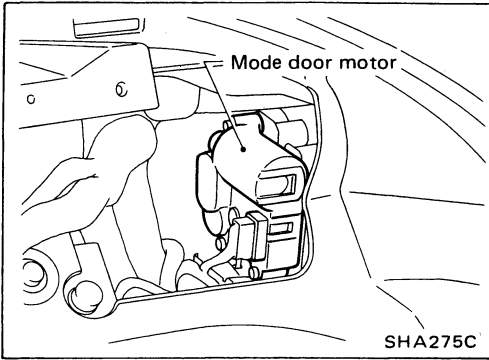

Mode door motor operation

Mode door motor operation

70	●	48
47	⊗	73 72

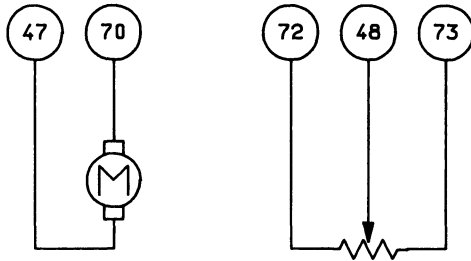

(47)	(70)	Mode door operation	Direction of side link rotation
⊖	⊕	VENT → DEF	Clockwise
⊖	⊖	STOP	STOP
⊕	⊖	DEF → VENT	Counterclockwise

SHA276C

System operation

The mode door motor is attached to the heater unit. The motor operates a cam assembly which moves the air outlet doors. The auto amplifier controls air distribution to the VENT, DEF and FOOT outlets. Outlet door position is conveyed to the auto amplifier by the P.B.R. built into the mode door motor.

The auto amplifier computes air outlet conditions according to ambient temperature, set temperature and sunload. When thermal loads are great, the air outlet computation is additionally influenced by the foot area temperature. The air outlet positions are smoothly adjusted in response to changes in ambient temperatures.

When the set temperature is decreased or when the sunload is increased, the air flow volume from the vent outlets is increased.

Specifications (Cont'd)

INTAKE DOOR MOTOR

Component and related parts

- Auto amplifier
- Intake door motor
- Upper in-vehicle sensor
- Vent duct sensor
- Ambient sensor
- Sunload sensor

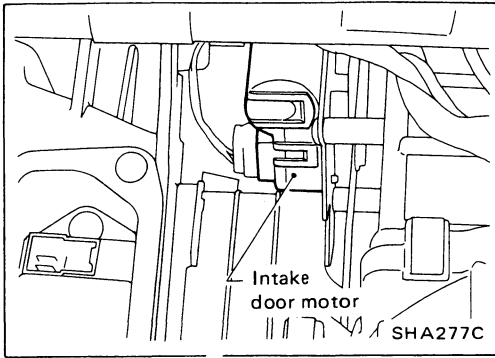

Intake door operation

Intake door operation

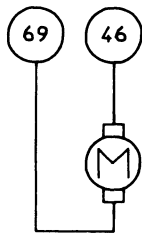
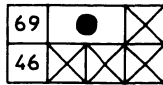

④6	⑥9	Intake door operation	Direction of lever rotation
⊖	⊕	REC → FRE	Counterclockwise
⊖	⊖	STOP	STOP
⊕	⊖	FRE → REC	Clockwise

SHA278C

System operation

The intake door motor is attached to the air intake unit. Intake door position is controlled approximately once every thirty seconds, according to the difference between target and actual vent air temperatures. When the actual outlet air temperature is higher than the target vent air temperature, the intake door will gradually shift toward the recirculation-air side. When the outlet air temperature reaches the target outlet air temperature, the intake door will gradually shift toward the fresh air side. However, when the ambient temperature is lower than 20°C (68°F), 100% fresh air is taken is regardless of outlet air temperatures.

When the compressor is "OFF" the auto amplifier sets the intake door at the "FRESH" position except when the "RECIRC" switch is "ON".

SYSTEM DESCRIPTION — Auto Air Conditioner

Specifications (Cont'd) TEMPERATURE SENSORS

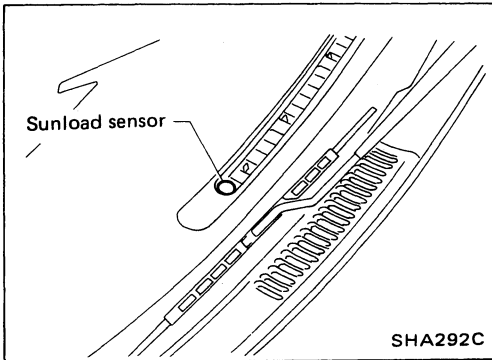
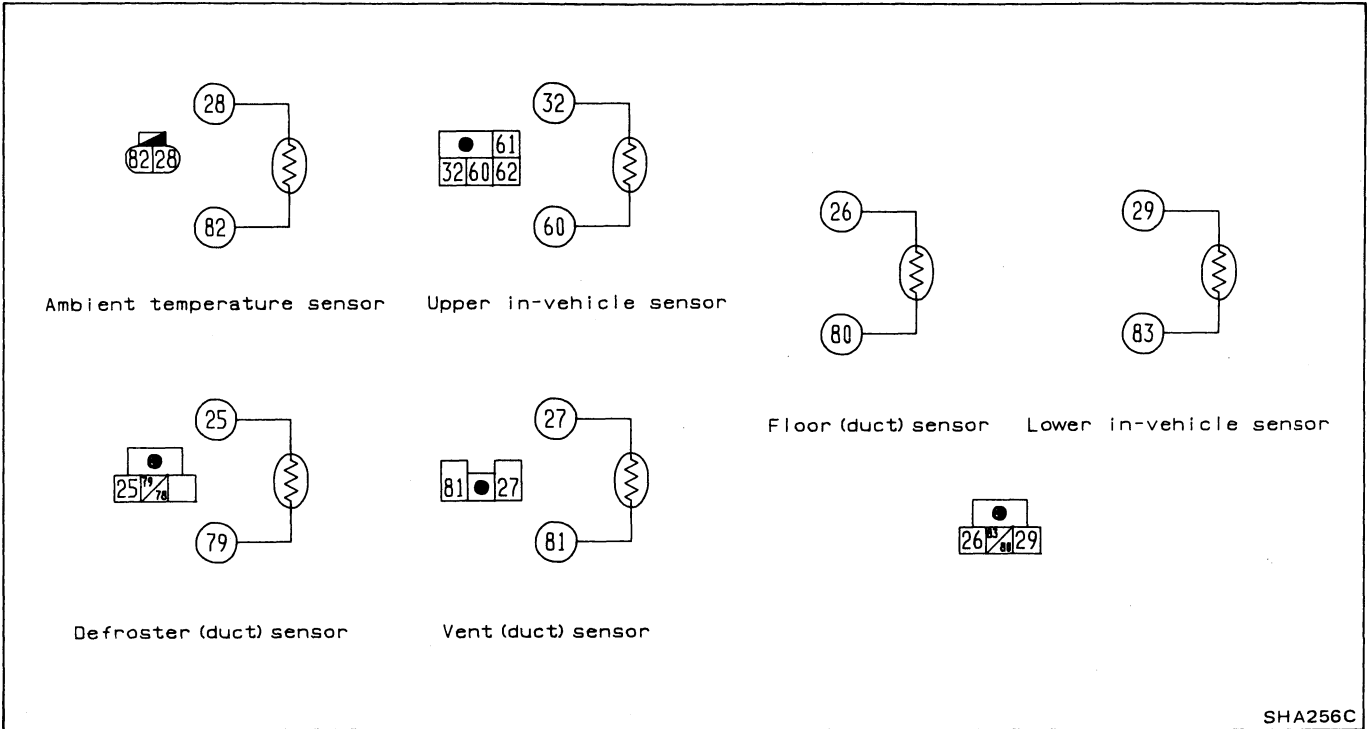

SUNLOAD SENSOR

The sunload sensor is located on the right defroster grille. It detects sunload entering through the windshield by means of a photo diode and converts it into a current value which is then input into the auto amplifier.

SYSTEM DESCRIPTION — Auto Air Conditioner

Specifications (Cont'd)

FAN CONTROL AMPLIFIER

The fan control amplifier is located on the cooling unit. It amplifies the base current flowing from the auto amplifier to change the blower speed.

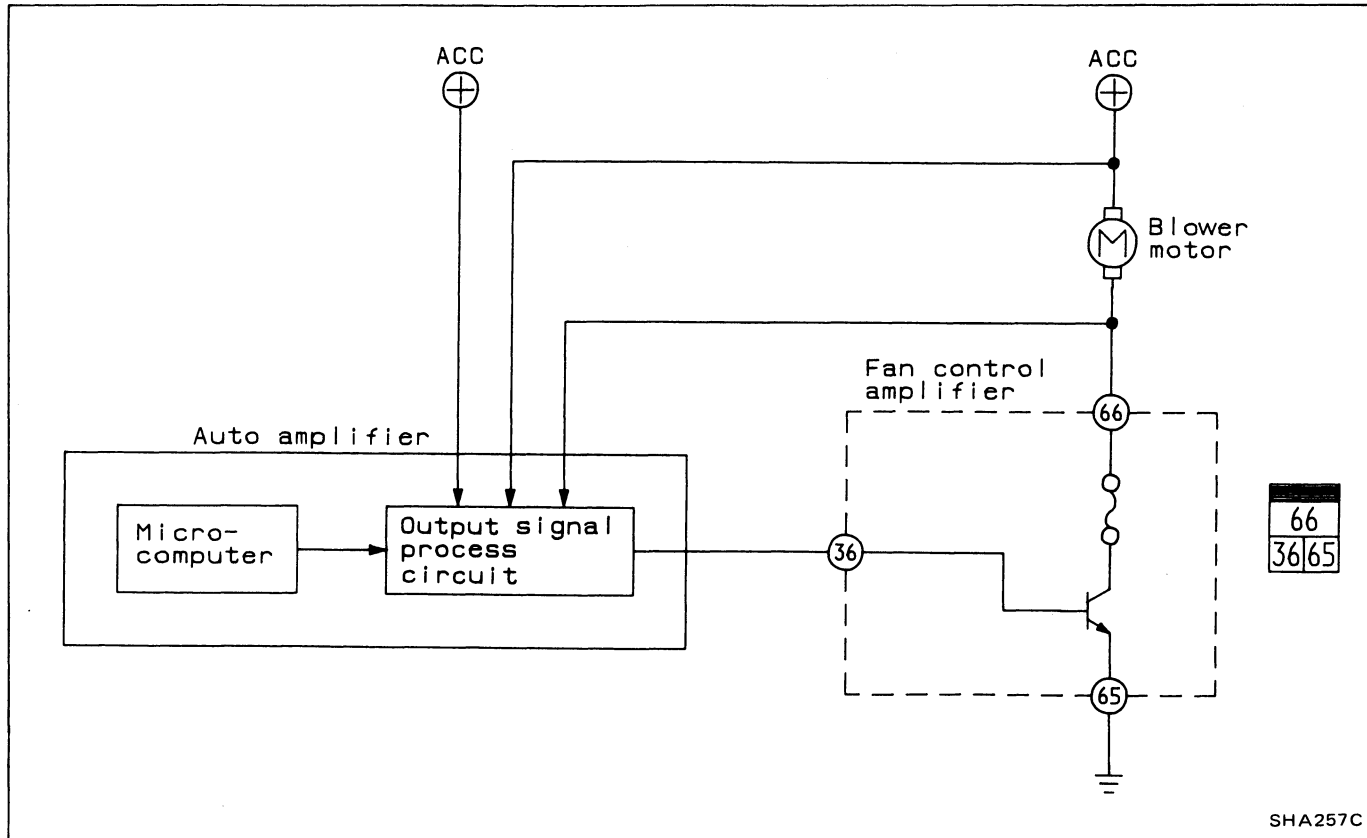

System Operation
SWITCH PANEL

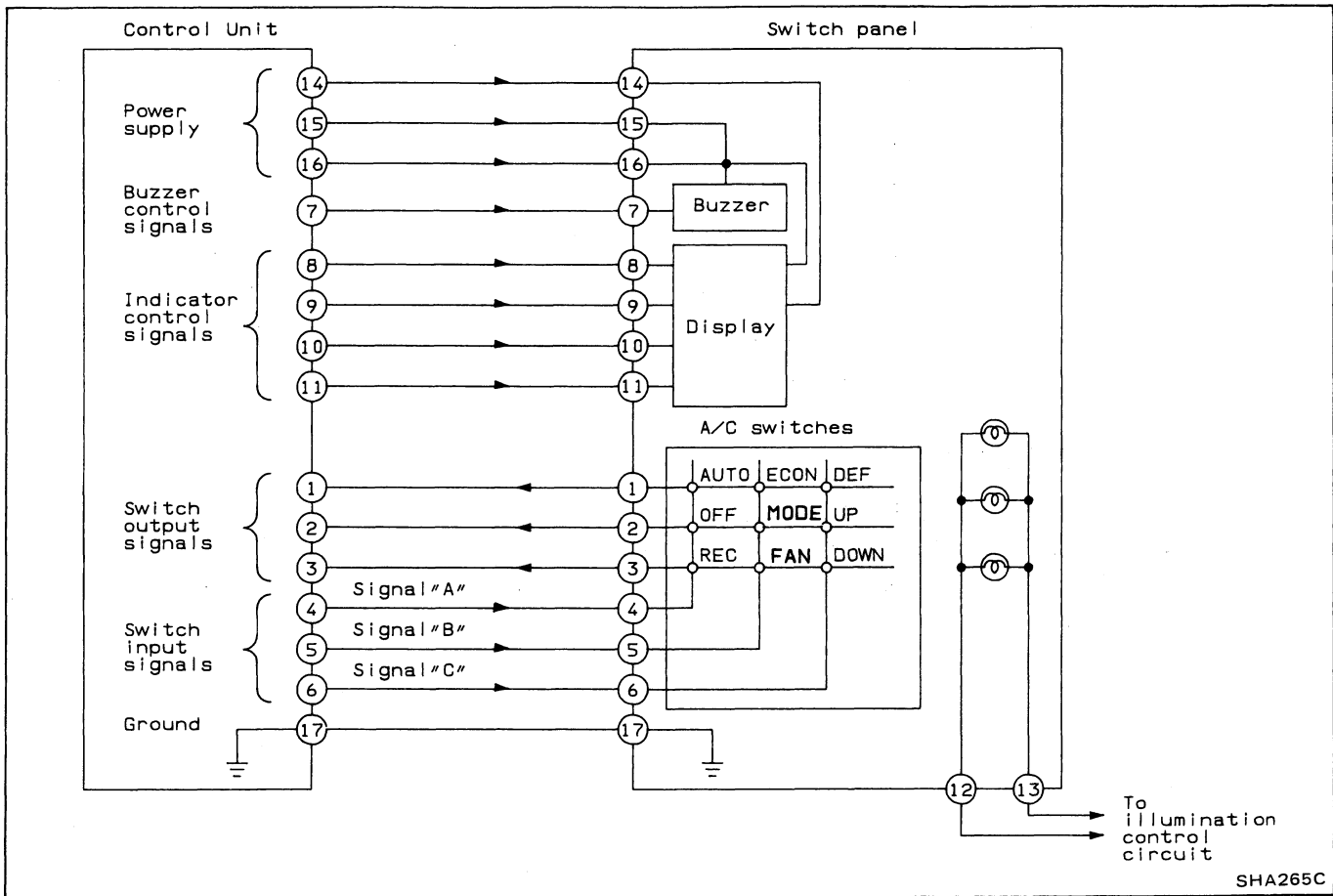

SHA265C

System operation

Except for illumination lamp terminals ⑫ and ⑬, the switch panel is operated by signals emitted from the control unit. There are three categories of signals.

- 1) Power and ground signals
- 2) Indicators (VFD and LED) and buzzer control signals
- 3) Switch input and output signals

The control unit always sends three different signals to the switch panel on three lines ④, ⑤, and ⑥.

For example, when the "Auto" switch is pushed, signal "A" returns to the control unit on line No. ①. And when the "Econ" switch is pushed, signal "B" returns to the control unit on line No. ①.

Similarly for the other switches; the control unit recognizes which signal returns on which line, and then identifies which switch is pushed.

SYSTEM DESCRIPTION — Auto Air Conditioner

System Operation (Cont'd)

AMBIENT TEMPERATURE INPUT PROCESS

For A.T.C. system operation an accurate ambient sensor signal is necessary. The auto amplifier contains a circuit to ensure accurate measurement of increases in ambient temperature. Sudden increase in temperature of 16°C (61°F) or more, which may be detected after encountering heavy traffic after a period of high speed cruising, are processed through a delay circuit. The delay circuit processes any temperature increase in increments of 0.06°C (0.11°F) every 12 seconds and, in this way, the A.T.C. system is protected from any sudden changes in ambient sensor signal due to low air flow around the sensor.

Temperature decreases are not processed through the time delay circuit.

Example:

In the case of a signal stop after high-speed cruising, the ambient temperature will rise suddenly.

The ambient temperature input process functions at this time to prevent unpleasant air conditioning system changes.

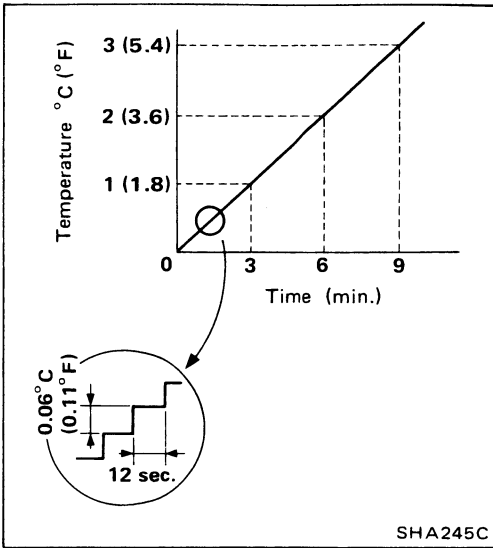

SUNLOAD INPUT PROCESS

The sunload input circuit in the auto amplifier also features a time delay to prevent abrupt A.T.C. system changes. This feature operates under rapid increases and decreases in sunload.

Example:

When entering a tunnel the sunload will change suddenly. The sunload input process system functions at this time to prevent unpleasant air conditioning system changes.

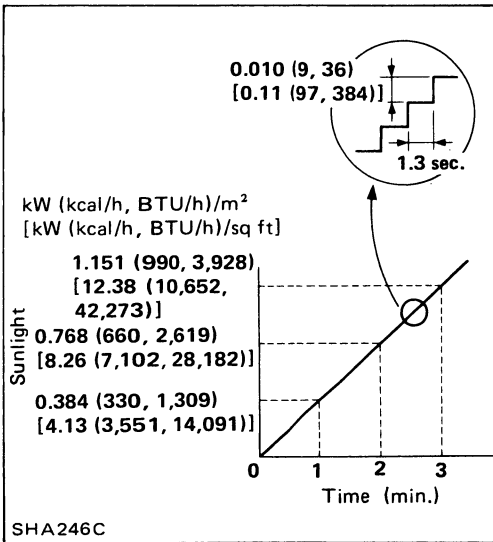

System Operation (Cont'd)

SENSOR INPUT PROCESS

A fixed resistor is built into the auto amplifier. 12V DC is converted to 5V DC by the constant voltage circuit where it is then applied to the ground line of the auto amplifier by the fixed resistor and sensors. The auto amplifier monitors the voltage between each sensor and the fixed resistor. The resistance of each sensor varies according to temperature.

Accordingly, the voltage at each sensor varies according to the temperature. The voltage signal is processed by the auto amplifier for A.T.C. system operation.

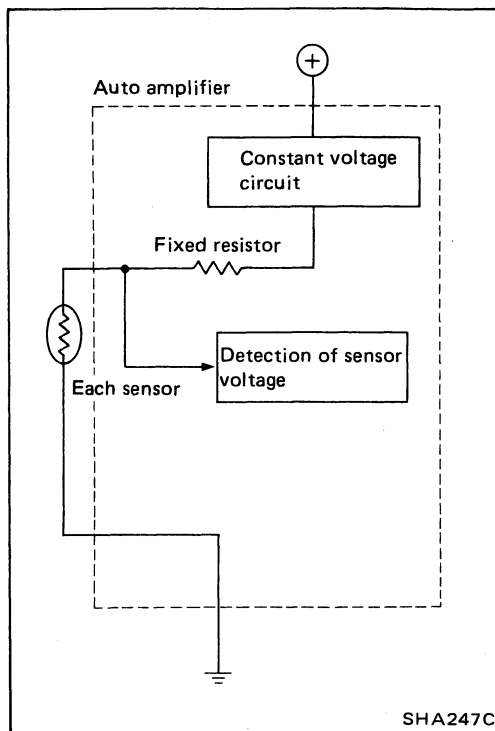

STARTING FAN SPEED AND OUTLET DOOR CONTROL

Component parts

Starting fan speed control components are:

- Auto amplifier
- Fan control amplifier
- In-vehicle sensors (Upper and Lower)
- Duct sensor (Defroster, Ventilator and Floor)
- Ambient sensor
- sunload sensor
- Thermal transmitter (Engine coolant temperature sensor)

System operation

- Fan speed control

At a set temperature of 25°C (77°F), when the upper compartment temperature is below 21°C (70°F) and the outlet duct temperature is lower than 35°C (95°F), the fan starts at minimum flow rate. As the discharge air temperature increases, the air flow rate increases to bring the compartment temperature to the target level as quickly as possible.

When the ambient temperature is above 40°C (104°F), fan air flow rate is at full volume.

As interior temperature begins to reach the target temperature, fan speed decreases.

Under heavy sunload conditions, fan speed is increased to maintain uniform interior temperature. Fan speed also increases if the set temperature is decreased.

- Outlet door control

At a set temperature of 25°C (77°F), when the upper in-vehicle temperature is lower than 21°C (70°F) and all of the outlet air temperatures are lower than 24°C (75°F), the system starts with the minimum airflow rate in the defroster mode. When defroster duct temperature rises above 24°C (75°F), the air outlet mode changes from the defroster mode to the DEF/FOOT mode. When floor duct temperature exceeds 39°C (102°F), the starting fan speed control and outlet door control mode is replaced by the normal automatic control mode. When the upper in-vehicle temperature is far greater than the lower in-vehicle temperature because of a large sunload, the system starts with the ventilator mode, which is replaced by the automatic control mode as the coolant temperature and outlet air temperature increases.

SYSTEM DESCRIPTION — Auto Air Conditioner

System Operation (Cont'd)

Starting fan speed and outlet door control specifications

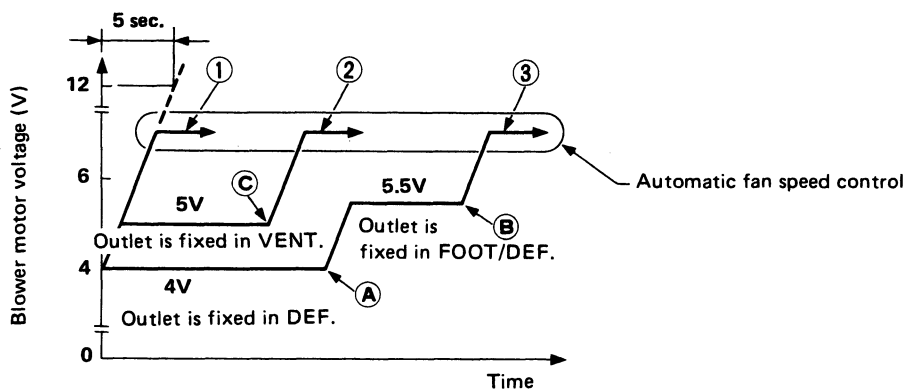

- ① : When both upper and lower in-vehicle temperatures are much higher than set temperature.
- ② : When upper in-vehicle temperature is higher than set temperature.
- ③ : When upper in-vehicle temperature is lower than set temperature.
- (A) : When DEF duct temperature rises above 24°C (75°F)
(Exact temperature depends on ambient temperature.)
- (B) : When FLOOR duct temperature rises above 39°C (102°F)
(Exact temperature depends on ambient temperature.)
- (C) : When water temperature rises above 40°C (104°F) and difference between outlet air temperature and target temperature is lower than 5°C (9°F).

SHA290C

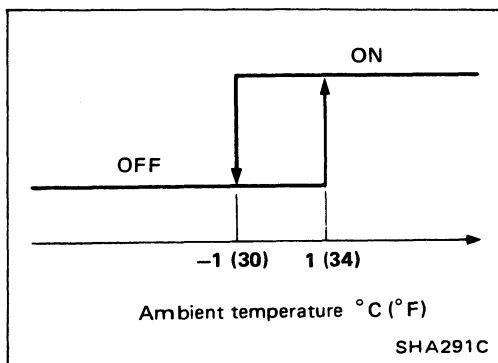

MAGNET CLUTCH CONTROL

The auto amplifier controls compressor operation by the ambient temperature and signals from the E.C.C.S. unit.

The auto amplifier will turn the compressor "ON" or "OFF" as determined by a signal detected by the ambient temperature sensor.

SHA291C

SERVICE DATA AND SPECIFICATIONS (S.D.S.)

General Specifications

COMPRESSOR

Model	DIESEL-KIKI make DKS-16H
Type	Swash plate
Displacement cm ³ (cu in)/Rev.	167 (10.19)
Cylinder bore x stroke mm (in)	37.0 x 25.8 (1.457 x 1.016)
Direction of rotation	Clockwise (viewed from drive end)
Drive belt	Poly V

LUBRICATION OIL

Model	DIESEL-KIKI make DKS-16H
Type	SUNISO 5GS
Capacity m ² (US fl oz, Imp fl oz) Total in system	200 (6.8, 7.0)
Amount of oil which can be drained	130 (4.4, 4.6)
Compressor (Service parts) charging amount	200 (6.8, 7.0)

REFRIGERANT

Type	R12
Capacity kg (lb)	0.75 - 0.85 (1.65 - 1.87)

Inspection and Adjustment

ENGINE IDLING SPEED (When A/C is ON.)

- Refer to EF & EC section.

BELT TENSION

- Refer to Checking Drive Belts (MA section).

COMPRESSOR

Model	DKS-16H
Clutch disc-pulley clearance mm (in)	0.3 - 0.6 (0.012 - 0.024)

ELECTRICAL SYSTEM

SECTION **EL**

When you read wiring diagrams:

- Read GI section, "HOW TO READ WIRING DIAGRAMS".

CONTENTS

PRECAUTIONS	EL- 2
HARNESS CONNECTOR	EL- 3
STANDARDIZED RELAY	EL- 4
POWER SUPPLY ROUTING	EL- 6
BATTERY	EL- 11
STARTING SYSTEM	EL- 19
STARTING SYSTEM — Starter —	EL- 21
CHARGING SYSTEM	EL- 27
CHARGING SYSTEM — Alternator —	EL- 29
COMBINATION SWITCH	EL- 37
INSTRUMENT SWITCH	EL- 40
HEADLAMP	EL- 42
EXTERIOR LAMP	EL- 49
INTERIOR LAMP	EL- 54
METER AND GAUGES	EL- 57
WARNING LAMPS AND CHIME	EL- 63
TIME CONTROL SYSTEM	EL- 68
WIPER AND WASHER	EL- 83
HORN, CIGARETTE LIGHTER, CLOCK	EL- 88
REAR WINDOW DEFOGGER	EL- 89
AUDIO AND POWER ANTENNA	EL- 92
AUTOMATIC SPEED CONTROL DEVICE (A.S.C.D.)	EL- 98
THEFT WARNING SYSTEM	EL-115
LOCATION OF ELECTRICAL UNITS	EL-136
HARNESS LAYOUT	EL-141
SPECIAL SERVICE TOOLS	EL-155

WIRING DIAGRAM REFERENCE CHART

E.C.C.S.	EF & EC SECTION
AT CONTROL, SHIFT LOCK	AT SECTION
ADJUSTABLE SHOCK ABSORBER	FA SECTION
ANTI-LOCK BRAKING SYSTEM	BR SECTION
POWER STEERING, SUPER HICAS	ST SECTION
HEATER AND AIR CONDITIONER	HA SECTION
POWER WINDOW, POWER DOOR LOCK, DOOR MIRROR, POWER SEAT, AUTOMATIC SEAT BELT AND SRS "AIR BAG"	BF SECTION

EL

PRECAUTIONS

Supplemental Restraint System "AIR BAG"

The Supplemental Restraint System "Air Bag" helps to reduce the risk or severity of injury to the driver in a frontal collision. The Supplemental Restraint System consists of an air bag (located in the center of the steering wheel), sensors, a control unit, warning lamp, wiring harness and spiral cable. Information necessary to service the system safely is included in the **BF section** of this Service Manual.

WARNING:

- a. To avoid rendering the SRS inoperative, which could lead to personal injury or death in the event of a severe frontal collision, all maintenance must be performed by an authorized NISSAN dealer.
- b. Improper maintenance, including incorrect removal and installation of the SRS, can lead to personal injury caused by unintentional activation of the system.
- c. All SRS electrical wiring harnesses and connectors are covered with yellow outer insulation. Do not use electrical test equipment on any circuit related to the SRS "Air Bag".

HARNESS CONNECTOR

Description

HARNESS CONNECTOR

- All harness connectors have been modified to prevent accidental looseness or disconnection.
- The connector can be disconnected by pushing or lifting the locking section.

CAUTION:

Do not pull the harness when disconnecting the connector.

[Example]

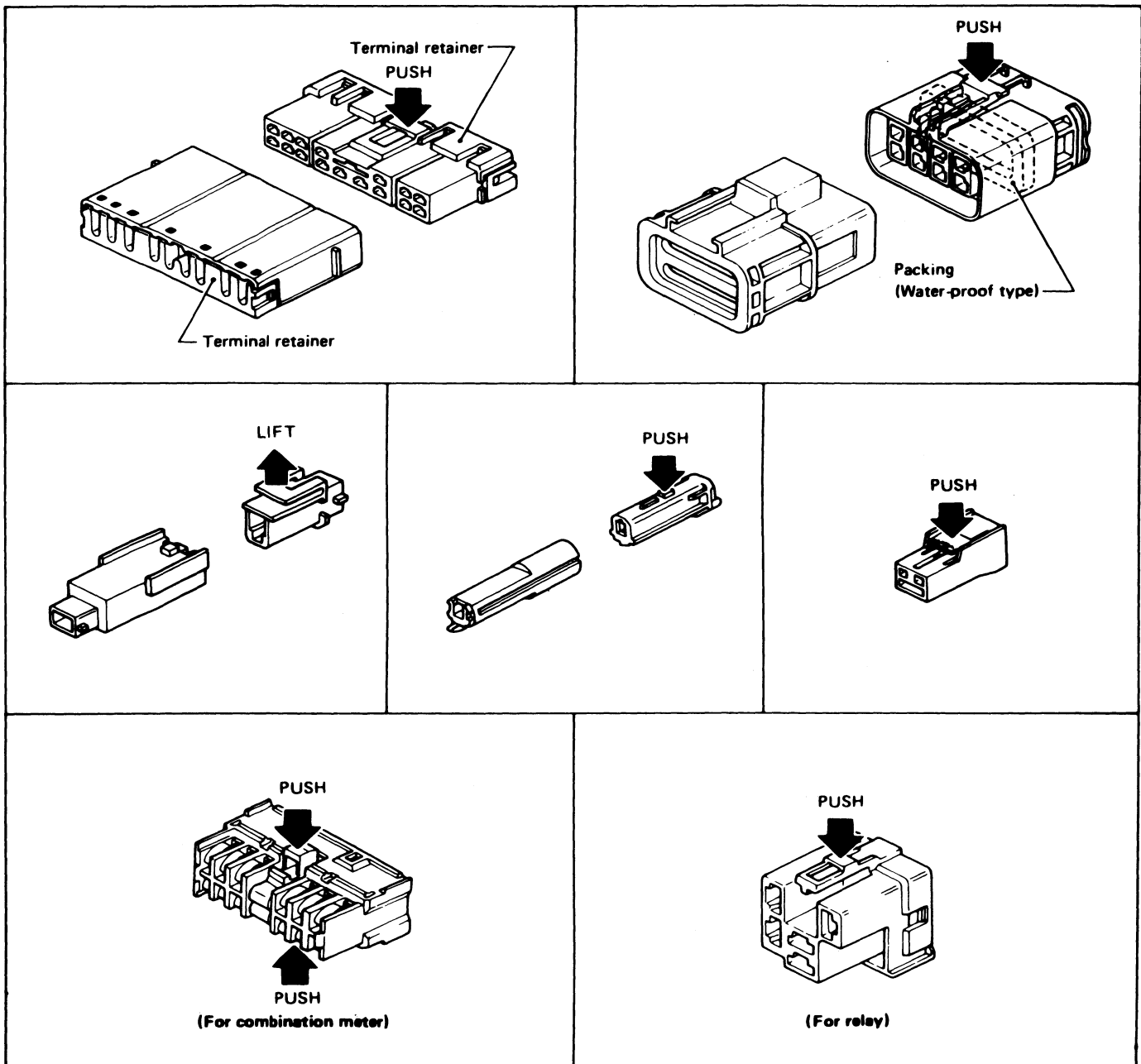

SEL769D

STANDARDIZED RELAY

Description

NORMAL OPEN, NORMAL CLOSED AND MIXED TYPE RELAYS

Relays can mainly be divided into three types: normal open, normal closed and mixed type relays.

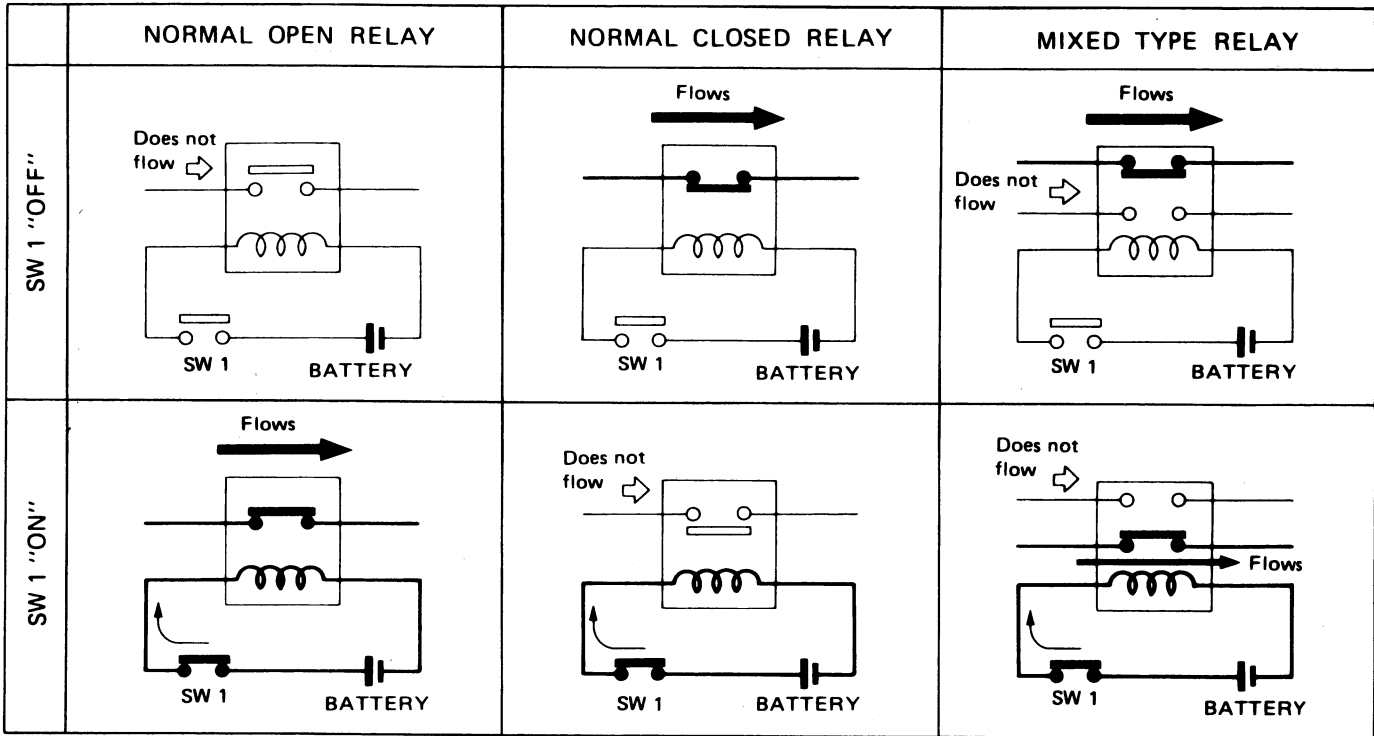

SEL881H

TYPE OF STANDARDIZED RELAYS

1M 1 Make 2M 2 Make
 1T 1 Transfer 1M·1B 1 Make 1 Break

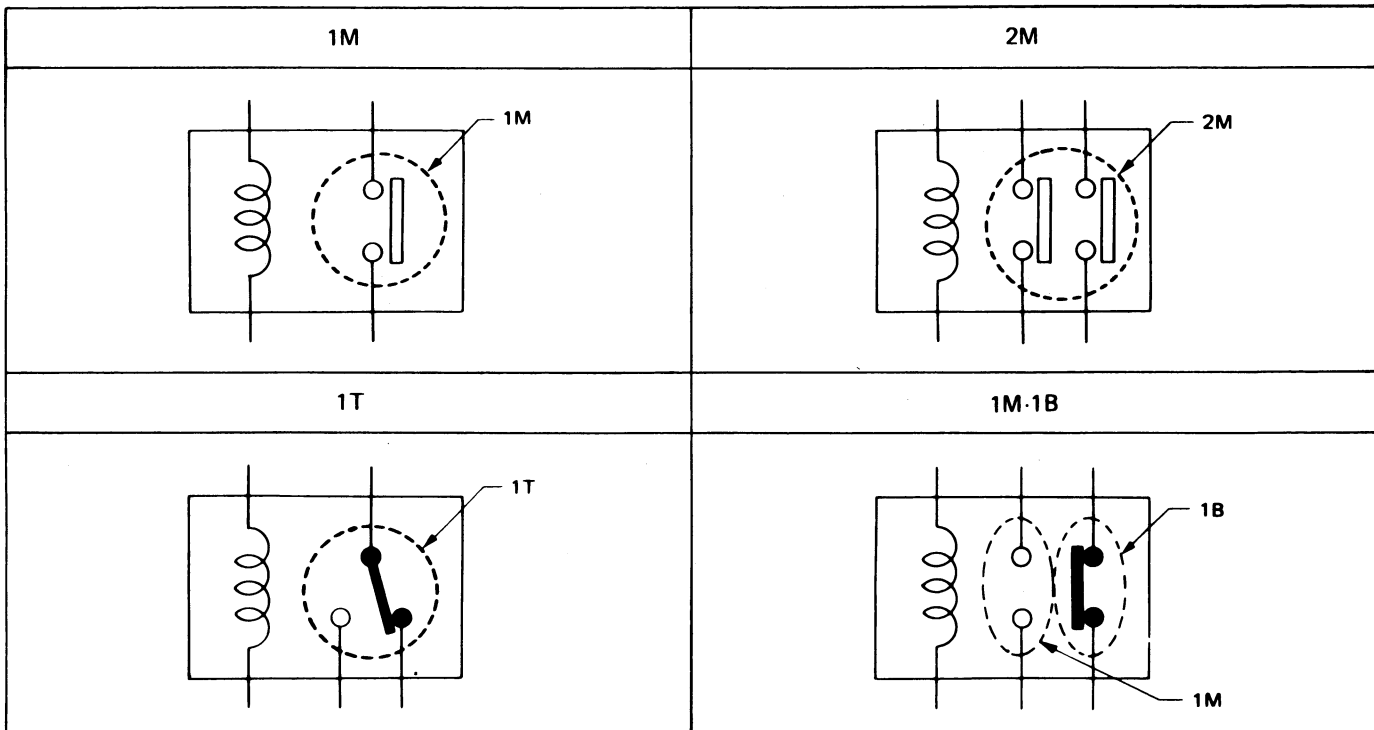

SEL882H

STANDARDIZED RELAY

Type	Outer view	Circuit	Connector symbol and connection	Case color
1T				BLACK
1M				BLUE or GREEN
2M				BROWN
1M-1B				GRAY

SEL883H

POWER SUPPLY ROUTING

Wiring Diagram

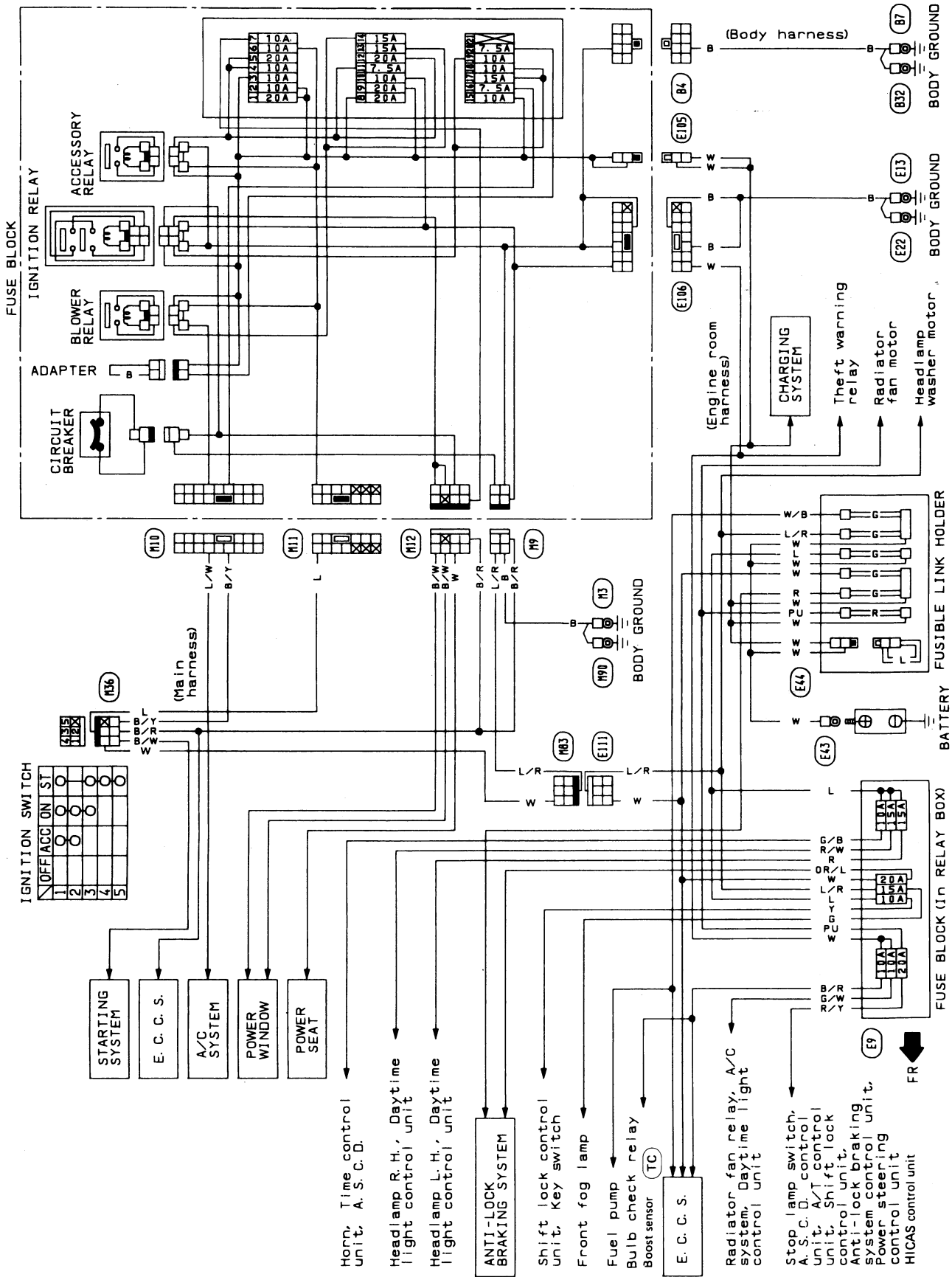

TC : Turbo model

POWER SUPPLY ROUTING

Wiring Diagram (Cont'd)

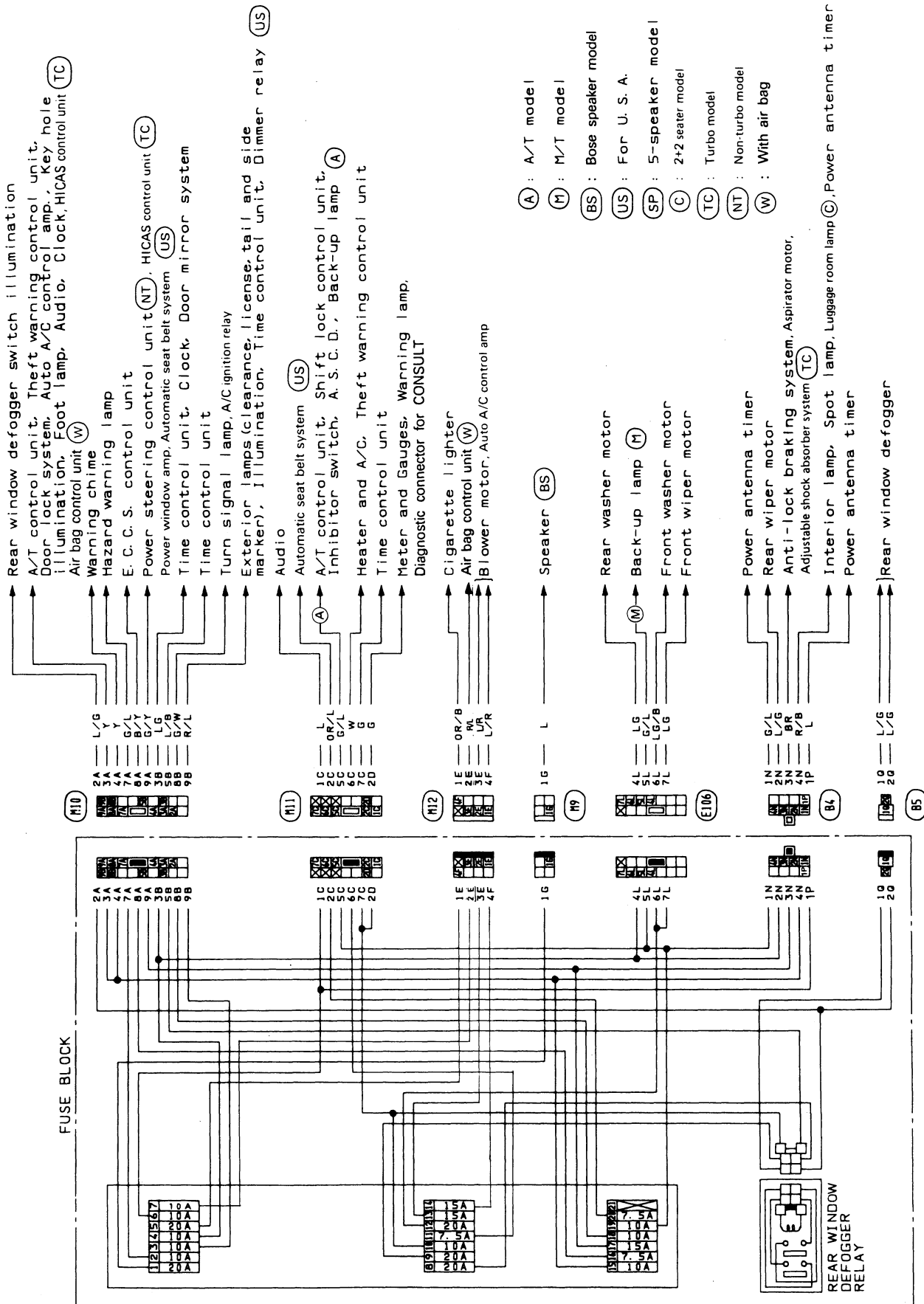

POWER SUPPLY ROUTING

Fuse Block Internal Circuit

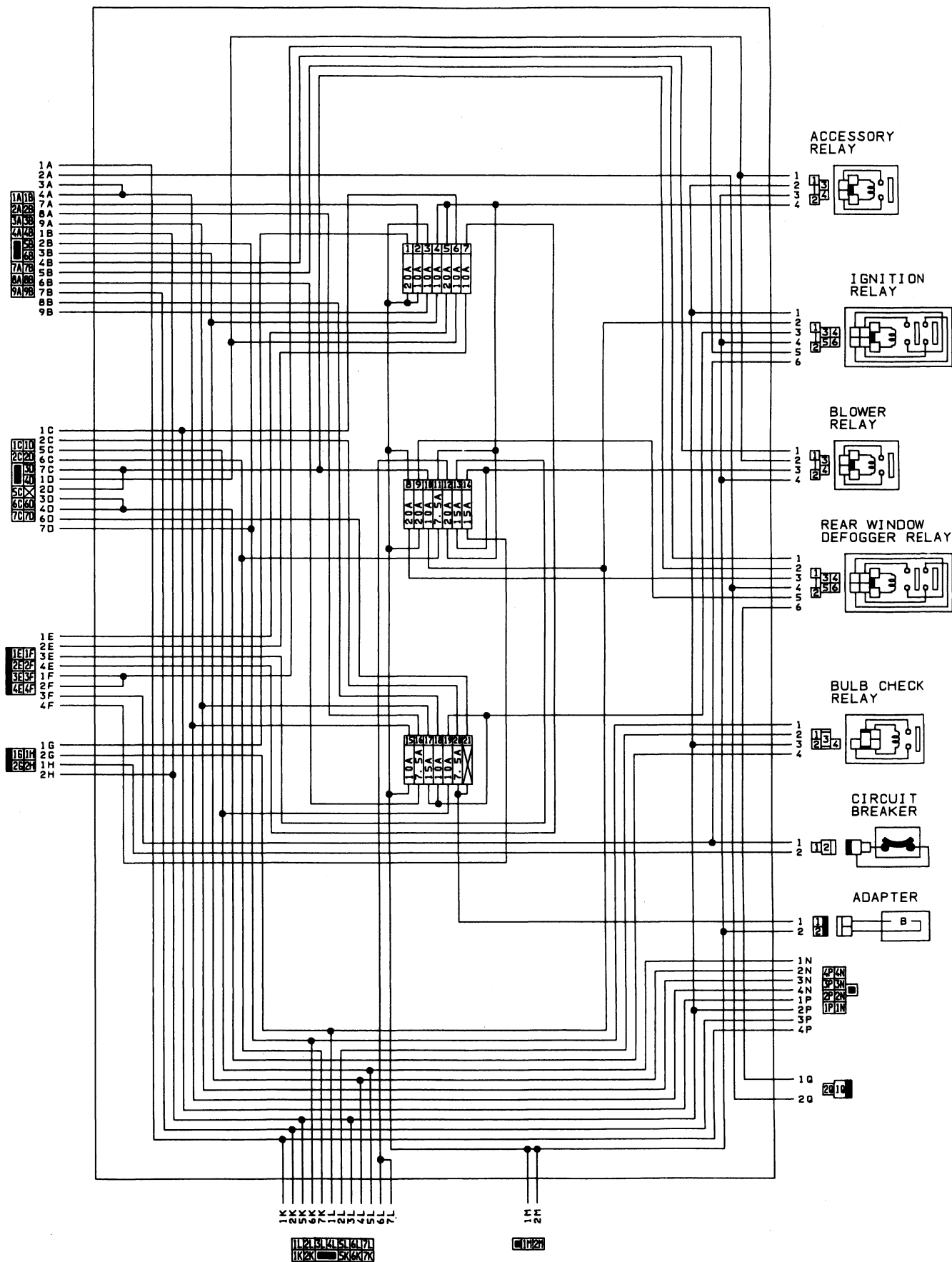

SEL919P

POWER SUPPLY ROUTING

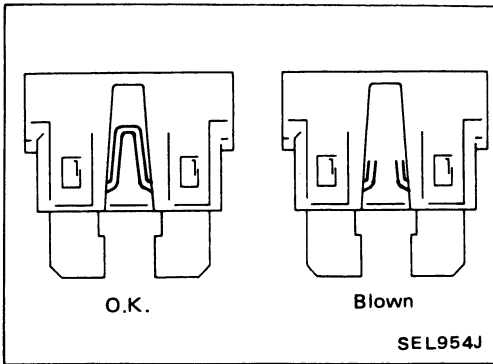

Fuse

- If fuse is blown, be sure to eliminate cause of problem before installing new fuse.
- Use fuse of specified rating. Never use fuse of more than specified rating.
- Do not install fuse in oblique direction; always insert it into fuse holder properly.
- Remove fuse for clock if vehicle is not used for a long period of time.

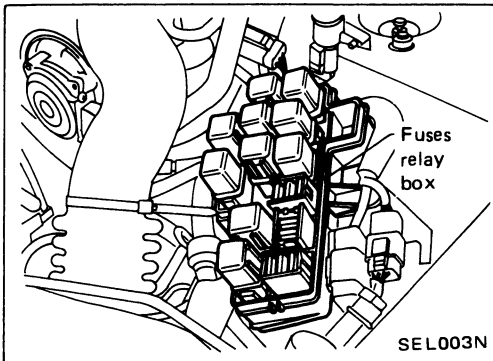

Fusible Link

A melted fusible link can be detected either by visual inspection or by feeling with finger tip. If its condition is questionable, use circuit tester or test lamp.

CAUTION:

- If fusible link should melt, it is possible that critical circuit (power supply or large current carrying circuit) is shorted. In such a case, carefully check and eliminate cause of problem.
- Never wrap periphery of fusible link with vinyl tape. Extreme care should be taken with this link to ensure that it does not come into contact with any other wiring harness or vinyl or rubber parts.

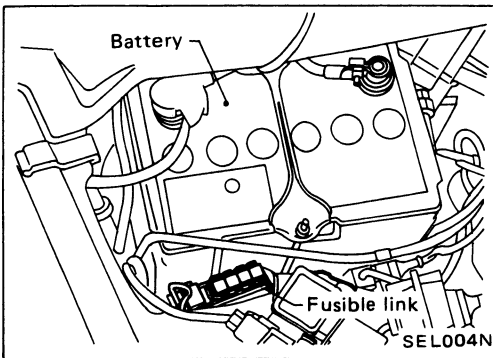

POWER SUPPLY ROUTING

NOTE

BATTERY

CAUTION:

- If it becomes necessary to start the engine with a booster battery and jumper cables, use a 12-volt booster battery.
- After connecting battery cables, ensure that they are tightly clamped to battery terminals for good contact.
- Never add distilled water through the hole used to check specific gravity.

How to Handle Battery

METHODS OF PREVENTING OVER-DISCHARGE

The following precautions must be taken to prevent over-discharging a battery.

- The battery surface (particularly its top) should always be kept clean and dry.
If the top surface of a battery is wet with electrolyte or water, leakage current will cause the battery to discharge. Always keep the battery clean and dry.

- When the vehicle is not going to be used over a long period of time, disconnect the negative battery terminal. (If the vehicle has an extended storage switch, turn it off.)

- Check the charge condition of the battery.
Periodically check the specific gravity of the electrolyte. Keep a close check on charge condition to prevent over-discharge.

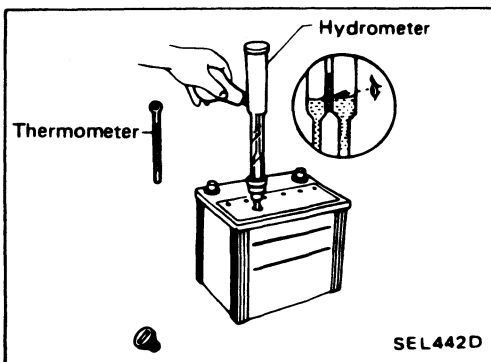
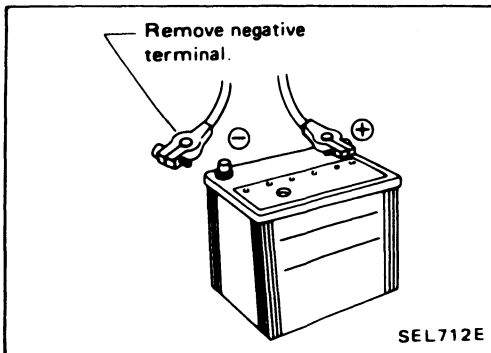
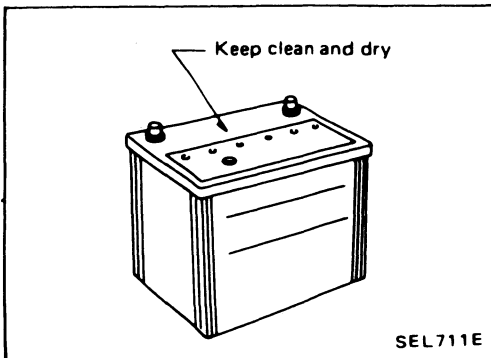

BATTERY

How to Handle Battery (Cont'd)

CHECKING ELECTROLYTE LEVEL

WARNING:

Do not allow battery fluid to come in contact with skin, eyes, fabrics, or painted surfaces. After touching a battery, do not touch or rub your eyes until you have thoroughly washed your hands. If the acid contacts the eyes, skin or clothing, immediately flush with water for 15 minutes and seek medical attention.

Normally the battery does not require additional water. However, when the battery is used under severe conditions, adding distilled water may be necessary during the battery life.

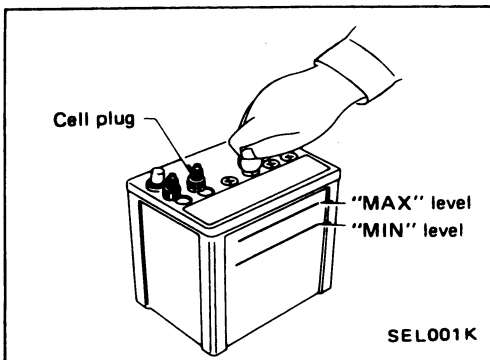

- Remove the cell plug using a suitable tool.
- Add distilled water up to the MAX level.

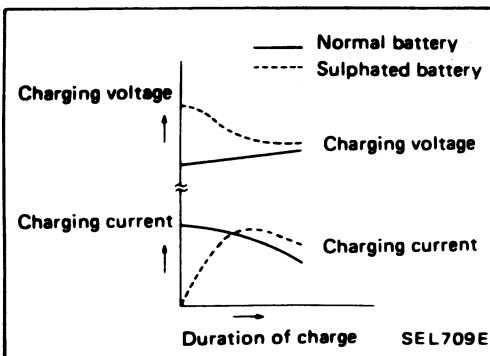

SULPHATION

When a battery has been left unattended for a long period of time and has a specific gravity of less than 1.100, it will be completely discharged, resulting in sulphation on the cell plates.

Compared with a battery discharged under normal conditions, the current flow in a "sulphated" battery is not as smooth although its voltage is high during the initial stage of charging, as shown in the figure at the left.

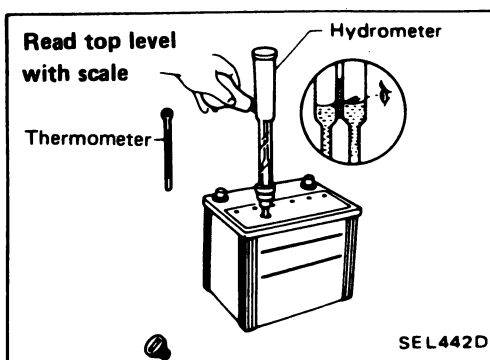

SPECIFIC GRAVITY CHECK

1. Read hydrometer and thermometer indications at eye level.

BATTERY

How to Handle Battery (Cont'd)

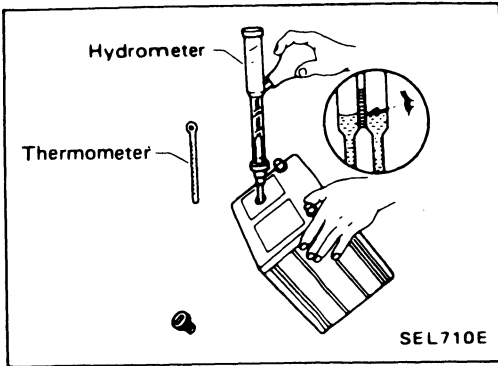

- When electrolyte level is too low, tilt battery case to raise it for easy measurement.

2. Convert into specific gravity at 20°C (68°F).

Example:

- When electrolyte temperature is 35°C (95°F) and specific gravity of electrolyte is 1.230, converted specific gravity at 20°C (68°F) is 1.240.
- When electrolyte temperature is 0°C (32°F) and specific gravity of electrolyte is 1.210, converted specific gravity at 20°C (68°F) is 1.196.

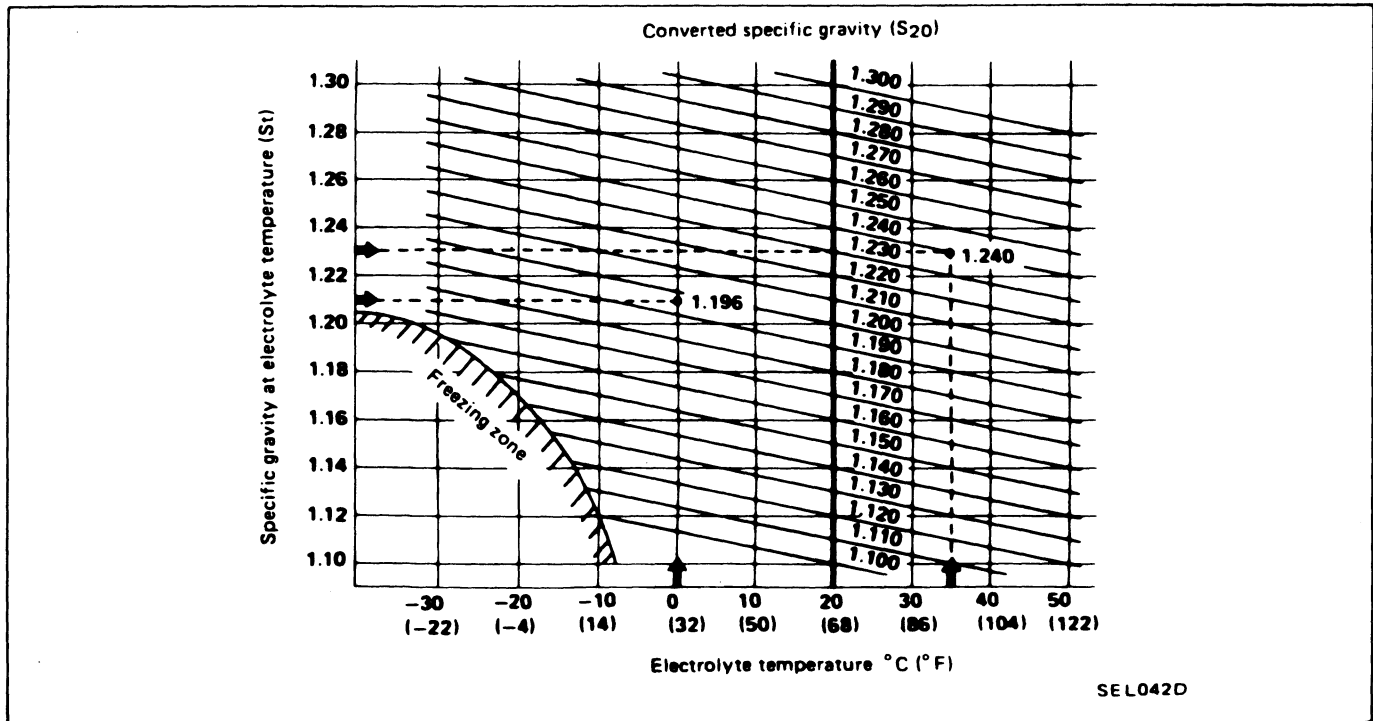

BATTERY

Battery Test and Charging Chart

Chart I

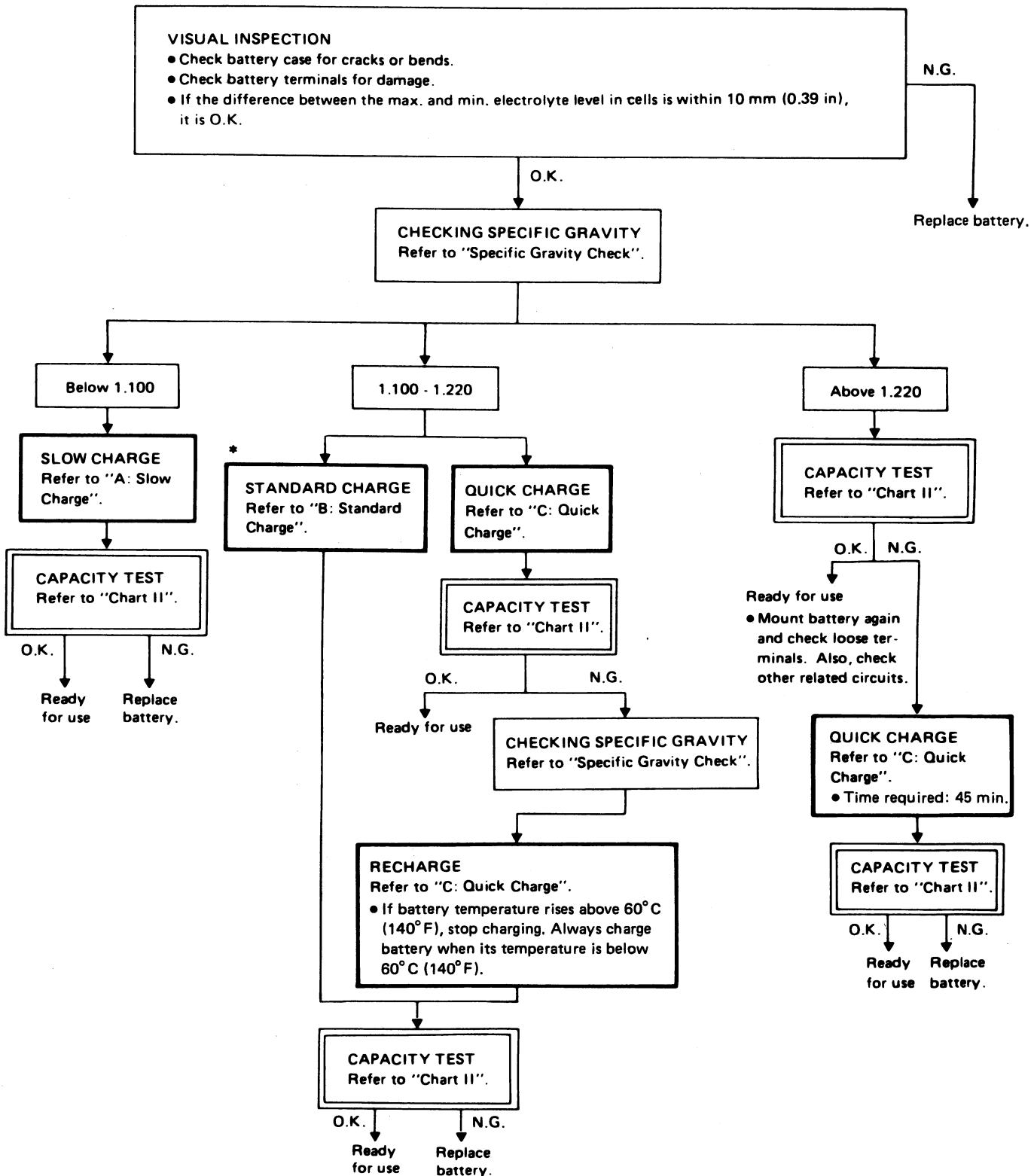

* "STANDARD CHARGE" is recommended in case that the vehicle is in storage after charging.

BATTERY

Battery Test and Charging Chart (Cont'd)

Chart II

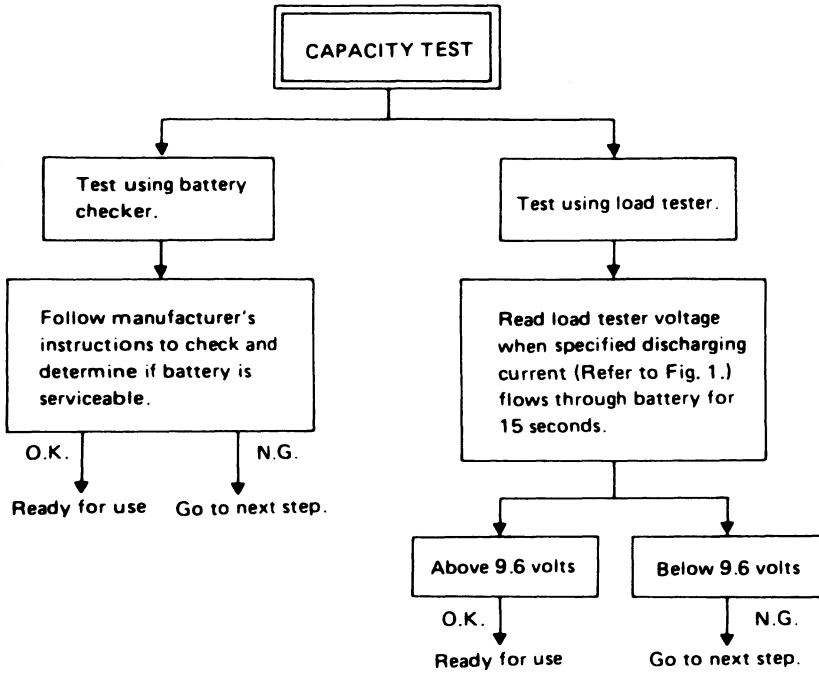

- Check battery type and determine the specified current using the following table.

Fig. 1 DISCHARGING CURRENT (Load tester)

Type	Current (A)
28B19R(L)	90
34B19R(L)	99
46B24R(L)	135
55B24R(L)	135
50D23R(L)	150
55D23R(L)	180
65D26R(L)	195
80D26R(L)	195
75D31R(L)	210
95D31R(L)	240
95E41R(L)	300
130E41R(L)	330

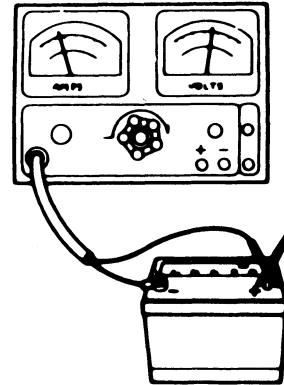

SEL697B

BATTERY

Battery Test and Charging Chart (Cont'd)

A: SLOW CHARGE

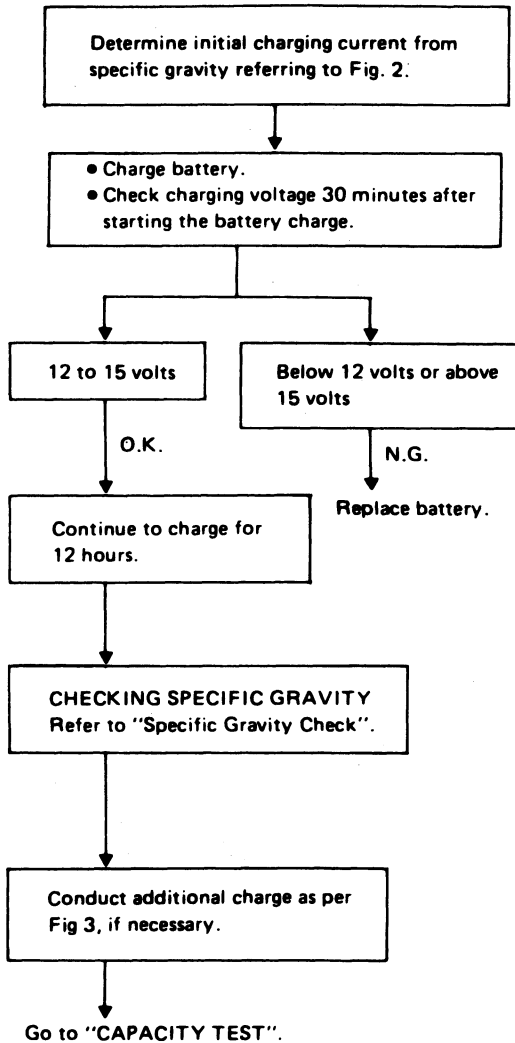
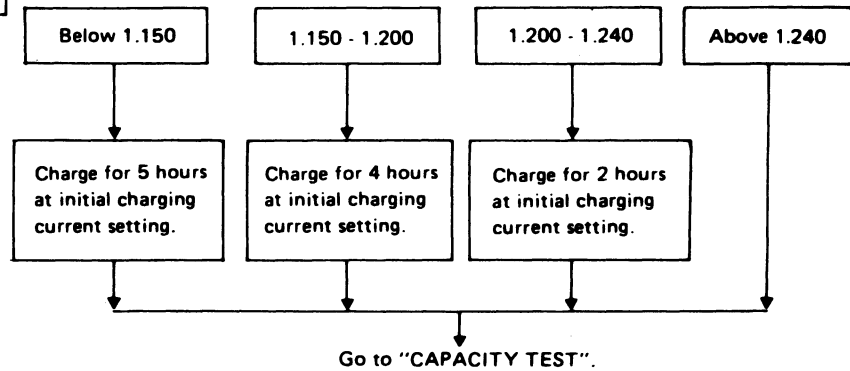

Fig. 2 INITIAL CHARGING CURRENT SETTING (Slow charge)

BATTERY TYPE CON- VERTED SPECIFIC GRAVITY	28B19R(L) 34B19R(L)	46B24R(L) 55B24R(L)	50D23R(L) 55D23R(L)	65D26R(L) 80D26R(L)	75D31R(L)	95D31R(L) 95E41R(L)	130E41R(L)
Below 1.100	4.0 (A)	5.0 (A)	7.0 (A)	8.0 (A)	9.0 (A)	10.0 (A)	14.0 (A)

- Check battery type and determine the specified current using the table shown above.
- After starting charging, adjustment of charging current is not necessary.

Fig. 3 ADDITIONAL CHARGE (Slow charge)



CAUTION:

- Set charging current to value specified in Fig. 2. If charger is not capable of producing specified current value, set its charging current as close to that value as possible.
- Keep battery away from open flame while it is being charged.
- When connecting charger, connect leads first, then turn on charger. Do not turn on charger first, as this may cause a spark.
- If battery temperature rises above 60°C (140°F), stop charging. Always charge battery when its temperature is below 60°C (140°F).

BATTERY

Battery Test and Charging Chart (Cont'd)

B: STANDARD CHARGE

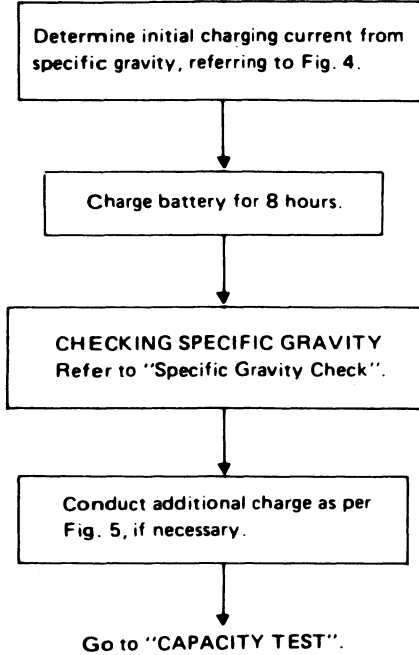
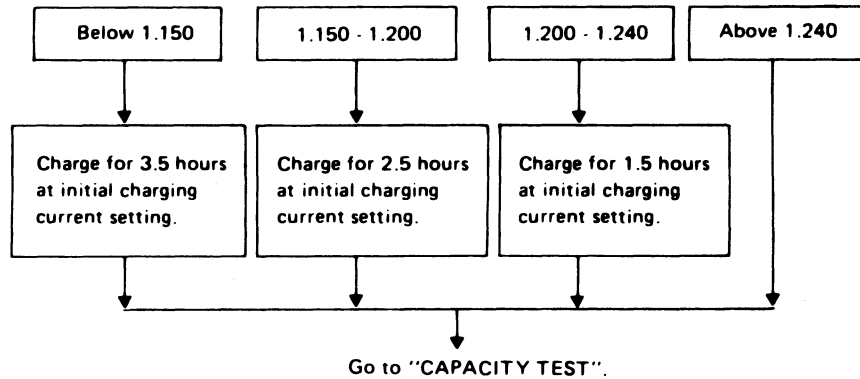

Fig. 4 INITIAL CHARGING CURRENT SETTING
(Standard charge)

BATTERY TYPE CON- VERTED SPECIFIC GRAVITY	28B19R(L) 34B19R(L)	46B24R(L) 55B24R(L)	50D23R(L) 55D23R(L)	65D26R(L) 80D26R(L)	75D31R(L)	95D31R(L) 95E41R(L)	130E41R(L)
	1.100 - 1.130	4.0 (A)	5.0 (A)	6.0 (A)	7.0 (A)	8.0 (A)	9.0 (A)
1.130 - 1.160	3.0 (A)	4.0 (A)	5.0 (A)	6.0 (A)	7.0 (A)	8.0 (A)	11.0 (A)
1.160 - 1.190	2.0 (A)	3.0 (A)	4.0 (A)	5.0 (A)	6.0 (A)	7.0 (A)	9.0 (A)
1.190 - 1.220	2.0 (A)	2.0 (A)	3.0 (A)	4.0 (A)	5.0 (A)	5.0 (A)	7.0 (A)

- Check battery type and determine the specified current using the table shown above.
- After starting charging, adjustment of charging current is not necessary.

Fig. 5 ADDITIONAL CHARGE (Standard charge)



CAUTION:

- Do not use standard charge method on a battery whose specific gravity is less than 1.100.
- Set charging current to value specified in Fig. 4. If charger is not capable of producing specified current value, set its charging current as close to that value as possible.
- Keep battery away from open flame while it is being charged.
- When connecting charger, connect leads first, then turn on charger. Do not turn on charger first, as this may cause a spark.
- If battery temperature rises above 60°C (140°F), stop charging. Always charge battery when its temperature is below 60°C (140°F).

BATTERY

Battery Test and Charging Chart (Cont'd)

C: QUICK CHARGE

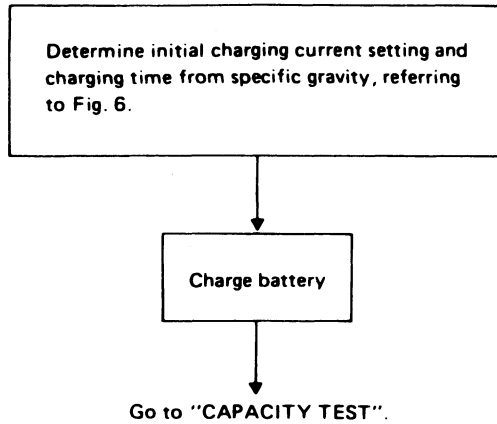

Fig. 6 INITIAL CHARGING CURRENT SETTING AND CHARGING TIME (Quick charge)

CON- VERTED SPECIFIC GRAVITY	BATTERY TYPE		CUR- RENT [A]	28B19R(L) 34B19R(L)	46B24R(L) 55B24R(L) 50D23R(L)	55D23R(L) 65D26R(L) 80D26R(L)	75D31R(L) 95D31R(L) 95E41R(L)	130E41R(L)
	10 (A)	15 (A)						
1.100 - 1.130	2.5 hours							
1.130 - 1.160	2.0 hours							
1.160 - 1.190	1.5 hours							
1.190 - 1.220	1.0 hours							
Above 1.220	0.75 hours (45 min.)							

- Check battery type and determine the specified current using the table shown above.
- After starting charging, adjustment of charging current is not necessary.

CAUTION:

- Do not use quick charge method on a battery whose specific gravity is less than 1.100.
- Set initial charging current to value specified in Fig. 6. If charger is not capable of producing specified current value, set its charging current as close to that value as possible.
- Keep battery away from open flame while it is being charged.
- When connecting charger, connect leads first, then turn on charger. Do not turn on charger first, as this may cause a spark.
- Be careful of a rise in battery temperature because a large current flow is required during quick-charge operation.
If battery temperature rises above 60°C (140°F), stop charging. Always charge battery when its temperature is below 60°C (140°F).
- Do not exceed the charging time specified in Fig. 6, because charging battery over the charging time can cause deterioration of the battery.

Service Data and Specifications (S.D.S.)

Applied model	M/T	A/T
Type	65D26L	80D26L
Capacity V-AH	12-65	

STARTING SYSTEM

Wiring Diagram

MODELS FOR U.S.A. AND A/T MODELS FOR CANADA

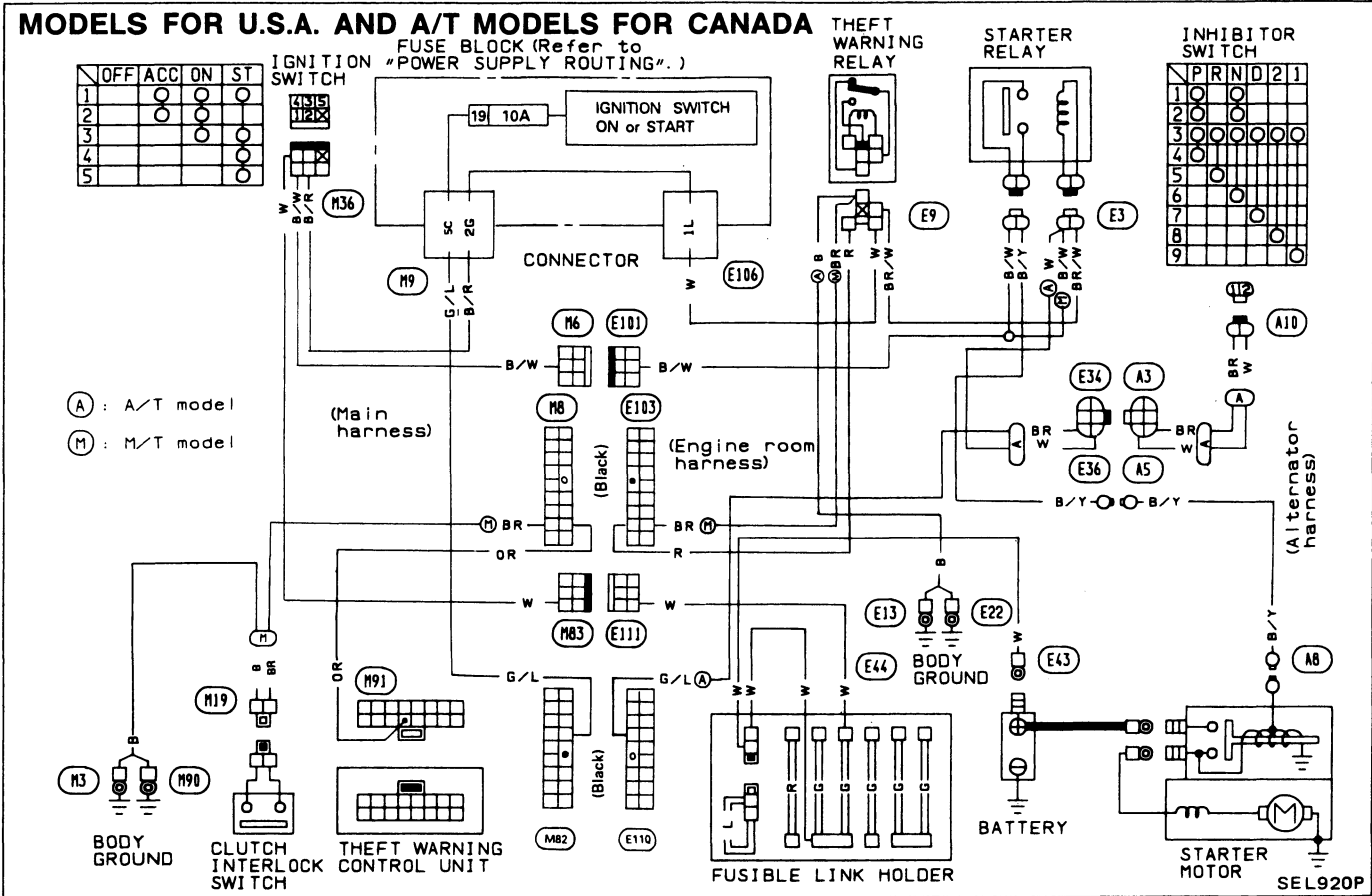

M/T MODELS FOR CANADA

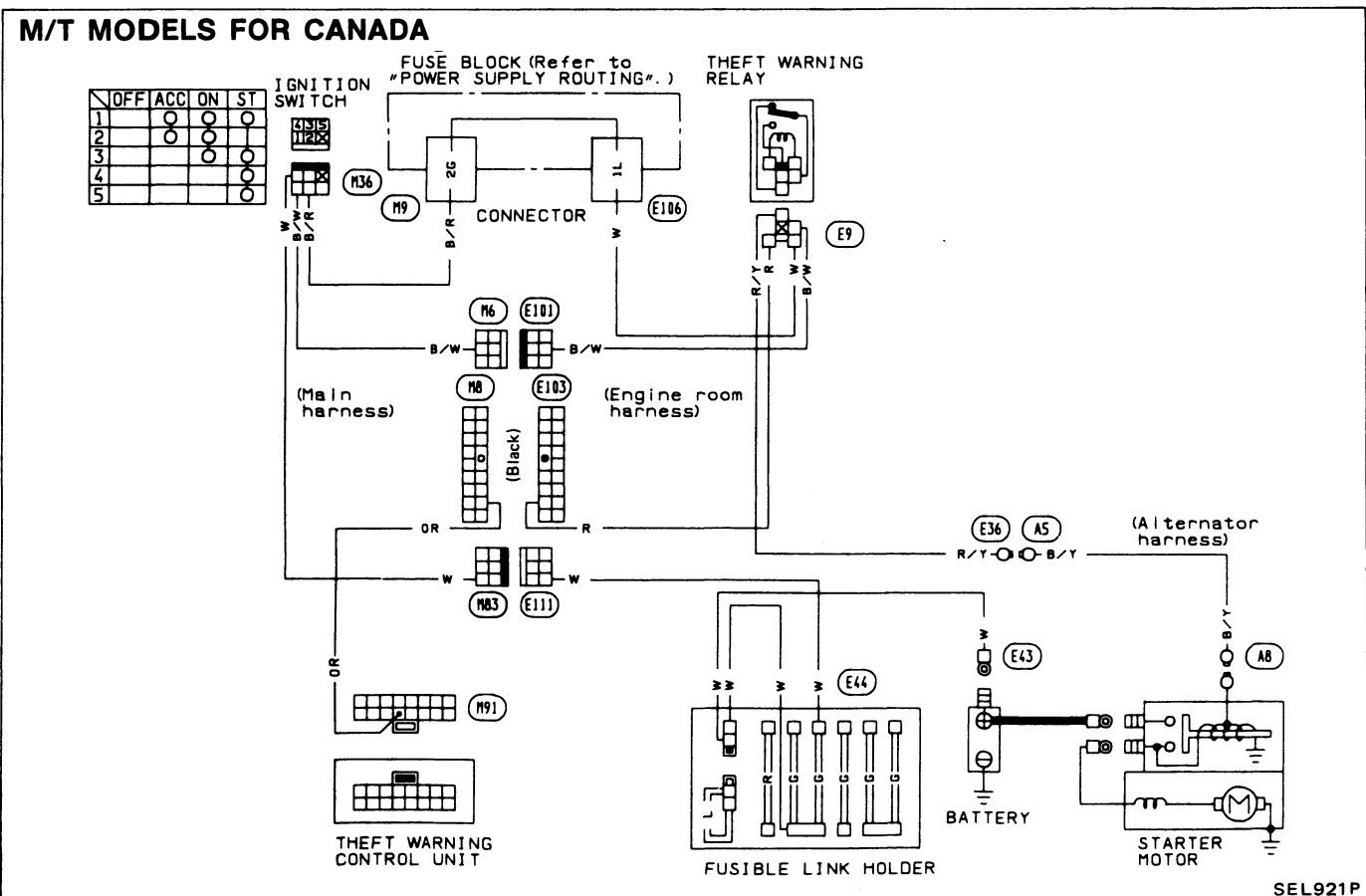

STARTING SYSTEM

Trouble-shooting

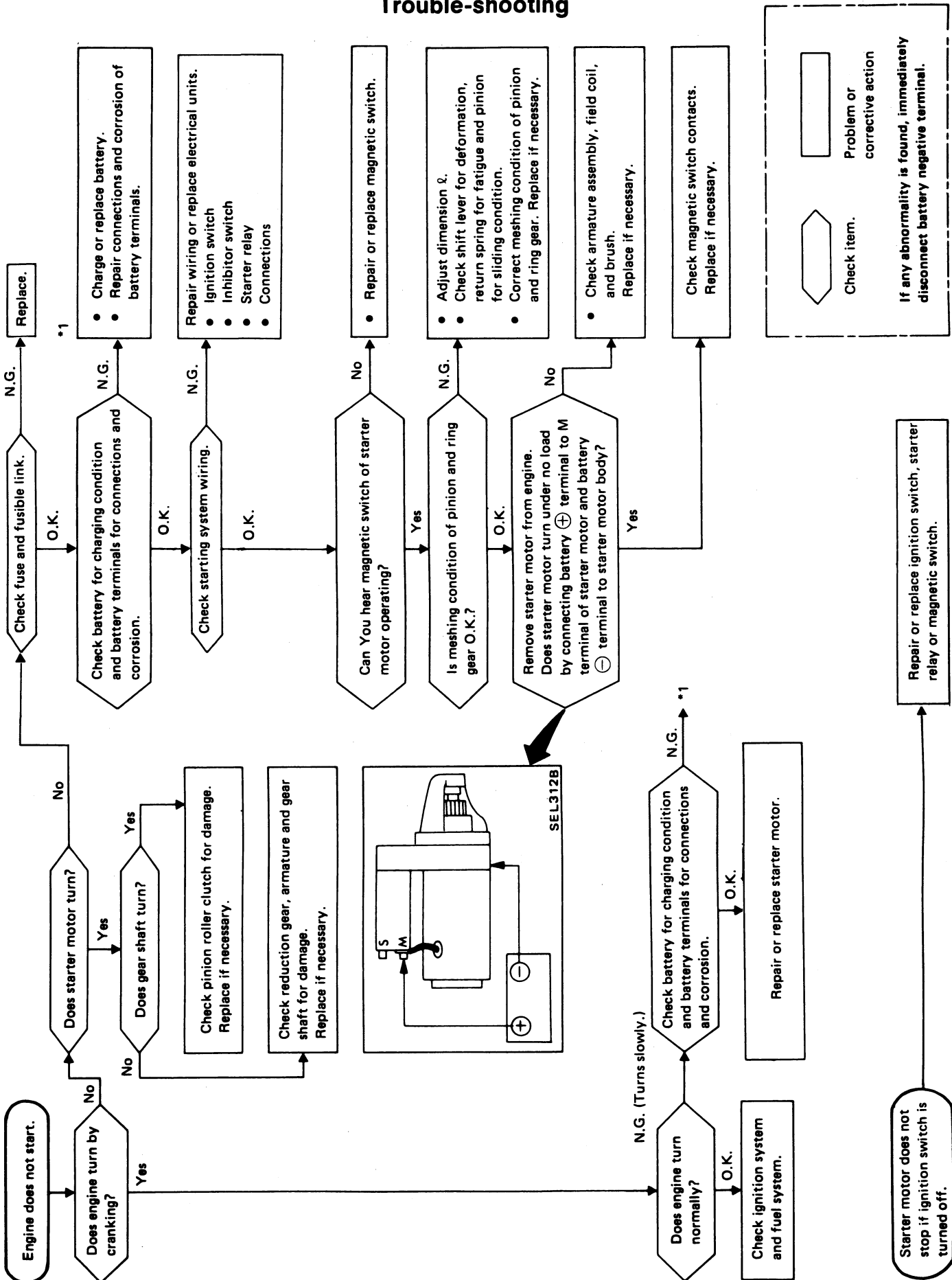

Construction

M2T25281

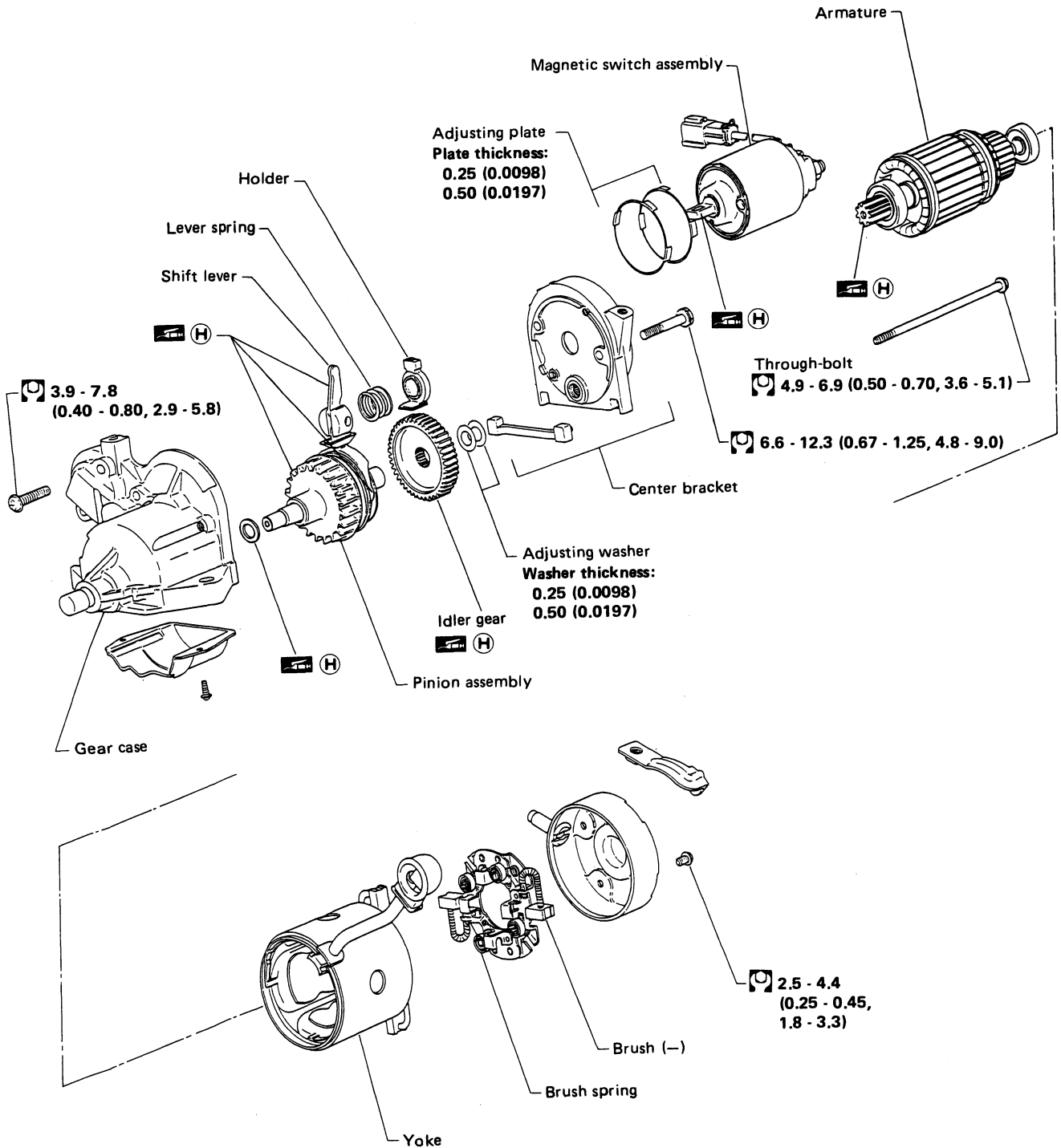

Unit: mm (in)
 [Torque symbol] : N·m (kg·m, ft·lb)
 [Grease symbol] (H) : High-temperature grease point

SEL038N

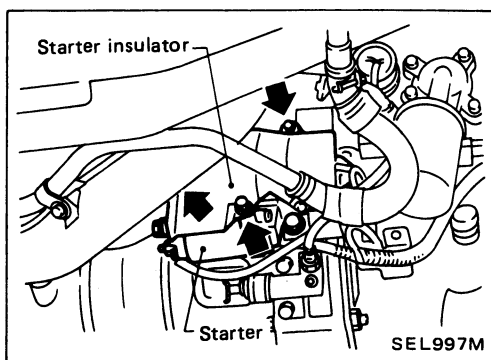

Removal and Installation

REMOVAL

1. Remove starter insulator.
2. Remove starter harness connector and cable.
3. Remove starter fixing bolt and nut and remove starter.

INSTALLATION

- Installation procedure is in reverse order of removal.

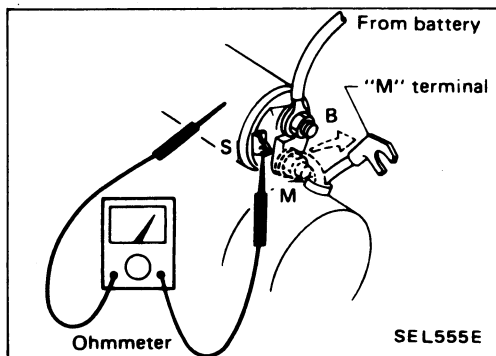

Magnetic Switch Check

- Before starting to check, disconnect battery ground cable.
 - Disconnect "M" terminal of starter motor.
1. Continuity test (between "S" terminal and switch body).
- No continuity ... Replace.

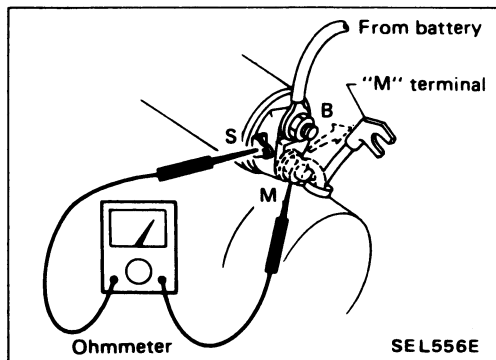

2. Continuity test (between "S" terminal and "M" terminal).
- No continuity ... Replace.

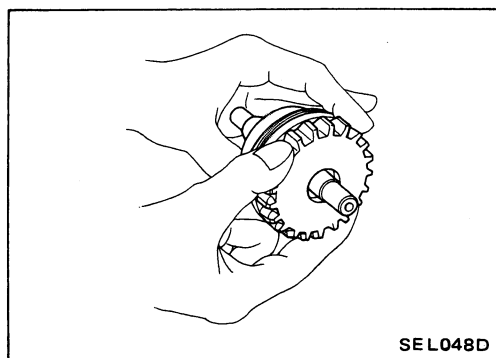

Pinion/Clutch Check

1. Inspect pinion teeth.
 - Replace pinion if teeth are worn or damaged. (Also check condition of ring gear teeth.)
2. Check to see if pinion locks in one direction and rotates smoothly in the opposite direction.
 - If it does not lock (or locks) in either direction or unusual resistance is evident ... Replace.
3. Inspect reduction gear teeth.
 - Replace reduction gear if teeth are worn or damaged. (Also check condition of armature shaft gear teeth.)

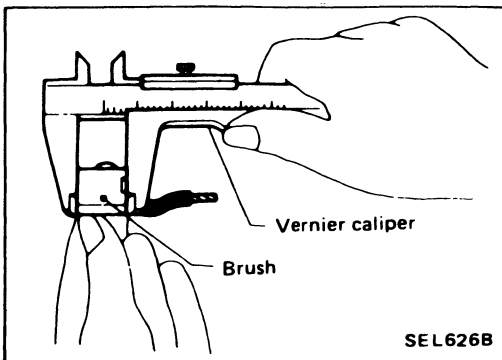

Brush Check

BRUSH

Check brush for wear.

Wear limit length:

Refer to S.D.S.

- Excessive wear ... Replace.

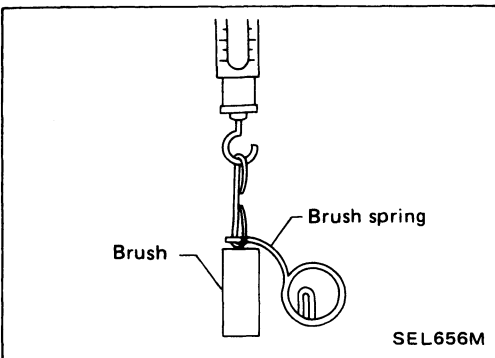

BRUSH SPRING PRESSURE

Check brush spring pressure with brush spring detached from brush.

Spring pressure (with new brush):

Refer to S.D.S.

- Not within the specified values ... Replace.

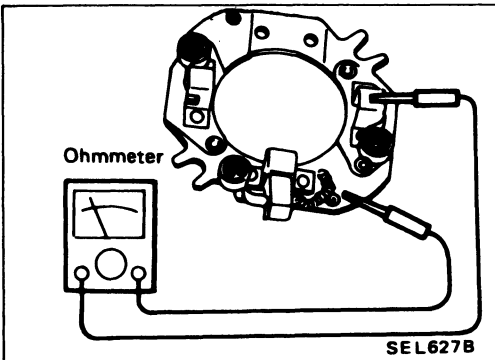

BRUSH HOLDER

1. Perform insulation test between brush holder (positive side) and its base (negative side).
 - Continuity exists. ... Replace.
2. Check brushes to see if they move smoothly.
 - If brush holder is bent, replace it; if surfaces of brush holder and base are dirty, clean them.

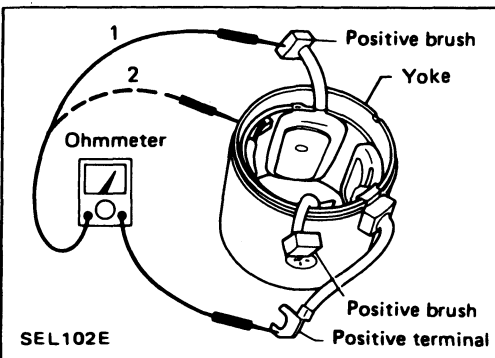

Field Coil Check

1. Continuity test (between field coil positive terminal and positive brushes).
 - No continuity ... Replace yoke.
2. Insulation test (between field coil positive terminal and yoke).
 - Continuity exists. ... Replace yoke.

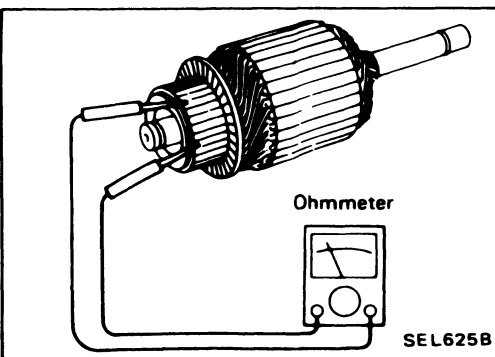

Armature Check

1. Continuity test (between two segments side by side).
 - No continuity ... Replace.

Armature Check (Cont'd)

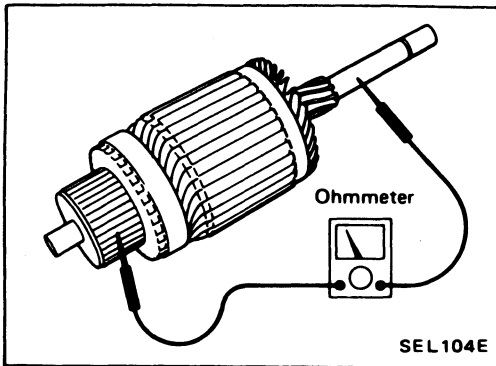

2. Insulation test (between each commutator bar and shaft).
 - Continuity exists. ... Replace.

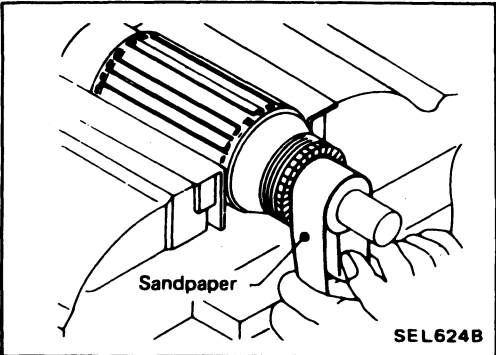

3. Check commutator surface.
 - Rough ... Sand lightly with No. 500 - 600 sandpaper.

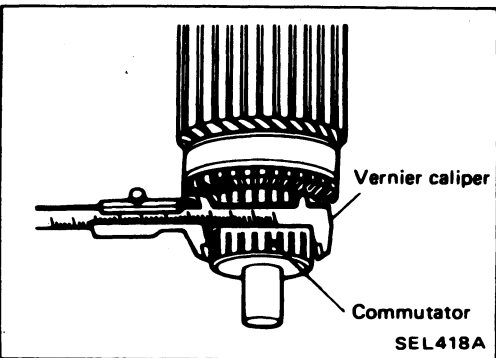

4. Check diameter of commutator.

**Commutator minimum diameter:
Refer to S.D.S.**

 - Less than specified value ... Replace.

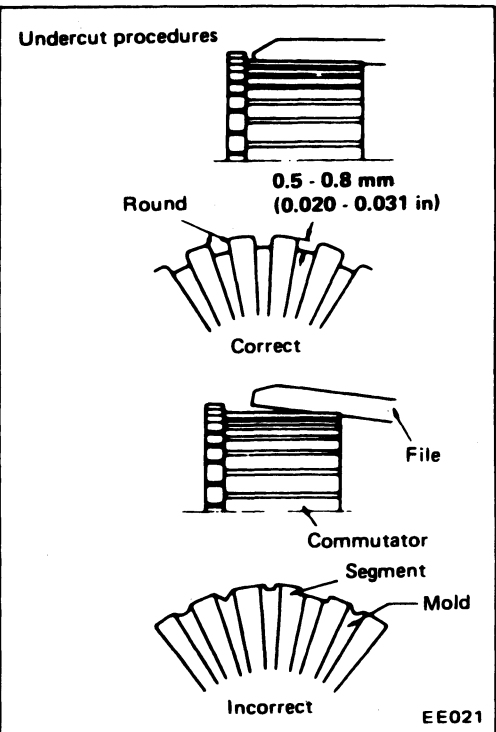

5. Check depth of insulating mold from commutator surface.
 - Less than 0.2 mm (0.008 in) ... Undercut to 0.5 to 0.8 mm (0.020 to 0.031 in)

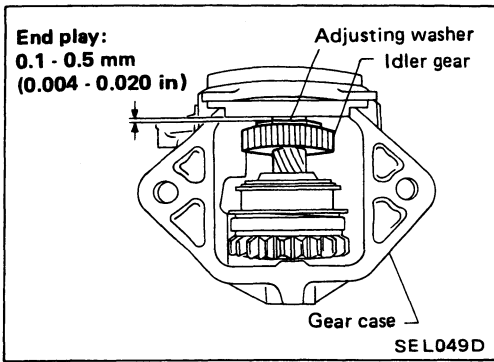

Reassembly

Carefully observe the following instructions.

a. Apply grease to:

- Rear cover metal
- Gear case metal
- Frictional surface of pinion
- Moving portion of shift lever
- Plunger of magnetic switch

b. After assembling gear case, pinion assembly, idler gear, adjusting washers and center bracket, turn idler gear with your hand in axial direction and adjust end play to the 0.1 to 0.5 mm (0.004 to 0.020 in) range using adjusting washer(s).

c. Check pinion to see if its engagement length is correct.

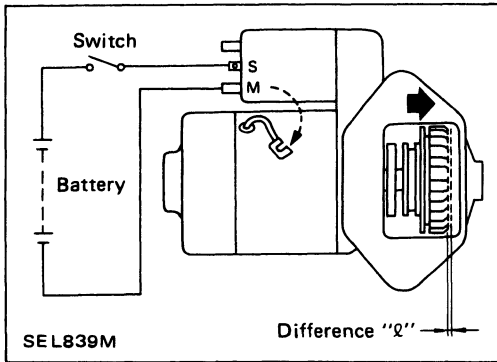

Measure difference in height "l" of pinion assembly front edge when pinion assembly is forced out by the magnetic switch and then when it is pulled out by hand.

Difference "l": 0.3 - 2.0 mm (0.012 - 0.079 in)

- Not in the specified value ... Adjust by adjusting plate.

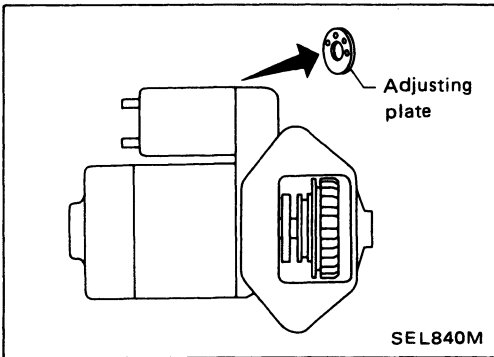

Service Data and Specifications (S.D.S.)**STARTER**

Type		M2T25281
		Reduction gear
System voltage		V 12
No-load	Terminal voltage	V 11.0
	Current	A 70
	Revolution	rpm More than 2,000
Minimum length of brush		mm (in) 11.5 (0.453)
Brush spring tension (With new brush)		N (kg, lb) 13.7 - 25.5 (1.4 - 2.6, 3.1 - 5.7)
Minimum diameter of commutator		mm (in) 31.4 (1.236)
Difference "ℓ" in height of pinion assembly		mm (in) 0.3 - 2.0 (0.012 - 0.079)

CHARGING SYSTEM

Wiring Diagram

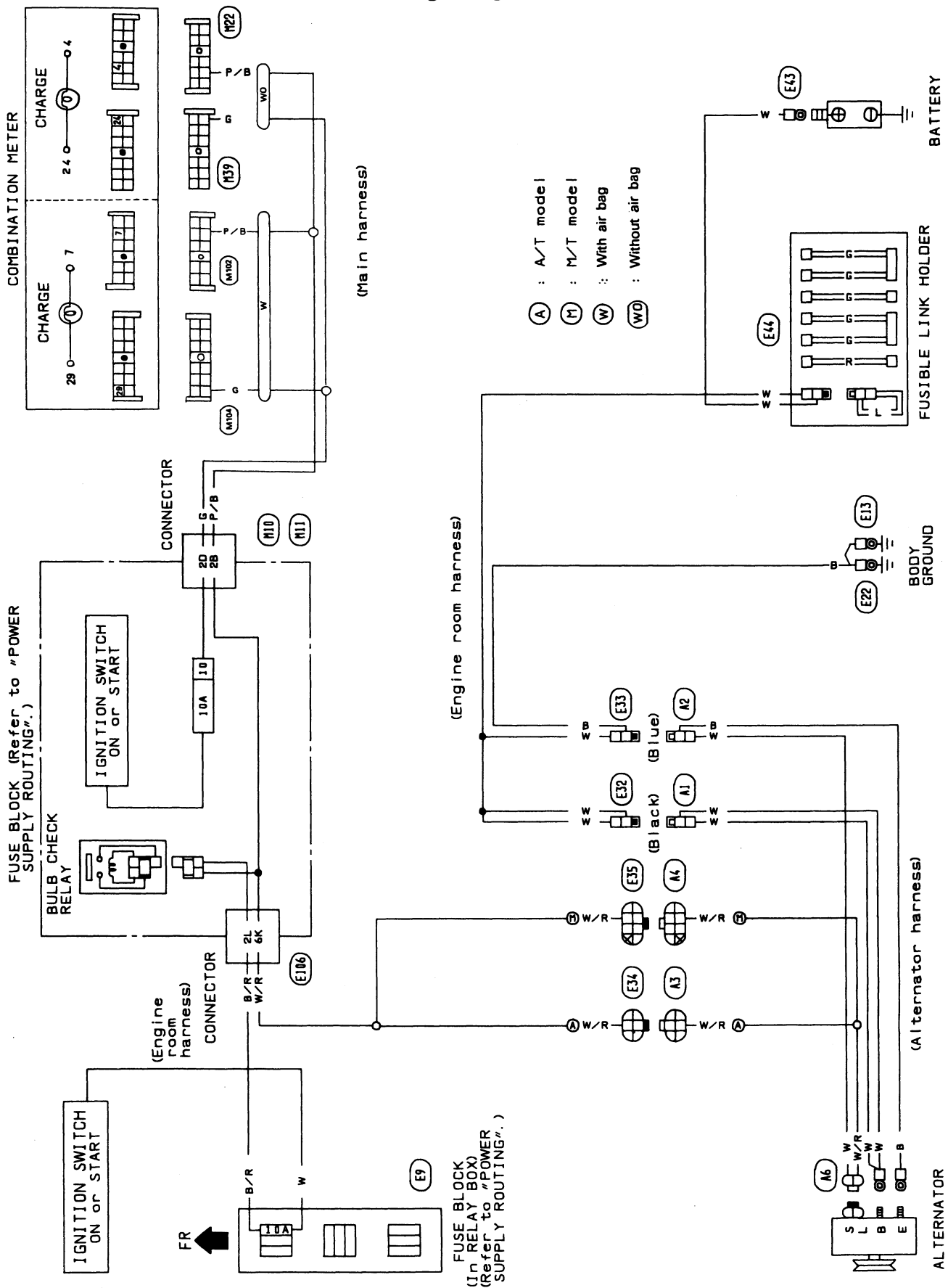

SEL922P

CHARGING SYSTEM

Trouble-shooting

Before conducting an alternator test, make sure that the battery is fully charged. A 30-volt voltmeter and suitable test probes are necessary for the test. The alternator can be checked easily by referring to the Inspection Table.

Before starting trouble-shooting, inspect the fusible link.

WITH IC REGULATOR

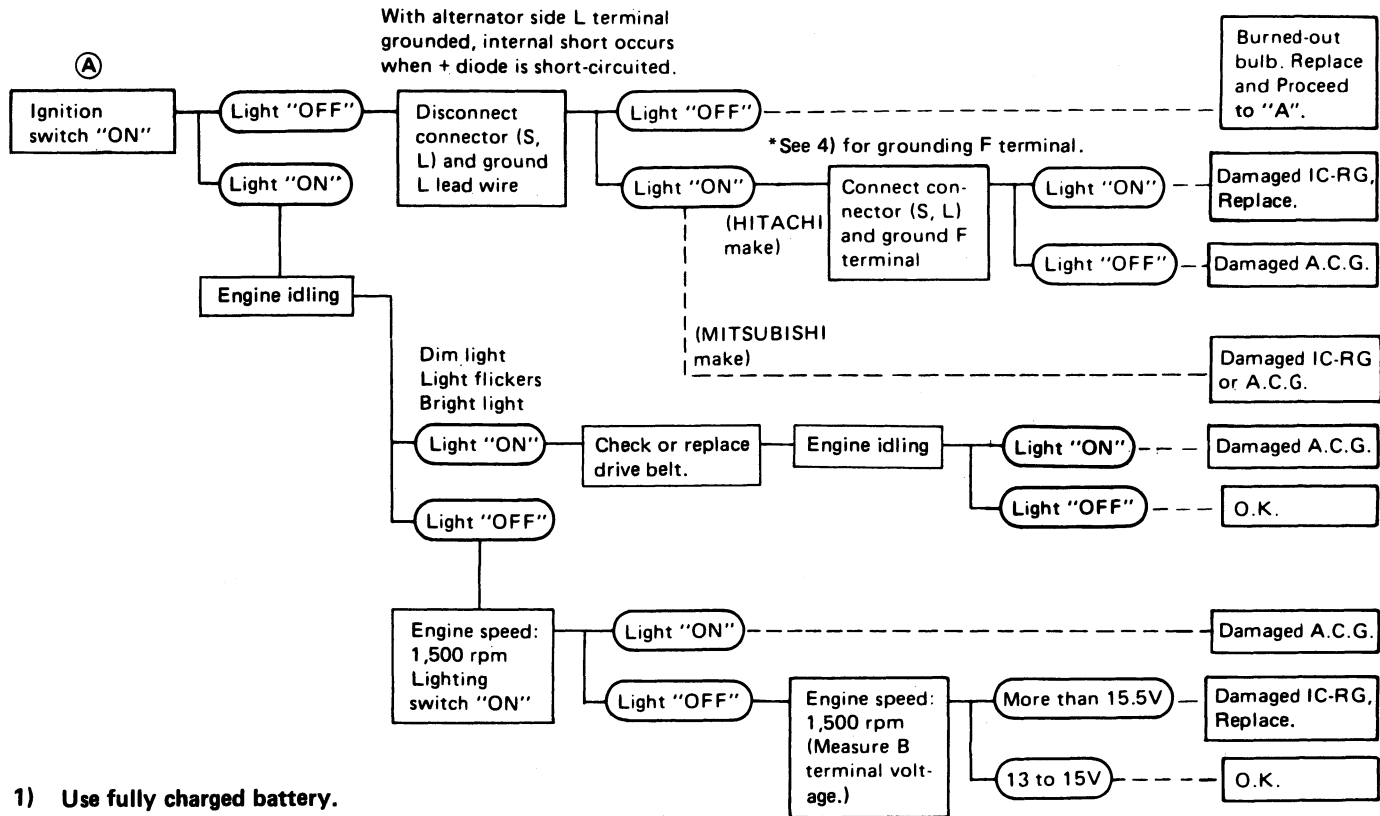

- 1) Use fully charged battery.
- 2) Light : Charge warning light
A.C.G. : Alternator parts except IC regulator
IC-RG : IC regulator
O.K. : IC alternator is in good condition.
- 3) When reaching "Damaged A.C.G.", remove alternator from vehicle and disassemble, inspect and correct or replace faulty parts.
- 4) *Method of grounding F terminal (HITACHI make only)

Gasoline engine model

Contact tip of wire with brush and attach wire to alternator body.

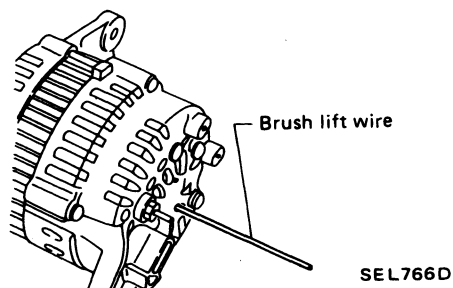

- 5) Terminals "S", "L", "B" and "E" are marked on rear cover of alternator.

Construction

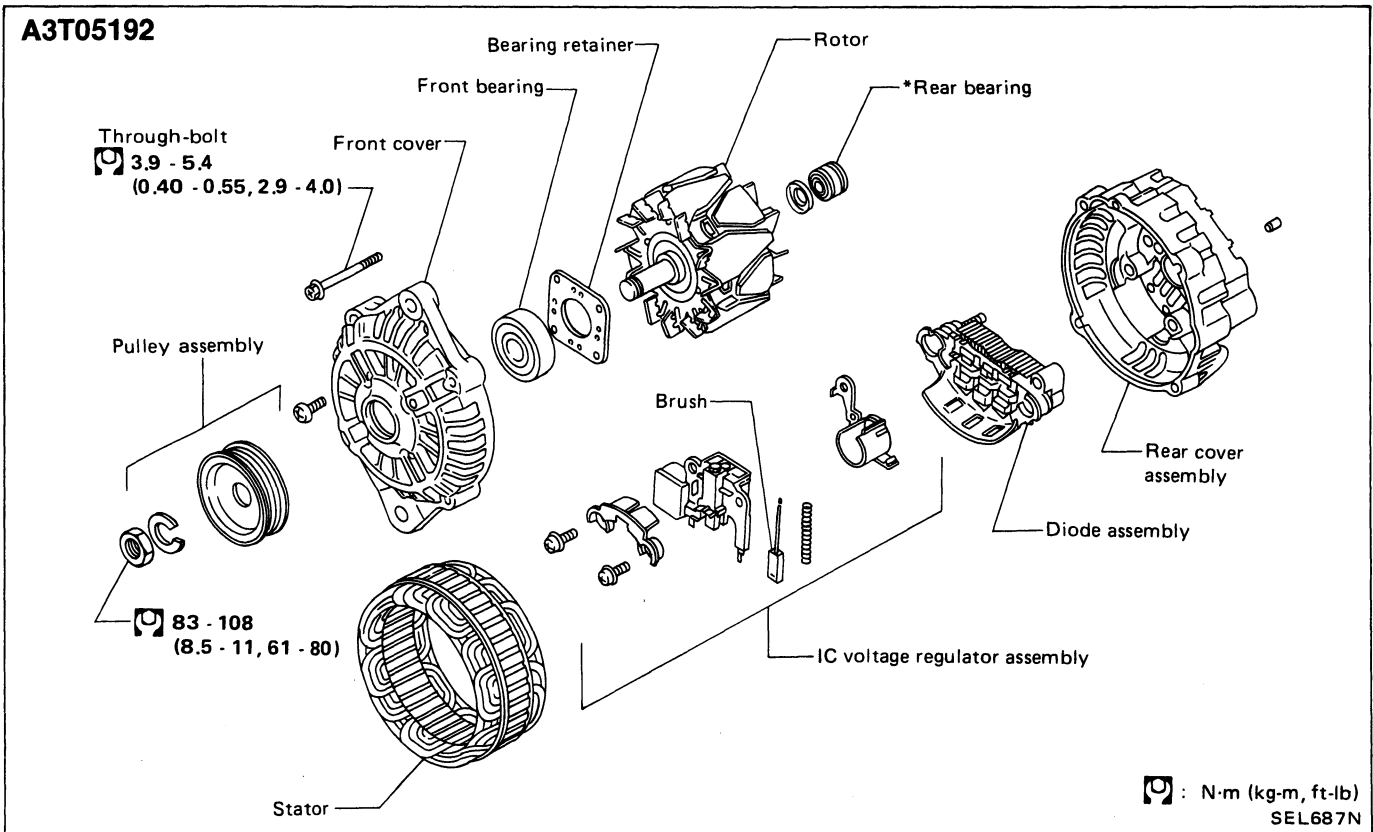
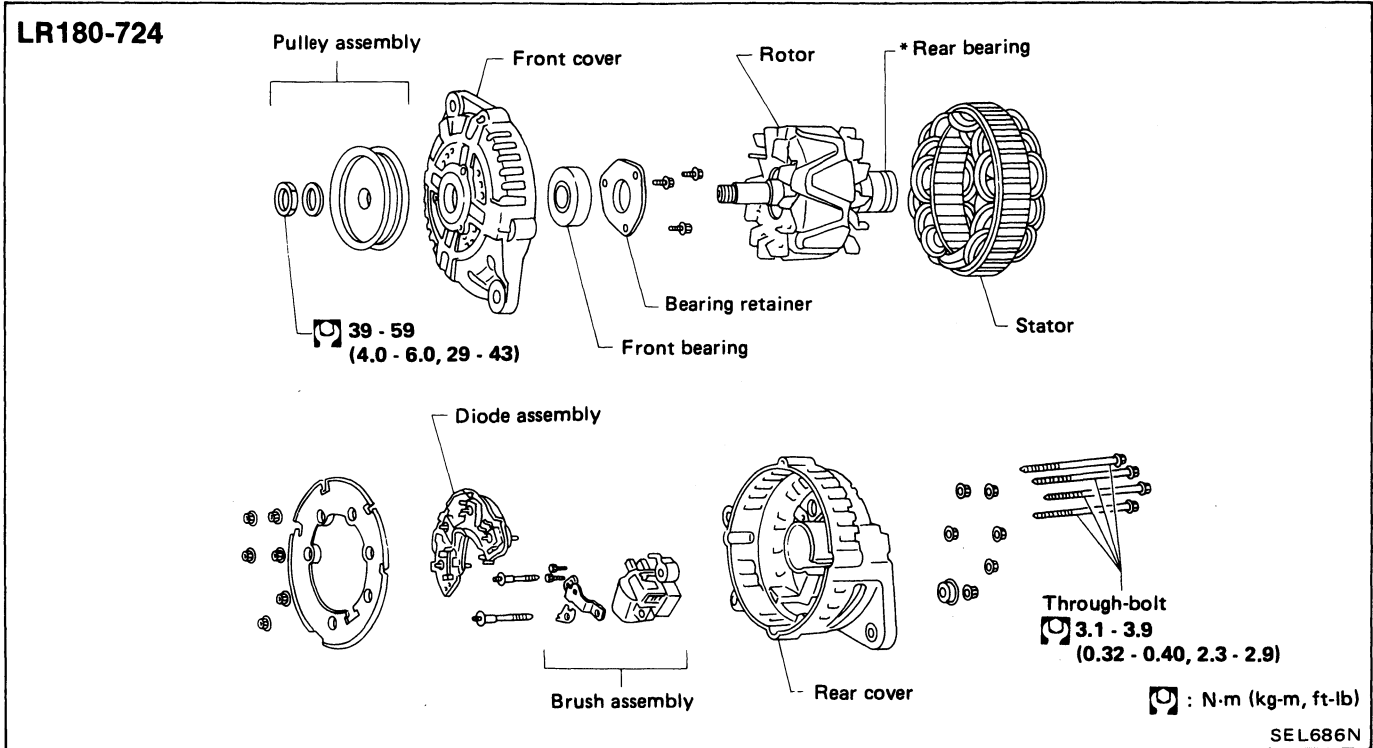

*Rear bearing

CAUTION:

Rear cover may be hard to remove because a ring is used to lock outer race of rear bearing. Be careful not to lose this ring during removal.

Removal and Installation

REMOVAL

1. Loosen alternator belt.
2. Remove alternator adjusting bar.
3. Remove harness connector and cable from alternator.

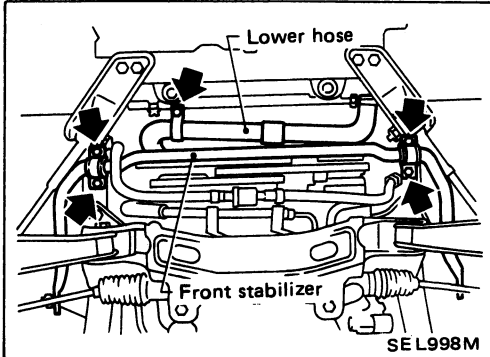

4. Remove stabilizer bracket fixing bolts.
5. Remove radiator lower hose bracket and push lower hose upward to make room.

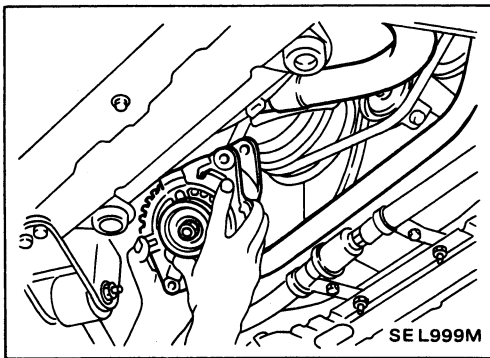

6. Remove alternator fixing bolt and take out alternator as shown in the figure.

INSTALLATION

- Installation procedure is in reverse order of removal.

Disassembly

REAR COVER REMOVAL

CAUTION:

Rear cover may be hard to remove because a ring is used to lock outer race of rear bearing. To facilitate removal of rear cover, heat just bearing box section with a 200W soldering iron.

Do not use a heat gun, as it can damage diode assembly.

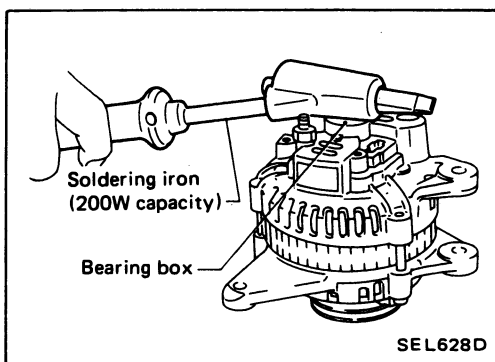

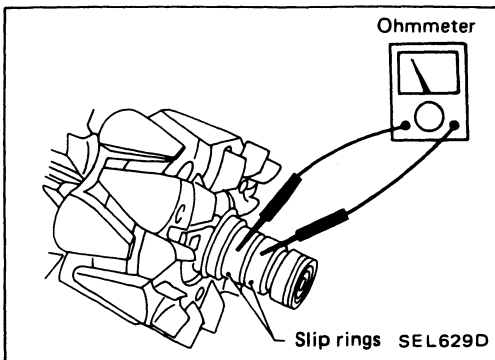

Rotor Slip Ring Check

1. Continuity test
 - No continuity ... Replace rotor.

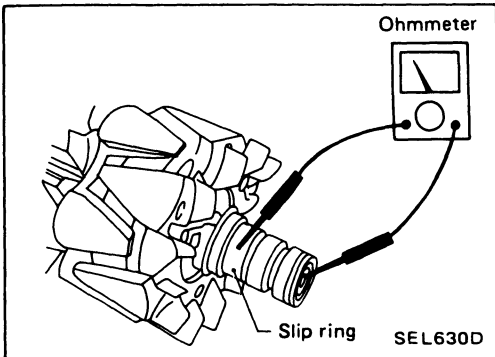

2. Insulator test
 - Continuity exists ... Replace rotor.
3. Check slip ring for wear.

Slip ring minimum outer diameter:
Refer to S.D.S.

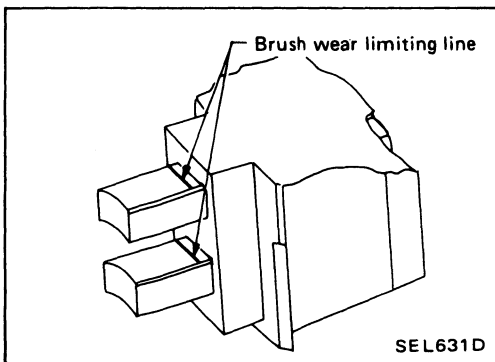

Brush Check

1. Check smooth movement of brush.
 - Not smooth ... Check brush holder and clean.
2. Check brush for wear.
 - Replace brush if it is worn down to the limit line.

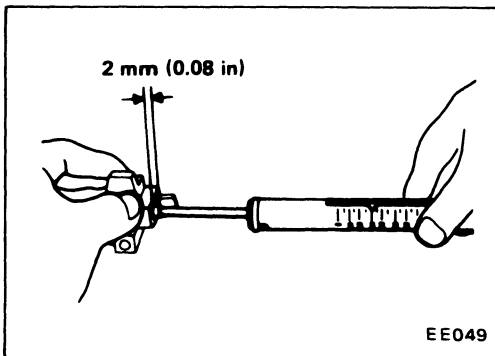

3. Check brush lead wire for damage.
 - Damaged ... Replace.
4. Check brush spring pressure.

Measure brush spring pressure with brush projected approximately 2 mm (0.08 in) from brush holder.

Spring pressure:
Refer to S.D.S.

 - Not within the specified values ... Replace.

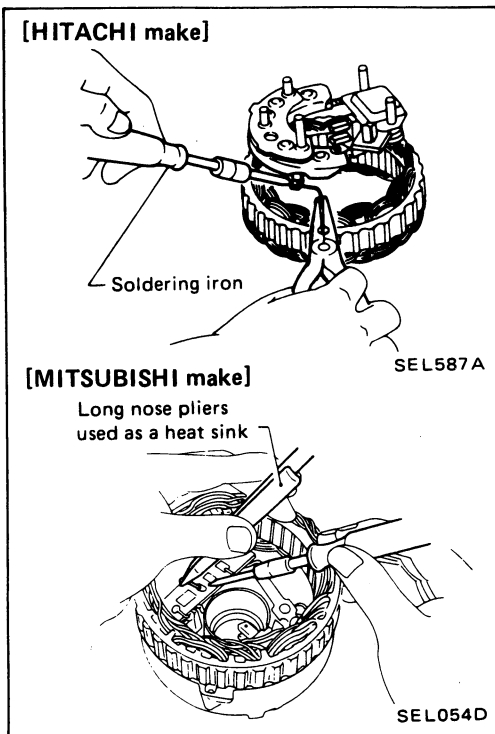

Stator Check

To test the stator or diode, you must separate them by unsoldering the connecting wires.

CAUTION:

Use only as much heat as required to melt solder. Otherwise, diodes will be damaged by excessive heat.

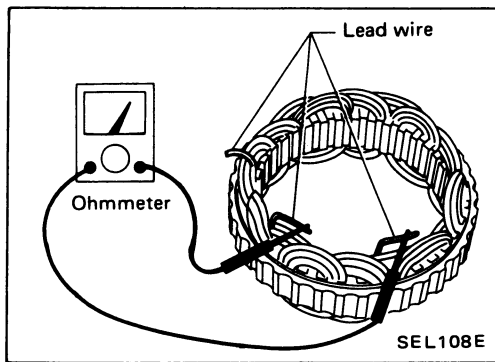

1. Continuity test

- No continuity ... Replace stator.

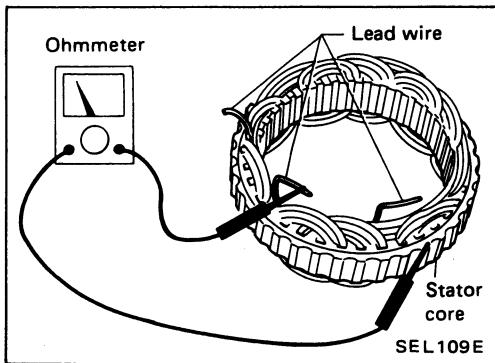

2. Ground test

- Continuity exists ... Replace stator.

Diode Check

MAIN DIODES

- Use an ohmmeter to check condition of diodes as indicated in chart below.
- If any of the test results is not satisfactory, replace diode assembly.

	Ohmmeter probes		Continuity
	Positive ⊕	Negative ⊖	
Diodes check (Positive side)	Positive diode plate	Diode terminals	Yes
	Diode terminals	Positive diode plate	No
Diodes check (Negative side)	Negative diode plate	Diode terminals	No
	Diode terminals	Negative diode plate	Yes

[HITACHI make]

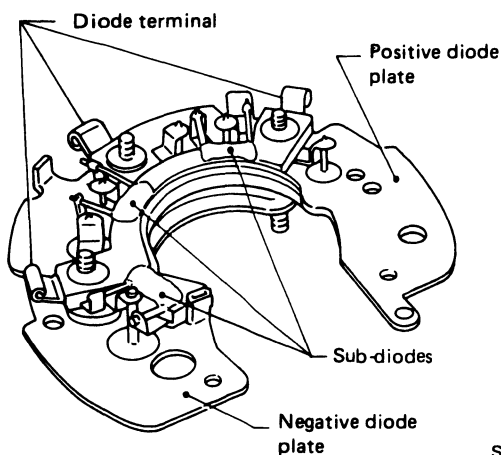

SEL768D

[MITSUBISHI make]

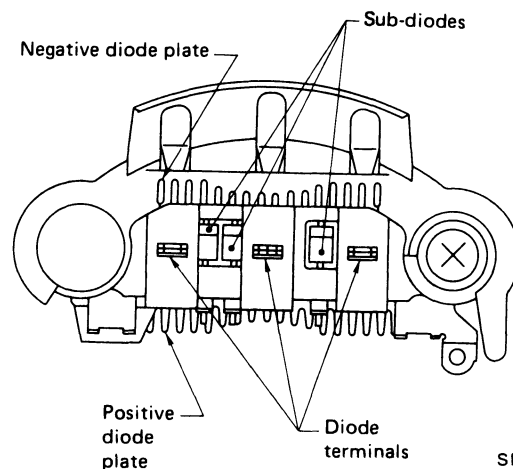

SEL493H

SUB-DIODES

- Attach ohmmeter's probe to each end of diode to check for continuity.
- Continuity is N.G. ... Replace diode assembly.

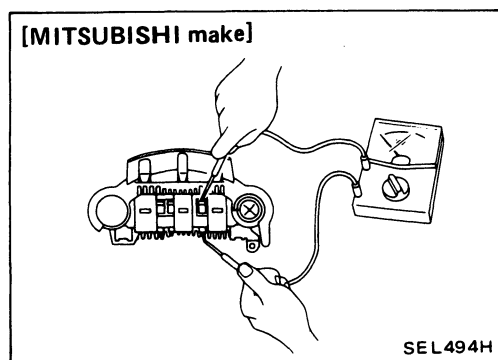
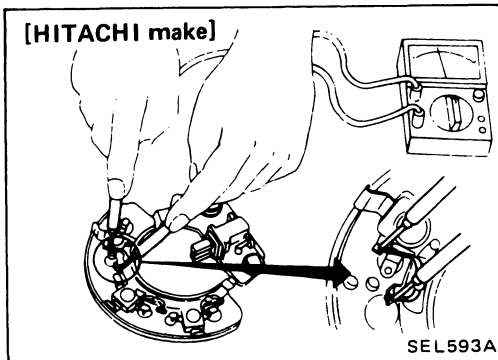

Assembly

Carefully observe the following instructions.

- When soldering each stator coil lead wire to diode assembly terminal, carry out the operation as fast as possible.

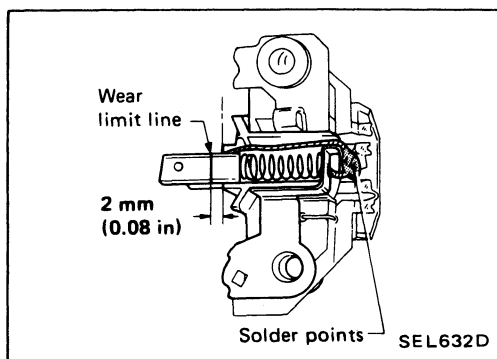

WHEN SOLDERING BRUSH LEAD WIRE [MITSUBISHI make]

- Position brush so that its wear limit line protrudes 2 mm (0.08 in) beyond end face of brush holder.

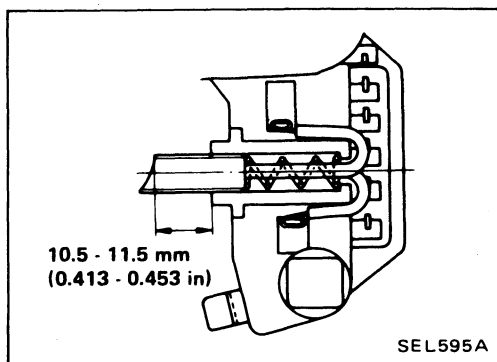

[HITACHI make]

- (1) Position brush so that it extends 10.5 - 11.5 mm (0.413 - 0.453 in) from brush holder.

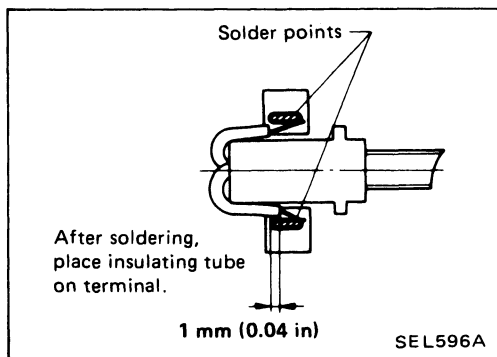

- (2) Coil lead wire 1.5 times around terminal groove. Solder outside of terminal.

When soldering, be careful not to let solder adhere to insulating tube as it will weaken the tube and cause it to break.

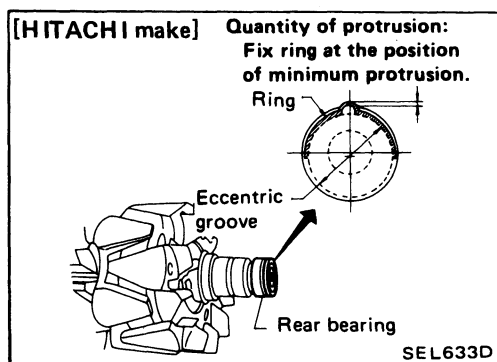

RING FITTING IN REAR BEARING

[HITACHI make]

- Fix ring into groove in rear bearing so that it is as close to the adjacent area as possible.

[MITSUBISHI make]

- Always press new bearing into place with ring groove toward slip ring.

Assembly (Cont'd)

REAR COVER INSTALLATION

- (1) Before installing front cover with pulley and rotor with rear cover, push brush up with fingers and retain brush by inserting brush lift wire into brush lift hole from outside.
- (2) After installing front and rear sides of alternator, pull out brush lift wire.

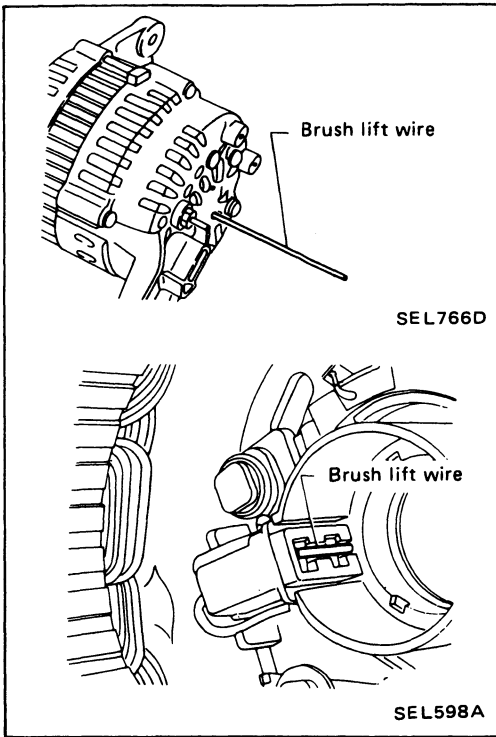

CHARGING SYSTEM — Alternator —

Service Data and Specifications (S.D.S.)

ALTERNATOR

Type		LR180-724	A3T05192
		HITACHI make	MITSUBISHI make
Applied engine		VG30DE	VG30DETT
Nominal rating	V-A	12-80	12-90
Ground polarity		Negative	
Minimum revolution under-no-load (when 13.5 volts is applied)	rpm	Less than 950	Less than 1,300
Hot output current	A/rpm	More than 65/2,500 More than 80/5,000	More than 65/2,500 More than 90/5,000
Regulated output voltage	V	14.1 - 14.7	
Minimum length of brush	mm (in)	More than 7.0 (0.276)	More than 8.0 (0.315)
Brush spring pressure	N (g, oz)	1.863 - 3.040 (190 - 310, 6.70 - 10.93)	3.040 - 4.217 (310 - 430, 10.93 - 15.17)
Slip ring minimum outer diameter	mm (in)	More than 30.6 (1.205)	More than 22.1 (0.870)

COMBINATION SWITCH

Combination Switch/Check

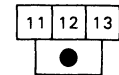
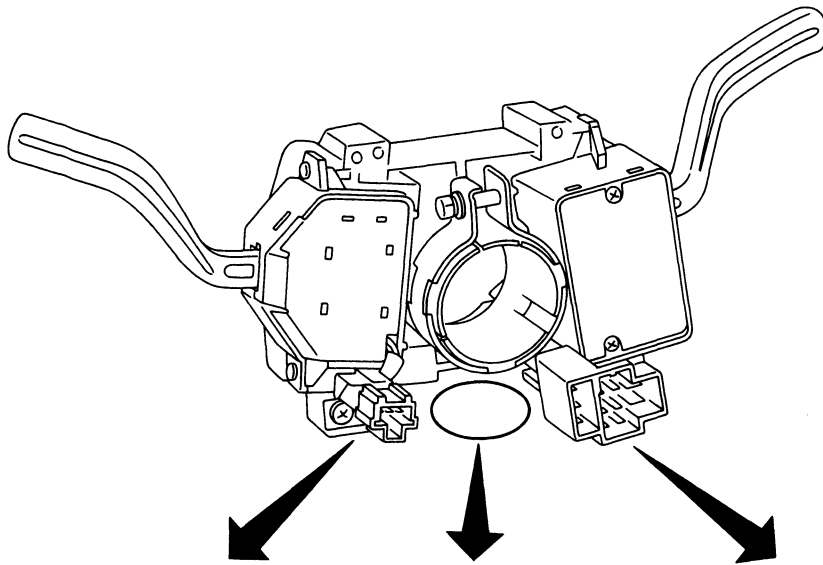
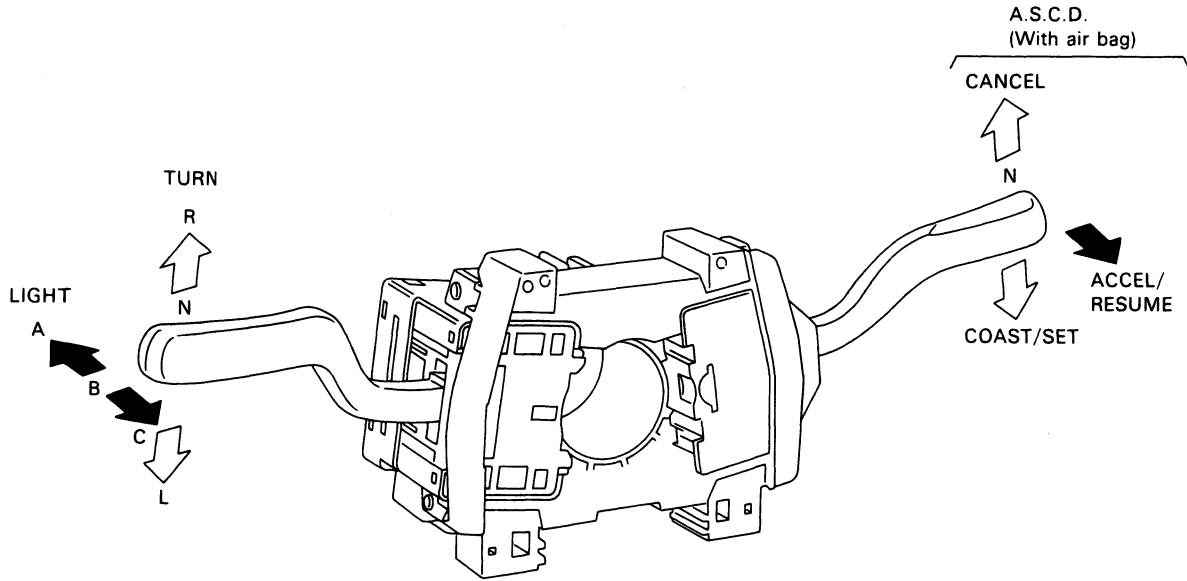

A.S.C.D. switch
(With air bag)

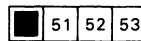

Horn and A.S.C.D. switch
(On the steering wheel pad)
(Non-turbo model without air bag)

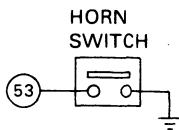
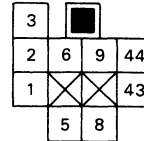

HORN SWITCH

A.S.C.D. SWITCH

	RESUME ACCEL	N	SET COAST	OFF	CANCEL
13 or 53					
12 or 52					
11 or 51					

DIMMER SWITCH

	A	B	C
5			
6			
8			
9			
43			
44			

TURN SIGNAL SWITCH

	R	N	L
1			
2			
3			

COMBINATION SWITCH

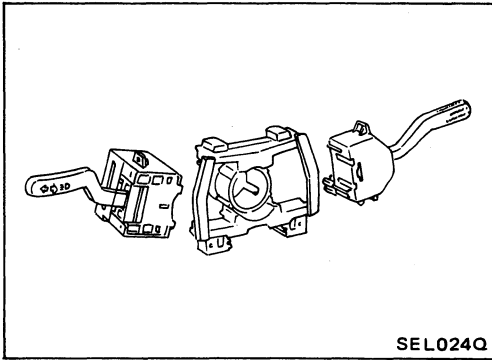

Combination Switch/Replacement

For removing/installing air bag module and spiral cable, refer to BF section.

- Each switch can be replaced without removing combination switch base.

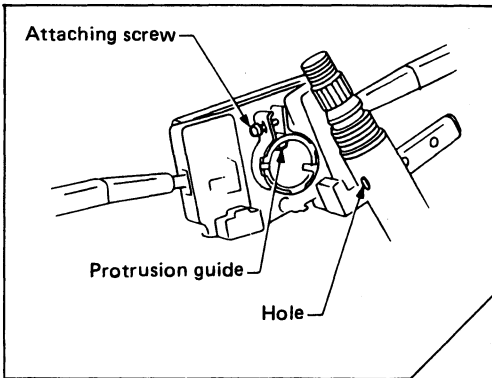

- To remove combination switch base, remove base attaching screw and turn after pushing on it.

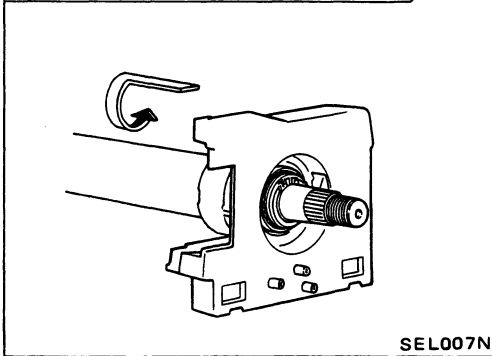

COMBINATION SWITCH

Steering Switch/Check

TURBO MODELS WITHOUT AIR BAG

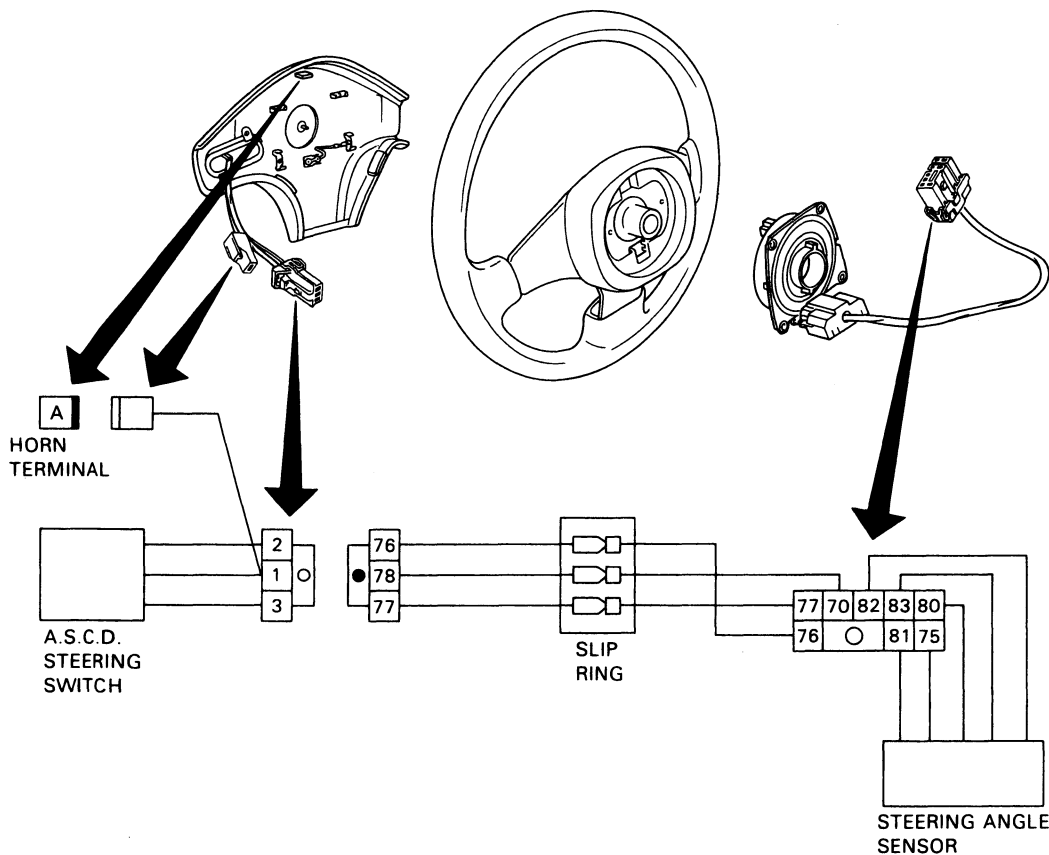
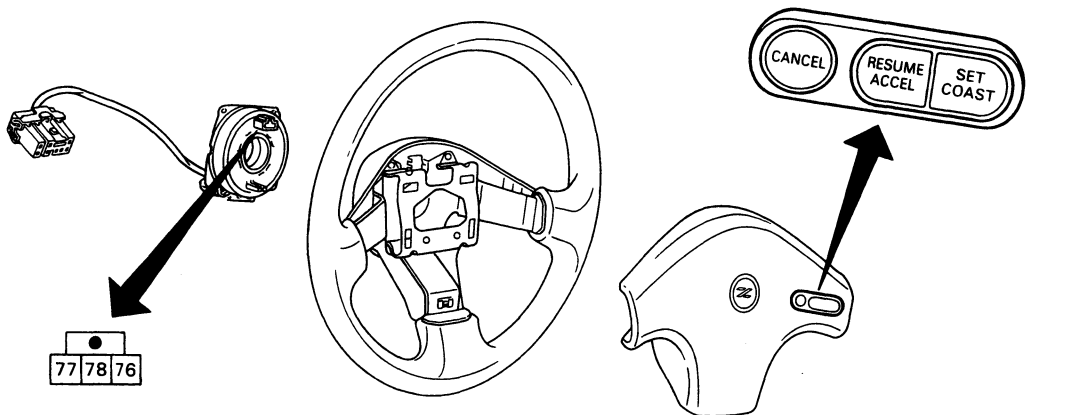

A.S.C.D. STEERING SWITCH

	RESUME ACCEL	N	SET COAST	OFF	CANCEL
1	○		○		○
2			○		○
3	○				○

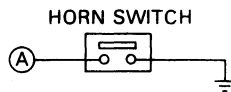

SEL528N

INSTRUMENT SWITCH

Check

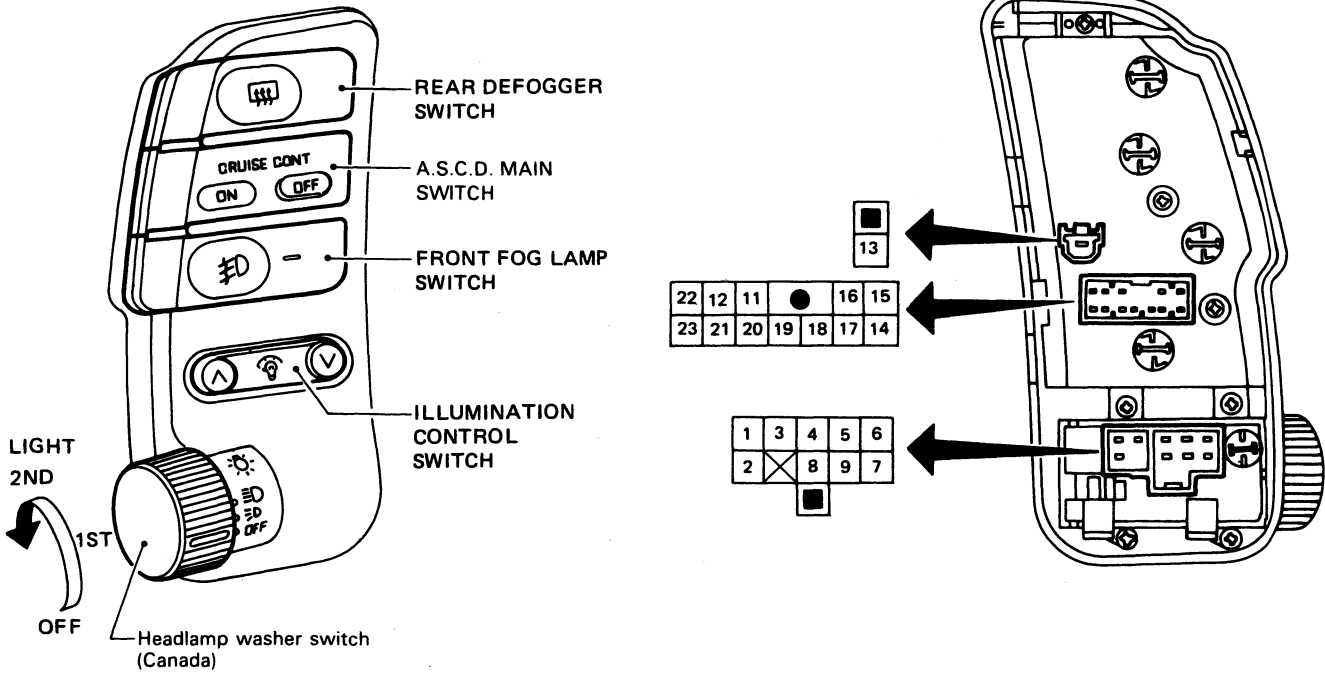

LIGHTING SWITCH

	OFF	1ST	2ND
1			○
2			○
3			○
4			○
5		○	○
6		○	○
7	⊗	○	○

REAR DEFOGGER SWITCH

	OFF	ON
11		○
12		○
13	⊗	Ⓢ

A S.C.D. MAIN SWITCH

	OFF	N	ON
14			○
15		○	○
16		○	○

FRONT FOG LAMP SWITCH

	OFF	ON
17		○
18		○
19	⊗	Ⓢ

HEADLAMP WASHER SWITCH

	OFF	ON
8		○
9		○

ILLUMINATION CONTROL SWITCH

	V	N	A
20			○
21	○		○
12	○		○

CLUSTER ILLUMINATION

22	○
23	Ⓢ

INSTRUMENT SWITCH

Check (Cont'd)

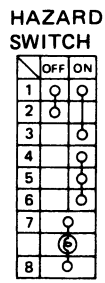
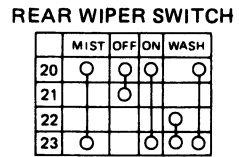
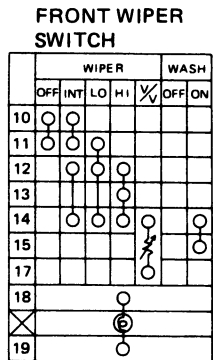
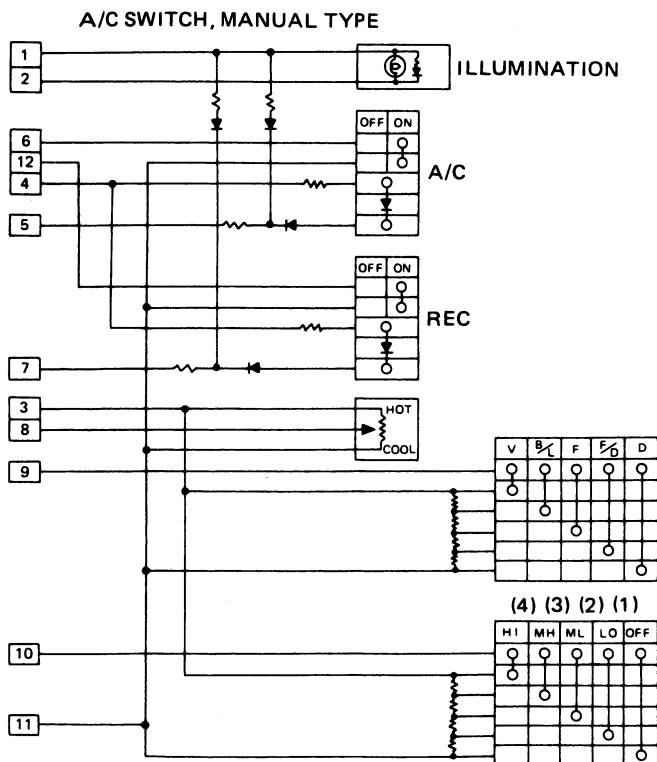
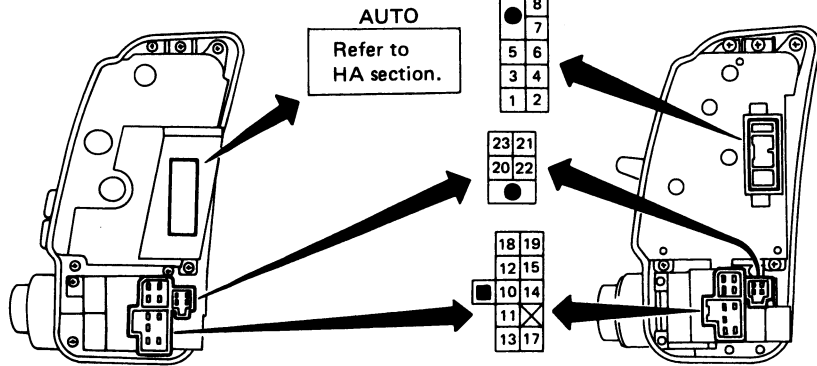
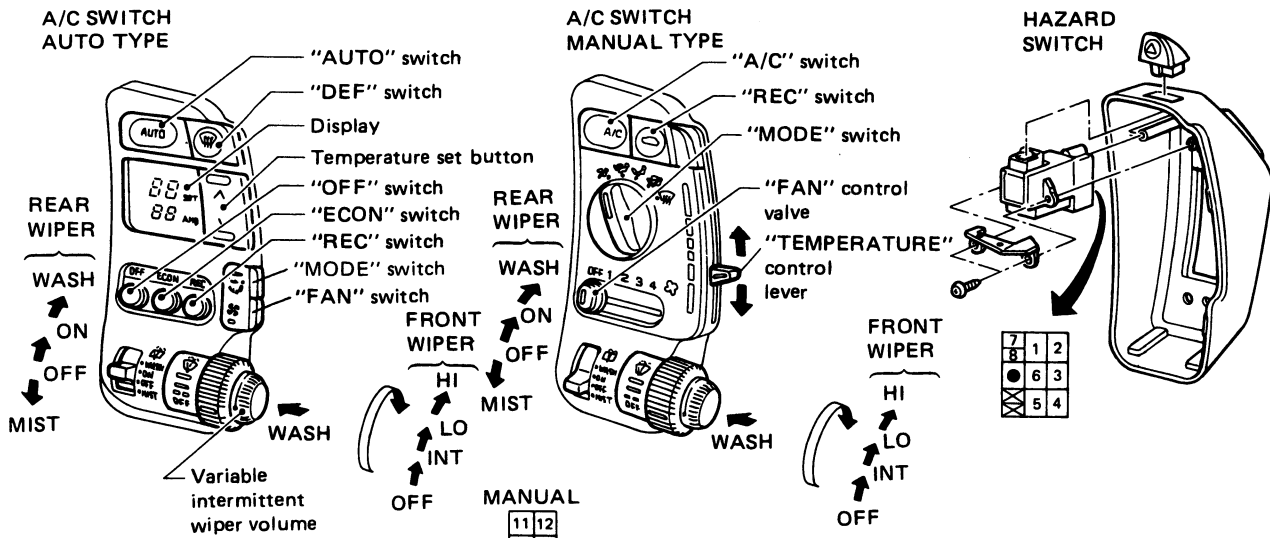

HEADLAMP

Operation (Daytime light system equipped model)

After starting the engine with the lighting switch in the "OFF" position, the headlamp high beam automatically turns on. Lighting switch operations other than the above are the same as conventional light systems.

Engine		With engine stopped									With engine running								
		OFF			1ST			2ND			OFF			1ST			2ND		
		A	B	C	A	B	C	A	B	C	A	B	C	A	B	C	A	B	C
Headlamp	High beam	X	X	O	X	X	O	O	X	O	△	△	O	△	△	O	O	X	O
	Low beam	X	X	X	X	X	X	X	O	X	X	X	X	X	X	X	X	O	X
Clearance and tail lamp		X	X	X	O	O	O	O	O	O	X	X	X	O	O	O	O	O	O
License and instrument illumination lamp		X	X	X	O	O	O	O	O	O	X	X	X	O	O	O	O	O	O

- O : Lamp "ON"
- X : Lamp "OFF"
- △ : Lamp dims.
- : Added functions

HEADLAMP

Schematic

FOR U.S.A.

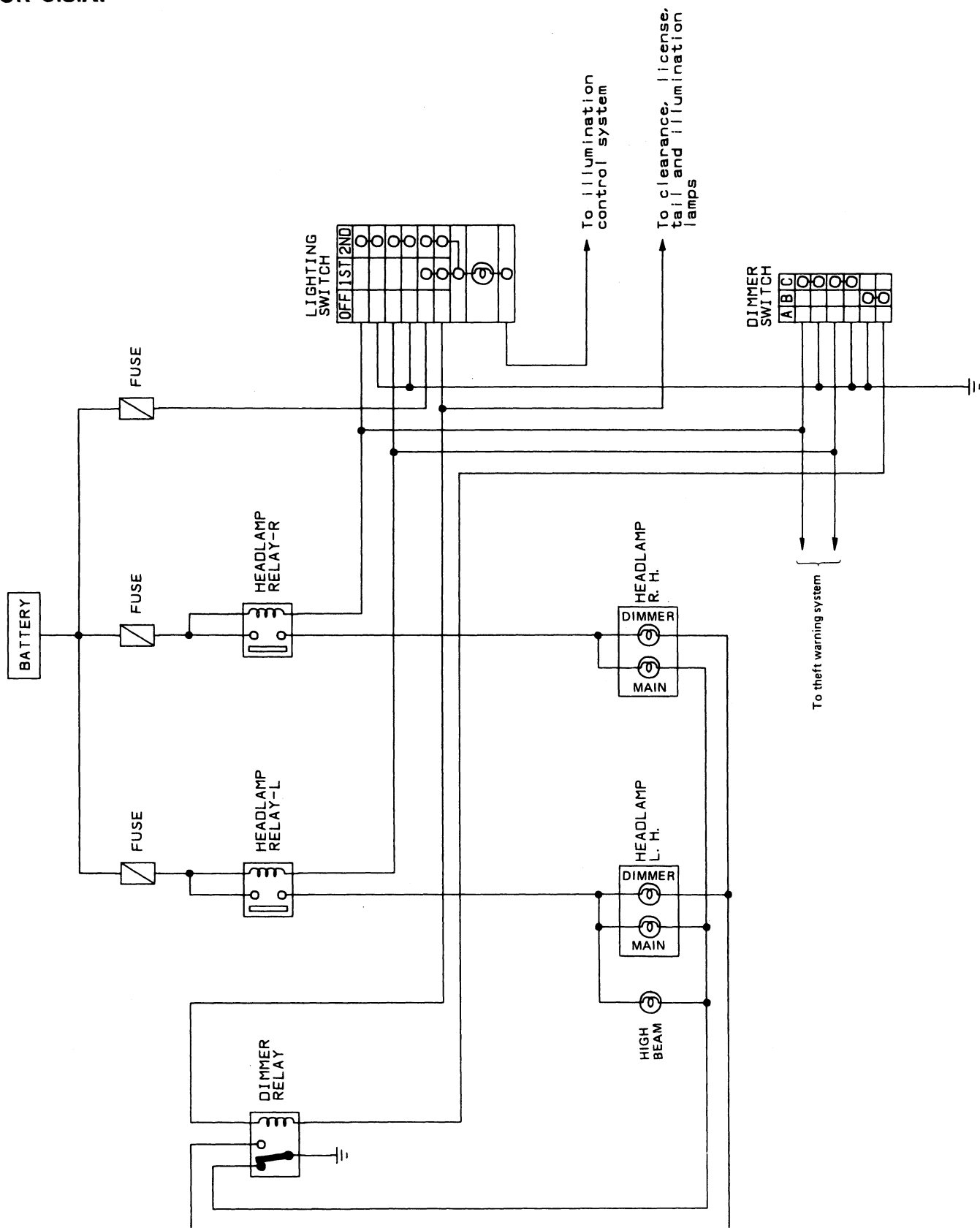

SEL530N

HEADLAMP

Schematic (Cont'd)

FOR CANADA

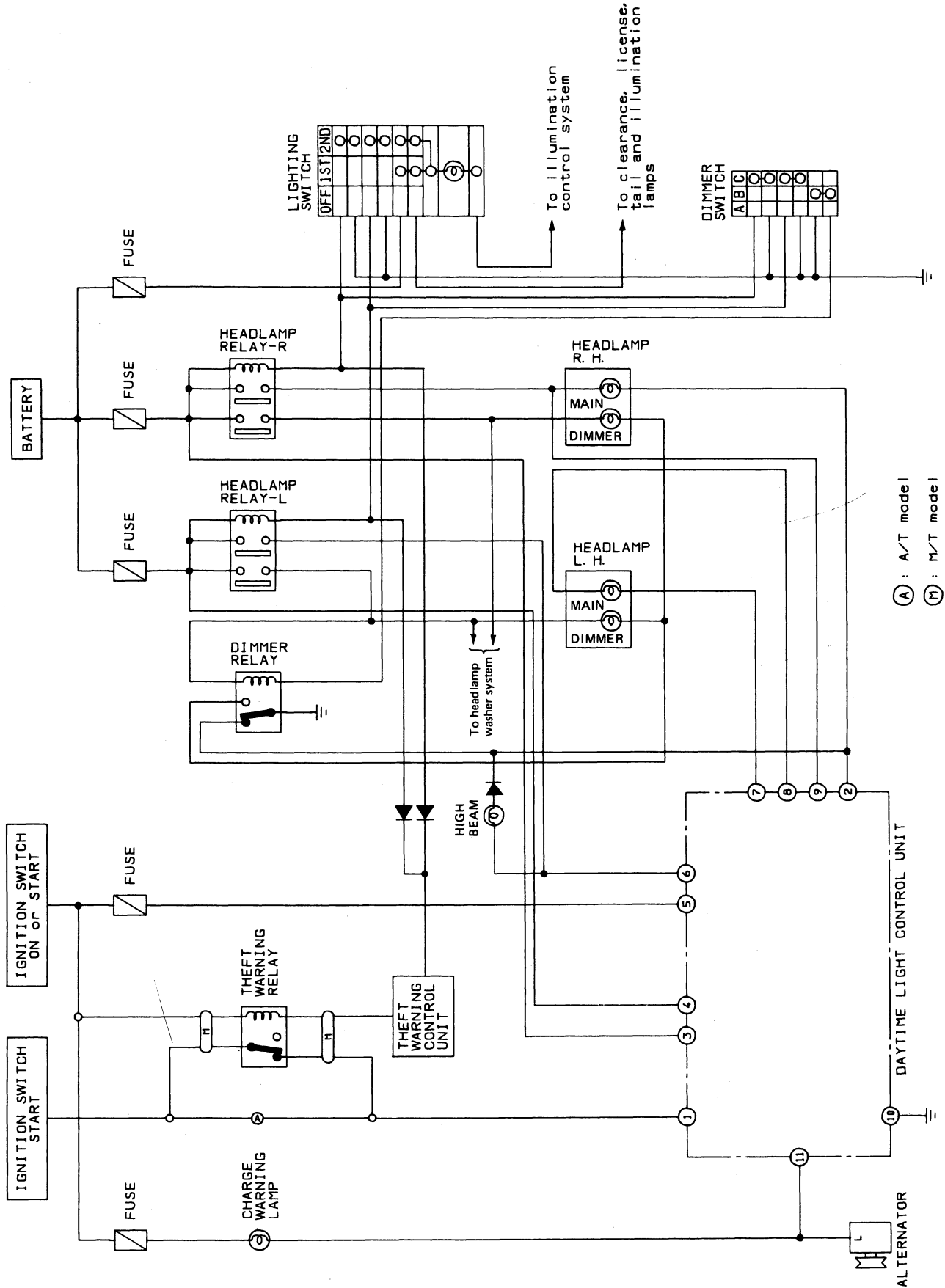

SEL531N

HEADLAMP

Wiring Diagram

FOR U.S.A.

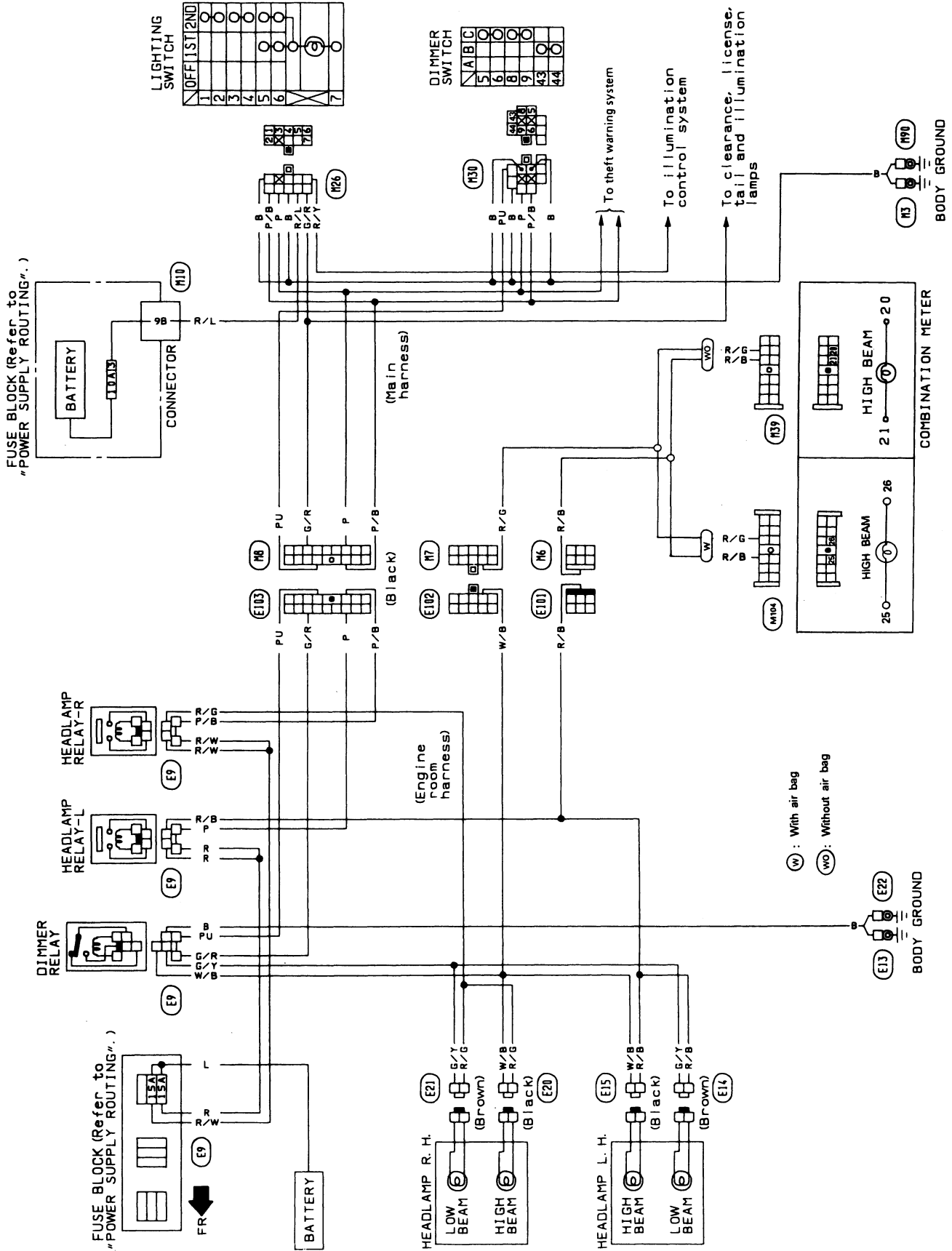

SEL923P

HEADLAMP

Wiring Diagram (Cont'd)

FOR CANADA

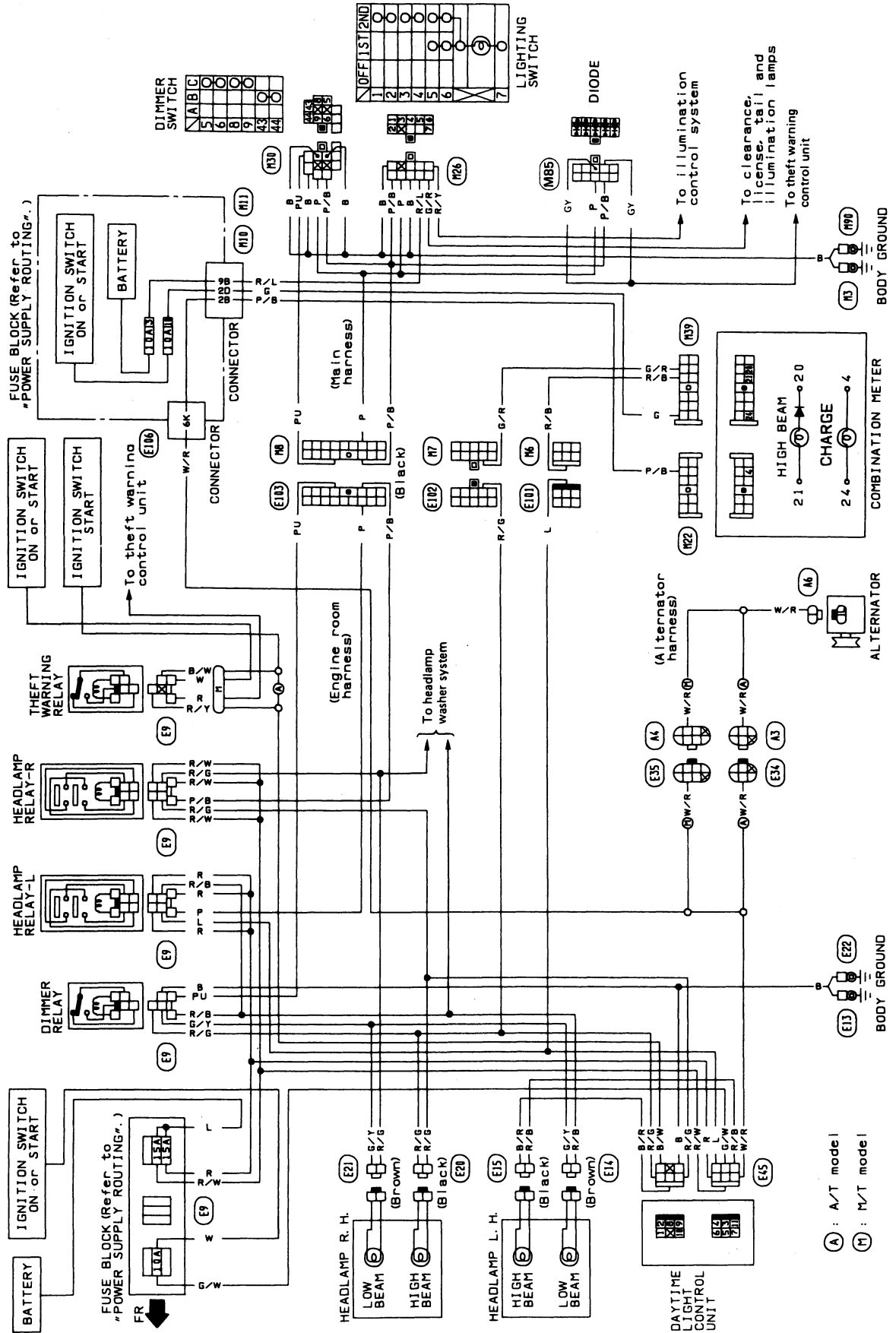

HEADLAMP

Aiming Adjustment

When performing headlamp aiming adjustment, use an aiming machine, aiming wall, screen or headlamp tester. When operating any aimer, it should be in good repair, calibrated and used according to the operation manual supplied with the unit.

HEADLAMP AIMER ADAPTER

Attach the headlamp aimer using Tool (aimer adapter). Place the aimer adapter on the 3 points of the headlamp, then push the lever down to secure it.

If no aimer is available, aiming adjustment can be done as follows:

For details, refer to the regulations in your own country.

CAUTION:

- Make sure tires are inflated to correct pressures.
- Place vehicle and tester on the same flat surface.
- See that there is no load in the vehicle (coolant, engine oil filled up to correct level and full fuel tank) other than the driver (or equivalent weight placed in driver's position).

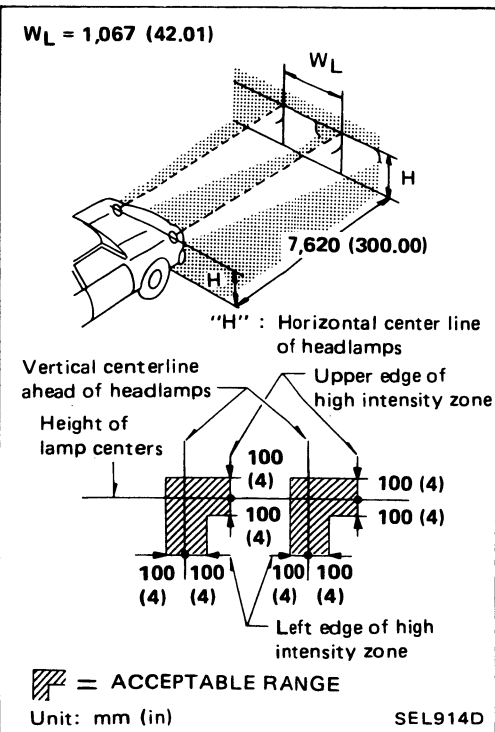
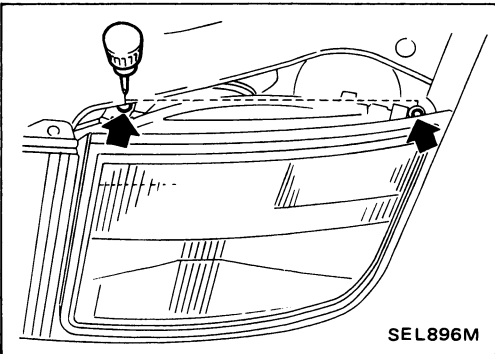
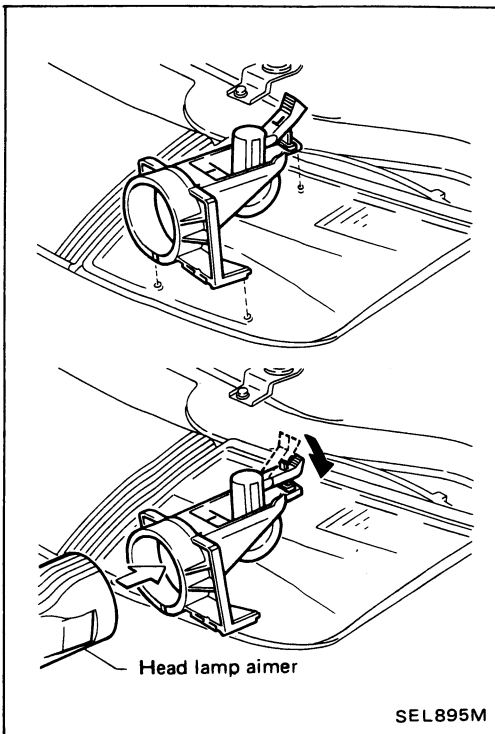

1. Turn headlamp low beam on.

2. Use adjusting screws to perform aiming adjustment.

- First tighten the adjusting screw all the way and then make adjustment by loosening the screw.

- Adjust headlamps so that upper edge and left edge of high intensity zone are within the acceptable range as shown at left.

- Dotted lines in illustration show center of headlamp.

"H": Horizontal center line of headlamps

"W_L": Distance between each headlamp center

HEADLAMP

Aiming Adjustment (Cont'd)

Push the tongue and pull the lever up to remove the adapter.

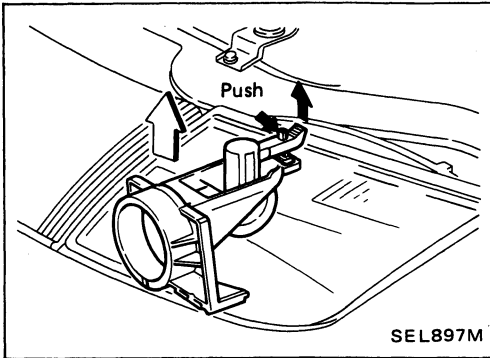

Bulb Replacement

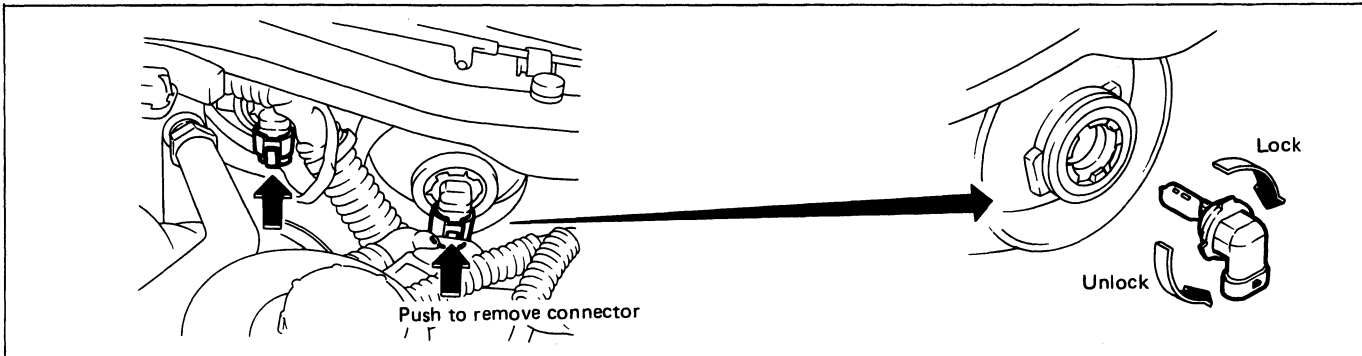

The Headlamp is a semi-sealed beam type which uses a replaceable Headlamp (halogen) bulb. A bulb can be replaced from inside the engine compartment without removing the Headlamp assembly.

CAUTION:

High pressure halogen gas is sealed inside the halogen bulb. The bulb may break if the glass envelope is scratched or the bulb is dropped.

Hold the plastic base when handling the bulb. Never touch the glass envelope.

REMOVING HEADLAMP BULB

1. Disconnect battery negative cable.
2. Disconnect electrical connector from rear end of bulb.
3. Turn plastic base counterclockwise until it is free from headlamp reflector, then remove it.
4. Remove headlamp bulb. Do not shake or rotate bulb when removing it.

REPLACING HEADLAMP BULB

1. Insert bulb into headlamp reflector with plastic base facing downward and turn it clockwise until it stops.
2. Push electrical connector into bulb plastic base until it snaps and stops.

CAUTION:

Do not touch the bulb.

- **Use the same number and wattage as originally installed:**

	Inside (High beam)	Outside (Low beam)
Wattage (W)	65	55
Bulb no.	9005	9006

EXTERIOR LAMP

Clearance, License, Tail and Stop Lamps/Wiring Diagram

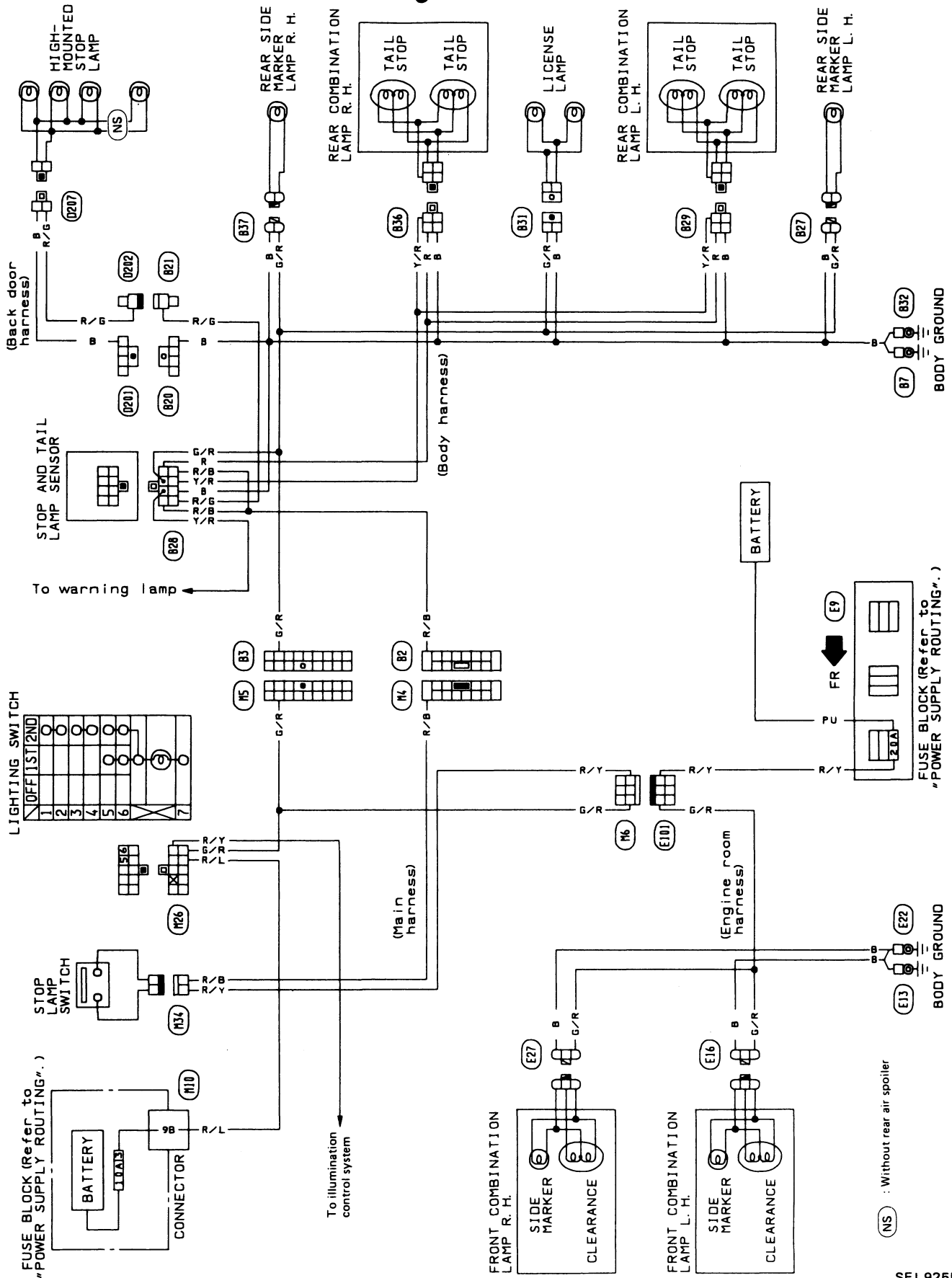

SEL925P

EXTERIOR LAMP

Back-up Lamp/Wiring Diagram

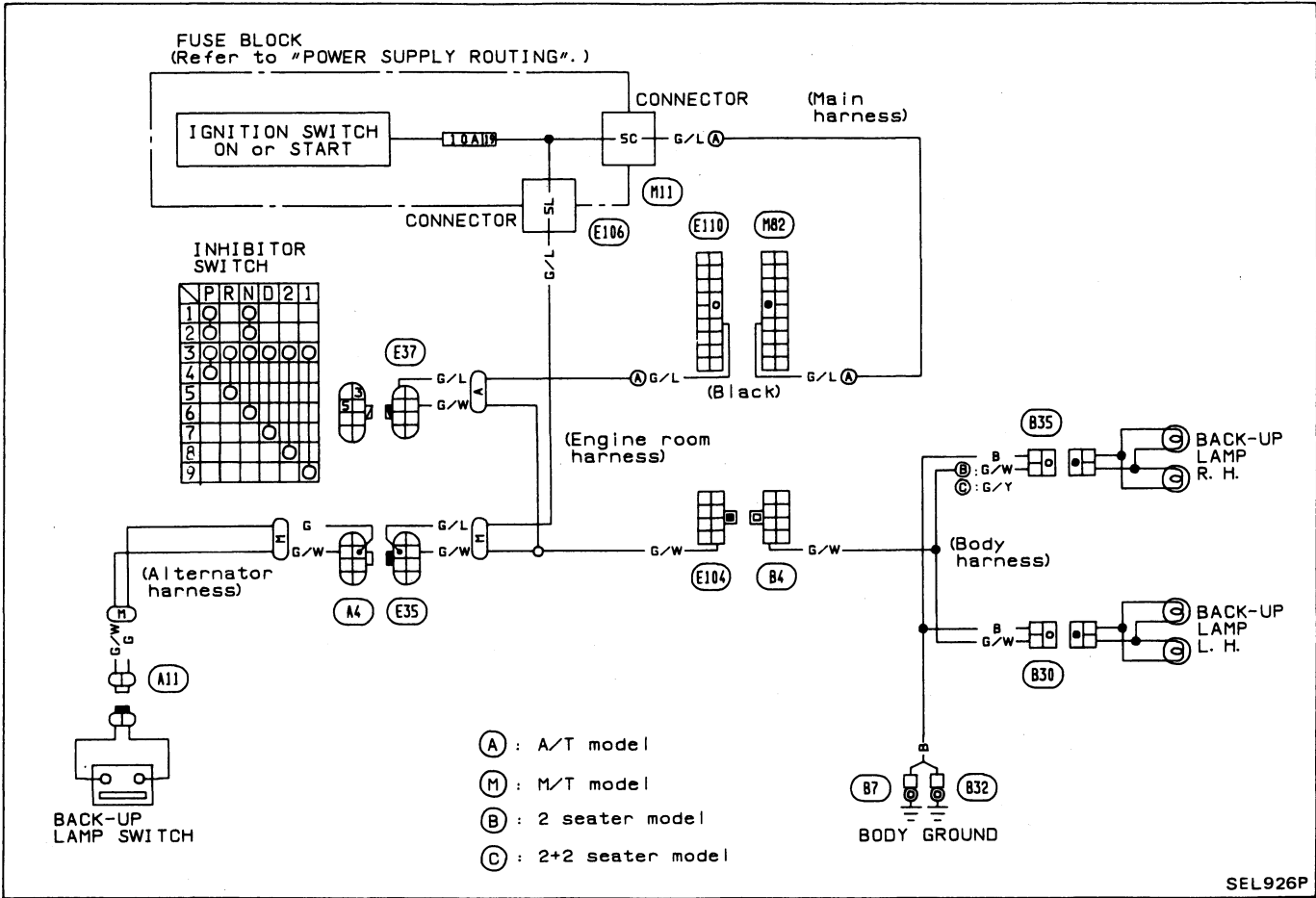

SEL926P

EXTERIOR LAMP

Front Fog Lamp/Wiring Diagram

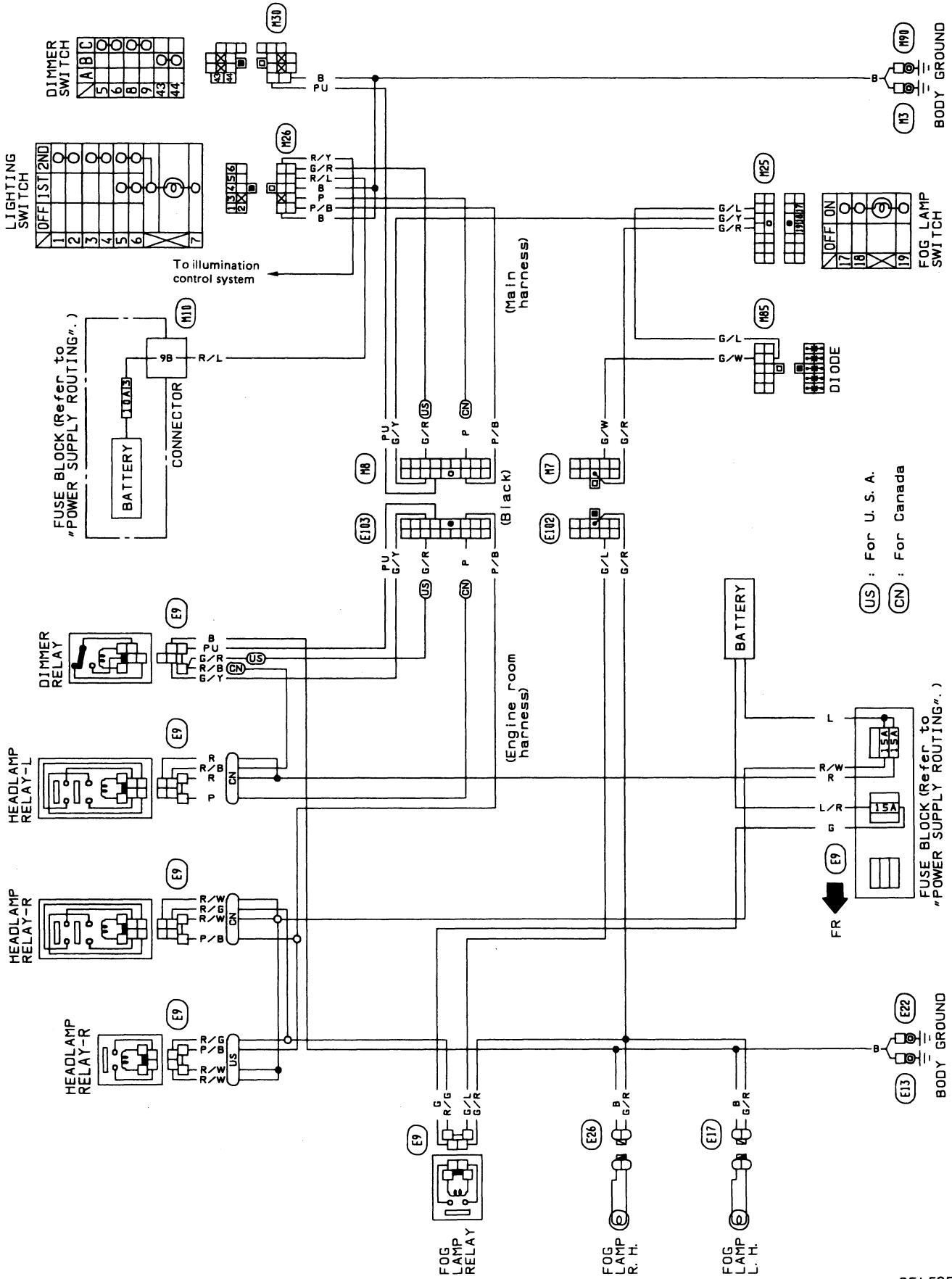

SEL535N

EXTERIOR LAMP

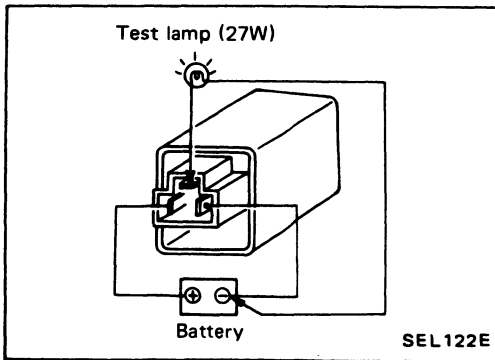
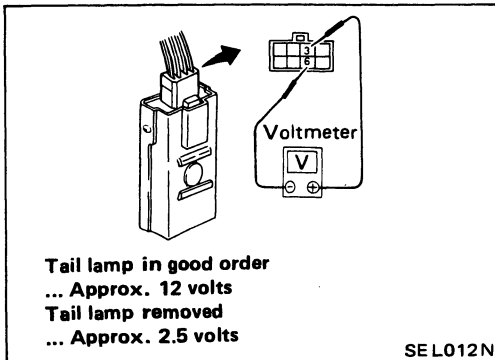
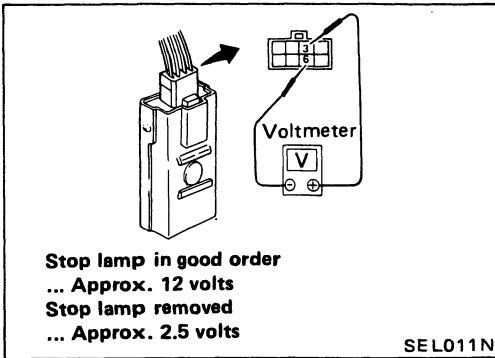

Stop and Tail Lamp Sensor Check

- Before checking, ensure that bulbs meet specifications.

STOP LAMP

1. Start engine.
2. Stop lamp switch on.

Tail Lamp

1. Start engine.
2. Lighting switch on.

Combination Flasher Unit Check

- Before checking, ensure that bulbs meet specifications.
- Connect a battery and test lamp to the combination flasher unit, as shown. Combination flasher unit is properly functioning if it blinks when power is supplied to the circuit.

Bulb Specifications

	Wattage (W)	Bulb No.
Front combination lamp		
Turn Signal/Clearance	27/8	1157
Front side marker	3.8	194
Rear combination lamp		
Turn signal	27	1156
Stop/Tail	27/8	1157
Back-up lamp	27	1156
Rear side marker lamp	3.8	194
License plate lamp	3.8	194
Front fog lamp	35	
High-mounted stop lamp	13	
Interior lamp	10	
Spot lamp	3.6	
Luggage room lamp	3.4	
Foot lamp	2	

INTERIOR LAMP

Illumination/Wiring Diagram

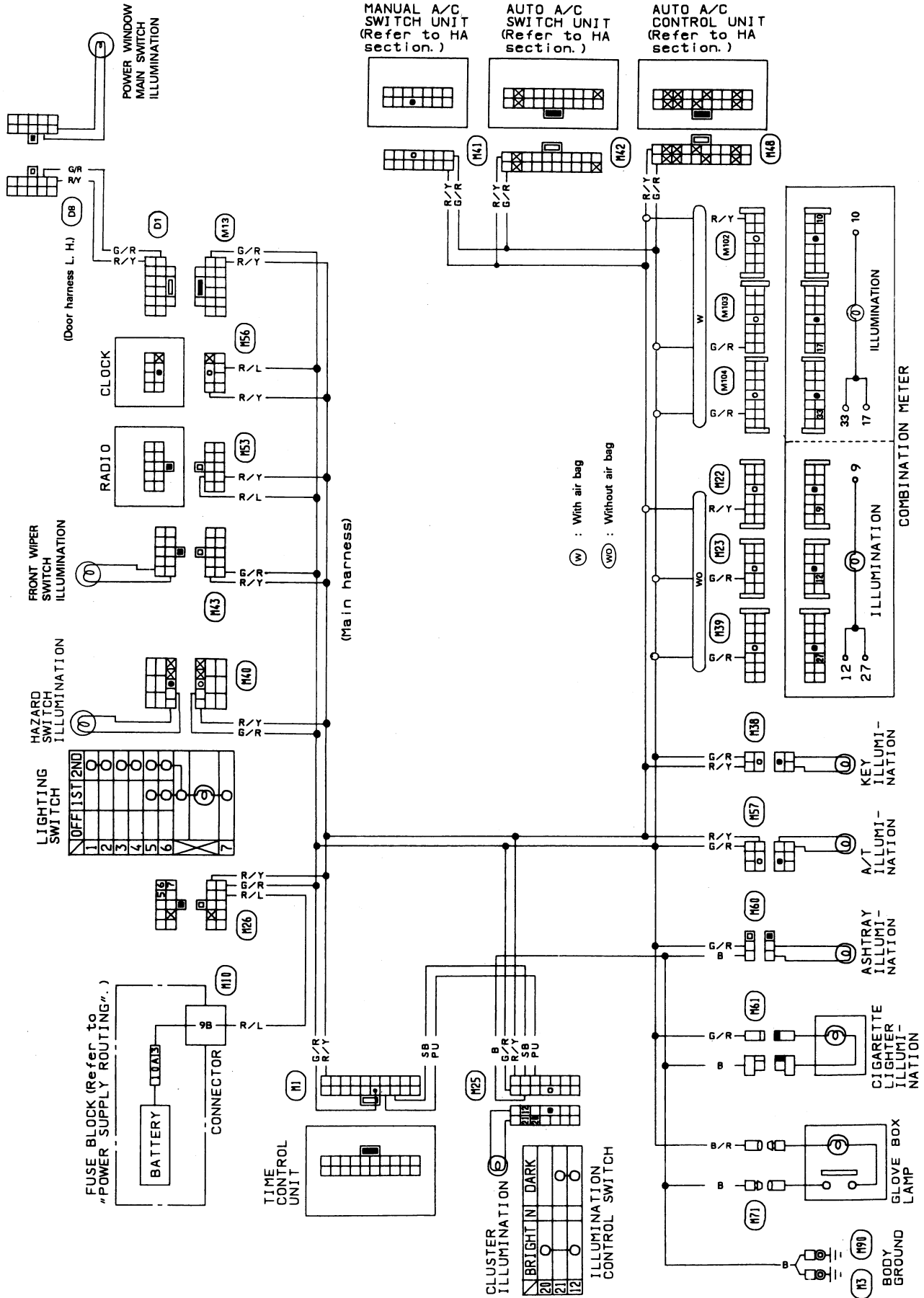

SEL928P

INTERIOR LAMP

Illuminated Entry System/Wiring Diagram

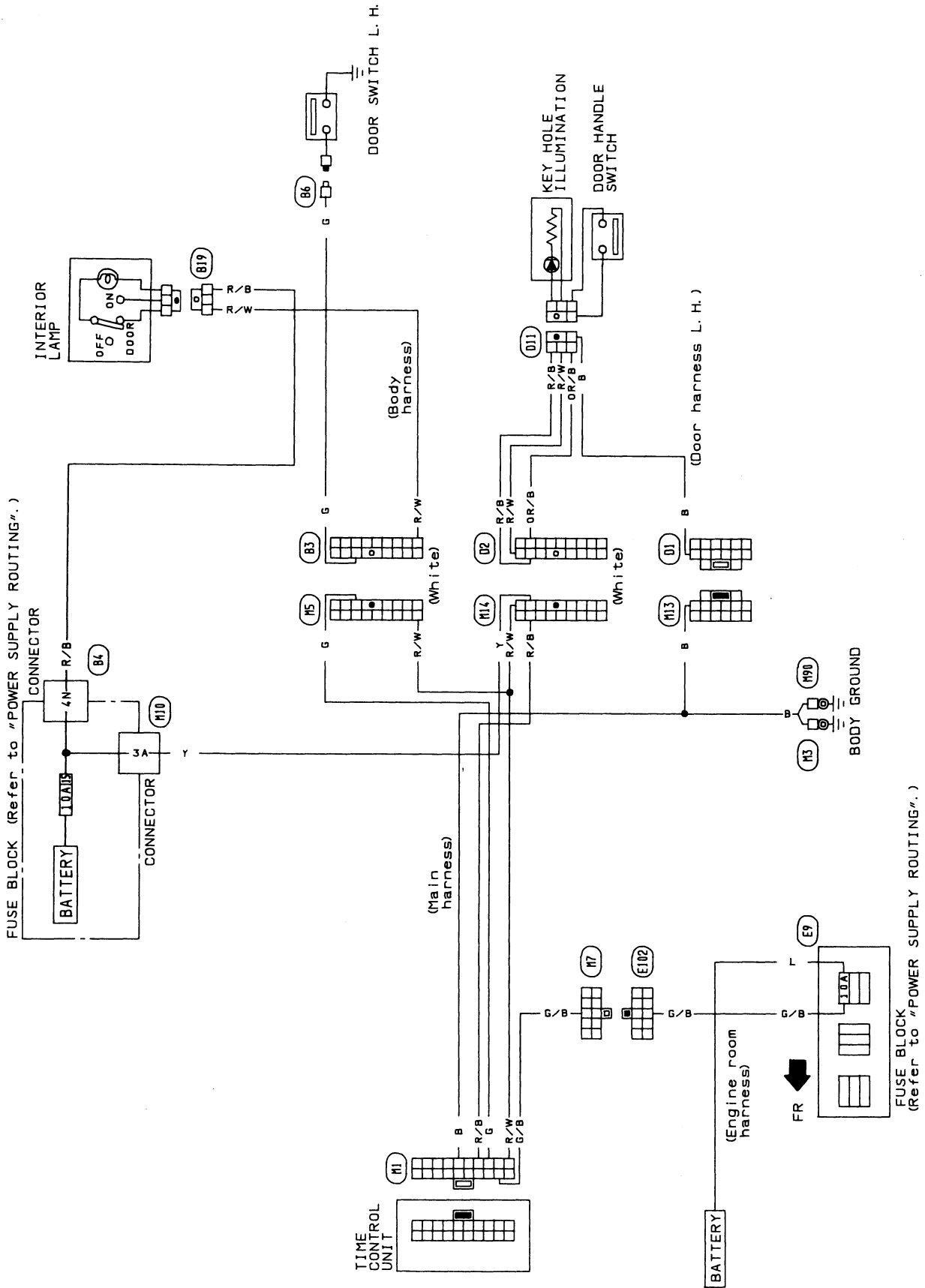

SEL966M

INTERIOR LAMP

Interior, Spot, Foot and Luggage Room Lamps/Wiring Diagram

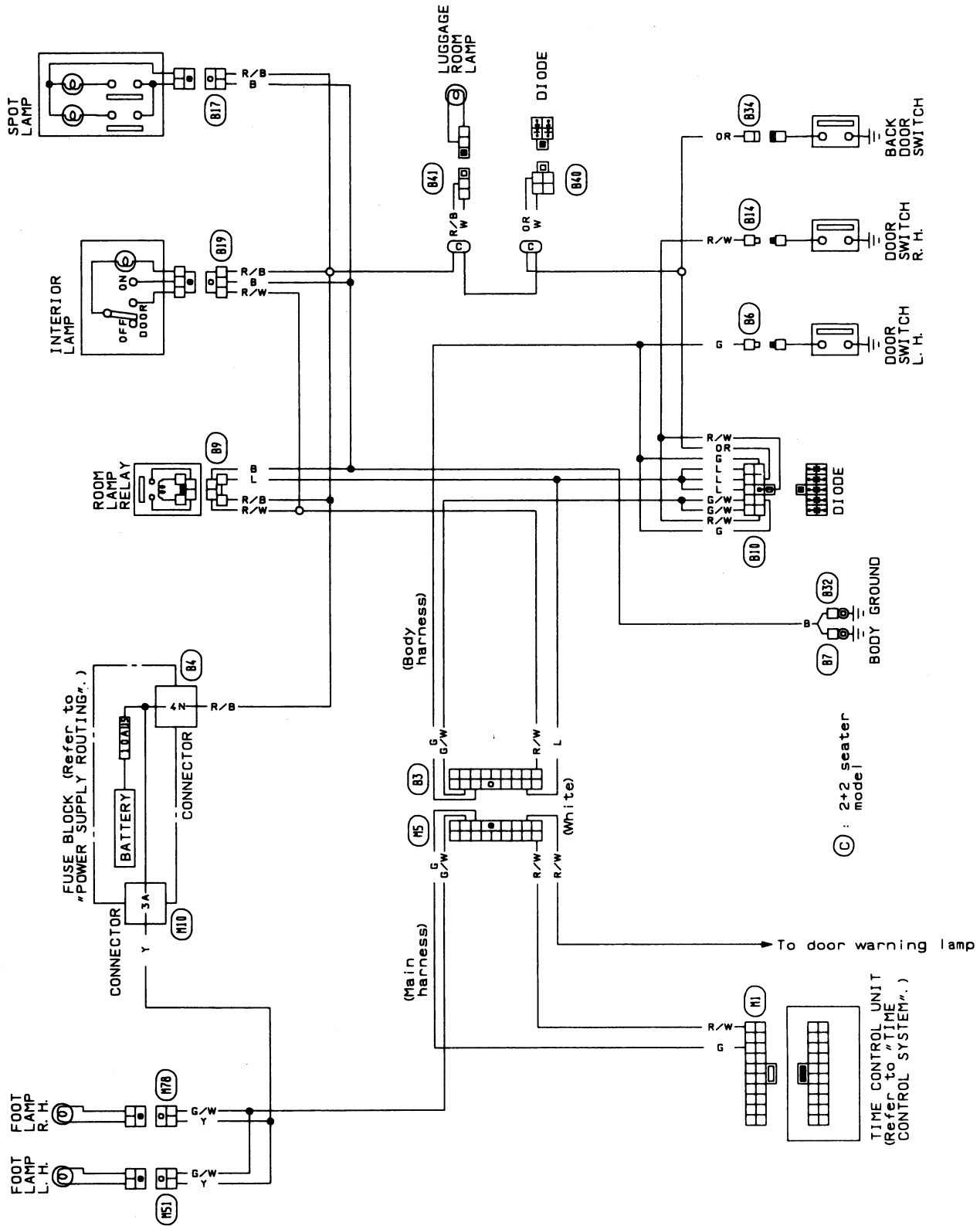

METER AND GAUGES

Combination Meter

TYPE A

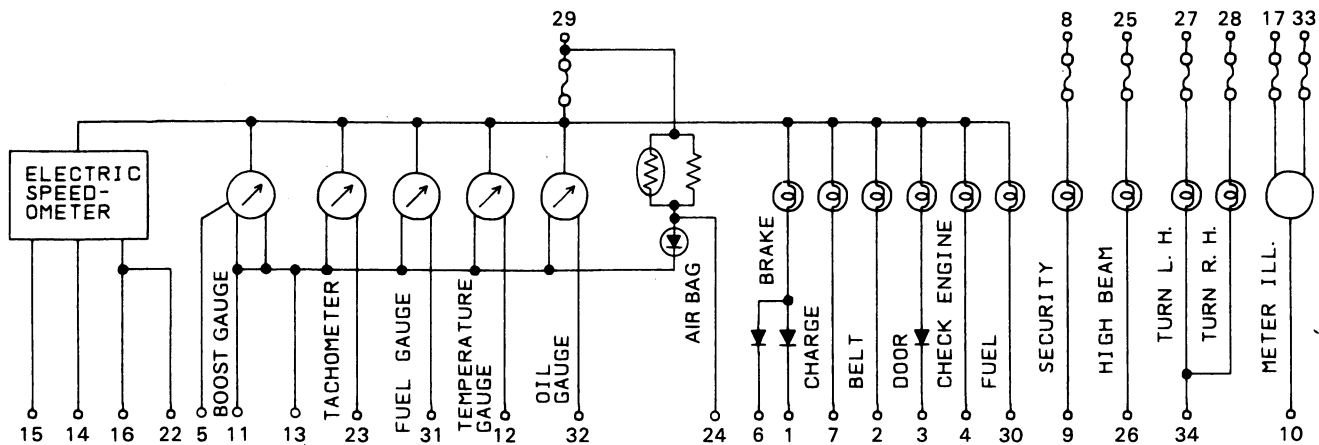
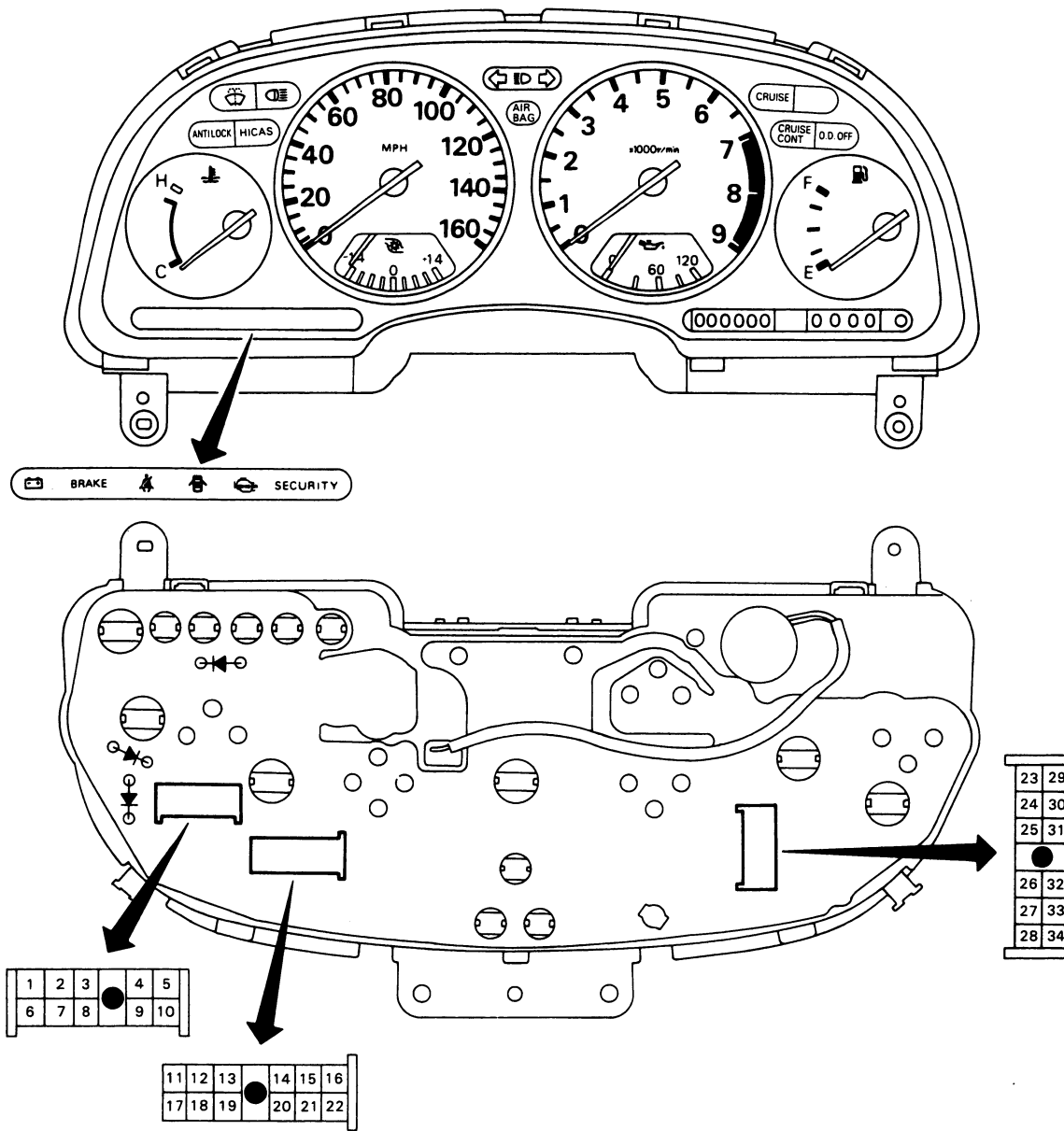

SEL0100

METER AND GAUGES

Combination Meter (Cont'd)

TYPE B

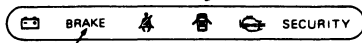
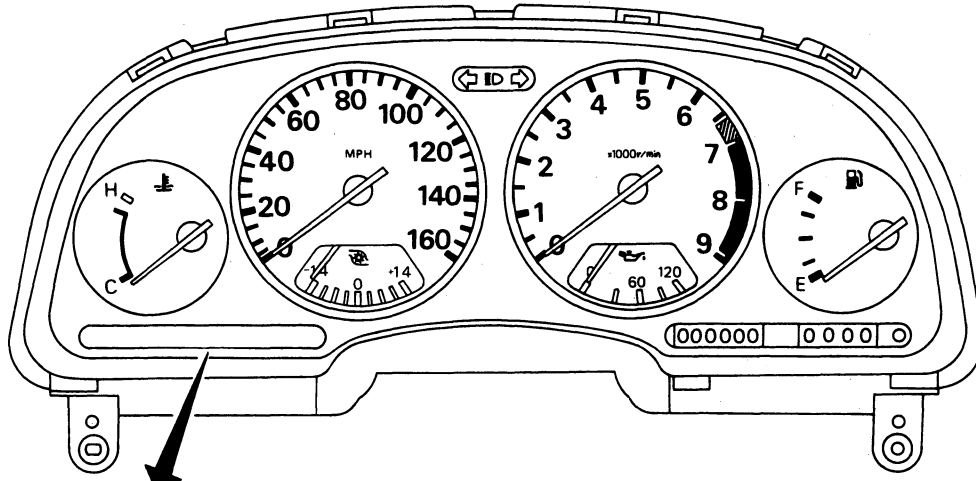

"BRAKE" or "O"

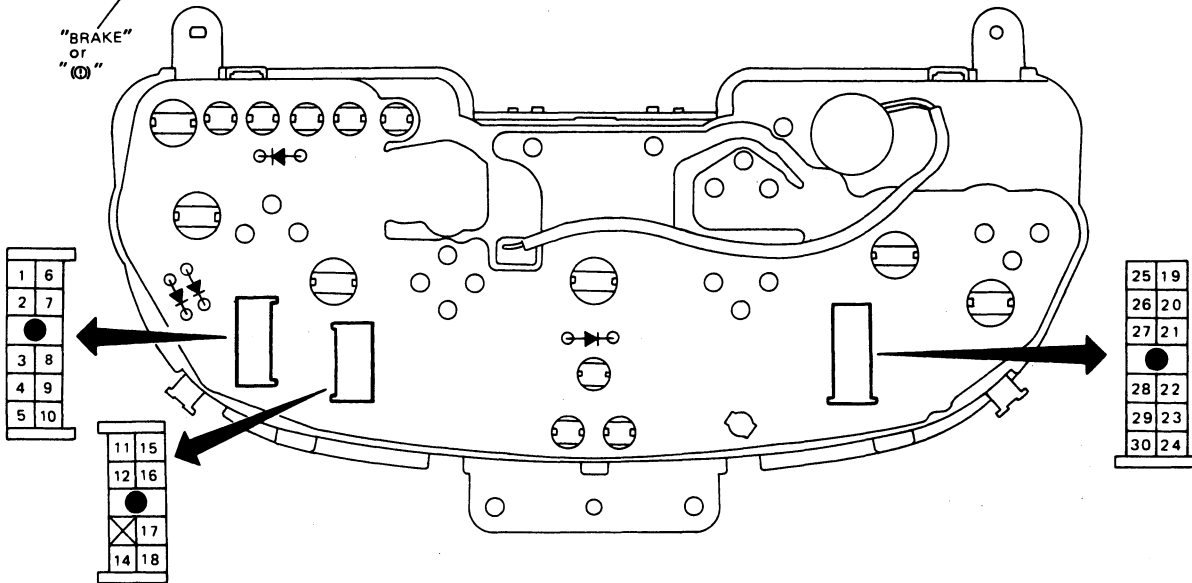

1	6
2	7
3	8
4	9
5	10

11	15
12	16
13	17
14	18

25	19
26	20
27	21
28	22
29	23
30	24

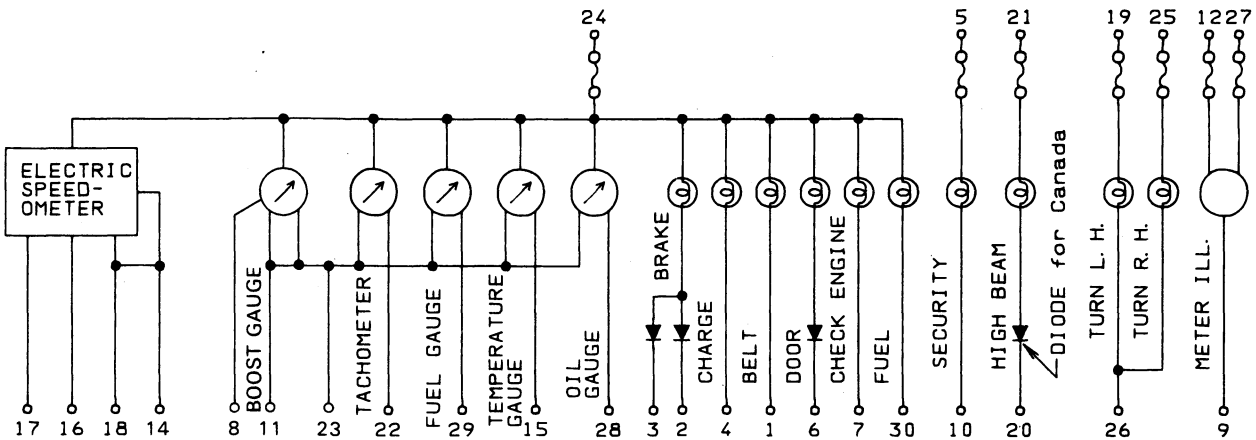

MEL028A

METER AND GAUGES

Speedometer, Tachometer, Temp., Oil, Fuel and Boost Gauges/Wiring Diagram

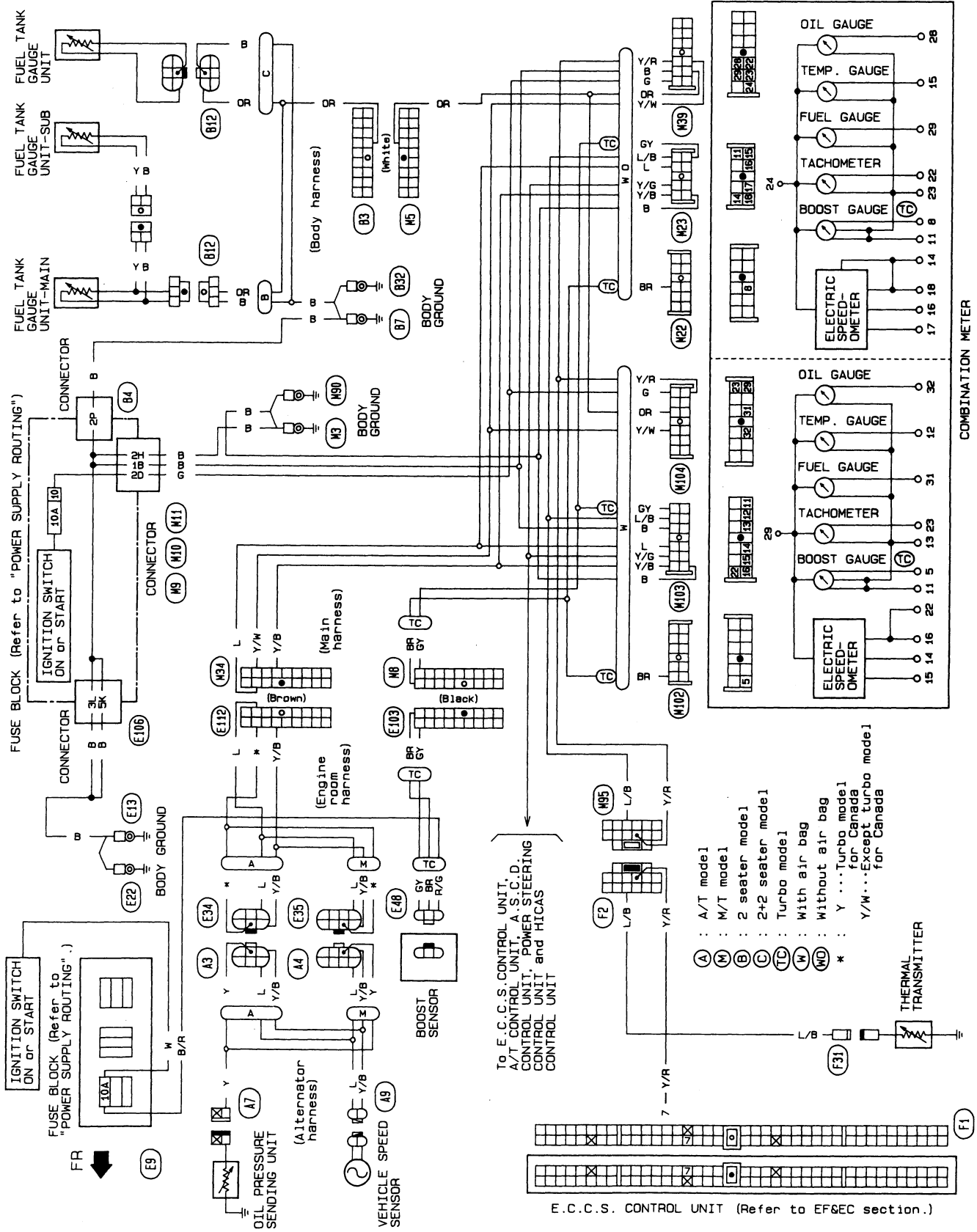

METER AND GAUGES

Inspection/Fuel Gauge and Water Temperature Gauge

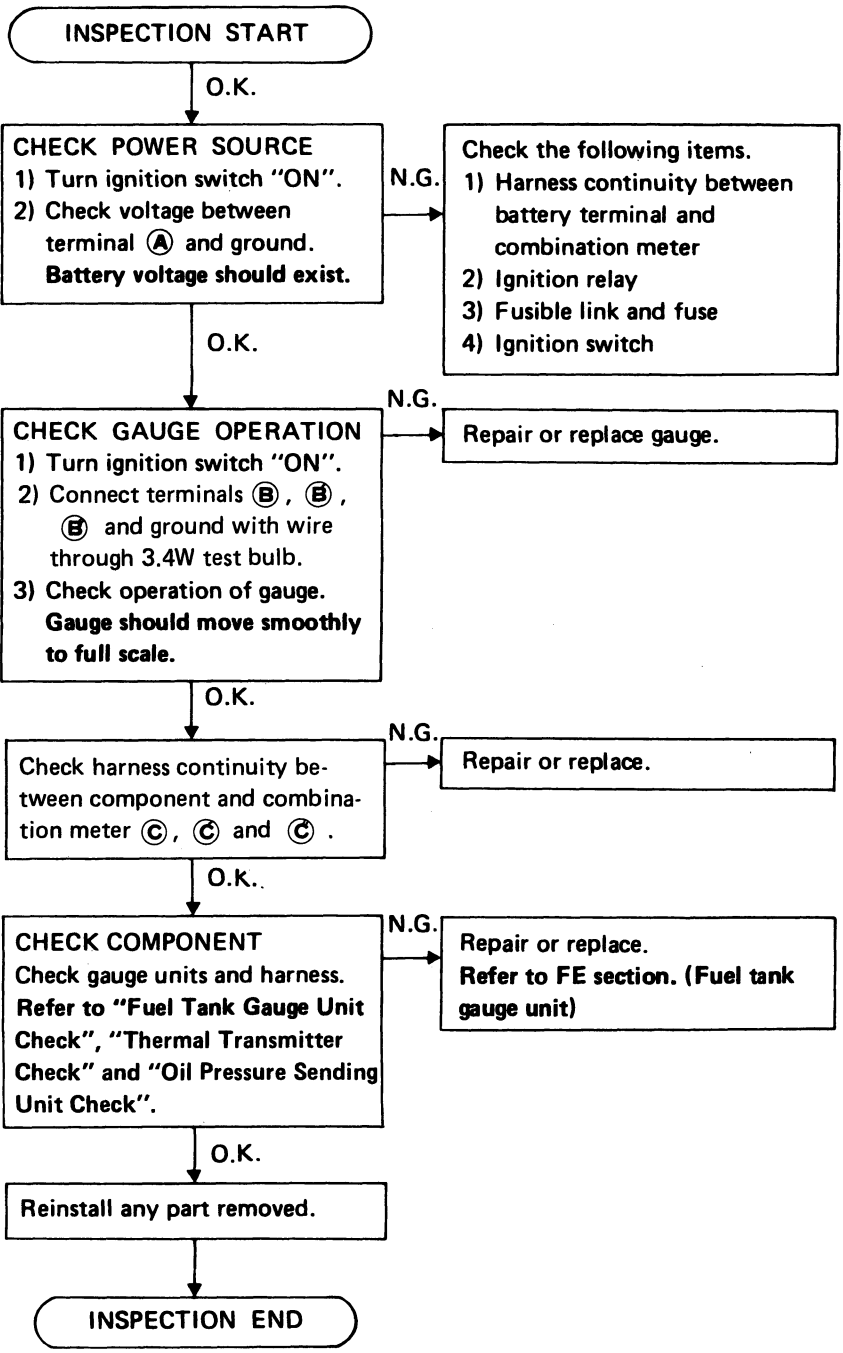
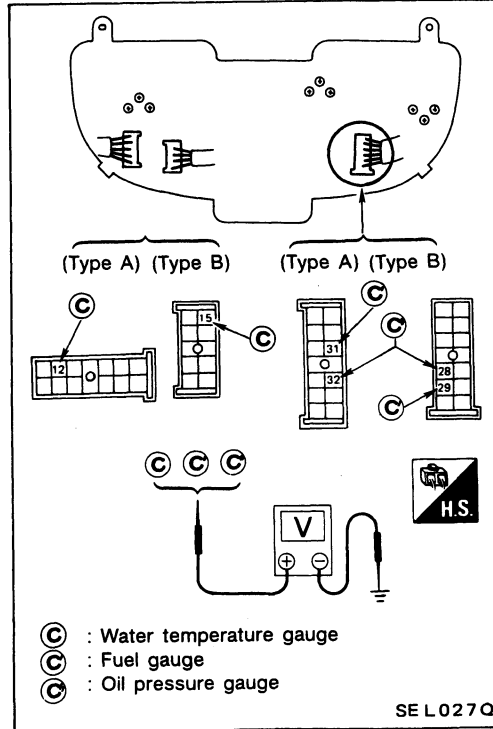
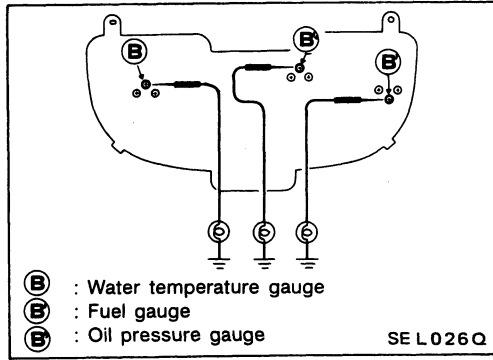
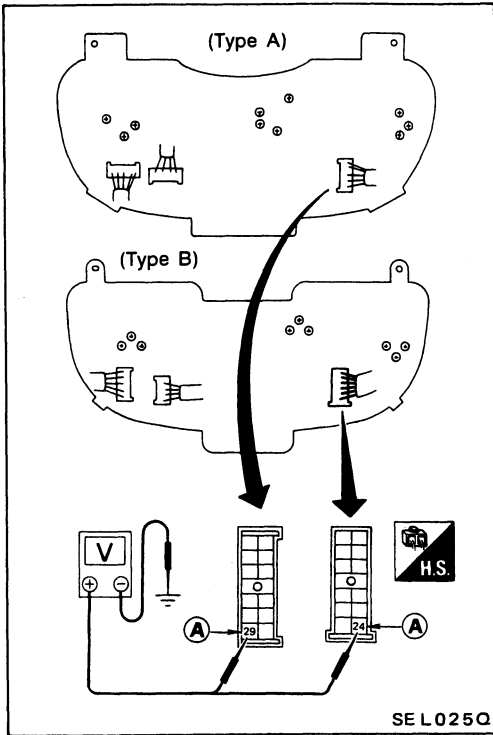

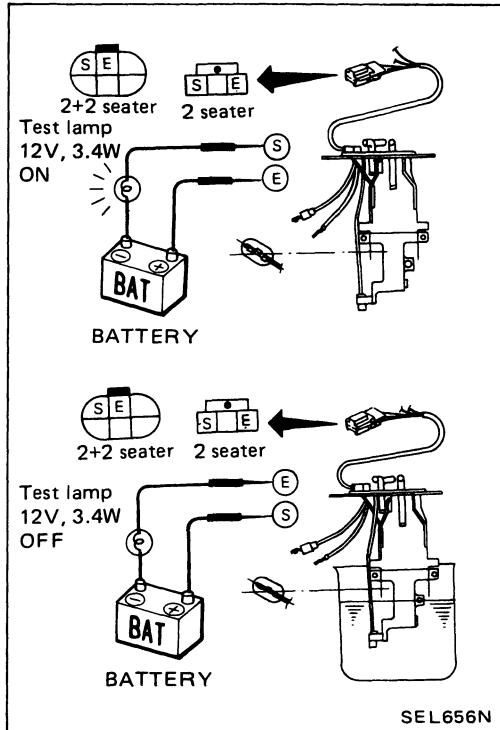
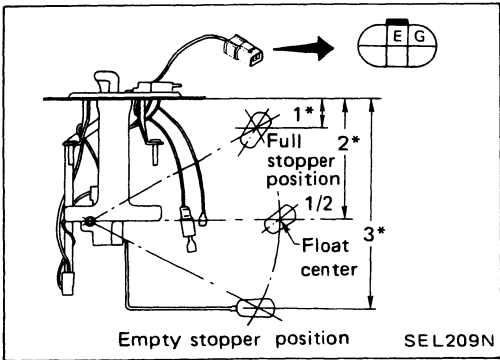
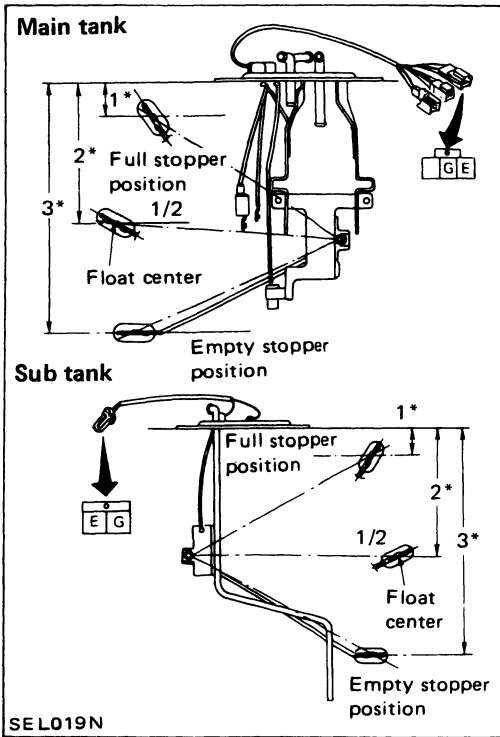

Fuel Tank Gauge Unit Check

● For removal, refer to FE section.
Check the resistance between terminals **G** and **E**.

2 seater model:

Ohmmeter		Float position mm (in)			Resistance value (Ω)	
(+)	(-)					
G	E	1*	Full	Main	41.0 (1.614)	8.6 - 11.6
				Sub	40.0 (1.575)	
		2*	1/2	Main	137.0 (5.39)	55.4 - 68.6
				Sub	139.5 (5.49)	
		3*	Empty	Main	232.0 (9.13)	157.6 - 170.6
				Sub	261.0 (10.28)	

1* and 3*: When float rod is in contact with stopper.

2+2 seater model:

Ohmmeter		Float position mm (in)		Resistance value (Ω)	
(+)	(-)				
G	E	1*	Full	21.0 (0.827)	4.3 - 5.8
		2*	1/2	115.0 (4.53)	27.7 - 34.3
		3*	Empty	207.0 (8.15)	78.3 - 84.8

1* and 3*: When float rod is in contact with stopper.

Fuel Warning Lamp Sensor Check

● It will take a short time for the bulb to light.

METER AND GAUGES

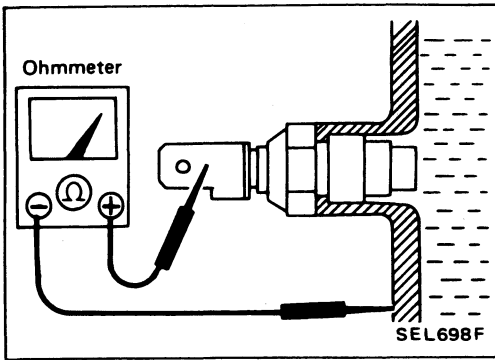

Thermal Transmitter Check

Check the resistance between the terminals of thermal transmitter and body ground.

Water temperature	Resistance
60°C (140°F)	Approx. 70 - 90Ω
100°C (212°F)	Approx. 21 - 24Ω

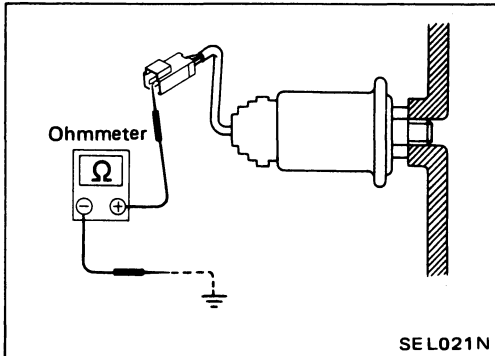

Oil Pressure Sending Unit Check

Check the resistance between the terminals of oil pressure sending unit and body ground.

Oil pressure kPa (kg/cm ² , psi)	Resistance value (Ω)
0 (0, 0) (Engine is stopped)	More than 83
392 (4, 57)	Approx. 26 - 37
588 (6, 85)	Approx. 18 - 26

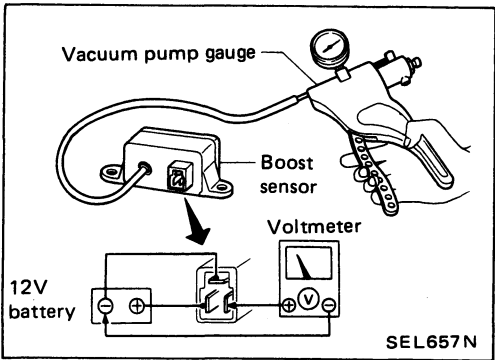

Boost Sensor Check

1. Connect vacuum pump gauge to boost sensor vacuum hose.
2. Disconnect harness connector from boost sensor and connect battery and voltmeter as shown.
3. Apply vacuum pressure to boost sensor by vacuum pump gauge and measure voltages.

Voltage:

**Approx. 2.2V at 0 kPa (0 kg/cm², 0 psi)
(Atmospheric pressure)**

Approx. 1.3V at -55 kPa (-0.56 kg/cm², -8 psi)

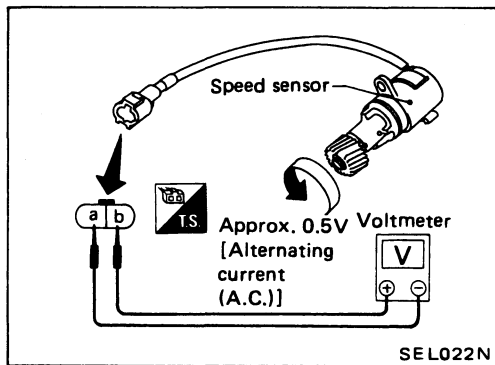

Speed Sensor Signal Check

1. Remove speed sensor from transmission.
Location: Refer to "LOCATION OF ELECTRICAL UNITS" in Service Manual.
2. Turn speedometer pinion quickly and measure voltage across (a) and (b).

WARNING LAMPS AND CHIME

Warning Lamps/Schematic

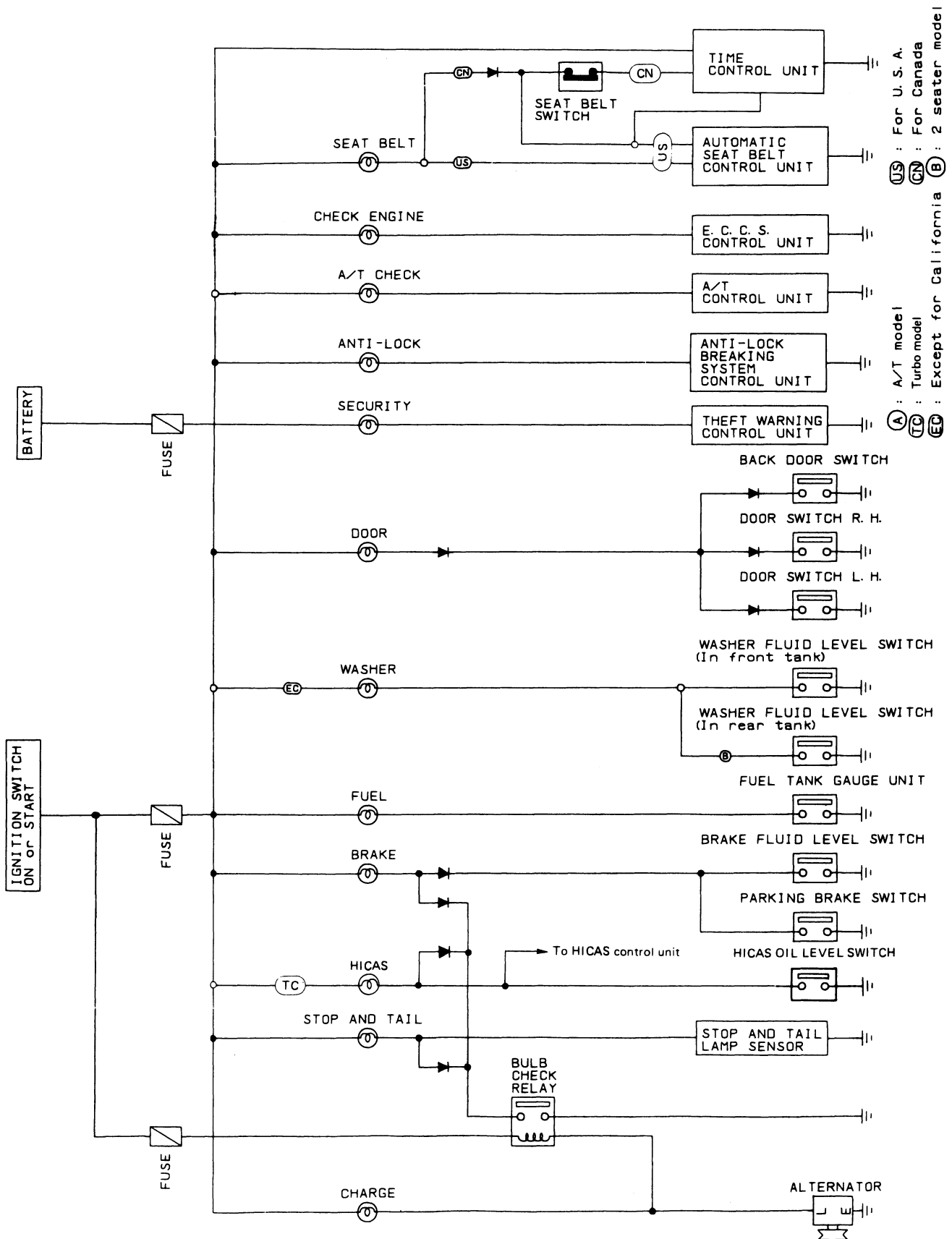

WARNING LAMPS AND CHIME

Warning Lamps/Wiring Diagram

WITH AIR BAG

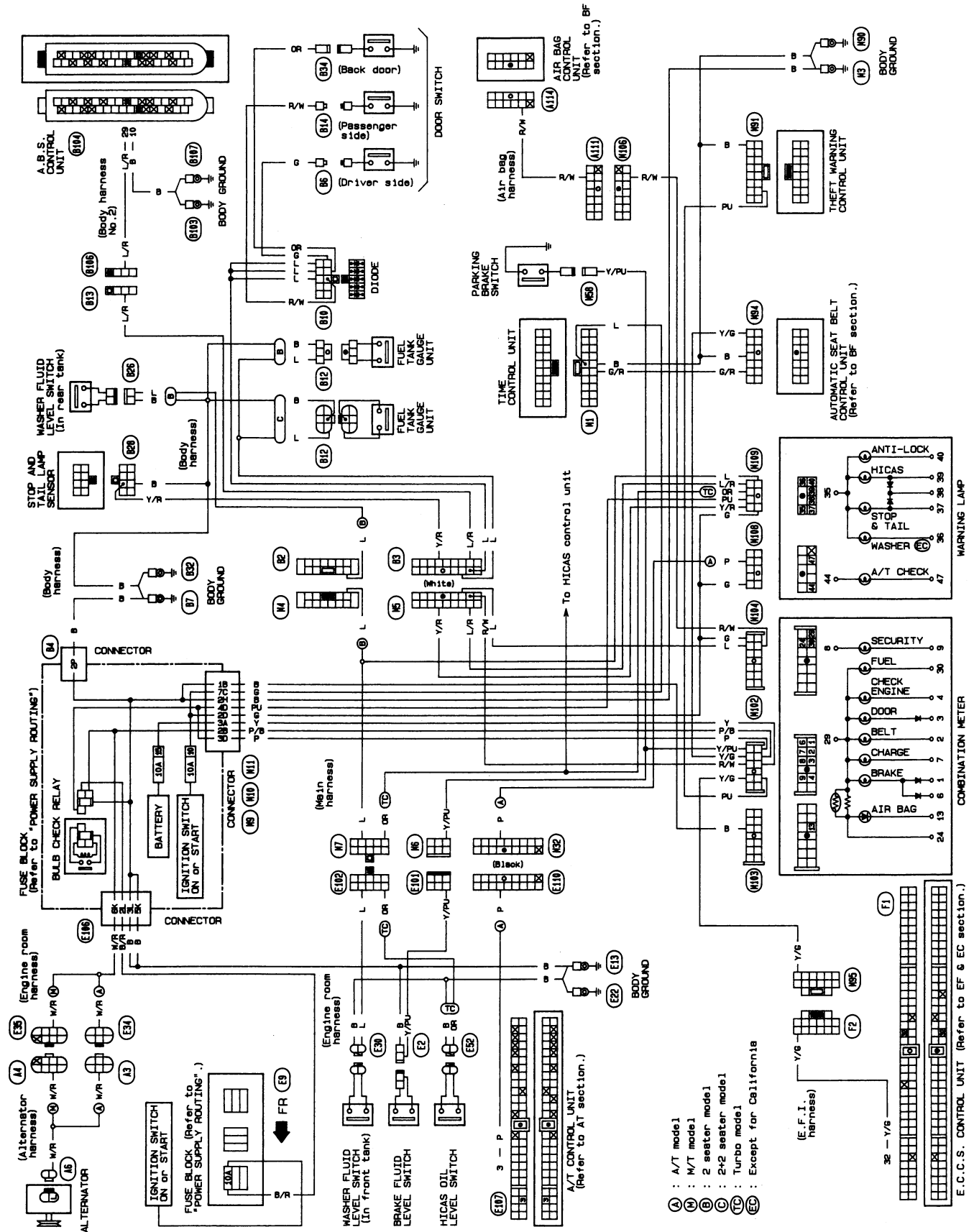

WARNING LAMPS AND CHIME

Warning Lamps/Wiring Diagram (Cont'd)

WITHOUT AIR BAG

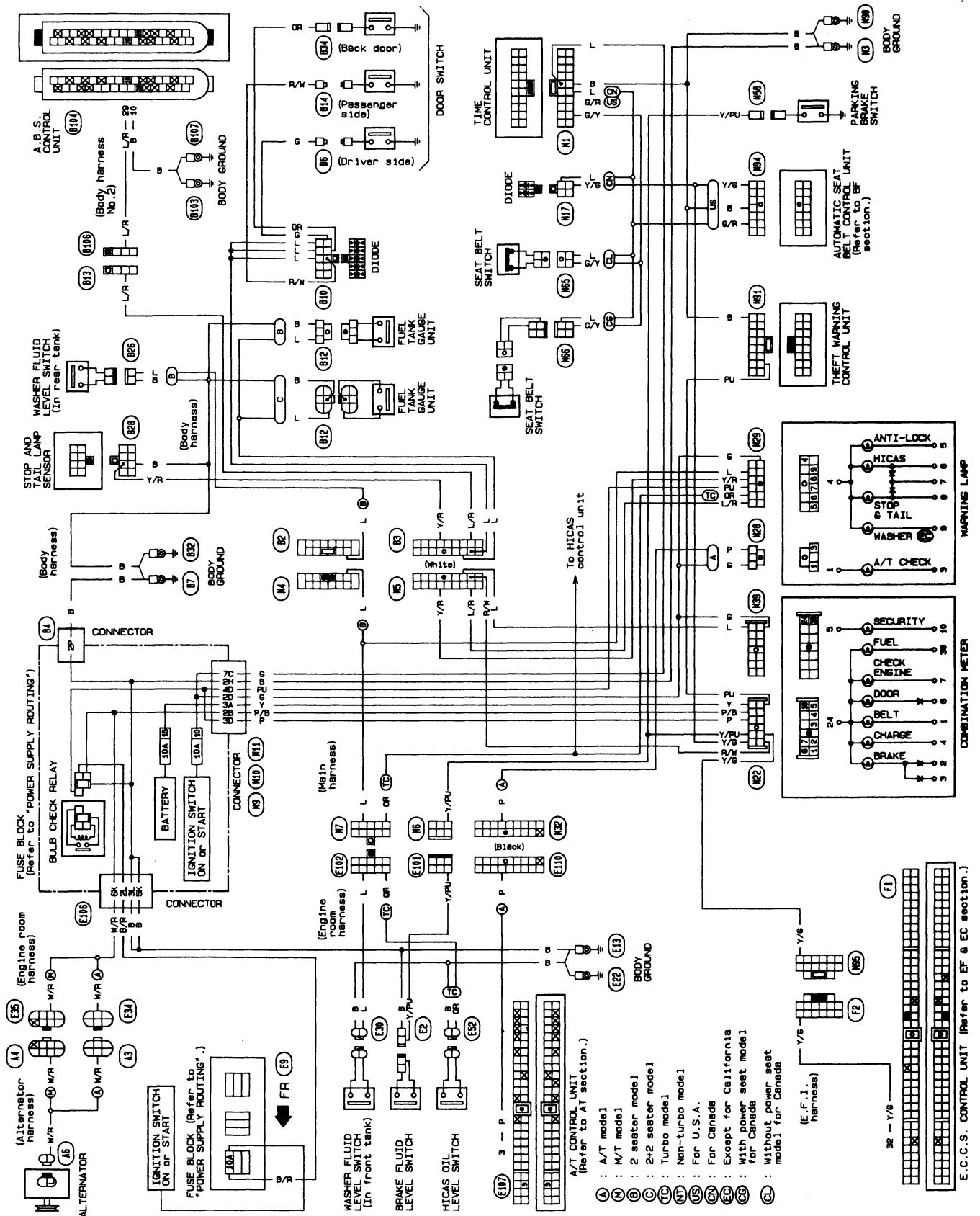

WARNING LAMPS AND CHIME

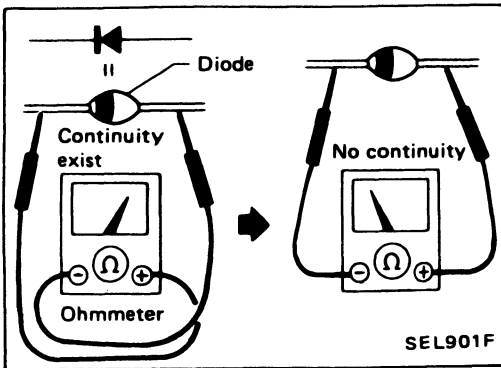

Diode Check

- Check continuity using an ohmmeter.
- Diode is functioning properly if test results are as shown in the figure at left.

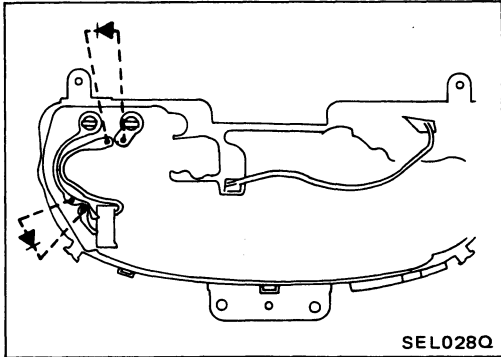

- Diodes for warning lamps are built into the combination meter printed circuit.

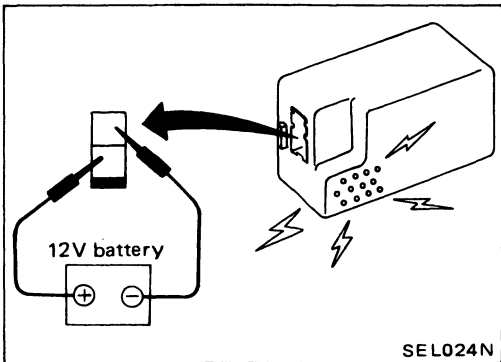

Warning Chime Check

TIME CONTROL SYSTEM

Description

FUNCTION

- Time control unit has the following functions.

Item		Details of control
1, 2	Intermittent wiper control	Regulates intermittent time from approximately 3 to 23 seconds depending on the intermittent wiper volume setting.
3	Washer and wiper combination control	Wiper is operated in conjunction with washer switch.
4	Light warning chime timer	When driver's door is opened with light switch ON and ignition switch OFF, warning chime sounds.
5	Ignition key warning chime timer	When driver's door is opened with ignition switch OFF, warning chime sounds.
6	Seat belt warning chime timer	Sounds warning chime for about 7 seconds if ignition switch is turned "ON" when seat belt switch is "ON" (seat belt is unfastened).
7	Seat belt warning lamp timer	Seat belt warning lamp blinks for about 7 seconds when ignition switch is turned to "ON".
8	Rear defogger timer	Rear defogger operates for about 15 minutes when defogger switch is ON.
9	Interior lamp timer	Fades out interior lamp when driver's side door is opened and closed.
10	Door key hole illumination	Illuminates for about 7 seconds when door outside handle is pulled.
11	Illumination control	The brightness of the instrument panel light can be adjusted.

TIME CONTROL SYSTEM

Wiring Diagram

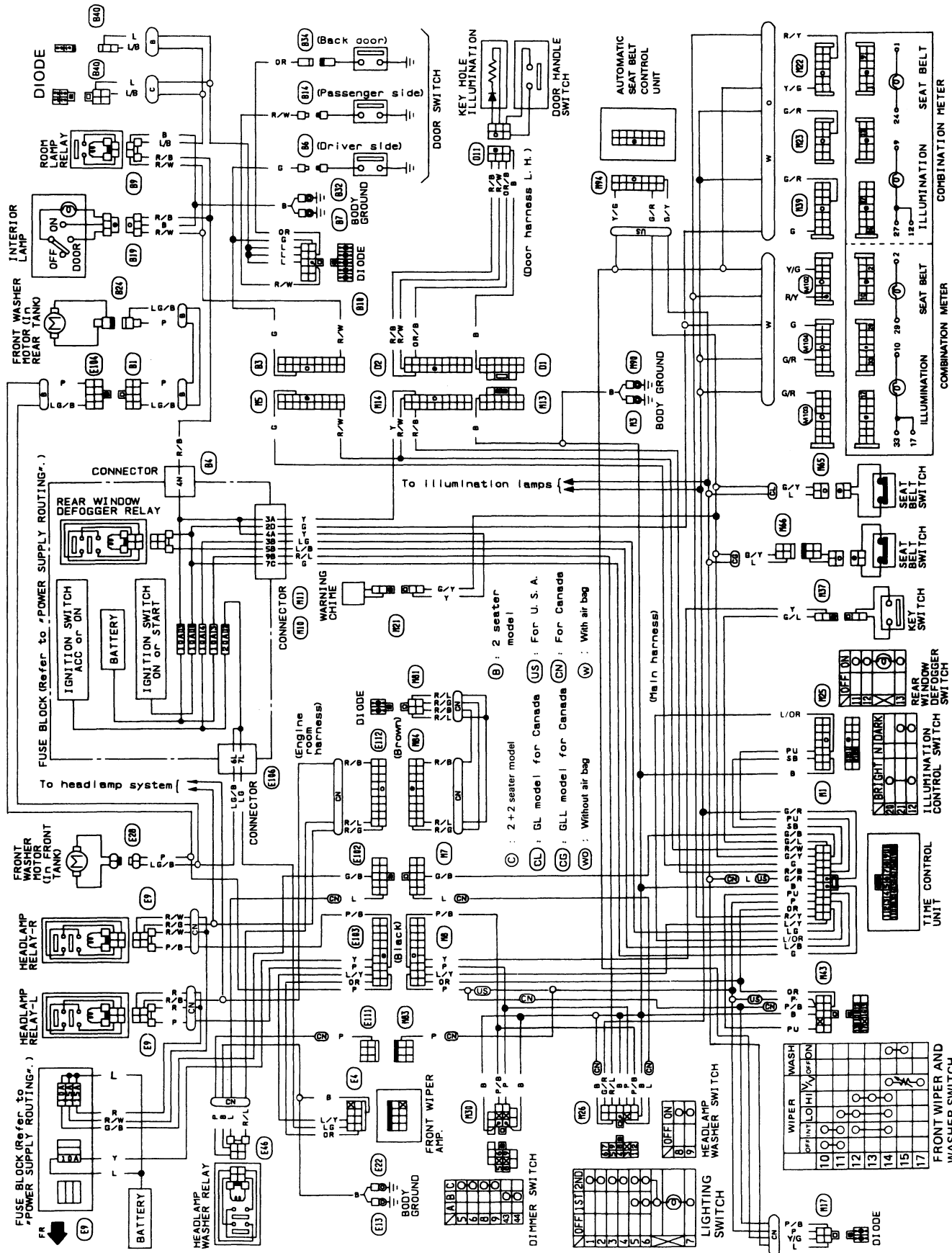

TIME CONTROL SYSTEM

Trouble Diagnoses

SYMPTOM CHART

PROCEDURE		Preliminary Check			Main Power Supply and Ground Circuit Check	Diagnostic Procedure										
		EL-71	EL-71	EL-71		EL-72	EL-74	EL-75	EL-75	EL-76	EL-77	EL-78	EL-79	EL-79	EL-80	EL-81
REFERENCE PAGE		EL-71	EL-71	EL-71	EL-72	EL-74	EL-75	EL-75	EL-76	EL-77	EL-78	EL-79	EL-79	EL-80	EL-81	EL-82
SYMPTOM		Procedure 1	Procedure 2	Procedure 3	Main power supply and Ground circuit	Diagnostic Procedure 1	Diagnostic Procedure 2	Diagnostic Procedure 3	Diagnostic Procedure 4	Diagnostic Procedure 5	Diagnostic Procedure 6	Diagnostic Procedure 7	Diagnostic Procedure 8	Diagnostic Procedure 9	Diagnostic Procedure 10	Diagnostic Procedure 11
Wiper & washer	Intermittent wiper does not operate.				○	○										
	Intermittent time of wiper cannot be adjusted.						○									
	Wiper and washer activate individually but not in combination.							○								
Warning	Light warning chime does not activate.	○			○				○							
	Ignition key warning chime does not activate.		○		○					○						
	Seat belt warning chime does not activate.			○	○						○					
	Seat belt warning lamp does not come on, or does not go off after coming on.				○							○				
Rear defogger	Rear defogger does not activate, or go off after activating.				○								○			
Illumination	Interior lamp does not fade out after driver's door is closed.				○									○		
	Door key hole illumination does not come on even if door handle is pulled.				○										○	
	Illumination control does not actuate.															○

TIME CONTROL SYSTEM

Trouble Diagnoses (Cont'd)

PRELIMINARY CHECK

Preliminary check 1

- Light warning chime does not activate.

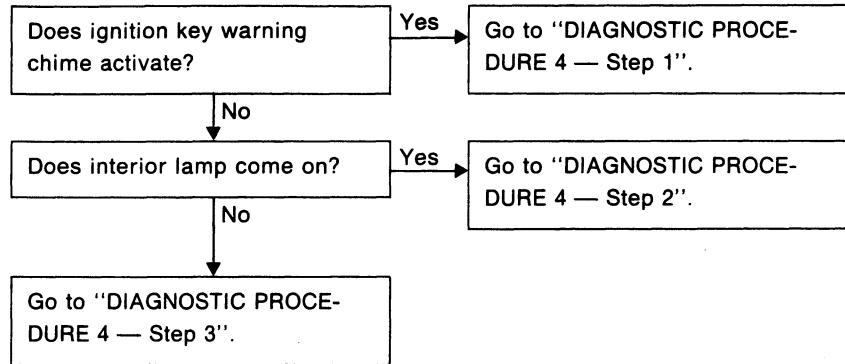

Preliminary check 2

- Ignition key warning chime does not activate.

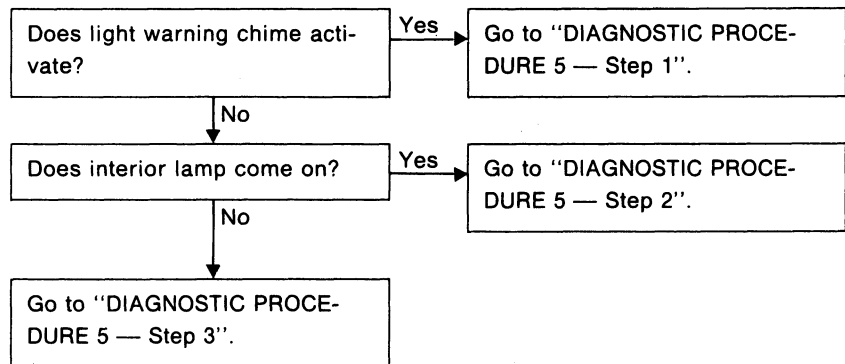

Preliminary check 3

- Seat belt warning chime does not activate.

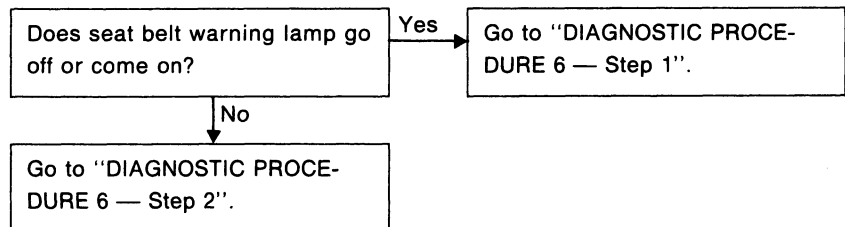

TIME CONTROL SYSTEM

Trouble Diagnoses (Cont'd)

MAIN POWER SUPPLY AND GROUND CIRCUIT CHECK

Main power supply

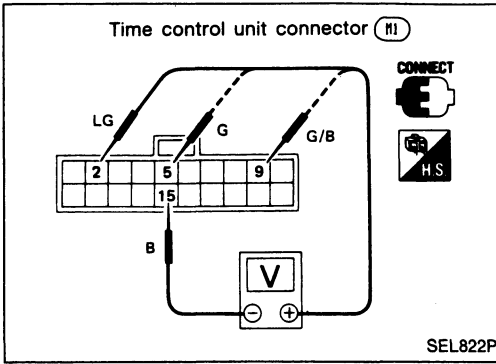

Terminals	Battery voltage existence condition		
	Ignition switch position		
	OFF	ACC	ON
⑨ - ⑮	Yes	Yes	Yes
⑤ - ⑮	No	No	Yes
② - ⑮	No	Yes	Yes

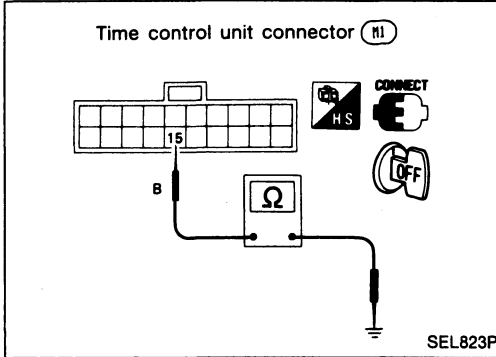

Ground circuit

Terminals	Continuity
⑮ - Ground	Yes

TIME CONTROL SYSTEM

Trouble Diagnoses (Cont'd)

CIRCUIT DIAGRAM FOR QUICK PINPOINT CHECK

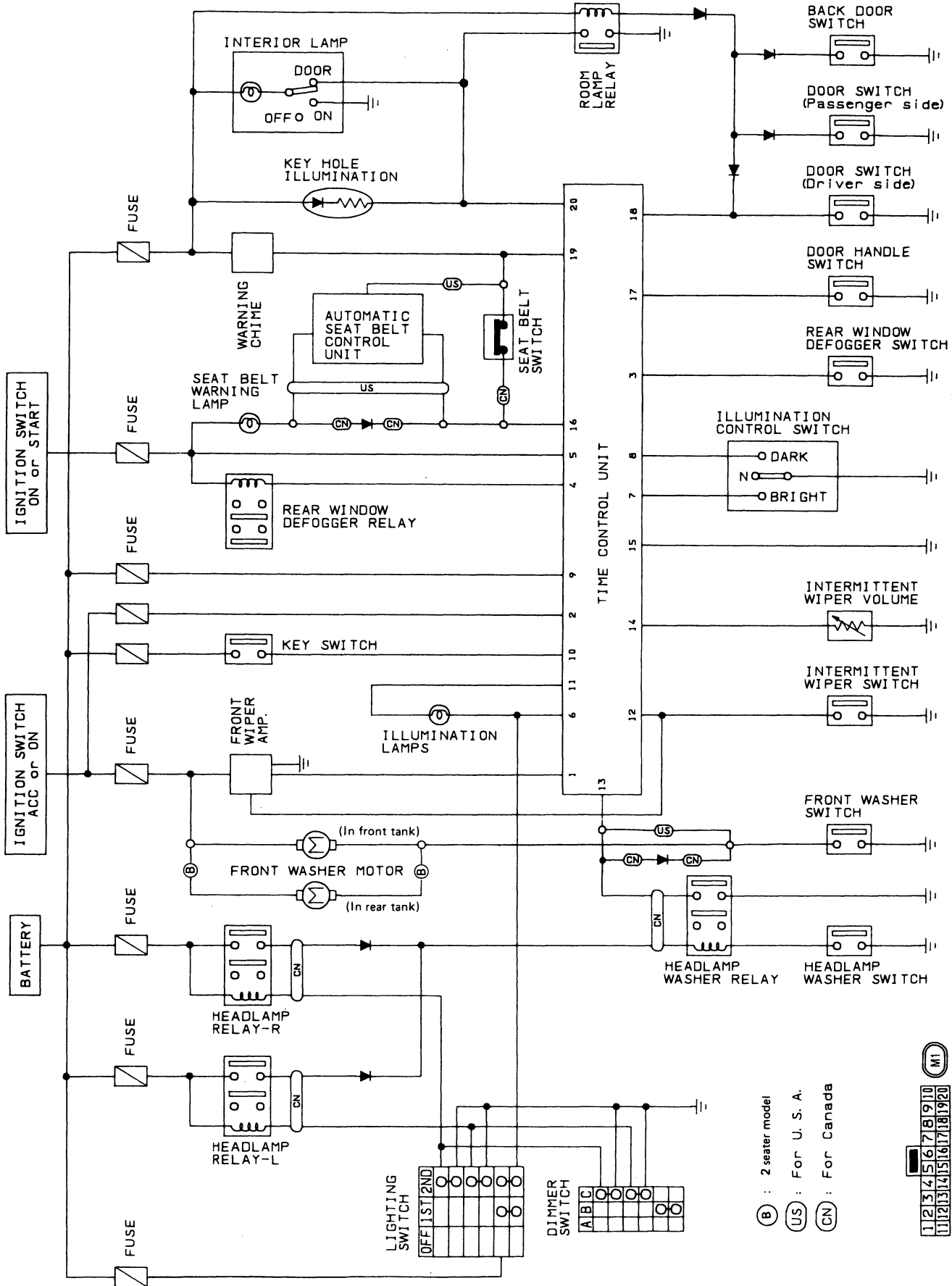

(B) : 2 seater model
 (US) : For U. S. A.
 (CN) : For Canada

112345678910
 11121314151617181920 (M1)

TIME CONTROL SYSTEM

Trouble Diagnoses (Cont'd)

DIAGNOSTIC PROCEDURE 1

SYMPTOM: Intermittent wiper does not operate.

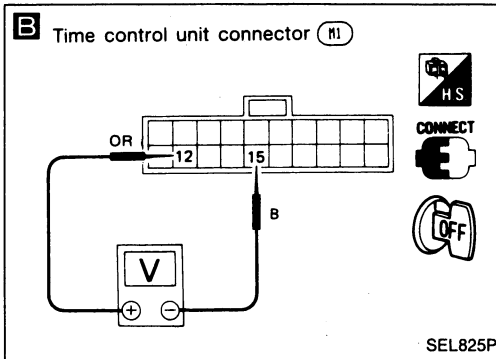
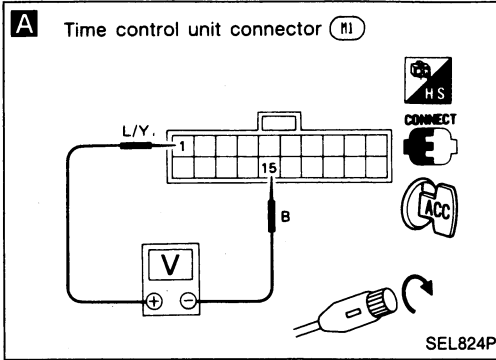

A

WIPER RELAY OUTPUT SIGNAL CHECK

- 1) Turn ignition switch to "ACC".
- 2) Turn wiper switch to "INT" or "OFF".
- 3) Measure voltage between control unit harness terminals ① and ⑮.

Condition of wiper switch	Voltage [V]
OFF	Approx. 12
INT	Pointer swings from 0 to 12 every 3 to 23 seconds

B

INTERMITTENT SWITCH INPUT SIGNAL CHECK

Measure voltage between control unit harness terminals ⑫ and ⑮.

Condition of wiper switch	Voltage [V]
OFF	Approx. 12
INT	0

O.K.

Check wiper amp.
Refer to "WIPER AND WASHER".

O.K.

N.G.

Replace wiper amp.

Check wiper amp. circuit.

N.G.

N.G.

Check wiper switch.
Check harness continuity between T.C.U. and wiper switch.

O.K.

Replace control unit.

TIME CONTROL SYSTEM

Trouble Diagnoses (Cont'd)

DIAGNOSTIC PROCEDURE 2

SYMPTOM: Intermittent time of wiper cannot be adjusted.

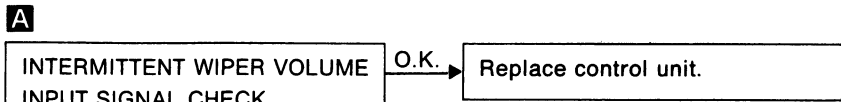
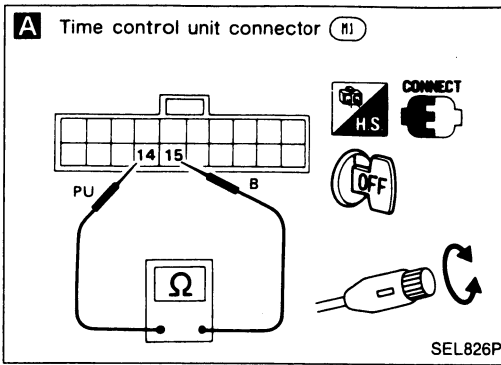

INTERMITTENT WIPER VOLUME INPUT SIGNAL CHECK

Measure resistance between control unit harness terminals ⑭ and ⑮ while turning intermittent wiper volume.

Position of wiper knob	Resistance [Ω]
S	0
L	Approx. 1 k

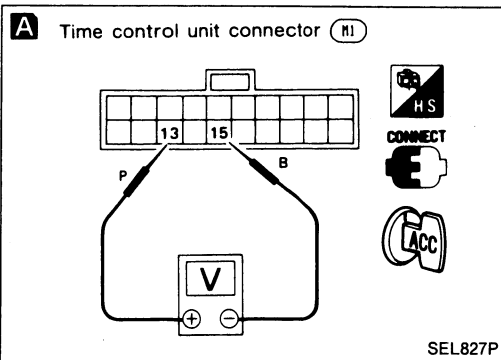
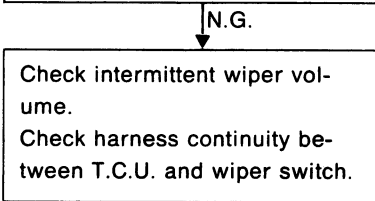

DIAGNOSTIC PROCEDURE 3

SYMPTOM: Wiper and washer activate individually but not in combination.

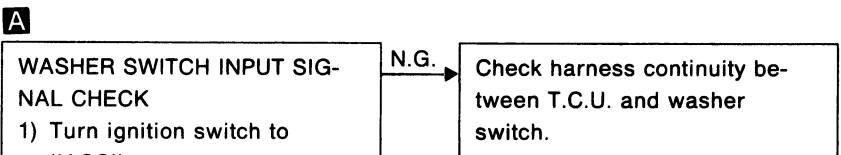

WASHER SWITCH INPUT SIGNAL CHECK

1) Turn ignition switch to "ACC".

2) Measure voltage between control unit harness terminals ⑬ and ⑮.

Condition of washer switch	Voltage [V]
OFF	Approx. 12
ON	0

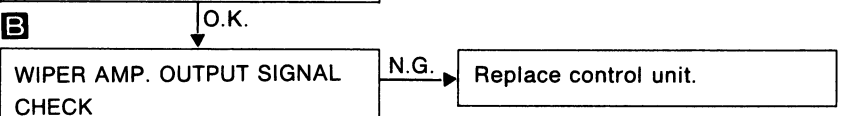

WIPER AMP. OUTPUT SIGNAL CHECK

Measure voltage between control unit harness terminals ① and ⑮ after operating washer switch.

0V for approx. 3 seconds after washer has operated.

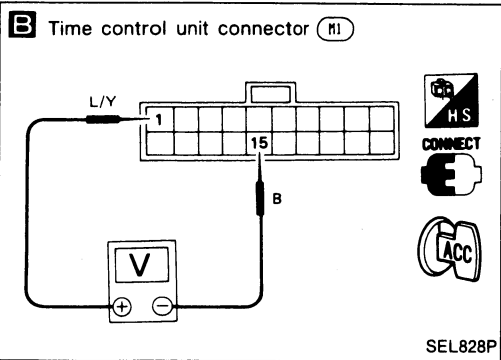
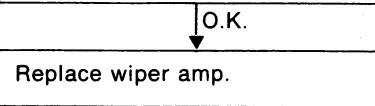

TIME CONTROL SYSTEM

Trouble Diagnoses (Cont'd)

DIAGNOSTIC PROCEDURE 4

SYMPTOM: Light warning chime does not activate.

- Perform "PRELIMINARY CHECK — Procedure 1" before referring to the following flow chart.

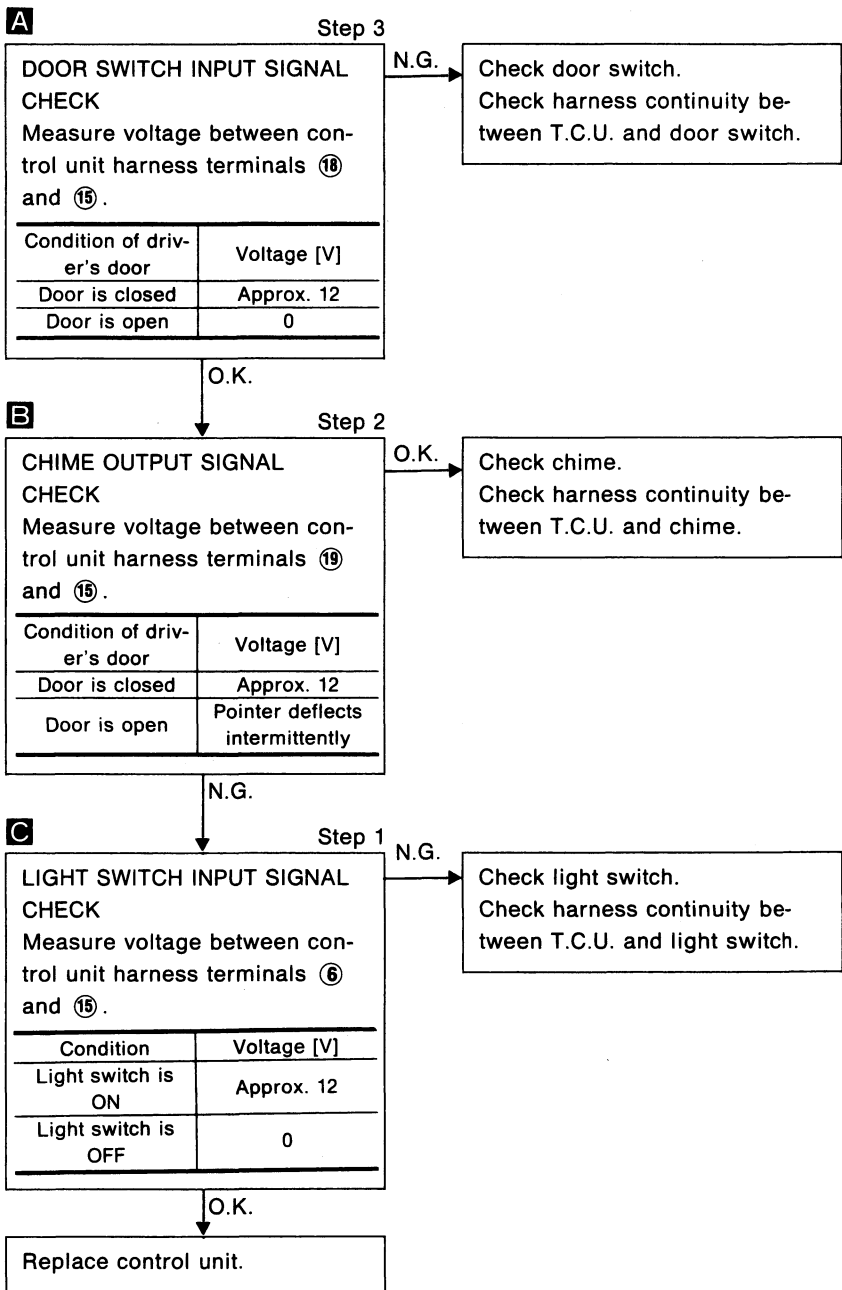
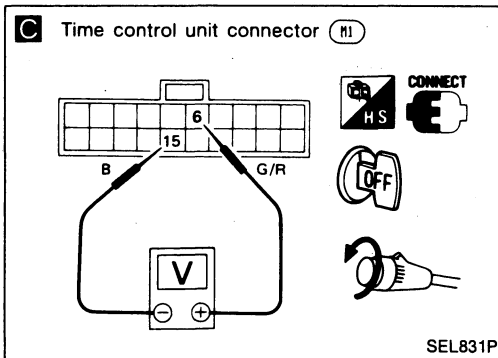
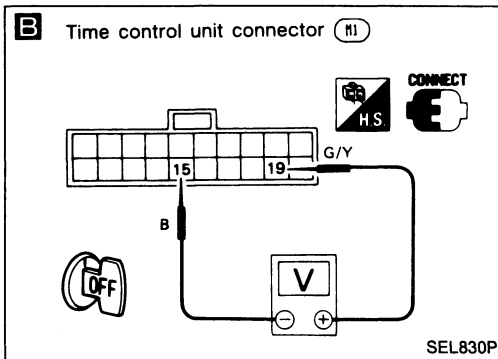
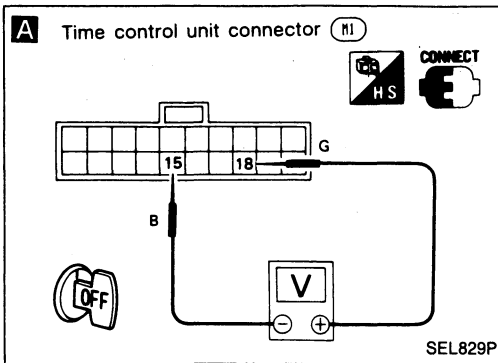

TIME CONTROL SYSTEM

Trouble Diagnoses (Cont'd)

DIAGNOSTIC PROCEDURE 5

SYMPTOM: Ignition key warning chime does not activate.

- Perform "PRELIMINARY CHECK — Procedure 2" before referring to the following flow chart.

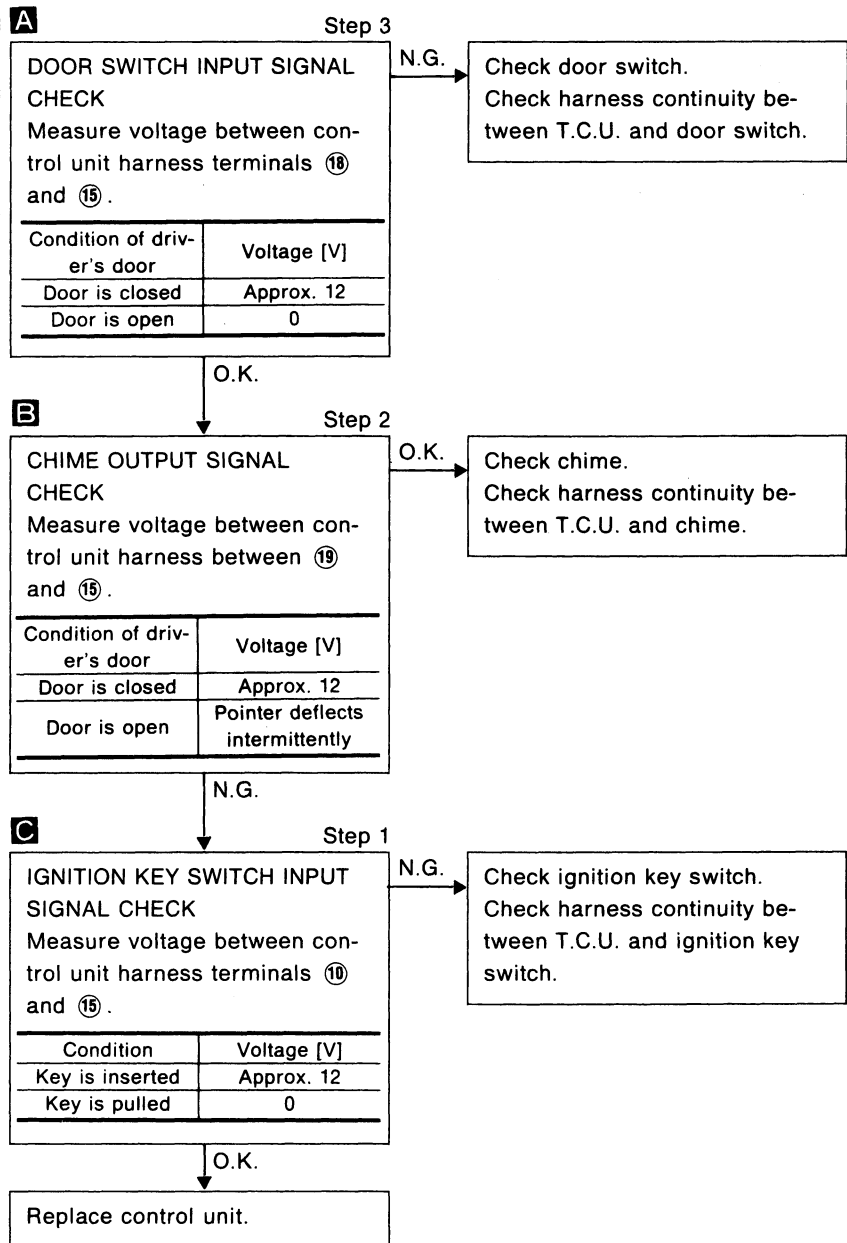
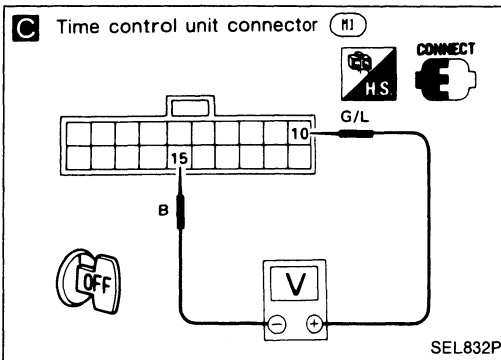
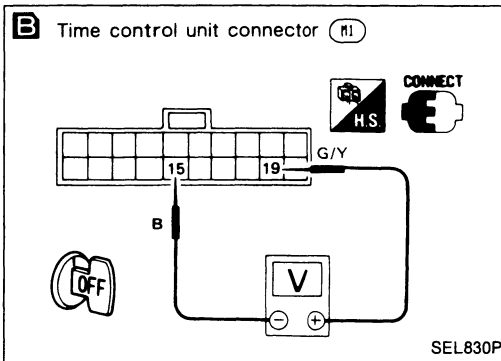
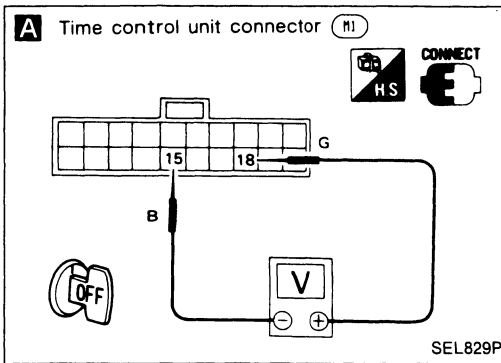

TIME CONTROL SYSTEM

Trouble Diagnoses (Cont'd)

DIAGNOSTIC PROCEDURE 6

SYMPTOM: Seat belt warning chime does not activate.

- Perform "PRELIMINARY CHECK — Procedure 3" before referring to the following flow chart.

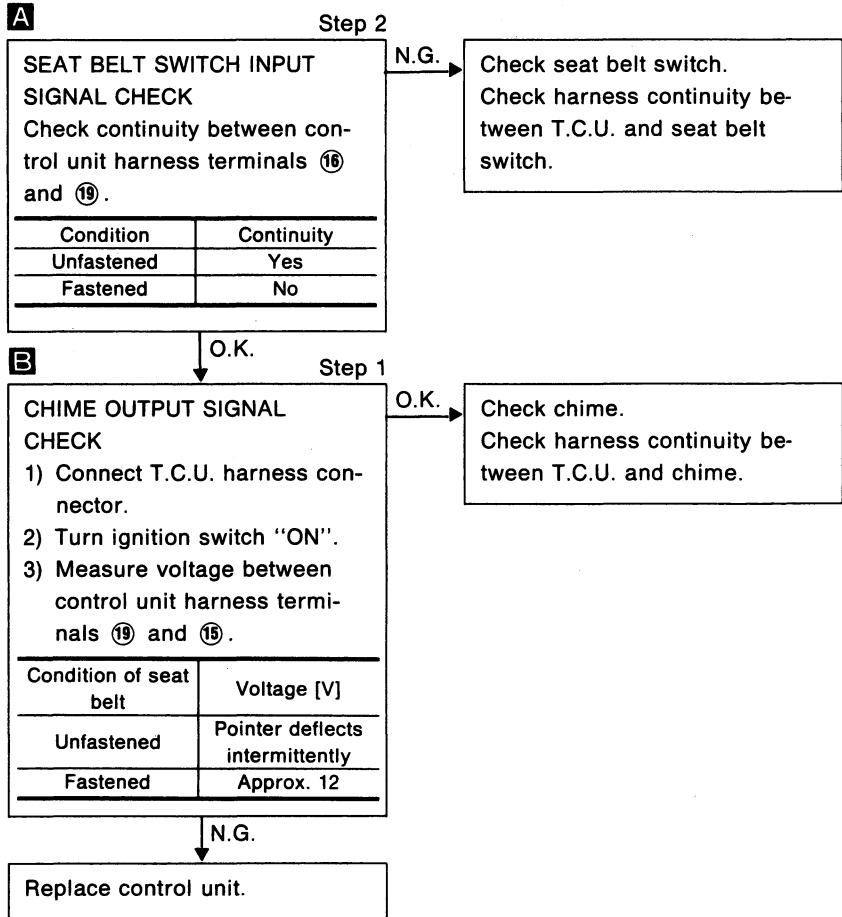
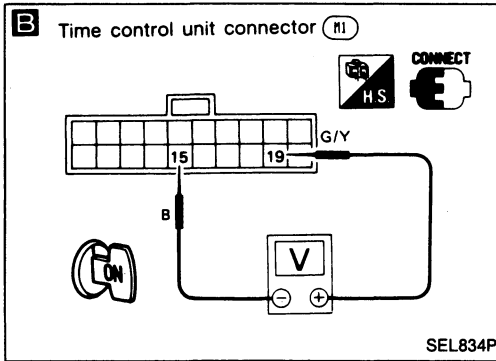
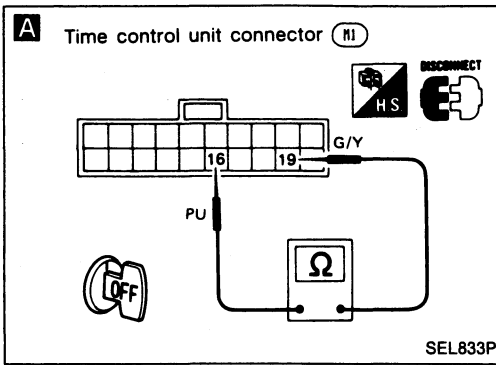

TIME CONTROL SYSTEM

Trouble Diagnoses (Cont'd)

DIAGNOSTIC PROCEDURE 7

SYMPTOM: Seat belt warning lamp does not come on, or does not go off after coming on.

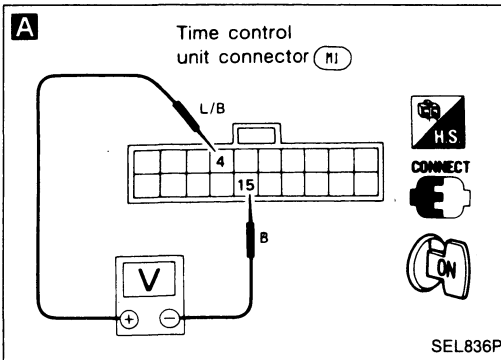
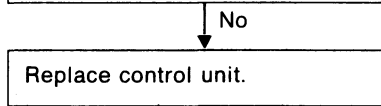
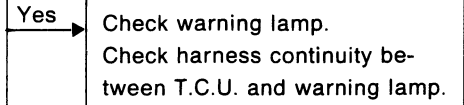
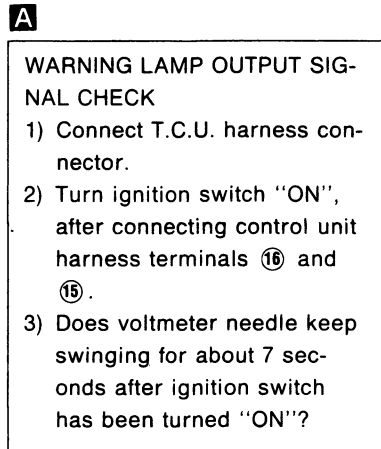
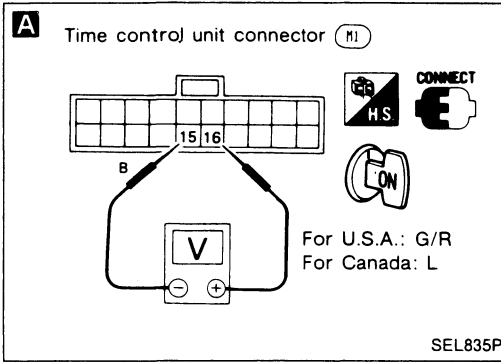

DIAGNOSTIC PROCEDURE 8

SYMPTOM: Rear defogger does not activate, or does not go off after activating.

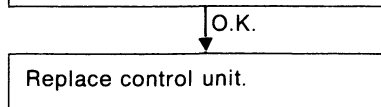
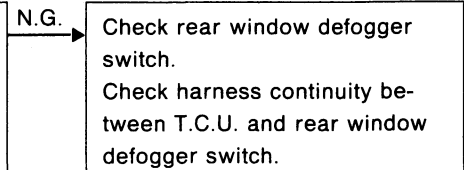
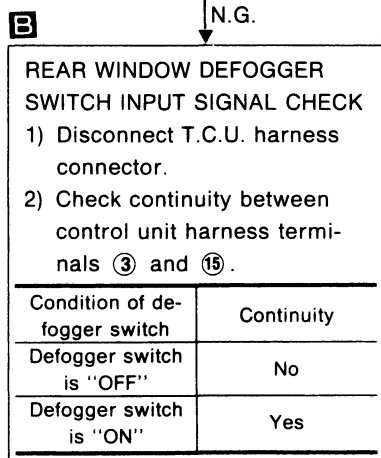
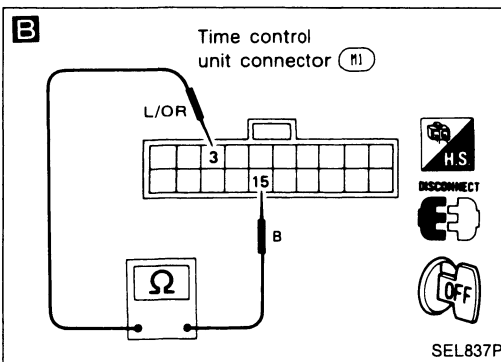
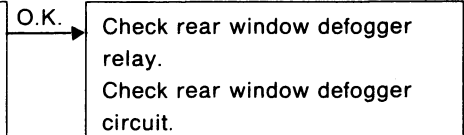
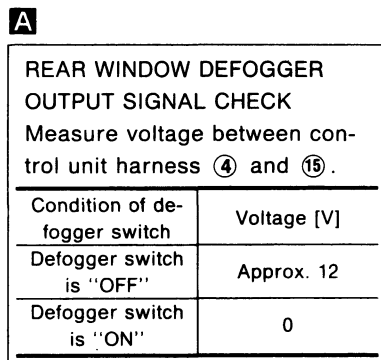

TIME CONTROL SYSTEM

Trouble Diagnoses (Cont'd)

DIAGNOSTIC PROCEDURE 9

SYMPTOM: Interior lamp does not fade out after driver's door is closed.

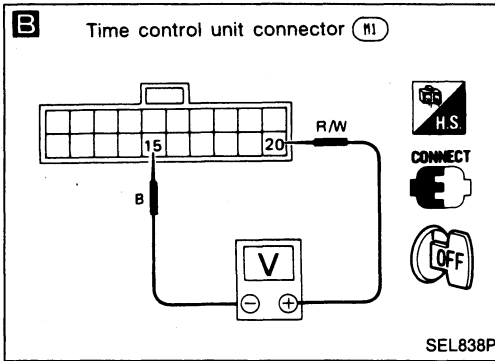
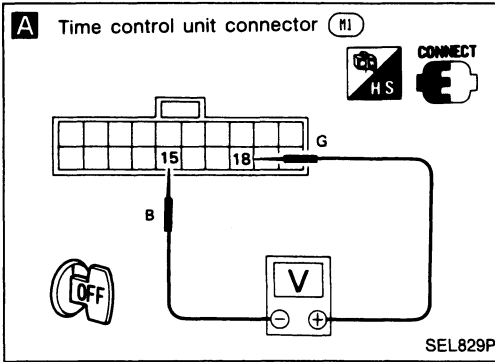

A

DOOR SWITCH INPUT SIGNAL CHECK
Measure voltage between control unit harness terminals ⑱ and ⑮.

Condition of driver's door	Voltage [V]
Door is closed	Approx. 12
Door is open	0

N.G. → Check door switch.
Check harness continuity between T.C.U. and door switch.

O.K. ↓

B

INTERIOR LAMP SIGNAL CHECK
Measure voltage between control unit harness terminals ⑳ and ⑮.

Condition of driver's door	Voltage [V]
Door is closed	0 → Approx. 12
Door is open	0

O.K. → Check interior lamp and harness between T.C.U. and interior lamp.

N.G. ↓
Replace T.C.U.

TIME CONTROL SYSTEM

Trouble Diagnoses (Cont'd)

DIAGNOSTIC PROCEDURE 10

SYMPTOM: Door key hole illumination does not come on even if door handle is pulled.

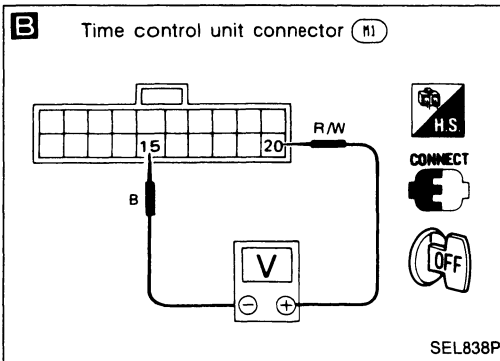
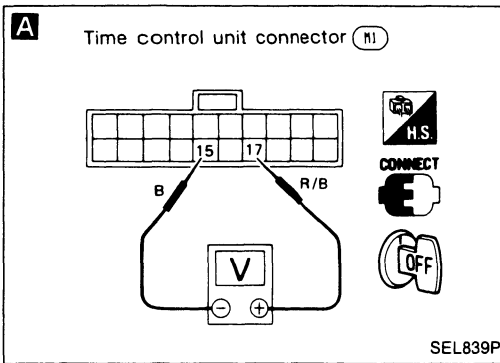

A

DOOR SWITCH INPUT SIGNAL CHECK
 Measure voltage between control unit harness terminals ⑰ and ⑮.

Condition of driver's handle	Voltage [V]
Handle is pulled	0
Handle is released	Approx. 12

N.G. → Check door handle switch. Check harness continuity between T.C.U. and door handle switch.

B

KEY HOLE ILLUMINATION SIGNAL CHECK
 Measure voltage between control unit harness terminals ⑳ and ⑮.

Condition of driver's door	Voltage [V]
Door is closed	0 → Approx. 12
Door is open	0

O.K. → Check key hole illumination and harness between T.C.U. and key hole illumination.

N.G. → Replace T.C.U.

TIME CONTROL SYSTEM

Trouble Diagnoses (Cont'd)

DIAGNOSTIC PROCEDURE 11

SYMPTOM: Illumination control does not actuate.

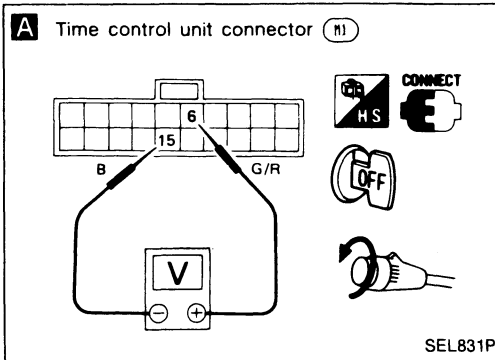

A

LIGHT SWITCH INPUT SIGNAL CHECK
Measure voltage between control unit harness terminals ⑥ and ⑮.

Condition	Voltage [V]
Light switch is on	Approx. 12
Light switch is off	0

N.G. → Check light switch.
Check harness continuity between T.C.U. and light switch.

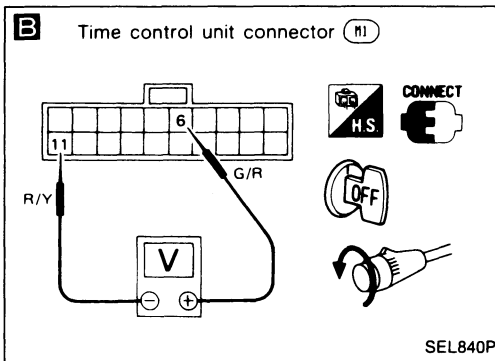

B

ILLUMINATION CIRCUIT CHECK
Measure voltage between control unit harness terminals ⑥ and ⑾.

Condition	Voltage [V]
Light switch is on	Approx. 12
Light switch is off	0

N.G. → Check meter illumination.
Check harness continuity of illumination circuit.

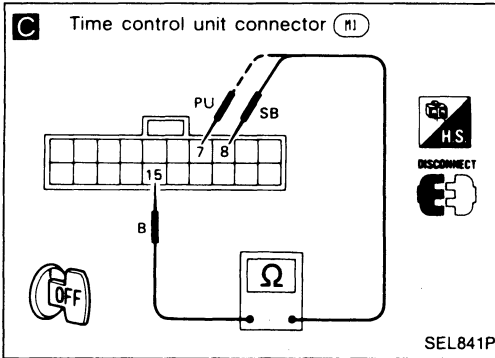

C

ILLUMINATION CIRCUIT CHECK
Measure resistance between control unit harness terminals ⑦ or ⑧ and ⑮.

Terminals	Illumination control switch condition	Resistance [Ω]
⑧ ⑮	DARK	0
	BRIGHT	Except 0
⑦ ⑮	DARK	Except 0
	BRIGHT	0

N.G. → Check illumination control switch.
Check harness continuity between T.C.U. and illumination switch.

O.K. → Replace T.C.U.

WIPER AND WASHER

Rear Wiper and Washer/Wiring Diagram

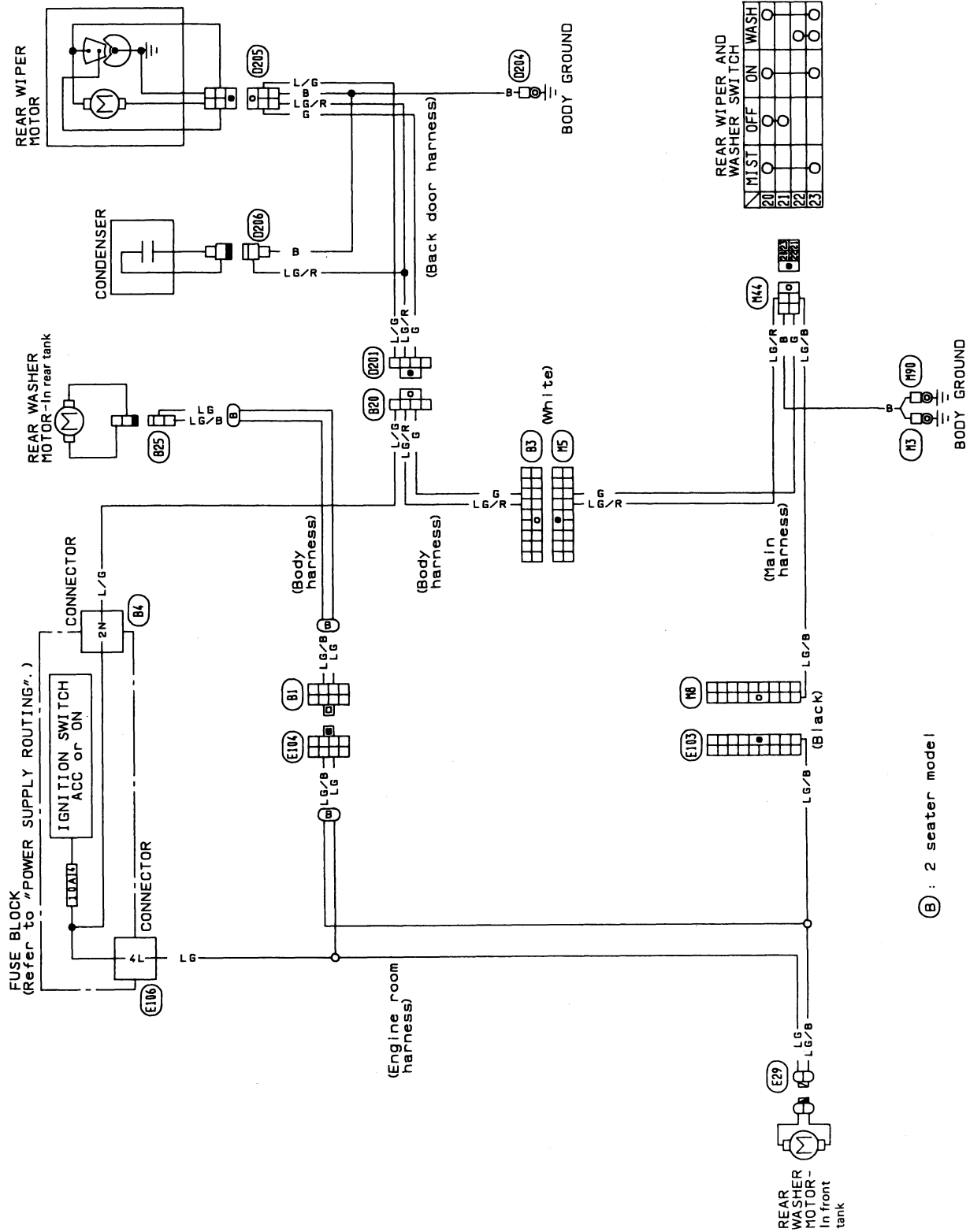

ⓔ : 2 seater model

WIPER AND WASHER

Headlamp Washer/Wiring Diagram

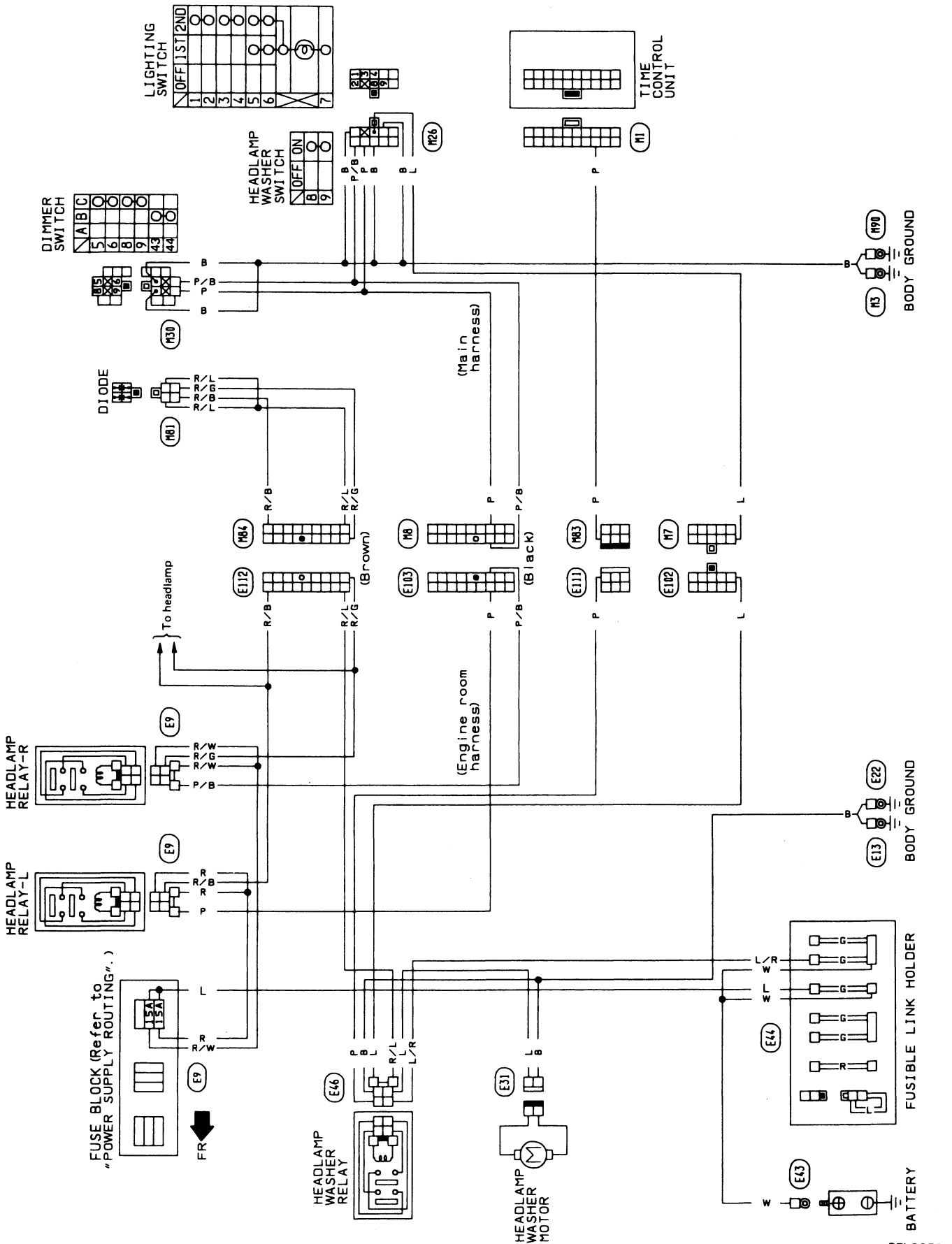

SEL935P

WIPER AND WASHER

Installation

1. Prior to wiper arm installation, turn on wiper switch to operate wiper motor and then turn it "OFF" (Auto Stop).
2. Lift the blade up and then set it down onto glass surface to set the blade center to clearance "C" or "D" immediately before tightening nut.
3. Eject washer fluid. Turn on wiper switch to operate wiper motor and then turn it "OFF".
4. Ensure that wiper blades stop within clearance "C" or "D".

Clearance "C": 0 - 10 mm (0 - 0.39 in)

Clearance "D": 73 - 88 mm (2.87 - 3.46 in)

- Tighten windshield wiper arm nuts to specified torque.

Front wiper:

: 26 - 32 N·m (2.7 - 3.3 kg-m, 20 - 24 ft-lb)

Rear wiper:

: 13 - 18 N·m (1.3 - 1.8 kg-m, 9 - 13 ft-lb)

Front wiper and washer

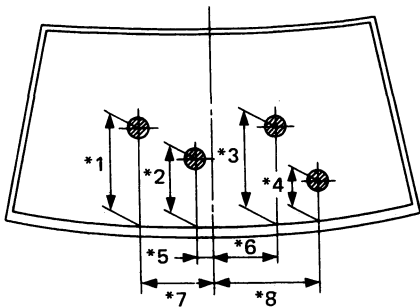

*1:	364 (14.33)
*2:	200 (7.87)
*3:	411 (16.18)
*4:	255 (10.04)
*5:	173 (6.81)
*6:	198 (7.80)
*7:	370 (14.57)
*8:	416 (16.38)

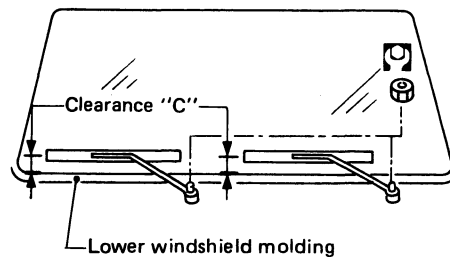

All the diameters of these circles are less than 80 (3.15).

Unit: mm (in)

SEL025N

Rear wiper and washer

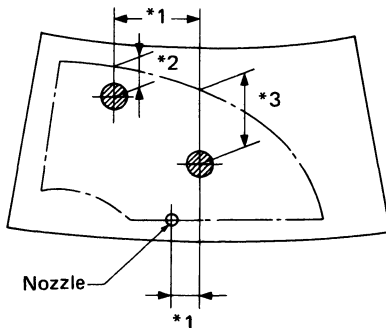

*1:	170 (6.69)
*2:	50 (1.97)
*3:	220 (8.66)

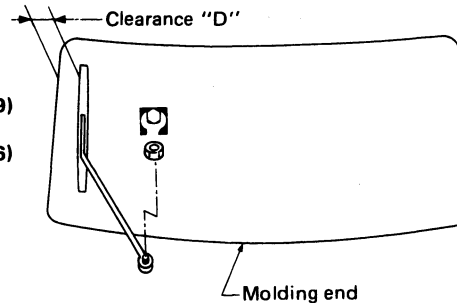

All the diameters of these circles are less than 80 (3.15).

Unit: mm (in)

SEL026N

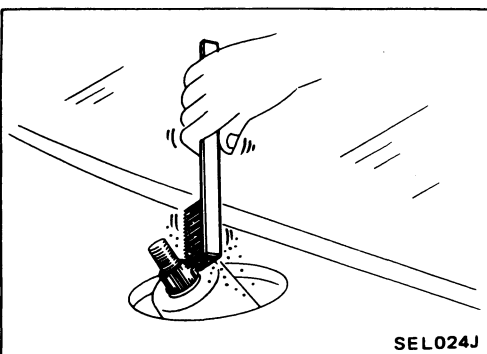

SEL024J

- Before reinstalling wiper arm, clean up the pivot area as illustrated. This will reduce possibility of wiper arm looseness.

WIPER AND WASHER

Washer Nozzle Adjustment

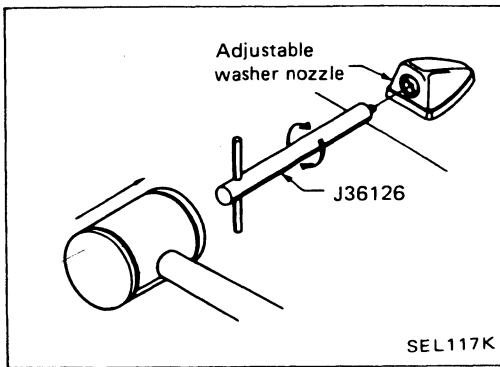

- Adjust washer nozzle with J36126 as shown in the figure at left. Before attempting to turn the nozzle, gently tap the end of the tool to free the nozzle. This will prevent "rounding out" the small female square in the center of the nozzle.

Check Valve

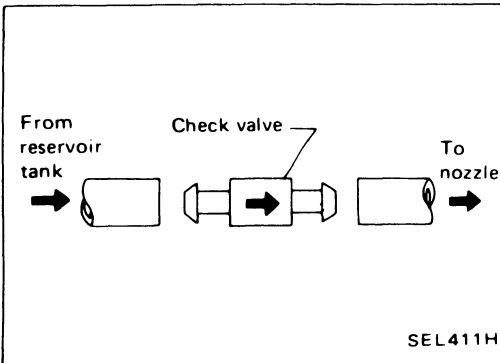

- A check valve is provided in the washer fluid line. Be careful not to connect check valve to washer tube in the wrong direction.

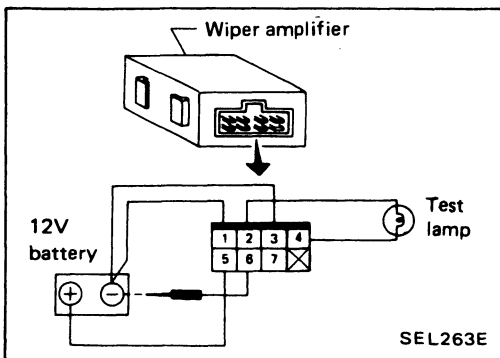
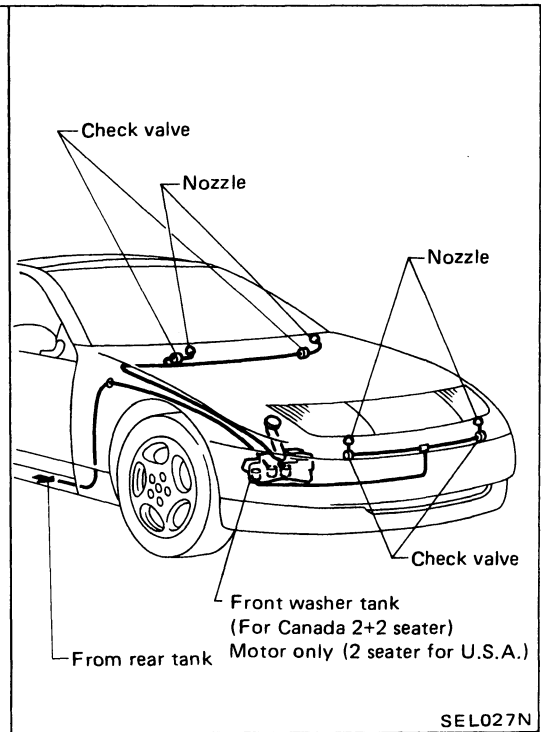
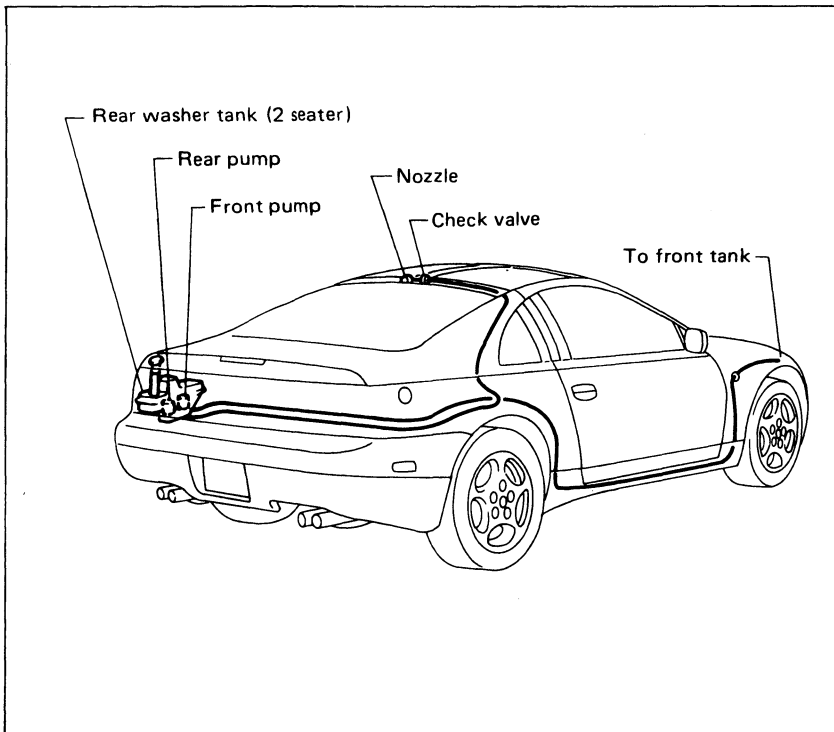

Wiper Amplifier Check

1. Connect as shown in the figure at left.
2. If test lamp comes on when connected to terminal ⑥ and battery ground, wiper amplifier is normal.

HORN, CIGARETTE LIGHTER, CLOCK

Wiring Diagram

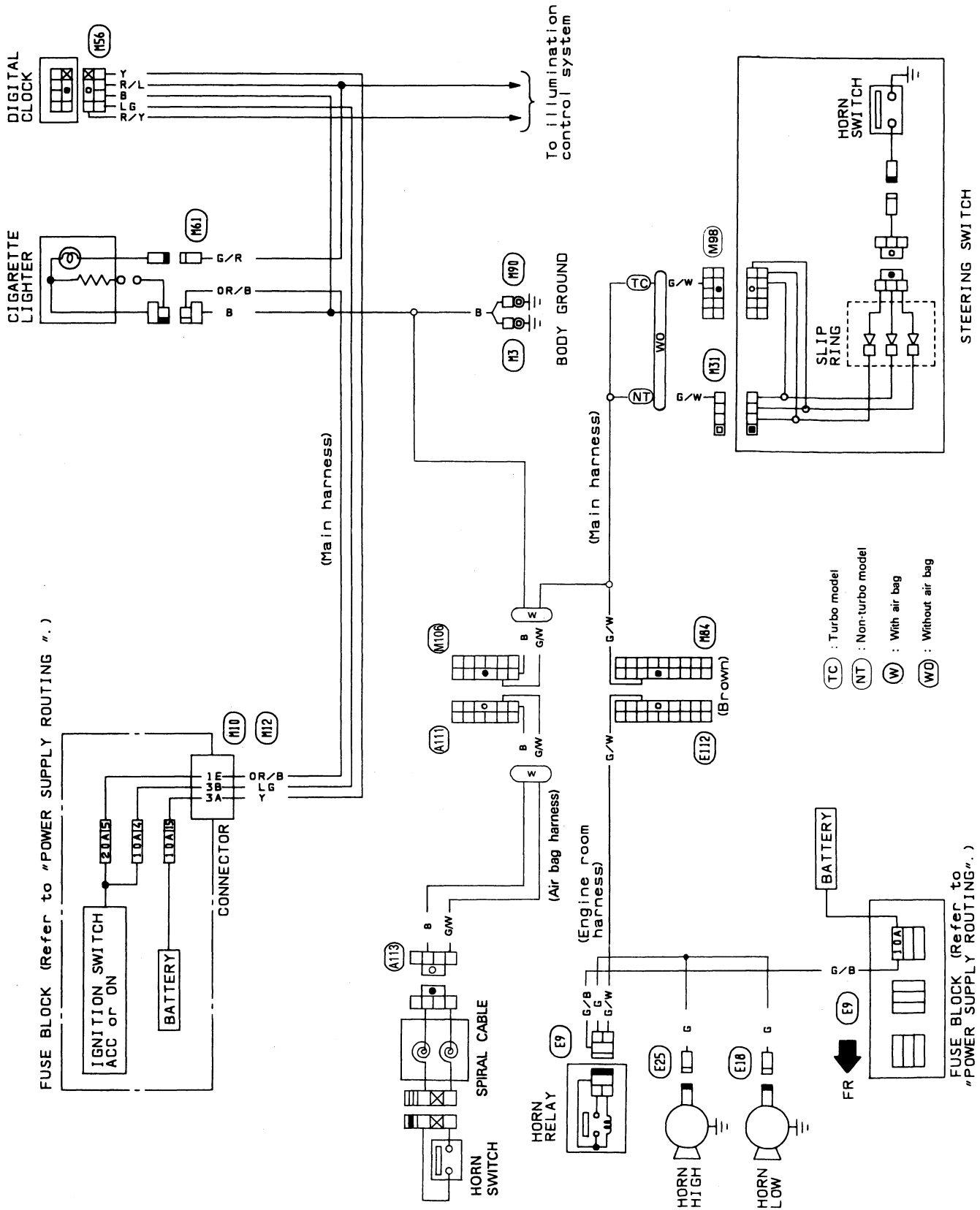

REAR WINDOW DEFOGGER

Wiring Diagram

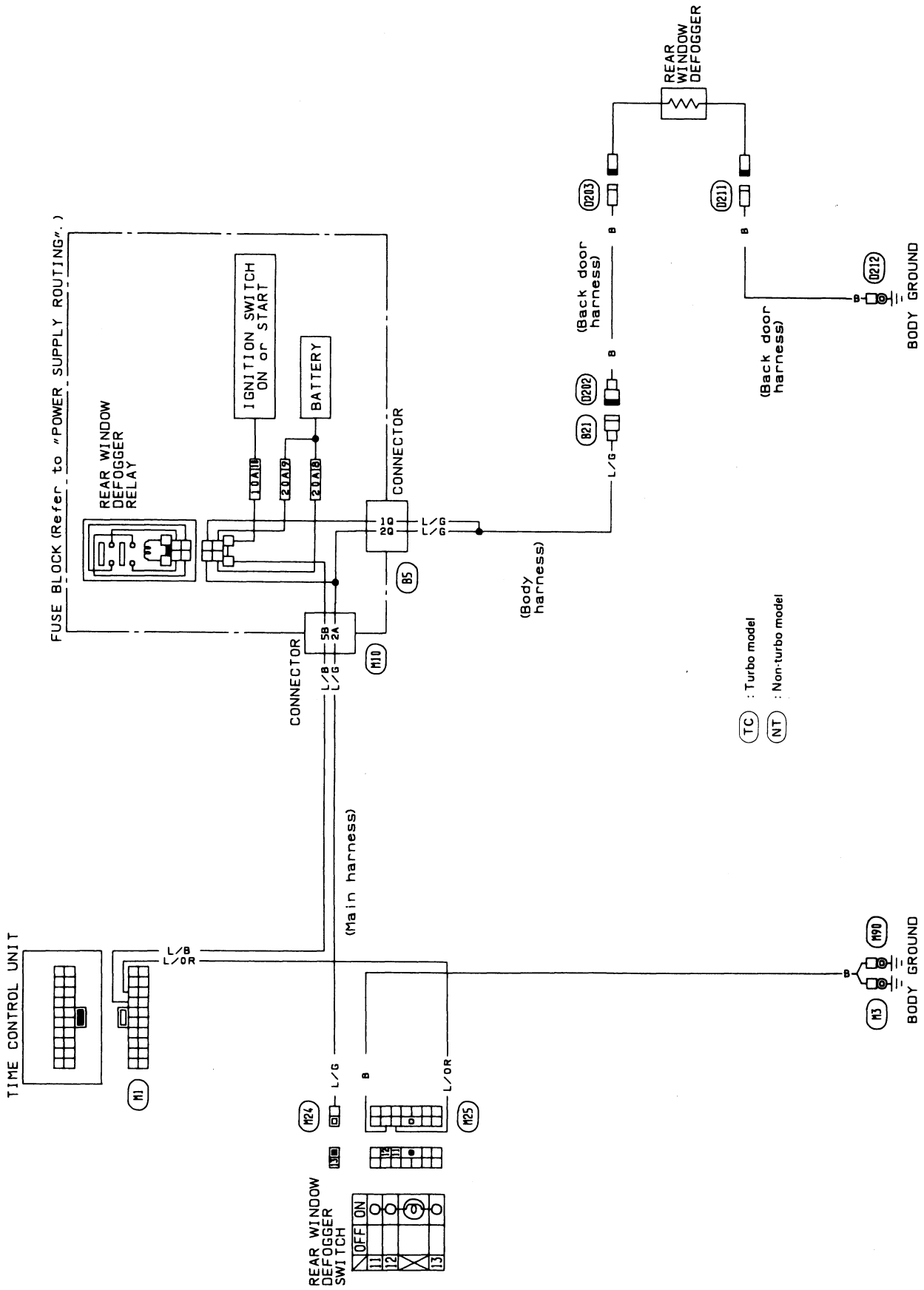

REAR WINDOW DEFOGGER

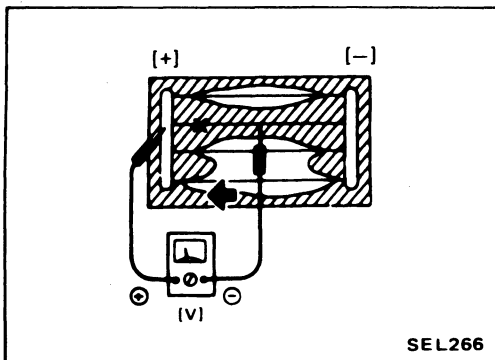
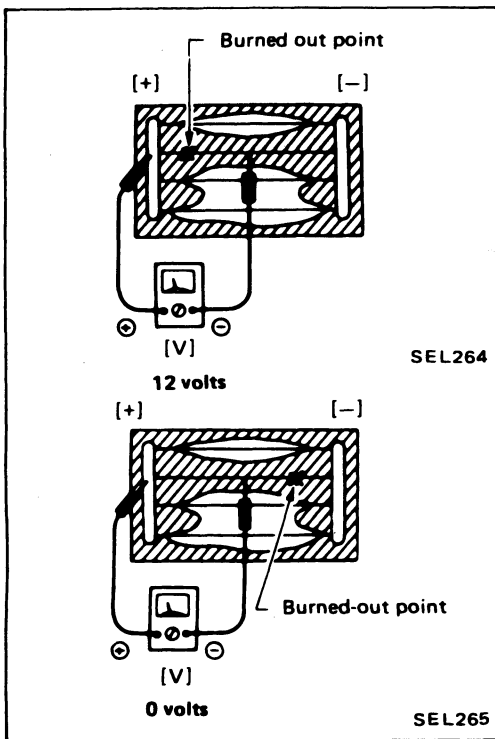
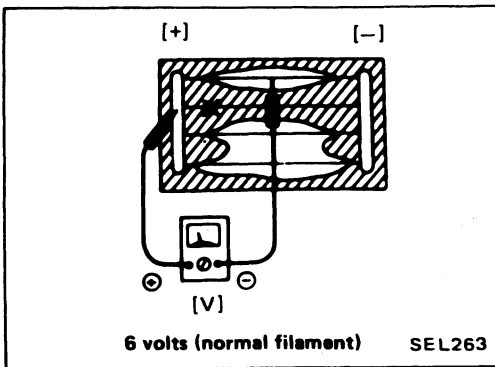

Filament Check

1. Attach probe circuit tester (in volt range) to middle portion of each filament.
2. If a filament is burned out, circuit tester registers 0 or 12 volts.
3. To locate burned out point, move probe to left and right along filament to determine point where tester needle swings abruptly.

REAR WINDOW DEFOGGER

Filament Repair

REPAIR EQUIPMENT

1. Conductive silver composition (Dupont No. 4817 or equivalent)
2. Ruler 30 cm (11.8 in) long
3. Drawing pen
4. Heat gun
5. Alcohol
6. Cloth

REPAIRING PROCEDURE

1. Wipe broken heat wire and its surrounding area clean with a cloth dampened in alcohol.
2. Apply a small amount of conductive silver composition to tip of drawing pen.

Shake silver composition container before use.

3. Place ruler on glass along broken line. Deposit conductive silver composition on break with drawing pen. Slightly overlap existing heat wire on both sides [preferably 5 mm (0.20 in)] of the break.
4. After repair has been completed, check repaired wire for continuity. This check should be conducted 10 minutes after silver composition is deposited.

Do not touch repaired area while test is being conducted.

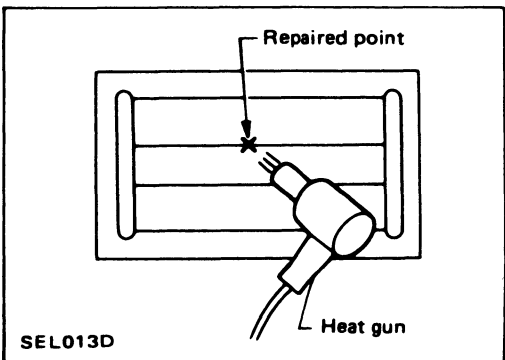
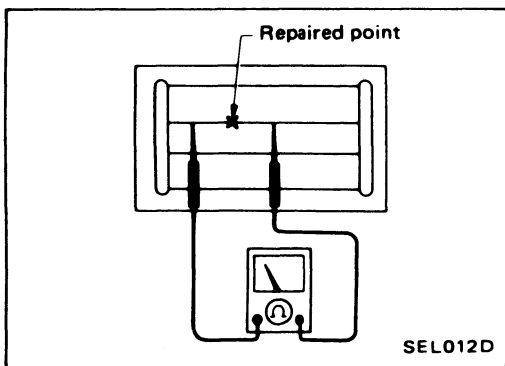
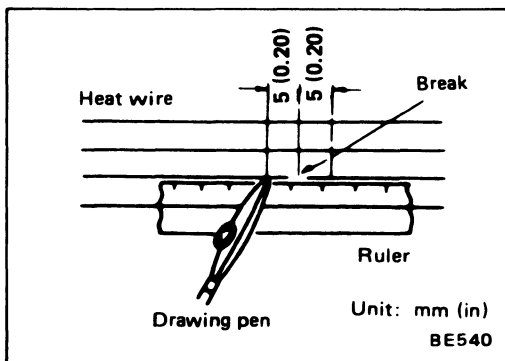

5. Apply a constant stream of hot air directly to the repaired area for approximately 20 minutes with a heat gun. A minimum distance of 3 cm (1.2 in) should be kept between repaired area and hot air outlet. If a heat gun is not available, let the repaired area dry for 24 hours.

AUDIO AND POWER ANTENNA

Audio/Wiring Diagram

EXCEPT BOSE SYSTEM

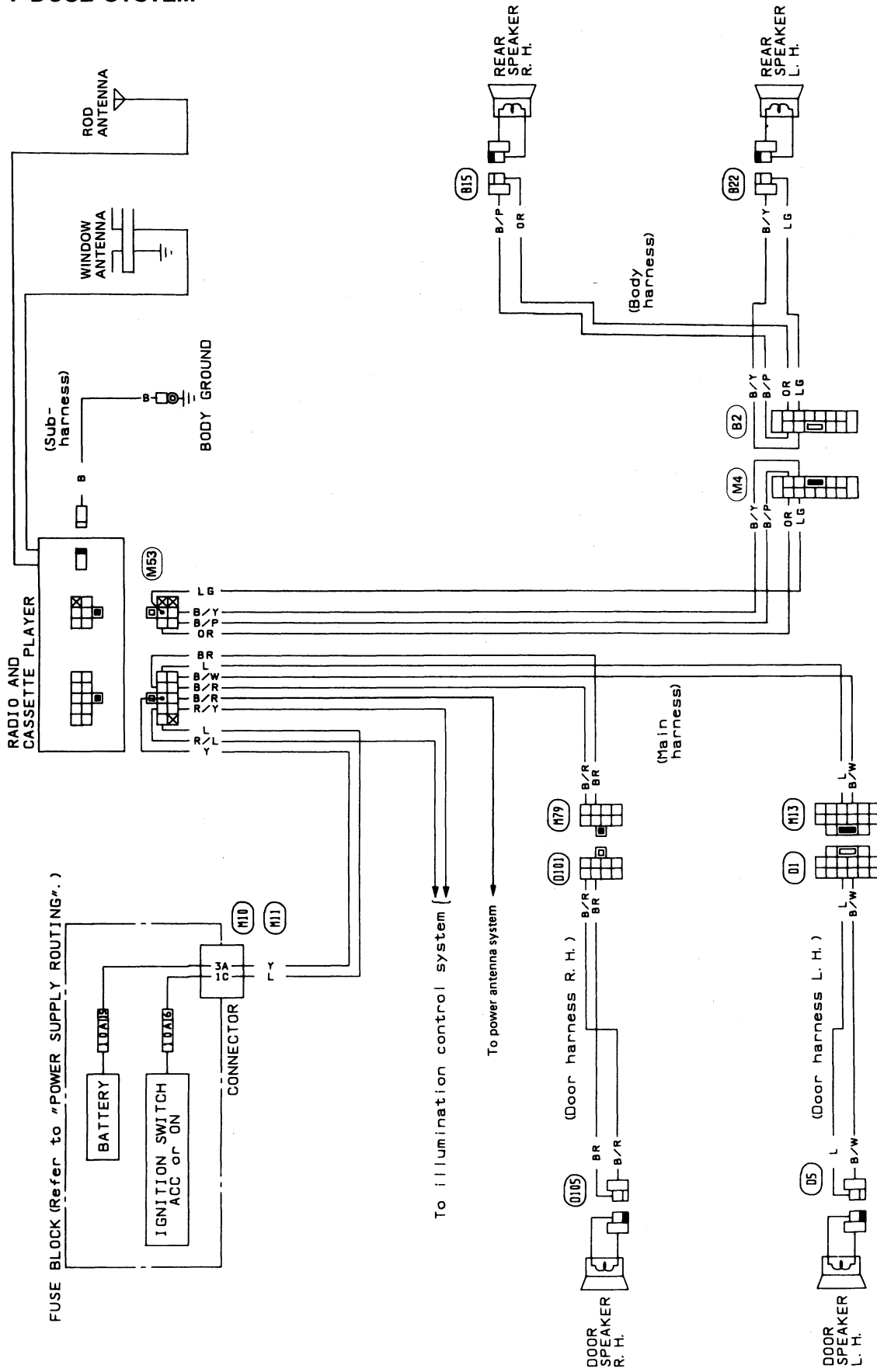

SEL938P

AUDIO AND POWER ANTENNA

Audio/Wiring Diagram (Cont'd)

BOSE SYSTEM

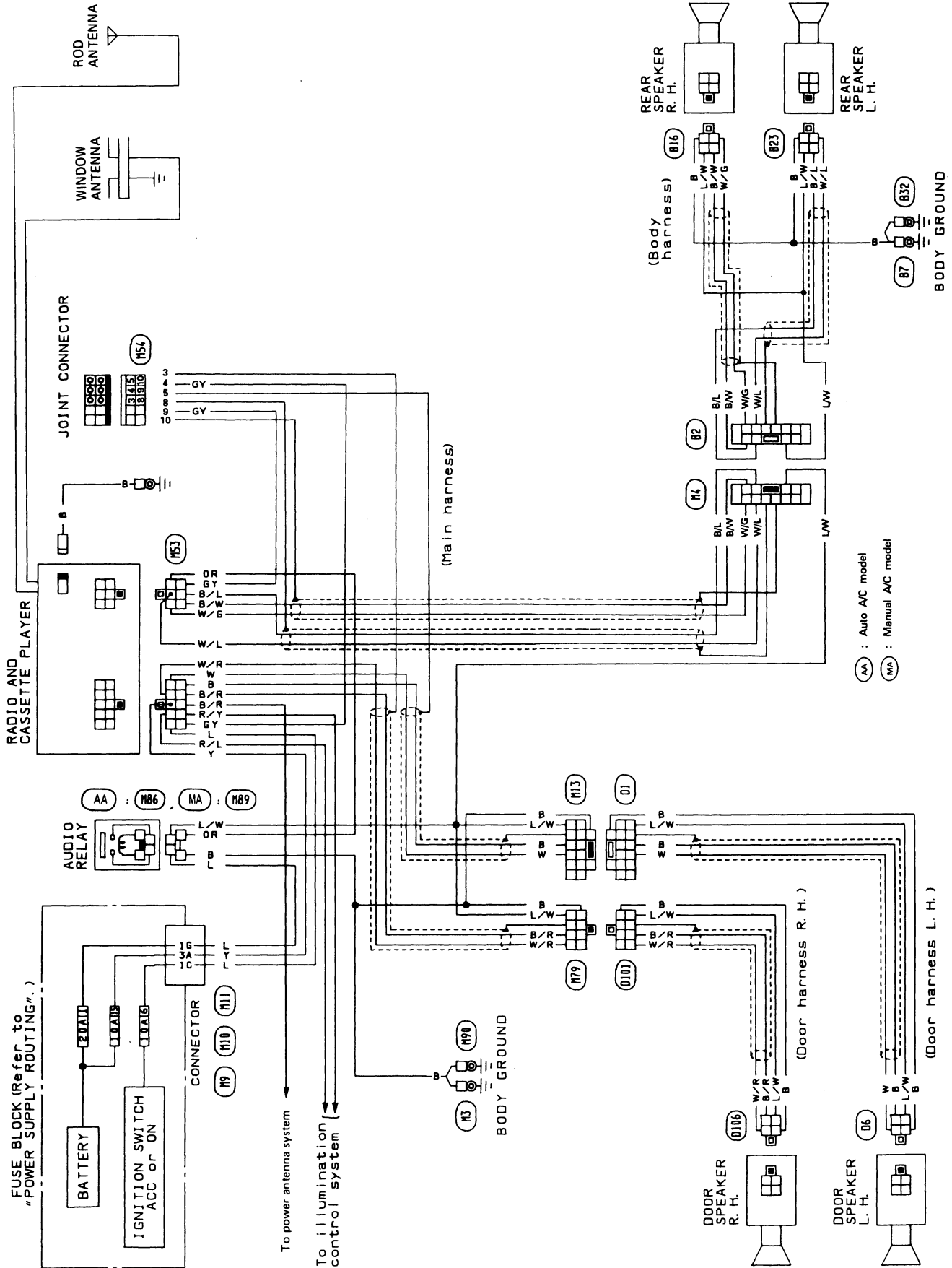

SEL939P

AUDIO AND POWER ANTENNA

Power Antenna/Wiring Diagram

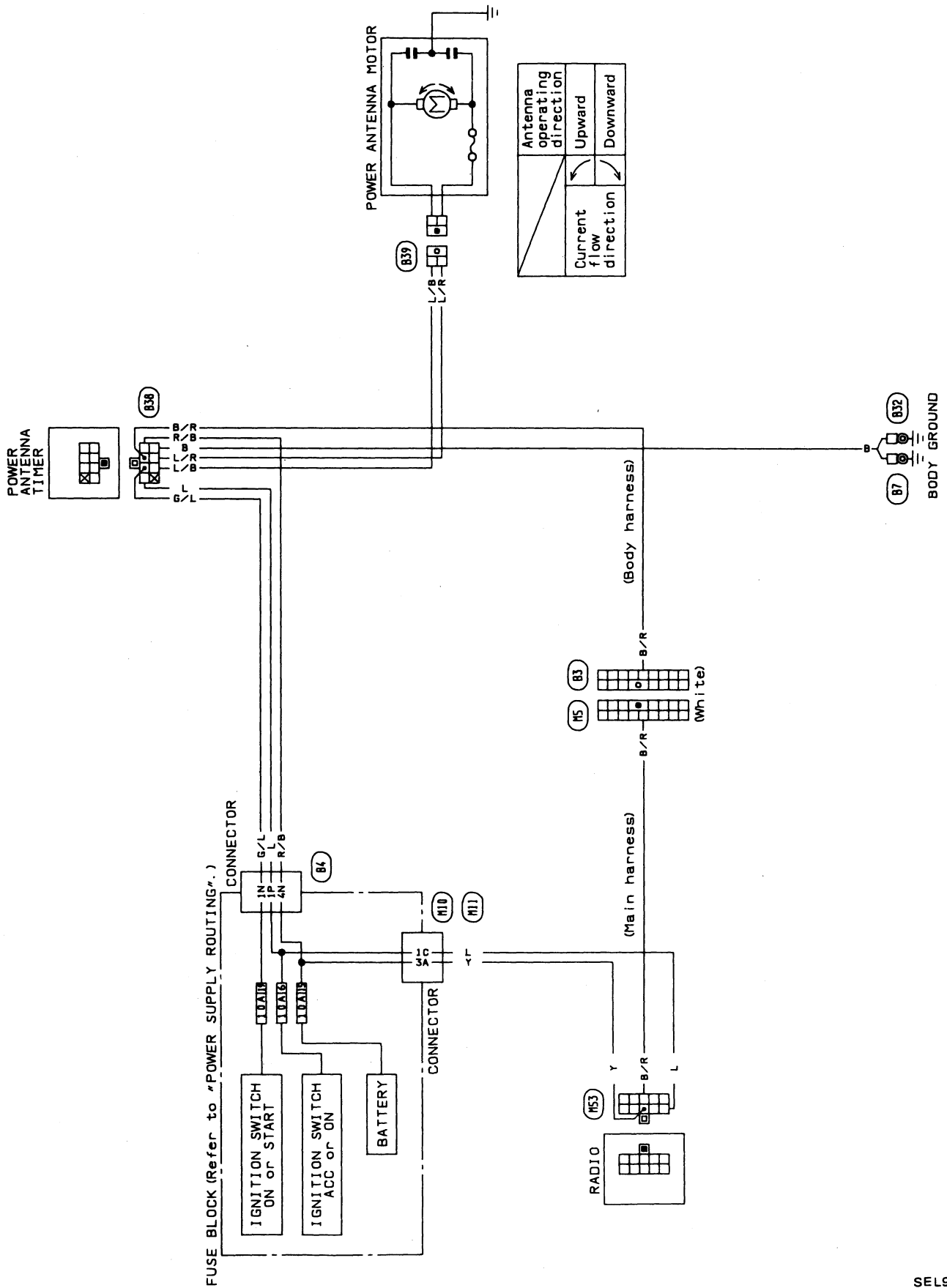

SEL940P

AUDIO AND POWER ANTENNA

Location of Antenna

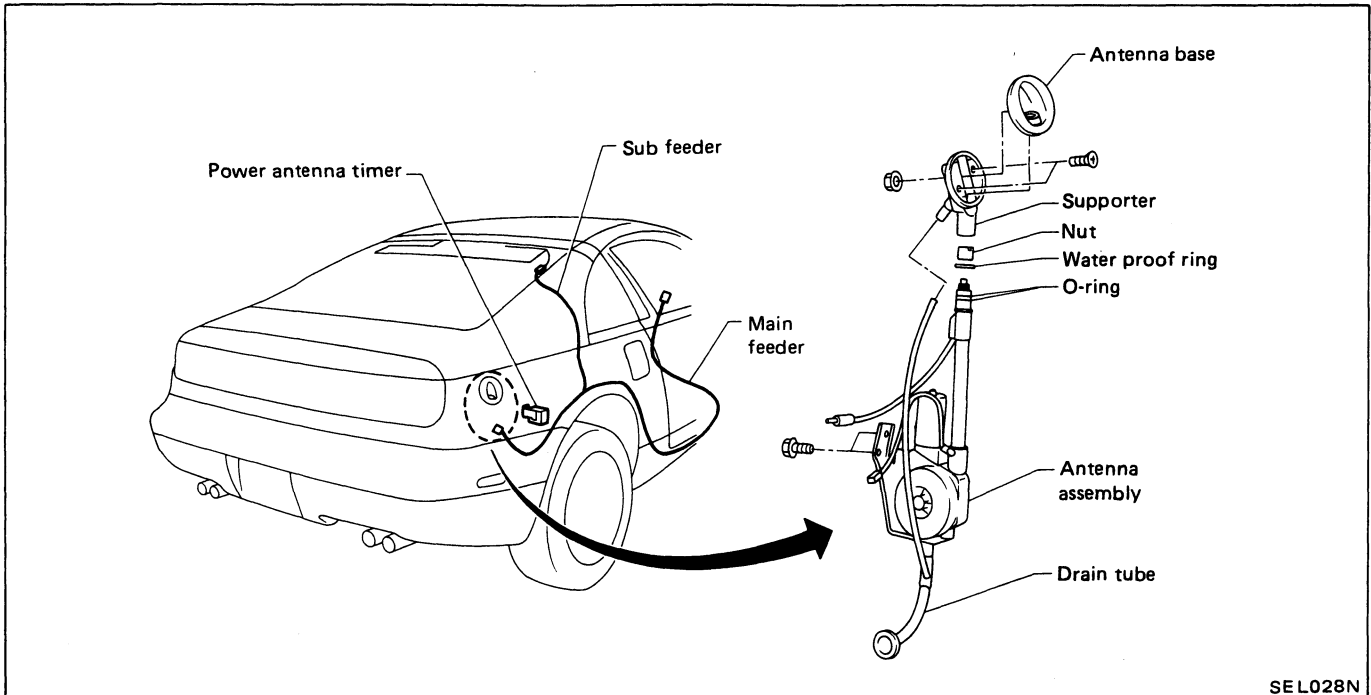

SEL028N

Antenna Rod Replacement REMOVAL

1. Remove antenna nut and antenna base.

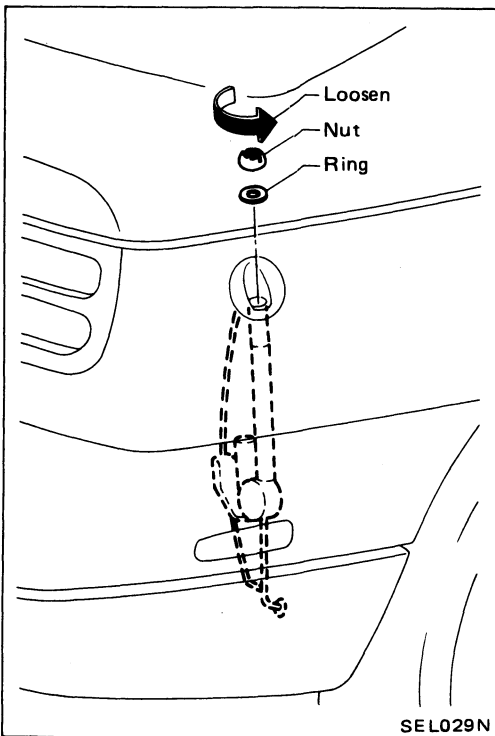

SEL029N

2. Withdraw antenna rod while raising it by operating antenna motor.

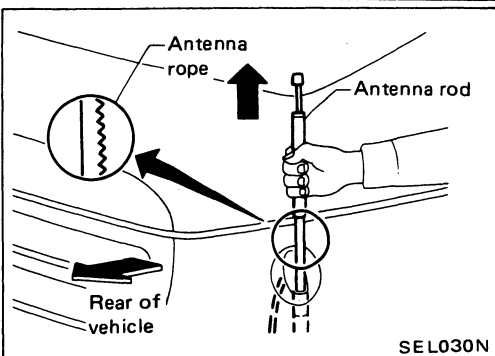

SEL030N

AUDIO AND POWER ANTENNA

Antenna Rod Replacement (Cont'd)

INSTALLATION

1. Lower antenna rod by operating antenna motor.
2. Insert gear section of antenna rope into place with it facing toward antenna motor.
3. As soon as antenna rope is wound on antenna motor, stop antenna motor. Insert antenna rod lower end into antenna motor pipe.
4. Retract antenna rod completely by operating antenna motor.
5. Install antenna nut and base.

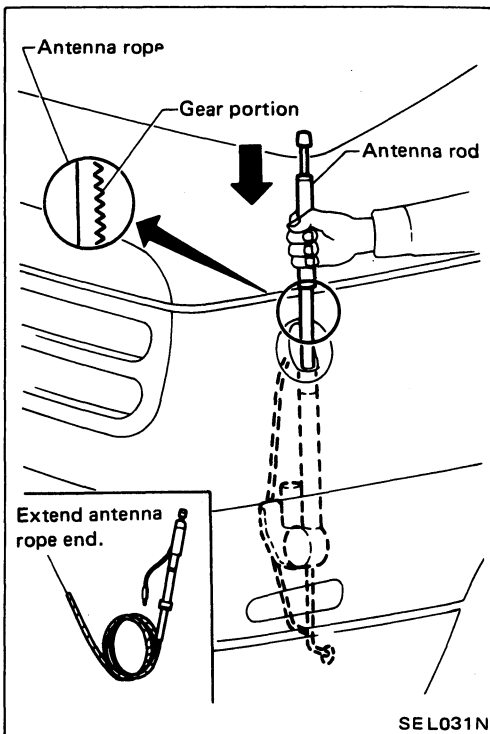

Radio Fuse Check

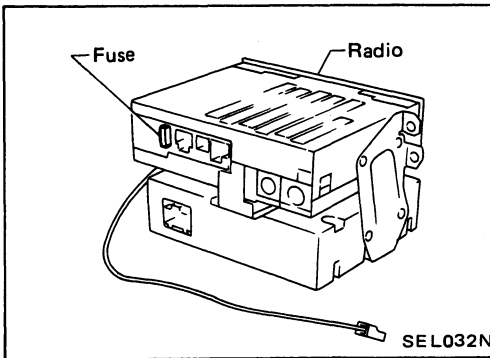

Window Antenna Repair

ELEMENT CHECK

1. Attach probe circuit tester (in ohm range) to antenna terminal on each side.

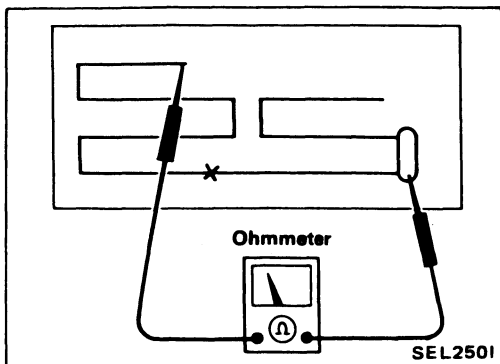

2. If an element is broken, no continuity will exist.

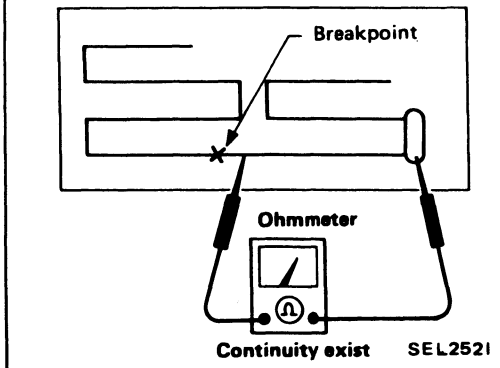
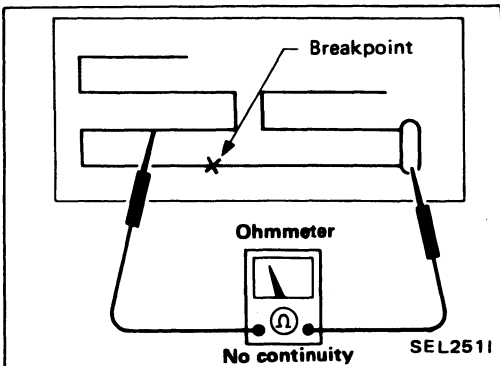

3. To locate broken point, move probe to left and right along element to determine point where tester needle swings abruptly.

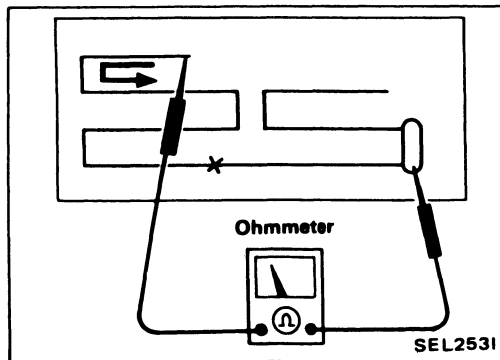

ELEMENT REPAIR

Refer to REAR WINDOW DEFOGGER "Filament Repair".

AUTOMATIC SPEED CONTROL DEVICE (A.S.C.D.)

Component Parts and Harness Connector Location

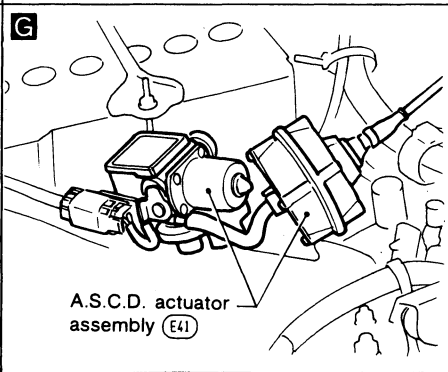
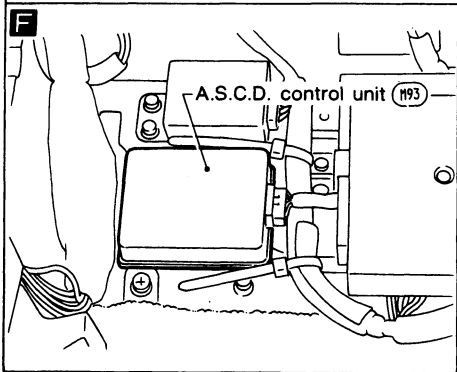
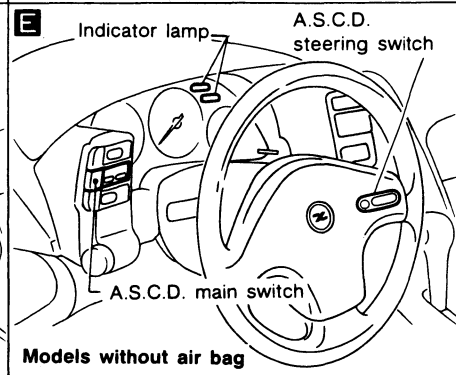
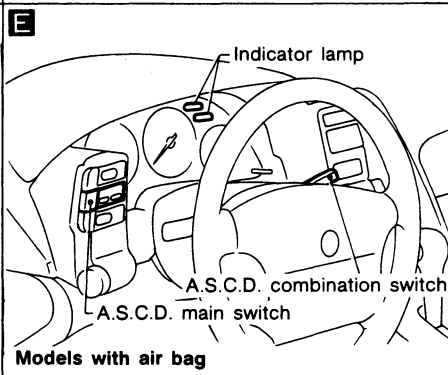
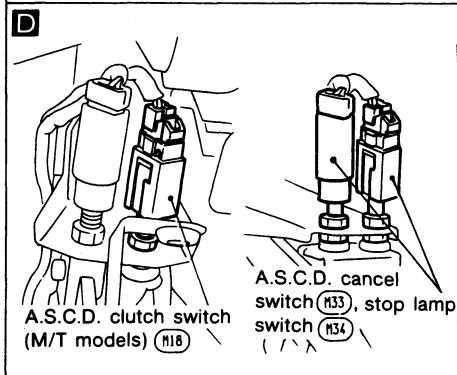
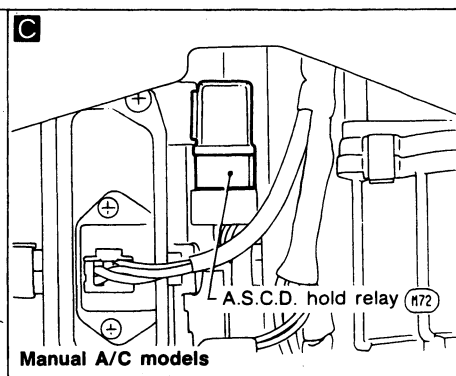
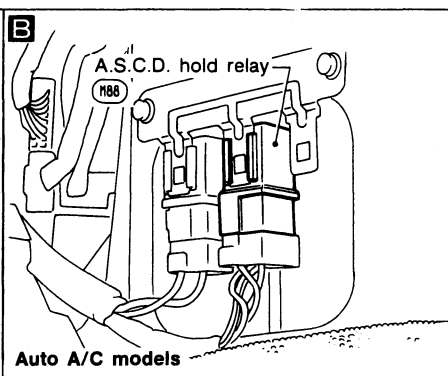
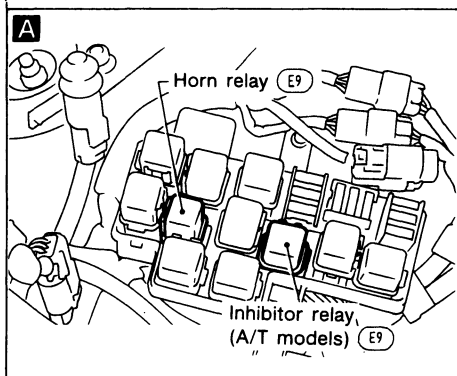
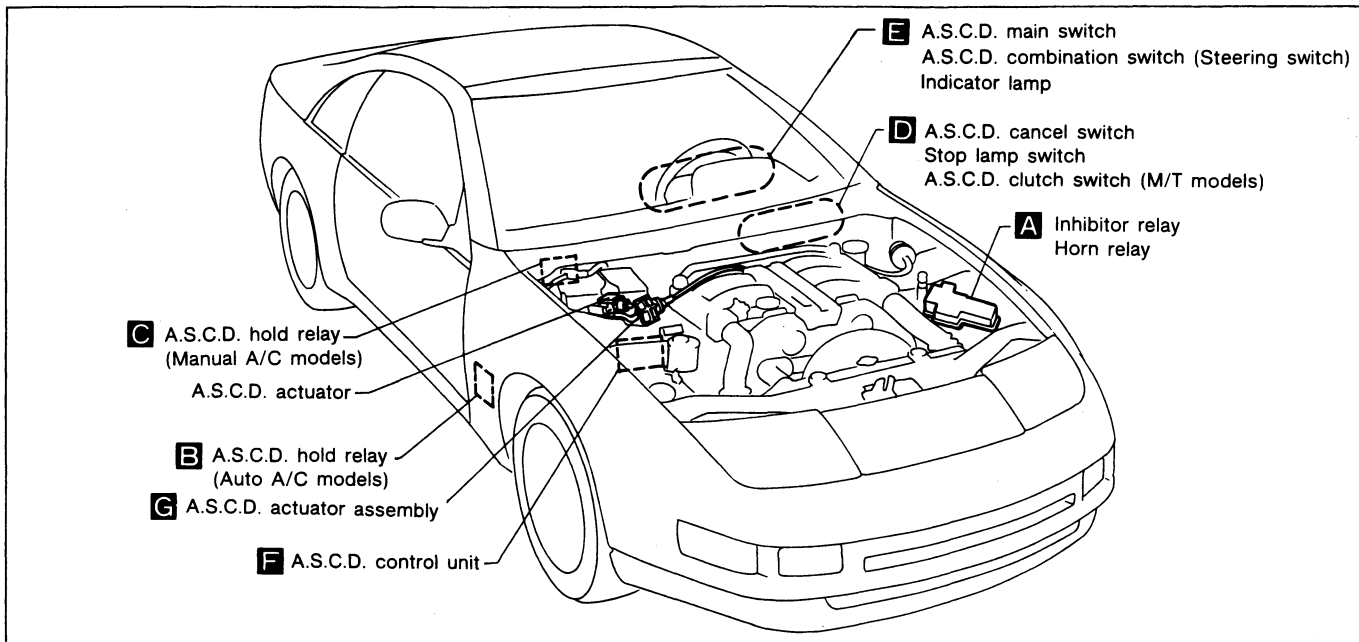

AUTOMATIC SPEED CONTROL DEVICE (A.S.C.D.)

Wiring Diagram

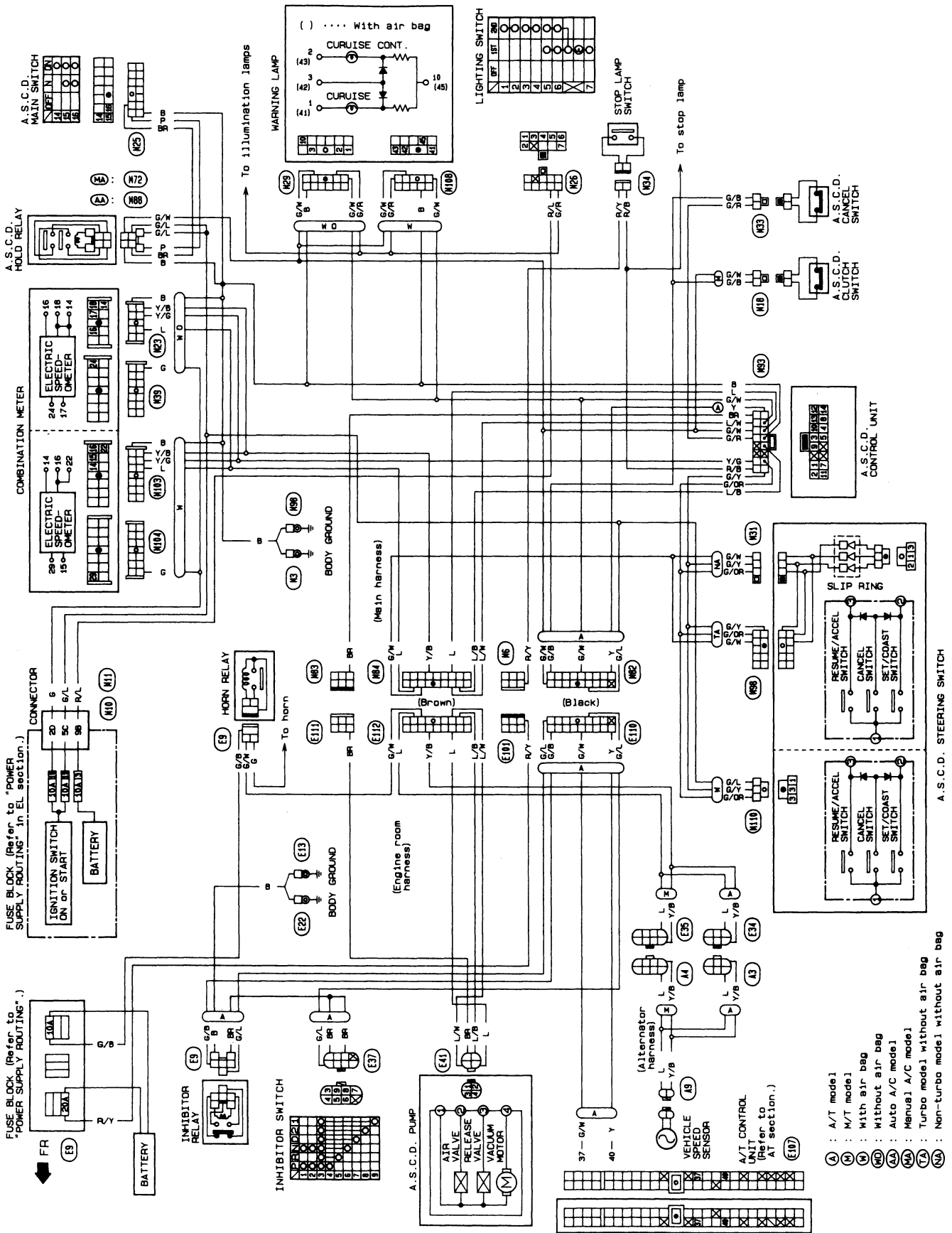

FUSE BLOCK (Refer to "POWER SUPPLY ROUTING" in EL section.)

FUSE BLOCK (Refer to "POWER SUPPLY ROUTING".)

- (A) : A/T model
- (M) : M/T model
- (H) : With air bag
- (N) : Without air bag
- (M) : Auto A/C model
- (MA) : Manual A/C model
- (TA) : Turbo model without air bag
- (NA) : Non-turbo model without air bag

AUTOMATIC SPEED CONTROL DEVICE (A.S.C.D.)

Trouble Diagnoses

SYMPTOM CHART

PROCEDURE	Diagnostic Procedure								Electrical Components Inspection							
REFERENCE PAGE	EL-102	EL-104	EL-104	EL-105	EL-106	EL-107	EL-108	EL-109	EL-110	EL-111	EL-112	EL-112	EL-112	EL-113	EL-113	EL-113
SYMPTOM	Diagnostic Procedure 1	Diagnostic Procedure 2	Diagnostic Procedure 3	Diagnostic Procedure 4	Diagnostic Procedure 5	Diagnostic Procedure 6	Diagnostic Procedure 7	Diagnostic Procedure 8	A.S.C.D. wire adjustment	A.S.C.D. actuator/A.S.C.D. pump	A.S.C.D. main switch	A.S.C.D. steering switch	A.S.C.D. cancel switch and stop lamp switch	A.S.C.D. clutch switch (For M/T models)	Inhibitor switch (For A/T models)	Speed sensor
A.S.C.D. control unit cannot be set properly.	<input type="radio"/>									<input type="radio"/>	<input type="radio"/>	<input type="radio"/>	<input type="radio"/>	<input type="radio"/>	<input type="radio"/>	<input type="radio"/>
Engine hunts		<input type="radio"/>							<input type="radio"/>	<input type="radio"/>						
Large difference between set speed and actual vehicle speed.			<input type="radio"/>						<input type="radio"/>	<input type="radio"/>						
Deceleration is greatest immediately after A.S.C.D. has been set.				<input type="radio"/>					<input type="radio"/>	<input type="radio"/>						
ACCEL switch will not operate.	<input type="radio"/>				<input type="radio"/>							<input type="radio"/>				
RESUME switch will not operate.	<input type="radio"/>					<input type="radio"/>						<input type="radio"/>	<input type="radio"/>	<input type="radio"/>		
Set speed cannot be cancelled.							<input type="radio"/>		<input type="radio"/>	<input type="radio"/>			<input type="radio"/>	<input type="radio"/>		
"CRUISE" indicator lamp blinks.								<input type="radio"/>		<input type="radio"/>		<input type="radio"/>	<input type="radio"/>			

AUTOMATIC SPEED CONTROL DEVICE (A.S.C.D.)

Trouble Diagnoses (Cont'd)

CIRCUIT DIAGRAM FOR QUICK PINPOINT CHECK

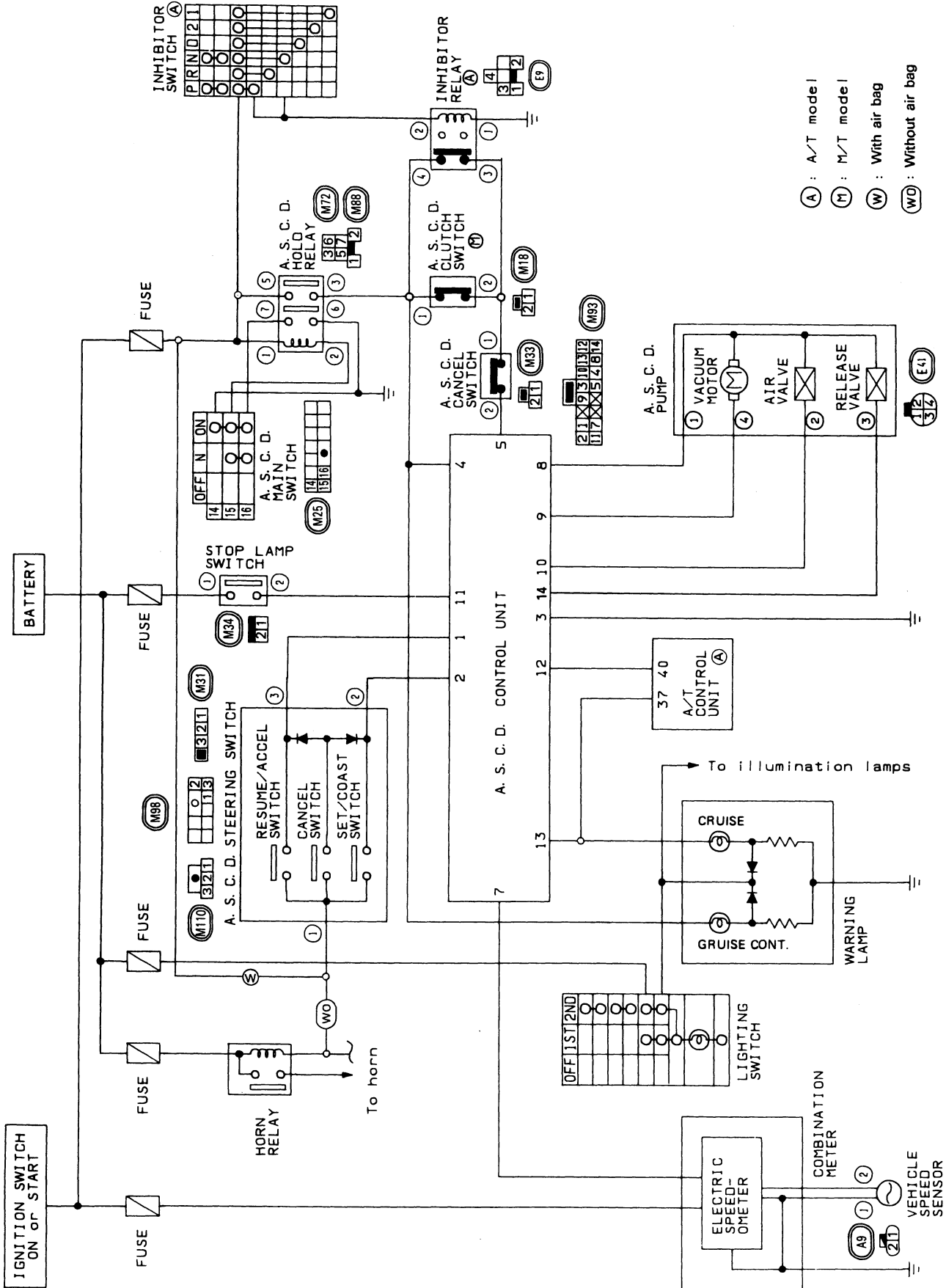

- (A) : A/T mode!
- (M) : M/T mode!
- (W) : With air bag
- (WD) : Without air bag

AUTOMATIC SPEED CONTROL DEVICE (A.S.C.D.)

Trouble Diagnoses (Cont'd)

DIAGNOSTIC PROCEDURE 1

SYMPTOM: A.S.C.D. control cannot be set.

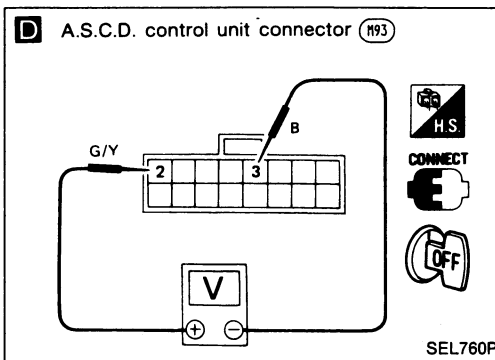
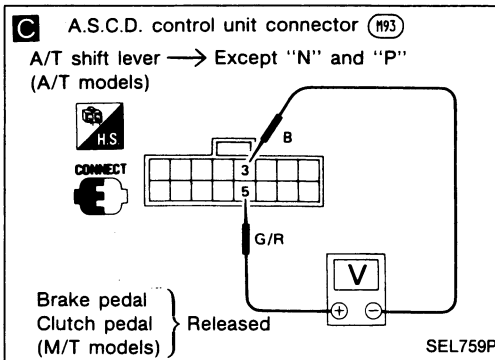
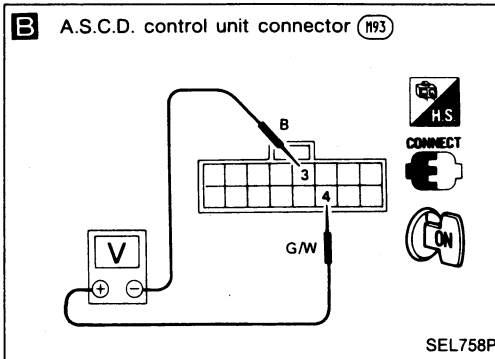
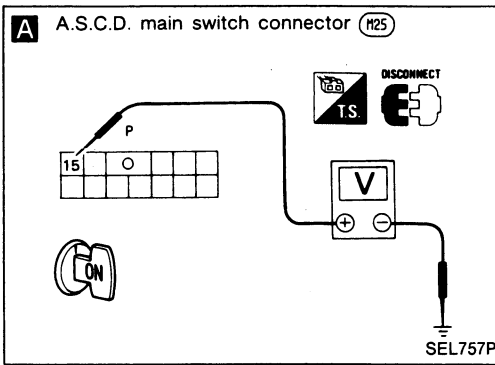

Turn A.S.C.D. main switch "OFF" and "ON" to make sure indicator illuminates.

N.G.

A
CHECK POWER SUPPLY FOR A.S.C.D. MAIN SWITCH.
1. Disconnect main switch harness connector.
2. Do approx. 12 volts exist between main switch harness terminal ⑮ and body ground?

No.

Yes

Check fuse and harness.

CHECK A.S.C.D. MAIN SWITCH.
Refer to "Electrical Components Inspection".
CHECK A.S.C.D. HOLD RELAY.

B
CHECK POWER SUPPLY CIRCUIT FOR A.S.C.D. CONTROL UNIT.
1. Turn A.S.C.D. main switch "ON".
2. Check voltage between control unit harness terminals ④ and ③.
Battery voltage should exist.

N.G.

Check continuity between control unit harness terminal ④ and A.S.C.D. hold relay.

C
CHECK CUT-OFF CIRCUIT FOR A.S.C.D. CONTROL UNIT.
Check voltage between control unit harness terminals ⑤ and ③.
Battery voltage should exist.

N.G.

CHECK A.S.C.D. CANCEL SWITCH, A.S.C.D. CLUTCH SWITCH (M/T models) AND INHIBITOR SWITCH (A/T models).
Refer to "Electrical Components Inspection".
CHECK INHIBITOR RELAY (A/T models).

D
CHECK SET/COAST SWITCH CIRCUIT FOR A.S.C.D. CONTROL UNIT.
1. Turn and keep on SET/COAST switch of A.S.C.D. combination (steering) switch.
2. Check voltage between control unit harness terminals ② and ③.
Battery voltage should exist.

N.G.

Does horn work?
No
Check fuse and horn relay.

Yes

CHECK A.S.C.D. COMBINATION (STEERING) SWITCH.
Refer to "Electrical Components Inspection".

O.K.

(Next page)

AUTOMATIC SPEED CONTROL DEVICE (A.S.C.D.)

Trouble Diagnoses (Cont'd)

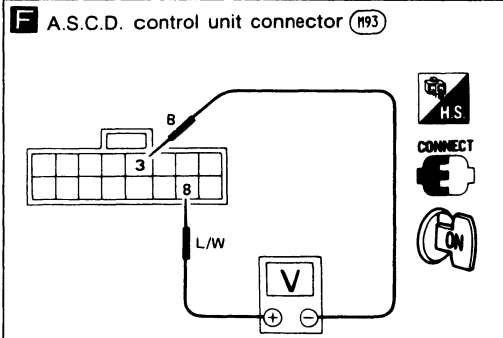
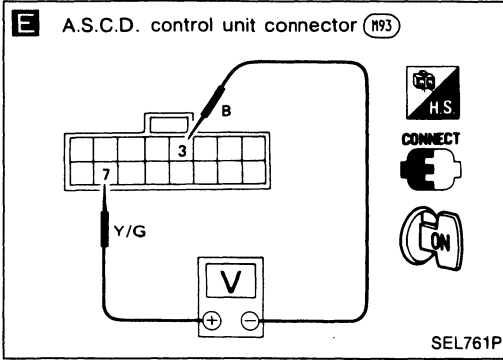

A.S.C.D. control unit connector (H93)

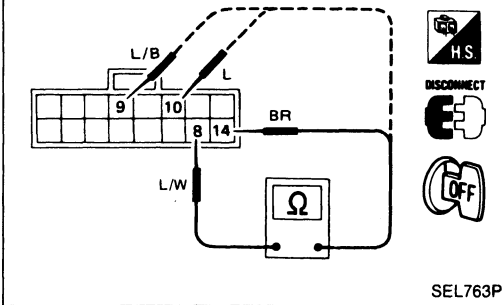

E **CHECK SPEED SENSOR CIRCUIT.**

1. Apply wheel chocks and jack up rear of vehicle.
2. Connect voltmeter between control unit harness terminals ⑦ and ③.
3. Slowly turn rear wheel.
4. Check deflection of voltmeter pointer.

N.G. → CHECK SPEED SENSOR. Refer to "Electrical Components Inspection".

O.K.

CHECK A.S.C.D. ACTUATOR/A.S.C.D. PUMP.
Refer to "Electrical Components Inspection".

N.G. → Replace A.S.C.D. actuator assembly.

O.K.

F **CHECK A.S.C.D. ACTUATOR/A.S.C.D. PUMP CIRCUIT.**

1. Check voltage between control unit harness terminals ⑧ and ③.
Voltage is 0V.
2. Disconnect A.S.C.D. control unit connector.
3. Measure resistance between control unit harness terminals ⑧ and ⑨, ⑩, ⑭.

N.G. → Repair short or open circuit in A.S.C.D. actuator assembly.

Terminals	Resistance [Ω]	
⑧	⑨	Approx. 8 - 45
	⑩	Approx. 65
	⑭	Approx. 65

O.K.

Replace A.S.C.D. control unit.

AUTOMATIC SPEED CONTROL DEVICE (A.S.C.D.)

Trouble Diagnoses (Cont'd)

DIAGNOSTIC PROCEDURE 2

SYMPTOM: Engine hunts.

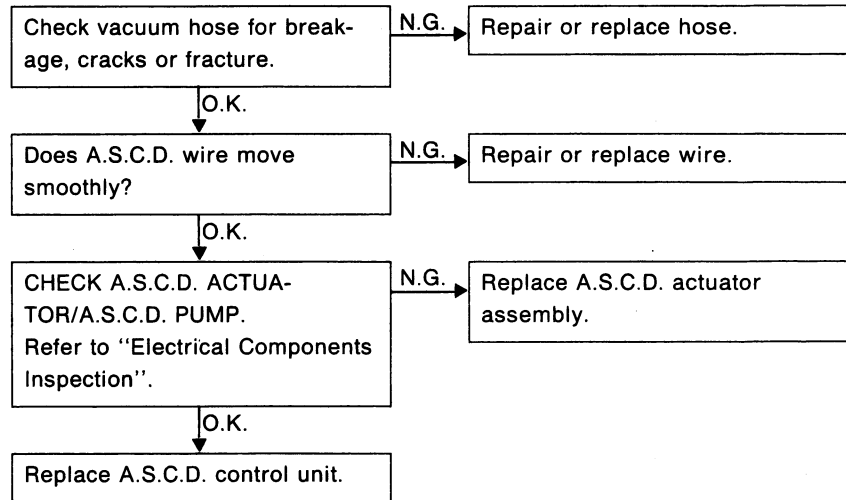

DIAGNOSTIC PROCEDURE 3

SYMPTOM: Large difference between set vehicle speed and actual speed.

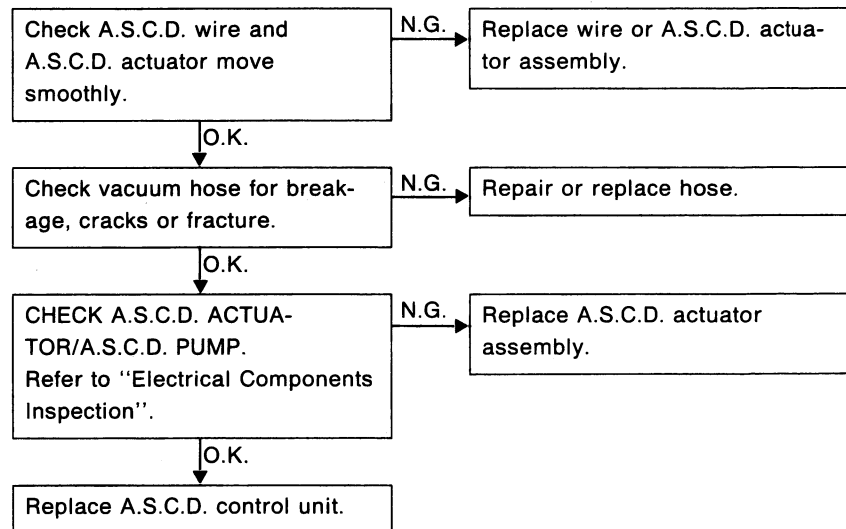

AUTOMATIC SPEED CONTROL DEVICE (A.S.C.D.)

Trouble Diagnoses (Cont'd)

DIAGNOSTIC PROCEDURE 4

SYMPTOM: Deceleration is greatest immediately after A.S.C.D. has been set.

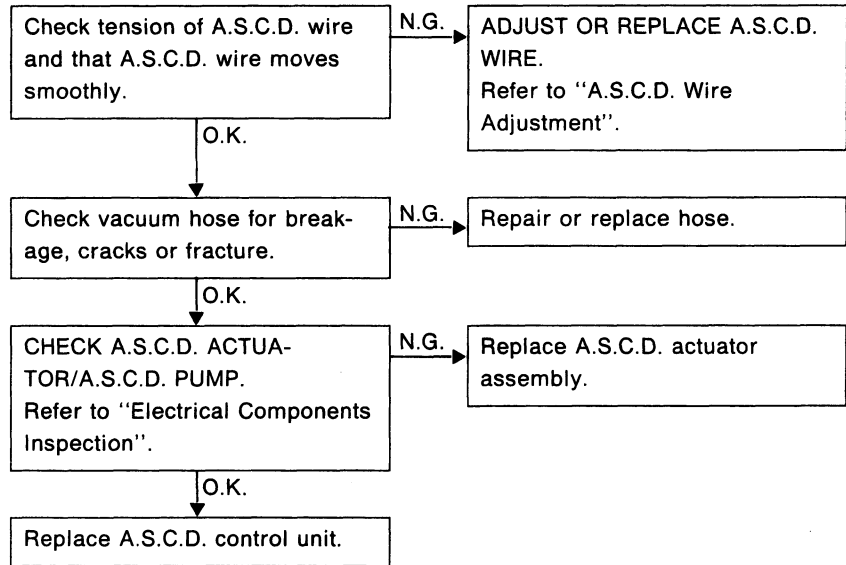

AUTOMATIC SPEED CONTROL DEVICE (A.S.C.D.)

Trouble Diagnoses (Cont'd)

DIAGNOSTIC PROCEDURE 5

SYMPTOM: ACCEL switch will not operate.

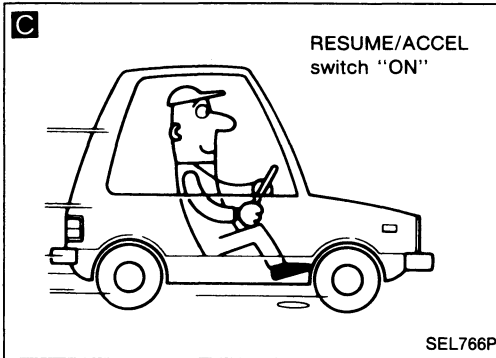
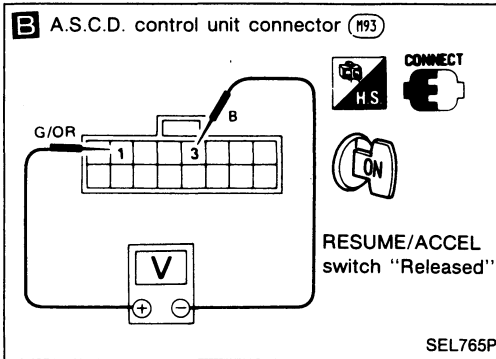
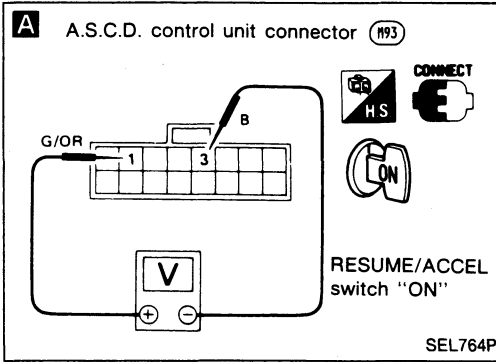

Check constant-speed function for operating using SET/COAST switch.

N.G. → Go to "DIAGNOSTIC PROCEDURE 1".

A Check voltage between control unit harness terminals ① and ③ after turning on and holding RESUME/ACCEL switch.
Battery voltage should exist.

N.G. →

B Check voltage between control unit harness terminals ① and ③ after releasing RESUME/ACCEL switch.
Voltage is 0V.

N.G. →

CHECK A.S.C.D. COMBINATION (STEERING) SWITCH. Refer to "Electrical Components Inspection".

C Does vehicle accelerate when RESUME/ACCEL switch is turned on?

No →

Replace control unit.

D Does vehicle maintain the new (faster) speed when RESUME/ACCEL switch is released?

No →

Replace control unit.

Yes
System is O.K.

AUTOMATIC SPEED CONTROL DEVICE (A.S.C.D.)

Trouble Diagnoses (Cont'd)

DIAGNOSTIC PROCEDURE 6

SYMPTOM: RESUME switch will not operate.

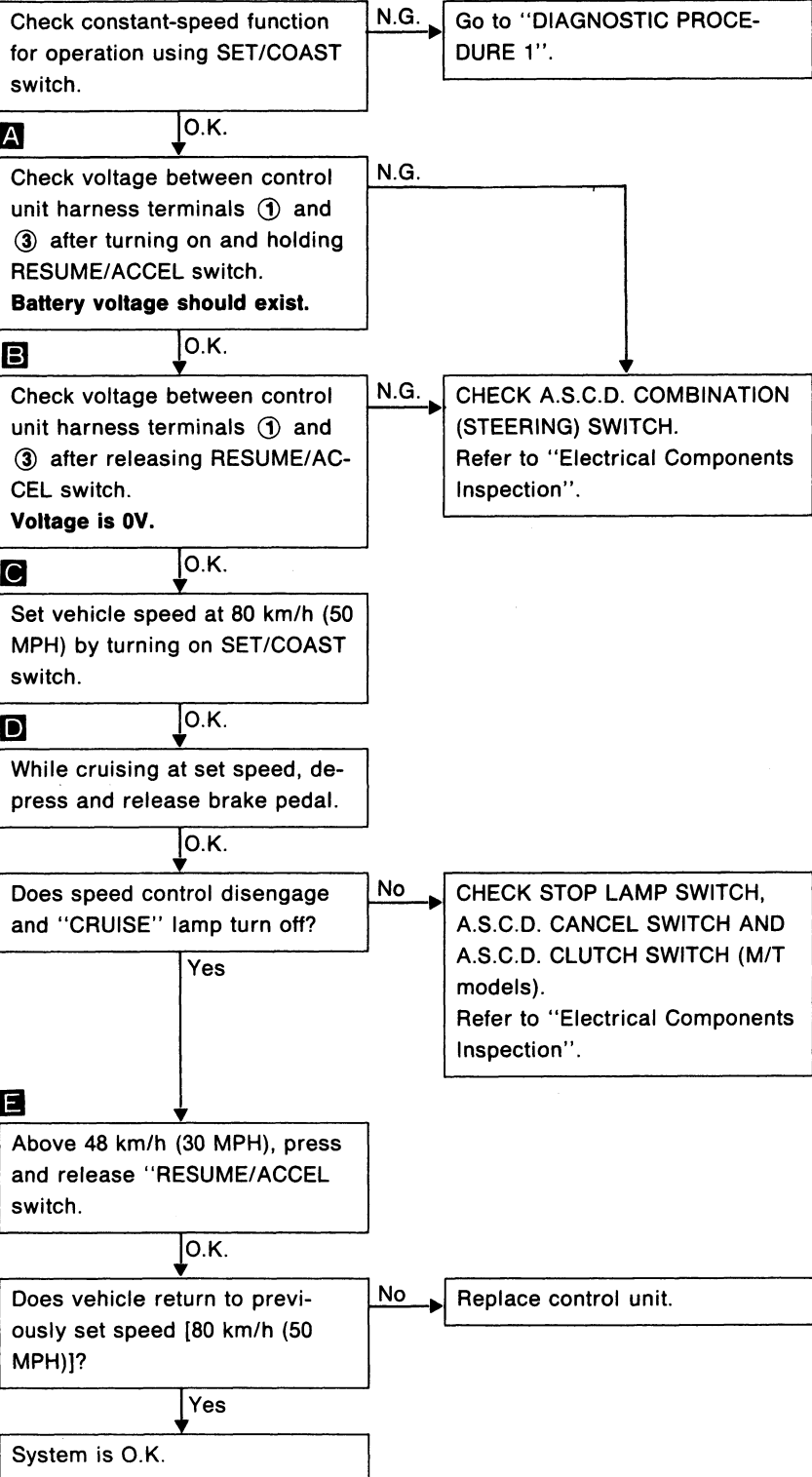
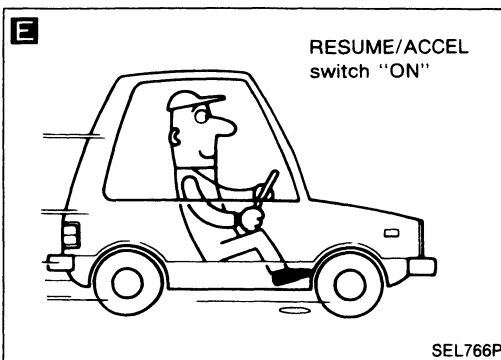
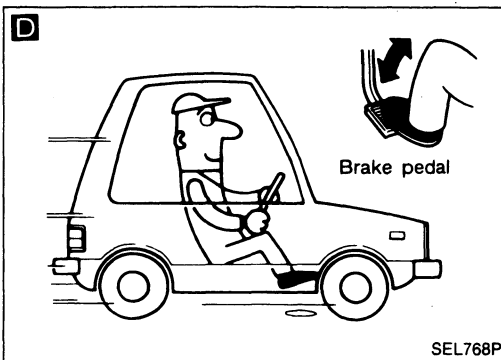
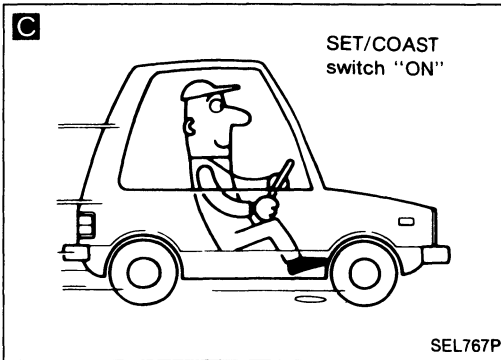
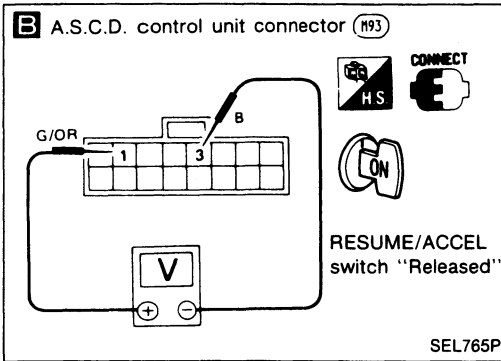
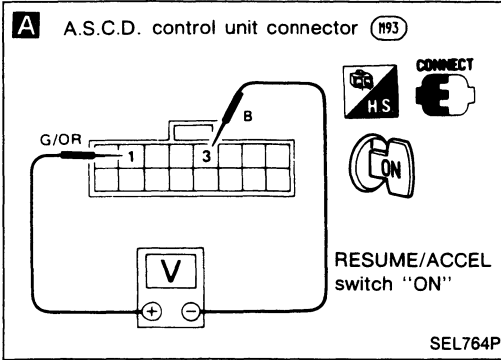

AUTOMATIC SPEED CONTROL DEVICE (A.S.C.D.)

Trouble Diagnoses (Cont'd)

DIAGNOSTIC PROCEDURE 7

SYMPTOM: Set speed cannot be cancelled.

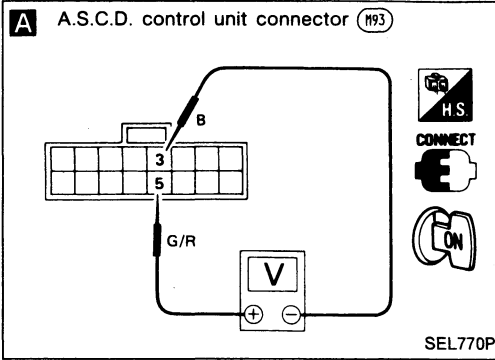

A

CHECK A.S.C.D. CANCEL, CLUTCH, INHIBITOR SWITCH CIRCUIT.

1. Turn A.S.C.D. main switch on.
2. Check voltage between control unit harness terminals ⑤ and ③.

Conditions		Voltage [V]	
M/T	A.S.C.D. cancel switch	Depressed Released	0 Approx. 12
	A.S.C.D. clutch switch	Depressed Released	0 Approx. 12
A/T	A/T shift lever position is at any position except N or P.		Approx. 12
	A/T shift lever position is at N or P.		0

N.G.

CHECK A.S.C.D. CANCEL, CLUTCH, and INHIBITOR SWITCH.
Refer to "Electrical Components Inspection".

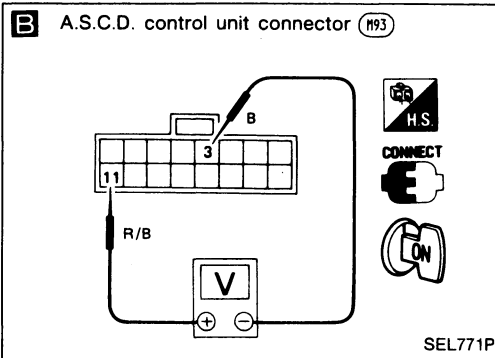

B

CHECK STOP LAMP SWITCH CIRCUIT.
Check voltage between control unit harness terminals ⑪ and ③.

Condition		Voltage [V]
Stop lamp switch	Depressed	Approx. 12
	Released	0

N.G.

CHECK STOP LAMP SWITCH.
Refer to "Electrical Components Inspection".

O.K.

O.K.

Check A.S.C.D. wire moves smoothly.

N.G.

Replace A.S.C.D. wire.

O.K.

CHECK A.S.C.D. ACTUATOR/A.S.C.D. PUMP.
Refer to "Electrical Components Inspection".

N.G.

Replace A.S.C.D. actuator assembly.

O.K.

Replace A.S.C.D. control unit.

AUTOMATIC SPEED CONTROL DEVICE (A.S.C.D.)

Trouble Diagnoses (Cont'd)

DIAGNOSTIC PROCEDURE 8

SYMPTOM: "CRUISE" indicator lamp blinks.

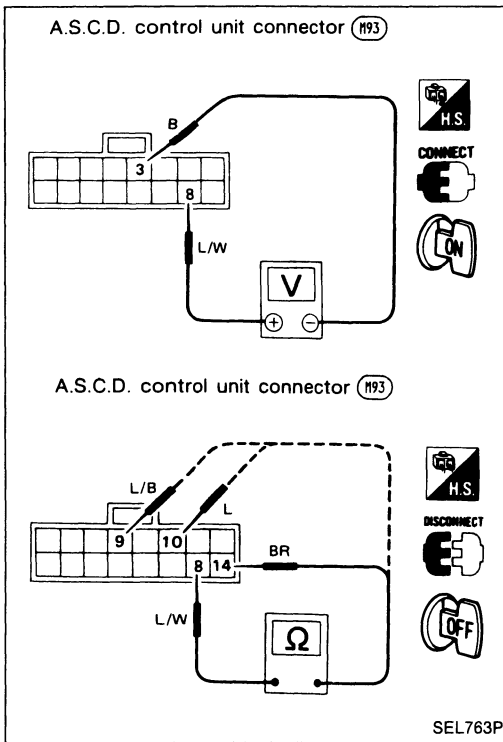
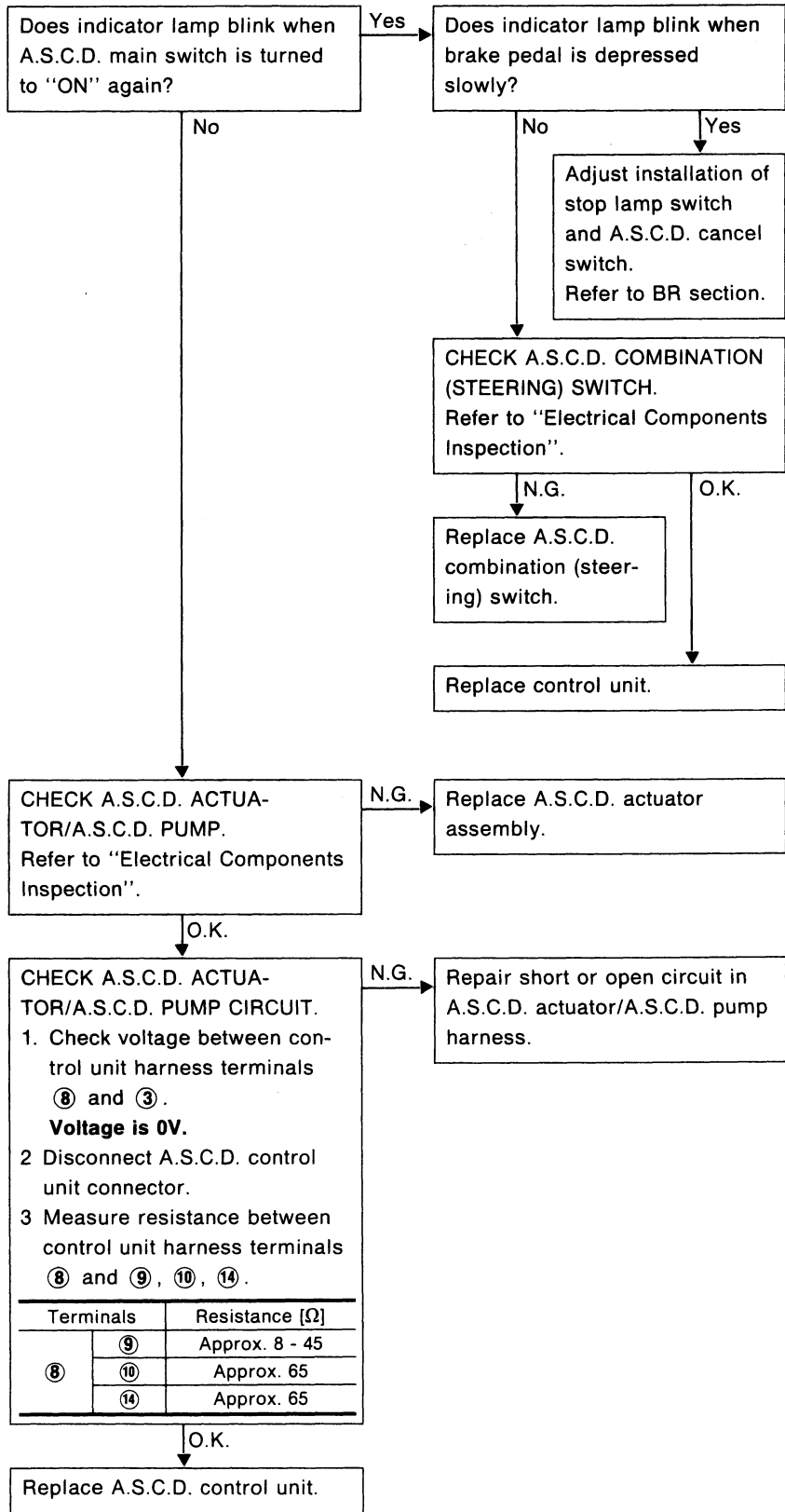

Terminals	Resistance [Ω]	
⑧	⑨	Approx. 8 - 45
	⑩	Approx. 65
	⑭	Approx. 65

AUTOMATIC SPEED CONTROL DEVICE (A.S.C.D.)

Trouble Diagnoses (Cont'd)

A.S.C.D. WIRE ADJUSTMENT

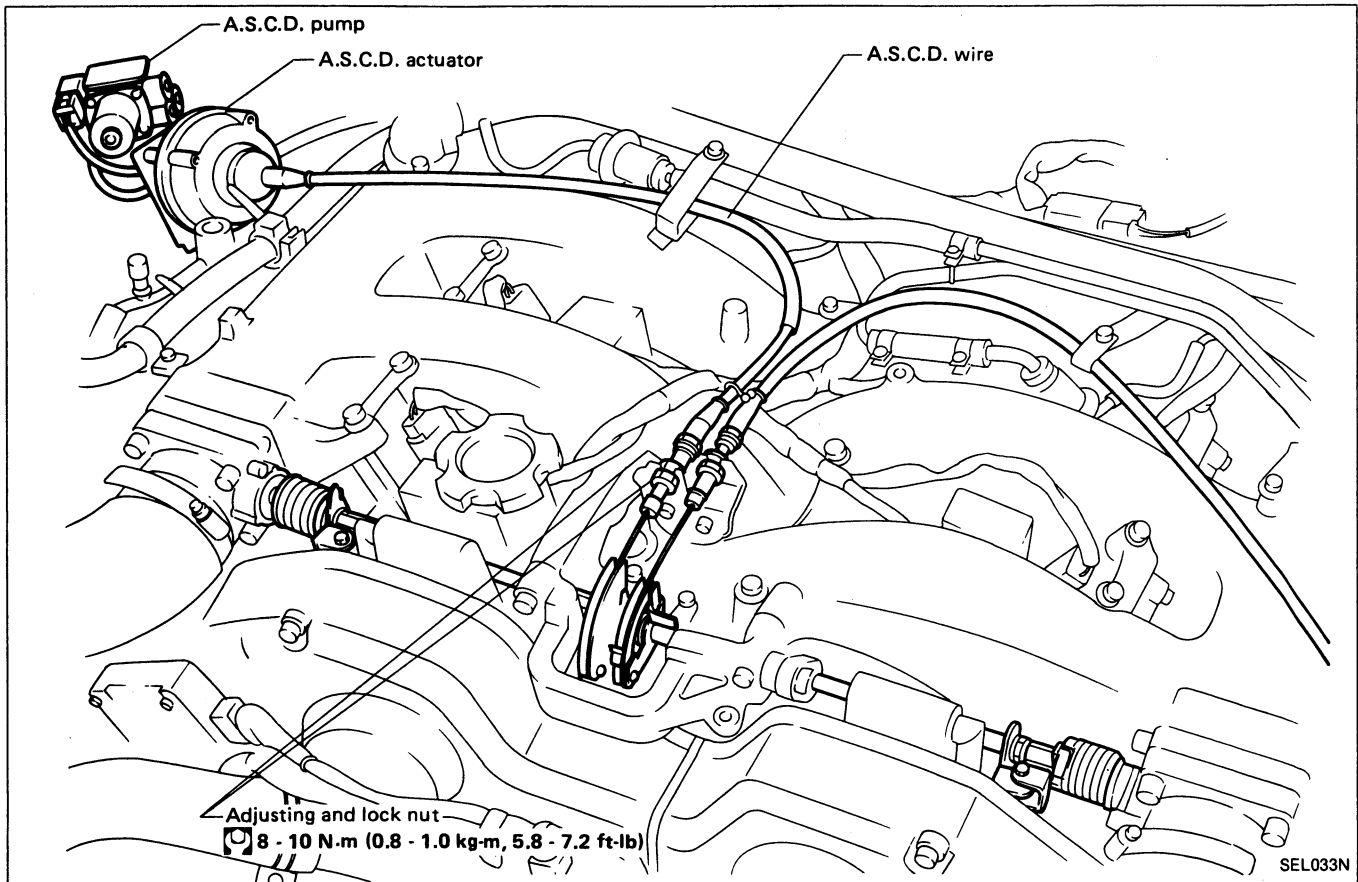

CAUTION:

- Be careful not to twist A.S.C.D. wire when removing it.
- Do not tense A.S.C.D. wire excessively during adjustment.

After confirming that accelerator wire is properly adjusted, adjust the tension of A.S.C.D. wire in the following manner.

- (1) After adjusting the length of the accelerator wire, turn a securing nut by 1/2 to 1 turn from throttle open starting position to the wire loosening direction to fix. (Must be securing carried out to prevent response delay of operation of the A.S.C.D.)
- (2) Securely tighten lock nut to hold adjusting nut in place.

AUTOMATIC SPEED CONTROL DEVICE (A.S.C.D.)

Trouble Diagnoses (Cont'd)

ELECTRICAL COMPONENTS INSPECTION

A.S.C.D. actuator/A.S.C.D. pump

1. Disconnect A.S.C.D. actuator/A.S.C.D. pump connector.
2. Check A.S.C.D. actuator/A.S.C.D. pump operations as shown.

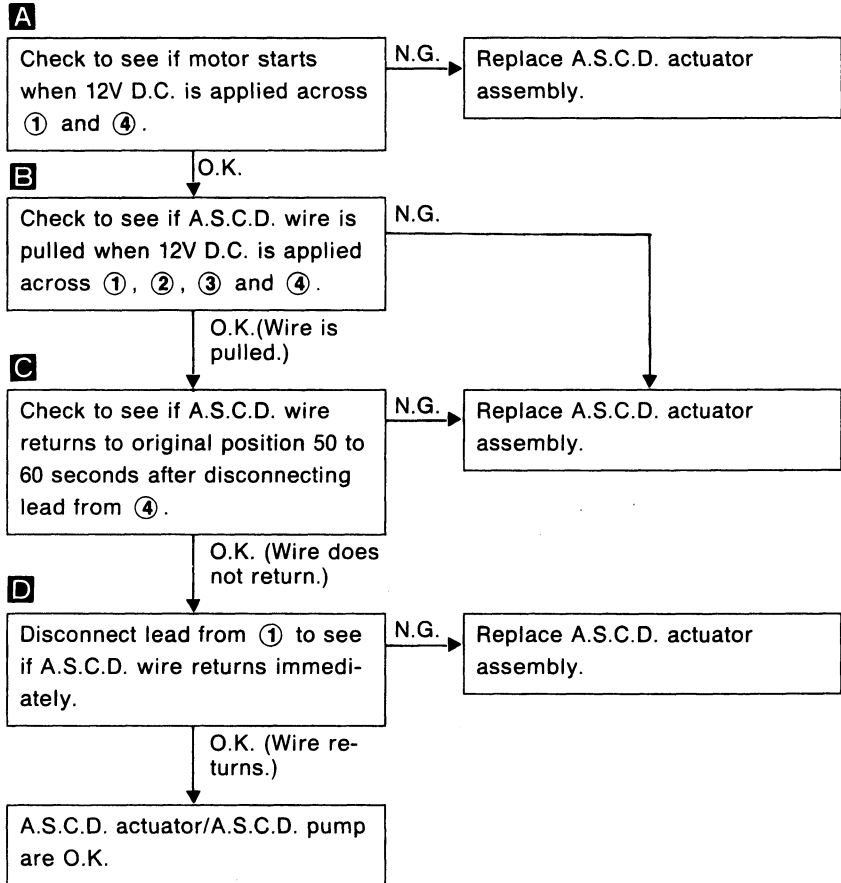
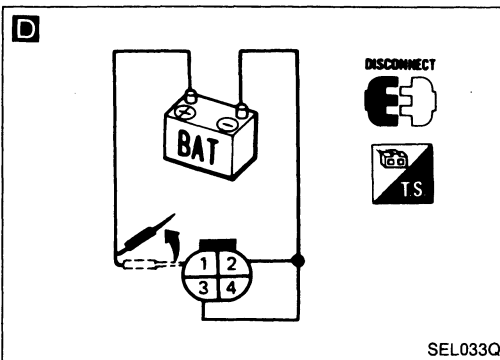
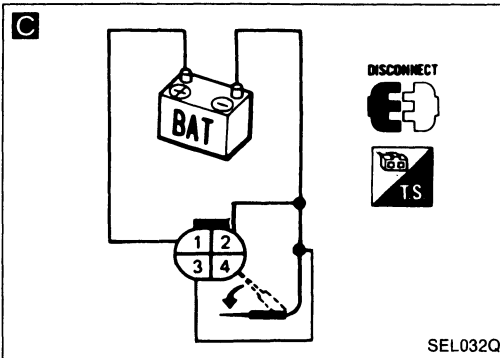
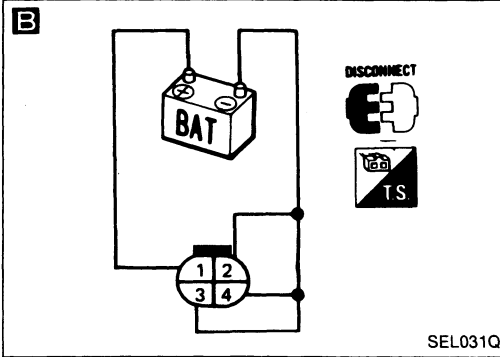
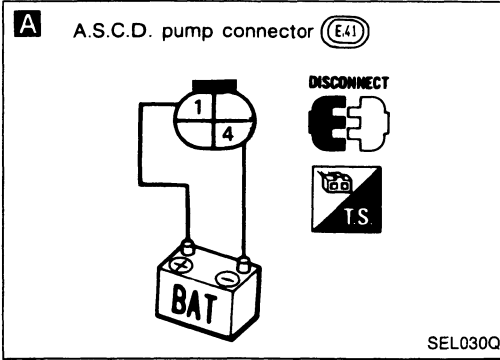

AUTOMATIC SPEED CONTROL DEVICE (A.S.C.D.)

Trouble Diagnoses (Cont'd)

A.S.C.D. main switch

Check continuity between terminals by pushing switch to each position.

Terminals	14	15	16
Switch position			
ON			
N			
OFF			

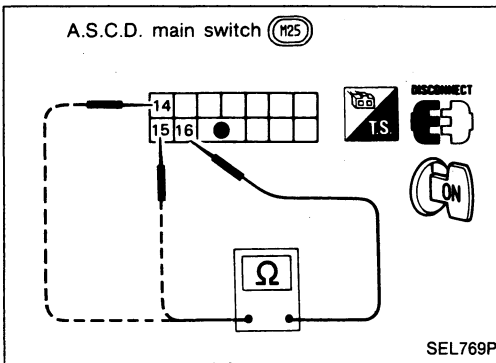

A.S.C.D. combination switch

Check continuity between terminals by turning lever.

Terminal	11	12	13
Lever			
SET/COAST			
RESUME/ACCEL			
CANCEL			

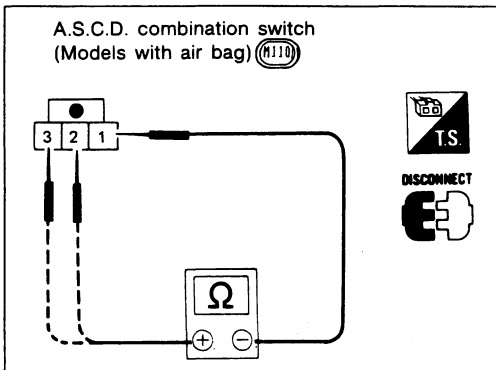

A.S.C.D. steering switch

Check continuity between terminals by pushing each button.

Terminal	1	2	3
Button			
SET/COAST			
RESUME/ACCEL			
CANCEL			

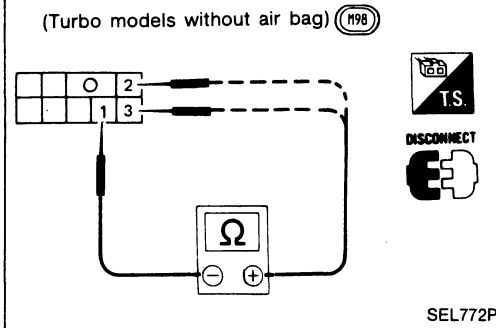
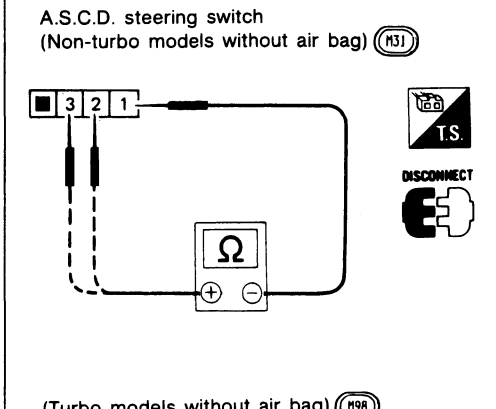

A.S.C.D. cancel switch and stop lamp switch

Condition	Continuity	
	A.S.C.D. cancel switch	Stop lamp switch
When brake pedal is depressed	No	Yes
When brake pedal is released	Yes	No

Check each switch after adjusting brake pedal — refer to BR section.

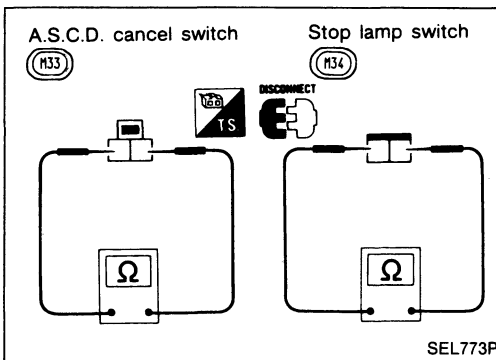

AUTOMATIC SPEED CONTROL DEVICE (A.S.C.D.)

Trouble Diagnoses (Cont'd)

Clutch switch (For M/T models)

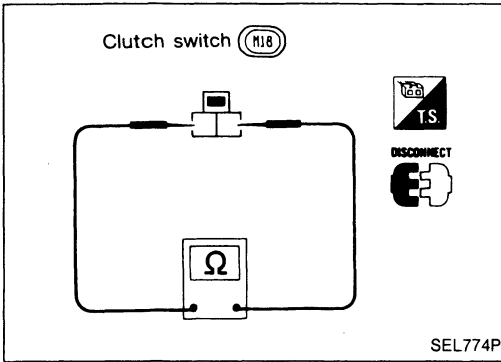

Condition	Continuity
When clutch pedal is depressed	No
When clutch pedal is released	Yes

Check switch after adjusting clutch pedal—refer to CL section.

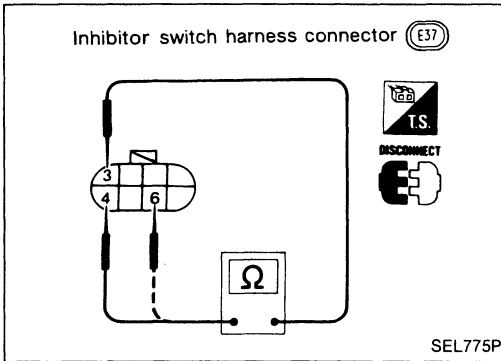

Inhibitor switch (For A/T models)

Shift lever position	Terminal		
	3	4	6
"P"	○	○	
"N"	○		○
Except "N" or "P"			

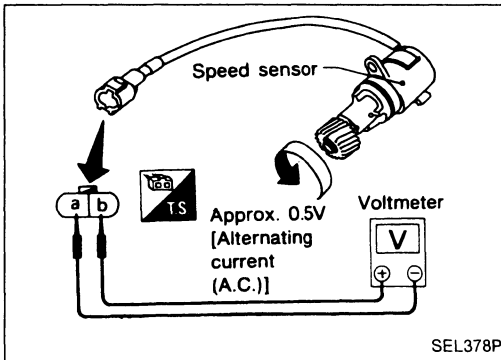

Speed sensor

1. Remove speed sensor from transaxle.
2. Turn speedometer pinion quickly and measure voltage across **a** and **b**.

AUTOMATIC SPEED CONTROL DEVICE (A.S.C.D.)

NOTE

THEFT WARNING SYSTEM

Component Parts and Harness Connector Location

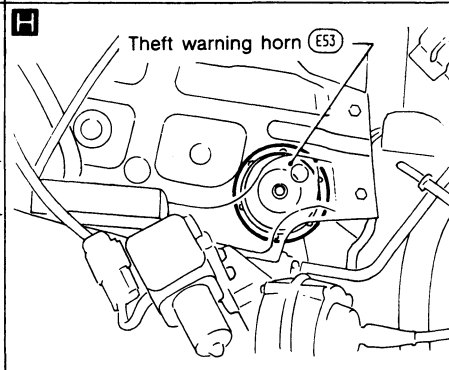
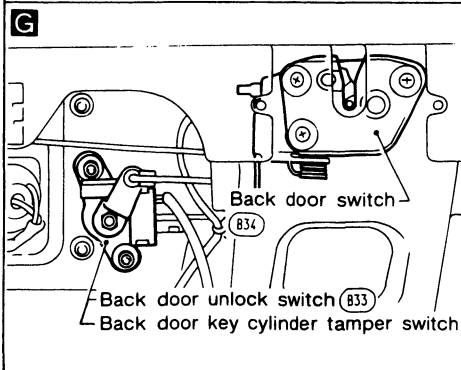
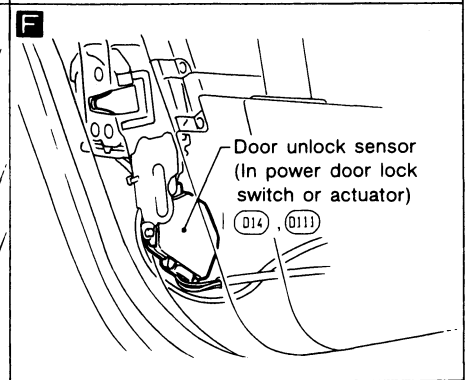
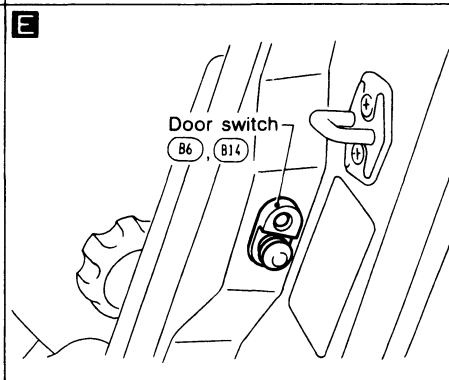
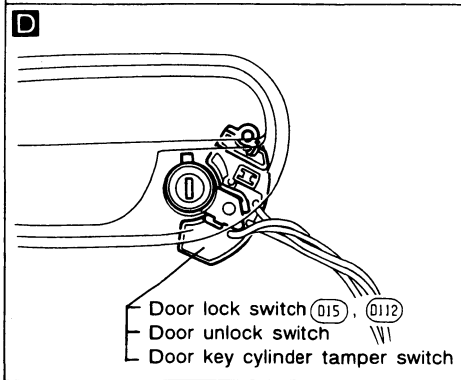
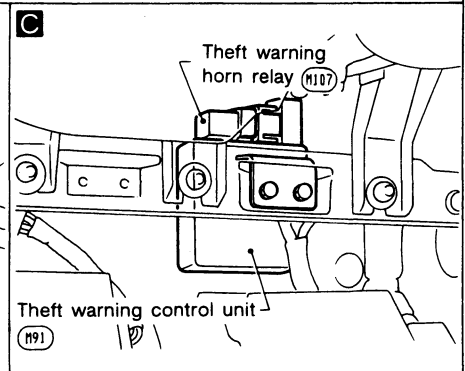
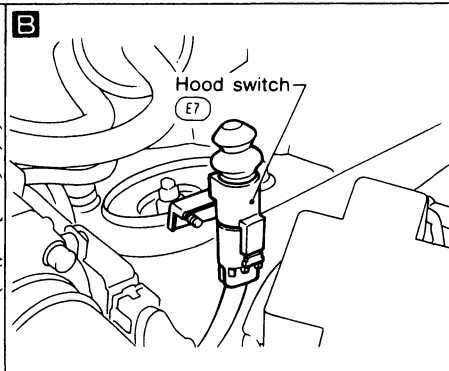
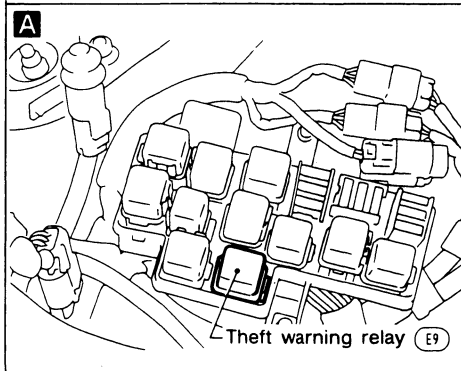
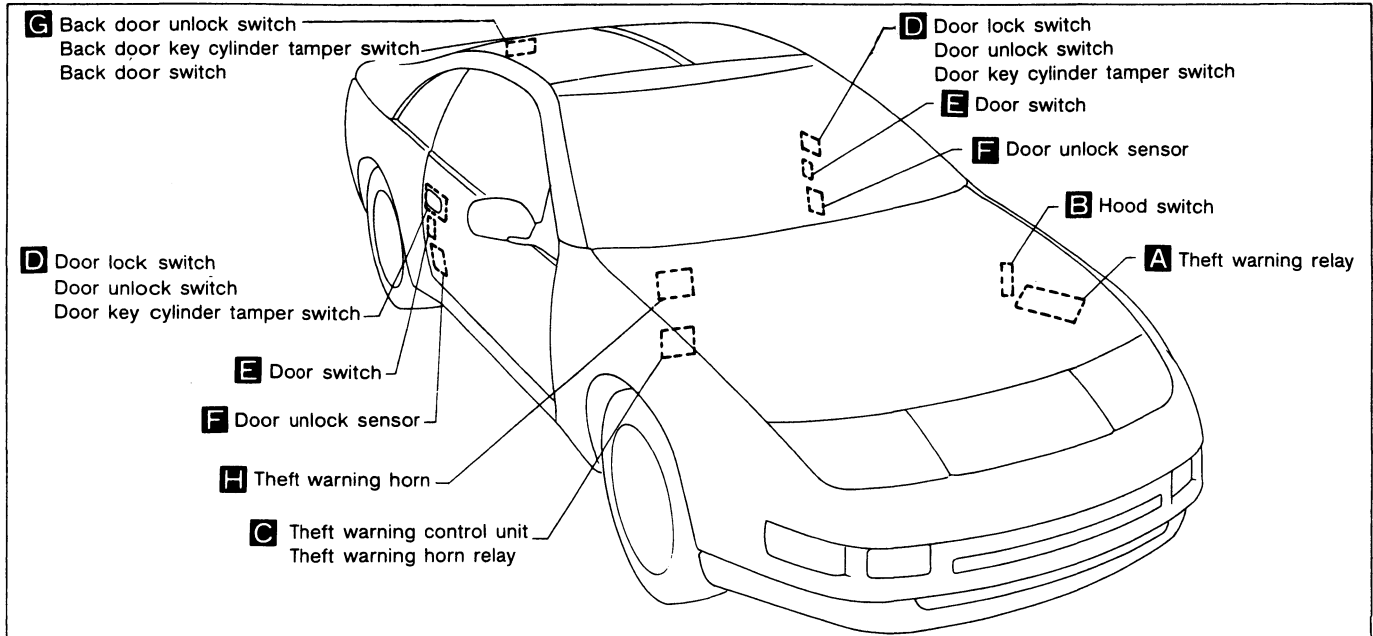

THEFT WARNING SYSTEM

Wiring Diagram

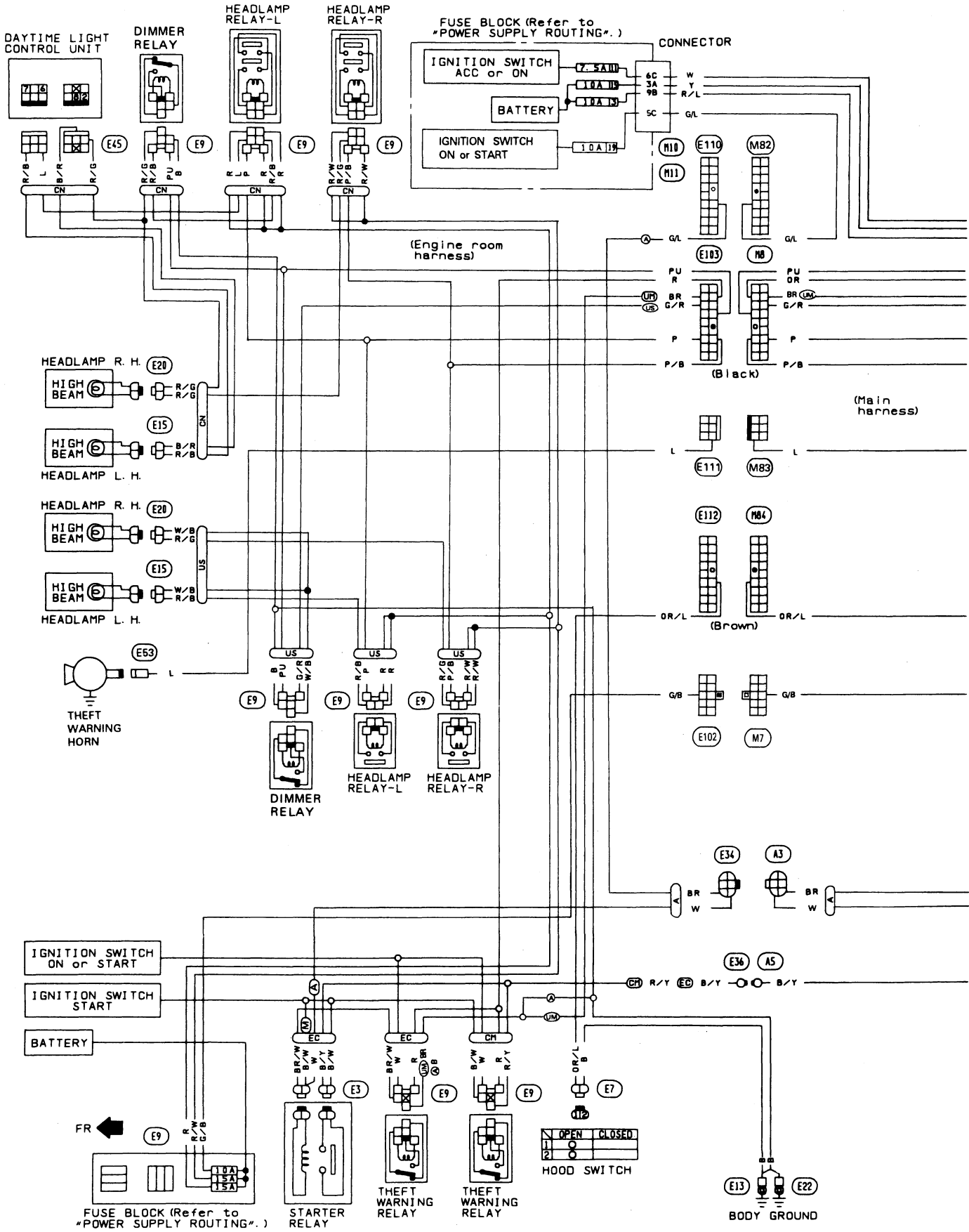

THEFT WARNING SYSTEM

Wiring Diagram (Cont'd)

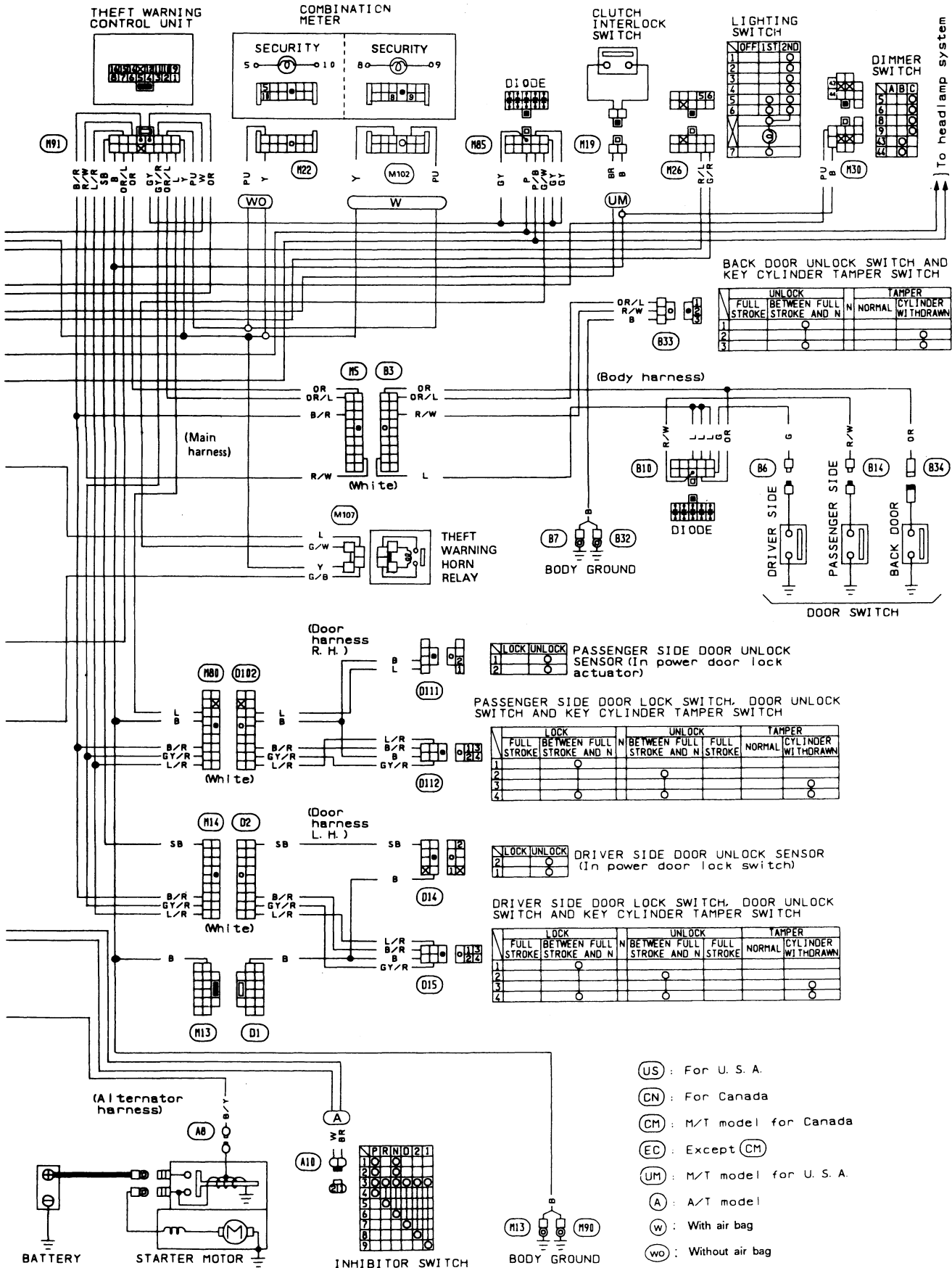

THEFT WARNING SYSTEM

Trouble Diagnoses

SYSTEM OPERATION CHECK

If ignition switch is set in the "ACC" position in the step of START to ARMED or in the ARMED state shown in this flow chart, the system operation is canceled.

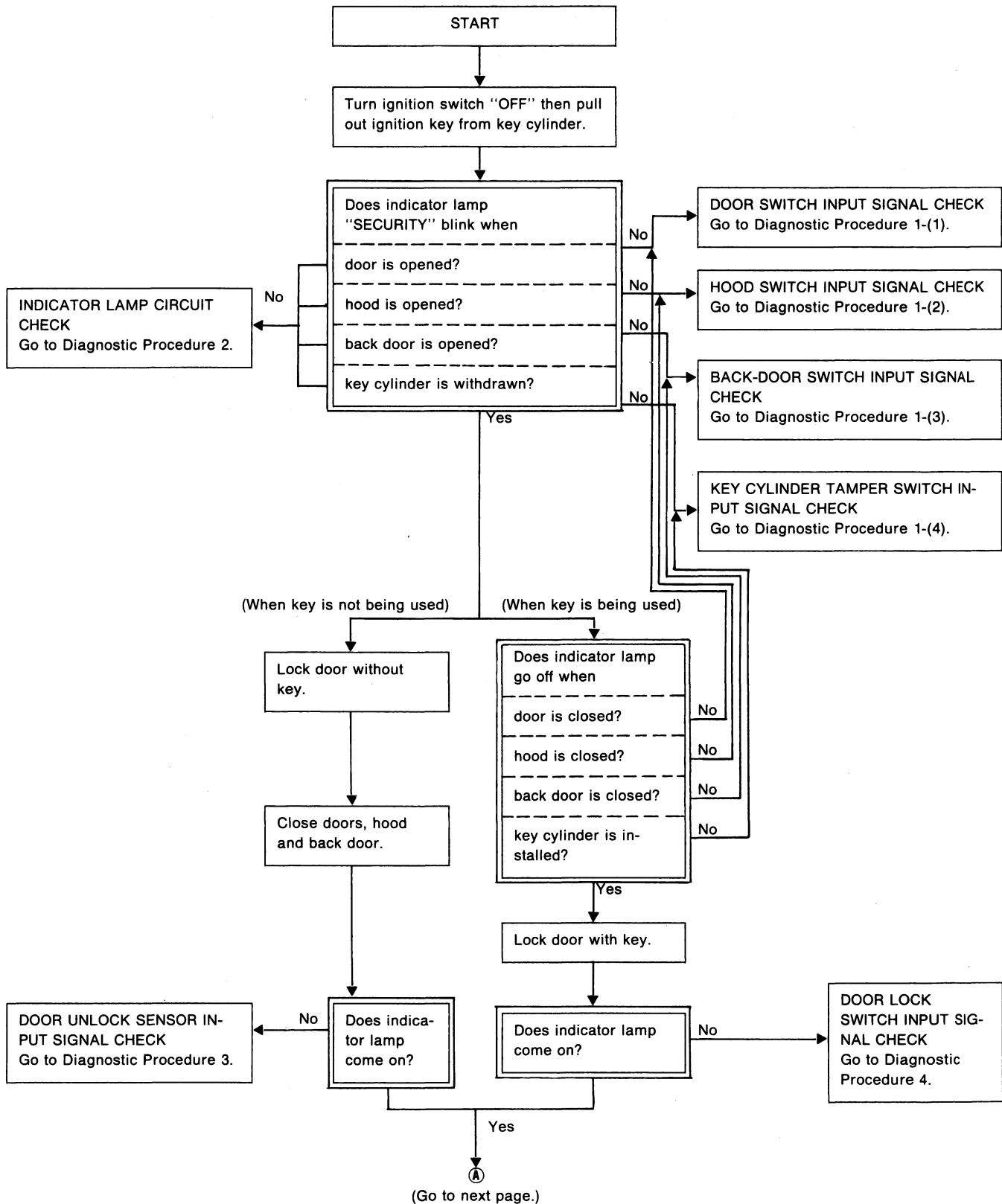

THEFT WARNING SYSTEM

Trouble Diagnoses (Cont'd)

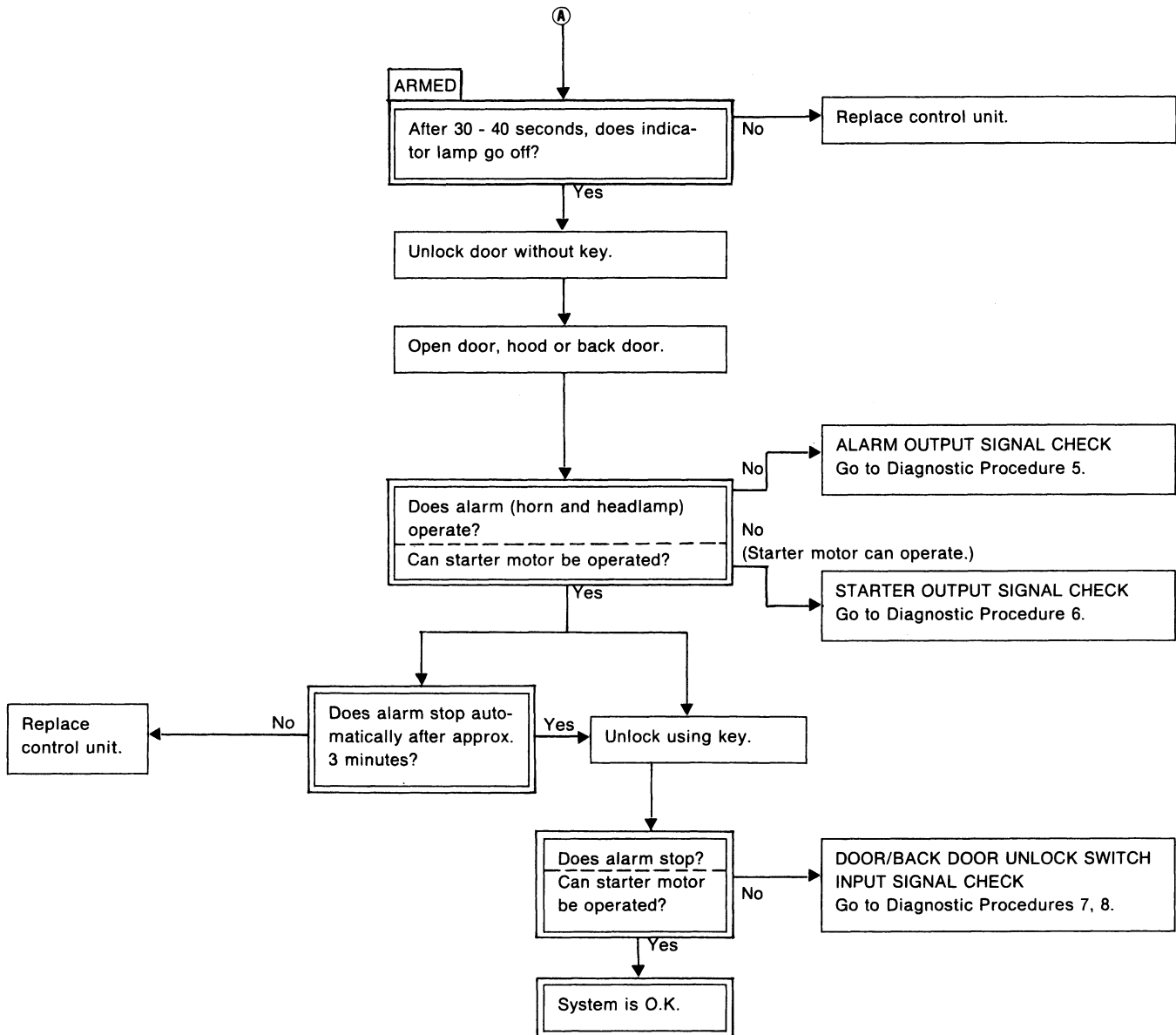

THEFT WARNING SYSTEM

Trouble Diagnoses (Cont'd)

CIRCUIT DIAGRAM FOR QUICK PINPOINT CHECK

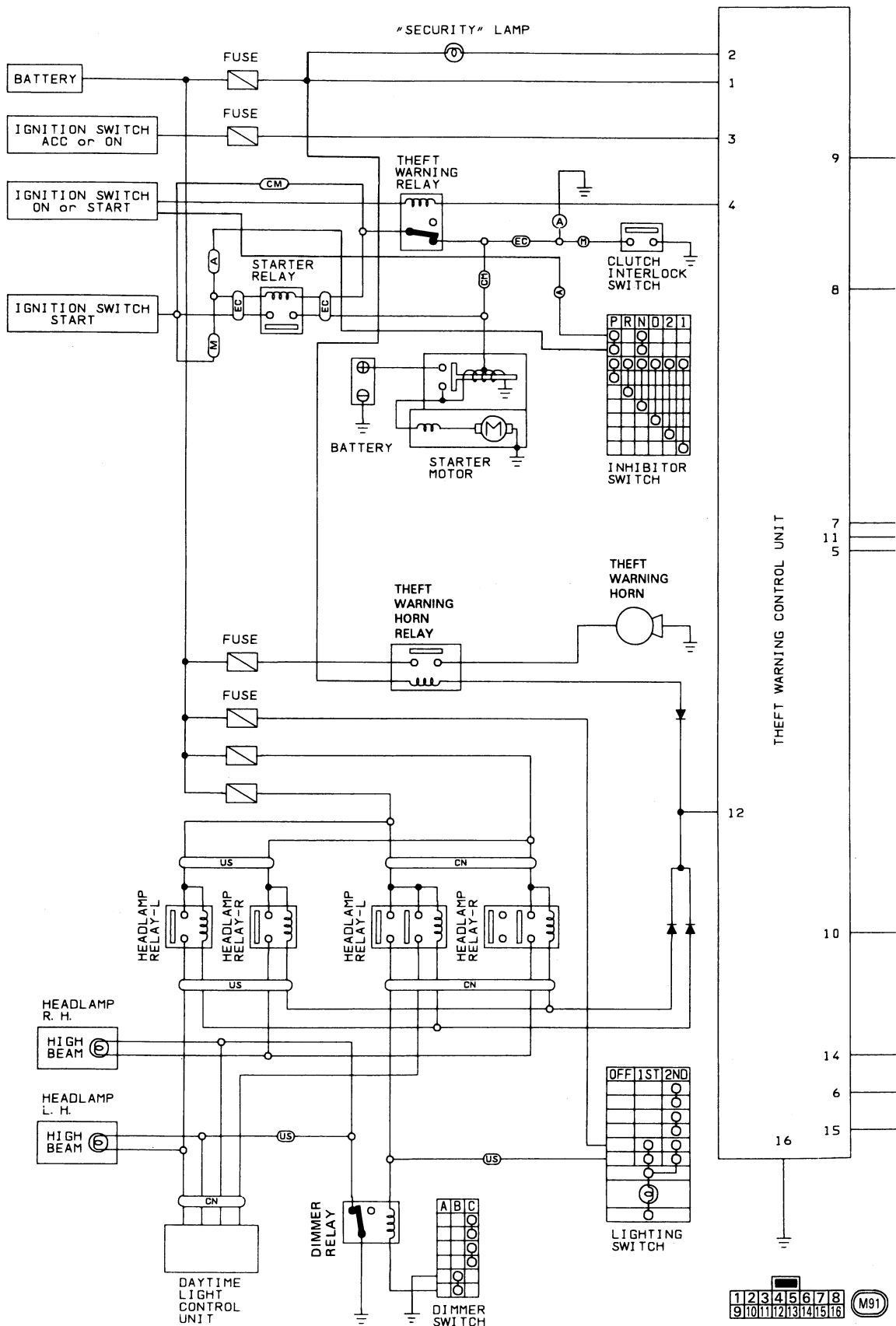

THEFT WARNING SYSTEM

Trouble Diagnoses (Cont'd)

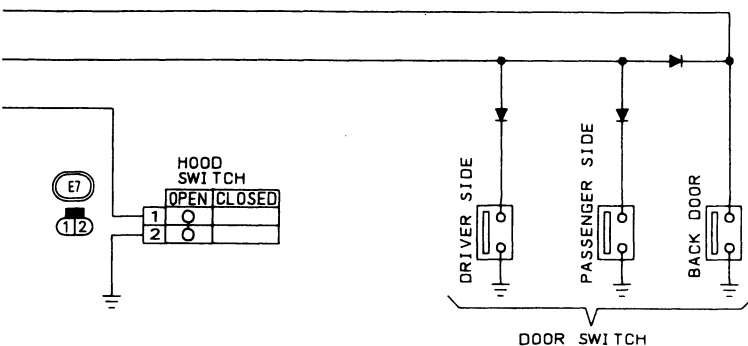
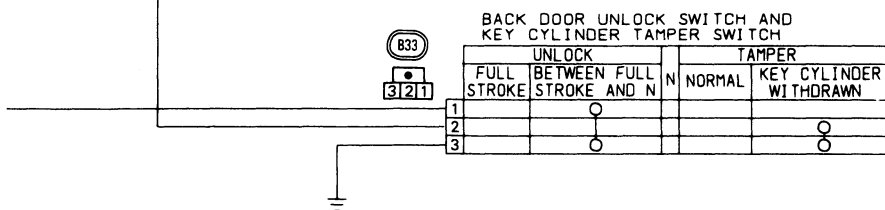
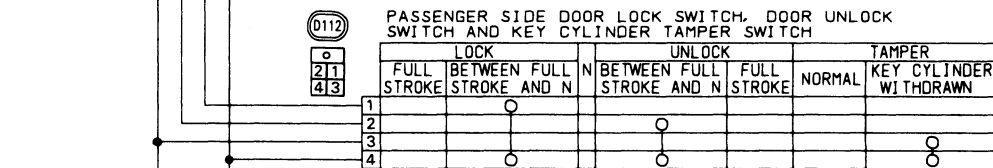
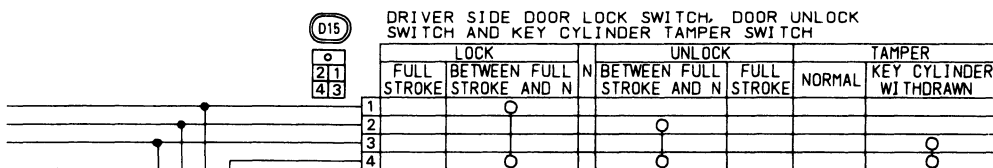
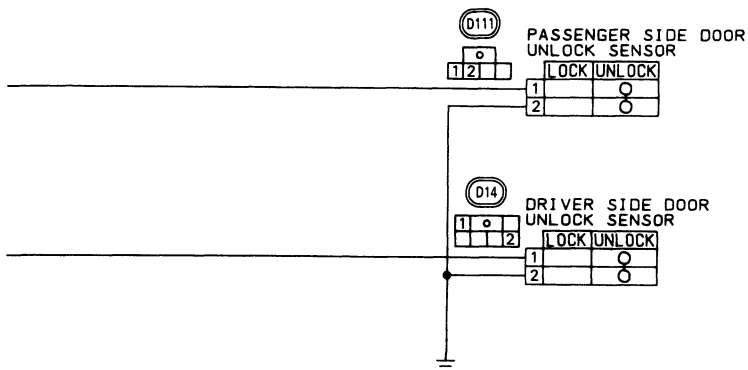

- (A) : A/T model
- (M) : M/T model
- (US) : For U. S. A.
- (CN) : For Canada
- (CM) : M/T model for Canada
- (EC) : Except (CM)

THEFT WARNING SYSTEM

Trouble Diagnoses (Cont'd)

POWER SUPPLY AND GROUND CIRCUIT CHECK

Main power supply circuit check

Terminals	Ignition switch position		
	OFF	ACC	ON
① - 16	Battery voltage	Battery voltage	Battery voltage

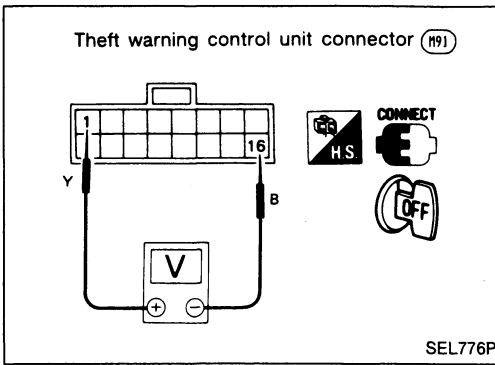

Power supply circuit check for system cancel

Terminals	Ignition switch position		
	OFF	ACC	ON
③ - 16	0V	Battery voltage	Battery voltage

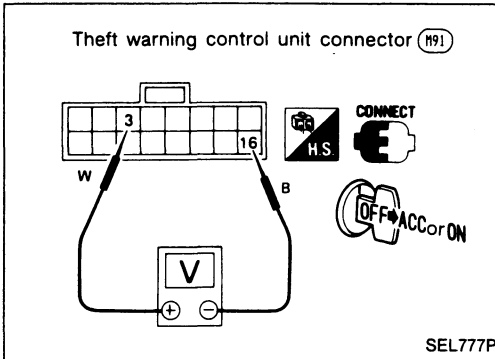

Ground circuit check

Terminals	Continuity
16 - Ground	Yes

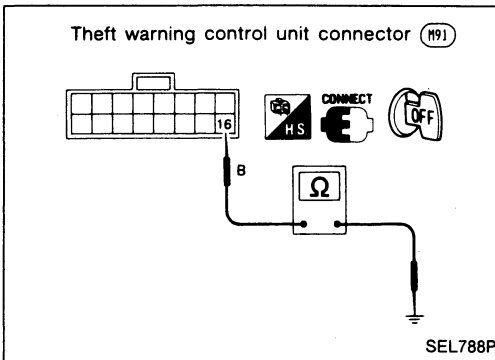

THEFT WARNING SYSTEM

Trouble Diagnoses (Cont'd)

DIAGNOSTIC PROCEDURE 1

- SYMPTOM:**
- Indicator lamp does not blink.
 - Indicator lamp remains blinking.

Diagnostic procedure 1-(1)

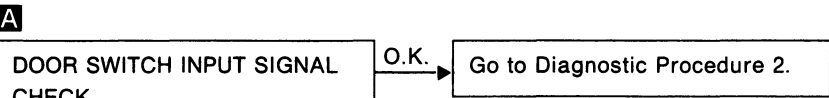
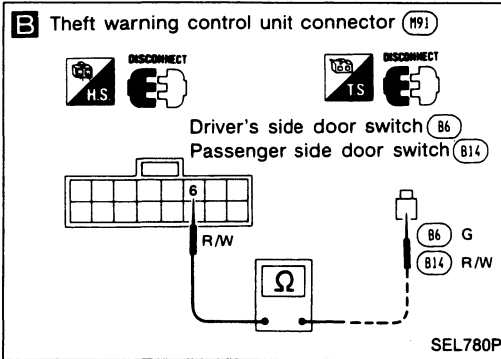
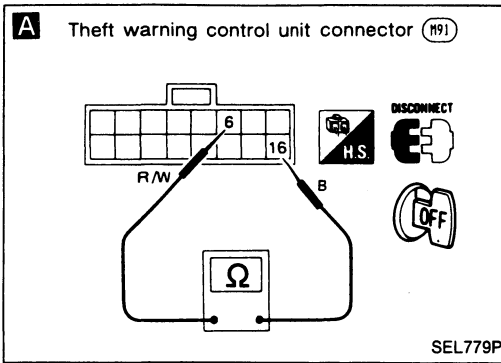

Condition	Voltage
All doors are closed	Battery voltage
At least one door is open	0V

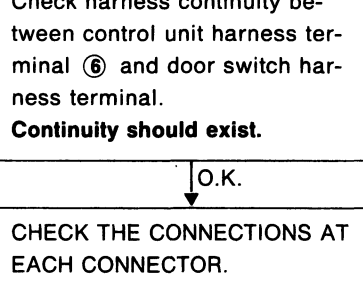
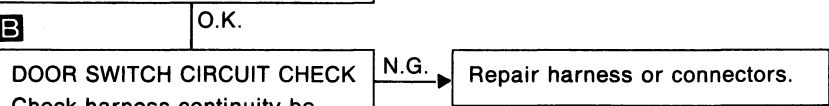
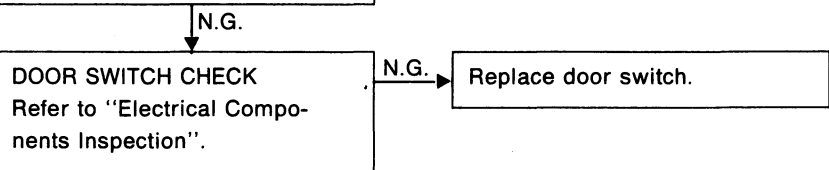

THEFT WARNING SYSTEM

Trouble Diagnoses (Cont'd)

Diagnostic procedure 1-(2)

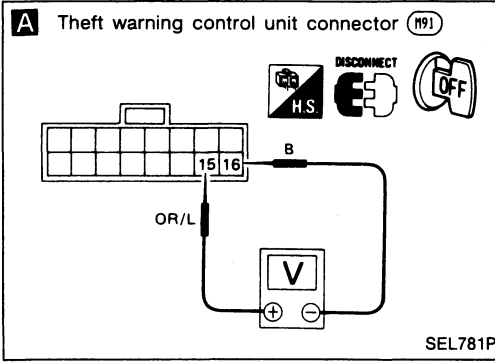

A

HOOD SWITCH INPUT SIGNAL CHECK
Check continuity between control unit harness terminals ⑮ and ⑯.

Condition	Continuity
Hood is open	Yes
Hood is closed	No

O.K. → Go to Diagnostic Procedure 2.

N.G.

Check hood switch and hood fitting condition.

N.G. → Adjust installation of hood switch or hood.

O.K.

HOOD SWITCH CHECK
Refer to "Electrical Components Inspection".

N.G. → Replace hood switch.

O.K.

B

HOOD SWITCH CIRCUIT CHECK

- Check harness continuity between control unit harness terminal ⑮ and hood switch harness terminal.
- Check harness continuity between hood switch terminal and body ground.

Continuity should exist.

N.G. → Repair harness or connectors.

O.K.

CHECK THE CONNECTIONS AT EACH CONNECTOR.

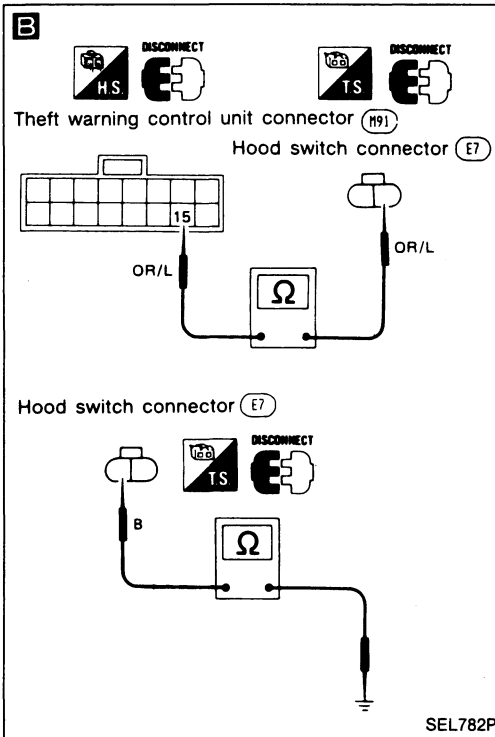

THEFT WARNING SYSTEM

Trouble Diagnoses (Cont'd)

Diagnostic procedure 1-(3)

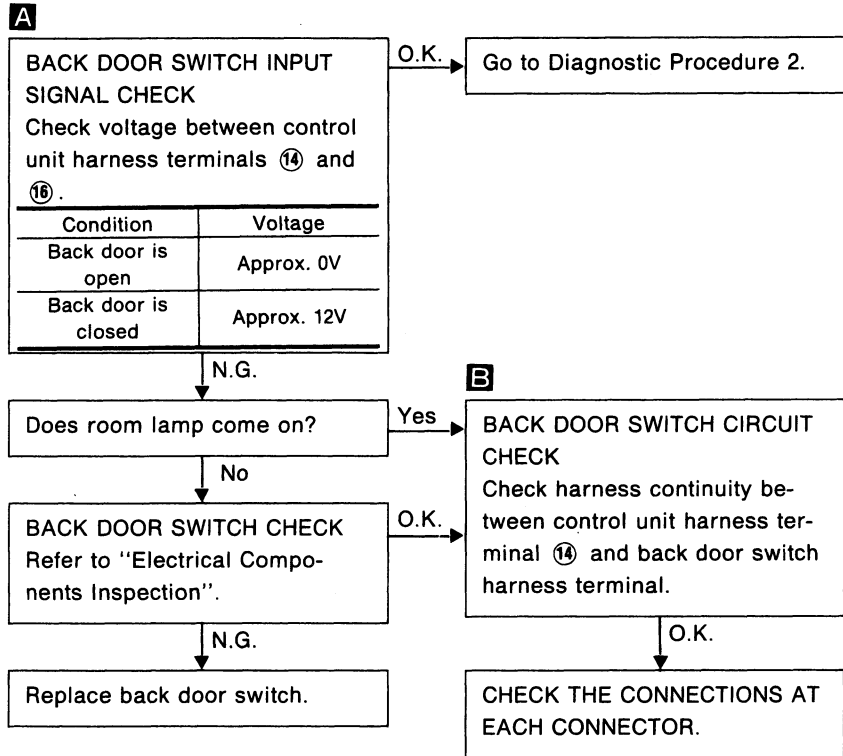
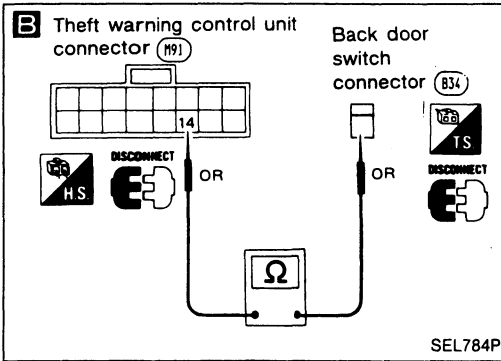
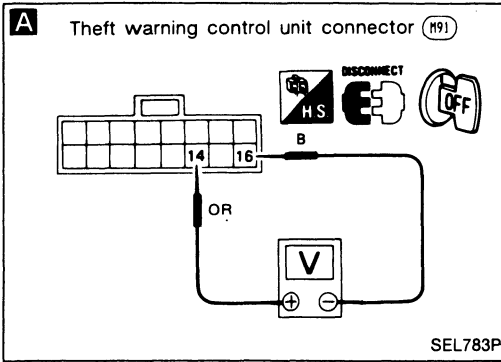

THEFT WARNING SYSTEM

Trouble Diagnoses (Cont'd)

Diagnostic procedure 1-(4)

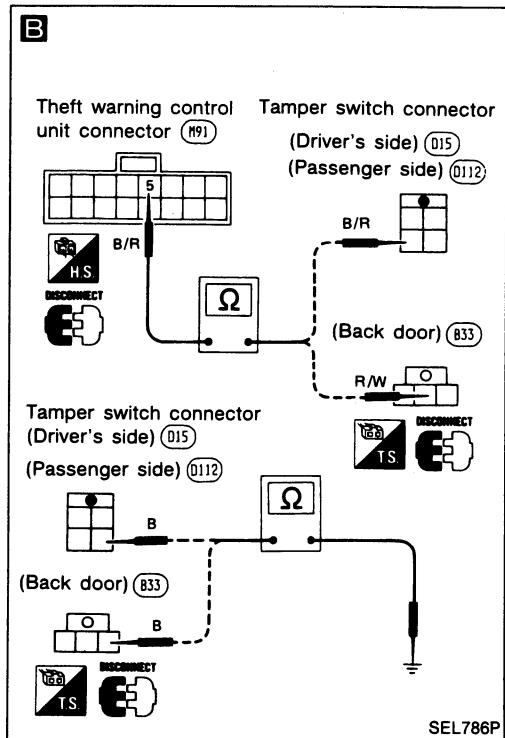
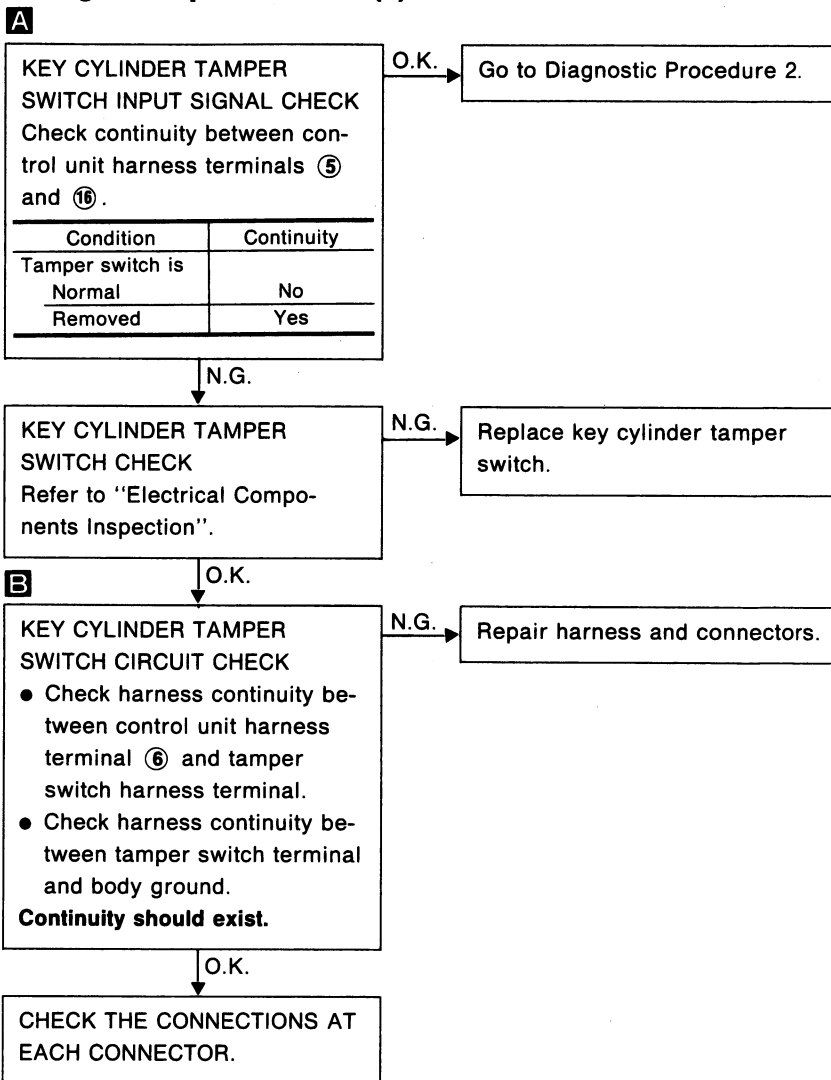
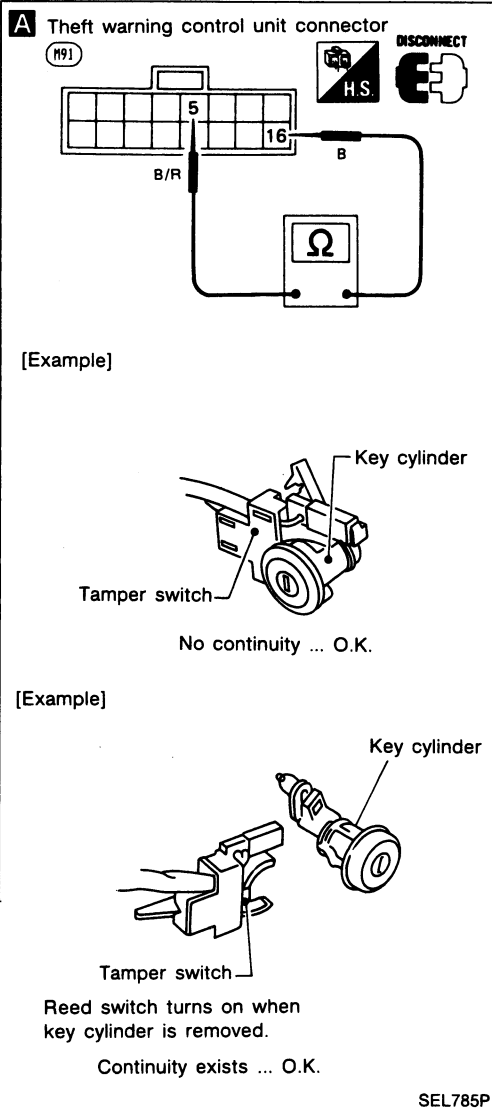

THEFT WARNING SYSTEM

Trouble Diagnoses (Cont'd)

DIAGNOSTIC PROCEDURE 2

SYMPTOM: Indicator lamp does not blink.

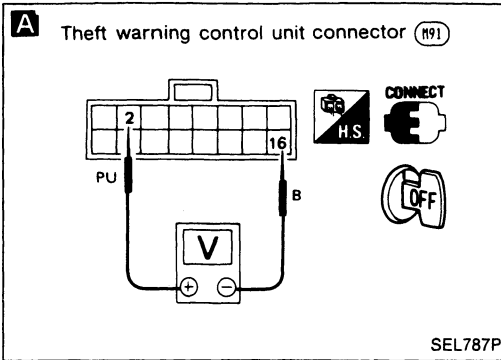

A

INDICATOR LAMP OUTPUT SIGNAL CHECK
 Check voltage between control unit harness terminals ② and ⑯.
Pointer of voltmeter should deflect intermittently.

N.G. → Replace control unit.

O.K.

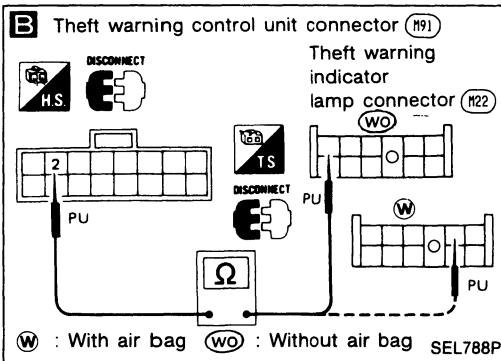

INDICATOR LAMP CHECK
 Refer to "Electrical Components Inspection".

N.G. → Replace indicator lamp.

O.K.

B

INDICATOR LAMP CIRCUIT CHECK
 Check harness continuity between control unit harness terminal ② and indicator lamp harness terminal.
Continuity should exist.

N.G. → Repair harness or connectors.

O.K.

CHECK THE CONNECTIONS AT EACH CONNECTOR.

THEFT WARNING SYSTEM

Trouble Diagnoses (Cont'd)

DIAGNOSTIC PROCEDURE 3

SYMPTOM: Indicator lamp does not come on.

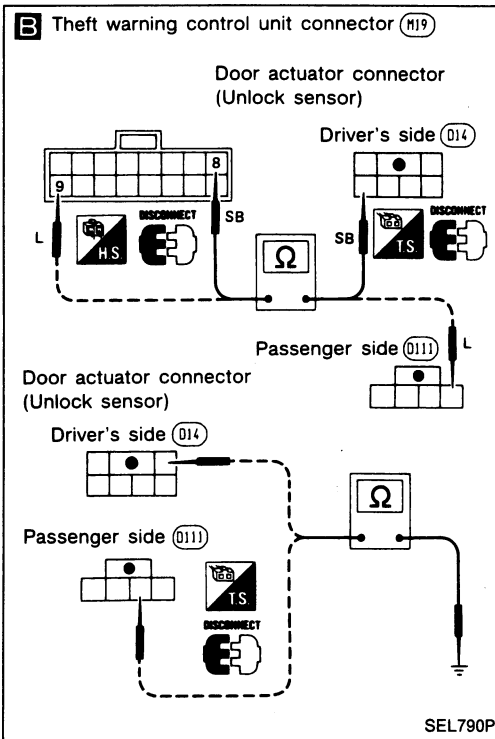
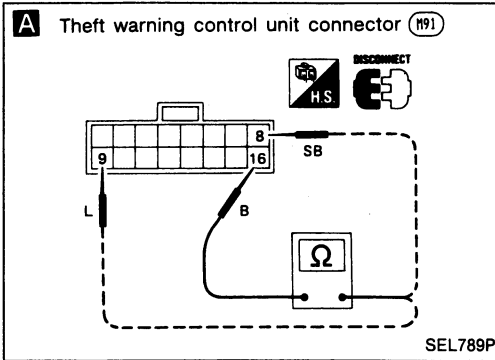

A

DOOR UNLOCK SENSOR INPUT SIGNAL CHECK
Check continuity between control unit harness terminals ⑧ (Driver's side) or ⑨ (Passenger side) and ⑩.

Condition	Continuity
Locked	No
Unlocked	Yes

N.G.

DOOR UNLOCK SENSOR CHECK
Refer to "Electrical Components Inspection".

O.K.

B

DOOR UNLOCK SENSOR CIRCUIT CHECK

- Check harness continuity between control unit harness terminal ⑧ (Driver's side) or ⑨ (Passenger side) and door actuator terminal.
- Check harness continuity between door actuator terminal and body ground.

Continuity should exist.

O.K.

CHECK THE CONNECTIONS AT EACH CONNECTOR.

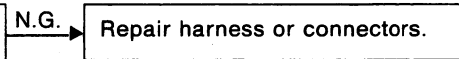
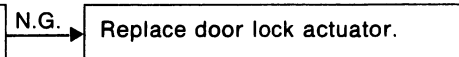
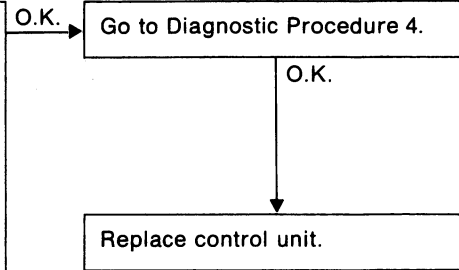

THEFT WARNING SYSTEM

Trouble Diagnoses (Cont'd)

DIAGNOSTIC PROCEDURE 4

SYMPTOM: Indicator lamp does not come on.

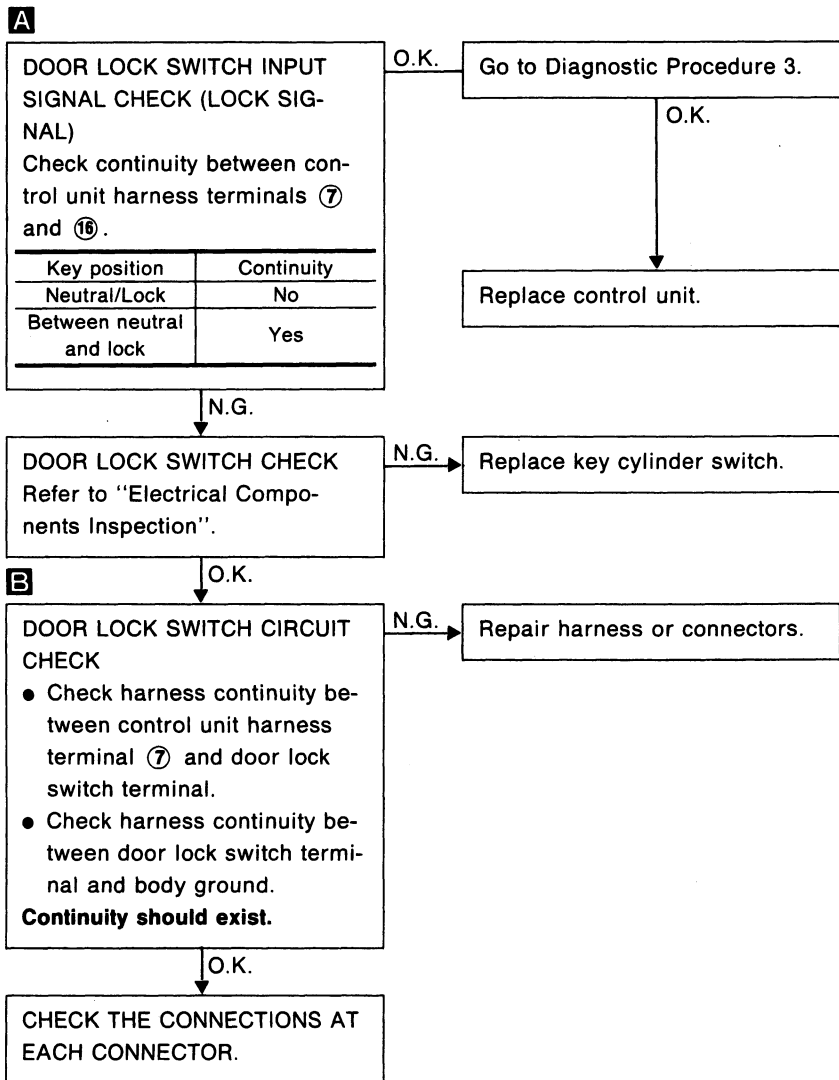
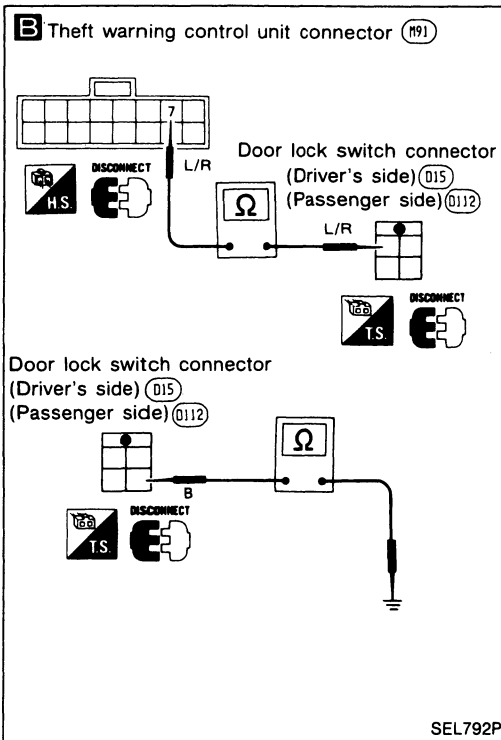
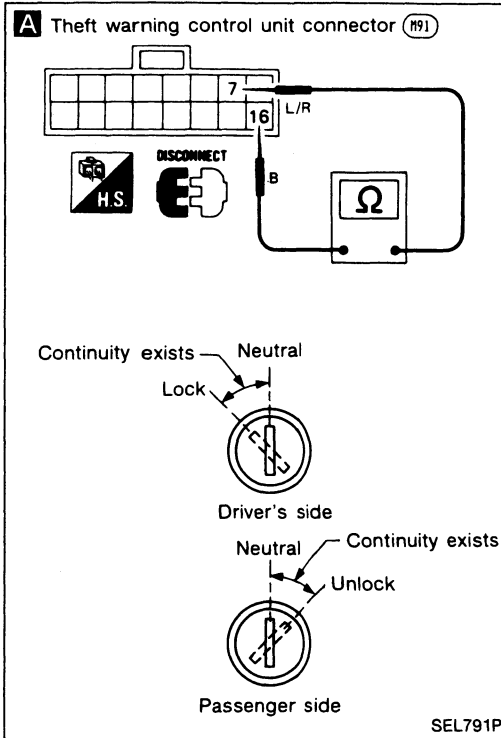

THEFT WARNING SYSTEM

Trouble Diagnoses (Cont'd)

DIAGNOSTIC PROCEDURE 5

SYMPTOM: Alarm does not operate.

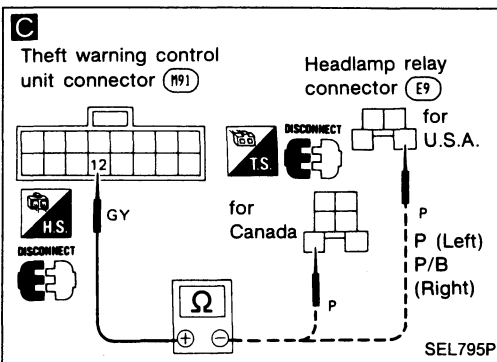
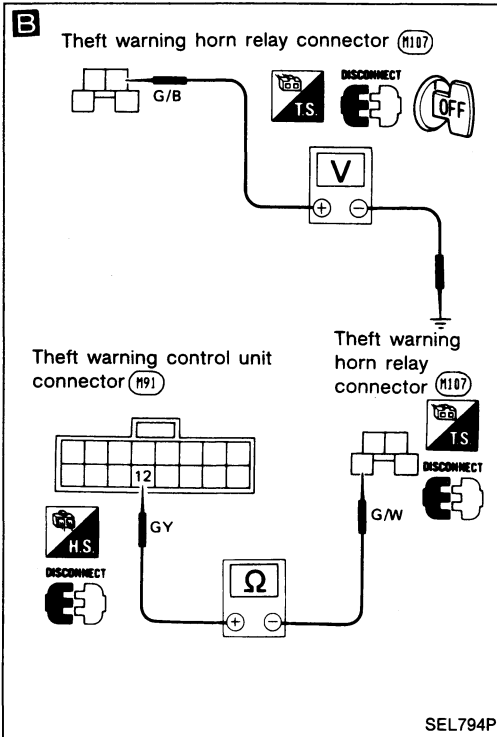
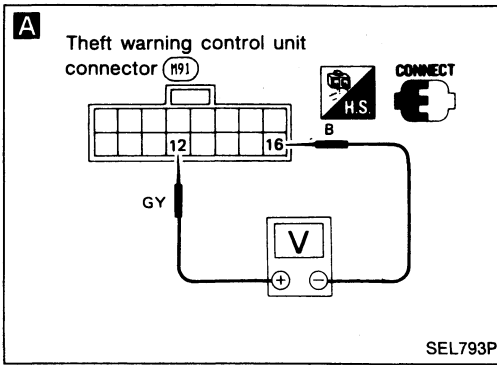

A

ALARM SIGNAL OUTPUT CHECK

Check voltage between control unit harness terminals ⑫ and ⑩.

Condition	Voltmeter
Except alarm phase	12V
Alarm phase	Pointer deflects intermittently

O.K.

Check theft warning horn relay.

O.K.

B

THEFT WARNING HORN CIRCUIT CHECK

Check if voltage across theft warning horn relay harness terminal and body is 12V.
Check continuity between theft warning horn relay terminal and control unit harness terminal ⑫.

Continuity should exist.

O.K.

C

THEFT WARNING HEADLAMP CIRCUIT CHECK

Check continuity between headlamp relay terminal and control unit harness terminal ⑫.

O.K.

Check headlamp system. Refer to "HEADLAMP".

N.G.

Replace control unit.

N.G.

Replace relay.

N.G.

Repair harness and connectors.

N.G.

Repair harness and connectors.

THEFT WARNING SYSTEM

Trouble Diagnoses (Cont'd)

DIAGNOSTIC PROCEDURE 6

SYMPTOM: STARTER MOTOR can be operated. (Starter killed phase)

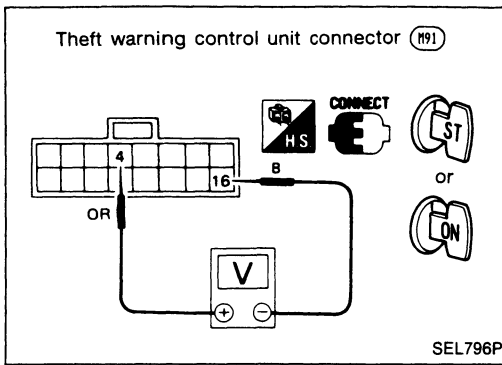

STARTER MOTOR KILL OUTPUT SIGNAL CHECK
Check voltage between control unit harness terminals ④ and ⑯ when ignition switch is turned to ON or "START".

Approx. 12V

Replace control unit.

Approx. 0 volt

Check theft warning relay.

N.G.

Replace theft warning relay.

O.K.

Repair harness between control unit and theft warning relay.

THEFT WARNING SYSTEM

Trouble Diagnoses (Cont'd)

DIAGNOSTIC PROCEDURE 7

SYMPTOM: Alarm does not stop even if stop signal is given.

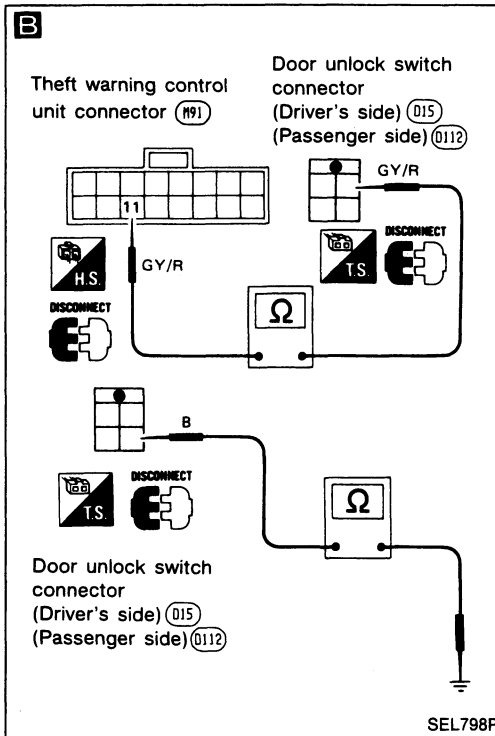
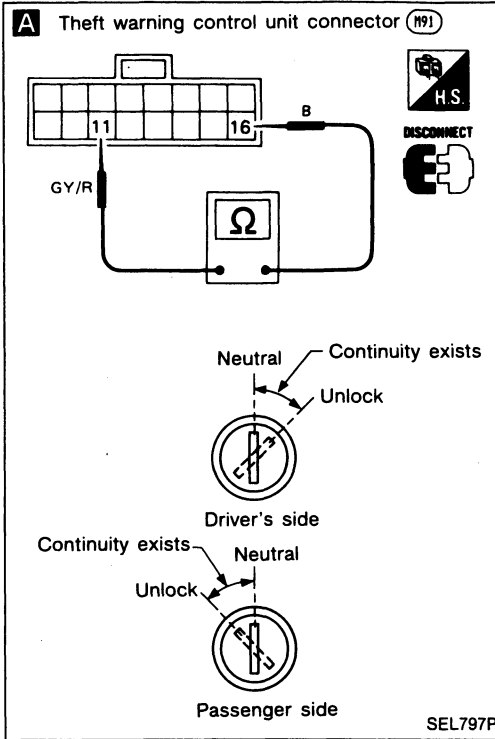

A

DOOR UNLOCK SWITCH INPUT SIGNAL CHECK (UNLOCK SIGNAL)
Check continuity between control unit harness terminals ⑪ and ⑩.

Key position	Continuity
Neutral/Unlock	No
Between neutral and unlock	Yes

N.G.

DOOR UNLOCK SWITCH CHECK
Refer to "Electrical Components Inspection".

N.G.

O.K.

B

DOOR UNLOCK SWITCH CIRCUIT CHECK

- Check harness continuity between control unit harness terminal ⑪ and door unlock switch terminal.
 - Check harness continuity between door unlock switch terminal and body ground.
- Continuity should exist.**

N.G.

O.K.

CHECK THE CONNECTIONS AT EACH CONNECTOR.

Replace control unit.

Replace key cylinder switch.

Repair harness or connectors.

THEFT WARNING SYSTEM

Trouble Diagnoses (Cont'd)

DIAGNOSTIC PROCEDURE 8

SYMPTOM: Alarm does not stop even if stop signal is given.

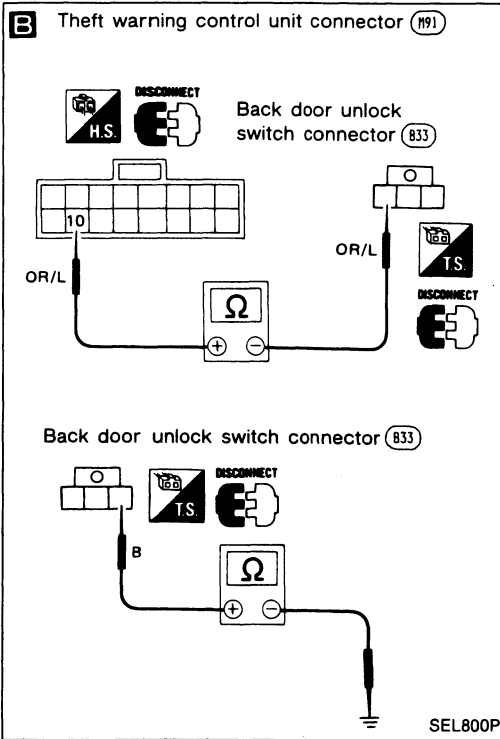
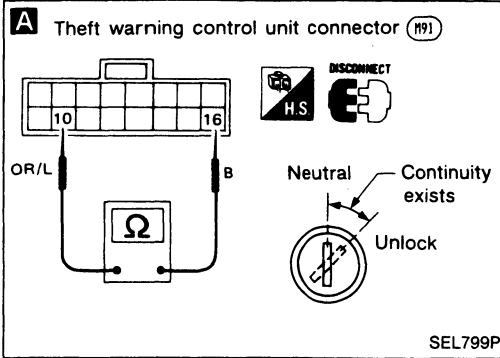

A

BACK DOOR UNLOCK SWITCH INPUT SIGNAL CHECK (UNLOCK SIGNAL)
Check continuity between control unit harness terminals ⑩ and ⑯.

Key position	Continuity
Neutral/Unlock	No
Between neutral and unlock	Yes

O.K.

Replace control unit.

N.G.

BACK DOOR UNLOCK SWITCH CHECK
Refer to "Electrical Components Inspection".

N.G.

Replace key cylinder switch.

O.K.

B

BACK DOOR UNLOCK SWITCH CIRCUIT CHECK

- Check harness continuity between control unit harness terminal ⑩ and back door unlock switch terminal.
- Check harness continuity between back door unlock switch terminal and body ground.

N.G.

Repair harness or connectors.

O.K.

CHECK THE CONNECTIONS AT EACH CONNECTOR.

THEFT WARNING SYSTEM

Trouble Diagnoses (Cont'd)

ELECTRICAL COMPONENTS INSPECTION

Door switches

Check continuity between terminal and switch body.

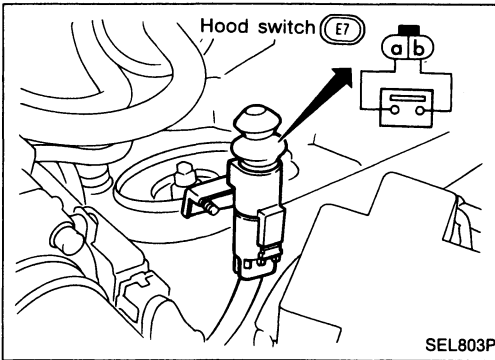
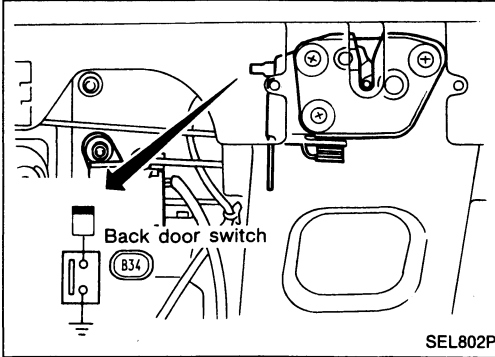
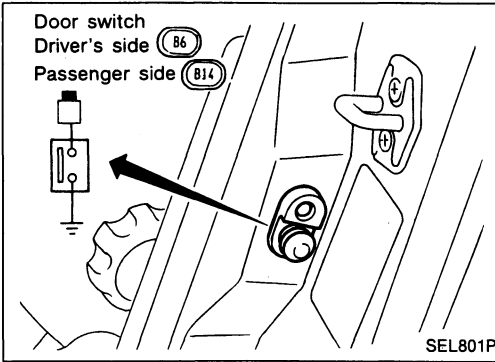

Hood switch

Check continuity between terminals when hood switch is pushed and released.

Terminal \	Pushed	Released
a		○
b		○

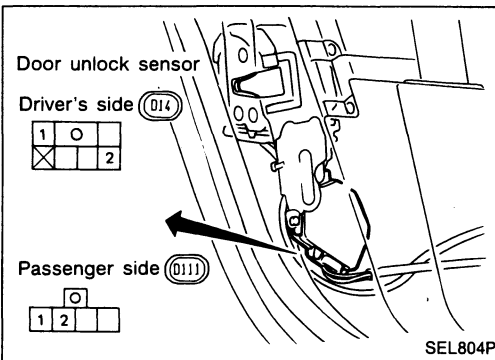

Door unlock sensor

	LOCK	UNLOCK
1		○
2		○

THEFT WARNING SYSTEM

Trouble Diagnoses (Cont'd)

Key cylinder tamper switch, door lock switch and door unlock switch

● Door

	TAMPER SWITCH		DOOR LOCK SWITCH		DOOR UNLOCK SWITCH		
	Key cylinder is installed	Key cylinder is removed	Full stroke	Between full stroke and neutral	Neutral	Between full stroke and neutral	Full stroke
1				○			
2				○		○	
3		○		○		○	
4		○		○		○	

● Back door

	TAMPER SWITCH		Back door unlock switch		
	Key cylinder is installed	Key cylinder is removed	Full stroke	Between full stroke and neutral	Neutral
1				○	
2		○		○	
3		○		○	

Tamper switch for door

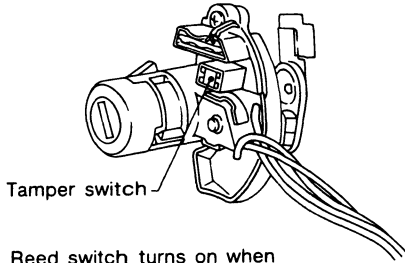

Reed switch turns on when tamper switch is removed from door.

Tamper switch for back door

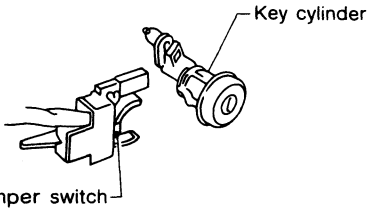

Reed switch turns on when key cylinder is removed.

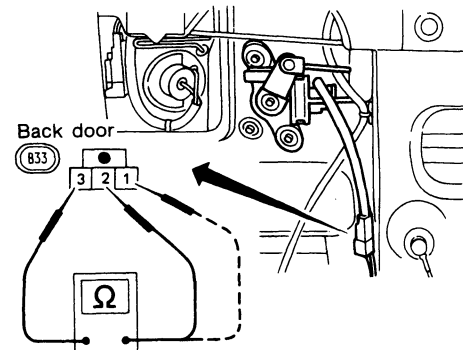
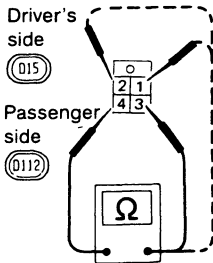
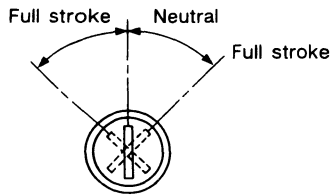

SEL805P

LOCATION OF ELECTRICAL UNITS

Engine Compartment

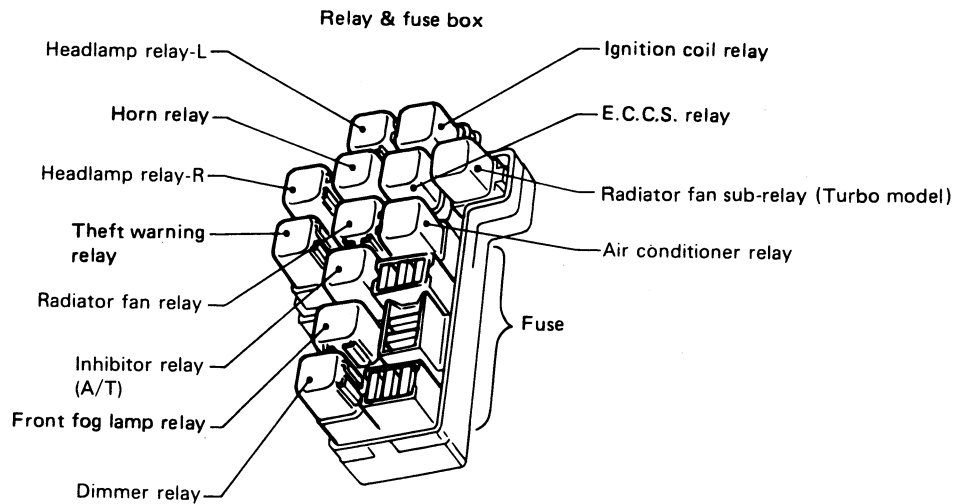
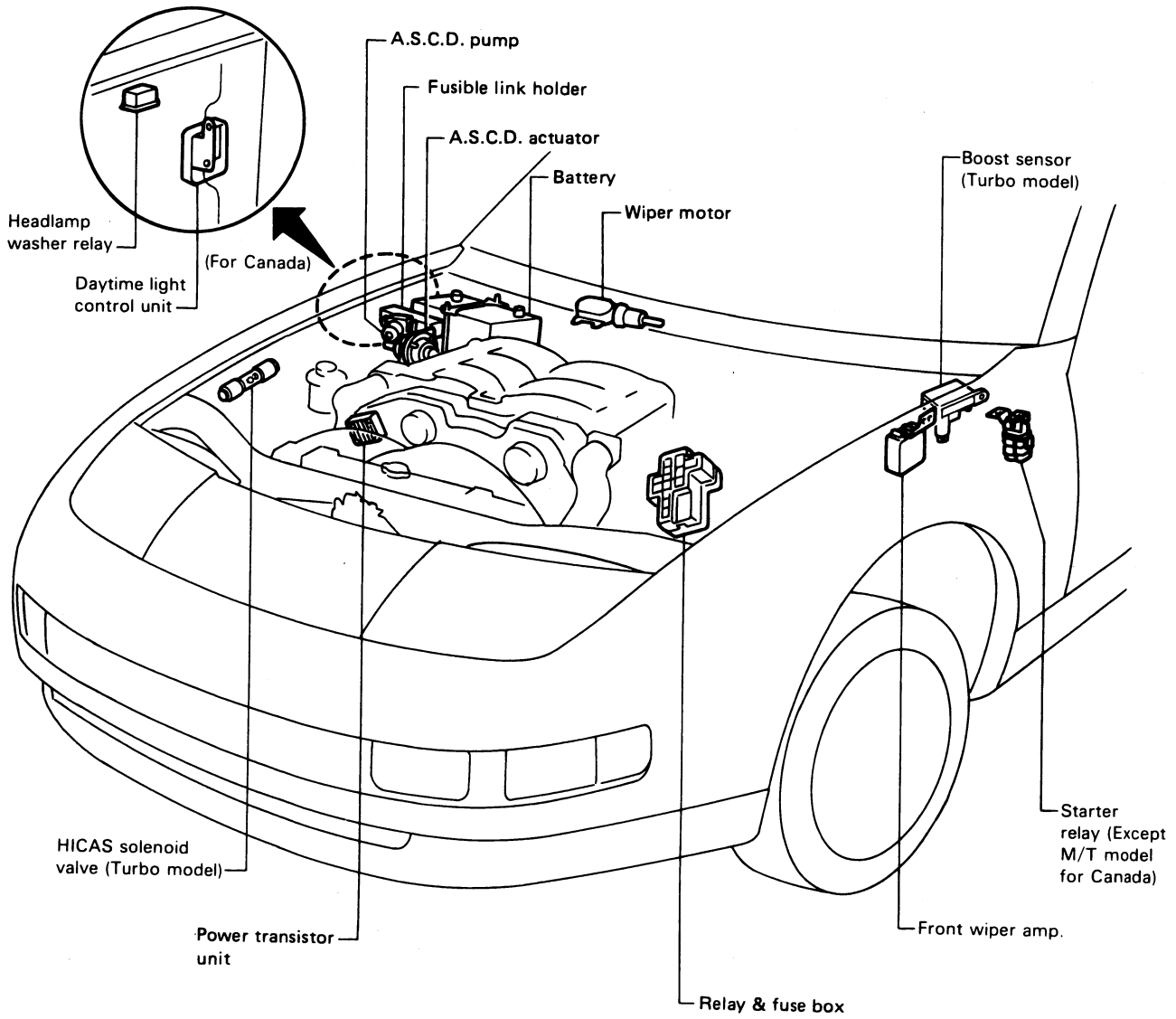

LOCATION OF ELECTRICAL UNITS

Passenger Compartment

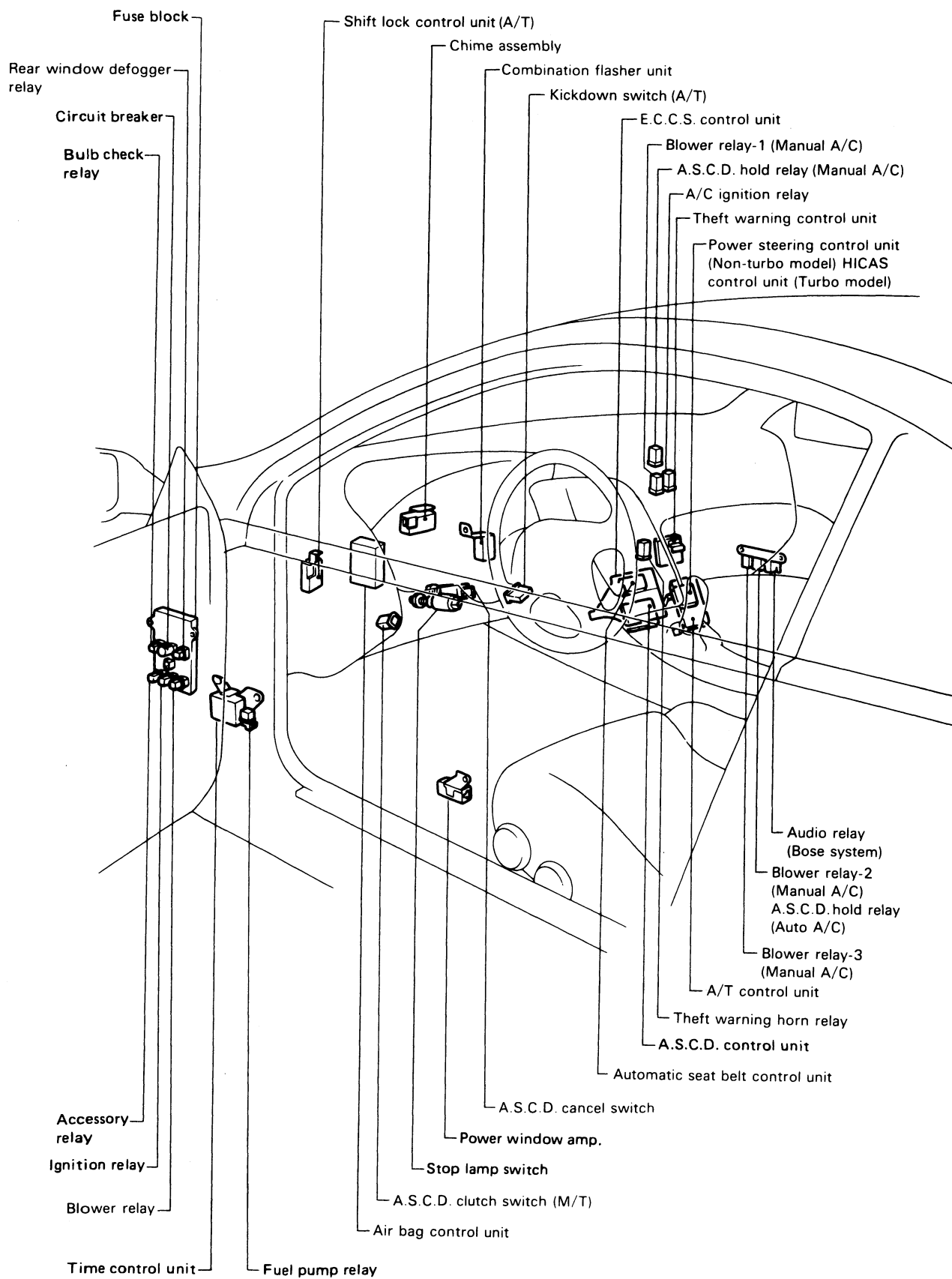

SEL013Q

LOCATION OF ELECTRICAL UNITS

Luggage Compartment

2 SEATER

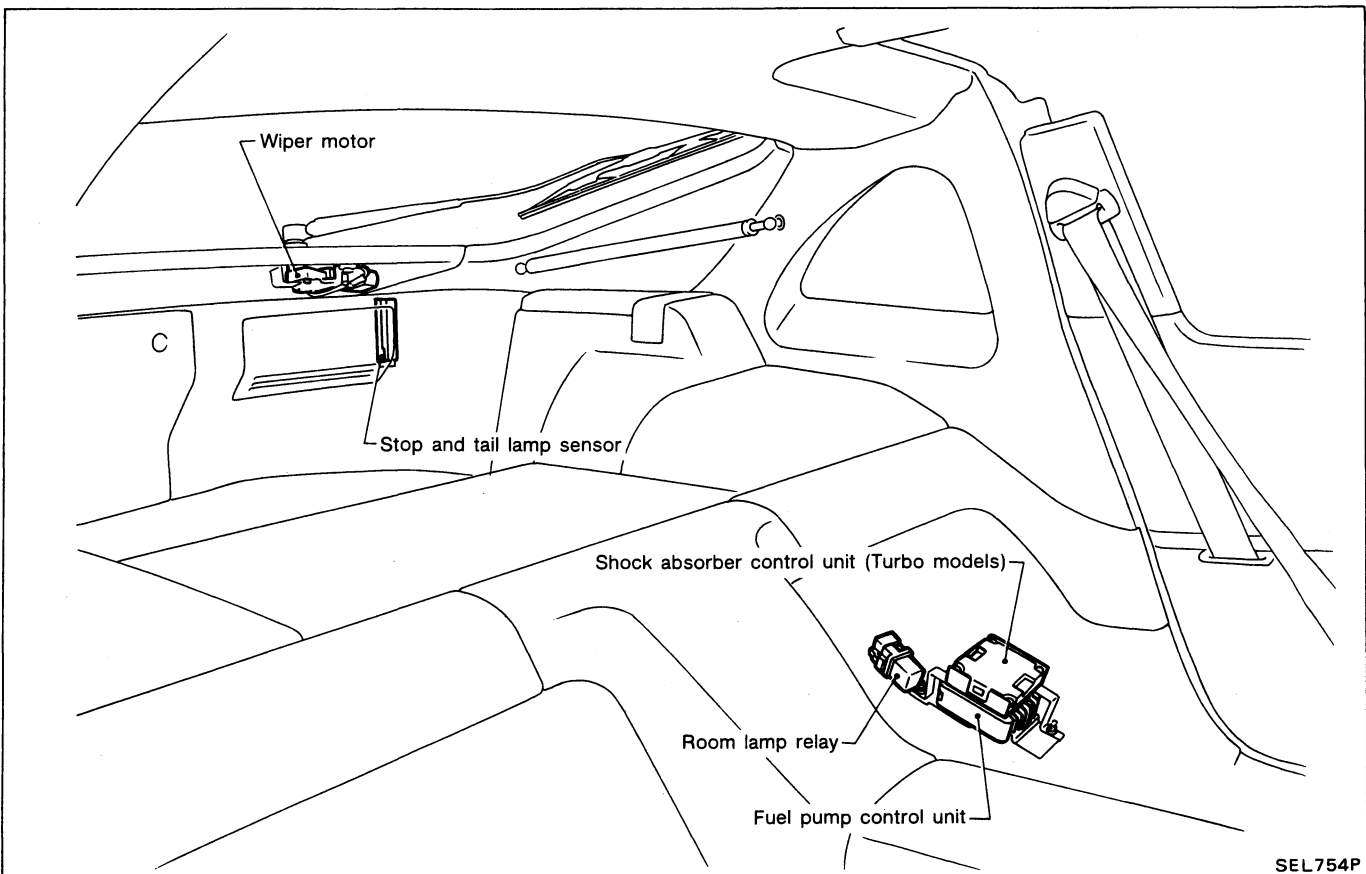
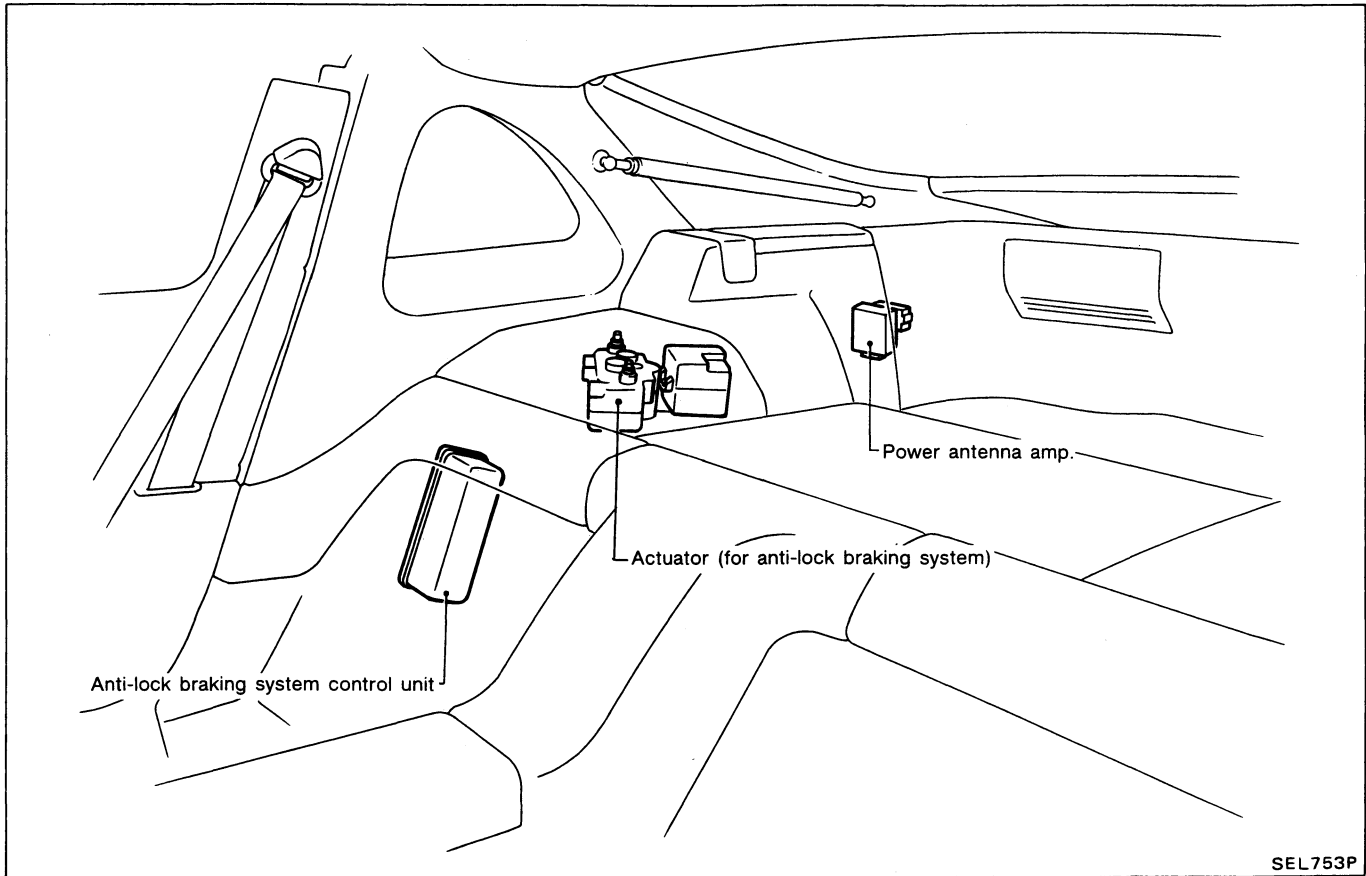

LOCATION OF ELECTRICAL UNITS

Luggage Compartment (Cont'd)

2+2 SEATER

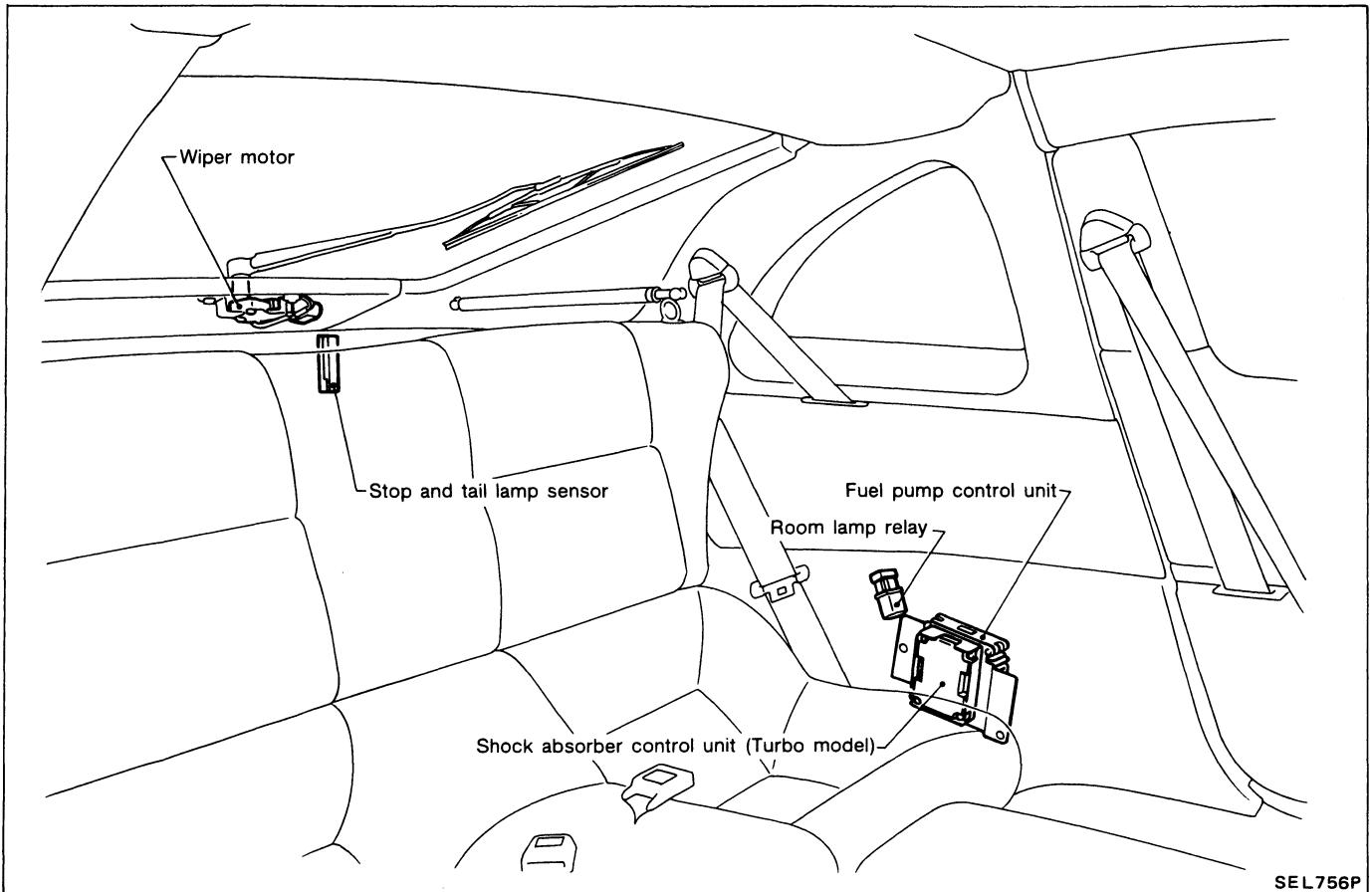
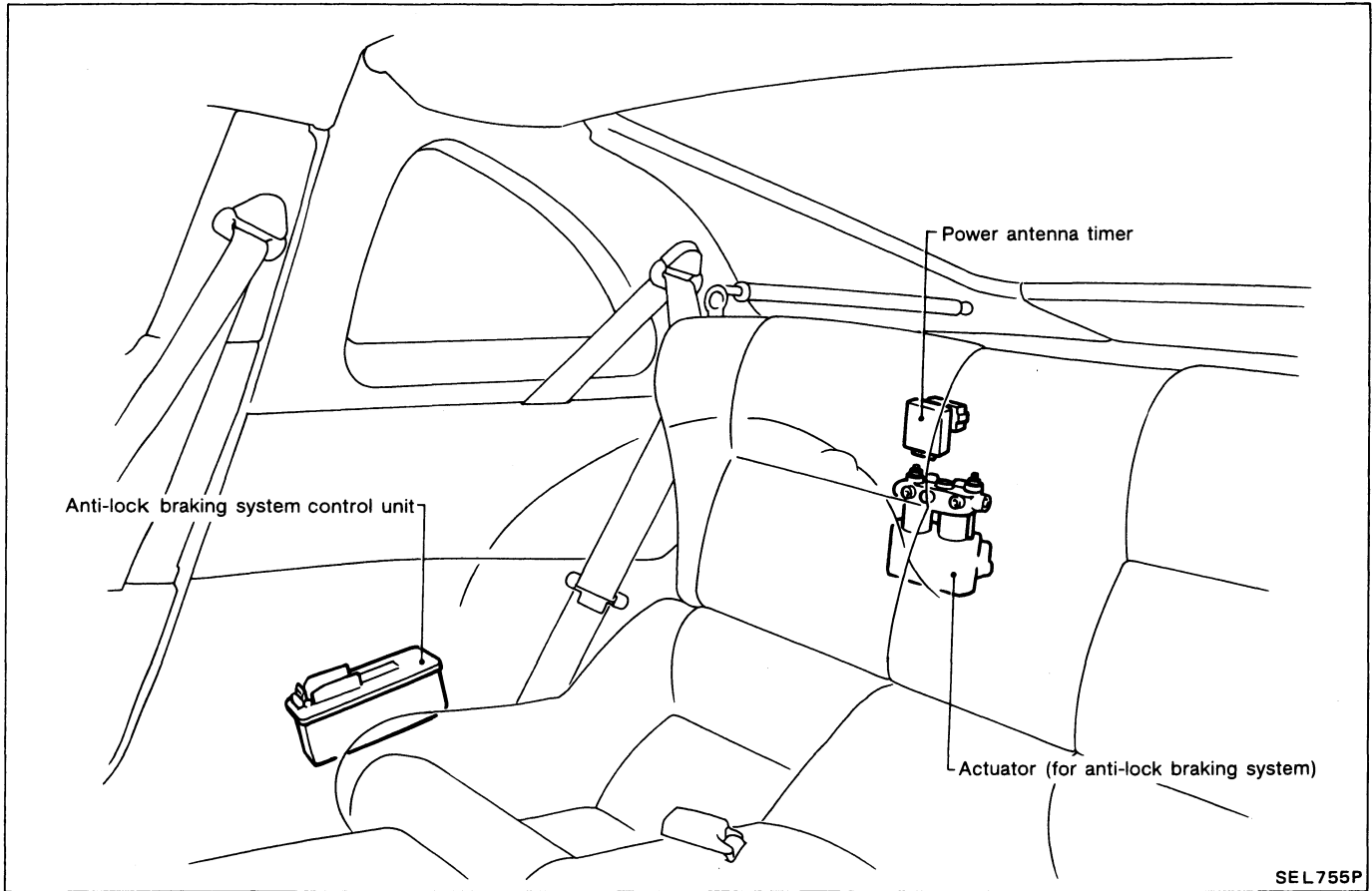

LOCATION OF ELECTRICAL UNITS

NOTE

HARNESS LAYOUT

Outline

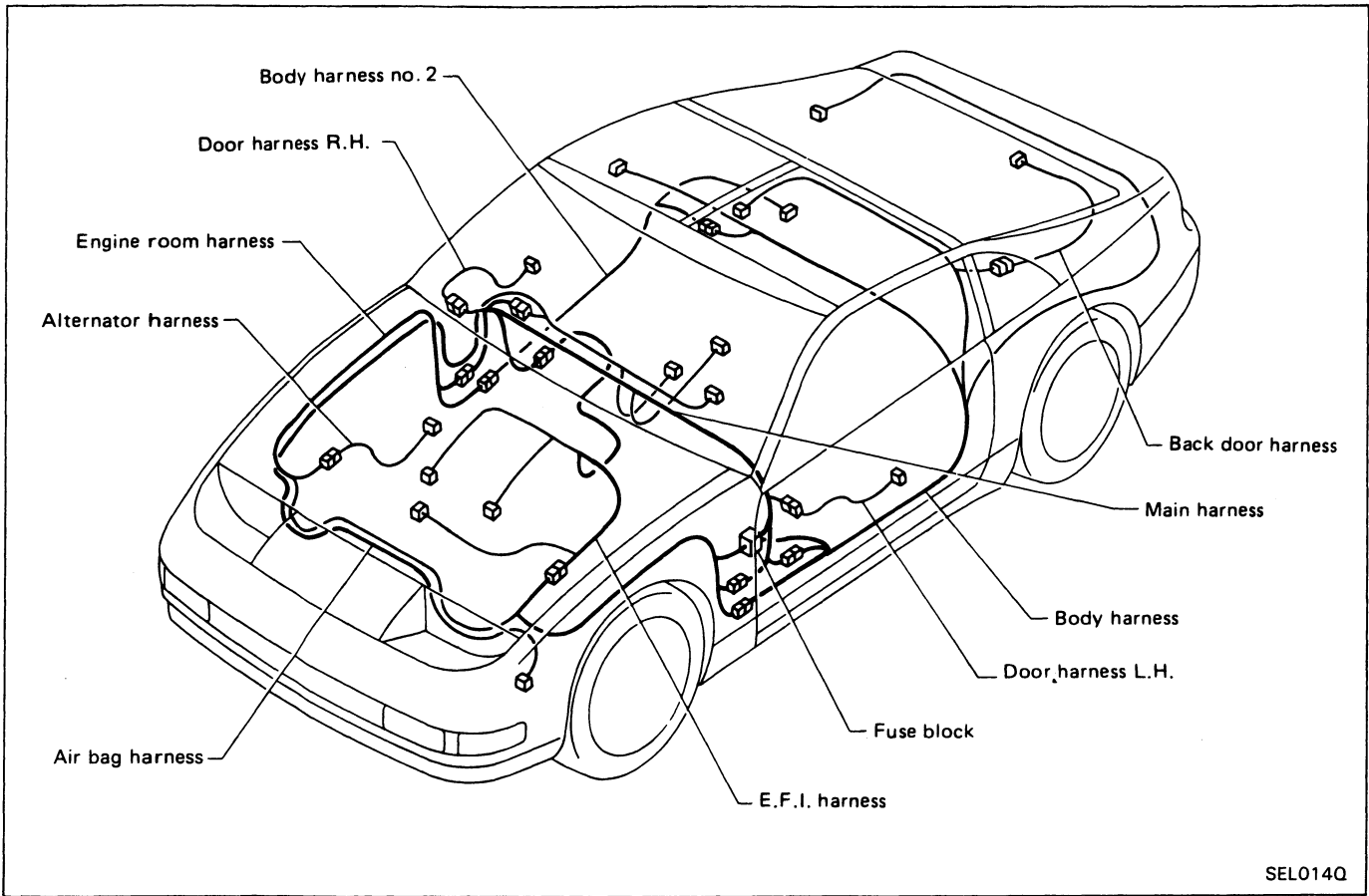

HARNESS LAYOUT

Main Harness

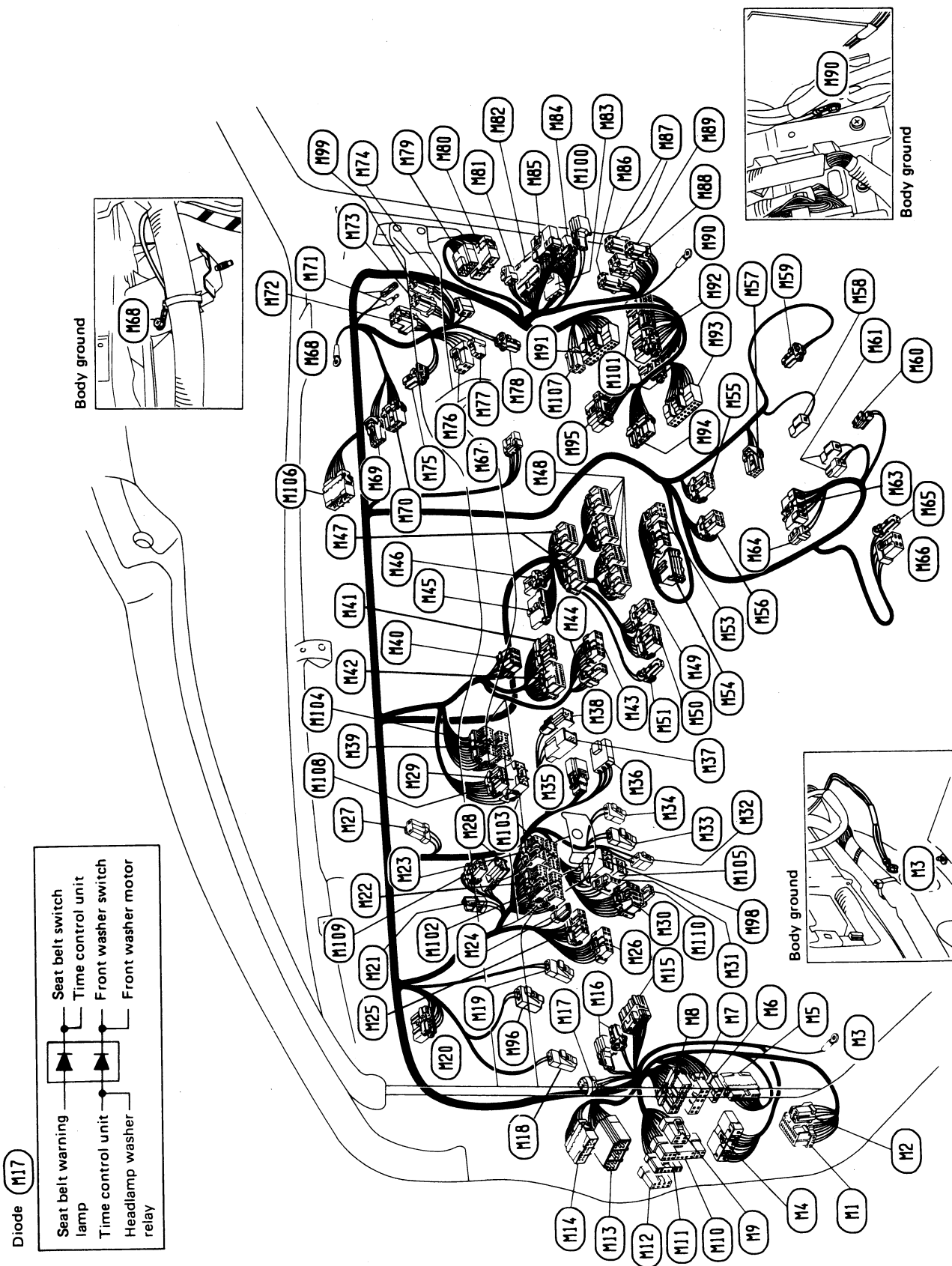

HARNES LAYOUT

Main Harness (Cont'd)

- (R11) : Time control unit
- (R12) : Fuel pump relay
- (R13) : Body ground
- (R14) : To body harness (E2)
- (R15) : To body harness (E3)
- (R16) : To engine room harness (E101)
- (R17) : To engine room harness (E102)
- (R18) : To engine room harness (E103) (Black)
- (R19) : Fuse block
- (R20) : Fuse block
- (R21) : Fuse block
- (R22) : Fuse block
- (R23) : To door harness L.H. (D1)
- (R24) : To door harness L.H. (D2)
- (R25) : Diagnostic connector for CONSULT
- (R26) : Joint connector (Turbo model)
- (R27) : Diode (For Canada)
- (R28) : A.S.C.D. clutch switch (Blue) (M/T model)
- (R29) : Clutch interlock switch (Blue) (M/T model for U.S.A.)
- (R30) : Shift lock control unit (A/T model)
- (R31) : Warning chime
- (R32) : Combination meter (Black)(Without air bag)
- (R33) : Combination meter (White)(Without air bag)
- (R34) : Cluster switch
- (R35) : Cluster switch
- (R36) : Lighting switch-Headlamp washer switch
- (R37) : Combination flasher unit
- (R38) : Warning lamp (A/T model)(Without air bag)
- (R39) : Warning lamp (Without air bag)
- (R40) : Dimmer switch
- (R41) : Steering switch (Non-turbo model without air bag)
- (R42) : Kickdown switch (White) (A/T model)
- (R43) : A.S.C.D. cancel switch (Blue)
- (R44) : Stop lamp switch (Black)
- (R45) : Key lock solenoid (A/T model)
- (R46) : Ignition switch
- (R47) : Key switch
- (R48) : Key hole illumination
- (R49) : Combination meter (Without air bag)
- (R50) : Hazard warning switch
- (R51) : A/C switch unit (Manual A/C model)
- (R52) : A/C switch unit (Auto A/C model)
- (R53) : Front wiper and washer switch
- (R54) : Rear wiper and washer switch
- (R55) : Mode door motor (Manual A/C model)
- (R56) : Mode door motor (Auto A/C model)
- (R57) : A/C control unit (Manual A/C model)
- (R58) : A/C control unit (Auto A/C model)
- (R59) : Air mix actuator (Manual A/C model)
- (R60) : To A/C sub-harness (Auto A/C model)
- (R61) : Foot lamp L.H.
- (R62) : Radio and cassette player
- (R63) : Joint connector (Bose system model)
- (R64) : Shift lock solenoid-Detention switch (A/T model)
- (R65) : Digital clock
- (R66) : O.D. control switch and A/T illumination (A/T model)
- (R67) : Parking brake switch
- (R68) : Seat belt switch R.H.
- (R69) : Ashtray illumination
- (R70) : Cigarette lighter
- (R71) : Door mirror control switch-Shock absorber select switch
- (R72) : Door mirror defogger switch
- (R73) : Seat belt switch L.H. (For Canada)
- (R74) : To seat sub-harness (With power seat)
- (R75) : Thermo control amplifier (Manual A/C model)
- (R76) : Body ground
- (R77) : Intake door motor (Manual A/C model)
- (R78) : Intake door motor (Auto A/C model)
- (R79) : Glove box lamp
- (R80) : A.S.C.D. hold relay (Manual A/C model)
- (R81) : Blower relay-1 (Manual A/C model)
- (R82) : Blower motor
- (R83) : A/C sensor (Auto A/C model)
- (R84) : Heater resistor (Manual A/C model)
- (R85) : Blower control amplifier (Auto A/C model)
- (R86) : Foot lamp R.H.
- (R87) : To door harness R.H. (D01)
- (R88) : To door harness R.H. (D02)
- (R89) : Diode (For Canada)
- (R90) : To engine room harness (E110) (Black)
- (R91) : To engine room harness (E111)
- (R92) : To engine room harness (E112) (Brown)
- (R93) : Diode
- (R94) : Blower relay-3 (Manual A/C model)
- (R95) : Audio relay (Auto A/C model)
- (R96) : Blower relay-2 (Manual A/C model)
- (R97) : A.S.C.D. hold relay (Auto A/C model)
- (R98) : Audio relay (Manual A/C model with Bose system)
- (R99) : Body ground
- (R100) : Theft warning control unit
- (R101) : Power steering control unit (Non-turbo model)
- (R102) : A.S.C.D. control unit
- (R103) : Automatic seat belt control unit (For U.S.A.)
- (R104) : To E.F.I. harness (E2)
- (R105) : Clutch switch (Black) (M/T)
- (R106) : Steering angle sensor-Steering switch (Turbo model without air bag)
- (R107) : A/C ignition relay
- (R108) : To body harness no.2 (E109) (Turbo model)
- (R109) : HICAS control unit (Turbo model)
- (R110) : Combination meter (With air bag)
- (R111) : Combination meter (With air bag)
- (R112) : Combination meter (With air bag)
- (R113) : Steering angle sensor (With air bag)
- (R114) : To air bag harness (A11)
- (R115) : Theft warning horn relay
- (R116) : Warning lamp (With air bag)
- (R117) : Warning lamp (With air bag)
- (R118) : Steering switch (With air bag)

Diode (R81)

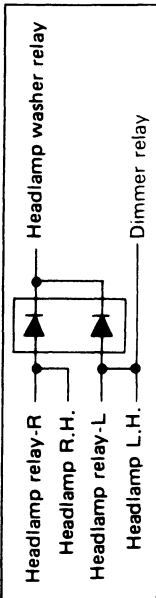

Diode (R85)

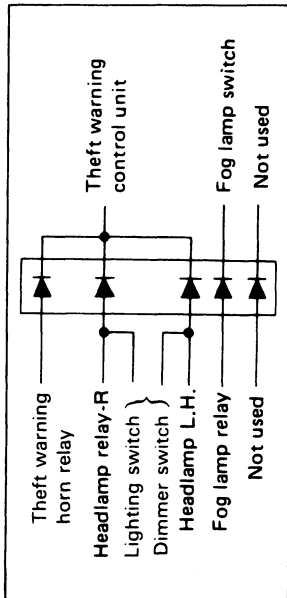

HARNES LAYOUT

Body Harness

2 SEATER

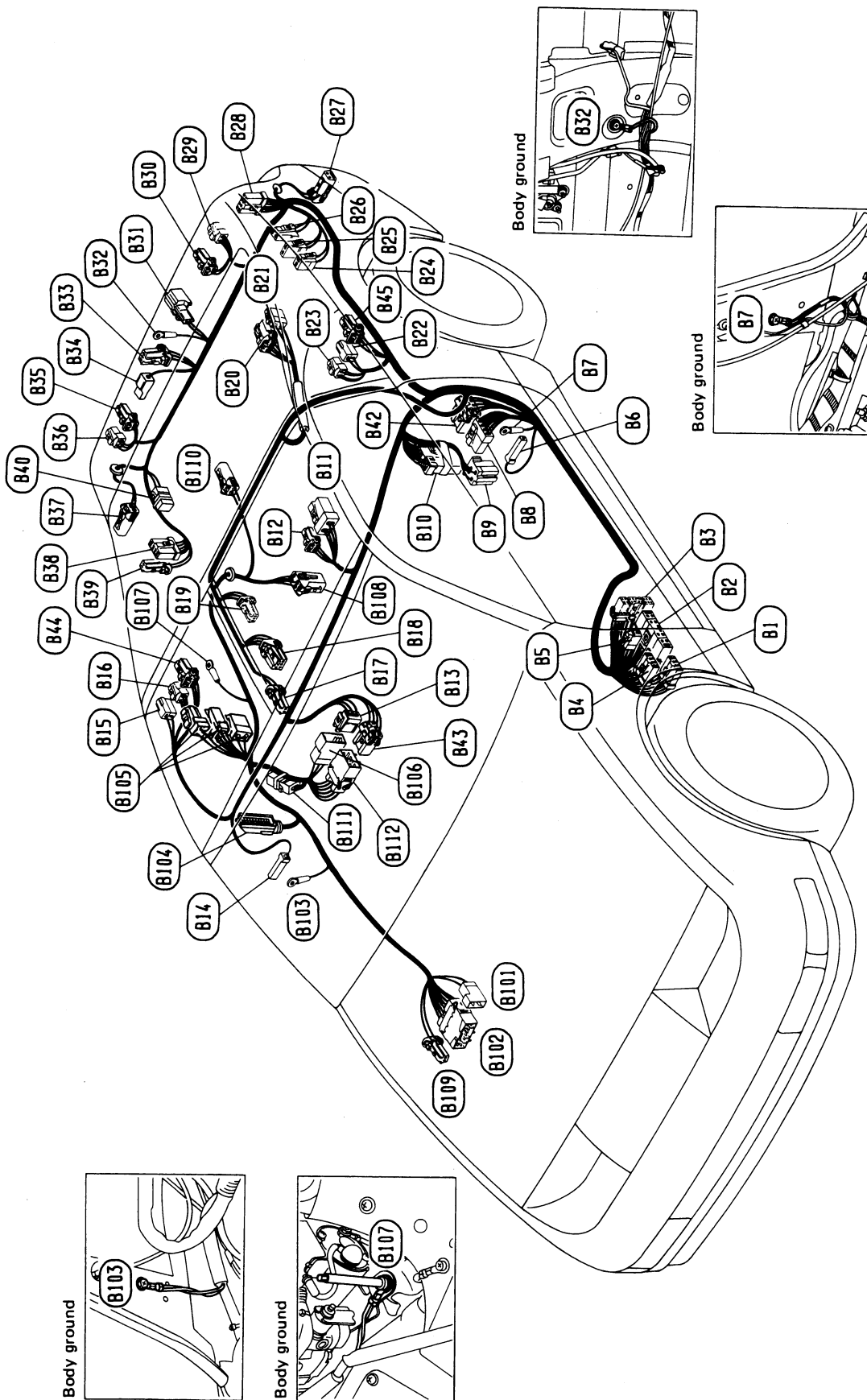

HARNESS LAYOUT

Body Harness (Cont'd)

Body harness

- 81 : To engine room harness (E104)
- 82 : To main harness (H4)
- 83 : To main harness (H5)
- 84 : Fuse block
- 85 : Fuse block
- 86 : Door switch L.H.
- 87 : Body ground
- 88 : Fuel pump control unit
- 89 : Room lamp relay
- 810 : Diode
- 811 : Fuel pump
- 812 : Fuel tank gauge unit
- 813 : To body harness no. 2 (8106)
- 814 : Door switch R.H.
- 815 : Rear speaker R.H. (Except Bose system)
- 816 : Rear speaker R.H. (Bose system)
- 817 : Spot lamp
- 818 : In-vehicle sensor upper Aspirator motor (Auto A/C model)
- 819 : Interior lamp
- 820 : To back door harness (0201)
- 821 : To back door harness (0202)
- 822 : Rear speaker L.H. (Except Bose system)

- 823 : Rear speaker L.H. (Bose system)
- 824 : Front washer motor (White)
- 825 : Rear washer motor (Green)
- 826 : Washer fluid level switch (Black)
- 827 : Rear side marker lamp L.H.
- 828 : Stop and tail lamp sensor
- 829 : Rear combination lamp L.H.
- 830 : Back-up lamp L.H.
- 831 : License lamp
- 832 : Body ground
- 833 : Back door key switch
- 834 : Back door switch
- 835 : Back-up lamp R.H.
- 836 : Rear combination lamp R.H.
- 837 : Rear side marker lamp R.H.
- 838 : Power antenna timer
- 839 : Power antenna motor
- 840 : Diode
- 842 : Shock absorber control unit (Turbo model)
- 843 : To body harness no.2 (8112) (Turbo model)
- 844 : Rear shock absorber actuator R.H. (Turbo model)
- 845 : Rear shock absorber actuator L.H. (Turbo model)

Body harness no. 2

- 8101 : To engine room harness (E108)
- 8102 : To engine room harness (E109)
- 8103 : Body ground
- 8104 : Anti-lock braking system control unit
- 8105 : Actuator (For anti-lock braking system)
- 8106 : To body harness (813)
- 8107 : Body ground
- 8108 : Rear sensor (For anti-lock braking system)
- 8109 : To main harness (8100) (Turbo model)
- 8110 : HICAS fail-safe solenoid valve (Turbo model)
- 8111 : Diode (Turbo model)
- 8112 : To body harness (843) (Turbo model)

Diode (8111)

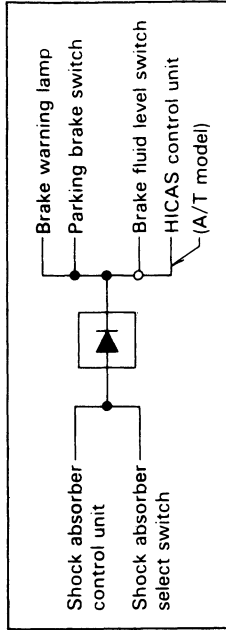

Diode (810) (840)

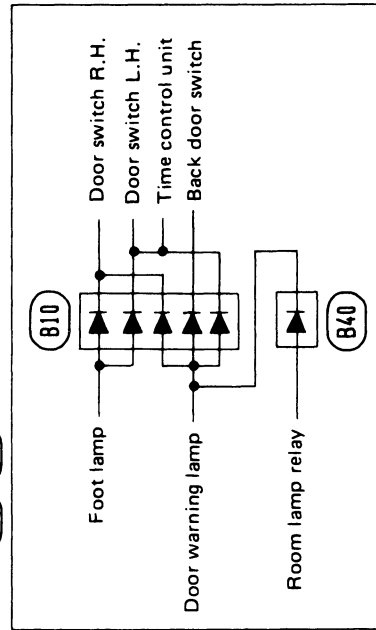

HARNES LAYOUT

Body Harness (Cont'd)

2+2 SEATER

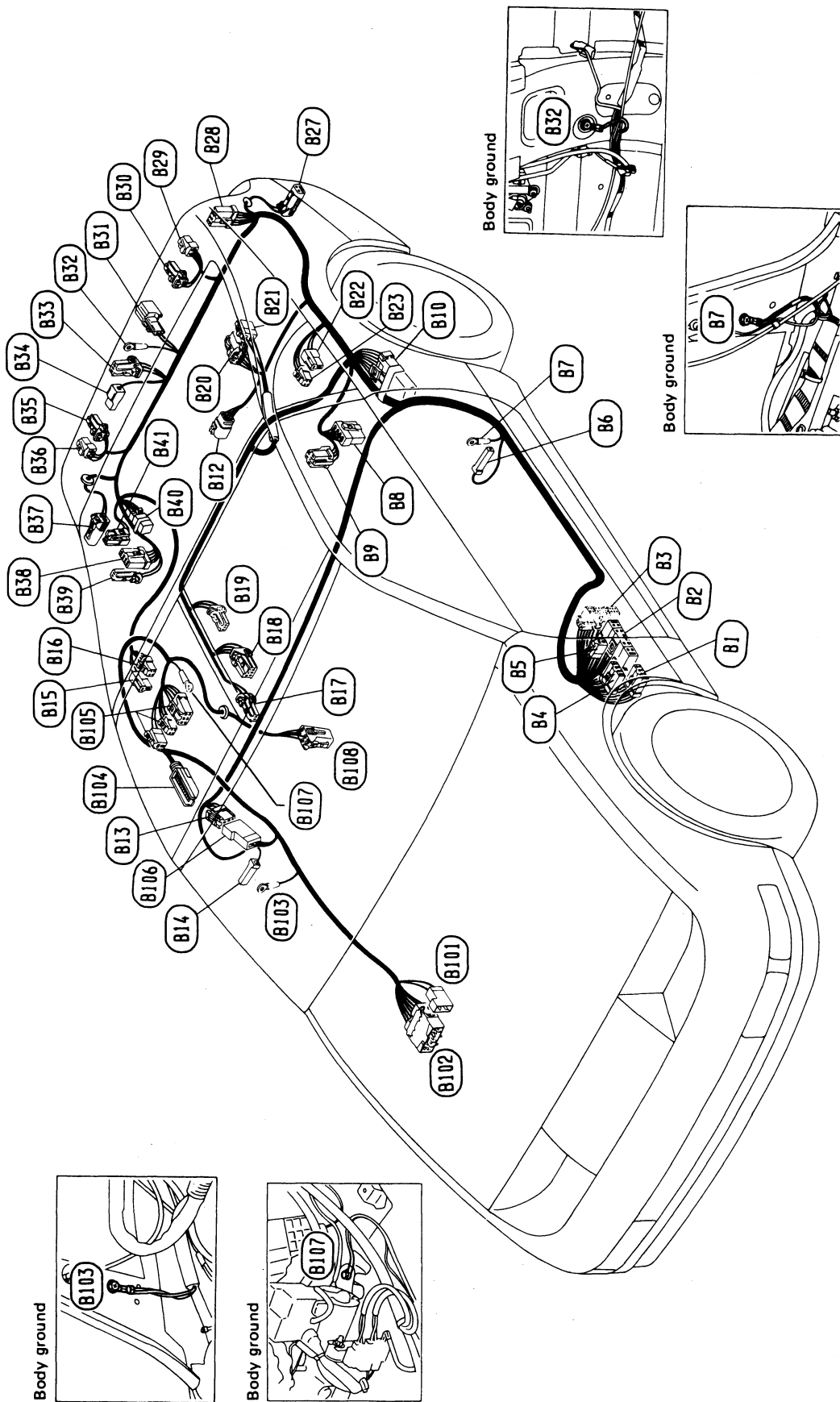

HARNESS LAYOUT

Body Harness (Cont'd)

Body harness

- (81) : To engine room harness (E10)
- (82) : To main harness (74)
- (83) : To main harness (15)
- (84) : Fuse block
- (85) : Fuse block
- (86) : Door switch L.H.
- (87) : Body ground
- (88) : Fuel pump control unit
- (89) : Room lamp relay
- (90) : Diode
- (91) : Fuel tank gauge unit
- (92) : To body harness no. 2 (6106)
- (93) : Door switch R.H.
- (94) : Rear speaker R.H. (Except Bose system)
- (95) : Rear speaker R.H.(Bose system)
- (96) : Spot lamp
- (97) : In-vehicle sensor upper Aspirator motor (Auto A/C model)
- (98) : Interior lamp

- (99) : To back door harness (020)
- (100) : To back door harness (0202)
- (101) : Rear speaker L.H. (Except Bose system)
- (102) : Rear speaker L.H. (Bose system)
- (103) : Rear side marker lamp L.H.
- (104) : Stop and tail lamp sensor
- (105) : Rear combination lamp L.H.
- (106) : Back-up lamp L.H.
- (107) : License lamp
- (108) : Body ground
- (109) : Back door key switch
- (110) : Back door switch
- (111) : Back-up lamp R.H.
- (112) : Rear combination lamp R.H.
- (113) : Rear side marker lamp R.H.
- (114) : Power antenna timer
- (115) : Power antenna motor
- (116) : Diode
- (117) : Luggage room lamp

Body harness no. 2

- (118) : To engine room harness (E106)
- (119) : To engine room harness (E10)
- (120) : Body ground
- (121) : Anti-lock braking system control unit
- (122) : Actuator (For anti-lock braking system)
- (123) : To body harness (813)
- (124) : Body ground
- (125) : Rear sensor (For anti-lock braking system)

Diode (B10) (B40)

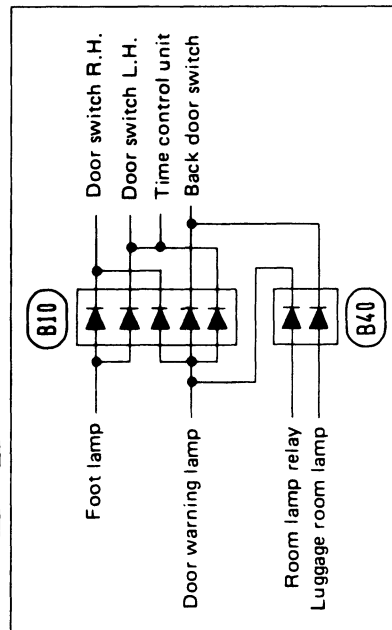

HARNESS LAYOUT

Engine Room Harness

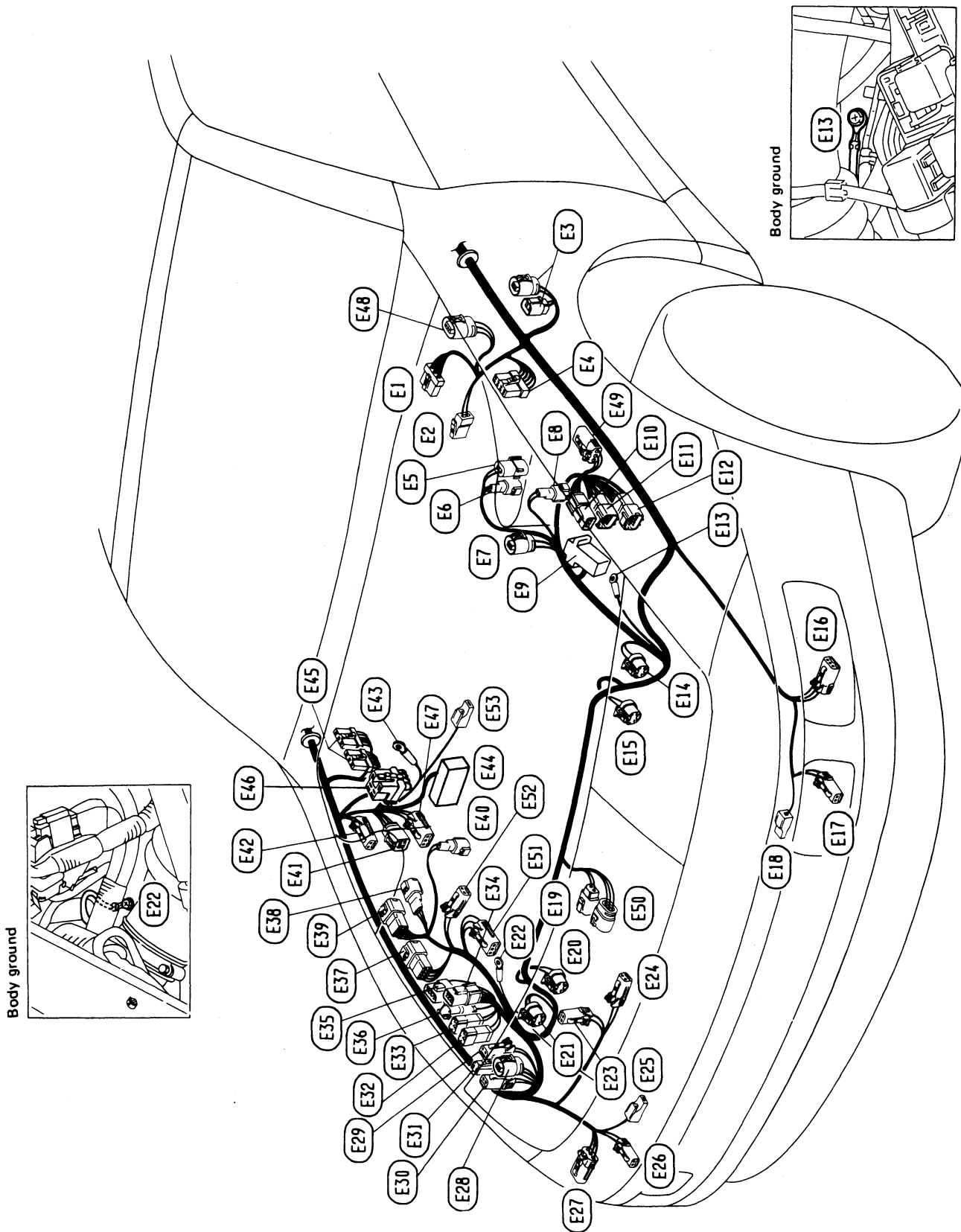

HARNES LAYOUT

Engine Room Harness (Cont'd)

(E1)	: Front wiper motor	(E28)	: Front washer motor (White)
(E2)	: Brake fluid level switch	(E29)	: Rear washer motor (Gray)
(E3)	: Starter relay (Except M/T model for Canada)	(E30)	: Washer fluid level switch (Brown)
(E4)	: Front wiper amplifier	(E31)	: Headlamp washer motor (Black) (For Canada)
(E5)	: Power steering oil pressure switch (Black)	(E32)	: To alternator harness (A1) (Black)
(E6)	: Power steering solenoid (Gray)	(E33)	: To alternator harness (A2) (Blue)
(E7)	: Hood switch	(E34)	: To alternator harness (A3) (A/T model)
(E8)	: Front sensor L.H. (For anti-lock braking system)	(E35)	: To alternator harness (A4) (M/T model)
(E9)	: Relay box (Refer to page EL-)	(E36)	: To alternator harness (A5)
(E10)	: To E.F.I. harness (E23) (White)	(E37)	: Inhibitor switch (A/T model)
(E11)	: To E.F.I. harness (E24) (Gray)	(E38)	: Revolution sensor (A/T model)
(E12)	: To E.F.I. harness (E25) (Brown)	(E39)	: To A/T solenoid harness (A/T model)
(E13)	: Body ground	(E40)	: Front sensor R.H. (For anti-lock braking system)
(E14)	: Headlamp L.H. (Low beam) (Brown)	(E41)	: A.S.C.D. pump
(E15)	: Headlamp L.H. (High beam) (Black)	(E42)	: Dropping resistor (A/T model)
(E16)	: Front combination lamp L.H.	(E43)	: Battery
(E17)	: Front fog lamp L.H.	(E44)	: Fusible link holder
(E18)	: Horn-low	(E45)	: Daytime light control unit (For Canada)
(E19)	: Radiator fan motor (Non-turbo model)	(E46)	: Headlamp washer relay (For Canada)
(E20)	: Headlamp R.H. (High beam) (Black)	(E47)	: Front shock absorber actuator R.H. (Turbo model)
(E21)	: Headlamp R.H. (Low beam) (Brown)	(E48)	: Boost sensor (Turbo model)
(E22)	: Body ground	(E49)	: Front shock absorber actuator L.H. (Turbo model)
(E23)	: Ambient sensor (Auto A/C model)	(E50)	: Radiator fan motor (Turbo model)
(E24)	: Low-pressure switch	(E51)	: HICAS solenoid valve (Turbo model)
(E25)	: Horn-high	(E52)	: HICAS oil level switch (Turbo model)
(E26)	: Front fog lamp R.H.	(E53)	: Theft warning horn
(E27)	: Front combination lamp R.H.		

HARNESS LAYOUT

Engine Room Harness (Cont'd)

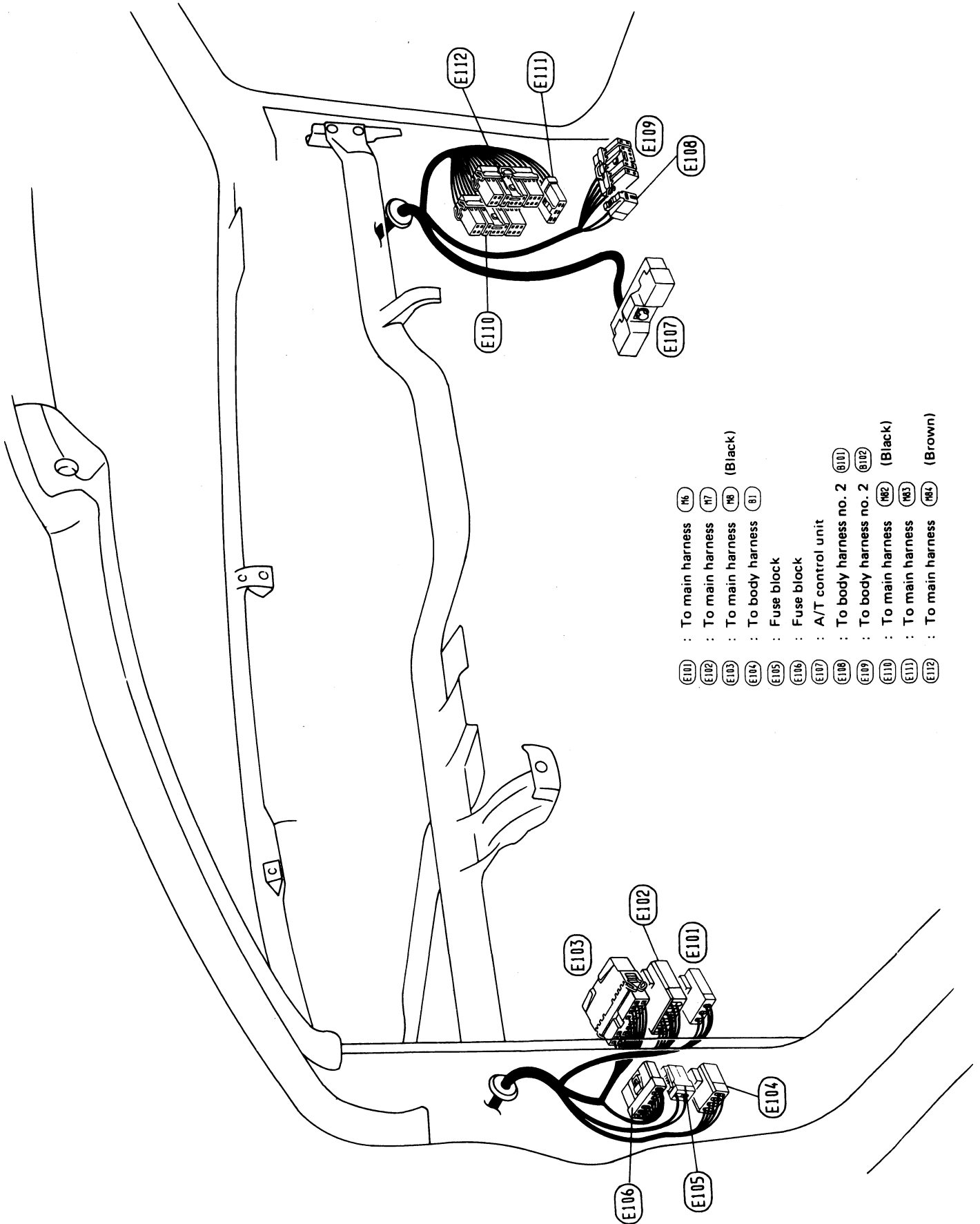

- (E101) : To main harness (M6)
- (E102) : To main harness (M7) (Black)
- (E103) : To main harness (M8) (Black)
- (E104) : To body harness (B1)
- (E105) : Fuse block
- (E106) : Fuse block
- (E107) : A/T control unit
- (E108) : To body harness no. 2 (B101)
- (E109) : To body harness no. 2 (B102)
- (E110) : To main harness (M82) (Black)
- (E111) : To main harness (M83)
- (E112) : To main harness (M84) (Brown)

HARNESS LAYOUT

E.F.I. Harness

- (F30) : Crank angle sensor
- (F31) : Thermal transmitter
- (F32) : Engine temperature sensor
- (F33) : Power transistor unit
- (F34) : Power transistor unit
- (F36) : V.T.C. solenoid valve - R.H.
- (F37) : Exhaust gas sensor - R.H.
- (F38) : A.I.V. control solenoid valve
- (F39) : Engine ground
- (F40) : Injector No. 5
- (F41) : Ignition coil No. 5
- (F42) : Injector No. 3

- (E22) : Compressor
- (E23) : To engine room harness (White)
- (E24) : To engine room harness (Gray)
- (E25) : To engine room harness (Brown)
- (E26) : Check connector
- (E27) : Check connector
- (E28) : Body ground
- (E29) : Air flow meter

- (F1) : E.C.C.S. control unit
- (F2) : To main harness (MS)
- (F3) : Resistor
- (F4) : Exhaust gas temperature sensor (For California)
- (F5) : V.T.C. solenoid valve - L.H.
- (F6) : Exhaust gas sensor - L.H.
- (F7) : Air regulator
- (F8) : To detonation sensor sub-harness
- (F9) : Injector No. 6

- (F10) : Ignition coil No. 6
- (F11) : Engine ground
- (F12) : A.A.C. valve
- (F13) : Injector No. 4
- (F14) : F.I.C.D. solenoid valve
- (F15) : Ignition coil No. 4
- (F16) : P.R.V.R. control solenoid valve
- (F17) : Fuel temperature sensor

- (F18) : Injector No. 2
- (F19) : Ignition coil No. 2
- (F20) : Throttle valve switch
- (F21) : Throttle sensor

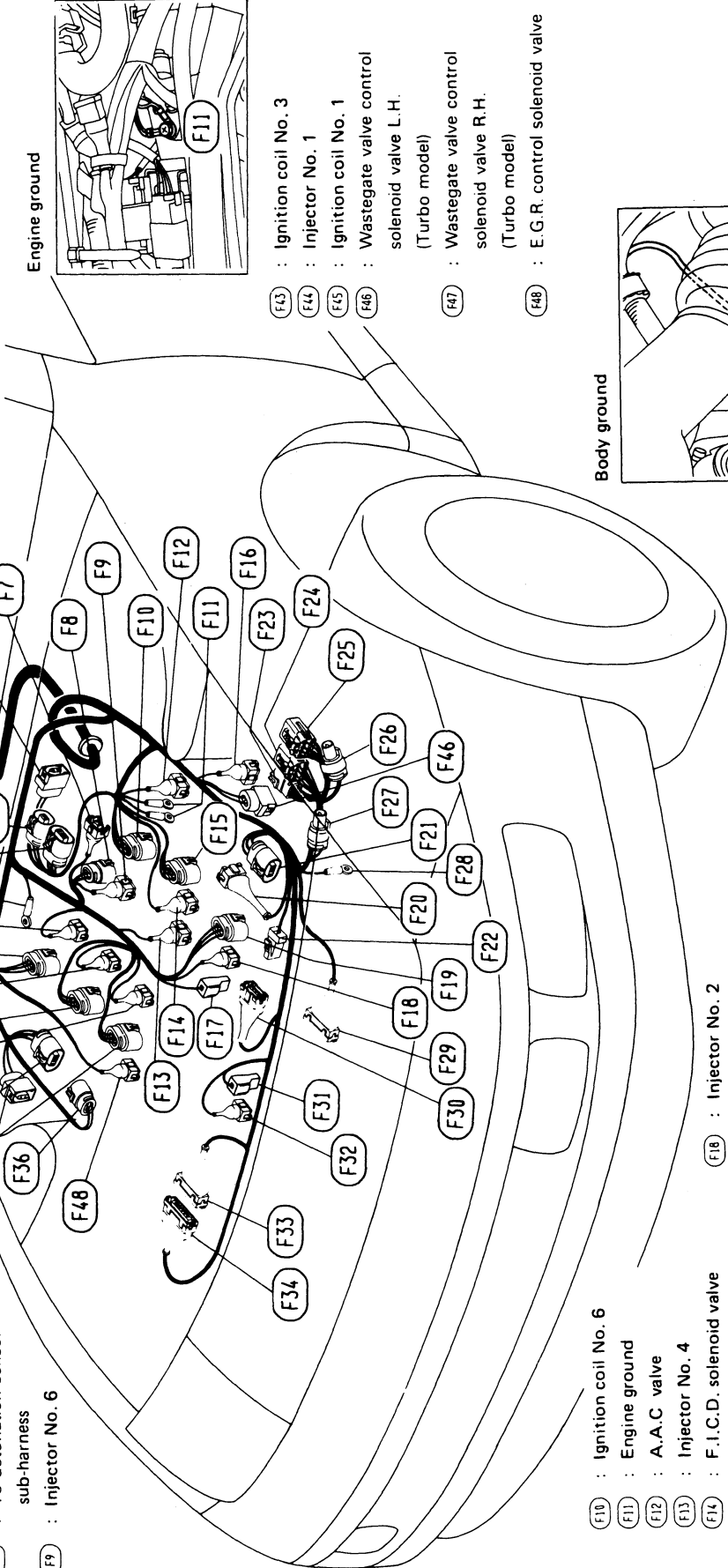

Engine ground



- (F43) : Ignition coil No. 3
- (F44) : Injector No. 1
- (F45) : Ignition coil No. 1
- (F46) : Wastegate valve control solenoid valve L.H. (Turbo model)

- (F47) : Wastegate valve control solenoid valve R.H. (Turbo model)

- (F48) : E.G.R. control solenoid valve

Body ground

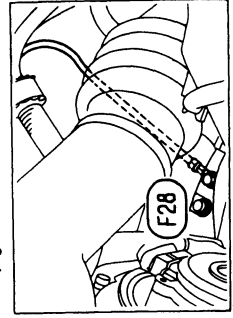

HARNES LAYOUT

Air Bag Harness

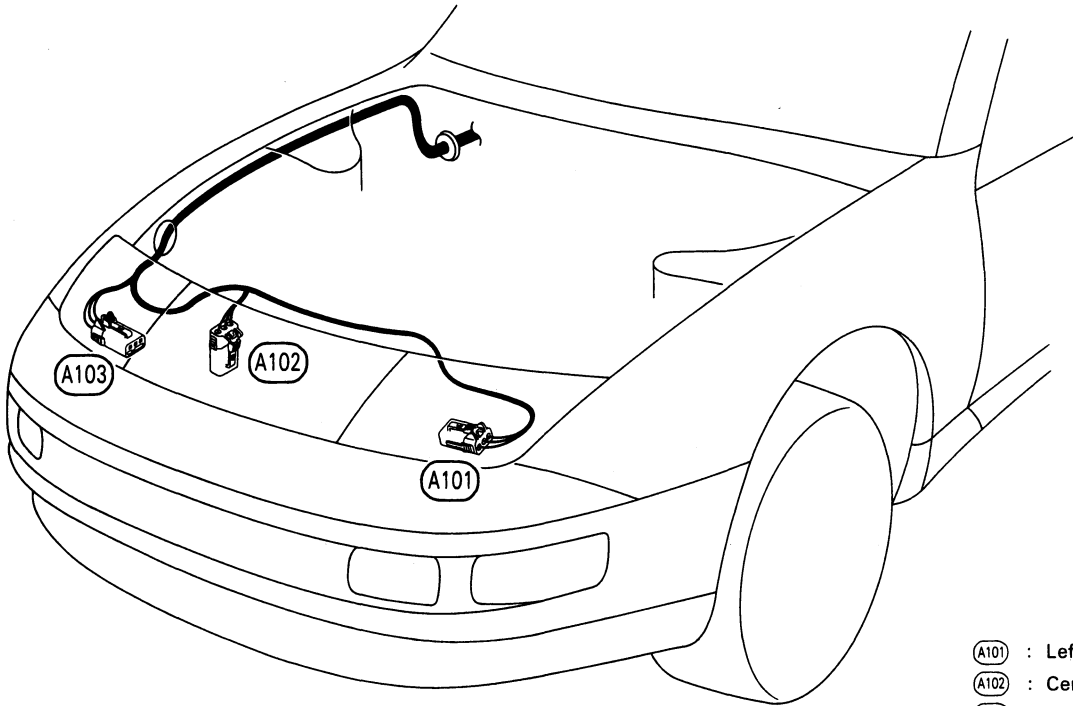

- (A101) : Left crash zone sensor
- (A102) : Center crash zone sensor
- (A103) : Right crash zone sensor
- (A111) : To main harness
- (A112) : Tunnel and safing sensor
- (A113) : Air bag module
- (A114) : Air bag control unit

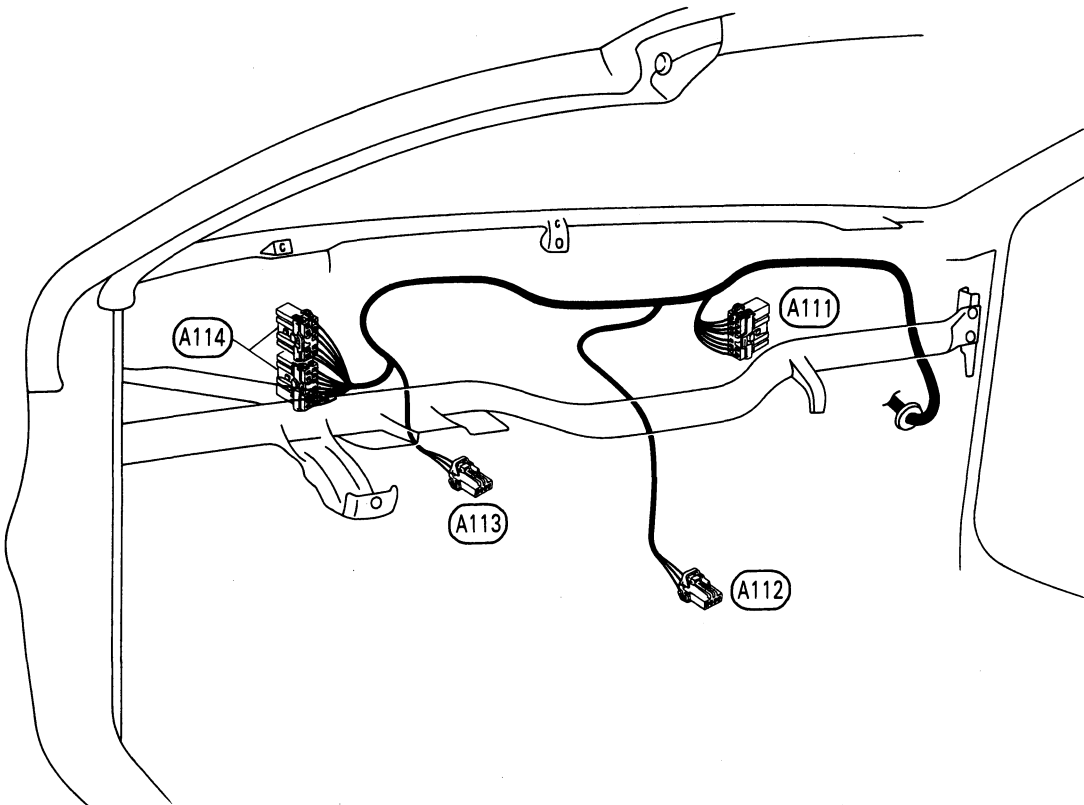

HARNESS LAYOUT

Door Harness L.H.

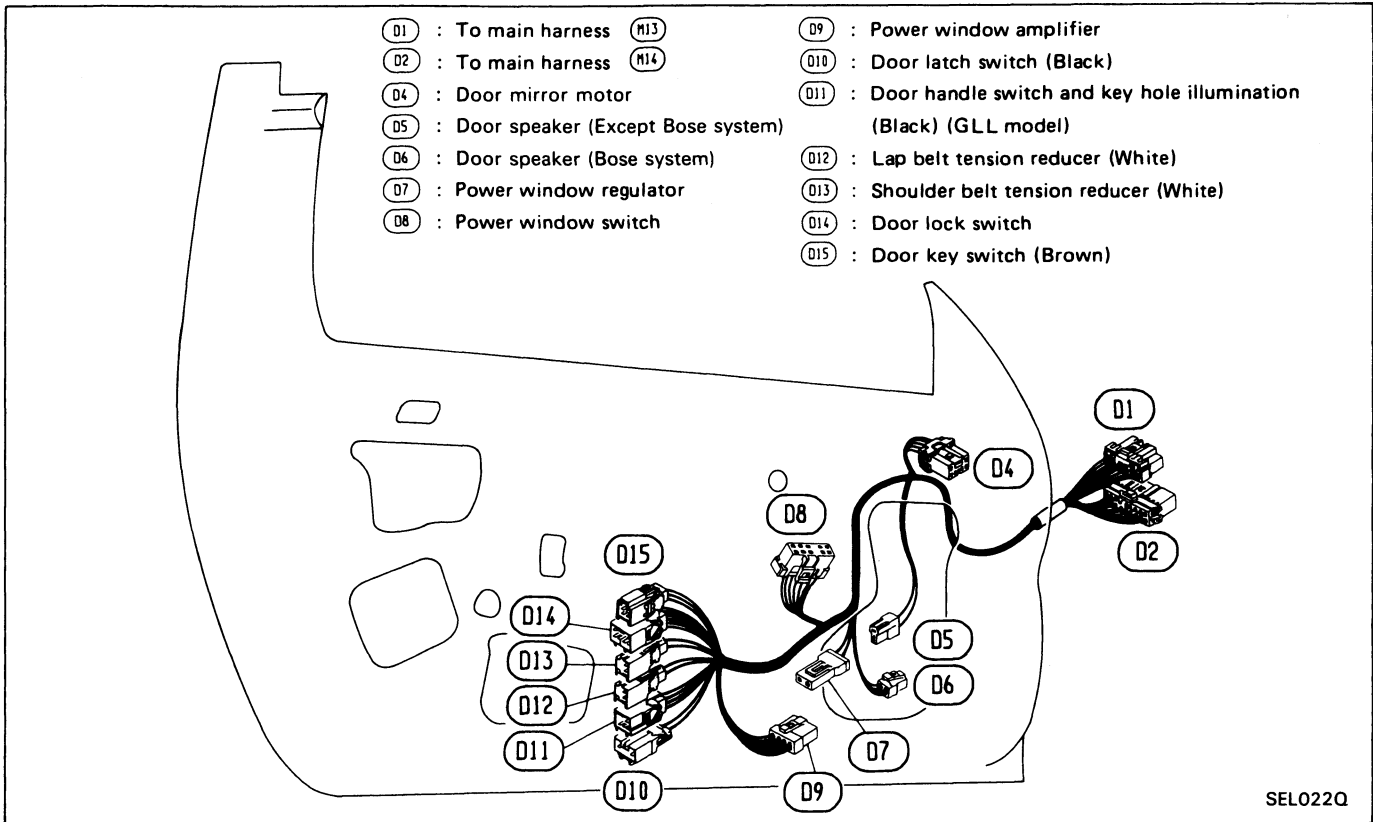

Door Harness R.H.

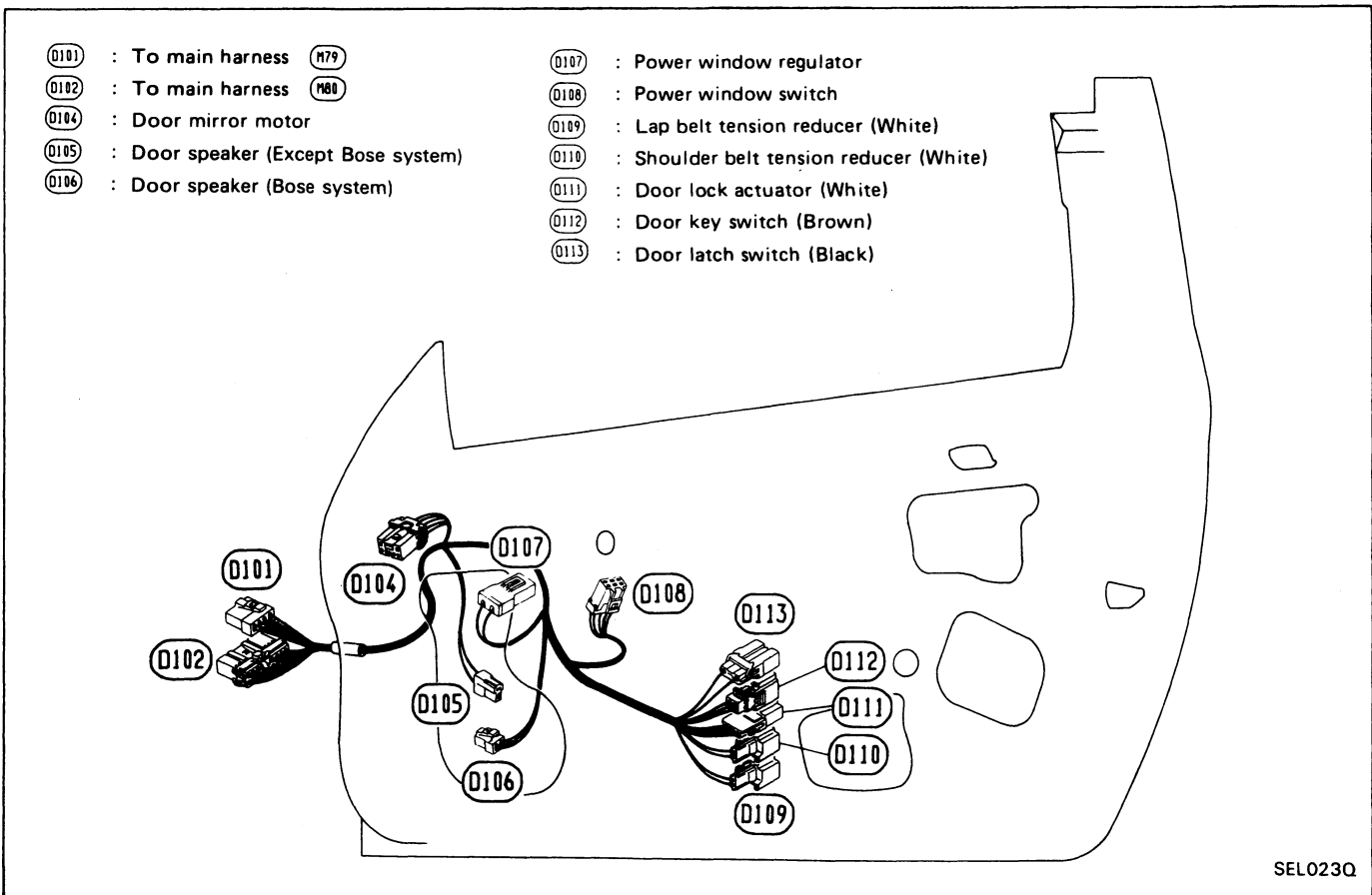

HARNESS LAYOUT

Back Door Harness

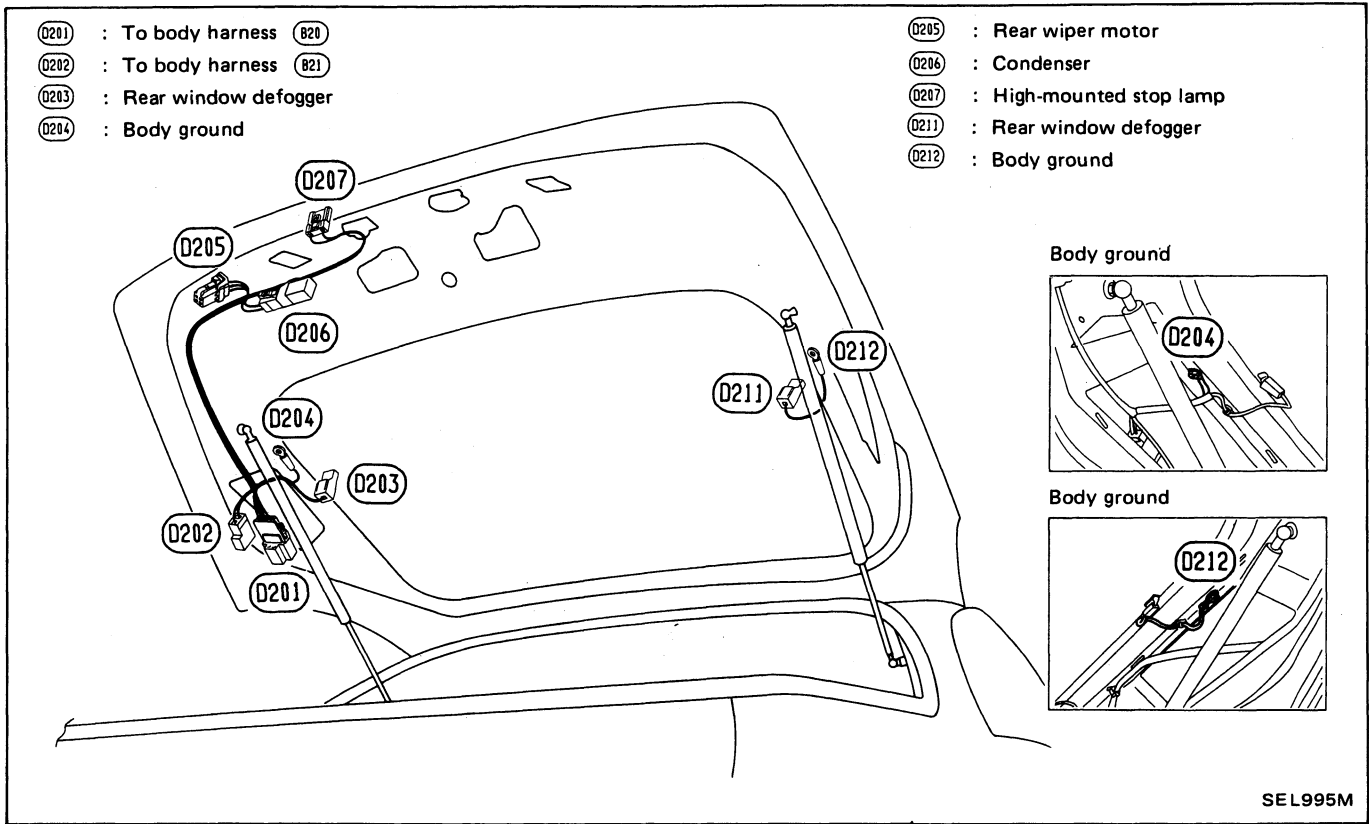

Alternator Harness

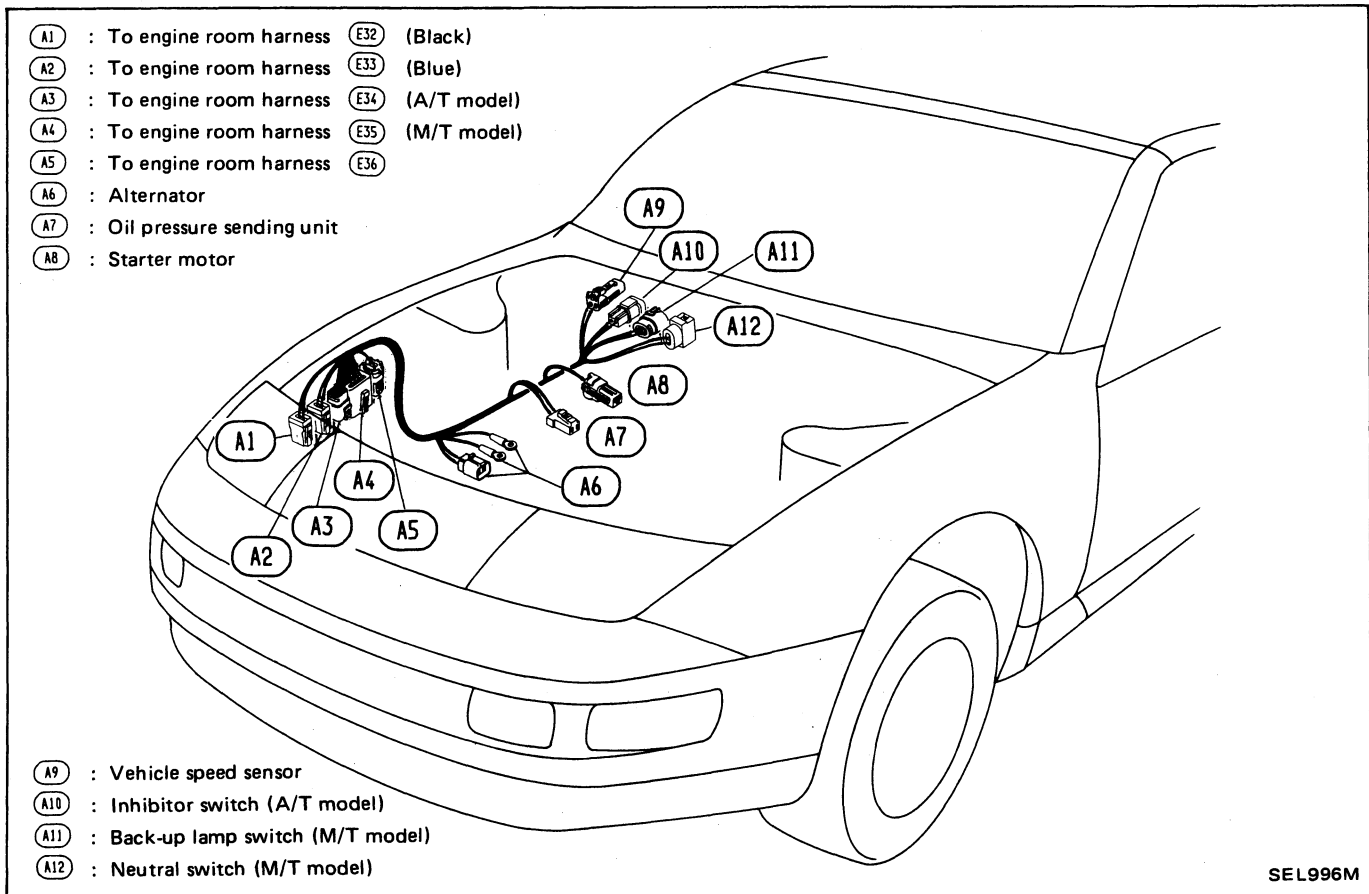

SPECIAL SERVICE TOOLS

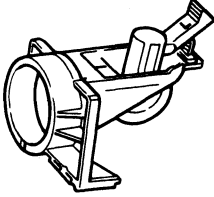
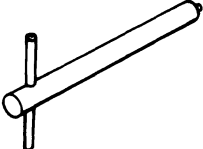
Tool number (Kent-Moore No.) Tool name	Description
26081 30P00 (right) 26086 30P00 (left) Headlamp aimer adapter	 <p data-bbox="1060 283 1344 310">Attaching headlamp aimer</p>
(J36126) Washer nozzle adjusting tool	 <p data-bbox="1060 493 1320 520">Adjusting washer nozzle</p>

QUICK REFERENCE CHART : 300ZX 1991

ENGINE TUNE-UP DATA

Engine model	VG30DE		VG30DETT
Firing order	1-2-3-4-5-6		
Idle speed rpm	M/T	700±50	
	A/T (in "N" position)	770±50	750±50
Ignition timing (degree B.T.D.C. at idle speed)	15±2		
CO% at idle	Idle mixture screw is preset and sealed at factory.		
Drive belt deflection (Cold) mm (in)	Used belt deflection		Deflection of new belt
	Limit	Deflection after adjustment	
Alternator	11.5 (0.453)	7 - 8 (0.28 - 0.31)	6.5 - 7.5 (0.256 - 0.295)
Air conditioner compressor	12.5 (0.492)	8 - 9 (0.31 - 0.35)	7 - 8 (0.28 - 0.31)
Power steering oil pump	19 (0.75)	12 - 13.5 (0.472 - 0.531)	10.5 - 11.5 (0.413 - 0.453)
Applied pressed force N (kg, lb)	98 (10, 22)		
Radiator cap relief pressure kPa (kg/cm ² , psi)	78 - 98 (0.8 - 1.0, 11 - 14)		
Cooling system leakage testing pressure kPa (kg/cm ² , psi)	98 (1.0, 14)		
Compression pressure kPa (kg/cm ² , psi)/rpm	Standard	1,285 (13.1, 186)/300	1,177 (12.0, 171)
	Minimum	981 (10.0, 142)/300	883 (9.0, 128)
Spark plug	Type (Standard)	PFR6B-11	PFR5B-11B
	Gap mm (in)	1.0 - 1.1 (0.039 - 0.043)	

CLUTCH PEDAL

Unit: mm (in)

Engine	VG30DE	VG30DETT
Pedal height	197 - 207 (7.76 - 8.15)	183 - 193 (7.20 - 7.60)
Pedal free play	1 - 3 (0.04 - 0.12)	

FRONT WHEEL ALIGNMENT (Unladen*)

Camber	degree	-1°35' to -0°05'
Caster	degree	9°00' - 10°30'
Toe-in	mm (in)	0 - 2 (0 - 0.08)
	degree	0' - 11' (Total toe-in angle)
Wheel turning angle (Full turn)	degree	
	Inside	32°20' - 36°20'
Outside	26°30' - 30°30'	

*: Fuel, radiator coolant and engine oil full.
Spare tire, jack, hand tools and mats in designated positions.

REAR WHEEL ALIGNMENT (Unladen*)

Camber	degree	-1°36' to -0°36'
	mm (in)	0 - 4 (0 - 0.16)
Toe-in	degree	0' - 23' (Total toe-in angle)

*: Fuel, radiator coolant and engine oil full.
Spare tire, jack, hand tools and mats in designated positions.

BRAKE

Unit: mm (in)

Front brake			
Pad wear limit			2.0 (0.079)
Rotor repair limit	VG30DE engine model		24.0 (0.945)
	VG30DETT engine model		28.0 (1.102)
Rear brake			
Pad wear limit			2.0 (0.079)
Rotor repair limit			16.0 (0.630)
Pedal free height	M/T model		182 - 192 (7.17 - 7.56)
	A/T model		191 - 201 (7.52 - 7.91)
Pedal depressed height*1	M/T model	With A.B.S.	105 (4.13) or more
		Without A.B.S.	95 (3.74) or more
	A/T model	With A.B.S.	110 (4.33) or more
		Without A.B.S.	105 (4.13) or more
Parking brake	Number of notches*2		6 - 7

*1 Under force of 490 N (50 kg, 110 lb) with engine running

*2 At pulling force: 196 N (20 kg, 44 lb)

REFILL CAPACITIES

	Unit	Liter	US measure	
Fuel tank		72	19 gal	
Coolant		10	10-5/8 qt	
Engine	With oil filter	3.4	3-5/8 qt	
	Without oil filter	3.0	3-1/8 qt	
Transmission	M/T	2.8	5-7/8 pt	
	A/T	Non-turbo	8.3	8-3/4 qt
		Turbo	8.2	8-5/8 qt
	Differential carrier	Non-turbo	1.5	3-1/8 pt
Turbo		2.1	4-1/2 pt	
Power steering system	Without SUPER HICAS	1.3	1-3/8 qt	
	With SUPER HICAS	2.0	2-1/8 qt	
Air conditioning system	Compressor oil	0.20	6.8 fl oz	
	Refrigerant	0.75 - 0.85 kg	1.65 - 1.87 lb	



NISSAN MOTOR CO., LTD.

Overseas Service Department
Tokyo, Japan

Edition: August 1990
Printing: August 1990 (04)
Publication No. SM1E-0Z32U0
Printed in Japan