

SECTION **FAX**  
FRONT AXLE

A  
B  
C

FAX

CONTENTS

E

<b>PREPARATION</b> .....	2	WHEEL BEARING INSPECTION .....	4	F
Special Service Tools (SST) .....	2	Removal and Installation .....	4	
Commercial Service Tools .....	2	REMOVAL .....	4	
<b>NOISE, VIBRATION AND HARSHNESS (NVH)</b>		INSPECTION AFTER REMOVAL .....	5	G
<b>TROUBLESHOOTING</b> .....	3	INSTALLATION .....	6	
NVH Troubleshooting Chart .....	3	<b>SERVICE DATA</b> .....	7	
<b>FRONT WHEEL HUB AND KNUCKLE</b> .....	4	Wheel Bearing .....	7	H
On-Vehicle Inspection and Service .....	4	BALL JOINT .....	7	

I  
J  
K  
L  
M

# PREPARATION

## PREPARATION

PFP:00002

### Special Service Tools (SST)

ADS00031

The actual shapes of Kent-Moore tools may differ from those of special service tools illustrated here.

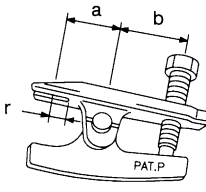
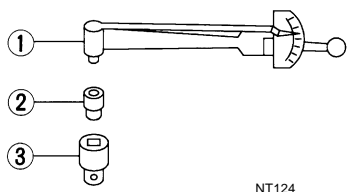
Tool number (Kent-Moore No.) Tool name	Description
HT72520000 (J25730-A) Ball joint remover a: 33 mm (1.30 in) b: 50 mm (1.97 in) r: 11.5 mm (0.453 in)	 <p style="text-align: center;">NT546</p> Removing steering outer socket
ST3127S000 (See J25742-1) Preload gauge 1. GG91030000 Torque wrench (J25765) 2. HT62940000 ( — ) Socket adapter (1/2") 3. HT62900000 ( — ) Socket adapter (3/8")	 <p style="text-align: center;">NT124</p> Measuring rotating torque of ball joint

### Commercial Service Tools

ADS00032

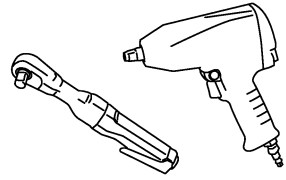
Tool name	Description
Power tool	 <p style="text-align: center;">PBIC0190E</p> <ul style="list-style-type: none"> <li>● Removing wheel nuts</li> <li>● Removing undercover</li> <li>● Removing brake caliper assembly</li> </ul>

# NOISE, VIBRATION AND HARSHNESS (NVH) TROUBLESHOOTING

## NOISE, VIBRATION AND HARSHNESS (NVH) TROUBLESHOOTING

PFP:00003

### NVH Troubleshooting Chart

ADS00033

Use chart below to help you find the cause of the symptom. If necessary, repair or replace these parts.

Reference page			FAX-4	—	FAX-4	NVH in WT section.	NVH in WT section.	NVH in PS section.
Possible cause and SUSPECTED PARTS			Improper installation, looseness	Parts interference	Wheel bearing damage	TIRES	ROAD WHEEL	STEERING
Symptom	FRONT AXLE	Noise	x	x		x	x	x
		Shake	x	x		x	x	x
		Vibration	x	x		x		x
		Shimmy	x	x		x	x	x
		Judder	x			x	x	x
		Poor quality ride or handling	x	x	x	x	x	

x: Applicable

A  
B  
C  
FAX  
E  
F  
G  
H  
I  
J  
K  
L  
M

# FRONT WHEEL HUB AND KNUCKLE

## FRONT WHEEL HUB AND KNUCKLE

PFP:40202

### On-Vehicle Inspection and Service

ADS00034

Make sure the mounting conditions (looseness, back lash) of each component and component status (wear, damage) are normal.

### WHEEL BEARING INSPECTION

- Move wheel hub in the axial direction by hand. Make sure there is no looseness of wheel bearing.

**Standard value**

**Axial end play : 0.05 mm (0.002 in) or less**

- Rotate wheel hub and make sure there is no unusual noise or other irregular conditions. If there are any irregular conditions, replace wheel hub and bearing assembly.

### Removal and Installation

ADS00035

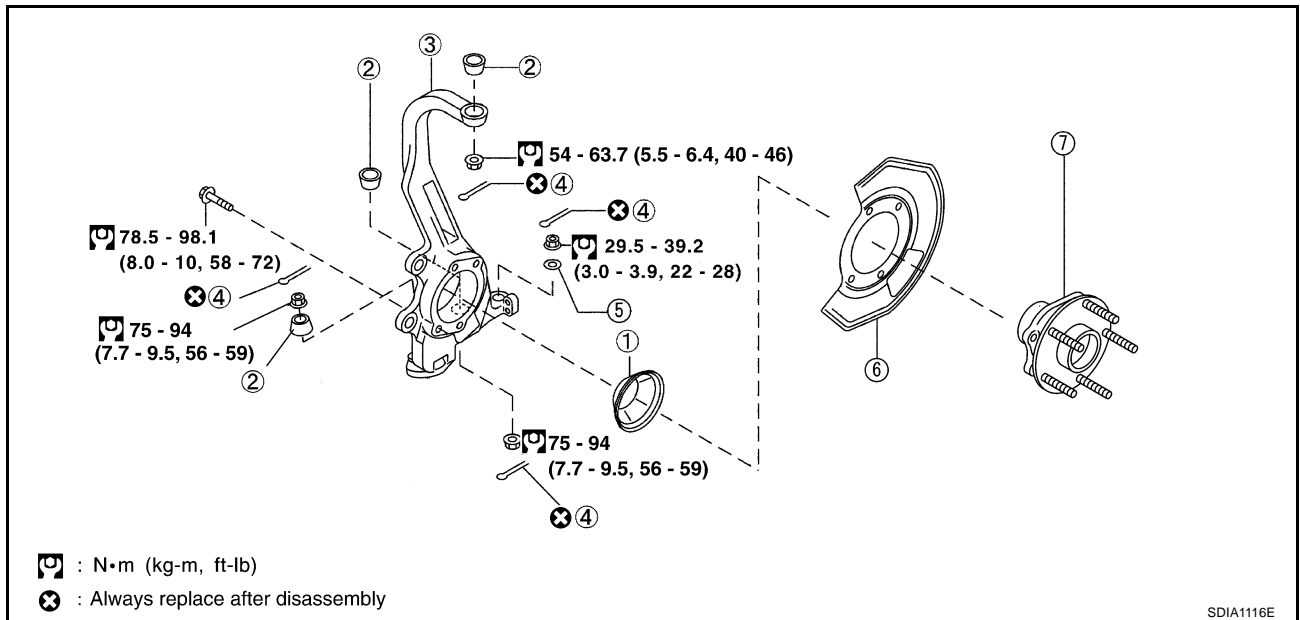

- |                                   |              |                     |
|-----------------------------------|--------------|---------------------|
| 1. Hub cap                        | 2. Ball seat | 3. Steering knuckle |
| 4. Cotter pin                     | 5. Washer    | 6. Splash guard     |
| 7. Wheel hub and bearing assembly |              |                     |

### REMOVAL

1. Remove tire from vehicle with power tool.
2. Remove undercover with power tool.
3. Remove brake caliper with power tool. Hang it in a place where it will not interfere with work. Refer to [BR-25, "FRONT DISC BRAKE \(CLZ25VD TYPE\)"](#), [BR-31, "FRONT DISC BRAKE \(OPB27VA TYPE\)"](#).

#### NOTE:

Avoid depressing brake pedal while brake caliper is removed.

4. Remove disc rotor.
5. Remove wheel sensor from steering knuckle. Refer to [BRC-83, "WHEEL SENSORS"](#) (with TCS), [BRC-143, "WHEEL SENSORS"](#) (with VDC).

#### CAUTION:

**Do not pull on wheel sensor harness.**

6. Remove brake hose bracket from steering knuckle. Refer to [BR-11, "BRAKE PIPING AND HOSE"](#).
7. Remove cotter pin at steering outer socket, then loosen mounting nut.

# FRONT WHEEL HUB AND KNUCKLE

8. Use a ball joint remover (SST) to remove steering outer socket from steering knuckle. Be careful not to damage ball joint boot.

**CAUTION:**

**Tighten temporarily mounting nut to prevent damage to threads and to prevent ball joint remover (SST) from coming off.**

9. After removing upper link, transverse link, compression rod and cotter pin at steering knuckle, loosen mounting nut.
10. Use a ball joint remover (suitable tool) to remove upper link, transverse link and compression rod from steering knuckle. Be careful not to damage ball joint boot.

**CAUTION:**

**Tighten temporarily mounting nut to prevent damage to threads and to prevent ball joint remover (suitable tool) from coming off.**

11. Remove steering knuckle and wheel hub and bearing assembly fixing bolt.
12. Remove wheel hub and bearing assembly from steering knuckle.

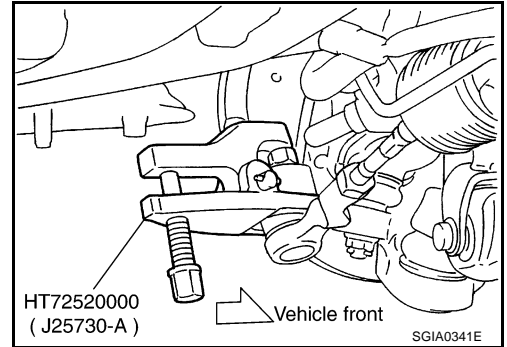

## INSPECTION AFTER REMOVAL

- About the inspection for upper link, compression rod, steering outer socket, refer to [FSU-14, "UPPER LINK"](#) , [FSU-16, "COMPRESSION ROD"](#) , [PS-17, "POWER STEERING GEAR AND LINKAGE"](#) .

## Visual Inspection

- Check steering knuckle and ball seat for deformation, cracks, and other damage. Replace steering knuckle and ball seat if cracks, deformation or other damage is found.
- Check ball joint boot for deformation, damage, and also for grease leakage. Replace steering knuckle assembly if cracks, deformation or also for grease leakage is found.

## Steering Knuckle Ball Joint Inspection

- Manually move ball stud to confirm it moves smoothly with no binding.

## Swing Torque Inspection

**CAUTION:**

**Before measurement, move ball joint at least ten times by hand to check for smooth movement.**

- Hook spring scale at cotter pin mounting hole. Confirm spring scale measurement value is within specifications when ball stud begins moving.

**Standard value**

**Swing force:**

**0.147 - 1.4 N·m (0.02 - 0.14 kg·m, 2 - 12 in·lb)**

**Measurement force:**

**2.23 - 21.2 N (0.22 - 2.16 kg, 0.50 - 4.77 lb)**

- If the value is outside the standard, replace steering knuckle.

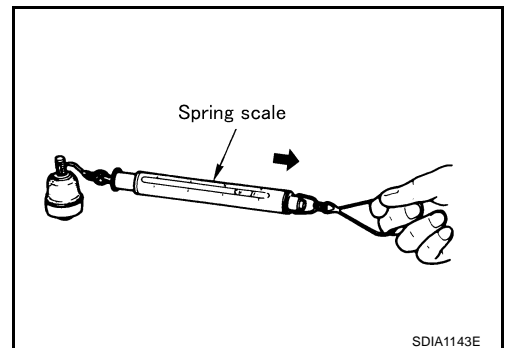

## Rotating Torque Inspection

- Attach mounting nut to ball stud. Check that rotating torque is within specifications with a preload gauge (SST).

**Standard value**

**Rotating torque:**

**0.147 - 1.4 N·m (0.02 - 0.14 kg·m, 2 - 12 in·lb)**

- If the value is outside the standard, replace steering knuckle.

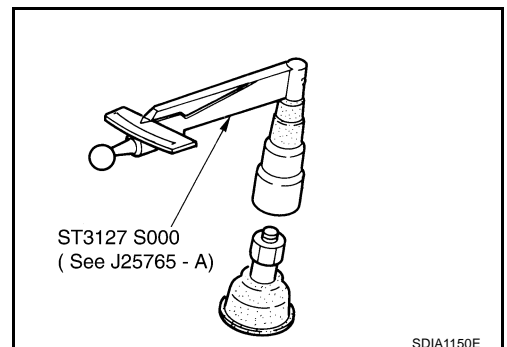

# FRONT WHEEL HUB AND KNUCKLE

## Axial End Play Inspection

- Move tip of ball joint in axial direction to check for looseness.

**Standard value**

**Axial end play : 0 mm (0 in)**

- If the value is outside the standard, replace steering knuckle.

## INSTALLATION

- Refer to [FAX-4, "Removal and Installation"](#) for tightening torque. Install in the reverse order of removal.

### NOTE:

Refer to component parts location and do not reuse non-reusable parts.

- Wheel hub and bearing assembly and disc must be installed to fit the marked position each other.

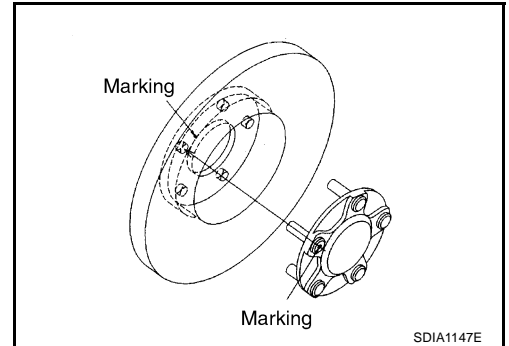

# SERVICE DATA

## SERVICE DATA

PFP:00030

### Wheel Bearing

ADS00036

Axial end play limit	0.05 mm (0.002 in) or less
----------------------	----------------------------

### BALL JOINT

Swing force	0.147 - 1.4 N·m (0.02 - 0.14 kg-m, 2 - 12 in-lb)
Measurement on spring balance (Spring scale hooking position: cotter pin mounting hole)	2.23 - 21.2 N (0.22 - 2.16 kg, 0.50 - 4.77 lb)
Rotating torque	0.147 - 1.4 N·m (0.02 - 0.14 kg-m, 2 - 12 in-lb)
Axial end play limit	0 mm (0 in)

A

B

C

FAX

E

F

G

H

I

J

K

L

M

**SERVICE DATA**

---