

A  
B  
CL  
D  
E  
F  
G  
H  
I  
J  
K  
L  
M

# SECTION **CL** CLUTCH

## CONTENTS

<p><b>PRECAUTIONS</b> ..... 2</p> <p style="padding-left: 20px;">Precautions for Battery Service ..... 2</p> <p style="padding-left: 20px;">Caution ..... 2</p> <p><b>PREPARATION</b> ..... 3</p> <p style="padding-left: 20px;">Special Service Tools ..... 3</p> <p style="padding-left: 20px;">Commercial Service Tools ..... 3</p> <p><b>NOISE, VIBRATION AND HARSHNESS (NVH)</b></p> <p><b>TROUBLESHOOTING</b> ..... 4</p> <p style="padding-left: 20px;">NVH Troubleshooting Chart ..... 4</p> <p><b>CLUTCH PEDAL</b> ..... 5</p> <p style="padding-left: 20px;">On-Vehicle Inspection and Adjustment ..... 5</p> <p style="padding-left: 20px;">Removal and Installation ..... 6</p> <p style="padding-left: 40px;">REMOVAL ..... 6</p> <p style="padding-left: 40px;">INSPECTION AFTER REMOVAL ..... 6</p> <p style="padding-left: 40px;">INSTALLATION ..... 6</p> <p><b>CLUTCH FLUID</b> ..... 7</p> <p style="padding-left: 20px;">Bleeding ..... 7</p> <p><b>CLUTCH MASTER CYLINDER</b> ..... 8</p> <p style="padding-left: 20px;">Removal and Installation ..... 8</p> <p style="padding-left: 40px;">REMOVAL ..... 8</p> <p style="padding-left: 40px;">INSTALLATION ..... 9</p> <p style="padding-left: 20px;">Disassembly and Assembly ..... 9</p> <p style="padding-left: 40px;">DISASSEMBLY ..... 9</p> <p style="padding-left: 40px;">INSPECTION AFTER DISASSEMBLY ..... 10</p> <p style="padding-left: 40px;">ASSEMBLY ..... 10</p> <p><b>OPERATING CYLINDER</b> ..... 11</p> <p style="padding-left: 20px;">Removal and Installation ..... 11</p> <p style="padding-left: 40px;">REMOVAL ..... 11</p>	<p style="padding-left: 20px;">INSTALLATION ..... 11</p> <p style="padding-left: 20px;">Disassembly and Assembly ..... 11</p> <p style="padding-left: 40px;">DISASSEMBLY ..... 11</p> <p style="padding-left: 40px;">INSPECTION AFTER DISASSEMBLY ..... 11</p> <p style="padding-left: 40px;">ASSEMBLY ..... 11</p> <p><b>CLUTCH PIPING</b> ..... 12</p> <p style="padding-left: 20px;">Removal and Installation ..... 12</p> <p><b>CLUTCH RELEASE MECHANISM</b> ..... 13</p> <p style="padding-left: 20px;">Removal and Installation ..... 13</p> <p style="padding-left: 40px;">REMOVAL ..... 13</p> <p style="padding-left: 40px;">INSPECTION AFTER REMOVAL ..... 13</p> <p style="padding-left: 40px;">INSTALLATION ..... 14</p> <p><b>CLUTCH DISC, CLUTCH COVER</b> ..... 15</p> <p style="padding-left: 20px;">Removal and Installation (M/T Model Code Number: CD008) ..... 15</p> <p style="padding-left: 40px;">REMOVAL ..... 15</p> <p style="padding-left: 40px;">INSPECTION AND ADJUSTMENT AFTER REMOVAL ..... 15</p> <p style="padding-left: 40px;">INSTALLATION ..... 16</p> <p style="padding-left: 20px;">Removal and Installation (M/T Model Code Number: CD009) ..... 17</p> <p style="padding-left: 40px;">REMOVAL ..... 17</p> <p style="padding-left: 40px;">INSPECTION AND ADJUSTMENT AFTER REMOVAL ..... 17</p> <p style="padding-left: 40px;">INSTALLATION ..... 18</p> <p><b>SERVICE DATA AND SPECIFICATIONS (SDS)</b> ..... 19</p> <p style="padding-left: 20px;">Clutch Control System ..... 19</p> <p style="padding-left: 20px;">Clutch Master Cylinder ..... 19</p> <p style="padding-left: 20px;">Clutch Operating Cylinder ..... 19</p> <p style="padding-left: 20px;">Clutch Disc ..... 19</p> <p style="padding-left: 20px;">Clutch Cover ..... 19</p> <p style="padding-left: 20px;">Clutch Pedal ..... 19</p>
---	---

# PRECAUTIONS

## PRECAUTIONS

PFP:00001

### Precautions for Battery Service

ACS006FW

Before disconnecting the battery, lower both the driver and passenger windows. This will prevent any interference between the window edge and the vehicle when the door is opened/closed. During normal operation, the window slightly raises and lowers automatically to prevent any window to vehicle interference. The automatic window function will not work with the battery disconnected.

### Caution

ACS004MV

- Recommended fluid is brake fluid "DOT 3". Refer to [MA-12. "RECOMMENDED FLUIDS AND LUBRICANTS"](#).
- Never reuse drained brake fluid.
- Be careful not to splash brake fluid on painted areas.
- When removing and installing clutch piping, use Tool.
- Use new brake fluid to clean or wash all parts of master cylinder and operating cylinder.
- Never use mineral oils such as gasoline or kerosene. It will ruin the rubber parts of the hydraulic system.

### **WARNING:**

After cleaning clutch disc, wipe it with a dust collector. Do not use compressed air.

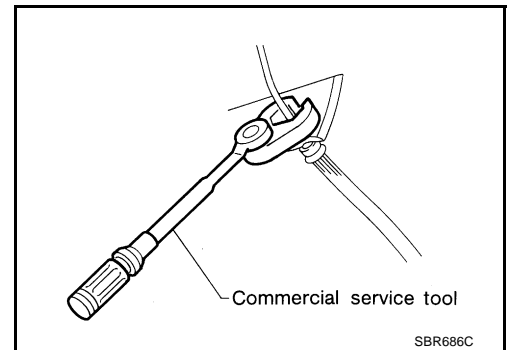

# PREPARATION

## PREPARATION

PPF:00002

### Special Service Tools

ACS004MW

The actual shapes of Kent-Moore tool may differ from those of special service tools illustrated here.

Tool number (Kent-Moore No.) Tool name	Description
KV30101400 ( — ) Drift a: 51 mm (2.01 in) dia. b: 44 mm (1.73 in) dia.	Installing release bearing
ST20050240 ( — ) Diaphragm adjusting wrench	Adjusting unevenness of diaphragm spring of clutch cover
ST20670000 ( — ) Clutch aligning bar a: 15 mm (0.59 in) dia. b: 23 mm (0.91 in) dia.	Installing clutch disc

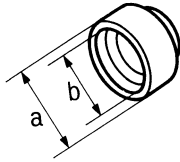

ZZA0838D



ZZA0508D

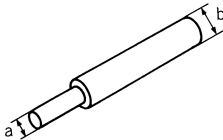

ZZA1178D

## Commercial Service Tools

ACS004MX

Tool name	Description
Pin punch Tip diameter: 4.5 mm (0.177 in) dia.	Removing and installing master cylinder spring pin
1. Flare nut crowfoot 2. Torque wrench a: 10 mm (0.39 in)	Removing and installing clutch piping
Power tool	Loosening bolts and nuts



ZZA0515D

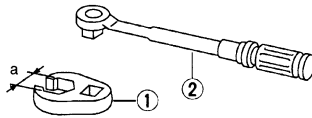

S-NT360

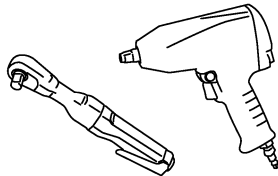

PBIC0190E

# NOISE, VIBRATION AND HARSHNESS (NVH) TROUBLESHOOTING

## NOISE, VIBRATION AND HARSHNESS (NVH) TROUBLESHOOTING

PFP:00003

### NVH Troubleshooting Chart

ACS004MY

Use the chart below to help you find the cause of the symptom. The numbers indicate the order of the inspection. If necessary, repair or replace these parts.

Reference page	M/T model code number: CD008	<a href="#">CL-5</a>	<a href="#">CL-7</a>	<a href="#">CL-9</a>	<a href="#">CL-11</a>	<a href="#">EM-131</a>	<a href="#">CL-13</a>											<a href="#">EM-166</a>		
	M/T model code number: CD009							<a href="#">CL-17</a>	<a href="#">CL-15</a>											
SUSPECTED PARTS (Possible cause)		CLUTCH PEDAL (Free play out of adjustment)	CLUTCH LINE (Air in line)	MASTER CYLINDER PISTON CUP (Damaged)	OPERATING CYLINDER PISTON CUP (Damaged)	ENGINE MOUNTING (Loose)	RELEASE BEARING (Worn, dirty or damaged)	CLUTCH DISC (Out of true)	CLUTCH DISC (Runout is excessive)	CLUTCH DISC (Lining broken)	CLUTCH DISC (Dirty or burned)	CLUTCH DISC (Oily)	CLUTCH DISC (Worn out)	CLUTCH DISC (Hardened)	CLUTCH DISC (Lack of spline grease)	DIAPHRAGM SPRING (Damaged)	DIAPHRAGM SPRING (Out of tip alignment)	PRESSURE PLATE (Distortion)	FLYWHEEL (Distortion)	
Symptom	Clutch grabs/chatters					1			2			2	2	2				2		
	Clutch pedal spongy		1	2	2															
	Clutch noisy						1													
	Clutch slips	1										2	2					4	5	
	Clutch does not disengage	1	2	3	4				5	5	5	5			5	6	6	7		

# CLUTCH PEDAL

## CLUTCH PEDAL

PF:46540

### On-Vehicle Inspection and Adjustment

ACS004MZ

1. Check to see if the clevis pin floats freely in the bore of the clutch pedal. It should not be bound by the clevis or clutch pedal.
  - a. If the clevis pin is not free, check that the ASCD clutch switch is not applying pressure to the clutch pedal causing the clevis pin to bind. To adjust, loosen lock nut and turn ASCD clutch switch.
  - b. Tighten the lock nut.
  - c. Verify that the clevis pin floats in the bore of the clutch pedal. It should not be bound by the clutch pedal.
  - d. If the clevis pin is still not free, remove the clevis pin and check for deformation or damage. Replace clevis pin if necessary. Leave pin removed for step 2.
2. Check clutch pedal stroke for free range of movement.
  - a. With the clevis pin removed, manually move the clutch pedal up and down to determine if it moves freely.
  - b. If any sticking is noted, replace the related parts (clutch pedal bracket, assist spring, bushing etc.). Re-assemble the clutch pedal and re-verify that the clevis pin floats freely in the bore of the clutch pedal.
3. Adjust clearance "C" while depressing clutch pedal fully. (With clutch interlock switch)

**Clearance C : 0.1 - 1.0mm (0.004 - 0.039 in)**

4. Check clutch hydraulic and system components (clutch master cylinder, clutch operating cylinder, clutch withdrawal lever, clutch release bearing, etc.) for sticking or binding.
  - a. If any sticking or binding noted, repair or replace related parts as necessary.
  - b. If hydraulic system repair was necessary, bleed the clutch hydraulic system. Refer to [CL-7, "Bleeding"](#).

#### NOTE:

Do not use a vacuum assist or any other type of power bleeder on this system. Use of a vacuum assist or power bleeder will not purge all the air from the system.

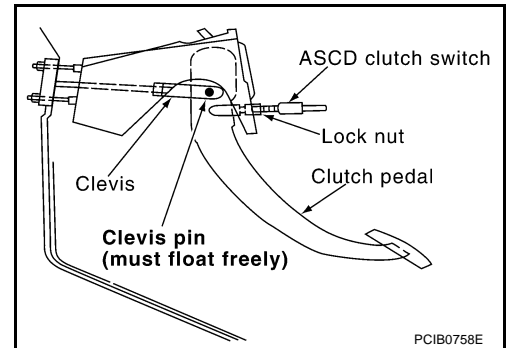

PCIB0758E

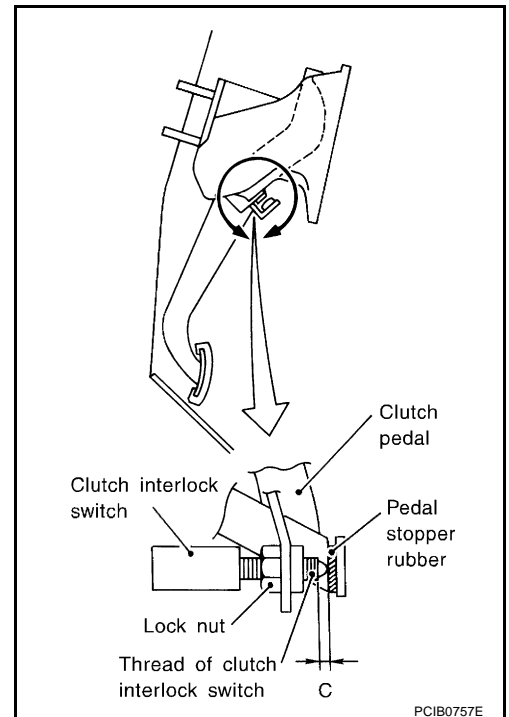

PCIB0757E

A  
B  
CL  
D  
E  
F  
G  
H  
I  
J  
K  
L  
M

# CLUTCH PEDAL

ACS004NO

## Removal and Installation

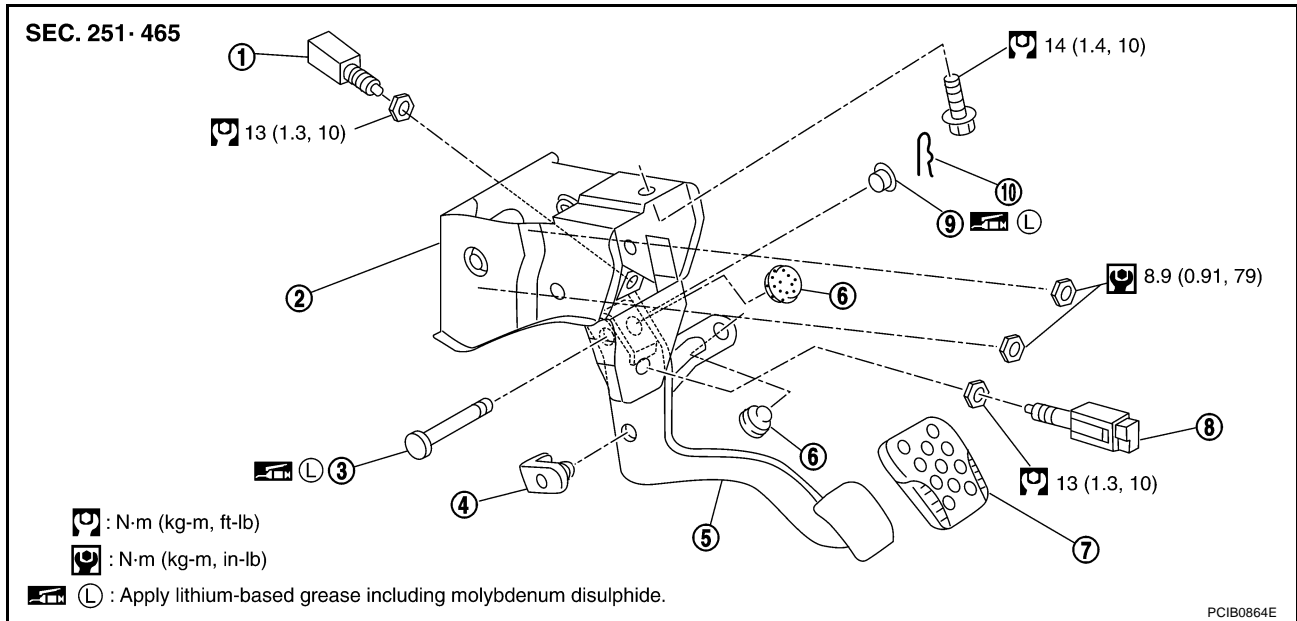

- |                            |                       |                   |
|----------------------------|-----------------------|-------------------|
| 1. Clutch interlock switch | 2. Bracket            | 3. Clevis pin     |
| 4. Pedal stopper rubber    | 5. Clutch pedal       | 6. Stopper rubber |
| 7. Pedal pad               | 8. ASCD clutch switch | 9. Bushing        |
| 10. Snap pin               |                       |                   |

### REMOVAL

1. Remove kicking plate. Refer to [EI-35, "Removal and Installation \(for Coupe Models\)"](#) or [EI-37, "Removal and Installation \(for Roadster Models\)"](#).
2. Remove footrest. Refer to [EI-43, "Removal and Installation"](#).
3. Remove dash side finisher (LH). Refer to [IP-11, "Removal and Installation"](#).
4. Remove instrument driver panel lower. Refer to [IP-11, "Removal and Installation"](#).
5. Remove VDC/TCS/ABS control unit. (VDC/TCS/ABS models) Refer to [BRC-145, "Removal and Installation"](#).
6. Remove the clutch interlock switch and ASCD clutch switch connectors and harness.
7. Remove the snap pin and clevis pin.
8. Remove the pedal bracket mounting bolt and nuts and then remove the clutch pedal assembly.

### INSPECTION AFTER REMOVAL

- Check clutch pedal for bend, damage, or a cracked weld. If bend, damage, or a cracked weld is found, replace the clutch pedal assembly.

### INSTALLATION

To install, reverse the removal procedure, following the cautions below:

- Install clutch pedal assembly and adjust the pedal height. Tighten ASCD clutch switch lock nut to the specified torque.
- After installing the clutch interlock switch, adjust the switch position.

### NOTE:

Tighten the ASCD clutch switch lock nut to the specified torque after installing the clutch pedal assembly in the vehicle and adjusting the pedal free play.

# CLUTCH FLUID

## CLUTCH FLUID

PFP:00017

### Bleeding

ACS004N1

#### CAUTION:

- Monitor fluid level in the reservoir tank to make sure it does not empty.
- Do not spill clutch fluid onto painted surfaces. If it spills, wipe up immediately and wash the affected area with water.

#### NOTE:

Do not use a vacuum assist or any other type of power bleeder on this system. Use of a vacuum assist or power bleeder will not purge all the air from the system.

1. Fill the master cylinder reservoir tank with new clutch fluid.
2. Connect a transparent vinyl hose to the air bleeder.
3. Depress the clutch pedal quickly and fully a few times and hold it.
4. With clutch pedal depressed, open air bleeder to release air.
5. Close air bleeder.
6. Release clutch pedal and wait for 5 seconds.
7. Repeat steps 3 to 6 until no bubbles can be observed in the brake fluid.
8. Tighten air bleeder to the specified torque. Refer to [CL-11, "Removal and Installation"](#).

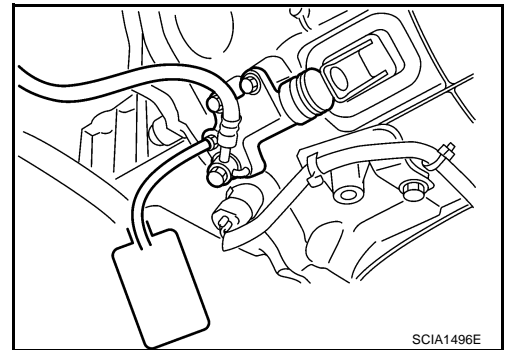

A

B

CL

D

E

F

G

H

I

J

K

L

M

# CLUTCH MASTER CYLINDER

PFP:30610

ACS004N2

## CLUTCH MASTER CYLINDER

### Removal and Installation

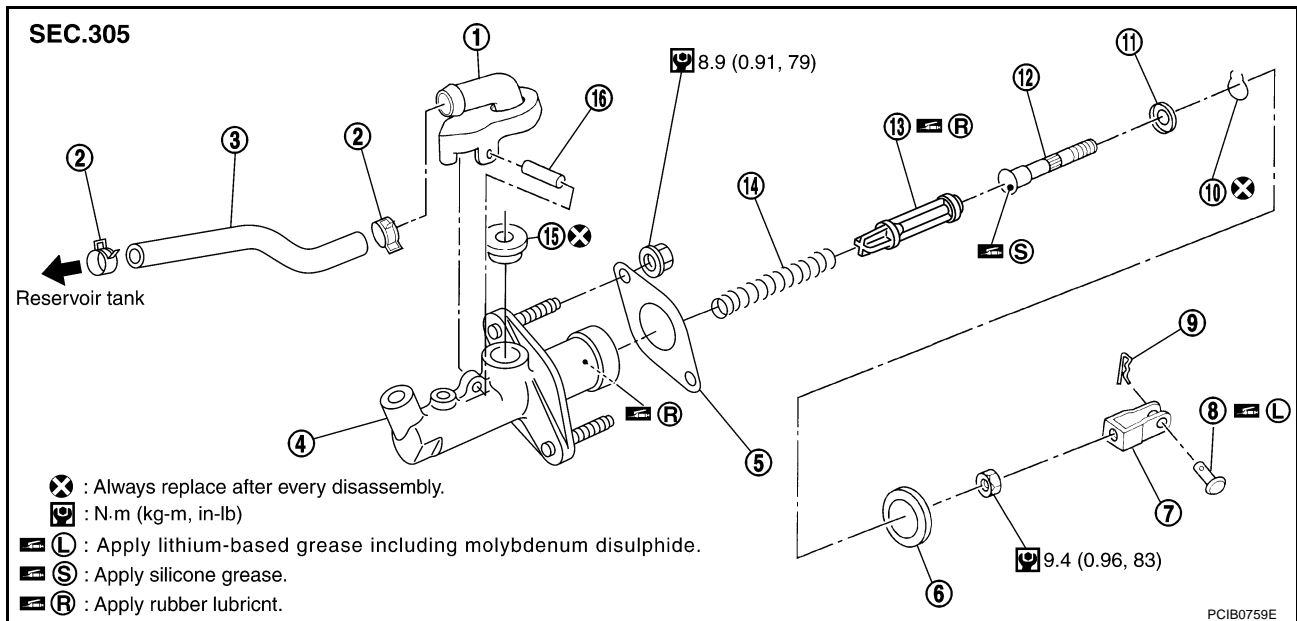

- |                     |                   |                    |
|---------------------|-------------------|--------------------|
| 1. Nipple           | 2. Clamp          | 3. Reservoir hose  |
| 4. Cylinder body    | 5. Packing        | 6. Seat            |
| 7. Clevis           | 8. Clevis pin     | 9. Snap pin        |
| 10. Stopper ring    | 11. Stopper       | 12. Push rod       |
| 13. Piston assembly | 14. Return spring | 15. Reservoir seal |
| 16. Spring pin      |                   |                    |

### REMOVAL

1. Remove kicking plate. Refer to [EI-35, "Removal and Installation \(for Coupe Models\)"](#) or [EI-37, "Removal and Installation \(for Roadster Models\)"](#).
  2. Remove footrest. Refer to [EI-43, "Removal and Installation"](#).
  3. Remove dash side finisher. Refer to [IP-11, "Removal and Installation"](#).
  4. Remove instrument driver panel lower. Refer to [IP-11, "Removal and Installation"](#).
  5. Remove VDC/TCS/ABS control unit. (VDC/TCS/ABS models) Refer to [BRC-145, "Removal and Installation"](#).
  6. Remove snap pin and clevis pin from the clevis, and separate it from clutch pedal.
  7. Remove hoodledge cover.
  8. Drain clutch fluid in reservoir tank and remove reservoir hose.
- CAUTION:**  
**Do not spill clutch fluid onto painted surfaces. If it spills, wipe up immediately and wash the affected area with water.**
9. Remove reservoir tank.
  10. Remove clutch tube using a flare nut wrench. Refer to [CL-12, "Removal and Installation"](#).
  11. Remove master cylinder assembly.

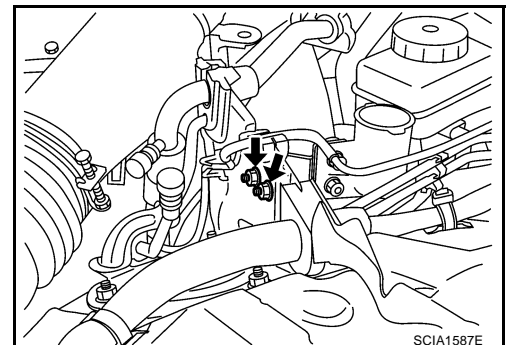



# CLUTCH MASTER CYLINDER

## INSTALLATION

1. Connect clutch tube to master cylinder assembly and temporarily tighten flare nut.
2. Install master cylinder assembly and tighten mounting nuts to the specified torque.
3. Tighten clutch tube flare nut to the specified torque using a flare nut torque wrench. Refer to [CL-12, "Removal and Installation"](#) .
4. Install clevis to the clutch pedal, and fix clevis with clevis pin.
5. Install snap pin to the clevis pin.
6. Install reservoir hose to the nipple. Install the reservoir tank to the vehicle, and then tighten mounting nuts to the specified torque.

: **5.8 N·m (0.59 Kg-m, 51 in-lb)**

7. After completing this procedure, inspect and adjust for clutch pedal and then bleed the clutch hydraulic system. Refer to [CL-5, "On-Vehicle Inspection and Adjustment"](#) and [CL-7, "Bleeding"](#) .
8. Install hoodledge cover.
9. Install VDC/TCS/ABS control unit. (VDC/TCS/ABS models) Refer to [BRC-145, "Removal and Installation"](#) .
10. Install instrument driver panel lower. Refer to [IP-11, "Removal and Installation"](#) .
11. Install dash side finisher. Refer to [IP-11, "Removal and Installation"](#) .
12. Install footrest. Refer to [EI-43, "FLOOR TRIM"](#) .
13. Install kicking plate. Refer to [EI-35, "Removal and Installation \(for Coupe Models\)"](#) or [EI-37, "Removal and Installation \(for Roadster Models\)"](#) .

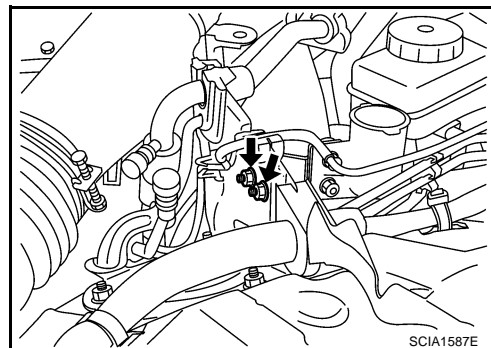

## Disassembly and Assembly

### DISASSEMBLY

1. Remove spring pin, nipple and reservoir seal from cylinder body using a pin punch.
2. Loosen push rod lock nut. Remove clevis and lock nut.
3. Remove the seat from the cylinder body.
4. Remove the stopper ring and stopper, and then remove the push rod, piston assembly and return spring from the cylinder body.

### CAUTION:

**Restrain the push rod while doing this because there is a danger the piston assembly will fly out of the cylinder body.**

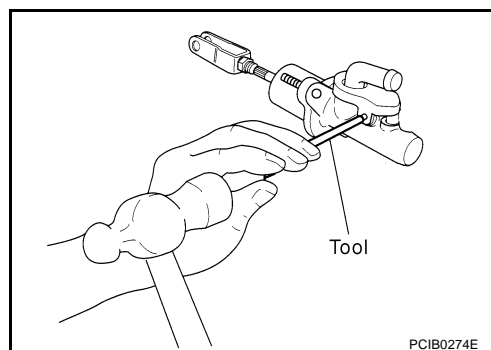

# CLUTCH MASTER CYLINDER

---

## INSPECTION AFTER DISASSEMBLY

Check for any of the conditions shown below. If any malfunction is found, replace the part concerned.

- Damaged cylinder internal wall, foreign matter, wear, corrosion, or pin hole
- Damaged or deformed nipple or reservoir tank
- Settling of the spring
- Cracked and deformed seat

## ASSEMBLY

1. Apply rubber lubricant to internal surface of the cylinder body, sliding surface of piston assembly, and the piston cup. Insert return spring and piston assembly to the cylinder body.
2. Apply silicone grease to the push rod and install the stopper before installing the stopper ring.

### **CAUTION:**

**Restrain the push rod while doing this because there is a danger the piston assembly will fly out of the master cylinder.**

3. Install seat to the cylinder body.
4. Install clevis to the push rod and tighten lock nut to the specified torque. Refer to [CL-8, "Removal and Installation"](#).
5. Install reservoir seal and nipple to cylinder body. Install spring pin using a pin punch.



# CLUTCH PIPING

## CLUTCH PIPING

PFP:30650

### Removal and Installation

ACS004N6

#### M/T model code number: CD008

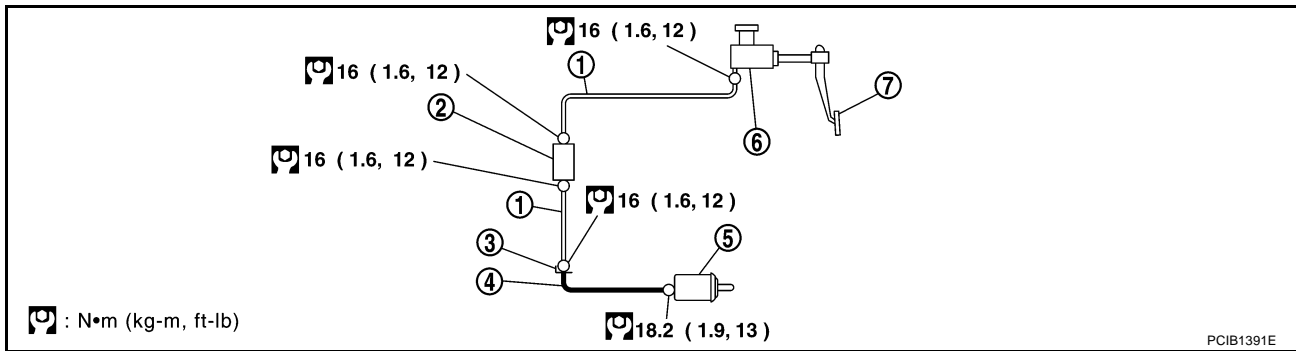

- |                 |                       |                    |
|-----------------|-----------------------|--------------------|
| 1. Clutch tube  | 2. Clutch orifice     | 3. Lock plate      |
| 4. Clutch hose  | 5. Operating cylinder | 6. Master cylinder |
| 7. Clutch pedal |                       |                    |

#### M/T model code number: CD009

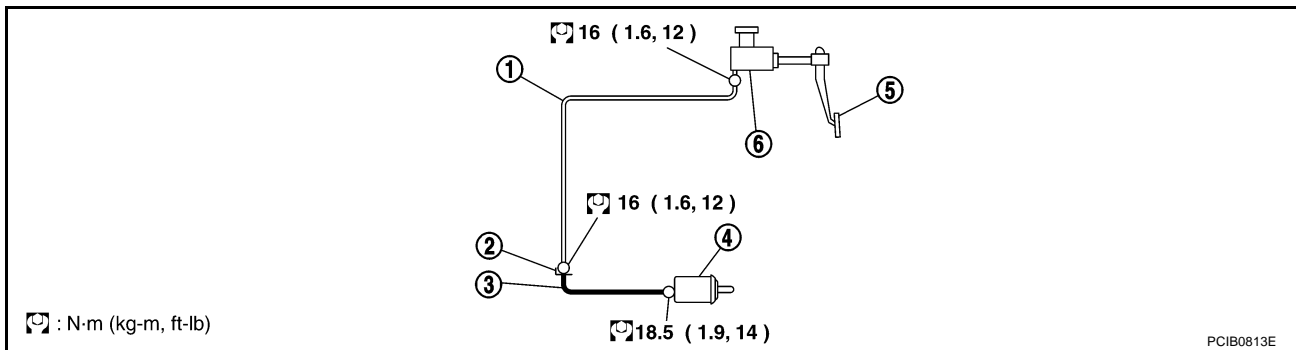

- |                       |                 |                    |
|-----------------------|-----------------|--------------------|
| 1. Clutch tube        | 2. Lock plate   | 3. Clutch hose     |
| 4. Operating cylinder | 5. Clutch pedal | 6. Master cylinder |

Carefully observe the following steps during clutch tube removal and installation.

- Do not spill clutch fluid onto painted surfaces. If it spills, wipe up immediately and wash the affected area with water.
- When fixing clutch hose to bracket, align clutch hose metal fittings with bracket positioning emboss and lock plate to secure. At this time, prevent twisting or damage of clutch hose. In addition, be careful not to damage clutch hose.
- Tighten clutch tube flare nut to the specified torque.

**CAUTION:**

**Be careful not to damage flare nut and clutch tube.**

- Tighten the union bolt to the specified torque. Refer to [CL-11, "Removal and Installation"](#).

**CAUTION:**

**Do not reuse the copper washer.**

- After installation, bleed the clutch hydraulic system. Refer to [CL-7, "Bleeding"](#).

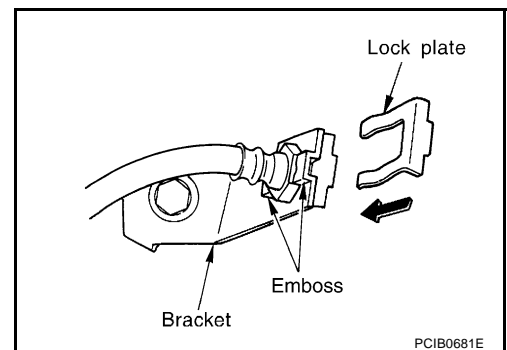

# CLUTCH RELEASE MECHANISM

## CLUTCH RELEASE MECHANISM

PFP:30502

### Removal and Installation

ACS004N7

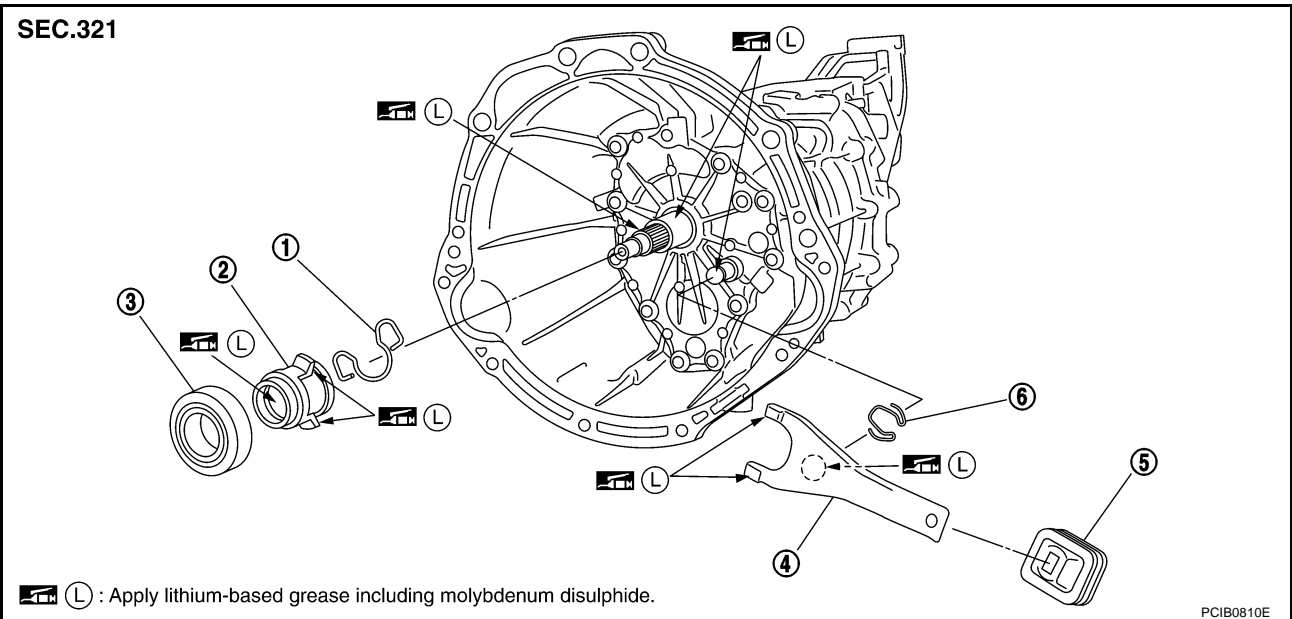

- |                     |                           |                    |
|---------------------|---------------------------|--------------------|
| 1. Holder spring    | 2. Release bearing sleeve | 3. Release bearing |
| 4. Withdrawal lever | 5. Dust cover             | 6. Snap spring     |

### REMOVAL

1. Remove manual transmission from the vehicle. Refer to [MT-18, "Removal and Installation from Vehicle"](#).
2. Remove release bearing sleeve assembly, holder spring and withdrawal lever from inside the clutch housing.
3. Remove dust cover.
4. Remove snap spring from withdrawal lever.
5. Remove release bearing from release bearing sleeve using a puller.

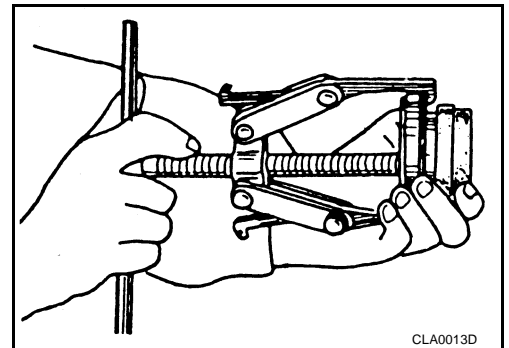

### INSPECTION AFTER REMOVAL

- If release bearing is seized, damaged, not properly centered or does not rotate smoothly, replace it.
- If contact surface of withdrawal lever is excessively worn out, replace it.
- If dust cover is cracked or deformed, replace it.

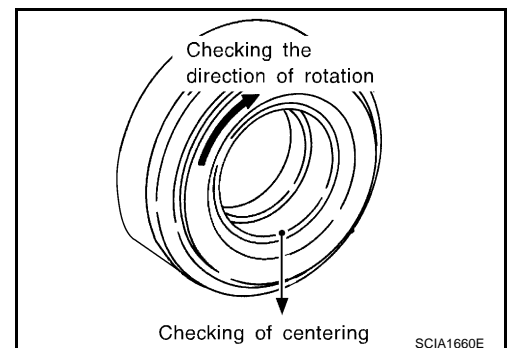

# CLUTCH RELEASE MECHANISM

## INSTALLATION

### CAUTION:

- Be sure to apply grease to the points specified. Otherwise, noise, poor disengagement, or damage to the clutch may result. Excessive grease may cause slip or quiver. Wipe off any grease oozing from the parts.
  - Be careful not to bring any grease into contact with the clutch disc facing, pressure plate surface and flywheel surface.
1. Install release bearing to release bearing sleeve using the drift.

Tool number : KV30101400 ( — )

### CAUTION:

Press bearing inner race by pushing with the drift.

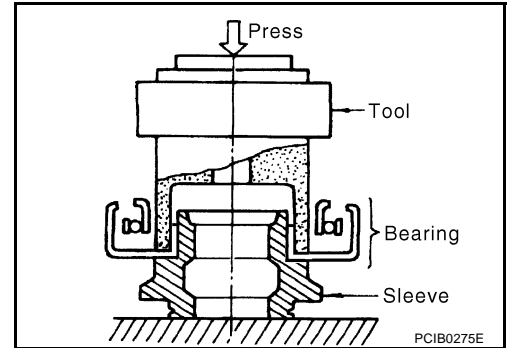

2. Following the instructions below, apply grease to the specified points.

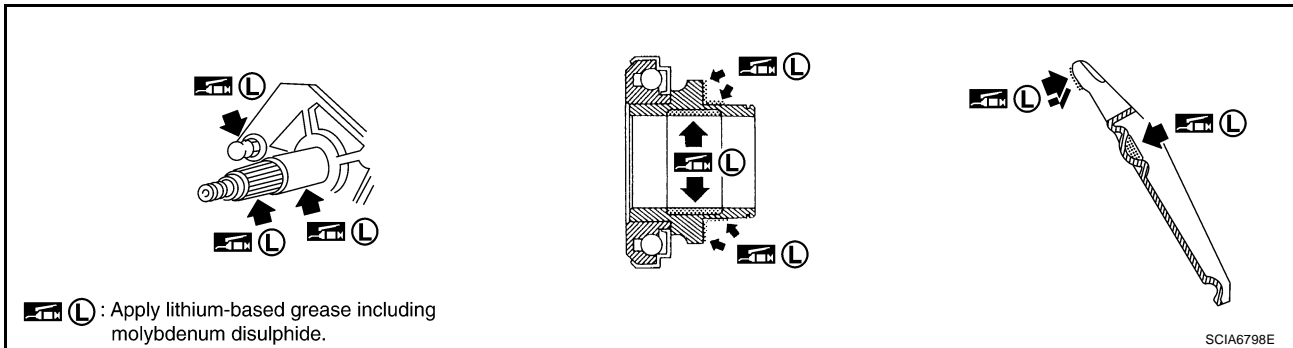

### CAUTION:

Wipe off any old grease, debris, or powdery residue left on the surfaces.

- Evenly apply a 1 mm (0.04 in) thick coating of recommended grease to withdrawal lever and release bearing sleeve or holder spring sliding surface.
  - Apply recommended grease to ball pin contact surface of withdrawal lever and inner slots of release bearing. The grease surface should be level with the surrounding area.
  - Evenly apply a thin coat of recommended grease to release bearing sliding surface. Install release bearing. Wipe off any excess grease that oozes from the parts and then remove release bearing.
3. To install, reverse the removal procedure, following the cautions below.

### CAUTION:

- Before installing manual transmission to the vehicle, check that each sliding surface slides smoothly by operating withdrawal lever.
- When assembling, make sure that both ends of snap spring touch the end face of withdrawal lever.
- Be careful with the orientation of installation.

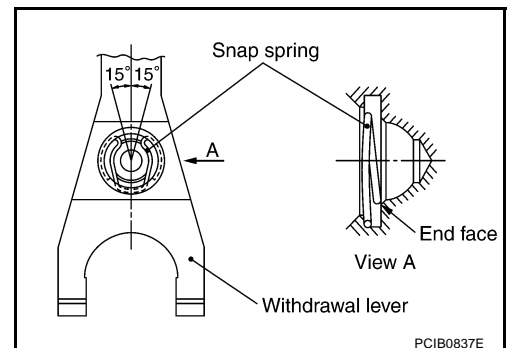

# CLUTCH DISC, CLUTCH COVER

## CLUTCH DISC, CLUTCH COVER

PFP:30100

### Removal and Installation (M/T Model Code Number: CD008)

ACS004N8

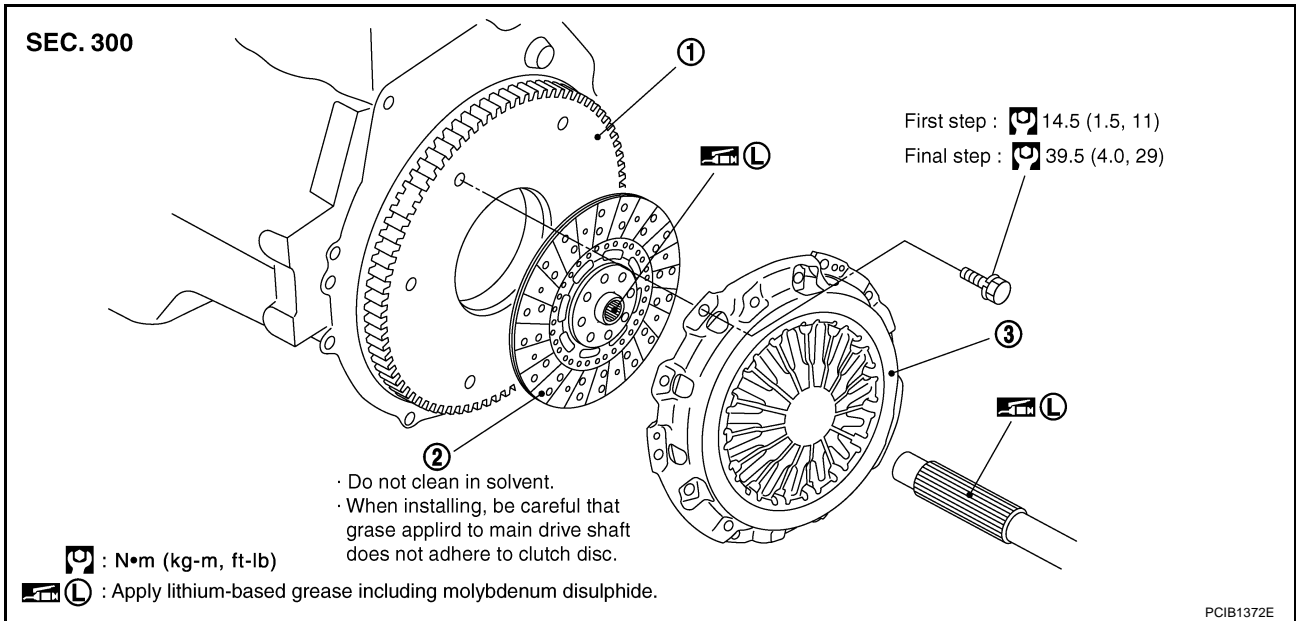

1. Flywheel

2. Clutch disc

3. Clutch cover

#### CAUTION:

- Be careful not to bring any grease into contact with the clutch disc facing, pressure plate surface and flywheel surface.
- If flywheel is removed, align dowel pin with the smallest hole of flywheel. Refer to [EM-144, "ASSEMBLY"](#).

#### REMOVAL

1. Remove manual transmission from the vehicle. Refer to [MT-18, "Removal and Installation from Vehicle"](#).
2. Loosen clutch cover mounting bolts with power tool. Remove clutch cover and clutch disc.

#### INSPECTION AND ADJUSTMENT AFTER REMOVAL

##### Clutch Disc

- Measure circumference runout relative to the clutch disc center spline. If it is outside the specification, replace the clutch disc.

##### Runout limit/diameter of the area to be measured

**:0.7 mm (0.028 in) or less/240 mm (9.45 in) dia.**

- Measure backlash for clutch disc spline and main drive shaft spline at the circumference of the disc. If it is outside the specified range, replace the clutch disc.

##### Maximum backlash of spline

**:1.0 mm (0.039 in)**

- Measure the depth to clutch disc facing rivet heads using calipers. If it exceeds the allowable wear limit, replace the clutch disc.

##### Facing wear limit (depth to the rivet head)

**:0.3 mm (0.012 in)**

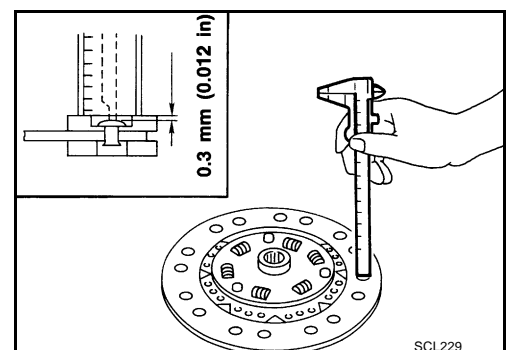
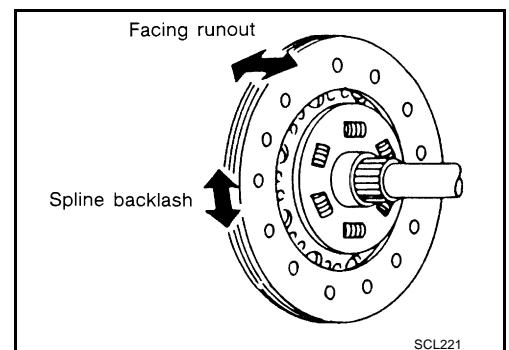

# CLUTCH DISC, CLUTCH COVER

## Clutch Cover

Check diaphragm spring lever claws for unevenness with the lever still on the vehicle. If they exceed the tolerance, adjust lever height using the diaphragm adjusting wrench.

**Tolerance for diaphragm spring lever unevenness**  
**:0.5mm (0.020 in)**

**Tool number** : ST20050240 ( — )

- Check clutch cover thrust ring for wear or breakage. If wear or breakage is found, replace clutch cover assembly.

### NOTE:

- Worn thrust ring will generate a beating noise when tapped at the rivet with a hammer.
- Broken thrust ring will make a clinking sound when cover is shaken up and down.
- If a trace of burn or discoloration is found on the clutch cover pressure plate to clutch disc contact surface, repair the surface with sandpaper. If surface is damaged or distorted, replace the assembly.

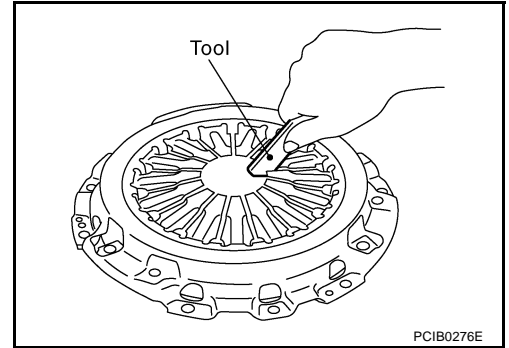

## INSTALLATION

1. Apply recommended grease to clutch disc and main drive shaft spline.

### CAUTION:

**Be sure to apply grease to the points specified. Otherwise, noise, poor disengagement, or damage to the clutch may result. Excessive grease may cause slip or quiver. Wipe off any grease oozing from the parts.**

2. Install clutch disc and clutch cover. Pre-tighten mounting bolts and install clutch aligning bar.

**Tool number** : ST20670000 ( — )

3. Tighten clutch cover mounting bolts evenly in two steps in the order shown in the figure. Refer to [CL-15, "Removal and Installation \(M/T Model Code Number: CD008\)"](#) .
4. Install manual transmission. Refer to [MT-18, "Removal and Installation from Vehicle"](#) .

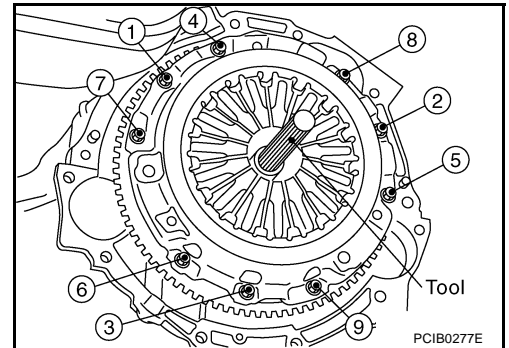



# CLUTCH DISC, CLUTCH COVER

## Removal and Installation (M/T Model Code Number: CD009)

ACS00A28

A  
B  
CL  
D  
E  
F  
G  
H  
I  
J  
K  
L  
M

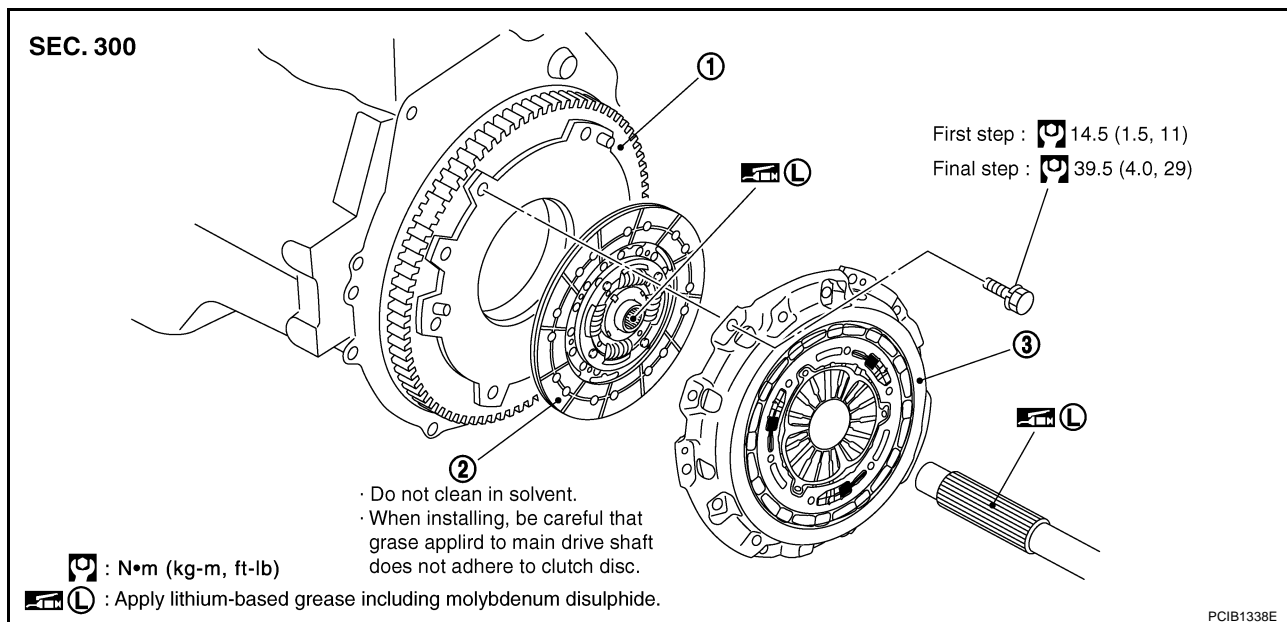

### CAUTION:

- Be careful not to bring any grease into contact with the clutch disc facing, pressure plate surface and flywheel surface.
- If flywheel is removed, align dowel pin with the smallest hole of flywheel. Refer to [EM-144, "ASSEMBLY"](#).
- Replace clutch disc and clutch cover as a set.

### REMOVAL

1. Remove manual transmission from the vehicle. Refer to [MT-18, "Removal and Installation from Vehicle"](#).
2. Loosen clutch cover mounting bolts with power tool. Remove clutch cover and clutch disc.

### INSPECTION AND ADJUSTMENT AFTER REMOVAL

#### Clutch Disc

- Measure circumference runout relative to the clutch disc center spline. If it is outside the specification, replace clutch disc and clutch cover as a set.

**Runout limit/diameter of the area to be measured**  
**:1.0 mm (0.039 in) or less/230 mm (9.06 in) dia.**

- Measure backlash for clutch disc spline and main drive shaft spline at the circumference of the clutch disc. If it is outside the specified range, replace clutch disc and clutch cover as a set.

**Maximum backlash of spline**  
**:1.0 mm (0.039 in)**

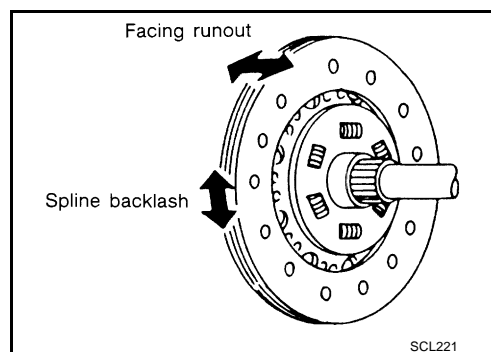

# CLUTCH DISC, CLUTCH COVER

- Using calipers, measure the depth to the clutch disc facing rivet heads. If it exceeds the allowable wear limit, replace clutch disc and clutch cover as a set.

**Facing wear limit (depth to the rivet head)**  
**:0.3 mm (0.012 in)**

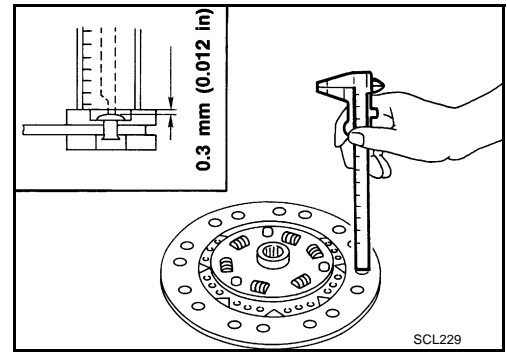

## Clutch Cover

Check diaphragm spring lever claws for unevenness with the lever still on the vehicle. If they exceed the tolerance, adjust lever height using the diaphragm adjusting wrench.

**Tolerance for diaphragm spring lever unevenness**  
**:0.8 mm (0.031 in)**

**Tool number** : ST20050240 ( — )

- Check clutch cover thrust ring for wear or breakage. If wear or breakage is found, replace clutch disc and clutch cover as a set.

### NOTE:

- Worn thrust ring will generate a beating noise when tapped at the rivet with a hammer.
- Broken thrust ring will make a clinking sound when cover is shaken up and down.
- If a trace of burn or discoloration is found on the clutch cover pressure plate to clutch disc contact surface, repair the surface with sandpaper. If surface is damaged or distorted, replace clutch disc and clutch cover as a set.

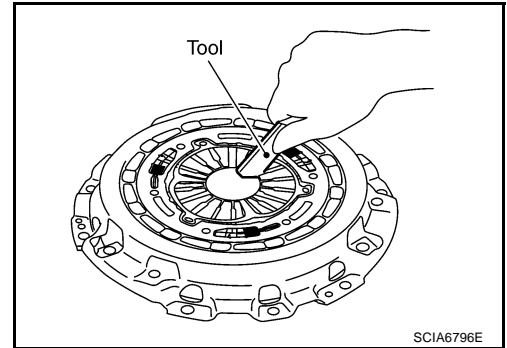

## INSTALLATION

- Apply recommended grease to clutch disc and main drive shaft spline.

### CAUTION:

**Be sure to apply grease to the points specified. Otherwise, noise, poor disengagement, or damage to the clutch may result. Excessive grease may cause slip or quiver. Wipe off any grease oozing from the parts.**

- Install clutch disc and clutch cover. Pre-tighten mounting bolts and install clutch aligning bar.

**Tool number** : ST20670000 ( — )

- Tighten clutch cover mounting bolts evenly in two steps in the order shown in the figure. Refer to [CL-17, "Removal and Installation \(M/T Model Code Number: CD009\)"](#).
- Install manual transmission. Refer to [MT-18, "Removal and Installation from Vehicle"](#).

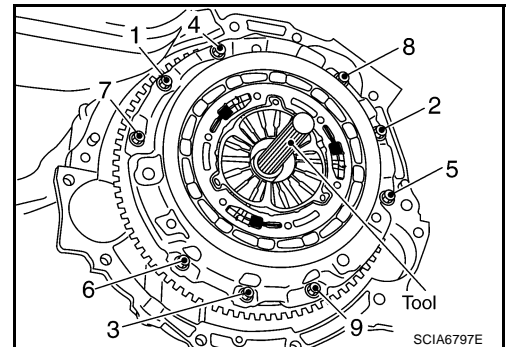

# SERVICE DATA AND SPECIFICATIONS (SDS)

## SERVICE DATA AND SPECIFICATIONS (SDS)

PFP:00030

### Clutch Control System

ACS004N9

Type of clutch control	Hydraulic
------------------------	-----------

### Clutch Master Cylinder

ACS004NA

Unit: mm (in)

Inner diameter	15.87 (5/8)
----------------	-------------

### Clutch Operating Cylinder

ACS004NB

Unit: mm (in)

Inner diameter	19.05 (3/4)
----------------	-------------

### Clutch Disc

ACS004NC

Unit: mm (in)

Engine model	VQ35DE	
M/T model code number	CD008	CD009
Model	250	240
Facing size (Outer dia. × inner dia. × thickness)	250 × 170 × 3.2 (9.84 × 6.69 × 0.126)	240 × 160 × 3.8 (9.45 × 6.30 × 0.150)
Wear limit (depth to the rivet head)	0.3 (0.012)	
Runout limit/diameter of the area to be measured	0.7 (0.028) or less/240 (9.45) dia.	1.0 (0.039) or less/230 (9.06) dia.
Maximum backlash of spline (at outer edge disc)	1.0 (0.039)	

### Clutch Cover

ACS004ND

Unit: mm (in)

Engine model	VQ35DE	
M/T model code number	CD008	CD009
Model	250	240
Set-load	8,630 N (880 kg)	9,900 N (1,009 kg)
Diaphragm spring lever height	39.5 - 41.5 (1.555 - 1.634)	41.9 - 44.1 (1.650 - 1.736)
Uneven limit of diaphragm spring toe height	0.5 (0.020)	0.8 (0.031)

### Clutch Pedal

ACS004NE

Unit: mm (in)

Clearance "C" between pedal stopper rubber and clutch interlock switch threaded while clutch pedal is fully depressed.	0.1 - 1.0 (0.004 - 0.039)
--	---------------------------

# SERVICE DATA AND SPECIFICATIONS (SDS)

---