

SECTION **PR**
PROPELLER SHAFT

A
B
C

PR

CONTENTS

E

PRECAUTIONS	2	PROPELLER SHAFT VIBRATION	5	F
Precautions for Propeller Shaft	2	Components	6	
PREPARATION	3	Removal and Installation	6	
Special Service Tools	3	REMOVAL	6	G
NOISE, VIBRATION AND HARSHNESS (NVH)		INSPECTION	7	
TROUBLESHOOTING	4	INSTALLATION	8	
NVH Troubleshooting Chart	4	SERVICE DATA AND SPECIFICATIONS (SDS)	10	H
REAR PROPELLER SHAFT	5	General Specifications	10	
On-Vehicle Inspection	5	Propeller Shaft Runout Limit	10	
APPEARANCE AND NOISE INSPECTION	5			I

H

I

J

K

L

M

PRECAUTIONS

PRECAUTIONS

PFP:00001

Precautions for Propeller Shaft

ADS001AS

- If propeller shaft is dropped, replace propeller shaft with new one.
- Do not hit, impact, or damage tube.
- If damage such as cracks or peeling off in sealing (joint between yoke and tube) is found, replace propeller shaft with new one.
- If there is chipping or bend in tube, replace propeller shaft with new one.
- Check that the clearance is between tube and yoke flange. If there is no clearance, replace propeller shaft.
- Protect propeller shaft with protector (special service tool) during work.

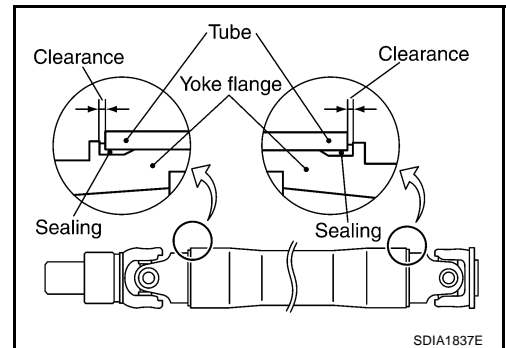

PREPARATION

PREPARATION

PPF:00002

Special Service Tools

ADS001AU

The actual shapes of Kent-Moore tools may differ from those of special service tools illustrated here.

Tool number (Kent-Moore No.) Tool name	Description
— (J-46208) Propeller shaft protector	Removing and installing propeller shaft

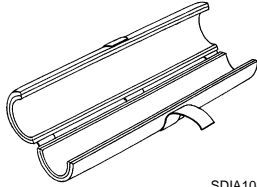

SDIA1086E

A
B
C
PR
E
F
G
H
I
J
K
L
M

PR

NOISE, VIBRATION AND HARSHNESS (NVH) TROUBLESHOOTING

NOISE, VIBRATION AND HARSHNESS (NVH) TROUBLESHOOTING

PF0:00003

NVH Troubleshooting Chart

ADS0018W

Use the chart below to help you find the cause of the symptom. If necessary, repair or replace these parts.

Symptom		Possible cause and SUSPECTED PARTS													
		Uneven rotating torque	Center bearing improper installation	Excessive center bearing axial end play	Center bearing mounting (insulator) cracks, damage or deterioration	Excessive joint angle	Rotation imbalance	Excessive runout	DIFFERENTIAL	AXLE AND SUSPENSION	TIRES	ROAD WHEEL	DRIVE SHAFT	BRAKES	STEERING
Reference page	Noise	PR-5	—	—	—	—	PR-5	PR-7	NVH in RFD section	NVH in FAX, RAX, FSU, and RSU section	NVH in WT section	NVH in WT section	NVH in RAX section	NVH in BR section	NVH in PS section
	Shake														
	Vibration														

x: Applicable

REAR PROPELLER SHAFT

REAR PROPELLER SHAFT

PFP:37000

On-Vehicle Inspection

ADS0018X

APPEARANCE AND NOISE INSPECTION

- Check the propeller shaft tube surface for dents or cracks. If damaged, replace propeller shaft assembly.
- If damage such as cracks or peeling off sealing (joint between yoke and tube) is found, replace propeller shaft with new one.
- Check that the gap is between tube and yoke flange. If there is no gap, replace propeller shaft.

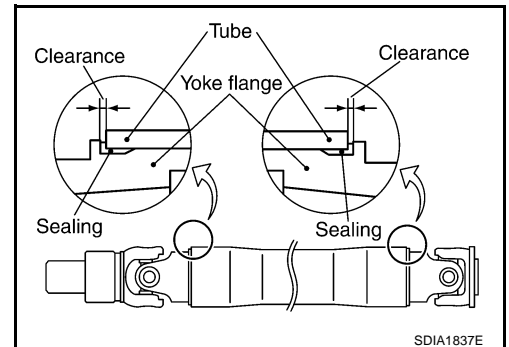

PROPELLER SHAFT VIBRATION

If vibration is present at high speed, inspect propeller shaft runout first.

1. Measure propeller shaft runout at runout measuring points by rotating final drive companion flange with hands.

Propeller shaft runout limit : 1.5 mm (0.059 in) or less

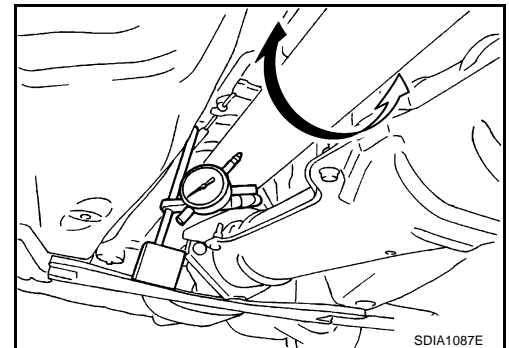

Propeller shaft runout measuring points

Dimension for M/T models
A: 340 mm (13.39 in)
B: 660.5 mm (26.00 in)
C: 340 mm (13.39 in)

Dimension for A/T models
A: 340 mm (13.39 in)
B: 641.5 mm (25.26 in)
C: 340 mm (13.39 in)

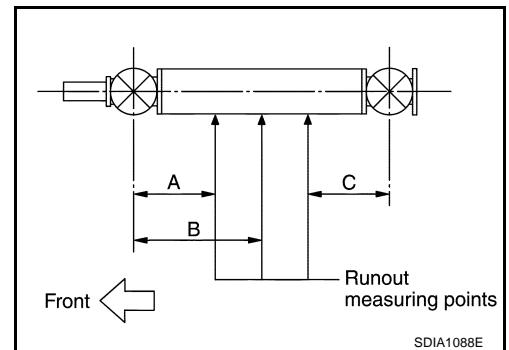

2. If runout still exceeds specifications, separate propeller shaft at final drive companion flange; then rotate companion flange 90, 180, 270 degrees and install propeller shaft.
3. Check runout again. If runout still exceeds specifications, replace propeller shaft assembly.
4. Check the vibration by driving vehicle.

REAR PROPELLER SHAFT

Components

ADS001BA

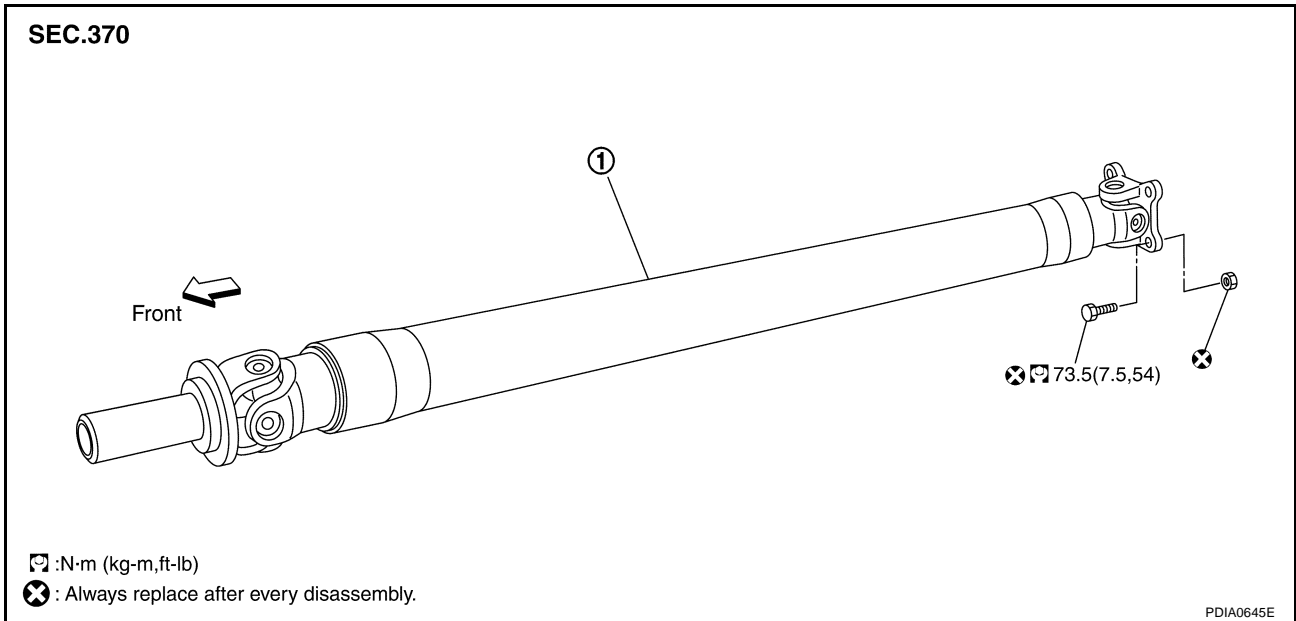

1. Propeller shaft

Removal and Installation

REMOVAL

ADS0018Y

1. Set transmission to neutral position.
2. Release parking brake.
3. To keep space for removing propeller shaft, first detach rear-side mounts (5 locations) of exhaust tube and main muffler. Then lower exhaust tube and main muffler, and support them with jack or equivalent. (See the figure.)

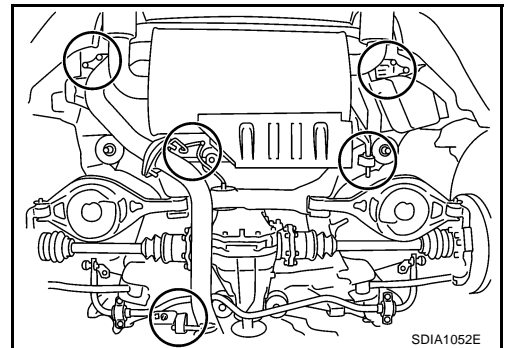

4. Attach protector (special service tool) to propeller shaft. (When reused.)

Tool number : — **(J-46208)**

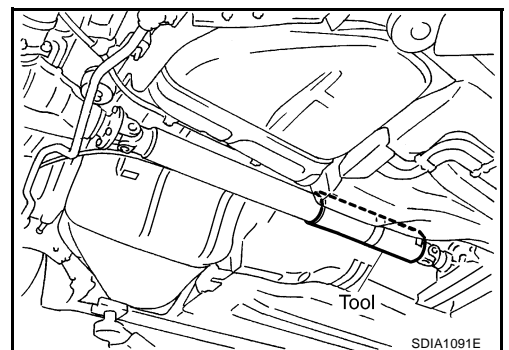

REAR PROPELLER SHAFT

- Put matching marks on flange yoke with final drive companion flange. (When reused.)

CAUTION:

For matching mark, use paint. Do not damage flange yoke and companion flange.

- Remove propeller shaft fixing bolts and nuts. Then propeller shaft.

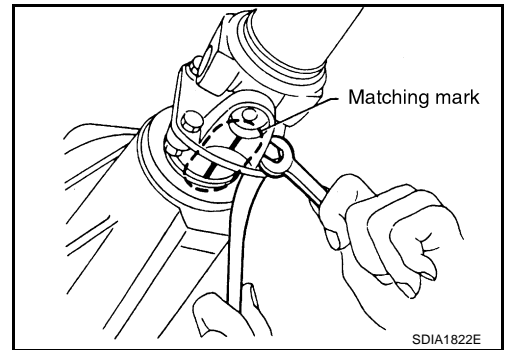

A
B
C

PR

INSPECTION

- Inspect propeller shaft runout at measuring points. If runout exceeds specifications, replace propeller shaft assembly.

Propeller shaft runout limit : 1.5 mm (0.059 in) or less

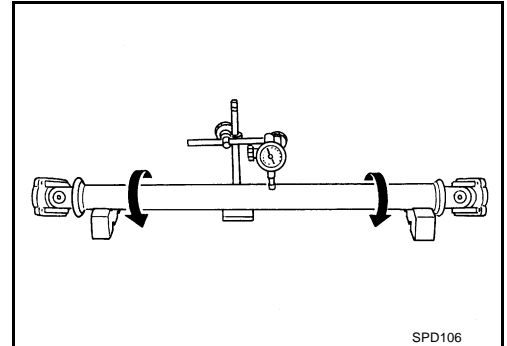

E
F
G

Propeller shaft runout measuring points

Dimension for M/T models
A: 340 mm (13.39 in)
B: 660.5 mm (26.00 in)
C: 340 mm (13.39 in)

Dimension for A/T models
A: 340 mm (13.39 in)
B: 641.5 mm (25.26 in)
C: 340 mm (13.39 in)

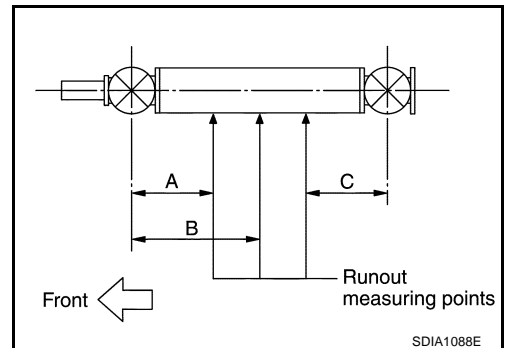

H
I
J
K

- Inspect journal axial play. If the play exceeds specifications, replace propeller shaft assembly.

Journal axial play : 0 mm (0 in)

- Check propeller shaft for bend and damage. If damage is detected, replace propeller shaft assembly.

CAUTION:

Do not disassemble joints.

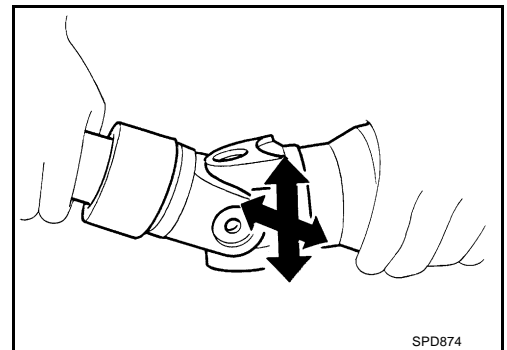

L
M

REAR PROPELLER SHAFT

INSTALLATION

When Installing New Propeller Shaft

CAUTION:

- When installing propeller shaft, handle it carefully.
- Propeller shaft must be installed with packing material attached (delivered condition). Do not install propeller shaft with packing material removed.

1. Insert propeller shaft with packing material between floor reinforcement and floor panel.

CAUTION:

After insertion, check that shift control boot does not come off (M/T models).

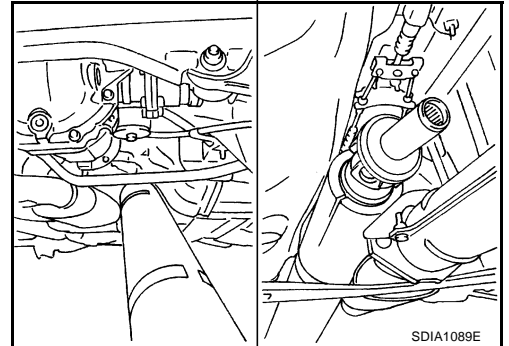

2. Install propeller shaft while aligning its matching mark A with the matching mark B on the joint as close as possible.
3. Temporarily tighten bolts and nuts.

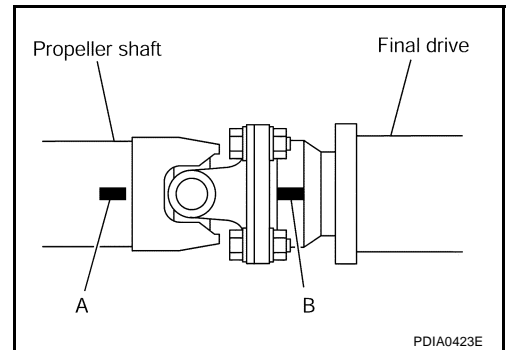

4. Press down propeller shaft with matching mark C facing upward. Then tighten fixing bolts and nuts to the specified torque. Refer to [PR-6, "Components"](#).

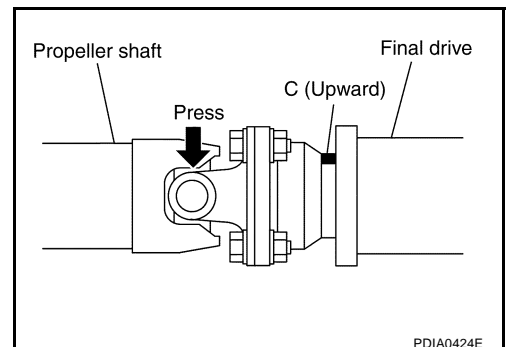

5. Remove packing material from propeller shaft.
6. Return exhaust system to its original position. For tightening torque, [EX-3, "EXHAUST SYSTEM"](#).
7. After assembly, perform a driving test to check propeller shaft vibration. If vibration occurred, separate propeller shaft from final drive. Reinstall companion flange after rotating it by 90, 180, 270 degrees. Then perform driving test and check propeller shaft vibration again at each point.

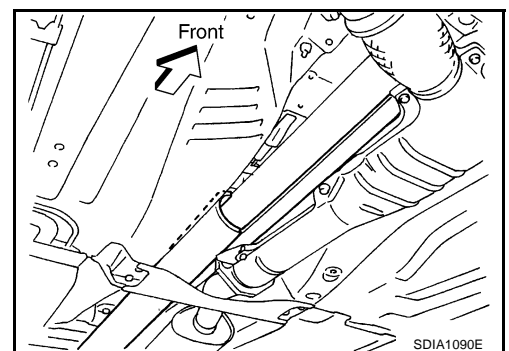

REAR PROPELLER SHAFT

When Installing Reused Propeller Shaft

CAUTION:

When installing propeller shaft, handle it carefully.

1. With protector (special service tool) attached, align matching marks to install propeller shaft to final drive companion flange, and then tighten to specified torque. Refer to [PR-6, "Components"](#) .
2. Remove protector (special service tool) from propeller shaft.
3. Return exhaust system to its original position. For tightening torque, [EX-3, "EXHAUST SYSTEM"](#) .
4. After assembly, perform a driving test to check propeller shaft vibration. If vibration occurred, separate propeller shaft from final drive. Reinstall companion flange after rotating it by 90, 180, 270 degrees. Then perform driving test and check propeller shaft vibration again at each point.

A

B

C

PR

E

F

G

H

I

J

K

L

M

SERVICE DATA AND SPECIFICATIONS (SDS)

SERVICE DATA AND SPECIFICATIONS (SDS)

PFP:00030

General Specifications

ADS0018Z

Applied model	VQ35DE	
	M/T	A/T
Propeller shaft model	2S80A CFRP	
Number of joints	2	
Coupling method with transmission	Sleeve type	
Type of journal bearings	Shell type (Non-disassembly type)	
Distance between yokes	95 mm (3.74 in)	
Shaft length (Spider to spider)	1321 mm (52.007 in)	1283 mm (50.512 in)
Shaft outer diameter	85.0 mm (3.346 in)	

Propeller Shaft Runout Limit

ADS00191

Model	2S80A CFRP	
Propeller shaft runout limit	1.5 mm (0.059 in) or less	