

A
B
C

SECTION INL

INTERIOR LIGHTING SYSTEM

CONTENTS

<p>BASIC INSPECTION 3</p> <p>DIAGNOSIS AND REPAIR WORKFLOW 3</p> <p style="padding-left: 20px;">Work Flow3</p> <p>SYSTEM DESCRIPTION 5</p> <p>INTERIOR ROOM LAMP CONTROL SYSTEM 5</p> <p style="padding-left: 20px;">System Diagram5</p> <p style="padding-left: 20px;">System Description5</p> <p style="padding-left: 20px;">Component Parts Location7</p> <p style="padding-left: 20px;">Component Description7</p> <p>INTERIOR ROOM LAMP BATTERY SAVER SYSTEM 8</p> <p style="padding-left: 20px;">System Diagram8</p> <p style="padding-left: 20px;">System Description8</p> <p style="padding-left: 20px;">Component Parts Location9</p> <p style="padding-left: 20px;">Component Description9</p> <p>ILLUMINATION CONTROL SYSTEM10</p> <p style="padding-left: 20px;">System Diagram10</p> <p style="padding-left: 20px;">System Description10</p> <p style="padding-left: 20px;">Component Parts Location11</p> <p style="padding-left: 20px;">Component Description11</p> <p>DIAGNOSIS SYSTEM (BCM)12</p> <p>COMMON ITEM12</p> <p style="padding-left: 20px;">COMMON ITEM : CONSULT-III Function (BCM - COMMON ITEM) 12</p> <p>INT LAMP13</p> <p style="padding-left: 20px;">INT LAMP : CONSULT-III Function (BCM - INT LAMP) 14</p> <p>BATTERY SAVER15</p> <p style="padding-left: 20px;">BATTERY SAVER : CONSULT-III Function (BCM - BATTERY SAVER) 15</p> <p>DTC/CIRCUIT DIAGNOSIS18</p>	<p>POWER SUPPLY AND GROUND CIRCUIT18</p> <p>BCM18</p> <p style="padding-left: 20px;">BCM : Diagnosis Procedure18</p> <p>INTERIOR ROOM LAMP POWER SUPPLY CIRCUIT19</p> <p style="padding-left: 20px;">Description19</p> <p style="padding-left: 20px;">Component Function Check19</p> <p style="padding-left: 20px;">Diagnosis Procedure19</p> <p>INTERIOR ROOM LAMP CONTROL CIRCUIT21</p> <p style="padding-left: 20px;">Description21</p> <p style="padding-left: 20px;">Component Function Check21</p> <p style="padding-left: 20px;">Diagnosis Procedure21</p> <p>LUGGAGE ROOM LAMP CIRCUIT23</p> <p style="padding-left: 20px;">Description23</p> <p style="padding-left: 20px;">Component Function Check23</p> <p style="padding-left: 20px;">Diagnosis Procedure23</p> <p>PUSH-BUTTON IGNITION SWITCH ILLUMINATION CIRCUIT25</p> <p style="padding-left: 20px;">Description25</p> <p style="padding-left: 20px;">Component Function Check25</p> <p style="padding-left: 20px;">Diagnosis Procedure25</p> <p>INTERIOR ROOM LAMP CONTROL SYSTEM27</p> <p style="padding-left: 20px;">Wiring Diagram - INTERIOR ROOM LAMP -27</p> <p>ILLUMINATION33</p> <p style="padding-left: 20px;">Wiring Diagram - ILLUMINATION -33</p> <p>ECU DIAGNOSIS INFORMATION42</p> <p>BCM (BODY CONTROL MODULE)42</p> <p style="padding-left: 20px;">Reference Value42</p> <p style="padding-left: 20px;">Wiring Diagram - BCM -65</p> <p style="padding-left: 20px;">Fail-safe70</p> <p style="padding-left: 20px;">DTC Inspection Priority Chart73</p>
---	---

A
B
C
D
E
F
G
H
I
J
K
INL

DTC Index	74	MAP LAMP	95
COMBINATION METER	77	Exploded View	95
Reference Value	77	Removal and Installation	95
Wiring Diagram - METER -	84	Replacement	95
Fail-Safe	91	VANITY MIRROR LAMP	96
DTC Index	92	Exploded View	96
SYMPTOM DIAGNOSIS	93	Replacement	96
INTERIOR LIGHTING SYSTEM SYMPTOMS...	93	LUGGAGE ROOM LAMP	97
Symptom Table	93	Exploded View	97
PRECAUTION	94	Removal and Installation	97
PRECAUTIONS	94	Replacement	97
Precaution for Supplemental Restraint System (SRS) "AIR BAG" and "SEAT BELT PRE-TEN- SIONER"	94	SERVICE DATA AND SPECIFICATIONS (SDS)	98
Precaution for Battery Service	94	SERVICE DATA AND SPECIFICATIONS (SDS)	98
REMOVAL AND INSTALLATION	95	Bulb Specifications	98

DIAGNOSIS AND REPAIR WORKFLOW

< BASIC INSPECTION >

BASIC INSPECTION

DIAGNOSIS AND REPAIR WORKFLOW

Work Flow

INFOID:000000004402403

OVERALL SEQUENCE

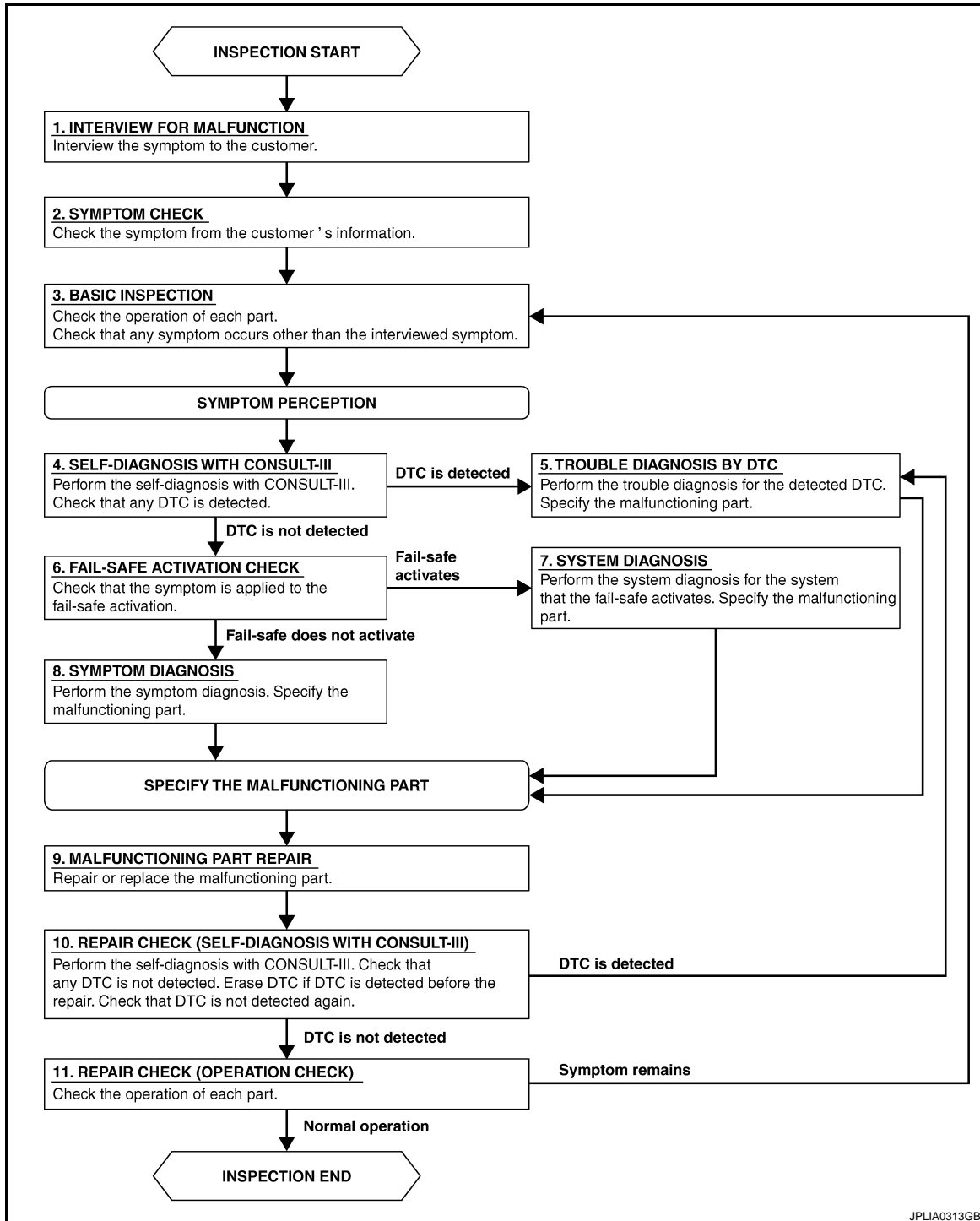

DETAILED FLOW

1. INTERVIEW FOR MALFUNCTION

Interview the symptom to the customer.

DIAGNOSIS AND REPAIR WORKFLOW

< BASIC INSPECTION >

>> GO TO 2.

2. SYMPTOM CHECK

Check the symptom from the customer's information.

>> GO TO 3.

3. BASIC INSPECTION

Check the operation of each part. Check that any symptom occurs other than the interviewed symptom.

>> GO TO 4.

4. SELF-DIAGNOSIS WITH CONSULT-III

Perform the self-diagnosis with CONSULT-III. Check that any DTC is detected.

Is any DTC detected?

YES >> GO TO 5.

NO >> GO TO 6.

5. TROUBLE DIAGNOSIS BY DTC

Perform the trouble diagnosis for the detected DTC. Specify the malfunctioning part.

>> GO TO 9.

6. FAIL-SAFE ACTIVATION CHECK

Check that the symptom is applied to the fail-safe activation.

Does the fail-safe activate?

YES >> GO TO 7.

NO >> GO TO 8.

7. SYSTEM DIAGNOSIS

Perform the system diagnosis for the system that the fail-safe activates. Specify the malfunctioning part.

>> GO TO 9.

8. SYMPTOM DIAGNOSIS

Perform the symptom diagnosis. Specify the malfunctioning part.

>> GO TO 9.

9. MALFUNCTION PART REPAIR

Repair or replace the malfunctioning part.

>> GO TO 10.

10. REPAIR CHECK (SELF-DIAGNOSIS WITH CONSULT-III)

Perform the self-diagnosis with CONSULT-III. Check that any DTC is not detected. Erase DTC if DTC is detected before the repair. Check that DTC is not detected again.

Is any DTC detected?

YES >> GO TO 5.

NO >> GO TO 11.

11. REPAIR CHECK (OPERATION CHECK)

Check the operation of each part.

Does it operate normally?

YES >> INSPECTION END

NO >> GO TO 3.

INTERIOR ROOM LAMP CONTROL SYSTEM

< SYSTEM DESCRIPTION >

SYSTEM DESCRIPTION

INTERIOR ROOM LAMP CONTROL SYSTEM

System Diagram

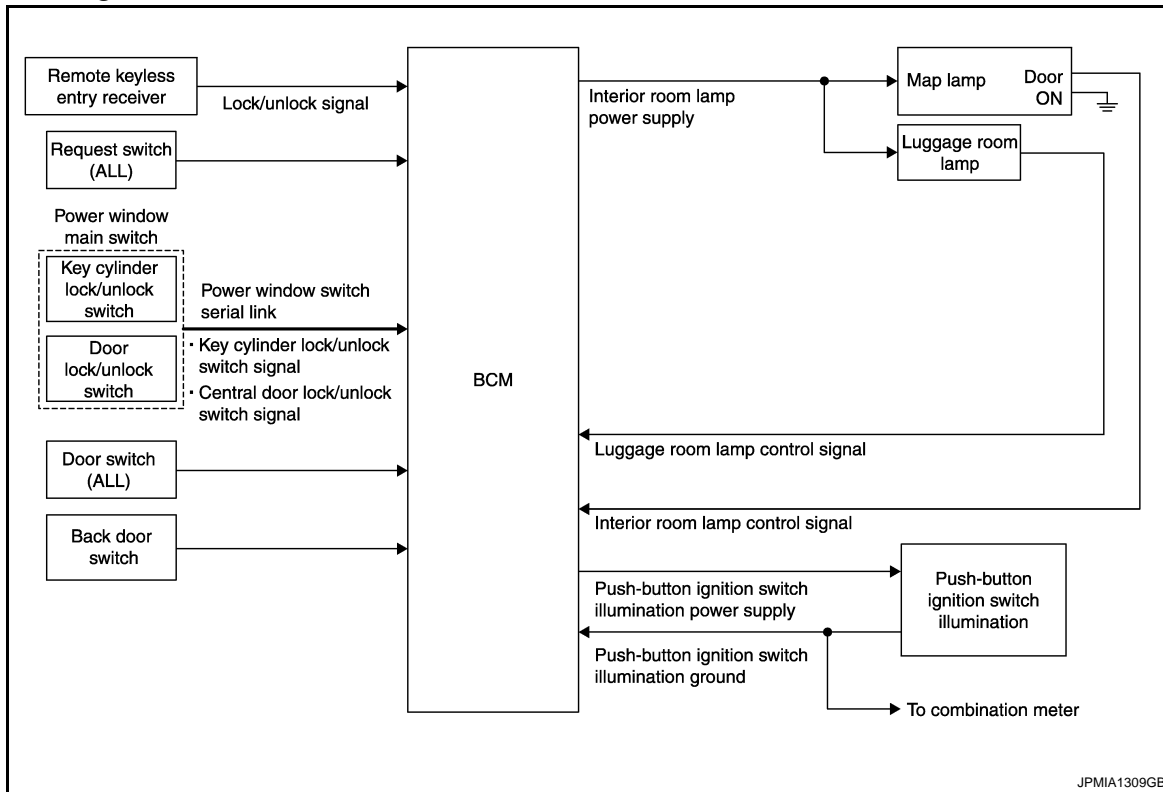

System Description

INFOID:000000004402405

OUTLINE

- Interior room lamps* are controlled by interior room lamp timer control function of BCM.
- *: Map lamp (when map lamp switch is in DOOR position).
- Luggage room lamp is controlled by luggage room lamp control function of BCM.
- Push-button ignition switch illumination is controlled by the push-button ignition switch illumination control function of BCM.

INTERIOR ROOM LAMP TIMER CONTROL

Interior Room Lamp Timer Basic Operation

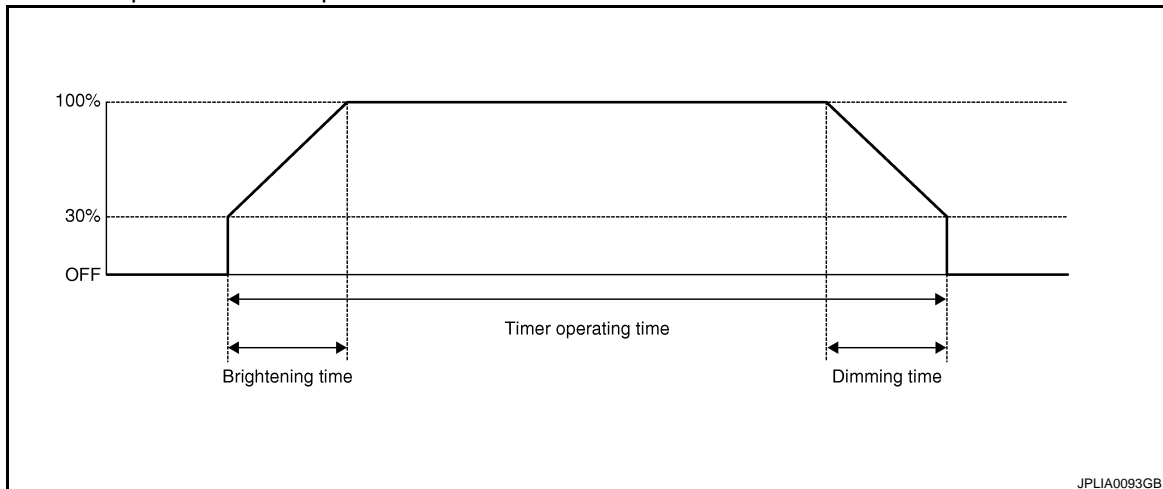

- The interior room lamp turns ON and OFF (gradual brightening and dimming) by the interior room timer.

INTERIOR ROOM LAMP CONTROL SYSTEM

< SYSTEM DESCRIPTION >

- BCM judges the vehicle condition with the following items. It activates the interior room timer.
 - Ignition switch status
 - Door switch signal (ALL)
 - Door lock/unlock signal (Remote keyless entry receiver, each request switch, key cylinder lock/unlock switch, central door lock/unlock switch)

NOTE:

Each function of interior room lamp timer can be set by CONSULT-III. Refer to [INL-14. "INT LAMP : CONSULT-III Function \(BCM - INT LAMP\)"](#).

Interior Room Lamp ON Operation

- BCM always turns the interior room lamp ON when any door opens.
- BCM activates the interior room timer in any of the following conditions to turn the interior room lamp ON for a period of time.
 - Any door opens before all doors close.
 - Ignition switch is turned ON → OFF.
 - Any door unlock signal is detected when all doors close with ignition switch OFF.

NOTE:

Restart the timer if new condition is input during the timer operating time.

Interior Room Lamp OFF Operation

BCM stops the timer in any of the following conditions to turn the interior room lamp OFF.

- The timer operating time is expired.
- Ignition switch position is other than OFF with all doors close.
- Any door lock operation is detected with all doors close.

LUGGAGE ROOM LAMP CONTROL

BCM controls the luggage room lamp (ground-side) to turn ON with the luggage room lamp switch ON.

PUSH-BUTTON IGNITION SWITCH ILLUMINATION CONTROL

Push-button Ignition Switch Illumination Basic Operation

- BCM provides the power supply and the ground to turn the push-button ignition switch illumination ON.
- BCM cuts the ground supply while the each illumination (tail lamp) ON. BCM switches to the ground control with the meter illumination control function.

Push-button Ignition Switch Illumination ON Operation

BCM turns the push-button ignition switch illumination ON in the following conditions.

- Ignition switch ON
- Each illumination (tail lamp) ON
- Any of the following conditions with ignition switch OFF
 - Engine start permission is entered.
 - Intelligent Key inserted into the key slot.
 - Driver door is LOCK → UNLOCK.
 - Driver door is open.

Push-button Ignition Switch Illumination OFF Operation

BCM turns the push-button ignition switch illumination OFF in any of the following conditions.

- The push-button ignition switch illumination ON conditions do not satisfy.
- All of the following conditions with ignition switch OFF
 - Each illumination (tail lamp) OFF
 - The push-button ignition switch illumination ON conditions do not change (15 seconds after the ignition switch OFF) or the driver door is UNLOCK → LOCK.

INTERIOR ROOM LAMP CONTROL SYSTEM

< SYSTEM DESCRIPTION >

Component Parts Location

INFOID:000000004402406

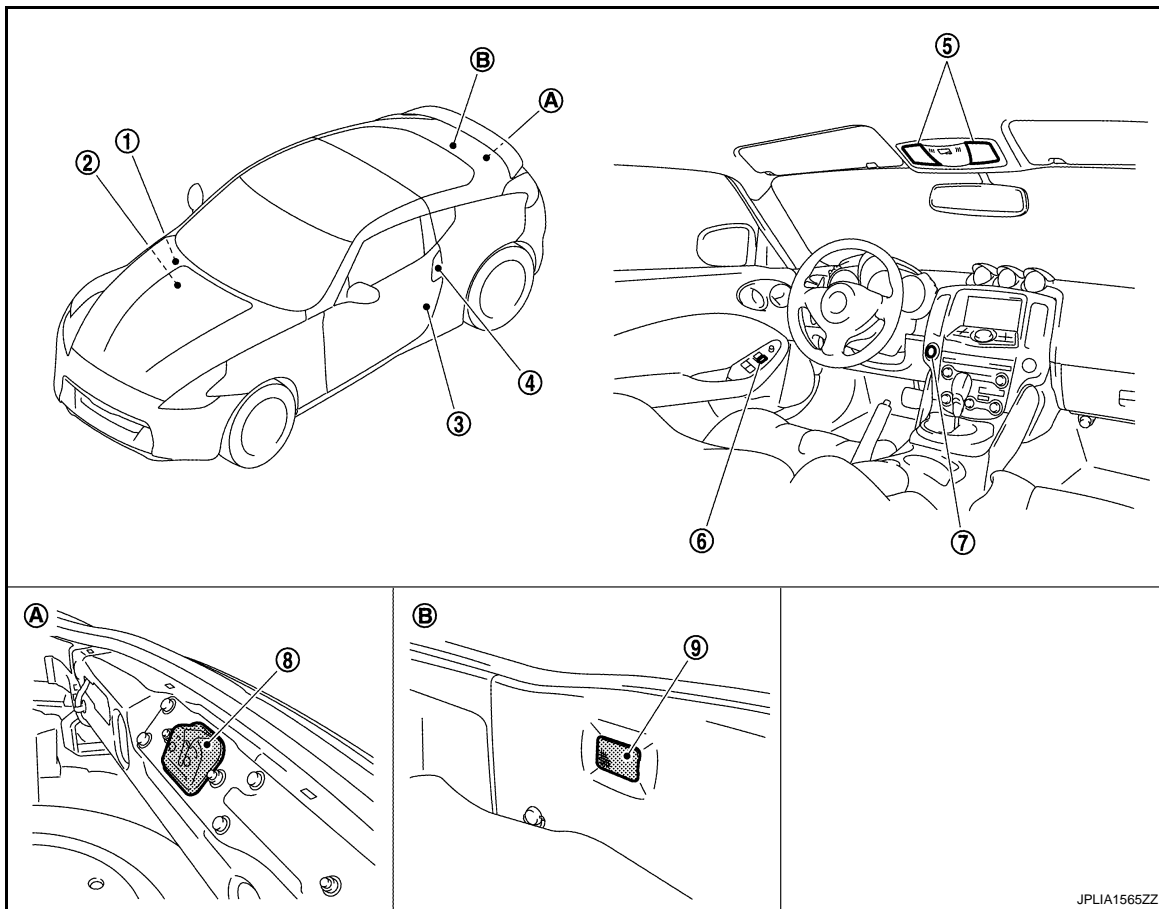

- | | | |
|---|--|--------------------------------|
| 1. Remote keyless entry receiver
Refer to SEC-12. "Component Parts Location" . | 2. BCM
Refer to BCS-8. "Component Parts Location" . | 3. Door switch |
| 4. • Key cylinder switch
• Request switch | 5. Map lamp | 6. Door lock and unlock switch |
| 7. Push-button ignition switch
(Push-button ignition switch illumination) | 8. Back door switch | 9. Luggage room lamp |
| A. Back door lock assembly | B. Luggage room | |

Component Description

INFOID:000000004402407

Part	Description
BCM	<ul style="list-style-type: none"> Activates the interior room lamp timer depending on the vehicle condition to turn the interior room lamp ON/OFF. Turns the luggage room lamp ON /OFF according to the luggage room lamp switch status.
Remote keyless entry receiver	Transmits the lock/unlock signal to BCM.
<ul style="list-style-type: none"> Door lock and unlock switch Key cylinder switch 	Transmits a switch signal by power window switch serial link.
<ul style="list-style-type: none"> Request switch Door switch 	Inputs a switch signal to BCM.

INTERIOR ROOM LAMP BATTERY SAVER SYSTEM

< SYSTEM DESCRIPTION >

INTERIOR ROOM LAMP BATTERY SAVER SYSTEM

System Diagram

INFOID:000000004402408

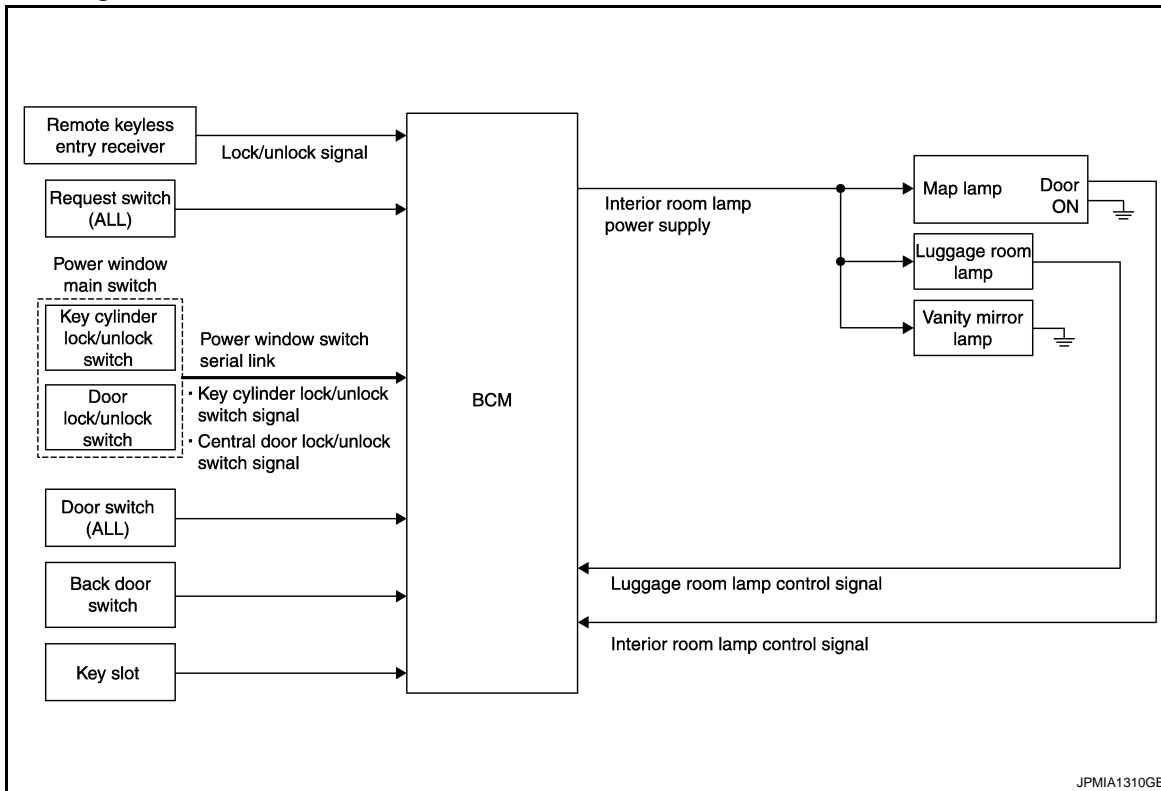

System Description

INFOID:000000004402409

OUTLINE

- Interior room lamp battery saver is controlled by BCM.
- BCM turns applicable lamps OFF depending on the vehicle condition. This function prevents the battery from over-discharging if the driver neglect turning OFF the any lamps.

Applicable lamps

- Map lamp
- Luggage room lamp
- Vanity mirror lamp

INTERIOR ROOM LAMP BATTERY SAVER FUNCTION

- When the ignition switch is turned OFF, BCM operates the timer for a period of time to cut the interior room lamp power supply.
- BCM restart the timer when any of the following signals changes while operating the timer.
 - Ignition switch status
 - Door switch signal (ALL)
 - Door lock/unlock signal (Remote keyless entry receiver, each request switch, key cylinder lock/unlock switch, central door lock/unlock switch)
 - Back door switch signal
 - Key switch signal (Key slot)
- BCM provides the interior room lamp power supply continuously when the ignition switch position is other than OFF.

NOTE:

Each function of interior room lamp battery saver can be set by CONSULT-III. Refer to [INL-15. "BATTERY SAVER : CONSULT-III Function \(BCM - BATTERY SAVER\)"](#).

INTERIOR ROOM LAMP BATTERY SAVER SYSTEM

< SYSTEM DESCRIPTION >

Component Parts Location

INFOID:000000004402410

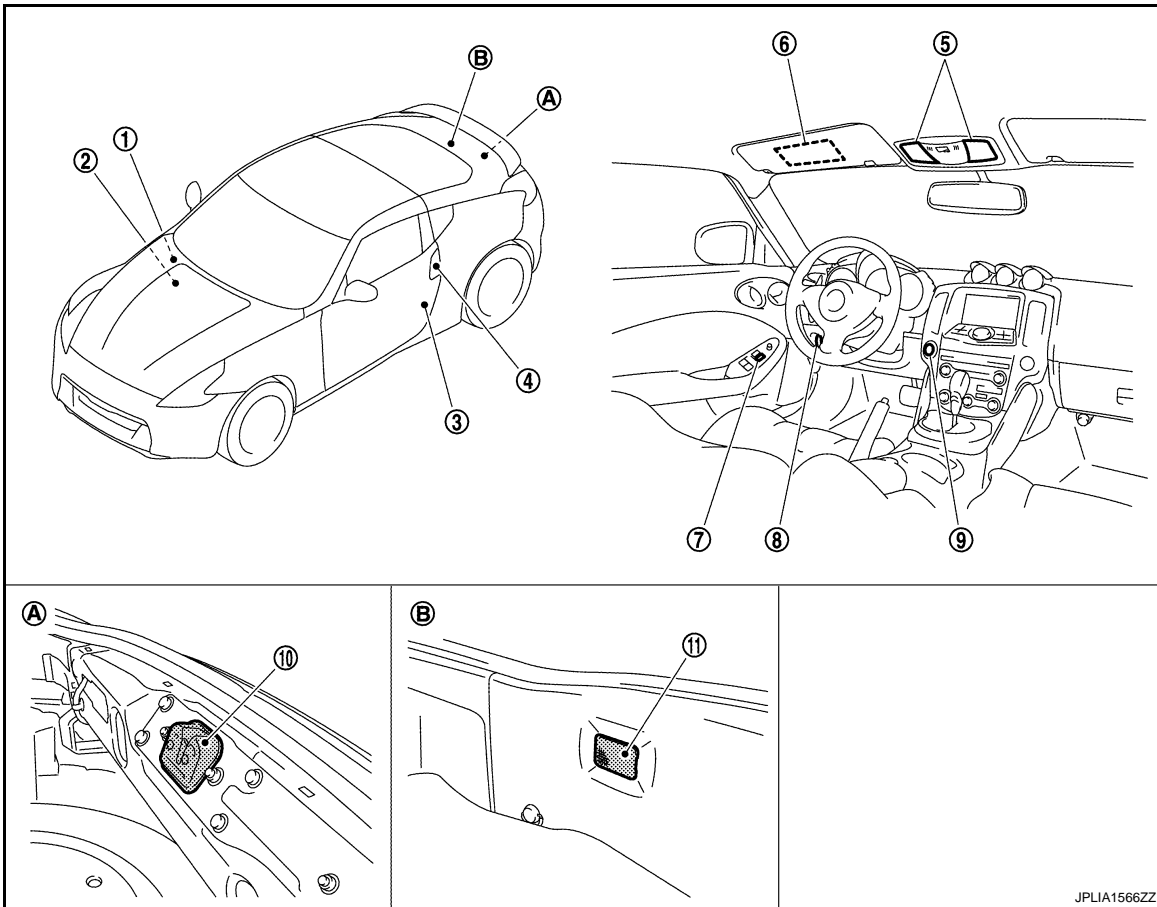

- | | | |
|--|--|--------------------------------|
| 1. Remote keyless entry receiver
Refer to DLK-30. "REMOTE KEY-LESS ENTRY FUNCTION : Component Parts Location" . | 2. BCM
Refer to BCS-8. "Component Parts Location" . | 3. Door switch |
| 4. • Key cylinder switch
• Request switch | 5. Map lamp | 6. Vanity mirror lamp |
| 7. Door lock and unlock switch | 8. Key slot | 9. Push-button ignition switch |
| 10. Back door switch | 11. Luggage room lamp | |
| A. Back door lock assembly | B. Luggage room | |

Component Description

INFOID:000000004402411

Part	Description
BCM	Operates the interior room lamp battery saver depending on the vehicle condition to cut the interior room lamp power supply.
Remote keyless entry receiver	Transmits the lock/unlock signal to BCM.
• Door lock and unlock switch • Key cylinder switch	Transmits a switch signal by power window switch serial link.
• Request switch • Door switch	Inputs a switch signal to BCM.
Key slot	Inputs the key switch status to BCM.

ILLUMINATION CONTROL SYSTEM

< SYSTEM DESCRIPTION >

ILLUMINATION CONTROL SYSTEM

System Diagram

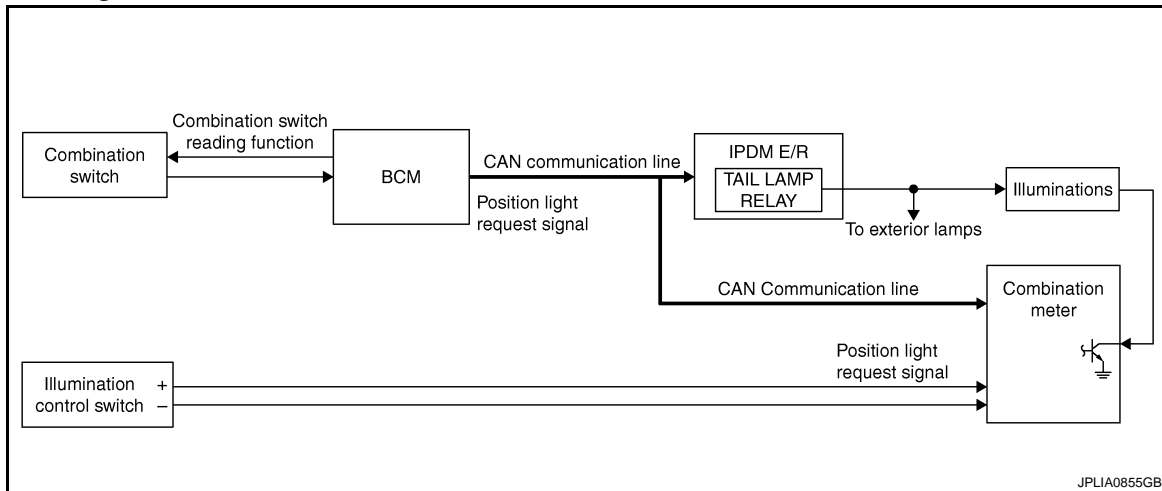

System Description

INFOID:000000004402413

OUTLINE

Each illumination lamp is controlled by each function of BCM, IPDM E/R and combination meter.

Control by BCM

- Combination switch reading function
- Headlamp control function

Control by IPDM E/R

- Relay control function

Control by combination meter

- Meter illumination control function (Refer to [MWI-23, "METER ILLUMINATION CONTROL : System Diagram."](#))

ILLUMINATION CONTROL

- BCM detects the combination switch condition by the combination switch reading function.
- BCM transmits position light request signal to IPDM E/R and combination meter according to tail lamp ON condition.

Tail lamp ON condition

- Lighting switch 1ST
- Lighting switch 2ND
- Lighting switch AUTO, and the auto light function ON judgment
- IPDM E/R turns the integrated tail lamp relay ON according to position light request signal. It provides the power supply to each illumination lamp.
- Combination meter enters in the nighttime mode according to position light request signal. Under the nighttime mode the combination meter controls the illuminance by controlling the each illumination lamp (ground side).

ILLUMINATION CONTROL SYSTEM

< SYSTEM DESCRIPTION >

Component Parts Location

INFOID:000000004402414

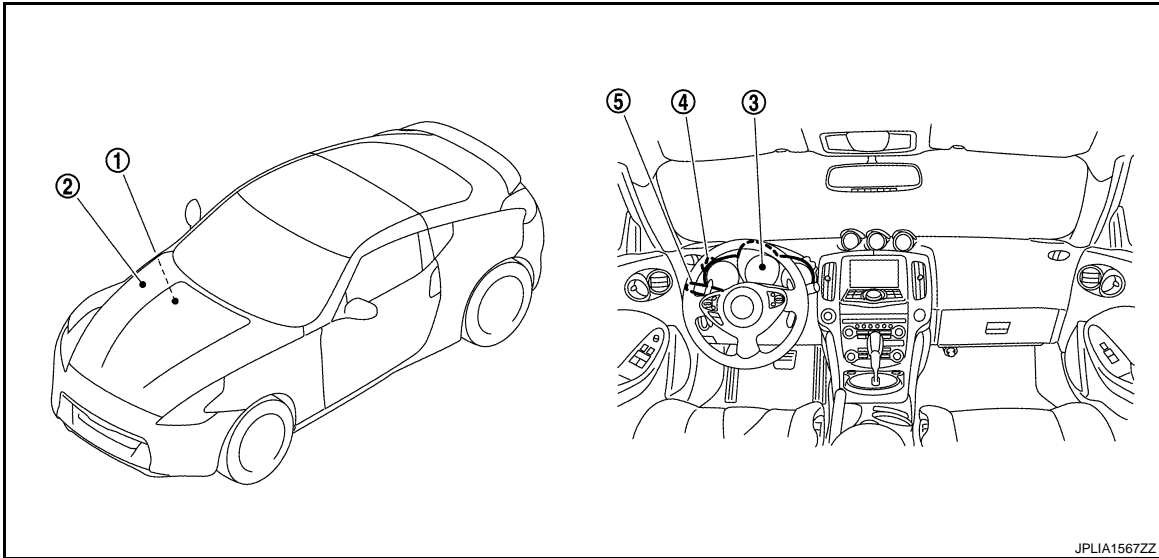

1. BCM
Refer to [BCS-8, "Component Parts Location"](#).
2. IPDM E/R
Refer to [PCS-5, "Component Parts Location"](#).
3. Combination meter
4. Illumination control switch
5. Combination switch

Component Description

INFOID:000000004402415

Part	Description
BCM	<ul style="list-style-type: none"> • Detects each switch condition by the combination switch reading function. • Judges the illumination lamp ON/OFF status depending on the vehicle condition. And then it transmits position light request signal to IPDM E/R and combination meter (with CAN communication).
IPDM E/R	Controls the integrated relay according to the request from BCM (with CAN communication).
Combination meter	<ul style="list-style-type: none"> • Enters in nighttime mode according to the request from BCM (with CAN communication). • Controls the each illumination in the nighttime mode. Refer to MWI-23, "METER ILLUMINATION CONTROL : System Diagram".
Combination switch (Lighting & turn signal switch)	Refer to BCS-9, "System Diagram" .

DIAGNOSIS SYSTEM (BCM)

< SYSTEM DESCRIPTION >

DIAGNOSIS SYSTEM (BCM)

COMMON ITEM

COMMON ITEM : CONSULT-III Function (BCM - COMMON ITEM)

INFOID:000000004703675

APPLICATION ITEM

CONSULT-III performs the following functions via CAN communication with BCM.

Diagnosis mode	Function Description
Work Support	Changes the setting for each system function.
Self Diagnostic Result	Displays the diagnosis results judged by BCM.
CAN Diag Support Monitor	Monitors the reception status of CAN communication viewed from BCM. Refer to CONSULT-III operation manual.
Data Monitor	The BCM input/output signals are displayed.
Active Test	The signals used to activate each device are forcibly supplied from BCM.
Ecu Identification	The BCM part number is displayed.
Configuration	<ul style="list-style-type: none"> Read and save the vehicle specification. Write the vehicle specification when replacing BCM.

SYSTEM APPLICATION

BCM can perform the following functions for each system.

NOTE:

It can perform the diagnosis modes except the following for all sub system selection items.

×: Applicable item

System	Sub system selection item	Diagnosis mode		
		Work Support	Data Monitor	Active Test
Door lock	DOOR LOCK	×	×	×
Rear window defogger	REAR DEFOGGER		×	×
Warning chime	BUZZER		×	×
Interior room lamp timer	INT LAMP	×	×	×
Exterior lamp	HEAD LAMP	×	×	×
Wiper and washer	WIPER	×	×	×
Turn signal and hazard warning lamps	FLASHER	×	×	×
—	AIR CONDITONER*			
<ul style="list-style-type: none"> Intelligent Key system Engine start system 	INTELLIGENT KEY	×	×	×
Combination switch	COMB SW		×	
Body control system	BCM	×		
IVIS - NATS	IMMU		×	×
Interior room lamp battery saver	BATTERY SAVER	×	×	×
Trunk lid open	TRUNK		×	×
Vehicle security system	THEFT ALM	×	×	×
RAP system	RETAINED PWR		×	
Signal buffer system	SIGNAL BUFFER		×	×
TPMS	TPMS (AIR PRESSURE MONITOR)	×	×	×

NOTE:

*: This item is displayed, but is not used.

FREEZE FRAME DATA (FFD)

The BCM records the following vehicle condition at the time a particular DTC is detected, and displays on CONSULT-III.

DIAGNOSIS SYSTEM (BCM)

< SYSTEM DESCRIPTION >

CONSULT screen item	Indication/Unit	Description		
Vehicle Speed	km/h	Vehicle speed of the moment a particular DTC is detected		A
Odo/Trip Meter	km	Total mileage (Odometer value) of the moment a particular DTC is detected		
Vehicle Condition	SLEEP>LOCK	Power position status of the moment a particular DTC is detected	While turning BCM status from low power consumption mode to normal mode (Power supply position is "LOCK")	B
	SLEEP>OFF		While turning BCM status from low power consumption mode to normal mode (Power supply position is "OFF".)	C
	LOCK>ACC		While turning power supply position from "LOCK" to "ACC"	
	ACC>ON		While turning power supply position from "ACC" to "IGN"	D
	RUN>ACC		While turning power supply position from "RUN" to "ACC" (Vehicle is stopping and selector lever is except P position.)	
	CRANK>RUN		While turning power supply position from "CRANKING" to "RUN" (From cranking up the engine to run it)	E
	RUN>URGENT		While turning power supply position from "RUN" to "ACC" (Emergency stop operation)	
	ACC>OFF		While turning power supply position from "ACC" to "OFF"	F
	OFF>LOCK		While turning power supply position from "OFF" to "LOCK"	
	OFF>ACC		While turning power supply position from "OFF" to "ACC"	G
	ON>CRANK		While turning power supply position from "IGN" to "CRANKING"	
	OFF>SLEEP		While turning BCM status from normal mode (Power supply position is "OFF".) to low power consumption mode	H
	LOCK>SLEEP		While turning BCM status from normal mode (Power supply position is "LOCK".) to low power consumption mode	
	LOCK		Power supply position is "LOCK" (Ignition switch OFF with steering is locked.)	I
	OFF		Power supply position is "OFF" (Ignition switch OFF with steering is unlocked.)	J
	ACC		Power supply position is "ACC" (Ignition switch ACC)	
	ON		Power supply position is "IGN" (Ignition switch ON with engine stopped)	K
ENGINE RUN	Power supply position is "RUN" (Ignition switch ON with engine running)			
CRANKING	Power supply position is "CRANKING" (At engine cranking)	INL		
IGN Counter	0 - 39	The number of times that ignition switch is turned ON after DTC is detected <ul style="list-style-type: none"> • The number is 0 when a malfunction is detected now. • The number increases like 1 → 2 → 3...38 → 39 after returning to the normal condition whenever ignition switch OFF → ON. • The number is fixed to 39 until the self-diagnosis results are erased if it is over 39. 		M

INT LAMP

DIAGNOSIS SYSTEM (BCM)

< SYSTEM DESCRIPTION >

INT LAMP : CONSULT-III Function (BCM - INT LAMP)

INFOID:000000004402417

WORK SUPPORT

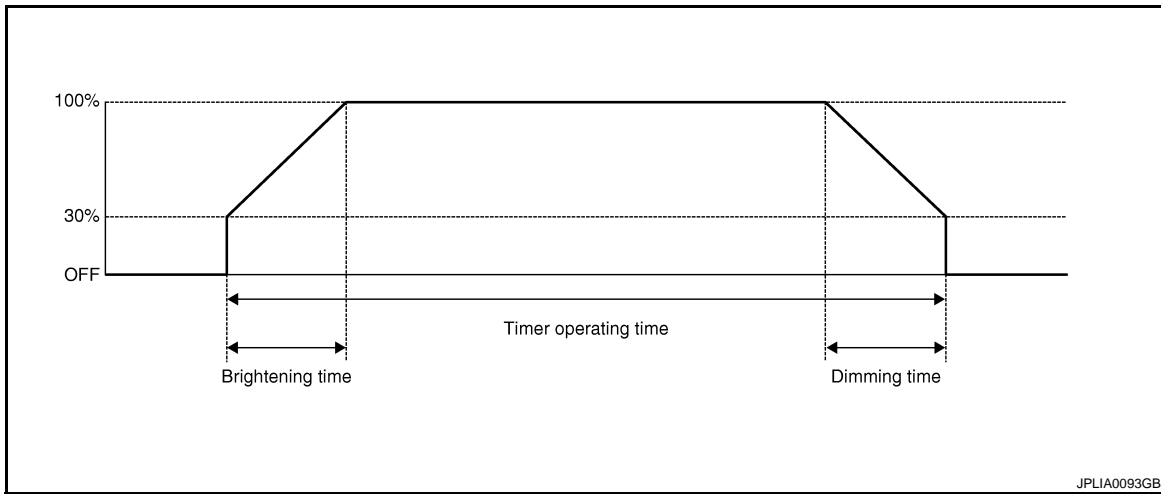

Service item	Setting item	Setting	
SET I/L D-UNLCK INTCON	ON*	With the interior room lamp timer function	
	OFF	Without the interior room lamp timer function	
ROOM LAMP TIMER SET	MODE 2	7.5 sec.	Sets the interior room lamp ON time. (Timer operating time)
	MODE 3*	15 sec.	
	MODE 4	30 sec.	
ROOM LAMP ON TIME SET	MODE 1	0.5 sec.	Sets the interior room lamp gradual brightening time.
	MODE 2*	1 sec.	
	MODE 3	2 sec.	
	MODE 4	3 sec.	
	MODE 5	0 sec.	
ROOM LAMP OFF TIME SET	MODE 1	0.5 sec.	Sets the interior room lamp gradual dimming time.
	MODE 2	1 sec.	
	MODE 3	2 sec.	
	MODE 4*	3 sec.	
	MODE 5	0 sec.	
R LAMP TIMER LOGIC SET	MODE 1*	Interior room lamp timer activates with synchronizing all doors.	
	MODE 2	Interior room lamp timer activates with synchronizing the driver door only.	

*: Factory setting

DATA MONITOR

Monitor item [Unit]	Description
REQ SW-DR [On/Off]	The switch status input from request switch (driver side)
REQ SW-AS [On/Off]	The switch status input from front request switch (passenger side)
REQ SW-RR [On/Off]	NOTE: The item is indicated, but not monitored.
REQ SW-RL [On/Off]	

DIAGNOSIS SYSTEM (BCM)

< SYSTEM DESCRIPTION >

Monitor item [Unit]	Description
PUSH SW [On/Off]	The switch status input from push-button ignition switch
ACC RLY-F/B [On/Off]	NOTE: The item is indicated, but not monitored.
UNLK SEN-DR [On/Off]	Driver door unlock status input from unlock sensor
KEY SW-SLOT [On/Off]	Key switch status input from key slot
DOOR SW-DR [On/Off]	The switch status input from driver side door switch
DOOR SW-AS [On/Off]	The switch status input from passenger side door switch
DOOR SW-RR [On/Off]	NOTE: The item is indicated, but not monitored.
DOOR SW-RL [On/Off]	
DOOR SW-BK [On/Off]	The switch status input from back door switch
CDL LOCK SW [On/Off]	Lock switch status received from the door lock and unlock switch
CDL UNLOCK SW [On/Off]	Unlock switch status received from the door lock and unlock switch
KEY CYL LK-SW [On/Off]	Lock switch status received from key cylinder switch
KEY CYL UN-SW [On/Off]	Unlock switch status received from key cylinder switch
TRNK/HAT MNTR [On/Off]	NOTE: The item is indicated, but not monitored.
RKE-LOCK [On/Off]	Lock signal status received from remote keyless entry receiver
RKE-UNLOCK [On/Off]	Unlock signal status received from remote keyless entry receiver

ACTIVE TEST

Test item	Operation	Description
INT LAMP	On	Outputs the interior room lamp control signal to turn map lamp ON (Map lamp switch is in DOOR position).
	Off	Stops the interior room lamp control signal to turn map lamp OFF.
STEP LAMP TEST	On	NOTE: The item is displayed, but cannot be tested.
	Off	
LUGGAGE LAMP TEST	On	Outputs the luggage room lamp control signal to turn the luggage room lamp ON.
	Off	Stops the luggage room lamp control signal to turn the luggage room lamp OFF.

BATTERY SAVER

BATTERY SAVER : CONSULT-III Function (BCM - BATTERY SAVER)

INFOID:000000004402418

WORK SUPPORT

DIAGNOSIS SYSTEM (BCM)

< SYSTEM DESCRIPTION >

Service item	Setting item	Setting	
BATTERY SAVER SET	On*	With the exterior lamp battery saver function	
	Off	Without the exterior lamp battery saver function	
ROOM LAMP BAT SAV SET	On*	With the interior room lamp battery saver function	
	Off	Without the interior room lamp battery saver function	
ROOM LAMP TIMER SET	MODE 1*	30 min.	Sets the interior room lamp battery saver timer operating time.
	MODE 2	60 min.	

*: Factory setting

DATA MONITOR

Monitor item [Unit]	Description
REQ SW-DR [On/Off]	The switch status input from request switch (driver side)
REQ SW-AS [On/Off]	The switch status input from front request switch (passenger side)
REQ SW-RR [On/Off]	NOTE: The item is indicated, but not monitored.
REQ SW-RL [On/Off]	
PUSH SW [On/Off]	The switch status input from push-button ignition switch
ACC RLY-F/B [On/Off]	NOTE: The item is indicated, but not monitored.
KEY SW-SLOT [On/Off]	Key switch status input from key slot
UNLK SEN-DR [On/Off]	Driver door unlock status input from unlock sensor
DOOR SW-DR [On/Off]	The switch status input driver side front door switch
DOOR SW-AS [On/Off]	The switch status input from passenger side door switch
DOOR SW-RR [On/Off]	NOTE: The item is indicated, but not monitored.
DOOR SW-RL [On/Off]	
DOOR SW-BK [On/Off]	The switch status input from back door switch
CDL LOCK SW [On/Off]	Lock switch status received from the door lock and unlock switch
CDL UNLOCK SW [On/Off]	Unlock switch status received from the door lock and unlock switch
KEY CYL LK-SW [On/Off]	Lock switch status received from key cylinder switch
KEY CYL UN-SW [On/Off]	Unlock switch status received from key cylinder switch
TRNK/HAT MNTR [On/Off]	NOTE: The item is indicated, but not monitored.
RKE-LOCK [On/Off]	Lock signal status received from remote keyless entry receiver
RKE-UNLOCK [On/Off]	Unlock signal status received from remote keyless entry receiver

DIAGNOSIS SYSTEM (BCM)

< SYSTEM DESCRIPTION >

ACTIVE TEST

Test item	Operation	Description
BATTERY SAVER	Off	Cuts the interior room lamp power supply to turn interior room lamp OFF.
	On	Outputs the interior room lamp power supply to turn interior room lamp ON.*

*: Each lamp switch is in ON position.

A

B

C

D

E

F

G

H

I

J

K

INL

M

N

O

P

POWER SUPPLY AND GROUND CIRCUIT

< DTC/CIRCUIT DIAGNOSIS >

DTC/CIRCUIT DIAGNOSIS

POWER SUPPLY AND GROUND CIRCUIT

BCM

BCM : Diagnosis Procedure

INFOID:000000004703677

1. CHECK FUSE AND FUSIBLE LINK

Check that the following fuse and fusible link are not blown.

Signal name	Fuse and fusible link No.
Battery power supply	K
	10

Is the fuse fusing?

YES >> Replace the blown fuse or fusible link after repairing the affected circuit if a fuse or fusible link is blown.

NO >> GO TO 2.

2. CHECK POWER SUPPLY CIRCUIT

1. Turn ignition switch OFF.
2. Disconnect BCM connectors.
3. Check voltage between BCM harness connector and ground.

Terminals		Voltage (Approx.)
(+)	(-)	
BCM		Ground Battery voltage
Connector	Terminal	
M118	1	
M119	11	

Is the measurement value normal?

YES >> GO TO 3.

NO >> Repair harness or connector.

3. CHECK GROUND CIRCUIT

Check continuity between BCM harness connector and ground.

BCM		Ground	Continuity
Connector	Terminal		
M119	13		Existed

Does continuity exist?

YES >> INSPECTION END

NO >> Repair harness or connector.

INTERIOR ROOM LAMP POWER SUPPLY CIRCUIT

< DTC/CIRCUIT DIAGNOSIS >

INTERIOR ROOM LAMP POWER SUPPLY CIRCUIT

Description

INFOID:000000004402420

Provides the interior room lamp power supply. Also cuts the power supply when the interior room lamp battery saver activating.

Component Function Check

INFOID:000000004402421

1. CHECK INTERIOR ROOM LAMP POWER SUPPLY FUNCTION

CONSULT-III ACTIVE TEST

1. Turn the ignition switch ON.
2. Turn each interior room lamp ON.
 - Map lamp
 - Vanity mirror lamp
 - Luggage room lamp
3. Select "BATTERY SAVER" of BCM (BATTERY SAVER) active test item.
4. With operating the test items, check that each interior room lamp turns ON/OFF.

Off : Interior room lamp OFF

On : Interior room lamp ON

Does the interior room lamp turn ON/OFF?

- YES >> Interior room lamp power supply circuit is normal.
NO >> Refer to [INL-19, "Diagnosis Procedure"](#).

Diagnosis Procedure

INFOID:000000004402422

1. CHECK INTERIOR ROOM LAMP POWER SUPPLY OUTPUT

CONSULT-III ACTIVE TEST

1. Turn the ignition switch ON.
2. Select "BATTERY SAVER" of BCM (BATTERY SAVER) active test item.
3. With operating the test item, check voltage between BCM harness connector and the ground.

Terminals		Test item	Voltage (Approx.)
(+)	(-)		
BCM		BATTERY SAVER	0 V
Connector	Terminal		
M119	4	Off	0 V
		On	Battery voltage

Is the measurement value normal?

- YES >> GO TO 2.
NO >> Replace BCM.

2. CHECK INTERIOR ROOM LAMP POWER SUPPLY OPEN CIRCUIT

1. Turn the ignition switch OFF.
2. Disconnect the following connectors.
 - Map lamp
 - Vanity mirror lamp (LH)
 - Vanity mirror lamp (RH)
 - Luggage room lamp
3. Check continuity between BCM harness connector and each interior room lamp harness connector.

INTERIOR ROOM LAMP POWER SUPPLY CIRCUIT

< DTC/CIRCUIT DIAGNOSIS >

BCM		Each interior room lamp			Continuity
Connector	Terminal	Connector		Terminal	
M119	4	Map lamp	R4	1	Existed
		Vanity mirror lamp (LH)	R2	2	
		Vanity mirror lamp (RH)	R3	2	
		Luggage room lamp	B53	1	

Does continuity exist?

YES >> GO TO 3.

NO >> Repair the harnesses or connectors.

3. CHECK INTERIOR ROOM LAMP POWER SUPPLY SHORT CIRCUIT

Check continuity between BCM harness connector and the ground.

BCM		Ground	Continuity
Connector	Terminal		
M119	4		Not existed

Does continuity exist?

YES >> Repair the harnesses or connectors.

NO >> Check that each interior room lamp has no internal short circuit.

INTERIOR ROOM LAMP CONTROL CIRCUIT

< DTC/CIRCUIT DIAGNOSIS >

INTERIOR ROOM LAMP CONTROL CIRCUIT

Description

INFOID:000000004402423

Controls each interior room lamp (ground side) by PWM signal.

NOTE:

PWM signal control period is approximately 250 Hz (in the gradual brightening/dimming).

Component Function Check

INFOID:000000004402424

CAUTION:

Before performing the diagnosis, check that the following is normal.

- Interior room lamp power supply
- Map lamp bulb

1.CHECK INTERIOR ROOM LAMP CONTROL FUNCTION

CONSULT-III ACTIVE TEST

1. Turn the ignition switch ON.
2. Switch the map lamp switch to DOOR.
3. Select "INT LAMP" of BCM (INT LAMP) active test item.
4. With operating the test items, check that each interior room lamp turns ON/OFF (gradual brightening/dimming).

On : Interior room lamp gradual brightening

Off : Interior room lamp gradual dimming

Does the interior room lamp turns ON/OFF (gradual brightening/dimming)?

YES >> Interior room lamp control circuit is normal.

NO >> Refer to [INL-21, "Diagnosis Procedure"](#).

Diagnosis Procedure

INFOID:000000004402425

1.CHECK INTERIOR ROOM LAMP CONTROL OUTPUT

CONSULT-III ACTIVE TEST

1. Turn the ignition switch OFF.
2. Remove all the bulbs of map lamp.
3. Turn the ignition switch ON.
4. Select "INT LAMP" of BCM (INT LAMP) active test item.
5. With operating the test item, check continuity between BCM harness connector and the ground.

BCM		Ground	Test item	Continuity
Connector	Terminal		INT LAMP	
M119	19		On	Existed
			Off	Not existed

Is the measurement value normal?

YES >> GO TO 2.

Fixed ON>>GO TO 3.

Fixed OFF>>Replace BCM.

2.CHECK INTERIOR ROOM LAMP CONTROL OPEN CIRCUIT

1. Turn the ignition switch OFF.
2. Disconnect BCM connector and map lamp connector.
3. Check continuity between BCM harness connector and map lamp harness connector.

INTERIOR ROOM LAMP CONTROL CIRCUIT

< DTC/CIRCUIT DIAGNOSIS >

BCM		Map lamp		Continuity
Connector	Terminal	Connector	Terminal	
M119	19	R4	2	Existed

Does continuity exist?

YES >> Replace the map lamp.

NO >> Repair the harnesses or connectors.

3. CHECK INTERIOR ROOM LAMP CONTROL SHORT CIRCUIT

1. Turn the ignition switch OFF.
2. Disconnect BCM connector and map lamp connector.
3. Check continuity between BCM harness connector and the ground.

BCM		Ground	Continuity
Connector	Terminal		
M119	19		Not existed

Does continuity exist?

YES >> Repair the harnesses or connectors.

NO >> Replace BCM.

LUGGAGE ROOM LAMP CIRCUIT

< DTC/CIRCUIT DIAGNOSIS >

LUGGAGE ROOM LAMP CIRCUIT

Description

INFOID:000000004402429

Controls the luggage room lamp (ground side) to turn the luggage room lamp ON and OFF.

Component Function Check

INFOID:000000004402430

CAUTION:

Before performing the diagnosis, check that the following is normal.

- Interior room lamp power supply
- Luggage room lamp bulb

1.CHECK LUGGAGE ROOM LAMP OPERATION

CONSULT-III ACTIVE TEST

1. Turn the ignition switch ON.
2. Select "LUGGAGE LAMP TEST" of BCM (INT LAMP) active test item.
3. With operating the test items, check that luggage room lamp turns ON/OFF.

On : Luggage room lamp ON

Off : Luggage room lamp OFF

Does the luggage room lamp turn ON/OFF?

- YES >> Luggage room lamp circuit is normal.
NO >> Refer to [INL-23, "Diagnosis Procedure"](#).

Diagnosis Procedure

INFOID:000000004402431

1.CHECK LUGGAGE ROOM LAMP OUTPUT

CONSULT-III ACTIVE TEST

1. Turn the ignition switch OFF.
2. Remove luggage room lamp bulb.
3. Turn the ignition switch ON.
4. Select "LUGGAGE LAMP TEST" of BCM (INT LAMP) active test item.
5. With operating the test item, check continuity between BCM harness connector and the ground.

BCM		Ground	Test item	Continuity
Connector	Terminal		LUGGAGE LAMP TEST	
M120	30		On	Existed
			Off	Not existed

Is the measurement value normal?

- YES >> GO TO 2.
Fixed ON>>GO TO 3.
Fixed OFF>>Replace BCM.

2.CHECK LUGGAGE ROOM LAMP OPEN CIRCUIT

1. Turn the ignition switch OFF.
2. Disconnect BCM connector and luggage room lamp connector.
3. Check continuity between BCM harness connector and luggage room lamp harness connector.

BCM		Luggage room lamp		Continuity
Connector	Terminal	Connector	Terminal	
M120	30	B53	2	Existed

Does continuity exist?

- YES >> Replace the luggage room lamp.

LUGGAGE ROOM LAMP CIRCUIT

< DTC/CIRCUIT DIAGNOSIS >

NO >> Repair the harnesses or connectors.

3.CHECK LUGGAGE ROOM LAMP SHORT CIRCUIT

1. Turn the ignition switch OFF.
2. Disconnect BCM connector and luggage room lamp connector.
3. Check continuity between BCM harness connector and the ground.

BCM		Ground	Continuity
Connector	Terminal		
M120	30		Not existed

Does continuity exist?

YES >> Repair the harnesses or connectors.

NO >> Replace BCM.

PUSH-BUTTON IGNITION SWITCH ILLUMINATION CIRCUIT

< DTC/CIRCUIT DIAGNOSIS >

PUSH-BUTTON IGNITION SWITCH ILLUMINATION CIRCUIT

Description

INFOID:000000004402432

Provides the power supply and the ground to control the push-button ignition switch illumination.

Component Function Check

INFOID:000000004402433

1.CHECK PUSH-BUTTON IGNITION SWITCH ILLUMINATION OPERATION

CONSULT-III ACTIVE TEST

1. Turn the ignition switch ON.
2. Select "ENGINE SW ILLUMI" of BCM (INTELLIGENT KEY) active test item.
3. With operating the test items, check that the push-button ignition switch illumination turns ON/OFF.

On : Push-button ignition switch illumination ON

Off : Push-button ignition switch illumination OFF

Does the push-button ignition switch illumination turn ON/OFF?

- YES >> Push-button ignition switch illumination circuit is normal.
NO >> Refer to [INL-25, "Diagnosis Procedure"](#).

Diagnosis Procedure

INFOID:000000004402434

1.CHECK ILLUMINATION CONTROL SWITCHING OPERATION

1. Turn the ignition switch ON.
2. With operating the lighting switch, check that the push-button ignition switch illumination turns ON/OFF.

Condition	Push-button ignition switch illumination
<ul style="list-style-type: none">• Ignition switch ON• Lighting switch 1ST	ON
<ul style="list-style-type: none">• Ignition switch OFF• Lighting switch OFF• Driver door LOCK	OFF

Does the push-button ignition switch illumination turn ON/OFF?

- YES >> GO TO 2.
NO >> GO TO 3.

2.CHECK PUSH-BUTTON IGNITION SWITCH ILLUMINATION GROUND CIRCUIT

1. Turn the ignition switch OFF.
2. Disconnect BCM connector and the push-button ignition switch connector.
3. Check continuity between BCM harness connector and the push-button ignition switch harness connector.

BCM		Push-button ignition switch		Continuity
Connector	Terminal	Connector	Terminal	
M119	14	M50	2	Existed

Does the continuity exist?

- YES >> Replace BCM.
NO >> Repair the harness or the connector.

3.CHECK PUSH-BUTTON IGNITION SWITCH ILLUMINATION POWER SUPPLY OUTPUT

CONSULT-III ACTIVE TEST

1. Turn the ignition switch ON.
2. Select "ENGINE SW ILLUMI" of BCM (INTELLIGENT KEY) active test item.
3. With operating the test item, check voltage between BCM harness connector and the ground.

PUSH-BUTTON IGNITION SWITCH ILLUMINATION CIRCUIT

< DTC/CIRCUIT DIAGNOSIS >

Terminals		Test item	Voltage (Approx.)
(+)	(-)		
BCM		ENGINE SW ILLUMI	5 V
Connector	Terminal		
M123	133	ON	5 V
		OFF	0 V

Is the measurement value normal?

- YES >> GO TO 4.
NO >> GO TO 5.

4. CHECK PUSH-BUTTON IGNITION SWITCH ILLUMINATION POWER SUPPLY OPEN CIRCUIT

1. Turn the ignition switch OFF.
2. Disconnect BCM connector and the push-button ignition switch connector.
3. Check continuity between BCM harness connector and the push-button ignition switch harness connector.

BCM		Push-button ignition switch		Continuity
Connector	Terminal	Connector	Terminal	
M123	133	M50	3	Existed

Does the continuity exist?

- YES >> Replace the push-button ignition switch.
NO >> Repair the harness or the connector.

5. CHECK PUSH-BUTTON IGNITION SWITCH ILLUMINATION POWER SUPPLY SHORT CIRCUIT

1. Turn the ignition switch OFF.
2. Disconnect BCM connector and the push-button ignition switch connector.
3. Check continuity between BCM harness connector and the ground.

BCM		Ground	Continuity
Connector	Terminal		
M123	133		Not existed

Does the continuity exist?

- YES >> Repair the harness or the connector.
NO >> Replace BCM.

INTERIOR ROOM LAMP CONTROL SYSTEM

< DTC/CIRCUIT DIAGNOSIS >

INTERIOR ROOM LAMP CONTROL SYSTEM

Wiring Diagram - INTERIOR ROOM LAMP -

INFOID:000000004402435

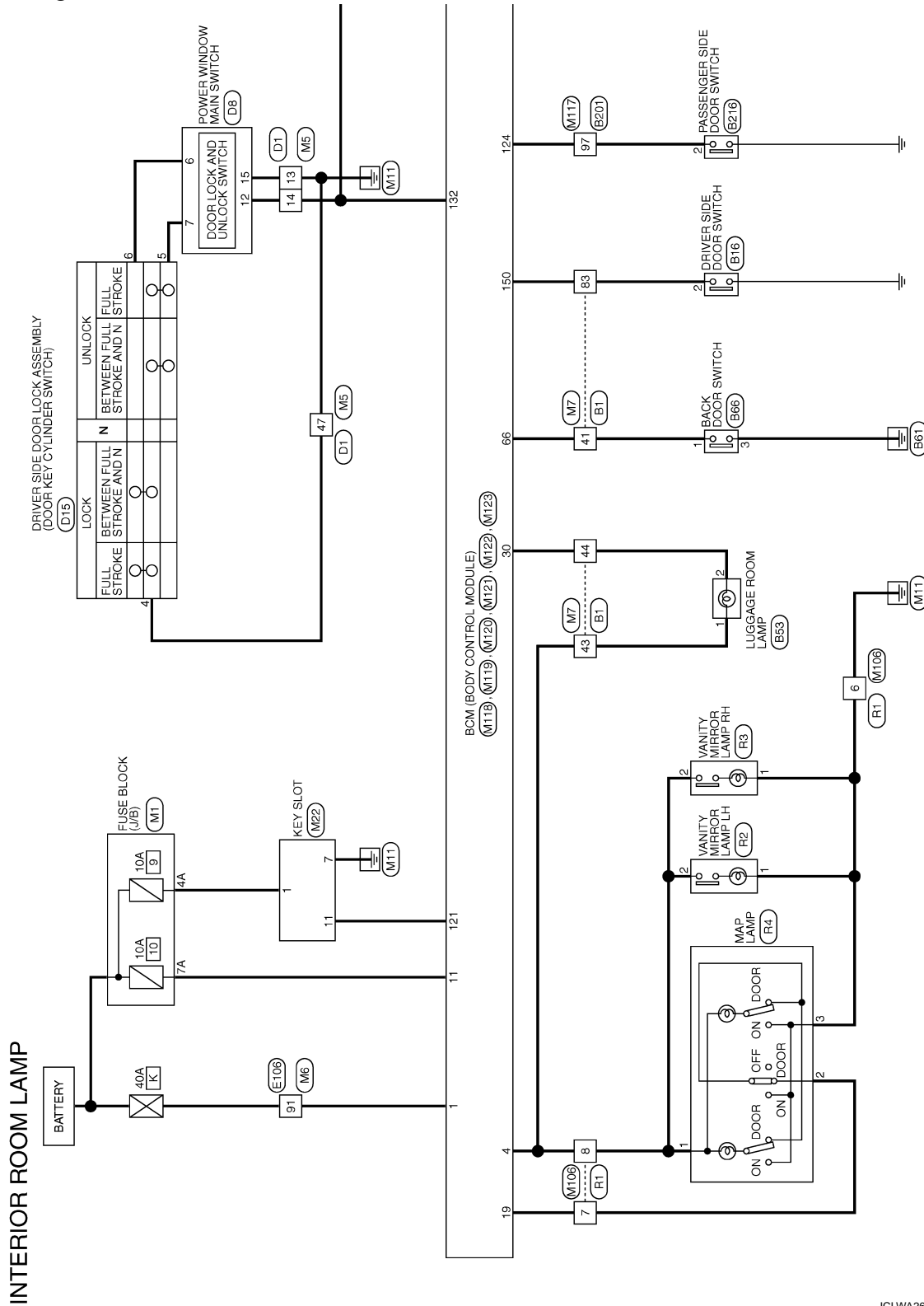

2008/09/12

JCLWA2635GB

A
B
C
D
E
F
G
H
I
J
K
L
M
N
O
P

INL

INTERIOR ROOM LAMP CONTROL SYSTEM

< DTC/CIRCUIT DIAGNOSIS >

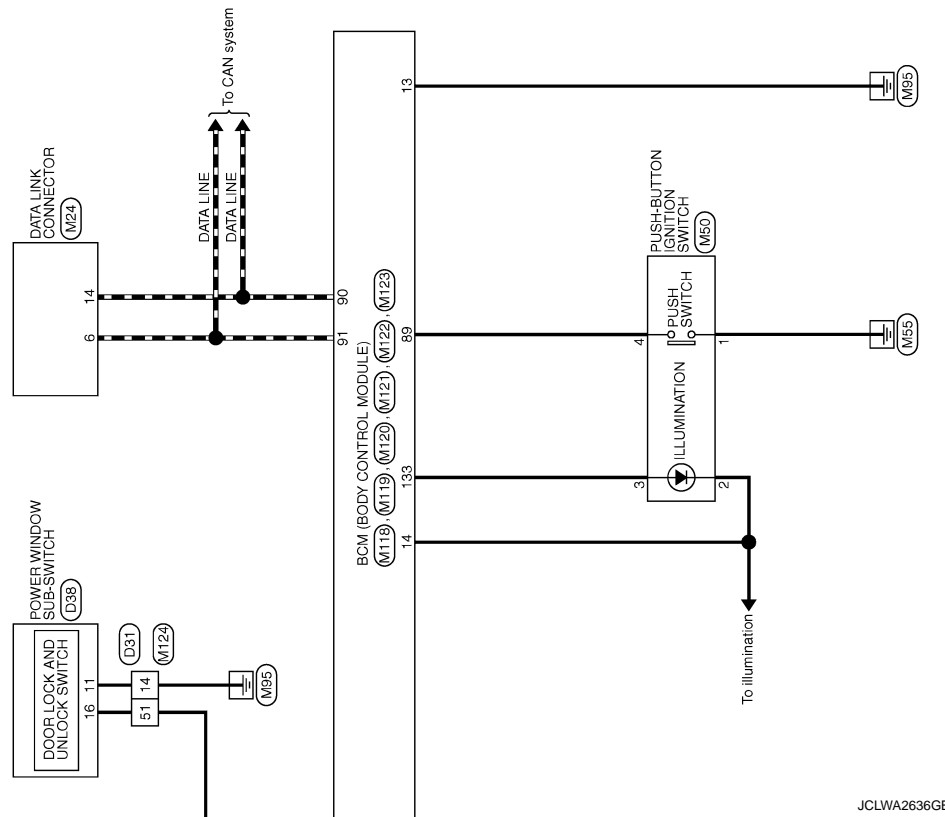

JCLWA2636GB

INTERIOR ROOM LAMP CONTROL SYSTEM

< DTC/CIRCUIT DIAGNOSIS >

INTERIOR ROOM LAMP

Connector No.	B1
Connector Name	WIRE TO WIRE
Connector Type	TH40FW-CS16-TM4

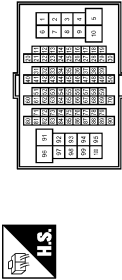

Terminal No.	Color of Wire	Signal Name [Specification]
41	L	-
43	BR	-
44	R	-
83	GR	-

Connector No.	B16
Connector Name	DRIVER SIDE DOOR SWITCH
Connector Type	A03FW



Terminal No.	Color of Wire	Signal Name [Specification]
2	GR	-

Connector No.	B53
Connector Name	LUGGAGE ROOM LAMP
Connector Type	C-02EFGY



Terminal No.	Color of Wire	Signal Name [Specification]
1	BR	-
2	R	-

Connector No.	B66
Connector Name	BACK DOOR SWITCH
Connector Type	A03FW



Terminal No.	Color of Wire	Signal Name [Specification]
1	L	-
3	B	-

Connector No.	B201
Connector Name	WIRE TO WIRE
Connector Type	TH40FW-CS16-TM4

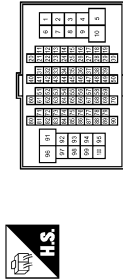

Terminal No.	Color of Wire	Signal Name [Specification]
97	LG	-

Connector No.	B216
Connector Name	PASSENGER SIDE DOOR SWITCH
Connector Type	A03FW



Terminal No.	Color of Wire	Signal Name [Specification]
2	LG	-

Connector No.	D1
Connector Name	WIRE TO WIRE
Connector Type	TH40FW-CS15

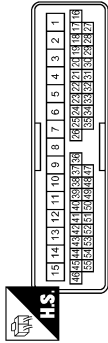

Terminal No.	Color of Wire	Signal Name [Specification]
13	B	-
14	SB	-
47	B	-

Connector No.	D8
Connector Name	POWER WINDOW MAIN SWITCH
Connector Type	NS16FW-CS

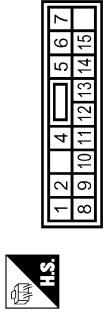

Terminal No.	Color of Wire	Signal Name [Specification]
6	GR	-
7	V	-
12	SB	-
15	B	-

A
B
C
D
E
F
G
H
I
J
K
L
M
N
O
P

INL

INTERIOR ROOM LAMP CONTROL SYSTEM

< DTC/CIRCUIT DIAGNOSIS >

INTERIOR ROOM LAMP

Connector No.	D15
Connector Name	DRIVER SIDE DOOR LOCK ASSEMBLY
Connector Type	EMFGY-RS



Terminal No.	Color of Wire	Signal Name [Specification]
4	B	
5	V	
6	GR	

Connector No.	D31
Connector Name	WIRE TO WIRE
Connector Type	TH40FW-CS15

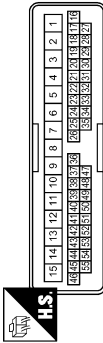

Terminal No.	Color of Wire	Signal Name [Specification]
14	B	
51	Y	

Connector No.	D38
Connector Name	POWER WINDOW SUB-SWITCH
Connector Type	NS16FW-CS

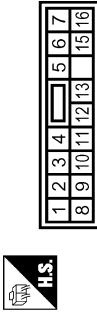

Terminal No.	Color of Wire	Signal Name [Specification]
11	B	
16	Y	

Connector No.	E106
Connector Name	WIRE TO WIRE
Connector Type	TH80FW-CS16-TM4

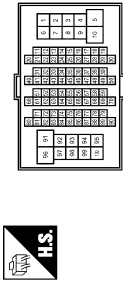

Terminal No.	Color of Wire	Signal Name [Specification]
91	W	

Connector No.	M1
Connector Name	FUSE BLOCK (J/B)
Connector Type	NS80FW-MZ



Terminal No.	Color of Wire	Signal Name [Specification]
4A	P	
7A	BR	

Connector No.	M5
Connector Name	WIRE TO WIRE
Connector Type	TH40MW-CS15

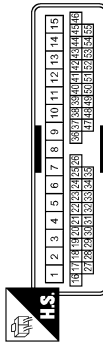

Terminal No.	Color of Wire	Signal Name [Specification]
13	B	
14	Y	
47	B	

Connector No.	M6
Connector Name	WIRE TO WIRE
Connector Type	TH80MW-CS16-TM4



Terminal No.	Color of Wire	Signal Name [Specification]
91	W	

Connector No.	M7
Connector Name	WIRE TO WIRE
Connector Type	TH80MW-CS16-TM4



Terminal No.	Color of Wire	Signal Name [Specification]
41	R	
43	R	
44	R	
83	GR	

JCLWA2638GB

INTERIOR ROOM LAMP CONTROL SYSTEM

< DTC/CIRCUIT DIAGNOSIS >

INTERIOR ROOM LAMP

Connector No.	M22
Connector Name	KEY SLOT
Connector Type	TH12FW-NH

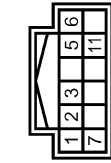

Terminal No.	Color of Wire	Signal Name [Specification]
1	P	BAT
7	B	GND
11	R	KEY SWITCH SIGNAL

Connector No.	M24
Connector Name	DATA LINK CONNECTOR
Connector Type	BD16FW

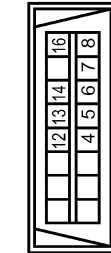

Terminal No.	Color of Wire	Signal Name [Specification]
6	L	-
14	P	-

Connector No.	M80
Connector Name	PUSH-BUTTON IGNITION SWITCH
Connector Type	TK08FBR

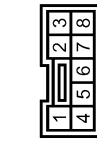

Terminal No.	Color of Wire	Signal Name [Specification]
1	B	-
2	R	-
3	G	-
4	BR	-

Connector No.	M106
Connector Name	WIRE TO WIRE
Connector Type	TH16MF-NH

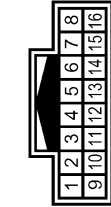

Terminal No.	Color of Wire	Signal Name [Specification]
6	B	-
7	V	-
8	R	-

Connector No.	M117
Connector Name	WIRE TO WIRE
Connector Type	TH80MW-CS16-TM4



Terminal No.	Color of Wire	Signal Name [Specification]
97	LG	-

Connector No.	M118
Connector Name	BCM (BODY CONTROL MODULE)
Connector Type	MG0FB-LC



Terminal No.	Color of Wire	Signal Name [Specification]
1	W	BAT (F/L)

Connector No.	M119
Connector Name	BCM (BODY CONTROL MODULE)
Connector Type	NS16FW-CS

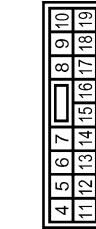

Terminal No.	Color of Wire	Signal Name [Specification]
4	R	INTERIOR ROOM LAMP POWER SUPPLY
11	BR	BAT. (FUSE)
13	B	GND
14	R	PUSH-BUTTON IGNITION SW ILL GND
19	V	ROOM LAMP-TIMER CONT

Connector No.	M120
Connector Name	BCM (BODY CONTROL MODULE)
Connector Type	NS12FW-CS

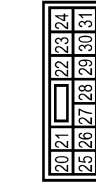

Terminal No.	Color of Wire	Signal Name [Specification]
30	R	LUGGAGE ROOM LAMP OUTPUT

JCLWA2639GB

A
B
C
D
E
F
G
H
I
J
K
L
M
N
O
P

INL

INTERIOR ROOM LAMP CONTROL SYSTEM

< DTC/CIRCUIT DIAGNOSIS >

INTERIOR ROOM LAMP

Connector No.	M121
Connector Name	BCM (BODY CONTROL MODULE)
Connector Type	TH10FG-NH

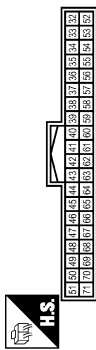

Terminal No.	Color of Wire	Signal Name [Specification]
66	R	BACK DOOR SW

Connector No.	M122
Connector Name	BCM (BODY CONTROL MODULE)
Connector Type	TH40FB-NH

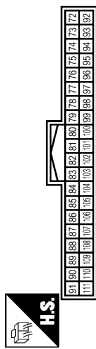

Terminal No.	Color of Wire	Signal Name [Specification]
89	BR	PUSH SW
90	P	CAN-L
91	L	CAN-H

Connector No.	M123
Connector Name	BCM (BODY CONTROL MODULE)
Connector Type	TH40FG-NH

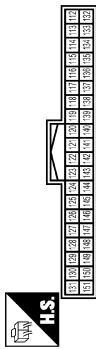

Terminal No.	Color of Wire	Signal Name [Specification]
121	R	KEY SLOT SW
124	LG	PASSENGER DOOR SW
132	Y	POWER WINDOW SW COMM
133	G	PUSH BUTTON IGNITION SW ILL POWER
150	GR	DRIVER DOOR SW

Connector No.	M124
Connector Name	WIRE TO WIRE
Connector Type	TH40MW-GS15

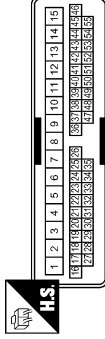

Terminal No.	Color of Wire	Signal Name [Specification]
51	B	
	Y	

Connector No.	R1
Connector Name	WIRE TO WIRE
Connector Type	TH10FW-NH

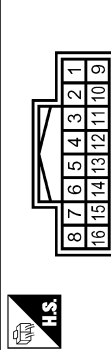

Terminal No.	Color of Wire	Signal Name [Specification]
6	B	
7	V	
8	R	

Connector No.	R2
Connector Name	VANITY MIRROR LAMP LH
Connector Type	MC402FW

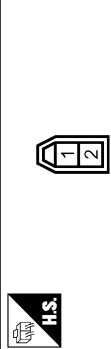

Terminal No.	Color of Wire	Signal Name [Specification]
1	B	
2	R	

Connector No.	R3
Connector Name	VANITY MIRROR LAMP RH
Connector Type	MC402FW



Terminal No.	Color of Wire	Signal Name [Specification]
1	B	
2	R	

Connector No.	R4
Connector Name	MAP LAMP
Connector Type	TK08FGY

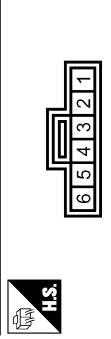

Terminal No.	Color of Wire	Signal Name [Specification]
1	R	
2	V	
3	B	

JCLWA2640GB

ILLUMINATION

< DTC/CIRCUIT DIAGNOSIS >

ILLUMINATION

Wiring Diagram - ILLUMINATION -

INFOID:000000004402436

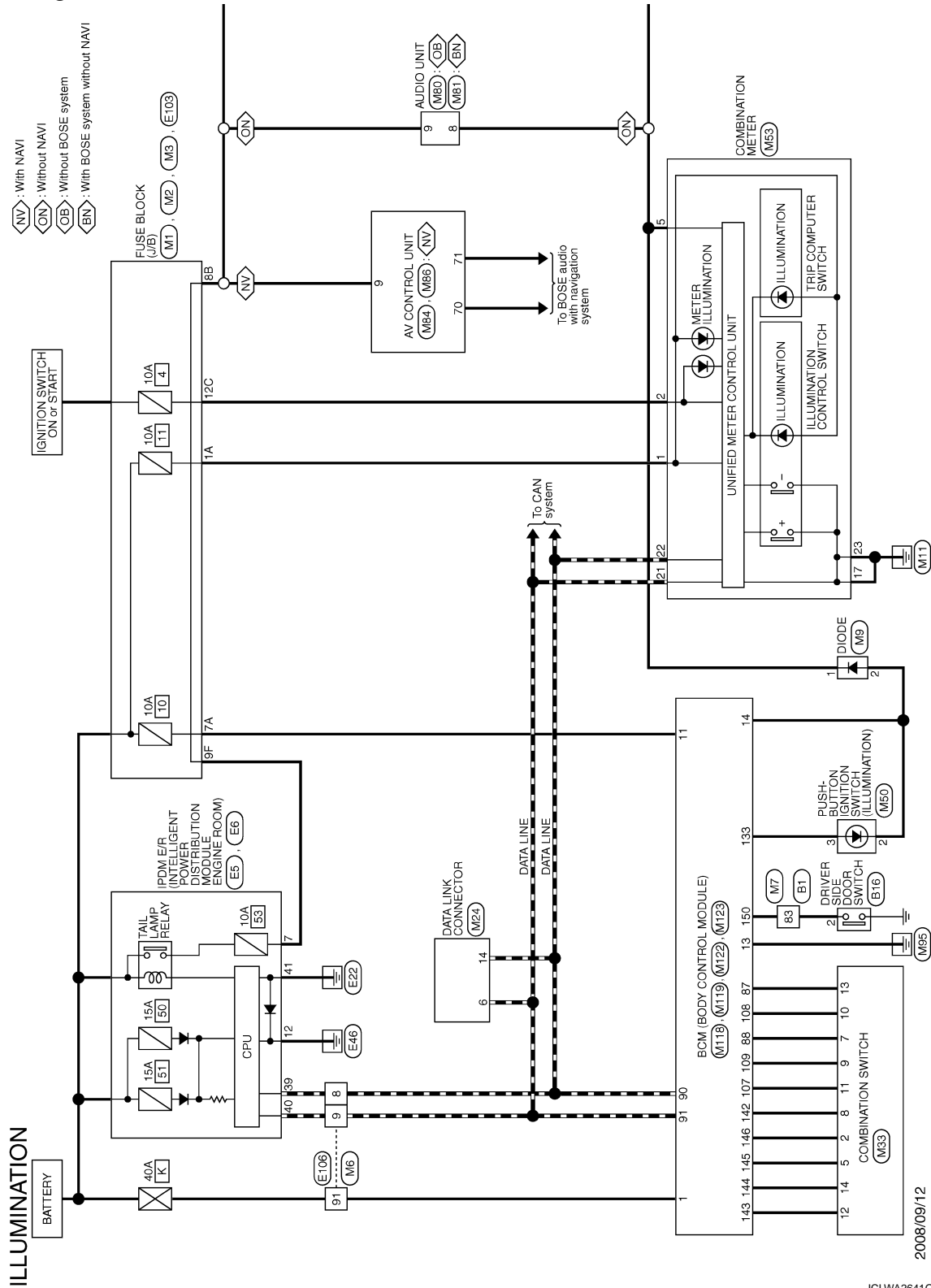

A
B
C
D
E
F
G
H
I
J
K
L
M
N
O
P

INL

ILLUMINATION

< DTC/CIRCUIT DIAGNOSIS >

- ◁ A ▷ : With A/T
- ◁ M ▷ : With M/T
- ◁ WP ▷ : With power seat
- ◁ ON ▷ : Without NAVI

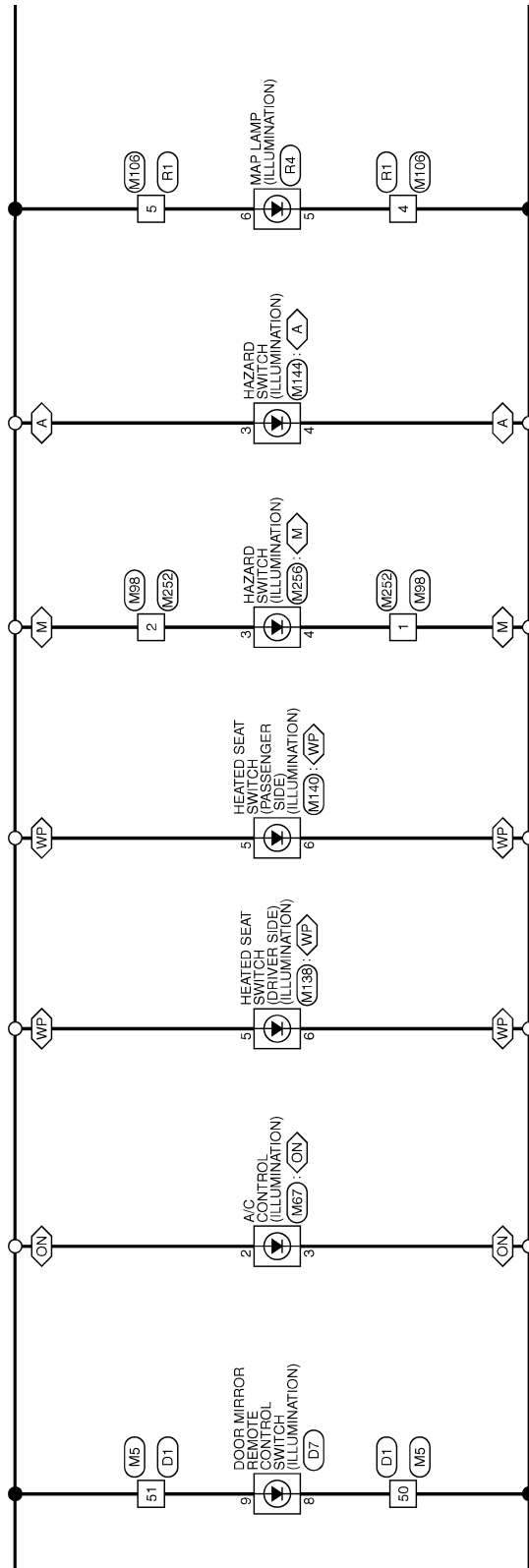

JCLWA2642GB

ILLUMINATION

< DTC/CIRCUIT DIAGNOSIS >

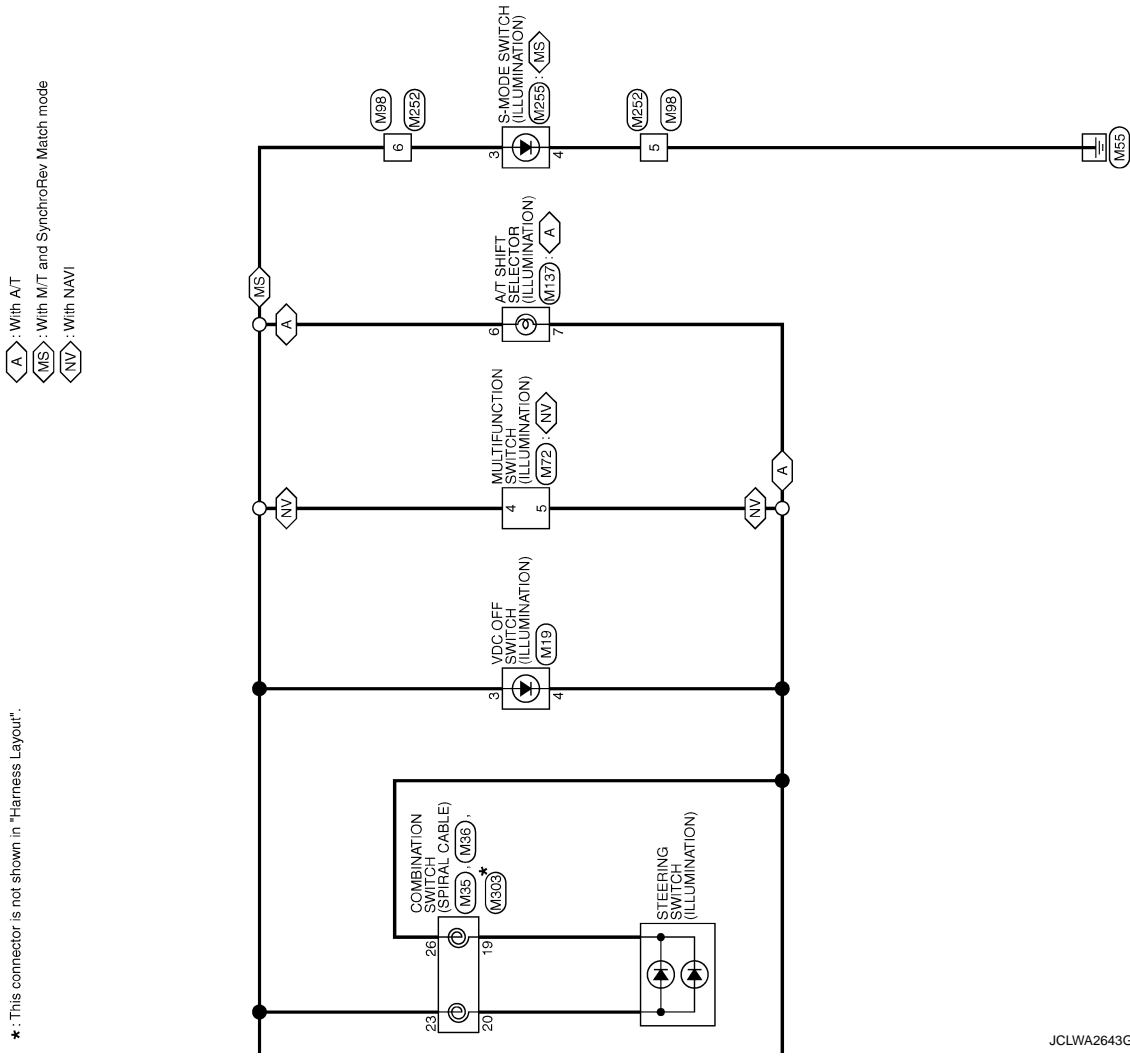

A
B
C
D
E
F
G
H
I
J
K
INL
M
N
O
P

ILLUMINATION

< DTC/CIRCUIT DIAGNOSIS >

ILLUMINATION

Connector No.	M1	Connector No.	M2	Connector No.	M3	Connector No.	M5
Connector Name	FUSE BLOCK (J/B)	Connector Name	FUSE BLOCK (J/B)	Connector Name	FUSE BLOCK (J/B)	Connector Name	WIRE TO WIRE
Connector Type	NS06FW-M2	Connector Type	NS10FW-CS	Connector Type	NS12FW-CS	Connector Type	TH40MW-CS15

Terminal No.	1A	7A	3A	2A	1A	1	2	3	4	5	6	7	8	9	10	11	12	13	14	15	
Color of Wire	V	BR																			
Signal Name [Specification]																					

Terminal No.	8B	Color of Wire	R	Signal Name [Specification]	
Terminal No.	8B	Color of Wire	R	Signal Name [Specification]	

Terminal No.	12C	Color of Wire	O	Signal Name [Specification]	
Terminal No.	12C	Color of Wire	O	Signal Name [Specification]	

Terminal No.	50	Color of Wire	W	Signal Name [Specification]	
Terminal No.	51	Color of Wire	R	Signal Name [Specification]	

Connector No.	M6	Connector No.	M7	Connector No.	M8	Connector No.	M9
Connector Name	WIRE TO WIRE	Connector Name	WIRE TO WIRE	Connector Name	DIODE	Connector Name	VDC OFF SWITCH
Connector Type	TH60MW-CS16-TM4	Connector Type	TH60MW-CS16-TM4	Connector Type	2435F-C9600	Connector Type	TK04FW

Terminal No.	8	Color of Wire	P	Signal Name [Specification]	
Terminal No.	9	Color of Wire	L	Signal Name [Specification]	
Terminal No.	91	Color of Wire	W	Signal Name [Specification]	

Terminal No.	83	Color of Wire	GR	Signal Name [Specification]	
Terminal No.	83	Color of Wire	GR	Signal Name [Specification]	

Terminal No.	1	Color of Wire	W	Signal Name [Specification]	
Terminal No.	2	Color of Wire	R	Signal Name [Specification]	

Terminal No.	3	Color of Wire	R	Signal Name [Specification]	
Terminal No.	4	Color of Wire	W	Signal Name [Specification]	

JCLWA2645GB

A
B
C
D
E
F
G
H
I
J
K
L
M
N
O
P

INL

ILLUMINATION

< DTC/CIRCUIT DIAGNOSIS >

ILLUMINATION

Connector No.	M24
Connector Name	DATA LINK CONNECTOR
Connector Type	BD16FW

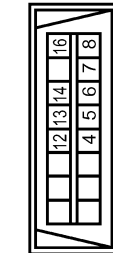

Terminal No.	Color of Wire	Signal Name [Specification]
6	L	—
14	P	—

Connector No.	M33
Connector Name	COMBINATION SWITCH
Connector Type	TH16FW-NH

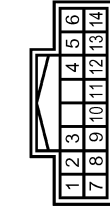

Terminal No.	Color of Wire	Signal Name [Specification]
2	SB	OUTPUT 4
5	L	OUTPUT 3
7	V	INPUT 3
8	O	OUTPUT 5
9	Y	INPUT 2
10	R	INPUT 4
11	LG	INPUT 1
12	P	OUTPUT 1
13	BR	INPUT 5
14	G	OUTPUT 2

Connector No.	M35
Connector Name	COMBINATION SWITCH (SPIRAL CABLE)
Connector Type	TK08FY-EX-IV



Terminal No.	Color of Wire	Signal Name [Specification]
23	W	—

Connector No.	M36
Connector Name	COMBINATION SWITCH (SPIRAL CABLE)
Connector Type	TK08FY-IV

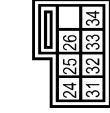

Terminal No.	Color of Wire	Signal Name [Specification]
26	W	—

Connector No.	M50
Connector Name	PUSH-BUTTON (IGNITION SWITCH)
Connector Type	TK08FBR

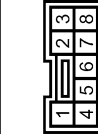

Terminal No.	Color of Wire	Signal Name [Specification]
2	R	—
3	G	—

Connector No.	M53
Connector Name	COMBINATION METER
Connector Type	TH24FW-NH

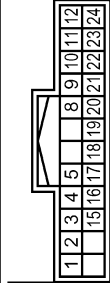

Terminal No.	Color of Wire	Signal Name [Specification]
1	V	BATTERY POWER SUPPLY
2	O	IGNITION SIGNAL
5	B	ILLUMINATION CONTROL SIGNAL
17	B	GROUND
21	L	CAN-H
22	P	CAN-L
23	B	GROUND

Connector No.	M67
Connector Name	A/C CONTROL
Connector Type	TH10FB-NH

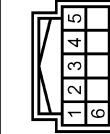

Terminal No.	Color of Wire	Signal Name [Specification]
2	R	ILL+
3	BR	ILL-

Connector No.	M72
Connector Name	MULTIFUNCTION SWITCH
Connector Type	TH16FW-NH

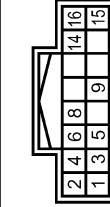

Terminal No.	Color of Wire	Signal Name [Specification]
4	R	ILL
5	W	ILL COMT

JCLWA2646GB

ILLUMINATION

< DTC/CIRCUIT DIAGNOSIS >

ILLUMINATION

Connector No.	M80
Connector Name	AUDIO UNIT
Connector Type	TH18FW-CSZ

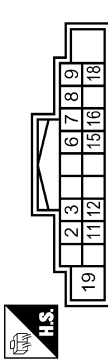

Terminal No.	Color of Wire	Signal Name [Specification]
8	W	ILL(-)
9	R	ILL(+)

Connector No.	M81
Connector Name	AUDIO UNIT
Connector Type	TH18FW-CSZ

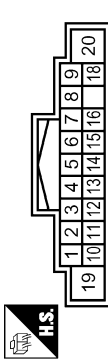

Terminal No.	Color of Wire	Signal Name [Specification]
8	W	ILL(-)
9	R	ILL(+)

Connector No.	M84
Connector Name	AV CONTROL UNIT
Connector Type	TH18FW-CSZ

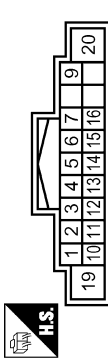

Terminal No.	Color of Wire	Signal Name [Specification]
9	R	ILLUMINATION

Connector No.	M88
Connector Name	AV CONTROL UNIT
Connector Type	TH12FW-NH

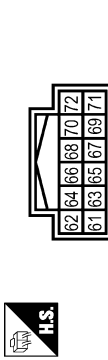

Terminal No.	Color of Wire	Signal Name [Specification]
70	R	COMM (CONT->DISP)
71	G	COMM (DISP->CONT)

Connector No.	M88
Connector Name	WIRE TO WIRE
Connector Type	TH18FW-NH

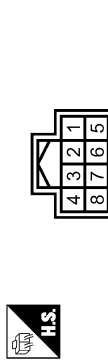

Terminal No.	Color of Wire	Signal Name [Specification]
1	B	-
2	B	-
5	B	-
6	L	-

Connector No.	M105
Connector Name	WIRE TO WIRE
Connector Type	TH18MW-NH



Terminal No.	Color of Wire	Signal Name [Specification]
4	W	-
5	R	-

Connector No.	M118
Connector Name	BCM (BODY CONTROL MODULE)
Connector Type	M03FB-LC



Terminal No.	Color of Wire	Signal Name [Specification]
1	W	BAT (F/L)

Connector No.	M119
Connector Name	BCM (BODY CONTROL MODULE)
Connector Type	NS16FW-CS

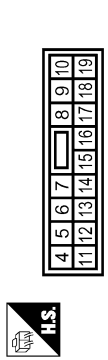

Terminal No.	Color of Wire	Signal Name [Specification]
11	BR	BAT FUSE
13	B	GND
14	R	PUSH-BUTTON IGNITION SW ILL GND

A
B
C
D
E
F
G
H
I
J
K
L
M
N
O
P

INL

JCLWA2647GB

ILLUMINATION

< DTC/CIRCUIT DIAGNOSIS >

ILLUMINATION

Connector No.	M122
Connector Name	BOM (BODY CONTROL MODULE)
Connector Type	TH0FB-NH



Terminal No.	Color of Wire	Signal Name [Specification]
87	BR	COMBI SW INPUT 5
88	V	COMBI SW INPUT 3
90	P	CAN-L
91	L	CAN-H
107	LG	COMBI SW INPUT 1
108	R	COMBI SW INPUT 4
109	Y	COMBI SW INPUT 2

Connector No.	M123
Connector Name	BOM (BODY CONTROL MODULE)
Connector Type	TH0FG-NH



Terminal No.	Color of Wire	Signal Name [Specification]
133	G	PUSH BUTTON IGNITION SW ILL POWER
142	O	COMBI SW OUTPUT 5
143	P	COMBI SW OUTPUT 1
144	G	COMBI SW OUTPUT 2
145	L	COMBI SW OUTPUT 3
146	SB	COMBI SW OUTPUT 4
150	GR	DRIVER DOOR SW

Connector No.	M137
Connector Name	A/T SHIFT SELECTOR
Connector Type	TK10FW



Terminal No.	Color of Wire	Signal Name [Specification]
6	R	-
7	W	-

Connector No.	M138
Connector Name	HEATED SEAT SWITCH (DRIVER SIDE)
Connector Type	NS06FW-CS

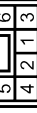

Terminal No.	Color of Wire	Signal Name [Specification]
5	R	-
6	W	-

Connector No.	M140
Connector Name	HEATED SEAT SWITCH (PASSENGER SIDE)
Connector Type	NS06FB-CS



Terminal No.	Color of Wire	Signal Name [Specification]
5	R	-
6	W	-

Connector No.	M144
Connector Name	HAZARD SWITCH (WITH A/T)
Connector Type	TK04FW



Terminal No.	Color of Wire	Signal Name [Specification]
3	R	ILL+
4	B	ILL-

Connector No.	M252
Connector Name	WIRE TO WIRE
Connector Type	TH08MW-NH



Terminal No.	Color of Wire	Signal Name [Specification]
1	O	-
2	SB	-
5	B	-
6	L	-

Connector No.	M255
Connector Name	S-MODE SWITCH
Connector Type	TK04FGY



Terminal No.	Color of Wire	Signal Name [Specification]
3	L	-
4	B	-

JCLWA2648GB

BCM (BODY CONTROL MODULE)

< ECU DIAGNOSIS INFORMATION >

ECU DIAGNOSIS INFORMATION

BCM (BODY CONTROL MODULE)

Reference Value

INFOID:000000004703678

VALUES ON THE DIAGNOSIS TOOL

CONSULT-III MONITOR ITEM

Monitor Item	Condition	Value/Status
FR WIPER HI	Other than front wiper switch HI	Off
	Front wiper switch HI	On
FR WIPER LOW	Other than front wiper switch LO	Off
	Front wiper switch LO	On
FR WASHER SW	Front washer switch OFF	Off
	Front washer switch ON	On
FR WIPER INT	Other than front wiper switch INT	Off
	Front wiper switch INT	On
FR WIPER STOP	Front wiper is not in STOP position	Off
	Front wiper is in STOP position	On
INT VOLUME	Wiper intermittent dial is in a dial position 1 - 7	Wiper intermittent dial position
TURN SIGNAL R	Other than turn signal switch RH	Off
	Turn signal switch RH	On
TURN SIGNAL L	Other than turn signal switch LH	Off
	Turn signal switch LH	On
TAIL LAMP SW	Other than lighting switch 1ST and 2ND	Off
	Lighting switch 1ST or 2ND	On
HI BEAM SW	Other than lighting switch HI	Off
	Lighting switch HI	On
HEAD LAMP SW 1	Other than lighting switch 2ND	Off
	Lighting switch 2ND	On
HEAD LAMP SW 2	Other than lighting switch 2ND	Off
	Lighting switch 2ND	On
PASSING SW	Other than lighting switch PASS	Off
	Lighting switch PASS	On
AUTO LIGHT SW	Other than lighting switch AUTO	Off
	Lighting switch AUTO	On
FR FOG SW	NOTE: The item is indicated, but not monitored.	Off
RR FOG SW	Rear fog lamp switch OFF	Off
	Rear fog lamp switch ON	On
DOOR SW-DR	Driver door closed	Off
	Driver door opened	On
DOOR SW-AS	Passenger door closed	Off
	Passenger door opened	On
DOOR SW-RR	NOTE: The item is indicated, but not monitored.	Off

BCM (BODY CONTROL MODULE)

< ECU DIAGNOSIS INFORMATION >

Monitor Item	Condition	Value/Status	
DOOR SW-RL	NOTE: The item is indicated, but not monitored.	Off	A
DOOR SW-BK	Back door closed	Off	B
	Back door opened	On	
CDL LOCK SW	Other than door lock and unlock switch LOCK	Off	C
	Door lock and unlock switch LOCK	On	
CDL UNLOCK SW	Other than door lock and unlock switch UNLOCK	Off	D
	Door lock and unlock switch UNLOCK	On	
KEY CYL LK-SW	Other than driver door key cylinder LOCK position	Off	E
	Driver door key cylinder LOCK position	On	
KEY CYL UN-SW	Other than driver door key cylinder UNLOCK position	Off	E
	Driver door key cylinder UNLOCK position	On	
KEY CYL SW-TR	NOTE: The item is indicated, but not monitored.	Off	F
HAZARD SW	Hazard switch is OFF	Off	G
	Hazard switch is ON	On	
REAR DEF SW NOTE: At models with NAVI this item is not monitored.	Rear window defogger switch OFF	Off	H
	Rear window defogger switch ON	On	
H/L WASH SW	NOTE: The item is indicated, but not monitored.	Off	I
TR CANCEL SW	NOTE: The item is indicated, but not monitored.	Off	I
TR/BD OPEN SW	Back door opener switch OFF	Off	J
	While the back door opener switch is turned ON	On	
TRNK/HAT MNTR	NOTE: The item is indicated, but not monitored.	Off	K
RKE-LOCK	LOCK button of the Intelligent Key is not pressed	Off	K
	LOCK button of the Intelligent Key is pressed	On	
RKE-UNLOCK	UNLOCK button of the Intelligent Key is not pressed	Off	INL
	UNLOCK button of the Intelligent Key is pressed	On	
RKE-TR/BD	NOTE: The item is indicated, but not monitored.	Off	M
RKE-PANIC	PANIC button of the Intelligent Key is not pressed	Off	N
	PANIC button of the Intelligent Key is pressed	On	
RKE-P/W OPEN	UNLOCK button of the Intelligent Key is not pressed	Off	O
	UNLOCK button of the Intelligent Key is pressed and held	On	
RKE-MODE CHG	LOCK/UNLOCK button of the Intelligent Key is not pressed and held simultaneously	Off	P
	LOCK/UNLOCK button of the Intelligent Key is pressed and held simultaneously	On	
OPTICAL SENSOR	Bright outside of the vehicle	Close to 5 V	P
	Dark outside of the vehicle	Close to 0 V	
REQ SW -DR	Driver door request switch is not pressed	Off	
	Driver door request switch is pressed	On	
REQ SW -AS	Passenger door request switch is not pressed	Off	
	Passenger door request switch is pressed	On	

BCM (BODY CONTROL MODULE)

< ECU DIAGNOSIS INFORMATION >

Monitor Item	Condition	Value/Status
REQ SW -RR	NOTE: The item is indicated, but not monitored.	Off
REQ SW -RL	NOTE: The item is indicated, but not monitored.	Off
REQ SW -BD/TR	Back door request switch is not pressed	Off
	Back door request switch is pressed	On
PUSH SW	Push-button ignition switch (push switch) is not pressed	Off
	Push-button ignition switch (push switch) is pressed	On
IGN RLY2 -F/B	Ignition switch in OFF or ACC position	Off
	Ignition switch in ON position	On
ACC RLY -F/B	NOTE: The item is indicated, but not monitored.	Off
CLUCH SW NOTE: At A/T models this item is not monitored.	The clutch pedal is not depressed	Off
	The clutch pedal is depressed	On
BRAKE SW 1	Stop lamp switch 1 signal circuit is open	Off
	Stop lamp switch 1 signal circuit is normal	On
BRAKE SW 2	The brake pedal is not depressed	Off
	The brake pedal is depressed	On
DETE/CANCL SW NOTE: At M/T models with SynchroRev Match mode this item is not monitored.	<ul style="list-style-type: none"> • Selector lever in P position (A/T models) • The clutch pedal is depressed (M/T models without SynchroRev Match mode) 	Off
	<ul style="list-style-type: none"> • Selector lever in any position other than P (A/T models) • The clutch pedal is not depressed (M/T models without SynchroRev Match mode) 	On
SFT PN/N SW NOTE: At M/T models without SynchroRev Match mode this item is not monitored.	<ul style="list-style-type: none"> • Selector lever in any position other than P and N (A/T models) • Control lever in any position other than neutral position (M/T models with SynchroRev Match mode) 	Off
	<ul style="list-style-type: none"> • Selector lever in P or N position (A/T models) • Control lever in neutral position (M/T models with SynchroRev Match mode) 	On
S/L -LOCK	Steering is unlocked	Off
	Steering is locked	On
S/L -UNLOCK	Steering is locked	Off
	Steering is unlocked	On
S/L RELAY-F/B	Ignition switch in OFF or ACC position	Off
	Ignition switch in ON position	On
UNLK SEN -DR	Driver door is unlocked	Off
	Driver door is locked	On
PUSH SW -IPDM	Push-button ignition switch (push-switch) is not pressed	Off
	Push-button ignition switch (push-switch) is pressed	On
IGN RLY1 -F/B	Ignition switch in OFF or ACC position	Off
	Ignition switch in ON position	On
DETE SW -IPDM	Selector lever in any position other than P	Off
	Selector lever in P position	On

BCM (BODY CONTROL MODULE)

< ECU DIAGNOSIS INFORMATION >

Monitor Item	Condition	Value/Status	
SFT PN -IPDM	<ul style="list-style-type: none"> • Selector lever in any position other than P and N (A/T models) • The clutch pedal is not depressed (M/T models) 	Off	A
	<ul style="list-style-type: none"> • Selector lever in P or N position (A/T models) • The clutch pedal is depressed (M/T models) 	On	B
SFT P -MET	Selector lever in any position other than P	Off	C
	Selector lever in P position	On	
SFT N -MET	Selector lever in any position other than N	Off	D
	Selector lever in N position	On	
ENGINE STATE	Engine stopped	Stop	E
	While the engine stalls	Stall	
	At engine cranking	Crank	
	Engine running	Run	
S/L LOCK-IPDM	Steering is unlocked	Off	F
	Steering is locked	On	
S/L UNLK-IPDM	Steering is locked	Off	G
	Steering is unlocked	On	
S/L RELAY-REQ	Steering lock system is not the LOCK condition and the changing condition from LOCK to UNLOCK	Off	H
	Steering lock system are not the LOCK condition or the changing condition from LOCK to UNLOCK	On	
VEH SPEED 1	While driving	Equivalent to speedometer reading	I
VEH SPEED 2	While driving	Equivalent to speedometer reading	J
DOOR STAT-DR	Driver door is locked	LOCK	K
	Wait with selective UNLOCK operation (60 seconds)	READY	
	Driver door is unlocked	UNLOCK	
DOOR STAT-AS	Passenger door is locked	LOCK	INL
	Wait with selective UNLOCK operation (60 seconds)	READY	
	Passenger door is unlocked	UNLOCK	
ID OK FLAG	Steering is locked	Reset	M
	Steering is unlocked	Set	
PRMT ENG STRT	The engine start is prohibited	Reset	N
	The engine start is permitted	Set	
PRMT RKE STRT	NOTE: The item is indicated, but not monitored.	Reset	O
KEY SW -SLOT	The Intelligent Key is not inserted into key slot	Off	P
	The Intelligent Key is inserted into key slot	On	
RKE OPE COUN1	During the operation of the Intelligent Key	Operation frequency of the Intelligent Key	
RKE OPE COUN2	NOTE: The item is indicated, but not monitored.	—	
CONFRM ID ALL	The key ID that the key slot receives is not recognized by any key ID registered to BCM.	Yet	
	The key ID that the key slot receives is recognized by any key ID registered to BCM.	Done	

BCM (BODY CONTROL MODULE)

< ECU DIAGNOSIS INFORMATION >

Monitor Item	Condition	Value/Status
CONFIRM ID4	The key ID that the key slot receives is not recognized by the fourth key ID registered to BCM.	Yet
	The key ID that the key slot receives is recognized by the fourth key ID registered to BCM.	Done
CONFIRM ID3	The key ID that the key slot receives is not recognized by the third key ID registered to BCM.	Yet
	The key ID that the key slot receives is recognized by the third key ID registered to BCM.	Done
CONFIRM ID2	The key ID that the key slot receives is not recognized by the second key ID registered to BCM.	Yet
	The key ID that the key slot receives is recognized by the second key ID registered to BCM.	Done
CONFIRM ID1	The key ID that the key slot receives is not recognized by the first key ID registered to BCM.	Yet
	The key ID that the key slot receives is recognized by the first key ID registered to BCM.	Done
TP 4	The ID of fourth Intelligent Key is not registered to BCM	Yet
	The ID of fourth Intelligent Key is registered to BCM	Done
TP 3	The ID of third Intelligent Key is not registered to BCM	Yet
	The ID of third Intelligent Key is registered to BCM	Done
TP 2	The ID of second Intelligent Key is not registered to BCM	Yet
	The ID of second Intelligent Key is registered to BCM	Done
TP 1	The ID of first Intelligent Key is not registered to BCM	Yet
	The ID of first Intelligent Key is registered to BCM	Done
AIR PRESS FL	Ignition switch ON (Only when the signal from the transmitter is received)	Air pressure of front LH tire
AIR PRESS FR	Ignition switch ON (Only when the signal from the transmitter is received)	Air pressure of front RH tire
AIR PRESS RR	Ignition switch ON (Only when the signal from the transmitter is received)	Air pressure of rear RH tire
AIR PRESS RL	Ignition switch ON (Only when the signal from the transmitter is received)	Air pressure of rear LH tire
ID REGST FL1	ID of front LH tire transmitter is registered	Done
	ID of front LH tire transmitter is not registered	Yet
ID REGST FR1	ID of front RH tire transmitter is registered	Done
	ID of front RH tire transmitter is not registered	Yet
ID REGST RR1	ID of rear RH tire transmitter is registered	Done
	ID of rear RH tire transmitter is not registered	Yet
ID REGST RL1	ID of rear LH tire transmitter is registered	Done
	ID of rear LH tire transmitter is not registered	Yet
WARNING LAMP	Tire pressure indicator OFF	Off
	Tire pressure indicator ON	On
BUZZER	Tire pressure warning alarm is not sounding	Off
	Tire pressure warning alarm is sounding	On

BCM (BODY CONTROL MODULE)

< ECU DIAGNOSIS INFORMATION >

TERMINAL LAYOUT

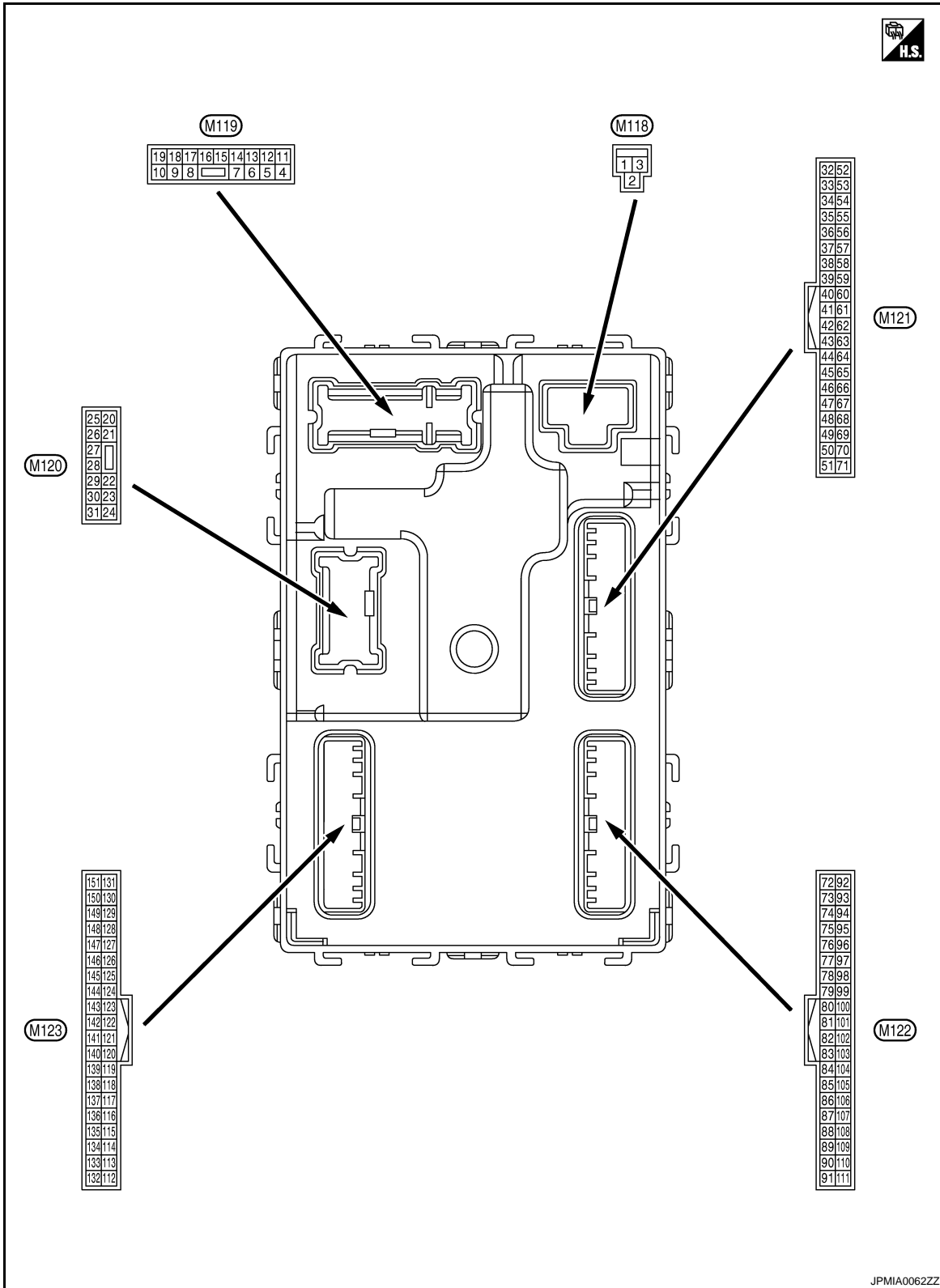

A
B
C
D
E
F
G
H
I
J
K
INL
M
N
O
P

PHYSICAL VALUES

BCM (BODY CONTROL MODULE)

< ECU DIAGNOSIS INFORMATION >

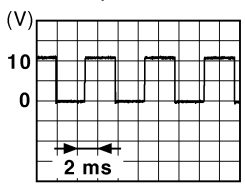
Terminal No. (Wire color)		Description		Condition		Value (Approx.)
		Signal name	Input/ Output			
+	-					
1 (W)	Ground	Battery power supply	Input	Ignition switch OFF		Battery voltage
2 (W)	Ground	P/W power supply (BAT)	Output	Ignition switch OFF		12 V
3 (Y)	Ground	P/W power supply (RAP)	Output	Ignition switch ON		12 V
4 (R)	Ground	Interior room lamp power supply	Output	Interior room lamp battery saver is activated. (Cuts the interior room lamp power supply)		0 V
				Interior room lamp battery saver is not activated. (Outputs the interior room lamp power supply)		12 V
5 (G)	Ground	Passenger door UN- LOCK	Output	Passenger door	UNLOCK (Actuator is activated)	12 V
					Other than UNLOCK (Actuator is not activated)	0 V
8 (V)	Ground	All doors, fuel lid LOCK	Output	All doors, fuel lid	LOCK (Actuator is activated)	12 V
					Other than LOCK (Actuator is not activated)	0 V
9 (G)	Ground	Driver door, fuel lid UNLOCK	Output	Driver door, fuel lid	UNLOCK (Actuator is activated)	12 V
					Other than UNLOCK (Actuator is not activated)	0 V
11 (BR)	Ground	Battery power supply	Input	Ignition switch OFF		Battery voltage
13 (B)	Ground	Ground	—	Ignition switch ON		0 V
14 (R)	Ground	Push-button ignition switch illumination ground	Output	Tail lamp	OFF	0 V
					ON	<p>NOTE: When the illumination brightening/dimming level is in the neutral position.</p>  <p style="text-align: right; font-size: small;">JSNIA0010GB</p>
15 (Y)	Ground	ACC indicator lamp	Output	Ignition switch	OFF (LOCK indicator is not illuminated)	Battery voltage
					ACC	0 V

BCM (BODY CONTROL MODULE)

< ECU DIAGNOSIS INFORMATION >

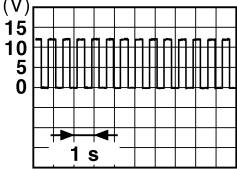
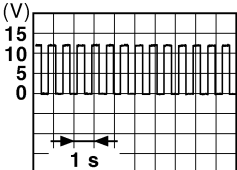
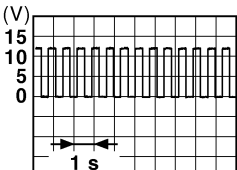
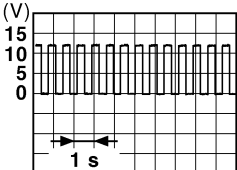
Terminal No. (Wire color)		Description		Condition	Value (Approx.)	
		Signal name	Input/ Output			
+	-					
17 (W)	Ground	Turn signal RH (Front and side)	Output	Ignition switch ON	Turn signal switch OFF	0 V
					Turn signal switch RH	 6.5 V
18 (O)	Ground	Turn signal LH (Front and side)	Output	Ignition switch ON	Turn signal switch OFF	0 V
					Turn signal switch LH	 6.5 V
19 (V)	Ground	Room lamp timer control	Output	Interior room lamp	OFF	12 V
					ON	0 V
20 (V)	Ground	Turn signal RH (Rear)	Output	Ignition switch ON	Turn signal switch OFF	0 V
					Turn signal switch RH	 6.5 V
23 (L)	Ground	Back door open	Output	Back door	OPEN (Back door opener actuator is activated)	12 V
					Other than OPEN (Back door opener actuator is not activated)	0 V
24*1 (O)	Ground	Rear fog lamp	Output	Rear fog lamp	OFF	0 V
					ON	12 V
25 (LG)	Ground	Turn signal LH (Rear)	Output	Ignition switch ON	Turn signal switch OFF	0 V
					Turn signal switch LH	 6.5 V
30 (R)	Ground	Luggage room lamp	Output	Luggage room lamp	ON	0 V
					OFF	12 V

A
B
C
D
E
F
G
H
I
J
K
L
M
N
O
P

INL

BCM (BODY CONTROL MODULE)

< ECU DIAGNOSIS INFORMATION >

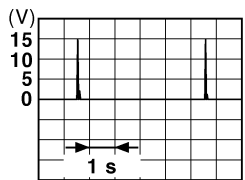
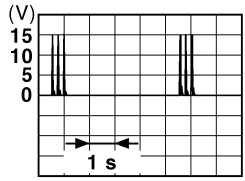
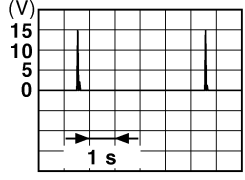
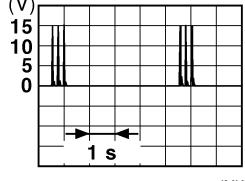
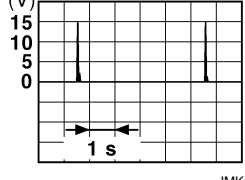
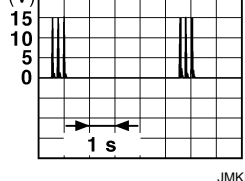
Terminal No. (Wire color)		Description		Condition	Value (Approx.)
		Signal name	Input/ Output		
+	-				
34 (G)	Ground	Luggage room antenna (-)	Output	Ignition switch OFF	 <p style="text-align: right; font-size: small;">JMKIA0062GB</p>
				Ignition switch OFF	 <p style="text-align: right; font-size: small;">JMKIA0063GB</p>
35 (R)	Ground	Luggage room antenna (+)	Output	Ignition switch OFF	 <p style="text-align: right; font-size: small;">JMKIA0062GB</p>
				Ignition switch OFF	 <p style="text-align: right; font-size: small;">JMKIA0063GB</p>
38 (B)	Ground	Rear bumper antenna (-)	Output	When the back door request switch is operated with ignition switch OFF	 <p style="text-align: right; font-size: small;">JMKIA0062GB</p>
				When the back door request switch is operated with ignition switch OFF	 <p style="text-align: right; font-size: small;">JMKIA0063GB</p>

BCM (BODY CONTROL MODULE)

< ECU DIAGNOSIS INFORMATION >

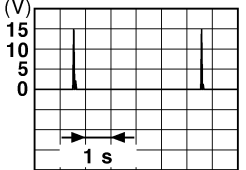
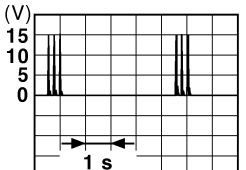
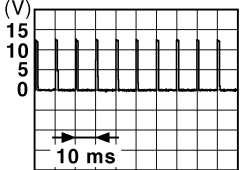
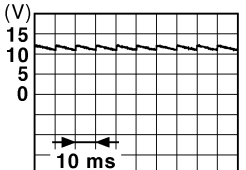
Terminal No. (Wire color)		Description		Condition	Value (Approx.)				
+	-	Signal name	Input/ Output						
39 (W)	Ground	Rear bumper antenna (+)	Output	When the back door request switch is operated with ignition switch OFF	 <p>JMKIA0062GB</p>				
				When Intelligent Key is not in the antenna detection area	 <p>JMKIA0063GB</p>				
47 (V)	Ground	Ignition relay (IPDM E/R) control	Output	Ignition switch	OFF or ACC: 12 V ON: 0 V				
52 (SB)	Ground	Starter relay control	Output	Ignition switch ON (A/T models)	When selector lever is in P or N position: 12 V When selector lever is not in P or N position: 0 V				
				Ignition switch ON (M/T models)	When the clutch pedal is depressed: Battery voltage When the clutch pedal is not depressed: 0 V				
				61 (W)	Ground	Back door request switch	Input	Back door request switch	ON (Pressed): 0 V OFF (Not pressed):  <p>JPMIA0016GB</p> <p>1.0 V</p>
				64 (G)	Ground	Intelligent Key warning buzzer	Output	Intelligent Key warning buzzer	Sounding: 0 V Not sounding: 12 V
66 (R)	Ground	Back door switch	Input	Back door switch	OFF (Door close):  <p>JPMIA0011GB</p> <p>11.8 V</p>				
				ON (Door open): 0 V					

A
B
C
D
E
F
G
H
I
J
K
M
N
O
P

INL

BCM (BODY CONTROL MODULE)

< ECU DIAGNOSIS INFORMATION >

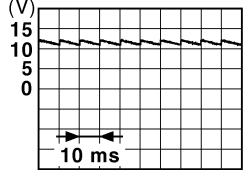
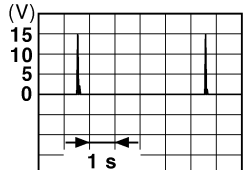
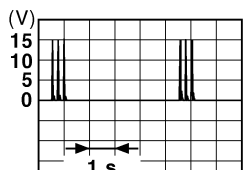
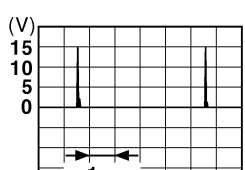
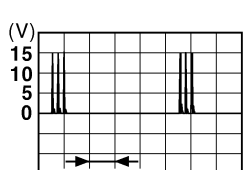
Terminal No. (Wire color)		Description		Condition		Value (Approx.)
+	-	Signal name	Input/ Output			
67 (GR)	Ground	Back door opener switch	Input	Back door opener switch	Pressed	0 V
					Not pressed	 <p style="text-align: right; font-size: small;">JPMIA0011GB</p>
72 (L)	Ground	Room antenna (-) (Center console)	Output	Ignition switch OFF	When Intelligent Key is in the passenger compart- ment	 <p style="text-align: right; font-size: small;">JMKIA0062GB</p>
					When Intelligent Key is not in the passenger compart- ment	 <p style="text-align: right; font-size: small;">JMKIA0063GB</p>
73 (P)	Ground	Room antenna (+) (Center console)	Output	Ignition switch OFF	When Intelligent Key is in the passenger compart- ment	 <p style="text-align: right; font-size: small;">JMKIA0062GB</p>
					When Intelligent Key is not in the passenger compart- ment	 <p style="text-align: right; font-size: small;">JMKIA0063GB</p>

BCM (BODY CONTROL MODULE)

< ECU DIAGNOSIS INFORMATION >

Terminal No. (Wire color)		Description		Condition	Value (Approx.)
+	-	Signal name	Input/ Output		
74 (SB)	Ground	Passenger door antenna (-)	Output	When Intelligent Key is in the antenna detection area	<p style="text-align: right; font-size: small;">JMKIA0062GB</p>
				When the passenger door request switch is operated with ignition switch OFF	<p style="text-align: right; font-size: small;">JMKIA0063GB</p>
75 (BR)	Ground	Passenger door antenna (+)	Output	When Intelligent Key is in the antenna detection area	<p style="text-align: right; font-size: small;">JMKIA0062GB</p>
				When the passenger door request switch is operated with ignition switch OFF	<p style="text-align: right; font-size: small;">JMKIA0063GB</p>
76 (V)	Ground	Driver door antenna (-)	Output	When Intelligent Key is in the antenna detection area	<p style="text-align: right; font-size: small;">JMKIA0062GB</p>
				When the driver door request switch is operated with ignition switch OFF	<p style="text-align: right; font-size: small;">JMKIA0063GB</p>

A
B
C
D
E
F
G
H
I
J
K
M
N
O
P

INL

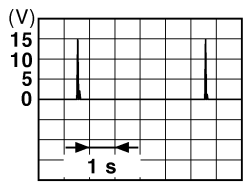
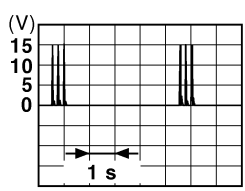
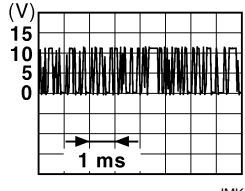
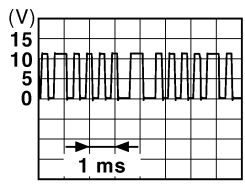

BCM (BODY CONTROL MODULE)

< ECU DIAGNOSIS INFORMATION >

Terminal No. (Wire color)		Description		Condition	Value (Approx.)	
+	-	Signal name	Input/ Output			
77 (LG)	Ground	Driver door antenna (+)	Output	When the driver door request switch is operated with ignition switch OFF		
				When Intelligent Key is in the antenna detection area		
80 (GR)	Ground	NATS antenna amp (Built in key slot)	Input/ Output	During waiting	Ignition switch is pressed while inserting the Intelligent Key into the key slot.	
81 (W)	Ground	NATS antenna amp (Built in key slot)	Input/ Output	During waiting	Ignition switch is pressed while inserting the Intelligent Key into the key slot.	
82 (R)	Ground	Ignition relay [Fuse block (J/B)] control	Output	Ignition switch	OFF or ACC	0 V
					ON	12 V
83 (GR)	Ground	Remote keyless entry receiver communication	Input/ Output	During waiting		
				When operating either button on the Intelligent Key		

BCM (BODY CONTROL MODULE)

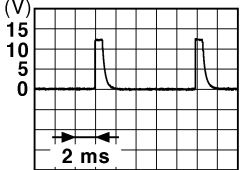
< ECU DIAGNOSIS INFORMATION >

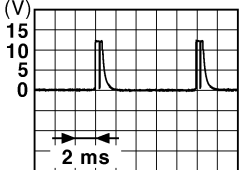

Terminal No. (Wire color)		Description		Condition	Value (Approx.)	
		Signal name	Input/ Output			
+	-					
87 (BR)	Ground	Combination switch INPUT 5	Input	Combination switch	All switches OFF (Wiper intermittent dial 4)	 1.4 V
				Combination switch	Rear fog lamp switch ON (Wiper intermittent dial 4)	 1.3 V
					Any of the conditions below with all switches OFF <ul style="list-style-type: none"> • Wiper intermittent dial 1 • Wiper intermittent dial 2 • Wiper intermittent dial 6 • Wiper intermittent dial 7 	 1.3 V

A
B
C
D
E
F
G
H
I
J
K
L
M
N
O
P

INL

BCM (BODY CONTROL MODULE)

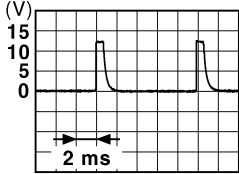
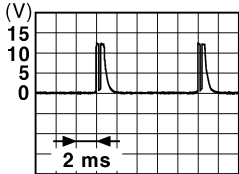
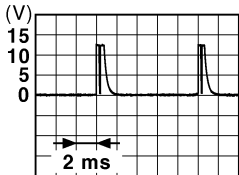
< ECU DIAGNOSIS INFORMATION >

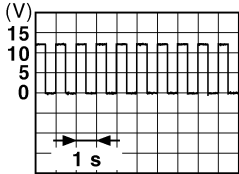
Terminal No. (Wire color)		Description		Condition	Value (Approx.)	
+	-	Signal name	Input/ Output			
88 (V)	Ground	Combination switch INPUT 3	Input	Combination switch	All switches OFF (Wiper intermittent dial 4)	 <p style="text-align: right; font-size: small;">JPMA0041GB</p> <p style="text-align: center;">1.4 V</p>
					Lighting switch HI (Wiper intermittent dial 4)	 <p style="text-align: right; font-size: small;">JPMA0036GB</p> <p style="text-align: center;">1.3 V</p>
					Lighting switch 2ND (Wiper intermittent dial 4)	 <p style="text-align: right; font-size: small;">JPMA0037GB</p> <p style="text-align: center;">1.3 V</p>
					Any of the conditions below with all switches OFF <ul style="list-style-type: none"> • Wiper intermittent dial 1 • Wiper intermittent dial 2 • Wiper intermittent dial 3 	 <p style="text-align: right; font-size: small;">JPMA0040GB</p> <p style="text-align: center;">1.3 V</p>
89 (BR)	Ground	Push-button ignition switch (Push switch)	Input	Push-button ignition switch (push switch)	Pressed	0 V
					Not pressed	Battery voltage
90 (P)	Ground	CAN-L	Input/ Output	—	—	
91 (L)	Ground	CAN-H	Input/ Output	—	—	
92 (LG)	Ground	Key slot illumination	Output	Key slot illumination	OFF	0 V
					Blinking	 <p style="text-align: right; font-size: small;">JPMA0015GB</p> <p style="text-align: center;">6.5 V</p>
					ON	12 V

BCM (BODY CONTROL MODULE)



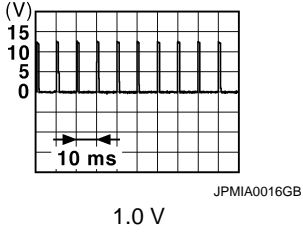
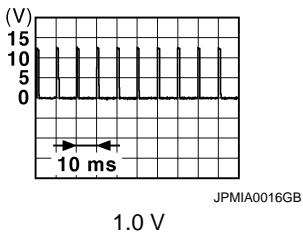

< ECU DIAGNOSIS INFORMATION >

Terminal No. (Wire color)		Description		Condition		Value (Approx.)
+	-	Signal name	Input/ Output			
93 (V)	Ground	ON indicator lamp	Output	Ignition switch	OFF (LOCK indicator is not illuminated)	Battery voltage
					ON	0 V
95 (O)	Ground	ACC relay control	Output	Ignition switch	OFF	0 V
					ACC or ON	12 V
96*2 (Y)	Ground	A/T shift selector (Detention switch) power supply	Output	—		12 V
97 (L)	Ground	Steering lock condition No. 1	Input	Steering lock	LOCK status	0 V
					UNLOCK status	12 V
98 (P)	Ground	Steering lock condition No. 2	Input	Steering lock	LOCK status	12 V
					UNLOCK status	0 V
99*3 (R)*2 (BR)*4	Ground	Selector lever P position switch (A/T models)	Input	Selector lever	P position	0 V
					Any position other than P	12 V
		Clutch pedal position switch (M/T models without SynchroRev Match mode)		Clutch pedal position switch	OFF (Clutch pedal is depressed)	0 V
					ON (Clutch pedal is not depressed)	Battery voltage
100 (GR)	Ground	Passenger door request switch	Input	Passenger door request switch	ON (Pressed)	0 V
					OFF (Not pressed)	
101 (Y)	Ground	Driver door request switch	Input	Driver door request switch	ON (Pressed)	0 V
					OFF (Not pressed)	
102 (O)	Ground	Blower fan motor relay control	Output	Ignition switch	OFF or ACC	0 V
					ON	12 V
103 (LG)	Ground	Remote keyless entry receiver power supply	Output	Ignition switch OFF		12 V
106 (W)	Ground	Steering lock unit power supply	Output	Ignition switch	OFF or ACC	12 V
					ON	0 V

A
B
C
D
E
F
G
H
I
J
K
INL
M
N
O
P

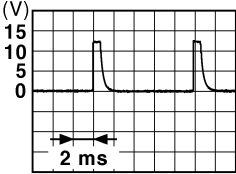

BCM (BODY CONTROL MODULE)

< ECU DIAGNOSIS INFORMATION >

Terminal No. (Wire color)		Description		Condition	Value (Approx.)	
		Signal name	Input/ Output			
+	-					
107 (LG)	Ground	Combination switch INPUT 1	Input	Combination switch (Wiper intermit- tent dial 4)	All switches OFF	 <p style="text-align: right; margin-right: 20px;">JPMIA0041GB</p> <p style="text-align: center;">1.4 V</p>
					Turn signal switch LH	 <p style="text-align: right; margin-right: 20px;">JPMIA0037GB</p> <p style="text-align: center;">1.3 V</p>
					Turn signal switch RH	 <p style="text-align: right; margin-right: 20px;">JPMIA0036GB</p> <p style="text-align: center;">1.3 V</p>
					Front wiper switch LO	 <p style="text-align: right; margin-right: 20px;">JPMIA0038GB</p> <p style="text-align: center;">1.3 V</p>
					Front washer switch ON	 <p style="text-align: right; margin-right: 20px;">JPMIA0039GB</p> <p style="text-align: center;">1.3 V</p>

BCM (BODY CONTROL MODULE)

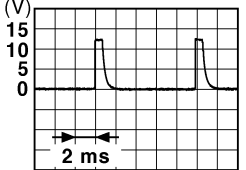
< ECU DIAGNOSIS INFORMATION >

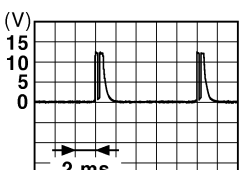
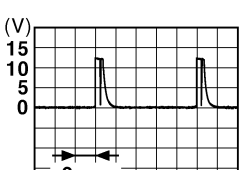
Terminal No. (Wire color)		Description		Condition	Value (Approx.)
		Signal name	Input/ Output		
+	-				
108 (R)	Ground	Combination switch INPUT 4	Input	Combination switch	All switches OFF (Wiper intermittent dial 4) <div style="text-align: right; margin-top: 10px;">  <p style="font-size: small; margin: 0;">JPMA0041GB</p> <p style="margin: 0;">1.4 V</p> </div>
				Lighting switch AUTO (Wiper intermittent dial 4)	Lighting switch AUTO (Wiper intermittent dial 4) <div style="text-align: right; margin-top: 10px;">  <p style="font-size: small; margin: 0;">JPMA0038GB</p> <p style="margin: 0;">1.3 V</p> </div>
				Lighting switch 1ST (Wiper intermittent dial 4)	Lighting switch 1ST (Wiper intermittent dial 4) <div style="text-align: right; margin-top: 10px;">  <p style="font-size: small; margin: 0;">JPMA0036GB</p> <p style="margin: 0;">1.3 V</p> </div>
				Any of the conditions below with all switches OFF	Any of the conditions below with all switches OFF <ul style="list-style-type: none"> Wiper intermittent dial 1 Wiper intermittent dial 5 Wiper intermittent dial 6 <div style="text-align: right; margin-top: 10px;">  <p style="font-size: small; margin: 0;">JPMA0039GB</p> <p style="margin: 0;">1.3 V</p> </div>

A
B
C
D
E
F
G
H
I
J
K
L
M
N
O
P

INL

BCM (BODY CONTROL MODULE)

< ECU DIAGNOSIS INFORMATION >

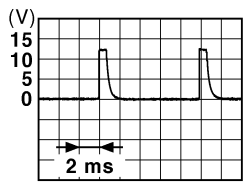
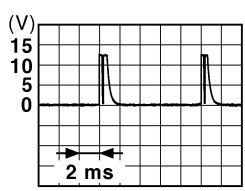
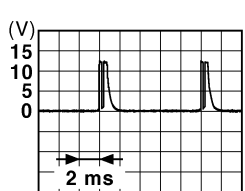
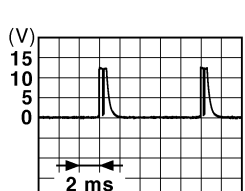
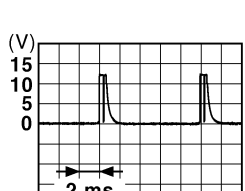
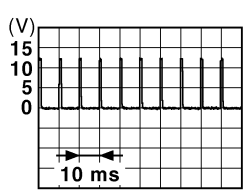
Terminal No. (Wire color)		Description		Condition	Value (Approx.)	
+	-	Signal name	Input/ Output			
109 (Y)	Ground	Combination switch INPUT 2	Input	Combination switch (Wiper intermittent dial 4)	All switches OFF	 <p style="text-align: right; font-size: small;">JPMIA0041GB</p> <p style="text-align: center;">1.4 V</p>
					Lighting switch PASS	 <p style="text-align: right; font-size: small;">JPMIA0037GB</p> <p style="text-align: center;">1.3 V</p>
					Lighting switch 2ND	 <p style="text-align: right; font-size: small;">JPMIA0036GB</p> <p style="text-align: center;">1.3 V</p>
					Front wiper switch INT	 <p style="text-align: right; font-size: small;">JPMIA0038GB</p> <p style="text-align: center;">1.3 V</p>
					Front wiper switch HI	 <p style="text-align: right; font-size: small;">JPMIA0040GB</p> <p style="text-align: center;">1.3 V</p>
110 (P)	Ground	Hazard switch	Input	Hazard switch	ON	0 V
					OFF	 <p style="text-align: right; font-size: small;">JPMIA0012GB</p> <p style="text-align: center;">1.1 V</p>

BCM (BODY CONTROL MODULE)

< ECU DIAGNOSIS INFORMATION >

Terminal No. (Wire color)		Description		Condition	Value (Approx.)	
		Signal name	Input/ Output			
+	-					
111 (Y)	Ground	Steering lock unit communication	Input/ Output	Steering lock	LOCK status	12 V
					LOCK or UNLOCK	<p style="text-align: right; font-size: small;">JMKIA0066GB</p>
					For 15 seconds after UNLOCK	12 V
					15 seconds or later after UNLOCK	0 V
113 (O)	Ground	Optical sensor	Input	Ignition switch ON	When bright outside of the vehicle	Close to 5 V
				When dark outside of the vehicle	Close to 0 V	
114*5 (R)	Ground	Clutch interlock switch	Input	Clutch interlock switch	OFF (Clutch pedal is not depressed)	0 V
					ON (Clutch pedal is depressed)	Battery voltage
116 (SB)	Ground	Stop lamp switch 1	Input	—	Battery voltage	
118 (P)	Ground	Stop lamp switch 2	Input	Stop lamp switch	OFF (Brake pedal is not depressed)	0 V
					ON (Brake pedal is depressed)	Battery voltage
119 (SB)	Ground	Driver side door lock assembly (Unlock sensor)	Input	Driver door	LOCK status (Unlock sensor switch OFF)	<p style="text-align: right; font-size: small;">JPMIA0012GB</p>
					UNLOCK status (Unlock switch sensor ON)	0 V
					1.1 V	
121 (R)	Ground	Key slot switch	Input	When the Intelligent Key is inserted into key slot	12 V	
				When the Intelligent Key is not inserted into key slot	0 V	
123 (W)	Ground	IGN feedback	Input	Ignition switch	OFF or ACC	0 V
				ON	Battery voltage	

A
B
C
D
E
F
G
H
I
J
K
L
M
N
O
P

INL

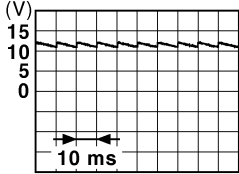
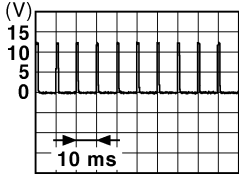
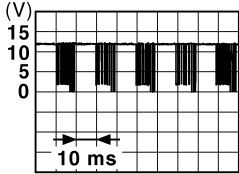
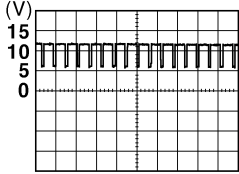

BCM (BODY CONTROL MODULE)

< ECU DIAGNOSIS INFORMATION >

Terminal No. (Wire color)		Description		Condition	Value (Approx.)	
+	-	Signal name	Input/ Output			
124 (LG)	Ground	Passenger door switch	Input	Passenger door switch	OFF (Door close)	 <p style="text-align: right; font-size: small;">JPMIA0011GB</p> <p style="text-align: center;">11.8 V</p>
					ON (Door open)	0 V
130 ^{*6} (L)	Ground	Rear window defog- ger switch	Input	Ignition switch ON	Rear window defogger switch OFF	 <p style="text-align: right; font-size: small;">JPMIA0012GB</p> <p style="text-align: center;">1.1 V</p>
					Rear window defogger switch ON	0 V
132 (Y)	Ground	Power window switch communication	Input/ Output	Ignition switch ON		 <p style="text-align: right; font-size: small;">JPMIA0013GB</p> <p style="text-align: center;">10.2 V</p>
					Ignition switch OFF or ACC	12 V
133 (G)	Ground	Push-button ignition switch illumination	Output	Push-button ig- nition switch il- lumination	ON (Tail lamps OFF)	9.5 V
					ON (Tail lamps ON)	<p style="text-align: center;">NOTE: The pulse width of this wave is varied by the illumination bright- ening/dimming level.</p>  <p style="text-align: right; font-size: small;">JPMIA0159GB</p>
				OFF	0 V	
134 (GR)	Ground	LOCK indicator lamp	Output	LOCK indicator lamp	OFF	Battery voltage
					ON	0 V
137 (P)	Ground	Receiver and sensor ground	Input	Ignition switch ON		0 V
138 (V)	Ground	Receiver and sensor power supply	Output	Ignition switch	OFF	0 V
					ACC or ON	5.0 V

BCM (BODY CONTROL MODULE)

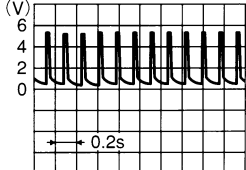
< ECU DIAGNOSIS INFORMATION >

Terminal No. (Wire color)		Description		Condition	Value (Approx.)
+	-	Signal name	Input/ Output		
139 (L)	Ground	Tire pressure receiver communication	Input/ Output	Ignition switch ON	Standby state  OCC3881D
				When receiving the signal from the transmitter  OCC3880D	
140*7 (G)	Ground	Selector lever P/N position (A/T models)	Input	Selector lever	P or N position 12 V Except P and N positions 0 V
				Ignition switch ON	Control lever in neutral position Battery voltage Control lever in any position other than neutral 0 V
		Transmission range switch (M/T models with SynchroRev Match mode)	Input		ON
				Security indicator	Output
OFF	12 V				
142 (O)	Ground	Combination switch OUTPUT 5	Output	Combination switch (Wiper intermittent dial 4)	All switches OFF 0 V Lighting switch 1ST Lighting switch HI Lighting switch 2ND Turn signal switch RH  JPMIA0031GB 10.7 V
				Combination switch	All switches OFF (Wiper intermittent dial 4) 0 V
					Front wiper switch HI (Wiper intermittent dial 4)
					Any of the conditions below with all switches OFF

A
B
C
D
E
F
G
H
I
J
K
L
M
N
O
P

INL

BCM (BODY CONTROL MODULE)

< ECU DIAGNOSIS INFORMATION >

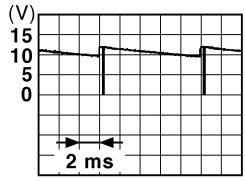
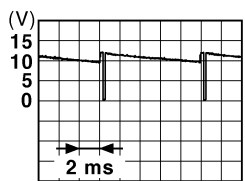
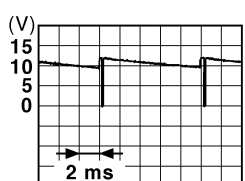
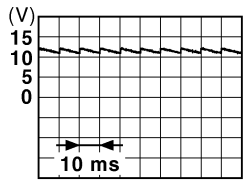
Terminal No. (Wire color)		Description		Condition	Value (Approx.)	
+	-	Signal name	Input/ Output			
144 (G)	Ground	Combination switch OUTPUT 2	Output	Combination switch	All switches OFF (Wiper intermittent dial 4)	0 V
					Front washer switch ON (Wiper intermittent dial 4)	
					Any of the conditions below with all switches OFF <ul style="list-style-type: none"> • Wiper intermittent dial 1 • Wiper intermittent dial 5 • Wiper intermittent dial 6 	
145 (L)	Ground	Combination switch OUTPUT 3	Output	Combination switch (Wiper intermittent dial 4)	All switches OFF	0 V
					Front wiper switch INT	
					Front wiper switch LO	
					Lighting switch AUTO	
					Rear fog lamp switch ON	
					10.7 V	
146 (SB)	Ground	Combination switch OUTPUT 4	Output	Combination switch (Wiper intermittent dial 4)	All switches OFF	0 V
					Lighting switch 2ND	
					Lighting switch PASS	
					Turn signal switch LH	
					10.7 V	
149 (W)	Ground	Tire pressure warning check switch	Input	—	12 V	
150 (GR)	Ground	Driver door switch	Input	Driver door switch	OFF (Door close)	
					ON (Door open)	
151 (G)	Ground	Rear window defogger relay control	Output	Rear window defogger	Active	0 V
				Not activated	Battery voltage	

- *1: For Canada
- *2: A/T models
- *3: Except M/T models with SynchroRev Match mode
- *4: M/T models without SynchroRev Match mode
- *5: M/T models
- *6: Without NAVI
- *7: Except M/T models without SynchroRev Match mode

BCM (BODY CONTROL MODULE)

< ECU DIAGNOSIS INFORMATION >

Wiring Diagram - BCM -

INFOID:000000004703679

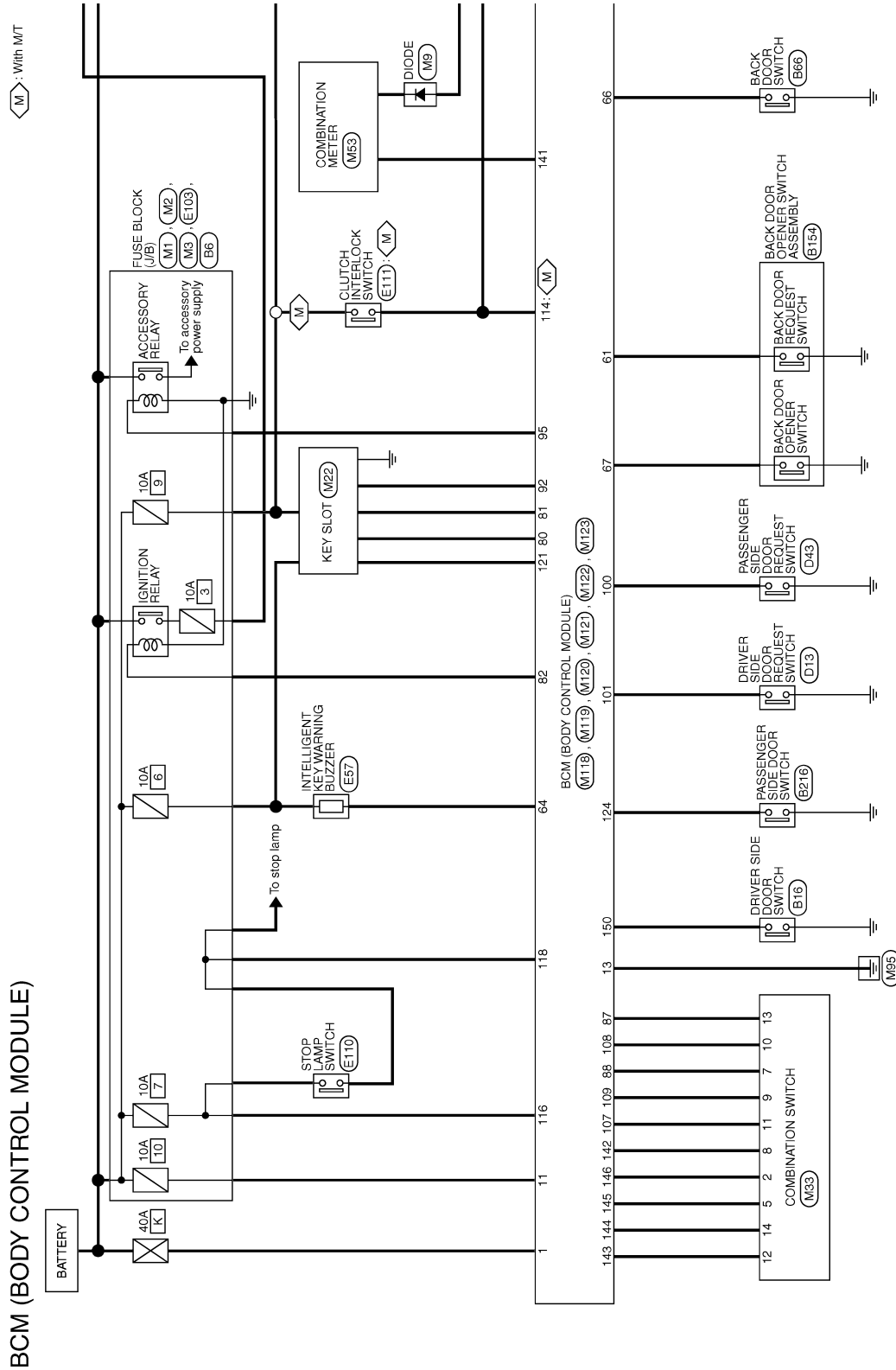

A
B
C
D
E
F
G
H
I
J
K
L
M
N
O
P

INL

2008/09/12

JCMWA3235GE

BCM (BODY CONTROL MODULE)

< ECU DIAGNOSIS INFORMATION >

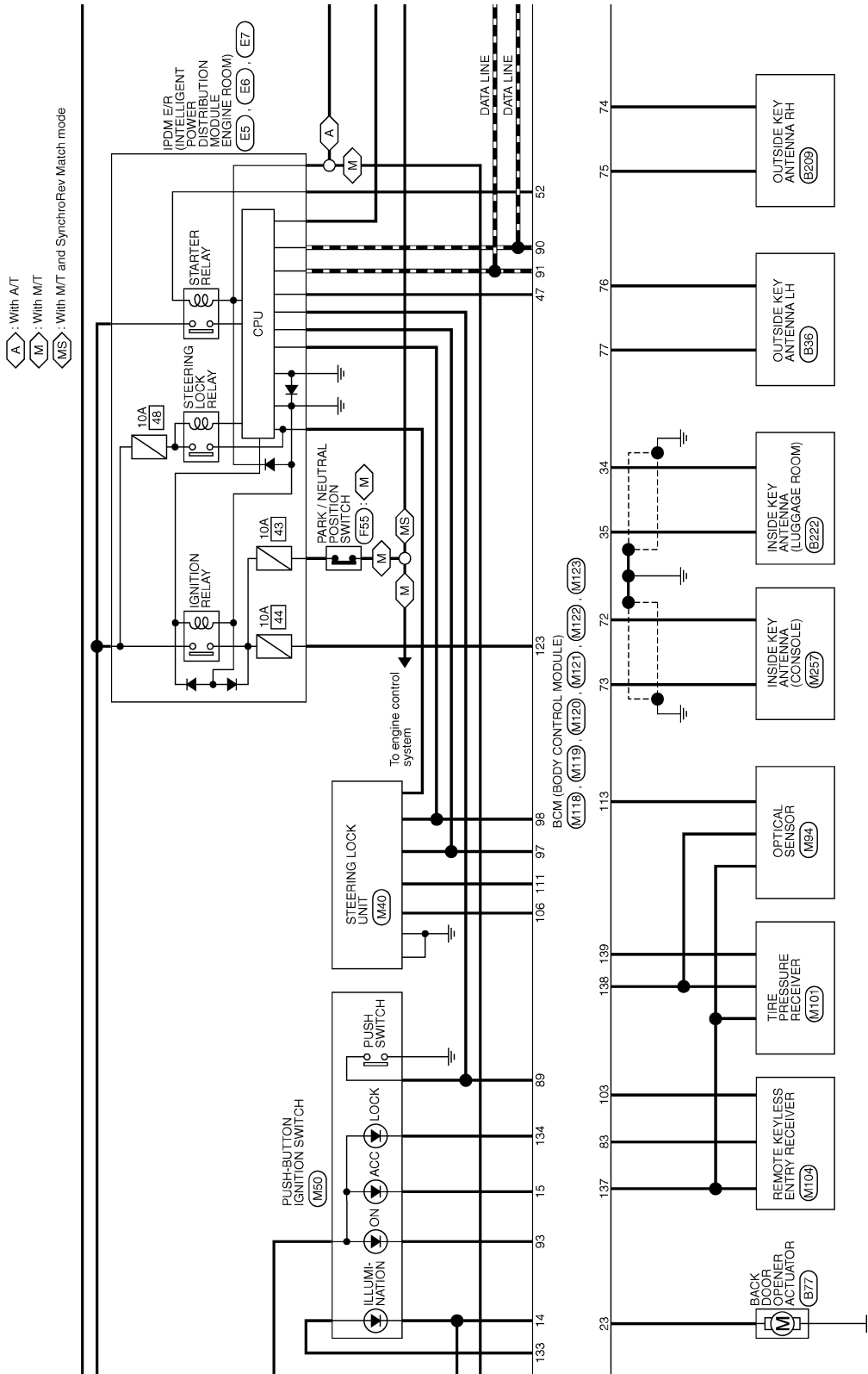

JCMWA3236Gf

BCM (BODY CONTROL MODULE)

< ECU DIAGNOSIS INFORMATION >

- <A> : With A/T
- <WP> : With power seat
- <ON> : Without NAVI
- <AM> : With A/T or with M/T and SynchroRev Match mode
- <AO> : With A/T or with M/T without SynchroRev Match mode
- <MS> : With M/T and SynchroRev Match mode
- <MO> : With M/T without SynchroRev Match mode

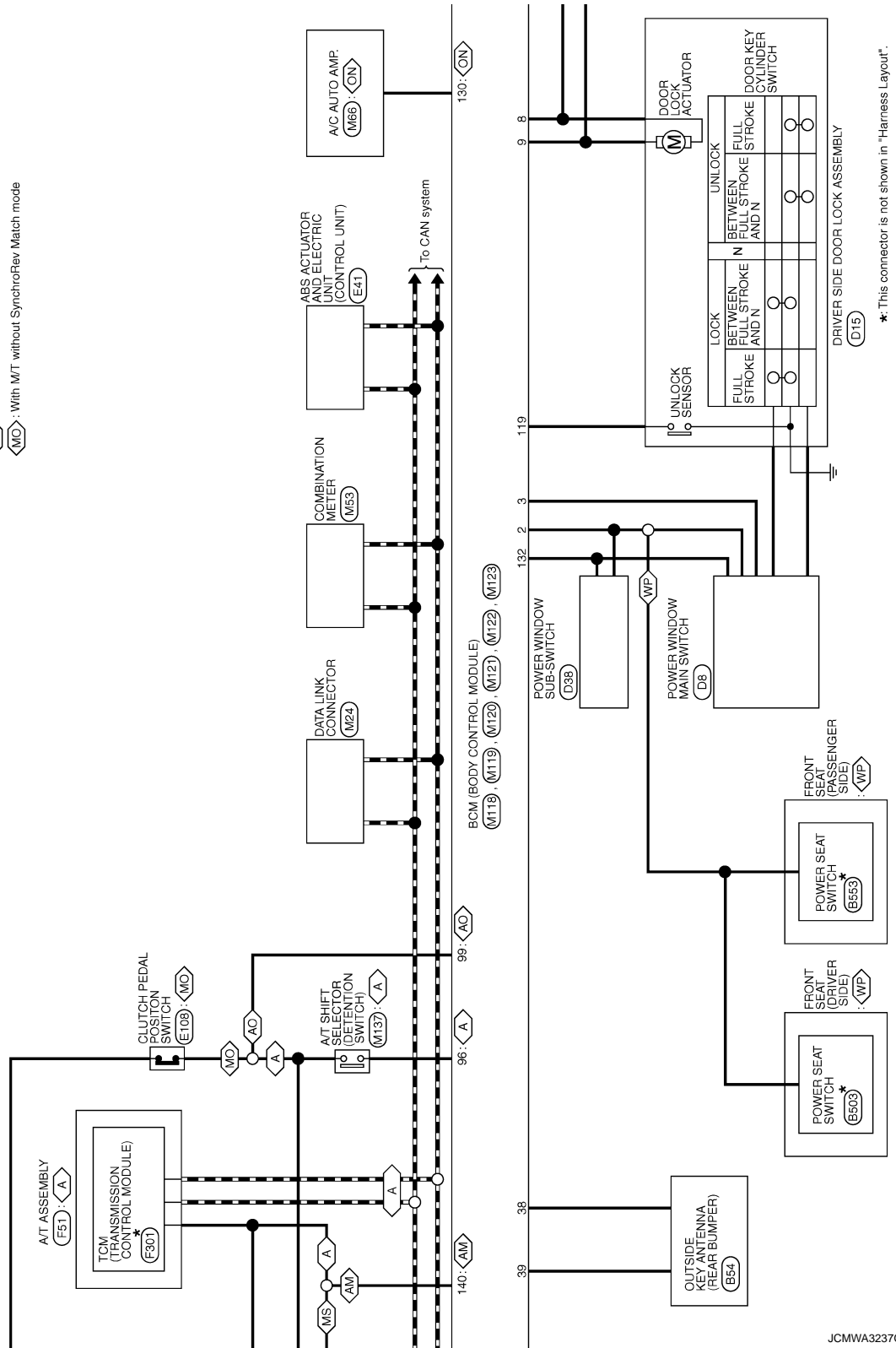

*: This connector is not shown in "Harness Layout".

JCMWA3237GE

A
B
C
D
E
F
G
H
I
J
K
L
M
N
O
P

INL

BCM (BODY CONTROL MODULE)

< ECU DIAGNOSIS INFORMATION >

A : With A/T
M : With M/T
C : For Canada

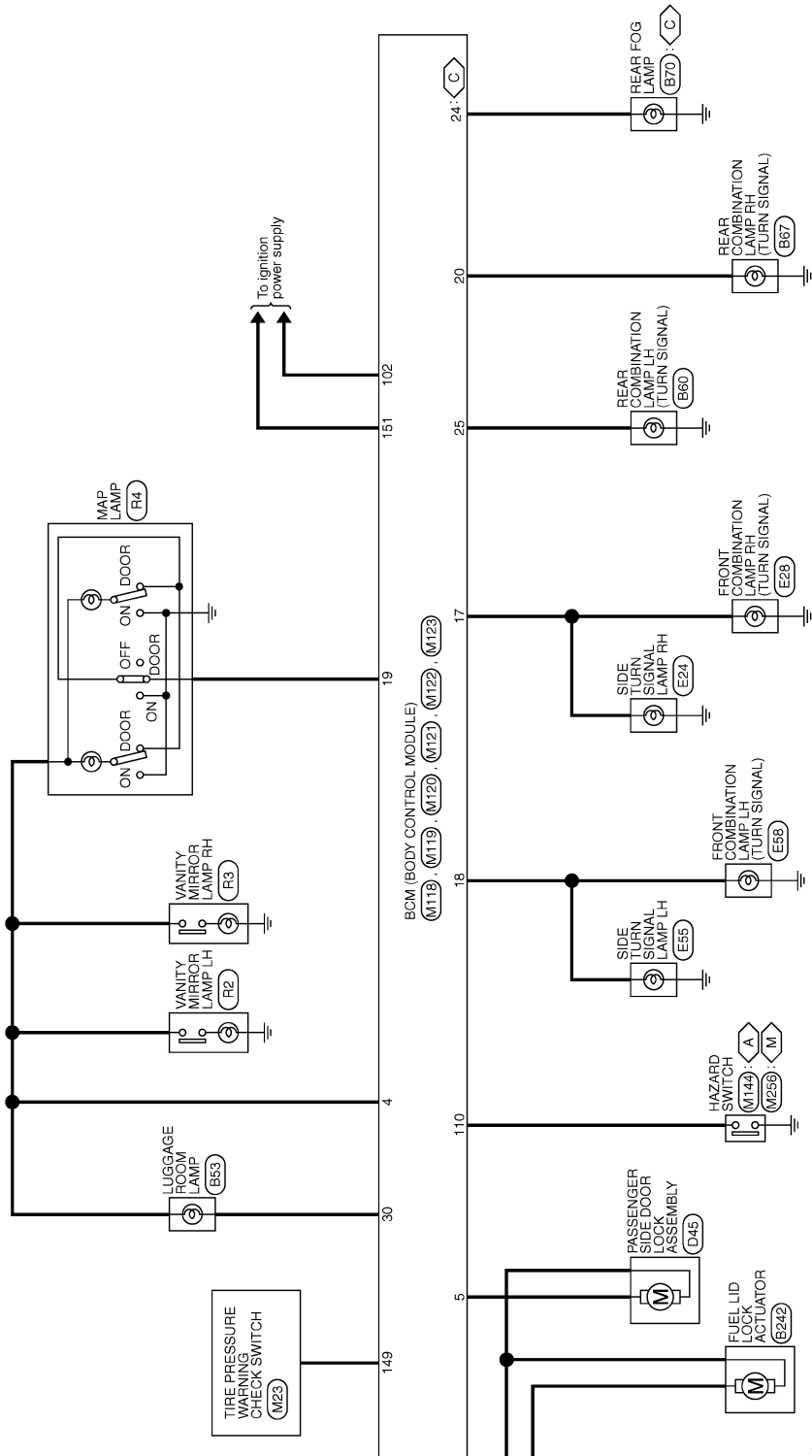

JCMWA3238Gf

BCM (BODY CONTROL MODULE)

< ECU DIAGNOSIS INFORMATION >

BCM (BODY CONTROL MODULE)

Connector No.	M33
Connector Name	COMBINATION SWITCH
Connector Type	TH16FW-NH

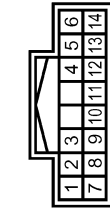

Terminal No.	Color of Wire	Signal Name [Specification]
2	SB	OUTPUT 4
5	L	OUTPUT 3
7	V	INPUT 3
8	O	OUTPUT 5
9	Y	INPUT 2
10	R	INPUT 4
11	LG	INPUT 1
12	P	OUTPUT 1
13	BR	INPUT 5
14	G	OUTPUT 2

Connector No.	M118
Connector Name	BCM (BODY CONTROL MODULE)
Connector Type	IM3FB-LC



Terminal No.	Color of Wire	Signal Name [Specification]
1	W	BAT (+/L)
2	W	POWER WINDOW POWER SUPPLY (BAT)
3	Y	POWER WINDOW POWER SUPPLY (RAP)

Connector No.	M119
Connector Name	BCM (BODY CONTROL MODULE)
Connector Type	NS16FW-CS

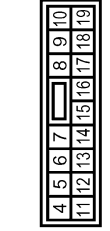

Terminal No.	Color of Wire	Signal Name [Specification]
4	R	INTERIOR ROOM LAMP POWER SUPPLY
5	G	PASSENGER DOOR UNLOCK OUTPUT
6	V	ALL DOOR FUEL LID LOCK OUTPUT
9	G	DRIVER DOOR FUEL LID UNLOCK OUTPUT
11	BR	BAT (FUSE)
13	B	GND
14	R	PUSH-BUTTON IGNITION SW ILL GND
15	Y	ASC IND
17	W	TURN SIGNAL RH (FRONT, SIDE)
18	O	TURN SIGNAL LH (FRONT, SIDE)
19	V	ROOM LAMP TIMER CONT

Connector No.	M120
Connector Name	BCM (BODY CONTROL MODULE)
Connector Type	NS12FW-CS

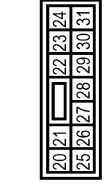

Terminal No.	Color of Wire	Signal Name [Specification]
20	V	TURN SIGNAL RH (REAR)
23	L	BACK DOOR OPEN OUTPUT
24	O	REAR FOG OUTPUT
25	LG	TURN SIGNAL LH (REAR)
30	R	LUGGAGE ROOM LAMP OUTPUT

Connector No.	M121
Connector Name	BCM (BODY CONTROL MODULE)
Connector Type	TH16FGV-NH

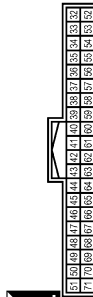

Terminal No.	Color of Wire	Signal Name [Specification]
34	G	LUGGAGE ROOM ANT-
35	R	LUGGAGE ROOM ANT+
36	B	BACK DOOR ANT-
39	W	BACK DOOR ANT+
47	V	IGN RELAY (PDM F/R) CONT
52	SB	STARTER RELAY CONT
61	W	BACK DOOR OPENER REQUEST SW
64	G	F-KEY WARN BUZZER (ENG ROOM)
66	R	BACK DOOR SW
67	GR	BACK DOOR OPENER SW

Connector No.	M122
Connector Name	BCM (BODY CONTROL MODULE)
Connector Type	TH40FB-NH

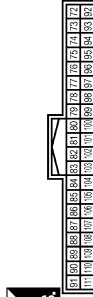

Terminal No.	Color of Wire	Signal Name [Specification]
72	L	ROOM ANT-
73	P	ROOM ANT+
74	SB	PASSENGER DOOR ANT-
75	BR	PASSENGER DOOR ANT+
76	V	DRIVER DOOR ANT-
77	LG	DRIVER DOOR ANT+
80	GR	IMMOBI ANTENNA CONTROL
81	W	IMMOBI ANTENNA SIGNAL
82	R	IGN RELAY (E/B) CONT
83	GR	KEYLESS ENTRY RECEIVER COMM
87	BR	COMBI SW INPUT 3

Terminal No.	Color of Wire	Signal Name [Specification]
88	V	COMBI SW INPUT 3
89	BR	PUSH SW
90	P	CAN-L
91	L	CAN-H
92	LG	KEY SLOT ILL
93	V	IGN IND
95	O	ACC RELAY CONT
96	Y	A/T SHIFT SELECTOR POWER SUPPLY
97	L	S/L CONDITION 1
98	P	S/L CONDITION 2
99	BR	ASC CLUTCH SW (With M/T, without Switch/By Match mode)
99	R	SHIFT P. (With A/T)
100	GR	PASSENGER DOOR REQUEST SW
101	Y	DRIVER DOOR REQUEST SW
102	O	BLOWER FAN MOTOR RELAY CONT
103	LG	KEYLESS ENTRY RECEIVER POWER SUPPLY
106	W	S/L UNIT POWER SUPPLY
107	LG	COMBI SW INPUT 1
108	R	COMBI SW INPUT 4
109	Y	COMBI SW INPUT 2
110	P	HAZARD SW
111	Y	S/L UNIT COMM

A
B
C
D
E
F
G
H
I
J
K
M
N
O
P

INL

BCM (BODY CONTROL MODULE)

< ECU DIAGNOSIS INFORMATION >

134	GR	LOCK IND
137	P	RECEIVER/SENSOR GND
138	V	RECEIVER/SENSOR POWER SUPPLY
139	L	TIRE PRESSURE RECEIVER COMM
140	G	FRONT REAR WHEEL SPEED SENSOR SW (Rear Left Wheel Speed Sensor) (Rear Wheel Speed)
140	G	SHIFT N/P (M/H/L & T)
141	Y	SECURITY INDICATOR
142	O	COMET SW OUTPUT 5
143	P	COMET SW OUTPUT 1
144	G	COMET SW OUTPUT 2
145	L	COMET SW OUTPUT 3
146	SB	COMET SW OUTPUT 4
149	W	TIRE PRESSURE WARN CHECK SW
150	GR	DRIVER DOOR SW
151	G	REAR WINDOW DEFOGGER RELAY CONT

BCM (BODY CONTROL MODULE)

Connector No.	M123
Connector Name	BCM (BODY CONTROL MODULE)
Connector Type	THRU-IG-RH



Terminal No.	Color of Wire	Signal Name (Specification)
113	O	OPTICAL SENSOR
114	R	CLUTCH INTERLOCK SW
116	SB	STOP LAMP SW 1
118	P	STOP LAMP SW 2
119	SB	DR DOOR UNLOCK SENSOR
121	R	KEY SLOT SW
123	W	IGN F/B
124	LG	PASSENGER DOOR SW
130	L	REAR DEFOGGER SW
132	Y	POWER WINDOW SW COMM
133	G	PUSH BUTTON IGNITION SW ILL POWER

JCMWA3240Gt

Fail-safe

INFOID:000000004703680

FAIL-SAFE CONTROL BY DTC

BCM performs fail-safe control when any DTC are detected.

BCM (BODY CONTROL MODULE)

< ECU DIAGNOSIS INFORMATION >

Display contents of CONSULT	Fail-safe	Cancellation	
B2013: ID DISCORD BCM-S/L	Inhibit engine cranking	Erase DTC	A
B2014: CHAIN OF S/L-BCM	Inhibit engine cranking	Erase DTC	
B2190: NATS ANTENNA AMP	Inhibit engine cranking	Erase DTC	B
B2191: DIFFERENCE OF KEY	Inhibit engine cranking	Erase DTC	
B2192: ID DISCORD BCM-ECM	Inhibit engine cranking	Erase DTC	C
B2193: CHAIN OF BCM-ECM	Inhibit engine cranking	Erase DTC	
B2195: ANTI SCANNING	Inhibit engine cranking	Ignition switch ON → OFF	
B2557: VEHICLE SPEED	Inhibit steering lock	When normal vehicle speed signals are received from ABS actuator and electric unit (control unit) for 500 ms	D
B2560: STARTER CONT RELAY	Inhibit engine cranking	500 ms after the following CAN signal communication status becomes consistent <ul style="list-style-type: none"> • Starter control relay signal • Starter relay status signal 	E
B2601: SHIFT POSITION	Inhibit steering lock	500 ms after the following signal reception status becomes consistent <ul style="list-style-type: none"> • Selector lever P position switch signal • P range signal (CAN) 	F
B2602: SHIFT POSITION	Inhibit steering lock	5 seconds after the following BCM recognition conditions are fulfilled <ul style="list-style-type: none"> • Ignition switch is in the ON position • Selector lever P position switch signal: Except P position (battery voltage) • Vehicle speed: 4 km/h (2.5 MPH) or more 	G
B2603: SHIFT POSI STATUS	Inhibit steering lock	500 ms after the following BCM recognition conditions are fulfilled <ul style="list-style-type: none"> • Ignition switch is in the ON position • Selector lever P position switch signal: Except P position (battery voltage) • Selector lever P/N position signal: Except P and N positions (0 V) 	H
B2604: PNP SW	Inhibit steering lock	500 ms after any of the following BCM recognition conditions are fulfilled <ul style="list-style-type: none"> • Status 1 <ul style="list-style-type: none"> - Ignition switch is in the ON position - Selector lever P/N position signal: P and N position (battery voltage) - P range signal or N range signal (CAN): ON • Status 2 <ul style="list-style-type: none"> - Ignition switch is in the ON position - Selector lever P/N position signal: Except P and N positions (0 V) - P range signal and N range signal (CAN): OFF 	I
B2605: PNP SW	Inhibit steering lock	500 ms after any of the following BCM recognition conditions are fulfilled <ul style="list-style-type: none"> • Status 1 <ul style="list-style-type: none"> - Ignition switch is in the ON position - Selector lever P/N position signal: Except P and N positions (0 V) - Interlock/PNP switch signal (CAN): OFF • Status 2 <ul style="list-style-type: none"> - Ignition switch is in the ON position - Selector lever P/N position signal: P or N position (battery voltage) - PNP switch signal (CAN): ON 	J
B2606: S/L RELAY	Inhibit engine cranking	500 ms after the following CAN signal communication status becomes consistent <ul style="list-style-type: none"> • Steering lock relay signal (Request signal) • Steering lock relay signal (Condition signal) 	K

INL

BCM (BODY CONTROL MODULE)

< ECU DIAGNOSIS INFORMATION >

Display contents of CONSULT	Fail-safe	Cancellation
B2607: S/L RELAY	Inhibit engine cranking	500 ms after the following CAN signal communication status has becomes consistent <ul style="list-style-type: none"> • Steering lock relay signal (Request signal) • Steering lock relay signal (Condition signal)
B2608: STARTER RELAY	Inhibit engine cranking	500 ms after the following signal communication status becomes consistent <ul style="list-style-type: none"> • Starter motor relay control signal • Starter relay status signal (CAN)
B2609: S/L STATUS	<ul style="list-style-type: none"> • Inhibit engine cranking • Inhibit steering lock 	When the following steering lock conditions agree <ul style="list-style-type: none"> • BCM steering lock control status • Steering lock condition No. 1 signal status • Steering lock condition No. 2 signal status
B260A: IGNITION RELAY	Inhibit engine cranking	500 ms after the following conditions are fulfilled <ul style="list-style-type: none"> • IGN relay (IPDM E/R) control signal: OFF (Battery voltage) • Ignition ON signal (CAN to IPDM E/R): OFF (Request signal) • Ignition ON signal (CAN from IPDM E/R): OFF (Condition signal)
B260F: ENG STATE SIG LOST	Maintains the power supply position attained at the time of DTC detection	When any of the following conditions are fulfilled <ul style="list-style-type: none"> • Power position changes to ACC • Receives engine status signal (CAN)
B2612: S/L STATUS	<ul style="list-style-type: none"> • Inhibit engine cranking • Inhibit steering lock 	When any of the following conditions are fulfilled <ul style="list-style-type: none"> • Steering lock unit status signal (CAN) is received normally • The BCM steering lock control status matches the steering lock status recognized by the steering lock unit status signal (CAN from IPDM E/R)
B2617: STARTER RELAY CIRC	Inhibit engine cranking	1 second after the starter motor relay control inside BCM becomes normal
B2618: BCM	Inhibit engine cranking	1 second after the ignition relay (IPDM E/R) control inside BCM becomes normal
B2619: BCM	Inhibit engine cranking	1 second after the steering lock unit power supply output control inside BCM becomes normal
B261E: VEHICLE TYPE	Inhibit engine cranking	BCM initialization
B26E8: CLUTCH SW	Inhibit engine cranking	When any of the following BCM recognition conditions are fulfilled <ul style="list-style-type: none"> • Status 1 <ul style="list-style-type: none"> - Clutch switch signal (CAN from ECM): ON - Clutch interlock switch signal: OFF (0 V) • Status 2 <ul style="list-style-type: none"> - Clutch switch signal (CAN from ECM): OFF - Clutch interlock switch signal: ON (Battery voltage)
B26E9: S/L STATUS	<ul style="list-style-type: none"> • Inhibit engine cranking • Inhibit steering lock 	When BCM transmits the LOCK request signal to steering lock unit, and receives LOCK response signal from steering lock unit, the following conditions are fulfilled <ul style="list-style-type: none"> • Steering condition No. 1 signal: LOCK (0 V) • Steering condition No. 2 signal: LOCK (Battery voltage)

HIGH FLASHER OPERATION

BCM detects the turn signal lamp circuit status by the current value.

BCM increases the turn signal lamp blinking speed if the bulb or harness open is detected with the turn signal lamp operating.

NOTE:

The blinking speed is normal while activating the hazard warning lamp.

FAIL-SAFE CONTROL BY RAIN SENSOR MALFUNCTION

- BCM judges the rain sensor serial link error by the rain sensor serial link condition and detects the rain sensor malfunction by rain sensor malfunction signal.
- When BCM detects the rain sensor serial link error or the rain sensor malfunction while front wiper AUTO operation, BCM operates a fail-safe control.

NOTE:

If rain sensor malfunction is detected when ignition switch is turned OFF ⇒ ON and front wiper switch is INT position, BCM operates a fail-safe control.

BCM (BODY CONTROL MODULE)

< ECU DIAGNOSIS INFORMATION >

DTC Inspection Priority Chart

INFOID:000000004703681

If some DTCs are displayed at the same time, perform inspections one by one based on the following priority chart.

Priority	DTC
1	B2562: LOW VOLTAGE
2	<ul style="list-style-type: none"> • U1000: CAN COMM CIRCUIT • U1010: CONTROL UNIT (CAN)
3	<ul style="list-style-type: none"> • B2190: NATS ANTENNA AMP • B2191: DIFFERENCE OF KEY • B2192: ID DISCORD BCM-ECM • B2193: CHAIN OF BCM-ECM • B2195: ANTI SCANNING
4	<ul style="list-style-type: none"> • B2013: ID DISCORD BCM-S/L • B2014: CHAIN OF S/L-BCM • B2553: IGNITION RELAY • B2555: STOP LAMP • B2556: PUSH-BTN IGN SW • B2557: VEHICLE SPEED • B2560: STARTER CONT RELAY • B2601: SHIFT POSITION • B2602: SHIFT POSITION • B2603: SHIFT POSI STATUS • B2604: PNP SW • B2605: PNP SW • B2606: S/L RELAY • B2607: S/L RELAY • B2608: STARTER RELAY • B2609: S/L STATUS • B260A: IGNITION RELAY • B260B: STEERING LOCK UNIT • B260C: STEERING LOCK UNIT • B260D: STEERING LOCK UNIT • B260F: ENG STATE SIG LOST • B2612: S/L STATUS • B2614: ACC RELAY CIRC • B2615: BLOWER RELAY CIRC • B2616: IGN RELAY CIRC • B2617: STARTER RELAY CIRC • B2618: BCM • B2619: BCM • B261A: PUSH-BTN IGN SW • B261E: VEHICLE TYPE • B26E8: CLUTCH SW • B26E9: S/L STATUS • B26EA: KEY REGISTRATION • C1729: VHCL SPEED SIG ERR • U0415: VEHICLE SPEED SIG

A
B
C
D
E
F
G
H
I
J
K
INL
M
N
O
P

BCM (BODY CONTROL MODULE)

< ECU DIAGNOSIS INFORMATION >

Priority	DTC
5	<ul style="list-style-type: none"> • C1704: LOW PRESSURE FL • C1705: LOW PRESSURE FR • C1706: LOW PRESSURE RR • C1707: LOW PRESSURE RL • C1708: [NO DATA] FL • C1709: [NO DATA] FR • C1710: [NO DATA] RR • C1711: [NO DATA] RL • C1712: [CHECKSUM ERR] FL • C1713: [CHECKSUM ERR] FR • C1714: [CHECKSUM ERR] RR • C1715: [CHECKSUM ERR] RL • C1716: [PRESSDATA ERR] FL • C1717: [PRESSDATA ERR] FR • C1718: [PRESSDATA ERR] RR • C1719: [PRESSDATA ERR] RL • C1720: [CODE ERR] FL • C1721: [CODE ERR] FR • C1722: [CODE ERR] RR • C1723: [CODE ERR] RL • C1724: [BATT VOLT LOW] FL • C1725: [BATT VOLT LOW] FR • C1726: [BATT VOLT LOW] RR • C1727: [BATT VOLT LOW] RL • C1734: CONTROL UNIT
6	<ul style="list-style-type: none"> • B2621: INSIDE ANTENNA • B2622: INSIDE ANTENNA • B2623: INSIDE ANTENNA

DTC Index

INFOID:000000004703682

NOTE:

The details of time display are as follows.

- CRNT: A malfunction is detected now.
- PAST: A malfunction was detected in the past.

IGN counter is displayed on Freeze Frame Data. For details of Freeze Frame Data, refer to [BCS-17, "COMMON ITEM : CONSULT-III Function \(BCM - COMMON ITEM\)"](#).

CONSULT display	Fail-safe	Freeze Frame Data •Vehicle Speed •Odo/Trip Meter •Vehicle condition	Intelligent Key warning lamp ON	Tire pressure monitor warning lamp ON	Refer- ence page
No DTC is detected. further testing may be required.	—	—	—	—	—
U1000: CAN COMM CIRCUIT	—	—	—	—	BCS-38
U1010: CONTROL UNIT (CAN)	—	—	—	—	BCS-39
U0415: VEHICLE SPEED SIG	—	—	—	—	BCS-40
B2013: ID DISCORD BCM-S/L	×	×	—	—	SEC-50
B2014: CHAIN OF S/L-BCM	×	×	—	—	SEC-51
B2190: NATS ANTENNA AMP	×	—	—	—	SEC-42
B2191: DIFFERENCE OF KEY	×	—	—	—	SEC-45
B2192: ID DISCORD BCM-ECM	×	—	—	—	SEC-46
B2193: CHAIN OF BCM-ECM	×	—	—	—	SEC-48
B2195: ANTI SCANNING	×	—	—	—	SEC-49
B2553: IGNITION RELAY	—	×	—	—	PCS-48
B2555: STOP LAMP	—	×	—	—	SEC-54

BCM (BODY CONTROL MODULE)

< ECU DIAGNOSIS INFORMATION >

CONSULT display	Fail-safe	Freeze Frame Data •Vehicle Speed •Odo/Trip Meter •Vehicle condition	Intelligent Key warning lamp ON	Tire pressure monitor warning lamp ON	Refer- ence page
B2556: PUSH-BTN IGN SW	—	×	×	—	SEC-56
B2557: VEHICLE SPEED	×	×	×	—	SEC-58
B2560: STARTER CONT RELAY	×	×	×	—	SEC-59
B2562: LOW VOLTAGE	—	×	—	—	BCS-41
B2601: SHIFT POSITION	×	×	×	—	SEC-60
B2602: SHIFT POSITION	×	×	×	—	SEC-63
B2603: SHIFT POSI STATUS	×	×	×	—	SEC-66
B2604: PNP SW	×	×	×	—	SEC-69
B2605: PNP SW	×	×	×	—	SEC-71
B2606: S/L RELAY	×	×	×	—	SEC-73
B2607: S/L RELAY	×	×	×	—	SEC-74
B2608: STARTER RELAY	×	×	×	—	SEC-76
B2609: S/L STATUS	×	×	×	—	SEC-78
B260A: IGNITION RELAY	×	×	×	—	PCS-50
B260B: STEERING LOCK UNIT	—	×	×	—	SEC-82
B260C: STEERING LOCK UNIT	—	×	×	—	SEC-83
B260D: STEERING LOCK UNIT	—	×	×	—	SEC-84
B260F: ENG STATE SIG LOST	×	×	×	—	SEC-85
B2612: S/L STATUS	×	×	×	—	SEC-90
B2614: ACC RELAY CIRC	—	×	×	—	PCS-52
B2615: BLOWER RELAY CIRC	—	×	×	—	PCS-55
B2616: IGN RELAY CIRC	—	×	×	—	PCS-58
B2617: STARTER RELAY CIRC	×	×	×	—	SEC-94
B2618: BCM	×	×	×	—	PCS-61
B2619: BCM	×	×	×	—	SEC-96
B261A: PUSH-BTN IGN SW	—	×	×	—	PCS-62
B261E: VEHICLE TYPE	×	×	× (Turn ON for 15 seconds)	—	SEC-97
B2622: INSIDE ANTENNA	—	×	—	—	DLK-55
B2623: INSIDE ANTENNA	—	×	—	—	DLK-57
B26E8: CLUTCH SW	×	×	×	—	SEC-86
B26E9: S/L STATUS	×	×	× (Turn ON for 15 seconds)	—	SEC-88
B26EA: KEY REGISTRATION	—	×	× (Turn ON for 15 seconds)	—	SEC-89
C1704: LOW PRESSURE FL	—	—	—	×	WT-16
C1705: LOW PRESSURE FR	—	—	—	×	
C1706: LOW PRESSURE RR	—	—	—	×	
C1707: LOW PRESSURE RL	—	—	—	×	
C1708: [NO DATA] FL	—	—	—	×	WT-18
C1709: [NO DATA] FR	—	—	—	×	
C1710: [NO DATA] RR	—	—	—	×	
C1711: [NO DATA] RL	—	—	—	×	

A
B
C
D
E
F
G
H
I
J
K
INL
M
N
O
P

BCM (BODY CONTROL MODULE)

< ECU DIAGNOSIS INFORMATION >

CONSULT display	Fail-safe	Freeze Frame Data •Vehicle Speed •Odo/Trip Meter •Vehicle condition	Intelligent Key warning lamp ON	Tire pressure monitor warning lamp ON	Refer- ence page
C1712: [CHECKSUM ERR] FL	—	—	—	×	WT-21
C1713: [CHECKSUM ERR] FR	—	—	—	×	
C1714: [CHECKSUM ERR] RR	—	—	—	×	
C1715: [CHECKSUM ERR] RL	—	—	—	×	
C1716: [PRESSDATA ERR] FL	—	—	—	×	WT-24
C1717: [PRESSDATA ERR] FR	—	—	—	×	
C1718: [PRESSDATA ERR] RR	—	—	—	×	
C1719: [PRESSDATA ERR] RL	—	—	—	×	
C1720: [CODE ERR] FL	—	—	—	×	WT-26
C1721: [CODE ERR] FR	—	—	—	×	
C1722: [CODE ERR] RR	—	—	—	×	
C1723: [CODE ERR] RL	—	—	—	×	
C1724: [BATT VOLT LOW] FL	—	—	—	×	WT-29
C1725: [BATT VOLT LOW] FR	—	—	—	×	
C1726: [BATT VOLT LOW] RR	—	—	—	×	
C1727: [BATT VOLT LOW] RL	—	—	—	×	
C1729: VHCL SPEED SIG ERR	—	—	—	×	WT-32
C1734: CONTROL UNIT	—	—	—	×	WT-34

COMBINATION METER

< ECU DIAGNOSIS INFORMATION >

COMBINATION METER

Reference Value

INFOID:000000004703685

VALUES ON THE DIAGNOSIS TOOL

Monitor Item	Condition		Value/Status
SPEED METER [km/h]	Ignition switch ON	While driving	Equivalent to speedometer reading NOTE: 655.35 is displayed when the malfunction signal is received
SPEED OUTPUT [km/h]	Ignition switch ON	While driving	Equivalent to speedometer reading NOTE: 655.35 is displayed when the malfunction signal is received
ODO OUTPUT [km/h or mph]	Ignition switch ON	—	Equivalent to odometer reading in combination meter
TACHO METER [rpm]	Ignition switch ON	While driving	Equivalent to tachometer reading NOTE: 8191.875 is displayed when the malfunction signal is received
FUEL METER [L]	Ignition switch ON	—	Values according to fuel level
W TEMP METER [°C]	Ignition switch ON	—	Values according to engine coolant temperature NOTE: 215 is displayed when the malfunction signal is input
ABS W/L	Ignition switch ON	ABS warning lamp ON	On
		ABS warning lamp OFF	Off
VDC/TCS IND	Ignition switch ON	VDC OFF indicator lamp ON	On
		VDC OFF indicator lamp OFF	Off
SLIP IND	Ignition switch ON	SLIP Indicator lamp ON	On
		SLIP indicator lamp OFF	Off
BRAKE W/L	Ignition switch ON	Brake warning lamp ON	On
		Brake warning lamp OFF	Off
DOOR W/L	Ignition switch ON	Door warning lamp ON	On
		Door warning lamp OFF	Off
HI-BEAM IND	Ignition switch ON	High-beam indicator lamp ON	On
		High-beam indicator lamp OFF	Off
TURN IND	Ignition switch ON	Turn signal indicator lamp ON	On
		Turn signal indicator lamp OFF	Off
RR FOG IND	Ignition switch ON	Rear fog lamp indicator lamp ON	On
		Rear fog lamp indicator lamp	Off
LIGHT IND	Ignition switch ON	Tail lamp indicator lamp ON	On
		Tail lamp indicator lamp OFF	Off
OIL W/L	Ignition switch ON	Oil pressure warning lamp ON	On
		Oil pressure warning lamp OFF	Off
MIL	Ignition switch ON	Malfunction indicator lamp ON	On
		Malfunction indicator lamp OFF	Off

A
B
C
D
E
F
G
H
I
J
K
L
M
N
O
P

INL



COMBINATION METER

< ECU DIAGNOSIS INFORMATION >

Monitor Item	Condition		Value/Status
CRUISE IND	Ignition switch ON	Cruise indicator lamp ON	On
		Cruise indicator lamp OFF	Off
ATC/T-AMT W/L	Ignition switch ON	A/T CHECK indicator lamp ON	On
		A/T CHECK indicator lamp OFF	Off
FUEL W/L	Ignition switch ON	Low-fuel warning displayed	On
		Low-fuel warning not displayed	Off
WASHER W/L	Ignition switch ON	Washer warning displayed	On
		Washer warning not displayed	Off
AIR PRES W/L	Ignition switch ON	Low tire pressure lamp ON	On
		Low tire pressure lamp OFF	Off
KEY G/Y W/L	Ignition switch ON	KEY warning lamp (yellow) ON	On
		KEY warning lamp (yellow) OFF	Off
MT SYNC REV IND	Ignition switch ON	S-MODE indicator ON	On
		S-MODE indicator OFF	Off
LCD	Ignition switch ON	Engine start information display (A/T models)	B&P I
		Engine start information display (M/T models)	C&P I
	Ignition switch LOCK or ACC	Engine start information display (A/T models)	B&P N
		Engine start information display (M/T models)	C&P N
	Ignition switch LOCK	Key ID warning display	ID NG
	Ignition switch LOCK	Steering lock information display	ROTAT
	Ignition switch LOCK	P position warning display	SFT P
	Ignition switch LOCK	Intelligent Key insert information display	INSRT
	Ignition switch LOCK	Intelligent Key low battery warning display	BATT
	Ignition switch ON	Take away warning display	NO KY
	Ignition switch LOCK	Key warning display	OUTKY
Ignition switch ON	ACC warning display	LK WN	

COMBINATION METER

< ECU DIAGNOSIS INFORMATION >

Monitor Item	Condition	Value/Status		
SHIFT IND	Ignition switch ON	Shift position indicator P display	P	A
		Shift position indicator R display	R	
		Shift position indicator N display	N	B
		Shift position indicator D display	D	
		Shift position indicator L display	L	
		Shift position indicator M1 display	M1	C
		Shift position indicator M2 display	M2	
		Shift position indicator M3 display	M3	D
		Shift position indicator M4 display	M4	
		Shift position indicator M5 display	M5	
		Shift position indicator M6 display	M6	E
Shift position indicator M7 display	M7			
AT S MODE SW	Ignition switch ON	NOTE: This item is displayed, but cannot be monitored.	Off	F
M RANGE SW	Ignition switch ON	Selector lever manual mode position	On	G
		Other than the above	Off	
NM RANGE SW	Ignition switch ON	Selector lever manual mode position	Off	H
		Other than the above	On	
AT SFT UP SW	Ignition switch ON	Selector lever + position	On	I
		Other than the above	Off	
AT SFT DWN SW	Ignition switch ON	Selector lever – position	On	J
		Other than the above	Off	
ST SFT UP SW	Ignition switch ON	Paddle shifter switch up operation	On	K
		Other than above	Off	
ST SFT DWN SW	Ignition switch ON	Paddle shifter switch down operation	On	INL
		Other than above	Off	
PKB SW	Ignition switch ON	Parking brake switch ON	On	M
		Parking brake switch OFF	Off	
BUCKLE SW	Ignition switch ON	Seat belt not fastened	On	N
		Seat belt fastened	Off	
BRAKE OIL SW	Ignition switch ON	Brake fluid level switch ON	On	O
		Brake fluid level switch OFF	Off	
A/C AMP CONN	Ignition switch ON	Other than the following	On	P
		Receives A/C auto amp. connection recognition signal	Off	
ENTER SW	Ignition switch ON	When  is pressed	On	
		Other than the above	Off	
SELECT SW	Ignition switch ON	When  is pressed	On	
		Other than the above	Off	
MT SYNC REV SW	Ignition switch ON	S-MODE switch ON	On	
		S-MODE switch OFF	Off	
DISTANCE [km]	Ignition switch ON	—	Possible driving distance calculated by combination meter	

COMBINATION METER

< ECU DIAGNOSIS INFORMATION >

Monitor Item	Condition		Value/Status
OUTSIDE TEMP [°C or °F]	Ignition switch ON	—	Equivalent to ambient temperature NOTE: This may not match the indicated value on the information display.
FUEL LOW SIG	Ignition switch ON	Low fuel warning displayed	On
		Low fuel warning not displayed	Off
CRANKING SIG	Ignition switch ON		On
	At engine cranking		Off
ST CNT SIG	Ignition switch ON		On
	At engine cranking		Off
BUZZER	Ignition switch ON	Buzzer ON	On
		Buzzer OFF	Off

NOTE:

Some items are not available according to vehicle specification.

TERMINAL LAYOUT

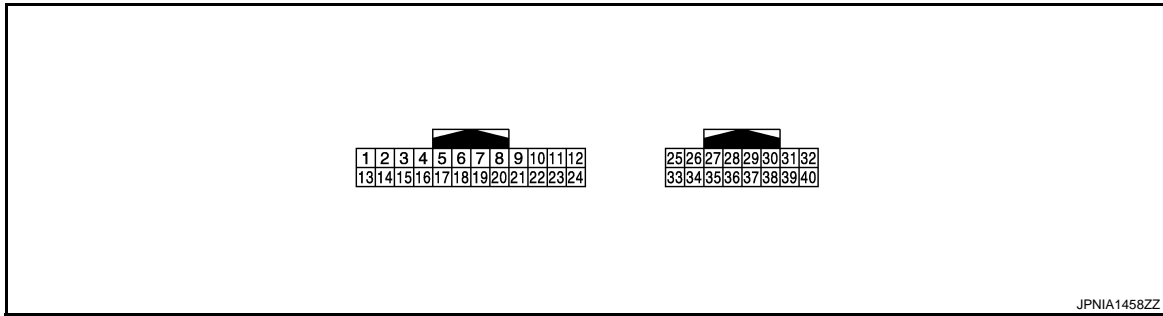

PHYSICAL VALUES

Terminal No. (Wire color)		Description		Condition		Value (Approx.)
+	-	Signal name	Input/ Output			
1 (V)	Ground	Battery power supply	Input	Ignition switch OFF	—	Battery voltage
2 (O)	Ground	Ignition signal	Input	Ignition switch ON	—	Battery voltage
3 (L)	Ground	Vehicle speed signal (2-pulse)	Output	Ignition switch ON	Speedometer operated [When vehicle speed is ap- prox. 40 km/h (25 MPH)]	<p>NOTE: The maximum voltage varies de- pending on the specification (destination unit).</p>

JSNIA0015GB

COMBINATION METER

< ECU DIAGNOSIS INFORMATION >

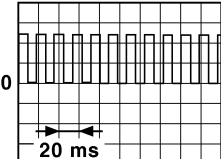
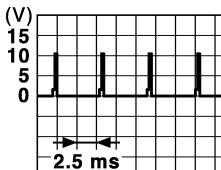
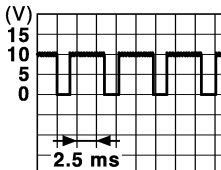
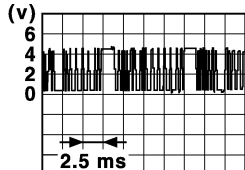
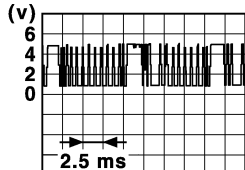
Terminal No. (Wire color)		Description		Condition		Value (Approx.)
+	-	Signal name	Input/ Output			
4 (Y)	Ground	Vehicle speed signal (8-pulse)	Output	Ignition switch ON	Speedometer operated [When vehicle speed is ap- prox. 40 km/h (25 MPH)]	<p>NOTE: The maximum voltage varies de- pending on the specification (destination unit).</p>  <p style="text-align: right; font-size: small;">JSNIA0012GB</p>
5 (B)	Ground	Illumination control signal	Output	Ignition switch ON	<ul style="list-style-type: none"> Lighting switch 1ST When meter illumination is maximum 	 <p style="text-align: right; font-size: small;">JPNIA1363GB</p>
					<ul style="list-style-type: none"> Lighting switch 1ST When meter illumination is step 12 	 <p style="text-align: right; font-size: small;">JPNIA1362GB</p>
					<ul style="list-style-type: none"> Lighting switch 1ST When meter illumination is minimum 	10 V
9 (BR)	Ground	Communication signal (METER⇒TRIPLE METER)	Output	Ignition switch ON	—	 <p style="text-align: right; font-size: small;">JPNIA1425GB</p>
10 (L)	Ground	Communication signal (TRIPLE METER⇒METER)	Input	Ignition switch ON	—	 <p style="text-align: right; font-size: small;">JPNIA1426GB</p>
12 (G)	Ground	S-MODE switch signal	Input	Ignition switch ON	S-MODE switch operation	12 V
					Other than the above	0 V
15 (L)	Ground	ACC power supply	Input	Ignition switch ACC	—	Battery voltage

A
B
C
D
E
F
G
H
I
J
K
L
M
N
O
P

INL

COMBINATION METER

< ECU DIAGNOSIS INFORMATION >

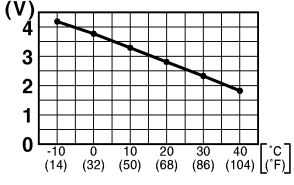
Terminal No. (Wire color)		Description		Condition		Value (Approx.)
+	-	Signal name	Input/ Output			
16 (R)	Ground	Air bag signal	Input	Ignition switch ON	Air bag warning lamp ON	4 V
					Air bag warning lamp OFF	0 V
17 (B)	Ground	Ground	—	Ignition switch ON	—	0 V
18 (V)	Ground	Ambient sensor signal	Input	Ignition switch ON	Changes depending to amb- ient temperature.	 <p style="text-align: right; font-size: small;">JSNIA0014GB</p>
19 (G)	Ground	A/C auto amp. connection recognition signal	Input	Ignition switch ON	—	5 V
20 (GR)	Ground	Ambient sensor ground	Input	Ignition switch ON	—	0 V
21 (L)	—	CAN-H	—	—	—	—
22 (P)	—	CAN-L	—	—	—	—
23 (B)	Ground	Ground	—	Ignition switch ON	—	0 V
24 (Y)	Ground	Fuel level sensor signal ground	—	Ignition switch ON	—	0 V
25 (W)	Ground	Alternator signal	Input	Ignition switch ON	Charge warning lamp ON	2 V
					Charge warning lamp OFF	12 V
26 (O)	Ground	Parking brake switch signal	Input	Engine idling	Parking brake ON	0 V
					Parking brake OFF	12 V
27 (LG)	Ground	Brake fluid level switch sig- nal	Input	Ignition switch ON	Brake fluid level is normal	12 V
					Brake fluid level is less than LOW level	0 V
28 (Y)	Ground	Security signal	Input	Ignition switch ON	Security warning lamp ON	0 V
					Security warning lamp OFF	12 V
29 (GR)	Ground	Washer level switch signal	Input	Ignition switch ON	Washer level switch ON	0 V
					Washer level switch OFF	5 V
32 (G)	Ground	Paddle shifter down signal	Input	Ignition switch ON	Paddle shifter down opera- tion	0 V
					Other than the above	5 V
33 (O)	Ground	Paddle shifter up signal	Input	Ignition switch ON	Paddle shifter up operation	0 V
					Other than the above	5 V

COMBINATION METER

< ECU DIAGNOSIS INFORMATION >

Terminal No. (Wire color)		Description		Condition		Value (Approx.)
+	-	Signal name	Input/ Output			
34 (BR)	Ground	Fuel level sensor signal	Input	Ignition switch ON	—	<p style="text-align: right; font-size: small;">JPNIA0740ZZ</p>
35 (L)	Ground	Seat belt buckle switch signal (driver side)	Input	Ignition switch ON	When driver seat belt is fastened.	12 V
					When driver seat belt is unfastened.	0 V
36 (P)	Ground	Passenger seat belt warning signal	Input	Ignition switch ON	<ul style="list-style-type: none"> • When getting in the passenger seat. • When passenger seat belt is fastened. 	12 V
					<ul style="list-style-type: none"> • When getting in the passenger seat. • When passenger seat belt is unfastened. 	0 V
37 (G)	Ground	Not manual mode signal	Input	Ignition switch ON	Manual mode	12 V
					Other than the above	0 V
38 (V)	Ground	Manual mode shift down signal	Input	Ignition switch ON	Selector lever down operation	0 V
					Other than the above	12 V
39 (L)	Ground	Manual mode shift up signal	Input	Ignition switch ON	Selector lever up operation	0 V
					Other than the above	12 V
40 (W)	Ground	Manual mode signal	Input	Ignition switch ON	Manual mode	0 V
					Other than the above	12 V

A
B
C
D
E
F
G
H
I
J
K
L
M
N
O
P

INL

COMBINATION METER

< ECU DIAGNOSIS INFORMATION >

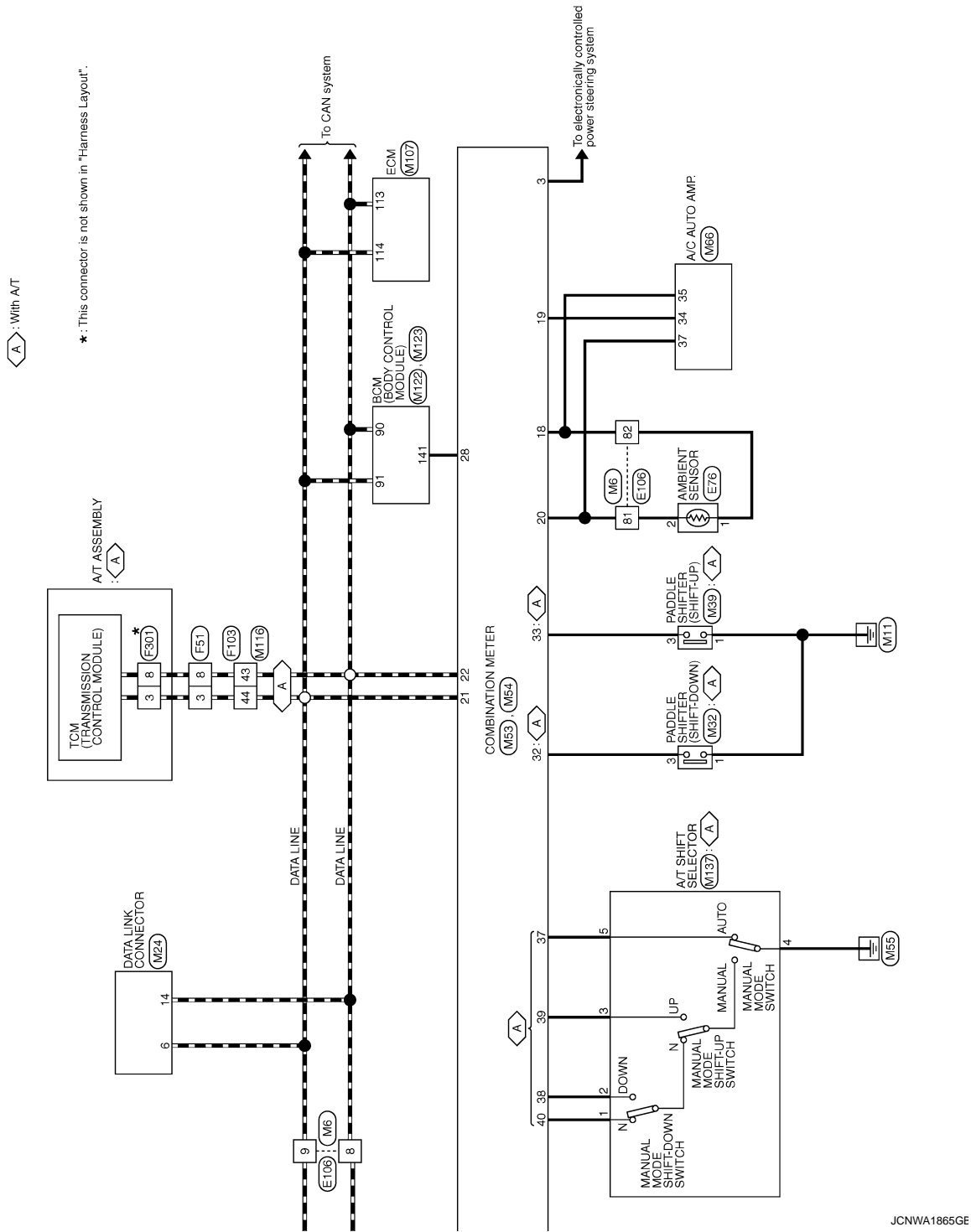





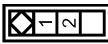

A
B
C
D
E
F
G
H
I
J
K
INL
M
N
O
P

COMBINATION METER

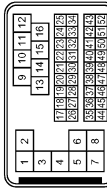
< ECU DIAGNOSIS INFORMATION >

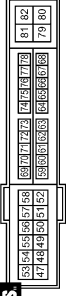
METER

Connector No. B1	WIRE TO WIRE THBDFW-GS16-TM4		Terminal No. 80 82 84	Color of Wire Y B G	Signal Name [Specification]
Connector No. B13	SEAT BELT BUCKLE SWITCH (DRIVER SIDE) A03EV		Terminal No. 1 2	Color of Wire G B	Signal Name [Specification]
Connector No. B21	FUEL LEVEL SENSOR UNIT (SUB) EQ2FGY-RS		Terminal No. 1 2	Color of Wire B W	Signal Name [Specification]
Connector No. B22	FUEL LEVEL SENSOR UNIT AND FUEL PUMP (MAIN) EB5FGY-RS		Terminal No. 2 5	Color of Wire W Y	Signal Name [Specification]
Connector No. E3	WIRE TO WIRE SAA3SMB-RS8-SH23		Terminal No. 21	Color of Wire SB	Signal Name [Specification]
Connector No. E6	IPDM E/R INTELLIGENT POWER DISTRIBUTION MODULE (ENGINE ROOM) THBDFV-NH		Terminal No. 39 40	Color of Wire P L	Signal Name [Specification]
Connector No. E7	IPDM E/R INTELLIGENT POWER DISTRIBUTION MODULE (ENGINE ROOM) TH2DFV-CS1Z-M4		Terminal No. 75	Color of Wire SB	Signal Name [Specification]
Connector No. E32	WASHER LEVEL SWITCH Z02FBR		Terminal No. 1 2	Color of Wire LG B	Signal Name [Specification]

JCNWA1866GE

COMBINATION METER

< ECU DIAGNOSIS INFORMATION >

METER

Connector No.	E41
Connector Name	ABS ACTUATOR AND ELECTRIC UNIT (CONTROL UNIT)
Connector Type	BA4AFB-ATZ4-LH

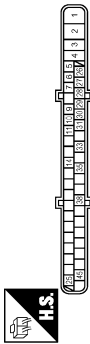

Terminal No.	Color of Wire	Signal Name [Specification]
14	P	CAN-L
35	L	CAN-H

Connector No.	E47
Connector Name	BRAKE FLUID LEVEL SWITCH
Connector Type	YV2FGY



Terminal No.	Color of Wire	Signal Name [Specification]
1	W	-
2	B	-

Connector No.	E76
Connector Name	AMBIENT SENSOR
Connector Type	RS02FB



Terminal No.	Color of Wire	Signal Name [Specification]
1	G	AMBIENT SENSOR SIGNAL
2	P	SENSOR GROUND

Connector No.	E106
Connector Name	WIRE TO WIRE
Connector Type	TH80FY-CS16-TM4

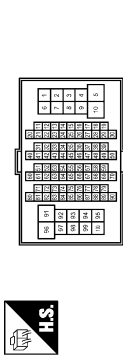

Terminal No.	Color of Wire	Signal Name [Specification]
8	P	-
9	L	-
20	LG	-
80	W	-
81	P	-
82	G	-

Connector No.	F1
Connector Name	WIRE TO WIRE
Connector Type	SA43FB-RSS-SH28

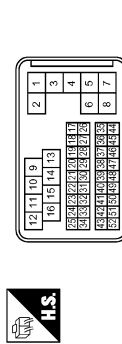

Terminal No.	Color of Wire	Signal Name [Specification]
21	BR	-

Connector No.	F36
Connector Name	ALTERNATOR
Connector Type	HS03FB



Terminal No.	Color of Wire	Signal Name [Specification]
2	G	L

Connector No.	F37
Connector Name	OIL PRESSURE SWITCH
Connector Type	EV1FGY-RS-AR



Terminal No.	Color of Wire	Signal Name [Specification]
1	BR	-

Connector No.	F51
Connector Name	A/T ASSEMBLY
Connector Type	FR10FG-DGY

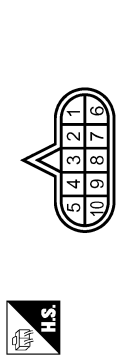

Terminal No.	Color of Wire	Signal Name [Specification]
3	L	-
8	P	-

JCNWA1867GE

A
B
C
D
E
F
G
H
I
J
K
INL
M
N
O
P

COMBINATION METER

< ECU DIAGNOSIS INFORMATION >

METER

Connector No.	F103
Connector Name	WIRE TO WIRE
Connector Type	TK36FW-RS10

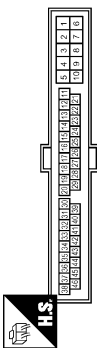

Terminal No.	Color of Wire	Signal Name [Specification]
2	G	-
43	P	-
44	L	-

Connector No.	F301
Connector Name	TOM (TRANSMISSION CONTROL MODULE)
Connector Type	SPT0FG



Terminal No.	Color of Wire	Signal Name [Specification]
3	R	CAN-H
8	BR	CAN-L

Connector No.	M1
Connector Name	FUSE BLOCK (J/B)
Connector Type	NS30FW-M2



Terminal No.	Color of Wire	Signal Name [Specification]
1A	V	-
2A	G	-
5A	L	-

Connector No.	M3
Connector Name	FUSE BLOCK (J/B)
Connector Type	NS12FW-GS

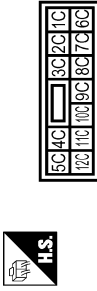

Terminal No.	Color of Wire	Signal Name [Specification]
12C	O	-

Connector No.	M6
Connector Name	WIRE TO WIRE
Connector Type	TH60MW-CS16-TM4



Terminal No.	Color of Wire	Signal Name [Specification]
8	P	-
9	L	-
20	GR	-
80	LG	-
81	GR	-
82	V	-

Connector No.	M7
Connector Name	WIRE TO WIRE
Connector Type	TH60MW-CS16-TM4

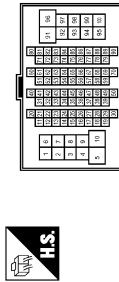

Terminal No.	Color of Wire	Signal Name [Specification]
80	Y	-
82	BR	-
84	L	-

Connector No.	M24
Connector Name	DATA LINK CONNECTOR
Connector Type	BD16FW

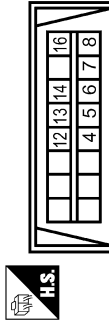

Terminal No.	Color of Wire	Signal Name [Specification]
6	L	-
14	P	-

Connector No.	M32
Connector Name	PADDLE SHIFTER (SHIFT-DOWN)
Connector Type	AD3FW



Terminal No.	Color of Wire	Signal Name [Specification]
1	W	-
3	G	-

JCNWA1868GE

COMBINATION METER

< ECU DIAGNOSIS INFORMATION >

METER

Connector No.	M39
Connector Name	PADDLE SHIFTER (SHIFT-UP)
Connector Type	304FW



Terminal No.	Color of Wire	Signal Name [Specification]
1	W	-
3	O	-

Connector No.	M47
Connector Name	WIRE TO WIRE
Connector Type	TH12FW-NH



Terminal No.	Color of Wire	Signal Name [Specification]
2	L	-
3	BR	-
4	O	-
5	V	-
6	B	-

Connector No.	M63
Connector Name	COMBINATION METER
Connector Type	TH24FW-NH

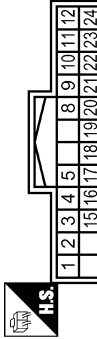

Terminal No.	Color of Wire	Signal Name [Specification]
1	V	BATTERY POWER SUPPLY
2	O	IGNITION SIGNAL
3	L	VEHICLE SPEED SIGNAL (2-PULSE)
4	Y	VEHICLE SPEED SIGNAL (6-PULSE)
5	B	ILLUMINATION CONTROL SIGNAL
9	BR	COMMUNICATION SIGNAL (METER->TRIPLE METER)
10	L	COMMUNICATION SIGNAL (TRIPLE METER->METER)
12	G	S-MODE SWITCH SIGNAL
15	L	ACC POWER SUPPLY
16	R	AIR BAG SIGNAL
17	B	GROUND

18	V	AMBIENT SENSOR SIGNAL
19	G	A/C AUTO AMP. CONNECTION/RECOGNITION SIGNAL
20	GR	AMBIENT SENSOR GROUND
21	L	CAN-H
22	P	CAN-L
23	B	GROUND
24	Y	FUEL LEVEL SENSOR GROUND

Connector No.	M64
Connector Name	COMBINATION METER
Connector Type	TH16FW-NH

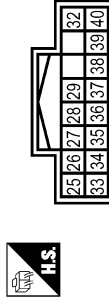

Terminal No.	Color of Wire	Signal Name [Specification]
25	W	ALTERNATOR SIGNAL
26	O	PARKING BRAKE SWITCH SIGNAL
27	LG	BRAKE FLUID LEVEL SWITCH SIGNAL
28	Y	SECURITY SIGNAL
29	GR	WASHER LEVEL SWITCH SIGNAL
32	G	PADDLE SHIFTER DOWN SIGNAL
33	O	PADDLE SHIFTER UP SIGNAL
34	BR	FUEL LEVEL SENSOR SIGNAL
38	L	SEAT BELT BUCKLE SWITCH SIGNAL (DRIVER SIDE)
36	P	PASSENGER SEAT BELT WARNING SIGNAL
37	G	NOT MANUAL MODE SIGNAL

Connector No.	M66
Connector Name	A/C AUTO AMP.
Connector Type	S480FW

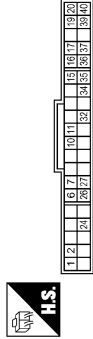

Terminal No.	Color of Wire	Signal Name [Specification]
34	G	A/C AUTO AMP. CONNECTION/RECOGNITION SIGNAL
35	V	AMBIENT SENSOR SIGNAL
37	GR	SENSOR GROUND

Connector No.	M68
Connector Name	PARKING BRAKE SWITCH
Connector Type	PF01FB-A

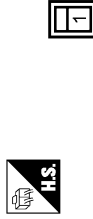

Terminal No.	Color of Wire	Signal Name [Specification]
1	O	-

JCNWA1869GE

A
B
C
D
E
F
G
H
I
J
K
INL
M
N
O
P

COMBINATION METER

< ECU DIAGNOSIS INFORMATION >

METER

Connector No.	M122
Connector Name	BCM (BODY CONTROL MODULE)
Connector Type	TH4GFEB-NH

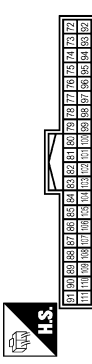

Terminal No.	Color of Wire	Signal Name [Specification]
90	P	CAN-L
91	L	CAN-H

Connector No.	M116
Connector Name	WIRE TO WIRE
Connector Type	TK33MW-NS/D



Terminal No.	Color of Wire	Signal Name [Specification]
2	W	-
43	P	-
44	L	-

Connector No.	M107
Connector Name	ECM
Connector Type	RH24EGY-F23-R-LH-Z

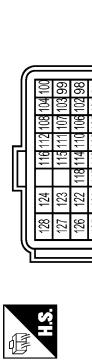

Terminal No.	Color of Wire	Signal Name [Specification]
113	P	VEHCAN-LI
114	L	VEHCAN-HI

Connector No.	M98
Connector Name	WIRE TO WIRE
Connector Type	TH8BFW-NH

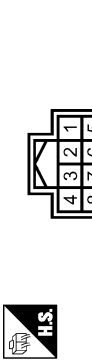

Terminal No.	Color of Wire	Signal Name [Specification]
7	B	-
8	G	-

Connector No.	M241
Connector Name	WIRE TO WIRE
Connector Type	TH12MP-NH

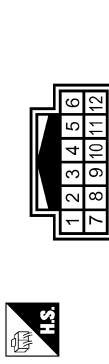

Terminal No.	Color of Wire	Signal Name [Specification]
2	L	-
3	Y	-
4	O	-
5	V	-
6	B	-

Connector No.	M147
Connector Name	AIR BAG DIAGNOSIS SENSOR UNIT
Connector Type	NH2BFY-EX

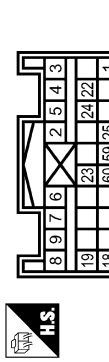

Terminal No.	Color of Wire	Signal Name [Specification]
23	R	AIRBAG W/L
24	P	SEAT BELT

Connector No.	M137
Connector Name	A/T SHIFT SELECTOR
Connector Type	TK10FW

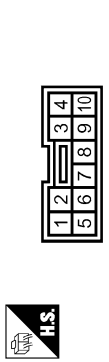

Terminal No.	Color of Wire	Signal Name [Specification]
1	W	-
2	V	-
3	L	-
4	B	-
5	G	-

Connector No.	M123
Connector Name	BCM (BODY CONTROL MODULE)
Connector Type	TH4UFG-NH

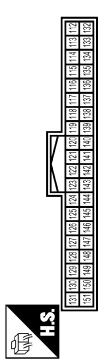

Terminal No.	Color of Wire	Signal Name [Specification]
141	Y	SECURITY INDICATOR

JCNWA1870GE

COMBINATION METER

< ECU DIAGNOSIS INFORMATION >

A
B
C
D
E
F
G
H
I
J
K
INL
M
N
O
P

METER

Connector No.	M242
Connector Name	TRIPLE METER
Connector Type	TH12FW-NH

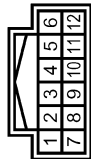

Terminal No.	Color of Wire	Signal Name [Specification]
1	B	GROUND
2	V	BATTERY POWER SUPPLY
3	O	IGNITION SIGNAL
4	Y	COMMUNICATION SIGNAL (METER->TRIPLE METER)
5	L	COMMUNICATION SIGNAL (TRIPLE METER->METER)

Connector No.	M232
Connector Name	WIRE TO WIRE
Connector Type	TH68MW-NH

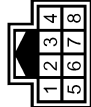
Terminal No.	Color of Wire	Signal Name [Specification]
7	G	
8	G	

Connector No.	M235
Connector Name	S-MODE SWITCH
Connector Type	TK04FGY

Terminal No.	Color of Wire	Signal Name [Specification]
1	G	
2	G	

Fail-Safe

FAIL-SAFE

The combination meter activates the fail-safe control if CAN communication with each unit is malfunctioning.

JCNWA1871GE

INFOID:000000004703687

COMBINATION METER

< ECU DIAGNOSIS INFORMATION >

Function		Specifications
Speedometer		Reset to zero by suspending communication.
Tachometer		
Water temperature gauge		
Illumination control		When suspending communication, changes to nighttime mode.
Information display	Door open warning	The display turns OFF by suspending communication.
	Parking brake release warning	
	Instantaneous fuel warning	<ul style="list-style-type: none"> When reception time of an abnormal signal is 2 seconds or less, the last received datum is used for calculation to indicate the result. When reception time of an abnormal signal is more than two seconds, the last result calculated during normal condition is indicated.
	Average fuel consumption	
	Average vehicle speed	
	Travel distance	
Buzzer		The buzzer turns off by suspending communication.
Warning lamp/indicator lamp	ABS warning lamp	The lamp turns ON by suspending communication.
	VDC OFF indicator lamp	
	SLIP indicator lamp	
	Brake warning lamp	
	Low tire pressure warning lamp	The lamp turns ON after flashing for 1 minute.
	High beam indicator lamp	The lamp turns OFF by suspending communication.
	Turn signal indicator lamp	
	Light indicator lamp	
	Rear fog lamp indicator lamp	
	Oil pressure warning lamp	
	Malfunction indicator lamp	
	CRUISE indicator lamp	
	Key warning lamp	

DTC Index

INFOID:000000004703688

Display contents of CONSULT-III	Diagnostic item is detected when ...	Refer to
CAN COMM CIRCUIT [U1000]	When combination meter is not transmitting or receiving CAN communication signal for 2 seconds or more.	MWI-37. "Diagnosis Procedure"
CONTROL UNIT (CAN) [U1010]	When detecting error during the initial diagnosis of the CAN controller of combination meter.	MWI-38. "Diagnosis Procedure"
COMM ERROR 1 [B2201]	If a communication error is present in the communication line between combination meter and triple meter for 2 seconds or more.	MWI-39. "Diagnosis Procedure"
VEHICLE SPEED [B2205]	The abnormal vehicle speed signal is input from the ABS actuator and electric unit (control unit) for 2 seconds or more.	MWI-41. "Diagnosis Procedure"
ENGINE SPEED [B2267]	If ECM continuously transmits abnormal engine speed signals for 2 seconds or more.	MWI-42. "Diagnosis Procedure"
WATER TEMP [B2268]	If ECM continuously transmits abnormal engine coolant temperature signals for 60 seconds or more.	MWI-43. "Diagnosis Procedure"

INTERIOR LIGHTING SYSTEM SYMPTOMS

< SYMPTOM DIAGNOSIS >

SYMPTOM DIAGNOSIS

INTERIOR LIGHTING SYSTEM SYMPTOMS

Symptom Table

INFOID:000000004402446

CAUTION:

Perform the self-diagnosis with CONSULT-III before the symptom diagnosis. Perform the trouble diagnosis if any DTC is detected.

Symptom	Possible cause	Inspection item
All the following lamps do not turn ON. <ul style="list-style-type: none"> • Map lamp • Luggage room lamp • Vanity mirror lamp 	<ul style="list-style-type: none"> • Harness between BCM and each interior room lamp • BCM 	Interior room lamp power supply circuit Refer to INL-19 .
<ul style="list-style-type: none"> • Interior room lamp does not turn ON even though the door is open. (It turns ON when turning the interior room lamp ON.) • Interior room lamp does not turn OFF even though the door is closed. 	<ul style="list-style-type: none"> • Harness between BCM and each door switch • Harness between BCM and each interior room lamp • BCM 	Door switch circuit Refer to DLK-60 .
		Interior room lamp control circuit Refer to INL-21 .
Interior room lamp timer does not activate. (It turns ON/ OFF when the door opens/closes.)	—	Check the interior room lamp setting. Refer to INL-14 .
<ul style="list-style-type: none"> • Luggage room lamp does not turn ON. (The bulb is normal.) • Luggage room lamp does not turn OFF. 	<ul style="list-style-type: none"> • Harness between BCM and back door switch • Harness between BCM and luggage room lamp • BCM 	Back door switch circuit Refer to DLK-60 .
		Luggage room lamp circuit Refer to INL-23 .
Push-button ignition switch illumination does not illuminate.	<ul style="list-style-type: none"> • Harness between BCM and push-button ignition switch • BCM 	Push-button ignition switch illumination circuit Refer to INL-25 .
Interior room lamp battery saver does not activate.	—	Check the interior room lamp battery saver setting. Refer to INL-15 .

A
B
C
D
E
F
G
H
I
J
K
L
M
N
O
P

INL

PRECAUTIONS

< PRECAUTION >

PRECAUTION

PRECAUTIONS

Precaution for Supplemental Restraint System (SRS) "AIR BAG" and "SEAT BELT PRE-TENSIONER"

INFOID:000000004703691

The Supplemental Restraint System such as "AIR BAG" and "SEAT BELT PRE-TENSIONER", used along with a front seat belt, helps to reduce the risk or severity of injury to the driver and front passenger for certain types of collision. This system includes seat belt switch inputs and dual stage front air bag modules. The SRS system uses the seat belt switches to determine the front air bag deployment, and may only deploy one front air bag, depending on the severity of a collision and whether the front occupants are belted or unbelted. Information necessary to service the system safely is included in the "SRS AIR BAG" and "SEAT BELT" of this Service Manual.

WARNING:

- To avoid rendering the SRS inoperative, which could increase the risk of personal injury or death in the event of a collision which would result in air bag inflation, all maintenance must be performed by an authorized NISSAN/INFINITI dealer.
- Improper maintenance, including incorrect removal and installation of the SRS, can lead to personal injury caused by unintentional activation of the system. For removal of Spiral Cable and Air Bag Module, see the "SRS AIR BAG".
- Do not use electrical test equipment on any circuit related to the SRS unless instructed to in this Service Manual. SRS wiring harnesses can be identified by yellow and/or orange harnesses or harness connectors.

PRECAUTIONS WHEN USING POWER TOOLS (AIR OR ELECTRIC) AND HAMMERS

WARNING:

- When working near the Air Bag Diagnosis Sensor Unit or other Air Bag System sensors with the ignition ON or engine running, DO NOT use air or electric power tools or strike near the sensor(s) with a hammer. Heavy vibration could activate the sensor(s) and deploy the air bag(s), possibly causing serious injury.
- When using air or electric power tools or hammers, always switch the ignition OFF, disconnect the battery, and wait at least 3 minutes before performing any service.

Precaution for Battery Service

INFOID:000000004703692

Before disconnecting the battery, lower both the driver and passenger windows. This will prevent any interference between the window edge and the vehicle when the door is opened/closed. During normal operation, the window slightly raises and lowers automatically to prevent any window to vehicle interference. The automatic window function will not work with the battery disconnected.

MAP LAMP

< REMOVAL AND INSTALLATION >

REMOVAL AND INSTALLATION

MAP LAMP

Exploded View

INFOID:000000004402449

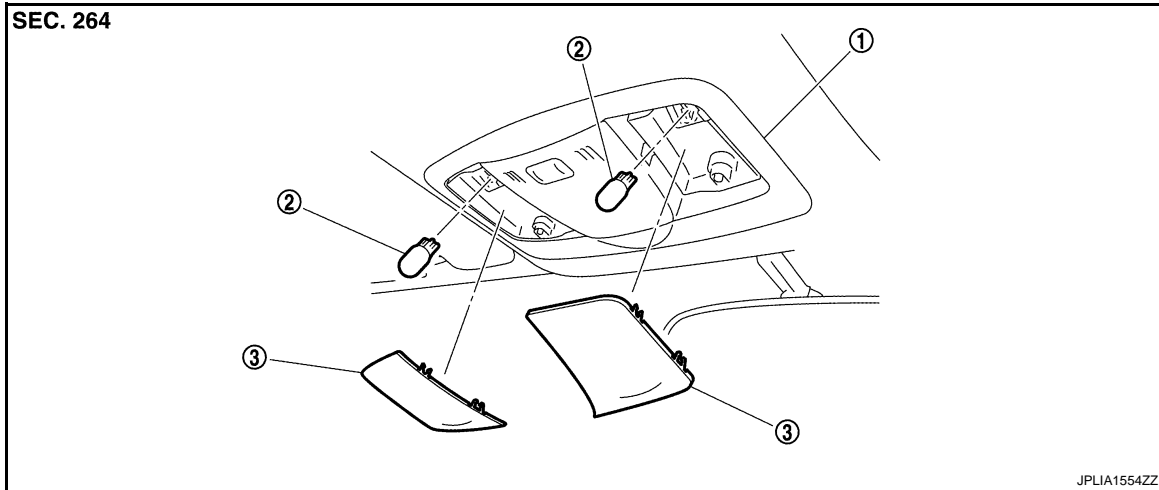

1. Map lamp assembly

2. Bulb

3. Lens

Removal and Installation

INFOID:000000004402450

Refer to [INT-23. "Exploded View"](#) for the map lamp assembly installation/removal.

Replacement

INFOID:000000004402451

CAUTION:

- Disconnect the battery negative terminal or remove the fuse.
- Never touch the glass of bulb directly by hand. Keep grease and other oily matters away from it.
- Never touch bulb by hand while it is lit or right after being turned off.
- Never leave bulb out of lamp reflector for a long time because dust, moisture smoke, etc. may affect the performance of lamp. When replacing bulb, be sure to replace it with new one.

MAP LAMP BULB

1. Insert any appropriate tool into the gap between the lens. Remove the lens.
2. Remove the bulb.

A
B
C
D
E
F
G
H
I
J
K
INL
M
N
O
P

VANITY MIRROR LAMP

< REMOVAL AND INSTALLATION >

VANITY MIRROR LAMP

Exploded View

INFOID:000000004402452

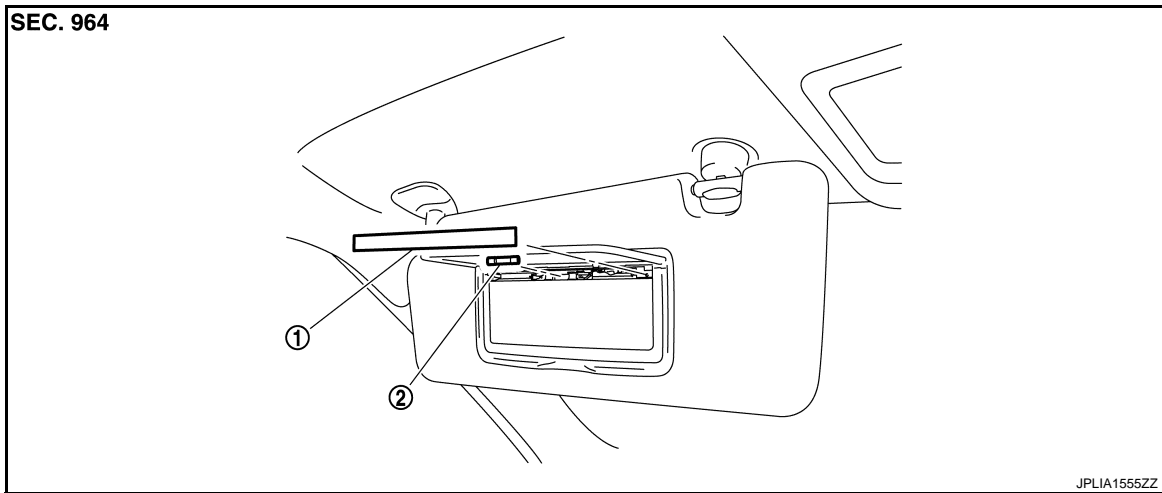

1. Lens

2. Bulb

Replacement

INFOID:000000004402453

CAUTION:

- Disconnect the battery negative terminal or remove the fuse.
- Never touch the glass of bulb directly by hand. Keep grease and other oily matters away from it.
- Never touch bulb by hand while it is lit or right after being turned off.
- Never leave bulb out of lamp reflector for a long time because dust, moisture smoke, etc. may affect the performance of lamp. When replacing bulb, be sure to replace it with new one.

VANITY MIRROR LAMP BULB

1. Insert any appropriate tool into the gap between the lens. Remove the lens.
2. Remove the bulb.

LUGGAGE ROOM LAMP

< REMOVAL AND INSTALLATION >

LUGGAGE ROOM LAMP

Exploded View

INFOID:000000004455882

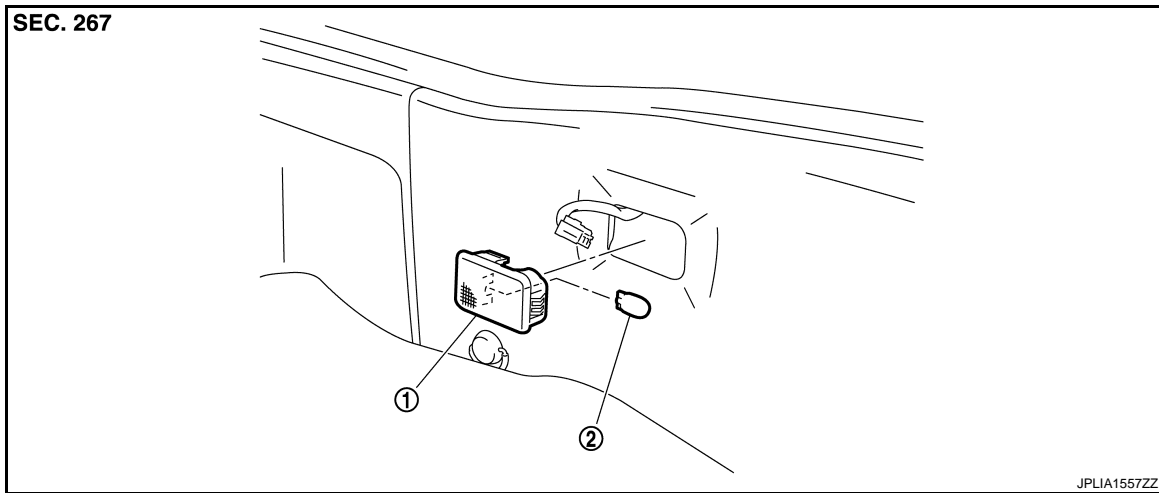

1. Luggage room lamp assembly
2. Bulb

Removal and Installation

INFOID:000000004455883

CAUTION:

Disconnect the battery negative terminal or remove the fuse.

REMOVAL

1. Insert any appropriate tool into the gap between the luggage room lamp assembly and luggage finisher lower. Remove the luggage room lamp assembly.
2. Disconnect the connector.

INSTALLATION

Install in the reverse order of removal.

Replacement

INFOID:000000004455884

CAUTION:

- **Disconnect the battery negative terminal or remove the fuse.**
- **Never touch the glass of bulb directly by hand. Keep grease and other oily matters away from it.**
- **Never touch bulb by hand while it is lit or right after being turned off.**
- **Never leave bulb out of lamp reflector for a long time because dust, moisture smoke, etc. may affect the performance of lamp. When replacing bulb, be sure to replace it with new one.**

LUGGAGE ROOM LAMP BULB

1. Remove the luggage room lamp assembly.
2. Remove the bulb.

A
B
C
D
E
F
G
H
I
J
K
INL
M
N
O
P

SERVICE DATA AND SPECIFICATIONS (SDS)

< SERVICE DATA AND SPECIFICATIONS (SDS)

SERVICE DATA AND SPECIFICATIONS (SDS)

SERVICE DATA AND SPECIFICATIONS (SDS)

Bulb Specifications

INFOID:000000004402464

Item	Type	Wattage (W)
Push-button ignition switch illumination	LED	—
Map lamp	Wedge	8
Vanity mirror lamp	—	2
Luggage room lamp	Wedge	5