

WT
SECTION
ROAD WHEELS & TIRES

A
B
C
D

WT

CONTENTS

REGULAR GRADE		
PRECAUTION	3	
PRECAUTIONS	3	
FOR USA AND CANADA	3	
FOR USA AND CANADA : Precaution for Supplemental Restraint System (SRS) "AIR BAG" and "SEAT BELT PRE-TENSIONER"	3	
FOR USA AND CANADA : Precaution for Battery Service	3	
FOR USA AND CANADA : Service Notice or Precautions	3	
FOR MEXICO	3	
FOR MEXICO : Precaution for Supplemental Restraint System (SRS) "AIR BAG" and "SEAT BELT PRE-TENSIONER"	3	
FOR MEXICO : Precaution for Battery Service	4	
FOR MEXICO : Service Notice or Precautions	4	
PREPARATION	5	
PREPARATION	5	
Special Service Tool	5	
Commercial Service Tool	5	
SYSTEM DESCRIPTION	6	
COMPONENT PARTS	6	
Component Parts Location	6	
Component Description	6	
BCM	7	
Transmitter	7	
Tire pressure receiver	7	
Tire pressure warning check switch	7	
Low tire pressure warning lamp	7	
SYSTEM	8	
TIRE PRESSURE MONITORING SYSTEM	8	
		TIRE PRESSURE MONITORING SYSTEM : System Diagram
		8
		TIRE PRESSURE MONITORING SYSTEM : System Description
		8
		TIRE PRESSURE MONITORING SYSTEM : Fail-safe
		8
		DIAGNOSIS SYSTEM (BCM)
		11
		COMMON ITEM
		11
		COMMON ITEM : CONSULT-III Function (BCM - COMMON ITEM)
		11
		AIR PRESSURE MONITOR
		12
		AIR PRESSURE MONITOR : Diagnosis Description
		12
		AIR PRESSURE MONITOR : CONSULT-III Function
		13
		ECU DIAGNOSIS INFORMATION
		15
		BCM
		15
		List of ECU Reference
		15
		WIRING DIAGRAM
		16
		TIRE PRESSURE MONITORING SYSTEM
		16
		Wiring Diagram
		16
		BASIC INSPECTION
		20
		DIAGNOSIS AND REPAIR WORK FLOW
		20
		Work Flow
		20
		TRANSMITTER WAKE UP OPERATION
		22
		Description
		22
		Special Repair Requirement
		22
		ID REGISTRATION PROCEDURE
		23
		Description
		23
		Special Repair Requirement
		23
		EMERGENCY TIRE PUNCTURE REPAIR
		25

F
G
H
I
J
K
L
M
N
O
P

Description	25	LOW TIRE PRESSURE WARNING LAMP DOES NOT TURN OFF	46
Draining	25	Description	46
DTC/CIRCUIT DIAGNOSIS	26	Diagnosis Procedure	46
C1704, C1705, C1706, C1707 LOW TIRE PRESSURE	26	LOW TIRE PRESSURE WARNING LAMP BLINKS	47
Description	26	Description	47
DTC Logic	26	Diagnosis Procedure	47
Diagnosis Procedure	26	TURN SIGNAL LAMP BLINKS	49
Special Repair Requirement	27	Description	49
C1708, C1709, C1710, C1711 TRANSMITTER	28	Diagnosis Procedure	49
.....	28	ID REGISTRATION CANNOT BE COMPLETED	50
DTC Logic	28	Description	50
Diagnosis Procedure	28	Diagnosis Procedure	50
Special Repair Requirement	30	NORMAL OPERATING CONDITION	51
C1716, C1717, C1718, C1719 TRANSMITTER	31	Description	51
.....	31	NOISE, VIBRATION AND HARSHNESS (NVH) TROUBLESHOOTING	52
DTC Logic	31	NVH Troubleshooting Chart	52
Diagnosis Procedure	31	PERIODIC MAINTENANCE	53
Special Repair Requirement	32	ROAD WHEEL TIRE ASSEMBLY	53
C1729 VEHICLE SPEED SIGNAL	33	Adjustment	53
Description	33	REMOVAL AND INSTALLATION	56
DTC Logic	33	ROAD WHEEL TIRE ASSEMBLY	56
Diagnosis Procedure	33	Exploded View	56
Special Repair Requirement	33	Removal and Installation	56
C1734 BCM	35	Inspection	56
DTC Logic	35	TRANSMITTER	58
Diagnosis Procedure	35	Exploded View	58
Special Repair Requirement	36	Removal and Installation	58
TIRE PRESSURE RECEIVER	37	TIRE PRESSURE RECEIVER	60
Component Function Check	37	Removal and Installation	60
Diagnosis Procedure	37	SERVICE DATA AND SPECIFICATIONS (SDS)	61
TIRE PRESSURE WARNING CHECK SWITCH	39	SERVICE DATA AND SPECIFICATIONS (SDS)	61
Component Function Check	39	Road Wheel	61
Diagnosis Procedure	39	Tire Air Pressure	61
LOW TIRE PRESSURE WARNING LAMP	40	Nismo 370Z	
Component Function Check	40	SPEC CHANGE INFORMATION	62
Diagnosis Procedure	40	ROAD WHEEL TIRE ASSEMBLY	62
POWER SUPPLY AND GROUND CIRCUIT	41	Road Wheel Tire Assembly	62
Diagnosis Procedure	41		
SYMPTOM DIAGNOSIS	42		
TPMS	42		
Symptom Table	42		
LOW TIRE PRESSURE WARNING LAMP DOES NOT BLINKS	45		
Description	45		
Diagnosis Procedure	45		

PRECAUTION

PRECAUTIONS

FOR USA AND CANADA

FOR USA AND CANADA : Precaution for Supplemental Restraint System (SRS) "AIR BAG" and "SEAT BELT PRE-TENSIONER"

INFOID:000000005549060

The Supplemental Restraint System such as "AIR BAG" and "SEAT BELT PRE-TENSIONER", used along with a front seat belt, helps to reduce the risk or severity of injury to the driver and front passenger for certain types of collision. This system includes seat belt switch inputs and dual stage front air bag modules. The SRS system uses the seat belt switches to determine the front air bag deployment, and may only deploy one front air bag, depending on the severity of a collision and whether the front occupants are belted or unbelted.

Information necessary to service the system safely is included in the "SRS AIR BAG" and "SEAT BELT" of this Service Manual.

WARNING:

- To avoid rendering the SRS inoperative, which could increase the risk of personal injury or death in the event of a collision which would result in air bag inflation, all maintenance must be performed by an authorized NISSAN/INFINITI dealer.
- Improper maintenance, including incorrect removal and installation of the SRS, can lead to personal injury caused by unintentional activation of the system. For removal of Spiral Cable and Air Bag Module, see the "SRS AIR BAG".
- Do not use electrical test equipment on any circuit related to the SRS unless instructed to in this Service Manual. SRS wiring harnesses can be identified by yellow and/or orange harnesses or harness connectors.

PRECAUTIONS WHEN USING POWER TOOLS (AIR OR ELECTRIC) AND HAMMERS

WARNING:

- When working near the Air Bag Diagnosis Sensor Unit or other Air Bag System sensors with the ignition ON or engine running, DO NOT use air or electric power tools or strike near the sensor(s) with a hammer. Heavy vibration could activate the sensor(s) and deploy the air bag(s), possibly causing serious injury.
- When using air or electric power tools or hammers, always switch the ignition OFF, disconnect the battery, and wait at least 3 minutes before performing any service.

FOR USA AND CANADA : Precaution for Battery Service

INFOID:000000005549061

Before disconnecting the battery, lower both the driver and passenger windows. This will prevent any interference between the window edge and the vehicle when the door is opened/closed. During normal operation, the window slightly raises and lowers automatically to prevent any window to vehicle interference. The automatic window function will not work with the battery disconnected.

FOR USA AND CANADA : Service Notice or Precautions

INFOID:000000005239907

- Low tire pressure warning lamp blinks for 1min, then turns ON when occurring any malfunction except low tire pressure. Delete the memory with CONSULT-III, or register the ID to turn low tire pressure warning lamp OFF. Refer to [WT-12. "AIR PRESSURE MONITOR : Diagnosis Description"](#), [WT-23. "Special Repair Requirement"](#).
- ID registration is required when replacing or rotating wheels, replacing transmitter or BCM. Refer to [BCS-92. "Exploded View"](#).
- Replace grommet seal, valve core and cap of transmitter in TPMS every tire replacement by reaching wear limit of tire. Refer to [WT-58. "Exploded View"](#).

FOR MEXICO

FOR MEXICO : Precaution for Supplemental Restraint System (SRS) "AIR BAG" and "SEAT BELT PRE-TENSIONER"

INFOID:000000005549066

The Supplemental Restraint System such as "AIR BAG" and "SEAT BELT PRE-TENSIONER", used along with a front seat belt, helps to reduce the risk or severity of injury to the driver and front passenger for certain

PRECAUTIONS

< PRECAUTION >

[REGULAR GRADE]

types of collision. Information necessary to service the system safely is included in the "SRS AIR BAG" and "SEAT BELT" of this Service Manual.

WARNING:

- To avoid rendering the SRS inoperative, which could increase the risk of personal injury or death in the event of a collision which would result in air bag inflation, all maintenance must be performed by an authorized NISSAN/INFINITI dealer.
- Improper maintenance, including incorrect removal and installation of the SRS, can lead to personal injury caused by unintentional activation of the system. For removal of Spiral Cable and Air Bag Module, see the "SRS AIR BAG".
- Do not use electrical test equipment on any circuit related to the SRS unless instructed to in this Service Manual. SRS wiring harnesses can be identified by yellow and/or orange harnesses or harness connectors.

PRECAUTIONS WHEN USING POWER TOOLS (AIR OR ELECTRIC) AND HAMMERS

WARNING:

- When working near the Air Bag Diagnosis Sensor Unit or other Air Bag System sensors with the ignition ON or engine running, DO NOT use air or electric power tools or strike near the sensor(s) with a hammer. Heavy vibration could activate the sensor(s) and deploy the air bag(s), possibly causing serious injury.
- When using air or electric power tools or hammers, always switch the ignition OFF, disconnect the battery, and wait at least 3 minutes before performing any service.

FOR MEXICO : Precaution for Battery Service

INFOID:000000005549067

Before disconnecting the battery, lower both the driver and passenger windows. This will prevent any interference between the window edge and the vehicle when the door is opened/closed. During normal operation, the window slightly raises and lowers automatically to prevent any window to vehicle interference. The automatic window function will not work with the battery disconnected.

FOR MEXICO : Service Notice or Precautions

INFOID:000000005549072

- Low tire pressure warning lamp blinks for 1min, then turns ON when occurring any malfunction except low tire pressure. Delete the memory with CONSULT-III, or register the ID to turn low tire pressure warning lamp OFF. Refer to [WT-12. "AIR PRESSURE MONITOR : Diagnosis Description"](#), [WT-23. "Special Repair Requirement"](#).
- ID registration is required when replacing or rotating wheels, replacing transmitter or BCM. Refer to [BCS-92. "Exploded View"](#).
- Replace grommet seal, valve core and cap of transmitter in TPMS every tire replacement by reaching wear limit of tire. Refer to [WT-58. "Exploded View"](#).

PREPARATION

< PREPARATION >

[REGULAR GRADE]

PREPARATION

PREPARATION

Special Service Tool

INFOID:000000005239908

The actual shapes of Kent-Moore tools may differ from those of special service tools illustrated here.

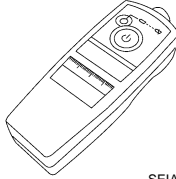
Tool number (Kent-Moore No.) Tool name	Description
- (J-45295) Transmitter activation tool  SEIA0462E	ID registration

A
B
C
D
WT

Commercial Service Tool

INFOID:000000005239909

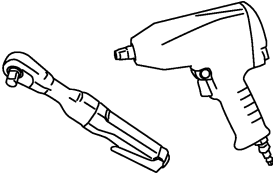
Tool name	Description
Power tool  PBIC0190E	Loosening wheel nuts

F
G
H
I
J
K
L
M
N
O
P

SYSTEM DESCRIPTION

COMPONENT PARTS

Component Parts Location

INFOID:000000005239840

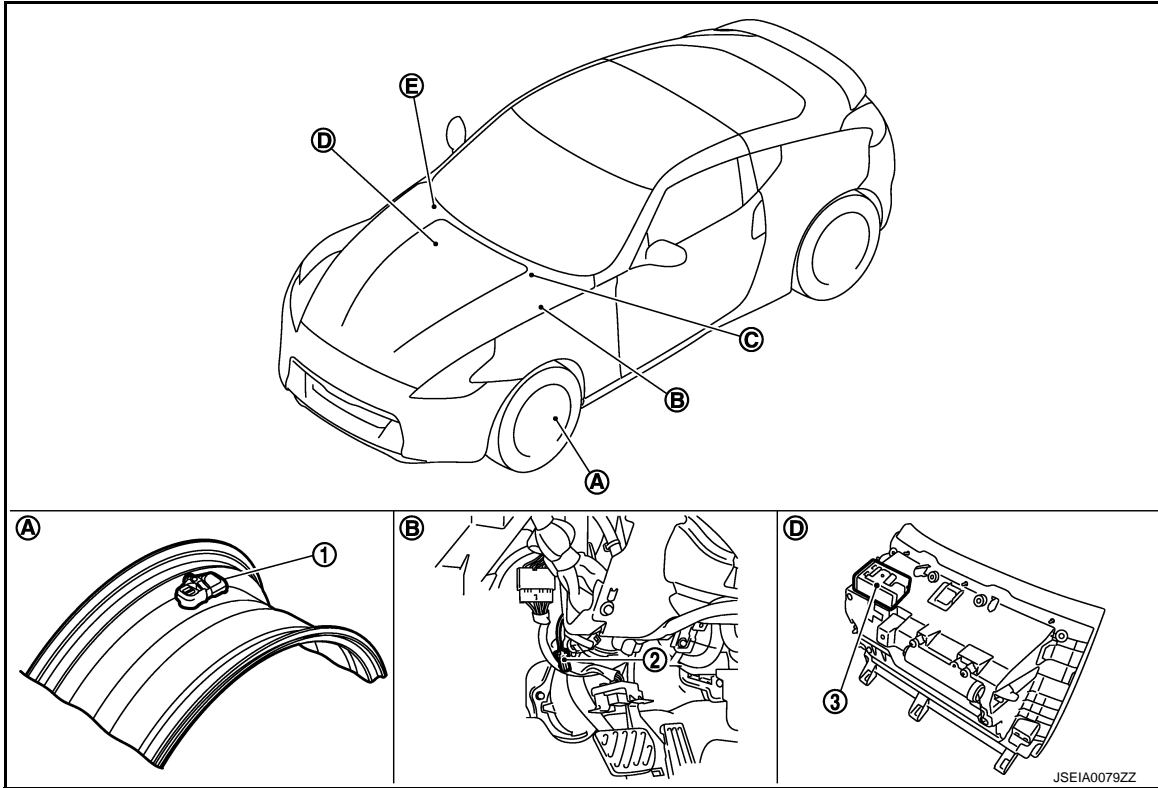

- 1. Transmitter
- 2. Tire pressure warning check switch
- 3. Tire pressure receiver
- A. Wheel
- B. Behind instrument lower panel LH
- C. Low tire pressure warning lamp (On the combination meter)
- D. Glove box assembly
- E. Refer to [BCS-9. "Component Parts Location"](#)

Component Description

INFOID:000000005485024

Component parts	Function
BCM (Body Control Module)	WT-7. "BCM" .
Transmitter	WT-7. "Transmitter" .
Tire pressure receiver	WT-7. "Tire pressure receiver" .
Tire pressure warning check switch	WT-7. "Tire pressure warning check switch" .
Turn signal lamp	ID registration of each wheel has been completed, turn signal lamp flashes.
Combination meter	Receives the following signals via CAN communication to BCM. <ul style="list-style-type: none"> • Low tire pressure warning lamp signal • Hazard lamp signal • Buzzer signal
Low tire pressure warning lamp	WT-7. "Low tire pressure warning lamp"

COMPONENT PARTS

< SYSTEM DESCRIPTION >

[REGULAR GRADE]

BCM

INFOID:000000005485025

The BCM reads the tire pressure signal received by the tire pressure receiver, and controls the low tire pressure warning lamp and the buzzer operations. It also has a judgment function to detect a system malfunction.

Transmitter

INFOID:000000005485026

The transmitter integrated with a valve is installed on a wheel, and transmits a detected tire pressure signal by radio wave.

Tire pressure receiver

INFOID:000000005485027

The tire pressure receiver receives the tire pressure signal transmitted by the transmitter in each wheel.

Tire pressure warning check switch

INFOID:000000005485028

Self-diagnosis can be performed by short-circuiting the tire pressure warning check switch to the ground. (Self-diagnosis indicates the location of the malfunction by the blinking of the low tire pressure warning lamp on the combination meter.)

NOTE:

If low tire pressure warning lamp blinks as shown in the figure, the system is normal.

- This mode shows transmitter status is in OFF-mode.
Perform transmitter wake up operation. Refer to [WT-22. "Special Repair Requirement"](#).

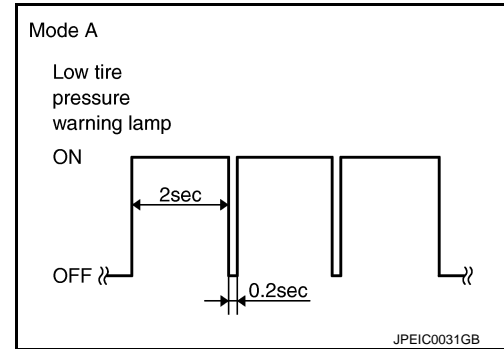

Low tire pressure warning lamp

INFOID:000000005485029

Uses CAN communication from the BCM to illuminate the low tire pressure warning lamp on the combination meter.

SYSTEM

TIRE PRESSURE MONITORING SYSTEM

TIRE PRESSURE MONITORING SYSTEM : System Diagram

INFOID:000000005239838

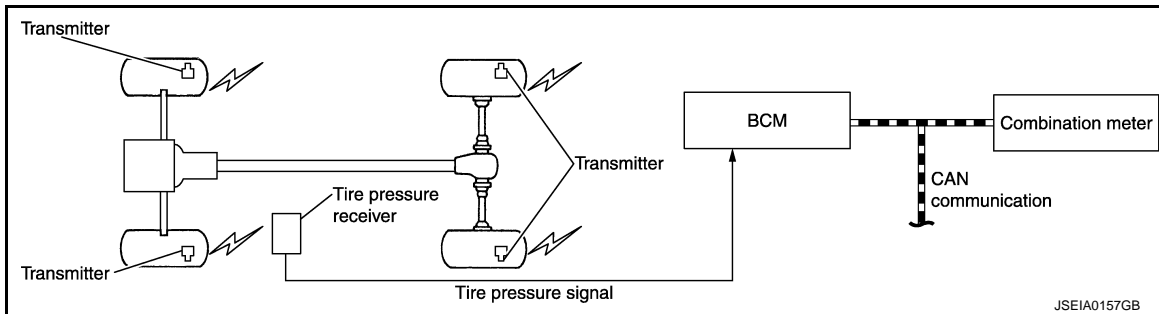

TIRE PRESSURE MONITORING SYSTEM : System Description

INFOID:000000005239839

DESCRIPTION

During driving, the TPMS (Tire Pressure Monitoring System) receives the signal transmitted from transmitter installed in each wheel. The BCM (Body Control Module) of this system has pressure judgment and trouble diagnosis functions. When the tire pressure monitoring system detects low inflation pressure or another unusual symptom, the low tire pressure warning lamps in the combination meter comes on.

LOW TIRE PRESSURE WARNING LAMP

Uses CAN communication from the BCM to illuminate the low tire pressure warning lamp on the combination meter.

Condition	Low tire pressure warning lamp
Ignition switch OFF.	OFF
Ignition switch ON.	Illuminates for 1 second, then turns OFF.
Less than * kPa (* kg/cm ² , * psi) [NOTE]	ON
Tire pressure monitoring system malfunction [Other diagnostic item]	Flashes for 1 minute, then stays illuminated.

NOTE:

- 189.6 kPa (1.9 kg/cm², 27 psi): Standard air pressure is for 240 kPa (2.4 kg/cm², 35 psi) vehicles.
- 205.1 kPa (2.1 kg/cm², 30 psi): Standard air pressure is for 260 kPa (2.6 kg/cm², 38 psi) vehicles.

TIRE PRESSURE MONITORING SYSTEM : Fail-safe

INFOID:000000005485168

FAIL-SAFE CONTROL BY DTC

BCM performs fail-safe control when any DTC are detected.

Display contents of CONSULT	Fail-safe	Cancellation
B2013: ID DISCORD BCM-S/L	Inhibit engine cranking	Erase DTC
B2014: CHAIN OF S/L-BCM	Inhibit engine cranking	Erase DTC
B2190: NATS ANTENNA AMP	Inhibit engine cranking	Erase DTC
B2191: DIFFERENCE OF KEY	Inhibit engine cranking	Erase DTC
B2192: ID DISCORD BCM-ECM	Inhibit engine cranking	Erase DTC
B2193: CHAIN OF BCM-ECM	Inhibit engine cranking	Erase DTC
B2195: ANTI SCANNING	Inhibit engine cranking	Ignition switch ON → OFF
B2557: VEHICLE SPEED	Inhibit steering lock	When normal vehicle speed signals are received from ABS actuator and electric unit (control unit) for 500 ms

SYSTEM

< SYSTEM DESCRIPTION >

[REGULAR GRADE]

Display contents of CONSULT	Fail-safe	Cancellation	
B2560: STARTER CONT RELAY	Inhibit engine cranking	500 ms after the following CAN signal communication status becomes consistent <ul style="list-style-type: none"> • Starter control relay signal • Starter relay status signal 	A
B2601: SHIFT POSITION	Inhibit steering lock	500 ms after the following signal reception status becomes consistent <ul style="list-style-type: none"> • Selector lever P position switch signal • P range signal (CAN) 	B C
B2602: SHIFT POSITION	Inhibit steering lock	5 seconds after the following BCM recognition conditions are fulfilled <ul style="list-style-type: none"> • Ignition switch is in the ON position • Selector lever P position switch signal: Except P position (battery voltage) • Vehicle speed: 4 km/h (2.5 MPH) or more 	D
B2603: SHIFT POSI STATUS	Inhibit steering lock	500 ms after the following BCM recognition conditions are fulfilled <ul style="list-style-type: none"> • Ignition switch is in the ON position • Selector lever P position switch signal: Except P position (battery voltage) • Selector lever P/N position signal: Except P and N positions (0 V) 	WT F
B2604: PNP SW	Inhibit steering lock	500 ms after any of the following BCM recognition conditions are fulfilled <ul style="list-style-type: none"> • Status 1 <ul style="list-style-type: none"> - Ignition switch is in the ON position - Selector lever P/N position signal: P and N position (battery voltage) - P range signal or N range signal (CAN): ON • Status 2 <ul style="list-style-type: none"> - Ignition switch is in the ON position - Selector lever P/N position signal: Except P and N positions (0 V) - P range signal and N range signal (CAN): OFF 	G H I
B2605: PNP SW	Inhibit steering lock	500 ms after any of the following BCM recognition conditions are fulfilled <ul style="list-style-type: none"> • Status 1 <ul style="list-style-type: none"> - Ignition switch is in the ON position - Selector lever P/N position signal: Except P and N positions (0 V) - Interlock/PNP switch signal (CAN): OFF • Status 2 <ul style="list-style-type: none"> - Ignition switch is in the ON position - Selector lever P/N position signal: P or N position (battery voltage) - PNP switch signal (CAN): ON 	J K L
B2606: S/L RELAY	Inhibit engine cranking	500 ms after the following CAN signal communication status becomes consistent <ul style="list-style-type: none"> • Steering lock relay signal (Request signal) • Steering lock relay signal (Condition signal) 	M
B2607: S/L RELAY	Inhibit engine cranking	500 ms after the following CAN signal communication status has become consistent <ul style="list-style-type: none"> • Steering lock relay signal (Request signal) • Steering lock relay signal (Condition signal) 	N
B2608: STARTER RELAY	Inhibit engine cranking	500 ms after the following signal communication status becomes consistent <ul style="list-style-type: none"> • Starter motor relay control signal • Starter relay status signal (CAN) 	O
B2609: S/L STATUS	<ul style="list-style-type: none"> • Inhibit engine cranking • Inhibit steering lock 	When the following steering lock conditions agree <ul style="list-style-type: none"> • BCM steering lock control status • Steering lock condition No. 1 signal status • Steering lock condition No. 2 signal status 	P

SYSTEM

< SYSTEM DESCRIPTION >

[REGULAR GRADE]

Display contents of CONSULT	Fail-safe	Cancellation
B260A: IGNITION RELAY	Inhibit engine cranking	500 ms after the following conditions are fulfilled <ul style="list-style-type: none"> • IGN relay (IPDM E/R) control signal: OFF (Battery voltage) • Ignition ON signal (CAN to IPDM E/R): OFF (Request signal) • Ignition ON signal (CAN from IPDM E/R): OFF (Condition signal)
B260F: ENG STATE SIG LOST	Maintains the power supply position attained at the time of DTC detection	When any of the following conditions are fulfilled <ul style="list-style-type: none"> • Power position changes to ACC • Receives engine status signal (CAN)
B2612: S/L STATUS	<ul style="list-style-type: none"> • Inhibit engine cranking • Inhibit steering lock 	When any of the following conditions are fulfilled <ul style="list-style-type: none"> • Steering lock unit status signal (CAN) is received normally • The BCM steering lock control status matches the steering lock status recognized by the steering lock unit status signal (CAN from IPDM E/R)
B2617: STARTER RELAY CIRC	Inhibit engine cranking	1 second after the starter motor relay control inside BCM becomes normal
B2618: BCM	Inhibit engine cranking	1 second after the ignition relay (IPDM E/R) control inside BCM becomes normal
B2619: BCM	Inhibit engine cranking	1 second after the steering lock unit power supply output control inside BCM becomes normal
B261E: VEHICLE TYPE	Inhibit engine cranking	BCM initialization
B26E8: CLUTCH SW	Inhibit engine cranking	When any of the following BCM recognition conditions are fulfilled <ul style="list-style-type: none"> • Status 1 <ul style="list-style-type: none"> - Clutch switch signal (CAN from ECM): ON - Clutch interlock switch signal: OFF (0 V) • Status 2 <ul style="list-style-type: none"> - Clutch switch signal (CAN from ECM): OFF - Clutch interlock switch signal: ON (Battery voltage)
B26E9: S/L STATUS	<ul style="list-style-type: none"> • Inhibit engine cranking • Inhibit steering lock 	When BCM transmits the LOCK request signal to steering lock unit, and receives LOCK response signal from steering lock unit, the following conditions are fulfilled <ul style="list-style-type: none"> • Steering condition No. 1 signal: LOCK (0 V) • Steering condition No. 2 signal: LOCK (Battery voltage)

HIGH FLASHER OPERATION

BCM detects the turn signal lamp circuit status by the current value.

BCM increases the turn signal lamp blinking speed if the bulb or harness open is detected with the turn signal lamp operating.

NOTE:

The blinking speed is normal while activating the hazard warning lamp.

FAIL-SAFE CONTROL BY RAIN SENSOR MALFUNCTION

- BCM judges the rain sensor serial link error by the rain sensor serial link condition and detects the rain sensor malfunction by rain sensor malfunction signal.
- When BCM detects the rain sensor serial link error or the rain sensor malfunction while front wiper AUTO operation, BCM operates a fail-safe control.

NOTE:

If rain sensor malfunction is detected when ignition switch is turned OFF ⇒ ON and front wiper switch is INT position, BCM operates a fail-safe control.

DIAGNOSIS SYSTEM (BCM)

< SYSTEM DESCRIPTION >

[REGULAR GRADE]

DIAGNOSIS SYSTEM (BCM)

COMMON ITEM

COMMON ITEM : CONSULT-III Function (BCM - COMMON ITEM)

INFOID:000000005239842

APPLICATION ITEM

CONSULT-III performs the following functions via CAN communication with BCM.

Diagnosis mode	Function Description
Work Support	Changes the setting for each system function.
Self Diagnostic Result	Displays the diagnosis results judged by BCM.
CAN Diag Support Monitor	Monitors the reception status of CAN communication viewed from BCM. Refer to CONSULT-III operation manual.
Data Monitor	The BCM input/output signals are displayed.
Active Test	The signals used to activate each device are forcibly supplied from BCM.
Ecu Identification	The BCM part number is displayed.
Configuration	<ul style="list-style-type: none"> • Read and save the vehicle specification. • Write the vehicle specification when replacing BCM.

SYSTEM APPLICATION

BCM can perform the following functions for each system.

NOTE:

It can perform the diagnosis modes except the following for all sub system selection items.

x: Applicable item

System	Sub system selection item	Diagnosis mode		
		Work Support	Data Monitor	Active Test
Door lock	DOOR LOCK	x	x	x
Rear window defogger	REAR DEFOGGER		x	x
Warning chime	BUZZER		x	x
Interior room lamp timer	INT LAMP	x	x	x
Exterior lamp	HEAD LAMP	x	x	x
Wiper and washer	WIPER	x	x	x
Turn signal and hazard warning lamps	FLASHER	x	x	x
—	AIR CONDITONER*			
<ul style="list-style-type: none"> • Intelligent Key system • Engine start system 	INTELLIGENT KEY	x	x	x
Combination switch	COMB SW		x	
Body control system	BCM	x		
IVIS - NATS	IMMU		x	x
Interior room lamp battery saver	BATTERY SAVER	x	x	x
Trunk lid open	TRUNK		x	x
Vehicle security system	THEFT ALM	x	x	x
RAP system	RETAINED PWR		x	
Signal buffer system	SIGNAL BUFFER		x	x
TPMS	TPMS (AIR PRESSURE MONITOR)	x	x	x

NOTE:

*: This item is displayed, but is not used.

FREEZE FRAME DATA (FFD)

The BCM records the following vehicle condition at the time a particular DTC is detected, and displays on CONSULT-III.

DIAGNOSIS SYSTEM (BCM)

[REGULAR GRADE]

< SYSTEM DESCRIPTION >

CONSULT screen item	Indication/Unit	Description	
Vehicle Speed	km/h	Vehicle speed of the moment a particular DTC is detected	
Odo/Trip Meter	km	Total mileage (Odometer value) of the moment a particular DTC is detected	
Vehicle Condition	SLEEP>LOCK	Power position status of the moment a particular DTC is detected	While turning BCM status from low power consumption mode to normal mode (Power supply position is "LOCK")
	SLEEP>OFF		While turning BCM status from low power consumption mode to normal mode (Power supply position is "OFF".)
	LOCK>ACC		While turning power supply position from "LOCK" to "ACC"
	ACC>ON		While turning power supply position from "ACC" to "IGN"
	RUN>ACC		While turning power supply position from "RUN" to "ACC" (Vehicle is stopping and selector lever is except P position.)
	CRANK>RUN		While turning power supply position from "CRANKING" to "RUN" (From cranking up the engine to run it)
	RUN>URGENT		While turning power supply position from "RUN" to "ACC" (Emergency stop operation)
	ACC>OFF		While turning power supply position from "ACC" to "OFF"
	OFF>LOCK		While turning power supply position from "OFF" to "LOCK"
	OFF>ACC		While turning power supply position from "OFF" to "ACC"
	ON>CRANK		While turning power supply position from "IGN" to "CRANKING"
	OFF>SLEEP		While turning BCM status from normal mode (Power supply position is "OFF".) to low power consumption mode
	LOCK>SLEEP		While turning BCM status from normal mode (Power supply position is "LOCK".) to low power consumption mode
	LOCK		Power supply position is "LOCK" (Ignition switch OFF with steering is locked.)
	OFF		Power supply position is "OFF" (Ignition switch OFF with steering is unlocked.)
	ACC		Power supply position is "ACC" (Ignition switch ACC)
	ON		Power supply position is "IGN" (Ignition switch ON with engine stopped)
	ENGINE RUN		Power supply position is "RUN" (Ignition switch ON with engine running)
CRANKING	Power supply position is "CRANKING" (At engine cranking)		
IGN Counter	0 - 39	<p>The number of times that ignition switch is turned ON after DTC is detected</p> <ul style="list-style-type: none"> • The number is 0 when a malfunction is detected now. • The number increases like 1 → 2 → 3...38 → 39 after returning to the normal condition whenever ignition switch OFF → ON. • The number is fixed to 39 until the self-diagnosis results are erased if it is over 39. 	

AIR PRESSURE MONITOR

AIR PRESSURE MONITOR : Diagnosis Description

INFOID:000000005239843

DESCRIPTION

During driving, the transmitter installed at each road wheel transmits the tire pressure information signal to the receiver. The receiver receives the tire pressure signal and transmits it to the BCM. The BCM judges whether or not the tire pressure is OK based on the tire pressure information signal, and if it judges that the tire pressure is low, it transmits the information via CAN communication to the combination meter.

After receiving the tire pressure information via CAN communication from the BCM, the combination meter illuminates the low tire pressure warning lamp and displays.

SELF DIAGNOSTIC PROCEDURE

1. Initiate diagnosis mode by short-circuiting the low tire pressure warning check switch to the ground.
2. The blinking pattern of the low tire pressure warning lamp indicates the conditions of the malfunction.

DIAGNOSIS SYSTEM (BCM)

< SYSTEM DESCRIPTION >

[REGULAR GRADE]

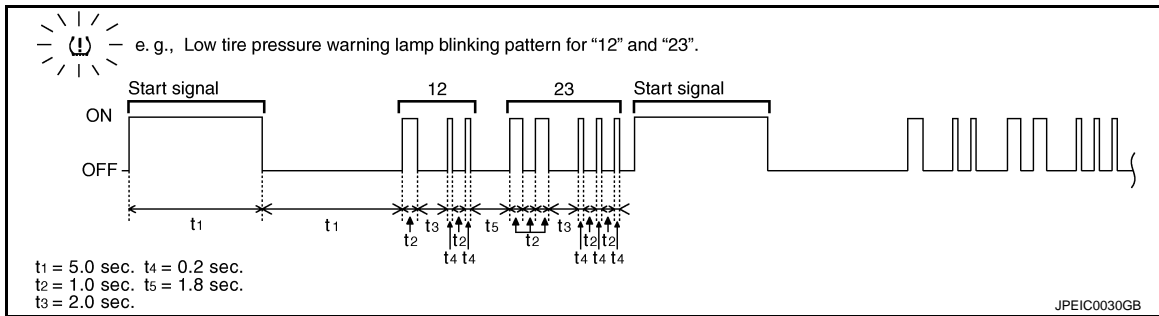

NOTE:

If the low tire pressure warning lamp is blinking repeatedly at 5 Hz, there is no malfunction occurring in the system.

Blinking pattern	Items	Diagnostic items detected when...	Check item
15	Tire pressure value (Front LH)	Front LH tire pressure drops to * kPa (* kg/cm ² , * psi) or less. [NOTE]	WT-26
16	Tire pressure value (Front RH)	Front RH tire pressure drops to * kPa (* kg/cm ² , * psi) or less. [NOTE]	
17	Tire pressure value (Rear RH)	Rear RH tire pressure drops to * kPa (* kg/cm ² , * psi) or less. [NOTE]	
18	Tire pressure value (Rear LH)	Rear LH tire pressure drops to * kPa (* kg/cm ² , * psi) or less. [NOTE]	
21	Transmitter no data (Front LH)	Data from front LH transmitter cannot be received.	WT-28
22	Transmitter no data (Front RH)	Data from front RH transmitter cannot be received.	
23	Transmitter no data (Rear RH)	Data from rear RH transmitter cannot be received.	
24	Transmitter no data (Rear LH)	Data from rear LH transmitter cannot be received.	
35	Transmitter pressure data error (Front LH)	Air pressure data from front LH transmitter is malfunction.	WT-31
36	Transmitter pressure data error (Front RH)	Air pressure data from front RH transmitter is malfunction.	
37	Transmitter pressure data error (Rear RH)	Air pressure data from rear RH transmitter is malfunction.	
38	Transmitter pressure data error (Rear LH)	Air pressure data from rear LH transmitter is malfunction.	
52	Vehicle speed signal error	Vehicle speed signal error.	WT-33
53	Control unit	Tire pressure monitoring system malfunction in BCM.	WT-35
No blinking	Tire pressure warning check switch	Tire pressure warning switch circuit is open.	-

NOTE:

- 189.6 kPa (1.9 kg/cm², 27 psi): Standard air pressure is for 240 kPa (2.4 kg/cm², 35 psi) vehicles.
- 205.1 kPa (2.1 kg/cm², 30 psi): Standard air pressure is for 260 kPa (2.6 kg/cm², 38 psi) vehicles.

ERASE SELF-DIAGNOSIS

After performing self-diagnosis by short-circuiting the tire pressure warning check switch to the body, turn the ignition switch OFF.

AIR PRESSURE MONITOR : CONSULT-III Function

INFOID:000000005239844

FUNCTION

The diagnosis functions (main functions) include the following: "WORK SUPPORT", "SELF DIAGNOSTIC RESULT", "DATA MONITOR" and "ACTIVE TEST".

DIAGNOSIS SYSTEM (BCM)

< SYSTEM DESCRIPTION >

[REGULAR GRADE]

Diagnostic test mode	Function
Work support	In this mode, it is possible to make quick and accurate adjustments by following the instructions on the CONSULT-III display.
Self diagnostic result	Receives self-diagnosis results from the low tire pressure warning control unit, and indicates DTCs and the number of malfunctions.
Data monitor	Receives input/output signals from the low tire pressure warning control unit and indicates and stores them to facilitate locating the causes of malfunctions.
Active test	Transmits command to the low tire pressure warning control unit to change output signals and check operation of output system.

WORK SUPPORT MODE

Refer to [WT-23, "Special Repair Requirement"](#).

SELF-DIAG RESULTS MODE

Refer to [BCS-86, "DTC Index"](#).

DATA MONITOR MODE

Screen of data monitor mode is displayed.

NOTE:

When malfunction is detected, CONSULT-III perform REAL-TIME DIAGNOSIS. Also, any malfunction detected while in this mode will be displayed at real time.

Monitor item (Unit)	Remark
AIR PRESS FL (kPa), (kg/cm ²), (Psi)	Air pressure of tires
AIR PRESS FR (kPa), (kg/cm ²), (Psi)	
AIR PRESS RR (kPa), (kg/cm ²), (Psi)	
AIR PRESS RL (kPa), (kg/cm ²), (Psi)	
ID REGST FL1	ID is registered: Done ID is not registered: Yet
ID REGST FR1	
ID REGST RR1	
ID REGST RL1	
WARNING LAMP	Low tire pressure warning lamp ON: On Low tire pressure warning lamp OFF: Off
BUZZER	Combination meter buzzer ON: On Combination meter buzzer OFF: Off

NOTE:

Before performing the self-diagnosis, be sure to register the ID, or erase the actual malfunction location may be different from that displayed on CONSULT-III.

ACTIVE TEST MODE

NOTE:

Before performing the self-diagnosis, be sure to register the ID, or erase the actual malfunction may be different from that displayed on CONSULT-III.

TEST ITEM LIST

Test item	Content
WARNING LAMP	This test is able to check to check that the low tire pressure warning lamp turns on.
ID REGIST WARNING	This test is able to check to check that the buzzer sounds or the low tire pressure warning lamp turns on.
FLASHER	This test is able to check to check that each turn signal lamp turns on.
HORN	This test is able to check to check that the horn sounds.

ECU DIAGNOSIS INFORMATION

BCM

List of ECU Reference

INFOID:000000005483994

ECU	Reference
BCM	BCS-51, "Reference Value"
BCM	BCS-82, "Fail-safe"
BCM	BCS-85, "DTC Inspection Priority Chart"
BCM	BCS-86, "DTC Index"

A

B

C

D

WT

F

G

H

I

J

K

L

M

N

O

P

TIRE PRESSURE MONITORING SYSTEM

< WIRING DIAGRAM >

[REGULAR GRADE]

WIRING DIAGRAM

TIRE PRESSURE MONITORING SYSTEM

Wiring Diagram

INFOID:000000005564622

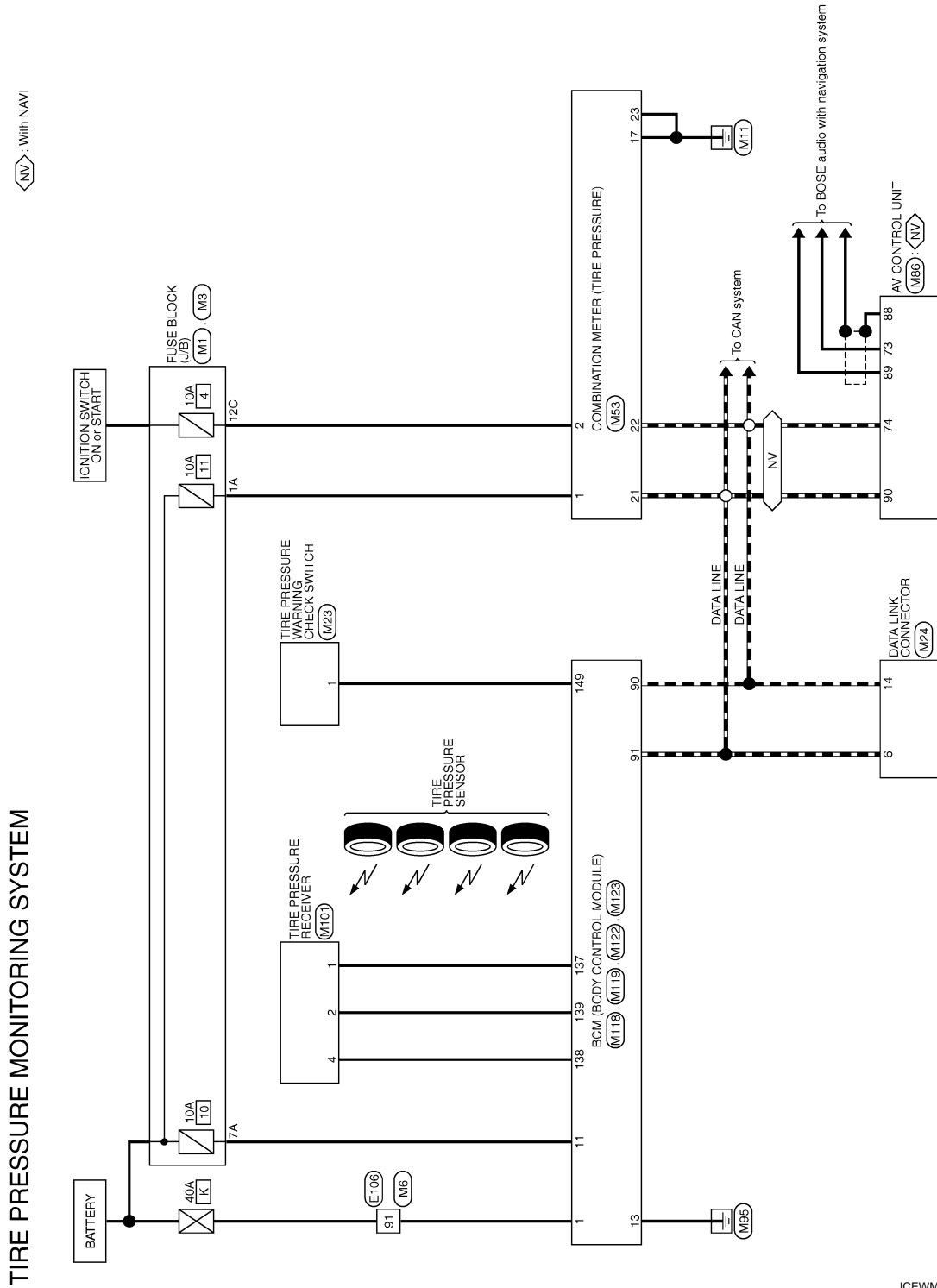

2009/07/10

JCEWM0120GB

TIRE PRESSURE MONITORING SYSTEM

< WIRING DIAGRAM >

[REGULAR GRADE]

TIRE PRESSURE MONITORING SYSTEM

Connector No.	E106
Connector Name	WIRE TO WIRE
Connector Type	TH80FW-CS16-TM4

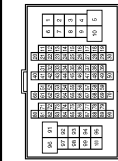

Terminal No.	Color of Wire	Signal Name [Specification]
1	Y	-
3	L	-
4	L	-
7	B	-
8	P	-
9	L	- [Coupe models]
9	B	- [Roadster models]
11	V	-
12	R	-
13	L	-
14	GR	-
15	P	-
16	W	-
17	SB	-
20	LG	-
21	BR	- [Coupe models]
21	G	- [Roadster models]
31	L	-
32	Y	-
33	P	-
34	L	-
36	BR	-
36	V	-
37	Y	-
38	R	-
38	B	-
40	W	-
41	LG	-
42	SB	-
43	G	-
44	R	- [Roadster models with M/T]
44	GR	- [Except for roadster models with M/T]
45	BG	- [Coupe models]
45	O	- [Roadster models]
46	W	-
47	P	-
58	SHIELD	-
58	L	-

70	P	-
80	W	-
81	P	-
82	G	-
83	V	-
84	L	-
85	BG	- [Coupe models]
85	O	- [Roadster models]
86	LG	-
87	R	-
89	P	-
91	W	-
92	L	-
93	G	-
94	Y	-
96	Y	-
97	BR	-
98	GR	-
99	LG	-
100	BG	- [Coupe models]
100	O	- [Roadster models]

Connector No.	M1
Connector Name	FUSE BLOCK (J/B)
Connector Type	NS06FW-M2

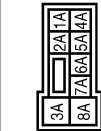

Terminal No.	Color of Wire	Signal Name [Specification]
1A	V	-
2A	G	-
3A	L	-
4A	P	-
5A	L	-
6A	Y	-
7A	BR	-
8A	L	-

Connector No.	M3
Connector Name	FUSE BLOCK (J/B)
Connector Type	NS12FW-CS

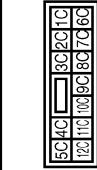

Terminal No.	Color of Wire	Signal Name [Specification]
8C	R	-
7C	B	-
9C	R	- [Coupe models]
9C	O	- [Roadster models]
10C	L	-
11C	LG	-
12C	O	-

Connector No.	M6
Connector Name	WIRE TO WIRE
Connector Type	TH80MW-CS16-TM4



Terminal No.	Color of Wire	Signal Name [Specification]
1	Y	-
3	L	-
4	L	-
7	B	-
8	P	-
9	L	- [Coupe models]
9	B	- [Roadster models]
11	GR	-
12	R	-
13	L	-
14	G	-
15	P	-
16	W	-
17	BR	-
20	GR	-

21	BR	- [Coupe models]
21	R	- [Roadster models]
31	L	- [Roadster models with M/T]
31	BR	- [Except for roadster models with M/T]
32	Y	- [Roadster models with M/T]
32	V	- [Except for roadster models with M/T]
33	P	-
34	L	-
35	BR	-
36	SB	-
37	Y	-
38	LG	-
39	SB	-
40	W	-
41	LG	-
42	R	-
43	G	-
44	G	- [With A/T]
44	R	- [With M/T]
45	O	-
46	G	-
47	BR	-
58	SHIELD	-
59	L	-
70	R	-
80	LG	-
81	GR	-
82	V	-
83	V	-
84	L	-
85	BR	-
86	Y	-
87	V	- [Roadster models with M/T]
87	G	- [Except for roadster models with M/T]
89	P	-
91	W	-
92	P	-
93	P	-
94	Y	-
96	P	-
97	GR	-
98	O	-
99	W	-
100	R	-

A
B
C
D
WT
F
G
H
I
J
K
L
M
N
O
P

TIRE PRESSURE MONITORING SYSTEM

< WIRING DIAGRAM >

[REGULAR GRADE]

TIRE PRESSURE MONITORING SYSTEM

Connector No.	M23
Connector Name	TIRE PRESSURE WARNING CHECK SWITCH
Connector Type	TK02FW



Terminal No.	Color of Wire	Signal Name [Specification]
1	W	-

Connector No.	M24
Connector Name	DATA LINK CONNECTOR
Connector Type	BD16RV



Terminal No.	Color of Wire	Signal Name [Specification]
3	Y	-
4	B	-
5	B	-
6	L	-
7	Y	- [Coupe models]
8	G	- [Reader models]
11	LG	-
14	P	-
16	Y	-

Connector No.	M63
Connector Name	COMBINATION METER
Connector Type	TK42FW-MH



Terminal No.	Color of Wire	Signal Name [Specification]
1	V	BATTERY POWER SUPPLY
2	O	IGNITION POWER SUPPLY
3	L	VEHICLE SPEED SIGNAL (2-PULSE)
4	Y	VEHICLE SPEED SIGNAL (8-PULSE)
5	B	ILLUMINATION CONTROL SIGNAL
6	R	ROOF STATUS SIGNAL
8	BR	COMMUNICATION SIGNAL (METER->TABLE METER)
10	L	COMMUNICATION SIGNAL (TABLE METER->METER)
12	G	S-MODE SWITCH SIGNAL
15	L	ACC POWER SUPPLY
16	R	AIR BAG SIGNAL
17	B	GROUND
18	V	AMBIENT SENSOR SIGNAL
19	G	A/C AUTO AMP CONNECTION RECOGNITION SIGNAL
20	GR	AMBIENT SENSOR GROUND
21	L	CAN-H
22	P	GROUND
23	B	GROUND
24	Y	FUEL LEVEL SENSOR GROUND

Connector No.	M66
Connector Name	AV CONTROL UNIT
Connector Type	TK42FW-MH



Terminal No.	Color of Wire	Signal Name [Specification]
65	V	PARKING BRAKE SIGNAL
67	B	COMPOSITE IMAGE GND
68	L	COMPOSITE IMAGE SIGNAL

Connector No.	M118
Connector Name	BCM (BODY CONTROL MODULE)
Connector Type	M03FB-LC



Terminal No.	Color of Wire	Signal Name [Specification]
1	W	BAT (F/L)
2	W	POWER WINDOW POWER SUPPLY (BAT)
3	Y	POWER WINDOW POWER SUPPLY (IGN)

Connector No.	M119
Connector Name	BCM (BODY CONTROL MODULE)
Connector Type	NS16FW-CS



Terminal No.	Color of Wire	Signal Name [Specification]
4	R	INTERIOR ROOM LAMP POWER SUPPLY
5	G	SUPER LOCK OUTPUT [Coupe models]
6	V	SUPER LOCK OUTPUT [Reader models]
8	V	ALL DOOR FUEL LD LOCK OUTPUT
9	G	DRIVER DOOR FUEL LD UNLOCK OUTPUT
11	BR	BAT (FUSE)
13	B	GND
14	R	PUSH-BUTTON IGNITION SW ILL POWER
15	Y	ACC IND
17	W	TURN SIGNAL RH (FRONT, SIDE)
18	O	TURN SIGNAL LH (FRONT, SIDE)
19	P	ROOM LAMP TIMER CONTROL [Coupe models]
19	V	ROOM LAMP TIMER CONTROL [Reader models]

Terminal No.	Color of Wire	Signal Name [Specification]
71	SHIELD	MICROPHONE GND
72	R	MICROPHONE VCC
73	G	COMM (CONT->DISP) [Coupe models]
73	R	COMM (CONT->DISP) [Reader models]
74	P	CAN-L [Coupe models]
74	L	CAN-L [Reader models]
75	Y	AV COMM (L)
76	Y	AV COMM (L)
79	R	ILL+
80	G	IGNITION SIGNAL
81	O	REVERSE SIGNAL
82	Y	VEHICLE SPEED SIGNAL (8-PULSE)
83	SHIELD	SHIELD
84	Y	-
87	G	MICROPHONE SIGNAL
88	SHIELD	SHIELD
89	R	COMM (DISP->CONT) [Coupe models]
89	G	COMM (DISP->CONT) [Reader models]
90	P	CAN-H [Coupe models]
90	B	CAN-H [Reader models]
91	LG	AV COMM (H)
92	LG	AV COMM (H)

Connector No.	M101
Connector Name	TIRE PRESSURE RECEIVER
Connector Type	TK04FW



Terminal No.	Color of Wire	Signal Name [Specification]
1	P	GND
2	L	SIGNAL
4	V	BATTERY

JCEWM0122GB

TIRE PRESSURE MONITORING SYSTEM

< WIRING DIAGRAM >

[REGULAR GRADE]

A
B
C
D
WT
F
G
H
I
J
K
L
M
N
O
P

TIRE PRESSURE MONITORING SYSTEM

Connector No.	M122
Connector Name	BCM (BODY CONTROL MODULE)
Connector Type	TH40FB-NH

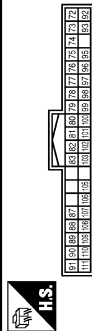

Terminal No.	Color of Wire	Signal Name [Specification]
72	R	ROOM ANT 2- [Roadster models with M/T]
72	L	ROOM ANT 2- [Except for roadster models with M/T]
73	G	ROOM ANT 2+ [Roadster models with M/T]
73	P	ROOM ANT 2+ [Except for roadster models with M/T]
74	SB	PASSENGER DOOR ANT-
74	BR	PASSENGER DOOR ANT+
75	V	DRIVER DOOR ANT-
75	LG	DRIVER DOOR ANT+
76	L	ROOM ANT 1- [W/wh A/T]
76	Y	ROOM ANT 1- [W/wh M/T]
79	R	ROOM ANT 1+ [W/wh A/T]
79	BR	ROOM ANT 1+ [W/wh M/T]
80	GR	NATS ANT AMP
81	W	NATS ANT AMP
82	R	IGN RELAY (F: B) CONT
83	Y	KYLS ENT RECEIVER (FRONT) [Roadster models with M/T]
83	GR	KYLS ENT RECEIVER (FRONT) [Except for roadster models with M/T]
87	BR	COMBI SW INPUT 5
88	V	COMBI SW INPUT 3
89	BR	PUSH SW
90	P	CAN-H
91	L	CAN-L
92	LG	KEY SLOT ILL
93	V	ON IND
95	O	ACC RELAY CONT
96	Y	A/T SHIFT SELECTOR POWER SUPPLY
97	L	S/L CONDITION 1
98	P	S/L CONDITION 2
98	R	SHIFT P [W/wh A/T]
99	BR	CLUTCH PEDAL POS SW [Coupe models with M/T]
99	R	CLUTCH PEDAL POS SW [Roadster models with M/T]
100	G	PASSENGER DOOR REQUEST SW [Roadster models with M/T]
100	GR	PASSENGER DOOR REQUEST SW [Except for roadster models with M/T]
101	SB	DRIVER DOOR REQUEST SW [Roadster models with M/T]
101	Y	DRIVER DOOR REQUEST SW [Except for roadster models with M/T]
102	O	BLOWER FAN MOTOR RELAY CONT
103	LG	KYLS ENT RECEIVER (FRONT) PWR SUPPLY
105	GR	KYLS ENT RECEIVER (REAR) PWR SUPPLY

106	W	S/L UNIT POWER SUPPLY
107	LG	COMBI SW INPUT 1
108	R	COMBI SW INPUT 4
109	Y	COMBI SW INPUT 2
110	G	HAZARD SW [Roadster models with M/T]
110	P	HAZARD SW [Except for roadster models with M/T]
111	Y	S/L UNIT COMM

Connector No.	M123
Connector Name	BCM (BODY CONTROL MODULE)
Connector Type	TH40FC-NH

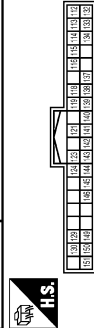

Terminal No.	Color of Wire	Signal Name [Specification]
113	O	OPTICAL SENSOR
114	R	CLUTCH INTERLOCK SW
115	O	SHOCK SENSOR
116	SB	STOP LAMP SW 1
118	P	STOP LAMP SW 2
119	SB	DR DOOR UNLOCK SENSOR
121	R	KEY SLOT SW
123	W	IGN F/B
124	LG	PASSENGER DOOR SW
129	O	TRUNK LID OPENER CANCEL SW
130	L	REAR DEFROGGER SW
132	Y	POWER WINDOW SW COM1 [Coupe models]
132	V	P/W SW & SOFT TOP C/L COM1 [Roadster models]
133	R	POWER WINDOW SW COM2 [Coupe models]
133	G	P/W SW & SOFT TOP C/L COM2 [Roadster models with M/T]
133	G	REAR DEFROGGER SW ILL [Except for roadster models with M/T]
134	GR	LOCK IND
137	O	RECEIVER/SENSOR GND [Roadster models with M/T]
137	P	RECEIVER/SENSOR AND [Except for roadster models with M/T]
138	V	RECEIVER / SENSOR POWER SUPPLY
139	L	TIRE PRESS: KYLS ENT (REAR) RECEIVE COMM
140	G	SHIFT N/P [W/wh A/T]
140	G	P/N POSITION SW [W/wh M/T]
141	Y	SECURITY INDICATOR
142	O	COMBI SW OUTPUT 5
143	P	COMBI SW OUTPUT 1
144	G	COMBI SW OUTPUT 2
145	L	COMBI SW OUTPUT 3
146	SR	COMBI SW OUTPUT 4
149	W	TIRE PRESSURE WARN CHECK SW

150	GR	DRIVER DOOR SW
151	G	REAR WINDOW DEFROGGER RELAY CONT

BASIC INSPECTION

DIAGNOSIS AND REPAIR WORK FLOW

Work Flow

INFOID:000000005484264

DETAILED FLOW

1. COLLECT THE INFORMATION FROM THE CUSTOMER

It is also important to clarify customer concerns before starting the inspection. Reproduce the symptom, and understand it fully. Interview the customer about the concerns carefully. In some cases, it is necessary to check the symptoms by driving the vehicle with the customer.

CAUTION:

Customers are not professionals. Never assume “maybe the customer means...” or “maybe the customer mentioned this symptom.”

>> GO TO 2.

2. BASIC INSPECTION

1. Turn the ignition switch ON.

CAUTION:

Never start the engine.

2. Check the tire pressure for all wheels and adjust to the specified value. Refer to [WT-61. "Tire Air Pressure"](#).

Is the inspection result normal?

YES >> GO TO 3.

NO >> Inspect or repair the tires or wheels.

3. CHECK LOW TIRE PRESSURE WARNING LAMP

Check low tire pressure warning lamp display.

Does not low tire pressure warning lamp turn OFF?

YES >> GO TO 4.

NO >> INSPECTION END

4. CRUISE TEST

Start the engine and drive the vehicle.

>> GO TO 5.

5. PERFORM SELF-DIAGNOSIS

Ⓜ With CONSULT-III

Perform “SELF-DIAG RESULTS” in “AIR PRESSURE MONITOR” of “BCM”.

Is any DTC detected?

YES >> GO TO 7.

NO >> GO TO 6.

6. CHECK SYMPTOM

Perform trouble diagnosis for the applicable symptom. Refer to [WT-42. "Symptom Table"](#).

Is the cause of the malfunction detected?

YES >> GO TO 8.

NO >> GO TO 10.

7. CIRCUIT DIAGNOSIS

Inspect the malfunctioning system indicated by the DTC code that is detected during self-diagnosis. Refer to [BCS-86. "DTC Index"](#).

>> GO TO 8.

DIAGNOSIS AND REPAIR WORK FLOW

< BASIC INSPECTION >

[REGULAR GRADE]

8. REPAIR WORK

Repair or replace the malfunctioning part.

>> GO TO 9.

9. PERFORM SELF-DIAGNOSIS

1. Select "SELF-DIAG RESULTS" in "AIR PRESSURE MONITOR" of "BCM".
2. Touch "ERASE" on CONSULT-III screen to erase memory of the low tire pressure warning control unit.
3. Drive the vehicle.
4. Perform "SELF-DIAG RESULTS" in "AIR PRESSURE MONITOR" of "BCM".

Is any DTC detected?

- YES >> GO TO 7.
NO >> GO TO 10.

10. FINAL CHECK

1. Perform a cruise test.
2. Check that the low tire pressure warning lamp turn OFF.

Dose the tire pressure warning lamp turn OFF?

- YES >> INSPECTION END
NO >> GO TO 2.

A
B
C
D
WT
F
G
H
I
J
K
L
M
N
O
P

TRANSMITTER WAKE UP OPERATION

< BASIC INSPECTION >

[REGULAR GRADE]

TRANSMITTER WAKE UP OPERATION

Description

INFOID:000000005239834

This procedure must be done after replacement of a transmitter, BCM, or rotation of wheels.

Special Repair Requirement

INFOID:000000005239835

1. TRANSMITTER WAKE-UP PROCEDURE







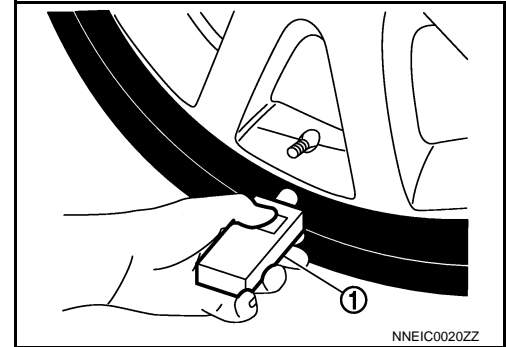

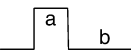

1. Turn the ignition switch ON.
2. Contact the transmitter activation tool (J-45295) (1) to the side of the tire at the location to the transmitter.
3. Press and hold the activation tool button while pushing the tool to the tire surface. (approximately for 5 seconds)

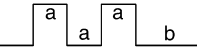
CAUTION:

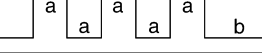
Perform the wake-up procedure starting from the vehicle front left wheel, then repeat the procedure in the order of the front right wheel, rear right wheel, and rear left wheel.

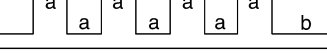

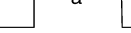
4. Check that the low tire pressure warning lamp blinks in the pattern shown as per the following. The pattern indicates that the transmitter wake-up procedure for the wheel is completed.

Low tire pressure warning lamp blinking timing		Activation tire position
ON  OFF 	a : 0.3 sec. b : 1.3 sec.	Front LH
ON  OFF 	a : 0.3 sec. b : 1.3 sec.	Front RH
ON  OFF 	a : 0.3 sec. b : 1.3 sec.	Rear RH
ON  OFF 	a : 0.3 sec. b : 1.3 sec.	Rear LH
ON  OFF 	a : 2 sec. b : 0.2 sec.	All tires

SEIA0762E

5. Check that the turn signal lamps blink twice when the transmitter wake-up procedure for all wheels is completed.
6. Check that the low tire pressure warning lamp turns OFF, after the transmitter wake-up procedure is completed for all wheels and turns OFF.

Is the transmitter wake-up procedure completed?

- YES >> Perform the transmitter ID registration procedure. Refer to [WT-23. "Special Repair Requirement"](#).
- NO >> Perform trouble diagnosis for the transmitter. Refer to [WT-28. "Diagnosis Procedure"](#).

ID REGISTRATION PROCEDURE

< BASIC INSPECTION >

[REGULAR GRADE]

ID REGISTRATION PROCEDURE

Description

INFOID:000000005239836

This procedure must be done after replacing or rotating wheels, replacing transmitter or BCM.

Special Repair Requirement

INFOID:000000005239837

1. TRANSMITTER ID REGISTRATION PROCEDURE

Ⓜ With CONSULT-III.

1. Display the "WORK SUPPORT" screen and select "ID REGIST".

Is the transmitter activation tool (J-45295) used for the transmitter ID registration procedure?

YES >> GO TO 2.

NO >> GO TO 3.

2. TRANSMITTER ID REGISTRATION PROCEDURE (WITH TRANSMITTER ACTIVATION TOOL)

1. Turn the ignition switch ON.
2. Select the start button on the "ID REGIST" screen.
3. Contact the transmitter activation tool (J-45295) (1) to the side of the tire at the location to the transmitter.
4. Press and hold the activation tool button while pushing the tool to the tire surface. (approximately for 5 seconds)

CAUTION:

Perform the ID registration procedure starting from the vehicle front left wheel, then repeat the procedure in the order of the front right wheel, rear right wheel, and rear left wheel.

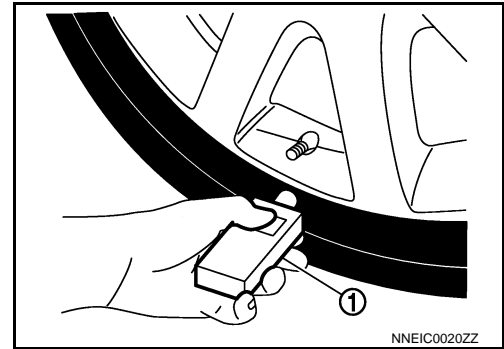

5. When ID registration is completed, check the following pattern at each wheel.

Se-quence	ID registration position	Turn signal lamp	CONSULT-III
1	Front left wheel	2 blinks	"Red" ↓ "Green"
2	Front right wheel		
3	Rear right wheel		
4	Rear left wheel		

6. After the ID registration procedure for all wheels is completed, press "END" to end ID registration, and check that ID registration for all wheels is completed.

Is the check result normal?

YES >> ID registration END.

NO >> Performs trouble-diagnosis of the Tire Pressure Monitoring System (TPMS). Refer to [WT-12, "AIR PRESSURE MONITOR : Diagnosis Description"](#).

3. TRANSMITTER ID REGISTRATION PROCEDURE (WITHOUT TRANSMITTER ACTIVATION TOOL)

1. Adjust the tire pressure for all wheels to match the list below.

Tire position	Tire pressure kPa (kg/cm ² , psi)
Front LH	240 (2.4, 35)
Front RH	220 (2.2, 31)
Rear RH	200 (2.0, 29)
Rear LH	180 (1.8, 26)

ID REGISTRATION PROCEDURE

< BASIC INSPECTION >

[REGULAR GRADE]

2. Drive the vehicle at a speed at more than 40 km/h (25 MPH) for 3 minutes or more, then perform the transmitter ID registration procedure.
3. After ID registration for all wheels is completed, press "END" to end ID registration.

ID registration position	CONSULT-III
Front LH	"Red" ↓ "Green"
Front RH	
Rear RH	
Rear LH	

4. Adjust the tire pressures for all wheels to the specified value. Refer to [WT-61, "Tire Air Pressure"](#).

Is ID registrations for all wheels completed?

YES >> ID registration END.

NO >> Performs trouble-diagnosis of the Tire Pressure Monitoring System (TPMS). Refer to [WT-12, "AIR PRESSURE MONITOR : Diagnosis Description"](#).

EMERGENCY TIRE PUNCTURE REPAIR

< BASIC INSPECTION >

[REGULAR GRADE]

EMERGENCY TIRE PUNCTURE REPAIR

Description

INFOID:000000005485037

Treat the sealant drained or the expired sealant collected from the customer as waste oil.

Draining

INFOID:000000005485038

DRAINING

CAUTION:

Never spill the sealant in the tire.

1. Remove tires.
2. Remove the valve core (1) from the transmitter (2) using a core wrench (A), and then bleed air.

CAUTION:

Cover the valve using a waste cloth to prevent the sealant from being splashed.

3. Separate transmitter from wheel.

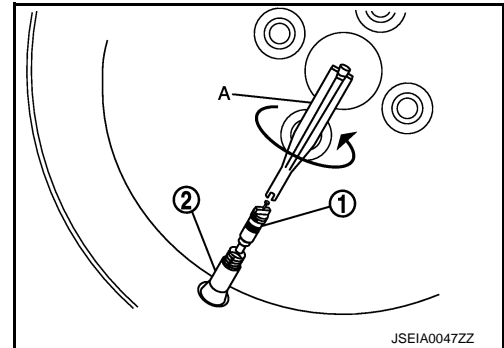

4. Install the filling hose to the empty bottle, and then insert the extension hose for draining into the end of filling hose.
 5. Insert the hose through the hole, and then prop the tire and further insert the hose until the end of hose sinks under the sealant level.
 6. Suck out the sealant by compressing the bottle.
- NOTE:**
Place the tire on the proper workbench and hold it higher than the bottle to suck the sealant out easily.
7. Repeat the procedure until the sealant cannot be sucked out while changing the position of hose end.

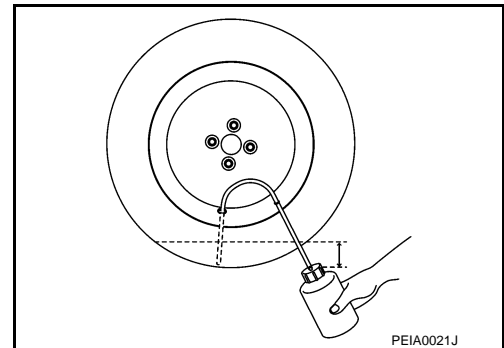

AFTER DRAINING

NOTE:

The aerosol-type sealant closes off the blowout hole. Therefore, the blowout hole may not be discovered according to the extent of damage, resulting the difficulty of blow out repair. In this case, check the tire pressure thoroughly, and then replace with new tire if the tire pressure decreases.

- Remove the tire from the wheel, and then wipe out the sealant on the tire and wheel.
- Replace transmitter. Refer to [WT-58. "Removal and Installation"](#).

CAUTION:

Never reuse the transmitter.

- Perform the blowout repair if it is possible. Replace with new tire if the blowout repair is impossible.

CAUTION:

Never discard the tire with the sealant applied.

- Treat the sealant drained as waste oil.

C1704, C1705, C1706, C1707 LOW TIRE PRESSURE

< DTC/CIRCUIT DIAGNOSIS >

[REGULAR GRADE]

DTC/CIRCUIT DIAGNOSIS

C1704, C1705, C1706, C1707 LOW TIRE PRESSURE

Description

INFOID:000000005239845

When the tire pressure monitoring system detects low inflation pressure, the low tire pressure warning lamps in the combination meter comes on.

DTC Logic

INFOID:000000005484269

DTC DETECTION LOGIC

DTC	Display item	Malfunction detected condition	Possible cause
C1704	LOW PRESSURE FL	Front LH tire pressure drops to * kPa (* kg/cm ² , * psi) or less. [NOTE]	• Low tire pressure • Transmitter malfunction
C1705	LOW PRESSURE FR	Front RH tire pressure drops to * kPa (* kg/cm ² , * psi) or less. [NOTE]	
C1706	LOW PRESSURE RR	Rear RH tire pressure drops to * kPa (* kg/cm ² , * psi) or less. [NOTE]	
C1707	LOW PRESSURE RL	Rear LH tire pressure drops to * kPa (* kg/cm ² , * psi) or less. [NOTE]	

NOTE:

- 189.6 kPa (1.9 kg/cm², 27 psi): Standard air pressure is for 240 kPa (2.4 kg/cm², 35 psi) vehicles.
- 205.1 kPa (2.1 kg/cm², 30 psi): Standard air pressure is for 260 kPa (2.6 kg/cm², 38 psi) vehicles.

DTC CONFIRMATION PROCEDURE

1. DTC REPRODUCTION PROCEDURE

Ⓜ With CONSULT-III

1. Turn the ignition switch ON.

CAUTION:

Never start the engine.

2. Check the tire pressure for all wheels and adjust to the specified value. Refer to [WT-61, "Tire Air Pressure"](#).
3. Perform "SELF-DIAG RESULTS" in "AIR PRESSURE MONITOR" of "BCM".

Is DTC "C1704", "C1705", "C1706", "C1707" detected?

- YES >> Perform trouble diagnosis. Refer to [WT-26, "Diagnosis Procedure"](#).
NO >> INSPECTION END

Diagnosis Procedure

INFOID:000000005484270

1. CHECK TIRE PRESSURE

Check the internal pressure of all wheels. Refer to [WT-61, "Tire Air Pressure"](#).

Is the inspection result normal?

- YES >> Replace the DTC-detected malfunctioning transmitter. Refer to [WT-58, "Exploded View"](#).
NO >> After adjusting the air pressure, GO TO 2.

2. CHECK TIRE PRESSURE SIGNAL

Ⓜ With CONSULT-III

1. Drive for 3 minutes at a speed of 40 km/h (25 MPH) or more, then drive normally for 10 minutes.
2. Perform "DATA MONITOR" in "AIR PRESSURE MONITOR" of "BCM".
3. Select "BCM" in "DATA MONITOR", and check that the tire pressures match the standard value.

C1704, C1705, C1706, C1707 LOW TIRE PRESSURE

< DTC/CIRCUIT DIAGNOSIS >

[REGULAR GRADE]

Monitor item	Condition	Displayed value
AIR PRESS FL	Drive for 3 minutes at a speed of 40 km/h (25 MPH) or more, then drive normally for 10 minutes.	Internal pressure of tires
AIR PRESS FR		
AIR PRESS RR		
AIR PRESS RL		

CAUTION:

Stop the vehicle and within 5 minutes, use "DATA MONITOR" in "AIR PRESSURE MONITOR" of "BCM" to display the tire pressure for all wheels.

Is the inspection result normal?

- YES >> Inspect or repair the tires or wheels and adjust the tire pressure to the specification.
- NO >> GO TO 1.

Special Repair Requirement

INFOID:000000005484271

WT

1.CHECK TIRE PRESSURE

Check all tires for tire pressures. Refer to [WT-61, "Tire Air Pressure"](#).

Does all tire pressure data meet the specification?

- YES >> GO TO 2.
- NO >> Inspect or repair the tires or wheels and adjust the tire pressure to the specification.

2.PERFORM ID REGISTRATION

Perform ID registration. Refer to [WT-23, "Special Repair Requirement"](#).

>> END

C1708, C1709, C1710, C1711 TRANSMITTER

< DTC/CIRCUIT DIAGNOSIS >

[REGULAR GRADE]

C1708, C1709, C1710, C1711 TRANSMITTER

DTC Logic

INFOID:000000005484272

DTC DETECTION LOGIC

DTC	Display item	Malfunction detected condition	Possible cause
C1708	[NO DATA] FL	Tire pressure data signal from the front left wheel transmitter cannot be detected.	<ul style="list-style-type: none">• Harness or connector (Tire pressure receiver, BCM)• ID registration is not finished• Transmitter malfunction• BCM malfunction
C1709	[NO DATA] FR	Tire pressure data signal from the front right wheel transmitter cannot be detected.	
C1710	[NO DATA] RR	Tire pressure data signal from the rear right wheel transmitter cannot be detected.	
C1711	[NO DATA] RL	Tire pressure data signal from the rear left wheel transmitter cannot be detected.	

DTC CONFIRMATION PROCEDURE

1. DTC REPRODUCTION PROCEDURE

④ With CONSULT-III

1. Drive for 3 minutes at a speed of 40 km/h (25 MPH) or more, then drive normally for 10 minutes.
2. Perform "SELF-DIAG RESULTS" in "AIR PRESSURE MONITOR" of "BCM".

Is DTC "C1708", "C1709", "C1710", "C1711" detected?

- YES >> Perform trouble diagnosis. Refer to [WT-28, "Diagnosis Procedure"](#).
NO >> INSPECTION END

Diagnosis Procedure

INFOID:000000005484273

1. CHECK TIRE PRESSURE SIGNAL

④ With CONSULT-III

1. Drive for 3 minutes at a speed of 40 km/h (25 MPH) or more, then drive normally for 10 minutes.
2. Perform "DATA MONITOR" in "AIR PRESSURE MONITOR" of "BCM".
3. Select "BCM" in "DATA MONITOR", and check that the tire pressures match the standard value.

Monitor item	Condition	Displayed value
AIR PRESS FL	Drive for 3 minutes at a speed of 40 km/h (25 MPH) or more, then drive normally for 10 minutes.	Internal pressure of tires
AIR PRESS FR		
AIR PRESS RR		
AIR PRESS RL		

CAUTION:

Stop the vehicle and within 5 minutes, use "DATA MONITOR" in "AIR PRESSURE MONITOR" of "BCM" to display the tire pressure for all wheels.

Is a tire pressure of 0 kPa (0 Psi) displayed for all wheels?

- YES >> GO TO 2.
NO >> GO TO 5.

2. CHECK HARNESS BETWEEN BCM AND TIRE PRESSURE RECEIVER

1. Turn the ignition switch OFF.
2. Disconnect BCM harness connector and tire pressure receiver harness connector.
3. Check the continuity between BCM harness connector and tire pressure receiver harness connector.

C1708, C1709, C1710, C1711 TRANSMITTER

< DTC/CIRCUIT DIAGNOSIS >

[REGULAR GRADE]

BCM		Tire pressure receiver		Continuity
Connector	Terminal	Connector	Terminal	
M123	137	M101	1	Existed
	138		4	
	139		2	

4. Check the continuity between BCM harness connector and ground.

BCM		—	Continuity
Connector	Terminal		
M123	137	Ground	Not existed
	138		
	139		

Is the inspection result normal?

YES >> GO TO 3.

NO >> Repair or replace damaged parts.

3. CHECK TIRE PRESSURE RECEIVER POWER SUPPLY CIRCUIT

1. Connect the BCM harness connector.

2. Turn the ignition switch ON.

CAUTION:

Never start the engine.

3. Check the voltage between the BCM harness connector and ground.

BCM		—	Voltage
Connector	Terminal		
M123	138	Ground	5 V

Is the inspection result normal?

YES >> GO TO 4.

NO >> Repair or replace damaged parts.

4. CHECK TIRE PRESSURE RECEIVER

Check tire pressure receiver. Refer to [WT-37, "Diagnosis Procedure"](#).

Is the inspection result normal?

YES >> GO TO 5.

NO >> Replace tire pressure receiver. Refer to [WT-60, "Removal and Installation"](#).

5. CHECK ID REGISTRATION

Perform ID registration of all transmitters. Refer to [WT-23, "Special Repair Requirement"](#).

Can ID registration of all transmitters be completed?

YES >> GO TO 6.

NO >> Replace transmitter. Refer to [WT-58, "Exploded View"](#).

6. CHECK TIRE PRESSURE MONITORING SYSTEM

Ⓜ With CONSULT-III

1. Drive at a speed of 40 km/h (25 MPH) or more for several minutes without stopping.

2. Perform "DATA MONITOR" in "AIR PRESSURE MONITOR" of "BCM".

3. Select "BCM" in "DATA MONITOR", and check that the tire pressures match the standard value.

C1708, C1709, C1710, C1711 TRANSMITTER

< DTC/CIRCUIT DIAGNOSIS >

[REGULAR GRADE]

Monitor item	Condition	Displayed value
AIR PRESS FL	Drive at a speed of 40 km/h (25 MPH) or more, for several minutes without stopping.	Internal pressure of tires
AIR PRESS FR		
AIR PRESS RR		
AIR PRESS RL		

CAUTION:

Stop the vehicle and within 15 minutes, use “DATA MONITOR” in “AIR PRESSURE MONITOR” of “BCM” to read the tire pressure for all wheels.

Is the inspection result normal?

YES >> Replace the DTC-detected malfunctioning transmitter. Refer to [WT-58. "Exploded View"](#).

NO >> Replace BCM. Refer to [BCS-92. "Exploded View"](#).

Special Repair Requirement

INFOID:000000005484521

1. CHECK TIRE PRESSURE

Check all tires for tire pressures. Refer to [WT-61. "Tire Air Pressure"](#).

Does all tire pressure data meet the specification?

YES >> GO TO 2.

NO >> Inspect or repair the tires or wheels and adjust the tire pressure to the specification.

2. PERFORM ID REGISTRATION

Perform ID registration. Refer to [WT-23. "Special Repair Requirement"](#).

>> END

C1716, C1717, C1718, C1719 TRANSMITTER

< DTC/CIRCUIT DIAGNOSIS >

[REGULAR GRADE]

C1716, C1717, C1718, C1719 TRANSMITTER

DTC Logic

INFOID:000000005527705

DTC DETECTION LOGIC

DTC	Display item	Malfunction detected condition	Possible case
C1716	[PRESSDATA ERR] FL	Malfunction in the tire pressure data from the front left wheel transmitter.	<ul style="list-style-type: none">ID registration is not finishedTransmitter malfunction
C1717	[PRESSDATA ERR] FR	Malfunction in the tire pressure data from the front right wheel transmitter.	
C1718	[PRESSDATA ERR] RR	Malfunction in the tire pressure data from the rear right wheel transmitter.	
C1719	[PRESSDATA ERR] RL	Malfunction in the tire pressure data from the rear left wheel transmitter.	

DTC CONFIRMATION PROCEDURE

1. DTC REPRODUCTION PROCEDURE

Ⓜ With CONSULT-III

- Turn the ignition switch ON.

CAUTION:

Never start the engine.

- Check the tire pressure for all wheels and adjust to the specified value. Refer to [WT-61, "Tire Air Pressure"](#).
- Perform "SELF-DIAG RESULTS" in "AIR PRESSURE MONITOR" of "BCM".

Is DTC "C1716", "C1717", "C1718", "C1719" detected?

- YES >> Perform trouble diagnosis. Refer to [WT-31, "Diagnosis Procedure"](#).
NO >> INSPECTION END

Diagnosis Procedure

INFOID:000000005527706

1. CHECK TIRE PRESSURE

Check the internal pressure of all wheels. Refer to [WT-61, "Tire Air Pressure"](#).

Is the inspection result normal?

- YES >> Replace the DTC-detected malfunctioning transmitter. Refer to [WT-58, "Exploded View"](#).
NO >> After adjusting the tire pressure, GO TO 2.

2. CHECK TIRE PRESSURE SIGNAL

Ⓜ With CONSULT-III

- Check and adjust the tire pressure for all wheels. Refer to [WT-61, "Tire Air Pressure"](#).
- Perform transmitter ID registration for all wheels. Refer to [WT-23, "Special Repair Requirement"](#).
- Drive for 3 minutes at a speed of 40 km/h (25 MPH) or more, then drive normally for 10 minutes.
- Perform "DATA MONITOR" in "AIR PRESSURE MONITOR" of "BCM".
- Select "BCM" in "DATA MONITOR", and check that the tire pressures match the standard value.

CAUTION:

Stop the vehicle and within 15 minutes, use CONSULT-III "DATA MONITOR" to display the tire pressure for all wheels.

- Check that "DATA MONITOR" displays tire pressure of 438.60 kPa (4.47 kg/cm², 63.60 Psi).

Is the inspection 438.60 kPa (4.47 kg/cm², 63.60 Psi)?

- YES >> Replace transmitter the tire pressure 438.60 kPa (4.386 bar, 4.47 kg/cm², 63.60 Psi) displayed.
Refer to [WT-58, "Exploded View"](#).
NO >> GO TO 1.

C1716, C1717, C1718, C1719 TRANSMITTER

< DTC/CIRCUIT DIAGNOSIS >

[REGULAR GRADE]

Special Repair Requirement

INFOID:00000000527712

1.CHECK TIRE PRESSURE

Check all tires for tire pressures. Refer to [WT-61, "Tire Air Pressure"](#).

Does all tire pressure data meet the specification?

YES >> GO TO 2.

NO >> Inspect or repair the tires or wheels and adjust the tire pressure to the specification.

2.PERFORM ID REGISTRATION

Perform ID registration. Refer to [WT-23, "Special Repair Requirement"](#).

>> END

C1729 VEHICLE SPEED SIGNAL

< DTC/CIRCUIT DIAGNOSIS >

[REGULAR GRADE]

C1729 VEHICLE SPEED SIGNAL

Description

INFOID:000000005239869

BCM detects no vehicle speed signal.

DTC Logic

INFOID:000000005484275

DTC DETECTION LOGIC

DTC number	Trouble diagnosis name	DTC detecting condition	Possible case
C1729	VHCL SPEED SIG ERR	Vehicle speed signal not detected.	<ul style="list-style-type: none">CAN communication errorCombination meter malfunction

DTC CONFIRMATION PROCEDURE

1. DTC REPRODUCTION PROCEDURE

Ⓜ With CONSULT-III

- Drive for several minutes at a speed of 40 km/h (25 MPH) or more, then stop the vehicle.
- Perform "SELF-DIAG RESULTS" in "AIR PRESSURE MONITOR" of "BCM".

Is DTC "C1729" detected?

- YES >> Perform trouble diagnosis. Refer to [WT-33, "Diagnosis Procedure"](#).
NO >> INSPECTION END

Diagnosis Procedure

INFOID:000000005484276

1. PERFORM COMBINATION METER SELF-DIAGNOSIS

Ⓜ With CONSULT-III

Perform "SELF-DIAG RESULTS" of "METER/M&A".

Is any DTC detected?

- YES >> Check the DTC. Refer to [BCS-86, "DTC Index"](#).
NO >> GO TO 2.

2. PERFORM SELF-DIAGNOSIS

Ⓜ With CONSULT-III

Perform "SELF-DIAG RESULTS" in "AIR PRESSURE MONITOR" of "BCM".

Is DTC "C1729" detected?

- YES >> Replace BCM. Refer to [WT-11, "COMMON ITEM : CONSULT-III Function \(BCM - COMMON ITEM\)"](#).
NO >> GO TO 3.

3. CHECK INFORMATION

Ⓜ With CONSULT-III

- Perform "DATA MONITOR" in "AIR PRESSURE MONITOR" of "BCM".
- Select "BCM" in "DATA MONITOR", and check the input/output values. Refer to [BCS-51, "Reference Value"](#).

Is the inspection result normal?

- YES >> Check pin terminal and connection of each harness connector for malfunctioning conditions.
NO >> Replace BCM. Refer to [BCS-92, "Exploded View"](#).

Special Repair Requirement

INFOID:000000005484664

1. CHECK TIRE PRESSURE

Check all tires for tire pressures. Refer to [WT-61, "Tire Air Pressure"](#).

Does all tire pressure data meet the specification?

- YES >> GO TO 2.

C1729 VEHICLE SPEED SIGNAL

< DTC/CIRCUIT DIAGNOSIS >

[REGULAR GRADE]

NO >> Inspect or repair the tires or wheels and adjust the tire pressure to the specification.

2.PERFORM ID REGISTRATION

Perform ID registration. Refer to [WT-23, "Special Repair Requirement"](#).

>> END

C1734 BCM

DTC Logic

INFOID:000000005484505

DTC DETECTION LOGIC

DTC	Display item	Malfunction detected condition	Possible case
C1734	CONTROL UNIT	Tire pressure monitoring system malfunction in BCM	BCM malfunction

DTC CONFIRMATION PROCEDURE

1. DTC REPRODUCTION PROCEDURE

Ⓜ With CONSULT-III

1. Drive at a speed of 40 km/h (25 MPH) or more for several minutes without stopping.
2. Perform "SELF-DIAG RESULTS" in "AIR PRESSURE MONITOR" of "BCM".

CAUTION:

Perform within 15 minutes after stop the vehicle.

Is DTC "C1734" detected?

- YES >> Perform trouble diagnosis. Refer to [WT-35, "Diagnosis Procedure"](#).
- NO >> INSPECTION END

Diagnosis Procedure

INFOID:000000005484506

1. CHECK BCM POWER SUPPLY

1. Turn the ignition switch OFF.
2. Disconnect BCM harness connector.
3. Check voltage between BCM harness connector terminals and ground.

BCM		—	Voltage
Connector	Terminal		
M118	1	Ground	Battery voltage
M119	11		

Is the power supply normal?

- YES >> GO TO 2.
- NO >> Check the following. If any items are damaged, repair or replace damage parts.
 - 40A fusible link [No. 1 located in the fuse block]. Refer to [PG-113, "Fuse and Fusible Link Arrangement"](#).
 - 10A fuse [No. 10 located in the fuse block (J/B)]. Refer to [PG-114, "Fuse, Connector and Terminal Arrangement"](#).
 - Harness for short or open between battery and BCM harness connector M118 terminal 1.
 - Harness for short or open between battery and BCM harness connector M119 terminal 11.
 - Check the Battery voltage.

2. CHECK BCM GROUND

Check the continuity between BCM harness connector and ground.

BCM		—	Continuity
Connector	Terminal		
M119	13	Ground	Existed

Is the inspection result normal?

- YES >> GO TO 3.
- NO >> Repair or replace damaged parts.

3. CHECK HARNESS BETWEEN BCM AND TIRE PRESSURE RECEIVER

1. Disconnect tire pressure receiver harness connector.
2. Check the continuity between BCM harness connector and tire pressure receiver harness connector.

C1734 BCM

< DTC/CIRCUIT DIAGNOSIS >

[REGULAR GRADE]

BCM		Tire pressure receiver		Continuity
Connector	Terminal	Connector	Terminal	
M123	137	M101	1	Existed
	138		4	
	139		2	

3. Check the continuity between BCM harness connector and ground.

BCM		—	Continuity
Connector	Terminal		
M123	137	Ground	Not existed
	138		
	139		

Is the inspection result normal?

YES >> GO TO 4.

NO >> Repair or replace damaged parts.

4.CHECK BCM

Check the BCM input/output signal. Refer to [BCS-51, "Reference Value"](#).

Is the inspection result normal?

YES >> INSPECTION END

NO >> GO TO 5.

5.CHECK BCM HARNESS CONNECTOR

Check the BCM pin terminals for damage or loose connection with harness connector.

Is the inspection result normal?

YES >> Replace BCM. Refer to [BCS-92, "Exploded View"](#).

NO >> Check for looseness or damage at the harness connector pins of the low tire pressure warning control unit. Repair or replace if necessary.

Special Repair Requirement

INFOID:000000005484665

1.CHECK TIRE PRESSURE

Check all tires for tire pressures. Refer to [WT-61, "Tire Air Pressure"](#).

Does all tire pressure data meet the specification?

YES >> GO TO 2.

NO >> Inspect or repair the tires or wheels and adjust the tire pressure to the specification.

2.PERFORM ID REGISTRATION

Perform ID registration. Refer to [WT-23, "Special Repair Requirement"](#).

>> END

TIRE PRESSURE RECEIVER

< DTC/CIRCUIT DIAGNOSIS >

[REGULAR GRADE]

TIRE PRESSURE RECEIVER

Component Function Check

INFOID:000000005239878

1. TIRE PRESSURE MONITORING SYSTEM OPERATION

④ With CONSULT-III

1. Drive for 3 minutes at a speed of 40 km/h (25 MPH) or more, then drive normally for 10 minutes.
2. On "DATA MONITOR", select "AIR PRESS FL", "AIR PRESS FR", "AIR PRESS RR" and "AIR PRESS RL", and check that the tire pressures match the standard value.

Monitor item	Condition	Displayed value
AIR PRESS FL	Drive for 3 minutes at a speed of 40 km/h (25 MPH) or more, then drive normally for 10 minutes.	Internal pressure of tires
AIR PRESS FR		
AIR PRESS RR		
AIR PRESS RL		

CAUTION:

Stop the vehicle and within 5 minutes, use CONSULT-III "DATA MONITOR" to display the tire pressure for all wheels.

Is the inspection result normal?

YES >> INSPECTION END

NO >> Perform trouble diagnosis. Refer to [WT-37, "Diagnosis Procedure"](#).

Diagnosis Procedure

INFOID:000000005239879

1. CHECK TIRE PRESSURE RECEIVER SIGNAL

1. Turn the ignition switch ON.

CAUTION:

Never start the engine.

2. Check tire pressure receiver connector and ground signal with oscilloscope.

Tire pressure receiver		—	Condition	Voltage (Approx.)
Connector	Terminal			
M101	2	Ground	Stand by state	<p>OCC3881D</p>
			When receiving the signal from the transmitter	<p>OCC3880D</p>

Is the inspection result normal?

YES >> INSPECTION END

NO >> GO TO 2.

2. CHECK TIRE PRESSURE RECEIVER INPUT VOLTAGE

1. Disconnect tire pressure receiver connector.
2. Check voltage between tire pressure receiver connector and ground.

TIRE PRESSURE RECEIVER

< DTC/CIRCUIT DIAGNOSIS >

[REGULAR GRADE]

Tire pressure receiver		—	Voltage (Approx.)
Connector	Terminal		
M101	4	Ground	5.0 V

Is the inspection result normal?

YES >> GO TO 3.

NO >> Repair or replace damaged parts.

3. CHECK TIRE PRESSURE RECEIVER GROUND CIRCUIT

1. Disconnect BCM harness connector.
2. Check continuity between BCM harness connector and tire pressure receiver connector.

BCM		Tire pressure receiver		Continuity
Connector	Terminal	Connector	Terminal	
M123	137	M101	1	Existed

3. Check continuity between BCM harness connector and ground.

BCM		—	Continuity
Connector	Terminal		
M123	137	Ground	Not existed

Is the inspection result normal?

YES >> GO TO 4.

NO >> Repair or replace damaged parts.

4. CHECK BCM CIRCUIT

Inspect the BCM circuit. Refer to [BCS-46, "Diagnosis Procedure"](#).

Is the BCM circuit normal?

YES >> Replace tire pressure receiver. Refer to [WT-60, "Removal and Installation"](#).

NO >> Replace BCM. Refer to [BCS-92, "Exploded View"](#).

TIRE PRESSURE WARNING CHECK SWITCH

< DTC/CIRCUIT DIAGNOSIS >

[REGULAR GRADE]

TIRE PRESSURE WARNING CHECK SWITCH

Component Function Check

INFOID:000000005239881

1. CHECK THE ILLUMINATION OF THE LOW TIRE PRESSURE WARNING LAMP

1. Turn the ignition switch ON.

CAUTION:

Never start the engine.

2. Short-circuit the tire pressure warning check switch connector terminal to the ground.
3. Check that the low tire pressure warning lamp blinking.

Is inspection result normal?

YES >> INSPECTION END

NO >> Perform diagnosis. Refer to [WT-39, "Diagnosis Procedure"](#).

Diagnosis Procedure

INFOID:000000005239882

1. CHECK TIRE PRESSURE WARNING CHECK SWITCH SIGNAL

1. Turn the ignition switch ON.

CAUTION:

Never start the engine.

2. Check the voltage between tire pressure warning check switch connector and ground.

Tire pressure warning check switch		—	Voltage (Approx.)
Connector	Terminal		
M23	1	Ground	12 V

Is the inspection result normal?

YES >> Replace BCM. Refer to [BCS-92, "Exploded View"](#).

NO >> GO TO 2.

2. CHECK TIRE PRESSURE WARNING CHECK SWITCH CIRCUIT

1. Turn the ignition switch OFF.
2. Disconnect BCM harness connector
3. Check the continuity between BCM harness connector and tire pressure warning check switch connector.

BCM		Tire pressure warning check switch		Continuity
Connector	Terminal	Connector	Terminal	
M123	149	M23	1	Existed

4. Check the continuity between BCM harness connector and ground.

BCM		—	Continuity
Connector	Terminal		
M123	149	Ground	Not existed

Is the inspection result normal?

YES >> Check BCM pin terminals for damage or loose connection with harness connector. If any items are damaged, repair or replace damaged parts. Replace BCM. Refer to [BCS-92, "Exploded View"](#).

NO >> Repair or replace damaged parts.

LOW TIRE PRESSURE WARNING LAMP

< DTC/CIRCUIT DIAGNOSIS >

[REGULAR GRADE]

LOW TIRE PRESSURE WARNING LAMP

Component Function Check

INFOID:000000005484508

1. CHECK THE ILLUMINATION OF THE LOW TIRE PRESSURE WARNING LAMP

Check that the low tire pressure warning lamp is turned OFF after illuminating for approximately 1 second, when the ignition switch is turned ON.

Is the inspection result normal?

YES >> INSPECTION END

NO >> Perform trouble diagnosis. Refer to [WT-40, "Diagnosis Procedure"](#).

Diagnosis Procedure

INFOID:000000005484509

1. POWER SUPPLY AND GROUND CIRCUIT

Check power supply and ground circuit. Refer to [WT-41, "Diagnosis Procedure"](#).

Is the inspection result normal?

YES >> GO TO 2.

NO >> Repair or replace damaged parts.

2. PERFORM SELF-DIAGNOSIS

Ⓜ With CONSULT-III

Perform "SELF-DIAG RESULTS" in "AIR PRESSURE MONITOR" of "BCM".

Is any DTC detected?

YES >> Check the DTC. Refer to [BCS-86, "DTC Index"](#).

NO >> GO TO 3.

3. CHECK LOW TIRE PRESSURE WARNING LAMP SIGNAL

Ⓜ With CONSULT-III

1. Turn the ignition switch ON.

CAUTION:

Never start the engine.

2. Perform "DATA MONITOR" in "AIR PRESSURE MONITOR" of "BCM".

3. Select "BCM" in "DATA MONITOR", and check that the low tire pressure warning lamp is turned OFF after illuminating for approximately 1 second, when the ignition switch is turned ON.

Is the inspection result normal?

YES >> Check the combination meter. Refer to [MWI-6, "METER SYSTEM : System Description"](#).

NO >> Replace the BCM. Refer to [BCS-92, "Exploded View"](#).

POWER SUPPLY AND GROUND CIRCUIT

< DTC/CIRCUIT DIAGNOSIS >

[REGULAR GRADE]

POWER SUPPLY AND GROUND CIRCUIT

Diagnosis Procedure

INFOID:000000005239886

1. POWER SUPPLY SYSTEM CHECK

1. Turn the ignition switch OFF.
2. Disconnect the BCM harness connector.
3. Turn the ignition switch ON.
CAUTION:
Never start the engine.
4. Check the voltage between the BCM harness connector and the ground.

BCM		—	Voltage
Connector	Terminal		
M118	1	Ground	Battery voltage
M119	11		

Is the inspection result normal?

- YES >> GO TO 2.
NO >> Repair or replace damaged parts.

2. GROUND SYSTEM INSPECTION

1. Turn the ignition switch OFF.
2. Check the continuity between the BCM harness connector and the ground.

BCM		—	Continuity
Connector	Terminal		
M119	13	Ground	Existed

Is the inspection result normal?

- YES >> • Check the 10 A fuse [No. 10 in fuse block (J/B)].
• Check the 40 A fusible link [No. K in fuse block].
NO >> Repair or replace damaged parts.

A
B
C
D
E
F
G
H
I
J
K
L
M
N
O
P

WT

SYMPTOM DIAGNOSIS

TPMS

Symptom Table















INFOID:000000005239893

LOW TIRE PRESSURE WARNING LAMP SYMPTOM CHART

TPMS

< SYMPTOM DIAGNOSIS >

[REGULAR GRADE]

Diagnosis items	Symptom (Ignition switch ON)	Low tire pressure warning lamp	Cause	Action
Low tire pressure warning lamp	The low tire pressure warning lamp illuminates for 1 second, then turns OFF.	  ON 1 sec > stays OFF <small>SEIA0592E</small>	Wake-up operation for all transmitters at wheels is completed.	No system malfunctions
	The low tire pressure warning lamp repeats blinking ON for 2 seconds and OFF for 0.2 seconds.	 Blinks:  ON 2 sec > OFF 0.2 sec <small>SEIA0593E</small>	Wake-up operation for all transmitters at wheels is not completed.	Perform the wake-up operation for all transmitters at wheels. Refer to WT-22 , " Special Repair Requirement ".
	The low tire pressure warning lamp blinks once.	 Blinks 1 time ON 0.3 sec > OFF 1.3 sec <small>SEIA0594E</small>	The front left transmitter is not activated.	Perform the wake-up operation for the transmitter at front left wheel. Refer to WT-22 , " Special Repair Requirement ".
	The low tire pressure warning lamp repeats blinking twice.	  Blinks 2 times ON 0.3 sec > OFF 0.3 sec <small>SEIA0595E</small>	The front right transmitter is not activated.	Perform the wake-up operation for the transmitter at front right wheel. Refer to WT-22 , " Special Repair Requirement ".
	The low tire pressure warning lamp repeats blinking for 3 times.	   Blinks 3 times ON 0.3 sec > OFF 0.3 sec <small>SEIA0596E</small>	The rear right transmitter is not activated.	Perform the wake-up operation for the transmitter at rear right wheel. Refer to WT-22 , " Special Repair Requirement ".
	The low tire pressure warning lamp repeats blinking for 4 times.	    Blinks 4 times ON 0.3 sec > OFF 0.3 sec <small>SEIA0597E</small>	The rear left transmitter is not activated.	Perform the wake-up operation for the transmitter at rear left wheel. Refer to WT-22 , " Special Repair Requirement ".
	The low tire pressure warning lamp turns ON and stays illuminated.	 Comes ON and stays ON <small>SEIA0598E</small>	Low tire pressure	Check the tire pressure for all wheels and adjust to the specified value. Refer to WT-61 , " Tire Air Pressure ".

A
B
C
D
WT
F
G
H
I
J
K
L
M
N
O
P

TPMS

< SYMPTOM DIAGNOSIS >

[REGULAR GRADE]

Diagnosis items	Symptom (Ignition switch ON)	Low tire pressure warning lamp	Cause	Action
Low tire pressure warning lamp	The low tire pressure warning lamp repeats blinking at 0.5-second intervals for 1 minute, and then stays illuminated.	 <p style="text-align: center;">Blinks 1 min</p> <p style="text-align: center;">ON 0.5 sec > OFF 0.5 sec and stays ON</p> <p style="text-align: center;"><small>SEIA0788E</small></p>	The combination meter fuse is open or removed (or pulled out).	Check and install the combination meter fuse. If necessary, replace the fuse.
			The low tire pressure warning control unit harness connector is removed.	Check the connection conditions of the low tire pressure warning control unit harness connector, and repair if necessary.
			Tire Pressure Monitoring System (TPMS) malfunction.	<ul style="list-style-type: none"> • Perform CONSULT-III self-diagnosis. Refer to WT-11, "COMMON ITEM : CONSULT-III Function (BCM - COMMON ITEM)". • If necessary, perform transmitter ID registration. Refer to WT-23, "Special Repair Requirement".
Turn signal lamp	The turn signal lamps do not blink twice when the transmitter is activated. Or the buzzer does not sound.	—	<ol style="list-style-type: none"> 1. The transmitter activation tool (J-45295) does not activate. 2. The ignition switch is OFF when the transmitter wake-up operation is performed. 3. The transmitter activation tool (J-45295) is not used in the correct position. 4. The transmitter is already waked up. 	<ol style="list-style-type: none"> 1. Replace the battery in the transmitter activation tool (J-45295). 2. Turn the ignition switch ON when performing the transmitter wake-up operation. 3. Operate the transmitter activation tool (J-45295) in the correct position when performing the wake-up operation. 4. No procedure.

NOTE:

If transmitter wake-up operation is not completed for two or more transmitters, the applicable low tire pressure warning lamp blinking patterns are displayed continuously.

(Example: Blinks once/OFF/blinks 3 times = Wake-up operation is not completed at the front left wheel and rear right wheel transmitters.)

LOW TIRE PRESSURE WARNING LAMP DOES NOT BLINKS

< SYMPTOM DIAGNOSIS >

[REGULAR GRADE]

LOW TIRE PRESSURE WARNING LAMP DOES NOT BLINKS

Description

INFOID:000000005484510

DESCRIPTION

The low tire pressure warning lamp illuminates for approximately 1 second and then turns OFF when the ignition switch is turned ON. This is to check that no abnormal condition is present in the tire pressure monitoring system.

The lamp bulb may be burnt out or the tire pressure monitoring system may be malfunctioning if the low tire pressure warning lamp does not illuminate when the ignition switch is turned ON.

Diagnosis Procedure

INFOID:000000005484511

1. CHECK LOW TIRE PRESSURE WARNING LAMP

Perform trouble diagnosis of the low tire pressure warning lamp. Refer to [WT-40, "Diagnosis Procedure"](#).

Is the inspection result normal?

- YES >> Check pin terminal and connection of each connector for damage and loose connection.
- NO >> Repair or replace damaged parts.

A
B
C
D
E
F
G
H
I
J
K
L
M
N
O
P

WT

LOW TIRE PRESSURE WARNING LAMP DOES NOT TURN OFF

< SYMPTOM DIAGNOSIS >

[REGULAR GRADE]

LOW TIRE PRESSURE WARNING LAMP DOES NOT TURN OFF

Description

INFOID:000000005484512

The low tire pressure warning lamp does not turn OFF after several seconds is passed after engine starts.

Diagnosis Procedure

INFOID:000000005484513

1. CHECK TIRE PRESSURE

1. Turn the ignition switch ON.

CAUTION:

Never start the engine.

2. Check the tire pressure for all wheels and adjust to the specified value. Refer to [WT-61, "Tire Air Pressure"](#).

Is the inspection result normal?

YES >> GO TO 2.

NO >> Inspect or repair the tires or wheels.

2. CHECK LOW TIRE PRESSURE WARNING LAMP

Check low tire pressure warning lamp display.

Does not low tire pressure warning lamp turn OFF?

YES >> GO TO 3.

NO >> INSPECTION END

3. CHECK BCM

Ⓟ With CONSULT-III

Perform "SELF-DIAG RESULTS" in "AIR PRESSURE MONITOR" of "BCM".

Is any DTC detected?

YES >> Check the DTC. Refer to [BCS-86, "DTC Index"](#).

NO >> GO TO 4.

4. CHECK BCM POWER SUPPLY AND GROUND

1. Turn the ignition switch OFF.
2. Disconnect the BCM harness connector.
3. Turn the ignition switch ON.
CAUTION:
Never start the engine.
4. Check the voltage between the BCM harness connector and the ground.

BCM		—	Voltage
Connector	Terminal		
M118	1	Ground	Battery voltage
M119	11		

Is the inspection result normal?

YES >> Replace BCM. Refer to [BCS-92, "Exploded View"](#).

NO >> Repair or replace damaged parts.

LOW TIRE PRESSURE WARNING LAMP BLINKS

< SYMPTOM DIAGNOSIS >

[REGULAR GRADE]

LOW TIRE PRESSURE WARNING LAMP BLINKS

Description

INFOID:000000005484514

DESCRIPTION

The low tire pressure warning lamp illuminates or blinks.

However, a check is necessary because the symptom may not be caused by a system malfunction. For example, the transmitter may not be initialized.

NOTE:

If low tire pressure warning lamp blinks as shown in the figure, the system is normal.

Blink Mode A

- This mode shows transmitter status is in OFF- mode. Perform transmitter wake up operation. Refer to [WT-22. "Special Repair Requirement"](#).

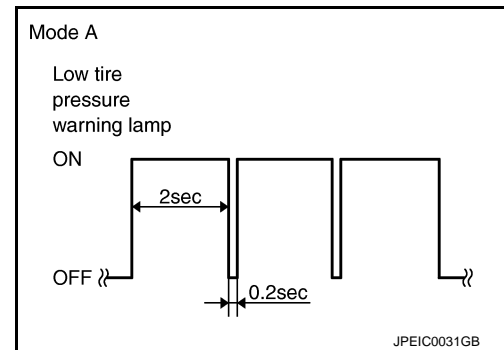

Diagnosis Procedure

INFOID:000000005484515

1. CHECK TIRE PRESSURE WARNING CHECK SWITCH POWER SUPPLY

- Turn the ignition switch ON.

CAUTION:

Never start the engine.

- Check voltage between tire pressure warning check switch connector and ground.

Tire pressure warning check switch		—	Voltage (Approx.)
Connector	Terminal		
M23	1	Ground	12 V

Is the inspection result normal?

YES >> GO TO 2.

NO >> Ripper or replace error-detected damaged parts.

2. CHECK TIRE PRESSURE WARNING CHECK SWITCH CIRCUIT

- Turn the ignition switch OFF.
- Disconnect BCM harness connector.
- Check the continuity between BCM harness connector and tire pressure warning check switch connector.

BCM		Tire pressure warning check switch		Continuity
Connector	Terminal	Connector	Terminal	
M123	149	M23	1	Existed

- Check the continuity between BCM harness connector and ground.

BCM		—	Continuity
Connector	Terminal		
M123	149	Ground	Not existed

Is the inspection result normal?

YES >> GO TO 3.

NO >> Ripper or replace error-detected damaged parts.

LOW TIRE PRESSURE WARNING LAMP BLINKS

< SYMPTOM DIAGNOSIS >

[REGULAR GRADE]

3.CHECK BCM

Check the BCM input/output signal. Refer to [BCS-51, "Reference Value"](#).

Is the inspection result normal?

- YES >> Check the tire pressure warning check switch. Refer to [WT-39, "Diagnosis Procedure"](#).
- NO >> Repair or replace the BCM.

TURN SIGNAL LAMP BLINKS

< SYMPTOM DIAGNOSIS >

[REGULAR GRADE]

TURN SIGNAL LAMP BLINKS

Description

INFOID:000000005484516

DESCRIPTION

The turn signal lamp blinks when the ignition switch is turned ON.
The BCM connector or circuit may have a malfunction.

Diagnosis Procedure

INFOID:000000005484517

1. CHECK TIRE PRESSURE WARNING CHECK SWITCH POWER SUPPLY CIRCUIT

1. Turn the ignition switch ON.

CAUTION:

Never start the engine.

2. Check voltage between tire pressure warning check switch connector and ground.

Tire pressure warning check switch		—	Voltage (Approx.)
Connector	Terminal		
M23	1	Ground	12 V

Is the inspection result normal?

YES >> GO TO 2.

NO >> Repair or replace damaged parts.

2. CHECK TIRE PRESSURE WARNING CHECK SWITCH CIRCUIT

1. Turn the ignition switch OFF.
2. Disconnect BCM harness connector.
3. Check the continuity between BCM harness connector and tire pressure warning check switch connector.

BCM		Tire pressure warning check switch		Continuity
Connector	Terminal	Connector	Terminal	
M123	149	M23	1	Existed

4. Check the continuity between BCM harness connector and ground.

BCM		—	Continuity
Connector	Terminal		
M123	149	Ground	Not existed

Is the inspection result normal?

YES >> Check the turn signal lamp operation. Refer to [BCS-39, "SIGNAL BUFFER : CONSULT-III Function \(BCM - SIGNAL BUFFER\)"](#).

NO >> Repair or replace damaged parts.

ID REGISTRATION CANNOT BE COMPLETED

< SYMPTOM DIAGNOSIS >

[REGULAR GRADE]

ID REGISTRATION CANNOT BE COMPLETED

Description

INFOID:000000005484518

DESCRIPTION

The ID of the transmitter installed in each wheel cannot be registered in the tire pressure monitoring system. Inspect the transmitter or the tire pressure monitoring system circuit.

Diagnosis Procedure

INFOID:000000005484519

1. CHECK TRANSMITTER ID REGISTRATION

1. Perform transmitter ID registration for all wheels. Refer to [WT-23, "Special Repair Requirement"](#).
2. Drive for 3 minutes at a speed of 40 km/h (25 MPH) or more, then drive normally for 10 minutes.
3. Perform "DATA MONITOR" in "AIR PRESSURE MONITOR" of "BCM".
4. Select "BCM" in "DATA MONITOR", and check that the tire pressures match the standard value.

Monitor item	Measuring condition	Displayed value
AIR PRESS FL	Drive for 3 minutes at a speed of 40 km/h (25 MPH) or more, then drive normally for 10 minutes.	Internal pressure of tires
AIR PRESS FR		
AIR PRESS RR		
AIR PRESS RL		

CAUTION:

Stop the vehicle and within 5 minutes, use "DATA MONITOR" in "AIR PRESSURE MONITOR" of "BCM" to display the tire pressure for all wheels.

Is the inspection result normal?

- YES >> INSPECTION END
NO >> GO TO 2.

2. CHECK TRANSMITTERS

1. Perform trouble diagnosis for the transmitter. Refer to [WT-28, "Diagnosis Procedure"](#).
2. Perform transmitter ID registration for all wheels. Refer to [WT-23, "Special Repair Requirement"](#).
3. Check that transmitter ID registration is completed for all wheels.

Is transmitter ID registration for all wheels been completed?

- YES >> INSPECTION END
NO >> Replace the transmitter. Refer to [WT-58, "Exploded View"](#).

NORMAL OPERATING CONDITION

Description

INFOID:000000005239904

LOW TIRE PRESSURE WARNING LAMP BLINKS

If the low tire pressure warning lamp blinks as shown in the figure after the ignition switch is turned ON, the transmitter is not waked up. Perform the transmitter wake-up operation. Refer to [WT-22. "Special Repair Requirement"](#).

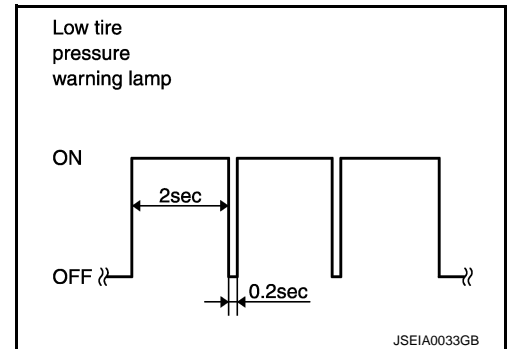

A
B
C
D
WT
F
G
H
I
J
K
L
M
N
O
P

NOISE, VIBRATION AND HARSHNESS (NVH) TROUBLESHOOTING

< SYMPTOM DIAGNOSIS >

[REGULAR GRADE]

NOISE, VIBRATION AND HARSHNESS (NVH) TROUBLESHOOTING

NVH Troubleshooting Chart

INFOID:000000005239905

Use chart below to find the cause of the symptom. If necessary, repair or replace these parts.

Symptom		Possible cause and SUSPECTED PARTS	Reference page																	
			Improper installation, looseness	Out-of-round	unbalance	Incorrect tire pressure	Uneven tire wear	Deformation or damage	Non-uniformity	Incorrect tire size	PROPELLER SHAFT	DIFFERENTIAL	FRONT AXLE AND FRONT SUSPENSION	REAR AXLE AND REAR SUSPENSION	TIRES	ROAD WHEELS	DRIVE SHAFT	BRAKE	STEERING	
TIRES	Noise		x	x	x	x	x	x	x		x	x	x	x		x	x	x	x	
	Shake		x	x	x	x	x	x		x	x		x	x		x	x	x	x	
	Vibration					x				x	x		x	x					x	
	Shimmy		x	x	x	x	x	x	x	x			x	x		x		x	x	
	Judder		x	x	x	x	x	x		x			x	x		x		x	x	
	Poor quality ride or handling		x	x	x	x	x	x		x			x		x	x				
ROAD WHEEL	Noise		x	x	x			x			x	x	x	x		x	x	x	x	
	Shake		x	x	x			x			x		x	x		x	x	x	x	
	Shimmy, Judder		x	x	x			x				x	x	x				x	x	
	Poor quality ride or handling		x	x	x			x					x	x	x					

x: Applicable

PERIODIC MAINTENANCE

ROAD WHEEL TIRE ASSEMBLY

Adjustment

INFOID:000000005239911

BALANCING WHEELS (BONDING WEIGHT TYPE)

Preparation Before Adjustment

Using releasing agent, remove double-faced adhesive tape from the road wheel.

CAUTION:

- Be careful not to scratch the road wheel during removal.
- After removing double-faced adhesive tape, wipe clean traces of releasing agent from the road wheel.

Wheel Balance Adjustment

If a tire balance machine has adhesion balance weight mode settings and drive-in weight mode setting, select and adjust a drive-in weight mode suitable for road wheels.

1. Set road wheel on tire balance machine using the center hole as a guide. Start the tire balance machine.
2. When inner and outer unbalance values are shown on the tire balance machine indicator, multiply outer unbalance value by 5/3 to determine balance weight that should be used. Select the outer balance weight with a value closest to the calculated value above and install to the designated outer position of, or at the designated angle in relation to the road wheel.

CAUTION:

- Do not install the inner balance weight before installing the outer balance weight.
- Before installing the balance weight, be sure to clean the mating surface of the road wheel.

- a. Indicated unbalance value $\times 5/3 =$ balance weight to be installed

Calculation example:

$23 \text{ g (0.81 oz)} \times 5/3 = 38.33 \text{ g (1.35 oz)} \Rightarrow 37.5 \text{ g (1.32 oz)}$ balance weight (closer to calculated balance weight value)

NOTE:

Note that balance weight value must be closer to the calculated balance weight value.

Example:

$36.2 \Rightarrow 35 \text{ g (1.23 oz)}$

$36.3 \Rightarrow 37.5 \text{ g (1.32 oz)}$

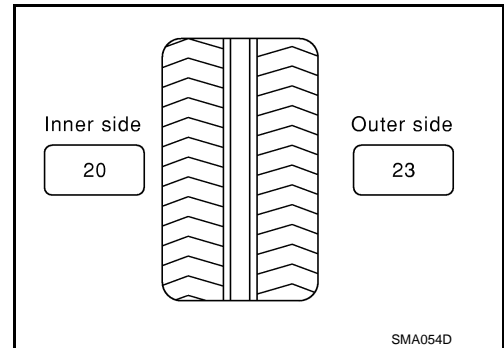

- b. Installed balance weight in the position.

ROAD WHEEL TIRE ASSEMBLY

< PERIODIC MAINTENANCE >

[REGULAR GRADE]

- When installing balance weight (1) to road wheels, set it into the grooved area (A) on the inner wall of the road wheel as shown in the figure so that the balance weight center (B) is aligned with the tire balance machine indication position (angle) (C).

CAUTION:

- Always use genuine NISSAN adhesion balance weights.
- Balance weights are non-reusable; always replace with new ones.
- Do not install more than three sheets of balance weight.

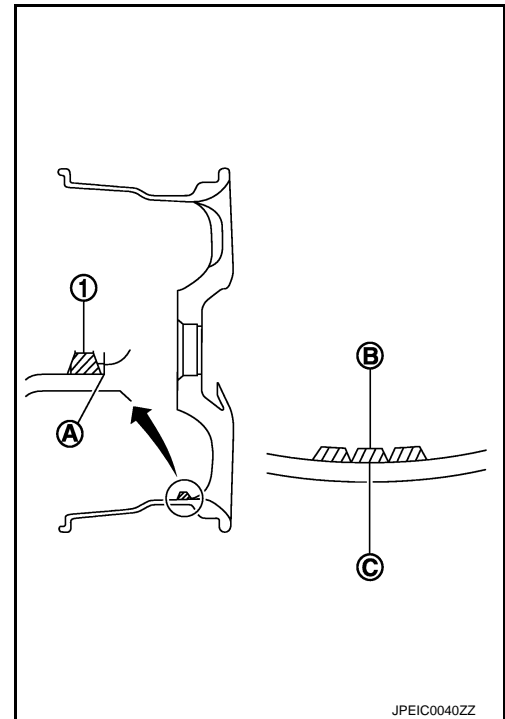

- c. If calculated balance weight value exceeds 50 g (1.76 oz), install two balance weight sheets in line with each other as shown in the figure.

CAUTION:

Do not install one balance weight sheet on top of another.

3. Start the tire balance machine again.
4. Install drive-in balance weight on inner side of road wheel in the tire balance machine indication position (angle).

CAUTION:

Do not install more than two balance weight.

5. Start the tire balance machine. Make sure that inner and outer residual unbalance values are 5 g (0.17 oz) each or below.
6. If either residual unbalance value exceeds 5 g (0.17 oz), repeat installation procedures.

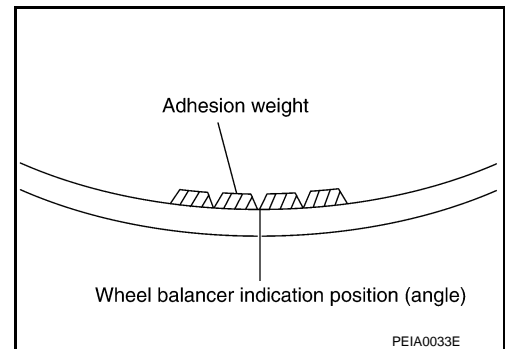

Limit

Dynamic (At flange) : Refer to [WT-61, "Road Wheel"](#).

Static (At flange) : Refer to [WT-61, "Road Wheel"](#).

TIRE ROTATION

- Tire cannot be rotated in vehicle, as front tire are different size from rear tire and the direction of wheel rotation is fixed in each tire.

Wheel nuts tightening torque : Refer to [WT-61, "Road Wheel"](#).

CAUTION:

- Never include the T-type spare tire when rotating the tires.
- Use NISSAN genuine wheel nuts for aluminum wheels.

Safety Device Preventing from Being Incorrectly installed

FRONT BRAKE DISC ROTOR AND FRONT WHEEL

ROAD WHEEL TIRE ASSEMBLY

< PERIODIC MAINTENANCE >

[REGULAR GRADE]

- Front and rear wheel size for this model differs, therefore special pin (1) is adopted to the front brake disc rotor (2). And a hole (3) that matches to this pin is adopted to the front wheel (4) (the rear wheel does not have this wheel). This structure prevents the rear wheel from being mistakenly installed on the front.

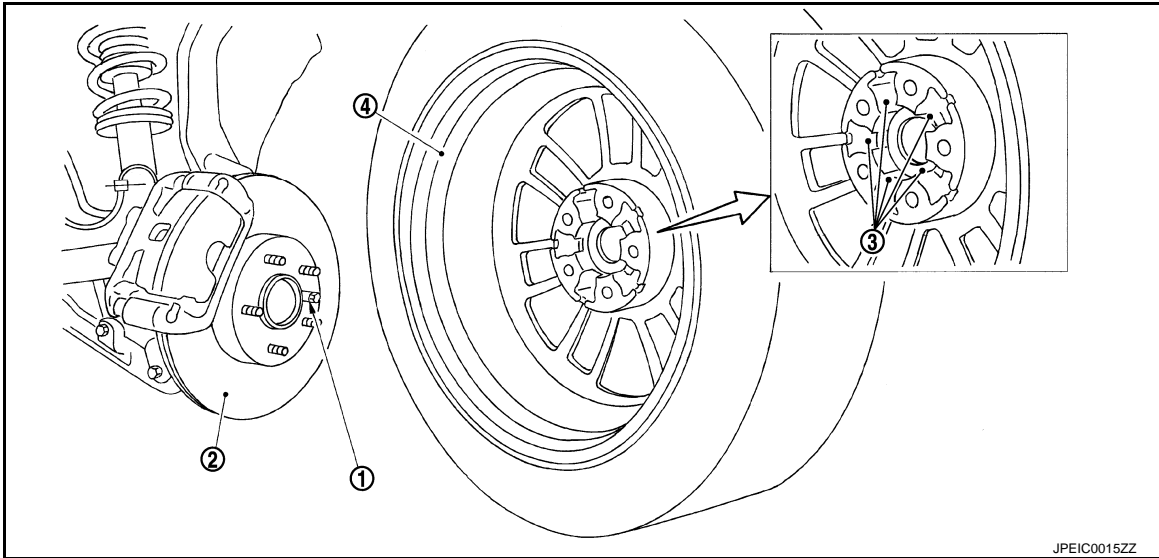

T-TYPE SPARE TIRE WHEEL

- Regarding spare tire (for emergency) wheel, wrong assembly protection pin through hole (1) has been set in addition to regular bolt holes (2) in order to enable installation to front wheel.

NOTE:

Protection pin through hole of 18 inch spare wheel is non-through type.

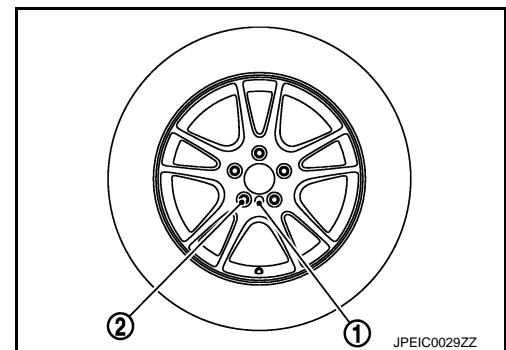

A
B
C
D
WT
F
G
H
I
J
K
L
M
N
O
P

REMOVAL AND INSTALLATION

ROAD WHEEL TIRE ASSEMBLY

Exploded View

INFOID:000000005484001

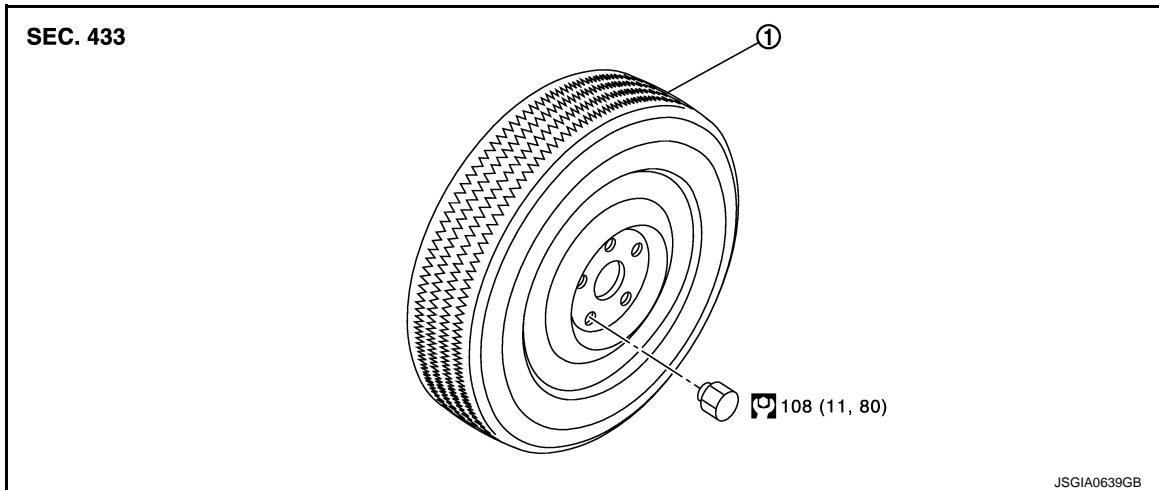

1. Tire assembly

Refer to [GI-4. "Components"](#) for symbols in the figure.

Removal and Installation

INFOID:000000005484002

REMOVAL

1. Remove wheel nuts.
2. Remove tire assembly.

INSTALLATION

Install in the reverse order of removal.

Inspection

INFOID:000000005239910

ALUMINUM WHEEL

1. Check tires for wear and improper inflation.
2. Check wheels for deformation, cracks and other damage. If deformed, remove wheel and check wheel runout.
 - a. Remove tire from aluminum wheel and mount on a tire balance machine.
 - b. Set dial indicator as shown in the figure.
 - c. If the lateral deflection (A) or vertical deflection (B) for radial runout value exceeds the limit, replace aluminum wheel.

Limit

A: Refer to [WT-61. "Road Wheel"](#).

B: Refer to [WT-61. "Road Wheel"](#).

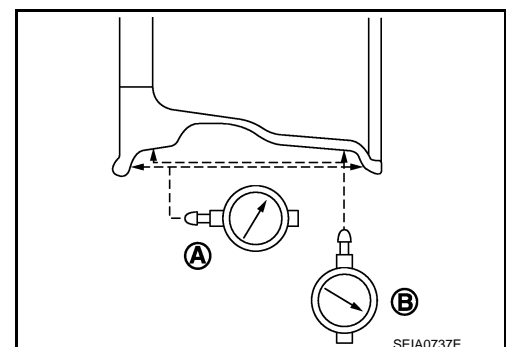

STEEL WHEEL

1. Check tires for were and improper inflation.

ROAD WHEEL TIRE ASSEMBLY

[REGULAR GRADE]

< REMOVAL AND INSTALLATION >

2. Check wheels for deformation, clacks and other damage. If deformed, remove wheel and check wheel runout.
 - a. Remove tire from steel wheel and mount wheel on a tire balance machine.
 - b. Set two dial indicators as shown in the illustration.
 - c. Set each dial indicator to "0".
 - d. Rotate wheel and check dial indicators at several points around the circumference of the wheel.
 - e. Calculate runout at each point as shown below.

Lateral runout limit (A): $(1+2)/2$

Radial runout limit (B): $(3+4)/2$

- f. Select maximum positive runout value and the maximum negative value. Add the two values to determine total runout.

CAUTION:

In case a positive or negative value is not available, use the maximum value (negative or positive) for total runout.

Limit

A: Refer to [WT-61, "Road Wheel"](#).

B: Refer to [WT-61, "Road Wheel"](#).

- g. If the total runout value exceeds limit, replace steel wheel.

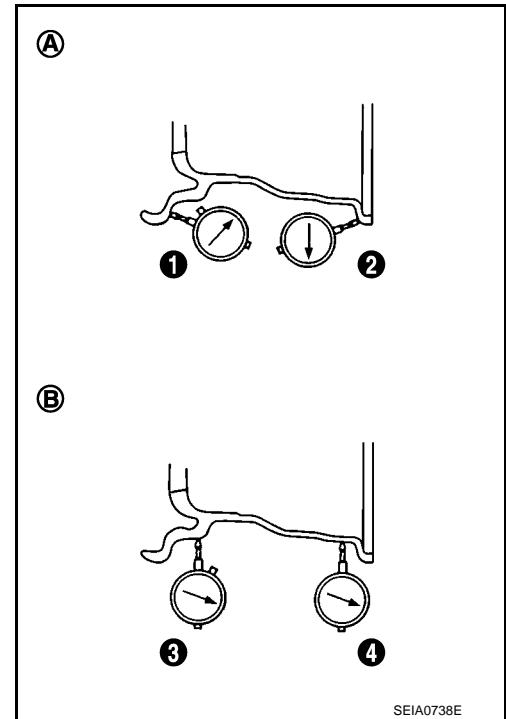

A
B
C
D
WT
F
G
H
I
J
K
L
M
N
O
P

TRANSMITTER

< REMOVAL AND INSTALLATION >

[REGULAR GRADE]

TRANSMITTER

Exploded View

INFOID:000000005239912

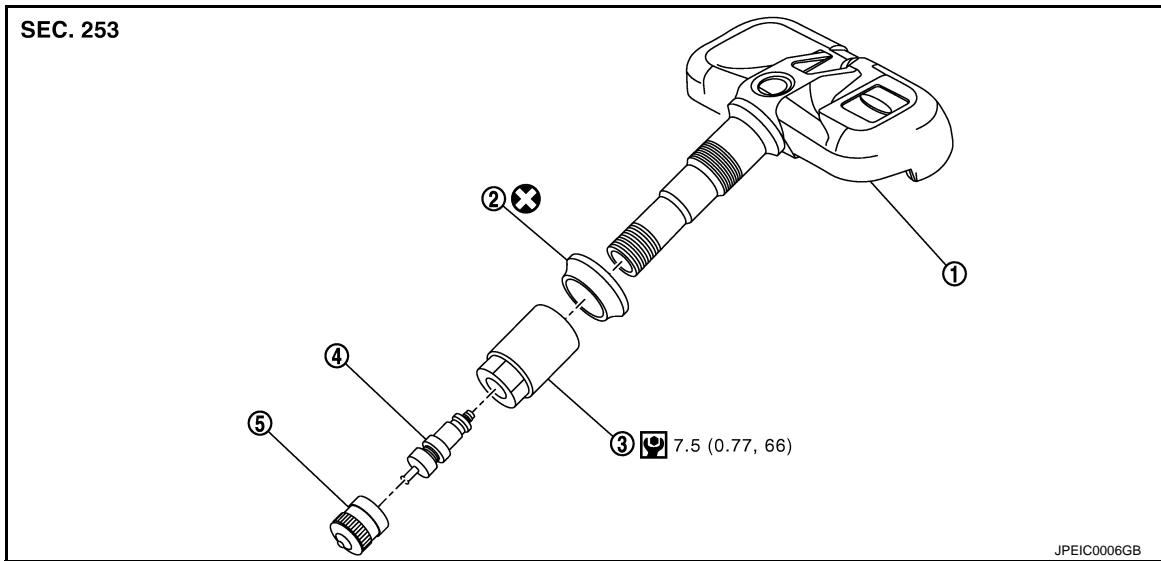

- | | | |
|----------------|-----------------|--------------|
| 1. Transmitter | 2. Grommet seal | 3. Valve nut |
| 4. Valve core | 5. Cap | |

Refer to [GI-4. "Components"](#) for symbols in figure.

Removal and Installation

INFOID:000000005239913

REMOVAL

1. Deflate tire. Unscrew transmitter retaining nut and allow transmitter to fall into tire.
2. Gently bounce tire so that transmitter falls to bottom of tire. Place on tire changing machine and break both tire beads ensuring that the transmitter remains at the bottom of the tire.

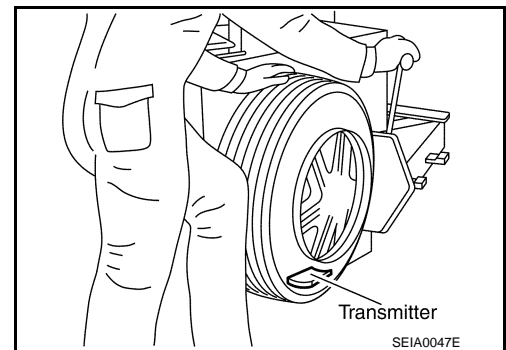

3. Turn tire so that valve hole is at bottom and bounce so that transmitter (1) is near valve hole. Carefully lift tire onto turntable and position valve hole (and transmitter) 270 degree from mounting/dismounting head (2).
4. Lubricate tire well and remove first side of the tire. Reach inside the tire and remove the transmitter.

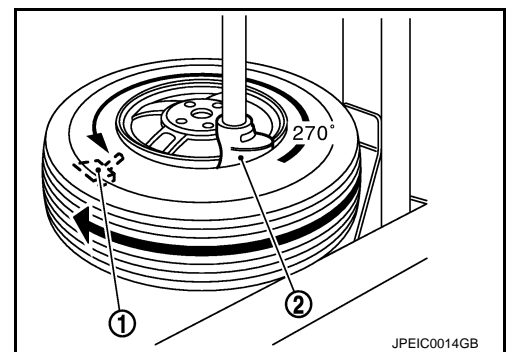

INSTALLATION

TRANSMITTER

< REMOVAL AND INSTALLATION >

[REGULAR GRADE]

1. Put first side of tire onto rim.

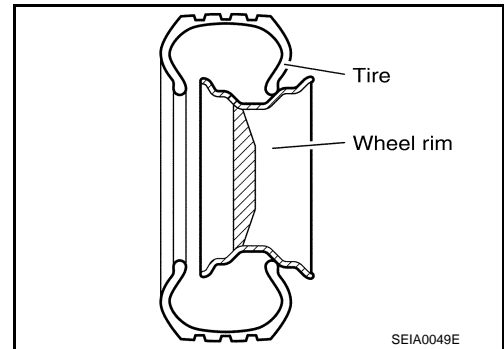

2. Mount transmitter on rim and tighten nut.

CAUTION:

Speed for tightening nut should be less than 10 rpm.

3. Place wheel on turntable of tire machine. Ensure that transmitter (1) is 270 degree from mounting head (2) when second side of tire is fitted.

NOTE:

Do not touch transmitter at mounting head.

4. Lubricate tire well and fit second side of tire as normal. Ensure that tire does not rotate relative to rim.
5. Inflate tire and fit to appropriate wheel position.

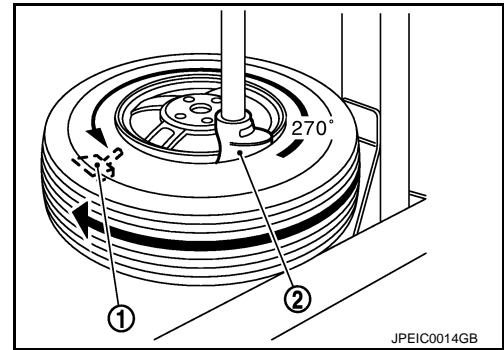

A
B
C
D

WT

F
G
H
I
J
K
L
M
N
O
P

TIRE PRESSURE RECEIVER

< REMOVAL AND INSTALLATION >

[REGULAR GRADE]

TIRE PRESSURE RECEIVER

Removal and Installation

INFOID:000000005239915

REMOVAL

1. Remove the glove box assembly. Refer to [IP-12, "Exploded View"](#).
2. Remove the instrument lower panel RH. Refer to [IP-12, "Exploded View"](#).
3. Disconnect tire pressure receiver harness connector.
4. Remove tire pressure receiver mounting screw.
5. Remove tire pressure receiver.

INSTALLATION

Install is the reverse order of removal.

SERVICE DATA AND SPECIFICATIONS (SDS)

< SERVICE DATA AND SPECIFICATIONS (SDS)

[REGULAR GRADE]

SERVICE DATA AND SPECIFICATIONS (SDS)

SERVICE DATA AND SPECIFICATIONS (SDS)

Road Wheel

INFOID:000000005239916

CONVENTIONAL

Item		Limit
Radial runout	Lateral deflection	Less than 0.3 mm (0.012 in)
	Vertical deflection	
Allowable unbalance	Dynamic (At flange)	Less than 5 g (0.17 oz) (one side)
	Static (At flange)	Less than 10 g (0.35 oz)

EMERGENCY

Item		Limit
Radial runout	Lateral deflection	Less than 1.5 mm (0.059 in)
	Vertical deflection	

Tire Air Pressure

INFOID:000000005239918

Unit: kPa (kg/cm², psi)

Tire size	Air pressure			
	Front		Rear	
	Coupe	Roadster	Coupe	Roadster
225/50R18 95W	240 (2.4, 35)	260 (2.6, 38)	-	
245/45R18 96W	-		240 (2.4, 35)	260 (2.6, 38)
245/40R19 94W	240 (2.4, 35)		-	
275/35R19 96W	-		240 (2.4, 35)	
T145/80D17	420 (4.2, 60)		420 (4.2, 60)	
T145/70R18	420 (4.2, 60)		420 (4.2, 60)	

ROAD WHEEL TIRE ASSEMBLY

< SPEC CHANGE INFORMATION >

[Nismo 370Z]

SPEC CHANGE INFORMATION

ROAD WHEEL TIRE ASSEMBLY

Road Wheel Tire Assembly

INFOID:000000005643469

- Dedicated aluminum wheels adopted.

NISMO models	Item		Data
Aluminum road wheels	Size	Front	19 × 9.5J
		Rear	19 × 10.5J
	Offset	Front	+40 mm (+1.57 in)
		Rear	+23 mm (+0.91 in)
Tires	Tire size	Front	245/40ZR19 98Y
		Rear	285/35ZR19 99Y

