

A  
B  
C

# SECTION **PB**

## PARKING BRAKE SYSTEM

### CONTENTS

<p><b>PRECAUTION</b> ..... 2</p> <p><b>PRECAUTIONS</b> ..... 2</p> <p style="padding-left: 20px;">Precautions for Removing Battery Terminal .....2</p> <p><b>PREPARATION</b> ..... 3</p> <p><b>PREPARATION</b> ..... 3</p> <p style="padding-left: 20px;">Commercial Service Tool .....3</p> <p><b>PERIODIC MAINTENANCE</b> ..... 4</p> <p><b>PARKING BRAKE SYSTEM</b> ..... 4</p> <p style="padding-left: 20px;">Inspection and Adjustment .....4</p> <p><b>PARKING BRAKE SHOE</b> ..... 6</p> <p style="padding-left: 20px;">Adjustment .....6</p> <p><b>REMOVAL AND INSTALLATION</b> ..... 7</p>	<p><b>PARKING BRAKE CONTROL</b> ..... 7</p> <p style="padding-left: 20px;">Exploded View ..... 7</p> <p style="padding-left: 20px;">Removal and Installation ..... 7</p> <p style="padding-left: 20px;">Adjustment ..... 7</p> <p><b>PARKING BRAKE SHOE</b> ..... 8</p> <p style="padding-left: 20px;">Exploded View ..... 8</p> <p style="padding-left: 20px;">Removal and Installation ..... 8</p> <p style="padding-left: 20px;">Inspection and Adjustment ..... 9</p> <p><b>SERVICE DATA AND SPECIFICATIONS (SDS)</b> .....11</p> <p><b>SERVICE DATA AND SPECIFICATIONS (SDS)</b> .....11</p> <p style="padding-left: 20px;">Parking Drum Brake .....11</p> <p style="padding-left: 20px;">Parking Brake Control .....11</p>
---	--

A  
B  
C  
D  
E  
**PB**  
G  
H  
I  
J  
K  
L  
M  
N  
O  
P

# PRECAUTIONS

< PRECAUTION >

## PRECAUTION

### PRECAUTIONS

#### Precautions for Removing Battery Terminal

INFOID:000000011190744

- When removing the 12V battery terminal, turn OFF the ignition switch and wait at least 30 seconds.

**NOTE:**

ECU may be active for several tens of seconds after the ignition switch is turned OFF. If the battery terminal is removed before ECU stops, then a DTC detection error or ECU data corruption may occur.

- For vehicles with the 2-batteries, be sure to connect the main battery and the sub battery before turning ON the ignition switch.

**NOTE:**

If the ignition switch is turned ON with any one of the terminals of main battery and sub battery disconnected, then DTC may be detected.

- After installing the 12V battery, always check "Self Diagnosis Result" of all ECUs and erase DTC.

**NOTE:**

The removal of 12V battery may cause a DTC detection error.

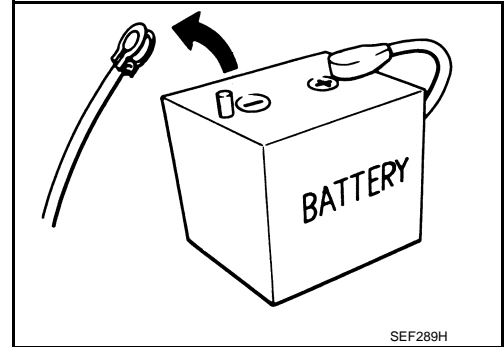

# PREPARATION

< PREPARATION >

## PREPARATION

### PREPARATION

#### Commercial Service Tool

INFOID:000000010837916

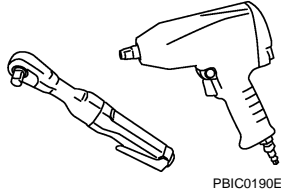
Tool name	Description
Power tool 	Loosening bolts and nuts

A

B

C

D

E

**PB**

G

H

I

J

K

L

M

N

O

P

# PARKING BRAKE SYSTEM

< PERIODIC MAINTENANCE >

## PERIODIC MAINTENANCE

### PARKING BRAKE SYSTEM

#### Inspection and Adjustment

INFOID:000000010837917

#### INSPECTION

##### Lever Stroke

- Operate the parking brake lever with a force of 196 N (20 kg, 44 lb). Check that the lever stroke is within the specified number of notches. (Check it by listening to the clicks of the ratchet.)

##### Standard

**Number of notches** : Refer to [PB-11, "Parking Brake Control"](#).

- When brake warning lamp turns ON, check that the lever stroke is within the specified number of notches. (Check it by listening to the clicks of the ratchet.)

##### Standard

**Number of notches** : Refer to [PB-11, "Parking Brake Control"](#).

##### Inspect Components

- Check each component for installation condition such as looseness.
- Check the parking brake lever assembly for bend, damage and cracks. Replace if necessary.
- Check the cables and equalizer for wear, damage and cracks. Replace if necessary.
- Check the parking brake switch, and replace it if necessary. Refer to [BRC-77, "Component Inspection"](#).

#### ADJUSTMENT

1. Remove rear tires with power tool.
2. Fix the disc rotor using wheel nuts.
3. Remove the cup holder assembly. Refer to [IP-25, "Exploded View"](#).
4. Release the parking brake lever by turning the adjusting nut (1) with a deep socket wrench and loosening the cable.

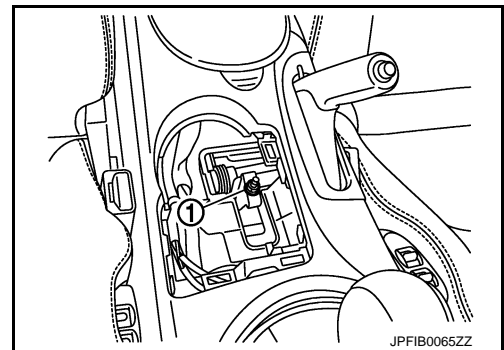

5. Remove the adjusting hole plug from the disc rotor. Turn the adjuster (1) in the direction (A) as shown in the figure using a suitable tool until the disc rotor is locked.
6. Turn back the adjuster 5 or 6 notches from the locked position.
7. Rotate the disc rotor to check that there is no drag. Install the adjusting hole plug.
8. Adjust the cable with the following procedure.
  - a. Operate the parking brake lever with a force of 294 N (30 kg, 66 lb) for 10 strokes or more.
  - b. Adjust the parking brake lever stroke by turning the adjusting nut with a deep socket wrench.

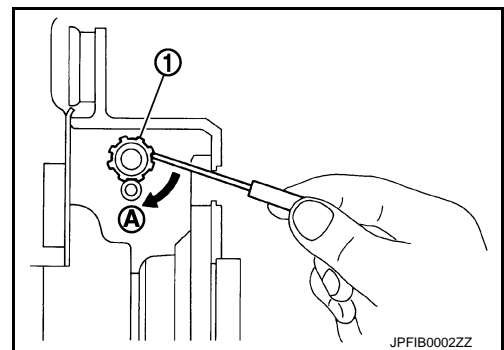

#### **CAUTION:**

**Never reuse the adjusting nut if the nut is removed.**

- c. Operate the parking brake lever with a force of 196 N (20 kg, 44lb). Check that the lever stroke is within the specified number of notches. (Check it by listening to the clicks of the ratchet.)

# PARKING BRAKE SYSTEM

< PERIODIC MAINTENANCE >

---

**Standard**

**Number of notches** : Refer to [PB-11, "Parking Brake Control"](#).

- d. Rotate the disc rotor with the parking brake lever released and check that there is no drag. Refer to [PB-9, "Inspection and Adjustment"](#).

A  
B  
C  
D  
E  
PB  
G  
H  
I  
J  
K  
L  
M  
N  
O  
P

# PARKING BRAKE SHOE

< PERIODIC MAINTENANCE >

---

## PARKING BRAKE SHOE

### Adjustment

INFOID:000000010837918

1. Adjust parking brake lever stroke. Refer to [PB-4, "Inspection and Adjustment"](#).
2. Perform parking brake break-in (drag on) operation by driving vehicle under the following conditions:
  - Drive forward
  - Vehicle speed: Approx. 40 km/h (25 MPH) set (constant and forward)
  - Parking brake operating force: 199.5 N (20.3 kg, 44.8 lb) set contact
  - Time: Approx. 15 sec.

**CAUTION:**

**To prevent lining from getting too hot, allow a cool off period of approximately 5 minutes after every break-in operation.**

3. After the break-in procedure, check parking brake lever stroke of parking brake.

**CAUTION:**

**If it is out of the specification, adjust again. Refer to [PB-4, "Inspection and Adjustment"](#).**

# PARKING BRAKE CONTROL

< REMOVAL AND INSTALLATION >

## REMOVAL AND INSTALLATION

### PARKING BRAKE CONTROL

#### Exploded View

INFOID:0000000010837919

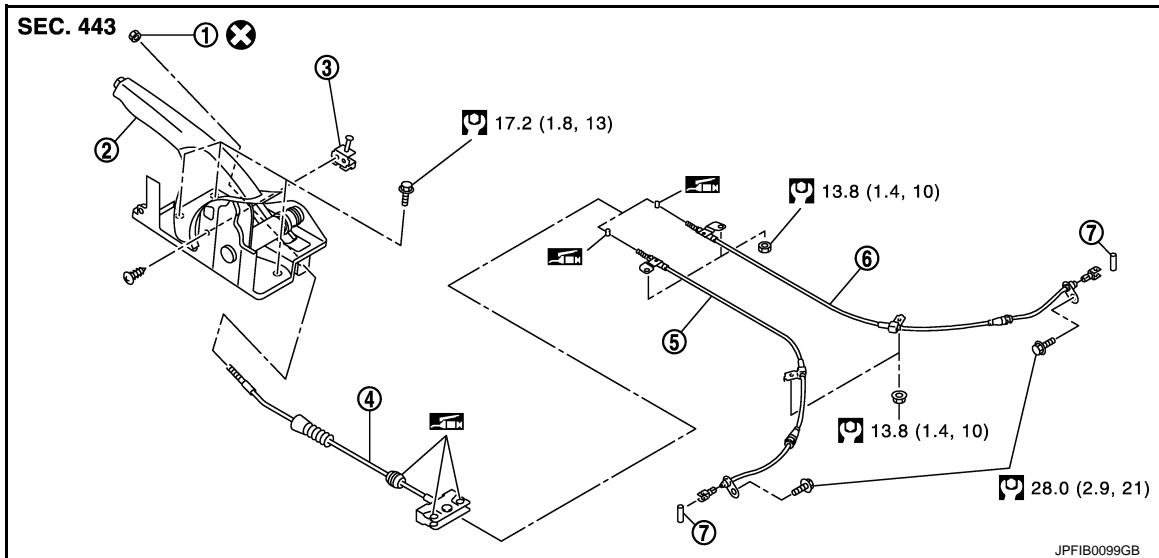

- |                  |                                 |                         |
|------------------|---------------------------------|-------------------------|
| 1. Adjusting nut | 2. Parking brake lever assembly | 3. Parking brake switch |
| 4. Front cable   | 5. Rear cable (LH)              | 6. Rear cable (RH)      |
| 7. Pin           |                                 |                         |

: Apply multi-purpose grease.

Refer to [GI-4, "Components"](#) for symbols not described on the above.

#### Removal and Installation

INFOID:0000000010837920

##### REMOVAL

1. Remove rear tires with power tool.
2. Remove the center console. Refer to [IP-25, "Exploded View"](#).
3. Disconnect the parking brake switch harness connector.
4. Remove adjusting nut and loosen front cable.
5. Remove the parking brake lever assembly.
6. Remove the center muffler. Refer to [EX-5, "Exploded View"](#).
7. Separate front cable from rear cable, and remove front cable.
8. Remove parking brake shoe, and remove rear cable from toggle lever. Refer to [PB-8, "Exploded View"](#).
9. Remove rear cable mounting bolts and nuts, pull out rear cable from vehicle.

##### INSTALLATION

Note the following, install in the reverse order of the removal.

- Never reuse adjusting nut.

##### Adjustment

INFOID:0000000010837921

##### ADJUSTMENT AFTER INSTALLATION

Adjust the parking brake lever stroke. Refer to [PB-4, "Inspection and Adjustment"](#).

# PARKING BRAKE SHOE

< REMOVAL AND INSTALLATION >

## PARKING BRAKE SHOE

Exploded View

INFOID:000000010837922

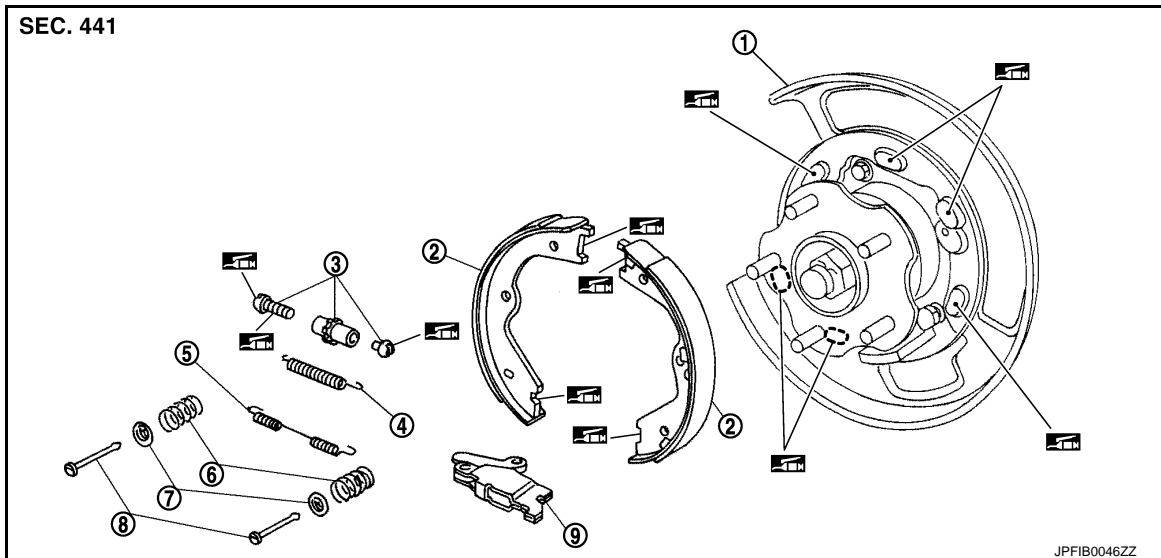

- |                    |                    |                       |
|--------------------|--------------------|-----------------------|
| 1. Back plate      | 2. Brake shoe      | 3. Adjuster           |
| 4. Adjuster spring | 5. Return spring   | 6. Anti-rattle spring |
| 7. Retainer        | 8. Anti-rattle pin | 9. Toggle lever       |

 Apply PBC (Poly Butyl Cuprysil) grease or silicone-based grease.

## Removal and Installation

INFOID:000000010837923

### REMOVAL

#### **WARNING:**

Since dust covering the parking brake has an affect on human body, the dust must be removed with a dust collector. Never splatter the dust with an air blow gun.

1. Remove rear tires with power tool.
2. Remove disc rotor.
  - 1 Piston type: Refer to [BR-59. "BRAKE CALIPER ASSEMBLY \(1 PISTON TYPE\) : Removal and Installation"](#).
  - 2 Piston type: Refer to [BR-64. "BRAKE CALIPER ASSEMBLY \(2 PISTON TYPE\) : Removal and Installation"](#).

#### **CAUTION:**

**Parking brake completely in the released position.**

3. If disc rotor cannot be removed, remove as follows:
  - a. Fix the disc rotor with wheel nuts and remove the adjusting hole plug.
  - b. Using suitable tool, rotate adjuster (1) in direction (B) to retract and loosen brake shoe.
4. Remove anti-rattle pins, retainers, anti-rattle springs, and return spring, adjuster spring.

#### **CAUTION:**

**Never drop the removed parts.**

5. Remove parking brake shoes, adjuster assembly, and toggle lever.

#### **CAUTION:**

- The parking brake shoes for the front wheels are made of different materials from those for the rear wheels. Never misidentify them when removing.
- Never drop the removed parts.

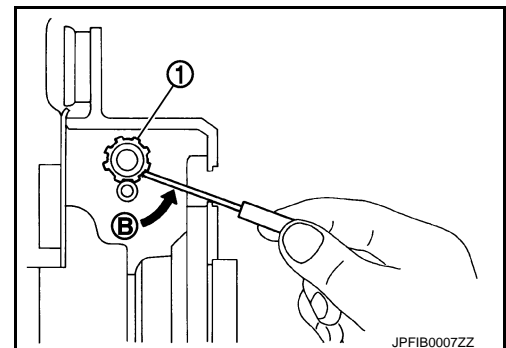



# PARKING BRAKE SHOE

## < REMOVAL AND INSTALLATION >

6. For the removal of back plate, refer to [RAX-7, "Exploded View"](#).

### INSTALLATION

Note the following, install in the reverse order of removal.

- Apply PBC (Poly Butyl Cuprysil) grease or silicone-based grease to the back plate and brake shoe.
- The parking brake shoes for the front wheels are made of different materials from those for the rear wheels. Never misidentify them when removing and replacing.
- Assemble adjusters so that threaded part is expanded when rotating it in the direction shown by arrow.

A: For RH brake

B: For LH brake

↔: Vehicle front

↻: Adjuster expands

- Shorten adjuster by rotating it.
- When disassembling apply PBC (Poly Butyl Cuprysil) grease or silicone-based grease to threads.
- Check brake shoe sliding surface and drum inner surface for grease. Wipe it off if it adhere on the surfaces.

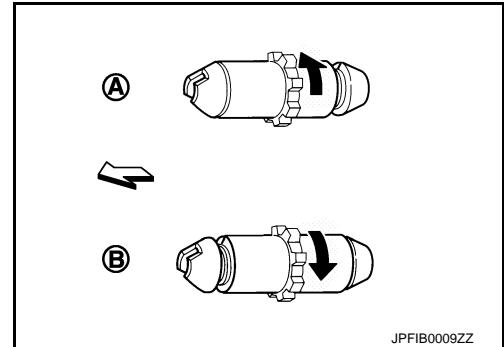

### Inspection and Adjustment

INFOID:0000000010837924

#### INSPECTION AFTER REMOVAL

Lining Thickness Inspection

- Check thickness (A) of lining.

**Limit**

**A** : Refer to [PB-11, "Parking Drum Brake"](#).

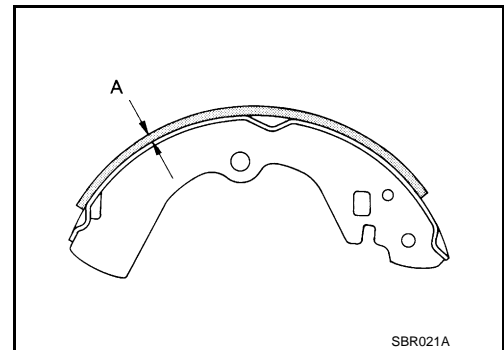

Drum Inner Diameter Inspection

- Check inner diameter (B) of drum.

**Limit**

**B** : Refer to [PB-11, "Parking Drum Brake"](#).

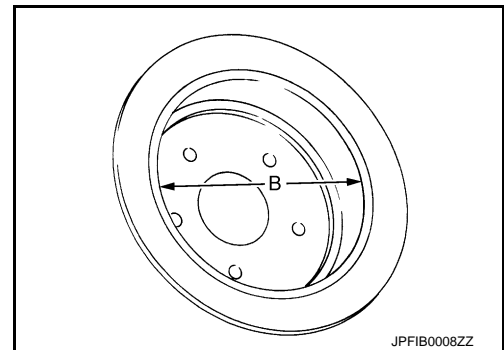

Other Inspections

Check the following items, and replace the parts if necessary.

- Lining for excessive wear, damage, and peeling.
- Brake shoe sliding surface for excessive wear and damage.
- Anti-rattle pin and retainer for excessive wear, damage and rust.
- Adjuster spring, return spring and anti-rattle spring for settling, excessive wear, damage, and rust.
- Adjuster for smoothness.
- Toggle lever for excessive wear, damage and rust.
- Visually check inside of the drum for excessive wear, cracks, and damage with a pair of vernier calipers.

#### ADJUSTMENT AFTER INSTALLATION

## PARKING BRAKE SHOE

### < REMOVAL AND INSTALLATION >

---

1. Adjust the parking brake lever stroke. Refer to [PB-4, "Inspection and Adjustment"](#).
2. Check a drag of the parking brake.  
**CAUTION:**  
If any drag is found, inspect the rear disc brake.
  - 1 Piston type: Refer to [BR-62, "BRAKE CALIPER ASSEMBLY \(1 PISTON TYPE\) : Inspection"](#).
  - 2 Piston type: Refer to [BR-66, "BRAKE CALIPER ASSEMBLY \(2 PISTON TYPE\) : Inspection"](#).
3. Adjust the parking brake shoe. Refer to [PB-4, "Inspection and Adjustment"](#).

# SERVICE DATA AND SPECIFICATIONS (SDS)

< SERVICE DATA AND SPECIFICATIONS (SDS)

## SERVICE DATA AND SPECIFICATIONS (SDS)

### SERVICE DATA AND SPECIFICATIONS (SDS)

#### Parking Drum Brake

INFOID:0000000010837925

Unit: mm (in)

Item		Limit
Brake lining	Wear thickness	1.5 (0.059)
Drum (disc)	Wear limit of inner diameter	173 (6.81)

#### Parking Brake Control

INFOID:0000000010837926

Item		Standard
Number of notches [under force of 196 N (20 kg, 44 lb)]		6 – 7 notches
Number of notches when brake warning lamp turns ON		1 notch

A  
B  
C  
D  
E  
PB  
G  
H  
I  
J  
K  
L  
M  
N  
O  
P