

SECTION **CL**
CLUTCH

A
B
C

CL

CONTENTS

E

PRECAUTION 3

PRECAUTIONS 3

FOR USA AND CANADA3

FOR USA AND CANADA : Precaution for Supplemental Restraint System (SRS) "AIR BAG" and "SEAT BELT PRE-TENSIONER"3

FOR USA AND CANADA : Precaution for Battery Service3

FOR USA AND CANADA : Service Notice or Precautions for Clutch3

FOR USA AND CANADA : Precautions for Removing Battery Terminal4

FOR MEXICO4

FOR MEXICO : Precaution for Supplemental Restraint System (SRS) "AIR BAG" and "SEAT BELT PRE-TENSIONER"4

FOR MEXICO : Precaution for Battery Service5

FOR MEXICO : Service Notice or Precautions for Clutch5

FOR MEXICO : Precautions for Removing Battery Terminal5

PREPARATION 6

PREPARATION 6

Special Service Tools6

Commercial Service Tools6

SYMPTOM DIAGNOSIS 7

NOISE, VIBRATION AND HARSHNESS (NVH) TROUBLESHOOTING 7

NVH Troubleshooting Chart7

PERIODIC MAINTENANCE 8

CLUTCH PEDAL 8

Inspection and Adjustment8

CLUTCH FLUID 9

Inspection 9

Draining 9

Refilling 9

Air Bleeding Procedure10

REMOVAL AND INSTALLATION11

CLUTCH PEDAL11

Exploded View11

Removal and Installation11

Inspection and Adjustment12

CLUTCH MASTER CYLINDER13

Exploded View13

Removal and Installation13

Disassembly and Assembly15

Inspection and Adjustment16

CLUTCH PIPING17

Exploded View17

Hydraulic Layout17

Removal and Installation18

Inspection and Adjustment18

UNIT REMOVAL AND INSTALLATION19

CSC (CONCENTRIC SLAVE CYLINDER)19

Exploded View19

Removal and Installation19

Inspection and Adjustment22

CLUTCH DISC AND CLUTCH COVER23

Exploded View23

Removal and Installation23

Inspection24

SERVICE DATA AND SPECIFICATIONS (SDS)26

SERVICE DATA AND SPECIFICATIONS (SDS)26

Clutch Control System26

F
G
H
I
J
K
L
M
N
O
P

| | | | |
|------------------------------|----|--------------------|----|
| Clutch Pedal | 26 | Clutch Disc | 26 |
| Clutch Master Cylinder | 26 | Clutch Cover | 26 |

PRECAUTIONS

< PRECAUTION >

PRECAUTION

PRECAUTIONS

FOR USA AND CANADA

FOR USA AND CANADA : Precaution for Supplemental Restraint System (SRS) "AIR BAG" and "SEAT BELT PRE-TENSIONER"

INFOID:000000011735140

The Supplemental Restraint System such as "AIR BAG" and "SEAT BELT PRE-TENSIONER", used along with a front seat belt, helps to reduce the risk or severity of injury to the driver and front passenger for certain types of collision. This system includes seat belt switch inputs and dual stage front air bag modules. The SRS system uses the seat belt switches to determine the front air bag deployment, and may only deploy one front air bag, depending on the severity of a collision and whether the front occupants are belted or unbelted. Information necessary to service the system safely is included in the "SRS AIR BAG" and "SEAT BELT" of this Service Manual.

WARNING:

Always observe the following items for preventing accidental activation.

- To avoid rendering the SRS inoperative, which could increase the risk of personal injury or death in the event of a collision that would result in air bag inflation, all maintenance must be performed by an authorized NISSAN/INFINITI dealer.
- Improper maintenance, including incorrect removal and installation of the SRS, can lead to personal injury caused by unintentional activation of the system. For removal of Spiral Cable and Air Bag Module, see "SRS AIR BAG".
- Never use electrical test equipment on any circuit related to the SRS unless instructed to in this Service Manual. SRS wiring harnesses can be identified by yellow and/or orange harnesses or harness connectors.

PRECAUTIONS WHEN USING POWER TOOLS (AIR OR ELECTRIC) AND HAMMERS

WARNING:

Always observe the following items for preventing accidental activation.

- When working near the Air Bag Diagnosis Sensor Unit or other Air Bag System sensors with the ignition ON or engine running, never use air or electric power tools or strike near the sensor(s) with a hammer. Heavy vibration could activate the sensor(s) and deploy the air bag(s), possibly causing serious injury.
- When using air or electric power tools or hammers, always switch the ignition OFF, disconnect the battery, and wait at least 3 minutes before performing any service.

FOR USA AND CANADA : Precaution for Battery Service

INFOID:000000011735141

Before disconnecting the battery, lower both the driver and passenger windows. This will prevent any interference between the window edge and the vehicle when the door is opened/closed. During normal operation, the window slightly raises and lowers automatically to prevent any window to vehicle interference. The automatic window function will not work with the battery disconnected.

FOR USA AND CANADA : Service Notice or Precautions for Clutch

INFOID:000000011735142

WARNING:

After cleaning clutch disc, wipe it with a dust collector. Never use compressed air.

CAUTION:

- Clutch fluid use refer to [MA-16, "FOR NORTH AMERICA : Fluids and Lubricants"](#).
- Never reuse drained clutch fluid.
- Keep painted surface on the body or other parts free of clutch fluid. If it spills, wipe up immediately and wash the affected area with water.
- When removing clutch tube, use a flare nut wrench.

PRECAUTIONS

< PRECAUTION >

- When installing clutch tube, use a flare nut torque wrench [Commercial service tool].
- Use new clutch fluid to clean or wash all parts of master cylinder.
- Never use mineral oils such as gasoline or kerosene. It will ruin the rubber parts of the hydraulic system.
- Never reuse CSC (Concentric Slave Cylinder) body and CSC tube. Because CSC slides back to the original position every time when removing transmission assembly. At this timing, dust on the sliding parts may damage a seal of CSC and may cause clutch fluid leakage. Refer to [CL-19, "Removal and Installation"](#).
- Never disassemble CSC body.

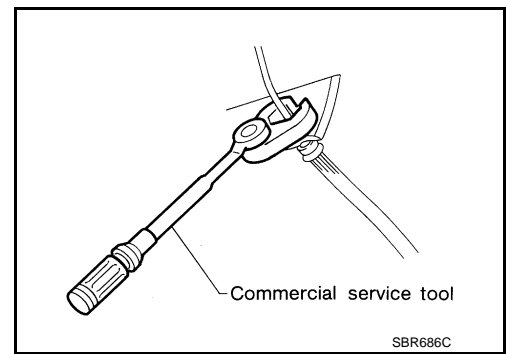

FOR USA AND CANADA : Precautions for Removing Battery Terminal

INFOID:000000011735143

- When removing the 12V battery terminal, turn OFF the ignition switch and wait at least 30 seconds.

NOTE:

ECU may be active for several tens of seconds after the ignition switch is turned OFF. If the battery terminal is removed before ECU stops, then a DTC detection error or ECU data corruption may occur.

- For vehicles with the 2-batteries, be sure to connect the main battery and the sub battery before turning ON the ignition switch.

NOTE:

If the ignition switch is turned ON with any one of the terminals of main battery and sub battery disconnected, then DTC may be detected.

- After installing the 12V battery, always check "Self Diagnosis Result" of all ECUs and erase DTC.

NOTE:

The removal of 12V battery may cause a DTC detection error.

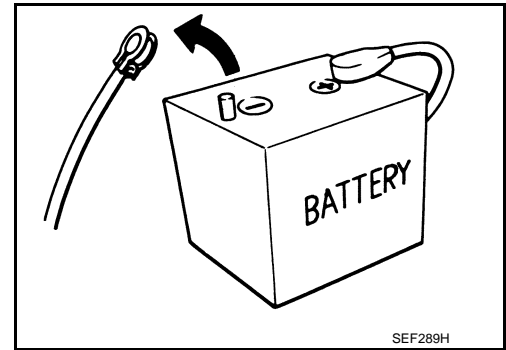

FOR MEXICO

FOR MEXICO : Precaution for Supplemental Restraint System (SRS) "AIR BAG" and "SEAT BELT PRE-TENSIONER"

INFOID:000000011735144

The Supplemental Restraint System such as "AIR BAG" and "SEAT BELT PRE-TENSIONER", used along with a front seat belt, helps to reduce the risk or severity of injury to the driver and front passenger for certain types of collision. Information necessary to service the system safely is included in the "SRS AIR BAG" and "SEAT BELT" of this Service Manual.

WARNING:

Always observe the following items for preventing accidental activation.

- To avoid rendering the SRS inoperative, which could increase the risk of personal injury or death in the event of a collision that would result in air bag inflation, all maintenance must be performed by an authorized NISSAN/INFINITI dealer.
- Improper maintenance, including incorrect removal and installation of the SRS, can lead to personal injury caused by unintentional activation of the system. For removal of Spiral Cable and Air Bag Module, see "SRS AIR BAG".
- Never use electrical test equipment on any circuit related to the SRS unless instructed to in this Service Manual. SRS wiring harnesses can be identified by yellow and/or orange harnesses or harness connectors.

PRECAUTIONS WHEN USING POWER TOOLS (AIR OR ELECTRIC) AND HAMMERS

WARNING:

Always observe the following items for preventing accidental activation.

- When working near the Air Bag Diagnosis Sensor Unit or other Air Bag System sensors with the ignition ON or engine running, never use air or electric power tools or strike near the sensor(s) with a hammer. Heavy vibration could activate the sensor(s) and deploy the air bag(s), possibly causing serious injury.

PRECAUTIONS

< PRECAUTION >

- When using air or electric power tools or hammers, always switch the ignition OFF, disconnect the battery, and wait at least 3 minutes before performing any service.

FOR MEXICO : Precaution for Battery Service

INFOID:000000011735145

Before disconnecting the battery, lower both the driver and passenger windows. This will prevent any interference between the window edge and the vehicle when the door is opened/closed. During normal operation, the window slightly raises and lowers automatically to prevent any window to vehicle interference. The automatic window function will not work with the battery disconnected.

FOR MEXICO : Service Notice or Precautions for Clutch

INFOID:000000011735146

WARNING:

After cleaning clutch disc, wipe it with a dust collector. Never use compressed air.

CAUTION:

- Clutch fluid use refer to [MA-18, "FOR MEXICO : Fluids and Lubricants"](#).
- Never reuse drained clutch fluid.
- Keep painted surface on the body or other parts free of clutch fluid. If it spills, wipe up immediately and wash the affected area with water.
- When removing clutch tube, use a flare nut wrench.
- When installing clutch tube, use a flare nut torque wrench [Commercial service tool].
- Use new clutch fluid to clean or wash all parts of master cylinder.
- Never use mineral oils such as gasoline or kerosene. It will ruin the rubber parts of the hydraulic system.
- Never reuse CSC (Concentric Slave Cylinder) body and CSC tube. Because CSC slides back to the original position every time when removing transmission assembly. At this timing, dust on the sliding parts may damage a seal of CSC and may cause clutch fluid leakage. Refer to [CL-19, "Removal and Installation"](#).
- Never disassemble CSC body.

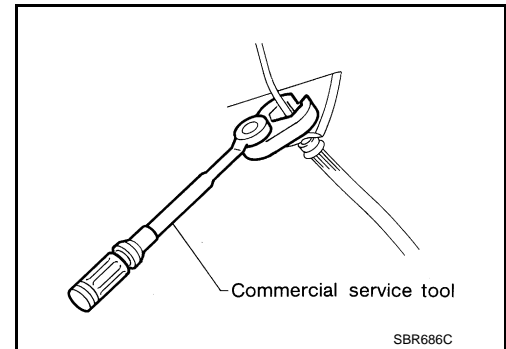

FOR MEXICO : Precautions for Removing Battery Terminal

INFOID:000000011735147

- When removing the 12V battery terminal, turn OFF the ignition switch and wait at least 30 seconds.

NOTE:

ECU may be active for several tens of seconds after the ignition switch is turned OFF. If the battery terminal is removed before ECU stops, then a DTC detection error or ECU data corruption may occur.

- For vehicles with the 2-batteries, be sure to connect the main battery and the sub battery before turning ON the ignition switch.

NOTE:

If the ignition switch is turned ON with any one of the terminals of main battery and sub battery disconnected, then DTC may be detected.

- After installing the 12V battery, always check "Self Diagnosis Result" of all ECUs and erase DTC.

NOTE:

The removal of 12V battery may cause a DTC detection error.

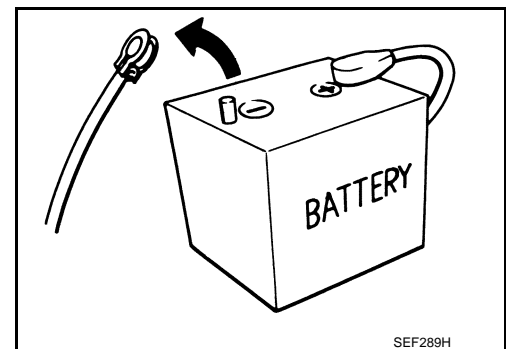

PREPARATION

< PREPARATION >

PREPARATION

PREPARATION

Special Service Tools

INFOID:000000011735148

The actual shapes of TechMate tools may differ from those of special service tools illustrated here.

| Tool number (TechMate No.) Tool name | Description |
|---|--|
| ST20050240 (-) Diaphragm adjusting wrench | Adjusting unevenness of diaphragm spring lever |
|  ZZA0508D | |

Commercial Service Tools

INFOID:000000011735149

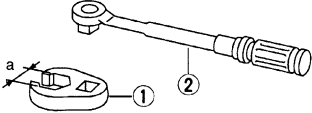
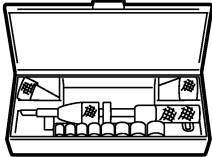
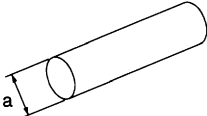
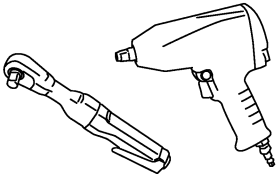
| Tool name | Description |
|--|--------------------------|
| Flare nut torque wrench 1. Flare nut crowfoot a: 10 mm (0.39 in) 2. Torque wrench | Installing clutch tube |
|  S-NT360 | |
| Clutch aligner | Installing clutch disc |
|  MCIB0404E | |
| Drift a: 10 mm (0.39 in) dia. | Removing bushing |
|  S-NT063 | |
| Power tool | Loosening bolts and nuts |
|  PBIC0190E | |

NOISE, VIBRATION AND HARSHNESS (NVH) TROUBLESHOOTING

< SYMPTOM DIAGNOSIS >

SYMPTOM DIAGNOSIS

NOISE, VIBRATION AND HARSHNESS (NVH) TROUBLESHOOTING

NVH Troubleshooting Chart

INFOID:000000011735150

Use the chart below to find the cause of the symptom. The numbers indicate the order of the inspection. If necessary, repair or replace these parts.

| SYMPTOM | | SUSPECTED PARTS (Possible cause) | | | | | | | | | | | | | | | | | |
|-----------|---------------------------|--|---------------------------|--------------------------------------|-------------------------|--|---------------------------|-----------------------------------|-----------------------------|-------------------------------|--------------------|------------------------|------------------------|-------------------------------------|----------------------------|---|-----------------------------|------------------------|---|
| | | CLUTCH PEDAL (Inspection and adjustment) | CLUTCH LINE (Air in line) | MASTER CYLINDER PISTON CUP (Damaged) | ENGINE MOUNTING (Loose) | CSC (Concentric Slave Cylinder) (Worn, dirty or damaged) | CLUTCH DISC (Out of true) | CLUTCH DISC (Runout is excessive) | CLUTCH DISC (Lining broken) | CLUTCH DISC (Dirty or burned) | CLUTCH DISC (Oily) | CLUTCH DISC (Worn out) | CLUTCH DISC (Hardened) | CLUTCH DISC (Lack of spline grease) | DIAPHRAGM SPRING (Damaged) | DIAPHRAGM SPRING (Out of tip alignment) | PRESSURE PLATE (Distortion) | FLYWHEEL (Distortion) | |
| Reference | | CL-8 | CL-10 | CL-13 | EM-72 | CL-19 | | | | | | | CL-23 | | | | | EM-126 | |
| Symptom | Clutch grabs/chatters | | | | 1 | | | | | 2 | | | 2 | 2 | 2 | | | 2 | |
| | Clutch pedal spongy | | 1 | 2 | | 2 | | | | | | | | | | | | | |
| | Clutch noisy | | | | | 1 | | | | | | | | | | | | | |
| | Clutch slips | 1 | | | | | | | | | 2 | 2 | | | | 3 | | 4 | 5 |
| | Clutch does not disengage | 1 | 2 | 3 | | 4 | 4 | 4 | 4 | 4 | 4 | | | 4 | 5 | 5 | 6 | | |

A
B
C
CL
E
F
G
H
I
J
K
L
M
N
O
P

CLUTCH PEDAL

< PERIODIC MAINTENANCE >

PERIODIC MAINTENANCE

CLUTCH PEDAL

Inspection and Adjustment

INFOID:000000011735151

INSPECTION

1. Make sure that clevis pin (1) floats freely in the bore of clutch pedal. It should not be bound by clevis or clutch pedal.
 - a. If clevis pin is not free, make sure that clutch pedal position switch (2) is not applying pressure to clutch pedal causing clevis pin to bind. To adjust, loosen lock nut (3) and turn clutch pedal position switch.
 - b. Tighten lock nut. Refer to [CL-11. "Exploded View"](#).
 - c. Make sure that clevis pin floats in the bore of clutch pedal. It should not be bound by clutch pedal.
 - d. If clevis pin is still not free, remove clevis pin and check for deformation or damage. Replace clevis pin if necessary. Leave clevis pin removed for step 2.
2. Check clutch pedal stroke for free range of movement.
 - a. With clevis pin removed, manually move clutch pedal up and down to determine if it moves freely.
 - b. If any sticking is found, replace related parts (bushing, clutch pedal, etc.). Reassemble clutch pedal and again make sure that clevis pin floats freely in the bore of clutch pedal.
3. Check clutch hydraulic and system components (clutch master cylinder, CSC, etc.) for sticking or binding.
 - a. If any sticking or binding is found, repair or replace related parts as necessary.
 - b. If hydraulic system repair was necessary, bleed the clutch hydraulic system. Refer to [CL-10. "Air Bleeding Procedure"](#).

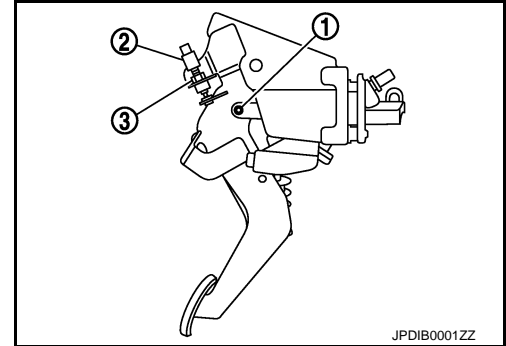

NOTE:

Do not use a vacuum assist or any other type of power bleeder on this system. Use of vacuum assist or power bleeder will not purge all the air from the system.

ADJUSTMENT

1. Adjust clutch interlock switch (1) position so that clearance between stopper rubber (2) and thread end (A) of clutch interlock switch with clutch pedal depressed is clearance "C".

Clearance "C" : Refer to [CL-26. "Clutch Pedal"](#).
2. After adjusting clearance "C", tighten lock nut (3) to the specified torque. Refer to [CL-11. "Exploded View"](#).

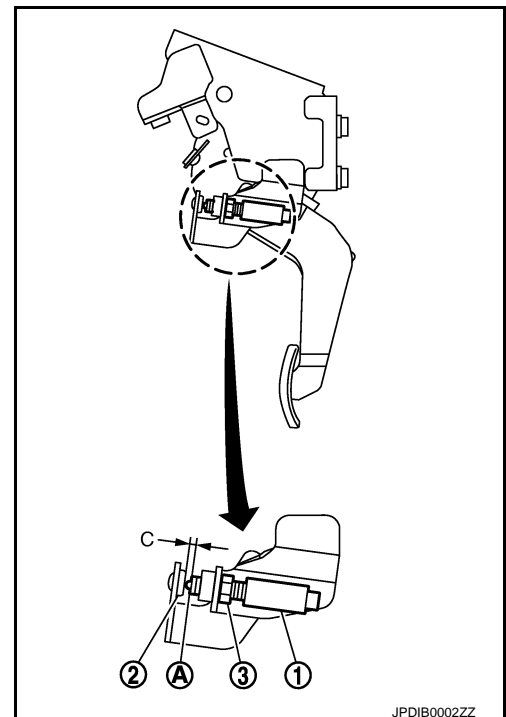

CLUTCH FLUID

< PERIODIC MAINTENANCE >

CLUTCH FLUID

Inspection

INFOID:000000011735152

FLUID LEAKAGE

- Check clutch line (tubes and hoses) for cracks, deterioration or other damage. Replace any damaged parts.
- Check for fluid leakage by fully depressing clutch pedal while engine is running.

CAUTION:

If leakage occurs around joints, retighten or, if necessary, replace damaged parts.

FLUID LEVEL

- Check that the fluid level in the reservoir tank is within the specified range (MAX – MIN lines).
- Visually check for any fluid leakage around the reservoir tank.
- Check the clutch system for any leakage if the fluid level is extremely low (lower than MIN).

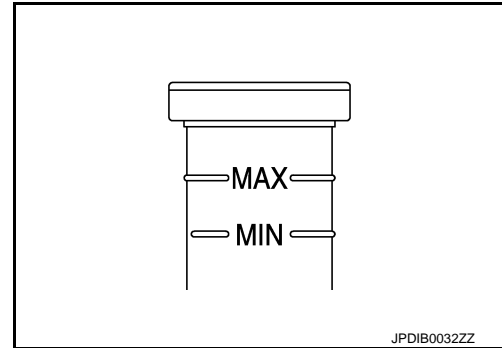

JPDIB0032ZZ

Draining

INFOID:000000011735153

CAUTION:

Keep painted surface on the body or other parts free of clutch fluid. If it spills, wipe up immediately and wash the affected area with water.

1. Connect a transparent vinyl hose to air bleeder valve.
2. Depress clutch pedal and loosen air bleeder valve to completely discharge clutch fluid.

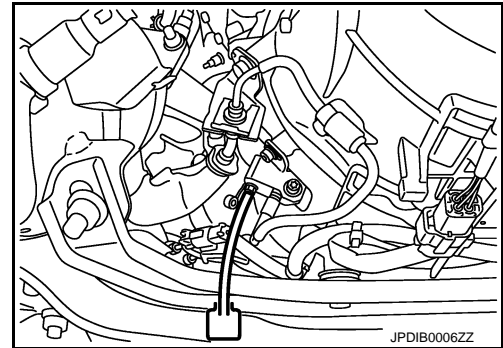

JPDIB0006ZZ

Refilling

INFOID:000000011735154

CAUTION:

- Keep painted surface on the body or other parts free of clutch fluid. If it spills, wipe up immediately and wash the affected area with water.
- Note the following instructions when filling with clutch fluid:
 - Never use fluid of which performance may be deteriorated because of not storing it in a cool and dark place with low humidity.
 - The bottle used for filling the reservoir tank with fluid must be free of foreign materials and liquid other than clutch fluid.
 - Check clutch fluid for bubbles and slowly fill with fluid to prevent the generation of bubbles. If bubbles are generated, then wait until the bubbles disappear.
 - While filling with fluid, never allow foreign materials to enter into the reservoir tank. If foreign matter enters into the reservoir tank, then remove them thoroughly with a clean waste or dropper.

1. Check that there is no foreign material in reservoir tank and then fill with new clutch fluid.

CAUTION:

- Never reuse drained clutch fluid.
- Remove foreign materials thoroughly from the reservoir tank, if any, with a clean waste or dropper.

A
B
C
CL

E
F
G

H
I
J
K
L

M
N
O
P

CLUTCH FLUID

< PERIODIC MAINTENANCE >

2. With the air bleeder valve loosened, repeat the following operation at intervals of two to three seconds until new clutch fluid drains: Fully depress the clutch pedal and release it completely.
3. Depress clutch pedal and loosen air bleeder valve to completely discharge clutch fluid.
4. Repeat steps 1 to 2 operations.
CAUTION:
Monitor clutch fluid level in reservoir tank to make sure it does not empty.
5. Tighten air bleeder valve with the clutch pedal depressed.
6. Perform the air bleeding. Refer to [CL-10, "Air Bleeding Procedure"](#).

Air Bleeding Procedure

INFOID:000000011735155

CAUTION:

- Monitor clutch fluid level in reservoir tank to make sure it does not empty.
- Keep painted surface on the body or other parts free of clutch fluid. If it spills, wipe up immediately and wash the affected area with water.
- Note the following instructions when filling with clutch fluid:
 - Never use fluid of which performance may be deteriorated because of not storing it in a cool and dark place with low humidity.
 - The bottle used for filling the reservoir tank with fluid must be free of foreign materials and liquid other than clutch fluid.
 - Check clutch fluid for bubbles and slowly fill with fluid to prevent the generation of bubbles. If bubbles are generated, then wait until the bubbles disappear.
 - While filling with fluid, never allow foreign materials to enter into the reservoir tank. If foreign matter enters into the reservoir tank, then remove them thoroughly with a clean waste or dropper.

NOTE:

Do not use a vacuum assist or any other type of power bleeder on this system. Use of vacuum assist or power bleeder will not purge all the air from the system.

1. Fill master cylinder reservoir tank with new clutch fluid.

CAUTION:

Never reuse drained clutch fluid.

2. Connect a transparent vinyl hose to air bleeder valve.
3. Quickly repeat the following operation five times or more: Fully depress the clutch pedal and release it completely. After completing this operation, depress the clutch pedal and maintain the condition.
4. With clutch pedal depressed, loosen air bleeder valve to release air.
5. Tighten air bleeder valve to the specified torque. Refer to [CL-19, "Exploded View"](#).
6. Release clutch pedal and wait for 5 seconds.
7. Repeat steps 3 to 6 until completely no bubbles can be observed in clutch fluid.
8. Check that the fluid level in the reservoir tank is within the specified range after air bleeding. Refer to [CL-9, "Inspection"](#).
9. Make sure that clevis pin floats freely in the bore of clutch pedal.
 - If clevis pin is not free, perform the air bleeding again to check that bubbles are completely removed. After the complete removal of bubbles, adjust clutch pedal.

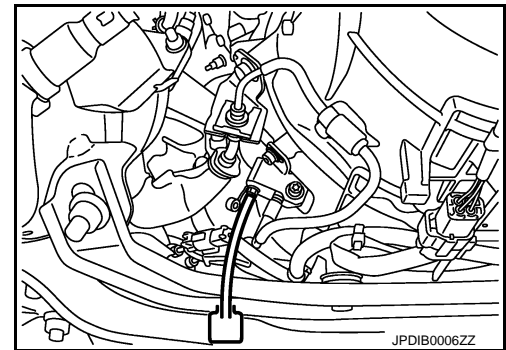

CAUTION:

When pressing the pedal pad to check the clevis pin condition, press the pedal pad until the development of load is felt by hand.

CLUTCH PEDAL

< REMOVAL AND INSTALLATION >

REMOVAL AND INSTALLATION

CLUTCH PEDAL

Exploded View

INFOID:000000011735156

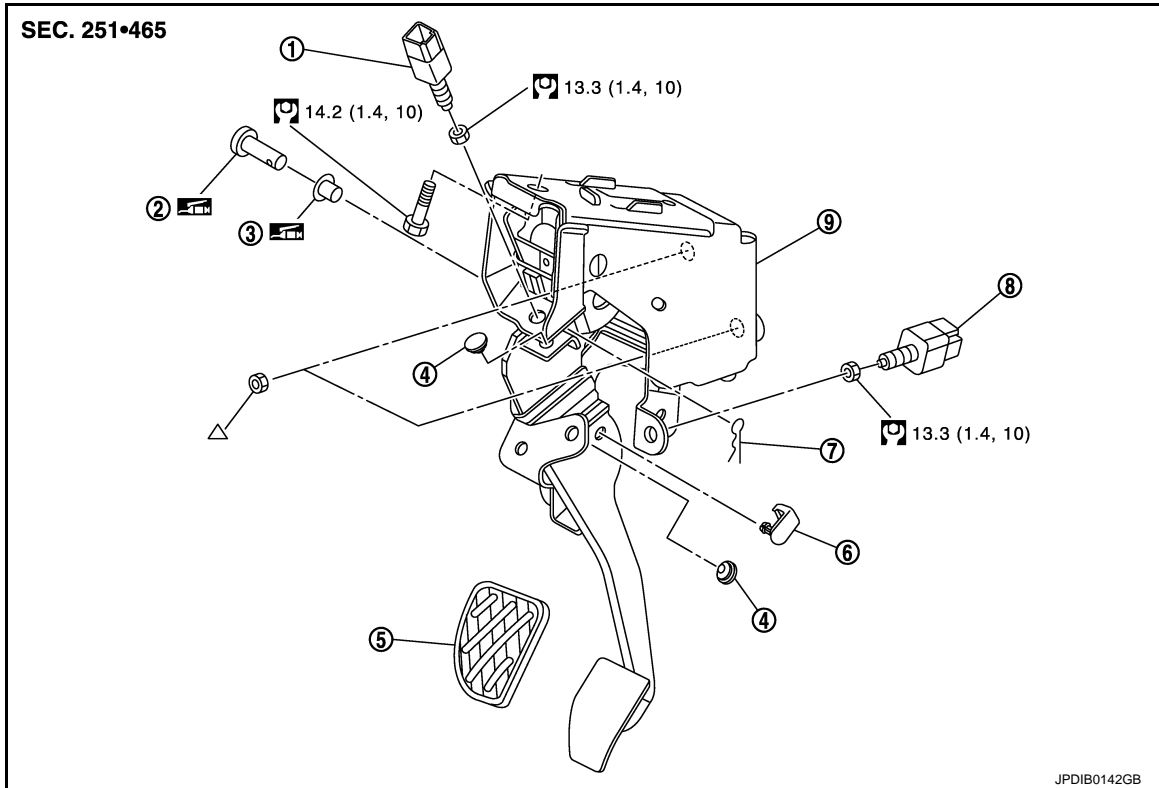

- | | | |
|---------------------------------|----------------------------|-------------------------|
| 1. Clutch pedal position switch | 2. Clevis pin | 3. Bushing |
| 4. Stopper rubber | 5. Pedal pad | 6. Pedal stopper rubber |
| 7. Snap pin | 8. Clutch interlock switch | 9. Clutch pedal |

: Apply lithium-based grease including molybdenum disulphide.

△: Refer to [CL-13. "Exploded View"](#) for the tightening torque.

Refer to [GI-4. "Components"](#) for symbols not described on the above.

Removal and Installation

INFOID:000000011735157

REMOVAL

1. Remove kicking plate inner. Refer to [INT-18. "FRONT PILLAR GARNISH : Removal and Installation"](#) (Coupe) or [INT-52. "KICKING PLATE INNER : Removal and Installation"](#) (Roadster).
2. Remove dash side finisher LH. Refer to [INT-18. "FRONT PILLAR GARNISH : Removal and Installation"](#) (Coupe) or [INT-53. "DASH SIDE FINISHER : Removal and Installation"](#) (Roadster).
3. Remove instrument lower panel LH. Refer to [IP-14. "Removal and Installation"](#).
4. Disconnect clutch pedal position switch and clutch interlock switch connectors and then remove clip of harness from clutch pedal.
5. Remove snap pin and clevis pin from clevis.
6. Remove clutch pedal position switch, clutch interlock switch, and pedal pad from clutch pedal.
7. Remove stopper rubbers and pedal stopper rubber from clutch pedal, using a suitable remover.
8. Remove clutch pedal from the vehicle.
9. Remove bushing from clutch pedal, using a suitable drift [Commercial service tool].

INSTALLATION

CLUTCH PEDAL

< REMOVAL AND INSTALLATION >

Note the following, and install in the reverse order of removal.

- Apply recommended grease to bushing.
- Apply recommended grease to clevis pin.

Inspection and Adjustment

INFOID:000000011735158

INSPECTION AFTER REMOVAL

Check the following items and replace clutch pedal if necessary.

- Check clutch pedal upper rivets (A) for deformation.

⇐ : Vehicle front

- Check the lapping length "L" of sub-bracket (B) and slide plate (C).

Lapping length "L" : More than 5 mm (0.20 in)

- Check clutch pedal for bend, damage, and cracks on the welded parts.

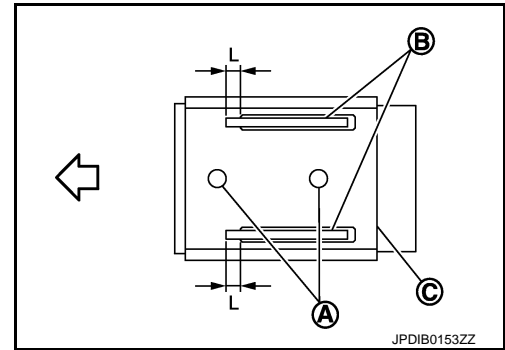

INSPECTION AFTER INSTALLATION

Check the clutch pedal free play. Refer to [CL-8, "Inspection and Adjustment"](#).

ADJUSTMENT AFTER INSTALLATION

Adjust the clutch interlock switch position. Refer to [CL-8, "Inspection and Adjustment"](#).

CLUTCH MASTER CYLINDER

< REMOVAL AND INSTALLATION >

CLUTCH MASTER CYLINDER

Exploded View

INFOID:000000011735159

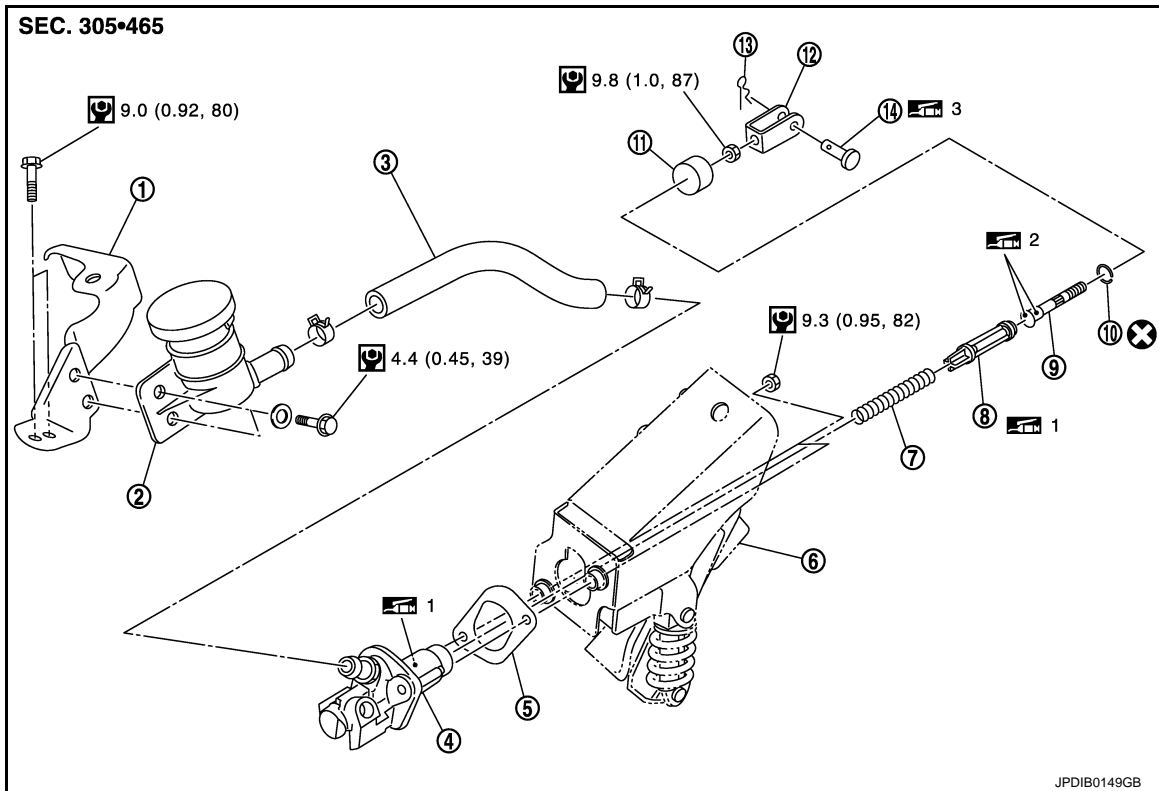

- | | | |
|--------------------|-------------------|-----------------|
| 1. Bracket | 2. Reservoir tank | 3. Hose |
| 4. Master cylinder | 5. Packing | 6. Clutch pedal |
| 7. Return spring | 8. Piston | 9. Push rod |
| 10. Stopper ring | 11. Boot | 12. Clevis |
| 13. Snap pin | 14. Clevis pin | |

 1: Apply rubber lubricant.

 2: Apply silicone grease.

 3: Apply lithium-based grease including molybdenum disulphide.

Refer to [GI-4, "Components"](#) for symbols not described on the above.

Removal and Installation

INFOID:000000011735160

CAUTION:

Keep painted surface on the body or other parts free of clutch fluid. If it spills, wipe up immediately and wash the affected area with water.

REMOVAL

1. Drain clutch fluid. Refer to [CL-9, "Draining"](#).
2. Remove brake master cylinder cover. Refer to [EXT-29, "Removal and Installation"](#).
3. Remove brake booster pressure sensor. Refer to [BR-38, "Removal and Installation"](#).

CLUTCH MASTER CYLINDER

< REMOVAL AND INSTALLATION >

4. Remove mounting bolts (←) and then remove reservoir tank assembly from the vehicle.

← : Vehicle front

5. Remove hose and clips from reservoir tank and master cylinder.
6. Remove reservoir tank mounting bolts and washers and then remove bracket from reservoir tank.
7. Remove clutch tube from master cylinder, using a flare nut wrench.
8. Remove snap pin and clevis pin from clevis and then separate clevis from clutch pedal.
9. Remove master cylinder mounting nuts and then remove packing (1) and master cylinder assembly (2) from the vehicle.

← : Vehicle front

CAUTION:

Never damage packing, brake booster, and dash lower.

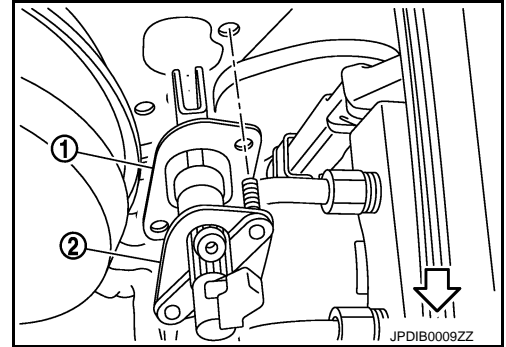
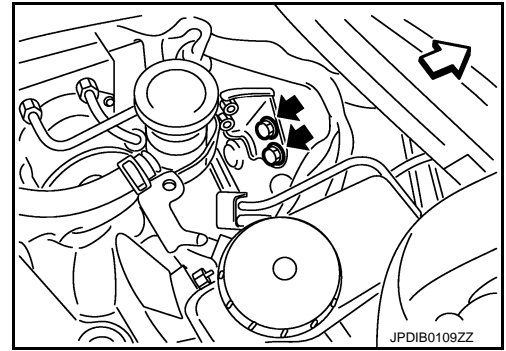

INSTALLATION

1. Install packing (1) and master cylinder assembly (2) to the vehicle.

← : Vehicle front

CAUTION:

• Never damage packing, brake booster, and dash lower.

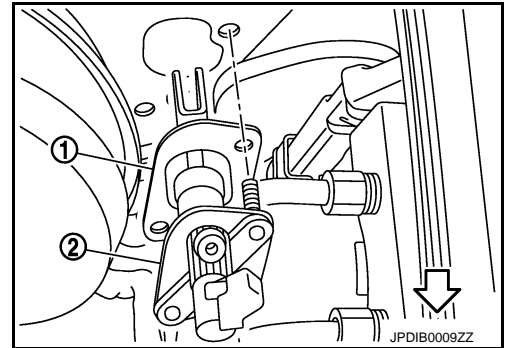

• Be careful with the orientation of packing. The figure is the view from the vehicle forward.

2. Tighten master cylinder mounting nuts to the specified torque.
3. Connect clutch tube to master cylinder and then temporarily tighten clutch tube flare nut, using a flare nut wrench.
4. Set clevis to clutch pedal.
5. Apply recommended grease to clevis pin and then install clevis pin to clevis.
6. Install snap pin to clevis pin.
7. Tighten clutch tube flare nut to the specified torque, using a flare nut torque wrench [Commercial service tool]. Refer to [CL-17, "Exploded View"](#).

CAUTION:

Never damage flare nut and clutch tube.

8. Install washers to reservoir tank mounting bolts.
9. Install bracket to reservoir tank and then tighten reservoir tank mounting bolts to the specified torque.

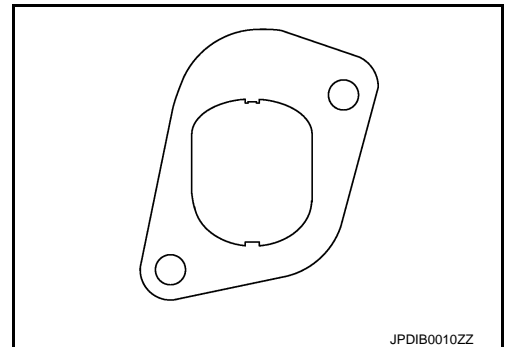

CLUTCH MASTER CYLINDER

< REMOVAL AND INSTALLATION >

10. Install hose (1) and clips to reservoir tank (2) and master cylinder (3).

← : Painted mark

CAUTION:
Set hose with painted mark facing upward.

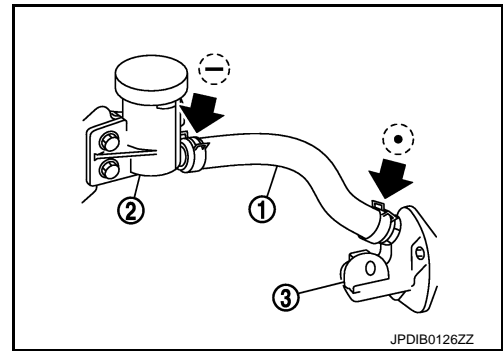

11. Install reservoir tank assembly to the vehicle and then tighten mounting bolts (↔) to the specified torque.

↔ : Vehicle front

12. Install brake booster pressure sensor. Refer to [BR-38, "Removal and Installation"](#).
13. Install brake master cylinder cover. Refer to [EXT-29, "Removal and Installation"](#).
14. Fill clutch fluid. Refer to [CL-9, "Refilling"](#).

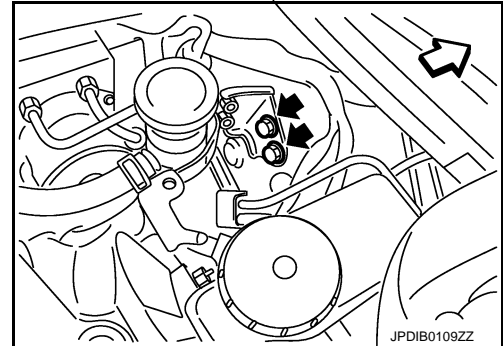

Disassembly and Assembly

INFOID:000000011735161

DISASSEMBLY

1. Remove clevis and push rod lock nut from push rod.
2. Remove boot from master cylinder.
3. Remove stopper ring from master cylinder while holding push rod.
4. Remove push rod, piston, and return spring from master cylinder.

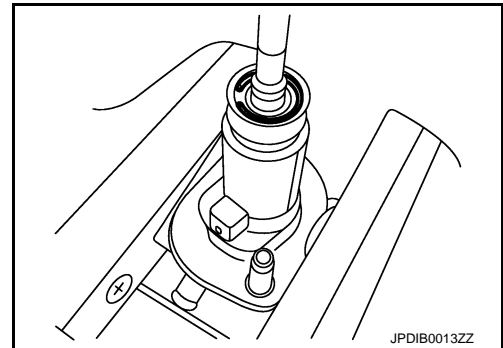

ASSEMBLY

1. Apply rubber lubricant to the internal surface of master cylinder, the sliding surface and piston cup of piston.
2. Install return spring and piston to master cylinder.
3. Apply silicon grease to push rod.
4. Install push rod to master cylinder.
5. Install stopper ring to master cylinder while holding push rod.
CAUTION:
Never reuse stopper ring.
6. Install boot to master cylinder.
7. Install push rod lock nut and clevis to push rod.

CLUTCH MASTER CYLINDER

< REMOVAL AND INSTALLATION >

- Adjust the length "L" between clevis (1) and master cylinder (2) to the standard value.

Length "L" between clevis and master cylinder : Refer to [CL-26, "Clutch Master Cylinder"](#).

NOTE:

Clutch pedal height is controlled with position of clevis and master cylinder.

- Tighten push rod lock nut (3) to the specified torque.

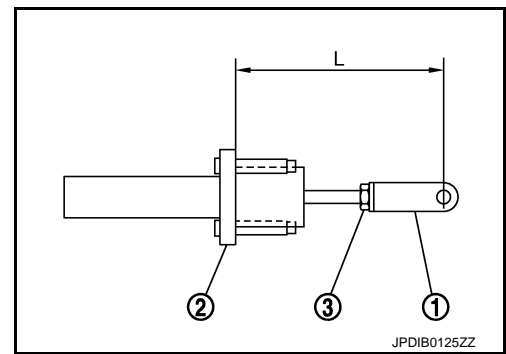

INFOID:000000011735162

Inspection and Adjustment

INSPECTION AFTER DISASSEMBLY

Check for any of the conditions shown below. If any malfunction is found, replace the part concerned.

- Damaged cylinder internal wall, foreign matter, wear, corrosion, or pinhole.
- Damaged or deformed reservoir tank.
- Settling of return spring.
- Cracked or deformed boot.
- Cracked or deformed packing.

ADJUSTMENT BEFORE INSTALLATION

- Check the length "L" between clevis (1) and master cylinder (2).

Length "L" between clevis and master cylinder : Refer to [CL-26, "Clutch Master Cylinder"](#).

- If measurement is outside the standard value, adjust the length "L" between clevis and master cylinder to the standard value.
- Tighten push rod lock nut (3) to the specified torque.

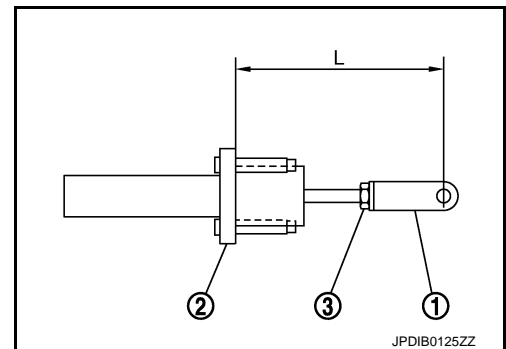

INSPECTION AFTER INSTALLATION

- Check the fluid leakage and the fluid level. Refer to [CL-9, "Inspection"](#).
- Check the clutch pedal free play. Refer to [CL-8, "Inspection and Adjustment"](#).

ADJUSTMENT AFTER INSTALLATION

- Adjust the clutch interlock switch position. Refer to [CL-8, "Inspection and Adjustment"](#).
- Perform the air bleeding. Refer to [CL-10, "Air Bleeding Procedure"](#).

CLUTCH PIPING

< REMOVAL AND INSTALLATION >

CLUTCH PIPING

Exploded View

INFOID:000000011735163

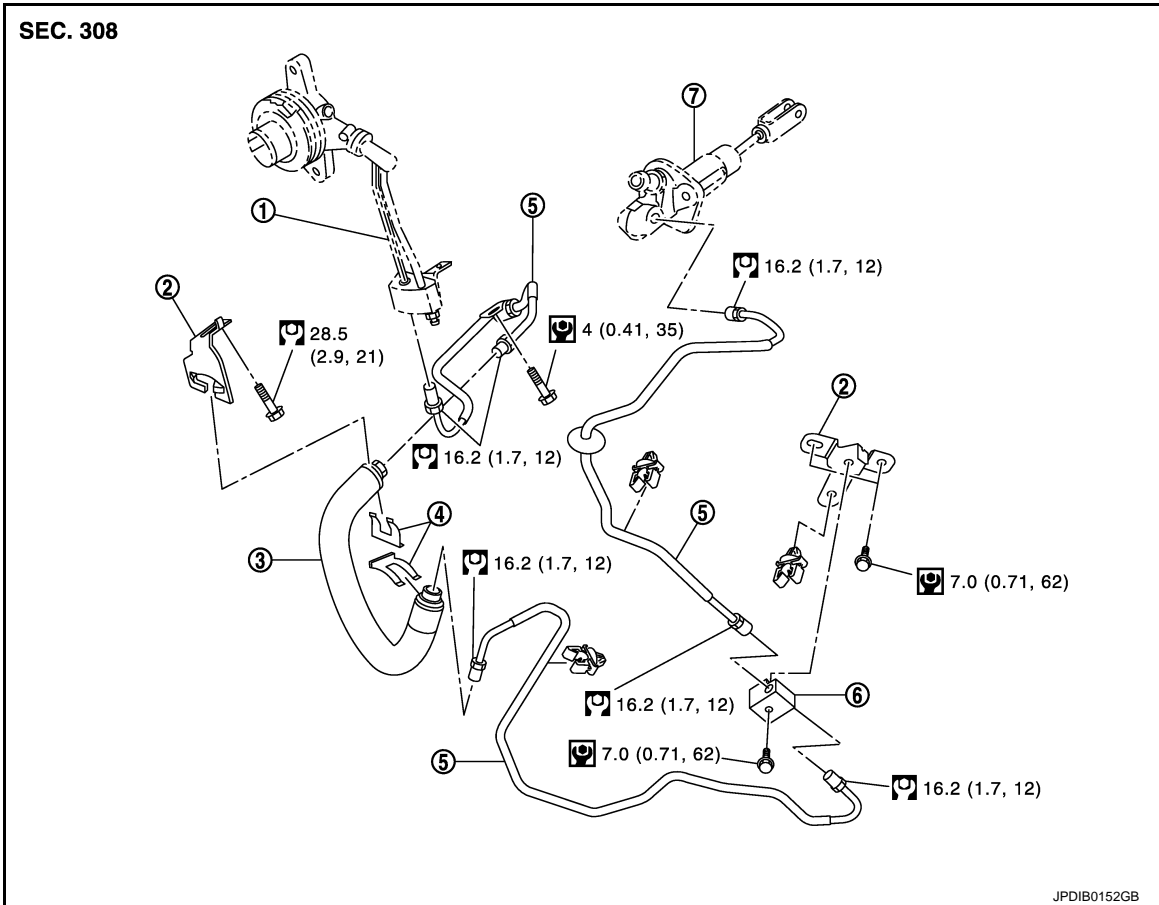

- | | | |
|---|----------------|----------------|
| 1. CSC (Concentric Slave Cylinder) assembly | 2. Bracket | 3. Clutch hose |
| 4. Lock plate | 5. Clutch tube | 6. Connector |
| 7. Master cylinder assembly | | |

Refer to [GI-4, "Components"](#) for the symbols in the figure.

Hydraulic Layout

INFOID:000000011735164

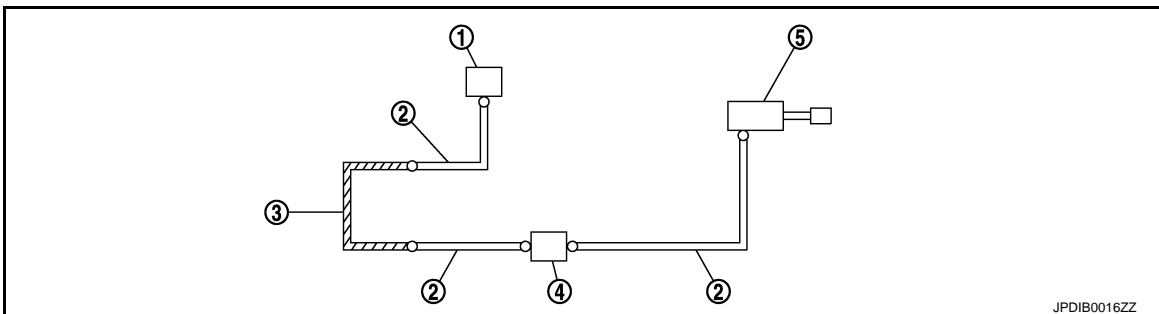

- | | | |
|---|-----------------------------|----------------|
| 1. CSC (Concentric Slave Cylinder) assembly | 2. Clutch tube | 3. Clutch hose |
| 4. Connector | 5. Master cylinder assembly | |

CLUTCH PIPING

< REMOVAL AND INSTALLATION >

Removal and Installation

INFOID:000000011735165

CAUTION:

Keep painted surface on the body or other parts free of clutch fluid. If it spills, wipe up immediately and wash the affected area with water.

REMOVAL

Note the following, and refer to [CL-17, "Exploded View"](#) for removal procedure.

- Drain clutch fluid. Refer to [CL-9, "Draining"](#).
- Remove clutch tube, using a flare nut wrench.

CAUTION:

Never damage flare nut and clutch tube.

INSTALLATION

Note the following, and refer to [CL-17, "Exploded View"](#) for installation procedure.

- To fix clutch hose on bracket, position clutch hose clasp on the emboss of bracket and drive lock plate vertically from above.

CAUTION:

- Never bend or twist clutch hose.
- Never scratch or damage clutch hose.
- Tighten clutch tube flare nut to the specified torque, using a flare nut torque wrench [Commercial service tool].

CAUTION:

Never damage flare nut and clutch tube.

- Fill clutch fluid. Refer to [CL-9, "Refilling"](#).

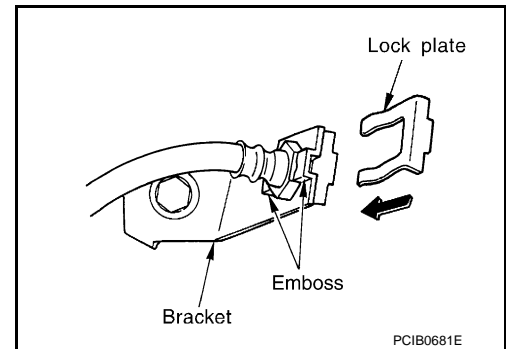

Inspection and Adjustment

INFOID:000000011735166

INSPECTION AFTER INSTALLATION

Check the fluid leakage and the fluid level. Refer to [CL-9, "Inspection"](#).

ADJUSTMENT AFTER INSTALLATION

Perform the air bleeding. Refer to [CL-10, "Air Bleeding Procedure"](#).

CSC (CONCENTRIC SLAVE CYLINDER)

< UNIT REMOVAL AND INSTALLATION >

UNIT REMOVAL AND INSTALLATION

CSC (CONCENTRIC SLAVE CYLINDER)

Exploded View

INFOID:000000011735167

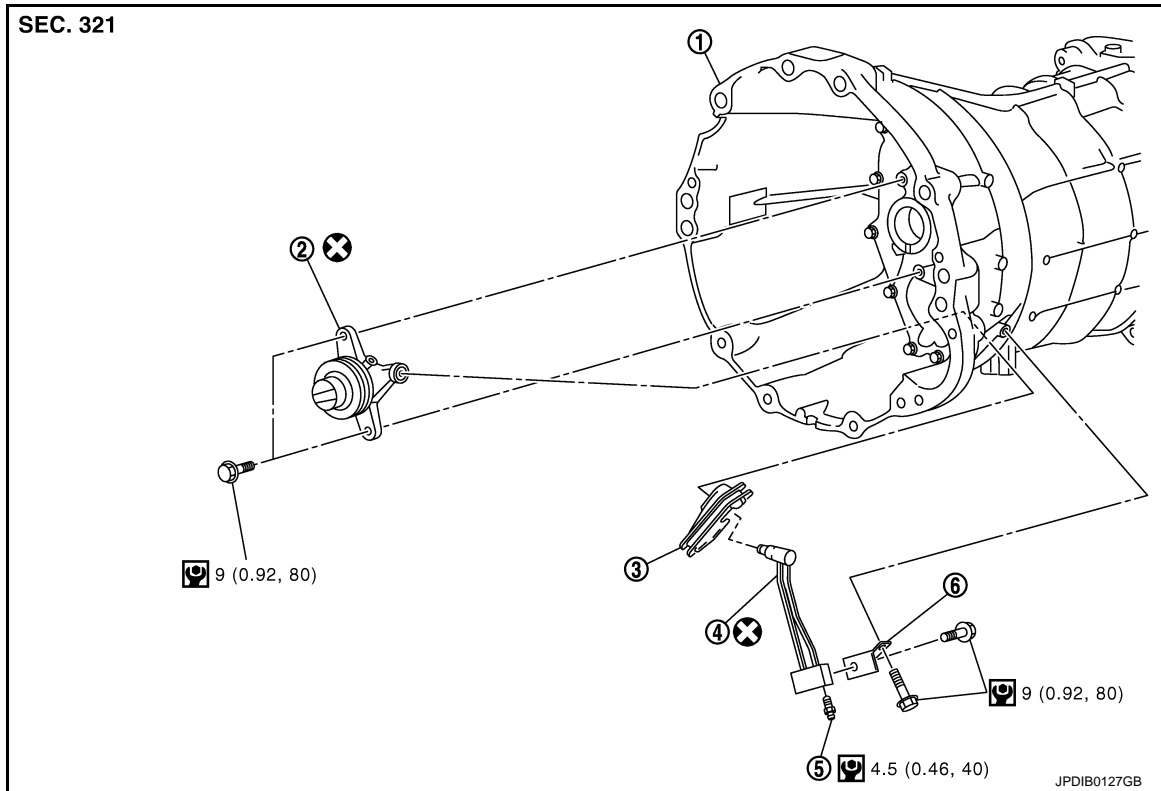

- | | | |
|---|---|---------------|
| 1. Transmission assembly | 2. CSC (Concentric Slave Cylinder) body | 3. Dust cover |
| 4. CSC (Concentric Slave Cylinder) tube | 5. Air bleeder valve | 6. Bracket |

Refer to [GI-4, "Components"](#) for the symbols in the figure.

Removal and Installation

INFOID:000000011735168

CAUTION:

- Never reuse CSC (Concentric Slave Cylinder) body and CSC tube. Because CSC slides back to the original position every time when removing transmission assembly. At this timing, dust on the sliding parts may damage a seal of CSC and may cause clutch fluid leakage.
- Never disassemble CSC body.
- Keep painted surface on the body or other parts free of clutch fluid. If it spills, wipe up immediately and wash the affected area with water.

REMOVAL

1. Remove transmission assembly from the engine. Refer to [TM-40, "WITHOUT S-MODE : Removal and Installation"](#) (Without S-MODE) or [TM-43, "WITH S-MODE : Removal and Installation"](#) (With S-MODE).

CSC (CONCENTRIC SLAVE CYLINDER)

< UNIT REMOVAL AND INSTALLATION >

2. Remove mounting bolt (←).

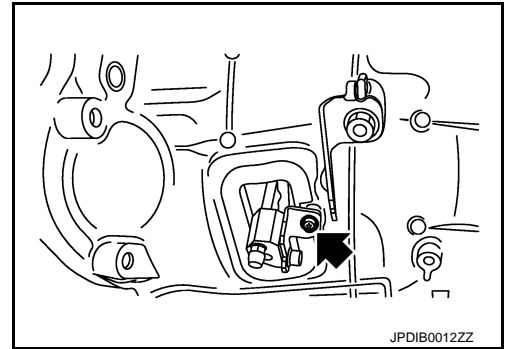

3. Pull up the lock pin of the CSC body.

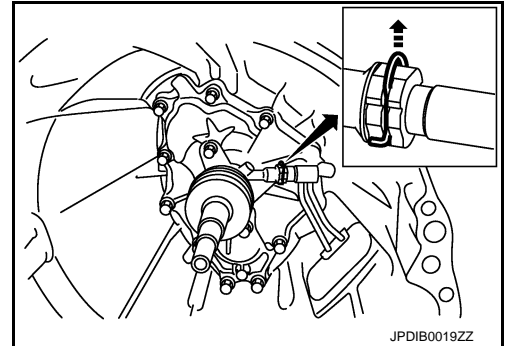

4. Pull out the CSC tube (1) from the CSC body (2).
5. Remove CSC tube and dust cover from transmission case.
6. Remove air bleeder valve and bracket from CSC tube.

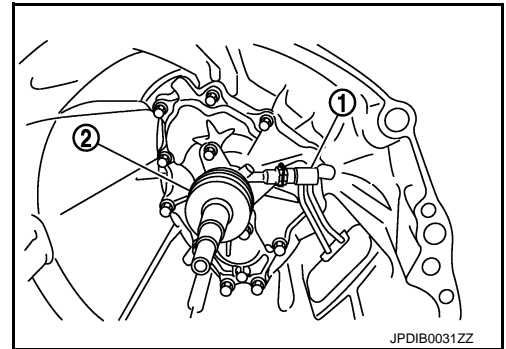

7. Remove CSC body from transmission case.

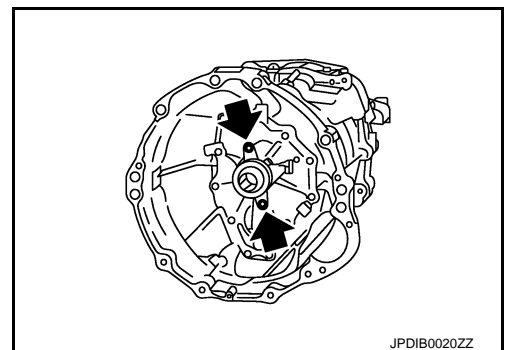

INSTALLATION

CSC (CONCENTRIC SLAVE CYLINDER)

< UNIT REMOVAL AND INSTALLATION >

1. Install CSC body to transmission case and then tighten mounting bolts (↔) to the specified torque.

CAUTION:

- Never reuse CSC body.
- Never insert and operate CSC body because piston and stopper of CSC body components may fall off.

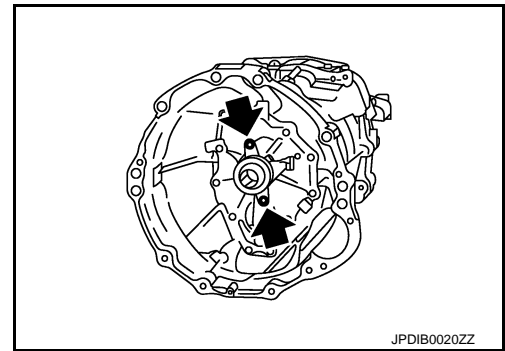

2. Install dust cover to transmission case.

↔ : Vehicle front

CAUTION:

Be careful with the orientation of dust cover.

3. Insert CSC tube to dust cover.

CAUTION:

- Never reuse CSC tube.
- Never damage O-ring of CSC tube.

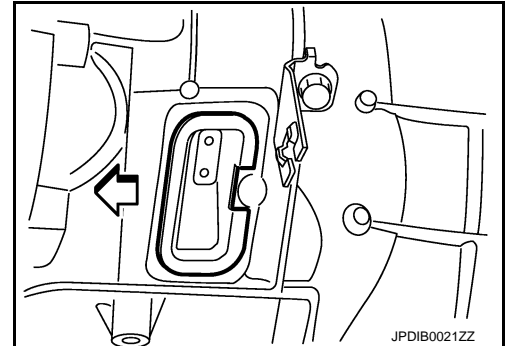

4. Press down the lock pin of the CSC body.

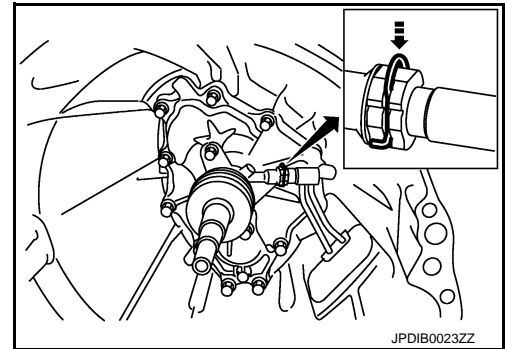

5. Insert the CSC tube (1) into the connector of the CSC body (2) until it clicks.

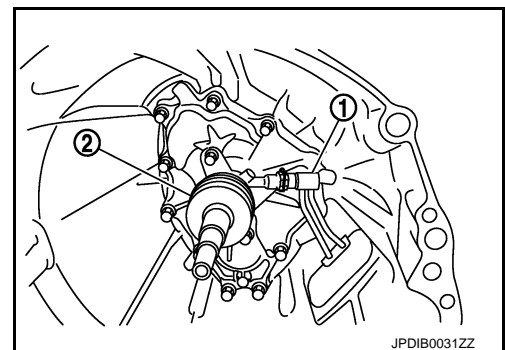

6. Install bracket and mounting bolts (↔) and then tighten mounting bolts to the specified torque in the numerical order as shown in the figure.

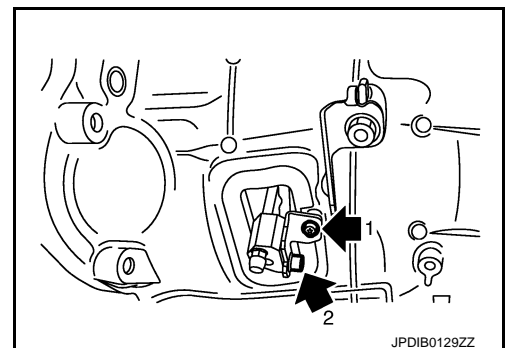

A
B
C
CL
E
F
G
H
I
J
K
L
M
N
O
P

CSC (CONCENTRIC SLAVE CYLINDER)

< UNIT REMOVAL AND INSTALLATION >

CAUTION:

- Check that CSC tube's (B) and bracket (1) are fit tightly before tightening the mounting bolt (A).
 - Tighten the mounting bolt within the range of bracket's mounting hole.
 - After replacing the CSC tube, the mounting bolt (C) is still temporary tightening. Never forget tightening the mounting bolt.
7. Install air bleeder valve to CSC tube and then tighten air bleeder valve to the specified torque.
 8. Install transmission assembly to the engine. Refer to [TM-40. "WITHOUT S-MODE : Removal and Installation"](#) (Without S-MODE) or [TM-43. "WITH S-MODE : Removal and Installation"](#) (With S-MODE).

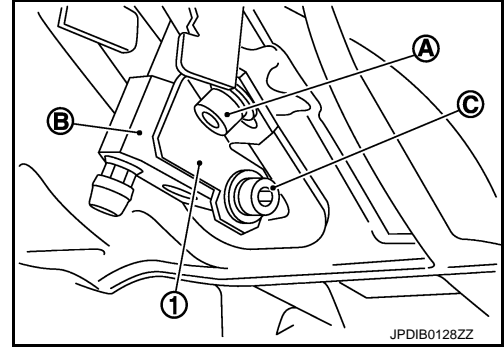

Inspection and Adjustment

INFOID:000000011735169

INSPECTION AFTER INSTALLATION

Check the fluid leakage and the fluid level. Refer to [CL-9. "Inspection"](#).

ADJUSTMENT AFTER INSTALLATION

Perform the air bleeding. Refer to [CL-10. "Air Bleeding Procedure"](#).

CLUTCH DISC AND CLUTCH COVER

< UNIT REMOVAL AND INSTALLATION >

CLUTCH DISC AND CLUTCH COVER

Exploded View

INFOID:000000011735170

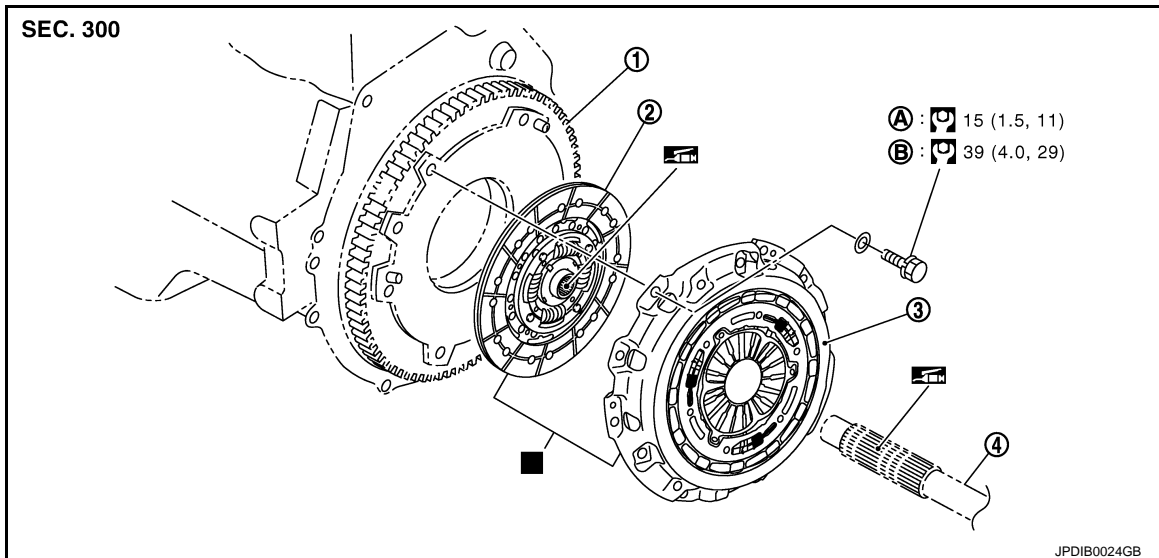

- 1. Flywheel
- 2. Clutch disc
- 3. Clutch cover
- 4. Main drive gear
- A. First step
- B. Final step

■ : Replace the parts as a set.

☑ : Apply lithium-based grease including molybdenum disulphide.

Refer to [GI-4, "Components"](#) for symbols not described on the above.

Removal and Installation

INFOID:000000011735171

CAUTION:

- Never reuse CSC (Concentric Slave Cylinder) body and CSC tube. Because CSC slides back to the original position every time when removing transmission assembly. At this timing, dust on the sliding parts may damage a seal of CSC and may cause clutch fluid leakage. Refer to [CL-19, "Removal and Installation"](#).

- Never bring any grease to the clutch disc facing, pressure plate surface and flywheel surface.
- Never clean clutch disc using solvent.

If flywheel is removed, align dowel pin with the smallest hole of flywheel. Refer to [EM-117, "Disassembly and Assembly"](#).

REMOVAL

1. Remove transmission assembly from the engine. Refer to [TM-40, "WITHOUT S-MODE : Removal and Installation"](#) (Without S-MODE) or [TM-43, "WITH S-MODE : Removal and Installation"](#) (With S-MODE).
2. Remove clutch cover mounting bolts and washers, using a power tool [Commercial service tool].
3. Remove clutch cover and clutch disc.

CAUTION:

Never drop clutch disc.

INSTALLATION

1. Clean clutch disc and main drive gear splines to remove grease and powder arisen from abrasion.
2. Apply recommended grease to clutch disc and main drive gear splines.

CAUTION:

Be sure to apply grease to the points specified. Otherwise, noise, poor disengagement, or damage to the clutch may result. Excessive grease may cause slip or judder. And if it adheres to seal of CSC body, it cause clutch fluid leakage. Wipe out excess grease. Wipe out any grease oozing from the parts.

CLUTCH DISC AND CLUTCH COVER

< UNIT REMOVAL AND INSTALLATION >

3. Install clutch disc, using a clutch aligner [Commercial service tool].

CAUTION:

If either clutch disc or clutch cover is needed to be replaced, replace them as a set.

4. Install washers to clutch cover mounting bolts.
5. Install clutch cover and then temporarily tighten clutch cover mounting bolts.

CAUTION:

If either clutch disc or clutch cover is needed to be replaced, replace them as a set.

6. Tighten clutch cover mounting bolts to the specified torque evenly in two steps in the numerical order as shown in the figure.
7. Install transmission assembly to the engine. Refer to [TM-40, "WITHOUT S-MODE : Removal and Installation"](#) (Without S-MODE) or [TM-43, "WITH S-MODE : Removal and Installation"](#) (With S-MODE).

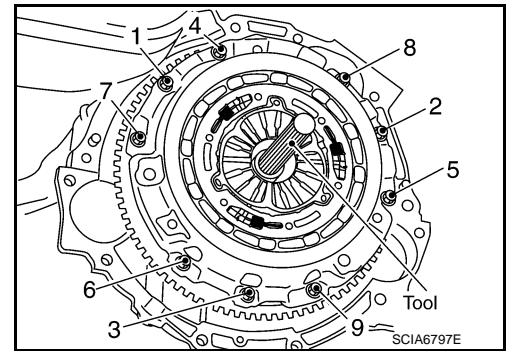

Inspection

INFOID:000000011735172

INSPECTION AFTER REMOVAL

CLUTCH DISC

- Measure circumferential runout relative to clutch disc center spline. If it is outside the specification, replace clutch disc and clutch cover as a set.

Runout limit/diameter of the area to be measured : Refer to [CL-26, "Clutch Disc"](#).

- Measure backlash to clutch disc spline and main drive gear spline at the circumference of clutch disc. If it is outside the specification, replace clutch disc and clutch cover as a set.

Maximum allowable spline backlash (at outer edge of disc) : Refer to [CL-26, "Clutch Disc"](#).

- Measure the depth "A" to clutch disc facing rivet heads, using a calipers. If it exceeds the allowable wear limit, replace clutch disc and clutch cover as a set.

Facing wear limit (depth to the rivet head) "A" : Refer to [CL-26, "Clutch Disc"](#).

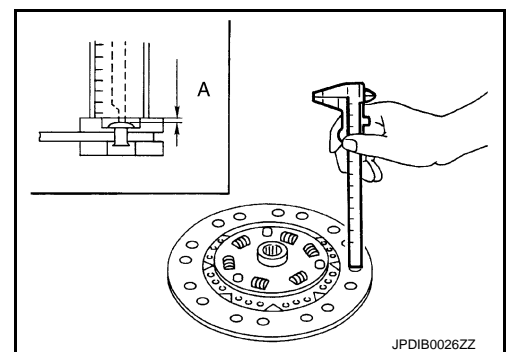
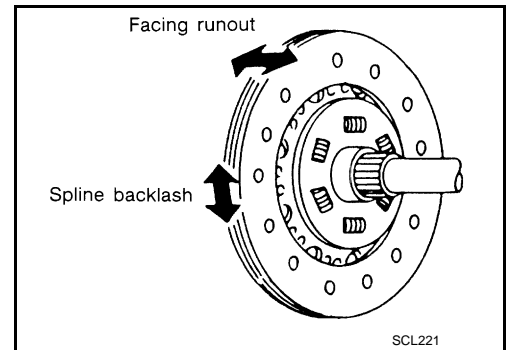

CLUTCH COVER

- Check clutch cover thrust ring for wear or breakage. If wear or breakage is found, replace clutch disc and clutch cover as a set.

NOTE:

- Worn thrust ring will generate a beating noise when tapped at the rivet with a hammer.
- Broken thrust ring will make a clinking sound when cover is shaken up and down.
- If a trace of burn or discoloration is found on the clutch cover pressure plate to clutch disc contact surface, repair the surface with sandpaper. If surface is damaged or distorted, replace clutch disc and clutch cover as a set.

INSPECTION AFTER INSTALLATION

CLUTCH COVER

CLUTCH DISC AND CLUTCH COVER

< UNIT REMOVAL AND INSTALLATION >

Check diaphragm spring lever claws for unevenness with the lever still on the vehicle. If they exceed the tolerance, adjust lever height, using the diaphragm adjusting wrench (A) [SST: ST20050240 (-)].

Tolerance for diaphragm spring lever unevenness : Refer to [CL-26, "Clutch Cover"](#).

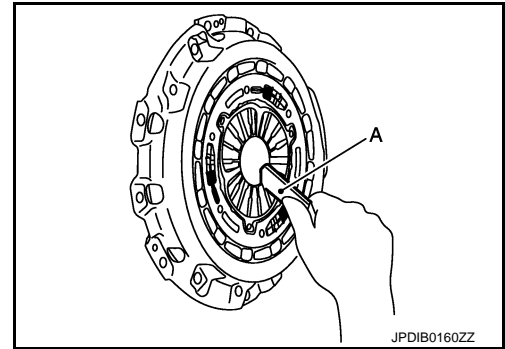

A
B
C

CL

E
F
G
H
I
J
K
L
M
N
O
P

SERVICE DATA AND SPECIFICATIONS (SDS)

< SERVICE DATA AND SPECIFICATIONS (SDS)

SERVICE DATA AND SPECIFICATIONS (SDS)

SERVICE DATA AND SPECIFICATIONS (SDS)

Clutch Control System

INFOID:0000000011735173

| | |
|------------------------|-----------|
| Type of clutch control | Hydraulic |
|------------------------|-----------|

Clutch Pedal

INFOID:0000000011735174

Unit: mm (in)

| | |
|--|---------------------------|
| Clearance "C" between pedal stopper rubber and clutch interlock switch threaded while clutch pedal is fully depressed. | 0.1 – 1.0 (0.004 – 0.039) |
|--|---------------------------|

Clutch Master Cylinder

INFOID:0000000011735175

Unit: mm (in)

| | |
|---|-----------------------------|
| Cylinder inner diameter | 17.46 (11/16) |
| Length "L" between clevis and master cylinder | 133.55 ± 0.5 (5.26 ± 0.020) |

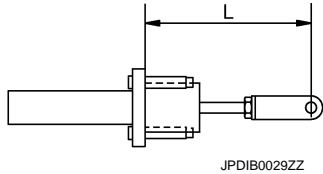

Clutch Disc

INFOID:0000000011735176

Unit: mm (in)

| | |
|---|---------------------------------------|
| Facing size (Outer dia. × Inner dia. × Thickness) | 240 × 160 × 3.8 (9.45 × 6.30 × 0.150) |
| Runout limit/diameter of the area to be measured | 1.0 (0.039) / 230 (9.06) dia. |
| Maximum allowable spline backlash (at outer edge of disc) | 1.0 (0.039) |
| Facing wear limit (depth to the rivet head) "A" | 0.3 (0.012) |

Clutch Cover

INFOID:0000000011735177

| | |
|---|---------------------------|
| Tolerance for diaphragm spring lever unevenness | 0.8 mm (0.031 in) or less |
|---|---------------------------|