



---

<b>FRONT PERFORMANCE DAMPER</b> .....	<b>23</b>	Removal and Installation .....	23
Exploded View .....	23		

# NOISE, VIBRATION AND HARSHNESS (NVH) TROUBLESHOOTING

< SYMPTOM DIAGNOSIS >

[REGULAR GRADE]

## SYMPTOM DIAGNOSIS

### NOISE, VIBRATION AND HARSHNESS (NVH) TROUBLESHOOTING

#### NVH Troubleshooting Chart

INFOID:000000004500898

Use chart below to find the cause of the symptom. If necessary, repair or replace these parts.

Reference page																		
Possible cause and SUSPECTED PARTS																		
Symptom	FRONT SUSPENSION	Noise	x	x	x	x	x	x	x				x	x	x	x	x	x
		Shake	x	x	x	x		x					x	x	x	x	x	x
		Vibration	x	x	x	x	x						x	x				x
		Shimmy	x	x	x	x				x			x	x	x	x	x	x
		Judder	x	x	x								x	x	x	x	x	x
		Poor quality ride or handling	x	x	x	x	x			x	x		x	x				

x: Applicable

A  
B  
C  
D  
E  
F  
G  
H  
I  
J  
K  
L  
M  
N  
O  
P

FSU

## PRECAUTION

### PRECAUTIONS

#### Precaution for Supplemental Restraint System (SRS) "AIR BAG" and "SEAT BELT PRE-TENSIONER"

INFOID:000000004721619

The Supplemental Restraint System such as "AIR BAG" and "SEAT BELT PRE-TENSIONER", used along with a front seat belt, helps to reduce the risk or severity of injury to the driver and front passenger for certain types of collision. This system includes seat belt switch inputs and dual stage front air bag modules. The SRS system uses the seat belt switches to determine the front air bag deployment, and may only deploy one front air bag, depending on the severity of a collision and whether the front occupants are belted or unbelted. Information necessary to service the system safely is included in the "SRS AIR BAG" and "SEAT BELT" of this Service Manual.

**WARNING:**

- To avoid rendering the SRS inoperative, which could increase the risk of personal injury or death in the event of a collision which would result in air bag inflation, all maintenance must be performed by an authorized NISSAN/INFINITI dealer.
- Improper maintenance, including incorrect removal and installation of the SRS, can lead to personal injury caused by unintentional activation of the system. For removal of Spiral Cable and Air Bag Module, see the "SRS AIR BAG".
- Do not use electrical test equipment on any circuit related to the SRS unless instructed to in this Service Manual. SRS wiring harnesses can be identified by yellow and/or orange harnesses or harness connectors.

#### PRECAUTIONS WHEN USING POWER TOOLS (AIR OR ELECTRIC) AND HAMMERS

**WARNING:**

- When working near the Air Bag Diagnosis Sensor Unit or other Air Bag System sensors with the ignition ON or engine running, DO NOT use air or electric power tools or strike near the sensor(s) with a hammer. Heavy vibration could activate the sensor(s) and deploy the air bag(s), possibly causing serious injury.
- When using air or electric power tools or hammers, always switch the ignition OFF, disconnect the battery, and wait at least 3 minutes before performing any service.

#### Precaution Necessary for Steering Wheel Rotation after Battery Disconnect

INFOID:000000004721621

**NOTE:**

- Before removing and installing any control units, first turn the push-button ignition switch to the LOCK position, then disconnect both battery cables.
- After finishing work, confirm that all control unit connectors are connected properly, then re-connect both battery cables.
- Always use CONSULT-III to perform self-diagnosis as a part of each function inspection after finishing work. If a DTC is detected, perform trouble diagnosis according to self-diagnosis results.

For vehicle with steering lock unit, if the battery is disconnected or discharged, the steering wheel will lock and cannot be turned.

If turning the steering wheel is required with the battery disconnected or discharged, follow the operation procedure below before starting the repair operation.

#### OPERATION PROCEDURE

1. Connect both battery cables.

**NOTE:**

Supply power using jumper cables if battery is discharged.

2. Turn the push-button ignition switch to ACC position.  
(At this time, the steering lock will be released.)
3. Disconnect both battery cables. The steering lock will remain released with both battery cables disconnected and the steering wheel can be turned.
4. Perform the necessary repair operation.

# PRECAUTIONS

< PRECAUTION >

[REGULAR GRADE]

5. When the repair work is completed, re-connect both battery cables. With the brake pedal released, turn the push-button ignition switch from ACC position to ON position, then to LOCK position. (The steering wheel will lock when the push-button ignition switch is turned to LOCK position.)
6. Perform self-diagnosis check of all control units using CONSULT-III.

## Precaution for Procedure without Cowl Top Cover

INFOID:000000004721622

When performing the procedure after removing cowl top cover, cover the lower end of windshield with urethane, etc.

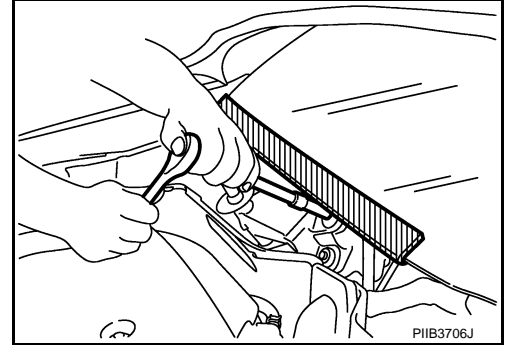

## Precautions for Suspension

INFOID:000000004500902

- When installing rubber bushings, the final tightening must be carried out under unladen conditions with tires on ground. Spilled oil might shorten the life of rubber bushings. Be sure to wipe off any spilled oil.
- Unladen conditions mean that fuel, engine coolant and lubricant are full. Spare tire, jack, hand tools and mats are in designated positions.
- After servicing suspension parts, be sure to check wheel alignment.
- Self-lock nuts are not reusable. Always use new ones when installing. Since new self-lock nuts are pre-oiled, tighten as they are.

# PREPARATION

< PREPARATION >

[REGULAR GRADE]

## PREPARATION

### PREPARATION

#### Special Service Tool

*INFOID:000000004500903*

The actual shapes of Kent-Moore tools may differ from those of special service tools illustrated here.

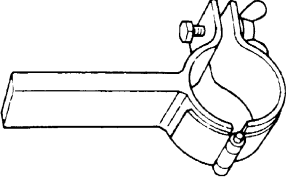
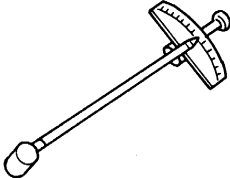
Tool number (Kent-Moore No.) Tool name		Description
ST35652000 ( - ) Shock absorber attachment	 <p style="text-align: center; font-size: small;">ZZA0807D</p>	Disassembling and assembling shock absorber
ST3127S000 (J-25765-A) Preload gauge	 <p style="text-align: center; font-size: small;">ZZA0806D</p>	Measuring rotating torque of ball joint

#### Commercial Service Tool

*INFOID:000000004500904*

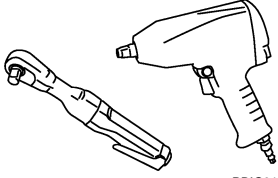
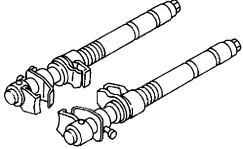
Tool name		Description
Power tool	 <p style="text-align: center; font-size: small;">PBIC0190E</p>	Loosening bolts and nuts
Spring compressor	 <p style="text-align: center; font-size: small;">S-NT717</p>	Removing and installing coil spring

# PERIODIC MAINTENANCE

## FRONT SUSPENSION ASSEMBLY

### Inspection

INFOID:000000004500905

#### MOUNTING INSPECTION

Make sure the mounting conditions (looseness, backlash) of each component and component conditions (wear, damage) are normal.

#### BALL JOINT AXIAL END PLAY

1. Set front wheels in a straight-ahead position.
2. Measure axial end play by playing and moving up/down with iron bar or equivalent between transverse link or upper link and steering knuckle. .

**Standard**

**Axial end play** : Refer to [FSU-20, "Ball Joint"](#).

**CAUTION:**

- Never depress brake pedal when measuring.
- Never perform with tires on level ground.
- Be careful not to damage ball joint boot. Never damage the installation position by applying excessive force.

#### Shock absorber

Check for oil leakage, damage. Replace it if necessary.

A  
B  
C  
D  
F  
G  
H  
I  
J  
K  
L  
M  
N  
O  
P



---

**WHEEL ALIGNMENT**
**Inspection**

INFOID:000000004500906

**DESCRIPTION****CAUTION:**

- **Camber, caster, kingpin inclination angles cannot be adjusted.**
- **If camber, caster, or kingpin inclination angle is outside the standard, check front suspension parts for wear and damage. Replace suspect parts if a malfunction is detected.**
- **Kingpin inclination angle is reference value, no inspection is required.**
- **Measure wheel alignment under unladen conditions.**

**NOTE:**

“Unladen conditions” means that fuel, engine coolant, and lubricant are full. Spare tire, jack, hand tools and mats are in designated positions.

**PRELIMINARY CHECK**

Check the following:

- Tires for improper air pressure and wear.
- Road wheels for runout. Refer to [WT-93, "Inspection"](#).
- Wheel bearing axial end play. Refer to [FAX-6, "Inspection"](#).
- Transverse link or upper link ball joint axial end play. Refer to [FSU-13, "Inspection"](#) or [FSU-15, "Inspection"](#).
- Shock absorber operation.
- Each mounting part of axle and suspension for looseness and deformation.
- Each of suspension member, shock absorber, upper link and transverse link for cracks, deformation and other damage.
- Vehicle height (posture).

**GENERAL INFORMATION AND RECOMMENDATIONS**

- A four-wheel thrust alignment should be performed.
- This type of alignment is recommended for any NISSAN/INFINITI vehicle.
- The four-wheel “thrust” process helps ensure that the vehicle is properly aligned and the steering wheel is centered.
- The alignment rack itself should be capable of accepting any NISSAN/INFINITI vehicle.
- The rack should be checked to ensure that it is level.
- Make sure the machine is properly calibrated.
- Your alignment equipment should be regularly calibrated in order to give correct information.
- Check with the manufacturer of your specific equipment for their recommended Service/Calibration Schedule.

**ALIGNMENT PROCESS****IMPORTANT:**

Use only the alignment specifications listed in this Service Manual.

- When displaying the alignment settings, many alignment machines use “indicators”: (Green/red, plus or minus, Go/No Go). **Never use these indicators.**
- The alignment specifications programmed into your machine that operate these indicators may not be correct.
- This may result in an ERROR.
- Some newer alignment machines are equipped with an “optional Rolling Compensation” method to “compensate” the sensors (alignment targets or head units). **Never use this “Rolling Compensation” method.**
- Use the “Jacking Compensation Method”. After installing the alignment targets or head units, raise the vehicle and rotate the wheels 1/2 turn both ways.
- See Instructions in the alignment machine you’re using for more information on this.



# FRONT COIL SPRING AND SHOCK ABSORBER

< REMOVAL AND INSTALLATION >

[REGULAR GRADE]

## REMOVAL AND INSTALLATION

### FRONT COIL SPRING AND SHOCK ABSORBER

Exploded View

INFOID:000000004500907

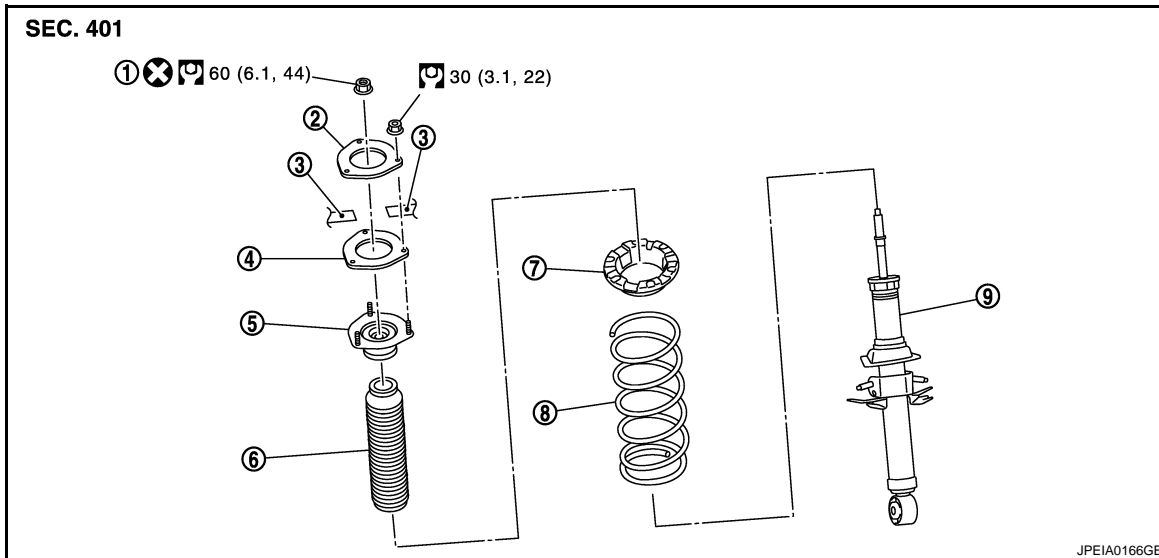

- |                        |                                    |                   |
|------------------------|------------------------------------|-------------------|
| 1. Piston rod lock nut | 2. Gusset                          | 3. Vehicle body   |
| 4. Mounting seal       | 5. Shock absorber mounting bracket | 6. Bound bumper   |
| 7. Rubber seat         | 8. Coil spring                     | 9. Shock absorber |

Refer to [GI-4, "Components"](#) for symbols in the figure.

## Removal and Installation

INFOID:000000004500908

### REMOVAL

1. Remove tires with power tool.
2. Remove wheel sensor and harness connector from shock absorber. Refer to [BRC-95, "FRONT WHEEL SENSOR : Exploded View"](#).
3. Remove brake hose bracket. Refer to [BR-20, "FRONT : Exploded View"](#).
4. Remove stabilizer connecting rod. Refer to [FSU-17, "Exploded View"](#).
5. Separate upper link from steering knuckle. Refer to [FAX-7, "Exploded View"](#).
6. Remove shock absorber assembly and gusset.

#### NOTE:

If removing shock absorber is difficult, loosen upper link mounting bolts (vehicle side).

### INSTALLATION

Note the following, and install in the reverse order of removal.

- Never tap on the ball joint cap of the stabilizer connecting rod with a hammer or a similar item when inserting the stabilizer connecting rod into the transverse link.
- Perform final tightening of bolts and nuts at the shock absorber lower side (rubber bushing), under unladen conditions with tires on level ground.

## Disassembly and Assembly

INFOID:000000004500909

### DISASSEMBLY

#### CAUTION:

Never damage shock absorber piston rod when removing components from shock absorber.

# FRONT COIL SPRING AND SHOCK ABSORBER

## < REMOVAL AND INSTALLATION >

[REGULAR GRADE]

1. Install shock absorber attachment (A) [SST: ST35652000 ( - )] to shock absorber and secure it in a vise.

**CAUTION:**

**When installing the shock absorber attachment to shock absorber, wrap a shop cloth around shock absorber to protect it from damage.**

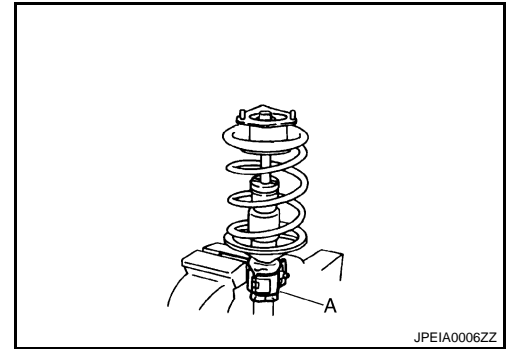

2. Using a spring compressor (A) (commercial service tool), compress coil spring between rubber seat and shock absorber until coil spring with a spring compressor is free.

**CAUTION:**

**Be sure a spring compressor is securely attached coil spring. Compress coil spring.**

3. Remove piston rod lock nut while securing the piston rod tip so that piston rod does not turn.

**CAUTION:**

**Make sure coil spring with a spring compressor between rubber seat and shock absorber is free.**

4. Remove mounting seal, shock absorber mounting bracket, rubber seat, bound bumper from shock absorber.

5. After remove coil spring with a spring compressor, and then gradually release a spring compressor.

**CAUTION:**

**Loosen while making sure coil spring attachment position does not move.**

6. Remove the shock absorber attachment from shock absorber.

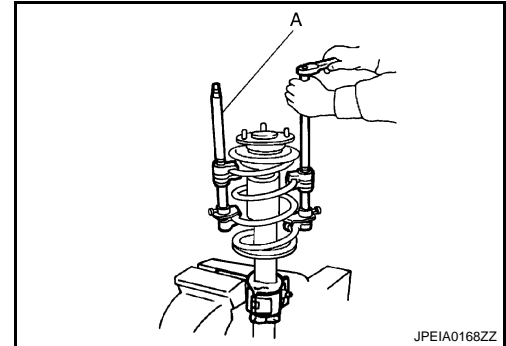

## ASSEMBLY

1. Install shock absorber attachment [SST: ST35652000 ( - )] to shock absorber and secure it in a vise.

**CAUTION:**

**When installing the shock absorber attachment to shock absorber, wrap a shop cloth around shock absorber to protect it from damage.**

2. Compress coil spring using a spring compressor (commercial service tool), and install it onto shock absorber.

**CAUTION:**

- Install with the large-diameter side (A) facing up and the small-diameter side (B) facing down.
- Be sure a spring compressor or is securely attached to coil spring. Compress coil spring.

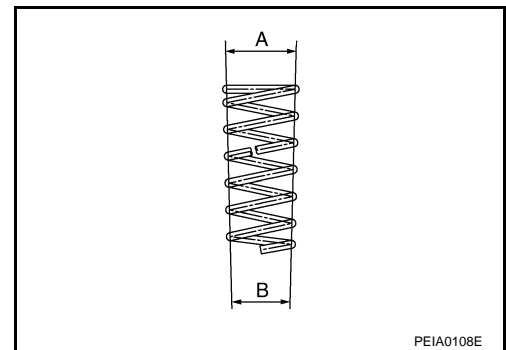



# FRONT COIL SPRING AND SHOCK ABSORBER

< REMOVAL AND INSTALLATION >

[REGULAR GRADE]

## Inspection

INFOID:000000004500910

### INSPECTION AFTER DISASSEMBLY

#### Shock absorber

Check the following items, and replace the part if necessary.

- Shock absorber for deformation, cracks or damage.
- Piston rod for damage, uneven wear or distortion.
- Oil leakage.

#### Shock absorber Mounting Bracket and Rubber Parts Inspection

Check shock absorber mounting bracket for cracks and rubber parts for wear. Replace it if necessary.

#### Coil Spring

Check coil spring for cracks, wear or damage. Replace it if necessary.

### INSPECTION AFTER INSTALLATION

1. Check wheel sensor harness for proper connection. Refer to [BRC-95, "FRONT WHEEL SENSOR : Exploded View"](#).
2. Check wheel alignment. Refer to [FSU-8, "Inspection"](#).
3. Adjust neutral position of steering angle sensor. Refer to [BRC-8, "ADJUSTMENT OF STEERING ANGLE SENSOR NEUTRAL POSITION : Special Repair Requirement"](#).

## Disposal

INFOID:000000004544078

1. Set shock absorber horizontally with the piston rod fully extended.
2. Drill 2 – 3 mm (0.08 – 0.12 in) hole at the position (●) from top as shown in the figure to release gas gradually.

#### CAUTION:

- Wear eye protection (safety glasses).
- Wear gloves.
- Be careful with metal chips or oil blown out by the compressed gas.

#### NOTE:

- Drill vertically in this direction (←).
- Directly to the outer tube avoiding brackets.
- The gas is clear, colorless, odorless, and harmless.

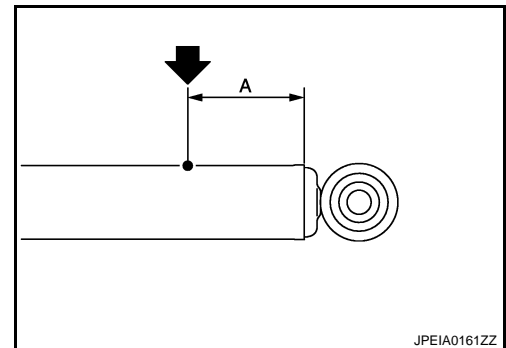

**A : 20 – 30 mm (0.79 – 1.18 in)**

3. Position the drilled hole downward and drain oil by moving the piston rod several times.

#### CAUTION:

**Dispose of drained oil according to the law and local regulations.**

# TRANSVERSE LINK

< REMOVAL AND INSTALLATION >

[REGULAR GRADE]

## TRANSVERSE LINK

### Exploded View

INFOID:000000004500911

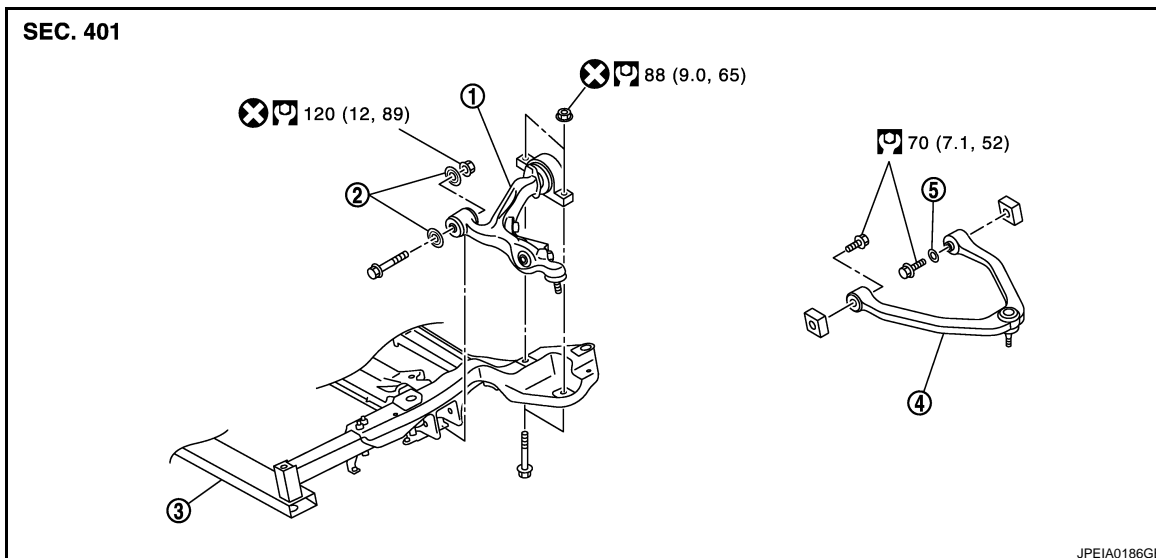

1. Transverse link
2. Stopper bush
3. Front suspension member
4. Upper link
5. Stopper rubber

Refer to [GI-4, "Components"](#) for symbols in the figure.

## Removal and Installation

INFOID:000000004500912

### REMOVAL

1. Remove tires with power tool.
2. Remove under cover with power tool.
3. Remove stabilizer connecting rod. Refer to [FSU-17, "Exploded View"](#).
4. Remove steering outer socket from steering knuckle. Refer to [ST-20, "Exploded View"](#).
5. Remove transverse link from steering knuckle. Refer to [FAX-7, "Exploded View"](#).
6. Set suitable jack under transverse link.
7. Remove transverse link.

### INSTALLATION

Note the following, and install in the reverse order of removal.

- Never tap on the ball joint cap of the stabilizer connecting rod with a hammer or a similar item when inserting the stabilizer connecting rod into the transverse link.
- Perform final tightening of bolts and nuts at the front suspension member installation and shock absorber lower side (rubber bushing), under unladen conditions with tires on level ground.

## Inspection

INFOID:000000004500913

### INSPECTION AFTER REMOVAL

#### Appearance

Check the following items, and replace the part if necessary.

- Transverse link and bushing for deformation, cracks or damage.
- Ball joint boot for cracks or other damage, and also for grease leakage.

#### Ball Joint Inspection

Manually move ball stud to confirm it moves smoothly with no binding.

#### Swing Torque Inspection

**NOTE:**

# TRANSVERSE LINK

## < REMOVAL AND INSTALLATION >

[REGULAR GRADE]

Before measurement, move ball stud at least ten times by hand to check for smooth movement.

1. Move the ball joint at least ten times by hand to check for smooth movement.
2. Hook a spring balance (A) at cotter pin mounting hole. Confirm spring balance measurement value is within specifications when ball stud begins moving.

### Standard

**Swing torque** : Refer to [FSU-20, "Ball Joint"](#).

- If swing torque exceeds standard range, replace transverse link assembly.

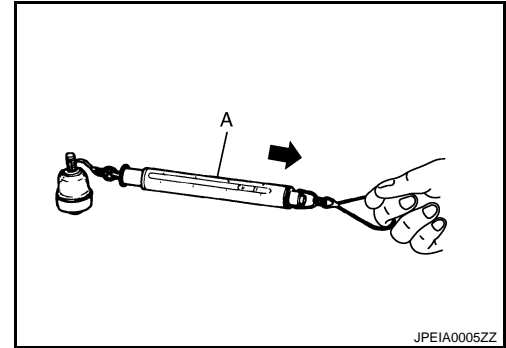

JPEIA0005ZZ

### Rotating Torque Inspection

1. Move the ball joint at least ten times by hand to check for smooth movement.
2. Attach mounting nut to ball stud. Make sure that rotating torque is within specifications with a preload gauge (A) [SST: ST3127S000 (J-25765-A)].

### Standard

**Rotating torque** : Refer to [FSU-20, "Ball Joint"](#).

- If rotating torque exceeds standard range, replace transverse link assembly.

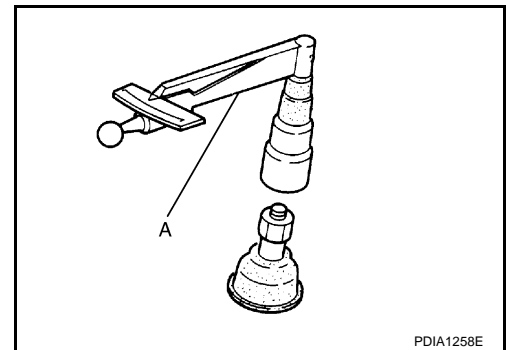

PDIA1258E

### Axial End Play Inspection

1. Move the ball joint at least ten times by hand to check for smooth movement.
2. Move tip of ball stud in axial direction to check for looseness.

### Standard

**Axial end play** : Refer to [FSU-20, "Ball Joint"](#).

- If axial end play exceeds standard range, replace transverse link assembly.

## INSPECTION AFTER INSTALLATION

1. Check wheel sensor harness for proper connection. Refer to [BRC-95, "FRONT WHEEL SENSOR : Exploded View"](#).
2. Check wheel alignment. Refer to [FSU-8, "Inspection"](#).
3. Adjust neutral position of steering angle sensor. Refer to [BRC-8, "ADJUSTMENT OF STEERING ANGLE SENSOR NEUTRAL POSITION : Special Repair Requirement"](#).

# UPPER LINK

< REMOVAL AND INSTALLATION >

[REGULAR GRADE]

## UPPER LINK

### Exploded View

INFOID:000000004500989

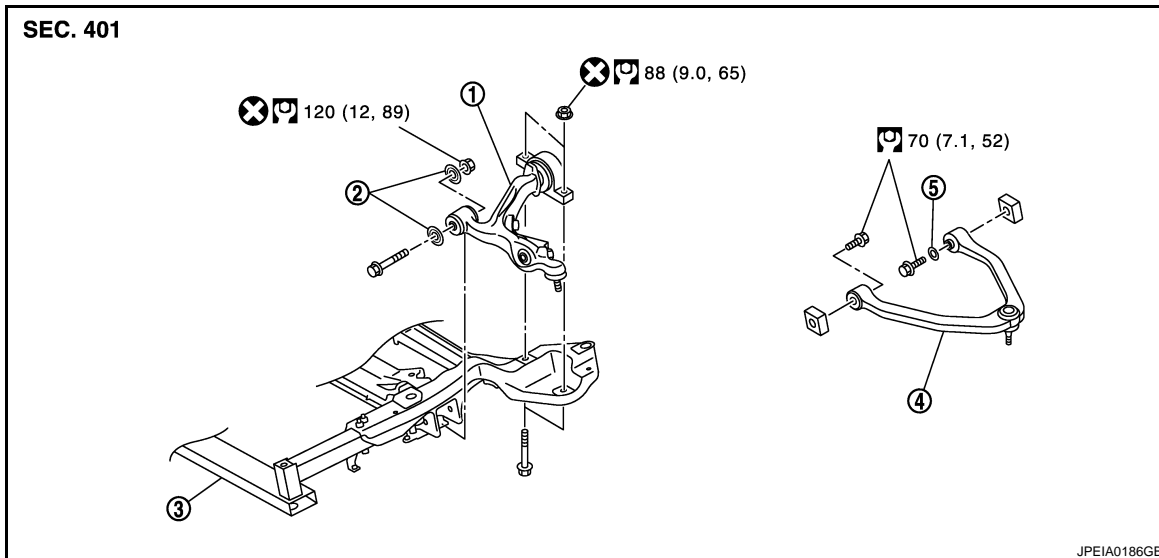

1. Transverse link
2. Stopper bush
3. Front suspension member
4. Upper link
5. Stopper rubber

Refer to [GI-4, "Components"](#) for symbols in the figure.

## Removal and Installation

INFOID:000000004500915

### REMOVAL

1. Remove tires with power tool.
2. Remove shock absorber assembly. Refer to [FSU-9, "Exploded View"](#).
3. Remove upper link from steering knuckle. Refer to [FAX-7, "Exploded View"](#).
4. Remove upper link and stopper rubber.

### INSTALLATION

Note the following, and install in the reverse order of removal.

- Perform final tightening of bolts and nuts at the vehicle installation position (rubber bushing), under unladen conditions with tires on level ground.

## Inspection

INFOID:000000004500916

### INSPECTION AFTER REMOVAL

#### Appearance

Check the following items, and replace the part if necessary.

- Upper link and bushing for deformation, cracks or damage.
- Ball joint boot for cracks or other damage, and also for grease leakage.

#### Ball Joint Inspection

Manually move ball stud to confirm it moves smoothly with no binding.

#### Swing Torque Inspection

##### NOTE:

Before measurement, move ball stud at least ten times by hand to check for smooth movement.

1. Move the ball joint at least ten times by hand to check for smooth movement.

## UPPER LINK

### < REMOVAL AND INSTALLATION >

[REGULAR GRADE]

- Hook a spring balance (A) at cutout on ball stud. Confirm spring balance measurement value is within specifications when ball stud begins moving.

#### Standard

#### Swing torque

: Refer to [FSU-20, "Ball Joint"](#).

- If swing torque exceeds standard range, replace upper link assembly.

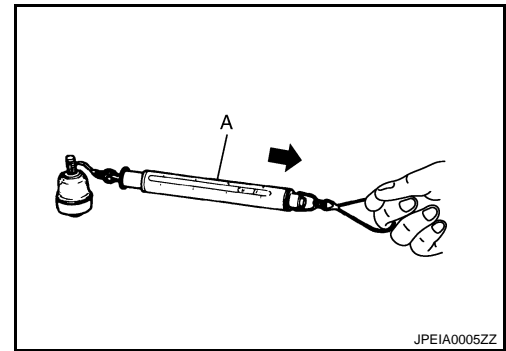

#### Axial End Play Inspection

- Move the ball joint at least ten times by hand to check for smooth movement.
- Move tip of ball stud in axial direction to check for looseness.

#### Standard

#### Axial end play

: Refer to [FSU-20, "Ball Joint"](#).

- If axial end play exceeds standard range, replace upper link assembly.

#### INSPECTION AFTER INSTALLATION

- Check wheel sensor harness for proper connection. Refer to [BRC-95, "FRONT WHEEL SENSOR : Exploded View"](#).
- Check wheel alignment. Refer to [FSU-8, "Inspection"](#).
- Adjust neutral position of steering angle sensor. Refer to [BRC-8, "ADJUSTMENT OF STEERING ANGLE SENSOR NEUTRAL POSITION : Special Repair Requirement"](#).



# FRONT STABILIZER

< REMOVAL AND INSTALLATION >

[REGULAR GRADE]

## FRONT STABILIZER

Exploded View

INFOID:000000004500917

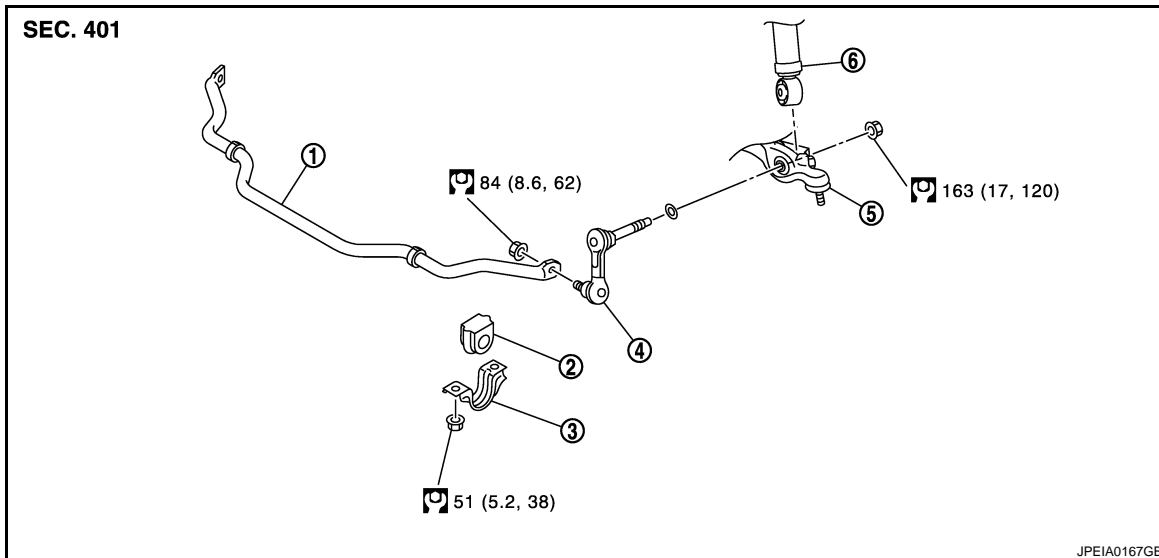

- |                              |                       |                     |
|------------------------------|-----------------------|---------------------|
| 1. Stabilizer bar            | 2. Stabilizer bushing | 3. Stabilizer clamp |
| 4. Stabilizer connecting rod | 5. Transverse link    | 6. Shock absorber   |

Refer to [GI-4, "Components"](#) for symbols in the figure.

## Removal and Installation

INFOID:000000004500918

### REMOVAL

1. Remove tires with power tool.
2. Remove under cover with power tool.
3. Remove stabilizer connecting rods.

#### **CAUTION:**

**Apply a matching mark to identify the installation position.**

4. Remove stabilizer clamps and stabilizer bushings.
5. Remove stabilizer bar.

### INSTALLATION

Note the following, and install in the reverse order of removal.

- Check the matching mark when installing.
- Tighten the mounting nut to the specified torque while holding a hexagonal part of stabilizer connecting rod side.

## Inspection

INFOID:000000004500919

### INSPECTION AFTER REMOVAL

Check stabilizer bar, stabilizer connecting rod, stabilizer bushing and stabilizer clamp for deformation, cracks or damage. Replace it if necessary.

# TOWER BAR

< REMOVAL AND INSTALLATION >

[REGULAR GRADE]

## TOWER BAR

### Exploded View

INFOID:000000004536550

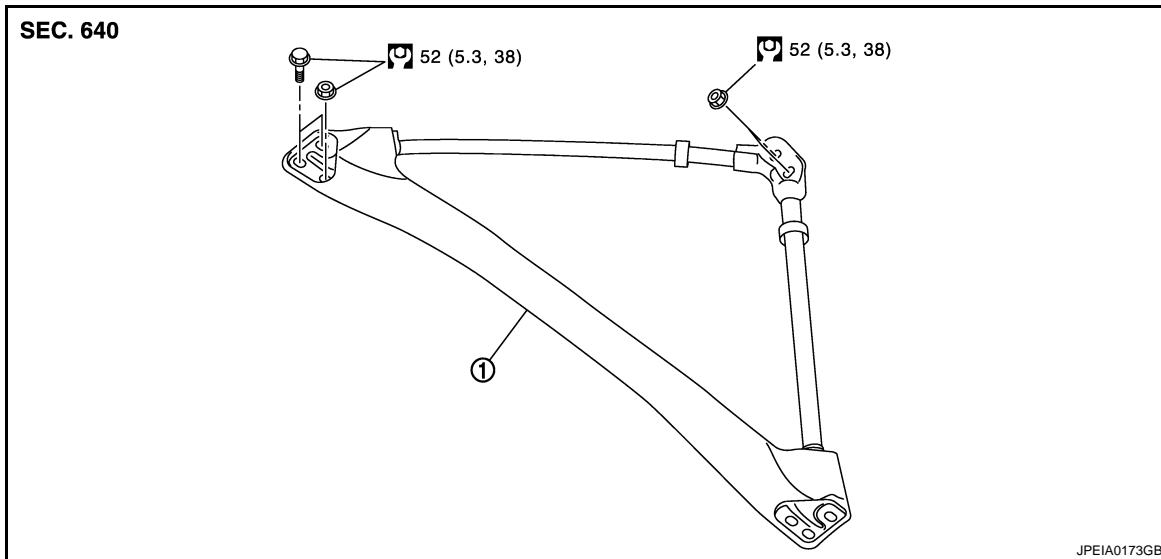

1. Front tower bar assembly

Refer to [GI-4, "Components"](#) for symbols in the figure.

## Removal and Installation

INFOID:000000004536551

### REMOVAL

1. Remove cowl top cover center. Refer to [EXT-21, "Exploded View"](#).
2. Remove front tower bar assembly mounting nuts and bolts.
3. Remove front tower bar assembly from vehicle.

### INSTALLATION

Note the following, and install in the reverse order of removal.

- Perform final tightening of bolts and nuts at the vehicle installation position, under condition with all tires above level ground.

# FRONT SUSPENSION MEMBER

< UNIT REMOVAL AND INSTALLATION >

[REGULAR GRADE]

## UNIT REMOVAL AND INSTALLATION

### FRONT SUSPENSION MEMBER

Exploded View

INFOID:000000004500920

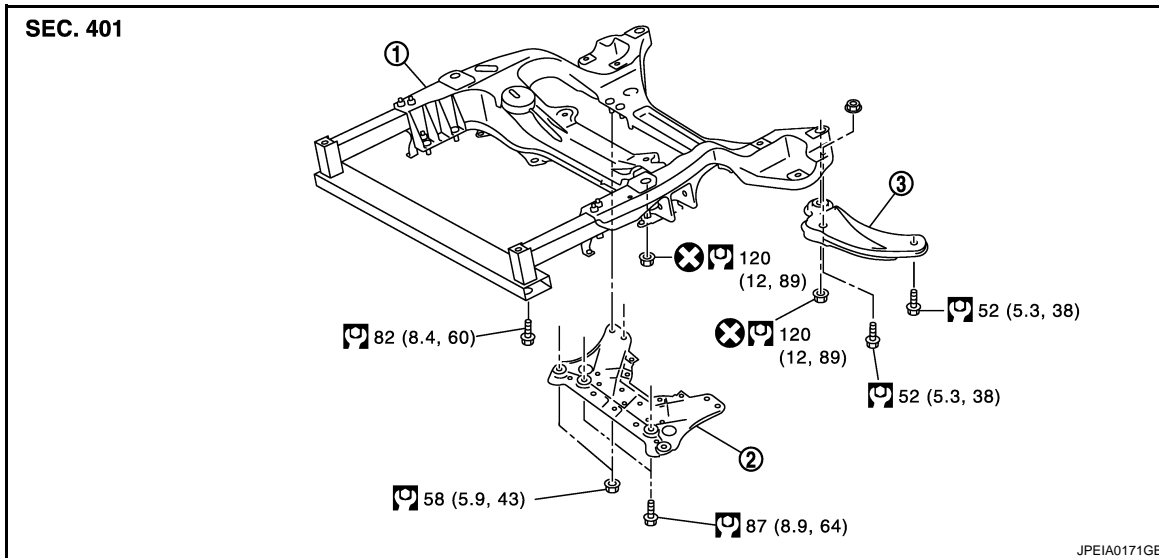

1. Front suspension member      2. Suspension member stay      3. Suspension member sub stay

Refer to [GI-4, "Components"](#) for symbols in the figure.

### Removal and Installation

INFOID:000000004500921

#### REMOVAL

- At first, remove engine and transmission assembly with front suspension member downward. Then separate engine, transmission assembly and front suspension member. Refer to [EM-68, "Exploded View"](#).
- Remove the following parts.
  - Steering knuckles and wheel hub and bearing assemblies. Refer to [FAX-7, "Exploded View"](#).
  - Steering gear assembly and hydraulic line. Refer to [ST-20, "Exploded View"](#), [ST-34, "Exploded View"](#).
  - Stabilizer bar and stabilizer connecting rods. Refer to [FSU-17, "Exploded View"](#).
  - Transverse links. Refer to [FSU-13, "Exploded View"](#).
  - Remove suspension member stay.
  - Remove suspension member sub stays.

#### INSTALLATION

Note the following, and install in the reverse order of removal.

- Perform final tightening of bolts and nuts at the vehicle installation position (rubber bushing), under unladen condition with tires on level ground.

### Inspection

INFOID:000000004500922

#### INSPECTION AFTER REMOVAL

Check the front suspension member for significant deformation, cracks, or damages. Replace if necessary.

#### INSPECTION AFTER INSTALLATION

- Check wheel sensor harness for proper connection. Refer to [BRC-95, "FRONT WHEEL SENSOR : Exploded View"](#).
- Check wheel alignment. Refer to [FSU-8, "Inspection"](#).
- Adjust the neutral position of the steering angle sensor. Refer to [BRC-8, "ADJUSTMENT OF STEERING ANGLE SENSOR NEUTRAL POSITION : Special Repair Requirement"](#).

# SERVICE DATA AND SPECIFICATIONS (SDS)

< SERVICE DATA AND SPECIFICATIONS (SDS)

[REGULAR GRADE]

## SERVICE DATA AND SPECIFICATIONS (SDS)

### SERVICE DATA AND SPECIFICATIONS (SDS)

#### Wheel Alignment

INFOID:000000004500923

Item		Standard	
Camber Degree minute (Decimal degree)	Minimum	-1° 25' (-1.41°)	
	Nominal	-0° 40' (-0.67°)	
	Maximum	0° 05' (0.08°)	
	Left and right difference	0° 33' (0.55°) or less	
Caster Degree minute (Decimal degree)	Minimum	4° 25' (4.42°)	
	Nominal	5° 10' (5.17°)	
	Maximum	5° 55' (5.91°)	
	Left and right difference	0° 39' (0.65°) or less	
Kingpin inclination Degree minute (Decimal degree)	Minimum	6° 55' (6.92°)	
	Nominal	7° 40' (7.67°)	
	Maximum	8° 25' (8.41°)	
Total toe-in	Distance	Minimum	In 1 mm (0.04 in)
		Nominal	In 2 mm (0.08 in)
		Maximum	In 3 mm (0.11 in)
	Angle (left wheel or right wheel) Degree minute (Decimal Degree)	Minimum	In 0° 03' (0.05°)
		Nominal	In 0° 05' (0.08°)
		Maximum	In 0° 07' (0.11°)

Measure value under unladen\* conditions.

\*: Fuel, engine coolant and lubricant are full. Spare tire, jack, hand tools and mats are in designated positions.

#### Ball Joint

INFOID:000000004500924

Item		Standard
Swing torque	Transverse link	0.5 – 3.6 N·m (0.06 – 0.36 kg·m, 5 – 31 in-lb)
	Upper link	0 – 2.0 N·m (0 – 0.20 kg·m, 0 – 17 in-lb)
Measurement on spring balance	Transverse link	7.8 – 56.3 N (0.8 – 5.7 kg, 1.8 – 12.6 lb)
	Upper link	0 – 61.5 N (0 – 6.2 kg, 0 – 13.8 lb)
Rotating torque	Transverse link	0.5 – 3.9 N·m (0.06 – 0.39 kg·m, 5 – 34 in-lb)
Axial end play		0 mm (0 in)

#### Wheelarch Height

INFOID:000000004500925

Item	Standard	
Wheel size	18 inch	19 inch
Front (Hf)	711 mm (27.99 in)	708 mm (27.87 in)

# SERVICE DATA AND SPECIFICATIONS (SDS)

< SERVICE DATA AND SPECIFICATIONS (SDS)

[REGULAR GRADE]

Item	Standard	
Wheel size	18 inch	19 inch
Rear (Hr)	711 mm (27.99 in)	

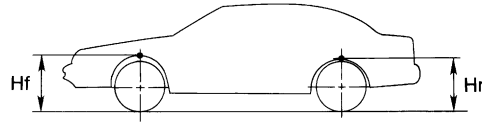

Measure value under unladen\* conditions

\*: Fuel, engine coolant and lubricant are full. Spare tire, jack, hand tools and mats are in designated positions.

A  
B  
C  
D  
F  
G  
H  
I  
J  
K  
L  
M  
N  
O  
P

FSU



# FRONT PERFORMANCE DAMPER

< REMOVAL AND INSTALLATION >

[Nismo 370Z]

## REMOVAL AND INSTALLATION

### FRONT PERFORMANCE DAMPER

Exploded View

INFOID:000000005400025

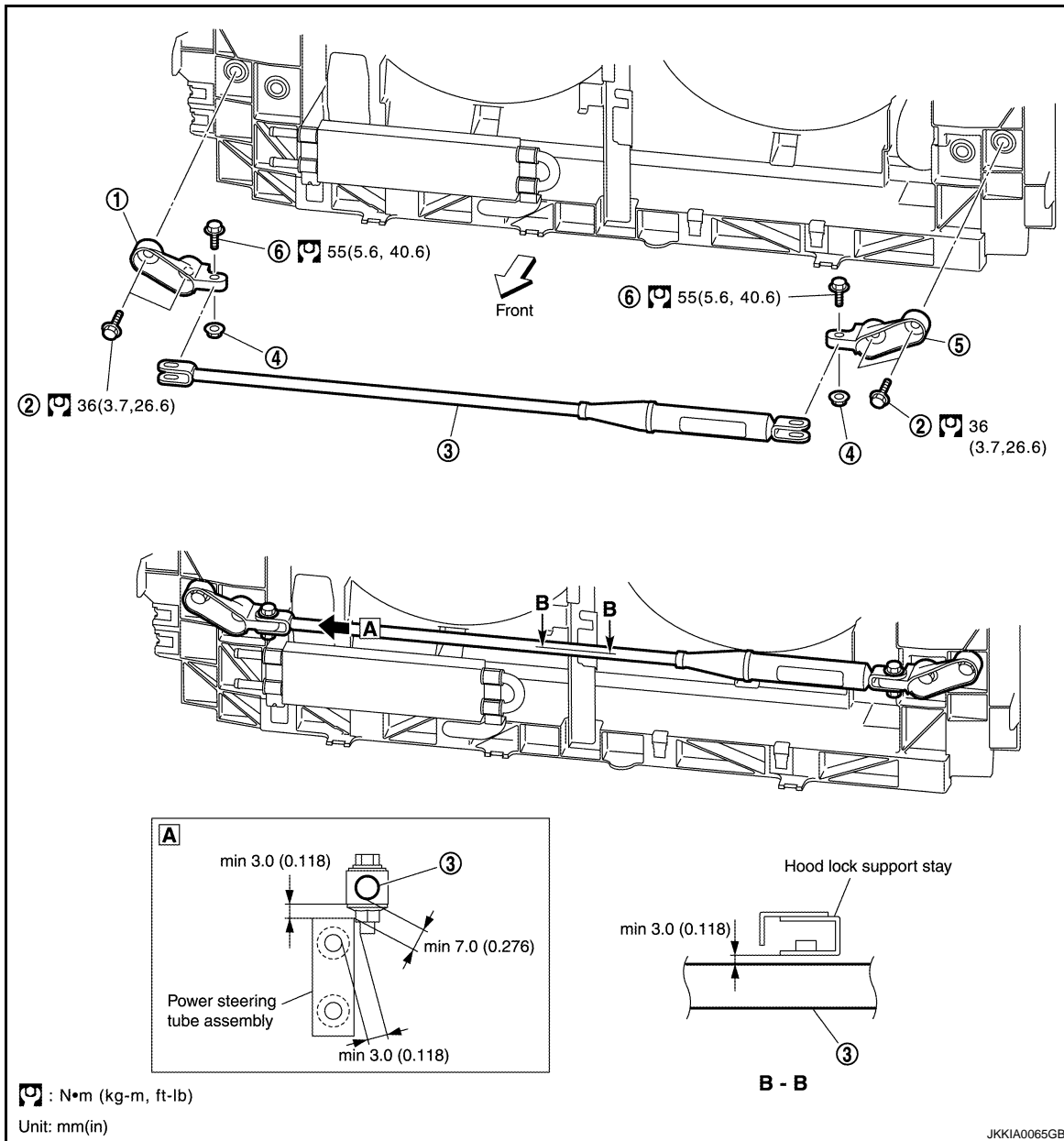

- |                        |                        |                             |
|------------------------|------------------------|-----------------------------|
| 1. Damper bracket (RH) | 2. Bolt (4)            | 3. Front performance damper |
| 4. Nut (2)             | 5. Damper bracket (LH) | 6. Bolt (2)                 |

### Removal and Installation

INFOID:000000005400026

#### REMOVAL

#### CAUTION:

- Perform the work in a level place while the vehicle is unladen in running order.
- Never tighten bolts while the vehicle is raised or jacked up.

1. Remove front bumper fascia.
2. Remove the bolts and nuts from the front performance damper.

# FRONT PERFORMANCE DAMPER

[Nismo 370Z]

## < REMOVAL AND INSTALLATION >

3. Remove the bolts and then remove the damper brackets (LH, RH).

### INSTALLATION

Install in the reverse order of removal.

#### **CAUTION:**

**When installing the front performance damper, check all clearances to make sure that there are no areas of interference.**

#### Front performance damper disposal method

This damper includes nitrogen gas under high pressure. Dealer should let out in following manner.

- Hold the front performance damper in a vise or other device and use a 2 mm (0.078 in) drill to slowly make a hole and release the gas as shown in the figure.

#### **CAUTION:**

- **The released gas is colorless, odorless, and harmless.**
- **Metal cuttings, etc., could be blown out by the force of the released gas, so wear safety goggles when performing this task.**

