

SECTION MA
MAINTENANCE

A
B
C
D
E
F
G
H
I
J
K
L
M
N
O

CONTENTS

REGULAR GRADE	
PREPARATION	3
PREPARATION	3
FOR NORTH AMERICA	3
FOR NORTH AMERICA : Special Service Tool	3
FOR NORTH AMERICA : Commercial Service Tool	3
EXCEPT FOR NORTH AMERICA	3
EXCEPT FOR NORTH AMERICA : Special Service Tool	3
EXCEPT FOR NORTH AMERICA : Commercial Service Tool	3
PERIODIC MAINTENANCE	5
GENERAL MAINTENANCE	5
FOR NORTH AMERICA	5
FOR NORTH AMERICA : Explanation of General Maintenance	5
EXCEPT FOR NORTH AMERICA	6
EXCEPT FOR NORTH AMERICA : General Maintenance	7
PERIODIC MAINTENANCE	8
FOR NORTH AMERICA	8
FOR NORTH AMERICA : Introduction of Periodic Maintenance	8
FOR NORTH AMERICA : Schedule 1	8
FOR NORTH AMERICA : Schedule 2	10
EXCEPT FOR NORTH AMERICA	11
EXCEPT FOR NORTH AMERICA : Periodic Maintenance	11
RECOMMENDED FLUIDS AND LUBRICANTS	14
	FOR NORTH AMERICA
	FOR NORTH AMERICA : Fluids and Lubricants
	FOR NORTH AMERICA : Engine Oil Recommendation
	FOR NORTH AMERICA : Anti-Freeze Coolant Mixture Ratio
	EXCEPT FOR NORTH AMERICA
	EXCEPT FOR NORTH AMERICA : Fluids and Lubricants
	EXCEPT FOR NORTH AMERICA : SAE Viscosity Number
	EXCEPT FOR NORTH AMERICA : Engine Coolant Mixture Ratio
	ENGINE MAINTENANCE
	DRIVE BELT
	DRIVE BELT : Exploded View
	DRIVE BELT : Checking
	DRIVE BELT : Tension Adjustment
	ENGINE COOLANT
	ENGINE COOLANT : Inspection
	ENGINE COOLANT : Draining
	ENGINE COOLANT : Refilling
	ENGINE COOLANT : Flushing
	RADIATOR CAP
	RADIATOR CAP : Inspection
	RADIATOR
	RADIATOR : Inspection
	FUEL LINES
	FUEL LINES : Inspection
	AIR CLEANER FILTER
	AIR CLEANER FILTER : Removal and Installation
	ENGINE OIL
	ENGINE OIL : Draining

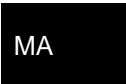

ENGINE OIL : Refilling	24	DISC BRAKE : Rear Disc Brake	36
OIL FILTER	24	STEERING GEAR AND LINKAGE	36
OIL FILTER : Removal and Installation	24	STEERING GEAR AND LINKAGE : Inspection	36
OIL FILTER : Inspection	25	POWER STEERING FLUID AND LINES	37
SPARK PLUG	25	POWER STEERING FLUID AND LINES : Inspec- tion	37
SPARK PLUG : Removal and Installation	25	AXLE AND SUSPENSION PARTS	37
SPARK PLUG : Inspection	26	AXLE AND SUSPENSION PARTS : Inspection	37
EVAP VAPOR LINES	26	BODY MAINTENANCE	39
EVAP VAPOR LINES : Inspection	26	LOCKS, HINGES AND HOOD LATCH	39
CHASSIS MAINTENANCE	27	LOCKS, HINGES AND HOOD LATCH : Lubricat- ing	39
EXHAUST SYSTEM	27	SEAT BELT, BUCKLES, RETRACTORS, AN- CHORS AND ADJUSTERS	39
EXHAUST SYSTEM : Inspection	27	SEAT BELT, BUCKLES, RETRACTORS, AN- CHORS AND ADJUSTERS : Inspection	39
GEAR OIL	27	SERVICE DATA AND SPECIFICATIONS (SDS)	40
GEAR OIL : Inspection	27	SERVICE DATA AND SPECIFICATIONS (SDS)	40
GEAR OIL : Draining	27	DRIVE BELT	40
GEAR OIL : Refilling	28	DRIVE BELT : Drive Belt	40
CLUTCH FLUID	28	ENGINE COOLANT	40
CLUTCH FLUID : Inspection	28	ENGINE COOLANT : Periodical Maintenance Specification	40
CLUTCH FLUID : Draining	28	ENGINE OIL	40
CLUTCH FLUID : Refilling	29	ENGINE OIL : Periodical Maintenance Specification	40
REAR PROPELLER SHAFT	29	SPARK PLUG	40
REAR PROPELLER SHAFT : Inspection	29	SPARK PLUG : Spark Plug	40
REAR DIFFERENTIAL GEAR OIL: R200	30	ROAD WHEEL	40
REAR DIFFERENTIAL GEAR OIL: R200 : Inspec- tion	30	ROAD WHEEL : Road Wheel	40
REAR DIFFERENTIAL GEAR OIL: R200 : Drain- ing	30	Nismo 370Z	
REAR DIFFERENTIAL GEAR OIL: R200 : Refill- ing	31	PERIODIC MAINTENANCE	42
REAR DIFFERENTIAL GEAR OIL: R200V	31	PERIODIC MAINTENANCE	42
REAR DIFFERENTIAL GEAR OIL: R200V : In- spection	31	FOR NORTH AMERICA	42
REAR DIFFERENTIAL GEAR OIL: R200V : Draining	31	FOR NORTH AMERICA : Schedule 1	42
REAR DIFFERENTIAL GEAR OIL: R200V : Refill- ing	32	FOR NORTH AMERICA : Schedule 2	42
WHEELS (BONDING WEIGHT TYPE)	32	SERVICE DATA AND SPECIFICATIONS (SDS)	43
WHEELS (BONDING WEIGHT TYPE) : Adjust- ment	32	SERVICE DATA AND SPECIFICATIONS (SDS)	43
BRAKE FLUID LEVEL AND LEAKS	34	SPARK PLUG	43
BRAKE FLUID LEVEL AND LEAKS : Inspection ...	34	SPARK PLUG : Spark Plug	43
BRAKE LINES AND CABLES	34		
BRAKE LINES AND CABLES : Inspection	35		
BRAKE FLUID	35		
BRAKE FLUID : Changing	35		
DISC BRAKE	35		
DISC BRAKE : Inspection	35		
DISC BRAKE : Front Disc Brake	36		

PREPARATION

< PREPARATION >

[REGULAR GRADE]

PREPARATION

PREPARATION FOR NORTH AMERICA

FOR NORTH AMERICA : Special Service Tool

INFOID:000000004498771

The actual shapes of Kent-Moore tools may differ from those of special service tools illustrated here.

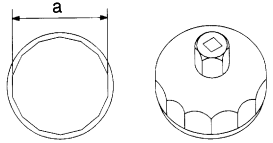
Tool number (Kent-Moore No.) Tool name	Description
KV10115801 (J-38956) Oil filter wrench	Removing and installing oil filter a: 64.3 mm (2.531 in)
 <p style="text-align: center;">S-NT375</p>	

FOR NORTH AMERICA : Commercial Service Tool

INFOID:000000004498772

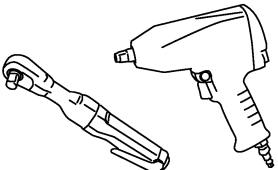
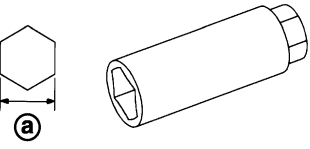
Tool name	Description
Power tool	Loosening nuts and bolts
 <p style="text-align: center;">PBIC0190E</p>	
Spark plug wrench	Removing and installing spark plug a: 14 mm (0.55 in)
 <p style="text-align: center;">JPBIA0399ZZ</p>	

EXCEPT FOR NORTH AMERICA

EXCEPT FOR NORTH AMERICA : Special Service Tool

INFOID:000000004639601

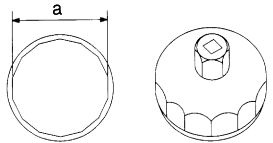
Tool number Tool name	Description
KV10115801 Oil filter wrench	Removing and installing oil filter a: 64.3 mm (2.531 in)
 <p style="text-align: center;">S-NT375</p>	

EXCEPT FOR NORTH AMERICA : Commercial Service Tool

INFOID:000000004639602



PREPARATION

< PREPARATION >

[REGULAR GRADE]

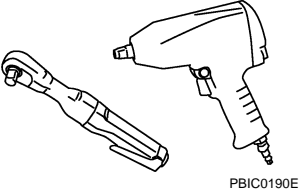
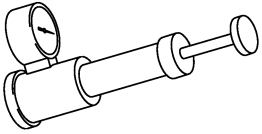
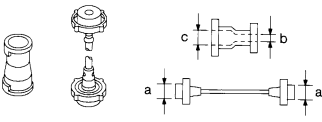
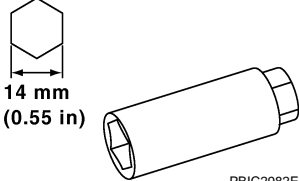
Tool name	Description
<p>Power tool</p>  <p style="text-align: right; margin-right: 50px;">PBIC0190E</p>	<p>Loosening nuts and bolts</p>
<p>Radiator cap tester</p>  <p style="text-align: right; margin-right: 50px;">PBIC1982E</p>	<p>Checking radiator and radiator cap</p>
<p>Radiator cap tester adapter</p>  <p style="text-align: right; margin-right: 50px;">S-NT564</p>	<p>Adapting radiator cap tester to radiator cap and radiator filler neck a: 28 (1.10) dia. b: 31.4 (1.236) dia. c: 41.3 (1.626) dia. Unit: mm (in)</p>
<p>Spark plug wrench</p>  <p style="text-align: right; margin-right: 50px;">PBIC2982E</p>	<p>Removing and installing spark plug</p>

PERIODIC MAINTENANCE

GENERAL MAINTENANCE
FOR NORTH AMERICA

FOR NORTH AMERICA : Explanation of General Maintenance

INFOID:000000004498773

General maintenance includes those items which should be checked during the normal day-to-day operation of the vehicle. They are essential if the vehicle is to continue operating properly. The owners can perform checks and inspections themselves or have their NISSAN dealers do them.

OUTSIDE THE VEHICLE

The maintenance items listed here should be performed from time to time, unless otherwise specified.

Item		Reference page
Tires	Check the pressure with a gauge often and always prior to long distance trips. Adjust the pressure in all tires, including the spare, to the pressure specified. Check carefully for damage, cuts or excessive wear.	WT-100
Wheel nuts	When checking the tires, make sure no nuts are missing, and check for any loose nuts. Tighten if necessary.	—
Tire rotation	Tires cannot be rotated, as front tires are different size from rear tires and the direction of wheel rotation is fixed in each tire.	MA-32
Tire Pressure Monitoring System (TPMS) transmitter components	Replace the TPMS transmitter grommet seal, valve core and cap when the tires are replaced due to wear or age.	WT-97
Wheel alignment and balance	If the vehicle should pull to either side while driving on a straight and level road, or if you detect uneven or abnormal tire wear, there may be a need for wheel alignment. If the steering wheel or seat vibrates at normal highway speeds, wheel balancing may be needed.	FSU-8 RSU-6 MA-32
Windshield	Clean the windshield on a regular basis. Check the windshield at least every six months for cracks or other damage. Repair as necessary.	—
Windshield wiper blades	Check for cracks or wear if they do not wipe properly.	—
Doors and engine hood	Check that all doors and the engine hood operate properly. Also make sure that all latches lock securely. Lubricate if necessary. Make sure that the secondary latch keeps the hood from opening when the primary latch is released. When driving in areas using road salt or other corrosive materials, check for lubrication frequently.	MA-39
Lamps	Make sure that the headlamps, stop lamps, tail lamps, turn signal lamps, and other lamps are all operating properly and installed securely. Also check headlamp aim. Clean the headlamps on a regular basis.	—

INSIDE THE VEHICLE

The maintenance items listed here should be checked on a regular basis, such as when performing periodic maintenance, cleaning the vehicle, etc.

Item		Reference page
Warning lamps and chimes	Make sure that all warning lamps and chimes are operating properly.	—
Windshield wiper and washer	Check that the wipers and washer operate properly and that the wipers do not streak.	—
Windshield defroster	Check that the air comes out of the defroster outlets properly and in sufficient quantity when operating the heater or air conditioner.	—
Steering wheel	Check that it has the specified play. Be sure to check for changes in the steering condition, such as excessive play, hard steering or strange noises. Free play: Less than 35 mm (1.38 in)	—

GENERAL MAINTENANCE

< PERIODIC MAINTENANCE >

[REGULAR GRADE]

Item		Reference page
Seats	Check seat position controls such as seat adjusters, seatback recliner, etc. to make sure they operate smoothly and that all latches lock securely in every position. Check that the head restraints move up and down smoothly and that the locks (if equipped) hold securely in all latched positions. Check that the latches lock securely for folding-down rear seatbacks.	—
Seat belts	Check that all parts of the seat belt system (e.g. buckles, anchors, adjusters and retractors) operate properly and smoothly and are installed securely. Check the belt webbing for cuts, fraying, wear or damage.	MA-39
Accelerator pedal	Check the pedal for smooth operation and make sure the pedal does not catch or require uneven effort. Keep the floor mats away from the pedal.	—
Brakes	Check that the brake does not pull the vehicle to one side when applied.	—
Brake pedal and booster	Check the lever or pedal for smooth operation and make sure it has the proper distance under it when depressed fully. Check the brake booster function. Be sure to keep the floor mats away from the pedal.	BR-7 BR-13
Clutch pedal	Make sure the pedal operates smoothly and check that it has the proper free play.	CL-5
Parking brake	Check that the lever has the proper travel and make sure that the vehicle is held securely on a fairly steep hill when only the parking brake is applied.	PB-3
Automatic transmission "Park" mechanism	Check that the lock release button on the selector lever operates properly and smoothly. On a fairly steep hill check that the vehicle is held securely with the selector lever in the P (Park) position without applying any brakes.	—

UNDER THE HOOD AND VEHICLE

The maintenance items listed here should be checked periodically (e.g. each time you check the engine oil or refuel).

Item		Reference page
Windshield washer fluid	Check that there is adequate fluid in the tank.	—
Engine coolant level	Check the coolant level when the engine is cold.	CO-7
Radiator and hoses	Check the front of the radiator and clean off any dirt, insects, leaves, etc., that may have accumulated. Make sure the hoses have no cracks, deformation, deterioration or loose connections.	—
Brake and clutch fluid level	Make sure that the brake and clutch fluid levels are between the "MAX" and "MIN" lines on the reservoir.	MA-34 MA-28
Battery	Check the fluid level in each cell. It should be between the "MAX" and "MIN" lines. Vehicles operated in high temperatures or under severe conditions require frequent checks of the battery fluid level.	PG-3
Engine drive belt	Make sure that no belt is frayed, worn, cracked or oily.	MA-18
Engine oil level	Check the level on the oil level gauge after parking the vehicle on a level spot and turning off the engine.	LU-6
Power steering fluid level and lines	Check the level on the dipstick with the engine off. Check the lines for improper attachment, leaks, cracks, etc.	MA-37
Exhaust system	Make sure there are no loose supports, cracks or holes. If the sound of the exhaust seems unusual or there is a smell of exhaust fumes, immediately locate the trouble and correct it.	MA-27
Underbody	The underbody is frequently exposed to corrosive substances such as those used on icy roads or to control dust. It is very important to remove these substances, otherwise rust will form on the floor pan, frame, fuel lines and around the exhaust system. At the end of winter, the underbody should be thoroughly flushed with plain water, being careful to clean those areas where mud and dirt can easily accumulate.	—
Fluid leaks	Check under the vehicle for fuel, oil, water or other fluid leaks after the vehicle has been parked for a while. Water dripping from the air conditioner after use is normal. If you should notice any leaks or gasoline fumes are evident, check for the cause and correct it immediately.	—

EXCEPT FOR NORTH AMERICA

GENERAL MAINTENANCE

< PERIODIC MAINTENANCE >

[REGULAR GRADE]

EXCEPT FOR NORTH AMERICA : General Maintenance

INFOID:000000004639604

General maintenance includes those items which should be checked during the normal day-to-day operation of the vehicle. They are essential if the vehicle is to continue operating properly. The owners can perform the checks and inspections themselves or they can have their NISSAN dealers do them for a normal charge.

OUTSIDE THE VEHICLE

The maintenance items listed here should be performed from time to time, unless otherwise specified.

	Item	Reference page
Tires	Check the pressure with a gauge often and always prior to long distance trips. Adjust the pressure in all tires, including the spare, to the pressure specified. Check carefully for damage, cuts or excessive wear.	WT-100
Windshield wiper blades	Check for cracks or wear if not functioning correctly.	—
Doors and engine hood	Check that all doors and the engine hood operate properly. Also make sure that all latches lock securely. Lubricate if necessary. Make sure that the secondary latch keeps the hood from opening when the primary latch is released. When driving in areas using road salt or other corrosive materials, check for lubrication frequently.	MA-39
Tire rotation	Tires cannot be rotated, as front tires are different size from rear tires and the direction of wheel rotation is fixed in each tire.	MA-32
Tire Pressure Monitoring System (TPMS) transmitter components	Replace the TPMS transmitter grommet seal, valve core and cap when the tires are replaced due to wear or age.	WT-97

INSIDE THE VEHICLE

The maintenance items listed here should be checked on a regular basis, such as when performing periodic maintenance, cleaning the vehicle, etc.

	Item	Reference page
Lamps	Make sure that the headlamps, stop lamps, tail lamps, turn signal lamps, and other lamps are all operating properly and installed securely. Also check headlamp aim.	—
Warning lamps and chimes	Make sure that all warning lamps and chimes are operating properly.	—
Steering wheel	Check that it has the specified play. Check for changes in the steering conditions, such as excessive free play, hard steering or strange noises. Free play: Less than 35 mm (1.38 in)	—
Seat belts	Check that all parts of the seat belt system (e.g. buckles, anchors, adjusters and retractors) operate properly and smoothly, and are installed securely. Check the belt webbing for cuts, fraying, wear or damage.	MA-39

UNDER THE HOOD AND VEHICLE

The maintenance items listed here should be checked periodically (e.g. each time you check the engine oil or refuel).

	Item	Reference page
Windshield washer fluid	Check that there is adequate fluid in the tank.	—
Engine coolant level	Check the coolant level when the engine is cold.	MA-18
Engine oil level	Check the level after parking the vehicle (on a level ground) and turning off the engine.	LU-6
Brake and clutch fluid levels	Make sure that the brake and clutch fluid levels are between the "MAX" and "MIN" lines on the reservoirs.	MA-34 MA-28
Battery	Check the fluid level in each cell. It should be between the "MAX" and "MIN" lines.	—

PERIODIC MAINTENANCE

< PERIODIC MAINTENANCE >

[REGULAR GRADE]

PERIODIC MAINTENANCE FOR NORTH AMERICA

FOR NORTH AMERICA : Introduction of Periodic Maintenance

INFOID:000000004498774

Two different maintenance schedules are provided, and should be used, depending upon the conditions in which the vehicle is mainly operated. **After 60,000 miles (96,000 km) or 48 months, continue the periodic maintenance at the same mileage/time intervals.**

Schedule 1	Follow Periodic Maintenance Schedule 1 if the driving habits frequently include one or more of the following driving conditions: <ul style="list-style-type: none"> • Repeated short trips of less than 5 miles (8 km). • Repeated short trips of less than 10 miles (16 km) with outside temperatures remaining below freezing. • Operating in hot weather in stop-and-go “rush hour” traffic. • Extensive idling and/or low speed driving for long distances, such as police, taxi or door-to-door delivery use. • Driving in dusty conditions. • Driving on rough, muddy, or salt spread roads. • Towing a trailer, using a camper or a car-top carrier. 	Emission Control System Maintenance	MA-8
		Chassis and Body Maintenance	
Schedule 2	Follow Periodic Maintenance Schedule 2 if none of driving conditions shown in Schedule 1 apply to the driving habits.	Emission Control System Maintenance	MA-10
		Chassis and Body Maintenance	

FOR NORTH AMERICA : Schedule 1

INFOID:000000004498775

EMISSION CONTROL SYSTEM MAINTENANCE

Abbreviations: R = Replace. I = Inspect. Correct or replace if necessary. []: At the mileage interval only

MAINTENANCE OPERATION		MAINTENANCE INTERVAL								Reference Section - Page or - Content Title
Perform at number of miles, kilometers or months, whichever comes first.	Miles × 1,000 (km × 1,000) Months	3.75 (6)	7.50 (12)	11.25 (18)	15 (24)	18.75 (30)	22.5 (36)	26.25 (42)	30 (48)	
Drive belt	NOTE (1)									MA-18
Air cleaner filter	NOTE (2)								[R]	MA-23
EVAP vapor lines									I*	MA-26
Fuel lines									I*	MA-23
Fuel filter	NOTE (3)									—
Engine coolant	NOTE (4)									MA-19
Engine oil		R	R	R	R	R	R	R	R	MA-23
Engine oil filter (Use genuine NISSAN engine oil filter or equivalent.)		R	R	R	R	R	R	R	R	MA-24
Spark plugs (Iridium-tipped type)	NOTE (5)	Replace every 105,000 miles (169,000 km).								MA-25
Intake & exhaust valve clearance*	NOTE (6)									EM-18

MAINTENANCE OPERATION		MAINTENANCE INTERVAL								Reference Section - Page or - Content Title
Perform at number of miles, kilometers or months, whichever comes first.	Miles × 1,000 (km × 1,000) Months	33.75 (54)	37.5 (60)	41.25 (66)	45 (72)	48.75 (78)	52.5 (84)	56.25 (90)	60 (96)	
Drive belt	NOTE (1)								I*	MA-18
Air cleaner filter	NOTE (2)								[R]	MA-23
EVAP vapor lines									I*	MA-26

PERIODIC MAINTENANCE

< PERIODIC MAINTENANCE >

[REGULAR GRADE]

MAINTENANCE OPERATION		MAINTENANCE INTERVAL								Reference Section - Page or - Content Title
Perform at number of miles, kilometers or months, whichever comes first.	Miles × 1,000 (km × 1,000) Months	33.75 (54) 27	37.5 (60) 30	41.25 (66) 33	45 (72) 36	48.75 (78) 39	52.5 (84) 42	56.25 (90) 45	60 (96) 48	
Fuel lines									I*	MA-23
Fuel filter	NOTE (3)									—
Engine coolant	NOTE (4)								R*	MA-19
Engine oil		R	R	R	R	R	R	R	R	MA-23
Engine oil filter (Use genuine NISSAN engine oil filter or equivalent.)		R	R	R	R	R	R	R	R	MA-24
Spark plugs (Iridium-tipped type)	NOTE (5)	Replace every 105,000 miles (169,000 km).								MA-25
Intake & exhaust valve clearance*	NOTE (6)									EM-18

NOTE:

- (1) After 60,000 miles (96,000 km) or 48 months, inspect every 15,000 miles (24,000 km) or 12 months. Replace the drive belt if found damaged or if the auto belt tensioner reading reaches the maximum limit.
- (2) If operating mainly in dusty conditions, more frequent maintenance may be required.
- (3) Maintenance-free item. For service procedures, refer to FL section.
- (4) After 60,000 miles (96,000 km) or 48 months, replace every 30,000 miles (48,000 km) or 24 months.
- (5) Replace spark plug when the spark plug gap exceeds 1.4 mm (0.055 in) even if within specified periodic replacement mileage.
- (6) Periodic maintenance is not required. However, if valve noise increases, inspect valve clearance.

* Maintenance items and intervals with “*” are recommended by NISSAN for reliable vehicle operation. The owner need not perform such maintenance in order to maintain the emission warranty or manufacturer recall liability. Other maintenance items and intervals are required.

CHASSIS AND BODY MAINTENANCE

Abbreviations: R = Replace. I = Inspect. Correct or replace if necessary.

MAINTENANCE OPERATION		MAINTENANCE INTERVAL								Reference Section - Page or - Content Title
Perform at number of miles, kilometers or months, whichever comes first.	Miles × 1,000 (km × 1,000) Months	3.75 (6) 3	7.50 (12) 6	11.25 (18) 9	15 (24) 12	18.75 (30) 15	22.5 (36) 18	26.25 (42) 21	30 (48) 24	
Brake lines & cables					I				I	MA-35
Brake pads & rotors			I		I		I		I	MA-35
Automatic transmission fluid	NOTE (3)									—
Manual transmission gear oil & differential gear oil	NOTE (1)				I				I	MA-27 MA-30 MA-31
Steering gear & linkage, axle & suspension parts			I		I		I		I	MA-36 MA-37
Tire rotation	NOTE (2)									MA-5 MA-32
Exhaust system			I		I		I		I	MA-27

MAINTENANCE OPERATION		MAINTENANCE INTERVAL								Reference Section - Page or - Content Title
Perform at number of miles, kilometers or months, whichever comes first.	Miles × 1,000 (km × 1,000) Months	33.75 (54) 27	37.5 (60) 30	41.25 (66) 33	45 (72) 36	48.75 (78) 39	52.5 (84) 42	56.25 (90) 45	60 (96) 48	
Brake lines & cables					I				I	MA-35
Brake pads & rotors			I		I		I		I	MA-35
Automatic transmission fluid	NOTE (3)									—

PERIODIC MAINTENANCE

< PERIODIC MAINTENANCE >

[REGULAR GRADE]

MAINTENANCE OPERATION		MAINTENANCE INTERVAL								Reference Section - Page or - Content Title
Perform at number of miles, kilometers or months, whichever comes first.	Miles × 1,000 (km × 1,000) Months	33.75 (54) 27	37.5 (60) 30	41.25 (66) 33	45 (72) 36	48.75 (78) 39	52.5 (84) 42	56.25 (90) 45	60 (96) 48	
Manual transmission gear oil & differential gear oil	NOTE (1)				I				I	MA-27 MA-30 MA-31
Steering gear & linkage, axle & suspension parts			I		I		I		I	MA-36 MA-37
Tire rotation	NOTE (2)									MA-5 MA-32
Exhaust system			I		I		I		I	MA-27

NOTE:

- (1) If towing a trailer, using a camper or a car-top carrier, or driving on rough or muddy roads, change (not just inspect) fluid/oil at every 30,000 miles (48,000 km) or 24 months.
- (2) Refer to "Tire rotation" under the "General maintenance" heading earlier in this section.
- (3) Automatic transmission fluid is maintenance-free.

FOR NORTH AMERICA : Schedule 2

INFOID:000000004498776

EMISSION CONTROL SYSTEM MAINTENANCE

Abbreviations: R = Replace. I = Inspect. Correct or replace if necessary. []: At the mileage interval only

MAINTENANCE OPERATION		MAINTENANCE INTERVAL								Reference Section - Page or - Content Title
Perform at number of miles, kilometers or months, whichever comes first.	Miles × 1,000 (km × 1,000) Months	7.5 (12) 6	15 (24) 12	22.5 (36) 18	30 (48) 24	37.5 (60) 30	45 (72) 36	52.5 (84) 42	60 (96) 48	
Drive belt	NOTE (1)								I*	MA-18
Air cleaner filter					[R]				[R]	MA-23
EVAP vapor lines					I*				I*	MA-26
Fuel lines					I*				I*	MA-23
Fuel filter	NOTE (2)									—
Engine coolant	NOTE (3)								R*	MA-19
Engine oil		R	R	R	R	R	R	R	R	MA-23
Engine oil filter (Use genuine NISSAN engine oil filter or equivalent.)		R	R	R	R	R	R	R	R	MA-24
Spark plugs (Iridium-tipped type)	NOTE (4)	Replace every 105,000 miles (169,000 km).								MA-25
Intake & exhaust valve clearance*	NOTE (5)									EM-18

NOTE:

- (1) After 60,000 miles (96,000 km) or 48 months, inspect every 15,000 miles (24,000 km) or 12 months. Replace the drive belt if found damaged or if the auto belt tensioner reading reaches the maximum limit.
- (2) Maintenance-free item. For service procedures, refer to FL section.
- (3) After 60,000 miles (96,000 km) or 48 months, replace every 30,000 miles (48,000 km) or 24 months.
- (4) Replace spark plug when the spark plug gap exceeds 1.4 mm (0.055 in) even if within specified periodic replacement mileage.
- (5) Periodic maintenance is not required. However, if valve noise increases, inspect valve clearance.

* Maintenance items and intervals with "*" are recommended by NISSAN for reliable vehicle operation. The owner need not perform such maintenance in order to maintain the emission warranty or manufacturer recall liability. Other maintenance items and intervals are required.

CHASSIS AND BODY MAINTENANCE

PERIODIC MAINTENANCE

< PERIODIC MAINTENANCE >

[REGULAR GRADE]

Abbreviations: R = Replace. I = Inspect. Correct or replace if necessary.

MAINTENANCE OPERATION		MAINTENANCE INTERVAL								Reference Section - Page or - Content Title
Perform at number of miles, kilometers or months, whichever comes first.	Miles × 1,000 (km × 1,000)	7.5 (12)	15 (24)	22.5 (36)	30 (48)	37.5 (60)	45 (72)	52.5 (84)	60 (96)	
	Months	6	12	18	24	30	36	42	48	
Brake lines & cables			I		I		I		I	MA-35
Brake pads & rotors			I		I		I		I	MA-35
Automatic transmission fluid	NOTE (2)									—
Manual transmission gear oil & differential gear oil			I		I		I		I	MA-27 MA-30 MA-31
Steering gear & linkage, axle & suspension parts					I				I	MA-36 MA-37
Tire rotation	NOTE (1)									MA-5 MA-32
Exhaust system					I				I	MA-27

NOTE:

(1) Refer to "Tire rotation" under the "General maintenance" heading earlier in this section.

(2) Automatic transmission fluid is maintenance-free.

EXCEPT FOR NORTH AMERICA

EXCEPT FOR NORTH AMERICA : Periodic Maintenance

INFOID:000000004639608

The following tables show the normal maintenance schedule. Depending upon weather and atmospheric conditions, varying road surfaces, individual driving habits and vehicle usage, additional or more frequent maintenance may be required.

Periodic maintenance beyond the last period shown on the tables requires similar maintenance.

ENGINE AND EMISSION CONTROL MAINTENANCE

Abbreviations: I = Inspect and correct or replace as necessary, R = Replace, E = Check and correct the engine coolant mixture ratio.

MAINTENANCE OPERATION		MAINTENANCE INTERVAL								Reference page
Perform either at number of kilometers (miles) or months, whichever comes first.	km × 1,000 (Miles × 1,000)	10 (6)	20 (12)	30 (18)	40 (24)	50 (30)	60 (36)	70 (42)	80 (48)	
	Months	6	12	18	24	30	36	42	48	
Underhood and under vehicle										
Intake & exhaust valve clearance	See NOTE (1)									EM-18
Drive belt	See NOTE (2)				I				I	MA-18
Engine oil (Use recommended oil.)★		R	R	R	R	R	R	R	R	MA-23
Engine oil filter (Use genuine NISSAN engine oil filter or equivalent)★		R	R	R	R	R	R	R	R	MA-24
Engine coolant (Use Genuine NISSAN Engine Coolant or equivalent in its quality.)	See NOTE (3)				E				R	MA-19
Cooling system			I		I		I		I	MA-18 MA-22 MA-22
Fuel lines					I				I	MA-23

PERIODIC MAINTENANCE

< PERIODIC MAINTENANCE >

[REGULAR GRADE]

MAINTENANCE OPERATION		MAINTENANCE INTERVAL								Reference page
Perform either at number of kilometers (miles) or months, whichever comes first.	km × 1,000 (Miles × 1,000) Months	10 (6) 6	20 (12) 12	30 (18) 18	40 (24) 24	50 (30) 30	60 (36) 36	70 (42) 42	80 (48) 48	
Air cleaner filter (Viscous paper type)★					R				R	MA-23
Fuel filter (In-tank type)	See NOTE (4)									—
Spark plugs (Iridium-tipped type)	See NOTE (5)	Replace every 100,000 km (60,000 miles)								MA-25
EVAP vapor lines (With carbon canister)					I				I	MA-26

NOTE:

- Maintenance items with “★” should be performed more frequently according to “Maintenance Under Severe Driving Conditions”.
- (1) Periodic maintenance is not required. However, if valve noise increases, check valve clearance.
- (2) Replace the drive belt if found damaged or if the auto belt tensioner reading reaches the maximum limit.
- (3) Use Genuine NISSAN Engine Coolant or equivalent in its quality, in order to avoid possible aluminum corrosion within the engine cooling system caused by the use of non-genuine engine coolant. After first replacement, replace every 40,000 km (24,000 miles) or 24 months.
- (4) Maintenance-free item. For service procedures, refer to FL section.
- (5) Replace spark plug when the spark plug gap exceeds 1.4 mm (0.055 in) even if within specified periodic replacement mileage.

CHASSIS AND BODY MAINTENANCE

Abbreviations: I = Inspect and correct or replace as necessary, R = Replace, L = Lubricate.

MAINTENANCE OPERATION		MAINTENANCE INTERVAL								Reference page
Perform either at number of kilometers (miles) or months, whichever comes first.	km × 1,000 (Miles × 1,000) Months	10 (6) 6	20 (12) 12	30 (18) 18	40 (24) 24	50 (30) 30	60 (36) 36	70 (42) 42	80 (48) 48	
Underhood and under vehicle										
Brake and clutch fluid (For level & leaks)		I	I	I	I	I	I	I	I	MA-34 MA-28
Brake fluid★					R				R	MA-35
Brake booster vacuum hoses, connections & check valve					I				I	BR-13
Brake, clutch & exhaust system		I	I	I	I	I	I	I	I	MA-34 MA-27
Automatic transmission fluid	See NOTE (1)									—
Manual transmission gear oil (For level & leaks)		I	I	I	I	I	I	I	I	MA-27
Differential gear oil (For level & leaks)★		I	I	I	I	I	I	I	I	MA-30 MA-31
Steering gear & linkage, axle & suspension parts, & propeller shaft★			I		I		I		I	MA-36 MA-37 MA-29
Outside and inside										
Wheel alignment (If necessary, balance wheels)			I		I		I		I	FSU-8 RSU-6 MA-32
Brake pads, rotors & other brake components★		I	I	I	I	I	I	I	I	BR-14 BR-16 MA-35
Locks, hinges & hood latch★		L	L	L	L	L	L	L	L	MA-39

PERIODIC MAINTENANCE

< PERIODIC MAINTENANCE >

[REGULAR GRADE]

MAINTENANCE OPERATION	km × 1,000 (Miles × 1,000)	10 (6)	20 (12)	30 (18)	40 (24)	50 (30)	60 (36)	70 (42)	80 (48)	Reference page
Perform either at number of kilometers (miles) or months, whichever comes first.	Months	6	12	18	24	30	36	42	48	
Seat belts, buckles, retractors, anchors & adjusters										MA-39
Foot brake, parking brake & clutch (For free play, stroke & operation)										BR-7 PB-3 CL-5

NOTE:

- Maintenance items with “★” should be performed more frequently according to “Maintenance Under Severe Driving Conditions”.
- (1) Automatic transmission fluid is maintenance-free.

MAINTENANCE UNDER SEVERE DRIVING CONDITIONS

The maintenance intervals shown on the preceding pages are for normal operating conditions. If the vehicle is mainly operated under severe driving conditions as shown below, more frequent maintenance must be performed on the following items as shown in the table.

Severe driving conditions

- A — Driving under dusty conditions
- B — Driving repeatedly short distances
- C — Towing a trailer or caravan
- D — Extensive idling
- E — Driving in extremely adverse weather conditions or in areas where ambient temperatures are either extremely low or extremely high
- F — Driving in high humidity or mountainous areas
- G — Driving in areas using salt or other corrosive materials
- H — Driving on rough and/or muddy roads or in the desert
- I — Driving with frequent use of braking or in mountainous areas
- J — Frequent driving in water

Driving condition	Maintenance item	Maintenance operation	Maintenance interval	Reference page
A	Air cleaner filter Viscous paper type	Replace	More frequently	MA-23
A B C D	Engine oil & engine oil filter	Replace	Every 5,000 km (3,000 miles) or 3 months	MA-23 MA-24
. F	Brake fluid	Replace	Every 20,000 km (12,000 miles) or 12 months	MA-35
. . C H	Differential gear oil	Replace	Every 40,000 km (24,000 miles) or 24 months	MA-30 MA-31
. G H	Steering gear & linkage, axle & suspension parts, & propeller shaft	Inspect	Every 10,000 km (6,000 miles) or 6 months	MA-36 MA-37 MA-29
A . C G H I	Brake pads, rotors & other brake components	Inspect	Every 5,000 km (3,000 miles) or 3 months	BR-14 BR-16 MA-35
. G	Locks, hinges & hood latch	Lubricate	Every 5,000 km (3,000 miles) or 3 months	MA-39

RECOMMENDED FLUIDS AND LUBRICANTS

< PERIODIC MAINTENANCE >

[REGULAR GRADE]

RECOMMENDED FLUIDS AND LUBRICANTS FOR NORTH AMERICA

FOR NORTH AMERICA : Fluids and Lubricants

INFOID:000000004498777

		Capacity (Approximate)			Recommended Fluids/Lubricants
		US measure	Imp measure	Liter	
Engine oil Drain and refill	With oil filter change	5-1/8 qt	4-3/8 qt	4.9	<ul style="list-style-type: none"> • Engine oil with API Certification Mark^{*1, *2} • Viscosity SAE 5W-30^{*1, *2}
	Without oil filter change	4-7/8 qt	4 qt	4.6	
Dry engine (Overhaul)		6 qt	5 qt	5.7	
Cooling system	With reservoir tank	A/T models	9 qt	7-1/2 qt	Genuine NISSAN Long Life Antifreeze/ Coolant or equivalent
		M/T models	9-1/8 qt	7-5/8 qt	
	Reservoir tank	7/8 qt	3/4 qt	0.8	
Automatic transmission fluid		9-3/4 qt ^{*7}	8-1/8 qt ^{*7}	9.2 ^{*7}	Genuine NISSAN Matic S ATF ^{*3}
Manual transmission gear oil		6 pt	5 pt	2.83	Genuine NISSAN Manual Transmission Fluid (MTF) HQ Multi 75W-85 or API GL-4, Viscosity SAE 75W-85 or 75W-90
Differential gear oil		3 pt	2-1/2 pt	1.40	For A/T models: Genuine NISSAN Differential Oil Synthetic 75W-90 or API GL-5 synthetic gear oil, Viscosity SAE 75W-90 ^{*8} For M/T models: Genuine NISSAN Differential Oil Hypoid Super GL-5 80W-90 or API GL-5, Viscosity SAE 80W-90 ^{*4}
Power steering fluid (PSF)		1-1/8 qt	7/8 qt	1.0	Genuine NISSAN PSF or equivalent ^{*5}
Brake and clutch fluid		—	—	—	Genuine NISSAN Super Heavy Duty Brake Fluid ^{*6} or equivalent DOT 3 (US FMVSS No. 116)
Multi-purpose grease		—	—	—	NLGI No. 2 (Lithium soap base)
Windshield washer fluid		—	—	—	Genuine NISSAN Windshield Washer Concentrate Cleaner & Antifreeze or equivalent
Fuel recommendation		—	—	—	Refer to GI-30, "Fuel" .

*1: For further details, see "Engine Oil Recommendation".

*2: NISSAN recommends Genuine NISSAN Ester Engine Oil available a NISSAN dealer.

***3: Using automatic transmission fluid other than Genuine NISSAN Matic S ATF will cause deterioration in driveability and automatic transmission durability, and may damage the automatic transmission, which is not covered by the NISSAN new vehicle limited warranty.**

*4: For hot climates, viscosity SAE 90 is suitable for ambient temperatures above 0°C (32°F).

*5: DEXRON™ VI type ATF or Canada NISSAN Automatic Transmission Fluid may also be used.

*6: Available in mainland U.S.A. through a NISSAN dealer.

*7: The fluid capacity is the reference value.

*8: See an INFINITI dealer service for synthetic oil.

FOR NORTH AMERICA : Engine Oil Recommendation

INFOID:000000004498778

NISSAN recommends the use of an energy conserving oil in order to improve fuel economy. Select only engine oils that meet the American Petroleum Institute (API) certification and International Lubricant Standardization and Approval Committee (ILSAC) certification and SAE viscosity standard. These oils have the API certification mark on the front of the container. Oils which do not have the specified quality label should not be used as they could cause engine damage.

RECOMMENDED FLUIDS AND LUBRICANTS

< PERIODIC MAINTENANCE >

[REGULAR GRADE]

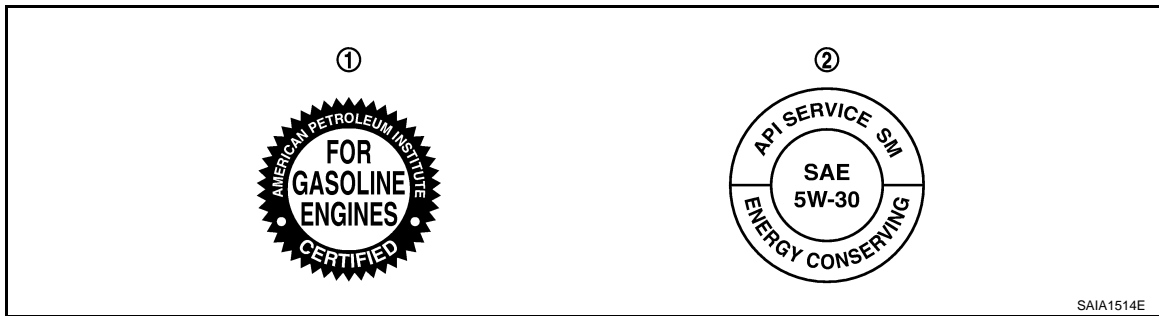

1. API certification mark
2. API service symbol

FOR NORTH AMERICA : Anti-Freeze Coolant Mixture Ratio

INFOID:000000004498779

The engine cooling system is filled at the factory with a high-quality, year-round, anti-freeze coolant solution. The anti-freeze solution contains rust and corrosion inhibitors. Therefore, additional cooling system additives are not necessary.

CAUTION:

When adding or replacing coolant, be sure to use only Genuine NISSAN Long Life Antifreeze/ Coolant or equivalent with the proper mixture ratio of 50% anti-freeze and 50% demineralized water/distilled water.

Other types of coolant solutions may damage your cooling system.

Outside temperature down to		Anti-freeze	Demineralized water or distilled water
°C	°F		
-35	-30	50%	50%

SMA947CA

EXCEPT FOR NORTH AMERICA

EXCEPT FOR NORTH AMERICA : Fluids and Lubricants

INFOID:000000004639613

		Capacity (Approximate)		Recommended Fluids/Lubricants
		Liter	Imp measure	
Engine oil Drain and refill	With oil filter change	4.9	4-3/8 qt	Genuine NISSAN engine oil ^{*1} API grade SL or SM ^{*1} ILSAC grade GF-2, GF-3 or GF-4 ^{*1} Viscosity SAE 10W-30
	Without oil filter change	4.6	4 qt	
Dry engine (engine overhaul)		5.7	5 qt	
Cooling system (with reservoir)	A/T models	8.5	7-1/2 qt	Genuine NISSAN Engine Coolant or equivalent in its quality ^{*2}
	M/T models	8.6	7-5/8 qt	
Reservoir tank		0.8	3/4 qt	
Automatic transmission fluid		9.2 ^{*4}	8-1/8 qt ^{*4}	Genuine NISSAN Matic S ATF ^{*3}
Manual transmission gear oil		2.83	5 pt	Genuine NISSAN Manual Transmission Fluid (MTF) HQ Multi 75W-85 or API GL-4, Viscosity SAE 75W-85 or 75W-90
Differential gear oil		1.40	2-1/2 pt	For A/T models Genuine NISSAN Differential Oil Synthetic 75W-90 or API GL-5 synthetic gear oil, Viscosity SAE 75W-90 ^{*5} For M/T models Genuine NISSAN Differential Oil Hypoid Super GL-5 80W-90 or API GL-5, Viscosity SAE 80W-90 ^{*1}
Brake and clutch fluid		—	—	DOT 3 (US FMVSS No. 116)
Multi-purpose grease		—	—	NLGI No. 2 (Lithium soap base)

*1: For further details, see "SAE Viscosity Number".

A
B
C
D
E
F
G
H
I
J
K
L
M
N
O

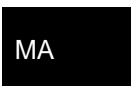

RECOMMENDED FLUIDS AND LUBRICANTS

< PERIODIC MAINTENANCE >

[REGULAR GRADE]

*2: Use Genuine NISSAN Engine Coolant or equivalent in its quality, in order to avoid possible aluminum corrosion within the engine cooling system caused by the use of non-genuine engine coolant.

Note that any repairs for the incidents within the engine cooling system while using non-genuine engine coolant may not be covered by the warranty even if such incidents occurred during the warranty period.

*3: Using automatic transmission fluid other than Genuine NISSAN Matic S ATF will cause deterioration in driveability and automatic transmission durability, and may damage the automatic transmission, which is not covered by warranty.

*4: The fluid capacity is the reference value.

*5: See an INFINITI dealer service for synthetic oil.

EXCEPT FOR NORTH AMERICA : SAE Viscosity Number

INFOID:000000004639614

GASOLINE ENGINE

- 10W-30 is preferable.
5W-30 is also preferable and will improve fuel economy.
If 10W-30 or 5W-30 is not available, select the viscosity, from the chart, that is suitable for the outside temperature range.

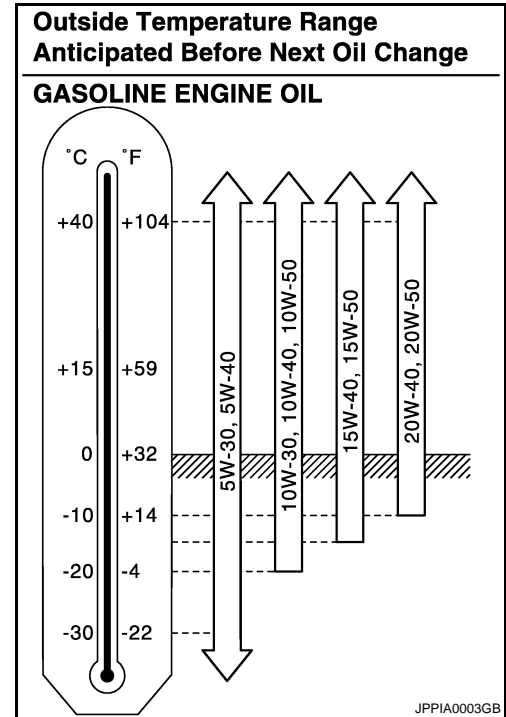

DIFFERENTIAL GEAR OIL

- For warm and areas: 80W-90 for the differential gear is preferable.
- For hot areas: 90 is suitable for ambient temperatures below 40°C (104°F).

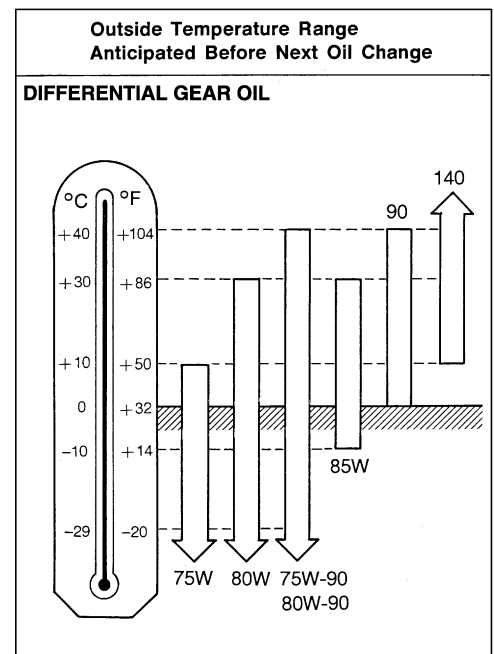

RECOMMENDED FLUIDS AND LUBRICANTS

< PERIODIC MAINTENANCE >

[REGULAR GRADE]

EXCEPT FOR NORTH AMERICA : Engine Coolant Mixture Ratio

INFOID:000000004639615

The engine cooling system is filled at the factory with a high-quality, year-round and extended life engine coolant. The high quality engine coolant contains the specific solutions effective for the anti-corrosion and the anti-freeze function. Therefore, additional cooling system additives are not necessary.

CAUTION:

- When adding or replacing coolant, be sure to use only Genuine NISSAN Engine Coolant or equivalent in its quality with the proper mixture ratio. See the examples shown right.

The use of other types of engine coolant may damage your cooling system.

- When checking the engine coolant mixture ratio by the coolant hydrometer, use the chart below to correct your hydrometer reading (specific gravity) according to coolant temperature.

Outside temperature down to		Composition	
°C	°F	Engine coolant (Concentrated)	Demineralized water or distilled water
-15	5	30%	70%
-35	-30	50%	50%

SMA089D

Mixed coolant specific gravity

Unit: specific gravity

Engine coolant mixture ratio	Coolant temperature °C (°F)			
	15 (59)	25 (77)	35 (95)	45 (113)
30%	1.046 - 1.050	1.042 - 1.046	1.038 - 1.042	1.033 - 1.038
50%	1.076 - 1.080	1.070 - 1.076	1.065 - 1.071	1.059 - 1.065

WARNING:

Never remove the radiator cap when the engine is hot. Serious burns could be caused by high pressure fluid escaping from the radiator. Wait until the engine and radiator cool down.

A
B
C
D
E
F
G
H
I
J
K
L
M
N
O

MA

ENGINE MAINTENANCE

DRIVE BELT

DRIVE BELT : Exploded View

INFOID:000000004751760

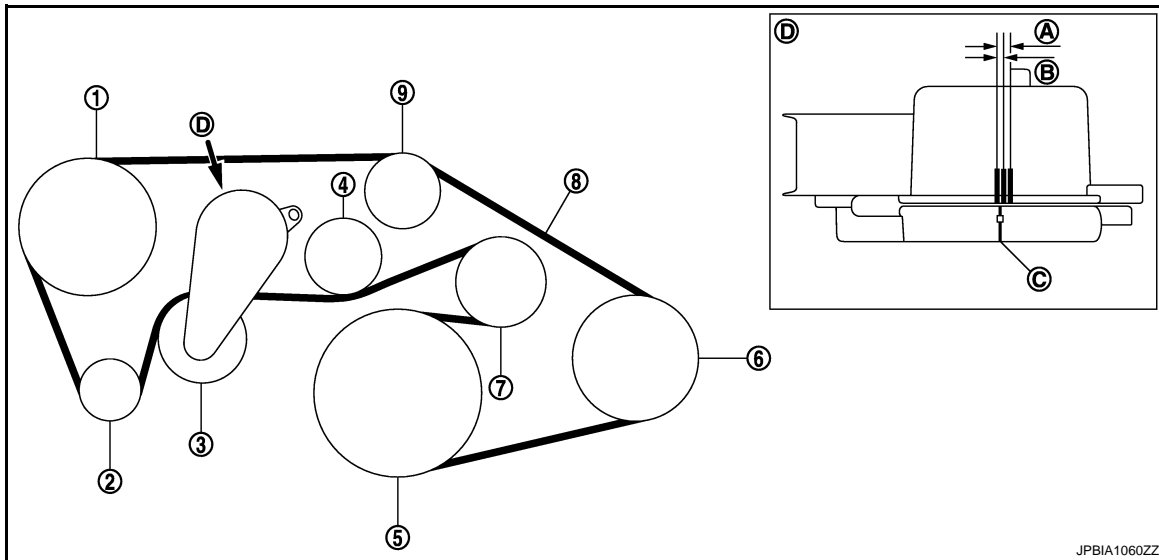

- | | | |
|----------------------------|---|------------------------------|
| 1. Power steering oil pump | 2. Alternator | 3. Drive belt auto-tensioner |
| 4. Idler pulley | 5. Crankshaft pulley | 6. A/C compressor |
| 7. Idler pulley | 8. Drive belt | 9. Idler pulley |
| A. Possible use range | B. Range when new drive belt is installed | C. Indicator |
| D. View D | | |

DRIVE BELT : Checking

INFOID:000000004751761

WARNING:

Be sure to perform this step when engine is stopped.

- Check that the indicator (C) (notch on fixed side) of drive belt auto-tensioner is within the possible use range (A).

NOTE:

- Check the drive belt auto-tensioner indication when the engine is cold.
- When new drive belt is installed, the indicator (notch on fixed side) should be within the range (B) in the figure.
- Visually check the entire drive belt for wear, damage or crack.
- If the indicator (notch on fixed side) is out of the possible use range or belt is damaged, replace drive belt.

DRIVE BELT : Tension Adjustment

INFOID:000000004751762

Refer to [EM-139. "Drive Belt"](#).

ENGINE COOLANT

ENGINE COOLANT : Inspection

INFOID:000000004751763

LEVEL

ENGINE MAINTENANCE

< PERIODIC MAINTENANCE >

[REGULAR GRADE]

- Check if the reservoir tank engine coolant level is within the “MIN” to “MAX” when the engine is cool.

A : MAX
B : MIN

- Adjust the engine coolant level if necessary.
- Check that the reservoir tank cap is tightened.

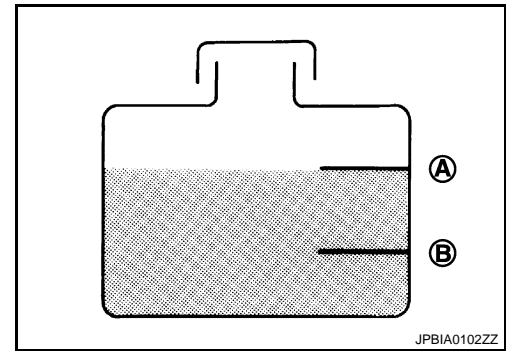

LEAKAGE

- To check for leakage, apply pressure to the cooling system with the radiator cap tester and radiator cap tester adapter (commercial service tool) (A).

Testing pressure : Refer to [CO-25. "Radiator"](#).

WARNING:

Never remove radiator cap when engine is hot. Serious burns could occur from high-pressure engine coolant escaping from water outlet (front).

CAUTION:

Higher test pressure than specified may cause radiator damage.

NOTE:

In a case that engine coolant decreases, replenish radiator with engine coolant.

- If anything is found, repair or replace damaged parts.

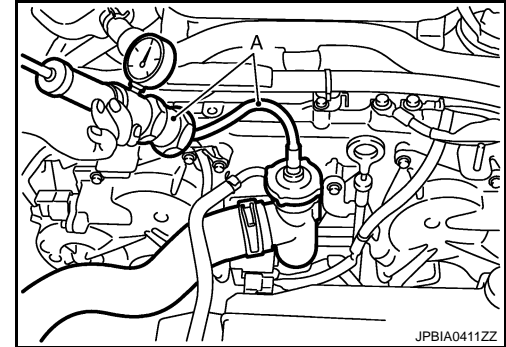

ENGINE COOLANT : Draining

INFOID:000000004751764

WARNING:

- To avoid being scalded, never change engine coolant when the engine is hot.
- Wrap a thick cloth around radiator cap and carefully remove radiator cap. First, turn radiator cap a quarter of a turn to release built-up pressure. Then turn radiator cap all the way.

1. Open radiator drain plug (2) at the bottom of radiator, and then remove radiator cap.

1 : Engine under cover
A : Radiator drain plug hole
⇐ : Vehicle front

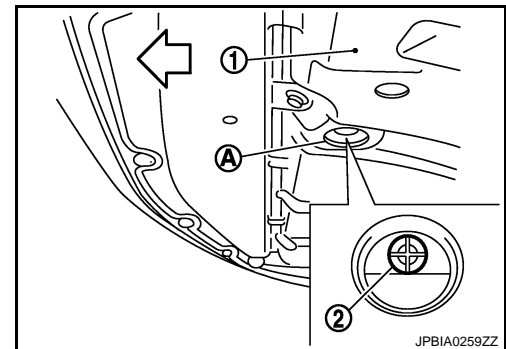

When draining all of engine coolant in the system, open water drain plugs on cylinder block. Refer to [EM-74. "Setting"](#).

2. Remove reservoir tank if necessary, and drain engine coolant and clean reservoir tank before installing.
3. Check drained engine coolant for contaminants such as rust, corrosion or discoloration. If contaminated, flush the engine cooling system. Refer to [MA-21. "ENGINE COOLANT : Flushing"](#).

ENGINE COOLANT : Refilling

INFOID:000000004751765

1. Install radiator drain plug.

CAUTION:

Be sure to clean drain plug and install with new O-ring.

A
B
C
D
E
F
G
H
I
J
K
L
M
N
O

MA

Tightening torque : Refer to [CO-13, "Exploded View"](#).

If water drain plugs on cylinder block are removed, close and tighten them. Refer to [EM-113, "Disassembly and Assembly"](#).

2. Remove air cleaner case (LH). Refer to [EM-27, "Exploded View"](#).
3. Install reservoir tank if removed.
4. Check that each hose clamp has been firmly tightened.
5. Remove air relief plug (2) on radiator left side.

- 1 : Reservoir tank
- 3 : Engine cover
- ⇐ : Vehicle front

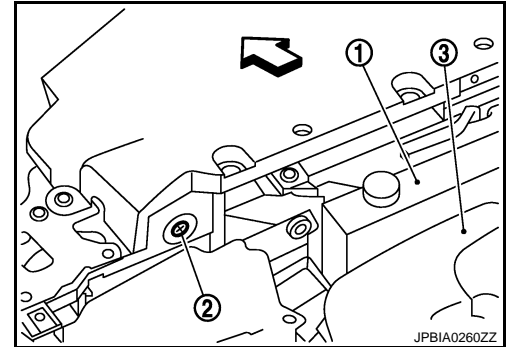

6. Fill radiator, and reservoir tank if removed, to specified level.
 - Pour engine coolant through engine coolant filler neck slowly of less than 2ℓ (2-1/8 US qt, 1-3/4 Imp qt) a minute to allow air in system to escape.
 - Use Genuine NISSAN Long Life Antifreeze/Coolant or equivalent mixed with water (distilled or demineralized). Refer to [MA-14, "FOR NORTH AMERICA : Fluids and Lubricants"](#) (FOR NORTH AMERICA) or [MA-15, "EXCEPT FOR NORTH AMERICA : Fluids and Lubricants"](#) (EXCEPT FOR NORTH AMERICA).

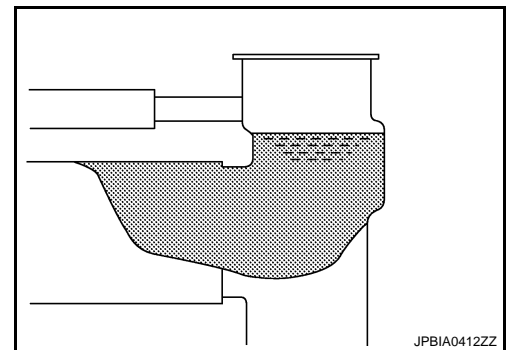

Engine coolant capacity : Refer to [CO-25, "Periodical Maintenance Specification"](#).
(With reservoir tank at "MAX" level)

Reservoir tank engine coolant capacity : Refer to [CO-25, "Periodical Maintenance Specification"](#).
(At "MAX" level)

- A : MAX
- B : MIN

7. When engine coolant overflows air relief hole on radiator, install air relief plug with new O-ring.

Tightening torque : Refer to [CO-13, "Exploded View"](#).

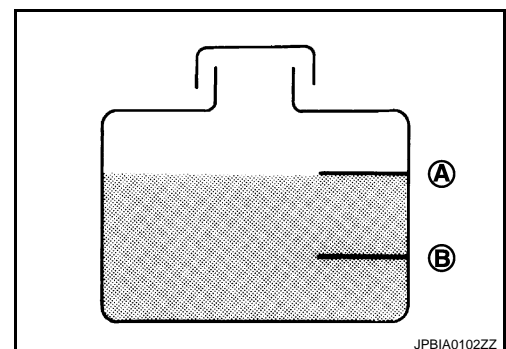

8. Repeat step 6.
9. Install air cleaner case (LH). Refer to [EM-27, "Exploded View"](#).
10. Install radiator cap.
11. Warm up engine until opening thermostat. Standard for warming-up time is approximately 10 minutes at 3,000 rpm.
 - Check thermostat opening condition by touching radiator hose (lower) to see a flow of warm water.

CAUTION:

Watch water temperature gauge so as not to overheat engine.

ENGINE MAINTENANCE

< PERIODIC MAINTENANCE >

[REGULAR GRADE]

12. Stop the engine and cool down to less than approximately 50°C (122°F).
 - Cool down using fan to reduce the time.
 - If necessary, refill radiator up to filler neck with engine coolant.
13. Refill reservoir tank to "MAX" level line with engine coolant.
14. Repeat steps 11 through 13 two or more times with radiator cap installed until engine coolant level no longer drops.
15. Check cooling system for leakage with engine running.
16. Warm up the engine, and check for sound of engine coolant flow while running engine from idle up to 3,000 rpm with heater temperature controller set at several position between "COOL" and "WARM".
 - Sound may be noticeable at heater unit.
17. Repeat step 16 three times.
18. If sound is heard, bleed air from cooling system by repeating step 6, and steps from 10 to 17 until engine coolant level no longer drops.
19. Check that the reservoir tank cap is tightened.

ENGINE COOLANT : Flushing

INFOID:000000004751766

1. Install radiator drain plug.

CAUTION:

Be sure to clean drain plug and install with new O-ring.

Tightening torque : Refer to [CO-13, "Exploded View"](#).

If water drain plugs on cylinder block are removed, close and tighten them. Refer to [EM-113, "Disassembly and Assembly"](#).

2. Remove air cleaner case (LH). Refer to [EM-27, "Exploded View"](#).
3. Install reservoir tank if removed.
4. Remove air relief plug (2) on radiator.

- 1 : Reservoir tank
- 3 : Engine cover
- ⇐ : Vehicle front

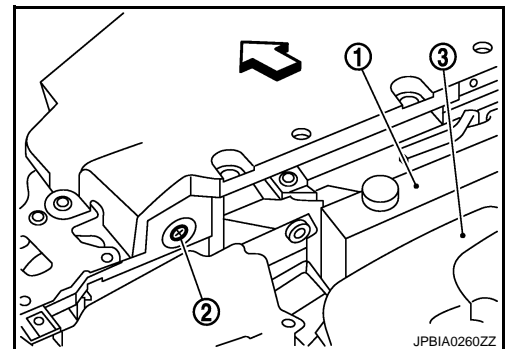

5. Fill radiator with water until water spills from the air relief hole, then close air relief plug.

Tightening torque : Refer to [CO-13, "Exploded View"](#).

6. Fill radiator and reservoir tank with water and reinstall radiator cap.
7. Install air cleaner case (LH). Refer to [EM-27, "Exploded View"](#).
8. Run the engine and warm it up to normal operating temperature.
9. Rev the engine two or three times under no-load.
10. Stop the engine and wait until it cools down.
11. Drain water from the system. Refer to [MA-19, "ENGINE COOLANT : Draining"](#).
12. Repeat steps 1 through 11 until clear water begins to drain from radiator.
13. Check that the reservoir tank cap is tightened.

RADIATOR CAP

RADIATOR CAP : Inspection

INFOID:000000004751767

- Check valve seat (A) of radiator cap.

B : Metal plunger

- Check if valve seat is swollen to the extent that the edge of the plunger cannot be seen when watching it vertically from the top.
- Check if valve seat has no soil and damage.

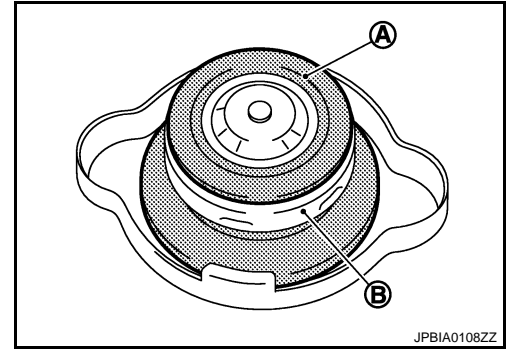

- Pull negative-pressure valve to open it, and check that it close completely when released.
- Check that there is no dirt or damage on the valve seat of radiator cap negative-pressure valve.
- Check that there are no unusualness in the opening and closing conditions of negative-pressure valve.

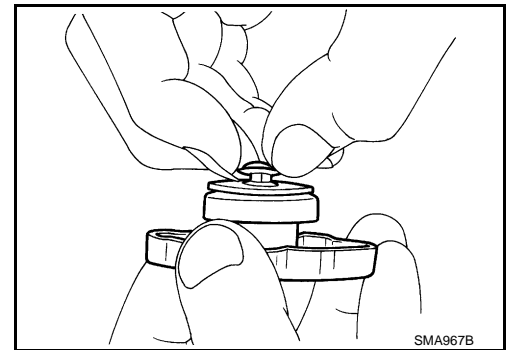

- Check radiator cap relief pressure.

Standard and limit : Refer to [CO-25. "Radiator"](#).

- When connecting radiator cap to the radiator cap tester and the radiator cap tester adapter (commercial service tool) (A), apply engine coolant to the cap seal surface.

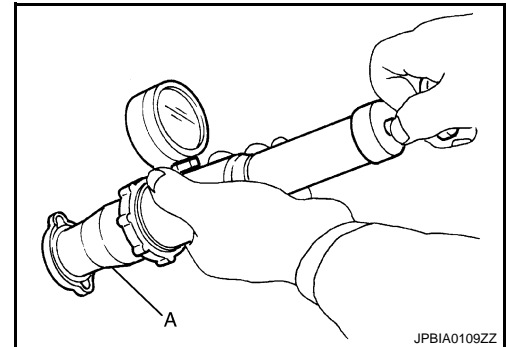

- Replace radiator cap if there is an unusualness related to the above three.

CAUTION:

When installing radiator cap, thoroughly wipe out the water outlet (front) filler neck to remove any waxy residue or foreign material.

RADIATOR

RADIATOR : Inspection

INFOID:000000004751768

Check radiator for mud or clogging. If necessary, clean radiator as follows:

- Be careful not to bend or damage radiator fins.
 - When radiator is cleaned without removal, remove all surrounding parts such as radiator cooling fan assembly and horns. Then tape harness and connectors to prevent water from entering.
1. Apply water by hose to the back side of the radiator core vertically downward.
 2. Apply water again to all radiator core surfaces once per minute.
 3. Stop washing if any stains no longer flow out from radiator.
 4. Blow air into the back side of radiator core vertically downward.
 - Use compressed air lower than 490 kPa (5 kg/cm², 71 psi) and keep distance more than 30 cm (11.8 in).
 5. Blow air again into all the radiator core surfaces once per minute until no water sprays out.

FUEL LINES

FUEL LINES : Inspection

INFOID:000000004751769

Inspect fuel lines, fuel filler cap and fuel tank for improper attachment, leakage, cracks, damage, loose connections, chafing or deterioration.

- A : Engine
- B : Fuel line
- C : Fuel tank

If necessary, repair or replace damaged parts.

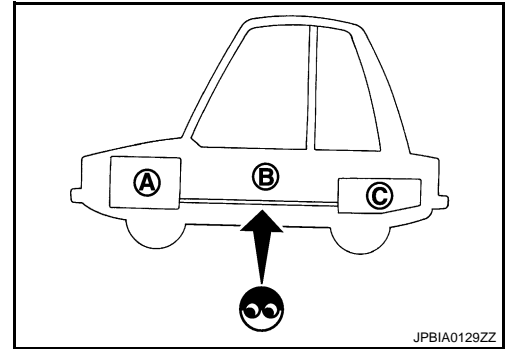

AIR CLEANER FILTER

AIR CLEANER FILTER : Removal and Installation

INFOID:000000004751770

REMOVAL

1. Unhook clips (A).

- 1 : Holder
- 2 : Air cleaner case

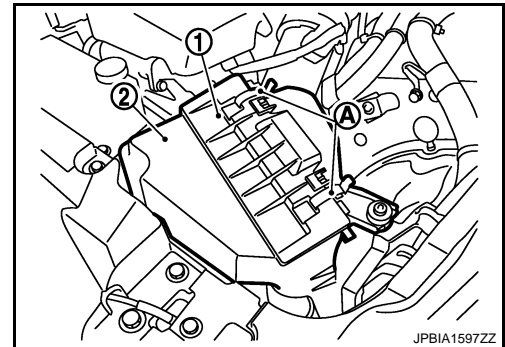

2. Remove holder (3) from air cleaner case (2), and then remove air cleaner filter (1) from holder.

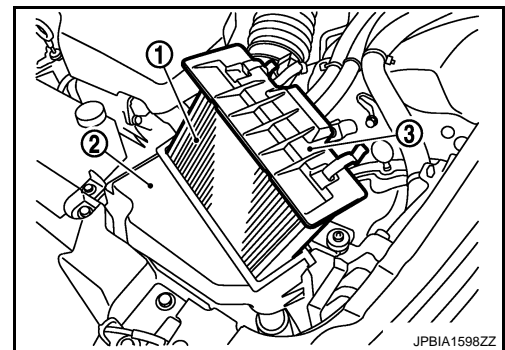

INSTALLATION

Note the following, and install in the reverse order of removal.

- Install the air cleaner filter by aligning the seal with the notch of air cleaner case.

ENGINE OIL

ENGINE OIL : Draining

INFOID:000000004751771

WARNING:

- Be careful not to get burn yourself, as engine oil may be hot.
- Prolonged and repeated contact with used engine oil may cause skin cancer. Try to avoid direct skin contact with used engine oil. If skin contact is made, wash thoroughly with soap or hand cleaner as soon as possible.

1. Warm up the engine, and check for engine oil leakage from engine components. Refer to [LU-6. "Inspection"](#).

A
B
C
D
E
F
G
H
I
J
K
L
M
N
O

MA

< PERIODIC MAINTENANCE >

2. Stop the engine and wait for 10 minutes.
3. Loosen oil filler cap.
4. Remove undercover with power tool.
5. Remove drain plug and then drain engine oil.

ENGINE OIL : Refilling

INFOID:000000004751772

1. Install drain plug with new washer. Refer to [EM-44, "Exploded View"](#).

CAUTION:

Be sure to clean drain plug and install with new washer.

Tightening torque : Refer to [EM-44, "Exploded View"](#).

2. Refill with new engine oil.

Engine oil specification and viscosity: Refer to [MA-14, "FOR NORTH AMERICA : Fluids and Lubricants"](#) (FOR AMERICA) or [MA-15, "EXCEPT FOR NORTH AMERICA : Fluids and Lubricants"](#) (EXCEPT FOR NORTH AMERICA).

Engine oil capacity : Refer to [LU-13, "Periodical Maintenance Specification"](#).

CAUTION:

- When filling engine oil, do not pull out oil level gauge.
- The refill capacity depends on the engine oil temperature and drain time. Use these specifications for reference only.
- Always use oil level gauge to determine the proper amount of engine oil in engine.

3. Warm up the engine and check area around drain plug and oil filter for engine oil leakage.
4. Stop the engine and wait for 10 minutes.
5. Check the engine oil level. Refer to [LU-6, "Inspection"](#).

OIL FILTER

OIL FILTER : Removal and Installation

INFOID:000000004751782

REMOVAL

CAUTION:

- Oil filter is provided with relief valve. Use genuine NISSAN oil filter or equivalent.
- Be careful not to get burned when engine and engine oil may be hot.
- When removing, prepare a shop cloth to absorb any engine oil leakage or spillage.
- Never allow engine oil to adhere to drive belt.
- Completely wipe off any engine oil that adheres to engine and vehicle.

1. Remove engine undercover with power tool.
2. Using oil filter wrench [SST: KV10115801 (J-38956)] (A), remove oil filter.

⇐ : Engine front

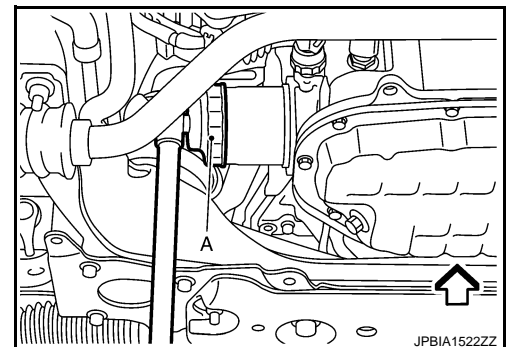

INSTALLATION

1. Remove foreign materials adhering to oil filter installation surface.

ENGINE MAINTENANCE

< PERIODIC MAINTENANCE >

[REGULAR GRADE]

2. Apply engine oil to the oil seal contact surface of new oil filter.

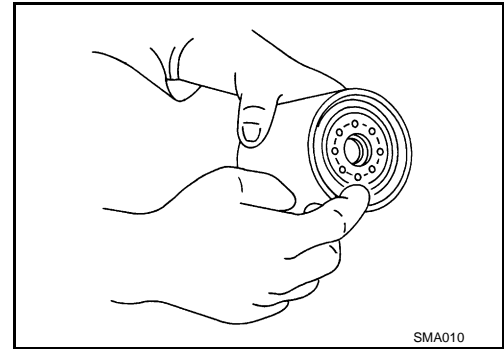

3. Screw oil filter manually until it touches the installation surface, then tighten it by 2/3 turn (A). Or tighten to the specification.

Oil filter:

: 17.7 N·m (1.8 kg·m, 13 ft·lb)

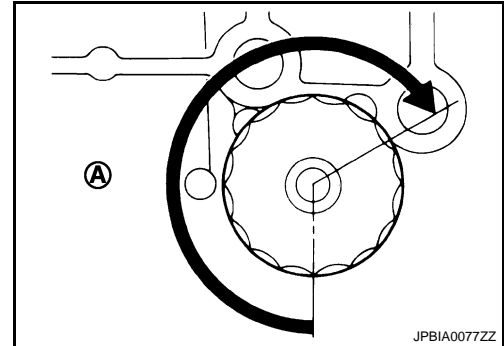

OIL FILTER : Inspection

INFOID:000000004751783

INSPECTION AFTER INSTALLATION

1. Check the engine oil level. Refer to [LU-6, "Inspection"](#).
2. Start the engine, and check there is no leakage of engine oil.
3. Stop the engine and wait for 10 minutes.
4. Check the engine oil level, and adjust the level. Refer to [LU-6, "Inspection"](#).

SPARK PLUG

SPARK PLUG : Removal and Installation

INFOID:000000004751784

REMOVAL

1. Remove engine cover with power tool. Refer to [EM-25, "Exploded View"](#).
2. Remove air cleaner case and air duct (RH and LH). Refer to [EM-27, "Exploded View"](#).
3. Remove electric throttle control actuator. Refer to [EM-29, "Exploded View"](#).
4. Remove ignition coil. Refer to [EM-47, "Removal and Installation"](#).
5. Remove spark plug with a spark plug wrench (commercial service tool).

a : 14 mm (0.55 in)

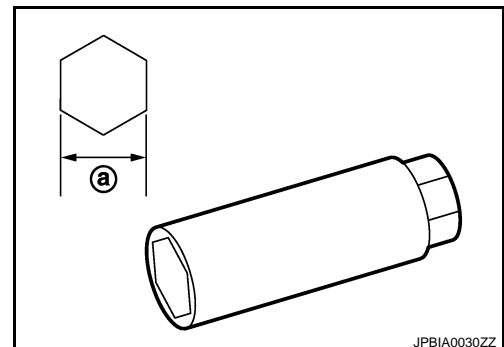

INSTALLATION

Installation is the reverse order of removal.

A
B
C
D
E
F
G
H
I
J
K
L
M
N
O

MA

SPARK PLUG : Inspection

INFOID:000000004751785

INSPECTION AFTER REMOVAL

Use the standard type spark plug for normal condition.

Spark plug (Standard type) : Refer to [EM-139, "Spark Plug"](#).

CAUTION:

- Never drop or shock spark plug.
- Never use a wire brush for cleaning.
- If plug tip is covered with carbon, use spark plug cleaner to clean.

Cleaner air pressure

: Less than 588 kPa (6 kg/cm², 85 psi)

Cleaning time

: Less than 20 seconds

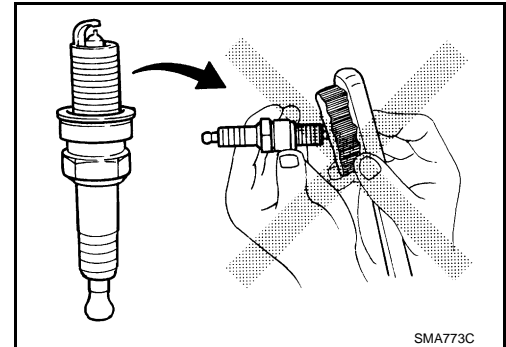

- Measure spark plug gap. When it exceeds the limit, replace spark plug even if it is within the specified replacement mileage. Refer to [EM-139, "Spark Plug"](#).
- Spark plug gap adjustment is not required between replacement intervals.

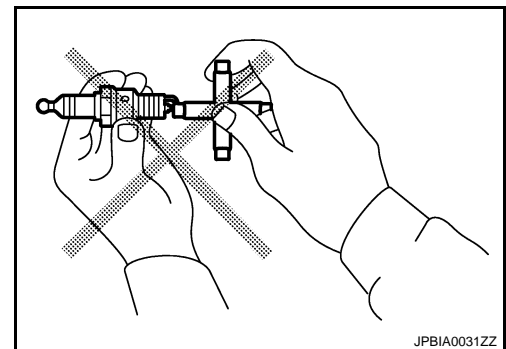

EVAP VAPOR LINES

EVAP VAPOR LINES : Inspection

INFOID:000000004498794

1. Visually inspect EVAP vapor lines for improper attachment and for cracks, damage, loose connections, chafing and deterioration.
2. Inspect fuel tank filler cap vacuum relief valve for clogging, sticking, etc.
Refer to [EC-604, "Inspection"](#).

CHASSIS MAINTENANCE

EXHAUST SYSTEM

EXHAUST SYSTEM : Inspection

INFOID:000000004751786

Check exhaust pipes, muffler, and mounting for improper attachment, leakage, cracks, damage or deterioration.

- If anything is found, repair or replace damaged parts.

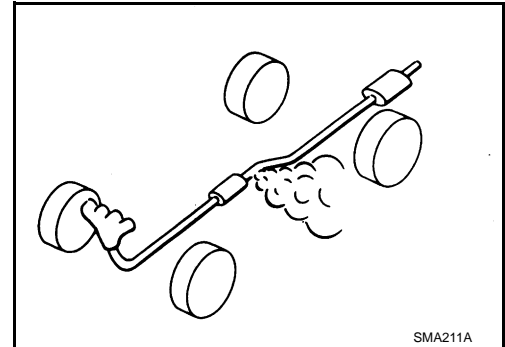

GEAR OIL

GEAR OIL : Inspection

INFOID:000000004689344

OIL LEAKAGE

Make sure that gear oil is not leaking from transmission or around it.

OIL LEVEL

1. Remove filler plug (1) and gasket from transmission case.
2. Check the oil level from filler plug mounting hole as shown in the figure.

CAUTION:

Never start engine while checking oil level.

3. Set a gasket on filler plug and then install it to transmission case.

CAUTION:

Never reuse gasket.

4. Tighten filler plug to the specified torque. Refer to [TM-42, "WITHOUT S-MODE : Exploded View"](#) (Without S-MODE) or [TM-74, "WITH S-MODE : Exploded View"](#) (With S-MODE).

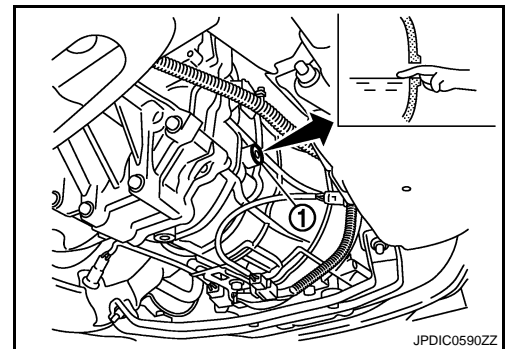

GEAR OIL : Draining

INFOID:000000004689345

1. Start the engine and let it run to warm up transmission.
2. Stop the engine.
3. Remove drain plug and gasket from transmission case and then drain gear oil.
4. Set a gasket on drain plug and install it to transmission case.

CAUTION:

Never reuse gasket.

5. Tighten drain plug to the specified torque. Refer to [TM-42, "WITHOUT S-MODE : Exploded View"](#) (Without S-MODE) or [TM-74, "WITH S-MODE : Exploded View"](#) (With S-MODE).

A
B
C
D
E
F
G
H
I
J
K
L
M
N
O

MA

CHASSIS MAINTENANCE

< PERIODIC MAINTENANCE >

[REGULAR GRADE]

GEAR OIL : Refilling

INFOID:000000004689346

1. Remove filler plug (1) and gasket from transmission case.
2. Fill with new gear oil to transmission as shown in the figure.

Oil grade and viscosity : Refer to [MA-14, "FOR NORTH AMERICA : Fluids and Lubricants"](#) (For North America) or [MA-15, "EXCEPT FOR NORTH AMERICA : Fluids and Lubricants"](#) (Except for North America).

Oil capacity : Refer to [TM-140, "General Specification"](#).

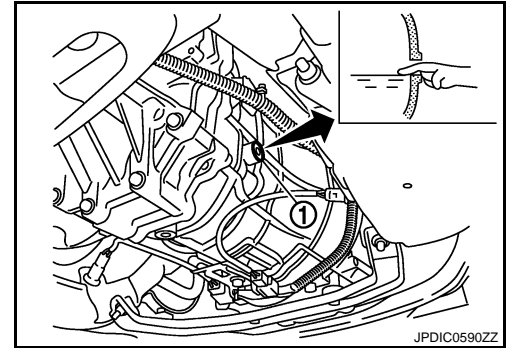

CAUTION:

Never reuse drained gear oil.

3. After refilling gear oil, check the oil level. Refer to [MA-27, "GEAR OIL : Inspection"](#).
4. Set a gasket on filler plug and then install it to transmission case.

CAUTION:

Never reuse gasket.

5. Tighten filler plug to the specified torque. Refer to [TM-42, "WITHOUT S-MODE : Exploded View"](#) (Without S-MODE) or [TM-74, "WITH S-MODE : Exploded View"](#) (With S-MODE).

CLUTCH FLUID

CLUTCH FLUID : Inspection

INFOID:000000004639651

FLUID LEAKAGE

- Check clutch line (tubes and hoses) for cracks, deterioration or other damage. Replace any damaged parts.
- Check for fluid leakage by fully depressing clutch pedal while engine is running.

CAUTION:

If leakage occurs around joints, retighten or, if necessary, replace damaged parts.

FLUID LEVEL

- Check that the fluid level in the reservoir tank is within the specified range (MAX – MIN lines).
- Visually check for any fluid leakage around the reservoir tank.
- Check the clutch system for any leakage if the fluid level is extremely low (lower than MIN).

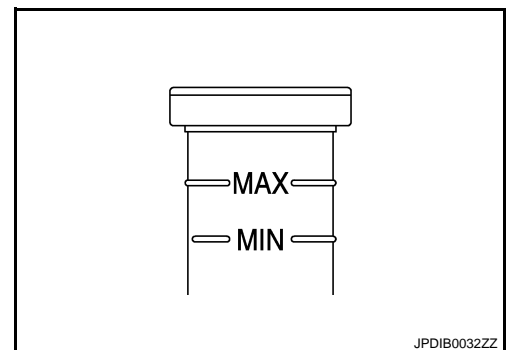

CLUTCH FLUID : Draining

INFOID:000000004689347

CAUTION:

Keep painted surface on the body or other parts free of clutch fluid. If it spills, wipe up immediately and wash the affected area with water.

CHASSIS MAINTENANCE

< PERIODIC MAINTENANCE >

[REGULAR GRADE]

1. Connect a transparent vinyl hose to air bleeder valve.
2. Depress clutch pedal and loosen air bleeder valve to gradually discharge clutch fluid.

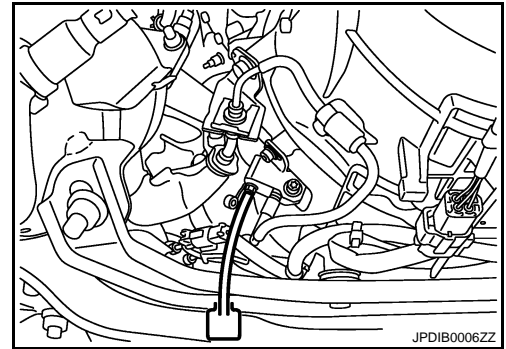

INFOID:000000004689348

CLUTCH FLUID : Refilling

CAUTION:

Keep painted surface on the body or other parts free of clutch fluid. If it spills, wipe up immediately and wash the affected area with water.

1. Check that there is no foreign material in reservoir tank and then fill with new clutch fluid.

CAUTION:

Never reuse drained clutch fluid.

2. Loosen air bleeder valve, slowly depress clutch pedal to the full stroke and then release clutch pedal.
3. Repeat this operation at intervals of 2 or 3 seconds until new clutch fluid is discharged.
4. Tighten air bleeder valve with the clutch pedal depressed.
5. Perform the air bleeding. Refer to [CL-6, "Air Bleeding Procedure"](#).

REAR PROPELLER SHAFT

REAR PROPELLER SHAFT : Inspection

INFOID:000000004751787

NOISE

- Check the propeller shaft tube surface for dents or cracks. If damaged, replace propeller shaft assembly.
- Check that there is clearance between the tube end and yoke flange. If no clearance is found, replace the propeller shaft.
- If there are cracks, peeling, or any other breakage on the seal (yoke and tube joint) replace the propeller shaft assembly.

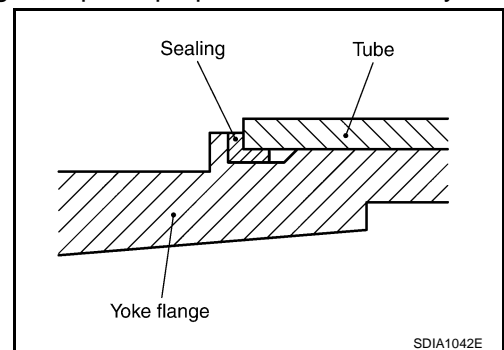

VIBRATION

If vibration is present at high speed, inspect propeller shaft runout first.

1. With a dial indicator, measure propeller shaft runout at runout measuring points by rotating final drive companion flange with hands.

Limit

Propeller shaft runout : Refer to [DLN-10, "Propeller Shaft Runout"](#).

2. If runout still exceeds specifications, separate propeller shaft at final drive companion flange; then rotate companion flange 90, 180, 270 degrees and install propeller shaft.
3. Check runout again. If runout still exceeds specifications, replace propeller shaft assembly.
4. Check the vibration by driving vehicle.

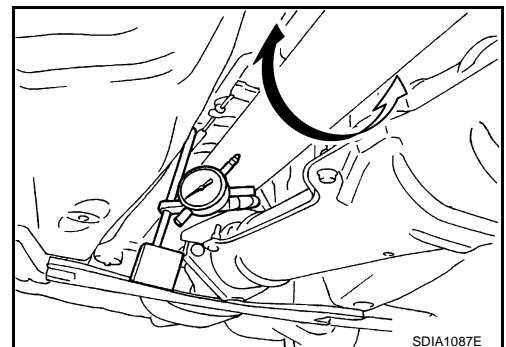

CHASSIS MAINTENANCE

< PERIODIC MAINTENANCE >

[REGULAR GRADE]

RUNOUT MEASURING POINT

Propeller shaft runout measuring point (Point "Δ").

↔: Vehicle front

Standard

M/T

A	: 340 mm (13.39 in)
B	: 610 mm (24.02 in)
C	: 340 mm (13.39 in)

A/T

A	: 340 mm (13.39 in)
B	: 580 mm (22.83 in)
C	: 340 mm (13.39 in)

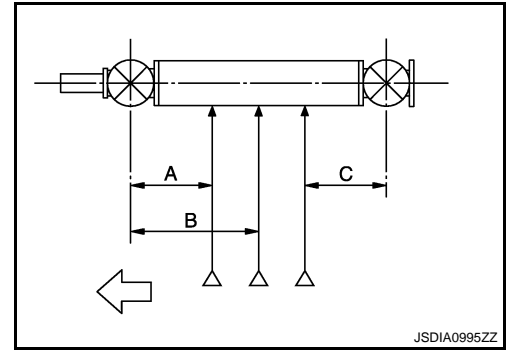

REAR DIFFERENTIAL GEAR OIL: R200

REAR DIFFERENTIAL GEAR OIL: R200 : Inspection

INFOID:000000004751788

OIL LEAKAGE

Make sure that oil is not leaking from final drive assembly or around it.

OIL LEVEL

- Remove filler plug (1) and check oil level from filler plug mounting hole as shown in the figure.

CAUTION:

Never start engine while checking oil level.

- Set a gasket on filler plug (1) and install it on final drive assembly. Refer to [DLN-28, "Exploded View"](#).

CAUTION:

Never reuse gasket.

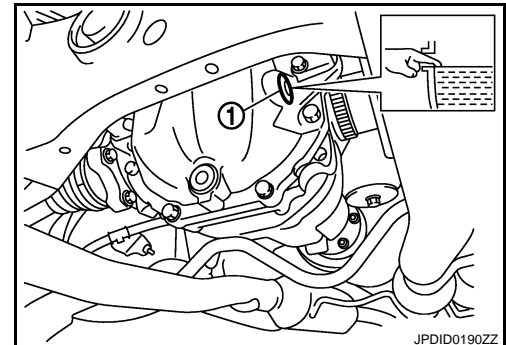

REAR DIFFERENTIAL GEAR OIL: R200 : Draining

INFOID:000000004751789

1. Stop the engine.
2. Remove drain plug (1) and drain gear oil.
3. Set a gasket on drain plug (1) and install it to final drive assembly and tighten to the specified torque. Refer to [DLN-28, "Exploded View"](#).

CAUTION:

Never reuse gasket.

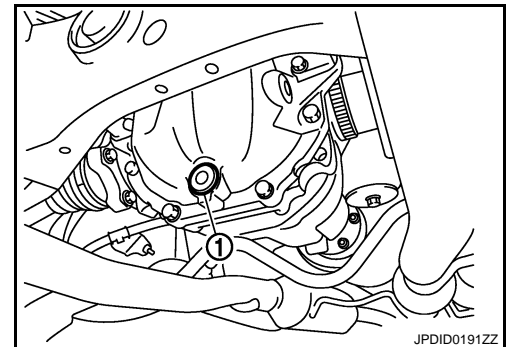

REAR DIFFERENTIAL GEAR OIL: R200 : Refilling

INFOID:000000004751790

1. Remove filler plug (1). Fill with new gear oil until oil level reaches the specified level near filler plug mounting hole.

Oil grade and viscosity : Refer to [MA-14, "FOR NORTH AMERICA : Fluids and Lubricants"](#) (for NORTH AMERICA), [MA-15, "EXCEPT FOR NORTH AMERICA : Fluids and Lubricants"](#) (except for NORTH AMERICA).

Oil capacity : Refer to [DLN-50, "General Specification"](#).

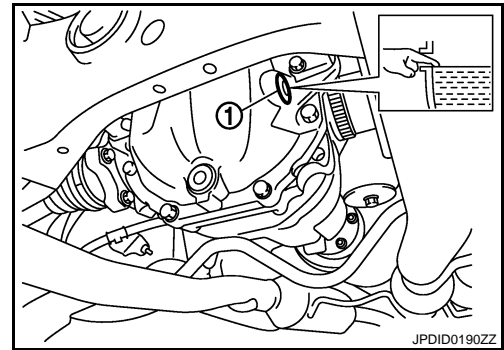

2. After refilling oil, check oil level. Set a gasket to filler plug (1), then install it to final drive assembly. Refer to [DLN-28, "Exploded View"](#).

CAUTION:
Never reuse gasket.

REAR DIFFERENTIAL GEAR OIL: R200V

REAR DIFFERENTIAL GEAR OIL: R200V : Inspection

INFOID:000000004751791

OIL LEAKAGE

Make sure that oil is not leaking from final drive assembly or around it.

OIL LEVEL

- Remove filler plug (1) and check oil level from filler plug mounting hole as shown in the figure.

CAUTION:
Never start engine while checking oil level.

- Set a gasket on filler plug (1) and install it on final drive assembly. Refer to [DLN-68, "Exploded View"](#).

CAUTION:
Never reuse gasket.

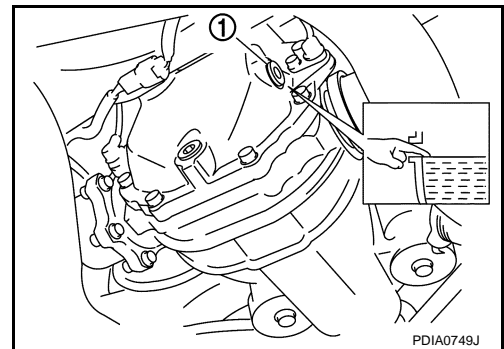

REAR DIFFERENTIAL GEAR OIL: R200V : Draining

INFOID:000000004751792

1. Stop the engine.
2. Remove drain plug (1) and drain gear oil.
3. Set a gasket on drain plug (1) and install it to final drive assembly and tighten to the specified torque. Refer to [DLN-68, "Exploded View"](#).

CAUTION:
Never reuse gasket.

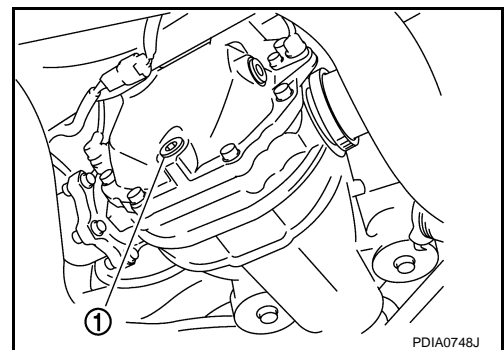

CHASSIS MAINTENANCE

< PERIODIC MAINTENANCE >

[REGULAR GRADE]

REAR DIFFERENTIAL GEAR OIL: R200V : Refilling

INFOID:000000004751793

1. Remove filler plug (1). Fill with new gear oil until oil level reaches the specified level near filler plug mounting hole.

Oil grade and viscosity

: Refer to [MA-14, "FOR NORTH AMERICA : Fluids and Lubricants"](#) (for NORTH AMERICA), [MA-15, "EXCEPT FOR NORTH AMERICA : Fluids and Lubricants"](#) (except for NORTH AMERICA).

Oil capacity

: Refer to [DLN-90, "General Specification"](#).

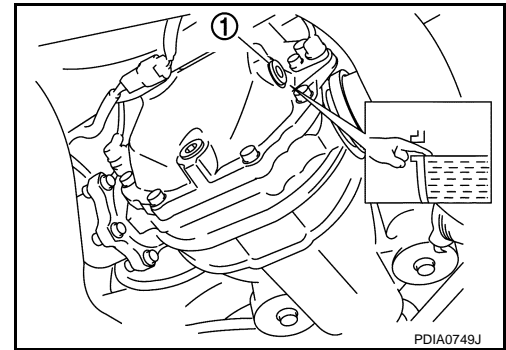

2. After refilling oil, check oil level. Set a gasket to filler plug (1), then install it to final drive assembly. Refer to [DLN-68, "Exploded View"](#).

CAUTION:

Never reuse gasket.

WHEELS (BONDING WEIGHT TYPE)

WHEELS (BONDING WEIGHT TYPE) : Adjustment

INFOID:000000004751794

BALANCING WHEELS (BONDING WEIGHT TYPE)

Preparation Before Adjustment

Using releasing agent, remove double-faced adhesive tape from the road wheel.

CAUTION:

- Be careful not to scratch the road wheel during removal.
- After removing double-faced adhesive tape, wipe clean traces of releasing agent from the road wheel.

Wheel Balance Adjustment

If a tire balance machine has adhesion balance weight mode settings and drive-in weight mode setting, select and adjust a drive-in weight mode suitable for road wheels.

1. Set road wheel on tire balance machine using the center hole as a guide. Start the tire balance machine.
2. When inner and outer unbalance values are shown on the tire balance machine indicator, multiply outer unbalance value by $5/3$ to determine balance weight that should be used. Select the outer balance weight with a value closest to the calculated value above and install to the designated outer position of, or at the designated angle in relation to the road wheel.

CAUTION:

- Do not install the inner balance weight before installing the outer balance weight.
- Before installing the balance weight, be sure to clean the mating surface of the road wheel.

- a. Indicated unbalance value $\times 5/3$ = balance weight to be installed

Calculation example:

$23 \text{ g (0.81 oz)} \times 5/3 = 38.33 \text{ g (1.35 oz)} \Rightarrow 37.5 \text{ g (1.32 oz)}$ balance weight (closer to calculated balance weight value)

NOTE:

Note that balance weight value must be closer to the calculated balance weight value.

Example:

$36.2 \Rightarrow 35 \text{ g (1.23 oz)}$

$36.3 \Rightarrow 37.5 \text{ g (1.32 oz)}$

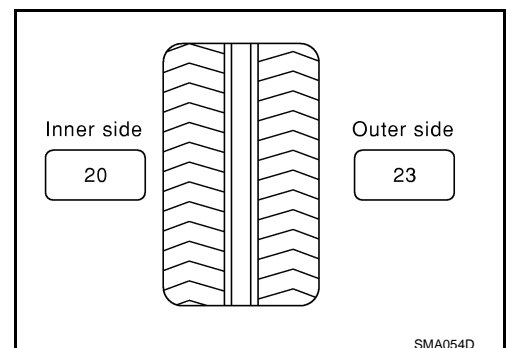

- b. Installed balance weight in the position.

CHASSIS MAINTENANCE

< PERIODIC MAINTENANCE >

[REGULAR GRADE]

- When installing balance weight (1) to road wheels, set it into the grooved area (A) on the inner wall of the road wheel as shown in the figure so that the balance weight center (B) is aligned with the tire balance machine indication position (angle) (C).

CAUTION:

- Always use genuine NISSAN adhesion balance weights.
- Balance weights are non-reusable; always replace with new ones.
- Do not install more than three sheets of balance weight.

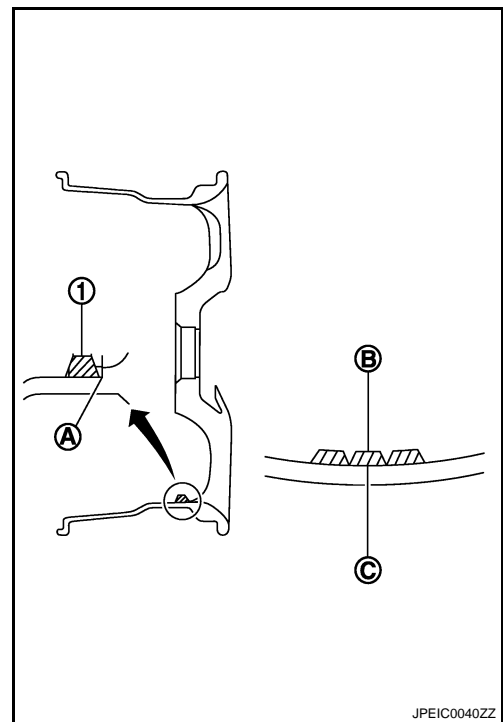

- c. If calculated balance weight value exceeds 50 g (1.76 oz), install two balance weight sheets in line with each other as shown in the figure.

CAUTION:

Do not install one balance weight sheet on top of another.

3. Start the tire balance machine again.
4. Install drive-in balance weight on inner side of road wheel in the tire balance machine indication position (angle).

CAUTION:

Do not install more than two balance weight.

5. Start the tire balance machine. Make sure that inner and outer residual unbalance values are 5 g (0.17 oz) each or below.
6. If either residual unbalance value exceeds 5 g (0.17 oz), repeat installation procedures.

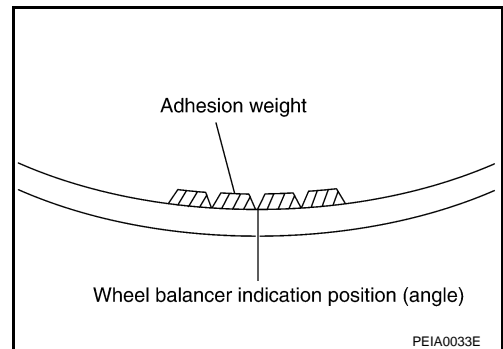

Limit

Dynamic (At flange) : Refer to [WT-100, "Road Wheel"](#).

Static (At flange) : Refer to [WT-100, "Road Wheel"](#).

TIRE ROTATION

- Tire cannot be rotated in vehicle, as front tire are different size from rear tire and the direction of wheel rotation is fixed in each tire.

Wheel nuts tightening torque : Refer to [WT-100, "Road Wheel"](#).

CAUTION:

- Never include the T-type spare tire when rotating the tires.
- Use NISSAN genuine wheel nuts for aluminum wheels.

Safety Device Preventing from Being Incorrectly installed

FRONT BRAKE DISC ROTOR AND FRONT WHEEL

A
B
C
D
E
F
G
H
I
J
K
L
M
N
O

MA

CHASSIS MAINTENANCE

< PERIODIC MAINTENANCE >

[REGULAR GRADE]

- Front and rear wheel size for this model differs, therefore special pin (1) is adopted to the front brake disc rotor (2). And a hole (3) that matches to this pin is adopted to the front wheel (4) (the rear wheel does not have this wheel). This structure prevents the rear wheel from being mistakenly installed on the front.

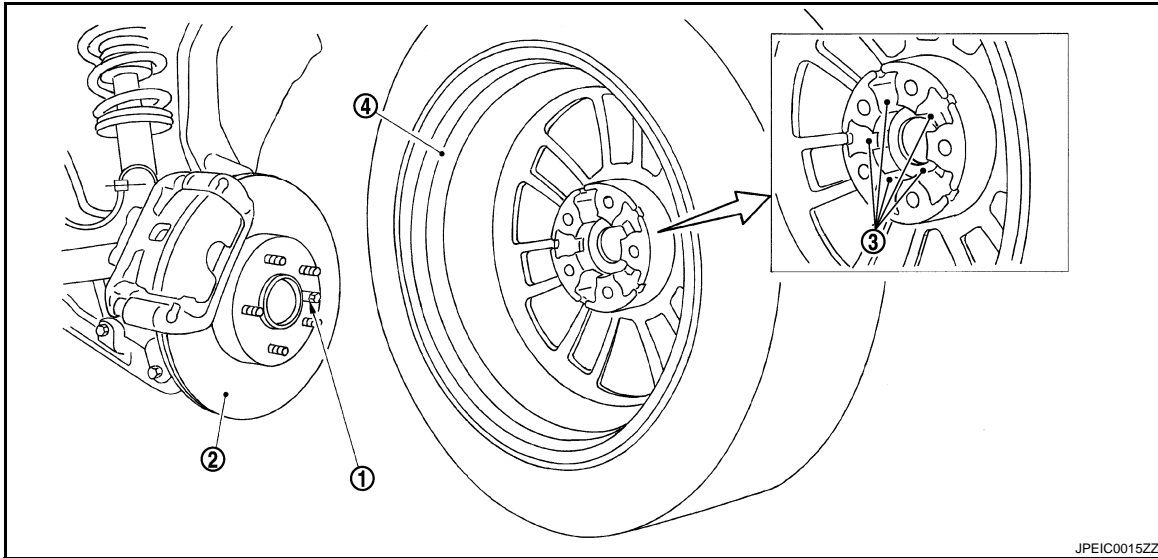

T-TYPE SPARE TIRE WHEEL

- Regarding spare tire (for emergency) wheel, wrong assembly protection pin through hole (1) has been set in addition to regular bolt holes (2) in order to enable installation to front wheel.

NOTE:

Protection pin through hole of 18 inch spare wheel is non-through type.

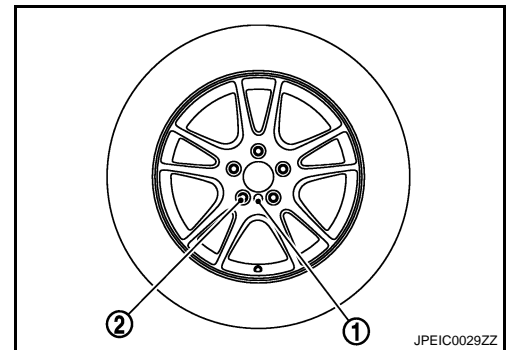

BRAKE FLUID LEVEL AND LEAKS

BRAKE FLUID LEVEL AND LEAKS : Inspection

- If fluid level is extremely low, check brake system for leaks.

INFOID:000000004498811

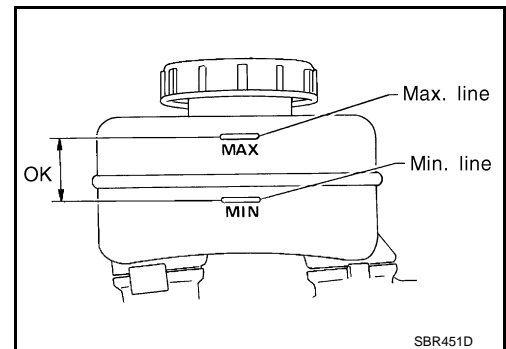

BRAKE LINES AND CABLES

CHASSIS MAINTENANCE

< PERIODIC MAINTENANCE >

[REGULAR GRADE]

BRAKE LINES AND CABLES : Inspection

INFOID:000000004498812

- Check brake fluid lines and parking brake cables for improper attachment, leaks, chafing, abrasions, deterioration, etc.

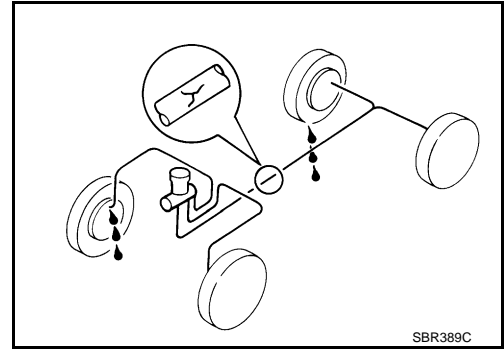

BRAKE FLUID

BRAKE FLUID : Changing

INFOID:000000004498813

1. Drain brake fluid from each bleed valve.
2. Refill until new brake fluid comes out from each bleed valve. Use same procedure as in bleeding hydraulic system to refill brake fluid.
Refer to [BR-11, "Bleeding Brake System"](#).
 - Refill with recommended Genuine NISSAN Super Heavy Duty Brake Fluid or equivalent DOT 3 (US FMVSS No. 116). Refer to [MA-14, "FOR NORTH AMERICA : Fluids and Lubricants"](#).
 - Never reuse drained brake fluid.
 - Be careful not to splash brake fluid on painted areas.

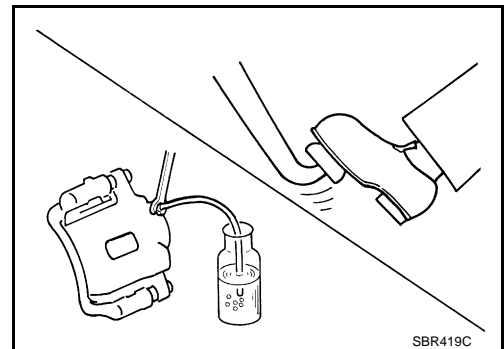

DISC BRAKE

DISC BRAKE : Inspection

INFOID:000000004498814

DISC ROTOR

Check condition, wear, and damage.

CALIPER

- Check for leakage.

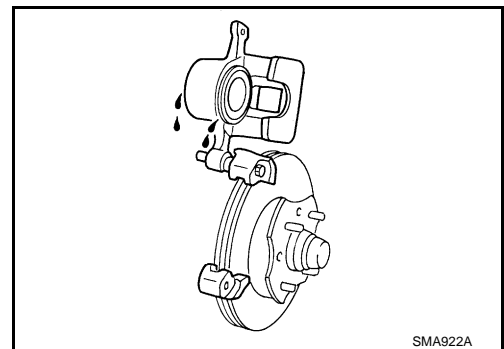

BRAKE PAD

A
B
C
D
E
F
G
H
I
J
K
L
M
N
O

MA

CHASSIS MAINTENANCE

< PERIODIC MAINTENANCE >

[REGULAR GRADE]

- Check for wear or damage.

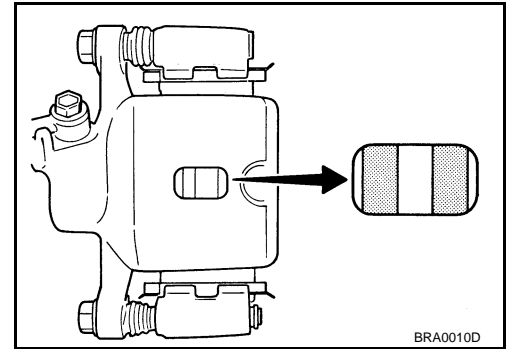

DISC BRAKE : Front Disc Brake

INFOID:000000004751795

2 PISTON TYPE

Unit: mm (in)

Item		Limit
Brake pad	Wear thickness	2.0 (0.079)
	Wear thickness	26.0 (1.024)
Disc rotor	Thickness variation (measured at 8 positions)	0.015 (0.0006)
	Runout (with it attached to the vehicle)	0.035 (0.0014)

4 PISTON TYPE

Unit: mm (in)

Item		Limit
Brake pad	Wear thickness	2.0 (0.079)
	Wear thickness	30.0 (1.181)
Disc rotor	Thickness variation (measured at 8 positions)	0.015 (0.0006)
	Runout (with it attached to the vehicle)	0.035 (0.0014)

DISC BRAKE : Rear Disc Brake

INFOID:000000004751796

1 PISTON TYPE

Unit: mm (in)

Item		Limit
Brake pad	Wear thickness	2.0 (0.079)
	Wear thickness	14.0 (0.551)
Disc rotor	Thickness variation (measured at 8 positions)	0.015 (0.0006)
	Runout (with it attached to the vehicle)	0.055 (0.0022)

2 PISTON TYPE

Unit: mm (in)

Item		Limit
Brake pad	Wear thickness	2.0 (0.079)
	Wear thickness	18.0 (0.709)
Disc rotor	Thickness variation (measured at 8 positions)	0.015 (0.0006)
	Runout (with it attached to the vehicle)	0.055 (0.0022)

STEERING GEAR AND LINKAGE

STEERING GEAR AND LINKAGE : Inspection

INFOID:000000004498817

STEERING GEAR

CHASSIS MAINTENANCE

< PERIODIC MAINTENANCE >

- Check gear housing and boots for looseness, damage and grease leakage.
- Check connection with steering column for looseness.

[REGULAR GRADE]

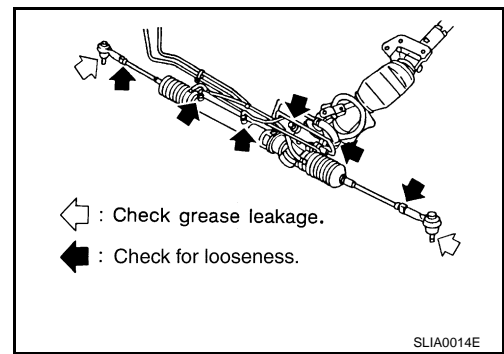

STEERING LINKAGE

Check ball joint, dust cover and other component parts for looseness, wear, damage and grease leakage.

POWER STEERING FLUID AND LINES

POWER STEERING FLUID AND LINES : Inspection

INFOID:000000004498818

Check fluid level in reservoir tank with engine off.

Use "HOT" range at fluid temperatures of 50 to 80°C (122 to 176°F) or "COLD" range at fluid temperatures of 0 to 30°C (32 to 86°F).

CAUTION:

- Do not overfill.
- Recommended fluid is Genuine NISSAN PSF or equivalent. Refer to [MA-14, "FOR NORTH AMERICA : Fluids and Lubricants"](#).

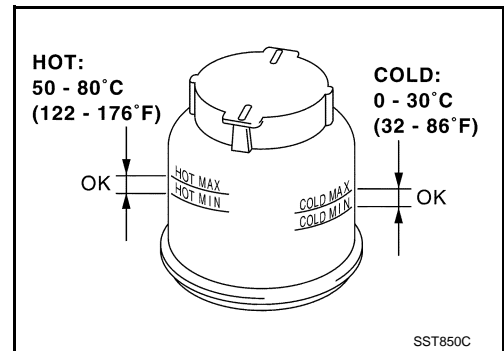

- Check lines for improper attachment, leaks, cracks, damage, loose connections, chafing and deterioration.
- Check rack boots for accumulation of power steering fluid.

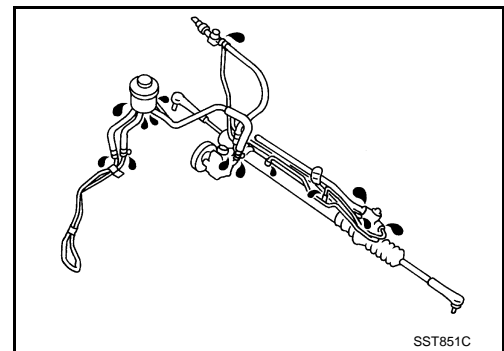

AXLE AND SUSPENSION PARTS

AXLE AND SUSPENSION PARTS : Inspection

INFOID:000000004498819

Check front and rear axle and suspension parts for excessive play, cracks, wear or other damage.

- Shake each wheel to check for excessive play.
- Check wheel bearings for smooth operation.
- Check axle and suspension nuts and bolts for looseness.
- Check strut (shock absorber) for oil leakage or other damage.
- Check suspension ball joint for grease leakage and ball joint dust cover for cracks or other damage.

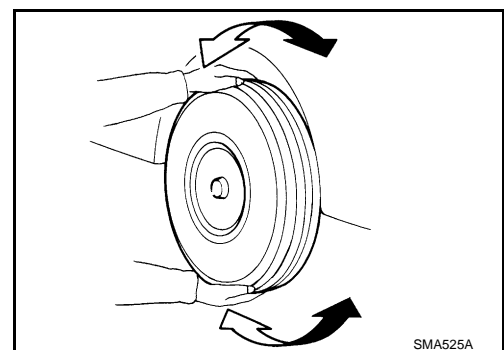

A
B
C
D
E
F
G
H
I
J
K
L
M
N
O

MA

CHASSIS MAINTENANCE

< PERIODIC MAINTENANCE >

[REGULAR GRADE]

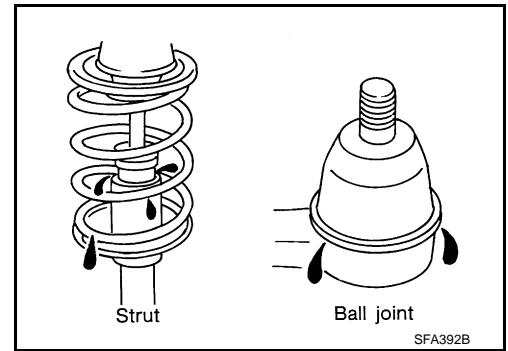

BODY MAINTENANCE

LOCKS, HINGES AND HOOD LATCH

LOCKS, HINGES AND HOOD LATCH : Lubricating

INFOID:000000004498820

For hood lock illustration. Refer to [DLK-199, "HOOD ASSEMBLY : Exploded View"](#) and [DLK-222, "Exploded View"](#).

For door lock illustration. Refer to [DLK-225, "DOOR LOCK : Exploded View"](#).

For back door lock illustration. Refer to [DLK-229, "Exploded View"](#).

SEAT BELT, BUCKLES, RETRACTORS, ANCHORS AND ADJUSTERS

SEAT BELT, BUCKLES, RETRACTORS, ANCHORS AND ADJUSTERS : Inspection

INFOID:000000004498821

For seat belt illustration. Refer to [SB-6, "SEAT BELT RETRACTOR : Exploded View"](#).

CAUTION:

- **After any collision, inspect all seat belt assemblies, including retractors and other attached hardware (i.e. anchor bolt, guide rail set). Nissan recommends to replace all seat belt assemblies in use during a collision, unless not damaged and properly operating after minor collision.**

Also inspect seat belt assemblies not in use during a collision, and replace if damaged or improperly operating.

Seat belt pre-tensioner should be replaced even if the seat belts are not in use during a frontal collision where the driver and passenger air bags are deployed.

- **If any component of seat belt assembly is questionable, do not repair.**

Replace as seat belt assembly.

- **If webbing is cut, frayed, or damaged, replace belt assembly.**

- **Never oil tongue and buckle.**

- **Use a genuine NISSAN seat belt assembly.**

For details, refer to [SB-4, "SEAT BELT RETRACTOR : Inspection"](#) in SB section.

- Check anchors for loose mounting
- Check belts for damage
- Check retractor for smooth operation
- Check function of buckles and tongues when buckled and released

A
B
C
D
E
F
G
H
I
J
K
L
M
N
O

MA

SERVICE DATA AND SPECIFICATIONS (SDS)

< SERVICE DATA AND SPECIFICATIONS (SDS)

[REGULAR GRADE]

SERVICE DATA AND SPECIFICATIONS (SDS)

SERVICE DATA AND SPECIFICATIONS (SDS)

DRIVE BELT

DRIVE BELT : Drive Belt

INFOID:000000004639636

DRIVE BELT

Tension of drive belt	Belt tension is not necessary, as it is automatically adjusted by drive belt auto-tensioner.
-----------------------	--

ENGINE COOLANT

ENGINE COOLANT : Periodical Maintenance Specification

INFOID:000000004639637

ENGINE COOLANT CAPACITY (APPROXIMATE)

Unit: ℓ (US qt, Imp qt)

Engine coolant capacity [With reservoir tank ("MAX" level)]	A/T models	8.5 (9, 7-1/2)
	M/T models	8.6 (9-1/8, 7-5/8)
Reservoir tank engine coolant capacity (At "MAX" level)		0.8 (7/8, 3/4)

ENGINE OIL

ENGINE OIL : Periodical Maintenance Specification

INFOID:000000004639638

ENGINE OIL CAPACITY (APPROXIMATE)

Unit: ℓ (US qt, Imp qt)

Drain and refill	With oil filter change	4.9 (5-1/8, 4-1/4)
	Without oil filter change	4.6 (4-7/8, 4)
Dry engine (Overhaul)		5.7 (6, 5)

SPARK PLUG

SPARK PLUG : Spark Plug

INFOID:000000004639639

SPARK PLUG

Unit: mm (in)

Make	DENSO	
Standard type	FXE24HR11	
Gap (Nominal)	Standard	1.1 (0.043)
	Limit	1.4 (0.055)

ROAD WHEEL

ROAD WHEEL : Road Wheel

INFOID:000000004639640

CONVENTIONAL

Item		Limit
Radial runout	Lateral deflection	Less than 0.3 mm (0.012 in)
	Vertical deflection	
Allowable unbalance	Dynamic (At flange)	Less than 5 g (0.17 oz) (one side)
	Static (At flange)	Less than 10 g (0.35 oz)

SERVICE DATA AND SPECIFICATIONS (SDS)

< SERVICE DATA AND SPECIFICATIONS (SDS)

[REGULAR GRADE]

EMERGENCY

Item		Limit
Radial runout	Lateral deflection	Less than 1.5 mm (0.059 in)
	Vertical deflection	
Allowable unbalance	Dynamic (At flange)	Less than 5 g (0.17 oz) (one side)
	Static (At flange)	Less than 10 g (0.35 oz)

A
B
C
D
E
F
G
H
I
J
K
L
M
N
O

MA

PERIODIC MAINTENANCE

< PERIODIC MAINTENANCE >

[Nismo 370Z]

PERIODIC MAINTENANCE

PERIODIC MAINTENANCE FOR NORTH AMERICA

FOR NORTH AMERICA : Schedule 1

INFOID:000000005390554

EMISSION CONTROL SYSTEM MAINTENANCE

NISMO models

MAINTENANCE OPERATION		MAINTENANCE INTERVAL							
Perform at number of miles, kilometers or months, whichever comes first.	Miles × 1,000	3.75	7.50	11.25	15	18.75	22.5	26.25	30
	(km × 1,000)	(6)	(12)	(18)	(24)	(30)	(36)	(42)	(48)
	Months	3	6	9	12	15	18	21	24
Spark plugs (Iridium-tipped type)	NOTE	Replace every 60,000 miles (96,000 km).							

MAINTENANCE OPERATION		MAINTENANCE INTERVAL							
Perform at number of miles, kilometers or months, whichever comes first.	Miles × 1,000	33.75	37.5	41.25	45	48.75	52.5	56.25	60
	(km × 1,000)	(54)	(60)	(66)	(72)	(78)	(84)	(90)	(96)
	Months	27	30	33	36	39	42	45	48
Spark plugs (Iridium-tipped type)	NOTE	Replace every 60,000 miles (96,000 km).							

NOTE:

Replace spark plug when the spark plug gap exceeds 1.3 mm (0.051 in) even if within specified periodic replacement mileage.

FOR NORTH AMERICA : Schedule 2

INFOID:000000005390555

EMISSION CONTROL SYSTEM MAINTENANCE

NISMO models

MAINTENANCE OPERATION		MAINTENANCE INTERVAL							
Perform at number of miles, kilometers or months, whichever comes first.	Miles × 1,000	7.5	15	22.5	30	37.5	45	52.5	60
	(km × 1,000)	(12)	(24)	(36)	(48)	(60)	(72)	(84)	(96)
	Months	6	12	18	24	30	36	42	48
Spark plugs (Iridium-tipped type)	NOTE	Replace every 60,000 miles (96,000 km).							

NOTE:

Replace spark plug when the spark plug gap exceeds 1.3 mm (0.051 in) even if within specified periodic replacement mileage.

SERVICE DATA AND SPECIFICATIONS (SDS)

< SERVICE DATA AND SPECIFICATIONS (SDS)

[Nismo 370Z]

SERVICE DATA AND SPECIFICATIONS (SDS)

SERVICE DATA AND SPECIFICATIONS (SDS)

SPARK PLUG

SPARK PLUG : Spark Plug

INFOID:000000005390560

SPARK PLUG

Unit: mm (in)

Make	DENSO	
Standard type	FXE24HR11	
Gap (Nominal)	Standard	1.1 (0.043)
	Limit	1.3 (0.051)

A
B
C
D
E
F
G
H
I
J
K
L
M
N
O

MA