

# SECTION HAC

## HEATER & AIR CONDITIONING CONTROL SYSTEM

### CONTENTS

<b>WITHOUT 7 INCH DISPLAY</b>		
<b>BASIC INSPECTION</b> .....	5	
<b>DIAGNOSIS AND REPAIR WORK FLOW</b> .....	5	
Work Flow .....	5	
<b>INSPECTION AND ADJUSTMENT</b> .....	7	
Description & Inspection .....	7	
Temperature Setting Trimmer .....	8	
Foot Position Setting Trimmer .....	8	
Inlet Port Memory Function (FRE) .....	9	
Inlet Port Memory Function (REC) .....	9	
<b>SYSTEM DESCRIPTION</b> .....	11	
<b>COMPRESSOR CONTROL FUNCTION</b> .....	11	
Description .....	11	
Fail-safe .....	12	
Component Parts Location .....	12	
Component Description .....	13	
<b>AUTOMATIC AIR CONDITIONER SYSTEM</b> ....	14	
System Diagram .....	14	
System Description .....	14	
Component Parts Location .....	22	
Component Description .....	22	
<b>DIAGNOSIS SYSTEM (HVAC)</b> .....	24	
CONSULT-III Function .....	24	
<b>DTC/CIRCUIT DIAGNOSIS</b> .....	26	
<b>U1000 CAN COMM CIRCUIT</b> .....	26	
Description .....	26	
DTC Logic .....	26	
Diagnosis Procedure .....	26	
<b>U1010 CONTROL UNIT (CAN)</b> .....	27	
Description .....	27	
DTC Logic .....	27	
Diagnosis Procedure .....	27	
<b>B257B, B257C AMBIENT SENSOR</b> .....	28	
Description .....	28	
DTC Logic .....	28	
Diagnosis Procedure .....	29	
Component Inspection .....	30	
<b>B2578, B2579 IN-VEHICLE SENSOR</b> .....	31	
Description .....	31	
DTC Logic .....	31	
Diagnosis Procedure .....	32	
Component Inspection .....	33	
<b>B2581, B2582 INTAKE SENSOR</b> .....	34	
Description .....	34	
DTC Logic .....	34	
Diagnosis Procedure .....	34	
Component Inspection .....	35	
<b>B2630, B2631 SUNLOAD SENSOR</b> .....	37	
Description .....	37	
DTC Logic .....	37	
Diagnosis Procedure .....	37	
Component Inspection .....	38	
<b>B2632, B2633 AIR MIX DOOR MOTOR PBR</b> ...	40	
Description .....	40	
DTC Logic .....	40	
Diagnosis Procedure .....	41	
<b>B2636, B2637, B2638, B2639, B2654, B2655</b>		
<b>MODE DOOR MOTOR</b> .....	42	
Description .....	42	
DTC Logic .....	42	
Diagnosis Procedure .....	43	
<b>B263D, B263E, B263F INTAKE DOOR MO-</b>		
<b>TOR</b> .....	44	
Description .....	44	
DTC Logic .....	44	
Diagnosis Procedure .....	45	
<b>POWER SUPPLY AND GROUND CIRCUIT</b> ....	46	

A  
B  
C  
D  
E  
F  
G  
H  
HAC  
J  
K  
L  
M  
N  
O  
P

<b>A/C AUTO AMP.</b> .....	<b>46</b>	<b>EXCEPT FOR MEXICO</b> .....	<b>81</b>
A/C AUTO AMP. : Diagnosis Procedure .....	46	EXCEPT FOR MEXICO : Precaution for Supplemental Restraint System (SRS) "AIR BAG" and "SEAT BELT PRE-TENSIONER" .....	81
<b>A/C CONTROL</b> .....	<b>46</b>	EXCEPT FOR MEXICO : Precaution Necessary for Steering Wheel Rotation after Battery Disconnect .....	81
A/C CONTROL : Diagnosis Procedure .....	46	EXCEPT FOR MEXICO : Precaution for Battery Service .....	82
<b>DOOR MOTOR COMMUNICATION CIRCUIT...</b>	<b>48</b>	<b>FOR MEXICO</b> .....	<b>82</b>
Description .....	48	FOR MEXICO : Precaution for Supplemental Restraint System (SRS) "AIR BAG" and "SEAT BELT PRE-TENSIONER" .....	82
Diagnosis Procedure .....	48	FOR MEXICO : Precaution Necessary for Steering Wheel Rotation after Battery Disconnect .....	82
<b>A/C CONTROL SIGNAL CIRCUIT</b> .....	<b>50</b>	FOR MEXICO : Precaution for Battery Service .....	83
Diagnosis Procedure .....	50	<b>REMOVAL AND INSTALLATION</b> .....	<b>84</b>
<b>A/C AUTO AMP.</b> .....	<b>51</b>	<b>A/C CONTROL</b> .....	<b>84</b>
Description .....	51	<b>BASE AUDIO</b> .....	<b>84</b>
Component Function Check .....	51	BASE AUDIO : Exploded View .....	84
Diagnosis Procedure .....	51	BASE AUDIO : Removal and Installation .....	84
<b>BLOWER MOTOR</b> .....	<b>52</b>	<b>BOSE AUDIO WITHOUT NAVIGATION</b> .....	<b>84</b>
Description .....	52	BOSE AUDIO WITHOUT NAVIGATION : Exploded View .....	85
Component Function Check .....	52	BOSE AUDIO WITHOUT NAVIGATION : Removal and Installation .....	85
Diagnosis Procedure .....	52	<b>A/C AUTO AMP.</b> .....	<b>86</b>
Component Inspection .....	54	<b>BASE AUDIO</b> .....	<b>86</b>
<b>MAGNET CLUTCH</b> .....	<b>56</b>	BASE AUDIO : Exploded View .....	86
Description .....	56	BASE AUDIO : Removal and Installation .....	86
Component Function Check .....	56	<b>BOSE AUDIO WITHOUT NAVIGATION</b> .....	<b>86</b>
Diagnosis Procedure .....	56	BOSE AUDIO WITHOUT NAVIGATION : Exploded View .....	87
<b>ECV (ELECTRICAL CONTROL VALVE)</b> .....	<b>58</b>	BOSE AUDIO WITHOUT NAVIGATION : Removal and Installation .....	87
Description .....	58	<b>A/C AUTO AMP.</b> .....	<b>86</b>
Diagnosis Procedure .....	58	<b>BASE AUDIO</b> .....	<b>86</b>
<b>ECU DIAGNOSIS INFORMATION</b> .....	<b>60</b>	BASE AUDIO : Exploded View .....	86
<b>A/C AUTO AMP.</b> .....	<b>60</b>	BASE AUDIO : Removal and Installation .....	86
Reference Value .....	60	<b>BOSE AUDIO WITHOUT NAVIGATION</b> .....	<b>86</b>
Wiring Diagram - AIR CONDITIONER CONTROL SYSTEM - .....	63	BOSE AUDIO WITHOUT NAVIGATION : Exploded View .....	87
Fail-safe .....	70	BOSE AUDIO WITHOUT NAVIGATION : Removal and Installation .....	87
DTC Inspection Priority Chart .....	71	<b>AMBIENT SENSOR</b> .....	<b>88</b>
DTC Index .....	71	Exploded View .....	88
<b>SYMPTOM DIAGNOSIS</b> .....	<b>73</b>	Removal and Installation .....	88
<b>AUTOMATIC AIR CONDITIONER SYSTEM</b> ....	<b>73</b>	<b>IN-VEHICLE SENSOR</b> .....	<b>89</b>
Diagnosis Chart By Symptom .....	73	Exploded View .....	89
<b>INSUFFICIENT COOLING</b> .....	<b>74</b>	Removal and Installation .....	89
Description .....	74	<b>SUNLOAD SENSOR</b> .....	<b>90</b>
Diagnosis Procedure .....	74	Exploded View .....	90
<b>INSUFFICIENT HEATING</b> .....	<b>76</b>	Removal and Installation .....	90
Description .....	76	<b>INTAKE SENSOR</b> .....	<b>91</b>
Diagnosis Procedure .....	76	Exploded View .....	91
<b>NOISE</b> .....	<b>79</b>	Removal and Installation .....	91
Description .....	79	<b>REFRIGERANT PRESSURE SENSOR</b> .....	<b>93</b>
Diagnosis Procedure .....	79	Exploded View .....	93
<b>PRECAUTION</b> .....	<b>81</b>		
<b>PRECAUTIONS</b> .....	<b>81</b>		

Removal and Installation .....	93	Component Inspection .....	122
<b>DOOR MOTOR .....</b>	<b>94</b>	<b>B2578, B2579 IN-VEHICLE SENSOR .....</b>	<b>123</b>
Exploded View .....	94	Description .....	123
<b>INTAKE DOOR MOTOR .....</b>	<b>94</b>	DTC Logic .....	123
INTAKE DOOR MOTOR : Removal and Installation .....	94	Diagnosis Procedure .....	124
<b>MODE DOOR MOTOR .....</b>	<b>95</b>	Component Inspection .....	125
MODE DOOR MOTOR : Removal and Installation...	95	<b>B2581, B2582 INTAKE SENSOR .....</b>	<b>126</b>
<b>AIR MIX DOOR MOTOR .....</b>	<b>95</b>	Description .....	126
AIR MIX DOOR MOTOR : Removal and Installation .....	95	DTC Logic .....	126
<b>WITH 7 INCH DISPLAY</b>		Diagnosis Procedure .....	126
<b>BASIC INSPECTION .....</b>	<b>96</b>	Component Inspection .....	127
<b>DIAGNOSIS AND REPAIR WORK FLOW .....</b>	<b>96</b>	<b>B2630, B2631 SUNLOAD SENSOR .....</b>	<b>129</b>
Work Flow .....	96	Description .....	129
<b>INSPECTION AND ADJUSTMENT .....</b>	<b>98</b>	DTC Logic .....	129
Description & Inspection .....	98	Diagnosis Procedure .....	129
Temperature Setting Trimmer .....	99	Component Inspection .....	130
Foot Position Setting Trimmer .....	100	<b>B2632, B2633 AIR MIX DOOR MOTOR PBR .</b>	<b>132</b>
Inlet Port Memory Function (FRE) .....	100	Description .....	132
Inlet Port Memory Function (REC) .....	101	DTC Logic .....	132
<b>SYSTEM DESCRIPTION .....</b>	<b>102</b>	Diagnosis Procedure .....	133
<b>COMPRESSOR CONTROL FUNCTION .....</b>	<b>102</b>	<b>B2636, B2637, B2638, B2639, B2654, B2655</b>	
Description .....	102	<b>MODE DOOR MOTOR .....</b>	<b>134</b>
Fail-safe .....	102	Description .....	134
Component Parts Location .....	103	DTC Logic .....	134
Component Description .....	104	Diagnosis Procedure .....	135
<b>AUTOMATIC AIR CONDITIONER SYSTEM ..</b>	<b>105</b>	<b>B263D, B263E, B263F INTAKE DOOR MO-</b>	
System Diagram .....	105	<b>TOR .....</b>	<b>136</b>
System Description .....	105	Description .....	136
Component Parts Location .....	114	DTC Logic .....	136
Component Description .....	114	Diagnosis Procedure .....	137
<b>DIAGNOSIS SYSTEM (HVAC) .....</b>	<b>116</b>	<b>POWER SUPPLY AND GROUND CIRCUIT ..</b>	<b>138</b>
CONSULT-III Function .....	116	<b>A/C AUTO AMP. ....</b>	<b>138</b>
<b>DTC/CIRCUIT DIAGNOSIS .....</b>	<b>118</b>	A/C AUTO AMP. : Diagnosis Procedure .....	138
<b>U1000 CAN COMM CIRCUIT .....</b>	<b>118</b>	<b>DOOR MOTOR COMMUNICATION CIRCUIT. 139</b>	
Description .....	118	Description .....	139
DTC Logic .....	118	Diagnosis Procedure .....	139
Diagnosis Procedure .....	118	<b>A/C AUTO AMP. ....</b>	<b>141</b>
<b>U1010 CONTROL UNIT (CAN) .....</b>	<b>119</b>	Description .....	141
Description .....	119	Component Function Check .....	141
DTC Logic .....	119	Diagnosis Procedure .....	141
Diagnosis Procedure .....	119	<b>BLOWER MOTOR .....</b>	<b>142</b>
<b>B257B, B257C AMBIENT SENSOR .....</b>	<b>120</b>	Description .....	142
Description .....	120	Component Function Check .....	142
DTC Logic .....	120	Diagnosis Procedure .....	142
Diagnosis Procedure .....	121	Component Inspection .....	144
		<b>MAGNET CLUTCH .....</b>	<b>146</b>
		Description .....	146
		Component Function Check .....	146
		Diagnosis Procedure .....	146

A  
B  
C  
D  
E  
F  
G  
H  
HAC  
J  
K  
L  
M  
N  
O  
P

<b>ECV (ELECTRICAL CONTROL VALVE) .....</b>	<b>148</b>	FOR MEXICO : Precaution for Supplemental Restraint System (SRS) "AIR BAG" and "SEAT BELT PRE-TENSIONER" .....	173
Description .....	148	FOR MEXICO : Precaution Necessary for Steering Wheel Rotation after Battery Disconnect .....	173
Diagnosis Procedure .....	148	FOR MEXICO : Precaution for Battery Service ...	174
<b>ECU DIAGNOSIS INFORMATION .....</b>	<b>150</b>	<b>REMOVAL AND INSTALLATION .....</b>	<b>175</b>
<b>A/C AUTO AMP. ....</b>	<b>150</b>	<b>PRESET SWITCH .....</b>	<b>175</b>
Reference Value .....	150	Exploded View .....	175
Wiring Diagram - AIR CONDITIONER CONTROL SYSTEM - .....	153	Removal and Installation .....	175
Fail-safe .....	160	<b>A/C AUTO AMP. ....</b>	<b>176</b>
DTC Inspection Priority Chart .....	161	Exploded View .....	176
DTC Index .....	161	Removal and Installation .....	176
<b>SYMPTOM DIAGNOSIS .....</b>	<b>163</b>	<b>AMBIENT SENSOR .....</b>	<b>177</b>
<b>AUTOMATIC AIR CONDITIONER SYSTEM ..</b>	<b>163</b>	Exploded View .....	177
Diagnosis Chart By Symptom .....	163	Removal and Installation .....	177
<b>INSUFFICIENT COOLING .....</b>	<b>164</b>	<b>IN-VEHICLE SENSOR .....</b>	<b>178</b>
Description .....	164	Exploded View .....	178
Diagnosis Procedure .....	164	Removal and Installation .....	178
<b>INSUFFICIENT HEATING .....</b>	<b>166</b>	<b>SUNLOAD SENSOR .....</b>	<b>179</b>
Description .....	166	Exploded View .....	179
Diagnosis Procedure .....	166	Removal and Installation .....	179
<b>NOISE .....</b>	<b>169</b>	<b>INTAKE SENSOR .....</b>	<b>180</b>
Description .....	169	Exploded View .....	180
Diagnosis Procedure .....	169	Removal and Installation .....	180
<b>MEMORY FUNCTION DOES NOT OPERATE</b>	<b>171</b>	<b>REFRIGERANT PRESSURE SENSOR .....</b>	<b>182</b>
Description .....	171	Exploded View .....	182
Diagnosis Procedure .....	171	Removal and Installation .....	182
<b>PRECAUTION .....</b>	<b>172</b>	<b>DOOR MOTOR .....</b>	<b>183</b>
<b>PRECAUTIONS .....</b>	<b>172</b>	Exploded View .....	183
<b>EXCEPT FOR MEXICO .....</b>	<b>172</b>	<b>INTAKE DOOR MOTOR .....</b>	<b>183</b>
EXCEPT FOR MEXICO : Precaution for Supplemental Restraint System (SRS) "AIR BAG" and "SEAT BELT PRE-TENSIONER" .....	172	INTAKE DOOR MOTOR : Removal and Installation .....	183
EXCEPT FOR MEXICO : Precaution Necessary for Steering Wheel Rotation after Battery Disconnect .....	172	<b>MODE DOOR MOTOR .....</b>	<b>184</b>
EXCEPT FOR MEXICO : Precaution for Battery Service .....	173	MODE DOOR MOTOR : Removal and Installation.	184
<b>FOR MEXICO .....</b>	<b>173</b>	<b>AIR MIX DOOR MOTOR .....</b>	<b>184</b>
		AIR MIX DOOR MOTOR : Removal and Installation .....	184

# DIAGNOSIS AND REPAIR WORK FLOW

< BASIC INSPECTION >

[WITHOUT 7 INCH DISPLAY]

## BASIC INSPECTION

### DIAGNOSIS AND REPAIR WORK FLOW

Work Flow

INFOID:000000005239120

#### OVERALL SEQUENCE

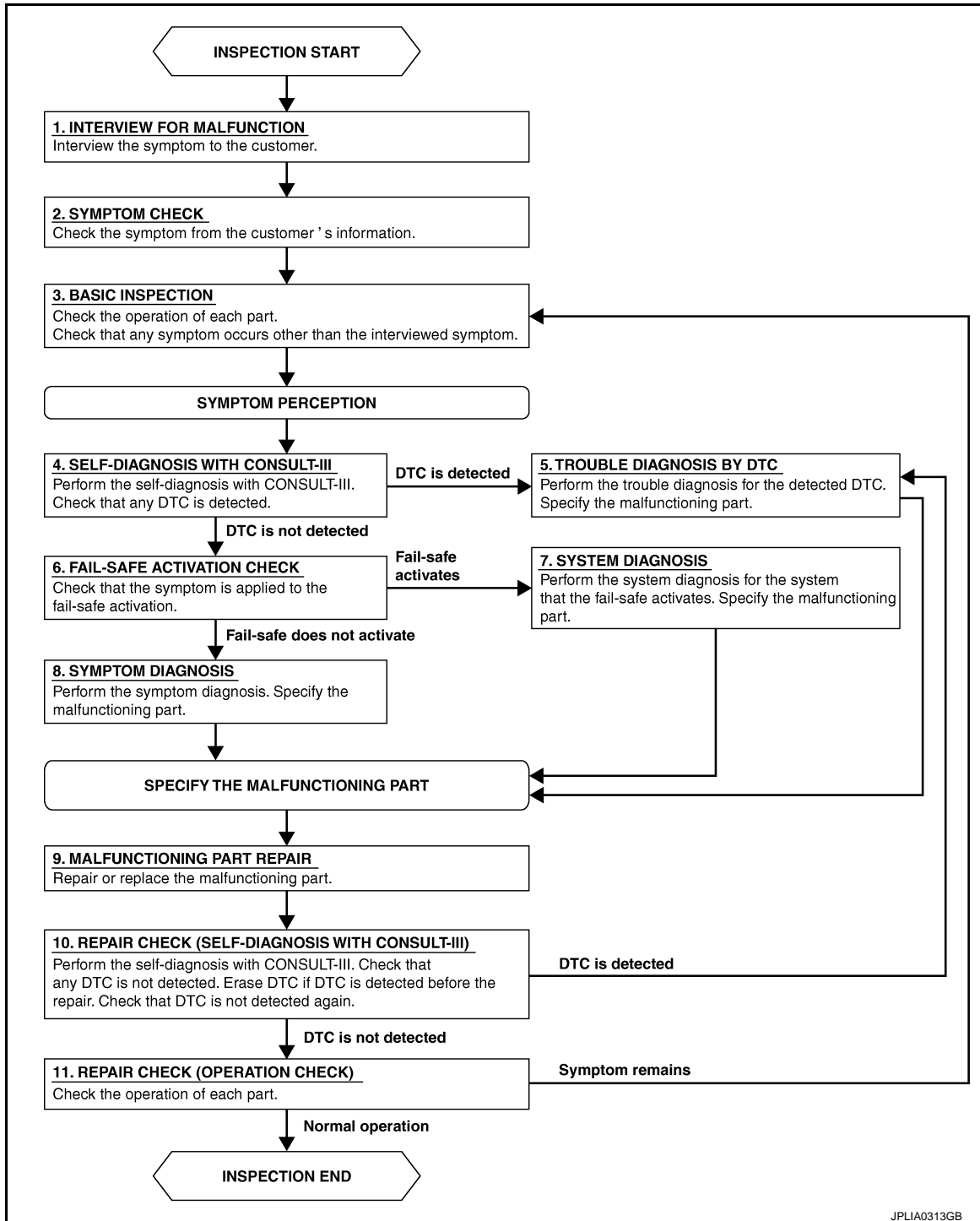

#### DETAILED FLOW

##### 1. INTERVIEW FOR MALFUNCTION

Interview the symptom to the customer.

# DIAGNOSIS AND REPAIR WORK FLOW

[WITHOUT 7 INCH DISPLAY]

< BASIC INSPECTION >

---

>> GO TO 2.

## 2. SYMPTOM CHECK

---

Check the symptom from the customer's information.

>> GO TO 3.

## 3. BASIC INSPECTION

---

Check the operation of each part. Check that any symptom occurs other than the interviewed symptom.

>> GO TO 4.

## 4. SELF-DIAGNOSIS WITH CONSULT-III

---

Perform the self-diagnosis with CONSULT-III. Check that any DTC is detected.

Is any DTC detected?

YES >> GO TO 5.

NO >> GO TO 6.

## 5. TROUBLE DIAGNOSIS BY DTC

---

Perform the trouble diagnosis for the detected DTC. Specify the malfunctioning part.

>> GO TO 9.

## 6. FAIL-SAFE ACTIVATION CHECK

---

Check that the symptom is applied to the fail-safe activation.

Does the fail-safe activate?

YES >> GO TO 7.

NO >> GO TO 8.

## 7. SYSTEM DIAGNOSIS

---

Perform the system diagnosis for the system that the fail-safe activates. Specify the malfunctioning part.

>> GO TO 9.

## 8. SYMPTOM DIAGNOSIS

---

Perform the symptom diagnosis. Specify the malfunctioning part.

>> GO TO 9.

## 9. MALFUNCTION PART REPAIR

---

Repair or replace the malfunctioning part.

>> GO TO 10.

## 10. REPAIR CHECK (SELF-DIAGNOSIS WITH CONSULT-III)

---

Perform the self-diagnosis with CONSULT-III. Check that any DTC is not detected. Erase DTC if DTC is detected before the repair. Check that DTC is not detected again.

Is any DTC detected?

YES >> GO TO 5.

NO >> GO TO 11.

## 11. REPAIR CHECK (OPERATION CHECK)

---

Check the operation of each part.

Does it operate normally?

YES >> INSPECTION END

NO >> GO TO 3.

# INSPECTION AND ADJUSTMENT

< BASIC INSPECTION >

[WITHOUT 7 INCH DISPLAY]

## INSPECTION AND ADJUSTMENT

### Description & Inspection

INFOID:000000005239121

#### DESCRIPTION

The purpose of the operational check is to check that the individual system operates normally.

**Check condition : Engine running at normal operating temperature.**

#### 1.CHECK BLOWER MOTOR

1. Start the engine.
2. Operate the fan control dial. Check that the fan speed changes. Check the operation for all fan speeds.
3. Leave blower on maximum speed.

Is the inspection result normal?

YES >> GO TO 2.

NO >> Blower motor system malfunction. Refer to [HAC-52. "Diagnosis Procedure"](#).

#### 2.CHECK DISCHARGE AIR

1. Turn mode control dial to each position.
2. Check that the air outlets change according to each indicated air outlet by placing a hand in front of the outlets. Refer to [VTL-3. "System Description"](#).

Is the inspection result normal?

YES >> GO TO 3.

NO >> Mode door system malfunction. Refer to [HAC-43. "Diagnosis Procedure"](#).

#### 3.CHECK INTAKE AIR

1. Press intake switch to set the air outlet to recirculation.
2. The REC indicator turns ON.
3. Listen to intake sound and confirm air inlets change.
4. Press intake switch again to set the air outlet to fresh air intake.
5. The FRE indicator turns ON.
6. Listen to intake sound and confirm air inlets change.

Is the inspection result normal?

YES >> GO TO 4.

NO >> Intake door system malfunction. Refer to [HAC-45. "Diagnosis Procedure"](#).

#### 4.CHECK A/C SWITCH

1. Press the A/C switch.
2. Check that the indicator of the A/C switch turns ON. Check visually and by sound that the compressor operates.
3. Press the A/C switch again.
4. Check that the indicator of the A/C switch turns OFF. Check that the compressor stops.

Is the inspection result normal?

YES >> GO TO 5.

NO >> Magnet clutch system malfunction. Refer to [HAC-56. "Diagnosis Procedure"](#).

#### 5.CHECK DISCHARGE AIR TEMPERATURE

Operate the temperature control dial. Check that the discharge air temperature changes.

Is the inspection result normal?

YES >> GO TO 6.

NO >> Air mix door malfunction. Refer to [HAC-41. "Diagnosis Procedure"](#).

#### 6.CHECK TEMPERATURE DECREASE

1. Operate the compressor.
2. Operate the temperature control dial and lower the set temperature to 18.0°C (60°F).
3. Check that the cool air blows from the outlets.

Is the inspection result normal?

A  
B  
C  
D  
E  
F  
G  
H  
J  
K  
L  
M  
N  
O  
P

HAC

# INSPECTION AND ADJUSTMENT

< BASIC INSPECTION >

[WITHOUT 7 INCH DISPLAY]

- YES >> GO TO 7.  
NO >> Insufficient cooling. Refer to [HAC-74, "Diagnosis Procedure"](#).

## 7. CHECK TEMPERATURE INCREASE

1. Turn temperature control dial and raise temperature setting to 32.0°C (90°F) after warming up the engine.
2. Check that warm air blows from outlets.

Is the inspection result normal?

- YES >> GO TO 8.  
NO >> Insufficient heating. Refer to [HAC-76, "Diagnosis Procedure"](#).

## 8. CHECK AUTO MODE

1. Operate the fan control dial and mode control dial to AUTO position.
2. Operate the temperature control dial. Check that the fan speed or air outlet changes (the air flow temperature or fan speed varies depending on the ambient temperature, in-vehicle temperature, and set temperature).

Is the inspection result normal?

- YES >> INSPECTION END  
NO >> Refer to [HAC-73, "Diagnosis Chart By Symptom"](#) and perform the appropriate diagnosis.

## Temperature Setting Trimmer

INFOID:000000005239122

### DESCRIPTION

If the temperature felt by the customer is different than the air flow temperature controlled by the temperature setting, the A/C auto amp. control temperature can be adjusted to compensate for the temperature setting.

### HOW TO SET

Ⓟ With CONSULT-III

Perform "TEMP SET CORRECT" of HVAC work support item.

Work support items	Display (°F)	Display (°C)
TEMP SET CORRECT	6	3.0
	5	2.5
	4	2.0
	3	1.5
	2	1.0
	1	0.5
	0 (initial status)	0 (initial status)
	-1	-0.5
	-2	-1.0
	-3	-1.5
	-4	-2.0
	-5	-2.5
	-6	-3.0

### NOTE:

- When -3.0°C (-6°F) is corrected on the temperature setting set as 25.0°C (77°F), the temperature controlled by A/C auto amp. is 25.0°C (77°F) - 3.0°C (-6°F) = 22.0°C (72°F) and the temperature becomes lower than the temperature setting.
- When the battery cable is disconnected from the negative terminal or when the battery voltage becomes 10 V or less, the setting of the difference between the set temperature and control temperature may be cancelled.

## Foot Position Setting Trimmer

INFOID:000000005239123

### DESCRIPTION

In FOOT mode, the air blowing to DEF can change ON/OFF.



# INSPECTION AND ADJUSTMENT

< BASIC INSPECTION >

[WITHOUT 7 INCH DISPLAY]

## HOW TO SET

④ With CONSULT-III

Perform the "BLOW SET" of HVAC work support item.

A  
B  
C  
D

Work support items	Display	Defroster door position	
		Auto control	Manual control
BLOW SET	Mode 1	OPEN	CLOSE
	Mode 2 (initial status)	OPEN	OPEN
	Mode 3	CLOSE	OPEN
	Mode 4	CLOSE	CLOSE

### NOTE:

When the battery cable is disconnected from the negative terminal or when the battery voltage becomes 10 V or less, the setting of the discharge air mix ratio in FOOT mode may be cancelled.

## Inlet Port Memory Function (FRE)

INFOID:000000005239124

### DESCRIPTION

- If the ignition switch is turned to the OFF position while the FRE indicator is set to ON (fresh air intake), "Perform the memory" or "Do not perform the memory" of FRE indicator ON (fresh air intake) condition can be selected.
- If "Perform the memory" was set, the FRE indicator will be ON (fresh air intake) when turning the ignition switch to the ON position again.
- If "Do not perform the memory" was set, the air inlets will be controlled automatically when turning the ignition switch to the ON position again.

F  
G  
H

## HOW TO SET

④ With CONSULT-III

Perform the "FRE MEMORY SET" of HVAC work support item.

HAC

Work support items	Display	Setting
FRE MEMORY SET	WITHOUT	Perform the memory of manual FRE
	WITH (initial status)	Do not perform the memory of manual FRE (auto control)

J  
K

### NOTE:

When the battery cable is disconnected from the negative terminal or when the battery voltage becomes 10 V or less, the setting of the FRE memory function may be cancelled.

## Inlet Port Memory Function (REC)

INFOID:000000005239125

### DESCRIPTION

- If the ignition switch is turned to the OFF position while the REC indicator is set to ON (recirculation), "Perform the memory" or "Do not perform the memory" of REC indicator ON (recirculation) condition can be selected.
- If "Perform the memory" was set, the REC indicator will be ON (recirculation) when turning the ignition switch to the ON position again.
- If "Do not perform the memory" was set, the air inlets will be controlled automatically when turning the ignition switch to the ON position again.

L  
M  
N  
O

## HOW TO SET

④ With CONSULT-III

Perform the "REC MEMORY SET" of HVAC work support item.

Work support items	Display	Setting
REC MEMORY SET	WITHOUT (initial status)	Perform the memory of manual REC
	WITH	Do not perform the memory of manual REC (auto control)

P

### NOTE:

## INSPECTION AND ADJUSTMENT

< BASIC INSPECTION >

[WITHOUT 7 INCH DISPLAY]

---

When the battery cable is disconnected from the negative terminal or when the battery voltage becomes 10 V or less, the setting of the REC memory function may be cancelled.

# COMPRESSOR CONTROL FUNCTION

< SYSTEM DESCRIPTION >

[WITHOUT 7 INCH DISPLAY]

## SYSTEM DESCRIPTION

### COMPRESSOR CONTROL FUNCTION

Description

INFOID:000000005239126

#### PRINCIPLE OF OPERATION

Functional circuit diagram

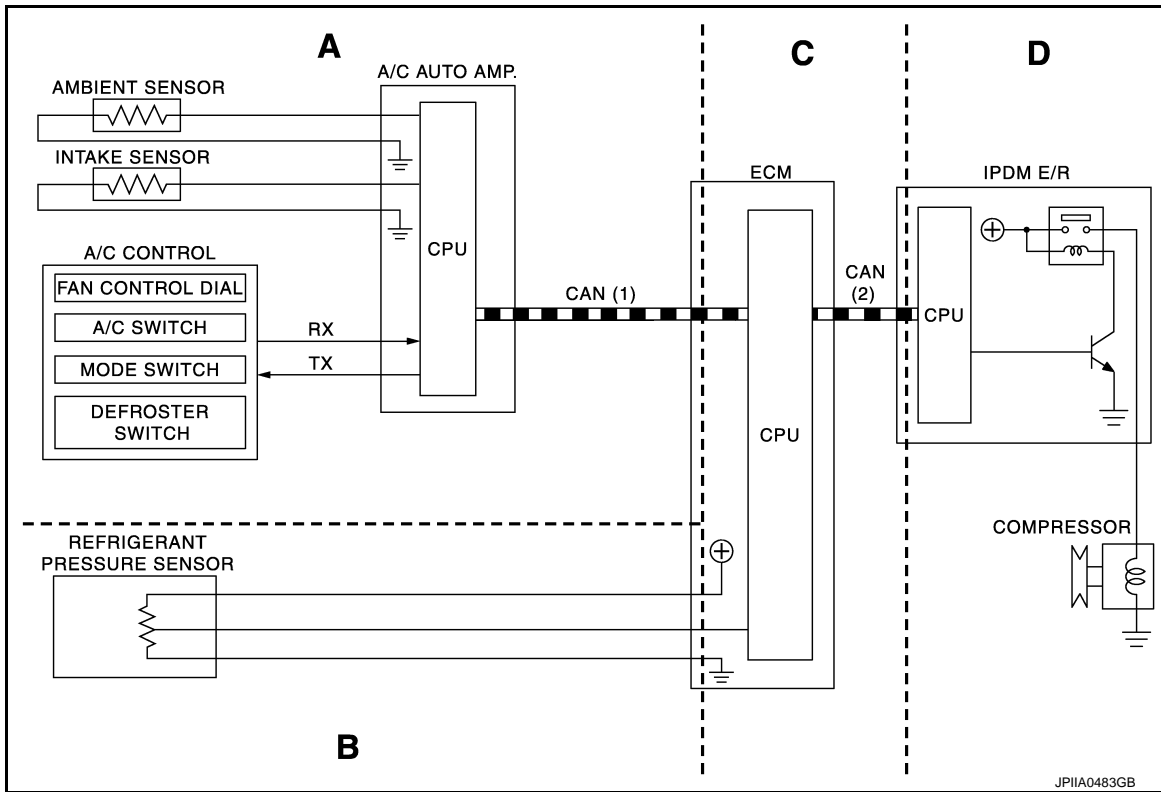

CAN (1) : A/C ON switch signal  
: Blower fan ON signal

CAN (2) : A/C compressor request signal

RX, TX : A/C switch signal  
: Fan ON signal  
: Defroster signal

#### Functional initial inspection chart

Control unit	Diagnosis Item	Location			
		A	B	C	D
A/C auto amp.	Self-diagnosis	×	—	—	—
	Data monitor	×	—	—	—
	Active test	×	—	—	×
ECM	Self-diagnosis (CAN system diagnosis)	—	—	×	—
	Data monitor	—	×	×	—
IPDM E/R	Self-diagnosis (CAN system diagnosis)	—	—	—	×
	Data monitor	—	—	×	—
	Auto active test	—	—	—	×

# COMPRESSOR CONTROL FUNCTION

< SYSTEM DESCRIPTION >

[WITHOUT 7 INCH DISPLAY]

## Fail-safe

INFOID:000000005239127

### FAIL-SAFE FUNCTION

When a communication malfunction between A/C auto amp. and A/C control continued for approximately 30 seconds or more, control the air conditioner under the following conditions.

- Compressor** : ON
- Air outlet** : AUTO
- Air inlet** : FRE (Fresh air intake)
- Fan speed** : AUTO
- Preset temperature** : Setting before communication malfunction

### Component Parts Location

INFOID:000000005239128

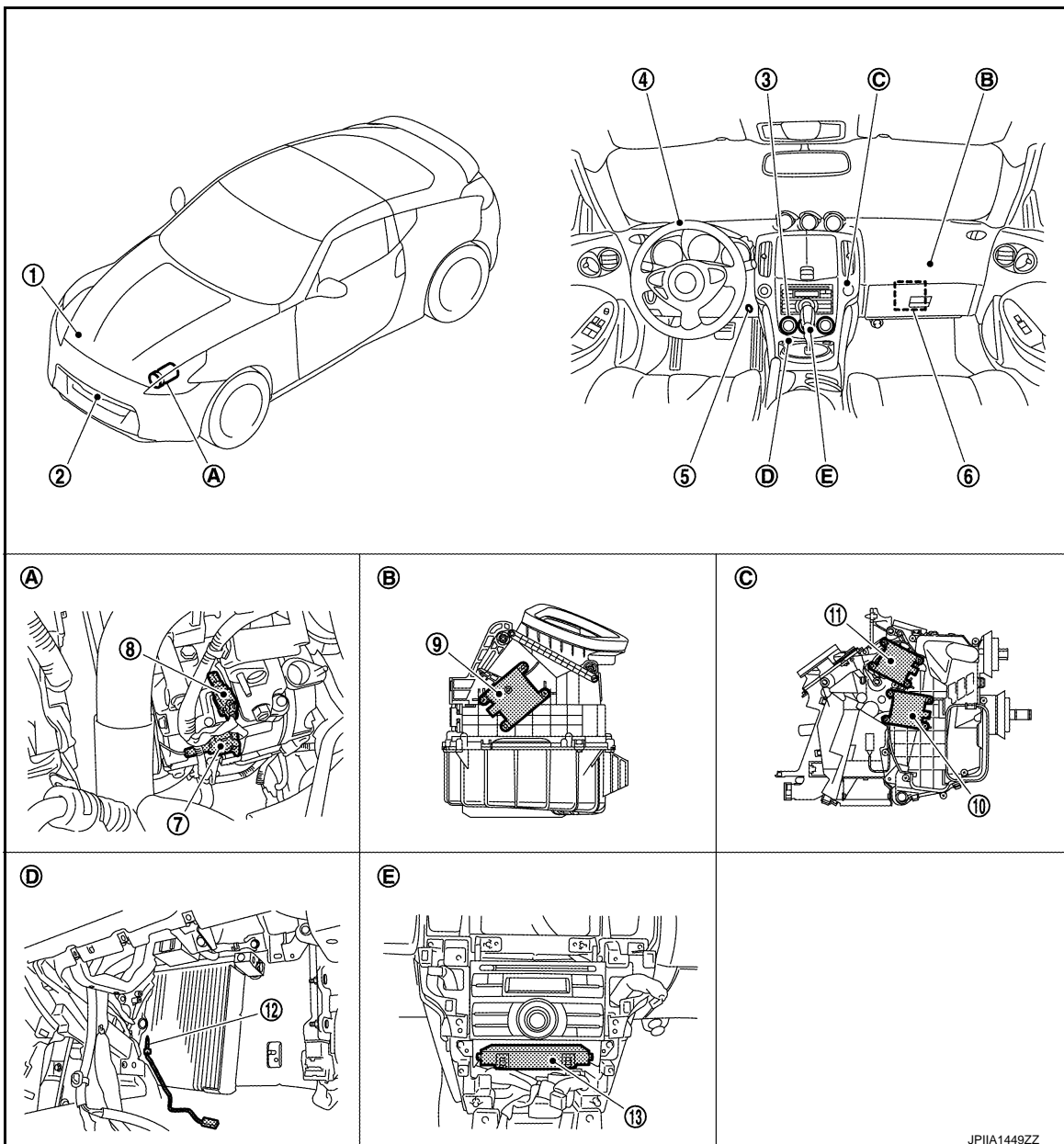

- |                                |                      |                 |
|--------------------------------|----------------------|-----------------|
| 1. Refrigerant pressure sensor | 2. Ambient sensor    | 3. A/C control  |
| 4. Sunload sensor              | 5. In-vehicle sensor | 6. Blower motor |

JPIIA1449ZZ

# COMPRESSOR CONTROL FUNCTION

< SYSTEM DESCRIPTION >

[WITHOUT 7 INCH DISPLAY]

- |                                |                                               |                                                         |
|--------------------------------|-----------------------------------------------|---------------------------------------------------------|
| 7. Magnet clutch               | 8. ECV                                        | 9. Intake door motor                                    |
| 10. Air mix door motor         | 11. Mode door motor                           | 12. Intake sensor                                       |
| 13. A/C auto amp.              |                                               |                                                         |
| A. Installed on the compressor | B. Installed to the blower unit assembly (RH) | C. Installed to the heater & cooling unit assembly (RH) |
| D. Located on the evaporator   | E. Behind of the cluster lid C                |                                                         |

## Component Description

INFOID:000000005239129

Component	Description
Ambient sensor	<a href="#">HAC-42. "Description"</a>
In-vehicle sensor	<a href="#">HAC-40. "Description"</a>
Intake sensor	<a href="#">HAC-44. "Description"</a>
Sunload sensor	<a href="#">HAC-52. "Description"</a>
Air mix door motor	<a href="#">HAC-56. "Description"</a>
Mode door motor	<a href="#">EC-511. "Description"</a>
Intake door motor	<a href="#">HAC-28. "Description"</a>
A/C control	The operation of the A/C control is communicated with the A/C auto amp. via communication line.
A/C auto amp.	<a href="#">HAC-31. "Description"</a>
Blower motor	<a href="#">HAC-37. "Description"</a>
Magnet clutch	<a href="#">HAC-56. "Description"</a>
ECV	<a href="#">HAC-58. "Description"</a>
Refrigerant pressure sensor	<a href="#">HAC-51. "Description"</a>

A  
B  
C  
D  
E  
F  
G  
H  
HAC  
J  
K  
L  
M  
N  
O  
P



# AUTOMATIC AIR CONDITIONER SYSTEM

[WITHOUT 7 INCH DISPLAY]

## < SYSTEM DESCRIPTION >

- Controller (A/C control) transmits the commands for air conditioner system operation to A/C auto amp. via communication line.

## OPERATION

Controller (A/C Control)

Except for Canada

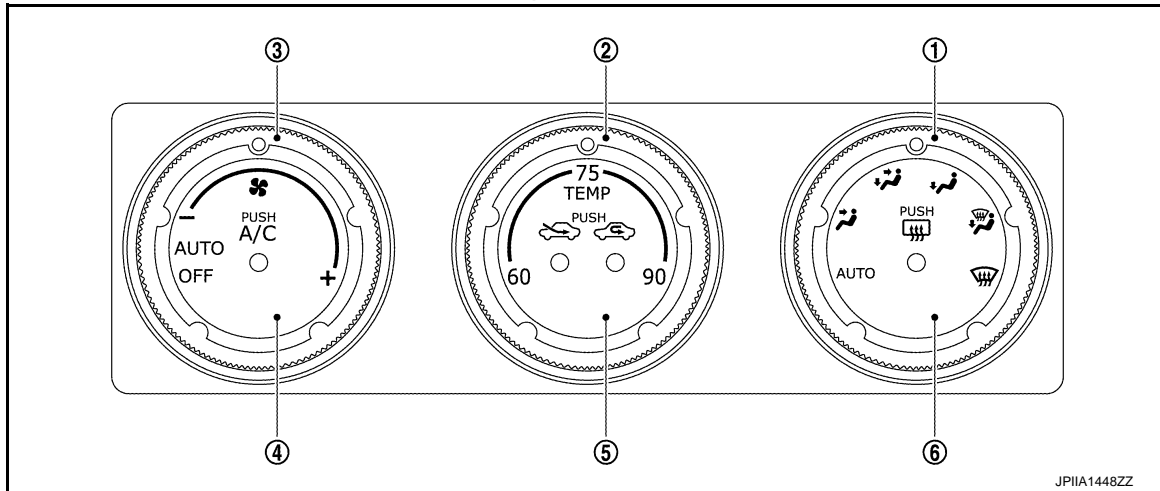

- |                      |                             |                                |
|----------------------|-----------------------------|--------------------------------|
| 1. Mode control dial | 2. Temperature control dial | 3. Fan control dial            |
| 4. A/C switch        | 5. Intake switch            | 6. Rear window defogger switch |

For Canada

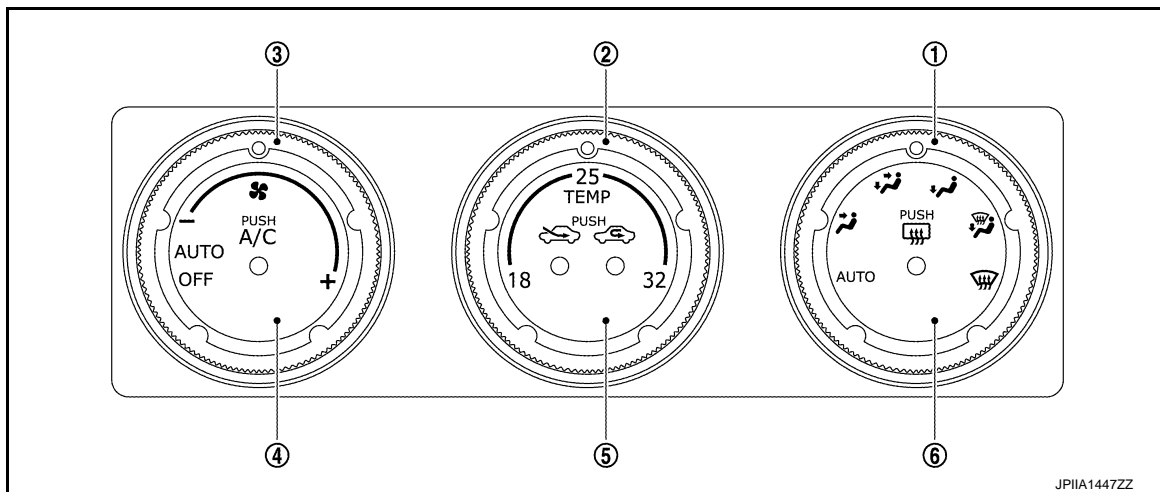

- |                      |                             |                                |
|----------------------|-----------------------------|--------------------------------|
| 1. Mode control dial | 2. Temperature control dial | 3. Fan control dial            |
| 4. A/C switch        | 5. Intake switch            | 6. Rear window defogger switch |

## Switch Operation

Mode control dial	<p>Selects mode position to an optimal position.</p> <ul style="list-style-type: none"> <li>• When AUTO is selected, the mode position is controlled automatically.</li> <li>• When D/F or DEF is selected while blower motor is activated, and air conditioner system becomes the following state. <ul style="list-style-type: none"> <li>- Compressor: ON</li> <li>- Air inlet: Fresh air intake</li> </ul> </li> </ul>
Temperature control dial	<p>Selects set temperature within a range between 18°C (60°F) - 32°C (90°F).</p> <p><b>NOTE:</b> When air conditioner system is in the OFF position, set temperature can be selected depending on temperature control dial operation.</p>

# AUTOMATIC AIR CONDITIONER SYSTEM

< SYSTEM DESCRIPTION >

[WITHOUT 7 INCH DISPLAY]

Fan control dial	<p>Selects fan speed within a range between 1st - 25th speed.</p> <ul style="list-style-type: none"> <li>• When AUTO is selected, fan speed is controlled automatically.</li> <li>• When OFF is selected, air conditioner system becomes the following state.             <ul style="list-style-type: none"> <li>- Air conditioner system: OFF</li> <li>- Air inlet: Fresh air intake</li> <li>- Air outlet: FOOT</li> </ul> </li> </ul>
A/C switch	<p>Turns the compressor control (switch indicator) between ON <math>\leftrightarrow</math> OFF each time while blower is activated.</p> <p><b>NOTE:</b> When A/C switch turns OFF, air inlet changes to fresh air intake.</p>
Intake switch	<ul style="list-style-type: none"> <li>• Selects air inlet changes between recirculation (REC) <math>\leftrightarrow</math> fresh air intake (FRE) each time.             <ul style="list-style-type: none"> <li>- FRE indicator ON: Fresh air intake</li> <li>- REC indicator ON: Recirculation</li> </ul> </li> <li>• Press and held for 2 seconds or more, intake switch indicator lamp blinks 2 times and air inlet is set to automatic control. (Air intake switch indicator indicates air inlet state during automatic control.)</li> </ul> <p><b>NOTE:</b></p> <ul style="list-style-type: none"> <li>• When air conditioner system is in the OFF position, air inlet can be selected.</li> <li>• When mode control dial is in the D/F or DEF position, air inlet cannot be selected to REC.</li> <li>• When intake switch is set to REC, the compressor is turned ON.</li> </ul>
Rear window defogger switch	<p>Turns rear window defogger (switch indicator) between ON <math>\leftrightarrow</math> OFF each time.</p> <p>Rear window defogger system details. Refer to <a href="#">DEF-92. "WITHOUT NAVIGATION : System Description"</a>.</p>

## AIR OUTLET CONTROL

- While air outlet is in automatic control, A/C auto amp. selects the mode door position depending on a target air mix door angle and outlet air temperature calculated from sunload.
- If ambient temperature is excessively low, D/F is selected to prevent windshield fogging when air outlet is set to FOOT.

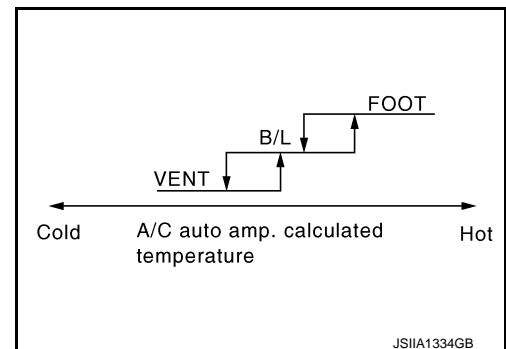

## TEMPERATURE CONTROL

- When ignition switch is in the ON position, A/C auto amp. always automatically controls temperature regardless of air conditioner operational state.
- A/C auto amp. calculates the target air mix door opening angle depending on set temperature, in-vehicle temperature, ambient temperature, and sunload.
- Air mix door is controlled depending on the comparison of current air mix door opening angle and target air mix door opening angle.
- Regardless of in-vehicle temperature, ambient temperature, and sunload, air mix door is fixed at the fully cold position when set temperature is 18.0°C (60°F), and at the fully hot position when set temperature is 32.0°C (90°F).

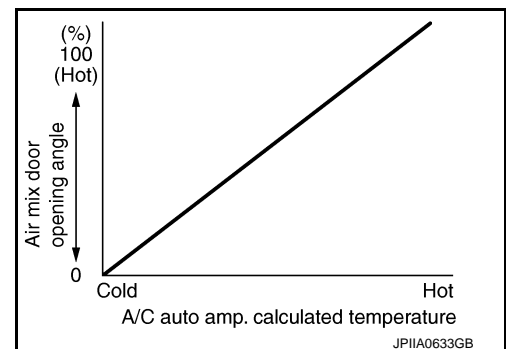

## AIR INLET FUNCTION



# AUTOMATIC AIR CONDITIONER SYSTEM

[WITHOUT 7 INCH DISPLAY]

## < SYSTEM DESCRIPTION >

While air inlet is in automatic control, A/C auto amp. selects air inlet (fresh air intake, 20 % fresh air intake, or recirculation) depending on set temperature, in-vehicle temperature, and ambient temperature.

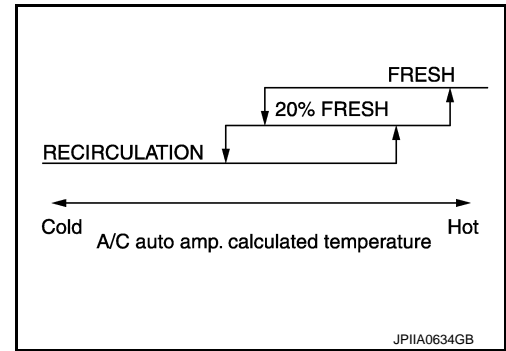

## AIR FLOW CONTROL

### Description

- A/C auto amp. changes duty ratio of blower motor drive signal and controls air flow continuously. When air flow is increased, duty ratio of blower motor drive signal gradually increases to prevent a sudden increase in air flow.
- In addition to manual control and automatic control, air flow control is composed of starting fan speed control, low coolant temperature starting control, high in-vehicle temperature starting control, blower speed control at door motor operation, and fan speed control at voice recognition.

### Automatic Air Flow Control

- A/C auto amp. decides target air flow depending on target air mix door opening angle.
- A/C auto amp. changes duty ratio of blower motor drive signal and controls air flow continuously so that air flow matches to target air flow.
- When air outlet is VENT or B/L, the minimum air flow is changed depending on sunload.

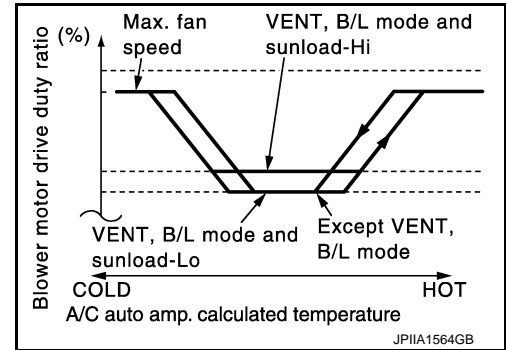

### Starting Fan Speed Control

When blower motor is activated, A/C auto amp. gradually increases duty ratio of blower fan drive signal to prevent a sudden increase in discharge air flow. (It takes approximately 8 seconds for air flow to reach HI from LOW)

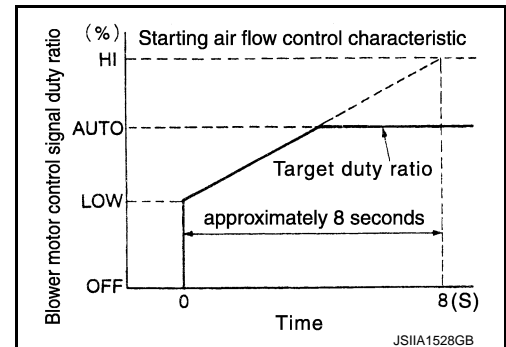

### Low Coolant Temperature Starting Control

# AUTOMATIC AIR CONDITIONER SYSTEM

< SYSTEM DESCRIPTION >

[WITHOUT 7 INCH DISPLAY]

If the engine coolant temperature is 56°C (133°F) or less, to prevent a cold discharged air flow, A/C auto amp. suspends blower motor activation for the maximum 150 seconds depending on target air mix door opening angle. After this, blower fan drive signal is increased gradually, and blower motor is activated.

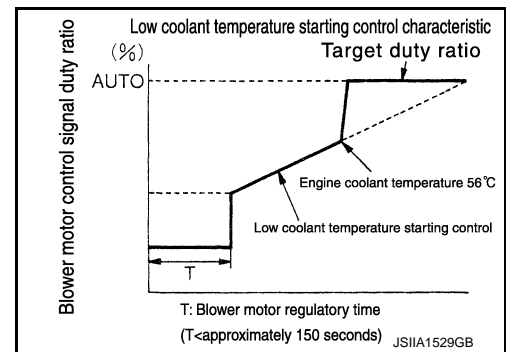

## High In-vehicle Temperature Starting Control

When evaporator temperature is high [intake air temperature sensor value is 35°C (95°F) or more], to prevent a hot discharged air flow, A/C auto amp. suspends blower motor activation for approximately 3 seconds so that evaporator is cooled by refrigerant.

## Fan speed Control at Door Motor Operation

When mode door motor is activated while air flow is more than the specified value, A/C auto amp. reduces temporarily fan speed so that mode door moves smoothly.

## Fan speed Control at Voice Recognition

When the voice control (voice command) switch is operated during air flow automatic control, A/C auto amp. decreases the air flow of the blower motor once and controls the air flow so as not to disturb the voice recognition function. This control continues while voice recognition function is operating.

## COMPRESSOR CONTROL

### Description

- When the compressor activation condition is satisfied while blower motor is activated, A/C auto amp. transmits A/C ON signal and blower fan ON signal to ECM via CAN communication.
- ECM judges that the compressor can be activated depending on each sensors state (refrigerant pressure sensor signal, throttle opening angle sensor signal, and others). And transmits air conditioner relay control signal to IPDM E/R via CAN communication.
- IPDM E/R turns air conditioner relay ON and activates the compressor depending on request from ECM.

### Compressor Protection Control at Pressure Malfunction

When high-pressure side value that is detected by refrigerant pressure sensor is as per the following state, ECM requests IPDM E/R to turn air conditioner relay OFF and stops the compressor.

- 3.12 MPa (31.8 kg/cm<sup>2</sup>·G) or more (When the engine speed is less than 1,500 rpm)
- 2.74 MPa (27.9 kg/cm<sup>2</sup>·G) or more (When the engine speed is 1,500 rpm or more)
- 0.14 MPa (1.4 kg/cm<sup>2</sup>·G) or less

### Compressor Oil Circulation Control

When the engine starts while the engine coolant temperature is 56°C (133°F) or less, ECM activates the compressor for approximately 6 seconds and circulates the compressor lubricant once.

### Low Temperature Protection Control

When intake air temperature sensor detects that air temperature after passing through evaporator is -5°C (23°F) or less, A/C auto amp. requests ECM to turn the compressor OFF, and stops the compressor.

When the air temperature returns to 1°C (34°F) or more, the compressor is activated.

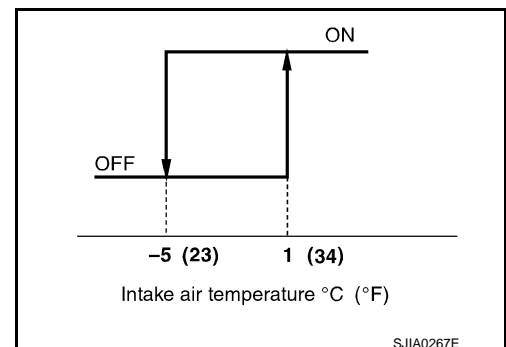

### Operating Rate Control

When set temperature is other than fully cold or air outlet is "VENT", "B/L" or "FOOT" A/C auto amp. controls the compressor activation depending on ambient temperature.

# AUTOMATIC AIR CONDITIONER SYSTEM

[WITHOUT 7 INCH DISPLAY]

## < SYSTEM DESCRIPTION >

### Air Conditioner Cut Control

When the engine is running in excessively high load condition, ECM requests IPDM E/R to turn air conditioner relay OFF, and stops the compressor. Refer to [EC-56. "System Description"](#) for details.

### DOOR MOTOR CONTROL

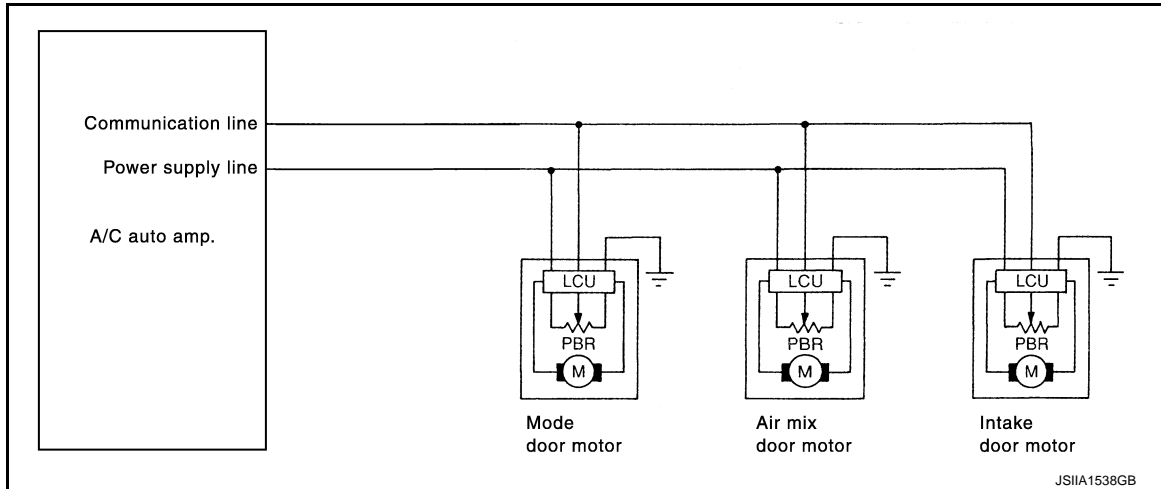

- LCU (Local Control Unit) is built in to each door motor. And detects door position by PBR (Potentiometer Balance Resistor).
- A/C auto amp. communicates with each LCU via communication line. And receives each door position feedback signal from each LCU.
- Each LCU controls each door to the appropriate position depending on the control signal from A/C auto amp. when the door movement is complete, transmits the signal of door movement completion to A/C auto amp.

### FAIL-SAFE CONTROL

When a communication malfunction occurs between A/C auto amp. and A/C control for 30 seconds or more, A/C auto amp. automatically controls air outlet and fan speed, fixes air inlet to fresh air intake, maintains set temperature data before the communication malfunction, and activates the compressor. Even if the condition before the communication error occurs is A/C OFF, A/C auto amp. turns the compressor ON with following conditions.

<b>Compressor</b>	<b>: ON</b>
<b>Air outlet</b>	<b>: AUTO</b>
<b>Air inlet</b>	<b>: FRE (Fresh air intake)</b>
<b>Fan speed</b>	<b>: AUTO</b>
<b>Preset temperature</b>	<b>: Setting before communication malfunction</b>

### SWITCHES AND THEIR CONTROL FUNCTIONS

# AUTOMATIC AIR CONDITIONER SYSTEM

< SYSTEM DESCRIPTION >

[WITHOUT 7 INCH DISPLAY]

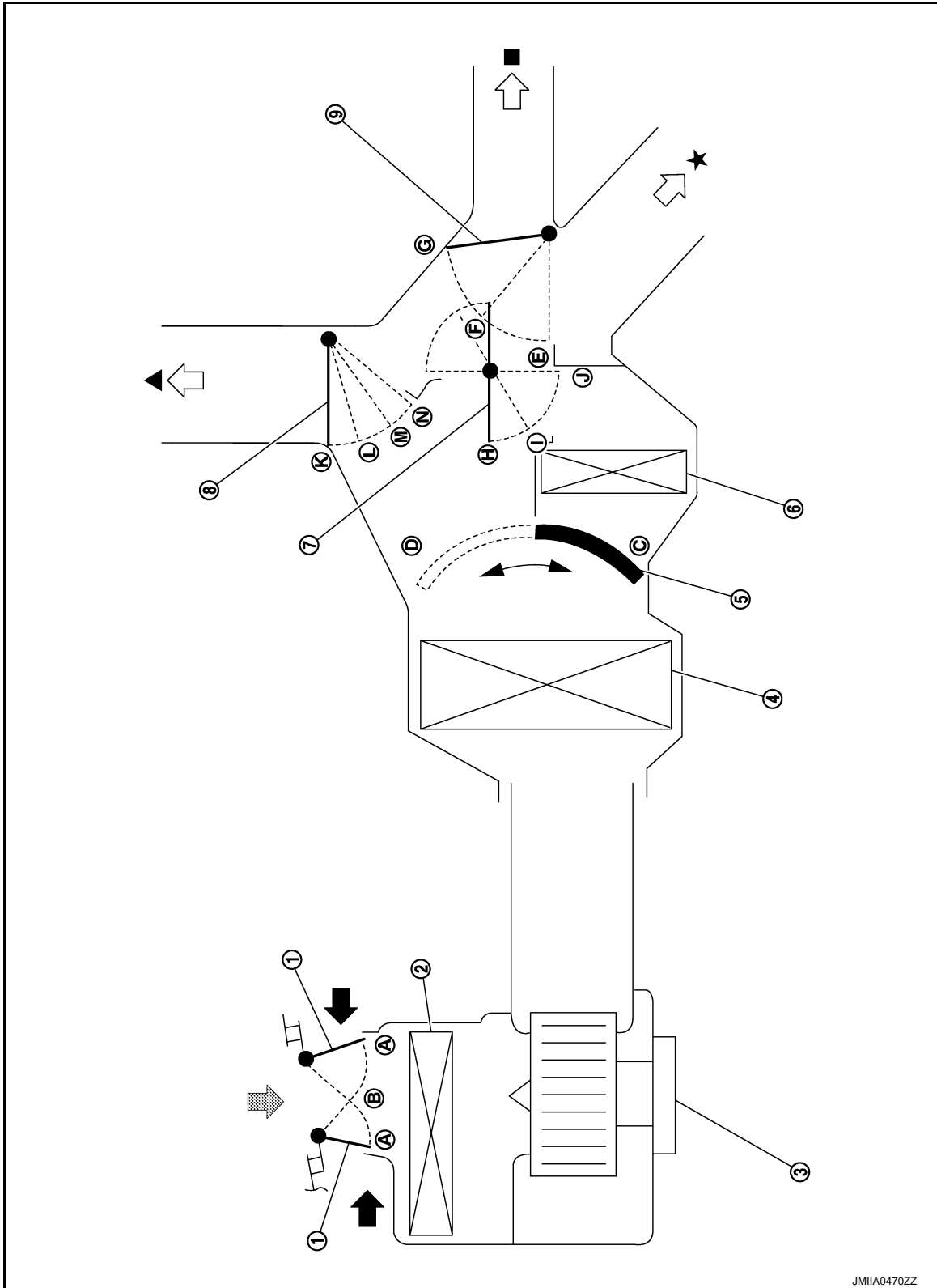

JMIIA0470ZZ







- |                    |                                                  |                    |
|--------------------|--------------------------------------------------|--------------------|
| 1. Intake door     | 2. In-cabine microfilter/Air conditioner filter* | 3. Blower motor    |
| 4. Evaporator      | 5. Air mix door                                  | 6. Heater core     |
| 7. Max. cool door  | 8. Defroster door                                | 9. Ventilator door |
| ◀ Fresh air intake | ◀ Recirculation air                              |                    |
| ▲ Defroster        | ■ Ventilator                                     | ★ Foot             |

# AUTOMATIC AIR CONDITIONER SYSTEM

< SYSTEM DESCRIPTION >





[WITHOUT 7 INCH DISPLAY]

\*: Models for Mexico

Switch /Dial position		Door position				
		Ventilator door	Max. cool door	Defroster door	Intake door	Air mix door
Mode control dial	AUTO	AUTO				
		E	H	K	—	—
		F	I			
		G	J	L		
				M	A	
	N			A		
Intake switch					B*	
					A*	
Temperature control dial	Full cold 18.0°C (60°F)	—	—	—	C	
	18.5°C -31.5°C (61°F - 89°F)			—	AUTO	
	Full hot 32.0°C (90°F)				D	
Fan control dial	OFF	G	J	L	A	—

\*: Inlet status is displayed by indicator when activating automatic control

## AIR DISTRIBUTION

Discharge air flow			
Mode position indication	Air outlet/distribution		
	Ventilator	Foot	Defroster
	100%	—	—
	60%	40%	—
	12%	62%	26%
	10%	52%	38%
	—	—	100%

A  
B  
C  
D  
E  
F  
G  
H  
HAC  
J  
K  
L  
M  
N  
O  
P

# AUTOMATIC AIR CONDITIONER SYSTEM

< SYSTEM DESCRIPTION >

[WITHOUT 7 INCH DISPLAY]

## Component Parts Location

INFOID:000000005239132

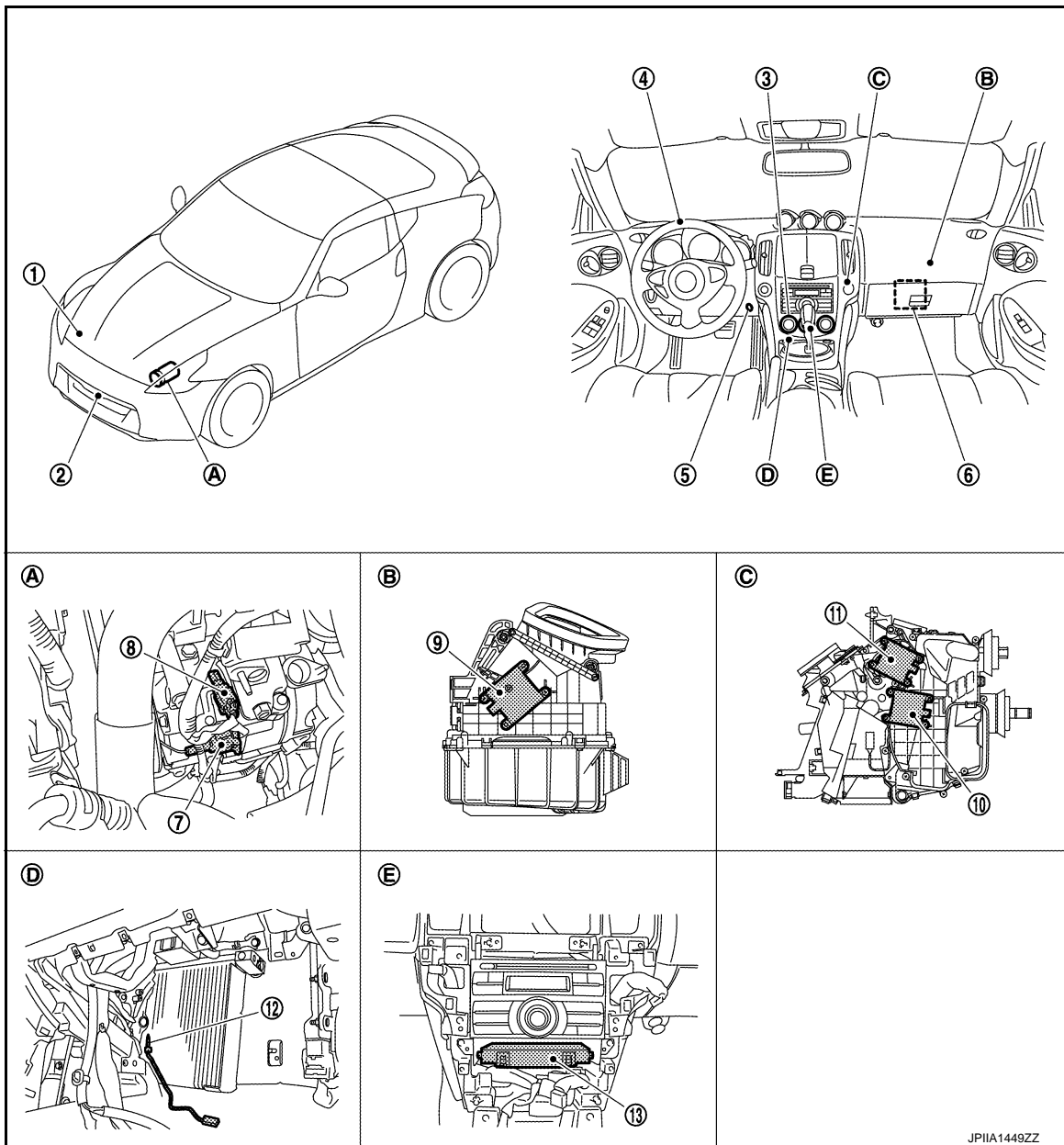

- |                                |                                               |                                                         |
|--------------------------------|-----------------------------------------------|---------------------------------------------------------|
| 1. Refrigerant pressure sensor | 2. Ambient sensor                             | 3. A/C control                                          |
| 4. Sunload sensor              | 5. In-vehicle sensor                          | 6. Blower motor                                         |
| 7. Magnet clutch               | 8. ECV                                        | 9. Intake door motor                                    |
| 10. Air mix door motor         | 11. Mode door motor                           | 12. Intake sensor                                       |
| 13. A/C auto amp.              |                                               |                                                         |
| A. Installed on the compressor | B. Installed to the blower unit assembly (RH) | C. Installed to the heater & cooling unit assembly (RH) |
| D. Located on the evaporator   | E. Behind of the cluster lid C                |                                                         |

## Component Description

INFOID:000000005239133

Component	Description
Ambient sensor	<a href="#">HAC-42, "Description"</a>
In-vehicle sensor	<a href="#">HAC-40, "Description"</a>

# AUTOMATIC AIR CONDITIONER SYSTEM

< SYSTEM DESCRIPTION >

[WITHOUT 7 INCH DISPLAY]

Component	Description
Intake sensor	<a href="#">HAC-44. "Description"</a>
Sunload sensor	<a href="#">HAC-52. "Description"</a>
Air mix door motor	<a href="#">HAC-56. "Description"</a>
Mode door motor	<a href="#">EC-511. "Description"</a>
Intake door motor	<a href="#">HAC-28. "Description"</a>
A/C control	The operation of the A/C control is communicated with the A/C auto amp. via communication line.
A/C auto amp.	<a href="#">HAC-31. "Description"</a>
Blower motor	<a href="#">HAC-37. "Description"</a>
Magnet clutch	<a href="#">HAC-56. "Description"</a>
ECV	<a href="#">HAC-58. "Description"</a>
Refrigerant pressure sensor	<a href="#">HAC-51. "Description"</a>

A  
B  
C  
D  
E  
F  
G  
H  
J  
K  
L  
M  
N  
O  
P

HAC

# DIAGNOSIS SYSTEM (HVAC)

< SYSTEM DESCRIPTION >

[WITHOUT 7 INCH DISPLAY]

## DIAGNOSIS SYSTEM (HVAC)

### CONSULT-III Function

INFOID:000000005239134

CONSULT-III performs the following functions via CAN communication with A/C auto amp.

Diagnostic mode	Description
Self diagnostic result	Displays the diagnosis results judged by A/C auto amp.
Data monitor	Displays the input/output signal of A/C auto amp.
Active test	The signals used to activate each device are forcibly supplied from A/C auto amp.
Work support	Changes the setting for each setting function.
ECU identification	Displays the part number of A/C auto amp.

#### NOTE:

Diagnosis should be performed with the engine running. Door motor operation speeds become slower and NO results may be returned even for normal operation if battery voltage drops below 12 V during self-diagnosis.

#### SELF-DIAGNOSIS RESULTS

Refer to [HAC-71, "DTC Index"](#).

#### DATA MONITOR

Display item list

Monitor item [Unit]	Description
COMP REQ SIG [On/Off]	Displays A/C switch ON/OFF status transmitted to other units via CAN communication
FAN REQ SIG [On/Off]	Displays fan switch ON/OFF status transmitted to other units via CAN communication
AMB TEMP SEN [°C]	Ambient sensor value converted from ambient sensor signal received from ambient sensor
IN-VEH TEMP [°C]	In-vehicle sensor value converted from in-vehicle sensor signal received from in-vehicle sensor
INT TEMP SEN [°C]	Intake sensor value converted from intake sensor signal received from intake sensor
SUNLOAD SEN [w/m <sup>2</sup> ]	Sunload sensor value converted from sunload sensor signal received from sunload sensor
AMB SEN CAL [°C]	Ambient sensor value calculated by A/C auto amp.
IN-VEH CAL [°C]	In-vehicle sensor value calculated by A/C auto amp.
INT TEMP CAL [°C]	Intake sensor value calculated by A/C auto amp.
SUNL SEN CAL [w/m <sup>2</sup> ]	Sunload sensor value calculated by A/C auto amp.
FAN DUTY	Duty ratio of blower motor judged by A/C auto amp.
XM	Target discharge air temperature judged by A/C auto amp. depending on the temperature setting and the value from each sensor
ENG COOL TEMP [°C]	Water temperature signal value received from ECM via CAN communication
VEHICLE SPEED [Mph (km/h)]	Vehicle speed signal value received from meter via CAN communication

#### ACTIVE TEST

Test item	Description
ALL SEG	The signals used to activate A/C control indicator are forcibly supplied from A/C auto amp.
HVAC TEST	The operation check of air conditioner system can be performed by selecting the mode. Refer to the following table for the conditions of each mode.

Check each output device



# DIAGNOSIS SYSTEM (HVAC)

< SYSTEM DESCRIPTION >

[WITHOUT 7 INCH DISPLAY]

	Test item						
	MODE 1	MODE 2	MODE 3	MODE 4	MODE 5	MODE 6	MODE 7
Mode door position	VENT	B/L 1	B/L 2	FOOT	D/F	DEF	—
Intake door position	REC	REC	20% FRE	FRE	FRE	FRE	—
Air mix door position	FULL COLD	FULL COLD	FULL HOT	FULL HOT	FULL HOT	FULL HOT	—
Blower motor control signal duty ratio	37%	91%	65%	65%	65%	91%	—
Magnet clutch	ON	ON	OFF	OFF	ON	ON	—
ECV duty ratio	100%	100%	0%	0%	50%	100%	—

**NOTE:**

- Perform the inspection of each output device after starting the engine because the compressor is operated.
- If the Mode 7 is selected, the malfunction is displayed but it is normal.

**WORK SUPPORT**

Work item	Description	Refer to
TEMP SET CORRECT (Temperature setting trimmer)	If the temperature felt by the customer is different than the air flow temperature controlled by the temperature setting, the A/C auto amp. control temperature can be adjusted to compensate for the temperature setting.	<a href="#">HAC-8. "Temperature Setting Trimmer"</a>
FRE MEMORY SET [Inlet port memory function (FRE)]	<ul style="list-style-type: none"> <li>• If the ignition switch is turned to the OFF position while the FRE indicator is set to ON (fresh air intake), "Perform the memory" or "Do not perform the memory" of FRE indicator ON (fresh air intake) condition can be selected.</li> <li>• If "Perform the memory" was set, the FRE indicator will be ON (fresh air intake) when turning the ignition switch to the ON position again.</li> <li>• If "Do not perform the memory" was set, the air inlets will be controlled automatically when turning the ignition switch to the ON position again.</li> </ul>	<a href="#">HAC-9. "Inlet Port Memory Function (FRE)"</a>
REC MEMORY SET [Inlet port memory function (REC)]	<ul style="list-style-type: none"> <li>• If the ignition switch is turned to the OFF position while the REC indicator is set to ON (recirculation), "Perform the memory" or "Do not perform the memory" of REC indicator ON (recirculation) condition can be selected.</li> <li>• If "Perform the memory" was set, the REC indicator will be ON (recirculation) when turning the ignition switch to the ON position again.</li> <li>• If "Do not perform the memory" was set, the air inlets will be controlled automatically when turning the ignition switch to the ON position again.</li> </ul>	<a href="#">HAC-9. "Inlet Port Memory Function (REC)"</a>
BLOWER SET (Foot position setting trimmer)	In FOOT mode, the air blowing to DEF can change ON/OFF.	<a href="#">HAC-8. "Foot Position Setting Trimmer"</a>

**NOTE:**

When the battery cable is disconnected from the negative terminal or when the battery voltage becomes 10 V or less, the setting of WORK SUPPORT may be cancelled.

A  
B  
C  
D  
E  
F  
G  
H  
J  
K  
L  
M  
N  
O  
P

HAC

## DTC/CIRCUIT DIAGNOSIS

### U1000 CAN COMM CIRCUIT

#### Description

INFOID:000000005239135

CAN (Controller Area Network) is a serial communication line for real time applications. It is an on-board multiplex communication line with high data communication speed and excellent error detection ability. A modern vehicle is equipped with many ECMs, and each control unit shares information and links with other control units during operation (not independent). In CAN communication, 2 control units are connected with 2 communication lines (CAN-L-line and CAN-H-line) allowing a high rate of information transmission with less wiring. Each control unit transmits/receives data but selectively reads required data only.

Refer to [LAN-26, "CAN Communication Signal Chart"](#) for details of the communication signal.

#### DTC Logic

INFOID:000000005239136

#### DTC DETECTION LOGIC

DTC	Items (CONSULT-III screen terms)	Diagnostic item is detected when...	Possible cause
U1000	CAN COMM CIRCUIT	When A/C auto amp. is not transmitting or receiving CAN communication signal for 2 or more seconds.	CAN communication system

#### Diagnosis Procedure

INFOID:000000005239137

### 1. PERFORM SELF-DIAGNOSIS

Ⓟ With CONSULT-III

1. Turn the ignition switch ON and wait for 2 seconds or more.
2. Perform the "SELF-DIAGNOSIS".
3. Check if any DTC is detected in the self-diagnostic results.

Is DTC "U1000" displayed?

- YES >> Perform the diagnosis for the CAN communication system. Refer to [LAN-16, "Trouble Diagnosis Flow Chart"](#).
- NO >> Perform the intermittent malfunction diagnosis. Refer to [GI-39, "Intermittent Incident"](#).

# U1010 CONTROL UNIT (CAN)

< DTC/CIRCUIT DIAGNOSIS >

[WITHOUT 7 INCH DISPLAY]

## U1010 CONTROL UNIT (CAN)

### Description

INFOID:000000005239138

Initial diagnosis of A/C auto amp.

### DTC Logic

INFOID:000000005239139

### DTC DETECTION LOGIC

DTC	Items (CONSULT-III screen terms)	Diagnostic item is detected when...	Possible cause
U1010	CONTROL UNIT (CAN)	When detecting error during the initial diagnosis of CAN controller of A/C auto amp.	A/C auto amp.

### Diagnosis Procedure

INFOID:000000005239140

#### 1. REPLACE A/C AUTO AMP.

When DTC "U1010" is detected, replace A/C auto amp.

>> INSPECTION END

A  
B  
C  
D  
E  
F  
G  
H  
J  
K  
L  
M  
N  
O  
P

HAC

# B257B, B257C AMBIENT SENSOR

< DTC/CIRCUIT DIAGNOSIS >

[WITHOUT 7 INCH DISPLAY]

## B257B, B257C AMBIENT SENSOR

### Description

INFOID:000000005239141

#### AMBIENT SENSOR

- The ambient sensor (1) is installed to the hood lock stay.
- The ambient sensor converts the ambient temperature detected with thermistor into the voltage, and the A/C auto amp. inputs this voltage.

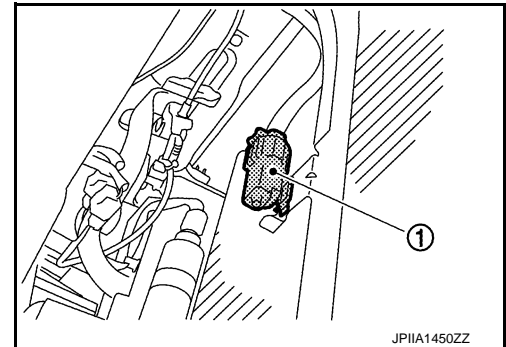

#### AMBIENT TEMPERATURE CORRECTION

- The A/C auto amp. inputs the temperature detected with the ambient sensor as the ambient temperature.
- Perform the correction of the temperature detected with the ambient sensor for air conditioner control and for ambient temperature display.
- Since the engine heat influences on the ambient sensor during idling condition, the A/C auto amp. retards the ambient temperature indication of the combination meter to avoid the effect of steep temperature change.
- Select and use the initial value of ambient temperature data depending on the coolant temperature when turning the ignition switch from OFF to ON. Use the detection temperature of the ambient sensor at low coolant temperature [less than approximately 56°C (133°F)]. Use the memory data (before the ignition switch is OFF) when the engine is warming up [approximately 56°C (133°F) or more].
- Do not perform the correction of the ambient temperature when the detection temperature of the ambient temperature is less than approximately -29°C (-20°F) (for ambient temperature display) or less than approximately -20°C (-4°F) (for air conditioner control).

#### SET TEMPERATURE CORRECTION

The A/C auto amp. performs the correction to the target temperature set by the temperature control dial so as to match the temperature felt by the passengers depending on the ambient temperature detected with the ambient sensor and controls it so that the interior air temperature is always the most suitable.

### DTC Logic

INFOID:000000005239142

#### DTC DETECTION LOGIC

DTC	Items (CONSULT-III screen terms)	Diagnostic item is detected when...	Possible causes
B257B	AMB TEMP SEN SHORT	The ambient sensor recognition temperature is too high.	<ul style="list-style-type: none"> <li>• Ambient sensor</li> <li>• A/C auto amp.</li> <li>• Harness and connector (Short in the ambient sensor circuit)</li> </ul>
B257C	AMB TEMP SEN OPEN	The ambient sensor recognition temperature is too low.	<ul style="list-style-type: none"> <li>• Ambient sensor</li> <li>• A/C auto amp.</li> <li>• Harness and connector (Open in the ambient sensor circuit)</li> </ul>

#### DTC CONFIRMATION PROCEDURE

##### 1. PERFORM SELF-DIAGNOSIS

Ⓜ With CONSULT-III

1. Perform the "SELF-DIAGNOSIS".
2. Check if any DTC is detected in the self-diagnostic results.

#### NOTE:

- If DTC is displayed along with DTC "U1000" or "U1010", first diagnose the DTC "U1000" or "U1010". Refer to [HAC-26. "DTC Logic"](#) or [HAC-27. "DTC Logic"](#).

# B257B, B257C AMBIENT SENSOR

< DTC/CIRCUIT DIAGNOSIS >

[WITHOUT 7 INCH DISPLAY]

- If there is an open circuit in the ambient sensor, A/C auto amp registers extreme cold [-30°C (-22°F)] and adjusts the temperature control warmer.

Is DTC "B257B" or "B257C" displayed?

- YES >> Perform the diagnosis for the ambient sensor. Refer to [HAC-29. "Diagnosis Procedure"](#).
- NO >> INSPECTION END

## Diagnosis Procedure

INFOID:000000005239143

### 1. CHECK AMBIENT SENSOR POWER SUPPLY CIRCUIT

1. Turn the ignition switch OFF.
2. Disconnect ambient sensor connector.
3. Turn the ignition switch ON.
4. Check voltage between ambient sensor harness connector and ground.

(+)		(-)	Voltage (Approx.)
Ambient sensor		—	
Connector	Terminal		
E76	1	Ground	5 V

Is the inspection result normal?

- YES >> GO TO 2.
- NO >> GO TO 4.

### 2. CHECK AMBIENT SENSOR CIRCUIT CONTINUITY

1. Turn the ignition switch OFF.
2. Disconnect the A/C auto amp. connector.
3. Check for continuity between the ambient sensor harness connector and A/C auto amp harness connector.

Ambient sensor		A/C auto amp.		Continuity
Connector	Terminal	Connector	Terminal	
E76	2	M66	37	Existed

Is the inspection result normal?

- YES >> GO TO 3.
- NO >> Repair the harnesses or connectors.

### 3. CHECK AMBIENT SENSOR

Check the ambient sensor components. Refer to [HAC-30. "Component Inspection"](#).

Is the inspection result normal?

- YES >> Replace the A/C auto amp.
- NO >> Replace the ambient sensor.

### 4. CHECK AMBIENT SENSOR CIRCUIT CONTINUITY

1. Turn the ignition switch OFF.
2. Disconnect the A/C auto amp. connector.
3. Check for continuity between the ambient sensor harness connector and A/C auto amp. harness connector.

Ambient sensor		A/C auto amp.		Continuity
Connector	Terminal	Connector	Terminal	
E76	1	M66	35	Existed

4. Check for continuity between ambient sensor harness connector and ground.

# B257B, B257C AMBIENT SENSOR

< DTC/CIRCUIT DIAGNOSIS >

[WITHOUT 7 INCH DISPLAY]

Ambient sensor		—	Continuity
Connector	Terminal		
E76	1	Ground	Not existed

Is the inspection result normal?

- YES >> Replace the A/C auto amp.  
NO >> Repair the harnesses or connectors.

## Component Inspection

INFOID:000000005239144

### 1. CHECK AMBIENT SENSOR

1. Turn the ignition switch OFF.
2. Remove the ambient sensor. Refer to [HAC-88. "Exploded View"](#).
3. Check the resistance between the ambient sensor terminals. Refer to the applicable table for the normal value.

Terminal	Condition	Resistance: kΩ	
			Temperature: °C (°F)
1	2	-15 (5)	12.73
		-10 (14)	9.92
		-5 (23)	7.80
		0 (32)	6.19
		5 (41)	4.95
		10 (50)	3.99
		15 (59)	3.24
		20 (68)	2.65
		25 (77)	2.19
		30 (86)	1.81
		35 (95)	1.51
		40 (104)	1.27
45 (113)	1.07		

Is the inspection result normal?

- YES >> INSPECTION END  
NO >> Replace the ambient sensor.

# B2578, B2579 IN-VEHICLE SENSOR

< DTC/CIRCUIT DIAGNOSIS >

[WITHOUT 7 INCH DISPLAY]

## B2578, B2579 IN-VEHICLE SENSOR

### Description

INFOID:000000005239146

#### IN-VEHICLE SENSOR

- The in-vehicle sensor (1) is installed to the instrument lower panel LH.
- The in-vehicle sensor converts the interior air temperature of the passenger room sucked by the aspirator detected with the thermistor into the voltage, and the A/C auto amp. inputs this voltage.

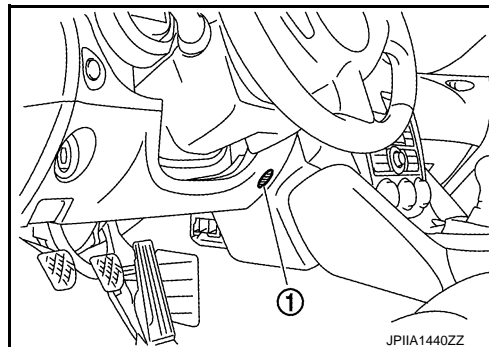

#### ASPIRATOR

The aspirator (1) generates the vacuum by the air blown from the heater & cooling unit and draws the air of the passenger room to the in-vehicle sensor area via the aspirator duct.

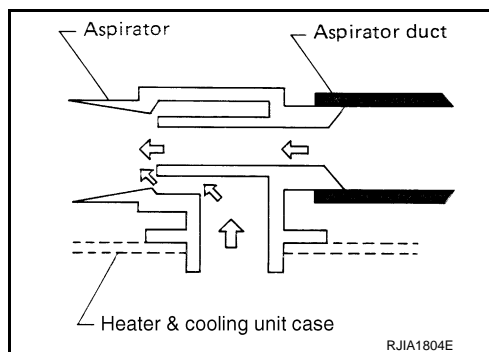
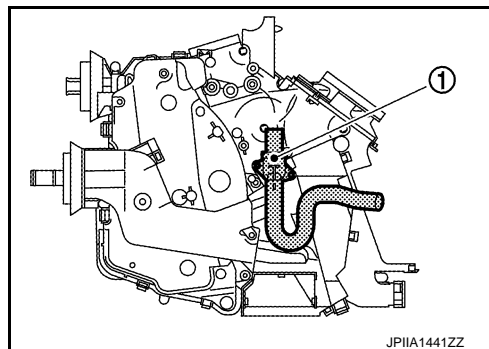

#### INTERIOR AIR TEMPERATURE CORRECTION

- The A/C auto amp. inputs the temperature detected with the in-vehicle sensor as the interior air temperature.
- Perform the correction of the temperature detected with the in-vehicle sensor for each air conditioner control.

### DTC Logic

INFOID:000000005239146

#### DTC DETECTION LOGIC

A  
B  
C  
D  
E  
F  
G  
H  
HAC  
J  
K  
L  
M  
N  
O  
P

# B2578, B2579 IN-VEHICLE SENSOR

< DTC/CIRCUIT DIAGNOSIS >

[WITHOUT 7 INCH DISPLAY]

DTC	Items (CONSULT-III screen terms)	Diagnostic item is detected when...	Possible causes
B2578	IN CAR SEN SHORT	The in-vehicle sensor recognition temperature is too high.	<ul style="list-style-type: none"> <li>In-vehicle sensor</li> <li>A/C auto amp.</li> <li>Harness and connector (Short in the in-vehicle sensor circuit)</li> </ul>
B2579	IN CAR SEN OPEN	The in-vehicle sensor recognition temperature is too low.	<ul style="list-style-type: none"> <li>In-vehicle sensor</li> <li>A/C auto amp.</li> <li>Harness and connector (Open in the in-vehicle sensor circuit)</li> </ul>

## DTC CONFIRMATION PROCEDURE

### 1.PERFORM SELF-DIAGNOSIS

ⓅWith CONSULT-III

1. Perform the "SELF-DIAGNOSIS".
2. Check if any DTC is detected in the self-diagnostic results.

#### NOTE:

If DTC is displayed along with DTC "U1000" or "U1010", first diagnose the DTC "U1000" or "U1010". Refer to [HAC-26. "DTC Logic"](#) or [HAC-27. "DTC Logic"](#).

Is DTC "B2578" or "B2579" displayed?

- YES >> Perform the diagnosis for the in-vehicle sensor. Refer to [HAC-32. "Diagnosis Procedure"](#).  
 NO >> INSPECTION END

## Diagnosis Procedure

INFOID:000000005239147

### 1.CHECK IN-VEHICLE SENSOR POWER SUPPLY CIRCUIT

1. Turn the ignition switch OFF.
2. Disconnect the in-vehicle sensor connector.
3. Turn the ignition switch ON.
4. Check voltage between in-vehicle sensor harness connector and ground.

(+)		(-)	Voltage (Approx.)
In-vehicle sensor		—	
Connector	Terminal		
M61	1	Ground	5 V

Is the inspection result normal?

- YES >> GO TO 2.  
 NO >> GO TO 4.

### 2.CHECK IN-VEHICLE SENSOR CIRCUIT CONTINUITY-

1. Turn the ignition switch OFF.
2. Disconnect the A/C auto amp. connector.
3. Check for continuity between the in-vehicle sensor harness connector and A/C auto amp. harness connector.

In-vehicle sensor		A/C auto amp.		Continuity
Connector	Terminal	Connector	Terminal	
M61	2	M66	37	Existed

Is the inspection result normal?

- YES >> GO TO 3.  
 NO >> Repair the harnesses or connectors.

### 3.CHECK IN-VEHICLE SENSOR

Check the in-vehicle sensor components. Refer to [HAC-33. "Component Inspection"](#).



## B2578, B2579 IN-VEHICLE SENSOR

< DTC/CIRCUIT DIAGNOSIS >

[WITHOUT 7 INCH DISPLAY]

Is the inspection result normal?

- YES >> Replace the A/C auto amp.  
 NO >> Replace the in-vehicle sensor.

### 4. CHECK IN-VEHICLE SENSOR CIRCUIT CONTINUITY

1. Turn the ignition switch OFF.
2. Disconnect the A/C auto amp. connector.
3. Check for continuity between the in-vehicle sensor harness connector and A/C auto amp. harness connector.

In-vehicle sensor		A/C auto amp.		Continuity
Connector	Terminal	Connector	Terminal	
M61	1	M66	36	Existed

4. Check for continuity between in-vehicle sensor harness connector and ground.

In-vehicle sensor		—	Continuity
Connector	Terminal		
M61	1	Ground	Not existed

Is the inspection result normal?

- YES >> Replace the A/C auto amp.  
 NO >> Repair the harnesses or connectors.

### Component Inspection

INFOID:000000005239148

### 1. CHECK IN-VEHICLE SENSOR

1. Turn the ignition switch OFF.
2. Remove the in-vehicle sensor. Refer to [HAC-89, "Exploded View"](#).
3. Check the resistance between the in-vehicle sensor terminals. Refer to the applicable table for the normal value.

Terminal		Condition	Resistance: kΩ
		Temperature: °C (°F)	
1	2	-15 (5)	12.73
		-10 (14)	9.92
		-5 (23)	7.80
		0 (32)	6.19
		5 (41)	4.95
		10 (50)	3.99
		15 (59)	3.24
		20 (68)	2.65
		25 (77)	2.19
		30 (86)	1.81
		35 (95)	1.51
		40 (104)	1.27
		45 (113)	1.07

Is the inspection result normal?

- YES >> INSPECTION END  
 NO >> Replace the in-vehicle sensor.

# B2581, B2582 INTAKE SENSOR

< DTC/CIRCUIT DIAGNOSIS >

[WITHOUT 7 INCH DISPLAY]

## B2581, B2582 INTAKE SENSOR

### Description

INFOID:000000005239149

#### INTAKE SENSOR

- Intake sensor (1) is located on the evaporator (2).
- The intake sensor converts the evaporator passing air temperature detected with thermistor into the voltage, and the A/C auto amp. inputs this voltage.

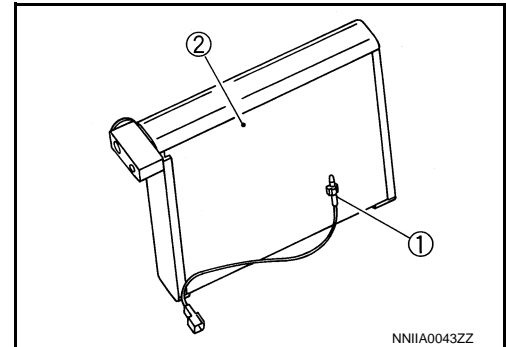

#### INTAKE TEMPERATURE CORRECTION

- The A/C auto amp. inputs the temperature detected with the intake sensor as the evaporator passing air temperature.
- Perform the correction of the temperature detected with the intake sensor for air conditioner control.
- The A/C auto amp. performs the correction so that the recognition intake temperature changes depending on the difference between the detected intake temperature and the recognition intake temperature. If the difference is large, the changing is early. The changing becomes slow as the difference becomes small.

### DTC Logic

INFOID:000000005239150

#### DTC DETECTION LOGIC

DTC	Items (CONSULT-III screen terms)	Diagnostic item is detected when...	Possible causes
B2581	EVAP TEMP SEN SHORT	The intake sensor recognition temperature is too high.	<ul style="list-style-type: none"><li>• Intake sensor</li><li>• A/C auto amp.</li><li>• Harness and connector (Short in the intake sensor circuit)</li></ul>
B2582	EVAP TEMP SEN OPEN	The intake sensor recognition temperature is too low.	<ul style="list-style-type: none"><li>• Intake sensor</li><li>• A/C auto amp.</li><li>• Harness and connector (Open in the intake sensor circuit)</li></ul>

#### DTC CONFIRMATION PROCEDURE

##### 1. PERFORM SELF-DIAGNOSIS

Ⓟ With CONSULT-III

1. Perform the "SELF-DIAGNOSIS".
2. Check if any DTC is detected in the self-diagnostic results.

#### NOTE:

If DTC is displayed along with DTC "U1000" or "U1010", first diagnose the DTC "U1000" or "U1010". Refer to [HAC-26, "DTC Logic"](#) or [HAC-27, "DTC Logic"](#).

Is DTC "B2581" or "B2582" displayed?

- YES >> Perform the diagnosis for the intake sensor. Refer to [HAC-34, "Diagnosis Procedure"](#).  
NO >> INSPECTION END

#### Diagnosis Procedure

INFOID:000000005239151

##### 1. CHECK INTAKE SENSOR POWER SUPPLY CIRCUIT

1. Turn the ignition switch OFF.
2. Disconnect the intake sensor connector.
3. Turn the ignition switch ON.

# B2581, B2582 INTAKE SENSOR

< DTC/CIRCUIT DIAGNOSIS >

[WITHOUT 7 INCH DISPLAY]

4. Check voltage between intake sensor harness connector and ground.

(+)		(-)	Voltage (Approx.)
Intake sensor		—	
Connector	Terminal		
M205	1	Ground	5 V

Is the inspection result normal?

- YES >> GO TO 2.  
NO >> GO TO 4.

## 2.CHECK INTAKE SENSOR CIRCUIT CONTINUITY

- Turn the ignition switch OFF.
- Disconnect the A/C auto amp. connector.
- Check for continuity between the intake sensor harness connector and A/C auto amp. harness connector.

Intake sensor		A/C auto amp.		Continuity
Connector	Terminal	Connector	Terminal	
M205	2	M66	37	Existed

Is the inspection result normal?

- YES >> GO TO 3.  
NO >> Repair the harnesses or connectors.

## 3.CHECK INTAKE SENSOR

Check the intake sensor components. Refer to [HAC-35, "Component Inspection"](#).

Is the inspection result normal?

- YES >> Replace the A/C auto amp.  
NO >> Replace the intake sensor.

## 4.CHECK INTAKE SENSOR CIRCUIT CONTINUITY

- Turn the ignition switch OFF.
- Disconnect the A/C auto amp. connector.
- Check for continuity between the intake sensor harness connector and A/C auto amp. harness connector.

Intake sensor		A/C auto amp.		Continuity
Connector	Terminal	Connector	Terminal	
M205	1	M66	16	Existed

4. Check for continuity between intake sensor harness connector and ground.

Intake sensor		(-)	Continuity
Connector	Terminal		
M205	1	Ground	Not existed.

Is the inspection result normal?

- YES >> Replace the A/C auto amp.  
NO >> Repair the harnesses or connectors.

## Component Inspection

INFOID:000000005239152

## 1.CHECK INTAKE SENSOR

- Turn the ignition switch OFF.
- Disconnect the intake sensor connector. Refer to [HAC-91, "Exploded View"](#).
- Check the resistance between the intake sensor terminals. Refer to the applicable table for the normal value.

## B2581, B2582 INTAKE SENSOR

< DTC/CIRCUIT DIAGNOSIS >

[WITHOUT 7 INCH DISPLAY]

Terminal		Condition	Resistance: kΩ
		Temperature: °C (°F)	
1	2	-15 (5)	12.28
		-10 (14)	9.58
		-5 (23)	7.55
		0 (32)	6.00
		5 (41)	4.81
		10 (50)	3.88
		15 (59)	3.16
		20 (68)	2.59
		25 (77)	2.14
		30 (86)	1.77
		35 (95)	1.48
		40 (104)	1.24
		45 (113)	1.05

Is the inspection result normal?

YES >> INSPECTION END

NO >> Replace the intake sensor.

# B2630, B2631 SUNLOAD SENSOR

< DTC/CIRCUIT DIAGNOSIS >

[WITHOUT 7 INCH DISPLAY]

## B2630, B2631 SUNLOAD SENSOR

### Description

INFOID:000000005239153

#### SUNLOAD SENSOR

- The sunload sensor (1) is installed to the front defroster grille LH.
- The sunload sensor converts the sunload amount (illuminance) into the current value with the photodiode. The A/C auto amp. calculates this current value to the voltage and inputs it.

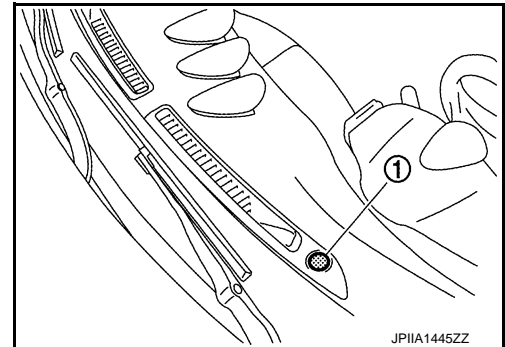

#### SUNLOAD AMOUNT CORRECTION

- The A/C auto amp. inputs the sunload amount detected with the sunload sensor.
- Perform the correction of the sunload amount detected with the sunload sensor for each air conditioner control.
- When the sunload amount suddenly changes, for example when entering a tunnel, perform the correction so that the recognition sunload amount of the A/C auto amp. changes slowly.

### DTC Logic

INFOID:000000005239154

#### DTC DETECTION LOGIC

DTC	Items (CONSULT-III screen terms)	Diagnostic item is detected when...	Possible causes
B2630	SUNLOAD SEN SHORT	Detected calorie at sunload sensor 2832 W/m <sup>2</sup> (2436 kcal/m <sup>2</sup> ·h) or more	<ul style="list-style-type: none"><li>• Sunload sensor</li><li>• A/C auto amp.</li><li>• Harness and connector (Short in the sunload sensor circuit)</li></ul>
B2631	SUNLOAD SEN OPEN	Detected calorie at sunload sensor 64.7 W/m <sup>2</sup> (56 kcal/m <sup>2</sup> ·h) or less	<ul style="list-style-type: none"><li>• Sunload sensor</li><li>• A/C auto amp.</li><li>• Harness and connector (Open in the sunload sensor circuit)</li></ul>

#### DTC REPRODUCTION PROCEDURE

##### 1. PERFORM SELF-DIAGNOSIS

Ⓜ With CONSULT-III

1. Perform the "SELF-DIAGNOSIS".
2. Check if any DTC is detected in the self-diagnostic results.

##### NOTE:

- If DTC is displayed along with DTC "U1000" or "U1010", first diagnose the DTC "U1000" or "U1010". Refer to [HAC-26. "DTC Logic"](#) or [HAC-27. "DTC Logic"](#).
- Sunload sensor may register a malfunction when indoors, at dusk, or at other times when light is insufficient. When performing the diagnosis indoors, use a lamp (60 W or more) that is pointed at the sunload sensor.

Is DTC "B2630" or "B2631" displayed?

- YES >> Perform the diagnosis for the sunload sensor. Refer to [HAC-37. "Diagnosis Procedure"](#).  
NO >> INSPECTION END

### Diagnosis Procedure

INFOID:000000005239155

##### 1. CHECK SUNLOAD SENSOR POWER SUPPLY CIRCUIT

1. Turn the ignition switch OFF.
2. Disconnect the sunload sensor connector.

## B2630, B2631 SUNLOAD SENSOR

< DTC/CIRCUIT DIAGNOSIS >

[WITHOUT 7 INCH DISPLAY]

3. Turn the ignition switch ON.
4. Check voltage between sunload sensor harness connector and ground.

(+)		(-)	Voltage (Approx.)
Sunload sensor		—	
Connector	Terminal		
M46	1	Ground	

Is the inspection result normal?

- YES >> GO TO 2.  
NO >> GO TO 4.

### 2.CHECK SUNLOAD SENSOR CIRCUIT CONTINUITY

1. Turn the ignition switch OFF.
2. Disconnect the A/C auto amp. connector.
3. Check for continuity between the sunload sensor harness connector and the A/C auto amp. harness connector.

Sunload sensor		A/C auto amp.		Continuity
Connector	Terminal	Connector	Terminal	
M46	2	M66	37	Existed

Is the inspection result normal?

- YES >> GO TO 3.  
NO >> Repair the harnesses or connectors.

### 3.CHECK SUNLOAD SENSOR

1. Connect the sunload sensor connector.
2. Connect the A/C auto amp. connector.
3. Check the sunload sensor components. Refer to [HAC-38, "Component Inspection"](#).

Is the inspection result normal?

- YES >> Replace the A/C auto amp.  
NO >> Replace the sunload sensor.

### 4.CHECK SUNLOAD SENSOR CIRCUIT CONTINUITY

1. Turn the ignition switch OFF.
2. Disconnect the A/C auto amp. connector.
3. Check for continuity between the sunload sensor harness connector and A/C auto amp. harness connector.

Sunload sensor		A/C auto amp.		Continuity
Connector	Terminal	Connector	Terminal	
M46	1	M66	15	Existed

4. Check for continuity between sunload sensor harness connector and ground.

Sunload sensor		(-)	Continuity
Connector	Terminal		
M46	1	Ground	Not existed

Is the inspection result normal?

- YES >> Replace A/C auto amp.  
NO >> Repair the harnesses or connectors.

## Component Inspection

INFOID:000000005239156

### 1.CHECK SUNLOAD SENSOR

# B2630, B2631 SUNLOAD SENSOR

## < DTC/CIRCUIT DIAGNOSIS >

[WITHOUT 7 INCH DISPLAY]

1. Turn the ignition switch ON.
2. Check the input voltage from the sunload sensor between the A/C auto amp. harness connector and ground. Refer to the applicable table for the normal value.

(+)		(-)
A/C auto amp.		—
Connector	Terminal	
M66	15	Ground

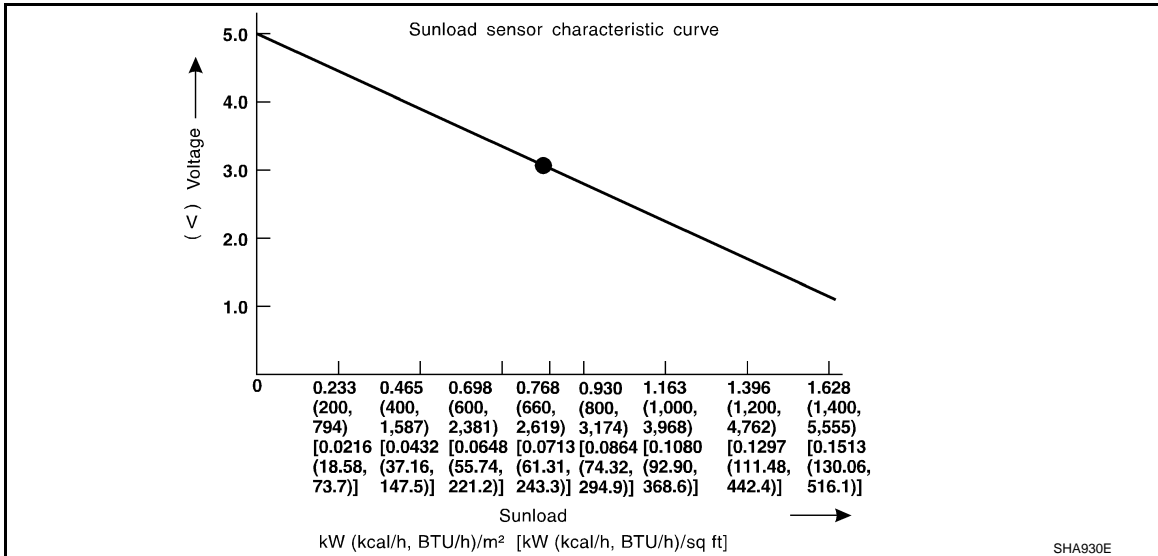

**NOTE:**

- When checking indoors, use a lamp of approximately 60 W. Move the lamp towards and away from the sensor to check.
- The sunload amount produced by direct sunshine in fair weather is equivalent to approximately 0.77 kW/m<sup>2</sup> (662 kcal/m<sup>2</sup>·h).

Is the inspection result normal?

- YES >> INSPECTION END  
 NO >> Replace the sunload sensor.

A  
B  
C  
D  
E  
F  
G  
H  
HAC  
J  
K  
L  
M  
N  
O  
P

# B2632, B2633 AIR MIX DOOR MOTOR PBR

< DTC/CIRCUIT DIAGNOSIS >

[WITHOUT 7 INCH DISPLAY]

## B2632, B2633 AIR MIX DOOR MOTOR PBR

### Description

INFOID:000000005239157

#### AIR MIX DOOR MOTOR

- The air mix door motor (1) is installed to the heater & cooling unit assembly.
- The LCU (Local Control Unit) is installed to each door motor so as to perform the multiplex communication control (LAN) between each door motor of the mode door motor, air mix door motor and intake door motor in one communication line.
- When each LCU receives the control signal (combination of the pulse wave with two types of amplitude) from the A/C auto amp., it moves each door to the appropriate position based on the door position detection signal of each PBR (Potentio Balance Resistor). When the movement was completed, each LCU transmits the signal that reports the movement completion to the A/C auto amp.

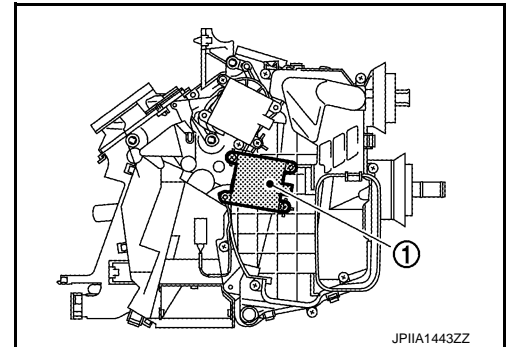

JPIIA1443ZZ

### DTC Logic

INFOID:000000005239158

#### DTC DETECTION LOGIC

DTC	Items (CONSULT-III screen terms)	Diagnostic item is detected when...	Possible causes
B2632	DR AIR MIX ACTR SHORT	Air mix door PBR position 95% or more	<ul style="list-style-type: none"><li>• Air mix door motor (PBR internal circuit is short)</li><li>• A/C auto amp.</li><li>• Harness and connector (LAN communication line is open or shorted)</li></ul>
B2633	DR AIR MIX ACTR OPEN	Air mix door PBR position 5% or less	<ul style="list-style-type: none"><li>• Air mix door motor (PBR internal circuit is open)</li><li>• A/C auto amp.</li><li>• Harness and connector (LAN communication line is open or shorted)</li></ul>

#### DTC CONFIRMATION PROCEDURE

##### 1. PERFORM SELF-DIAGNOSIS

Ⓜ With CONSULT-III

1. Perform the "SELF-DIAGNOSIS".
2. Check if any DTC is detected in the self-diagnostic results.

##### NOTE:

- If DTC is displayed along with DTC "U1000" or "U1010", first diagnose the DTC "U1000" or "U1010". Refer to [HAC-26, "DTC Logic"](#) or [HAC-27, "DTC Logic"](#).
- If all of door motors DTC (B2632 - B2655) are detected, check door motor communication circuit. Refer to [HAC-48, "Diagnosis Procedure"](#).

Is DTC "B2632" or "B2633" displayed?

- YES >> Perform the diagnosis of air mix door motor system. Refer to [HAC-41, "Diagnosis Procedure"](#).  
NO >> GO TO 2.

##### 2. FUNCTION INSPECTION

1. Turn temperature dial and raise temperature setting to 32.0°C (90°F) after warming up the engine.
2. Check that warm air blows from outlets.
3. Operate the compressor.
4. Operate the temperature control dial and lower the set temperature to 18.0°C (60°F).
5. Check that the cool air blows from the outlets.

Does it operate normally?



# B2632, B2633 AIR MIX DOOR MOTOR PBR

< DTC/CIRCUIT DIAGNOSIS >

[WITHOUT 7 INCH DISPLAY]

YES >> INSPECTION END

NO >> Check the air mix door motor system installation condition. Repair or replace the malfunctioning parts.

## Diagnosis Procedure

INFOID:000000005239159

### 1. CHECK BATTERY VOLTAGE OF AIR MIX DOOR MOTOR

1. Turn the ignition switch ON.
2. Check voltage between the air mix door motor harness connector and ground.

(+)		(-)	Voltage (Approx.)
Air mix door motor		—	
Connector	Terminal		
M204	1	Ground	12 V

Is the inspection result normal?

YES >> GO TO 2.

NO >> Repair the harnesses or connectors.

### 2. CHECK SIGNAL OF AIR MIX DOOR MOTOR

Check output waveform between the air mix door motor harness connector and ground with the oscilloscope.

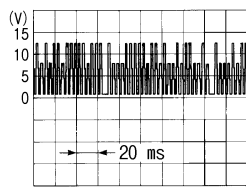
(+)		(-)	Output waveform
Air mix door motor		—	
Connector	Terminal		
M204	3	Ground	

Is the inspection result normal?

YES >> GO TO 3.

NO >> Repair the harnesses or connectors.

### 3. CHECK GROUND CIRCUIT OF AIR MIX DOOR MOTOR

1. Turn the ignition switch OFF.
2. Disconnect the air mix door motor connector.
3. Check for continuity between the air mix door motor harness connector and ground.

Air mix door motor		(-)	Continuity
Air mix door motor		—	
Connector	Terminal		
M204	2	Ground	Existed

Is the inspection result normal?

YES >> Replace the air mix door motor.

NO >> Repair the harnesses or connectors.

HAC

# B2636, B2637, B2638, B2639, B2654, B2655 MODE DOOR MOTOR

< DTC/CIRCUIT DIAGNOSIS >

[WITHOUT 7 INCH DISPLAY]

## B2636, B2637, B2638, B2639, B2654, B2655 MODE DOOR MOTOR

### Description

INFOID:000000005239160

#### MODE DOOR MOTOR

- The mode door motor (1) is installed to the heater & cooling unit assembly.
- The LCU (Local Control Unit) is installed to each door motor so as to perform the multiplex communication control (LAN) between each door motor of the mode door motor, air mix door motor and intake door motor in one communication line.
- When each LCU receives the control signal (combination of the pulse wave with two type of amplitude) from the A/C auto amp., it moves each door to the appropriate position based on the door position detection signal of each PBR (Potentio Balance Resistor). When the movement was completed, each LCU transmits the signal that reports the movement completion to the A/C auto amp.

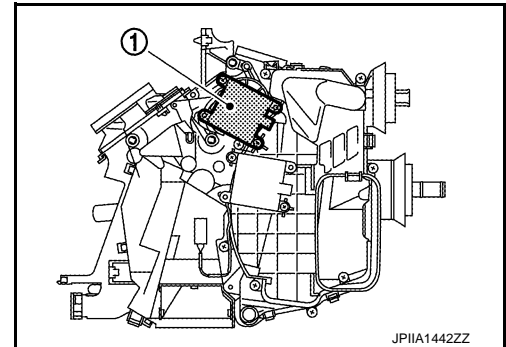

### DTC Logic

INFOID:000000005239161

#### DTC DETECTION LOGIC

DTC	Items (CONSULT-III screen terms)	Diagnostic item is detected when...	Possible cause
B2636	DR VENT DOOR FAIL	When the malfunctioning door position is detected at VENT position	<ul style="list-style-type: none"><li>• Mode door motor (PBR internal circuit is open or shorted)</li><li>• A/C auto amp.</li><li>• Harness and connector (LAN communication line is open or shorted)</li></ul>
B2637	DR B/L DOOR FAIL	When the malfunctioning door position is detected at B/L position	
B2638	DR D/F1 DOOR FAIL	When the malfunctioning door position is detected at FOOT position	
B2639	DR DEF DOOR FAIL	When the malfunctioning door position is detected at DEF position	
B2654	D/F2 DOOR FAIL	When the malfunctioning door position is detected at D/F position	
B2655	B/L2 DOOR FAIL	When the malfunctioning door position is detected at B/L2 position	

#### DTC CONFIRMATION PROCEDURE

##### 1. PERFORM SELF-DIAGNOSIS

1. Perform the "SELF-DIAGNOSIS".
2. Check if any DTC is detected in the self-diagnostic results.

##### NOTE:

- If DTC is displayed along with DTC "U1000" or "U1010", first diagnose the DTC "U1000" or "U1010". Refer to [HAC-26. "DTC Logic"](#) or [HAC-27. "DTC Logic"](#).
- If all of door motors DTC (B2632 - B2655) are detected, check door motor communication circuit. Refer to [HAC-48. "Diagnosis Procedure"](#).

Is DTC " B2636 ", " B2637 ", "B2638 ", "B2639 ", "B2654 " or "B2655 " displayed?

- YES >> Perform the diagnosis of mode door motor system. Refer to [HAC-43. "Diagnosis Procedure"](#).  
NO >> GO TO 2.

##### 2. FUNCTION INSPECTION

1. Turn mode control dial to each position.
2. Check that the air outlets change according to each indicated air outlet by placing a hand in front of the outlets. Refer to [VTL-3. "System Description"](#).

Does it operate normally?

- YES >> INSPECTION END  
NO >> Check the mode door system installation condition. Repair or replace the malfunctioning parts.

# B2636, B2637, B2638, B2639, B2654, B2655 MODE DOOR MOTOR

< DTC/CIRCUIT DIAGNOSIS >

[WITHOUT 7 INCH DISPLAY]

## Diagnosis Procedure

INFOID:000000005239162

### 1. CHECK MODE DOOR MOTOR POWER SUPPLY CIRCUIT

1. Turn the ignition switch ON.
2. Check voltage between the mode door motor harness connector and ground.

(+)		(-)	Voltage (Approx.)
Mode door motor		—	
Connector	Terminal		
M203	1	Ground	12 V

Is the inspection result normal?

- YES >> GO TO 2.  
 NO >> Repair the harnesses or connectors.

### 2. CHECK MODE DOOR MOTOR SIGNAL

Check output waveform between the mode door motor harness connector and ground with the oscilloscope.

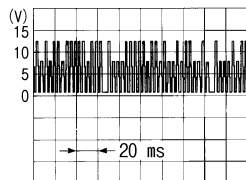
(+)		(-)	Output waveform
Mode door motor		—	
Connector	Terminal		
M203	3	Ground	 <p style="text-align: right; font-size: small;">SJIA1453J</p>

Is the inspection result normal?

- YES >> GO TO 3.  
 NO >> Repair the harnesses or connectors.

### 3. CHECK MODE DOOR MOTOR GROUND CIRCUIT

1. Turn the ignition switch OFF.
2. Disconnect the mode door motor connector.
3. Check for continuity between the mode door motor harness connector and ground.

Mode door motor		(-)	Continuity
Connector	Terminal	—	
M203	2	Ground	Existed

Is the inspection result normal?

- YES >> Replace the Mode door motor.  
 NO >> Repair the harnesses or connectors.

A  
B  
C  
D  
E  
F  
G  
H  
J  
K  
L  
M  
N  
O  
P

HAC

# B263D, B263E, B263F INTAKE DOOR MOTOR

< DTC/CIRCUIT DIAGNOSIS >

[WITHOUT 7 INCH DISPLAY]

## B263D, B263E, B263F INTAKE DOOR MOTOR

### Description

INFOID:000000005239163

#### INTAKE DOOR MOTOR

- The intake door motor (1) is installed to the blower unit.
- The LCU (Local Control Unit) is installed to each door motor so as to perform the multiplex communication control (LAN) between each door motor of the mode door motor, air mix door motor and intake door motor in one communication line.
- When each LCU receives the control signal (combination of the pulse wave with two type of amplitude) from the A/C auto amp., it moves each door to the appropriate position based on the door position detection signal of each PBR (Potentio Balance Resistor). When the movement was completed, each LCU transmits the signal that reports the movement completion to the A/C auto amp.

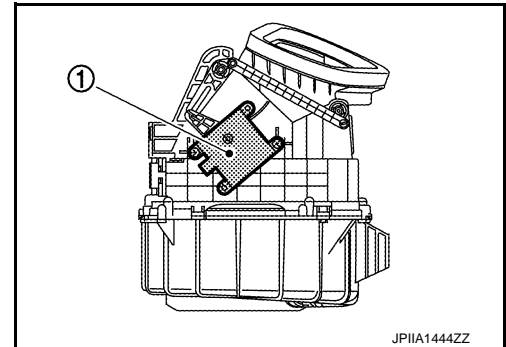

### DTC Logic

INFOID:000000005239164

#### DTC DETECTION LOGIC

DTC	Items (CONSULT-III screen terms)	Diagnostic item is detected when...	Possible cause
B263D	FRE DOOR FAIL	When the malfunctioning intake door position is detected at FRE position	<ul style="list-style-type: none"><li>• Intake door motor (PBR internal circuit is open or shorted)</li><li>• A/C auto amp.</li><li>• Harness and connector (LAN communication line is open or shorted)</li></ul>
B263E	20P FRE DOOR FAIL	When the malfunctioning intake door position is detected at 20%FRE position	
B263F	REC DOOR FAIL	When the malfunctioning intake door position is detected at REC position	

#### DTC CONFIRMATION PROCEDURE

##### 1. PERFORM SELF-DIAGNOSIS

ⓐ With CONSULT-III

1. Perform the "SELF-DIAGNOSIS".
2. Check if any DTC is detected in the self-diagnostic results.

##### NOTE:

- If DTC is displayed along with DTC "U1000" or "U1010", first diagnose the DTC "U1000" or "U1010". Refer to [HAC-26, "DTC Logic"](#) or [HAC-27, "DTC Logic"](#).
- If all of door motors DTC (B2632 - B2655) are detected, check door motor communication circuit. Refer to [HAC-48, "Diagnosis Procedure"](#).

Is DTC " B263D ", " B263E " or "B263F " ?

- YES >> Perform the diagnosis of intake door motor system. Refer to [HAC-45, "Diagnosis Procedure"](#).  
NO >> GO TO 2.

##### 2. FUNCTION INSPECTION

1. Press intake switch to set the air outlet to recirculation.
2. The REC indicator turns ON.
3. Listen to intake sound and confirm air inlets change.
4. Press intake switch again to set the air outlet to fresh air intake.
5. The FRE indicator turns ON.
6. Listen to intake sound and confirm air inlets change.

Does it operate normally?

- YES >> INSPECTION END  
NO >> Check the intake door system installation condition. Repair or replace the malfunctioning parts.

# B263D, B263E, B263F INTAKE DOOR MOTOR

< DTC/CIRCUIT DIAGNOSIS >

[WITHOUT 7 INCH DISPLAY]

## Diagnosis Procedure

INFOID:000000005239165

### 1. CHECK BATTERY VOLTAGE OF INTAKE DOOR MOTOR

1. Turn the ignition switch ON.
2. Check voltage between the intake door motor harness connector and ground.

(+)		(-)	Voltage (Approx.)
Intake door motor		—	
Connector	Terminal		
M206	1	Ground	12 V

Is the inspection result normal?

- YES >> GO TO 2.  
NO >> Repair the harnesses or connectors.

### 2. CHECK INTAKE DOOR MOTOR SIGNAL

Check output waveform between the intake door motor harness connector and ground with the oscilloscope.

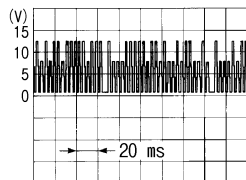
(+)		(-)	Output waveform
Intake door motor		—	
Connector	Terminal		
M206	3	Ground	 SJIA1453J

Is the inspection result normal?

- YES >> GO TO 3.  
NO >> Repair the harnesses or connectors.

### 3. CHECK INTAKE DOOR MOTOR GROUND CIRCUIT

1. Turn the ignition switch OFF.
2. Disconnect the intake door motor connector.
3. Check for continuity between the intake door motor harness connector and ground.

Intake door motor		(-)	Continuity
Connector	Terminal	—	
M206	2	Ground	Existed

Is the inspection result normal?

- YES >> Replace the Intake door motor.  
NO >> Repair the harnesses or connectors.

A  
B  
C  
D  
E  
F  
G  
H  
J  
K  
L  
M  
N  
O  
P

HAC

# POWER SUPPLY AND GROUND CIRCUIT

< DTC/CIRCUIT DIAGNOSIS >

[WITHOUT 7 INCH DISPLAY]

## POWER SUPPLY AND GROUND CIRCUIT

### A/C AUTO AMP.

#### A/C AUTO AMP. : Diagnosis Procedure

INFOID:000000005239166

#### 1. CHECK FUSE

Check 10A fuses [Nos. 3, 6 and 19, located in the fuse block (J/B)].

**NOTE:**

Refer to [PG-112. "Fuse, Connector and Terminal Arrangement"](#).

Is the inspection result normal?

YES >> GO TO 2.

NO >> Replace the fuse after repairing the applicable circuit.

#### 2. CHECK A/C AUTO AMP. POWER SUPPLY CIRCUIT

1. Turn the ignition switch OFF.
2. Disconnect the A/C auto amp. connector.
3. Check voltage between A/C auto amp. harness connector and ground.

(+)		(-)	Voltage		
A/C auto amp.		—	Ignition switch position		
Connector	Terminal		OFF	ACC	ON
M66	17	Ground	Approx. 0 V	Battery voltage	Battery voltage
	20		Approx. 0 V	Approx. 0 V	Battery voltage
	40		Battery voltage	Battery voltage	Battery voltage

Is the inspection result normal?

YES >> GO TO 3.

NO >> Repair the harnesses or connectors.

#### 3. CHECK A/C AUTO AMP. CIRCUIT CONTINUITY

1. Turn the ignition switch OFF.
2. Check continuity between A/C auto amp. harness connector and ground.

A/C auto amp.		(-)	Continuity
Connector	Terminal	—	Continuity
M66	19		
	39		

Is the inspection result normal?

YES >> INSPECTION END

NO >> Repair the harnesses or connectors.

### A/C CONTROL

#### A/C CONTROL : Diagnosis Procedure

INFOID:000000005239167

#### 1. CHECK A/C CONTROL POWER SUPPLY CIRCUIT

1. Turn the ignition switch OFF.
2. Disconnect the A/C control connector.
3. Turn the ignition switch ON.
4. Check voltage between A/C control harness connector and ground.

# POWER SUPPLY AND GROUND CIRCUIT

< DTC/CIRCUIT DIAGNOSIS >

[WITHOUT 7 INCH DISPLAY]

(+)		(-)	Voltage
A/C control		—	
Connector	Terminal		
M67	1	Ground	Battery voltage

Is the inspection result normal?

YES >> GO TO 2.

NO >> Check 10A fuse (No. 3, located in the fuse block). Refer to [PG-112. "Fuse, Connector and Terminal Arrangement"](#).

- If fuse is OK, check harness for open circuit. Repair or replace if necessary.
- If fuse is NG, replace fuse and check for short circuit. Repair or replace if necessary.

## 2. CHECK A/C CONTROL CIRCUIT CONTINUITY

1. Turn the ignition switch OFF.
2. Check continuity between A/C control harness connector and ground.

A/C control		—	Continuity
Connector	Terminal		
M67	6	Ground	Existed

Is the inspection result normal?

YES >> Replace the A/C control.

NO >> Repair the harnesses or connectors.

A  
B  
C  
D  
E  
F  
G  
H  
J  
K  
L  
M  
N  
O  
P

HAC

# DOOR MOTOR COMMUNICATION CIRCUIT

< DTC/CIRCUIT DIAGNOSIS >

[WITHOUT 7 INCH DISPLAY]

## DOOR MOTOR COMMUNICATION CIRCUIT

### Description

INFOID:000000005239168

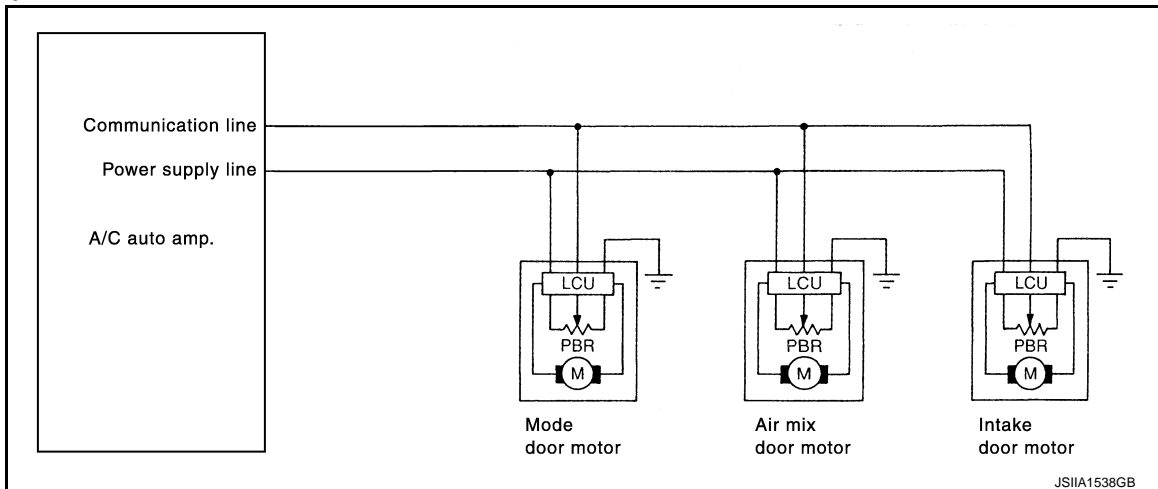

- LCU (Local Control Unit) is built in to each door motor. And detects door position by PBR (Potentiometer Balance Resistor).
- A/C auto amp. communicates with each LCU via communication line. And receives each door position feedback signal from each LCU.
- Each LCU control each door to the appropriate position depending on the control signal from A/C auto amp. When the door movement was completed, transmits the signal of door movement completion to A/C auto amp.

### Diagnosis Procedure

INFOID:000000005239169

#### NOTE:

If all of door motors DTC are detected, check this circuit.

#### 1. CHECK COMMUNICATION SIGNAL

1. Turn the ignition switch ON.
2. Check output waveform between A/C auto amp. harness connector and ground with the oscilloscope.

(+)		(-)	Output waveform
A/C auto amp.		—	
Connector	Terminal		
M66	10	Ground	

Is the inspection result normal?

- YES >> GO TO 3.  
NO >> GO TO 2.

#### 2. CHECK COMMUNICATION SIGNAL CIRCUIT FOR SHORT

1. Turn the ignition switch OFF.
2. Disconnect the following connectors:
  - A/C auto amp.
  - Mode door motor
  - Intake door motor
  - Air mix door motor
3. Check continuity between A/C auto amp. harness connector and ground.



# DOOR MOTOR COMMUNICATION CIRCUIT

< DTC/CIRCUIT DIAGNOSIS >

[WITHOUT 7 INCH DISPLAY]

A/C auto amp.		—	Continuity
Connector	Terminal		
M66	10	Ground	Not existed

Is the inspection result normal?

YES >> Replace A/C auto amp.

NO >> Repair the harnesses or connectors.

## 3. CHECK COMMUNICATION SIGNAL CIRCUIT FOR OPEN

1. Turn the ignition switch OFF.
2. Disconnect the A/C auto amp. and the mode door motor connectors.
3. Check continuity between A/C auto amp. harness connector and the mode door motor harness connector.

A/C auto amp.		Mode door motor		Continuity
Connector	Terminal	Connector	Terminal	
M66	10	M203	3	Existed

Is the inspection result normal?

YES >> Replace A/C auto amp.

NO >> Repair the harnesses or connectors.

A  
B  
C  
D  
E  
F  
G  
H  
J  
K  
L  
M  
N  
O  
P

HAC

# A/C CONTROL SIGNAL CIRCUIT

< DTC/CIRCUIT DIAGNOSIS >

[WITHOUT 7 INCH DISPLAY]

## A/C CONTROL SIGNAL CIRCUIT

### Diagnosis Procedure

INFOID:000000005239170

#### 1. SELF-DIAGNOSIS RESULT CHECK

Ⓜ With CONSULT-III

1. Perform the "SELF-DIAGNOSIS RESULTS" of HVAC.
2. Check if any DTC is displayed in the self-diagnosis results.

#### NOTE:

If DTC is displayed along with DTC "U1000" or "U1010", first diagnose the DTC "U1000" or "U1010". Refer to [HAC-26. "DTC Logic"](#) or [HAC-27. "DTC Logic"](#).

Is any DTC displayed?

YES >> Perform the diagnosis that is applicable to the sensor and actuator. Refer to [HAC-71. "DTC Index"](#).

NO >> GO TO 2.

#### 2. CHECK TX (A/C CONTROL → A/C AUTO AMP.) CIRCUIT CONTINUITY

1. Turn the ignition switch OFF.
2. Disconnect the A/C control and the A/C auto amp. connector.
3. Check continuity between A/C control harness connector and A/C auto amp. harness connector.

A/C control		A/C auto amp.		Continuity
Connector	Terminal	Connector	Terminal	
M67	5	M66	6	Existed

4. Check continuity between A/C control harness connector and ground.

A/C control		—	Continuity
Connector	Terminal		
M67	5	Ground	Not existed

Is the inspection result normal?

YES >> GO TO 3.

NO >> Repair harness or connector.

#### 3. CHECK RX (A/C AUTO AMP. → A/C CONTROL) CIRCUIT CONTINUITY

1. Disconnect the A/C control and the A/C auto amp. connector.
2. Check continuity between A/C control harness connector and A/C auto amp. harness connector.

A/C control		A/C auto amp.		Continuity
Connector	Terminal	Connector	Terminal	
M67	4	M66	7	Existed

3. Check continuity between A/C control harness connector and ground.

A/C control		—	Continuity
Connector	Terminal		
M67	4	Ground	Not existed

Is the inspection result normal?

YES >> Perform trouble diagnosis for the A/C control. Refer to [HAC-46. "A/C CONTROL : Diagnosis Procedure"](#).

NO >> Repair harness or connector.

## A/C AUTO AMP.

### Description

INFOID:000000005239171

#### A/C AUTO AMP. (AIR CONDITIONER AUTOMATIC AMPLIFIER)

- The A/C auto amp. (1) has a built-in microcomputer which processes information sent from various sensors needed for air conditioner operation.
- The air mix door motor, mode door motor, intake door motor, blower motor and the compressor are then controlled.
- When the various switches and dials are operated, data is input to the A/C auto amp. from the A/C control via communication line.
- Self-diagnosis functions are also built into A/C auto amp. to provide quick check of malfunctions in the auto air conditioner system.

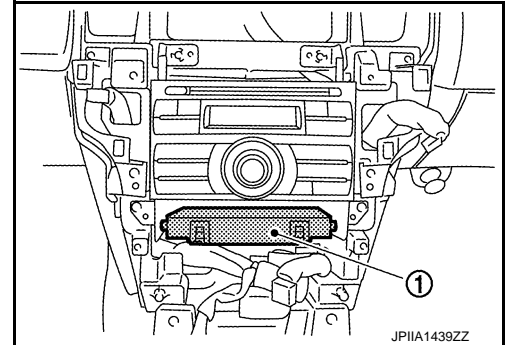

### Component Function Check

INFOID:000000005239172

#### 1. CHECK OPERATION

1. Operate the fan control dial to AUTO position.
2. Operate the temperature control dial. Check that the fan speed or discharge air changes (the discharge air temperature or fan speed varies depending on the ambient temperature, in-vehicle temperature, and set temperature).

##### Does it operate normally?

- YES >> INSPECTION END  
 NO >> Perform the diagnosis for the A/C auto amp. Refer to [HAC-51, "Diagnosis Procedure"](#).

### Diagnosis Procedure

INFOID:000000005239173

#### 1. INSPECTION BY FAIL-SAFE FUNCTION

1. Turn the ignition switch ON.
2. After approximately 30 seconds, check that the air conditioner is operated by the fail-safe function. Refer to [HAC-70, "Fail-safe"](#).

##### Is the fail-safe function operated?

- YES >> GO TO 3.  
 NO >> GO TO 2.

#### 2. CHECK A/C AUTO AMP. POWER SUPPLY CIRCUIT AND GROUND CIRCUIT

Check A/C auto amp. power supply circuit and ground circuit. Refer to [HAC-46, "A/C AUTO AMP. : Diagnosis Procedure"](#).

##### Is the inspection result normal?

- YES >> GO TO 3.  
 NO >> Repair or replace parts depending on the inspection results.

#### 3. CHECK A/C CONTROL SIGNAL CIRCUIT

Check the A/C control signal circuit. Refer to [HAC-50, "Diagnosis Procedure"](#).

##### Is the inspection result normal?

- YES >> Replace A/C auto amp.  
 NO >> Repair or replace parts according to the inspection results.

A  
B  
C  
D  
E  
F  
G  
H  
J  
K  
L  
M  
N  
O  
P

HAC

## BLOWER MOTOR

### Description

INFOID:000000005239174

- The blower motor utilizes a brush-less motor with a rotating magnet.
- Quietness is improved over previous motors where the brush was the point of contact and the coil rotated.

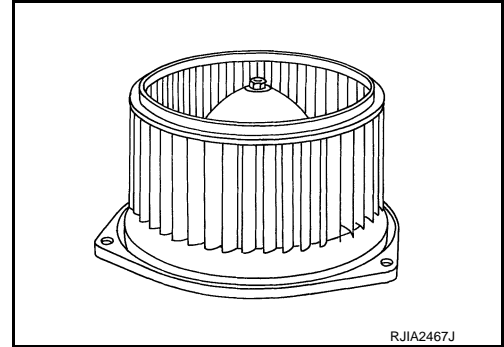

RJIA2467J

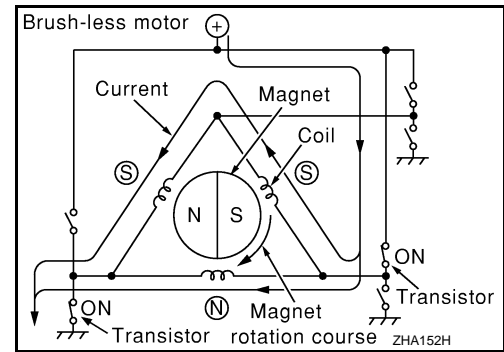

### Component Function Check

INFOID:000000005239175

#### 1. CHECK OPERATION

1. Warm up the engine.
2. Operate the fan control dial. Check that the fan speed and indicator unit are switched for all fan speeds.

#### Does it operate normally?

YES >> INSPECTION END

NO >> Perform the diagnosis for the blower motor. Refer to [HAC-52, "Diagnosis Procedure"](#).

### Diagnosis Procedure

INFOID:000000005239176

#### 1. SELF-DIAGNOSIS RESULT CHECK

Ⓟ With CONSULT-III

1. Perform the "SELF-DIAGNOSIS".
2. Check if any DTC is detected in the self-diagnostic results.

#### **NOTE:**

If DTC is displayed along with DTC "U1000" or "U1010", first diagnose the DTC "U1000" or "U1010". Refer to [HAC-26, "DTC Logic"](#) or [HAC-27, "DTC Logic"](#).

#### Is any DTC displayed?

YES >> Perform the diagnosis that is applicable to the sensor and actuator. Refer to [HAC-71, "DTC Index"](#).

NO >> GO TO 2.

#### 2. PERFORM ACTIVE TEST

Ⓟ With CONSULT-III

1. Perform the "HVAC TEST" of HVAC active test item.
2. Check that the blower motor control signal changes according to each indicator number.

# BLOWER MOTOR

< DTC/CIRCUIT DIAGNOSIS >

[WITHOUT 7 INCH DISPLAY]

	Test item						
	MODE 1	MODE 2	MODE 3	MODE 4	MODE 5	MODE 6	MODE 7
Blower fan motor control signal duty ratio	37%	91%	65%	65%	65%	91%	—

**NOTE:**

- Perform the inspection of each output device after starting the engine because the compressor is operated.
- If the Mode 7 is selected, the malfunction is displayed but it is normal.

Does it operate normally?

YES >> INSPECTION END

NO >> GO TO 3.

### 3.CHECK BLOWER MOTOR POWER SUPPLY CIRCUIT

1. Turn the ignition switch OFF.
2. Disconnect the blower motor connector.
3. Turn the ignition switch ON.
4. Check voltage between blower motor harness connector and ground.

Blower motor		(+)	(-)	Voltage
Connector	Terminal	—		
M109	1	Ground		Battery voltage

Is the inspection result normal?

YES >> GO TO 4.

NO >> GO TO 7.

### 4.CHECK BLOWER MOTOR GROUND CIRCUIT

1. Turn the ignition switch OFF.
2. Check for continuity between blower motor harness connector and ground.

Blower motor		—	Continuity
Connector	Terminal		
M109	3	Ground	Existed

Is the inspection result normal?

YES >> GO TO 5.

NO >> Repair the harnesses or connectors.

### 5.CHECK BLOWER MOTOR CIRCUIT CONTINUITY

1. Disconnect the A/C auto amp. connector.
2. Check for continuity between the blower motor harness connector and A/C auto amp. harness connector.

Blower motor		A/C auto amp.		Continuity
Connector	Terminal	Connector	Terminal	
M109	2	M66	32	Existed

Is the inspection result normal?

YES >> GO TO 6.

NO >> Repair the harnesses or connectors.

### 6.CHECK A/C AUTO AMP. OUTPUT SIGNAL

1. Reconnect blower motor connector and A/C auto amp. connector.
2. Turn the ignition switch ON.
3. Set the mode control dial to VENT position.

# BLOWER MOTOR

< DTC/CIRCUIT DIAGNOSIS >

[WITHOUT 7 INCH DISPLAY]

- Change fan speed from Lo to Hi, and check duty ratios between blower motor harness connector and ground by using an oscilloscope.

**NOTE:**

Calculate the drive signal duty ratio as shown in the figure.  
T2 = Approx. 1.6 ms

Blower motor		Condition	Duty ratio (Approx.)
Connector	Terminal	Fan speed (manual) VENT mode	
M109	2	1st	25 %
		5th	33 %
		10th	43 %
		15th	53 %
		20th	63 %
		25th	81 %

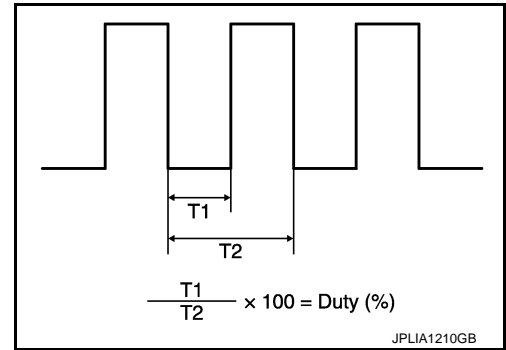

Is the inspection result normal?

- YES >> Replace blower motor after confirming the fan air flow does not change.
- NO >> Replace the A/C auto amp.

## 7. CHECK BLOWER MOTOR CIRCUIT CONTINUITY

- Turn the ignition switch OFF.
- Disconnect the blower motor connector and fuse block (J/B) connector.
- Check the continuity between the blower motor harness connector and fuse block (J/B) harness connector.

Blower motor		Fuse block (J/B)		Continuity
Connector	Terminal	Connector	Terminal	
M109	1	M1	3A	Existed
			8A	

- Check for continuity between blower motor harness connector and ground.

Blower motor		—	Continuity
Connector	Terminal		
M109	1	Ground	Not existed

Is the inspection result normal?

- YES >> GO TO 8.
- NO >> Repair the harnesses or connectors.

## 8. CHECK FUSE

Check 15A fuses [Nos. 21 and 22, located in the fuse block (J/B)].

**NOTE:**

Refer to [PG-112, "Fuse, Connector and Terminal Arrangement"](#).

Is the inspection result normal?

- YES >> Inspection the power supply circuit. Refer to [PG-55, "Wiring Diagram - IGNITION POWER SUPPLY -"](#).
- NO >> Replace the fuse after repairing the applicable circuit.

## Component Inspection

INFOID:000000005239177

### 1. CHECK BLOWER MOTOR

- Remove the blower motor. Refer to [VTL-13, "Exploded View"](#).

# BLOWER MOTOR

< DTC/CIRCUIT DIAGNOSIS >

[WITHOUT 7 INCH DISPLAY]

2. Check that the blower motor turns smoothly.

Is the inspection result normal?

YES >> INSPECTION END

NO >> Replace the blower motor.

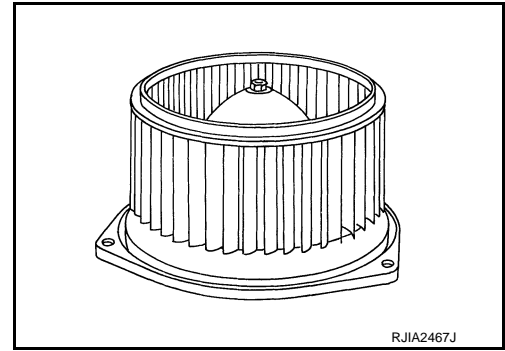

A

B

C

D

E

F

G

H

HAC

J

K

L

M

N

O

P

## MAGNET CLUTCH

### Description

INFOID:000000005239178

The magnet clutch is the device that drives the compressor with the signal from IPDM E/R.

### Component Function Check

INFOID:000000005239179

#### 1. CHECK OPERATION

1. Turn the fan control dial ON.
2. Press the A/C switch.
3. Check that the indicator of the A/C switch turns ON. Check visually and by sound that the compressor operates.
4. Press the A/C switch again.
5. Check that the indicator of the A/C switch turns OFF. Check visually and by sound that the compressor stops.

Does it operate normally?

- YES >> INSPECTION END  
 NO >> Go to diagnosis procedure. Refer to [HAC-56, "Diagnosis Procedure"](#).

### Diagnosis Procedure

INFOID:000000005239180

#### 1. CHECK CHARGED REFRIGERANT

Connect the recovery/recycling recharging equipment to the vehicle and perform the pressure inspection with the gauge. Refer to [HA-35, "Inspection"](#).

Is there refrigerant?

- YES >> GO TO 2.  
 NO >> Check for refrigerant leakages detecting fluorescent leak detector. Refer to [HA-27, "Leak Test"](#).

#### 2. CHECK MAGNET CLUTCH OPERATION

Perform auto active test of IPDM E/R. Refer to [PCS-11, "Diagnosis Description"](#).

Does it operate normally?

- YES >> GO TO 6.  
 NO >> GO TO 3.

#### 3. CHECK MAGNET CLUTCH

1. Turn the ignition switch OFF.
2. Disconnect the magnet clutch connector.
3. Directly apply the battery voltage to the magnet clutch. Check for operation visually and by sound.

Does it operate normally?

- YES >> GO TO 4.  
 NO >> Replace the compressor.

#### 4. CHECK MAGNET CLUTCH CIRCUIT CONTINUITY

1. Turn the ignition switch OFF.
2. Disconnect IPDM E/R connector.
3. Check continuity between the magnet clutch harness connector and IPDM E/R harness connector.

IPDM E/R		Magnet clutch		Continuity
Connector	Terminal	Connector	Terminal	
E7	48	F43	1	Existed

4. Check for continuity between IPDM E/R harness connector and ground.



# MAGNET CLUTCH

< DTC/CIRCUIT DIAGNOSIS >

[WITHOUT 7 INCH DISPLAY]

IPDM E/R		—	Continuity
Connector	Terminal		
E7	48	Ground	Not existed

Is the inspection result normal?

- YES >> GO TO 5.
- NO >> Repair the harnesses and connectors.

## 5. CHECK FUSE

Check 10A fuse (No. 49, located in the IPDM E/R).

### NOTE:

Refer to [PG-114, "Fuse, Connector and Terminal Arrangement"](#).

Is the inspection result normal?

- YES >> Replace IPDM E/R.
- NO >> Replace the fuse after repairing the applicable circuit.

## 6. CHECK SELF-DIAGNOSIS RESULT CHECK

④ With CONSULT-III

1. Perform the "SELF-DIAGNOSIS".
2. Check if any DTC is detected in the self-diagnostic results.

### NOTE:

If DTC is displayed along with DTC "U1000" or "U1010", first diagnose the DTC "U1000" or "U1010". Refer to [HAC-26, "DTC Logic"](#) or [HAC-27, "DTC Logic"](#).

Is any DTC displayed?

- YES >> Perform the diagnosis that is applicable to the sensor and actuator. Refer to [HAC-71, "DTC Index"](#).
- NO >> GO TO 7.

## 7. CHECK A/C AUTO AMP. OUTPUT SIGNAL

④ With CONSULT-III

1. Perform the "DATA MONITOR" of HVAC. Refer to [HAC-60, "Reference Value"](#).
2. Check A/C ON signal and blower fan ON switch signal.

Monitor item	Condition	Status
COMP REQ SIG	A/C switch: OFF	Off
	A/C switch: ON	On
FAN REQ SW	Fan control dial: OFF	Off
	Fan control dial: ON	On

Is the inspection result normal?

- YES >> GO TO 8.
- NO >> Replace A/C auto amp.

## 8. CHECK REFRIGERANT PRESSURE SENSOR

Check the refrigerant pressure sensor. Refer to [EC-511, "Diagnosis Procedure"](#).

Is the inspection result normal?

- YES >> INSPECTION END
- NO >> Repair or replace the malfunctioning parts.

# ECV (ELECTRICAL CONTROL VALVE)

< DTC/CIRCUIT DIAGNOSIS >

[WITHOUT 7 INCH DISPLAY]

## ECV (ELECTRICAL CONTROL VALVE)

### Description

INFOID:000000005239181

The ECV (electrical control valve) is installed on the compressor and controls it for emitting appropriate amount of refrigerant when necessary.

### Diagnosis Procedure

INFOID:000000005239182

#### 1. CHECK FUSE

Check 10A fuse [No. 3, located in the fuse block (J/B)].

**NOTE:**

Refer to [PG-112, "Fuse, Connector and Terminal Arrangement"](#).

Is the inspection result normal?

YES >> GO TO 2.

NO >> Replace the fuse after repairing the applicable circuit.

#### 2. CHECK ECV POWER SUPPLY CIRCUIT

1. Turn the ignition switch OFF.
2. Disconnect the ECV connector.
3. Turn the ignition switch ON.
4. Check voltage between the ECV harness connector and ground.

(+)		(-)	Voltage
ECV		—	
Connector	Terminal		
F44	2	Ground	Battery voltage

Is the inspection result normal?

YES >> GO TO 3.

NO >> Repair the harnesses or connectors.

#### 3. CHECK ECV CONTROL SIGNAL

Ⓜ With CONSULT-III

1. Turn the ignition switch OFF.
2. Connect the ECV connector.
3. Perform the "HVAC TEST": MODE 5 of HVAC active test mode.
4. Check output waveform between the A/C auto amp. harness connector and ground with the oscilloscope.

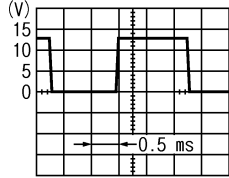
(+)		(-)	Condition	Output waveform
A/C auto amp.		—		
Connector	Terminal			
M66	24	Ground	HVAC TEST: MODE 5	Duty ratio: approx. 50 %  SJA1607E

Is the inspection result normal?

YES >> Replace the compressor.

NO >> GO TO 4.

#### 4. CHECK CONTINUITY BETWEEN ECV AND A/C AUTO AMP.

1. Turn the ignition switch OFF.
2. Disconnect the ECV connector.

# ECV (ELECTRICAL CONTROL VALVE)

[WITHOUT 7 INCH DISPLAY]

< DTC/CIRCUIT DIAGNOSIS >

- 3. Disconnect the A/C auto amp. connector.
- 4. Check continuity between the ECV harness connector and A/C auto amp. harness connector.

ECV		A/C auto amp.		Continuity
Connector	Terminal	Connector	Terminal	
F44	3	M66	24	Existed

- 5. Check for continuity between the ECV harness connector and ground.

ECV		—	Continuity
Connector	Terminal		
F44	3	Ground	Not existed

Is the inspection result normal?

- YES >> GO TO 5.
- NO >> Repair the harnesses or connectors.

## 5.CHECK ECV

Check continuity between the ECV connector terminals.

ECV				Continuity
Connector	Terminal	Connector	Terminal	
F44	2	F44	3	Existed

Is the inspection result normal?

- YES >> Replace the A/C auto amp.
- NO >> Replace the compressor.

A  
B  
C  
D  
E  
F  
G  
H  
J  
K  
L  
M  
N  
O  
P

HAC

# A/C AUTO AMP.

< ECU DIAGNOSIS INFORMATION >

[WITHOUT 7 INCH DISPLAY]

## ECU DIAGNOSIS INFORMATION

### A/C AUTO AMP.

Reference Value

INFOID:000000005239183

#### CONSULT-III DATA MONITOR REFERENCE VALUES

Monitor item	Condition		Value/Status
COMP REQ SIG	Engine: Run at idle after warming up	A/C switch: ON (Compressor operation status)	On
		A/C switch: OFF	Off
FAN REQ SIG	Engine: Run at idle after warming up	Blower motor: ON	On
		Blower motor: OFF	Off
AMB TEMP SEN	Ignition switch ON	—	-22 – 131°F (-30 – 55°C)
IN-VEH TEMP	Ignition switch ON	—	-22 – 131°F (-30 – 55°C)
INT TEMP SEN	Ignition switch ON	—	-22 – 131°F (-30 – 55°C)
SUNLOAD SEN	Ignition switch ON	—	0 – 1045 w/m <sup>2</sup> (0 – 900 kcal/m <sup>2</sup> ·h)
AMB SEN CAL	Ignition switch ON	—	-22 – 131°F (-30 – 55°C)
IN-VEH CAL	Ignition switch ON	—	-22 – 131°F (-30 – 55°C)
INT TEMP CAL	Ignition switch ON	—	-22 – 131°F (-30 – 55°C)
SUNL SEN CAL	Ignition switch ON	—	0 – 1045 w/m <sup>2</sup> (0 – 900 kcal/m <sup>2</sup> ·h)
FAN DUTY	Engine: Run at idle after warming up	Blower motor: ON	25 – 81
		Blower motor: OFF	0
XM	Ignition switch ON	—	-100 – 155
ENG COOL TEMP	Ignition switch ON	—	Values depending on coolant temperature
VEHICLE SPEED	Driving	—	Equivalent to speedometer reading

#### TERMINAL LAYOUT

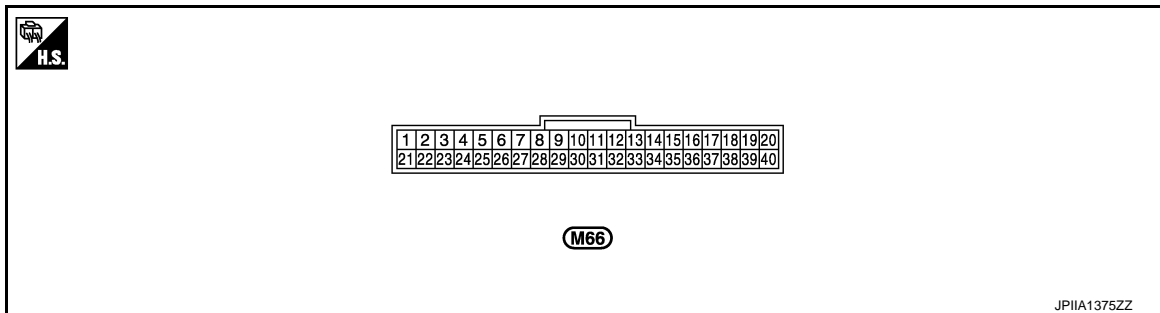

#### PHYSICAL VALUES

# A/C AUTO AMP.

< ECU DIAGNOSIS INFORMATION >

[WITHOUT 7 INCH DISPLAY]

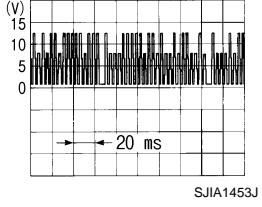
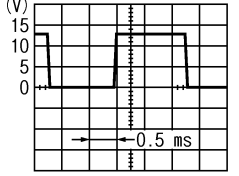
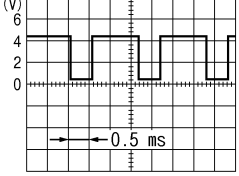
Terminal No. (Wire color)		Description		Condition	Value (Approx.)
+	-	Signal name	Input/ Output		
1 (L)	Ground	CAN - H	Input/ Output	—	—
2 (P)	Ground	CAN - L	Input/ Output	—	—
6 (L)	Ground	Communication signal (AMP-SW)	Input	—	—
7 (P)	Ground	Communication signal (SW - AMP)	Output	—	—
10 (BR)	Ground	A/C LAN signal	Input/ Output	Ignition switch ON	
11 (Y)	Ground	Each door motor power sup- ply	—	Ignition switch ON	12 V
15 (O)	Ground	Sunload sensor signal	Input	—	0 – 4.8 V Output voltage varies with sunload amount
16 (R)	Ground	Intake sensor signal	Input	—	0 – 4.8 V Output voltage varies with intake temperature
17 (L)	Ground	ACC power supply	—	Ignition switch ACC	Battery voltage
19 (B)	Ground	Ground	—	Ignition switch ON	0 V
20 (G)	Ground	Ignition power supply	—	Ignition switch ON	Battery voltage
24 (O)	Ground	ECV signal	Output	<ul style="list-style-type: none"> <li>Ignition switch ON</li> <li>Active test: MODE 5</li> </ul>	
32 (P)	Ground	Blower motor control signal	Output	<ul style="list-style-type: none"> <li>Ignition switch ON</li> <li>Fan speed: 1st speed (man- ual)</li> </ul>	
34 (G)	Ground	A/C auto amp. connecting recognition signal	Output	Ignition switch ON	5 V
35 (V)	Ground	Ambient sensor signal	Input	—	0 – 4.8 V Output voltage varies with ambient temperature

A  
B  
C  
D  
E  
F  
G  
H  
HAC  
J  
K  
L  
M  
N  
O  
P

# A/C AUTO AMP.

< ECU DIAGNOSIS INFORMATION >

[WITHOUT 7 INCH DISPLAY]

Terminal No. (Wire color)		Description		Condition	Value (Approx.)
+	-	Signal name	Input/ Output		
36 (LG)	Ground	In-vehicle sensor signal	Input	—	0 – 4.8 V Output voltage varies with in-vehicle temperature
37 (GR)	Ground	Sensor ground	—	Ignition switch ON	0 V
39 (B)	Ground	Ground	—	Ignition switch ON	0 V
40 (Y)	Ground	Battery power supply	—	Ignition switch OFF	Battery voltage



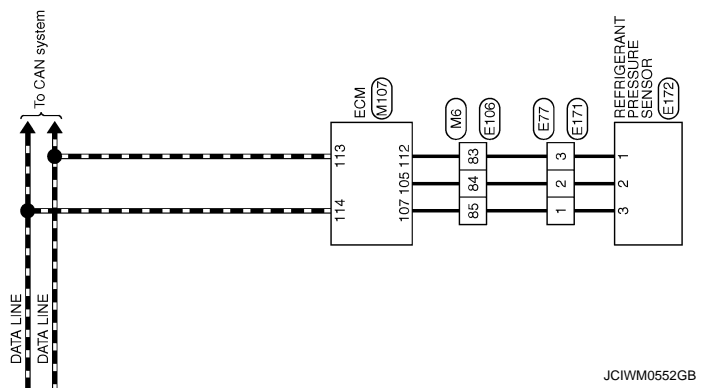



AUTOMATIC AIR CONDITIONING SYSTEM (WITHOUT NAVI)

Connector No.	E3
Connector Name	WIRE TO WIRE
Connector Type	SAA38MB-F32-SH2B

1	2	3	4	5	6	7	8	9	10	11	12	13	14	15	16	17	18	19	20	21	22	23	24	25	26	27	28	29	30	31	32	33	34	35	36	37	38
1	2	3	4	5	6	7	8	9	10	11	12	13	14	15	16	17	18	19	20	21	22	23	24	25	26	27	28	29	30	31	32	33	34	35	36	37	38



Terminal No.	Color of Wire	Signal Name [Specification]
1	L/Y	-
2	SHIELD	-
3	L/B	-
4	SHIELD	-
5	BR	-
7	G	-
8	W	-
9	W	-
10	Y	-
11	Y	-
12	SB	-
13	L	-
14	G	-
15	R	-
16	LG	-
17	GR	-
18	Y	-
19	BG	- [Coupe models]
19	O	- [Roadster models]
20	B	-
21	SB	-
22	W	-
23	SB	-
24	GR	-
25	V	-
27	GR	-
28	V	-
29	P	-
30	R	-
31	BR	-
32	Y	-
33	G	-
34	BG	- [Coupe models]
34	O	- [Roadster models]
36	GR	-
37	SHIELD	-
38	L	-
38	P	-

40	R	-
41	W	-
42	LG	-
43	G	-
45	SB	-
46	SHIELD	-
47	W	-
48	BR	-
49	G	-
50	B	-
51	SB	-
52	R	-

Connector No.	E5
Connector Name	ENGINE R INTELLIGENT POWER DISTRIBUTION MODULE (ENGINE ROOM)
Connector Type	TH20FW-CS12-M4-1V

1	2	3	4	5	6	7	8	9	10	11	12	13	14	15	16	17	18	19	20	21	22	23	24	25	26	27	28	29	30	31	32	33	34	35	36
1	2	3	4	5	6	7	8	9	10	11	12	13	14	15	16	17	18	19	20	21	22	23	24	25	26	27	28	29	30	31	32	33	34	35	36



Terminal No.	Color of Wire	Signal Name [Specification]
4	V	-
5	L	-
6	R	-
7	R	-
11	BR	-
12	B/W	-
13	Y	-
16	LG	-
19	W	-
23	G	-
27	Y	-
30	GR	-
32	L	-
33	P	-
36	G	-

Connector No.	E6
Connector Name	ENGINE R INTELLIGENT POWER DISTRIBUTION MODULE (ENGINE ROOM)
Connector Type	TH20FW-MH

42	41	40	39
46	45	44	43



Terminal No.	Color of Wire	Signal Name [Specification]
39	P	-
40	L	-
41	B/W	-
42	Y	-
43	SB	-
44	W	-
45	G	-
46	V	-

Connector No.	E7
Connector Name	ENGINE R INTELLIGENT POWER DISTRIBUTION MODULE (ENGINE ROOM)
Connector Type	TH20FW-CS12-M4

53	54	55	56	57	58	59	60	61	62	63	64	65	66	67	68	69	70	71	72
53	54	55	56	57	58	59	60	61	62	63	64	65	66	67	68	69	70	71	72



Terminal No.	Color of Wire	Signal Name [Specification]
48	L	-
49	BG	- [Coupe models]
49	O	- [Roadster models]
51	Y	-
53	W	-
54	V	-
55	SB	-
56	LG	-
57	G	-
59	P	-
69	BR	-
70	BG	- [Coupe models]
70	O	- [Roadster models]
72	GR	-

73	GR	-
74	G	-
75	SB	-
76	Y	-
77	R	-
80	W	-

Connector No.	E76
Connector Name	AMBIENT SENSOR
Connector Type	RS02FB



Terminal No.	Color of Wire	Signal Name [Specification]
1	G	-
2	P	-

Connector No.	E77
Connector Name	WIRE TO WIRE
Connector Type	RK03FB



Terminal No.	Color of Wire	Signal Name [Specification]
1	V	-
2	L	-
3	BG	- [Coupe models]
3	O	- [Roadster models]

A  
B  
C  
D  
E  
F  
G  
H  
HAC  
J  
K  
L  
M  
N  
O  
P

AUTOMATIC AIR CONDITIONING SYSTEM (WITHOUT NAVI)

Connector No.	E106
Connector Name	WIRE TO WIRE
Connector Type	THB07V-CS16-TM44



Terminal No.	Color of Wire	Signal Name [Specification]
1	Y	-
3	L	-
4	L	-
7	B	-
8	P	-
9	L	-
9	B	- [Coupe models]
11	V	- [Roadster models]
12	R	-
13	L	-
14	GR	-
15	P	-
16	W	-
17	SB	-
20	LG	-
21	BR	- [Coupe models]
21	G	- [Roadster models]
31	L	-
32	Y	-
33	P	-
34	L	-
35	BR	-
36	V	-
37	Y	-
38	R	-
39	B	-
40	W	-
41	LG	-
42	SB	-
43	G	-
44	R	- [Roadster models with M/T]
44	GR	- [Except for roadster models with M/T]
45	BG	- [Coupe models]
45	O	- [Roadster models]
46	W	-
47	P	-
58	SHIELD	-
59	L	-

Connector No.	E172
Connector Name	REFRIGERANT PRESSURE SENSOR
Connector Type	RKG3FB



Terminal No.	Color of Wire	Signal Name [Specification]
1	-	-
2	-	-
3	-	-

Connector No.	F1
Connector Name	WIRE TO WIRE
Connector Type	SAA38FB-RSS-SH28

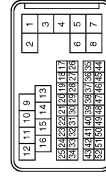

Terminal No.	Color of Wire	Signal Name [Specification]
1	L/Y	-
2	SHIELD	-
3	L/B	-
4	SHIELD	-
5	BR	-
7	G	-
8	W	-
9	W	-
10	G	-
11	R	-
12	P	-
13	BG	- [Coupe models]
13	O	- [Roadster models]
14	LG	-
15	BR	-
16	Y	-
17	W	-
18	LG	-
18	P	-

20	BG	- [Coupe models]
20	O	- [Roadster models]
21	BR	-
22	G	-
23	V	-
24	LG	-
25	V	-
27	GR	-
28	BR	-
29	L	-
30	R	-
31	P	-
32	W	-
33	SB	-
34	BG	- [Coupe models]
34	O	- [Roadster models]
36	GR	-
37	SHIELD	- [Coupe models]
37	B	- [Roadster models]
38	W	-
39	Y	-
40	G	-
41	B	-
42	GR	-
43	R	-
45	SB	-
46	SHIELD	-
47	W/L	-
48	LG	-
49	O/L	-
50	L/Y	-
51	W	-
52	L/G	-

Connector No.	F43
Connector Name	COMPRESSOR
Connector Type	RS01FB



Terminal No.	Color of Wire	Signal Name [Specification]
1	BG	MAGNET CLUTCH POWER SUPPLY [Coupe model]
1	O	MAGNET CLUTCH POWER SUPPLY [Roadster model]

JCIWM0554GB

AUTOMATIC AIR CONDITIONING SYSTEM (WITHOUT NAVI)

Connector No.	F44
Connector Name	COMPRESSOR
Connector Type	PK02FGY



Terminal No.	Color of Wire	Signal Name [Specification]
2	Y	ECV POWER SUPPLY
3	BG	ECV SIGNAL [Coupe models]
3	O	ECV SIGNAL [Roadster models]

Connector No.	F103
Connector Name	WIRE TO WIRE
Connector Type	TK36FW-NS10



Terminal No.	Color of Wire	Signal Name [Specification]
2	G	
3	W	
4	R	
5	B	
8	L	
9	Y	
10	GR	
19	BG	
20	Y	
28	B	
29	LG	
30	R	
31	BG	
39	W	
42	G	
43	P	
44	L	

45	Y	
46	Y	

Connector No.	M1
Connector Name	FUSE BLOCK (J/B)
Connector Type	NS10FW-M2



Terminal No.	Color of Wire	Signal Name [Specification]
1A	V	
2A	G	
3A	L	
4A	P	
5A	L	
6A	Y	
7A	BR	
8A	L	

Connector No.	M2
Connector Name	FUSE BLOCK (J/B)
Connector Type	NS10FW-CS



Terminal No.	Color of Wire	Signal Name [Specification]
1B	Y	
3B	P	
4B	G	
5B	O	
6B	Y	
8B	R	
9B	SB	

Connector No.	M3
Connector Name	FUSE BLOCK (J/B)
Connector Type	NS12FW-CS



Terminal No.	Color of Wire	Signal Name [Specification]
7C	R	
9C	B	
9C	O	
10C	L	
11C	LG	
12C	O	

Connector No.	M6
Connector Name	WIRE TO WIRE
Connector Type	TH80MW-CS16-TM4



Terminal No.	Color of Wire	Signal Name [Specification]
1	Y	
3	L	
4	L	
7	B	
8	P	
9	L	
9	B	
11	GR	
12	R	
13	L	
14	G	
15	P	
16	W	
17	BR	
20	GR	

21	BR	
21	R	
31	L	
31	BR	
32	Y	
33	P	
34	L	
35	BR	
36	SB	
37	Y	
38	LG	
39	SB	
40	W	
41	LG	
42	R	
43	G	
44	G	
44	O	
45	O	
46	G	
47	BR	
58	SHIELD	
59	L	
70	R	
80	LG	
81	GR	
82	V	
83	V	
84	L	
85	BR	
86	Y	
87	V	
87	G	
89	P	
91	W	
92	P	
93	P	
94	Y	
96	P	
97	GR	
98	O	
99	W	
100	R	

A  
B  
C  
D  
E  
F  
G  
H  
I  
J  
K  
L  
M  
N  
O  
P

HAC

**AUTOMATIC AIR CONDITIONING SYSTEM (WITHOUT NAVI)**

Connector No.	M24
Connector Name	DATA LINK CONNECTOR
Connector Type	BD16FW

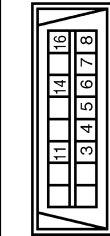

Terminal No.	Color of Wire	Signal Name [Specification]
3	Y	-
4	B	-
5	B	-
6	L	-
7	Y	-
7	V	- [Cruise models]
8	G	- [Radiator models]
11	LG	-
14	P	-
16	Y	-



Connector No.	M46
Connector Name	SUNLOAD SENSOR
Connector Type	K02FE



Terminal No.	Color of Wire	Signal Name [Specification]
1	O	SUNLOAD SENSOR SIGNAL
2	GR	SENSOR GROUND

Connector No.	M63
Connector Name	COMBINATION METER
Connector Type	TH24FW-NH

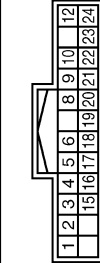

Terminal No.	Color of Wire	Signal Name [Specification]
1	V	BATTERY POWER SUPPLY
2	O	IGNITION POWER SUPPLY
3	L	VEHICLE SPEED SIGNAL (2-PULSE)
4	Y	VEHICLE SPEED SIGNAL (8-PULSE)
5	B	ILLUMINATION CONTROL SIGNAL
6	R	ROOF STATUS SIGNAL
8	BR	COMMUNICATION SIGNAL (METER-TURBLE METER)
10	L	COMMUNICATION SIGNAL (TRIPLE METER-METER)
12	G	S-MODE SWITCH SIGNAL
15	L	ACC POWER SUPPLY
16	R	AIR BAG SIGNAL
17	B	GROUND
18	V	AMBIENT SENSOR SIGNAL
19	G	A/C AUTO AMP CONNECTION RECOGNITION SIGNAL
20	GR	AMBIENT SENSOR GROUND
21	L	CAN-L
22	P	GROUND
23	B	FUEL LEVEL SENSOR GROUND
24	Y	FUEL LEVEL SENSOR GROUND



Connector No.	M61
Connector Name	IN-VEHICLE SENSOR
Connector Type	A02FW



Terminal No.	Color of Wire	Signal Name [Specification]
1	LG	IN-VEHICLE SENSOR SIGNAL
2	GR	SENSOR GROUND

Connector No.	M66
Connector Name	A/C AUTO AMP.
Connector Type	SAB40FW

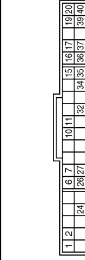

Terminal No.	Color of Wire	Signal Name [Specification]
1	L	CAN-H
2	P	CAN-L
6	L	TX (AMP:CONT)
7	P	RX (CONT:AMP)
10	BR	LAN SIGNAL
11	Y	EACH DOOR MOTOR POWER SUPPLY
15	O	SUNLOAD SENSOR SIGNAL
16	R	INTAKE SENSOR SIGNAL
17	L	ACC POWER SUPPLY
19	B	GROUND
20	G	IGNITION POWER SUPPLY
24	O	ECV SIGNAL
26	R	REAR WINDOW DEFOGGER FEEDBACK SIGNAL
27	L	REAR WINDOW DEFOGGER ON SIGNAL
32	P	BLOWER MOTOR CONTROL SIGNAL
34	G	A/C AUTO AMP CONNECTION RECOGNITION SIGNAL
35	V	AMBIENT SENSOR SIGNAL
38	LG	IN-VEHICLE SENSOR SIGNAL
37	GR	SENSOR GROUND
39	B	GROUND
40	Y	BATTERY POWER SUPPLY



Connector No.	M67
Connector Name	A/C CONTROL
Connector Type	TH10FB-NH

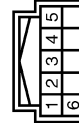

Terminal No.	Color of Wire	Signal Name [Specification]
1	G	IGNITION POWER SUPPLY

2	R	ILL+
3	W	ILL-
4	P	TX (SW:AMP)
5	L	RX (AMP:SW)
6	B	GROUND

Connector No.	M68
Connector Name	WIRE TO WIRE
Connector Type	A08FW



Terminal No.	Color of Wire	Signal Name [Specification]
1	GR	-
2	R	-
4	BR	-
5	B	-
6	Y	-

AUTOMATIC AIR CONDITIONING SYSTEM (WITHOUT NAVI)

Connector No.	M107
Connector Name	ECM
Connector Type	RH24FGY-R23-R-LH-Z

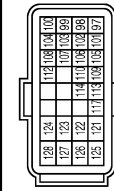

Connector No.	M109
Connector Name	BLOWER MOTOR
Connector Type	NS3GFPF-M3

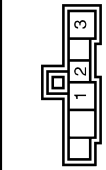

46	V	-
Connector No.	M201	
Connector Name	WIRE TO WIRE	
Connector Type	A03BW	



Connector No.	M204
Connector Name	AIR MIX DOOR MOTOR
Connector Type	A03FW

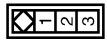

Terminal No.	Color of Wire	Signal Name [Specification]
97	R	APS 1
98	P	APS 2
99	L	AVCC 1-APS 1
100	W	GND4-APS 1
101	SB	ASCDSW
102	GR	FTPRS
103	G	AVCC2-APS 2
104	GR	GND-APS 2
105	L	PDPRESS
106	W	TF
107	BR	AVCC 2-FTPRS
108	Y	GND ASCDSW
109	G	NEUT-H
110	R	TACHO
112	SB	GND4-FTPRES
113	P	VEHCAN-LI
114	L	VEHCAN-HI
117	Y	KLINE [Coupe models]
117	V	KLINE [Roadster models]
121	LG	CDGV
122	P	BRAKE
123	B	GND
124	B	GND
124	R	VER
126	BR	BNGSW
127	B	GND
128	B	GND

Terminal No.	Color of Wire	Signal Name [Specification]
1	L	BLOWER MOTOR POWER SUPPLY
2	P	BLOWER MOTOR CONTROL SIGNAL
3	B	SENSOR GROUND

Connector No.	M116
Connector Name	WIRE TO WIRE
Connector Type	TK3BMW-MS10

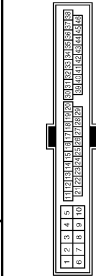

Terminal No.	Color of Wire	Signal Name [Specification]
1	G	DOOR MOTOR POWER SUPPLY [Coupe models]
1	L	DOOR MOTOR POWER SUPPLY [Roadster models]
2	B	SENSOR GROUND
3	L	A/C LAN SIGNAL

Connector No.	M205
Connector Name	INTAKE SENSOR
Connector Type	TK04FW



Terminal No.	Color of Wire	Signal Name [Specification]
2	W	-
3	BG	- [Coupe models]
3	O	- [Roadster models]
4	W	-
5	B	-
8	L	-
9	Y	-
10	R	-
19	O	-
20	G	-
28	B	-
29	LG	-
30	LG	-
31	O	-
39	G	-
42	G	-
43	P	-
44	L	-
45	BR	-

Connector No.	M203
Connector Name	MODE DOOR MOTOR
Connector Type	A03FW

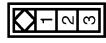

Terminal No.	Color of Wire	Signal Name [Specification]
1	R	INTAKE SENSOR SIGNAL
2	W	SENSOR GROUND [Coupe models]
2	GR	SENSOR GROUND [Roadster models]

Terminal No.	Color of Wire	Signal Name [Specification]
1	G	DOOR MOTOR POWER SUPPLY [Coupe models]
1	L	DOOR MOTOR POWER SUPPLY [Roadster models]
2	B	SENSOR GROUND
3	L	A/C LAN SIGNAL

A  
B  
C  
D  
E  
F  
G  
H  
HAC  
J  
K  
L  
M  
N  
O  
P

AUTOMATIC AIR CONDITIONING SYSTEM (WITHOUT NAVI)

Connector No.	M206
Connector Name	INTAKE DOOR MOTOR
Connector Type	AC3FW

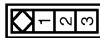

Terminal No.	Color of Wire	Signal Name [Specification]
1	G	DOOR MOTOR POWER SUPPLY [Coupe models]
1	L	DOOR MOTOR POWER SUPPLY [Roadster models]
2	B	SENSOR GROUND
3	L	A/C LAN SIGNAL

JCIWM0558GB

INFOID:000000005239185

Fail-safe

FAIL-SAFE FUNCTION

When a communication malfunction between A/C auto amp. and A/C control continued for approximately 30 seconds or more, control the air conditioner under the following conditions.

# A/C AUTO AMP.

< ECU DIAGNOSIS INFORMATION >

[WITHOUT 7 INCH DISPLAY]

**Compressor** : ON  
**Air outlet** : AUTO  
**Air inlet** : FRE (Fresh air intake)  
**Fan speed** : AUTO  
**Preset temperature** : Setting before communication malfunction

## DTC Inspection Priority Chart

INFOID:000000005239186

If some DTCs are displayed at the same time, perform inspections one by one based on the following priority chart.

Priority	Detected items (DTC)
1	<ul style="list-style-type: none"> <li>• U1000: CAN COMM CIRCUIT</li> <li>• U1010: CONTROL UNIT (CAN)</li> </ul>
2	<ul style="list-style-type: none"> <li>• B257B: AMB TEMP SEN SHORT</li> <li>• B257C: AMB TEMP SEN OPEN</li> <li>• B2578: IN CAR SEN SHORT</li> <li>• B2579: IN CAR SEN OPEN</li> <li>• B2581: EVAP TEMP SEN SHORT</li> <li>• B2582: EVAP TEMP SEN OPEN</li> <li>• B2630: SUNLOAD SEN SHORT</li> <li>• B2631: SUNLOAD SEN OPEN</li> <li>• B2632: DR AIRMIX ACTR SHORT</li> <li>• B2633: DR AIRMIX ACTR OPEN</li> <li>• B2636: DR VENT DOOR FAIL</li> <li>• B2637: DR B/L DOOR FAIL</li> <li>• B2638: DR D/F1 DOOR FAIL</li> <li>• B2639: DR DEF DOOR FAIL</li> <li>• B263D: FRE DOOR FAIL</li> <li>• B263E: 20P FRE DOOR FAIL</li> <li>• B263F: REC DOOR FAIL</li> <li>• B2654: D/F2 DOOR FAIL</li> <li>• B2655: B/L2 DOOR FAIL</li> </ul>

## DTC Index

INFOID:000000005239187

DTC	Items (CONSULT-III screen terms)	Reference
U1000	CAN COMM CIRCUIT	<a href="#">HAC-26, "DTC Logic"</a>
U1010	CONTROL UNIT (CAN)	<a href="#">HAC-27, "DTC Logic"</a>
B257B	AMB TEMP SEN SHORT	<a href="#">HAC-28, "DTC Logic"</a>
B257C	AMB TEMP SEN OPEN	<a href="#">HAC-28, "DTC Logic"</a>
B2578	IN CAR SEN SHORT	<a href="#">HAC-31, "DTC Logic"</a>
B2579	IN CAR SEN OPEN	<a href="#">HAC-31, "DTC Logic"</a>
B2581	EVAP TEMP SEN SHORT	<a href="#">HAC-34, "DTC Logic"</a>
B2582	EVAP TEMP SEN OPEN	<a href="#">HAC-34, "DTC Logic"</a>
B2630*	SUNLOAD SEN SHORT	<a href="#">HAC-37, "DTC Logic"</a>
B2631*	SUNLOAD SEN OPEN	<a href="#">HAC-37, "DTC Logic"</a>
B2632	DR AIRMIX ACTR SHORT	<a href="#">HAC-40, "DTC Logic"</a>
B2633	DR AIRMIX ACTR OPEN	<a href="#">HAC-40, "DTC Logic"</a>
B2636	DR VENT DOOR FAIL	<a href="#">HAC-42, "DTC Logic"</a>
B2637	DR B/L DOOR FAIL	<a href="#">HAC-42, "DTC Logic"</a>
B2638	DR D/F1 DOOR FAIL	<a href="#">HAC-42, "DTC Logic"</a>

## A/C AUTO AMP.

< ECU DIAGNOSIS INFORMATION >

[WITHOUT 7 INCH DISPLAY]

DTC	Items (CONSULT-III screen terms)	Reference
B2639	DR DEF DOOR FAIL	<a href="#">HAC-42, "DTC Logic"</a>
B263D	FRE DOOR FAIL	<a href="#">HAC-44, "DTC Logic"</a>
B263E	20P FRE DOOR FAIL	<a href="#">HAC-44, "DTC Logic"</a>
B263F	REC DOOR FAIL	<a href="#">HAC-44, "DTC Logic"</a>
B2654	D/F2 DOOR FAIL	<a href="#">HAC-42, "DTC Logic"</a>
B2655	B/L2 DOOR FAIL	<a href="#">HAC-42, "DTC Logic"</a>

\*: Perform self-diagnosis under sunshine. When performing indoors, aim a light (more than 60 W) at sunload sensor, otherwise self-diagnosis indicates even though the sunload sensor is functioning normally.

**NOTE:**

If all of door motors DTC (B2632, B2633, B2636, B2637, B2638, B2639, B263D, B263E, B263F, B2654 and B2655) are detected, check door motor communication circuit. Refer to [HAC-48, "Description"](#).



# AUTOMATIC AIR CONDITIONER SYSTEM

< SYMPTOM DIAGNOSIS >

[WITHOUT 7 INCH DISPLAY]

## SYMPTOM DIAGNOSIS

### AUTOMATIC AIR CONDITIONER SYSTEM

#### Diagnosis Chart By Symptom

INFOID:000000005239188

Symptom	Check item	Reference
A/C system does not activate.	Power supply and ground circuit	<ul style="list-style-type: none"> <li><a href="#">HAC-46, "A/C AUTO AMP. : Diagnosis Procedure"</a> (A/C auto amp.)</li> <li><a href="#">HAC-46, "A/C CONTROL : Diagnosis Procedure"</a> (A/C control)</li> </ul>
	A/C control signal circuit	<a href="#">HAC-50, "Diagnosis Procedure"</a>
A/C system cannot be controlled.	A/C auto amp.	<a href="#">HAC-51, "Diagnosis Procedure"</a>
<ul style="list-style-type: none"> <li>Air outlet does not change.</li> <li>Mode door motor does not operate normally.</li> </ul>	Mode door motor	<a href="#">HAC-43, "Diagnosis Procedure"</a>
<ul style="list-style-type: none"> <li>Discharge air temperature does not change.</li> <li>The air mix door motor does not operate normally.</li> </ul>	Air mix door motor	<a href="#">HAC-41, "Diagnosis Procedure"</a>
<ul style="list-style-type: none"> <li>Intake door does not change.</li> <li>Intake door motor does not operate normally.</li> </ul>	Intake door motor	<a href="#">HAC-45, "Diagnosis Procedure"</a>
Blower motor operation is malfunctioning.	Blower motor	<a href="#">HAC-52, "Diagnosis Procedure"</a>
Magnet clutch does not operate.	Magnet clutch	<a href="#">HAC-56, "Diagnosis Procedure"</a>
<ul style="list-style-type: none"> <li>Insufficient cooling</li> <li>No cool air comes out. (Air flow volume is normal.)</li> </ul>	ECV	<a href="#">HAC-58, "Diagnosis Procedure"</a>
	Insufficient cooling	<a href="#">HAC-74, "Diagnosis Procedure"</a>
<ul style="list-style-type: none"> <li>Insufficient heating</li> <li>No warm air comes out. (Air flow volume is normal.)</li> </ul>	Insufficient heating	<a href="#">HAC-76, "Diagnosis Procedure"</a>
	Noise	<a href="#">HAC-79, "Diagnosis Procedure"</a>
<ul style="list-style-type: none"> <li>Noise</li> <li>Noise is heard when the A/C system operates.</li> </ul>	Noise	<a href="#">HAC-79, "Diagnosis Procedure"</a>

A  
B  
C  
D  
E  
F  
G  
H  
HAC  
J  
K  
L  
M  
N  
O  
P

&lt; SYMPTOM DIAGNOSIS &gt;

**INSUFFICIENT COOLING****Description**

INFOID:000000005239189

## Symptom

- Insufficient cooling
- No cool air comes out. (Air flow volume is normal.)

**Diagnosis Procedure**

INFOID:000000005239190

**1.CHECK MAGNET CLUTCH OPERATION**

1. Turn the ignition switch ON.
2. Turn the fan control dial ON.
3. Press the A/C switch.
4. Check that the indicator of the A/C switch turns ON. Check visually and by sound that the compressor operates.
5. Press the A/C switch again.
6. Check that the indicator of the A/C switch turns OFF. Check that the compressor stops.

Is the inspection result normal?

YES &gt;&gt; GO TO 2.

NO >> Magnet clutch system malfunction. Refer to [HAC-56, "Diagnosis Procedure"](#).**2.CHECK DRIVE BELT**Check tension of the drive belt. Refer to [EM-17, "Checking"](#).Is the inspection result normal?

YES &gt;&gt; GO TO 3.

NO &gt;&gt; Adjust or replace drive belt depending on the inspection results.

**3.CHECK REFRIGERANT CYCLE PRESSURE**Connect the recovery/recycling recharging equipment to the vehicle and perform the pressure inspection with the gauge. Refer to [HA-7, "Symptom Table"](#).Is the inspection result normal?

YES &gt;&gt; GO TO 4.

NO &gt;&gt; Repair or replace the parts depending on the inspection results.

**4.CHECK PERFORMANCE CHART**Connect recovery/recycling recharging equipment to the vehicle and perform the performance test. Refer to [HA-35, "Inspection"](#).Is the inspection result normal?

YES &gt;&gt; GO TO 5.

NO &gt;&gt; GO TO 7.

**5.CHECK AMBIENT TEMPERATURE DISPLAY**

Check that there is not much difference between actual ambient temperature and indicated temperature on information display in combination meter.

Is the inspection result normal?

YES &gt;&gt; GO TO 6.

NO >> Perform the diagnosis for the A/C auto amp. connection recognition signal. Refer to [MWI-56, "Diagnosis Procedure"](#).**6.CHECK SETTING OF TEMPERATURE SETTING TRIMMER**

Ⓟ With CONSULT-III

1. Select "TEMP SET CORRECT" of HVAC work support item. Refer to [HAC-8, "Temperature Setting Trimmer"](#).
2. Check that the temperature setting trimmer is set to "+ direction".

**NOTE:**

The control temperature can be set with the setting of the temperature setting trimmer.

# INSUFFICIENT COOLING

< SYMPTOM DIAGNOSIS >

[WITHOUT 7 INCH DISPLAY]

3. Set the difference between the set temperature and control temperature to "0".

>> INSPECTION END

## 7. CHECK CHARGED REFRIGERANT AMOUNT

1. Connect recovery/recycling recharging equipment to the vehicle and discharge the refrigerant.
2. Recharge with the proper amount of refrigerant.

Are the symptoms solved?

YES >> INSPECTION END

NO >> Refer to [HAC-73, "Diagnosis Chart By Symptom"](#) and perform the appropriate diagnosis.

A  
B  
C  
D  
E  
F  
G  
H  
J  
K  
L  
M  
N  
O  
P

HAC

## INSUFFICIENT HEATING

## Description

INFOID:000000005239191

## Symptom

- Insufficient heating
- No warm air comes out. (Air flow volume is normal.)

## Diagnosis Procedure

INFOID:000000005239192

## 1. CHECK COOLING SYSTEM

1. Check the engine coolant level and check for leakage. Refer to [CO-9, "Inspection"](#).
2. Check radiator cap. Refer to [CO-12, "RADIATOR CAP : Inspection"](#).
3. Check water flow sounds of the engine coolant. Refer to [CO-10, "Refilling"](#).

Is the inspection result normal?

- YES >> GO TO 2.  
NO >> Refill the engine coolant and repair or replace the parts depending on the inspection results.

## 2. CHECK OPERATION

1. Turn temperature dial and raise temperature setting to 32.0°C (90°F) after warming up the engine.
2. Check that warm air blows from the outlets.

Is the inspection result normal?

- YES >> INSPECTION END  
NO >> GO TO 3.

## 3. CHECK SETTING OF TEMPERATURE SETTING TRIMMER

## Ⓜ With CONSULT-III

1. Select "TEMP SET CORRECT" of HVAC work support item. Refer to [HAC-8, "Temperature Setting Trimmer"](#).
2. Check that the temperature setting trimmer is set to "– direction".  
**NOTE:**  
The control temperature can be set by the temperature setting trimmer.
3. Set the difference between the set temperature and control temperature to "0".

Are the symptoms solved?

- YES >> INSPECTION END  
NO >> GO TO 4.

## 4. CHECK SELF-DIAGNOSIS RESULT CHECK

## Ⓜ With CONSULT-III

1. Perform the "SELF-DIAGNOSIS".
2. Check if any DTC is detected in the self-diagnostic results.

**NOTE:**

If DTC is displayed along with DTC "U1000" or "U1010", first diagnose the DTC "U1000" or "U1010". Refer to [HAC-26, "DTC Logic"](#) or [HAC-27, "DTC Logic"](#).

Is any DTC displayed?

- YES >> Perform the diagnosis that is applicable to the sensor and the door motor. Refer to [HAC-71, "DTC Index"](#).  
NO >> GO TO 5.

## 5. CHECK EACH OUTPUT DEVICE

## Ⓜ With CONSULT-III

1. Select "HVAC TEST" of HVAC active test item. Refer to [HAC-24, "CONSULT-III Function"](#).  
**NOTE:**  
Perform the ACTIVE TEST after starting the engine because the compressor is operated.
2. Refer to the table and check the outlet, inlet, air flow temperature, blower motor control signal, magnet clutch operation, and air mix ratio. Visually check each operating condition, by listening for noise, touching air outlets with a hand, etc.

# INSUFFICIENT HEATING

< SYMPTOM DIAGNOSIS >

[WITHOUT 7 INCH DISPLAY]

	Test item						
	MODE 1	MODE 2	MODE 3	MODE 4	MODE 5	MODE 6	MODE 7
Mode door position	VENT	B/L 1	B/L 2	FOOT	D/F	DEF	—
Intake door position	REC	REC	20% FRE	FRE	FRE	FRE	—
Air mix door position	FULL COLD	FULL COLD	FULL HOT	FULL HOT	FULL HOT	FULL HOT	—
Blower fan motor control signal duty ratio	37%	91%	65%	65%	65%	91%	—
Magnet clutch	ON	ON	OFF	OFF	ON	ON	—
ECV duty ratio	100%	100%	0%	0%	50%	100%	—

**NOTE:**

- Perform the inspection of each output device after starting the engine because the compressor is operated.
- If the MODE 7 is selected, the malfunction is displayed but it is normal.

Discharge air flow

Mode position indication	Air outlet/distribution		
	VENT	FOOT	DEF
	100%	—	—
	60%	40%	—
	12%	62%	26%
	10%	52%	38%
	—	—	100%

Does it operate normally?

- YES >> GO TO 6.  
 NO-1 >> Air outlet does not change. Refer to [HAC-43, "Diagnosis Procedure"](#).  
 NO-2 >> Air inlet does not change. Refer to [HAC-45, "Diagnosis Procedure"](#).  
 NO-3 >> Discharge air temperature does not change. Refer to [HAC-41, "Diagnosis Procedure"](#).  
 NO-4 >> Blower motor does not operate normally. Refer to [HAC-52, "Diagnosis Procedure"](#).  
 NO-5 >> Magnet clutch does not operate. Refer to [HAC-56, "Diagnosis Procedure"](#).

## 6. CHECK AIR LEAKAGE FROM DUCT

Check duct and nozzle, etc. of the air conditioner system for air leakage.

Is the inspection result normal?

- YES >> GO TO 7.  
 NO >> Repair or replace parts depending on the inspection results.

## 7. CHECK HEATER HOSE INSTALLATION CONDITION

Check the heater hose installation condition visually (for twists, crushes, etc.).

Is the inspection result normal?

- YES >> GO TO 8.  
 NO >> Repair or replace parts depending on the inspection results.

## 8. CHECK TEMPERATURE OF HEATER HOSE

1. Check the temperature of inlet hose and outlet hose of heater core.
2. Check that the inlet side of heater core is hot and the outlet side is slightly lower than/almost equal to the inlet side.

**CAUTION:**

**Always perform the temperature inspection in a short period of time because the engine coolant temperature is very hot.**

Is the inspection result normal?

- YES >> GO TO 9.

## INSUFFICIENT HEATING

< SYMPTOM DIAGNOSIS >

[WITHOUT 7 INCH DISPLAY]

---

NO >> Replace the heater core after performing the procedures after the cooling system inspection. GO TO 1.

### 9.REPLACE HEATER CORE

---

Replace the heater core. Refer to [HA-47. "Exploded View"](#).

Are symptoms solved?

YES >> INSPECTION END

NO >> Perform the procedures again after the cooling system inspection. GO TO 1.

## NOISE

### Description

INFOID:000000005239193

#### Symptom

- Noise
- Noise is heard when the A/C system operates.

### Diagnosis Procedure

INFOID:000000005239194

#### 1.CHECK OPERATION

1. Operate the A/C system and check the operation. Refer to [HAC-7. "Description & Inspection"](#).
2. Check the parts where noise is occurring.

#### Can the parts where noise is occurring be checked?

- YES-1 >> Noise from blower motor: GO TO 2.
- YES-2 >> Noise from compressor: GO TO 3.
- YES-3 >> Noise from expansion valve: GO TO 4.
- YES-4 >> Noise from cooler piping (pipe, flexible hose): GO TO 6.
- YES-5 >> Noise from drive belt: GO TO 7.
- NO >> INSPECTION END

#### 2.CHECK BLOWER MOTOR

1. Remove blower motor.
2. Remove foreign materials that are in the blower unit.
3. Check the noise from blower motor again.

#### Is the inspection result normal?

- YES >> INSPECTION END
- NO >> Replace blower motor.

#### 3.CHECK COMPRESSOR

Perform trouble diagnosis for the compressor and check the compressor. Refer to [HA-9. "Symptom Table"](#).

#### Is the inspection result normal?

- YES >> INSPECTION END
- NO >> Refill the refrigerant or replace the compressor depending on the inspection results.

#### 4.CHECK WITH GAUGE PRESSURE

Perform the diagnosis with the gauge pressure. Refer to [HA-7. "Trouble Diagnosis For Unusual Pressure"](#).

#### Is the inspection result normal?

- YES >> GO TO 5.
- NO >> Repair or replace parts depending on the inspection results.

#### 5.CHECK EXPANSION VALVE

1. Correct the refrigerant with recovery/recycling recharging equipment.
2. Recharge with the proper amount of the collected refrigerant after recycling or new refrigerant.
3. Check for the noise from expansion valve again.

#### Are the malfunction solved?

- YES >> INSPECTION END
- NO >> Replace expansion valve.

#### 6.CHECK COOLER PIPING (PIPE, FLEXIBLE HOSE)

1. Check the cooler piping (pipes, flexible hoses) (for deformation and damage, etc.).
2. Check the installation condition of clips and brackets, etc. of the cooler piping (pipes, flexible hoses).

#### Is the inspection result normal?

- YES >> Fix the line with rubber or come vibration absorbing material.
- NO >> Repair or replace parts depending on the inspection results.

#### 7.CHECK DRIVE BELT

A  
B  
C  
D  
E  
F  
G  
H  
J  
K  
L  
M  
N  
O  
P

HAC

## NOISE

< SYMPTOM DIAGNOSIS >

[WITHOUT 7 INCH DISPLAY]

Check tension of the drive belt. Refer to [EM-17. "Checking"](#).

Is the inspection result normal?

YES >> Check the noise from the compressor: GO TO 3.

NO >> Adjust or replace drive belt depending on the inspection results.



PRECAUTION

PRECAUTIONS  
EXCEPT FOR MEXICO

EXCEPT FOR MEXICO : Precaution for Supplemental Restraint System (SRS) "AIR BAG" and "SEAT BELT PRE-TENSIONER"

INFOID:000000005653526

The Supplemental Restraint System such as "AIR BAG" and "SEAT BELT PRE-TENSIONER", used along with a front seat belt, helps to reduce the risk or severity of injury to the driver and front passenger for certain types of collision. This system includes seat belt switch inputs and dual stage front air bag modules. The SRS system uses the seat belt switches to determine the front air bag deployment, and may only deploy one front air bag, depending on the severity of a collision and whether the front occupants are belted or unbelted. Information necessary to service the system safely is included in the "SRS AIR BAG" and "SEAT BELT" of this Service Manual.

**WARNING:**

- To avoid rendering the SRS inoperative, which could increase the risk of personal injury or death in the event of a collision which would result in air bag inflation, all maintenance must be performed by an authorized NISSAN/INFINITI dealer.
- Improper maintenance, including incorrect removal and installation of the SRS, can lead to personal injury caused by unintentional activation of the system. For removal of Spiral Cable and Air Bag Module, see the "SRS AIR BAG".
- Do not use electrical test equipment on any circuit related to the SRS unless instructed to in this Service Manual. SRS wiring harnesses can be identified by yellow and/or orange harnesses or harness connectors.

PRECAUTIONS WHEN USING POWER TOOLS (AIR OR ELECTRIC) AND HAMMERS

**WARNING:**

- When working near the Air Bag Diagnosis Sensor Unit or other Air Bag System sensors with the ignition ON or engine running, DO NOT use air or electric power tools or strike near the sensor(s) with a hammer. Heavy vibration could activate the sensor(s) and deploy the air bag(s), possibly causing serious injury.
- When using air or electric power tools or hammers, always switch the ignition OFF, disconnect the battery, and wait at least 3 minutes before performing any service.

EXCEPT FOR MEXICO : Precaution Necessary for Steering Wheel Rotation after Battery Disconnect

INFOID:000000005654766

**NOTE:**

- Before removing and installing any control units, first turn the push-button ignition switch to the LOCK position, then disconnect both battery cables.
- After finishing work, confirm that all control unit connectors are connected properly, then re-connect both battery cables.
- Always use CONSULT-III to perform self-diagnosis as a part of each function inspection after finishing work. If a DTC is detected, perform trouble diagnosis according to self-diagnosis results.

For vehicle with steering lock unit, if the battery is disconnected or discharged, the steering wheel will lock and cannot be turned.

If turning the steering wheel is required with the battery disconnected or discharged, follow the operation procedure below before starting the repair operation.

OPERATION PROCEDURE

1. Connect both battery cables.
  - NOTE:**  
Supply power using jumper cables if battery is discharged.
2. Turn the push-button ignition switch to ACC position.  
(At this time, the steering lock will be released.)
3. Disconnect both battery cables. The steering lock will remain released with both battery cables disconnected and the steering wheel can be turned.
4. Perform the necessary repair operation.

A  
B  
C  
D  
E  
F  
G  
H  
J  
K  
L  
M  
N  
O  
P

HAC

# PRECAUTIONS

< PRECAUTION >

[WITHOUT 7 INCH DISPLAY]

5. When the repair work is completed, re-connect both battery cables. With the brake pedal released, turn the push-button ignition switch from ACC position to ON position, then to LOCK position. (The steering wheel will lock when the push-button ignition switch is turned to LOCK position.)
6. Perform self-diagnosis check of all control units using CONSULT-III.

## EXCEPT FOR MEXICO : Precaution for Battery Service

INFOID:000000005653529

Before disconnecting the battery, lower both the driver and passenger windows. This will prevent any interference between the window edge and the vehicle when the door is opened/closed. During normal operation, the window slightly raises and lowers automatically to prevent any window to vehicle interference. The automatic window function will not work with the battery disconnected.

## FOR MEXICO

## FOR MEXICO : Precaution for Supplemental Restraint System (SRS) "AIR BAG" and "SEAT BELT PRE-TENSIONER"

INFOID:000000005653530

The Supplemental Restraint System such as "AIR BAG" and "SEAT BELT PRE-TENSIONER", used along with a front seat belt, helps to reduce the risk or severity of injury to the driver and front passenger for certain types of collision. Information necessary to service the system safely is included in the "SRS AIR BAG" and "SEAT BELT" of this Service Manual.

### WARNING:

- To avoid rendering the SRS inoperative, which could increase the risk of personal injury or death in the event of a collision which would result in air bag inflation, all maintenance must be performed by an authorized NISSAN/INFINITI dealer.
- Improper maintenance, including incorrect removal and installation of the SRS, can lead to personal injury caused by unintentional activation of the system. For removal of Spiral Cable and Air Bag Module, see the "SRS AIR BAG".
- Do not use electrical test equipment on any circuit related to the SRS unless instructed to in this Service Manual. SRS wiring harnesses can be identified by yellow and/or orange harnesses or harness connectors.

## PRECAUTIONS WHEN USING POWER TOOLS (AIR OR ELECTRIC) AND HAMMERS

### WARNING:

- When working near the Air Bag Diagnosis Sensor Unit or other Air Bag System sensors with the ignition ON or engine running, DO NOT use air or electric power tools or strike near the sensor(s) with a hammer. Heavy vibration could activate the sensor(s) and deploy the air bag(s), possibly causing serious injury.
- When using air or electric power tools or hammers, always switch the ignition OFF, disconnect the battery, and wait at least 3 minutes before performing any service.

## FOR MEXICO : Precaution Necessary for Steering Wheel Rotation after Battery Disconnect

INFOID:000000005654767

### NOTE:

- Before removing and installing any control units, first turn the push-button ignition switch to the LOCK position, then disconnect both battery cables.
- After finishing work, confirm that all control unit connectors are connected properly, then re-connect both battery cables.
- Always use CONSULT-III to perform self-diagnosis as a part of each function inspection after finishing work. If a DTC is detected, perform trouble diagnosis according to self-diagnosis results.

For vehicle with steering lock unit, if the battery is disconnected or discharged, the steering wheel will lock and cannot be turned.

If turning the steering wheel is required with the battery disconnected or discharged, follow the operation procedure below before starting the repair operation.

## OPERATION PROCEDURE

1. Connect both battery cables.

### NOTE:

Supply power using jumper cables if battery is discharged.

2. Turn the push-button ignition switch to ACC position.

# PRECAUTIONS

< PRECAUTION >

[WITHOUT 7 INCH DISPLAY]

(At this time, the steering lock will be released.)

3. Disconnect both battery cables. The steering lock will remain released with both battery cables disconnected and the steering wheel can be turned. A
4. Perform the necessary repair operation.
5. When the repair work is completed, re-connect both battery cables. With the brake pedal released, turn the push-button ignition switch from ACC position to ON position, then to LOCK position. (The steering wheel will lock when the push-button ignition switch is turned to LOCK position.) B
6. Perform self-diagnosis check of all control units using CONSULT-III. C

## FOR MEXICO : Precaution for Battery Service

INFOID:000000005653532

Before disconnecting the battery, lower both the driver and passenger windows. This will prevent any interference between the window edge and the vehicle when the door is opened/closed. During normal operation, the window slightly raises and lowers automatically to prevent any window to vehicle interference. The automatic window function will not work with the battery disconnected. D

E

F

G

H

HAC

J

K

L

M

N

O

P

## REMOVAL AND INSTALLATION

### A/C CONTROL

### BASE AUDIO

### BASE AUDIO : Exploded View

INFOID:000000005239198

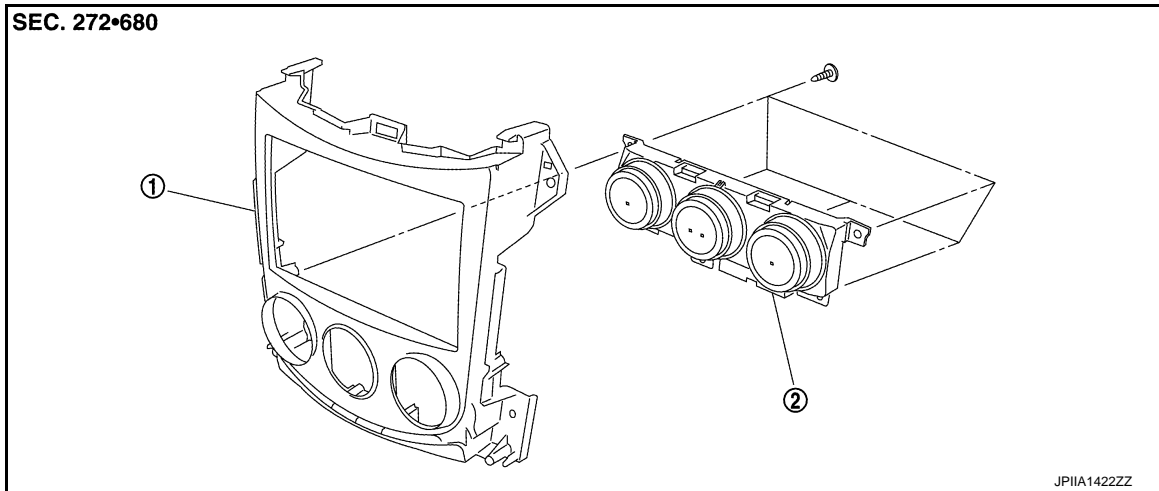

1. Cluster lid C finisher

2. A/C control

### BASE AUDIO : Removal and Installation

INFOID:000000005239199

#### REMOVAL

1. Remove cluster lid C finisher. Refer to [IP-12. "Exploded View"](#).
2. Remove mounting screws (A), and then remove A/C control (1).

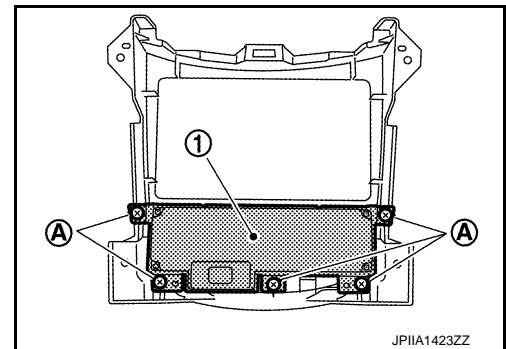

#### INSTALLATION

Installation is basically the reverse order of removal.  
**BOSE AUDIO WITHOUT NAVIGATION**

# A/C CONTROL

< REMOVAL AND INSTALLATION >

[WITHOUT 7 INCH DISPLAY]

## BOSE AUDIO WITHOUT NAVIGATION : Exploded View

INFOID:000000005239200

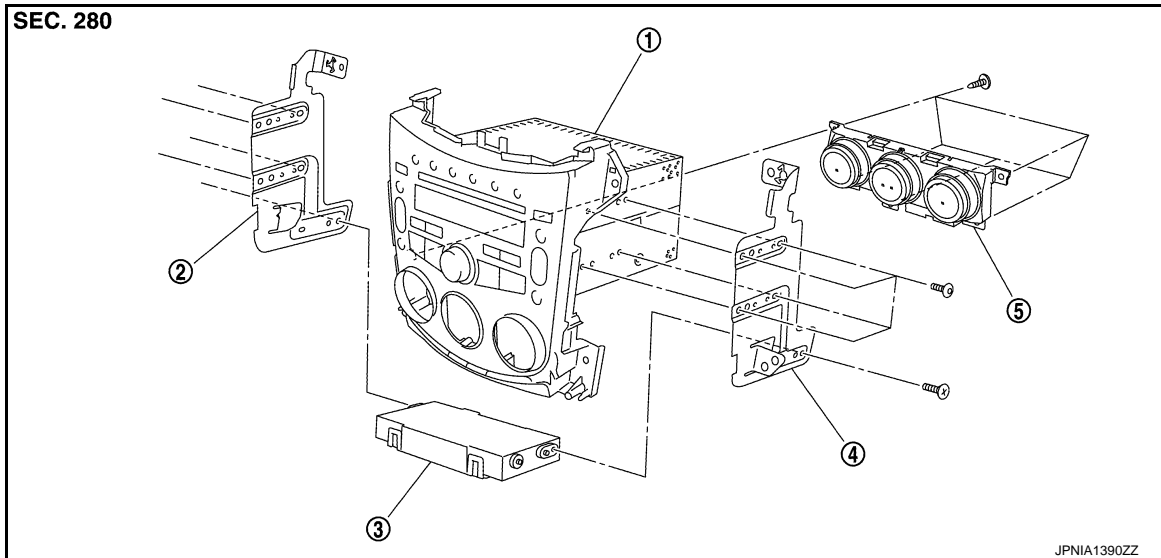

- 1. Audio unit
- 2. Bracket LH
- 3. A/C auto amp.
- 4. Bracket RH
- 5. A/C control

## BOSE AUDIO WITHOUT NAVIGATION : Removal and Installation

INFOID:000000005239201

### REMOVAL

1. Remove A/C auto amp. Refer to [HAC-87, "BOSE AUDIO WITHOUT NAVIGATION : Exploded View"](#).
2. Remove mounting screws (A), and then remove A/C control (1).

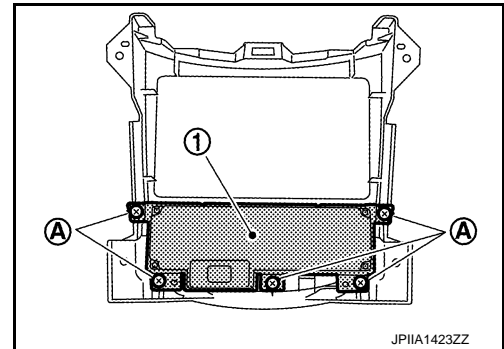

### INSTALLATION

Installation is basically the reverse order of removal.

# A/C AUTO AMP.

< REMOVAL AND INSTALLATION >

[WITHOUT 7 INCH DISPLAY]

## A/C AUTO AMP.

### BASE AUDIO

### BASE AUDIO : Exploded View

INFOID:000000005239202

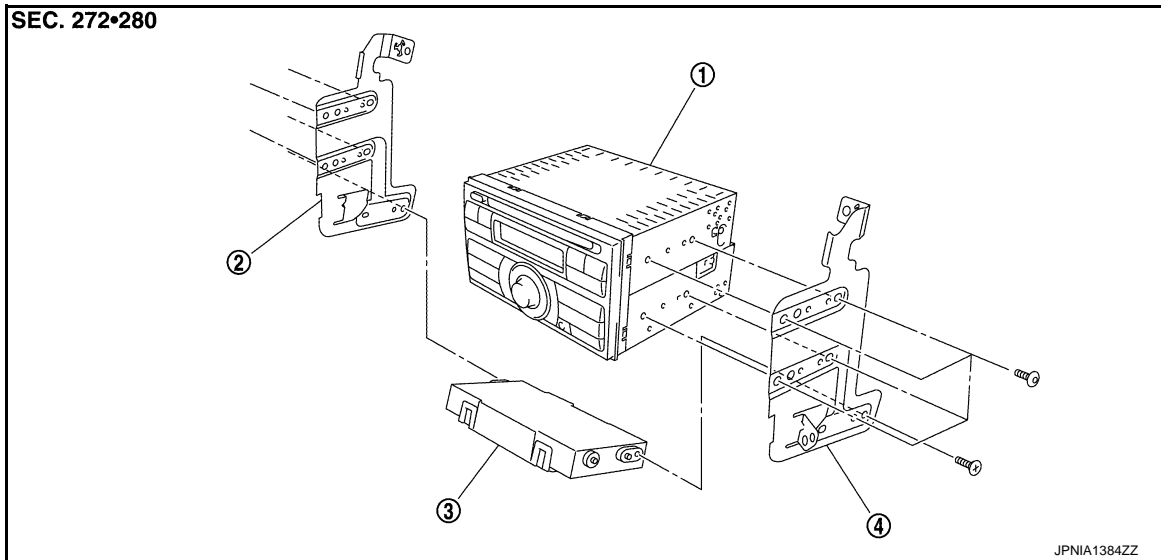

1. Audio unit
4. Bracket RH

2. Bracket LH

3. A/C auto amp.

### BASE AUDIO : Removal and Installation

INFOID:000000005239203

#### REMOVAL

1. Remove audio unit. Refer to [AV-33. "Exploded View"](#).
2. Remove mounting screws (A), and then remove A/C auto amp. (1).

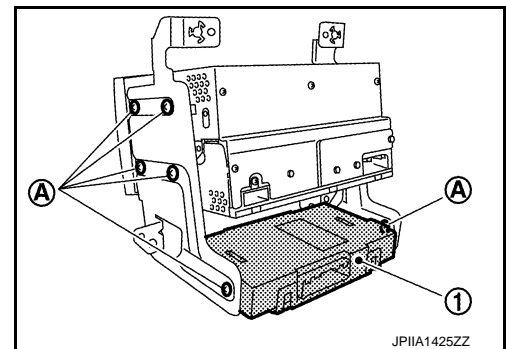

#### INSTALLATION

Installation is basically the reverse order of removal.  
**BOSE AUDIO WITHOUT NAVIGATION**

# A/C AUTO AMP.

< REMOVAL AND INSTALLATION >

[WITHOUT 7 INCH DISPLAY]

## BOSE AUDIO WITHOUT NAVIGATION : Exploded View

INFOID:000000005239204

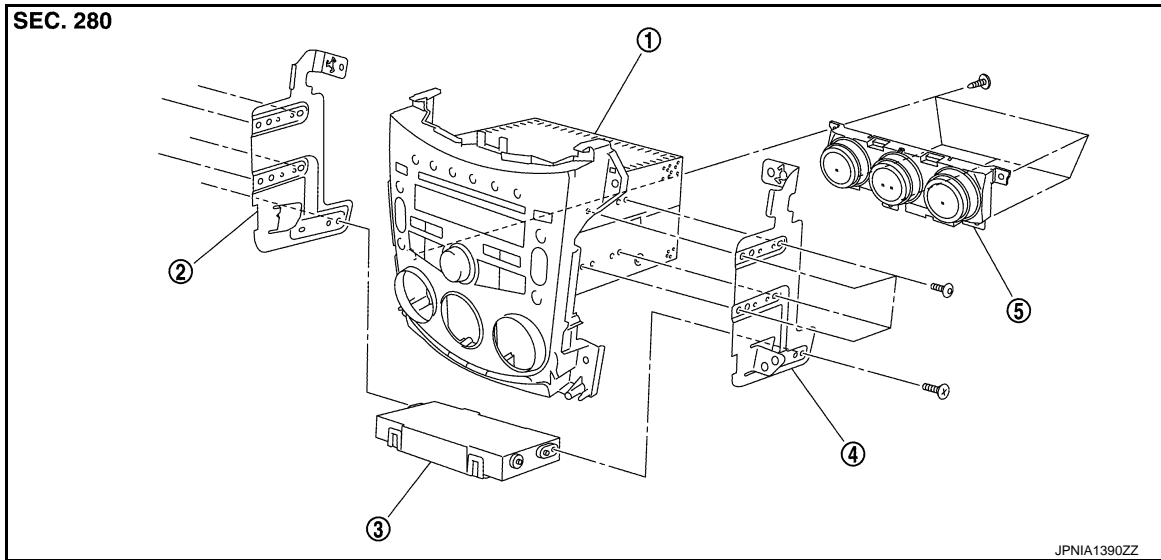

- |               |                |                  |
|---------------|----------------|------------------|
| 1. Audio unit | 2. Bracket LH  | 3. A/C auto amp. |
| 4. Bracket RH | 5. A/C control |                  |

## BOSE AUDIO WITHOUT NAVIGATION : Removal and Installation

INFOID:000000005239205

### REMOVAL

1. Remove audio unit. Refer to [AV-187, "Exploded View"](#).
2. Remove mounting screws, and then remove A/C auto amp.

### INSTALLATION

Installation is basically the reverse order of removal.

A  
B  
C  
D  
E  
F  
G  
H  
J  
K  
L  
M  
N  
O  
P

HAC

# AMBIENT SENSOR

< REMOVAL AND INSTALLATION >

[WITHOUT 7 INCH DISPLAY]

## AMBIENT SENSOR

### Exploded View

INFOID:000000005239206

1. Ambient sensor

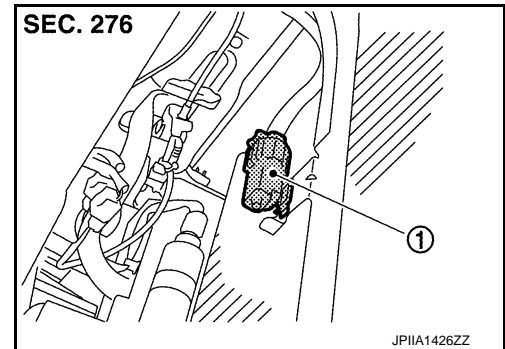

### Removal and Installation

INFOID:000000005239207

#### REMOVAL

1. Remove the engine under cover. Refer to [EXT-29, "ENGINE UNDER COVER : Exploded View"](#).
2. Disconnect ambient sensor connector, and then remove ambient sensor (1) from bracket.

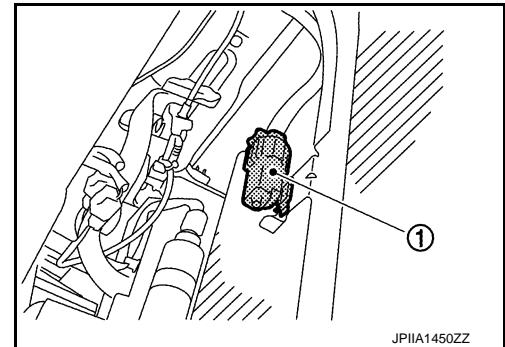

#### INSTALLATION

Installation is basically the reverse order of removal.



# IN-VEHICLE SENSOR

< REMOVAL AND INSTALLATION >

[WITHOUT 7 INCH DISPLAY]

## IN-VEHICLE SENSOR

### Exploded View

INFOID:000000005239208

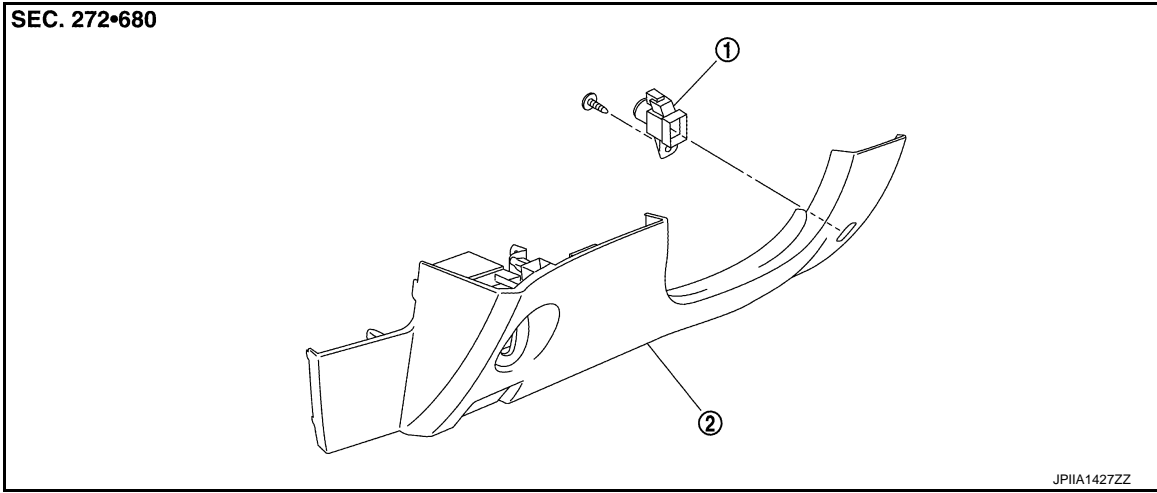

1. In-vehicle sensor

2. Instrument lower panel LH

### Removal and Installation

INFOID:000000005239209

#### REMOVAL

1. Remove instrument lower panel LH. Refer to [IP-12, "Exploded View"](#).
2. Remove mounting screw (A), and then remove in-vehicle sensor (1).

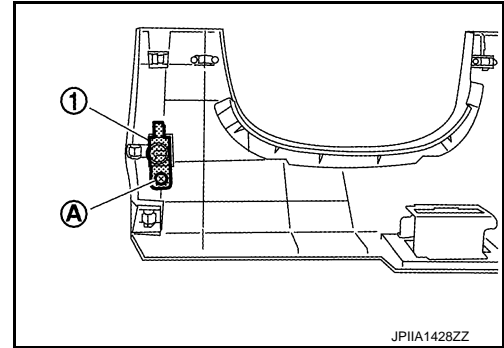

#### INSTALLATION

Installation is basically the reverse order of removal.

A  
B  
C  
D  
E  
F  
G  
H  
HAC  
J  
K  
L  
M  
N  
O  
P

# SUNLOAD SENSOR

< REMOVAL AND INSTALLATION >

[WITHOUT 7 INCH DISPLAY]

## SUNLOAD SENSOR

### Exploded View

INFOID:000000005239210

1. Sunload sensor

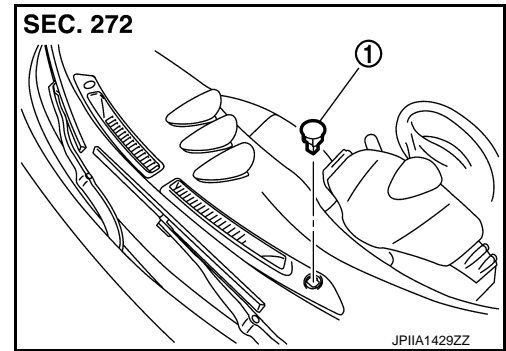

INFOID:000000005239211

### Removal and Installation

#### REMOVAL

Disconnect sunload sensor connector, and then remove sunload sensor.

#### INSTALLATION

Installation is basically the reverse order of removal.



## INTAKE SENSOR

< REMOVAL AND INSTALLATION >

[WITHOUT 7 INCH DISPLAY]

---

**CAUTION:**

- Replace O-rings with new ones. Then apply the compressor oil to them when installing.
- Mark the mounting position of intake sensor bracket prior to removal so that the reinstalled sensor can be located in the same position.
- Never rotate the bracket insertion part when removing and installing the intake sensor.
- Check for leakages when recharging refrigerant. Refer to [HA-27. "Leak Test"](#).

# REFRIGERANT PRESSURE SENSOR

< REMOVAL AND INSTALLATION >

[WITHOUT 7 INCH DISPLAY]

## REFRIGERANT PRESSURE SENSOR

Exploded View

INFOID:000000005239214

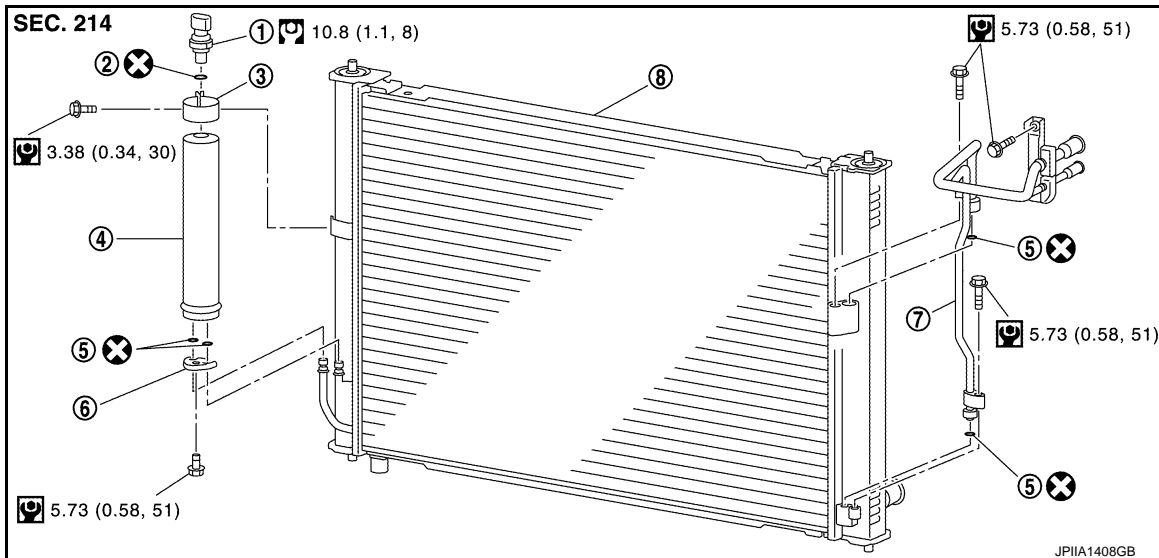

- |                                |                                  |                        |
|--------------------------------|----------------------------------|------------------------|
| 1. Refrigerant pressure sensor | 2. O-ring                        | 3. Liquid tank bracket |
| 4. Liquid tank                 | 5. O-ring                        | 6. Bracket             |
| 7. Condenser pipe assembly     | 8. Radiator & condenser assembly |                        |

Refer to [GI-4, "Components"](#) for symbols in the figure.

## Removal and Installation

INFOID:000000005239215

### REMOVAL

1. Remove liquid tank. Refer to [HA-43, "Exploded View"](#).
2. Fix the liquid tank (1) with a vise (A). Remove the refrigerant pressure sensor (2) with a wrench (B).

#### CAUTION:

**Be careful not to damage liquid tank.**

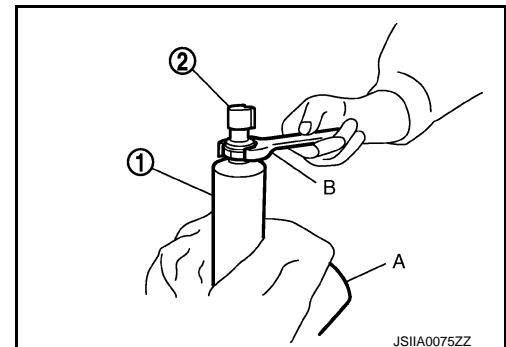

### INSTALLATION

Installation is basically the reverse order of removal.

#### CAUTION:

- Replace O-ring with new one. Then apply compressor oil to them when installing.
- Check for leakages when recharging refrigerant. Refer to [HA-27, "Leak Test"](#).

# DOOR MOTOR

< REMOVAL AND INSTALLATION >

[WITHOUT 7 INCH DISPLAY]

## DOOR MOTOR

Exploded View

INFOID:0000000052392.16

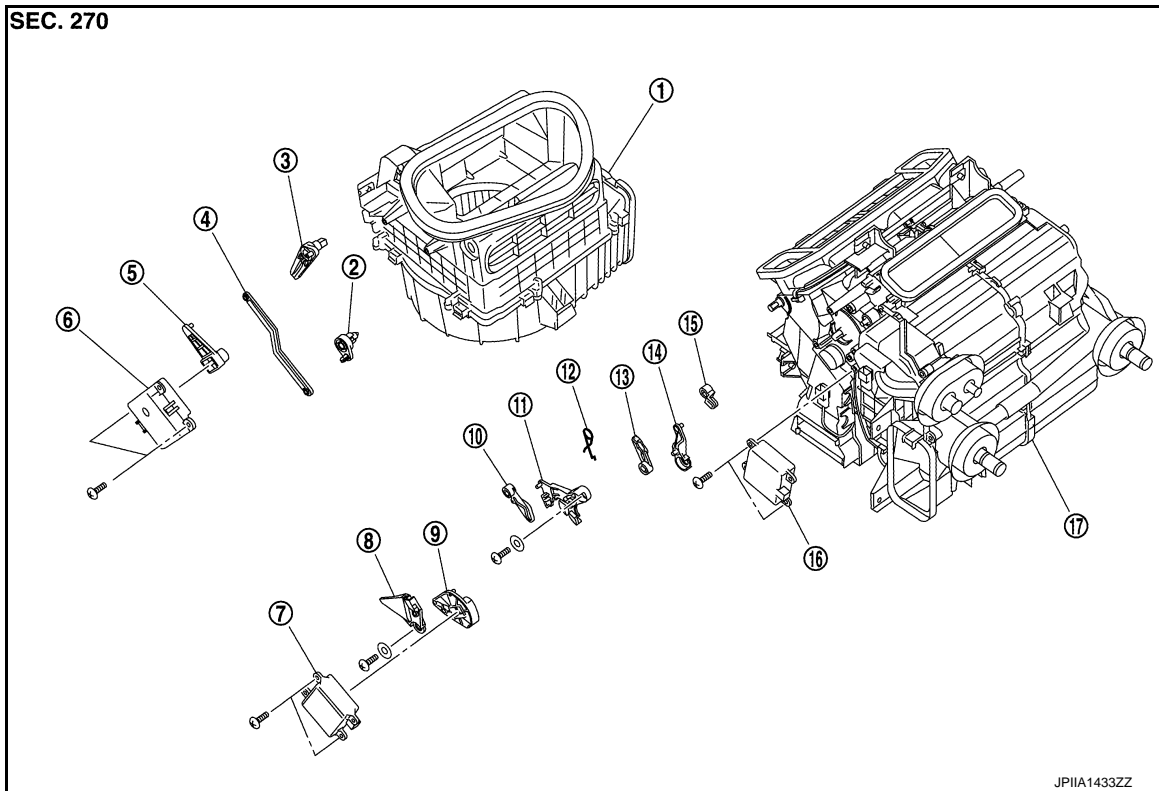

- |                           |                                    |                                  |
|---------------------------|------------------------------------|----------------------------------|
| 1. Bower unit             | 2. Intake door lever 3             | 3. Intake door lever 1           |
| 4. Intake door link       | 5. Intake door lever 2             | 6. Intake door motor             |
| 7. Mode door motor        | 8. Ventilator door link            | 9. Main link                     |
| 10. Ventilator door lever | 11. Main link sub                  | 12. Ventilator door lever spring |
| 13. Max. cool door lever  | 14. Defroster door link            | 15. Defroster door lever         |
| 16. Air mix door motor    | 17. Heater & cooling unit assembly |                                  |

## INTAKE DOOR MOTOR

### INTAKE DOOR MOTOR : Removal and Installation

INFOID:0000000052392.17

#### REMOVAL

1. Remove instrument lower panel RH. Refer to [IP-12. "Exploded View"](#).
2. Remove ECM.
3. Remove mounting screws (A), and then remove intake door motor (1).
4. Disconnect intake door motor connector.

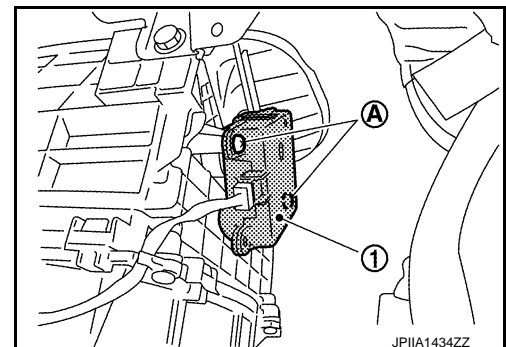

#### INSTALLATION

# DOOR MOTOR

< REMOVAL AND INSTALLATION >

[WITHOUT 7 INCH DISPLAY]

Installation is basically the reverse order of removal.

## MODE DOOR MOTOR

### MODE DOOR MOTOR : Removal and Installation

INFOID:000000005239218

#### REMOVAL

1. Remove blower unit. Refer to [VTL-13. "Exploded View"](#).
2. Remove mounting screws (A), and then remove mode door motor (1).
3. Disconnect mode door motor connector.

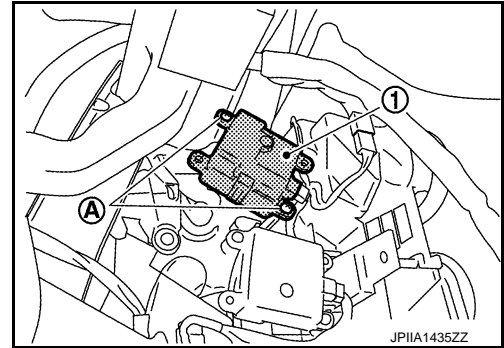

#### INSTALLATION

Installation is basically the reverse order of removal.

## AIR MIX DOOR MOTOR

### AIR MIX DOOR MOTOR : Removal and Installation

INFOID:000000005239219

#### REMOVAL

1. Set the temperature at 18.0°C (60°F).  
**CAUTION:**  
**The angle may be out, when installing the air mix door motor to the air mix door, unless the above procedure is performed.**
2. Disconnect the battery cable from the negative terminal.
3. Remove instrument lower panel RH. Refer to [IP-12. "Exploded View"](#).
4. Remove mounting screws (A), and then remove air mix door motor (1).
5. Disconnect air mix door motor connector.

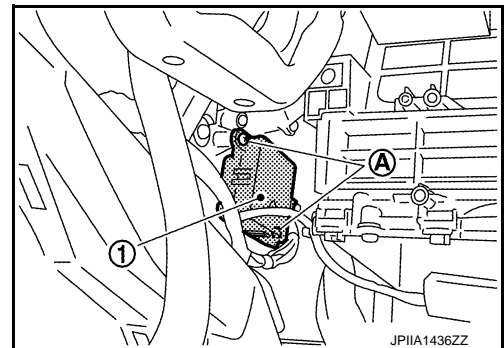

#### INSTALLATION

Installation is basically the reverse order of removal.

A  
B  
C  
D  
E  
F  
G  
H  
HAC  
J  
K  
L  
M  
N  
O  
P

# DIAGNOSIS AND REPAIR WORK FLOW

< BASIC INSPECTION >

[WITH 7 INCH DISPLAY]

## BASIC INSPECTION

### DIAGNOSIS AND REPAIR WORK FLOW

Work Flow

INFOID:000000005239220

#### OVERALL SEQUENCE

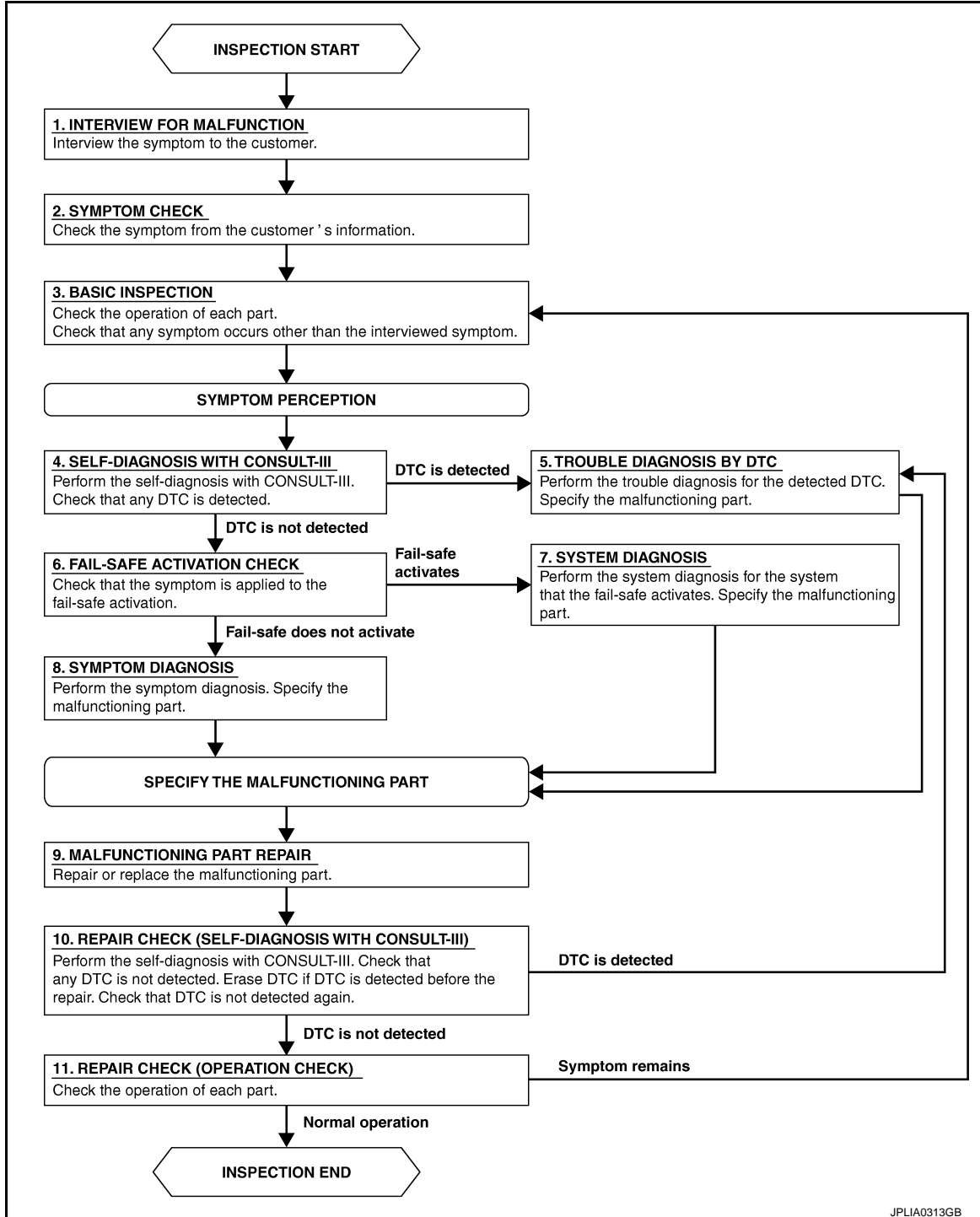

#### DETAILED FLOW

##### 1. INTERVIEW FOR MALFUNCTION

Interview the symptom to the customer.



# DIAGNOSIS AND REPAIR WORK FLOW

< BASIC INSPECTION >

[WITH 7 INCH DISPLAY]

>> GO TO 2.

## 2. SYMPTOM CHECK

Check the symptom from the customer's information.

>> GO TO 3.

## 3. BASIC INSPECTION

Check the operation of each part. Check that any symptom occurs other than the interviewed symptom.

>> GO TO 4.

## 4. SELF-DIAGNOSIS WITH CONSULT-III

Perform the self-diagnosis with CONSULT-III. Check that any DTC is detected.

Is any DTC detected?

YES >> GO TO 5.

NO >> GO TO 6.

## 5. TROUBLE DIAGNOSIS BY DTC

Perform the trouble diagnosis for the detected DTC. Specify the malfunctioning part.

>> GO TO 9.

## 6. FAIL-SAFE ACTIVATION CHECK

Check that the symptom is applied to the fail-safe activation.

Does the fail-safe activate?

YES >> GO TO 7.

NO >> GO TO 8.

## 7. SYSTEM DIAGNOSIS

Perform the system diagnosis for the system that the fail-safe activates. Specify the malfunctioning part.

>> GO TO 9.

## 8. SYMPTOM DIAGNOSIS

Perform the symptom diagnosis. Specify the malfunctioning part.

>> GO TO 9.

## 9. MALFUNCTION PART REPAIR

Repair or replace the malfunctioning part.

>> GO TO 10.

## 10. REPAIR CHECK (SELF-DIAGNOSIS WITH CONSULT-III)

Perform the self-diagnosis with CONSULT-III. Check that any DTC is not detected. Erase DTC if DTC is detected before the repair. Check that DTC is not detected again.

Is any DTC detected?

YES >> GO TO 5.

NO >> GO TO 11.

## 11. REPAIR CHECK (OPERATION CHECK)

Check the operation of each part.

Does it operate normally?

YES >> INSPECTION END

NO >> GO TO 3.

A

B

C

D

E

F

G

H

HAC

J

K

L

M

N

O

P

## INSPECTION AND ADJUSTMENT

## Description &amp; Inspection

INFOID:000000005239221

## DESCRIPTION

The purpose of the operational check is to check that the individual system operates normally.

**Check condition : Engine running at normal operating temperature.**

**1. CHECK MEMORY FUNCTION**

1. Turn the ignition switch ON.
2. Set temperature control dial to 32.0°C (90°F).
3. Press the OFF switch.
4. Turn the ignition switch OFF.
5. Turn the ignition switch ON.
6. Press the AUTO switch.
7. Check that the set temperature is maintained.

Is the inspection result normal?

YES >> GO TO 2.

NO >> Memory function malfunction. Refer to [HAC-171, "Diagnosis Procedure"](#).

**2. CHECK BLOWER MOTOR**

1. Start the engine.
2. Operate the fan control dial. Check that the fan speed changes. Check the operation for all fan speeds.
3. Leave blower on maximum speed.

Is the inspection result normal?

YES >> GO TO 3.

NO >> Blower motor system malfunction. Refer to [HAC-142, "Diagnosis Procedure"](#).

**3. CHECK DISCHARGE AIR**

1. Operate MODE switch and DEF switch.
2. Check that the air outlets change according to each indicated air outlet by placing a hand in front of the outlets. Refer to [VTL-3, "System Description"](#).

Is the inspection result normal?

YES >> GO TO 4.

NO >> Mode door system malfunction. Refer to [HAC-135, "Diagnosis Procedure"](#).

**4. CHECK INTAKE AIR**

1. Press intake switch to set the air outlet to recirculation.
2. The REC indicator turns ON.
3. Listen to intake sound and confirm air inlets change.
4. Press intake switch again to set the air outlet to fresh air intake.
5. The FRE indicator turns ON.
6. Listen to intake sound and confirm air inlets change.

Is the inspection result normal?

YES >> GO TO 5.

NO >> Intake door system malfunction. Refer to [HAC-137, "Diagnosis Procedure"](#).

**5. CHECK A/C SWITCH**

1. Press the A/C switch.
2. Check that the indicator of the A/C switch turns ON. Check visually and by sound that the compressor operates.
3. Press the A/C switch again.
4. Check that the indicator of the A/C switch turns OFF. Check that the compressor stops.

Is the inspection result normal?

YES >> GO TO 6.

NO >> Magnet clutch system malfunction. Refer to [HAC-146, "Diagnosis Procedure"](#).

# INSPECTION AND ADJUSTMENT

< BASIC INSPECTION >

[WITH 7 INCH DISPLAY]

## 6. CHECK DISCHARGE AIR TEMPERATURE

Operate the temperature control dial. Check that the discharge air temperature changes.

Is the inspection result normal?

YES >> GO TO 7.

NO >> Air mix door malfunction. Refer to [HAC-133, "Diagnosis Procedure"](#).

## 7. CHECK TEMPERATURE DECREASE

1. Operate the compressor.
2. Operate the temperature control dial and lower the set temperature to 18.0°C (60°F).
3. Check that the cool air blows from the outlets.

Is the inspection result normal?

YES >> GO TO 8.

NO >> Insufficient cooling. Refer to [HAC-164, "Diagnosis Procedure"](#).

## 8. CHECK TEMPERATURE INCREASE

1. Turn temperature control dial and raise temperature setting to 32.0°C (90°F) after warming up the engine.
2. Check that warm air blows from outlets.

Is the inspection result normal?

YES >> GO TO 9.

NO >> Insufficient heating. Refer to [HAC-166, "Diagnosis Procedure"](#).

## 9. CHECK AUTO MODE

1. Press the AUTO switch, and then check that "AUTO" is shown on the display.
2. Operate the temperature control dial. Check that the fan speed or air outlet changes (the air flow temperature or fan speed varies depending on the ambient temperature, in-vehicle temperature, and set temperature).

Is the inspection result normal?

YES >> INSPECTION END

NO >> Refer to [HAC-163, "Diagnosis Chart By Symptom"](#) and perform the appropriate diagnosis.

## Temperature Setting Trimmer

INFOID:000000005239222

### DESCRIPTION

If the temperature felt by the customer is different than the air flow temperature controlled by the temperature setting, the A/C auto amp. control temperature can be adjusted to compensate for the temperature setting.

### HOW TO SET

Ⓜ With CONSULT-III

Perform "TEMP SET CORRECT" of HVAC work support item.

A  
B  
C  
D  
E  
F  
G  
H  
J  
K  
L  
M  
N  
O  
P

HAC

# INSPECTION AND ADJUSTMENT

< BASIC INSPECTION >

[WITH 7 INCH DISPLAY]

Work support items	Display (°F)	Display (°C)
TEMP SET CORRECT	6	3.0
	5	2.5
	4	2.0
	3	1.5
	2	1.0
	1	0.5
	0 (initial status)	0 (initial status)
	-1	-0.5
	-2	-1.0
	-3	-1.5
	-4	-2.0
	-5	-2.5
	-6	-3.0

**NOTE:**

- When  $-3.0^{\circ}\text{C}$  ( $-6^{\circ}\text{F}$ ) is corrected on the temperature setting set as  $25.0^{\circ}\text{C}$  ( $77^{\circ}\text{F}$ ), the temperature controlled by A/C auto amp. is  $25.0^{\circ}\text{C}$  ( $77^{\circ}\text{F}$ )  $- 3.0^{\circ}\text{C}$  ( $-6^{\circ}\text{F}$ ) =  $22.0^{\circ}\text{C}$  ( $72^{\circ}\text{F}$ ) and the temperature becomes lower than the temperature setting.
- When the battery cable is disconnected from the negative terminal or when the battery voltage becomes 10 V or less, the setting of the difference between the set temperature and control temperature may be cancelled.

## Foot Position Setting Trimmer

INFOID:000000005239223

### DESCRIPTION

In FOOT mode, the air blowing to DEF can change ON/OFF.

### HOW TO SET

With CONSULT-III

Perform the "BLOW SET" of HVAC work support item.

Work support items	Display	Defroster door position	
		Auto control	Manual control
BLOW SET	Mode 1	OPEN	CLOSE
	Mode 2 (initial status)	OPEN	OPEN
	Mode 3	CLOSE	OPEN
	Mode 4	CLOSE	CLOSE

**NOTE:**

When the battery cable is disconnected from the negative terminal or when the battery voltage becomes 10 V or less, the setting of the discharge air mix ratio in FOOT mode may be cancelled.

## Inlet Port Memory Function (FRE)

INFOID:000000005239224

### DESCRIPTION

- If the ignition switch is turned to the OFF position while the FRE indicator is set to ON (fresh air intake), "Perform the memory" or "Do not perform the memory" of FRE indicator ON (fresh air intake) condition can be selected.
- If "Perform the memory" was set, the FRE indicator will be ON (fresh air intake) when turning the ignition switch to the ON position again.
- If "Do not perform the memory" was set, the air inlets will be controlled automatically when turning the ignition switch to the ON position again.

### HOW TO SET

# INSPECTION AND ADJUSTMENT

< BASIC INSPECTION >

[WITH 7 INCH DISPLAY]

Ⓜ With CONSULT-III  
Perform the “FRE MEMORY SET” of HVAC work support item.

Work support items	Display	Setting
FRE MEMORY SET	WITHOUT	Perform the memory of manual FRE
	WITH (initial status)	Do not perform the memory of manual FRE (auto control)

**NOTE:**

When the battery cable is disconnected from the negative terminal or when the battery voltage becomes 10 V or less, the setting of the FRE memory function may be cancelled.

## Inlet Port Memory Function (REC)

INFOID:000000005239225

### DESCRIPTION

- If the ignition switch is turned to the OFF position while the REC indicator is set to ON (recirculation), “Perform the memory” or “Do not perform the memory” of REC indicator ON (recirculation) condition can be selected.
- If “Perform the memory” was set, the REC indicator will be ON (recirculation) when turning the ignition switch to the ON position again.
- If “Do not perform the memory” was set, the air inlets will be controlled automatically when turning the ignition switch to the ON position again.

### HOW TO SET

Ⓜ With CONSULT-III  
Perform the “REC MEMORY SET” of HVAC work support item.

Work support items	Display	Setting
REC MEMORY SET	WITHOUT (initial status)	Perform the memory of manual REC
	WITH	Do not perform the memory of manual REC (auto control)

**NOTE:**

When the battery cable is disconnected from the negative terminal or when the battery voltage becomes 10 V or less, the setting of the REC memory function may be cancelled.

A  
B  
C  
D  
E  
F  
G  
H  
J  
K  
L  
M  
N  
O  
P

HAC

# COMPRESSOR CONTROL FUNCTION

< SYSTEM DESCRIPTION >

[WITH 7 INCH DISPLAY]

## SYSTEM DESCRIPTION

### COMPRESSOR CONTROL FUNCTION

Description

INFOID:000000005239226

PRINCIPLE OF OPERATION

Functional circuit diagram

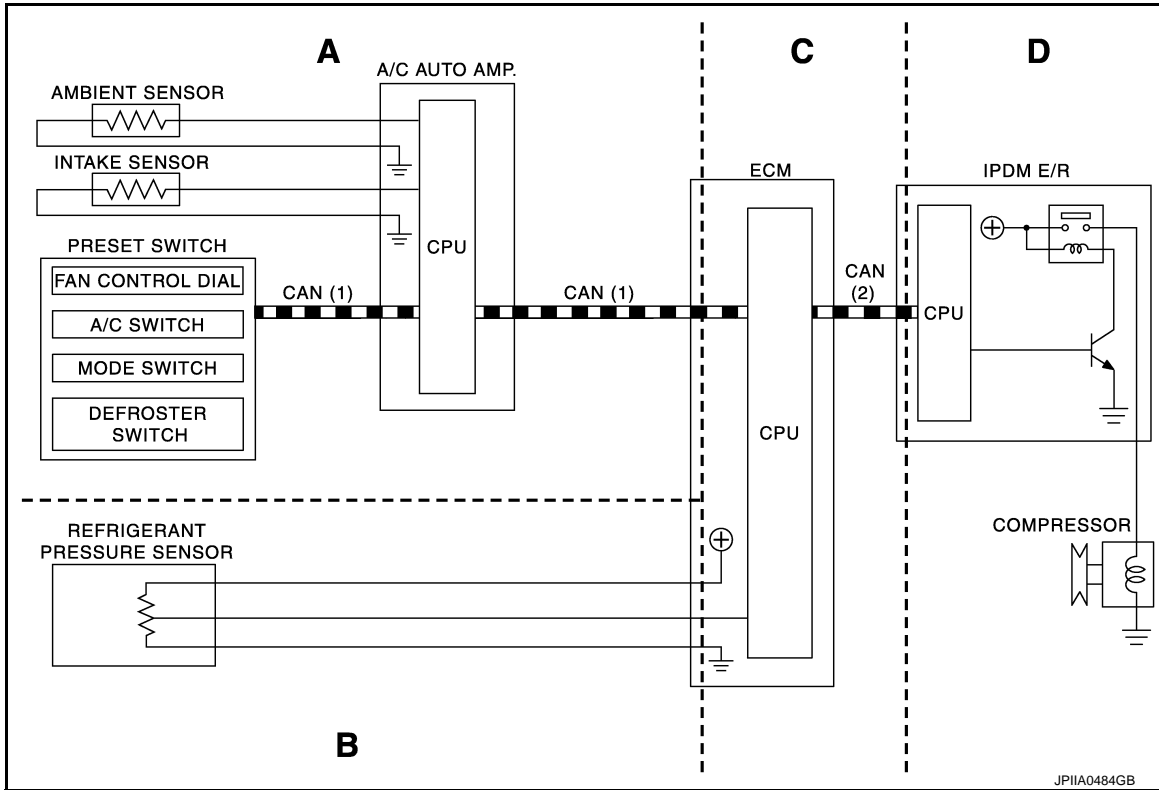

CAN (1) : A/C ON switch signal  
: Blower fan ON signal

CAN (2) : A/C compressor request signal

Functional initial inspection chart

×: Applicable

Control unit	Diagnosis item	Location			
		A	B	C	D
A/C auto amp.	ⓐ "HVAC"	×	—	—	—
	Self-diagnosis	×	—	—	—
	Data monitor	×	—	—	—
ECM	ⓐ "ENGINE"	×	—	—	×
	Self-diagnosis function (CAN system diagnosis)	—	—	×	—
	Data monitor	—	×	×	—
IPDM E/R	ⓐ "IPDM E/R"	—	—	—	×
	Self-diagnosis function (CAN system diagnosis)	—	—	×	—
	Data monitor	—	—	×	—
	Auto active test	—	—	—	×

Fail-safe

INFOID:000000005239227

FAIL-SAFE FUNCTION

# COMPRESSOR CONTROL FUNCTION

< SYSTEM DESCRIPTION >

[WITH 7 INCH DISPLAY]

When a communication malfunction between A/C auto amp. and AV control unit and preset switch continued for approximately 30 seconds or more, control the air conditioner under the following conditions.

- Compressor** : ON
- Air outlet** : AUTO
- Air inlet** : FRE (Fresh air intake)
- Fan speed** : AUTO
- Preset temperature** : Setting before communication malfunction

## Component Parts Location

INFOID:000000005239228

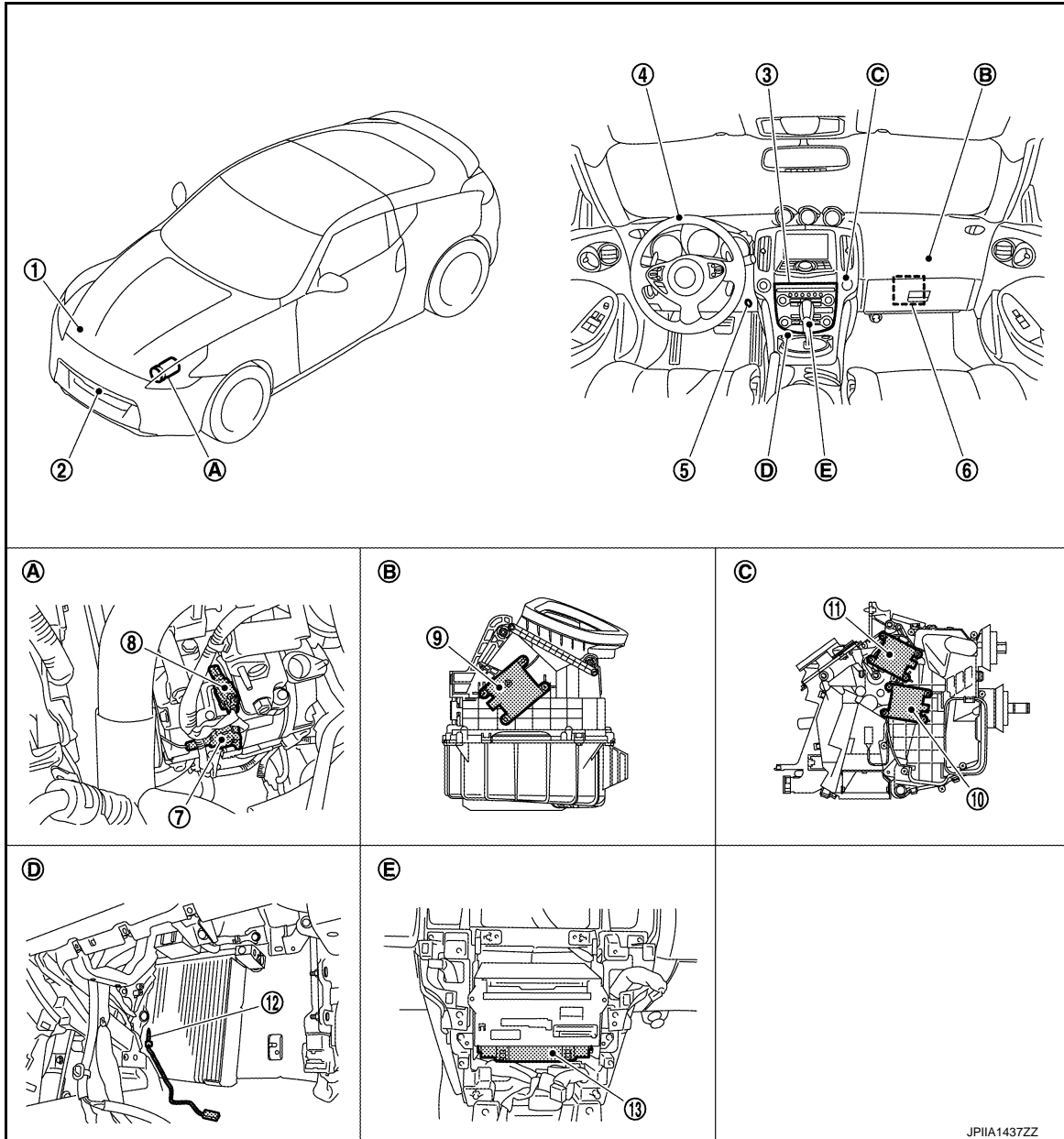

- |                                |                      |                      |
|--------------------------------|----------------------|----------------------|
| 1. Refrigerant pressure sensor | 2. Ambient sensor    | 3. Preset switch     |
| 4. Sunload sensor              | 5. In-vehicle sensor | 6. Blower motor      |
| 7. Magnet clutch               | 8. ECV               | 9. Intake door motor |
| 10. Air mix door motor         | 11. Mode door motor  | 12. Intake sensor    |
| 13. A/C auto amp.              |                      |                      |

# COMPRESSOR CONTROL FUNCTION

< SYSTEM DESCRIPTION >

[WITH 7 INCH DISPLAY]

- |                                |                                               |                                                         |
|--------------------------------|-----------------------------------------------|---------------------------------------------------------|
| A. Installed on the compressor | B. Installed to the blower unit assembly (RH) | C. Installed to the heater & cooling unit assembly (RH) |
| D. Located on the evaporator   | E. Behind of the cluster lid C                |                                                         |

## Component Description

INFOID:000000005239229

Component	Description
Ambient sensor	<a href="#">HAC-120. "Description"</a>
In-vehicle sensor	<a href="#">HAC-123. "Description"</a>
Intake sensor	<a href="#">HAC-126. "Description"</a>
Sunload sensor	<a href="#">HAC-129. "Description"</a>
Air mix door motor	<a href="#">HAC-132. "Description"</a>
Mode door motor	<a href="#">HAC-134. "Description"</a>
Intake door motor	<a href="#">HAC-136. "Description"</a>
A/C auto amp.	<a href="#">HAC-141. "Description"</a>
Blower motor	<a href="#">HAC-142. "Description"</a>
Magnet clutch	<a href="#">HAC-146. "Description"</a>
ECV	<a href="#">HAC-148. "Description"</a>
Refrigerant pressure sensor	<a href="#">EC-511. "Description"</a>
Preset switch	The preset switch integrated with the controller for A/C operation and AV switch is installed to the center of the instrument panel. The operation and display data of the preset switch are communicated with the A/C auto amp. through AV control unit via CAN communication.



# AUTOMATIC AIR CONDITIONER SYSTEM

< SYSTEM DESCRIPTION >

[WITH 7 INCH DISPLAY]

## AUTOMATIC AIR CONDITIONER SYSTEM

### System Diagram

INFOID:000000005239230

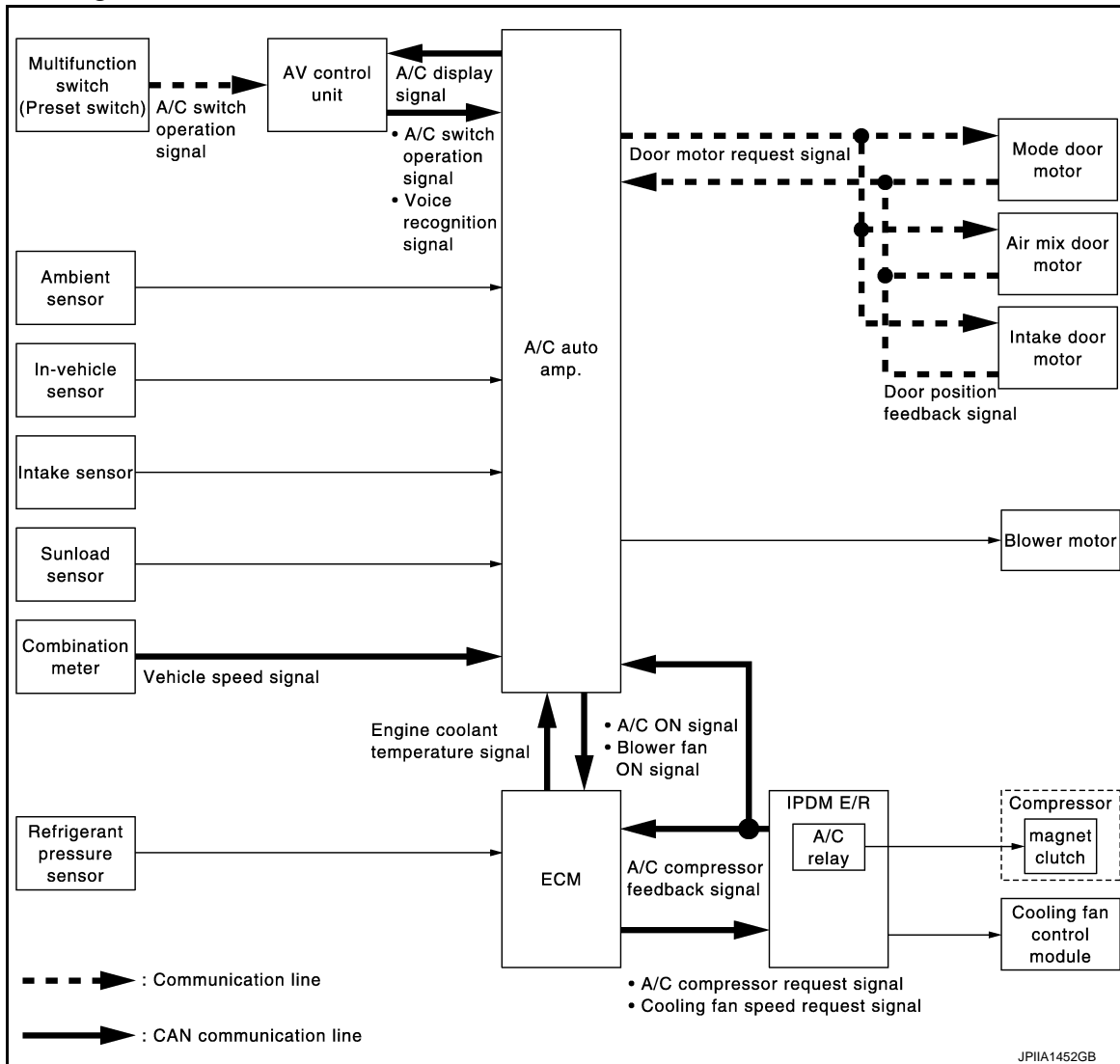

A

B

C

D

E

F

G

H

HAC

J

K

L

### System Description

INFOID:000000005239231

#### OUTLINE

- Automatic air conditioner system is controlled by each function of A/C auto amp., ECM and IPDM E/R.

Control by A/C auto amp.

- Air outlet control
- Temperature control
- Air inlet control
- Air flow control
- Compressor control
- Door motor control (LCU communication control)

Control by ECM

- Cooling fan control. (Refer to [EC-76, "System Description"](#).)
- Air conditioning cut control. (Refer to [EC-56, "System Description"](#).)

Control by IPDM E/R

- Relay control. (Refer to [PCS-4, "System Description"](#).)
- Cooling fan control. (Refer to [PCS-7, "System Description"](#).)

M

N

O

P

# AUTOMATIC AIR CONDITIONER SYSTEM

## < SYSTEM DESCRIPTION >

[WITH 7 INCH DISPLAY]

- Controller (preset switch) transmits the commands for air conditioner system operation to AV control unit via communication line, then AV control unit transmits the commands to A/C auto amp. via CAN communication. A/C auto amp. transmits each indication information to AV control unit via CAN communication. AV control unit displays each indication information that is received.

## OPERATION AND DISPLAY

### A/C Display

- Air conditioner system state is indicated on the display.
- When "Status" on multifunction switch is pressed while air conditioner system is in the ON position, the display changes to state indication display of air conditioner system. When air conditioner is operated while navigation system or audio system is displayed, air conditioner system state is indicated in the lower portion of display for several seconds.
- When MODE switch is pressed while air conditioner system is in the OFF position, state indication display is indicated for several seconds.

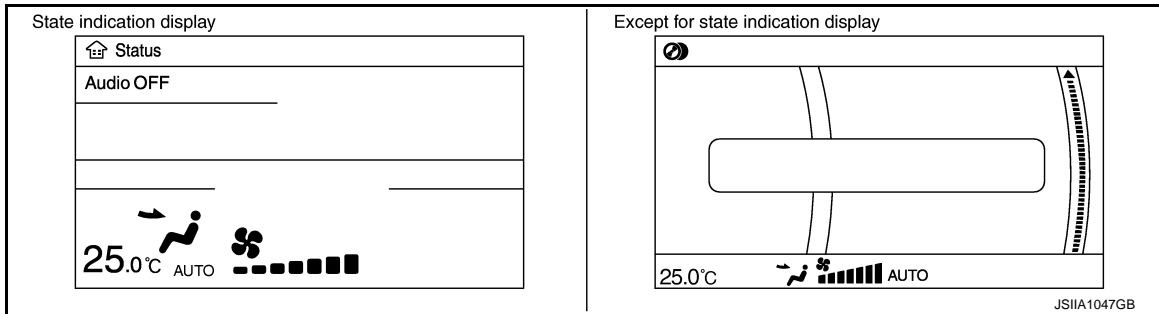

### Controller (Preset Switch)

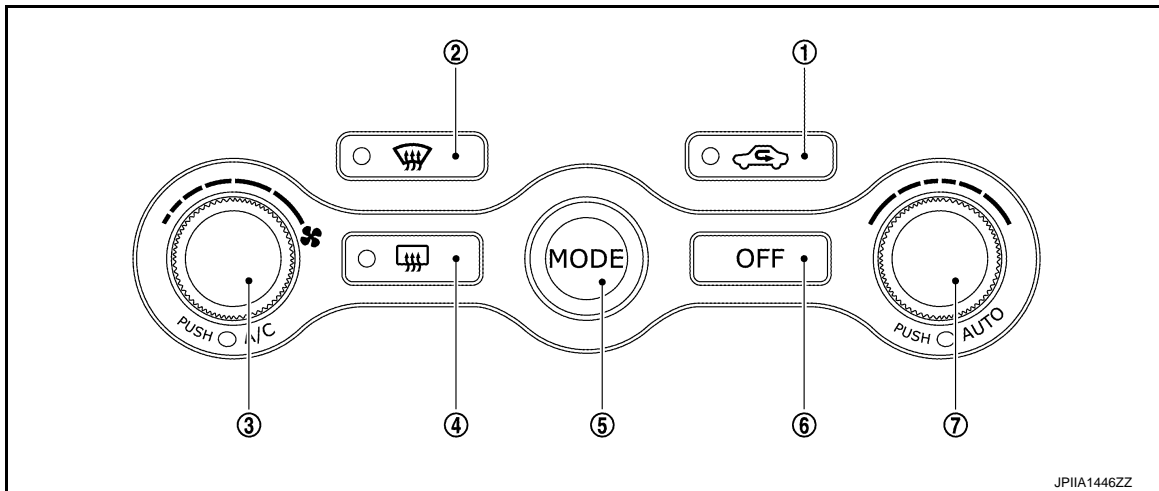

- |                                           |                |                                  |
|-------------------------------------------|----------------|----------------------------------|
| 1. Intake switch                          | 2. DEF switch  | 3. A/C switch / Fan control dial |
| 4. Rear window defogger switch            | 5. MODE switch | 6. OFF switch                    |
| 7. AUTO switch / Temperature control dial |                |                                  |

### Switch Operation

# AUTOMATIC AIR CONDITIONER SYSTEM

< SYSTEM DESCRIPTION >

[WITH 7 INCH DISPLAY]

Intake switch	<ul style="list-style-type: none"> <li>• Selects air inlet between recirculation (REC) ↔ fresh air intake (FRE) each time.</li> <li>- REC indicator OFF: Fresh air intake</li> <li>- REC indicator ON: Recirculation</li> <li>• Press and held for 2 seconds or more, intake switch indicator blinks 2 times and air inlet is set to automatic control.</li> </ul> <p><b>NOTE:</b></p> <ul style="list-style-type: none"> <li>• When air conditioner system is in the OFF position, air inlet can be selected.</li> <li>• When MODE switch and DEF switch is in the D/F or DEF position, air inlet cannot be selected to REC.</li> </ul>	A B C
DEF switch	<p>Turns DEF mode (switch indicator) between ON ↔ OFF each time while air conditioner system is in the ON position.</p> <ul style="list-style-type: none"> <li>• When DEF mode is turned ON, air conditioner system becomes the following state.</li> <li>- Air outlet: DEF</li> <li>- Compressor: ON</li> <li>- Air inlet: FRE</li> <li>- Blower fan: Automatic control (If fan speed other than AUTO is selected before pressing DEF switch, fan speed is manual control.)</li> <li>• When DEF mode is turned OFF, air conditioner system state returns to the previous state before DEF mode is selected. But, the following state is continued.</li> <li>- A/C switch: ON</li> <li>- Intake switch: FRE</li> </ul> <p>When DEF switch is pressed while air conditioner system is in the OFF position.</p> <ul style="list-style-type: none"> <li>• Air conditioner system is turned ON and becomes the following state.</li> <li>- Air outlet: DEF</li> <li>- Compressor: ON</li> <li>- Air inlet: FRE</li> <li>- Blower fan: Automatic control</li> <li>• When DEF mode is turned OFF, entire air conditioner system is set to auto mode.</li> </ul> <p><b>NOTE:</b></p> <p>When DEF mode turns ON while air conditioner system is in automatic control ("AUTO" is indicated), automatic control is released ("AUTO" turns OFF)</p>	D E F G H
A/C switch	<ul style="list-style-type: none"> <li>• Turns the compressor control (A/C switch indicator) between ↔ OFF each time.</li> <li>• When A/C switch turns OFF, air conditioner system becomes the following state.</li> </ul> <p><b>NOTE:</b></p> <ul style="list-style-type: none"> <li>• When the compressor control (A/C switch indicator) is in the OFF position, air inlet is fresh air intake (FRE).</li> <li>• When blower motor is in the OFF position, the compressor control cannot be activated.</li> </ul>	J K
Fan control dial	<p>Selects blower speed is within a range of 1st – 7th speed.</p> <p><b>NOTE:</b></p> <ul style="list-style-type: none"> <li>• When fan control dial is rotated while air conditioner system is in the OFF position, air conditioner system is activated.</li> <li>• When fan control dial is operated while air conditioner system is in automatic control (AUTO is indicated), automatic control is released (AUTO turns OFF).</li> </ul>	L
Rear window defogger switch	<p>Turns rear window defogger (switch indicator) between ON ↔ OFF each time.</p> <p>Rear window defogger system details. Refer to <a href="#">DEF-90. "WITH NAVIGATION : System Description"</a>.</p>	M
MODE switch	<p>Selects air outlet sequentially from VENT⇒B/L⇒FOOT⇒D/F⇒VENT each time.</p> <p><b>NOTE:</b></p> <ul style="list-style-type: none"> <li>• When air conditioner system is in the OFF position, air outlet can be selected</li> <li>• When MODE switch is pressed while air conditioner system is in automatic control ("AUTO" is indicated), automatic control is released ("AUTO" turns OFF).</li> </ul>	N
OFF switch	<ul style="list-style-type: none"> <li>• Turns air conditioner system OFF.</li> <li>• When air conditioner system turns OFF, air inlet and air outlet become the following state.</li> <li>- Air inlet: FRE (except REC is manually selected.)</li> <li>- Air outlet: FOOT</li> </ul>	O P

HAC

# AUTOMATIC AIR CONDITIONER SYSTEM

< SYSTEM DESCRIPTION >

[WITH 7 INCH DISPLAY]

AUTO switch	Turns the switch indicator lamp and "AUTO" indicator on the display ON, and then air conditioner system starts automatic control. <b>NOTE:</b> When air outlet is not selected manually, air outlet changes to automatic control.
Temperature control dial	Selects set temperature within a range between 18.0° (60°F) – 32.0°C (90°F) at a rate of 0.5°C (1.0°F) each time the dial is rotated. <ul style="list-style-type: none"> <li>• Clockwise rotation: Set temperature increases.</li> <li>• Counterclockwise rotation: Set temperature decreases.</li> </ul> <b>NOTE:</b> When air conditioner system is in the OFF position, set temperature can be selected only while air conditioner system state (when MODE switch is pressed) is indicated on the display.

## AIR OUTLET CONTROL

- While air outlet is in automatic control, A/C auto amp. selects the mode door position depending on a target air mix door angle and outlet air temperature calculated from sunload.
- If ambient temperature is excessively low, D/F is selected to prevent windshield fogging when air outlet is set to FOOT.

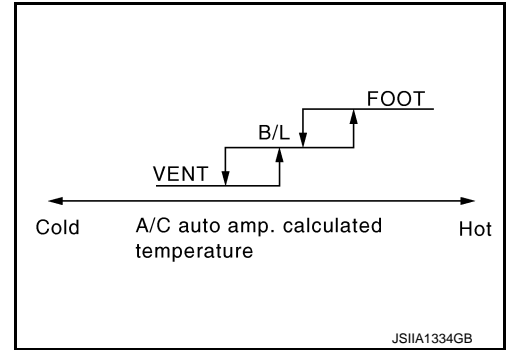

## TEMPERATURE CONTROL

- When ignition switch is in the ON position, A/C auto amp. always automatically controls temperature regardless of air conditioner operational state.
- A/C auto amp. calculates the target air mix door opening angle depending on set temperature, in-vehicle temperature, ambient temperature, and sunload.
- Air mix door is controlled depending on the comparison of current air mix door opening angle and target air mix door opening angle.
- Regardless of in-vehicle temperature, ambient temperature, and sunload, air mix door is fixed at the fully cold position when set temperature is 18.0°C (60°F), and at the fully hot position when set temperature is 32.0°C (90°F).

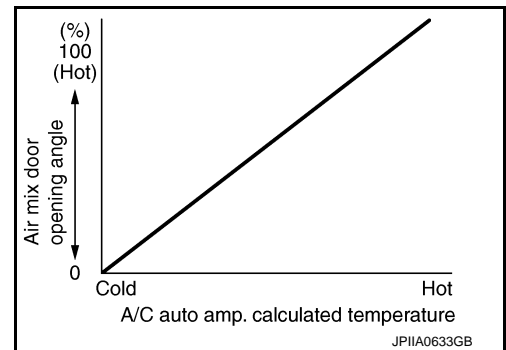

## AIR INLET FUNCTION

While air inlet is in automatic control, A/C auto amp. selects air inlet (fresh air intake, 20% fresh air intake, or recirculation) depending on set temperature, in-vehicle temperature, and ambient temperature.

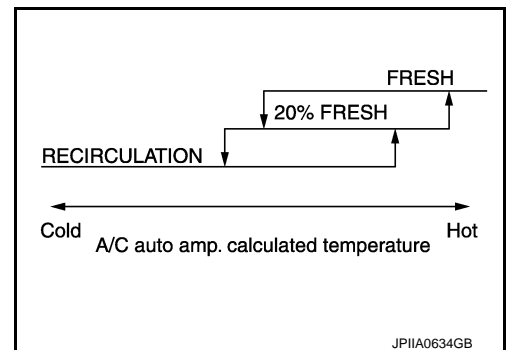

## AIR FLOW CONTROL

### Description

- A/C auto amp. changes duty ratio of blower motor drive signal and controls air flow continuously. When air flow is increased, duty ratio of blower motor drive signal gradually increases to prevent a sudden increase in air flow.
- In addition to manual control and automatic control, air flow control is composed of starting fan speed control, low coolant temperature starting control, high in-vehicle temperature starting control, fan speed control at door motor operation, and fan speed control at voice recognition.

# AUTOMATIC AIR CONDITIONER SYSTEM

[WITH 7 INCH DISPLAY]

## < SYSTEM DESCRIPTION >

### Automatic Air Flow Control

- A/C auto amp. decides target air flow depending on target air mix door opening angle.
- A/C auto amp. changes duty ratio of blower motor drive signal and controls air flow continuously so that air flow matches to target air flow.
- When air outlet is VENT or B/L, the minimum air flow is changed depending on sunload.

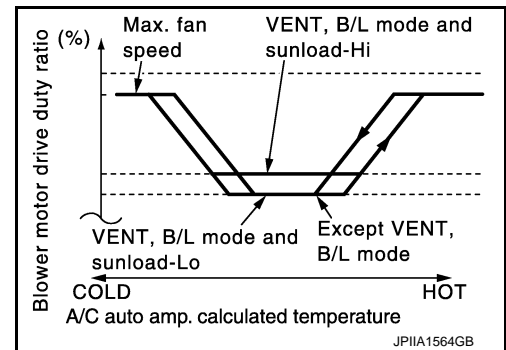

### Starting Fan Speed Control

When blower motor is activated, A/C auto amp. gradually increases duty ratio of blower fan drive signal to prevent a sudden increase in discharge air flow. (It takes approximately 8 seconds for air flow to reach HI from LOW)

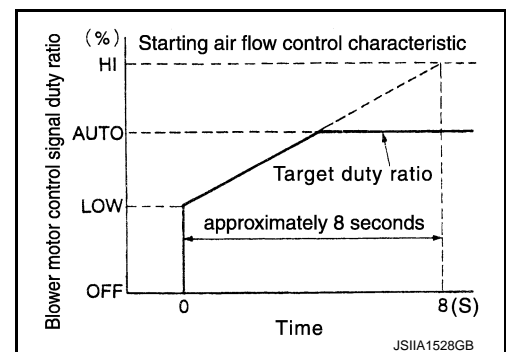

### Low Coolant Temperature Starting Control

If the engine coolant temperature is 56°C (133°F) or less, to prevent a cold discharged air flow, A/C auto amp. suspends blower motor activation for the maximum 150 seconds depending on target air mix door opening angle. After this, blower fan drive signal is increased gradually, and blower motor is activated.

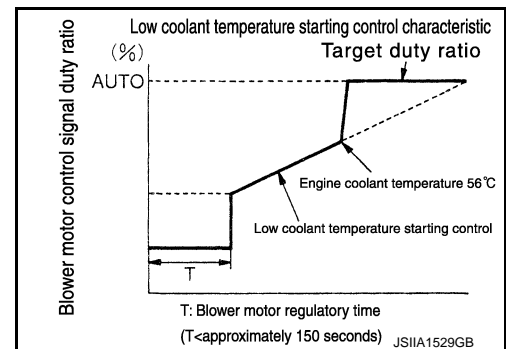

### High In-vehicle Temperature Starting Control

When evaporator temperature is high [intake air temperature sensor value is 35°C (95°F) or more], to prevent a hot discharged air flow, A/C auto amp. suspends blower motor activation for approximately 3 seconds so that evaporator is cooled by refrigerant.

### Fan speed Control at Door Motor Operation

When mode door motor is activated while air flow is more than the specified value, A/C auto amp. reduces temporarily fan speed so that mode door moves smoothly.

### Fan speed Control at Voice Recognition

When the voice control (voice command) switch is operated during air flow automatic control, A/C auto amp. decreases the air flow of the blower motor once and controls the air flow so as not to disturb the voice recognition function. This control continues while voice recognition function is operating.

## COMPRESSOR CONTROL

### Description

- When the compressor activation condition is satisfied while blower motor is activated, A/C auto amp. transmits A/C ON signal and blower fan ON signal to ECM via CAN communication.

A  
B  
C  
D  
E  
F  
G  
H  
HAC  
J  
K  
L  
M  
N  
O  
P

# AUTOMATIC AIR CONDITIONER SYSTEM

## < SYSTEM DESCRIPTION >

[WITH 7 INCH DISPLAY]

- ECM judges that the compressor can be activated depending on each sensors state (refrigerant pressure sensor signal, throttle opening angle sensor signal, and others). And transmits air conditioner relay control signal to IPDM E/R via CAN communication.
- IPDM E/R turns air conditioner relay ON and activates the compressor depending on request from ECM.

### Compressor Protection Control at Pressure Malfunction

When high-pressure side value that is detected by refrigerant pressure sensor is as per the following state, ECM requests IPDM E/R to turn air conditioner relay OFF and stops the compressor.

- 3.12 MPa (31.8 kg/cm<sup>2</sup>·G) or more (When the engine speed is less than 1,500 rpm)
- 2.74 MPa (27.9 kg/cm<sup>2</sup>·G) or more (When the engine speed is 1,500 rpm or more)
- 0.14 MPa (1.4 kg/cm<sup>2</sup>·G) or less

### Compressor Oil Circulation Control

When the engine starts while the engine coolant temperature is 56°C (133°F) or less, ECM activates the compressor for approximately 6 seconds and circulates the compressor lubricant once.

### Low Temperature Protection Control

When intake air temperature sensor detects that air temperature after passing through evaporator is -5°C (23°F) or less, A/C auto amp. requests ECM to turn the compressor OFF, and stops the compressor.

When the air temperature returns to 1°C (34°F) or more, the compressor is activated.

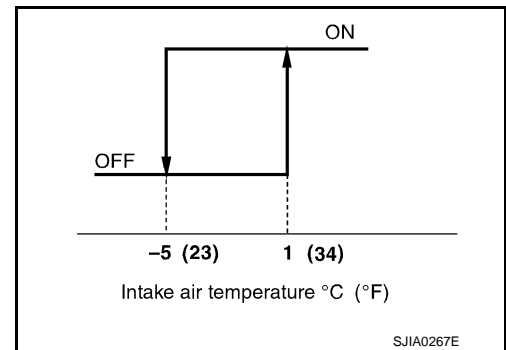

### Operating Rate Control

When set temperature is other than fully cold or air outlet is "VENT", "B/L" or "FOOT" A/C auto amp. controls the compressor activation depending on ambient temperature.

### Air Conditioner Cut Control

When the engine is running in excessively high load condition, ECM requests IPDM E/R to turn air conditioner relay OFF, and stops the compressor. Refer to [EC-56, "System Description"](#) for details.

## DOOR MOTOR CONTROL

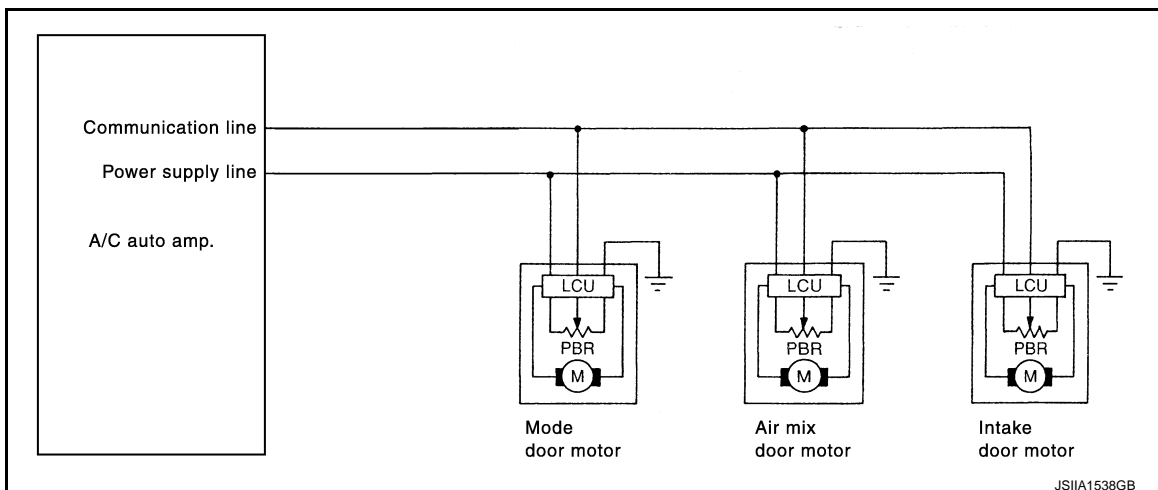

- LCU (Local Control Unit) is built in to each door motor. And detects door position by PBR (Potentiometer Balance Resistor).
- A/C auto amp. communicates with each LCU via communication line. And receives each door position signal from each LCU.
- Each LCU controls each door to the appropriate position depending on the control signal from A/C auto amp. when the door movement is complete, transmits the signal of door movement completion to A/C auto amp.

## FAIL-SAFE CONTROL

# AUTOMATIC AIR CONDITIONER SYSTEM

< SYSTEM DESCRIPTION >

[WITH 7 INCH DISPLAY]

When a communication malfunction occurs between A/C auto amp. and AV control unit or preset switch for 30 seconds or more, A/C auto amp. automatically controls air outlet and fan speed, fixes air inlet to fresh air intake, maintains set temperature data before the communication malfunction, and activates the compressor. Even if the condition before the communication error occurs is A/C OFF, A/C auto amp. turns the compressor ON with following conditions.

<b>Compressor</b>	<b>: ON</b>
<b>Air outlet</b>	<b>: AUTO</b>
<b>Air inlet</b>	<b>: FRE (Fresh air intake)</b>
<b>Fan speed</b>	<b>: AUTO</b>
<b>Preset temperature</b>	<b>: Setting before communication malfunction</b>

SWITCHES AND THEIR CONTROL FUNCTIONS

A  
B  
C  
D  
E  
F  
G  
H  
J  
K  
L  
M  
N  
O  
P

HAC

# AUTOMATIC AIR CONDITIONER SYSTEM

< SYSTEM DESCRIPTION >

[WITH 7 INCH DISPLAY]

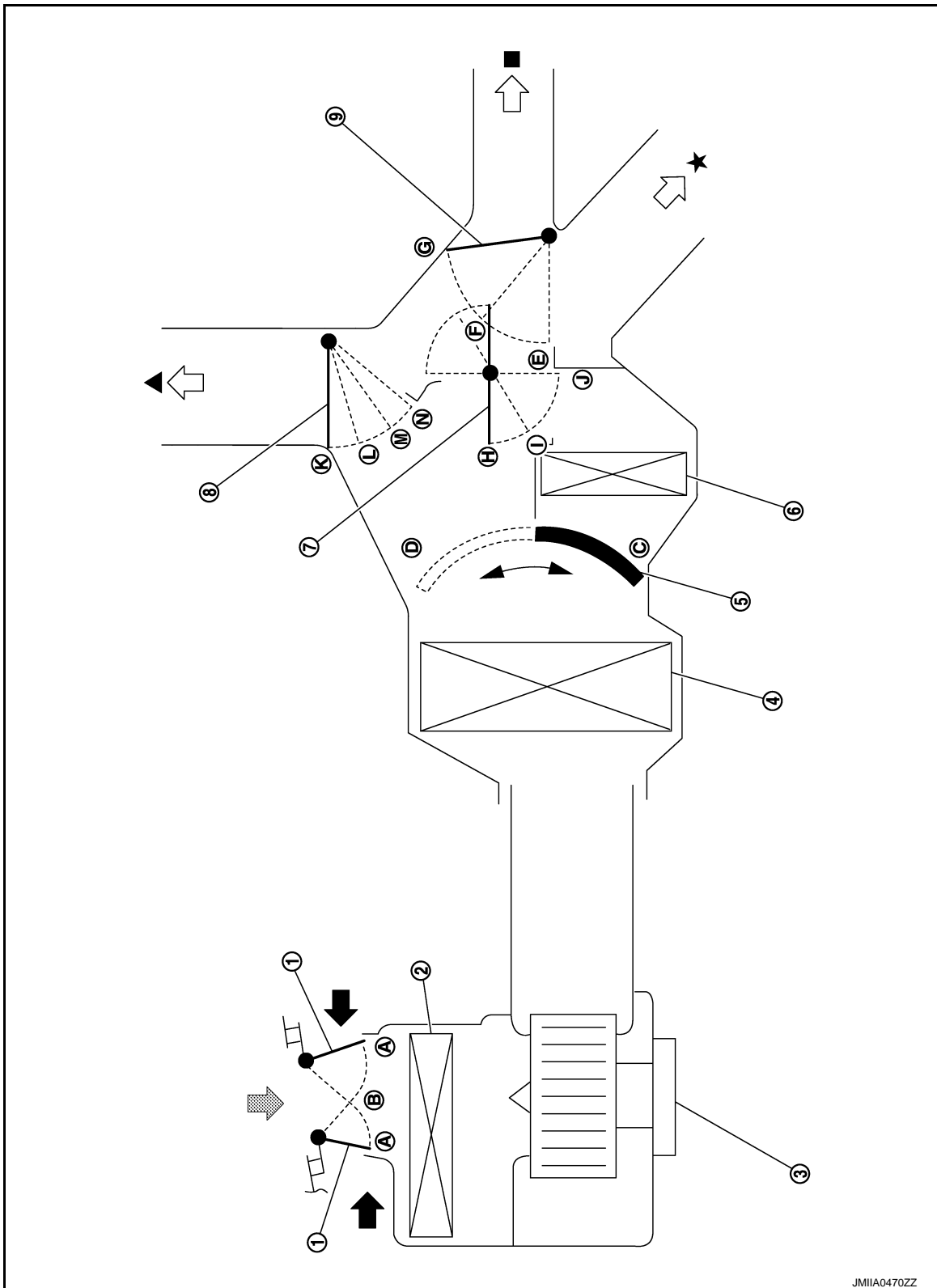

JMIIA0470ZZ

- |                    |                                                  |                    |
|--------------------|--------------------------------------------------|--------------------|
| 1. Intake door     | 2. In-cabine microfilter/Air conditioner filter* | 3. Blower motor    |
| 4. Evaporator      | 5. Air mix door                                  | 6. Heater core     |
| 7. Max. cool door  | 8. Defroster door                                | 9. Ventilator door |
| ↖ Fresh air intake | ← Recirculation air                              | ★ Foot             |
| ▲ Defroster        | ■ Ventilator                                     |                    |









# AUTOMATIC AIR CONDITIONER SYSTEM

< SYSTEM DESCRIPTION >





[WITH 7 INCH DISPLAY]

\*: Models for Mexico

Switch /Dial position		DOOR position				
		Ventilator door	Max. cool door	Defroster door	Intake door	Air mix door
AUTO switch	ON	AUTO				
Mode switch		E	H	K	—	—
		F	I			
		G	J	L	A	
				M		
DEF switch	 ON				N	A
Intake switch	 ON				B*	
					OFF	A*
Temperature control dial	Full cold 18.0°C (60°F)	—	—	—	—	C
	18.5°C -31.5°C (61°F - 89°F)					AUTO
	Full hot 32.0°C (90°F)					D
OFF switch		G	J	L	A	—

\*: Inlet status is displayed by indicator when activating automatic control

## AIR DISTRIBUTION

Discharge air flow			
Mode position indication	Air outlet/distribution		
	VENT	FOOT	DEF
	100%	—	—
	60%	40%	—
	12%	62%	26%
	10%	52%	38%
	—	—	100%

# AUTOMATIC AIR CONDITIONER SYSTEM

< SYSTEM DESCRIPTION >

[WITH 7 INCH DISPLAY]

## Component Parts Location

INFOID:0000000052392.32

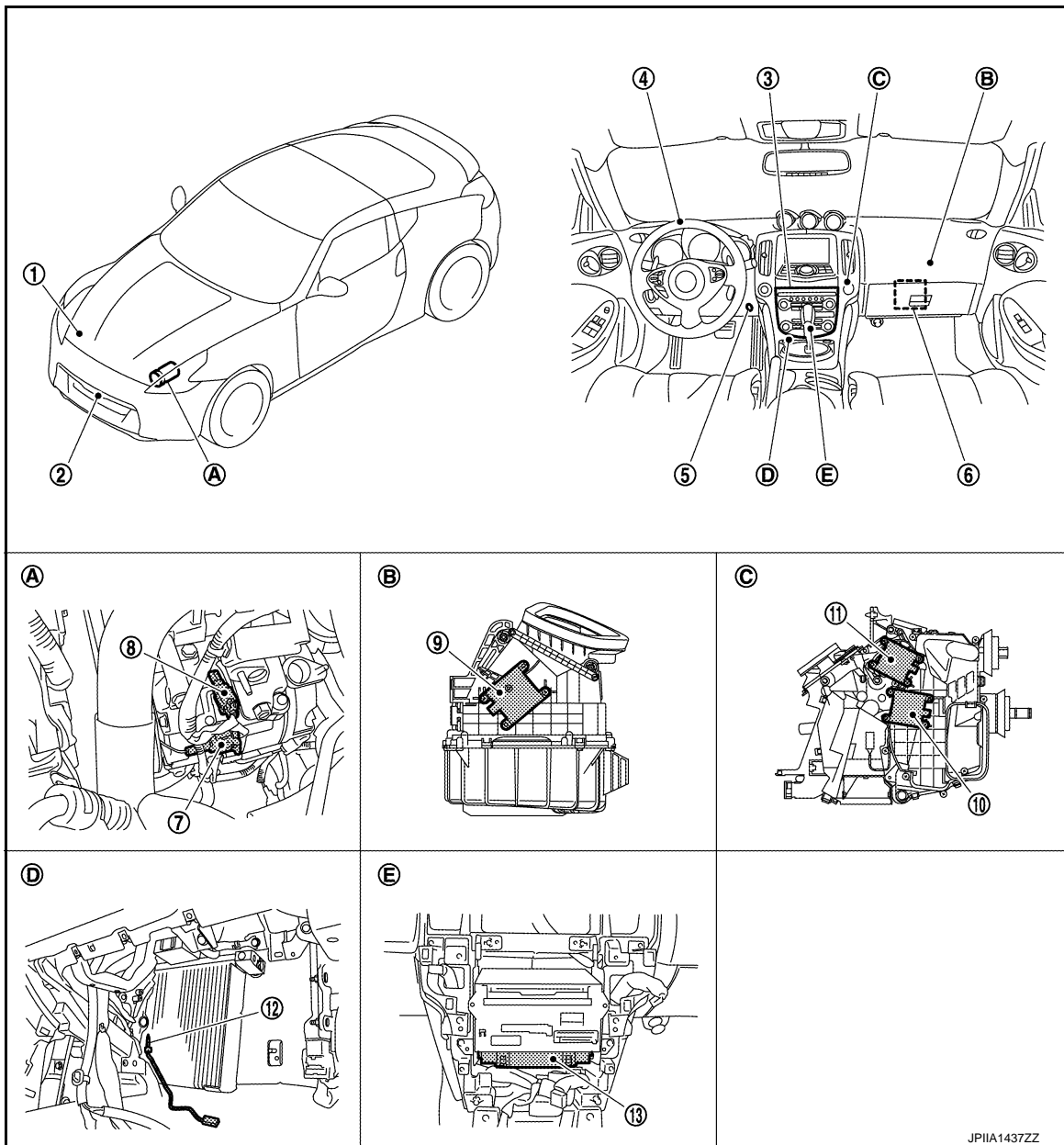

- |                                |                                               |                                                         |
|--------------------------------|-----------------------------------------------|---------------------------------------------------------|
| 1. Refrigerant pressure sensor | 2. Ambient sensor                             | 3. Preset switch                                        |
| 4. Sunload sensor              | 5. In-vehicle sensor                          | 6. Blower motor                                         |
| 7. Magnet clutch               | 8. ECV                                        | 9. Intake door motor                                    |
| 10. Air mix door motor         | 11. Mode door motor                           | 12. Intake sensor                                       |
| 13. A/C auto amp.              |                                               |                                                         |
| A. Installed on the compressor | B. Installed to the blower unit assembly (RH) | C. Installed to the heater & cooling unit assembly (RH) |
| D. Located on the evaporator   | E. Behind of the cluster lid C                |                                                         |

## Component Description

INFOID:0000000052392.33

Component	Description
Ambient sensor	<a href="#">HAC-120. "Description"</a>
In-vehicle sensor	<a href="#">HAC-123. "Description"</a>

# AUTOMATIC AIR CONDITIONER SYSTEM

< SYSTEM DESCRIPTION >

[WITH 7 INCH DISPLAY]

Component	Description
Intake sensor	<a href="#">HAC-126. "Description"</a>
Sunload sensor	<a href="#">HAC-129. "Description"</a>
Air mix door motor	<a href="#">HAC-132. "Description"</a>
Mode door motor	<a href="#">HAC-134. "Description"</a>
Intake door motor	<a href="#">HAC-136. "Description"</a>
A/C auto amp.	<a href="#">HAC-141. "Description"</a>
Blower motor	<a href="#">HAC-142. "Description"</a>
Magnet clutch	<a href="#">HAC-146. "Description"</a>
ECV	<a href="#">HAC-148. "Description"</a>
Refrigerant pressure sensor	<a href="#">EC-511. "Description"</a>
Preset switch	The preset switch integrated with the controller for A/C operation and AV switch is installed to the center of the instrument panel. The operation and display data of the preset switch are communicated with the A/C auto amp. through AV control unit via CAN communication.

A  
B  
C  
D  
E  
F  
G  
H  
J  
K  
L  
M  
N  
O  
P

HAC

## DIAGNOSIS SYSTEM (HVAC)

### CONSULT-III Function

INFOID:000000005239234

CONSULT-III performs the following functions via CAN communication with A/C auto amp.

Diagnostic mode	Description
Self diagnostic result	Displays the diagnosis results judged by A/C auto amp.
Data monitor	Displays the input/output signal of A/C auto amp.
Active test	The signals used to activate each device are forcibly supplied from A/C auto amp.
Work support	Changes the setting for each setting function.
ECU identification	Displays the part number of A/C auto amp.

**NOTE:**

Diagnosis should be performed with engine running. Door motor operation speeds become slower and NO results may be returned even for normal operation if battery voltage drops below 12 V during self-diagnosis.

### SELF-DIAGNOSIS RESULTS

Refer to [HAC-161, "DTC Index"](#).

### DATA MONITOR

Display item list

Monitor item [Unit]	Description
COMP REQ SIG [On/Off]	Displays A/C switch ON/OFF status transmitted to other units via CAN communication
FAN REQ SIG [On/Off]	Displays fan switch ON/OFF status transmitted to other units via CAN communication
AMB TEMP SEN [°C]	Ambient sensor value converted from ambient sensor signal received from ambient sensor
IN-VEH TEMP [°C]	In-vehicle sensor value converted from in-vehicle sensor signal received from in-vehicle sensor
INT TEMP SEN [°C]	Intake sensor value converted from intake sensor signal received from intake sensor
SUNLOAD SEN [w/m <sup>2</sup> ]	Sunload sensor value converted from sunload sensor signal received from sunload sensor
AMB SEN CAL [°C]	Ambient sensor value calculated by A/C auto amp.
IN-VEH CAL [°C]	In-vehicle sensor value calculated by A/C auto amp.
INT TEMP CAL [°C]	Intake sensor value calculated by A/C auto amp.
SUNL SEN CAL [w/m <sup>2</sup> ]	Sunload sensor value calculated by A/C auto amp.
FAN DUTY	Duty ratio of blower motor judged by A/C auto amp.
XM	Target discharge air temperature judged by A/C auto amp. depending on the temperature setting and the value from each sensor
ENG COOL TEMP [°C]	Water temperature signal value received from ECM via CAN communication
VEHICLE SPEED [Mph (km/h)]	Vehicle speed signal value received from meter via CAN communication

### ACTIVE TEST

Test item	Description
HVAC TEST	The operation check of air conditioner system can be performed by selecting the mode. Refer to the following table for the conditions of each mode.

Check each output device

# DIAGNOSIS SYSTEM (HVAC)

< SYSTEM DESCRIPTION >

[WITH 7 INCH DISPLAY]

	Test item						
	MODE 1	MODE 2	MODE 3	MODE 4	MODE 5	MODE 6	MODE 7
Mode door position	VENT	B/L 1	B/L 2	FOOT	D/F	DEF	—
Intake door position	REC	REC	20% FRE	FRE	FRE	FRE	—
Air mix door position	FULL COLD	FULL COLD	FULL HOT	FULL HOT	FULL HOT	FULL HOT	—
Blower motor control signal duty ratio	37%	91%	65%	65%	65%	91%	—
Magnet clutch	ON	ON	OFF	OFF	ON	ON	—
ECV duty ratio	100%	100%	0%	0%	50%	100%	—

**NOTE:**

- Perform the inspection of each output device after starting the engine because the compressor is operated.
- If the Mode 7 is selected, the malfunction is displayed but it is normal.

**WORK SUPPORT**

Work item	Description	Refer to
TEMP SET CORRECT (Temperature setting trimmer)	If the temperature felt by the customer is different than the air flow temperature controlled by the temperature setting, the A/C auto amp. control temperature can be adjusted to compensate for the temperature setting.	<a href="#">HAC-99, "Temperature Setting Trimmer"</a>
FRE MEMORY SET [Inlet port memory function (FRE)]	<ul style="list-style-type: none"> <li>• If the ignition switch is turned to the OFF position while the FRE indicator is set to ON (fresh air intake), "Perform the memory" or "Do not perform the memory" of FRE indicator ON (fresh air intake) condition can be selected.</li> <li>• If "Perform the memory" was set, the FRE indicator will be ON (fresh air intake) when turning the ignition switch to the ON position again.</li> <li>• If "Do not perform the memory" was set, the air inlets will be controlled automatically when turning the ignition switch to the ON position again.</li> </ul>	<a href="#">HAC-100, "Inlet Port Memory Function (FRE)"</a>
REC MEMORY SET [Inlet port memory function (REC)]	<ul style="list-style-type: none"> <li>• If the ignition switch is turned to the OFF position while the REC indicator is set to ON (recirculation), "Perform the memory" or "Do not perform the memory" of REC indicator ON (recirculation) condition can be selected.</li> <li>• If "Perform the memory" was set, the REC indicator will be ON (recirculation) when turning the ignition switch to the ON position again.</li> <li>• If "Do not perform the memory" was set, the air inlets will be controlled automatically when turning the ignition switch to the ON position again.</li> </ul>	<a href="#">HAC-101, "Inlet Port Memory Function (REC)"</a>
BLOWER SET (Foot position setting trimmer)	In FOOT mode, the air blowing to DEF can change ON/OFF.	<a href="#">HAC-100, "Foot Position Setting Trimmer"</a>

**NOTE:**

When the battery cable is disconnected from the negative terminal or when the battery voltage becomes 10 V or less, the setting of WORK SUPPORT may be cancelled.

A  
B  
C  
D  
E  
F  
G  
H  
J  
K  
L  
M  
N  
O  
P

HAC

## DTC/CIRCUIT DIAGNOSIS

### U1000 CAN COMM CIRCUIT

#### Description

INFOID:000000005239235

CAN (Controller Area Network) is a serial communication line for real time applications. It is an on-board multiplex communication line with high data communication speed and excellent error detection ability. A modern vehicle is equipped with many ECMs, and each control unit shares information and links with other control units during operation (not independent). In CAN communication, 2 control units are connected with 2 communication lines (CAN-L-line and CAN-H-line) allowing a high rate of information transmission with less wiring. Each control unit transmits/receives data but selectively reads required data only.

Refer to [LAN-26, "CAN Communication Signal Chart"](#) for details of the communication signal.

#### DTC Logic

INFOID:000000005239236

#### DTC DETECTION LOGIC

DTC	Items (CONSULT-III screen terms)	Diagnostic item is detected when...	Possible cause
U1000	CAN COMM CIRCUIT	When A/C auto amp. is not transmitting or receiving CAN communication signal for 2 or more seconds.	CAN communication system

#### Diagnosis Procedure

INFOID:000000005239237

### 1. PERFORM SELF-DIAGNOSIS

Ⓟ With CONSULT-III

1. Turn the ignition switch ON and wait for 2 seconds or more.
2. Perform the "SELF-DIAGNOSIS".
3. Check if any DTC is detected in the self-diagnostic results.

Is DTC "U1000" displayed?

- YES >> Perform the diagnosis for the CAN communication system. Refer to [LAN-16, "Trouble Diagnosis Flow Chart"](#).
- NO >> Perform the intermittent malfunction diagnosis. Refer to [GI-39, "Intermittent Incident"](#).

# U1010 CONTROL UNIT (CAN)

< DTC/CIRCUIT DIAGNOSIS >

[WITH 7 INCH DISPLAY]

## U1010 CONTROL UNIT (CAN)

### Description

INFOID:000000005239238

Initial diagnosis of A/C auto amp.

### DTC Logic

INFOID:000000005239239

### DTC DETECTION LOGIC

DTC	Items (CONSULT-III screen terms)	Diagnostic item is detected when...	Possible cause
U1010	CONTROL UNIT (CAN)	When detecting error during the initial diagnosis of CAN controller of A/C auto amp.	A/C auto amp.

### Diagnosis Procedure

INFOID:000000005239240

#### 1. REPLACE A/C AUTO AMP.

When DTC "U1010" is detected, replace A/C auto amp.

>> INSPECTION END

A  
B  
C  
D  
E  
F  
G  
H  
J  
K  
L  
M  
N  
O  
P

HAC

# B257B, B257C AMBIENT SENSOR

< DTC/CIRCUIT DIAGNOSIS >

[WITH 7 INCH DISPLAY]

## B257B, B257C AMBIENT SENSOR

### Description

INFOID:000000005239241

#### AMBIENT SENSOR

- The ambient sensor (1) is installed to the hood lock stay.
- The ambient sensor converts the ambient temperature detected with thermistor into the voltage, and the A/C auto amp. inputs this voltage.

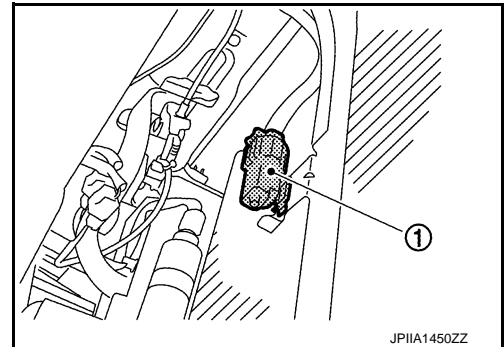

#### AMBIENT TEMPERATURE CORRECTION

- The A/C auto amp. inputs the temperature detected with the ambient sensor as the ambient temperature.
- Perform the correction of the temperature detected with the ambient sensor for air conditioner control and for ambient temperature display.
- Since the engine heat influences on the ambient sensor during idling condition, the A/C auto amp. retards the ambient temperature indication of the combination meter to avoid the effect of steep temperature change.
- Select and use the initial value of ambient temperature data depending on the coolant temperature when turning the ignition switch from OFF to ON. Use the detection temperature of the ambient sensor at low coolant temperature [less than approximately 56°C (133°F)]. Use the memory data (before the ignition switch is OFF) when the engine is warming up [approximately 56°C (133°F) or more].
- Do not perform the correction of the ambient temperature when the detection temperature of the ambient temperature is less than approximately -29°C (-20°F) (for ambient temperature display) or less than approximately -20°C (-4°F) (for air conditioner control).

#### SET TEMPERATURE CORRECTION

The A/C auto amp. performs the correction to the target temperature set by the temperature control dial so as to match the temperature felt by the passengers depending on the ambient temperature detected with the ambient sensor and controls it so that the interior air temperature is always the most suitable.

### DTC Logic

INFOID:000000005239242

#### DTC DETECTION LOGIC

DTC	Items (CONSULT-III screen terms)	Diagnostic item is detected when...	Possible causes
B257B	AMB TEMP SEN SHORT	The ambient sensor recognition temperature is too high.	<ul style="list-style-type: none"> <li>• Ambient sensor</li> <li>• A/C auto amp.</li> <li>• Harness and connector (Short in the ambient sensor circuit)</li> </ul>
B257C	AMB TEMP SEN OPEN	The ambient sensor recognition temperature is too low.	<ul style="list-style-type: none"> <li>• Ambient sensor</li> <li>• A/C auto amp.</li> <li>• Harness and connector (Open in the ambient sensor circuit)</li> </ul>

#### DTC CONFIRMATION PROCEDURE

##### 1. PERFORM SELF-DIAGNOSIS

Ⓜ With CONSULT-III

1. Perform the "SELF-DIAGNOSIS".
2. Check if any DTC is detected in the self-diagnostic results.

#### NOTE:

- If DTC is displayed along with DTC "U1000" or "U1010", first diagnose the DTC "U1000" or "U1010". Refer to [HAC-118. "DTC Logic"](#) or [HAC-119. "DTC Logic"](#).



# B257B, B257C AMBIENT SENSOR

[WITH 7 INCH DISPLAY]

## < DTC/CIRCUIT DIAGNOSIS >

- If there is an open circuit in the ambient sensor, A/C auto amp registers extreme cold [-30°C (-22°F)] and adjusts the temperature control warmer.

Is DTC "B257B" or "B257C" displayed?

- YES >> Perform the diagnosis for the ambient sensor. Refer to [HAC-121. "Diagnosis Procedure"](#).
- NO >> INSPECTION END

## Diagnosis Procedure

INFOID:000000005239243

### 1. CHECK AMBIENT SENSOR POWER SUPPLY CIRCUIT

1. Turn the ignition switch OFF.
2. Disconnect ambient sensor connector.
3. Turn the ignition switch ON.
4. Check voltage between ambient sensor harness connector and ground.

(+)		(-)	Voltage (Approx.)
Ambient sensor		—	
Connector	Terminal		
E76	1	Ground	5 V

Is the inspection result normal?

- YES >> GO TO 2.
- NO >> GO TO 4.

### 2. CHECK AMBIENT SENSOR CIRCUIT CONTINUITY

1. Turn the ignition switch OFF.
2. Disconnect the A/C auto amp. connector.
3. Check for continuity between the ambient sensor harness connector and A/C auto amp harness connector.

Ambient sensor		A/C auto amp.		Continuity
Connector	Terminal	Connector	Terminal	
E76	2	M66	37	Existed

Is the inspection result normal?

- YES >> GO TO 3.
- NO >> Repair the harnesses or connectors.

### 3. CHECK AMBIENT SENSOR

Check the ambient sensor components. Refer to [HAC-122. "Component Inspection"](#).

Is the inspection result normal?

- YES >> Replace the A/C auto amp.
- NO >> Replace the ambient sensor.

### 4. CHECK AMBIENT SENSOR CIRCUIT CONTINUITY

1. Turn the ignition switch OFF.
2. Disconnect the A/C auto amp. connector.
3. Check for continuity between the ambient sensor harness connector and A/C auto amp. harness connector.

Ambient sensor		A/C auto amp.		Continuity
Connector	Terminal	Connector	Terminal	
E76	1	M66	35	Existed

4. Check for continuity between ambient sensor harness connector and ground.

# B257B, B257C AMBIENT SENSOR

< DTC/CIRCUIT DIAGNOSIS >

[WITH 7 INCH DISPLAY]

Ambient sensor		—	Continuity
Connector	Terminal		
E76	1	Ground	Not existed

Is the inspection result normal?

- YES >> Replace the A/C auto amp.  
NO >> Repair the harnesses or connectors.

## Component Inspection

INFOID:000000005239244

### 1. CHECK AMBIENT SENSOR

1. Turn the ignition switch OFF.
2. Remove the ambient sensor. Refer to [HAC-177. "Exploded View"](#).
3. Check the resistance between the ambient sensor terminals. Refer to the applicable table for the normal value.

Terminal		Condition	Resistance: kΩ
		Temperature: °C (°F)	
1	2	-15 (5)	12.73
		-10 (14)	9.92
		-5 (23)	7.80
		0 (32)	6.19
		5 (41)	4.95
		10 (50)	3.99
		15 (59)	3.24
		20 (68)	2.65
		25 (77)	2.19
		30 (86)	1.81
		35 (95)	1.51
		40 (104)	1.27
45 (113)	1.07		

Is the inspection result normal?

- YES >> INSPECTION END  
NO >> Replace the ambient sensor.

# B2578, B2579 IN-VEHICLE SENSOR

< DTC/CIRCUIT DIAGNOSIS >

[WITH 7 INCH DISPLAY]

## B2578, B2579 IN-VEHICLE SENSOR

### Description

INFOID:000000005239245

#### IN-VEHICLE SENSOR

- The in-vehicle sensor (1) is installed to the instrument lower panel LH.
- The in-vehicle sensor converts the interior air temperature of the passenger room sucked by the aspirator detected with the thermistor into the voltage, and the A/C auto amp. inputs this voltage.

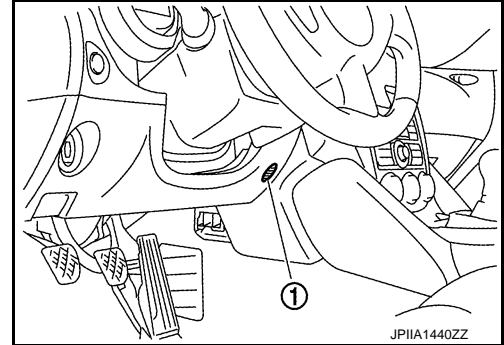

#### ASPIRATOR

The aspirator (1) generates the vacuum by the air blown from the heater & cooling unit and draws the air of the passenger room to the in-vehicle sensor area via the aspirator duct.

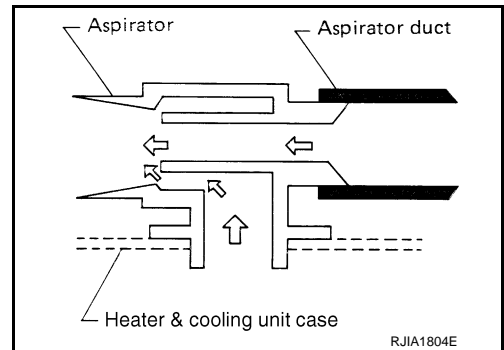
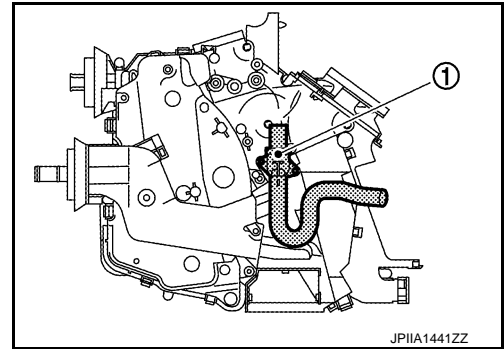

#### INTERIOR AIR TEMPERATURE CORRECTION

- The A/C auto amp. inputs the temperature detected with the in-vehicle sensor as the interior air temperature.
- Perform the correction of the temperature detected with the in-vehicle sensor for each air conditioner control.

### DTC Logic

INFOID:000000005239246

#### DTC DETECTION LOGIC

A  
B  
C  
D  
E  
F  
G  
H  
HAC  
J  
K  
L  
M  
N  
O  
P

# B2578, B2579 IN-VEHICLE SENSOR

< DTC/CIRCUIT DIAGNOSIS >

[WITH 7 INCH DISPLAY]

DTC	Items (CONSULT-III screen terms)	Diagnostic item is detected when...	Possible causes
B2578	IN CAR SEN SHORT	The in-vehicle sensor recognition temperature is too high.	<ul style="list-style-type: none"> <li>In-vehicle sensor</li> <li>A/C auto amp.</li> <li>Harness and connector (Short in the in-vehicle sensor circuit)</li> </ul>
B2579	IN CAR SEN OPEN	The in-vehicle sensor recognition temperature is too low.	<ul style="list-style-type: none"> <li>In-vehicle sensor</li> <li>A/C auto amp.</li> <li>Harness and connector (Open in the in-vehicle sensor circuit)</li> </ul>

## DTC CONFIRMATION PROCEDURE

### 1.PERFORM SELF-DIAGNOSIS

ⓅWith CONSULT-III

1. Perform the "SELF-DIAGNOSIS".
2. Check if any DTC is detected in the self-diagnostic results.

#### NOTE:

If DTC is displayed along with DTC "U1000" or "U1010", first diagnose the DTC "U1000" or "U1010". Refer to [HAC-118. "DTC Logic"](#) or [HAC-119. "DTC Logic"](#).

Is DTC "B2578" or "B2579" displayed?

- YES >> Perform the diagnosis for the in-vehicle sensor. Refer to [HAC-124. "Diagnosis Procedure"](#).  
 NO >> INSPECTION END

## Diagnosis Procedure

INFOID:000000005239247

### 1.CHECK IN-VEHICLE SENSOR POWER SUPPLY CIRCUIT

1. Turn the ignition switch OFF.
2. Disconnect the in-vehicle sensor connector.
3. Turn the ignition switch ON.
4. Check voltage between in-vehicle sensor harness connector and ground.

(+)		(-)	Voltage (Approx.)
In-vehicle sensor		—	
Connector	Terminal		
M61	1	Ground	5 V

Is the inspection result normal?

- YES >> GO TO 2.  
 NO >> GO TO 4.

### 2.CHECK IN-VEHICLE SENSOR CIRCUIT CONTINUITY-

1. Turn the ignition switch OFF.
2. Disconnect the A/C auto amp. connector.
3. Check for continuity between the in-vehicle sensor harness connector and A/C auto amp. harness connector.

In-vehicle sensor		A/C auto amp.		Continuity
Connector	Terminal	Connector	Terminal	
M61	2	M66	37	Existed

Is the inspection result normal?

- YES >> GO TO 3.  
 NO >> Repair the harnesses or connectors.

### 3.CHECK IN-VEHICLE SENSOR

Check the in-vehicle sensor components. Refer to [HAC-125. "Component Inspection"](#).

## B2578, B2579 IN-VEHICLE SENSOR

< DTC/CIRCUIT DIAGNOSIS >

[WITH 7 INCH DISPLAY]

Is the inspection result normal?

- YES >> Replace the A/C auto amp.
- NO >> Replace the in-vehicle sensor.

### 4. CHECK IN-VEHICLE SENSOR CIRCUIT CONTINUITY

1. Turn the ignition switch OFF.
2. Disconnect the A/C auto amp. connector.
3. Check for continuity between the in-vehicle sensor harness connector and A/C auto amp. harness connector.

In-vehicle sensor		A/C auto amp.		Continuity
Connector	Terminal	Connector	Terminal	
M61	1	M66	36	Existed

4. Check for continuity between in-vehicle sensor harness connector and ground.

In-vehicle sensor		—	Continuity
Connector	Terminal		
M61	1	Ground	Not existed

Is the inspection result normal?

- YES >> Replace the A/C auto amp.
- NO >> Repair the harnesses or connectors.

### Component Inspection

INFOID:000000005239248

### 1. CHECK IN-VEHICLE SENSOR

1. Turn the ignition switch OFF.
2. Remove the in-vehicle sensor. Refer to [HAC-178, "Exploded View"](#).
3. Check the resistance between the in-vehicle sensor terminals. Refer to the applicable table for the normal value.

Terminal		Condition	Resistance: kΩ
		Temperature: °C (°F)	
1	2	-15 (5)	12.73
		-10 (14)	9.92
		-5 (23)	7.80
		0 (32)	6.19
		5 (41)	4.95
		10 (50)	3.99
		15 (59)	3.24
		20 (68)	2.65
		25 (77)	2.19
		30 (86)	1.81
		35 (95)	1.51
		40 (104)	1.27
		45 (113)	1.07

Is the inspection result normal?

- YES >> INSPECTION END
- NO >> Replace the in-vehicle sensor.

# B2581, B2582 INTAKE SENSOR

< DTC/CIRCUIT DIAGNOSIS >

[WITH 7 INCH DISPLAY]

## B2581, B2582 INTAKE SENSOR

### Description

INFOID:000000005239249

#### INTAKE SENSOR

- Intake sensor (1) is located on the evaporator (2).
- The intake sensor converts the evaporator passing air temperature detected with thermistor into the voltage, and the A/C auto amp. inputs this voltage.

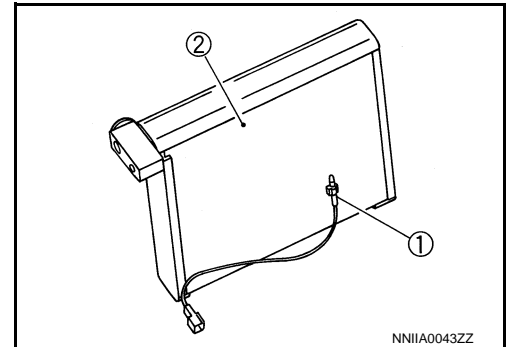

#### INTAKE TEMPERATURE CORRECTION

- The A/C auto amp. inputs the temperature detected with the intake sensor as the evaporator passing air temperature.
- Perform the correction of the temperature detected with the intake sensor for air conditioner control.
- The A/C auto amp. performs the correction so that the recognition intake temperature changes depending on the difference between the detected intake temperature and the recognition intake temperature. If the difference is large, the changing is early. The changing becomes slow as the difference becomes small.

### DTC Logic

INFOID:000000005239250

#### DTC DETECTION LOGIC

DTC	Items (CONSULT-III screen terms)	Diagnostic item is detected when...	Possible causes
B2581	EVAP TEMP SEN SHORT	The intake sensor recognition temperature is too high.	<ul style="list-style-type: none"> <li>• Intake sensor</li> <li>• A/C auto amp.</li> <li>• Harness and connector (Short in the intake sensor circuit)</li> </ul>
B2582	EVAP TEMP SEN OPEN	The intake sensor recognition temperature is too low.	<ul style="list-style-type: none"> <li>• Intake sensor</li> <li>• A/C auto amp.</li> <li>• Harness and connector (Open in the intake sensor circuit)</li> </ul>

#### DTC CONFIRMATION PROCEDURE

##### 1. PERFORM SELF-DIAGNOSIS

Ⓟ With CONSULT-III

1. Perform the "SELF-DIAGNOSIS".
2. Check if any DTC is detected in the self-diagnostic results.

#### NOTE:

If DTC is displayed along with DTC "U1000" or "U1010", first diagnose the DTC "U1000" or "U1010". Refer to [HAC-118, "DTC Logic"](#) or [HAC-119, "DTC Logic"](#).

Is DTC "B2581" or "B2582" displayed?

- YES >> Perform the diagnosis for the intake sensor. Refer to [HAC-126, "Diagnosis Procedure"](#).  
 NO >> INSPECTION END

### Diagnosis Procedure

INFOID:000000005239251

#### 1. CHECK INTAKE SENSOR POWER SUPPLY CIRCUIT

1. Turn the ignition switch OFF.
2. Disconnect the intake sensor connector.
3. Turn the ignition switch ON.

# B2581, B2582 INTAKE SENSOR

< DTC/CIRCUIT DIAGNOSIS >

[WITH 7 INCH DISPLAY]

4. Check voltage between intake sensor harness connector and ground.

(+)		(-)	Voltage (Approx.)
Intake sensor		—	
Connector	Terminal		
M205	1	Ground	5 V

Is the inspection result normal?

- YES >> GO TO 2.  
NO >> GO TO 4.

## 2.CHECK INTAKE SENSOR CIRCUIT CONTINUITY

1. Turn the ignition switch OFF.
2. Disconnect the A/C auto amp. connector.
3. Check for continuity between the intake sensor harness connector and A/C auto amp. harness connector.

Intake sensor		A/C auto amp.		Continuity
Connector	Terminal	Connector	Terminal	
M205	2	M66	37	Existed

Is the inspection result normal?

- YES >> GO TO 3.  
NO >> Repair the harnesses or connectors.

## 3.CHECK INTAKE SENSOR

Check the intake sensor components. Refer to [HAC-127, "Component Inspection"](#).

Is the inspection result normal?

- YES >> Replace the A/C auto amp.  
NO >> Replace the intake sensor.

## 4.CHECK INTAKE SENSOR CIRCUIT CONTINUITY

1. Turn the ignition switch OFF.
2. Disconnect the A/C auto amp. connector.
3. Check for continuity between the intake sensor harness connector and A/C auto amp. harness connector.

Intake sensor		A/C auto amp.		Continuity
Connector	Terminal	Connector	Terminal	
M205	1	M66	16	Existed

4. Check for continuity between intake sensor harness connector and ground.

Intake sensor		—	Continuity
Connector	Terminal		
M205	1	Ground	Not existed.

Is the inspection result normal?

- YES >> Replace the A/C auto amp.  
NO >> Repair the harnesses or connectors.

## Component Inspection

INFOID:000000005239252

## 1.CHECK INTAKE SENSOR

1. Turn the ignition switch OFF.
2. Disconnect the intake sensor connector. Refer to [HAC-180, "Exploded View"](#).
3. Check the resistance between the intake sensor terminals. Refer to the applicable table for the normal value.

## B2581, B2582 INTAKE SENSOR

< DTC/CIRCUIT DIAGNOSIS >

[WITH 7 INCH DISPLAY]

Terminal		Condition	Resistance: k $\Omega$
		Temperature: °C (°F)	
1	2	-15 (5)	12.28
		-10 (14)	9.58
		-5 (23)	7.55
		0 (32)	6.00
		5 (41)	4.81
		10 (50)	3.88
		15 (59)	3.16
		20 (68)	2.59
		25 (77)	2.14
		30 (86)	1.77
		35 (95)	1.48
		40 (104)	1.24
		45 (113)	1.05

Is the inspection result normal?

YES >> INSPECTION END

NO >> Replace the intake sensor.



# B2630, B2631 SUNLOAD SENSOR

< DTC/CIRCUIT DIAGNOSIS >

[WITH 7 INCH DISPLAY]

## B2630, B2631 SUNLOAD SENSOR

### Description

INFOID:000000005239253

#### SUNLOAD SENSOR

- The sunload sensor (1) is installed to the front defroster grille LH.
- The sunload sensor converts the sunload amount (illuminance) into the current value with the photodiode. The A/C auto amp. calculates this current value to the voltage and inputs it.

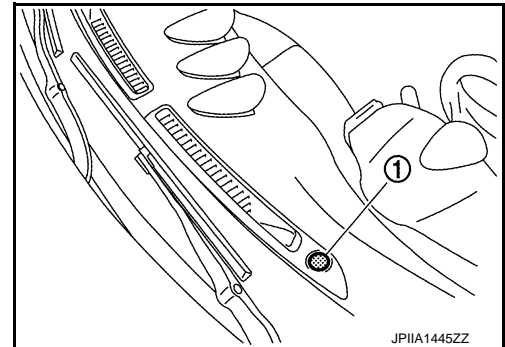

#### SUNLOAD AMOUNT CORRECTION

- The A/C auto amp. inputs the sunload amount detected with the sunload sensor.
- Perform the correction of the sunload amount detected with the sunload sensor for each air conditioner control.
- When the sunload amount suddenly changes, for example when entering a tunnel, perform the correction so that the recognition sunload amount of the A/C auto amp. changes slowly.

### DTC Logic

INFOID:000000005239254

#### DTC DETECTION LOGIC

DTC	Items (CONSULT-III screen terms)	Diagnostic item is detected when...	Possible causes
B2630	SUNLOAD SEN SHORT	Detected calorie at sunload sensor 2832 W/m <sup>2</sup> (2436 kcal/m <sup>2</sup> ·h) or more	<ul style="list-style-type: none"><li>• Sunload sensor</li><li>• A/C auto amp.</li><li>• Harness and connector (Short in the sunload sensor circuit)</li></ul>
B2631	SUNLOAD SEN OPEN	Detected calorie at sunload sensor 64.7 W/m <sup>2</sup> (56 kcal/m <sup>2</sup> ·h) or less	<ul style="list-style-type: none"><li>• Sunload sensor</li><li>• A/C auto amp.</li><li>• Harness and connector (Open in the sunload sensor circuit)</li></ul>

#### DTC REPRODUCTION PROCEDURE

##### 1. PERFORM SELF-DIAGNOSIS

Ⓜ With CONSULT-III

1. Perform the "SELF-DIAGNOSIS".
2. Check if any DTC is detected in the self-diagnostic results.

##### NOTE:

- If DTC is displayed along with DTC "U1000" or "U1010", first diagnose the DTC "U1000" or "U1010". Refer to [HAC-118. "DTC Logic"](#) or [HAC-119. "DTC Logic"](#).
- Sunload sensor may register a malfunction when indoors, at dusk, or at other times when light is insufficient. When performing the diagnosis indoors, use a lamp (60 W or more) that is pointed at the sunload sensor.

Is DTC "B2630" or "B2631" displayed?

- YES >> Perform the diagnosis for the sunload sensor. Refer to [HAC-129. "Diagnosis Procedure"](#).  
NO >> INSPECTION END

### Diagnosis Procedure

INFOID:000000005239255

##### 1. CHECK SUNLOAD SENSOR POWER SUPPLY CIRCUIT

1. Turn the ignition switch OFF.
2. Disconnect the sunload sensor connector.

# B2630, B2631 SUNLOAD SENSOR

[WITH 7 INCH DISPLAY]

## < DTC/CIRCUIT DIAGNOSIS >

- Turn the ignition switch ON.
- Check voltage between sunload sensor harness connector and ground.

(+)		(-)	Voltage (Approx.)
Sunload sensor		—	
Connector	Terminal		
M46	1	Ground	5 V

Is the inspection result normal?

- YES >> GO TO 2.  
NO >> GO TO 4.

## 2.CHECK SUNLOAD SENSOR CIRCUIT CONTINUITY

- Turn the ignition switch OFF.
- Disconnect the A/C auto amp. connector.
- Check for continuity between the sunload sensor harness connector and the A/C auto amp. harness connector.

Sunload sensor		A/C auto amp.		Continuity
Connector	Terminal	Connector	Terminal	
M46	2	M66	37	Existed

Is the inspection result normal?

- YES >> GO TO 3.  
NO >> Repair the harnesses or connectors.

## 3.CHECK SUNLOAD SENSOR

- Connect the sunload sensor connector.
- Connect the A/C auto amp. connector.
- Check the sunload sensor components. Refer to [HAC-130, "Component Inspection"](#).

Is the inspection result normal?

- YES >> Replace the A/C auto amp.  
NO >> Replace the sunload sensor.

## 4.CHECK SUNLOAD SENSOR CIRCUIT CONTINUITY

- Turn the ignition switch OFF.
- Disconnect the A/C auto amp. connector.
- Check for continuity between the sunload sensor harness connector and A/C auto amp. harness connector.

Sunload sensor		A/C auto amp.		Continuity
Connector	Terminal	Connector	Terminal	
M46	1	M66	15	Existed

- Check for continuity between sunload sensor harness connector and ground.

Sunload sensor		—	Continuity
Connector	Terminal		
M46	1	Ground	Not existed

Is the inspection result normal?

- YES >> Replace A/C auto amp.  
NO >> Repair the harnesses or connectors.

## Component Inspection

INFOID:000000005239256

## 1.CHECK SUNLOAD SENSOR

# B2630, B2631 SUNLOAD SENSOR

[WITH 7 INCH DISPLAY]

## < DTC/CIRCUIT DIAGNOSIS >

1. Turn the ignition switch ON.
2. Check the input voltage from the sunload sensor between the A/C auto amp. harness connector and ground. Refer to the applicable table for the normal value.

(+)		(-)
A/C auto amp.		—
Connector	Terminal	
M66	15	Ground

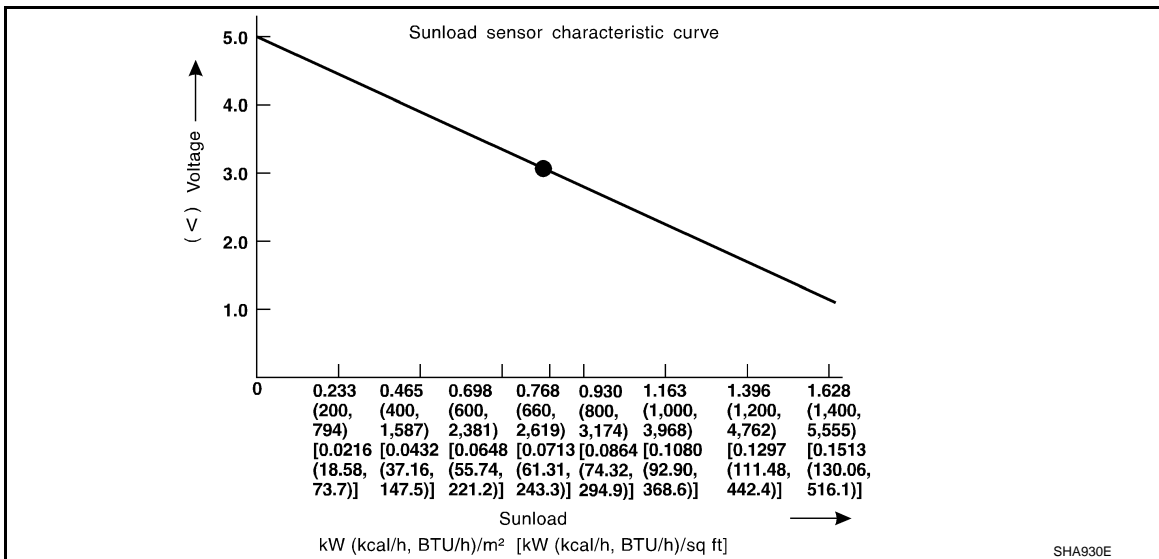

### NOTE:

- When checking indoors, use a lamp of approximately 60 W. Move the lamp towards and away from the sensor to check.
- The sunload amount produced by direct sunshine in fair weather is equivalent to approximately 0.77 kW/m<sup>2</sup> (662 kcal/m<sup>2</sup>·h).

Is the inspection result normal?

- YES >> INSPECTION END  
 NO >> Replace the sunload sensor.

HAC

# B2632, B2633 AIR MIX DOOR MOTOR PBR

< DTC/CIRCUIT DIAGNOSIS >

[WITH 7 INCH DISPLAY]

## B2632, B2633 AIR MIX DOOR MOTOR PBR

### Description

INFOID:000000005239257

#### AIR MIX DOOR MOTOR

- The air mix door motor (1) is installed to the heater & cooling unit assembly.
- The LCU (Local Control Unit) is installed to each door motor so as to perform the multiplex communication control (LAN) between each door motor of the mode door motor, air mix door motor and intake door motor in one communication line.
- When each LCU receives the control signal (combination of the pulse wave with two types of amplitude) from the A/C auto amp., it moves each door to the appropriate position based on the door position detection signal of each PBR (Potentio Balance Resistor). When the movement was completed, each LCU transmits the signal that reports the movement completion to the A/C auto amp.

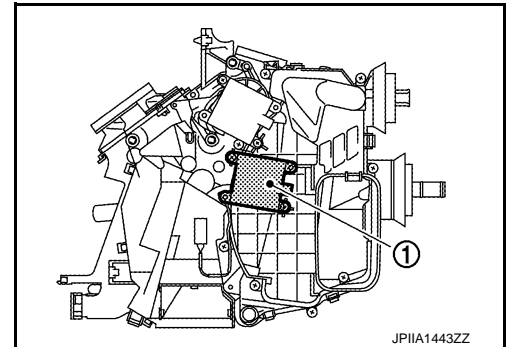

JPIIA1443ZZ

### DTC Logic

INFOID:000000005239258

#### DTC DETECTION LOGIC

DTC	Items (CONSULT-III screen terms)	Diagnostic item is detected when...	Possible causes
B2632	DR AIR MIX ACTR SHORT	Air mix door PBR position 95% or more	<ul style="list-style-type: none"><li>• Air mix door motor (PBR internal circuit is short)</li><li>• A/C auto amp.</li><li>• Harness and connector (LAN communication line is open or shorted)</li></ul>
B2633	DR AIR MIX ACTR OPEN	Air mix door PBR position 5% or less	<ul style="list-style-type: none"><li>• Air mix door motor (PBR internal circuit is open)</li><li>• A/C auto amp.</li><li>• Harness and connector (LAN communication line is open or shorted)</li></ul>

#### DTC CONFIRMATION PROCEDURE

##### 1. PERFORM SELF-DIAGNOSIS

ⓐ With CONSULT-III

1. Perform the "SELF-DIAGNOSIS".
2. Check if any DTC is detected in the self-diagnostic results.

##### NOTE:

- If DTC is displayed along with DTC "U1000" or "U1010", first diagnose the DTC "U1000" or "U1010". Refer to [HAC-118, "DTC Logic"](#) or [HAC-119, "DTC Logic"](#).
- If all of door motors DTC (B2632 - B2655) are detected, check door motor communication circuit. Refer to [HAC-139, "Diagnosis Procedure"](#).

Is DTC "B2632" or "B2633" displayed?

- YES >> Perform the diagnosis of air mix door motor system. Refer to [HAC-133, "Diagnosis Procedure"](#).  
NO >> GO TO 2.

##### 2. FUNCTION INSPECTION

1. Turn temperature dial and raise temperature setting to 32.0°C (90°F) after warming up the engine.
2. Check that warm air blows from outlets.
3. Operate the compressor.
4. Operate the temperature control dial and lower the set temperature to 18.0°C (60°F).
5. Check that the cool air blows from the outlets.

Does it operate normally?

# B2632, B2633 AIR MIX DOOR MOTOR PBR

< DTC/CIRCUIT DIAGNOSIS >

[WITH 7 INCH DISPLAY]

YES >> INSPECTION END

NO >> Check the air mix door motor system installation condition. Repair or replace the malfunctioning parts.

## Diagnosis Procedure

INFOID:000000005239259

### 1. CHECK BATTERY VOLTAGE OF AIR MIX DOOR MOTOR

1. Turn the ignition switch ON.
2. Check voltage between the air mix door motor harness connector and ground.

(+)		(-)	Voltage (Approx.)
Air mix door motor		—	
Connector	Terminal		
M204	1	Ground	12 V

Is the inspection result normal?

YES >> GO TO 2.

NO >> Repair the harnesses or connectors.

### 2. CHECK SIGNAL OF AIR MIX DOOR MOTOR

Check output waveform between the air mix door motor harness connector and ground with the oscilloscope.

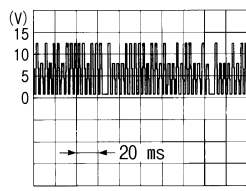
(+)		(-)	Output waveform
Air mix door motor		—	
Connector	Terminal		
M204	3	Ground	 <p style="text-align: right; font-size: small;">SJIA1453J</p>

Is the inspection result normal?

YES >> GO TO 3.

NO >> Repair the harnesses or connectors.

### 3. CHECK GROUND CIRCUIT OF AIR MIX DOOR MOTOR

1. Turn the ignition switch OFF.
2. Disconnect the air mix door motor connector.
3. Check for continuity between the air mix door motor harness connector and ground.

Air mix door motor		(-)	Continuity
Connector	Terminal	—	
Connector	Terminal		
M204	2	Ground	Existed

Is the inspection result normal?

YES >> Replace the air mix door motor.

NO >> Repair the harnesses or connectors.

# B2636, B2637, B2638, B2639, B2654, B2655 MODE DOOR MOTOR

< DTC/CIRCUIT DIAGNOSIS >

[WITH 7 INCH DISPLAY]

## B2636, B2637, B2638, B2639, B2654, B2655 MODE DOOR MOTOR

### Description

INFOID:000000005239260

#### MODE DOOR MOTOR

- The mode door motor (1) is installed to the heater & cooling unit assembly.
- The LCU (Local Control Unit) is installed to each door motor so as to perform the multiplex communication control (LAN) between each door motor of the mode door motor, air mix door motor and intake door motor in one communication line.
- When each LCU receives the control signal (combination of the pulse wave with two type of amplitude) from the A/C auto amp., it moves each door to the appropriate position based on the door position detection signal of each PBR (Potentio Balance Resistor). When the movement was completed, each LCU transmits the signal that reports the movement completion to the A/C auto amp.

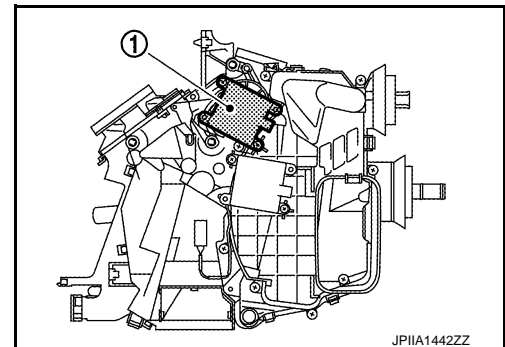

### DTC Logic

INFOID:000000005239261

#### DTC DETECTION LOGIC

DTC	Items (CONSULT-III screen terms)	Diagnostic item is detected when...	Possible cause
B2636	DR VENT DOOR FAIL	When the malfunctioning door position is detected at VENT position	<ul style="list-style-type: none"><li>• Mode door motor (PBR internal circuit is open or shorted)</li><li>• A/C auto amp.</li><li>• Harness and connector (LAN communication line is open or shorted)</li></ul>
B2637	DR B/L DOOR FAIL	When the malfunctioning door position is detected at B/L position	
B2638	DR D/F1 DOOR FAIL	When the malfunctioning door position is detected at FOOT position	
B2639	DR DEF DOOR FAIL	When the malfunctioning door position is detected at DEF position	
B2654	D/F2 DOOR FAIL	When the malfunctioning door position is detected at D/F position	
B2655	B/L2 DOOR FAIL	When the malfunctioning door position is detected at B/L2 position	

#### DTC CONFIRMATION PROCEDURE

##### 1. PERFORM SELF-DIAGNOSIS

1. Perform the "SELF-DIAGNOSIS".
2. Check if any DTC is detected in the self-diagnostic results.

##### NOTE:

- If DTC is displayed along with DTC "U1000" or "U1010", first diagnose the DTC "U1000" or "U1010". Refer to [HAC-118, "DTC Logic"](#) or [HAC-119, "DTC Logic"](#).
- If all of door motors DTC (B2632 - B2655) are detected, check door motor communication circuit. Refer to [HAC-139, "Diagnosis Procedure"](#).

Is DTC " B2636 ", " B2637 ", "B2638 ", "B2639 ", "B2654 " or "B2655 " displayed?

- YES >> Perform the diagnosis of mode door motor system. Refer to [HAC-135, "Diagnosis Procedure"](#).  
NO >> GO TO 2.

##### 2. FUNCTION INSPECTION

1. Turn mode control dial to each position.
2. Check that the air outlets change according to each indicated air outlet by placing a hand in front of the outlets. Refer to [VTL-3, "System Description"](#).

Does it operate normally?

- YES >> INSPECTION END  
NO >> Check the mode door system installation condition. Repair or replace the malfunctioning parts.

# B2636, B2637, B2638, B2639, B2654, B2655 MODE DOOR MOTOR

< DTC/CIRCUIT DIAGNOSIS >

[WITH 7 INCH DISPLAY]

## Diagnosis Procedure

INFOID:000000005239262

### 1. CHECK MODE DOOR MOTOR POWER SUPPLY CIRCUIT

1. Turn the ignition switch ON.
2. Check voltage between the mode door motor harness connector and ground.

(+)		(-)	Voltage (Approx.)
Mode door motor		—	
Connector	Terminal		
M203	1	Ground	12 V

Is the inspection result normal?

- YES >> GO TO 2.  
 NO >> Repair the harnesses or connectors.

### 2. CHECK MODE DOOR MOTOR SIGNAL

Check output waveform between the mode door motor harness connector and ground with the oscilloscope.

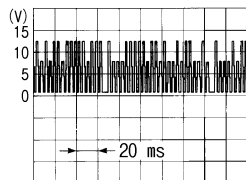
(+)		(-)	Output waveform
Mode door motor		—	
Connector	Terminal		
M203	3	Ground	 <p style="text-align: right; font-size: small;">SJA1453J</p>

Is the inspection result normal?

- YES >> GO TO 3.  
 NO >> Repair the harnesses or connectors.

### 3. CHECK MODE DOOR MOTOR GROUND CIRCUIT

1. Turn the ignition switch OFF.
2. Disconnect the mode door motor connector.
3. Check for continuity between the mode door motor harness connector and ground.

Mode door motor		(-)	Continuity
Connector	Terminal	—	
M203	2	Ground	Existed

Is the inspection result normal?

- YES >> Replace the Mode door motor.  
 NO >> Repair the harnesses or connectors.

A  
B  
C  
D  
E  
F  
G  
H  
J  
K  
L  
M  
N  
O  
P

HAC

# B263D, B263E, B263F INTAKE DOOR MOTOR

< DTC/CIRCUIT DIAGNOSIS >

[WITH 7 INCH DISPLAY]

## B263D, B263E, B263F INTAKE DOOR MOTOR

### Description

INFOID:000000005239263

#### INTAKE DOOR MOTOR

- The intake door motor (1) is installed to the blower unit.
- The LCU (Local Control Unit) is installed to each door motor so as to perform the multiplex communication control (LAN) between each door motor of the mode door motor, air mix door motor and intake door motor in one communication line.
- When each LCU receives the control signal (combination of the pulse wave with two type of amplitude) from the A/C auto amp., it moves each door to the appropriate position based on the door position detection signal of each PBR (Potentio Balance Resistor). When the movement was completed, each LCU transmits the signal that reports the movement completion to the A/C auto amp.

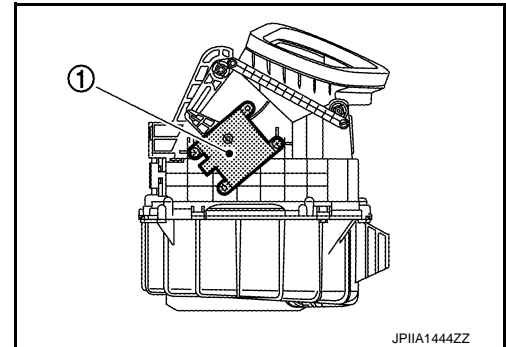

INFOID:000000005239264

### DTC Logic

#### DTC DETECTION LOGIC

DTC	Items (CONSULT-III screen terms)	Diagnostic item is detected when...	Possible cause
B263D	FRE DOOR FAIL	When the malfunctioning intake door position is detected at FRE position	<ul style="list-style-type: none"> <li>• Intake door motor (PBR internal circuit is open or shorted)</li> <li>• A/C auto amp.</li> <li>• Harness and connector (LAN communication line is open or shorted)</li> </ul>
B263E	20P FRE DOOR FAIL	When the malfunctioning intake door position is detected at 20%FRE position	
B263F	REC DOOR FAIL	When the malfunctioning intake door position is detected at REC position	

#### DTC CONFIRMATION PROCEDURE

##### 1. PERFORM SELF-DIAGNOSIS

Ⓜ With CONSULT-III

1. Perform the "SELF-DIAGNOSIS".
2. Check if any DTC is detected in the self-diagnostic results.

##### NOTE:

- If DTC is displayed along with DTC "U1000" or "U1010", first diagnose the DTC "U1000" or "U1010". Refer to [HAC-118, "DTC Logic"](#) or [HAC-119, "DTC Logic"](#).
- If all of door motors DTC (B2632 - B2655) are detected, check door motor communication circuit. Refer to [HAC-139, "Diagnosis Procedure"](#).

Is DTC " B263D ", " B263E " or "B263F " displayed?

- YES >> Perform the diagnosis of intake door motor system. Refer to [HAC-137, "Diagnosis Procedure"](#).  
 NO >> GO TO 2.

##### 2. FUNCTION INSPECTION

1. Press intake switch to set the air outlet to recirculation.
2. The intake switch indicator is turned ON.
3. Listen to intake sound and confirm air inlets change.
4. Press intake switch again to set the air outlet to fresh air intake.
5. The intake switch indicator is turned OFF.
6. Listen to intake sound and confirm air inlets change.

Does it operate normally?

- YES >> INSPECTION END  
 NO >> Check the intake door system installation condition. Repair or replace the malfunctioning parts.



# B263D, B263E, B263F INTAKE DOOR MOTOR

< DTC/CIRCUIT DIAGNOSIS >

[WITH 7 INCH DISPLAY]

## Diagnosis Procedure

INFOID:000000005239265

### 1. CHECK BATTERY VOLTAGE OF INTAKE DOOR MOTOR

1. Turn the ignition switch ON.
2. Check voltage between the intake door motor harness connector and ground.

(+)		(-)	Voltage (Approx.)
Intake door motor		—	
Connector	Terminal		
M206	1	Ground	12 V

Is the inspection result normal?

- YES >> GO TO 2.  
NO >> Repair the harnesses or connectors.

### 2. CHECK INTAKE DOOR MOTOR SIGNAL

Check output waveform between the intake door motor harness connector and ground with the oscilloscope.

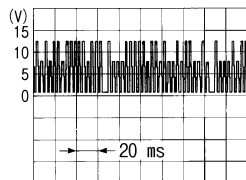
(+)		(-)	Output waveform
Intake door motor		—	
Connector	Terminal		
M206	3	Ground	 SJIA1453J

Is the inspection result normal?

- YES >> GO TO 3.  
NO >> Repair the harnesses or connectors.

### 3. CHECK INTAKE DOOR MOTOR GROUND CIRCUIT

1. Turn the ignition switch OFF.
2. Disconnect the intake door motor connector.
3. Check for continuity between the intake door motor harness connector and ground.

Intake door motor		(-)	Continuity
Connector	Terminal	—	
M206	2	Ground	Existed

Is the inspection result normal?

- YES >> Replace the Intake door motor.  
NO >> Repair the harnesses or connectors.

A  
B  
C  
D  
E  
F  
G  
H  
J  
K  
L  
M  
N  
O  
P

HAC

# POWER SUPPLY AND GROUND CIRCUIT

< DTC/CIRCUIT DIAGNOSIS >

[WITH 7 INCH DISPLAY]

## POWER SUPPLY AND GROUND CIRCUIT

A/C AUTO AMP.

A/C AUTO AMP. : Diagnosis Procedure

INFOID:000000005239266

### 1. CHECK FUSE

Check 10A fuses [Nos. 3, 6 and 19, located in the fuse block (J/B)].

**NOTE:**

Refer to [PG-112. "Fuse, Connector and Terminal Arrangement"](#).

Is the inspection result normal?

YES >> GO TO 2.

NO >> Replace the fuse after repairing the applicable circuit.

### 2. CHECK A/C AUTO AMP. POWER SUPPLY CIRCUIT

1. Turn the ignition switch OFF.
2. Disconnect the A/C auto amp. connector.
3. Check voltage between A/C auto amp. harness connector and ground.

(+)		(-)	Voltage		
A/C auto amp.		—	Ignition switch position		
Connector	Terminal		OFF	ACC	ON
M66	17	Ground	Approx. 0 V	Battery voltage	Battery voltage
	20		Approx. 0 V	Approx. 0 V	Battery voltage
	40		Battery voltage	Battery voltage	Battery voltage

Is the inspection result normal?

YES >> GO TO 3.

NO >> Repair the harnesses or connectors.

### 3. CHECK A/C AUTO AMP. CIRCUIT CONTINUITY

1. Turn the ignition switch OFF.
2. Check continuity between A/C auto amp. harness connector and ground.

A/C auto amp.		(-)	Continuity
Connector	Terminal	—	Continuity
M66	19		
	39		

Is the inspection result normal?

YES >> INSPECTION END

NO >> Repair the harnesses or connectors.

# DOOR MOTOR COMMUNICATION CIRCUIT

< DTC/CIRCUIT DIAGNOSIS >

[WITH 7 INCH DISPLAY]

## DOOR MOTOR COMMUNICATION CIRCUIT

### Description

INFOID:000000005239267

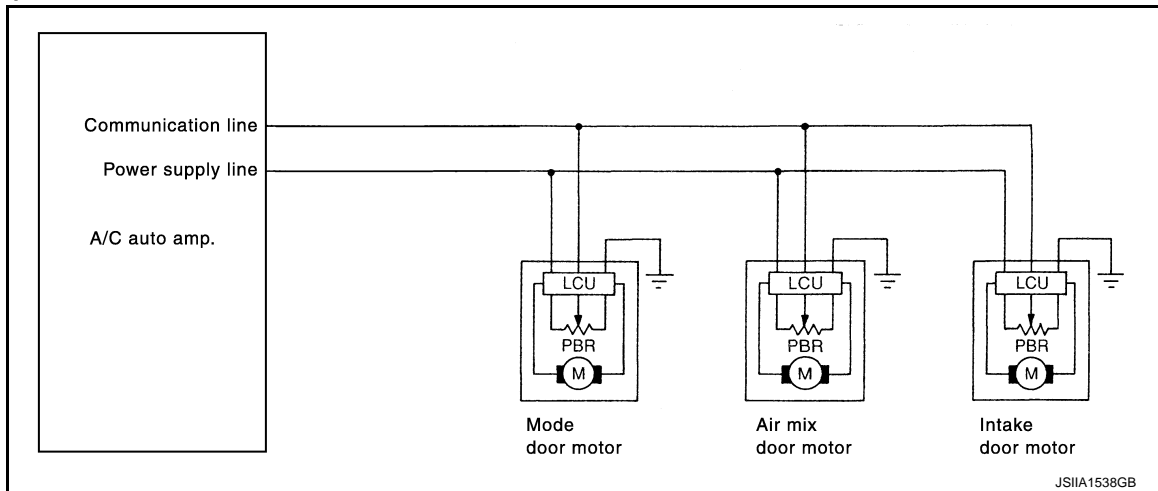

- LCU (Local Control Unit) is built in to each door motor. And detects door position by PBR (Potentiometer Balance Resistor).
- A/C auto amp. communicates with each LCU via communication line. And receives each door position feedback signal from each LCU.
- Each LCU control each door to the appropriate position depending on the control signal from A/C auto amp. When the door movement was completed, transmits the signal of door movement completion to A/C auto amp.

### Diagnosis Procedure

INFOID:000000005239268

#### NOTE:

If all of door motors DTC are detected, check this circuit.

#### 1. CHECK COMMUNICATION SIGNAL

1. Turn the ignition switch ON.
2. Check output waveform between A/C auto amp. harness connector and ground with the oscilloscope.

(+)		(-)	Output waveform
A/C auto amp.		—	
Connector	Terminal		
M66	10	Ground	<p>SJIA1453J</p>

Is the inspection result normal?

- YES >> GO TO 3.  
NO >> GO TO 2.

#### 2. CHECK COMMUNICATION SIGNAL CIRCUIT FOR SHORT

1. Turn the ignition switch OFF.
2. Disconnect the following connectors:
  - A/C auto amp.
  - Mode door motor
  - Intake door motor
  - Air mix door motor
3. Check continuity between A/C auto amp. harness connector and ground.

# DOOR MOTOR COMMUNICATION CIRCUIT

< DTC/CIRCUIT DIAGNOSIS >

[WITH 7 INCH DISPLAY]

A/C auto amp.		—	Continuity
Connector	Terminal		
M66	10	Ground	Not existed

Is the inspection result normal?

YES >> Replace A/C auto amp.

NO >> Repair the harnesses or connectors.

## 3. CHECK COMMUNICATION SIGNAL CIRCUIT FOR OPEN

1. Turn the ignition switch OFF.
2. Disconnect the A/C auto amp. and the mode door motor connectors.
3. Check continuity between A/C auto amp. harness connector and the mode door motor harness connector.

A/C auto amp.		Mode door motor		Continuity
Connector	Terminal	Connector	Terminal	
M66	10	M203	3	Existed

Is the inspection result normal?

YES >> Replace A/C auto amp.

NO >> Repair the harnesses or connectors.

## A/C AUTO AMP.

### Description

INFOID:000000005239269

#### A/C AUTO AMP. (AIR CONDITIONER AUTOMATIC AMPLIFIER)

- The A/C auto amp. (1) has a built-in microcomputer which processes information sent from various sensors needed for air conditioner operation.
- The air mix door motor, mode door motor, intake door motor, blower motor and the compressor are then controlled.
- When the various switches and temperature control dial are operated, data is input to the A/C auto amp. from the AV control unit using CAN communication.
- Self-diagnosis functions are also built into A/C auto amp. to provide quick check of malfunctions in the auto air conditioner system.

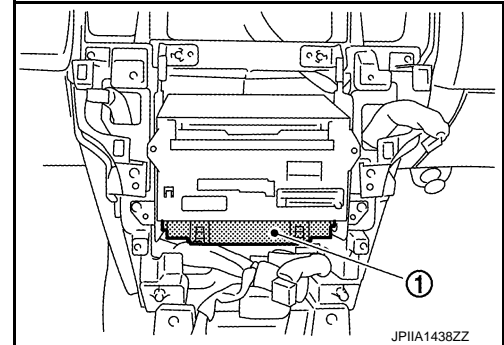

### Component Function Check

INFOID:000000005239270

#### 1. CHECK OPERATION

1. Press the AUTO switch, and then check that "AUTO" is shown on the display.
2. Operate the temperature control dial. Check that the fan speed or discharge air changes (the discharge air temperature or fan speed varies depending on the ambient temperature, in-vehicle temperature, and set temperature).

#### Does it operate normally?

YES >> INSPECTION END

NO >> Perform the diagnosis for the A/C auto amp. Refer to [HAC-141, "Diagnosis Procedure"](#).

### Diagnosis Procedure

INFOID:000000005239271

#### 1. INSPECTION BY FAIL-SAFE FUNCTION

1. Turn the ignition switch ON.
2. After approximately 30 seconds, check that the air conditioner is operated by the fail-safe function (the operation display of air conditioner is not performed). Refer to [HAC-160, "Fail-safe"](#).

#### Is the fail-safe function operated?

YES >> GO TO 3.

NO >> GO TO 2.

#### 2. CHECK A/C AUTO AMP. POWER SUPPLY CIRCUIT AND GROUND CIRCUIT

Check A/C auto amp. power supply circuit and ground circuit. Refer to [HAC-138, "A/C AUTO AMP. : Diagnosis Procedure"](#).

#### Is the inspection result normal?

YES >> GO TO 3.

NO >> Repair or replace parts depending on the inspection results.

#### 3. CHECK PRESET SWITCH

Check the preset switch. Refer to [AV-321, "Symptom Table"](#).

#### Is the inspection result normal?

YES >> Replace A/C auto amp.

NO >> Repair or replace parts according to the inspection results.

## BLOWER MOTOR

### Description

INFOID:000000005239272

- The blower motor utilizes a brush-less motor with a rotating magnet.
- Quietness is improved over previous motors where the brush was the point of contact and the coil rotated.

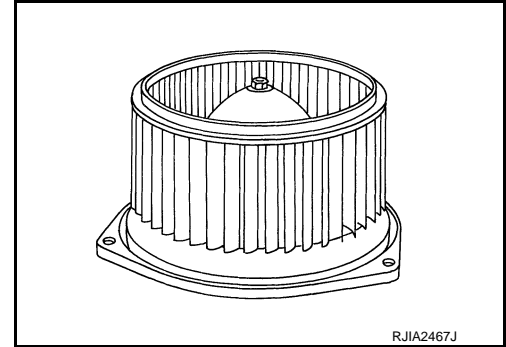

RJIA2467J

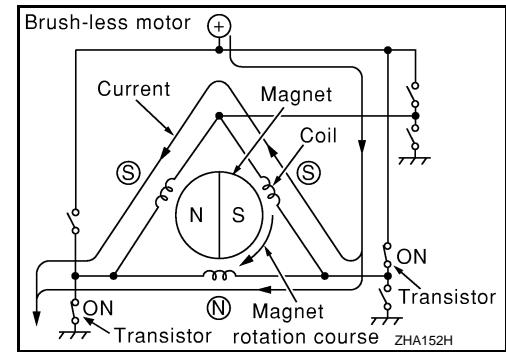

### Component Function Check

INFOID:000000005239273

#### 1. CHECK OPERATION

1. Warm up the engine.
2. Operate the fan control dial. Check that the fan speed and indicator unit are switched for all fan speeds.

#### Does it operate normally?

YES >> INSPECTION END

NO >> Perform the diagnosis for the blower motor. Refer to [HAC-146, "Diagnosis Procedure"](#).

### Diagnosis Procedure

INFOID:000000005239274

#### 1. SELF-DIAGNOSIS RESULT CHECK

Ⓟ With CONSULT-III

1. Perform the "SELF-DIAGNOSIS".
2. Check if any DTC is detected in the self-diagnostic results.

#### **NOTE:**

If DTC is displayed along with DTC "U1000" or "U1010", first diagnose the DTC "U1000" or "U1010". Refer to [HAC-118, "DTC Logic"](#) or [HAC-119, "DTC Logic"](#).

#### Is any DTC displayed?

YES >> Perform the diagnosis that is applicable to the sensor and actuator. Refer to [HAC-161, "DTC Index"](#).

NO >> GO TO 2.

#### 2. PERFORM ACTIVE TEST

Ⓟ With CONSULT-III

1. Perform the "HVAC TEST" of HVAC active test item.
2. Check that the blower motor control signal changes according to each indicator number.

# BLOWER MOTOR

< DTC/CIRCUIT DIAGNOSIS >

[WITH 7 INCH DISPLAY]

	Test item						
	MODE 1	MODE 2	MODE 3	MODE 4	MODE 5	MODE 6	MODE 7
Blower fan motor control signal duty ratio	37%	91%	65%	65%	65%	91%	—

**NOTE:**

- Perform the inspection of each output device after starting the engine because the compressor is operated.
- If the Mode 7 is selected, the malfunction is displayed but it is normal.

Does it operate normally?

YES >> INSPECTION END

NO >> GO TO 3.

### 3.CHECK BLOWER MOTOR POWER SUPPLY CIRCUIT

1. Disconnect the blower motor connector.
2. Turn the ignition switch ON.
3. Check voltage between blower motor harness connector and ground.

(+)		(-)	Voltage
Blower motor		—	
Connector	Terminal		
M109	1	Ground	Battery voltage

Is the inspection result normal?

YES >> GO TO 4.

NO >> GO TO 7.

### 4.CHECK BLOWER MOTOR GROUND CIRCUIT

1. Turn the ignition switch OFF.
2. Check for continuity between blower motor harness connector and ground.

Blower motor		—	Continuity
Connector	Terminal		
M109	3	Ground	Existed

Is the inspection result normal?

YES >> GO TO 5.

NO >> Repair the harnesses or connectors.

### 5.CHECK BLOWER MOTOR CIRCUIT CONTINUITY

1. Disconnect the A/C auto amp. connector.
2. Check for continuity between the blower motor harness connector and A/C auto amp. harness connector.

Blower motor		A/C auto amp.		Continuity
Connector	Terminal	Connector	Terminal	
M109	2	M66	32	Existed

Is the inspection result normal?

YES >> GO TO 6.

NO >> Repair the harnesses or connectors.

### 6.CHECK A/C AUTO AMP. OUTPUT SIGNAL

1. Reconnect blower motor connector and A/C auto amp. connector.
2. Turn the ignition switch ON.
3. Set the MODE control dial to VENT position.
4. Change fan speed from Lo to Hi, and check duty ratios between blower motor harness connector and ground by using an oscilloscope.

A  
B  
C  
D  
E  
F  
G  
H  
J  
K  
L  
M  
N  
O  
P

HAC

# BLOWER MOTOR

< DTC/CIRCUIT DIAGNOSIS >

[WITH 7 INCH DISPLAY]

**NOTE:**

Calculate the drive signal duty ratio as shown in the figure.  
T2 = Approx. 1.6 ms

Blower motor		Condition	Duty ratio (Approx.)
Connector	Terminal	Fan speed (manual) VENT mode	
M109	2	1st	25 %
		2nd	33 %
		3rd	41 %
		4th	51 %
		5th	61 %
		6th	69 %
		7th	81 %

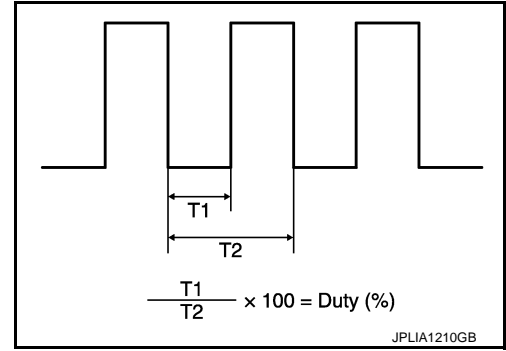

Is the inspection result normal?

- YES >> Replace blower motor after confirming the fan air flow does not change.
- NO >> Replace the A/C auto amp.

## 7. CHECK BLOWER MOTOR CIRCUIT CONTINUITY

1. Turn the ignition switch OFF.
2. Disconnect the blower motor connector and fuse block (J/B) connector.
3. Check the continuity between the blower motor harness connector and fuse block (J/B) harness connector.

Blower motor		Fuse block (J/B)		Continuity
Connector	Terminal	Connector	Terminal	
M109	1	M1	3A	Existed
			8A	

4. Check for continuity between blower motor harness connector and ground.

Blower motor		—	Continuity
Connector	Terminal		
M109	1	Ground	Not existed

Is the inspection result normal?

- YES >> GO TO 8.
- NO >> Repair the harnesses or connectors.

## 8. CHECK FUSE

Check 15A fuses [Nos. 21 and 22, located in the fuse block (J/B)].

**NOTE:**

Refer to [PG-112. "Fuse, Connector and Terminal Arrangement"](#).

Is the inspection result normal?

- YES >> Inspection the power supply circuit. Refer to [PG-55. "Wiring Diagram - IGNITION POWER SUPPLY -"](#).
- NO >> Replace the fuse after repairing the applicable circuit.

## Component Inspection

INFOID:000000005239275

### 1. CHECK BLOWER MOTOR

1. Remove the blower motor. Refer to [VTL-13. "Exploded View"](#).



# BLOWER MOTOR

< DTC/CIRCUIT DIAGNOSIS >

[WITH 7 INCH DISPLAY]

2. Check that the blower motor turns smoothly.

Is the inspection result normal?

YES >> INSPECTION END

NO >> Replace the blower motor.

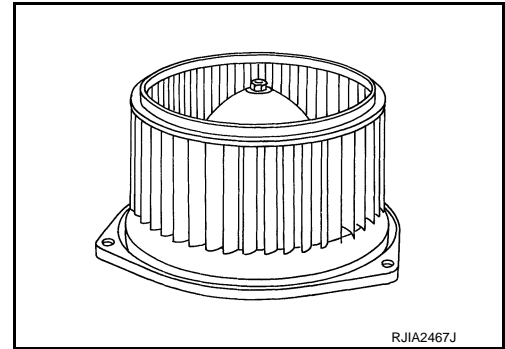

A

B

C

D

E

F

G

H

HAC

J

K

L

M

N

O

P

## MAGNET CLUTCH

### Description

INFOID:000000005239276

The magnet clutch is the device that drives the compressor with the signal from IPDM E/R.

### Component Function Check

INFOID:000000005239277

#### 1. CHECK OPERATION

1. Turn the fan control dial ON.
2. Press the A/C switch.
3. Check that the indicator of the A/C switch turns ON. Check visually and by sound that the compressor operates.
4. Press the A/C switch again.
5. Check that the indicator of the A/C switch turns OFF. Check visually and by sound that the compressor stops.

Does it operate normally?

- YES >> INSPECTION END  
 NO >> Go to diagnosis procedure. Refer to [HAC-146, "Diagnosis Procedure"](#).

### Diagnosis Procedure

INFOID:000000005239278

#### 1. CHECK CHARGED REFRIGERANT

Connect the recovery/recycling recharging equipment to the vehicle and perform the pressure inspection with the gauge. Refer to [HA-35, "Inspection"](#).

Is there refrigerant?

- YES >> GO TO 2.  
 NO >> Check for refrigerant leakages detecting fluorescent leak detector. Refer to [HA-27, "Leak Test"](#).

#### 2. CHECK MAGNET CLUTCH OPERATION

Perform auto active test of IPDM E/R. Refer to [PCS-11, "Diagnosis Description"](#).

Does it operate normally?

- YES >> GO TO 6.  
 NO >> GO TO 3.

#### 3. CHECK MAGNET CLUTCH

1. Turn the ignition switch OFF.
2. Disconnect the magnet clutch connector.
3. Directly apply the battery voltage to the magnet clutch. Check for operation visually and by sound.

Does it operate normally?

- YES >> GO TO 4.  
 NO >> Replace the compressor.

#### 4. CHECK MAGNET CLUTCH CIRCUIT CONTINUITY

1. Turn the ignition switch OFF.
2. Disconnect IPDM E/R connector.
3. Check continuity between the magnet clutch harness connector and IPDM E/R harness connector.

IPDM E/R		Magnet clutch		Continuity
Connector	Terminal	Connector	Terminal	
E7	48	F43	1	Existed

4. Check for continuity between IPDM E/R harness connector and ground.

# MAGNET CLUTCH

< DTC/CIRCUIT DIAGNOSIS >

[WITH 7 INCH DISPLAY]

IPDM E/R		—	Continuity
Connector	Terminal		
E7	48	Ground	Not existed

Is the inspection result normal?

- YES >> GO TO 5.
- NO >> Repair the harnesses and connectors.

## 5. CHECK FUSE

Check 10A fuse (No. 49, located in the IPDM E/R).

### NOTE:

Refer to [PG-114. "Fuse, Connector and Terminal Arrangement"](#).

Is the inspection result normal?

- YES >> Replace IPDM E/R.
- NO >> Replace the fuse after repairing the applicable circuit.

## 6. CHECK SELF-DIAGNOSIS RESULT CHECK

☞ With CONSULT-III

1. Perform the "SELF-DIAGNOSIS".
2. Check if any DTC is detected in the self-diagnostic results.

### NOTE:

If DTC is displayed along with DTC "U1000" or "U1010", first diagnose the DTC "U1000" or "U1010". Refer to [HAC-118. "DTC Logic"](#) or [HAC-119. "DTC Logic"](#).

Is any DTC displayed?

- YES >> Perform the diagnosis that is applicable to the sensor and actuator. Refer to [HAC-161. "DTC Index"](#).
- NO >> GO TO 7.

## 7. CHECK A/C AUTO AMP. OUTPUT SIGNAL

☞ With CONSULT-III

1. Perform the "DATA MONITOR" of HVAC. Refer to [HAC-150. "Reference Value"](#).
2. Check A/C ON signal and blower fan ON switch signal.

Monitor item	Condition	Status
COMP REQ SIG	A/C switch: OFF	Off
	A/C switch: ON	On
FAN REQ SW	Fan control dial: OFF	Off
	Fan control dial: ON	On

Is the inspection result normal?

- YES >> GO TO 8.
- NO >> Replace A/C auto amp.

## 8. CHECK REFRIGERANT PRESSURE SENSOR

Check the refrigerant pressure sensor. Refer to [EC-511. "Diagnosis Procedure"](#).

Is the inspection result normal?

- YES >> INSPECTION END
- NO >> Repair or replace the malfunctioning parts.

# ECV (ELECTRICAL CONTROL VALVE)

< DTC/CIRCUIT DIAGNOSIS >

[WITH 7 INCH DISPLAY]

## ECV (ELECTRICAL CONTROL VALVE)

### Description

INFOID:000000005239279

The ECV (electrical control valve) is installed on the compressor and controls it for emitting appropriate amount of refrigerant when necessary.

### Diagnosis Procedure

INFOID:000000005239280

#### 1. CHECK FUSE

Check 10A fuse [No. 3, located in the fuse block (J/B)].

**NOTE:**

Refer to [PG-112, "Fuse, Connector and Terminal Arrangement"](#).

Is the inspection result normal?

YES >> GO TO 2.

NO >> Replace the fuse after repairing the applicable circuit.

#### 2. CHECK ECV POWER SUPPLY CIRCUIT

1. Turn the ignition switch OFF.
2. Disconnect the ECV connector.
3. Turn the ignition switch ON.
4. Check voltage between the ECV harness connector and ground.

(+)		(-)	Voltage
ECV		—	
Connector	Terminal		
F44	2	Ground	Battery voltage

Is the inspection result normal?

YES >> GO TO 3.

NO >> Repair the harnesses or connectors.

#### 3. CHECK ECV CONTROL SIGNAL

④ With CONSULT-III

1. Turn the ignition switch OFF.
2. Connect the ECV connector.
3. Perform the "HVAC TEST": MODE 5 of HVAC active test mode.
4. Check output waveform between the A/C auto amp. harness connector and ground with the oscilloscope.

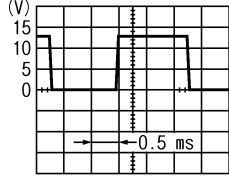
(+)		(-)	Condition	Output waveform
A/C auto amp.		—		
Connector	Terminal			
M66	24	Ground	HVAC TEST: MODE 5	Duty ratio: approx. 50 %  SJIA1607E

Is the inspection result normal?

YES >> Replace the compressor.

NO >> GO TO 4.

#### 4. CHECK CONTINUITY BETWEEN ECV AND A/C AUTO AMP.

1. Turn the ignition switch OFF.
2. Disconnect the ECV connector.

# ECV (ELECTRICAL CONTROL VALVE)

< DTC/CIRCUIT DIAGNOSIS >

[WITH 7 INCH DISPLAY]

- 3. Disconnect the A/C auto amp. connector.
- 4. Check continuity between the ECV harness connector and A/C auto amp. harness connector.

ECV		A/C auto amp.		Continuity
Connector	Terminal	Connector	Terminal	
F44	3	M66	24	Existed

- 5. Check for continuity between the ECV harness connector and ground.

ECV		—	Continuity
Connector	Terminal		
F44	3	Ground	Not existed

Is the inspection result normal?

- YES >> GO TO 5.
- NO >> Repair the harnesses or connectors.

## 5.CHECK ECV

Check continuity between the ECV connector terminals.

ECV				Continuity
Connector	Terminal	Connector	Terminal	
F44	2	F44	3	Existed

Is the inspection result normal?

- YES >> Replace the A/C auto amp.
- NO >> Replace the compressor.

A  
B  
C  
D  
E  
F  
G  
H  
J  
K  
L  
M  
N  
O  
P

HAC

# A/C AUTO AMP.

< ECU DIAGNOSIS INFORMATION >

[WITH 7 INCH DISPLAY]

## ECU DIAGNOSIS INFORMATION

### A/C AUTO AMP.

#### Reference Value

INFOID:000000005239281

#### CONSULT-III DATA MONITOR REFERENCE VALUES

Monitor item	Condition		Value/Status
COMP REQ SIG	Engine: Run at idle after warming up	A/C switch: ON (Compressor operation status)	On
		A/C switch: OFF	Off
FAN REQ SIG	Engine: Run at idle after warming up	Blower motor: ON	On
		Blower motor: OFF	Off
AMB TEMP SEN	Ignition switch ON	—	-22 – 131°F (-30 – 55°C)
IN-VEH TEMP	Ignition switch ON	—	-22 – 131°F (-30 – 55°C)
INT TEMP SEN	Ignition switch ON	—	-22 – 131°F (-30 – 55°C)
SUNLOAD SEN	Ignition switch ON	—	0 – 1045 w/m <sup>2</sup> (0 – 900 kcal/m <sup>2</sup> ·h)
AMB SEN CAL	Ignition switch ON	—	-22 – 131°F (-30 – 55°C)
IN-VEH CAL	Ignition switch ON	—	-22 – 131°F (-30 – 55°C)
INT TEMP CAL	Ignition switch ON	—	-22 – 131°F (-30 – 55°C)
SUNL SEN CAL	Ignition switch ON	—	0 – 1045 w/m <sup>2</sup> (0 – 900 kcal/m <sup>2</sup> ·h)
FAN DUTY	Engine: Run at idle after warming up	Blower motor: ON	25 – 81
		Blower motor: OFF	0
XM	Ignition switch ON	—	-100 – 155
ENG COOL TEMP	Ignition switch ON	—	Values depending on coolant temperature
VEHICLE SPEED	Driving	—	Equivalent to speedometer reading

#### TERMINAL LAYOUT

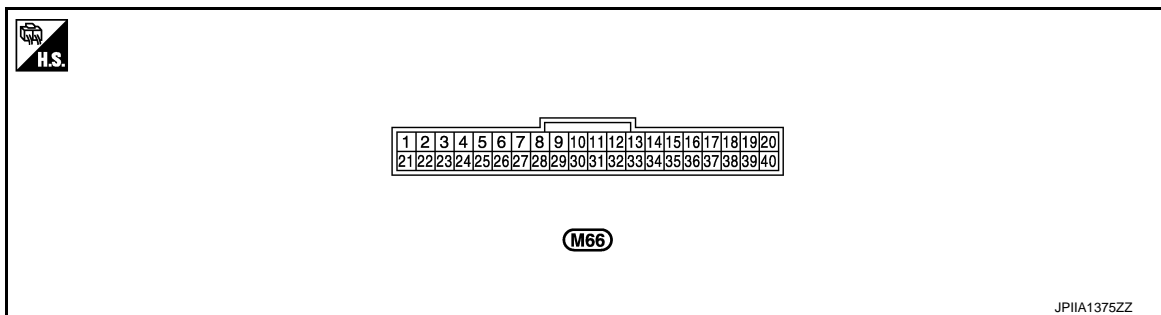

#### PHYSICAL VALUES

# A/C AUTO AMP.

< ECU DIAGNOSIS INFORMATION >

[WITH 7 INCH DISPLAY]

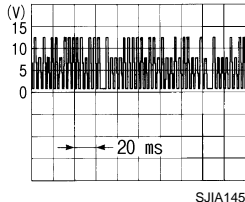
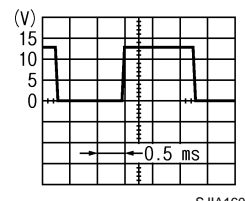
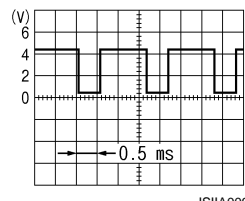
Terminal No. (Wire color)		Description		Condition	Value (Approx.)
+	-	Signal name	Input/ Output		
1 (L)	Ground	CAN - H	Input/ Output	—	—
2 (P)	Ground	CAN - L	Input/ Output	—	—
10 (BR)	Ground	A/C LAN signal	Input/ Output	Ignition switch ON	
11 (Y)	Ground	Each door motor power supply	—	Ignition switch ON	12 V
15 (O)	Ground	Sunload sensor signal	Input	—	0 – 4.8 V Output voltage varies with sunload amount
16 (R)	Ground	Intake sensor signal	Input	—	0 – 4.8 V Output voltage varies with intake temperature
17 (L)	Ground	ACC power supply	—	Ignition switch ACC	Battery voltage
19 (B)	Ground	Ground	—	Ignition switch ON	0 V
20 (G)	Ground	Ignition power supply	—	Ignition switch ON	Battery voltage
24 (O)	Ground	ECV signal	Output	<ul style="list-style-type: none"> <li>• Ignition switch ON</li> <li>• Active test: MODE 5</li> </ul>	
32 (P)	Ground	Blower motor control signal	Output	<ul style="list-style-type: none"> <li>• Ignition switch ON</li> <li>• Fan speed: 1st speed (manual)</li> </ul>	
34 (G)	Ground	A/C auto amp. connecting recognition signal	Output	Ignition switch ON	5 V
35 (V)	Ground	Ambient sensor signal	Input	—	0 – 4.8 V Output voltage varies with ambient temperature
36 (LG)	Ground	In-vehicle sensor signal	Input	—	0 – 4.8 V Output voltage varies with in-vehicle temperature
37 (GR)	Ground	Sensor ground	—	Ignition switch ON	0 V

A  
B  
C  
D  
E  
F  
G  
H  
HAC  
J  
K  
L  
M  
N  
O  
P



# A/C AUTO AMP.

< ECU DIAGNOSIS INFORMATION >

[WITH 7 INCH DISPLAY]

Terminal No. (Wire color)		Description		Condition	Value (Approx.)
+	-	Signal name	Input/ Output		
39 (B)	Ground	Ground	—	Ignition switch ON	0 V
40 (Y)	Ground	Battery power supply	—	Ignition switch OFF	Battery voltage





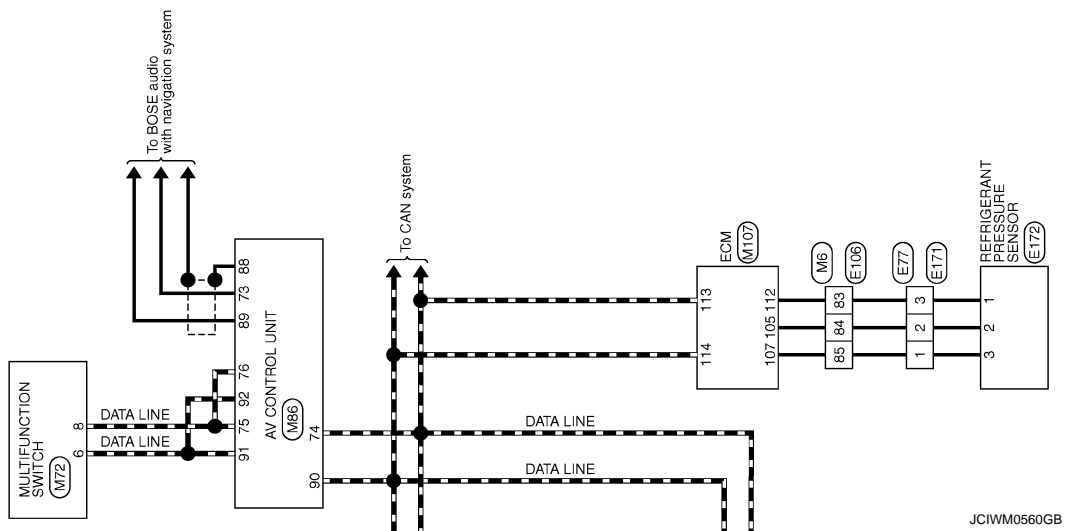

AUTOMATIC AIR CONDITIONING SYSTEM (WITH NAVI)

Connector No.	E3
Connector Name	WIRE TO WIRE
Connector Type	SA33MB-F32-SH2B

1	2	3	4	5	6	7	8
13	10	11	12	14	15	16	17
18	19	20	21	22	23	24	25
26	27	28	29	30	31	32	33
34	35	36	37	38	39	40	41



Terminal No.	Color of Wire	Signal Name [Specification]
1	L/Y	-
2	SHIELD	-
3	L/B	-
4	SHIELD	-
5	BR	-
7	G	-
8	W	-
9	W	-
10	Y	-
11	Y	-
12	SB	-
13	L	-
14	G	-
15	R	-
16	LG	-
17	GR	-
18	Y	-
19	BG	- [Coupe models]
19	O	- [Roadster models]
20	B	-
21	SB	-
22	W	-
23	SB	-
24	GR	-
25	V	-
27	GR	-
28	V	-
29	P	-
30	R	-
31	BR	-
32	Y	-
33	G	-
34	BG	- [Coupe models]
34	O	- [Roadster models]
36	GR	-
37	SHIELD	-
38	L	-
38	P	-

40	R	-
41	W	-
42	LG	-
43	G	-
45	SB	-
46	SHIELD	-
47	W	-
48	BR	-
49	G	-
50	B	-
51	SB	-
52	R	-

Connector No.	E5
Connector Name	ENGINE R INTELLIGENT POWER DISTRIBUTION MODULE (ENGINE ROOM)
Connector Type	TH20FW-CS12-M4-1V

1	2	3	4	5	6	7	8	9	10	11	12	13	14	15	16	17	18	19
25	26	27	28	29	30	31	32	33	34	35	36	37	38	39	40	41	42	43



Terminal No.	Color of Wire	Signal Name [Specification]
4	V	-
5	L	-
6	R	-
7	R	-
11	BR	-
12	B/W	-
13	Y	-
16	LG	-
18	W	-
19	W	-
23	G	-
27	Y	-
28	L	-
30	GR	-
32	L	-
33	P	-
36	G	-

Connector No.	E6
Connector Name	ENGINE R INTELLIGENT POWER DISTRIBUTION MODULE (ENGINE ROOM)
Connector Type	TH20FW-MH

42	41	40	39
46	45	44	43



Terminal No.	Color of Wire	Signal Name [Specification]
39	P	-
40	L	-
41	B/W	-
42	Y	-
43	SB	-
44	W	-
45	G	-
46	V	-

Connector No.	E7
Connector Name	ENGINE R INTELLIGENT POWER DISTRIBUTION MODULE (ENGINE ROOM)
Connector Type	TH20FW-CS12-M4

53	54	55	56	57	58	59	60	61	62
63	64	65	66	67	68	69	70	71	72



Terminal No.	Color of Wire	Signal Name [Specification]
48	L	-
49	BG	- [Coupe models]
49	O	- [Roadster models]
51	Y	-
53	W	-
54	V	-
55	SB	-
56	LG	-
57	G	-
59	P	-
69	BR	-
70	BG	- [Coupe models]
70	O	- [Roadster models]
72	GR	-

73	GR	-
74	G	-
75	SB	-
76	Y	-
77	R	-
80	W	-

Connector No.	E76
Connector Name	AMBIENT SENSOR
Connector Type	RS02FB



Terminal No.	Color of Wire	Signal Name [Specification]
1	G	-
2	P	-

Connector No.	E77
Connector Name	WIRE TO WIRE
Connector Type	RK03FB



Terminal No.	Color of Wire	Signal Name [Specification]
1	V	-
2	L	-
3	BG	- [Coupe models]
3	O	- [Roadster models]

A  
B  
C  
D  
E  
F  
G  
H  
HAC  
J  
K  
L  
M  
N  
O  
P

AUTOMATIC AIR CONDITIONING SYSTEM (WITH NAVI)

Connector No.	E106
Connector Name	WIRE TO WIRE
Connector Type	THB07V-CS16-TM44

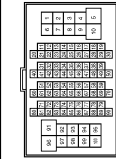

Terminal No.	Color of Wire	Signal Name [Specification]
1	Y	-
3	L	-
4	L	-
7	B	-
8	P	-
9	L	-
9	B	- [Coupe models]
11	V	- [Roadster models]
12	R	-
13	L	-
14	GR	-
15	P	-
16	W	-
17	SB	-
20	LG	-
21	BR	- [Coupe models]
21	G	- [Roadster models]
31	L	-
32	Y	-
33	P	-
34	L	-
35	BR	-
36	V	-
37	Y	-
38	R	-
39	B	-
40	W	-
41	LG	-
42	SB	-
43	G	-
44	R	- [Roadster models with M/T]
44	GR	- [Except for roadster models with M/T]
45	BG	- [Coupe models]
45	O	- [Roadster models]
46	W	-
47	P	-
58	SHIELD	-
59	L	-

Connector No.	E172
Connector Name	REFRIGERANT PRESSURE SENSOR
Connector Type	RKG3FB



Terminal No.	Color of Wire	Signal Name [Specification]
1	-	-
2	-	-
3	-	-

Connector No.	F1
Connector Name	WIRE TO WIRE
Connector Type	SAA38FB-RSS-S128

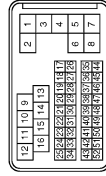

Terminal No.	Color of Wire	Signal Name [Specification]
1	L/Y	-
2	SHIELD	-
3	L/B	-
4	SHIELD	-
5	BR	-
7	G	-
8	W	-
9	W	-
10	G	-
11	R	-
12	P	-
13	BG	- [Coupe models]
13	O	- [Roadster models]
14	LG	-
15	BR	-
16	Y	-
17	W	-
18	LG	-
19	P	-

20	BG	- [Coupe models]
20	O	- [Roadster models]
21	BR	-
22	G	-
23	Y	-
24	LG	-
25	V	-
27	GR	-
28	BR	-
29	L	-
30	R	-
31	P	-
32	W	-
33	SB	-
34	BG	- [Coupe models]
34	O	- [Roadster models]
36	GR	-
37	SHIELD	- [Coupe models]
37	B	- [Roadster models]
38	W	-
39	Y	-
40	G	-
41	B	-
42	GR	-
43	R	-
45	SB	-
46	SHIELD	-
47	W/L	-
48	LG	-
49	O/L	-
50	L/Y	-
51	W	-
52	L/G	-

Connector No.	F43
Connector Name	COMPRESSOR
Connector Type	RS01FB



Terminal No.	Color of Wire	Signal Name [Specification]
1	BG	MAGNET CLUTCH POWER SUPPLY [Coupe model]
1	O	MAGNET CLUTCH POWER SUPPLY [Roadster model]

JCIWM0562GB

AUTOMATIC AIR CONDITIONING SYSTEM (WITH NAVI)

Connector No.	F44
Connector Name	COMPRESSOR
Connector Type	PK02FGY



Terminal No.	Color of Wire	Signal Name [Specification]
2	Y	ECV POWER SUPPLY
3	BG	ECV SIGNAL [Coupe models]
3	O	ECV SIGNAL [Roadster models]

Connector No.	F103
Connector Name	WIRE TO WIRE
Connector Type	TK06FW-NS10



Terminal No.	Color of Wire	Signal Name [Specification]
2	G	-
3	W	-
4	R	-
5	B	-
8	L	-
9	Y	-
10	GR	-
19	BG	- [Coupe models]
19	O	- [Roadster models]
20	Y	-
28	B	-
29	LG	-
30	R	-
31	BG	- [Coupe models]
31	O	- [Roadster models]
39	W	-
42	G	-
43	P	-
44	L	-

45	Y	-
46	Y	-

Connector No.	M1
Connector Name	FUSE BLOCK (J/B)
Connector Type	NS06FW-M2



Terminal No.	Color of Wire	Signal Name [Specification]
1A	V	-
2A	G	-
3A	L	-
4A	P	-
5A	L	-
6A	Y	-
7A	BR	-
8A	L	-

Connector No.	M2
Connector Name	FUSE BLOCK (J/B)
Connector Type	NS10FW-CS



Terminal No.	Color of Wire	Signal Name [Specification]
1B	Y	-
3B	P	-
4B	G	-
5B	O	-
6B	Y	-
8B	R	-
9B	SB	-

Connector No.	M3
Connector Name	FUSE BLOCK (J/B)
Connector Type	NS12FW-CS



Terminal No.	Color of Wire	Signal Name [Specification]
7C	R	-
9C	B	- [Coupe models]
9C	O	- [Roadster models]
10C	L	-
11C	LG	-
12C	O	-

Connector No.	M6
Connector Name	WIRE TO WIRE
Connector Type	TH00MW-CS16-TM4



Terminal No.	Color of Wire	Signal Name [Specification]
1	Y	-
3	L	-
4	L	-
7	B	-
8	P	-
9	L	- [Coupe models]
9	B	- [Roadster models]
11	GR	-
12	R	-
13	L	-
14	G	-
15	P	-
16	W	-
17	BR	-
20	GR	-

21	BR	- [Coupe models]
21	R	- [Roadster models]
31	L	- [Roadster models with M/T]
31	BR	- [Except for roadster models with M/T]
32	Y	- [Roadster models with M/T]
32	V	- [Except for roadster models with M/T]
33	P	-
34	L	-
35	BR	-
36	SB	-
37	Y	-
38	LG	-
39	SB	-
40	W	-
41	LG	-
42	R	-
43	G	-
44	G	- [With A/T]
44	R	- [With M/T]
45	O	-
46	G	-
47	BR	-
58	SHIELD	-
59	L	-
70	R	-
80	LG	-
81	GR	-
82	V	-
83	V	-
84	L	-
85	BR	-
86	Y	-
87	V	- [Roadster models with M/T]
87	G	- [Except for roadster models with M/T]
89	P	-
91	W	-
92	P	-
93	P	-
94	Y	-
96	P	-
97	GR	-
98	O	-
99	W	-
100	R	-

A  
B  
C  
D  
E  
F  
G  
H  
I  
J  
K  
L  
M  
N  
O  
P

HAC

## AUTOMATIC AIR CONDITIONING SYSTEM (WITH NAVI)

Connector No.	M24
Connector Name	DATA LINK CONNECTOR
Connector Type	BD16FV

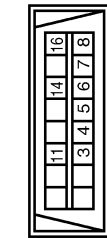

Terminal No.	Color of Wire	Signal Name [Specification]
3	Y	-
4	B	-
5	B	-
6	L	-
7	Y	- [Coupe models]
7	V	- [Roadster models]
8	G	-
11	LG	-
14	P	-
16	Y	-



Connector No.	M46
Connector Name	SUNLOAD SENSOR
Connector Type	K02FE

Terminal No.	Color of Wire	Signal Name [Specification]
1	O	SUNLOAD SENSOR SIGNAL
2	GR	SENSOR GROUND

Connector No.	M63
Connector Name	COMBINATION METER
Connector Type	TH24FW-NH

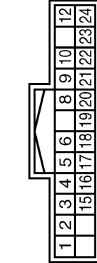

Terminal No.	Color of Wire	Signal Name [Specification]
1	V	BATTERY POWER SUPPLY
2	O	IGNITION POWER SUPPLY
3	L	VEHICLE SPEED SIGNAL (2-PULSE)
4	Y	VEHICLE SPEED SIGNAL (8-PULSE)
5	B	ILLUMINATION CONTROL SIGNAL
6	R	ROOF STATUS SIGNAL
8	BR	COMMUNICATION SIGNAL (METER-TURBLE METER)
10	L	COMMUNICATION SIGNAL (TRIPLE METER-METER)
12	G	S-MODE SWITCH SIGNAL
15	L	ACC POWER SUPPLY
16	R	AIR BAG SIGNAL
17	B	GROUND
18	V	AMBIENT SENSOR SIGNAL
19	G	A/C AUTO AMP CONNECTION RECOGNITION SIGNAL
20	GR	AMBIENT SENSOR GROUND
21	L	CAN-H
22	P	CAN-L
23	B	GROUND
24	Y	FUEL LEVEL SENSOR GROUND



Connector No.	M61
Connector Name	IN-VEHICLE SENSOR
Connector Type	A02FW

Terminal No.	Color of Wire	Signal Name [Specification]
1	LG	IN-VEHICLE SENSOR SIGNAL
2	GR	SENSOR GROUND

Connector No.	M66
Connector Name	A/C AUTO AMP.
Connector Type	SAB4QFV



Terminal No.	Color of Wire	Signal Name [Specification]
1	L	CAN-H
2	P	CAN-L
6	L	TX (AMP)-CONT
7	P	RX (CONT)-AMP
10	BR	LAN SIGNAL
11	Y	EACH DOOR MOTOR POWER SUPPLY
15	O	SUNLOAD SENSOR SIGNAL
16	R	INTAKE SENSOR SIGNAL
17	L	ACC POWER SUPPLY
19	B	GROUND
20	G	IGNITION POWER SUPPLY
24	O	ECV SIGNAL
26	R	REAR WINDOW DEFOGGER FEEDBACK SIGNAL
27	L	REAR WINDOW DEFOGGER ON SIGNAL
32	P	BLOWER MOTOR CONTROL SIGNAL
34	G	A/C AUTO AMP CONNECTION RECOGNITION SIGNAL
35	V	AMBIENT SENSOR SIGNAL
38	LG	IN-VEHICLE SENSOR SIGNAL
37	GR	SENSOR GROUND
39	B	GROUND
40	Y	BATTERY POWER SUPPLY



Connector No.	M72
Connector Name	MULTIFUNCTION SWITCH
Connector Type	TH10FW-NH

Terminal No.	Color of Wire	Signal Name [Specification]
1	B	GROUND

3	V	ACC
4	R	ILL
5	R	ILL CONT
6	LC	AV COMM (H) [Coupe models]
8	L	AV COMM (L) [Roadster models]
8	Y	AV COMM (L) [Coupe models]
8	P	AV COMM (L) [Roadster models]
9	BR	SW GND
14	SB	DISK EJECT SIGNAL

Connector No.	M86
Connector Name	AV CONTROL UNIT
Connector Type	TH32FW-NH

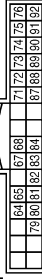

Terminal No.	Color of Wire	Signal Name [Specification]
65	V	PARKING BRAKE SIGNAL
67	B	COMPOSITE IMAGE GND
68	L	COMPOSITE IMAGE SIGNAL
71	SHIELD	MICROPHONE GND
72	R	MICROPHONE VCC
73	G	COMM (CONT->DISP) [Coupe models]
73	R	COMM (CONT->DISP) [Roadster models]
74	P	CAN-L [Coupe models]
74	L	CAN-L [Roadster models]
75	Y	AV COMM (L)
76	Y	AV COMM (L)
79	R	ILL*
80	G	IGNITION SIGNAL
81	O	REVERSE SIGNAL
82	Y	VEHICLE SPEED SIGNAL (8-PULSE)
83	SHIELD	SHIELD
84	Y	-
87	G	MICROPHONE SIGNAL
88	SHIELD	SHIELD
89	R	COMM (DISP->CONT) [Coupe models]
89	G	COMM (DISP->CONT) [Roadster models]
90	L	CAN-H [Coupe models]
90	P	CAN-H [Roadster models]
91	LG	AV COMM (H)
92	LG	AV COMM (H)

AUTOMATIC AIR CONDITIONING SYSTEM (WITH NAVI)

Connector No.	M89B
Connector Name	WIRE TO WIRE
Connector Type	A08FW



Terminal No.	Color of Wire	Signal Name [Specification]
1	GR	-
2	R	-
4	BR	-
5	B	-
6	Y	-

Connector No.	M107
Connector Name	ECM
Connector Type	RH24FGY-R28-R-LH-Z

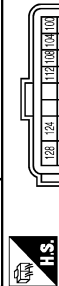

Terminal No.	Color of Wire	Signal Name [Specification]
97	R	APS 1
98	P	APS 2
99	L	AVCC 1-APS 1
100	W	GND-APS 1
101	SB	ASCDSW
102	GR	FTPRS
103	G	AVCC2-APS 2
104	GR	GND-APS 2
105	L	PODPRESS
106	W	TF
107	BR	AVCC 2-FTPRS
108	Y	GND ASCDSW
109	G	NEUT-H
110	R	TAGHO
112	SB	GND-FTPRES
113	P	VEHCAN-L1
114	L	VEHCAN-H1

Terminal No.	Color of Wire	Signal Name [Specification]
117	Y	KLINE [Coupe models]
117	V	KLINE [Roadster models]
121	LG	CD3CV
122	P	BRAKE
123	B	GND
124	B	GND
125	R	VBR
126	BR	BNGSW
127	B	GND
128	B	GND

Connector No.	M109
Connector Name	BLOWER MOTOR
Connector Type	NS03FW-M3



Terminal No.	Color of Wire	Signal Name [Specification]
1	L	BLOWER MOTOR POWER SUPPLY
2	P	BLOWER MOTOR CONTROL SIGNAL
3	B	SENSOR GROUND

Connector No.	M116
Connector Name	WIRE TO WIRE
Connector Type	TK38MW-NS10



Terminal No.	Color of Wire	Signal Name [Specification]
2	W	-
3	BG	- [Coupe models]
3	O	- [Roadster models]
4	W	-
5	B	-
8	L	-
9	Y	-

Terminal No.	Color of Wire	Signal Name [Specification]
10	R	-
19	O	-
20	G	-
22	B	-
23	LG	-
30	LG	-
31	O	-
39	G	-
42	G	-
43	P	-
44	L	-
45	BR	-
46	V	-

Connector No.	M201
Connector Name	WIRE TO WIRE
Connector Type	A08BW

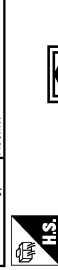

Terminal No.	Color of Wire	Signal Name [Specification]
1	W	- [Coupe models]
1	GR	- [Roadster models]
2	R	-
4	L	-
5	B	-
6	G	- [Coupe models]
8	L	- [Roadster models with NAVI]
8	R	- [Roadster models without NAVI]

Connector No.	M203
Connector Name	MODE DOOR MOTOR
Connector Type	A03FW



Terminal No.	Color of Wire	Signal Name [Specification]
1	G	DOOR MOTOR POWER SUPPLY [Coupe models]
1	L	DOOR MOTOR POWER SUPPLY [Roadster models]
2	B	SENSOR GROUND
3	L	A/C LAM SIGNAL

Connector No.	M204
Connector Name	AIR MIX DOOR MOTOR
Connector Type	A03FW



Terminal No.	Color of Wire	Signal Name [Specification]
1	G	DOOR MOTOR POWER SUPPLY [Coupe models]
1	L	DOOR MOTOR POWER SUPPLY [Roadster models]
2	B	SENSOR GROUND
3	L	A/C LAM SIGNAL

Connector No.	M205
Connector Name	INTAKE SENSOR
Connector Type	TK04FW



Terminal No.	Color of Wire	Signal Name [Specification]
1	R	INTAKE SENSOR SIGNAL
2	W	SENSOR GROUND [Coupe models]
2	GR	SENSOR GROUND [Roadster models]

A  
B  
C  
D  
E  
F  
G  
H  
HAC  
J  
K  
L  
M  
N  
O  
P

AUTOMATIC AIR CONDITIONING SYSTEM (WITH NAVI)

Connector No.	M206
Connector Name	INTAKE DOOR MOTOR
Connector Type	AC3FW

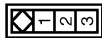

Terminal No.	Color of Wire	Signal Name [Specification]
1	G	DOOR MOTOR POWER SUPPLY [Coupe models]
1	L	DOOR MOTOR POWER SUPPLY [Roadster models]
2	B	SENSOR GROUND
3	L	A/C LAN SIGNAL

JCIWM0566GB

INFOID:000000005239283

Fail-safe

FAIL-SAFE FUNCTION

When a communication malfunction between A/C auto amp. and AV control unit and preset switch continued for approximately 30 seconds or more, control the air conditioner under the following conditions.



# A/C AUTO AMP.

< ECU DIAGNOSIS INFORMATION >

[WITH 7 INCH DISPLAY]

**Compressor** : ON  
**Air outlet** : AUTO  
**Air inlet** : FRE (Fresh air intake)  
**Fan speed** : AUTO  
**Preset temperature** : Setting before communication malfunction

## DTC Inspection Priority Chart

INFOID:000000005239284

If some DTCs are displayed at the same time, perform inspections one by one based on the following priority chart.

Priority	Detected items (DTC)
1	<ul style="list-style-type: none"> <li>U1000: CAN COMM CIRCUIT</li> <li>U1010: CONTROL UNIT (CAN)</li> </ul>
2	<ul style="list-style-type: none"> <li>B257B: AMB TEMP SEN SHORT</li> <li>B257C: AMB TEMP SEN OPEN</li> <li>B2578: IN CAR SEN SHORT</li> <li>B2579: IN CAR SEN OPEN</li> <li>B2581: EVAP TEMP SEN SHORT</li> <li>B2582: EVAP TEMP SEN OPEN</li> <li>B2630: SUNLOAD SEN SHORT</li> <li>B2631: SUNLOAD SEN OPEN</li> <li>B2632: DR AIRMIX ACTR SHORT</li> <li>B2633: DR AIRMIX ACTR OPEN</li> <li>B2636: DR VENT DOOR FAIL</li> <li>B2637: DR B/L DOOR FAIL</li> <li>B2638: DR D/F1 DOOR FAIL</li> <li>B2639: DR DEF DOOR FAIL</li> <li>B263D: FRE DOOR FAIL</li> <li>B263E: 20P FRE DOOR FAIL</li> <li>B263F: REC DOOR FAIL</li> <li>B2654: D/F2 DOOR FAIL</li> <li>B2655: B/L2 DOOR FAIL</li> </ul>

## DTC Index

INFOID:000000005239285

DTC	Items (CONSULT-III screen terms)	Reference
U1000	CAN COMM CIRCUIT	<a href="#">HAC-118, "DTC Logic"</a>
U1010	CONTROL UNIT (CAN)	<a href="#">HAC-119, "DTC Logic"</a>
B257B	AMB TEMP SEN SHORT	<a href="#">HAC-120, "DTC Logic"</a>
B257C	AMB TEMP SEN OPEN	<a href="#">HAC-120, "DTC Logic"</a>
B2578	IN CAR SEN SHORT	<a href="#">HAC-123, "DTC Logic"</a>
B2579	IN CAR SEN OPEN	<a href="#">HAC-123, "DTC Logic"</a>
B2581	EVAP TEMP SEN SHORT	<a href="#">HAC-126, "DTC Logic"</a>
B2582	EVAP TEMP SEN OPEN	<a href="#">HAC-126, "DTC Logic"</a>
B2630*	SUNLOAD SEN SHORT	<a href="#">HAC-129, "DTC Logic"</a>
B2631*	SUNLOAD SEN OPEN	<a href="#">HAC-129, "DTC Logic"</a>
B2632	DR AIRMIX ACTR SHORT	<a href="#">HAC-132, "DTC Logic"</a>
B2633	DR AIRMIX ACTR OPEN	<a href="#">HAC-132, "DTC Logic"</a>
B2636	DR VENT DOOR FAIL	<a href="#">HAC-134, "DTC Logic"</a>
B2637	DR B/L DOOR FAIL	<a href="#">HAC-134, "DTC Logic"</a>
B2638	DR D/F1 DOOR FAIL	<a href="#">HAC-134, "DTC Logic"</a>

## A/C AUTO AMP.

< ECU DIAGNOSIS INFORMATION >

[WITH 7 INCH DISPLAY]

DTC	Items (CONSULT-III screen terms)	Reference
B2639	DR DEF DOOR FAIL	<a href="#">HAC-134, "DTC Logic"</a>
B263D	FRE DOOR FAIL	<a href="#">HAC-136, "DTC Logic"</a>
B263E	20P FRE DOOR FAIL	<a href="#">HAC-136, "DTC Logic"</a>
B263F	REC DOOR FAIL	<a href="#">HAC-44, "DTC Logic"</a>
B2654	D/F2 DOOR FAIL	<a href="#">HAC-134, "DTC Logic"</a>
B2655	B/L2 DOOR FAIL	<a href="#">HAC-134, "DTC Logic"</a>

\*: Perform self-diagnosis under sunshine. When performing indoors, aim a light (more than 60 W) at sunload sensor, otherwise self-diagnosis indicates even though the sunload sensor is functioning normally.

**NOTE:**

If all of door motors DTC (B2632, B2633, B2636, B2637, B2638, B2639, B263D, B263E, B263F, B2654 and B2655) are detected, check door motor communication circuit. Refer to [HAC-139, "Description"](#).

# AUTOMATIC AIR CONDITIONER SYSTEM

< SYMPTOM DIAGNOSIS >

[WITH 7 INCH DISPLAY]

## SYMPTOM DIAGNOSIS

### AUTOMATIC AIR CONDITIONER SYSTEM

#### Diagnosis Chart By Symptom

INFOID:000000005239286

A  
B  
C  
D  
E  
F  
G  
H  
J  
K  
L  
M  
N  
O  
P

HAC

Symptom	Check item	Reference
A/C system does not activate.	Power supply and ground circuit	<a href="#">HAC-138. "A/C AUTO AMP. : Diagnosis Procedure"</a>
A/C system cannot be controlled.	A/C auto amp.	<a href="#">HAC-141. "Diagnosis Procedure"</a>
<ul style="list-style-type: none"> <li>• Air outlet does not change.</li> <li>• Mode door motor does not operate normally.</li> </ul>	Mode door motor	<a href="#">HAC-135. "Diagnosis Procedure"</a>
<ul style="list-style-type: none"> <li>• Discharge air temperature does not change.</li> <li>• The air mix door motor does not operate normally.</li> </ul>	Air mix door motor	<a href="#">HAC-133. "Diagnosis Procedure"</a>
<ul style="list-style-type: none"> <li>• Intake door does not change.</li> <li>• Intake door motor does not operate normally.</li> </ul>	Intake door motor	<a href="#">HAC-137. "Diagnosis Procedure"</a>
Blower motor operation is malfunctioning.	Blower motor	<a href="#">HAC-142. "Diagnosis Procedure"</a>
Magnet clutch does not operate.	Magnet clutch	<a href="#">HAC-146. "Diagnosis Procedure"</a>
<ul style="list-style-type: none"> <li>• Insufficient cooling</li> <li>• No cool air comes out. (Air flow volume is normal.)</li> </ul>	ECV	<a href="#">HAC-148. "Diagnosis Procedure"</a>
	Insufficient cooling	<a href="#">HAC-164. "Diagnosis Procedure"</a>
<ul style="list-style-type: none"> <li>• Insufficient heating</li> <li>• No warm air comes out. (Air flow volume is normal.)</li> </ul>	Insufficient heating	<a href="#">HAC-166. "Diagnosis Procedure"</a>
<ul style="list-style-type: none"> <li>• Noise</li> <li>• Noise is heard when the A/C system operates.</li> </ul>	Noise	<a href="#">HAC-169. "Diagnosis Procedure"</a>
<ul style="list-style-type: none"> <li>• Memory function does not operate normally.</li> <li>• The setting is not maintained. (It returns to the initial condition)</li> </ul>	Memory function	<a href="#">HAC-171. "Diagnosis Procedure"</a>

## INSUFFICIENT COOLING

## Description

INFOID:000000005239287

## Symptom

- Insufficient cooling
- No cool air comes out. (Air flow volume is normal.)

## Diagnosis Procedure

INFOID:000000005239288

**1.CHECK MAGNET CLUTCH OPERATION**

1. Turn the ignition switch ON.
2. Turn the fan control dial ON.
3. Press the A/C switch.
4. Check that the indicator of the A/C switch turns ON. Check visually and by sound that the compressor operates.
5. Press the A/C switch again.
6. Check that the indicator of the A/C switch turns OFF. Check that the compressor stops.

Is the inspection result normal?

YES &gt;&gt; GO TO 2.

NO >> Magnet clutch system malfunction. Refer to [HAC-146, "Diagnosis Procedure"](#).**2.CHECK DRIVE BELT**Check tension of the drive belt. Refer to [EM-17, "Checking"](#).Is the inspection result normal?

YES &gt;&gt; GO TO 3.

NO &gt;&gt; Adjust or replace drive belt depending on the inspection results.

**3.CHECK REFRIGERANT CYCLE PRESSURE**Connect the recovery/recycling recharging equipment to the vehicle and perform the pressure inspection with the gauge. Refer to [HA-7, "Symptom Table"](#).Is the inspection result normal?

YES &gt;&gt; GO TO 4.

NO &gt;&gt; Repair or replace the parts depending on the inspection results.

**4.CHECK PERFORMANCE CHART**Connect recovery/recycling recharging equipment to the vehicle and perform the performance test. Refer to [HA-35, "Inspection"](#).Is the inspection result normal?

YES &gt;&gt; GO TO 5.

NO &gt;&gt; GO TO 7.

**5.CHECK AMBIENT TEMPERATURE DISPLAY**

Check that there is not much difference between actual ambient temperature and indicated temperature on information display in combination meter.

Is the inspection result normal?

YES &gt;&gt; GO TO 6.

NO >> Perform the diagnosis for the A/C auto amp. connection recognition signal. Refer to [MWI-56, "Diagnosis Procedure"](#).**6.CHECK SETTING OF TEMPERATURE SETTING TRIMMER**

## Ⓟ With CONSULT-III

1. Select "TEMP SET CORRECT" of HVAC work support item. Refer to [HAC-99, "Temperature Setting Trimmer"](#).
2. Check that the temperature setting trimmer is set to "+ direction".

**NOTE:**

The control temperature can be set with the setting of the temperature setting trimmer.

# INSUFFICIENT COOLING

< SYMPTOM DIAGNOSIS >

[WITH 7 INCH DISPLAY]

3. Set the difference between the set temperature and control temperature to "0".

>> INSPECTION END

## 7. CHECK CHARGED REFRIGERANT AMOUNT

1. Connect recovery/recycling recharging equipment to the vehicle and discharge the refrigerant.
2. Recharge with the proper amount of refrigerant.

Are the symptoms solved?

YES >> INSPECTION END

NO >> Refer to [HAC-163, "Diagnosis Chart By Symptom"](#) and perform the appropriate diagnosis.

A  
B  
C  
D  
E  
F  
G  
H  
J  
K  
L  
M  
N  
O  
P

HAC

## INSUFFICIENT HEATING

## Description

INFOID:000000005239289

## Symptom

- Insufficient heating
- No warm air comes out. (Air flow volume is normal.)

## Diagnosis Procedure

INFOID:000000005239290

## 1. CHECK COOLING SYSTEM

1. Check the engine coolant level and check for leakage. Refer to [CO-9, "Inspection"](#).
2. Check radiator cap. Refer to [CO-12, "RADIATOR CAP : Inspection"](#).
3. Check water flow sounds of the engine coolant. Refer to [CO-10, "Refilling"](#).

Is the inspection result normal?

- YES >> GO TO 2.  
NO >> Refill the engine coolant and repair or replace the parts depending on the inspection results.

## 2. CHECK OPERATION

1. Turn temperature dial and raise temperature setting to 32.0°C (90°F) after warming up the engine.
2. Check that warm air blows from the outlets.

Is the inspection result normal?

- YES >> INSPECTION END  
NO >> GO TO 3.

## 3. CHECK SETTING OF TEMPERATURE SETTING TRIMMER

## Ⓜ With CONSULT-III

1. Select "TEMP SET CORRECT" of HVAC work support item. Refer to [HAC-99, "Temperature Setting Trimmer"](#).
2. Check that the temperature setting trimmer is set to "– direction".  
**NOTE:**  
The control temperature can be set by the temperature setting trimmer.
3. Set the difference between the set temperature and control temperature to "0".

Are the symptoms solved?

- YES >> INSPECTION END  
NO >> GO TO 4.

## 4. CHECK SELF-DIAGNOSIS RESULT CHECK

## Ⓜ With CONSULT-III

1. Perform the "SELF-DIAGNOSIS".
2. Check if any DTC is detected in the self-diagnostic results.

**NOTE:**

If DTC is displayed along with DTC "U1000" or "U1010", first diagnose the DTC "U1000" or "U1010". Refer to [HAC-118, "DTC Logic"](#) or [HAC-119, "DTC Logic"](#).

Is any DTC displayed?

- YES >> Perform the diagnosis that is applicable to the sensor and the door motor. Refer to [HAC-161, "DTC Index"](#).  
NO >> GO TO 5.

## 5. CHECK EACH OUTPUT DEVICE

## Ⓜ With CONSULT-III

1. Select "HVAC TEST" of HVAC active test item. Refer to [HAC-116, "CONSULT-III Function"](#).

**NOTE:**

Perform the ACTIVE TEST after starting the engine because the compressor is operated.

2. Refer to the table and check the outlet, inlet, air flow temperature, blower motor control signal, magnet clutch operation, and air mix ratio. Visually check each operating condition, by listening for noise, touching air outlets with a hand, etc.

# INSUFFICIENT HEATING

< SYMPTOM DIAGNOSIS >





[WITH 7 INCH DISPLAY]

	Test item						
	MODE 1	MODE 2	MODE 3	MODE 4	MODE 5	MODE 6	MODE 7
Mode door position	VENT	B/L 1	B/L 2	FOOT	D/F	DEF	—
Intake door position	REC	REC	20% FRE	FRE	FRE	FRE	—
Air mix door position	FULL COLD	FULL COLD	FULL HOT	FULL HOT	FULL HOT	FULL HOT	—
Blower fan motor control signal duty ratio	37%	91%	65%	65%	65%	91%	—
Magnet clutch	ON	ON	OFF	OFF	ON	ON	—
ECV duty ratio	100%	100%	0%	0%	50%	100%	—

**NOTE:**

- Perform the inspection of each output device after starting the engine because the compressor is operated.
- If the MODE 7 is selected, the malfunction is displayed but it is normal.

Discharge air flow

Mode position indication	Air outlet/distribution		
	VENT	FOOT	DEF
	100%	—	—
	60%	40%	—
	12%	62%	26%
	10%	52%	38%
	—	—	100%

Does it operate normally?

- YES >> GO TO 6.
- NO-1 >> Air outlet does not change. Refer to [HAC-135, "Diagnosis Procedure"](#).
- NO-2 >> Air inlet does not change. Refer to [HAC-137, "Diagnosis Procedure"](#).
- NO-3 >> Discharge air temperature does not change. Refer to [HAC-133, "Diagnosis Procedure"](#).
- NO-4 >> Blower motor does not operate normally. Refer to [HAC-142, "Diagnosis Procedure"](#).
- NO-5 >> Magnet clutch does not operate. Refer to [HAC-146, "Diagnosis Procedure"](#).

## 6. CHECK AIR LEAKAGE FROM DUCT

Check duct and nozzle, etc. of the air conditioner system for air leakage.

Is the inspection result normal?

- YES >> GO TO 7.
- NO >> Repair or replace parts depending on the inspection results.

## 7. CHECK HEATER HOSE INSTALLATION CONDITION

Check the heater hose installation condition visually (for twists, crushes, etc.).

Is the inspection result normal?

- YES >> GO TO 8.
- NO >> Repair or replace parts depending on the inspection results.

## 8. CHECK TEMPERATURE OF HEATER HOSE

1. Check the temperature of inlet hose and outlet hose of heater core.
2. Check that the inlet side of heater core is hot and the outlet side is slightly lower than/almost equal to the inlet side.

**CAUTION:**

**Always perform the temperature inspection in a short period of time because the engine coolant temperature is very hot.**

Is the inspection result normal?

- YES >> GO TO 9.

## INSUFFICIENT HEATING

< SYMPTOM DIAGNOSIS >

[WITH 7 INCH DISPLAY]

---

NO >> Replace the heater core after performing the procedures after the cooling system inspection. GO TO 1.

### 9.REPLACE HEATER CORE

---

Replace the heater core. Refer to [HA-47. "Exploded View"](#).

Are symptoms solved?

YES >> INSPECTION END

NO >> Perform the procedures again after the cooling system inspection. GO TO 1.



**NOISE****Description**

INFOID:000000005239291

## Symptom

- Noise
- Noise is heard when the A/C system operates.

**Diagnosis Procedure**

INFOID:000000005239292

**1.CHECK OPERATION**

1. Operate the A/C system and check the operation. Refer to [HAC-98. "Description & Inspection"](#).
2. Check the parts where noise is occurring.

Can the parts where noise is occurring be checked?

- YES-1 >> Noise from blower motor: GO TO 2.
- YES-2 >> Noise from compressor: GO TO 3.
- YES-3 >> Noise from expansion valve: GO TO 4.
- YES-4 >> Noise from cooler piping (pipe, flexible hose): GO TO 6.
- YES-5 >> Noise from drive belt: GO TO 7.
- NO >> INSPECTION END

**2.CHECK BLOWER MOTOR**

1. Remove blower motor.
2. Remove foreign materials that are in the blower unit.
3. Check the noise from blower motor again.

Is the inspection result normal?

- YES >> INSPECTION END
- NO >> Replace blower motor.

**3.CHECK COMPRESSOR**

Perform trouble diagnosis for the compressor and check the compressor. Refer to [HA-9. "Symptom Table"](#).

Is the inspection result normal?

- YES >> INSPECTION END
- NO >> Refill the refrigerant or replace the compressor depending on the inspection results.

**4.CHECK WITH GAUGE PRESSURE**

Perform the diagnosis with the gauge pressure. Refer to [HA-7. "Trouble Diagnosis For Unusual Pressure"](#).

Is the inspection result normal?

- YES >> GO TO 5.
- NO >> Repair or replace parts depending on the inspection results.

**5.CHECK EXPANSION VALVE**

1. Correct the refrigerant with recovery/recycling recharging equipment.
2. Recharge with the proper amount of the collected refrigerant after recycling or new refrigerant.
3. Check for the noise from expansion valve again.

Are the malfunction solved?

- YES >> INSPECTION END
- NO >> Replace expansion valve.

**6.CHECK COOLER PIPING (PIPE, FLEXIBLE HOSE)**

1. Check the cooler piping (pipes, flexible hoses) (for deformation and damage, etc.).
2. Check the installation condition of clips and brackets, etc. of the cooler piping (pipes, flexible hoses).

Is the inspection result normal?

- YES >> Fix the line with rubber or come vibration absorbing material.
- NO >> Repair or replace parts depending on the inspection results.

**7.CHECK DRIVE BELT**

## NOISE

< SYMPTOM DIAGNOSIS >

[WITH 7 INCH DISPLAY]

---

Check tension of the drive belt. Refer to [EM-17. "Checking"](#).

Is the inspection result normal?

YES >> Check the noise from the compressor: GO TO 3.

NO >> Adjust or replace drive belt depending on the inspection results.

# MEMORY FUNCTION DOES NOT OPERATE

< SYMPTOM DIAGNOSIS >

[WITH 7 INCH DISPLAY]

## MEMORY FUNCTION DOES NOT OPERATE

### Description

INFOID:000000005239293

#### Symptom

- Memory function does not operate normally.
- The setting is not maintained. (It returns to the initial condition.)

### Diagnosis Procedure

INFOID:000000005239294

#### 1.CHECK OPERATION

1. Turn the ignition switch ON.
2. Set temperature control dial to 32.0°C (90°F).
3. Press the OFF switch.
4. Turn the ignition switch OFF.
5. Turn the ignition switch ON.
6. Press the AUTO switch.
7. Check that the set temperature is maintained.

#### Is the inspection result normal?

YES >> INSPECTION END

NO >> GO TO 2.

#### 2.CHECK POWER SUPPLY AND GROUND CIRCUIT OF A/C AUTO AMP.

Check power supply and ground circuit of the A/C auto amp. Refer to [HAC-138, "A/C AUTO AMP. : Diagnosis Procedure"](#).

#### Is the inspection result normal?

YES >> Replace the A/C auto amp.

NO >> Repair or replace malfunctioning parts.

A  
B  
C  
D  
E  
F  
G  
H  
J  
K  
L  
M  
N  
O  
P

HAC

&lt; PRECAUTION &gt;

**PRECAUTION****PRECAUTIONS****EXCEPT FOR MEXICO****EXCEPT FOR MEXICO : Precaution for Supplemental Restraint System (SRS) "AIR BAG" and "SEAT BELT PRE-TENSIONER"**

INFOID:000000005653822

The Supplemental Restraint System such as "AIR BAG" and "SEAT BELT PRE-TENSIONER", used along with a front seat belt, helps to reduce the risk or severity of injury to the driver and front passenger for certain types of collision. This system includes seat belt switch inputs and dual stage front air bag modules. The SRS system uses the seat belt switches to determine the front air bag deployment, and may only deploy one front air bag, depending on the severity of a collision and whether the front occupants are belted or unbelted.

Information necessary to service the system safely is included in the "SRS AIR BAG" and "SEAT BELT" of this Service Manual.

**WARNING:**

- **To avoid rendering the SRS inoperative, which could increase the risk of personal injury or death in the event of a collision which would result in air bag inflation, all maintenance must be performed by an authorized NISSAN/INFINITI dealer.**
- **Improper maintenance, including incorrect removal and installation of the SRS, can lead to personal injury caused by unintentional activation of the system. For removal of Spiral Cable and Air Bag Module, see the "SRS AIR BAG".**
- **Do not use electrical test equipment on any circuit related to the SRS unless instructed to in this Service Manual. SRS wiring harnesses can be identified by yellow and/or orange harnesses or harness connectors.**

**PRECAUTIONS WHEN USING POWER TOOLS (AIR OR ELECTRIC) AND HAMMERS****WARNING:**

- **When working near the Air Bag Diagnosis Sensor Unit or other Air Bag System sensors with the ignition ON or engine running, DO NOT use air or electric power tools or strike near the sensor(s) with a hammer. Heavy vibration could activate the sensor(s) and deploy the air bag(s), possibly causing serious injury.**
- **When using air or electric power tools or hammers, always switch the ignition OFF, disconnect the battery, and wait at least 3 minutes before performing any service.**

**EXCEPT FOR MEXICO : Precaution Necessary for Steering Wheel Rotation after Battery Disconnect**

INFOID:000000005655065

**NOTE:**

- Before removing and installing any control units, first turn the push-button ignition switch to the LOCK position, then disconnect both battery cables.
- After finishing work, confirm that all control unit connectors are connected properly, then re-connect both battery cables.
- Always use CONSULT-III to perform self-diagnosis as a part of each function inspection after finishing work. If a DTC is detected, perform trouble diagnosis according to self-diagnosis results.

For vehicle with steering lock unit, if the battery is disconnected or discharged, the steering wheel will lock and cannot be turned.

If turning the steering wheel is required with the battery disconnected or discharged, follow the operation procedure below before starting the repair operation.

**OPERATION PROCEDURE**

1. Connect both battery cables.

**NOTE:**

Supply power using jumper cables if battery is discharged.

2. Turn the push-button ignition switch to ACC position.  
(At this time, the steering lock will be released.)
3. Disconnect both battery cables. The steering lock will remain released with both battery cables disconnected and the steering wheel can be turned.
4. Perform the necessary repair operation.

# PRECAUTIONS

[WITH 7 INCH DISPLAY]

< PRECAUTION >

5. When the repair work is completed, re-connect both battery cables. With the brake pedal released, turn the push-button ignition switch from ACC position to ON position, then to LOCK position. (The steering wheel will lock when the push-button ignition switch is turned to LOCK position.)
6. Perform self-diagnosis check of all control units using CONSULT-III.

## EXCEPT FOR MEXICO : Precaution for Battery Service

INFOID:000000005653824

Before disconnecting the battery, lower both the driver and passenger windows. This will prevent any interference between the window edge and the vehicle when the door is opened/closed. During normal operation, the window slightly raises and lowers automatically to prevent any window to vehicle interference. The automatic window function will not work with the battery disconnected.

## FOR MEXICO

## FOR MEXICO : Precaution for Supplemental Restraint System (SRS) "AIR BAG" and "SEAT BELT PRE-TENSIONER"

INFOID:000000005653825

The Supplemental Restraint System such as "AIR BAG" and "SEAT BELT PRE-TENSIONER", used along with a front seat belt, helps to reduce the risk or severity of injury to the driver and front passenger for certain types of collision. Information necessary to service the system safely is included in the "SRS AIR BAG" and "SEAT BELT" of this Service Manual.

### WARNING:

- To avoid rendering the SRS inoperative, which could increase the risk of personal injury or death in the event of a collision which would result in air bag inflation, all maintenance must be performed by an authorized NISSAN/INFINITI dealer.
- Improper maintenance, including incorrect removal and installation of the SRS, can lead to personal injury caused by unintentional activation of the system. For removal of Spiral Cable and Air Bag Module, see the "SRS AIR BAG".
- Do not use electrical test equipment on any circuit related to the SRS unless instructed to in this Service Manual. SRS wiring harnesses can be identified by yellow and/or orange harnesses or harness connectors.

## PRECAUTIONS WHEN USING POWER TOOLS (AIR OR ELECTRIC) AND HAMMERS

### WARNING:

- When working near the Air Bag Diagnosis Sensor Unit or other Air Bag System sensors with the ignition ON or engine running, DO NOT use air or electric power tools or strike near the sensor(s) with a hammer. Heavy vibration could activate the sensor(s) and deploy the air bag(s), possibly causing serious injury.
- When using air or electric power tools or hammers, always switch the ignition OFF, disconnect the battery, and wait at least 3 minutes before performing any service.

## FOR MEXICO : Precaution Necessary for Steering Wheel Rotation after Battery Disconnect

INFOID:000000005655066

### NOTE:

- Before removing and installing any control units, first turn the push-button ignition switch to the LOCK position, then disconnect both battery cables.
- After finishing work, confirm that all control unit connectors are connected properly, then re-connect both battery cables.
- Always use CONSULT-III to perform self-diagnosis as a part of each function inspection after finishing work. If a DTC is detected, perform trouble diagnosis according to self-diagnosis results.

For vehicle with steering lock unit, if the battery is disconnected or discharged, the steering wheel will lock and cannot be turned.

If turning the steering wheel is required with the battery disconnected or discharged, follow the operation procedure below before starting the repair operation.

## OPERATION PROCEDURE

1. Connect both battery cables.

### NOTE:

Supply power using jumper cables if battery is discharged.

2. Turn the push-button ignition switch to ACC position.

## PRECAUTIONS

< PRECAUTION >

[WITH 7 INCH DISPLAY]

(At this time, the steering lock will be released.)

3. Disconnect both battery cables. The steering lock will remain released with both battery cables disconnected and the steering wheel can be turned.
4. Perform the necessary repair operation.
5. When the repair work is completed, re-connect both battery cables. With the brake pedal released, turn the push-button ignition switch from ACC position to ON position, then to LOCK position. (The steering wheel will lock when the push-button ignition switch is turned to LOCK position.)
6. Perform self-diagnosis check of all control units using CONSULT-III.

### FOR MEXICO : Precaution for Battery Service

INFOID:000000005653826

Before disconnecting the battery, lower both the driver and passenger windows. This will prevent any interference between the window edge and the vehicle when the door is opened/closed. During normal operation, the window slightly raises and lowers automatically to prevent any window to vehicle interference. The automatic window function will not work with the battery disconnected.

# PRESET SWITCH

< REMOVAL AND INSTALLATION >

[WITH 7 INCH DISPLAY]

## REMOVAL AND INSTALLATION

### PRESET SWITCH

Exploded View

INFOID:000000005239298

DISASSEMBLY

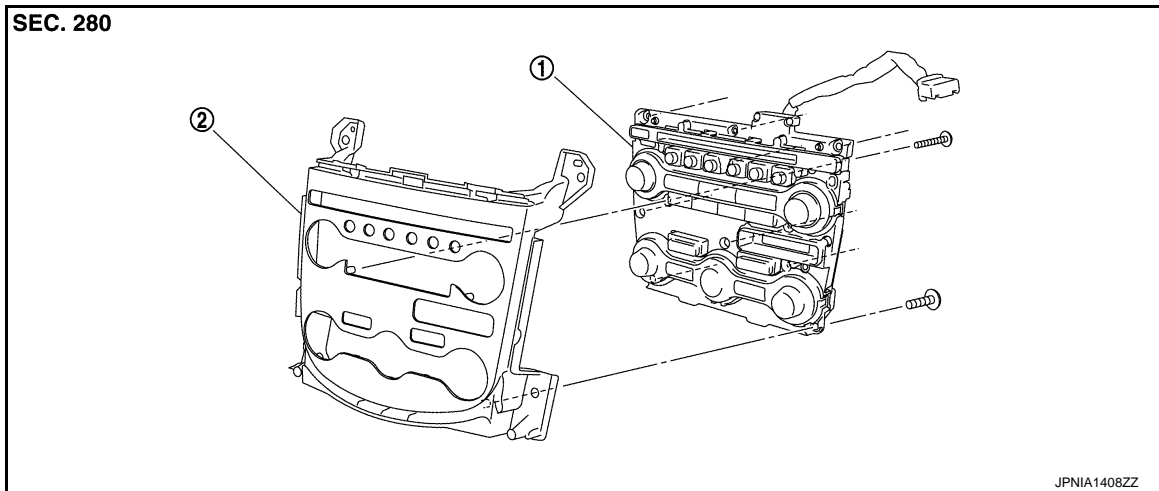

1. Preset switch

2. Cluster lid C finisher

### Removal and Installation

INFOID:000000005239299

#### REMOVAL

Refer to [AV-345, "Exploded View"](#).

#### INSTALLATION

Installation is basically the reverse order of removal.

A

B

C

D

E

F

G

H

HAC

J

K

L

M

N

O

P

# A/C AUTO AMP.

< REMOVAL AND INSTALLATION >

[WITH 7 INCH DISPLAY]

## A/C AUTO AMP.

Exploded View

INFOID:000000005239300

DISASSEMBLY

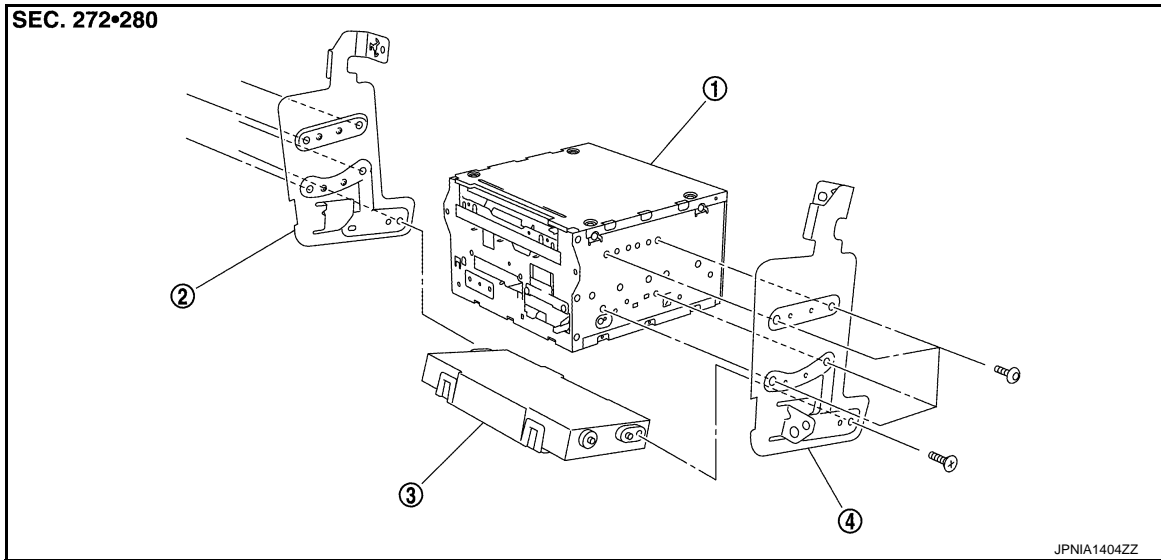

- 1. AV control unit
- 4. Bracket RH

2. Bracket LH

3. A/C auto amp.

## Removal and Installation

INFOID:000000005239301

### REMOVAL

1. Remove AV control unit. Refer to [AV-333. "Exploded View"](#).
2. Remove mounting screws (A), and then remove A/C auto amp. (1).

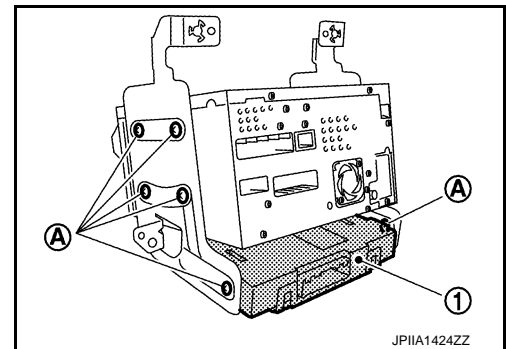

### INSTALLATION

Installation is basically the reverse order of removal.



# AMBIENT SENSOR

< REMOVAL AND INSTALLATION >

[WITH 7 INCH DISPLAY]

## AMBIENT SENSOR

### Exploded View

INFOID:000000005239302

1. Ambient sensor

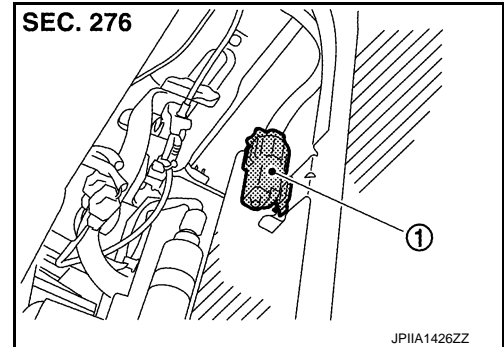

### Removal and Installation

INFOID:000000005239303

#### REMOVAL

1. Remove the engine under cover. Refer to [EXT-29, "ENGINE UNDER COVER : Exploded View"](#).
2. Disconnect ambient sensor connector, and then remove ambient sensor (1) from bracket.

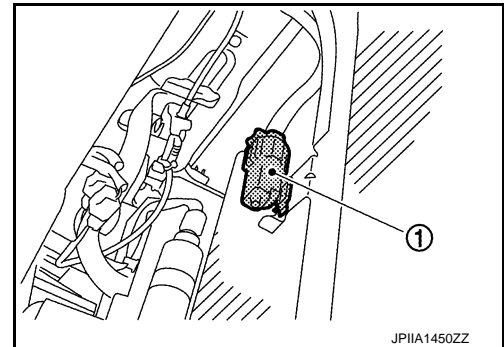

#### INSTALLATION

Installation is basically the reverse order of removal.

A  
B  
C  
D  
E  
F  
G  
H  
HAC  
J  
K  
L  
M  
N  
O  
P

# IN-VEHICLE SENSOR

< REMOVAL AND INSTALLATION >

[WITH 7 INCH DISPLAY]

## IN-VEHICLE SENSOR

### Exploded View

INFOID:000000005239304

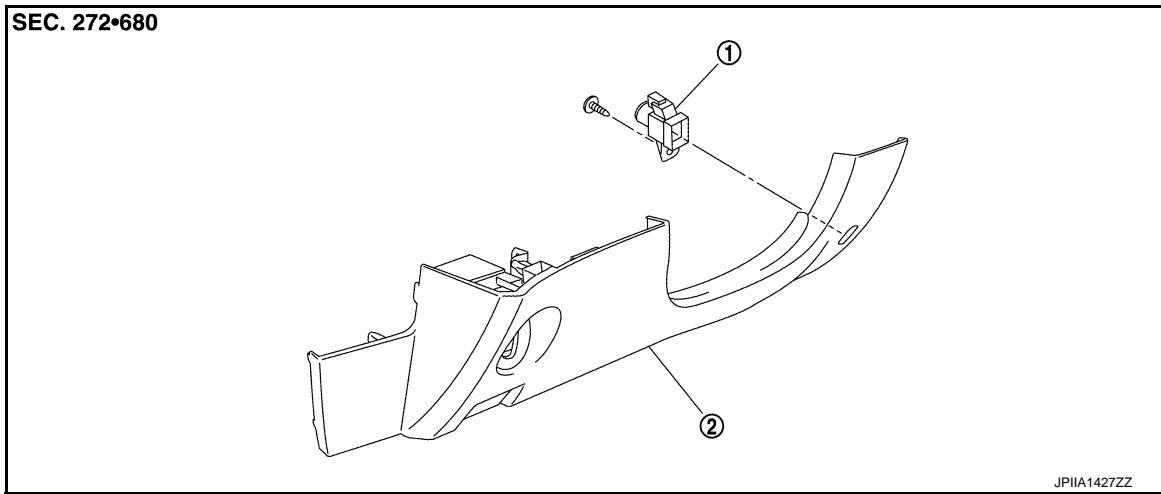

1. In-vehicle sensor

2. Instrument lower panel LH

### Removal and Installation

INFOID:000000005239305

#### REMOVAL

1. Remove instrument lower panel LH. Refer to [IP-12, "Exploded View"](#).
2. Remove mounting screw (A), and then remove in-vehicle sensor (1).

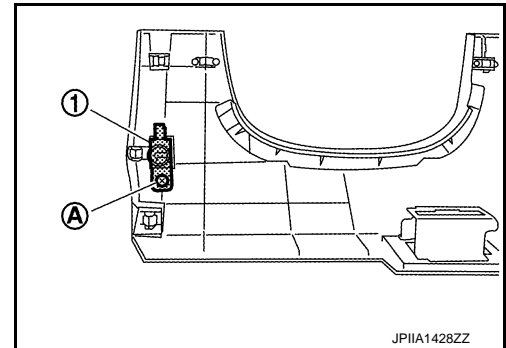

#### INSTALLATION

Installation is basically the reverse order of removal.

# SUNLOAD SENSOR

< REMOVAL AND INSTALLATION >

[WITH 7 INCH DISPLAY]

## SUNLOAD SENSOR

### Exploded View

INFOID:000000005239306

1. Sunload sensor

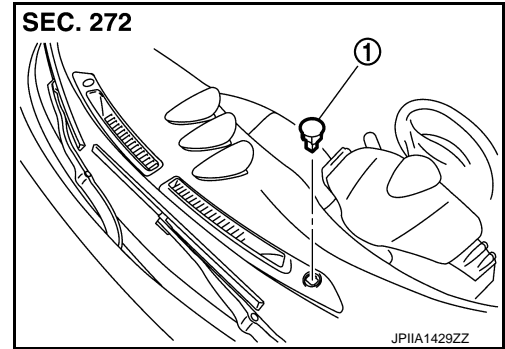

### Removal and Installation

INFOID:000000005239307

#### REMOVAL

Disconnect sunload sensor connector, and then remove sunload sensor.

#### INSTALLATION

Installation is basically the reverse order of removal.

A  
B  
C  
D  
E  
F  
G  
H  
J  
K  
L  
M  
N  
O  
P

HAC

# INTAKE SENSOR

< REMOVAL AND INSTALLATION >

[WITH 7 INCH DISPLAY]

## INTAKE SENSOR

### Exploded View

INFOID:000000005239308

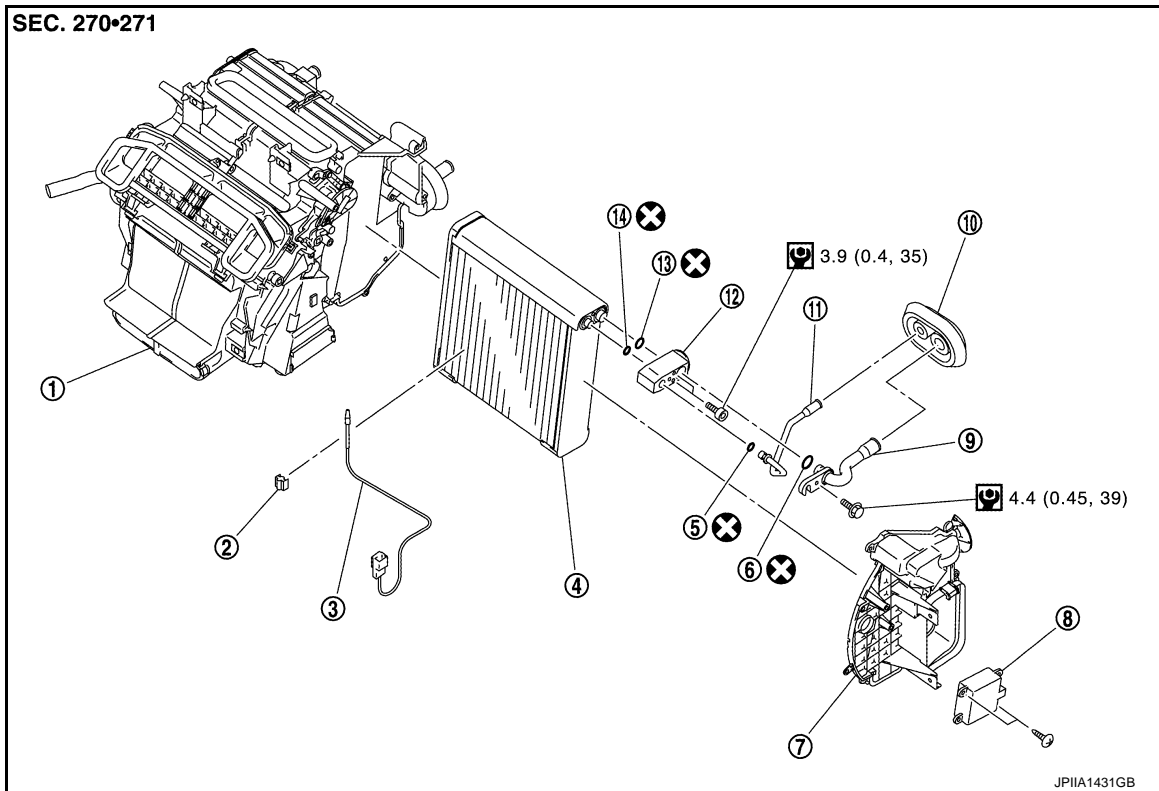

- |                                   |                                   |                                 |
|-----------------------------------|-----------------------------------|---------------------------------|
| 1. Heater & cooling unit assembly | 2. Intake sensor bracket          | 3. Intake sensor                |
| 4. Evaporator                     | 5. O-ring                         | 6. O-ring                       |
| 7. Evaporator cover               | 8. Air mix door motor             | 9. Low-pressure evaporator pipe |
| 10. Cooler pipe grommet           | 11. High-pressure evaporator pipe | 12. Expansion valve             |
| 13. O-ring                        | 14. O-ring                        |                                 |

Refer to [GI-4. "Components"](#) for symbols in the figure.

## Removal and Installation

INFOID:000000005239309

### REMOVAL

1. Remove high-pressure evaporator pipe and low-pressure evaporator pipe. Refer to [HA-52. "Exploded View"](#).
2. Disconnect intake sensor connector.
3. Slide evaporator (1) toward the right side of the vehicle (as shown in the figure), and then remove intake sensor (2).

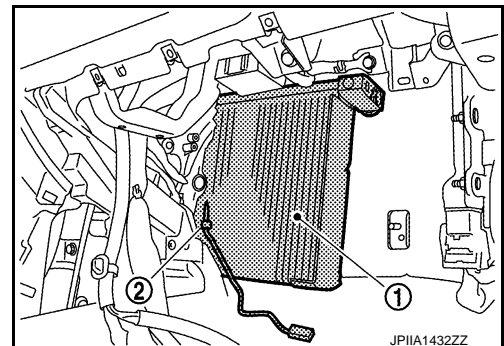

### INSTALLATION

Installation is basically the reverse order of removal.

# INTAKE SENSOR

< REMOVAL AND INSTALLATION >

[WITH 7 INCH DISPLAY]

**CAUTION:**

- Replace O-rings with new ones. Then apply the compressor oil to them when installing.
- Mark the mounting position of intake sensor bracket prior to removal so that the reinstalled sensor can be located in the same position.
- Never rotate the bracket insertion part when removing and installing the intake sensor.
- Check for leakages when recharging refrigerant. Refer to [HA-27, "Leak Test"](#).

A  
B  
C  
D  
E  
F  
G  
H  
J  
K  
L  
M  
N  
O  
P

HAC

# REFRIGERANT PRESSURE SENSOR

< REMOVAL AND INSTALLATION >

[WITH 7 INCH DISPLAY]

## REFRIGERANT PRESSURE SENSOR

Exploded View

INFOID:000000005239310

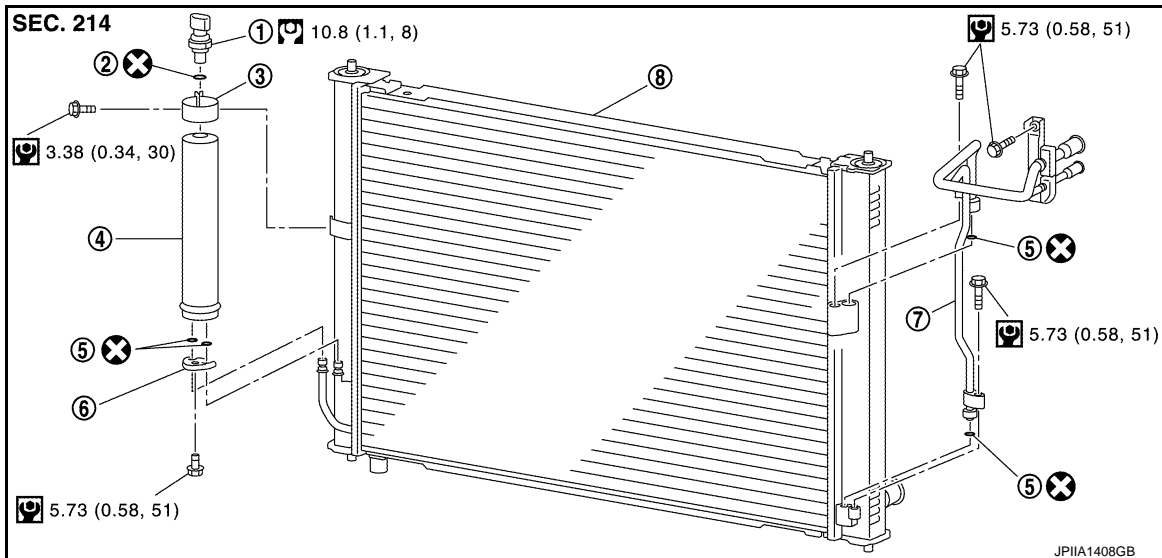

- |                                |                                  |                        |
|--------------------------------|----------------------------------|------------------------|
| 1. Refrigerant pressure sensor | 2. O-ring                        | 3. Liquid tank bracket |
| 4. Liquid tank                 | 5. O-ring                        | 6. Bracket             |
| 7. Condenser pipe assembly     | 8. Radiator & condenser assembly |                        |

Refer to [GI-4, "Components"](#) for symbols in the figure.

## Removal and Installation

INFOID:000000005239311

### REMOVAL

1. Remove liquid tank. Refer to [HA-43, "Exploded View"](#).
2. Fix the liquid tank (1) with a vise (A). Remove the refrigerant pressure sensor (2) with a wrench (B).

**CAUTION:**

**Be careful not to damage liquid tank.**

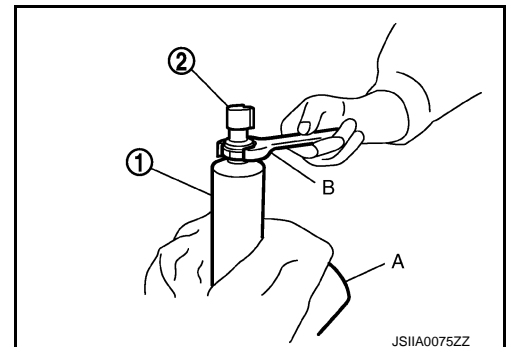

### INSTALLATION

Installation is basically the reverse order of removal.

**CAUTION:**

- Replace O-ring with new one. Then apply compressor oil to them when installing.
- Check for leakages when recharging refrigerant. Refer to [HA-27, "Leak Test"](#).

# DOOR MOTOR

< REMOVAL AND INSTALLATION >

[WITH 7 INCH DISPLAY]

## DOOR MOTOR

Exploded View

INFOID:000000005239312

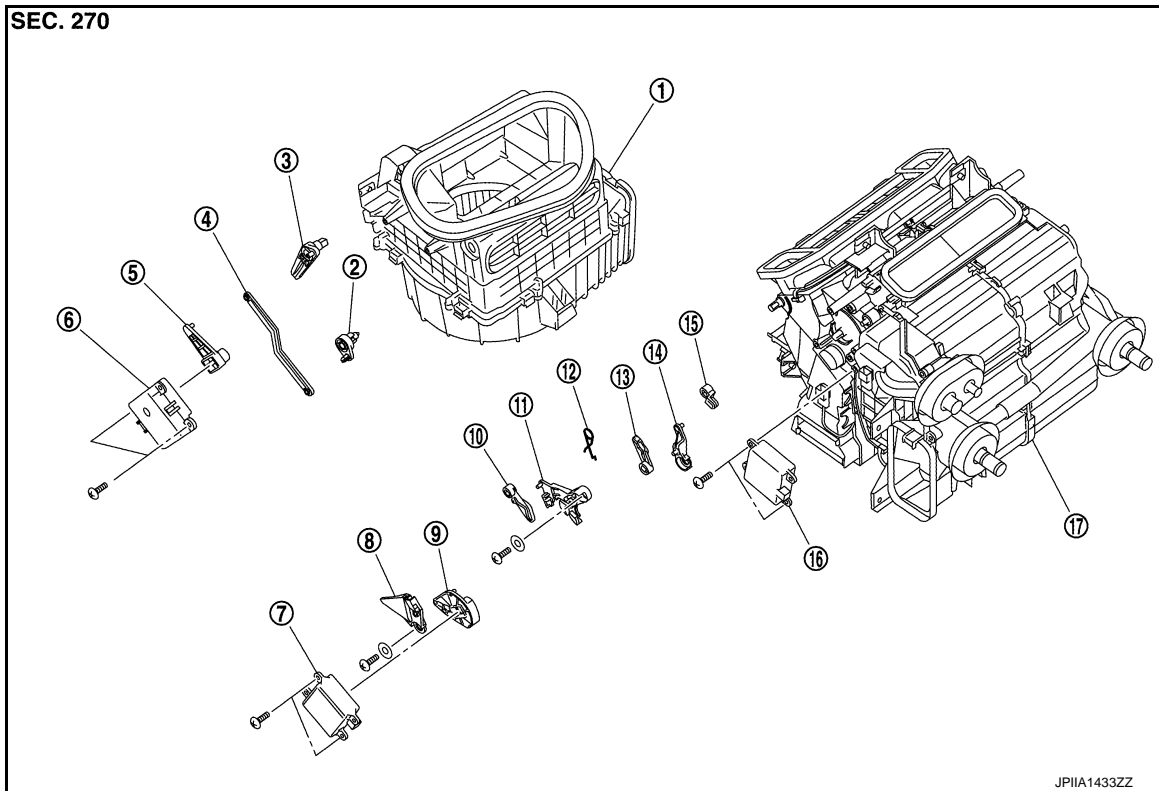

- |                           |                                    |                                  |
|---------------------------|------------------------------------|----------------------------------|
| 1. Bower unit             | 2. Intake door lever 3             | 3. Intake door lever 1           |
| 4. Intake door link       | 5. Intake door lever 2             | 6. Intake door motor             |
| 7. Mode door motor        | 8. Ventilator door link            | 9. Main link                     |
| 10. Ventilator door lever | 11. Main link sub                  | 12. Ventilator door lever spring |
| 13. Max. cool door lever  | 14. Defroster door link            | 15. Defroster door lever         |
| 16. Air mix door motor    | 17. Heater & cooling unit assembly |                                  |

## INTAKE DOOR MOTOR

### INTAKE DOOR MOTOR : Removal and Installation

INFOID:000000005239313

#### REMOVAL

1. Remove instrument lower panel RH. Refer to [IP-12. "Exploded View"](#).
2. Remove ECM.
3. Remove mounting screws (A), and then remove intake door motor (1).
4. Disconnect intake door motor connector.

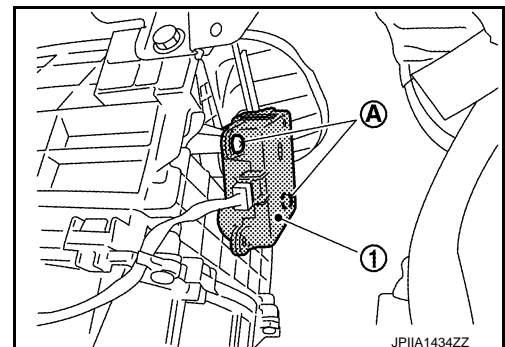

#### INSTALLATION

A  
B  
C  
D  
E  
F  
G  
H  
HAC  
J  
K  
L  
M  
N  
O  
P

# DOOR MOTOR

< REMOVAL AND INSTALLATION >

[WITH 7 INCH DISPLAY]

Installation is basically the reverse order of removal.

## MODE DOOR MOTOR

### MODE DOOR MOTOR : Removal and Installation

INFOID:000000005239314

#### REMOVAL

1. Remove blower unit. Refer to [VTL-13, "Exploded View"](#).
2. Remove mounting screws (A), and then remove mode door motor (1).
3. Disconnect mode door motor connector.

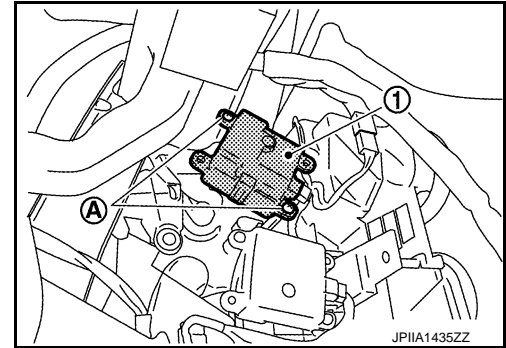

#### INSTALLATION

Installation is basically the reverse order of removal.

## AIR MIX DOOR MOTOR

### AIR MIX DOOR MOTOR : Removal and Installation

INFOID:000000005239315

#### REMOVAL

1. Set the temperature at 18.0°C (60°F).  
**CAUTION:**  
**The angle may be out, when installing the air mix door motor to the air mix door, unless the above procedure is performed.**
2. Disconnect the battery cable from the negative terminal.
3. Remove instrument lower panel RH. Refer to [IP-12, "Exploded View"](#).
4. Remove mounting screws (A), and then remove air mix door motor (1).
5. Disconnect air mix door motor connector.

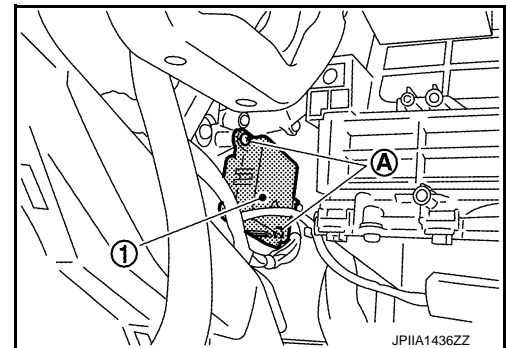

#### INSTALLATION

Installation is basically the reverse order of removal.