

SECTION **RSU**
 REAR SUSPENSION

A
 B
 C
 D

RSU

CONTENTS

<p>REGULAR GRADE</p> <p>SYMPTOM DIAGNOSIS 2</p> <p>NOISE, VIBRATION AND HARSHNESS (NVH) TROUBLESHOOTING 2</p> <p> NVH Troubleshooting Chart2</p> <p>PRECAUTION 3</p> <p>PRECAUTIONS 3</p> <p> Precautions for Suspension3</p> <p>PREPARATION 4</p> <p>PREPARATION 4</p> <p> Special Service Tool4</p> <p> Commercial Service Tool4</p> <p>PERIODIC MAINTENANCE 5</p> <p>REAR SUSPENSION ASSEMBLY 5</p> <p> Inspection5</p> <p>WHEEL ALIGNMENT 6</p> <p> Inspection6</p> <p> Adjustment6</p> <p>REMOVAL AND INSTALLATION 8</p> <p>REAR LOWER LINK & COIL SPRING 8</p> <p> Exploded View8</p> <p> Removal and Installation8</p> <p> Inspection9</p> <p>REAR SHOCK ABSORBER10</p> <p> Exploded View10</p> <p> Removal and Installation10</p> <p> Disassembly and Assembly10</p> <p> Inspection11</p> <p> Disposal11</p> <p>SUSPENSION ARM12</p>	<p> Exploded View12</p> <p> Removal and Installation12</p> <p> Inspection12</p> <p>RADIUS ROD14</p> <p> Exploded View14</p> <p> Removal and Installation14</p> <p> Inspection14</p> <p>FRONT LOWER LINK15</p> <p> Exploded View15</p> <p> Removal and Installation15</p> <p> Inspection15</p> <p>REAR STABILIZER16</p> <p> Exploded View16</p> <p> Removal and Installation16</p> <p> Inspection16</p> <p>UNIT REMOVAL AND INSTALLATION17</p> <p>REAR SUSPENSION MEMBER17</p> <p> Exploded View17</p> <p> Removal and Installation17</p> <p> Inspection18</p> <p>SERVICE DATA AND SPECIFICATIONS (SDS)19</p> <p>SERVICE DATA AND SPECIFICATIONS (SDS)19</p> <p> Wheel Alignment19</p> <p> Ball Joint19</p> <p> Wheelarch Height19</p> <p style="text-align: center;">Nismo 370Z</p> <p>REMOVAL AND INSTALLATION20</p> <p>REAR PERFORMANCE DAMPER20</p> <p> Exploded View20</p> <p> Removal and Installation20</p>	<p>F G H I J K L M N O P</p>
---	---	--

NOISE, VIBRATION AND HARSHNESS (NVH) TROUBLESHOOTING

< SYMPTOM DIAGNOSIS >

[REGULAR GRADE]

SYMPTOM DIAGNOSIS

NOISE, VIBRATION AND HARSHNESS (NVH) TROUBLESHOOTING

NVH Troubleshooting Chart

INFOID:000000005239800

Use chart below to find the cause of the symptom. If necessary, repair or replace these parts.

Symptom		Possible cause and SUSPECTED PARTS		Reference page													
				RSU-8, RSU-10, RSU-12, RSU-14, RSU-15, RSU-16, RSU-17	RSU-11	—	—	—	RSU-8, RSU-10, RSU-12, RSU-14, RSU-15, RSU-16, RSU-17	RSU-16	NVH in DLN section.	NVH in DLN section.	NVH in RAX and RSU sections.	NVH in WT section.	NVH in WT section.	NVH in RAX section.	NVH in BR section.
REAR SUSPENSION	Noise	x	x	x	x	x	x			x	x	x	x	x	x	x	x
	Shake	x	x	x	x		x			x		x	x	x	x	x	x
	Vibration	x	x	x	x	x				x		x	x		x		x
	Shimmy	x	x	x	x			x				x	x	x		x	x
	Judder	x	x	x								x	x	x		x	x
	Poor quality ride or handling	x	x	x	x	x		x	x				x	x	x		

x: Applicable

PRECAUTION

PRECAUTIONS

Precautions for Suspension

INFOID:000000005239801

- When installing rubber bushings, the final tightening must be carried out under unladen conditions with tires on ground. Spilled oil might shorten the life of rubber bushings. Be sure to wipe off any spilled oil.
- Unladen conditions mean that fuel, engine coolant and lubricant are full. Spare tire, jack, hand tools and mats are in designated positions.
- After servicing suspension parts, be sure to check wheel alignment.
- Self-lock nuts are not reusable. Always use new ones when installing. Since new self-lock nuts are pre-oiled, tighten as they are.

A
B
C
D
F
G
H
I
J
K
L
M
N
O
P

RSU

PREPARATION

< PREPARATION >

[REGULAR GRADE]

PREPARATION

PREPARATION

Special Service Tool

INFOID:000000005239802

The actual shapes of Kent-Moore tools may differ from those of special service tools illustrated here.

Tool number (Kent-Moore No.) Tool name	Description
ST3127S000 (J-25765-A) Preload gauge	Measuring rotating torque of ball joint

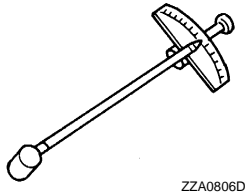

Commercial Service Tool

INFOID:000000005239803

Tool name	Description
Power tool	Loosening bolts and nuts
Ball joint remover	Removing ball joint from axle housing

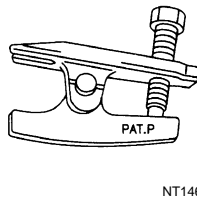
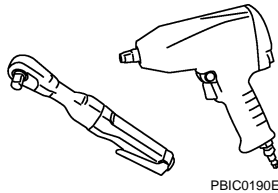

PERIODIC MAINTENANCE

REAR SUSPENSION ASSEMBLY

Inspection

INFOID:000000005239804

MOUNTING INSPECTION

Make sure the mounting conditions (looseness, backlash) of each component and component conditions (wear, damage) are normal.

BALL JOINT AXIAL END PLAY

Measure axial end play by placing and moving up/down with an iron bar or equivalent between suspension arm and axle assembly.

Axial end play : Refer to [RSU-19, "Ball Joint"](#).

CAUTION:

- Never depress brake pedal when measuring.
- Never perform with tires on level ground.
- Be careful not to damage ball joint boot. Never damage the installation position by applying excessive force.

SHOCK ABSORBER

Check for oil leakage and damage. Replace it if necessary.

A
B
C
D
F
G
H
I
J
K
L
M
N
O
P

RSU

WHEEL ALIGNMENT

Inspection

INFOID:000000005239805

DESCRIPTION

Measure wheel alignment under unladen conditions.

NOTE:

"Unladen conditions" means that fuel, engine coolant, and lubricant are full. Spare tire, jack, hand tools and mats are in designated positions.

PRELIMINARY CHECK

Check the following:

- Tires for improper air pressure and wear.
- Road wheels for runout. Refer to [WT-56, "Inspection"](#).
- Wheel bearing axial end play. Refer to [RAX-5, "Inspection"](#).
- Ball joint axial end play of suspension arm. Refer to [RSU-12, "Inspection"](#).
- Shock absorber operation.
- Each mounting point of axle and suspension for looseness and deformation.
- Each of front lower link, rear lower link, radius rod, rear suspension member, suspension arm and shock absorber for cracks, deformation, and other damage.
- Vehicle height (posture).

GENERAL INFORMATION AND RECOMMENDATIONS

- A four-wheel thrust alignment should be performed.
- This type of alignment is recommended for any NISSAN/INFINITI vehicle.
- The four-wheel "thrust" process helps ensure that the vehicle is properly aligned and the steering wheel is centered.
- The alignment rack itself should be capable of accepting any NISSAN/INFINITI vehicle.
- The rack should be checked to ensure that it is level.
- Make sure the machine is properly calibrated.
- Your alignment equipment should be regularly calibrated in order to give correct information.
- Check with the manufacturer of your specific equipment for their recommended Service/Calibration Schedule.

ALIGNMENT PROCESS

IMPORTANT:

Use only the alignment specifications listed in this Service Manual.

- When displaying the alignment settings, many alignment machines use "indicators": (Green/red, plus or minus, Go/No Go). **Never use these indicators.**
- The alignment specifications programmed into your machine that operate these indicators may not be correct.
- This may result in an ERROR.
- Some newer alignment machines are equipped with an optional "Rolling Compensation" method to "compensate" the sensors (alignment targets or head units). **Never use this "Rolling Compensation" method.**
- Use the "Jacking Compensation Method". After installing the alignment targets or head units, raise the vehicle and rotate the wheels 1/2 turn both ways.
- See Instructions in the alignment machine you're using for more information on this.

Adjustment

INFOID:000000005239806

CAMBER

WHEEL ALIGNMENT

< PERIODIC MAINTENANCE >

[REGULAR GRADE]

Adjust with adjusting bolt (1) in front lower link (2).

Camber: Refer to [RSU-19, "Wheel Alignment"](#).

CAUTION:

After adjusting camber, be sure to check toe-in.

- If camber is not still within the specification, inspect and replace any damaged or worn suspension parts.

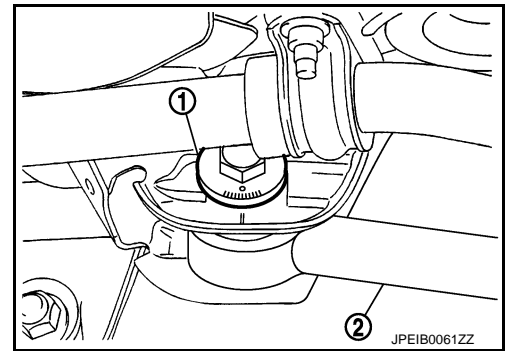

TOE-IN

Adjust with adjusting bolt (1) in rear lower link (2).

Toe-In: Refer to [RSU-19, "Wheel Alignment"](#).

CAUTION:

Be sure to adjust equally on right and left side with adjusting bolt.

- If toe-in is not still within the specification, inspect and replace any damaged or worn suspension parts.

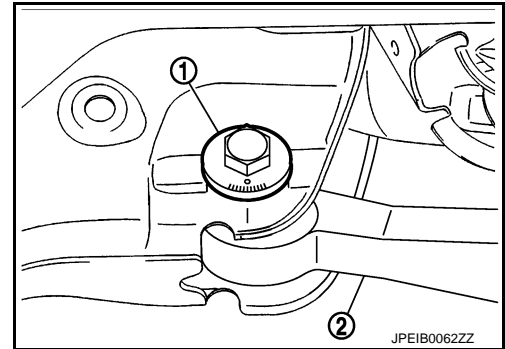

A
B
C
D

RSU

F
G
H
I
J
K
L
M
N
O
P

REAR LOWER LINK & COIL SPRING

< REMOVAL AND INSTALLATION >

[REGULAR GRADE]

REMOVAL AND INSTALLATION

REAR LOWER LINK & COIL SPRING

Exploded View

INFOID:000000005239807

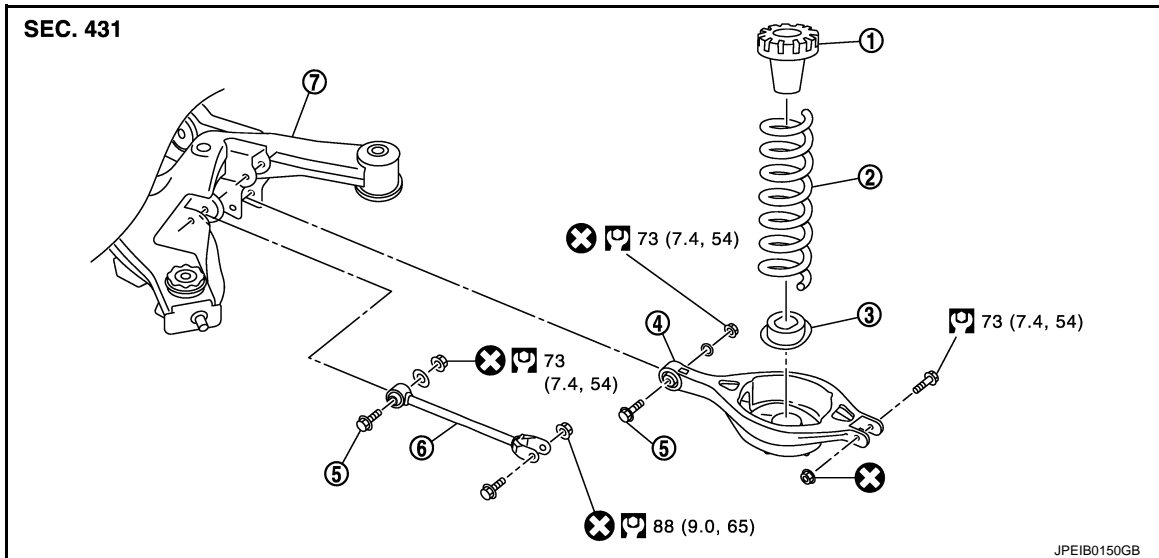

- | | | |
|---------------------------|-------------------|---------------------|
| 1. Upper seat | 2. Coil spring | 3. Rubber seat |
| 4. Rear lower link | 5. Adjusting bolt | 6. Front lower link |
| 7. Rear suspension member | | |

Refer to [GI-4, "Components"](#) for symbols in the figure.

Removal and Installation

INFOID:000000005239808

REMOVAL

1. Remove tires with power tool.
2. Set suitable jack under rear lower link to relieve the coil spring tension.
3. Loosen rear lower link mounting nuts (rear suspension member side).
4. Remove rear lower link (axle housing side).
5. Slowly lower jack, then remove upper seat, coil spring and rubber sheet from rear lower link.
6. Remove rear lower link.

INSTALLATION

Note the following, and install in the reverse order of removal.

- Make sure that upper seat is attached as shown in the figure.

CAUTION:

Make sure that the projecting parts (A) of floor panel (2) is securely fitted with upper seat (1) tab (B).

← : Body side

- Match up rubber seat indentions and rear lower link grooves and attach.

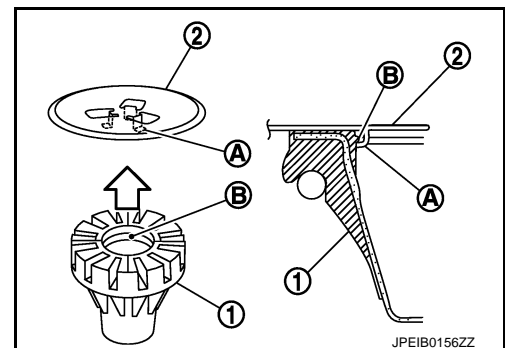

REAR LOWER LINK & COIL SPRING

< REMOVAL AND INSTALLATION >

[REGULAR GRADE]

- Install the coil spring by aligning the lower end of the large diameter side to the step (A) between the rubber seat (1) and the rear lower link (2).

CAUTION:

Make sure spring is not up side down. The top and bottom are indicated by paint color.

- Perform the final tightening of rear suspension member and axle installation position (rubber bushing) under unladen condition with tires on level ground.

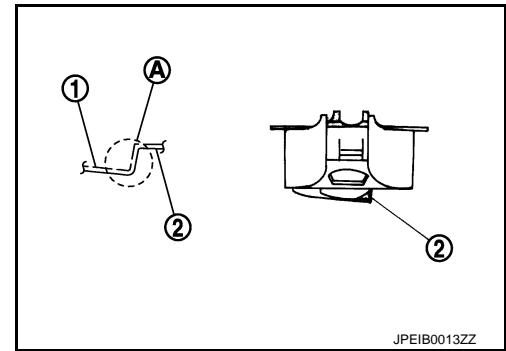

INFOID:000000005239809

Inspection

INSPECTION AFTER REMOVAL

Check rear lower link, bushing and coil spring for deformation, crack, and damage. Replace it if necessary.

INSPECTION AFTER INSTALLATION

1. Check wheel alignment. Refer to [RSU-6, "Inspection"](#).
2. Adjust neutral position of steering angle sensor. Refer to [BRC-8, "ADJUSTMENT OF STEERING ANGLE SENSOR NEUTRAL POSITION : Special Repair Requirement"](#).

A
B
C
D

RSU

F
G
H
I
J
K
L
M
N
O
P

REAR SHOCK ABSORBER

< REMOVAL AND INSTALLATION >

[REGULAR GRADE]

REAR SHOCK ABSORBER

Exploded View

INFOID:000000005239810

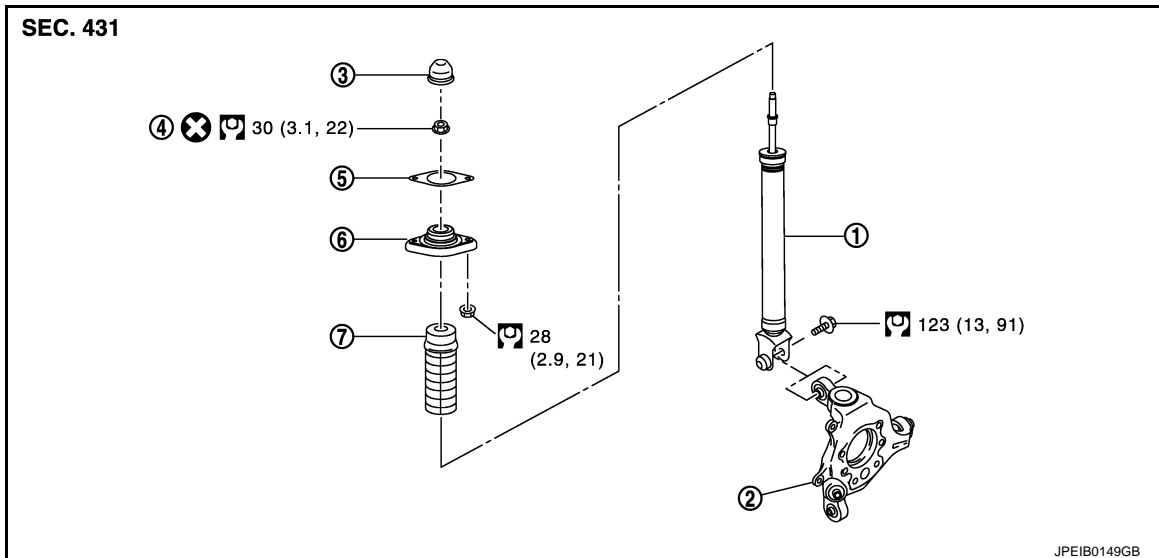

- | | | |
|------------------------|------------------|------------------------------------|
| 1. Shock absorber | 2. Axle housing | 3. Cap |
| 4. Piston rod lock nut | 5. Mounting seal | 6. Shock absorber mounting bracket |
| 7. Bound bumper cover | | |

Refer to [GI-4, "Components"](#) for symbols in the figure.

Removal and Installation

INFOID:000000005239811

REMOVAL

1. Remove tires with power tool.
2. Set suitable jack under axle assembly to relieve the coil spring tension.
3. Gradually lower the jack and separate shock absorber (lower side) from axle housing.
4. Remove shock absorber assembly mounting nuts (upper side) (←), and then remove shock absorber assembly.

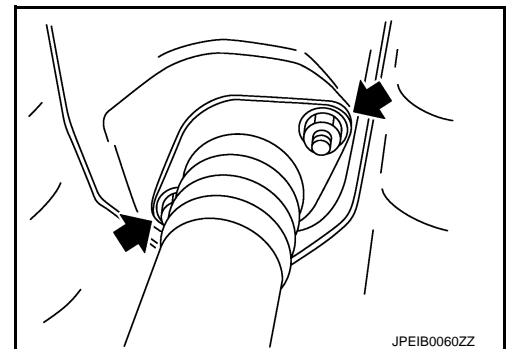

INSTALLATION

Note the following, and install in the reverse order of removal.

- Perform final tightening of bolts and nuts at the shock absorber lower side (rubber bushing), under unladen conditions with tires on level ground.

Disassembly and Assembly

INFOID:000000005239812

DISASSEMBLY

CAUTION:

Never damage shock absorber piston rod when removing components from shock absorber.

1. Remove cap.

REAR SHOCK ABSORBER

[REGULAR GRADE]

< REMOVAL AND INSTALLATION >

2. Wrap a shop cloth around lower side of shock absorber and fix it with a vise.
CAUTION:
Never set the cylindrical part of shock absorber with a vise.
3. Secure the piston rod tip so that piston rod does not turn, and remove piston rod lock nut.
4. Remove mounting seal, shock absorber mounting bracket and bound bumper cover from shock absorber.

ASSEMBLY

Assembly in the reverse order of disassembly.

Inspection

INFOID:000000005239813

INSPECTION AFTER REMOVAL

Check the following items, and replace the parts if necessary.

- Shock absorber assembly for deformation, cracks, damage.
- Welded and sealed areas for oil leakage.

INSPECTION AFTER DISASSEMBLY

Bound Bumper and Bushing

Check bound bumper cover and bushing for cracks and damage. Replace it if necessary.

Shock Absorber

Check the following items, and replace the part if necessary.

- Shock absorber for deformation, cracks, and other damage.
- Piston rod for damage, uneven wear, and distortion.
- Welded and sealed areas for oil leakage.

INSPECTION AFTER ASSEMBLY

Make sure piston rod on shock absorber is not damaged when attaching components to shock absorber.

INSPECTION AFTER INSTALLATION

1. Check wheel alignment. Refer to [RSU-6, "Inspection"](#).
2. Adjust neutral position of steering angle sensor. Refer to [BRC-8, "ADJUSTMENT OF STEERING ANGLE SENSOR NEUTRAL POSITION : Special Repair Requirement"](#).

Disposal

INFOID:000000005239814

1. Set shock absorber horizontally with the piston rod fully extended.
2. Drill 2 – 3 mm (0.08 – 0.12 in) hole at the position (●) from top as shown in the figure to release gas gradually.

CAUTION:

- **Wear eye protection (safety glasses).**
- **Wear gloves.**
- **Be careful with metal chips or oil blown out by the compressed gas.**

NOTE:

- Drill vertically in this direction (←).
- Directly to the outer tube avoiding brackets.
- The gas is clear, colorless, odorless, and harmless.

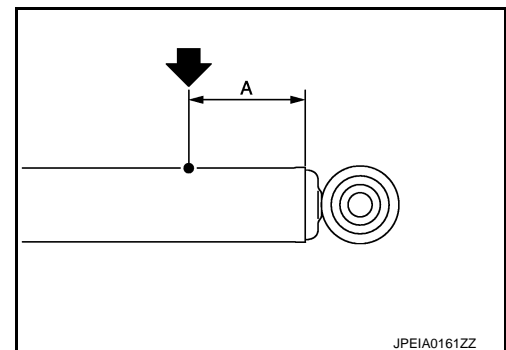

A : 20 – 30 mm (0.79 – 1.18 in)

3. Position the drilled hole downward and drain oil by moving the piston rod several times.

CAUTION:

Dispose of drained oil according to the law and local regulations.

SUSPENSION ARM

< REMOVAL AND INSTALLATION >

[REGULAR GRADE]

SUSPENSION ARM

Exploded View

INFOID:000000005239815

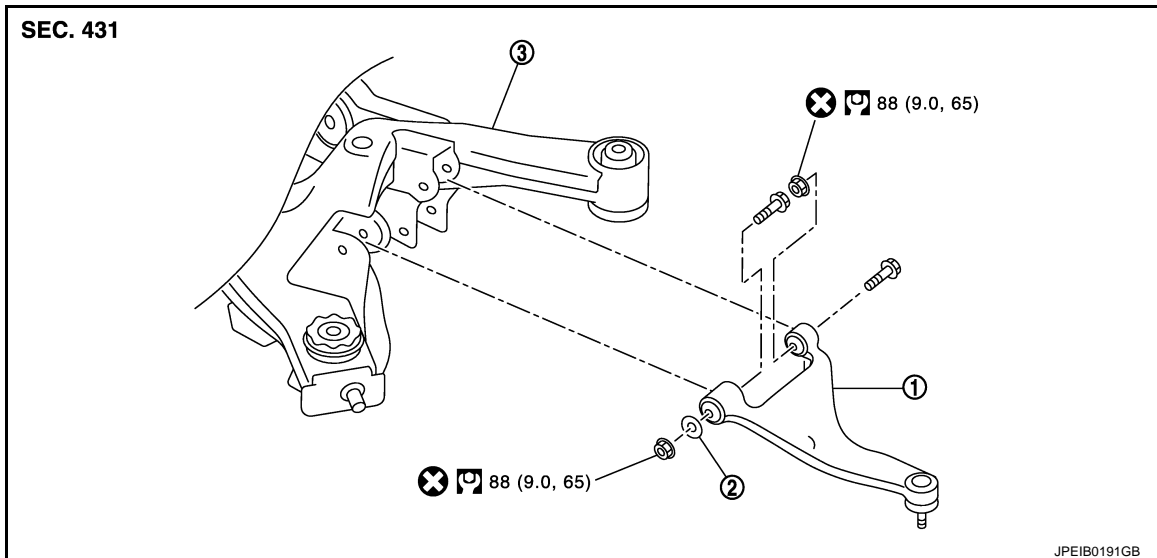

1. Suspension arm
2. Stopper rubber
3. Rear suspension member

Refer to [GI-4. "Components"](#) for symbols in the figure.

Removal and Installation

INFOID:000000005239816

REMOVAL

1. Remove tires with power tool.
2. Remove diag brace. Refer to [RSU-17. "Exploded View"](#).
3. Remove stabilizer connecting rod. Refer to [RSU-16. "Exploded View"](#).
4. Remove drive shaft. Refer to [RAX-10. "Exploded View"](#).
5. Remove cotter pin of suspension arm ball joint, and loosen nut. Refer to [RAX-7. "Exploded View"](#).
6. Remove suspension arm (rear suspension member side).
7. Use the ball joint remover to remove suspension arm from axle housing.

CAUTION:

- Be careful not to damage ball joint boot.
- Tighten temporarily mounting nut to prevent damage to threads and to prevent ball joint remover from coming off.

8. Remove suspension arm.
9. Remove stabilizer connecting rod mounting bracket. Refer to [RSU-16. "Exploded View"](#).

INSTALLATION

Note the following and, install in the reverse order of removal.

- Perform final tightening of rear suspension member installation position (rubber bussing), under unladen conditions with tires on level ground.

Inspection

INFOID:000000005239817

INSPECTION AFTER REMOVAL

Appearance

Check the following items, and replace the part if necessary.

- Suspension arm and bushing for deformation, cracks or damage.
- Boot of ball joint for cracks or damage, and also for grease leakage.

Ball Joint Inspection

SUSPENSION ARM

< REMOVAL AND INSTALLATION >

[REGULAR GRADE]

Manually move ball stud at least ten times by hand to check for smooth movement.

Swing Torque Inspection

1. Move the ball joint at least ten times by hand to check for smooth movement.
2. Hook spring balance (A) at cotter pin mounting hole. Confirm spring balance measurement value is within specifications when ball stud begins moving.

Swing torque : Refer to [RSU-19. "Ball Joint"](#).

- If swing torque exceeds the standard range, replace suspension arm assembly.

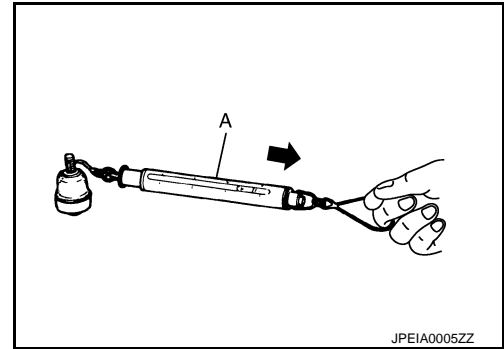

Rotating Torque Inspection

1. Move the ball joint at least ten times by hand to check for smooth movement.
2. Attach the mounting nut to ball stud. Make sure that rotating torque is within the specifications with a preload gauge (A) [SST: ST3127S000 (J-25765-A)].

Rotating torque : Refer to [RSU-19. "Ball Joint"](#).

- If rotating torque exceeds the standard range, replace suspension arm assembly.

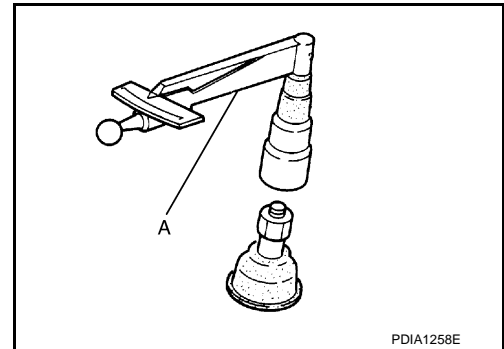

Axial End Play Inspection

1. Move the ball joint at least ten times by hand to check for smooth movement.
2. Move tip of ball stud in axial direction to check for looseness.

Axial end play : Refer to [RSU-19. "Ball Joint"](#).

- If axial end play exceeds the standard range, replace suspension arm assembly.

INSPECTION AFTER INSTALLATION

1. Check wheel alignment. Refer to [RSU-6. "Inspection"](#).
2. Adjust neutral position of steering angle sensor. Refer to [BRC-8. "ADJUSTMENT OF STEERING ANGLE SENSOR NEUTRAL POSITION : Special Repair Requirement"](#).

RADIUS ROD

< REMOVAL AND INSTALLATION >

[REGULAR GRADE]

RADIUS ROD

Exploded View

INFOID:000000005239818

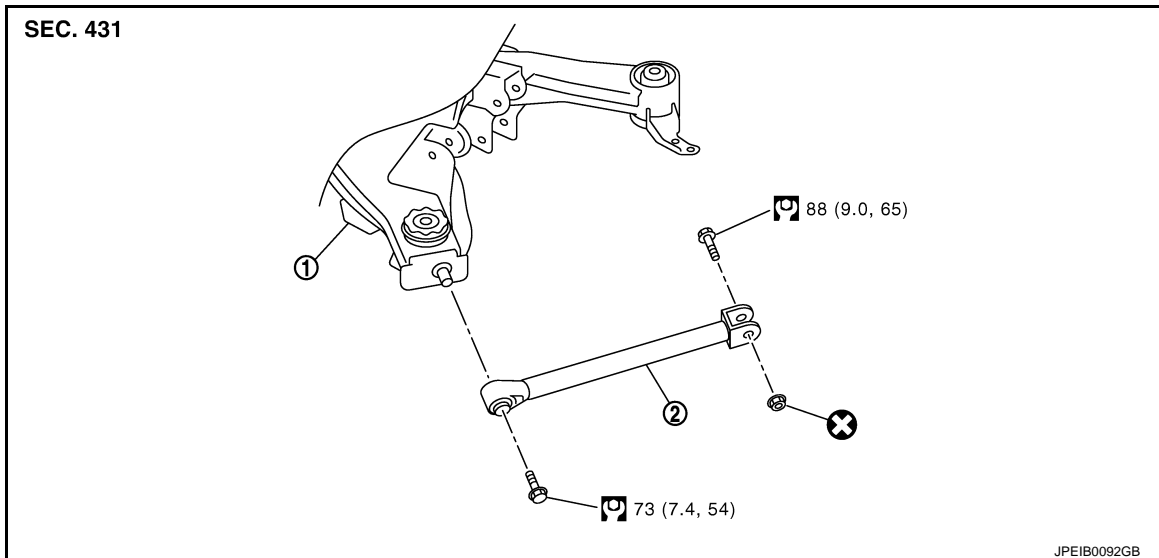

1. Rear suspension member
2. Radius rod

Refer to [GI-4. "Components"](#) for symbols in the figure.

Removal and Installation

INFOID:000000005239819

REMOVAL

1. Remove tires with power tool.
2. Remove radius rod.

INSTALLATION

Note the following, and install in the reverse order of removal.

- Perform final tightening of rear suspension member and axle installation position (rubber bushing), under unladen conditions with tires on level ground.

Inspection

INFOID:000000005239820

INSPECTION AFTER REMOVAL

Check radius rod and bushing for any deformation, cracks, or damage. Replace it if necessary.

INSPECTION AFTER INSTALLATION

1. Check wheel alignment. Refer to [RSU-6. "Inspection"](#).
2. Adjust neutral position of steering angle sensor. Refer to [BRC-8. "ADJUSTMENT OF STEERING ANGLE SENSOR NEUTRAL POSITION : Special Repair Requirement"](#).

FRONT LOWER LINK

< REMOVAL AND INSTALLATION >

[REGULAR GRADE]

FRONT LOWER LINK

Exploded View

INFOID:000000005239821

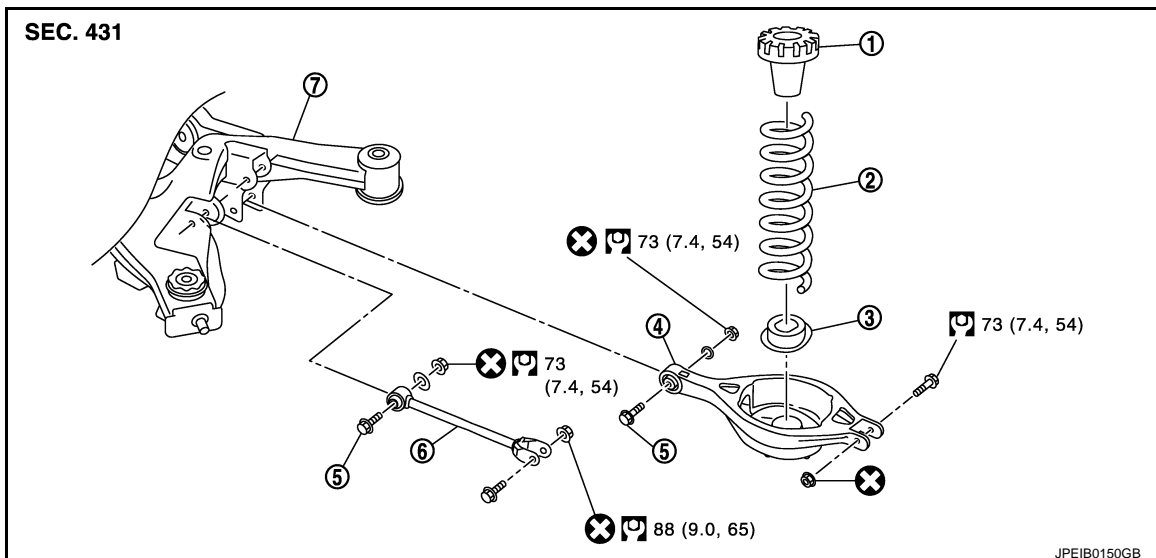

- | | | |
|---------------------------|-------------------|---------------------|
| 1. Upper seat | 2. Coil spring | 3. Rubber seat |
| 4. Rear lower link | 5. Adjusting bolt | 6. Front lower link |
| 7. Rear suspension member | | |

Refer to [GI-4, "Components"](#) for symbols in the figure.

Removal and Installation

INFOID:000000005239822

REMOVAL

1. Remove tires with power tool.
2. Set suitable jack under axle assembly to relieve the coil spring tension.
3. Remove front lower link.

INSTALLATION

Note the following, and install in the reverse order of removal.

- Perform final tightening of rear suspension member and axle installation position (rubber bushing), under unladen conditions with tires on level ground.

Inspection

INFOID:000000005239823

INSPECTION AFTER REMOVAL

Check front lower link and bushing for any deformation, cracks, or damage. Replace it if necessary.

INSPECTION AFTER INSTALLATION

1. Check wheel alignment. Refer to [RSU-6, "Inspection"](#).
2. Adjust neutral position of steering angle sensor. Refer to [BRC-8, "ADJUSTMENT OF STEERING ANGLE SENSOR NEUTRAL POSITION : Special Repair Requirement"](#).

REAR STABILIZER

< REMOVAL AND INSTALLATION >

[REGULAR GRADE]

REAR STABILIZER

Exploded View

INFOID:000000005239824

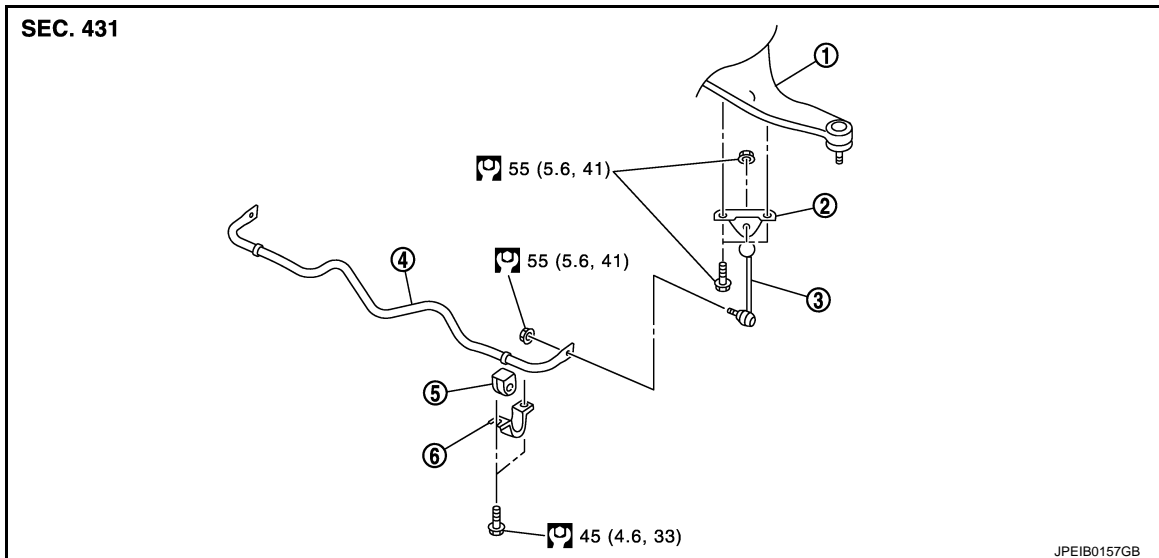

- | | | |
|-------------------|---|------------------------------|
| 1. Suspension arm | 2. Stabilizer connecting rod mounting bracket | 3. Stabilizer connecting rod |
| 4. Stabilizer bar | 5. Stabilizer bushing | 6. Stabilizer clamp |

Refer to [GI-4, "Components"](#) for symbols in the figure.

Removal and Installation

INFOID:000000005239825

REMOVAL

1. Remove diag brace. Refer to [RSU-17, "Exploded View"](#).
2. Remove stabilizer connecting rods.
3. Remove stabilizer clamps, and then remove stabilizer bushings.
4. Remove stabilizer bar.
5. Remove stabilizer connecting rod mounting brackets from suspension arm.

INSTALLATION

Note the following, and install in the reverse order of removal.

- Tighten the mounting nut to the specified torque while holding a hexagonal part of stabilizer connecting rod side.

Inspection

INFOID:000000005239826

INSPECTION AFTER REMOVAL

Check stabilizer bar, stabilizer connecting rod, stabilizer bushing and stabilizer clamp for deformation, cracks or damage. Replace it if necessary.

REAR SUSPENSION MEMBER

< UNIT REMOVAL AND INSTALLATION >

[REGULAR GRADE]

UNIT REMOVAL AND INSTALLATION

REAR SUSPENSION MEMBER

Exploded View

INFOID:000000005239827

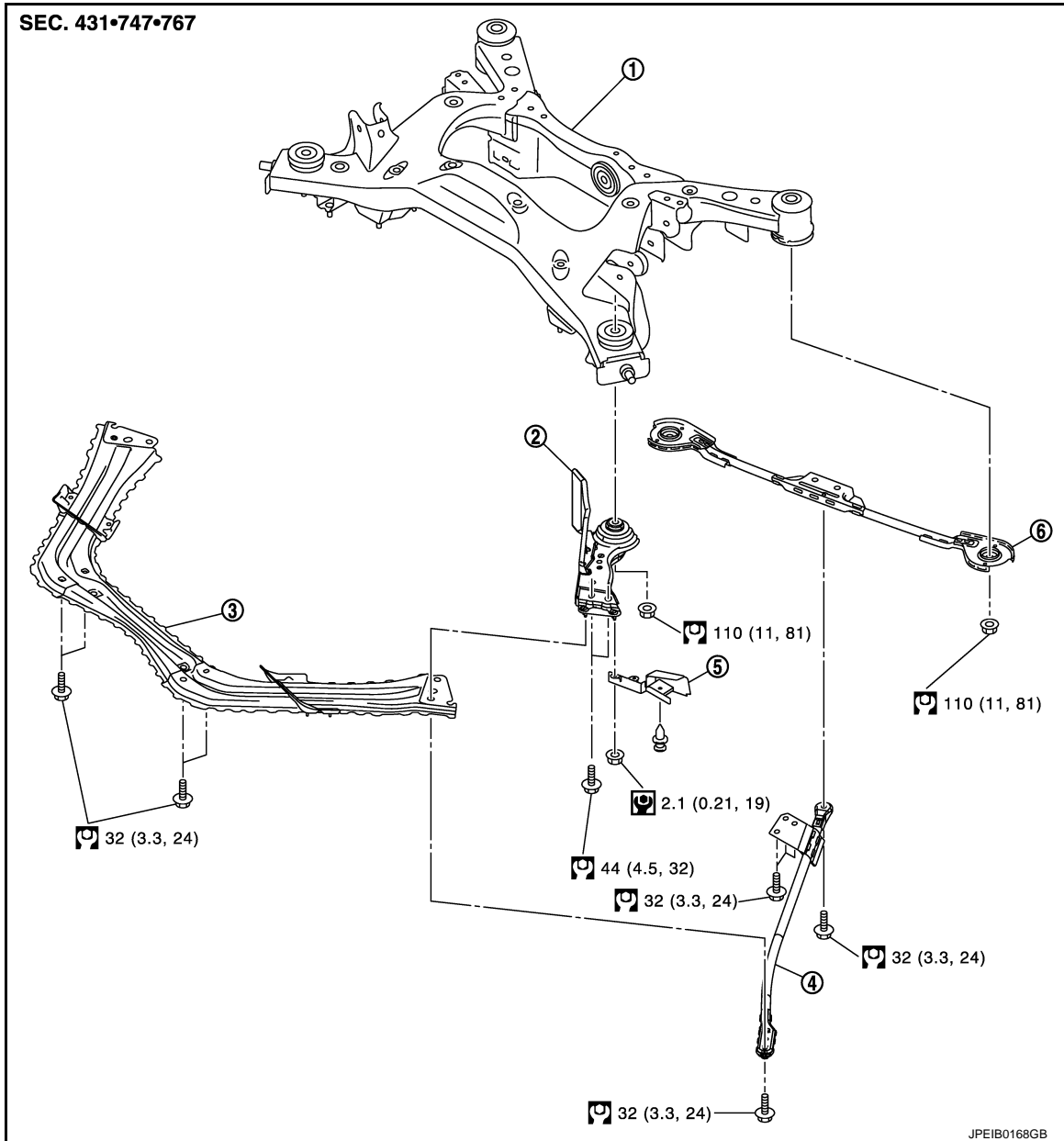

- | | | |
|---------------------------|--------------------------------|----------------|
| 1. Rear suspension member | 2. Rear suspension member stay | 3. Tunnel stay |
| 4. Diag brace | 5. Deflector mudguard | 6. Pin stay |

Refer to [GI-4, "Components"](#) for symbols in the figure.

Removal and Installation

INFOID:000000005239828

REMOVAL

1. Remove tires with power tool.
2. Remove caliper assemblies. Hang caliper assembly in a place where it will not interfere with work. Refer to [BR-56, "BRAKE CALIPER ASSEMBLY \(1 PISTON TYPE\) : Exploded View"](#) (1 piston type), [BR-60, "BRAKE CALIPER ASSEMBLY \(2 PISTON TYPE\) : Exploded View"](#) (2 piston type).

REAR SUSPENSION MEMBER

< UNIT REMOVAL AND INSTALLATION >

[REGULAR GRADE]

CAUTION:

Avoid depressing brake pedal while brake caliper is removed.

3. Remove disc rotors. Refer to [BR-57, "BRAKE CALIPER ASSEMBLY \(1 PISTON TYPE\) : Removal and Installation"](#) (1 piston type), [BR-61, "BRAKE CALIPER ASSEMBLY \(2 PISTON TYPE\) : Removal and Installation"](#) (2 piston type).
4. Remove wheel sensors and sensor harness from rear suspension member. Refer to [BRC-97, "FRONT WHEEL SENSOR : Exploded View"](#).
5. Remove diag braces.
6. Remove tunnel stay.
7. Remove center muffler and main muffler. Refer to [EX-5, "Exploded View"](#).
8. Remove stabilizer bar. Refer to [RSU-16, "Exploded View"](#).
9. Remove drive shafts. Refer to [RAX-10, "Exploded View"](#).
10. Remove propeller shaft. Refer to [DLN-7, "Exploded View"](#).
11. Remove final drive. Refer to [DLN-26, "Exploded View"](#) (R200), [DLN-67, "Exploded View"](#) (R200V).
12. Remove parking brake cable mounting bolts and separate parking brake cables from vehicle and rear suspension member. Refer to [PB-6, "Exploded View"](#).
13. Separate shock absorbers (lower side) from axle housing. Refer to [RSU-10, "Exploded View"](#).
14. Remove rear lower links and coil springs. Refer to [RSU-8, "Exploded View"](#).
15. Set suitable jack under rear suspension member.
16. Remove deflector mudguards.
17. Remove rear suspension member stay mounting bolts.
18. Remove rear suspension member mounting nuts, then remove rear suspension member stays and pin stay.
19. Slowly lower jack, then remove rear suspension member, radius rods, suspension arms, front lower links, wheel hubs and axle housings from vehicle as a unit.
20. Remove mounting bolts and nuts, then remove radius rods, suspension arms, front lower links, wheel hubs and axle housings from rear suspension member. Refer to [RSU-12, "Exploded View"](#), [RSU-15, "Exploded View"](#), [RAX-7, "Exploded View"](#).

INSTALLATION

Note the following, and install in the reverse order of the removal.

- Perform the final tightening of each of parts under unladen conditions, which were removed when removing rear suspension assembly.
- Check wheel sensor harness for proper connection. Refer to [BRC-97, "FRONT WHEEL SENSOR : Exploded View"](#).
- Never reuse cotter pin.

Inspection

INFOID:000000005239829

INSPECTION AFTER REMOVAL

Check rear suspension member for deformation, cracks, or any other damage. Replace if necessary.

INSPECTION AFTER INSTALLATION

1. Adjust parking brake operation (stroke). Refer to [PB-3, "Inspection and Adjustment"](#).
2. Check wheel alignment. Refer to [RSU-6, "Inspection"](#).
3. Adjust neutral position of steering angle sensor. Refer to [BRC-8, "ADJUSTMENT OF STEERING ANGLE SENSOR NEUTRAL POSITION : Special Repair Requirement"](#).

SERVICE DATA AND SPECIFICATIONS (SDS)

< SERVICE DATA AND SPECIFICATIONS (SDS)

[REGULAR GRADE]

SERVICE DATA AND SPECIFICATIONS (SDS)

SERVICE DATA AND SPECIFICATIONS (SDS)

Wheel Alignment

INFOID:000000005239830

Item		Standard	
Wheel size		18 inch	19 inch
Camber Degree minute (Decimal degree)		Minimum	-2° 10' (-2.16°)
		Nominal	-1° 40' (-1.67°)
		Maximum	-1° 10' (-1.17°)
Toe-in	Total toe-in Distance	Minimum	In 2.0 mm (0.079 in)
		Nominal	In 3.8 mm (0.150 in)
		Maximum	In 5.6 mm (0.221 in)
	Toe angle (left wheel or right wheel) Degree minute (Decimal degree)	Minimum	In 0° 05' (0.09°)
		Nominal	In 0° 09' (0.15°)
		Maximum	In 0° 13' (0.21°)

Measure value under unladen* conditions.

*: Fuel, engine coolant and lubricant are full. Spare tire, jack, hand tools and mats are in designated positions.

Ball Joint

INFOID:000000005239831

Item	Standard
Swing torque	0.5 – 3.4 N·m (0.06 – 0.34 kg-m, 5 – 30 in-lb)
Measurement on spring balance (cotter pinhole position)	8.1 – 54.8 N (0.83 – 5.59 kg, 1.83 – 12.31 lb)
Rotating torque	0.5 – 3.4 N·m (0.06 – 0.34 kg-m, 5 – 30 in-lb)
Axial end play	0 mm (0 in)

Wheelarch Height

INFOID:000000005239832

Item	Standard	
	18 inch	19 inch
Wheel size	18 inch	19 inch
Front (Hf)	711 mm (27.99 in)	708 mm (27.87 in)
Rear (Hr)	711 mm (27.99 in)	

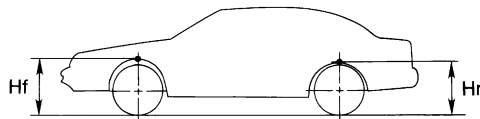

SFA818A

Measure value under unladen* conditions

*: Fuel, engine coolant and lubricant are full. Spare tire, jack, hand tools and mats are in designated positions.

REAR PERFORMANCE DAMPER

< REMOVAL AND INSTALLATION >

[Nismo 370Z]

REMOVAL AND INSTALLATION

REAR PERFORMANCE DAMPER

Exploded View

INFOID:000000005643467

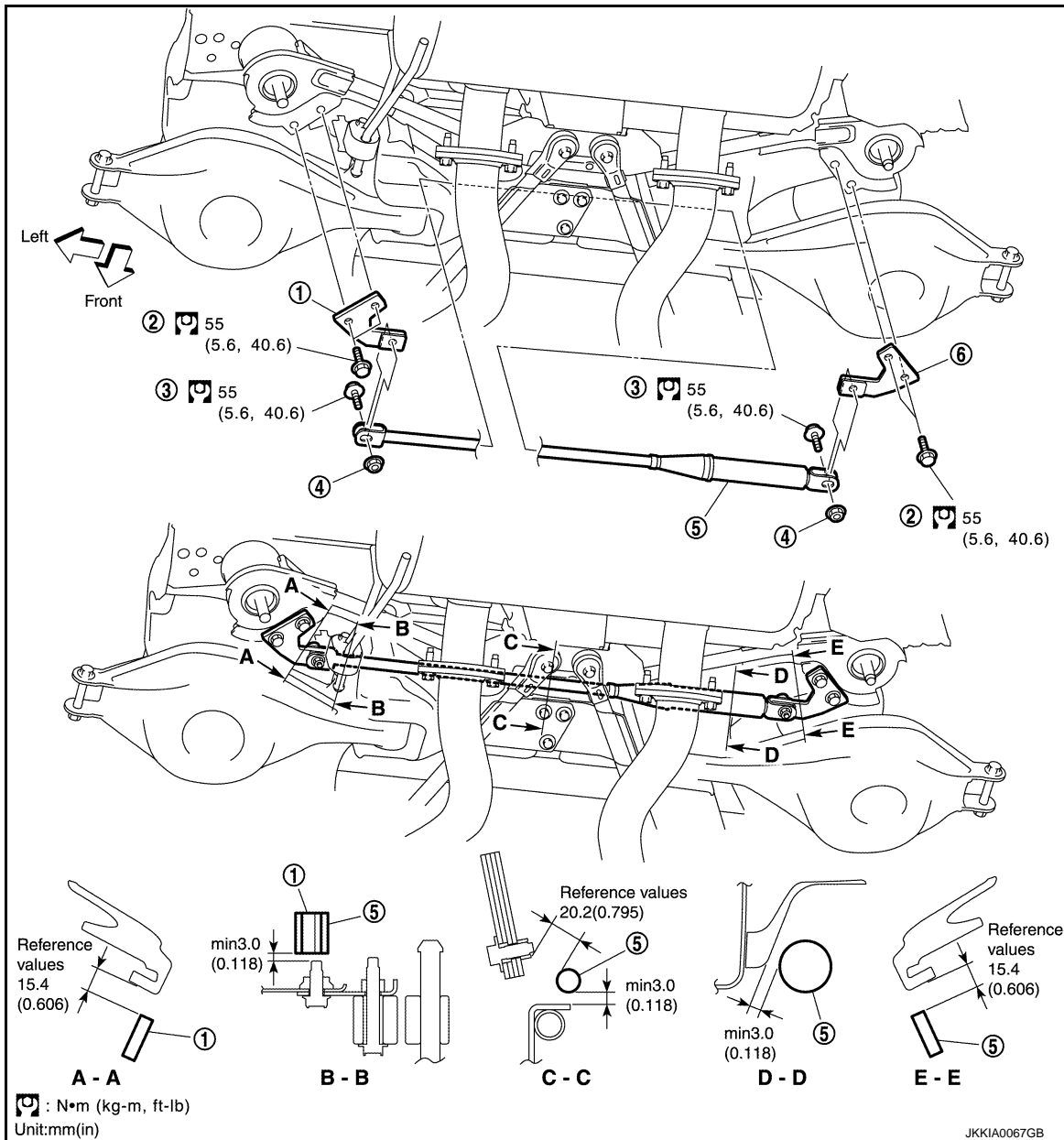

- | | | |
|------------------------|----------------------------|------------------------|
| 1. Damper bracket (LH) | 2. Bolt (4) | 3. Bolt (2) |
| 4. Nut (2) | 5. Rear performance damper | 6. Damper bracket (RH) |

Removal and Installation

INFOID:000000005643468

REMOVAL

CAUTION:

- Perform the work in a level place while the vehicle is unladen in running order.
- Never tighten bolts while the vehicle is raised or jacked up.

1. Remove the bolts and nuts from the rear performance damper.
2. Remove the bolts and then remove the damper brackets (LH, RH).

REAR PERFORMANCE DAMPER

< REMOVAL AND INSTALLATION >

[Nismo 370Z]

INSTALLATION

Install in the reverse order of removal.

CAUTION:

When installing the front performance damper, check all clearances to make sure that there are no areas of interference.

Rear performance damper disposal method

This damper includes nitrogen gas under high pressure. Dealer should let out in following manner.

- Hold the front performance damper in a vise or other device and use a 2 mm (0.078 in) drill to slowly make a hole and release the gas as shown in the figure.

CAUTION:

- **The released gas is colorless, odorless, and harmless.**
- **Metal cuttings, etc., could be blown out by the force of the released gas, so wear safety goggles when performing this task.**

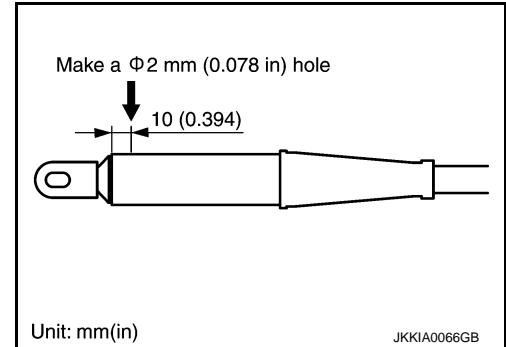

A
B
C
D
RSU
F
G
H
I
J
K
L
M
N
O
P