

**SECTION** **VTL**  
**VENTILATION SYSTEM**

A

B

C

D

E

F

G

H

VTL

J

K

L

M

N

O

P

**CONTENTS**

<b>SYSTEM DESCRIPTION</b> .....	3	<b>SIDE VENTILATOR GRILLE : Removal and Installation</b> .....	9
<b>VENTILATION SYSTEM</b> .....	3	<b>FRONT DEFROSTER GRILLE</b> .....	9
System Description .....	3	FRONT DEFROSTER GRILLE : Removal and Installation .....	9
<b>PRECAUTION</b> .....	4	<b>SIDE DEFROSTER GRILLE</b> .....	9
<b>PRECAUTIONS</b> .....	4	SIDE DEFROSTER GRILLE : Removal and Installation .....	9
<b>FOR USA AND CANADA</b> .....	4	<b>VENTILATOR DUCT</b> .....	10
FOR USA AND CANADA : Precaution for Supplemental Restraint System (SRS) "AIR BAG" and "SEAT BELT PRE-TENSIONER" .....	4	VENTILATOR DUCT : Removal and Installation ....	10
FOR USA AND CANADA : Precautions Necessary for Steering Wheel Rotation After Battery Disconnection .....	4	<b>SIDE VENTILATOR DUCT</b> .....	10
FOR USA AND CANADA : Precaution for Battery Service .....	5	SIDE VENTILATOR DUCT : Removal and Installation .....	10
<b>FOR MEXICO</b> .....	5	<b>FRONT DEFROSTER NOZZLE</b> .....	10
FOR MEXICO : Precaution for Supplemental Restraint System (SRS) "AIR BAG" and "SEAT BELT PRE-TENSIONER" .....	5	FRONT DEFROSTER NOZZLE : Removal and Installation .....	10
FOR MEXICO : Precautions Necessary for Steering Wheel Rotation After Battery Disconnection .....	5	<b>SIDE DEFROSTER NOZZLE</b> .....	11
FOR MEXICO : Precaution for Battery Service .....	6	SIDE DEFROSTER NOZZLE : Removal and Installation .....	11
<b>PREPARATION</b> .....	7	<b>FOOT GRILLE</b> .....	11
<b>PREPARATION</b> .....	7	FOOT GRILLE : Removal and Installation .....	11
Commercial Service Tool .....	7	<b>FOOT DUCT</b> .....	11
<b>REMOVAL AND INSTALLATION</b> .....	8	FOOT DUCT : Removal and Installation .....	11
<b>DUCT AND GRILLE</b> .....	8	<b>BLOWER UNIT</b> .....	13
Exploded View .....	8	Exploded View .....	13
<b>CENTER VENTILATOR GRILLE</b> .....	8	<b>BLOWER UNIT</b> .....	14
CENTER VENTILATOR GRILLE : Removal and Installation .....	8	BLOWER UNIT : Removal and Installation .....	14
<b>SIDE VENTILATOR GRILLE</b> .....	9	<b>BLOWER MOTOR</b> .....	15
		BLOWER MOTOR : Removal and Installation .....	15
		<b>IN-CABIN MICROFILTER</b> .....	16
		Exploded View .....	16
		Removal and Installation .....	16



# VENTILATION SYSTEM

< SYSTEM DESCRIPTION >

## SYSTEM DESCRIPTION

### VENTILATION SYSTEM

#### System Description

INFOID:000000006353324

#### OUTLINE

Ventilation system is controlled by A/C auto amp. For details of automatic air conditioner system, refer to [HAC-14. "System Description"](#) (WITHOUT 7 INCH DISPLAY) or [HAC-103. "System Description"](#) (WITH 7 INCH DISPLAY).

#### AIR FLOW

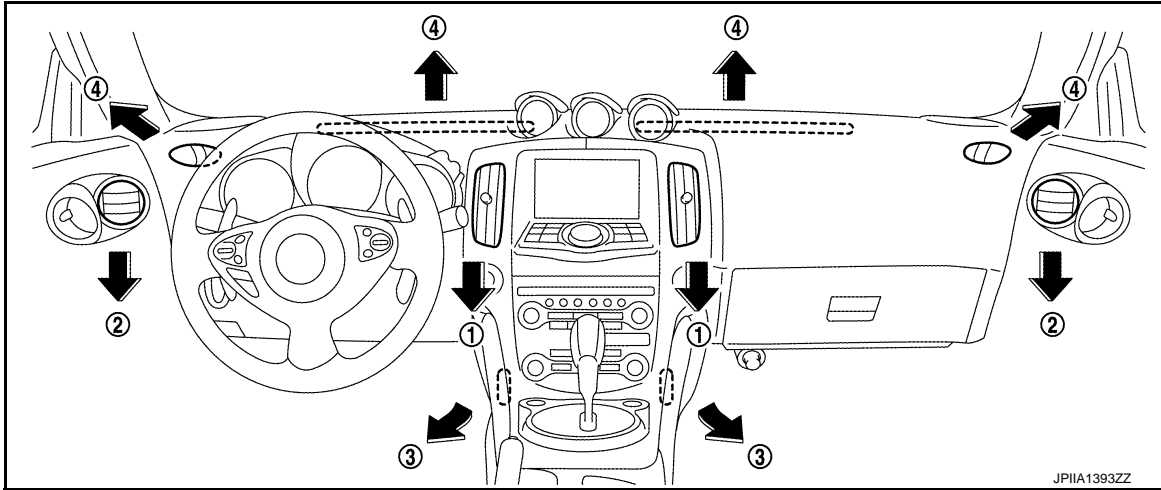

JPIIA1393ZZ

MODE/DEF position indication	AIR OUTLET			
	Ventilator (1)	Ventilator (2)	Foot (3)	Defroster (4)
	x	x	—	—
	x	x	x	—
	x	x	x	x
	x	x	x	x
	—	—	—	x

x: Applicable

A  
B  
C  
D  
E  
F  
G  
H  
J  
K  
L  
M  
N  
O  
P

VTL

# PRECAUTIONS

< PRECAUTION >

## PRECAUTION

### PRECAUTIONS

#### FOR USA AND CANADA

#### FOR USA AND CANADA : Precaution for Supplemental Restraint System (SRS) "AIR BAG" and "SEAT BELT PRE-TENSIONER"

INFOID:00000000635325

The Supplemental Restraint System such as "AIR BAG" and "SEAT BELT PRE-TENSIONER", used along with a front seat belt, helps to reduce the risk or severity of injury to the driver and front passenger for certain types of collision. This system includes seat belt switch inputs and dual stage front air bag modules. The SRS system uses the seat belt switches to determine the front air bag deployment, and may only deploy one front air bag, depending on the severity of a collision and whether the front occupants are belted or unbelted. Information necessary to service the system safely is included in the "SRS AIR BAG" and "SEAT BELT" of this Service Manual.

#### **WARNING:**

Always observe the following items for preventing accidental activation.

- To avoid rendering the SRS inoperative, which could increase the risk of personal injury or death in the event of a collision that would result in air bag inflation, all maintenance must be performed by an authorized NISSAN/INFINITI dealer.
- Improper maintenance, including incorrect removal and installation of the SRS, can lead to personal injury caused by unintentional activation of the system. For removal of Spiral Cable and Air Bag Module, see "SRS AIR BAG".
- Never use electrical test equipment on any circuit related to the SRS unless instructed to in this Service Manual. SRS wiring harnesses can be identified by yellow and/or orange harnesses or harness connectors.

#### PRECAUTIONS WHEN USING POWER TOOLS (AIR OR ELECTRIC) AND HAMMERS

#### **WARNING:**

Always observe the following items for preventing accidental activation.

- When working near the Air Bag Diagnosis Sensor Unit or other Air Bag System sensors with the ignition ON or engine running, never use air or electric power tools or strike near the sensor(s) with a hammer. Heavy vibration could activate the sensor(s) and deploy the air bag(s), possibly causing serious injury.
- When using air or electric power tools or hammers, always switch the ignition OFF, disconnect the battery, and wait at least 3 minutes before performing any service.

#### FOR USA AND CANADA : Precautions Necessary for Steering Wheel Rotation After Battery Disconnection

INFOID:00000000635326

#### **CAUTION:**

Comply with the following cautions to prevent any error and malfunction.

- Before removing and installing any control units, first turn the ignition switch to the LOCK position, then disconnect both battery cables.
- After finishing work, confirm that all control unit connectors are connected properly, then re-connect both battery cables.
- Always use CONSULT to perform self-diagnosis as a part of each function inspection after finishing work. If a DTC is detected, perform trouble diagnosis according to self-diagnosis results.

For vehicle with steering lock unit, if the battery is disconnected or discharged, the steering wheel will lock and cannot be turned.

If turning the steering wheel is required with the battery disconnected or discharged, follow the operation procedure below before starting the repair operation.

#### OPERATION PROCEDURE

1. Connect both battery cables.

#### **NOTE:**

Supply power using jumper cables if battery is discharged.

2. Turn the ignition switch to ACC position.  
(At this time, the steering lock will be released.)

# PRECAUTIONS

## < PRECAUTION >

3. Disconnect both battery cables. The steering lock will remain released with both battery cables disconnected and the steering wheel can be turned.
4. Perform the necessary repair operation.
5. When the repair work is completed, re-connect both battery cables. With the brake pedal released, turn the ignition switch from ACC position to ON position, then to LOCK position. (The steering wheel will lock when the ignition switch is turned to LOCK position.)
6. Perform self-diagnosis check of all control units using CONSULT.

### FOR USA AND CANADA : Precaution for Battery Service

INFOID:00000000635327

Before disconnecting the battery, lower both the driver and passenger windows. This will prevent any interference between the window edge and the vehicle when the door is opened/closed. During normal operation, the window slightly raises and lowers automatically to prevent any window to vehicle interference. The automatic window function will not work with the battery disconnected.

### FOR MEXICO

### FOR MEXICO : Precaution for Supplemental Restraint System (SRS) "AIR BAG" and "SEAT BELT PRE-TENSIONER"

INFOID:00000000635328

The Supplemental Restraint System such as "AIR BAG" and "SEAT BELT PRE-TENSIONER", used along with a front seat belt, helps to reduce the risk or severity of injury to the driver and front passenger for certain types of collision. Information necessary to service the system safely is included in the "SRS AIR BAG" and "SEAT BELT" of this Service Manual.

#### **WARNING:**

Always observe the following items for preventing accidental activation.

- To avoid rendering the SRS inoperative, which could increase the risk of personal injury or death in the event of a collision that would result in air bag inflation, all maintenance must be performed by an authorized NISSAN/INFINITI dealer.
- Improper maintenance, including incorrect removal and installation of the SRS, can lead to personal injury caused by unintentional activation of the system. For removal of Spiral Cable and Air Bag Module, see "SRS AIR BAG".
- Never use electrical test equipment on any circuit related to the SRS unless instructed to in this Service Manual. SRS wiring harnesses can be identified by yellow and/or orange harnesses or harness connectors.

### PRECAUTIONS WHEN USING POWER TOOLS (AIR OR ELECTRIC) AND HAMMERS

#### **WARNING:**

Always observe the following items for preventing accidental activation.

- When working near the Air Bag Diagnosis Sensor Unit or other Air Bag System sensors with the ignition ON or engine running, never use air or electric power tools or strike near the sensor(s) with a hammer. Heavy vibration could activate the sensor(s) and deploy the air bag(s), possibly causing serious injury.
- When using air or electric power tools or hammers, always switch the ignition OFF, disconnect the battery, and wait at least 3 minutes before performing any service.

### FOR MEXICO : Precautions Necessary for Steering Wheel Rotation After Battery Disconnection

INFOID:00000000635329

#### **CAUTION:**

Comply with the following cautions to prevent any error and malfunction.

- Before removing and installing any control units, first turn the ignition switch to the LOCK position, then disconnect both battery cables.
- After finishing work, confirm that all control unit connectors are connected properly, then re-connect both battery cables.
- Always use CONSULT to perform self-diagnosis as a part of each function inspection after finishing work. If a DTC is detected, perform trouble diagnosis according to self-diagnosis results.

For vehicle with steering lock unit, if the battery is disconnected or discharged, the steering wheel will lock and cannot be turned.

If turning the steering wheel is required with the battery disconnected or discharged, follow the operation procedure below before starting the repair operation.

A

B

C

D

E

F

G

H

VTL

J

K

L

M

N

O

P

# PRECAUTIONS

< PRECAUTION >

---

## OPERATION PROCEDURE

1. Connect both battery cables.  
**NOTE:**  
Supply power using jumper cables if battery is discharged.
2. Turn the ignition switch to ACC position.  
(At this time, the steering lock will be released.)
3. Disconnect both battery cables. The steering lock will remain released with both battery cables disconnected and the steering wheel can be turned.
4. Perform the necessary repair operation.
5. When the repair work is completed, re-connect both battery cables. With the brake pedal released, turn the ignition switch from ACC position to ON position, then to LOCK position. (The steering wheel will lock when the ignition switch is turned to LOCK position.)
6. Perform self-diagnosis check of all control units using CONSULT.

## FOR MEXICO : Precaution for Battery Service

INFOID:000000006353330

Before disconnecting the battery, lower both the driver and passenger windows. This will prevent any interference between the window edge and the vehicle when the door is opened/closed. During normal operation, the window slightly raises and lowers automatically to prevent any window to vehicle interference. The automatic window function will not work with the battery disconnected.

# PREPARATION

< PREPARATION >

## PREPARATION

### PREPARATION

#### Commercial Service Tool

INFOID:000000006353331

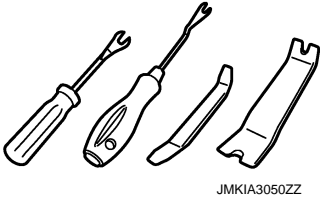
Tool name	Description
Remover tool  JMKIA3050ZZ	Remove clips, pawls, metal clips

A

B

C

D

E

F

G

H

VTL

J

K

L

M

N

O

P

# DUCT AND GRILLE

< REMOVAL AND INSTALLATION >

## REMOVAL AND INSTALLATION

### DUCT AND GRILLE

Exploded View

INFOID:000000006353332

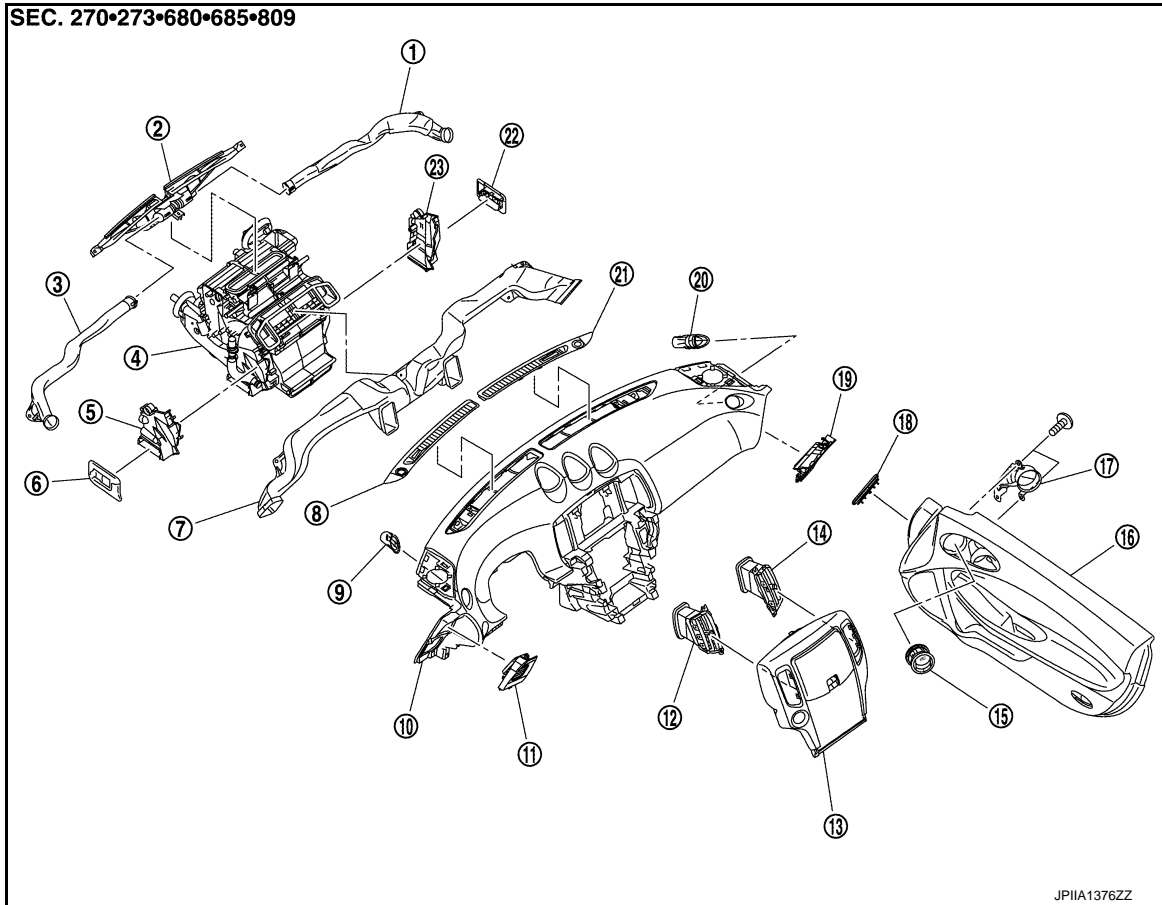

- |                                   |                                 |                                 |
|-----------------------------------|---------------------------------|---------------------------------|
| 1. Side defroster nozzle RH       | 2. Front defroster nozzle       | 3. Side defroster nozzle LH     |
| 4. Heater & cooling unit assembly | 5. Foot duct LH                 | 6. Foot grille LH               |
| 7. Ventilator duct                | 8. Front defroster grille LH    | 9. Side defroster grille LH     |
| 10. Instrument panel assembly     | 11. Instrument side finisher LH | 12. Center ventilator grille LH |
| 13. Cluster lid C                 | 14. Center ventilator grille RH | 15. Side ventilator grille RH   |
| 16. Door finisher RH              | 17. Side ventilator duct RH     | 18. Seal                        |
| 19. Instrument side finisher RH   | 20. Side defroster grille RH    | 21. Front defroster grille RH   |
| 22. Foot grille RH                | 23. Foot duct RH                |                                 |

### CENTER VENTILATOR GRILLE

#### CENTER VENTILATOR GRILLE : Removal and Installation

INFOID:000000006353333

##### REMOVAL

1. Remove cluster lid C. Refer to [IP-14, "Exploded View"](#).



# DUCT AND GRILLE

## < REMOVAL AND INSTALLATION >

2. Remove mounting screws (A), and then remove center ventilator grille (1).

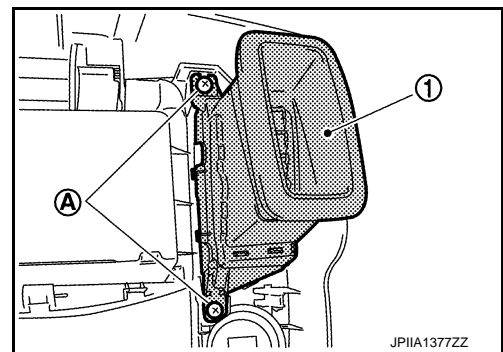

## INSTALLATION

Installation is basically the reverse order of removal.

## SIDE VENTILATOR GRILLE

### SIDE VENTILATOR GRILLE : Removal and Installation

INFOID:000000006353334

## REMOVAL

1. Remove side ventilator duct. Refer to [VTL-8. "Exploded View"](#).
2. Disengage the pawls, and then remove side ventilator grille (1).

 : pawl

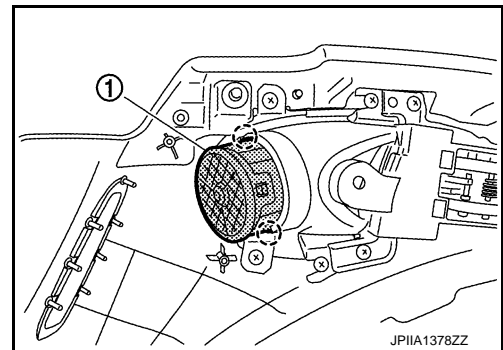

## INSTALLATION

Installation is basically the reverse order of removal.

## FRONT DEFROSTER GRILLE

### FRONT DEFROSTER GRILLE : Removal and Installation

INFOID:000000006353335

## REMOVAL

1. Remove front defroster grilles (1), using remover tools (A).
2. Remove sensors from front defroster grilles.

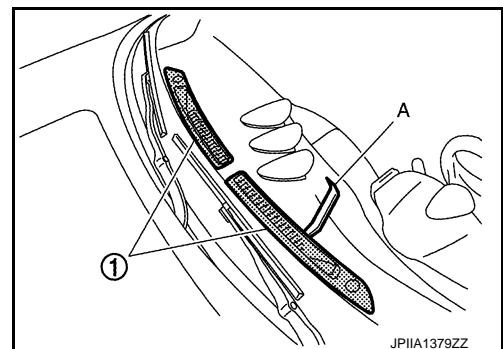

## INSTALLATION

Installation is basically the reverse order of removal.

## SIDE DEFROSTER GRILLE

### SIDE DEFROSTER GRILLE : Removal and Installation

INFOID:000000006353336

## REMOVAL

Remove side defroster grille from instrument panel assembly, using remover tools.

A  
B  
C  
D  
E  
F  
G  
H  
VTL  
J  
K  
L  
M  
N  
O  
P

# DUCT AND GRILLE

< REMOVAL AND INSTALLATION >

## INSTALLATION

Installation is basically the reverse order of removal.

### VENTILATOR DUCT

#### VENTILATOR DUCT : Removal and Installation

INFOID:000000006353337

#### REMOVAL

1. Remove front defroster nozzle. Refer to [VTL-8, "Exploded View"](#).
2. Remove clips (A), and then remove ventilator duct (1).

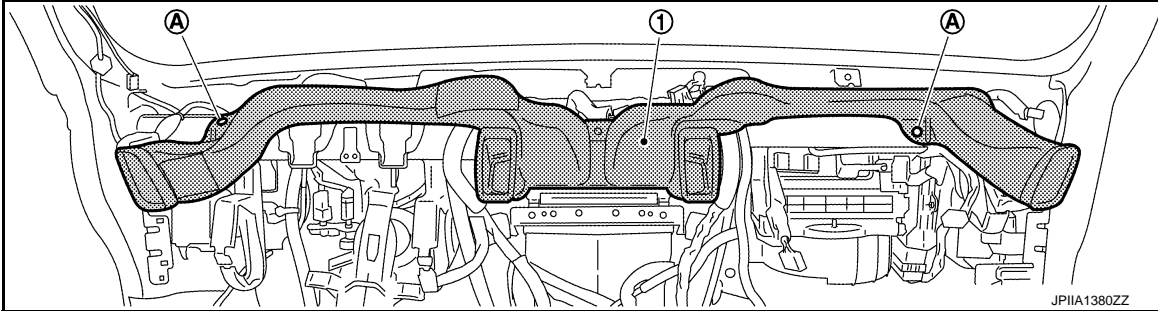

#### INSTALLATION

Installation is basically the reverse order of removal.

### SIDE VENTILATOR DUCT

#### SIDE VENTILATOR DUCT : Removal and Installation

INFOID:000000006353338

#### REMOVAL

1. Remove door finisher. Refer to [INT-15, "Exploded View"](#).
2. Remove mounting screws (A), and then remove side ventilator duct (1).

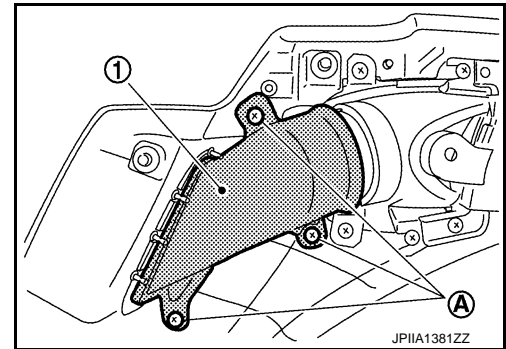

#### INSTALLATION

Installation is basically the reverse order of removal.

### FRONT DEFROSTER NOZZLE

#### FRONT DEFROSTER NOZZLE : Removal and Installation

INFOID:000000006353339

#### REMOVAL

1. Remove side defroster nozzles. Refer to [VTL-8, "Exploded View"](#).

# DUCT AND GRILLE

## < REMOVAL AND INSTALLATION >

2. Remove mounting screw (A), and then remove front defroster nozzle (1).

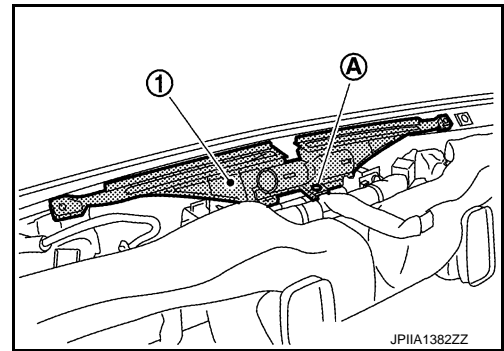

### INSTALLATION

Installation is basically the reverse order of removal.

## SIDE DEFROSTER NOZZLE

### SIDE DEFROSTER NOZZLE : Removal and Installation

INFOID:000000006353340

### REMOVAL

1. Remove instrument panel assembly. Refer to [JP-14, "Exploded View"](#).
2. Remove clip (A), and then remove side defroster nozzle (1).

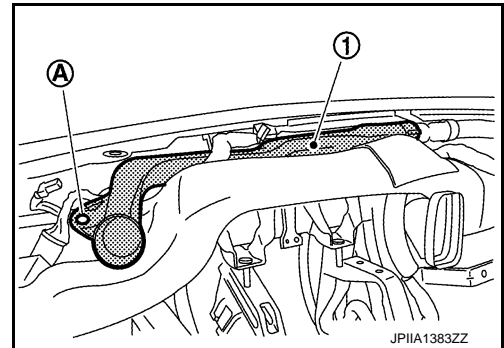

### INSTALLATION

Installation is basically the reverse order of removal.

## FOOT GRILLE

### FOOT GRILLE : Removal and Installation

INFOID:000000006353341

### REMOVAL

Disengage the pawls, and then remove foot grille (1).

 : Pawl

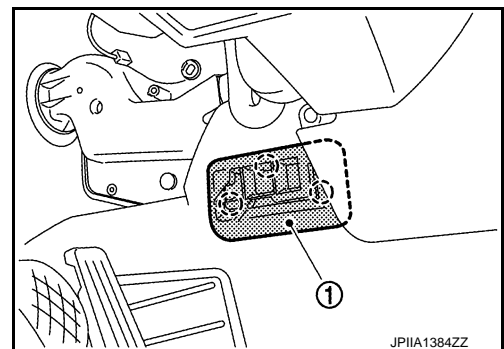

### INSTALLATION

Installation is basically the reverse order of removal.

## FOOT DUCT

### FOOT DUCT : Removal and Installation

INFOID:000000006353342

### REMOVAL

A  
B  
C  
D  
E  
F  
G  
H  
VTL  
J  
K  
L  
M  
N  
O  
P

# DUCT AND GRILLE

## < REMOVAL AND INSTALLATION >

### Driver side

1. Remove heater & cooling unit assembly. Refer to [HA-49, "Exploded View"](#).
2. Remove heater pipe cover. Refer to [HA-49, "Exploded View"](#).
3. Disengage the pawls, and then remove foot duct LH (1).

 : Pawl

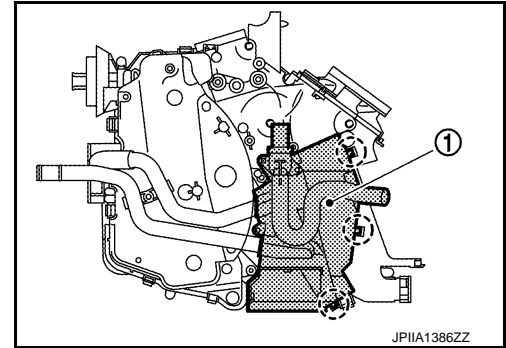

### Passenger side

1. Set the temperature at 18.0°C (60°F).  
**CAUTION:**  
**The angle may be out, when installing the air mix door motor to the air mix door, unless the above procedure is performed.**
2. Disconnect the battery cable from the negative terminal.
3. Remove heater & cooling unit assembly. Refer to [HA-49, "Exploded View"](#).
4. Remove air mix door motor and mode door motor. Refer to [HAC-92, "Exploded View"](#) (WITHOUT 7 INCH DISPLAY) or [HAC-181, "Exploded View"](#) (WITH 7 INCH DISPLAY).
5. Remove evaporator cover. Refer to [HA-54, "Exploded View"](#).
6. Disengage the pawls, and then remove foot duct RH (1).

 : Pawl

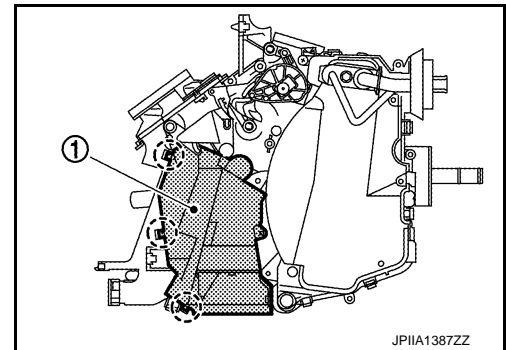

## INSTALLATION

Installation is basically the reverse order of removal.

# BLOWER UNIT

< REMOVAL AND INSTALLATION >

## BLOWER UNIT

Exploded View

INFOID:000000006353343

REMOVAL

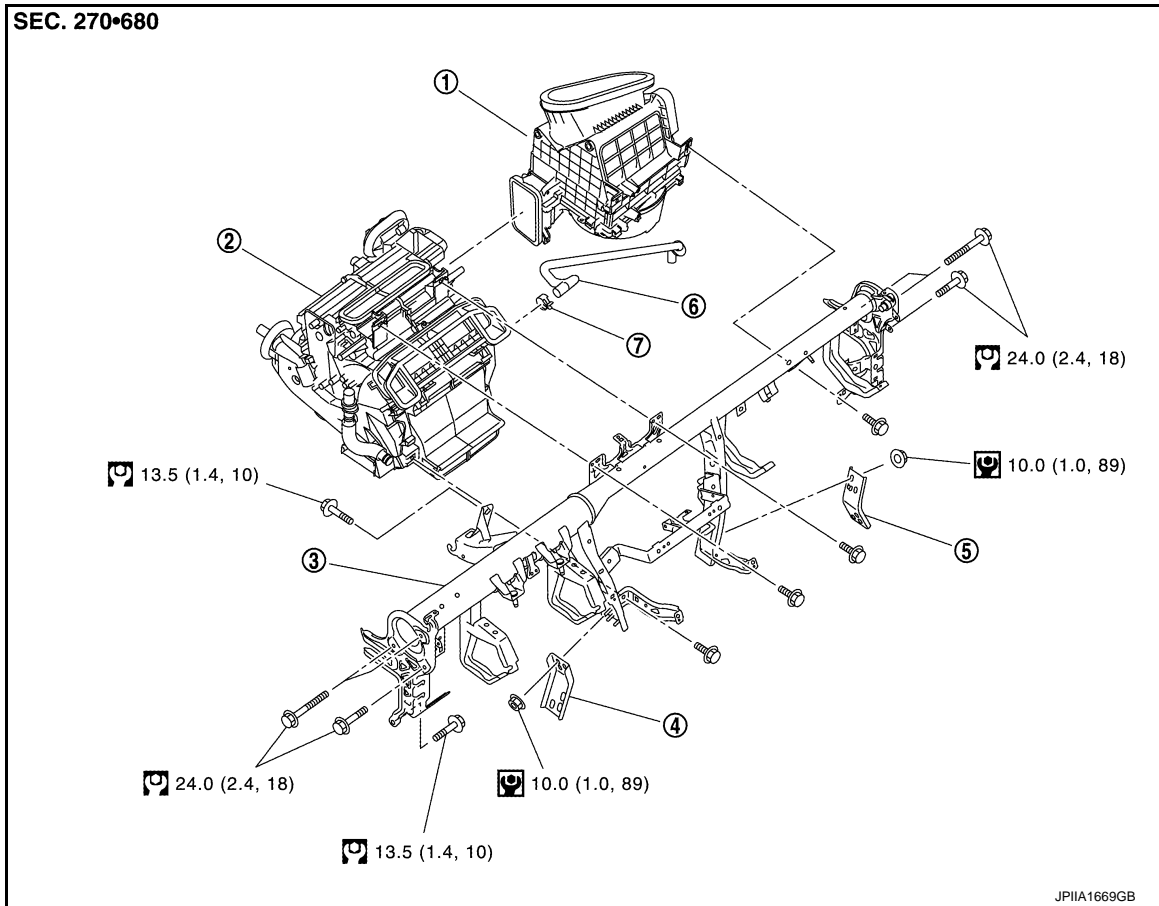

- |                       |                                   |                    |
|-----------------------|-----------------------------------|--------------------|
| 1. Blower unit        | 2. Heater & cooling unit assembly | 3. Steering member |
| 4. Instrument stay LH | 5. Instrument stay RH             | 6. Drain hose      |
| 7. Clamp              |                                   |                    |

Refer to [GI-4, "Components"](#) for symbols in the figure.

DISASSEMBLY

A  
B  
C  
D  
E  
F  
G  
H  
VTL  
J  
K  
L  
M  
N  
O  
P

# BLOWER UNIT

## < REMOVAL AND INSTALLATION >

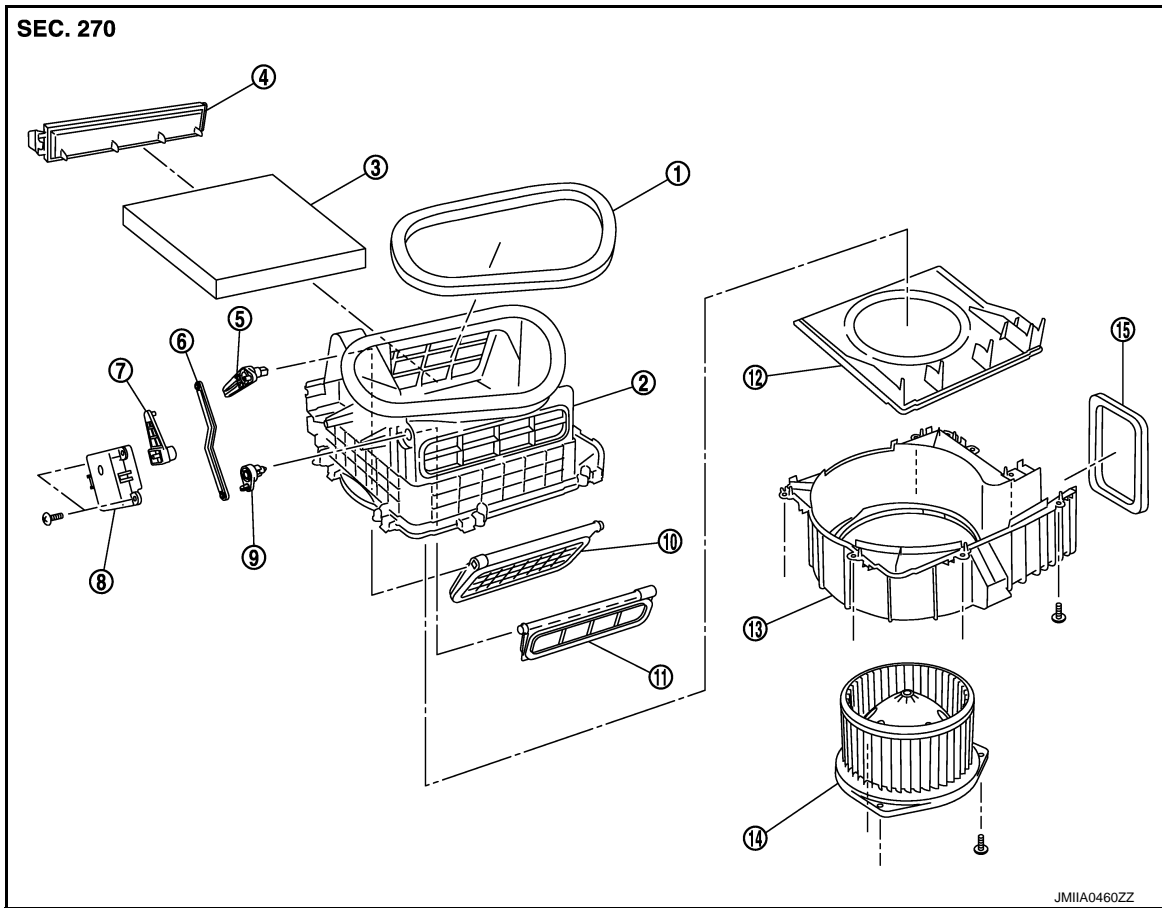

- |                        |                           |   |
|------------------------|---------------------------|---|
| 1. Seal                | 2. Intake upper case      | 3. In-cabin microfilter/Air conditioner filter* |
| 4. Filter cover        | 5. Intake door lever 1    | 6. Intake door link                             |
| 7. Intake door lever 2 | 8. Intake door motor      | 9. Intake door lever 3                          |
| 10. Intake door 2      | 11. Intake door 1         | 12. Intake bell mouth                           |
| 13. Intake lower case  | 14. Blower motor assembly | 15. Seal  |

\*: Models for Mexico.

## BLOWER UNIT

### BLOWER UNIT : Removal and Installation

INFOID:000000006353344

#### REMOVAL

1. Remove instrument lower panel RH. Refer to [IP-14, "Exploded View"](#).
2. Disconnect intake door motor connector.
3. Disconnect blower motor connector.
4. Remove mounting bolt (A) and screws (B), from blower unit (1).
5. Remove blower unit.

#### **CAUTION:**

**Move blower unit rightward, and remove locating pin (1 part) and joint. Then remove blower unit downward.**

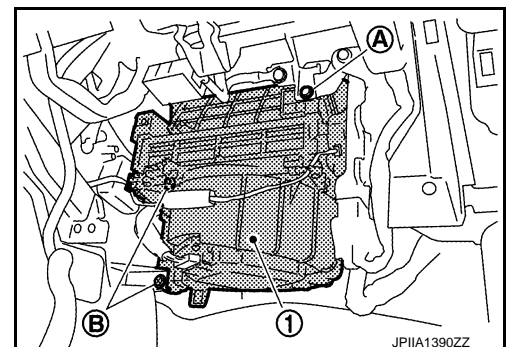

# BLOWER UNIT

## < REMOVAL AND INSTALLATION >

### INSTALLATION

Installation is basically the reverse order of removal.

#### **CAUTION:**

**Check locating pin (A) and joint (B) are securely inserted.**

← : Vehicle front

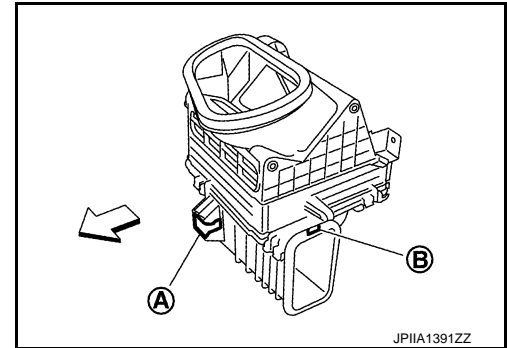

### BLOWER MOTOR

#### BLOWER MOTOR : Removal and Installation

INFOID:000000006353345

### REMOVAL

1. Disconnect blower motor connector.
2. Remove mounting screws (A), and then remove blower motor (1).

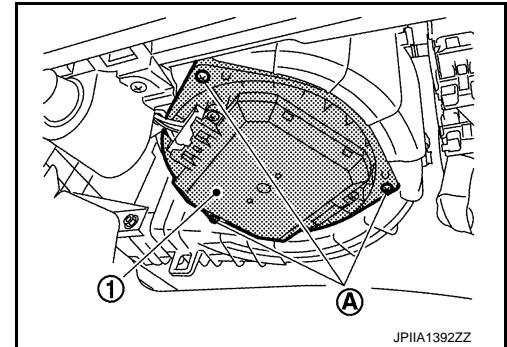

### INSTALLATION

Installation is basically the reverse order of removal.

A  
B  
C  
D  
E  
F  
G  
H  
VTL  
J  
K  
L  
M  
N  
O  
P

# IN-CABIN MICROFILTER

< REMOVAL AND INSTALLATION >

## IN-CABIN MICROFILTER

Exploded View

INFOID:000000006353346

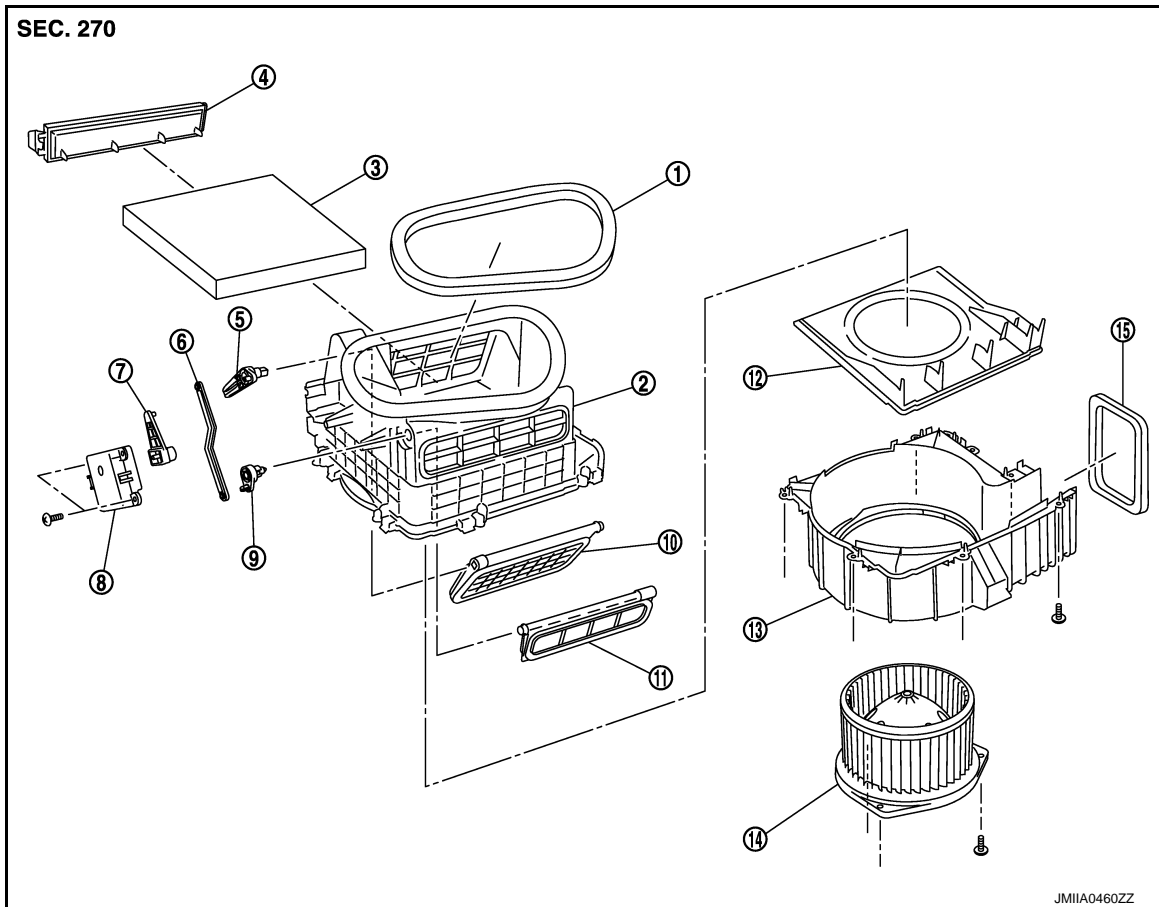

JMIA0460ZZ

- |                        |                           |   |
|------------------------|---------------------------|---|
| 1. Seal                | 2. Intake upper case      | 3. In-cabin microfilter/Air conditioner filter* |
| 4. Filter cover        | 5. Intake door lever 1    | 6. Intake door link                             |
| 7. Intake door lever 2 | 8. Intake door motor      | 9. Intake door lever 3                          |
| 10. Intake door 2      | 11. Intake door 1         | 12. Intake bell mouth                           |
| 13. Intake lower case  | 14. Blower motor assembly | 15. Seal  |

\*: Models for Mexico.

## Removal and Installation

INFOID:000000006353347

### REMOVAL

1. Remove instrument lower panel RH. Refer to [IP-14, "Exploded View"](#).
2. Remove filter cover, and then remove in-cabin microfilter/air conditioner filter.

### INSTALLATION

Installation is basically the reverse order of removal.

#### **CAUTION:**

- If the filter is deformed/damaged when removing, replace it with a new one. Deformed/damaged filter may deteriorate the duct collecting performance.
- When installing, handle the filter with extreme care to avoid deforming/damaging.

### Replacement

INFOID:000000006353348

Replace in-cabin microfilter/air conditioner filter.



## IN-CABIN MICROFILTER

### < REMOVAL AND INSTALLATION >

For NOATH AMERICA: Refer to [MA-8. "FOR NORTH AMERICA : Schedule 1"](#) and [MA-10. "FOR NORTH AMERICA : Schedule 2"](#).

For MEXICO: Refer to [MA-11. "FOR MEXICO : Periodic Maintenance"](#).

Affix a caution label inside the glove box when replacing filter.

A

B

C

D

E

F

G

H

VTL

J

K

L

M

N

O

P