

A
B
C

SECTION FAX

FRONT AXLE

FAX

CONTENTS

<p>SYMPTOM DIAGNOSIS 2</p> <p>NOISE, VIBRATION AND HARSHNESS (NVH) TROUBLESHOOTING 2</p> <p style="padding-left: 20px;">NVH Troubleshooting Chart2</p> <p>PRECAUTION 3</p> <p>PRECAUTIONS 3</p> <p>FOR USA AND CANADA3</p> <p style="padding-left: 20px;">FOR USA AND CANADA : Precaution for Supplemental Restraint System (SRS) "AIR BAG" and "SEAT BELT PRE-TENSIONER"3</p> <p style="padding-left: 20px;">FOR USA AND CANADA : Precaution for Battery Service3</p> <p>FOR MEXICO3</p> <p style="padding-left: 20px;">FOR MEXICO : Precaution for Supplemental Restraint System (SRS) "AIR BAG" and "SEAT BELT PRE-TENSIONER"3</p> <p style="padding-left: 20px;">FOR MEXICO : Precaution for Battery Service4</p>	<p>PREPARATION 5</p> <p>PREPARATION 5</p> <p style="padding-left: 20px;">Commercial Service Tool 5</p> <p>PERIODIC MAINTENANCE 6</p> <p>FRONT WHEEL HUB AND KNUCKLE 6</p> <p style="padding-left: 20px;">Inspection 6</p> <p>REMOVAL AND INSTALLATION 7</p> <p>FRONT WHEEL HUB AND KNUCKLE 7</p> <p style="padding-left: 20px;">Exploded View 7</p> <p style="padding-left: 20px;">Removal and Installation 7</p> <p style="padding-left: 20px;">Inspection 8</p> <p>SERVICE DATA AND SPECIFICATIONS (SDS) 9</p> <p>SERVICE DATA AND SPECIFICATIONS (SDS) 9</p> <p style="padding-left: 20px;">Wheel Bearing 9</p>	<p>E F G H I J K L M N O P</p>
---	--	--

NOISE, VIBRATION AND HARSHNESS (NVH) TROUBLESHOOTING

< SYMPTOM DIAGNOSIS >

SYMPTOM DIAGNOSIS

NOISE, VIBRATION AND HARSHNESS (NVH) TROUBLESHOOTING

NVH Troubleshooting Chart

INFOID:000000007624899

Use chart below to find the cause of the symptom. If necessary, repair or replace these parts.

Reference		FAX-7	—	FAX-6	NVH in FAX and FSU sections	NVH in WT section	NVH in WT section	NVH in BR section	NVH in ST section	
Possible cause and SUSPECTED PARTS		Improper installation, looseness	Parts interference	Wheel bearing damage	FRONT AXLE AND FRONT SUSPENSION	TIRE	ROAD WHEEL	BRAKE	STEERING	
Symptom	FRONT AXLE	Noise	x	x	x	x	x	x	x	
		Shake	x	x	x	x	x	x	x	
		Vibration	x	x	x	x	x			x
		Shimmy	x	x		x	x	x	x	x
		Judder	x			x	x	x	x	x
		Poor quality ride or handling	x	x		x	x	x		

x: Applicable

PRECAUTIONS

< PRECAUTION >

PRECAUTION

PRECAUTIONS

FOR USA AND CANADA

FOR USA AND CANADA : Precaution for Supplemental Restraint System (SRS) "AIR BAG" and "SEAT BELT PRE-TENSIONER"

INFOID:000000007624900

The Supplemental Restraint System such as "AIR BAG" and "SEAT BELT PRE-TENSIONER", used along with a front seat belt, helps to reduce the risk or severity of injury to the driver and front passenger for certain types of collision. This system includes seat belt switch inputs and dual stage front air bag modules. The SRS system uses the seat belt switches to determine the front air bag deployment, and may only deploy one front air bag, depending on the severity of a collision and whether the front occupants are belted or unbelted. Information necessary to service the system safely is included in the "SRS AIR BAG" and "SEAT BELT" of this Service Manual.

WARNING:

Always observe the following items for preventing accidental activation.

- To avoid rendering the SRS inoperative, which could increase the risk of personal injury or death in the event of a collision that would result in air bag inflation, all maintenance must be performed by an authorized NISSAN/INFINITI dealer.
- Improper maintenance, including incorrect removal and installation of the SRS, can lead to personal injury caused by unintentional activation of the system. For removal of Spiral Cable and Air Bag Module, see "SRS AIR BAG".
- Never use electrical test equipment on any circuit related to the SRS unless instructed to in this Service Manual. SRS wiring harnesses can be identified by yellow and/or orange harnesses or harness connectors.

PRECAUTIONS WHEN USING POWER TOOLS (AIR OR ELECTRIC) AND HAMMERS

WARNING:

Always observe the following items for preventing accidental activation.

- When working near the Air Bag Diagnosis Sensor Unit or other Air Bag System sensors with the ignition ON or engine running, never use air or electric power tools or strike near the sensor(s) with a hammer. Heavy vibration could activate the sensor(s) and deploy the air bag(s), possibly causing serious injury.
- When using air or electric power tools or hammers, always switch the ignition OFF, disconnect the battery, and wait at least 3 minutes before performing any service.

FOR USA AND CANADA : Precaution for Battery Service

INFOID:000000007624901

Before disconnecting the battery, lower both the driver and passenger windows. This will prevent any interference between the window edge and the vehicle when the door is opened/closed. During normal operation, the window slightly raises and lowers automatically to prevent any window to vehicle interference. The automatic window function will not work with the battery disconnected.

FOR MEXICO

FOR MEXICO : Precaution for Supplemental Restraint System (SRS) "AIR BAG" and "SEAT BELT PRE-TENSIONER"

INFOID:000000007624903

The Supplemental Restraint System such as "AIR BAG" and "SEAT BELT PRE-TENSIONER", used along with a front seat belt, helps to reduce the risk or severity of injury to the driver and front passenger for certain types of collision. Information necessary to service the system safely is included in the "SRS AIR BAG" and "SEAT BELT" of this Service Manual.

WARNING:

Always observe the following items for preventing accidental activation.

- To avoid rendering the SRS inoperative, which could increase the risk of personal injury or death in the event of a collision that would result in air bag inflation, all maintenance must be performed by an authorized NISSAN/INFINITI dealer.

A
B
C
FAX
E
F
G
H
I
J
K
L
M
N
O
P

PRECAUTIONS

< PRECAUTION >

- **Improper maintenance, including incorrect removal and installation of the SRS, can lead to personal injury caused by unintentional activation of the system. For removal of Spiral Cable and Air Bag Module, see “SRS AIR BAG”.**
- **Never use electrical test equipment on any circuit related to the SRS unless instructed to in this Service Manual. SRS wiring harnesses can be identified by yellow and/or orange harnesses or harness connectors.**

PRECAUTIONS WHEN USING POWER TOOLS (AIR OR ELECTRIC) AND HAMMERS

WARNING:

Always observe the following items for preventing accidental activation.

- **When working near the Air Bag Diagnosis Sensor Unit or other Air Bag System sensors with the ignition ON or engine running, never use air or electric power tools or strike near the sensor(s) with a hammer. Heavy vibration could activate the sensor(s) and deploy the air bag(s), possibly causing serious injury.**
- **When using air or electric power tools or hammers, always switch the ignition OFF, disconnect the battery, and wait at least 3 minutes before performing any service.**

FOR MEXICO : Precaution for Battery Service

INFOID:000000007624904

Before disconnecting the battery, lower both the driver and passenger windows. This will prevent any interference between the window edge and the vehicle when the door is opened/closed. During normal operation, the window slightly raises and lowers automatically to prevent any window to vehicle interference. The automatic window function will not work with the battery disconnected.

PREPARATION

< PREPARATION >

PREPARATION

PREPARATION

Commercial Service Tool

INFOID:0000000007624906

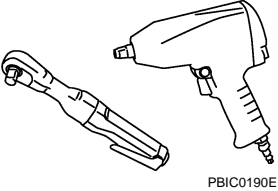
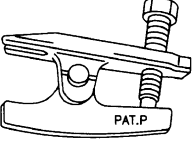
Tool name	Description
<p data-bbox="167 415 277 443">Power tool</p>  <p data-bbox="829 632 901 646">PBIC0190E</p>	<p data-bbox="1011 415 1263 443">Loosening bolts and nuts</p>
<p data-bbox="167 667 342 695">Ball joint remover</p>  <p data-bbox="792 825 829 840">PAT.P</p> <p data-bbox="829 884 868 898">NT146</p>	<p data-bbox="1011 667 1404 695">Removing ball joint for steering knuckle</p>

A

B

C

FAX

E

F

G

H

I

J

K

L

M

N

O

P

FRONT WHEEL HUB AND KNUCKLE

< PERIODIC MAINTENANCE >

PERIODIC MAINTENANCE

FRONT WHEEL HUB AND KNUCKLE

Inspection

INFOID:000000007624907

MOUNTING INSPECTION

Make sure that the mounting conditions (looseness, backlash) of each component and component conditions (wear, damage) are normal.

WHEEL BEARING INSPECTION

- Move wheel hub and bearing assembly in the axial direction by hand. Make sure there is no looseness of wheel bearing.

Axial end play : Refer to [FAX-9, "Wheel Bearing"](#).

- Rotate wheel hub and bearing assembly and make sure that is no unusual noise or other irregular conditions. If there is any of irregular conditions, replace wheel hub and bearing assembly.

FRONT WHEEL HUB AND KNUCKLE

< REMOVAL AND INSTALLATION >

REMOVAL AND INSTALLATION

FRONT WHEEL HUB AND KNUCKLE

Exploded View

INFOID:000000007624908

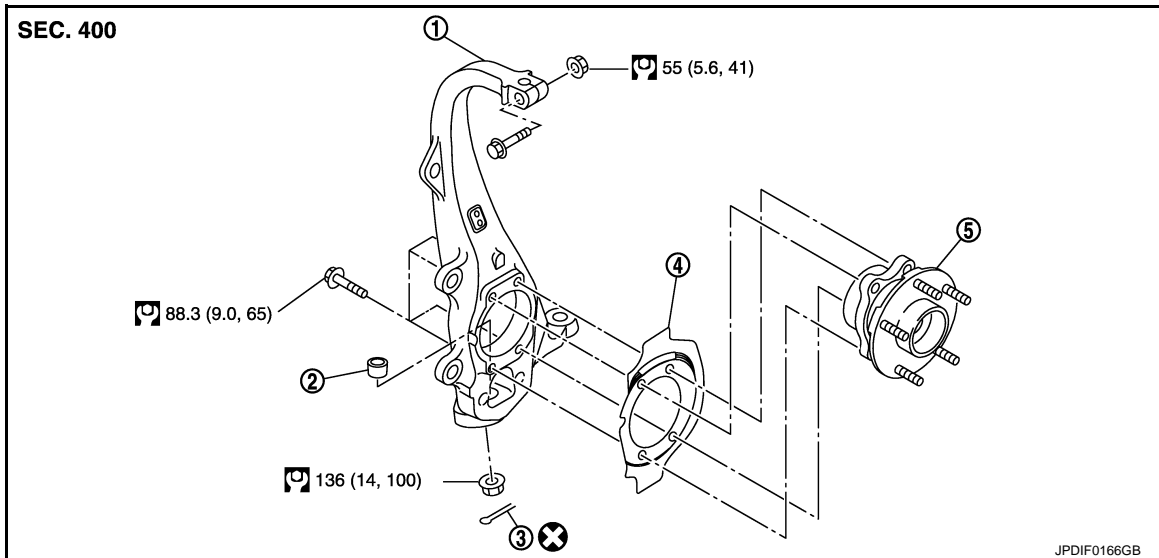

- | | | |
|---------------------|-----------------------------------|---------------|
| 1. Steering knuckle | 2. Ball seat | 3. Cotter pin |
| 4. Splash guard | 5. Wheel hub and bearing assembly | |

Refer to [GI-4, "Components"](#) for symbols in the figure.

Removal and Installation

INFOID:000000007624909

REMOVAL

1. Remove tires with power tool.
2. Remove wheel sensor and sensor harness. Refer to [BRC-105, "FRONT WHEEL SENSOR : Exploded View"](#).
CAUTION:
Never pull on wheel sensor harness.
3. Remove brake hose bracket. Refer to [BR-21, "FRONT : Exploded View"](#).
4. Remove caliper assembly. Hang caliper assembly in a place where it will not interfere with work. Refer to [BR-42, "BRAKE CALIPER ASSEMBLY \(2 PISTON TYPE\) : Exploded View"](#) (2 piston type), [BR-46, "BRAKE CALIPER ASSEMBLY \(4 PISTON TYPE\) : Exploded View"](#) (4 piston type).
CAUTION:
Never depress brake pedal while brake caliper is removed.
5. Remove disc rotor. Refer to [BR-43, "BRAKE CALIPER ASSEMBLY \(2 PISTON TYPE\) : Removal and Installation"](#) (2 piston type), [BR-47, "BRAKE CALIPER ASSEMBLY \(4 PISTON TYPE\) : Removal and Installation"](#) (4 piston type).
6. Remove wheel hub and bearing assembly, and then remove splash guard.
7. Remove steering outer socket. Refer to [ST-19, "Exploded View"](#).
8. Remove cotter pin of transverse link and steering knuckle, and then loosen nut.
9. Separate upper link from steering knuckle.
10. Separate transverse link from steering knuckle, using the ball joint remover (commercial service tool), and then remove steering knuckle.
CAUTION:
Temporarily tighten the nut to prevent damage to threads and to prevent the ball joint remover from suddenly coming off.

INSTALLATION

FRONT WHEEL HUB AND KNUCKLE

< REMOVAL AND INSTALLATION >

Note the following, and install in the reverse order of the removal.

- Perform the final tightening of each of parts under unladen conditions, which were removed when removing wheel hub and bearing assembly and steering knuckle.
- Never reuse cotter pin.

Inspection

INFOID:000000007624910

INSPECTION AFTER REMOVAL

Check components for deformation, cracks, and other damage. Replace it if necessary.

Ball Joint Inspection

Check boots of transverse link and steering outer socket ball joint for breakage, axial play, and torque. Refer to [FSU-15. "Inspection"](#) and [ST-25. "Inspection"](#).

INSPECTION AFTER INSTALLATION

1. Check wheel sensor harness for proper connection. Refer to [BRC-105. "FRONT WHEEL SENSOR : Exploded View"](#).
2. Check the wheel alignment. Refer to [FSU-9. "Inspection"](#).
3. Adjust neutral position of steering angle sensor. Refer to [BRC-8. "ADJUSTMENT OF STEERING ANGLE SENSOR NEUTRAL POSITION : Special Repair Requirement"](#).

SERVICE DATA AND SPECIFICATIONS (SDS)

< SERVICE DATA AND SPECIFICATIONS (SDS)

SERVICE DATA AND SPECIFICATIONS (SDS)

SERVICE DATA AND SPECIFICATIONS (SDS)

Wheel Bearing

INFOID:000000007624911

Item	Standard
Axial end play	0.05 mm (0.002 in) or less

A
B
C
E
F
G
H
I
J
K
L
M
N
O
P

FAX