

ENGINE LUBRICATION SYSTEM

CONTENTS

SYSTEM DESCRIPTION	2	REMOVAL AND INSTALLATION	12
DESCRIPTION	2	OIL COOLER	12
Engine Lubrication System	2	Exploded View	12
Engine Lubrication System Schematic	2	Removal and Installation	12
PRECAUTION	4	Inspection	13
PRECAUTIONS	4	OIL PUMP	14
Precautions For Engine Service	4	Exploded View	14
Liquid Gasket	4	Removal and Installation	14
PREPARATION	6	Inspection	14
PREPARATION	6	UNIT DISASSEMBLY AND ASSEMBLY ...	15
Special Service Tools	6	OIL PUMP	15
Commercial Service Tools	6	Disassembly	15
PERIODIC MAINTENANCE	8	Assembly	15
ENGINE OIL	8	Inspection	15
Inspection	8	SERVICE DATA AND SPECIFICATIONS	
Draining	9	(SDS)	17
Refilling	10	SERVICE DATA AND SPECIFICATIONS	
OIL FILTER	11	(SDS)	17
Removal and Installation	11	Periodical Maintenance Specification	17
Inspection	11	Engine Oil Pressure	17
		Oil Pump	17
		Regulator Valve	17

DESCRIPTION

< SYSTEM DESCRIPTION >

SYSTEM DESCRIPTION

DESCRIPTION

Engine Lubrication System

INFOID:000000007623819

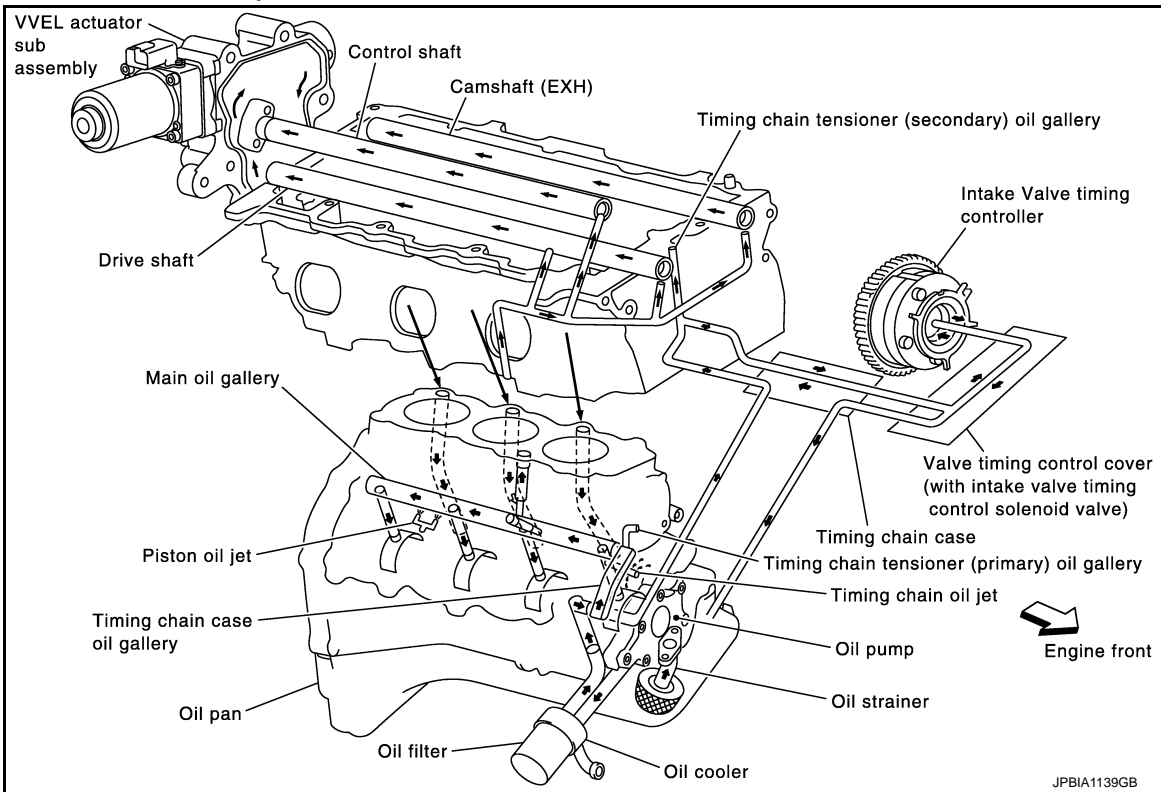

NOTE:
Without oil cooler for MEXICO.

Engine Lubrication System Schematic

INFOID:000000007623820

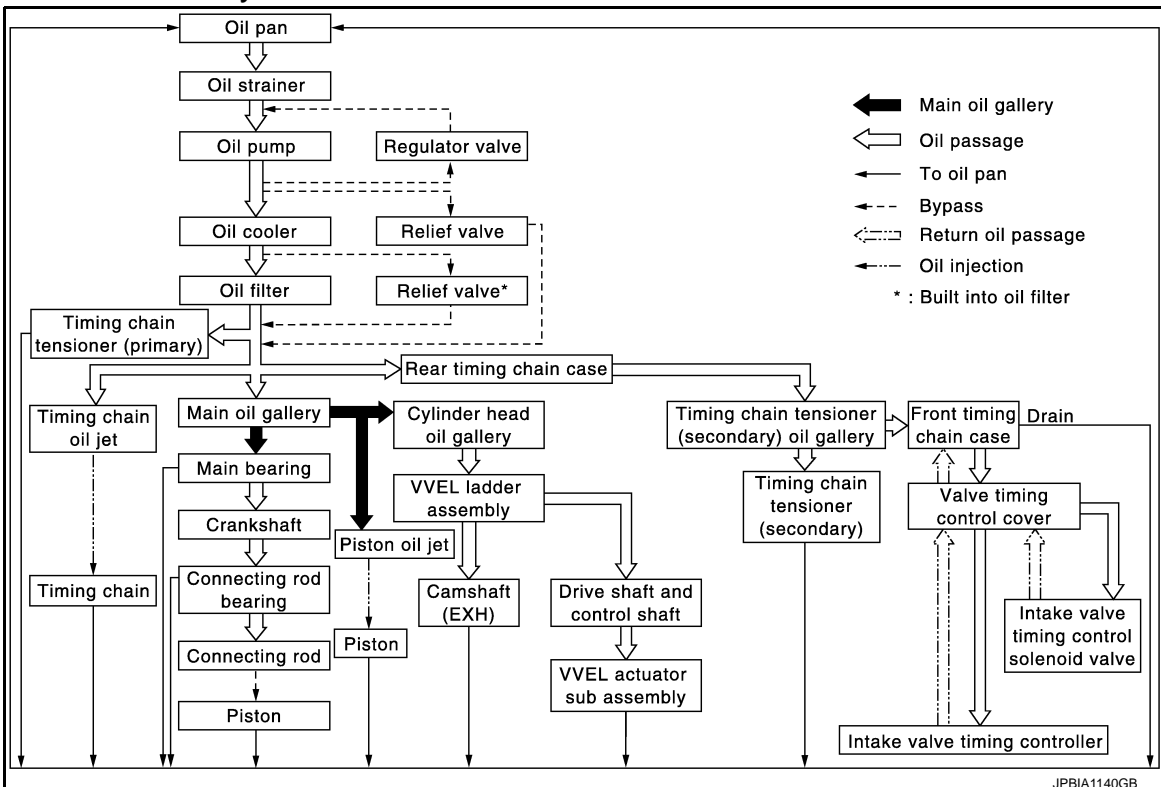

NOTE:

DESCRIPTION

< SYSTEM DESCRIPTION >

Without oil cooler for MEXICO.

A

LU

C

D

E

F

G

H

I

J

K

L

M

N

O

P

PRECAUTIONS

< PRECAUTION >

PRECAUTION

PRECAUTIONS

Precautions For Engine Service

INFOID:000000007800451

DISCONNECTING FUEL PIPING

- Before starting work, check no fire or spark producing items are in the work area.
- Release fuel pressure before disconnecting and disassembly.
- After disconnecting pipes, plug openings to stop fuel leakage.

DRAINING ENGINE COOLANT

Drain engine coolant and engine oil when the engine is cooled.

INSPECTION, REPAIR AND REPLACEMENT

Before repairing or replacing, thoroughly inspect parts. Inspect new replacement parts in the same way, and replace if necessary.

REMOVAL AND DISASSEMBLY

- When instructed to use SST, use specified tools. Always be careful to work safely, avoid forceful or uninstructed operations.
- Exercise maximum care to avoid damage to mating or sliding surfaces.
- Dowel pins are used for several parts alignment. When replacing and reassembling parts with dowel pins, check that dowel pins are installed in the original position.
- Must cover openings of engine system with a tape or equivalent, to seal out foreign materials.
- Mark and arrange disassembly parts in an organized way for easy troubleshooting and reassembly.
- When loosening nuts and bolts, as a basic rule, start with the one furthest outside, then the one diagonally opposite, and so on. If the order of loosening is specified, do exactly as specified. Power tools may be used in the step.

ASSEMBLY AND INSTALLATION

- Use torque wrench to tighten bolts or nuts to specification.
- When tightening nuts and bolts, as a basic rule, equally tighten in several different steps starting with the ones in center, then ones on inside and outside diagonally in this order. If the order of tightening is specified, do exactly as specified.
- Replace with new gasket, packing, oil seal or O-ring.
- Thoroughly wash, clean, and air-blow each part. Carefully check engine oil or engine coolant passages for any restriction and blockage.
- Avoid damaging sliding or mating surfaces. Completely remove foreign materials such as cloth lint or dust. Before assembly, oil sliding surfaces well.
- After disassembling and opening the engine, change engine oil and replace oil filter with a new one.
- Release air within route when refilling after draining engine coolant.
- After repairing, start the engine and increase engine speed to check engine coolant, fuel, engine oil, and exhaust gases for leakage.

Liquid Gasket

INFOID:000000007623821

LIQUID GASKET APPLICATION PROCEDURE

1. Remove old liquid gasket adhering to the liquid gasket application surface and the mating surface.
 - Remove liquid gasket completely from the liquid gasket application surface, mounting bolts, and bolt holes.
2. Wipe the liquid gasket application surface and the mating surface with white gasoline (lighting and heating use) to remove adhering moisture, grease and foreign materials.
3. Apply liquid gasket to the liquid gasket application surface.
Use Genuine RTV Silicone Sealant or equivalent. Refer to [GI-22, "Recommended Chemical Products and Sealants"](#).
 - Within five minutes of liquid gasket application, install the mating component.

PRECAUTIONS

< PRECAUTION >

- If liquid gasket protrudes, wipe it off immediately.
- Do not retighten mounting bolts or nuts after the installation.
- After 30 minutes or more have passed from the installation, fill engine oil and engine coolant.

A

LU

C

D

E

F

G

H

I

J

K

L

M

N

O

P

PREPARATION

< PREPARATION >

PREPARATION

PREPARATION

Special Service Tools

INFOID:000000007623822

The actual shapes of Kent-Moore tools may differ from those of special service tools illustrated here.

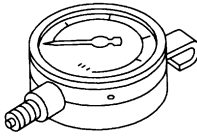
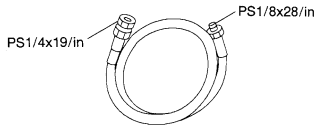
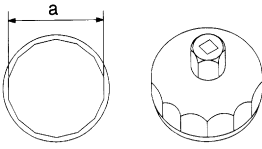
Tool number (Kent-Moore No.) Tool name	Description
ST25051001 (J-25695-1) Oil pressure gauge  <p style="text-align: center;">NT050</p>	Measuring oil pressure Maximum measuring range: 2,452 kPa (25 kg/cm², 356 psi)
ST25052000 (J-25695-2) Hose  <p style="text-align: center;">S-NT559</p>	Adapting oil pressure gauge to oil pan (upper)
KV10115801 (J-38956) Oil filter wrench  <p style="text-align: center;">S-NT375</p>	Removing and installing oil filter a: 64.3 mm (2.531 in)

Commercial Service Tools

INFOID:000000007623823

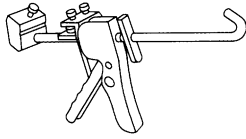
Tool name	Description
Tube presser  <p style="text-align: center;">NT052</p>	Pressing tube of liquid gasket

PREPARATION

< PREPARATION >

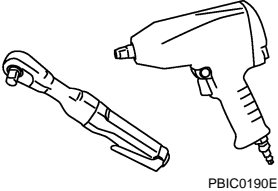
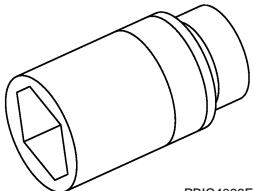
Tool name	Description
Power tools 	Loosening bolts and nuts
Deep socket 	Removing and installing oil pressure switch 27 mm (1.06 in)

A

LU

C

D

E

F

G

H

I

J

K

L

M

N

O

P

ENGINE OIL

< PERIODIC MAINTENANCE >

PERIODIC MAINTENANCE

ENGINE OIL

Inspection

INFOID:000000007623824

ENGINE OIL LEVEL

NOTE:

Before starting engine, put vehicle horizontally and check the engine oil level. If engine is already started, stop it and allow 10 minutes before checking.

1. Pull out oil level gauge and wipe it clean.
2. Insert oil level gauge and check the engine oil level is within the range (A) shown in the figure.
3. If it is out of range, adjust it.

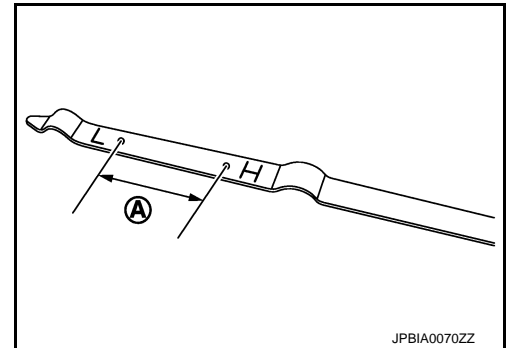

NOTE:

When checking the engine oil level, insert oil level gauge (1) with its tip aligned with oil level gauge guide.

2 : Engine cover

⇐ : Engine front

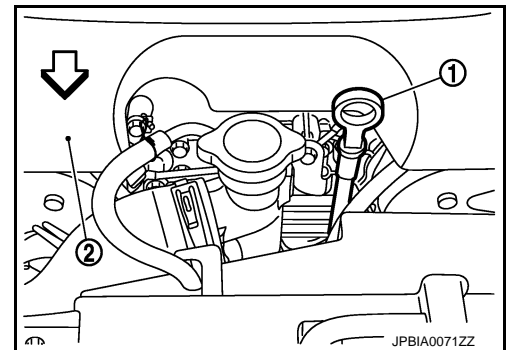

ENGINE OIL APPEARANCE

- Check engine oil for white turbidity or heavy contamination.
- If engine oil becomes turbid and white, it is highly probable that it is contaminated with engine coolant. Repair or replace damaged parts.

ENGINE OIL LEAKAGE

Check for engine oil leakage around the following areas:

- Oil pans (lower and upper)
- Oil pan drain plug
- Oil pressure switch
- Oil temperature sensor
- Oil filter
- Oil cooler (models with oil cooler)
- Valve timing control cover
- Mating surface between cylinder head and rocker cover
- Mating surface between front timing chain case and rear timing chain case
- Mating surface between rear timing chain case and cylinder head
- Mating surface between rear timing chain case and cylinder block
- Mating surface between rear timing chain case and oil pan (upper)
- Mating surface between cylinder block and cylinder head
- Mating surface between lower cylinder block and cylinder block
- Crankshaft oil seals (front and rear)
- Camshaft position sensor (PHASE) and intake valve timing control solenoid valve

ENGINE OIL

< PERIODIC MAINTENANCE >

OIL PRESSURE CHECK

WARNING:

- Be careful not to get burn yourself, as engine oil may be hot.
- Oil pressure check should be done in "Neutral position" (M/T models) or "Parking position" (A/T models).

1. Check the engine oil level.
2. Remove engine undercover with power tool.
3. Disconnect harness connector at oil pressure switch, and remove oil pressure switch using deep socket (commercial service tool).

1 : Oil pressure switch

← : Engine front

CAUTION:

Never drop or shock oil pressure switch.

NOTE:

The figure shows models with oil cooler.

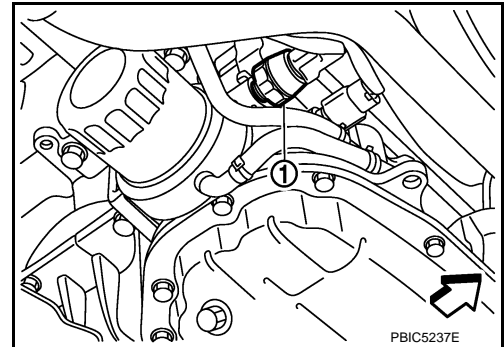

4. Install the oil pressure gauge [SST: ST25051001 (J-25695-1)] (A) and hose [SST: ST25052000 (J-25695-2)] (B).

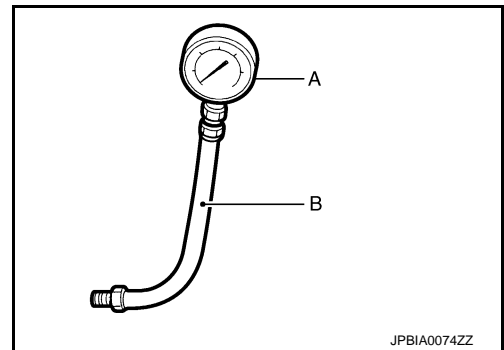

5. Start the engine and warm it up to normal operating temperature.
6. Check the engine oil pressure with engine running under no-load.

NOTE:

When the engine oil temperature is low, the engine oil pressure becomes high.

Engine oil pressure : Refer to [LU-17, "Engine Oil Pressure"](#).

If difference is extreme, check engine oil passage and oil pump for engine oil leakage.

7. After the inspections, install oil pressure switch as follows:
 - a. Remove old liquid gasket adhering to oil pressure switch and the mating surface.
 - b. Apply liquid gasket and tighten oil pressure switch to the specification.

Use Genuine RTV Silicone Sealant or equivalent. Refer to [GI-22, "Recommended Chemical Products and Sealants"](#).

Tightening torque : Refer to [EM-49, "Exploded View"](#).

- c. After warming up engine, check there is no leakage of engine oil with running engine.

Draining

INFOID:000000007623825

WARNING:

- Be careful not to get burn yourself, as engine oil may be hot.
- Prolonged and repeated contact with used engine oil may cause skin cancer. Try to avoid direct skin contact with used engine oil. If skin contact is made, wash thoroughly with soap or hand cleaner as soon as possible.

1. Warm up the engine, and check for engine oil leakage from engine components. Refer to [LU-8, "Inspection"](#).

ENGINE OIL

< PERIODIC MAINTENANCE >

2. Stop the engine and wait for 10 minutes.
3. Loosen oil filler cap.
4. Remove undercover with power tool.
5. Remove drain plug and then drain engine oil.

Refilling

INFOID:000000007623826

1. Install drain plug with new washer. Refer to [EM-49, "Exploded View"](#).

CAUTION:

Be sure to clean drain plug and install with new washer.

Tightening torque : Refer to [EM-49, "Exploded View"](#).

2. Refill with new engine oil.

Engine oil specification and viscosity: Refer to [MA-14, "FOR NORTH AMERICA : Fluids and Lubricants"](#) (FOR NORTH AMERICA) or [MA-15, "FOR MEXICO : Fluids and Lubricants"](#) (FOR MEXICO).

Engine oil capacity : Refer to [LU-17, "Periodical Maintenance Specification"](#).

CAUTION:

- When filling engine oil, do not pull out oil level gauge.
- The refill capacity depends on the engine oil temperature and drain time. Use these specifications for reference only.
- Always use oil level gauge to determine the proper amount of engine oil in engine.

3. Warm up the engine and check area around drain plug and oil filter for engine oil leakage.
4. Stop the engine and wait for 10 minutes.
5. Check the engine oil level. Refer to [LU-8, "Inspection"](#).

OIL FILTER

< PERIODIC MAINTENANCE >

OIL FILTER

Removal and Installation

INFOID:000000007623827

REMOVAL

CAUTION:

- Oil filter is provided with relief valve. Use genuine NISSAN oil filter or equivalent.
- Be careful not to get burned when engine and engine oil may be hot.
- When removing, prepare a shop cloth to absorb any engine oil leakage or spillage.
- Never allow engine oil to adhere to drive belt.
- Completely wipe off any engine oil that adheres to engine and vehicle.

1. Remove engine undercover with power tool.
2. Using oil filter wrench [SST: KV10115801 (J-38956)] (A), remove oil filter.

← : Engine front

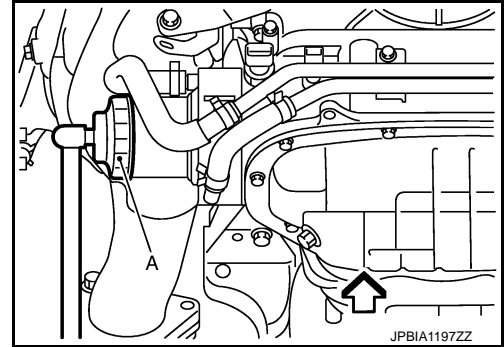

INSTALLATION

1. Remove foreign materials adhering to oil filter installation surface.
2. Apply engine oil to the oil seal contact surface of new oil filter.

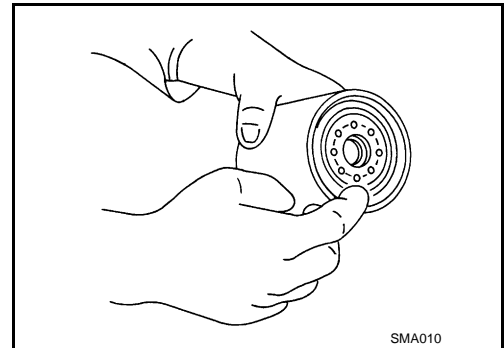

3. Screw oil filter manually until it touches the installation surface, then tighten it by 2/3 turn (A). Or tighten to the specification.

Oil filter:

: 17.7 N·m (1.8 kg·m, 13 ft·lb)

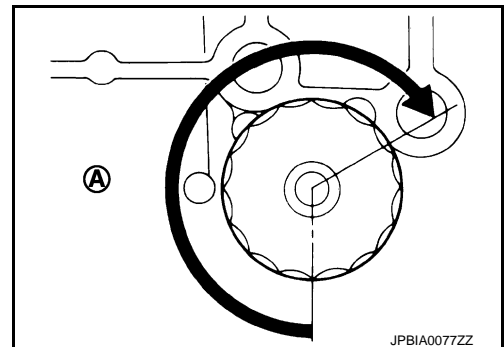

Inspection

INFOID:000000007623828

INSPECTION AFTER INSTALLATION

1. Check the engine oil level. Refer to [LU-8. "Inspection"](#).
2. Start the engine, and check there is no leakage of engine oil.
3. Stop the engine and wait for 10 minutes.
4. Check the engine oil level, and adjust the level. Refer to [LU-8. "Inspection"](#).

A
LU
C
D
E
F
G
H
I
J
K
L
M
N
O
P

OIL COOLER

< REMOVAL AND INSTALLATION >

REMOVAL AND INSTALLATION

OIL COOLER

Exploded View

INFOID:000000007784201

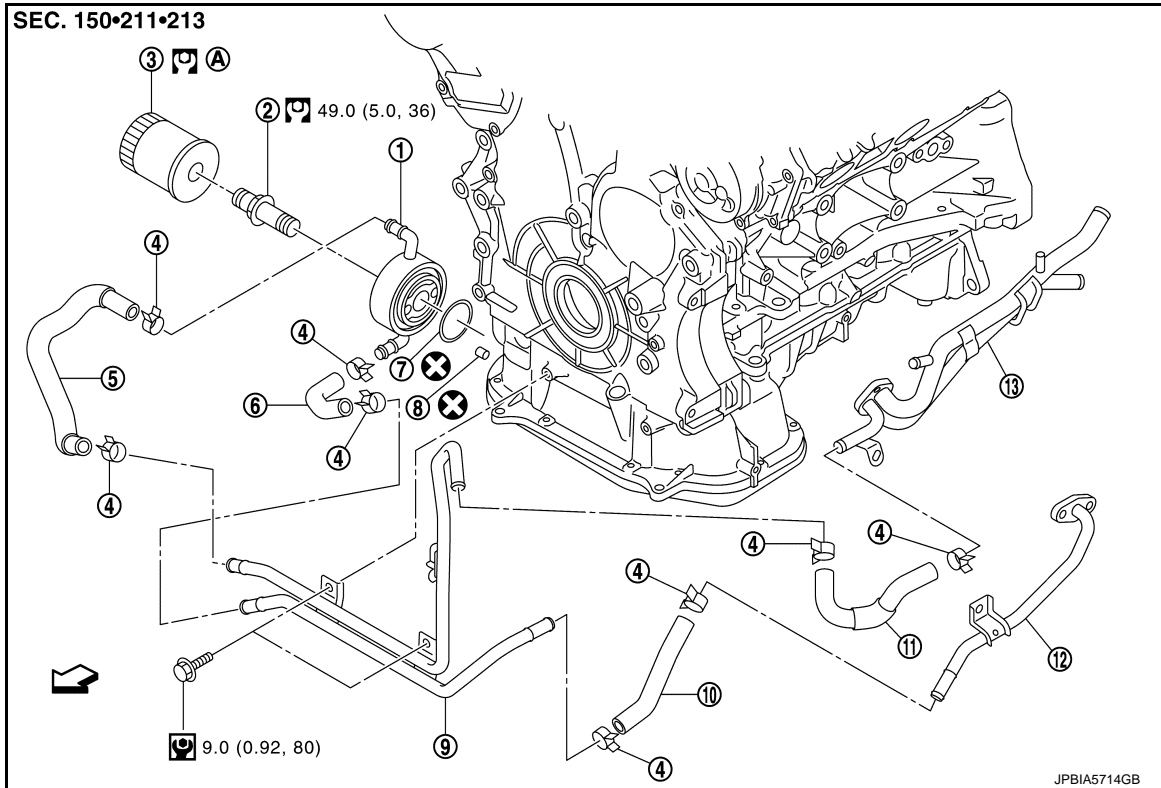

- | | | |
|-----------------|-------------------|----------------|
| 1. Oil cooler | 2. Connector bolt | 3. Oil filter |
| 4. Clamp | 5. Water hose | 6. Water hose |
| 7. O-ring | 8. Relief valve | 9. Water pipe |
| 10. Water hose | 11. Water hose | 12. Water pipe |
| 13. Heater pipe | | |

A. Refer to [LU-11](#)

↶ : Engine front

Refer to [GI-4, "Components"](#) for symbols in the figure.

Removal and Installation

INFOID:000000007784202

REMOVAL

WARNING:

Be careful not to get burn yourself, as engine oil and engine coolant may be hot.

NOTE:

When removing oil cooler only, step 2 is unnecessary.

1. Remove engine undercover with power tool.
2. Drain engine coolant from radiator and cylinder block. Refer to [CO-11, "Draining"](#) and [EM-80, "Setting"](#).

NOTE:

Perform this step when removing water pipes.

3. Disconnect water hoses from oil cooler.
 - When removing oil cooler only, pinching water hoses near oil cooler to prevent engine coolant from spilling out.
 - Remaining engine coolant in piping will come out. Use a tray to collect it.

OIL COOLER

< REMOVAL AND INSTALLATION >

CAUTION:

- Perform this step when the engine is cold.
- Never spill engine coolant on drive belt.

4. Using oil filter wrench [SST: KV10115801], remove oil filter. Refer to [LU-11. "Removal and Installation"](#).

CAUTION:

Never spill engine oil on drive belt.

5. Remove connector bolt, and oil cooler.

CAUTION:

Never spill engine oil to rubber parts such as drive belt and engine mounting insulator.

6. Remove water pipes, if necessary.

INSTALLATION

Note the following, and install in the reverse order of removal.

- Check that no foreign objects are adhering to the installation planes of oil filter and oil cooler bracket.
- Align cutout on oil cooler with protrusion on oil pan side, and tighten connector bolt.

- 1 : Oil cooler
- A : Engine right side
- B : Cutout
- C : Protrusion
- ⇐ : Engine front

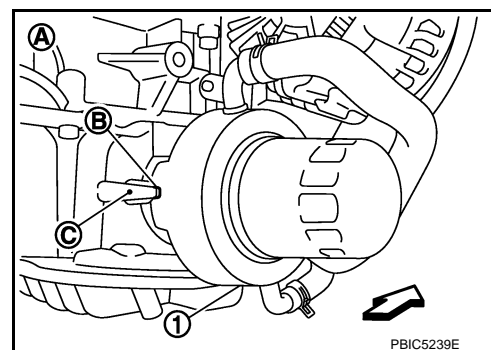

INFOID:000000007784203

Inspection

INSPECTION AFTER REMOVAL

Oil Cooler

Check oil cooler for cracks. Check oil cooler for clogging by blowing through engine coolant inlet. If necessary, replace oil cooler.

Relief Valve

Check relief valve with the following procedure.

- Press steel ball of relief valve using a clean plastic stick. Check that valve moves smoothly and proper spring repulsion is felt.
- Replace relief valve, if necessary, with the following procedure.
- Remove the relief valve by prying using a screwdriver.

CAUTION:

Be careful not to damage the mounting hole.

- Press in the relief valve until it reaches a depth of 7 mm (0.28 in) from end surface of oil pan (upper) using approximately 10 mm (0.39 in) diameter drift.

CAUTION:

Carefully press in the relief valve by aligning its mounting hole side with the axle center so as not to cause deformation.

INSPECTION AFTER INSTALLATION

1. Check the engine oil level and the engine coolant level and add engine oil and engine coolant. Refer to [LU-8. "Inspection"](#) and [CO-11. "Inspection"](#).
2. Start the engine, and check there is no leakage of engine oil or engine coolant.
3. Stop the engine and wait for 10 minutes.
4. Check the engine oil level and the engine coolant level again. Refer to [LU-8. "Inspection"](#) and [CO-11. "Inspection"](#).

OIL PUMP

< REMOVAL AND INSTALLATION >

OIL PUMP

Exploded View

INFOID:000000007623829

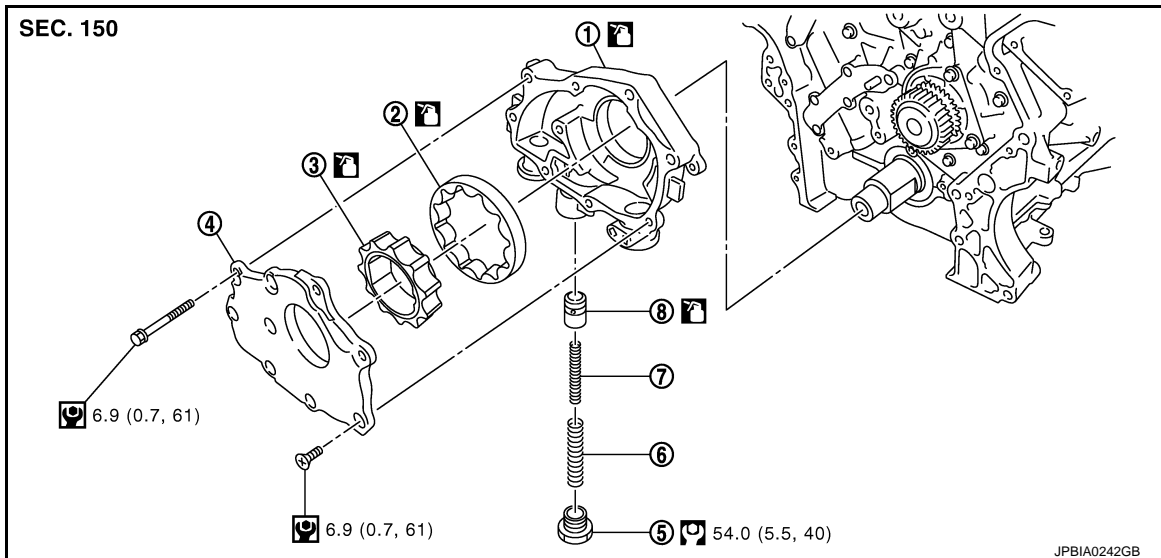

- | | | |
|---------------------------|-------------------------|---------------------------|
| 1. Oil pump body | 2. Oil pump outer rotor | 3. Oil pump inner rotor |
| 4. Oil pump cover | 5. Regulator valve plug | 6. Regulator valve spring |
| 7. Regulator valve spring | 8. Regulator valve | |

Refer to [GI-4, "Components"](#) for symbols in the figure.

Removal and Installation

INFOID:000000007623830

REMOVAL

1. Remove oil pan (upper and lower) and oil strainer. Refer to [EM-83, "Exploded View"](#).
2. Remove front timing chain case and timing chain (primary). Refer to [EM-56, "Exploded View"](#).
3. Remove oil pump assembly.

INSTALLATION

CAUTION:

Before installation, apply new engine oil to the parts as instructed in the figure.

Note the following, and install in the reverse order of removal.

- When installing, align crankshaft flat faces with oil pump inner rotor flat faces.

Inspection

INFOID:000000007623831

INSPECTION AFTER INSTALLATION

1. Check the engine oil level. Refer to [LU-8, "Inspection"](#).
2. Start the engine, and check there is no leakage of engine oil.
3. Stop the engine and wait for 10 minutes.
4. Check the engine oil level and adjust the level. Refer to [LU-8, "Inspection"](#).

OIL PUMP

< UNIT DISASSEMBLY AND ASSEMBLY >

UNIT DISASSEMBLY AND ASSEMBLY

OIL PUMP

Disassembly

INFOID:000000007623832

LU

1. Remove oil pump cover.
2. Remove oil pump inner rotor and oil pump outer rotor from oil pump body.
3. After removing regulator valve plug, remove regulator valve spring and regulator valve.

Assembly

INFOID:000000007623833

Note the following, and assemble in the reverse order of disassembly.

- Install oil pump inner rotor with the groove faced to oil pump cover side.

- A : Oil pump body side
- B : Oil pump cover side
- C : Groove

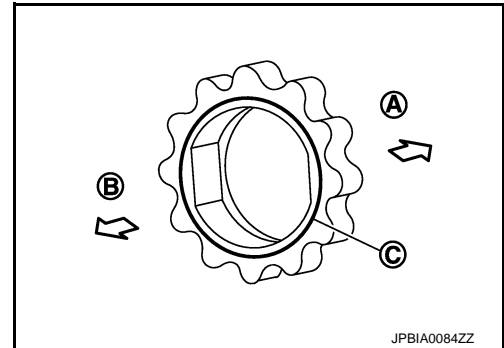

Inspection

INFOID:000000007623834

INSPECTION AFTER DISASSEMBLY

Oil Pump Clearance

- Measure the clearance with feeler gauge (C).
- Clearance between oil pump outer rotor and oil pump body [position (B)]

Standard : Refer to [LU-17, "Oil Pump"](#).

- Tip clearance between oil pump inner rotor and oil pump outer rotor [position (A)]

Standard : Refer to [LU-17, "Oil Pump"](#).

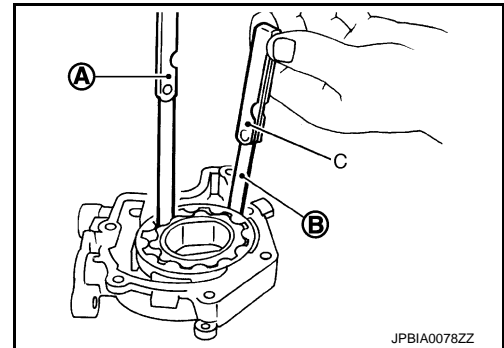

- Measure the clearance with feeler gauge and straightedge (A).
- Side clearance between oil pump inner rotor and oil pump body [position (C)]

Standard : Refer to [LU-17, "Oil Pump"](#).

- Side clearance between oil pump outer rotor and oil pump body [position (B)]

Standard : Refer to [LU-17, "Oil Pump"](#).

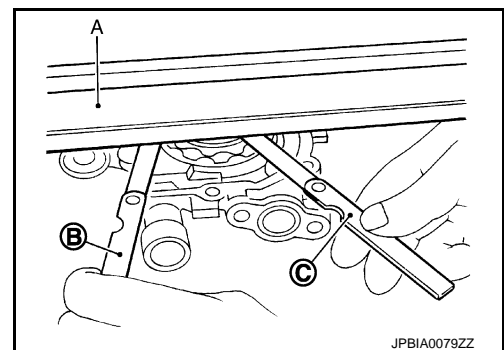

- Calculate the clearance between oil pump inner rotor and oil pump body as follows:

OIL PUMP BODY INNER DIAMETER

OIL PUMP

< UNIT DISASSEMBLY AND ASSEMBLY >

- Measure the inner diameter of oil pump body with inside micrometer. [position (A)]

OIL PUMP INNER ROTOR OUTER DIAMETER

- Measure the outer diameter of protruded portion of oil pump inner rotor (1) with micrometer. [position (B)]

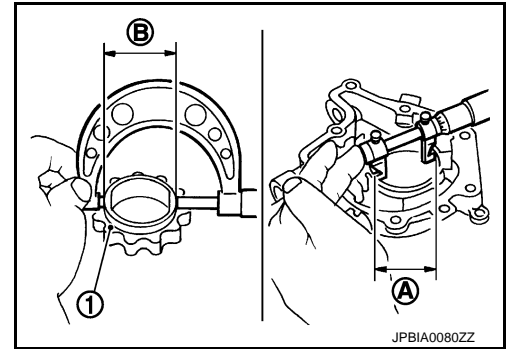

OIL PUMP INNER ROTOR TO OIL PUMP BODY CLEARANCE

- (Clearance) = (Oil pump body inner diameter) – (Oil pump inner rotor outer diameter)

Standard : Refer to [LU-17, "Oil Pump"](#).

- If measured/calculated values are out of the standard, replace oil pump assembly.

Regulator Valve Clearance

- (Clearance) = (Regulator valve hole diameter) – (Regulator valve outer diameter)

1 : Regulator valve

2 : Oil pump body

Standard : Refer to [LU-17, "Regulator Valve"](#).

- If the calculated value is out of the standard, replace oil pump assembly.

CAUTION:

- Coat regulator valve with engine oil.
- Check that it falls smoothly into valve hole by its own weight.

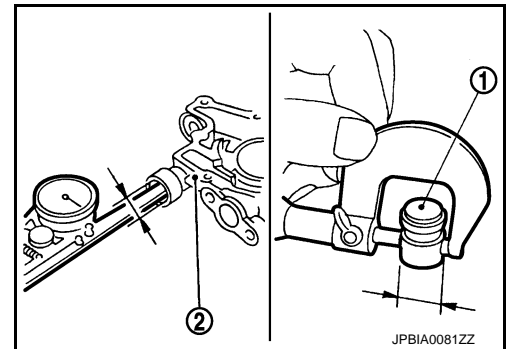

SERVICE DATA AND SPECIFICATIONS (SDS)

< SERVICE DATA AND SPECIFICATIONS (SDS)

SERVICE DATA AND SPECIFICATIONS (SDS)

SERVICE DATA AND SPECIFICATIONS (SDS)

Periodical Maintenance Specification

INFOID:0000000007623835

ENGINE OIL CAPACITY (APPROXIMATE)

Unit: ℓ (US qt, Imp qt)

Drain and refill	With oil filter change	4.9 (5-1/8, 4-1/4)
	Without oil filter change	4.6 (4-7/8, 4)
Dry engine (Overhaul)		5.7 (6, 5)

Engine Oil Pressure

INFOID:0000000007623836

Unit: kPa (kg/cm², psi)

Engine speed	Approximate discharge pressure*
Idle speed	More than 98 (1.0, 14)
2,000 rpm	More than 294 (3.0, 43)

*: Engine oil temperature at 80°C (176°F)

Oil Pump

INFOID:0000000007623837

Unit: mm (in)

Oil pump body to oil pump outer rotor radial clearance	0.114 - 0.260 (0.0045 - 0.0102)
Oil pump inner rotor to oil pump outer rotor tip clearance	Below 0.180 (0.0071)
Oil pump body to oil pump inner rotor axial clearance	0.030 - 0.070 (0.0012 - 0.0028)
Oil pump body to oil pump outer rotor axial clearance	0.030 - 0.090 (0.0012 - 0.0035)
Oil pump inner rotor to brazed portion of housing clearance	0.045 - 0.091 (0.0018 - 0.0036)

Regulator Valve

INFOID:0000000007623838

Unit: mm (in)

Regulator valve to oil pump cover clearance	0.040 - 0.097 (0.0016 - 0.0038)
---	---------------------------------