

RF
SECTION
ROOF

A
B
C
D
E
F
G
H
I
J
RF
L
M
N
O
P

CONTENTS

<p>HOW TO USE THIS MANUAL 6</p> <p>HOW TO USE THIS SECTION 6</p> <p style="padding-left: 20px;">Caution6</p> <p>PRECAUTION 7</p> <p>PRECAUTIONS 7</p> <p>EXCEPT FOR MEXICO7</p> <p style="padding-left: 20px;">EXCEPT FOR MEXICO : Precaution for Supplemental Restraint System (SRS) "AIR BAG" and "SEAT BELT PRE-TENSIONER"7</p> <p style="padding-left: 20px;">EXCEPT FOR MEXICO : Precaution for Battery Service7</p> <p style="padding-left: 20px;">EXCEPT FOR MEXICO : Precaution for Hydraulic System7</p> <p style="padding-left: 20px;">EXCEPT FOR MEXICO : Service Notice8</p> <p style="padding-left: 20px;">EXCEPT FOR MEXICO : Precaution for Work8</p> <p>FOR MEXICO8</p> <p style="padding-left: 20px;">FOR MEXICO : Precaution for Supplemental Restraint System (SRS) "AIR BAG" and "SEAT BELT PRE-TENSIONER"8</p> <p style="padding-left: 20px;">FOR MEXICO : Precaution for Battery Service9</p> <p style="padding-left: 20px;">FOR MEXICO : Precaution for Hydraulic System.....9</p> <p style="padding-left: 20px;">FOR MEXICO : Service Notice9</p> <p style="padding-left: 20px;">FOR MEXICO : Precaution for Work9</p> <p>PREPARATION10</p> <p>PREPARATION10</p> <p style="padding-left: 20px;">Commercial Service Tool 10</p> <p>SYSTEM DESCRIPTION11</p> <p>COMPONENT PARTS11</p> <p style="padding-left: 20px;">Component Parts Location 11</p> <p style="padding-left: 20px;">Component Description 12</p> <p style="padding-left: 20px;">5th Bow Latch Close Sensor 12</p> <p style="padding-left: 20px;">5th Bow Latch Open Sensor 13</p> <p style="padding-left: 20px;">5th Bow Status Sensor 13</p>	<p style="padding-left: 20px;">5th Bow Striker Sensor13</p> <p style="padding-left: 20px;">Hydraulic Pump Relay13</p> <p style="padding-left: 20px;">Hydraulic Pump Motor13</p> <p style="padding-left: 20px;">Hydraulic Pump Temperature Sensor13</p> <p style="padding-left: 20px;">Hydraulic Unit13</p> <p style="padding-left: 20px;">Roof Latch Lock Sensor13</p> <p style="padding-left: 20px;">Roof Open/Close Switch13</p> <p style="padding-left: 20px;">Roof Status Sensor13</p> <p style="padding-left: 20px;">Roof Striker Sensor14</p> <p style="padding-left: 20px;">Soft Top Control Unit14</p> <p style="padding-left: 20px;">Storage Lid Status Sensor14</p> <p style="padding-left: 20px;">Switching Valve14</p> <p>SYSTEM 15</p> <p>SOFT TOP SYSTEM15</p> <p style="padding-left: 20px;">SOFT TOP SYSTEM : System Diagram15</p> <p style="padding-left: 20px;">SOFT TOP SYSTEM : System Description16</p> <p style="padding-left: 20px;">SOFT TOP SYSTEM : Door Request Switch Control16</p> <p style="padding-left: 20px;">SOFT TOP SYSTEM : Power Window Interlock Control16</p> <p style="padding-left: 20px;">SOFT TOP SYSTEM : Rear Window Defogger Control16</p> <p style="padding-left: 20px;">SOFT TOP SYSTEM : Soft Top Open/Close Control16</p> <p style="padding-left: 20px;">SOFT TOP SYSTEM : System Protect Control20</p> <p style="padding-left: 20px;">SOFT TOP SYSTEM : Trunk Lid Open Control21</p> <p style="padding-left: 20px;">SOFT TOP SYSTEM : Warning Control21</p> <p style="padding-left: 20px;">SOFT TOP SYSTEM : Fail-safe22</p> <p style="padding-left: 20px;">SOFT TOP SYSTEM : Correspondence in Emergency23</p> <p>DIAGNOSIS SYSTEM (SOFT TOP CONTROL UNIT)28</p> <p style="padding-left: 20px;">CONSULT Function28</p> <p>ECU DIAGNOSIS INFORMATION31</p> <p>SOFT TOP CONTROL UNIT31</p> <p style="padding-left: 20px;">Reference Value31</p> <p style="padding-left: 20px;">Fail-safe38</p>
---	--

DTC Inspection Priority Chart	39	B171A HYDRAULIC PUMP (LH)	73
DTC Index	40	DTC Logic	73
WIRING DIAGRAM	43	Diagnosis Procedure	73
SOFT TOP SYSTEM	43	Component Inspection	74
Wiring Diagram	43	B171B HYDRAULIC PUMP (RH)	76
BASIC INSPECTION	47	DTC Logic	76
DIAGNOSIS AND REPAIR WORK FLOW	47	Diagnosis Procedure	76
Work Flow	47	Component Inspection	77
WATER LEAKAGE TROUBLE DIAGNOSIS ...	51	B171C SWITCHING VALVE 1	79
Repairing Method for Water Leakage Around		DTC Logic	79
Doors	51	Diagnosis Procedure	79
Water Leakage Test	58	B171D SWITCHING VALVE 2	81
DTC/CIRCUIT DIAGNOSIS	59	DTC Logic	81
U1000 CAN COMM CIRCUIT	59	Diagnosis Procedure	81
Description	59	B172C ROOF STATUS SIGNAL (TRUNK)	83
DTC Logic	59	Description	83
Diagnosis Procedure	59	DTC Logic	83
U1010 CONTROL UNIT (CAN)	60	Diagnosis Procedure	83
DTC Logic	60	B1731 HYDRAULIC STATE 1	85
Diagnosis Procedure	60	DTC Logic	85
U0140 LOCAL COMMUNICATION-1	61	Diagnosis Procedure	85
Description	61	B1758 THERMO PROTECTION	86
DTC Logic	61	DTC Logic	86
Diagnosis Procedure	61	Diagnosis Procedure	86
U0215 LOCAL COMMUNICATION-2	62	B175C POWER SOURCE (ROOF)	87
Description	62	Description	87
DTC Logic	62	DTC Logic	87
Diagnosis Procedure	62	Diagnosis Procedure	87
B1701 ROOF CONTROL UNIT	64	B175D POWER SOURCE (ROOF)	88
DTC Logic	64	Description	88
Diagnosis Procedure	64	DTC Logic	88
B1702 ROOF CONTROL UNIT	65	Diagnosis Procedure	88
DTC Logic	65	B175E POWER SOURCE (POWER WIN-	
Diagnosis Procedure	65	DOW)	89
B1709 ROOF OPEN/CLOSE SWITCH		Description	89
(OPEN)	66	DTC Logic	89
DTC Logic	66	Diagnosis Procedure	89
Diagnosis Procedure	66	B175F POWER SOURCE (POWER WIN-	
Component Inspection	67	DOW)	91
B170A ROOF OPEN/CLOSE SWITCH		Description	91
(CLOSE)	68	DTC Logic	91
DTC Logic	68	Diagnosis Procedure	91
Diagnosis Procedure	68	B1766 SWITCHING VALVE 3	93
Component Inspection	69	DTC Logic	93
B170F SENSOR POWER SUPPLY	70	Diagnosis Procedure	93
DTC Logic	70	B1767 SWITCHING VALVE 4	95
Diagnosis Procedure	71	DTC Logic	95
		Diagnosis Procedure	95
		B1768 SWITCHING VALVE 5	97

DTC Logic	97	B1778 TRUNK OPEN OUTPUT SIGNAL	125	
Diagnosis Procedure	97	DTC Logic	125	A
B176A THERMO PROTECTION	99	Diagnosis Procedure	125	
DTC Logic	99	B1779 HYDRAULIC PUMP TEMPERATURE		B
Diagnosis Procedure	99	SENSOR	127	
B176B ROOF WARNING LAMP	100	DTC Logic	127	C
DTC Logic	100	Diagnosis Procedure	127	
Diagnosis Procedure	100	B177A ROOF STATUS INCORRECT	129	D
B176C STRIKER SENSOR (RH)	102	DTC Logic	129	
DTC Logic	102	Diagnosis Procedure	129	
Diagnosis Procedure	102	B177B ROOF STATUS INCORRECT	130	E
B176D STRIKER SENSOR (LH)	104	DTC Logic	130	
DTC Logic	104	Diagnosis Procedure	130	
Diagnosis Procedure	104	B177C THERMO PROTECTION	131	F
B176E ROOF LATCH LOCK SENSOR	106	DTC Logic	131	
DTC Logic	106	Diagnosis Procedure	131	
Diagnosis Procedure	106	B177D 5TH BOW LATCH OPEN SENSOR ...	132	G
B176F ROOF STATUS SENSOR (LH)	108	DTC Logic	132	
DTC Logic	108	Diagnosis Procedure	132	
Diagnosis Procedure	108	B177E 5TH BOW LATCH CLOSE SENSOR .	134	H
B1770 ROOF STATUS SENSOR (RH)	110	DTC Logic	134	
DTC Logic	110	Diagnosis Procedure	134	
Diagnosis Procedure	110	B177F 5TH BOW STRIKER SENSOR	136	I
B1771 ROOF STATUS SENSOR (LH)	112	DTC Logic	136	
DTC Logic	112	Diagnosis Procedure	136	
Diagnosis Procedure	112	POWER SUPPLY AND GROUND CIRCUIT ..	138	J
B1772 5TH BOW STATUS SENSOR (LH)	114	Diagnosis Procedure	138	
DTC Logic	114	BACK-UP LAMP CIRCUIT	139	RF
Diagnosis Procedure	114	Component Function Check	139	
B1773 5TH BOW STATUS SENSOR (RH)	116	Diagnosis Procedure	139	
DTC Logic	116	ROOF OPEN/CLOSE SWITCH	141	L
Diagnosis Procedure	116	Component Function Check	141	
B1774 STORAGE LID STATUS SENSOR		Diagnosis Procedure	141	
(LH)	118	ROOF WARNING LAMP	143	M
DTC Logic	118	Component Function Check	143	
Diagnosis Procedure	118	Diagnosis Procedure	143	
B1775 STORAGE LID STATUS SENSOR		TRUNK ROOM LAMP SWITCH	144	N
(RH)	120	Component Function Check	144	
DTC Logic	120	Diagnosis Procedure	144	O
Diagnosis Procedure	120	Component Inspection	145	
B1776 STORAGE LID STATUS SENSOR		SYMPTOM DIAGNOSIS	146	P
(RH)	122	SOFT TOP DOES NOT OPERATE USING		
DTC Logic	122	DOOR REQUEST SWITCH	146	
Diagnosis Procedure	122	Description	146	
B1777 REAR WINDOW DEFOGGER OUT-		Diagnosis Procedure	146	
PUT SIGNAL	124	SOFT TOP DOES NOT OPERATE USING		
DTC Logic	124	ROOF OPEN/CLOSE SWITCH	147	
Diagnosis Procedure	124			

Description	147	STORAGE LID ASSEMBLY : Removal and Instal-	
Diagnosis Procedure	147	lation	202
ROOF WARNING LAMP DOES NOT ILLUMI-		STORAGE LID ASSEMBLY : Adjustment	203
NATE WHEN SOFT TOP OPERATES	148	STORAGE LID HINGE	207
Description	148	STORAGE LID HINGE : Exploded View	208
Diagnosis Procedure	148	STORAGE LID HINGE : Removal and Installation. 209	
SQUEAK AND RATTLE TROUBLE DIAG-		STORAGE LID STRIKER	209
NOSES	149	STORAGE LID STRIKER : Exploded View	210
Work Flow	149	STORAGE LID STRIKER : Removal and Installa-	
Inspection Procedure	151	tion	211
Diagnostic Worksheet	153	STORAGE LID LOCK	211
REMOVAL AND INSTALLATION	155	STORAGE LID LOCK : Exploded View	212
SOFT TOP	155	STORAGE LID LOCK : Removal and Installation. 213	
SOFT TOP ASSEMBLY	155	STORAGE LID DEVICE ASSEMBLY	213
SOFT TOP ASSEMBLY : Exploded View	155	STORAGE LID DEVICE ASSEMBLY : Exploded	
SOFT TOP ASSEMBLY : Removal and Installa-		View	214
tion	156	STORAGE LID DEVICE ASSEMBLY : Removal	
SOFT TOP ASSEMBLY : Adjustment	158	and Installation	215
SOFT TOP COVER OUTER	162	STORAGE LID BRACKET ASSEMBLY	216
SOFT TOP COVER OUTER : Exploded View	163	STORAGE LID BRACKET ASSEMBLY : Explod-	
SOFT TOP COVER OUTER : Removal and Instal-		ed View	216
lation	164	STORAGE LID BRACKET ASSEMBLY : Removal	
SOFT TOP COVER INNER	172	and Installation	217
SOFT TOP COVER INNER : Exploded View	173	STORAGE OUTER PROTECTOR	218
SOFT TOP COVER INNER : Removal and Instal-		STORAGE OUTER PROTECTOR : Exploded	
lation	174	View	219
FRONT LOCK STRIKER	184	STORAGE OUTER PROTECTOR : Removal and	
FRONT LOCK STRIKER : Exploded View	184	Installation	219
FRONT LOCK STRIKER : Removal and Installa-		STORAGE LID WEATHER-STRIP	220
tion	184	STORAGE LID WEATHER-STRIP : Exploded	
REAR LOCK STRIKER	185	View	221
REAR LOCK STRIKER : Exploded View	186	STORAGE LID WEATHER-STRIP : Removal and	
REAR LOCK STRIKER : Removal and Installation		Installation	221
..	187	STORAGE ROOM FINISHER	222
ROOF SEALING	187	STORAGE ROOM FINISHER : Exploded View ...	222
ROOF SEALING : Exploded View	188	STORAGE ROOM FINISHER : Removal and In-	
ROOF SEALING : Removal and Installation	188	stallation	222
1ST BOW LATCH	191	STORAGE LID EMERGENCY OPENER	223
1ST BOW LATCH : Exploded View	192	STORAGE LID EMERGENCY OPENER : Explod-	
1ST BOW LATCH : Removal and Installation	192	ed View	223
1ST BOW LATCH : Inspection and Adjustment ...	195	STORAGE LID EMERGENCY OPENER : Re-	
5TH BOW BUNGEE CORD	196	moval and Installation	223
5TH BOW BUNGEE CORD : Exploded View	196	HYDRAULIC SYSTEM	226
5TH BOW BUNGEE CORD : Removal and Instal-		Exploded View	226
lation	197	Removal and Installation	226
STORAGE LID	201	ROOF OPEN/CLOSE SWITCH	234
STORAGE LID ASSEMBLY	201	Exploded View	234
STORAGE LID ASSEMBLY : Exploded View	201	Removal and Installation	234
STORAGE LID ASSEMBLY : Removal and Instal-		SOFT TOP CONTROL UNIT	235
ation	202	Exploded View	235
STORAGE LID ASSEMBLY : Adjustment	203		

Removal and Installation	235	5TH BOW LATCH/STRIKER SENSOR AS-	
ROOF LATCH LOCK SENSOR	236	SEMBLY	237
Exploded View	236	Exploded View	237
Removal and Installation	236	Removal and Installation	237

A

B

C

D

E

F

G

H

I

J

RF

L

M

N

O

P

HOW TO USE THIS SECTION

< HOW TO USE THIS MANUAL >

HOW TO USE THIS MANUAL

HOW TO USE THIS SECTION

Caution

INFOID:000000007625363

In this section, portion (A) of soft top linkage assembly (1) is referred to as 1st bow and portion (B) is referred to as 5th bow.

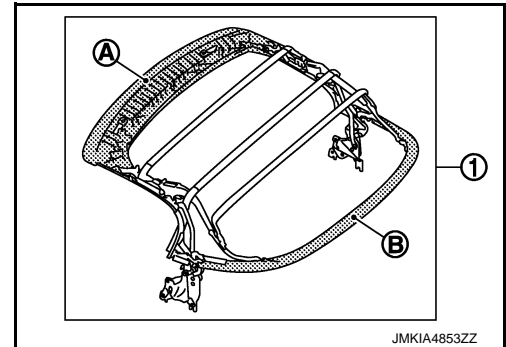

PRECAUTIONS

< PRECAUTION >

PRECAUTION

PRECAUTIONS

EXCEPT FOR MEXICO

EXCEPT FOR MEXICO : Precaution for Supplemental Restraint System (SRS) "AIR BAG" and "SEAT BELT PRE-TENSIONER"

INFOID:000000007625364

The Supplemental Restraint System such as "AIR BAG" and "SEAT BELT PRE-TENSIONER", used along with a front seat belt, helps to reduce the risk or severity of injury to the driver and front passenger for certain types of collision. This system includes seat belt switch inputs and dual stage front air bag modules. The SRS system uses the seat belt switches to determine the front air bag deployment, and may only deploy one front air bag, depending on the severity of a collision and whether the front occupants are belted or unbelted.

Information necessary to service the system safely is included in the "SRS AIR BAG" and "SEAT BELT" of this Service Manual.

WARNING:

Always observe the following items for preventing accidental activation.

- To avoid rendering the SRS inoperative, which could increase the risk of personal injury or death in the event of a collision that would result in air bag inflation, all maintenance must be performed by an authorized NISSAN/INFINITI dealer.
- Improper maintenance, including incorrect removal and installation of the SRS, can lead to personal injury caused by unintentional activation of the system. For removal of Spiral Cable and Air Bag Module, see "SRS AIR BAG".
- Never use electrical test equipment on any circuit related to the SRS unless instructed to in this Service Manual. SRS wiring harnesses can be identified by yellow and/or orange harnesses or harness connectors.

PRECAUTIONS WHEN USING POWER TOOLS (AIR OR ELECTRIC) AND HAMMERS

WARNING:

Always observe the following items for preventing accidental activation.

- When working near the Air Bag Diagnosis Sensor Unit or other Air Bag System sensors with the ignition ON or engine running, never use air or electric power tools or strike near the sensor(s) with a hammer. Heavy vibration could activate the sensor(s) and deploy the air bag(s), possibly causing serious injury.
- When using air or electric power tools or hammers, always switch the ignition OFF, disconnect the battery, and wait at least 3 minutes before performing any service.

EXCEPT FOR MEXICO : Precaution for Battery Service

INFOID:000000007625366

Before disconnecting the battery, lower both the driver and passenger windows. This will prevent any interference between the window edge and the vehicle when the door is opened/closed. During normal operation, the window slightly raises and lowers automatically to prevent any window to vehicle interference. The automatic window function will not work with the battery disconnected.

EXCEPT FOR MEXICO : Precaution for Hydraulic System

INFOID:000000007625367

CAUTION:

- Never bend or twist hydraulic hoses sharply, or strongly pull them.
- Serviceable parts for hydraulic circuit are not various. Before disassembly refer to [RF-226](#), "[Exploded View](#)".

WARNING:

- The soft top assembly and storage lid assembly may fall suddenly. Avoid working on the vehicle with hydraulic circuit under pressure. Always depressurize the system before starting. To depressurize the system, disconnect both battery cables starting by negative terminal.
- Never allow hydraulic fluid to come in contact with skin, eyes, fabrics, or.
- After touching hydraulic fluid, never touch or rub your eyes until you have thoroughly washed your hands.
- If hydraulic fluid contacts cloths, change them immediately.
- If hydraulic fluid contacts skin, wash skin with soap and water.

PRECAUTIONS

< PRECAUTION >

- If hydraulic fluid contacts eyes, immediately flush with water for 15 minutes and seek medical attention.

EXCEPT FOR MEXICO : Service Notice

INFOID:000000007625368

- When removing or installing various parts, place a cloth or padding onto the vehicle body to prevent scratches.
- Handle trim, molding, instruments, grille, etc. carefully during removing or installing. Be careful not to oil or damage them.
- Apply sealing compound where necessary when installing parts.
- When applying sealing compound, be careful that the sealing compound does not protrude from parts.
- When replacing any metal parts (for example body outer panel, members, etc.), be sure to take rust prevention measures.

EXCEPT FOR MEXICO : Precaution for Work

INFOID:000000007625369

- When removing or disassembling each component, be careful not to damage or deform it. If a component may be subject to interference, be sure to protect it with a shop cloth.
- When removing (disengaging) components with a screwdriver or similar tool, be sure to wrap the component with a shop cloth or vinyl tape to protect it.
- Protect the removed parts with a shop cloth and keep them.
- Replace a deformed or damaged clip.
- If a part is specified as a non-reusable part, always replace it with new one.
- Be sure to tighten bolts and nuts securely to the specified torque.
- After re-installation is completed, be sure to check that each part works normally.
- Follow the steps below to clean components.
 - Water soluble foul: Dip a soft cloth into lukewarm water, and wring the water out of the cloth to wipe the fouled area.
Then rub with a soft and dry cloth.
 - Oily foul: Dip a soft cloth into lukewarm water with mild detergent (concentration: within 2 to 3%), and wipe the fouled area.
Then dip a cloth into fresh water, and wring the water out of the cloth to wipe the detergent off. Then rub with a soft and dry cloth.
- Do not use organic solvent such as thinner, benzene, alcohol, and gasoline.
- For genuine leather seats, use a genuine leather seat cleaner.

FOR MEXICO

FOR MEXICO : Precaution for Supplemental Restraint System (SRS) "AIR BAG" and "SEAT BELT PRE-TENSIONER"

INFOID:000000007625370

The Supplemental Restraint System such as "AIR BAG" and "SEAT BELT PRE-TENSIONER", used along with a front seat belt, helps to reduce the risk or severity of injury to the driver and front passenger for certain types of collision. Information necessary to service the system safely is included in the "SRS AIR BAG" and "SEAT BELT" of this Service Manual.

WARNING:

Always observe the following items for preventing accidental activation.

- **To avoid rendering the SRS inoperative, which could increase the risk of personal injury or death in the event of a collision that would result in air bag inflation, all maintenance must be performed by an authorized NISSAN/INFINITI dealer.**
- **Improper maintenance, including incorrect removal and installation of the SRS, can lead to personal injury caused by unintentional activation of the system. For removal of Spiral Cable and Air Bag Module, see "SRS AIR BAG".**
- **Never use electrical test equipment on any circuit related to the SRS unless instructed to in this Service Manual. SRS wiring harnesses can be identified by yellow and/or orange harnesses or harness connectors.**

PRECAUTIONS WHEN USING POWER TOOLS (AIR OR ELECTRIC) AND HAMMERS

WARNING:

Always observe the following items for preventing accidental activation.

- **When working near the Air Bag Diagnosis Sensor Unit or other Air Bag System sensors with the ignition ON or engine running, never use air or electric power tools or strike near the sensor(s) with**

PRECAUTIONS

< PRECAUTION >

a hammer. Heavy vibration could activate the sensor(s) and deploy the air bag(s), possibly causing serious injury.

- When using air or electric power tools or hammers, always switch the ignition OFF, disconnect the battery, and wait at least 3 minutes before performing any service.

FOR MEXICO : Precaution for Battery Service

INFOID:000000007625372

Before disconnecting the battery, lower both the driver and passenger windows. This will prevent any interference between the window edge and the vehicle when the door is opened/closed. During normal operation, the window slightly raises and lowers automatically to prevent any window to vehicle interference. The automatic window function will not work with the battery disconnected.

FOR MEXICO : Precaution for Hydraulic System

INFOID:000000007625373

CAUTION:

- Never bend or twist hydraulic hoses sharply, or strongly pull them.
- Serviceable parts for hydraulic circuit are not various. Before disassembly refer to [RF-226](#), "[Exploded View](#)".

WARNING:

- The soft top assembly and storage lid assembly may fall suddenly. Avoid working on the vehicle with hydraulic circuit under pressure. Always depressurize the system before starting. To depressurize the system, disconnect both battery cables starting by negative terminal.
- Never allow hydraulic fluid to come in contact with skin, eyes, fabrics, or.
- After touching hydraulic fluid, never touch or rub your eyes until you have thoroughly washed your hands.
- If hydraulic fluid contacts cloths, change them immediately.
- If hydraulic fluid contacts skin, wash skin with soap and water.
- If hydraulic fluid contacts eyes, immediately flush with water for 15 minutes and seek medical attention.

FOR MEXICO : Service Notice

INFOID:000000007625374

- When removing or installing various parts, place a cloth or padding onto the vehicle body to prevent scratches.
- Handle trim, molding, instruments, grille, etc. carefully during removing or installing. Be careful not to oil or damage them.
- Apply sealing compound where necessary when installing parts.
- When applying sealing compound, be careful that the sealing compound does not protrude from parts.
- When replacing any metal parts (for example body outer panel, members, etc.), be sure to take rust prevention measures.

FOR MEXICO : Precaution for Work

INFOID:000000007625375

- When removing or disassembling each component, be careful not to damage or deform it. If a component may be subject to interference, be sure to protect it with a shop cloth.
- When removing (disengaging) components with a screwdriver or similar tool, be sure to wrap the component with a shop cloth or vinyl tape to protect it.
- Protect the removed parts with a shop cloth and keep them.
- Replace a deformed or damaged clip.
- If a part is specified as a non-reusable part, always replace it with new one.
- Be sure to tighten bolts and nuts securely to the specified torque.
- After re-installation is completed, be sure to check that each part works normally.
- Follow the steps below to clean components.
- Water soluble foul: Dip a soft cloth into lukewarm water, and wring the water out of the cloth to wipe the fouled area.
Then rub with a soft and dry cloth.
- Oily foul: Dip a soft cloth into lukewarm water with mild detergent (concentration: within 2 to 3%), and wipe the fouled area.
Then dip a cloth into fresh water, and wring the water out of the cloth to wipe the detergent off. Then rub with a soft and dry cloth.
- Do not use organic solvent such as thinner, benzene, alcohol, and gasoline.
- For genuine leather seats, use a genuine leather seat cleaner.

PREPARATION

< PREPARATION >

PREPARATION

PREPARATION

Commercial Service Tool

INFOID:000000007625376

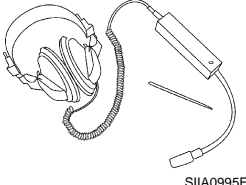
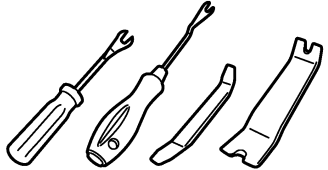
Tool name	Description
<p data-bbox="159 520 267 546">Engine ear</p>  <p data-bbox="771 630 836 646">SIA0995E</p>	<p data-bbox="1006 520 1185 546">Locates the noise</p>
<p data-bbox="159 772 292 798">Remover tool</p>  <p data-bbox="771 882 868 898">JMKIA3050ZZ</p>	<p data-bbox="1006 772 1421 798">Removes the clips, pawls and metal clips</p>

COMPONENT PARTS

< SYSTEM DESCRIPTION >

SYSTEM DESCRIPTION

COMPONENT PARTS

Component Parts Location

INFOID:000000007625377

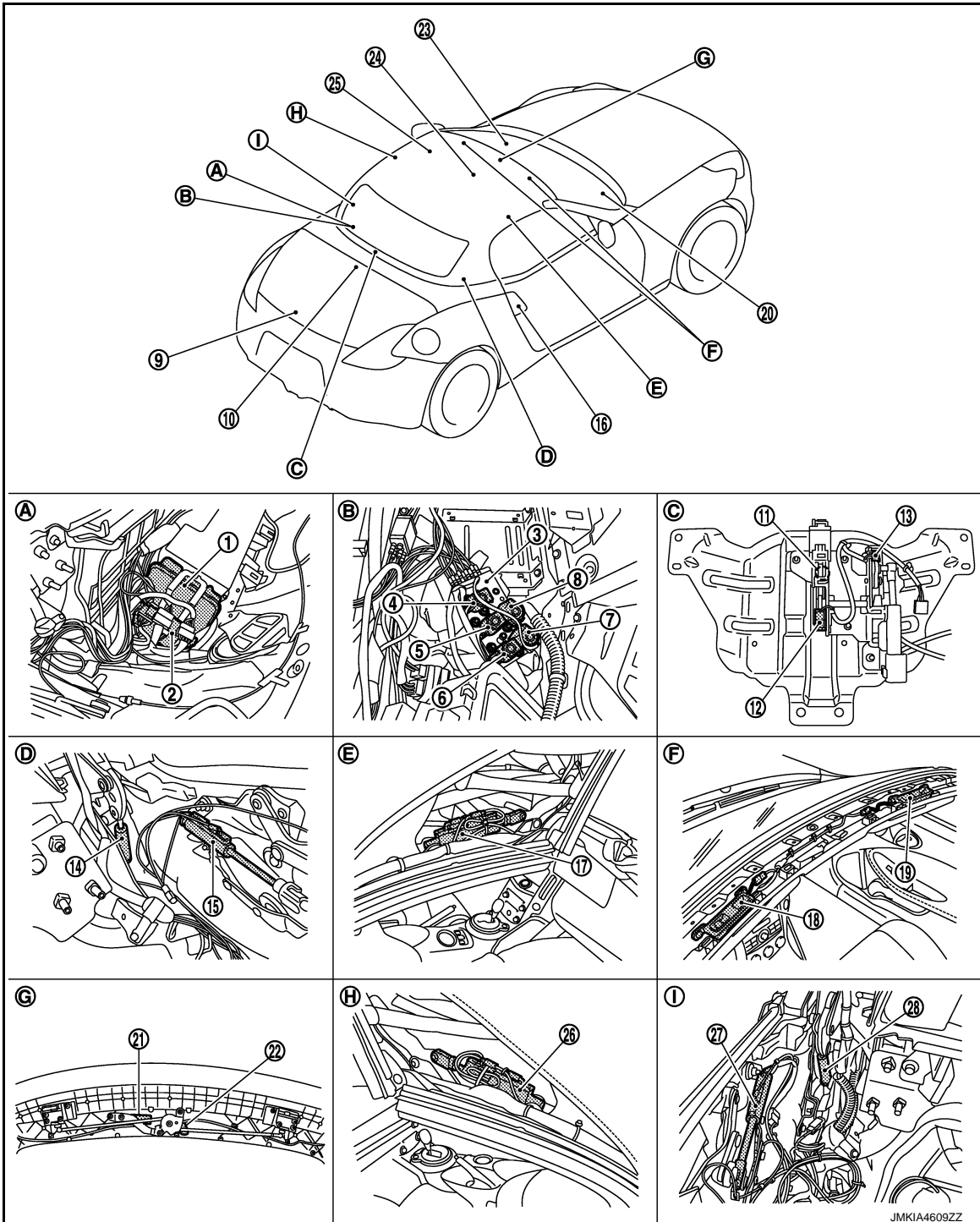

- | | | |
|----------------------------|----------------------------|-------------------------------|
| 1. Hydraulic unit | 2. Soft top control unit | 3. Hydraulic unit |
| 4. Switching valve 2 | 5. Switching valve 5 | 6. Switching valve 3 |
| 7. Switching valve 1 | 8. Switching valve 4 | 9. Trunk closure |
| 10. Trunk room lamp switch | 11. 5th bow striker sensor | 12. 5th bow latch open sensor |

COMPONENT PARTS

< SYSTEM DESCRIPTION >

- | | | |
|---|---|---|
| 13. 5th bow latch close sensor | 14. Roof drive cylinder RH (with roof status sensor RH) | 15. Storage lid drive cylinder RH (with storage lid status sensor RH) |
| 16. • Door outside handle LH (request switch)
• Door outside handle RH (request switch) | 17. 5th bow drive cylinder RH (with 5th bow status sensor RH) | 18. Roof striker sensor LH |
| 19. Roof striker sensor RH | 20. BCM
Refer to BCS-9, "Component Parts Location" | 21. Roof latch cylinder |
| 22. Roof latch lock sensor | 23. Combination meter
Refer to MWI-10, "METER SYSTEM : Component Parts Location" | 24. Roof open/close switch |
| 25. Power window main switch
Refer to PWC-96, "Component Parts Location" | 26. 5th bow drive cylinder LH (with 5th bow status sensor LH) | 27. Storage lid drive cylinder LH (with storage lid status sensor LH) |
| 28. Roof drive cylinder LH (with roof status sensor LH) | | |
| A. Behind storage room trim LH | B. Behind storage room trim LH | C. Backside of storage lid |
| D. Behind storage room trim RH | E. 2nd bow RH side | F. Behind roof front finisher |
| G. Behind front roof garnish | H. 2nd bow LH side | I. Behind storage room trim LH |

Component Description

INFOID:000000007625378

	Component	Reference page
Control unit	Soft top control unit	RF-14
	AV control unit	AV-11 (Base audio) AV-41 (Bose audio without navigation) AV-126 (Bose audio with navigation)
	BCM	BCS-8
	Combination meter	MWI-10
Input	5th bow latch close sensor	RF-12
	5th bow latch open sensor	RF-13
	5th bow status sensor (LH/RH)	RF-13
	5th bow striker sensor	RF-13
	Hydraulic pump temperature sensor	RF-13
	Roof latch lock sensor	RF-13
	Roof open/close switch	RF-13
	Roof striker sensor (LH/RH)	RF-14
	Storage lid status sensor (LH/RH)	RF-14
Trunk room lamp switch	DLK-185	
Output	Hydraulic pump relay (1/2)	RF-13
	Hydraulic pump motor	RF-13
	Switching valve (1/2/3/4/5)	RF-14
	Trunk opener actuator	DLK-185

5th Bow Latch Close Sensor

INFOID:000000007625379

5th bow close sensor is installed to storage lid inside and detects 5th bow latch state by movement of linkage. ON signal (5th bow latch close signal) is transmitted to soft top control unit when linkage lock position is detected by hydraulic control.

COMPONENT PARTS

< SYSTEM DESCRIPTION >

5th Bow Latch Open Sensor

INFOID:000000007625380

5th bow latch open sensor is installed to storage lid inside and detects 5th bow latch state by movement of linkage.

ON signal (5th bow latch open signal) is transmitted to soft top control unit when linkage lock position is detected by hydraulic control.

5th Bow Status Sensor

INFOID:000000007625381

5th bow status sensor is installed to 5th bow drive cylinder and is a hall sensor.

When 5th bow drive bow cylinder is extended or retracted, the position of piston and sensor in the cylinder changes and the magnetic field around the sensor changes.

By this operation, sensor output current changes. Soft top control unit judges the state of 5th bow by this amount of current.

5th Bow Striker Sensor

INFOID:000000007625382

5th bow striker sensor is installed to 5th bow latch linkage and detects engaging state of striker and latch.

5th bow striker sensor transmits ON signal to soft top control unit when engaging state of 5th bow striker and 5th bow latch is detected.

Hydraulic Pump Relay

INFOID:000000007625383

Hydraulic pump relay is controlled by soft top control unit and controls the rotation direction of hydraulic pump motor.

Hydraulic Pump Motor

INFOID:000000007625384

Hydraulic pump motor drives hydraulic pump and controls the rotation direction using hydraulic pump motor relay.

Hydraulic Pump Temperature Sensor

INFOID:000000007625385

Hydraulic pump temperature sensor measures the temperature of hydraulic pump motor.

This sensor uses a thermistor and its electrical resistance varies as the temperature varies.

Electrical resistance decreases as the temperature increases.

Hydraulic Unit

INFOID:000000007625386

Hydraulic unit consists of hydraulic pump motor that drives hydraulic pump, hydraulic pump relay 1/2 that controls the rotation direction, switching valve 1/2/3/4/5 that switches the hydraulic circuits for each cylinder, and hydraulic pump temperature sensor that measures the temperature of hydraulic pump.

Hydraulic pump controls hydraulic operation according to control signal from soft top control unit.

Roof Latch Lock Sensor

INFOID:000000007625387

Roof latch lock sensor is installed in front roof garnish. The sensor detects the lock state by rod movement of roof lock assembly and transmits the signal to soft top control unit.

Soft top control unit uses this signal for judgement of roof latch cylinder hydraulic control or soft top lock state.

Roof Open/Close Switch

INFOID:000000007625388

Soft top can be opened and closed by roof open/close switch operation. Soft top operates only while roof open/close switch is being operated.

Roof Status Sensor

INFOID:000000007625389

Roof status sensor is installed to roof drive cylinder and is a hall sensor.

When roof drive cylinder is extended or retracted, the position of piston and sensor in the cylinder changes and the magnetic field around the sensor changes.

By this operation, sensor output current changes. Soft top control unit judges the state of soft top by this amount of current.

A
B
C
D
E
F
G
H
I
J
RF
L
M
N
O
P

COMPONENT PARTS

< SYSTEM DESCRIPTION >

Roof Striker Sensor

INFOID:000000007625390

Roof striker sensor is installed to roof front finisher LH and RH. It detects engaging state of roof lock assembly hook and front lock striker and transmits ON signal to soft top control unit.

Soft Top Control Unit

INFOID:000000007625391

Soft top control unit is a main unit that controls soft top system. It is installed on the left side of soft top storage room.

Storage Lid Status Sensor

INFOID:000000007625392

Storage lid status sensor is installed to storage lid drive cylinder and is a hall sensor. When storage lid drive cylinder is extended or retracted, the position of piston and sensor in the cylinder changes and the magnetic field around the sensor changes. By this operation, sensor output current changes. Soft top control unit judges storage lid state by this amount of current.

Switching Valve

INFOID:000000007625393

Switching valve is integrated in hydraulic unit, switches hydraulic circuit by ON/OFF of valve 1/2/3/4/5, and controls hydraulic operation to each cylinder.

SYSTEM

< SYSTEM DESCRIPTION >

SYSTEM

SOFT TOP SYSTEM

SOFT TOP SYSTEM : System Diagram

INFOID:000000007625394

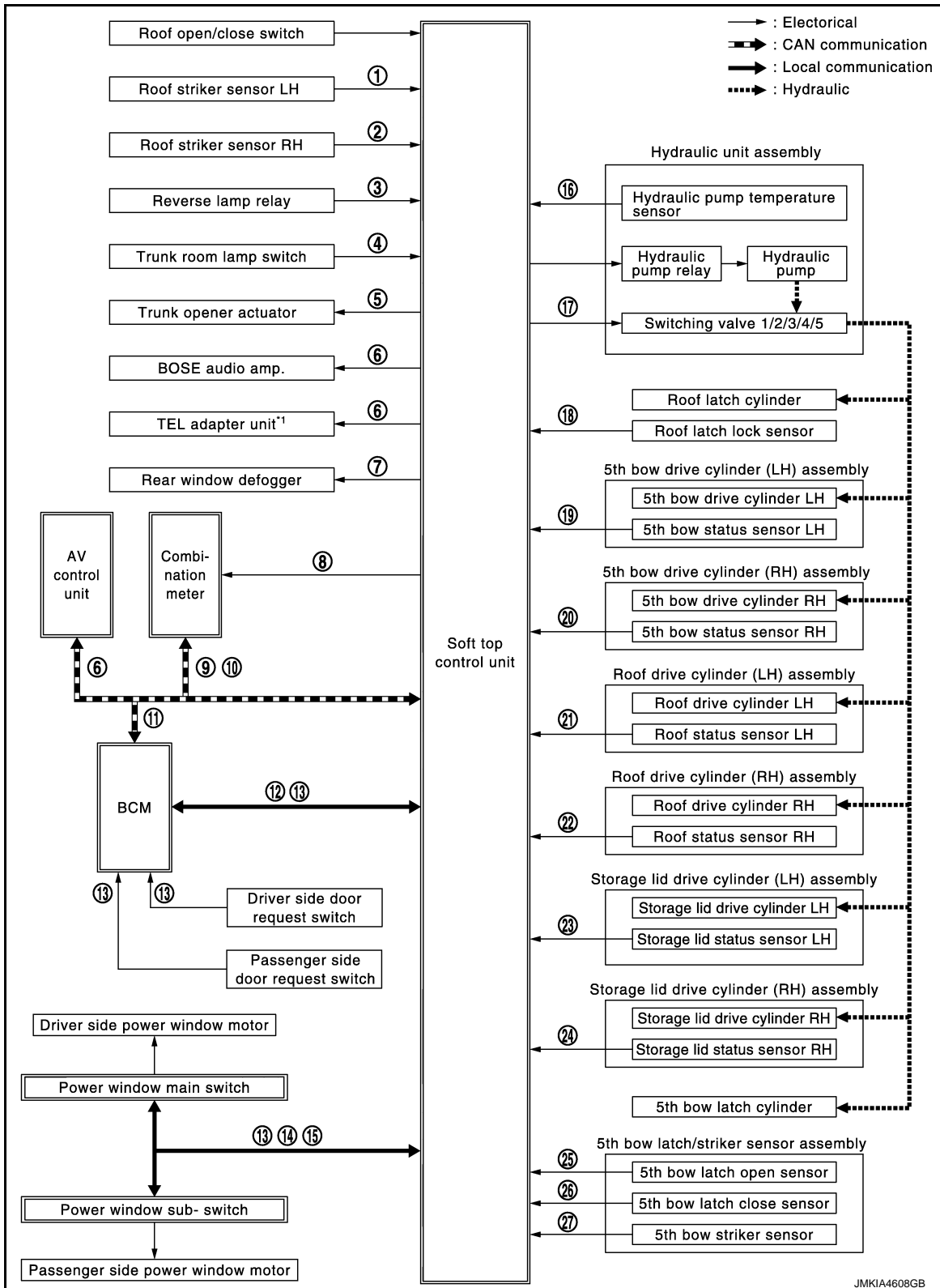

A
B
C
D
E
F
G
H
I
J
RF
L
M
N
O
P

SYSTEM

< SYSTEM DESCRIPTION >

- | | | |
|---------------------------------------|--------------------------------------|---|
| 1. Roof striker position signal (LH) | 2. Roof striker position signal (RH) | 3. Reverse signal |
| 4. Trunk lid open/close status signal | 5. Trunk open signal | 6. Roof position signal |
| 7. Rear window defogger on signal | 8. Roof warning lamp signal | 9. Vehicle speed signal |
| 10. Buzzer output signal | 11. Ignition on signal | 12. Trunk open signal |
| 13. Door request switch signal | 14. Power window open signal | 15. Power window operation prohibition signal |
| 16. Hydraulic pump temperature signal | 17. Switching valve on/off signal | 18. Roof latch lock signal |
| 19. 5th bow status signal (LH) | 20. 5th bow status signal (RH) | 21. Roof status signal (LH) |
| 22. Roof status signal (RH) | 23. Storage lid status signal (LH) | 24. Storage lid status signal (RH) |
| 25. 5th bow latch open signal | 26. 5th bow latch close signal | 27. 5th bow striker position signal |

*1: Without navigation models

SOFT TOP SYSTEM : System Description

INFOID:000000007625395

DESCRIPTION

Soft top system is a system that opens or closes roof using hydraulic pressure generated by each electric system part and hydraulic pump when operating roof open/close switch.

Soft top control unit relates to the following function and control.

- Manual operation function
- Door request switch control
- Power window interlock control
- Rear window defogger control
- Soft top open/close control
- System protect control
- Trunk lid open control
- Warning control

SOFT TOP SYSTEM : Door Request Switch Control

INFOID:000000007625396

DOOR REQUEST SWITCH CONTROL

In addition to roof open/close switch, door request switch (LH/RH) can perform an open operation. When BCM detects that door request switch is operated, BCM requests an open operation of soft top to soft top control unit via local communication.

SOFT TOP SYSTEM : Power Window Interlock Control

INFOID:000000007625397

POWER WINDOW INTERLOCK CONTROL

If power window is not fully open during when open and close operations of soft top are performed, soft top control unit opens power window. Power window is operated via local communication between power window main switch/sub-switch.

Soft top control unit prohibits power window open control during roof intermediate position. Soft top control unit allows power window open control when soft top control unit released hydraulic pressure when roof position is intermediate.

SOFT TOP SYSTEM : Rear Window Defogger Control

INFOID:000000007625398

REAR WINDOW DEFOGGER CONTROL

BCM turns rear window defogger relay ON when rear window defogger switch turns ON.

Power supply is supplied to soft top control unit when rear window defogger relay turns ON.

Soft top control unit judges soft top open/close state. Soft top control unit supplies power supply to rear window defogger when soft top is closed. Power supply is not supplied when soft top is open.

Indicator illuminates when rear window switch is pressed while soft top is open and power supply is not supplied to rear window defogger.

SOFT TOP SYSTEM : Soft Top Open/Close Control

INFOID:000000007625399

Soft top open/close control

Open operation

SYSTEM

< SYSTEM DESCRIPTION >

When roof open/close switch is operated to OPEN, soft top system checks that operation conditions are satisfied and performs an open operation. Parts state (CONSULT display) is shown in the following table.

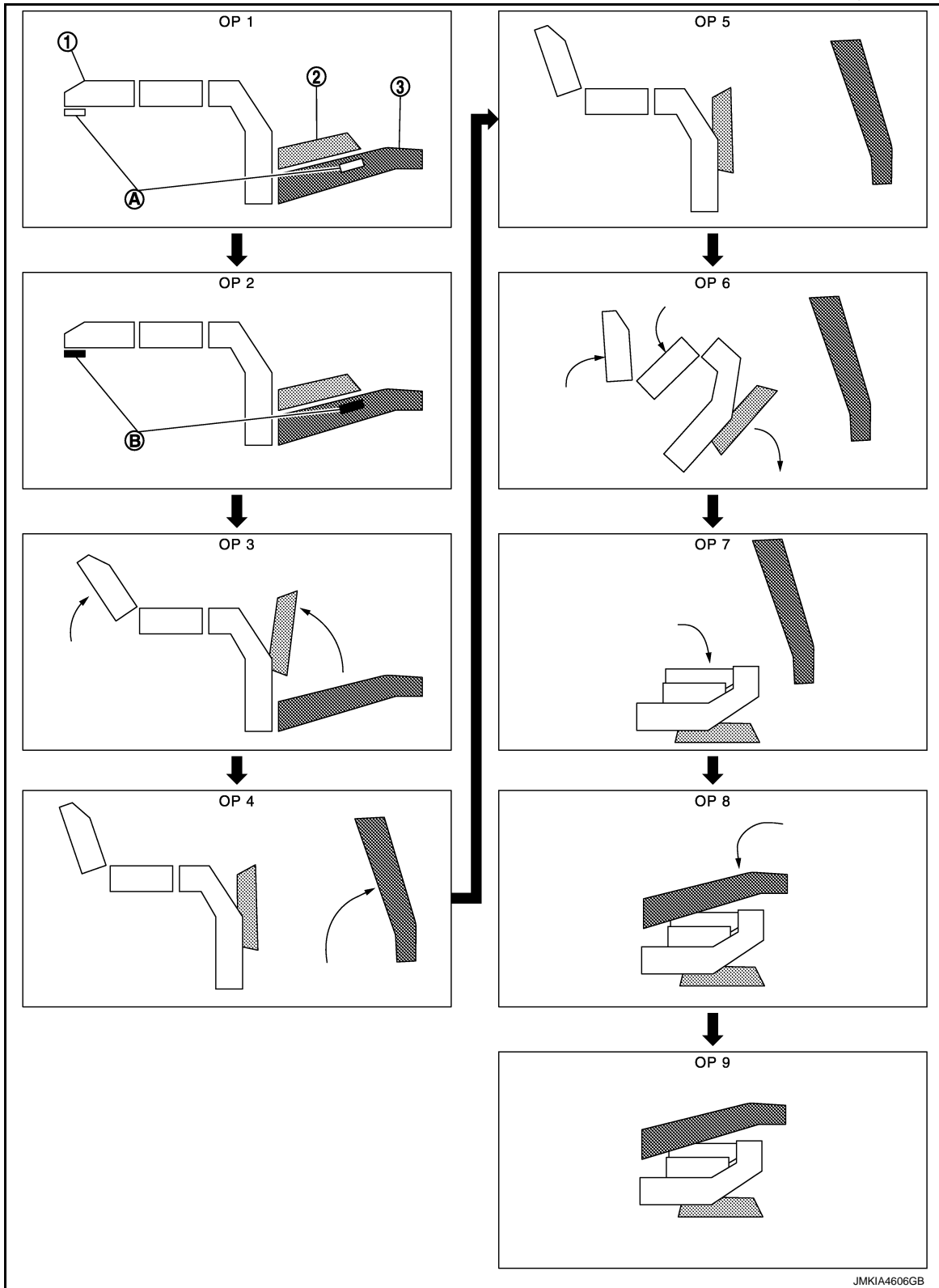

1. 1st bow
A. Lock

2. 5th bow
B. Unlock

3. Storage lid

A
B
C
D
E
F
G
H
I
J
RF
L
M
N
O
P

SYSTEM

< SYSTEM DESCRIPTION >

—	CONSULT data monitor item	SOFT TOP STATE																	
		OP 1	→	OP 2	→	OP 3	→	OP 4	→	OP 5	→	OP 6	→	OP 7	→	OP 8	→	OP 9	
Input	ROOF LATCHED LH	ON	—	OFF	—	OFF	—	OFF	—	OFF	—	OFF	—	OFF	—	OFF	—	OFF	
	ROOF LATCHED RH	ON	—	OFF	—	OFF	—	OFF	—	OFF	—	OFF	—	OFF	—	OFF	—	OFF	
	F/CENTER LOCK	ON	—	OFF	—	OFF	—	OFF	—	OFF	—	OFF	—	OFF	—	OFF	—	OFF	
	R/RAIL RAISED LH	ON	—	ON	—	ON	—	ON	—	ON	—	OFF	—	OFF	—	OFF	—	OFF	
	R/RAIL RAISED RH	ON	—	ON	—	ON	—	ON	—	ON	—	OFF	—	OFF	—	OFF	—	OFF	
	R/RAIL LOWERED	OFF	—	OFF	—	OFF	—	OFF	—	OFF	—	OFF	—	ON	—	ON	—	ON	
	5TH BOW LOWERED	ON	—	ON	—	OFF	—	OFF	—	OFF	—	OFF	—	OFF	—	OFF	—	OFF	
	5TH BOW RAISED	OFF	—	OFF	—	ON	—	ON	—	ON	—	ON	—	ON	—	ON	—	ON	
	S/LID OPEN LH	OFF	—	OFF	—	OFF	—	ON	—	ON	—	ON	—	ON	—	OFF	—	OFF	
	S/LID OPEN RH	OFF	—	OFF	—	OFF	—	ON	—	ON	—	ON	—	ON	—	OFF	—	OFF	
	S/LID CLOSE RH	ON	—	ON	—	ON	—	OFF	—	OFF	—	OFF	—	OFF	—	ON	—	ON	
	5TH BOW STRIK LATCH	ON	—	OFF	—	OFF	—	OFF	—	OFF	—	OFF	—	OFF	—	OFF	—	OFF	
	5TH BOW LATCH CL	ON	—	OFF	—	OFF	—	OFF	—	OFF	—	OFF	—	OFF	—	OFF	—	OFF	
5TH BOW LATCH OP	OFF	—	ON	—	ON	—	ON	—	ON	—	ON	—	ON	—	ON	—	ON		
Output	PUMP OUT (RH)	—	ON	—	ON	—	ON	—	ON	—	ON	—	ON	—	ON	—	OFF	—	
	PUMP OUT (LH)	—	OFF	—	OFF	—	OFF	—	OFF	—	OFF	—	OFF	—	OFF	—	OFF	—	
	SWITCHING VALVE 1	—	ON	—	ON	—	ON	—	ON	—	ON	—	ON	—	ON	—	OFF	—	
	SWITCHING VALVE 2	—	OFF	—	OFF	—	ON	—	ON	—	ON	—	ON	—	OFF	—	OFF	—	
	SWITCHING VALVE 3	—	ON	—	ON	—	OFF	—	ON	—	ON	—	ON	—	ON	—	OFF	—	
	SWITCHING VALVE 4	—	ON	—	ON	—	ON	—	OFF	—	OFF	—	OFF	—	OFF	—	OFF	—	
SWITCHING VALVE 5	—	OFF	—	ON	—	ON	—	ON	—	OFF	—	OFF	—	OFF	—	OFF	—		

Close operation

SYSTEM

< SYSTEM DESCRIPTION >

When roof open/close switch is operated to CLOSE, soft top system checks that operation conditions are satisfied and performs an close operation. Parts state (CONSULT display) is shown in the following table.

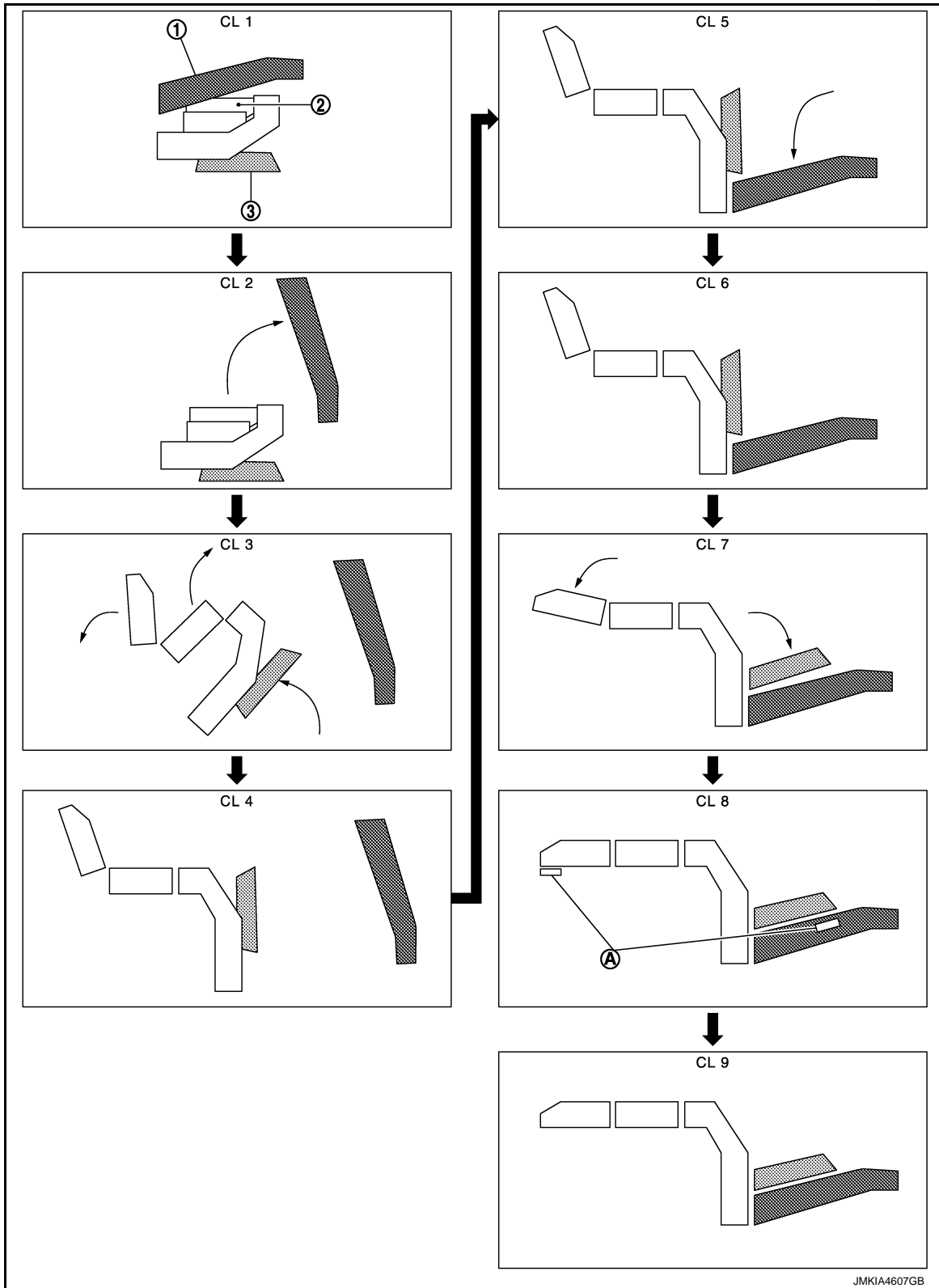

1. Storage lid

2. 1st bow

3. 5th bow

A. Lock

JMKIA4607GB

A
B
C
D
E
F
G
H
I
J
RF
L
M
N
O
P

SYSTEM

< SYSTEM DESCRIPTION >

—	CONSULT data monitor item	SOFT TOP STATE																	
		CL1	→	CL2	→	CL3	→	CL4	→	CL5	→	CL6	→	CL7	→	CL8	→	CL9	
Input	ROOF LATCHED LH	OFF	—	OFF	—	OFF	—	OFF	—	OFF	—	OFF	—	OFF	—	ON	—	ON	
	ROOF LATCHED RH	OFF	—	OFF	—	OFF	—	OFF	—	OFF	—	OFF	—	OFF	—	ON	—	ON	
	F/CENTER LOCK	OFF	—	OFF	—	OFF	—	OFF	—	OFF	—	OFF	—	OFF	—	ON	—	ON	
	R/RAIL RAISED LH	OFF	—	OFF	—	ON	—	ON	—	ON	—	ON	—	ON	—	ON	—	ON	
	R/RAIL RAISED RH	OFF	—	OFF	—	ON	—	ON	—	ON	—	ON	—	ON	—	ON	—	ON	
	R/RAIL LOWERED	ON	—	ON	—	OFF	—	OFF	—	OFF	—	OFF	—	OFF	—	OFF	—	OFF	
	5TH BOW LOWERED	OFF	—	OFF	—	OFF	—	OFF	—	OFF	—	OFF	—	ON	—	ON	—	ON	
	5TH BOW RAISED	ON	—	ON	—	ON	—	ON	—	ON	—	ON	—	OFF	—	OFF	—	OFF	
	S/LID OPEN LH	OFF	—	ON	—	ON	—	ON	—	OFF	—	OFF	—	OFF	—	OFF	—	OFF	
	S/LID OPEN RH	OFF	—	ON	—	ON	—	ON	—	OFF	—	OFF	—	OFF	—	OFF	—	OFF	
	S/LID CLOSE RH	ON	—	OFF	—	OFF	—	OFF	—	ON	—	ON	—	ON	—	ON	—	ON	
	5TH BOW STRIK LATCH	OFF	—	OFF	—	OFF	—	OFF	—	OFF	—	OFF	—	OFF	—	ON	—	ON	
	5TH BOW LATCH CL	OFF	—	OFF	—	OFF	—	OFF	—	OFF	—	OFF	—	OFF	—	ON	—	ON	
	5TH BOW LATCH OP	ON	—	ON	—	ON	—	ON	—	ON	—	ON	—	ON	—	OFF	—	OFF	
Output	PUMP OUT (RH)	—	ON	—	ON	—	ON	—	ON	—	OFF	—	OFF	—	OFF	—	OFF	—	
	PUMP OUT (LH)	—	OFF	—	OFF	—	OFF	—	OFF	—	OFF	—	ON	—	ON	—	OFF	—	
	SWITCHING VALVE 1	—	ON	—	ON	—	ON	—	ON	—	ON	—	ON	—	OFF	—	OFF	—	
	SWITCHING VALVE 2	—	ON	—	ON	—	ON	—	OFF	—	OFF	—	OFF	—	OFF	—	OFF	—	
	SWITCHING VALVE 3	—	OFF	—	OFF	—	OFF	—	ON	—	ON	—	ON	—	ON	—	OFF	—	
	SWITCHING VALVE 4	—	OFF	—	ON	—	ON	—	ON	—	ON	—	ON	—	ON	—	OFF	—	
SWITCHING VALVE 5	—	OFF	—	OFF	—	ON	—	ON	—	ON	—	OFF	—	OFF	—	OFF	—		

SOFT TOP SYSTEM : System Protect Control

INFOID:000000007625400

System protect control

Soft top control unit restricts or inhibits the operation due to safety and system protection reasons, when detecting an operation and activation that are not normal.

SYSTEM

< SYSTEM DESCRIPTION >

PRECONDITIONS FOR SOFT TOP

If all of the following conditions are not satisfied, the roof system does not operate.

Item	Condition
Air temperature	More than 0°C (32°F)
Battery voltage	More than 10 V
Ignition switch position	ON (not in START) *
Power window system	State that can be operated
Self diagnostic result	DTC is not detected
Selector lever position	Not in R position
Trunk lid	Closed
Vehicle speed	0 km/h (roof starts to operate)
	5 km/h or less (roof operates)

*: Except for operating with Intelligent Key (door request switch LH/RH).

THERMO PROTECT FUNCTION

Soft top control unit inhibits soft top operation due to system protection reasons under the following conditions.

- When soft top is operated excessively, operation is inhibited to avoid hydraulic pump or hydraulic system overheating and DTC is detected.
- Do not operate when ambient temperature is low or when operation may cause system or mechanism to be damaged.
- When soft top stops in the halfway position for 4 minutes or more, operation is inhibited and switching valve is released to avoid switching valve damage.

CAUTION:

An unintentional operation of soft top or storage lid may occur due to its own weight because oil pressure is not maintained when switching valve is released. Be careful not to pinch hands.

NOTE:

Open or close operation is possible 5 minutes after turning ignition switch OFF.

SOFT TOP SYSTEM : Trunk Lid Open Control

INFOID:000000007625401

TRUNK LID OPEN CONTROL

Soft top control unit judges trunk lid open or close state by trunk room lamp switch signal. Soft top system does not operate when trunk lid is open.

Soft top control unit inhibits open operation by trunk opener when soft top is not in the fully open or close position.

SOFT TOP SYSTEM : Warning Control

INFOID:000000007625402

WARNING CONTROL

Soft top control unit indicates soft top system state or warning by the warning lamp or buzzer in the combination meter.

WARNING LAMP FUNCTION

Combination meter displays the following items.

Condition	Indicator lamp		
	Not operation		Operation
	Full open/close position	Half position	
Ignition switch OFF	OFF	OFF	OFF
Ignition switch ON	OFF	Lighting	Lighting
Trunk lid is not close	OFF	Lighting	Lighting
Ambient temperature is too low	OFF	Lighting	Lighting
When the vehicle speed exceeds 5 km/h	OFF	Blinking	Blinking
Voltage malfunction of power window system	OFF	Blinking	Blinking

SYSTEM

< SYSTEM DESCRIPTION >

Condition	Indicator lamp		
	Not operation		Operation
	Full open/close position	Half position	
Shift selector position is R	OFF	Blinking	Blinking
Battery voltage (10.5 V or less/16 V or more)	Lighting *	Lighting	Lighting
DTC is detected	Lighting *	Lighting	Lighting

*:It is not illuminated when ignition switch OFF. (It does not illuminate or blink.)

BUZZER FUNCTION

Buzzer sounds due to the following conditions.

Operation/condition	Buzzer sounds	Cause	Action
Normal • When roof open /close switch is turned ON • Operation is complete (fully closed or fully open)	Pi-	—	
Release roof open/close switch	Pi, Pi	Roof state is not in end position (not in fully close or fully open position)	Operate soft top to end position.
Soft top system does not operate		Shift selector position is R	Shift the shift selector to P or N
		Trunk lid is not closed	Close trunk lid
		Impossible operation is requested (A close operation while the roof is fully closed or an open operation while the roof is fully open)	—
The vehicle is driven	Pi-----...	Soft top is not fully closed or fully open	Fully close or fully open soft top
Open operation by door request switch	Not sound	—	

SOFT TOP SYSTEM : Fail-safe

INFOID:000000007804843

FAIL-SAFE CONTROL BY DTC

Soft top control unit performs fail-safe control when any of the following DTCs is detected.

Display contents of CONSULT		Fail-safe	Cancellation
U1000	CAN COMM CIRCUIT	Inhibit soft top operation.	Communication is normal.
U1010	CONTROL UNIT (CAN)	Inhibit soft top operation.	Communication is normal.
U0140	LOCAL COMM-1	Inhibit soft top operation.	Communication is normal.
U0215	LOCAL COMM-2	Inhibit soft top operation.	Communication is normal.
B1701	ROOF CONTROL UNIT	Inhibit soft top operation.	Replace soft top control unit.
B1702	ROOF CONTROL UNIT	Inhibit soft top operation.	Replace soft top control unit.
B1709	ROOF SWITCH(OPEN)	Inhibit soft top operation.	Detects roof open/close switch (OPEN) is OFF.
B170A	ROOF SWITCH(CLOSE)	Inhibit soft top operation.	Detects roof open/close switch (CLOSE) is OFF.
B170F	SENSOR POWER SUPPLY	Inhibit soft top operation.	Detects normal value.
B171A	HYDRAULIC PMP(LH)	Inhibit soft top operation.	Detects normal value.
B171B	HYDRAULIC PMP(RH)	Inhibit soft top operation.	Detects normal value.
B171C	SWITCHING VALVE 1	Inhibit soft top operation.	Detects normal value.
B171D	SWITCHING VALVE 2	Inhibit soft top operation.	Detects normal value.
B172C	ROOF STATE SIG(TRUNK)*	Inhibit soft top operation.	Detects normal value.
B1731	HYDRAULIC STATE 1	Inhibit soft top operation.	Turn ignition switch OFF.

SYSTEM

< SYSTEM DESCRIPTION >

Display contents of CONSULT		Fail-safe	Cancellation
B1758	THERMO PROTECTION	Inhibit soft top operation.	Turn ignition switch OFF and wait at least 5 minutes.
B175C	PWR SOURCE(ROOF)	Inhibit soft top operation.	Power source is 11.4 (V) or more for 0.5 second.
B175D	PWR SOURCE(ROOF)	Inhibit soft top operation.	Power source is 14.5 (V) or more for 4 seconds.
B175E	PWR SOURCE(WINDOW)	Inhibit soft top operation and rear power window operation.	Power source (power window) is 9.5 (V) or more.
B175F	PWR SOURCE(WINDOW)	Inhibit soft top operation and rear power window operation.	Power source (power window) is 15.5 (V) or more.
B1766	SWITCHING VALVE 3	Inhibit soft top operation.	Detects normal value.
B1767	SWITCHING VALVE 4	Inhibit soft top operation.	Detects normal value.
B1768	SWITCHING VALVE 5	Inhibit soft top operation.	Detects normal value.
B176A	THERMO PROTECTION	Inhibit soft top operation.	Turn ignition switch OFF and wait at least 5 minutes.
B176B	ROOF WARNING LAMP	Inhibit soft top operation.	Detects normal value.
B176C	STRIKER SENSOR RH	Inhibit soft top operation.	Detects normal value.
B176D	STRIKER SENSOR LH	Inhibit soft top operation.	Detects normal value.
B176E	ROOF LATCH LOCK SENSOR	Inhibit soft top operation.	Detects normal value.
B176F	ROOF STATUS SEN LH	Inhibit soft top operation.	Detects normal value.
B1770	ROOF STATUS SEN RH	Inhibit soft top operation.	Detects normal value.
B1771	ROOF STATUS SEN LH	Inhibit soft top operation.	Detects normal value.
B1772	5BOW STATUS SEN LH	Inhibit soft top operation.	Detects normal value.
B1773	5BOW STATUS SEN RH	Inhibit soft top operation.	Detects normal value.
B1774	S/LID STATUS SEN LH	Inhibit soft top operation.	Detects normal value.
B1775	S/LID STATUS SEN RH	Inhibit soft top operation.	Detects normal value.
B1776	S/LID STATUS SEN RH	Inhibit soft top operation.	Detects normal value.
B1777	REAR DEF OUT SIG	Inhibit soft top and rear window defogger operation.	Detects normal value.
B1778	TRUNK OPEN OUT SIG	Inhibit soft top and trunk lid opener actuator operation.	Detects normal value.
B1779	THERMO PROTECTION	Inhibit soft top operation.	Detects normal value.
B177A	ROOF STATE INCORRECT	Inhibit soft top operation.	Detects normal value.
B177B	ROOF STATE INCORRECT	Inhibit soft top operation.	Detects normal value.
B177C	THERMO PROTECTION	Inhibit soft top operation.	Detects normal value.
B177D	5BOW LATCH OPEN SEN	Inhibit soft top operation.	Detects normal value.
B177E	5BOW LATCH CLOSE SEN	Inhibit soft top operation.	Detects normal value.
B177F	5BOW STRIKER SENSOR	Inhibit soft top operation.	Detects normal value.

*: This item indicates the roof status signal (Audio).

SOFT TOP SYSTEM : Correspondence in Emergency

INFOID:000000007625404

If the soft top cannot be operated electrically because of a discharged battery or any other system malfunction, the soft top needs to be closed manually or opened manually according to the following procedures.

MANUAL OPERATION (SOFT TOP FULLY OPEN ⇒ FULLY CLOSE)

1. Open Trunk Lid.
2. Open storage lid

SYSTEM

< SYSTEM DESCRIPTION >

- Remove trunk finisher front (2) inside of trunk by removing clips (1).
- Pull emergency cable (right and left) (3). Close trunk lid.
- Manually open storage lid from left and right side of the vehicle.

CAUTION:

Use a cloth or other tool to protect your hands when pulling on the lock release.

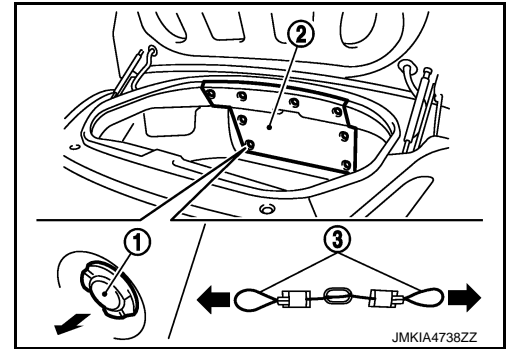

CAUTION:

- This is a heavy component. 2 workers are required.
- Fully close trunk lid before opening storage lid. Otherwise, storage lid may contact with trunk lid.

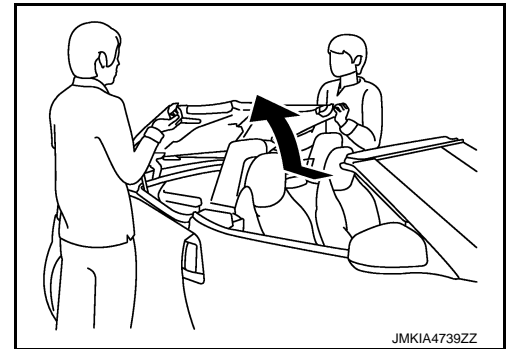

3. Close soft top.
- Pull up and close soft top from right and left side of the vehicle.

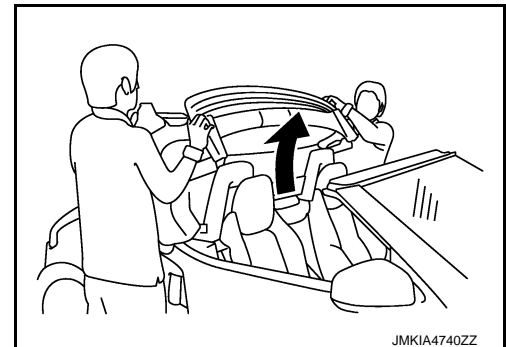

- Close top storage lid. Close the front and rear parts of soft top.

CAUTION:

Fully close storage lid. Otherwise, storage lid may contact with soft top.

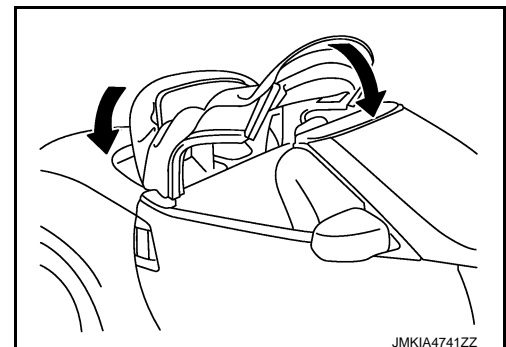

4. Lock the 1st Bow of soft top.

SYSTEM

< SYSTEM DESCRIPTION >

- Remove cap (1).
 - Insert a hexagonal wrench (2) into the hole and turn clockwise.
- CAUTION:**
Be careful not to leave the vehicle outside for a long period of time or drive at high speeds.
The soft top is not locked completely, and this may allow wind, rain and foreign matter to get into the vehicle.

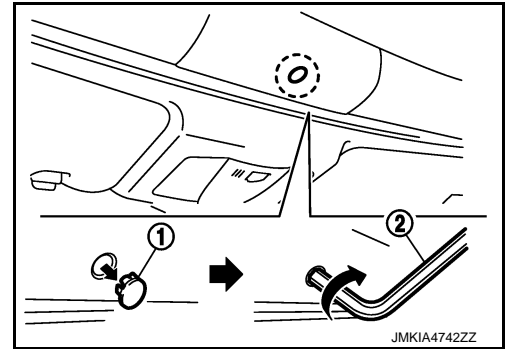

MANUAL OPERATION (SOFT TOP FULLY CLOSE ⇒ FULLY OPEN)

1. Unlock the 1st Bow of soft top.
 - Remove cap (1).
 - Insert a hexagonal wrench (2) into the hole and turn counter-clockwise.

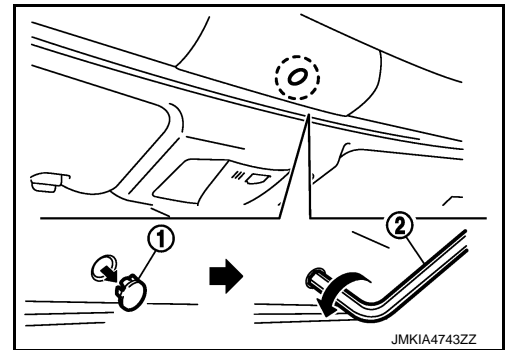

2. Remove rear lock striker.
 - Remove storage lid deflector. Refer to [INT-58, "STORAGE LID DEFLECTOR : Removal and Installation"](#).
 - Lift up soft top cover inner (1) from passenger room and remove soft top cover inner clips (2).

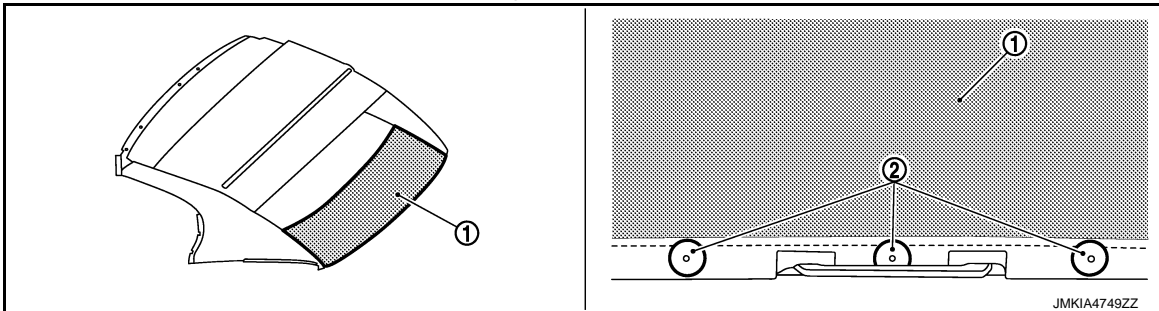

- Remove rear lock striker mounting bolts (3) from the service hole.
- CAUTION:**
Be careful not to damage storage lid during the operation.

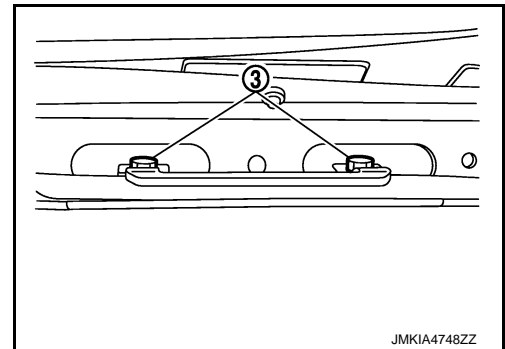

3. Open 1st bow and 5th bow.

SYSTEM

< SYSTEM DESCRIPTION >

- Simultaneously lift up 1st bow and 5th bow. Fold soft top.

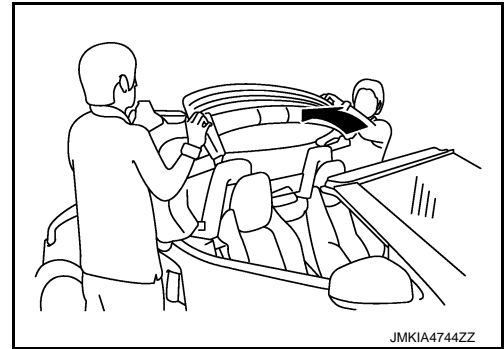

4. Open Trunk Lid.
5. Open storage lid.
 - Remove trunk finisher front (2) inside of trunk by removing clips (1).
 - Pull emergency cables (right and left) (3). Close trunk lid.
 - Manually open storage lid from left and right side of the vehicle.
 - Place soft top in storage lid.

CAUTION:

- Use a cloth or other tool to protect your hands when pulling on the lock release.
- This is a heavy component. 2 workers are required.
- Fully close trunk lid before opening storage lid. Otherwise, storage lid may contact with trunk lid.

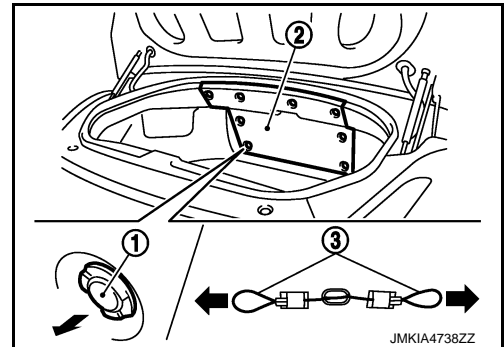

6. Release 5th bow holder. Remove rear lock striker.
 - Remove storage bracket assembly (2) from storage lid (1).

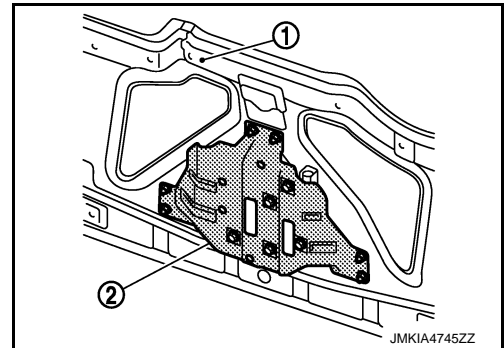

- Remove hydraulic cylinder (1).

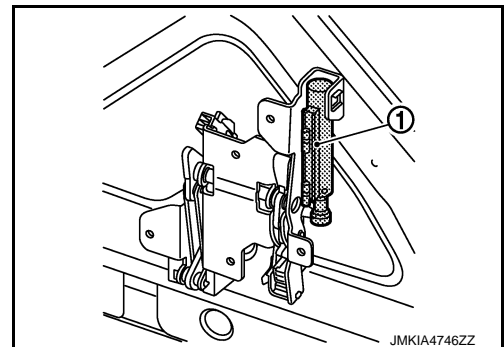

SYSTEM

< SYSTEM DESCRIPTION >

- Rotate hydraulic cylinder mounting pivot (1). Release 5th bow. Remove the striker.

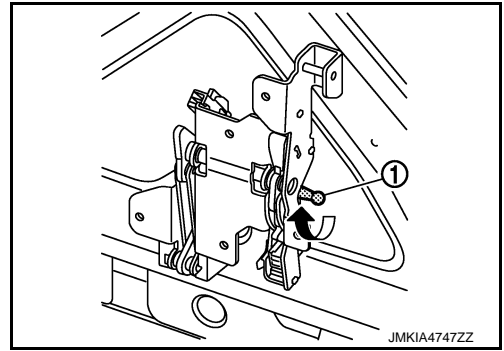

A
B
C
D
E
F
G
H
I
J
RF
L
M
N
O
P

DIAGNOSIS SYSTEM (SOFT TOP CONTROL UNIT)

< SYSTEM DESCRIPTION >

DIAGNOSIS SYSTEM (SOFT TOP CONTROL UNIT)

CONSULT Function

INFOID:000000007625405

APPLICATION ITEM

CONSULT performs the following functions via CAN communication with soft top control unit.

Diagnosis mode	Function Description
ECU Identification	The soft top control unit part number is displayed.
Self Diagnostic Result	Displays the diagnosis results judged by soft top control unit.
Freeze Frame Data	The soft top control unit records the vehicle condition at the time when the DTC is detected, and displays.
Data Monitor	The soft top control unit input/output signals are displayed.
Active Test	The signals used to activate each device are forcibly supplied from soft top control unit.
CAN Diag Support Monitor	Monitors the reception status of CAN communication viewed from soft top control unit. Refer to CONSULT operation manual.

SELF-DIAG RESULT

Refer to [RF-40, "DTC Index"](#).

Freeze Frame Data

The soft top control unit records the following vehicle condition at the time when the DTC is detected, and displays on CONSULT.

CONSULT display		Description
Item	Indication	
ROOF SW (OPEN)	ON/OFF	OPEN input state of roof open/close switch is displayed.
ROOF SW (CLOSE)	ON/OFF	CLOSE input state of roof open/close switch is displayed.
ROOF LATCHED LH	ON/OFF	Input state of roof striker sensor LH is displayed.
ROOF LATCHED RH	ON/OFF	Input state of roof striker sensor RH is displayed.
F/CENTER LOCK	ON/OFF	Input state of roof latch lock sensor is displayed.
R/RAIL RAISED LH	ON/OFF	Input state of roof status sensor LH is displayed.
R/RAIL RAISED RH	ON/OFF	Input state of roof status sensor RH is displayed.
R/RAIL LOWERED	ON/OFF	Input state of roof status sensor LH is displayed.
5BOW LOWERED	ON/OFF	Input state of 5th bow status sensor LH is displayed.
5BOW RAISED	ON/OFF	Input state of 5th bow status sensor RH is displayed.
TRUNK STATUS SEN	ON/OFF	Input state of trunk status sensor is displayed.
S/LID OPEN LH	ON/OFF	Input state of storage lid status sensor LH is displayed.
S/LID OPEN RH	ON/OFF	Input state of storage lid status sensor RH is displayed.
S/LID CLOSE RH	ON/OFF	Input state of storage lid status sensor RH is displayed.
5TH BOW LATCH OP	ON/OFF	Input state of 5th bow latch open sensor is displayed.
5TH BOW LATCH CL	ON/OFF	Input state of 5th bow latch close sensor is displayed.
5BOW STRIK LATCH	ON/OFF	Input state of 5th bow striker sensor is displayed.
FLPD LIMIT SW(DWN)	ON/OFF	Input state of flipper door limit switch (DOWN) is displayed.
SWITCH VALVE 1	ON/OFF	Output state to switching valve 1 is displayed.
SWITCH VALVE 2	ON/OFF	Output state to switching valve 2 is displayed.
SWITCH VALVE 3	ON/OFF	Output state to switching valve 3 is displayed.
SWITCH VALVE 4	ON/OFF	Output state to switching valve 4 is displayed.
SWITCH VALVE 5	ON/OFF	Output state to switching valve 5 is displayed.

DIAGNOSIS SYSTEM (SOFT TOP CONTROL UNIT)

< SYSTEM DESCRIPTION >

CONSULT display		Description
Item	Indication	
PUMP OUT (LH)	ON/OFF	Right rotation output state to hydraulic motor is displayed.
PUMP OUT (RH)	ON/OFF	Left rotation output state to hydraulic motor is displayed.

DATA MONITOR

CONSULT display		Description
Item	Indication/Unit	
ROOF LATCHED LH	ON/OFF/NG	Input state of roof striker sensor LH is displayed.
ROOF LATCHED RH	ON/OFF/NG	Input state of roof striker sensor RH is displayed.
F/CENTER LOCK	ON/OFF/NG	Input state of roof latch lock sensor is displayed.
R/RAIL RAISED LH	ON/OFF/NG	Input state of roof status sensor LH is displayed.
R/RAIL RAISED RH	ON/OFF/NG	Input state of roof status sensor RH is displayed.
R/RAIL LOWERED	ON/OFF/NG	Input state of roof status sensor LH is displayed.
5TH BOW LOWERED	ON/OFF/NG	Input state of 5th bow status sensor LH is displayed.
5TH BOW RAISED	ON/OFF/NG	Input state of 5th bow status sensor RH is displayed.
S/LID OPEN LH	ON/OFF/NG	Input state of storage lid status sensor LH is displayed.
S/LID OPEN RH	ON/OFF/NG	Input state of storage lid status sensor RH is displayed.
S/LID CLOSE RH	ON/OFF/NG	Input state of storage lid status sensor RH is displayed.
5TH BOW LATCH OP	ON/OFF/NG	Input state of 5th bow latch open sensor is displayed.
SWITCHING VALVE 1	ON/OFF/NG	Output state to switching valve 1 is displayed.
SWITCHING VALVE 2	ON/OFF/NG	Output state to switching valve 2 is displayed.
SWITCHING VALVE 3	ON/OFF/NG	Output state to switching valve 3 is displayed.
SWITCHING VALVE 4	ON/OFF/NG	Output state to switching valve 4 is displayed.
SWITCHING VALVE 5	ON/OFF/NG	Output state to switching valve 5 is displayed.
PUMP OUT (RH)	ON/OFF/NG	Right rotation output state to hydraulic motor is displayed.
PUMP OUT (LH)	ON/OFF/NG	Left rotation output state to hydraulic motor is displayed.
5TH BOW LATCH CL	ON/OFF/NG	Input state of 5th bow latch close sensor is displayed.
ROOF SW (OPEN)	ON/OFF	OPEN input state of roof open/close switch is displayed.
ROOF SW (CLOSE)	ON/OFF	CLOSE input state of roof open/close switch is displayed.
SHIFT R SIGNAL	ON/OFF	Input state of shift position (R position) is displayed.
TRUNK OPEN OUT	ON/OFF	Output state to trunk open signal is displayed.
THER PROTEC PUMP	OK/NG	Non-operation state of thermo protection (hydraulic pump) is displayed.
THER PROTEC RCU	OK/NG	Non-operation state of thermo protection (soft top control unit) is displayed.
PWR COND RCU	OK/NG	Diagnosis result of power supply (soft top control unit) is displayed.
PWR COND P/W	OK/NG	Diagnosis result of power supply (power window) is displayed.
LOCAL COMM 1	NG/SLEEP/NG	State of serial link 1 is displayed.
LOCAL COMM 2	NG/SLEEP/NG	State of serial link 2 is displayed.
REAR DEF OUT	OK/NG	Output state to rear window defogger is displayed.
5BOW STRIK LATCH	ON/OFF/NG	Input state of 5th bow striker sensor is displayed.
P/W OP REQ SW SIG	ON/OFF	Input state of power window open signal from request switch is displayed.
PROHIBIT P/W UP	ON/OFF	Output state to power window operation prohibition signal is displayed.
IGN ON SIG (BCM)	ON/OFF	Receiving state of ignition ON signal from BCM is displayed.
RF OP REQ SW SIG	ON/OFF	Input state of soft top open signal from request switch is displayed.

ACTIVE TEST

DIAGNOSIS SYSTEM (SOFT TOP CONTROL UNIT)

< SYSTEM DESCRIPTION >

CONSULT display		Description
Item	Indication	
ROOF LATCHED LH/RH	LOCK	Roof lock assembly performs lock operation.
	UNLOCK	Roof lock assembly performs unlock operation.
STORAGE LID	OPEN	Storage lid performs open operation.
	CLOSE	Storage lid performs close operation.
SOFT TOP SYSTEM	UP	Soft top performs close operation.
	DOWN	Soft top performs open operation.
ROOF SYSTEM	OPEN	Soft top system performs open operation.
	CLOSE	Soft top system performs close operation.
5TH BOW SYSTEM	OPEN	1st bow and 5th bow performs fold operation.
	CLOSE	1st bow and 5th bow performs spread operation.
HYDRAULIC PRESSURE RELEASE	ON	Switching valve performs OFF operation.
TRUNK OPENER	ON	Trunk lid opener actuator performs unlock operation.
ROOF STATE OUTPUT (AUDIO)	ON	Full open position signal of roof is transmitted to audio unit.
	OFF	Full close position signal of roof is transmitted to audio unit.
POWER WINDOW (LH/RH)	UP	Power window (LH/RH) performs close operation.
	DOWN	Power window (LH/RH) performs open operation.
REAR WINDOW DEFOGGER	ON	Rear window defogger performs ON operation.
	OFF	Rear window defogger performs OFF operation.

SOFT TOP CONTROL UNIT

< ECU DIAGNOSIS INFORMATION >

ECU DIAGNOSIS INFORMATION

SOFT TOP CONTROL UNIT

Reference Value

INFOID:0000000007625406

VALUES ON THE DIAGNOSIS TOOL

CONSULT MONITOR ITEM

Monitor Item	Condition	Status/Value
ROOF LATCHED RH	Lock position	ON
	Other than above	OFF
	Roof striker sensor RH circuit is open or short	NG
ROOF LATCHED LH	Lock position	ON
	Other than above	OFF
	Roof striker sensor LH circuit is open or short	NG
F/CENTER LOCK	Lock	ON
	Other than above	OFF
	Roof latch lock sensor circuit is open or short	NG
R/RAIL RAISED LH	Soft top is close	ON
	Other than above	OFF
	Roof status sensor LH circuit is open or short	NG
R/RAIL RAISED RH	Soft top is close	ON
	Other than above	OFF
	Roof status sensor RH circuit is open or short	NG
R/RAIL LOWERED	Soft top is open	ON
	Other than above	OFF
	Roof status sensor LH circuit is open or short	NG
5TH BOW LOWERED	5th bow is close	ON
	Other than above	OFF
	5th bow status sensor LH circuit is open or short	NG
5TH BOW RAISED	5th bow is open	ON
	Other than above	OFF
	5th bow status sensor RH circuit is open or short	NG
S/LID OPEN LH	Storage lid is open	ON
	Other than above	OFF
	Storage lid status sensor LH circuit is open or short	NG
S/LID OPEN RH	Storage lid is open	ON
	Other than above	OFF
	Storage lid status sensor RH circuit is open or short	NG

A

B

C

D

E

F

G

H

I

J

RF

L

M

N

O

P

SOFT TOP CONTROL UNIT

< ECU DIAGNOSIS INFORMATION >

Monitor Item	Condition	Status/Value	
S/LID CLOSE RH	State of storage lid drive cylinder RH	Storage lid is close	ON
		Other than above	OFF
		Storage lid status sensor RH circuit is open or short	NG
5TH BOW LATCH OP	State of 5th bow latch cylinder	Unlock	ON
		Other than above	OFF
		5th bow latch open sensor circuit is open or short	NG
SWITCHING VALVE 1	Operation of switching valve 1	Operate	ON
		Stop	OFF
		Switching valve 1 circuit is short	NG
SWITCHING VALVE 2	Operation of switching valve 2	Operate	ON
		Stop	OFF
		Switching valve 2 circuit is short	NG
SWITCHING VALVE 3	Operation of switching valve 3	Operate	ON
		Stop	OFF
		Switching valve 3 circuit is short	NG
SWITCHING VALVE 4	Operation of switching valve 4	Operate	ON
		Stop	OFF
		Switching valve 4 circuit is short	NG
SWITCHING VALVE 5	Operation of switching valve 5	Operate	ON
		Stop	OFF
		Switching valve 5 circuit is short	NG
PUMP OUT (RH)	Operation of hydraulic pump motor	Turning clockwise	ON
		Other than above	OFF
		Hydraulic pump motor (RH) circuit is short	NG
PUMP OUT (LH)	Operation of hydraulic pump motor	Turning counterclockwise	ON
		Other than above	OFF
		Hydraulic pump motor (LH) circuit is short	NG
5TH BOW LATCH CL	State of 5th bow latch cylinder	Lock	ON
		Other than above	OFF
		5th bow latch close sensor circuit is open or short	NG
ROOF SW (OPEN)	State of roof open/close switch	OPEN operation is in operation	ON
		Other than above	OFF
ROOF SW (CLOSE)	State of roof open/close switch	CLOSE operation is in operation	ON
		Other than above	OFF
SHIFT R SIGNAL	Shift position	R position	ON
		Other than R position	OFF
TRUNK OPEN OUT	Operation of trunk lid opener actuator	OPEN operation is in operation	ON
		Other than above	OFF
THER PROTEC PUMP	Thermo protection hydraulic pump	In non-operation	OK
		In operation	NG
THER PROTEC RCU	Thermo protection soft top control unit	In non-operation	OK
		In operation	NG

SOFT TOP CONTROL UNIT

< ECU DIAGNOSIS INFORMATION >

Monitor Item	Condition	Status/Value		
PWR COND RCU	Power supply voltage state of soft top control unit	Normal	OK	A
		Malfunction	NG	
PWR COND P/W	Power supply voltage state of power window	Normal	OK	B
		Malfunction	NG	
LOCAL COMM 1	State of local communication 1	Normal	OK	C
		It is in sleep mode	SLEEP	
		Communication error	NG	
LOCAL COMM 2	State of local communication 2	Normal	OK	D
		It is in sleep mode	SLEEP	
		Communication error	NG	
REAR DEF OUT	Operation of rear window defogger	Roof position is full close	OK	E
		Other than above	NG	
5BOW STRIK LATCH	State of 5th bow latch	5th bow striker is in 5th bow latch	ON	F
		Other than above	OFF	
		5th bow striker sensor circuit is open or short	NG	G
P/W OP REQ SW SIG	State of request switch signal	OPEN operation is in operation	ON	
		Stop	OFF	H
PROHIBIT P/W UP	Prohibit of power window up	In operation	ON	
		In non-operation	OFF	I
IGN ON SIG(BCM)	Power position signal	Ignition switch ON	ON	
		Other than above	OFF	J
RF OP REQ SW SIG	State of request switch signal	OPEN operation is in operation	ON	
		Stop	OFF	

RF

L

M

N

O

P

SOFT TOP CONTROL UNIT

< ECU DIAGNOSIS INFORMATION >

TERMINAL LAYOUT

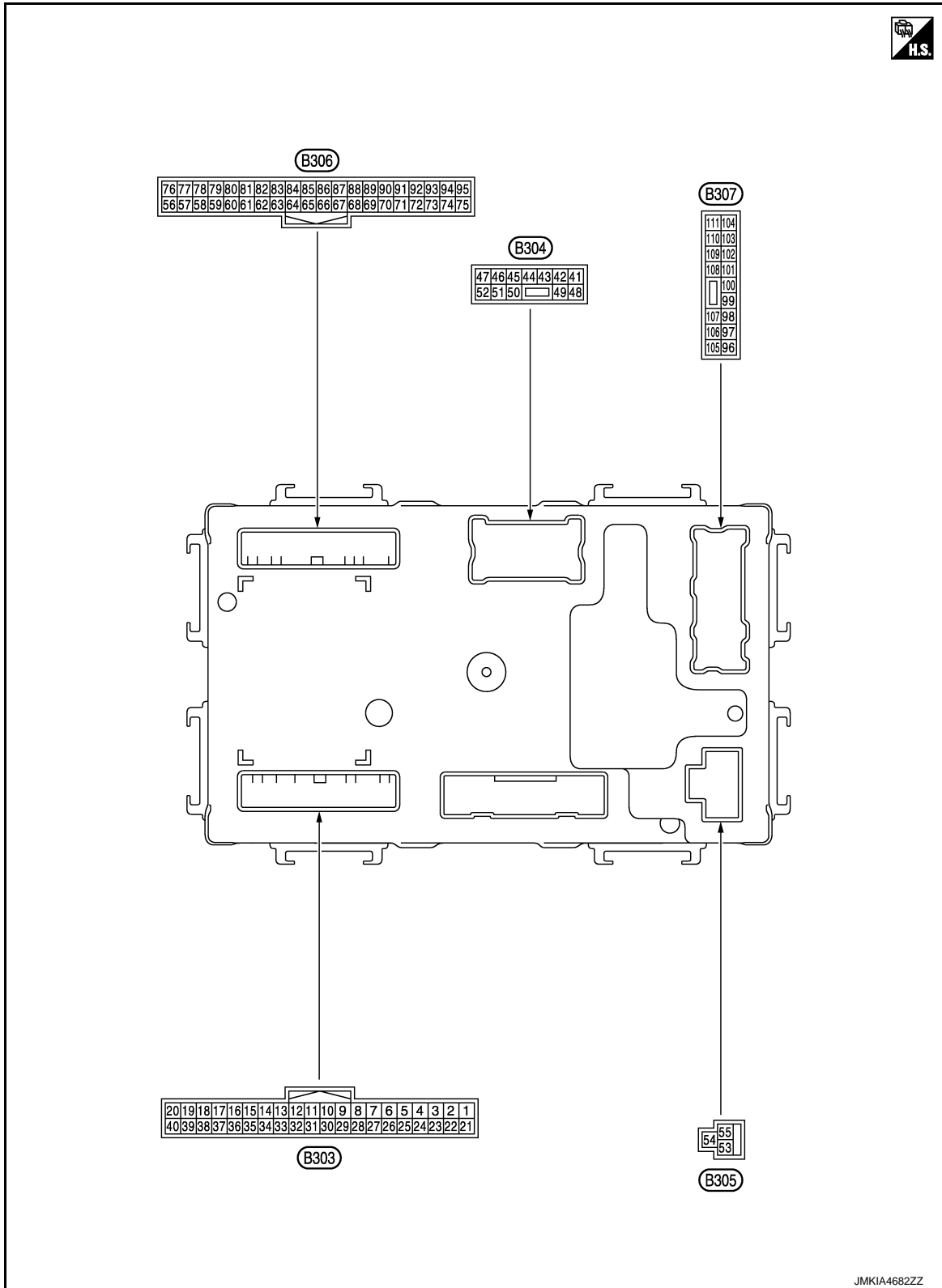

PHYSICAL VALUES

SOFT TOP CONTROL UNIT

< ECU DIAGNOSIS INFORMATION >

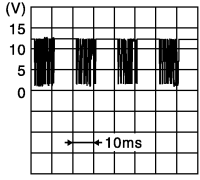
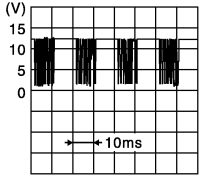
Terminal No. (Wire color)		Description		Condition	Value (Approx.)
+	-	Signal name	Input/ Output		
1 (BR)	Ground	Sensor power supply (Roof striker sensor LH)	Output	[Engine is running]	12 V
3 (DG)	Ground	Roof striker sensor RH	Input	[Engine is running] • Roof lock assembly	Hooked 0.8 V Released 3.0 V
4 (W)	Ground	Roof striker sensor LH	Input	[Engine is running] • Roof lock assembly	Hooked 0.8 V Released 3.0 V
8 (Y)	Ground	Back up lamp signal	Input	[Ignition switch: ON] • Shift position	R position Battery voltage Other than above 0 V
9 (SB)	Ground	Power source (Power window)	Input	[Ignition switch: OFF]	Battery voltage
10 (O)	Ground	Trunk lid open re- quest signal (BCM)	Input	[Ignition switch: ON] • Trunk opener	Operate 0 V → Battery voltage → 0 V Other than above 0 V
11 (O)	Ground	Roof status signal (Indicator lamp)	Output	[Engine is running] • Soft top indicator lamp	Illuminate 0 V Not illuminate Battery voltage
12 (SB)	Ground	Roof status signal (Audio)	Output	[Engine is running] • Soft top system	Fully open 9.5 V Other than above 0 V
14 (L)	Ground	Roof open/close switch (Close)	Input	[Engine is running] • Close switch	Pressed 0 V Released Battery voltage
15 (LG)	Ground	Roof open/close switch (Open)	Input	[Engine is running] • Open switch	Pressed 0 V Released Battery voltage
16 (V)	Ground	Trunk room lamp switch	Input	[Ignition switch: ON] • Trunk lid	Open 0 V Other than above Battery voltage
17 (BG)	Ground	CAN-H	Input/ Output	—	—
18 (P)	Ground	CAN-L	Input/ Output	—	—
19 (LG)	Ground	Local communication (Power window)	Input/ Output	—	 JMKIA4024GB
20 (V)	Ground	Local communication (BCM)	Input/ Output	—	 JMKIA4024GB

A
B
C
D
E
F
G
H
I
J
RF
L
M
N
O
P

SOFT TOP CONTROL UNIT

< ECU DIAGNOSIS INFORMATION >

Terminal No. (Wire color)		Description		Condition		Value (Approx.)
+	-	Signal name	Input/ Output			
21 (BR)	Ground	Sensor power supply (Roof striker sensor RH)	Output	[Engine is running]		12 V
29 (DG)	Ground	Ground	—	—		—
35 (P)	Ground	Ground (Roof open/close switch)	—	—		—
41 (DG)	Ground	Trunk lid opener ac- tuator	Output	Trunk lid opener	Operate	0 V → Battery voltage → 0 V
					Stop	0 V
48 (R)	Ground	Power source (Rear window defog- ger)	Input	[Engine is running] • Rear window defogger	Active	Battery voltage
					Not active	0 V
49 (R)	Ground	Power source (Rear window defog- ger)	Input	[Engine is running] • Rear window defogger	Active	Battery voltage
					Not active	0 V
53 (R)	Ground	Power source (Roof)	Input	[Engine is running]		Battery voltage
54 (B)	Ground	Ground (Roof)	—	—		—
56 (W)	Ground	5th bow latch close sensor	Input	[Engine is running] • 5th bow latch	Lock	0.8 V
					Other than above	3.0 V
57 (G)	Ground	5th bow latch open sensor	Input	[Engine is running] • 5th bow latch	Unlock	0.8 V
					Other than above	3.0 V
58 (LG)	Ground	Storage lid status sensor RH (Open)	Input	[Engine is running] • Storage lid	Full open	0.8 V
					Other than above	3.0 V
59 (W)	Ground	Storage lid status sensor RH (Close)	Input	[Engine is running] • Storage lid	Full close	0.8 V
					Other than above	3.0 V
60 (DG)	Ground	Storage lid status sensor LH (Open)	Input	[Engine is running] • Storage lid	Full open	0.8 V
					Other than above	3.0 V
61 (Y)	Ground	Roof status sensor RH (Close)	Input	[Engine is running] • Soft top	Raised	0.8 V
					Other than above	3.0 V
66 (L)	Ground	Roof status sensor LH (Open)	Input	[Engine is running] • Soft top	Lowered	0.8 V
					Other than above	3.0 V
68 (P)	Ground	5th bow status sen- sor RH	Input	[Engine is running] • 5th bow	Raised	0.8 V
					Other than above	3.0 V
69 (V)	Ground	Roof status sensor LH (Close)	Input	[Engine is running] • Soft top	Raised	0.8 V
					Other than above	3.0 V

SOFT TOP CONTROL UNIT

< ECU DIAGNOSIS INFORMATION >

Terminal No. (Wire color)		Description		Condition		Value (Approx.)
+	-	Signal name	Input/ Output			
70 (O)	Ground	5th bow status sensor LH	Input	[Engine is running] • 5th bow	Lowered	0.8 V
					Other than above	3.0 V
71 (SB)	Ground	Roof latch lock sensor	Input	[Engine is running] • Roof lock assembly	Lock	0.8 V
					Other than above	3.0 V
72 (W/R)	Ground	Hydraulic pump temperature sensor	Input	[Engine is running]		0 - 4.8 V Output voltage varies with hydraulic pump temperature.
73 (R)	Ground	Hydraulic pump relay 2 ON signal	Input	[Engine is running] • Hydraulic pump motor (Right rotation)	Active	12 V
					Inactive	0 V
74 (R/B)	Ground	Hydraulic pump relay 1 ON signal	Input	[Engine is running] • Hydraulic pump motor (Left rotation)	Active	12 V
					Inactive	0 V
75 (BR)	Ground	Sensor power supply (Roof status sensor LH/5th bow latch open sensor/5th bow latch close sensor/5th bow striker sensor)	Output	[Engine is running]		12 V
76 (L)	Ground	5th bow striker sensor	Input	[Engine is running] • 5th bow striker	Hooked	0.8 V
					Released	3.0 V
92 (BG)	Ground	Sensor ground (Hydraulic pump temperature sensor)	—	—		—
93 (BR)	Ground	Sensor power supply (Roof status sensor RH/Storage lid status sensor RH)	Output	[Engine is running]		12 V
94 (BR)	Ground	Sensor power supply (Roof latch lock sensor/5th bow status sensor LH)	Output	[Engine is running]		12 V
95 (BR)	Ground	Sensor power supply (Storage lid status sensor/5th bow status sensor RH)	Output	[Engine is running]		12 V
96 (W)	Ground	Switching valve 4	Output	[Engine is running] • Switching valve 4	Active	12 V
					Inactive	0 V
97 (LG)	Ground	Switching valve 3	Output	[Engine is running] • Switching valve 3	Active	12 V
					Inactive	0 V
98 (L)	Ground	Switching valve 2	Output	[Engine is running] • Switching valve 2	Active	12 V
					Inactive	0 V
99 (O)	Ground	Switching valve 1	Output	[Engine is running] • Switching valve 1	Active	12 V
					Inactive	0 V
100 (BR)	Ground	Hydraulic pump relay 2	Output	[Engine is running] • Hydraulic pump motor (Right rotation)	Active	12 V
					Inactive	0 V

A
B
C
D
E
F
G
H
I
J
RF
L
M
N
O
P

SOFT TOP CONTROL UNIT

< ECU DIAGNOSIS INFORMATION >

Terminal No. (Wire color)		Description		Condition		Value (Approx.)
+	-	Signal name	Input/ Output			
101 (SB)	Ground	Hydraulic pump relay 1	Output	[Engine is running]	Active	12 V
				• Hydraulic pump motor (Left rotation)	Inactive	0 V
102 (P)	Ground	Switching valve 5	Output	[Engine is running]	Active	12 V
				• Switching valve 5	Inactive	0 V
103 (B)	Ground	Hydraulic unit ground	—	—		—
104 (R)	Ground	Rear window defogger power supply	Output	[Engine is running]	Active	Battery voltage
				• Rear window defogger NOTE: Roof is fully closed.	Not active	0 V
111 (R)	Ground	Rear window defogger power supply	Output	[Engine is running]	Active	Battery voltage
				• Rear window defogger NOTE: Roof is fully closed.	Not active	0 V

Fail-safe

INFOID:0000000007625407

FAIL-SAFE CONTROL BY DTC

Soft top control unit performs fail-safe control when any of the following DTCs is detected.

Display contents of CONSULT		Fail-safe	Cancellation
U1000	CAN COMM CIRCUIT	Inhibit soft top operation.	Communication is normal.
U1010	CONTROL UNIT (CAN)	Inhibit soft top operation.	Communication is normal.
U0140	LOCAL COMM-1	Inhibit soft top operation.	Communication is normal.
U0215	LOCAL COMM-2	Inhibit soft top operation.	Communication is normal.
B1701	ROOF CONTROL UNIT	Inhibit soft top operation.	Replace soft top control unit.
B1702	ROOF CONTROL UNIT	Inhibit soft top operation.	Replace soft top control unit.
B1709	ROOF SWITCH(OPEN)	Inhibit soft top operation.	Detects roof open/close switch (OPEN) is OFF.
B170A	ROOF SWITCH(CLOSE)	Inhibit soft top operation.	Detects roof open/close switch (CLOSE) is OFF.
B170F	SENSOR POWER SUPPLY	Inhibit soft top operation.	Detects normal value.
B171A	HYDRAULIC PMP(LH)	Inhibit soft top operation.	Detects normal value.
B171B	HYDRAULIC PMP(RH)	Inhibit soft top operation.	Detects normal value.
B171C	SWITCHING VALVE 1	Inhibit soft top operation.	Detects normal value.
B171D	SWITCHING VALVE 2	Inhibit soft top operation.	Detects normal value.
B172C	ROOF STATE SIG(TRUNK)*	Inhibit soft top operation.	Detects normal value.
B1731	HYDRAULIC STATE 1	Inhibit soft top operation.	Turn ignition switch OFF.
B1758	THERMO PROTECTION	Inhibit soft top operation.	Turn ignition switch OFF and wait at least 5 minutes.
B175C	PWR SOURCE(ROOF)	Inhibit soft top operation.	Power source is 11.4 (V) or more for 0.5 second.
B175D	PWR SOURCE(ROOF)	Inhibit soft top operation.	Power source is 14.5 (V) or more for 4 seconds.
B175E	PWR SOURCE(WINDOW)	Inhibit soft top operation and rear power window operation.	Power source (power window) is 9.5 (V) or more.
B175F	PWR SOURCE(WINDOW)	Inhibit soft top operation and rear power window operation.	Power source (power window) is 15.5 (V) or more.
B1766	SWITCHING VALVE 3	Inhibit soft top operation.	Detects normal value.
B1767	SWITCHING VALVE 4	Inhibit soft top operation.	Detects normal value.

SOFT TOP CONTROL UNIT

< ECU DIAGNOSIS INFORMATION >

Display contents of CONSULT		Fail-safe	Cancellation
B1768	SWITCHING VALVE 5	Inhibit soft top operation.	Detects normal value.
B176A	THERMO PROTECTION	Inhibit soft top operation.	Turn ignition switch OFF and wait at least 5 minutes.
B176B	ROOF WARNING LAMP	Inhibit soft top operation.	Detects normal value.
B176C	STRIKER SENSOR RH	Inhibit soft top operation.	Detects normal value.
B176D	STRIKER SENSOR LH	Inhibit soft top operation.	Detects normal value.
B176E	ROOF LATCH LOCK SENSOR	Inhibit soft top operation.	Detects normal value.
B176F	ROOF STATUS SEN LH	Inhibit soft top operation.	Detects normal value.
B1770	ROOF STATUS SEN RH	Inhibit soft top operation.	Detects normal value.
B1771	ROOF STATUS SEN LH	Inhibit soft top operation.	Detects normal value.
B1772	5BOW STATUS SEN LH	Inhibit soft top operation.	Detects normal value.
B1773	5BOW STATUS SEN RH	Inhibit soft top operation.	Detects normal value.
B1774	S/LID STATUS SEN LH	Inhibit soft top operation.	Detects normal value.
B1775	S/LID STATUS SEN RH	Inhibit soft top operation.	Detects normal value.
B1776	S/LID STATUS SEN RH	Inhibit soft top operation.	Detects normal value.
B1777	REAR DEF OUT SIG	Inhibit soft top and rear window defogger operation.	Detects normal value.
B1778	TRUNK OPEN OUT SIG	Inhibit soft top and trunk lid opener actuator operation.	Detects normal value.
B1779	THERMO PROTECTION	Inhibit soft top operation.	Detects normal value.
B177A	ROOF STATE INCORRECT	Inhibit soft top operation.	Detects normal value.
B177B	ROOF STATE INCORRECT	Inhibit soft top operation.	Detects normal value.
B177C	THERMO PROTECTION	Inhibit soft top operation.	Detects normal value.
B177D	5BOW LATCH OPEN SEN	Inhibit soft top operation.	Detects normal value.
B177E	5BOW LATCH CLOSE SEN	Inhibit soft top operation.	Detects normal value.
B177F	5BOW STRIKER SENSOR	Inhibit soft top operation.	Detects normal value.

*: This item indicates the roof status signal (Audio).

DTC Inspection Priority Chart

INFOID:000000007625408

If some DTCs are displayed at the same time, perform inspections one by one based on the following priority chart.

Priority	Display contents of CONSULT	
1	U1000	CAN COMM CIRCUIT
	U1010	CONTROL UNIT (CAN)
	B170F	SENSOR POWER SUPPLY
	B175C	PWR SOURCE(ROOF)
	B175D	PWR SOURCE(ROOF)
	B175E	PWR SOURCE(WINDOW)
	B175F	PWR SOURCE(WINDOW)
	B1701	ROOF CONTROL UNIT
	B1702	ROOF CONTROL UNIT

SOFT TOP CONTROL UNIT

< ECU DIAGNOSIS INFORMATION >

Priority	Display contents of CONSULT	
2	B1709	ROOF SWITCH(OPEN)
	B170A	ROOF SWITCH(CLOSE)
	B176B	ROOF WARNING LAMP
	B176C	STRIKER SENSOR RH
	B176D	STRIKER SENSOR LH
	B176E	ROOF LATCH LOCK SEN
	B176F	ROOF STATUS SEN LH
	B1770	ROOF STATUS SEN RH
	B1771	ROOF STATUS SEN LH
	B1772	5BOW STATUS SEN LH
	B1773	5BOW STATUS SEN RH
	B1774	S/LID STATUS SEN LH
	B1775	S/LID STATUS SEN RH
	B1776	S/LID STATUS SEN RH
	B177D	5BOW LATCH OPEN SEN
	B177E	5BOW LATCH CLOSE SEN
	B177F	5BOW STRIKER SENSOR
	3	U0140
U0215		LOCAL COMM-2
B171A		HYDRAULIC PMP(LH)
B171B		HYDRAULIC PMP(RH)
B171C		SWITCHING VALVE 1
B171D		SWITCHING VALVE 2
B172C		ROOF STATE SIG(TRUNK)*
B1731		HYDRAULIC STATE 1
B1758		THERMO PROTECTION
B1766		SWITCHING VALVE 3
B1767		SWITCHING VALVE 4
B1768		SWITCHING VALVE 5
B176A		THERMO PROTECTION
B1777		REAR DEF OUT SIG
B1778		TRUNK OPEN OUT SIG
B1779		THERMO PROTECTION
B177A		ROOF STATE INCORRECT
B177B		ROOF STATE INCORRECT
B177C	THERMO PROTECTION	

*: This item indicates the roof status signal (Audio).

DTC Index

INFOID:000000007625409

NOTE:

For details of Freeze Frame Data, refer to [RF-28, "CONSULT Function"](#).

Display contents of CONSULT		Fail-safe	Freeze Frame Data	Reference page
No DTC is detected. Further testing may be required.		—	—	—
U1000	CAN COMM CIRCUIT	×	×	RF-59

SOFT TOP CONTROL UNIT

< ECU DIAGNOSIS INFORMATION >

Display contents of CONSULT		Fail-safe	Freeze Frame Data	Reference page
U1010	CONTROL UNIT (CAN)	×	×	RF-60
U0140	LOCAL COMM-1	×	×	RF-61
U0215	LOCAL COMM-2	×	×	RF-62
B1701	ROOF CONTROL UNIT	×	×	RF-64
B1702	ROOF CONTROL UNIT	×	×	RF-65
B1709	ROOF SWITCH-OPEN	×	×	RF-66
B170A	ROOF SWITCH-CLOSE	×	×	RF-68
B170F	SENSOR POWER SUPPLY	×	×	RF-70
B171A	HYDRAULIC PMP(LH)	×	×	RF-73
B171B	HYDRAULIC PMP(RH)	×	×	RF-76
B171C	SWITCHING VALVE 1	×	×	RF-79
B171D	SWITCHING VALVE 2	×	×	RF-81
B172C	ROOF STATE SIG(TRUNK)*	×	×	RF-83
B1731	HYDRAULIC STATE 1	×	×	RF-85
B1758	THERMO PROTECTION	×	×	RF-86
B175C	PWR SOURCE(ROOF)	×	×	RF-87
B175D	PWR SOURCE(ROOF)	×	×	RF-88
B175E	PWR SOURCE(WINDOW)	×	×	RF-89
B175F	PWR SOURCE(WINDOW)	×	×	RF-91
B1766	SWITCHING VALVE 3	×	×	RF-93
B1767	SWITCHING VALVE 4	×	×	RF-95
B1768	SWITCHING VALVE 5	×	×	RF-97
B176A	THERMO PROTECTION	×	×	RF-99
B176B	ROOF WARNING LAMP	×	×	RF-100
B176C	STRIKER SENSOR RH	×	×	RF-102
B176D	STRIKER SENSOR LH	×	×	RF-104
B176E	ROOF LATCH LOCK SEN	×	×	RF-106
B176F	ROOF STATUS SEN LH	×	×	RF-108
B1770	ROOF STATUS SEN RH	×	×	RF-110
B1771	ROOF STATUS SEN LH	×	×	RF-112
B1772	5BOW STATUS SEN LH	×	×	RF-114
B1773	5BOW STATUS SEN RH	×	×	RF-116
B1774	S/LID STATUS SEN LH	×	×	RF-118
B1775	S/LID STATUS SEN RH	×	×	RF-120
B1776	S/LID STATUS SEN RH	×	×	RF-122
B1777	REAR DEF OUT SIG	×	×	RF-124
B1778	TRUNK OPEN OUT SIG	×	×	RF-125
B1779	THERMO PROTECTION	×	×	RF-127
B177A	ROOF STATE INCORRECT	×	×	RF-129
B177B	ROOF STATE INCORRECT	×	×	RF-130
B177C	THERMO PROTECTION	×	×	RF-131
B177D	5BOW LATCH OPEN SEN	×	×	RF-132
B177E	5BOW LATCH CLOSE SEN	×	×	RF-134
B177F	5BOW STRIKER SENSOR	×	×	RF-136

A

B

C

D

E

F

G

H

I

J

RF

L

M

N

O

P

SOFT TOP CONTROL UNIT

< ECU DIAGNOSIS INFORMATION >

*: This item indicates the roof status signal (Audio).

SOFT TOP SYSTEM

< WIRING DIAGRAM >

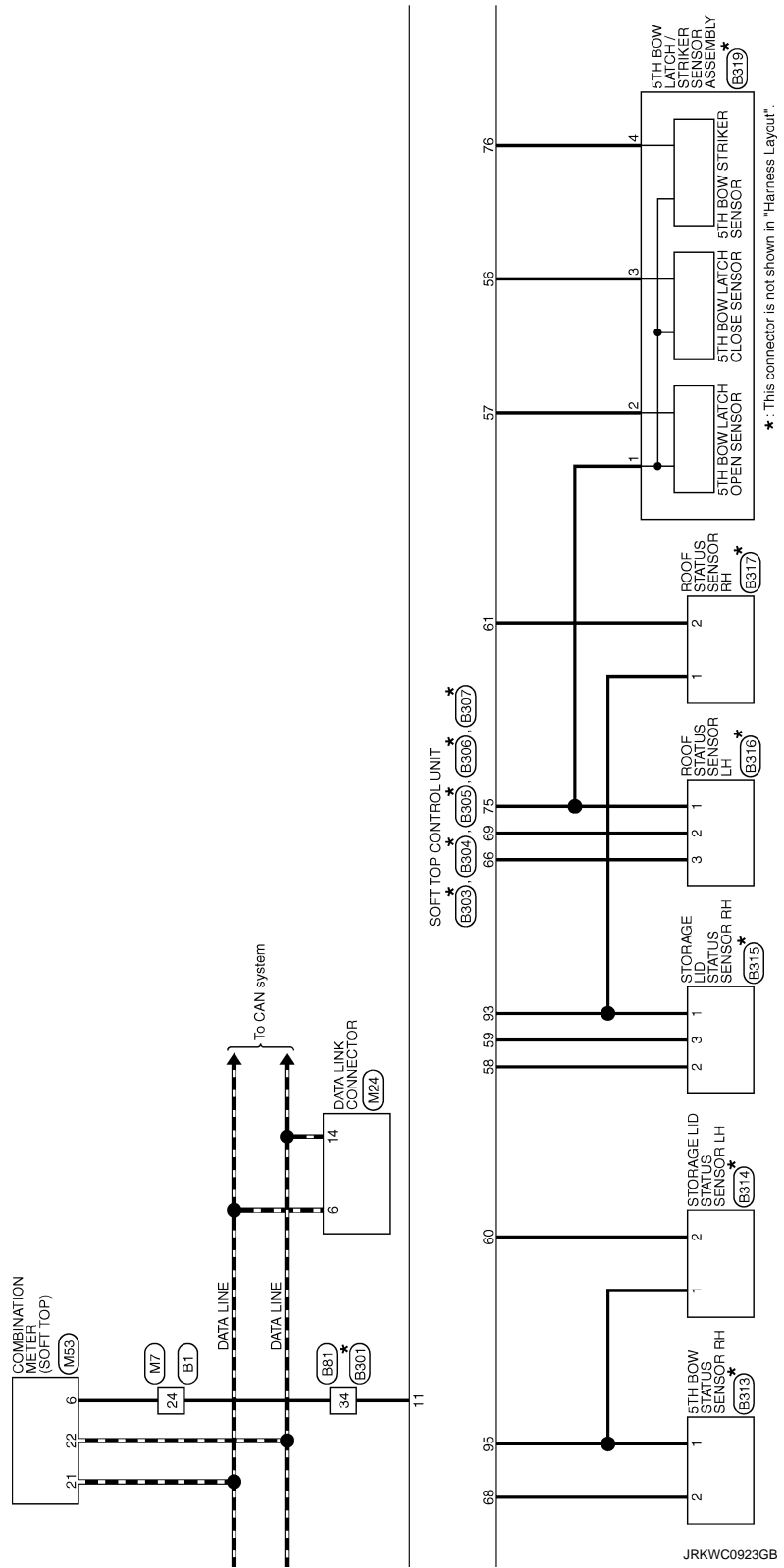

A
B
C
D
E
F
G
H
I
J
RF
L
M
N
O
P

DIAGNOSIS AND REPAIR WORK FLOW

< BASIC INSPECTION >

BASIC INSPECTION

DIAGNOSIS AND REPAIR WORK FLOW

Work Flow

INFOID:000000007625411

OVERALL SEQUENCE

NOTE:

A

B

C

D

E

F

G

H

I

J

RF

L

M

N

O

P

DIAGNOSIS AND REPAIR WORK FLOW

< BASIC INSPECTION >

Perform operation manually if roof does not open/close automatically. Refer to [RF-23, "SOFT TOP SYSTEM: Correspondence in Emergency"](#).

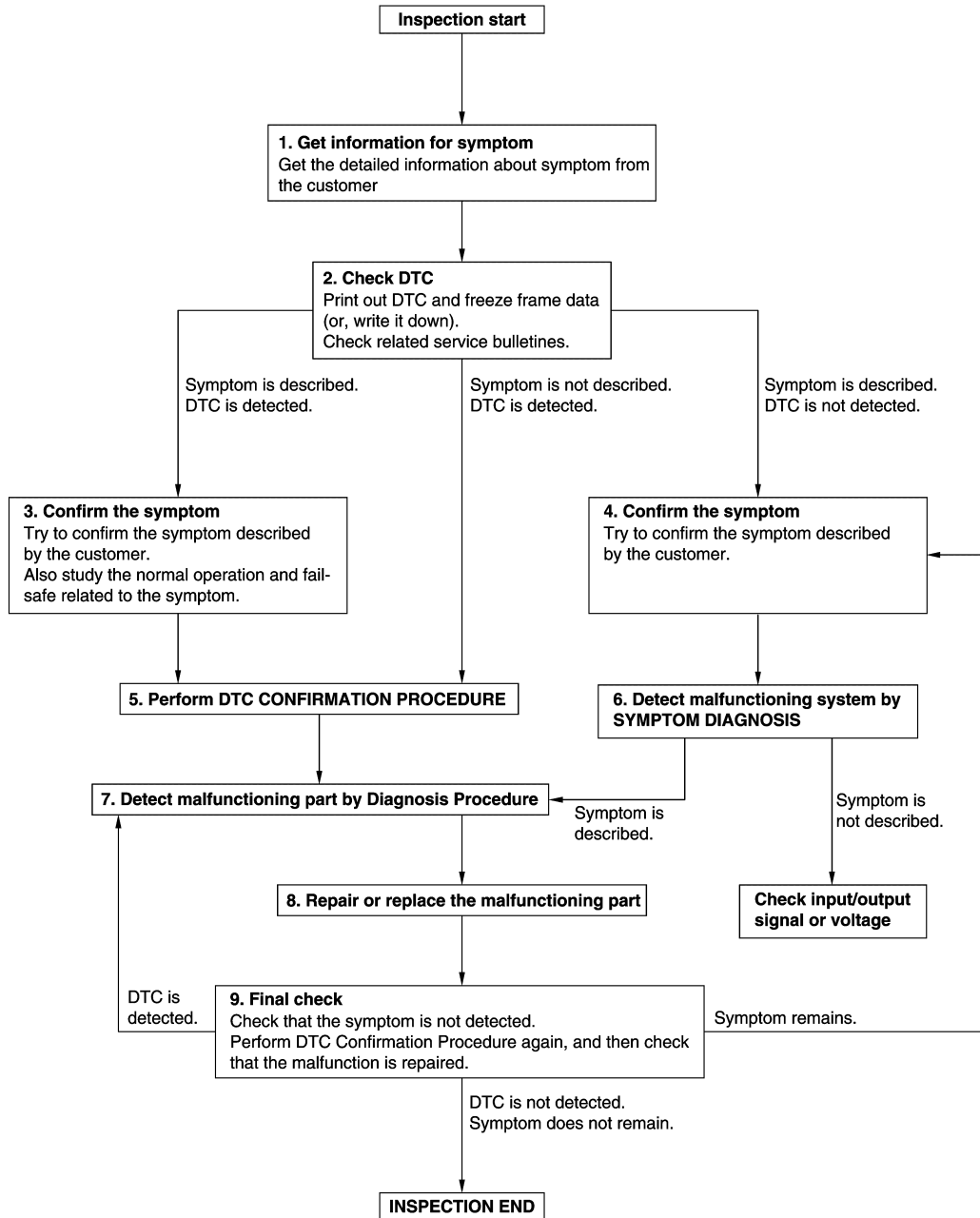

JMKIA8652GB

DETAILED FLOW

NOTE:

Perform operation manually if roof does not open/close automatically. Refer to [RF-23, "SOFT TOP SYSTEM: Correspondence in Emergency"](#).

1. GET INFORMATION FOR SYMPTOM

DIAGNOSIS AND REPAIR WORK FLOW

< BASIC INSPECTION >

1. Get detailed information from the customer about the symptom (the condition and the environment when the incident/malfunction occurs).
2. Check operation condition of the function that is malfunctioning.

>> GO TO 2.

2.CHECK DTC

1. Check DTC.
2. Perform the following procedure if DTC is detected.
 - Record DTC and freeze frame data (Print them out using CONSULT.)
 - Erase DTC.
 - Study the relationship between the cause detected by DTC and the symptom described by the customer.
3. Check related service bulletins for information.

Are any symptoms described and any DTC detected?

- Symptom is described, DTC is detected>>GO TO 3.
- Symptom is described, DTC is not detected>>GO TO 4.
- Symptom is not described, DTC is detected>>GO TO 5.

3.CONFIRM THE SYMPTOM

Try to confirm the symptom described by the customer.
Also study the normal operation and fail-safe related to the symptom.
Verify relation between the symptom and the condition when the symptom is detected.

>> GO TO 5.

4.CONFIRM THE SYMPTOM

Try to confirm the symptom described by the customer.
Verify relation between the symptom and the condition when the symptom is detected.

>> GO TO 6.

5.PERFORM DTC CONFIRMATION PROCEDURE

Perform DTC CONFIRMATION PROCEDURE for the detected DTC, and then check that DTC is detected again. At this time, always connect CONSULT to the vehicle, and check self diagnostic results in real time. If two or more DTCs are detected, refer to DTC INSPECTION PRIORITY CHART, and determine trouble diagnosis order.

NOTE:

- Freeze frame data is useful if the DTC is not detected.
- Perform Component Function Check if DTC CONFIRMATION PROCEDURE is not included on Service Manual. This simplified check procedure is an effective alternative though DTC cannot be detected during this check.
If the result of Component Function Check is NG, it is the same as the detection of DTC by DTC CONFIRMATION PROCEDURE.

Is DTC detected?

- YES >> GO TO 7.
- NO >> Check according to [GI-44. "Intermittent Incident"](#).

6.DETECT MALFUNCTIONING SYSTEM BY SYMPTOM DIAGNOSIS

Detect malfunctioning system according to SYMPTOM DIAGNOSIS based on the confirmed symptom in step 4, and determine the trouble diagnosis order based on possible causes and symptom.

Is the symptom described?

- YES >> GO TO 7.
- NO >> Monitor input data from related sensors or check voltage of related module terminals using CONSULT.

7.DETECT MALFUNCTIONING PART BY DIAGNOSIS PROCEDURE

Inspect according to Diagnosis Procedure of the system.

Is malfunctioning part detected?

A
B
C
D
E
F
G
H
I
J
RF
L
M
N
O
P

DIAGNOSIS AND REPAIR WORK FLOW

< BASIC INSPECTION >

- YES >> GO TO 8.
NO >> Check according to [GI-44, "Intermittent Incident"](#).

8. REPAIR OR REPLACE THE MALFUNCTIONING PART

1. Repair or replace the malfunctioning part.
2. Reconnect parts or connectors disconnected during Diagnosis Procedure again after repair and replacement.
3. Check DTC. If DTC is detected, erase it.

>> GO TO 9.

9. FINAL CHECK

When DTC is detected in step 2, perform DTC CONFIRMATION PROCEDURE again, and then check that the malfunction is repaired securely.

When symptom is described by the customer, refer to confirmed symptom in step 3 or 4, and check that the symptom is not detected.

Is DTC detected and does symptom remain?

- YES-1 >> DTC is detected: GO TO 7.
YES-2 >> Symptom remains: GO TO 4.
NO >> Before returning the vehicle to the customer, always erase DTC.

WATER LEAKAGE TROUBLE DIAGNOSIS

< BASIC INSPECTION >

WATER LEAKAGE TROUBLE DIAGNOSIS

Repairing Method for Water Leakage Around Doors

INFOID:000000007625412

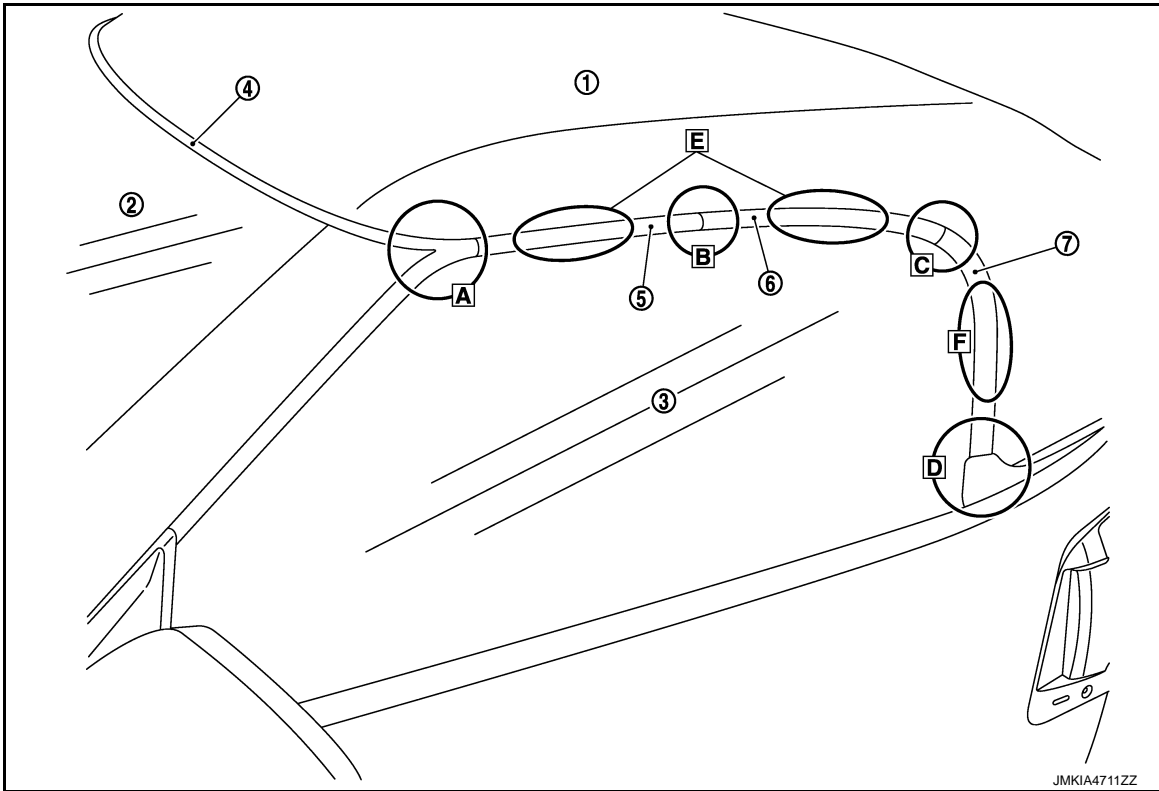

- | | | |
|----------------------------------|-----------------------------|------------------------------|
| 1. Soft top assembly | 2. Windshield glass | 3. Door glass |
| 4. Front side glass run assembly | 5. Front rail weather-strip | 6. Center rail weather-strip |
| 7. Rear rail weather-strip | | |

WATER LEAKAGE FROM A

- Water may be entering passenger room through back of front pillar.
CAUSE: It is determined that butyl tape between front side glass run assembly and front roof panel is not completely fitted and the water leaks into passenger room through peeling portion.

Repair Procedure 1

- Check that glass run assembly drain is not blocked.
- Replace front side glass run assembly with a new one. Refer to [EXT-37. "FRONT PILLAR FINISHER \(Roadster\) : Removal and Installation"](#).
- Apply butyl tape (1) from corner end (B) to a point 5-10mm (0.20-0.39in) short of next step.

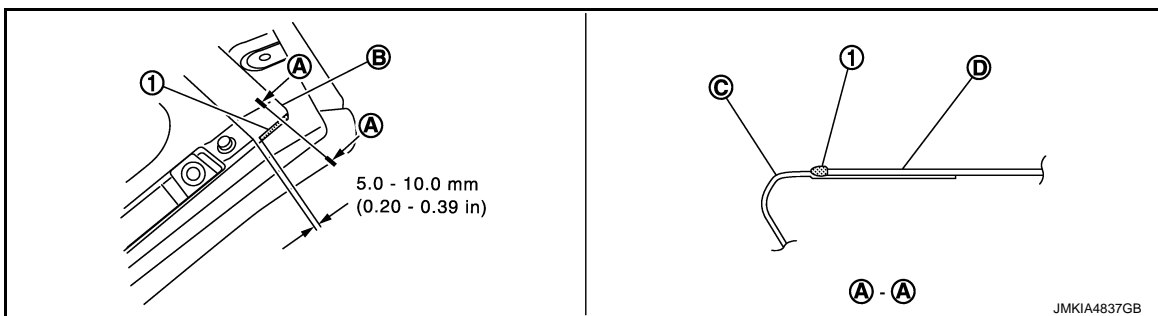

NOTE:

Check that no step or clearance is detected between front pillar panel (C) and front roof panel (D).

CAUTION:

WATER LEAKAGE TROUBLE DIAGNOSIS

< BASIC INSPECTION >

Completely fit butyl tape of front side glass run assembly to front roof panel.

Position alignment when installing front side glass run assembly

- Align position mark (A) of front side glass run assembly to corner (B) of front pillar finisher.
- Align shape of front side glass run assembly to corner of front pillar finisher.
- There must not be a difference in height between the front side glass run assembly and the front pillar finisher.

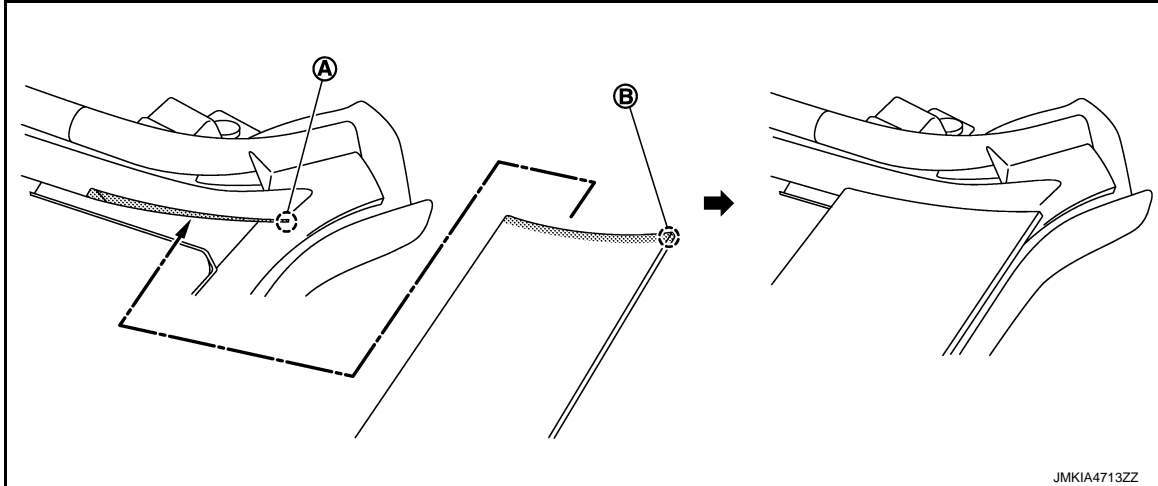

2. Water may be entering through connection between front pillar finisher and front edge of soft top.
Cause: There may be a gap between front side glass run assembly and front rail weather-strip of soft top.
Repair Procedure 2
- Replace front side glass run assembly with a new one. Refer to [EXT-37. "FRONT PILLAR FINISHER \(Roadster\) : Removal and Installation"](#).
 - If the step or the gap is not eliminated after replacing front side glass run assembly, then perform the following procedure.
- Repair Procedure 3
- Loosen retainer screws (1).

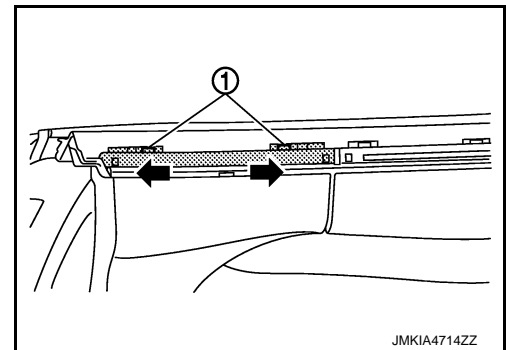

- Adjust overlap value of front rail weather-strip and front side glass run assembly to the following standard.

0.5 mm - 3.0 mm (0.02 - 0.12 in)

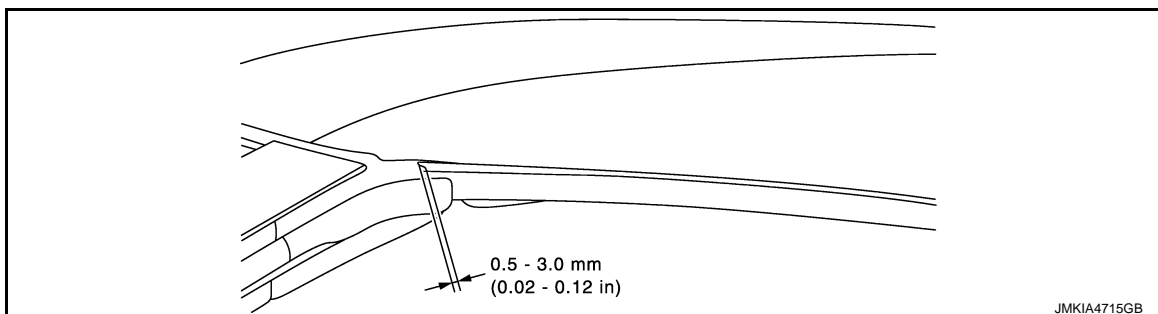

WATER LEAKAGE TROUBLE DIAGNOSIS

< BASIC INSPECTION >

Close soft top until front side glass run assembly (1) contacts front rail wether strip (2). Measure the lower end position.

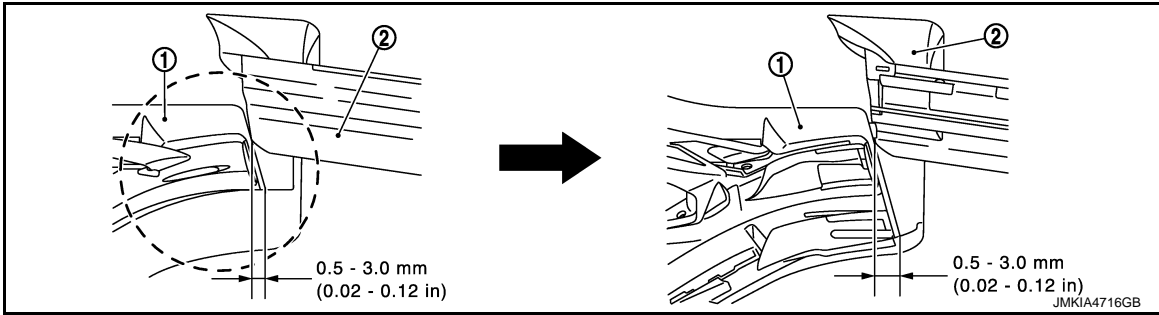

Check that front side glass run assembly (1) fitted normally.

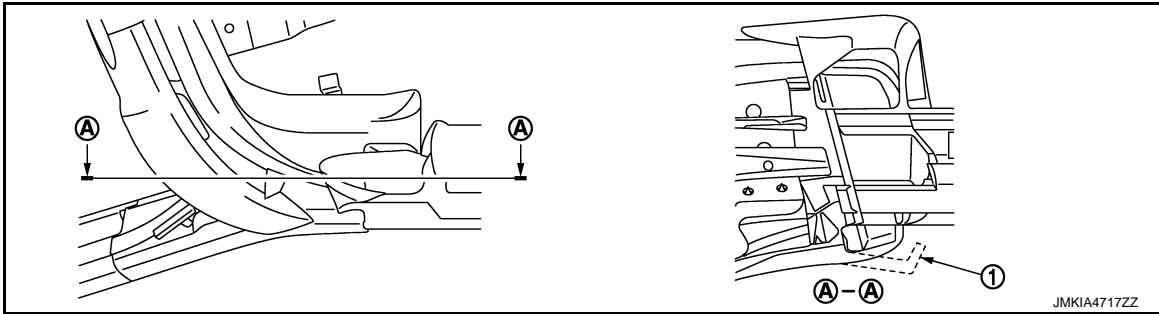

WATER LEAKAGE FROM B

Water may be entering through a joint between soft top weather-strips.

Cause: There may be a step or a gap at the weather-strips joint. (A)

Repair Procedure 4

- Replace weather-strip (front rail and center rail) and retainer with a new one. Refer to [RF-188. "ROOF SEALING : Removal and Installation"](#).
- If the step or the gap is not eliminated after replacing weather-strip and retainer, then perform the following procedure.

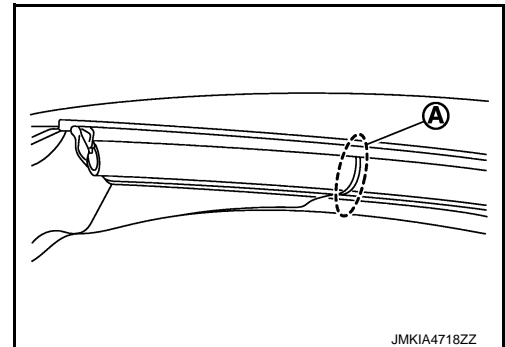

Repair Procedure 5

- Loosen retainer screws (1).
- Adjust retainer (2) frontward and rearward. Check that front rail weather-strip and center rail weather-strip completely contact each other.

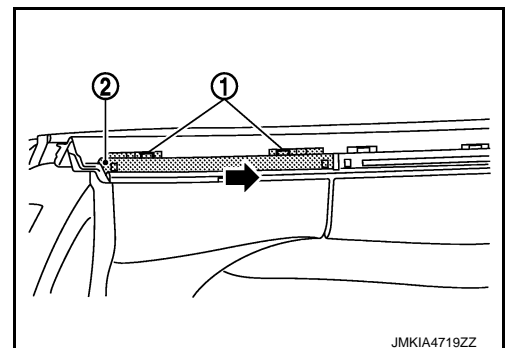

A
B
C
D
E
F
G
H
I
J
RF
L
M
N
O
P

WATER LEAKAGE TROUBLE DIAGNOSIS

< BASIC INSPECTION >

Use a thin plastic card (1) to check that resistance is detected, when card is inserted, because weather-strips completely contact each other.

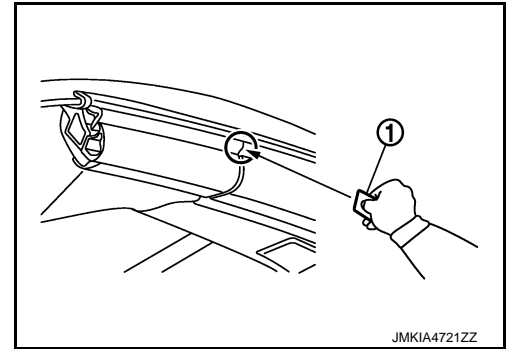

JMKIA4721ZZ

CAUTION:

Weather-strip is compressed. Extend both ends of weather-strip (2) when installing retainer (1) and weather-strip.

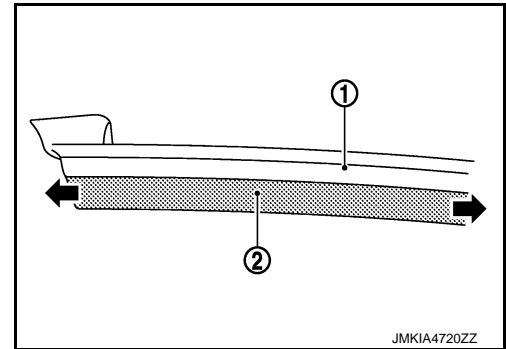

JMKIA4720ZZ

WATER LEAKAGE FROM C

Water may be entering through a joint between soft top weather-strips.

Cause: There may be a step or a gap at the weather-strips joint. (A)

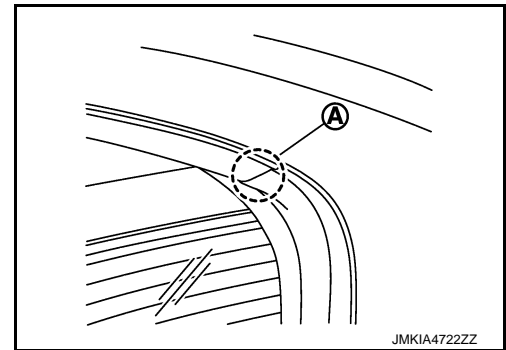

JMKIA4722ZZ

Repair Procedure 6

- Replace weather-strip (center rail and rear rail) and retainer with a new one. Refer to [RF-188, "ROOF SEALING : Removal and Installation"](#).
- If the step or the gap is not eliminated after replacing weather-strip, and retainer, then perform the following procedure.

Repair Procedure 7

- Loosen retainer screws (1).
- Adjust retainer (2) frontward and rearward. Check that front rail weather-strip and center rail weather-strip completely contact each other.

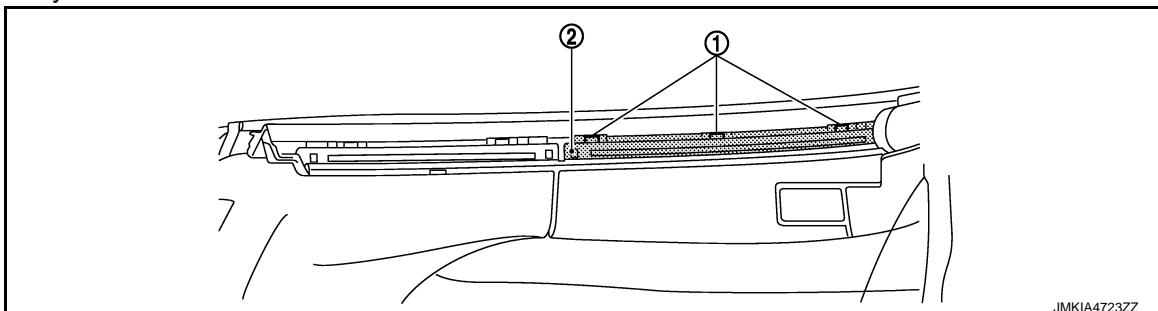

JMKIA4723ZZ

WATER LEAKAGE TROUBLE DIAGNOSIS

< BASIC INSPECTION >

Use a thin plastic card (1) to check that resistance is detected, when card is inserted, because weather-strips completely contact each other.

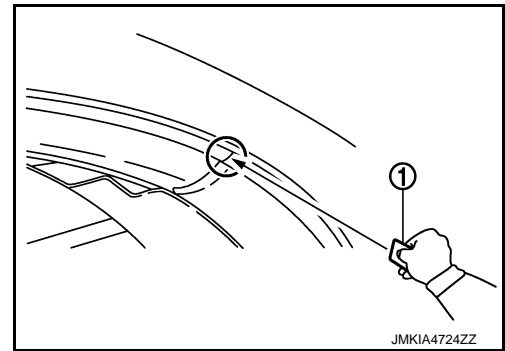

WATER LEAKAGE FROM D

1. Water may be entering passenger room through weather-strip lower end (A).
Cause: There may be poor contact between rear rail weather-strip (1) of soft top and door glass.

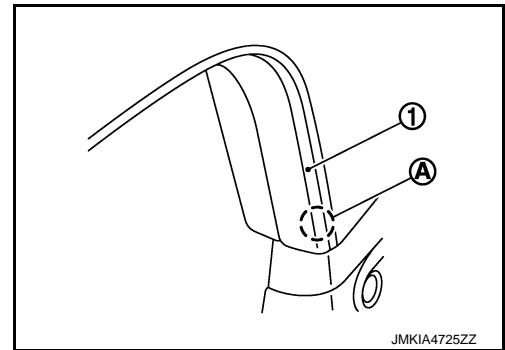

Repair Procedure 8

- Replace rear rail weather-strip with a new one. Refer to [RF-188, "ROOF SEALING : Removal and Installation"](#).
- If the step or the gap is not eliminated after replacing rear rail weather-strip, then perform the following procedure.

Repair Procedure 9

- Loosen retainer screws (1).
- Adjust retainer (2) toward vehicle outside.

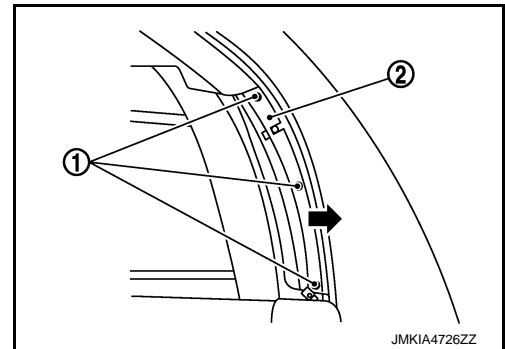

2. Water may be entering passenger room through weather-strip lower end (A).
Cause: There may be poor contact between body side weather-strip (1) of soft top and door glass.

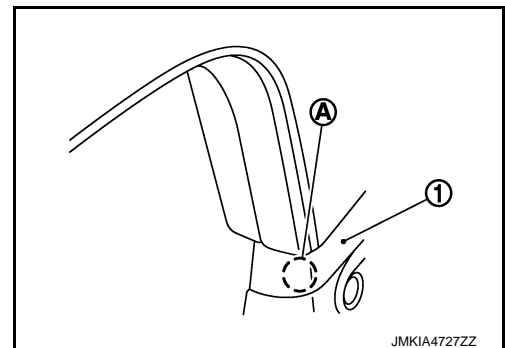

Repair Procedure 10

A
B
C
D
E
F
G
H
I
J
RF
L
M
N
O
P

WATER LEAKAGE TROUBLE DIAGNOSIS

< BASIC INSPECTION >

- Replace body side weather-strip new one. Refer to [EXT-37. "FRONT PILLAR FINISHER \(Roadster\) : Exploded View"](#).
3. The water overflows (A) from body side weather-strip (1) and leaks to passenger room.
CAUSE: It is estimated that gap or clearance occurs at connecting point (B) of weather-strip and the entering water level exceeds the allowable drainage volume.

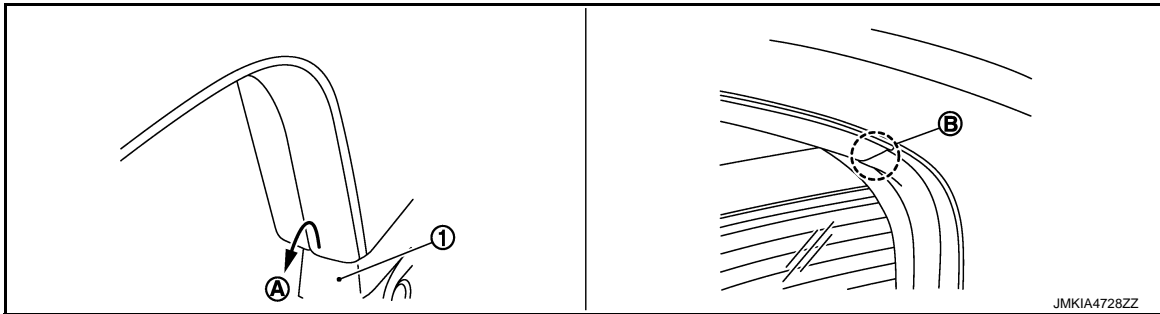

Repair Procedure 11

- Check that body side weather-strip drain is not blocked.
- Replace weather-strip (center rail and rear rail) and retainer with a new one. Refer to [RF-188. "ROOF SEALING : Removal and Installation"](#).
- If the step or the gap is not eliminated after replacing weather-strip, and retainer, then perform the following procedure.

Repair Procedure 12

- Loosen retainer screws (1).
- Adjust retainer (2) frontward and rearward. Check that front rail weather-strip and center rail weather-strip completely contact each other.

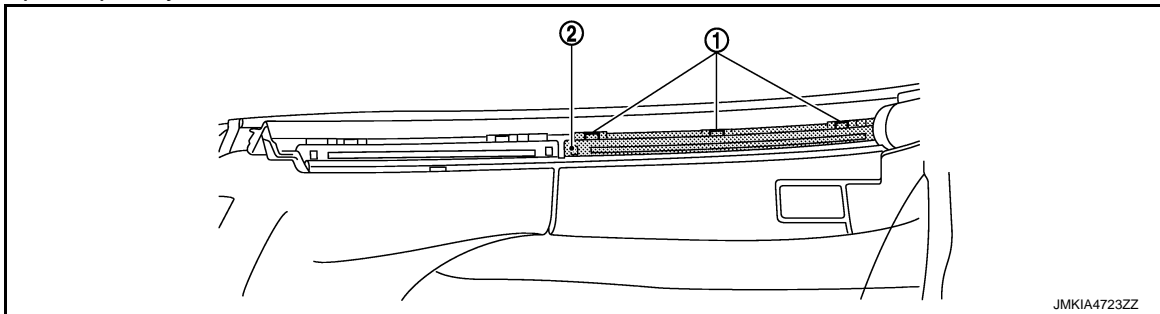

Use a thin plastic card (1) to check that resistance is detected, when card is inserted, because weather-strips completely contact each other.

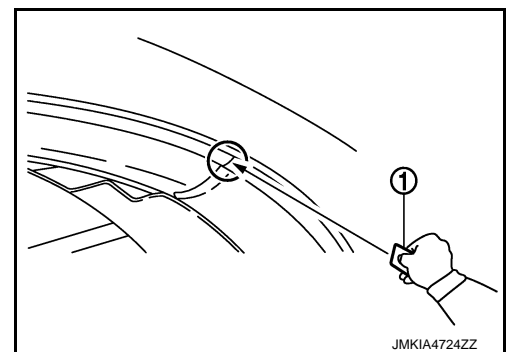

WATER LEAKAGE FROM E

Water may be entering through door glass upper inside edge.

Cause: There may be poor contact between weather-strip of soft top and door glass.

Repair Procedure 13

WATER LEAKAGE TROUBLE DIAGNOSIS

< BASIC INSPECTION >

- Adjust door glass (1) position frontward/backward or upward/downward against soft top assembly.

(A): 5.4 mm (0.21 in)

(B): 7.6 mm (0.3 in)

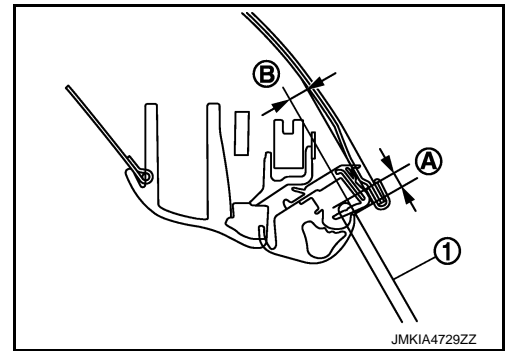

- Adjust door glass tilt contact by rotating adjusting bolt on regulator lower edge. Refer to [GW-24, "Inspection and Adjustment"](#)

Adjust door glass tilt contact by rotating adjusting bolt on regulator lower edge.

Checking procedure for overlap value of weather-strip and door glass

- Apply tape (1) to door glass upper end.

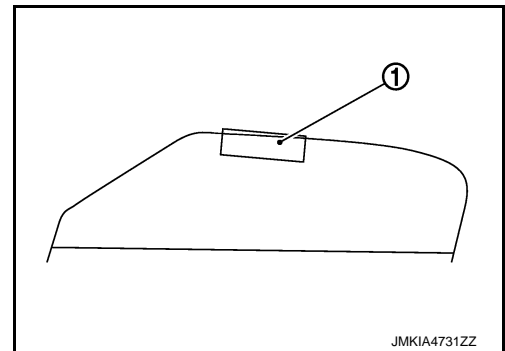

- Fully close glass. Put a mark (2) on tape that shows the weather-strip lower end position.

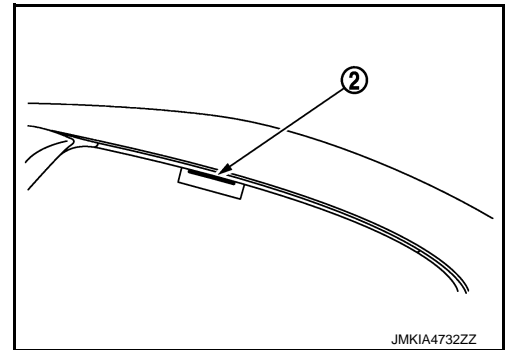

- Open door glass and measure (A).

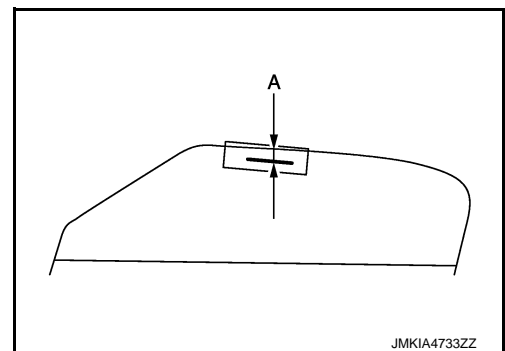

CAUTION:

- Visually check that weather-strip is not twisted by door glass (1) upper end.

A
B
C
D
E
F
G
H
I
J
RF
L
M
N
O
P

WATER LEAKAGE TROUBLE DIAGNOSIS

< BASIC INSPECTION >

- Soft top assembly position may be incorrect when glass upper position is low even if door glass adjustment is performed. Perform soft top assembly adjustment, if necessary. Refer to [RF-158, "SOFT TOP ASSEMBLY : Adjustment"](#)

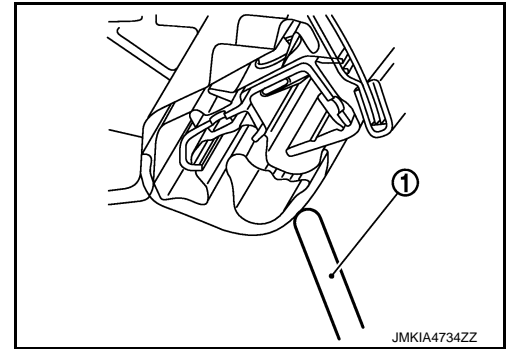

WATER LEAKAGE FROM F

Water may be entering through inside door glass rear.

Cause: There may be poor contact between rear weather-strip of soft top and door glass.

Repair Procedure 14

- Adjust door glass (1) position frontward/backward or upward/downward against soft top.

(A): 1.2 - 5.2 mm (0.05 - 0.20 in)

(B): 6.4 - 10.4 mm (0.25 - 0.41 in)

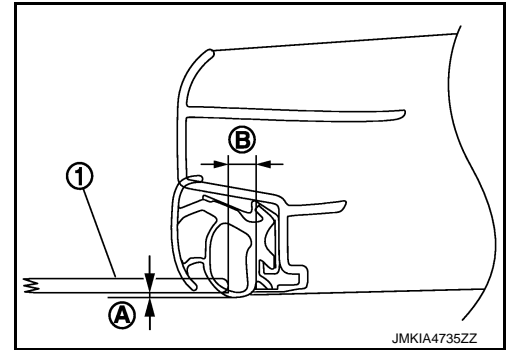

- Adjust door glass tilt contact by rotating adjusting bolt on regulator lower edge. Refer to [GW-24, "Inspection and Adjustment"](#)

CAUTION:

Soft top assembly position may be incorrect in the case of glass upper position is low even if door glass adjustment is performed. Perform soft top assembly adjustment if necessary. Refer to [RF-158, "SOFT TOP ASSEMBLY : Adjustment"](#)

Water Leakage Test

INFOID:000000007625413

Visually check for water leakage after repairing.

1. 2 workers are required. One worker checks inside the vehicle, and the other one washes with water.
2. Use 13 mm (0.51 in) diameter hose. Adjust water pressure by following method. Hold the hose horizontally, and release water at 1000 mm (39.37 in) height from ground. Adjust the distance, between the ground point just below the hose and the water dropping point, to reach 700 mm (27.56 in). (See the figure.)
3. Keeping the distance between the hose and the testing area by 100 mm (3.94 in), apply water along the area 3 times. During applying water, move the hose by 100 mm (3.94 in)/sec speed.
4. Visually check for water leakage.

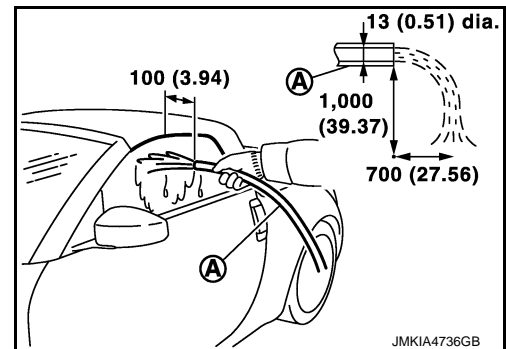

U1000 CAN COMM CIRCUIT

< DTC/CIRCUIT DIAGNOSIS >

DTC/CIRCUIT DIAGNOSIS

U1000 CAN COMM CIRCUIT

Description

INFOID:000000007625414

CAN (Controller Area Network) is a serial communication line for real time applications. It is an on-vehicle multiplex communication line with high data communication speed and excellent error detection ability. Modern vehicle is equipped with many electronic control unit, and each control unit shares information and links with other control units during operation (not independent). In CAN communication, control units are connected with 2 communication lines (CAN H-line, CAN L-line) allowing a high rate of information transmission with less wiring. Each control unit transmits/receives data but selectively reads required data only.

DTC Logic

INFOID:000000007625415

DTC DETECTION LOGIC

NOTE:

If two or more DTCs are detected, refer to [RF-39. "DTC Inspection Priority Chart"](#), and determine trouble diagnosis order.

DTC No.	Trouble diagnosis name	DTC detection condition	Possible cause
U1000	CAN COMM CIRCUIT	When soft top control unit cannot communicate CAN communication signal continuously for 2 seconds or more.	CAN communication system

Diagnosis Procedure

INFOID:000000007625416

1. PERFORM SELF DIAGNOSTIC

1. Turn ignition switch ON and wait for 2 seconds or more.
2. Select "Self Diagnostic Result" mode of "CONVERTIBLE ROOF" using CONSULT.
3. Check DTC.

Is DTC detected?

- YES >> Refer to [LAN-15. "Trouble Diagnosis Flow Chart"](#).
NO >> Refer to [GI-44. "Intermittent Incident"](#).

A
B
C
D
E
F
G
H
I
J
L
M
N
O
P

RF

U1010 CONTROL UNIT (CAN)

< DTC/CIRCUIT DIAGNOSIS >

U1010 CONTROL UNIT (CAN)

DTC Logic

INFOID:000000007625417

DTC DETECTION LOGIC

DTC No.	Trouble diagnosis name	DTC detection condition	Possible cause
U1010	CONTROL UNIT (CAN)	Soft top control unit detected internal CAN communication circuit malfunction.	Soft top control unit

Diagnosis Procedure

INFOID:000000007625418

1. REPLACE SOFT TOP CONTROL UNIT

When DTC "U1010" is detected, replace soft top control unit.

>> Replace soft top control unit. Refer to [RF-235, "Removal and Installation"](#).

U0140 LOCAL COMMUNICATION-1

< DTC/CIRCUIT DIAGNOSIS >

U0140 LOCAL COMMUNICATION-1

Description

INFOID:000000007625419

Door request switch signal is transmitted to soft top control unit via communication line.

DTC Logic

INFOID:000000007625420

DTC DETECTION LOGIC

NOTE:

If two or more DTCs are detected, refer to [RF-39, "DTC Inspection Priority Chart"](#), and determine trouble diagnosis order.

DTC No.	Trouble diagnosis name	DTC detecting condition	Possible cause
U0140	LOCAL COMM-1	The communication between soft top control unit and BCM is interrupted for a period of time.	<ul style="list-style-type: none">• Communication line• BCM

DTC CONFIRMATION PROCEDURE

1. PERFORM DTC CONFIRMATION PROCEDURE

1. Start engine.
2. Operate soft top to fully open and fully close.
3. Select "Self Diagnostic Result" mode of "CONVERTIBLE ROOF" using CONSULT.
4. Check DTC.

Is DTC detected?

- YES >> Perform diagnosis procedure. Refer to [RF-61, "Diagnosis Procedure"](#).
NO >> INSPECTION END

Diagnosis Procedure

INFOID:000000007625421

1. CHECK COMMUNICATION LINE

1. Turn ignition switch OFF.
2. Disconnect soft top control unit and BCM connector.
3. Check continuity between soft top control unit harness connector and BCM harness connector.

Soft top control unit		BCM		Continuity
Connector	Terminal	Connector	Terminal	
B303	20	M123	132	Existed

4. Also check harness for short to ground and short to power.

Is the inspection result normal?

- YES >> Replace BCM. Refer to [BCS-92, "Removal and Installation"](#).
NO >> Repair or replace harness.

U0215 LOCAL COMMUNICATION-2

< DTC/CIRCUIT DIAGNOSIS >

U0215 LOCAL COMMUNICATION-2

Description

INFOID:000000007625422

Soft top control unit performs local communication with BCM, power window main switch and power window sub-switch using communication line.

DTC Logic

INFOID:000000007625423

DTC DETECTION LOGIC

NOTE:

If two or more DTCs are detected, refer to [RF-39, "DTC Inspection Priority Chart"](#), and determine trouble diagnosis order.

DTC No.	Trouble diagnosis name	DTC detecting condition	Possible cause
U0215	LOCAL COMM-2	The communication between soft top control unit, power window main switch and power window sub-switch is interrupted for a period of time.	<ul style="list-style-type: none">• Communication line• Power window main switch• Power window sub-switch

DTC CONFIRMATION PROCEDURE

1. PERFORM DTC CONFIRMATION PROCEDURE

1. Start engine.
2. Operate soft top to fully open and fully close.
3. Select "Self Diagnostic Result" mode of "CONVERTIBLE ROOF" using CONSULT.
4. Check DTC.

Is DTC detected?

- YES >> Perform diagnosis procedure. Refer to [RF-62, "Diagnosis Procedure"](#).
NO >> INSPECTION END

Diagnosis Procedure

INFOID:000000007625424

1. CHECK POWER WINDOW MAIN SWITCH

Check power window main switch. Refer to [PWC-101, "POWER WINDOW MAIN SWITCH : Diagnosis Procedure"](#).

Is the inspection result normal?

- YES >> GO TO 2.
NO >> Repair or replace malfunctioning part.

2. CHECK POWER WINDOW SUB-SWITCH

Check power window sub-switch. Refer to [PWC-102, "POWER WINDOW SUB-SWITCH : Diagnosis Procedure"](#).

Is the inspection result normal?

- YES >> GO TO 3.
NO >> Repair or replace malfunctioning part.

3. CHECK COMMUNICATION LINE-I

1. Turn ignition switch OFF.
2. Disconnect soft top control unit, power window main switch connector and power window sub-switch connector.
3. Check continuity between soft top control unit harness connector and power window main switch harness connector.

Soft top control unit		Power window main switch		Continuity
Connector	Terminal	Connector	Terminal	
B303	19	D8	12	Existed

4. Also check harness for short to ground and short to power.

U0215 LOCAL COMMUNICATION-2

< DTC/CIRCUIT DIAGNOSIS >

Is the inspection result normal?

YES >> GO TO 4.

NO >> Repair or replace harness.

4. CHECK COMMUNICATION LINE-II

1. Check continuity between soft top control unit harness connector and power window sub-switch harness connector.

Soft top control unit		Power window sub-switch		Continuity
Connector	Terminal	Connector	Terminal	
B303	19	D38	16	Existed

2. Also check harness for short to ground and short to power.

Is the inspection result normal?

YES >> Check intermittent incident. Refer to [GI-44. "Intermittent Incident"](#).

NO >> Repair or replace harness.

A
B
C
D
E
F
G
H
I
J
RF
L
M
N
O
P

B1701 ROOF CONTROL UNIT

< DTC/CIRCUIT DIAGNOSIS >

B1701 ROOF CONTROL UNIT

DTC Logic

INFOID:000000007625425

DTC DETECTION LOGIC

NOTE:

If two or more DTCs are detected, refer to [RF-39, "DTC Inspection Priority Chart"](#), and determine trouble diagnosis order.

DTC No.	Trouble diagnosis name	DTC detecting condition	Possible cause
B1701	ROOF CONTROL UNIT	Soft top control unit detects internal malfunction.	Soft top control unit

DTC CONFIRMATION PROCEDURE

1. PERFORM DTC CONFIRMATION PROCEDURE

1. Turn ignition switch ON.
2. Select "Self Diagnostic Result" mode of "CONVERTIBLE ROOF" using CONSULT.
3. Check DTC.

Is DTC detected?

- YES >> Refer to [RF-64, "Diagnosis Procedure"](#).
NO >> INSPECTION END

Diagnosis Procedure

INFOID:000000007625426

1. REPLACE SOFT TOP CONTROL UNIT

1. Turn ignition switch OFF.
2. Replace soft top control unit. Refer to [RF-235, "Removal and Installation"](#).
3. Perform DTC Confirmation Procedure. Refer to [RF-64, "DTC Logic"](#).

>> INSPECTION END

B1702 ROOF CONTROL UNIT

< DTC/CIRCUIT DIAGNOSIS >

B1702 ROOF CONTROL UNIT

DTC Logic

INFOID:000000007625427

DTC DETECTION LOGIC

NOTE:

If two or more DTCs are detected, refer to [RF-39, "DTC Inspection Priority Chart"](#), and determine trouble diagnosis order.

DTC No.	Trouble diagnosis name	DTC detecting condition	Possible cause
B1702	ROOF CONTROL UNIT	Soft top control unit detects internal mal-function.	Soft top control unit

DTC CONFIRMATION PROCEDURE

1. PERFORM DTC CONFIRMATION PROCEDURE

1. Turn ignition switch ON.
2. Select "Self Diagnostic Result" mode of "CONVERTIBLE ROOF" using CONSULT.
3. Check DTC.

Is DTC detected?

- YES >> Refer to [RF-65, "Diagnosis Procedure"](#).
NO >> INSPECTION END

Diagnosis Procedure

INFOID:000000007625428

1. REPLACE SOFT TOP CONTROL UNIT

1. Turn ignition switch OFF.
2. Replace soft top control unit. Refer to [RF-235, "Removal and Installation"](#).
3. Perform DTC Confirmation Procedure. Refer to [RF-65, "DTC Logic"](#).

>> INSPECTION END

A
B
C
D
E
F
G
H
I
J
L
M
N
O
P

RF

B1709 ROOF OPEN/CLOSE SWITCH (OPEN)

< DTC/CIRCUIT DIAGNOSIS >

B1709 ROOF OPEN/CLOSE SWITCH (OPEN)

DTC Logic

INFOID:000000007625429

DTC DETECTION LOGIC

NOTE:

If two or more DTCs are detected, refer to [RF-39, "DTC Inspection Priority Chart"](#), and determine trouble diagnosis order.

DTC No.	Trouble diagnosis name		DTC detecting condition	Possible cause
B1709	ROOF SWITCH-OPEN	[TIMEOUT]	Soft top control unit detects roof open/close switch (open) operation for 120 seconds	<ul style="list-style-type: none">• Harness or connectors (The roof open/close switch circuit is shorted.)• Soft top control unit• Roof open/close switch

DTC CONFIRMATION PROCEDURE

1. CHECK ROOF OPEN/CLOSE SWITCH SIGNAL

1. Start engine.
2. Operate soft top to fully open and fully close.
3. Select "Self Diagnostic Result" mode of "CONVERTIBLE ROOF" using CONSULT.
4. Check DTC.

Is DTC detected?

- YES >> Go to [RF-66, "Diagnosis Procedure"](#).
NO >> INSPECTION END

Diagnosis Procedure

INFOID:000000007625430

1. CHECK ROOF OPEN/CLOSE SWITCH POWER SUPPLY CIRCUIT-I

1. Turn ignition switch OFF.
2. Disconnect roof open/close switch harness connector.
3. Turn ignition switch ON.
4. Check the voltage between roof open/close switch harness connector and ground.

(+)		(-)	Voltage (V) (Approx.)
Roof open/close switch			
Connector	Terminal		
M15	3	Ground	Battery voltage

Is the inspection result normal?

- YES >> GO TO 3.
NO >> GO TO 2.

2. CHECK ROOF OPEN/CLOSE SWITCH POWER SUPPLY CIRCUIT-II

1. Turn ignition switch OFF.
2. Disconnect soft top control unit harness connector.
3. Check the continuity between soft top control unit harness connector and roof open/close switch harness connector.

Soft top control unit		Roof open/close switch		Continuity
Connector	Terminal	Connector	Terminal	
B303	15	M15	3	Existed

4. Also check harness for short to ground.

Is the inspection result normal?

- YES >> Replace soft top control unit. Refer to [RF-235, "Removal and Installation"](#).
NO >> Repair open circuit or short to ground in harness or connectors.

B1709 ROOF OPEN/CLOSE SWITCH (OPEN)

< DTC/CIRCUIT DIAGNOSIS >

3.CHECK ROOF OPEN/CLOSE SWITCH

Check roof open/close switch. Refer to [RF-67. "Component Inspection"](#).

Is the inspection result normal?

YES >> GO TO 4.

NO >> Replace roof open/close switch. Refer to [RF-234. "Removal and Installation"](#).

4.REPLACE SOFT TOP CONTROL UNIT

Replace soft top control unit. Refer to [RF-235. "Removal and Installation"](#).

Is the inspection result normal?

YES >> INSPECTION END

NO >> GO TO 5.

5.CHECK INTERMITTENT INCIDENT

Refer to [GI-44. "Intermittent Incident"](#).

>> INSPECTION END

Component Inspection

INFOID:000000007625431

1.CHECK ROOF OPEN/CLOSE SWITCH

1. Turn ignition switch OFF.
2. Disconnect roof open/close switch harness connector.
3. Check the continuity between roof open/close switch terminals under the following conditions.

Terminal	Condition	Continuity
1 and 3	Open pressed	Existed
	Except above	Not existed
1 and 4	Close pressed	Existed
	Except above	Not existed

Is the inspection result normal?

YES >> INSPECTION END

NO >> Replace roof open/close switch. Refer to [RF-234. "Removal and Installation"](#).

B170A ROOF OPEN/CLOSE SWITCH (CLOSE)

< DTC/CIRCUIT DIAGNOSIS >

B170A ROOF OPEN/CLOSE SWITCH (CLOSE)

DTC Logic

INFOID:000000007625432

DTC DETECTION LOGIC

NOTE:

If two or more DTCs are detected, refer to [RF-39, "DTC Inspection Priority Chart"](#), and determine trouble diagnosis order.

DTC No.	Trouble diagnosis name		DTC detecting condition	Possible cause
B170A	ROOF SWITCH-CLOSE	[TIMEOUT]	Soft top control unit detects roof open/close switch (close) operation for 120 seconds	<ul style="list-style-type: none">• Harness or connectors (The roof open/close switch circuit is shorted.)• Soft top control unit• Roof open/close switch

DTC CONFIRMATION PROCEDURE

1.CHECK ROOF OPEN/CLOSE SWITCH SIGNAL

1. Start engine.
2. Operate soft top to fully open and fully close.
3. Select "Self Diagnostic Result" mode of "CONVERTIBLE ROOF" using CONSULT.
4. Check DTC.

Is DTC detected?

- YES >> Go to [RF-68, "Diagnosis Procedure"](#).
NO >> INSPECTION END

Diagnosis Procedure

INFOID:000000007625433

1.CHECK ROOF OPEN/CLOSE SWITCH POWER SUPPLY CIRCUIT-I

1. Turn ignition switch OFF.
2. Disconnect roof open/close switch harness connector.
3. Turn ignition switch ON.
4. Check the voltage between roof open/close switch harness connector and ground.

(+)		(-)	Voltage (V) (Approx.)
Roof open/close switch			
Connector	Terminal		
M15	4	Ground	Battery voltage

Is the inspection result normal?

- YES >> GO TO 3.
NO >> GO TO 2.

2.CHECK ROOF OPEN/CLOSE SWITCH POWER SUPPLY CIRCUIT-II

1. Turn ignition switch OFF.
2. Disconnect soft top control unit harness connector.
3. Check the continuity between soft top control unit harness connector and roof open/close switch harness connector.

Soft top control unit		Roof open/close switch		Continuity
Connector	Terminal	Connector	Terminal	
B303	14	M15	4	Existed

4. Also check harness for short to ground.

Is the inspection result normal?

- YES >> Replace soft top control unit. Refer to [RF-235, "Removal and Installation"](#).
NO >> Repair open circuit or short to ground in harness or connectors.

B170A ROOF OPEN/CLOSE SWITCH (CLOSE)

< DTC/CIRCUIT DIAGNOSIS >

3.CHECK ROOF OPEN/CLOSE SWITCH

Check roof open/close switch. Refer to [RF-69. "Component Inspection"](#).

Is the inspection result normal?

YES >> GO TO 4.

NO >> Replace roof open/close switch. Refer to [RF-234. "Removal and Installation"](#).

4.REPLACE SOFT TOP CONTROL UNIT

Replace soft top control unit. Refer to [RF-235. "Removal and Installation"](#).

Is the inspection result normal?

YES >> INSPECTION END

NO >> GO TO 5.

5.CHECK INTERMITTENT INCIDENT

Refer to [GI-44. "Intermittent Incident"](#).

>> INSPECTION END

Component Inspection

INFOID:000000007625434

1.CHECK ROOF OPEN/CLOSE SWITCH

1. Turn ignition switch OFF.
2. Disconnect roof open/close switch harness connector.
3. Check the continuity between roof open/close switch terminals under the following conditions.

Terminal	Condition	Continuity
1 and 3	Open pressed	Existed
	Except above	Not existed
1 and 4	Close pressed	Existed
	Except above	Not existed

Is the inspection result normal?

YES >> INSPECTION END

NO >> Replace roof open/close switch. Refer to [RF-234. "Removal and Installation"](#).

B170F SENSOR POWER SUPPLY

< DTC/CIRCUIT DIAGNOSIS >

B170F SENSOR POWER SUPPLY

DTC Logic

INFOID:000000007625435

DTC DETECTION LOGIC

NOTE:

If two or more DTCs are detected, refer to [RF-39, "DTC Inspection Priority Chart"](#), and determine trouble diagnosis order.

DTC No.	Trouble diagnosis name		DTC detecting condition	Possible cause
B170F	SENSOR POWER SUPPLY	[GND-SHORT]	Sensor power supply circuit is open, short to ground or short to power.	<ul style="list-style-type: none"> • Harness or connectors (Roof striker sensor LH circuit is open or shorted.) (Roof striker sensor RH circuit is open or shorted.) (Roof latch lock sensor circuit is open or shorted.) (Roof latch lock sensor circuit is open or shorted.) (5th bow status sensor LH circuit is open or shorted.) (5th bow status sensor RH circuit is open or shorted.) (Roof status sensor LH circuit is open or shorted.) (Roof status sensor RH circuit is open or shorted.) (Strage lid status sensor LH circuit is open or shorted.) (Strage lid status sensor RH circuit is open or shorted.) (5th bow latch open sensor circuit is open or shorted.) (5th bow latch close sensor circuit is open or shorted.) (5th bow striker sensor circuit is open or shorted.) • Roof striker sensor LH • Roof striker sensor RH • Roof latch lock sensor • Hydraulic unit (5th bow status sensor LH, 5th bow status sensor RH, roof status sensor LH, roof status sensor RH, strage lid status sensor LH or strage lid status sensor RH) • 5th bow latch/striker sensor assembly (5th bow latch open sensor, 5th bow latch close sensor or 5th bow striker sensor) • Soft top control unit
		[PWR-SHORT/OPEN]		

DTC CONFIRMATION PROCEDURE

1. PERFORM DTC CONFIRMATION PROCEDURE

1. Start engine.
2. Operate soft top fully open and fully close.
3. Select "Self Diagnostic Result" mode of "CONVERTIBLE ROOF" using CONSULT.
4. Check DTC.

Is DTC detected?

- YES >> Go to [RF-71, "Diagnosis Procedure"](#).
 NO >> INSPECTION END

B170F SENSOR POWER SUPPLY

< DTC/CIRCUIT DIAGNOSIS >

Diagnosis Procedure

INFOID:000000007625436

1. CHECK SENSOR POWER SUPPLY CIRCUIT-I

1. Turn ignition switch OFF.
2. Disconnect roof striker sensor LH harness connector.
3. Turn ignition switch ON.
4. Check the voltage between roof striker sensor LH harness connector and ground.

(+)		(-)	Voltage (V) (Approx.)
Roof striker sensor LH			
Connector	Terminal	Ground	12
M262	2		

Is the inspection result normal?

- YES >> GO TO 3.
NO >> GO TO 2.

2. CHECK SENSOR POWER SUPPLY CIRCUIT-II

1. Disconnect following parts harness connector.
 - Roof striker sensor RH
 - Roof latch lock sensor
 - 5th bow status sensor LH
 - 5th bow status sensor RH
 - Roof status sensor LH
 - Roof status sensor RH
 - Strage lid status sensor LH
 - Strage lid status sensor RH
 - 5th bow latch/striker sensor assembly
 - Soft top control unit
2. Check the continuity between the following terminals.

Soft top control unit		Sensor			Continuity
Connector	Terminal	Name	Connector	Terminal	
B303	1	Roof striker sensor LH	M262	2	Existed
	21	Roof striker sensor RH	M261	1	
B306	75	Roof status sensor LH	B316	1	
		5th bow latch/striker sensor assembly	B319	1	
	93	Strage lid status sensor RH	B315	1	
		Roof status sensor RH	B317	1	
	94	Roof latch lock sensor	B310	1	
		5th bow status sensor LH	B312	1	
	95	5th bow status sensor RH	B313	1	
		Strage lid status sensor LH	B314	1	

3. Also check harness for short to ground and short to power.

Is the inspection result normal?

- YES >> GO TO 3.
NO >> Repair open circuit, short to ground or short to power in harness connectors.

3. REPLACE SOFT TOP CONTROL UNIT

Replace soft top control unit. Refer to [RF-235, "Removal and Installation"](#).

Is the inspection result normal?

- YES >> INSPECTION END
NO >> GO TO 4.

B170F SENSOR POWER SUPPLY

< DTC/CIRCUIT DIAGNOSIS >

4.CHECK INTERMITTENT INCIDENT

Refer to [GI-44, "Intermittent Incident"](#).

>> INSPECTION END

B171A HYDRAULIC PUMP (LH)

< DTC/CIRCUIT DIAGNOSIS >

B171A HYDRAULIC PUMP (LH)

DTC Logic

INFOID:000000007625437

DTC DETECTION LOGIC

NOTE:

If two or more DTCs are detected, refer to [RF-39, "DTC Inspection Priority Chart"](#), and determine trouble diagnosis order.

DTC No.	Trouble diagnosis name		DTC detecting condition	Possible causes
B171A	HYDRAULIC PMP(LH)	[GND-SHORT]	Hydraulic pump relay 1 or hydraulic pump motor circuit is open, short to ground or short to power.	<ul style="list-style-type: none"> • Harness or connectors (The hydraulic pump relay-1 circuit is open or shorted.) (The hydraulic pump motor circuit is open or shorted.) • Hydraulic unit (Hydraulic pump relay 1 or hydraulic pump motor) • Soft top control unit
		[PWR-SHORT/OPEN]		
		[GND-SHORT]		

DTC CONFIRMATION PROCEDURE

1. PERFORM DTC CONFIRMATION PROCEDURE

1. Start engine.
2. Operate soft top to fully open and fully close.
3. Select "Self Diagnostic Result" mode of "CONVERTIBLE ROOF" using CONSULT.
4. Check DTC.

Is DTC detected?

- YES >> Go to [RF-73, "Diagnosis Procedure"](#).
 NO >> INSPECTION END

Diagnosis Procedure

INFOID:000000007625438

1.CHECK FUSIBLE LINK

Check 40A fusible link (letter I).

Is the inspection result normal?

- YES >> GO TO 2.
 NO >> Replace fusible link after repairing the applicable circuit.

2.CHECK HYDRAULIC PUMP RELAY 1 POWER SUPPLY CIRCUIT-I

1. Turn ignition switch OFF.
2. Disconnect hydraulic unit harness connector.
3. Check the voltage between hydraulic unit harness connector and ground.

(+)		(-)	Voltage (V) (Approx)
Hydraulic unit			
Connector	Terminal		
B309	13	Ground	Battery voltage

Is the inspection result normal?

- YES >> GO TO 5.
 NO >> GO TO 3.

3.CHECK HYDRAULIC PUMP RELAY 1 POWER SUPPLY CIRCUIT-II

1. Disconnect circuit breaker harness connector.
2. Check the continuity between hydraulic unit harness connector and circuit breaker harness connector.

B171A HYDRAULIC PUMP (LH)

< DTC/CIRCUIT DIAGNOSIS >

Hydraulic unit		Circuit breaker		Continuity
Connector	Terminal	Connector	Terminal	
B309	13	M78	2	Existed

3. Also check harness for short to ground.

Is the inspection result normal?

YES >> GO TO 4.

NO >> Repair open circuit or short to ground in harness or connectors.

4.CHECK CIRCUIT BREAKER

Check circuit breaker. Refer to [RF-74, "Component Inspection"](#).

Is the inspection result normal?

YES >> Repair the harness or connector between circuit breaker and fusible link.

NO >> Replace circuit breaker.

5.CHECK CONTINUITY HYDRAULIC UNIT AND SOFT TOP CONTROL UNIT

1. Disconnect soft top control unit harness connector.

2. Check the continuity between hydraulic unit harness connector and soft top control unit harness connector.

Hydraulic unit		Soft top control unit		Continuity
Connector	Terminal	Connector	Terminal	
B308	12	B306	74	Existed
	7	B307	101	
	6		103	

3. Also check harness for short to ground and short to power.

Is the inspection result normal?

YES >> GO TO 6.

NO >> Repair open circuit, short to ground and short to power.

6.REPLACE HYDRAULIC UNIT

Replace hydraulic unit. Refer to [RF-226, "Removal and Installation"](#).

Is the inspection result normal?

YES >> INSPECTION END

NO >> GO TO 7.

7.REPLACE SOFT TOP CONTROL UNIT

Replace soft top control unit. Refer to [RF-235, "Removal and Installation"](#).

Is the inspection result normal?

YES >> INSPECTION END

NO >> GO TO 8.

8.CHECK INTERMITTENT INCIDENT

Refer to [GI-44, "Intermittent Incident"](#).

>> INSPECTION END

Component Inspection

INFOID:000000007625439

1.CHECK CIRCUIT BREAKER

1. Turn ignition switch OFF.

2. Disconnect circuit breaker harness connector.

3. Check resistance between circuit breaker terminals as follows.

B171A HYDRAULIC PUMP (LH)

< DTC/CIRCUIT DIAGNOSIS >

Terminals	Resistance (Ω)
1 and 2	Except 0 or ∞ [at 25°C (77°F)]

Is the inspection result normal?

YES >> INSPECTION END
NO >> Replace circuit breaker.

A

B

C

D

E

F

G

H

I

J

RF

L

M

N

O

P

B171B HYDRAULIC PUMP (RH)

< DTC/CIRCUIT DIAGNOSIS >

B171B HYDRAULIC PUMP (RH)

DTC Logic

INFOID:000000007625440

DTC DETECTION LOGIC

NOTE:

If two or more DTCs are detected, refer to [RF-39, "DTC Inspection Priority Chart"](#), and determine trouble diagnosis order.

DTC No.	Trouble diagnosis name		DTC detecting condition	Possible causes
B171B	HYDRAULIC PMP (RH)	[GND-SHORT]	Hydraulic pump relay 2 or hydraulic pump circuit is open, short to ground or short to power.	<ul style="list-style-type: none"> • Harness or connectors (The hydraulic pump relay-2 circuit is open or shorted.) (The hydraulic pump motor circuit is open or shorted.) • Hydraulic unit (Hydraulic pump relay 2 or hydraulic pump motor) • Soft top control unit
		[PWR-SHORT/OPEN]		
		[GND-SHORT]		

DTC CONFIRMATION PROCEDURE

1. PERFORM DTC CONFIRMATION PROCEDURE

1. Start engine.
2. Operate soft top to fully open and fully close.
3. Select "Self Diagnostic Result" mode of "CONVERTIBLE ROOF" using CONSULT.
4. Check DTC.

Is DTC detected?

- YES >> Go to [RF-76, "Diagnosis Procedure"](#).
 NO >> INSPECTION END

Diagnosis Procedure

INFOID:000000007625441

1. CHECK FUSIBLE LINK

Check 40A fusible link (letter I).

Is the inspection result normal?

- YES >> GO TO 2.
 NO >> Replace fusible link after repairing the applicable circuit.

2. CHECK HYDRAULIC PUMP RELAY 2 POWER SUPPLY CIRCUIT-I

1. Turn ignition switch OFF.
2. Disconnect hydraulic unit harness connector.
3. Check the voltage between hydraulic unit harness connector and ground.

(+)		(-)	Voltage (V) (Approx)
Hydraulic unit			
Connector	Terminal	Ground	Battery voltage
B309	13		

Is the inspection result normal?

- YES >> GO TO 5.
 NO >> GO TO 3.

3. CHECK HYDRAULIC PUMP RELAY 2 POWER SUPPLY CIRCUIT-II

1. Disconnect circuit breaker harness connector.
2. Check the continuity between hydraulic unit harness connector and circuit breaker harness connector.

B171B HYDRAULIC PUMP (RH)

< DTC/CIRCUIT DIAGNOSIS >

Hydraulic unit		Circuit breaker		Continuity
Connector	Terminal	Connector	Terminal	
B309	13	M78	2	Existed

3. Also check harness for short to ground.

Is the inspection result normal?

YES >> GO TO 4.

NO >> Repair open circuit or short to ground in harness or connectors.

4.CHECK CIRCUIT BREAKER

Check circuit breaker. Refer to [RF-77, "Component Inspection"](#).

Is the inspection result normal?

YES >> Repair the harness or connector between circuit breaker and fusible link.

NO >> Replace circuit breaker.

5.CHECK CONTINUITY HYDRAULIC UNIT AND SOFT TOP CONTROL UNIT

1. Disconnect soft top control unit harness connector.

2. Check the continuity between hydraulic unit harness connector and soft top control unit harness connector.

Hydraulic unit		Soft top control unit		Continuity
Connector	Terminal	Connector	Terminal	
B308	11	B306	73	Existed
	8	B307	100	
	6		103	

3. Also check harness for short to ground and short to power.

Is the inspection result normal?

YES >> GO TO 6.

NO >> Repair open circuit, short to ground and short to power.

6.REPLACE HYDRAULIC UNIT

Replace hydraulic unit. Refer to [RF-226, "Removal and Installation"](#).

Is the inspection result normal?

YES >> INSPECTION END

NO >> GO TO 7.

7.REPLACE SOFT TOP CONTROL UNIT

Replace soft top control unit. Refer to [RF-235, "Removal and Installation"](#).

Is the inspection result normal?

YES >> INSPECTION END

NO >> GO TO 8.

8.CHECK INTERMITTENT INCIDENT

Refer to [GI-44, "Intermittent Incident"](#).

>> INSPECTION END

Component Inspection

INFOID:000000007625442

1.CHECK CIRCUIT BREAKER

1. Turn ignition switch OFF.

2. Disconnect circuit breaker harness connector.

3. Check resistance between circuit breaker terminals as follows.

B171B HYDRAULIC PUMP (RH)

< DTC/CIRCUIT DIAGNOSIS >

Terminals	Resistance (Ω)
1 and 2	Except 0 or ∞ [at 25°C (77°F)]

Is the inspection result normal?

YES >> INSPECTION END

NO >> Replace circuit breaker.

B171C SWITCHING VALVE 1

< DTC/CIRCUIT DIAGNOSIS >

B171C SWITCHING VALVE 1

DTC Logic

INFOID:000000007625443

DTC DETECTION LOGIC

NOTE:

If two or more DTCs are detected, refer to [RF-39, "DTC Inspection Priority Chart"](#), and determine trouble diagnosis order.

DTC No.	Trouble diagnosis name		DTC detecting condition	Possible causes
B171C	SWITCHING VALVE 1	[GND-SHORT]	Switching valve 1 circuit is open, short to ground or short to power.	<ul style="list-style-type: none"> • Harness or connectors (The switching valve 1 circuit is open or shorted.) • Hydraulic unit (switching valve 1) • Soft top control unit
		[PWR-SHORT/OPEN]		

DTC CONFIRMATION PROCEDURE

1. PERFORM DTC CONFIRMATION PROCEDURE

1. Start engine.
2. Operate soft top to fully open and fully close.
3. Select "Self Diagnostic Result" mode of "CONVERTIBLE ROOF" using CONSULT.
4. Check DTC.

Is DTC detected?

- YES >> Go to [RF-79, "Diagnosis Procedure"](#).
 NO >> INSPECTION END

Diagnosis Procedure

INFOID:000000007625444

1. CHECK SWITCHING VALVE 1 POWER SUPPLY CIRCUIT

1. Turn ignition switch OFF.
2. Disconnect hydraulic unit and soft top control unit harness connector.
3. Check the continuity between hydraulic unit harness connector and soft top control unit harness connector.

Hydraulic unit		Soft top control unit		Continuity
Connector	Terminal	Connector	Terminal	
B308	1	B307	99	Existed

4. Also check harness for short to ground and short to power.

Is the inspection result normal?

- YES >> GO TO 2.
 NO >> Repair open circuit or short to ground or short to power in harness or connectors.

2. CHECK SWITCHING VALVE 1 GROUND CIRCUIT

1. Check the continuity between hydraulic unit harness connector and soft top control unit harness connector.

Hydraulic unit		Soft top control unit		Continuity
Connector	Terminal	Connector	Terminal	
B308	6	B307	103	Existed

2. Also check harness for short to power.

Is the inspection result normal?

- YES >> GO TO 3.
 NO >> Repair open circuit or short to power in harness or connectors.

B171C SWITCHING VALVE 1

< DTC/CIRCUIT DIAGNOSIS >

3.REPLACE HYDRAULIC UNIT

Replace hydraulic unit. Refer to [RF-226. "Removal and Installation"](#).

Is the inspection result normal?

YES >> INSPECTION END

NO >> GO TO 4.

4.REPLACE SOFT TOP CONTROL UNIT

Replace soft top control unit. Refer to [RF-235. "Removal and Installation"](#).

Is the inspection result normal?

YES >> INSPECTION END

NO >> GO TO 5.

5.CHECK INTERMITTENT INCIDENT

Refer to [GI-44. "Intermittent Incident"](#).

>> INSPECTION END

B171D SWITCHING VALVE 2

< DTC/CIRCUIT DIAGNOSIS >

B171D SWITCHING VALVE 2

DTC Logic

INFOID:000000007625445

DTC DETECTION LOGIC

NOTE:

If two or more DTCs are detected, refer to [RF-39, "DTC Inspection Priority Chart"](#), and determine trouble diagnosis order.

DTC No.	Trouble diagnosis name		DTC detecting condition	Possible causes
B171D	SWITCHING VALVE 2	[GND-SHORT]	Switching valve 2 circuit is open, short to ground or short to power.	<ul style="list-style-type: none"> • Harness or connectors (The switching valve 2 circuit is open or shorted.) • Hydraulic unit (Switching valve 2) • Soft top control unit
		[PWR-SHORT/OPEN]		

DTC CONFIRMATION PROCEDURE

1. PERFORM DTC CONFIRMATION PROCEDURE

1. Start engine.
2. Operate soft top to fully open and fully close.
3. Select "Self Diagnostic Result" mode of "CONVERTIBLE ROOF" using CONSULT.
4. Check DTC.

Is DTC detected?

- YES >> Go to [RF-79, "Diagnosis Procedure"](#).
 NO >> INSPECTION END

Diagnosis Procedure

INFOID:000000007625446

1. CHECK SWITCHING VALVE 2 POWER SUPPLY CIRCUIT

1. Turn ignition switch OFF.
2. Disconnect hydraulic unit and soft top control unit harness connector.
3. Check the continuity between hydraulic unit harness connector and soft top control unit harness connector.

Hydraulic unit		Soft top control unit		Continuity
Connector	Terminal	Connector	Terminal	
B308	2	B307	98	Existed

4. Also check harness for short to ground and short to power.

Is the inspection result normal?

- YES >> GO TO 2.
 NO >> Repair open circuit or short to ground or short to power in harness or connectors.

2. CHECK SWITCHING VALVE 2 GROUND CIRCUIT

1. Check the continuity between hydraulic unit harness connector and soft top control unit harness connector.

Hydraulic unit		Soft top control unit		Continuity
Connector	Terminal	Connector	Terminal	
B308	6	B307	103	Existed

2. Also check harness for short to power.

Is the inspection result normal?

- YES >> GO TO 3.
 NO >> Repair open circuit or short to power in harness or connectors.

B171D SWITCHING VALVE 2

< DTC/CIRCUIT DIAGNOSIS >

3.REPLACE HYDRAULIC UNIT

Replace hydraulic unit. Refer to [RF-226. "Removal and Installation"](#).

Is the inspection result normal?

YES >> INSPECTION END

NO >> GO TO 4.

4.REPLACE SOFT TOP CONTROL UNIT

Replace soft top control unit. Refer to [RF-235. "Removal and Installation"](#).

Is the inspection result normal?

YES >> INSPECTION END

NO >> GO TO 5.

5.CHECK INTERMITTENT INCIDENT

Refer to [GI-44. "Intermittent Incident"](#).

>> INSPECTION END

B172C ROOF STATUS SIGNAL (TRUNK)

< DTC/CIRCUIT DIAGNOSIS >

B172C ROOF STATUS SIGNAL (TRUNK)

Description

INFOID:000000007625447

- Soft top control unit transmits roof position signal to BOSE amp. and tel adapter unit (Without NAVI).
- BOSE amp. uses this signal for sound equalizer automatic switching function. Refer to [AV-40, "System Description"](#) (BOSE audio without navigation) or [AV-131, "MULTI AV SYSTEM : System Description"](#) (BOSE audio with navigation).
- Tel adapter unit (Without NAVI) uses this signal for voice recognition function. Refer to [AV-51, "Diagnosis Description"](#).

DTC Logic

INFOID:000000007625448

DTC DETECTION LOGIC

NOTE:

If two or more DTCs are detected, refer to [RF-39, "DTC Inspection Priority Chart"](#), and determine trouble diagnosis order.

DTC No.	Trouble diagnosis name		DTC detecting condition	Possible cause
B172C	ROOF STATE SIG(TRUNK)	[PWR-SHORT]	BOSE amp. or tel adapter unit (Without NAVI) circuit is short to power.	<ul style="list-style-type: none"> • Harness or connectors (The BOSE amp. or tel adapter unit circuit is shorted) • BOSE amp. • Tel adapter unit (Without NAVI) • Soft top control unit

DTC CONFIRMATION PROCEDURE

1. PERFORM DTC CONFIRMATION PROCEDURE

1. Start engine.
2. Operate soft top to fully open and fully close.
3. Select "Self Diagnostic Result" mode of "CONVERTIBLE ROOF" using CONSULT.
4. Check DTC.

Is DTC detected?

- YES >> Go to [RF-79, "Diagnosis Procedure"](#).
 NO >> INSPECTION END

Diagnosis Procedure

INFOID:000000007625449

1. CHECK ROOF POSITION SIGNAL CIRCUIT-I

1. Turn ignition switch OFF.
2. Disconnect soft top control unit harness connector.
3. Turn ignition switch ON.
4. Check voltage between soft top control unit harness connector and ground.

Soft top control unit		(-)	Voltage (V) (Approx.)
Connector	Terminal		
B303	12	Ground	9.5 V

Is the inspection result normal?

- YES >> GO TO 5.
 NO >> GO TO 2.

2. CHECK ROOF POSITION SIGNAL CIRCUIT-II

1. Turn ignition switch OFF.
2. Disconnect BOSE amp. and tel adapter unit (Without NAVI) harness connector.
3. Check continuity between soft top control unit harness connector and battery.

B172C ROOF STATUS SIGNAL (TRUNK)

< DTC/CIRCUIT DIAGNOSIS >

Soft top control unit		—	Continuity
Connector	Terminal		
B303	12	Battery	Not existed

Is the inspection result normal?

YES >> GO TO 3.

NO >> Repair short to power in harness or connectors.

3.CHECK BOSE AMP.

Check BOSE amp. Refer to [AV-37. "Work Flow"](#) (BOSE audio without navigation) or [AV-173. "Work Flow"](#) (BOSE audio with navigation).

Is the inspection result normal?

YES-I >> BOSE audio without navigation: GO TO 4.

YES-II >> BOSE audio with navigation: GO TO 6.

NO >> Replace BOSE amp. Refer to [AV-113. "ROADSTER : Removal and Installation"](#) (BOSE audio without navigation) or [AV-248. "ROADSTER : Removal and Installation"](#) (BOSE audio with navigation).

4.CHECK TEL ADAPTER UNIT

Check tel adapter unit. Refer to [AV-37. "Work Flow"](#).

Is the inspection result normal?

YES >> GO TO 6.

NO >> Replace tel adapter unit. Refer to [AV-119. "Removal and Installation"](#).

5.REPLACE SOFT TOP CONTROL UNIT

Replace soft top control unit. Refer to [RF-235. "Removal and Installation"](#).

Is the inspection result normal?

YES >> INSPECTION END

NO >> GO TO 6.

6.CHECK INTERMITTENT INCIDENT

Refer to [GI-44. "Intermittent Incident"](#).

>> INSPECTION END

B1731 HYDRAULIC STATE 1

< DTC/CIRCUIT DIAGNOSIS >

B1731 HYDRAULIC STATE 1

DTC Logic

INFOID:000000007625450

DTC DETECTION LOGIC

NOTE:

If two or more DTCs are detected, refer to [RF-39, "DTC Inspection Priority Chart"](#), and determine trouble diagnosis order.

DTC No.	Trouble diagnosis name		DTC detecting condition	Possible cause
B1731	HYDRAULIC STATE 1	[TIMEOUT]	When soft top operation is not detected after 15 seconds or more of operation.	Soft top system component

DTC CONFIRMATION PROCEDURE

1. PERFORM DTC CONFIRMATION PROCEDURE

1. Start engine.
2. Operate soft top to fully open and fully close.
3. Select "Self Diagnostic Result" mode of "CONVERTIBLE ROOF" using CONSULT.
4. Check DTC.

Is DTC detected?

- YES >> Go to [RF-85, "Diagnosis Procedure"](#).
NO >> INSPECTION END

Diagnosis Procedure

INFOID:000000007625451

1. CHECK SOFT TOP SYSTEM COMPONENT-I

Check that no foreign material is pinched by soft top system component.

Is the inspection result normal?

- YES >> GO TO 2.
NO >> Remove foreign material from soft top system.

2. CHECK SOFT TOP SYSTEM COMPONENT-II

Check that soft top system component is installed normally and is not damaged.

Is the inspection result normal?

- YES >> INSPECTION END
NO >> Repair or replace malfunctioning part.

B1758 THERMO PROTECTION

< DTC/CIRCUIT DIAGNOSIS >

B1758 THERMO PROTECTION

DTC Logic

INFOID:000000007625452

DTC DETECTION LOGIC

NOTE:

If two or more DTCs are detected, refer to [RF-39, "DTC Inspection Priority Chart"](#), and determine trouble diagnosis order.

DTC No.	Trouble diagnosis name		DTC detecting condition	Possible cause
B1758	THERMO PROTECTION	[ACTIVE]	Thermo protection is active. (Thermo protection: Refer to RF-20, "SOFT TOP SYSTEM : System Protect Control")	<ul style="list-style-type: none">Soft top system is operated continuouslySoft top control unit

DTC CONFIRMATION PROCEDURE

1.COOL DOWN HYDRAULIC SYSTEM

Turn ignition switch OFF and wait at least 5 minutes.

>> GO TO 2.

2.PERFORM DTC CONFIRMATION PROCEDURE

- Turn ignition switch ON.
- Select "Self Diagnostic Result" mode of "CONVERTIBLE ROOF" using CONSULT.
- Check DTC.

Is DTC detected?

- YES >> Go to [RF-86, "Diagnosis Procedure"](#).
NO >> INSPECTION END

Diagnosis Procedure

INFOID:000000007625453

1.REPLACE SOFT TOP CONTROL UNIT

- Turn ignition switch OFF.
- Replace soft top control unit. Refer to [RF-235, "Removal and Installation"](#).

>> INSPECTION END

B175C POWER SOURCE (ROOF)

< DTC/CIRCUIT DIAGNOSIS >

B175C POWER SOURCE (ROOF)

Description

INFOID:000000007625454

Power supply (roof) voltage for soft top control unit is monitored. Soft top system operation is inhibited when voltage outside the specified value is detected.

DTC Logic

INFOID:000000007625455

DTC DETECTION LOGIC

NOTE:

If two or more DTCs are detected, refer to [RF-39, "DTC Inspection Priority Chart"](#), and determine trouble diagnosis order.

DTC No.	Trouble diagnosis name		DTC detecting condition	Possible causes
B175C	PWR SOURCE(ROOF)	[LOW VOLTAGE]	10.5 V or less input to soft top control unit power source (roof) terminal is detected.	<ul style="list-style-type: none">• Power source circuit• Battery condition• Charging system

DTC CONFIRMATION PROCEDURE

1. PERFORM DTC CONFIRMATION PROCEDURE

1. Start engine.
2. Operate soft top to fully open and close.
3. Select "Self Diagnostic Result" mode of "CONVERTIBLE ROOF" using CONSULT.
4. Check DTC.

Is DTC detected?

- YES >> Go to [RF-86, "Diagnosis Procedure"](#).
NO >> INSPECTION END

Diagnosis Procedure

INFOID:000000007625456

1. CHECK CHARGING SYSTEM

Check charging system. Refer to [CHG-3, "Work Flow"](#).

Is the inspection result normal?

- YES >> GO TO 2.
NO >> Repair or replace malfunction parts.

2. CHECK POWER SUPPLY AND GROUND CIRCUIT

Check power supply and ground circuit for soft top control unit. Refer to [RF-138, "Diagnosis Procedure"](#).

Is the inspection result normal?

- YES >> Check intermittent incident. Refer to [GI-44, "Intermittent Incident"](#).
NO >> Repair or replace malfunction parts.

B175D POWER SOURCE (ROOF)

< DTC/CIRCUIT DIAGNOSIS >

B175D POWER SOURCE (ROOF)

Description

INFOID:000000007625457

Power supply (roof) voltage for soft top control unit is monitored. Soft top system operation is inhibited when voltage outside the specified value is detected.

DTC Logic

INFOID:000000007625458

DTC DETECTION LOGIC

NOTE:

If two or more DTCs are detected, refer to [RF-39, "DTC Inspection Priority Chart"](#), and determine trouble diagnosis order.

DTC No.	Trouble diagnosis name		DTC detecting condition	Possible causes
B175D	PWR SOURCE(ROOF)	[HIGH VOLTAGE]	16.0 V or more input to soft top control unit power source (roof) terminal is detected.	<ul style="list-style-type: none">• Power source circuit• Battery condition• Charging system

DTC CONFIRMATION PROCEDURE

1. PERFORM DTC CONFIRMATION PROCEDURE

1. Start engine.
2. Operate soft top to fully open and fully close.
3. Select "Self Diagnostic Result" mode of "CONVERTIBLE ROOF" using CONSULT.
4. Check DTC.

Is DTC detected?

- YES >> Go to [RF-86, "Diagnosis Procedure"](#).
NO >> INSPECTION END

Diagnosis Procedure

INFOID:000000007625459

1. CHECK CHARGING SYSTEM

Check charging system. Refer to [CHG-3, "Work Flow"](#).

Is the inspection result normal?

- YES >> GO TO 2.
NO >> Repair or replace malfunction parts.

2. CHECK POWER SUPPLY AND GROUND CIRCUIT

Check power supply and ground circuit for soft top control unit. Refer to [RF-138, "Diagnosis Procedure"](#).

Is the inspection result normal?

- YES >> Check intermittent incident. Refer to [GI-44, "Intermittent Incident"](#).
NO >> Repair or replace malfunction parts.

B175E POWER SOURCE (POWER WINDOW)

< DTC/CIRCUIT DIAGNOSIS >

B175E POWER SOURCE (POWER WINDOW)

Description

INFOID:000000007625460

Soft top control unit watches power supply condition of power supply (power window) terminal.

DTC Logic

INFOID:000000007625461

DTC DETECTION LOGIC

NOTE:

If two or more DTCs are detected, refer to [RF-39, "DTC Inspection Priority Chart"](#), and determine trouble diagnosis order.

DTC No.	Trouble diagnosis name		DTC detecting condition	Possible causes
B175E	PWR SOURCE(WINDOW)	[LOW VOLTAGE]	9.0 V or less input to soft top control unit power source (power window) terminal is detected.	<ul style="list-style-type: none"> Power source circuit (for power window) Battery condition Charging system BCM power supply and ground

DTC CONFIRMATION PROCEDURE

1.PERFORM DTC CONFIRMATION PROCEDURE

1. Start engine.
2. Operate soft top to fully open and fully close.
3. Select "Self Diagnostic Result" mode of "CONVERTIBLE ROOF" using CONSULT.
4. Check DTC.

Is DTC detected?

- YES >> Go to [RF-86, "Diagnosis Procedure"](#).
 NO >> INSPECTION END

Diagnosis Procedure

INFOID:000000007625462

1.CHECK BCM POWER SUPPLY AND GROUND CIRCUIT

Check BCM power supply and ground circuit. Refer to [BCS-50, "Diagnosis Procedure"](#).

Is the inspection result normal?

- YES >> GO TO 2.
 NO >> Repair or replace malfunctioning part.

2.CHECK VOLTAGE POWER WINDOW POWER SUPPLY CIRCUIT

1. Turn ignition switch OFF.
2. Disconnect soft top control unit connector.
3. Check voltage between soft top control unit harness connector and ground.

(+)		(-)	Voltage (V) (Approx.)
Soft top control unit			
Connector	Terminal		
B303	9	Ground	Battery voltage

Is the inspection result normal?

- YES >> GO TO 4.
 NO >> GO TO 3.

3.CHECK CONTINUITY POWER WINDOW POWER SUPPLY CIRCUIT

1. Disconnect BCM connector.
2. Check continuity between BCM harness connector and soft top control unit harness connector.

B175E POWER SOURCE (POWER WINDOW)

< DTC/CIRCUIT DIAGNOSIS >

BCM		Soft top control unit		Continuity
Connector	Terminal	Connector	Terminal	
M118	2	B303	9	Existed

3. Also check harness for short to ground and short to power.

Is the inspection result normal?

YES >> Replace BCM. Refer to [BCS-92. "Removal and Installation"](#).

NO >> Repair open circuit, short to ground or short to power in harness or connectors.

4. CHECK INTERMITTENT INCIDENT

Refer to [GI-44. "Intermittent Incident"](#).

>> INSPECTION END

B175F POWER SOURCE (POWER WINDOW)

< DTC/CIRCUIT DIAGNOSIS >

B175F POWER SOURCE (POWER WINDOW)

Description

INFOID:000000007625463

Soft top control unit watches power supply condition of power supply (power window) terminal.

DTC Logic

INFOID:000000007625464

DTC DETECTION LOGIC

NOTE:

If two or more DTCs are detected, refer to [RF-39, "DTC Inspection Priority Chart"](#), and determine trouble diagnosis order.

DTC No.	Trouble diagnosis name		DTC detecting condition	Possible causes
B175F	PWR SOURCE(WINDOW)	[HIGH VOLTAGE]	16.0 V or more input to soft top control unit power source (power window) terminal is detected.	<ul style="list-style-type: none"> Power source circuit (for power window) Battery condition Charging system BCM power supply and ground

DTC CONFIRMATION PROCEDURE

1. PERFORM DTC CONFIRMATION PROCEDURE

- Start engine.
- Operate soft top fully open and fully close.
- Select "Self Diagnostic Result" mode of "CONVERTIBLE ROOF" using CONSULT.
- Check DTC.

Is DTC detected?

- YES >> Go to [RF-91, "Diagnosis Procedure"](#).
 NO >> INSPECTION END

Diagnosis Procedure

INFOID:000000007625465

1. CHECK BCM POWER SUPPLY AND GROUND CIRCUIT

Check BCM power supply and ground circuit. Refer to [BCS-50, "Diagnosis Procedure"](#).

Is the inspection result normal?

- YES >> GO TO 2.
 NO >> Repair or replace malfunctioning part.

2. CHECK VOLTAGE POWER WINDOW POWER SUPPLY CIRCUIT

- Turn ignition switch OFF.
- Disconnect soft top control unit connector.
- Turn ignition switch ON.
- Check voltage between soft top control unit harness connector and ground.

(+)		(-)	Voltage (V) (Approx.)
Soft top control unit			
Connector	Terminal		
B303	9	Ground	Battery voltage

Is the inspection result normal?

- YES >> GO TO 4.
 NO >> GO TO 3.

3. CHECK CONTINUITY POWER WINDOW POWER SUPPLY CIRCUIT

- Turn ignition switch OFF.
- Disconnect BCM connector.
- Check continuity between BCM harness connector and soft top control unit harness connector.

B175F POWER SOURCE (POWER WINDOW)

< DTC/CIRCUIT DIAGNOSIS >

BCM		Soft top control unit		Continuity
Connector	Terminal	Connector	Terminal	
M118	2	B303	9	Existed

4. Also check harness for short to ground and short to power.

Is the inspection result normal?

YES >> Replace BCM. Refer to [BCS-92. "Removal and Installation"](#).

NO >> Repair open circuit, short to ground or short to power in harness or connectors.

4. CHECK INTERMITTENT INCIDENT

Refer to [GI-44. "Intermittent Incident"](#).

>> INSPECTION END

B1766 SWITCHING VALVE 3

< DTC/CIRCUIT DIAGNOSIS >

B1766 SWITCHING VALVE 3

DTC Logic

INFOID:000000007625466

DTC DETECTION LOGIC

NOTE:

If two or more DTCs are detected, refer to [RF-39, "DTC Inspection Priority Chart"](#), and determine trouble diagnosis order.

DTC No.	Trouble diagnosis name		DTC detecting condition	Possible causes
B1766	SWITCHING VALVE 3	[GND-SHORT]	Switching valve 3 circuit is open, short to ground or short to power.	<ul style="list-style-type: none"> • Harness or connectors (The switching valve 3 circuit is open or shorted.) • Hydraulic unit (Switching valve 3) • Soft top control unit
		[PWR-SHORT/OPEN]		

DTC CONFIRMATION PROCEDURE

1. PERFORM DTC CONFIRMATION PROCEDURE

1. Start engine.
2. Operate soft top to fully open and fully close.
3. Select "Self Diagnostic Result" mode of "CONVERTIBLE ROOF" using CONSULT.
4. Check DTC.

Is DTC detected?

- YES >> Go to [RF-97, "Diagnosis Procedure"](#).
 NO >> INSPECTION END

Diagnosis Procedure

INFOID:000000007625467

1. CHECK SWITCHING VALVE 3 POWER SUPPLY CIRCUIT

1. Turn ignition switch OFF.
2. Disconnect hydraulic unit and soft top control unit harness connector.
3. Check the continuity between hydraulic unit harness connector and soft top control unit harness connector.

Hydraulic unit		Soft top control unit		Continuity
Connector	Terminal	Connector	Terminal	
B308	3	B307	97	Existed

4. Also check harness for short to ground and short to power.

Is the inspection result normal?

- YES >> GO TO 2.
 NO >> Repair open circuit or short to ground or short to power in harness or connectors.

2. CHECK SWITCHING VALVE 3 GROUND CIRCUIT

1. Check the continuity between hydraulic unit harness connector and soft top control unit harness connector.

Hydraulic unit		Soft top control unit		Continuity
Connector	Terminal	Connector	Terminal	
B308	6	B307	103	Existed

2. Also check harness for short to power.

Is the inspection result normal?

- YES >> GO TO 3.
 NO >> Repair open circuit or short to power in harness or connectors.

B1766 SWITCHING VALVE 3

< DTC/CIRCUIT DIAGNOSIS >

3.REPLACE HYDRAULIC UNIT

Replace hydraulic unit. Refer to [RF-226. "Removal and Installation"](#).

Is the inspection result normal?

YES >> INSPECTION END

NO >> GO TO 4.

4.REPLACE SOFT TOP CONTROL UNIT

Replace soft top control unit. Refer to [RF-235. "Removal and Installation"](#).

Is the inspection result normal?

YES >> INSPECTION END

NO >> GO TO 5.

5.CHECK INTERMITTENT INCIDENT

Refer to [GI-44. "Intermittent Incident"](#).

>> INSPECTION END

B1767 SWITCHING VALVE 4

< DTC/CIRCUIT DIAGNOSIS >

B1767 SWITCHING VALVE 4

DTC Logic

INFOID:000000007625468

DTC DETECTION LOGIC

NOTE:

If two or more DTCs are detected, refer to [RF-39, "DTC Inspection Priority Chart"](#), and determine trouble diagnosis order.

DTC No.	Trouble diagnosis name		DTC detecting condition	Possible causes
B1767	SWITCHING VALVE 4	[GND-SHORT]	Switching valve 4 circuit is open, short to ground or short to power.	<ul style="list-style-type: none"> • Harness or connectors (The switching valve 4 circuit is open or shorted.) • Hydraulic unit (Switching valve 4) • Soft top control unit
		[PWR-SHORT/OPEN]		

DTC CONFIRMATION PROCEDURE

1. PERFORM DTC CONFIRMATION PROCEDURE

1. Start engine.
2. Operate soft top to fully open and fully close.
3. Select "Self Diagnostic Result" mode of "CONVERTIBLE ROOF" using CONSULT.
4. Check DTC.

Is DTC detected?

- YES >> Go to [RF-97, "Diagnosis Procedure"](#).
 NO >> INSPECTION END

Diagnosis Procedure

INFOID:000000007625469

1. CHECK SWITCHING VALVE 4 POWER SUPPLY CIRCUIT

1. Turn ignition switch OFF.
2. Disconnect hydraulic unit and soft top control unit harness connector.
3. Check the continuity between hydraulic unit harness connector and soft top control unit harness connector.

Hydraulic unit		Soft top control unit		Continuity
Connector	Terminal	Connector	Terminal	
B308	4	B307	96	Existed

4. Also check harness for short to ground and short to power.

Is the inspection result normal?

- YES >> GO TO 2.
 NO >> Repair open circuit or short to ground or short to power in harness or connectors.

2. CHECK SWITCHING VALVE 4 GROUND CIRCUIT

1. Check the continuity between hydraulic unit harness connector and soft top control unit harness connector.

Hydraulic unit		Soft top control unit		Continuity
Connector	Terminal	Connector	Terminal	
B308	6	B307	103	Existed

2. Also check harness for short to power.

Is the inspection result normal?

- YES >> GO TO 3.
 NO >> Repair open circuit or short to power in harness or connectors.

B1767 SWITCHING VALVE 4

< DTC/CIRCUIT DIAGNOSIS >

3.REPLACE HYDRAULIC UNIT

Replace hydraulic unit. Refer to [RF-226. "Removal and Installation"](#).

Is the inspection result normal?

YES >> INSPECTION END

NO >> GO TO 4.

4.REPLACE SOFT TOP CONTROL UNIT

Replace soft top control unit. Refer to [RF-235. "Removal and Installation"](#).

Is the inspection result normal?

YES >> INSPECTION END

NO >> GO TO 5.

5.CHECK INTERMITTENT INCIDENT

Refer to [GI-44. "Intermittent Incident"](#).

>> INSPECTION END

B1768 SWITCHING VALVE 5

< DTC/CIRCUIT DIAGNOSIS >

B1768 SWITCHING VALVE 5

DTC Logic

INFOID:000000007625470

DTC DETECTION LOGIC

NOTE:

If two or more DTCs are detected, refer to [RF-39, "DTC Inspection Priority Chart"](#), and determine trouble diagnosis order.

DTC No.	Trouble diagnosis name		DTC detecting condition	Possible causes
B1768	SWITCHING VALVE 5	[GND-SHORT]	Switching valve 5 circuit is open, short to ground or short to power.	<ul style="list-style-type: none"> • Harness or connectors (The switching valve 5 circuit is open or shorted.) • Hydraulic unit (Switching valve 5) • Soft top control unit
		[PWR-SHORT/OPEN]		

DTC CONFIRMATION PROCEDURE

1. PERFORM DTC CONFIRMATION PROCEDURE

1. Start engine.
2. Operate soft top to fully open and fully close.
3. Select "Self Diagnostic Result" mode of "CONVERTIBLE ROOF" using CONSULT.
4. Check DTC.

Is DTC detected?

- YES >> Go to [RF-97, "Diagnosis Procedure"](#).
 NO >> INSPECTION END

Diagnosis Procedure

INFOID:000000007625471

1. CHECK SWITCHING VALVE 5 POWER SUPPLY CIRCUIT

1. Turn ignition switch OFF.
2. Disconnect hydraulic unit and soft top control unit harness connector.
3. Check the continuity between hydraulic unit harness connector and soft top control unit harness connector.

Hydraulic unit		Soft top control unit		Continuity
Connector	Terminal	Connector	Terminal	
B308	5	B307	102	Existed

4. Also check harness for short to ground and short to power.

Is the inspection result normal?

- YES >> GO TO 2.
 NO >> Repair open circuit or short to ground or short to power in harness or connectors.

2. CHECK SWITCHING VALVE 5 GROUND CIRCUIT

1. Check the continuity between hydraulic unit harness connector and soft top control unit harness connector.

Hydraulic unit		Soft top control unit		Continuity
Connector	Terminal	Connector	Terminal	
B308	6	B307	103	Existed

2. Also check harness for short to power.

Is the inspection result normal?

- YES >> GO TO 3.
 NO >> Repair open circuit or short to power in harness or connectors.

B1768 SWITCHING VALVE 5

< DTC/CIRCUIT DIAGNOSIS >

3.REPLACE HYDRAULIC UNIT

Replace hydraulic unit. Refer to [RF-226. "Removal and Installation"](#).

Is the inspection result normal?

YES >> INSPECTION END

NO >> GO TO 4.

4.REPLACE SOFT TOP CONTROL UNIT

Replace soft top control unit. Refer to [RF-235. "Removal and Installation"](#).

Is the inspection result normal?

YES >> INSPECTION END

NO >> GO TO 5.

5.CHECK INTERMITTENT INCIDENT

Refer to [GI-44. "Intermittent Incident"](#).

>> INSPECTION END

B176A THERMO PROTECTION

< DTC/CIRCUIT DIAGNOSIS >

B176A THERMO PROTECTION

DTC Logic

INFOID:000000007625472

DTC DETECTION LOGIC

NOTE:

If two or more DTCs are detected, refer to [RF-39, "DTC Inspection Priority Chart"](#), and determine trouble diagnosis order.

DTC No.	Trouble diagnosis name		DTC detecting condition	Possible cause
B176A	THERMO PROTECTION	[ACTIVE]	Thermo protection is active. (Thermo protection: Refer to RF-20, "SOFT TOP SYSTEM : System Protect Control")	Soft top control unit

DTC CONFIRMATION PROCEDURE

1. PERFORM DTC CONFIRMATION PROCEDURE

1. Move the vehicle to a location where ambient temperature is 0°C or more and wait for a period of time.
2. Turn ignition switch ON.
3. Select "Self Diagnostic Result" mode of "CONVERTIBLE ROOF" using CONSULT.
4. Check DTC.

Is DTC detected?

- YES >> Go to [RF-131, "Diagnosis Procedure"](#).
NO >> INSPECTION END

Diagnosis Procedure

INFOID:000000007625473

1. REPLACE SOFT TOP CONTROL UNIT

1. Turn ignition switch OFF.
2. Replace soft top control unit. Refer to [RF-235, "Removal and Installation"](#).

>> INSPECTION END

A
B
C
D
E
F
G
H
I
J
L
M
N
O
P

RF

B176B ROOF WARNING LAMP

< DTC/CIRCUIT DIAGNOSIS >

B176B ROOF WARNING LAMP

DTC Logic

INFOID:000000007625474

DTC DETECTION LOGIC

NOTE:

If two or more DTCs are detected, refer to [RF-39, "DTC Inspection Priority Chart"](#), and determine trouble diagnosis order.

DTC No.	Trouble diagnosis name	DTC detecting condition	Possible cause
B176B	ROOF WARNING LAMP	Roof warning lamp circuit is short to battery.	<ul style="list-style-type: none">• Harness or connectors (The roof warning lamp circuit is shorted.)• Combination meter• Soft top control unit

DTC CONFIRMATION PROCEDURE

1.PERFORM DTC CONFIRMATION PROCEDURE

1. Start engine.
2. Operate soft top to fully open and fully close.
3. Select "Self Diagnostic Result" mode of "CONVERTIBLE ROOF" using CONSULT.
4. Check DTC.

Is DTC detected?

- YES >> Go to [RF-100, "Diagnosis Procedure"](#).
NO >> INSPECTION END

Diagnosis Procedure

INFOID:000000007625475

1.CHECK ROOF WARNING LAMP CIRCUIT

1. Turn ignition switch OFF.
2. Disconnect soft top control unit harness connector and combination meter harness connector.
3. Check continuity between soft top control unit harness connector and battery.

Soft top control unit		—	Continuity
Connector	Terminal		
B303	11	Battery	Not existed

Is the inspection result normal?

- YES >> GO TO 2.
NO >> Repair short to power in harness or connectors.

2.REPLACE COMBINATION METER

Replace combination meter. Refer to [MWI-92, "Removal and Installation"](#).

Is the inspection result normal?

- YES >> INSPECTION END
NO >> GO TO 3.

3.REPLACE SOFT TOP CONTROL UNIT

Replace soft top control unit. Refer to [RF-235, "Removal and Installation"](#).

Is the inspection result normal?

- YES >> INSPECTION END
NO >> GO TO 4.

4.CHECK INTERMITTENT INCIDENT

Refer to [GI-44, "Intermittent Incident"](#).

B176B ROOF WARNING LAMP

< DTC/CIRCUIT DIAGNOSIS >

>> INSPECTION END

A

B

C

D

E

F

G

H

I

J

RF

L

M

N

O

P

B176C STRIKER SENSOR (RH)

< DTC/CIRCUIT DIAGNOSIS >

B176C STRIKER SENSOR (RH)

DTC Logic

INFOID:000000007625476

DTC DETECTION LOGIC

NOTE:

If two or more DTCs are detected, refer to [RF-39, "DTC Inspection Priority Chart"](#), and determine trouble diagnosis order.

DTC No.	Trouble diagnosis name		DTC detecting condition	Possible cause
B176C	STRIKER SENSOR RH	[GND-SHORT]	Roof striker sensor RH circuit is open, short to ground or short to power.	<ul style="list-style-type: none">• Harness or connectors (The sensor circuit is open or shorted.)• Soft top control unit• Roof striker sensor RH
		[PWR-SHORT/OPEN]		
		[OPEN]		

DTC CONFIRMATION PROCEDURE

1. PERFORM DTC CONFIRMATION PROCEDURE

1. Start engine.
2. Operate soft top to fully open and fully close.
3. Select "Self Diagnostic Result" mode of "CONVERTIBLE ROOF" using CONSULT.
4. Check DTC.

Is DTC detected?

- YES >> Go to [RF-102, "Diagnosis Procedure"](#).
NO >> INSPECTION END

Diagnosis Procedure

INFOID:000000007625477

1. CHECK ROOF STRIKER SENSOR RH CIRCUIT

1. Turn ignition switch OFF.
2. Disconnect roof striker sensor RH and soft top control unit harness connector.
3. Check the continuity between roof striker sensor RH harness connector and soft top control unit harness connector.

Roof striker sensor RH		Soft top control unit		Continuity
Connector	Terminal	Connector	Terminal	
M261	3	B303	3	Existed

4. Also check harness for short to ground and short to power.

Is the inspection result normal?

- YES >> GO TO 2.
NO >> Repair open circuit, short to ground or short to power in harness or connectors.

2. REPLACE ROOF STRIKER SENSOR RH

Replace roof striker sensor RH. Refer to [RF-184, "FRONT LOCK STRIKER : Removal and Installation"](#).

Is the inspection result normal?

- YES >> INSPECTION END
NO >> GO TO 3.

3. REPLACE SOFT TOP CONTROL UNIT

Replace soft top control unit. Refer to [RF-235, "Removal and Installation"](#).

Is the inspection result normal?

- YES >> INSPECTION END
NO >> GO TO 4.

4. CHECK INTERMITTENT INCIDENT

B176C STRIKER SENSOR (RH)

< DTC/CIRCUIT DIAGNOSIS >

Refer to [GI-44. "Intermittent Incident"](#).

>> INSPECTION END

A

B

C

D

E

F

G

H

I

J

RF

L

M

N

O

P

B176D STRIKER SENSOR (LH)

< DTC/CIRCUIT DIAGNOSIS >

B176D STRIKER SENSOR (LH)

DTC Logic

INFOID:000000007625478

DTC DETECTION LOGIC

NOTE:

If two or more DTCs are detected, refer to [RF-39, "DTC Inspection Priority Chart"](#), and determine trouble diagnosis order.

DTC No.	Trouble diagnosis name		DTC detecting condition	Possible cause
B176D	STRIKER SENSOR LH	[GND-SHORT]	Roof striker sensor LH circuit is open, short to ground or short to power.	<ul style="list-style-type: none">• Harness or connectors (The sensor circuit is open or shorted.)• Soft top control unit• Roof striker sensor LH
		[PWR-SHORT/OPEN]		
		[OPEN]		

DTC CONFIRMATION PROCEDURE

1. PERFORM DTC CONFIRMATION PROCEDURE

1. Start engine.
2. Operate soft top to fully open and fully close.
3. Select "Self Diagnostic Result" mode of "CONVERTIBLE ROOF" using CONSULT.
4. Check DTC.

Is DTC detected?

- YES >> Go to [RF-104, "Diagnosis Procedure"](#).
NO >> INSPECTION END

Diagnosis Procedure

INFOID:000000007625479

1. CHECK ROOF STRIKER SENSOR LH CIRCUIT

1. Turn ignition switch OFF.
2. Disconnect roof striker sensor LH and soft top control unit harness connector.
3. Check the continuity between roof striker sensor LH harness connector and soft top control unit harness connector.

Roof striker sensor LH		Soft top control unit		Continuity
Connector	Terminal	Connector	Terminal	
M262	4	B303	4	Existed

4. Also check harness for short to ground and short to power.

Is the inspection result normal?

- YES >> GO TO 2.
NO >> Repair open circuit, short to ground or short to power in harness or connectors.

2. REPLACE ROOF STRIKER SENSOR LH

Replace roof striker sensor LH. Refer to [RF-184, "FRONT LOCK STRIKER : Removal and Installation"](#).

Is the inspection result normal?

- YES >> INSPECTION END
NO >> GO TO 3.

3. REPLACE SOFT TOP CONTROL UNIT

Replace soft top control unit. Refer to [RF-235, "Removal and Installation"](#).

Is the inspection result normal?

- YES >> INSPECTION END
NO >> GO TO 4.

4. CHECK INTERMITTENT INCIDENT

B176D STRIKER SENSOR (LH)

< DTC/CIRCUIT DIAGNOSIS >

Refer to [GI-44. "Intermittent Incident"](#).

>> INSPECTION END

A

B

C

D

E

F

G

H

I

J

RF

L

M

N

O

P

B176E ROOF LATCH LOCK SENSOR

< DTC/CIRCUIT DIAGNOSIS >

B176E ROOF LATCH LOCK SENSOR

DTC Logic

INFOID:000000007625480

DTC DETECTION LOGIC

NOTE:

If two or more DTCs are detected, refer to [RF-39, "DTC Inspection Priority Chart"](#), and determine trouble diagnosis order.

DTC No.	Trouble diagnosis name		DTC detecting condition	Possible cause
B176E	ROOF LATCH LOCK SEN	[GND-SHORT]	Roof latch lock sensor circuit is open, short to ground or short to power.	<ul style="list-style-type: none">• Harness or connectors (The sensor circuit is open or shorted.)• Soft top control unit• Roof latch lock sensor
		[PWR-SHORT/OPEN]		
		[OPEN]		

DTC CONFIRMATION PROCEDURE

1. PERFORM DTC CONFIRMATION PROCEDURE

1. Start engine.
2. Operate soft top to fully open and fully close.
3. Select "Self Diagnostic Result" mode of "CONVERTIBLE ROOF" using CONSULT.
4. Check DTC.

Is DTC detected?

- YES >> Go to [RF-106, "Diagnosis Procedure"](#).
NO >> INSPECTION END

Diagnosis Procedure

INFOID:000000007625481

1. CHECK ROOF LATCH LOCK SENSOR CIRCUIT

1. Turn ignition switch OFF.
2. Disconnect roof latch lock sensor and soft top control unit harness connector.
3. Check the continuity between roof latch lock sensor harness connector and soft top control unit harness connector.

Roof latch lock sensor		Soft top control unit		Continuity
Connector	Terminal	Connector	Terminal	
B310	2	B306	71	Existed

4. Also check harness for short to ground and short to power.

Is the inspection result normal?

- YES >> GO TO 2.
NO >> Repair open circuit, short to ground or short to power in harness or connectors.

2. REPLACE ROOF LATCH LOCK SENSOR

Replace roof striker sensor RH. Refer to [RF-236, "Removal and Installation"](#).

Is the inspection result normal?

- YES >> INSPECTION END
NO >> GO TO 3.

3. REPLACE SOFT TOP CONTROL UNIT

Replace soft top control unit. Refer to [RF-235, "Removal and Installation"](#).

Is the inspection result normal?

- YES >> INSPECTION END
NO >> GO TO 4.

4. CHECK INTERMITTENT INCIDENT

B176E ROOF LATCH LOCK SENSOR

< DTC/CIRCUIT DIAGNOSIS >

Refer to [GI-44. "Intermittent Incident"](#).

>> INSPECTION END

A

B

C

D

E

F

G

H

I

J

RF

L

M

N

O

P

B176F ROOF STATUS SENSOR (LH)

< DTC/CIRCUIT DIAGNOSIS >

B176F ROOF STATUS SENSOR (LH)

DTC Logic

INFOID:000000007625482

DTC DETECTION LOGIC

NOTE:

If two or more DTCs are detected, refer to [RF-39, "DTC Inspection Priority Chart"](#), and determine trouble diagnosis order.

DTC No.	Trouble diagnosis name		DTC detecting condition	Possible cause
B176F	ROOF STATUS SEN LH	[GND-SHORT]	Roof status sensor LH circuit is open, short to ground or short to power.	<ul style="list-style-type: none">• Harness or connectors (The sensor circuit is open or shorted.)• Soft top control unit• Hydraulic unit (Roof status sensor LH)
		[PWR-SHORT/OPEN]		
		[OPEN]		

DTC CONFIRMATION PROCEDURE

1. PERFORM DTC CONFIRMATION PROCEDURE

1. Start engine.
2. Operate soft top to fully open and fully close.
3. Select "Self Diagnostic Result" mode of "CONVERTIBLE ROOF" using CONSULT.
4. Check DTC.

Is DTC detected?

- YES >> Go to [RF-108, "Diagnosis Procedure"](#).
NO >> INSPECTION END

Diagnosis Procedure

INFOID:000000007625483

1. CHECK ROOF STATUS SENSOR LH CIRCUIT

1. Turn ignition switch OFF.
2. Disconnect roof status sensor LH and soft top control unit harness connector.
3. Check the continuity between roof status sensor LH harness connector and soft top control unit harness connector.

Roof status sensor LH		Soft top control unit		Continuity
Connector	Terminal	Connector	Terminal	
B316	2	B306	69	Existed

4. Also check harness for short to ground and short to power.

Is the inspection result normal?

- YES >> GO TO 2.
NO >> Repair open circuit, short to ground or short to power in harness or connectors.

2. REPLACE HYDRAULIC UNIT

Replace hydraulic unit. Refer to [RF-226, "Removal and Installation"](#).

Is the inspection result normal?

- YES >> INSPECTION END
NO >> GO TO 3.

3. REPLACE SOFT TOP CONTROL UNIT

Replace soft top control unit. Refer to [RF-235, "Removal and Installation"](#).

Is the inspection result normal?

- YES >> INSPECTION END
NO >> GO TO 4.

4. CHECK INTERMITTENT INCIDENT

B176F ROOF STATUS SENSOR (LH)

< DTC/CIRCUIT DIAGNOSIS >

Refer to [GI-44. "Intermittent Incident"](#).

>> INSPECTION END

A

B

C

D

E

F

G

H

I

J

RF

L

M

N

O

P

B1770 ROOF STATUS SENSOR (RH)

< DTC/CIRCUIT DIAGNOSIS >

B1770 ROOF STATUS SENSOR (RH)

DTC Logic

INFOID:000000007625484

DTC DETECTION LOGIC

NOTE:

If two or more DTCs are detected, refer to [RF-39, "DTC Inspection Priority Chart"](#), and determine trouble diagnosis order.

DTC No.	Trouble diagnosis name		DTC detecting condition	Possible cause
B1770	ROOF STATUS SEN RH	[GND-SHORT]	Roof status sensor RH circuit is open, short to ground or short to power.	<ul style="list-style-type: none">• Harness or connectors (The sensor circuit is open or shorted.)• Soft top control unit• Hydraulic unit (Roof status sensor RH)
		[PWR-SHORT/OPEN]		
		[OPEN]		

DTC CONFIRMATION PROCEDURE

1. PERFORM DTC CONFIRMATION PROCEDURE

1. Start engine.
2. Operate soft top to fully open and fully close.
3. Select "Self Diagnostic Result" mode of "CONVERTIBLE ROOF" using CONSULT.
4. Check DTC.

Is DTC detected?

- YES >> Go to [RF-110, "Diagnosis Procedure"](#).
NO >> INSPECTION END

Diagnosis Procedure

INFOID:000000007625485

1. CHECK ROOF STATUS SENSOR RH CIRCUIT

1. Turn ignition switch OFF.
2. Disconnect roof status sensor RH and soft top control unit harness connector.
3. Check the continuity between roof status sensor RH harness connector and soft top control unit harness connector.

Roof status sensor RH		Soft top control unit		Continuity
Connector	Terminal	Connector	Terminal	
B317	2	B306	61	Existed

4. Also check harness for short to ground and short to power.

Is the inspection result normal?

- YES >> GO TO 2.
NO >> Repair open circuit, short to ground or short to power in harness or connectors.

2. REPLACE HYDRAULIC UNIT

Replace hydraulic unit. Refer to [RF-226, "Removal and Installation"](#).

Is the inspection result normal?

- YES >> INSPECTION END
NO >> GO TO 3.

3. REPLACE SOFT TOP CONTROL UNIT

Replace soft top control unit. Refer to [RF-235, "Removal and Installation"](#).

Is the inspection result normal?

- YES >> INSPECTION END
NO >> GO TO 4.

4. CHECK INTERMITTENT INCIDENT

B1770 ROOF STATUS SENSOR (RH)

< DTC/CIRCUIT DIAGNOSIS >

Refer to [GI-44. "Intermittent Incident"](#).

>> INSPECTION END

A

B

C

D

E

F

G

H

I

J

RF

L

M

N

O

P

B1771 ROOF STATUS SENSOR (LH)

< DTC/CIRCUIT DIAGNOSIS >

B1771 ROOF STATUS SENSOR (LH)

DTC Logic

INFOID:000000007625486

DTC DETECTION LOGIC

NOTE:

If two or more DTCs are detected, refer to [RF-39, "DTC Inspection Priority Chart"](#), and determine trouble diagnosis order.

DTC No.	Trouble diagnosis name		DTC detecting condition	Possible cause
B1771	ROOF STATUS SEN LH	[GND-SHORT]	Roof status sensor LH circuit is open, short to ground or short to power.	<ul style="list-style-type: none">• Harness or connectors (The sensor circuit is open or shorted.)• Soft top control unit• Hydraulic unit (Roof status sensor LH)
		[PWR-SHORT/OPEN]		
		[OPEN]		

DTC CONFIRMATION PROCEDURE

1. PERFORM DTC CONFIRMATION PROCEDURE

1. Start engine.
2. Operate soft top to fully open and fully close.
3. Select "Self Diagnostic Result" mode of "CONVERTIBLE ROOF" using CONSULT.
4. Check DTC.

Is DTC detected?

- YES >> Go to [RF-112, "Diagnosis Procedure"](#).
NO >> INSPECTION END

Diagnosis Procedure

INFOID:000000007625487

1. CHECK ROOF STATUS SENSOR LH CIRCUIT

1. Turn ignition switch OFF.
2. Disconnect roof status sensor LH and soft top control unit harness connector.
3. Check the continuity between roof status sensor LH harness connector and soft top control unit harness connector.

Roof status sensor LH		Soft top control unit		Continuity
Connector	Terminal	Connector	Terminal	
B316	3	B306	66	Existed

4. Also check harness for short to ground and short to power.

Is the inspection result normal?

- YES >> GO TO 2.
NO >> Repair open circuit, short to ground or short to power in harness or connectors.

2. REPLACE HYDRAULIC UNIT

Replace hydraulic unit. Refer to [RF-226, "Removal and Installation"](#).

Is the inspection result normal?

- YES >> INSPECTION END
NO >> GO TO 3.

3. REPLACE SOFT TOP CONTROL UNIT

Replace soft top control unit. Refer to [RF-235, "Removal and Installation"](#).

Is the inspection result normal?

- YES >> INSPECTION END
NO >> GO TO 4.

4. CHECK INTERMITTENT INCIDENT

B1771 ROOF STATUS SENSOR (LH)

< DTC/CIRCUIT DIAGNOSIS >

Refer to [GI-44. "Intermittent Incident"](#).

>> INSPECTION END

A

B

C

D

E

F

G

H

I

J

RF

L

M

N

O

P

B1772 5TH BOW STATUS SENSOR (LH)

< DTC/CIRCUIT DIAGNOSIS >

B1772 5TH BOW STATUS SENSOR (LH)

DTC Logic

INFOID:000000007625488

DTC DETECTION LOGIC

NOTE:

If two or more DTCs are detected, refer to [RF-39, "DTC Inspection Priority Chart"](#), and determine trouble diagnosis order.

DTC No.	Trouble diagnosis name		DTC detecting condition	Possible cause
B1772	5BOW STATUS SEN LH	[GND-SHORT]	5th bow status sensor LH circuit is open, short to ground or short to power.	<ul style="list-style-type: none">• Harness or connectors (The sensor circuit is open or shorted.)• Soft top control unit• 5th bow status sensor LH
		[PWR-SHORT/ OPEN]		
		[OPEN]		

DTC CONFIRMATION PROCEDURE

1. PERFORM DTC CONFIRMATION PROCEDURE

1. Start engine.
2. Operate soft top to fully open and fully close.
3. Select "Self Diagnostic Result" mode of "CONVERTIBLE ROOF" using CONSULT.
4. Check DTC.

Is DTC detected?

- YES >> Go to [RF-114, "Diagnosis Procedure"](#).
NO >> INSPECTION END

Diagnosis Procedure

INFOID:000000007625489

1. CHECK 5TH BOW STATUS SENSOR LH CIRCUIT

1. Turn ignition switch OFF.
2. Disconnect 5th bow status sensor LH and soft top control unit harness connector.
3. Check the continuity between 5th bow status sensor LH harness connector and soft top control unit harness connector.

5th bow status sensor LH		Soft top control unit		Continuity
Connector	Terminal	Connector	Terminal	
B312	2	B306	70	Existed

4. Also check harness for short to ground and short to power.

Is the inspection result normal?

- YES >> GO TO 2.
NO >> Repair open circuit, short to ground or short to power in harness or connectors.

2. REPLACE HYDRAULIC UNIT

Replace hydraulic unit. Refer to [RF-226, "Removal and Installation"](#).

Is the inspection result normal?

- YES >> INSPECTION END
NO >> GO TO 3.

3. REPLACE SOFT TOP CONTROL UNIT

Replace soft top control unit. Refer to [RF-235, "Removal and Installation"](#).

Is the inspection result normal?

- YES >> INSPECTION END
NO >> GO TO 4.

4. CHECK INTERMITTENT INCIDENT

B1772 5TH BOW STATUS SENSOR (LH)

< DTC/CIRCUIT DIAGNOSIS >

Refer to [GI-44. "Intermittent Incident"](#).

>> INSPECTION END

A

B

C

D

E

F

G

H

I

J

RF

L

M

N

O

P

B1773 5TH BOW STATUS SENSOR (RH)

< DTC/CIRCUIT DIAGNOSIS >

B1773 5TH BOW STATUS SENSOR (RH)

DTC Logic

INFOID:000000007625490

DTC DETECTION LOGIC

NOTE:

If two or more DTCs are detected, refer to [RF-39, "DTC Inspection Priority Chart"](#), and determine trouble diagnosis order.

DTC No.	Trouble diagnosis name		DTC detecting condition	Possible cause
B1773	5BOW STATUS SEN RH	[GND-SHORT]	5th bow status sensor RH circuit is open, short to ground or short to power.	<ul style="list-style-type: none">• Harness or connectors (The sensor circuit is open or shorted.)• Soft top control unit• 5th bow status sensor RH
		[PWR-SHORT/ OPEN]		
		[OPEN]		

DTC CONFIRMATION PROCEDURE

1. PERFORM DTC CONFIRMATION PROCEDURE

1. Start engine.
2. Operate soft top to fully open and fully close.
3. Select "Self Diagnostic Result" mode of "CONVERTIBLE ROOF" using CONSULT.
4. Check DTC.

Is DTC detected?

- YES >> Go to [RF-116, "Diagnosis Procedure"](#).
NO >> INSPECTION END

Diagnosis Procedure

INFOID:000000007625491

1. CHECK 5TH BOW STATUS SENSOR RH CIRCUIT

1. Turn ignition switch OFF.
2. Disconnect 5th bow status sensor RH and soft top control unit harness connector.
3. Check the continuity between 5th bow status sensor RH harness connector and soft top control unit harness connector.

5th bow status sensor RH		Soft top control unit		Continuity
Connector	Terminal	Connector	Terminal	
B313	2	B306	68	Existed

4. Also check harness for short to ground and short to power.

Is the inspection result normal?

- YES >> GO TO 2.
NO >> Repair open circuit, short to ground or short to power in harness or connectors.

2. REPLACE HYDRAULIC UNIT

Replace hydraulic unit. Refer to [RF-226, "Removal and Installation"](#).

Is the inspection result normal?

- YES >> INSPECTION END
NO >> GO TO 3.

3. REPLACE SOFT TOP CONTROL UNIT

Replace soft top control unit. Refer to [RF-235, "Removal and Installation"](#).

Is the inspection result normal?

- YES >> INSPECTION END
NO >> GO TO 4.

4. CHECK INTERMITTENT INCIDENT

B1773 5TH BOW STATUS SENSOR (RH)

< DTC/CIRCUIT DIAGNOSIS >

Refer to [GI-44. "Intermittent Incident"](#).

>> INSPECTION END

A

B

C

D

E

F

G

H

I

J

RF

L

M

N

O

P

B1774 STORAGE LID STATUS SENSOR (LH)

< DTC/CIRCUIT DIAGNOSIS >

B1774 STORAGE LID STATUS SENSOR (LH)

DTC Logic

INFOID:000000007625492

DTC DETECTION LOGIC

NOTE:

If two or more DTCs are detected, refer to [RF-39, "DTC Inspection Priority Chart"](#), and determine trouble diagnosis order.

DTC No.	Trouble diagnosis name		DTC detecting condition	Possible cause
B1774	S/LID STATUS SEN LH	[GND-SHORT]	Strage lid status sensor LH circuit is open, short to ground or short to power.	<ul style="list-style-type: none">• Harness or connectors (The sensor circuit is open or shorted.)• Soft top control unit• Strage lid status sensor LH
		[PWR-SHORT/ OPEN]		
		[OPEN]		

DTC CONFIRMATION PROCEDURE

1. PERFORM DTC CONFIRMATION PROCEDURE

1. Start engine.
2. Operate soft top to fully open and fully close.
3. Select "Self Diagnostic Result" mode of "CONVERTIBLE ROOF" using CONSULT.
4. Check DTC.

Is DTC detected?

- YES >> Go to [RF-118, "Diagnosis Procedure"](#).
NO >> INSPECTION END

Diagnosis Procedure

INFOID:000000007625493

1. CHECK STRAGE LID STATUS SENSOR LH CIRCUIT

1. Turn ignition switch OFF.
2. Disconnect strage lid status sensor LH and soft top control unit harness connector.
3. Check the continuity between strage lid status sensor LH harness connector and soft top control unit harness connector.

Strage lid status sensor LH		Soft top control unit		Continuity
Connector	Terminal	Connector	Terminal	
B314	2	B306	60	Existed

4. Also check harness for short to ground and short to power.

Is the inspection result normal?

- YES >> GO TO 2.
NO >> Repair open circuit, short to ground or short to power in harness or connectors.

2. REPLACE HYDRAULIC UNIT

Replace hydraulic unit. Refer to [RF-226, "Removal and Installation"](#).

Is the inspection result normal?

- YES >> INSPECTION END
NO >> GO TO 3.

3. REPLACE SOFT TOP CONTROL UNIT

Replace soft top control unit. Refer to [RF-235, "Removal and Installation"](#).

Is the inspection result normal?

- YES >> INSPECTION END
NO >> GO TO 4.

4. CHECK INTERMITTENT INCIDENT

B1774 STORAGE LID STATUS SENSOR (LH)

< DTC/CIRCUIT DIAGNOSIS >

Refer to [GI-44. "Intermittent Incident"](#).

>> INSPECTION END

A

B

C

D

E

F

G

H

I

J

RF

L

M

N

O

P

B1775 STORAGE LID STATUS SENSOR (RH)

< DTC/CIRCUIT DIAGNOSIS >

B1775 STORAGE LID STATUS SENSOR (RH)

DTC Logic

INFOID:000000007625494

DTC DETECTION LOGIC

NOTE:

If two or more DTCs are detected, refer to [RF-39, "DTC Inspection Priority Chart"](#), and determine trouble diagnosis order.

DTC No.	Trouble diagnosis name		DTC detecting condition	Possible cause
B1775	S/LID STATUS SEN RH	[GND-SHORT]	Strage lid status sensor RH circuit is open, short to ground or short to power.	<ul style="list-style-type: none">• Harness or connectors (The sensor circuit is open or shorted.)• Soft top control unit• Strage lid status sensor RH
		[PWR-SHORT/ OPEN]		
		[OPEN]		

DTC CONFIRMATION PROCEDURE

1. PERFORM DTC CONFIRMATION PROCEDURE

1. Start engine.
2. Operate soft top to fully open and fully close.
3. Select "Self Diagnostic Result" mode of "CONVERTIBLE ROOF" using CONSULT.
4. Check DTC.

Is DTC detected?

- YES >> Go to [RF-120, "Diagnosis Procedure"](#).
NO >> INSPECTION END

Diagnosis Procedure

INFOID:000000007625495

1. CHECK STRAGE LID STATUS SENSOR RH CIRCUIT

1. Turn ignition switch OFF.
2. Disconnect and strage lid status sensor and soft top control unit harness connector.
3. Check the continuity between strage lid status sensor RH harness connector and soft top control unit harness connector.

Strage lid status sensor RH		Soft top control unit		Continuity
Connector	Terminal	Connector	Terminal	
B315	2	B306	58	Existed

4. Also check harness for short to ground and short to power.

Is the inspection result normal?

- YES >> GO TO 2.
NO >> Repair open circuit, short to ground or short to power in harness or connectors.

2. REPLACE HYDRAULIC UNIT

Replace hydraulic unit. Refer to [RF-226, "Removal and Installation"](#).

Is the inspection result normal?

- YES >> INSPECTION END
NO >> GO TO 3.

3. REPLACE SOFT TOP CONTROL UNIT

Replace soft top control unit. Refer to [RF-235, "Removal and Installation"](#).

Is the inspection result normal?

- YES >> INSPECTION END
NO >> GO TO 4.

4. CHECK INTERMITTENT INCIDENT

B1775 STORAGE LID STATUS SENSOR (RH)

< DTC/CIRCUIT DIAGNOSIS >

Refer to [GI-44. "Intermittent Incident"](#).

>> INSPECTION END

A

B

C

D

E

F

G

H

I

J

RF

L

M

N

O

P

B1776 STORAGE LID STATUS SENSOR (RH)

< DTC/CIRCUIT DIAGNOSIS >

B1776 STORAGE LID STATUS SENSOR (RH)

DTC Logic

INFOID:000000007625496

DTC DETECTION LOGIC

NOTE:

If two or more DTCs are detected, refer to [RF-39, "DTC Inspection Priority Chart"](#), and determine trouble diagnosis order.

DTC No.	Trouble diagnosis name		DTC detecting condition	Possible cause
B1776	S/LID STATUS SEN RH	[GND-SHORT]	Strage lid status sensor RH circuit is open, short to ground or short to power.	<ul style="list-style-type: none">• Harness or connectors (The sensor circuit is open or shorted.)• Soft top control unit• Strage lid status sensor RH
		[PWR-SHORT/ OPEN]		
		[OPEN]		

DTC CONFIRMATION PROCEDURE

1. PERFORM DTC CONFIRMATION PROCEDURE

1. Start engine.
2. Operate soft top to fully open and fully close.
3. Select "Self Diagnostic Result" mode of "CONVERTIBLE ROOF" using CONSULT.
4. Check DTC.

Is DTC detected?

- YES >> Go to [RF-122, "Diagnosis Procedure"](#).
NO >> INSPECTION END

Diagnosis Procedure

INFOID:000000007625497

1. CHECK STRAGE LID STATUS SENSOR RH CIRCUIT

1. Turn ignition switch OFF.
2. Disconnect strage lid status sensor RH and soft top control unit harness connector.
3. Check the continuity between strage lid status sensor RH harness connector and soft top control unit harness connector.

Strage lid status sensor RH		Soft top control unit		Continuity
Connector	Terminal	Connector	Terminal	
B315	3	B303	59	Existed

4. Also check harness for short to ground and short to power.

Is the inspection result normal?

- YES >> GO TO 2.
NO >> Repair open circuit, short to ground or short to power in harness or connectors.

2. REPLACE HYDRAULIC UNIT

Replace hydraulic unit. Refer to [RF-226, "Removal and Installation"](#).

Is the inspection result normal?

- YES >> INSPECTION END
NO >> GO TO 3.

3. REPLACE SOFT TOP CONTROL UNIT

Replace soft top control unit. Refer to [RF-235, "Removal and Installation"](#).

Is the inspection result normal?

- YES >> INSPECTION END
NO >> GO TO 4.

4. CHECK INTERMITTENT INCIDENT

B1776 STORAGE LID STATUS SENSOR (RH)

< DTC/CIRCUIT DIAGNOSIS >

Refer to [GI-44. "Intermittent Incident"](#).

>> INSPECTION END

A

B

C

D

E

F

G

H

I

J

RF

L

M

N

O

P

B1777 REAR WINDOW DEFOGGER OUTPUT SIGNAL

< DTC/CIRCUIT DIAGNOSIS >

B1777 REAR WINDOW DEFOGGER OUTPUT SIGNAL

DTC Logic

INFOID:000000007625498

DTC DETECTION LOGIC

NOTE:

If two or more DTCs are detected, refer to [RF-39, "DTC Inspection Priority Chart"](#), and determine trouble diagnosis order.

DTC No.	Trouble diagnosis name		DTC detecting condition	Possible cause
B1777	REAR DEF OUT SIG	[PWR-SHORT]	Rear window defogger output signal circuit is short to power.	<ul style="list-style-type: none">• Harness or connectors (Rear window defogger output signal circuit is shorted.)• Rear window defogger

DTC CONFIRMATION PROCEDURE

1. PERFORM DTC CONFIRMATION PROCEDURE

1. Start engine.
2. Operate soft top to fully open and fully close.
3. Select "Self Diagnostic Result" mode of "CONVERTIBLE ROOF" using CONSULT.
4. Check DTC.

Is DTC detected?

- YES >> Go to [RF-124, "Diagnosis Procedure"](#).
NO >> INSPECTION END

Diagnosis Procedure

INFOID:000000007625499

Refer to [DEF-89, "Diagnosis Procedure"](#).

B1778 TRUNK OPEN OUTPUT SIGNAL

< DTC/CIRCUIT DIAGNOSIS >

B1778 TRUNK OPEN OUTPUT SIGNAL

DTC Logic

INFOID:000000007625500

DTC DETECTION LOGIC

NOTE:

If two or more DTCs are detected, refer to [RF-39, "DTC Inspection Priority Chart"](#), and determine trouble diagnosis order.

DTC No.	Trouble diagnosis name		DTC detecting condition	Possible cause
B1778	TRUNK OPEN OUT SIG	[PWR-SHORT/ OPEN]	Trunk lid opener output signal circuit is open, short to ground or short to power.	<ul style="list-style-type: none"> • Harness or connectors (Trunk lid opener output signal circuit is open or shorted.) • Trunk lid lock assembly
		[GND-SHORT]		

DTC CONFIRMATION PROCEDURE

1. PERFORM DTC CONFIRMATION PROCEDURE

1. Start engine.
2. Operate soft top to fully open and fully close.
3. Select "Self Diagnostic Result" mode of "CONVERTIBLE ROOF" using CONSULT.
4. Check DTC.

Is DTC detected?

- YES >> Go to [RF-125, "Diagnosis Procedure"](#).
 NO >> INSPECTION END

Diagnosis Procedure

INFOID:000000007625501

1. CHECK TRUNK LID OPENER OUTPUT SIGNAL

1. Turn ignition switch OFF.
2. Disconnect trunk lid lock assembly harness connector.
3. Turn ignition switch ON.
4. Select "CONVERTIBLE ROOF" using CONSULT.
5. Select "TRUNK OPENER" in "ACTIVE TEST" mode.
6. Touch "ON" to check voltage between trunk lid lock assembly harness connector and ground.

RF

(+)		(-)	Active test		Voltage (V) (Approx.)
Trunk lid lock assembly Connector	Terminal				
B76	2	Ground	TRUNK OPENER	ON	0 → Battery voltage → 0

Is the inspection result normal?

- YES >> GO TO 3.
 NO >> GO TO 2.

2. CHECK TRUNK LID OPENER OUTPUT SIGNAL CIRCUIT

1. Disconnect soft top control unit harness connector.
2. Check continuity between soft top control unit harness connector and soft top control unit harness connector.

Trunk lid lock assembly		Soft top control unit		Continuity
Connector	Terminal	Connector	Terminal	
B76	2	B303	10	Existed

3. Also check harness for short to ground and short to power.

Is the inspection result normal?

- YES >> Replace soft top control unit. Refer to [RF-235, "Removal and Installation"](#).
 NO >> Repair open circuit, short to ground or short to power in harness or connectors.

B1778 TRUNK OPEN OUTPUT SIGNAL

< DTC/CIRCUIT DIAGNOSIS >

3.CHECK TRUNK LID OPENER ACTUATOR GROUND

Check continuity between trunk lid lock assembly harness connector and ground.

Trunk lid lock assembly		Ground	Continuity
Connector	Terminal		
B76	3		Existed

Is the inspection result normal?

YES >> Replace trunk lid lock assembly.

NO >> GO TO 4.

4.CHECK INTERMITTENT INCIDENT

Refer to [GI-44, "Intermittent Incident"](#).

>> INSPECTION END

B1779 HYDRAULIC PUMP TEMPERATURE SENSOR

< DTC/CIRCUIT DIAGNOSIS >

B1779 HYDRAULIC PUMP TEMPERATURE SENSOR

DTC Logic

INFOID:000000007625502

DTC DETECTION LOGIC

NOTE:

If two or more DTCs are detected, refer to [RF-39, "DTC Inspection Priority Chart"](#), and determine trouble diagnosis order.

DTC No.	Trouble diagnosis name		DTC detecting condition	Possible cause
B1779	HYDRAULIC PMP T/SEN	[GND-SHORT]	Hydraulic pump temperature sensor circuit is open, short to ground or short to power.	<ul style="list-style-type: none"> • Harness or connectors (Hydraulic pump temperature sensor circuit is open or shorted.) • Hydraulic unit (Hydraulic pump temperature) • Soft top control unit
		[PWR-SHORT/OPEN]		

DTC CONFIRMATION PROCEDURE

1. PERFORM DTC CONFIRMATION PROCEDURE

1. Turn ignition switch ON.
2. Select "Self Diagnostic Result" mode of "CONVERTIBLE ROOF" using CONSULT.
3. Check DTC.

Is DTC detected?

- YES >> Go to [RF-127, "Diagnosis Procedure"](#).
 NO >> INSPECTION END

Diagnosis Procedure

INFOID:000000007625503

1. CHECK HYDRAULIC PUMP TEMPERATURE SENSOR POWER SUPPLY CIRCUIT-I

1. Turn ignition switch OFF.
2. Disconnect hydraulic unit harness connector.
3. Turn ignition switch ON.
4. Check the voltage between hydraulic unit harness connector and ground.

(+)		(-)	Voltage (V) (Approx.)
Hydraulic unit			
Connector	Terminal	Ground	5
B308	10		

Is the inspection result normal?

- YES >> GO TO 3.
 NO >> GO TO 2.

2. CHECK HYDRAULIC PUMP TEMPERATURE SENSOR POWER SUPPLY CIRCUIT-II

1. Turn ignition switch OFF.
2. Disconnect soft top control unit harness connector.
3. Check the continuity between hydraulic unit harness connector and soft top control unit harness connector.

Hydraulic unit		Soft top control unit		Continuity
Connector	Terminal	Connector	Terminal	
B308	10	B306	72	Existed

4. Also check harness for short to ground and short to power.

Is the inspection result normal?

- YES >> Replace soft top control unit. Refer to [RF-235, "Removal and Installation"](#).
 NO >> Repair open circuit, short to ground or short to power in harness or connectors.

B1779 HYDRAULIC PUMP TEMPERATURE SENSOR

< DTC/CIRCUIT DIAGNOSIS >

3. CHECK HYDRAULIC PUMP TEMPERATURE SENSOR GROUND CIRCUIT

1. Turn ignition switch OFF.
2. Disconnect soft top control unit harness connector.
3. Check the continuity between hydraulic unit harness connector and soft top control unit harness connector.

5th bow latch/striker sensor assembly		Soft top control unit		Continuity
Connector	Terminal	Connector	Terminal	
B308	9	B306	92	Existed

4. Also check harness for short to ground and short to power.

Is the inspection result normal?

YES >> GO TO 4.

NO >> Repair open circuit, short to ground or short to power in harness or connectors.

4. REPLACE HYDRAULIC UNIT

Replace hydraulic unit. Refer to [RF-226, "Removal and Installation"](#).

Is the inspection result normal?

YES >> INSPECTION END

NO >> GO TO 5.

5. CHECK INTERMITTENT INCIDENT

Refer to [GI-44, "Intermittent Incident"](#).

>> INSPECTION END

B177A ROOF STATUS INCORRECT

< DTC/CIRCUIT DIAGNOSIS >

B177A ROOF STATUS INCORRECT

DTC Logic

INFOID:000000007625504

DTC DETECTION LOGIC

NOTE:

If two or more DTCs are detected, refer to [RF-39, "DTC Inspection Priority Chart"](#), and determine trouble diagnosis order.

DTC No.	Trouble diagnosis name	DTC detecting condition	Possible cause
B177A	ROOF STATE INCORRECT	When soft top control unit detects that soft top status is not normal.	Soft top system component

DTC CONFIRMATION PROCEDURE

1. ADJUST SOFT TOP POSITION

1. Turn ignition switch OFF and wait at least 4 minutes.
2. Manually operate soft top to fully open.

>> GO TO 2.

2. PERFORM DTC CONFIRMATION PROCEDURE

1. Start engine.
2. Operate soft top to fully open and fully close.
3. Select "Self Diagnostic Result" mode of "CONVERTIBLE ROOF" using CONSULT.
4. Check DTC.

Is DTC detected?

- YES >> Go to [RF-130, "Diagnosis Procedure"](#).
NO >> INSPECTION END

Diagnosis Procedure

INFOID:000000007625505

1. CHECK SOFT TOP SYSTEM COMPONENT

Check that soft top system component is installed normally and is not damaged.

Is the inspection result normal?

- YES >> INSPECTION END
NO >> Repair or replace malfunctioning part.

A
B
C
D
E
F
G
H
I
J
RF
L
M
N
O
P

B177B ROOF STATUS INCORRECT

< DTC/CIRCUIT DIAGNOSIS >

B177B ROOF STATUS INCORRECT

DTC Logic

INFOID:000000007625506

DTC DETECTION LOGIC

NOTE:

If two or more DTCs are detected, refer to [RF-39, "DTC Inspection Priority Chart"](#), and determine trouble diagnosis order.

DTC No.	Trouble diagnosis name	DTC detecting condition	Possible cause
B177B	ROOF STATE INCORRECT	When soft top is not set by soft top control unit.	<ul style="list-style-type: none">• Soft top status• Soft top control unit

DTC CONFIRMATION PROCEDURE

1. ADJUST SOFT TOP POSITION

1. Turn ignition switch OFF and wait at least 4 minutes.
2. Manually operate soft top to fully open.

>> GO TO 2.

2. PERFORM DTC CONFIRMATION PROCEDURE

1. Start engine.
2. Operate soft top to fully open and fully close.
3. Select "Self Diagnostic Result" mode of "CONVERTIBLE ROOF" using CONSULT.
4. Check DTC.

Is DTC detected?

- YES >> Go to [RF-130, "Diagnosis Procedure"](#).
NO >> INSPECTION END

Diagnosis Procedure

INFOID:000000007625507

1. PERFORM DTC CONFIRMATION PROCEDURE

Perform DTC Confirmation Procedure. Refer to [RF-130, "DTC Logic"](#).

Is the DTC displayed again?

- YES >> Replace soft top control unit. Refer to [RF-235, "Removal and Installation"](#).
NO >> INSPECTION END

B177C THERMO PROTECTION

< DTC/CIRCUIT DIAGNOSIS >

B177C THERMO PROTECTION

DTC Logic

INFOID:000000007625508

DTC DETECTION LOGIC

NOTE:

If two or more DTCs are detected, refer to [RF-39, "DTC Inspection Priority Chart"](#), and determine trouble diagnosis order.

DTC No.	Trouble diagnosis name	DTC detecting condition	Possible cause
B177C	THERMO PROTECTION	Thermo protection is active. (Thermo protection: Refer to RF-20, "SOFT TOP SYSTEM : System Protect Control")	<ul style="list-style-type: none">• Soft top system is operated continuously• Soft top control unit

DTC CONFIRMATION PROCEDURE

1. COOL DOWN HYDRAULIC SYSTEM

Turn ignition switch off and wait at least 5 minutes.

>> GO TO 2.

2. PERFORM DTC CONFIRMATION PROCEDURE

1. Turn ignition switch ON.
2. Select "Self Diagnostic Result" mode of "CONVERTIBLE ROOF" using CONSULT.
3. Check DTC.

Is DTC detected?

- YES >> Go to [RF-131, "Diagnosis Procedure"](#).
NO >> INSPECTION END

Diagnosis Procedure

INFOID:000000007625509

1. PERFORM DTC CONFIRMATION PROCEDURE

Perform DTC Confirmation Procedure. Refer to [RF-64, "DTC Logic"](#).

Is the DTC displayed again?

- YES >> Replace soft top control unit. Refer to [RF-235, "Removal and Installation"](#).
NO >> INSPECTION END

B177D 5TH BOW LATCH OPEN SENSOR

< DTC/CIRCUIT DIAGNOSIS >

B177D 5TH BOW LATCH OPEN SENSOR

DTC Logic

INFOID:000000007625510

DTC DETECTION LOGIC

NOTE:

If two or more DTCs are detected, refer to [RF-39, "DTC Inspection Priority Chart"](#), and determine trouble diagnosis order.

DTC No.	Trouble diagnosis name		DTC detecting condition	Possible cause
B177D	5BOW LATCH OPEN SEN	[GND-SHORT]	5th bow latch open sensor circuit is open, short to ground or short to power.	<ul style="list-style-type: none">• Harness or connectors (The sensor circuit is open or shorted.)• Soft top control unit• 5th bow latch open sensor
		[PWR-SHORT/ OPEN]		
		[OPEN]		

DTC CONFIRMATION PROCEDURE

1. PERFORM DTC CONFIRMATION PROCEDURE

1. Start engine.
2. Operate soft top to fully open and fully close.
3. Select "Self Diagnostic Result" mode of "CONVERTIBLE ROOF" using CONSULT.
4. Check DTC.

Is DTC detected?

- YES >> Go to [RF-132, "Diagnosis Procedure"](#).
NO >> INSPECTION END

Diagnosis Procedure

INFOID:000000007625511

1. CHECK 5TH BOW LATCH OPEN SENSOR GROUND CIRCUIT

1. Turn ignition switch OFF.
2. Disconnect 5th bow latch/striker sensor assembly and soft top control unit harness connector.
3. Check the continuity between 5th bow latch/striker sensor assembly harness connector and soft top control unit harness connector.

5th bow latch/striker sensor assembly		Soft top control unit		Continuity
Connector	Terminal	Connector	Terminal	
B319	2	B306	57	Existed

4. Also check harness for short to ground and short to power.

Is the inspection result normal?

- YES >> GO TO 2.
NO >> Repair open circuit, short to ground or short to power in harness or connectors.

2. REPLACE 5TH BOW LATCH/STRIKER SENSOR ASSEMBLY

Replace 5th bow latch/striker sensor assembly. Refer to [RF-237, "Removal and Installation"](#).

Is the inspection result normal?

- YES >> INSPECTION END
NO >> GO TO 3.

3. REPLACE SOFT TOP CONTROL UNIT

Replace soft top control unit. Refer to [RF-235, "Removal and Installation"](#).

Is the inspection result normal?

- YES >> INSPECTION END
NO >> GO TO 4.

4. CHECK INTERMITTENT INCIDENT

B177D 5TH BOW LATCH OPEN SENSOR

< DTC/CIRCUIT DIAGNOSIS >

Refer to [GI-44. "Intermittent Incident"](#).

>> INSPECTION END

A

B

C

D

E

F

G

H

I

J

RF

L

M

N

O

P

B177E 5TH BOW LATCH CLOSE SENSOR

< DTC/CIRCUIT DIAGNOSIS >

B177E 5TH BOW LATCH CLOSE SENSOR

DTC Logic

INFOID:000000007625512

DTC DETECTION LOGIC

NOTE:

If two or more DTCs are detected, refer to [RF-39, "DTC Inspection Priority Chart"](#), and determine trouble diagnosis order.

DTC No.	Trouble diagnosis name		DTC detecting condition	Possible cause
B177E	5BOW LATCH CLOSE SEN	[GND-SHORT]	5th bow latch close sensor circuit is open, short to ground or short to power.	<ul style="list-style-type: none">• Harness or connectors (The sensor circuit is open or shorted.)• Soft top control unit• 5th bow latch close sensor
		[PWR-SHORT/ OPEN]		
		[OPEN]		

DTC CONFIRMATION PROCEDURE

1. PERFORM DTC CONFIRMATION PROCEDURE

1. Start engine.
2. Operate soft top to fully open and fully close.
3. Select "Self Diagnostic Result" mode of "CONVERTIBLE ROOF" using CONSULT.
4. Check DTC.

Is DTC detected?

- YES >> Go to [RF-134, "Diagnosis Procedure"](#).
NO >> INSPECTION END

Diagnosis Procedure

INFOID:000000007625513

1. CHECK 5TH BOW LATCH CLOSE SENSOR GROUND CIRCUIT

1. Turn ignition switch OFF.
2. Disconnect 5th bow latch/striker sensor assembly and soft top control unit harness connector.
3. Check the continuity between 5th bow latch/striker sensor assembly harness connector and soft top control unit harness connector.

5th bow latch/striker sensor assembly		Soft top control unit		Continuity
Connector	Terminal	Connector	Terminal	
B319	3	B306	56	Existed

4. Also check harness for short to ground and short to power.

Is the inspection result normal?

- YES >> GO TO 2.
NO >> Repair open circuit, short to ground or short to power in harness or connectors.

2. REPLACE 5TH BOW LATCH/STRIKER SENSOR ASSEMBLY

Replace 5th bow latch/striker sensor assembly. Refer to [RF-237, "Removal and Installation"](#).

Is the inspection result normal?

- YES >> INSPECTION END
NO >> GO TO 3.

3. REPLACE SOFT TOP CONTROL UNIT

Replace soft top control unit. Refer to [RF-235, "Removal and Installation"](#).

Is the inspection result normal?

- YES >> INSPECTION END
NO >> GO TO 4.

4. CHECK INTERMITTENT INCIDENT

B177E 5TH BOW LATCH CLOSE SENSOR

< DTC/CIRCUIT DIAGNOSIS >

Refer to [GI-44. "Intermittent Incident"](#).

>> INSPECTION END

A

B

C

D

E

F

G

H

I

J

RF

L

M

N

O

P

B177F 5TH BOW STRIKER SENSOR

< DTC/CIRCUIT DIAGNOSIS >

B177F 5TH BOW STRIKER SENSOR

DTC Logic

INFOID:000000007625514

DTC DETECTION LOGIC

NOTE:

If two or more DTCs are detected, refer to [RF-39, "DTC Inspection Priority Chart"](#), and determine trouble diagnosis order.

DTC No.	Trouble diagnosis name		DTC detecting condition	Possible cause
B177F	5BOW STRIKER SENSOR	[GND-SHORT]	5th bow striker sensor circuit is open, short to ground or short to power.	<ul style="list-style-type: none">• Harness or connectors (The sensor circuit is open or shorted.)• Soft top control unit• 5th bow striker sensor
		[PWR-SHORT/OPEN]		
		[OPEN]		

DTC CONFIRMATION PROCEDURE

1. PERFORM DTC CONFIRMATION PROCEDURE

1. Start engine.
2. Operate soft top to fully open and fully close.
3. Select "Self Diagnostic Result" mode of "CONVERTIBLE ROOF" using CONSULT.
4. Check DTC.

Is DTC detected?

- YES >> Go to [RF-136, "Diagnosis Procedure"](#).
NO >> INSPECTION END

Diagnosis Procedure

INFOID:000000007625515

1. CHECK 5TH BOW STRIKER SENSOR GROUND CIRCUIT

1. Turn ignition switch OFF.
2. Disconnect 5th bow latch/striker sensor assembly and soft top control unit harness connector.
3. Check the continuity between 5th bow latch/striker sensor assembly harness connector and soft top control unit harness connector.

5th bow latch/striker sensor assembly		Soft top control unit		Continuity
Connector	Terminal	Connector	Terminal	
B319	4	B306	76	Existed

4. Also check harness for short to ground and short to power.

Is the inspection result normal?

- YES >> GO TO 2.
NO >> Repair open circuit, short to ground or short to power in harness or connectors.

2. REPLACE 5TH BOW LATCH/STRIKER SENSOR ASSEMBLY

Replace 5th bow latch/striker sensor assembly. Refer to [RF-237, "Removal and Installation"](#).

Is the inspection result normal?

- YES >> INSPECTION END
NO >> GO TO 3.

3. REPLACE SOFT TOP CONTROL UNIT

Replace soft top control unit. Refer to [RF-235, "Removal and Installation"](#).

Is the inspection result normal?

- YES >> INSPECTION END
NO >> GO TO 4.

4. CHECK INTERMITTENT INCIDENT

B177F 5TH BOW STRIKER SENSOR

< DTC/CIRCUIT DIAGNOSIS >

Refer to [GI-44. "Intermittent Incident"](#).

>> INSPECTION END

A

B

C

D

E

F

G

H

I

J

RF

L

M

N

O

P

POWER SUPPLY AND GROUND CIRCUIT

< DTC/CIRCUIT DIAGNOSIS >

POWER SUPPLY AND GROUND CIRCUIT

Diagnosis Procedure

INFOID:000000007625516

1. CHECK FUSE

Check 15 A fuse (No. 33).

Is the inspection result normal?

YES >> GO TO 2.

NO >> Replace the fuse after repairing the applicable circuit.

2. CHECK SOFT TOP CONTROL UNIT POWER SUPPLY CIRCUIT

1. Turn ignition switch OFF.
2. Disconnect soft top control unit connectors.
3. Check voltage between soft top control unit harness connector and ground.

(+)		(-)	Voltage (Approx.)
Soft top control unit		Ground	
Connector	Terminal		
B305	53		Battery voltage

Is the measurement value normal?

YES >> GO TO 3.

NO >> Repair harness or connector.

3. CHECK SOFT TOP CONTROL UNIT GROUND CIRCUIT

Check continuity between soft top control unit harness connector and ground.

Soft top control unit		Ground	Continuity
Connector	Terminal		
B303	29		Existed
B305	54		

Does continuity exist?

YES >> INSPECTION END

NO >> Repair harness or connector.

BACK-UP LAMP CIRCUIT

< DTC/CIRCUIT DIAGNOSIS >

BACK-UP LAMP CIRCUIT

Component Function Check

INFOID:000000007625517

1. CHECK FUNCTION

Ⓜ With CONSULT

- Turn ignition switch ON.
- Check "SHIFT R SIG" in "DATA MONITOR" mode of "CONVERTIBLE ROOF" using CONSULT.

Monitor item	Condition		Status
SHIFT R SIG	Shift position	Other than R position	OFF
		R position	ON

Is the inspection result normal?

- YES >> INSPECTION END
 NO >> Go to [RF-139, "Diagnosis Procedure"](#).

Diagnosis Procedure

INFOID:000000007625518

1. CHECK BACK-UP LAMP RELAY OR BACK-UP LAMP SWITCH POWER SUPPLY

- Turn ignition switch OFF.
- Disconnect back-up lamp relay (A/T models) or back-up lamp switch (M/T models) harness connector.
- Check the voltage between back-up lamp relay (A/T models) or back-up lamp switch (M/T models) harness connector and ground.

(+)		(-)	Voltage (V) (Approx.)
Back-up lamp relay			
Connector	Terminal	Ground	Battery voltage
M69	3		

(+)		(-)	Voltage (V) (Approx.)
Back-up lamp switch			
Connector	Terminal	Ground	Battery voltage
F56	1		

Is the inspection result normal?

- YES >> GO TO 2.
 NO-1 >> Check 10 A fuse [No. 4 located in the fuse block (J/B)].
 NO-2 >> Check harness for open or short between back-up lamp relay (A/T models) or back-up lamp switch (M/T models) and fuse.

2. CHECK BACK-UP LAMP RELAY OR BACK-UP LAMP SWITCH GROUND CIRCUIT

- Disconnect soft top control unit connector.
- Check the continuity between soft top control unit harness connector and back-up lamp relay (A/T models) or back-up lamp switch (M/T models) harness connector.

Soft top control unit		Back-up lamp relay		Continuity
Connector	Terminal	Connector	Terminal	
B303	8	M69	5	Existed

Soft top control unit		Back-up lamp switch		Continuity
Connector	Terminal	Connector	Terminal	
B303	8	F56	2	Existed

- Also check harness for short to ground and short to power.

BACK-UP LAMP CIRCUIT

< DTC/CIRCUIT DIAGNOSIS >

Is the inspection result normal?

YES >> GO TO 3.

NO >> Repair open circuit, short to ground or short to power in harness or connectors.

3.CHECK BACK-UP LAMP RELAY OR BACK-UP LAMP SWITCH

Check back-up lamp relay (A/T models) (refer to [TM-149, "Diagnosis Flow"](#)) or back-up lamp switch (M/T models) (refer to [TM-17, "Component Inspection"](#))

Is the inspection result normal?

YES >> GO TO 4.

NO >> Repair or replace malfunctioning part.

4.REPLACE SOFT TOP CONTROL UNIT

Replace soft top control unit. Refer to [RF-235, "Removal and Installation"](#).

Is the inspection result normal?

YES >> INSPECTION END

NO >> GO TO 5.

5.CHECK INTERMITTENT INCIDENT

Refer to [GI-44, "Intermittent Incident"](#).

>> INSPECTION END

ROOF OPEN/CLOSE SWITCH

< DTC/CIRCUIT DIAGNOSIS >

ROOF OPEN/CLOSE SWITCH

Component Function Check

INFOID:000000007625519

1. CHECK ROOF OPEN/CLOSE SWITCH FUNCTION

④ With CONSULT

1. Turn ignition switch ON.
2. Check "ROOF SW (OPEN)" and "ROOF SW (CLOSE)" in "DATA MONITOR" mode of "CONVERTIBLE ROOF" using CONSULT.

Monitor item	Condition	Status
ROOF SW (OPEN)	Roof open/close switch	Open ON
		Closed OFF
ROOF SW (CLOSE)	Roof open/close switch	Open OFF
		Closed ON

Is the inspection result normal?

- YES >> Roof open/close switch is normal.
NO >> Refer to [RF-141, "Diagnosis Procedure"](#).

Diagnosis Procedure

INFOID:000000007625520

1. CHECK VOLTAGE ROOF OPEN/CLOSE SWITCH POWER SUPPLY

1. Turn ignition switch OFF.
2. Disconnect roof open/close switch connector.
3. Turn ignition switch ON.
4. Check the voltage between roof open/close switch harness connector and ground.

(+)		(-)	Voltage (V) (Approx.)
Roof open/close switch			
Connector	Terminal	Ground	Battery voltage
M15	3		
	4		

Is the inspection result normal?

- YES >> GO TO 3.
NO >> GO TO 2.

2. CHECK ROOF OPEN/CLOSE SWITCH POWER SUPPLY CIRCUIT

1. Turn ignition switch OFF.
2. Disconnect soft top control unit harness connector.
3. Check the continuity between soft top control unit harness connector and roof open/close switch harness connector.

Soft top control unit		Roof open/close switch		Continuity
Connector	Terminal	Connector	Terminal	
B303	14	M15	4	Existed
	15		3	

4. Also check harness for short to ground and short to power.

Is the inspection result normal?

- YES >> Replace soft top control unit. Refer to [RF-235, "Removal and Installation"](#).
NO >> Repair open circuit, short to ground or short to power in harness or connectors.

3. CHECK ROOF OPEN/CLOSE SWITCH GROUND CIRCUIT

1. Turn ignition switch OFF.

ROOF OPEN/CLOSE SWITCH

< DTC/CIRCUIT DIAGNOSIS >

2. Disconnect soft top control unit connector.
3. Check the continuity between soft top control unit harness connector and roof open/close switch harness connector.

Soft top control unit		Roof open/close switch		Continuity
Connector	Terminal	Connector	Terminal	
B303	35	M15	1	Existed

4. Also check harness for short to power.

Is the inspection result normal?

YES >> GO TO 4.

NO >> Repair open circuit and short to power in harness or connectors.

4.CHECK ROOF OPEN/CLOSE SWITCH

Refer to [RF-67, "Component Inspection"](#).

Is the inspection result normal?

YES >> GO TO 5.

NO >> Replace roof open/close switch. Refer to [RF-234, "Removal and Installation"](#).

5.CHECK INTERMITTENT INCIDENT

Refer to [GI-44, "Intermittent Incident"](#).

>> INSPECTION END

ROOF WARNING LAMP

< DTC/CIRCUIT DIAGNOSIS >

ROOF WARNING LAMP

Component Function Check

INFOID:000000007625521

1.CHECK ROOF WARNING LAMP FUNCTION

1. Start engine.
2. Operate soft top to fully open and fully close.
3. Make sure that roof warning lamp illuminates.

Is the inspection result normal?

- YES >> INSPECTION END
 NO >> Go to [EC-522. "Diagnosis Procedure"](#).

Diagnosis Procedure

INFOID:000000007625522

1.CHECK ROOF WARNING LAMP CIRCUIT-I

1. Turn ignition switch OFF.
2. Disconnect soft top control unit harness connector.
3. Turn ignition switch ON.
4. Check voltage between soft top control unit harness connector and ground.

Soft top control unit		(-)	Voltage (V) (Approx.)
(+) Connector			
Terminal	Terminal		
B303	11	Ground	Battery voltage

Is the inspection result normal?

- YES >> GO TO 3.
 NO >> GO TO 2.

2.CHECK ROOF WARNING LAMP CIRCUIT-II

1. Turn ignition switch OFF.
2. Disconnect combination meter harness connector.
3. Check continuity between soft top control unit harness connector and combination meter harness connector.

Soft top control unit		Combination meter		Continuity
Connector	Terminal	Connector	Terminal	
B303	11	B87	2	Existed

4. Also check harness for short to ground and short to power.

Is the inspection result normal?

- YES >> Replace combination meter. Refer to [MWI-92. "Removal and Installation"](#).
 NO >> Repair open circuit, short to ground or short to power in harness or connectors.

3.REPLACE SOFT TOP CONTROL UNIT

Replace soft top control unit. Refer to [RF-235. "Removal and Installation"](#).

Is the inspection result normal?

- YES >> INSPECTION END
 NO >> GO TO 4.

4.CHECK INTERMITTENT INCIDENT

Refer to [GI-44. "Intermittent Incident"](#).

>> INSPECTION END

TRUNK ROOM LAMP SWITCH

< DTC/CIRCUIT DIAGNOSIS >

TRUNK ROOM LAMP SWITCH

Component Function Check

INFOID:000000007625523

1.CHECK FUNCTION

1. Select "DOOR LOCK" of "BCM" using CONSULT.
2. Select "DOOR SW-BK" in "DATA MONITOR" mode.
3. Check that the function operates normally according to the following conditions.

Monitor item	Condition		Status
DOOR SW-BK	Trunk lid	Open	ON
		Closed	OFF

Is the inspection result normal?

- YES >> Trunk room lamp switch is OK.
 NO >> Refer to [RF-144. "Diagnosis Procedure"](#).

Diagnosis Procedure

INFOID:000000007625524

1.CHECK TRUNK ROOM LAMP SWITCH INPUT SIGNAL

1. Turn ignition switch OFF.
2. Disconnect trunk lid lock assembly connector.
3. Check signal between trunk lid lock assembly harness connector and ground using oscilloscope.

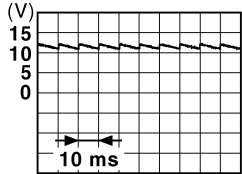
(+)		(-)	Signal (Reference value)
Trunk lid lock assembly			
Connector	Terminal		
B76	1	Ground	 <p style="text-align: right;">JPMAI0011GB</p>

Is the inspection result normal?

- YES >> GO TO 3.
 NO >> GO TO 2.

2.CHECK TRUNK ROOM LAMP SWITCH CIRCUIT

1. Disconnect BCM connector and soft top control unit connector.
2. Check continuity between BCM harness connector and trunk lid lock assembly harness connector.

BCM		Trunk lid lock assembly		Continuity
Connector	Terminal	Connector	Terminal	
M121	66	B76	1	Existed

3. Check continuity between BCM harness connector and ground.

BCM		Ground	Continuity
Connector	Terminal		
M121	66		Not existed

Is the inspection result normal?

- YES >> Replace BCM. Refer to [BCS-92. "Removal and Installation"](#).
 NO >> Repair harness or connector.

TRUNK ROOM LAMP SWITCH

< DTC/CIRCUIT DIAGNOSIS >

3.CHECK TRUNK ROOM LAMP SWITCH GROUND

Check continuity between trunk lid lock assembly harness connector and ground.

Trunk lid lock assembly		Ground	Continuity
Connector	Terminal		
B76	3		Existed

Is the inspection result normal?

YES >> GO TO 4.

NO >> Repair or replace harness.

4.CHECK TRUNK ROOM LAMP SWITCH

Refer to [RF-145, "Component Inspection"](#).

Is the inspection result normal?

YES >> GO TO 5.

NO >> Replace trunk lid lock assembly.

5.CHECK INTERMITTENT INCIDENT

Refer to [GI-44, "Intermittent Incident"](#).

>> INSPECTION END

Component Inspection

INFOID:000000007625525

1.CHECK TRUNK ROOM LAMP SWITCH

1. Turn ignition switch OFF.
2. Disconnect trunk lid lock assembly connector.
3. Check continuity between trunk lid lock assembly terminals.

Trunk lid lock assembly		Condition	Continuity
Terminal			
1	3	Trunk lid lock assembly	Unlocked Existed
			Locked Not existed

Is the inspection result normal?

YES >> INSPECTION END

NO >> Replace trunk lid lock assembly.

SOFT TOP DOES NOT OPERATE USING DOOR REQUEST SWITCH

< SYMPTOM DIAGNOSIS >

SYMPTOM DIAGNOSIS

SOFT TOP DOES NOT OPERATE USING DOOR REQUEST SWITCH

Description

INFOID:000000007625526

Soft top does not operate using door request switch.

Diagnosis Procedure

INFOID:000000007625527

1. CHECK DOOR LOCK FUNCTION

Check door lock function (with door request switch LH/RH).

Does door lock/unlock with door request switch (LH/RH)?

YES >> GO TO 2.

NO (All request switch) >> Refer to [DLK-279, "ALL DOOR : Diagnosis Procedure"](#).

NO (Door request switch LH) >> Refer to [DLK-279, "DRIVER SIDE : Diagnosis Procedure"](#).

NO (Door request switch RH) >> Refer to [DLK-280, "PASSENGER SIDE : Diagnosis Procedure"](#).

2. CONFIRM THE OPERATION

Confirm the operation again.

Is the result normal?

YES >> Check intermittent incident. Refer to [GI-44, "Intermittent Incident"](#).

NO >> Replace soft top control unit. Refer to [RF-235, "Removal and Installation"](#).

SOFT TOP DOES NOT OPERATE USING ROOF OPEN/CLOSE SWITCH

< SYMPTOM DIAGNOSIS >

SOFT TOP DOES NOT OPERATE USING ROOF OPEN/CLOSE SWITCH

Description

INFOID:000000007625528

Soft top does not operate using roof open/close switch.

Diagnosis Procedure

INFOID:000000007625529

1.CHECK TRUNK ROOM LAMP SIGNAL

Check trunk room ramp switch circuit. Refer to [DLK-247, "Diagnosis Procedure"](#).

Is the inspection result normal?

YES >> GO TO 2.

NO >> Repair or replace the malfunctioning parts.

2.CHECK BACK-UP LAMP SIGNAL

Check back-up lamp circuit. Refer to [RF-139, "Component Function Check"](#).

Is the inspection result normal?

YES >> GO TO 3.

NO >> Repair or replace the malfunctioning parts.

3.CHECK ROOF OPEN/CLOSE SWITCH

Check roof open/close switch circuit. Refer to [RF-141, "Component Function Check"](#).

Is the inspection result normal?

YES >> GO TO 4.

NO >> Repair or replace the malfunctioning parts.

4.REPLACE SOFT TOP CONTROL UNIT

Replace soft top control unit. Refer to [RF-235, "Removal and Installation"](#).

Is the inspection result normal?

YES >> INSPECTION END

NO >> Check intermittent incident. Refer to [GI-44, "Intermittent Incident"](#).

A
B
C
D
E
F
G
H
I
J
RF
L
M
N
O
P

ROOF WARNING LAMP DOES NOT ILLUMINATE WHEN SOFT TOP OPERATES

< SYMPTOM DIAGNOSIS >

ROOF WARNING LAMP DOES NOT ILLUMINATE WHEN SOFT TOP OPERATES

Description

INFOID:000000007625530

Roof warning lamp does not illuminate when soft top operates.

Diagnosis Procedure

INFOID:000000007625531

1. CHECK ROOF WARNING LAMP SIGNAL

Check roof warning lamp signal circuit. Refer to [RF-100, "Diagnosis Procedure"](#).

Is the inspection result normal?

YES >> GO TO 2.

NO >> Repair or replace malfunctioning parts.

2. REPLACE SOFT TOP CONTROL UNIT

Replace soft top control unit. Refer to [RF-143, "Diagnosis Procedure"](#).

Is the inspection result normal?

YES >> INSPECTION END

NO >> Check intermittent incident. Refer to [GI-44, "Intermittent Incident"](#).

SQUEAK AND RATTLE TROUBLE DIAGNOSES

< SYMPTOM DIAGNOSIS >

SQUEAK AND RATTLE TROUBLE DIAGNOSES

Work Flow

INFOID:000000007625532

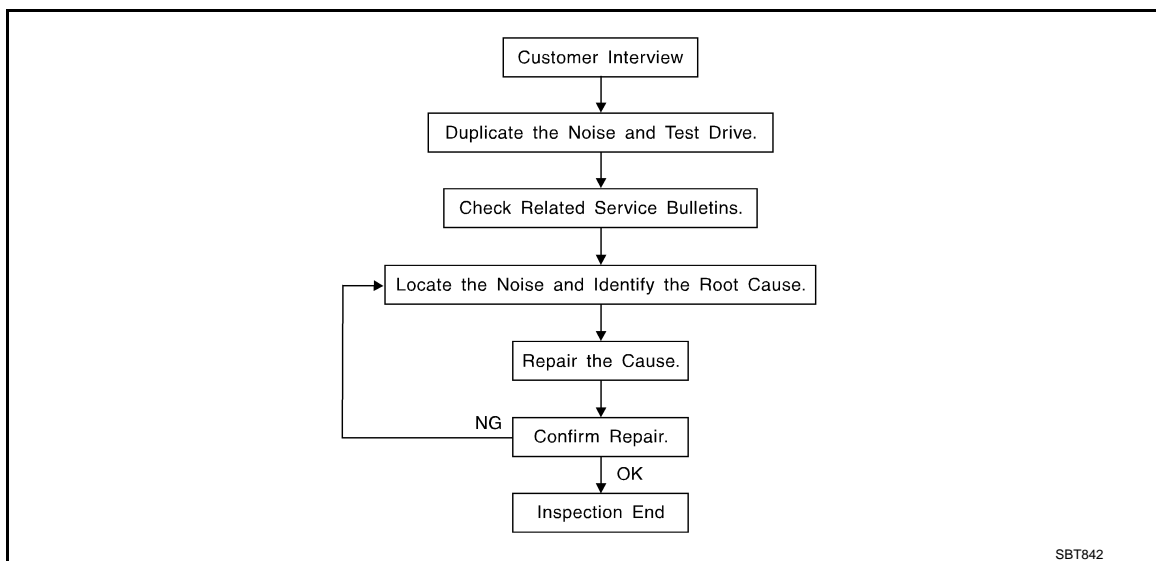

CUSTOMER INTERVIEW

Interview the customer if possible, to determine the conditions that exist when the noise occurs. Use the Diagnostic Worksheet during the interview to document the facts and conditions when the noise occurs and any of the customer's comments; refer to [RF-153, "Diagnostic Worksheet"](#). This information is necessary to duplicate the conditions that exist when the noise occurs.

- The customer may not be able to provide a detailed description or the location of the noise. Attempt to obtain all the facts and conditions that exist when the noise occurs (or does not occur).
- If there is more than one noise in the vehicle, be sure to diagnose and repair the noise that the customer is concerned about. This can be accomplished by a test drive with the customer.
- After identifying the type of noise, isolate the noise in terms of its characteristics. The noise characteristics are provided so the customer, service adviser and technician are all speaking the same language when defining the noise.
- Squeak – (Like tennis shoes on a clean floor)
Squeak characteristics include the light contact/fast movement/brought on by road conditions/hard surfaces = higher pitch noise/softer surfaces = lower pitch noises/edge to surface = chirping
- Creak – (Like walking on an old wooden floor)
Creak characteristics include firm contact/slow movement/twisting with a rotational movement/pitch dependent on materials/often brought on by activity.
- Rattle – (Like shaking a baby rattle)
Rattle characteristics include the fast repeated contact/vibration or similar movement/loose parts/missing clip or fastener/incorrect clearance.
- Knock – (Like a knock on a door)
Knock characteristics include hollow sounding/sometimes repeating/often brought on by driver action.
- Tick – (Like a clock second hand)
Tick characteristics include gentle contacting of light materials/loose components/can be caused by driver action or road conditions.
- Thump – (Heavy, muffled knock noise)
Thump characteristics include softer knock/dead sound often brought on by activity.
- Buzz – (Like a bumble bee)
Buzz characteristics include high frequency rattle/firm contact.
- Often the degree of acceptable noise level will vary depending upon the person. A noise that a technician may judge as acceptable may be very irritating to the customer.
- Weather conditions, especially humidity and temperature, may have a great effect on noise level.

DUPLICATE THE NOISE AND TEST DRIVE

If possible, drive the vehicle with the customer until the noise is duplicated. Note any additional information on the Diagnostic Worksheet regarding the conditions or location of the noise. This information can be used to duplicate the same conditions when the repair is reconfirmed.

SQUEAK AND RATTLE TROUBLE DIAGNOSES

< SYMPTOM DIAGNOSIS >

If the noise can be duplicated easily during the test drive, to help identify the source of the noise, try to duplicate the noise with the vehicle stopped by doing one or all of the following:

- 1) Close a door.
 - 2) Tap or push/pull around the area where the noise appears to be coming from.
 - 3) Rev the engine.
 - 4) Use a floor jack to recreate vehicle "twist".
 - 5) At idle, apply engine load (electrical load, half-clutch on M/T model, drive position on A/T model).
 - 6) Raise the vehicle on a hoist and hit a tire with a rubber hammer.
- Drive the vehicle and attempt to duplicate the conditions the customer states exist when the noise occurs.
 - If it is difficult to duplicate the noise, drive the vehicle slowly on an undulating or rough road to stress the vehicle body.

LOCATE THE NOISE AND IDENTIFY THE ROOT CAUSE

1. Narrow down the noise to a general area. To help pinpoint the source of the noise, use a listening tool (Engine Ear or mechanics stethoscope).
2. Narrow down the noise to a more specific area and identify the cause of the noise by:
 - Removing the components in the area that is are suspected to be the cause of the noise.
Do not use too much force when removing clips and fasteners, otherwise clips and fastener can be broken or lost during the repair, resulting in the creation of new noise.
 - Tapping or pushing/pulling the component that is are suspected to be the cause of the noise.
Do not tap or push/pull the component with excessive force, otherwise the noise will be eliminated only temporarily.
 - Feeling for a vibration by hand by touching the component(s) that is are suspected to be the cause of the noise.
 - Placing a piece of paper between components that is are suspected to be the cause of the noise.
 - Looking for loose components and contact marks.
Refer to [RF-151, "Inspection Procedure"](#).

REPAIR THE CAUSE

- If the cause is a loose component, tighten the component securely.
- If the cause is insufficient clearance between components:
 - Separate components by repositioning or loosening and retightening the component, if possible.
 - Insulate components with a suitable insulator such as urethane pads, foam blocks, felt cloth tape or urethane tape. These insulators are available through the authorized Nissan Parts Department.

CAUTION:

Never use excessive force as many components are constructed of plastic and may be damaged.

NOTE:

- URETHANE PADS
Insulates connectors, harness, etc.
- INSULATOR (Foam blocks)
Insulates components from contact. Can be used to fill space behind a panel.
- INSULATOR (Light foam block)
- FELT CLOTHTAPE
Used to insulate where movement does not occur. Ideal for instrument panel applications.
The following materials, not available through NISSAN Parts Department, can also be used to repair squeaks and rattles.
- UHMW(TEFLON) TAPE
Insulates where slight movement is present. Ideal for instrument panel applications.
- SILICONE GREASE
Used in place of UHMW tape that is be visible or does not fit.
Note: Will only last a few months.
- SILICONE SPRAY
Used when grease cannot be applied.
- DUCT TAPE
Used to eliminate movement.

CONFIRM THE REPAIR

Confirm that the cause of a noise is repaired by test driving the vehicle. Operate the vehicle under the same conditions as when the noise originally occurred. Refer to the notes on the Diagnostic Worksheet.

SQUEAK AND RATTLE TROUBLE DIAGNOSES

< SYMPTOM DIAGNOSIS >

Inspection Procedure

INFOID:000000007625533

Refer to Table of Contents for specific component removal and installation information.

INSTRUMENT PANEL

Most incidents are caused by contact and movement between:

1. Cluster lid A and instrument panel
2. Acrylic lens and combination meter housing
3. Instrument panel to front pillar garnish
4. Instrument panel to windshield
5. Instrument panel mounting pins
6. Wiring harnesses behind the combination meter
7. A/C defroster duct and duct joint

These incidents can usually be located by tapping or moving the components to duplicate the noise or by pressing on the components while driving to stop the noise. Most of these incidents can be repaired by applying felt cloth tape or silicon spray (in hard to reach areas). Urethane pads can be used to insulate wiring harness.

CAUTION:

Never use silicone spray to isolate a squeak or rattle. If the area is saturated with silicone, the recheck of repair becomes impossible.

CENTER CONSOLE

Components to pay attention to include:

1. Shifter assembly cover to finisher
2. A/C control unit and cluster lid C
3. Wiring harnesses behind audio and A/C control unit

The instrument panel repair and isolation procedures also apply to the center console.

DOORS

Pay attention to the following:

1. Finisher and inner panel making a slapping noise
2. Inside handle escutcheon to door finisher
3. Wiring harnesses tapping
4. Door striker out of alignment causing a popping noise on starts and stops

Tapping or moving the components or pressing on them while driving to duplicate the conditions can isolate many of these incidents. The areas can usually be insulated with felt cloth tape or insulator foam blocks to repair the noise.

TRUNK

Trunk noises are often caused by a loose jack or loose items put into the trunk by the customer.

In addition look for the following:

1. Trunk lid dumpers out of adjustment
2. Trunk lid striker out of adjustment
3. Trunk lid torsion bars knocking together
4. A loose license plate or bracket

Most of these incidents can be repaired by adjusting, securing or insulating the item(s) or component(s) causing the noise.

SUNROOF/HEADLINING

Noises in the sunroof/headlining area can often be traced to one of the following:

1. Sunroof lid, rail, linkage or seals making a rattle or light knocking noise
2. Sunvisor shaft shaking in the holder
3. Front or rear windshield touching headlining and squeaking

Again, pressing on the components to stop the noise while duplicating the conditions can isolate most of these incidents. Repairs usually consist of insulating with felt cloth tape.

A
B
C
D
E
F
G
H
I
J
L
M
N
O
P

RF

SQUEAK AND RATTLE TROUBLE DIAGNOSES

< SYMPTOM DIAGNOSIS >

SEATS

When isolating seat noise it is important to note the position the seat is in and the load placed on the seat when the noise occurs. These conditions should be duplicated when verifying and isolating the cause of the noise.

Cause of seat noise include:

1. Headrest rods and holder
2. A squeak between the seat pad cushion and frame
3. Rear seatback lock and bracket

These noises can be isolated by moving or pressing on the suspected components while duplicating the conditions under which the noise occurs. Most of these incidents can be repaired by repositioning the component or applying urethane tape to the contact area.

UNDERHOOD

Some interior noise may be caused by components under the hood or on the engine wall. The noise is then transmitted into the passenger compartment.

Causes of transmitted underhood noise include:

1. Any component mounted to the engine wall
2. Components that pass through the engine wall
3. Engine wall mounts and connectors
4. Loose radiator mounting pins
5. Hood bumpers out of adjustment
6. Hood striker out of adjustment

These noises can be difficult to isolate since they cannot be reached from the interior of the vehicle. The best method is to secure, move or insulate one component at a time and test drive the vehicle. Also, engine RPM or load can be changed to isolate the noise. Repairs can usually be made by moving, adjusting, securing, or insulating the component causing the noise.

SQUEAK AND RATTLE TROUBLE DIAGNOSES

< SYMPTOM DIAGNOSIS >

Diagnostic Worksheet

INFOID:000000007625534



SQUEAK & RATTLE DIAGNOSTIC WORKSHEET

Dear Infiniti Customer:

We are concerned about your satisfaction with your Infiniti vehicle. Repairing a squeak or rattle sometimes can be very difficult. To help us fix your Infiniti right the first time, please take a moment to note the area of the vehicle where the squeak or rattle occurs and under what conditions. You may be asked to take a test drive with a service consultant or technician to ensure we confirm the noise you are hearing.

I. WHERE DOES THE NOISE COME FROM? (circle the area of the vehicle)

The illustrations are for reference only, and may not reflect the actual configuration of your vehicle.

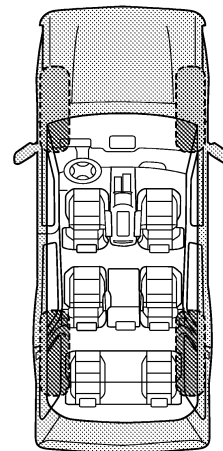
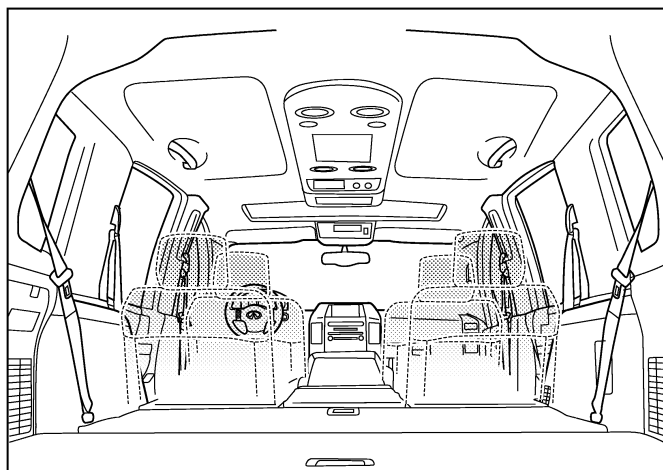
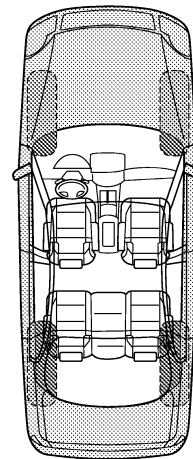
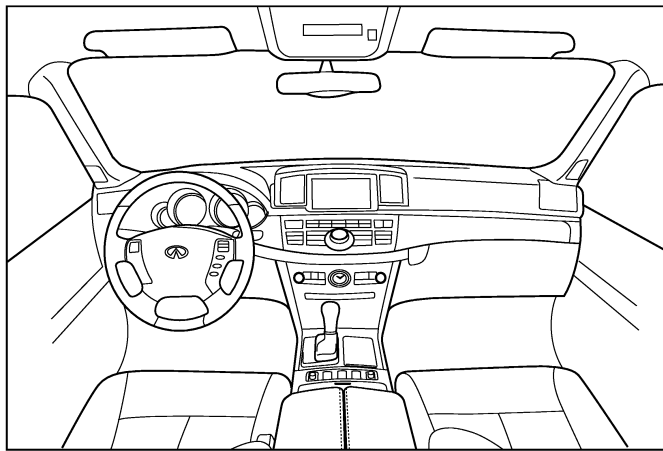

Continue to page 2 of the worksheet and briefly describe the location of the noise or rattle. In addition, please indicate the conditions which are present when the noise occurs.

PIIB8741E

A
B
C
D
E
F
G
H
I
J
RF
L
M
N
O
P

SQUEAK AND RATTLE TROUBLE DIAGNOSES

< SYMPTOM DIAGNOSIS >

SQUEAK & RATTLE DIAGNOSTIC WORKSHEET - page 2

Briefly describe the location where the noise occurs:

II. WHEN DOES IT OCCUR? (please check the boxes that apply)

- | | |
|---|--|
| <input type="checkbox"/> anytime | <input type="checkbox"/> after sitting out in the rain |
| <input type="checkbox"/> 1st time in the morning | <input type="checkbox"/> when it is raining or wet |
| <input type="checkbox"/> only when it is cold outside | <input type="checkbox"/> dry or dusty conditions |
| <input type="checkbox"/> only when it is hot outside | <input type="checkbox"/> other: |

III. WHEN DRIVING:

- through driveways
- over rough roads
- over speed bumps
- only about ____ mph
- on acceleration
- coming to a stop
- on turns: left, right or either (circle)
- with passengers or cargo
- other: _____
- after driving ____ miles or ____ minutes

IV. WHAT TYPE OF NOISE

- squeak (like tennis shoes on a clean floor)
- creak (like walking on an old wooden floor)
- rattle (like shaking a baby rattle)
- knock (like a knock at the door)
- tick (like a clock second hand)
- thump (heavy, muffled knock noise)
- buzz (like a bumble bee)

TO BE COMPLETED BY DEALERSHIP PERSONNEL

Test Drive Notes:

	YES	NO	Initials of person performing
Vehicle test driven with customer	<input type="checkbox"/>	<input type="checkbox"/>	_____
- Noise verified on test drive	<input type="checkbox"/>	<input type="checkbox"/>	_____
- Noise source located and repaired	<input type="checkbox"/>	<input type="checkbox"/>	_____
- Follow up test drive performed to confirm repair	<input type="checkbox"/>	<input type="checkbox"/>	_____

VIN: _____ Customer Name: _____
W.O.# _____ Date: _____

This form must be attached to Work Order

PIIB8742E

SOFT TOP

< REMOVAL AND INSTALLATION >

REMOVAL AND INSTALLATION

SOFT TOP

SOFT TOP ASSEMBLY

SOFT TOP ASSEMBLY : Exploded View

INFOID:000000007625535

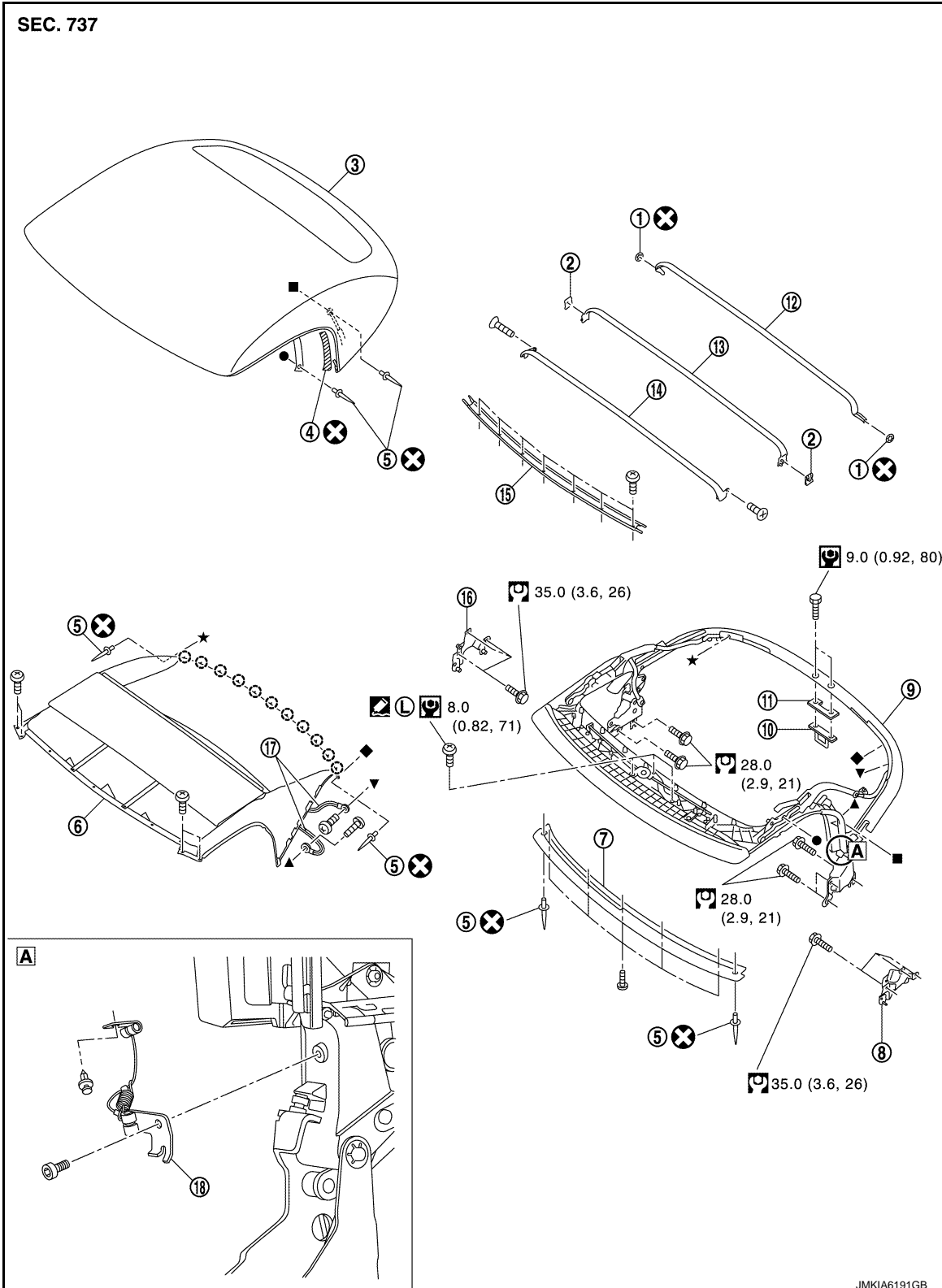

A
B
C
D
E
F
G
H
I
J
L
M
N
O
P

SOFT TOP

< REMOVAL AND INSTALLATION >

- | | | |
|--|---------------------------------|-----------------------------------|
| 1. Push on nut | 2. Retaining plate | 3. Soft top cover outer |
| 4. Double-sided tape | 5. Rivet | 6. Soft top cover inner |
| 7. Soft top cover outer front retainer | 8. Soft top mounting bracket LH | 9. Soft top linkage assembly |
| 10. Rear lock striker | 11. Rear lock striker bracket | 12. 4th bow |
| 13. 3rd bow | 14. 2nd bow | 15. Soft top cover inner retainer |
| 16. Soft top mounting bracket RH | 17. Bungee cord | 18. Flipper door cable |

 : Clip

Refer to [GI-4. "Components"](#) for symbols in the figure.

SOFT TOP ASSEMBLY : Removal and Installation

INFOID:000000007625536

REMOVAL

CAUTION:

Protect the vehicle body using fender cover.

1. Operate soft top assembly as shown in the figure.

CAUTION:

Storage lid assembly may close due to low oil pressure.
Always support storage lid assembly to the fully open position using a supporting block.

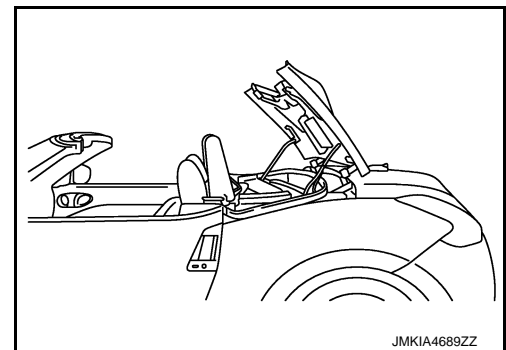

2. Remove seat belt shoulder anchor bolt (LH and RH). Refer to [SB-8. "SEAT BELT RETRACTOR : Exploded View"](#).
3. Remove kicking plate inner (LH and RH), body side welt (LH and RH) (rear side finisher portion), and rear side finisher (LH and RH). Refer to [INT-18. "Exploded View"](#).
4. Remove seat belt from seat belt guide (LH and RH). Refer to [SB-8. "SEAT BELT RETRACTOR : Exploded View"](#).
5. Remove mounting screw (A) and clip (B). Remove flipper door cable.

CAUTION:

Be careful not to drop mounting screw and clip into storage lid room.

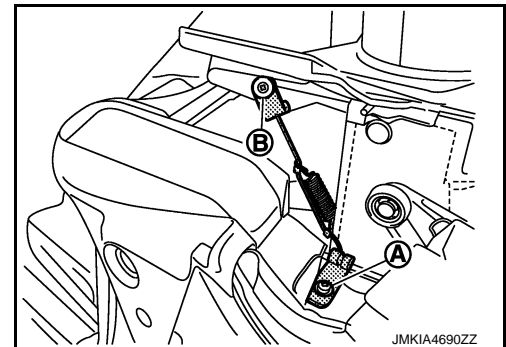

6. Operate soft top assembly as shown in the figure.

CAUTION:

Storage lid assembly may close due to low oil pressure.
Always support storage lid assembly to the fully open position using a supporting block.

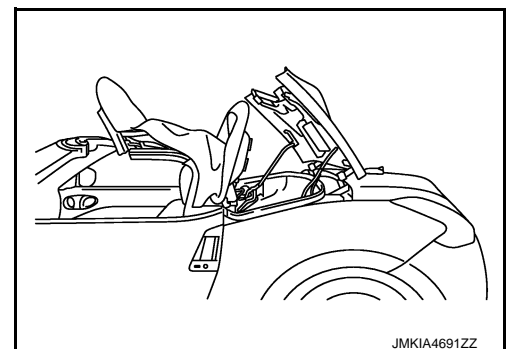

SOFT TOP

< REMOVAL AND INSTALLATION >

7. Disconnect battery cable from negative terminal.
8. Remove bumper rubber, and then pull up storage room finisher. Refer to [RF-222, "STORAGE ROOM FINISHER : Exploded View"](#).
9. Remove storage room spacer. Refer to [RF-222, "STORAGE ROOM FINISHER : Exploded View"](#).
10. Remove harness bracket from storage device assembly. Refer to [RF-214, "STORAGE LID DEVICE ASSEMBLY : Exploded View"](#).
11. Remove oil pressure hose fixing clips from storage lid assembly.
NOTE:
Write a short note to describe the fixing clip positions.
CAUTION:
Never sharply bend, twist, or strongly pull oil pressure hose.
12. Disconnect 5th bow latch cylinder and harness connector from storage lid bracket assembly. Refer to [RF-217, "STORAGE LID BRACKET ASSEMBLY : Removal and Installation"](#).
13. Disconnect storage lid drive cylinder from storage lid device assembly (LH and RH). Refer to [RF-215, "STORAGE LID DEVICE ASSEMBLY : Removal and Installation"](#).
CAUTION:
Never sharply bend, twist or strongly pull oil pressure hose.
14. Remove oil pressure hose fixing clips and bolts located in storage room.
NOTE:
Write a short note to describe the fixing clip positions.
CAUTION:
Never sharply bend, twist, or strongly pull oil pressure hose.
15. Disconnect vehicle harness connectors (A).

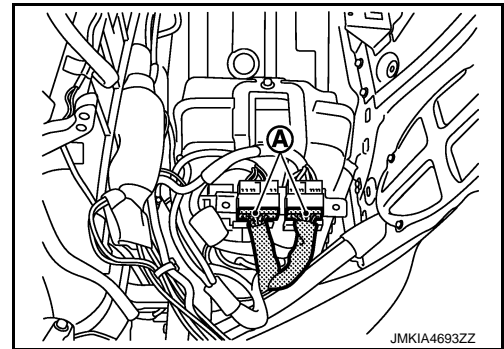

16. Remove hydraulic pump mounting nuts (A).

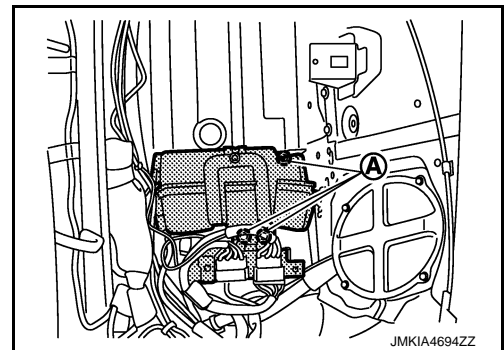

17. Remove soft top assembly mounting bolts (A) (LH and RH).
CAUTION:
Never remove soft top mounting bracket.

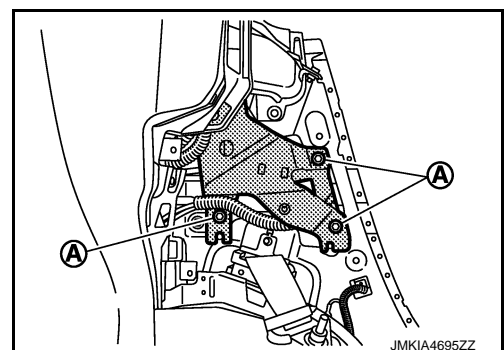

SOFT TOP

< REMOVAL AND INSTALLATION >

18. Remove soft top assembly.

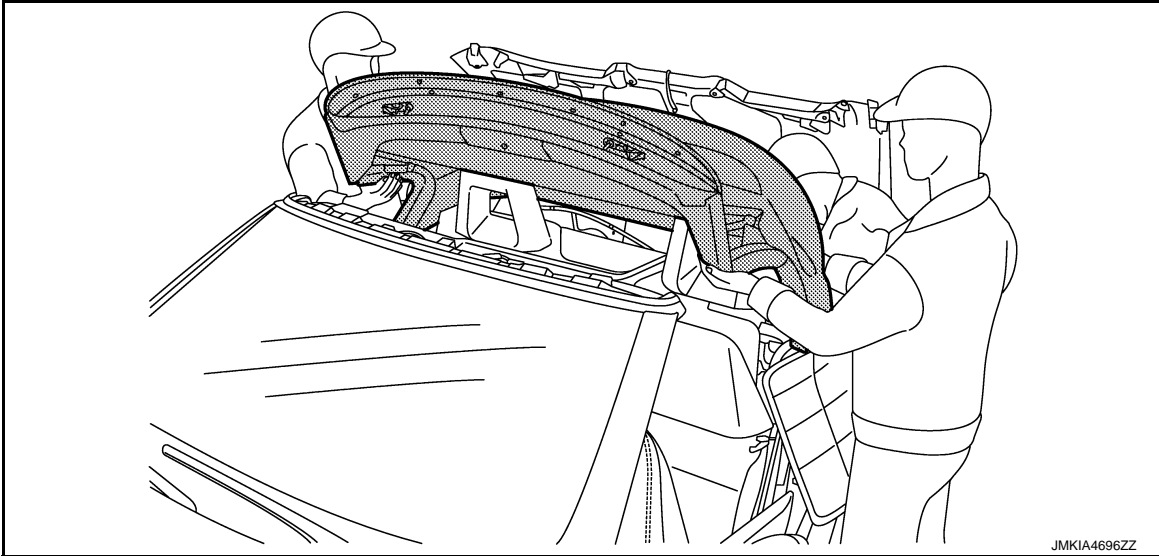

CAUTION:

- This is a heavy component. 3 or more workers are required.
- Be careful that soft top assembly does not interfere with the vehicle body.
- Never sharply bend, twist, or strongly pull oil pressure hose.
- Place soft top assembly after removal as shown in the figure.

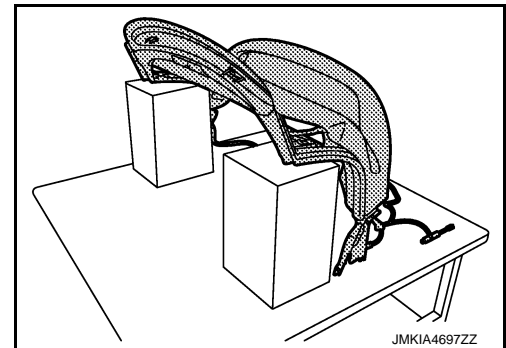

INSTALLATION

Note the following items, and install in the reverse order of removal.

CAUTION:

- Manually operate and check that soft top assembly operates without interfering with other portions of the vehicle body.
Before manually operating each cylinder of the hydraulic system, turn ignition switch OFF or disconnect battery cable from the negative terminal, then wait for 4 minutes or more. (Each cylinder maintains oil pressure and therefore it takes a period of time to lower oil pressure.)
- Perform fitting adjustment after installing soft top assembly. Refer to [RF-158, "SOFT TOP ASSEMBLY : Adjustment"](#).
- Perform door glass fitting adjustment after soft top assembly fitting adjustment. Refer to [GW-21, "Inspection and Adjustment"](#).
- Perform leakage test. Refer to [RF-58, "Water Leakage Test"](#).

SOFT TOP ASSEMBLY : Adjustment

INFOID:000000007625537

FITTING ADJUSTMENT

SOFT TOP

< REMOVAL AND INSTALLATION >

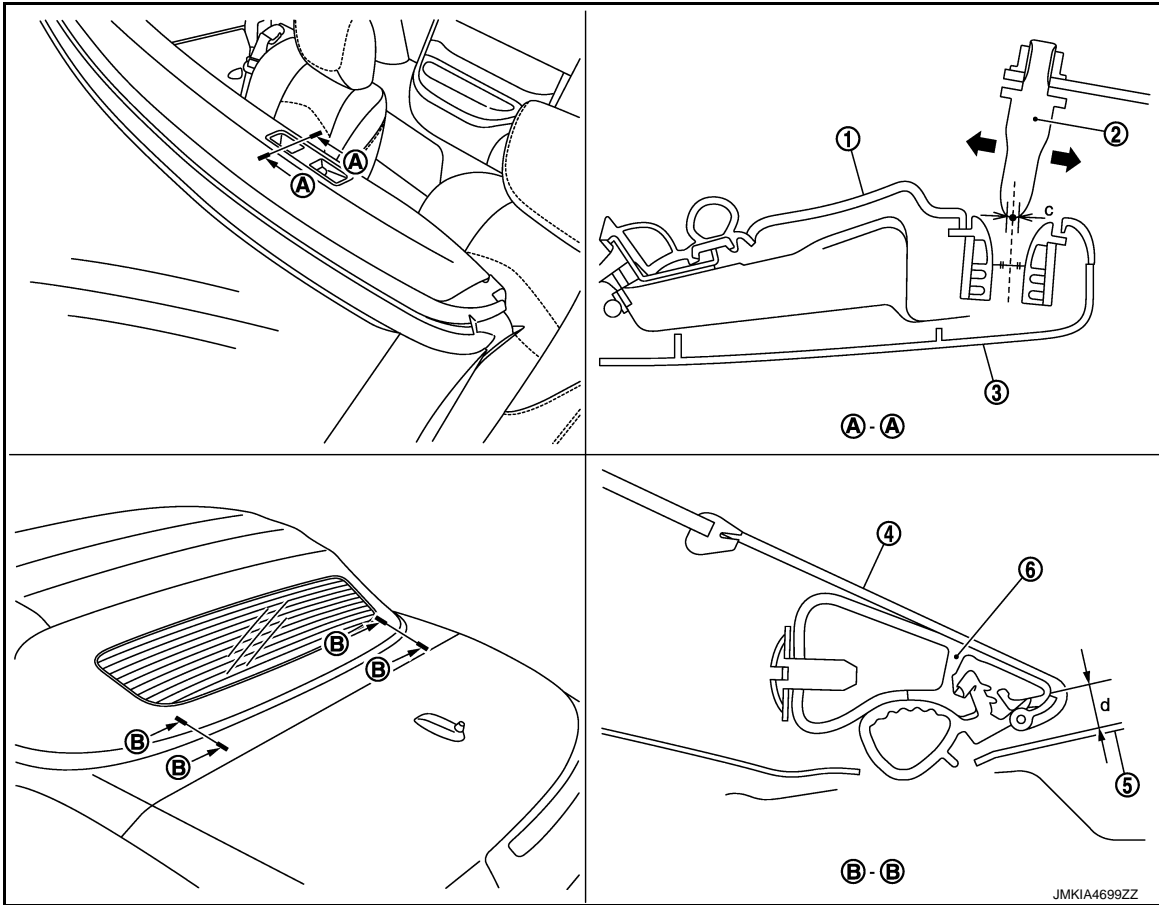

- | | | |
|--|-------------------------|------------------------|
| 1. Front roof cover | 2. Locating pin | 3. Roof front finisher |
| 4. Soft top assembly | 5. Storage lid assembly | 6. 5th bow |
| c. (-2.0) - (+2.0) mm [(-0.079) - (+0.079) in] | | |
| d. 7.0 - 13.0 mm (0.276 - 0.512 in) | | |

Visually and tactually check that the clearance and surface height difference of the soft top assembly and each part satisfy the standard. If they are outside the specified value, adjust them with the following procedure.

CAUTION:

Before manually operating each cylinder of hydraulic system, turn ignition switch OFF or disconnect battery cable from the negative terminal, then wait for 4 minutes or more. (Each cylinder maintains oil pressure and therefore it takes a period of time to lower oil pressure.)

FITTING ADJUSTMENT PROCEDURE

- Check soft top installation status.
 - Remove the rear side finisher (LH and RH). Refer to [INT-18, "Exploded View"](#).
 - Check that soft top assembly (1) overrides front and rear pins (A) of soft top mounting bracket (2) without clearance.

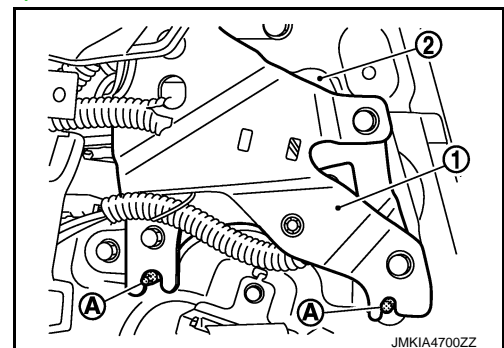

- Check and adjust the locating pin position.
Check the position.

A
B
C
D
E
F
G
H
I
J

RF

L
M
N
O
P

SOFT TOP

< REMOVAL AND INSTALLATION >

- Operate soft top as shown in the figure.

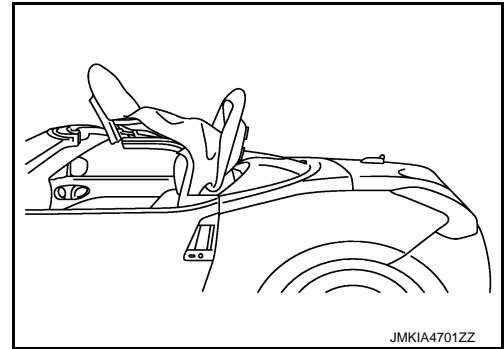

- Set clay (A) on the position that striker locating pin enters (LH and RH).

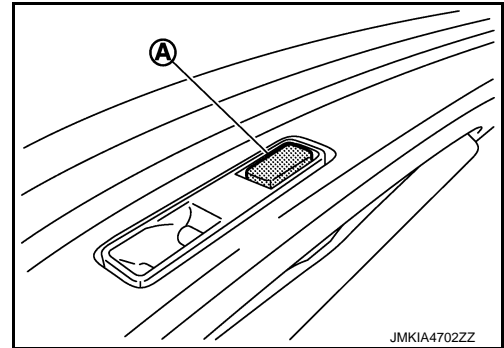

- Manually operate soft top assembly so that the locating pin touches the clay. Check the locating pin position (LH and RH).

Position adjustment

- Fully open storage lid assembly. Completely store soft top assembly.

CAUTION:

**Storage lid assembly may close due to low oil pressure.
Always support storage lid assembly in the fully open position.**

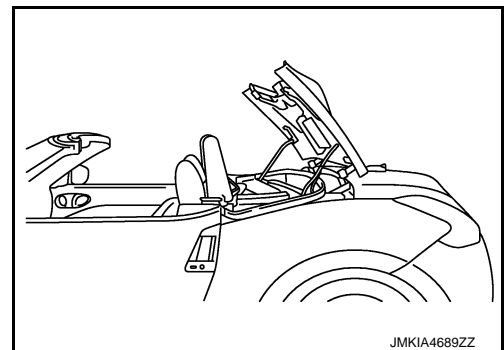

- Remove mounting screw (A) and clip (B). Remove flipper door cable (LH and RH).

CAUTION:

Be careful not to drop mounting screw and clip into storage lid room.

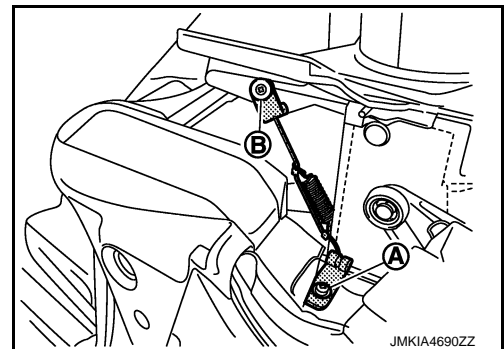

- Adjust the position using adjusting bolt (A) so that the locating pin comes to $(-2.0) - (+2.0)$ mm [$(-0.079) - (+0.079)$ in] of the striker center position.

SOFT TOP

< REMOVAL AND INSTALLATION >

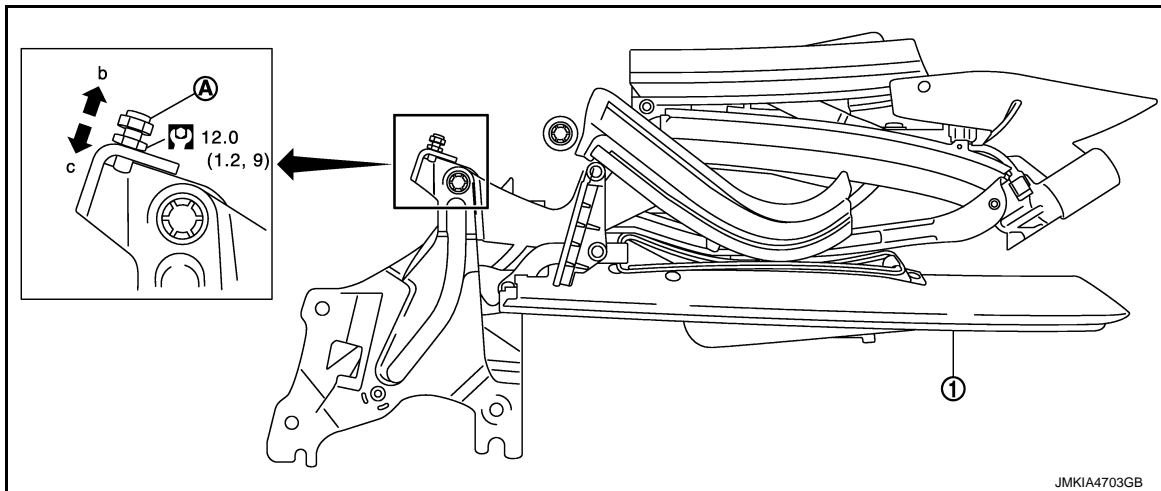

1. Soft top assembly
- b. Adjusting direction when the locating pin position is excessively frontward
- c. Adjusting direction when the locating pin position is excessively rearward

- Install the removed parts.

3. Check and adjust the 5th bow position.
Check the position.
 - Operate soft top as shown in the figure.

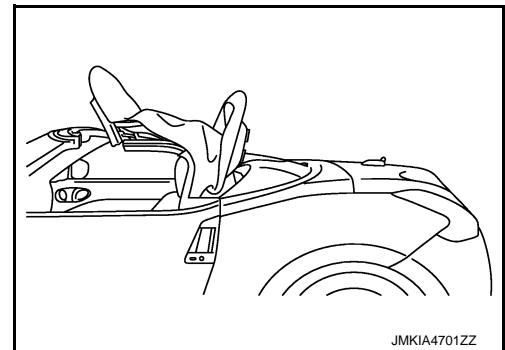

- Manually open storage lid assembly and soft top assembly fully. Lock 1st bow latch. Refer to [RF-23, "SOFT TOP SYSTEM : Correspondence in Emergency"](#).

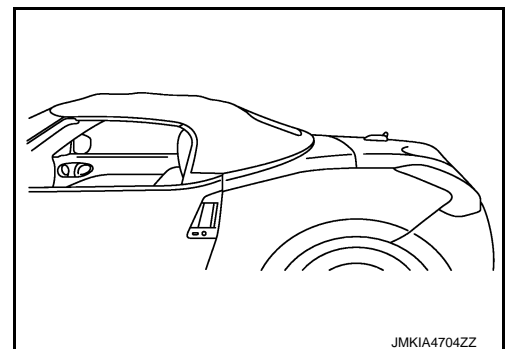

- Check the clearance between 5th bow and storage lid assembly.
Position adjustment

SOFT TOP

< REMOVAL AND INSTALLATION >

- Operate soft top as shown in the figure.

CAUTION:

Storage lid assembly may close due to low oil pressure.
Always support storage lid assembly in the fully open position using a supporting block.

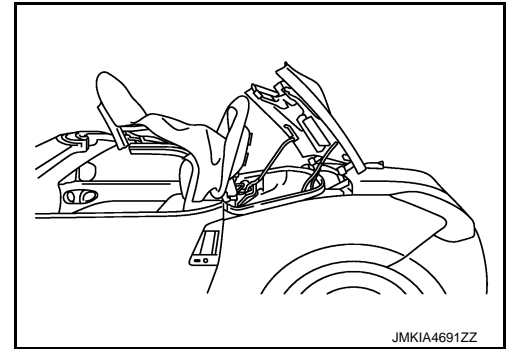

- Adjust the clearance between 5th bow and storage lid assembly to the standard using adjusting bolt.

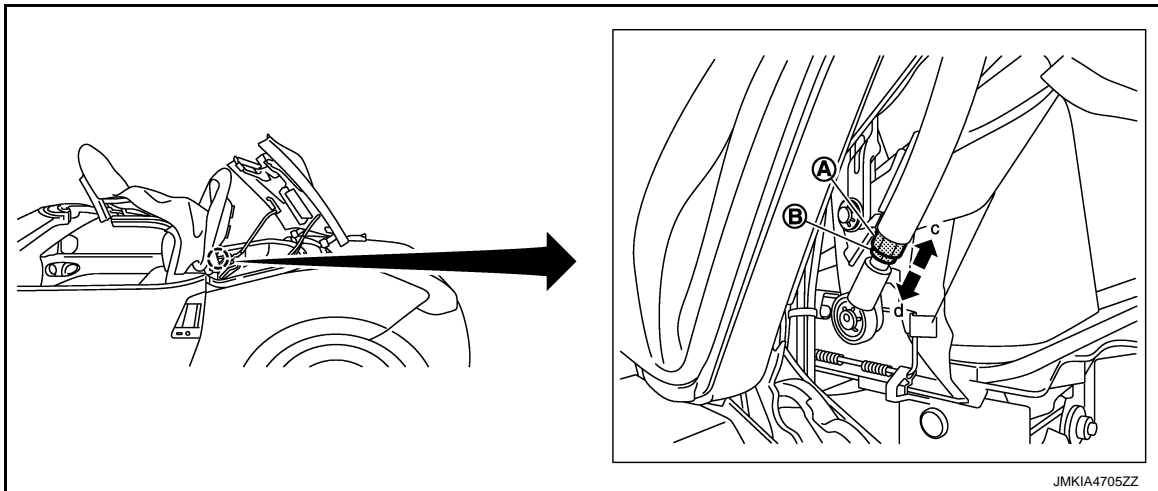

- A. Adjusting bolt
- B. Lock nut
- c. Clearance is narrowed.
- d. Clearance is widened.

4. Install the removed parts.

SOFT TOP COVER OUTER

SOFT TOP

< REMOVAL AND INSTALLATION >

SOFT TOP COVER OUTER : Exploded View

INFOID:000000007625538

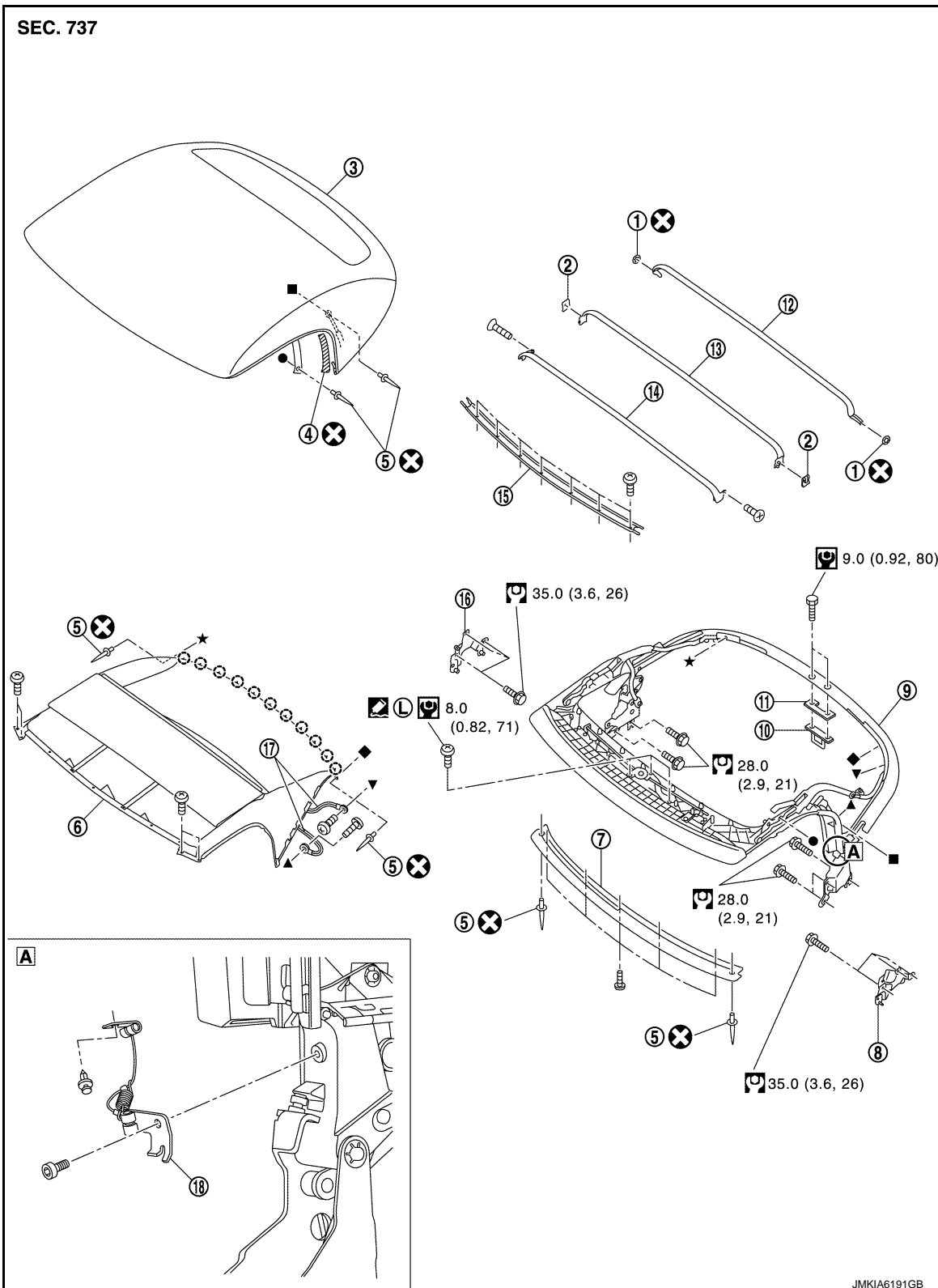

- | | | |
|--|---------------------------------|------------------------------|
| 1. Push on nut | 2. Retaining plate | 3. Soft top cover outer |
| 4. Double-sided tape | 5. Rivet | 6. Soft top cover inner |
| 7. Soft top cover outer front retainer | 8. Soft top mounting bracket LH | 9. Soft top linkage assembly |
| 10. Rear lock striker | 11. Rear lock striker bracket | 12. 4th bow |

SOFT TOP

< REMOVAL AND INSTALLATION >

- | | | |
|----------------------------------|-----------------|-----------------------------------|
| 13. 3rd bow | 14. 2nd bow | 15. Soft top cover inner retainer |
| 16. Soft top mounting bracket RH | 17. Bungee cord | 18. Flipper door cable |

○ : Clip

Refer to [GI-4, "Components"](#) for symbols in the figure.

SOFT TOP COVER OUTER : Removal and Installation

INFOID:000000007625539

REMOVAL

1. Operate soft top as shown in the figure.

CAUTION:

Storage lid assembly may close due to low oil pressure. Always support storage lid assembly in the fully open position using a supporting block.

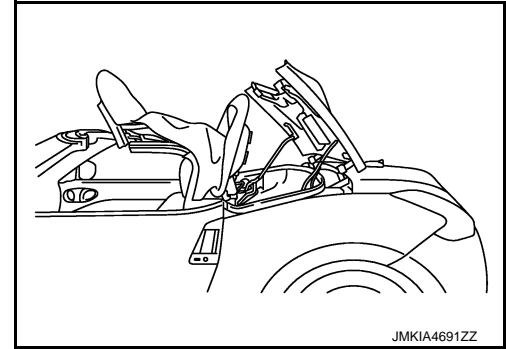

2. Remove front rail weather-strip (LH and RH). Refer to [RF-188, "ROOF SEALING : Exploded View"](#).
3. Remove front rail weather-strip retainer (LH and RH). Refer to [RF-188, "ROOF SEALING : Exploded View"](#).
4. Remove soft top cover outer front retainer mounting screws (A).

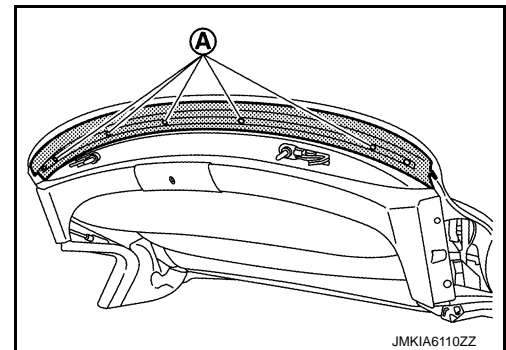

5. Lift up soft top cover outer front retainer (1), and then pull up soft top cover outer (2) portion (A) to outside (both LH and RH).

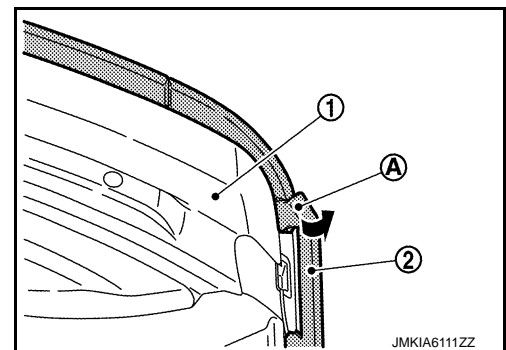

SOFT TOP

< REMOVAL AND INSTALLATION >

6. Pull out soft top cover outer wire (2) from soft top linkage assembly (1) (both LH and RH).

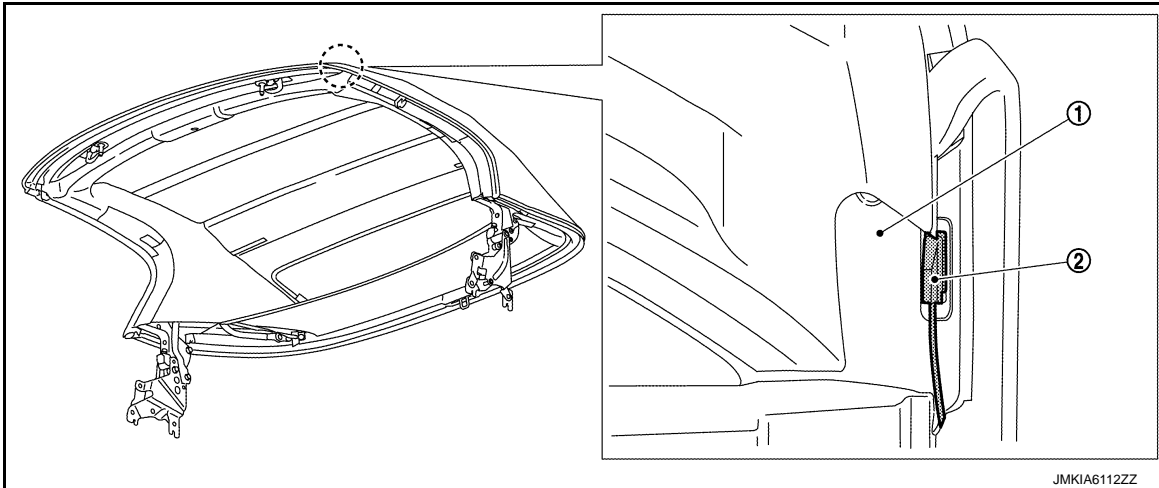

7. Pull up front end of soft top cover outer.

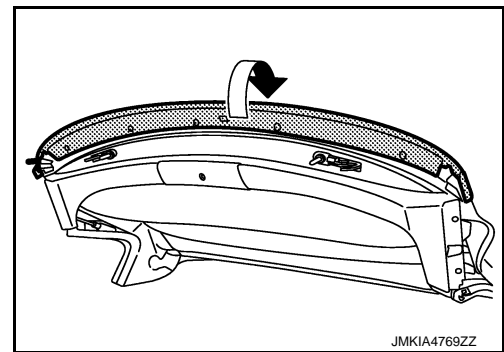

8. Remove mounting rivet (A) of soft top outer bungee cord (1) from soft top linkage assembly (2) (LH and RH).

CAUTION:
Cover the surrounding area because iron powder is spread when using a drill.

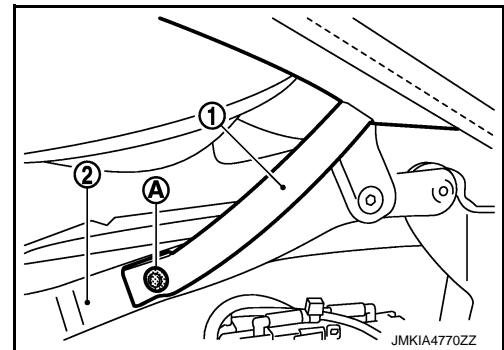

NOTE:
Removal and Installation of Rivet

A
B
C
D
E
F
G
H
I
J
RF
L
M
N
O
P

SOFT TOP

< REMOVAL AND INSTALLATION >

- Grind the head of rivet (1) with a drill (A) [bit of ϕ 4.0 mm (ϕ 0.157 in)].
- Securely crimp the bungee cord with the soft top linkage assembly using a hand riveter (B).

Crimping thickness : 9.5 - 12.7 mm (0.374 - 0.500 in)
Prepared hole diameter : ϕ 4.1 - 4.2 mm (0.161 - 0.165 in)
Used rivet head diameter : ϕ 7.5 mm (0.295 in)

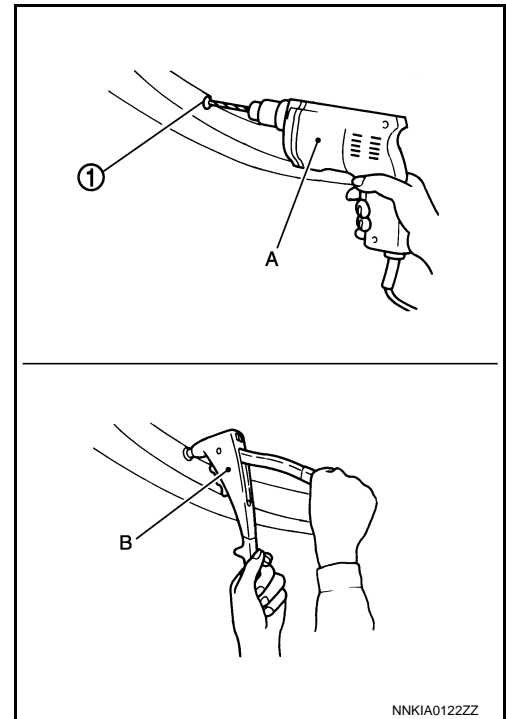

9. Remove soft top cover inner mounting screws (A) from 1st bow (1) (LH and RH).

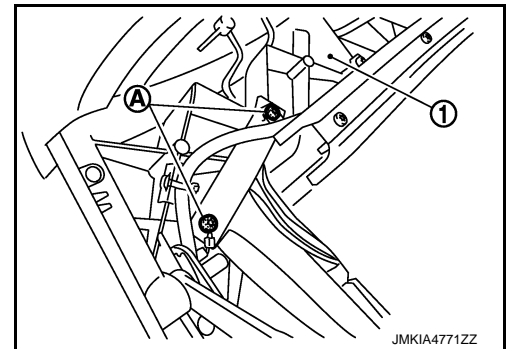

10. Remove mounting screws (A) of soft top cover inner retainer (2) from 1st bow (1).

NOTE:

Soft top cover inner straps (B) and soft top cover inner are tightened together to 1st bow.

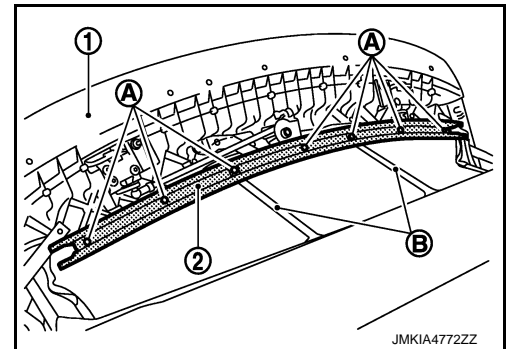

11. Remove 2nd bow mounting bolts.

12. Remove soft top linkage assembly bungee cord (A) from 2nd bow (1) (LH and RH).

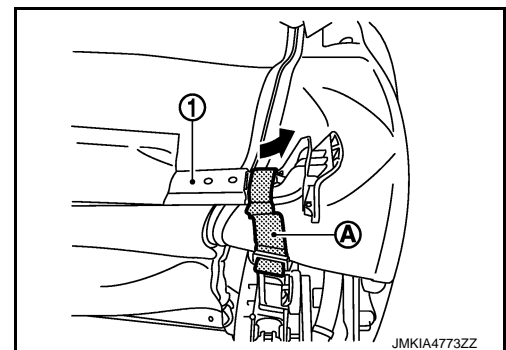

SOFT TOP

< REMOVAL AND INSTALLATION >

13. Pull out wire (2) from soft top cover outer (1) (LH and RH).

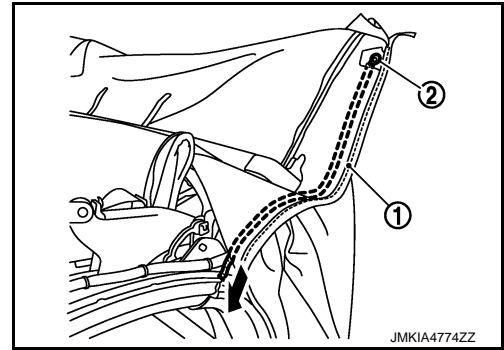

14. Pull out soft top cover inner strap through soft top cover outer hole.

NOTE:

Locations of soft top cover outer (1), strap (2), and soft top cover inner (3) for 2nd bow are as shown in the figure.

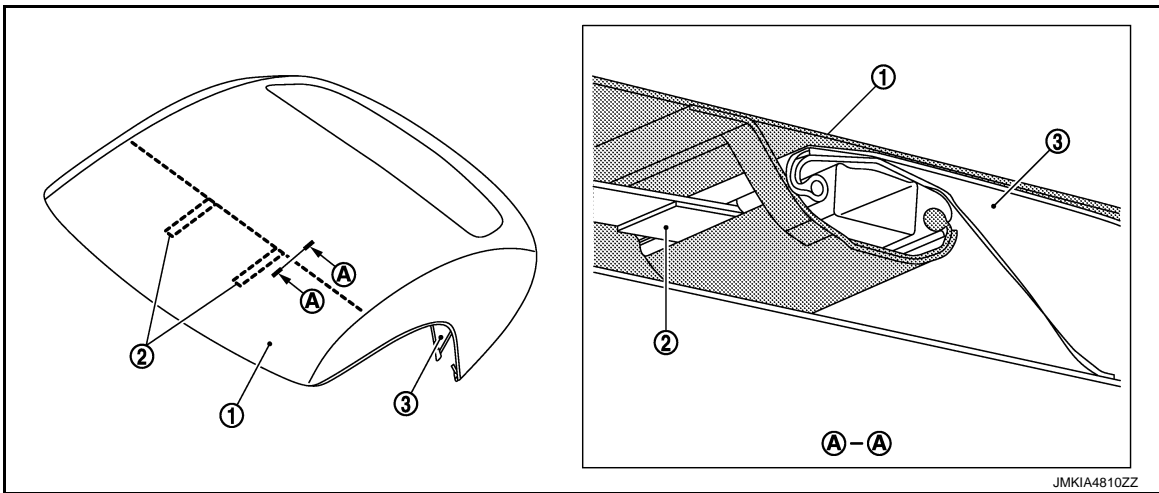

15. Pull out 2nd bow from soft top cover outer and soft top cover inner.

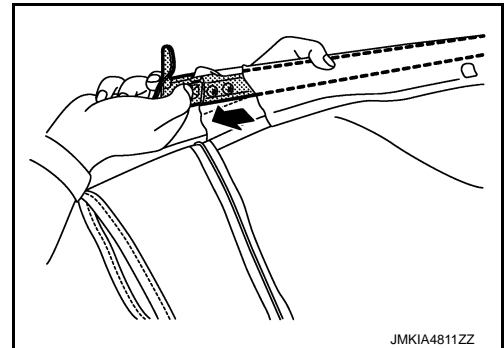

NOTE:

A
B
C
D
E
F
G
H
I
J
RF
L
M
N
O
P

SOFT TOP

< REMOVAL AND INSTALLATION >

Locations of soft top cover outer (2) and soft top cover inner (3) for 2nd bow (1) are as shown in the figure.

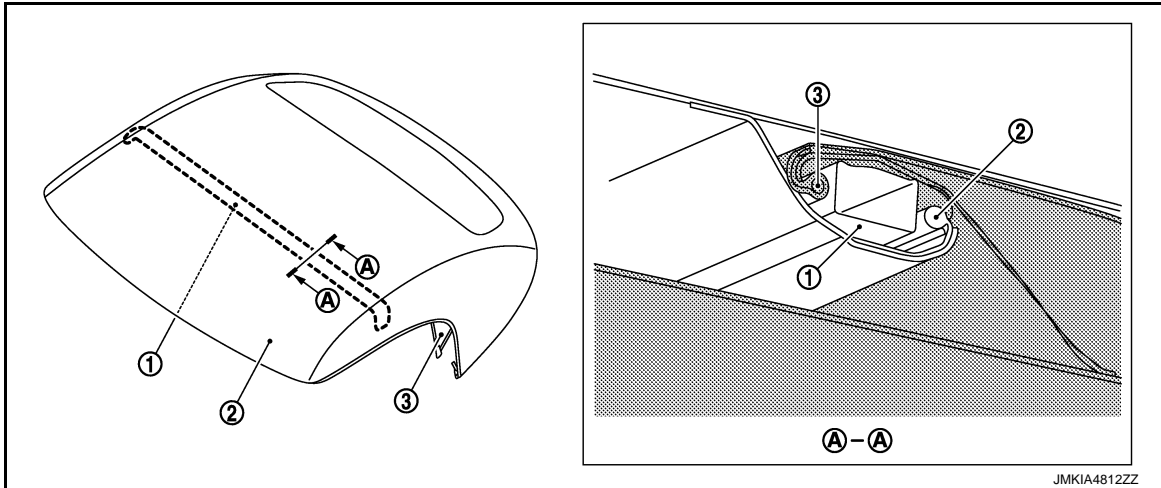

16. Remove stopper. Manually disconnect zipper connection (A) of soft top cover outer (1) and soft top cover inner (2).

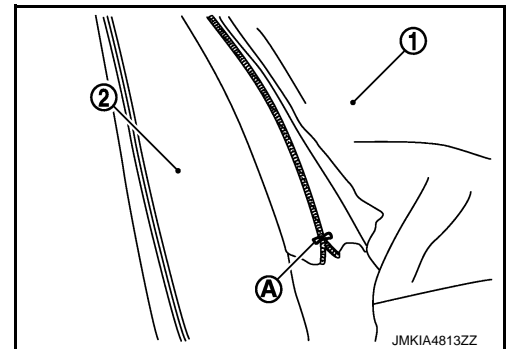

17. Remove rear rail weather-strip. Refer to [RF-188, "ROOF SEALING : Exploded View"](#).
18. Remove rear rail weather-strip retainer (LH and RH). Refer to [RF-188, "ROOF SEALING : Exploded View"](#).
19. Remove rear end of soft top cover outer (2) from 5th bow (1).

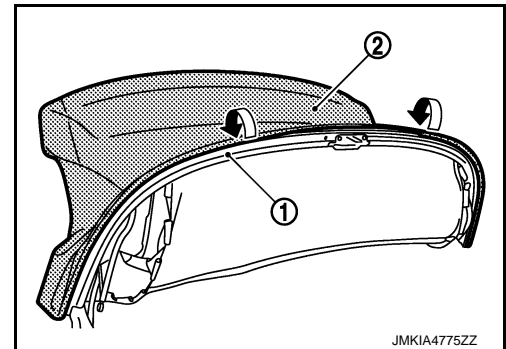

20. Pull up soft top cover outer lateral side to outside from upper to lower. Remove double-sided tape (A) (LH and RH).

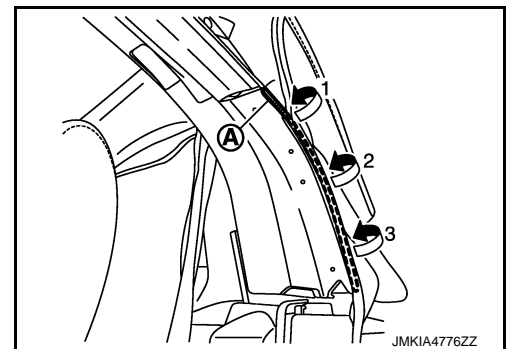

SOFT TOP

< REMOVAL AND INSTALLATION >

21. Remove E-clips (A). Disengage connection of soft top cover outer wire (2) from soft top linkage assembly pin (1) (LH and RH).

← : Vehicle front

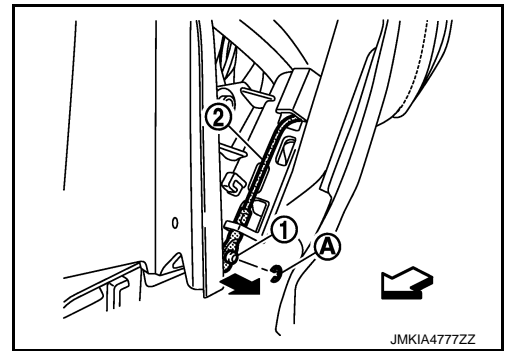

22. Slide soft top cover outer (1) in the direction shown by the arrow. Simultaneously pull out retainer (3) and wire (4) from soft top linkage assembly (2) (LH and RH).

CAUTION:

Write a short note to describe the wire locations and the retainer mounting positions.

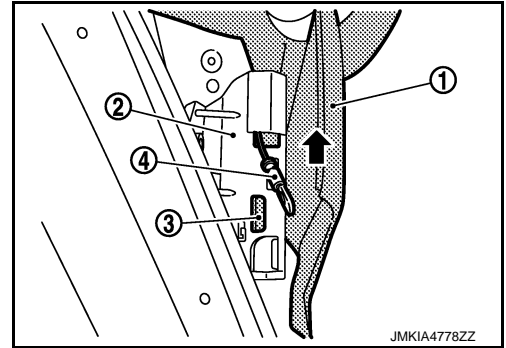

23. Manually operate soft top linkage assembly to the open position.
24. Pull up soft top cover outer lateral side to outside. Remove rivet (A) and screw (B) that secure soft top cover outer bungee cord (1) (LH and RH).

CAUTION:

Cover the surrounding area because iron powder is spread when using a drill.

← : Vehicle front

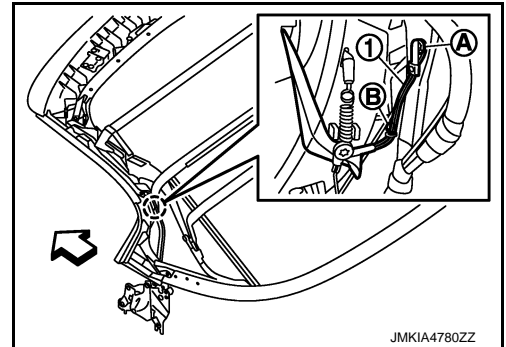

NOTE:

Removal and Installation of Rivet

A
B
C
D
E
F
G
H
I
J
RF
L
M
N
O
P

SOFT TOP

< REMOVAL AND INSTALLATION >

- Grind the head of rivet (1) with a drill (A) [bit of ϕ 4.0 mm (ϕ 0.157 in)].
- Securely crimp the bungee cord with the soft top linkage assembly using a hand riveter (B).

Crimping thickness	: 4.8 - 8.0 mm (0.189 - 0.315 in)
Prepared hole diameter	: ϕ 4.1 - 4.2 mm (0.161 - 0.165 in)
Used rivet head diameter	: ϕ 12.0 mm (0.472 in)

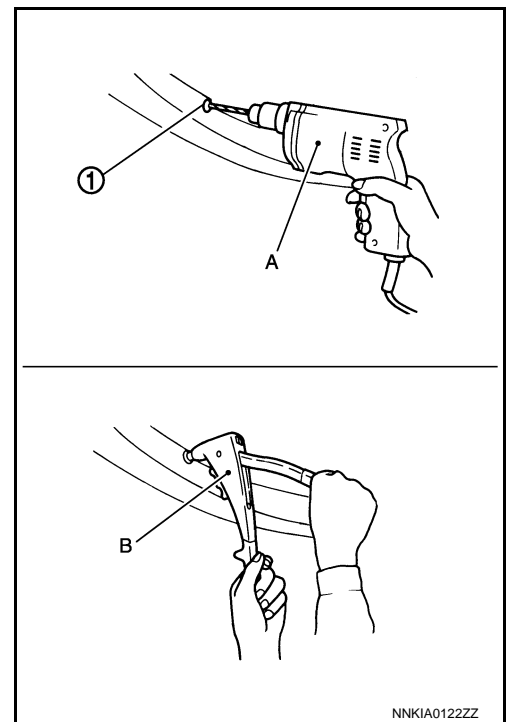

25. Remove rear defogger connector. Pull out rear defogger harness from soft top inner (LH and RH).
26. Pull up soft top cover outer rear end.

CAUTION:

Be careful when performing operation because rear glass is moved.

27. Remove mounting screw (A). Pull out soft top cover outer bungee cord (1) from D-ring (B) (LH and RH).

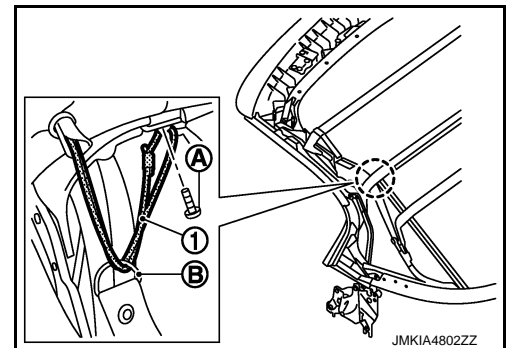

28. Remove retaining plate (A) of 3rd bow (1), and then remove pin (2) (LH and RH).

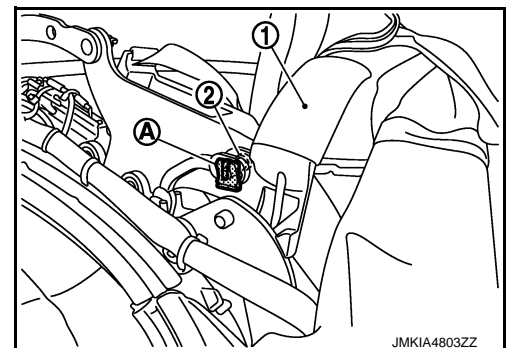

SOFT TOP

< REMOVAL AND INSTALLATION >

29. Press inside 3rd bow soft top linkage assembly mounting portion. Disengage and remove the connections (A) one side at a time.

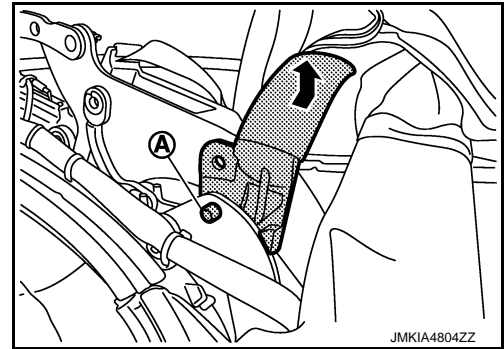

30. Remove push on nut (A) from 4th bow (1) (LH and RH).

31. Remove 4th bow from soft top linkage assembly.

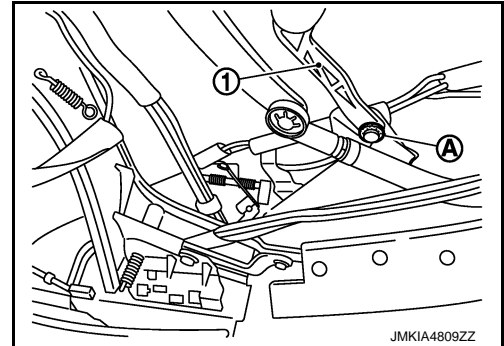

32. Pull out and remove 4th bow and soft top cover outer from soft top cover inner as a set.

33. Pull out and remove soft top cover outer from 4th bow.

NOTE:

Locations of soft top cover outer (2) and soft top cover inner (3) for 4th bow (1) are as shown in the figure.

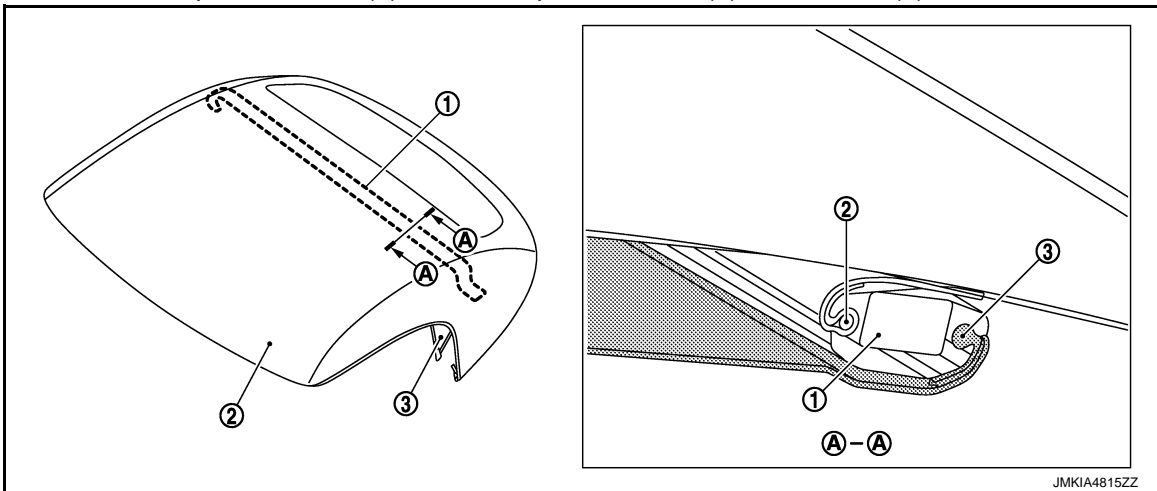

INSTALLATION

Note the following items, and install in the reverse order of removal.

CAUTION:

- Replace double-sided tape that fixes soft top cover outer to soft top linkage assembly with new tape.
- Perform door glass fitting adjustment after soft top assembly fitting adjustment. Refer to [GW-21, "Inspection and Adjustment"](#).
- Perform leakage test. Refer to [RF-58, "Water Leakage Test"](#).

NOTE:

A
B
C
D
E
F
G
H
I
J
RF
L
M
N
O
P

SOFT TOP

< REMOVAL AND INSTALLATION >

- When installing soft top cover outer (2) to 5th bow (1), install soft top cover outer portion (B) to 5th bow rear end groove using a removal tool as shown in the figure.

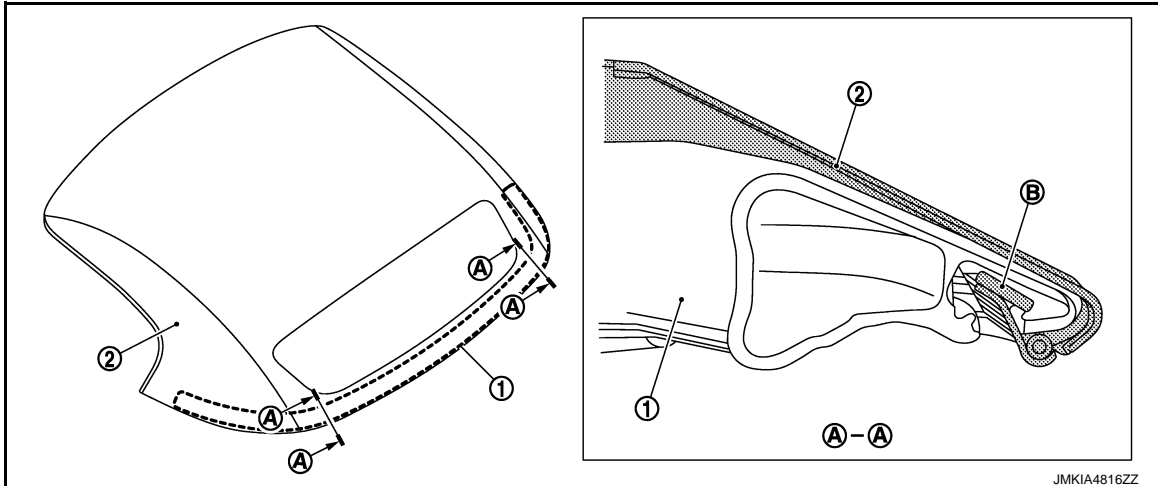

- Connecting procedure for soft top cover outer and soft top cover inner

- Connect using a slider (A).
- Align zipper ends of soft top cover outer (1) and soft top cover inner (2). Slightly slide slider. Fix connecting portion of zipper using a stopper (B).

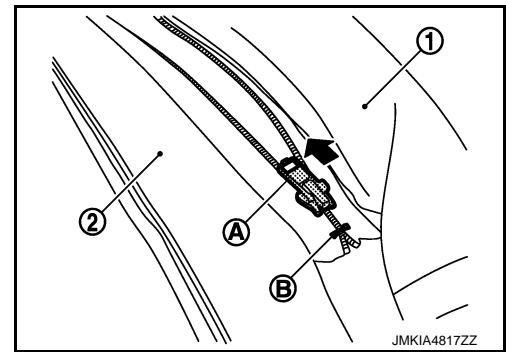

- Slide slider until slider is removed from zipper. Using a stopper (A), fix connection portion of zipper on the side where slider is removed.

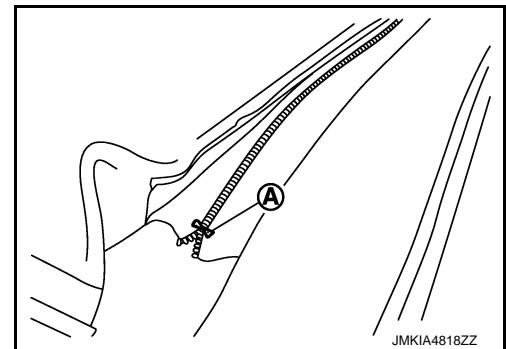

- When installing push on nut (1), crimp it using water pump pliers (A) and socket (B).

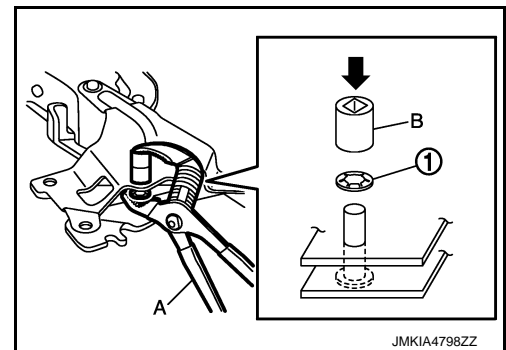

SOFT TOP COVER INNER

SOFT TOP

< REMOVAL AND INSTALLATION >

SOFT TOP COVER INNER : Exploded View

INFOID:000000007625540

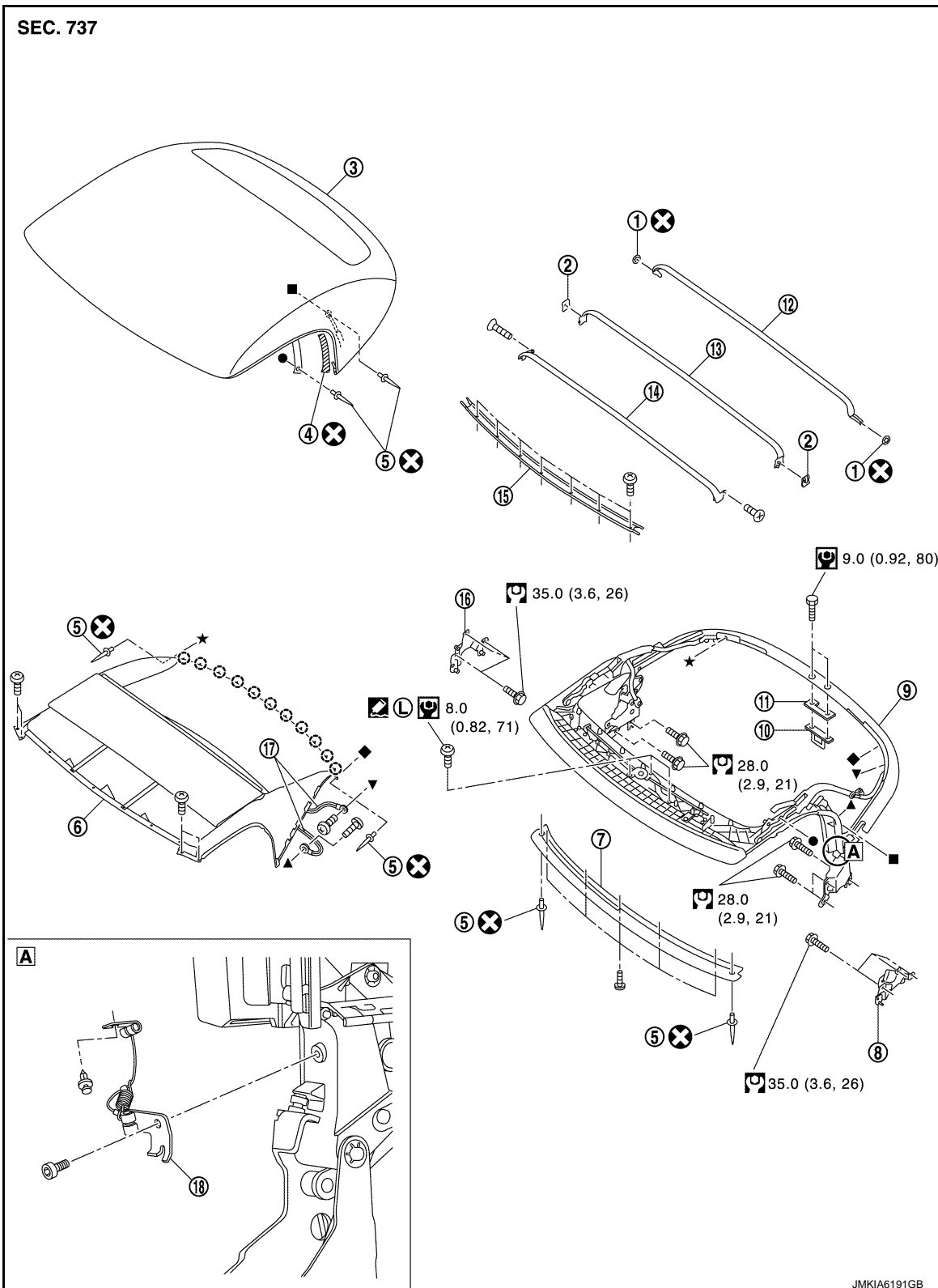

A
B
C
D
E
F
G
H
I
J
RF
L
M
N
O
P

- | | | |
|--|---------------------------------|------------------------------|
| 1. Push on nut | 2. Retaining plate | 3. Soft top cover outer |
| 4. Double-sided tape | 5. Rivet | 6. Soft top cover inner |
| 7. Soft top cover outer front retainer | 8. Soft top mounting bracket LH | 9. Soft top linkage assembly |
| 10. Rear lock striker | 11. Rear lock striker bracket | 12. 4th bow |

JMKIA6191GB

SOFT TOP

< REMOVAL AND INSTALLATION >

- | | | |
|----------------------------------|-----------------|-----------------------------------|
| 13. 3rd bow | 14. 2nd bow | 15. Soft top cover inner retainer |
| 16. Soft top mounting bracket RH | 17. Bungee cord | 18. Flipper door cable |

○ : Clip

Refer to [GI-4, "Components"](#) for symbols in the figure.

SOFT TOP COVER INNER : Removal and Installation

INFOID:000000007625541

REMOVAL

1. Operate soft top as shown in the figure.

CAUTION:

Storage lid assembly may close due to low oil pressure. Always support storage lid assembly in the fully open position using a supporting block.

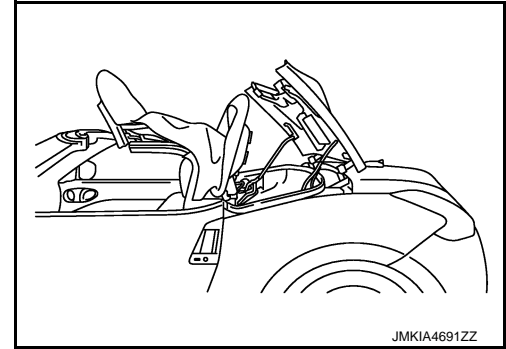

2. Remove front rail weather-strip. (LH and RH) Refer to [RF-188, "ROOF SEALING : Exploded View"](#).
3. Remove front rail weather-strip retainer. (LH and RH) Refer to [RF-188, "ROOF SEALING : Exploded View"](#).
4. Remove soft top cover outer front retainer mounting screws (A).

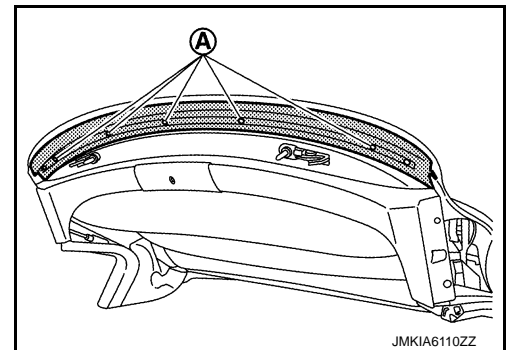

5. Lift up soft top cover outer front retainer (1), and then pull up soft top cover outer (2) portion (A) to outside (both LH and RH).

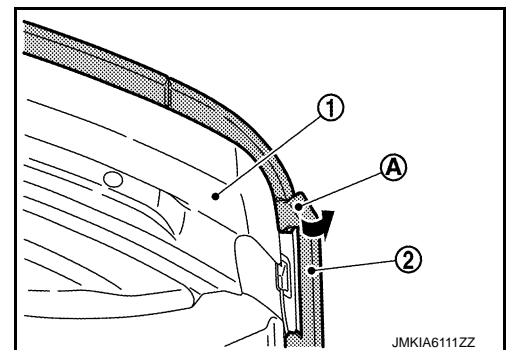

SOFT TOP

< REMOVAL AND INSTALLATION >

6. Pull out soft top cover outer wire (2) from soft top linkage assembly (1) (both LH and RH).

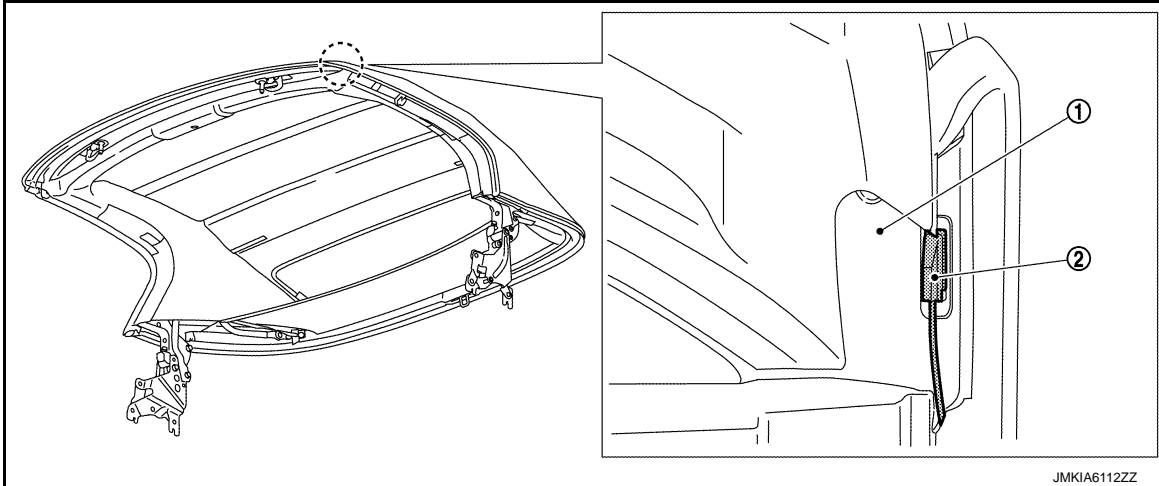

7. Pull up front end of soft top cover outer.

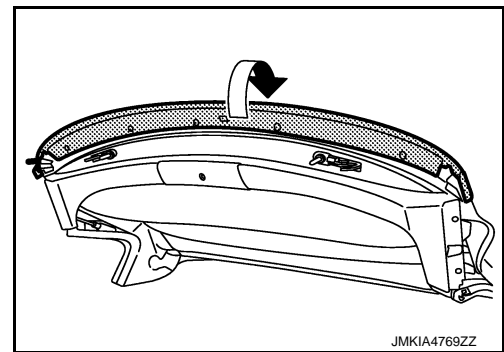

8. Remove mounting rivet (A) of soft top outer bungee cord (1) from soft top linkage assembly (2) (LH and RH).

CAUTION:

Cover the surrounding area because iron powder is spread when using a drill.

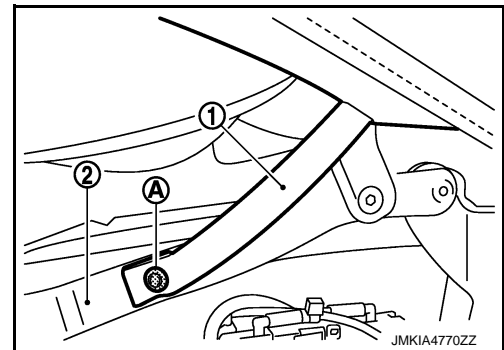

NOTE:

Removal and Installation of Rivet

A
B
C
D
E
F
G
H
I
J
RF
L
M
N
O
P

SOFT TOP

< REMOVAL AND INSTALLATION >

- Grind the head of rivet (1) with a drill (A) [bit of ϕ 4.0 mm (ϕ 0.157 in)].
- Securely crimp the bungee cord with the soft top linkage assembly using a hand riveter (B).

Crimping thickness	: 9.5 - 12.7 mm (0.374 - 0.500 in)
Prepared hole diameter	: ϕ 4.1 - 4.2 mm (0.161 - 0.165 in)
Used rivet head diameter	: ϕ 7.5 mm (0.295 in)

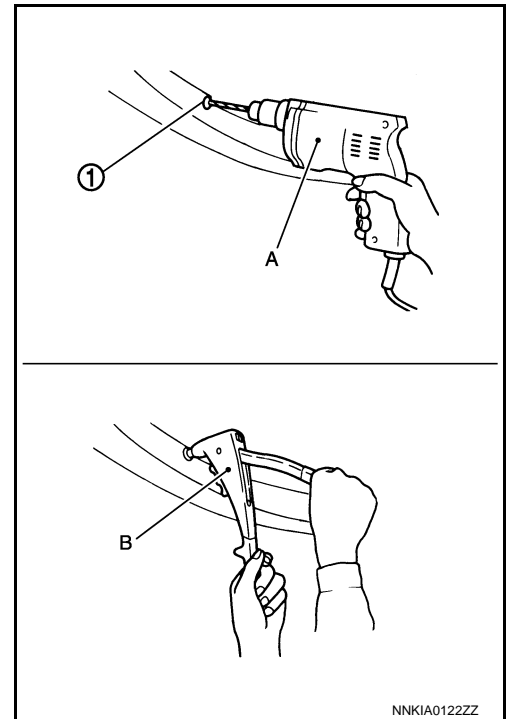

9. Remove soft top cover inner mounting screws (A) from 1st bow (1) (LH and RH).

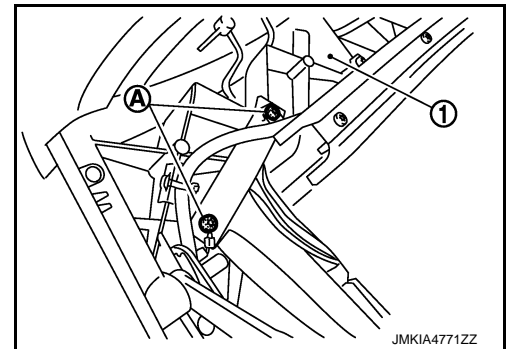

10. Remove mounting screws (A) of soft top cover inner retainer (2) from 1st bow (1).

NOTE:

Soft top cover inner straps (B) and soft top cover inner are tightened together to 1st bow.

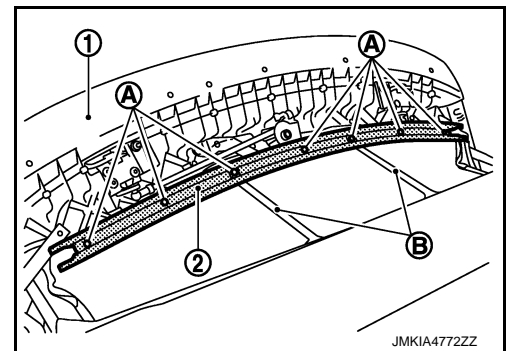

11. Remove 2nd bow mounting bolts.

12. Remove soft top linkage assembly bungee cord (A) from 2nd bow (1) (LH and RH).

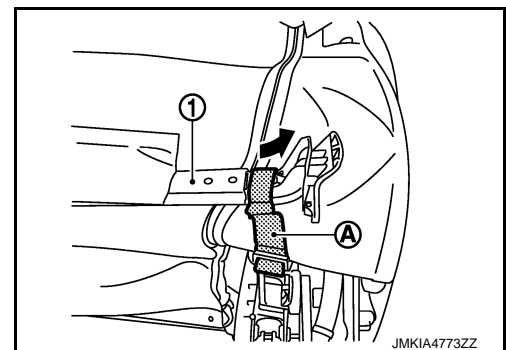

SOFT TOP

< REMOVAL AND INSTALLATION >

13. Pull out wire (2) from soft top cover outer (1) (LH and RH).

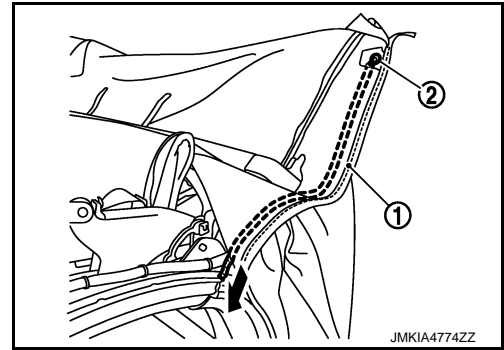

14. Remove rear rail weather-strip. Refer to [RF-188, "ROOF SEALING : Exploded View"](#).

15. Remove rear rail weather-strip retainer (LH and RH). Refer to [RF-188, "ROOF SEALING : Exploded View"](#).

16. Remove rear end of soft top cover outer (2) from 5th bow (1).

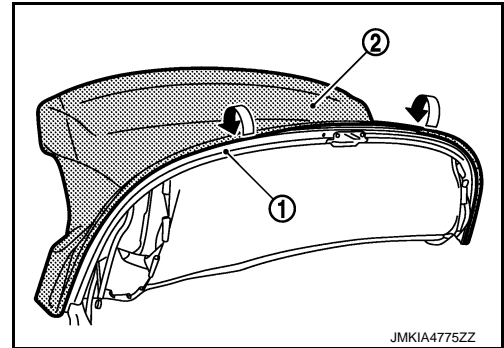

17. Pull up soft top cover outer lateral side to outside from upper to lower. Remove double-sided tape (A) (LH and RH).

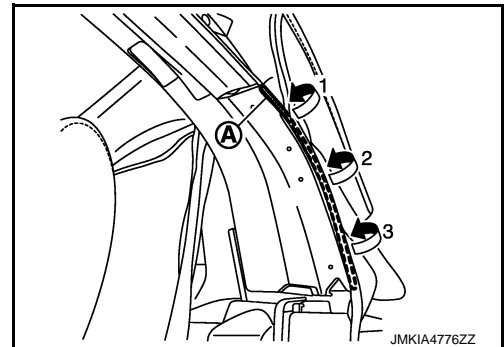

18. Remove E-clips (A). Disengage connection of soft top cover outer wire (2) from soft top linkage assembly pin (1) (LH and RH).

← : Vehicle front

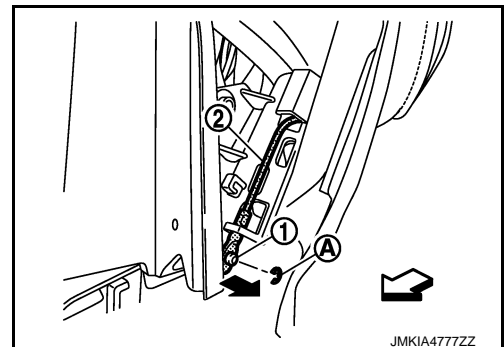

A
B
C
D
E
F
G
H
I
J
RF
L
M
N
O
P

SOFT TOP

< REMOVAL AND INSTALLATION >

19. Slide soft top cover outer (1) in the direction shown by the arrow. Simultaneously pull out retainer (3) and wire (4) from soft top linkage assembly (2) (LH and RH).

CAUTION:

Write a short note to describe the wire locations and the retainer mounting positions.

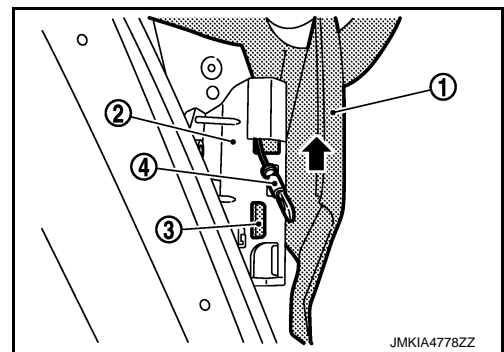

20. Manually operate soft top linkage assembly to the open position.

21. Pull up soft top cover outer lateral side to outside. Remove rivet (A) and screw (B) that secure soft top cover outer bungee cord (1) (LH and RH).

CAUTION:

Cover the surrounding area because iron powder is spread when using a drill.

← : Vehicle front

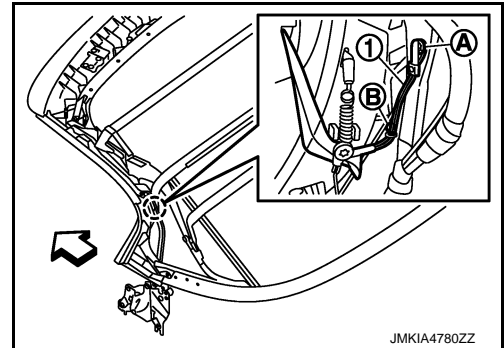

NOTE:

Removal and Installation of Rivet

- Grind the head of rivet (1) with a drill (A) [bit of ϕ 4.0 mm (ϕ 0.157 in)].
- Securely crimp the bungee cord with the soft top linkage assembly using a hand riveter (B).

Crimping thickness : 4.8 - 8.0 mm (0.189 - 0.315 in)

Prepared hole diameter : ϕ 4.1 - 4.2 mm (0.161 - 0.165 in)

Used rivet head diameter : ϕ 12.0 mm (0.472 in)

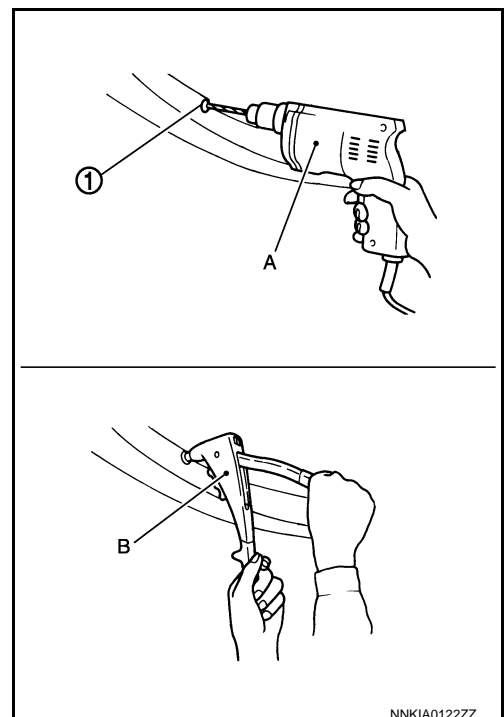

22. Remove rear defogger connector. Pull out rear defogger harness from soft top inner (LH and RH).

23. Pull up soft top cover outer rear end.

CAUTION:

Be careful when performing operation because rear glass is moved.

SOFT TOP

< REMOVAL AND INSTALLATION >

24. Remove mounting screw (A). Pull out soft top cover outer bungee cord (1) from D-ring (B) (LH and RH).

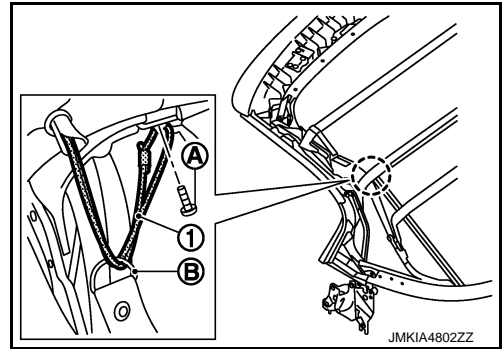

25. Remove retaining plate (A) of 3rd bow (1), and then remove pin (2) (LH and RH).

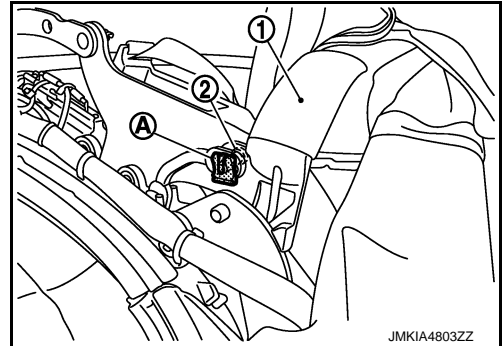

26. Press inside 3rd bow soft top linkage assembly mounting portion. Disengage and remove the connections (A) one side at a time.

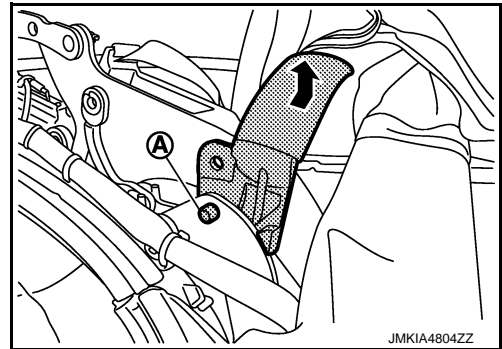

27. Remove mounting screw (A). Remove soft top inner cover bungee cord (2) from soft top linkage assembly (1) (LH and RH).

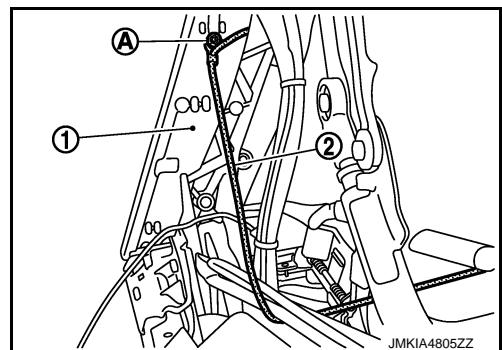

28. Remove mounting screws (A). Remove soft top cover inner lateral portion from soft top linkage assembly (LH and RH).

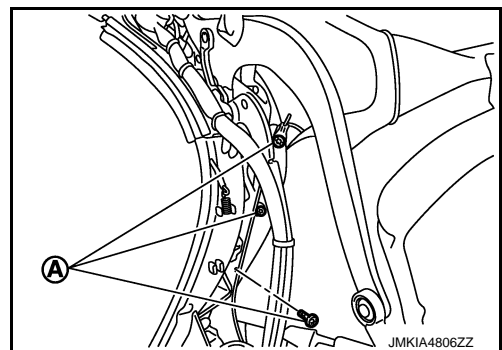

A
B
C
D
E
F
G
H
I
J
RF
L
M
N
O
P

SOFT TOP

< REMOVAL AND INSTALLATION >

29. Remove mounting screw (A). Remove soft top cover inner bungee cord (1) (LH and RH).

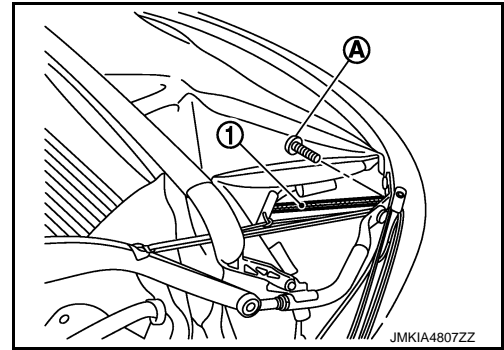

30. Remove rear lock striker. Refer to [RF-186. "REAR LOCK STRIKER : Exploded View"](#).

31. Remove clip from soft top cover inner rear end.

32. Remove rivet (A) from soft top cover inner rear end using a drill (B) (LH and RH).

CAUTION:

Cover the surrounding area because iron powder is spread when using a drill.

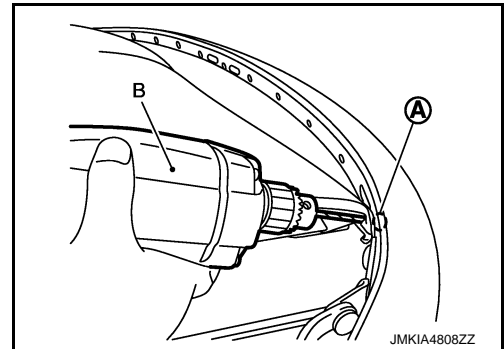

NOTE:

Removal and Installation of Rivet

- Grind the head of rivet (1) with a drill (A) [bit of ϕ .0 mm (ϕ 0.197 in)]
- Securely crimp the soft top cover inner with the soft top linkage assembly using a hand riveter (B).

Crimping thickness : 3.2 - 6.4 mm (0.126 - 0.252 in)

Prepared hole diameter : ϕ 4.9 - 5.0 mm (0.193 - 0.197 in)

Used rivet head diameter : ϕ 9.0 mm (0.354 in)

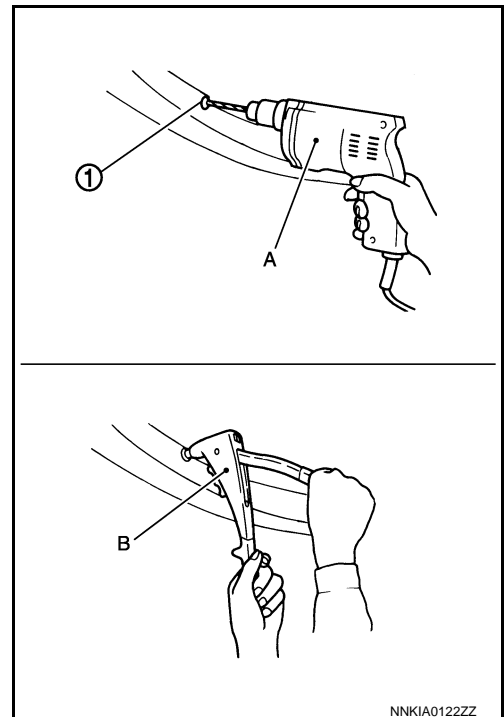

SOFT TOP

< REMOVAL AND INSTALLATION >

33. Remove push on nut (A) from 4th bow (1) (LH and RH).

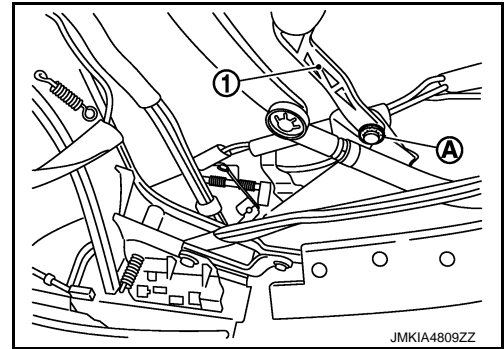

34. Remove 2nd bow, 4th bow, soft top cover outer, and soft top cover inner from soft top linkage as a set.

35. Pull out and remove soft top cover inner retainer (2) from soft top cover inner (1).

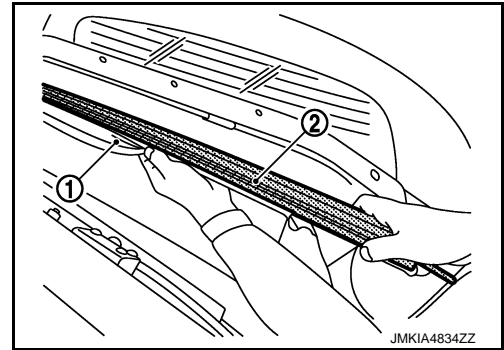

36. Pull out soft top cover inner strap through soft top cover outer hole.

NOTE:

Locations of soft top cover outer (1), strap (2), and soft top cover inner (3) for 2nd bow are as shown in the figure.

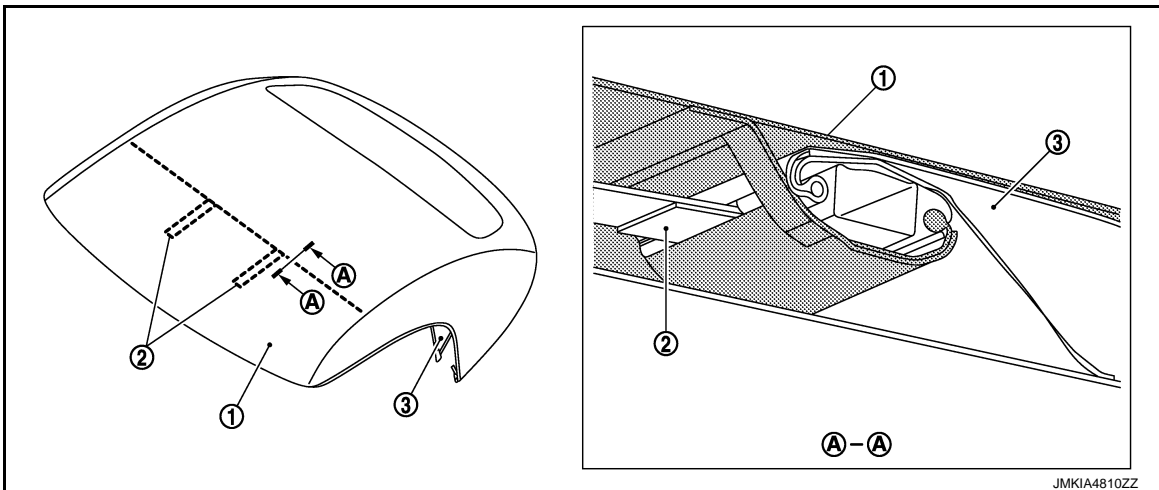

37. Pull out 2nd bow from soft top cover outer and soft top cover inner.

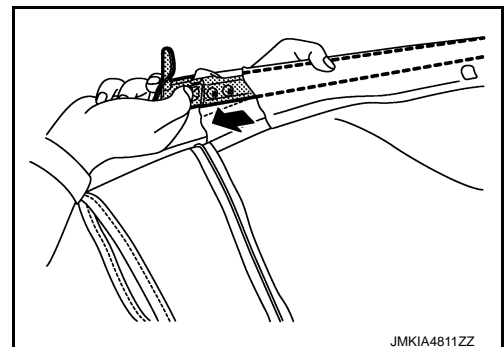

NOTE:

A
B
C
D
E
F
G
H
I
J
RF
L
M
N
O
P

SOFT TOP

< REMOVAL AND INSTALLATION >

Locations of soft top cover outer (2) and soft top cover inner (3) for 2nd bow (1) are as shown in the figure.

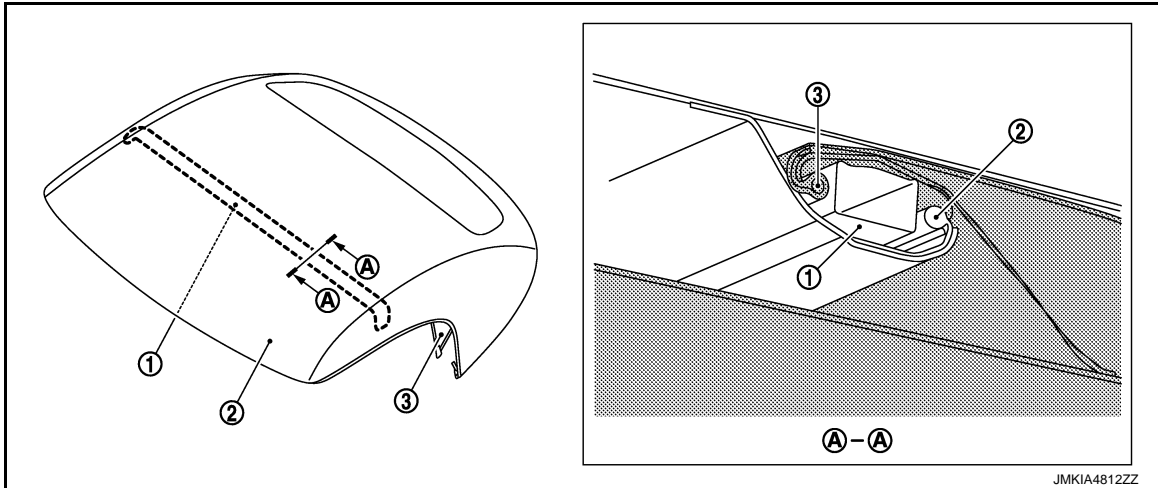

38. Remove stopper. Manually disconnect zipper connection (A) of soft top cover outer (1) and soft top cover inner (2).

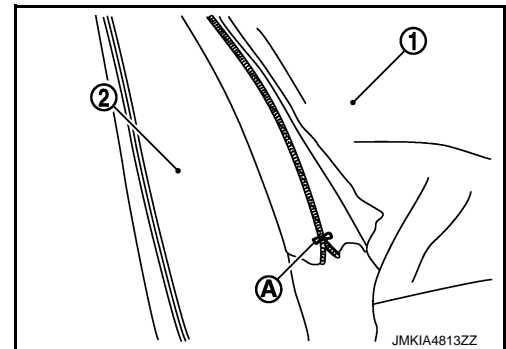

39. Pull out and remove soft top cover inner (2) from 4th bow (1).

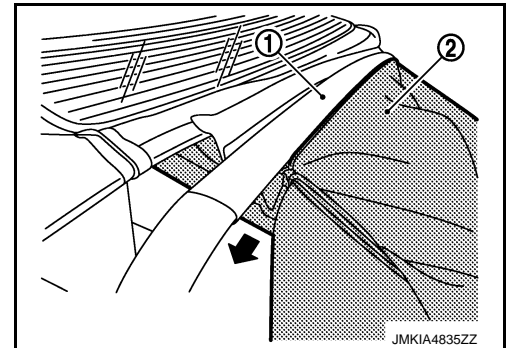

NOTE:

Locations of soft top cover outer (2) and soft top cover inner (3) for 4th bow (1) are as shown in the figure.

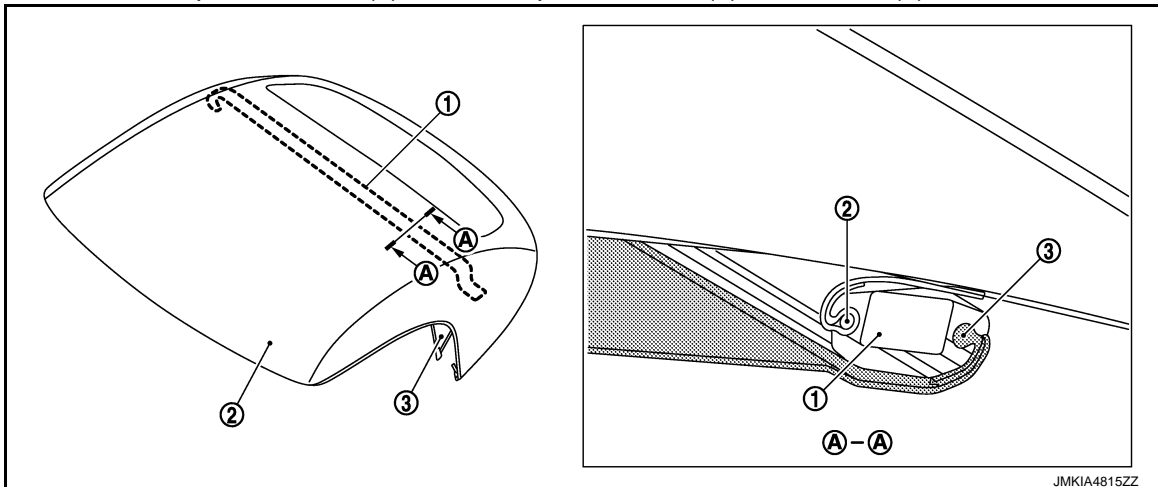

SOFT TOP

< REMOVAL AND INSTALLATION >

INSTALLATION

Note the following items, and install in the reverse order of removal.

CAUTION:

- Replace double-sided tape that fixes soft top cover outer to soft top linkage assembly with new tape.
- Perform door glass fitting adjustment after soft top assembly fitting adjustment. Refer to [GW-21, "Inspection and Adjustment"](#).
- Perform leakage test. Refer to [RF-58, "Water Leakage Test"](#).

NOTE:

- When installing soft top cover outer (2) to 5th bow (1), install soft top cover outer portion (B) to 5th bow rear end groove using a removal tool as shown in the figure.

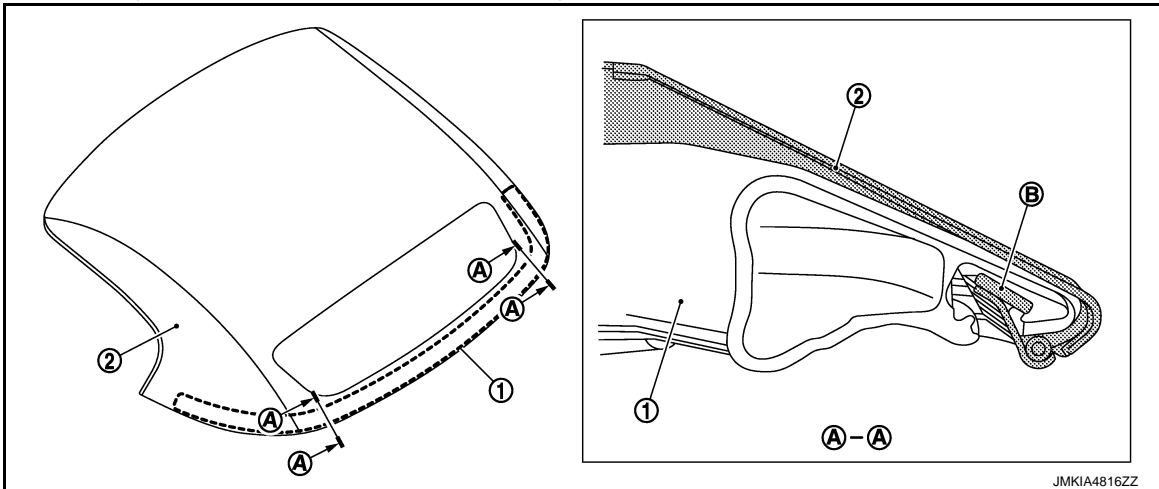

- Connecting procedure for soft top cover outer and soft top cover inner
- Connect using a slider (A).
- Align zipper ends of soft top cover outer (1) and soft top cover inner (2). Slightly slide slider. Fix connecting portion of zipper using a stopper (B).

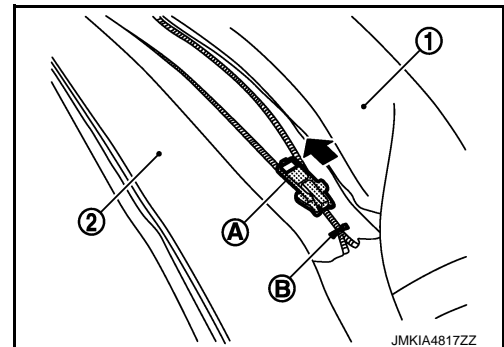

- Slide slider until slider is removed from zipper. Using a stopper (A), fix connection portion of zipper on the side where slider is removed.

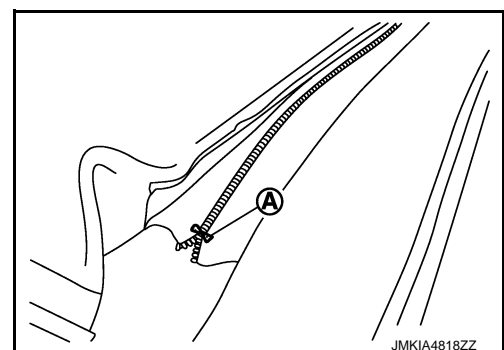

A
B
C
D
E
F
G
H
I
J
RF
L
M
N
O
P

SOFT TOP

< REMOVAL AND INSTALLATION >

- When installing push on nut (1), crimp it using water pump pliers (A) and socket (B).

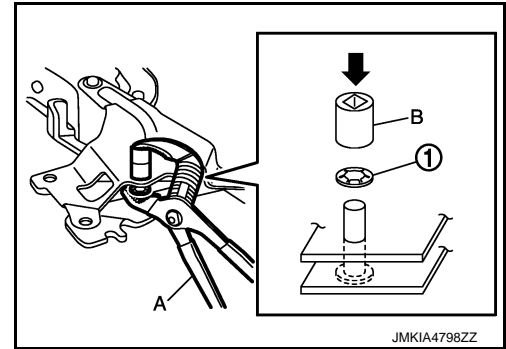

FRONT LOCK STRIKER

FRONT LOCK STRIKER : Exploded View

INFOID:000000007625542

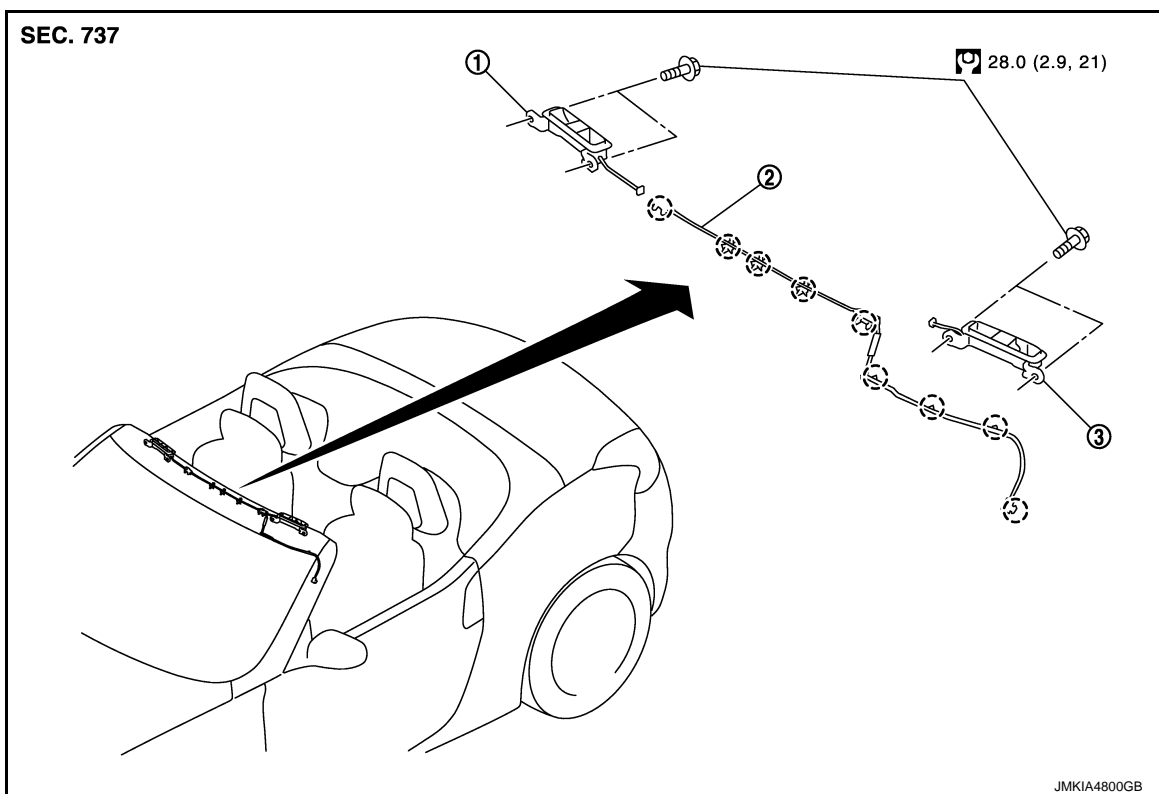

1. Front lock striker RH

2. Sub harness

3. Front lock striker LH

 : Clip

Refer to [GI-4. "Components"](#) for symbols in the figure.

FRONT LOCK STRIKER : Removal and Installation

INFOID:000000007625543

REMOVAL

1. Remove front roof cover. Refer to [EXT-37. "FRONT PILLAR FINISHER \(Roadster\) : Exploded View"](#).

SOFT TOP

< REMOVAL AND INSTALLATION >

2. Mark 3 positions (a), (b), and (c) on the body side.
3. Disconnect front lock striker harness connector (D).

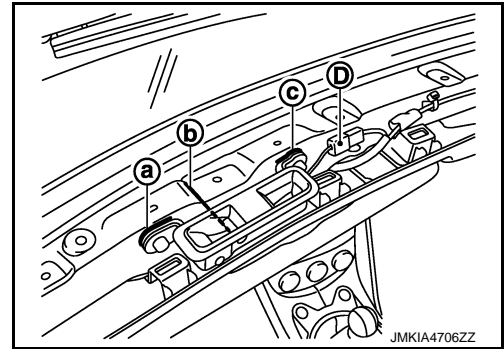

4. Loosen front lock striker mounting bolts (A).
5. Press down roof front finisher. Remove mounting bolts.

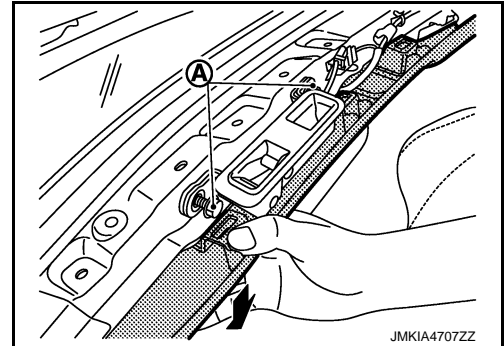

6. Remove front lock striker.

INSTALLATION

Note the following items, and install in the reverse order of removal.

CAUTION:

- After installation, check soft top open/close lock/unlock operation.
- Install front lock striker aligning with the marks.
- Check dimensions between front lock striker (LH and RH).

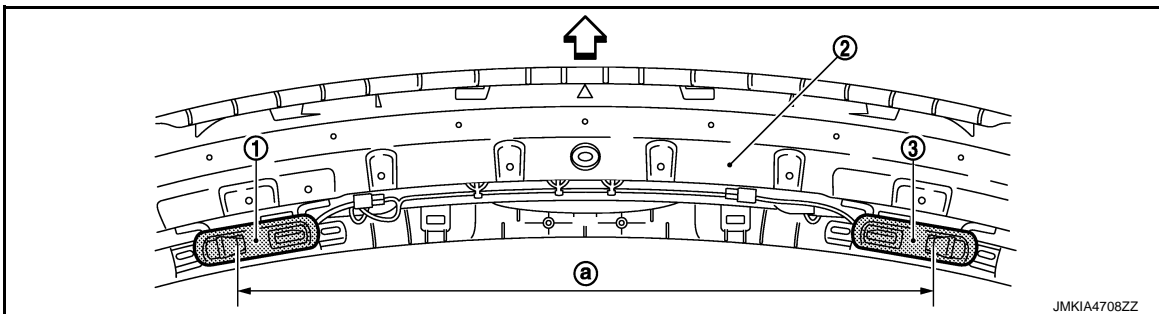

1. Front lock striker LH
- a. 774.6 mm (30.496 in)

2. Front roof rail

3. Front lock striker RH

↔ : Vehicle front

REAR LOCK STRIKER

A
B
C
D
E
F
G
H
I
J
RF
L
M
N
O
P

SOFT TOP

< REMOVAL AND INSTALLATION >

REAR LOCK STRIKER : Exploded View

INFOID:000000007625544

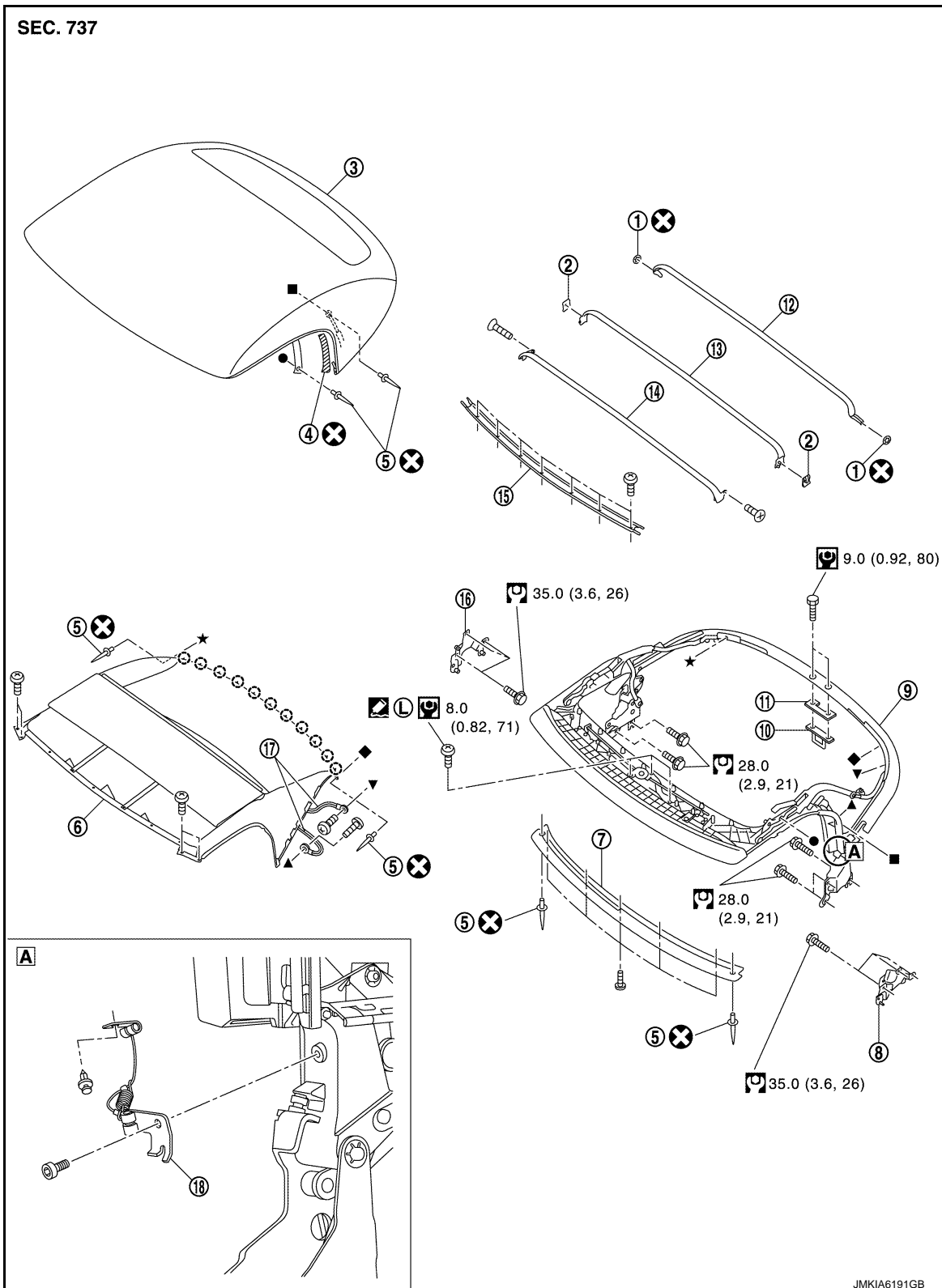

JMKIA6191GB

- | | | |
|--|---------------------------------|------------------------------|
| 1. Push on nut | 2. Retaining plate | 3. Soft top cover outer |
| 4. Double-sided tape | 5. Rivet | 6. Soft top cover inner |
| 7. Soft top cover outer front retainer | 8. Soft top mounting bracket LH | 9. Soft top linkage assembly |
| 10. Rear lock striker | 11. Rear lock striker bracket | 12. 4th bow |

SOFT TOP

< REMOVAL AND INSTALLATION >

- | | | |
|----------------------------------|-----------------|-----------------------------------|
| 13. 3rd bow | 14. 2nd bow | 15. Soft top cover inner retainer |
| 16. Soft top mounting bracket RH | 17. Bungee cord | 18. Flipper door cable |

 : Clip

Refer to [GI-4, "Components"](#) for symbols in the figure.

REAR LOCK STRIKER : Removal and Installation

INFOID:000000007625545

REMOVAL

1. Operate soft top as shown in the figure.

CAUTION:

Storage lid assembly may close due to low oil pressure. Always support storage lid assembly in the fully open position using a supporting block.

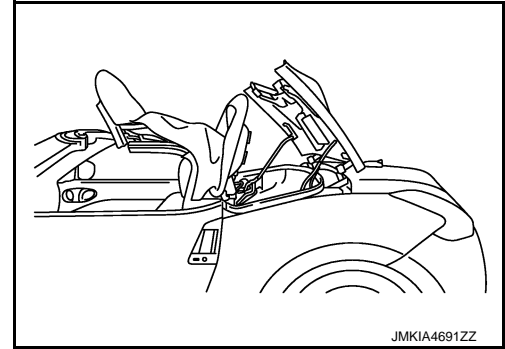

2. Lift up soft top cover inner (1) from passenger room and remove soft top cover inner clips (2).

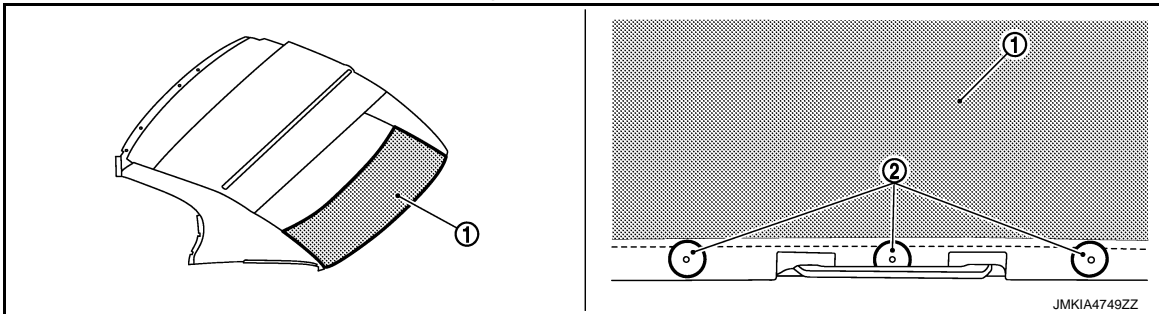

3. Remove rear lock striker mounting bolts (3) from the service hole, and then remove rear lock striker.

CAUTION:

Be careful not to damage storage lid during the operation.

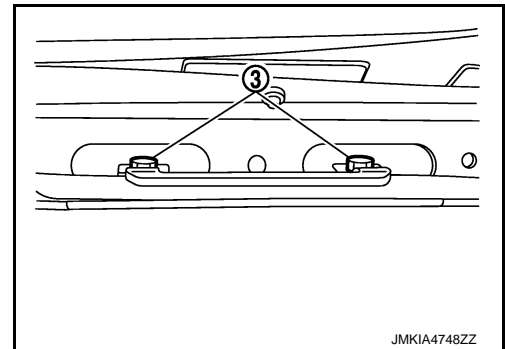

INSTALLATION

Install in the reverse order of removal.

CAUTION:

After installation, check soft top open/close lock/unlock operation.

ROOF SEALING

A
B
C
D
E
F
G
H
I
J
RF
L
M
N
O
P

SOFT TOP

< REMOVAL AND INSTALLATION >

ROOF SEALING : Exploded View

INFOID:000000007625546

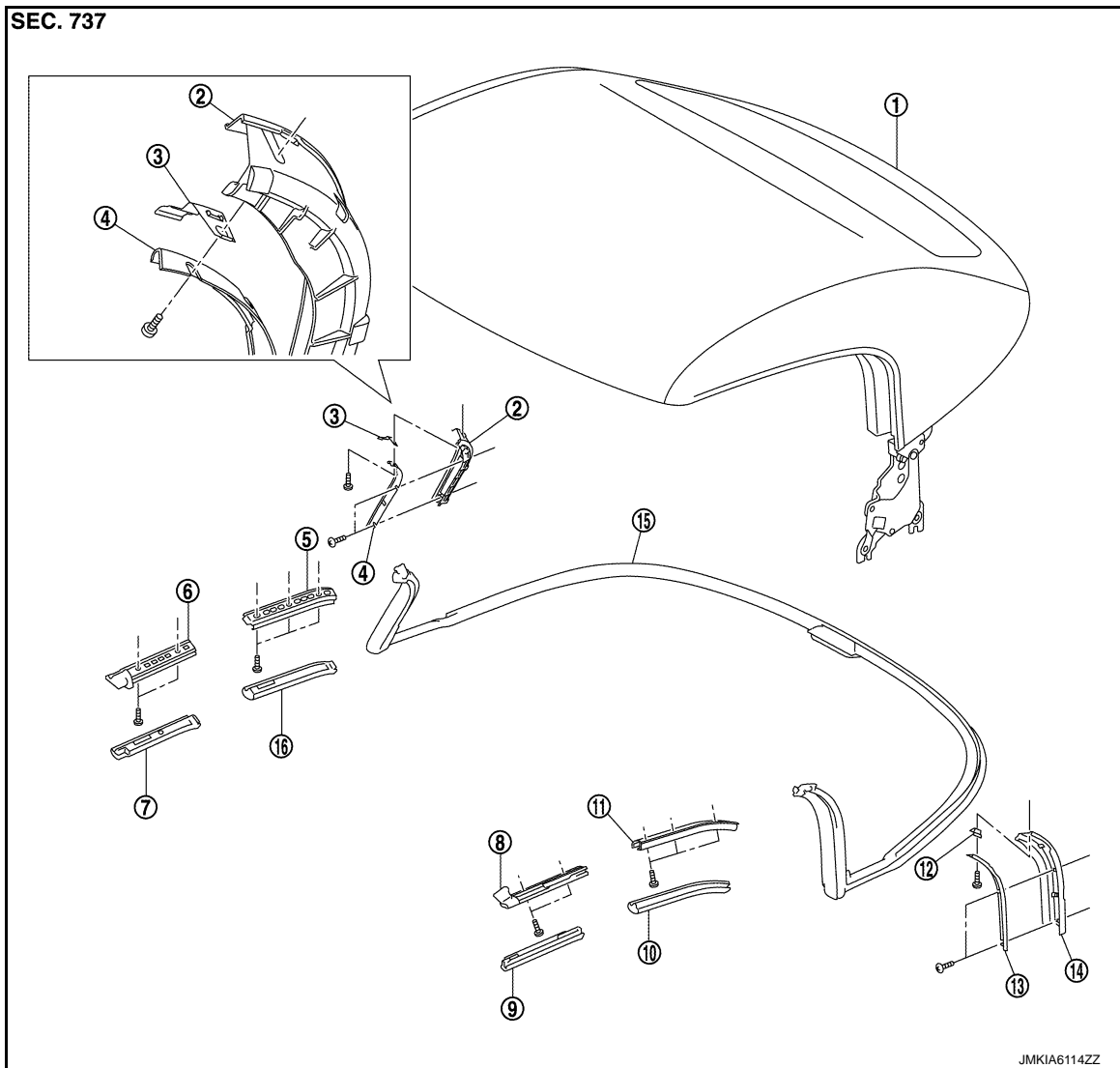

- | | | |
|---|---|---|
| 1. Soft top assembly | 2. Rear rail weather-strip inner retainer | 3. Rear rail clip RH |
| 4. Rear rail weather-strip outer retainer RH | 5. Center rail weather-strip retainer RH | 6. Front rail weather-strip retainer RH |
| 7. Front rail weather-strip RH | 8. Front rail weather-strip retainer LH | 9. Front rail weather-strip LH |
| 10. Center rail weather-strip LH | 11. Center rail weather-strip retainer LH | 12. Rear rail clip LH |
| 13. Rear rail weather-strip outer retainer LH | 14. Rear rail weather-strip inner retainer LH | 15. Rear rail weather-strip |
| 16. Center rail weather-strip RH | | |

ROOF SEALING : Removal and Installation

INFOID:000000007625547

FRONT RAIL WEATHER-STRIP

Removal

SOFT TOP

< REMOVAL AND INSTALLATION >

1. Operate soft top assembly as shown in the figure.

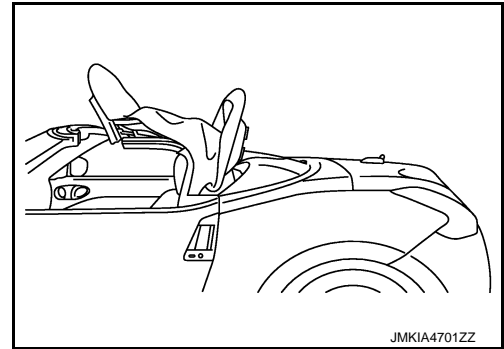

2. Disengage connection of front rail weather-strip end, slide downward, and remove.

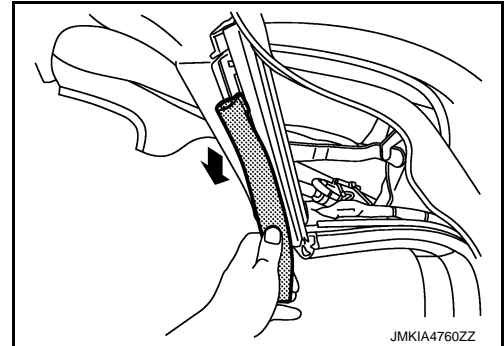

Installation

Note the following items, and install in the reverse order of removal.

CAUTION:

- Perform door glass fixing adjustment. Refer to [GW-21, "Inspection and Adjustment"](#).
- Perform leakage test. Refer to [RF-58, "Water Leakage Test"](#).

CENTER RAIL WEATHER-STRIP

Removal

1. Operate soft top assembly as shown in the figure.

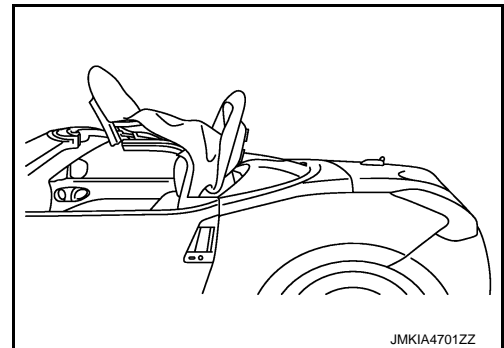

2. Disengage connection of center weather-strip end, slide forward, and remove.

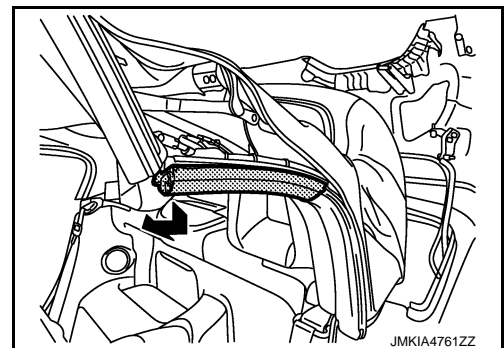

Installation

Note the following items, and install in the reverse order of removal.

CAUTION:

- Perform door glass fixing adjustment. Refer to [GW-21, "Inspection and Adjustment"](#).

A
B
C
D
E
F
G
H
I
J
RF
L
M
N
O
P

SOFT TOP

< REMOVAL AND INSTALLATION >

- Perform leakage test. Refer to [RF-58, "Water Leakage Test"](#).

REAR RAIL WEATHER-STRIP

Removal

1. Operate soft top assembly as shown in the figure.

CAUTION:

Storage lid assembly may close due to low oil pressure.
Always support storage lid assembly in the fully open position using a supporting block.

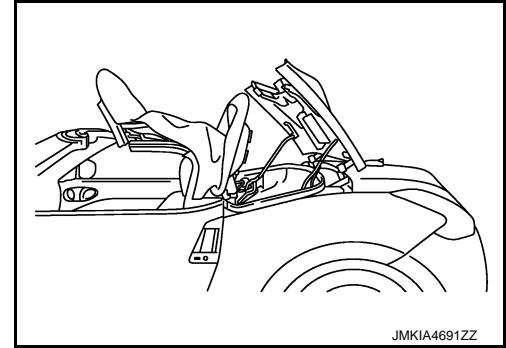

2. Remove cutout (A) of rear rail weather-strip (1) from stay portion (B) of soft top linkage assembly (2).

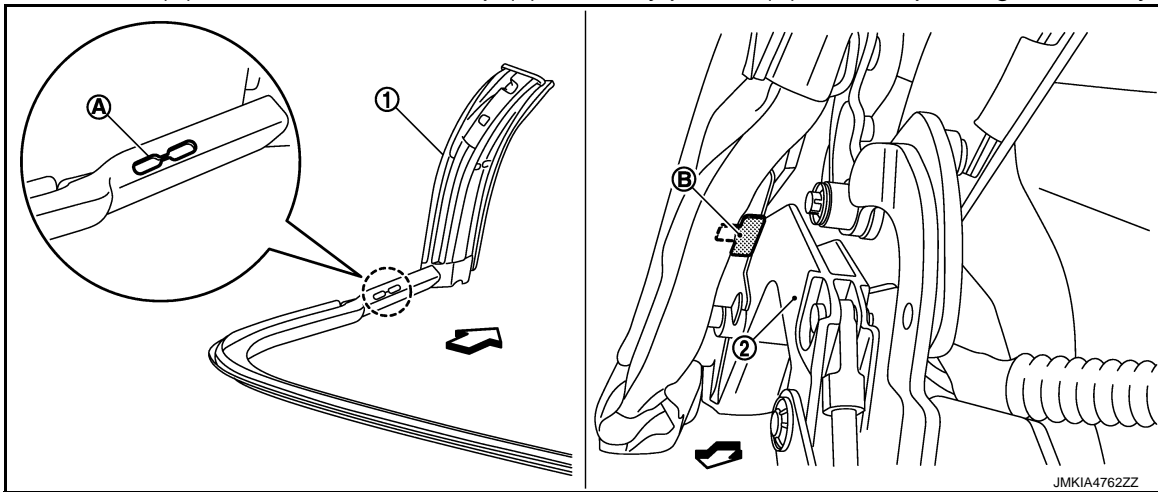

← : Vehicle front

3. Disengage rear rail weather-strip fixing metal clip.
4. Disengage connection of rear rail weather-strip end and pull back (LH and RH).

□ : Metal clip

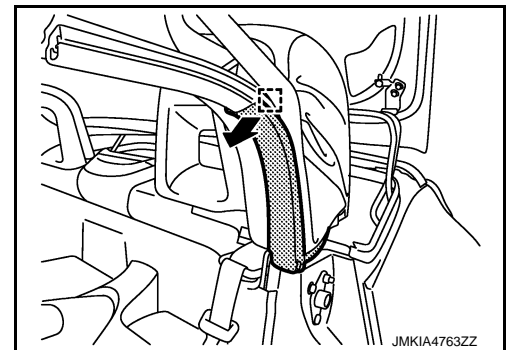

5. Remove rear rail weather-strip from 5th bow.

Installation

1. Install rear rail weather-strip to 5th bow.
 - Check that rear end of soft top cover outer (2) is fitted in 5th bow (1).

SOFT TOP

< REMOVAL AND INSTALLATION >

- Check that retainer (3) is installed to 5th bow as shown in the figure.

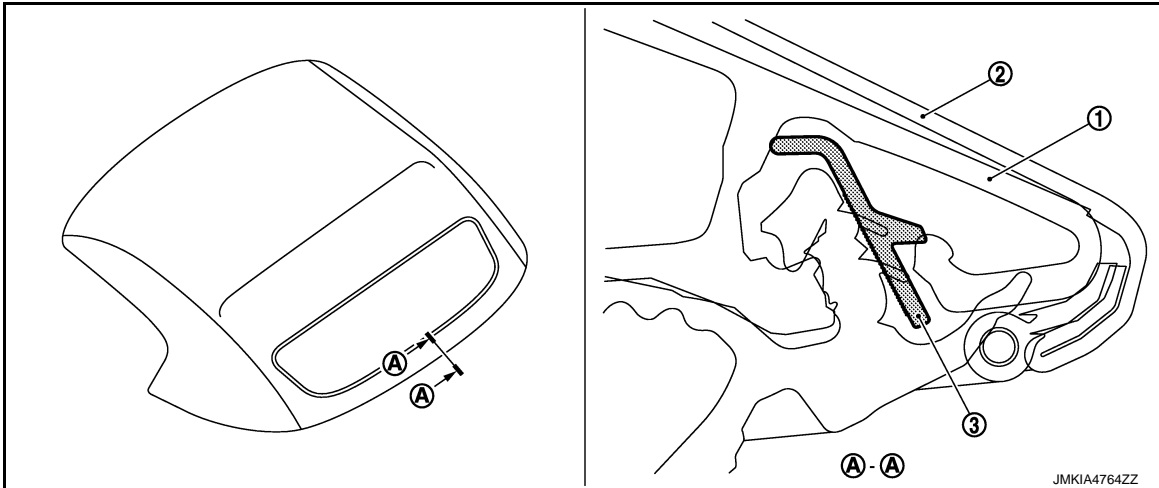

- Install rear rail weather-strip rear end to 5th bow.

NOTE:

- Apply soapy water to rear rail weather-strip rear end for smooth fitting.
- If rear rail weather-strip is not easily fitted to 5th bow, lightly tap the weather-strip using a rubber hammer and install.

2. Install rear rail weather-strip to rear rail weather-strip retainer (LH and RH).
3. Install cutout (A) of rear rail weather-strip (1) to stay portion (B) of soft top linkage assembly (2).

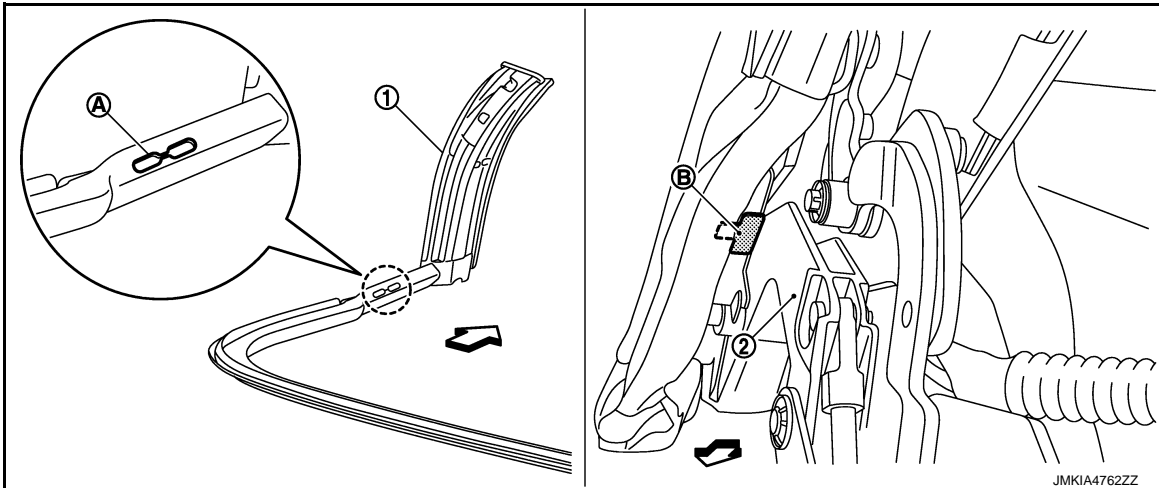

← : Vehicle front

4. Install the removed parts.

CAUTION:

- Perform door glass fixing adjustment. Refer to [GW-21, "Inspection and Adjustment"](#).
- Perform leakage test. Refer to [RF-58, "Water Leakage Test"](#).

1ST BOW LATCH

A
B
C
D
E
F
G
H
I
J
RF
L
M
N
O
P

SOFT TOP

< REMOVAL AND INSTALLATION >

1ST BOW LATCH : Exploded View

INFOID:000000007625548

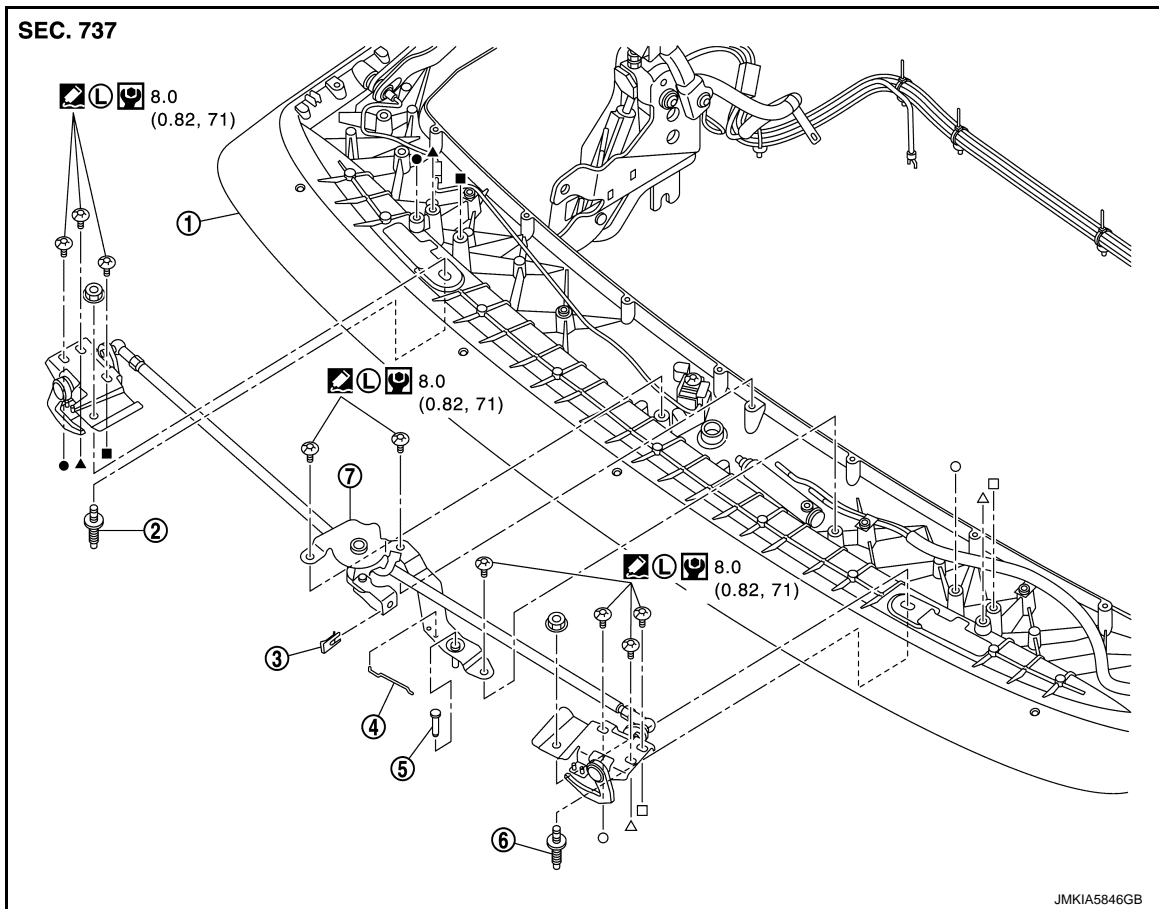

- | | | |
|---------------------------|--------------------------|--------------------|
| 1. 1st bow | 2. Locating pin RH | 3. Retaining plate |
| 4. Lock spring | 5. Cylinder mounting pin | 6. Locating pin LH |
| 7. 1st bow latch assembly | | |

 (L) : Sealing point with locking sealant

 : N·m (kg-m, in-lb)

1ST BOW LATCH : Removal and Installation

INFOID:000000007625549

REMOVAL

1. Operate soft top assembly as shown in the figure.

CAUTION:

Storage lid assembly may close due to low oil pressure. Always support storage lid assembly to the fully open position using a supporting block.

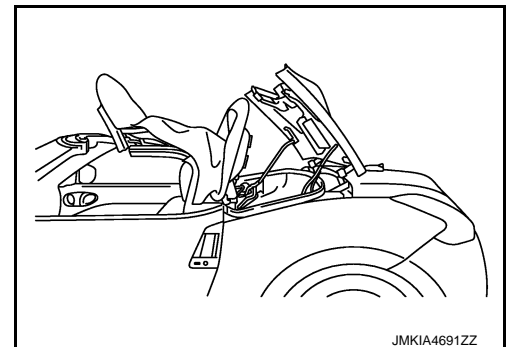

2. Remove front rail weather-strip (LH and RH). Refer to [RF-188. "ROOF SEALING : Removal and Installation"](#).
3. Remove front rail weather-strip retainer (LH and RH). Refer to [RF-188. "ROOF SEALING : Removal and Installation"](#).

SOFT TOP

< REMOVAL AND INSTALLATION >

4. Remove soft top cover outer front retainer mounting screws (A).

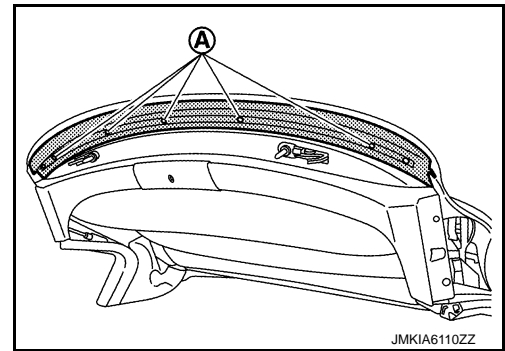

5. Lift up soft top cover outer front retainer (1), and then pull up soft top cover outer (2) portion (A) to outside (both LH and RH).

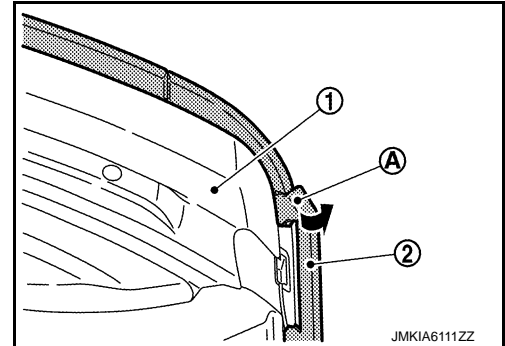

6. Pull out soft top cover outer wire (2) from soft top linkage assembly (1) (both LH and RH).

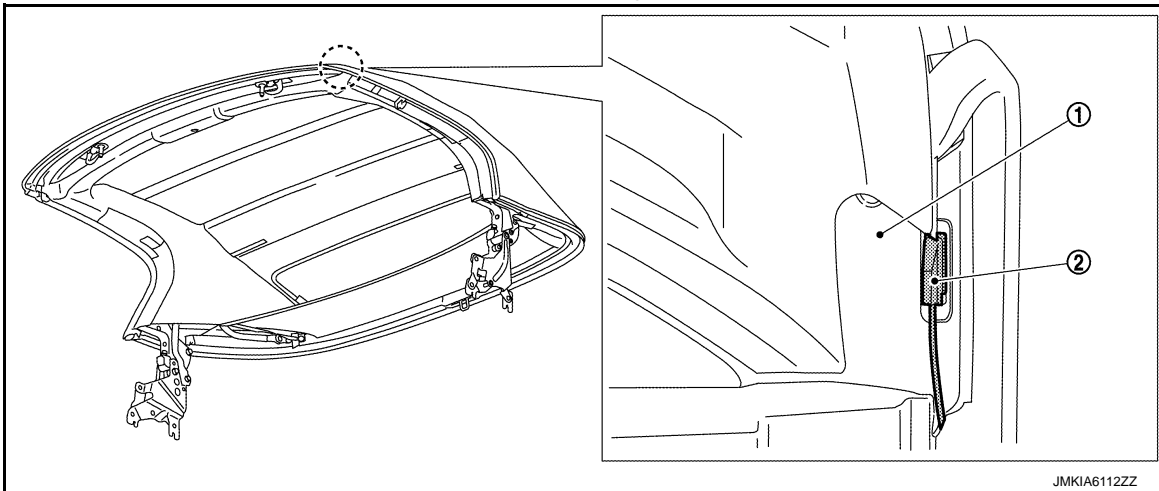

7. Pull up front end of soft top cover outer.

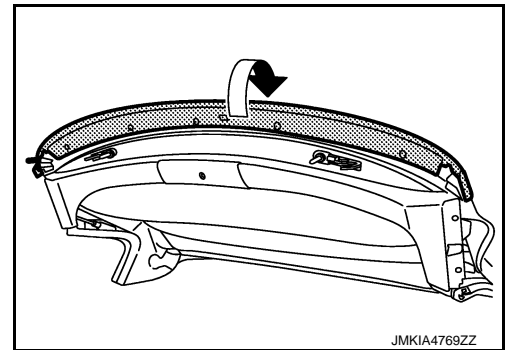

A
B
C
D
E
F
G
H
I
J
RF
L
M
N
O
P

SOFT TOP

< REMOVAL AND INSTALLATION >

8. Remove soft top cover inner mounting screws (A) from 1st bow (1) (LH and RH).

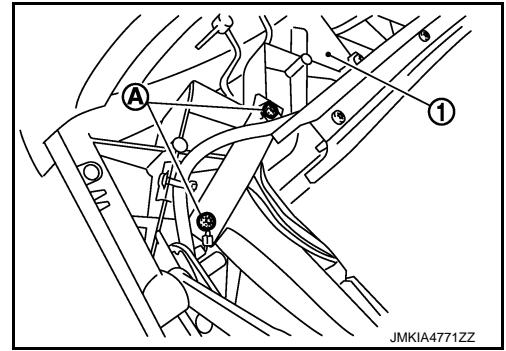

9. Remove mounting screws (A) of soft top cover inner retainer (2) from 1st bow (1).

NOTE:

Soft top cover inner straps (B) and soft top cover inner are tightened together to 1st bow.

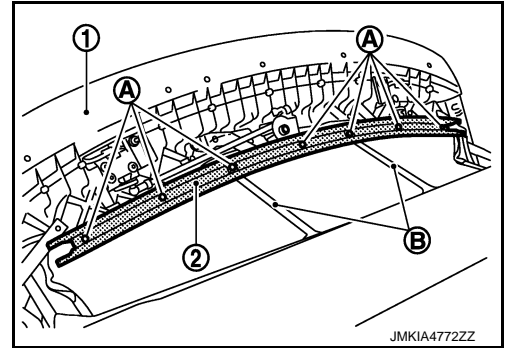

10. Mark (A) on 1st bow (2) for positioning of locating pin (1) (both LH and RH).

↔ : Vehicle front

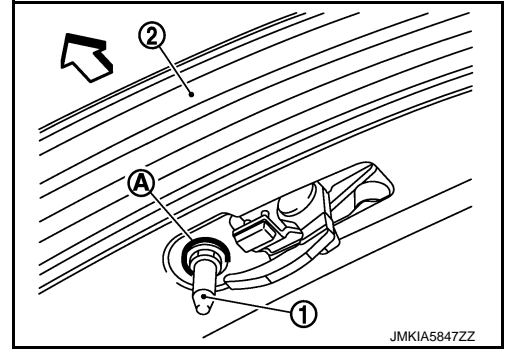

11. Remove 1st bow latch assembly mounting bolts (A) and locating pin mounting nut (B) (both LH and RH).

↔ : Vehicle front

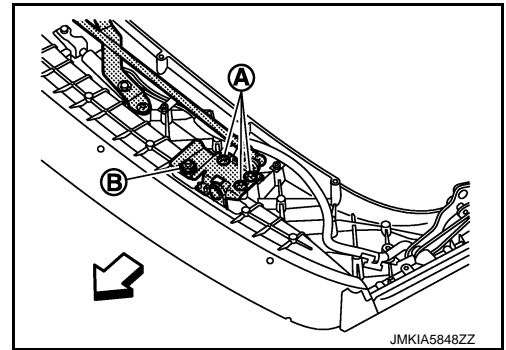

12. Remove spring lock (A). Pull out cylinder mounting pin (1) toward upper side of vehicle.

13. Remove TORX bolts (B). Remove soft top lock assembly center bracket (2).

↔ : Vehicle front

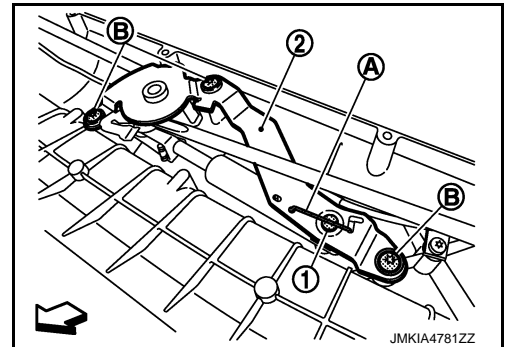

SOFT TOP

< REMOVAL AND INSTALLATION >

14. Lift up center portion of 1st bow latch assembly (1). Remove retaining plate (A) of roof latch cylinder (2).

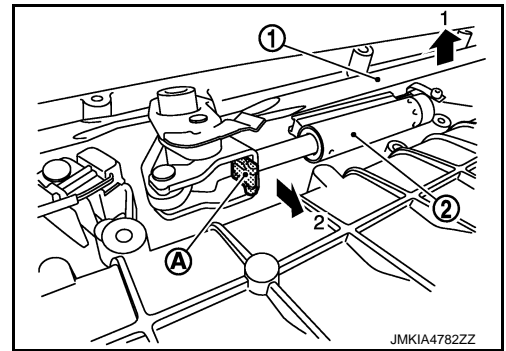

15. Remove 1st bow latch assembly from 1st bow.

INSTALLATION

Note the following items, and install in the reverse order of removal.

CAUTION:

- Apply “” when installing 1st bow latch assembly mounting bolts.
- Check that dimension between hook RH (1) and hook LH (2) is within the standard after installing 1st bow latch assembly.

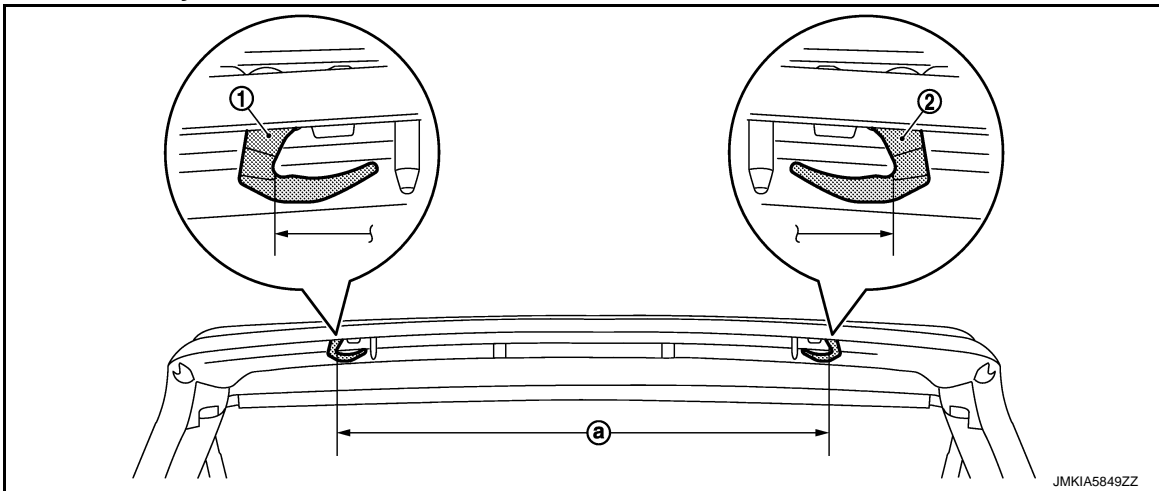

(a) Standard : 772.11 – 773.11 mm (30.398 – 30.437 in)

- Adjust the push rod length by loosening nut (A), removing snap pin (1), and turning stud ball cap when the dimension (a) is outside the standard.

← : Vehicle front

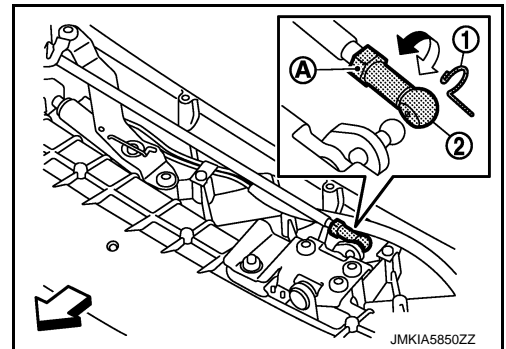

- Align locating pins with marks and install.
- Adjust hook contact length of 1st bow latch hook (LH and RH). Refer to [RF-195, "1ST BOW LATCH : Inspection and Adjustment"](#).
- Check the open/close operation of soft top assembly after installation.
- Perform water leakage test. Refer to [RF-58, "Water Leakage Test"](#).

1ST BOW LATCH : Inspection and Adjustment

INFOID:000000007625550

Inspection and Adjustment

SOFT TOP

< REMOVAL AND INSTALLATION >

1. Open soft top, and then apply red lead or dye penetrant testing agent to 1st bow latch hook [engagement with striker (both for LH and RH)].
2. Fully open soft top, and then engage 1st bow latch.
3. Open soft top, and then check that the red lead or dye penetrant testing agent peeled off from the 1st bow latch exceeds “”

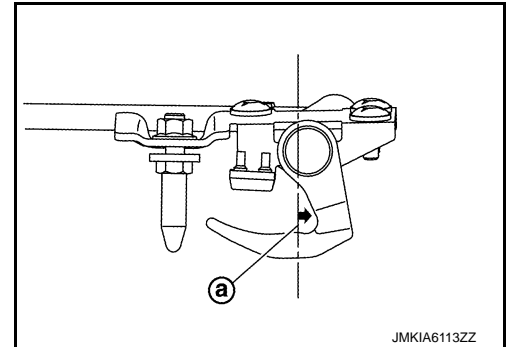

4. If not exceeded, adjust hook contact length of 1st bow latch hook (LH and RH), and then adjust the push rod length by loosening nut (A), removing clip (1), and turning stud ball cap (2).

CAUTION:

- Adjust front lock rod LH and front lock rod RH simultaneously.
- Check that dimension between hook RH and hook LH is within the standard.

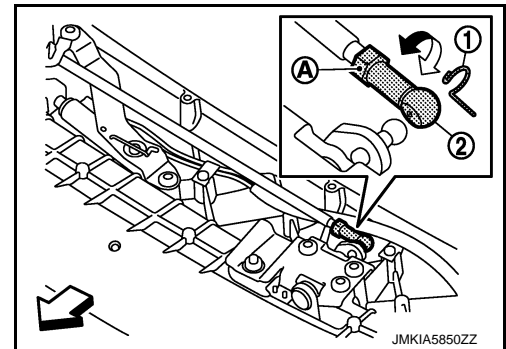

← : Vehicle front

CAUTION:

If 1st bow latch hook (center) does not exceed “”

5TH BOW BUNGEE CORD

5TH BOW BUNGEE CORD : Exploded View

INFOID:000000007625551

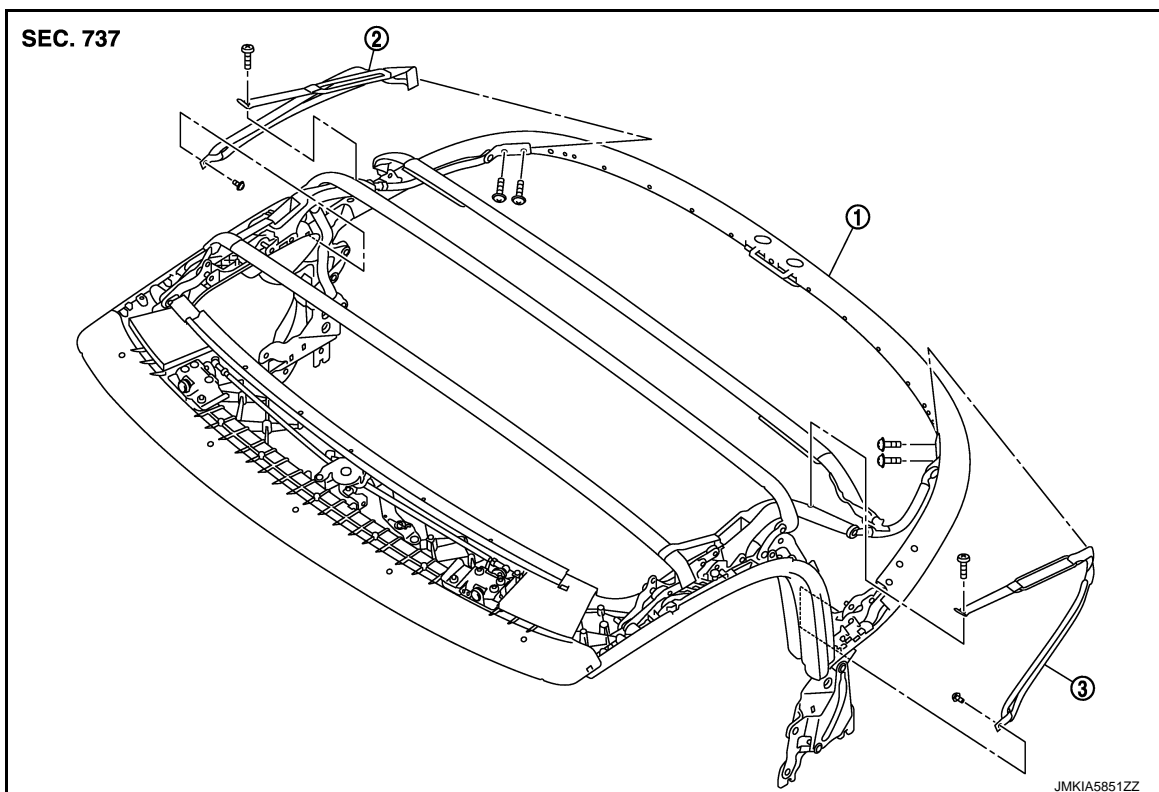

SOFT TOP

< REMOVAL AND INSTALLATION >

1. Soft top linkage assembly
2. 5th bow bungee cord RH
3. 5th bow bungee cord LH

5TH BOW BUNGEE CORD : Removal and Installation

INFOID:000000007625552

CAUTION:

Two or more workers are required. Reaction force of bungee cord is very large.

REMOVAL

1. Operate soft top assembly as shown in the figure.

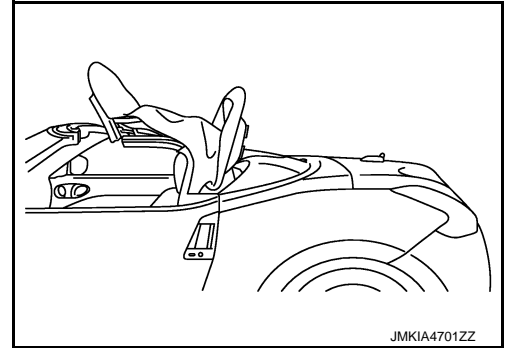

2. Remove rear rail weather-strip from 5th bow. Refer to [RF-188, "ROOF SEALING : Removal and Installation"](#).
3. Remove rear end of soft top cover outer (2) from 5th bow (1).

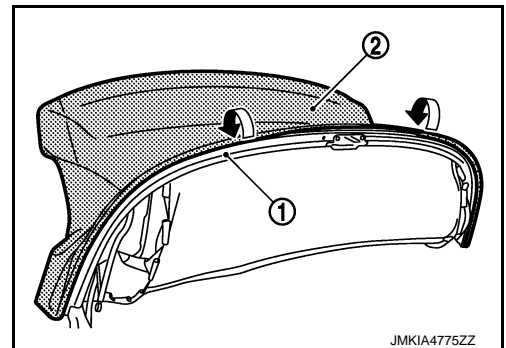

4. Remove 3rd bow bungee cord (1) from 3rd bow (2).

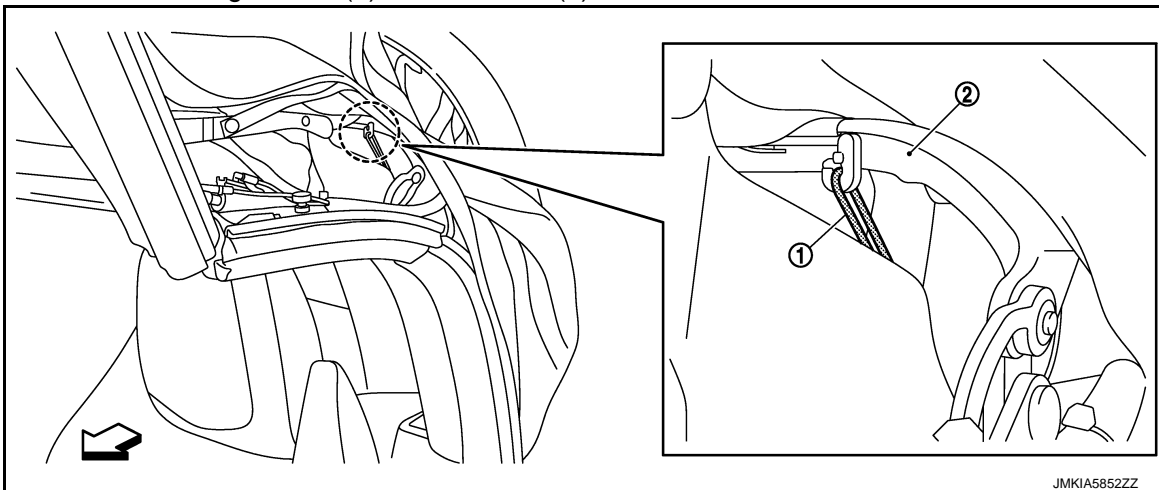

← : Vehicle front

SOFT TOP

< REMOVAL AND INSTALLATION >

5. Pull out 3rd bow bungee cords (1) from 5th bow bungee cord ring (2).

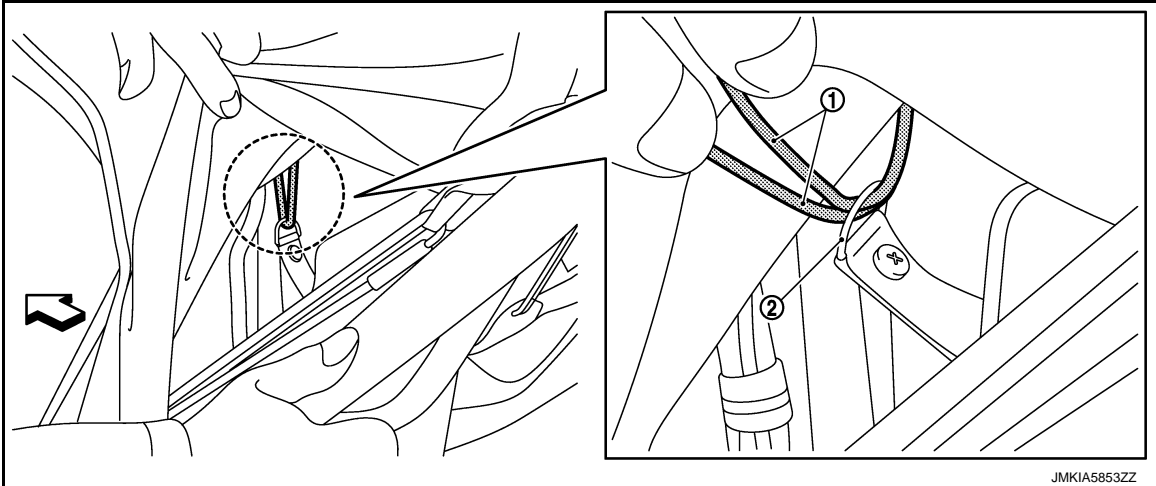

← : Vehicle front

6. Remove 5th bow bungee cord ring screw (A). Remove 5th bow bungee cord (1) front end from soft top linkage assembly (2).

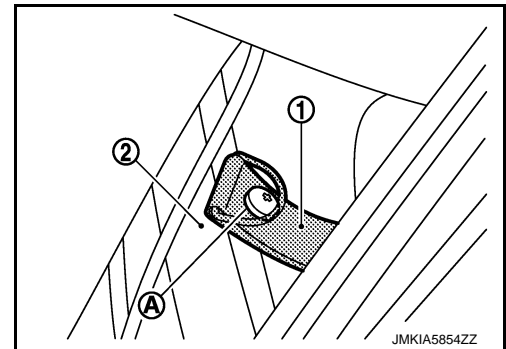

7. Move 5th bow and remove screw (A), and then remove 5th bow bungee cord (1) center from soft top linkage assembly (2).

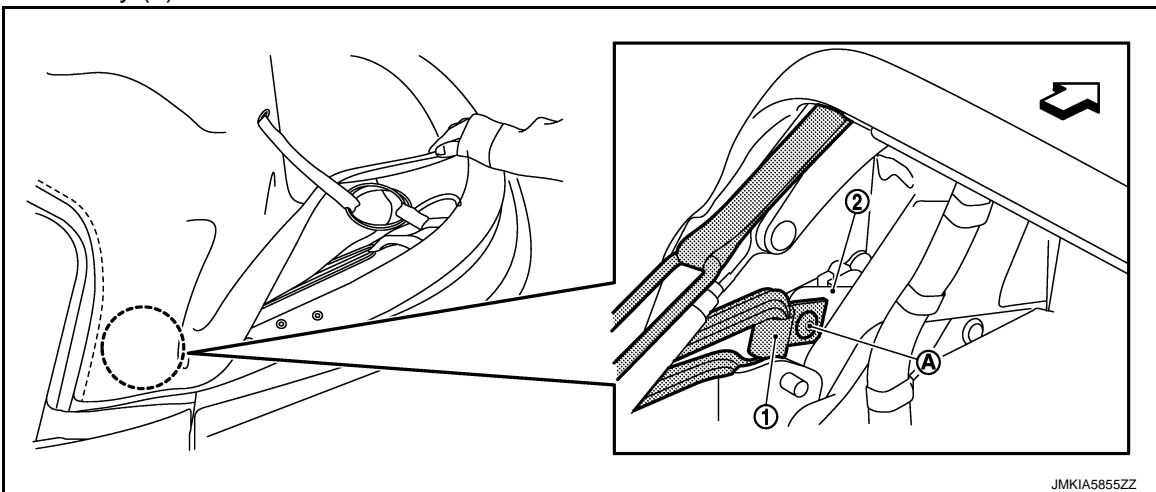

← : Vehicle front

SOFT TOP

< REMOVAL AND INSTALLATION >

8. Cut tie wrap (A), and then remove soft top cover inner bungee cord (1) from pressure ring bracket (2).

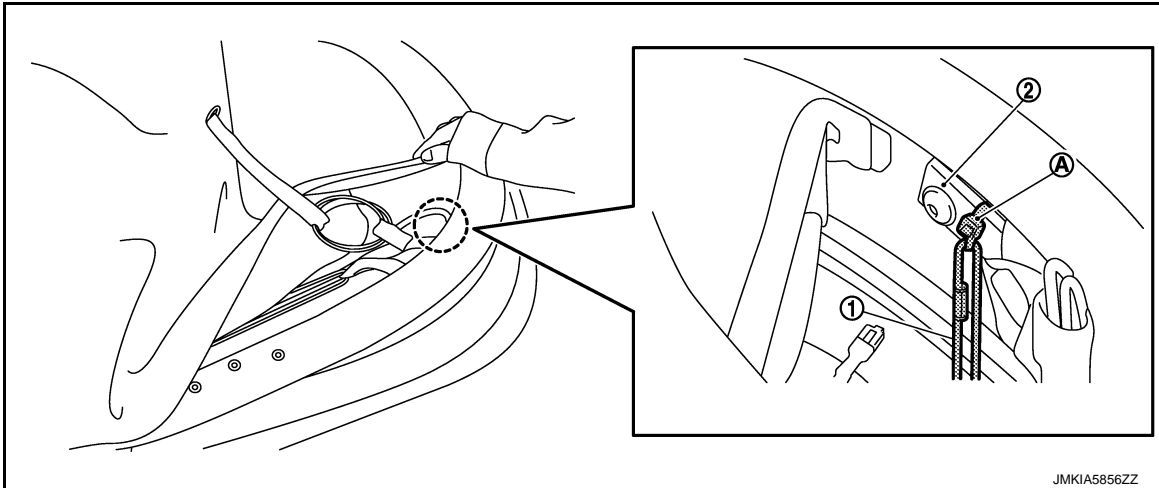

9. Remove screws (A). Separate pressure ring bracket (1) from 5th bow (2).

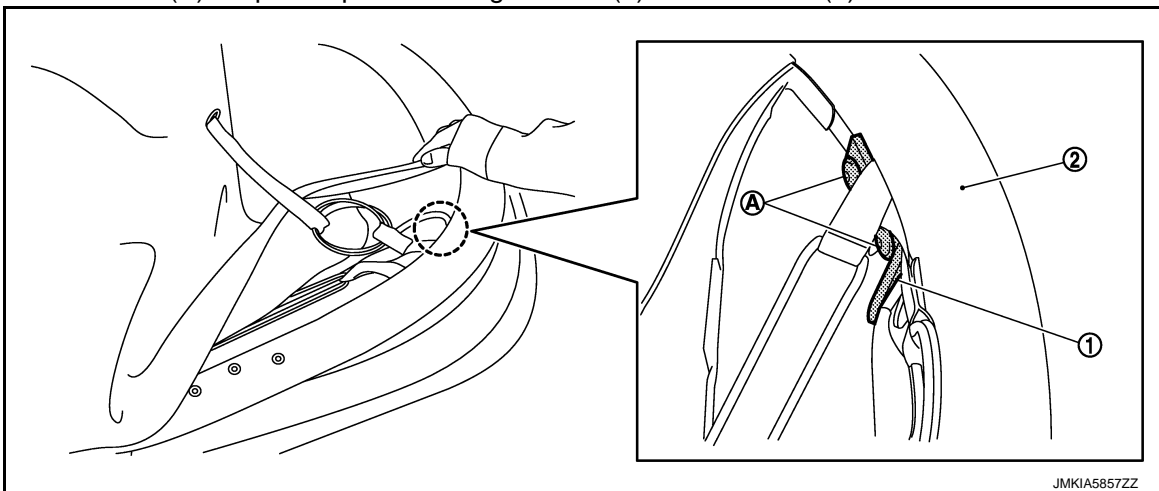

10. Pull out 5th bow bungee cord (1) from pressure ring bracket (2).

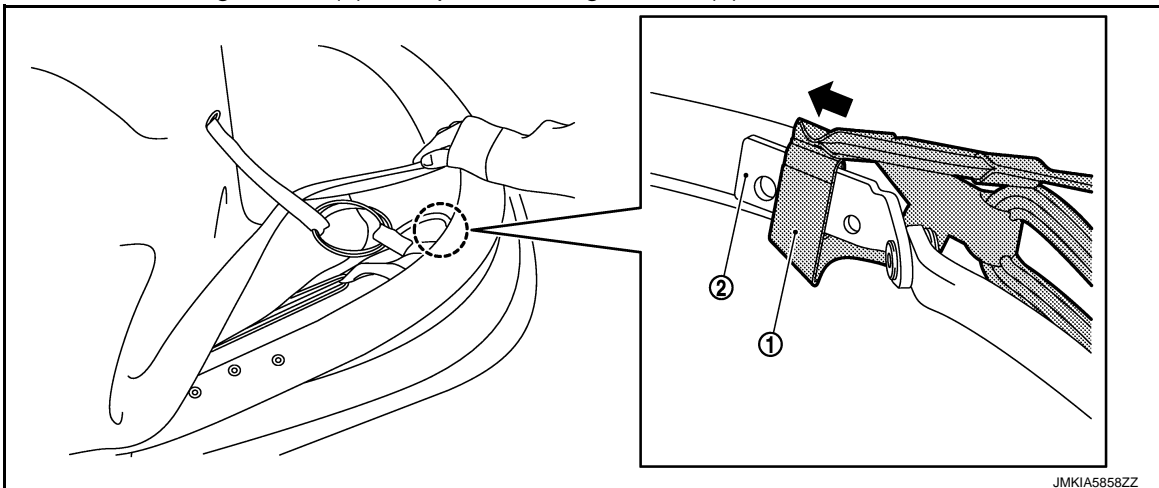

11. Remove 5th bow bungee cord from the vehicle body.

INSTALLATION

Note the following items, and install in the reverse order of removal.

CAUTION:

- **Never reuse tie wraps that secure soft top cover inner bungee cord. Always replace them with new one.**

A
B
C
D
E
F
G
H
I
J
RF
L
M
N
O
P

SOFT TOP

< REMOVAL AND INSTALLATION >

- Pressure ring bracket (1) mounting hole is a long hole. When installing to 5th bow (2), temporarily tighten screw (A), set pressure ring bracket to fully upward position, and then tighten. (for securing clearance between pressure ring and storage lid when soft top is closed)

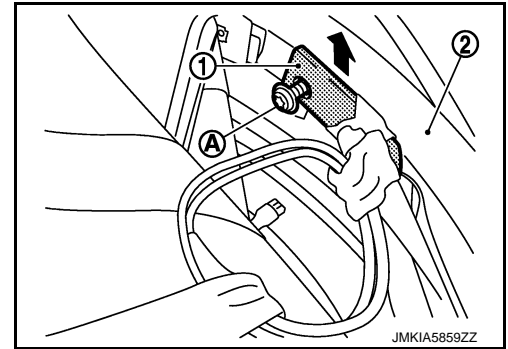

- Check the open/close operation of soft top assembly after installation.
- Perform water leakage test. Refer to [RF-58, "Water Leakage Test"](#).

STORAGE LID

< REMOVAL AND INSTALLATION >

STORAGE LID

STORAGE LID ASSEMBLY

STORAGE LID ASSEMBLY : Exploded View

INFOID:000000007625553

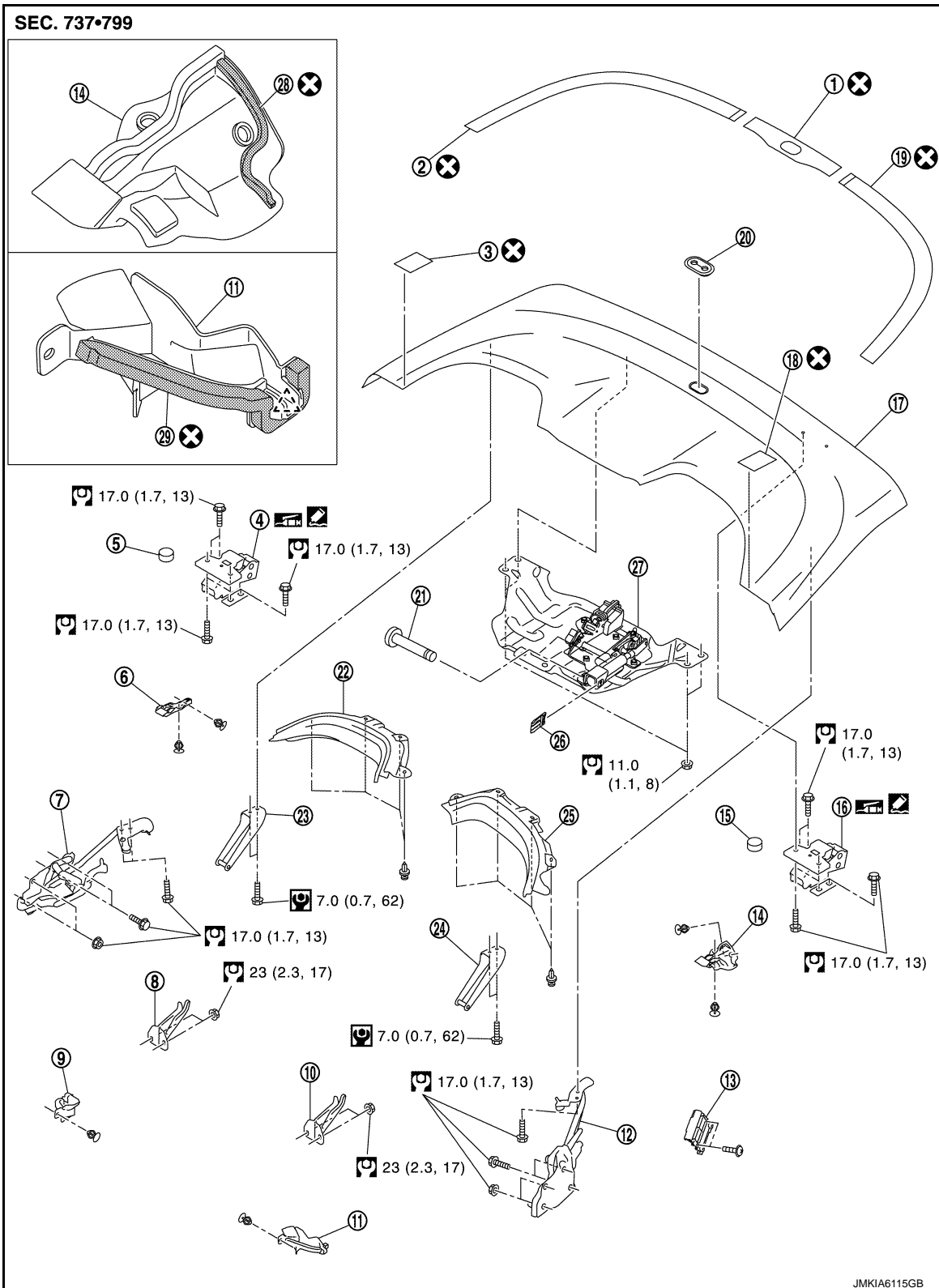

A
B
C
D
E
F
G
H
I
J
RF
L
M
N
O
P

STORAGE LID

< REMOVAL AND INSTALLATION >

- | | | |
|-------------------------------------|---------------------------------|--|
| 1. Storage outer protector (center) | 2. Storage outer protector (RH) | 3. Front storage outer protector (RH) |
| 4. Storage lid hinge (RH) | 5. Cap | 6. Front rubber seal (RH) |
| 7. Storage lid device assembly (RH) | 8. Storage lid lock (RH) | 9. Storage lid drip (RH) |
| 10. Storage lid lock (LH) | 11. Storage lid drip (LH) | 12. Storage lid device assembly (LH) |
| 13. Harness bracket | 14. Front rubber seal (LH) | 15. Cap |
| 16. Storage lid hinge (LH) | 17. Storage lid assembly | 18. Front storage outer protector (LH) |
| 19. Storage outer protector (LH) | 20. Soft top lock protector | 21. Cylinder mounting pin |
| 22. Rear parcel board (RH) | 23. Storage lid striker (RH) | 24. Storage lid striker (LH) |
| 25. Rear parcel board (LH) | 26. Cylinder mounting clip | 27. Storage bracket assembly |
| 28. Butyl tape | 29. Butyl tape | |

 : Pawl

Refer to [GI-4, "Components"](#) for symbols in the figure.

STORAGE LID ASSEMBLY : Removal and Installation

INFOID:000000007625554

REMOVAL

1. Operate soft top as shown in the figure.

CAUTION:

Storage lid assembly may close due to low oil pressure. Always support storage lid assembly in the fully open position using a supporting block.

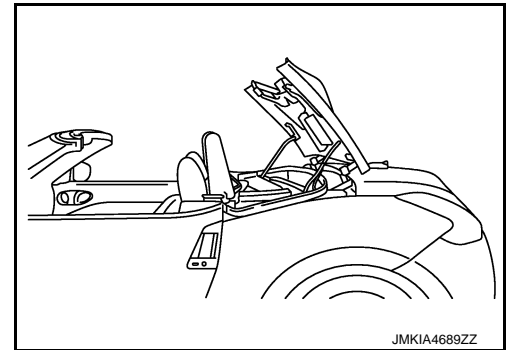

2. Remove oil pressure hose fixing clips from storage lid assembly.

NOTE:

Write a short note to describe the fixing clip positions.

CAUTION:

Never sharply bend, twist or strongly pull oil pressure hose.

3. Disconnect storage lid bracket assembly. Refer to [RF-216, "STORAGE LID BRACKET ASSEMBLY : Exploded View"](#).
4. Remove bolts (A). Disconnect storage lid device assembly from storage lid assembly (LH and RH). Refer to [RF-214, "STORAGE LID DEVICE ASSEMBLY : Exploded View"](#).

CAUTION:

Always support storage lid assembly so that storage lid hinge link does not contact with the trunk lid.

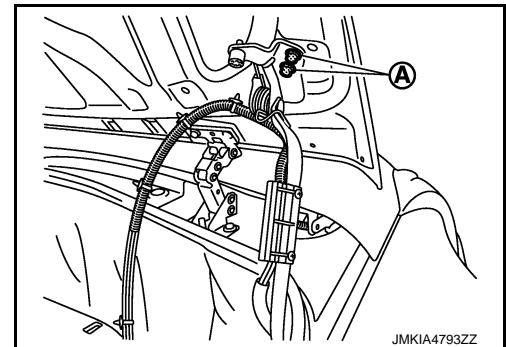

STORAGE LID

< REMOVAL AND INSTALLATION >

5. Remove bolts (A). Remove storage lid assembly from storage lid hinge. Refer to [RF-208, "STORAGE LID HINGE : Exploded View"](#).

CAUTION:

- Always support storage lid assembly so that it does not drop.
- This is a heavy component. It requires 2 workers for removal and installation.

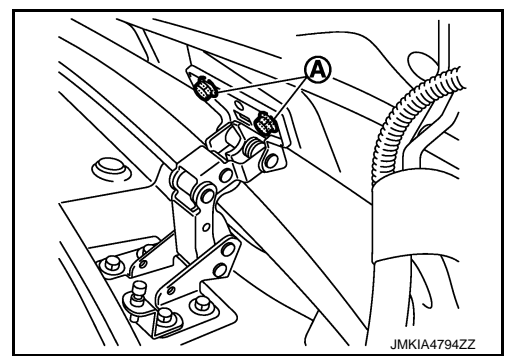

6. Remove the following parts after removing storage lid assembly.
- Remove the storage lid striker. Refer to [RF-210, "STORAGE LID STRIKER : Exploded View"](#).
 - Remove clips and then remove front rubber seal (LH and RH).
 - Remove rear parcel board. Refer to [INT-55, "Exploded View"](#).
 - Remove soft top lock protector.
 - Remove storage outer protector.

INSTALLATION

Note the following items, and install in the reverse order of removal.

CAUTION:

After installing storage lid assembly, perform fitting adjustment. Refer to [RF-203, "STORAGE LID ASSEMBLY : Adjustment"](#).

STORAGE LID ASSEMBLY : Adjustment

INFOID:000000007625555

FITTING ADJUSTMENT

A
B
C
D
E
F
G
H
I
J
L
M
N
O
P

RF

STORAGE LID

< REMOVAL AND INSTALLATION >

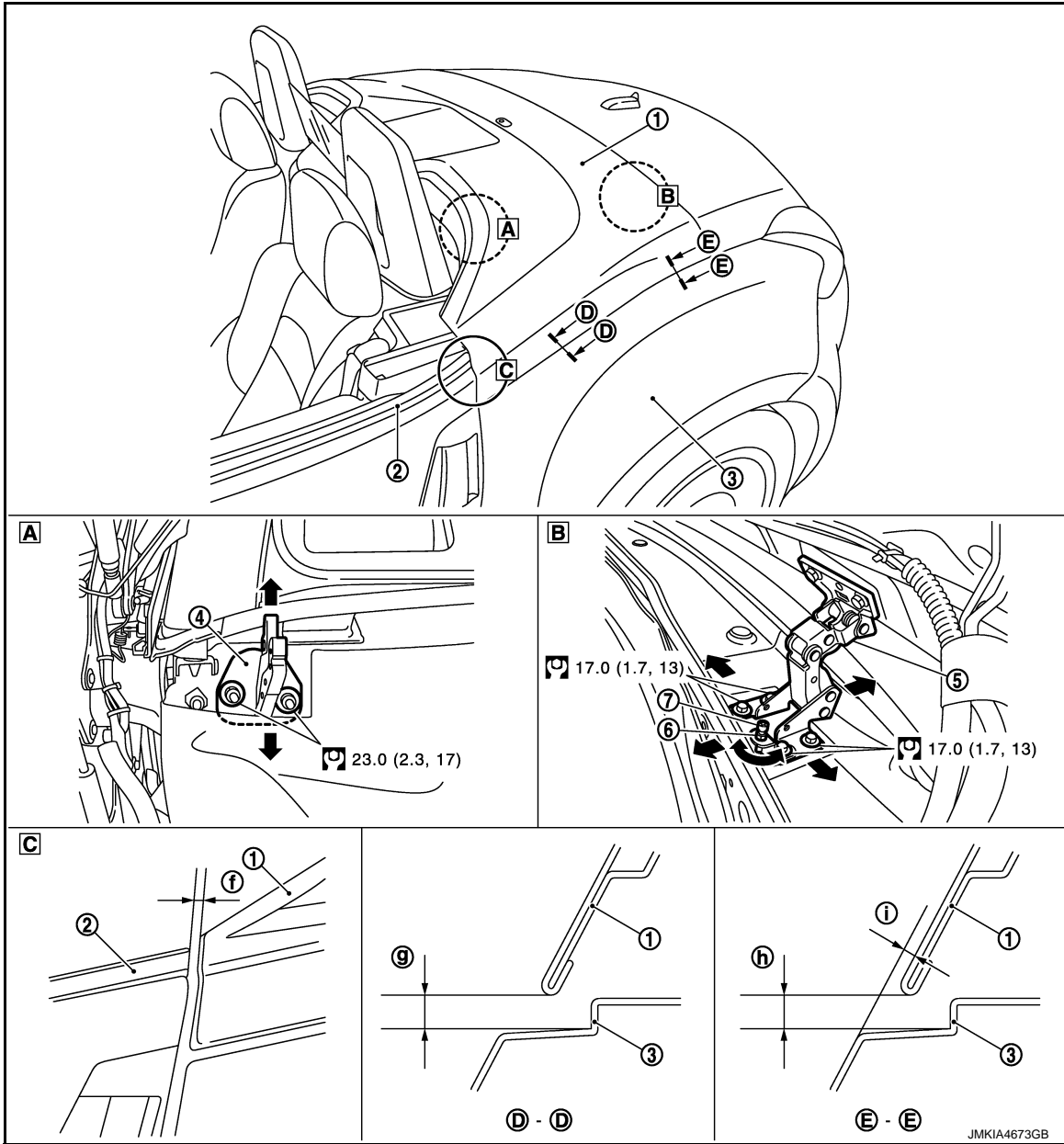

- | | | |
|-------------------------|--------------------------|----------------|
| 1. Storage lid assembly | 2. Door out side molding | 3. Rear fender |
| 4. Storage lid lock | 5. Storage lid hinge | 6. Lock nut |
| 7. Adjust bolt | | |

Refer to [GI-4, "Components"](#) for the symbols shown in the figure.

Visually and tactually check that the clearance and surface height difference of the storage lid assembly and each part satisfy the standard. If they are outside the specified value, adjust them with the following procedure.

Portion				Standard	Difference between
Storage lid front end and door outside molding	C	f	Clearance	3.5 - 6.5 mm (0.138 - 0.256 in)	—
Storage lid front end and rear fender	D - D	g	Clearance	5.0 mm (0.197 in)	—

STORAGE LID

< REMOVAL AND INSTALLATION >

Portion			Standard	Difference between
Storage lid rear end and rear fender	E - E	h	Clearance	5.0 mm (0.197 in)
		i	Surface difference	(-1.5) - (+1.5) mm [(-0.059) - (+0.059) in]

FITTING ADJUSTMENT PROCEDURE

1. Manually operate and check that storage lid assembly opens and closes without interfering with other portions of the vehicle body.

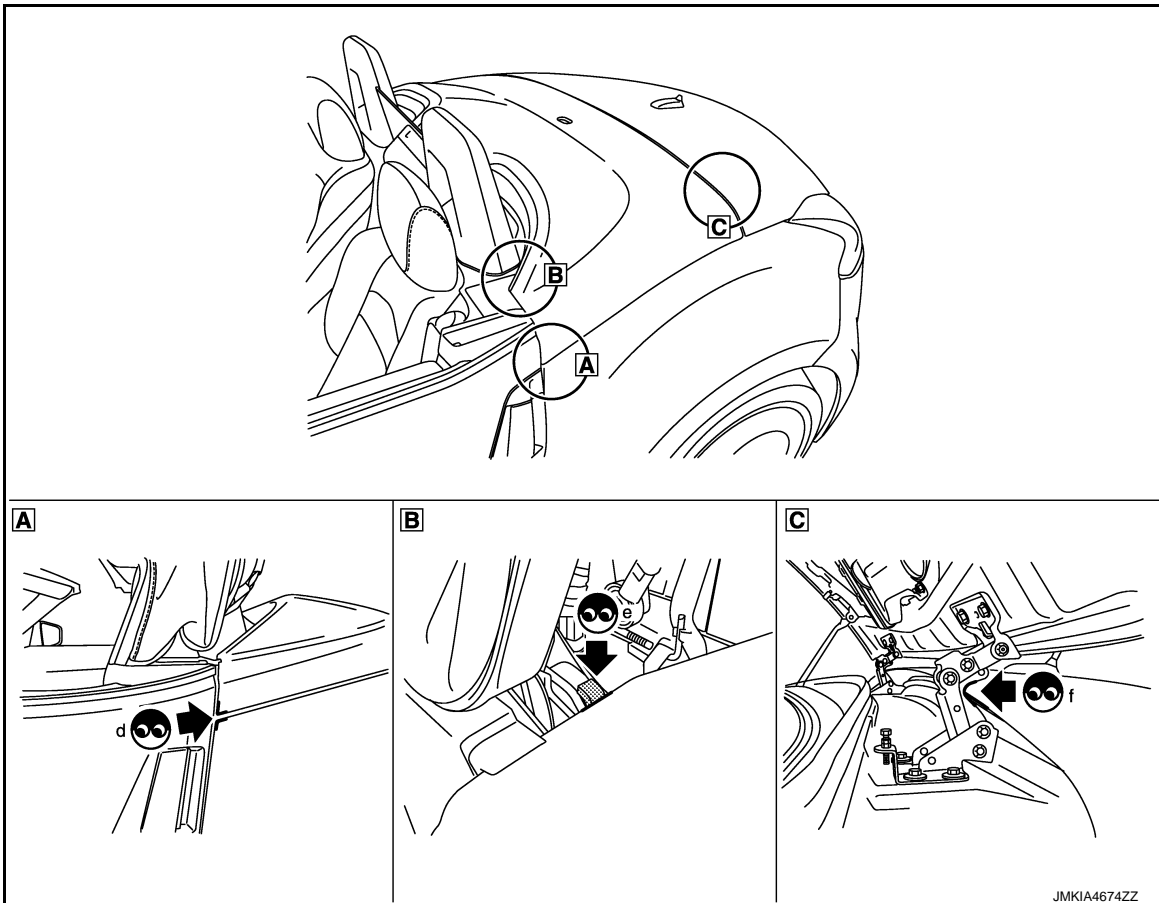

- d : Interference of rear fender and storage lid assembly
 e : Interference of soft top assembly and storage lid assembly
 f : Interference of trunk lid and storage lid hinge

Refer to [GI-4, "Components"](#) for symbols in the figure.

CAUTION:

- Before manually operating each cylinder of the hydraulic system, turn ignition switch OFF or disconnect battery cable from the negative terminal, then wait for 4 minutes or more. (Each cylinder maintains oil pressure and therefore it takes a period of time to lower oil pressure.)
 - Be careful since the storage lid assembly may interfere with rear fender while opening and closing when clearance is 5.0 mm (0.197 in) or less.
2. Close storage lid assembly and soft top assembly using the auto operation.
 3. Measure clearance and surface height difference.

STORAGE LID

< REMOVAL AND INSTALLATION >

4. Operate soft top as shown in the figure.

CAUTION:

Storage lid assembly may close due to low oil pressure. Always support storage lid assembly in the fully open position using a supporting block.

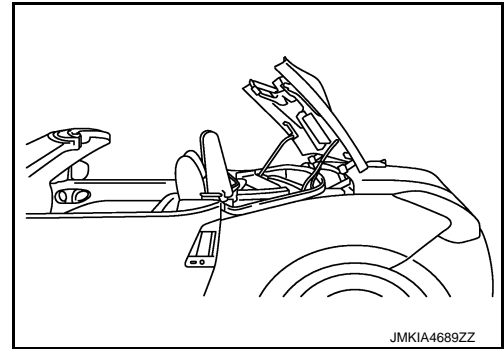

5. Loosen front bolts (A) of storage lid hinge mounting bolts.

CAUTION:

Never loosen storage lid hinge mounting bolts (B) while storage lid assembly is open.

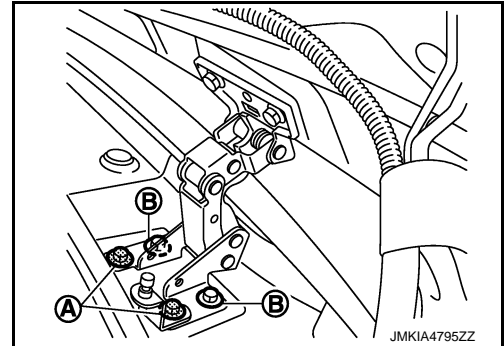

6. Close storage lid assembly and soft top assembly using the auto operation.

7. Open trunk lid. Loosen rear bolts (A) of storage lid hinge mounting bolts.

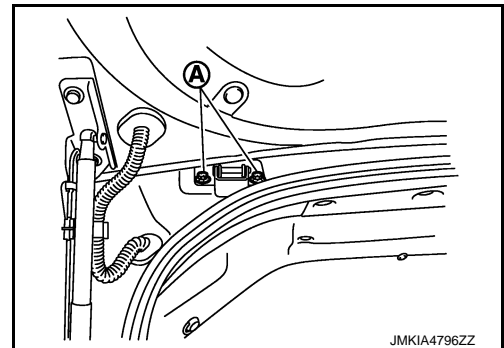

8. Move storage lid hinge. Adjust front and rear clearance of storage lid assembly front end to the standard.

9. Move storage lid hinge. Adjust surface height difference to the standard.

10. Tighten rear bolts of storage hinge mounting bolts. Close trunk lid.

11. Operate soft top as shown in the figure.

CAUTION:

Storage lid assembly may close due to low oil pressure. Always support storage lid assembly in the fully open position using a supporting block.

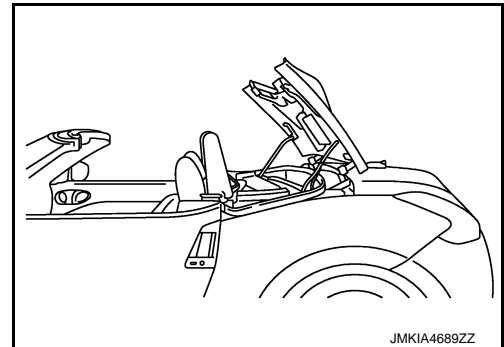

12. Tighten front bolts of storage lid hinge mounting bolts.

13. Loosen storage lid lock assembly mounting nuts.

14. Move storage lid lock. Adjust upper and lower clearance of storage lid assembly front end to the standard.

CAUTION:

Be careful since the storage lid assembly may interfere with rear fender while opening and closing when clearance is 5.0 mm (0.197 in) or less.

STORAGE LID

< REMOVAL AND INSTALLATION >

15. Tighten storage lid lock assembly mounting nuts.
16. Loosen storage lid hinge adjusting lock nut. A
17. Move adjuster bolt upward or downward. Adjust upper and lower clearance of storage lid assembly rear end to the standard.
18. Tighten storage lid hinge adjusting lock nut. B
19. Repeat the above operation, if necessary.

STORAGE LID HINGE

C

D

E

F

G

H

I

J

RF

L

M

N

O

P

STORAGE LID

< REMOVAL AND INSTALLATION >

STORAGE LID HINGE : Exploded View

INFOID:000000007625556

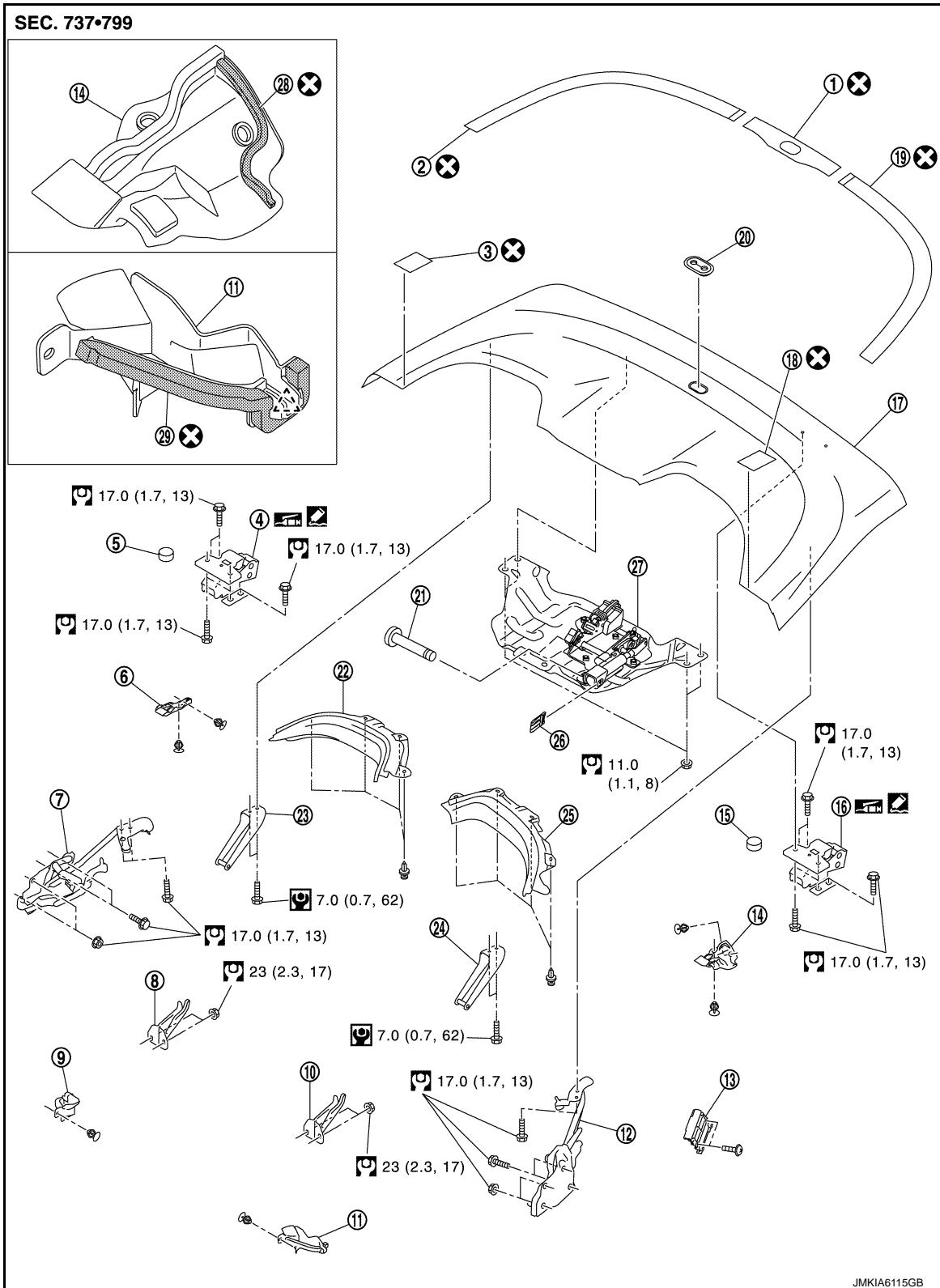

- | | | |
|-------------------------------------|---------------------------------|---------------------------------------|
| 1. Storage outer protector (center) | 2. Storage outer protector (RH) | 3. Front storage outer protector (RH) |
| 4. Storage lid hinge (RH) | 5. Cap | 6. Front rubber seal (RH) |
| 7. Storage lid device assembly (RH) | 8. Storage lid lock (RH) | 9. Storage lid drip (RH) |
| 10. Storage lid lock (LH) | 11. Storage lid drip (LH) | 12. Storage lid device assembly (LH) |

STORAGE LID

< REMOVAL AND INSTALLATION >

- | | | |
|----------------------------------|------------------------------|--|
| 13. Harness bracket | 14. Front rubber seal (LH) | 15. Cap |
| 16. Storage lid hinge (LH) | 17. Storage lid assembly | 18. Front storage outer protector (LH) |
| 19. Storage outer protector (LH) | 20. Soft top lock protector | 21. Cylinder mounting pin |
| 22. Rear parcel board (RH) | 23. Storage lid striker (RH) | 24. Storage lid striker (LH) |
| 25. Rear parcel board (LH) | 26. Cylinder mounting clip | 27. Storage bracket assembly |
| 28. Butyl tape | 29. Butyl tape | |

 : Pawl

Refer to [GI-4, "Components"](#) for symbols in the figure.

STORAGE LID HINGE : Removal and Installation

INFOID:000000007625557

REMOVAL

1. Operate soft top as shown in the figure.

CAUTION:

Storage lid assembly may close due to low oil pressure. Always support storage lid assembly in the fully open position using a supporting block.

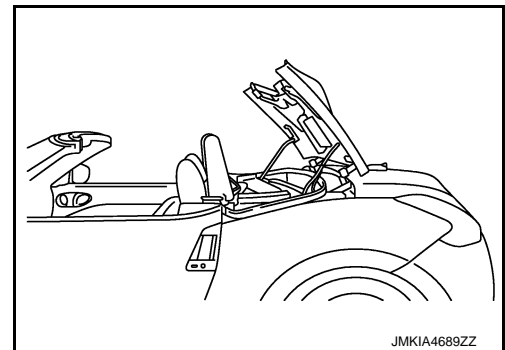

2. Remove bolts. Disconnect storage lid hinge from storage lid assembly.

NOTE:

Support storage lid assembly so that it does not drop. When replacing, replace storage lid hinges one side at a time.

3. Remove storage lid hinge mounting bolts. Remove storage lid hinge.

INSTALLATION

Note the following items, and install in the reverse order of removal.

CAUTION:

After installing storage lid assembly, perform fitting adjustment. Refer to [RF-203, "STORAGE LID ASSEMBLY : Adjustment"](#).

STORAGE LID STRIKER

STORAGE LID

< REMOVAL AND INSTALLATION >

STORAGE LID STRIKER : Exploded View

INFOID:000000007625558

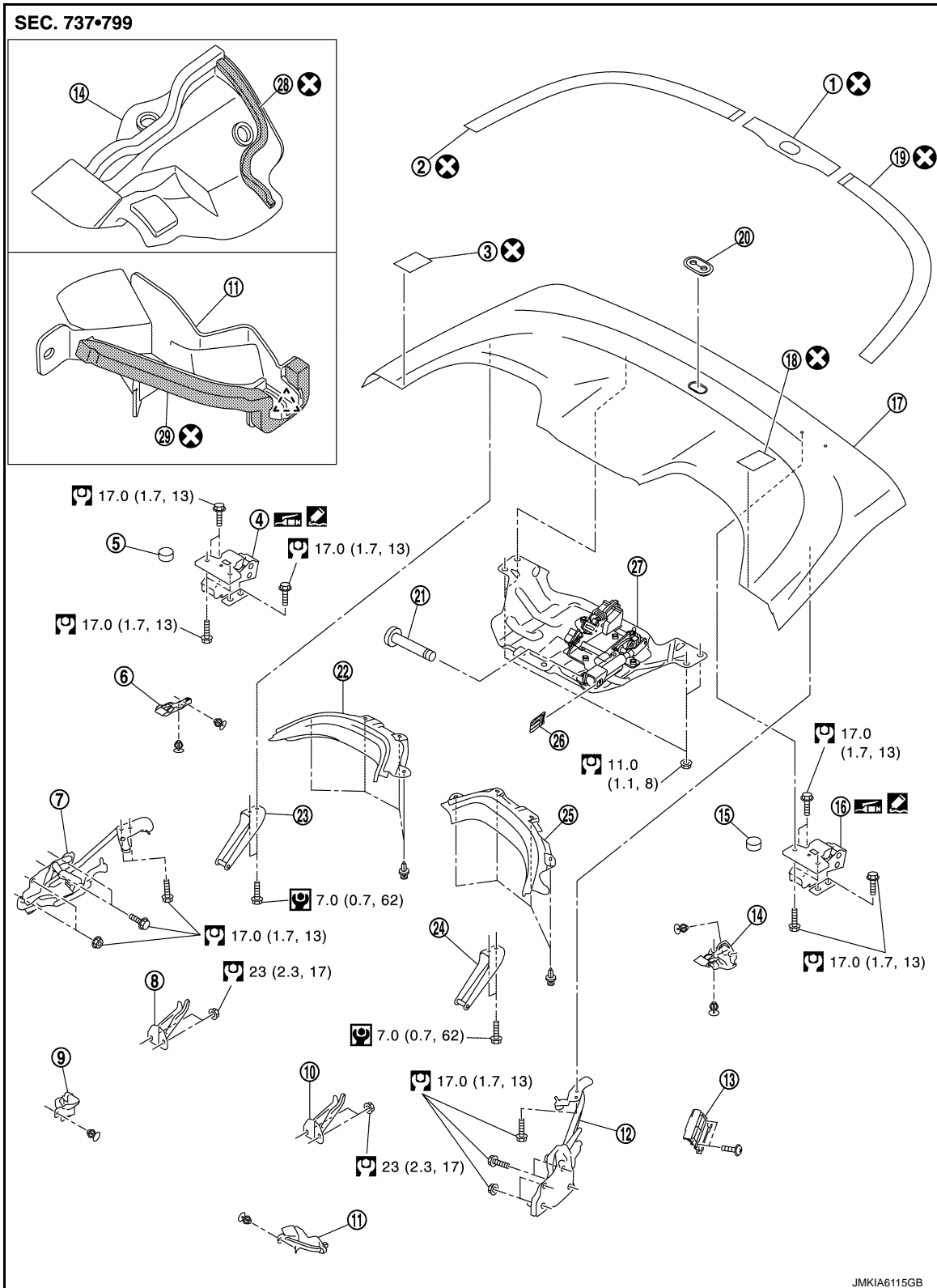

- | | | |
|-------------------------------------|---------------------------------|---------------------------------------|
| 1. Storage outer protector (center) | 2. Storage outer protector (RH) | 3. Front storage outer protector (RH) |
| 4. Storage lid hinge (RH) | 5. Cap | 6. Front rubber seal (RH) |
| 7. Storage lid device assembly (RH) | 8. Storage lid lock (RH) | 9. Storage lid drip (RH) |
| 10. Storage lid lock (LH) | 11. Storage lid drip (LH) | 12. Storage lid device assembly (LH) |

STORAGE LID

< REMOVAL AND INSTALLATION >

- | | | |
|----------------------------------|------------------------------|--|
| 13. Harness bracket | 14. Front rubber seal (LH) | 15. Cap |
| 16. Storage lid hinge (LH) | 17. Storage lid assembly | 18. Front storage outer protector (LH) |
| 19. Storage outer protector (LH) | 20. Soft top lock protector | 21. Cylinder mounting pin |
| 22. Rear parcel board (RH) | 23. Storage lid striker (RH) | 24. Storage lid striker (LH) |
| 25. Rear parcel board (LH) | 26. Cylinder mounting clip | 27. Storage bracket assembly |
| 28. Butyl tape | 29. Butyl tape | |

 : Pawl

Refer to [GI-4, "Components"](#) for symbols in the figure.

STORAGE LID STRIKER : Removal and Installation

INFOID:000000007625559

REMOVAL

1. Operate soft top as shown in the figure.

CAUTION:

Storage lid assembly may close due to low oil pressure. Always support storage lid assembly in the fully open position using a supporting block.

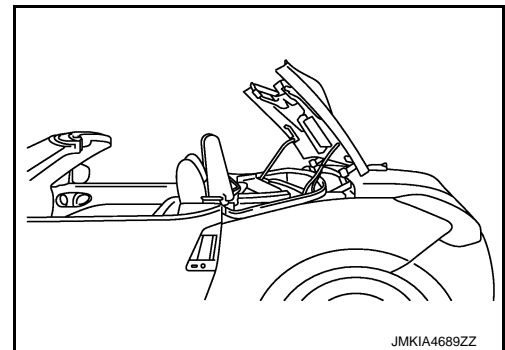

2. Remove storage lid striker mounting bolts, and then remove storage lid striker.

INSTALLATION

Install in the reverse order of removal.

CAUTION:

After installation, check storage lid open/close lock/unlock operation.

STORAGE LID LOCK

A
B
C
D
E
F
G
H
I
J
RF
L
M
N
O
P

STORAGE LID

< REMOVAL AND INSTALLATION >

STORAGE LID LOCK : Exploded View

INFOID:000000007625560

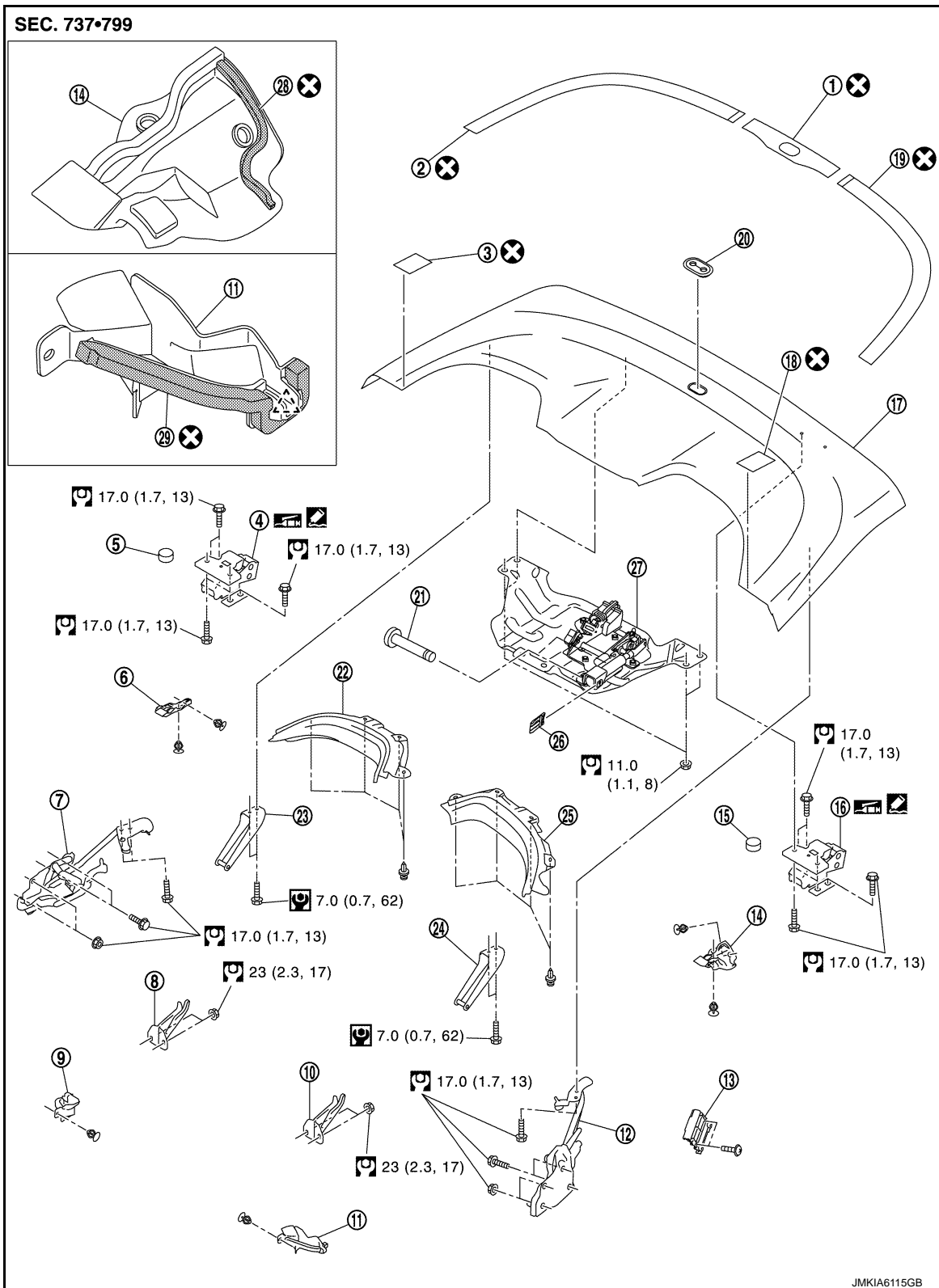

JMKIA6115GB

- | | | |
|-------------------------------------|---------------------------------|---------------------------------------|
| 1. Storage outer protector (center) | 2. Storage outer protector (RH) | 3. Front storage outer protector (RH) |
| 4. Storage lid hinge (RH) | 5. Cap | 6. Front rubber seal (RH) |
| 7. Storage lid device assembly (RH) | 8. Storage lid lock (RH) | 9. Storage lid drip (RH) |
| 10. Storage lid lock (LH) | 11. Storage lid drip (LH) | 12. Storage lid device assembly (LH) |

STORAGE LID

< REMOVAL AND INSTALLATION >

- | | | |
|----------------------------------|------------------------------|--|
| 13. Harness bracket | 14. Front rubber seal (LH) | 15. Cap |
| 16. Storage lid hinge (LH) | 17. Storage lid assembly | 18. Front storage outer protector (LH) |
| 19. Storage outer protector (LH) | 20. Soft top lock protector | 21. Cylinder mounting pin |
| 22. Rear parcel board (RH) | 23. Storage lid striker (RH) | 24. Storage lid striker (LH) |
| 25. Rear parcel board (LH) | 26. Cylinder mounting clip | 27. Storage bracket assembly |
| 28. Butyl tape | 29. Butyl tape | |

 : Pawl

Refer to [GI-4, "Components"](#) for symbols in the figure.

STORAGE LID LOCK : Removal and Installation

INFOID:000000007625561

REMOVAL

1. Operate soft top as shown in the figure.

CAUTION:

Storage lid assembly may close due to low oil pressure. Always support storage lid assembly in the fully open position using a supporting block.

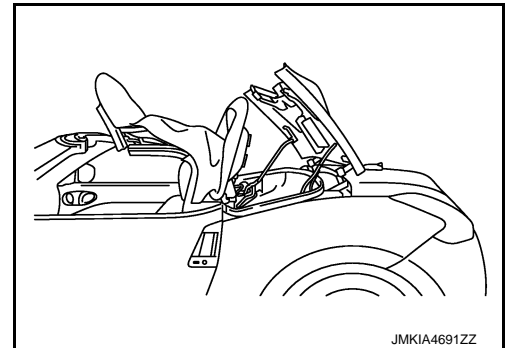

2. Remove storage lid lock mounting nuts. Remove storage lid lock.

INSTALLATION

Note the following items, and install in the reverse order of removal.

CAUTION:

After installing storage lid assembly, perform fitting adjustment. Refer to [RF-203, "STORAGE LID ASSEMBLY : Adjustment"](#).

STORAGE LID DEVICE ASSEMBLY

A
B
C
D
E
F
G
H
I
J
RF
L
M
N
O
P

STORAGE LID

< REMOVAL AND INSTALLATION >

STORAGE LID DEVICE ASSEMBLY : Exploded View

INFOID:000000007625562

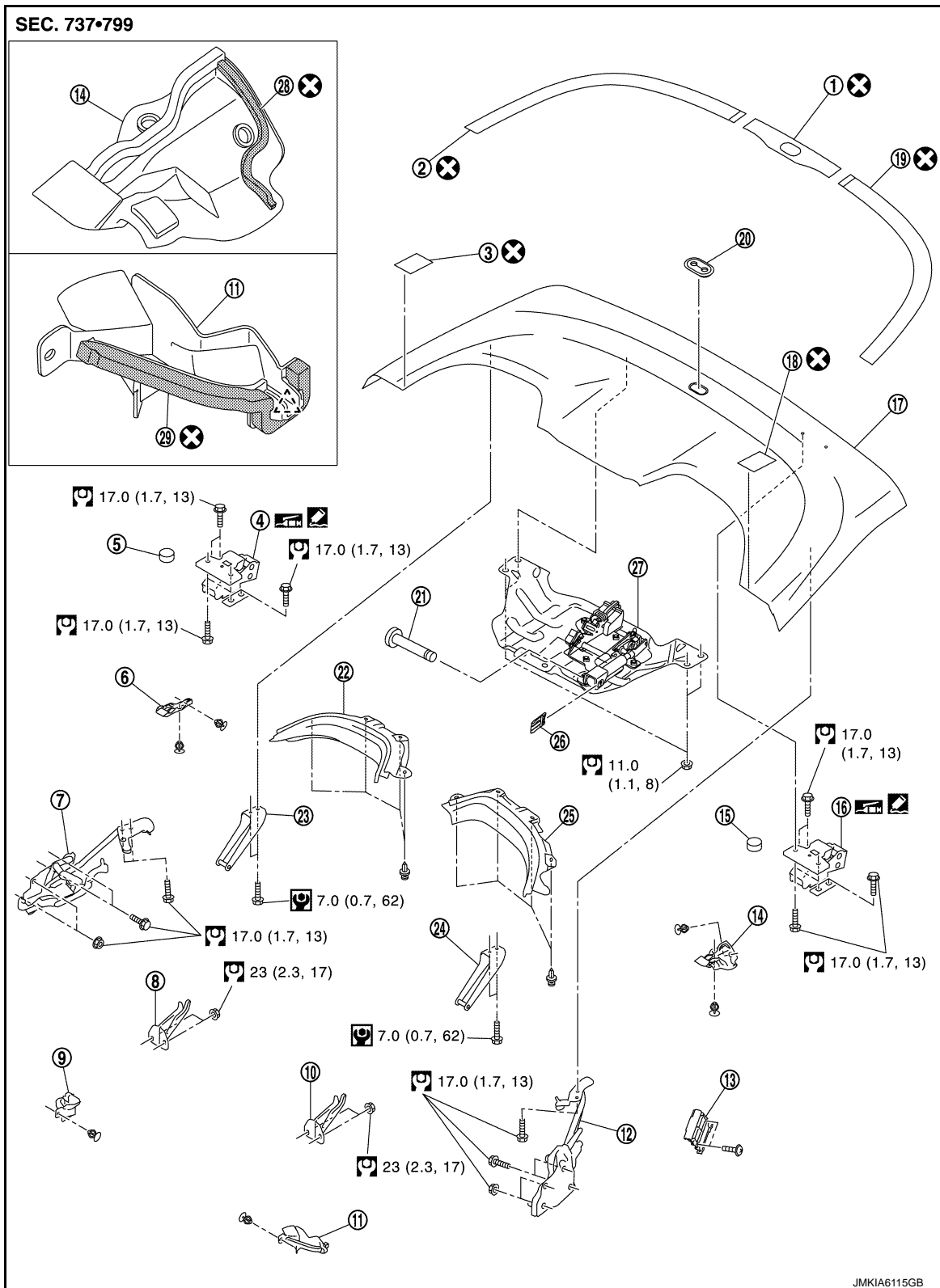

- | | | |
|-------------------------------------|---------------------------------|---------------------------------------|
| 1. Storage outer protector (center) | 2. Storage outer protector (RH) | 3. Front storage outer protector (RH) |
| 4. Storage lid hinge (RH) | 5. Cap | 6. Front rubber seal (RH) |
| 7. Storage lid device assembly (RH) | 8. Storage lid lock (RH) | 9. Storage lid drip (RH) |
| 10. Storage lid lock (LH) | 11. Storage lid drip (LH) | 12. Storage lid device assembly (LH) |

STORAGE LID

< REMOVAL AND INSTALLATION >

- | | | |
|----------------------------------|------------------------------|--|
| 13. Harness bracket | 14. Front rubber seal (LH) | 15. Cap |
| 16. Storage lid hinge (LH) | 17. Storage lid assembly | 18. Front storage outer protector (LH) |
| 19. Storage outer protector (LH) | 20. Soft top lock protector | 21. Cylinder mounting pin |
| 22. Rear parcel board (RH) | 23. Storage lid striker (RH) | 24. Storage lid striker (LH) |
| 25. Rear parcel board (LH) | 26. Cylinder mounting clip | 27. Storage bracket assembly |
| 28. Butyl tape | 29. Butyl tape | |

 : Pawl

Refer to [GI-4, "Components"](#) for symbols in the figure.

STORAGE LID DEVICE ASSEMBLY : Removal and Installation

INFOID:000000007625563

REMOVAL

1. Operate soft top as shown in the figure.

CAUTION:

Storage lid assembly may close due to low oil pressure. Always support storage lid assembly in the fully open position using a supporting block.

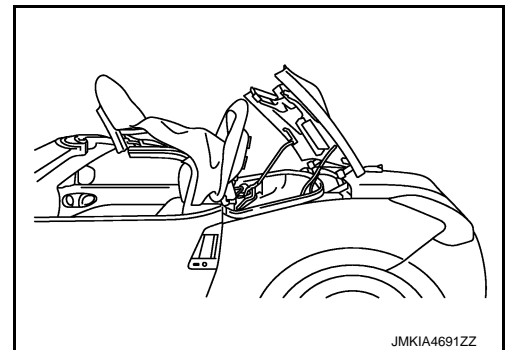

2. Remove emergency cable from storage lid device assembly. Refer to [RF-223, "STORAGE LID EMERGENCY OPENER : Exploded View"](#).
3. Remove harness bracket from storage device assembly. (LH only)
4. Disengage cylinder mounting pin (2) from storage lid drive cylinder (1). Pull and remove to vehicle inside.

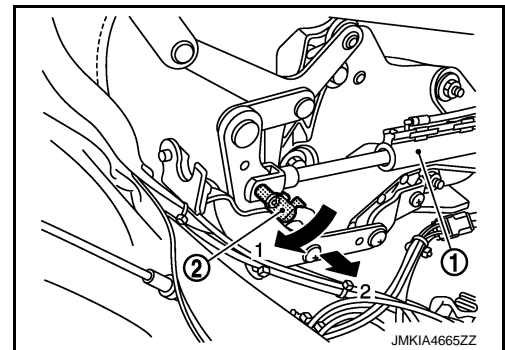

5. Disengage metal clip using a flat-bladed screwdriver (A). Disconnect storage lid drive cylinder from storage lid device assembly.

CAUTION:

- Before manually operating each cylinder of hydraulic system, turn ignition switch OFF or disconnect battery cable from the negative terminal, then wait for 4 minutes or more. (Each cylinder maintains oil pressure and it takes a period time to lower oil pressure.)
- Never sharply bend, twist or strongly pull oil pressure hose.

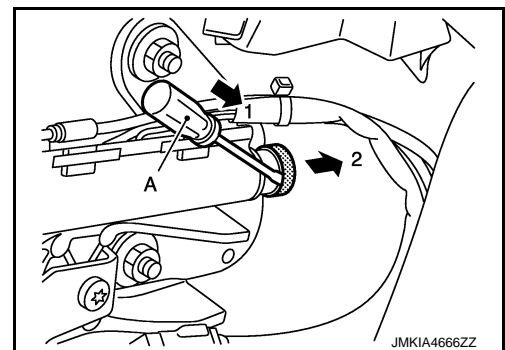

6. Remove bolts. Disconnect storage lid device assembly from storage lid assembly.

CAUTION:

Always support storage lid so that storage lid hinge does not contact with trunk lid.

7. Remove storage lid device mounting bolts and nuts. Remove storage lid device assembly.

CAUTION:

Always support storage lid so that storage lid hinge does not contact with trunk lid.

STORAGE LID

< REMOVAL AND INSTALLATION >

INSTALLATION

Install in the reverse order of removal.

CAUTION:

After installation, check storage lid open/close lock/unlock operation.

STORAGE LID BRACKET ASSEMBLY

STORAGE LID BRACKET ASSEMBLY : Exploded View

INFOID:000000007625564

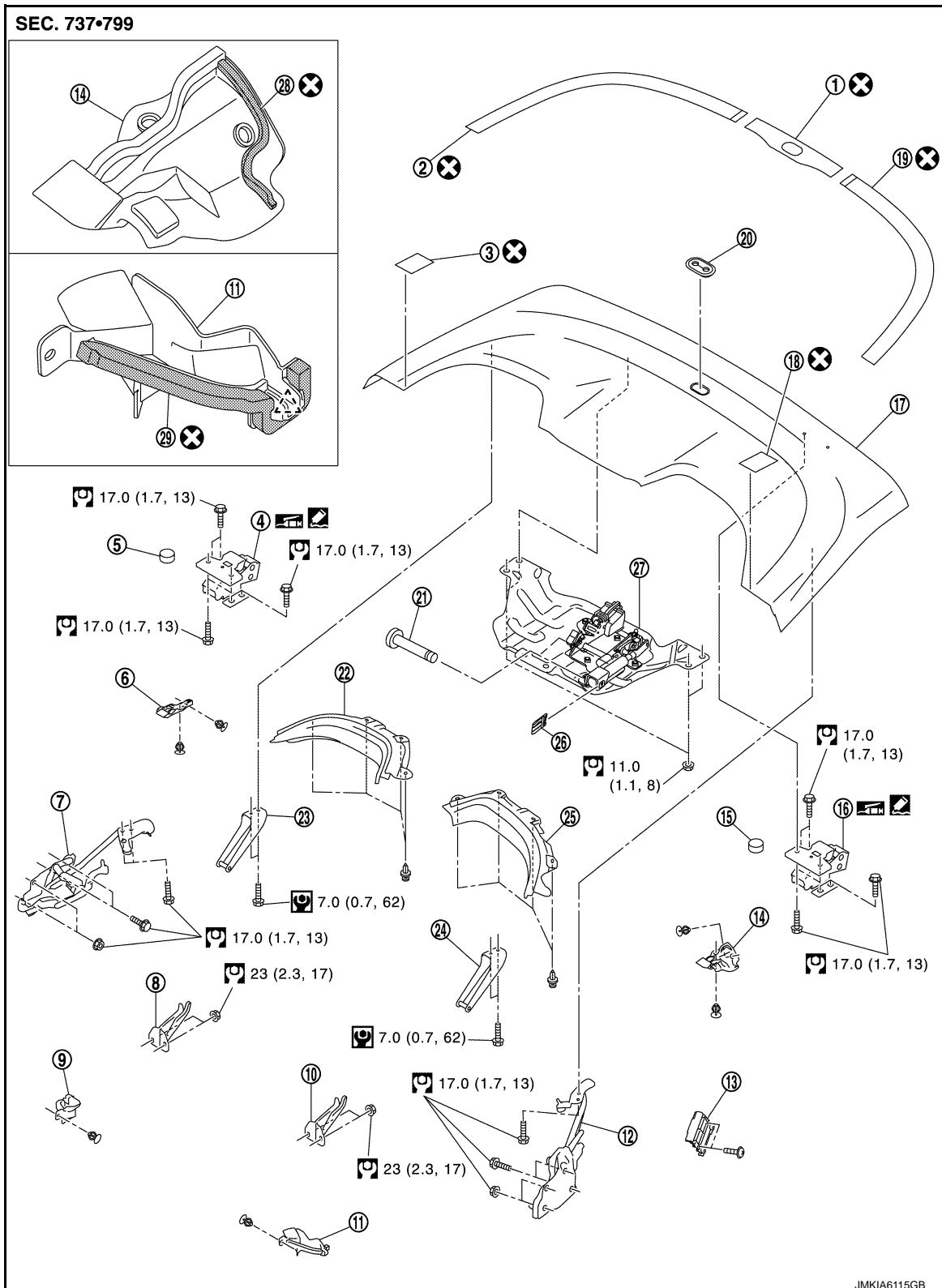

STORAGE LID

< REMOVAL AND INSTALLATION >

- | | | |
|-------------------------------------|---------------------------------|--|
| 1. Storage outer protector (center) | 2. Storage outer protector (RH) | 3. Front storage outer protector (RH) |
| 4. Storage lid hinge (RH) | 5. Cap | 6. Front rubber seal (RH) |
| 7. Storage lid device assembly (RH) | 8. Storage lid lock (RH) | 9. Storage lid drip (RH) |
| 10. Storage lid lock (LH) | 11. Storage lid drip (LH) | 12. Storage lid device assembly (LH) |
| 13. Harness bracket | 14. Front rubber seal (LH) | 15. Cap |
| 16. Storage lid hinge (LH) | 17. Storage lid assembly | 18. Front storage outer protector (LH) |
| 19. Storage outer protector (LH) | 20. Soft top lock protector | 21. Cylinder mounting pin |
| 22. Rear parcel board (RH) | 23. Storage lid striker (RH) | 24. Storage lid striker (LH) |
| 25. Rear parcel board (LH) | 26. Cylinder mounting clip | 27. Storage bracket assembly |
| 28. Butyl tape | 29. Butyl tape | |

 : Pawl

Refer to [GI-4, "Components"](#) for symbols in the figure.

STORAGE LID BRACKET ASSEMBLY : Removal and Installation

INFOID:000000007625565

REMOVAL

1. Operate soft top as shown in the figure.

CAUTION:

Storage lid assembly may close due to low oil pressure. Always support storage lid assembly in the fully open position using a supporting block.

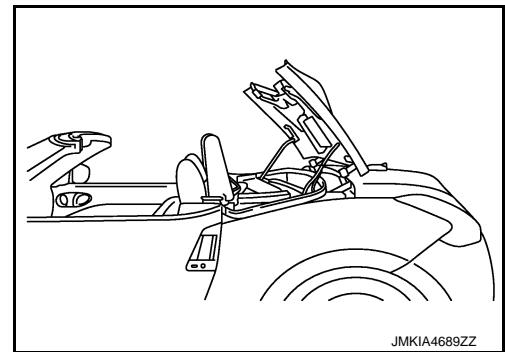

2. Remove oil pressure hose fixing clips from storage lid assembly.

NOTE:

Write a short note to describe the fixing clip positions.

CAUTION:

Never sharply bend, twist or strongly pull oil pressure hose.

3. Remove storage lid bracket assembly mounting nuts. Pull out storage lid bracket assembly from storage lid assembly.
4. Disconnect harness connector that enters in storage lid bracket assembly.

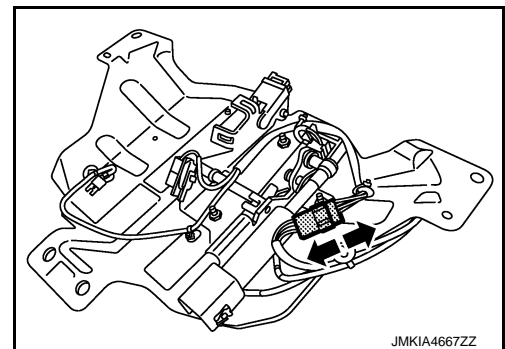

STORAGE LID

< REMOVAL AND INSTALLATION >

5. Remove cylinder mounting clip (B) using a flat-bladed screwdriver (A). Remove cylinder mounting pin (1).

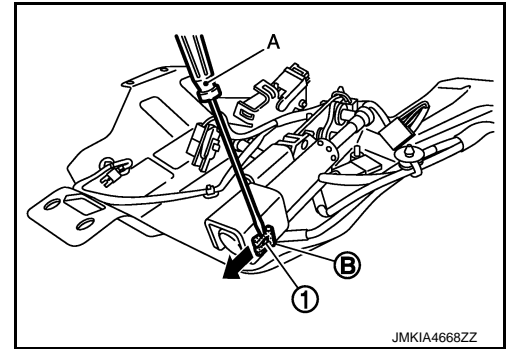

6. Manually retract 5th bow latch cylinder.

CAUTION:

- Before manually operating each cylinder of hydraulic system, turn ignition switch OFF or disconnect battery cable from the negative terminal, then wait for 4 minutes or more. (Each cylinder maintains oil pressure and it takes a period time to lower oil pressure.)
- Never sharply bend, twist or strongly pull oil pressure hose.

7. Disengage metal clip using a flat-bladed screwdriver (A). Disconnect 5th bow latch cylinder (1) from storage lid bracket assembly (2).

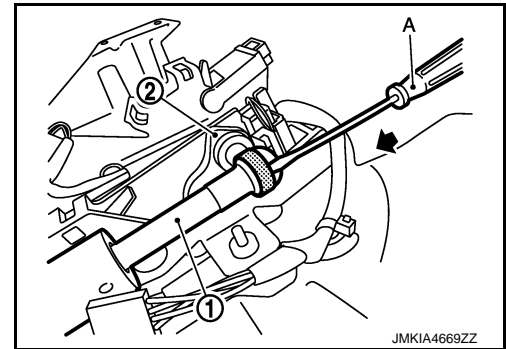

8. Remove storage bracket assembly.

INSTALLATION

Install in the reverse order of removal.

CAUTION:

After installation, check storage lid open/close lock/unlock operation.

STORAGE OUTER PROTECTOR

STORAGE LID

< REMOVAL AND INSTALLATION >

STORAGE OUTER PROTECTOR : Exploded View

INFOID:000000007625566

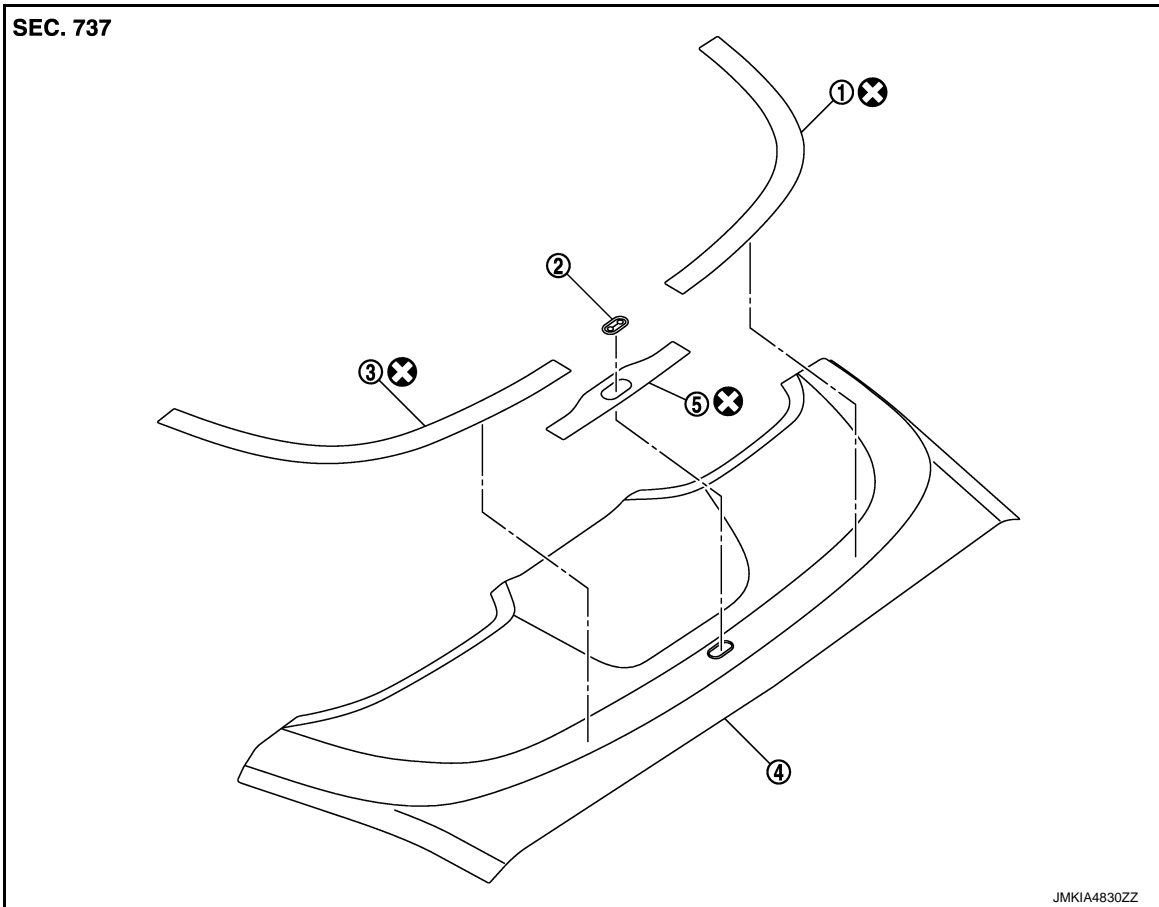

- | | | |
|-----------------------------------|---|-----------------------------------|
| 1. Storage lid outer protector RH | 2. Soft top lock protector | 3. Storage lid outer protector LH |
| 4. Storage lid assembly | 5. Storage lid outer protector (Center) | |

Refer to [GI-4, "Components"](#) for symbols in the figure.

STORAGE OUTER PROTECTOR : Removal and Installation

INFOID:000000007625567

REMOVAL

Heat bonded area of storage lid outer protector using a dryer and remove storage lid outer protector.

NOTE:

Do not reuse storage lid outer protector.

INSTALLATION

1. Clean storage lid surface.
2. Apply IPA solution (isopropyl alcohol : water = 1 : 1) on the lid, and set the storage outer protector position from one side. Perform the same procedure to the side.
3. Align storage lid outer protector (center) (1) to soft top lock protector (2). Affix storage lid outer protector (center) to storage lid assembly while peeling pattern paper.

CAUTION:

When affixing, gradually peel pattern paper while bleeding air.

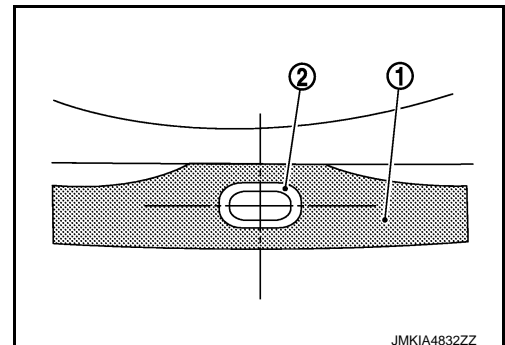

STORAGE LID

< REMOVAL AND INSTALLATION >

- Overlap storage lid outer protector LH (1) end to storage lid outer protector (center) (2) end as shown in the figure and affix to storage lid assembly while peeling pattern paper.

(b) : 19.0 - 21.0 mm (0.748 - 0.827 in)

CAUTION:

When affixing, gradually peel pattern paper while bleeding air.

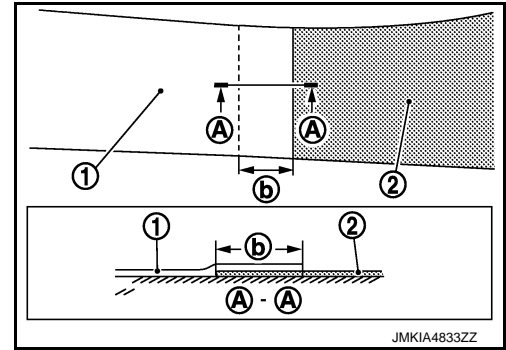

- Install storage lid outer protector end to storage lid assembly front end as shown in the figure.

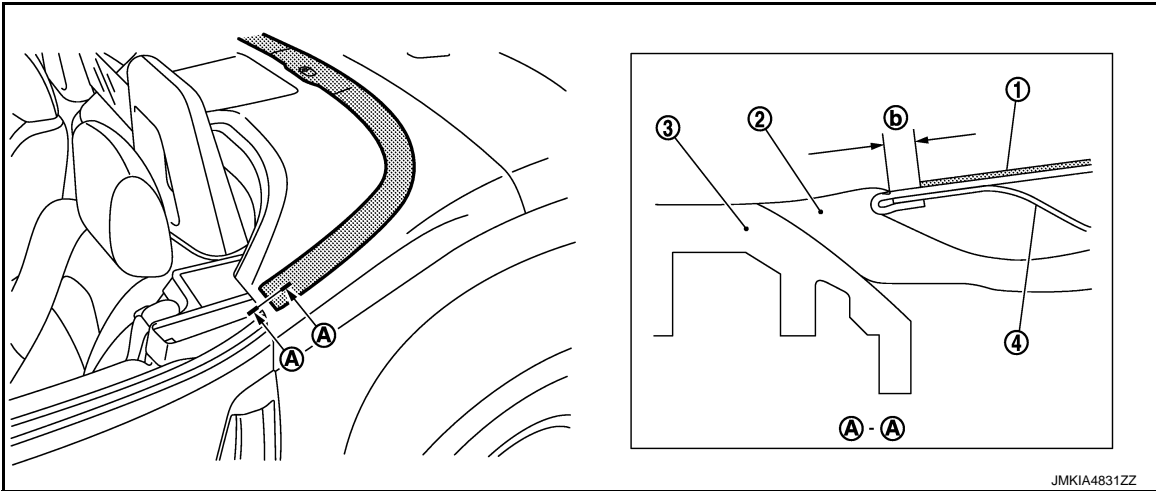

- | | | |
|--------------------------------|----------------------|----------------------------|
| 1. Storage lid outer protector | 2. Front rubber seal | 3. Body side weather-strip |
| 4. Storage lid assembly | | |

(b) : 0.0 - 5.0 mm (0.000 - 0.197 in)

- Affix storage outer protector RH as well.

CAUTION:

When affixing, gradually peel pattern paper while bleeding air.

STORAGE LID WEATHER-STRIP

STORAGE LID

< REMOVAL AND INSTALLATION >

STORAGE LID WEATHER-STRIP : Exploded View

INFOID:000000007625568

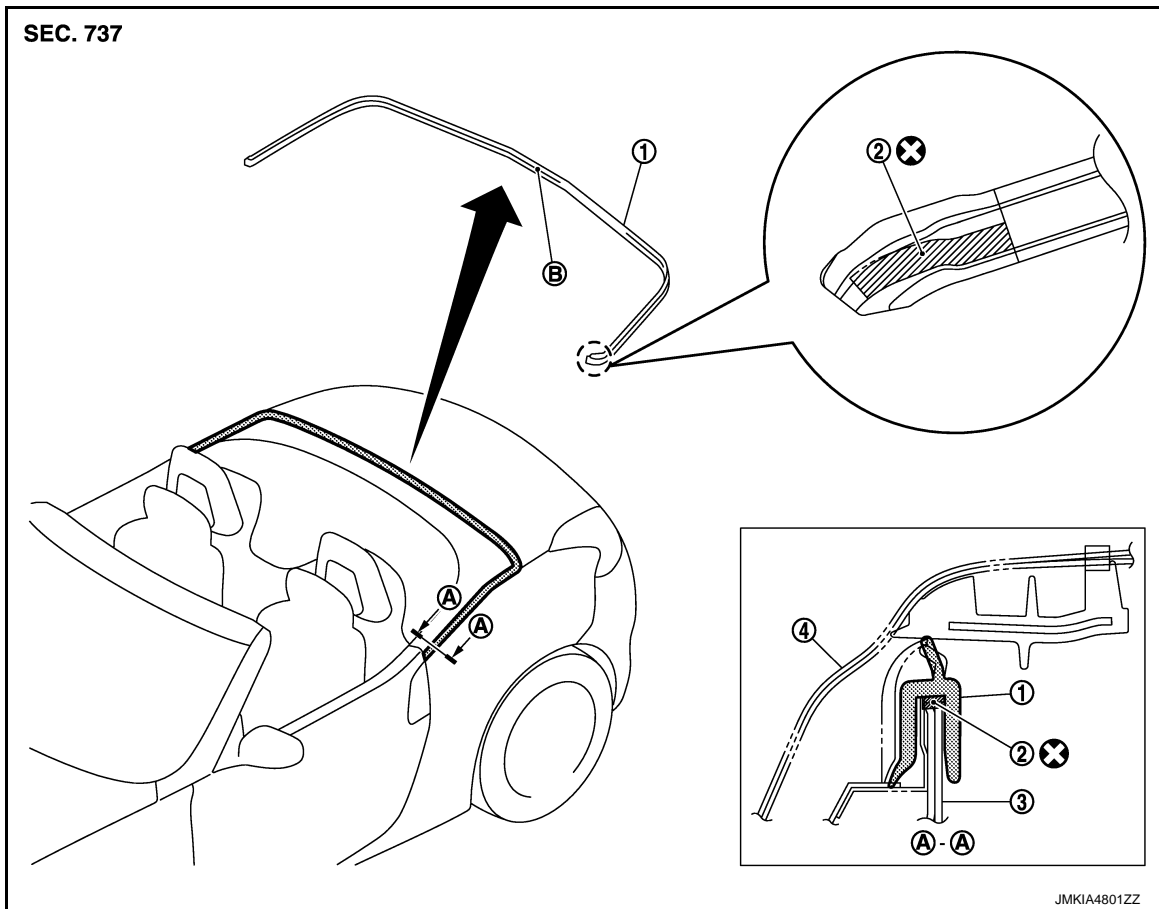

1. Storage lid weather-strip 2. Butyl tape 3. Body side panel

4. Storage lid assembly

B : Center mark

Refer to [GI-4. "Components"](#) for symbols in the figure.

STORAGE LID WEATHER-STRIP : Removal and Installation

INFOID:000000007625569

REMOVAL

1. Operate soft top as shown in the figure.

CAUTION:

Storage lid assembly may close due to low oil pressure. Always support storage lid assembly in the fully open position using a supporting block.

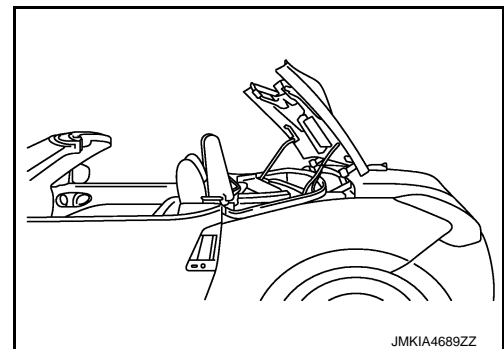

2. Pull upward, disconnect engagement of weather-strip and vehicle body, and then remove weather-strip.

CAUTION:

- Never strongly pull weather-strip while disconnecting and removing.
- Install after peeling off butyl tape on body panel and cleaning body panel.

NOTE:

Install after aligning body center mark and weather-strip center mark.

A
B
C
D
E
F
G
H
I
J

RF

L
M
N
O
P

STORAGE LID

< REMOVAL AND INSTALLATION >

INSTALLATION

Install in the reverse order of removal.

STORAGE ROOM FINISHER

STORAGE ROOM FINISHER : Exploded View

INFOID:000000007625570

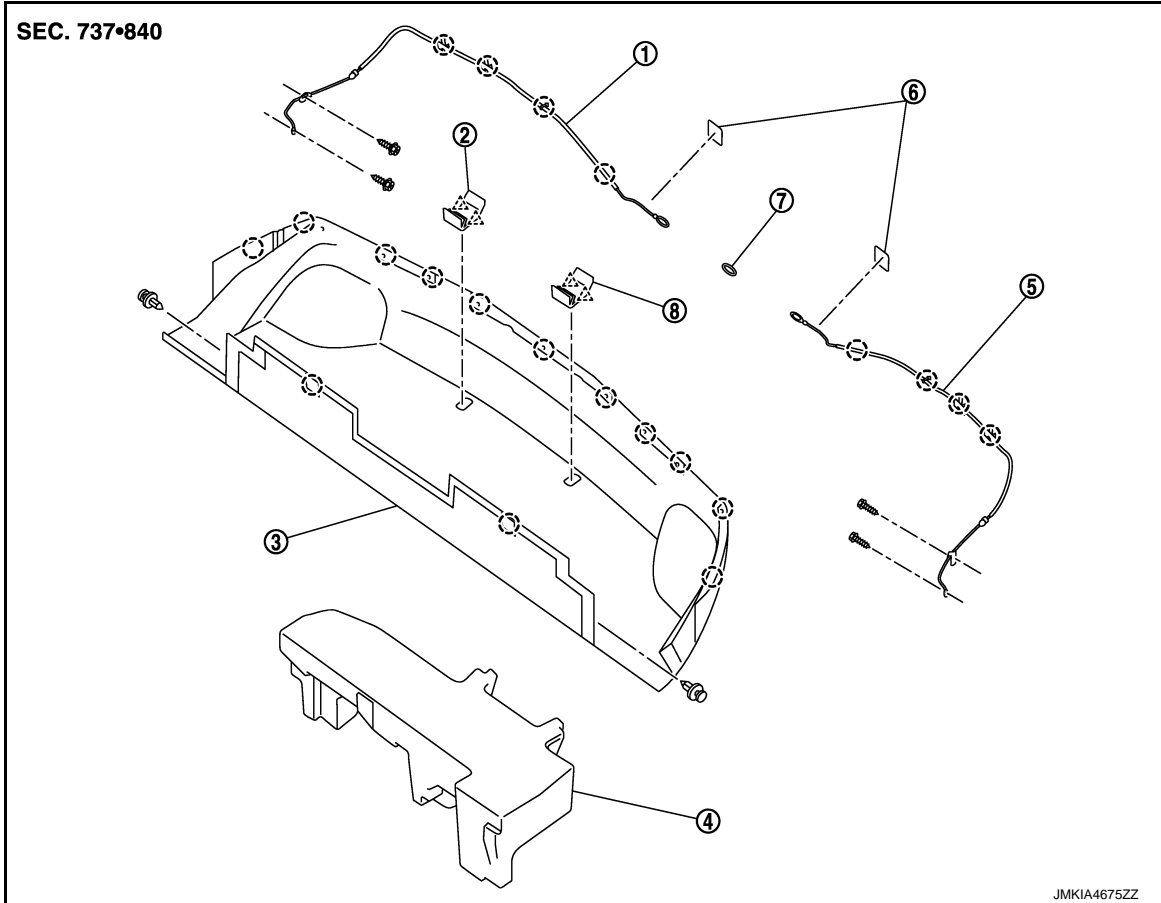

- | | | |
|-------------------------|--------------------------------|--------------------------|
| 1. Emergency cable (RH) | 2. Soft top bumper rubber (RH) | 3. Storage room finisher |
| 4. Storage room spacer | 5. Emergency cable (LH) | 6. Tape |
| 7. Grommet | 8. Soft top bumper rubber (LH) | |

○ : Clip

△ : Pawl

STORAGE ROOM FINISHER : Removal and Installation

INFOID:000000007625571

REMOVAL

1. Operate soft top as shown in the figure.

CAUTION:

Storage lid assembly may close due to low oil pressure. Always support storage lid assembly in the fully open position using a supporting block.

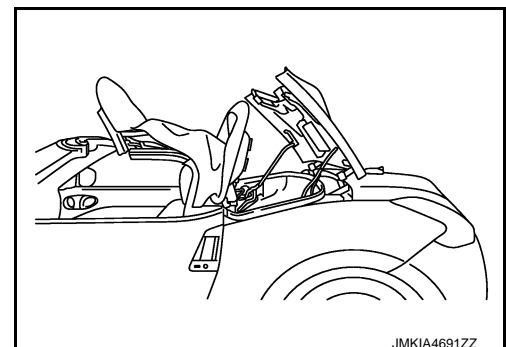

STORAGE LID

< REMOVAL AND INSTALLATION >

2. Remove emergency cable from storage lid device assembly (LH and RH). Refer to [RF-223. "STORAGE LID EMERGENCY OPENER : Exploded View"](#).
3. Remove bumper rubber (LH and RH).
4. Disengage mounting clips. Remove storage room finisher.

INSTALLATION

Install in the reverse order of removal.

STORAGE LID EMERGENCY OPENER

STORAGE LID EMERGENCY OPENER : Exploded View

INFOID:000000007625572

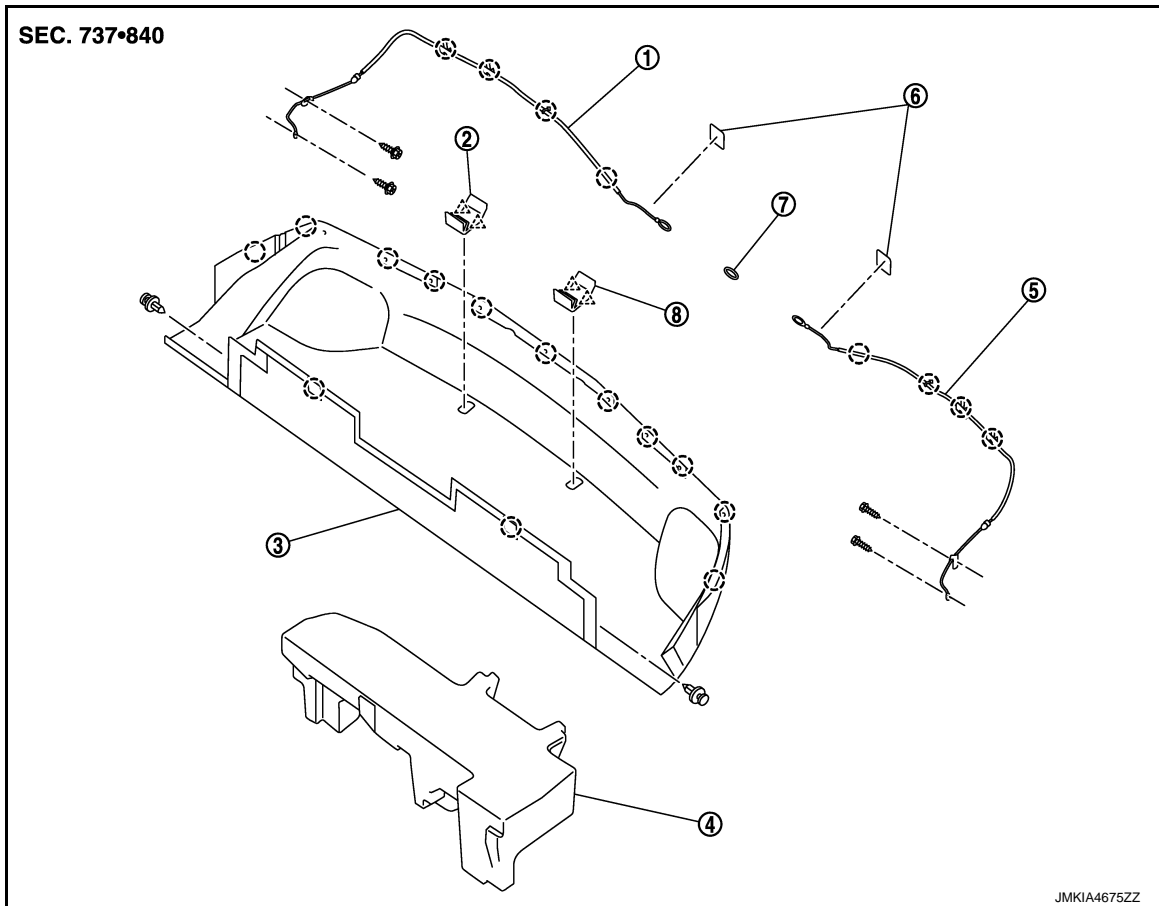

- | | | |
|-------------------------|--------------------------------|--------------------------|
| 1. Emergency cable (RH) | 2. Soft top bumper rubber (RH) | 3. Storage room finisher |
| 4. Storage room spacer | 5. Emergency cable (LH) | 6. Tape |
| 7. Grommet | 8. Soft top bumper rubber (LH) | |

○ : Clip

△ : Pawl

STORAGE LID EMERGENCY OPENER : Removal and Installation

INFOID:000000007625573

REMOVAL

1. Remove trunk finisher front. Refer to [INT-75. "Exploded View"](#).

STORAGE LID

< REMOVAL AND INSTALLATION >

2. Remove tapes (1).

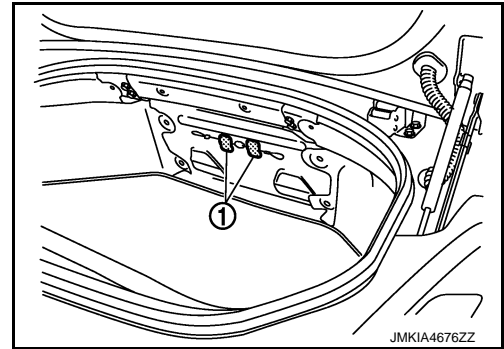

3. Operate soft top as shown in the figure.

CAUTION:

Storage lid assembly may close due to low oil pressure. Always support storage lid assembly in the fully open position using a supporting block.

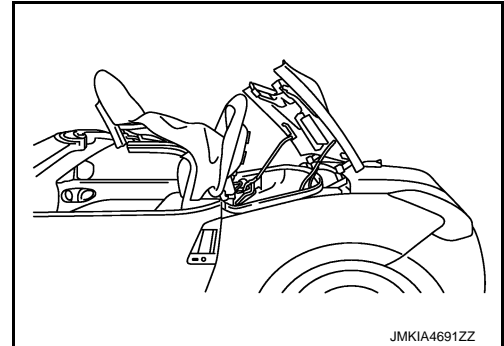

4. Remove bolts (A). Remove emergency cable upward.

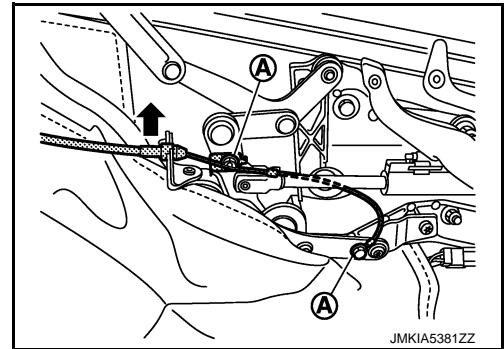

5. Remove rear mounting clips of storage room finisher.

6. Pull out emergency cable through storage room finisher hole (A).

7. Pull out emergency cable through hole (B) to trunk room.

 : Clip

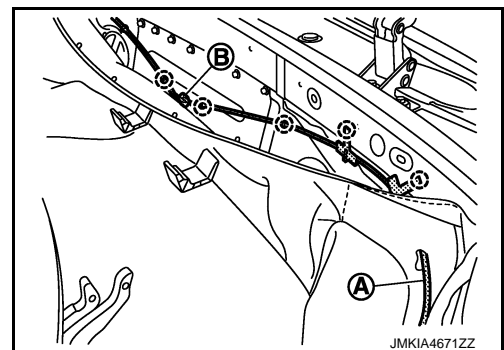

8. Disengage clip connecting emergency cable. Remove emergency cable.

INSTALLATION

Install in the reverse order of removal.

CAUTION:

• After installation, check storage lid open/close lock/unlock operation.

STORAGE LID

< REMOVAL AND INSTALLATION >

- When installing emergency cable, route it behind storage lid cylinder and fix using mounting bolts (A), for prevention of unwinding while soft top is retracted.

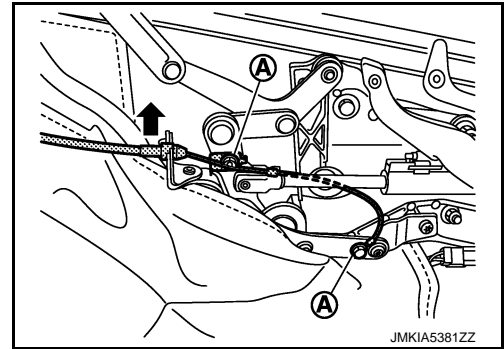

A

B

C

D

E

F

G

H

I

J

RF

L

M

N

O

P

HYDRAULIC SYSTEM

< REMOVAL AND INSTALLATION >

HYDRAULIC SYSTEM

Exploded View

INFOID:000000007625574

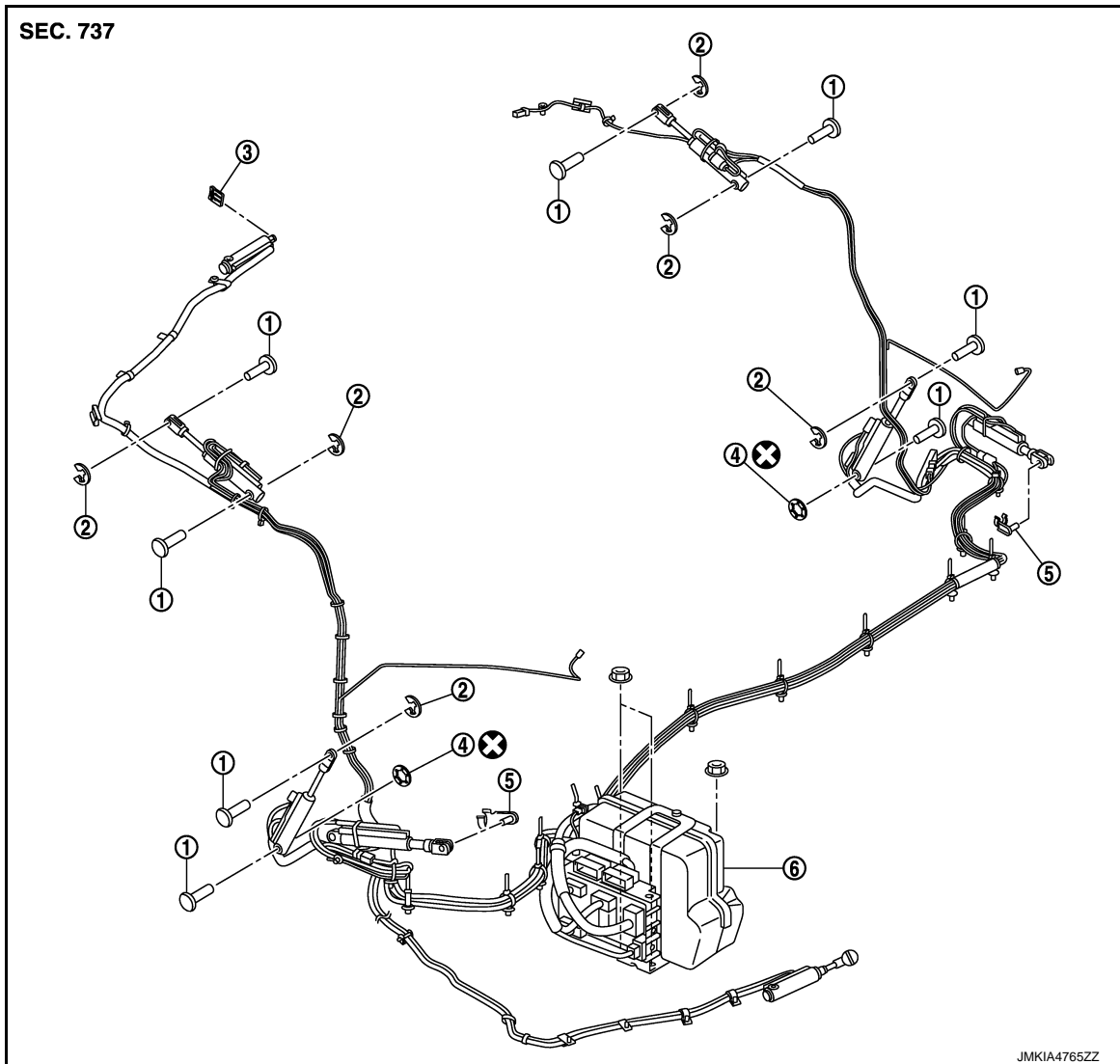

- | | | |
|--------------------------|-----------------------|----------------------------|
| 1. Cylinder mounting pin | 2. E-clip | 3. Retaining plate |
| 4. Push on nut | 5. Piston rod bracket | 6. Hydraulic unit assembly |

Refer to [GI-4. "Components"](#) for the symbols shown in the figure.

Removal and Installation

INFOID:000000007625575

CAUTION:

It is prohibited to disassemble the hydraulic unit assembly components. Never remove cylinders and oil pressure hoses.

REMOVAL

1. Remove soft top assembly from the vehicle. Refer to [RF-155. "SOFT TOP ASSEMBLY : Exploded View"](#).
2. Remove soft top control unit. Refer to [RF-235. "Exploded View"](#).
3. Remove bolt. Remove hydraulic pump bracket and hydraulic pump case.
4. Remove front rail weather-strip (LH and RH). Refer to [RF-188. "ROOF SEALING : Exploded View"](#).
5. Remove front rail weather-strip retainer (LH and RH). Refer to [RF-188. "ROOF SEALING : Exploded View"](#).

HYDRAULIC SYSTEM

< REMOVAL AND INSTALLATION >

6. Remove soft top cover outer front retainer mounting screws (A).

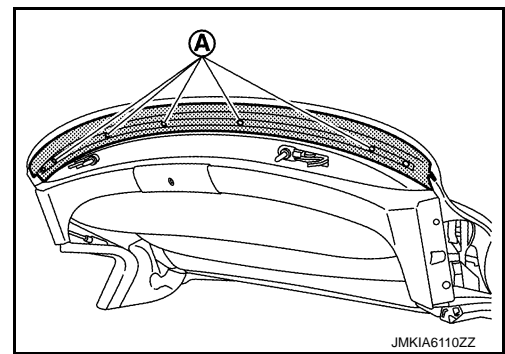

7. Lift up soft top cover outer front retainer (1), and then pull up soft top cover outer (2) portion (A) to outside (both LH and RH).

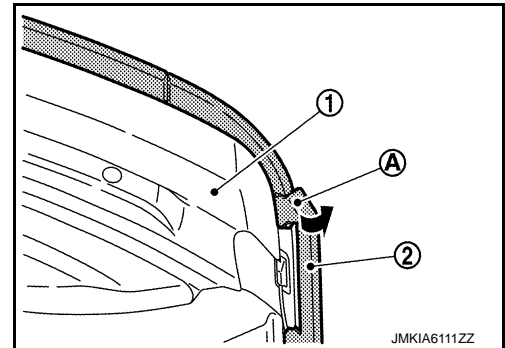

8. Pull out soft top cover outer wire (2) from soft top linkage assembly (1) (both LH and RH).

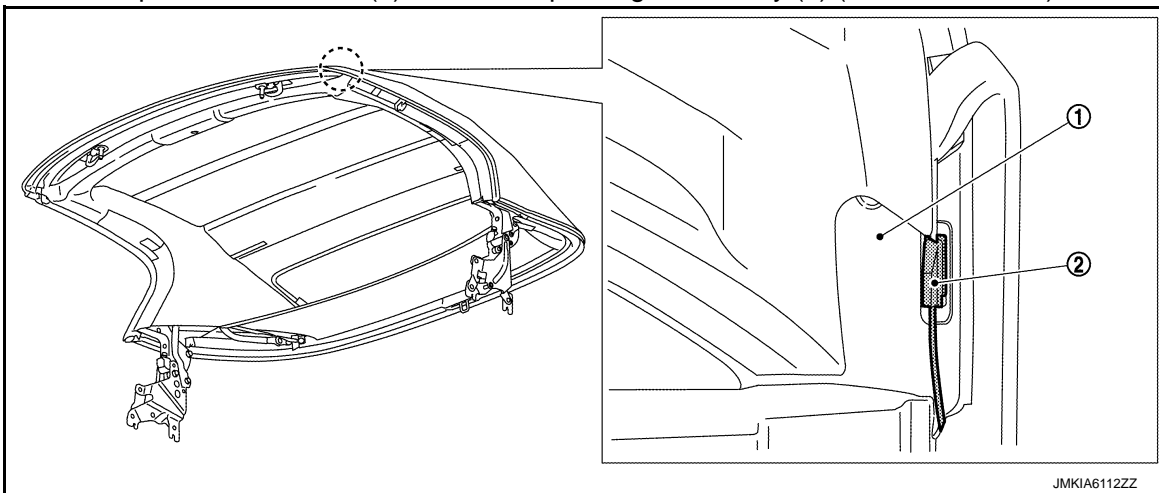

9. Pull up front end of soft top cover outer.

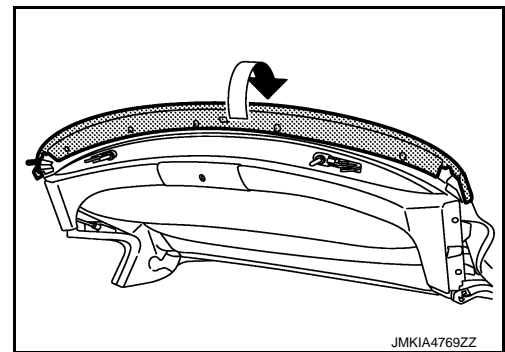

A
B
C
D
E
F
G
H
I
J
RF
L
M
N
O
P

HYDRAULIC SYSTEM

< REMOVAL AND INSTALLATION >

10. Remove mounting rivet (A) of soft top outer bungee cord (1) from soft top linkage assembly (2) (LH and RH).

CAUTION:

Cover the surrounding area because iron powder is spread when using a drill.

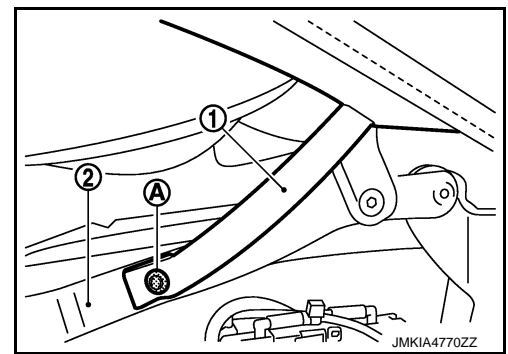

NOTE:

Removal and Installation of Rivet

- Grind the head of rivet (1) with a drill (A) [bit of ϕ 4.0 mm (ϕ 0.157 in)].
- Securely crimp the bungee cord with the soft top linkage assembly using a hand riveter (B).

Crimping thickness	: 9.5 - 12.7 mm (0.374 - 0.500 in)
Prepared hole diameter	: ϕ 4.1 - 4.2 mm (0.161 - 0.165 in)
Used rivet head diameter	: ϕ 7.5 mm (0.295 in)

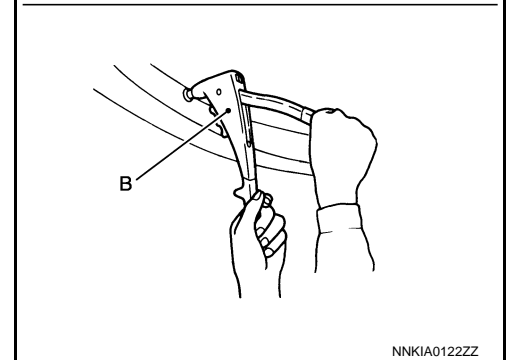
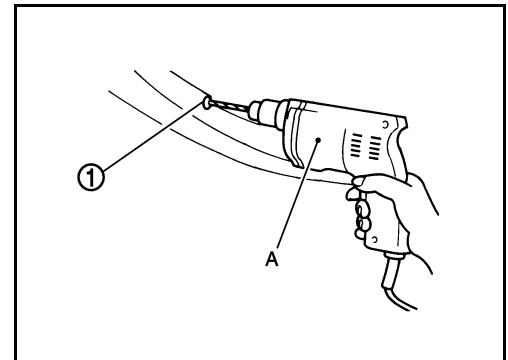

11. Remove soft top cover inner mounting screws (A) from 1st bow (1) (LH and RH).

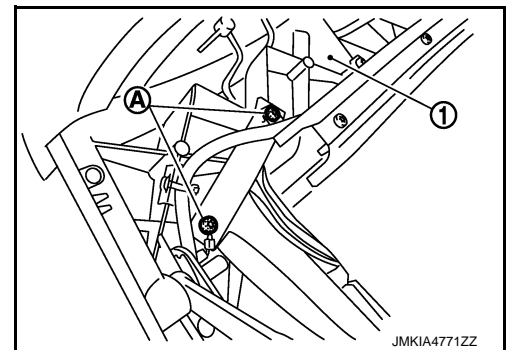

HYDRAULIC SYSTEM

< REMOVAL AND INSTALLATION >

12. Remove mounting screws (A) of soft top cover inner retainer (2) from 1st bow (1).

NOTE:

Soft top cover inner strap (B) and soft top cover inner are tightened together to 1st bow.

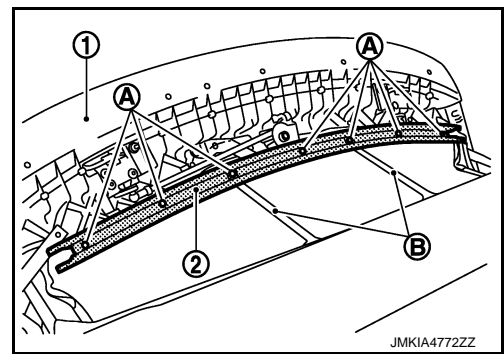

13. Remove 2nd bow mounting bolts.

14. Remove soft top linkage assembly bungee cord (A) from 2nd bow (1) (LH and RH).

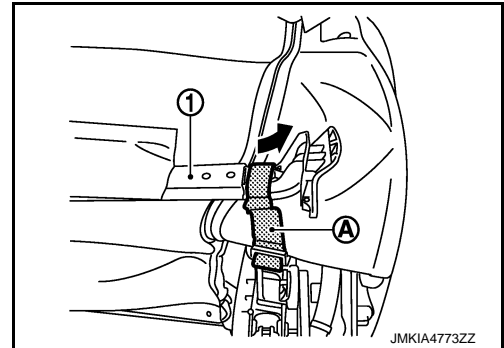

15. Pull out wire (2) from soft top cover outer (1) (LH and RH).

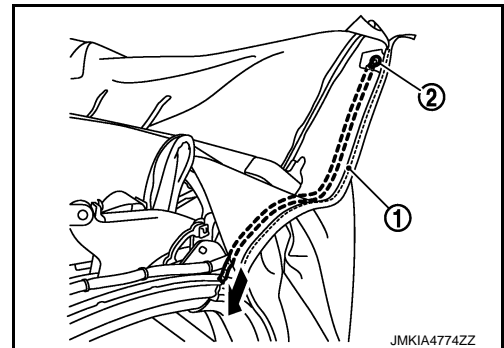

16. Remove rear rail weather-strip. Refer to [RF-188, "ROOF SEALING : Exploded View"](#).

17. Remove rear rail weather-strip retainer (LH and RH). Refer to [RF-188, "ROOF SEALING : Exploded View"](#).

18. Remove rear end of soft top cover outer (2) from 5th bow (1).

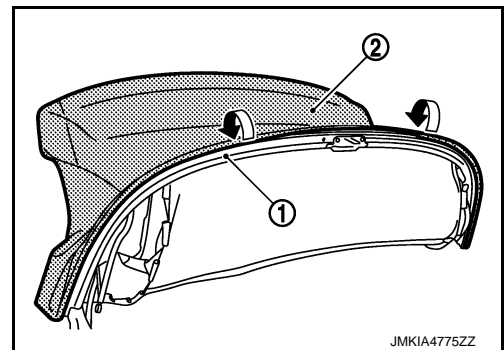

A
B
C
D
E
F
G
H
I
J
RF
L
M
N
O
P

HYDRAULIC SYSTEM

< REMOVAL AND INSTALLATION >

19. Pull up soft top cover outer lateral side to outside from upper to lower. Remove double-sided tape (A) (LH and RH).

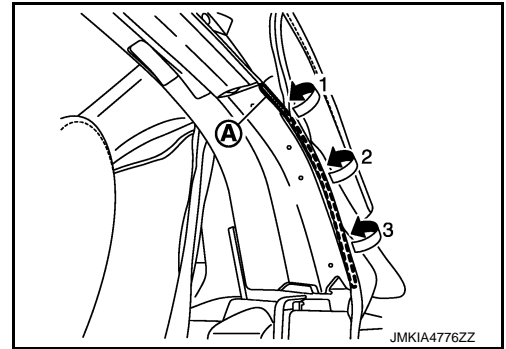

20. Remove E-clips (A). Disengage connection of soft top cover outer wire (2) from soft top linkage assembly pin (1) (LH and RH).

← : Vehicle front

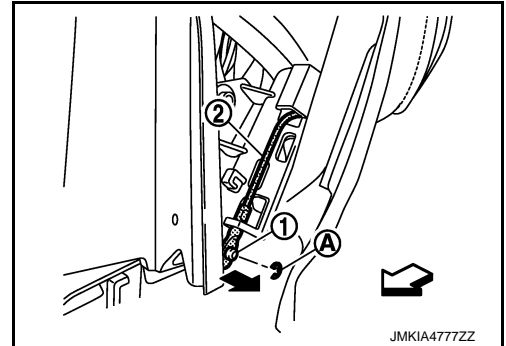

21. Slide soft top cover outer (1) in the direction shown by the arrow. Simultaneously pull out retainer (3) and wire (4) from soft top linkage assembly (2) (LH and RH).

CAUTION:

Write a short note to describe the wire locations and the retainer mounting positions.

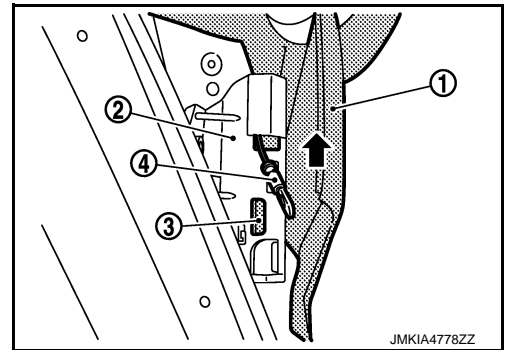

22. Manually operate soft top linkage assembly to the open position.

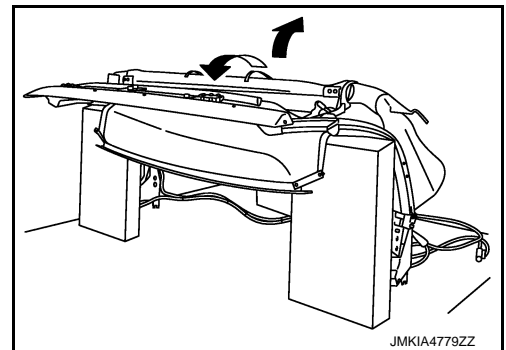

23. Pull up soft top cover outer lateral side to outside. Remove rivet (A) and screw (B) that secure soft top cover outer bungee cord (1) (LH and RH).

CAUTION:

Cover the surrounding area because iron powder is spread when using a drill.

← : Vehicle front

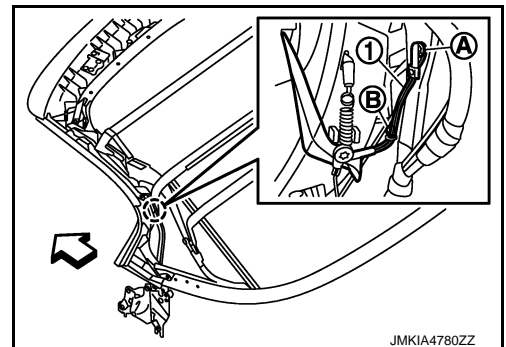

HYDRAULIC SYSTEM

< REMOVAL AND INSTALLATION >

NOTE:

Removal and Installation of Rivet

- Grind the head of rivet (1) with a drill (A) [bit of ϕ 4.0 mm (ϕ 0.157 in)].
- Securely crimp the bungee cord with the soft top linkage assembly using a hand riveter (B).

Crimping thickness : 4.8 - 8.0 mm (0.189 - 0.315 in)

Prepared hole diameter : ϕ 4.1 - 4.2 mm (0.161 - 0.165 in)

Used rivet head diameter : ϕ 12.0 mm (0.472 in)

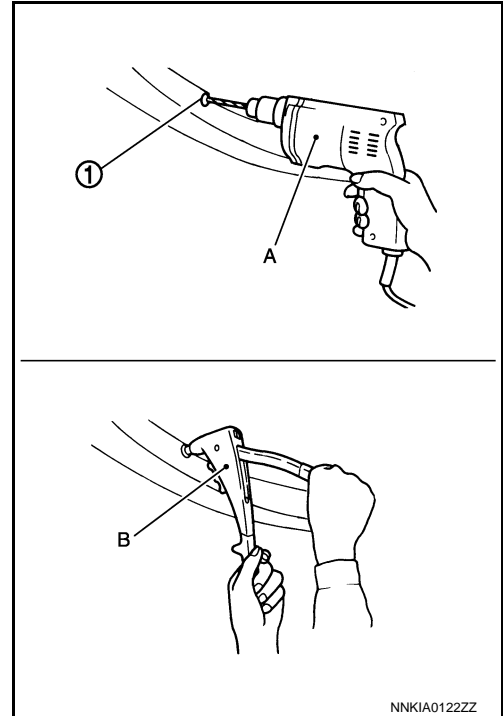

- Remove rear defogger connector. Pull out rear defogger harness from soft top inner (LH and RH).
- Remove roof latch lock sensor harness connector. Refer to [RF-236. "Exploded View"](#).
- Remove spring lock (A). Pull out cylinder mounting pin (1) toward upper side of vehicle.
- Remove TORX bolts (B). Remove 1st bow latch assembly center bracket (2).

↔ : Vehicle front

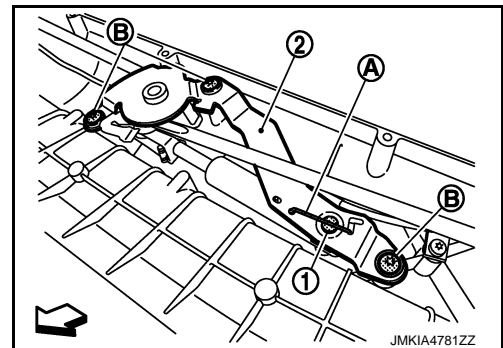

- Lift up center portion of 1st bow latch assembly (1). Remove retaining plate (A) of roof latch cylinder (2).

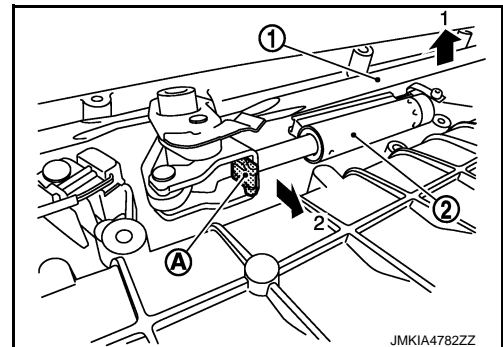

- Remove band and screw that fix oil pressure hose to soft top linkage assembly.

NOTE:

Write a short note to describe the band and screw locations.

CAUTION:

Never sharply bend, twist or strongly pull oil pressure hose.

HYDRAULIC SYSTEM

< REMOVAL AND INSTALLATION >

30. Remove E-clips (A) of 5th bow drive cylinder (1). Remove cylinder mounting pins (2) (LH and RH).

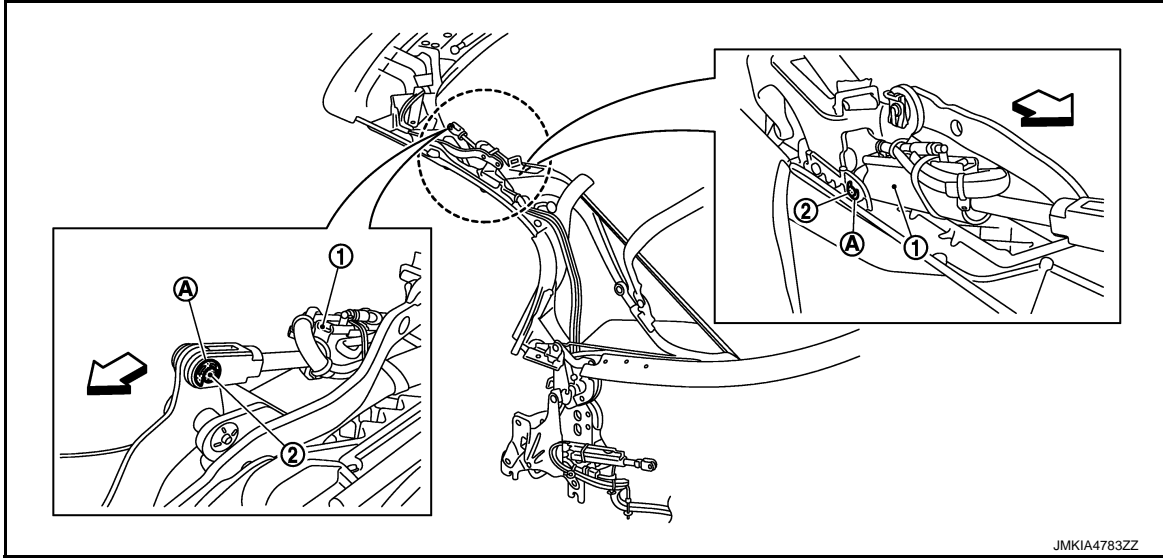

⇐ : Vehicle front

31. Remove E-clip (A) and pin (1).

32. Lift up linkage (2). Pull out roof latch cylinder and oil pressure hose.

⇐ : Vehicle front

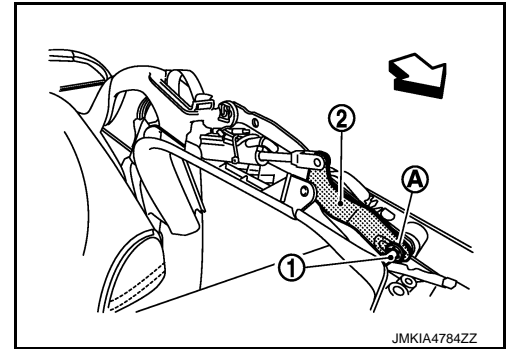

33. Place soft top assembly as shown in the figure. Maintain clearance (a).

NOTE:

Do not allow soft top assembly to apply its own weight to installation portion of the vehicle body.

CAUTION:

Be careful not to turn over soft top assembly.

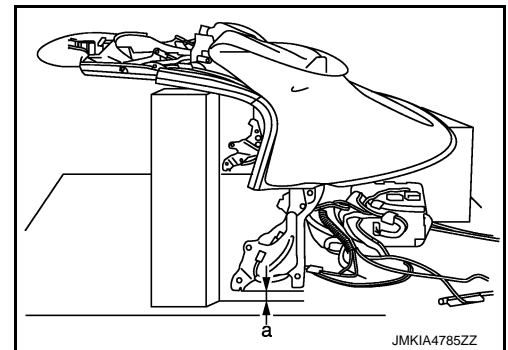

34. Remove E-clip (A). Remove mounting pin (2) of roof drive cylinder (1) (LH and RH).

⇐ : Vehicle front

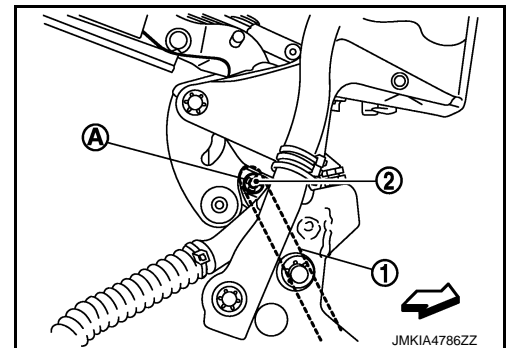

HYDRAULIC SYSTEM

< REMOVAL AND INSTALLATION >

35. Remove push on nut (A). Remove mounting pin (2) of roof drive cylinder (1) (LH and RH).

CAUTION:

Be careful not to allow excessive twisting of rotating axis portion (b).

← : Vehicle front

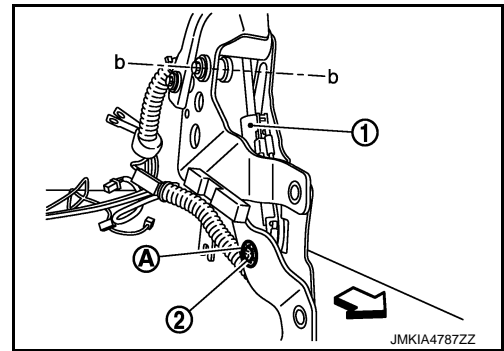

36. Remove hydraulic unit assembly from soft top linkage assembly.

CAUTION:

Never sharply bend, twist or strongly pull oil pressure hose.

INSTALLATION

Note the following items, and install in the reverse order of removal.

CAUTION:

- Tighten soft top cover inner front end and bungee cord (2) together to soft top linkage assembly using screw (A), when installing soft top cover inner (1).

← : Vehicle front

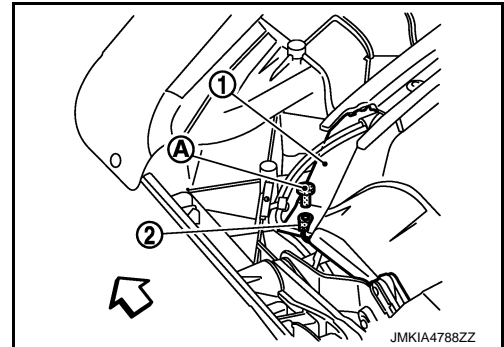

- After installing hydraulic unit assembly, manually operate soft top linkage assembly and check that oil pressure hose is not pinched.
- Manually operate and check that soft top assembly operates without interfering with other portions of the vehicle body.
- Before manually operating each cylinder of the hydraulic system, turn ignition switch OFF or disconnect battery cable from the negative terminal, then wait for 4 minutes or more. (Each cylinder maintains oil pressure and therefore it takes a period of time to lower oil pressure.)
- Perform fitting adjustment after installing soft top assembly. Refer to [RF-158, "SOFT TOP ASSEMBLY : Adjustment"](#).
- Perform door glass fitting adjustment after soft top assembly fitting adjustment. Refer to [GW-21, "Inspection and Adjustment"](#).
- Perform leakage test.

NOTE:

- When installing push on nut (1), crimp it using water pump pliers (A) and socket (B).

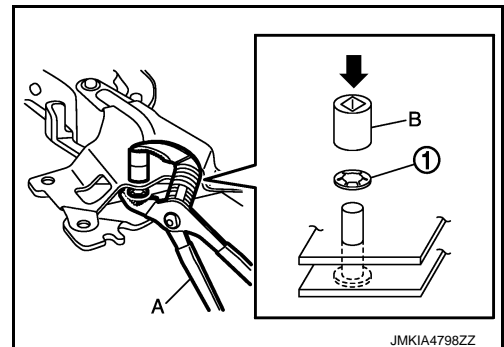

A
B
C
D
E
F
G
H
I
J
RF
L
M
N
O
P

ROOF OPEN/CLOSE SWITCH

< REMOVAL AND INSTALLATION >

ROOF OPEN/CLOSE SWITCH

Exploded View

INFOID:000000007625576

Refer to [IP-25, "Exploded View"](#).

Removal and Installation

INFOID:000000007625577

Removal

1. Remove cup holder assembly. Refer to [IP-26, "Removal and Installation"](#).
2. Remove roof open/close switch and disconnect the connector.

Installation

Install in the reverse order of removal.

SOFT TOP CONTROL UNIT

< REMOVAL AND INSTALLATION >

SOFT TOP CONTROL UNIT

Exploded View

INFOID:000000007625578

Refer to [RF-11, "Component Parts Location"](#).

Removal and Installation

INFOID:000000007625579

REMOVAL

1. Operate soft top as shown in the figure.

CAUTION:

Storage lid and 5th bow may close due to low oil pressure. Always support storage lid and 5th bow in the fully open position using a support block.

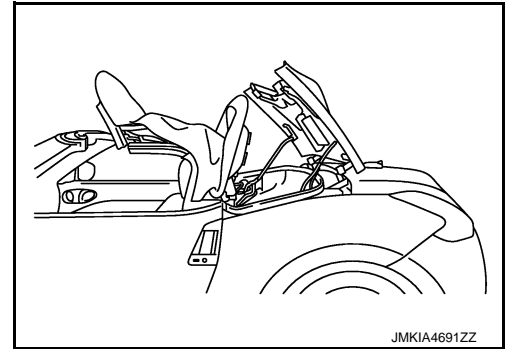

2. Turn ignition switch OFF.
3. Disconnect battery cable from the negative terminal. Refer to [PG-110, "Removal and Installation"](#).
4. Remove storage room finisher LH. Refer to [RF-222, "STORAGE ROOM FINISHER : Removal and Installation"](#).
5. Disconnect soft top control unit (1) harness connector and hydraulic unit harness connectors (A).

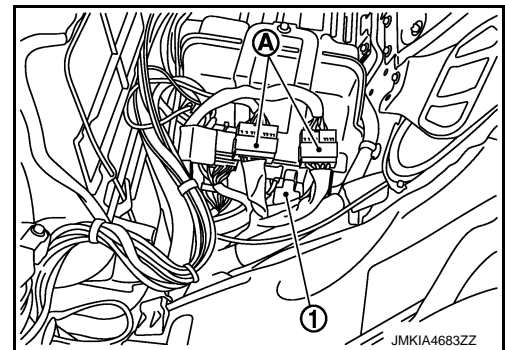

6. Remove soft top control unit from hydraulic unit bracket.

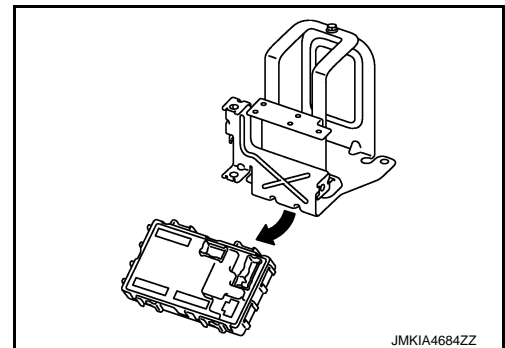

INSTALLATION

Install in the reverse order of removal.

A
B
C
D
E
F
G
H
I
J
RF
L
M
N
O
P

ROOF LATCH LOCK SENSOR

< REMOVAL AND INSTALLATION >

ROOF LATCH LOCK SENSOR

Exploded View

INFOID:000000007625580

Refer to [RF-163. "SOFT TOP COVER OUTER : Exploded View"](#).

Removal and Installation

INFOID:000000007625581

REMOVAL

1. Operate soft top as shown in the figure.

CAUTION:

Storage lid and 5th bow may close due to low oil pressure.
Always support storage lid and 5th bow in the fully open position using a support block.

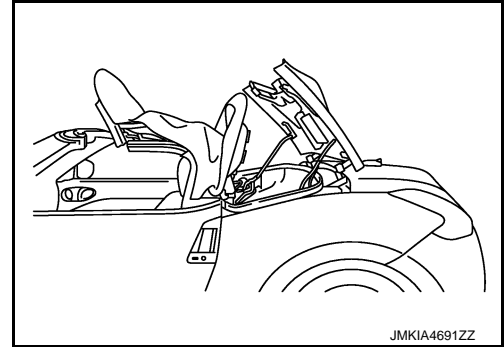

2. Turn ignition switch OFF.
3. Pull up front end of soft top cover outer. Refer to [RF-164. "SOFT TOP COVER OUTER : Removal and Installation"](#).
4. Remove roof lock assembly center (1).
5. Lift up roof lock assembly and remove roof latch lock sensor (2).

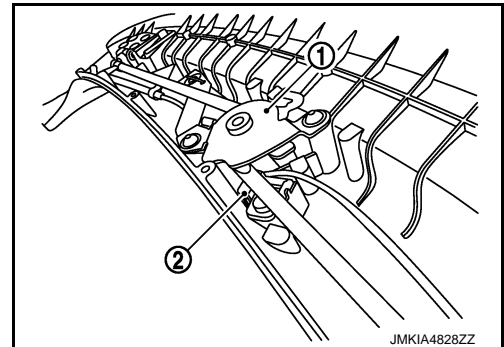

INSTALLATION

Install in the reverse order of removal.

5TH BOW LATCH/STRIKER SENSOR ASSEMBLY

< REMOVAL AND INSTALLATION >

5TH BOW LATCH/STRIKER SENSOR ASSEMBLY

Exploded View

INFOID:000000007625582

Refer to [RF-201, "STORAGE LID ASSEMBLY : Exploded View"](#).

Removal and Installation

INFOID:000000007625583

REMOVAL

1. Operate soft top as shown in the figure.

CAUTION:

Storage lid and 5th bow may close due to low oil pressure. Always support storage lid and 5th bow in the fully open position using a support block.

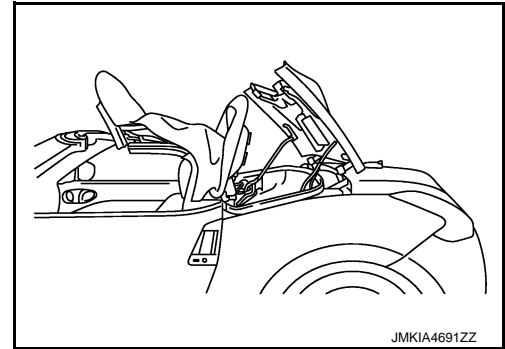

2. Turn ignition switch OFF.
3. Remove storage lid bracket assembly mounting nuts. Pull out storage lid bracket assembly from storage lid assembly.
4. Disconnect 5th bow latch/striker sensor assembly harness connector.
5. Remove 5th bow latch/striker sensor assembly.

INSTALLATION

Install in the reverse order of removal.

A
B
C
D
E
F
G
H
I
J
L
M
N
O
P

RF