

**SECTION** **ST**  
**STEERING SYSTEM**

A  
 B  
 C  
 D  
 E  
 F  
**ST**  
 H  
 I  
 J  
 K  
 L  
 M  
 N  
 O  
 P

**CONTENTS**

<p style="text-align: center;"><b>REGULAR GRADE</b></p> <p><b>SYMPTOM DIAGNOSIS</b> ..... 3</p> <p><b>NOISE, VIBRATION AND HARSHNESS (NVH) TROUBLESHOOTING</b> ..... 3</p> <p style="padding-left: 20px;">NVH Troubleshooting Chart .....3</p> <p><b>PRECAUTION</b> ..... 4</p> <p><b>PRECAUTIONS</b> ..... 4</p> <p><b>FOR USA AND CANADA</b> .....4</p> <p style="padding-left: 20px;">FOR USA AND CANADA : Precaution for Supplemental Restraint System (SRS) "AIR BAG" and "SEAT BELT PRE-TENSIONER" .....4</p> <p style="padding-left: 20px;">FOR USA AND CANADA : Precaution for Battery Service .....4</p> <p style="padding-left: 20px;">FOR USA AND CANADA : Service Notice or Precautions for Steering System .....4</p> <p><b>FOR MEXICO</b> .....4</p> <p style="padding-left: 20px;">FOR MEXICO : Precaution for Supplemental Restraint System (SRS) "AIR BAG" and "SEAT BELT PRE-TENSIONER" .....4</p> <p style="padding-left: 20px;">FOR MEXICO : Precaution for Battery Service .....5</p> <p style="padding-left: 20px;">FOR MEXICO : Service Notice or Precautions for Steering System .....5</p> <p><b>PREPARATION</b> ..... 6</p> <p><b>PREPARATION</b> ..... 6</p> <p style="padding-left: 20px;">Special Service Tools .....6</p> <p style="padding-left: 20px;">Commercial Service Tools .....7</p> <p><b>PERIODIC MAINTENANCE</b> ..... 8</p> <p><b>POWER STEERING FLUID</b> ..... 8</p> <p style="padding-left: 20px;">Inspection .....8</p> <p><b>STEERING WHEEL</b> .....10</p> <p style="padding-left: 20px;">Inspection ..... 10</p>	<p><b>REMOVAL AND INSTALLATION</b> .....13</p> <p><b>STEERING WHEEL</b> .....13</p> <p style="padding-left: 20px;">Exploded View .....13</p> <p style="padding-left: 20px;">Removal and Installation .....13</p> <p><b>STEERING COLUMN</b> .....14</p> <p style="padding-left: 20px;">Exploded View .....14</p> <p style="padding-left: 20px;">Removal and Installation .....14</p> <p style="padding-left: 20px;">Inspection .....15</p> <p><b>LOWER SHAFT</b> .....17</p> <p style="padding-left: 20px;">Exploded View .....17</p> <p style="padding-left: 20px;">Removal and Installation .....17</p> <p style="padding-left: 20px;">Inspection .....18</p> <p><b>STEERING GEAR AND LINKAGE</b> .....19</p> <p style="padding-left: 20px;">Exploded View .....19</p> <p style="padding-left: 20px;">Removal and Installation .....20</p> <p style="padding-left: 20px;">Disassembly and Assembly .....21</p> <p style="padding-left: 20px;">Inspection .....25</p> <p><b>POWER STEERING OIL PUMP</b> .....27</p> <p style="padding-left: 20px;">Exploded View .....27</p> <p style="padding-left: 20px;">Removal and Installation .....28</p> <p style="padding-left: 20px;">Disassembly and Assembly .....28</p> <p style="padding-left: 20px;">Inspection .....31</p> <p><b>HYDRAULIC LINE</b> .....33</p> <p style="padding-left: 20px;">Exploded View .....33</p> <p><b>SERVICE DATA AND SPECIFICATIONS (SDS)</b> .....34</p> <p><b>SERVICE DATA AND SPECIFICATIONS (SDS)</b> .....34</p> <p style="padding-left: 20px;">General Specifications .....34</p> <p style="padding-left: 20px;">Steering Wheel Axial End Play and Play .....34</p> <p style="padding-left: 20px;">Steering Wheel Turning Torque .....34</p> <p style="padding-left: 20px;">Steering Angle .....34</p> <p style="padding-left: 20px;">Steering Column Length .....34</p> <p style="padding-left: 20px;">Steering Column Mounting Dimensions .....34</p>
---	--

---

Steering Column Operating Range .....	34	Relief Oil Pressure .....	35
Lower Shaft .....	35	<b>Nismo 370Z</b>	
Rack Sliding Force .....	35	<b>SPEC CHANGE INFORMATION .....</b>	<b>36</b>
Rack Stroke .....	35	<b>STEERING WHEEL .....</b>	<b>36</b>
Socket Swing Force and Rotating Torque .....	35	Steering Wheel .....	36
Socket Axial End Play .....	35		
Inner Socket Length .....	35		

# NOISE, VIBRATION AND HARSHNESS (NVH) TROUBLESHOOTING

< SYMPTOM DIAGNOSIS >

[REGULAR GRADE]

## SYMPTOM DIAGNOSIS

### NOISE, VIBRATION AND HARSHNESS (NVH) TROUBLESHOOTING

#### NVH Troubleshooting Chart

INFOID:0000000007623215

Use the chart below to find the cause of the symptom. If necessary, repair or replace these parts.

Symptom		Possible cause and SUSPECTED PARTS											Reference												
		Fluid level	Air in hydraulic system	Outer/inner socket ball joint swinging torque	Outer/inner socket ball joint rotating torque	Outer/inner socket ball joint end play	Steering fluid leakage	Steering wheel play	Steering gear rack sliding force	Drive belt looseness	Improper steering wheel	Improper installation or looseness of tilt lock lever		Mounting looseness	Steering column deformation or damage	Improper installation or looseness of steering column	Steering linkage looseness	PROPELLER SHAFT	DIFFERENTIAL	AXLE and SUSPENSION	TIRE	ROAD WHEEL	DRIVE SHAFT	BRAKE	
Steering	Noise	x	x	x	x	x	x	x	x	x				x	x				x	x	x	x	x	x	ST-8. "Inspection" ST-8. "Inspection" ST-25. "Inspection" ST-25. "Inspection" ST-25. "Inspection" ST-25. "Inspection" ST-10. "Inspection" ST-10. "Inspection" EM-17. "Checking" ST-10. "Inspection" — ST-19. "Exploded View" ST-15. "Inspection" ST-14. "Exploded View" ST-19. "Exploded View"
	Shake									x	x	x				x	x		x	x	x	x	x	NVH in DLN section. NVH in DLN section. NVH in FAX, RAX, FSU, RSU section. NVH in WT section. NVH in WT section. NVH in RAX section. NVH in BR section.	
	Vibration									x	x	x	x	x					x	x		x			
	Shimmy									x			x		x				x	x	x			x	
	Judder										x	x				x				x	x	x		x	

x: Applicable

A  
B  
C  
D  
E  
F  
ST  
H  
I  
J  
K  
L  
M  
N  
O  
P

## PRECAUTION

### PRECAUTIONS

#### FOR USA AND CANADA

#### FOR USA AND CANADA : Precaution for Supplemental Restraint System (SRS) "AIR BAG" and "SEAT BELT PRE-TENSIONER"

INFOID:000000007623216

The Supplemental Restraint System such as "AIR BAG" and "SEAT BELT PRE-TENSIONER", used along with a front seat belt, helps to reduce the risk or severity of injury to the driver and front passenger for certain types of collision. This system includes seat belt switch inputs and dual stage front air bag modules. The SRS system uses the seat belt switches to determine the front air bag deployment, and may only deploy one front air bag, depending on the severity of a collision and whether the front occupants are belted or unbelted.

Information necessary to service the system safely is included in the "SRS AIR BAG" and "SEAT BELT" of this Service Manual.

**WARNING:**

Always observe the following items for preventing accidental activation.

- To avoid rendering the SRS inoperative, which could increase the risk of personal injury or death in the event of a collision that would result in air bag inflation, all maintenance must be performed by an authorized NISSAN/INFINITI dealer.
- Improper maintenance, including incorrect removal and installation of the SRS, can lead to personal injury caused by unintentional activation of the system. For removal of Spiral Cable and Air Bag Module, see "SRS AIR BAG".
- Never use electrical test equipment on any circuit related to the SRS unless instructed to in this Service Manual. SRS wiring harnesses can be identified by yellow and/or orange harnesses or harness connectors.

#### PRECAUTIONS WHEN USING POWER TOOLS (AIR OR ELECTRIC) AND HAMMERS

**WARNING:**

Always observe the following items for preventing accidental activation.

- When working near the Air Bag Diagnosis Sensor Unit or other Air Bag System sensors with the ignition ON or engine running, never use air or electric power tools or strike near the sensor(s) with a hammer. Heavy vibration could activate the sensor(s) and deploy the air bag(s), possibly causing serious injury.
- When using air or electric power tools or hammers, always switch the ignition OFF, disconnect the battery, and wait at least 3 minutes before performing any service.

#### FOR USA AND CANADA : Precaution for Battery Service

INFOID:000000007623218

Before disconnecting the battery, lower both the driver and passenger windows. This will prevent any interference between the window edge and the vehicle when the door is opened/closed. During normal operation, the window slightly raises and lowers automatically to prevent any window to vehicle interference. The automatic window function will not work with the battery disconnected.

#### FOR USA AND CANADA : Service Notice or Precautions for Steering System

INFOID:000000007623219

- In case of removing steering gear assembly, make the final tightening with grounded and unloaded vehicle condition, and then check wheel alignment.
- Observe the following precautions when disassembling.
  - Before disassembly, thoroughly clean the outside of the unit.
  - Disassembly should be done in a clean work area. It is important to prevent the internal parts from becoming contaminated by dirt or other foreign matter.
  - For easier and proper assembly, place disassembled parts in order on a parts rack.
  - Use nylon cloth or paper towels to clean the parts; common shop rags can leave lint that might interfere with their operation.
  - Never reuse non-reusable parts.
  - Before assembling, apply the specified grease to the directed parts.

#### FOR MEXICO

#### FOR MEXICO : Precaution for Supplemental Restraint System (SRS) "AIR BAG" and

# PRECAUTIONS

< PRECAUTION >

[REGULAR GRADE]

## "SEAT BELT PRE-TENSIONER"

INFOID:000000007623220

The Supplemental Restraint System such as "AIR BAG" and "SEAT BELT PRE-TENSIONER", used along with a front seat belt, helps to reduce the risk or severity of injury to the driver and front passenger for certain types of collision. Information necessary to service the system safely is included in the "SRS AIR BAG" and "SEAT BELT" of this Service Manual.

### **WARNING:**

Always observe the following items for preventing accidental activation.

- To avoid rendering the SRS inoperative, which could increase the risk of personal injury or death in the event of a collision that would result in air bag inflation, all maintenance must be performed by an authorized NISSAN/INFINITI dealer.
- Improper maintenance, including incorrect removal and installation of the SRS, can lead to personal injury caused by unintentional activation of the system. For removal of Spiral Cable and Air Bag Module, see "SRS AIR BAG".
- Never use electrical test equipment on any circuit related to the SRS unless instructed to in this Service Manual. SRS wiring harnesses can be identified by yellow and/or orange harnesses or harness connectors.

## PRECAUTIONS WHEN USING POWER TOOLS (AIR OR ELECTRIC) AND HAMMERS

### **WARNING:**

Always observe the following items for preventing accidental activation.

- When working near the Air Bag Diagnosis Sensor Unit or other Air Bag System sensors with the ignition ON or engine running, never use air or electric power tools or strike near the sensor(s) with a hammer. Heavy vibration could activate the sensor(s) and deploy the air bag(s), possibly causing serious injury.
- When using air or electric power tools or hammers, always switch the ignition OFF, disconnect the battery, and wait at least 3 minutes before performing any service.

## FOR MEXICO : Precaution for Battery Service

INFOID:000000007623222

Before disconnecting the battery, lower both the driver and passenger windows. This will prevent any interference between the window edge and the vehicle when the door is opened/closed. During normal operation, the window slightly raises and lowers automatically to prevent any window to vehicle interference. The automatic window function will not work with the battery disconnected.

## FOR MEXICO : Service Notice or Precautions for Steering System

INFOID:000000007623223

- In case of removing steering gear assembly, make the final tightening with grounded and unloaded vehicle condition, and then check wheel alignment.
- Observe the following precautions when disassembling.
  - Before disassembly, thoroughly clean the outside of the unit.
  - Disassembly should be done in a clean work area. It is important to prevent the internal parts from becoming contaminated by dirt or other foreign matter.
  - For easier and proper assembly, place disassembled parts in order on a parts rack.
  - Use nylon cloth or paper towels to clean the parts; common shop rags can leave lint that might interfere with their operation.
  - Never reuse non-reusable parts.
  - Before assembling, apply the specified grease to the directed parts.

# PREPARATION

< PREPARATION >

[REGULAR GRADE]

## PREPARATION

### PREPARATION

#### Special Service Tools

INFOID:000000007623224

The actual shapes of Kent-Moore tools may differ from those of special service tools illustrated here.

Tool number (Kent-Moore No.) Tool name	Description
ST27180001 (J-25726-A) Steering wheel puller	Removing steering wheel
ST3127S000 (J-25765-A) Preload gauge	<ul style="list-style-type: none"> <li>• Measuring steering wheel turning torque</li> <li>• Measuring steering column rotating torque</li> <li>• Measuring pinion rotating torque</li> <li>• Measuring ball joint rotating torque</li> </ul>
KV48103400 ( — ) Preload adapter	Measuring pinion rotating torque
ST35300000 ( — ) Drift a: 45.1 mm (1.776 in) dia. b: 59.0 mm (2.323 in) dia.	Installing oil pump oil seal
KV48103500 (J-26357) Oil pressure gauge	Measuring oil pump relief pressure
KV48102500 (J-33914) Oil pressure gauge adapter	Measuring oil pump relief pressure

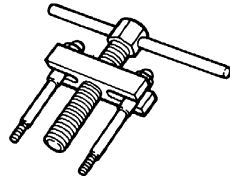

ZZA0819D

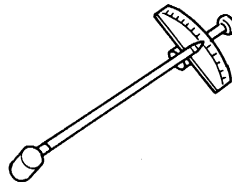

ZZA0806D

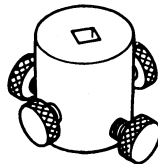

ZZA0824D

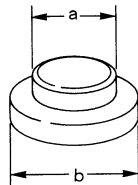

ZZA0881D

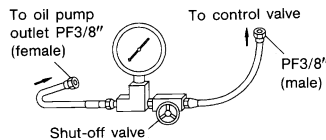

S-NT547

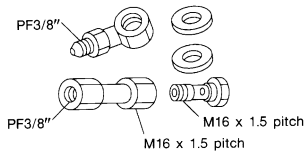

S-NT542

# PREPARATION

< PREPARATION >

[REGULAR GRADE]

## Commercial Service Tools

INFOID:000000007623225

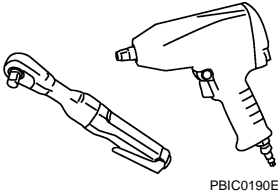
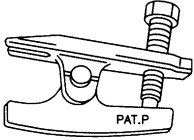
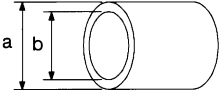
Tool name	Description
<p>Power tool</p>  <p>PBI0190E</p>	<p>Loosening bolts and nuts</p>
<p>Ball joint remover</p>  <p>PAT.P</p> <p>S-NT146</p>	<p>Removing steering outer socket</p>
<p>Drift</p> <p>a: 15 mm (0.59 in) dia.</p> <p>b: 10 mm (0.39 in) dia.</p>  <p>S-NT474</p>	<p>Installing rotor snap ring</p>

A

B

C

D

E

F

**ST**

H

I

J

K

L

M

N

O

P

PERIODIC MAINTENANCE

POWER STEERING FLUID

Inspection

INFOID:000000007623226

FLUID LEVEL

1. Check fluid level with engine stopped.
2. Ensure that fluid level is between MIN and MAX.
3. Fluid levels at HOT and COLD are different. Do not confuse them.

**HOT** : Fluid temperature 50 – 80°C (122 – 176°F)

**COLD** : Fluid temperature 0 – 30°C (32 – 86°F)

**Recommended fluid** : Refer to [MA-14, "FOR NORTH AMERICA : Fluids and Lubricants"](#) (For North America), [MA-15, "FOR MEXICO : Fluids and Lubricants"](#) (Except for North America).

**Fluid capacity** : Refer to [ST-34, "General Specifications"](#).

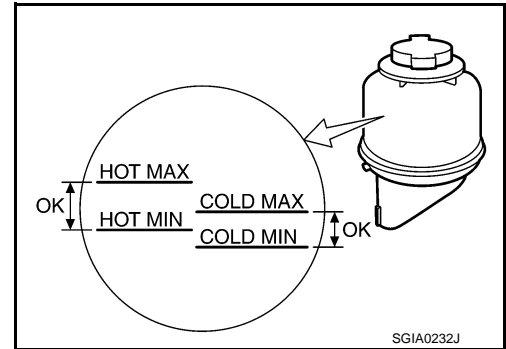

**CAUTION:**

- The fluid level should not exceed the MAX line. Excessive fluid causes fluid leakage from the cap.
- Never reuse drained power steering fluid.

FLUID LEAKAGE

Check hydraulic connections for fluid leakage, cracks, damage, looseness, or wear.

1. Run the engine until the fluid temperature reaches 50 to 80°C (122 to 176°F) in reservoir tank, and keep engine speed idle.
2. Turn steering wheel several times from full left stop to full right stop.
3. Hold steering wheel at each lock position for five seconds and carefully check for fluid leakage.

**CAUTION:**

**Never hold the steering wheel in a locked position for more than 10 seconds. (There is the possibility that power steering oil pump assembly may be damaged.)**

4. If fluid leakage at connections is noticed, then loosen flare nut and then retighten. Do not overtighten connector as this can damage O-ring, washer and connector.
5. If fluid leakage from oil pump is noticed, check oil pump.
6. Check steering gear boots for accumulation of fluid leaked from steering gear.

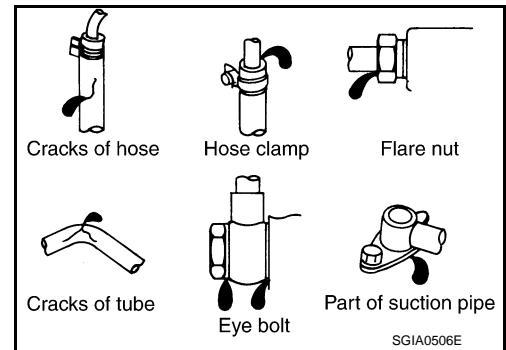

AIR BLEEDING HYDRAULIC SYSTEM

If air bleeding is not complete, the following symptoms can be observed.

- Bubbles are created in reservoir tank.
- Clicking noise can be heard from oil pump.
- Excessive buzzing in the oil pump.

**NOTE:**

Fluid noise may occur in the steering gear or oil pump. This does not affect performance or durability of the system.

1. Turn steering wheel several times from full left stop to full right stop with engine off.



# POWER STEERING FLUID

< PERIODIC MAINTENANCE >

[REGULAR GRADE]

**CAUTION:**

Fill reservoir tank with a sufficient amount of fluid so that fluid level is not below the MIN line while turning steering wheel.

- 2. Start the engine and hold steering wheel at each lock position for 3 second at idle to check for fluid leakage.
- 3. Repeat step 2 above several times at approximately 3 second intervals.

**CAUTION:**

Never hold the steering wheel in a locked position for more than 10 seconds. (There is the possibility that oil pump may be damaged.)

- 4. Check fluid for bubbles and white contamination.
- 5. Stop the engine if bubbles and white contamination do not drain out. Perform step 2 and 3 above after waiting until bubbles and white contamination drain out.
- 6. Stop the engine, and then check fluid level.

A  
B  
C  
D  
E  
F  
ST  
H  
I  
J  
K  
L  
M  
N  
O  
P

ST

## STEERING WHEEL

### Inspection

INFOID:000000007623227

#### STEERING WHEEL AXIAL END PLAY

1. Check installation conditions of steering gear assembly, front suspension assembly, axle and steering column assembly.
2. Check if movement exists when steering wheel is moved up and down, to the left and right and to the axial direction.

#### Standard

**Steering wheel axial end play** : Refer to [ST-34, "Steering Wheel Axial End Play and Play"](#).

3. Check the following items if steering wheel axial end play is out of the standard.
  - Check the steering column assembly mounting condition. Refer to [ST-14, "Exploded View"](#).
  - Check steering gear assembly mounting condition for looseness. Refer to [ST-19, "Exploded View"](#).

#### STEERING WHEEL PLAY

1. Turn steering wheel so that front wheels come to the straight-ahead position.
2. Start the engine and lightly turn steering wheel to the left and right until front wheels start to move.
3. Measure steering wheel movement on the outer circumference.

#### Standard

**Steering wheel play** : Refer to [ST-34, "Steering Wheel Axial End Play and Play"](#).

4. Check the following items if steering wheel play is out of the standard.
  - Check backlash for each joint of steering column assembly.
  - Check installation condition of steering gear assembly.

#### NEUTRAL POSITION STEERING WHEEL

1. Check that steering gear assembly, steering column assembly and steering wheel are installed in the correct position.
2. Perform neutral position inspection after wheel alignment. Refer to [FSU-9, "Inspection"](#).
3. Set the vehicle to the straight-ahead position and check that the steering wheel is in the neutral position.
4. Loosen outer socket lock nut and turn inner socket to left and right equally to make fine adjustments if steering wheel is not in the neutral position.

#### STEERING WHEEL TURNING TORQUE

1. Park the vehicle on a level and dry surface, apply parking brake.
2. Tires need to be inflated to the specified pressure. Refer to [WT-51, "Tire Air Pressure"](#).
3. Remove driver air bag module. Refer to [SR-14, "Exploded View"](#).
4. Start the engine.
5. Check that the power steering fluid is at the operating temperature.

**Fluid temperature** : 50 – 80°C (122 – 176°F)

# STEERING WHEEL

< PERIODIC MAINTENANCE >

[REGULAR GRADE]

6. Make sure that the reading is within the following specified range using preload gauge (A) [SST: ST3127S000 (J-25765-A)].

## Standard

**Steering wheel turning torque**

: Refer to [ST-34, "Steering Wheel Turning Torque"](#).

7. If steering wheel turning force is out of the specification, check rack sliding force and relief hydraulic pressure of oil pump. Regarding relief hydraulic pressure of oil pump, refer to [ST-31, "Inspection"](#).

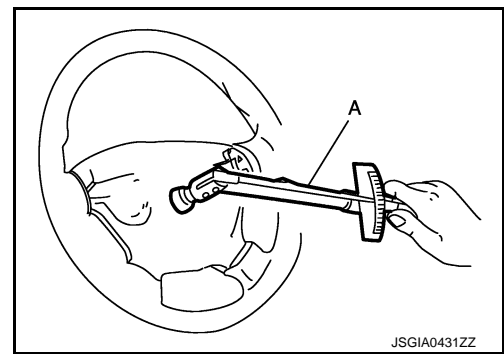

## RACK SLIDING FORCE

1. Disconnect lower joint and steering knuckle from steering gear assembly. Refer to [ST-19, "Exploded View"](#).
2. Start and run the engine at idle to make sure steering fluid reaches normal operating temperature.

## Fluid temperature

: 50 – 80°C (122 – 176°F)

3. While pulling outer socket slowly in  $\pm 11.5$  mm ( $\pm 0.453$  in) range from neutral position, check that rack sliding force is within specification.

## Standard

**Rack sliding force**

: Refer to [ST-35, "Rack Sliding Force"](#).

4. If rack sliding force is not within specification, overhaul steering gear assembly.

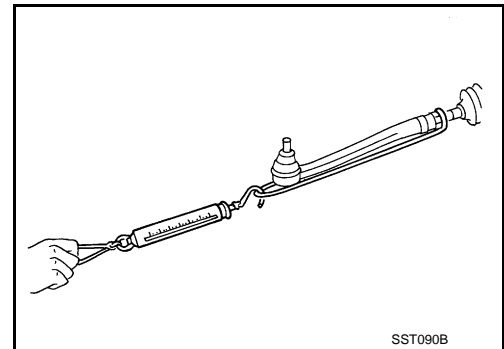

## FRONT WHEEL TURNING ANGLE

1. Check front wheel turning angle after toe-in inspection. Refer to [FSU-9, "Inspection"](#).
2. Place front wheels on turning radius gauges and rear wheels on stands, so that vehicle can be level.
3. Check the maximum inner and outer wheel turning angles for LH and RH road wheels.

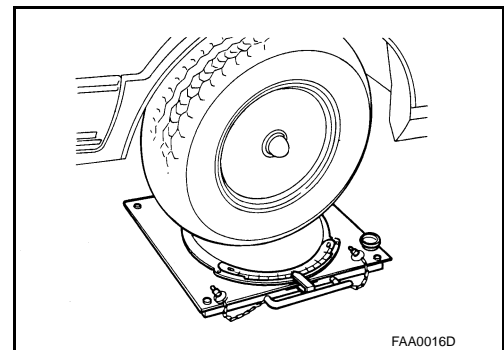

4. With the engine at idle, turn steering wheel from full left stop to full right stop and measure the turning angles.

## Standard

**Inner wheel (Angle: A)**

: Refer to [ST-34, "Steering Angle"](#).

**Outer wheel (Angle: B)**

: Refer to [ST-34, "Steering Angle"](#).

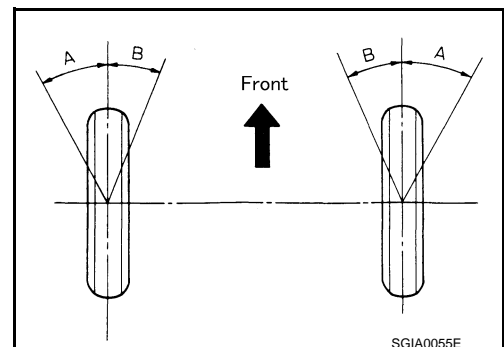

# STEERING WHEEL

< PERIODIC MAINTENANCE >

[REGULAR GRADE]

5. Check the following items if turning angle is out of the specified value.
- a. Check the neutral position of the rack stroke (L).

**Standard**

**Rack stroke neutral position (L) : Refer to [ST-35](#), "[Rack Stroke](#)".**

- b. Disassemble steering gear assembly to check the cause that rack stroke is outside of the specified value.
- Steering angles are not adjustable. Check steering gear assembly, steering column assembly and front suspension components for wear or damage if any of the turning angles are different from the specified value. Replace damaged or malfunctioning parts if necessary.

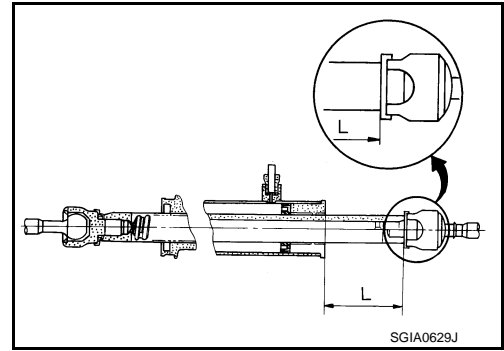

## REMOVAL AND INSTALLATION

### STEERING WHEEL

#### Exploded View

INFOID:000000007623228

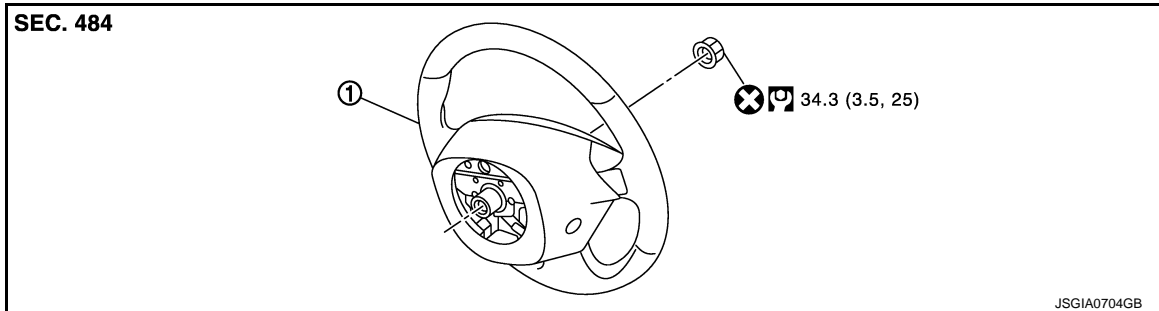

1. Steering wheel

Refer to [GI-4, "Components"](#) for symbols in the figure.

#### Removal and Installation

INFOID:000000007623229

##### REMOVAL

###### NOTE:

When reconnecting spiral cable, fix cable with a tape so that fixing case and rotating part keep aligned. This omits neutral position alignment procedure during spiral cable installation.

1. Set the vehicle to the straight-ahead position.
2. Remove driver air bag module. Refer to [SR-14, "Exploded View"](#).
3. Remove steering wheel lock nut after steering is locked.
4. Remove steering wheel with the steering wheel puller (A) [SST: ST27180001 (J-25726-A)].

###### NOTE:

Put paint marks on the steering wheel and the column shaft head for supporting accurate positioning during the installation procedure.

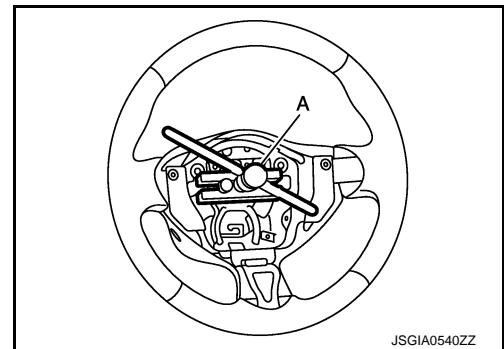

##### INSTALLATION

Note the following, and install in the reverse order of removal.

- Check the spiral cable neutral position after replacing or rotating spiral cable. Refer to [SR-17, "Exploded View"](#).

###### CAUTION:

**Never twist spiral cable freely on excessively after it becomes tight (doing so may cause the cable to tear off).**

- Never reuse steering wheel lock nut.

# STEERING COLUMN

< REMOVAL AND INSTALLATION >

[REGULAR GRADE]

## STEERING COLUMN

### Exploded View

INFOID:000000007623230

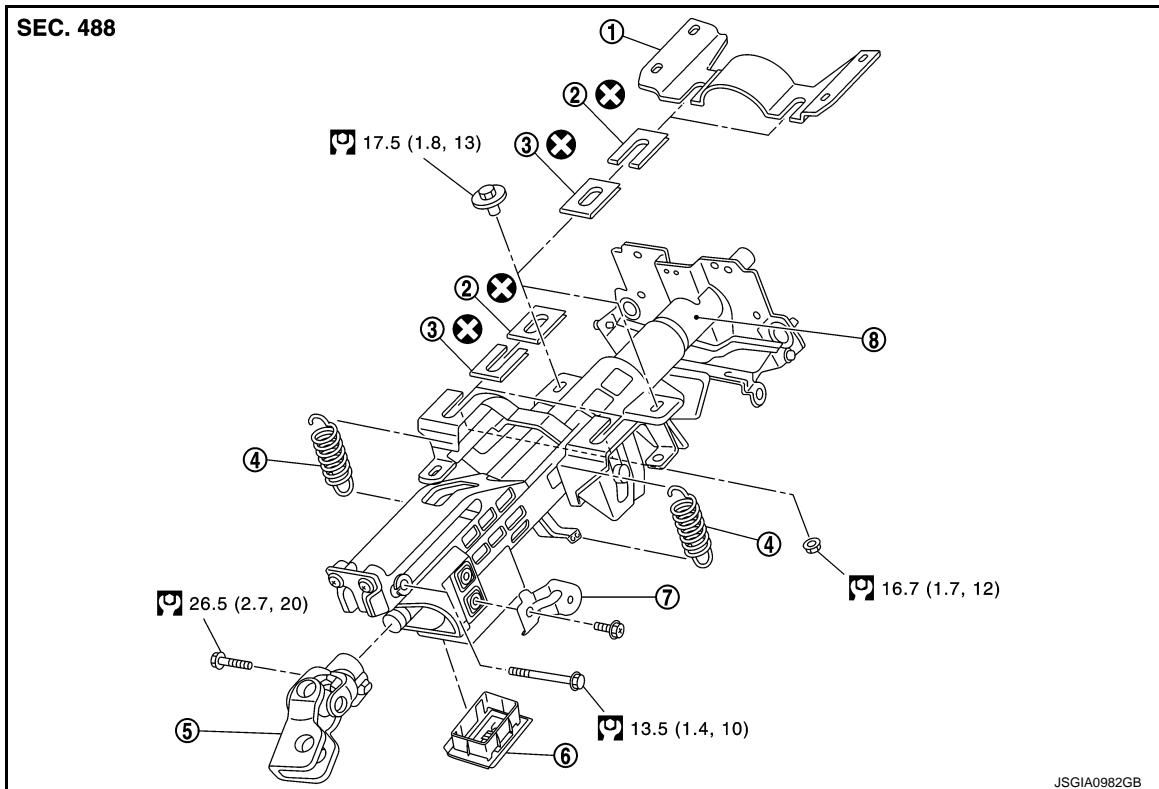

- |            |                             |                |
|------------|-----------------------------|----------------|
| 1. Bracket | 2. Slide plate              | 3. Slide plate |
| 4. Spring  | 5. Upper joint              | 6. Dust cover  |
| 7. Bracket | 8. Steering column assembly |                |

Refer to [GI-4, "Components"](#) for symbols in the figure.

## Removal and Installation

INFOID:000000007623231

### REMOVAL

1. Set the vehicle to the straight-ahead position.
2. Place the tilt to the highest level.
3. Remove driver air bag module. Refer to [SR-14, "Exploded View"](#).
4. Remove steering wheel. Refer to [ST-13, "Exploded View"](#).
5. Remove the instrument lower panel LH. Refer to [IP-14, "Exploded View"](#).
6. Remove combination meter. Refer to [IP-14, "Exploded View"](#).
7. Remove the steering column cover. Refer to [IP-14, "Exploded View"](#).
8. Remove spiral cable. Refer to [SR-17, "Exploded View"](#).
9. Remove combination switch. Refer to [BCS-93, "Exploded View"](#).
10. Remove knee protector.
11. Disconnect each harness connectors installed to steering column assembly.
12. Remove the upper joint mounting bolt and nut (lower shaft side), and separate the joint from lower shaft.

### CAUTION:

**When removing upper joint, never insert a tool, such as a screwdriver, into the yoke groove to pull out the upper joint. In case of the violation of the above, replace upper joint with a new one.**

13. Remove steering column assembly.

# STEERING COLUMN

< REMOVAL AND INSTALLATION >

[REGULAR GRADE]

**CAUTION:**

- Never give axial impact to steering column assembly during removal.
- Never move steering gear assembly when removing steering column assembly.
- Never rotate the lower shaft.

14. Remove dust cover from steering column assembly.

**CAUTION:**

Remove dust cover only when necessary.

## INSTALLATION

Note the following, and install in the reverse order of removal.

- To install dust cover (1), face the arrow of dust cover toward the hole (A) of steering column assembly (2) as shown in the figure.

**CAUTION:**

Check that there is no clearance between dust cover and steering column assembly.

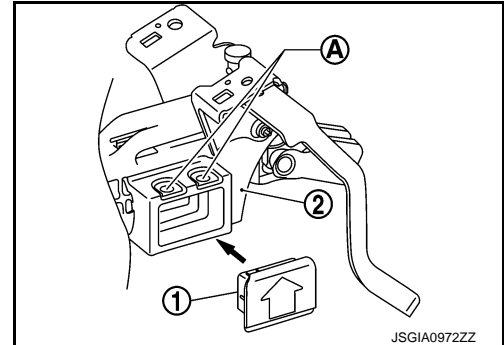

- Make sure there is no space between slide plate (1) and steering column assembly (2).

**CAUTION:**

Never reuse the slide plate.

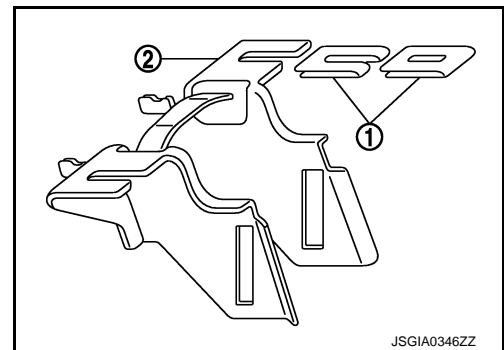

- Tighten the mounting nuts in the order shown in the figure steering member, when installing the steering column assembly.
- Be careful of the following points when installing the steering column assembly.

**CAUTION:**

- Never give axial impact to steering column assembly during installation.
- Never move steering gear assembly.
- Never reuse the joint mounting nut (lower shaft side).
- Adjust neutral position of steering angle sensor. Refer to [BRC-8, "ADJUSTMENT OF STEERING ANGLE SENSOR NEUTRAL POSITION : Special Repair Requirement"](#).

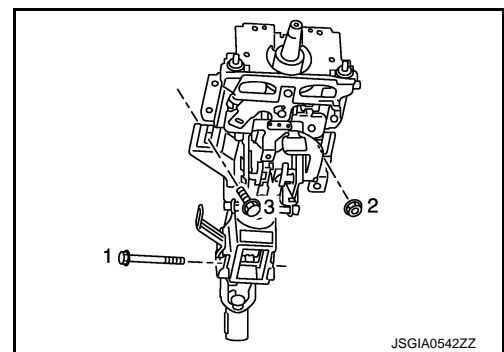

## Inspection

INFOID:000000007623232

### INSPECTION AFTER REMOVAL

- Check each part of steering column assembly for damage or other malfunctions. Replace if necessary.
- Measure steering column assembly rotating torque using a preload gauge [SST: ST3127S000 (J-25765-A)]. Replace steering column assembly if outside the standard.

# STEERING COLUMN

< REMOVAL AND INSTALLATION >

[REGULAR GRADE]

## Standard

### Rotating torque

: Refer to [ST-34, "Steering Column Operating Range"](#).

- Measure the length (L) as shown, if vehicle has been involved in a minor collision. Replace steering column assembly if out side the standard.

## Standard

### Steering column length (L)

: Refer to [ST-34, "Steering Column Length"](#).

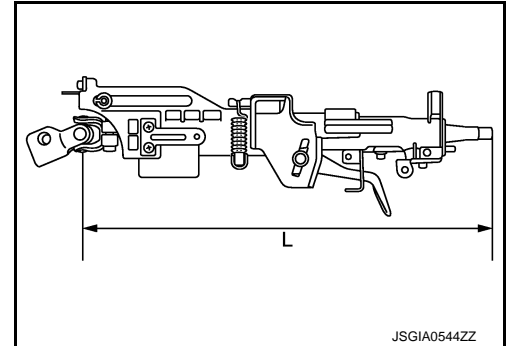

- Install the bracket (1) and steering column housing (2) so that the clearance (A) is within the specified range as described below. Replace steering column assembly if out side the standard.

## Standard

### Mounting dimensions (A)

: Refer to [ST-34, "Steering Column Mounting Dimensions"](#).

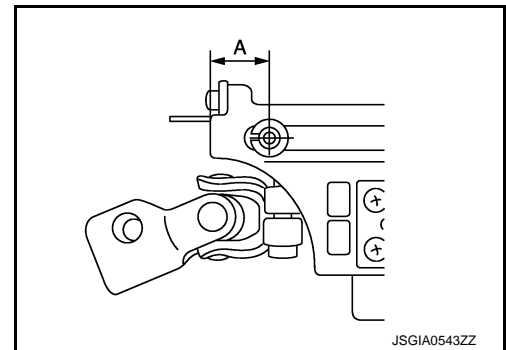

## INSPECTION AFTER INSTALLATION

- Check each part of steering column assembly for damage or other malfunctions. Replace if necessary.
- Check the steering wheel play, neutral position steering wheel, steering wheel turning force, and front wheel turning angle. Refer to [ST-10, "Inspection"](#).
- Check tilt mechanism operating range (L), as shown in the figure.

## Standard

### Tilt operating range (L)

: Refer to [ST-34, "Steering Column Operating Range"](#).

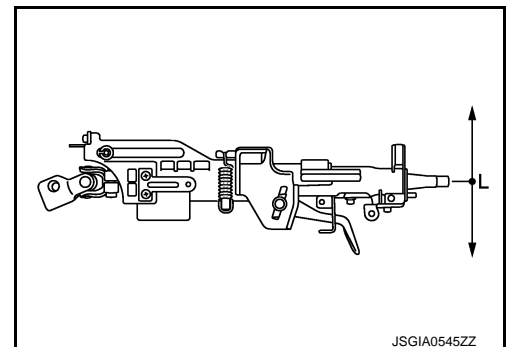



# LOWER SHAFT

< REMOVAL AND INSTALLATION >

[REGULAR GRADE]

## LOWER SHAFT

### Exploded View

INFOID:000000007623233

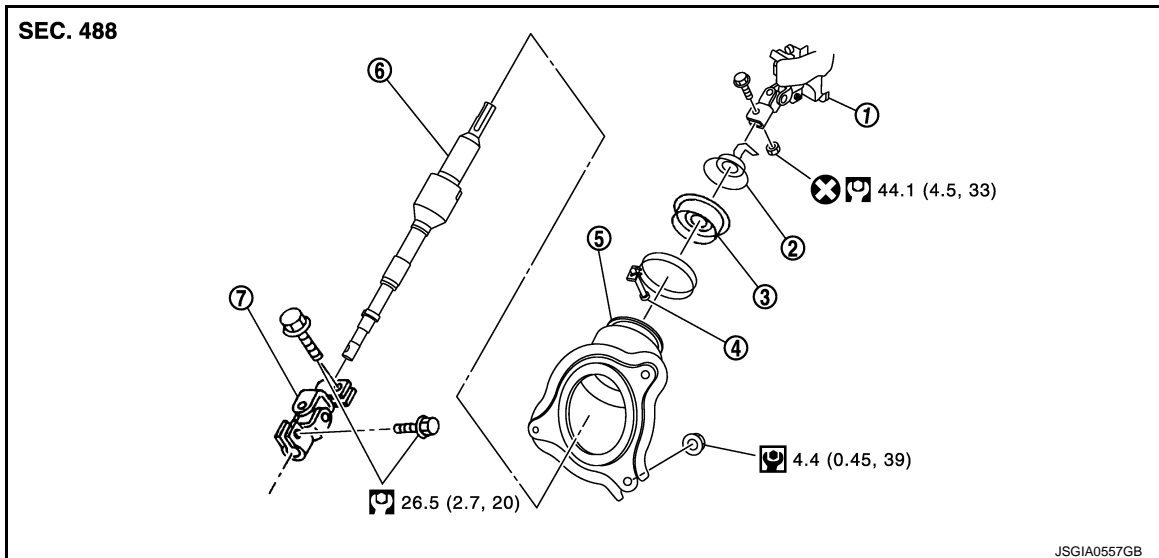

- |                             |               |                    |
|-----------------------------|---------------|--------------------|
| 1. Steering column assembly | 2. Collar     | 3. Hole cover seal |
| 4. Clamp                    | 5. Hole cover | 6. Lower shaft     |
| 7. Lower joint              |               |                    |

Refer to [GI-4, "Components"](#) for symbols in the figure.

## Removal and Installation

INFOID:000000007623234

### REMOVAL

1. Set the vehicle to the straight-ahead position.
2. Fix the steering wheel.
3. Remove lower joint fixing bolt (steering gear side).
4. Separate the lower joint from the steering gear assembly by sliding the slide shaft (A: sliding range).

#### CAUTION:

- Spiral cable may be cut if steering wheel turns while separating steering column assembly and steering gear assembly. Be sure to secure steering wheel using string to avoid turning.
- When removing lower joint, never insert a tool, such as a screwdriver, into the yoke groove to pull out the lower joint. In case of the violation of the above, replace lower joint with a new one.

5. Remove the accelerator pedal assembly. Refer to [ACC-4, "Exploded View"](#).
6. Remove the hole cover mounting nuts.
7. Remove the upper joint fixing bolt and nut (lower shaft side).
8. Remove the lower shaft and hole cover.
9. Remove collar, hole cover seal, clamp and hole cover.

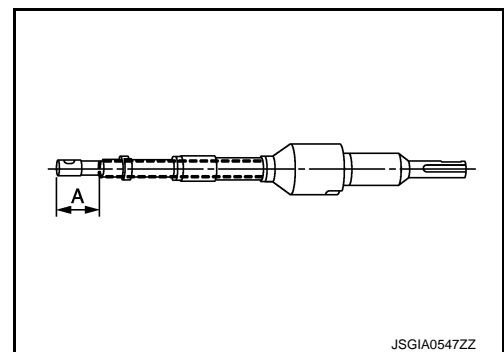

JSGIA0547ZZ

### INSTALLATION

Note the following, and install in the reverse order of removal.

#### CAUTION:

# LOWER SHAFT

< REMOVAL AND INSTALLATION >

[REGULAR GRADE]

**Spiral cable may be cut if steering wheel rotates while separating steering column assembly and steering gear assembly. Always fix the steering wheel using string to avoid turning.**

- Tighten the clamp to the specified torque and check the clamp length (A).

**A** : 14.0 – 18.0 mm (0.551 – 0.709 in)

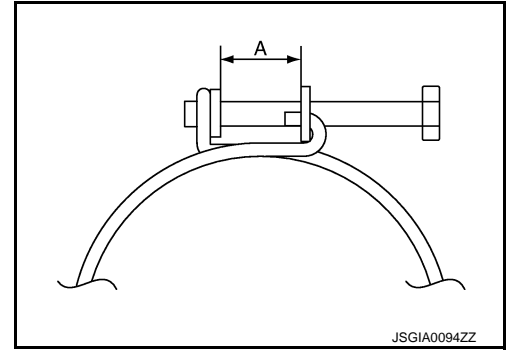

- Install clamp as shown in the figure.

↔ : Vehicle front

- When installing lower joint to steering gear assembly, follow the procedure listed below.
- Set rack of steering gear in the neutral position.

**NOTE:**

To get the neutral position of rack, turn gear-sub assembly and measure the distance of inner socket, and then measure the intermediate position of the distance.

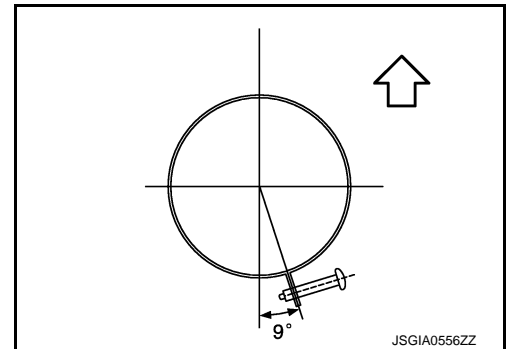

- Align rear cover cap projection (A) with the marking position of gear housing assembly (B).

← : Bolt

- Install slit part of lower joint (C) aligning with the rear cover cap projection (A). Check that the slit part of lower joint (C) is aligned with rear cover cap projection (A) and the marking position of gear housing assembly (B).
- Make sure there is no clearance between the lower joint, gear housing assembly and mounting bolt.

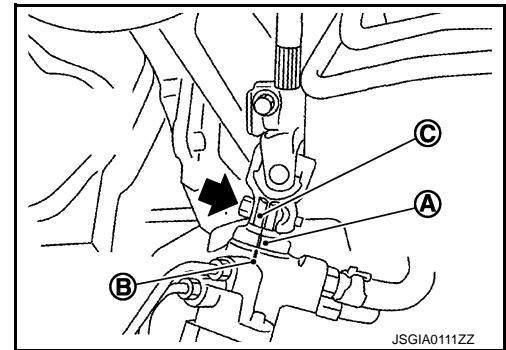

- Adjust neutral position of steering angle sensor. Refer to [BRC-8. "ADJUSTMENT OF STEERING ANGLE SENSOR NEUTRAL POSITION : Special Repair Requirement"](#).

- Check the following after installation:

- Check if steering wheel turns smoothly when it is turned several times fully to the end of the left and right.
- Check the steering wheel play, neutral position steering wheel, steering wheel turning force, and front wheel turning angle. Refer to [ST-10. "Inspection"](#).

## Inspection

INFOID:000000007623235

- Check the length (L) (extended position) of the lower shaft.

**Standard**

**Lower shaft length (L)** : Refer to [ST-35. "Lower Shaft"](#).

- Check each part of lower shaft for damage or other malfunctions. Replace if there are.

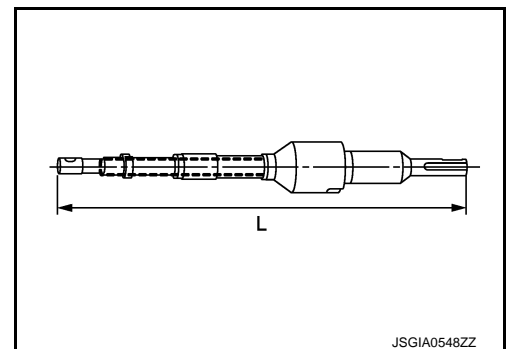

# STEERING GEAR AND LINKAGE

< REMOVAL AND INSTALLATION >

[REGULAR GRADE]

## STEERING GEAR AND LINKAGE

Exploded View

INFOID:000000007623236

### REMOVAL

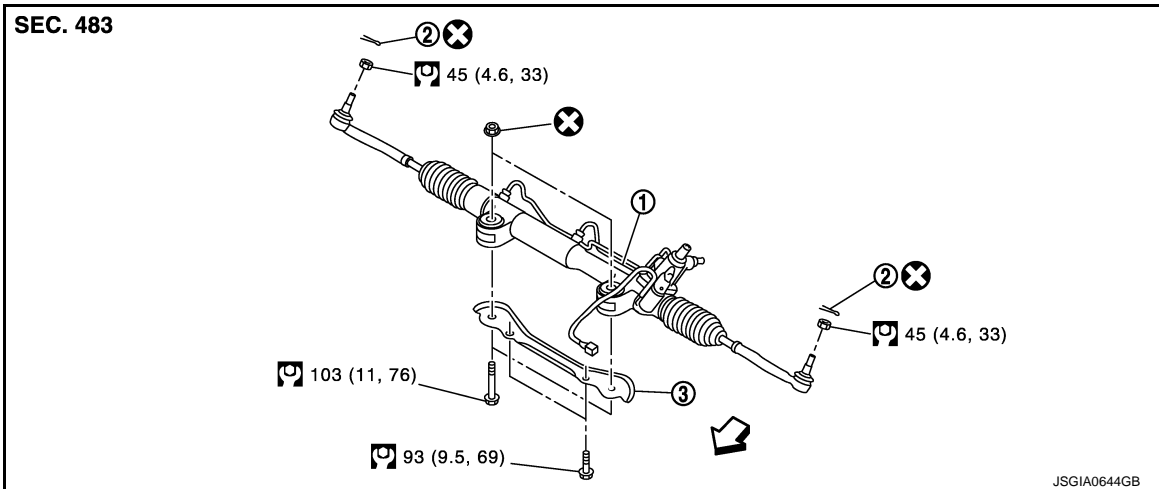

- 1. Steering gear assembly
- 2. Cotter pin
- 3. Rack stay

← Vehicle front

Refer to [GI-4, "Components"](#) for symbols in the figure.

### DISASSEMBLY

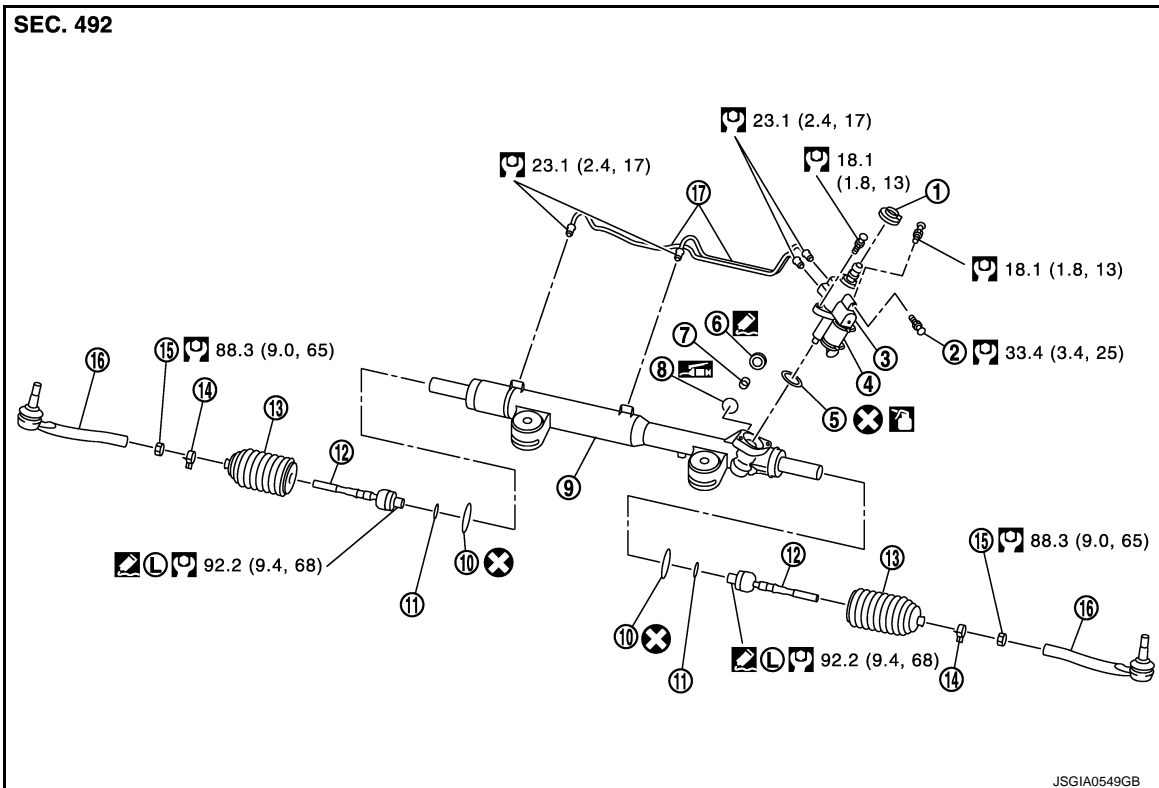

- 1. Rear cover cap
- 2. Low pressure piping
- 3. Gear-sub assembly
- 4. Power steering solenoid valve
- 5. O-ring
- 6. Adjusting screw
- 7. Spring
- 8. Retainer
- 9. Gear housing assembly

# STEERING GEAR AND LINKAGE

## < REMOVAL AND INSTALLATION >

[REGULAR GRADE]

- |                                 |                    |                           |
|---------------------------------|--------------------|---------------------------|
| 10. Boot clamp (stainless wire) | 11. Spacer         | 12. Inner socket          |
| 13. Boot                        | 14. Boot clamp     | 15. Outer socket lock nut |
| 16. Outer socket                | 17. Cylinder tubes |                           |

: Apply power steering fluid.

: Apply Genuine High Performance Thread Sealant or equivalent. Refer to [GI-22, "Recommended Chemical Products and Sealants"](#).

L: Apply Genuine Medium Strength Thread Locking Sealant or equivalent. Refer to [GI-22, "Recommended Chemical Products and Sealants"](#).

: Apply multi-purpose grease.

Refer to [GI-4, "Components"](#) for symbols not described on the above.

## Removal and Installation

INFOID:000000007623237

### REMOVAL

1. Set the vehicle to the straight-ahead position.
2. Remove tires with a power tool.
3. Remove front suspension member stay. Refer to [FSU-21, "Exploded View"](#).

4. Remove cotter pin (1), and then loosen the nut.
5. Remove steering outer socket (2) from steering knuckle (3) so as not to damage ball joint boot (4) using suitable ball joint remover (commercial service tool).

#### CAUTION:

**Temporarily tighten the nut to prevent damage to threads and to prevent the ball joint remover from sudden drop.**

6. Remove high pressure piping and low pressure piping of hydraulic piping, and then drain power steering fluid.
7. Remove power steering solenoid valve harness connector.
8. Remove rack stay. Refer to [ST-19, "Exploded View"](#).
9. Remove lower joint fixing bolt (steering gear side).
10. Separate the lower joint from the steering gear assembly by sliding the slide shaft (A: sliding range).

#### CAUTION:

- **Spiral cable may be cut if steering wheel turns while separating steering column assembly and steering gear assembly. Be sure to secure steering wheel using string to avoid turning.**
- **When removing lower joint, never insert a tool, such as a screwdriver, into the yoke groove to pull out the lower joint. In case of the violation of the above, replace lower joint with a new one.**

11. Remove the mounting bolts and nuts of steering gear assembly.
12. Remove steering gear assembly.

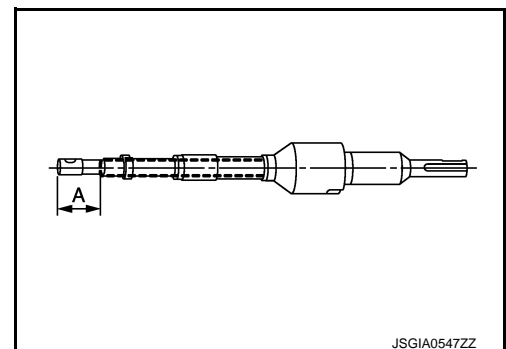
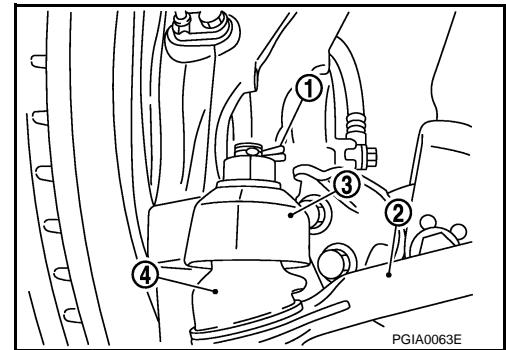

### INSTALLATION

Note the following, and install in the reverse order of removal.

#### CAUTION:

**Spiral cable may be cut if steering wheel turns while separating steering column assembly and steering gear assembly. Always fix the steering wheel using string to avoid turning.**

# STEERING GEAR AND LINKAGE

## < REMOVAL AND INSTALLATION >

[REGULAR GRADE]

- Tighten the mounting bolts in the order shown in the figure when installing the steering gear assembly.

Temporary tightening: 1 ⇒ 2 ⇒ 3 ⇒ 4

Final tightening: 1 ⇒ 2 ⇒ 3 ⇒ 4

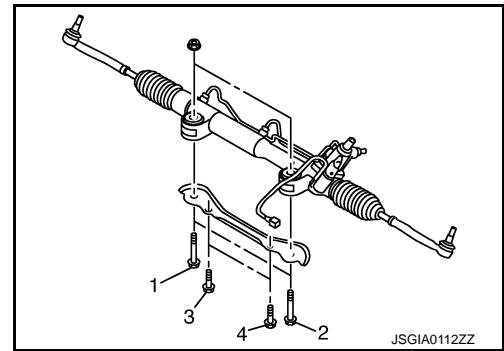

- When installing suction hoses (1), refer to the figure.

### CAUTION:

- Never apply fluid to the hose (1) and tube (2).
- Insert hose securely until it contacts spool (A) of tube.
- Install clamp (3) to the hose at 3 – 8 mm (0.12 – 0.31 in) (L) from the edge of the hose.

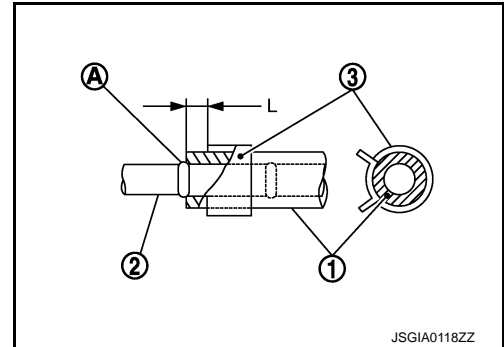

- When installing lower joint to steering gear assembly, follow the procedure listed below.
- Set rack of steering gear in the neutral position.

### NOTE:

To get the neutral position of rack, turn gear-sub assembly and measure the distance of inner socket, and then measure the intermediate position of the distance.

- Align rear cover cap projection (A) with the marking position of gear housing assembly (B).

← : Bolt

- Install slit part of lower joint (C) aligning with the rear cover cap projection (A). Make sure that the slit part of lower joint (C) is aligned with rear cover cap projection (A) and the marking position of gear housing assembly (B).
- Make sure there is no clearance between the lower joint, gear housing assembly and mounting bolt.
- After installation, bleed air from the steering hydraulic system. Refer to [ST-8, "Inspection"](#).
- Perform final tightening of nuts and bolts on each part under unladen conditions with tires on level ground when removing steering gear assembly. Check wheel alignment. Refer to [FSU-9, "Inspection"](#).
- Adjust neutral position of steering angle sensor after checking wheel alignment. Refer to [BRC-8, "ADJUSTMENT OF STEERING ANGLE SENSOR NEUTRAL POSITION : Special Repair Requirement"](#).

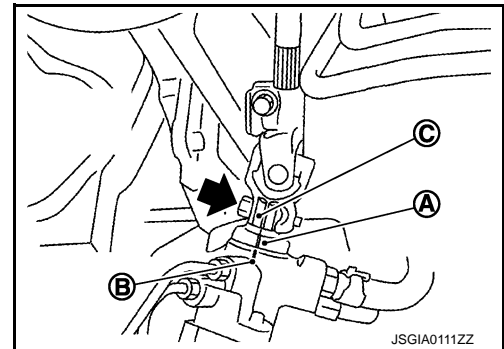

## Disassembly and Assembly

INFOID:000000007623238

### DISASSEMBLY

1. Remove low pressure piping.

### CAUTION:

- Disassemble and assemble steering gear assembly by fixing the mounting area with a vise using copper plates.
  - Clean steering gear assembly with kerosene before disassembling. Be careful to avoid splashing or applying any kerosene over connector of discharge port or return port.
2. Remove cylinder tubes from gear housing assembly.
  3. Remove rear cover cap from gear-sub assembly.

# STEERING GEAR AND LINKAGE

## < REMOVAL AND INSTALLATION >

[REGULAR GRADE]

4. Measure adjusting screw height "H", and loosen adjusting screw.

**CAUTION:**

- Never loosen adjusting screw 2 turns or more.
- Replace steering gear assembly if adjusting screw is loosened 2 turns or more and it is removed.

5. Remove gear-sub assembly from gear housing assembly.
6. Remove O-ring from gear housing assembly.
7. Loosen outer socket lock nut, and remove outer socket.
8. Remove boot clamps, and then remove boot from inner socket.

**CAUTION:**

Never damage inner socket and gear housing assembly when removing boot. Inner socket and gear housing assembly must be replaced if inner socket and gear housing assembly are damaged because it may cause foreign material interfusion.

9. Remove inner socket from gear housing assembly.
10. Remove spacer from gear housing assembly.

## ASSEMBLY

1. Apply recommended fluid to O-ring, and then install O-ring to gear housing assembly.

**CAUTION:**

Never reuse O-ring.

2. Install gear-sub assembly to gear housing assembly.

**CAUTION:**

In order to protect oil seal from any damage, insert gear-sub assembly straightly.

3. Install inner socket to gear housing assembly with the following procedure.

- a. Install spacer to gear housing assembly.
- b. Apply thread sealant into the thread of inner socket.

Use Genuine Medium Strength Thread Locking Sealant or equivalent. Refer to [GI-22, "Recommended Chemical Products and Sealants"](#).

4. Decide on the neutral position of the rack stroke (L).

### Standard

Rack stroke neutral position (L) : Refer to [ST-35, "Rack Stroke"](#).

5. Install rear cover cap to gear sub-assembly.

**CAUTION:**

Check that the projection of rear cover cap is aligned with the marking position of gear housing assembly.

6. Apply recommended thread sealant to the thread (2 turns thread), and then screw in the adjusting screw until it reaches height "H" from gear housing assembly measured before disassembling.

Use Genuine High Performance Thread Sealant or equivalent. Refer to [GI-22, "Recommended Chemical Products and Sealants"](#).

7. Move rack assembly 10 strokes throughout the full stroke so that the parts can fit with each other.

8. Adjust pinion rotating torque with the following procedure.

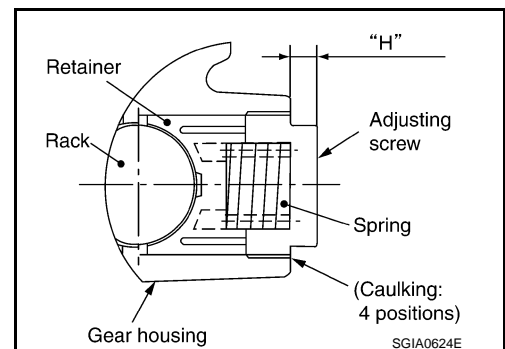
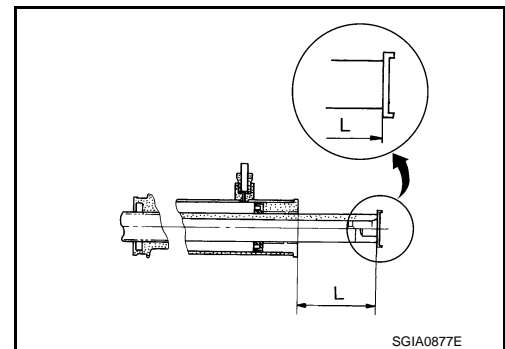
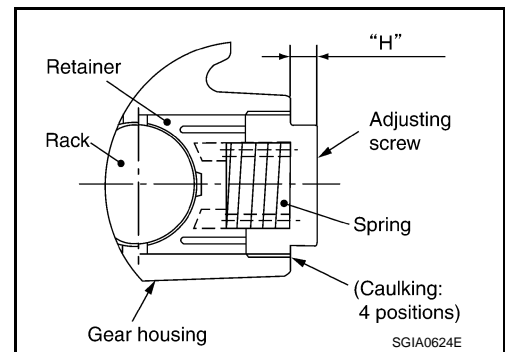

# STEERING GEAR AND LINKAGE

## < REMOVAL AND INSTALLATION >

[REGULAR GRADE]

- a. Measure pinion rotating torque within  $\pm 180^\circ$  of neutral position of the rack assembly using tools. Stop the gear at the point where highest torque is read.

A: Preload gauge [SST: ST3127S000 (J-25765-A)]

B: Preload adapter [SST: KV48103400 ( — )]

- b. Loosen adjusting screw and retighten to 5.4 N·m (0.55 kg·m, 48 in·lb), and then loosen by 20 to 40°.

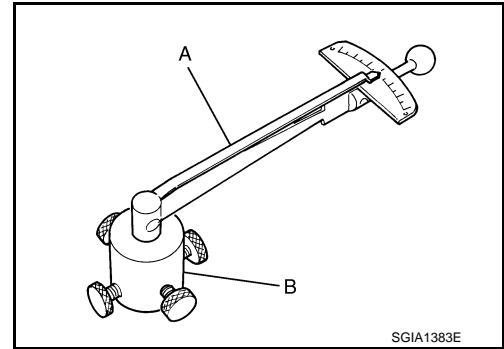

- c. Measure pinion rotating torque using tools to check that the measured value is within the specified value. Readjust if the value is outside the standard. Replace steering gear assembly, if the value is out of the specified value after readjusting, or adjusting screw rotating torque is 5 N·m (0.51 kg·m, 44 in·lb) or less.

### Pinion rotating torque

**Around neutral position** : 1.95 – 2.58 N·m (0.20 – 2.66 kg·m, 18 – 22 in·lb)  
**(within  $\pm 100^\circ$ ) average (A)** : 0.26 kg·m, 18 – 22 in·lb

**Maximum variation (B)** : 0.98 N·m (0.10 kg·m, 9.0 in·lb)

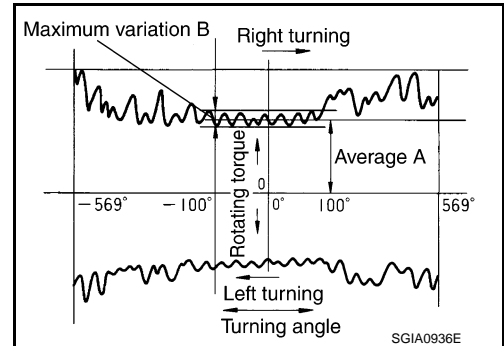

- d. Turn pinion fully to left.
- e. Install dial gauge at 5 mm (0.20 in) (L) from the edge of gear housing assembly (1), and tooth point.
- f. Measure vertical movement of rack assembly when pinion is turned clockwise with torque of 19.6 N·m (2.0 kg·m, 14 ft·lb). Readjust adjusting screw angle if the measured value is out of the specified value.

**Vertical movement** : 0.265 mm (0.0104 in)

- If reading is outside of the specification, readjust screw angle with adjusting screw.

### CAUTION:

- If reading is still outside of specification, or if the rotating torque of adjusting screw is less than 5 N·m (0.51 kg·m, 44 in·lb), replace steering gear assembly.
- Never turn adjusting screw more than twice.
- Replace steering gear assembly when adjusting screw is removed or turned more than twice.

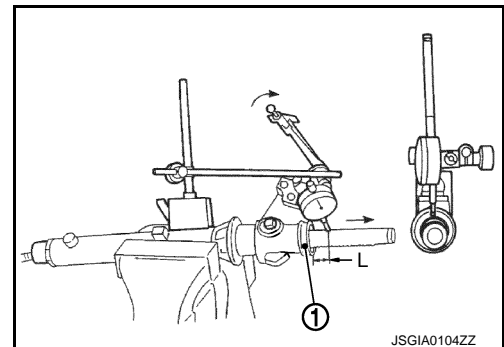

9. Install large end of boot to gear housing assembly.
10. Install small end of boot to inner socket boot mounting groove.
11. Install boot clamp to boot small end.

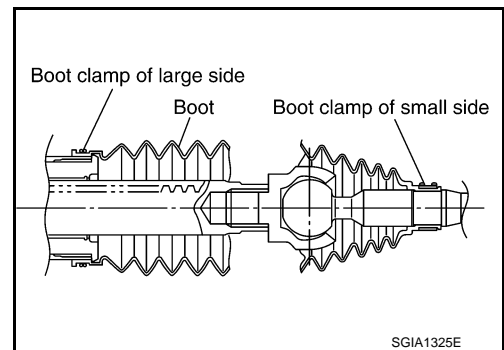

12. Install boot clamp to the large side of boot with the following procedure.

### CAUTION:

**Never reuse boot clamp.**

# STEERING GEAR AND LINKAGE

## < REMOVAL AND INSTALLATION >

[REGULAR GRADE]

- a. Tighten large side of boot with boot clamp (stainless wire).

**Wire length (L) : 370 mm (14.57 in)**

- b. Wrap clamp around boot groove for two turns. Insert a flat-bladed screwdriver in loops on both ends of wire. Twist 4 to 4.5 turns while pulling them with force of approximately 98 N (10 kg, 22 lb).

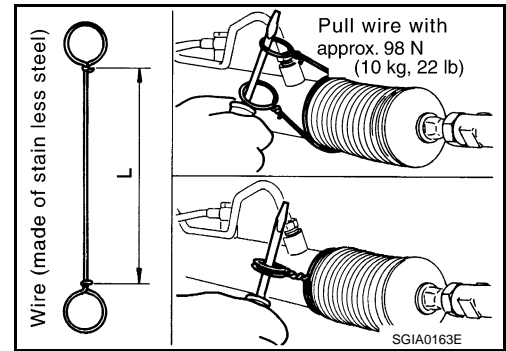

- c. Twist boot clamp as shown. Pay attention to relationship between winding and twisting directions.

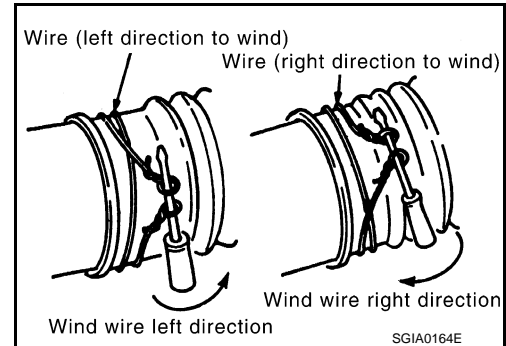

- d. Twisted area (A) of clamp is in the adjusting screw side (1) as shown in the figure (to prevent contact with other parts).

**A : 90°**

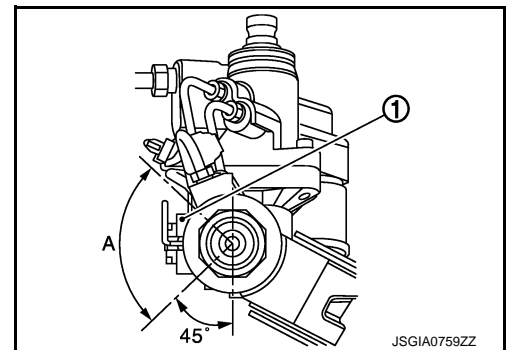

- e. Bend cut end of the wire within the area (A) shown in the figure after twisting the wire 4 to 4.5 turns so that the cut end does not contact with boot.

**CAUTION:**

**Keep the clearance from cylinder tube 5.0 mm (0.20 in) or more.**

**A : 45°**

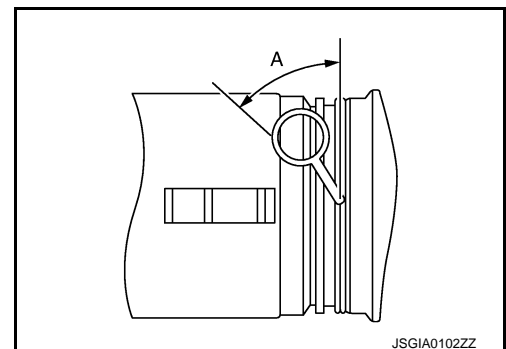

13. Install cylinder tubes to gear housing assembly.

14. Install low pressure piping.

15. Adjust inner socket to standard length (L), and then tighten lock nut (1) to the specified torque. Check length again after tightening lock nut.

**Standard**

**Inner socket length (L)**

**: Refer to [ST-35](#), "[Inner Socket Length](#)".**

**CAUTION:**

**Adjust toe-in after this procedure. The length achieved after toe-in adjustment is not necessary the above value.**

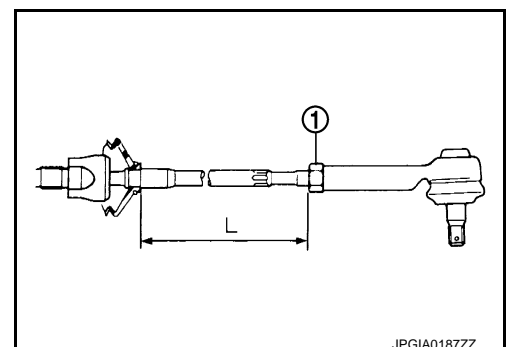



# STEERING GEAR AND LINKAGE

< REMOVAL AND INSTALLATION >

[REGULAR GRADE]

## Inspection

INFOID:000000007623239

### INSPECTION AFTER INSTALLATION

- Check if steering wheel turns smoothly when it is turned several times fully to the end of the left and right.
- Check the steering wheel play, neutral position steering wheel, steering wheel turning force, and front wheel turning angle. Refer to [ST-10. "Inspection"](#).
- Check the fluid level, fluid leakage, and air bleeding hydraulic system. Refer to [ST-8. "Inspection"](#).

### INSPECTION AFTER DISASSEMBLY

#### Boot

Check boot for cracks, and replace it if a malfunction is detected.

#### Rack Assembly

Check rack for damage or wear, and replace it if a malfunction is detected.

#### Gear-Sub Assembly

- Check gear-sub assembly for damage or wear, and replace it if a malfunction is detected.
- Rotate gear-sub assembly and check for torque variation or rattle, and replace it if a malfunction is detected.

#### Gear Housing Assembly

Check gear housing assembly for damage and scratches (inner wall). Replace if there are.

#### Outer Socket and Inner Socket

Check the following items and replace the component if it does not meet the standard.

### BALL JOINT SWINGING TORQUE

Hook a spring balance at the point shown in the figure and pull the spring balance. Make sure that the spring balance reads the specified value when ball stud and inner socket start to move. Replace outer socket and inner socket if they are outside the standard.

#### Standard

(Measuring point of outer socket: Stud cotter pin mounting hole)

Outer socket

: Refer to [ST-35. "Socket Swing Force and Rotating Torque"](#).

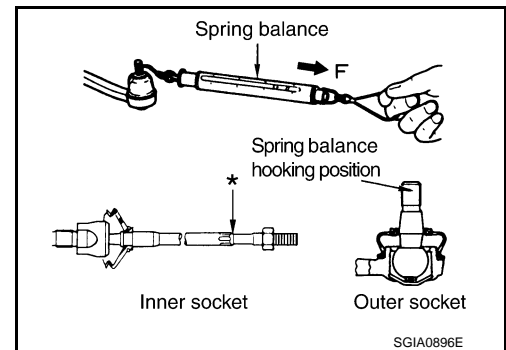

#### Standard

(Measuring point of inner socket: "\*" mark shown in the figure)

Inner socket

: Refer to [ST-35. "Socket Swing Force and Rotating Torque"](#).

### BALL JOINT ROTATING TORQUE

Make sure that the reading is within the following specified range using preload gauge (A) [SST: ST3127S000 (J-25765-A)]. Replace outer socket if the reading is outside the specified value.

#### Standard

Rotating torque

: Refer to [ST-35. "Socket Swing Force and Rotating Torque"](#).

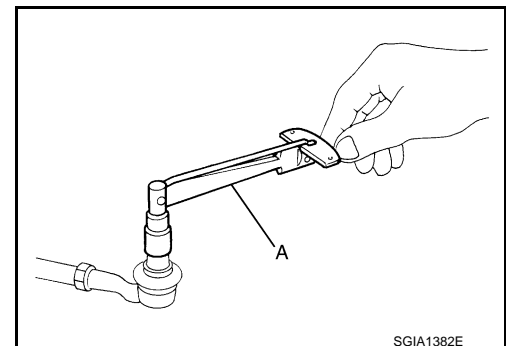

### BALL JOINT AXIAL END PLAY

## STEERING GEAR AND LINKAGE

< REMOVAL AND INSTALLATION >

[REGULAR GRADE]

Apply an axial load of 490 N (50 kg, 110 lb) to ball stud. Using a dial gauge, measure amount of stud movement, and then make sure that the value is within the following specified range. Replace outer socket (1) and inner socket (2) if the measured value is outside the standard.

### Standard

Outer socket

: Refer to [ST-35, "Socket Axial End Play"](#).

Inner socket

: Refer to [ST-35, "Socket Axial End Play"](#).

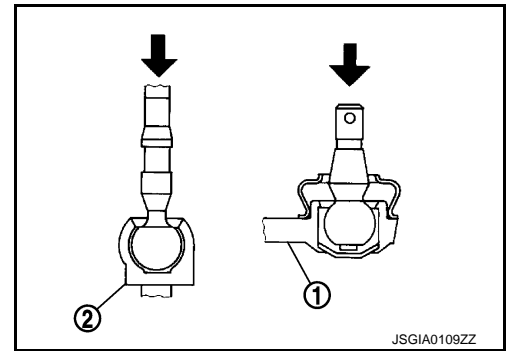

# POWER STEERING OIL PUMP

< REMOVAL AND INSTALLATION >

[REGULAR GRADE]

## POWER STEERING OIL PUMP

Exploded View

INFOID:000000007623240

### REMOVAL

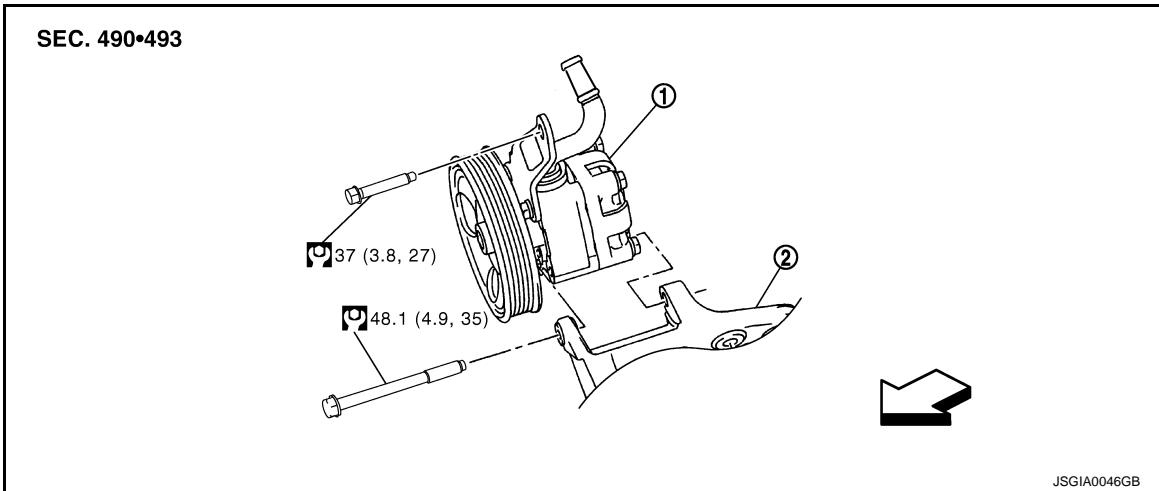

- 1. Power steering oil pump
- 2. Bracket

← Vehicle front

Refer to [GI-4, "Components"](#) for symbols in the figure.

### DISASSEMBLY

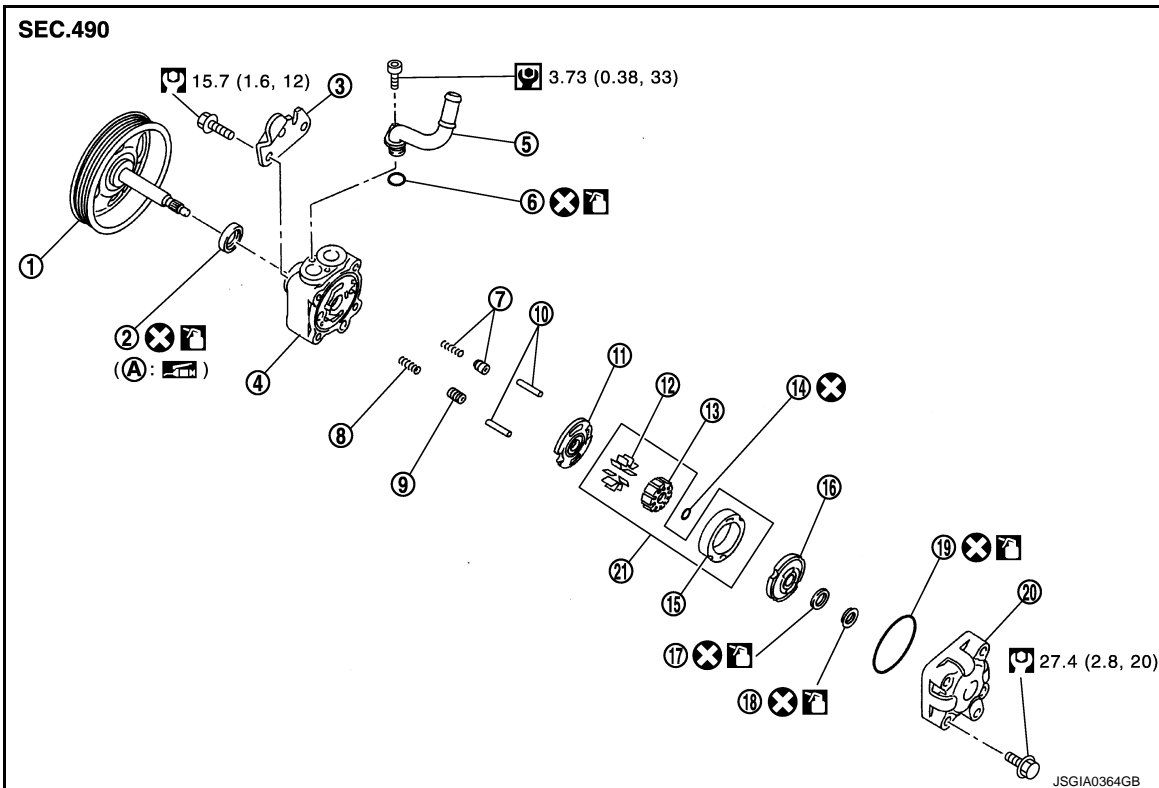

- 1. Pulley
- 2. Oil seal
- 3. Bracket
- 4. Body assembly
- 5. Suction pipe
- 6. O-ring
- 7. Flow control valve B assembly
- 8. Flow control valve spring
- 9. Flow control valve A

# POWER STEERING OIL PUMP

## < REMOVAL AND INSTALLATION >

[REGULAR GRADE]

- |                     |                      |                 |
|---------------------|----------------------|-----------------|
| 10. Dowel pin       | 11. Front side plate | 12. Vane        |
| 13. Rotor           | 14. Rotor snap ring  | 15. Cam ring    |
| 16. Rear side plate | 17. O-ring           | 18. Teflon ring |
| 19. O-ring          | 20. Rear cover       | 21. Cartridge   |
| A. Oil seal lip     |                      |                 |

: Apply power steering fluid.

: Apply multi-purpose grease.

Refer to [GI-4, "Components"](#) for symbols not described on the above.

## Removal and Installation

INFOID:000000007623241

### REMOVAL

1. Drain power steering fluid from reservoir tank.
2. Remove the right of the air cleaner and the right of the air duct. Refer to [EM-31, "Exploded View"](#).
3. Loosen drive belt. Refer to [EM-17, "Exploded View"](#).
4. Remove drive belt from oil pump pulley.
5. Remove pressure sensor connector.
6. Remove copper washers and eye bolt (drain fluid from their pipings).
7. Remove suction hose (drain fluid from their pipings).
8. Remove cooling fan assembly. Refer to [CO-22, "Exploded View"](#).
9. Remove oil pump mounting bolts, and then remove oil pump.

### INSTALLATION

Note the following, and install in the reverse order of removal.

- When installing suction hoses (1), refer to the figure.

#### CAUTION:

- Never apply fluid to the hose (1) and tube (2).
- Insert hose securely until it contacts spool (A) of tube.
- Leave clearance (L) when installing clamp (3).

Standard

L : 3 – 8 mm (0.12 – 0.31 in)

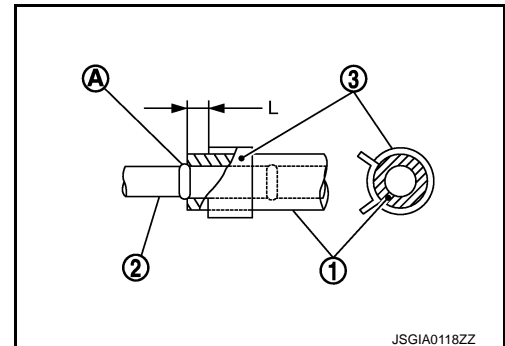

- When installing eye bolt (1) and copper washer (2) to oil pump (3), refer to the figure.

#### CAUTION:

- Never reuse copper washer.
- Apply power steering fluid to around copper washers, then install eye bolt.
- Install eye bolt with eye joint (assembled to high pressure hose) (B) protrusion (A) facing with pump side cutout, and then tighten it to the specified torque after tightening by hand. Refer to [ST-33, "Exploded View"](#).
- Securely insert harness connector to pressure sensor.
- Adjust belt tension. Refer to [EM-17, "Tension Adjustment"](#).
- Check fluid level, fluid leakage and air bleeding hydraulic system after the installation. Refer to [ST-8, "Inspection"](#).

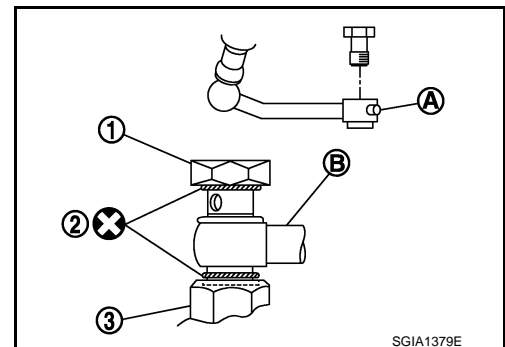

## Disassembly and Assembly

INFOID:000000007623242

### DISASSEMBLY

1. Remove rear cover mounting bolts, and then remove rear cover from body assembly.

#### CAUTION:

# POWER STEERING OIL PUMP

## < REMOVAL AND INSTALLATION >

[REGULAR GRADE]

- Fix oil pump with a vise if necessary.
  - Use copper plates when fixing with a vise.
2. Remove O-ring from body assembly.
  3. Remove rear side plate from cartridge, and then remove Teflon ring and O-ring from rear side plate.
  4. Remove rotor snap ring using a snap ring pliers, and remove pulley from body assembly.

**CAUTION:**

Never damage pulley, when removing rotor snap ring.

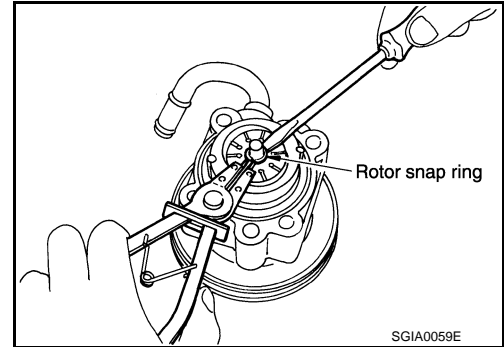

5. Remove cartridge and front side plate.
6. Remove flow control valve A (1), flow control valve spring (2) and flow control valve B assembly (3) from body assembly (4).

**CAUTION:**

Never drop and damage flow control valve A and flow control valve B assembly when removing.

7. Remove oil seal from body assembly.
8. Remove mounting bolt of suction pipe, and then remove suction pipe from body assembly.
9. Remove O-ring from body assembly.
10. Remove bracket mounting bolts, and then remove bracket from body assembly.

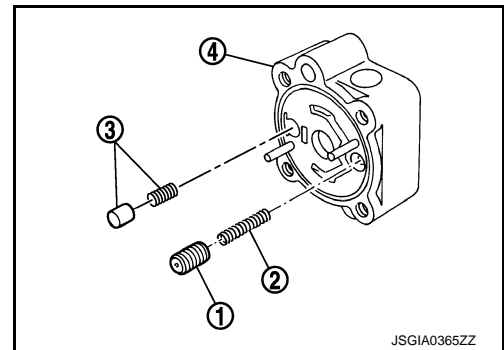

## ASSEMBLY

1. Apply recommended grease to oil seal lips. Apply recommended fluid to around oil seal, and then install oil seal to body assembly using a drift [SST: ST35300000 ( — )]

**CAUTION:**

- Fix oil pump with a vise if necessary.
- Use copper plates when fixing with a vise.

2. Install bracket to body assembly.
3. If dowel pin has been removed, insert it into body assembly by hand. If it cannot be inserted by hand, lightly tap with a hammer.

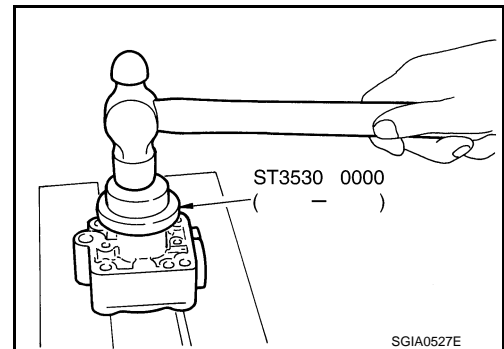

4. Install flow control valve A (1), flow control valve spring (2) and flow control valve B assembly (3) to body assembly (4).

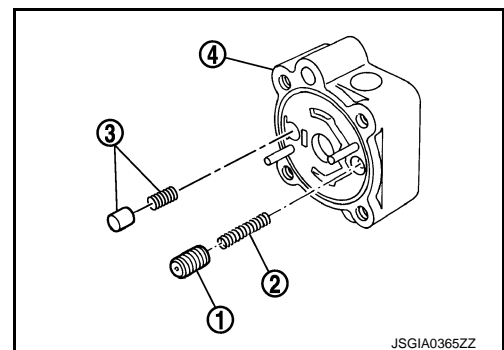

# POWER STEERING OIL PUMP

[REGULAR GRADE]

## < REMOVAL AND INSTALLATION >

5. Install front side plate (3) with dowel pin (2) on flow control valve A (1) side as shown in the figure aligning with front side plate cutout (A) to body assembly (4).

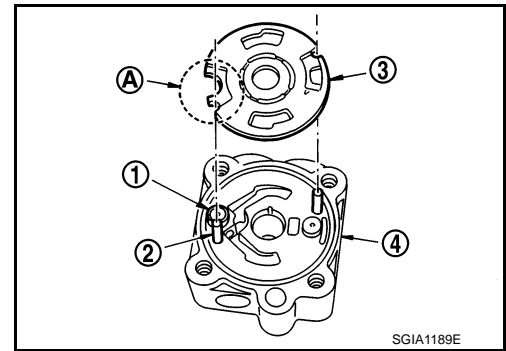

6. Install cam ring as shown in the figure.  
7. Install pulley to body assembly.

**CAUTION:**

**Never damage oil seal when installing pulley.**

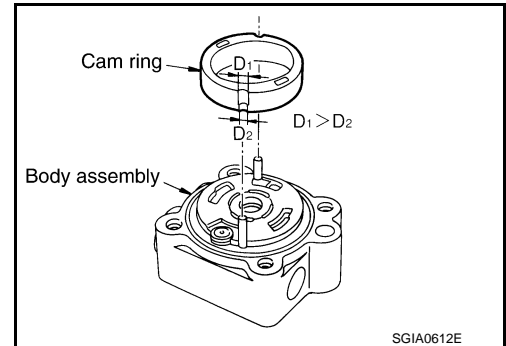

8. Be careful with the orientation of rotor, and then install it to pulley shaft.

- A : Rear cover side  
B : Body assembly side

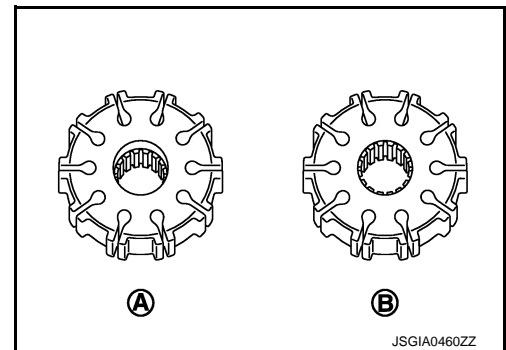

9. Install vane to rotor so that arc of vane faces cam ring side.  
10. Install rotor snap ring to slit of pulley shaft using a hammer and drift (commercial service tool).

**CAUTION:**

- Never damage rotor and pulley shaft.
- Oil pump assembly must be replaced if rotor is damaged.

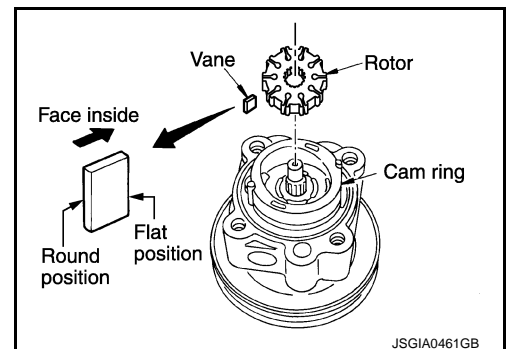

# POWER STEERING OIL PUMP

[REGULAR GRADE]

## < REMOVAL AND INSTALLATION >

11. Install rear side plate with dowel pin A on flow control valve A side as shown in the figure aligning with rear side plate cutout B to cartridge.
12. Apply recommended fluid to O-ring, and then install O-ring to body assembly.
13. Apply recommended fluid to O-ring, and then install O-ring to rear side plate.
14. Apply recommended fluid to Teflon ring, and then install Teflon ring to rear side plate.
15. Install rear cover to body assembly.
16. Apply recommended fluid to O-ring, and then install O-ring to body assembly.
17. Install suction pipe to body assembly.

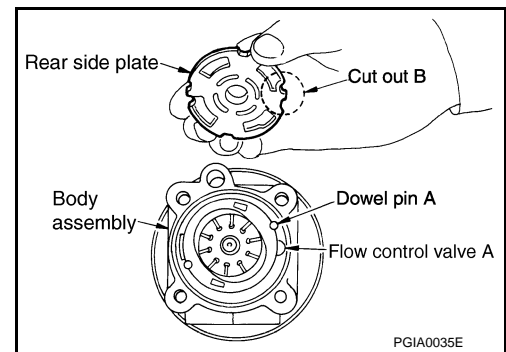

## Inspection

INFOID:000000007623243

## RELIEF OIL PRESSURE

### CAUTION:

Check that belt tension is normal before starting the following procedure.

1. Connect the oil pressure gauge [SST: KV48103500 (J-26357)] and the oil pressure gauge adapter [SST: KV48102500 (J-33914)] between oil pump discharge connector and high-pressure hose. Bleed air from the hydraulic circuit while opening valve fully. Refer to [ST-8, "Inspection"](#).
2. Start engine. Run engine until oil temperature reaches 50 to 80°C (122 to 176°F).

### CAUTION:

- Leave the valve of the oil pressure gauge fully open while starting and running engine. If engine is started with the valve closed, the hydraulic pressure in oil pump goes up to the relief pressure along with unusual increase of oil temperature.
- Always keep hose clear of belts and other parts when engine is started.

3. Fully close the oil pressure gauge valve with engine at idle and measure the relief oil pressure.

Standard

Relief oil pressure

: Refer to [ST-35, "Relief Oil Pressure"](#).

### CAUTION:

Never keep valve fully closed for 10 seconds or longer.

4. Open the valve slowly after measuring. Repair oil pump if the relief oil pressure is outside the standard. Refer to [ST-28, "Disassembly and Assembly"](#).
5. Disconnect the oil pressure gauge from hydraulic circuit.
6. When installing eye bolt (1) and copper washer (2) to oil pump (3), refer to the figure.

### CAUTION:

- Never reuse copper washers.
- Apply power steering fluid or equivalent to around copper washer, then install eye bolt.
- Install eye bolt with eye joint (assembled to high pressure hose) (B) protrusion (A) facing with pump side cutout, and then tighten it to the specified torque after tightening by hand. Refer to [ST-33, "Exploded View"](#).
- Securely insert harness connector to pressure sensor.

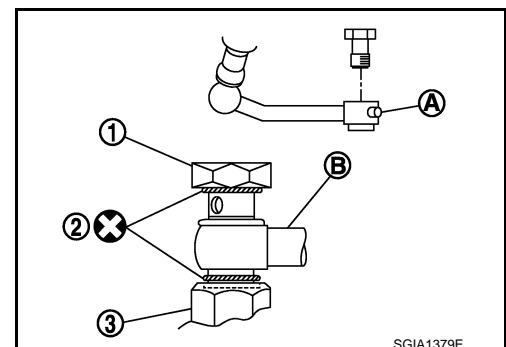
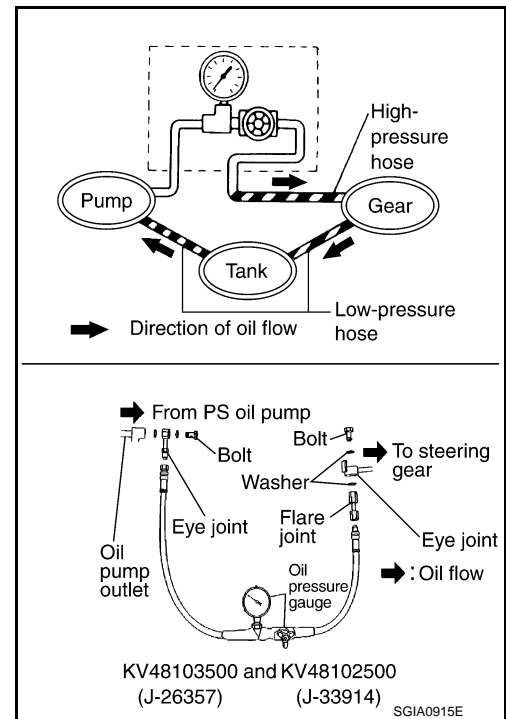

## POWER STEERING OIL PUMP

< REMOVAL AND INSTALLATION >

[REGULAR GRADE]

7. Check fluid level, fluid leakage and air bleeding hydraulic system after the installation. Refer to [ST-8](#), "[Inspection](#)".

### BEFORE DISASSEMBLY

Disassemble oil pump only when the following malfunctions occur.

- If oil leakage is found on oil pump.
- Oil pump pulley is damaged or deformed.
- Performance of oil pump is low.

### AFTER DISASSEMBLY

#### Body Assembly and Rear Cover Inspection

Check body assembly and rear cover for internal damage. Replace rear cover if it is damaged. Replace oil pump assembly if body assembly is damaged.

#### Cartridge Assembly Inspection

Check cam ring, rotor and vane for damage. Replace cartridge assembly if necessary.

#### Side Plate Inspection

Check side plate for damage. Replace side plate if there are.

#### Flow Control Valve Inspection

Check flow control valve and spring for damage. Replace if necessary.



# HYDRAULIC LINE

< REMOVAL AND INSTALLATION >

[REGULAR GRADE]

## HYDRAULIC LINE

### Exploded View

INFOID:000000007623244

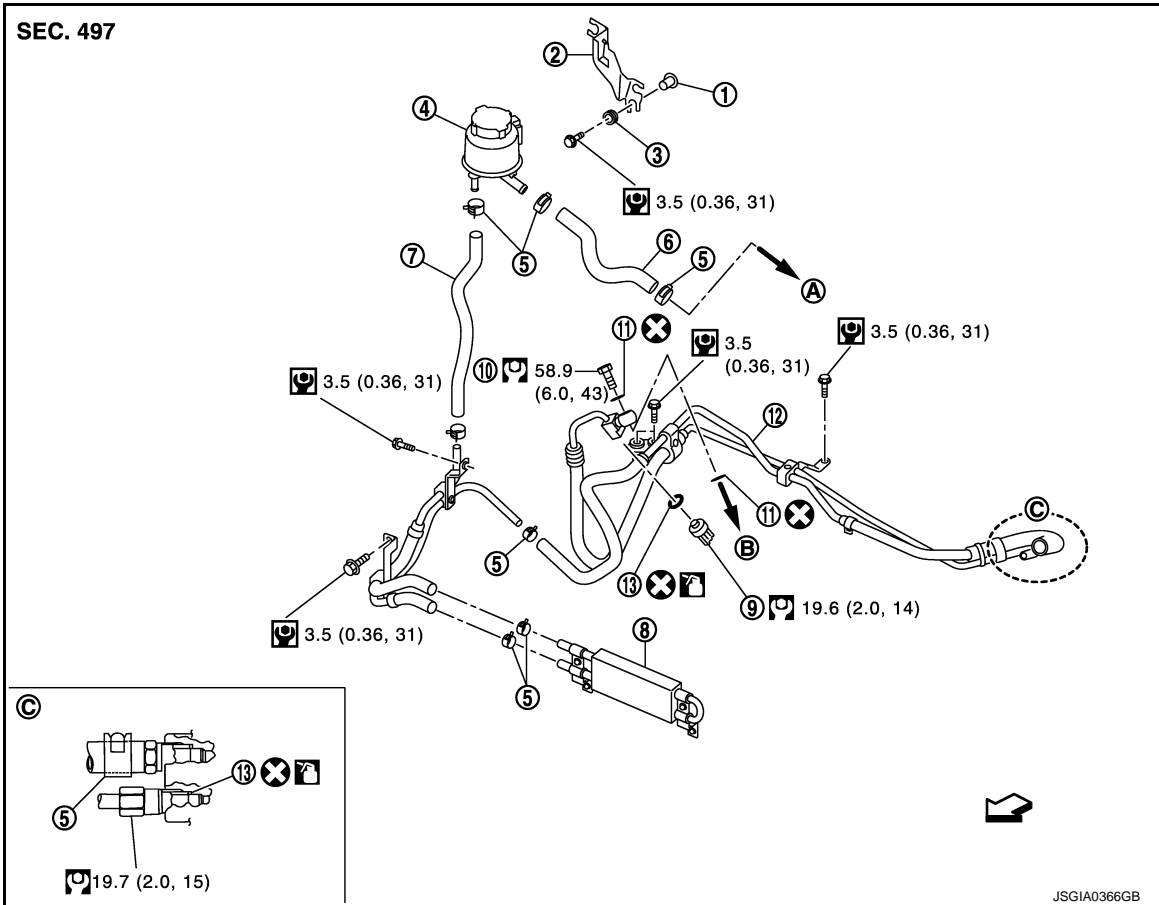

- |                   |                           |  |
|-------------------|---------------------------|--|
| 1. Collar         | 2. Reservoir tank bracket | 3. Bushing                                       |
| 4. Reservoir tank | 5. Clamp                  | 6. Suction hose                                  |
| 7. Return hose    | 8. Oil cooler             | 9. Pressure sensor                               |
| 10. Eye bolt      | 11. Copper washer         | 12. High pressure piping and low pressure piping |
| 13. O-ring        |                           |  |
- A. To power steering oil pump suction piping.    B. To power steering oil pump piping.

←: Vehicle front

: Apply power steering fluid.

Refer to [GI-4, "Components"](#) for symbols in the figure.

# SERVICE DATA AND SPECIFICATIONS (SDS)

< SERVICE DATA AND SPECIFICATIONS (SDS)

[REGULAR GRADE]

## SERVICE DATA AND SPECIFICATIONS (SDS)

### SERVICE DATA AND SPECIFICATIONS (SDS)

#### General Specifications

INFOID:0000000007623245

Steering gear model	PR26AF
Fluid capacity (Approx.)	ℓ (US qt, Imp qt) 1.0 (1-1/8, 7/8)

#### Steering Wheel Axial End Play and Play

INFOID:0000000007623246

Unit: mm (in)

Item	Standard
Steering wheel axial end play	0 (0)
Steering wheel play on the outer circumference	0 – 35 (0 – 1.38)

#### Steering Wheel Turning Torque

INFOID:0000000007623247

Unit: N·m (kg·m, in·lb)

Item	Standard
Steering wheel turning force	7.45 (0.76, 66)

#### Steering Angle

INFOID:0000000007623248

Unit: Degree minute (Decimal degree)

Item		Standard	
		Wheel size: 18 inch	Wheel size: 19 inch
Inner wheel	Minimum	36°40' (36.67°)	34°10' (34.17°)
	Nominal	39°40' (39.67°)	37°10' (37.17°)
	Maximum	40°40' (40.66°)	38°10' (38.16°)
Outer wheel	Minimum	33°20' (30.34°)	31°50' (31.84°)

#### Steering Column Length

INFOID:0000000007623249

Unit: mm (in)

Item	Standard
Steering column length	491 – 495 (19.33 – 19.49)

#### Steering Column Mounting Dimensions

INFOID:0000000007623250

Unit: mm (in)

Item	Standard
Mounting dimension	30.0 – 32.0 (1.18 – 1.26)

#### Steering Column Operating Range

INFOID:0000000007623251

Item	Standard
Tilt operating range	65 mm (2.56 in)
Rotating torque	0.39 N·m (0.04 kg·m, 3 in·lb)

# SERVICE DATA AND SPECIFICATIONS (SDS)

< SERVICE DATA AND SPECIFICATIONS (SDS)

[REGULAR GRADE]

## Lower Shaft

INFOID:0000000007623252

Unit: mm (in)

Item	Standard
Lower shaft length	508.8 (20.03) or less

## Rack Sliding Force

INFOID:0000000007623253

Unit: N (kg, lb)

Item	Standard
Rack sliding force	217 – 275 (22.2 – 28.0, 48.8 – 61.8)

## Rack Stroke

INFOID:0000000007623254

Unit: mm (in)

Item	Standard	
	Wheel size: 18 inch	Wheel size: 19 inch
Rack stroke neutral position	69.0 (2.72)	66.0 (2.60)

## Socket Swing Force and Rotating Torque

INFOID:0000000007623255

### SWING FORCE

Unit: N (kg, lb)

Item	Standard
Outer socket	4.81 – 45.7 (0.5 – 4.6, 1.1 – 10.2)
Inner socket	8.9 – 64 (0.91 – 6.5, 2.01 – 14.3)

### ROTATING TORQUE

Unit: N·m (kg·m, in·lb)

Item	Standard
Outer socket	0.3 – 2.9 (0.03 – 0.29, 3 – 25)
Inner socket	1.0 – 7.8 (0.11 – 0.79, 9 – 69)

## Socket Axial End Play

INFOID:0000000007623256

Unit: mm (in)

Item	Standard
Outer socket	0.5 (0.02) or less
Inner socket	0.2 (0.008) or less

## Inner Socket Length

INFOID:0000000007623257

Unit: mm (in)

Item	Standard
Inner socket length	63.3 (2.492)

## Relief Oil Pressure

INFOID:0000000007623258

Unit: kPa (kg/cm<sup>2</sup>, psi)

Item	Standard
Relief oil pressure	8,500 – 9,300 (86.7 – 94.9, 1,233 – 1,349)

A  
B  
C  
D  
E  
F

ST

H  
I  
J  
K

L  
M

N  
O

P

# STEERING WHEEL

< SPEC CHANGE INFORMATION >

[Nismo 370Z]

## SPEC CHANGE INFORMATION

### STEERING WHEEL

#### Steering Wheel

INFOID:000000007623259

Dedicated genuine leather adopted, with red and parallel stitches.

