

A
STR
C
D
E
F
G
H
I
J
K
L
M
N
O
P

SECTION STR

STARTING SYSTEM

CONTENTS

BASIC INSPECTION	PRECAUTIONS	13
DIAGNOSIS AND REPAIR WORK FLOW	EXCEPT FOR MEXICO	13
Work Flow	EXCEPT FOR MEXICO : Precaution for Supplemental Restraint System (SRS) "AIR BAG" and "SEAT BELT PRE-TENSIONER"	13
SYSTEM DESCRIPTION	EXCEPT FOR MEXICO : Precaution for Battery Service	13
STARTING SYSTEM	FOR MEXICO	13
M/T	FOR MEXICO : Precaution for Supplemental Restraint System (SRS) "AIR BAG" and "SEAT BELT PRE-TENSIONER"	13
M/T : System Diagram	FOR MEXICO : Precaution for Battery Service	14
M/T : System Description	PREPARATION	15
M/T : Component Parts Location	PREPARATION	15
M/T : Component Description	Special Service Tools	15
A/T	Commercial Service Tools	15
A/T : System Diagram	REMOVAL AND INSTALLATION	16
A/T : System Description	STARTER MOTOR	16
A/T : Component Parts Location	Exploded View	16
A/T : Component Description	M/T	17
DTC/CIRCUIT DIAGNOSIS	M/T : Removal and Installation	17
B TERMINAL CIRCUIT	A/T	18
Description	A/T : Removal and Installation	18
Diagnosis Procedure	Inspection	19
S CONNECTOR CIRCUIT	SERVICE DATA AND SPECIFICATIONS (SDS)	20
Description	SERVICE DATA AND SPECIFICATIONS (SDS)	20
Diagnosis Procedure	Starter Motor	20
STARTING SYSTEM		
Wiring Diagram - STARTING SYSTEM -		
SYMPTOM DIAGNOSIS		
STARTING SYSTEM		
Symptom Table		
PRECAUTION		

DIAGNOSIS AND REPAIR WORK FLOW

< BASIC INSPECTION >

BASIC INSPECTION

DIAGNOSIS AND REPAIR WORK FLOW

Work Flow

INFOID:000000007625643

OVERALL SEQUENCE

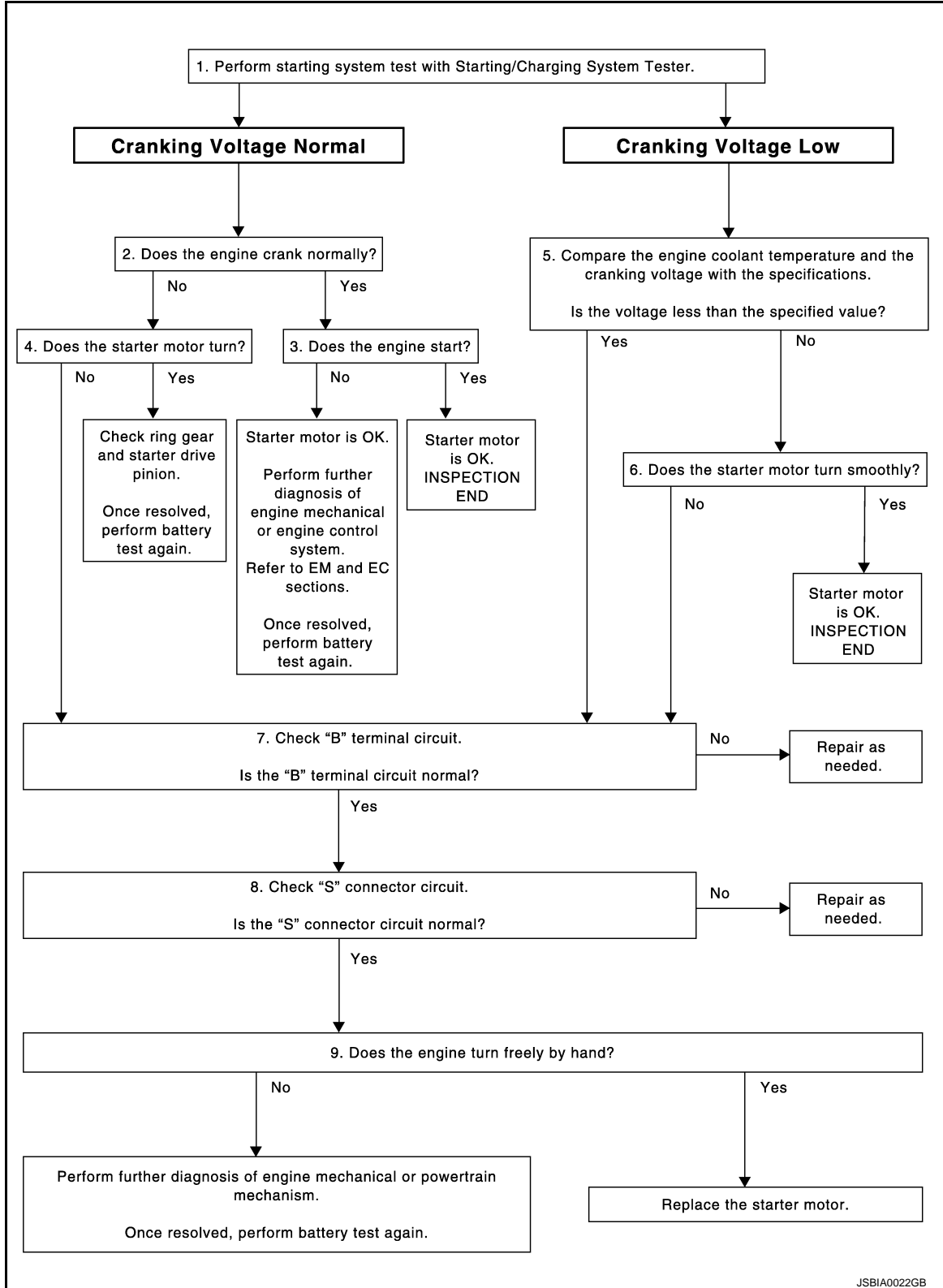

JSBIA0022GB

DETAILED FLOW

DIAGNOSIS AND REPAIR WORK FLOW

< BASIC INSPECTION >

NOTE:

To ensure a complete and thorough diagnosis, the battery, starter motor and alternator test segments must be done as a set from start to finish.

1. DIAGNOSIS WITH STARTING/CHARGING SYSTEM TESTER

Perform the starting system test with Starting/Charging System Tester (SST: J-44373). For details and operating instructions, refer to Technical Service Bulletin.

Test result

CRANKING VOLTAGE NORMAL>>GO TO 2.

CRANKING VOLTAGE LOW>>GO TO 5.

CHARGE BATTERY>>Perform the slow battery charging procedure. (Initial rate of charge is 10A for 12 hours.) Perform battery test again. Refer to Technical Service Bulletin.

REPLACE BATTERY>>Before replacing battery, clean the battery cable clamps and battery posts. Perform battery test again. Refer to Technical Service Bulletin. If second test result is "REPLACE BATTERY", then do so. Perform battery test again to confirm repair.

2. CRANKING CHECK

Check that the starter motor operates correctly.

Does the engine crank normally?

YES >> GO TO 3.

NO >> GO TO 4.

3. ENGINE START CHECK

Check that the engine starts.

Does the engine start?

YES >> Starter motor is OK. INSPECTION END

NO >> Starter motor is OK. Perform further diagnosis of engine mechanical or engine control system. Refer EM and EC sections. Once resolved, perform battery test again.

4. STARTER MOTOR ACTIVATION

Check that the starter motor operates.

Does the starter motor turn?

YES >> Check ring gear and starter motor drive pinion. Once resolved, perform battery test again.

NO >> GO TO 7.

5. COMPARISON BETWEEN ENGINE COOLANT AND CRANKING VOLTAGE

Compare the engine coolant temperature and the cranking voltage with the specifications.

Minimum Specification of Cranking Voltage Referencing Coolant Temperature

Engine coolant temperature [°C (°F)]	Voltage [V]
-30 to -20 (-22 to -4)	8.6
-19 to -10 (-2 to 14)	9.1
-9 to 0 (16 to 32)	9.5
More than 1 (More than 34)	9.9

Is the voltage less than the specified value?

YES >> GO TO 7.

NO >> GO TO 6.

6. STARTER OPERATION

Check the starter operation status.

Does the starter motor turn smoothly?

YES >> Starter motor is OK. INSPECTION END

NO >> GO TO 7.

7. "B" TERMINAL CIRCUIT INSPECTION

Check "B" terminal circuit. Refer to [STR-9, "Diagnosis Procedure"](#).

Is "B" terminal circuit normal?

A

STR

C

D

E

F

G

H

I

J

K

L

M

N

O

P

DIAGNOSIS AND REPAIR WORK FLOW

< BASIC INSPECTION >

- YES >> GO TO 8.
- NO >> Repair as needed.

8. "S" CONNECTOR CIRCUIT INSPECTION

Check "S" connector circuit. Refer to [STR-10. "Diagnosis Procedure"](#).

Is "S" connector circuit normal?

- YES >> GO TO 9.
- NO >> Repair as needed.

9. ENGINE ROTATION STATUS

Check that the engine can be rotated by hand.

Does the engine turn freely by hand?

- YES >> Replace starter motor.
- NO >> Perform further diagnosis of engine mechanical or powertrain mechanism. Once resolved, perform battery test again. Refer to Technical Service Bulletin.

STARTING SYSTEM

< SYSTEM DESCRIPTION >

SYSTEM DESCRIPTION

STARTING SYSTEM

M/T

M/T : System Diagram

INFOID:000000007625644

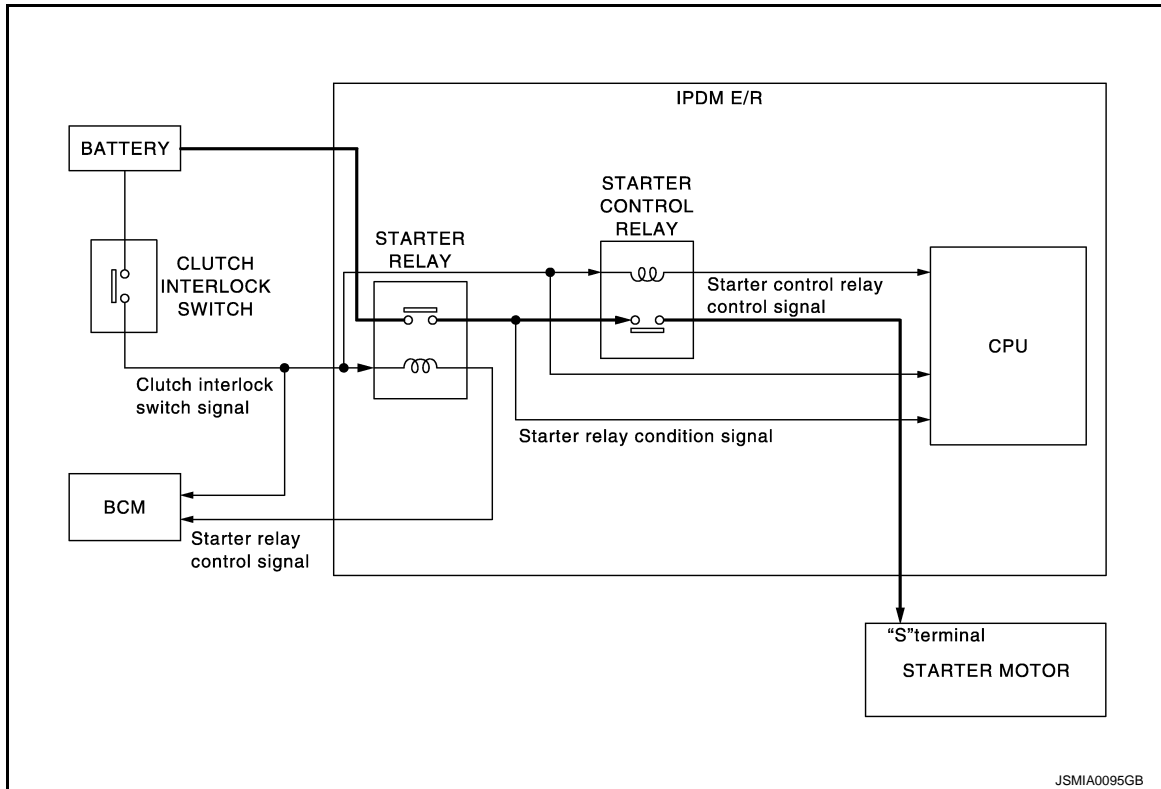

M/T : System Description

INFOID:000000007625645

- When the clutch interlock switch is turned ON, power is supplied to starter relay and starter control relay. And BCM and IPDM E/R (CPU) detect clutch interlock switch condition by the inputted signal.
- When starter operating condition is satisfied, IPDM E/R turns starter control relay ON by starter control relay control signal.
- When engine cranking condition is satisfied, BCM turns starter relay ON by starter relay control signal.
- Then battery power is supplied to starter motor ("S" terminal) through starter control relay and starter relay. And IPDM E/R (CPU) detect starter relay condition by the inputted signal.

STARTING SYSTEM

< SYSTEM DESCRIPTION >

M/T : Component Parts Location

INFOID:000000007625646

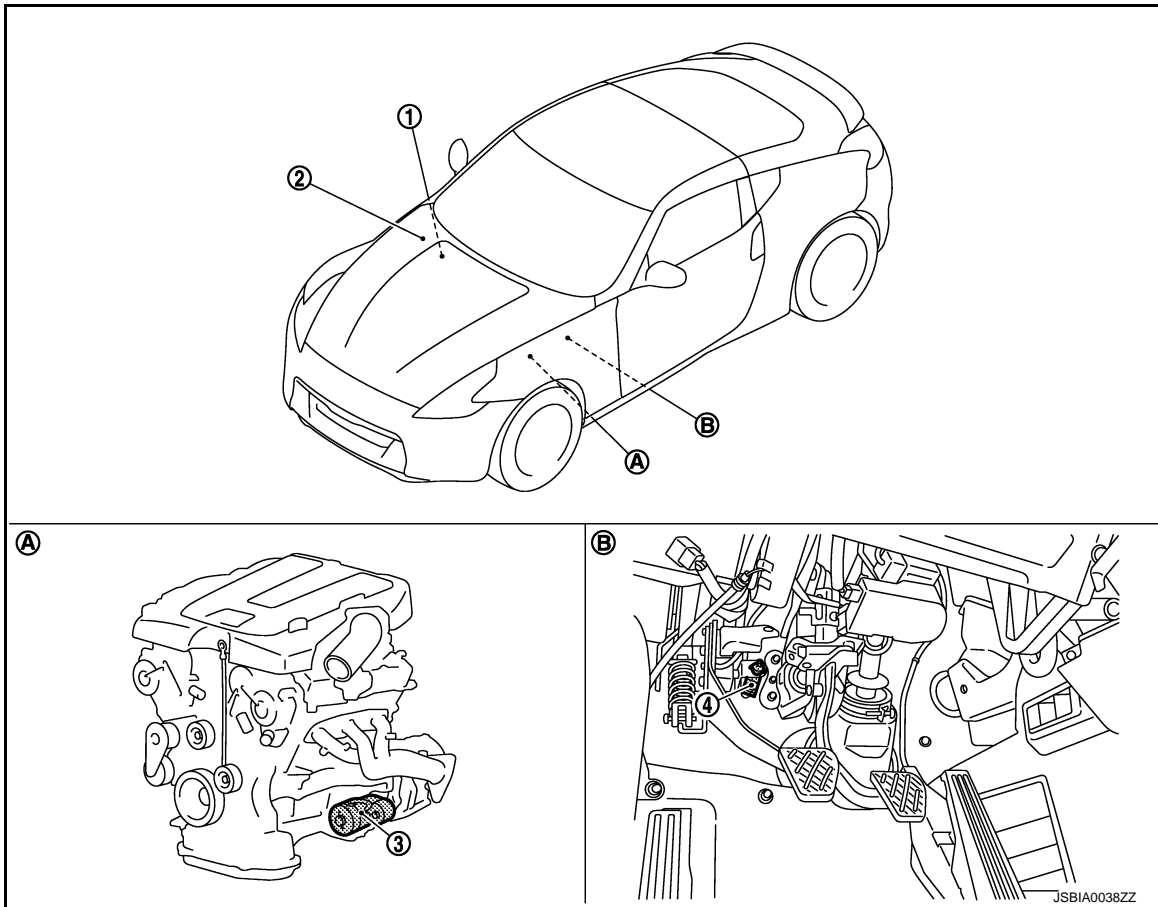

- | | | |
|--|---|------------------|
| 1. BCM
Refer to BCS-9. "Component Parts Location" . | 2. IPDM E/R
Refer to PCS-5. "Component Parts Location" . | 3. Starter motor |
| 4. Clutch interlock switch | A. Engine | B. Clutch pedal |

M/T : Component Description

INFOID:000000007625647

Component part	Description
Clutch interlock switch	The switch turns ON and electric power is supplied to the starter relay and starter control relay inside IPDM E/R when the clutch pedal is depressed.
BCM	BCM controls the starter relay inside IPDM E/R.
IPDM E/R	CPU inside IPDM E/R controls the starter control relay.
Starter motor	The starter motor plunger closes and the motor is supplied with battery power, which in turn cranks the engine, when the "S" terminal is supplied with electric power.

A/T

STARTING SYSTEM

< SYSTEM DESCRIPTION >

A/T : System Diagram

INFOID:000000007625648

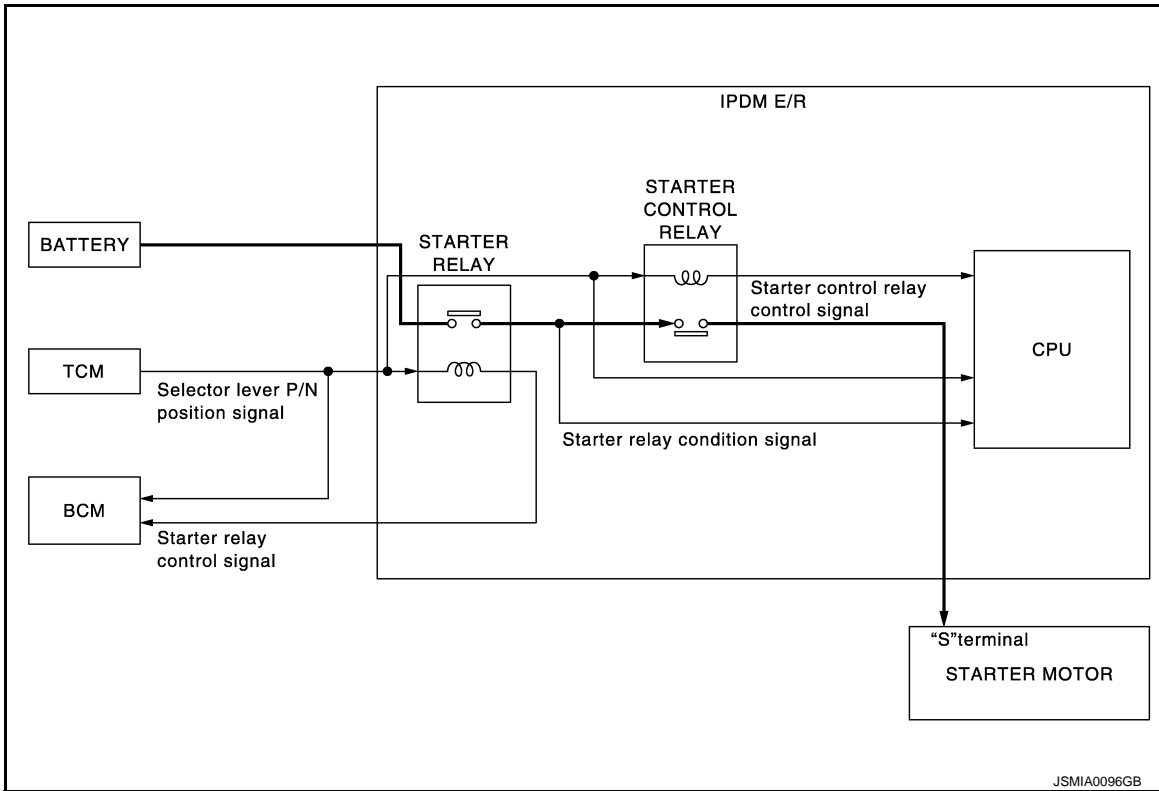

A/T : System Description

INFOID:000000007625649

- When selector lever is P or N, power is supplied to starter relay and starter control relay by TCM. And BCM and IPDM E/R (CPU) detect selector lever P/N condition by the inputted signal.
- When starter operating condition is satisfied, IPDM E/R turns starter control relay ON by starter control relay control signal.
- When engine cranking condition is satisfied, BCM turns starter relay ON by starter relay control signal.
- Then battery power is supplied to starter motor ("S" terminal) through starter control relay and starter relay. And IPDM E/R (CPU) detect starter relay condition by the inputted signal.

A/T : Component Parts Location

INFOID:000000007625650

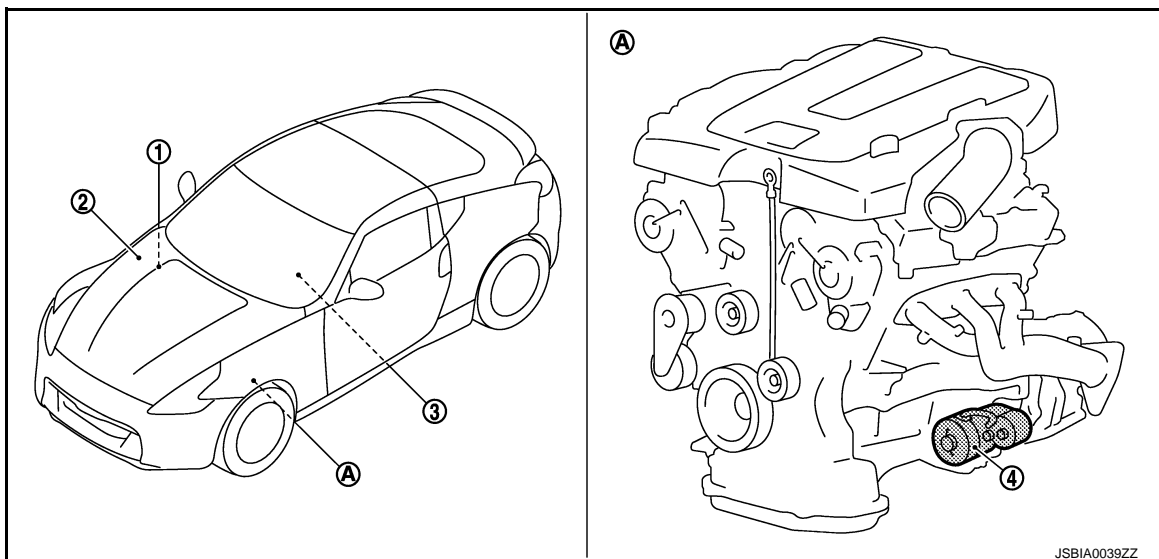

STARTING SYSTEM

< SYSTEM DESCRIPTION >

1. BCM
Refer to [BCS-9, "Component Parts Location"](#).
2. IPDM E/R
Refer to [PCS-5, "Component Parts Location"](#).
3. TCM
Refer to [TM-154, "Component Description"](#).
4. Starter motor
- A. Engine

A/T : Component Description

INFOID:000000007625651

Component part	Description
TCM	TCM supplies power to the starter relay and starter control relay inside IPDM E/R when the selector lever is shifted to the P or N position.
BCM	BCM controls the starter relay inside IPDM E/R.
IPDM E/R	CPU inside IPDM E/R controls the starter control relay.
Starter motor	The starter motor plunger closes and the motor is supplied with battery power, which in turn cranks the engine, when the "S" terminal is supplied with electric power.

B TERMINAL CIRCUIT

< DTC/CIRCUIT DIAGNOSIS >

DTC/CIRCUIT DIAGNOSIS

B TERMINAL CIRCUIT

Description

INFOID:0000000007625652

STR

The "B" terminal is constantly supplied with battery power.

Diagnosis Procedure

INFOID:0000000007625653

CAUTION:

Perform diagnosis under the condition that engine cannot start by the following procedure.

1. Remove fuel pump fuse.
2. Crank or start the engine (where possible) until the fuel pressure is released.

1. CHECK "B" TERMINAL CIRCUIT

1. Turn ignition switch OFF.
2. Check that starter motor "B" terminal connection is clean and tight.
3. Check voltage between starter motor "B" terminal and ground.

Terminals		Voltage (Approx.)
(+)	(-)	
Starter motor "B" terminal	Terminal	Battery voltage
E204	2	
	Ground	

Is the inspection result normal?

YES >> GO TO 2.

NO >> Check harness between battery and starter motor for open circuit.

2. CHECK BATTERY CABLE CONNECTION STATUS (VOLTAGE DROP TEST)

1. Shift A/T selector lever to "P" or "N" position. (A/T models)
Keep depressing clutch pedal fully. (M/T models)
2. Check voltage between battery positive terminal and starter motor "B" terminal.

Terminals		Condition	Voltage (Approx.)
(+)	(-)		
	Starter motor "B" terminal	When the ignition switch is in START position	Less than 0.5 V
	Terminal		
Battery positive terminal	E204		
	2		

Is the inspection result normal?

YES >> GO TO 3.

NO >> Check harness between the battery and the starter motor for poor continuity.

3. CHECK GROUND CIRCUIT STATUS (VOLTAGE DROP TEST)

1. Shift A/T selector lever to "P" or "N" position. (A/T models)
Keep depressing clutch pedal fully. (M/T models)
2. Check voltage between starter motor case and battery negative terminal.

Terminals		Condition	Voltage (Approx.)
(+)	(-)		
Starter motor case	Battery negative terminal	When the ignition switch is in START position	Less than 0.2 V

Is the inspection result normal?

YES >> "B" terminal circuit is OK. Further inspection is necessary. Refer to [STR-2, "Work Flow"](#).

NO >> Check the starter motor case and ground for poor continuity.

S CONNECTOR CIRCUIT

< DTC/CIRCUIT DIAGNOSIS >

S CONNECTOR CIRCUIT

Description

INFOID:000000007625654

The starter motor magnetic switch is supplied with power when the ignition switch is turned to the START position while the selector lever is in the P or N position for A/T models or the clutch pedal is depressed for M/T models.

Diagnosis Procedure

INFOID:000000007625655

CAUTION:

Perform diagnosis under the condition that engine cannot start by the following procedure.

1. Remove fuel pump fuse.
2. Crank or start the engine (where possible) until the fuel pressure is released.

1. CHECK "S" CONNECTOR CIRCUIT

1. Turn ignition switch OFF.
2. Disconnect starter motor connector.
3. Shift A/T selector lever to "P" or "N" position. (A/T models)
Keep depressing clutch pedal fully. (M/T models)
4. Check voltage between starter motor harness connector and ground.

Terminals		(-)	Condition	Voltage (Approx.)
(+)	Terminal			
Starter motor harness connector				
F52	1	Ground	When the ignition switch is in START position	Battery voltage

Is the inspection result normal?

- YES >> "S" connector circuit is OK. Further inspection is necessary. Refer to [STR-2, "Work Flow"](#).
NO >> GO TO 2.

2. CHECK HARNESS CONTINUITY (OPEN CIRCUIT)

1. Disconnect IPDM E/R connector.
2. Check continuity between starter motor harness connector and IPDM E/R harness connector.

Starter motor harness connector		IPDM E/R harness connector		Continuity
Connector No.	Terminal No.	Connector No.	Terminal No.	
F52	1	E7	80	Existed

Is the inspection result normal?

- YES >> Further inspection is necessary. Refer to [STR-2, "Work Flow"](#).
NO >> Repair the harness.

STARTING SYSTEM

< DTC/CIRCUIT DIAGNOSIS >

STARTING SYSTEM

Wiring Diagram - STARTING SYSTEM -

INFOID:000000007625656

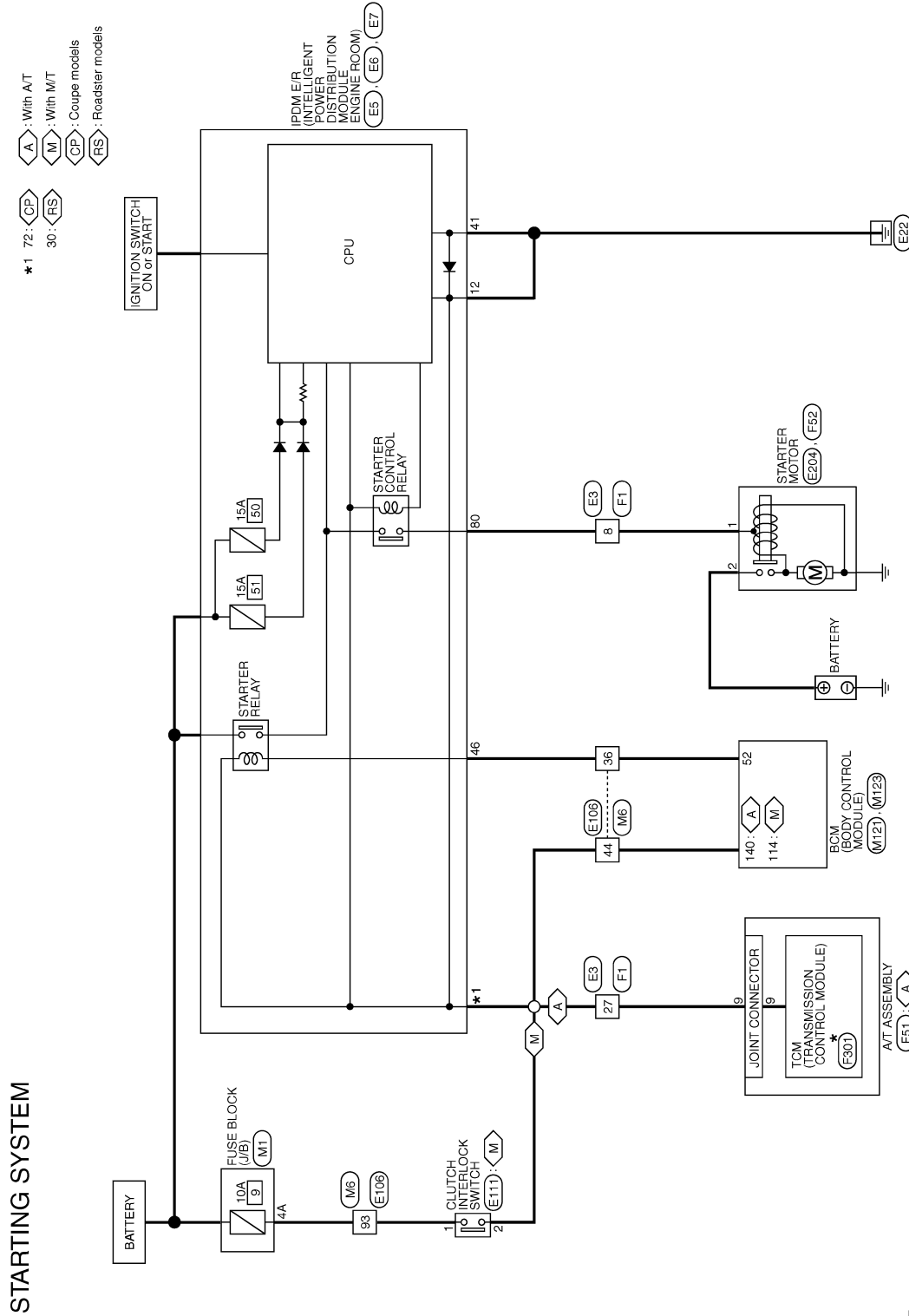

*: This connector is not shown in "Harness Layout".

2011/07/19

JRBWC0637GB

A
C
D
E
F
G
H
I
J
K
L
M
N
O
P

STR

STARTING SYSTEM

< SYMPTOM DIAGNOSIS >

SYMPTOM DIAGNOSIS

STARTING SYSTEM

Symptom Table

INFOID:000000007625657

Symptom	Reference
No normal cranking	Refer to STR-2, "Work Flow" .
Starter motor does not rotate	

PRECAUTIONS

< PRECAUTION >

PRECAUTION

PRECAUTIONS

EXCEPT FOR MEXICO

EXCEPT FOR MEXICO : Precaution for Supplemental Restraint System (SRS) "AIR BAG" and "SEAT BELT PRE-TENSIONER"

INFOID:000000007625658

The Supplemental Restraint System such as "AIR BAG" and "SEAT BELT PRE-TENSIONER", used along with a front seat belt, helps to reduce the risk or severity of injury to the driver and front passenger for certain types of collision. This system includes seat belt switch inputs and dual stage front air bag modules. The SRS system uses the seat belt switches to determine the front air bag deployment, and may only deploy one front air bag, depending on the severity of a collision and whether the front occupants are belted or unbelted. Information necessary to service the system safely is included in the "SRS AIR BAG" and "SEAT BELT" of this Service Manual.

WARNING:

Always observe the following items for preventing accidental activation.

- To avoid rendering the SRS inoperative, which could increase the risk of personal injury or death in the event of a collision that would result in air bag inflation, all maintenance must be performed by an authorized NISSAN/INFINITI dealer.
- Improper maintenance, including incorrect removal and installation of the SRS, can lead to personal injury caused by unintentional activation of the system. For removal of Spiral Cable and Air Bag Module, see "SRS AIR BAG".
- Never use electrical test equipment on any circuit related to the SRS unless instructed to in this Service Manual. SRS wiring harnesses can be identified by yellow and/or orange harnesses or harness connectors.

PRECAUTIONS WHEN USING POWER TOOLS (AIR OR ELECTRIC) AND HAMMERS

WARNING:

Always observe the following items for preventing accidental activation.

- When working near the Air Bag Diagnosis Sensor Unit or other Air Bag System sensors with the ignition ON or engine running, never use air or electric power tools or strike near the sensor(s) with a hammer. Heavy vibration could activate the sensor(s) and deploy the air bag(s), possibly causing serious injury.
- When using air or electric power tools or hammers, always switch the ignition OFF, disconnect the battery, and wait at least 3 minutes before performing any service.

EXCEPT FOR MEXICO : Precaution for Battery Service

INFOID:000000007625659

Before disconnecting the battery, lower both the driver and passenger windows. This will prevent any interference between the window edge and the vehicle when the door is opened/closed. During normal operation, the window slightly raises and lowers automatically to prevent any window to vehicle interference. The automatic window function will not work with the battery disconnected.

FOR MEXICO

FOR MEXICO : Precaution for Supplemental Restraint System (SRS) "AIR BAG" and "SEAT BELT PRE-TENSIONER"

INFOID:000000007625660

The Supplemental Restraint System such as "AIR BAG" and "SEAT BELT PRE-TENSIONER", used along with a front seat belt, helps to reduce the risk or severity of injury to the driver and front passenger for certain types of collision. Information necessary to service the system safely is included in the "SRS AIR BAG" and "SEAT BELT" of this Service Manual.

WARNING:

Always observe the following items for preventing accidental activation.

- To avoid rendering the SRS inoperative, which could increase the risk of personal injury or death in the event of a collision that would result in air bag inflation, all maintenance must be performed by an authorized NISSAN/INFINITI dealer.

PRECAUTIONS

< PRECAUTION >

- **Improper maintenance, including incorrect removal and installation of the SRS, can lead to personal injury caused by unintentional activation of the system. For removal of Spiral Cable and Air Bag Module, see “SRS AIR BAG”.**
- **Never use electrical test equipment on any circuit related to the SRS unless instructed to in this Service Manual. SRS wiring harnesses can be identified by yellow and/or orange harnesses or harness connectors.**

PRECAUTIONS WHEN USING POWER TOOLS (AIR OR ELECTRIC) AND HAMMERS

WARNING:

Always observe the following items for preventing accidental activation.

- **When working near the Air Bag Diagnosis Sensor Unit or other Air Bag System sensors with the ignition ON or engine running, never use air or electric power tools or strike near the sensor(s) with a hammer. Heavy vibration could activate the sensor(s) and deploy the air bag(s), possibly causing serious injury.**
- **When using air or electric power tools or hammers, always switch the ignition OFF, disconnect the battery, and wait at least 3 minutes before performing any service.**

FOR MEXICO : Precaution for Battery Service

INFOID:000000007625661

Before disconnecting the battery, lower both the driver and passenger windows. This will prevent any interference between the window edge and the vehicle when the door is opened/closed. During normal operation, the window slightly raises and lowers automatically to prevent any window to vehicle interference. The automatic window function will not work with the battery disconnected.

PREPARATION

< PREPARATION >

PREPARATION

PREPARATION

Special Service Tools

INFOID:000000007625662

A

STR

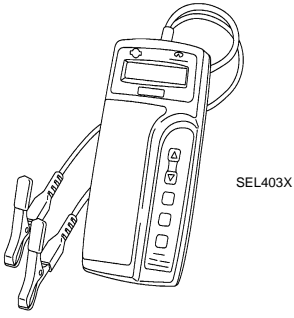
Tool number (Kent-Moore No.) Tool name	Description
<p>— (J-44373 Model MCR620) Starting/Charging System Tester</p>  <p>SEL403X</p>	<p>Tests starting and charging systems. For operating instructions, refer to Technical Service Bulletin.</p>

C

D

E

F

G

Commercial Service Tools

INFOID:000000007625663

H

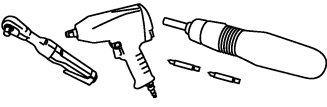
Tool name	Description
<p>Power tool</p>  <p>PIIB1407E</p>	<p>Loosening bolts, nuts and screws</p>

I

J

K

L

M

N

O

P

STARTER MOTOR

< REMOVAL AND INSTALLATION >

REMOVAL AND INSTALLATION

STARTER MOTOR

Exploded View

INFOID:000000007625664

REMOVAL

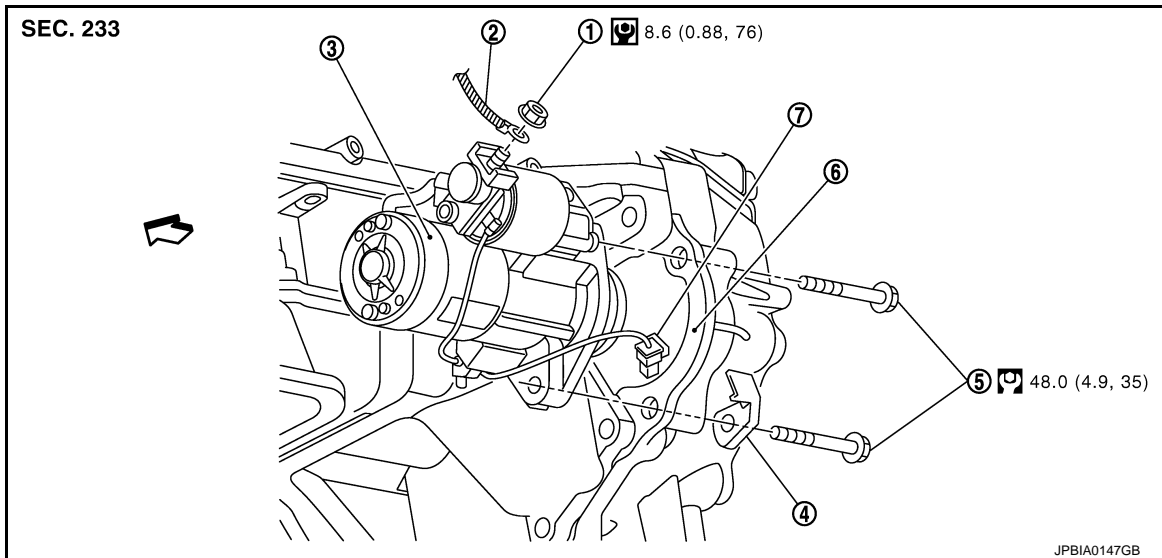

- | | | |
|-------------------------|--------------------------------|---|
| 1. "B" terminal nut | 2. "B" terminal harness | 3. Starter motor |
| 4. Harness clip bracket | 5. Starter motor mounting bolt | 6. Converter housing (A/T models)
Transmission case (M/T models) |
| 7. "S" connector | | |

↙: Engine front

Refer to [GI-4, "Components"](#) for symbols in the figure.

DISASSEMBLY

STARTER MOTOR

< REMOVAL AND INSTALLATION >

Type: 114-932

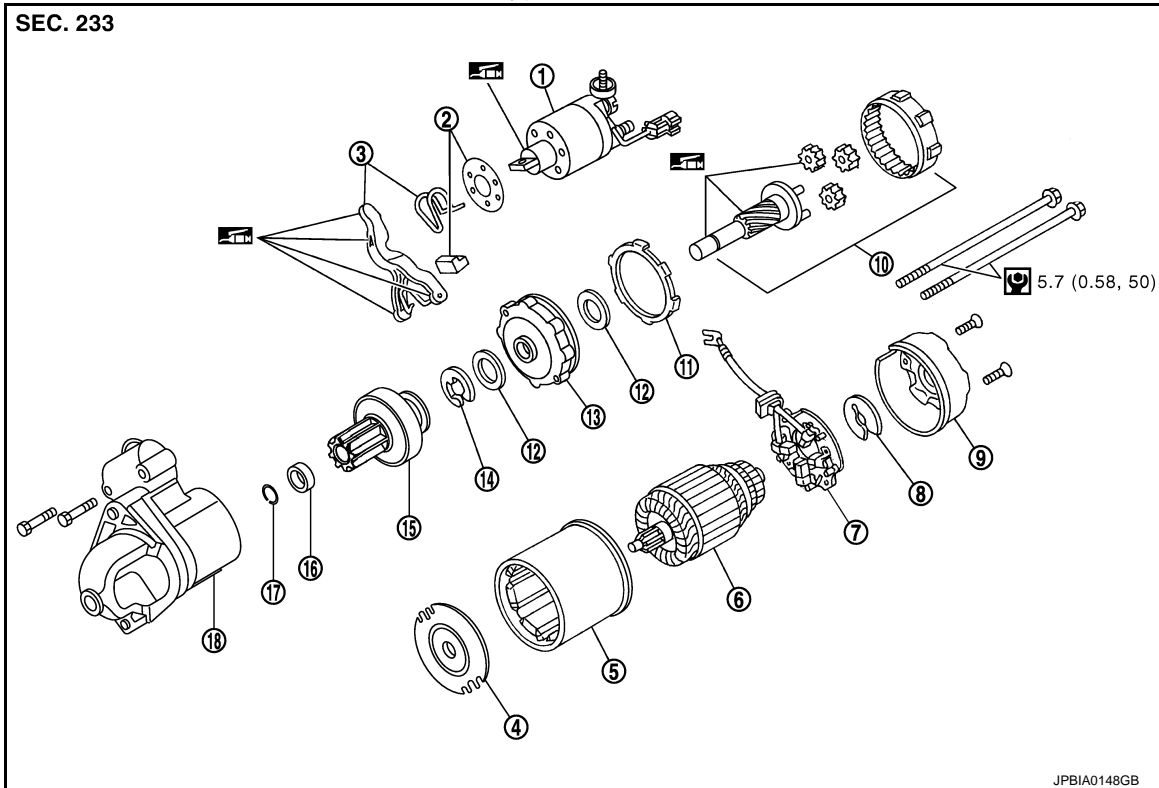

- | | | |
|-----------------------------|-------------------------|------------------------|
| 1. Magnetic switch assembly | 2. Dust cover kit | 3. Shift lever set |
| 4. Center bracket (A) | 5. Yoke assembly | 6. Armature assembly |
| 7. Brush holder assembly | 8. Thrust washer | 9. Rear cover assembly |
| 10. Shaft gear assembly | 11. Packing | 12. Thrust washer |
| 13. Center bracket (P) | 14. E-ring | 15. Pinion assembly |
| 16. Pinion stopper | 17. Pinion stopper clip | 18. Gear case assembly |

: High-temperature grease point

Refer to [GI-4. "Components"](#) for symbols not described on the above.

M/T

M/T : Removal and Installation

INFOID:000000007625665

Removal

1. Disconnect the battery cable from the negative terminal.
2. Remove engine undercover using power tools.
3. Remove "B" terminal nut (1).

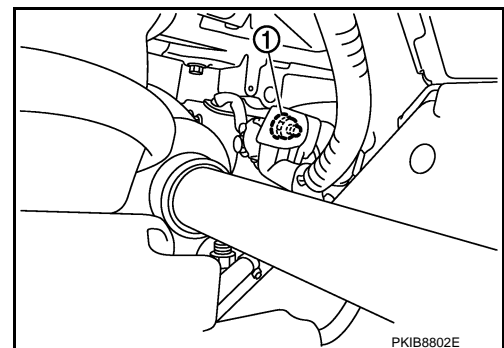

STARTER MOTOR

< REMOVAL AND INSTALLATION >

4. Disconnect "S" connector (A).
5. Remove starter motor mounting bolts (B) and harness bracket, using power tools.

⇐ : Vehicle front

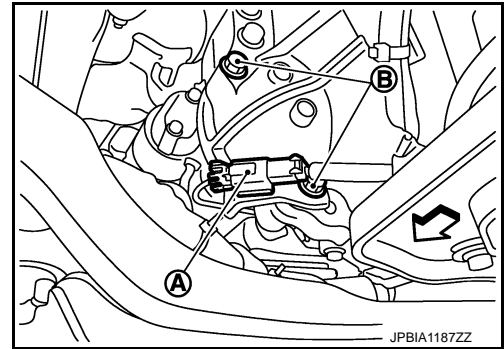

6. Remove starter motor (1) forward from the vehicle.

⇐ : Vehicle front

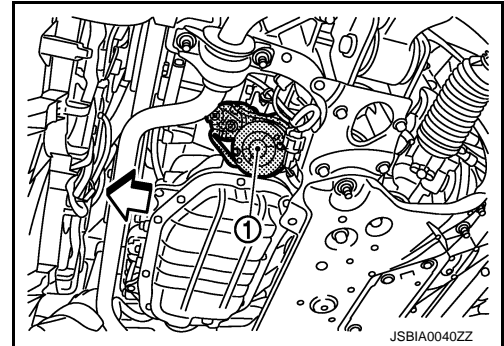

INSTALLATION

Install in the reverse order of removal.

CAUTION:

Be sure to tighten "B" terminal nut carefully.

A/T

A/T : Removal and Installation

INFOID:000000007625666

Removal

1. Disconnect the battery cable from the negative terminal.
2. Remove engine undercover using power tools.
3. Remove "B" terminal nut (1).

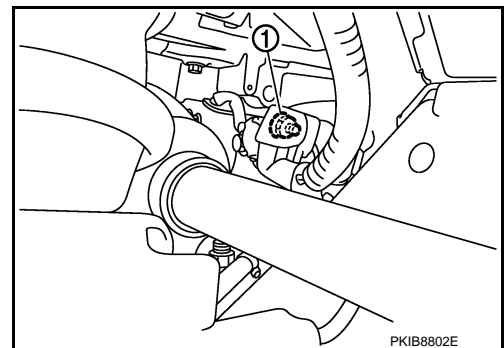

4. Disconnect "S" connector (A).
5. Remove starter motor mounting bolts (B) and harness bracket, using power tools.

⇐ : Vehicle front

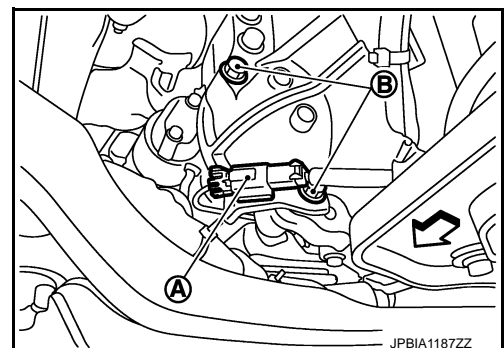

STARTER MOTOR

< REMOVAL AND INSTALLATION >

6. Remove the bolt (A) and remove the harness bracket (1).

↔ : Vehicle front

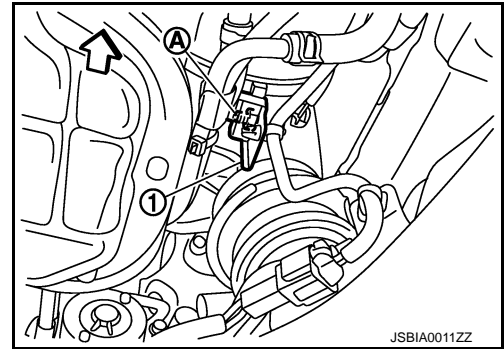

7. Remove A/T fluid cooler tube clip bolts and bracket. Refer to [TM-339, "Exploded View"](#).
8. Move A/T fluid cooler tube (1) downward.
9. Remove starter motor (2) forward from the vehicle.

↔ : Vehicle front

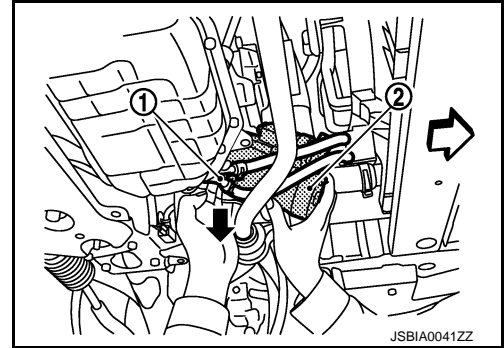

INSTALLATION

Install in the reverse order of removal.

CAUTION:

Be sure to tighten "B" terminal nut carefully.

Inspection

INFOID:000000007625667

INSPECTION AFTER DISASSEMBLY

Pinion/Clutch Check

1. Inspect pinion teeth.
 - Replace pinion if teeth are worn or damaged. (Also check condition of ring gear teeth.)
2. Inspect reduction gear teeth.
 - Replace reduction gear if teeth are worn or damaged. (Also check condition of armature shaft gear teeth.)
3. Check to see if pinion locks in one direction and rotates smoothly in the opposite direction.
 - If it locks or rotates in both directions, or unusual resistance is evident, replace.

SERVICE DATA AND SPECIFICATIONS (SDS)

< SERVICE DATA AND SPECIFICATIONS (SDS)

SERVICE DATA AND SPECIFICATIONS (SDS)

SERVICE DATA AND SPECIFICATIONS (SDS)

Starter Motor

INFOID:000000007625668

Type		S114-932
		HITACHI make
		Reduction gear type
System voltage [V]		12
No-load	Terminal voltage [V]	11
	Current [A]	Less than 110
	Revolution [rpm]	More than 2,700
Minimum diameter of commutator [mm (in)]		28.0 (1.102)
Minimum length of brush [mm (in)]		10.5 (0.413)
Brush spring tension [N (kg, lb)]		16.2 (1.65, 3.6)
Clearance between bearing metal and armature shaft [mm (in)]		Less than 0.2 (0.008)
Clearance between pinion front edge and pinion stopper [mm (in)]		0.3 - 2.5 (0.012 – 0.098)