

SECTION **EX**
EXHAUST SYSTEM

A

EX

C

D

E

CONTENTS

REGULAR GRADE		
PRECAUTION	2	
PRECAUTIONS	2	
Removal and Installation	2	
PREPARATION	3	
PREPARATION	3	
Special Service Tool	3	
Commercial Service Tool	3	
PERIODIC MAINTENANCE	4	
EXHAUST SYSTEM	4	F
Inspection	4	
REMOVAL AND INSTALLATION	5	G
EXHAUST SYSTEM	5	
Exploded View	5	
Removal and Installation	6	H
Inspection	6	
Nismo 370Z		
REMOVAL AND INSTALLATION	7	I
EXHAUST SYSTEM	7	J
Exploded View	7	
		K
		L
		M
		N
		O
		P

PRECAUTION

PRECAUTIONS

Removal and Installation

INFOID:000000008193969

CAUTION:

- Be sure to use genuine exhaust system parts or equivalents which are specially designed for heat resistance, corrosion resistance, and shape.
- Perform the operation with the exhaust system fully cooled down because the system will be hot just after engine stops.
- Be careful not to cut your hand on the heat insulator edge.

PREPARATION

< PREPARATION >

[REGULAR GRADE]

PREPARATION

PREPARATION

Special Service Tool

INFOID:000000008193970

A

EX

The actual shapes of Kent-Moore tools may differ from those of special service tools illustrated here.

Tool number (Kent-Moore No.) Tool name	Description
KV10114400 (J-38365) Heated oxygen sensor wrench	Loosening or tightening heated oxygen sensor 2 a: 22 mm (0.87 in) (a) width hexagon nut

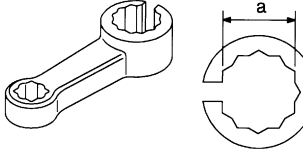

S-NT636

C

D

E

Commercial Service Tool

INFOID:000000008193971

(Kent-Moore No.) Tool name	Description
A: (J-43897-18) B: (J-43897-12) Heated oxygen sensor thread cleaner	Reconditioning the exhaust system threads before installing a new heated oxygen sensor (Use with anti-seize lubricant shown below.) A: J-43897-18 [18 mm (0.71 in) dia.] for zirconia heated oxygen sensor B: J-43897-12 [12 mm (0.47 in) dia.] for titania heated oxygen sensor C: Mating surface shave cylinder D: Flutes
(—) Anti-seize lubricant (Permatex 133AR or equivalent meeting MIL specification MIL-A-907)	Lubricating heated oxygen sensor thread cleaner when reconditioning exhaust system threads
(—) Power tool	Loosening bolts and nuts

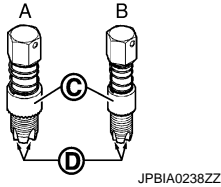

JPBIA0238ZZ

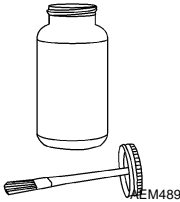

EM489

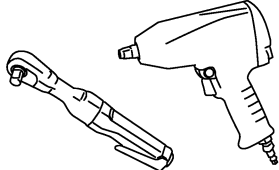

PBIC0190E

F

G

H

I

J

K

L

M

N

O

P

PERIODIC MAINTENANCE

EXHAUST SYSTEM

Inspection

INFOID:000000008193972

Check exhaust pipes, muffler, and mounting for improper attachment, leakage, cracks, damage or deterioration.

- If anything is found, repair or replace damaged parts.

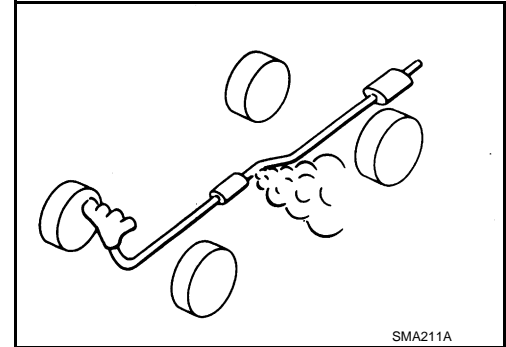

EXHAUST SYSTEM

< REMOVAL AND INSTALLATION >

[REGULAR GRADE]

REMOVAL AND INSTALLATION

EXHAUST SYSTEM

Exploded View

INFOID:000000008193973

A

EX

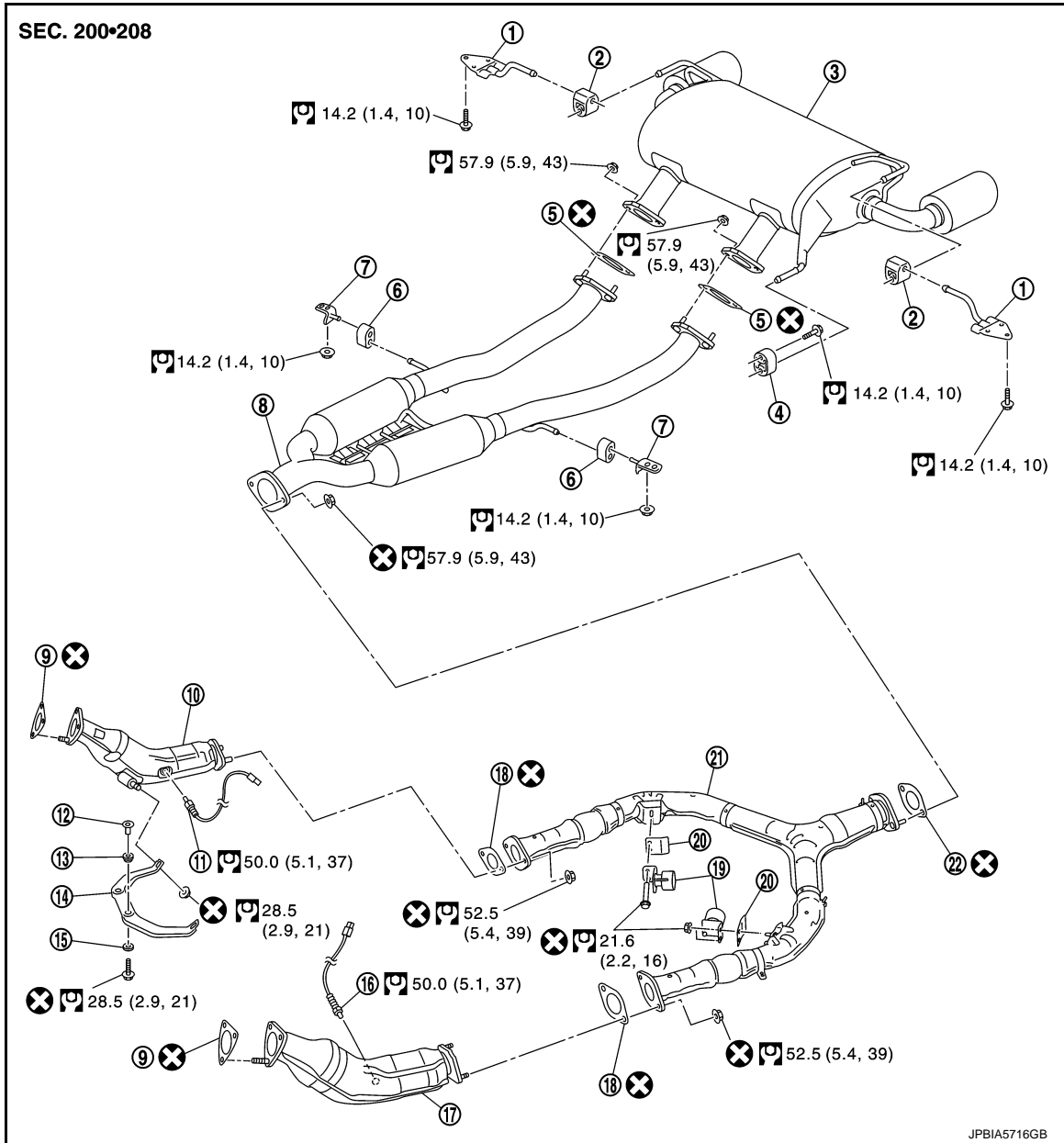

- | | | |
|-------------------------------------|-------------------------------------|------------------------|
| 1. Mounting bracket | 2. Mounting rubber | 3. Main muffler |
| 4. Mounting rubber | 5. Gasket | 6. Mounting rubber |
| 7. Mounting bracket | 8. Center muffler | 9. Gasket |
| 10. Three way catalyst (bank 1) | 11. Heated oxygen sensor 2 (bank 1) | 12. Collar |
| 13. Grommet | 14. Exhaust mounting bracket | 15. Grommet |
| 16. Heated oxygen sensor 2 (bank 2) | 17. Three way catalyst (bank 2) | 18. Gasket |
| 19. Dynamic damper | 20. Insulator | 21. Exhaust front tube |
| 22. Gasket | | |

Refer to [GI-4, "Components"](#) for symbols in the figure.

C

D

E

F

G

H

I

J

K

L

M

N

O

P

EXHAUST SYSTEM

< REMOVAL AND INSTALLATION >

[REGULAR GRADE]

Removal and Installation

INFOID:000000008193974

REMOVAL

- Disconnect each joint and mounting using power tool.
- For removing and installing parts around propeller shaft, be careful of the following caution.

CAUTION:

Be sure to prevent propeller shaft from interfering parts and tools. If necessary, install protector to propeller shaft to prevent damage. Refer to [DLN-7, "Removal and Installation"](#).

- Remove heated oxygen sensor 2 as follows:
 - Using heated oxygen sensor wrench [SST: KV10114400 (J-38365)] (C), removal heated oxygen sensor 2.

A : Bank 1

B : Bank 2

⇐ : Vehicle front

CAUTION:

Be careful not to damage heated oxygen sensor 2.

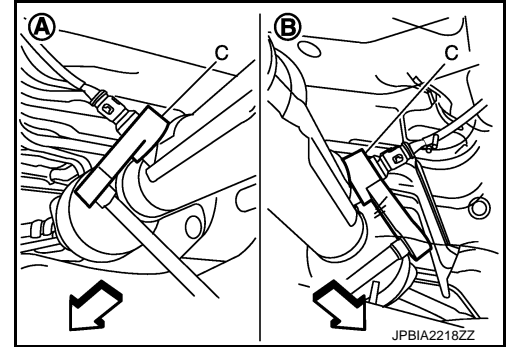

INSTALLATION

Note the following, and install in the reverse order of removal.

- Check for deformation of the grommets (13 and 15 of Components).
- Insert the collar (12 of Components) vertically.
- Temporarily tighten bolts and nuts when installing exhaust pipe assembly. Tighten them to the specified torque when connecting the vehicle rear to the vehicle front.

CAUTION:

- **Always replace exhaust tube gaskets with new ones when reassembling.**
- **Discard any heated oxygen sensor 2 which has been dropped onto a hard surface such as a concrete floor. Use a new one.**
- **Before installing a new heated oxygen sensor 2, clean exhaust system threads using the heated oxygen sensor thread cleaner (commercial service tool: J-43897-18 or J-43897-12), and apply the anti-seize lubricant (commercial service tool).**
- **Never over torque heated oxygen sensor 2. Doing so may cause damage to heated oxygen sensor 2, resulting in the "MIL" coming on.**
- **Prevent rust preventives from adhering to the sensor body.**
- **If heat insulator is badly deformed, repair or replace it. If deposits such as mud pile up on the heat insulator, remove them.**
- **When installing heat insulator avoid large gaps or interference between heat insulator and each exhaust pipe.**
- **Remove deposits from the sealing surface of each connection. Connect them securely to avoid gases leakage.**
- **Temporarily tighten mounting nuts on the exhaust manifold side and mounting bolts on the vehicle side. Check each part for unusual interference, and then tighten them to the specified torque.**
- **When installing each mounting rubber, avoid twisting or unusual extension in up/down and right/left directions.**

Inspection

INFOID:000000008193975

INSPECTION AFTER INSTALLATION

- Check clearance between tail tube and rear bumper is even.
- With engine running, check exhaust tube joints for gas leakage and unusual noises.
- Check to ensure that mounting brackets and mounting rubbers are installed properly and free from undue stress. Improper installation could result in excessive noise and vibration.

EXHAUST SYSTEM

< REMOVAL AND INSTALLATION >

[Nismo 370Z]

REMOVAL AND INSTALLATION

EXHAUST SYSTEM

Exploded View

INFOID:000000008193976

EX

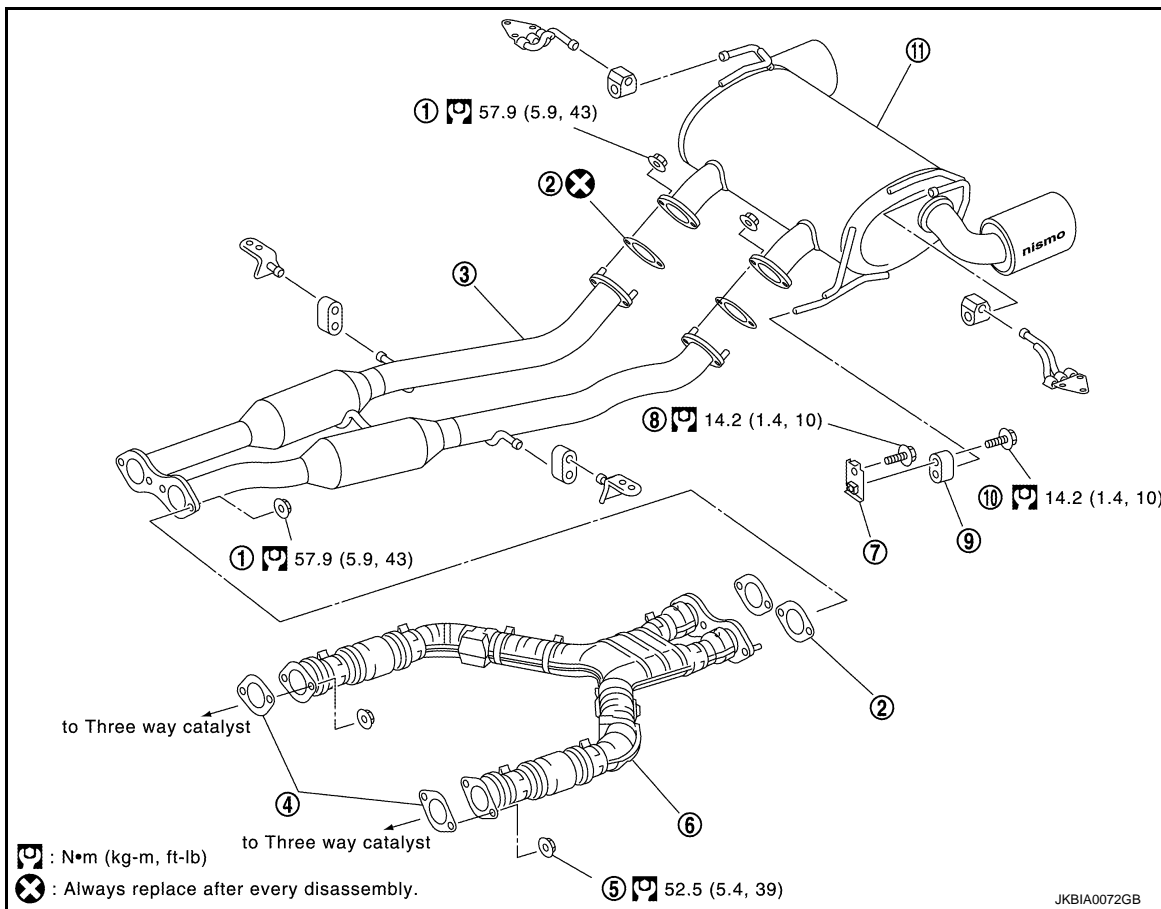

- | | | |
|-----------------------------|------------------|-----------------------|
| 1. Nut (8) | 2. Gasket (4) | 3. Center muffler |
| 4. Gasket | 5. Nut (4) | 6. Exhaust front tube |
| 7. Exhaust mounting bracket | 8. Bolt | 9. Mounting rubber |
| 10. Bolt | 11. Main muffler | |