

SECTION **INT**
INTERIOR

A
B
C

CONTENTS

D
E

COUPE (REGULAR GRADE)	REMOVAL AND INSTALLATION	15	F
PRECAUTION	DOOR FINISHER	15	G
PRECAUTIONS	Exploded View	15	
FOR USA AND CANADA	Removal and Installation	15	
FOR USA AND CANADA : Precaution for Supplemental Restraint System (SRS) "AIR BAG" and "SEAT BELT PRE-TENSIONER"	BODY SIDE TRIM	18	H
FOR USA AND CANADA : Precaution for Battery Service	Exploded View	18	
FOR USA AND CANADA : Precaution for Procedure without Cowl Top Cover	FRONT PILLAR GARNISH	18	I
FOR USA AND CANADA : Precaution for Work	FRONT PILLAR GARNISH : Removal and Installation	18	
FOR MEXICO	KICKING PLATE INNER	19	INT
FOR MEXICO : Precaution for Supplemental Restraint System (SRS) "AIR BAG" and "SEAT BELT PRE-TENSIONER"	KICKING PLATE INNER : Removal and Installation	19	
FOR MEXICO : Precaution for Battery Service	KICKING PLATE OUTER	20	K
FOR MEXICO : Precaution for Procedure without Cowl Top Cover	KICKING PLATE OUTER : Removal and Installation	20	
FOR MEXICO : Precaution for Work	DASH SIDE FINISHER	20	L
PREPARATION	DASH SIDE FINISHER : Removal and Installation	20	
PREPARATION	BODY SIDE WELT	20	M
Special Service Tools	BODY SIDE WELT : Removal and Installation	21	
Commercial Service Tools	REAR SIDE FINISHER	21	N
CLIP LIST	REAR SIDE FINISHER : Removal and Installation	21	
Clip List	REAR PILLAR FINISHER	21	O
SYMPTOM DIAGNOSIS	REAR PILLAR FINISHER : Removal and Installation	21	
SQUEAK AND RATTLE TROUBLE DIAGNOSES	REAR TRIM	23	P
Work Flow	Exploded View	23	
Inspection Procedure	Removal and Installation	24	
Diagnostic Worksheet	FLOOR TRIM	26	
	Exploded View	26	
	Removal and Installation	26	

F

G

H

I

INT

K

L

M

N

O

P

HEADLINING	28	Exploded View	47
Exploded View	28	Removal and Installation	48
Removal and Installation	28		
LUGGAGE FLOOR TRIM	31	BODY SIDE TRIM	51
Exploded View	31	Exploded View	51
Removal and Installation	32	FRONT PILLAR GARNISH	51
BACK DOOR TRIM	33	FRONT PILLAR GARNISH : Removal and Instal-	
Exploded View	33	lation	51
Removal and Installation	33	KICKING PLATE INNER	52
COUPE (Nismo 370Z)		KICKING PLATE INNER : Removal and Installa-	
SPEC CHANGE INFORMATION	35	tion	52
REAR TRIM	35	KICKING PLATE OUTER	53
Serialized Authenticity Plate	35	KICKING PLATE OUTER : Removal and Installa-	
ROADSTER		tion	53
PRECAUTION	36	DASH SIDE FINISHER	53
PRECAUTIONS	36	DASH SIDE FINISHER : Removal and Installation	
FOR USA AND CANADA	36	... 53	
FOR USA AND CANADA : Precaution for Supple-		BODY SIDE WELT	53
mental Restraint System (SRS) "AIR BAG" and		BODY SIDE WELT : Removal and Installation	53
"SEAT BELT PRE-TENSIONER"	36	REAR SIDE FINISHER	54
FOR USA AND CANADA : Precaution for Battery		REAR SIDE FINISHER : Removal and Installation	
Service	36	... 54	
FOR USA AND CANADA : Precaution for Proce-		REAR TRIM	55
dure without Cowl Top Cover	36	Exploded View	55
FOR USA AND CANADA : Precaution for Work	37	REAR BOARD PARCEL SHELF SIDE FINISHER ...	56
FOR MEXICO	37	REAR BOARD PARCEL SHELF SIDE FINISHER	
FOR MEXICO : Precaution for Supplemental Re-		: Removal and Installation	56
straint System (SRS) "AIR BAG" and "SEAT BELT		GUARD FRAME PROTECTOR ASSEMBLY	56
PRE-TENSIONER"	37	GUARD FRAME PROTECTOR ASSEMBLY : Re-	
FOR MEXICO : Precaution for Battery Service	37	moval and Installation	56
FOR MEXICO : Precaution for Procedure without		GUARD FRAME PLATE ASSEMBLY	57
Cowl Top Cover	37	GUARD FRAME PLATE ASSEMBLY : Removal	
FOR MEXICO : Precaution for Work	37	and Installation	57
PREPARATION	39	STORAGE LID DEFLECTOR	58
PREPARATION	39	STORAGE LID DEFLECTOR : Removal and In-	
Special Service Tools	39	stallation	58
Commercial Service Tools	39	REAR PARCEL SHELF FINISHER COVER	59
CLIP LIST	40	REAR PARCEL SHELF FINISHER COVER : Re-	
Clip List	40	moval and Installation	59
SYMPTOM DIAGNOSIS	41	REAR PARCEL SHELF COVER	60
SQUEAK AND RATTLE TROUBLE DIAG-		REAR PARCEL SHELF COVER : Removal and	
NOSES	41	Installation	60
Work Flow	41	REAR PARCEL SHELF FINISHER HOLDER	60
Inspection Procedure	43	REAR PARCEL SHELF FINISHER HOLDER :	
Diagnostic Worksheet	45	Removal and Installation	60
REMOVAL AND INSTALLATION	47	SEATBACK CENTER FINISHER	61
DOOR FINISHER	47	SEATBACK CENTER FINISHER : Removal and	
		Installation	61

BACK TRIM ASSEMBLY	61	TRUNK SIDE FINISHER	76	
BACK TRIM ASSEMBLY : Removal and Installation	61	TRUNK SIDE FINISHER : Removal and Installation	77	A
REAR PARCEL SHELF FINISHER ASSEMBLY	67	TRUNK SIDE BOX ASSEMBLY	77	
REAR PARCEL SHELF FINISHER ASSEMBLY : Removal and Installation	67	TRUNK SIDE BOX ASSEMBLY : Removal and Installation	77	B
FRONT ROOF FINISHER	71	TRUNK TRIM REAR BRACKET	77	
Exploded View	71	TRUNK TRIM REAR BRACKET : Removal and Installation	77	C
FLOOR TRIM	73	STORAGE ROOM FINISHER	77	
Exploded View	73	STORAGE ROOM FINISHER : Removal and Installation	77	D
TRUNK ROOM TRIM	75	STORAGE ROOM SPACER	78	
Exploded View	75	STORAGE ROOM SPACER : Removal and Installation	78	E
TRUNK REAR PLATE	76	TRUNK LID TRIM	79	
TRUNK REAR PLATE : Removal and Installation...	76	Exploded View	79	F
TRUNK FINISHER FRONT	76	Removal and Installation	79	G
TRUNK FINISHER FRONT : Removal and Installation	76			H
				I

INT

K
L
M
N
O
P

< PRECAUTION >

PRECAUTION

PRECAUTIONS

FOR USA AND CANADA

FOR USA AND CANADA : Precaution for Supplemental Restraint System (SRS) "AIR BAG" and "SEAT BELT PRE-TENSIONER"

INFOID:000000008195004

The Supplemental Restraint System such as "AIR BAG" and "SEAT BELT PRE-TENSIONER", used along with a front seat belt, helps to reduce the risk or severity of injury to the driver and front passenger for certain types of collision. This system includes seat belt switch inputs and dual stage front air bag modules. The SRS system uses the seat belt switches to determine the front air bag deployment, and may only deploy one front air bag, depending on the severity of a collision and whether the front occupants are belted or unbelted. Information necessary to service the system safely is included in the "SRS AIR BAG" and "SEAT BELT" of this Service Manual.

WARNING:

Always observe the following items for preventing accidental activation.

- To avoid rendering the SRS inoperative, which could increase the risk of personal injury or death in the event of a collision that would result in air bag inflation, all maintenance must be performed by an authorized NISSAN/INFINITI dealer.
- Improper maintenance, including incorrect removal and installation of the SRS, can lead to personal injury caused by unintentional activation of the system. For removal of Spiral Cable and Air Bag Module, see "SRS AIR BAG".
- Never use electrical test equipment on any circuit related to the SRS unless instructed to in this Service Manual. SRS wiring harnesses can be identified by yellow and/or orange harnesses or harness connectors.

PRECAUTIONS WHEN USING POWER TOOLS (AIR OR ELECTRIC) AND HAMMERS

WARNING:

Always observe the following items for preventing accidental activation.

- When working near the Air Bag Diagnosis Sensor Unit or other Air Bag System sensors with the ignition ON or engine running, never use air or electric power tools or strike near the sensor(s) with a hammer. Heavy vibration could activate the sensor(s) and deploy the air bag(s), possibly causing serious injury.
- When using air or electric power tools or hammers, always switch the ignition OFF, disconnect the battery, and wait at least 3 minutes before performing any service.

FOR USA AND CANADA : Precaution for Battery Service

INFOID:000000008195005

Before disconnecting the battery, lower both the driver and passenger windows. This will prevent any interference between the window edge and the vehicle when the door is opened/closed. During normal operation, the window slightly raises and lowers automatically to prevent any window to vehicle interference. The automatic window function will not work with the battery disconnected.

FOR USA AND CANADA : Precaution for Procedure without Cowl Top Cover

INFOID:000000008195006

When performing the procedure after removing cowl top cover, cover the lower end of windshield with urethane, etc to prevent damage to windshield.

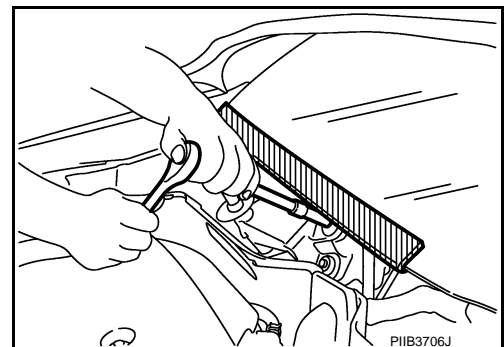

PRECAUTIONS

[COUPE (REGULAR GRADE)]

< PRECAUTION >

FOR USA AND CANADA : Precaution for Work

INFOID:000000008195007

- After removing and installing the opening/closing parts, be sure to carry out fitting adjustments to check their operation.
- Check the lubrication level, damage, and wear of each part. If necessary, grease or replace it.

FOR MEXICO

FOR MEXICO : Precaution for Supplemental Restraint System (SRS) "AIR BAG" and "SEAT BELT PRE-TENSIONER"

INFOID:000000008195008

The Supplemental Restraint System such as "AIR BAG" and "SEAT BELT PRE-TENSIONER", used along with a front seat belt, helps to reduce the risk or severity of injury to the driver and front passenger for certain types of collision. Information necessary to service the system safely is included in the "SRS AIR BAG" and "SEAT BELT" of this Service Manual.

WARNING:

Always observe the following items for preventing accidental activation.

- To avoid rendering the SRS inoperative, which could increase the risk of personal injury or death in the event of a collision that would result in air bag inflation, all maintenance must be performed by an authorized NISSAN/INFINITI dealer.
- Improper maintenance, including incorrect removal and installation of the SRS, can lead to personal injury caused by unintentional activation of the system. For removal of Spiral Cable and Air Bag Module, see "SRS AIR BAG".
- Never use electrical test equipment on any circuit related to the SRS unless instructed to in this Service Manual. SRS wiring harnesses can be identified by yellow and/or orange harnesses or harness connectors.

PRECAUTIONS WHEN USING POWER TOOLS (AIR OR ELECTRIC) AND HAMMERS

WARNING:

Always observe the following items for preventing accidental activation.

- When working near the Air Bag Diagnosis Sensor Unit or other Air Bag System sensors with the ignition ON or engine running, never use air or electric power tools or strike near the sensor(s) with a hammer. Heavy vibration could activate the sensor(s) and deploy the air bag(s), possibly causing serious injury.
- When using air or electric power tools or hammers, always switch the ignition OFF, disconnect the battery, and wait at least 3 minutes before performing any service.

FOR MEXICO : Precaution for Battery Service

INFOID:000000008195009

Before disconnecting the battery, lower both the driver and passenger windows. This will prevent any interference between the window edge and the vehicle when the door is opened/closed. During normal operation, the window slightly raises and lowers automatically to prevent any window to vehicle interference. The automatic window function will not work with the battery disconnected.

FOR MEXICO : Precaution for Procedure without Cowl Top Cover

INFOID:000000008195010

When performing the procedure after removing cowl top cover, cover the lower end of windshield with urethane, etc.

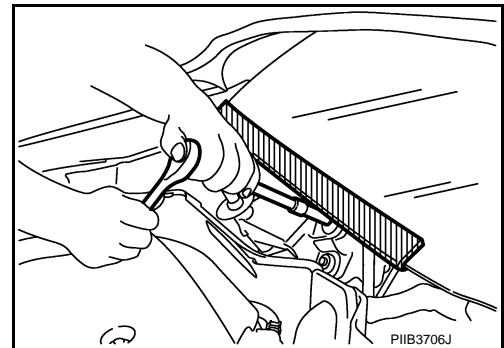

FOR MEXICO : Precaution for Work

INFOID:000000008195011

- After removing and installing the opening/closing parts, be sure to carry out fitting adjustments to check their operation.

PRECAUTIONS

< PRECAUTION >

[COUPE (REGULAR GRADE)]

- Check the lubrication level, damage, and wear of each part. If necessary, grease or replace it.

PREPARATION

< PREPARATION >

[COUPE (REGULAR GRADE)]

PREPARATION

PREPARATION

Special Service Tools

INFOID:000000008195012

The actual shapes of Kent-Moore tools may differ from those of special service tools illustrated here.

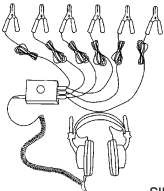
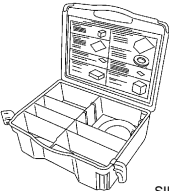
Tool number (Kent-Moore No.) Tool name	Description
(J-39570) Chassis ear  SIIA0993E	Locates the noise
(J-43980) NISSAN Squeak and Rattle Kit  SIIA0994E	Repairs the cause of noise

Commercial Service Tools

INFOID:000000008195013

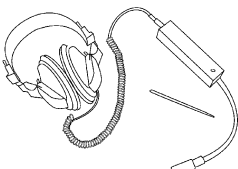
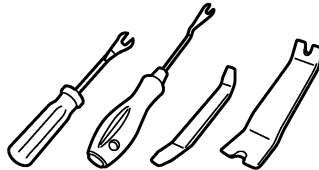
Tool name	Description
Engine ear  SIIA0995E	Locates the noise
Remover tool  JMKIA3050ZZ	Removes clips, pawls, and metal clips

CLIP LIST









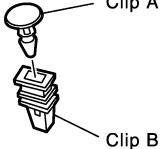
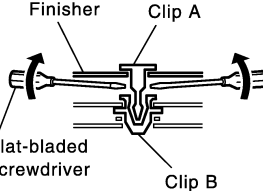

< PREPARATION >

[COUPE (REGULAR GRADE)]

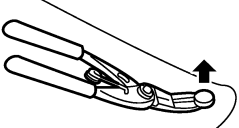
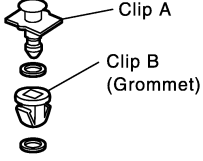
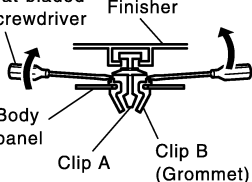
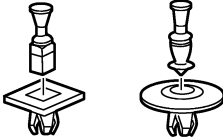
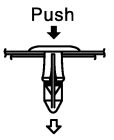
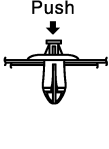
CLIP LIST

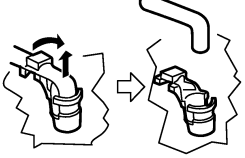
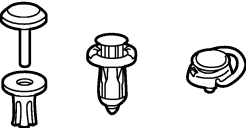
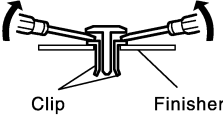
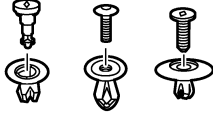
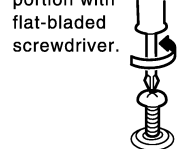
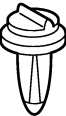
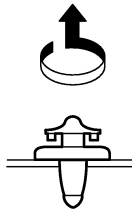
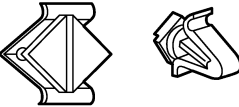
Clip List

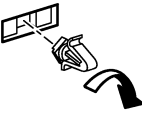
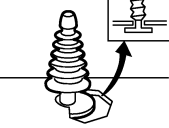
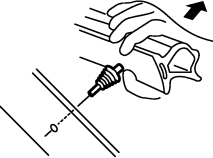
INFOID:000000008195014

Shapes	Removal & Installation		Shapes	Removal & Installation	
	<p>Removal: Remove by bending up with flat-bladed screwdrivers or clip remover.</p> 			<p>Removal:</p> 	
	<p>Removal: Remove with a clip remover.</p> 			<p>Removal:</p> 	
	<p>Removal: Push center pin to catching position. (Do not remove center pin by hitting it.)</p> 	<p>Installation:</p> 		<p>Removal: Holder portion of clip must be spread out to remove rod.</p> 	
	<p>Removal: Remove by bending up with flat-bladed screwdrivers or clip remover.</p> 			<p>Removal:</p> <ol style="list-style-type: none"> 1. Screw out with a Phillips screwdriver. 2. Remove female portion with flat-bladed screwdriver. 	
	<p>Removal:</p> 			<p>Removal:</p>  <p>Rotate 45° to remove.</p>	<p>Installation:</p> 
	<p>Removal:</p> 			<p>Removal:</p> 	

JMJIA3734GB

SQUEAK AND RATTLE TROUBLE DIAGNOSES

< SYMPTOM DIAGNOSIS >

[COUPE (REGULAR GRADE)]

SYMPTOM DIAGNOSIS

SQUEAK AND RATTLE TROUBLE DIAGNOSES

Work Flow

INFOID:000000008195015

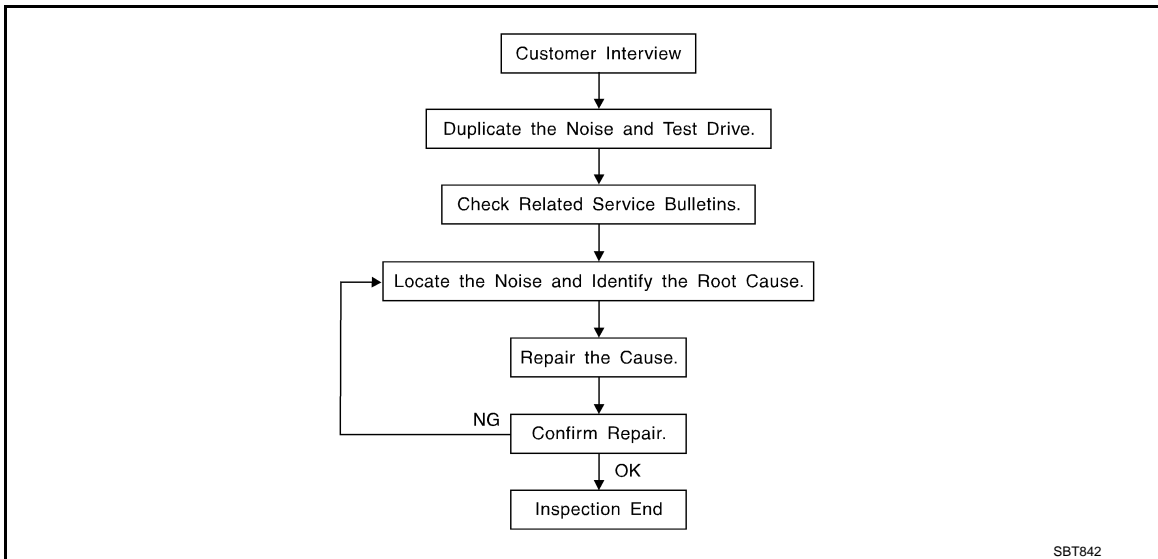

CUSTOMER INTERVIEW

Interview the customer if possible, to determine the conditions that exist when the noise occurs. Use the Diagnostic Worksheet during the interview to document the facts and conditions when the noise occurs and any customer comments. Refer to [INT-13, "Diagnostic Worksheet"](#). This information is necessary to duplicate the conditions that exist when the noise occurs.

- The customer may not be able to provide a detailed description or the location of the noise. Attempt to obtain all the facts and conditions that exist when the noise occurs (or does not occur).
- If there is more than one noise in the vehicle, perform a diagnosis and repair the noise that the customer is concerned about. This can be accomplished by performing a test drive with the customer.
- After identifying the type of noise, isolate the noise in terms of its characteristics. The noise characteristics are provided so that the customer, service adviser, and technician use the same language when describing the noise.
- Squeak – (Like tennis shoes on a clean floor)
Squeak characteristics include the light contact / fast movement / brought on by road conditions / hard surfaces = high-pitched noise / softer surfaces = low-pitched noises / edge to surface = chirping
- Creak – (Like walking on an old wooden floor)
Creak characteristics include firm contact / slow movement/twisting with a rotational movement / pitch dependent on materials / often brought on by activity.
- Rattle – (Like shaking a baby rattle)
Rattle characteristics include fast repeated contact / vibration or similar movement / loose parts/missing clip or fastener / incorrect clearance.
- Knock – (Like a knock on a door)
Knock characteristics include hollow sounds / sometimes repeating / often brought on by driver action.
- Tick – (Like a clock second hand)
Tick characteristics include gentle contacting of light materials / loose components / can be caused by driver action or road conditions.
- Thump – (Heavy, muffled knock noise)
Thump characteristics include softer knock / dull sounds often brought on by activity.
- Buzz – (Like a bumblebee)
Buzz characteristics include high frequency rattle / firm contact.
- Often the degree of acceptable noise level varies depending upon the person. A noise that a technician may judge as acceptable may be very irritating to a customer.
- Weather conditions, especially humidity and temperature, may have a great effect on noise level.

DUPLICATE THE NOISE AND TEST DRIVE

SQUEAK AND RATTLE TROUBLE DIAGNOSES

< SYMPTOM DIAGNOSIS >

[COUPE (REGULAR GRADE)]

If possible, drive the vehicle with the customer until the noise is duplicated. Note any additional information on the Diagnostic Worksheet regarding the conditions or location of the noise. This information can be used to duplicate the same conditions when the repair is reconfirmed.

If the noise can be duplicated easily during the test drive, to help identify the source of the noise, try to duplicate the noise with the vehicle stopped by doing one or all of the following items:

- 1) Close a door.
 - 2) Tap or push/pull around the area where the noise appears to be coming from.
 - 3) Rev the engine.
 - 4) Use a floor jack to recreate vehicle "twist".
 - 5) At idle, apply engine load (electrical load, half-clutch on M/T models, drive position on A/T models).
 - 6) Raise the vehicle on a hoist and hit a tire with a rubber hammer.
- Drive the vehicle and attempt to duplicate the conditions the customer states exist when the noise occurs.
 - If it is difficult to duplicate the noise, drive the vehicle slowly on an undulating or rough road to stress the vehicle body.

CHECK RELATED SERVICE BULLETINS

After verifying the customer concern or symptom, check ASIST for Technical Service Bulletins (TSBs) related to the concern or symptom.

If a TSB relates to the symptom, follow the procedure to repair the noise.

LOCATE THE NOISE AND IDENTIFY THE ROOT CAUSE

1. Narrow down the noise to a general area. To help pinpoint the source of the noise, use a listening tool (Chassis ear: J-39570, engine ear, and mechanics stethoscope).
2. Narrow down the noise to a more specific area and identify the cause of the noise by:
 - Removing the component(s) in the area that is / are suspected to be the cause of the noise.
Do not use too much force when removing clips and fasteners, otherwise clips and fasteners can be broken or lost during the repair, resulting in the creation of new noise.
 - Tapping or pushing/pulling the component(s) that is / are suspected to be the cause of the noise.
Do not tap or push/pull the component(s) with excessive force, otherwise the noise is eliminated only temporarily.
 - Feeling for a vibration by hand by touching the component(s) that is / are suspected to be the cause of the noise.
 - Placing a piece of paper between components that are suspected to be the cause of the noise.
 - Looking for loose components and contact marks.
Refer to [INT-11, "Inspection Procedure"](#).

REPAIR THE CAUSE

- If the cause is a loose component, tighten the component securely.
- If the cause is insufficient clearance between components:
 - Separate components by repositioning or loosening and retightening the components, if possible.
 - Insulate components with a suitable insulator such as urethane pads, foam blocks, felt cloth tape, or urethane tape. A NISSAN Squeak and Rattle Kit (J-43980) is available through the authorized NISSAN Parts Department.

CAUTION:

Never use excessive force as many components are constructed of plastic and may be damaged.

NOTE:

Always check with the Parts Department for the latest parts information.

The following materials are contained in the NISSAN Squeak and Rattle Kit (J-43980). Each item can be ordered separately as needed.

URETHANE PADS [1.5 mm (0.059 in) thick]

Insulates connectors, harness, etc.

- 76268-9E005: 100 × 135 mm (3.937 × 5.315 in)
- 76884-71L01: 60 × 85 mm (2.362 × 3.346 in)
- 76884-71L02: 15 × 25 mm (0.591 × 0.984 in)

INSULATOR (Foam blocks)

Insulates components from contact. Can be used to fill space behind a panel.

- 73982-9E000: 45 mm (1.772 in) thick, 50 × 50 mm (1.969 × 1.969 in)
- 73982-50Y00: 10 mm (0.394 in) thick, 50 × 50 mm (1.969 × 1.969 in)

INSULATOR (Light foam block)

80845-71L00: 30 mm (1.18 in) thick, 30 × 50 mm (1.181 × 1.969 in)

FELT CLOTHTAPE

SQUEAK AND RATTLE TROUBLE DIAGNOSES

[COUPE (REGULAR GRADE)]

< SYMPTOM DIAGNOSIS >

Used to insulate where movement does not occur. Ideal for instrument panel applications.

- 68370-4B000: 15 × 25 mm (0.591 × 0.984 in) pad
- 68239-13E00: 5 mm (0.197 in) wide tape roll

The following materials, not found in the kit, can also be used to repair squeaks and rattles.

UHMW (TEFLON) TAPE

Insulates where slight movement is present. Ideal for instrument panel applications.

SILICONE GREASE

Used in place of UHMW tape that is visible or does not fit. Only lasts a few months.

SILICONE SPRAY

Used when grease cannot be applied.

DUCT TAPE

Used to eliminate movement.

CONFIRM THE REPAIR

After repair is complete, test drive the vehicle to confirm that the cause of noise is repaired by test driving the vehicle. Operate the vehicle under the same conditions as when the noise originally occurred. Refer to the notes on the Diagnostic Worksheet.

Inspection Procedure

INFOID:000000008195016

Refer to Table of Contents for specific component removal and installation information.

INSTRUMENT PANEL

Most incidents are caused by contact and movement between:

1. The cluster lid A and instrument panel
2. Acrylic lens and combination meter housing
3. Instrument panel to front pillar garnish
4. Instrument panel to windshield
5. Instrument panel mounting pins
6. Wiring harnesses behind the combination meter
7. A/C defroster duct and duct joint

These incidents can usually be located by tapping or moving the components to duplicate the noise or by pressing on the components while driving to stop the noise. Most of these incidents can be repaired by applying felt cloth tape or silicon spray (in hard to reach areas). Urethane pads can be used to insulate wiring harness.

CAUTION:

Never use silicone spray to isolate a squeak or rattle. If the area is saturated with silicone, the recheck of repair becomes impossible.

CENTER CONSOLE

Components to check include:

1. Shifter assembly cover to finisher
2. A/C control unit and cluster lid C
3. Wiring harnesses behind audio and A/C control unit

The instrument panel repair and isolation procedures also apply to the center console.

DOORS

Check the following items:

1. Finisher and inner panel making a slapping noise
2. Inside handle escutcheon connection to door finisher
3. Wiring harnesses tapping
4. Door striker out of alignment causing a popping noise on starts and stops

Tapping, moving the components, or pressing on them while driving to duplicate the conditions can isolate many of these incidents. The areas can usually be insulated with felt cloth tape or insulator foam blocks from the NISSAN Squeak and Rattle Kit (J-43980) to repair the noise.

TRUNK

Trunk noises are often caused by a loose jack or loose items put into the trunk by the customer.

In addition check for the following items:

A

B

C

D

E

F

G

H

I

INT

K

L

M

N

O

P

SQUEAK AND RATTLE TROUBLE DIAGNOSES

< SYMPTOM DIAGNOSIS >

[COUPE (REGULAR GRADE)]

1. Trunk lid dumpers out of adjustment
2. Trunk lid striker out of adjustment
3. Trunk lid torsion bars knocking together
4. A loose license plate or bracket

Most of these incidents can be repaired by adjusting, securing, or insulating the item(s) or component(s) causing the noise.

SUNROOF/HEADLINING

Noises in the sunroof / headlining area can often be traced to one of the following items:

1. Sunroof lid, rail, linkage, or seals making a rattle or light knocking noise
2. Sunvisor shaft shaking in the holder
3. Front or rear windshield touching headlining and squeaking

Again, pressing on the components to stop the noise while duplicating the conditions can isolate most of these incidents. Repairs usually consist of insulating with felt cloth tape.

SEATS

When isolating seat noise it is important to note the position the seat is in and the load placed on the seat when the noise occurs. These conditions should be duplicated when verifying and isolating the cause of the noise.

Causes of seat noise include:

1. Headrest rods and holder
2. A squeak between the seat pad cushion and frame
3. The rear seatback lock and bracket

These noises can be isolated by moving or pressing on the suspected components while duplicating the conditions under which the noise occurs. Most of these incidents can be repaired by repositioning the component or applying urethane tape to the contact area.

UNDERHOOD

Some interior noise may be caused by components under the hood or on the engine wall. The noise is then transmitted into the passenger compartment.

Causes of transmitted underhood noise include:

1. Any component mounted to the engine wall
2. Components that pass through the engine wall
3. Engine wall mounts and connectors
4. Loose radiator mounting pins
5. Hood bumpers out of adjustment
6. Hood striker out of adjustment

These noises can be difficult to isolate since they cannot be reached from the interior of the vehicle. The best method is to secure, move, or insulate one component at a time and test drive the vehicle. Also, engine RPM or load can be changed to isolate the noise. Repairs can usually be made by moving, adjusting, securing, or insulating the component causing the noise.

SQUEAK AND RATTLE TROUBLE DIAGNOSES

< SYMPTOM DIAGNOSIS >

[COUPE (REGULAR GRADE)]

Diagnostic Worksheet

INFOID:000000008195017



SQUEAK & RATTLE DIAGNOSTIC WORKSHEET

Dear Nissan Customer:

We are concerned about your satisfaction with your Nissan vehicle. Repairing a squeak or rattle sometimes can be very difficult. To help us fix your Nissan right the first time, please take a moment to note the area of the vehicle where the squeak or rattle occurs and under what conditions. You may be asked to take a test drive with a service advisor or technician to ensure we confirm the noise you are hearing.

I. WHERE DOES THE NOISE COME FROM? (circle the area of the vehicle)

The illustrations are for reference only, and may not reflect the actual configuration of your vehicle.

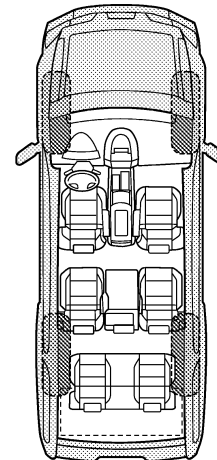
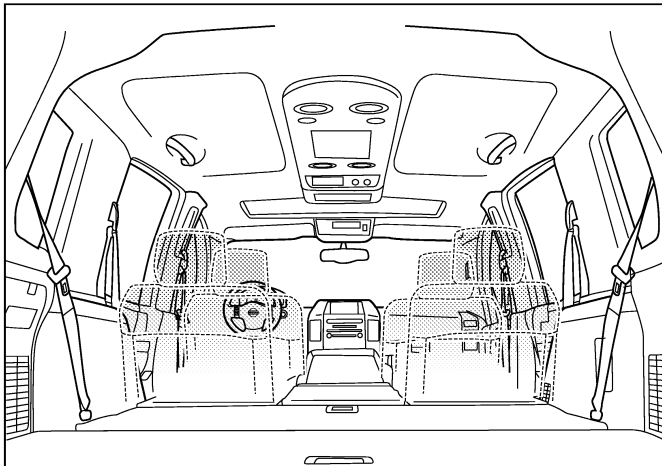
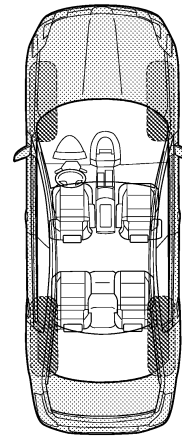
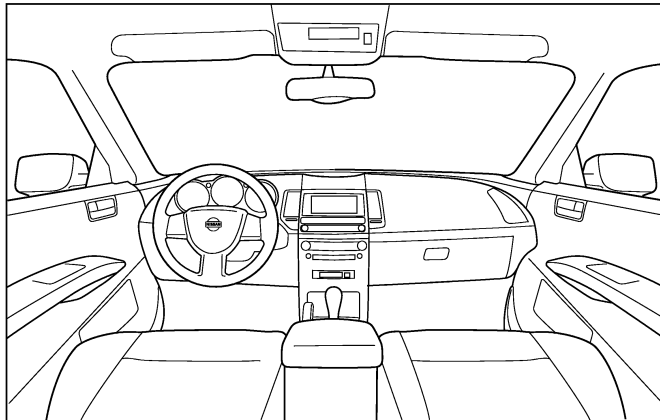

Continue to page 2 of the worksheet and briefly describe the location of the noise or rattle. In addition, please indicate the conditions which are present when the noise occurs.

PIIB8740E

A
B
C
D
E
F
G
H
I
INT
K
L
M
N
O
P

SQUEAK AND RATTLE TROUBLE DIAGNOSES

< SYMPTOM DIAGNOSIS >

[COUPE (REGULAR GRADE)]

SQUEAK & RATTLE DIAGNOSTIC WORKSHEET - page 2

Briefly describe the location where the noise occurs:

II. WHEN DOES IT OCCUR? (please check the boxes that apply)

- | | |
|---|--|
| <input type="checkbox"/> anytime | <input type="checkbox"/> after sitting out in the rain |
| <input type="checkbox"/> 1st time in the morning | <input type="checkbox"/> when it is raining or wet |
| <input type="checkbox"/> only when it is cold outside | <input type="checkbox"/> dry or dusty conditions |
| <input type="checkbox"/> only when it is hot outside | <input type="checkbox"/> other: |

III. WHEN DRIVING:

- through driveways
- over rough roads
- over speed bumps
- only about ____ mph
- on acceleration
- coming to a stop
- on turns: left, right or either (circle)
- with passengers or cargo
- other: _____
- after driving ____ miles or ____ minutes

IV. WHAT TYPE OF NOISE

- squeak (like tennis shoes on a clean floor)
- creak (like walking on an old wooden floor)
- rattle (like shaking a baby rattle)
- knock (like a knock at the door)
- tick (like a clock second hand)
- thump (heavy, muffled knock noise)
- buzz (like a bumble bee)

TO BE COMPLETED BY DEALERSHIP PERSONNEL

Test Drive Notes:

	YES	NO	Initials of person performing
Vehicle test driven with customer	<input type="checkbox"/>	<input type="checkbox"/>	_____
- Noise verified on test drive	<input type="checkbox"/>	<input type="checkbox"/>	_____
- Noise source located and repaired	<input type="checkbox"/>	<input type="checkbox"/>	_____
- Follow up test drive performed to confirm repair	<input type="checkbox"/>	<input type="checkbox"/>	_____

VIN: _____ Customer Name: _____
W.O.# _____ Date: _____

This form must be attached to Work Order

PIIB8742E

REMOVAL AND INSTALLATION

DOOR FINISHER

Exploded View

INFOID:000000008195018

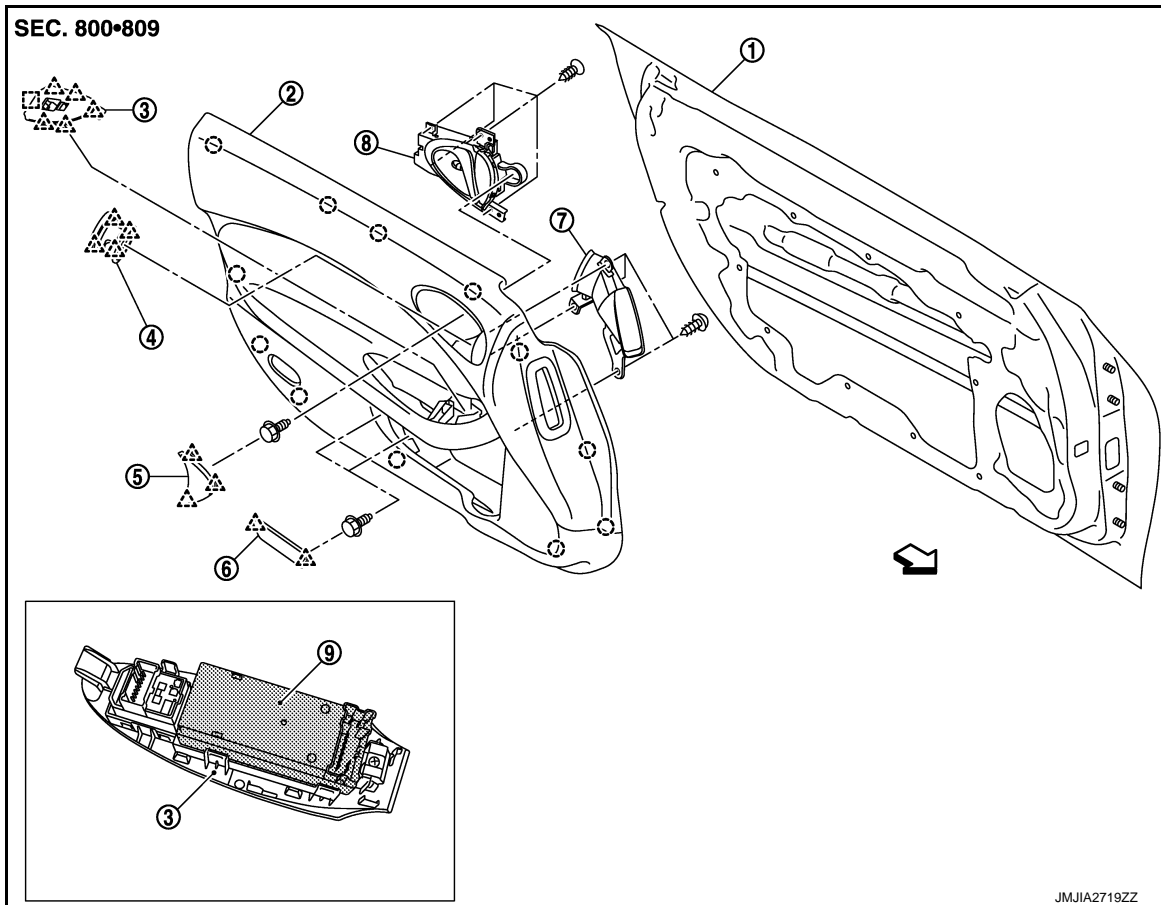

- | | | |
|---------------------------|----------------------|--------------------------------------|
| 1. Door panel | 2. Door finisher | 3. Power window main switch finisher |
| 4. Side ventilator grille | 5. Door finisher cap | 6. Door grip mask |
| 7. Side ventilator duct | 8. Inside handle | 9. Power window main switch |

- : Clip
- △ : Pawl
- : Metal clip
- ← : Vehicle front

Removal and Installation

INFOID:000000008195019

CAUTION:

- Wrap the tip of flat-bladed screwdriver with a cloth before removal.
- When removing, always use a remover tool that is made of plastic.

REMOVAL

1. Fully open door window.

DOOR FINISHER

[COUPE (REGULAR GRADE)]

< REMOVAL AND INSTALLATION >

2. Remove door finisher cap with remover tool.

 : Pawl

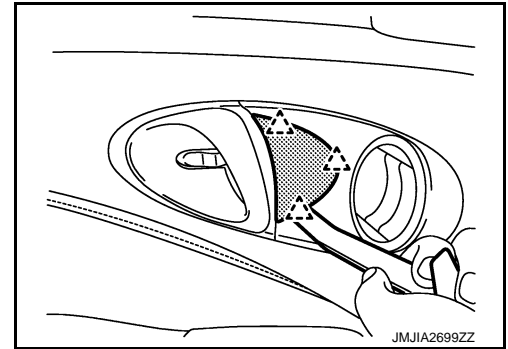

3. Remove bolt (A) located behind door finisher cap.

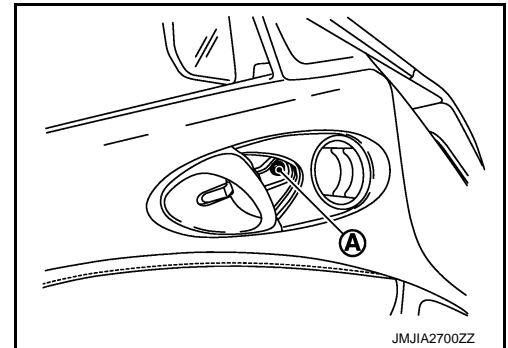

4. Remove door grip mask with remover tool.

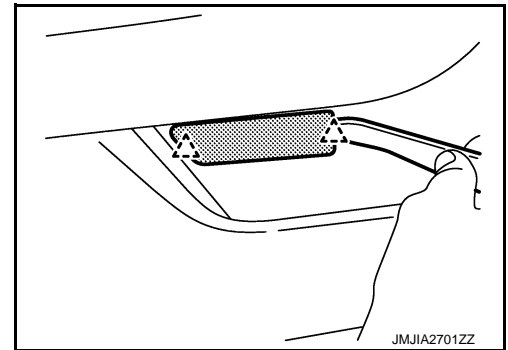

 : Pawl

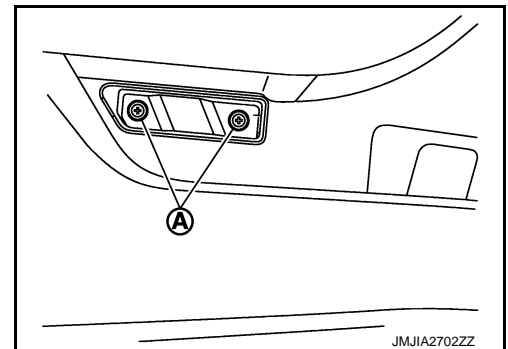

5. Remove both bolts (A), located behind door grip mask.



6. Remove power window main switch finisher with remover tool and disconnect the harness connectors.

 : Pawl
 : Metal clip

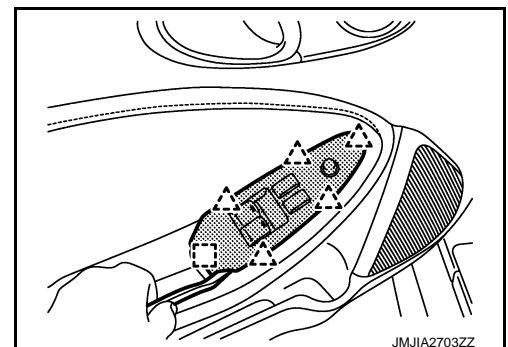

DOOR FINISHER

[COUPE (REGULAR GRADE)]

< REMOVAL AND INSTALLATION >

7. Insert remover tool into clips on door finisher, and disengage the clips.

CAUTION:

Insert remover tool into the part shown in the figure. (Between the clip and the body side panel).

 : Clip

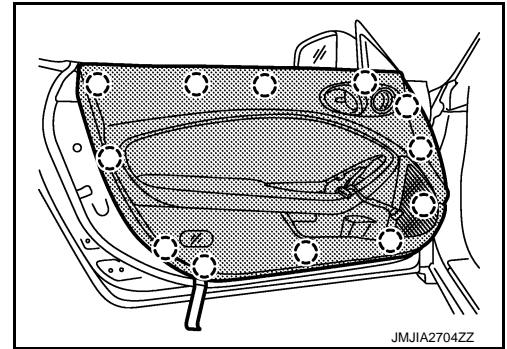

8. Disconnect inside handle cable and lock knob cable from door inside handle assembly. Refer to [DLK-163, "INSIDE HANDLE : Exploded View"](#).
9. Remove door finisher from door panel.
10. Remove the following parts after removing door finisher.
- Door inside handle. Refer to [DLK-163, "INSIDE HANDLE : Removal and Installation"](#).
 - Side ventilator duct. Refer to [VTL-8, "SIDE VENTILATOR DUCT : Removal and Installation"](#).
 - Side ventilator grille. Refer to [VTL-7, "SIDE VENTILATOR GRILLE : Removal and Installation"](#).

INSTALLATION

Note the following item, and then install in the reverse order of removal.

CAUTION:

When installing door finisher, check that clips are securely fitted in panel holes on body, and then press them in.

A
B
C
D
E
F
G
H
I
K
L
M
N
O
P

INT

BODY SIDE TRIM

< REMOVAL AND INSTALLATION >

[COUPE (REGULAR GRADE)]

BODY SIDE TRIM

Exploded View

INFOID:000000008195020

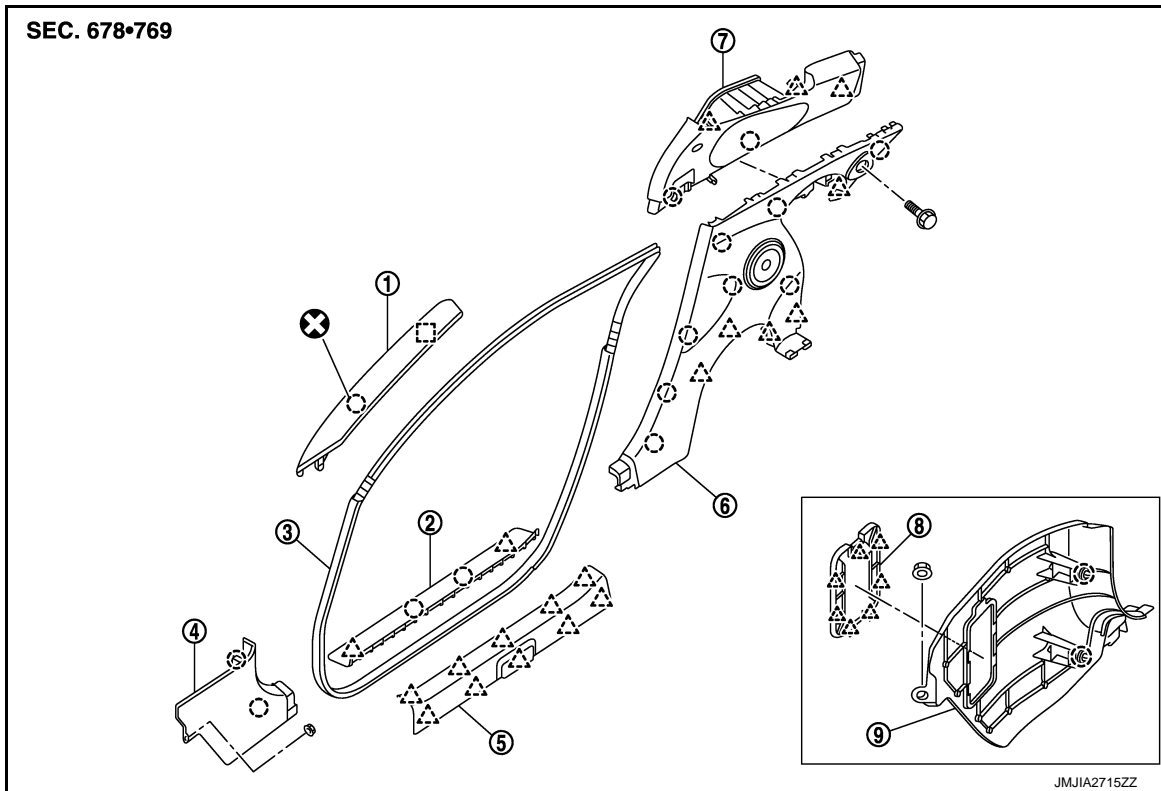

- | | | |
|--------------------------|-----------------------------|--------------------------|
| 1. Front pillar garnish | 2. Kicking plate outer | 3. Body side welt |
| 4. Dash side finisher RH | 5. Kicking plate inner | 6. Rear side finisher |
| 7. Rear pillar finisher | 8. Dash side finisher cover | 9. Dash side finisher LH |

○ : Clip

△ : Pawl

□ : Metal clip

⊗ : Always replace after every disassembly.

FRONT PILLAR GARNISH

FRONT PILLAR GARNISH : Removal and Installation

INFOID:000000008195021

CAUTION:

- When removing, always use a remover tool that is made of plastic.
- Never damage the body.

REMOVAL

1. Release front pillar portion of body side welt.

BODY SIDE TRIM

< REMOVAL AND INSTALLATION >

[COUPE (REGULAR GRADE)]

- Disengage front pillar garnish fixing clip and metal clip with remover tool (A), cut clip (2) with cutter knife, and then remove front pillar garnish (1).

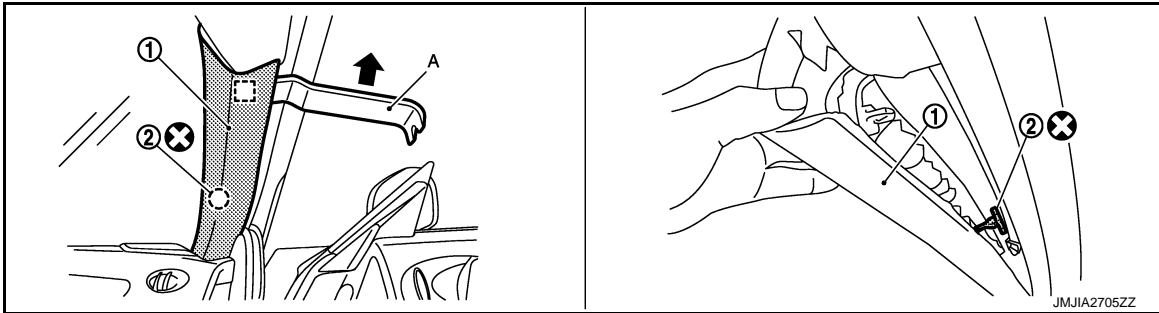

- : Clip
□ : Metal clip

INSTALLATION

Note the following item, and then install in the reverse order of removal.

CAUTION:

Check that clip and metal clip are securely fitted in panel holes on body when installing, and then press them in.

KICKING PLATE INNER

KICKING PLATE INNER : Removal and Installation

INFOID:000000008195022

CAUTION:

Never damage the body.

REMOVAL

- While disengaging pawls in the rear and side of kicking plate inner, lift up the kicking plate inner toward upper side of the vehicle, and then disengage pawls in the rear half of kicking plate inner.

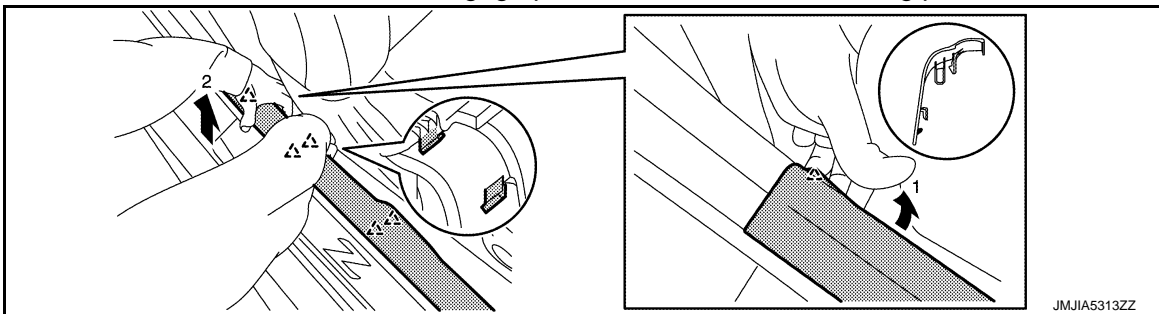

- △ : Pawl

- While disengaging pawls in the front and side of kicking plate inner, lift up the kicking plate inner toward upper side of the vehicle, disengage the remaining pawls, and then remove the kicking plate inner.

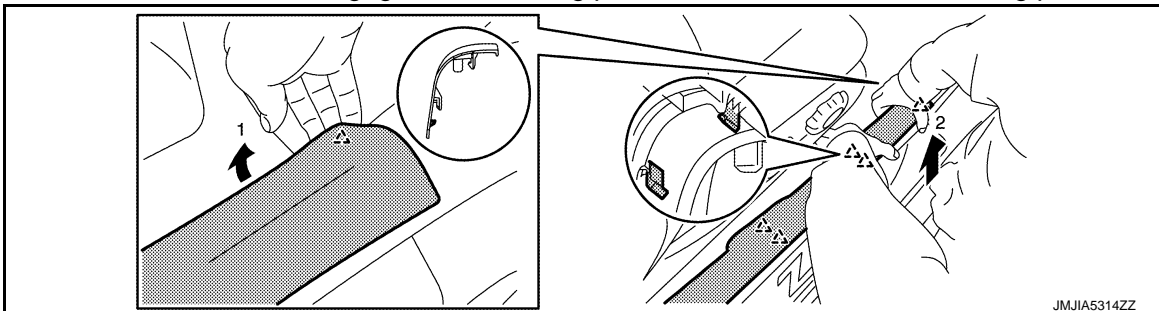

- △ : Pawl

BODY SIDE TRIM

< REMOVAL AND INSTALLATION >

[COUPE (REGULAR GRADE)]

INSTALLATION

Note the following item, and install in the reverse order of removal.

CAUTION:

When installing, check that all pawls are securely fitted in panel holes on body, and then press them in.

KICKING PLATE OUTER

KICKING PLATE OUTER : Removal and Installation

INFOID:000000008195023

CAUTION:

- When removing, always use a remover tool that is made of plastic.
- Never damage the body.

REMOVAL

Remove kicking plate outer fixing clips with a remover tool, and then remove kicking plate outer.

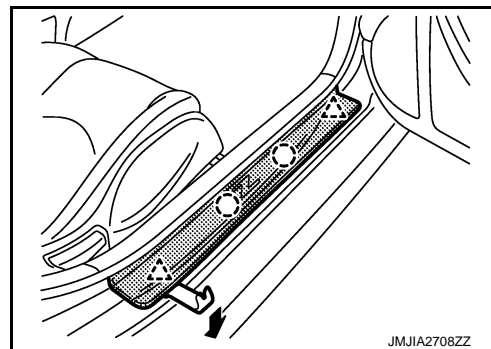
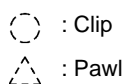

INSTALLATION

Note the following item, and then install in the reverse order of removal.

CAUTION:

Check that clips are securely fitted in panel holes on body when installing, and then press them in.

DASH SIDE FINISHER

DASH SIDE FINISHER : Removal and Installation

INFOID:000000008195024

CAUTION:

- When removing, always use a remover tool that is made of plastic.
- Never damage the body.

REMOVAL

1. Remove kicking plate inner.
2. Remove clip (A).
3. Remove dash side finisher (1) fixing clips with remover tool (B), and then remove dash side finisher.

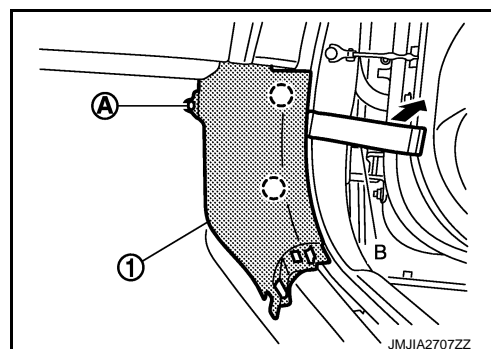
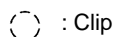

INSTALLATION

Note the following item, and then install in the reverse order of removal.

CAUTION:

Check that clips are securely fitted in panel holes on body when installing, and then press them in.

BODY SIDE WELT

BODY SIDE WELT : Removal and Installation

INFOID:000000008195025

REMOVAL

1. Remove kicking plate inner.
2. Remove body side welt.

INSTALLATION

Install in the reverse order of removal.

REAR SIDE FINISHER

REAR SIDE FINISHER : Removal and Installation

INFOID:000000008195026

CAUTION:

- When removing, always use a remover tool that is made of plastic.
- Never damage the body.

REMOVAL

1. Remove kicking plate inner.
2. Slide the seat assembly toward the frontmost position (Driver and passenger side).
3. Remove body side welt from the rear side finisher.
4. Remove tonneau cover (With tonneau cover). Refer to [INT-23. "Exploded View"](#).
5. Remove the rear side finisher mounting bolts (A) (LH and RH) after removing the tonneau cover.

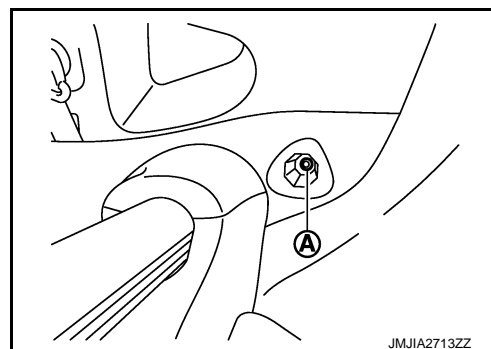

6. Remove the rear parcel shelf side finisher (LH and RH). Refer to [INT-24. "Removal and Installation"](#).
 7. Remove the rear parcel shelf cover (LH and RH). Refer to [INT-24. "Removal and Installation"](#).
- NOTE:**
Remove rear parcel shelf finisher holder before removing rear parcel shelf cover (Passenger side).
8. Remove rear parcel shelf finisher holder. Refer to [INT-24. "Removal and Installation"](#).
 9. Remove the luggage side finisher upper (LH and RH). Refer to [INT-32. "Removal and Installation"](#).
 10. Insert remover tool into the clearance between rear side finisher and body panel, disengage the clips, pawls and disconnect the rear speaker harness connector (with BOSE audio).
 11. Remove rear side finisher.

INSTALLATION

Note the following item, and then install in the reverse order of removal.

CAUTION:

Check that clips are securely fitted in panel holes on body when installing, and then press them in.

REAR PILLAR FINISHER

REAR PILLAR FINISHER : Removal and Installation

INFOID:000000008195027

CAUTION:

- When removing, always use a remover tool that is made of plastic.
- Never damage the body.

REMOVAL

1. Remove rear side finisher.

BODY SIDE TRIM

[COUPE (REGULAR GRADE)]

< REMOVAL AND INSTALLATION >

2. Remove seat belt shoulder anchor mounting bolt. Refer to [SB-7. "SEAT BELT RETRACTOR : Exploded View"](#).
3. Remove seat belt floor anchor bolt. Refer to [SB-10. "SEAT BELT BUCKLE : Exploded View"](#).
4. Insert remover tool between body panel and rear pillar finisher to disengage the pawls and clips.

- : Clip
△ : Pawl

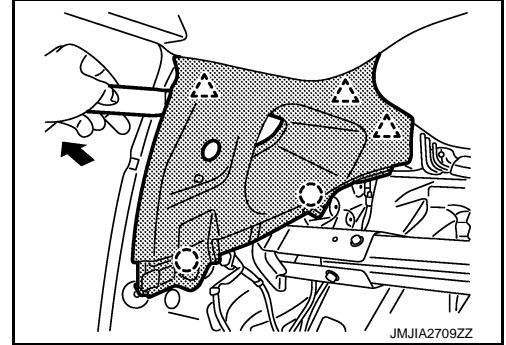

5. Disconnect the outside key antenna harness connectors.
6. Remove rear pillar finisher from the body panel.

INSTALLATION

Note the following item, and then install in the reverse order of removal.

CAUTION:

Check that clips are securely fitted in panel holes on body when installing, and then press them in.

REAR TRIM

< REMOVAL AND INSTALLATION >

[COUPE (REGULAR GRADE)]

REAR TRIM

Exploded View

INFOID:000000008195028

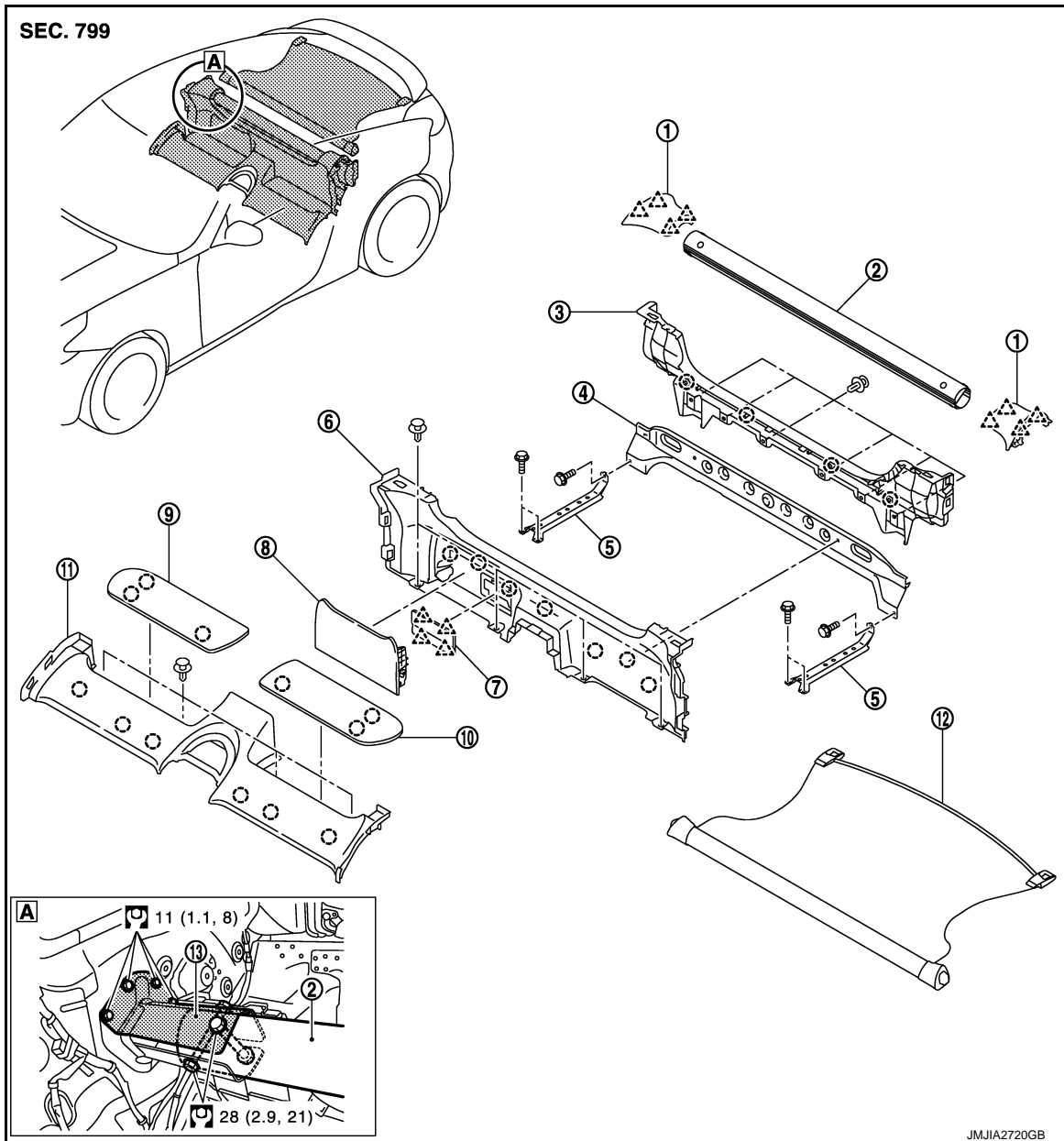

- | | | |
|--|---|---|
| 1. Rear parcel shelf side finisher (LH/RH) | 2. Rear tower bar | 3. Back panel finisher assembly |
| 4. Rear parcel shelf bracket | 5. Rear parcel shelf side bracket (LH/RH) | 6. Rear parcel shelf finisher |
| 7. Rear parcel shelf lid | 8. Rear parcel shelf finisher holder | 9. Rear parcel shelf cover RH |
| 10. Rear parcel shelf cover LH | 11. Seatback center finisher | 12. Tonneau cover assembly (With tonneau cover) |

13. Body side bracket

○ : Clip

△ : Pawl

⊕ : N·m (kg·m, ft·lb)

A
B
C
D
E
F
G
H
I
INT
K
L
M
N
O
P

Removal and Installation

REMOVAL

REAR PARCEL SHELF SIDE FINISHER

1. Remove tonneau cover (with tonneau cover).
2. Slide rear parcel shelf side finisher toward the direction of the arrow to remove.

 : Pawl

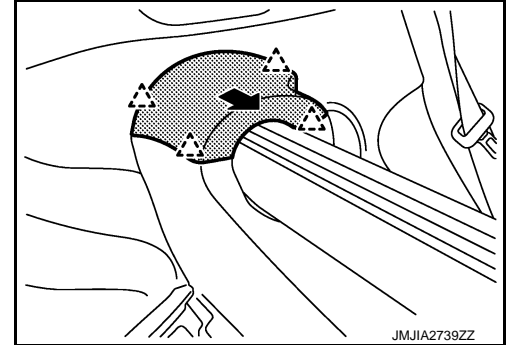

REAR PARCEL SHELF COVER

Remove rear parcel shelf cover LH with remover tool as shown in the figure.

 : Clip

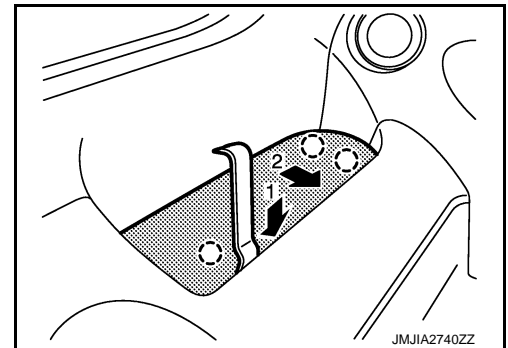

REAR PARCEL SHELF FINISHER HOLDER

1. Fully open rear parcel shelf finisher holder in three steps as shown in the figure below. (approximately 45 degree)
2. Pull back to remove.

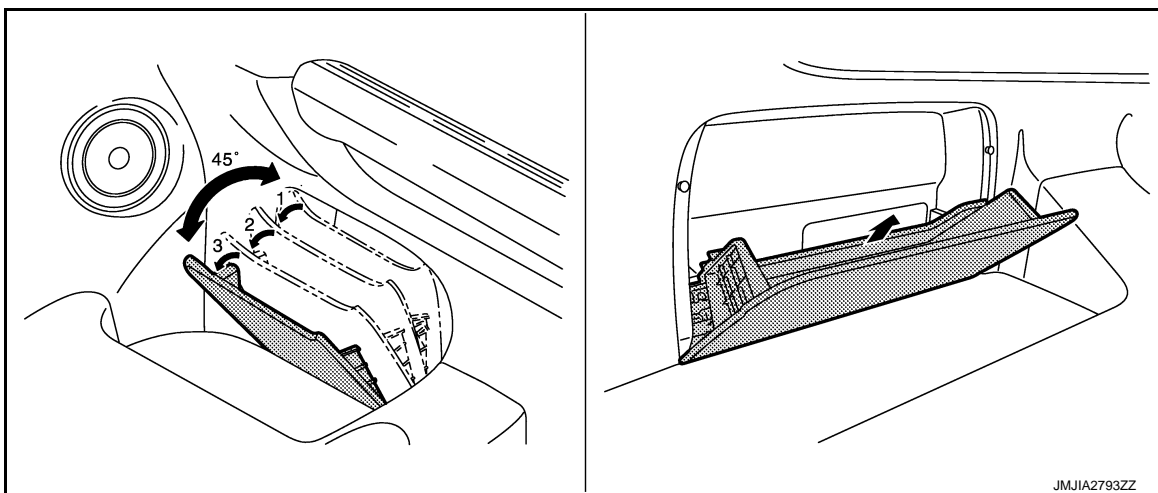

SEATBACK CENTER FINISHER

1. Remove center console assembly. Refer to [JP-26. "Removal and Installation"](#).
2. Remove rear side finisher. Refer to [INT-18. "FRONT PILLAR GARNISH : Removal and Installation"](#).
3. Disconnect seatback center finisher fixing clips, and then pull it up to remove.

REAR PARCEL SHELF FINISHER

REAR TRIM

[COUPE (REGULAR GRADE)]

< REMOVAL AND INSTALLATION >

1. Remove seatback center finisher.
2. Remove the clips (A) with a remover tool.
3. Hold rear parcel shelf finisher (1) from both sides, and then pull it back to remove.

○ : Clip

⇐ : Vehicle front

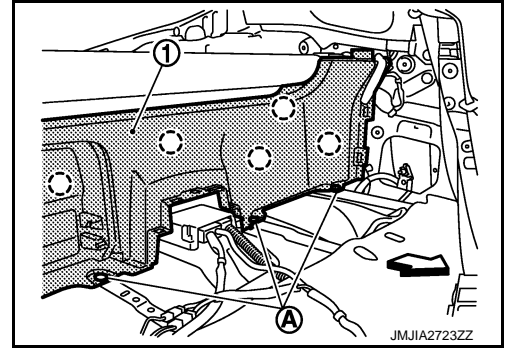

REAR PARCEL SHELF BRACKET

1. Remove rear parcel shelf finisher.
2. Remove rear parcel shelf bracket (1) mounting bolts (A) (LH and RH).

⇐ : Vehicle front

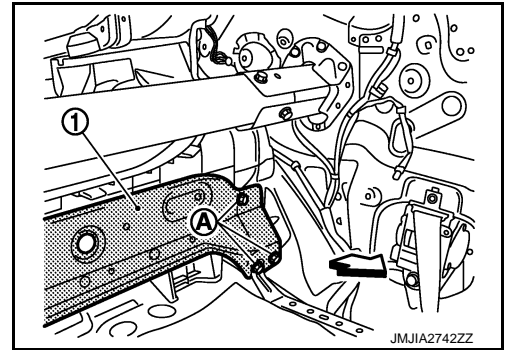

BACK PANEL FINISHER ASSEMBLY

1. Remove luggage floor spacer front. Refer to [INT-31, "Exploded View"](#).
2. Remove rear side finisher. Refer to [INT-18, "FRONT PILLAR GARNISH : Removal and Installation"](#).
3. Remove rear pillar finisher. Refer to [INT-18, "FRONT PILLAR GARNISH : Removal and Installation"](#).
4. Remove the clips (A) fixing the back panel finisher assembly (1) to the rear parcel shelf bracket.

○ : Clip

⇐ : Vehicle front

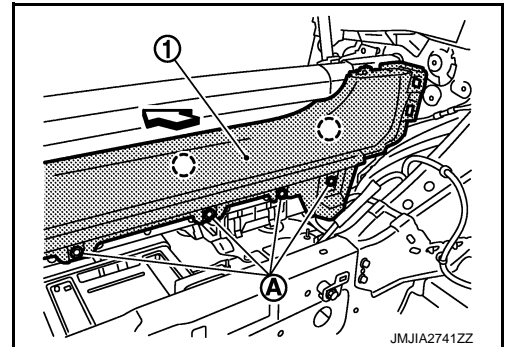

5. Pull back panel finisher assembly to remove.

INSTALLATION

Note the following item, and then install in the reverse order of removal.

CAUTION:

Check that clips are securely fitted in panel holes on body when installing, and then press them in.

FLOOR TRIM

< REMOVAL AND INSTALLATION >

[COUPE (REGULAR GRADE)]

FLOOR TRIM

Exploded View

INFOID:000000008195030

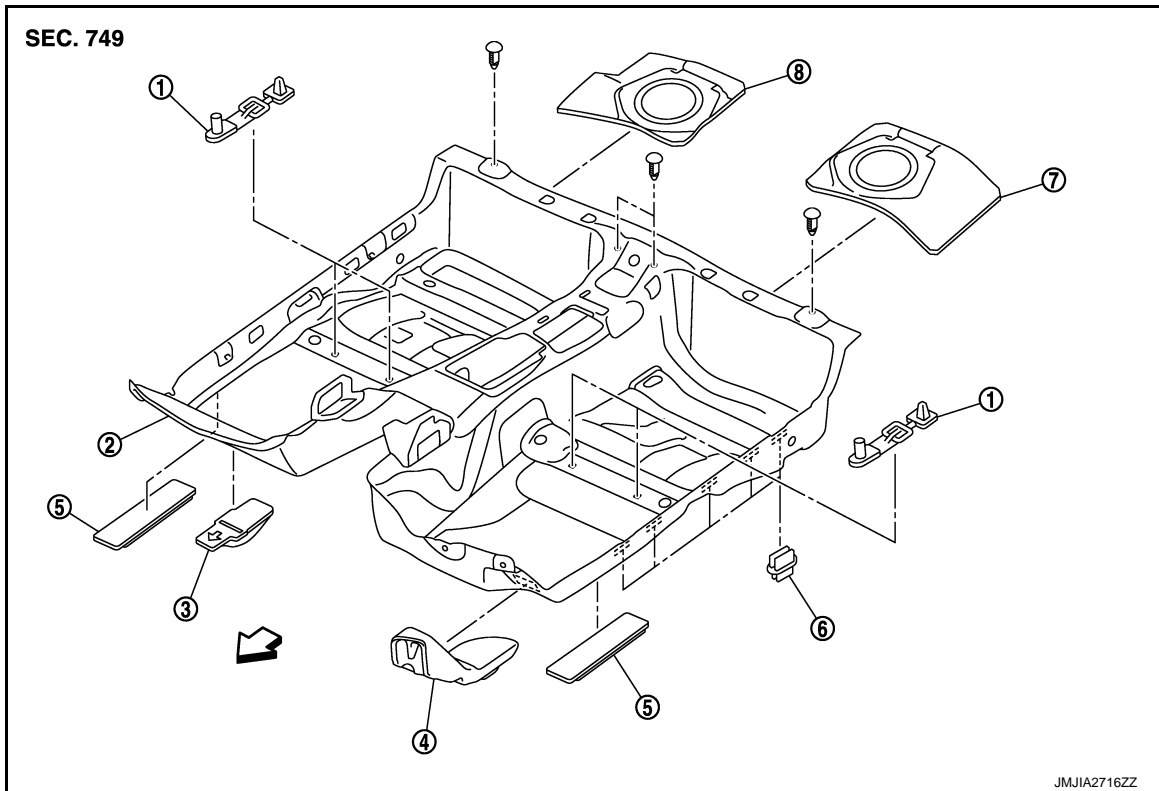

- | | | |
|-----------------------|-------------------------------|--------------------------|
| 1. Floor hook | 2. Floor trim | 3. Front floor spacer RH |
| 4. Footrest | 5. Front floor spacer (LH/RH) | 6. Fixing clip |
| 7. Rear floor felt LH | 8. Rear floor felt RH | |

← : Vehicle front

Removal and Installation

INFOID:000000008195031

REMOVAL

1. Remove the seat assembly (LH and RH). Refer to [SE-71, "Removal and Installation"](#).
2. Remove accelerator pedal pad. Refer to [BR-19, "Removal and Installation"](#).
3. Disengage clip of floor hook (1) with remover tool (A).

○ : Clip

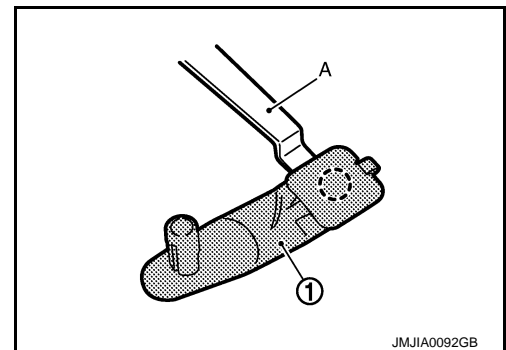

4. Remove foot grille. Refer to [VTL-9, "FOOT GRILLE : Removal and Installation"](#).
5. Remove the seat belt floor anchor bolt (LH and RH). Refer to [SB-10, "SEAT BELT BUCKLE : Exploded View"](#).
6. Remove center console assembly. Refer to [IP-26, "Removal and Installation"](#).

FLOOR TRIM

[COUPE (REGULAR GRADE)]

< REMOVAL AND INSTALLATION >

7. Remove instrument lower cover (LH and RH), glove box assembly, instrument lower panel RH and instrument side panel (LH and RH). Refer to [IP-26, "Removal and Installation"](#).
8. Remove seatback center finisher. Refer to [INT-24, "Removal and Installation"](#).
9. Disconnect the harness connector (A), (B), (C) and (D) from the diagnosis sensor unit (1) and then remove the clips fixing the harness to the floor trim as shown in the figure.

- : Harness clip
◄ : Clip

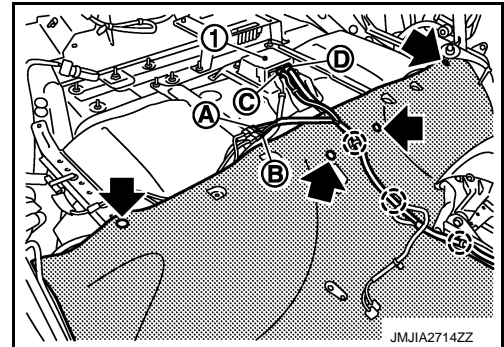

10. Remove console panel (LH and RH). Refer to [IP-26, "Removal and Installation"](#).
11. Remove the kicking plate inner (LH and RH), dash side finisher (LH and RH) and body side welt (LH and RH). Refer to [INT-18, "FRONT PILLAR GARNISH : Removal and Installation"](#).
12. Remove floor trim fixing clips.
13. Remove floor trim from floor trim fixing clips and remove floor trim.

INSTALLATION

Install in the reverse order of removal.

A
B
C
D
E
F
G
H
I
K
L
M
N
O
P

INT

HEADLINING

< REMOVAL AND INSTALLATION >

[COUPE (REGULAR GRADE)]

HEADLINING

Exploded View

INFOID:000000008195032

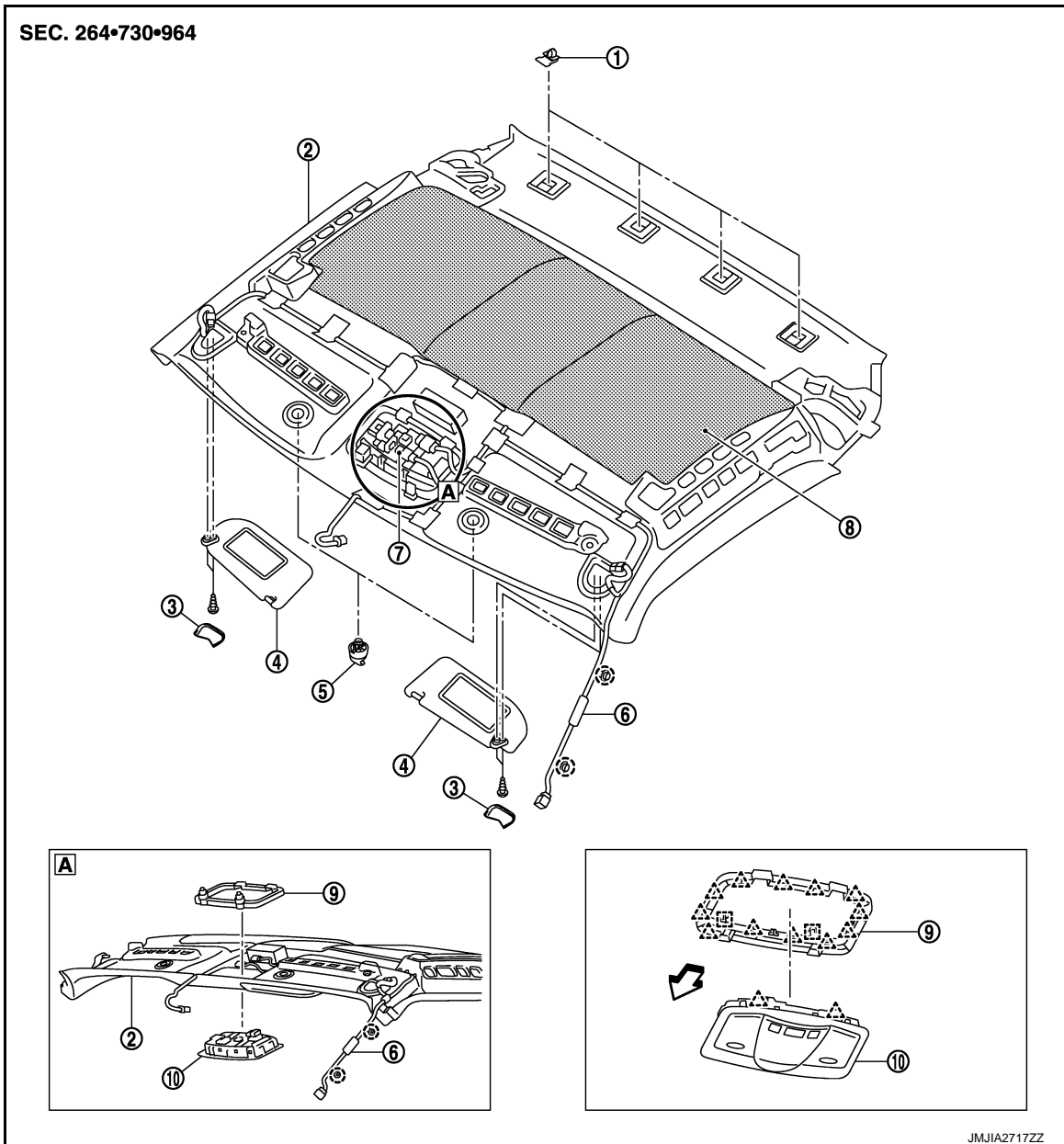

- | | | |
|--------------------------|------------------------|--------------------------|
| 1. Headlining clip | 2. Headlining assembly | 3. Sun visor cover |
| 4. Sun visor assembly | 5. Sun visor holder | 6. Roof harness assembly |
| 7. Roof console assembly | 8. Insulator roof | 9. Roof bracket |
| 10. Map lamp assembly | | |

- : Clip
- △ : Pawl
- - - : Metal clip
- ← : Vehicle front

Removal and Installation

INFOID:000000008195033

REMOVAL

Revision: 2012 August

INT-28

2013 370Z

HEADLINING

[COUPE (REGULAR GRADE)]

< REMOVAL AND INSTALLATION >

1. Remove body side welt (LH and RH). Refer to [INT-21, "BODY SIDE WELT : Removal and Installation"](#).
2. Remove front pillar garnish (LH and RH). Refer to [INT-18, "FRONT PILLAR GARNISH : Removal and Installation"](#).
3. Remove roof harness assembly fixing clips (B) with remover tool, and then disconnect roof harness connector (A).

 : Clip

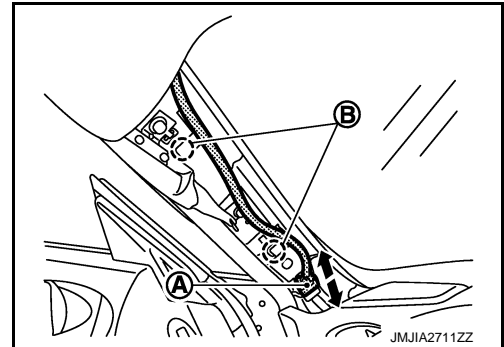

4. Disconnect inside mirror harness connector.
5. Remove sun visor assembly (LH and RH).
 1. Remove sun visor cover.
 2. Remove sun visor assembly fixing screws.
 3. Disconnect vanity mirror lamp harness connectors.
6. Insert small flat-bladed screwdriver into the hole of sun visor holder, press while rotating approximately 90 degrees to remove.

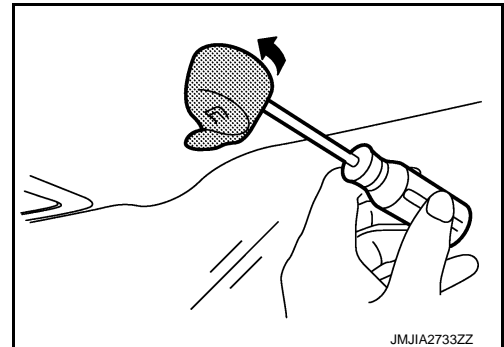

7. Remove kicking plate inner (LH and RH) and rear pillar finisher (LH and RH). Refer to [INT-18, "FRONT PILLAR GARNISH : Removal and Installation"](#).
8. Insert remover tool between roof panel and roof console assembly (front edge) to disengage the metal clips as shown in the figure.

 : Metal clip

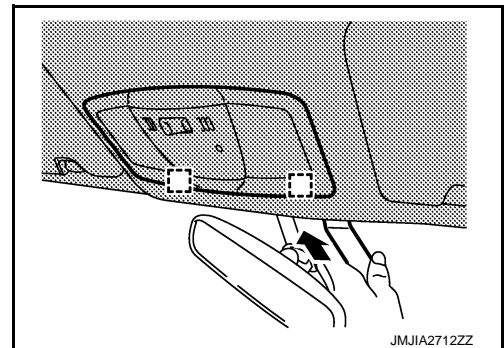

9. With remover tool, remove headlining clip from rear end of headlining.
10. Put front seat to rearmost and recline backward.

HEADLINING

< REMOVAL AND INSTALLATION >

[COUPE (REGULAR GRADE)]

11. Remove headlining, turn and take out from right side door.

CAUTION:

- When removing headlining, 2 workers are required. (1 for the front and rear of headlining)
- Cover center console finisher upper surface with a shop cloth to prevent it from being damaged.
- Never bend headlining when removing.

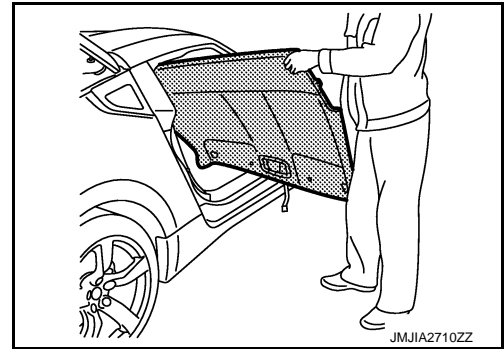

12. Remove the following parts after removing headlining.

- Map lamp assembly. Refer to [INT-28, "Exploded View"](#).
- Roof harness assembly.

INSTALLATION

Note the following items, and then install in the reverse order of removal.

CAUTION:

- Install headlining assembly after inserting clips to clip holder of headlining rear end.
- Never bend headlining when installing.

LUGGAGE FLOOR TRIM

< REMOVAL AND INSTALLATION >

[COUPE (REGULAR GRADE)]

LUGGAGE FLOOR TRIM

Exploded View

INFOID:000000008195034

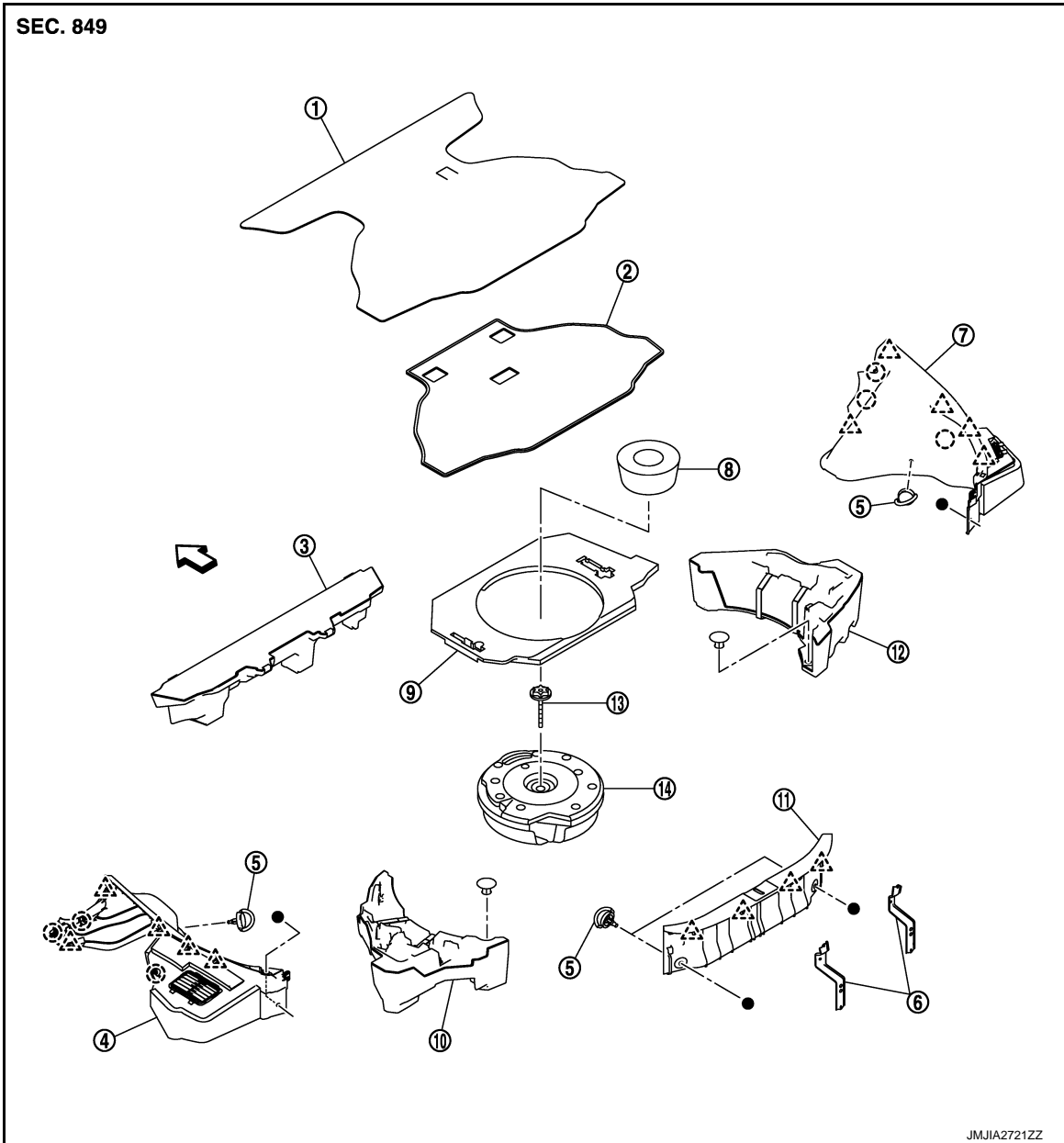

- | | | |
|----------------------------------|--|----------------------------------|
| 1. Luggage floor carpet assembly | 2. Spare tire cover | 3. Luggage spacer center front |
| 4. Luggage side finisher LH | 5. Trunk net hook | 6. Luggage bracket (LH/RH) |
| 7. Luggage side finisher RH | 8. Luggage floor spacer center rear (without BOSE audio) | 9. Luggage spacer |
| 10. Luggage side box assembly LH | 11. Luggage rear plate | 12. Luggage side box assembly RH |
| 13. Clamp | 14. Woofer (with BOSE audio) | |

- : Clip
- △ : Pawl
- ← : Vehicle front

A
B
C
D
E
F
G
H
I
INT
K
L
M
N
O
P

Removal and Installation

INFOID:000000008195035

REMOVAL

1. Fully open back door.
2. Remove tonneau cover assembly (with tonneau cover). Refer to [INT-23, "Exploded View"](#).
3. Remove luggage floor carpet assembly.
4. Remove spare tire cover.
5. Remove back door weather-strip.
6. Remove luggage rear plate.
 1. Remove luggage rear plate fixing trunk net hook.
 2. Insert remover tool between body panel and luggage rear plate to disengage the fixing pawls.
 3. Disconnect luggage room lamp harness connector. Refer to [INL-40, "Removal and Installation"](#).
7. Remove luggage spacer.
8. Remove woofer and spare tire (BOSE audio with navigation). Refer to [AV-249, "Removal and Installation"](#).
9. Remove luggage side finisher upper (LH and RH).
 1. Remove trunk net hook fixing the luggage side upper to body panel.
 2. Insert a remover tool between body panel and luggage side finisher upper to disengage the fixing pawls and clips.
10. Remove luggage side box assembly (LH and RH).
11. Remove luggage spacer center front.

INSTALLATION

Note the following item, and then install in the reverse order of removal.

CAUTION:

Check that clips, pawls, metal clips are securely fitted in panel holes on body when installing, and then press them in.

BACK DOOR TRIM

< REMOVAL AND INSTALLATION >

[COUPE (REGULAR GRADE)]

BACK DOOR TRIM

Exploded View

INFOID:000000008195036

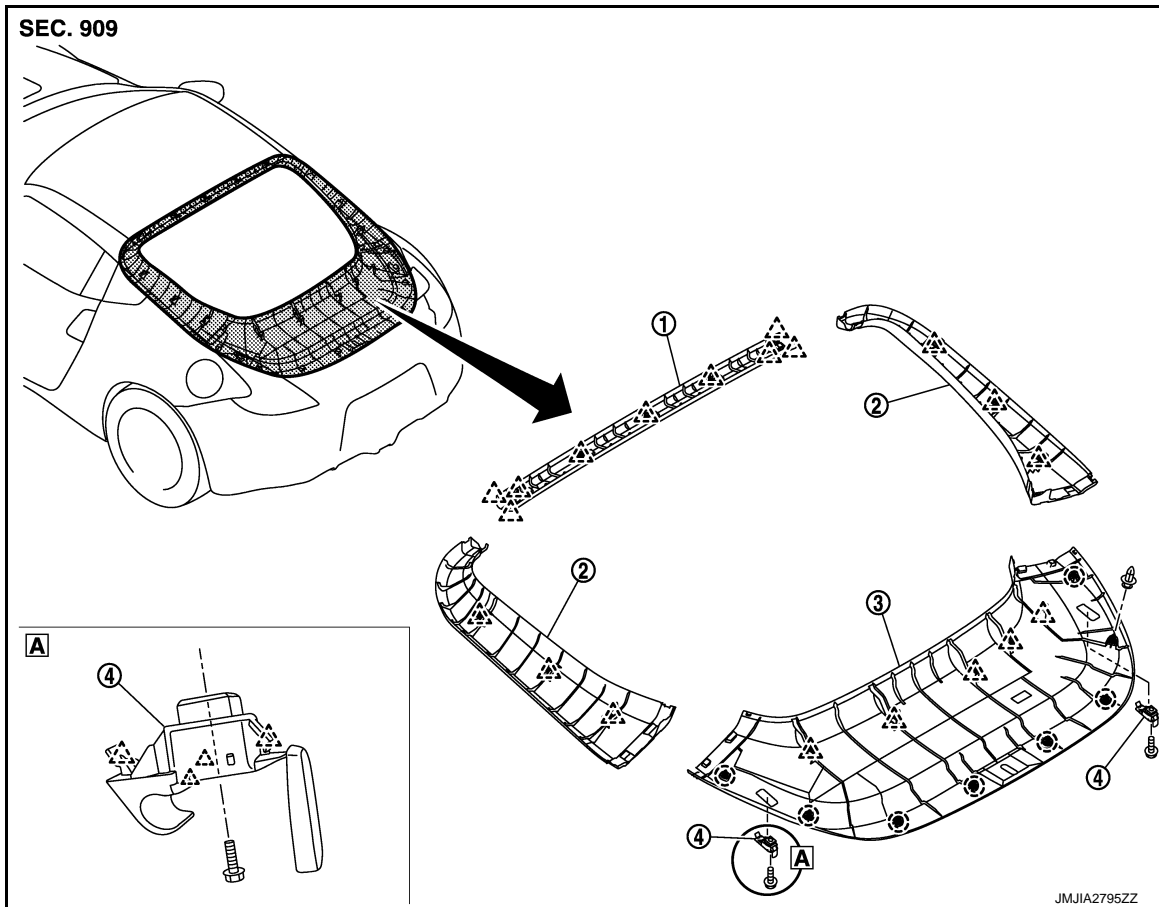

1. Back door finisher upper
2. Back door finisher side (LH/RH)
3. Back door finisher lower
4. Back door finisher hook (with tonneau cover)

- : Clip
△ : Pawl

Removal and Installation

INFOID:000000008195037

REMOVAL

1. Fully open the back door.
2. Insert a remover tool between back door panel and back door finisher upper to disengage the pawls, and then remove the back door finisher upper.
3. Remove back door finisher lower.

BACK DOOR TRIM

< REMOVAL AND INSTALLATION >

[COUPE (REGULAR GRADE)]

1. Remove the cap of back door finisher hook (1) with a small flat-bladed screwdriver (A) wrapped into a tape (B).

 : Pawl

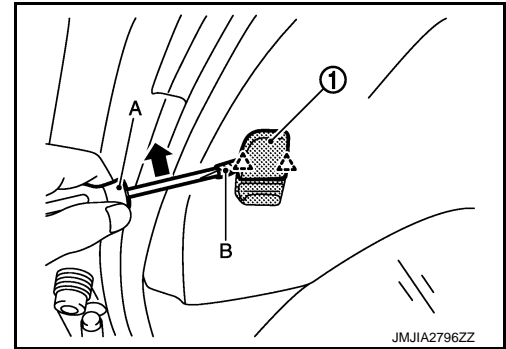

2. Remove the mounting bolt.

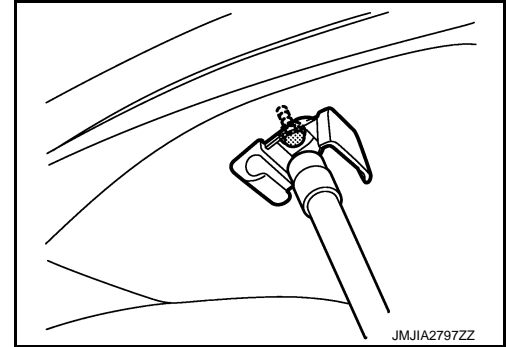

3. Remove back door finisher hook with remover tool.

 : Pawl

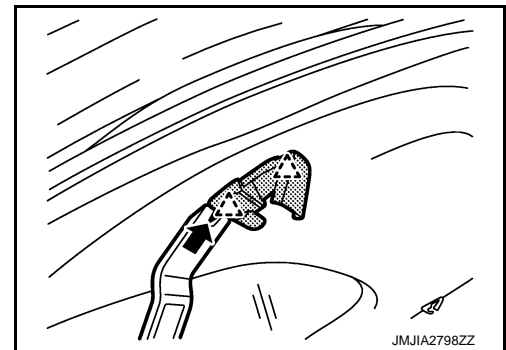

4. Insert a remover tool between back door panel and back door finisher lower to disengage the pawls and clips and remove the back door finisher lower.
4. Insert a remover tool between back door panel and back door finisher side to disengage the pawls, and the remove the back door finisher side (LH and RH).

INSTALLATION

Install in the reverse order of removal.

< SPEC CHANGE INFORMATION >

SPEC CHANGE INFORMATION

REAR TRIM

Serialized Authenticity Plate

INFOID:000000008195038

- NISMO Serialized Authenticity Plate is placed on the rear parcel shelf finisher.

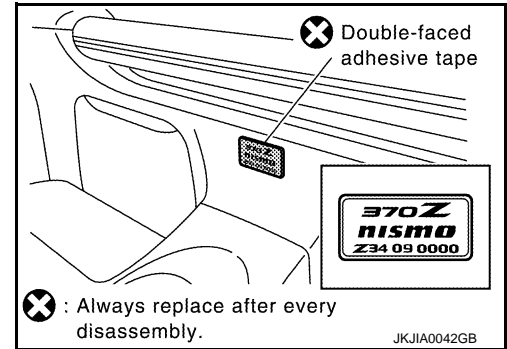

A
B
C
D
E
F
G
H
I
INT
K
L
M
N
O
P

PRECAUTION

PRECAUTIONS
FOR USA AND CANADA

FOR USA AND CANADA : Precaution for Supplemental Restraint System (SRS) "AIR BAG" and "SEAT BELT PRE-TENSIONER"

INFOID:000000008195039

The Supplemental Restraint System such as "AIR BAG" and "SEAT BELT PRE-TENSIONER", used along with a front seat belt, helps to reduce the risk or severity of injury to the driver and front passenger for certain types of collision. This system includes seat belt switch inputs and dual stage front air bag modules. The SRS system uses the seat belt switches to determine the front air bag deployment, and may only deploy one front air bag, depending on the severity of a collision and whether the front occupants are belted or unbelted. Information necessary to service the system safely is included in the "SRS AIR BAG" and "SEAT BELT" of this Service Manual.

WARNING:

Always observe the following items for preventing accidental activation.

- To avoid rendering the SRS inoperative, which could increase the risk of personal injury or death in the event of a collision that would result in air bag inflation, all maintenance must be performed by an authorized NISSAN/INFINITI dealer.
- Improper maintenance, including incorrect removal and installation of the SRS, can lead to personal injury caused by unintentional activation of the system. For removal of Spiral Cable and Air Bag Module, see "SRS AIR BAG".
- Never use electrical test equipment on any circuit related to the SRS unless instructed to in this Service Manual. SRS wiring harnesses can be identified by yellow and/or orange harnesses or harness connectors.

PRECAUTIONS WHEN USING POWER TOOLS (AIR OR ELECTRIC) AND HAMMERS

WARNING:

Always observe the following items for preventing accidental activation.

- When working near the Air Bag Diagnosis Sensor Unit or other Air Bag System sensors with the ignition ON or engine running, never use air or electric power tools or strike near the sensor(s) with a hammer. Heavy vibration could activate the sensor(s) and deploy the air bag(s), possibly causing serious injury.
- When using air or electric power tools or hammers, always switch the ignition OFF, disconnect the battery, and wait at least 3 minutes before performing any service.

FOR USA AND CANADA : Precaution for Battery Service

INFOID:000000008195040

Before disconnecting the battery, lower both the driver and passenger windows. This will prevent any interference between the window edge and the vehicle when the door is opened/closed. During normal operation, the window slightly raises and lowers automatically to prevent any window to vehicle interference. The automatic window function will not work with the battery disconnected.

FOR USA AND CANADA : Precaution for Procedure without Cowl Top Cover

INFOID:000000008195041

When performing the procedure after removing cowl top cover, cover the lower end of windshield with urethane, etc to prevent damage to windshield.

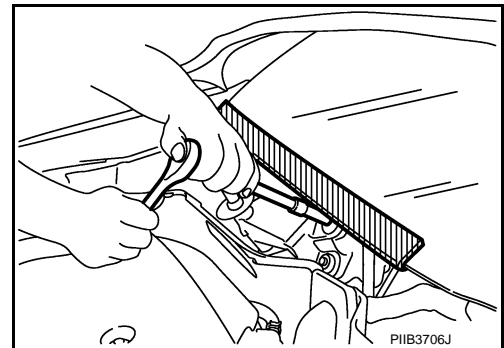

PRECAUTIONS

[ROADSTER]

< PRECAUTION >

FOR USA AND CANADA : Precaution for Work

INFOID:000000008195042

- After removing and installing the opening/closing parts, be sure to carry out fitting adjustments to check their operation.
- Check the lubrication level, damage, and wear of each part. If necessary, grease or replace it.

FOR MEXICO

FOR MEXICO : Precaution for Supplemental Restraint System (SRS) "AIR BAG" and "SEAT BELT PRE-TENSIONER"

INFOID:000000008195043

The Supplemental Restraint System such as "AIR BAG" and "SEAT BELT PRE-TENSIONER", used along with a front seat belt, helps to reduce the risk or severity of injury to the driver and front passenger for certain types of collision. Information necessary to service the system safely is included in the "SRS AIR BAG" and "SEAT BELT" of this Service Manual.

WARNING:

Always observe the following items for preventing accidental activation.

- To avoid rendering the SRS inoperative, which could increase the risk of personal injury or death in the event of a collision that would result in air bag inflation, all maintenance must be performed by an authorized NISSAN/INFINITI dealer.
- Improper maintenance, including incorrect removal and installation of the SRS, can lead to personal injury caused by unintentional activation of the system. For removal of Spiral Cable and Air Bag Module, see "SRS AIR BAG".
- Never use electrical test equipment on any circuit related to the SRS unless instructed to in this Service Manual. SRS wiring harnesses can be identified by yellow and/or orange harnesses or harness connectors.

PRECAUTIONS WHEN USING POWER TOOLS (AIR OR ELECTRIC) AND HAMMERS

WARNING:

Always observe the following items for preventing accidental activation.

- When working near the Air Bag Diagnosis Sensor Unit or other Air Bag System sensors with the ignition ON or engine running, never use air or electric power tools or strike near the sensor(s) with a hammer. Heavy vibration could activate the sensor(s) and deploy the air bag(s), possibly causing serious injury.
- When using air or electric power tools or hammers, always switch the ignition OFF, disconnect the battery, and wait at least 3 minutes before performing any service.

FOR MEXICO : Precaution for Battery Service

INFOID:000000008195044

Before disconnecting the battery, lower both the driver and passenger windows. This will prevent any interference between the window edge and the vehicle when the door is opened/closed. During normal operation, the window slightly raises and lowers automatically to prevent any window to vehicle interference. The automatic window function will not work with the battery disconnected.

FOR MEXICO : Precaution for Procedure without Cowl Top Cover

INFOID:000000008195045

When performing the procedure after removing cowl top cover, cover the lower end of windshield with urethane, etc.

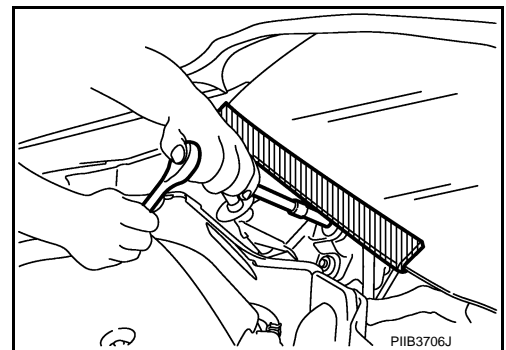

FOR MEXICO : Precaution for Work

INFOID:000000008195046

- After removing and installing the opening/closing parts, be sure to carry out fitting adjustments to check their operation.

PRECAUTIONS

[ROADSTER]

< PRECAUTION >

-
- Check the lubrication level, damage, and wear of each part. If necessary, grease or replace it.

PREPARATION

< PREPARATION >

[ROADSTER]

PREPARATION

PREPARATION

Special Service Tools

INFOID:000000008195047

The actual shapes of Kent-Moore tools may differ from those of special service tools illustrated here.

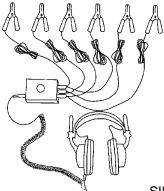
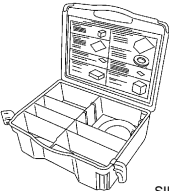
Tool number (Kent-Moore No.) Tool name	Description
<p>(J-39570) Chassis ear</p>  <p>SIIA0993E</p>	<p>Locates the noise</p>
<p>(J-43980) NISSAN Squeak and Rattle Kit</p>  <p>SIIA0994E</p>	<p>Repairs the cause of noise</p>

Commercial Service Tools

INFOID:000000008195048

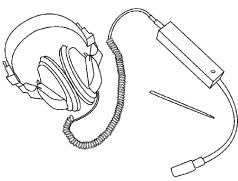
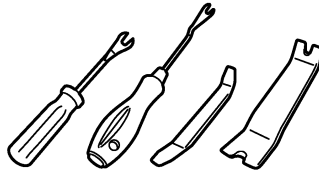
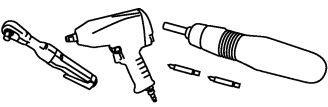
Tool name	Description
<p>Engine ear</p>  <p>SIIA0995E</p>	<p>Locates the noise</p>
<p>Remover tool</p>  <p>JMKIA3050ZZ</p>	<p>Removes clips, pawls and metal clips</p>
<p>Power tool</p>  <p>PIIB1407E</p>	

CLIP LIST

< PREPARATION >

[ROADSTER]

CLIP LIST

Clip List

INFOID:000000008195049

Shapes	Removal & Installation	Shapes	Removal & Installation
	<p>Removal: Remove by bending up with flat-bladed screwdrivers or clip remover.</p>		<p>Removal:</p>
	<p>Removal: Remove with a clip remover.</p>		<p>Removal:</p>
	<p>Removal: Push center pin to catching position. (Do not remove center pin by hitting it.)</p> <p>Installation:</p>		<p>Removal: Holder portion of clip must be spread out to remove rod.</p>
	<p>Removal: Remove by bending up with flat-bladed screwdrivers or clip remover.</p>		<p>Removal:</p> <ol style="list-style-type: none"> Screw out with a Phillips screwdriver. Remove female portion with flat-bladed screwdriver.
	<p>Removal:</p>		<p>Removal:</p> <p>Rotate 45° to remove.</p> <p>Installation:</p>
	<p>Removal:</p>		<p>Removal:</p>

JMJIA3734GB

SYMPTOM DIAGNOSIS

SQUEAK AND RATTLE TROUBLE DIAGNOSES

Work Flow

INFOID:000000008195050

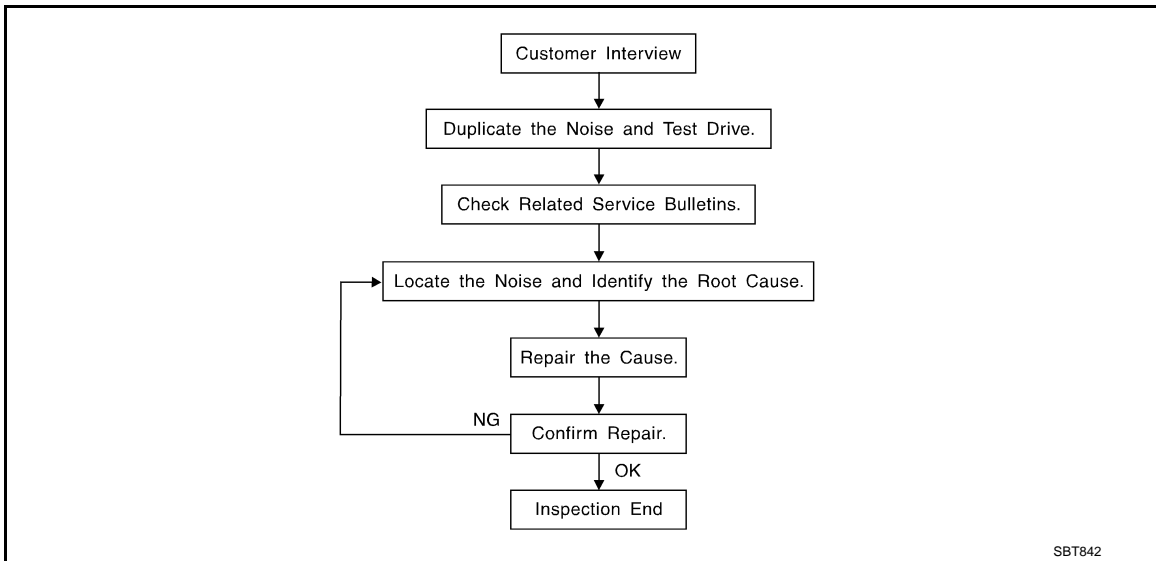

CUSTOMER INTERVIEW

Interview the customer if possible, to determine the conditions that exist when the noise occurs. Use the Diagnostic Worksheet during the interview to document the facts and conditions when the noise occurs and any customer comments. Refer to [INT-45. "Diagnostic Worksheet"](#). This information is necessary to duplicate the conditions that exist when the noise occurs.

- The customer may not be able to provide a detailed description or the location of the noise. Attempt to obtain all the facts and conditions that exist when the noise occurs (or does not occur).
- If there is more than one noise in the vehicle, perform a diagnosis and repair the noise that the customer is concerned about. This can be accomplished by performing a test drive with the customer.
- After identifying the type of noise, isolate the noise in terms of its characteristics. The noise characteristics are provided so that the customer, service adviser, and technician use the same language when describing the noise.
- Squeak – (Like tennis shoes on a clean floor)
Squeak characteristics include the light contact / fast movement / brought on by road conditions / hard surfaces = high-pitched noise / softer surfaces = low-pitched noises / edge to surface = chirping
- Creak – (Like walking on an old wooden floor)
Creak characteristics include firm contact / slow movement/twisting with a rotational movement / pitch dependent on materials / often brought on by activity.
- Rattle – (Like shaking a baby rattle)
Rattle characteristics include fast repeated contact / vibration or similar movement / loose parts/missing clip or fastener / incorrect clearance.
- Knock – (Like a knock on a door)
Knock characteristics include hollow sounds / sometimes repeating / often brought on by driver action.
- Tick – (Like a clock second hand)
Tick characteristics include gentle contacting of light materials / loose components / can be caused by driver action or road conditions.
- Thump – (Heavy, muffled knock noise)
Thump characteristics include softer knock / dull sounds often brought on by activity.
- Buzz – (Like a bumblebee)
Buzz characteristics include high frequency rattle / firm contact.
- Often the degree of acceptable noise level varies depending upon the person. A noise that a technician may judge as acceptable may be very irritating to a customer.
- Weather conditions, especially humidity and temperature, may have a great effect on noise level.

DUPLICATE THE NOISE AND TEST DRIVE

SQUEAK AND RATTLE TROUBLE DIAGNOSES

[ROADSTER]

< SYMPTOM DIAGNOSIS >

If possible, drive the vehicle with the customer until the noise is duplicated. Note any additional information on the Diagnostic Worksheet regarding the conditions or location of the noise. This information can be used to duplicate the same conditions when the repair is reconfirmed.

If the noise can be duplicated easily during the test drive, to help identify the source of the noise, try to duplicate the noise with the vehicle stopped by doing one or all of the following items:

- 1) Close a door.
 - 2) Tap or push/pull around the area where the noise appears to be coming from.
 - 3) Rev the engine.
 - 4) Use a floor jack to recreate vehicle "twist".
 - 5) At idle, apply engine load (electrical load, half-clutch on M/T models, drive position on A/T models).
 - 6) Raise the vehicle on a hoist and hit a tire with a rubber hammer.
- Drive the vehicle and attempt to duplicate the conditions the customer states exist when the noise occurs.
 - If it is difficult to duplicate the noise, drive the vehicle slowly on an undulating or rough road to stress the vehicle body.

CHECK RELATED SERVICE BULLETINS

After verifying the customer concern or symptom, check ASIST for Technical Service Bulletins (TSBs) related to the concern or symptom.

If a TSB relates to the symptom, follow the procedure to repair the noise.

LOCATE THE NOISE AND IDENTIFY THE ROOT CAUSE

1. Narrow down the noise to a general area. To help pinpoint the source of the noise, use a listening tool (Chassis ear: J-39570, engine ear, and mechanics stethoscope).
2. Narrow down the noise to a more specific area and identify the cause of the noise by:
 - Removing the component(s) in the area that is / are suspected to be the cause of the noise.
Do not use too much force when removing clips and fasteners, otherwise clips and fasteners can be broken or lost during the repair, resulting in the creation of new noise.
 - Tapping or pushing/pulling the component(s) that is / are suspected to be the cause of the noise.
Do not tap or push/pull the component(s) with excessive force, otherwise the noise is eliminated only temporarily.
 - Feeling for a vibration by hand by touching the component(s) that is / are suspected to be the cause of the noise.
 - Placing a piece of paper between components that are suspected to be the cause of the noise.
 - Looking for loose components and contact marks.
Refer to [INT-43, "Inspection Procedure"](#).

REPAIR THE CAUSE

- If the cause is a loose component, tighten the component securely.
- If the cause is insufficient clearance between components:
 - Separate components by repositioning or loosening and retightening the components, if possible.
 - Insulate components with a suitable insulator such as urethane pads, foam blocks, felt cloth tape, or urethane tape. A NISSAN Squeak and Rattle Kit (J-43980) is available through the authorized NISSAN Parts Department.

CAUTION:

Never use excessive force as many components are constructed of plastic and may be damaged.

NOTE:

Always check with the Parts Department for the latest parts information.

The following materials are contained in the NISSAN Squeak and Rattle Kit (J-43980). Each item can be ordered separately as needed.

URETHANE PADS [1.5 mm (0.059 in) thick]

Insulates connectors, harness, etc.

- 76268-9E005: 100 × 135 mm (3.937 × 5.315 in)
- 76884-71L01: 60 × 85 mm (2.362 × 3.346 in)
- 76884-71L02: 15 × 25 mm (0.591 × 0.984 in)

INSULATOR (Foam blocks)

Insulates components from contact. Can be used to fill space behind a panel.

- 73982-9E000: 45 mm (1.772 in) thick, 50 × 50 mm (1.969 × 1.969 in)
- 73982-50Y00: 10 mm (0.394 in) thick, 50 × 50 mm (1.969 × 1.969 in)

INSULATOR (Light foam block)

80845-71L00: 30 mm (1.18 in) thick, 30 × 50 mm (1.181 × 1.969 in)

FELT CLOTHTAPE

SQUEAK AND RATTLE TROUBLE DIAGNOSES

[ROADSTER]

< SYMPTOM DIAGNOSIS >

Used to insulate where movement does not occur. Ideal for instrument panel applications.

- 68370-4B000: 15 × 25 mm (0.591 × 0.984 in) pad
- 68239-13E00: 5 mm (0.197 in) wide tape roll

The following materials, not found in the kit, can also be used to repair squeaks and rattles.

UHMW (TEFLON) TAPE

Insulates where slight movement is present. Ideal for instrument panel applications.

SILICONE GREASE

Used in place of UHMW tape that is visible or does not fit. Only lasts a few months.

SILICONE SPRAY

Used when grease cannot be applied.

DUCT TAPE

Used to eliminate movement.

CONFIRM THE REPAIR

After repair is complete, test drive the vehicle to confirm that the cause of noise is repaired by test driving the vehicle. Operate the vehicle under the same conditions as when the noise originally occurred. Refer to the notes on the Diagnostic Worksheet.

Inspection Procedure

INFOID:000000008195051

Refer to Table of Contents for specific component removal and installation information.

INSTRUMENT PANEL

Most incidents are caused by contact and movement between:

1. The cluster lid A and instrument panel
2. Acrylic lens and combination meter housing
3. Instrument panel to front pillar garnish
4. Instrument panel to windshield
5. Instrument panel mounting pins
6. Wiring harnesses behind the combination meter
7. A/C defroster duct and duct joint

These incidents can usually be located by tapping or moving the components to duplicate the noise or by pressing on the components while driving to stop the noise. Most of these incidents can be repaired by applying felt cloth tape or silicon spray (in hard to reach areas). Urethane pads can be used to insulate wiring harness.

CAUTION:

Never use silicone spray to isolate a squeak or rattle. If the area is saturated with silicone, the recheck of repair becomes impossible.

CENTER CONSOLE

Components to check include:

1. Shifter assembly cover to finisher
2. A/C control unit and cluster lid C
3. Wiring harnesses behind audio and A/C control unit

The instrument panel repair and isolation procedures also apply to the center console.

DOORS

Check the following items:

1. Finisher and inner panel making a slapping noise
2. Inside handle escutcheon connection to door finisher
3. Wiring harnesses tapping
4. Door striker out of alignment causing a popping noise on starts and stops

Tapping, moving the components, or pressing on them while driving to duplicate the conditions can isolate many of these incidents. The areas can usually be insulated with felt cloth tape or insulator foam blocks from the NISSAN Squeak and Rattle Kit (J-43980) to repair the noise.

TRUNK

Trunk noises are often caused by a loose jack or loose items put into the trunk by the customer.

In addition check for the following items:

A

B

C

D

E

F

G

H

I

INT

K

L

M

N

O

P

SQUEAK AND RATTLE TROUBLE DIAGNOSES

[ROADSTER]

< SYMPTOM DIAGNOSIS >

1. Trunk lid dumpers out of adjustment
2. Trunk lid striker out of adjustment
3. Trunk lid torsion bars knocking together
4. A loose license plate or bracket

Most of these incidents can be repaired by adjusting, securing, or insulating the item(s) or component(s) causing the noise.

SUNROOF/HEADLINING

Noises in the sunroof / headlining area can often be traced to one of the following items:

1. Sunroof lid, rail, linkage, or seals making a rattle or light knocking noise
2. Sunvisor shaft shaking in the holder
3. Front or rear windshield touching headlining and squeaking

Again, pressing on the components to stop the noise while duplicating the conditions can isolate most of these incidents. Repairs usually consist of insulating with felt cloth tape.

SEATS

When isolating seat noise it is important to note the position the seat is in and the load placed on the seat when the noise occurs. These conditions should be duplicated when verifying and isolating the cause of the noise.

Causes of seat noise include:

1. Headrest rods and holder
2. A squeak between the seat pad cushion and frame
3. The rear seatback lock and bracket

These noises can be isolated by moving or pressing on the suspected components while duplicating the conditions under which the noise occurs. Most of these incidents can be repaired by repositioning the component or applying urethane tape to the contact area.

UNDERHOOD

Some interior noise may be caused by components under the hood or on the engine wall. The noise is then transmitted into the passenger compartment.

Causes of transmitted underhood noise include:

1. Any component mounted to the engine wall
2. Components that pass through the engine wall
3. Engine wall mounts and connectors
4. Loose radiator mounting pins
5. Hood bumpers out of adjustment
6. Hood striker out of adjustment

These noises can be difficult to isolate since they cannot be reached from the interior of the vehicle. The best method is to secure, move, or insulate one component at a time and test drive the vehicle. Also, engine RPM or load can be changed to isolate the noise. Repairs can usually be made by moving, adjusting, securing, or insulating the component causing the noise.

SQUEAK AND RATTLE TROUBLE DIAGNOSES

< SYMPTOM DIAGNOSIS >

[ROADSTER]

Diagnostic Worksheet

INFOID:000000008195052



SQUEAK & RATTLE DIAGNOSTIC WORKSHEET

Dear Nissan Customer:

We are concerned about your satisfaction with your Nissan vehicle. Repairing a squeak or rattle sometimes can be very difficult. To help us fix your Nissan right the first time, please take a moment to note the area of the vehicle where the squeak or rattle occurs and under what conditions. You may be asked to take a test drive with a service advisor or technician to ensure we confirm the noise you are hearing.

I. WHERE DOES THE NOISE COME FROM? (circle the area of the vehicle)

The illustrations are for reference only, and may not reflect the actual configuration of your vehicle.

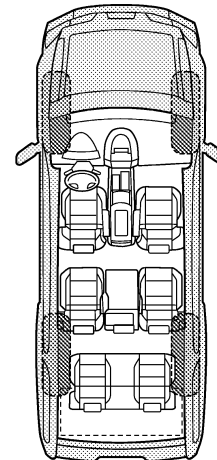
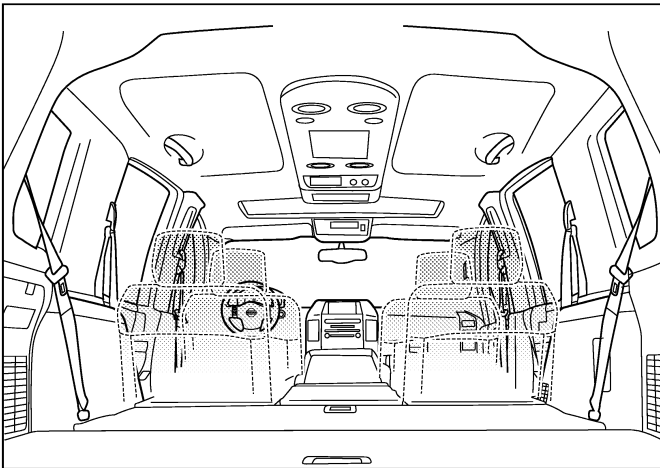
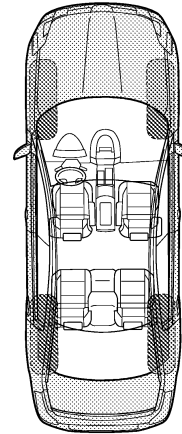
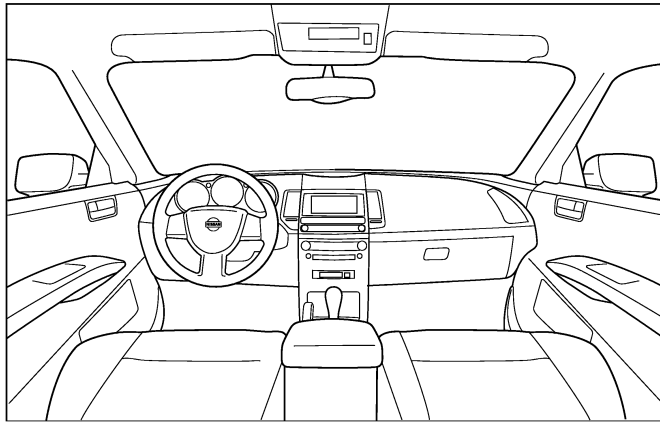

Continue to page 2 of the worksheet and briefly describe the location of the noise or rattle. In addition, please indicate the conditions which are present when the noise occurs.

PIIB8740E

A
B
C
D
E
F
G
H
I
INT
K
L
M
N
O
P

SQUEAK AND RATTLE TROUBLE DIAGNOSES

< SYMPTOM DIAGNOSIS >

[ROADSTER]

SQUEAK & RATTLE DIAGNOSTIC WORKSHEET - page 2

Briefly describe the location where the noise occurs:

II. WHEN DOES IT OCCUR? (please check the boxes that apply)

- | | |
|---|--|
| <input type="checkbox"/> anytime | <input type="checkbox"/> after sitting out in the rain |
| <input type="checkbox"/> 1st time in the morning | <input type="checkbox"/> when it is raining or wet |
| <input type="checkbox"/> only when it is cold outside | <input type="checkbox"/> dry or dusty conditions |
| <input type="checkbox"/> only when it is hot outside | <input type="checkbox"/> other: |

III. WHEN DRIVING:

- through driveways
- over rough roads
- over speed bumps
- only about ____ mph
- on acceleration
- coming to a stop
- on turns: left, right or either (circle)
- with passengers or cargo
- other: _____
- after driving ____ miles or ____ minutes

IV. WHAT TYPE OF NOISE

- squeak (like tennis shoes on a clean floor)
- creak (like walking on an old wooden floor)
- rattle (like shaking a baby rattle)
- knock (like a knock at the door)
- tick (like a clock second hand)
- thump (heavy, muffled knock noise)
- buzz (like a bumble bee)

TO BE COMPLETED BY DEALERSHIP PERSONNEL

Test Drive Notes:

	YES	NO	Initials of person performing
Vehicle test driven with customer	<input type="checkbox"/>	<input type="checkbox"/>	_____
- Noise verified on test drive	<input type="checkbox"/>	<input type="checkbox"/>	_____
- Noise source located and repaired	<input type="checkbox"/>	<input type="checkbox"/>	_____
- Follow up test drive performed to confirm repair	<input type="checkbox"/>	<input type="checkbox"/>	_____

VIN: _____ Customer Name: _____

W.O.# _____ Date: _____

This form must be attached to Work Order

PIIB8742E

REMOVAL AND INSTALLATION

DOOR FINISHER

Exploded View

INFOID:000000008195053

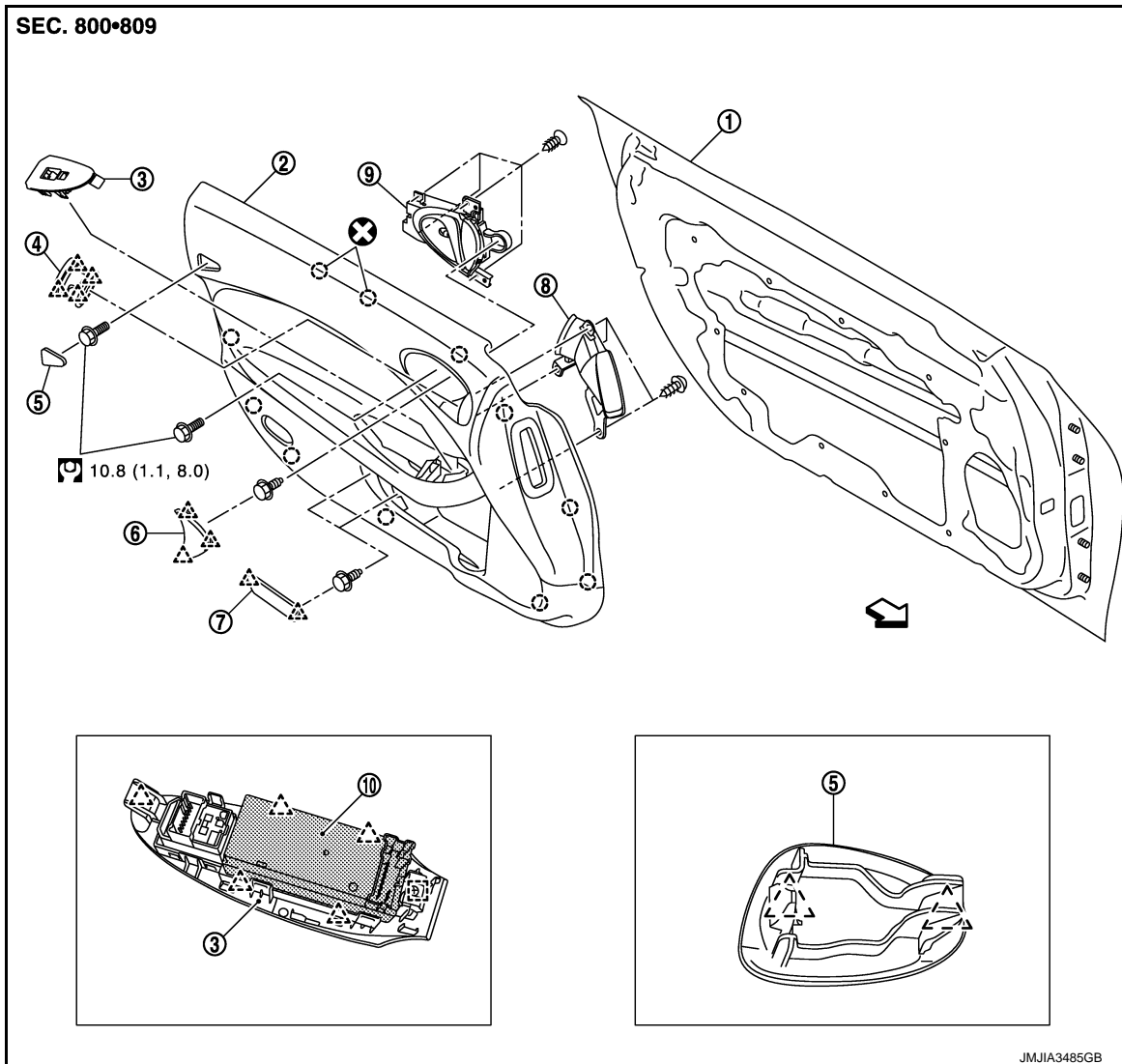

- | | | |
|------------------------------|-------------------------|--------------------------------------|
| 1. Door panel | 2. Door finisher | 3. Power window main switch finisher |
| 4. Side ventilator grille | 5. Door finisher cap | 6. Inside handle escutcheon |
| 7. Door grip mask | 8. Side ventilator duct | 9. Inside handle |
| 10. Power window main switch | | |

○ : Clip

△ : Pawl

□ : Metal clip

← : Vehicle front

⊗ : Always replace after every disassembly.

⊕ : N·m (kg·m, ft·lb)

A
B
C
D
E
F
G
H
I
INT
K
L
M
N
O
P

Removal and Installation

INFOID:000000008195054

WARNING:

- Before servicing, turn ignition switch OFF, disconnect battery negative terminal and wait 3 minutes or more.
- Never use the air tools or electric tools for servicing.

CAUTION:

- Wrap the tip of flat-bladed screwdriver with a shop cloth before removal.
- When removing, always use a remover tool that is made of plastic.

REMOVAL

1. Fully open door window.
2. Remove door finisher cap with a remover tool, and then remove door-mounted curtain air bag module mounting bolt.

 : Pawl

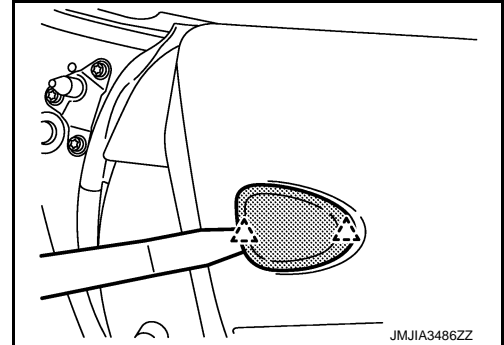

3. Remove inside handle escutcheon with a remover tool.

 : Pawl

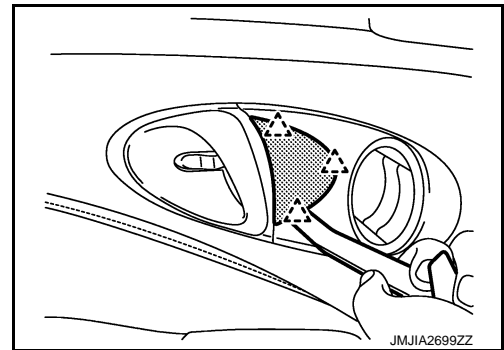

4. Remove door-mounted curtain air bag module mounting bolt (A) and inside handle mounting bolt (B).

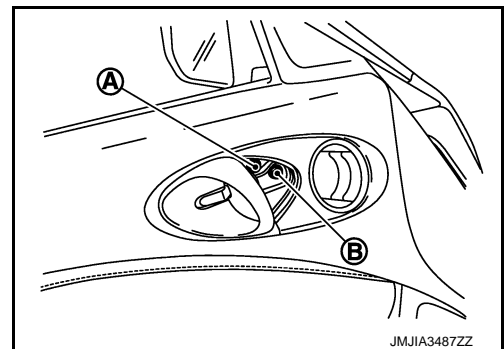

5. Remove door grip mask with a remover tool.

 : Pawl

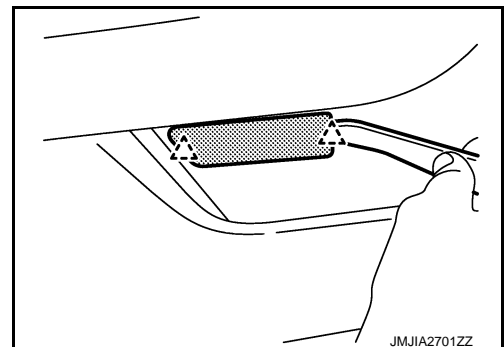

DOOR FINISHER

[ROADSTER]

< REMOVAL AND INSTALLATION >

6. Remove both bolts (A), located behind door grip mask.

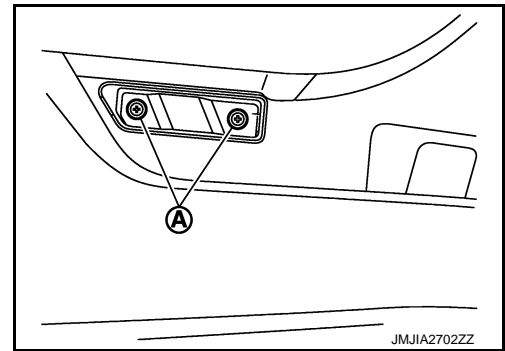

7. Remove power window main switch finisher with a remover tool, and then disconnect the harness connectors.

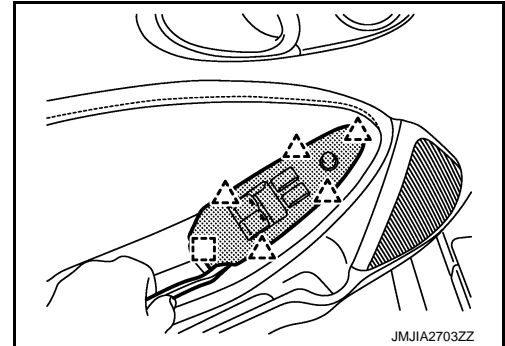
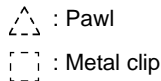

8. Insert a remover tool between the door panel and door finisher to disengage the clips.

CAUTION:

Insert a remover tool into the part shown in the figure. (Between the clips and the door panel)

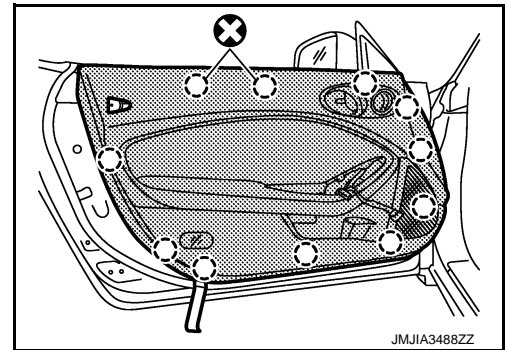
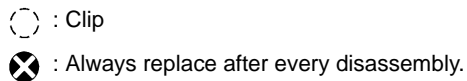

9. Pull slightly the door finisher, and disconnect first the door-mounted curtain air bag harness connector before disconnecting others harness connectors.

CAUTION:

- For installing or removing the door-mounted curtain air bag module harness connector, insert a flat-bladed screwdriver wrapped in tape into notch, lift lock and remove the connector.
- Install the connector with lock raised, and push lock into the connector.
- After installing the connector, check that the lock is pushed securely into it.

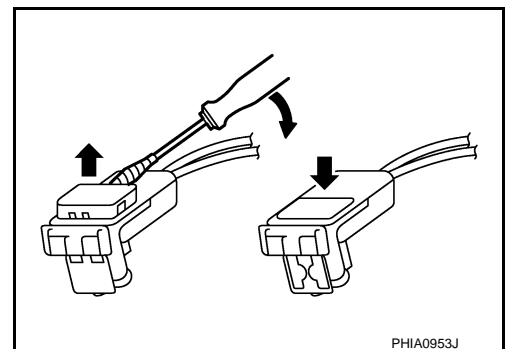

10. Disconnect lock knob cable and inside handle cable from inside handle. Refer to [DLK-338, "INSIDE HANDLE : Exploded View"](#).

11. Remove door finisher from door panel.

12. Remove the following parts after removing door finisher.

- Door inside handle assembly. Refer to [DLK-338, "INSIDE HANDLE : Removal and Installation"](#).
- Side ventilator duct. Refer to [VTL-8, "SIDE VENTILATOR DUCT : Removal and Installation"](#).
- Side ventilator grille. Refer to [VTL-7, "SIDE VENTILATOR GRILLE : Removal and Installation"](#).

CAUTION:

DOOR FINISHER

< REMOVAL AND INSTALLATION >

[ROADSTER]

- When removing, always use a remover tool that is made of plastic.
- Never impact the door-mounted curtain air bag module.
- Replace the door-mounted curtain air bag module if it has been dropped or sustained an impact.



- Never insert any foreign objects (screwdriver, etc.) into the door-mounted curtain air bag module.
- Never disassemble the door-mounted curtain air bag module.
- Never expose the door-mounted curtain air bag module to temperature exceeding 90 °C (194 °F).
- Never allow oil, grease, detergent, or water to come in contact with the door-mounted curtain air bag module.

INSTALLATION

Note the following items, and install in the reverse order of removal.

CAUTION:

- When removing door-mounted curtain air bag module from door finisher, never reuse door finisher.
- Never damage the harness while installing.
- When installing door finisher, check that all clips are securely fitted in panel holes on body, and then press them in.

BODY SIDE TRIM

Exploded View

INFOID:000000008195055

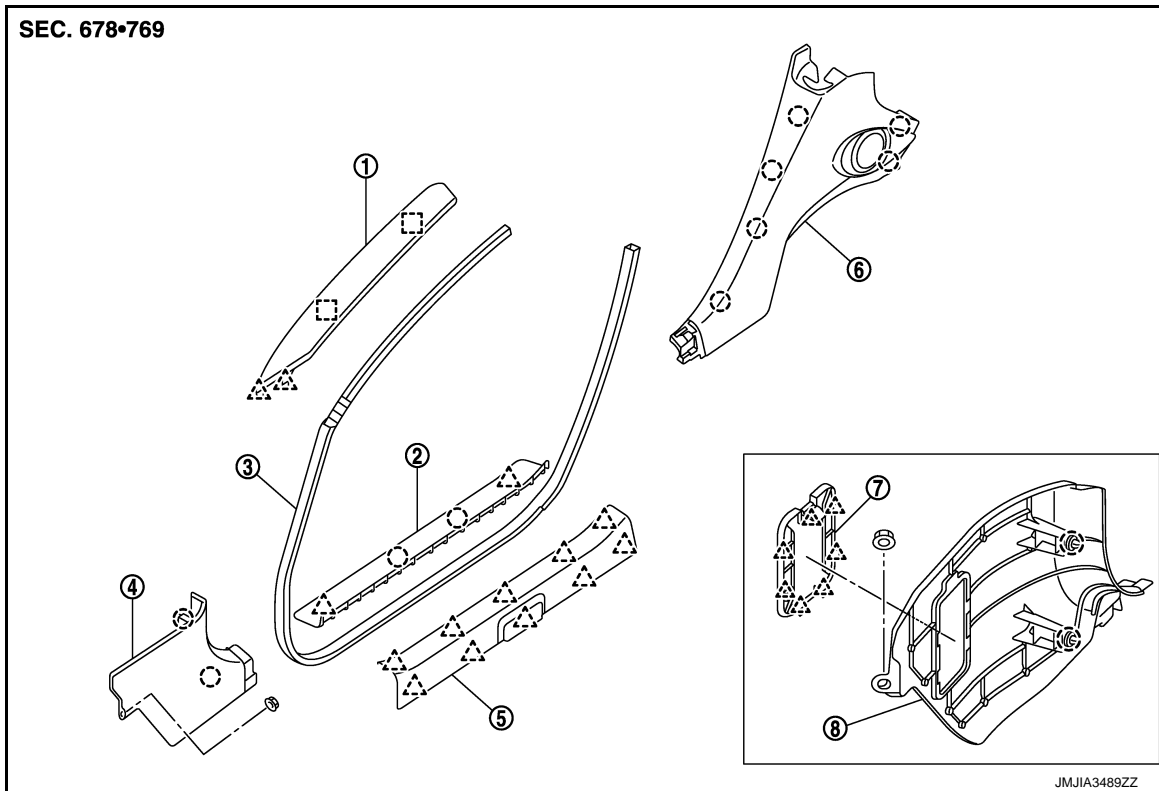

- | | | |
|--------------------------|--------------------------|-----------------------|
| 1. Front pillar garnish | 2. Kicking plate outer | 3. Body side welt |
| 4. Dash side finisher RH | 5. Kicking plate inner | 6. Rear side finisher |
| 7. Fuse lid | 8. Dash side finisher LH | |

- : Clip
- : Pawl
- : Metal clip

FRONT PILLAR GARNISH

FRONT PILLAR GARNISH : Removal and Installation

INFOID:000000008195056

CAUTION:

- When removing, always use a remover tool that is made of plastic.
- Never damage the body.

REMOVAL

1. Release front pillar portion of body side welt.

A
B
C
D
E
F
G
H
I
INT
K
L
M
N
O
P

BODY SIDE TRIM

< REMOVAL AND INSTALLATION >

[ROADSTER]

2. Disengage front pillar garnish fixing metal clips with remover tool, and then pull up front pillar garnish to remove the pawls.

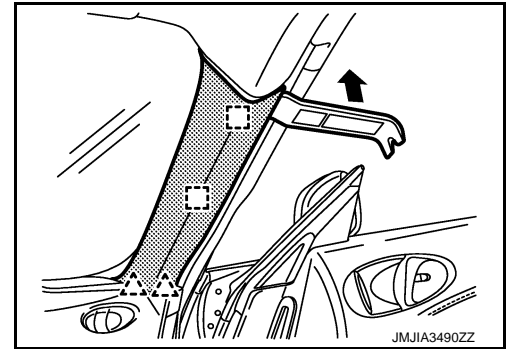
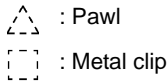

INSTALLATION

Note the following item, and install in the reverse order of removal.

CAUTION:

When installing, check that all pawls and metal clips are securely fitted in panel holes on body, and then press them in.

KICKING PLATE INNER

KICKING PLATE INNER : Removal and Installation

INFOID:000000008195057

CAUTION:

Never damage the body.

REMOVAL

1. While disengaging pawls in the rear and side of kicking plate inner, lift up the kicking plate inner toward upper side of the vehicle, and then disengage pawls in the rear half of kicking plate inner.

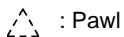
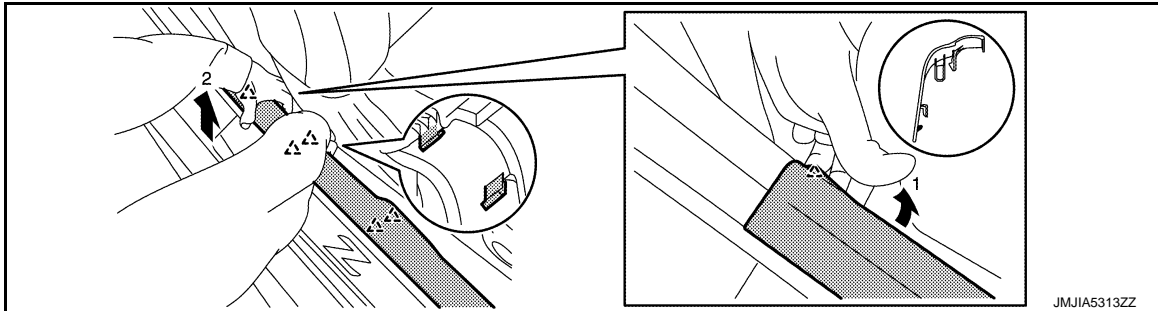

2. While disengaging pawls in the front and side of kicking plate inner, lift up the kicking plate inner toward upper side of the vehicle, disengage the remaining pawls, and then remove the kicking plate inner.

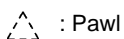
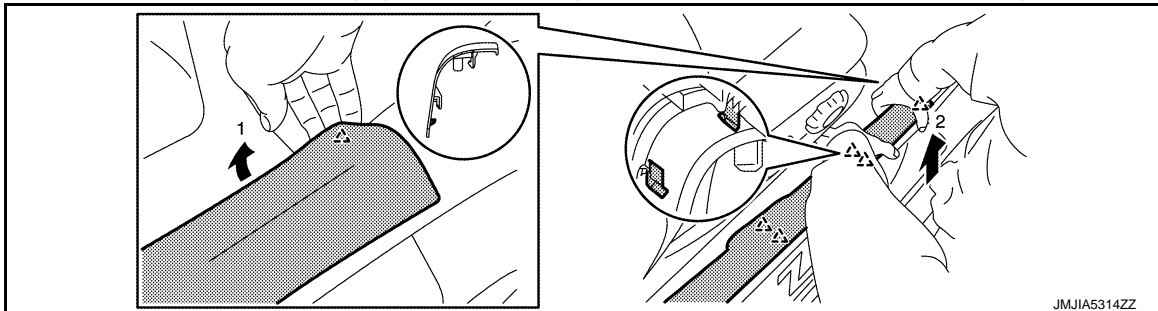

INSTALLATION

Note the following item, and install in the reverse order of removal.

CAUTION:

When installing, check that all pawls are securely fitted in panel holes on body, and then press them in.

KICKING PLATE OUTER

KICKING PLATE OUTER : Removal and Installation

INFOID:000000008195058

CAUTION:

- When removing, always use a remover tool that is made of plastic.
- Never damage the body.

REMOVAL

1. Disengage kicking plate outer fixing clips and pawls with a remover tool.
2. Remove kicking plate outer from body panel.

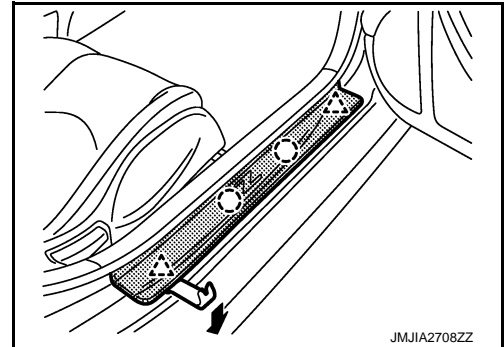
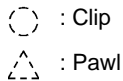

INSTALLATION

Note the following item, and install in the reverse order of removal.

CAUTION:

When installing, check that all clips and pawls are securely fitted in panel holes on body, and then press them in.

DASH SIDE FINISHER

DASH SIDE FINISHER : Removal and Installation

INFOID:000000008195059

CAUTION:

- When removing, always use a remover tool that is made of plastic.
- Never damage the body.

REMOVAL

1. Remove kicking plate inner. Refer to [INT-52, "KICKING PLATE INNER : Removal and Installation"](#).
2. Remove clip (A).
3. Remove dash side finisher (1) fixing clips with remover tool (B), and then remove dash side finisher.

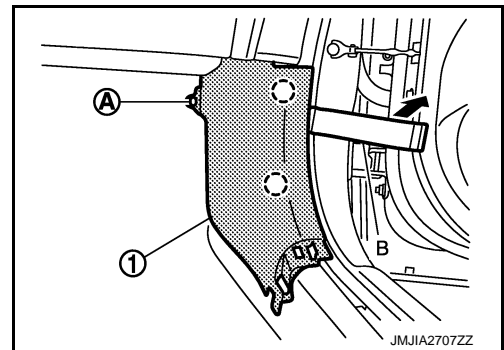
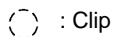

INSTALLATION

Note the following item, and install in the reverse order of removal.

CAUTION:

When installing, check that all clips are securely fitted in panel holes on body, and then press them in.

BODY SIDE WELT

BODY SIDE WELT : Removal and Installation

INFOID:000000008195060

CAUTION:

- When removing, always use a remover tool that is made of plastic.
- Never damage the body.

A
B
C
D
E
F
G
H
I
K
L
M
N
O
P

INT

< REMOVAL AND INSTALLATION >

REMOVAL

1. Remove kicking plate inner. Refer to [INT-52. "KICKING PLATE INNER : Removal and Installation"](#).
2. Remove body side welt.

INSTALLATION

Install in the reverse order of removal.

REAR SIDE FINISHER

REAR SIDE FINISHER : Removal and Installation

INFOID:000000008195061

CAUTION:

- When removing, always use a remover tool that is made of plastic.
- Never damage the body.

REMOVAL

1. Slide seat assembly toward the frontmost position (driver or passenger side).
2. Remove kicking plate inner. Refer to [INT-52. "KICKING PLATE INNER : Removal and Installation"](#).
3. Remove body side welt from rear side finisher. Refer to [INT-53. "BODY SIDE WELT : Removal and Installation"](#).
4. Remove the shoulder anchor. Refer to [SB-8. "SEAT BELT RETRACTOR : Removal and Installation"](#).
5. Remove rear side finisher.
 1. Disengage rear side finisher fixing clips with a remover tool as shown in the figure.
 2. Pull out carefully rear side finisher, and then disconnect side speaker connector located behind rear side finisher.
 3. Remove rear side finisher from body side panel.

 : Clip

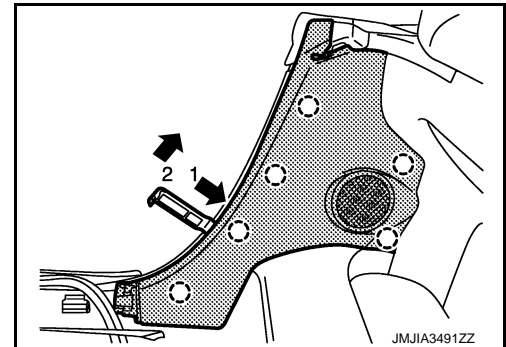

INSTALLATION

Note the following item, and install in the reverse order of removal.

CAUTION:

When installing, check that all clips are securely fitted in panel holes on body, and then press them in.

REAR TRIM

< REMOVAL AND INSTALLATION >

[ROADSTER]

REAR TRIM

Exploded View

INFOID:000000008195062

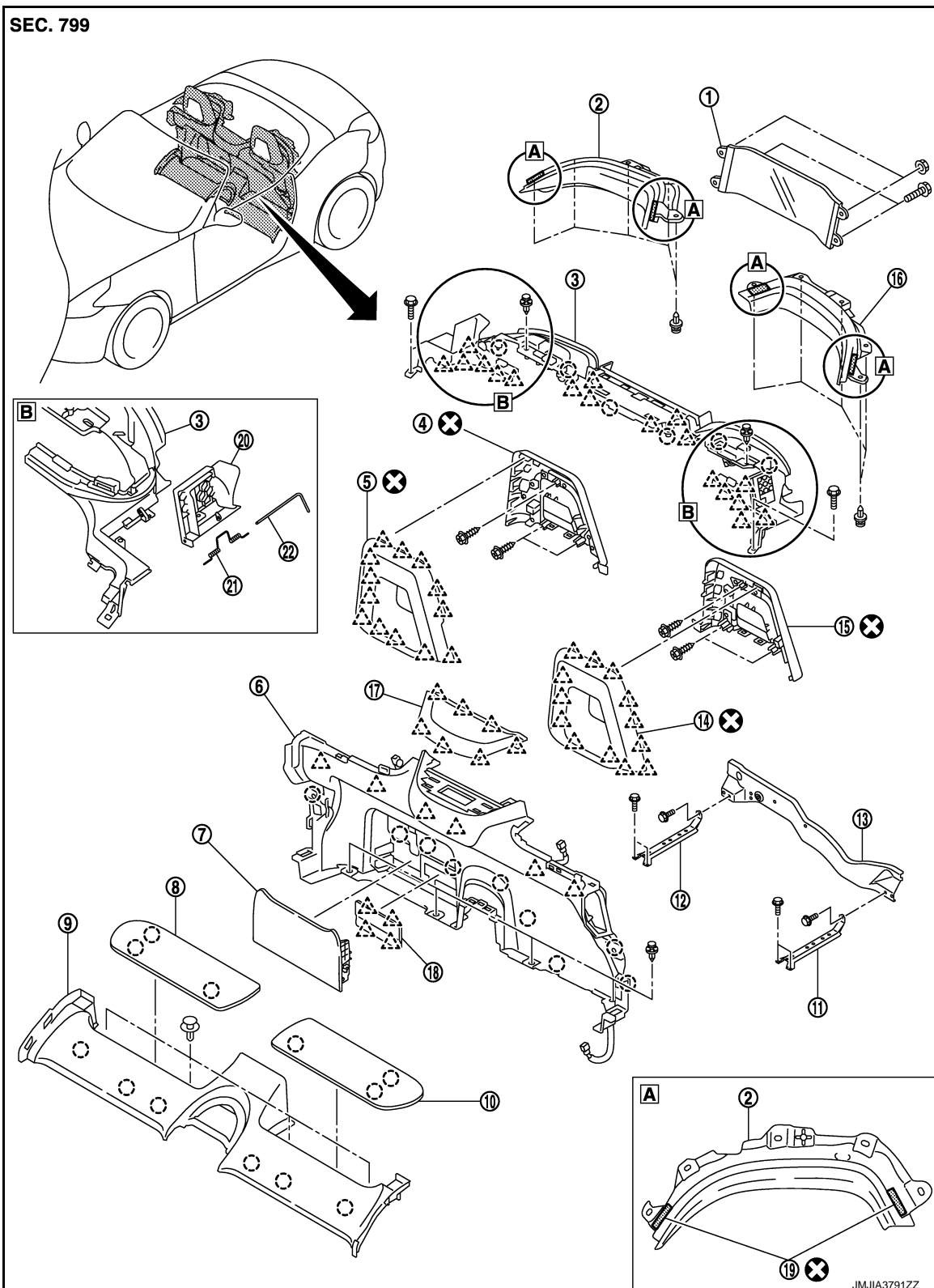

- | | | |
|----------------------------------|--|--|
| 1. Storage lid deflector | 2. Rear board parcel shelf side finisher | 3. Back trim assembly |
| | RH | |
| 4. Guard frame plate assembly RH | 5. Guard frame protector assembly RH | 6. Rear parcel shelf finisher assembly |

REAR TRIM

[ROADSTER]

< REMOVAL AND INSTALLATION >

- | | | |
|--|---------------------------------------|---------------------------------------|
| 7. Rear parcel shelf finisher holder | 8. Rear parcel shelf cover RH | 9. Seatback center finisher |
| 10. Rear parcel shelf cover LH | 11. Rear parcel shelf side bracket LH | 12. Rear parcel shelf side bracket RH |
| 13. Rear parcel shelf bracket | 14. Guard frame protector assembly LH | 15. Guard frame plate assembly LH |
| 16. Rear board parcel shelf side finisher LH | 17. Rear parcel shelf finisher cover | 18. Rear parcel shelf lid |
| 19. Double-sided tape | 20. Back trim lid | 21. Spring |
| 22. Shaft | | |

○ : Clip

△ : Pawl

⊗ : Always replace after every disassembly.

REAR BOARD PARCEL SHELF SIDE FINISHER

REAR BOARD PARCEL SHELF SIDE FINISHER : Removal and Installation

INFOID:000000008195063

REMOVAL

1. Stop storage lid assembly as shown in the figure. (during open operation).

CAUTION:

Storage lid assembly may close due to low oil pressure. Always support storage lid assembly in the fully open position.

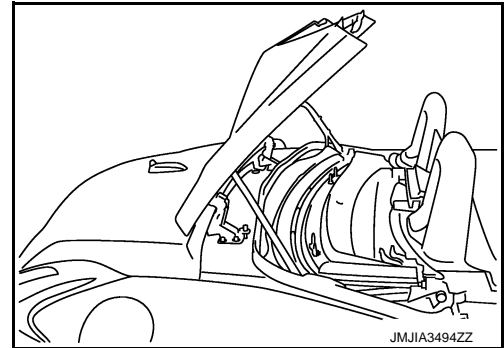

2. Remove rear board parcel shelf side finisher (1).
 1. Remove the fixing clips (A).
 2. Pull out to remove double-sided tapes (B) from storage lid assembly.
 3. Remove rear board parcel shelf side finisher from storage lid assembly.

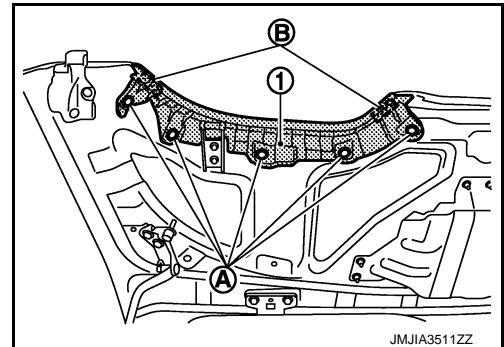

INSTALLATION

Note the following items, and install in the reverse order of removal.

CAUTION:

- Always replace double sided tape on the back surface when reusing rear board parcel shelf side finisher.
- Before installing the new double-side tape, wipe up the panel surface and apply primer.

GUARD FRAME PROTECTOR ASSEMBLY

GUARD FRAME PROTECTOR ASSEMBLY : Removal and Installation

INFOID:000000008195064

CAUTION:

Replace guard frame protector assembly with a new part after removal as it cannot be reused.

REMOVAL

REAR TRIM

[ROADSTER]

< REMOVAL AND INSTALLATION >

1. Stop storage lid assembly as shown in the figure. (during open operation).

CAUTION:

Storage lid assembly may close due to low oil pressure. Always support storage lid assembly in the fully open position.

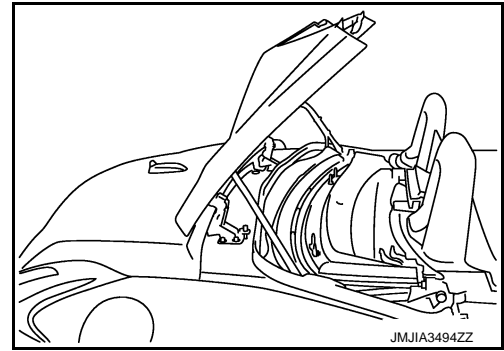

2. Disengage guard frame protector assembly (1) fixing pawls with a remover tool (A).

 : Pawl

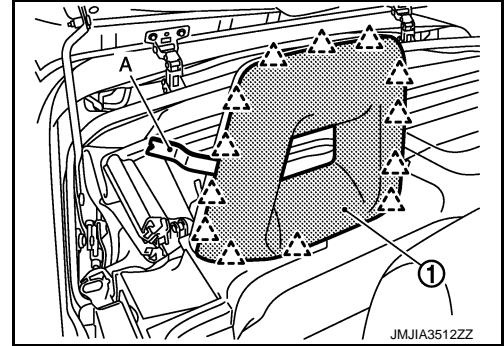

3. Remove guard frame protector assembly.

INSTALLATION

Install in the reverse order of removal.

GUARD FRAME PLATE ASSEMBLY

GUARD FRAME PLATE ASSEMBLY : Removal and Installation

INFOID:000000008195065

CAUTION:

Replace guard frame plate assembly with a new part after removal as it cannot be reused.

REMOVAL

1. Stop storage lid assembly as shown in the figure. (during open operation).

CAUTION:

Storage lid assembly may close due to low oil pressure. Always support storage lid assembly in the fully open position.

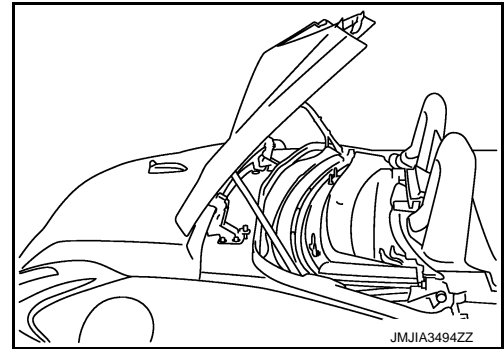

2. Disengage guard frame protector assembly (1) fixing pawls with a remover tool (A).

 : Pawl

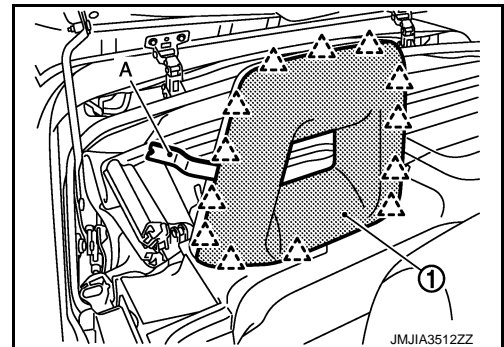

A
B
C
D
E
F
G
H
I
K
L
M
N
O
P

INT

REAR TRIM

[ROADSTER]

< REMOVAL AND INSTALLATION >

3. Remove guard frame protector assembly.
4. Remove guard frame plate assembly mounting bolts (A).

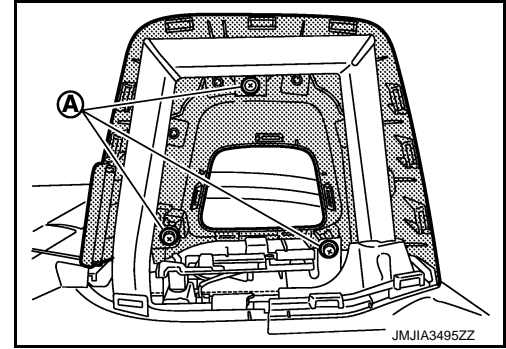

5. Remove guard frame plate assembly.

INSTALLATION

Install in the reverse order of removal.

STORAGE LID DEFLECTOR

STORAGE LID DEFLECTOR : Removal and Installation

INFOID:000000008195066

REMOVAL

1. Stop storage lid assembly as shown in the figure. (during open operation).

CAUTION:

Storage lid assembly may close due to low oil pressure. Always support storage lid assembly in the fully open position.

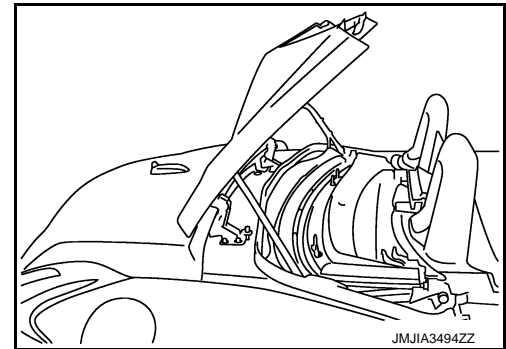

2. Disengage guard frame protector assembly (1) fixing pawls with a remover tool (A).

 : Pawl

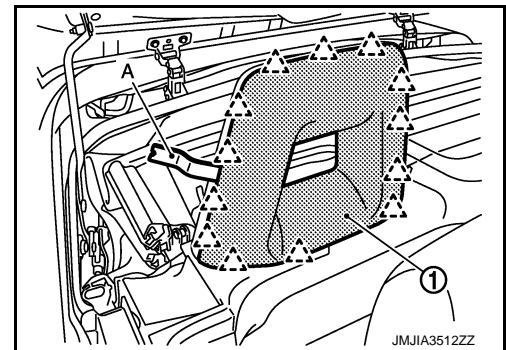

3. Remove guard frame protector assembly.
4. Remove guard frame plate assembly mounting bolts (A).

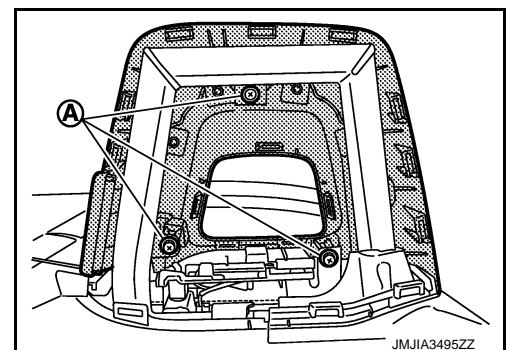

REAR TRIM

< REMOVAL AND INSTALLATION >

[ROADSTER]

5. Remove guard frame plate assembly.
6. Remove storage lid deflector (1) mounting nuts (A) and bolts (B), and then remove storage lid deflector.

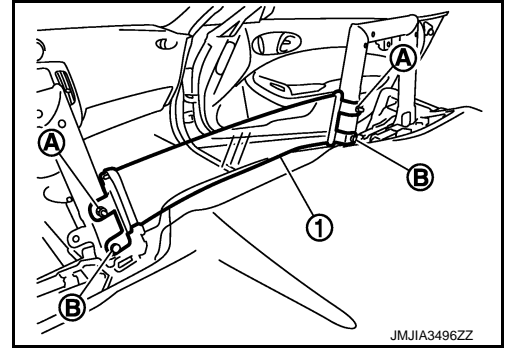

INSTALLATION

Install in the reverse order of removal.

REAR PARCEL SHELF FINISHER COVER

REAR PARCEL SHELF FINISHER COVER : Removal and Installation

INFOID:000000008195067

REMOVAL

1. Stop storage lid assembly as shown in the figure. (during open operation).

CAUTION:

Storage lid assembly may close due to low oil pressure. Always support storage lid assembly in the fully open position.

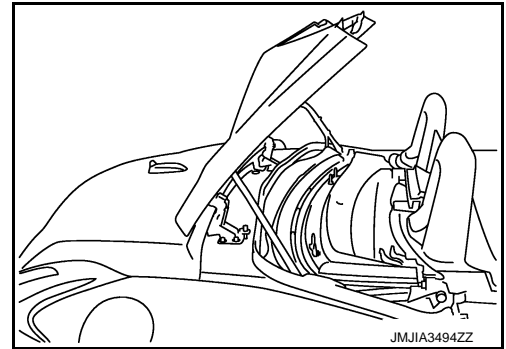

2. Disengage guard frame protector assembly (1) fixing pawls with a remover tool (A).

 : Pawl

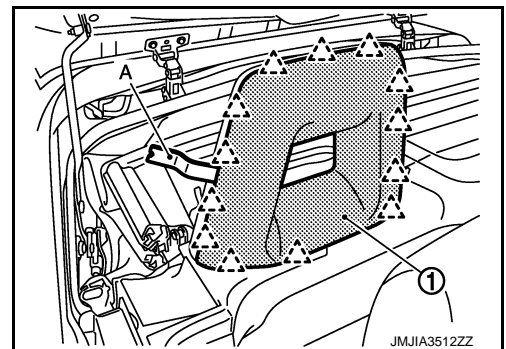

3. Remove guard frame protector assembly.
4. Remove guard frame plate assembly mounting bolts (A).

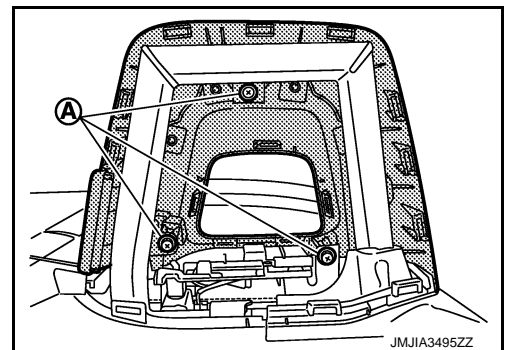

5. Remove guard frame plate assembly.

A
B
C
D
E
F
G
H
I
INT
K
L
M
N
O
P

REAR TRIM

[ROADSTER]

< REMOVAL AND INSTALLATION >

6. Remove storage lid deflector (1) mounting nuts (A) and bolts (B), and then remove storage lid deflector.

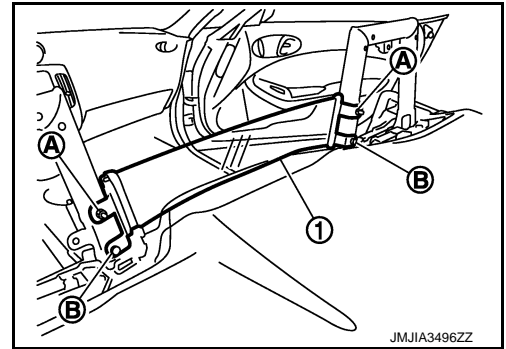

7. Disengage rear parcel shelf finisher cover fixing pawls with a remover tool (A) and then remove rear parcel shelf finisher cover.

NOTE:

- Remove according to the steps indicated in the figure to avoid damaging the fixing pawls.
- Apply protective tape (B) around rear parcel shelf finisher cover to protect the painted surface from damage.

 : Pawl

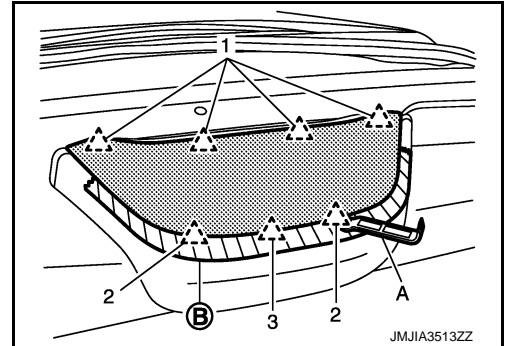

INSTALLATION

Note the following item, and install in the reverse order of removal.

CAUTION:

Check that all pawls are securely fitted in panel holes on body when installing, and then press them in.

REAR PARCEL SHELF COVER

REAR PARCEL SHELF COVER : Removal and Installation

INFOID:000000008195068

REMOVAL

1. Remove rear parcel shelf cover LH with remover tool as shown in the figure.

 : Clip

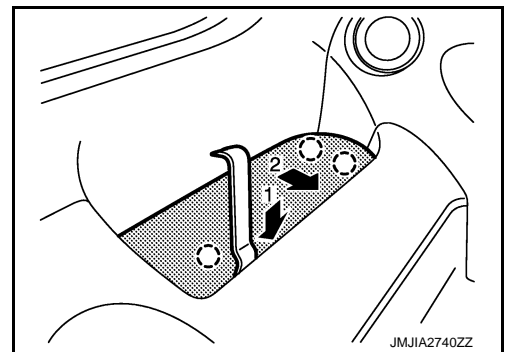

2. Remove rear parcel shelf finisher holder. Refer to [INT-60. "REAR PARCEL SHELF FINISHER HOLDER : Removal and Installation"](#).
3. Remove rear parcel shelf cover RH with a remover tool.

INSTALLATION

Note the following items, and install in the reverse order of removal.

CAUTION:

Check that clips are securely fitted in panel holes on body when installing, and then press them in.

REAR PARCEL SHELF FINISHER HOLDER

REAR PARCEL SHELF FINISHER HOLDER : Removal and Installation

INFOID:000000008195069

REMOVAL

REAR TRIM

< REMOVAL AND INSTALLATION >

[ROADSTER]

1. Fully open rear parcel shelf finisher holder in three steps as shown in the figure below. (Approximately 45 degree)
2. Pull back to remove.

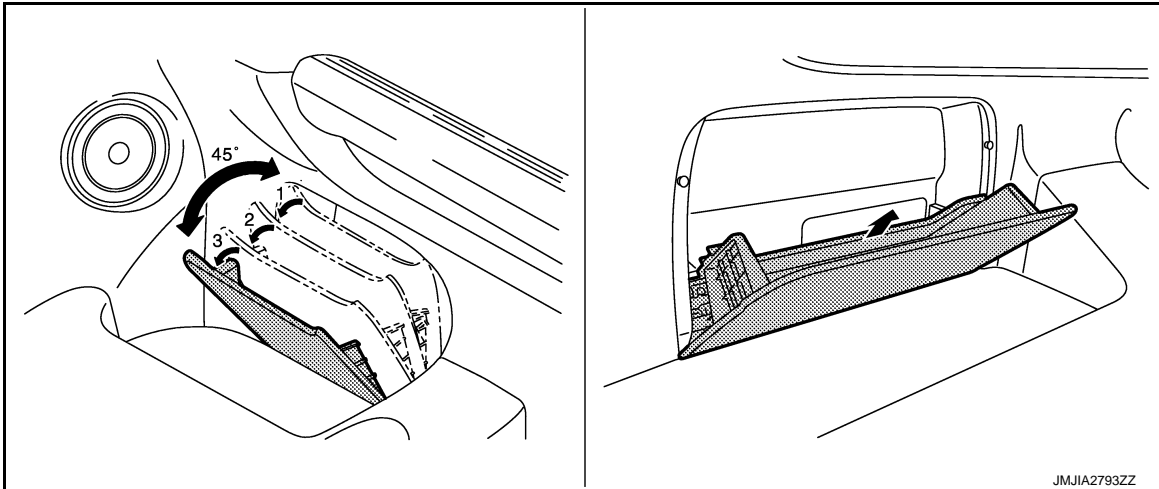

3. Remove rear parcel shelf lid.

INSTALLATION

Install in the reverse order of removal.

SEATBACK CENTER FINISHER

SEATBACK CENTER FINISHER : Removal and Installation

INFOID:000000008195070

REMOVAL

1. Remove both seat assembly. Refer to [SE-71, "Removal and Installation"](#).
2. Remove center console assembly. Refer to [IP-26, "Removal and Installation"](#).
3. Remove rear side finisher (LH and RH). Refer to [INT-54, "REAR SIDE FINISHER : Removal and Installation"](#).
4. Remove rear parcel shelf cover (LH and RH). Refer to [INT-60, "REAR PARCEL SHELF COVER : Removal and Installation"](#).
5. Remove seatback center finisher fixing clips.
6. Remove rear side finisher speaker harness connector (A) from seatback center finisher (1) as shown in the figure.

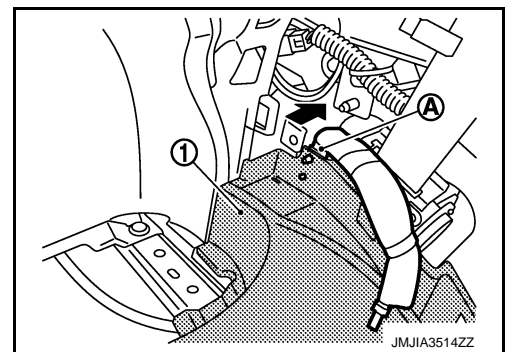

7. Pull seatback center finisher up to remove.

INSTALLATION

Note the following item, and install in the reverse order of removal.

CAUTION:

Check that clips are securely fitted in panel holes on body when installing, and then press them in.

BACK TRIM ASSEMBLY

BACK TRIM ASSEMBLY : Removal and Installation

INFOID:000000008195071

REMOVAL

REAR TRIM

[ROADSTER]

< REMOVAL AND INSTALLATION >

1. Stop storage lid assembly as shown in the figure. (soft top is halfway closed).

CAUTION:

Storage lid assembly may close due to low oil pressure. Always support storage lid assembly in the fully open position.

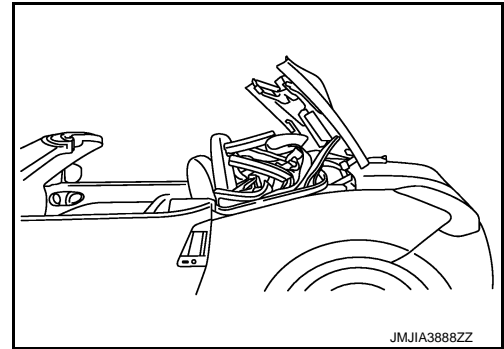

2. Remove mounting clip (A) of flipper door cable.

CAUTION:

Be careful not to drop mounting clips into storage room.

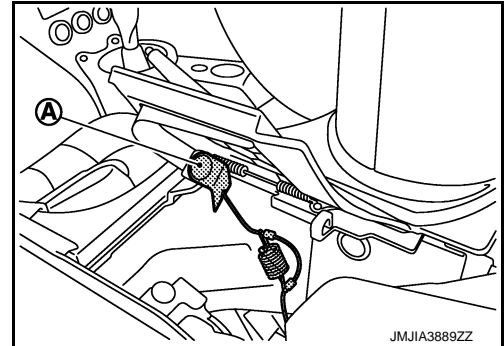

3. Stop storage lid assembly as shown in the figure. (soft top is fully closed).

CAUTION:

Storage lid assembly may close due to low oil pressure. Always support storage lid assembly in the fully open position.

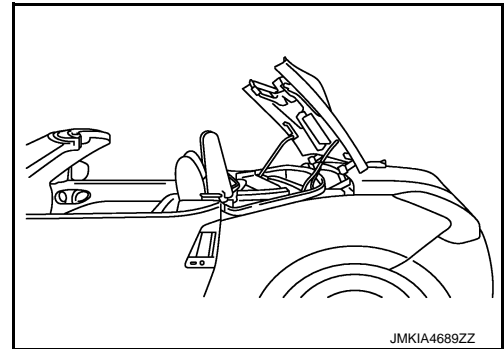

4. Disengage guard frame protector assembly (1) fixing pawls with a remover tool (A).

 : Pawl

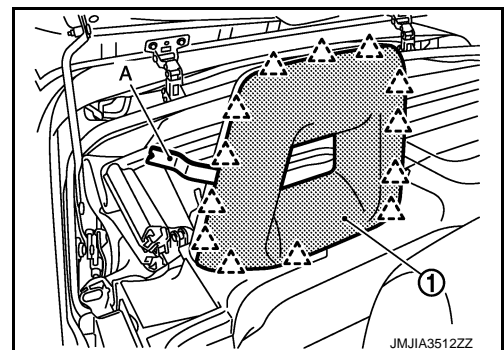

5. Remove guard frame protector assembly.

REAR TRIM

< REMOVAL AND INSTALLATION >

[ROADSTER]

6. Remove guard frame plate assembly mounting bolts (A).

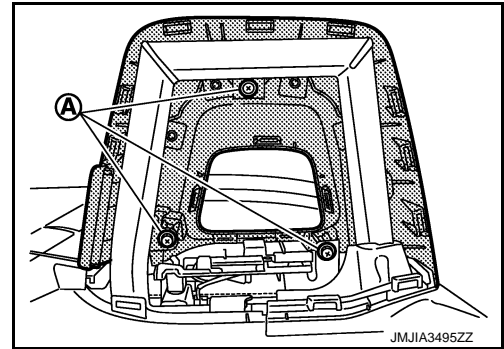

7. Remove guard frame plate assembly.
8. Remove storage lid deflector (1) mounting nuts (A) and bolts (B), and then remove storage lid deflector.

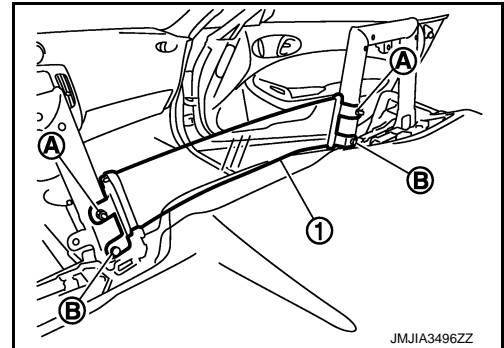

9. Disengage rear parcel shelf finisher cover fixing pawls with a remover tool (A) and then remove rear parcel shelf finisher cover.
1. Disengage pawls on vehicle rear side.
2. Disengage pawls on both ends of vehicle front side.
3. Disengage pawl on center of vehicles front side.

CAUTION:

Apply protective tape (B) around rear parcel shelf finisher cover to protect the painted surface from damage.

 : Pawl

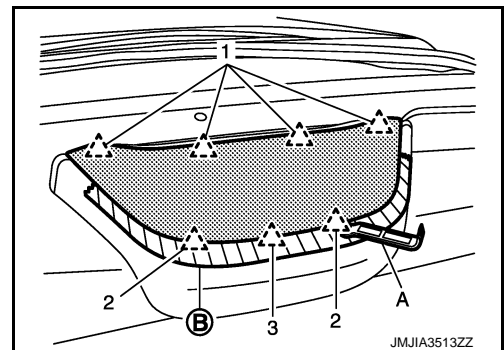

10. Remove rear side finisher (LH and RH). Refer to [INT-54. "REAR SIDE FINISHER : Removal and Installation"](#).
11. Remove back trim assembly.
1. Remove both mounting bolts as shown by the figure below.
2. Disengage all clips and pawls.
3. Disconnect outside key antenna connector. Refer to [DLK-182. "DOOR LOCK : Component Parts Location"](#).

REAR TRIM

< REMOVAL AND INSTALLATION >

[ROADSTER]

4. Pull up back trim assembly from one side to the other side and remove back trim assembly.

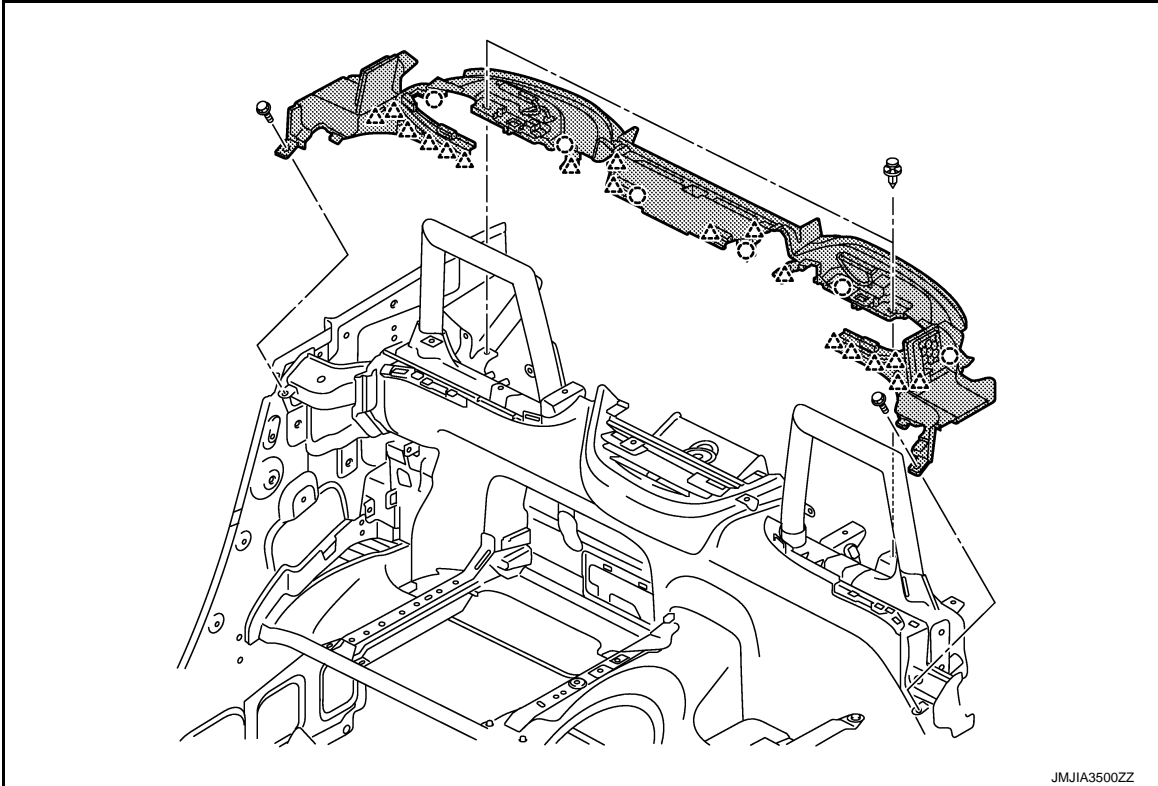

- : Clip
- △ : Pawl

INSTALLATION

Note the following items, and install in the reverse order of removal.

CAUTION:

- Check that clips are securely fitted in panel holes on body when installing, and then press them in.
- Fully close the back trim lid (1).
- Set clearance (B) of front and of back trim lid to 1.5 mm and tighten bolts (A).

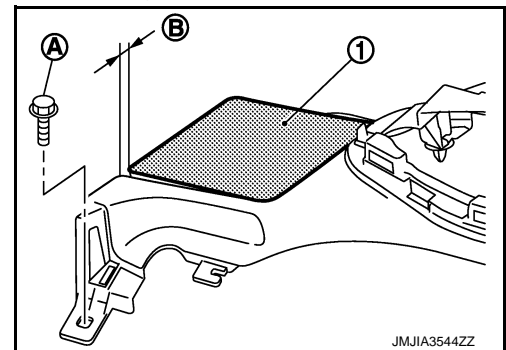

Removal and installation of back trim lid

REMOVAL

REAR TRIM

< REMOVAL AND INSTALLATION >

[ROADSTER]

1. Set soft top assembly to the status (soft top is halfway closed) as shown in the figure.

CAUTION:

Storage lid may close due to low oil pressure. Always support storage lid in the fully open position using a supporting block.

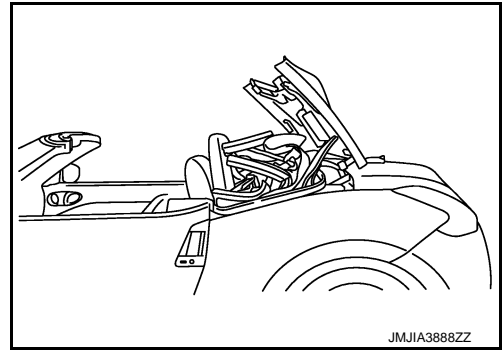

2. Remove mounting clip (A) of flipper door cable.

CAUTION:

Be careful not to drop mounting clips into storage room.

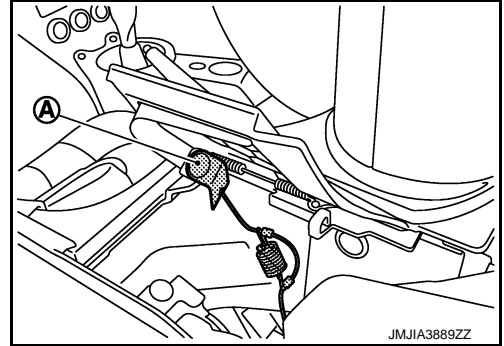

3. Set storage lid to the status (soft top is fully closed) as shown in the figure.

CAUTION:

Storage lid may close due to low oil pressure. Always support storage lid in the fully open position using a supporting block.

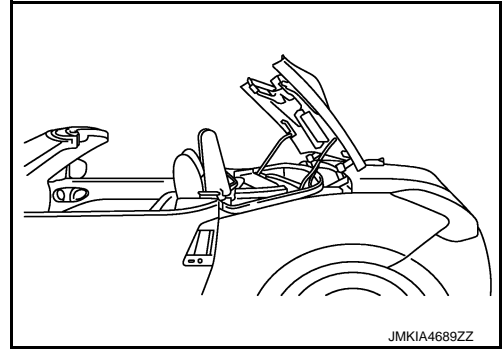

4. Disengage shaft (2) from pawl portion (A) of back trim lid (1). Remove shaft toward vehicle rear.

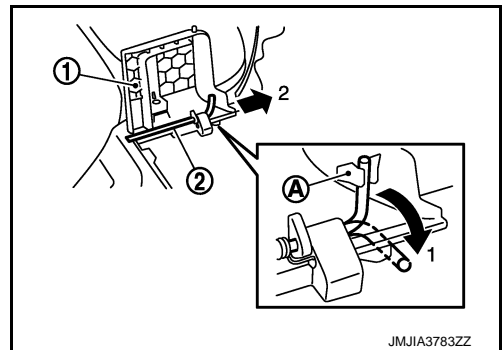

5. Remove spring.

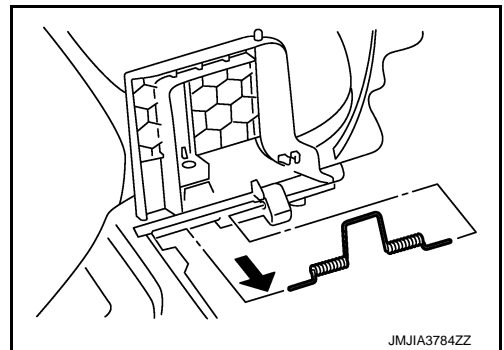

A
B
C
D
E
F
G
H
I
INT
K
L
M
N
O
P

REAR TRIM

< REMOVAL AND INSTALLATION >

[ROADSTER]

6. Remove back trim lid.

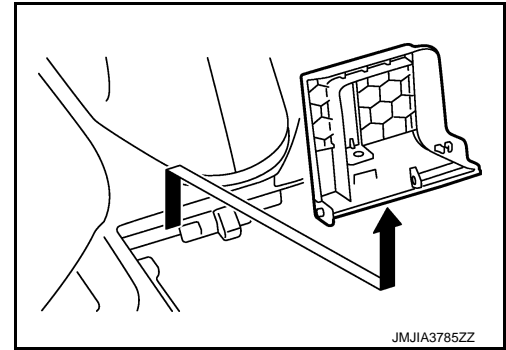

INSTALLATION

1. Align back trim lid to back trim assembly.

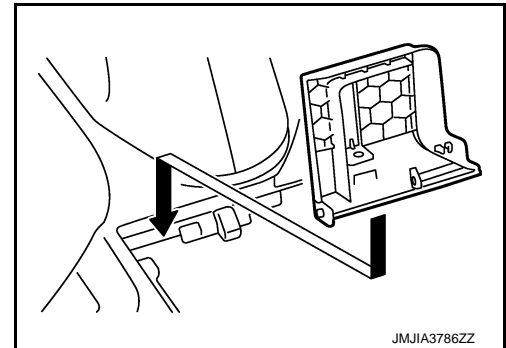

2. Align spring to the hole positions of back trim lid and install spring.

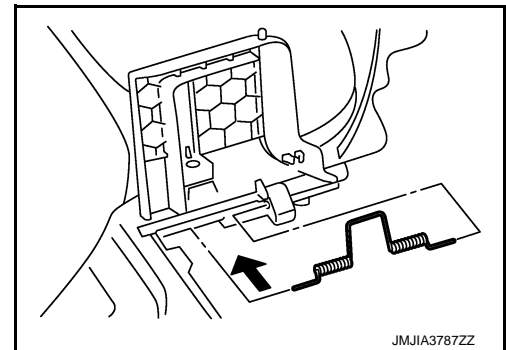

CAUTION:

- Be careful to insert spring to the correct position, otherwise damage may be caused.

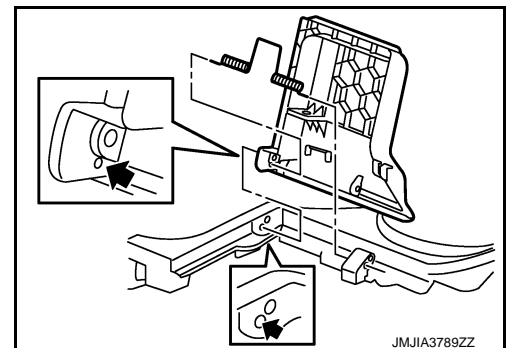

REAR TRIM

< REMOVAL AND INSTALLATION >

[ROADSTER]

- Be careful not to install spring reverse, otherwise damage may be caused.

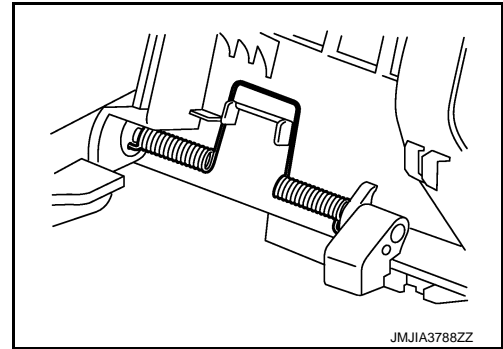

3. Insert shaft. Engage shaft to pawl portion (A) of back trim lid.
4. Install flipper door cable.

REAR PARCEL SHELF FINISHER ASSEMBLY

REAR PARCEL SHELF FINISHER ASSEMBLY : Removal and Installation INFOID:000000008195072

REMOVAL

1. Stop storage lid assembly as shown in the figure. (during open operation).
CAUTION:
Storage lid assembly may close due to low oil pressure. Always support storage lid assembly in the fully open position.

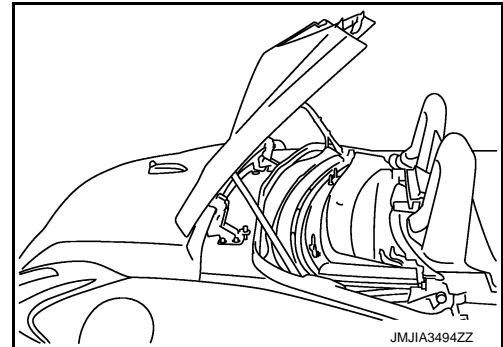

2. Remove both seat assembly. Refer to [SE-71. "Removal and Installation"](#).
3. Disengage guard frame protector assembly (1) fixing pawls with a remover tool (A).

 : Pawl

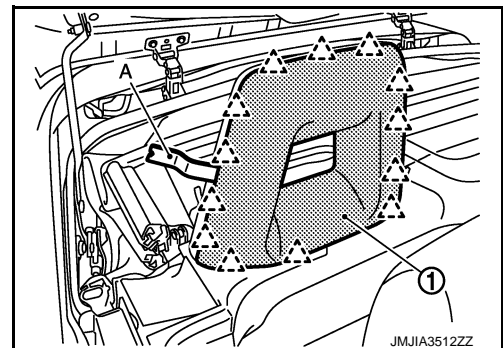

4. Remove guard frame protector assembly.
5. Remove guard frame plate assembly mounting bolts (A).

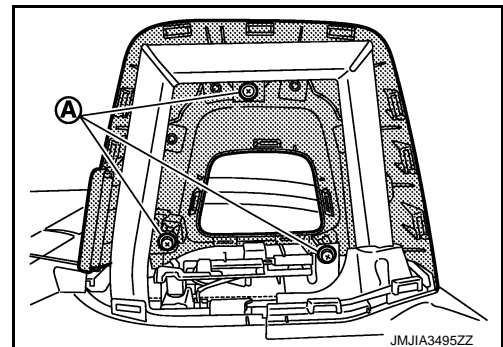

6. Remove guard frame plate assembly.

A
B
C
D
E
F
G
H
I
INT
K
L
M
N
O
P

REAR TRIM

[ROADSTER]

< REMOVAL AND INSTALLATION >

7. Remove storage lid deflector (1) mounting nuts (A) and bolts (B), and then remove storage lid deflector.

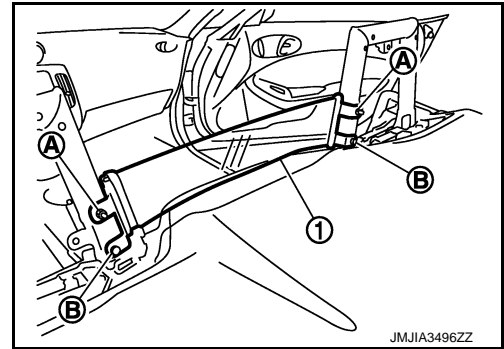

8. Disengage rear parcel shelf finisher cover fixing pawls with a remover tool (A) and then remove rear parcel shelf finisher cover.

NOTE:

- Remove according to the steps indicated in the figure to avoid damaging the fixing pawls.
- Apply protective tape (B) around rear parcel shelf finisher cover to protect the painted surface from damage.

 : Pawl

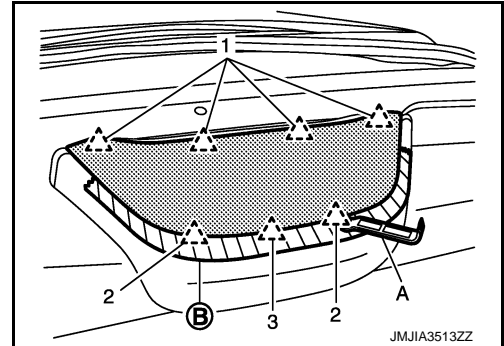

9. Remove rear side finisher (LH and RH). Refer to [INT-54, "REAR SIDE FINISHER : Removal and Installation"](#).

10. Remove spring (1).

1. Remove clip (A).
2. Disconnect spring (1) from back trim assembly (2).
3. Remove clip (B).

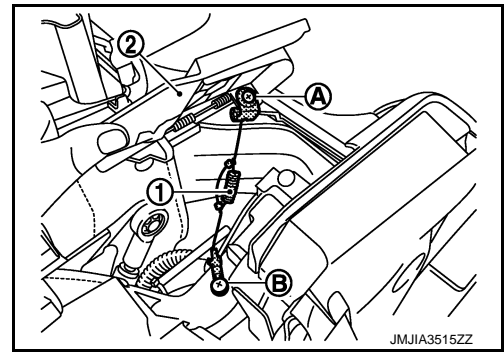

11. Remove back trim assembly.

1. Remove both mounting bolts as shown by the figure below.
2. Disengage all clips and pawls.
3. Disconnect outside key antenna harness connector. Refer to [DLK-182, "DOOR LOCK : Component Parts Location"](#).

REAR TRIM

< REMOVAL AND INSTALLATION >

[ROADSTER]

4. Pull up back trim assembly from one side to the other side and remove back trim assembly.

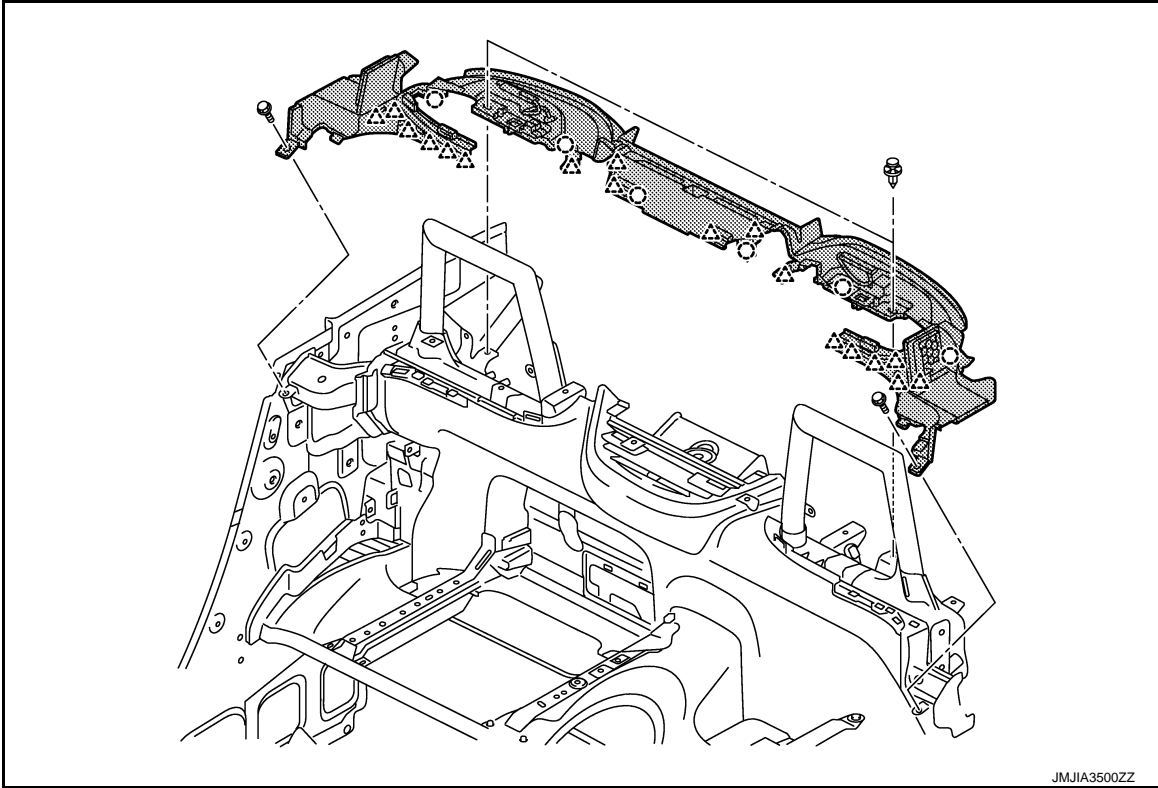

- : Clip
- △ : Pawl

12. Remove both seat assembly. Refer to [SE-71, "Removal and Installation"](#).
13. Remove center console assembly. Refer to [IP-26, "Removal and Installation"](#).
14. Remove rear parcel shelf cover (LH and RH). Refer to [INT-60, "REAR PARCEL SHELF COVER : Removal and Installation"](#).
15. Remove seatback center finisher fixing clips.
16. Remove rear side finisher speaker harness connector (A) from seatback center finisher (1) as shown in the figure.

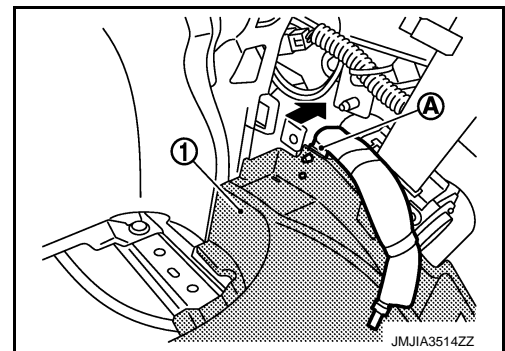

17. Pull seatback center finisher up to remove.
18. Remove the connector located on the left side under the bracket.
19. Remove the clips fixing rear parcel shelf finisher assembly to rear parcel shelf bracket.

A
B
C
D
E
F
G
H
I
INT
K
L
M
N
O
P

REAR TRIM

[ROADSTER]

< REMOVAL AND INSTALLATION >

20. Remove rear parcel shelf finisher assembly (1).
 1. Remove the clips (A) fixing rear parcel shelf finisher assembly (1) to rear parcel shelf side bracket.
 2. Pull out rear parcel shelf finisher assembly to disengage the fixing clips and pawls.
 3. Remove rear parcel shelf finisher assembly.

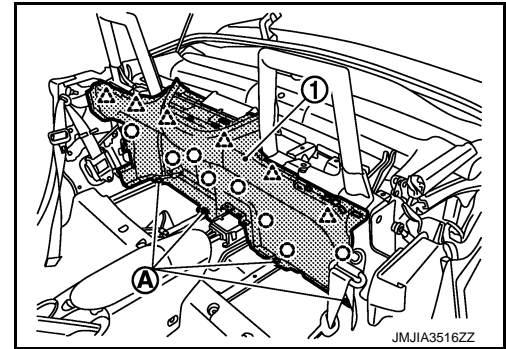
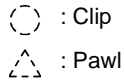

21. Remove rear parcel shelf side bracket mounting bolts and then remove rear parcel shelf side bracket.

INSTALLATION

Note the following item, and install in the reverse order of removal.

CAUTION:

Check that clips and pawls are securely fitted in panel holes on body when installing, and then press them in.

FRONT ROOF FINISHER

< REMOVAL AND INSTALLATION >

[ROADSTER]

FRONT ROOF FINISHER

Exploded View

INFOID:000000008195073

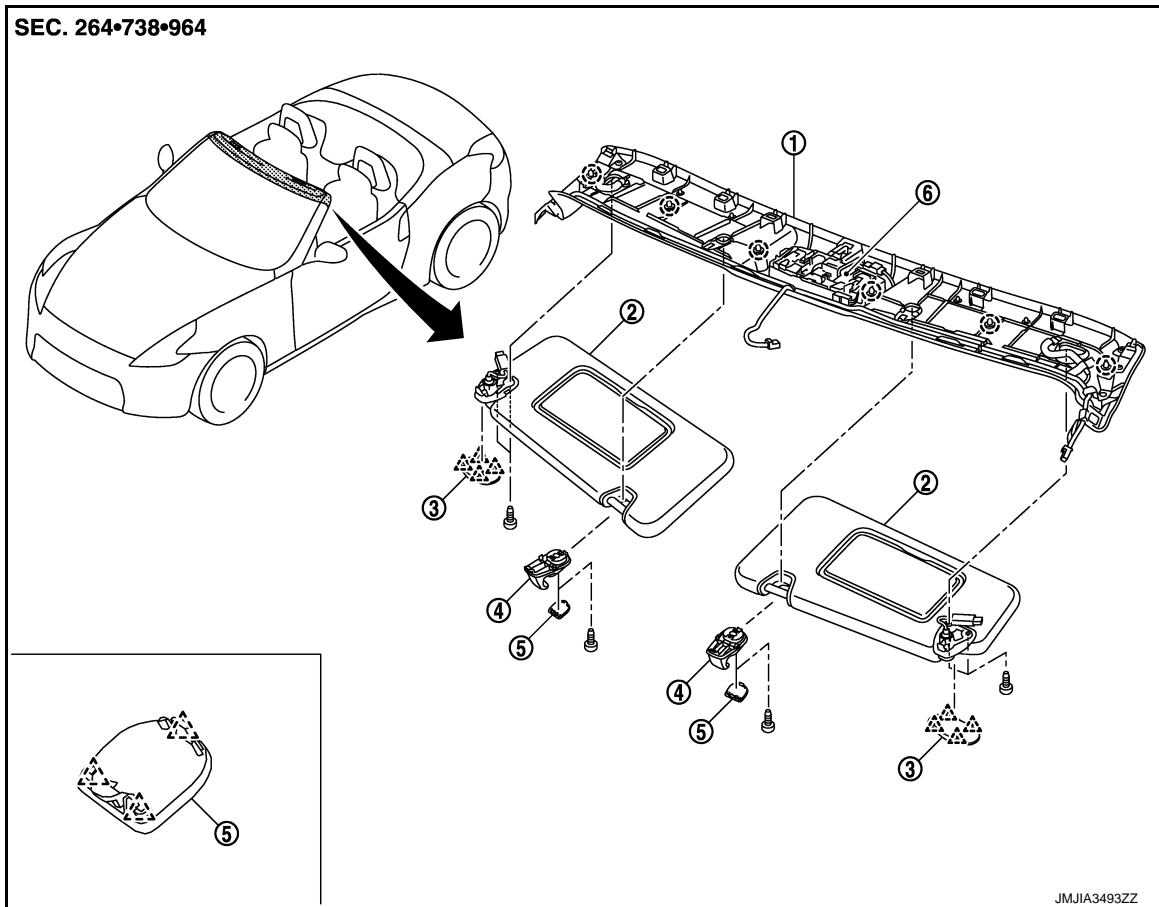

- | | | |
|-----------------------------|---------------------------------|----------------------|
| 1. Front roof finisher | 2. Sun visor assembly (LH/RH) | 3. Sun visor cap |
| 4. Sun visor holder (LH/RH) | 5. Sun visor holder cap (LH/RH) | 6. Map lamp assembly |

- : Clip
 △ : Pawl

Removal and Installation

INFOID:000000008195074

REMOVAL

1. Remove sun visor assembly (LH and RH).
 1. Remove sun visor cap (1) fixing pawls with a small flat-bladed screwdriver (A) wrapped into a tape (B).
 2. Remove sun visor assembly fixing screws.
 3. Disconnect vanity mirror lamp harness connectors.

- △ : Pawl

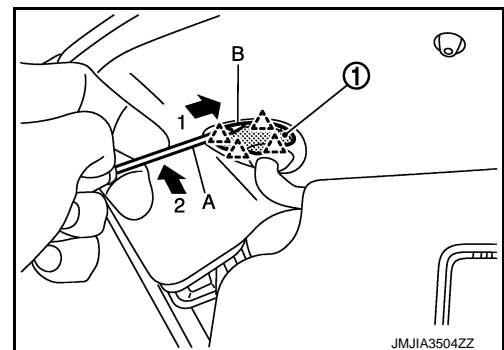

FRONT ROOF FINISHER

[ROADSTER]

< REMOVAL AND INSTALLATION >

2. Remove sun visor holder (LH and RH).
 1. Remove sun visor holder fixing pawls with a small flat-bladed screwdriver (A) wrapped into a tape (B).
 2. Remove sun visor holder mounting screw.

 : Pawl

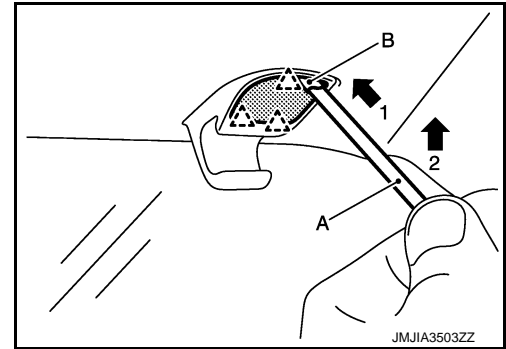

3. Remove body side welt (LH and RH). Refer to [INT-53, "BODY SIDE WELT : Removal and Installation"](#).
4. Remove front pillar garnish (LH and RH). Refer to [INT-51, "FRONT PILLAR GARNISH : Removal and Installation"](#).
5. Remove front roof finisher harness connector (A).

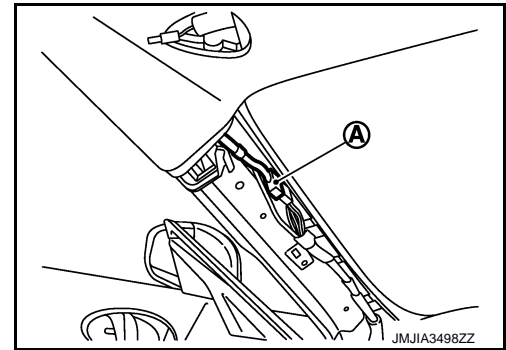

6. Pull down carefully front roof finisher to disengage the clips and then remove front roof finisher as shown by the steps in the figure below.

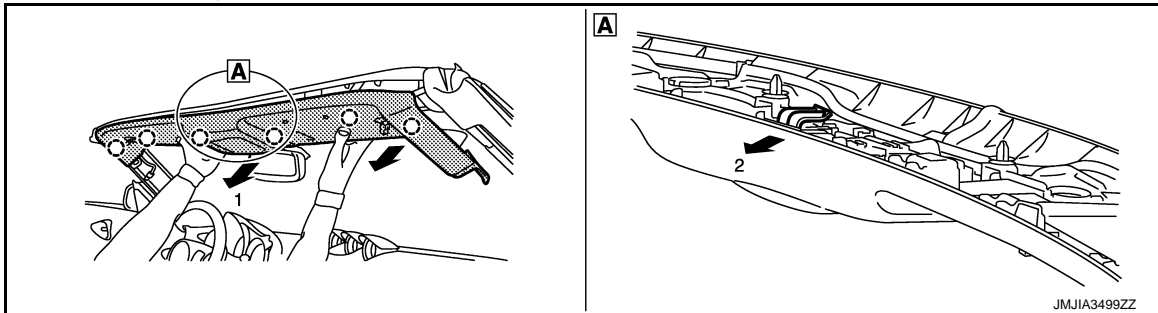

 : Clip

CAUTION:

- Be careful not to damage front roof finisher bracket when removing front roof finisher.
- Never bend front roof finisher when removing.

7. Remove map lamp assembly after removing front roof finisher.

INSTALLATION

Note the following item, and install in the reverse order of removal.

CAUTION:

Never bend front roof finisher when installing.

FLOOR TRIM

Exploded View

INFOID:000000008195075

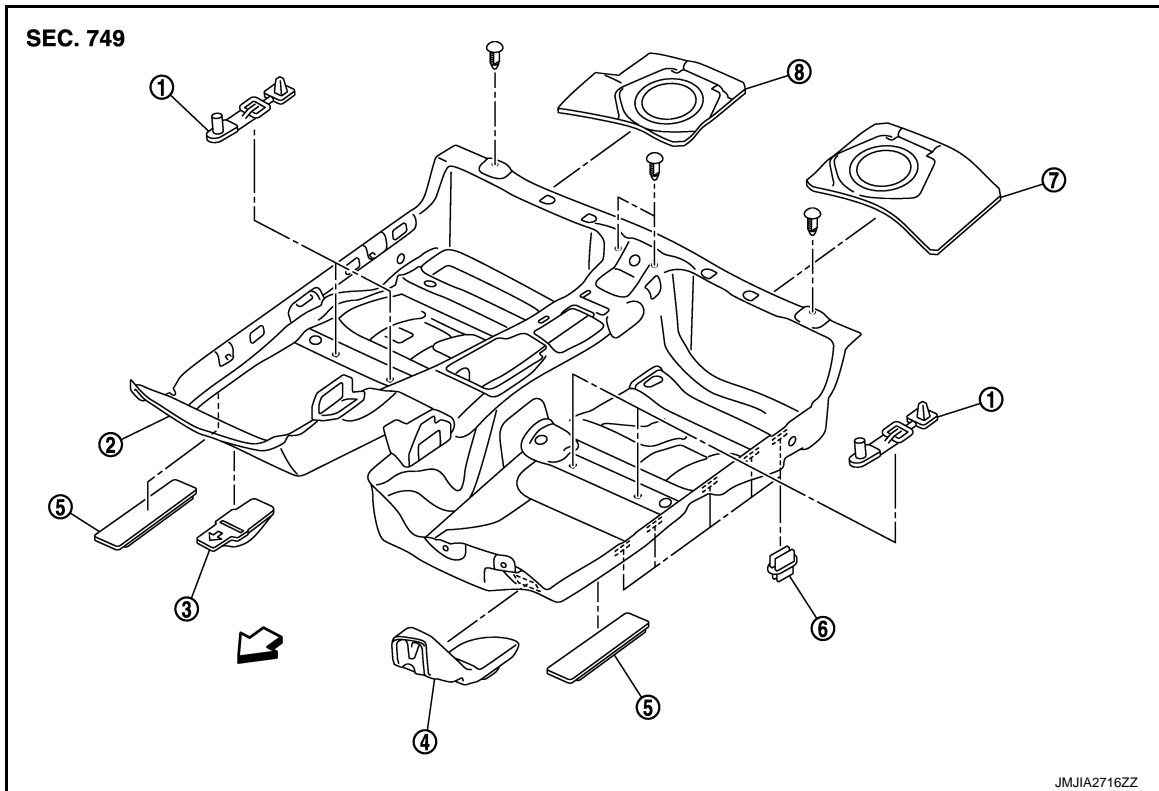

- | | | |
|-----------------------|-------------------------------|------------------------------|
| 1. Floor hook | 2. Floor trim | 3. Front floor spacer center |
| 4. Footrest | 5. Front floor spacer (LH/RH) | 6. Fixing clip |
| 7. Rear floor felt LH | 8. Rear floor felt RH | |

↔ : Vehicle front

Removal and Installation

INFOID:000000008195076

REMOVAL

1. Remove both seat assembly. Refer to [SE-71, "Removal and Installation"](#).
2. Remove accelerator pedal assembly. Refer to [ACC-4, "Removal and Installation"](#).
3. Remove foot grille (LH and RH). Refer to [VTL-9, "FOOT GRILLE : Removal and Installation"](#).
4. Remove console panel (LH and RH). Refer to [IP-26, "Removal and Installation"](#).
5. Remove center console assembly. Refer to [IP-26, "Removal and Installation"](#).
6. Disengage clip of floor hook (1) with remover tool (A).

○ : Clip

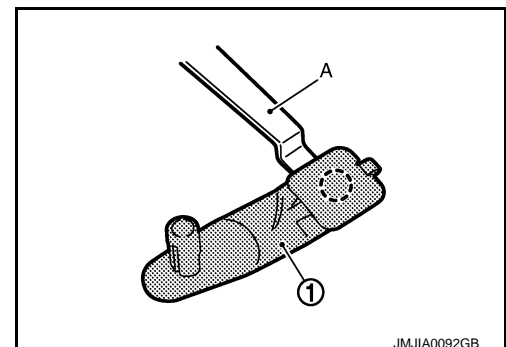

A
B
C
D
E
F
G
H
I
INT
K
L
M
N
O
P

FLOOR TRIM

[ROADSTER]

< REMOVAL AND INSTALLATION >

7. Remove the kicking plate inner (LH and RH). Refer to [INT-52. "KICKING PLATE INNER : Removal and Installation"](#).
8. Remove dash side finisher (LH and RH). Refer to [INT-53. "DASH SIDE FINISHER : Removal and Installation"](#).
9. Remove body side welt (LH and RH). Refer to [INT-53. "BODY SIDE WELT : Removal and Installation"](#).
10. Remove the seat belt shoulder anchor and outer anchor (LH and RH). Refer to [SB-7. "SEAT BELT RETRACTOR : Exploded View"](#).
11. Remove rear side finisher (LH and RH). Refer to [INT-54. "REAR SIDE FINISHER : Removal and Installation"](#).
12. Remove seatback center finisher. Refer to [INT-61. "SEATBACK CENTER FINISHER : Removal and Installation"](#).
13. Disconnect the harness connector (A), (B), (C) and (D) from the diagnosis sensor unit (1) and then remove the clips fixing the harness to the floor trim as shown in the figure.

- : Harness clip
◀ : Clip

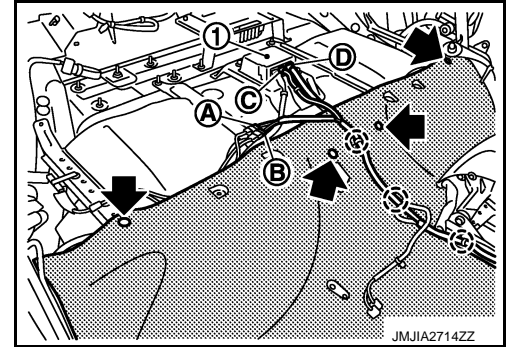

14. Remove all floor trim fixing clips.
15. Remove floor trim from the vehicle.

INSTALLATION

Install in the reverse order of removal.

TRUNK ROOM TRIM

< REMOVAL AND INSTALLATION >

[ROADSTER]

TRUNK ROOM TRIM

Exploded View

INFOID:000000008195077

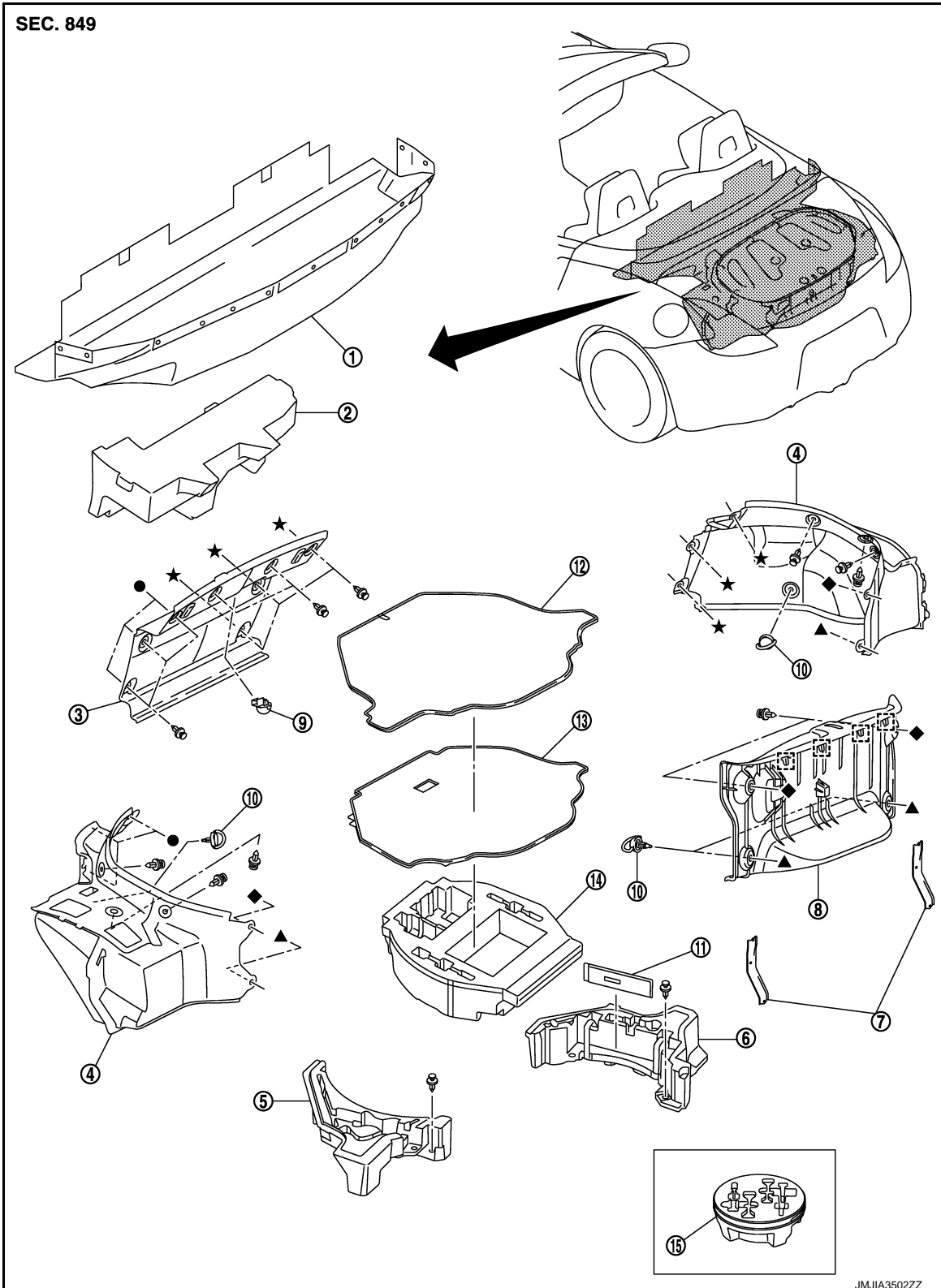

- | | | |
|--------------------------------|-------------------------------|-------------------------------|
| 1. Storage room finisher | 2. Storage room spacer | 3. Trunk finisher front |
| 4. Trunk side finisher (LH/RH) | 5. Trunk side box assembly LH | 6. Trunk side box assembly RH |
| 7. Trunk trim rear bracket | 8. Trunk rear plate | 9. Trunk room lamp assembly |

A
B
C
D
E
F
G
H
I
INT
K
L
M
N
O
P

TRUNK ROOM TRIM

< REMOVAL AND INSTALLATION >

[ROADSTER]

- | | | |
|----------------------|--|---|
| 10. Hook net | 11. Cover spare tire front | 12. Trunk floor carpet |
| 13. Spare tire cover | 14. Trunk floor box cover (without spare tire) | 15. Trunk floor box cover (with spare tire) |

 : Metal clip

TRUNK REAR PLATE

TRUNK REAR PLATE : Removal and Installation

INFOID:000000008195078

REMOVAL

1. Fully open trunk lid assembly.
2. Remove trunk floor carpet.
3. Remove spare tire cover.
4. Remove trunk floor box cover (without spare tire).
5. Remove trunk floor box cover (with spare tire).
6. Remove spare tire clamp and then remove spare tire.
7. Remove trunk lid weather-strip. Refer to [DLK-333. "TRUNK LID WEATHER-STRIP : Removal and Installation"](#).
8. Remove trunk rear plate fixing hook net and clips.
9. Disengage rear trunk lid emergency handle holder (1) fixing clip with a remover tool (A).

 : Clip

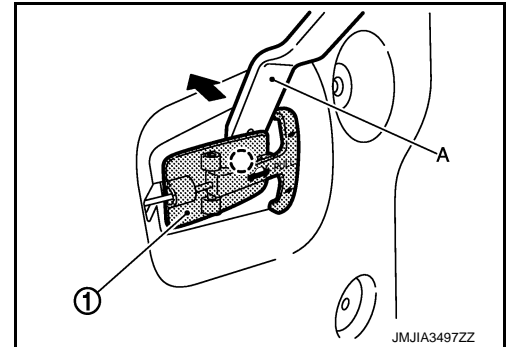

10. Disengage trunk rear plate fixing metal clips with a remover tool.
11. Pull up the trunk rear plate to remove.

INSTALLATION

Note the following item, and then install in the reverse order of removal.

CAUTION:

When installing, check that all clips are securely fitted in panel holes on body when installing, and then press them in.

TRUNK FINISHER FRONT

TRUNK FINISHER FRONT : Removal and Installation

INFOID:000000008195079

REMOVAL

1. Fully open trunk lid assembly.
2. Remove trunk finisher front fixing clips.
3. Remove trunk finisher front.

INSTALLATION

Note the following item, and then install in the reverse order of removal.

CAUTION:

When installing, check that clips are securely fitted in panel holes on body when installing, and then press them in.

TRUNK SIDE FINISHER

TRUNK ROOM TRIM

< REMOVAL AND INSTALLATION >

[ROADSTER]

TRUNK SIDE FINISHER : Removal and Installation

INFOID:000000008195080

REMOVAL

1. Fully open trunk lid assembly.
2. Remove trunk rear plate. Refer to [INT-76. "TRUNK REAR PLATE : Removal and Installation"](#).
3. Remove trunk finisher front. Refer to [INT-76. "TRUNK FINISHER FRONT : Removal and Installation"](#).
4. Remove trunk side finisher fixing hook net.
5. Remove trunk side finisher fixing clips.
6. Remove trunk side finisher.

INSTALLATION

Note the following item, and then install in the reverse order of removal.

CAUTION:

When installing, check that clips are securely fitted in panel holes on body when installing, and then press them in.

TRUNK SIDE BOX ASSEMBLY

TRUNK SIDE BOX ASSEMBLY : Removal and Installation

INFOID:000000008195081

REMOVAL

1. Fully open trunk lid assembly.
2. Remove trunk rear plate. Refer to [INT-76. "TRUNK REAR PLATE : Removal and Installation"](#).
3. Remove trunk finisher front. Refer to [INT-76. "TRUNK FINISHER FRONT : Removal and Installation"](#).
4. Remove trunk side finisher (LH and RH). Refer to [INT-77. "TRUNK SIDE FINISHER : Removal and Installation"](#).
5. Remove trunk side box assembly fixing clips.
6. Remove cover spare tire front from trunk side box assembly RH.
7. Remove trunk side box assembly.

INSTALLATION

Note the following item, and then install in the reverse order of removal.

CAUTION:

When installing, check that clips, pawls, metal clips are securely fitted in panel holes on body when installing, and then press them in.

TRUNK TRIM REAR BRACKET

TRUNK TRIM REAR BRACKET : Removal and Installation

INFOID:000000008195082

REMOVAL

1. Fully open trunk lid assembly.
2. Remove trunk rear plate. Refer to [INT-76. "TRUNK REAR PLATE : Removal and Installation"](#).
3. Remove trunk trim rear bracket mounting bolts and then remove trunk trim rear bracket.

INSTALLATION

Note the following item, and then install in the reverse order of removal.

CAUTION:

When installing, check that clips, pawls, metal clips are securely fitted in panel holes on body when installing, and then press them in.

STORAGE ROOM FINISHER

STORAGE ROOM FINISHER : Removal and Installation

INFOID:000000008195083

REMOVAL

STORAGE ROOM FINISHER

Refer to [RF-222. "STORAGE ROOM FINISHER : Removal and Installation"](#).

A
B
C
D
E
F
G
H
I
K
L
M
N
O
P

INT

TRUNK ROOM TRIM

[ROADSTER]

< REMOVAL AND INSTALLATION >

INSTALLATION

Install in the reverse order of removal.

STORAGE ROOM SPACER

STORAGE ROOM SPACER : Removal and Installation

INFOID:000000008195084

REMOVAL

STORAGE ROOM SPACER

Refer to [RF-222, "STORAGE ROOM FINISHER : Removal and Installation"](#).

INSTALLATION

Note the following item, and then install in the reverse order of removal.

CAUTION:

When installing, check that clips, pawls, metal clips are securely fitted in panel holes on body when installing, and then press them in.

TRUNK LID TRIM

Exploded View

INFOID:000000008195085

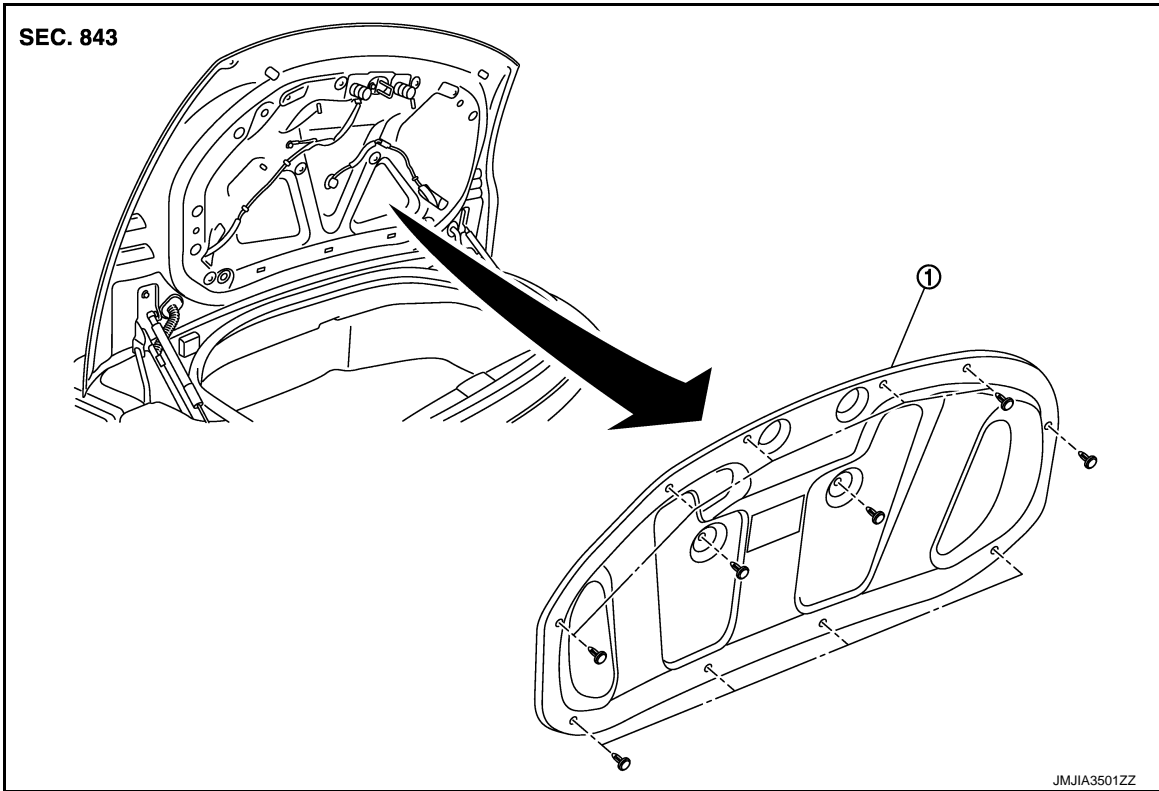

- 1. Trunk lid finisher inner

Removal and Installation

INFOID:000000008195086

REMOVAL

- 1. Fully open trunk lid assembly.
- 2. Remove trunk lid finisher inner fixing clips, and then remove trunk lid finisher inner.

INSTALLATION

Install in the reverse order of removal.

A
B
C
D
E
F
G
H
I

INT

K
L
M
N
O
P