

SECTION **SE**
SEAT

A
B
C

CONTENTS

D
E

REGULAR GRADE		
BASIC INSPECTION	4	
DIAGNOSIS AND REPAIR WORK FLOW	4	
Work Flow	4	
SYSTEM DESCRIPTION	5	
POWER SEAT	5	
System Description	5	
Component Parts Location	5	
Component Description	6	
HEATED SEAT	7	
System Description	7	
Component Parts Location	7	
Component Description	7	
CLIMATE CONTROLLED SEAT	9	
System Diagram	9	
System Description	9	
Component Parts Location	10	
Component Description	10	
DTC/CIRCUIT DIAGNOSIS	12	
POWER SUPPLY AND GROUND CIRCUIT	12	
CLIMATE CONTROLLED SEAT CONTROL UNIT	12	
CLIMATE CONTROLLED SEAT CONTROL UNIT		
: Diagnosis Procedure	12	
CLIMATE CONTROLLED SEAT CONTROL UNIT		
: Component Inspection	15	
CLIMATE CONTROLLED SEAT SWITCH	17	
Description	17	
Component Function Check	17	
Diagnosis Procedure	17	
Component Inspection	19	
SEATBACK THERMAL ELECTRIC DEVICE	20	
Description	20	
Component Function Check	20	F
Diagnosis Procedure	20	
SEATBACK THERMAL ELECTRIC DEVICE		
SENSOR	22	G
Description	22	
Diagnosis Procedure	22	
SEAT CUSHION THERMAL ELECTRIC DE-		
VICE	24	H
Description	24	
Component Function Check	24	
Diagnosis Procedure	24	
SEAT CUSHION THERMAL ELECTRIC DE-		
VICE SENSOR	26	I
Description	26	
Diagnosis Procedure	26	
CLIMATE CONTROLLED SEATBACK		
BLOWER MOTOR	28	SE
Description	28	
Component Function Check	28	
Diagnosis Procedure	28	
CLIMATE CONTROLLED SEAT CUSHION		
BLOWER MOTOR	31	K
Description	31	
Component Function Check	31	
Diagnosis Procedure	31	
CLIMATE CONTROLLED SEAT SWITCH IN-		
DIATOR	34	L
Description	34	
Component Function Check	34	
Diagnosis Procedure	34	
CLIMATE CONTROLLED SEAT BLOWER		
FILTER	36	M
SEATBACK BLOWER MOTOR	36	N
		O
		P

SEATBACK BLOWER MOTOR : Diagnosis Procedure	36	SEAT CUSHION BLOWER MOTOR : Description...	53
SEAT CUSHION BLOWER MOTOR	36	SEAT CUSHION BLOWER MOTOR : Diagnosis Procedure	53
SEAT CUSHION BLOWER MOTOR : Diagnosis Procedure	36	SEAT SWITCH INDICATOR IS NOT ILLUMINATED IN HEAT OR COOL POSITION	55
POWER SEAT	37	Diagnosis Procedure	55
Wiring Diagram - POWER SEAT FOR DRIVER SIDE -	37	SQUEAK AND RATTLE TROUBLE DIAGNOSIS	56
Wiring Diagram - POWER SEAT FOR PASSENGER SIDE -	38	Work Flow	56
HEATED SEAT	39	Inspection Procedure	58
Wiring Diagram - HEATED SEAT -	39	Diagnostic Worksheet	60
ECU DIAGNOSIS INFORMATION	40	PRECAUTION	62
CLIMATE CONTROLLED SEAT CONTROL UNIT	40	PRECAUTIONS	62
Reference Value	40	FOR USA AND CANADA	62
Wiring Diagram - CLIMATE CONTROLLED SEAT CONTROL SYSTEM -	42	FOR USA AND CANADA : Precaution for Supplemental Restraint System (SRS) "AIR BAG" and "SEAT BELT PRE-TENSIONER"	62
Fail-safe	44	FOR USA AND CANADA : Precaution for Battery Service	62
SYMPTOM DIAGNOSIS	47	FOR USA AND CANADA : Service Notice	62
CLIMATE CONTROLLED SEAT DOES NOT OPERATE.	47	FOR USA AND CANADA : Precaution for Work	62
DRIVER SIDE	47	FOR MEXICO	63
DRIVER SIDE : Diagnosis Procedure	47	FOR MEXICO : Precaution for Supplemental Restraint System (SRS) "AIR BAG" and "SEAT BELT PRE-TENSIONER"	63
PASSENGER SIDE	48	FOR MEXICO : Precaution for Battery Service	63
PASSENGER SIDE : Diagnosis Procedure	48	FOR MEXICO : Service Notice	63
TEMPERATURE ADJUSTMENT IS IMPOSSIBLE	50	FOR MEXICO : Precaution for Work	64
SEATBACK BLOWER MOTOR	50	PREPARATION	65
SEATBACK BLOWER MOTOR : Description	50	PREPARATION	65
SEATBACK BLOWER MOTOR : Diagnosis Procedure	50	Special Service Tool	65
SEAT CUSHION BLOWER MOTOR	50	Commercial Service Tool	65
SEAT CUSHION BLOWER MOTOR : Description..	50	CLIP LIST	66
SEAT CUSHION BLOWER MOTOR : Diagnosis Procedure	50	Clip List	66
CLIMATE CONTROLLED SEAT DOES NOT OPERATES WHEN SWITCH IS DONE IN HEAT OR COOL.	52	REMOVAL AND INSTALLATION	67
Diagnosis Procedure	52	SEAT	67
CLIMATE CONTROLLED SEAT ACTIVATES ONCE BUT STOPS IMMEDIATELY	53	Exploded View	67
SEATBACK BLOWER MOTOR	53	Removal and Installation	71
SEATBACK BLOWER MOTOR : Description	53	Disassembly and Assembly	71
SEATBACK BLOWER MOTOR : Diagnosis Procedure	53	POWER SEAT SWITCH	78
SEAT CUSHION BLOWER MOTOR	53	Exploded View	78
		Removal and Installation	78
		HEATED SEAT SWITCH	79
		Exploded View	79
		Removal and Installation	79
		CLIMATE CONTROLLED SEAT SWITCH	80
		Exploded View	80
		Removal and Installation	80

**CLIMATE CONTROLLED SEAT BLOWER
 FILTER81**

SEAT CUSHION81
 SEAT CUSHION : Exploded View81
 SEAT CUSHION : Removal and Installation81

SEATBACK81
 SEATBACK : Exploded View81

SEATBACK : Removal and Installation81

Nismo 370Z

SPEC CHANGE INFORMATION82

SEAT82
 Seat82

A
 B
 C
 D
 E
 F
 G
 H
 I
 SE
 K
 L
 M
 N
 O
 P

SE

BASIC INSPECTION

DIAGNOSIS AND REPAIR WORK FLOW

Work Flow

INFOID:000000008194173

DETAILED FLOW

1.OBTAIN INFORMATION ABOUT SYMPTOM

Interview the customer to obtain the malfunction information (conditions and environment when the malfunction occurred) as much as possible when the customer brings the vehicle in.

>> GO TO 2.

2.REPRODUCE THE MALFUNCTION INFORMATION

Check the malfunction on the vehicle that the customer describes.
Inspect the relation of the symptoms and the condition when the symptoms occur.

>> GO TO 3.

3.IDENTIFY THE MALFUNCTIONING SYSTEM WITH "SYMPTOM DIAGNOSIS"

Use "Symptom diagnosis" from the symptom inspection result in step 2 and then identify where to start performing the diagnosis based on possible causes and symptoms.

>> GO TO 4.

4.IDENTIFY THE MALFUNCTIONING PARTS WITH "COMPONENT DIAGNOSIS"

Perform the diagnosis with "Component diagnosis" of the applicable system.

>> GO TO 5.

5.REPAIR OR REPLACE THE MALFUNCTIONING PARTS

Repair or replace the specified malfunctioning parts.

>> GO TO 6.

6.FINAL CHECK

Check that malfunctions are not reproduced when obtaining the malfunction information from the customer, referring to the symptom inspection result in step 2.

Are the malfunctions corrected?

YES >> INSPECTION END

NO >> GO TO 3.

SYSTEM DESCRIPTION

POWER SEAT

System Description

INFOID:000000008194174

BCM can operate regardless of the ignition switch position, because battery power is supplied at all times to power seat switch.

SLIDING OPERATION

While operating the sliding switch located in power seat switch, sliding motor operates and makes possible the seat front and back position adjustment.

RECLINING OPERATION

While operating the reclining switch located in power seat switch, reclining motor operates and makes possible the seat back forward and backward position adjustment.

Component Parts Location

INFOID:000000008194175

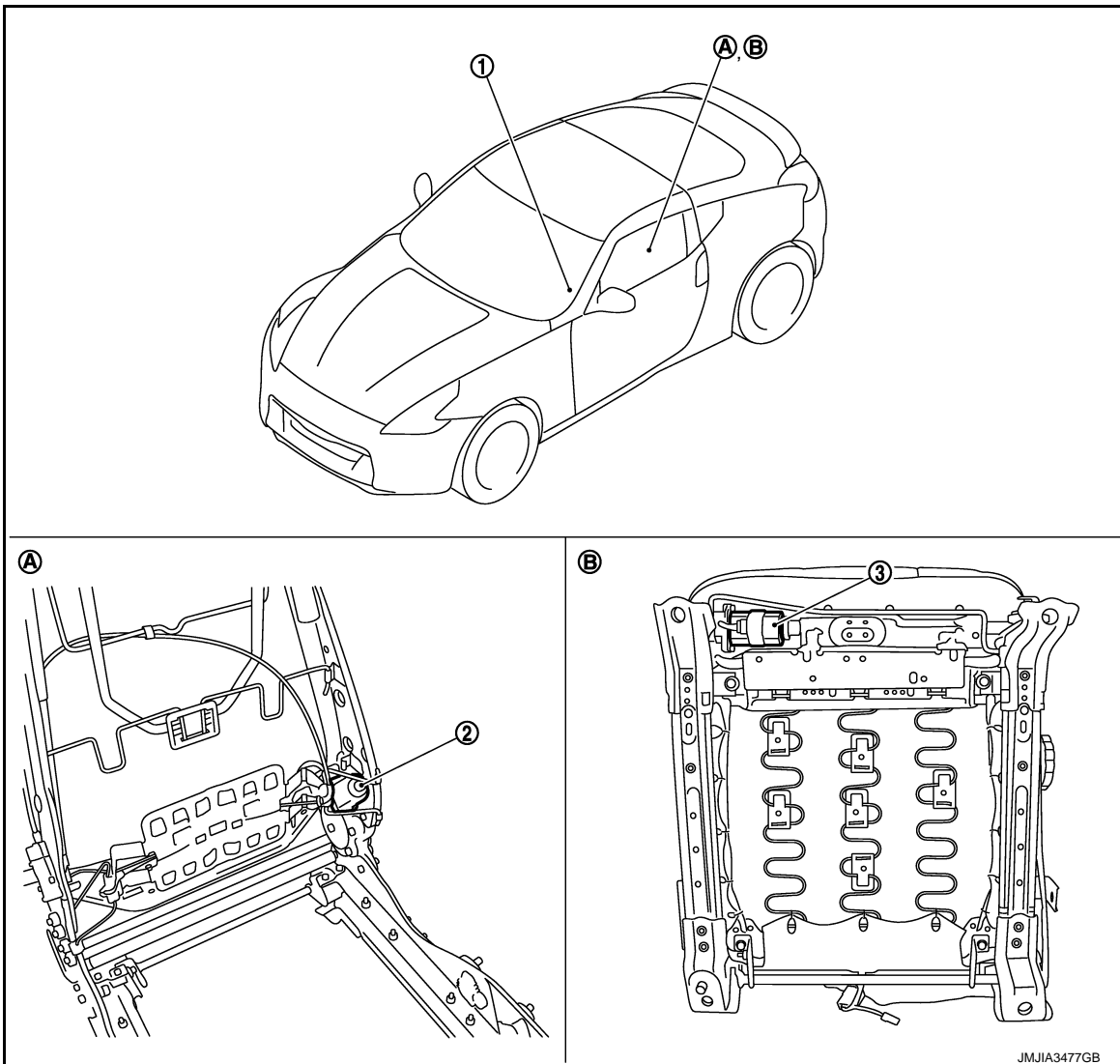

- 1. Power seat switch (driver side)
- 2. Reclining motor
- 3. Sliding motor
- A. View with the seat cushion pad and seat back pad removed
- B. Backside of the seat cushion

JMJIA3477GB

A
B
C
D
E
F
G
H
I
SE
K
L
M
N
O
P

POWER SEAT

< SYSTEM DESCRIPTION >

[REGULAR GRADE]

Component Description

INFOID:000000008194176

Item	Function
BCM	Supplies at all times the power received from battery to power seat switch.
Power seat switch	Built-in reclining switch, sliding switch controls the power supplied to each motor.
Reclining motor	With the power supplied to power seat switch, operates the forward and backward movement of seat-back.
Sliding motor	With the power supplied to power seat switch, operates the forward and backward slide of seat.

HEATED SEAT

< SYSTEM DESCRIPTION >

[REGULAR GRADE]

HEATED SEAT

System Description

INFOID:000000008194177

Heated seat is a system that operates when ignition switch is in ON position.

HEATER OPERATION

- While operating the heated seat switch, seat cushion heater and seat back heater operate.
- Temperature of seat can be adjusted by operating on heated seat switch.

Component Parts Location

INFOID:000000008194178

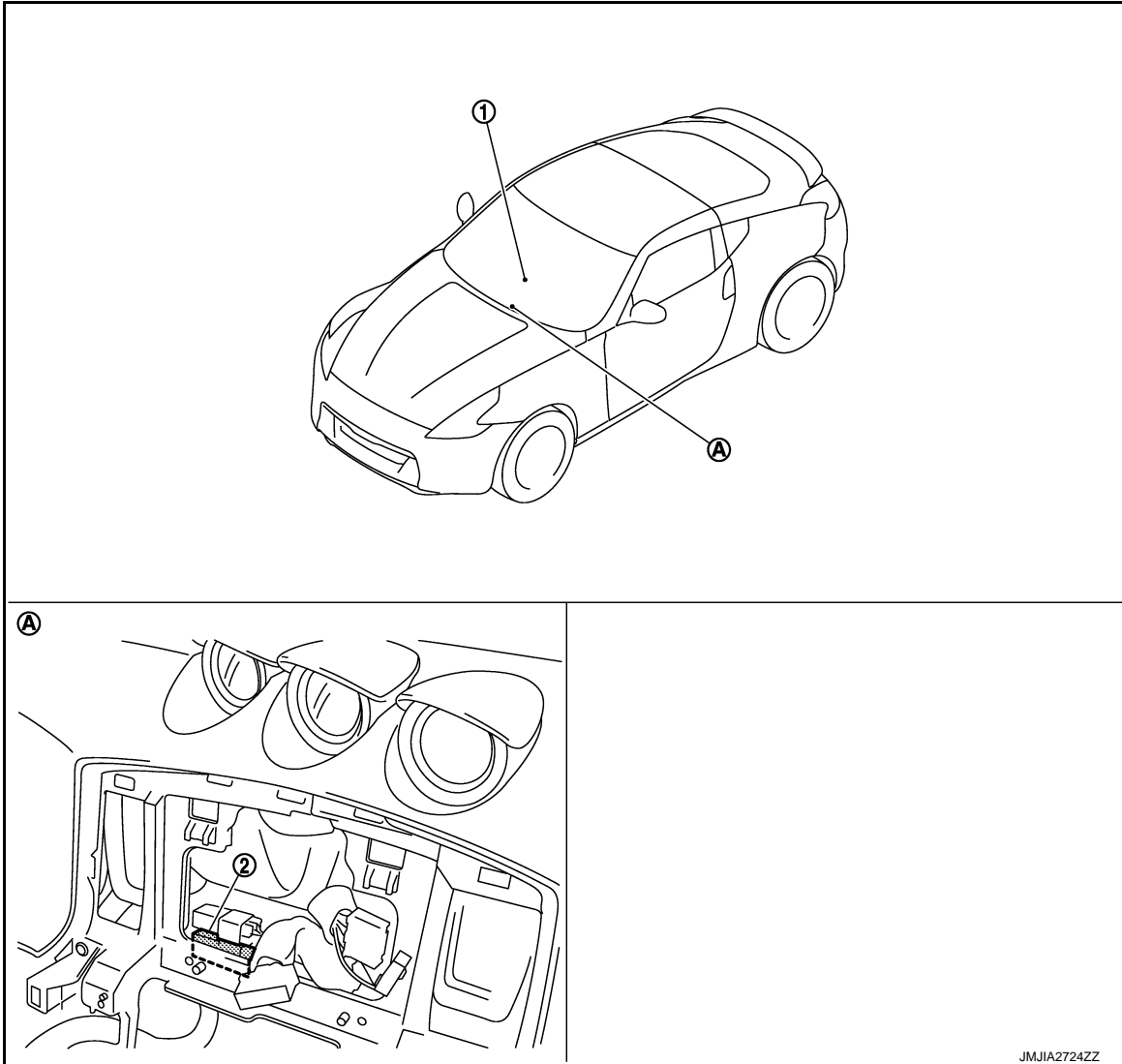

1. Heated seat switch 2. Heated seat relay
A. Behind display

Component Description

INFOID:000000008194179

Item	Function
Heated seat switch	<ul style="list-style-type: none">• Power is supplied to each heater.• Depending on LOW/HIGH position of switch, operating heater number is changeable.

HEATED SEAT

< SYSTEM DESCRIPTION >

[REGULAR GRADE]

Item	Function
Seat cushion heater	Built-in seat cushion, the heater operates with the power supplied by heater seat switch.
Seat back heater	Built-in seatback, the heater operates with the power supplied by heater seat switch.

CLIMATE CONTROLLED SEAT

System Diagram

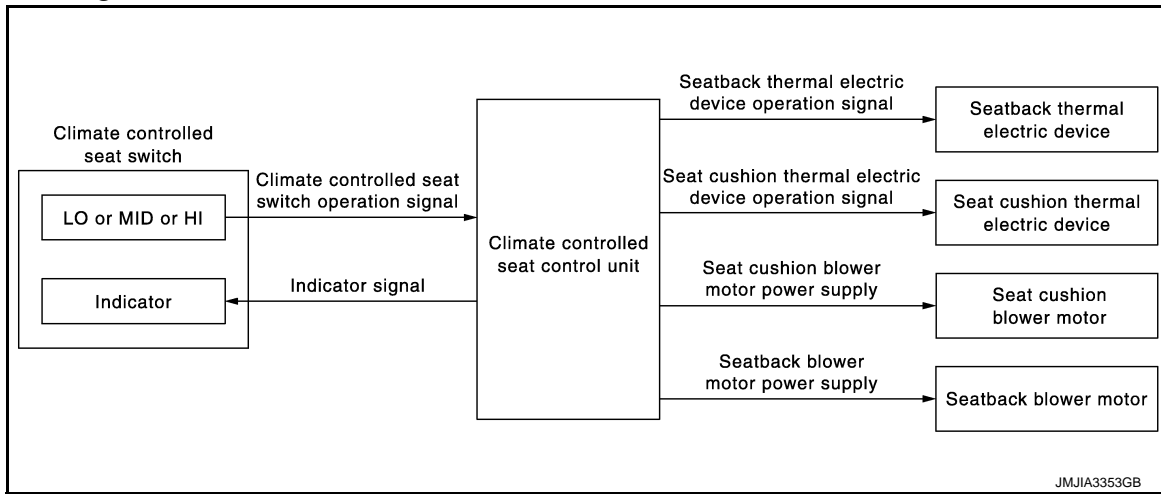

System Description

INFOID:000000008194181

- The climate controlled seat system is controlled by the climate controlled seat control unit.
- Operation of the climate controlled switch sends heated or cooled airflow and adjusts the seat temperature.

SEAT CUSHION AND SEATBACK TEMPERATURE ADJUSTMENT FUNCTION

- One thermal electric device (TED) unit is installed in each seat cushion and seatback. The device heats or cools, sends airflow to the seat surface, and adjusts the seat temperature.
- The thermal electric device (TED) is a heat exchanger that has a function to heat or cool the airflow from the seat cushion blower motor and seatback blower motor. (By changing the direction of the current from the power supply, the device takes or gives heat, and adjusts exchange process depending on voltage.)

CAUTION:

- **The thermal electric device (TED) has a dual-climate function that allows one side to operate at a high temperature and the other to operate at a low temperature simultaneously.**
- **Before starting always turn OFF the switch and check that the electric device is cold.**

FAIL-SAFE

The fail-safe function is adopted for the climate controlled seat control to [SE-44, "Fail-safe"](#).

CLIMATE CONTROLLED SEAT

< SYSTEM DESCRIPTION >

[REGULAR GRADE]

Component Parts Location

INFOID:000000008194182

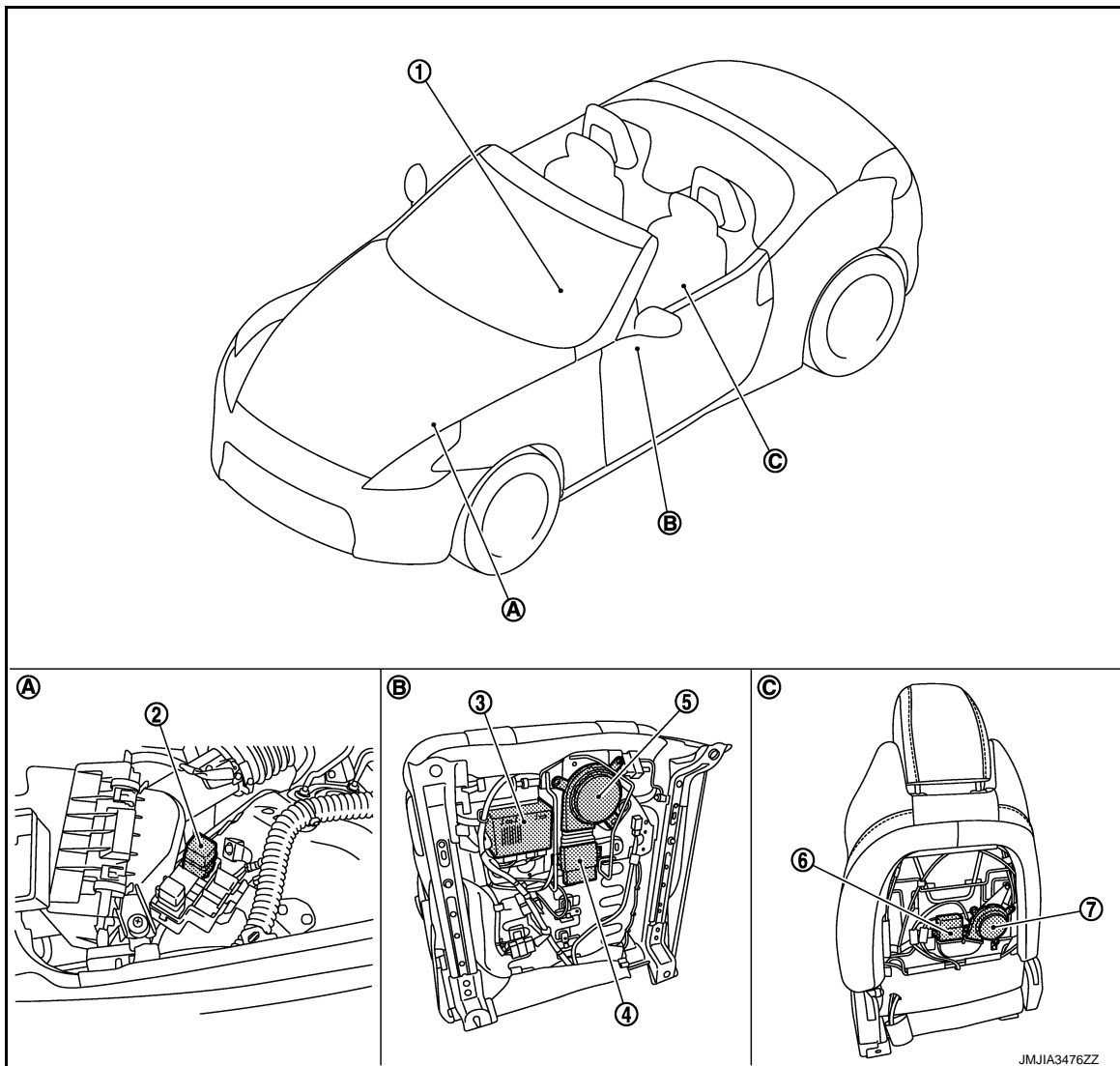

- | | | |
|---|---|---|
| 1. Climate controlled seat switch | 2. Climate controlled seat relay | 3. Climate controlled seat control unit |
| 4. Seat cushion thermal electric device | 5. Climate controlled seat cushion blower motor | 6. Seatback thermal electric device |
| 7. Climate controlled seatback blower motor | | |
| A. Engine room fuse, fusible link and relay box | B. Back side of seat cushion. | C. View with seatback board. |

Component Description

INFOID:000000008194183

Item	Function
Climate controlled seat relay	Supplies power to the climate controlled seat control unit in accordance with the key switch position that is ON or START
Climate controlled seat control unit	Installed in the seat cushion backside and controls the seat cushion blower motor, seatback blower motor, seatback thermal electric device, and seat cushion thermal electric device in accordance with the input signal.
Climate controlled seat switch	Installed in the center console and transmits signals to climate controlled seat control unit in accordance with the HEAT (heated airflow) or COOL (cooled airflow) switch operation and the temperature switch operation

CLIMATE CONTROLLED SEAT

< SYSTEM DESCRIPTION >

[REGULAR GRADE]

Item	Function
Seatback blower motor	Installed in the seatback and sends the airflow to the seatback thermal electric device in accordance with the control from the climate controlled seat control unit
Seat cushion blower motor	Installed in the seat cushion backside and sends the airflow to the seat cushion thermal electric device in accordance with the control from the climate controlled seat control unit
Seatback thermal electric device	Installed in the seatback backside and heats or cools the airflow from the climate controlled seat blower motor in accordance with the control from the climate controlled seat control unit
Seat cushion thermal electric device	Installed in the seat cushion backside and heats or cools the airflow from the climate controlled seat blower motor in accordance with the control from the climate controlled seat control unit

A
B
C
D
E
F
G
H
I
K
L
M
N
O
P

SE

POWER SUPPLY AND GROUND CIRCUIT

< DTC/CIRCUIT DIAGNOSIS >

[REGULAR GRADE]

DTC/CIRCUIT DIAGNOSIS

POWER SUPPLY AND GROUND CIRCUIT CLIMATE CONTROLLED SEAT CONTROL UNIT

CLIMATE CONTROLLED SEAT CONTROL UNIT : Diagnosis Procedure INFOID:000000008194184

Driver side

1. CHECK FUSE

Check that the following fuse and fusible link are not fusing.

Signal name	Fuse No.
Battery power supply	37(15A)
IGN power supply	3 (10A)

Is the fuse fusing?

YES >> Replace the blown fuse after repairing the affected circuit if a fuse are blown.

NO >> GO TO 2.

2. CHECK CLIMATE CONTROLLED SEAT CONTROL UNIT (DRIVER SIDE) POWER SUPPLY

1. Turn ignition switch OFF.
2. Disconnect climate controlled seat control unit (driver side) connector.
3. Turn ignition switch ON.
4. Check voltage between climate controlled seat control unit (driver side) harness connector and ground.

(+) Climate controlled seat control unit (driver side)		(-)	Voltage (V) (Approx.)
Connector	Terminal		
B509	89	Ground	Battery voltage
B508	93		

Is the inspection result normal?

YES >> GO TO 3.

NO >> GO TO 4.

3. CHECK CLIMATE CONTROLLED SEAT CONTROL UNIT (DRIVER SIDE) GROUND CIRCUIT

1. Turn ignition switch OFF.
2. Check continuity between climate control unit (driver side) harness connector and ground.

Climate controlled seat control unit (driver side)		Ground	Continuity
Connector	Terminal		
B509	90		Existed

Is the inspection result normal?

YES >> INSPECTION END

NO >> Repair or replace harness or connector.

4. CHECK CLIMATE CONTROLLED SEAT CONTROL UNIT (DRIVER SIDE) POWER SUPPLY CIRCUIT

1. Turn ignition switch OFF.
2. Disconnect climate controlled seat relay.
3. Check continuity between climate controlled seat control unit (driver side) harness connector and climate controlled seat relay harness connector.

POWER SUPPLY AND GROUND CIRCUIT

< DTC/CIRCUIT DIAGNOSIS >

[REGULAR GRADE]

Climate controlled seat control unit (driver side)		Climate controlled seat relay		Continuity
Connector	Terminal	Connector	Terminal	
B509	89	E66	6	Existed
B508	93			

4. Check continuity between climate controlled seat control unit (driver side) harness connector and ground.

Climate controlled seat control unit (driver side)		Ground	Continuity
Connector	Terminal		
B509	89		Not existed
B508	93		

Is the inspection result normal?

YES >> GO TO 5.

NO >> Repair or replace harness or connector.

5. CHECK CLIMATE CONTROLLED SEAT RELAY POWER SUPPLY CIRCUIT

1. Turn ignition switch ON.
2. Check voltage between climate controlled seat relay harness connector and ground.

Climate controlled seat relay (+)		Climate controlled seat relay (-)	Voltage (V) (Approx.)
Connector	Terminal		
E66	2	Ground	Battery voltage
	7		

Is the inspection result normal?

YES >> GO TO 6.

NO >> Repair or replace harness or connector.

6. CHECK CLIMATE CONTROLLED SEAT RELAY GROUND CIRCUIT

1. Turn ignition switch OFF.
2. Check continuity between climate controlled seat relay harness connector and ground.

Climate controlled seat relay		Ground	Continuity
Connector	Terminal		
E66	1		Existed

Is the inspection result normal?

YES >> GO TO 7.

NO >> Repair or replace harness.

7. CHECK CLIMATE CONTROLLED SEAT RELAY

Check climate controlled seat relay.

Refer to [SE-15. "CLIMATE CONTROLLED SEAT CONTROL UNIT : Component Inspection"](#).

Is the inspection result normal?

YES >> GO TO 8.

NO >> Replace climate controlled seat relay.

8. CHECK INTERMITTENT INCIDENT

Refer to [GI-45. "Intermittent Incident"](#).

>> INSPECTION END

Passenger side

1. CHECK FUSE

POWER SUPPLY AND GROUND CIRCUIT

< DTC/CIRCUIT DIAGNOSIS >

[REGULAR GRADE]

Check that the following fuse and fusible link are not fusing.

Signal name	Fuse No.
Battery power supply	35 (15A)
IGN power supply	3 (10A)

Is the fuse fusing?

YES >> Replace the blown fuse after repairing the affected circuit if a fuse is blown.

NO >> GO TO 2.

2. CHECK CLIMATE CONTROLLED SEAT CONTROL UNIT (PASSENGER SIDE) POWER SUPPLY

1. Turn ignition switch OFF.
2. Disconnect climate controlled seat control unit (passenger side) connector.
3. Turn ignition switch ON.
4. Check voltage between climate controlled seat control unit (passenger side) harness connector and ground.

(+)		(-)	Voltage (V) (Approx.)
Climate controlled seat control unit (passenger side)			
Connector	Terminal	Ground	Battery voltage
B559	89		
B558	93		

Is the inspection result normal?

YES >> GO TO 3.

NO >> GO TO 4.

3. CHECK CLIMATE CONTROLLED SEAT CONTROL UNIT (PASSENGER SIDE) GROUND CIRCUIT

1. Turn ignition switch OFF.
2. Check continuity between harness connector and ground.

Climate controlled seat control unit (passenger side)		Ground	Continuity
Connector	Terminal		
B559	90		Existed

Is the inspection result normal?

YES >> INSPECTION END

NO >> Repair harness or connector.

4. CHECK CLIMATE CONTROLLED SEAT CONTROL UNIT (PASSENGER SIDE) POWER SUPPLY CIRCUIT

1. Turn ignition switch OFF.
2. Disconnect climate controlled seat relay.
3. Check continuity between climate controlled seat control unit (passenger side) harness connector and climate controlled seat relay harness connector.

Climate controlled seat control unit (passenger side)		Climate controlled seat relay		Continuity
Connector	Terminal	Connector	Terminal	
B559	89	E66	3	Existed
B558	93			

4. Check continuity between climate controlled seat control unit (passenger side) harness connector and ground.

POWER SUPPLY AND GROUND CIRCUIT

< DTC/CIRCUIT DIAGNOSIS >

[REGULAR GRADE]

Climate controlled seat control unit (passenger side)		Ground	Continuity
Connector	Terminal		Not existed
B559	89		
B558	93		

Is the inspection result normal?

YES >> GO TO 5.

NO >> Repair or replace harness or connector.

5.CHECK CLIMATE CONTROLLED SEAT RELAY POWER SUPPLY CIRCUIT

1. Turn ignition switch ON.
2. Check voltage between climate controlled seat relay harness connector and ground.

(+)		(-)	Voltage (V) (Approx.)
Climate controlled seat relay			
Connector	Terminal	Ground	Battery voltage
E66	2		
	5		

Is the inspection result normal?

YES >> GO TO 6.

NO >> Repair or replace harness or connector.

6.CHECK CLIMATE CONTROLLED SEAT RELAY GROUND CIRCUIT

1. Turn ignition switch OFF.
2. Check continuity between climate controlled seat relay harness connector and ground.

Climate controlled seat relay		Ground	Continuity
Connector	Terminal		Existed
E66	1		

Is the inspection result normal?

YES >> GO TO 7.

NO >> Repair or replace harness.

7.CHECK CLIMATE CONTROLLED SEAT RELAY

Check climate controlled seat relay.

Refer to [SE-15. "CLIMATE CONTROLLED SEAT CONTROL UNIT : Component Inspection"](#).

Is the inspection result normal?

YES >> GO TO 8.

NO >> Replace climate controlled seat relay.

8.CHECK INTERMITTENT INCIDENT

Refer to [GI-45. "Intermittent Incident"](#).

>> INSPECTION END

CLIMATE CONTROLLED SEAT CONTROL UNIT : Component Inspection INFOID:000000008194185

1.CHECK CLIMATE CONTROLLED SEAT RELAY

1. Turn ignition switch OFF.
2. Remove climate controlled seat relay.

POWER SUPPLY AND GROUND CIRCUIT

< DTC/CIRCUIT DIAGNOSIS >

[REGULAR GRADE]

3. Check the continuity between climate controlled seat relay terminals under the following conditions.

Terminal	Condition	Continuity	
3	5	12 V direct current supply between terminals 1 and 2.	Existed
		No current supply	Not existed
6	7	12 V direct current supply between terminals 1 and 2.	Existed
		No current supply	Not existed

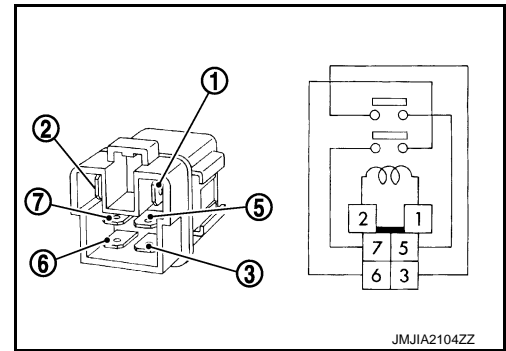

Is the inspection result normal?

YES >> INSPECTION END.

NO >> Replace climate controlled seat relay.

CLIMATE CONTROLLED SEAT SWITCH

< DTC/CIRCUIT DIAGNOSIS >

[REGULAR GRADE]

CLIMATE CONTROLLED SEAT SWITCH

Description

INFOID:000000008194186

Installed in the center console and transmits signals to climate controlled seat control unit in accordance with the HEAT or COOL switch operation of the climate controlled seat switch.

Component Function Check

INFOID:000000008194187

1. CHECK CLIMATE CONTROLLED SEAT SWITCH FUNCTION

Check that climate controlled seat activates when operating climate controlled seat control switch.

Is the inspection result normal?

- YES >> Climate controlled seat switch is OK.
- NO >> Refer to [SE-17. "Diagnosis Procedure"](#).

Diagnosis Procedure

INFOID:000000008194188

1. CHECK CLIMATE CONTROLLED SEAT CONTROL UNIT INPUT SIGNAL

1. Turn ignition switch ON.
2. Check voltage between climate controlled seat control unit harness connector and ground.

(+)		(-)	Condition	Voltage (V) (Approx.)	
Climate controlled seat control unit					
Connector	Terminal				
Driver side	B508	92	Climate controlled seat switch	LO COOL	0.8 - 1.5
				MID COOL	1.6 - 2.5
				HI COOL	2.6 - 4.2
				OFF	0
	91	Climate controlled seat switch	LO HEAT	0.8 - 1.5	
			MID HEAT	1.6 - 2.5	
			HI HEAT	2.6 - 4.2	
			OFF	0	
Passenger side	B558	92	Climate controlled seat switch	LO COOL	0.8 - 1.5
				MID COOL	1.6 - 2.5
				HI COOL	2.6 - 4.2
				OFF	0
	91	Climate controlled seat switch	LO HEAT	0.8 - 1.5	
			MID HEAT	1.6 - 2.5	
			HI HEAT	2.6 - 4.2	
			OFF	0	

Is the inspection result normal?

- YES >> Climate controlled seat switch circuit is OK.
- NO-1 >> HEAT or COOL mode is NG :GO TO 2.
- NO-2 >> HEAT and COOL modes are NG : GO TO 3.

2. CHECK CLIMATE CONTROLLED SEAT SWITCH CIRCUIT

1. Turn ignition switch OFF.
2. Disconnect climate controlled seat switch connector and climate controlled seat control unit connector.
3. Check continuity between climate controlled seat switch harness connector and climate controlled seat control unit harness connector.

CLIMATE CONTROLLED SEAT SWITCH

< DTC/CIRCUIT DIAGNOSIS >

[REGULAR GRADE]

Climate controlled seat switch			Climate cotrolled seat control unit		Continuity
Connector		Terminal	Connector	Terminal	
Driver side	COOL	M64	B508	2	Existed
	HEAT			3	
Passenger side	COOL	M65	B558	2	
	HEAT			3	
				92	
				91	
				92	
				91	

4. Check continuity between climate controlled seat switch harness connector and ground.

Climate controlled seat switch			Terminal	Ground	Continuity
Connector					
Driver side	COOL	M64	2	Ground	Not existed
	HEAT		3		
Passenger side	COOL	M65	2		
	HEAT		3		

Is the inspection result normal?

YES >> GO TO 5.

NO >> Repair or replace harness.

3. CHECK CLIMATE CONTROLLED SEAT SWITCH POWER SUPPLY

1. Turn ignition switch OFF.
2. Disconnect climate controlled seat switch connector.
3. Turn ignition switch ON.
4. Check voltage between climate controlled seat switch harness connector and ground.

Climate controlled seat switch			Terminal	(-)	Voltage (V) (Approx.)
Connector					
Driver side	M64		1	Ground	Battery voltage
Passenger side	M65		1		

Is the inspection result normal?

YES >> GO TO 5.

NO >> GO TO 4.

4. CHECK CLIMATE CONTROLLED SEAT SWITCH POWER SUPPLY CIRCUIT

1. Turn ignition switch OFF.
2. Disconnect climate controlled seat control unit connector.
3. Check continuity between climate controlled seat switch harness connector and climate controlled seat control unit harness connector.

Climate controlled seat switch			Climate cotrolled seat control unit		Continuity
Connector		Terminal	Connector	Terminal	
Driver side	M64	1	B508	94	Existed
Passenger side	M65	1	B558	94	

4. Check continuity between climate controlled seat switch harness connector and ground.

Climate controlled seat switch			Terminal	Ground	Continuity
Connector					
Driver side	M64		1	Ground	Not existed
Passenger side	M65		1		

Is the inspection result normal?

CLIMATE CONTROLLED SEAT SWITCH

[REGULAR GRADE]

< DTC/CIRCUIT DIAGNOSIS >

- YES >> Replace climate controlled seat control unit. Refer to [SE-71. "Disassembly and Assembly"](#).
 NO >> Repair or replace harness.

5. CHECK CLIMATE CONTROLLED SEAT SWITCH

Check climate controlled seat switch.
 Refer to [SE-19. "Component Inspection"](#).

Is the inspection result normal?

- YES >> GO TO 6.
 NO >> Replace climate controlled seat switch. Refer to [SE-80. "Removal and Installation"](#).

6. CHECK INTERMITTENT INCIDENT

Refer to [GI-45. "Intermittent Incident"](#).

>> INSPECTION END

Component Inspection

INFOID:000000008194189

1. CHECK CLIMATE CONTROLLED SEAT SWITCH

1. Turn ignition switch OFF.
2. Disconnect climate controlled seat switch connector.
3. Check the continuity between climate controlled seat switch terminals under the following conditions.

Connector		Terminal		Condition	Continuity	
Driver side	M64	2	1		COOL mode	ON
				OFF		Not existed
		3		HEAT mode	ON	Existed
					OFF	Not existed
Passenger side	M65	2	1	COOL mode	ON	Existed
					OFF	Not existed
		3		HEAT mode	ON	Existed
					OFF	Not existed

Is the inspection result normal?

- YES >> INSPECTION END
 NO >> Replace climate controlled seat switch. Refer to [SE-80. "Removal and Installation"](#).

SEATBACK THERMAL ELECTRIC DEVICE

< DTC/CIRCUIT DIAGNOSIS >

[REGULAR GRADE]

SEATBACK THERMAL ELECTRIC DEVICE

Description

INFOID:000000008194190

Installed in the seatback backside and heats or cools the airflow from the climate controlled seat blower motor in accordance with the control from the climate controlled seat control unit.

Component Function Check

INFOID:000000008194191

1. CHECK SEATBACK THERMAL ELECTRIC DEVICE FUNCTION

Check whether or not the temperature of the seatback thermal electric device changes in accordance with the HEAT or COOL switch operation of the climate controlled seat control switch.

Is the inspection result normal?

YES >> Seatback thermal device function is OK.

NO >> Refer to [SE-20, "Diagnosis Procedure"](#).

Diagnosis Procedure

INFOID:000000008194192

1. CHECK SEATBACK THERMAL ELECTRIC DEVICE SIGNAL

1. Turn ignition switch ON.
2. Check voltage between seatback thermal electric device harness connector and ground.

(+)		(-)	Condition	Voltage (V) (Approx.)	
Seatback thermal electric device					
Connector	Terminal				
Driver side	B511	Ground	Climate controlled seat switch	HEAT or COOL	0 - battery voltage*
				Other than above	0
				HEAT or COOL	0 - battery voltage*
				Other than above	0
Passenger side	B651		Climate controlled seat switch	HEAT or COOL	0 - battery voltage*
				Other than above	0
				HEAT or COOL	0 - battery voltage*
				Other than above	0

*:It changes between battery voltage and 0 V

NOTE:

Wait 1 minute or more after the activation start, and then start the measurement.

Is the inspection result normal?

YES >> Replace seatback thermal electric device.

NO >> GO TO 2.

2. CHECK SEATBACK THERMAL ELECTRIC DEVICE CIRCUIT

1. Turn ignition switch OFF.
2. Disconnect climate controlled seat control unit connector and seatback thermal electric device connector.
3. Check continuity between climate controlled seat control unit harness connector and seatback thermal electric device harness connector.

Climate controlled seat control unit		Seatback thermal electric device		Continuity
Connector	Terminal	Connector	Terminal	
Driver side	B509	B511	88	Existed
			85	
Passenger side	B559		88	
			85	

4. Check continuity between climate controlled seat control unit harness connector and ground.

SEATBACK THERMAL ELECTRIC DEVICE

< DTC/CIRCUIT DIAGNOSIS >

[REGULAR GRADE]

Climate controlled seat control unit				Continuity	
Connector		Terminal		Ground	
Driver side	B509	88	Ground		Not existed
		85			
Passenger side	B559	88			
		85			

Is the inspection result normal?

- YES >> Replace climate controlled seat control unit. Refer to [SE-71, "Disassembly and Assembly"](#).
- NO >> Repair or replace harness.

A
B
C
D
E
F
G
H
I
K
L
M
N
O
P

SE

SEATBACK THERMAL ELECTRIC DEVICE SENSOR

< DTC/CIRCUIT DIAGNOSIS >

[REGULAR GRADE]

SEATBACK THERMAL ELECTRIC DEVICE SENSOR

Description

INFOID:000000008194193

Measures seatback temperature.

Diagnosis Procedure

INFOID:000000008194194

1. CHECK SEATBACK THERMAL ELECTRIC DEVICE SENSOR SIGNAL

1. Turn ignition switch ON.
2. Check voltage between climate controlled seat control unit harness connector and ground.

(+)		Terminal	(-)	Condition	Voltage (V) (Approx.)
Climate controlled seat control unit					
Connector					
Driver side	B510	105	Ground	Climate controlled seat operated	1 - 5
Passenger side	B560				

Is the inspection result normal?

YES >> Seatback thermal electric device sensor circuit is OK.

NO >> GO TO 2.

2. CHECK SEATBACK THERMAL ELECTRIC DEVICE SENSOR CIRCUIT

1. Turn ignition switch OFF.
2. Disconnect climate controlled seat control unit connector and seatback thermal electric device connector.
3. Check continuity between climate controlled seat control unit harness connector and seatback thermal electric device harness connector.

Climate controlled seat control unit		Seatback thermal electric device		Continuity
Connector	Terminal	Connector	Terminal	
Driver side	B510	B511	105	Existed
			104	
Passenger side	B560	B561	105	
			104	

4. Check continuity between climate controlled seat control unit harness connector and ground.

Climate controlled seat control unit		Terminal	Ground	Continuity
Connector				
Driver side	B510	105	Ground	Not existed
		104		
Passenger side	B560	105		
		104		

Is the inspection result normal?

YES >> GO TO 3.

NO >> Repair or replace harness.

3. CHECK SEATBACK THERMAL ELECTRIC DEVICE SENSOR

Check resistance between seatback thermal electric device connector.

Seatback thermal electric device			Resistance (KΩ) (Approx.)
Connector	Terminal		
Driver side	B511	105	1
Passenger side			

SEATBACK THERMAL ELECTRIC DEVICE SENSOR

< DTC/CIRCUIT DIAGNOSIS >

[REGULAR GRADE]

Is the inspection result normal?

- YES >> Replace climate controlled seat control unit. Refer to [SE-71, "Disassembly and Assembly"](#).
- NO >> Replace seatback thermal electric device.

A
B
C
D
E
F
G
H
I
SE
K
L
M
N
O
P

SEAT CUSHION THERMAL ELECTRIC DEVICE

< DTC/CIRCUIT DIAGNOSIS >

[REGULAR GRADE]

SEAT CUSHION THERMAL ELECTRIC DEVICE

Description

INFOID:000000008194195

Seat cushion thermal electric device is installed in the seat cushion backside and heats or cools the airflow from the climate controlled seat blower motor in accordance with the control from the climate controlled seat control unit.

Component Function Check

INFOID:000000008194196

1. CHECK SEAT CUSHION THERMAL ELECTRIC DEVICE FUNCTION

Check whether or not the temperature of the seat cushion thermal electric device changes in accordance with the HEAT or COOL switch operation of the climate controlled seat control switch.

Is the inspection result normal?

YES >> Seatback thermal device function is OK.

NO >> Refer to [SE-20, "Diagnosis Procedure"](#).

Diagnosis Procedure

INFOID:000000008194197

1. CHECK SEAT CUSHION THERMAL ELECTRIC DEVICE SIGNAL

1. Turn ignition switch ON.
2. Check voltage between seat cushion thermal electric device harness connector and ground.

(+)		Terminal	(-)	Condition	Voltage (V) (Approx.)	
Seat cushion thermal electric device						
Connector						
Driver side	B512	87	Ground	Climate controlled seat switch	HEAT or COOL	0 - battery voltage*
					Other than above	0
		86		HEAT or COOL	0 - battery voltage*	
				Other than above	0	
Passenger side	B562	87		Climate controlled seat switch	HEAT or COOL	0 - battery voltage*
					Other than above	0
		86			HEAT or COOL	0 - battery voltage*
					Other than above	0

*:It changes between battery voltage and 0 V

NOTE:

Wait 1 minute or more after the activation start, and then start the measurement.

Is the inspection result normal?

YES >> Replace seat cushion thermal electric device.

NO >> GO TO 2.

2. CHECK SEAT CUSHION THERMAL ELECTRIC DEVICE CIRCUIT

1. Turn ignition switch OFF.
2. Disconnect climate controlled seat control unit connector and seat cushion thermal electric device connector.
3. Check continuity between climate controlled seat control unit harness connector and seat cushion thermal electric device harness connector.

SEAT CUSHION THERMAL ELECTRIC DEVICE

< DTC/CIRCUIT DIAGNOSIS >

[REGULAR GRADE]

Climate controlled seat control unit		Seat cushion thermal electric device		Continuity
Connector		Terminal	Connector	
Driver side	B509	87	B512	87
		86		86
Passenger side	B559	87	B562	87
		86		86

A
B
C

4. Check continuity between climate controlled seat control unit harness connector and ground.

Climate controlled seat control unit		Ground	Continuity
Connector			
Driver side	B509	87	Not existed
		86	
Passenger side	B559	87	
		86	

D
E
F

Is the inspection result normal?

YES >> Replace climate controlled seat control unit. Refer to [SE-71, "Disassembly and Assembly"](#).

NO >> Repair or replace harness.

G
H
I

SE

K
L
M
N
O
P

SEAT CUSHION THERMAL ELECTRIC DEVICE SENSOR

< DTC/CIRCUIT DIAGNOSIS >

[REGULAR GRADE]

SEAT CUSHION THERMAL ELECTRIC DEVICE SENSOR

Description

INFOID:000000008194198

Measures seat cushion temperature.

Diagnosis Procedure

INFOID:000000008194199

1. CHECK SEAT CUSHION THERMAL ELECTRIC DEVICE SENSOR SIGNAL

1. Turn ignition switch ON.
2. Check voltage between climate controlled seat control unit harness connector and ground.

(+)		Terminal	(-)	Condition	Voltage (V) (Approx.)
Climate controlled seat control unit					
Connector					
Driver side	B510	103	Ground	Climate controlled seat operated	1 - 5
Passenger side	B560				

Is the inspection result normal?

YES >> Seat cushion thermal electric device sensor circuit is OK.

NO >> GO TO 2.

2. CHECK SEAT CUSHION THERMAL ELECTRIC DEVICE SENSOR CIRCUIT

1. Turn ignition switch OFF.
2. Disconnect climate controlled seat control unit connector and seat cushion thermal electric device connector.
3. Check continuity between climate controlled seat control unit harness connector and seat cushion thermal electric device harness connector.

Climate controlled seat control unit		Seat cushion thermal electric device		Continuity
Connector	Terminal	Connector	Terminal	
Driver side	B510	B512	103	Existed
			102	
Passenger side	B560	B562	103	
			102	

4. Check continuity between climate controlled seat control unit harness connector and ground.

Climate controlled seat control unit		Terminal	Ground	Continuity
Connector				
Driver side	B510	103	Ground	Not existed
		102		
Passenger side	B560	103		
		102		

Is the inspection result normal?

YES >> GO TO 3.

NO >> Repair or replace harness.

3. CHECK SEAT CUSHION THERMAL ELECTRIC DEVICE SENSOR

Check resistance between seat cushion thermal electric device connector.

SEAT CUSHION THERMAL ELECTRIC DEVICE SENSOR

< DTC/CIRCUIT DIAGNOSIS >

[REGULAR GRADE]

Seat cushion thermal electric device				Resistance (KΩ) (Approx.)
Connector		Terminal		
Driver side	B512	102	103	1
Passenger side	B562			

Is the inspection result normal?

- YES >> Replace climate controlled seat control unit. Refer to [SE-71. "Disassembly and Assembly"](#).
- NO >> Replace seat cushion thermal electric device.

A
B
C
D
E
F
G
H
I
K
L
M
N
O
P

SE

CLIMATE CONTROLLED SEATBACK BLOWER MOTOR

< DTC/CIRCUIT DIAGNOSIS >

[REGULAR GRADE]

CLIMATE CONTROLLED SEATBACK BLOWER MOTOR

Description

INFOID:000000008194200

Sends air flow to the seatback.

Component Function Check

INFOID:000000008194201

1.CHECK CLIMATE CONTROLLED SEATBACK BLOWER MOTOR FUNCTION

When turning the climate controlled seat switch to the HEAT or COOL mode position, check that the climate controlled seatback blower is operated in each specific mode.

Is the inspection result normal?

YES >> Climate controlled seatback blower motor is OK.

NO >> Refer to [SE-31, "Diagnosis Procedure"](#).

Diagnosis Procedure

INFOID:000000008194202

1.CHECK CLIMATE CONTROLLED SEATBACK BLOWER MOTOR POWER SUPPLY

1. Turn ignition switch ON.
2. Check voltage between climate controlled seatback blower motor harness connector and ground.

(+)		Terminal	(-)	Condition	Voltage (V) (Approx.)	
Climate controlled seatback blower motor						
Connector						
Driver side	B513	99	Ground	Climate controlled seat switch	HEAT mode	Battery voltage
					COOL mode	
					Other than above	
Passenger side	B563			Climate controlled seat switch	HEAT mode	Battery voltage
					COOL mode	
					Other than above	

Is the inspection result normal?

YES >> GO TO 3.

NO >> GO TO 2.

2.CHECK CLIMATE CONTROLLED SEATBACK BLOWER MOTOR POWER SUPPLY CIRCUIT

1. Turn ignition switch OFF.
2. Disconnect climate controlled seatback blower motor connector and climate controlled seat control unit connector.
3. Check continuity between climate controlled seatback blower motor harness connector and climate controlled seat control unit harness connector.

Climate controlled seatback blower motor		Climate controlled seat control unit		Continuity
Connector	Terminal	Connector	Terminal	
Driver side	B513	B510	99	Existed
Passenger side	B563			

4. Check continuity between climate controlled seatback blower motor harness connector and ground.

Climate controlled seatback blower motor		Ground	Continuity
Connector	Terminal		
Driver side	B513	99	Not existed
Passenger side	B563		

Is the inspection result normal?

YES >> Replace climate controlled seat control unit. Refer to [SE-71, "Disassembly and Assembly"](#).

CLIMATE CONTROLLED SEATBACK BLOWER MOTOR

< DTC/CIRCUIT DIAGNOSIS >

[REGULAR GRADE]

NO >> Repair or replace harness.

3. CHECK CLIMATE CONTROLLED SEATBACK BLOWER MOTOR SPEED CONTROL SIGNAL

Check voltage between climate controlled seatback blower motor harness connector and ground.

(+)		(-)	Condition	Voltage (V) (Approx.)			
Climate controlled seatback blower motor							
Connector	Terminal	Ground	Climate controlled seat switch	Climate controlled seat switch			
Driver side	B513				96	HEAT mode	5 - 9
						LO COOL	6
						MID COOL	8
						HI COOL	10
						Other than above	0
Passenger side	B563				96	HEAT mode	5 - 9
						LO COOL	6
		MID COOL	8				
		HI COOL	10				
		Other than above	0				

Is the inspection result normal?

YES >> GO TO 5.

NO >> GO TO 4.

4. CHECK CLIMATE CONTROLLED SEATBACK BLOWER MOTOR SPEED CONTROL SIGNAL CIRCUIT

1. Turn ignition switch OFF.
2. Disconnect climate controlled seatback blower motor connector and climate controlled seat control unit connector.
3. Check continuity between climate controlled seatback blower motor harness connector and climate controlled seat control unit harness connector.

Climate controlled seatback blower motor		Climate controlled seat control unit		Continuity
Connector	Terminal	Connector	Terminal	
Driver side	B513	B510	96	Existed
Passenger side	B563	B560		

4. Check continuity between climate controlled seatback blower motor harness connector and ground.

Climate controlled seatback blower motor		Ground	Continuity
Connector	Terminal		
Driver side	B513	96	Not existed
Passenger side	B563		

Is the inspection result normal?

YES >> Replace climate controlled seat control unit. Refer to [SE-71. "Disassembly and Assembly"](#).

NO >> Repair or replace harness.

5. CHECK CLIMATE CONTROLLED SEATBACK BLOWER MOTOR GROUND CIRCUIT

1. Turn ignition switch OFF.
2. Disconnect climate controlled seatback blower motor and climate controlled seat control unit connector.
3. Check continuity between climate controlled seatback blower motor harness connector and climate controlled seat control unit harness connector.

CLIMATE CONTROLLED SEATBACK BLOWER MOTOR

< DTC/CIRCUIT DIAGNOSIS >

[REGULAR GRADE]

Climate controlled seatback blower motor		Climate controlled seat control unit		Continuity
Connector	Terminal	Connector	Terminal	
Driver side	B513	98	B510	Existed
Passenger side	B563		B560	

4. Check continuity between climate controlled seatback blower motor harness connector and ground.

Climate controlled seatback blower motor		Ground	Continuity
Connector	Terminal		
Driver side	B513	98	Not existed
Passenger side	B563		

Is the inspection result normal?

YES >> GO TO 6.

NO >> Repair or replace harness.

6. CHECK CLIMATE CONTROLLED SEATBACK BLOWER MOTOR GROUND

1. Connect climate controlled seat control unit connector.
2. Check continuity between climate controlled seatback blower motor harness connector and ground.

Climate controlled seatback blower motor		Ground	Continuity
Connector	Terminal		
Driver side	B513	98	Existed
Passenger side	B563		

Is the inspection result normal?

YES >> Replace climate controlled seatback blower motor. Refer to [SE-71, "Disassembly and Assembly"](#).

NO >> Replace climate controlled seat control unit. Refer to [SE-71, "Disassembly and Assembly"](#).

CLIMATE CONTROLLED SEAT CUSHION BLOWER MOTOR

< DTC/CIRCUIT DIAGNOSIS >

[REGULAR GRADE]

CLIMATE CONTROLLED SEAT CUSHION BLOWER MOTOR

Description

INFOID:000000008194203

Sends air flow to the seat cushion.

Component Function Check

INFOID:000000008194204

1. CHECK CLIMATE CONTROLLED SEAT CUSHION BLOWER MOTOR FUNCTION

When turning the climate controlled seat switch to the HEAT or COOL mode position, check that the climate controlled seat cushion blower is operated in each specific mode.

Is the inspection result normal?

- YES >> Climate controlled seat cushion blower motor is OK.
- NO >> Refer to [SE-31. "Diagnosis Procedure"](#).

Diagnosis Procedure

INFOID:000000008194205

1. CHECK CLIMATE CONTROLLED SEAT CUSHION BLOWER MOTOR POWER SUPPLY

1. Turn ignition switch ON.
2. Check voltage between climate controlled seat cushion blower motor harness connector and ground.

(+)		Terminal	(-)	Condition	Voltage (V) (Approx.)	
Climate controlled seat cushion blower motor						
Connector						
Driver side	B514	101	Ground	Climate controlled seat switch	HEAT mode	Battery voltage
					COOL mode	
					Other than above	
Passenger side	B564			Climate controlled seat switch	HEAT mode	Battery voltage
					COOL mode	
					Other than above	

Is the inspection result normal?

- YES >> GO TO 3.
- NO >> GO TO 2.

2. CHECK CLIMATE CONTROLLED SEAT CUSHION BLOWER MOTOR POWER SUPPLY CIRCUIT

1. Turn ignition switch OFF.
2. Disconnect climate controlled seat cushion blower motor connector and climate controlled seat control unit connector.
3. Check continuity between climate controlled seat cushion blower motor harness connector and climate controlled seat control unit harness connector.

Climate controlled seat cushion blower motor		Climate controlled seat control unit		Continuity
Connector	Terminal	Connector	Terminal	
Driver side	B514	B510	101	Existed
Passenger side	B564	B560		

4. Check continuity between climate controlled seat cushion blower motor harness connector and ground.

Climate controlled seat cushion blower motor		Terminal	Ground	Continuity
Connector				
Driver side	B514	101		Not existed
Passenger side	B564			

Is the inspection result normal?

- YES >> Replace climate controlled seat control unit. Refer to [SE-71. "Disassembly and Assembly"](#).

CLIMATE CONTROLLED SEAT CUSHION BLOWER MOTOR

< DTC/CIRCUIT DIAGNOSIS >

[REGULAR GRADE]

NO >> Repair or replace harness.

3. CHECK CLIMATE CONTROLLED SEAT CUSHION BLOWER MOTOR SPEED CONTROL SIGNAL

Check voltage between climate controlled seat cushion blower motor harness connector and ground.

(+)		(-)	Condition	Voltage (V) (Approx.)	
Climate controlled seat cushion blower motor					
Connector	Terminal	97	Ground	Climate controlled seat switch	
Driver side	B514				97
		LO COOL	6		
		MID COOL	8		
		HI COOL	12		
		Other than above	0		
Passenger side	B564	97	Ground	HEAT mode	5 - 9
				LO COOL	6
				MID COOL	8
				HI COOL	12
				Other than above	0

Is the inspection result normal?

YES >> GO TO 5.

NO >> GO TO 4.

4. CHECK CLIMATE CONTROLLED SEAT CUSHION BLOWER MOTOR SPEED CONTROL SIGNAL CIRCUIT

1. Turn ignition switch OFF.
2. Disconnect climate controlled seat cushion blower motor connector and climate controlled seat control unit connector.
3. Check continuity between climate controlled seat cushion blower motor harness connector and climate controlled seat control unit harness connector.

Climate controlled seat cushion blower motor		Climate controlled seat control unit		Continuity
Connector	Terminal	Connector	Terminal	
Driver side	B514	B510	97	Existed
Passenger side	B564	B560		

4. Check continuity between climate controlled seat cushion blower motor harness connector and ground.

Climate controlled seat cushion blower motor		Ground	Continuity
Connector	Terminal		
Driver side	B514	97	Not existed
Passenger side	B564		

Is the inspection result normal?

YES >> Replace climate controlled seat control unit. Refer to [SE-71, "Disassembly and Assembly"](#).

NO >> Repair or replace harness.

5. CHECK CLIMATE CONTROLLED SEAT CUSHION BLOWER MOTOR GROUND CIRCUIT

1. Turn ignition switch OFF.
2. Disconnect climate controlled seat cushion blower motor and climate controlled seat control unit connector.
3. Check continuity between climate controlled seat cushion blower motor harness connector and climate controlled seat control unit harness connector.

CLIMATE CONTROLLED SEAT CUSHION BLOWER MOTOR

< DTC/CIRCUIT DIAGNOSIS >

[REGULAR GRADE]

Climate controlled seat cushion blower motor		Climate controlled seat control unit		Continuity
Connector	Terminal	Connector	Terminal	
Driver side	B514	98	B510	Existed
Passenger side	B564		B560	

4. Check continuity between climate controlled seat cushion blower motor harness connector and ground.

Climate controlled seat cushion blower motor		Ground	Continuity
Connector	Terminal		
Driver side	B514	98	Not existed
Passenger side	B564		

Is the inspection result normal?

YES >> GO TO 6.

NO >> Repair or replace harness.

6. CHECK CLIMATE CONTROLLED SEAT BLOWER MOTOR GROUND

1. Connect climate controlled seat control unit connector.
2. Check continuity between climate controlled seat cushion blower motor harness connector and ground.

Climate controlled seat cushion blower motor		Ground	Continuity
Connector	Terminal		
Driver side	B514	98	Existed
Passenger side	B564		

Is the inspection result normal?

YES >> Replace climate controlled seat cushion blower motor. Refer to [SE-71, "Disassembly and Assembly"](#).

NO >> Replace climate controlled seat control unit. Refer to [SE-71, "Disassembly and Assembly"](#).

A
B
C
D
E
F
G
H
I
K
L
M
N
O
P

SE

CLIMATE CONTROLLED SEAT SWITCH INDICATOR

< DTC/CIRCUIT DIAGNOSIS >

[REGULAR GRADE]

CLIMATE CONTROLLED SEAT SWITCH INDICATOR

Description

INFOID:000000008194206

Turns ON the indicator that indicates the operating status of climate controlled seat HEAT or COOL mode.

Component Function Check

INFOID:000000008194207

1. CHECK CLIMATE CONTROLLED SEAT SWITCH INDICATOR FUNCTION

Check that the related indicator lamp illuminates when climate controlled seat switch is set to HEAT or COOL mode.

Is the inspection result normal?

YES >> Climate controlled seat switch indicator function is OK.

NO >> Refer to [SE-34, "Diagnosis Procedure"](#).

Diagnosis Procedure

INFOID:000000008194208

1. CHECK CLIMATE CONTROLLED SEAT CONTROL UNIT OUTPUT SIGNAL

1. Turn ignition switch ON.
2. Check voltage between climate controlled seat control unit harness connector and ground.

(+)		Terminal	(-)	Condition	Voltage (V) (Approx.)
Climate controlled seat control unit					
Connector					
Driver side	B510	95	Ground	Climate controlled seat switch	HEAT mode Battery voltage
		100		OFF	0
Passenger side	B560			95	Climate controlled seat switch
		100		OFF	0

Is the inspection result normal?

YES >> GO TO 2.

NO >> Replace climate controlled seat control unit. Refer to [SE-71, "Disassembly and Assembly"](#).

2. CHECK CLIMATE CONTROLLED SEAT SWITCH INDICATOR CIRCUIT

1. Turn ignition switch OFF.
2. Disconnect climate controlled seat control unit connector.
3. Check continuity between climate controlled seat switch harness connector and climate controlled seat control unit harness connector.

Climate controlled seat switch		Climate controlled seat control unit		Continuity
Connector	Terminal	Connector	Terminal	
Driver side	M64	B510	4	100
			5	95
Passenger side	M65	B560	4	100
			5	95

4. Check continuity between climate controlled seat switch harness connector and ground.

CLIMATE CONTROLLED SEAT SWITCH INDICATOR

< DTC/CIRCUIT DIAGNOSIS >

[REGULAR GRADE]

Climate controlled seat switch			Ground	Continuity	
Connector		Terminal		Not existed	
Driver side	M64	4	Ground		Not existed
		5			
Passenger side	M65	4			
		5			

Is the inspection result normal?

YES >> GO TO 3.

NO >> Repair or replace harness.

3. CHECK CLIMATE CONTROLLED SEAT SWITCH GROUND CIRCUIT

1. Turn ignition switch OFF.
2. Disconnect climate controlled seat switch connector.
3. Check continuity between climate controlled seat switch harness connector and ground.

Climate controlled seat switch			Ground	Continuity	
Connector		Terminal		Existed	
Driver side	M64	6	Ground		Existed
Passenger side	M65				

Is the inspection result normal?

YES >> Replace climate controlled seat switch. Refer to [SE-80, "Removal and Installation"](#).

NO >> Repair or replace harness.

A
B
C
D
E
F
G
H
I
K
L
M
N
O
P

SE

CLIMATE CONTROLLED SEAT BLOWER FILTER

< DTC/CIRCUIT DIAGNOSIS >

[REGULAR GRADE]

CLIMATE CONTROLLED SEAT BLOWER FILTER SEATBACK BLOWER MOTOR

SEATBACK BLOWER MOTOR : Diagnosis Procedure

INFOID:000000008194209

1. CHECK CLIMATE CONTROLLED SEATBACK BLOWER FILTER

Remove climate controlled seatback blower filter and check that there is no clogging by dirt or foreign matters.

Is the inspection result normal?

YES >> INSPECTION END

NO >> Replace climate controlled seatback blower filter. Refer to [SE-81, "SEATBACK : Removal and Installation"](#).

SEAT CUSHION BLOWER MOTOR

SEAT CUSHION BLOWER MOTOR : Diagnosis Procedure

INFOID:000000008194210

1. CHECK CLIMATE CONTROLLED SEAT CUSHION BLOWER FILTER

Remove climate controlled seat cushion blower filter and check that there is no clogging by dirt or foreign matters.

Is the inspection result normal?

YES >> INSPECTION END

NO >> Replace climate controlled seat cushion blower filter. Refer to [SE-81, "SEAT CUSHION : Removal and Installation"](#).

POWER SEAT

Wiring Diagram - POWER SEAT FOR DRIVER SIDE -

INFOID:000000008194211

For connector terminal arrangements, harness layouts, and alphabets in a  (option abbreviation; if not described in wiring diagram), refer to [GI-12, "Connector Information"](#).

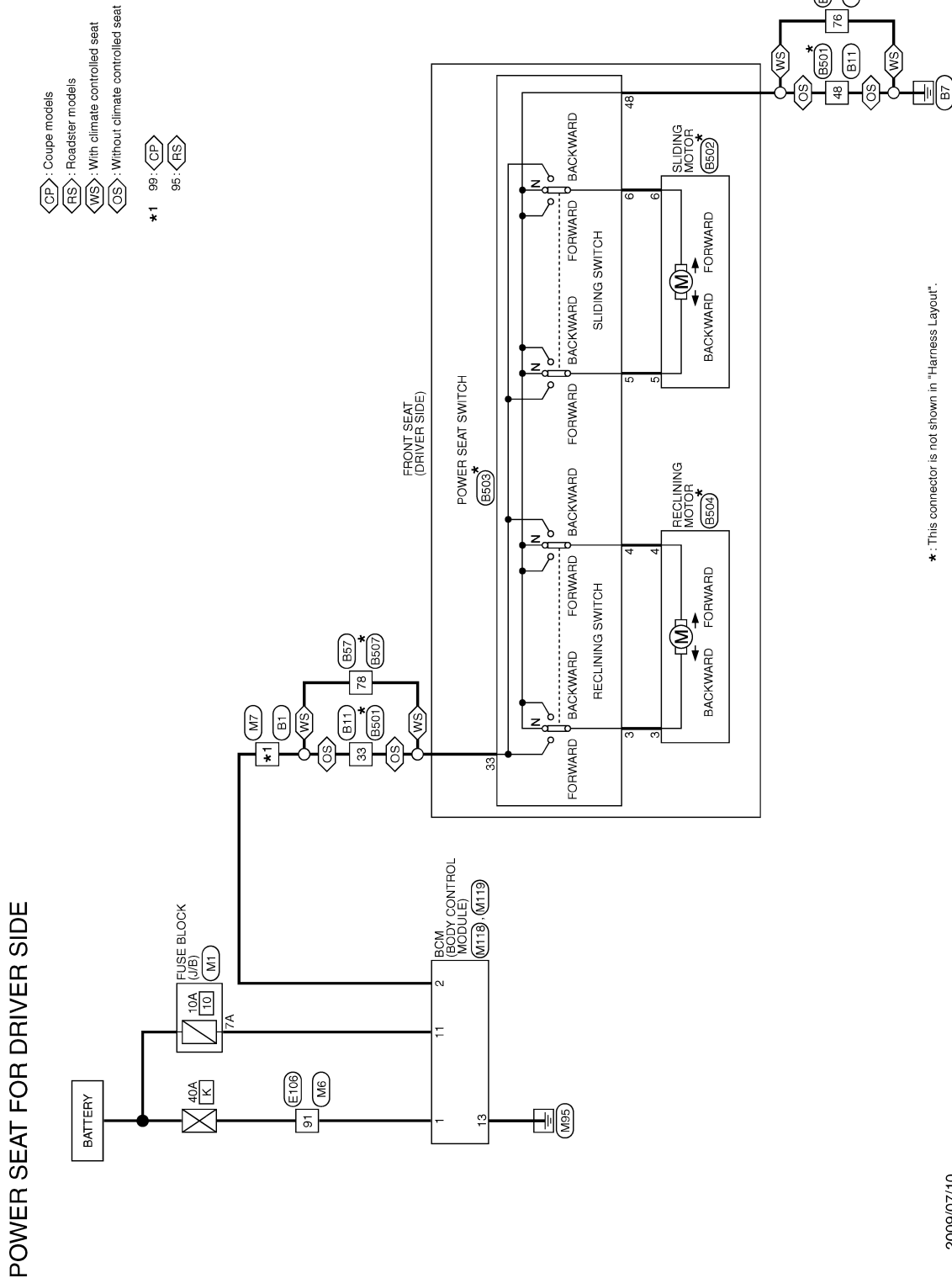

A
B
C
D
E
F
G
H
I
SE
K
L
M
N
O
P

POWER SEAT

< DTC/CIRCUIT DIAGNOSIS >

[REGULAR GRADE]

Wiring Diagram - POWER SEAT FOR PASSENGER SIDE -

INFOID:000000008194212

For connector terminal arrangements, harness layouts, and alphabets in a  (option abbreviation; if not described in wiring diagram), refer to [GI-12, "Connector Information"](#).

POWER SEAT FOR PASSENGER SIDE

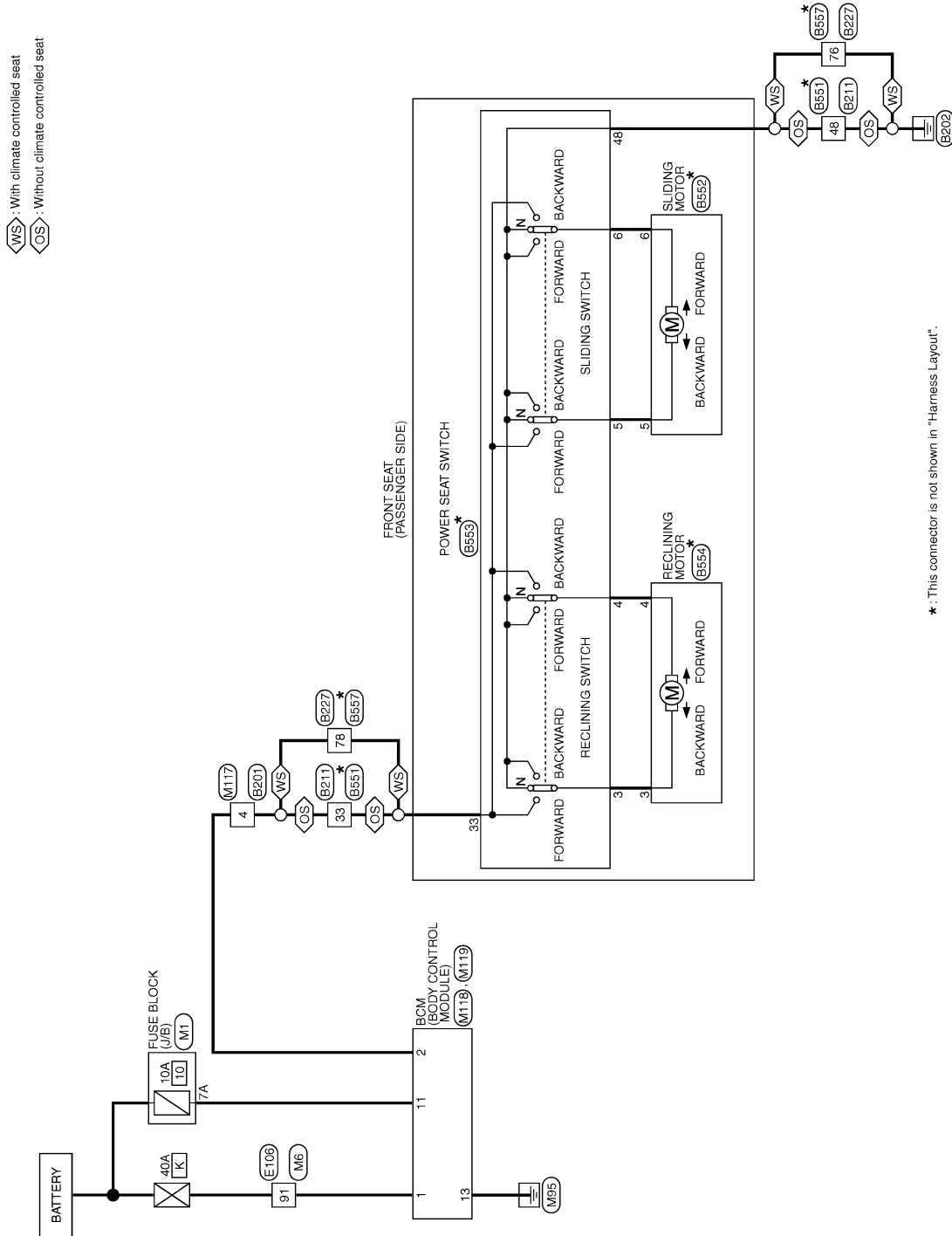

*: This connector is not shown in "Harness Layout".

2009/07/10

JCJWM0973GB

HEATED SEAT

< DTC/CIRCUIT DIAGNOSIS >

[REGULAR GRADE]

HEATED SEAT

Wiring Diagram - HEATED SEAT -

INFOID:000000008194213

For connector terminal arrangements, harness layouts, and alphabets in a  (option abbreviation; if not described in wiring diagram), refer to [GI-12, "Connector Information"](#).

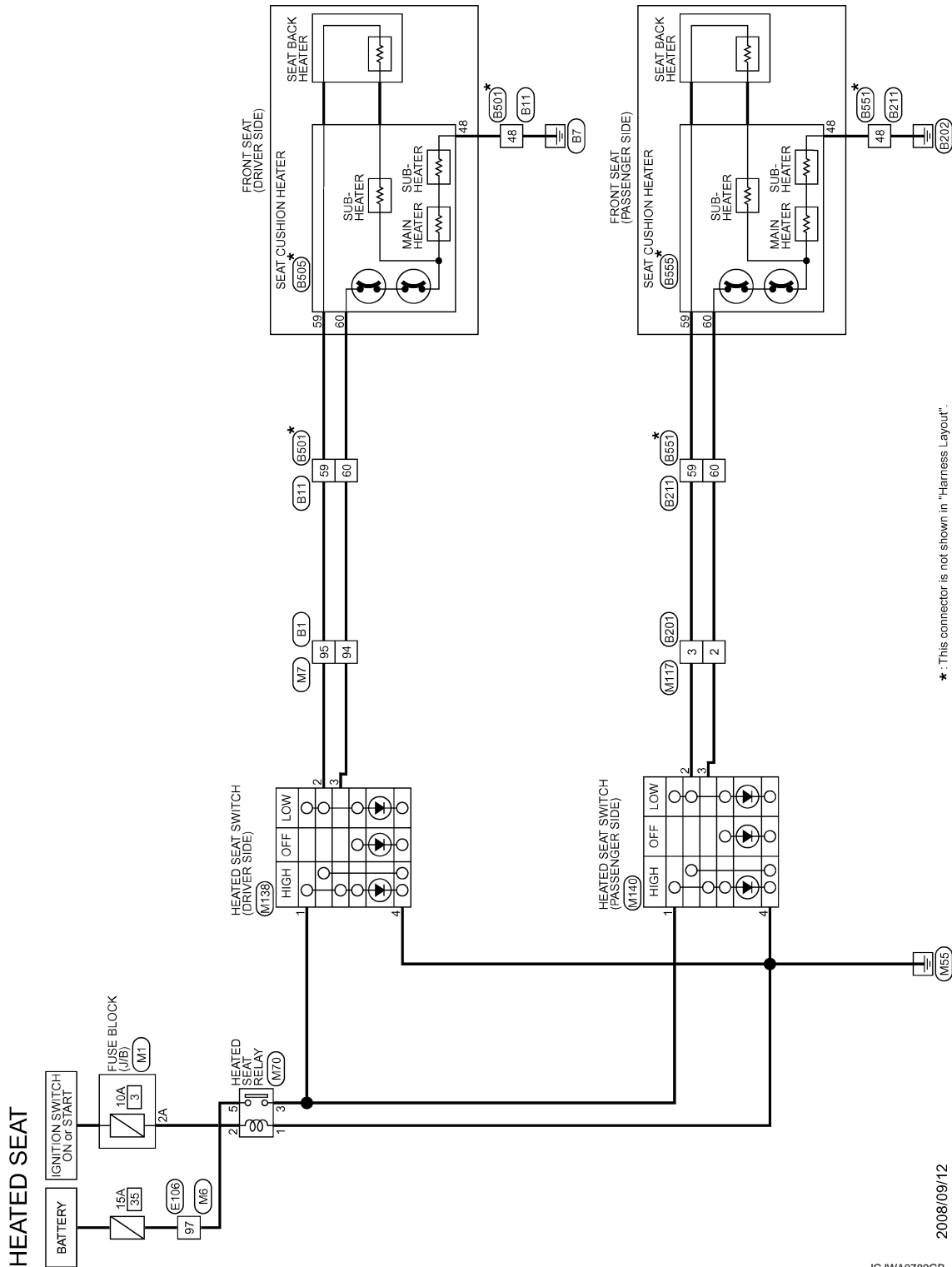

CLIMATE CONTROLLED SEAT CONTROL UNIT

< ECU DIAGNOSIS INFORMATION >

[REGULAR GRADE]

ECU DIAGNOSIS INFORMATION

CLIMATE CONTROLLED SEAT CONTROL UNIT

Reference Value

INFOID:000000008194214

TERMINAL LAYOUT

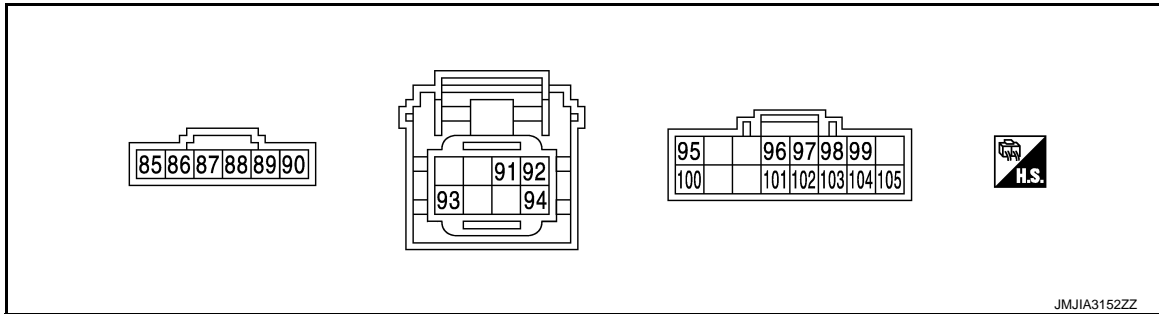

PHYSICAL VALUES

Terminal No. (Wire color)		Description		Condition	Voltage (V) (Approx.)	
+	-	Signal name	Input/ Output			
85 (G)	Ground	Seatback thermal electric device COOL signal	Output	Climate controlled seat switch	HEAT or COOL	0 - Battery voltage*
					OFF	0
86 (G/W)	Ground	Seat cushion thermal electric device COOL signal	Output	Climate controlled seat switch	HEAT or COOL	0 - Battery voltage*
					OFF	0
87 (G/B)	Ground	Seat cushion thermal electric device HEAT signal	Output	Climate controlled seat switch	HEAT or COOL	0 - Battery voltage*
					OFF	0
88 (G/R)	Ground	Seatback thermal electric device HEAT signal	Output	Climate controlled seat switch	HEAT or COOL	0 - Battery voltage*
					OFF	0
89 (R/W)	Ground	Ignition switch power supply	Input	Ignition switch ON	Battery voltage	
90 (L)	Ground	Ground	—	—	0	
91 (Y)	Ground	HEAT switch signal	Input	Climate controlled seat switch	HI HEAT	2.6 - 4.2
					MID HEAT	1.6 - 2.5
					LO HEAT	0.8 - 1.5
					OFF	0
92 (W)	Ground	COOL switch signal	Input	Climate controlled seat switch	HI COOL	2.6 - 4.2
					MID COOL	1.6 - 2.5
					LO COOL	0.8 - 1.5
					OFF	0
93 (R/W)	Ground	Ignition switch power supply	Input	Ignition switch ON	Battery voltage	
94 (W/R)	Ground	Climate controlled seat switch power supply	Output	Ignition switch ON	Battery voltage	
95 (R/L)	Ground	HEAT switch indicator signal	Output	Climate controlled seat switch	HEAT	Battery voltage
					OFF	0

CLIMATE CONTROLLED SEAT CONTROL UNIT

< ECU DIAGNOSIS INFORMATION >

[REGULAR GRADE]

Terminal No. (Wire color)		Description		Condition	Voltage (V) (Approx.)	
+	-	Signal name	Input/ Output			
96 (W/R)	Ground	Seatback blower motor speed control signal	Output	Climate controlled seat switch	HEAT	5 - 9
					HI COOL	10
					MID COOL	8
					LO COOL	6
97 (L/R)	Ground	seat cushion blower motor speed control signal	Output	Climate controlled seat switch	HEAT	5 - 9
					HI COOL	12
					MID COOL	8
					LO COOL	6
98 (L)	Ground	Blower motor ground	—	—	0	
99 (L/W)	Ground	Seatback blower motor power supply	Output	Climate controlled seat switch	HEAT or COOL	Battery voltage
				Other than the above		0
100 (GR)	Ground	COOL switch indicator signal	Output	Climate controlled seat switch	COOL	Battery voltage
					OFF	0
101 (GR/R)	Ground	Seat cushion blower motor power supply	Output	Climate controlled seat switch	HEAT or COOL	Battery voltage
				Other than the above		0
102 (V)	Ground	Seat cushion thermal electric device sensor ground	—	Ignition switch ON	0	
103 (BR)	Ground	Seat cushion thermal electric device sensor signal	Input	Climate controlled seat operated	1 - 5	
104 (V/W)	Ground	Seatback thermal electric device sensor ground	—	Ignition switch ON	0	
105 (LG)	Ground	Seatback thermal electric device sensor signal	Input	Climate controlled seat operated	1 - 5	

*:It value changes between battery voltage and 0 V

NOTE:

- Measure the value on the condition that the battery voltage is 14 V
- Wait 1 minute or more after thermal electric device is activated, and then start the measurement

A
B
C
D
E
F
G
H
I
SE
K
L
M
N
O
P

CLIMATE CONTROLLED SEAT CONTROL UNIT

< ECU DIAGNOSIS INFORMATION >

[REGULAR GRADE]

Wiring Diagram - CLIMATE CONTROLLED SEAT CONTROL SYSTEM - INFOID:0000000081942.15

For connector terminal arrangements, harness layouts, and alphabets in a  (option abbreviation; if not described in wiring diagram), refer to [GI-12, "Connector Information"](#).

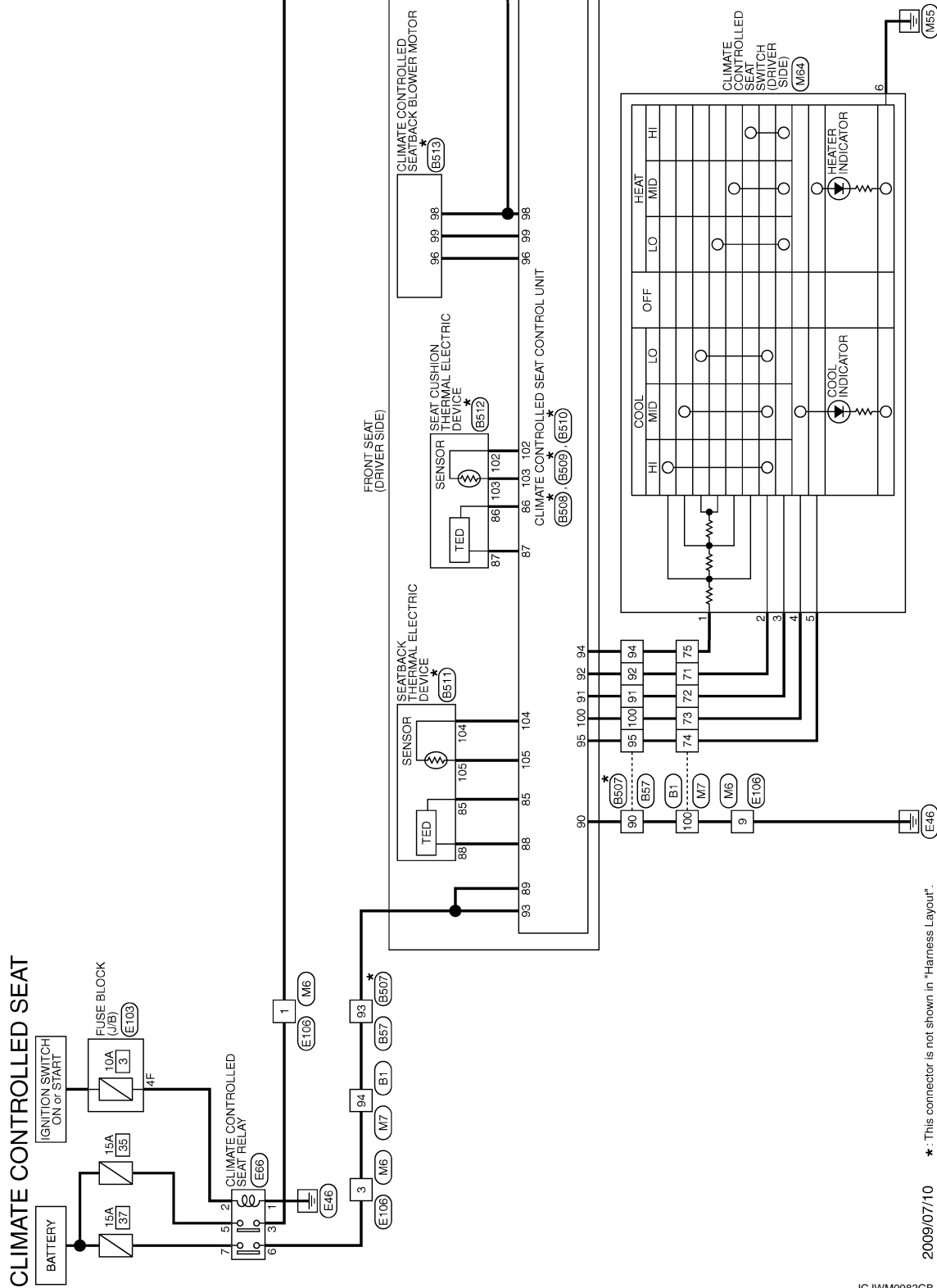

* This connector is not shown in "Harness Layout".

2009/07/10

JCJWM0982GB

CLIMATE CONTROLLED SEAT CONTROL UNIT

< ECU DIAGNOSIS INFORMATION >

[REGULAR GRADE]

* : This connector is not shown in "Harness Layout".

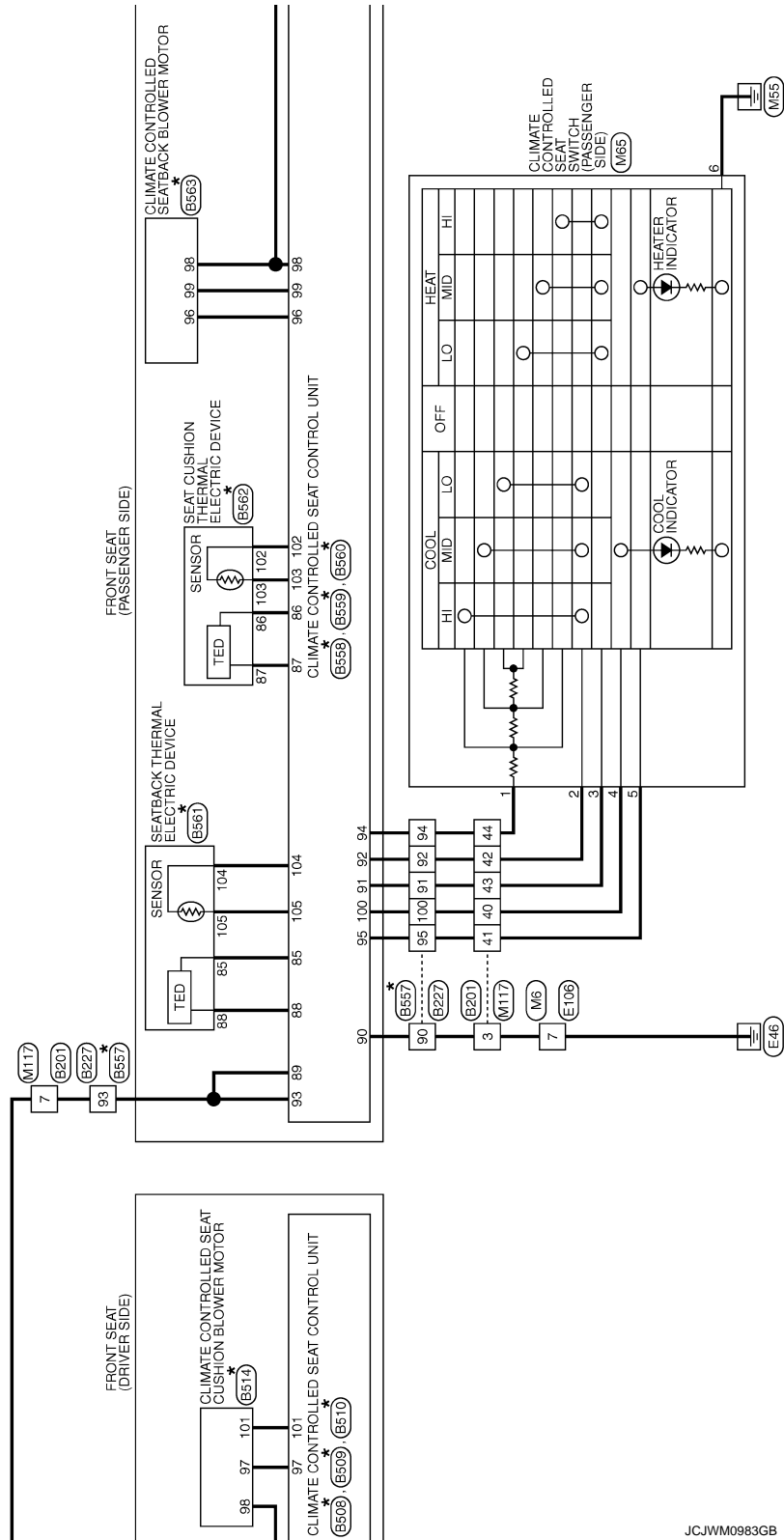

JCJWM0983GB

A
B
C
D
E
F
G
H
I
SE
K
L
M
N
O
P

CLIMATE CONTROLLED SEAT CONTROL UNIT

< ECU DIAGNOSIS INFORMATION >

[REGULAR GRADE]

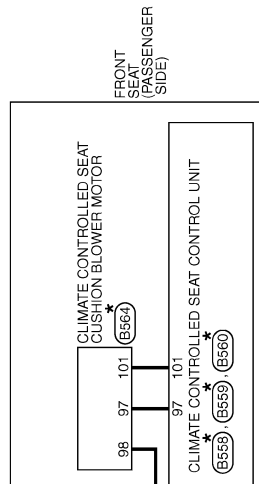

*: This connector is not shown in "Harness Layout".

JCJWM0984GB

Fail-safe

INFOID:000000008194216

- Climate controlled seat control unit equips fail-safe function.
- When a malfunction occurs in the systems shown below, climate controlled seat control unit stops output.

CLIMATE CONTROLLED SEAT CONTROL UNIT

< ECU DIAGNOSIS INFORMATION >

[REGULAR GRADE]

Malfunction	Malfunctioning condition	A
<p>The temperature difference between the seatback thermal electric device and seat cushion thermal electric device is more than 30°C</p>	<ul style="list-style-type: none"> • When it detects for 4 seconds that the temperature difference between the seatback thermal electric device and seat cushion thermal electric device is more than 30°, it stops the output to the thermal electric device, activates the climate controlled seat blower motor at the maximum position, and sends the external airflow for 30 seconds • If the temperature difference is still more than 30°C after 30 seconds pass, it stops all output and enters the system OFF condition • When the temperature difference between seatback thermal electric device and seat cushion thermal electric device becomes less than 20°C, the system recovers automatically • If it detects that the temperature difference is more than 30°C after the automatic system recovery, it immediately stops all output and enters the system OFF condition <p>NOTE: When the switch operation is performed before entering the system OFF condition, the fail-safe mode is reset.</p>	<p>B</p> <p>C</p> <p>D</p> <p>E</p>
<p>The temperature of thermal electric device is more than 110°C in the HEAT mode (any thermal electric device in the seatback or seat cushion)</p>	<ul style="list-style-type: none"> • When it detects for 4 seconds that the temperature of the thermal electric device is more than 110°C, it stops the output to the thermal electric device, activates the climate controlled seat blower motor at the maximum position, and sends the external airflow for 30 seconds • If the temperature does not become less than 105°C after 30 seconds pass, it stops all output and enters the system OFF condition • When the temperature of the thermal electric device becomes less than 105°C, the system recovers automatically • If it detects that the temperature of the thermal electric device is more than 110°C after the automatic system recovery, it immediately stops all output and enters the system OFF condition 	<p>F</p> <p>G</p> <p>H</p>
<p>The temperature of the thermal electric device is more than 45°C in the COOL mode (any thermal electric device in the seatback or seat cushion)</p>	<ul style="list-style-type: none"> • When it detects for 4 seconds that the temperature of the thermal electric device is more than 45°C and less than 70°C, it starts the temperature monitoring of the thermal electric device at 3 second intervals • While monitoring, if it detects that the temperature continuously rises 2°C or more 4 times or reaches 70°C or more, it stops all output and enters the system OFF condition • If it detects other results of monitoring, it continues activating in the COOL mode 	<p>I</p> <p style="background-color: black; color: white; text-align: center; padding: 2px;">SE</p>
<p>Thermal electric device sensor open circuit (in either the back and the cushion TED)</p>	<ul style="list-style-type: none"> • When it detects for 4 seconds that the thermal electric device sensor is an open circuit, it stops all output and enters the system OFF condition 	<p>K</p>
<p>Climate controlled seat blower motor system open circuit (in either the back and the cushion blower)</p>	<ul style="list-style-type: none"> • When it detects for 2 seconds that climate controlled seat blower motor is an open circuit while the climate controlled seat is being activated, and the battery status has been stable for the same 2 second period. it stops output to the thermal electric device • When it detects for 10 seconds that the climate controlled seat blower motor is an open circuit while the climate controlled seat is being activated, and the battery status has been stable for the same 10second period. it stops all output and enters the system OFF condition <p>NOTE: After detecting the climate seat blower motor system open circuit for 2 seconds, the system recovers automatically if the activation of the climate controlled seat blower motor is detected for 1 second or more.</p>	<p>L</p> <p>M</p> <p>N</p>
<p>Switch input out of the specified range (either heat input or cool input)</p>	<ul style="list-style-type: none"> • When it detects for 4 seconds that the rotary switch input is less than 30% of the vehicle battery voltage, it stops all output and enters the system OFF condition • When the switch input returns to a value within the specified range, the system recovers automatically 	<p>O</p> <p>P</p>

CLIMATE CONTROLLED SEAT CONTROL UNIT

< ECU DIAGNOSIS INFORMATION >

[REGULAR GRADE]

Malfunction	Malfunctioning condition
HEAT or COOL switch input out of the specified range	<ul style="list-style-type: none">• During the standby mode, heating or cooling states, if the rotary switch input is 6% or less of the vehicle battery voltage, it stops all output and enters the system OFF condition• When the switch input returns to a value within the specified range, the system recovers automatically
System voltage out of range	<ul style="list-style-type: none">• If the system voltage at the climate controlled seat control unit falls outside of the 8.5 to 16.5 V operating range, it stops all output after a 500ms time period.• When the system voltage returns to the normal operating range (10.5-15.5V with a 500ms hysteresis), the system recovers automatically.

*: System voltage is the voltage between the climate controlled seat control unit power source and ground.

NOTE:

When the ignition status changes to OFF during the fail-safe mode, the control unit shall enter the OFF condition. If the ignition is turned ON, the system shall return to the standby mode. If the system enters in the fail-safe mode again after performing ignition cycle, start the diagnosis.

CLIMATE CONTROLLED SEAT DOES NOT OPERATE.

< SYMPTOM DIAGNOSIS >

[REGULAR GRADE]

SYMPTOM DIAGNOSIS

CLIMATE CONTROLLED SEAT DOES NOT OPERATE.
DRIVER SIDE

DRIVER SIDE : Diagnosis Procedure

INFOID:000000008194217

Both sides

1. CHECK CLIMATE CONTROLLED SEAT CONTROL UNIT POWER SUPPLY AND GROUND CIRCUIT

Check climate controlled seat control unit power supply and ground circuit.

Refer to [SE-12. "CLIMATE CONTROLLED SEAT CONTROL UNIT : Diagnosis Procedure"](#).

Is the inspection result normal?

YES >> GO TO 2.

NO >> Repair or replace the malfunctioning parts.

2. CHECK CLIMATE CONTROLLED SEAT SWITCH

Check climate controlled seat switch.

Refer to [SE-17. "Component Function Check"](#).

Is the inspection result normal?

YES >> GO TO 3.

NO >> Repair or replace the malfunctioning parts.

3. CONFIRM THE OPERATION

Confirm the operation again.

Is the inspection result normal?

YES >> Check intermittent incident. Refer to [GI-45. "Intermittent Incident"](#).

NO >> GO TO 1.

seatback

1. CHECK CLIMATE CONTROLLED SEATBACK BLOWER MOTOR

Check climate controlled seatback blower motor.

Refer to [SE-28. "Component Function Check"](#).

Is the inspection result normal?

YES >> GO TO 2.

NO >> Repair or replace the malfunctioning parts.

2. CONFIRM THE OPERATION

Confirm the operation again.

Is the inspection result normal?

YES >> Check intermittent incident. Refer to [GI-45. "Intermittent Incident"](#).

NO >> GO TO 1.

seat cushion

1. CHECK CLIMATE CONTROLLED SEAT CUSHION BLOWER MOTOR

Check climate controlled seat cushion blower motor.

Refer to [SE-31. "Component Function Check"](#).

Is the inspection result normal?

YES >> GO TO 2.

NO >> Repair or replace the malfunctioning parts.

2. CONFIRM THE OPERATION

Confirm the operation again.

Is the inspection result normal?

A
B
C
D
E
F
G
H
I
SE
K
L
M
N
O
P

CLIMATE CONTROLLED SEAT DOES NOT OPERATE.

< SYMPTOM DIAGNOSIS >

[REGULAR GRADE]

YES >> Check intermittent incident. Refer to [GI-45. "Intermittent Incident"](#).
NO >> GO TO 1.

PASSENGER SIDE

PASSENGER SIDE : Diagnosis Procedure

INFOID:000000008194218

Both sides

1.CHECK CLIMATE CONTROLLED SEAT CONTROL UNIT POWER SUPPLY AND GROUND CIRCUIT

Check climate controlled seat control unit power supply and ground circuit.
Refer to [SE-12. "CLIMATE CONTROLLED SEAT CONTROL UNIT : Diagnosis Procedure"](#).

Is the inspection result normal?

YES >> GO TO 2.
NO >> Repair or replace the malfunctioning parts.

2.CHECK CLIMATE CONTROLLED SEAT SWITCH

Check climate controlled seat switch.
Refer to [SE-17. "Component Function Check"](#).

Is the inspection result normal?

YES >> GO TO 3.
NO >> Repair or replace the malfunctioning parts.

3.CONFIRM THE OPERATION

Confirm the operation again.

Is the inspection result normal?

YES >> Check intermittent incident. Refer to [GI-45. "Intermittent Incident"](#).
NO >> GO TO 1.

Seatback

1.CHECK CLIMATE CONTROLLED SEATBACK BLOWER MOTOR

Check climate controlled seatback blower motor.
Refer to [SE-28. "Component Function Check"](#).

Is the inspection result normal?

YES >> GO TO 2.
NO >> Repair or replace the malfunctioning parts.

2.CONFIRM THE OPERATION

Confirm the operation again.

Is the inspection result normal?

YES >> Check intermittent incident. Refer to [GI-45. "Intermittent Incident"](#).
NO >> GO TO 1.

Seat cushion

1.CHECK CLIMATE CONTROLLED SEAT CUSHION BLOWER MOTOR

Check climate controlled seat cushion blower motor.
Refer to [SE-31. "Component Function Check"](#).

Is the inspection result normal?

YES >> GO TO 2.
NO >> Repair or replace the malfunctioning parts.

2.CONFIRM THE OPERATION

Confirm the operation again.

Is the inspection result normal?

YES >> Check intermittent incident. Refer to [GI-45. "Intermittent Incident"](#).

CLIMATE CONTROLLED SEAT DOES NOT OPERATE.

< SYMPTOM DIAGNOSIS >

[REGULAR GRADE]

NO >> GO TO 1.

A

B

C

D

E

F

G

H

I

SE

K

L

M

N

O

P

TEMPERATURE ADJUSTMENT IS IMPOSSIBLE

< SYMPTOM DIAGNOSIS >

[REGULAR GRADE]

TEMPERATURE ADJUSTMENT IS IMPOSSIBLE

SEATBACK BLOWER MOTOR

SEATBACK BLOWER MOTOR : Description

INFOID:000000008194219

Blower fan motor noise is constant though performing temperature adjustment operation.

NOTE:

When turning climate controlled seat switch ON, blower fan motor may stay in the low speed operation for approximately 60 seconds. But this is not a malfunction.

SEATBACK BLOWER MOTOR : Diagnosis Procedure

INFOID:000000008194220

1.CHECK CLIMATE CONTROLLED SEATBACK BLOWER FILTER

Check climate controlled seatback blower filter.

Refer to [SE-36. "SEATBACK BLOWER MOTOR : Diagnosis Procedure"](#).

Is the inspection result normal?

YES >> GO TO 2.

NO >> Repair or replace the malfunctioning parts.

2.CHECK CLIMATE CONTROLLED SEAT SWITCH

Check climate controlled seat switch.

Refer to [SE-17. "Component Function Check"](#).

Is the inspection result normal?

YES >> GO TO 3.

NO >> Repair or replace the malfunctioning parts.

3.CHECK CLIMATE CONTROLLED SEATBACK BLOWER MOTOR

Check climate controlled seatback blower motor.

Refer to [SE-28. "Component Function Check"](#).

Is the inspection result normal?

YES >> GO TO 4.

NO >> Repair or replace the malfunctioning parts.

4.CONFIRM THE OPERATION

Confirm the operation again.

Is the inspection result normal?

YES >> Check intermittent incident. Refer to [GI-45. "Intermittent Incident"](#).

NO >> GO TO 1.

SEAT CUSHION BLOWER MOTOR

SEAT CUSHION BLOWER MOTOR : Description

INFOID:000000008194221

Blower fan motor noise is constant though performing temperature adjustment operation.

NOTE:

When turning climate controlled seat switch ON, blower fan motor may stay in the low speed operation for approximately 60 seconds. But this is not a malfunction.

SEAT CUSHION BLOWER MOTOR : Diagnosis Procedure

INFOID:000000008194222

1.CHECK CLIMATE CONTROLLED SEAT CUSHION BLOWER FILTER

Check climate controlled seat cushion blower filter.

Refer to [SE-36. "SEAT CUSHION BLOWER MOTOR : Diagnosis Procedure"](#).

Is the inspection result normal?

YES >> GO TO 2.

NO >> Repair or replace the malfunctioning parts.

2.CHECK CLIMATE CONTROLLED SEAT SWITCH

TEMPERATURE ADJUSTMENT IS IMPOSSIBLE

< SYMPTOM DIAGNOSIS >

[REGULAR GRADE]

Check climate controlled seat switch.

Refer to [SE-17, "Component Function Check"](#).

Is the inspection result normal?

YES >> GO TO 3.

NO >> Repair or replace the malfunctioning parts.

3.CHECK CLIMATE CONTROLLED SEAT CUSHION BLOWER MOTOR

Check climate controlled seat cushion blower motor.

Refer to [SE-31, "Component Function Check"](#).

Is the inspection result normal?

YES >> GO TO 4.

NO >> Repair or replace the malfunctioning parts.

4.CONFIRM THE OPERATION

Confirm the operation again.

Is the inspection result normal?

YES >> Check intermittent incident. Refer to [GI-45, "Intermittent Incident"](#).

NO >> GO TO 1.

A
B
C
D
E
F
G
H
I
K
L
M
N
O
P

SE

CLIMATE CONTROLLED SEAT DOES NOT OPERATES WHEN SWITCH IS DONE IN HEAT OR COOL.

< SYMPTOM DIAGNOSIS >

[REGULAR GRADE]

CLIMATE CONTROLLED SEAT DOES NOT OPERATES WHEN SWITCH IS DONE IN HEAT OR COOL.

Diagnosis Procedure

INFOID:000000008194223

1.CHECK CLIMATE CONTROLLED SEAT SWITCH

Check climate controlled seat switch.

Refer to [SE-17, "Component Function Check"](#).

Is the inspection result normal?

YES >> GO TO 2.

NO >> Repair or replace the malfunctioning parts.

2.CONFIRM THE OPERATION

Confirm the operation again.

Is the inspection result normal?

YES >> Check intermittent incident. Refer to [GI-45, "Intermittent Incident"](#).

NO >> GO TO 1.

CLIMATE CONTROLLED SEAT ACTIVATES ONCE BUT STOPS IMMEDIATELY

SEATBACK BLOWER MOTOR

SEATBACK BLOWER MOTOR : Description

INFOID:000000008194224

When turning climate controlled seat switch ON (COOL or HEAT), climate controlled seat activates once but stops immediately.(Repeats the same operation when turning ignition switch OFF and turning ignition switch ON again.)

SEATBACK BLOWER MOTOR : Diagnosis Procedure

INFOID:000000008194225

1.CHECK CLIMATE CONTROLLED SEATBACK BLOWER FILTER

Check climate controlled seatback blower filter.

Refer to [SE-36. "SEATBACK BLOWER MOTOR : Diagnosis Procedure"](#).

Is the inspection result normal?

YES >> GO TO 2.

NO >> Repair or replace the malfunctioning parts.

2.CHECK SEATBACK THERMAL ELECTRIC DEVICE SENSOR

Check seatback thermal electric device sensor.

Refer to [SE-22. "Diagnosis Procedure"](#).

Is the inspection result normal?

YES >> GO TO 3.

NO >> Repair or replace the malfunctioning parts.

3.CHECK SEATBACK THERMAL ELECTRIC DEVICE

Check seatback thermal electric device.

Refer to [SE-20. "Component Function Check"](#).

Is the inspection result normal?

YES >> GO TO 4.

NO >> Repair or replace the malfunctioning parts.

4.CHECK CLIMATE CONTROLLED SEATBACK BLOWER MOTOR

Check climate controlled seatback blower motor.

Refer to [SE-28. "Component Function Check"](#).

Is the inspection result normal?

YES >> GO TO 5.

NO >> Repair or replace the malfunctioning parts.

5.CONFIRM THE OPERATION

Confirm the operation again.

Is the inspection result normal?

YES >> Check intermittent incident. Refer to [GI-45. "Intermittent Incident"](#).

NO >> GO TO 1.

SEAT CUSHION BLOWER MOTOR

SEAT CUSHION BLOWER MOTOR : Description

INFOID:000000008194226

When turning climate controlled seat switch ON (COOL or HEAT), climate controlled seat activates once but stops immediately. (Repeats the same operation when turning ignition switch OFF and turning ignition switch ON again.)

SEAT CUSHION BLOWER MOTOR : Diagnosis Procedure

INFOID:000000008194227

1.CHECK CLIMATE CONTROLLED SEAT CUSHION BLOWER FILTER

CLIMATE CONTROLLED SEAT ACTIVATES ONCE BUT STOPS IMMEDIATELY
< SYMPTOM DIAGNOSIS > **[REGULAR GRADE]**

Check climate controlled seat cushion blower filter.

Refer to [SE-36, "SEAT CUSHION BLOWER MOTOR : Diagnosis Procedure"](#).

Is the inspection result normal?

YES >> GO TO 2.

NO >> Repair or replace the malfunctioning parts.

2.CHECK SEAT CUSHION THERMAL ELECTRIC DEVICE SENSOR

Check seat cushion thermal electric device sensor.

Refer to [SE-26, "Diagnosis Procedure"](#).

Is the inspection result normal?

YES >> GO TO 3.

NO >> Repair or replace the malfunctioning parts.

3.CHECK SEAT CUSHION THERMAL ELECTRIC DEVICE

Check seat cushion thermal electric device.

Refer to [SE-24, "Component Function Check"](#).

Is the inspection result normal?

YES >> GO TO 4.

NO >> Repair or replace the malfunctioning parts.

4.CHECK CLIMATE CONTROLLED SEAT CUSHION BLOWER MOTOR

Check climate controlled seat cushion blower motor.

Refer to [SE-31, "Component Function Check"](#).

Is the inspection result normal?

YES >> GO TO 5.

NO >> Repair or replace the malfunctioning parts.

5.CONFIRM THE OPERATION

Confirm the operation again.

Is the inspection result normal?

YES >> Check intermittent incident. Refer to [GI-45, "Intermittent Incident"](#).

NO >> GO TO 1.

SEAT SWITCH INDICATOR IS NOT ILLUMINATED IN HEAT OR COOL POSITION

< SYMPTOM DIAGNOSIS >

[REGULAR GRADE]

SEAT SWITCH INDICATOR IS NOT ILLUMINATED IN HEAT OR COOL POSITION

Diagnosis Procedure

INFOID:000000008194228

1. CHECK CLIMATE CONTROLLED SEAT SWITCH INDICATOR

Check climate controlled seat switch indicator.
Refer to [SE-34, "Component Function Check"](#).

Is the inspection result normal?

YES >> GO TO 2.

NO >> Repair or replace the malfunctioning parts.

2. CONFIRM THE OPERATION

Confirm the operation again.

Is the inspection result normal?

YES >> Check intermittent incident. Refer to [GI-45, "Intermittent Incident"](#).

NO >> GO TO 1.

A
B
C
D
E
F
G
H
I
K
L
M
N
O
P

SE

SQUEAK AND RATTLE TROUBLE DIAGNOSIS

< SYMPTOM DIAGNOSIS >

[REGULAR GRADE]

SQUEAK AND RATTLE TROUBLE DIAGNOSIS

Work Flow

INFOID:00000008194229

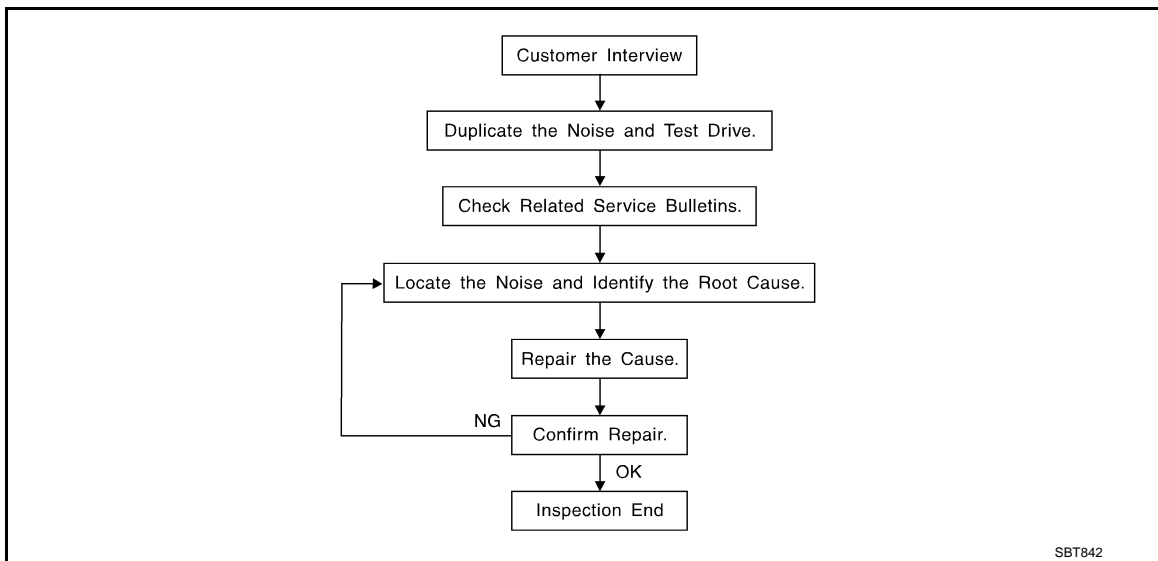

CUSTOMER INTERVIEW

Interview the customer if possible, to determine the conditions that exist when the noise occurs. Use the Diagnostic Worksheet during the interview to document the facts and conditions when the noise occurs and any of customer's comments; refer to [SE-60, "Diagnostic Worksheet"](#). This information is necessary to duplicate the conditions that exist when the noise occurs.

- The customer may not be able to provide a detailed description or the location of the noise. Attempt to obtain all the facts and conditions that exist when the noise occurs (or does not occur).
- If there is more than one noise in the vehicle, perform a diagnosis and repair the noise that the customer is concerned about. This can be accomplished by performing a cruise test on the vehicle with the customer.
- After identifying the type of noise, isolate the noise in terms of its characteristics. The noise characteristics are provided so the customer, service adviser and technician are all speaking the same language when defining the noise.
- Squeak – (Like tennis shoes on a clean floor)
Squeak characteristics include the light contact/fast movement/brought on by road conditions/hard surfaces = higher pitch noise/softer surfaces = lower pitch noises/edge to surface = chirping
- Creak – (Like walking on an old wooden floor)
Creak characteristics include firm contact/slow movement/twisting with a rotational movement/pitch dependent on materials/often brought on by activity.
- Rattle – (Like shaking a baby rattle)
Rattle characteristics include the fast repeated contact/vibration or similar movement/loose parts/missing clip or fastener/incorrect clearance.
- Knock – (Like a knock on a door)
Knock characteristics include hollow sounding/sometimes repeating/often brought on by driver action.
- Tick – (Like a clock second hand)
Tick characteristics include gentle contacting of light materials/loose components/can be caused by driver action or road conditions.
- Thump – (Heavy, muffled knock noise)
Thump characteristics include softer knock/dead sound often brought on by activity.
- Buzz – (Like a bumblebee)
Buzz characteristics include high frequency rattle/firm contact.
- Often the degree of acceptable noise level will vary depending up on the person. A noise that a technician may judge as acceptable may be very irritating to the customer.
- Weather conditions, especially humidity and temperature, may have a great effect on noise level.

DUPLICATE THE NOISE AND TEST DRIVE

If possible, drive the vehicle with the customer until the noise is duplicated. Note any additional information on the Diagnostic Worksheet regarding the conditions or location of the noise. This information can be used to duplicate the same conditions when the repair is reconfirmed.

SQUEAK AND RATTLE TROUBLE DIAGNOSIS

< SYMPTOM DIAGNOSIS >

[REGULAR GRADE]

If the noise can be duplicated easily during the test drive, to help identify the source of the noise, try to duplicate the noise with the vehicle stopped by doing one or all of the following:

- 1) Close a door.
 - 2) Tap or push/pull around the area where the noise appears to be coming from.
 - 3) Rev the engine.
 - 4) Use a floor jack to recreate vehicle "twist".
 - 5) At idle, apply engine load (electrical load, half-clutch on M/T models, drive position on A/T models).
 - 6) Raise the vehicle on a hoist and hit a tire with a rubber hammer.
- Drive the vehicle and attempt to duplicate the conditions the customer states exist when the noise occurs.
 - If it is difficult to duplicate the noise, drive the vehicle slowly on an undulating or rough road to stress the vehicle body.

CHECK RELATED SERVICE BULLETINS

After verifying the customer concern or symptom, check ASIST for Technical Service Bulletins (TSBs) related to that concern or symptom.

If a TSB relates to the symptom, follow the procedure to repair the noise.

LOCATE THE NOISE AND IDENTIFY THE ROOT CAUSE

1. Narrow down the noise to a general area. To help pinpoint the source of the noise, use a listening tool (Chassis ear: J-39570, Engine ear and mechanics stethoscope).
2. Narrow down the noise to a more specific area and identify the cause of the noise by:
 - Removing the components in the area that is are suspected to be the cause of the noise.
Do not use too much force when removing clips and fasteners, otherwise clips and fastener can be broken or lost during the repair, resulting in the creation of new noise.
 - Tapping or pushing/pulling the component that is are suspected to be the cause of the noise.
Do not tap or push/pull the component with excessive force, otherwise the noise will be eliminated only temporarily.
 - Feeling for a vibration by hand by touching the component(s) that is are suspected to be the cause of the noise.
 - Placing a piece of paper between components that are suspected to be the cause of the noise.
 - Looking for loose components and contact marks.
Refer to [SE-58. "Inspection Procedure"](#).

REPAIR THE CAUSE

- If the cause is a loose component, tighten the component securely.
- If the cause is insufficient clearance between components:
 - Separate components by repositioning or loosening and retightening the component, if possible.
 - Insulate components with a suitable insulator such as urethane pads, foam blocks, felt cloth tape or urethane tape. A Nissan Squeak and Rattle Kit (J-43980) is available through the authorized Nissan Parts Department.

CAUTION:

Never use excessive force as many components are constructed of plastic and may be damaged.

NOTE:

Always check with the Parts Department for the latest parts information.

The following materials are contained in the Nissan Squeak and Rattle Kit (J-43980). Each item can be ordered separately as needed.

URETHANE PADS [1.5 mm (0.059 in) thick]

Insulates connectors, harness, etc.

76268-9E005: 100 × 135 mm (3.94 × 5.31 in)/76884-71L01: 60 × 85 mm (2.36 × 3.35 in)/76884-71L02: 15 × 25 mm (0.59 × 0.98 in)

INSULATOR (Foam blocks)

Insulates components from contact. Can be used to fill space behind a panel.

73982-9E000: 45 mm (1.77 in) thick, 50 × 50 mm (1.97 × 1.97 in)/73982-

50Y00: 10 mm (0.39 in) thick, 50 × 50 mm (1.97 × 1.97 in)

INSULATOR (Light foam block)

80845-71L00: 30 mm (1.18 in) thick, 30 × 50 mm (1.18 × 1.97in)

FELT CLOTHTAPE

Used to insulate where movement does not occur. Ideal for instrument panel applications.

68370-4B000: 15 × 25 mm (0.59 × 0.98 in) pad/68239-13E00: 5 mm (0.20 in) wide tape roll

The following materials, not found in the kit, can also be used to repair squeaks and rattles.

UHMW (TEFLON) TAPE

SQUEAK AND RATTLE TROUBLE DIAGNOSIS

< SYMPTOM DIAGNOSIS >

[REGULAR GRADE]

Insulates where slight movement is present. Ideal for instrument panel applications.

SILICONE GREASE

Used in place of UHMW tape that is be visible or does not fit. Will only last a few months.

SILICONE SPRAY

Used when grease cannot be applied.

DUCT TAPE

Used to eliminate movement.

CONFIRM THE REPAIR

Confirm that the cause of a noise is repaired by test driving the vehicle. Operate the vehicle under the same conditions as when the noise originally occurred. Refer to the notes on the Diagnostic Worksheet.

Inspection Procedure

INFOID:000000008194230

Refer to Table of Contents for specific component removal and installation information.

INSTRUMENT PANEL

Most incidents are caused by contact and movement between:

1. The cluster lid A and instrument panel
2. Acrylic lens and combination meter housing
3. Instrument panel to front pillar garnish
4. Instrument panel to windshield
5. Instrument panel mounting pins
6. Wiring harnesses behind the combination meter
7. A/C defroster duct and duct joint

These incidents can usually be located by tapping or moving the components to duplicate the noise or by pressing on the components while driving to stop the noise. Most of these incidents can be repaired by applying felt cloth tape or silicon spray (in hard to reach areas). Urethane pads can be used to insulate wiring harness.

CAUTION:

Never use silicone spray to isolate a squeak or rattle. If the area is saturated with silicone, the recheck of repair becomes impossible.

CENTER CONSOLE

Components to pay attention to include:

1. Shifter assembly cover to finisher
2. A/C control unit and cluster lid C
3. Wiring harnesses behind audio and A/C control unit

The instrument panel repair and isolation procedures also apply to the center console.

DOORS

Pay attention to the following:

1. Finisher and inner panel making a slapping noise
2. Inside handle escutcheon to door finisher
3. Wiring harnesses tapping
4. Door striker out of alignment causing a popping noise on starts and stops

Tapping or moving the components or pressing on them while driving to duplicate the conditions can isolate many of these incidents. The areas can usually be insulated with felt cloth tape or insulator foam blocks from the Nissan Squeak and Rattle Kit (J-43980) to repair the noise.

TRUNK

Trunk noises are often caused by a loose jack or loose items put into the trunk by the customer.

In addition look for the following:

1. Trunk lid dumpers out of adjustment
2. Trunk lid striker out of adjustment
3. The trunk lid torsion bars knocking together
4. A loose license plate or bracket

SQUEAK AND RATTLE TROUBLE DIAGNOSIS

< SYMPTOM DIAGNOSIS >

[REGULAR GRADE]

Most of these incidents can be repaired by adjusting, securing or insulating the item(s) or component(s) causing the noise.

SUNROOF/HEADLINING

Noises in the sunroof/headlining area can often be traced to one of the following:

1. Sunroof lid, rail, linkage or seals making a rattle or light knocking noise
2. Sunvisor shaft shaking in the holder
3. Front or rear windshield touching headlining and squeaking

Again, pressing on the components to stop the noise while duplicating the conditions can isolate most of these incidents. Repairs usually consist of insulating with felt cloth tape.

SEATS

When isolating seat noise it's important to note the position the seats in and the load placed on the seat when the noise occurs. These conditions should be duplicated when verifying and isolating the cause of the noise.

Cause of seat noise include:

1. Headrest rods and holder
2. A squeak between the seat pad cushion and frame
3. The rear seatback lock and bracket

These noises can be isolated by moving or pressing on the suspected components while duplicating the conditions under which the noise occurs. Most of these incidents can be repaired by repositioning the component or applying urethane tape to the contact area.

UNDERHOOD

Some interior noise may be caused by components under the hood or on the engine wall. The noise is then transmitted into the passenger compartment.

Causes of transmitted underhood noise include:

1. Any component mounted to the engine wall
2. Components that pass through the engine wall
3. Engine wall mounts and connectors
4. Loose radiator mounting pins
5. Hood bumpers out of adjustment
6. Hood striker out of adjustment

These noises can be difficult to isolate since they cannot be reached from the interior of the vehicle. The best method is to secure, move or insulate one component at a time and test drive the vehicle. Also, engine RPM or load can be changed to isolate the noise. Repairs can usually be made by moving, adjusting, securing, or insulating the component causing the noise.

A
B
C
D
E
F
G
H
I
K
L
M
N
O
P

SE

SQUEAK AND RATTLE TROUBLE DIAGNOSIS

< SYMPTOM DIAGNOSIS >

[REGULAR GRADE]

Diagnostic Worksheet

INFOID:000000008194231



SQUEAK & RATTLE DIAGNOSTIC WORKSHEET

Dear Nissan Customer:

We are concerned about your satisfaction with your Nissan vehicle. Repairing a squeak or rattle sometimes can be very difficult. To help us fix your Nissan right the first time, please take a moment to note the area of the vehicle where the squeak or rattle occurs and under what conditions. You may be asked to take a test drive with a service advisor or technician to ensure we confirm the noise you are hearing.

I. WHERE DOES THE NOISE COME FROM? (circle the area of the vehicle)

The illustrations are for reference only, and may not reflect the actual configuration of your vehicle.

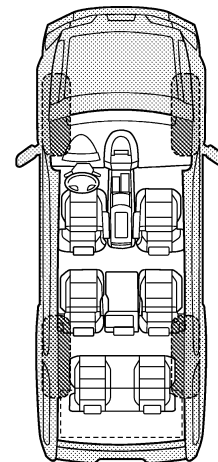
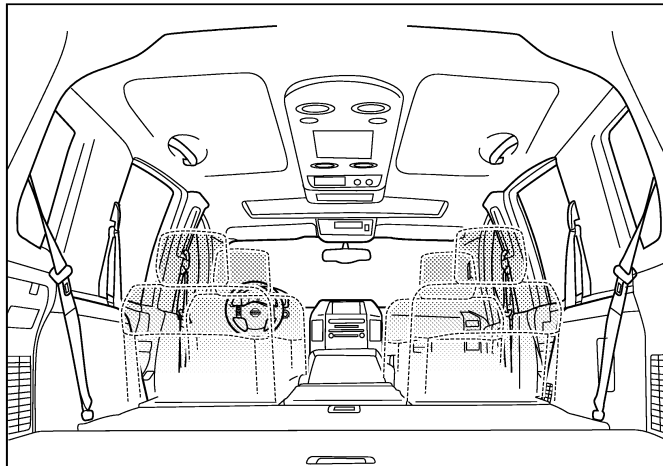
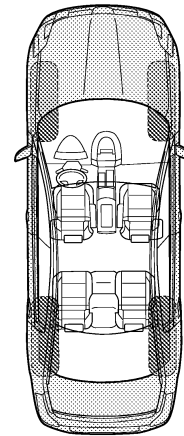
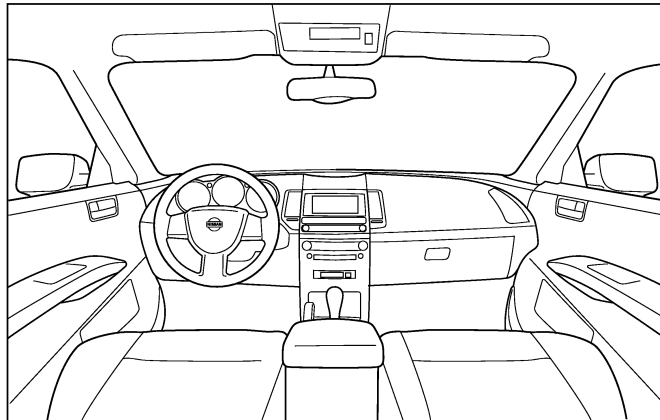

Continue to page 2 of the worksheet and briefly describe the location of the noise or rattle. In addition, please indicate the conditions which are present when the noise occurs.

PIIB8740E

SQUEAK AND RATTLE TROUBLE DIAGNOSIS

< SYMPTOM DIAGNOSIS >

[REGULAR GRADE]

SQUEAK & RATTLE DIAGNOSTIC WORKSHEET - page 2

Briefly describe the location where the noise occurs:

II. WHEN DOES IT OCCUR? (please check the boxes that apply)

- | | |
|---|--|
| <input type="checkbox"/> anytime | <input type="checkbox"/> after sitting out in the rain |
| <input type="checkbox"/> 1st time in the morning | <input type="checkbox"/> when it is raining or wet |
| <input type="checkbox"/> only when it is cold outside | <input type="checkbox"/> dry or dusty conditions |
| <input type="checkbox"/> only when it is hot outside | <input type="checkbox"/> other: |

III. WHEN DRIVING:

- through driveways
- over rough roads
- over speed bumps
- only about ____ mph
- on acceleration
- coming to a stop
- on turns: left, right or either (circle)
- with passengers or cargo
- other: _____
- after driving ____ miles or ____ minutes

IV. WHAT TYPE OF NOISE

- squeak (like tennis shoes on a clean floor)
- creak (like walking on an old wooden floor)
- rattle (like shaking a baby rattle)
- knock (like a knock at the door)
- tick (like a clock second hand)
- thump (heavy, muffled knock noise)
- buzz (like a bumble bee)

TO BE COMPLETED BY DEALERSHIP PERSONNEL

Test Drive Notes:

	YES	NO	Initials of person performing
Vehicle test driven with customer	<input type="checkbox"/>	<input type="checkbox"/>	_____
- Noise verified on test drive	<input type="checkbox"/>	<input type="checkbox"/>	_____
- Noise source located and repaired	<input type="checkbox"/>	<input type="checkbox"/>	_____
- Follow up test drive performed to confirm repair	<input type="checkbox"/>	<input type="checkbox"/>	_____

VIN: _____ Customer Name: _____
W.O.# _____ Date: _____

This form must be attached to Work Order

PIIB8742E

A
B
C
D
E
F
G
H
I
SE
K
L
M
N
O
P

PRECAUTION**PRECAUTIONS****FOR USA AND CANADA****FOR USA AND CANADA : Precaution for Supplemental Restraint System (SRS) "AIR BAG" and "SEAT BELT PRE-TENSIONER"**

INFOID:000000008194232

The Supplemental Restraint System such as "AIR BAG" and "SEAT BELT PRE-TENSIONER", used along with a front seat belt, helps to reduce the risk or severity of injury to the driver and front passenger for certain types of collision. This system includes seat belt switch inputs and dual stage front air bag modules. The SRS system uses the seat belt switches to determine the front air bag deployment, and may only deploy one front air bag, depending on the severity of a collision and whether the front occupants are belted or unbelted.

Information necessary to service the system safely is included in the "SRS AIR BAG" and "SEAT BELT" of this Service Manual.

WARNING:

Always observe the following items for preventing accidental activation.

- **To avoid rendering the SRS inoperative, which could increase the risk of personal injury or death in the event of a collision that would result in air bag inflation, all maintenance must be performed by an authorized NISSAN/INFINITI dealer.**
- **Improper maintenance, including incorrect removal and installation of the SRS, can lead to personal injury caused by unintentional activation of the system. For removal of Spiral Cable and Air Bag Module, see "SRS AIR BAG".**
- **Never use electrical test equipment on any circuit related to the SRS unless instructed to in this Service Manual. SRS wiring harnesses can be identified by yellow and/or orange harnesses or harness connectors.**

PRECAUTIONS WHEN USING POWER TOOLS (AIR OR ELECTRIC) AND HAMMERS**WARNING:**

Always observe the following items for preventing accidental activation.

- **When working near the Air Bag Diagnosis Sensor Unit or other Air Bag System sensors with the ignition ON or engine running, never use air or electric power tools or strike near the sensor(s) with a hammer. Heavy vibration could activate the sensor(s) and deploy the air bag(s), possibly causing serious injury.**
- **When using air or electric power tools or hammers, always switch the ignition OFF, disconnect the battery, and wait at least 3 minutes before performing any service.**

FOR USA AND CANADA : Precaution for Battery Service

INFOID:000000008194233

Before disconnecting the battery, lower both the driver and passenger windows. This will prevent any interference between the window edge and the vehicle when the door is opened/closed. During normal operation, the window slightly raises and lowers automatically to prevent any window to vehicle interference. The automatic window function will not work with the battery disconnected.

FOR USA AND CANADA : Service Notice

INFOID:000000008194234

- When removing or installing various parts, place a cloth or padding onto the vehicle body to prevent scratches.
- Handle trim, molding, instruments, grille, etc. carefully during removing or installing. Be careful not to oil or damage them.
- Apply sealing compound where necessary when installing parts.
- When applying sealing compound, be careful that the sealing compound never protrudes from parts.
- When replacing any metal parts (for example body outer panel, members, etc.), always take rust prevention measures.

FOR USA AND CANADA : Precaution for Work

INFOID:000000008194235

- When removing or disassembling each component, be careful not to damage or deform it. If a component may be subject to interference, always protect it with a shop cloth.
- When removing (disengaging) components with a screwdriver or similar tool, always wrap the component with a shop cloth or vinyl tape to protect it.

PRECAUTIONS

[REGULAR GRADE]

< PRECAUTION >

- Protect the removed parts with a shop cloth and keep them.
- Replace a deformed or damaged clip.
- If a part is specified as a non-reusable part, always replace it with new one.
- Always tighten bolts and nuts securely to the specified torque.
- After reinstallation is complete, always check that each part works normally.
- Follow the steps below to clean components.
- Water soluble foul: Dip a soft cloth into lukewarm water, and wring the water out of the cloth to wipe the fouled area.
Then rub with a soft and dry cloth.
- Oily foul: Dip a soft cloth into lukewarm water with mild detergent (concentration: within 2 to 3%), and wipe the fouled area.
Then dip a cloth into fresh water, and wring the water out of the cloth to wipe the detergent off. Then rub with a soft and dry cloth.
- Never use organic solvent such as thinner, benzene, alcohol, and gasoline.
- For genuine leather seats, and use a genuine leather seat cleaner.

FOR MEXICO

FOR MEXICO : Precaution for Supplemental Restraint System (SRS) "AIR BAG" and "SEAT BELT PRE-TENSIONER"

INFOID:000000008194236

The Supplemental Restraint System such as "AIR BAG" and "SEAT BELT PRE-TENSIONER", used along with a front seat belt, helps to reduce the risk or severity of injury to the driver and front passenger for certain types of collision. Information necessary to service the system safely is included in the "SRS AIR BAG" and "SEAT BELT" of this Service Manual.

WARNING:

Always observe the following items for preventing accidental activation.

- **To avoid rendering the SRS inoperative, which could increase the risk of personal injury or death in the event of a collision that would result in air bag inflation, all maintenance must be performed by an authorized NISSAN/INFINITI dealer.**
- **Improper maintenance, including incorrect removal and installation of the SRS, can lead to personal injury caused by unintentional activation of the system. For removal of Spiral Cable and Air Bag Module, see "SRS AIR BAG".**
- **Never use electrical test equipment on any circuit related to the SRS unless instructed to in this Service Manual. SRS wiring harnesses can be identified by yellow and/or orange harnesses or harness connectors.**

PRECAUTIONS WHEN USING POWER TOOLS (AIR OR ELECTRIC) AND HAMMERS

WARNING:

Always observe the following items for preventing accidental activation.

- **When working near the Air Bag Diagnosis Sensor Unit or other Air Bag System sensors with the ignition ON or engine running, never use air or electric power tools or strike near the sensor(s) with a hammer. Heavy vibration could activate the sensor(s) and deploy the air bag(s), possibly causing serious injury.**
- **When using air or electric power tools or hammers, always switch the ignition OFF, disconnect the battery, and wait at least 3 minutes before performing any service.**

FOR MEXICO : Precaution for Battery Service

INFOID:000000008194237

Before disconnecting the battery, lower both the driver and passenger windows. This will prevent any interference between the window edge and the vehicle when the door is opened/closed. During normal operation, the window slightly raises and lowers automatically to prevent any window to vehicle interference. The automatic window function will not work with the battery disconnected.

FOR MEXICO : Service Notice

INFOID:000000008194238

- When removing or installing various parts, place a cloth or padding onto the vehicle body to prevent scratches.
- Handle trim, molding, instruments, grille, etc. carefully during removing or installing. Be careful not to oil or damage them.
- Apply sealing compound where necessary when installing parts.
- When applying sealing compound, be careful that the sealing compound never protrudes from parts.

PRECAUTIONS

[REGULAR GRADE]

< PRECAUTION >

- When replacing any metal parts (for example body outer panel, members, etc.), always take rust prevention measures.

FOR MEXICO : Precaution for Work

INFOID:000000008194239

- When removing or disassembling each component, be careful not to damage or deform it. If a component may be subject to interference, always protect it with a shop cloth.
- When removing (disengaging) components with a screwdriver or similar tool, always wrap the component with a shop cloth or vinyl tape to protect it.
- Protect the removed parts with a shop cloth and keep them.
- Replace a deformed or damaged clip.
- If a part is specified as a non-reusable part, always replace it with new one.
- Always tighten bolts and nuts securely to the specified torque.
- After reinstallation is complete, always check that each part works normally.
- Follow the steps below to clean components.
 - Water soluble foul: Dip a soft cloth into lukewarm water, and wring the water out of the cloth to wipe the fouled area.
Then rub with a soft and dry cloth.
 - Oily foul: Dip a soft cloth into lukewarm water with mild detergent (concentration: within 2 to 3%), and wipe the fouled area.
Then dip a cloth into fresh water, and wring the water out of the cloth to wipe the detergent off. Then rub with a soft and dry cloth.
- Never use organic solvent such as thinner, benzene, alcohol, and gasoline.
- For genuine leather seats, and use a genuine leather seat cleaner.

PREPARATION

< PREPARATION >

[REGULAR GRADE]

PREPARATION

PREPARATION

Special Service Tool

INFOID:000000008194240

The actual shapes of Kent-Moore tools may differ from those of special service tools illustrated here.

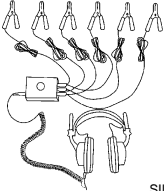
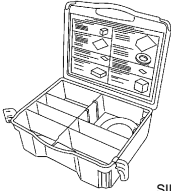
Tool number (Kent-Moore No.) Tool name	Description
<p>(J39570) Chassis ear</p>  <p>SIIA0993E</p>	<p>Locates the noise</p>
<p>(J43980) NISSAN Squeak and Rattle Kit</p>  <p>SIIA0994E</p>	<p>Repairs the cause of noise</p>

Commercial Service Tool

INFOID:000000008194241

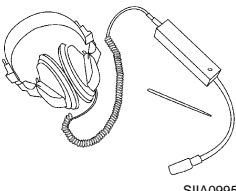
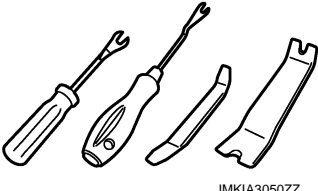
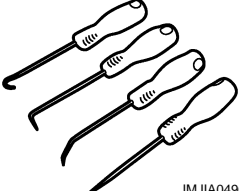
Tool name	Description
<p>Engine ear</p>  <p>SIIA0995E</p>	<p>Locates the noise</p>
<p>Remover tool</p>  <p>JMKIA3050ZZ</p>	<p>Removes clips, pawls, and metal clips</p>
<p>Hook and pick tool</p>  <p>JMJA0490ZZ</p>	<p>Removes the snap pins</p>

CLIP LIST

< PREPARATION >

[REGULAR GRADE]

CLIP LIST

Clip List

INFOID:000000008194242

Shapes	Removal & Installation	Shapes	Removal & Installation
	<p>Removal: Remove by bending up with flat-bladed screwdrivers or clip remover.</p>		<p>Removal: Finisher Clip A Flat-bladed screwdriver Clip B</p>
	<p>Removal: Remove with a clip remover.</p>		<p>Removal: Flat-bladed screwdriver Finisher Body panel Clip A Clip B (Grommet)</p>
	<p>Removal: Push center pin to catching position. (Do not remove center pin by hitting it.)</p> <p>Installation: Push</p>		<p>Removal: Holder portion of clip must be spread out to remove rod.</p>
	<p>Removal: Remove by bending up with flat-bladed screwdrivers or clip remover.</p> <p>Clip Finisher</p>		<p>Removal: 1. Screw out with a Phillips screwdriver. 2. Remove female portion with flat-bladed screwdriver.</p>
	<p>Removal:</p>		<p>Removal: Rotate 45° to remove.</p> <p>Installation:</p>
	<p>Removal:</p>		<p>Removal:</p>

JMJIA3734GB

SEAT

< REMOVAL AND INSTALLATION >

[REGULAR GRADE]

REMOVAL AND INSTALLATION

SEAT

Exploded View

INFOID:000000008194243

CAUTION:

Never disassembly the component parts only from passenger seat in the dotted lines shown in the figure below. (USA/Canada model only)

POWER SEAT

SEC. 870

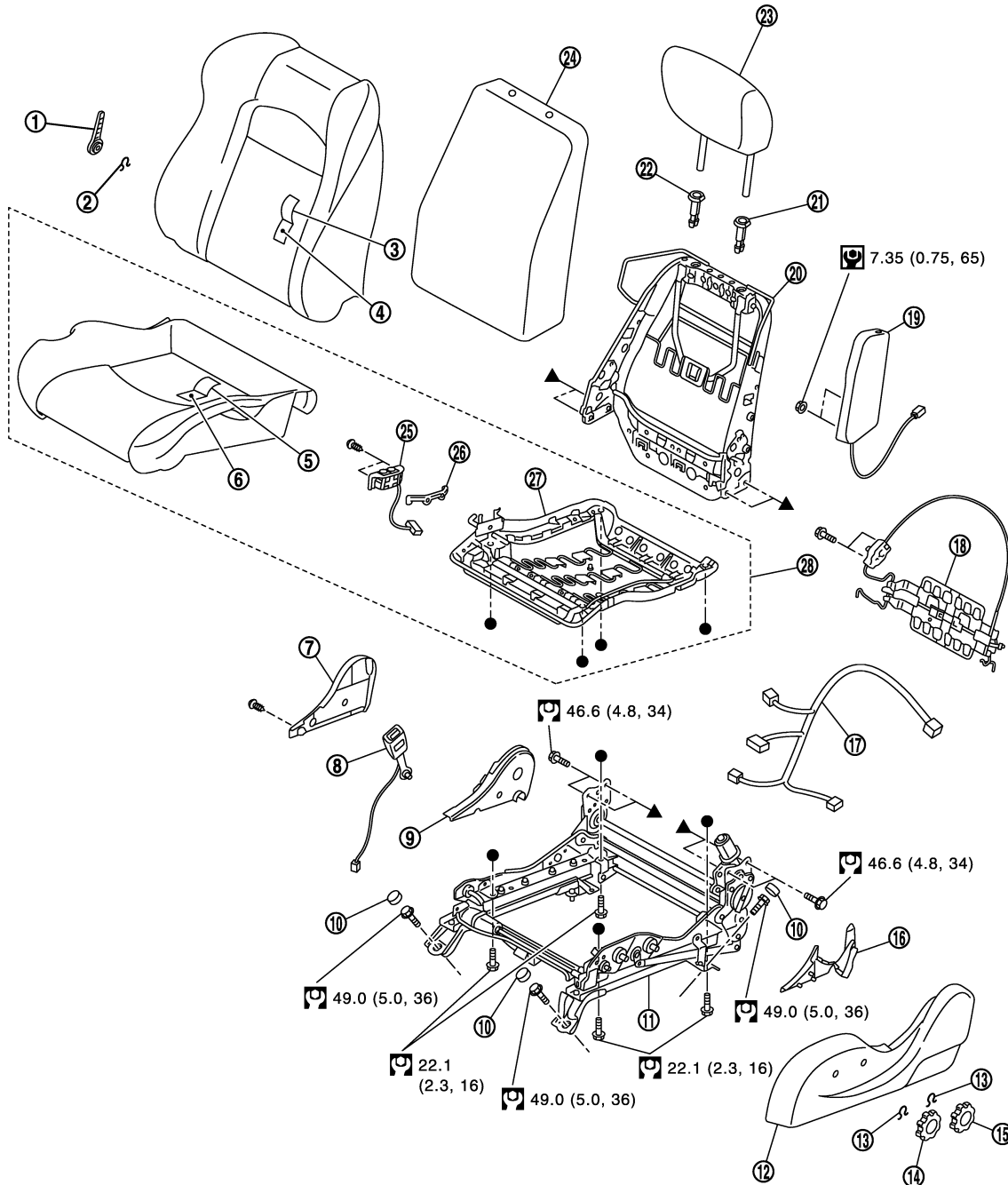

JMJIA3505GB

SEAT

< REMOVAL AND INSTALLATION >

[REGULAR GRADE]

- | | | |
|---|---|--|
| 1. Lumbar support lever knob (Driver seat only) | 2. Snap ring (Driver seat only) | 3. Seatback trim |
| 4. Seatback pad | 5. Seat cushion trim | 6. Seat cushion pad |
| 7. Seat cushion inner finisher | 8. Seat belt buckle | 9. Reclining device inner cover |
| 10. Bolt cap | 11. Seat adjuster assembly | 12. Seat cushion outer finisher |
| 13. Snap ring (Driver seat only) | 14. Thigh support dial (Driver seat only) | 15. Lifter dial (Driver seat only) |
| 16. Reclining device outer cover | 17. Seat harness | 18. Lumbar support unit (Driver seat only) |
| 19. Side air bag module | 20. Seatback frame | 21. Headrest holder (locked) |
| 22. Headrest holder (free) | 23. Headrest | 24. Seatback silencer |
| 25. Power seat switch | 26. Switch bracket cover | 27. Seat cushion frame |
| 28. Seat cushion assembly (USA/Canada model passenger only) | | |

Refer to [GI-4. "Components"](#) for symbols in the figure.

MANUAL SEAT

SEAT

< REMOVAL AND INSTALLATION >

[REGULAR GRADE]

SEC. 870

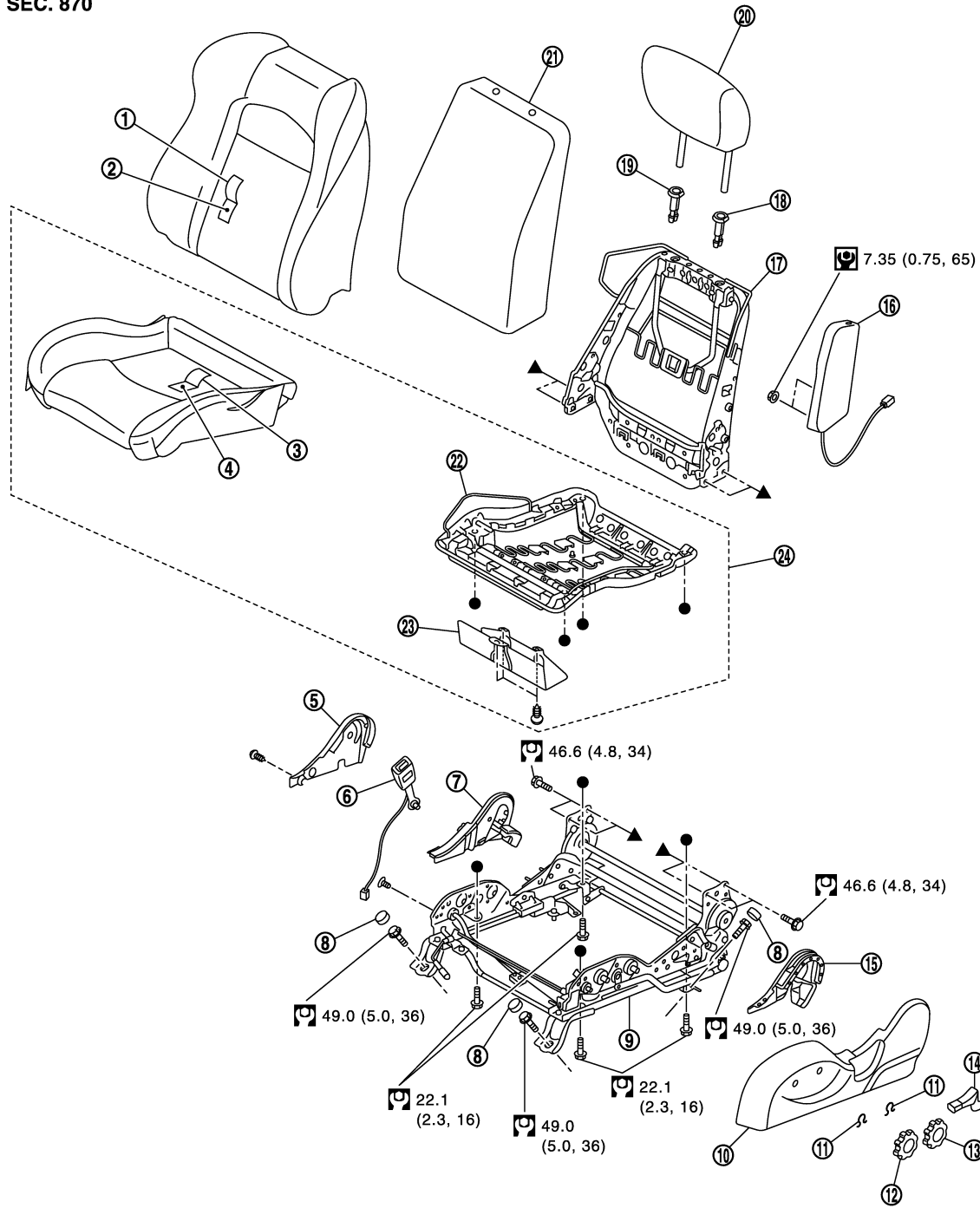

JMJIA3506GB

- | | | |
|------------------------------------|--|---|
| 1. Seatback trim | 2. Seatback pad | 3. Seat cushion trim |
| 4. Seat cushion pad | 5. Seat cushion inner finisher | 6. Seat belt buckle |
| 7. Reclining device inner cover | 8. Bolt cap | 9. Seat adjuster assembly |
| 10. Seat cushion outer finisher | 11. Snap ring (Driver seat only) | 12. Thigh support dial (Driver seat only) |
| 13. Lifter dial (Driver seat only) | 14. Reclining lever knob | 15. Reclining device outer cover |
| 16. Side air bag module | 17. Seatback frame | 18. Headrest holder (locked) |
| 19. Headrest holder (free) | 20. Headrest | 21. Seatback silencer |
| 22. Seat cushion frame | 23. Harness connector bracket (Driver seat only) | 24. Seat cushion assembly (USA/Canada model passenger only) |

Refer to [GI-4, "Components"](#) for symbols in the figure.

SEAT

< REMOVAL AND INSTALLATION >

[REGULAR GRADE]

NET SEAT

SEC. 870

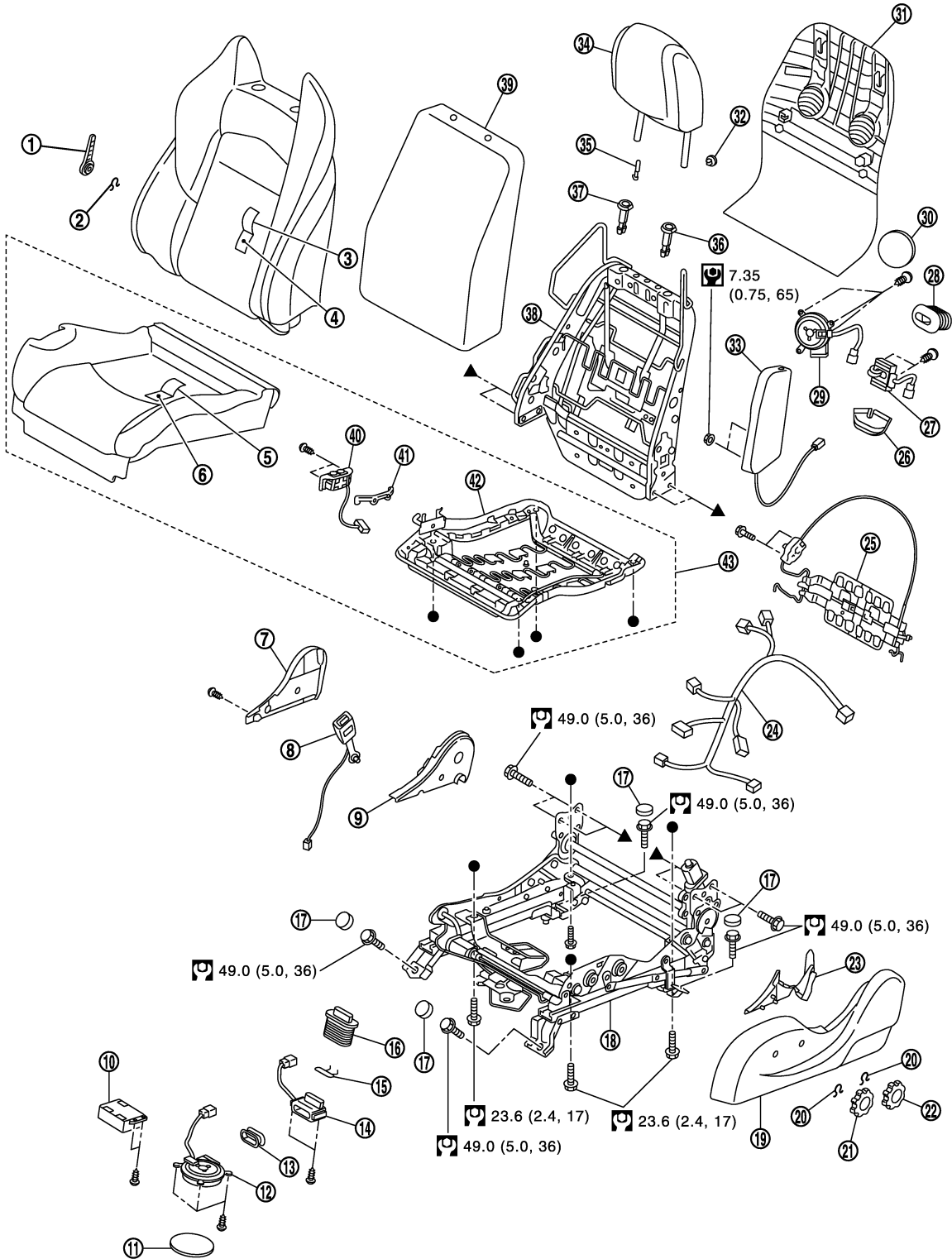

JMJIA3478GB

- | | | |
|---|---------------------------------|---------------------------------|
| 1. Lumbar support lever knob (Driver seat only) | 2. Snap ring (Driver seat only) | 3. Seatback trim |
| 4. Seatback pad | 5. Seat cushion trim | 6. Seat cushion pad |
| 7. Seat cushion inner finisher | 8. Seat belt buckle | 9. Reclining device inner cover |
| 10. Climate controlled seat control unit | 11. Blower filter | 12. Seat cushion blower motor |

SEAT

< REMOVAL AND INSTALLATION >

[REGULAR GRADE]

- | | | | |
|---|--|--|---|
| 13. Seat cushion duct A | 14. Seat cushion thermal electric device (TED) | 15. Clamp wire | A |
| 16. Seat cushion duct B | 17. Bolt cap | 18. Seat adjuster assembly | |
| 19. Seat cushion outer finisher | 20. Snap ring (Driver seat only) | 21. Thigh support dial (Driver seat only) | B |
| 22. Lifter dial (Driver seat only) | 23. Reclining device outer cover | 24. Seat harness | B |
| 25. Lumbar support unit (Driver seat only) | 26. Seatback duct A | 27. Seatback thermal electric device (TED) | |
| 28. Seatback duct B | 29. Seatback blower motor | 30. Blower filter | C |
| 31. Seatback board | 32. Clip | 33. Side air bag module | |
| 34. Headrest | 35. Headrest stopper | 36. Headrest holder (locked) | |
| 37. Headrest holder (free) | 38. Seatback frame | 39. Seatback silencer | D |
| 40. Power seat switch | 41. Switch bracket cover | 42. Seat cushion frame | |
| 43. Seat cushion assembly (USA/Canada model passenger only) | | | E |

Refer to [GI-4, "Components"](#) for symbols in the figure.

Removal and Installation

INFOID:000000008194244

REMOVAL

1. Remove the headrest. (Except net seat)
2. Remove the mounting bolts on the rear side of the seat.
 - Slide the seat to the front-most position.
 - Remove the bolt caps.
 - Remove the mounting bolts.
3. Remove the mounting bolts on the front side of the seat.
 - Slide the seat to the rear-most position.
 - Remove the bolt caps.
 - Remove the mounting bolts.
4. Set seatback in a standing position.
5. Disconnect harness connector under the seat and remove harness securing clips.
CAUTION:
Before removal, turn ignition switch OFF, disconnect battery negative terminal and then wait 3 minutes or more.
6. Remove seat from the vehicle.
CAUTION:
When removing and installing, use shop cloths to protect parts from damage.

INSTALLATION

Install in the reverse order of removal.

- CAUTION:**
- **Before installation, turn ignition switch OFF, disconnect battery negative terminal and then wait 3 minutes or more.**
 - **Clamp the harness in position.**

Disassembly and Assembly

INFOID:000000008194245

SEATBACK

Disassembly

1. Remove the dials. (Driver seat only)

SEAT

< REMOVAL AND INSTALLATION >

[REGULAR GRADE]

- Hang snap ring (1) on hook and pick tool (A) and pull it up to remove.
- Remove the thigh support dial (2) and lifter dial (3).

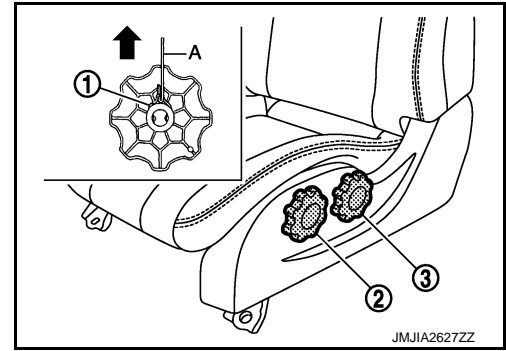

2. Remove the seat cushion outer finisher.

a. Power seat and net seat

Remove the metal clips and pawls, and then pull out seat cushion outer finisher.

□ : Metal clip

△ : Pawl

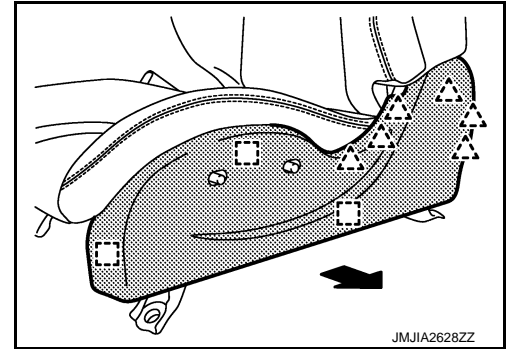

b. Manual seat

• Pull out the reclining lever knob while holding and raising the pawl.

△ : Pawl

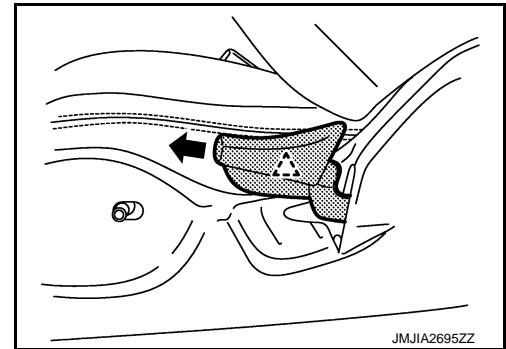

• Remove the metal clips, clip and pawls, and then pull out seat cushion outer finisher.

○ : Clip

□ : Metal clip

△ : Pawl

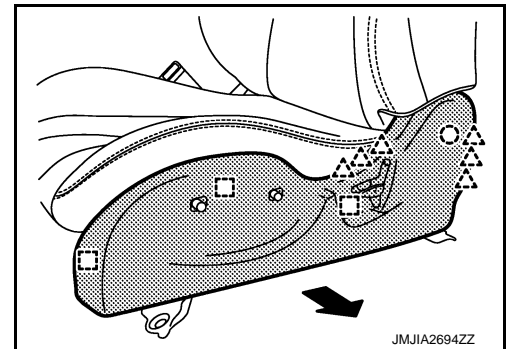

3. Remove the seat cushion inner finisher.

SEAT

< REMOVAL AND INSTALLATION >

[REGULAR GRADE]

- Remove the mounting screw (A).
- Remove the pawls then pull out seat cushion inner finisher.

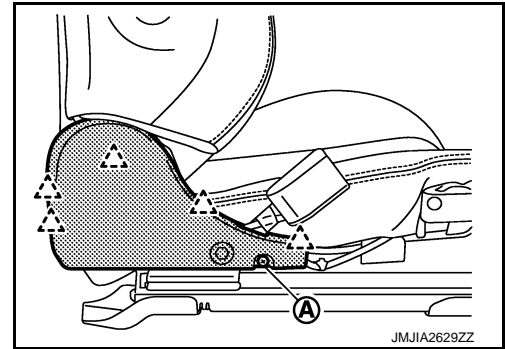

 : Pawl

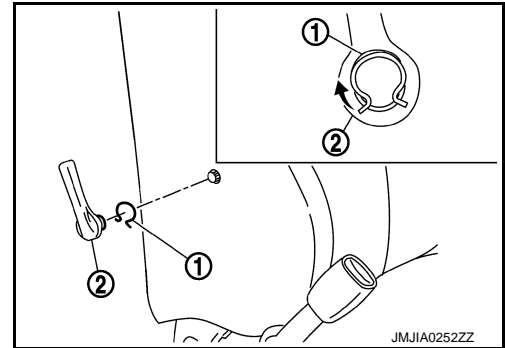

4. Remove the lumbar support lever knob. (Power and net driver seat)
Pull snap ring (1) upward, and remove lumbar support lever knob (2) from seatback frame with hook and pick tool.



5. Remove the seatback board. (Net seat only)
• Remove the hook from seat cushion underside.
• Remove the clips and pawls, and then pull out seatback lower side.
• Pull down the seatback board to release the upper pawls.

 : Clip
 : Pawl

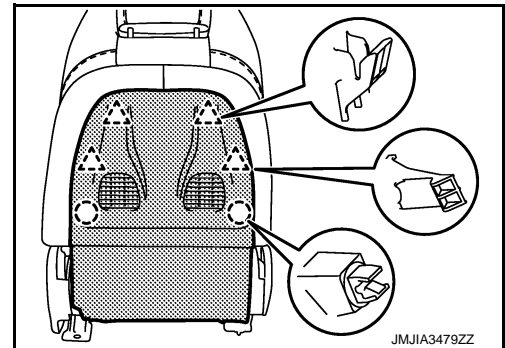

6. Remove the headrest. (Net seat only)
Pull out headrest to upper side while hold headrest stopper.

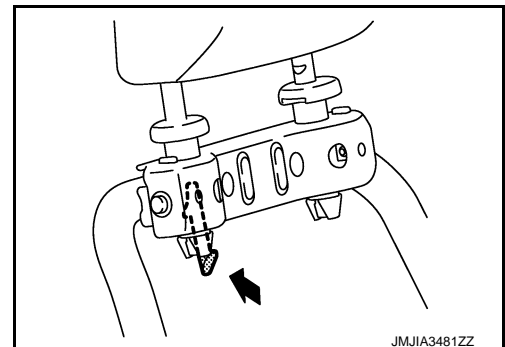

7. Remove the seatback trim and seatback pad.

SEAT

< REMOVAL AND INSTALLATION >

[REGULAR GRADE]

- Remove the seatback retainer (1), and then open the fastener (2). (Except net seat)

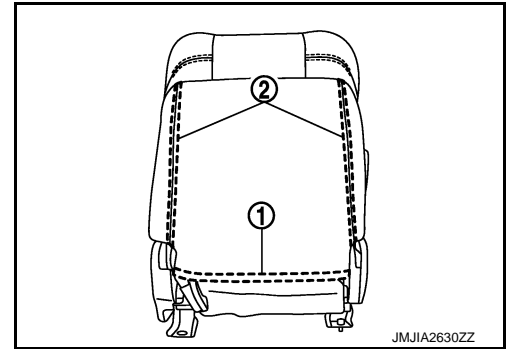

- Remove the seatback retainer. (Net seat only)

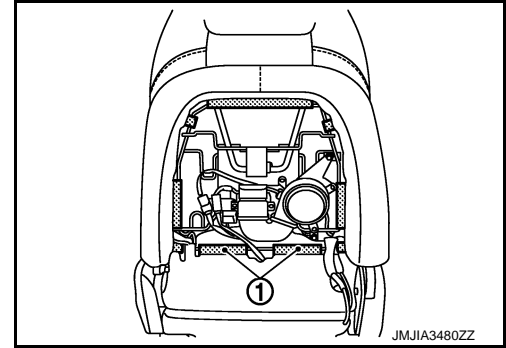

- Remove the headrest holder.

CAUTION:

Before installing headrest holder check its orientation. (front/rear and right/left)

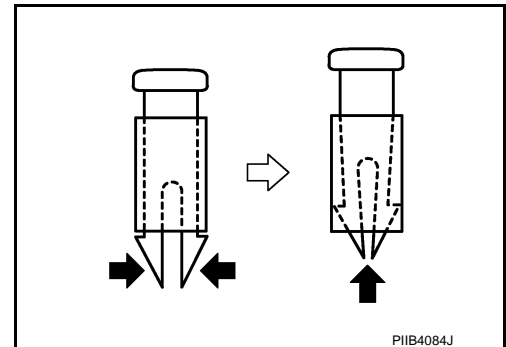

- Remove the side air bag module mounting nuts.
- Disconnect the seatback heater unit harness connector. (Power seat only)
- Remove the seatback trim and seatback pad from the seatback frame.
- Remove the hog rings, and separate the seatback trim and seatback pad.

8. Remove the seatback silencer.

9. Disconnect the harness connectors and remove the harness clamp. (Power seat and net seat only)

10. Remove the seatback frame.

Remove the seatback frame mounting bolt.

Assembly

Assemble in the reverse order of disassembly.

CAUTION:

Install the hog rings of seatback trim in position, and then securely connect the trim or trim cord with the pad side wire.

SEAT CUSHION

Disassembly

CAUTION:

Never disassemble front passenger seat cushion assembly. (USA/Canada model only)

Always replace as an assembly.

For front passenger seat service parts, refer to the service part catalogue.

1. Remove the dials. (Driver seat only)

SEAT

< REMOVAL AND INSTALLATION >

[REGULAR GRADE]

- Hang snap ring (1) on hook and pick tool (A) and pull it up to remove.
- Remove the thigh support dial (2) and lifter dial (3).

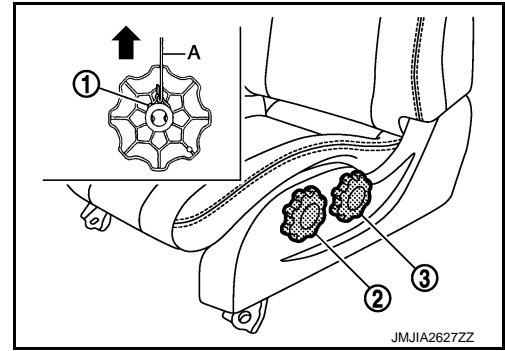

2. Remove the seat cushion outer finisher.

a. Power seat and net seat

Remove the metal clips and pawls, and then pull out seat cushion outer finisher.

□ : Metal clip

△ : Pawl

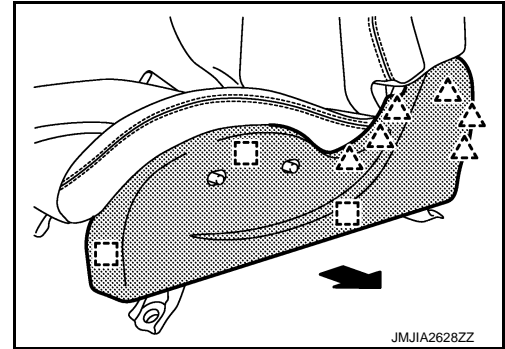

b. Manual seat

- Pull out the reclining lever knob while holding and raising the pawl.

△ : Pawl

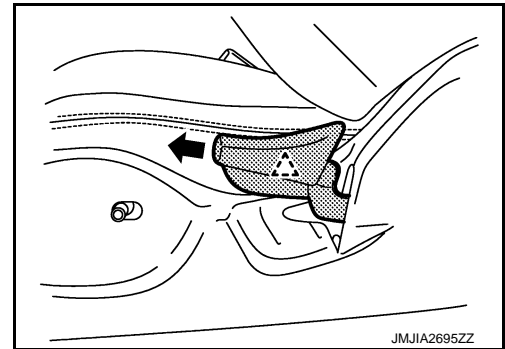

- Remove the metal clips, clip and pawls, and then pull out seat cushion outer finisher.

○ : Clip

□ : Metal clip

△ : Pawl

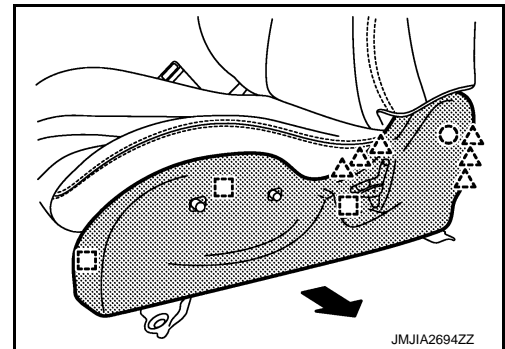

3. Remove the seat cushion inner finisher.

A
B
C
D
E
F
G
H
I
SE
K
L
M
N
O
P

SEAT

< REMOVAL AND INSTALLATION >

[REGULAR GRADE]

- Remove the mounting screw (A).
- Remove the pawls then pull out seat cushion inner finisher.

 : Pawl

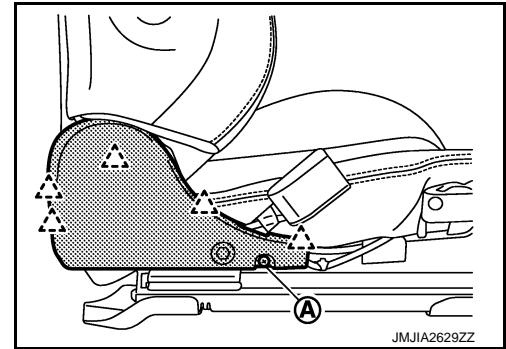

4. Remove the seatback board. (Net seat only)
 - Remove the hook from seat cushion underside.
 - Remove the clips and pawls, and then pull out seatback lower side.
 - Pull down the seatback board to release the upper pawls.

 : Clip

 : Pawl

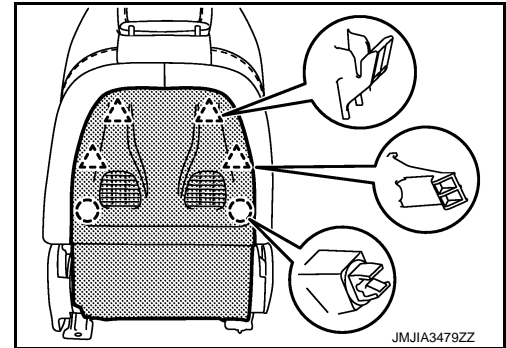

5. Remove the seatback assembly.
 - Remove the seatback retainer (1), and then open the fastener (2). (Except net seat)

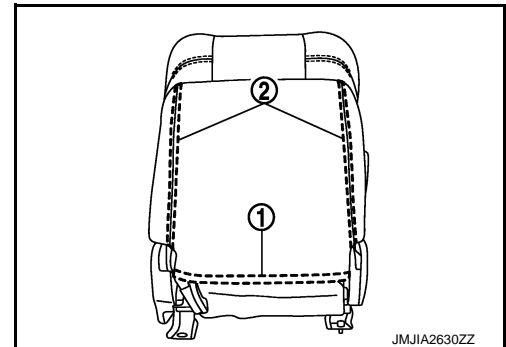

- Disconnect the harness connectors and remove the harness clamp. (Power seat and net seat)
 - Disconnect seatback heater unit harness connector. (Power seat only)
 - Remove the side air bag module harness clamp.
 - Remove the seatback mounting bolts, and then remove the seatback assembly.
6. Remove the seat belt buckle. Refer to [SB-10. "SEAT BELT BUCKLE : Removal and Installation"](#).
 7. Remove the seat control switch. (Power seat and net seat)
 - Disconnect the seat control switch harness connector.
 - Remove the mounting screw, and then remove harness clamp.
 8. Remove the seat cushion trim and seat cushion pad.
 - Disconnect the harness connector and remove the harness clamp. (Power seat and net seat)
 - Remove the harness clamps.
 - Disconnect the seat cushion heater unit harness connector. (Power seat only)
 - Remove the seat cushion inside clip. (Manual seat only)
 - Remove the harness connector bracket. (Manual driver seat only)
 - Remove the seat cushion mounting bolts, and then remove the seat cushion assembly.
 - Remove the hog rings, and separate seat cushion frame, seat cushion trim and seat cushion pad. (Except USA/Canada model passenger seat only)
 9. Remove the reclining device outer cover.
 10. Remove the reclining device inner cover.

< REMOVAL AND INSTALLATION >

Assembly

Assemble in the reverse order of disassembly.

CAUTION:

Install the hog rings of seat cushion trim in position, and then securely connect the trim or trim cord with the pad side wire.

CLIMATE CONTROLLED SEAT UNIT

Disassembly

1. Remove the seatback thermal electric device (TED) and seatback blower motor.
 - Disconnect the harness connectors (A), and then remove the harness clamp.
 - Remove the screws (B).

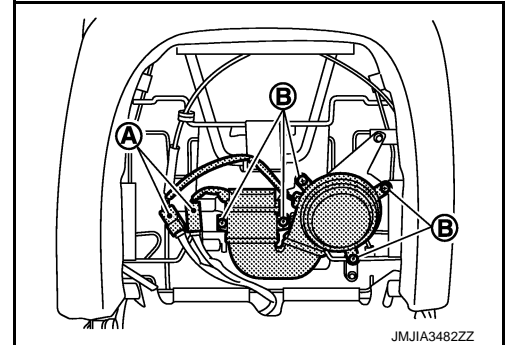

2. Remove the seatback duct B.
3. Remove the seat cushion thermal electric device (TED) and cushion back blower motor.
 - Disconnect the harness connectors (A), and then remove the harness clamp.
 - Remove the screws (B).

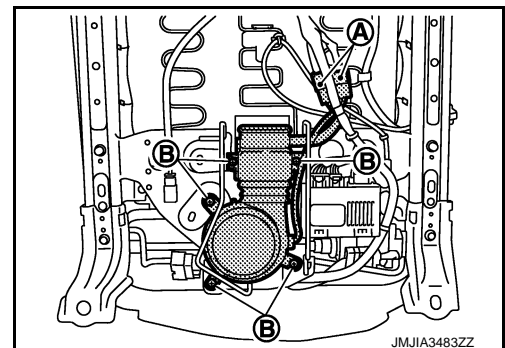

4. Remove the seat cushion duct B.
5. Remove the climate controlled seat control unit.
 - Disconnect the harness connectors (A).
 - Remove the screws (B).

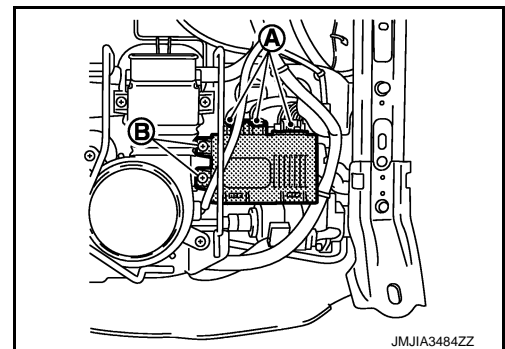

Assembly

Assemble in the reverse order of disassembly.

A
B
C
D
E
F
G
H
I
SE
K
L
M
N
O
P

POWER SEAT SWITCH

< REMOVAL AND INSTALLATION >

[REGULAR GRADE]

POWER SEAT SWITCH

Exploded View

INFOID:000000008194246

Refer to [SE-67. "Exploded View"](#).

Removal and Installation

INFOID:000000008194247

REMOVAL

CAUTION:

When removing and installing, use shop cloths to protect parts from damage.

1. Remove the seat. Refer to [SE-71. "Removal and Installation"](#).
2. Disconnect power seat switch connector.
3. Remove the screws.
4. Remove the power seat switch from the seat.

INSTALLATION

Install in the reverse order of removal.

HEATED SEAT SWITCH

< REMOVAL AND INSTALLATION >

[REGULAR GRADE]

HEATED SEAT SWITCH

Exploded View

INFOID:000000008194248

Refer to [IP-25. "Exploded View"](#)

Removal and Installation

INFOID:000000008194249

REMOVAL

1. Remove the cup holder assembly. Refer to [IP-26. "Removal and Installation"](#)
2. Remove heated seat switch bracket from cup holder assembly with flat bladed screwdriver.

INSTALLATION

Install in the reverse order of removal.

A
B
C
D
E
F
G
H
I
K
L
M
N
O
P

SE

CLIMATE CONTROLLED SEAT SWITCH

< REMOVAL AND INSTALLATION >

[REGULAR GRADE]

CLIMATE CONTROLLED SEAT SWITCH

Exploded View

INFOID:000000008194250

Refer to [IP-25, "Exploded View"](#).

Removal and Installation

INFOID:000000008194251

REMOVAL

CAUTION:

When removing and installing, use shop cloths to protect parts from damage.

1. Remove the console upper finisher, console finisher assembly, cup holder assembly and console switch finisher. Refer to [IP-26, "Removal and Installation"](#).
2. Remove climate controlled seat switch from console switch finisher using flat-bladed screwdriver etc.

INSTALLATION

Install in the reverse order of removal.

CLIMATE CONTROLLED SEAT BLOWER FILTER

< REMOVAL AND INSTALLATION >

[REGULAR GRADE]

CLIMATE CONTROLLED SEAT BLOWER FILTER

SEAT CUSHION

SEAT CUSHION : Exploded View

INFOID:000000008194252

Refer to [SE-67, "Exploded View"](#).

SEAT CUSHION : Removal and Installation

INFOID:000000008194253

REMOVAL

CAUTION:

When removing and installing, use shop cloths to protect parts from damage.

1. Remove the seat.
2. Turn blower filter counter clockwise and remove it from climate controlled seat cushion blower motor.

INSTALLATION

Install in the reverse order of removal.

SEATBACK

SEATBACK : Exploded View

INFOID:000000008194254

Refer to [SE-67, "Exploded View"](#).

SEATBACK : Removal and Installation

INFOID:000000008194255

REMOVAL

CAUTION:

When removing and installing, use shop cloths to protect parts from damage.

1. Remove the seatback board.
2. Turn blower filter counter clockwise and remove it from climate controlled seat blower motor.

INSTALLATION

Install in the reverse order of removal.

A
B
C
D
E
F
G
H
I
K
L
M
N
O
P

SE

SPEC CHANGE INFORMATION

SEAT

Seat

INFOID:000000008194256

Seats covered with dedicated cloth in special color with red stitches (with nismo logo embroidery).

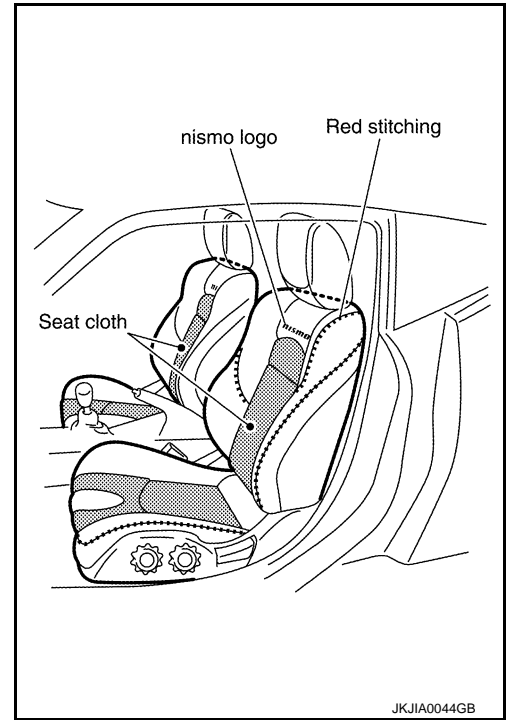

JKJIA0044GB