

A  
EX  
C  
D  
E  
F  
G  
H  
I  
J  
K  
L  
M  
N  
O  
P

**SECTION EX**  
**EXHAUST SYSTEM**

**CONTENTS**

<b>REGULAR GRADE</b>	
<b>PRECAUTION</b> ..... 2	<b>EXHAUST SYSTEM</b> ..... 4
<b>PRECAUTIONS</b> ..... 2	Inspection ..... 4
Removal and Installation ..... 2	<b>REMOVAL AND INSTALLATION</b> ..... 5
<b>PREPARATION</b> ..... 3	<b>EXHAUST SYSTEM</b> ..... 5
<b>PREPARATION</b> ..... 3	Exploded View ..... 5
Special Service Tool ..... 3	Removal and Installation ..... 6
Commercial Service Tool ..... 3	Inspection ..... 6
<b>PERIODIC MAINTENANCE</b> ..... 4	<b>Nismo 370Z</b>
	<b>REMOVAL AND INSTALLATION</b> ..... 7
	<b>EXHAUST SYSTEM</b> ..... 7
	Exploded View ..... 7

## PRECAUTION

### PRECAUTIONS

#### Removal and Installation

INFOID:000000009361309

**CAUTION:**

- Be sure to use genuine exhaust system parts or equivalents which are specially designed for heat resistance, corrosion resistance, and shape.
- Perform the operation with the exhaust system fully cooled down because the system will be hot just after engine stops.
- Be careful not to cut your hand on the heat insulator edge.

# PREPARATION

< PREPARATION >

[REGULAR GRADE]

## PREPARATION

### PREPARATION

#### Special Service Tool

INFOID:000000009361310

A

EX

The actual shapes of Kent-Moore tools may differ from those of special service tools illustrated here.

Tool number (Kent-Moore No.) Tool name	Description
KV10114400 (J-38365) Heated oxygen sensor wrench	Loosening or tightening heated oxygen sensor 2 <b>a: 22 mm (0.87 in) (a) width hexagon nut</b>

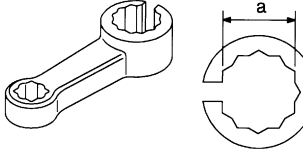

S-NT636

C

D

E

#### Commercial Service Tool

INFOID:000000009361311

(Kent-Moore No.) Tool name	Description
A: (J-43897-18) B: (J-43897-12) Heated oxygen sensor thread cleaner	Reconditioning the exhaust system threads before installing a new heated oxygen sensor (Use with anti-seize lubricant shown below.) <b>A: J-43897-18 [18 mm (0.71 in) dia.] for zirconia heated oxygen sensor</b> <b>B: J-43897-12 [12 mm (0.47 in) dia.] for titania heated oxygen sensor</b> <b>C: Mating surface shave cylinder</b> <b>D: Flutes</b>
( — ) Anti-seize lubricant (Permatex 133AR or equivalent meeting MIL specification MIL-A-907)	Lubricating heated oxygen sensor thread cleaner when reconditioning exhaust system threads
( — ) Power tool	Loosening bolts and nuts

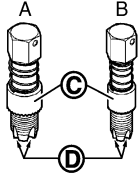

JPBIA0238ZZ

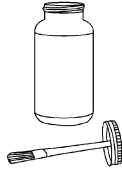

AEM489

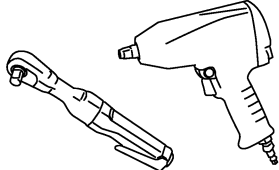

PBIC0190E

F

G

H

I

J

K

L

M

N

O

P

## PERIODIC MAINTENANCE

### EXHAUST SYSTEM

#### Inspection

INFOID:000000009361312

Check exhaust pipes, muffler, and mounting for improper attachment, leakage, cracks, damage or deterioration.

- If anything is found, repair or replace damaged parts.

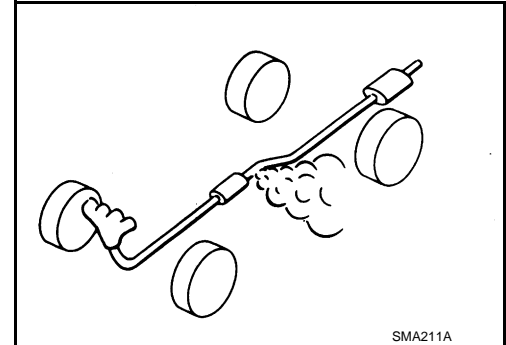

SMA211A

# EXHAUST SYSTEM

< REMOVAL AND INSTALLATION >

[REGULAR GRADE]

## REMOVAL AND INSTALLATION

### EXHAUST SYSTEM

Exploded View

INFOID:000000009361313

A

EX

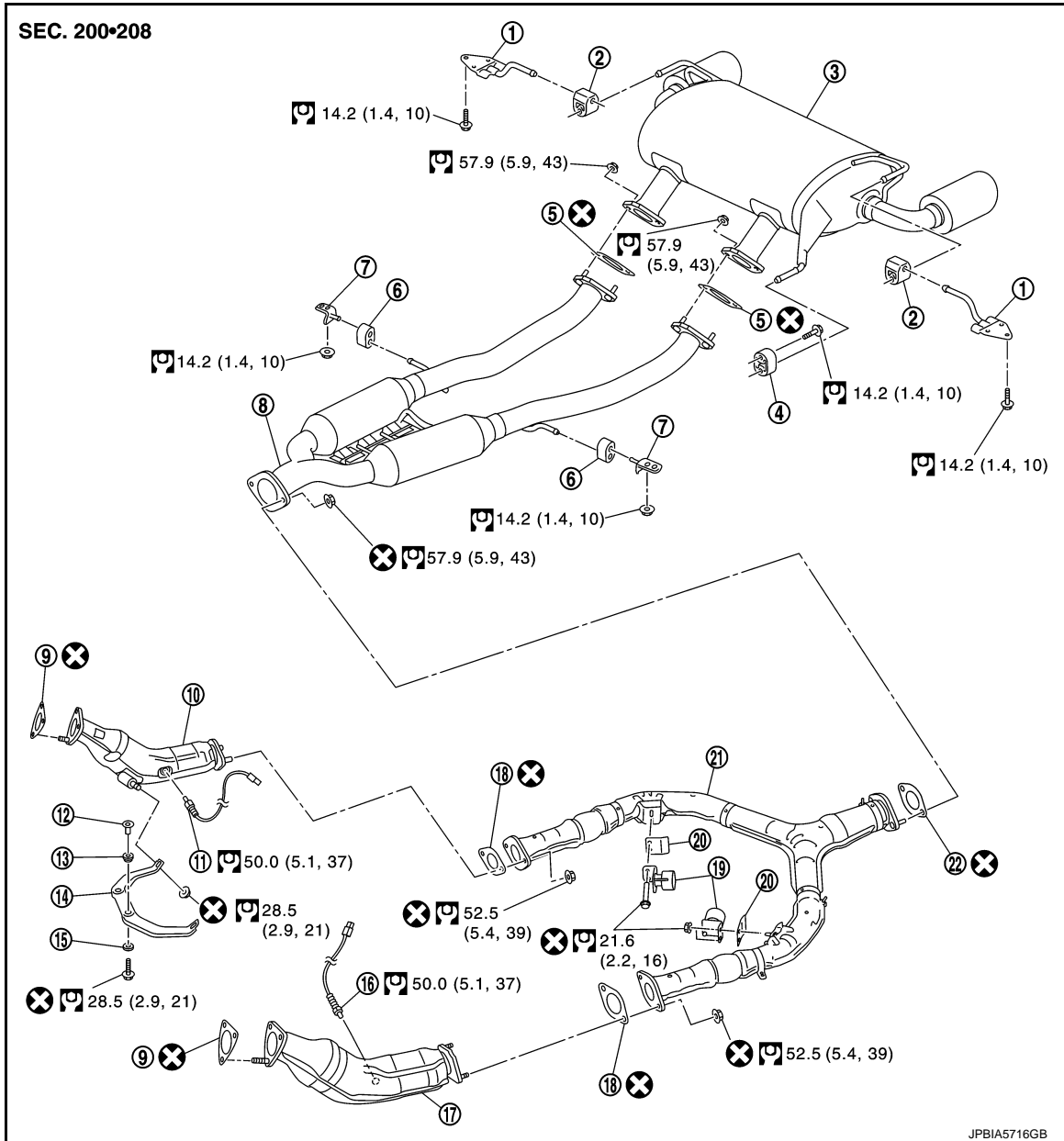

- |                                     |                                     |                        |
|-------------------------------------|-------------------------------------|------------------------|
| 1. Mounting bracket                 | 2. Mounting rubber                  | 3. Main muffler        |
| 4. Mounting rubber                  | 5. Gasket                           | 6. Mounting rubber     |
| 7. Mounting bracket                 | 8. Center muffler                   | 9. Gasket              |
| 10. Three way catalyst (bank 1)     | 11. Heated oxygen sensor 2 (bank 1) | 12. Collar             |
| 13. Grommet                         | 14. Exhaust mounting bracket        | 15. Grommet            |
| 16. Heated oxygen sensor 2 (bank 2) | 17. Three way catalyst (bank 2)     | 18. Gasket             |
| 19. Dynamic damper                  | 20. Insulator                       | 21. Exhaust front tube |
| 22. Gasket                          |                                     |                        |

Refer to [GI-4, "Components"](#) for symbols in the figure.

C

D

E

F

G

H

I

J

K

L

M

N

O

P

# EXHAUST SYSTEM

< REMOVAL AND INSTALLATION >

[REGULAR GRADE]

## Removal and Installation

INFOID:00000009361314

### REMOVAL

- Disconnect each joint and mounting using power tool.
- For removing and installing parts around propeller shaft, be careful of the following caution.

#### CAUTION:

**Be sure to prevent propeller shaft from interfering parts and tools. If necessary, install protector to propeller shaft to prevent damage. Refer to [DLN-7, "Removal and Installation"](#).**

- Remove heated oxygen sensor 2 as follows:
  - Using heated oxygen sensor wrench [SST: KV10114400 (J-38365)] (C), removal heated oxygen sensor 2.

A : Bank 1

B : Bank 2

⇐ : Vehicle front

#### CAUTION:

**Be careful not to damage heated oxygen sensor 2.**

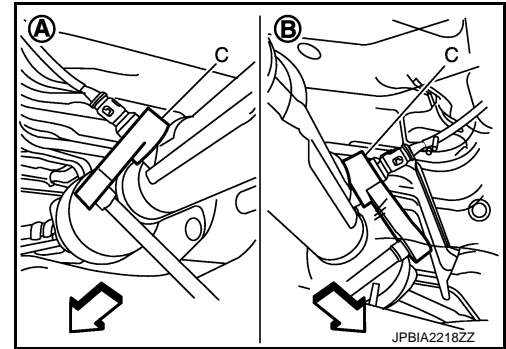

### INSTALLATION

Note the following, and install in the reverse order of removal.

- Check for deformation of the grommets (13 and 15 of Components).
- Insert the collar (12 of Components) vertically.
- Temporarily tighten bolts and nuts when installing exhaust pipe assembly. Tighten them to the specified torque when connecting the vehicle rear to the vehicle front.

#### CAUTION:

- **Always replace exhaust tube gaskets with new ones when reassembling.**
- **Discard any heated oxygen sensor 2 which has been dropped onto a hard surface such as a concrete floor. Use a new one.**
- **Before installing a new heated oxygen sensor 2, clean exhaust system threads using the heated oxygen sensor thread cleaner (commercial service tool: J-43897-18 or J-43897-12), and apply the anti-seize lubricant (commercial service tool).**
- **Never over torque heated oxygen sensor 2. Doing so may cause damage to heated oxygen sensor 2, resulting in the "MIL" coming on.**
- **Prevent rust preventives from adhering to the sensor body.**
- **If heat insulator is badly deformed, repair or replace it. If deposits such as mud pile up on the heat insulator, remove them.**
- **When installing heat insulator avoid large gaps or interference between heat insulator and each exhaust pipe.**
- **Remove deposits from the sealing surface of each connection. Connect them securely to avoid gases leakage.**
- **Temporarily tighten mounting nuts on the exhaust manifold side and mounting bolts on the vehicle side. Check each part for unusual interference, and then tighten them to the specified torque.**
- **When installing each mounting rubber, avoid twisting or unusual extension in up/down and right/left directions.**

### Inspection

INFOID:00000009361315

### INSPECTION AFTER INSTALLATION

- Check clearance between tail tube and rear bumper is even.
- With engine running, check exhaust tube joints for gas leakage and unusual noises.
- Check to ensure that mounting brackets and mounting rubbers are installed properly and free from undue stress. Improper installation could result in excessive noise and vibration.

# EXHAUST SYSTEM

< REMOVAL AND INSTALLATION >

[Nismo 370Z]

## REMOVAL AND INSTALLATION

### EXHAUST SYSTEM

Exploded View

INFOID:000000009361316

A

EX

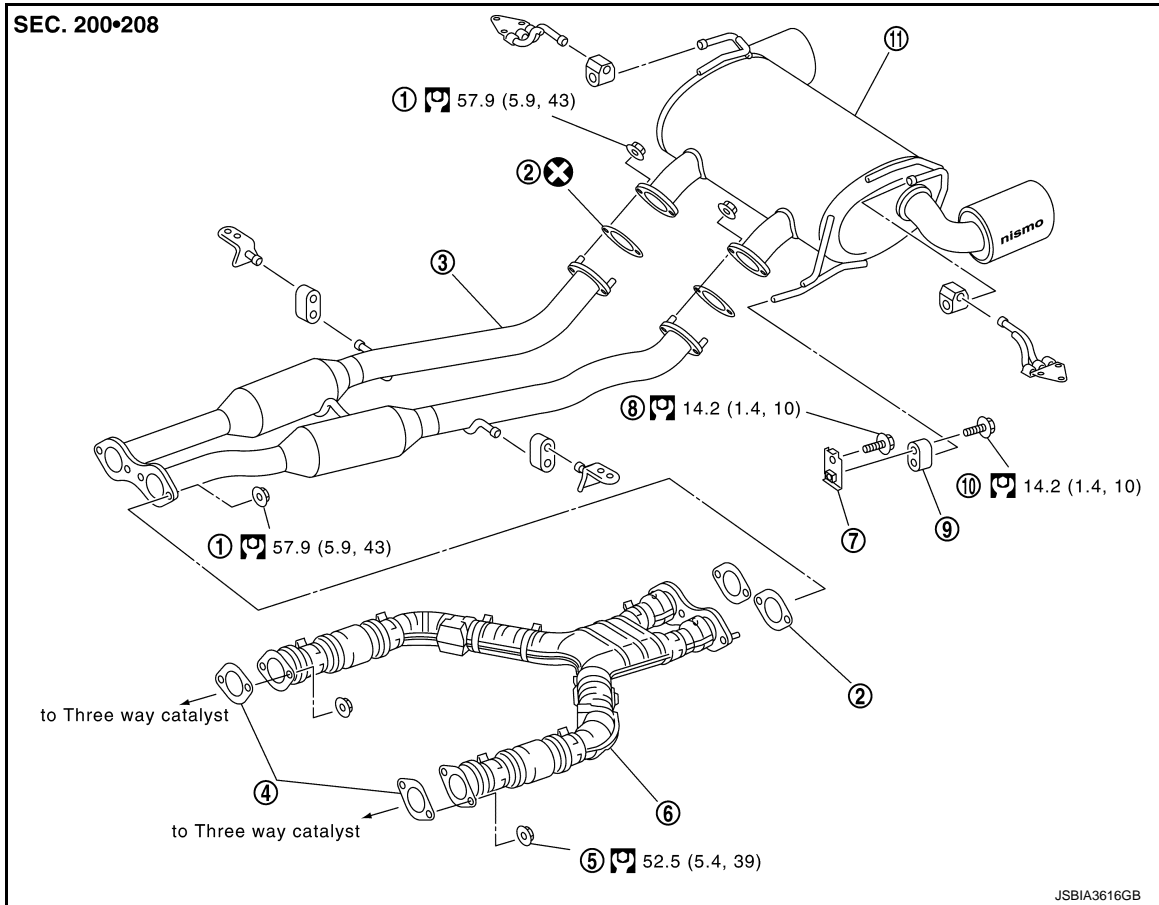

C

D

E

F

G

H

I

J

K

- |                             |                  |                       |
|-----------------------------|------------------|-----------------------|
| 1. Nut (8)                  | 2. Gasket (4)    | 3. Center muffler     |
| 4. Gasket                   | 5. Nut (4)       | 6. Exhaust front tube |
| 7. Exhaust mounting bracket | 8. Bolt          | 9. Mounting rubber    |
| 10. Bolt                    | 11. Main muffler |                       |

Refer to [GI-4, "Components"](#) for symbols in the figure.

L

M

N

O

P