

SECTION **CHG**  
CHARGING SYSTEM

A  
B  
C  
D  
E  
F  
G  
H  
I  
J  
K  
L  
N  
O  
P

CONTENTS

<b>BASIC INSPECTION</b> .....	3	<b>CHARGING SYSTEM</b> .....	23
<b>DIAGNOSIS AND REPAIR WORK FLOW</b> .....	3	Symptom Table .....	23
Work Flow (With EXP-800 NI or GR8-1200 NI) .....	3	<b>PRECAUTION</b> .....	24
Work Flow (Without EXP-800 NI or GR8-1200 NI).....	7	<b>PRECAUTIONS</b> .....	24
<b>SYSTEM DESCRIPTION</b> .....	10	<b>EXCEPT FOR MEXICO</b> .....	24
<b>CHARGING SYSTEM</b> .....	10	EXCEPT FOR MEXICO : Precautions for Supplemental Restraint System (SRS) "AIR BAG" and "SEAT BELT PRE-TENSIONER" .....	24
System Diagram .....	10	EXCEPT FOR MEXICO : Precaution for Battery Service .....	24
System Description .....	10	EXCEPT FOR MEXICO : Precaution for Power Generation Voltage Variable Control System .....	24
Component Parts Location .....	10	EXCEPT FOR MEXICO : Precaution for Procedure without Cowl Top Cover .....	25
Component Description .....	11	EXCEPT FOR MEXICO : Precautions For Xenon Headlamp Service .....	25
<b>POWER GENERATION VOLTAGE VARIABLE CONTROL SYSTEM</b> .....	12	EXCEPT FOR MEXICO : Precautions for Removing Battery Terminal .....	25
System Diagram .....	12	<b>FOR MEXICO</b> .....	25
System Description .....	12	FOR MEXICO : Precaution for Supplemental Restraint System (SRS) "AIR BAG" and "SEAT BELT PRE-TENSIONER" .....	25
Component Parts Location .....	12	FOR MEXICO : Precaution for Battery Service .....	26
Component Description .....	13	FOR MEXICO : Precaution for Power Generation Voltage Variable Control System .....	26
<b>DTC/CIRCUIT DIAGNOSIS</b> .....	14	FOR MEXICO : Precaution for Procedure without Cowl Top Cover .....	26
<b>B TERMINAL CIRCUIT</b> .....	14	FOR MEXICO : Precautions For Xenon Headlamp Service .....	26
Description .....	14	FOR MEXICO : Precautions for Removing Battery Terminal .....	27
Diagnosis Procedure .....	14	<b>PREPARATION</b> .....	28
<b>L TERMINAL CIRCUIT (OPEN)</b> .....	15	<b>PREPARATION</b> .....	28
Description .....	15	Special Service Tools .....	28
Diagnosis Procedure .....	15	Commercial Service Tools .....	28
<b>L TERMINAL CIRCUIT (SHORT)</b> .....	17		
Description .....	17		
Diagnosis Procedure .....	17		
<b>S TERMINAL CIRCUIT</b> .....	18		
Description .....	18		
Diagnosis Procedure .....	18		
<b>CHARGING SYSTEM</b> .....	19		
Wiring Diagram - CHARGING SYSTEM - .....	19		
<b>SYMPTOM DIAGNOSIS</b> .....	23		

**CHG**

<b>PERIODIC MAINTENANCE .....</b>	<b>29</b>	<b>ALTERNATOR .....</b>	<b>32</b>
<b>CHARGING SYSTEM PRELIMINARY IN- SPECTION .....</b>	<b>29</b>	Exploded View .....	32
Inspection Procedure .....	29	Removal and Installation .....	33
<b>POWER GENERATION VOLTAGE VARI- ABLE CONTROL SYSTEM OPERATION IN- SPECTION .....</b>	<b>30</b>	Inspection .....	34
Inspection Procedure .....	30	<b>SERVICE DATA AND SPECIFICATIONS (SDS) .....</b>	<b>35</b>
<b>REMOVAL AND INSTALLATION .....</b>	<b>32</b>	<b>SERVICE DATA AND SPECIFICATIONS (SDS) .....</b>	<b>35</b>
		Alternator .....	35

# DIAGNOSIS AND REPAIR WORK FLOW

< BASIC INSPECTION >

## BASIC INSPECTION

### DIAGNOSIS AND REPAIR WORK FLOW

Work Flow (With EXP-800 NI or GR8-1200 NI)

INFOID:0000000010840659

#### CHARGING SYSTEM DIAGNOSIS WITH EXP-800 NI OR GR8-1200 NI

To test the charging system, use the following special service tools:

- EXP-800 NI Battery and electrical diagnostic analyzer
- GR8-1200 NI Multitasking battery and electrical diagnostic station

**NOTE:**

Refer to the applicable Instruction Manual for proper charging system diagnosis procedures.

A  
B  
C  
D  
E  
F  
G  
H  
I  
J  
K  
L  
N  
O  
P

CHG

# DIAGNOSIS AND REPAIR WORK FLOW

< BASIC INSPECTION >

## OVERALL SEQUENCE

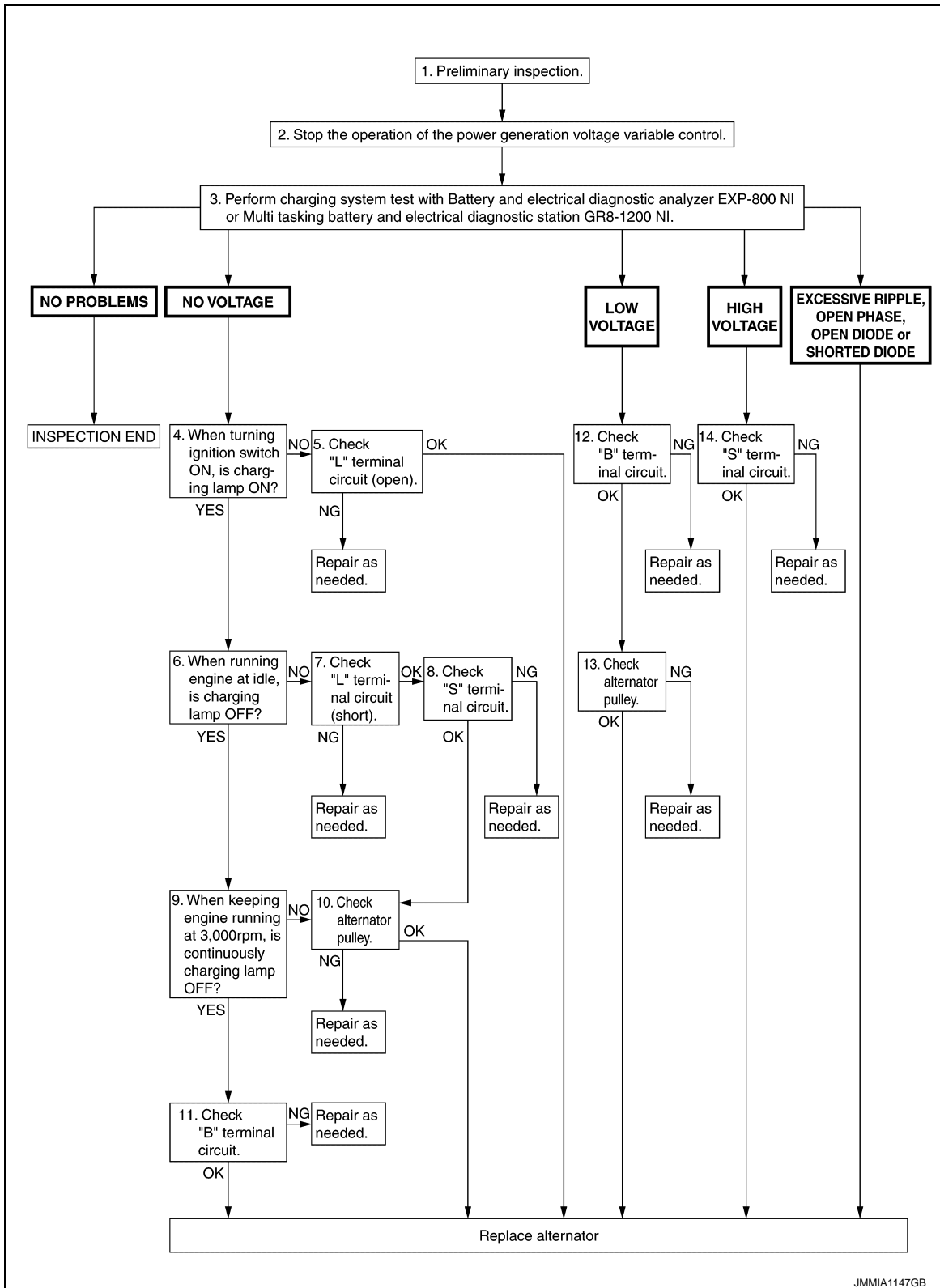

### DETAILED FLOW

#### NOTE:

To ensure a complete and thorough diagnosis, the battery, starter and alternator test segments must be done as a set from start to finish.

#### 1. PRELIMINARY INSPECTION

Perform the preliminary inspection. Refer to [CHG-29, "Inspection Procedure"](#).

# DIAGNOSIS AND REPAIR WORK FLOW

## < BASIC INSPECTION >

---

>> GO TO 2.

### 2. STOP POWER GENERATION VOLTAGE VARIABLE CONTROL SYSTEM

---

Stop the operation of the power generation voltage variable control in either of the following procedures.

- After selecting “ENGINE” of “SELECT SYSTEM” using CONSULT, set the DUTY value of “ALTERNATOR DUTY” to 0 % by selecting “ALTERNATOR DUTY” of “Active Test”. Continue “Active Test” until the end of inspection. (When the DUTY value is 0 or 100 %, the normal power generation is performed according to the characteristic of the IC voltage regulator of the alternator.)
- Turn the ignition switch OFF, and disconnect the battery current sensor connector. [However, DTC (P1550 - P1554) of the engine might remain. After finishing the inspection, connect the battery current sensor connector and erase the self-diagnosis results history of the engine using CONSULT.]

>> GO TO 3.

### 3. DIAGNOSIS WITH EXP-800 NI OR GR8-1200 NI

---

Perform the charging system test using Multitasking battery and electrical diagnostic station GR8-1200 NI or Battery and electrical diagnostic analyzer EXP-800 NI. Refer to the applicable Instruction Manual for proper testing procedures.

#### Test result

NO PROBLEMS>>Charging system is normal and will also show “DIODE RIPPLE” test result.

NO VOLTAGE>>GO TO 4.

LOW VOLTAGE>>GO TO 12.

HIGH VOLTAGE>>GO TO 14.

EXCESSIVE RIPPLE, OPEN PHASE, OPEN DIODE or SHORTED DIODE>>Replace the alternator. Perform “DIODE RIPPLE” test again using Multitasking battery and electrical diagnostic station GR8-1200 NI or Battery and electrical diagnostic analyzer EXP-800 NI to confirm repair.

### 4. INSPECTION WITH CHARGE WARNING LAMP (IGNITION SWITCH IS ON)

---

Turn the ignition switch ON.

Does the charge warning lamp illuminate?

YES >> GO TO 6.

NO >> GO TO 5.

### 5. “L” TERMINAL CIRCUIT (OPEN) INSPECTION

---

Check “L” terminal circuit (open). Refer to [CHG-15, "Diagnosis Procedure"](#).

Is the “L” terminal circuit normal?

YES >> Replace alternator. Refer to [CHG-33, "Removal and Installation"](#).

NO >> Repair as needed.

### 6. INSPECTION WITH CHARGE WARNING LAMP (IDLING)

---

Start the engine and run it at idle.

Does the charge warning lamp turn OFF?

YES >> GO TO 9.

NO >> GO TO 7.

### 7. “L” TERMINAL CIRCUIT (SHORT) INSPECTION

---

Check “L” terminal circuit (short). Refer to [CHG-17, "Diagnosis Procedure"](#).

Is the “L” terminal circuit normal?

YES >> GO TO 8.

NO >> Repair as needed.

### 8. “S” TERMINAL CIRCUIT INSPECTION

---

Check “S” terminal circuit. Refer to [CHG-18, "Diagnosis Procedure"](#).

Is the “S” terminal circuit normal?

YES >> GO TO 10.

NO >> Repair as needed.

A

B

C

D

E

F

G

H

I

J

K

L

CHG

N

O

P

## DIAGNOSIS AND REPAIR WORK FLOW

< BASIC INSPECTION >

---

### 9. INSPECTION WITH CHARGE WARNING LAMP (ENGINE AT 3,000 RPM)

---

Increase and maintain the engine speed at 3,000 rpm.

Does the charge warning lamp remain off?

YES >> GO TO 11.

NO >> GO TO 10.

### 10. INSPECTION OF ALTERNATOR PULLEY

---

Check alternator pulley. Refer to [CHG-34, "Inspection"](#).

Is alternator pulley normal?

YES >> Replace alternator. Refer to [CHG-33, "Removal and Installation"](#).

NO >> Repair as needed.

### 11. "B" TERMINAL CIRCUIT INSPECTION

---

Check "B" terminal circuit. Refer to [CHG-14, "Diagnosis Procedure"](#).

Is "B" terminal circuit normal?

YES >> Replace alternator. Refer to [CHG-33, "Removal and Installation"](#).

NO >> Repair as needed.

### 12. "B" TERMINAL CIRCUIT INSPECTION

---

Check "B" terminal circuit. Refer to [CHG-14, "Diagnosis Procedure"](#).

Is "B" terminal circuit normal?

YES >> GO TO 13.

NO >> Repair as needed.

### 13. INSPECTION OF ALTERNATOR PULLEY

---

Check alternator pulley. Refer to [CHG-34, "Inspection"](#).

Is alternator pulley normal?

YES >> Replace alternator. Refer to [CHG-33, "Removal and Installation"](#).

NO >> Repair as needed.

### 14. "S" TERMINAL CIRCUIT INSPECTION

---

Check "S" terminal circuit. Refer to [CHG-18, "Diagnosis Procedure"](#).

Is the "S" terminal circuit normal?

YES >> Replace alternator. Refer to [CHG-33, "Removal and Installation"](#).

NO >> Repair as needed.

# DIAGNOSIS AND REPAIR WORK FLOW

< BASIC INSPECTION >

Work Flow (Without EXP-800 NI or GR8-1200 NI)

INFOID:000000010840660

## OVERALL SEQUENCE

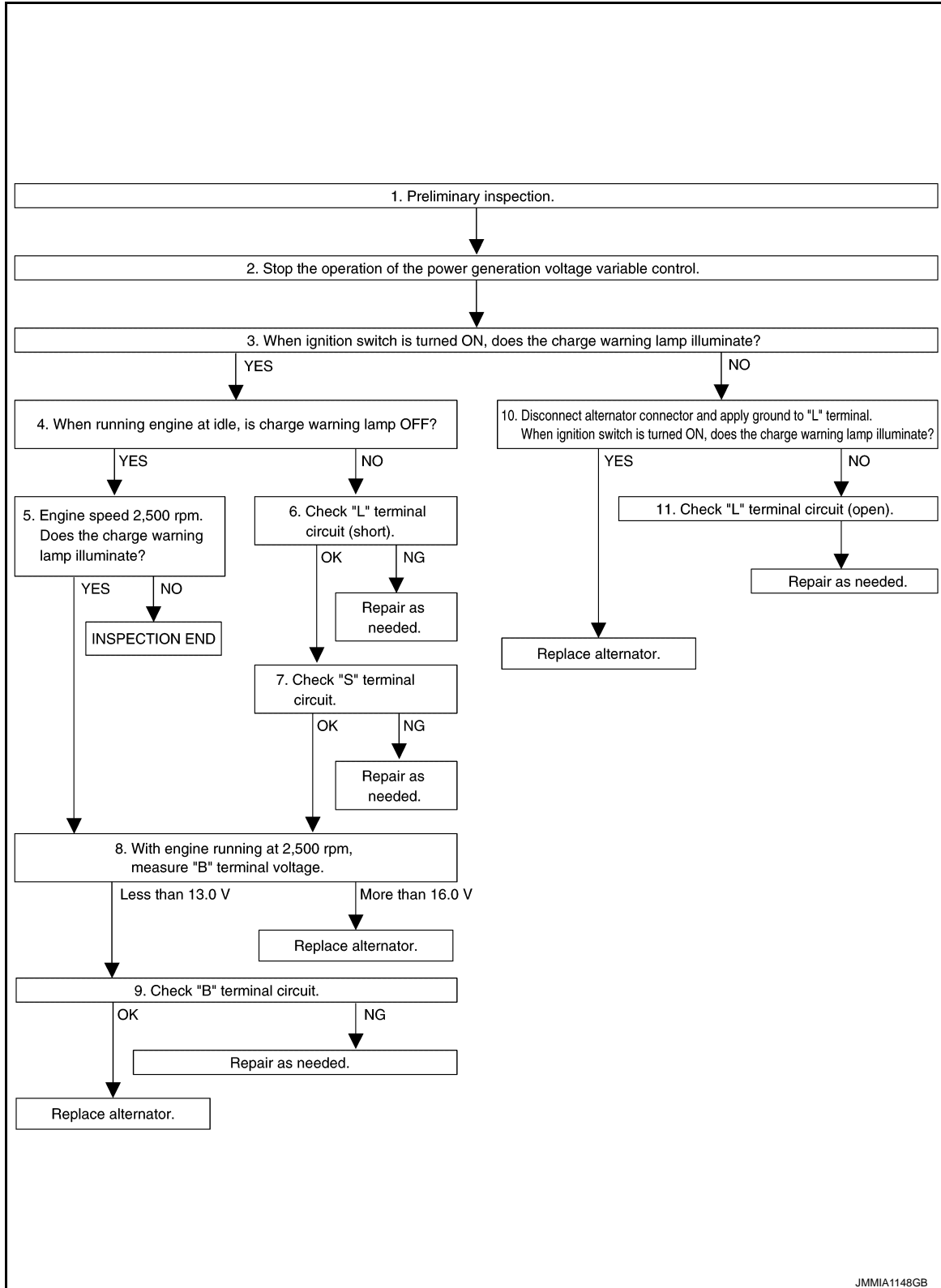

## DETAILED FLOW

### 1. PRELIMINARY INSPECTION

Perform the preliminary inspection. Refer to [CHG-29, "Inspection Procedure"](#).

A  
B  
C  
D  
E  
F  
G  
H  
I  
J  
K  
L  
N  
O  
P

CHG

# DIAGNOSIS AND REPAIR WORK FLOW

## < BASIC INSPECTION >

---

>> GO TO 2.

### 2. STOP POWER GENERATION VOLTAGE VARIABLE CONTROL SYSTEM

---

Stop the operation of the power generation voltage variable control in either of the following procedures.

- After selecting "ENGINE" of "SELECT SYSTEM" using CONSULT, set the DUTY value of "ALTERNATOR DUTY" to 0 % by selecting "ALTERNATOR DUTY" of "Active Test". Continue "Active Test" until the end of inspection. (When the DUTY value is 0 or 100 %, the normal power generation is performed according to the characteristic of the IC regulator of the alternator.)
- Turn the ignition switch OFF, and disconnect the battery current sensor connector. [However, DTC (P1550 - P1554) of the engine might remain. After finishing the inspection, connect the battery current sensor connector and erase the self-diagnostic results history of the engine using CONSULT.]

>> GO TO 3.

### 3. INSPECTION WITH CHARGE WARNING LAMP (IGNITION SWITCH IS TURNED ON)

---

When ignition switch is turned ON

Does the charge warning lamp illuminate?

YES >> GO TO 4.

NO >> GO TO 10.

### 4. INSPECTION WITH CHARGE WARNING LAMP (IDLING)

---

Start the engine and run it at idle.

Does the charge warning lamp turn OFF?

YES >> GO TO 5.

NO >> GO TO 6.

### 5. INSPECTION WITH CHARGE WARNING LAMP (ENGINE AT 2,500 RPM)

---

Increase and maintain the engine speed at 2,500 rpm.

Does the charge warning lamp illuminate?

YES >> GO TO 8.

NO >> INSPECTION END

### 6. "L" TERMINAL CIRCUIT (SHORT) INSPECTION

---

Check "L" terminal circuit (short). Refer to [CHG-17, "Diagnosis Procedure"](#).

Is the inspection result normal?

YES >> GO TO 7.

NO >> Repair as needed.

### 7. "S" TERMINAL CIRCUIT INSPECTION

---

Check "S" terminal circuit. Refer to [CHG-18, "Diagnosis Procedure"](#).

Is the inspection result normal?

YES >> GO TO 8.

NO >> Repair as needed.

### 8. MEASURE "B" TERMINAL VOLTAGE

---

Start engine. With engine running at 2,500 rpm, measure "B" terminal voltage.

What voltage does the measurement result show?

Less than 13.0 V >> GO TO 9.

More than 16.0 V >> Replace alternator. Refer to [CHG-33, "Removal and Installation"](#).

### 9. "B" TERMINAL CIRCUIT INSPECTION

---

Check "B" terminal circuit. Refer to [CHG-14, "Diagnosis Procedure"](#).

Is the inspection result normal?

YES >> Replace alternator. Refer to [CHG-33, "Removal and Installation"](#).

NO >> Repair as needed.

### 10. INSPECTION WITH CHARGE WARNING LAMP (IGNITION SWITCH IS ON)

---



# DIAGNOSIS AND REPAIR WORK FLOW

## < BASIC INSPECTION >

---

1. Disconnect alternator connector and apply ground to "L" terminal.
2. Turn the ignition switch ON.

Does the charge warning lamp illuminate?

YES >> Replace alternator. Refer to [CHG-33. "Removal and Installation"](#).

NO >> GO TO 11.

## 11.CHECK "L" TERMINAL CIRCUIT (OPEN)

---

Check "L" terminal circuit (open). Refer to [CHG-15. "Diagnosis Procedure"](#).

>> Repair as needed.

A  
B  
C  
D  
E  
F  
G  
H  
I  
J  
K  
L  
N  
O  
P

CHG

# CHARGING SYSTEM

< SYSTEM DESCRIPTION >

## SYSTEM DESCRIPTION

### CHARGING SYSTEM

#### System Diagram

INFOID:000000010840661

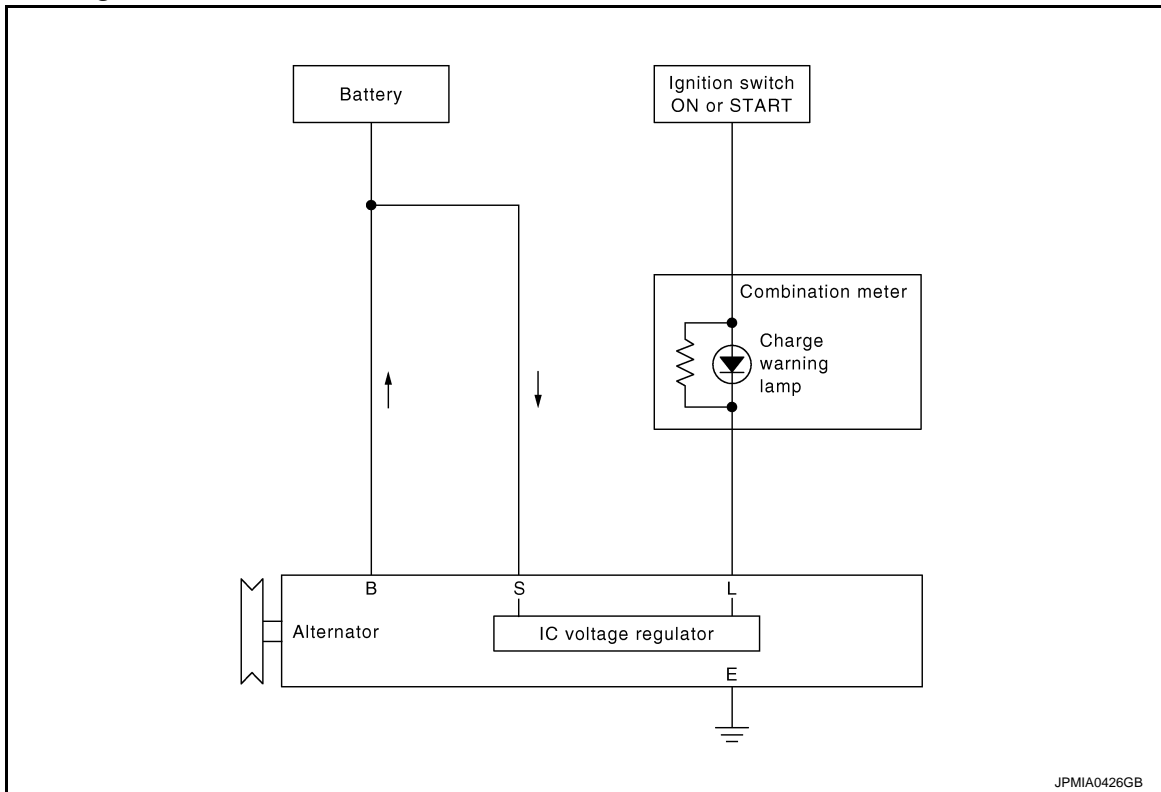

JPMIA0426GB

#### System Description

INFOID:000000010840662

The alternator provides DC voltage to operate the vehicle's electrical system and to keep the battery charged. The voltage output is controlled by the IC voltage regulator.

#### Component Parts Location

INFOID:000000010840663

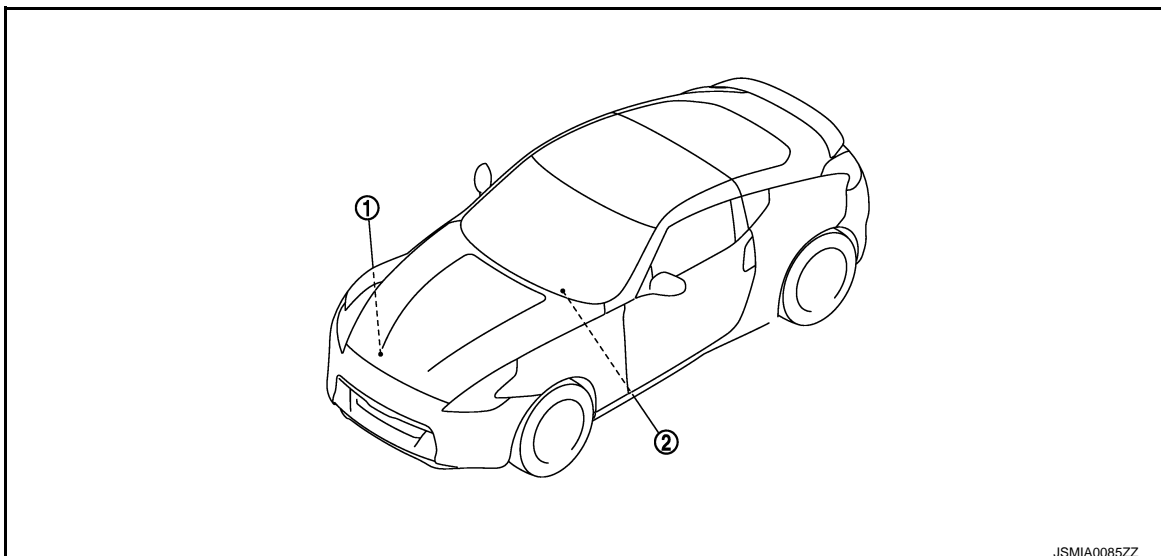

JSMIA0085ZZ

1. Alternator

2. Charge warning lamp (On the combination meter)

# CHARGING SYSTEM

< SYSTEM DESCRIPTION >

## Component Description

INFOID:000000010840664

Component part	Description
Alternator	The alternator provides DC voltage to operate the vehicle electrical system and to keep the battery charged.
Combination meter (Charge warning lamp)	The IC voltage regulator warning function activates to illuminate the charge warning lamp, if any of the following symptoms occur while alternator is operating: <ul style="list-style-type: none"><li>• Excessive voltage is produced.</li><li>• No voltage is produced.</li></ul>

A

B

C

D

E

F

G

H

I

J

K

L

**CHG**

N

O

P

# POWER GENERATION VOLTAGE VARIABLE CONTROL SYSTEM

< SYSTEM DESCRIPTION >

## POWER GENERATION VOLTAGE VARIABLE CONTROL SYSTEM

### System Diagram

INFOID:000000010840665

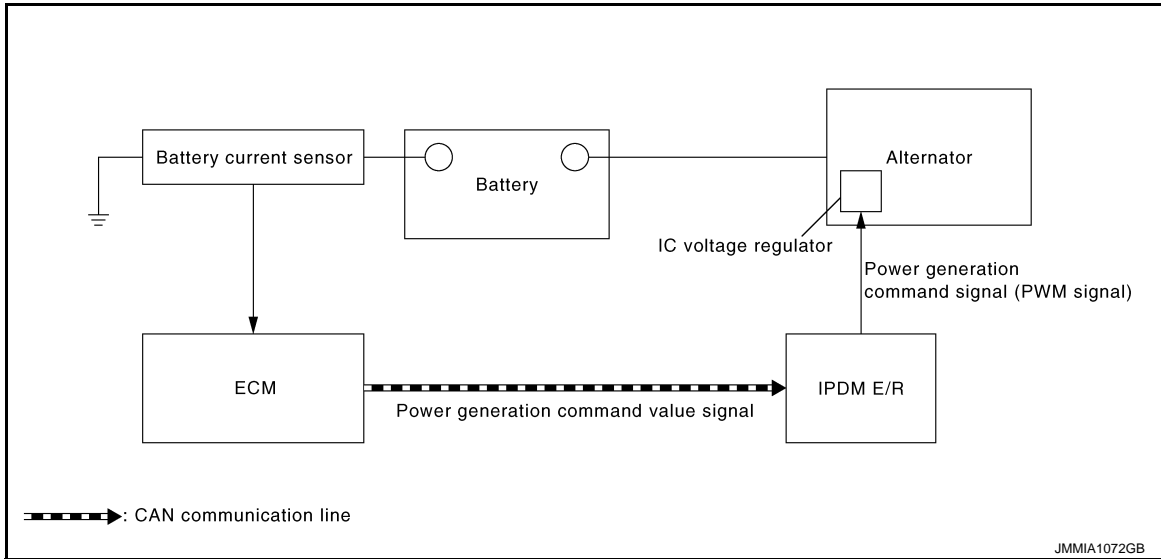

### System Description

INFOID:000000010840666

By performing the power generation voltage variable control, the engine load due to the power generation of the alternator is reduced and fuel consumption is decreased.

**NOTE:**

When any malfunction is detected in the power generation voltage variable control system, the power generation is performed according to the characteristic of the IC voltage regulator of the alternator.

### Component Parts Location

INFOID:000000010840667

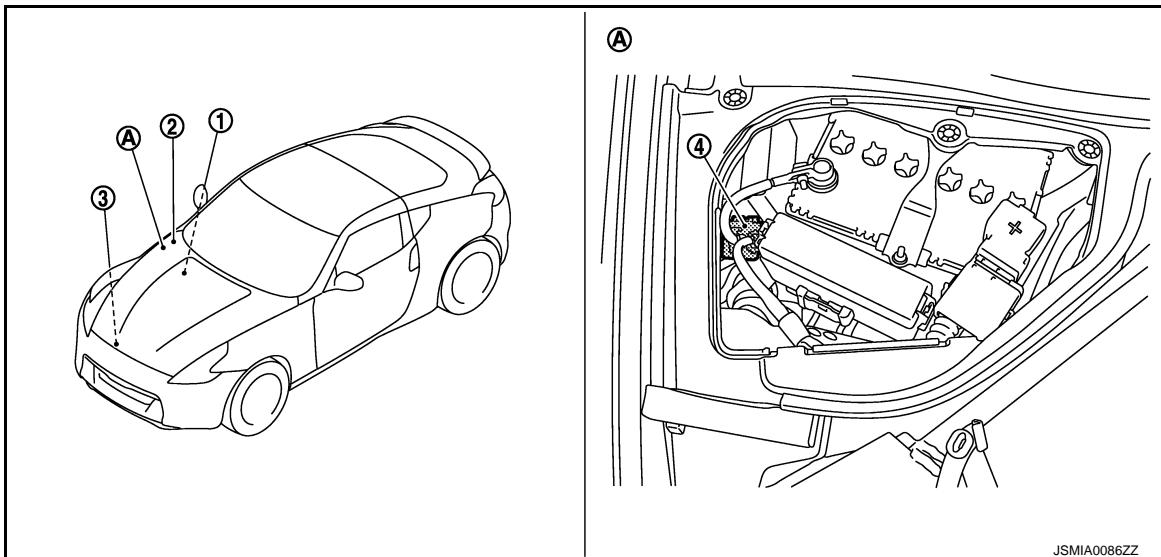

- |   |   |                      |
|---|---|----------------------|
| <p>1. IPDM E/R<br/>Refer to <a href="#">PCS-5, "Component Parts Location"</a>.</p> <p>4. Battery current sensor</p> | <p>2. ECM<br/>Refer to <a href="#">EC-40, "Component Parts Location"</a>.</p> | <p>3. Alternator</p> |
| <p>A. Engine room dash panel RH</p>   |   |                      |

JSMIA0086ZZ

# POWER GENERATION VOLTAGE VARIABLE CONTROL SYSTEM

< SYSTEM DESCRIPTION >

## Component Description

INFOID:000000010840668

Component part	Description
Battery current sensor	Battery current sensor is installed to the battery cable at the negative terminal, and it detects the charging/discharging current of the battery and sends the voltage signal to ECM according to the current value.
ECM	Battery current sensor detects the charging/discharging current of the battery. ECM judges the battery condition based on this signal. ECM judges whether to perform the power generation voltage variable control according to the battery condition. When performing the power generation voltage variable control, ECM calculates the target power generation voltage according to the battery condition and sends the calculated value as the power generation command value to IPDM E/R.
IPDM E/R	IPDM E/R converts the received power generation command value into the power generation command signal (PWM signal) and sends it to the IC voltage regulator.
Alternator (IC voltage regulator)	IC voltage regulator controls the power generation voltage by the target power generation voltage based on the received power generation command signal. When there is no power generation command signal, the alternator performs the normal power generation according to the characteristic of the IC voltage regulator.

A  
B  
C  
D  
E  
F  
G  
H  
I  
J  
K  
L

CHG

N  
O  
P

# B TERMINAL CIRCUIT

< DTC/CIRCUIT DIAGNOSIS >

## DTC/CIRCUIT DIAGNOSIS

### B TERMINAL CIRCUIT

#### Description

INFOID:0000000010840669

"B" terminal circuit supplies power to charge the battery and to operate the vehicle's electrical system.

#### Diagnosis Procedure

INFOID:0000000010840670

#### 1. CHECK "B" TERMINAL CONNECTION

1. Turn ignition switch OFF.
2. Check if "B" terminal is clean and tight.

Is the inspection result normal?

YES >> GO TO 2.

NO >> Repair "B" terminal connection. Confirm repair by performing complete Charging system test using EXP-800 NI or GR8-1200 NI (if available). Refer to the applicable Instruction Manual for proper testing procedures.

#### 2. CHECK "B" TERMINAL CIRCUIT

Check voltage between alternator "B" terminal and ground.

Terminals			Voltage (Approx.)
(+)	(-)		
Alternator "B" terminal	Terminal		
E203	1	Ground	Battery voltage

Is the inspection result normal?

YES >> GO TO 3.

NO >> Check harness for open between alternator and fusible link.

#### 3. CHECK "B" TERMINAL CONNECTION (VOLTAGE DROP TEST)

1. Start engine, then engine running at idle and warm.
2. Check voltage between battery positive terminal and alternator "B" terminal.

Terminals			Voltage (Approx.)
(+)	(-)		
	Alternator "B" terminal	Terminal	
Battery positive terminal	E203	1	Less than 0.2 V

Is the inspection result normal?

YES >> "B" terminal circuit is normal. Refer to [CHG-3. "Work Flow \(With EXP-800 NI or GR8-1200 NI\)"](#) or [CHG-7. "Work Flow \(Without EXP-800 NI or GR8-1200 NI\)"](#).

NO >> Check harness between battery and alternator for poor continuity.

# L TERMINAL CIRCUIT (OPEN)

< DTC/CIRCUIT DIAGNOSIS >

## L TERMINAL CIRCUIT (OPEN)

### Description

INFOID:000000010840671

The "L" terminal circuit controls the charge warning lamp. The charge warning lamp illuminates when the ignition switch is set to ON or START. When the alternator is providing sufficient voltage with the engine running, the charge warning lamp will go off. If the charge warning lamp illuminates with the engine running, a malfunction is indicated.

### Diagnosis Procedure

INFOID:000000010840672

#### 1. CHECK "L" TERMINAL CONNECTION

1. Turn ignition switch OFF.
2. Check if "L" terminal is clean and tight.

Is the inspection result normal?

YES >> GO TO 2.

NO >> Repair "L" terminal connection. Confirm repair by performing complete Charging system test using EXP-800 NI or GR8-1200 NI (if available). Refer to the applicable Instruction Manual for proper testing procedures.

#### 2. CHECK "L" TERMINAL CIRCUIT (OPEN)

1. Disconnect alternator connector.
2. Apply ground to alternator harness connector terminal.
3. Check condition of the charge warning lamp with the ignition switch in the ON position.

Alternator harness connector	Terminal	Ground	Condition	
			Ignition switch position	Charge warning lamp
F36	2		ON	Illuminate

Does it illuminate?

YES >> "L" terminal circuit is normal. Refer to [CHG-3, "Work Flow \(With EXP-800 NI or GR8-1200 NI\)"](#) or [CHG-7, "Work Flow \(Without EXP-800 NI or GR8-1200 NI\)"](#).

NO >> GO TO 3.

#### 3. CHECK HARNESS CONTINUITY (OPEN CIRCUIT)

1. Disconnect the battery cable from the negative terminal.
2. Disconnect the combination meter connector.
3. Check continuity between alternator harness connector and combination meter harness connector.

Alternator harness connector		Combination meter harness connector		Continuity
Connector No.	Terminal No.	Connector No.	Terminal No.	
F36	2	M54	25	Existed

Is the inspection result normal?

YES >> GO TO 4.

NO >> Repair the harness or connector.

#### 4. CHECK HARNESS CONTINUITY (OPEN CIRCUIT)

Check continuity between combination meter harness connector and fuse block.

Combination meter harness connector		Fuse block		Continuity
Connector No.	Terminal No.	Connector No.	Terminal No.	
M53	2	M3	12C	Existed

Is the inspection result normal?

YES >> GO TO 5.

NO >> Repair the harness.

A  
B  
C  
D  
E  
F  
G  
H  
I  
J  
K  
L

CHG

N  
O  
P

## L TERMINAL CIRCUIT (OPEN)

< DTC/CIRCUIT DIAGNOSIS >

### 5. CHECK POWER SUPPLY CIRCUIT

1. Connect the battery cable to the negative terminal.
2. Check voltage between combination meter harness connector and ground.

Terminals		(-)	Condition	Voltage (Approx.)
(+)	Terminal			
Combination meter harness connector				
M53	2	Ground	When the ignition switch is in ON position	Battery voltage

Is the inspection result normal?

YES >> Replace combination meter.

NO >> Inspect the power supply circuit. Refer to [PG-39. "Wiring Diagram - IGNITION POWER SUPPLY -](#)  
".



# L TERMINAL CIRCUIT (SHORT)

< DTC/CIRCUIT DIAGNOSIS >

## L TERMINAL CIRCUIT (SHORT)

### Description

INFOID:000000010840673

The "L" terminal circuit controls the charge warning lamp. The charge warning lamp illuminates when the ignition switch is set to ON or START. When the alternator is providing sufficient voltage with the engine running, the charge warning lamp will go off. If the charge warning lamp illuminates with the engine running, a malfunction is indicated.

### Diagnosis Procedure

INFOID:000000010840674

#### 1. CHECK "L" TERMINAL CIRCUIT (SHORT)

1. Turn ignition switch OFF.
2. Disconnect alternator connector.
3. Turn ignition switch ON.

Does charge warning lamp illuminate?

YES >> GO TO 2.

NO >> Refer to [CHG-3. "Work Flow \(With EXP-800 NI or GR8-1200 NI\)"](#) or [CHG-7. "Work Flow \(Without EXP-800 NI or GR8-1200 NI\)"](#).

#### 2. CHECK HARNESS CONTINUITY (SHORT CIRCUIT)

1. Turn ignition switch OFF.
2. Disconnect the battery cable from the negative terminal.
3. Disconnect combination meter connector.
4. Check continuity between combination meter harness connector and ground.

Combination meter harness connector		Ground	Continuity
Connector No.	Terminal No.		
M54	25		Not existed

Is the inspection result normal?

YES >> Replace combination meter.

NO >> Repair the harness.

A  
B  
C  
D  
E  
F  
G  
H  
I  
J  
K  
L

CHG

N  
O  
P

# S TERMINAL CIRCUIT

< DTC/CIRCUIT DIAGNOSIS >

## S TERMINAL CIRCUIT

### Description

INFOID:000000010840675

The output voltage of the alternator is controlled by the IC voltage regulator at the "S" terminal detecting the input voltage.

The "S" terminal circuit detects the battery voltage to adjust the alternator output voltage with the IC voltage regulator.

### Diagnosis Procedure

INFOID:000000010840676

#### 1. CHECK "S" TERMINAL CONNECTION

1. Turn ignition switch OFF.
2. Check if "S" terminal is clean and tight.

Is the inspection result normal?

YES >> GO TO 2.

NO >> Repair "S" terminal connection. Confirm repair by performing complete Charging system test using EXP-800 NI or GR8-1200 NI (if available). Refer to the applicable Instruction Manual for proper testing procedures.

#### 2. CHECK "S" TERMINAL CIRCUIT

Check voltage between alternator harness connector and ground.

Terminals		Voltage (Approx.)
(+)	(-)	
Alternator harness connector	Terminal	Battery voltage
F36	3	
	Ground	

Is the inspection result normal?

YES >> Refer to [CHG-3, "Work Flow \(With EXP-800 NI or GR8-1200 NI\)"](#) or [CHG-7, "Work Flow \(Without EXP-800 NI or GR8-1200 NI\)"](#).

NO >> Check harness for open between alternator and fuse.

# CHARGING SYSTEM

< DTC/CIRCUIT DIAGNOSIS >

## CHARGING SYSTEM

### Wiring Diagram - CHARGING SYSTEM -

INFOID:000000010840677

### CHARGING SYSTEM

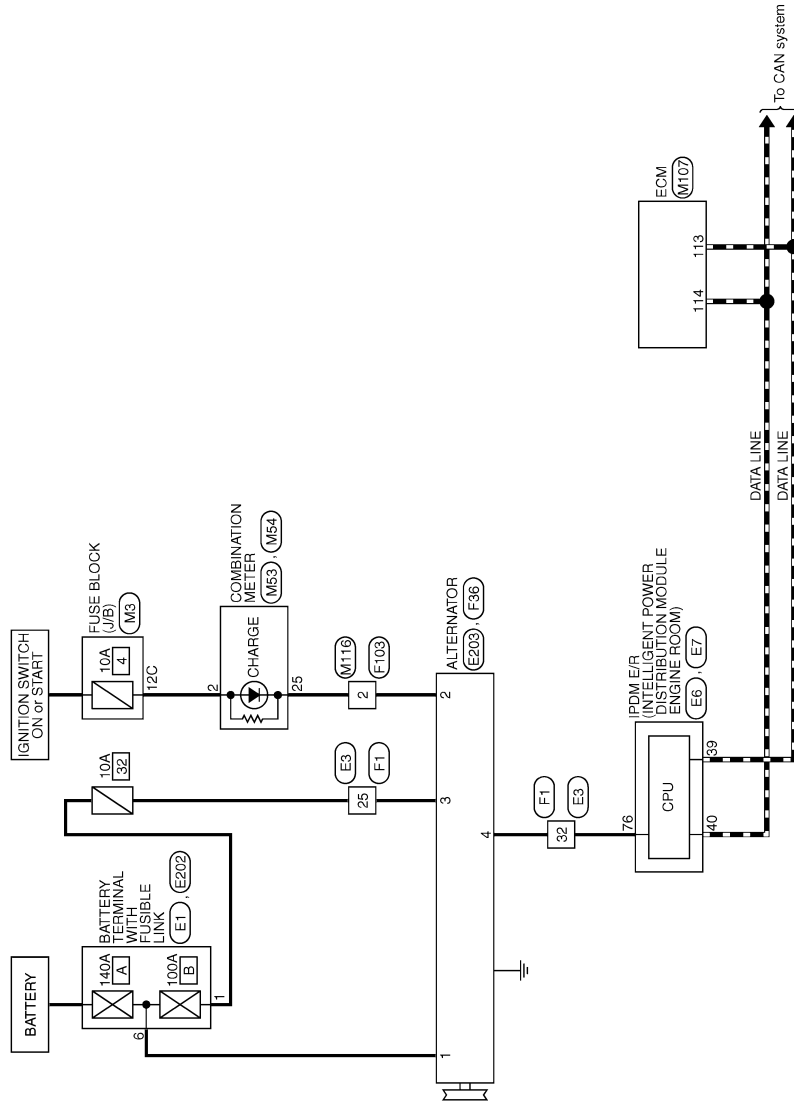

2009/07/10

JCMWM4775GB

A  
B  
C  
D  
E  
F  
G  
H  
I  
J  
K  
L  
N  
O  
P

CHG

# CHARGING SYSTEM

< DTC/CIRCUIT DIAGNOSIS >

## CHARGING SYSTEM

Connector No.	E1
Connector Name	BATTERY TERMINAL WITH FUSIBLE LINK
Connector Type	L02FBR-MC



Terminal No.	1	2
Color Of Wire	R	W
Signal Name [Specification]		

Connector No.	E3
Connector Name	WIRE TO WIRE
Connector Type	SAA38MB-RSS-SHZ8

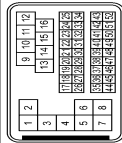

Terminal No.	1	2	3	4	5	6	7	8	9	10	11	12	13	14	15	16	17	18
Color Of Wire	L/Y	SHIELD	L/B	SHIELD	BR	G	W	W	W	V	V	SB	L	G	R	LG	GR	Y
Signal Name [Specification]																		

19	BG	-
20	B	-
21	SB	-
22	G	-
23	SB	-
24	GR	-
25	V	-
27	GR	-
28	V	-
29	L	-
30	R	-
31	BR	-
32	Y	-
33	SB	-
34	BG	-
36	GR	-
37	SHIELD	-
38	L	-
39	P	-
40	R	-
41	W	-
42	LG	-
43	G	-
45	SB	-
46	SHIELD	-
47	W	-
48	BR	-
49	G	-
50	B	-
51	SB	-
52	R	-

Connector No.	E6
Connector Name	INTELLIGENT POWER DISTRIBUTION MODULE (ENGINE ROOM)
Connector Type	TH08FW-NH



Terminal No.	39	40	41	42	43	44	45	46
Color Of Wire	P	L	B/W	Y	SB	W	G	V
Signal Name [Specification]								

Connector No.	E7
Connector Name	INTELLIGENT POWER DISTRIBUTION MODULE (ENGINE ROOM)
Connector Type	TH20FW-CSI2-M4



Terminal No.	48	49	51	53	54	55	56	57	58	69	70	72	73	74	75	76	77	80
Color Of Wire	L	BG	Y	W	V	SB	LG	G	P	BR	BG	GR	GR	G	SB	Y	R	W
Signal Name [Specification]																		

Connector No.	E202
Connector Name	BATTERY TERMINAL WITH FUSIBLE LINK
Connector Type	Z4340_78905



Terminal No.	6
Color Of Wire	B/GY
Signal Name [Specification]	

Connector No.	E203
Connector Name	ALTERNATOR
Connector Type	Z4340_65F45



Terminal No.	1
Color Of Wire	B/GY
Signal Name [Specification]	B

Connector No.	F1
Connector Name	WIRE TO WIRE
Connector Type	SAA38FB-RSS-SHZ8

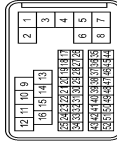

JRMWF7345GB

# CHARGING SYSTEM

< DTC/CIRCUIT DIAGNOSIS >

## CHARGING SYSTEM

Terminal No.	Color Of Wire	Signal Name [Specification]
1	L/Y	-
2	SHIELD	-
3	L/B	-
4	SHIELD	-
5	BR	-
7	G	-
8	W	-
9	W	-
10	G	-
11	R	-
12	P	-
13	O	-
14	LG	-
15	BR	-
16	Y	-
17	W	-
18	LG	-
19	P	-
20	O	-
21	BR	-
22	G	-
23	Y	-
24	LG	-
25	V	-
27	GR	-
28	BR	-
29	L	-
30	R	-
31	P	-
32	W	-
33	SB	-
34	O	-
36	GR	-
37	SHIELD	-
38	W	-
39	Y	-
40	G	-
41	B	-
42	GR	-
43	R	-
45	SB	-
46	SHIELD	-
47	W/L	-
48	LG	-
48	OL	-
50	L/Y	-
51	W	-
52	L/G	-

Connector No.	F36
Connector Name	ALTERNATOR
Connector Type	HS03FB



Terminal No.	Color Of Wire	Signal Name [Specification]
2	G	L
3	V	S
4	W	C

Connector No.	F103
Connector Name	WIRE TO WIRE
Connector Type	TK38FW-NS10



Terminal No.	Color Of Wire	Signal Name [Specification]
2	G	-
3	W	-
4	R	-
5	B	-
8	L	-
9	Y	-
10	GR	-
19	O	-
20	Y	-
28	B	-
29	LG	-
30	R	-
31	O	-
38	W	-
42	G	-
43	P	-
44	L	-

Terminal No.	45	Y	-
Terminal No.	46	V	-

Connector No.	M3
Connector Name	FUSE BLOCK (JIB)
Connector Type	NS12FW-CS

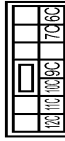

Terminal No.	Color Of Wire	Signal Name [Specification]
10C	L	-
11C	LG	-
12C	O	-
8C	R	-
7C	B	-
9C	O	-

Connector No.	M53
Connector Name	COMBINATION METER
Connector Type	TH24FW-NH



Terminal No.	Color Of Wire	Signal Name [Specification]
1	V	BATTERY POWER SUPPLY
2	O	IGNITION SIGNAL
3	L	VEHICLE SPEED SIGNAL (2 PULSE)
4	V	VEHICLE SPEED SIGNAL (PULSE) (For Meter)
4	Y	VEHICLE SPEED SIGNAL (PULSE) (For Meter)
5	R	ILLUMINATION CONTROL SIGNAL
6	R	ROOF STATUS SIGNAL
9	BR	COMMUNICATION SIGNAL (METER-TRIPE METER)
10	L	COMMUNICATION SIGNAL (TRIPLE METER-METER)
12	G	S-MODE SWITCH SIGNAL

Terminal No.	15	L	ACC POWER SUPPLY
Terminal No.	16	R	AIR BAG SIGNAL
Terminal No.	17	B	GROUND
Terminal No.	18	V	AMBIENT SENSOR SIGNAL
Terminal No.	19	G	AC AUTOAMP CONNECTION RECOGNITION SIGNAL
Terminal No.	20	GR	AMBIENT SENSOR GROUND
Terminal No.	21	L	CAN-H
Terminal No.	22	P	CAN-L
Terminal No.	23	B	GROUND
Terminal No.	24	Y	FUEL LEVEL SENSOR GROUND

Connector No.	M54
Connector Name	COMBINATION METER
Connector Type	TH16FW-NH

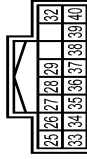

Terminal No.	Color Of Wire	Signal Name [Specification]
25	W	ALTERNATOR SIGNAL
26	O	PARKING BRAKE SWITCH SIGNAL
27	LG	BRAKE FLUID LEVEL SWITCH SIGNAL
28	Y	SECURITY SIGNAL
29	GR	WASHER LEVEL SWITCH SIGNAL
32	G	PADDLE SHIFTER DOWN SIGNAL
33	O	PADDLE SHIFTER UP SIGNAL
34	BR	FUEL LEVEL SENSOR SIGNAL
35	L	SEAT BELT BUCKLE SWITCH SIGNAL (DRIVER SIDE)
36	L	PASSENGER SEAT BELT WARNINGS SIGNAL (For Meter)
36	P	PASSENGER SEAT BELT WARNINGS SIGNAL (For Meter)
37	G	NON-MANUAL MODE SIGNAL
38	V	MANUAL MODE SHIF DOWN SIGNAL
39	L	MANUAL MODE SHIF UP SIGNAL
40	W	MANUAL MODE SIGNAL

A  
B  
C  
D  
E  
F  
G  
H  
I  
J  
K  
L  
N  
O  
P

CHG

JRMWF7346GB

# CHARGING SYSTEM

< DTC/CIRCUIT DIAGNOSIS >

## CHARGING SYSTEM

Connector No.	M107
Connector Name	ECM
Connector Type	RH24FGY-RZB-R-LH-Z

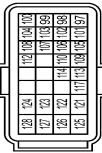

Terminal No.	Color Of Wire	Signal Name [Specification]
97	R	ACCELERATOR PEDAL POSITION SENSOR1
98	P	ACCELERATOR PEDAL POSITION SENSOR2
99	L	SENSOR POWER SUPPLY
100	W	SENSOR GROUND
101	SB	ASCD STEERING SWITCH
102	GR	EVAP CONTROL SYSTEM PRESSURE SENSOR
103	G	SENSOR POWER SUPPLY
104	GR	SENSOR GROUND
105	L	REFRIGERANT PRESSURE SENSOR
106	W	FUEL TANK TEMPERATURE SENSOR
107	BR	SENSOR POWER SUPPLY
108	Y	SENSOR GROUND
109	G	PNF SIGNAL
110	R	ENGINE SPEED OUTPUT SIGNAL
112	SB	SENSOR GROUND
113	P	CAN COMMUNICATION LINE
114	L	CAN COMMUNICATION LINE
117	Y	DATA LINK CONNECTOR
121	LG	EVAP CANISTER VENT CONTROL VALVE
122	P	STOP LAMP SWITCH
123	B	ECM GROUND
124	B	ECM GROUND
125	R	POWER SUPPLY FOR ECM
126	BR	ASCD BRAKE SWITCH
127	B	ECM GROUND
128	B	ECM GROUND

Connector No.	M116
Connector Name	WIRE TO WIRE
Connector Type	TK36MW-NS10



Terminal No.	Color Of Wire	Signal Name [Specification]
2	W	-
3	BG	- [Course models]
4	O	- [Passer models]
4	W	-
5	B	-
6	B	-
8	L	-
9	Y	-
10	R	-
19	O	-
20	G	-
28	B	-
29	LG	-
30	LG	-
31	O	-
39	G	-
42	G	-
43	P	-
44	L	-
45	BR	-
46	V	-

JRMWF7347GB

# CHARGING SYSTEM

< SYMPTOM DIAGNOSIS >

## SYMPTOM DIAGNOSIS

### CHARGING SYSTEM

#### Symptom Table

INFOID:000000010840678

Symptom	Reference
Discharged battery	Refer to <a href="#">CHG-3, "Work Flow (With EXP-800 NI or GR8-1200 NI)"</a> or <a href="#">CHG-7, "Work Flow (Without EXP-800 NI or GR8-1200 NI)"</a> .
The charge warning lamp does not illuminate when the ignition switch is set to ON.	
The charge warning lamp does not turn OFF after the engine starts.	
The charging warning lamp turns ON when increasing the engine speed.	

A

B

C

D

E

F

G

H

I

J

K

L

CHG

N

O

P

# PRECAUTIONS

< PRECAUTION >

## PRECAUTION

### PRECAUTIONS

#### EXCEPT FOR MEXICO

#### EXCEPT FOR MEXICO : Precautions for Supplemental Restraint System (SRS) "AIR BAG" and "SEAT BELT PRE-TENSIONER"

INFOID:000000010840679

The Supplemental Restraint System such as "AIR BAG" and "SEAT BELT PRE-TENSIONER", used along with a front seat belt, helps to reduce the risk or severity of injury to the driver and front passenger for certain types of collision. This system includes seat belt switch inputs and dual stage front air bag modules. The SRS system uses the seat belt switches to determine the front air bag deployment, and may only deploy one front air bag, depending on the severity of a collision and whether the front occupants are belted or unbelted. Information necessary to service the system safely is included in the "SRS AIR BAG" and "SEAT BELT" of this Service Manual.

#### **WARNING:**

Always observe the following items for preventing accidental activation.

- To avoid rendering the SRS inoperative, which could increase the risk of personal injury or death in the event of a collision that would result in air bag inflation, all maintenance must be performed by an authorized NISSAN/INFINITI dealer.
- Improper maintenance, including incorrect removal and installation of the SRS, can lead to personal injury caused by unintentional activation of the system. For removal of Spiral Cable and Air Bag Module, see "SRS AIR BAG".
- Never use electrical test equipment on any circuit related to the SRS unless instructed to in this Service Manual. SRS wiring harnesses can be identified by yellow and/or orange harnesses or harness connectors.

#### PRECAUTIONS WHEN USING POWER TOOLS (AIR OR ELECTRIC) AND HAMMERS

#### **WARNING:**

Always observe the following items for preventing accidental activation.

- When working near the Air Bag Diagnosis Sensor Unit or other Air Bag System sensors with the ignition ON or engine running, never use air or electric power tools or strike near the sensor(s) with a hammer. Heavy vibration could activate the sensor(s) and deploy the air bag(s), possibly causing serious injury.
- When using air or electric power tools or hammers, always switch the ignition OFF, disconnect the battery, and wait at least 3 minutes before performing any service.

#### EXCEPT FOR MEXICO : Precaution for Battery Service

INFOID:000000010840680

Before disconnecting the battery, lower both the driver and passenger windows. This will prevent any interference between the window edge and the vehicle when the door is opened/closed. During normal operation, the window slightly raises and lowers automatically to prevent any window to vehicle interference. The automatic window function will not work with the battery disconnected.

#### EXCEPT FOR MEXICO : Precaution for Power Generation Voltage Variable Control System

INFOID:000000010840681

#### **CAUTION:**

For this model, the battery current sensor that is installed to the battery cable at the negative terminal measures the charging/discharging current of the battery, and performs various controls. If the electrical component or the ground wire is connected directly to the battery terminal, the current other than that being measured with the battery current sensor is charging to or discharging from the battery. This condition causes the malfunction of the control, and then the battery discharge may occur. Do not connect the electrical component or the ground wire directly to the battery terminal.



# PRECAUTIONS

< PRECAUTION >

## EXCEPT FOR MEXICO : Precaution for Procedure without Cowl Top Cover

INFOID:0000000011326991

When performing the procedure after removing cowl top cover, cover the lower end of windshield with urethane, etc to prevent damage to windshield.

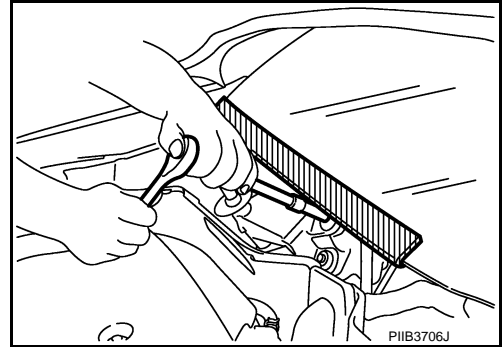

## EXCEPT FOR MEXICO : Precautions For Xenon Headlamp Service

INFOID:0000000011326993

### WARNING:

Comply with the following warnings to prevent any serious accident.

- Disconnect the battery cable (negative terminal) or the power supply fuse before installing, removing, or touching the xenon headlamp (bulb included). The xenon headlamp contains high-voltage generated parts.
- Never work with wet hands.
- Check the xenon headlamp ON-OFF status after assembling it to the vehicle. Never turn the xenon headlamp ON in other conditions. Connect the power supply to the vehicle-side connector. (Turning it ON outside the lamp case may cause fire or visual impairments.)
- Never touch the bulb glass immediately after turning it OFF. It is extremely hot.

### CAUTION:

Comply with the following cautions to prevent any error and malfunction.

- Install the xenon bulb securely. (Insufficient bulb socket installation may melt the bulb, the connector, the housing, etc. by high-voltage leakage or corona discharge.)
- Never perform HID circuit inspection with a tester.
- Never touch the xenon bulb glass with hands. Never put oil and grease on it.
- Dispose of the used xenon bulb after packing it in thick vinyl without breaking it.
- Never wipe out dirt and contamination with organic solvent (thinner, gasoline, etc.).

## EXCEPT FOR MEXICO : Precautions for Removing Battery Terminal

INFOID:0000000011326995

- When removing the 12V battery terminal, turn OFF the ignition switch and wait at least 30 seconds.

### NOTE:

ECU may be active for several tens of seconds after the ignition switch is turned OFF. If the battery terminal is removed before ECU stops, then a DTC detection error or ECU data corruption may occur.

- For vehicles with the 2-batteries, be sure to connect the main battery and the sub battery before turning ON the ignition switch.

### NOTE:

If the ignition switch is turned ON with any one of the terminals of main battery and sub battery disconnected, then DTC may be detected.

- After installing the 12V battery, always check "Self Diagnosis Result" of all ECUs and erase DTC.

### NOTE:

The removal of 12V battery may cause a DTC detection error.

## FOR MEXICO

## FOR MEXICO : Precaution for Supplemental Restraint System (SRS) "AIR BAG" and "SEAT BELT PRE-TENSIONER"

INFOID:0000000010840682

The Supplemental Restraint System such as "AIR BAG" and "SEAT BELT PRE-TENSIONER", used along with a front seat belt, helps to reduce the risk or severity of injury to the driver and front passenger for certain

A  
B  
C  
D  
E  
F  
G  
H  
I  
J  
K  
L  
N  
O  
P

CHG

# PRECAUTIONS

## < PRECAUTION >

types of collision. Information necessary to service the system safely is included in the “SRS AIR BAG” and “SEAT BELT” of this Service Manual.

### **WARNING:**

Always observe the following items for preventing accidental activation.

- To avoid rendering the SRS inoperative, which could increase the risk of personal injury or death in the event of a collision that would result in air bag inflation, all maintenance must be performed by an authorized NISSAN/INFINITI dealer.
- Improper maintenance, including incorrect removal and installation of the SRS, can lead to personal injury caused by unintentional activation of the system. For removal of Spiral Cable and Air Bag Module, see “SRS AIR BAG”.
- Never use electrical test equipment on any circuit related to the SRS unless instructed to in this Service Manual. SRS wiring harnesses can be identified by yellow and/or orange harnesses or harness connectors.

## PRECAUTIONS WHEN USING POWER TOOLS (AIR OR ELECTRIC) AND HAMMERS

### **WARNING:**

Always observe the following items for preventing accidental activation.

- When working near the Air Bag Diagnosis Sensor Unit or other Air Bag System sensors with the ignition ON or engine running, never use air or electric power tools or strike near the sensor(s) with a hammer. Heavy vibration could activate the sensor(s) and deploy the air bag(s), possibly causing serious injury.
- When using air or electric power tools or hammers, always switch the ignition OFF, disconnect the battery, and wait at least 3 minutes before performing any service.

## FOR MEXICO : Precaution for Battery Service

INFOID:0000000110840683

Before disconnecting the battery, lower both the driver and passenger windows. This will prevent any interference between the window edge and the vehicle when the door is opened/closed. During normal operation, the window slightly raises and lowers automatically to prevent any window to vehicle interference. The automatic window function will not work with the battery disconnected.

## FOR MEXICO : Precaution for Power Generation Voltage Variable Control System

INFOID:0000000110840684

### **CAUTION:**

For this model, the battery current sensor that is installed to the battery cable at the negative terminal measures the charging/discharging current of the battery, and performs various controls. If the electrical component or the ground wire is connected directly to the battery terminal, the current other than that being measured with the battery current sensor is charging to or discharging from the battery. This condition causes the malfunction of the control, and then the battery discharge may occur. Do not connect the electrical component or the ground wire directly to the battery terminal.

## FOR MEXICO : Precaution for Procedure without Cowl Top Cover

INFOID:000000011326992

When performing the procedure after removing cowl top cover, cover the lower end of windshield with urethane, etc to prevent damage to windshield.

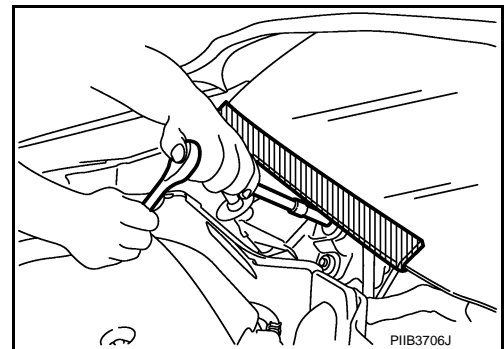

## FOR MEXICO : Precautions For Xenon Headlamp Service

INFOID:000000011326994

### **WARNING:**

Comply with the following warnings to prevent any serious accident.

# PRECAUTIONS

## < PRECAUTION >

- Disconnect the battery cable (negative terminal) or the power supply fuse before installing, removing, or touching the xenon headlamp (bulb included). The xenon headlamp contains high-voltage generated parts.
- Never work with wet hands.
- Check the xenon headlamp ON-OFF status after assembling it to the vehicle. Never turn the xenon headlamp ON in other conditions. Connect the power supply to the vehicle-side connector. (Turning it ON outside the lamp case may cause fire or visual impairments.)
- Never touch the bulb glass immediately after turning it OFF. It is extremely hot.

### CAUTION:

Comply with the following cautions to prevent any error and malfunction.

- Install the xenon bulb securely. (Insufficient bulb socket installation may melt the bulb, the connector, the housing, etc. by high-voltage leakage or corona discharge.)
- Never perform HID circuit inspection with a tester.
- Never touch the xenon bulb glass with hands. Never put oil and grease on it.
- Dispose of the used xenon bulb after packing it in thick vinyl without breaking it.
- Never wipe out dirt and contamination with organic solvent (thinner, gasoline, etc.).

## FOR MEXICO : Precautions for Removing Battery Terminal

INFOID:000000011326996

- When removing the 12V battery terminal, turn OFF the ignition switch and wait at least 30 seconds.

### NOTE:

ECU may be active for several tens of seconds after the ignition switch is turned OFF. If the battery terminal is removed before ECU stops, then a DTC detection error or ECU data corruption may occur.

- For vehicles with the 2-batteries, be sure to connect the main battery and the sub battery before turning ON the ignition switch.

### NOTE:

If the ignition switch is turned ON with any one of the terminals of main battery and sub battery disconnected, then DTC may be detected.

- After installing the 12V battery, always check "Self Diagnosis Result" of all ECUs and erase DTC.

### NOTE:

The removal of 12V battery may cause a DTC detection error.

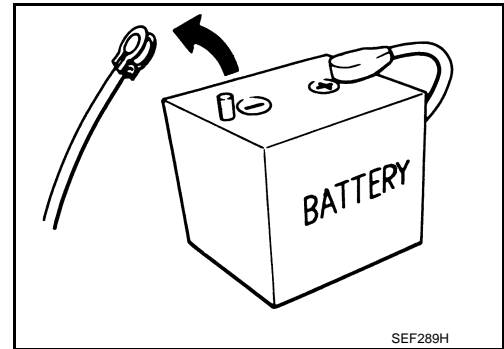

A  
B  
C  
D  
E  
F  
G  
H  
I  
J  
K  
L

CHG

N  
O  
P

# PREPARATION

< PREPARATION >

## PREPARATION

### PREPARATION

#### Special Service Tools

INFOID:000000010840685

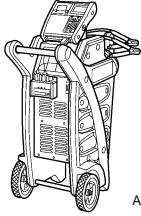
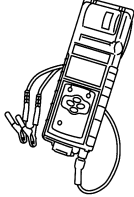
Tool number (Kent-Moore No.) Tool name	Description
<p>— (—) Model GR8-1200 NI Multitasking battery and electrical diagnostic station</p>  <p style="text-align: right; font-size: small;">AWIA1239ZZ</p>	<p>Tests batteries, starting and charging systems and charges batteries. For operating instructions, refer to diagnostic station instruction manual.</p>
<p>— (—) Model EXP-800 NI Battery and electrical diagnostic analyzer</p>  <p style="text-align: right; font-size: small;">JSMIA0806ZZ</p>	<p>Tests batteries and charging systems. For operating instructions, refer to diagnostic analyzer instruction manual.</p>

#### Commercial Service Tools

INFOID:000000010840686

Tool name	Description
<p>Power tool</p>  <p style="text-align: right; font-size: small;">PIIB1407E</p>	<p>Loosening bolts, nuts and screws</p>

# CHARGING SYSTEM PRELIMINARY INSPECTION

< PERIODIC MAINTENANCE >

## PERIODIC MAINTENANCE

### CHARGING SYSTEM PRELIMINARY INSPECTION

#### Inspection Procedure

INFOID:0000000010840687

#### 1. CHECK BATTERY TERMINALS CONNECTION

Check if battery terminals are clean and tight.

Is the inspection result normal?

YES >> GO TO 2.

NO >> Repair battery terminals connection.

#### 2. CHECK FUSE

Check for blown fuse and fusible link.

Unit	Power source (Power supply terminals)	Fuse No.
Alternator	Battery ("S" terminal)	32
Combination meter	Ignition switch ON ("L" terminal)	4

Is the inspection result normal?

YES >> GO TO 3.

NO >> Be sure to eliminate the cause of malfunction before installing new fuse.

#### 3. CHECK "E" TERMINAL CONNECTION (ALTERNATOR GROUND)

Check if "E" terminal (alternator ground) is clean and tight.

Is the inspection result normal?

YES >> GO TO 4.

NO >> Repair "E" terminal (alternator ground) connection.

#### 4. CHECK DRIVE BELT TENSION

Check drive belt tension. Refer to [EM-18. "Checking"](#).

Is the inspection result normal?

YES >> INSPECTION END

NO >> Repair as needed.

A  
B  
C  
D  
E  
F  
G  
H  
I  
J  
K  
L  
N  
O  
P

CHG

# POWER GENERATION VOLTAGE VARIABLE CONTROL SYSTEM OPERATION INSPECTION

< PERIODIC MAINTENANCE >

## POWER GENERATION VOLTAGE VARIABLE CONTROL SYSTEM OPERATION INSPECTION

### Inspection Procedure

INFOID:000000010840688

#### CAUTION:

When performing this inspection, always use a charged battery that has completed the battery inspection. (When the charging rate of the battery is low, the response speed of the voltage change will become slow. This can cause an incorrect inspection.)

#### 1. CHECK ECM (CONSULT)

Perform ECM self-diagnosis with CONSULT. Refer to [EC-155, "CONSULT Function"](#).

##### Self-diagnostic results content

No malfunction detected>> GO TO 2.

Malfunction detected>> Check applicable parts, and repair or replace corresponding parts.

#### 2. CHECK OPERATION OF POWER GENERATION VOLTAGE VARIABLE CONTROL SYSTEM

1. Connect CONSULT and start the engine.
2. The selector lever is in "P" or "N" position (A/T models) or shifter lever is in neutral position (M/T models) and all of the electric loads and A/C, etc. are turned OFF.
3. Select "ALTERNATOR DUTY" at "Active Test" of "ENGINE", and then check the value of "BATTERY VOLT" monitor when DUTY value of "ALTERNATOR DUTY" is set to 40.0%.

##### "BATTERY VOLT"

**2 seconds after setting the DUTY value of "ALTERNATOR DUTY" to 40.0%** : 12 - 13.6 V

4. Check the value of "BATTERY VOLT" monitor when DUTY value of "ALTERNATOR DUTY" is set to 80.0%.

##### "BATTERY VOLT"

**20 seconds after setting the DUTY value of "ALTERNATOR DUTY" to 80.0%** : +0.5 V or more against the value of "BATTERY VOLT" monitor when DUTY value is 40.0%

Is the measurement value within the specification?

YES >> INSPECTION END

NO >> GO TO 3.

#### 3. CHECK IPDM E/R (CONSULT)

Perform IPDM E/R self-diagnosis with CONSULT. Refer to [PCS-12, "CONSULT Function \(IPDM E/R\)"](#).

##### Self-diagnostic results content

No malfunction detected>> GO TO 4.

Malfunction detected>> Check applicable parts, and repair or replace corresponding parts.

#### 4. CHECK HARNESS BETWEEN ALTERNATOR AND IPDM E/R

1. Turn ignition switch OFF.
2. Disconnect alternator connector and IPDM E/R connector.
3. Check continuity between alternator harness connector and IPDM E/R harness connector.

Alternator harness connector		IPDM E/R harness connector		Continuity
Connector	Terminal	Connector	Terminal	
F36	4	E7	76	Existed

4. Check continuity between alternator harness connector and ground.

# POWER GENERATION VOLTAGE VARIABLE CONTROL SYSTEM OPERATION INSPECTION

< PERIODIC MAINTENANCE >

Alternator harness connector		Ground	Continuity
Connector	Terminal		
F36	4		Not existed

Is the inspection result normal?

YES >> Replace IPDM E/R.

NO >> Repair harness or connector between IPDM E/R and alternator.

A  
B  
C  
D  
E  
F  
G  
H  
I  
J  
K  
L

**CHG**

N  
O  
P

# ALTERNATOR

< REMOVAL AND INSTALLATION >

## REMOVAL AND INSTALLATION

### ALTERNATOR

Exploded View

INFOID:000000010840689

#### REMOVAL

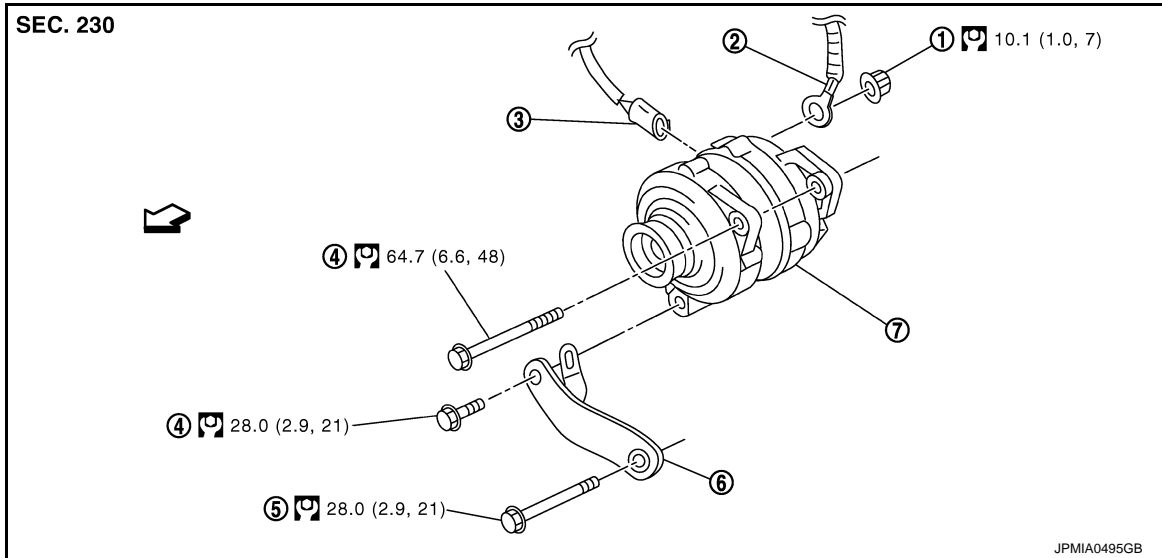

- |                             |                                  |                         |
|-----------------------------|----------------------------------|-------------------------|
| 1. "B" terminal nut         | 2. "B" terminal harness          | 3. Alternator connector |
| 4. Alternator mounting bolt | 5. Alternator stay mounting bolt | 6. Alternator stay      |
| 7. Alternator               |                                  |                         |
- ← : Engine front
- : N·m (kg-m, ft-lb)

#### DISASSEMBLY



# ALTERNATOR

## < REMOVAL AND INSTALLATION >

Type: A003TJ1991B

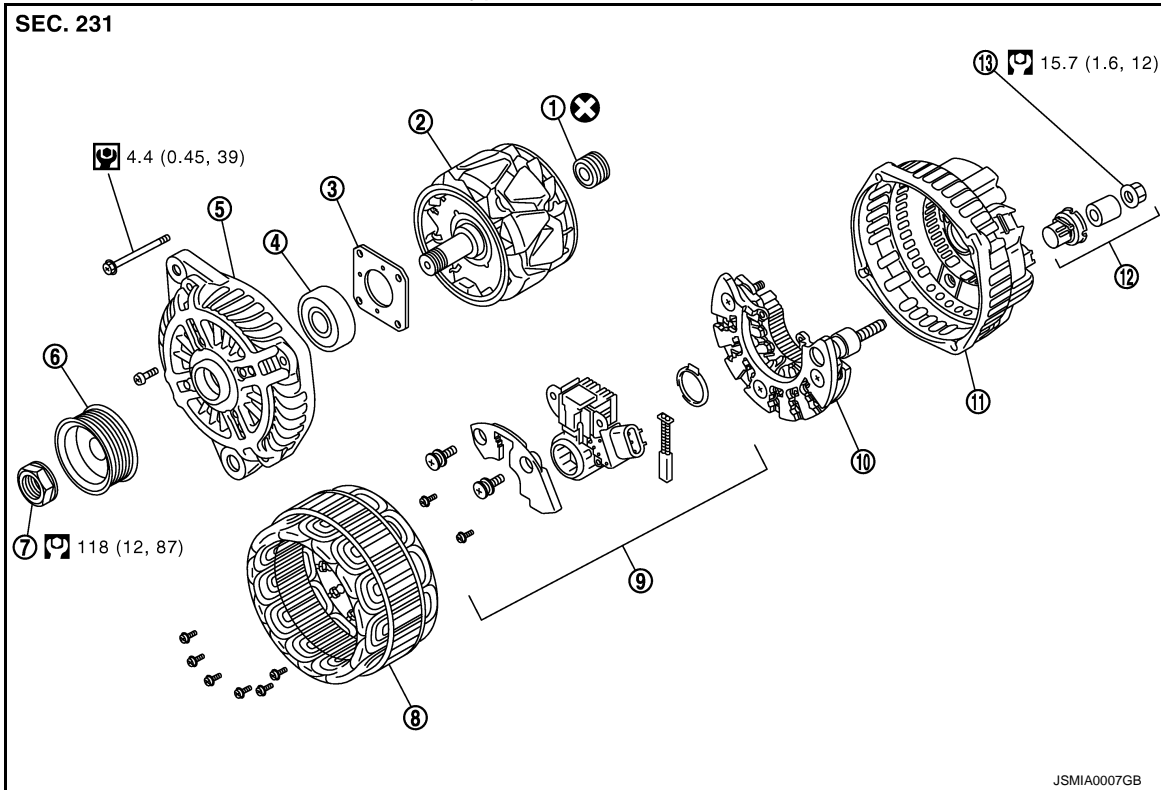

- |                      |                           |                                  |
|----------------------|---------------------------|----------------------------------|
| 1. Rear bearing      | 2. Rotor assembly         | 3. Retainer                      |
| 4. Front bearing     | 5. Front bracket assembly | 6. Pulley                        |
| 7. Pulley nut        | 8. Stator assembly        | 9. IC voltage regulator assembly |
| 10. Diode assembly   | 11. Rear bracket assembly | 12. Terminal set                 |
| 13. "B" terminal nut |                           |                                  |

⊗ : Always replace after every disassembly.

Ⓜ : N·m (kg·m, ft·lb)

Ⓜ : N·m (kg·m, in·lb)

## Removal and Installation

INFOID:0000000010840690

### REMOVAL

1. Disconnect the battery cable from the negative terminal. Refer to [PG-106, "Removal and Installation"](#).
2. Remove engine front undercover, using power tools.
3. Remove radiator cooling fan assembly. Refer to [CO-22, "Exploded View"](#).
4. Remove drive belt. Refer to [EM-18, "Removal and Installation"](#).
5. Disconnect alternator connector (1).
6. Remove "B" terminal nut (A).
7. Remove the harness bracket bolts (B).

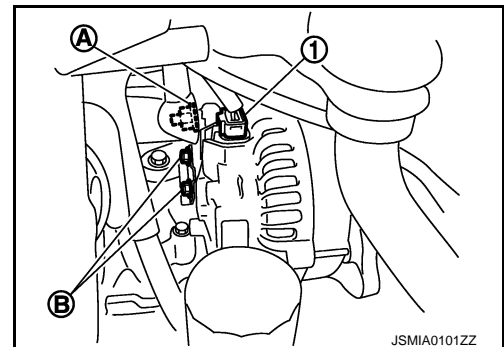

JSMIA0101ZZ

# ALTERNATOR

## < REMOVAL AND INSTALLATION >

8. Remove oil pressure switch harness clip (C) from alternator stay (1).
9. Disconnect oil pressure switch connector (D) and oil temperature sensor connector (E).
10. Remove alternator mounting bolt (B) and alternator stay mounting bolt (F) using power tools, then remove alternator stay.
11. Remove alternator mounting bolt (A), using power tools.

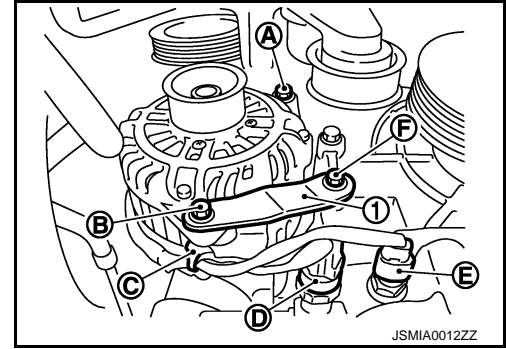

12. Remove alternator assembly downward from the vehicle.

## INSTALLATION

Install in the reverse order of removal.

### **CAUTION:**

**Be sure to tighten "B" terminal nut carefully.**

- Install alternator, and check tension of belt. Refer to [EM-18, "Checking"](#).
- For this model, the power generation voltage variable control system that controls the power generation voltage of the alternator has been adopted. Therefore, the power generation voltage variable control system operation inspection should be performed after replacing the alternator, and then make sure that the system operates normally. Refer to [CHG-30, "Inspection Procedure"](#).

## Inspection

INFOID:000000010840691

## ALTERNATOR PULLEY INSPECTION

Perform the following.

- Make sure that alternator pulley does not rattle.
- Make sure that alternator pulley nut is tight. Refer to [CHG-32, "Exploded View"](#).

# SERVICE DATA AND SPECIFICATIONS (SDS)

< SERVICE DATA AND SPECIFICATIONS (SDS)

## SERVICE DATA AND SPECIFICATIONS (SDS)

### SERVICE DATA AND SPECIFICATIONS (SDS)

Alternator

INFOID:0000000010840692

Type		A003TJ1991B
		MITSUBISHI make
Nominal rating	[V - A]	12 -130
Ground polarity		Negative
Minimum revolution under no-load (When 13.5 V is applied)	[rpm]	Less than 1,300
Hot output current (When 13.5 V is applied)	[A/rpm]	More than 108/2,500 More than 124/5,000
Regulated output voltage	[V]	14.1 - 14.7*

\*: Adjustment range of power generation voltage variable control is 11.4 - 15.6 V.

A  
B  
C  
D  
E  
F  
G  
H  
I  
J  
K  
L  
N  
O  
P

CHG